

**MECCANO**<sup>TM</sup>  
M A K E R S Y S T E M

**THUNDERBIRD 2**  
AUXILIARY EQUIPMENT TRANSPORT  
TRANSPORT D'ENGINS DE SAUVETAGE

15309

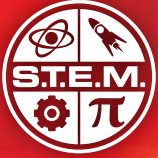

 **12+**

Instructions  
Notice de montage  
Instrucciones de construccion  
Bauanleitung

Bouwinstructie  
Istruzioni  
Instruções  
Инструкции



## NEW TOOLS / NOUVEAUX OUTILS

NUEVAS HERRAMIENTAS / NEUE WERKZEUGE

NIEUW GEREEDSCHAP / NUOVI ATTREZZI

NOVAS FERRAMENTAS / НОВЫЕ ИНСТРУМЕНТЫ

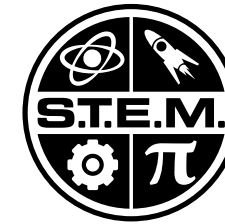
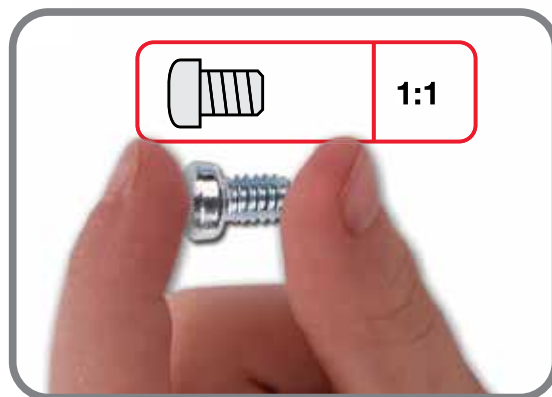
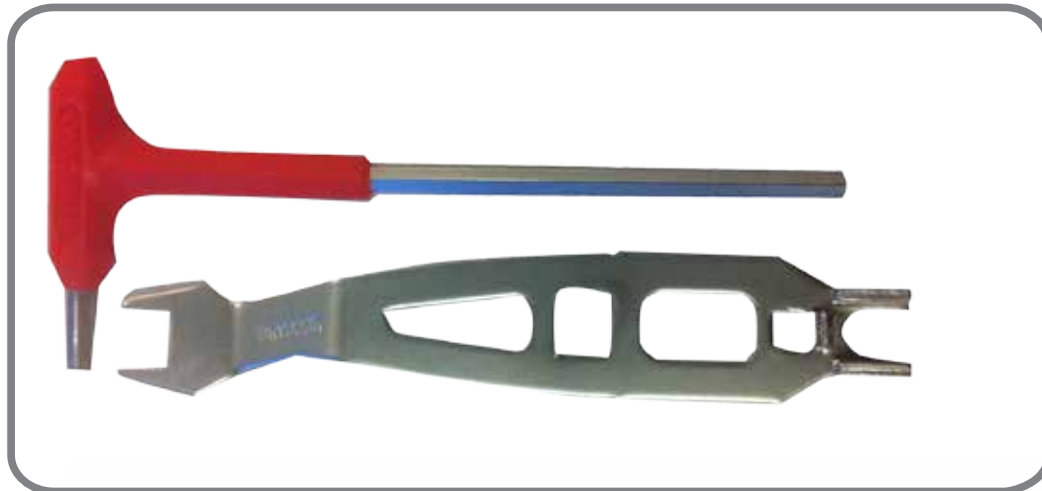

**GB.** For information on how this product supports today's STEM curriculum, visit [www.meccano.com](http://www.meccano.com).

**F.** Pour découvrir l'intérêt pédagogique de ce produit dans le cadre des matières STEM, rendez-vous sur [www.meccano.com](http://www.meccano.com).

**E.** Para mayor información sobre cómo este producto respalda las materias STEM visita: [www.meccano.com](http://www.meccano.com).

**D.** Für Informationen wie dieses Produkt den technisch-mathematischen Lehrplan (STEM) unterstützt, besuchen Sie bitte [www.meccano.com](http://www.meccano.com).

**NL.** Ga naar [www.meccano.com](http://www.meccano.com) voor meer informatie over hoe dit product het huidige STEM-curriculum ondersteunt.

**I.** Per informazioni su come questo prodotto contribuisce ad aiutare i ragazzi nelle materie STEM "scientifiche e tecniche", visitare il sito [www.meccano.com](http://www.meccano.com).

**P.** Para informações sobre a compatibilidade deste produto com os programas atuais STEM, acesse [www.meccano.com](http://www.meccano.com).

**R.** Информация о том, как с помощью этого продукта можно повысить эффективность процесса изучения дисциплин STEM, представлена на сайте [www.meccano.com](http://www.meccano.com).

# TABLE OF CONTENTS/SOMMAIRE

ÍNDICE / INHALTSVERZEICHNIS / INHOUD / INDICE / ÍNDICE / СОДЕРЖАНИЕ



- GB. Content : 627 parts, 2 real tools, 1 sticker sheet and 1 instruction sheet for 1 model.  
F. Contenu : 627 pièces, 2 vrais outils, 1 feuillet d'autocollants et 1 notice de montage pour 1 modèle.  
E. Contenido: 627 piezas, 2 herramientas reales, 1 hoja de calcomanías y 1 guía de instrucciones para 1 modelo.  
D. Inhalt: 627 Teile, 2 echte Werkzeuge, 1 Bogen mit Aufklebern und 1 Bauanleitung für 1 Modell.  
NL. Inhoud: 627 onderdelen, 2 stuks gereedschap, 1 stickervel en 1 bouwinstructie voor 1 model.  
I. Contenuto: 627 pezzi, 2 attrezzi, 1 foglio di adesivi e 1 guida per l'uso per 1 modello.  
P. Conteúdo: 627 peças, 2 ferramentas reais, 1 cartela de adesivos e 1 folha de instruções para 1 modelo.  
R. В коробке: 627 деталей, 2 настоящих инструмента, 1 лист с наклейками и 1 инструкция по сборке 1 модели.



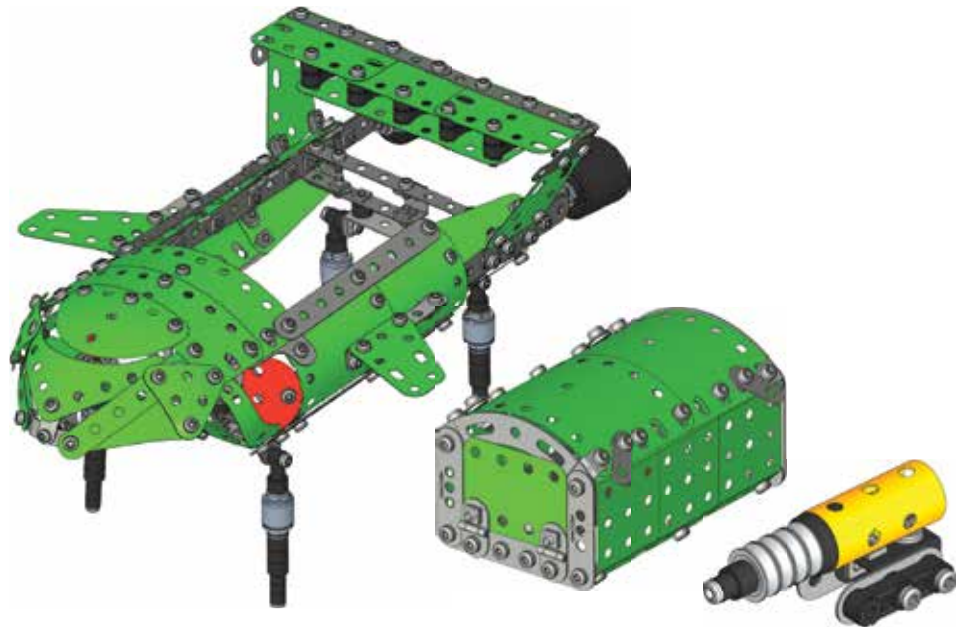

- 1**
- x1
  - 5,8 mm | 15/64" x1
  - 5,8 mm | 15/64" x1
  - 5,8 mm | 15/64" x1
  - S1 1:1

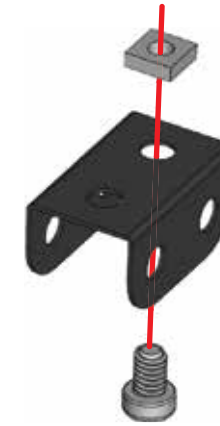

- 2**
- x1
  - 12 mm | 1/2" x1
  - 12 mm | 1/2" x1
  - 12 mm | 1/2" x1
  - 12 mm | 1/2" x1
  - S3 1:1

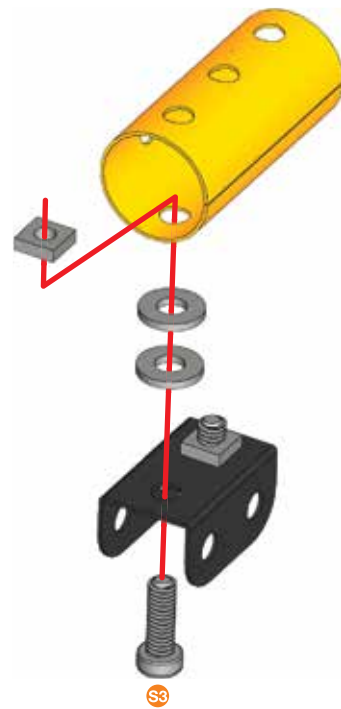

- 3**
- x1
  - x1
  - 9,5 mm | 3/8" x2
  - 9,5 mm | 3/8" x2
  - S2 1:1

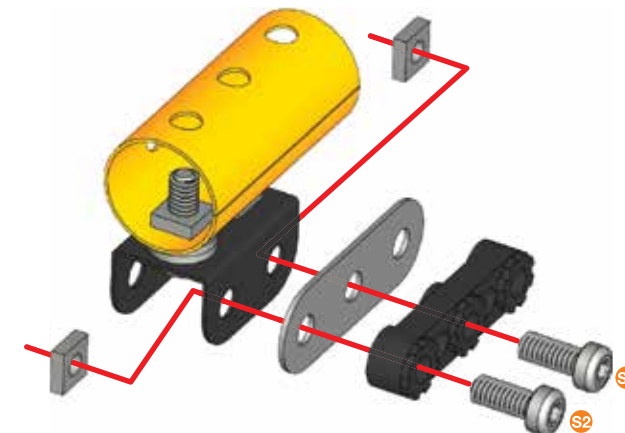

4

- x1
- x1
- x2
- x2

- 1:1

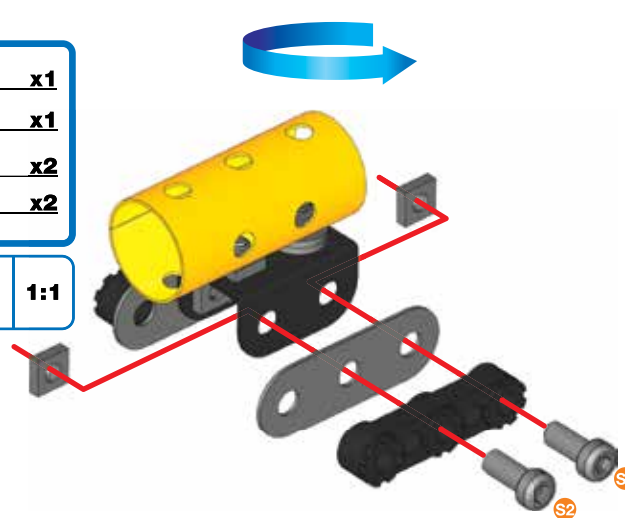

5

- x1
- x1
- x1
- x2
- x1
- x1

- x1
- x1
- x1
- x1

- 1:1

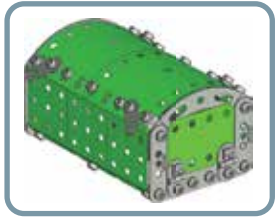
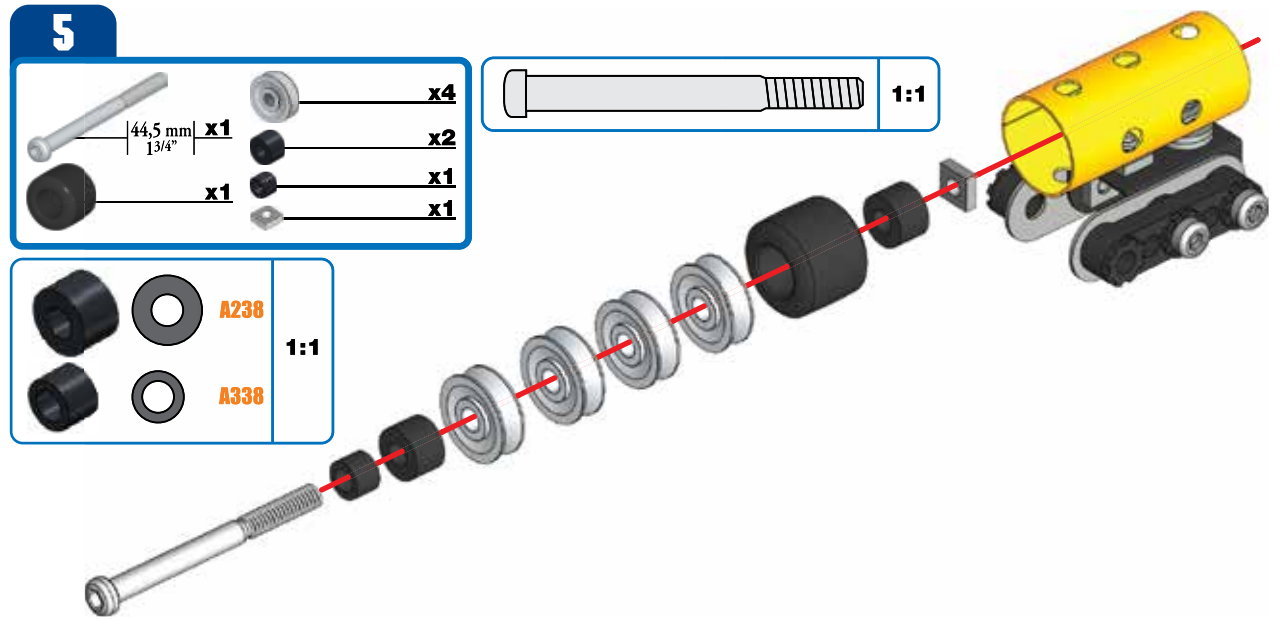

6

- x1
- x1
- x1
- x1
- x1
- x2
- x2

- 1:1

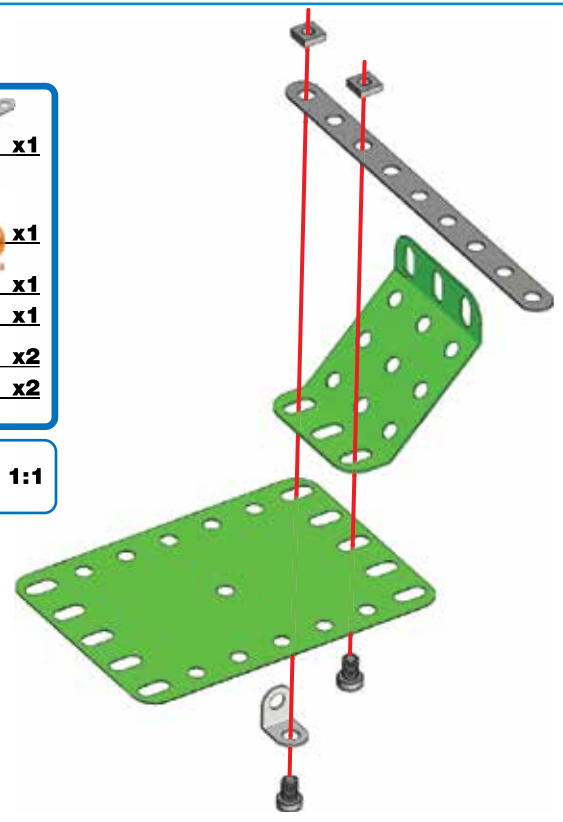



7

- x1
- x1
- x1
- x2
- x2

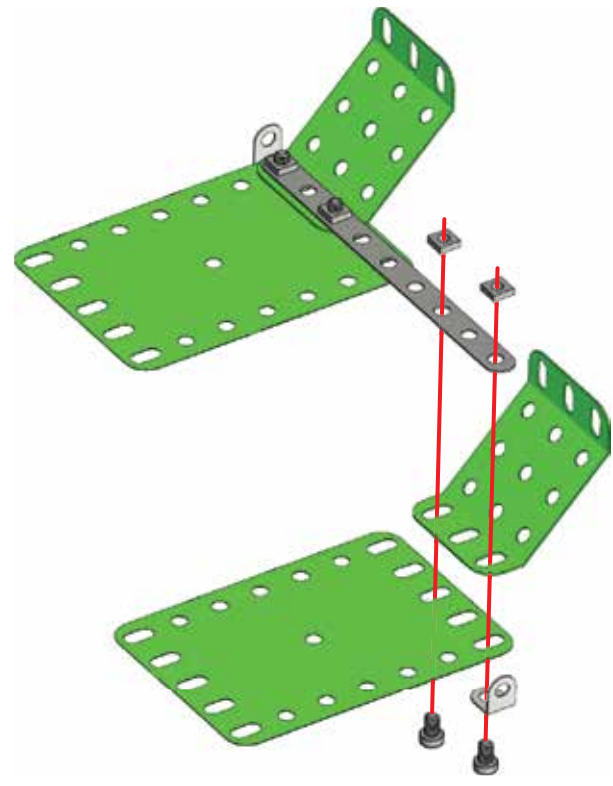
- 1:1





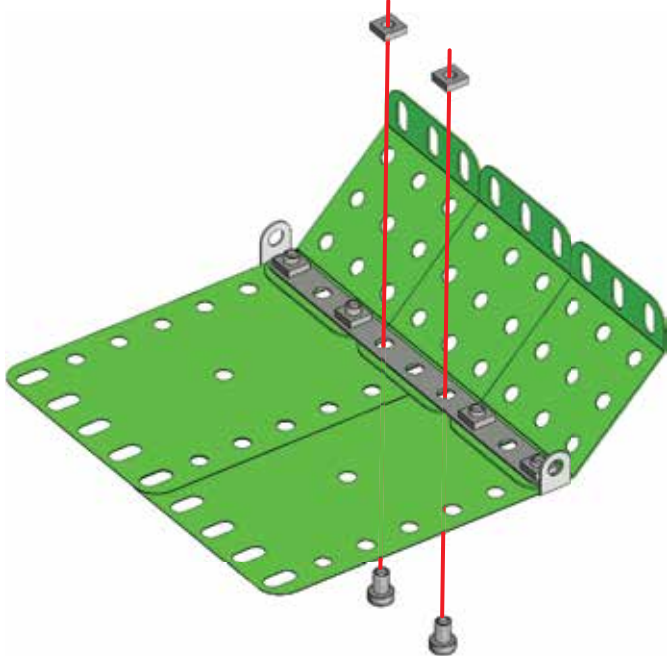

**8**

	<b>x1</b>
 5,8 mm	<b>x2</b>
	<b>x2</b>

	<b>S1</b>	<b>1:1</b>
---	-----------	------------





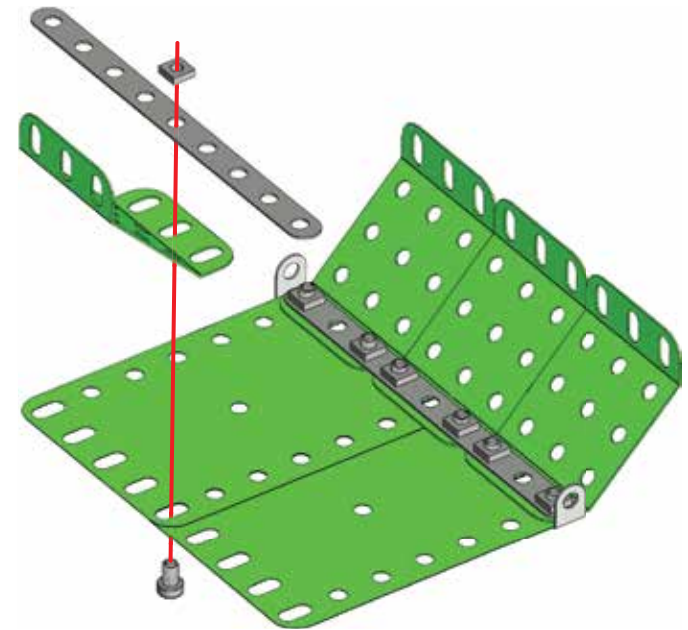

**9**

	<b>x1</b>
	<b>x1</b>
 5,8 mm	<b>x1</b>
	<b>x1</b>

	<b>S1</b>	<b>1:1</b>
---	-----------	------------





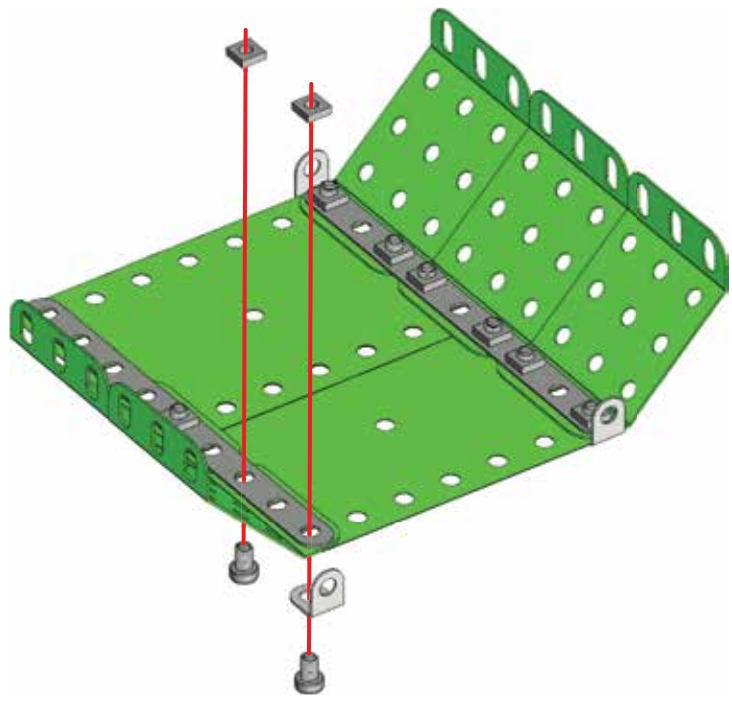

**10**

	<b>x1</b>
	<b>x1</b>
 5,8 mm	<b>x2</b>
	<b>x2</b>

	<b>S1</b>	<b>1:1</b>
---	-----------	------------



**11**



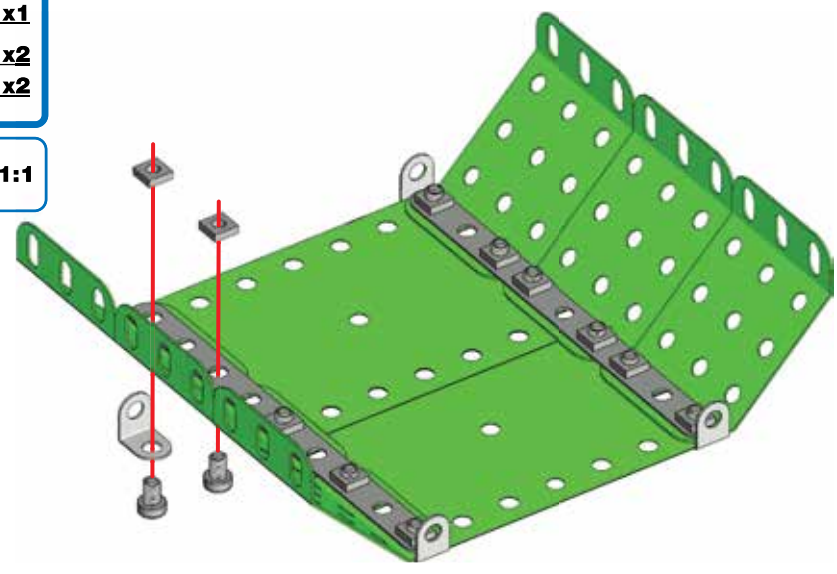

	<b>x1</b>
	<b>x1</b>
 5,8 mm	<b>x2</b>
	<b>x2</b>

	<b>S1</b>	<b>1:1</b>
---	-----------	------------







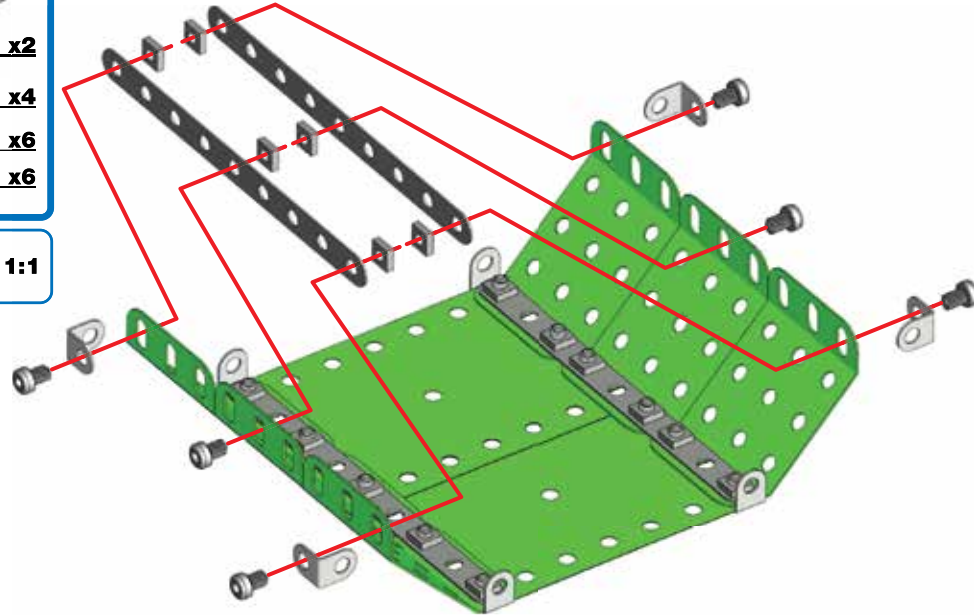

12

-  x2
-  x4
-  x6
-  x6

-  1:1





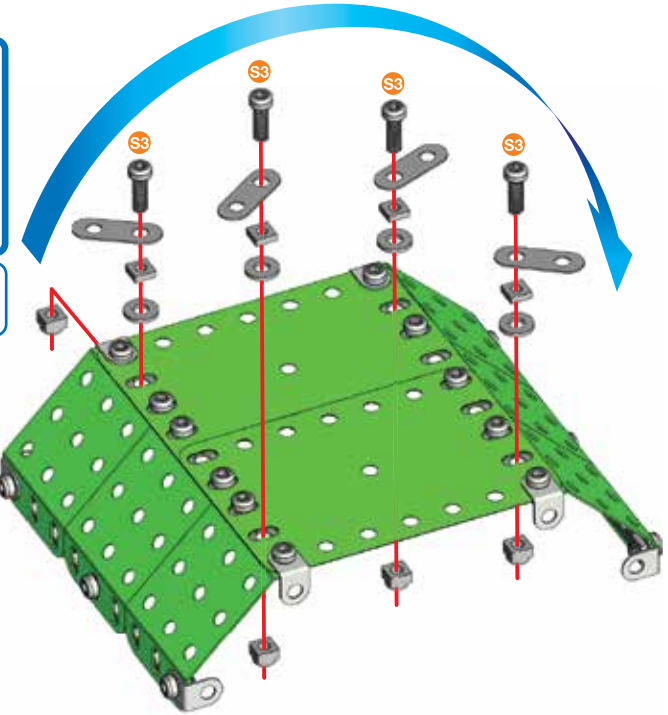
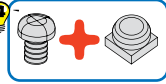

13

-  x4
-  x4
-  x4
-  x4

-  1:1





14

-  x1
-  x2
-  x2
-  x2

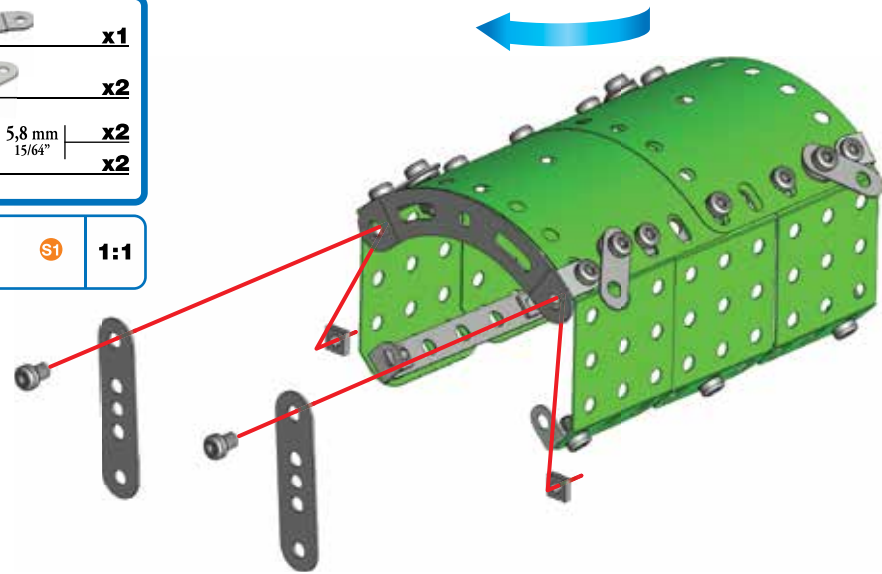
-  1:1



15

-  x1
-  x2
-  x2

-  1:1

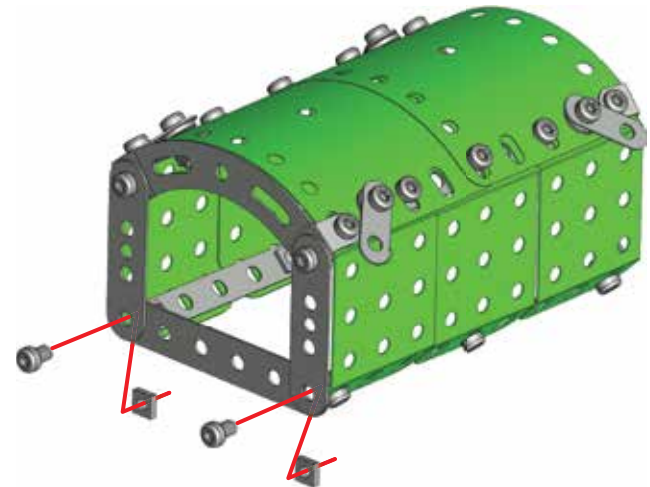

**16**

	<b>x1</b>
	<b>x2</b>
	<b>x2</b>
	<b>x2</b>

	<b>1:1</b>
--	------------

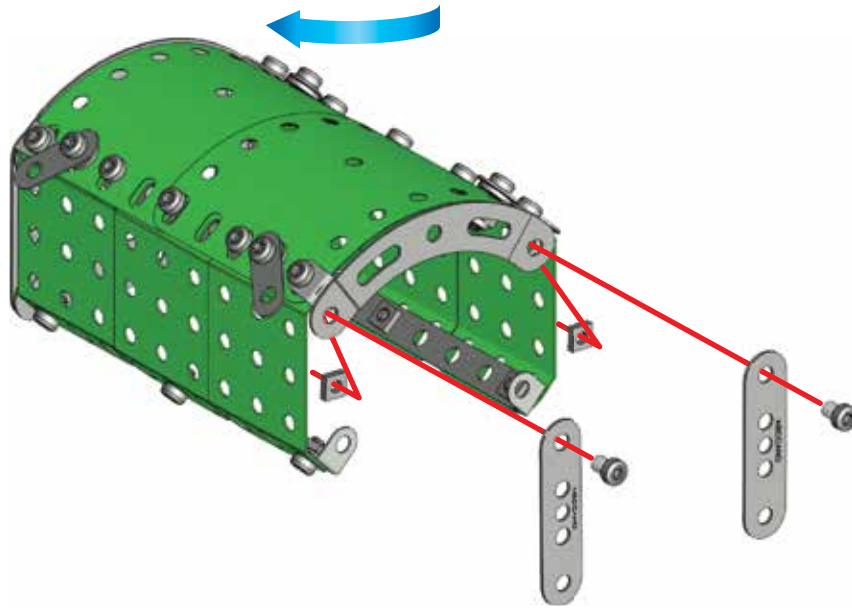

**17**

	<b>x1</b>
	<b>x2</b>
	<b>x2</b>

	<b>1:1</b>
--	------------

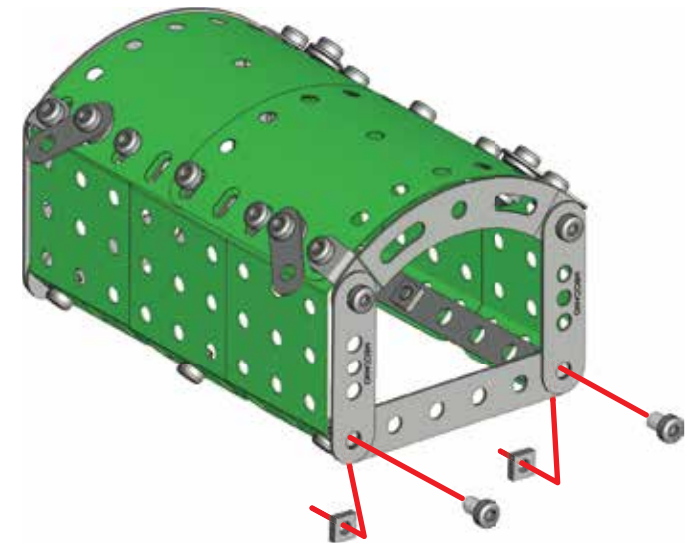

**18**

	<b>x1</b>
	<b>x1</b>
	<b>x1</b>
	<b>x1</b>

	<b>1:1</b>
--	------------

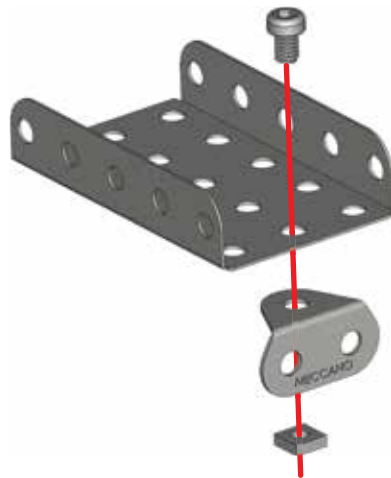

**19** (17)+(18)+

	<b>x2</b>
	<b>x2</b>
	<b>x2</b>

	<b>1:1</b>
--	------------

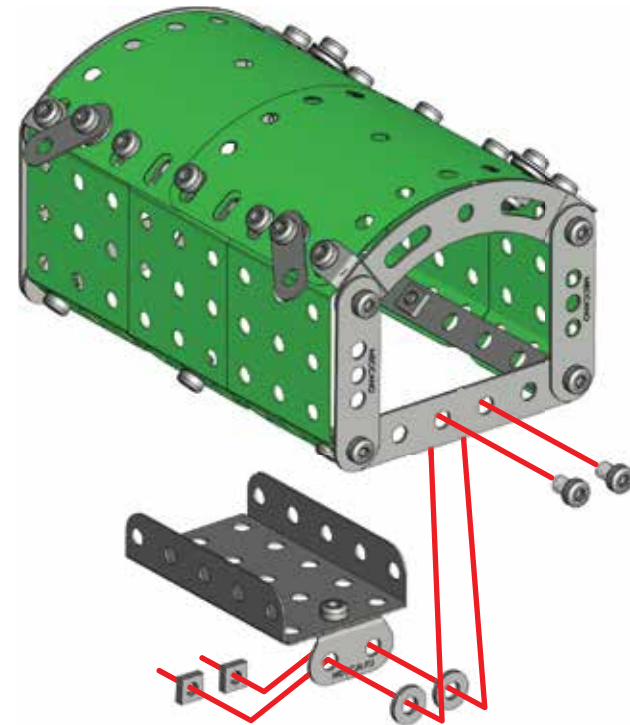



**20**

	<b>x1</b>
	<b>x2</b>
	<b>x2</b>
	<b>x2</b>

	<b>1:1</b>
--	------------

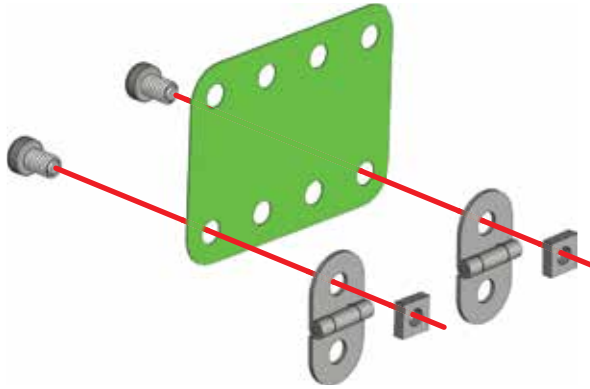

**21** (19)+(20)+

	<b>x2</b>
	<b>x2</b>

	<b>1:1</b>
--	------------

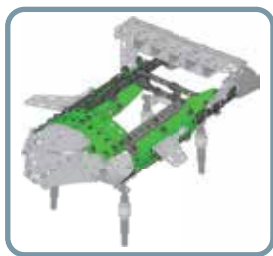
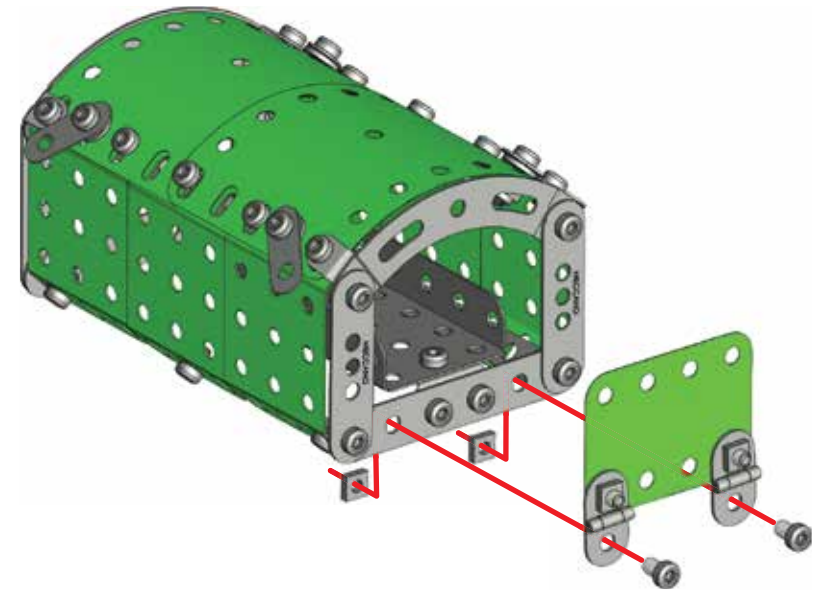

**22**

	<b>x2</b>
	<b>x2</b>
	<b>x6</b>
	<b>x2</b>
	<b>x6</b>
	<b>x6</b>

	<b>1:1</b>
--	------------

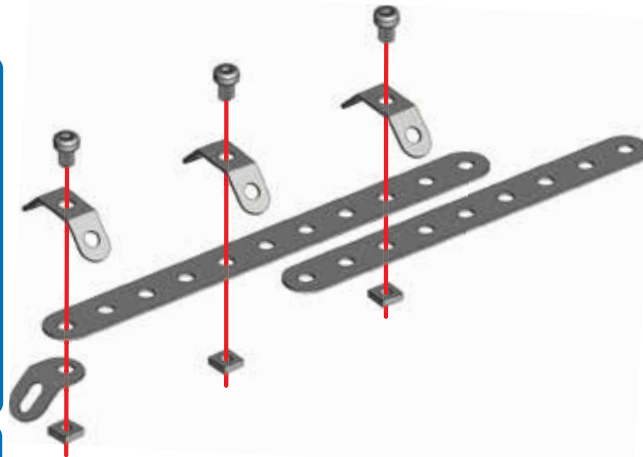



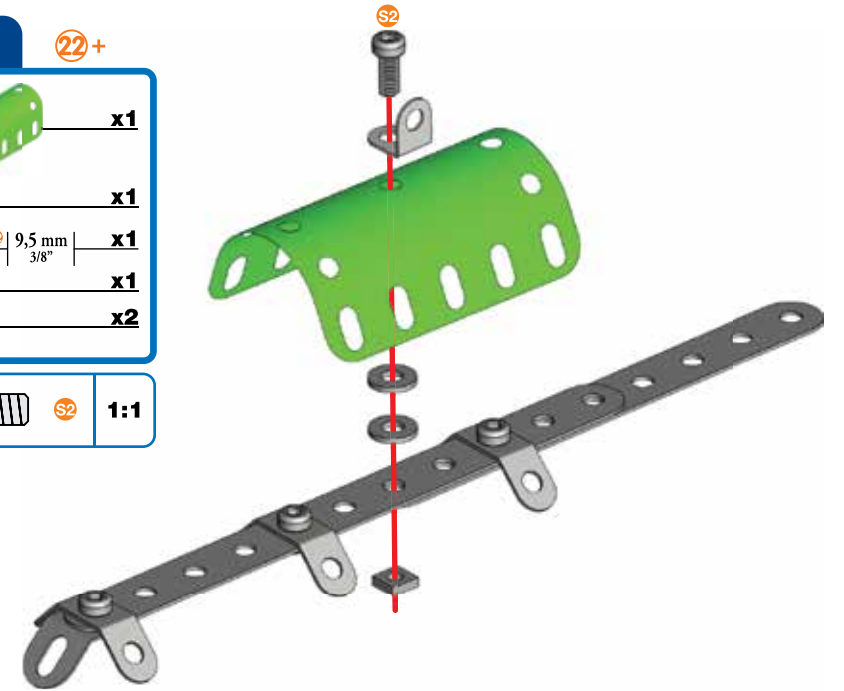

**23** (22)+

	<b>x1</b>
	<b>x1</b>
	<b>x1</b>
	<b>x1</b>
	<b>x2</b>

	<b>1:1</b>
--	------------





24

-  x1
-  x1
-  9,5 mm | 3/8" x1
-  x1
-  x2

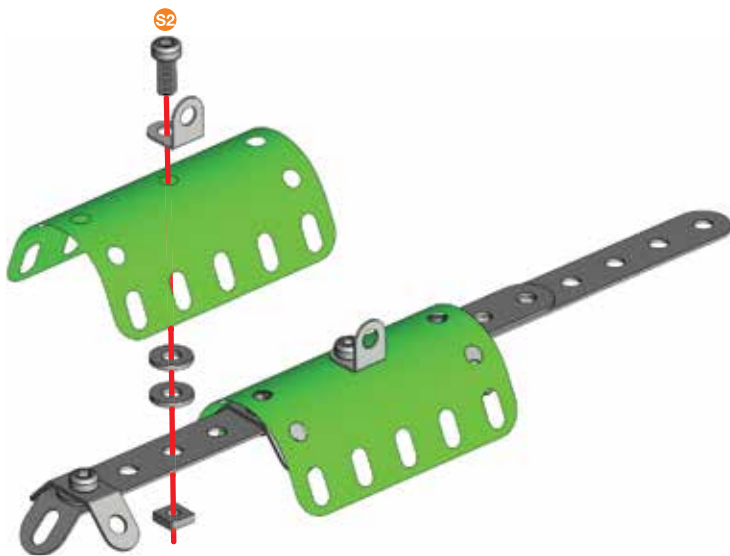
-  S2 1:1





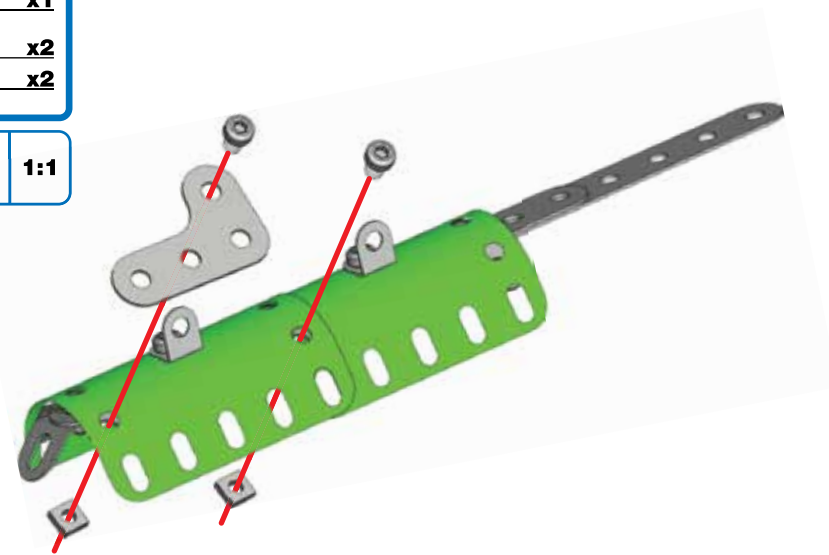

25

-  x1
-  5,8 mm | 15/64" x2
-  x2

-  S1 1:1





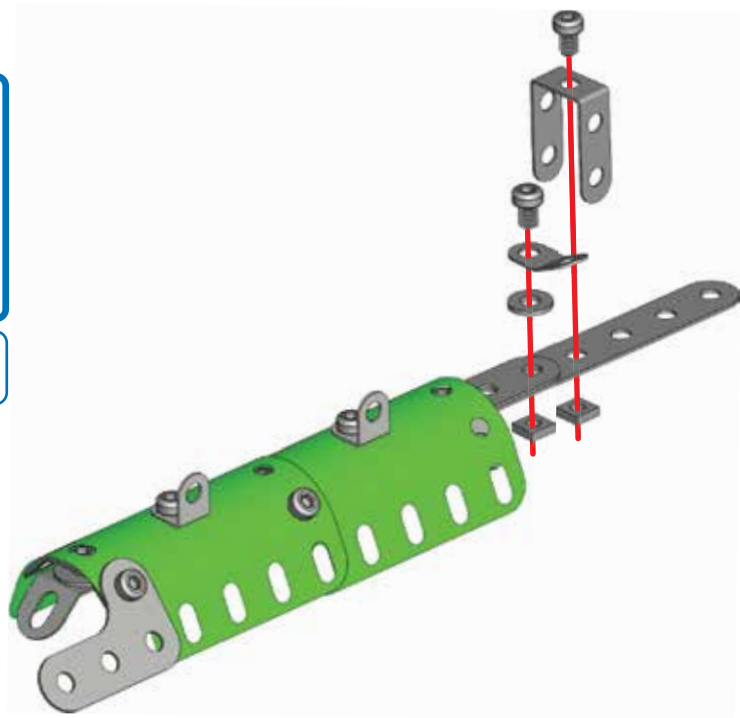

26

-  x1
-  x1
-  5,8 mm | 15/64" x2
-  x2
-  x1

-  S1 1:1



27

-  x1
-  x1
-  5,8 mm | 15/64" x1
-  x1
-  x1

-  S1 1:1

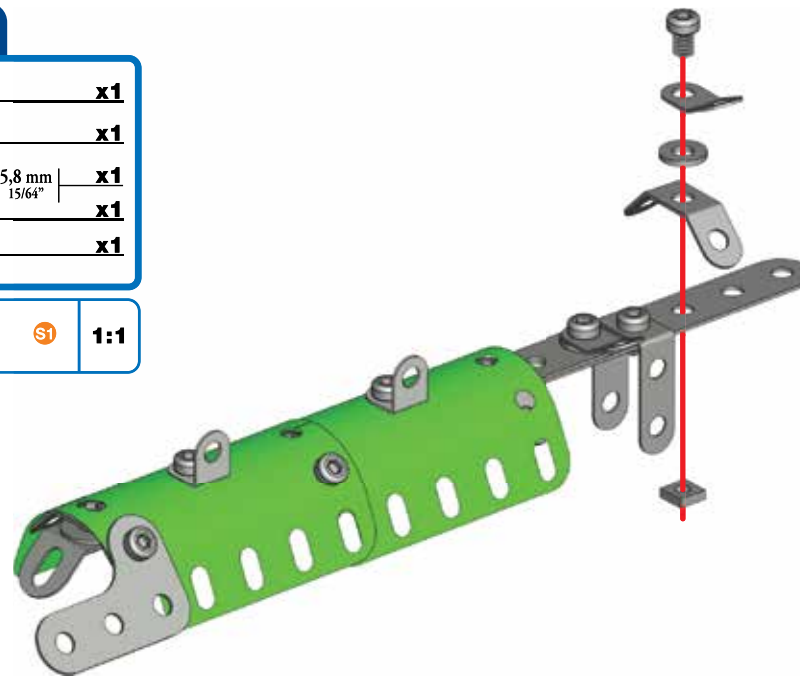

**28** 22+

	x1
	x1
	x1
	x1
	x2

	<span style="border: 1px solid black; border-radius: 50%; padding: 2px;">S2</span> 1:1
--	--

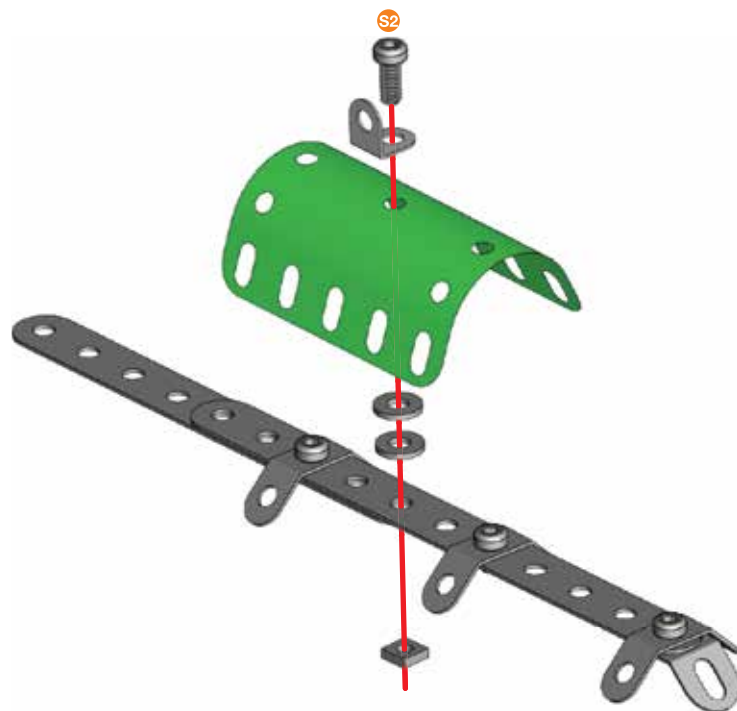

**29**

	x1
	x1
	x1
	x1
	x2

	<span style="border: 1px solid black; border-radius: 50%; padding: 2px;">S2</span> 1:1
--	--

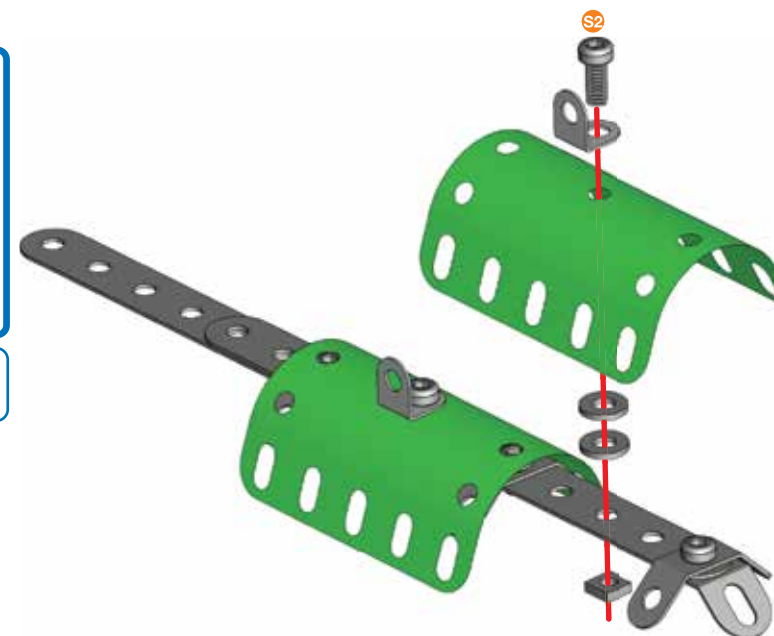

**30**

	x1
	x2
	x2

	<span style="border: 1px solid black; border-radius: 50%; padding: 2px;">S1</span> 1:1
--	--

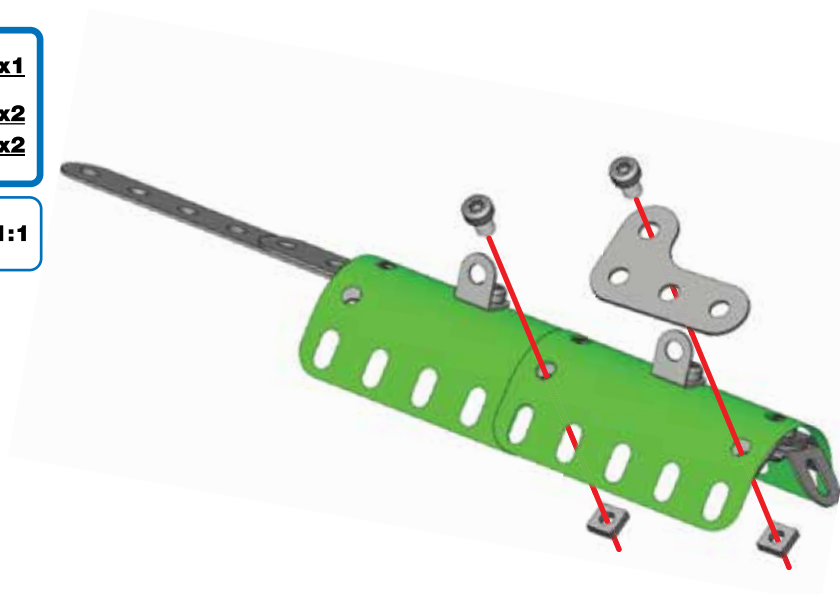

**31**

	x1
	x1
	x2
	x2
	x1

	<span style="border: 1px solid black; border-radius: 50%; padding: 2px;">S1</span> 1:1
--	--

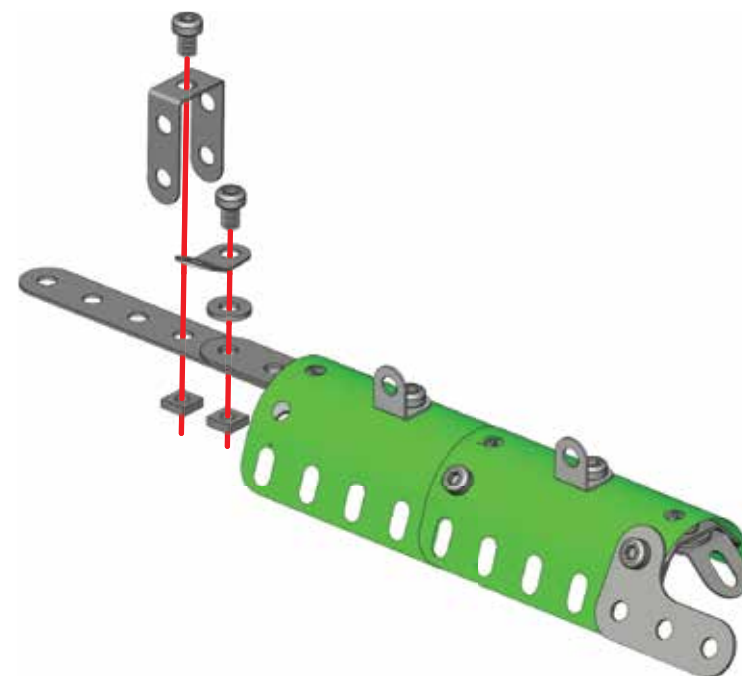



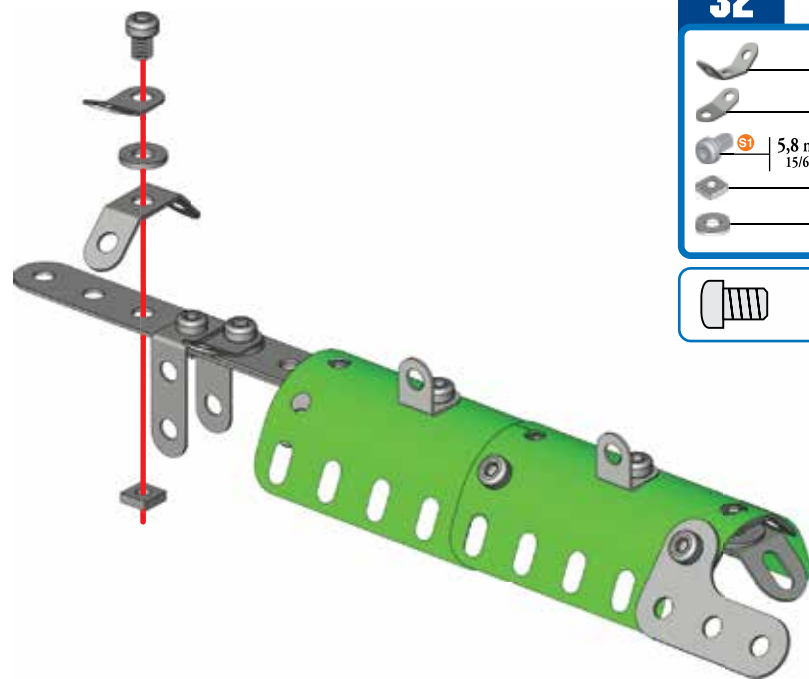

- 32**
- x1
  - x1
  - 5,8 mm 15/64" x1
  - x1
  - x1
- S1 1:1

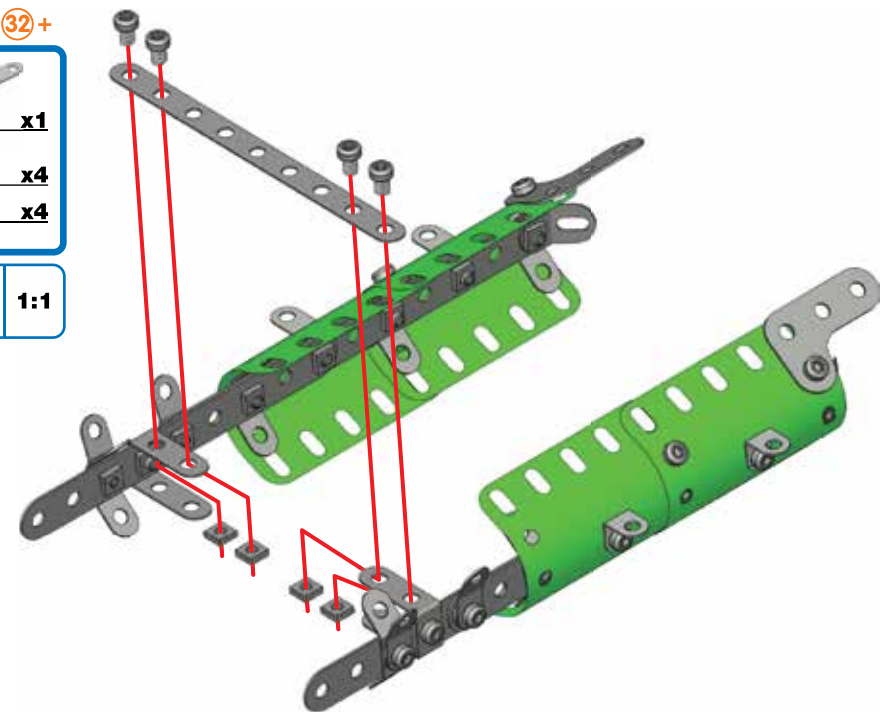

- 33** (27) + (32) +
- x1
  - 5,8 mm 15/64" x4
  - x4
- S1 1:1

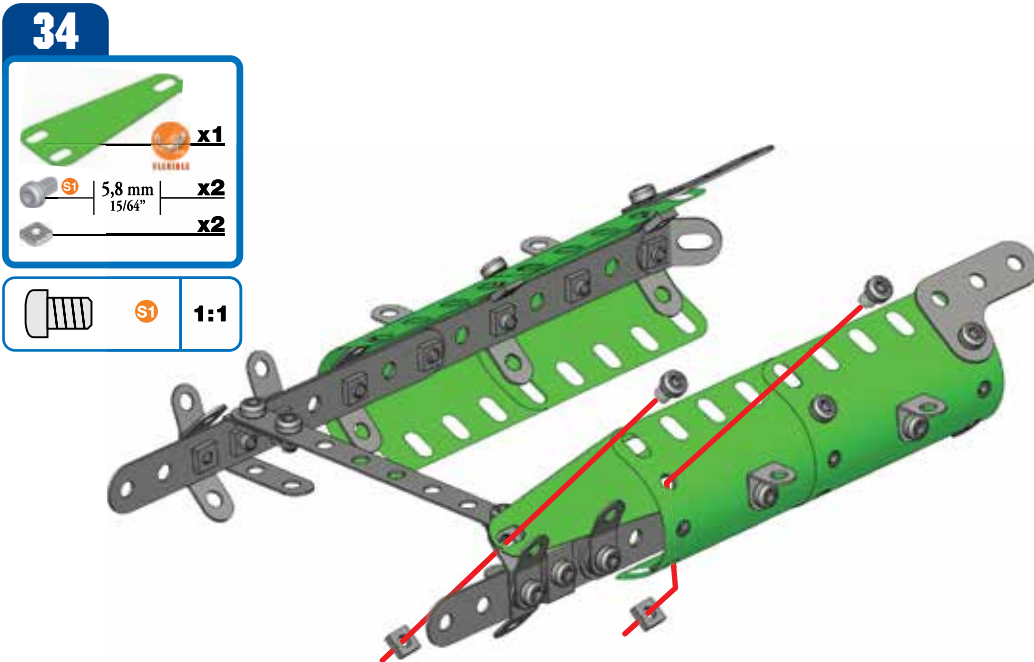

- 34**
- x1
  - 5,8 mm 15/64" x2
  - x2
- S1 1:1

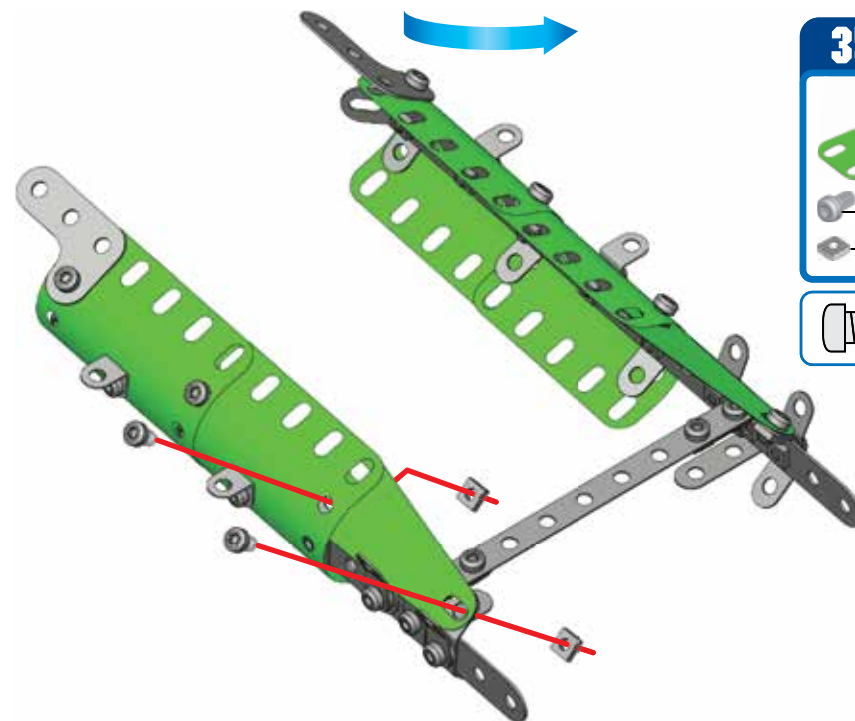

- 35**
- x1
  - 5,8 mm 15/64" x2
  - x2
- S1 1:1

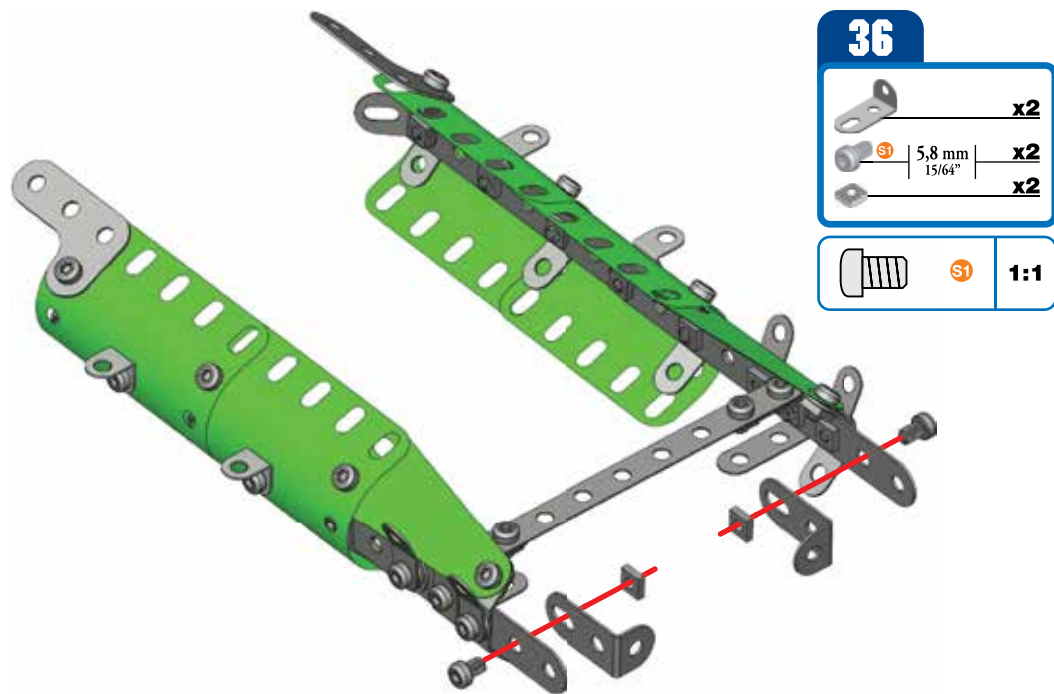

**36**

	<b>x2</b>
	<b>x2</b>
	<b>x2</b>
	<b>1:1</b>

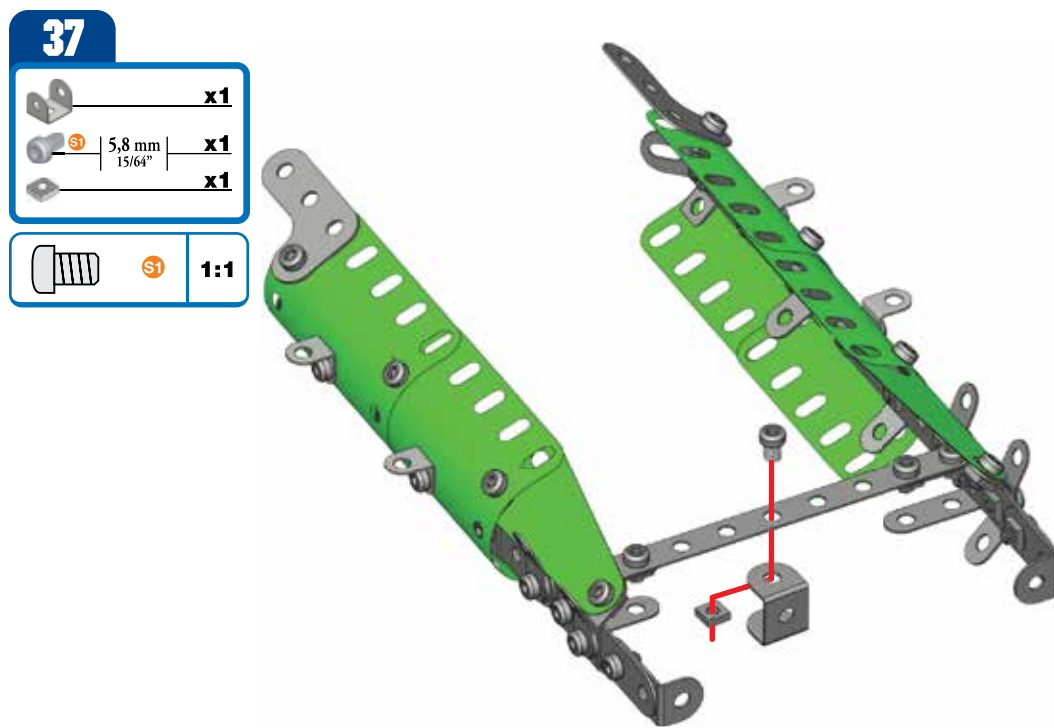

**37**

	<b>x1</b>
	<b>x1</b>
	<b>x1</b>
	<b>1:1</b>

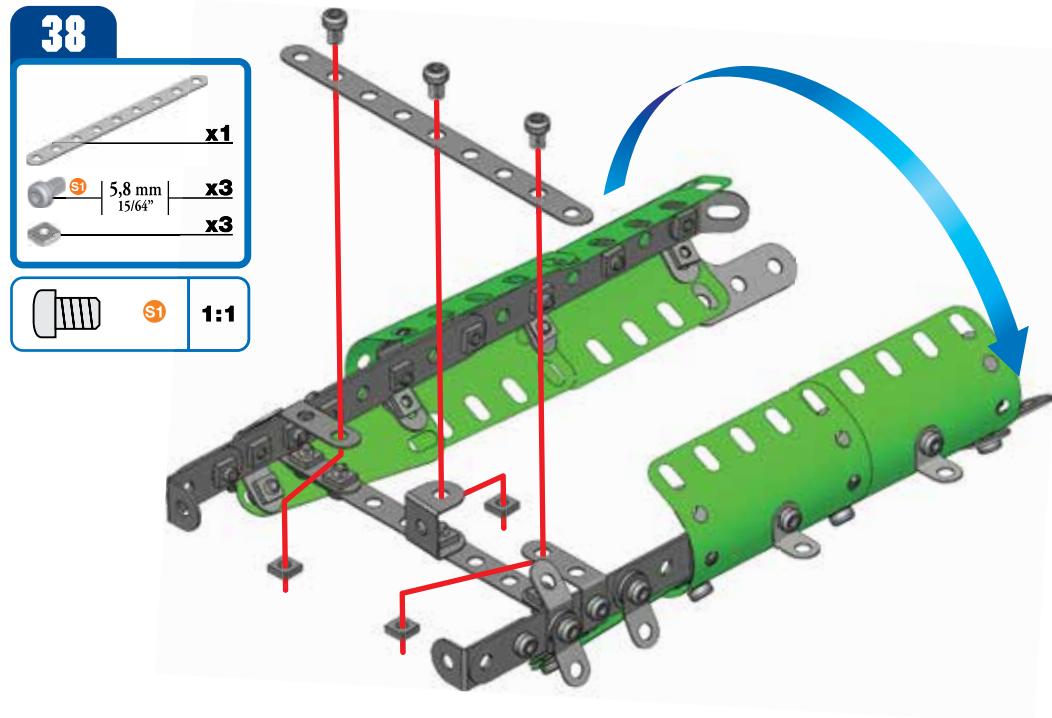

**38**

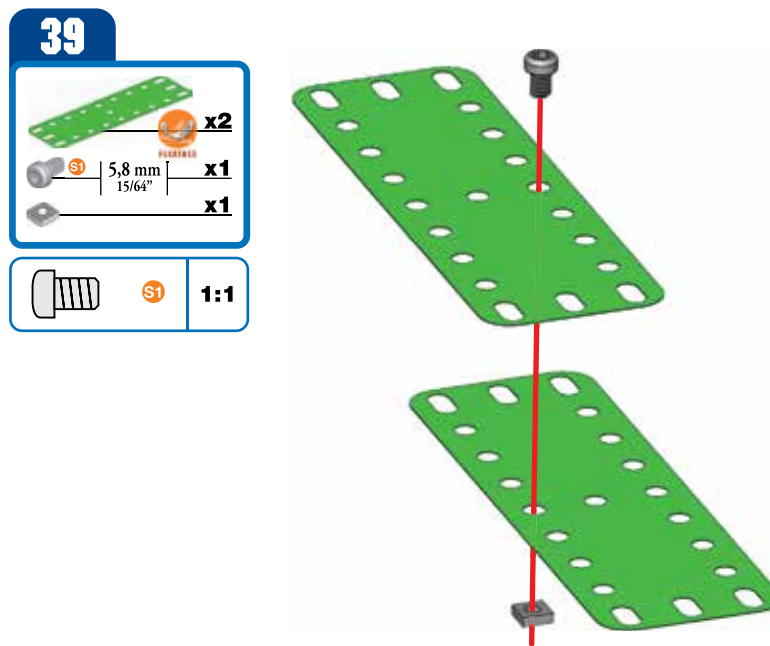

	<b>x1</b>
	<b>x3</b>
	<b>x3</b>
	<b>1:1</b>



**39**

	<b>x2</b>
	<b>x1</b>
	<b>x1</b>
	<b>1:1</b>



**40** 38+39+

	<b>x1</b>
 5,8 mm   15/64"	<b>x4</b>
	<b>x4</b>

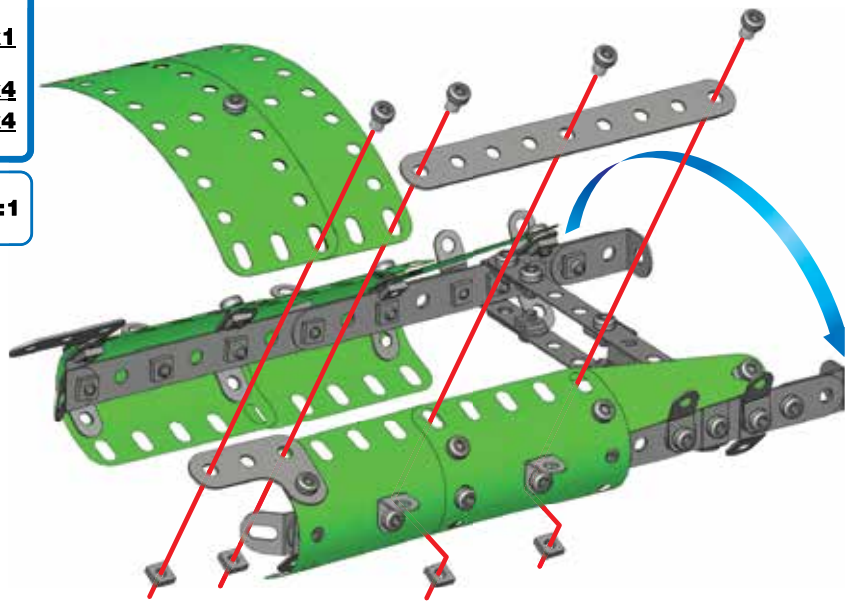
	<b>S1</b>	<b>1:1</b>
---	-----------	------------





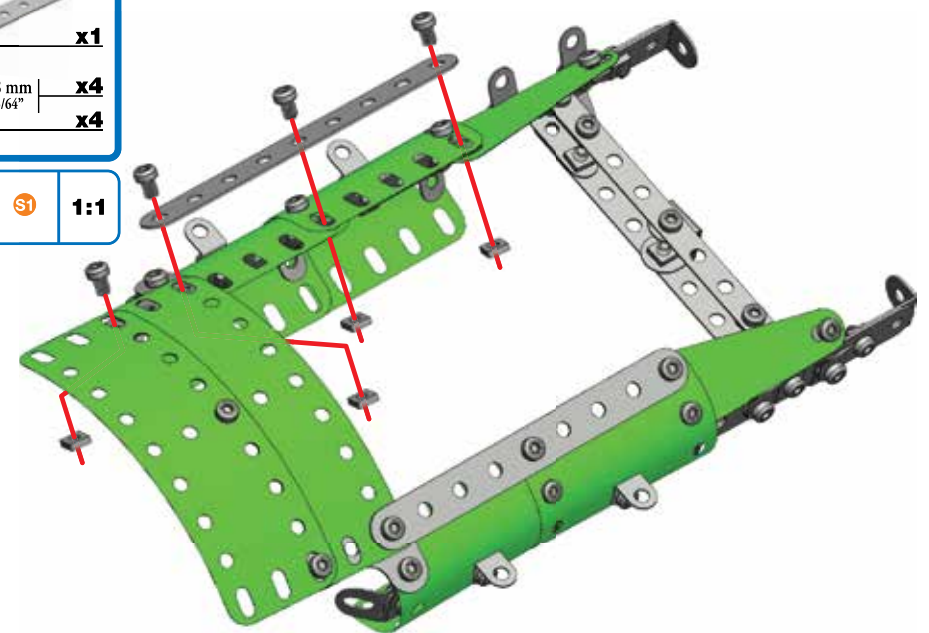

**41**

	<b>x1</b>
 5,8 mm   15/64"	<b>x4</b>
	<b>x4</b>

	<b>S1</b>	<b>1:1</b>
---	-----------	------------







**42**

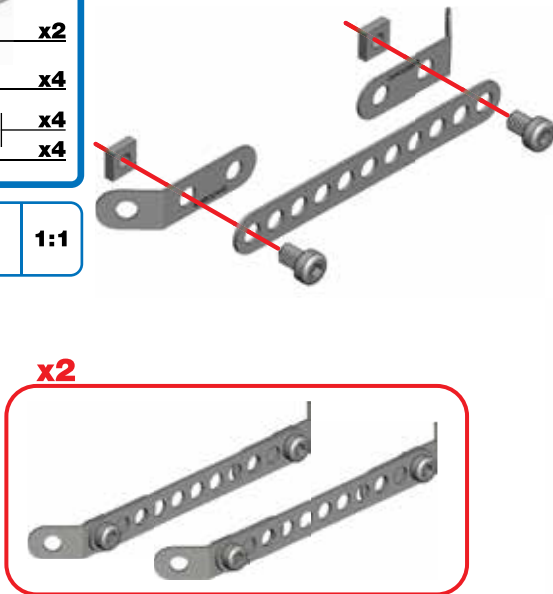



	<b>x2</b>
	<b>x4</b>
 5,8 mm   15/64"	<b>x4</b>
	<b>x4</b>

	<b>S1</b>	<b>1:1</b>
---	-----------	------------

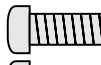

**43**

	<b>x2</b>
	<b>x2</b>
 12 mm   1/2"	<b>x2</b>
 5,8 mm   15/64"	<b>x2</b>
	<b>x4</b>

		<b>A236</b>
	<b>S3</b>	<b>1:1</b>
	<b>S1</b>	

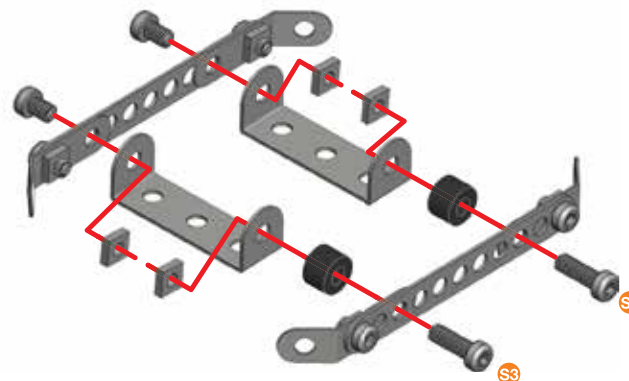

**44**

	<b>x1</b>
 5,8 mm   15/64"	<b>x2</b>
	<b>x2</b>



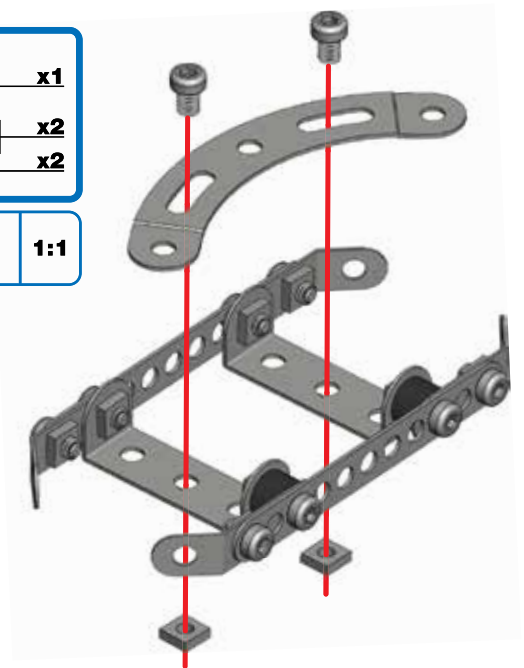

	<b>S1</b>	<b>1:1</b>
---	-----------	------------





# 45



(41) + (44) +

-  **x2**
-  **23 mm** | **x1**  
15/16"
-  **x1**
-  **x3**

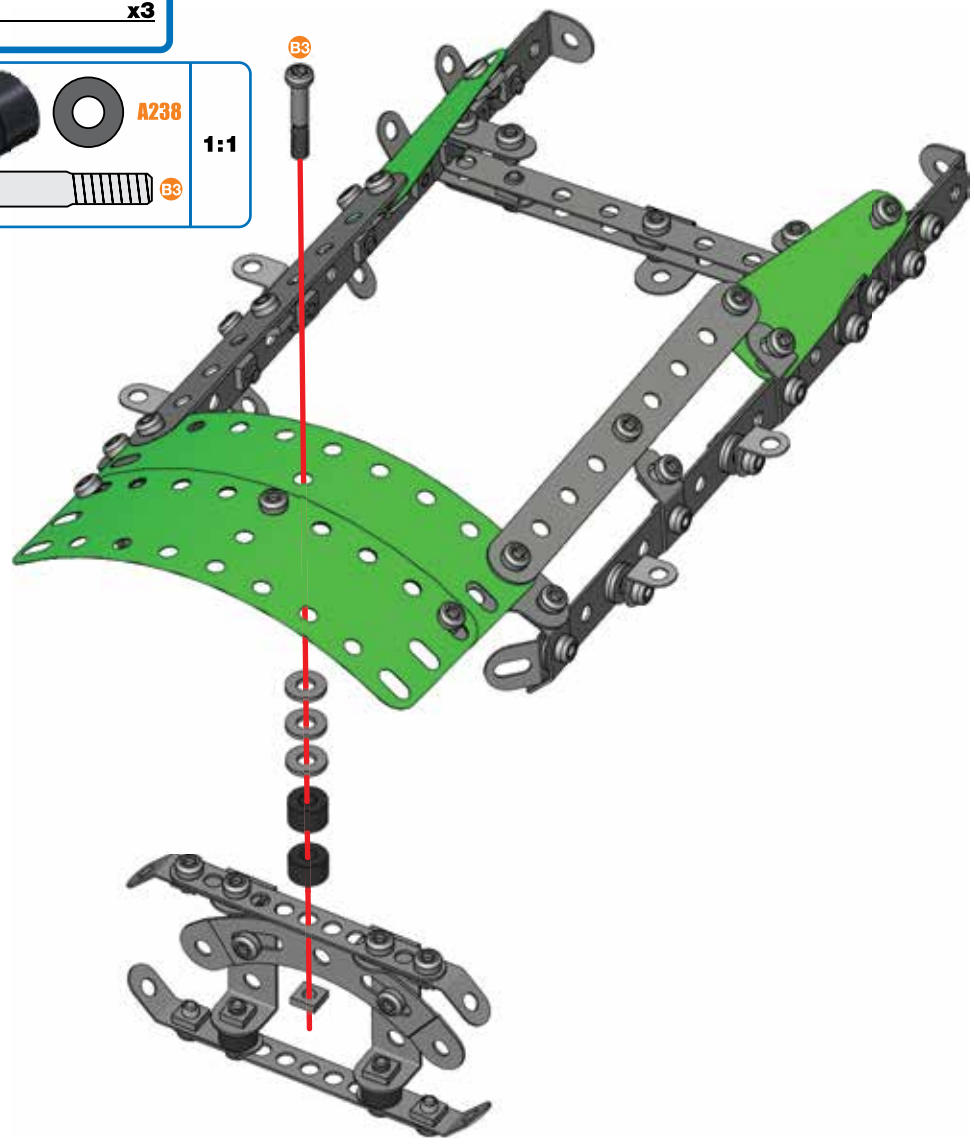
-  **A238**
-  **1:1**
-  **33**





# 46

-  **5,8 mm** | **x1**  
15/64"
-  **x1**
-  **x2**

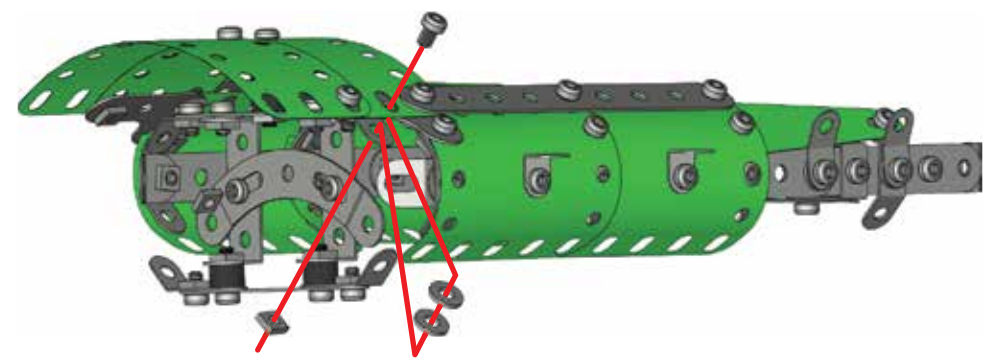
-  **S1** | **1:1**





# 47

-  **5,8 mm** | **x1**  
15/64"
-  **x1**
-  **x2**

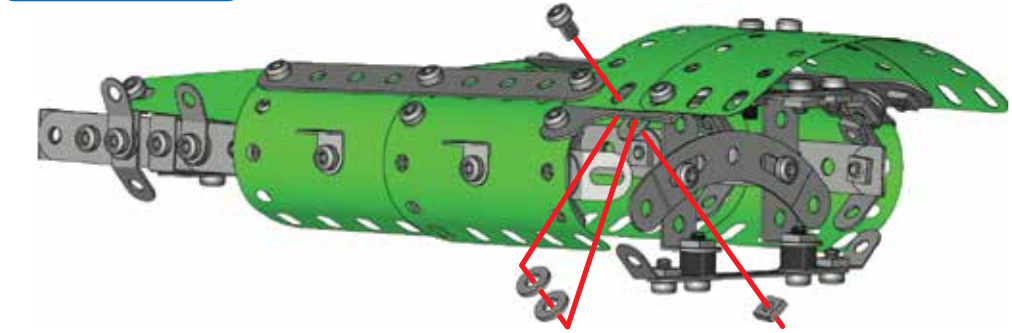
-  **S1** | **1:1**





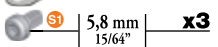
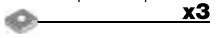

48

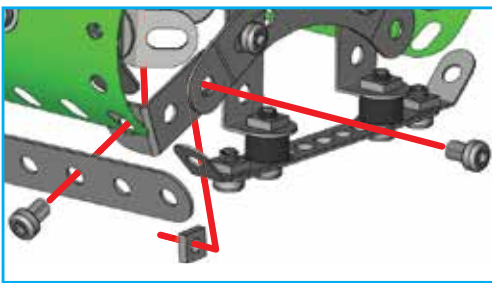
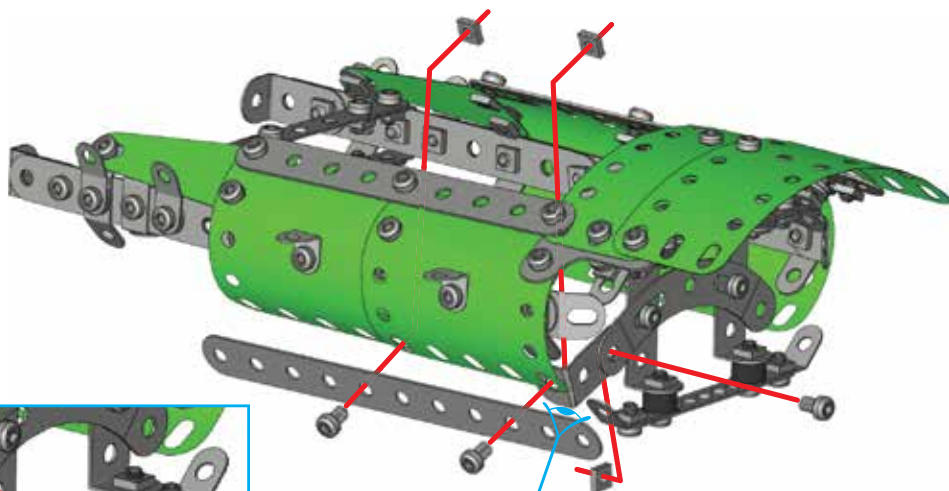
-  x1
-  x1
-  5,8 mm | 15/64" x3
-  x3

-  S1 1:1





50

-  x2
-  x2
-  12 mm | 1/2" x2
-  x2

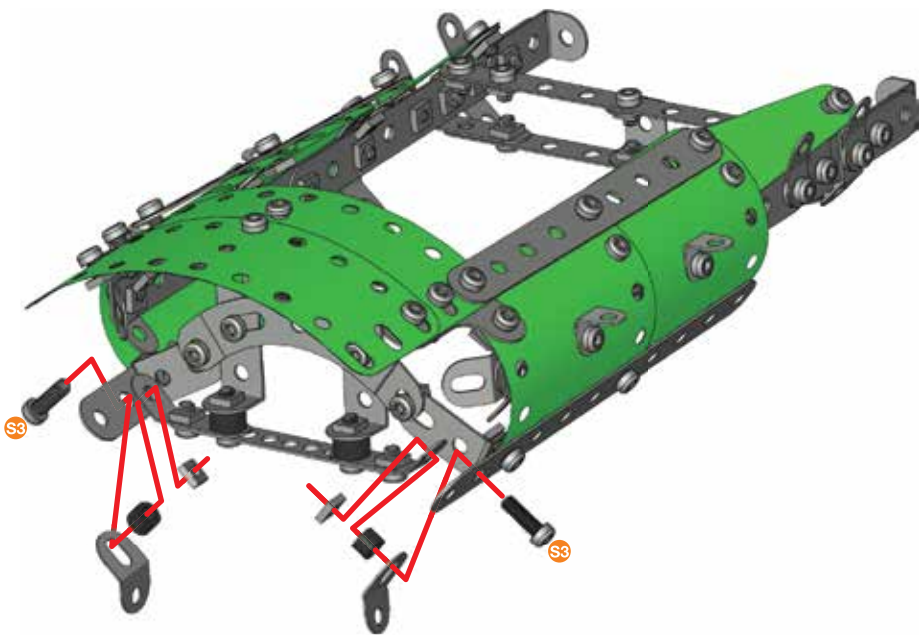
-   A338 1:1
-  S3 1:1

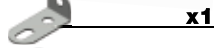
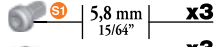

49

-  x1
-  x1
-  5,8 mm | 15/64" x3
-  x3

-  S1 1:1

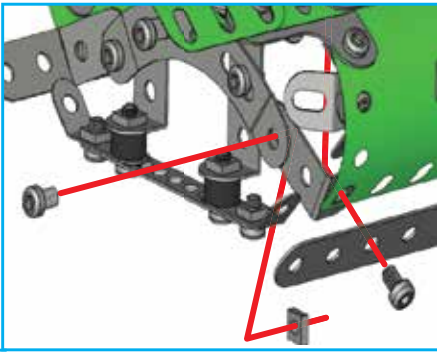
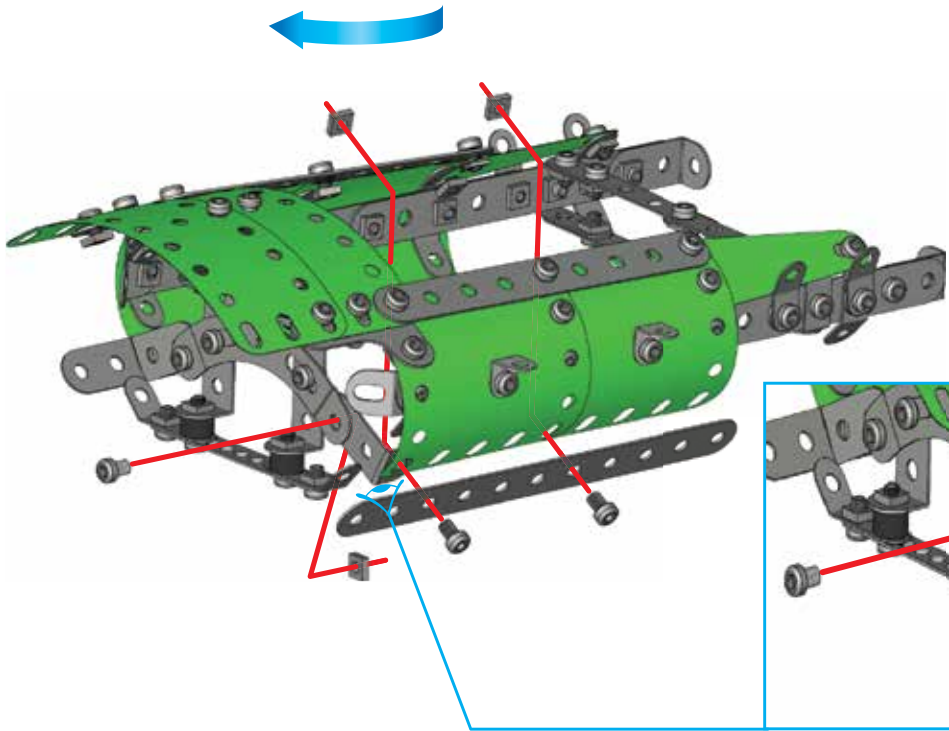



51

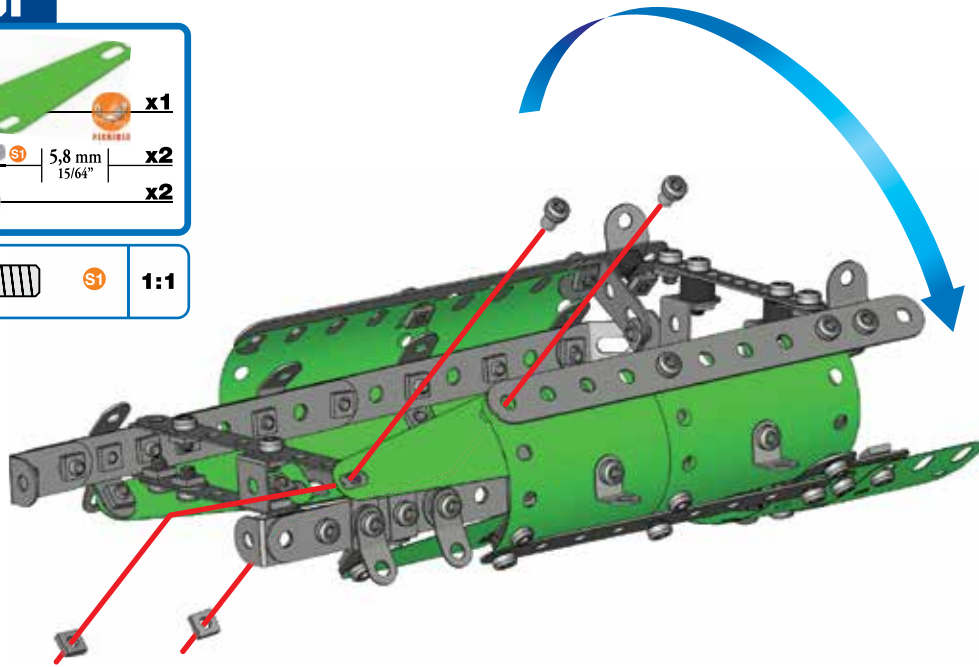
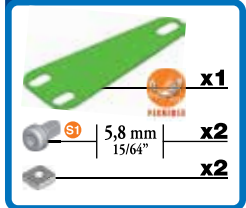

52

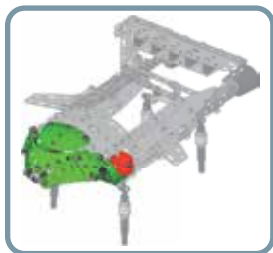
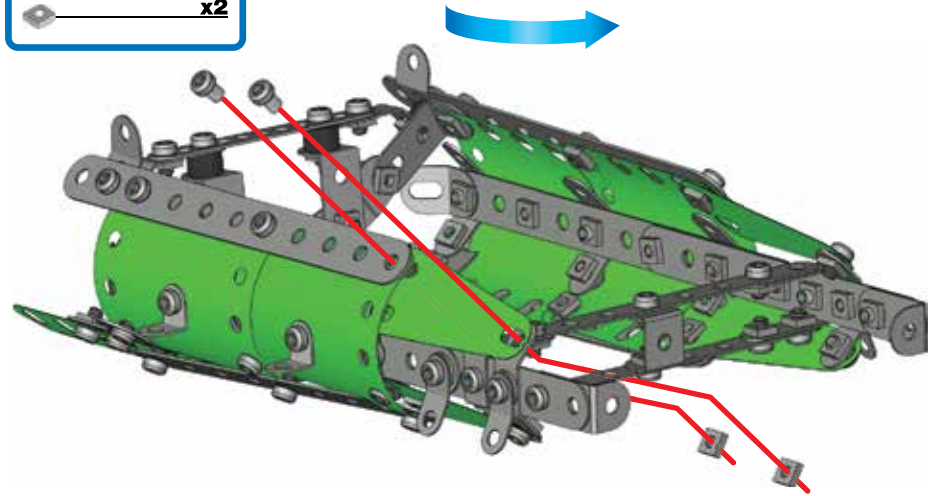
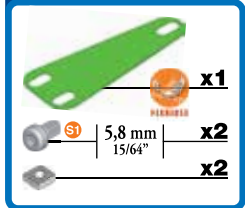

53

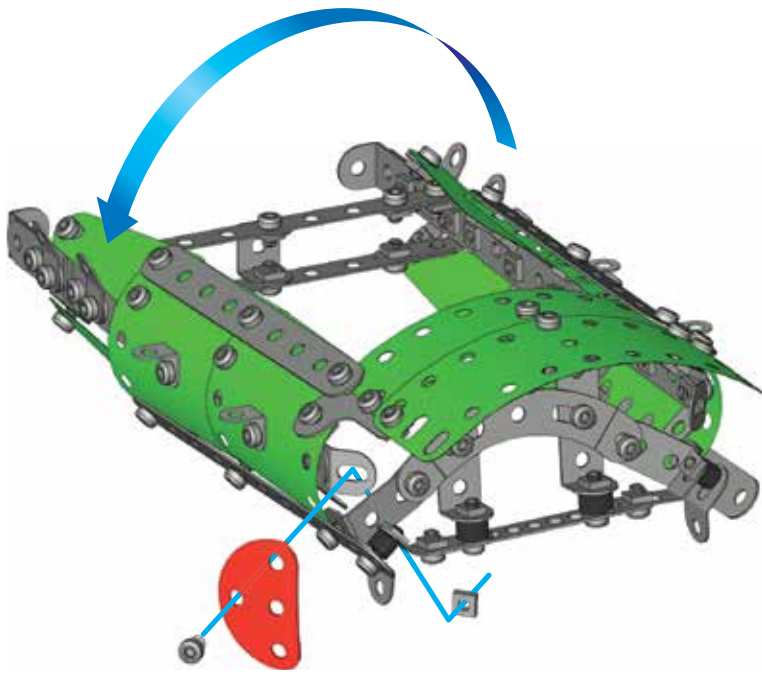
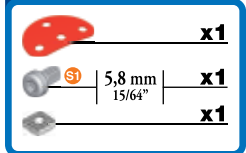

54

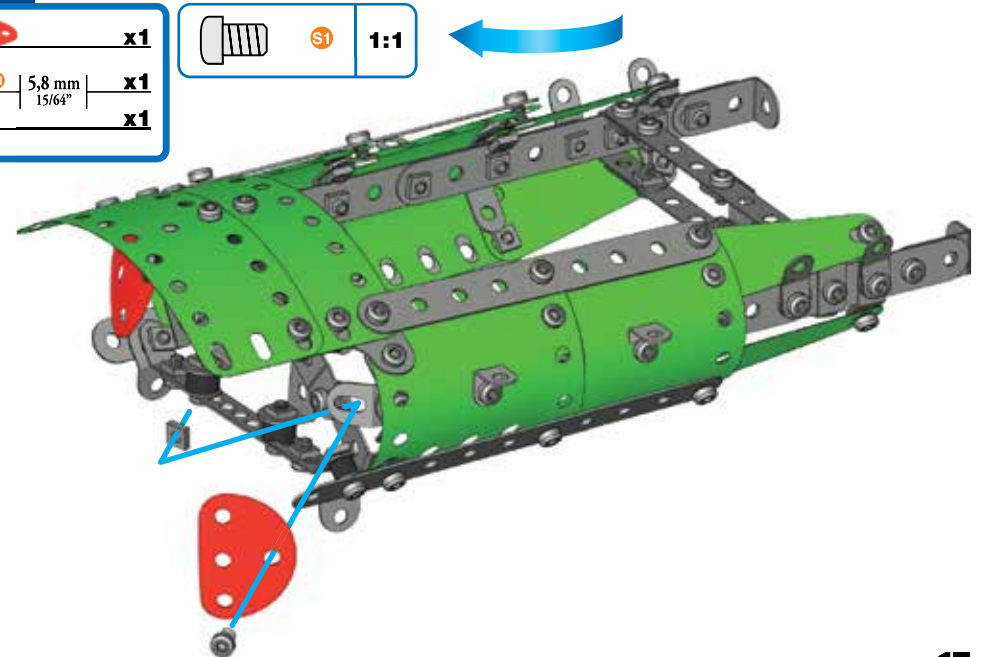
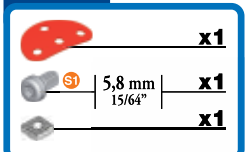



**55**

	<b>x1</b>
	<b>x3</b>
	<b>x3</b>

	<b>S1</b>	<b>1:1</b>
--	-----------	------------

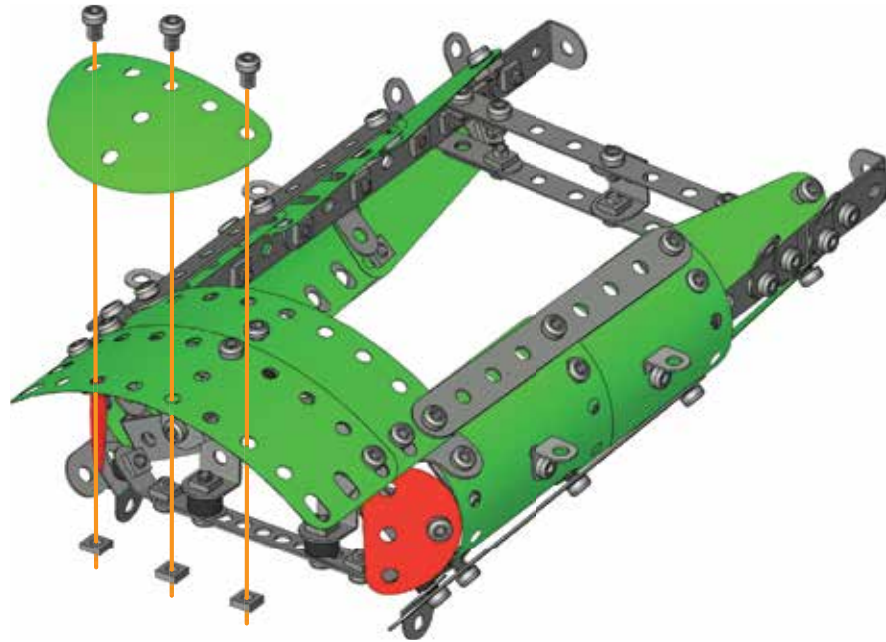

**56**

	<b>x1</b>
	<b>x1</b>
	<b>x1</b>

	<b>S1</b>	<b>1:1</b>
--	-----------	------------

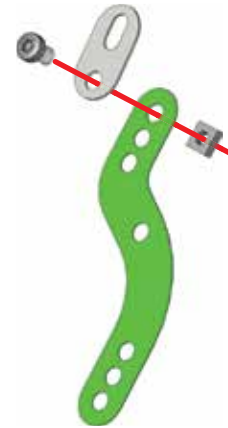

**57**

**55 + 56 +**

	<b>x1</b>
	<b>x1</b>

	<b>S1</b>	<b>1:1</b>
--	-----------	------------

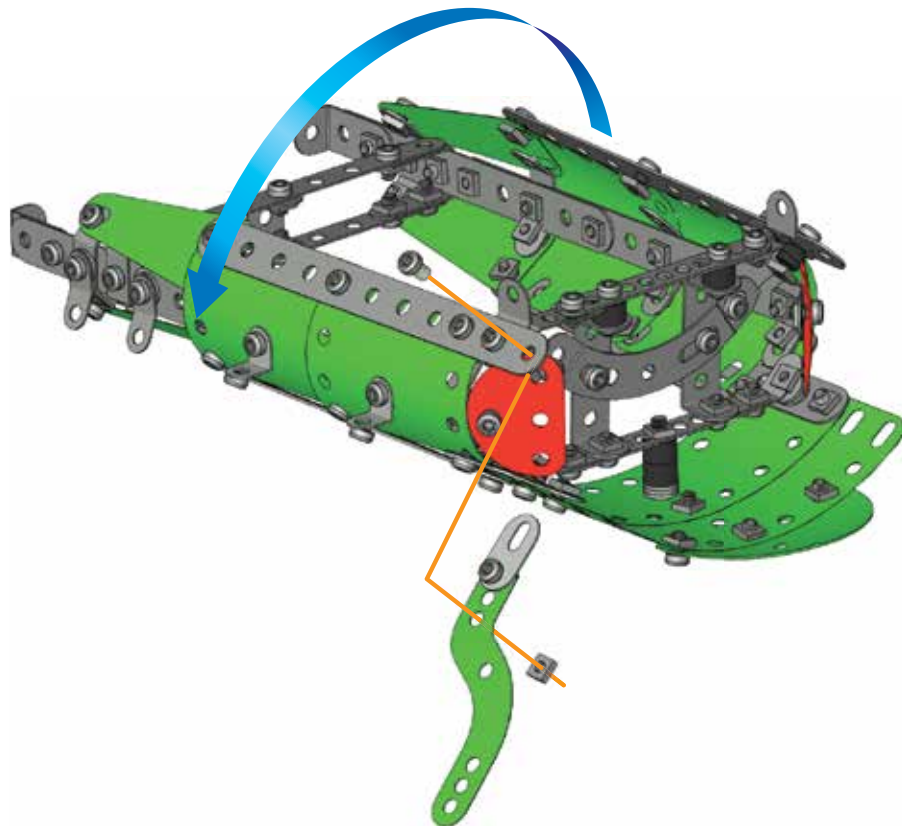



**58**

	<b>x1</b>
	<b>x1</b>
	<b>x1</b>

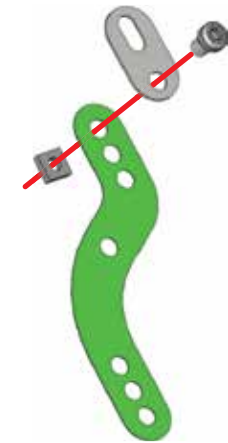
	<b>S1</b>	<b>1:1</b>
--	-----------	------------





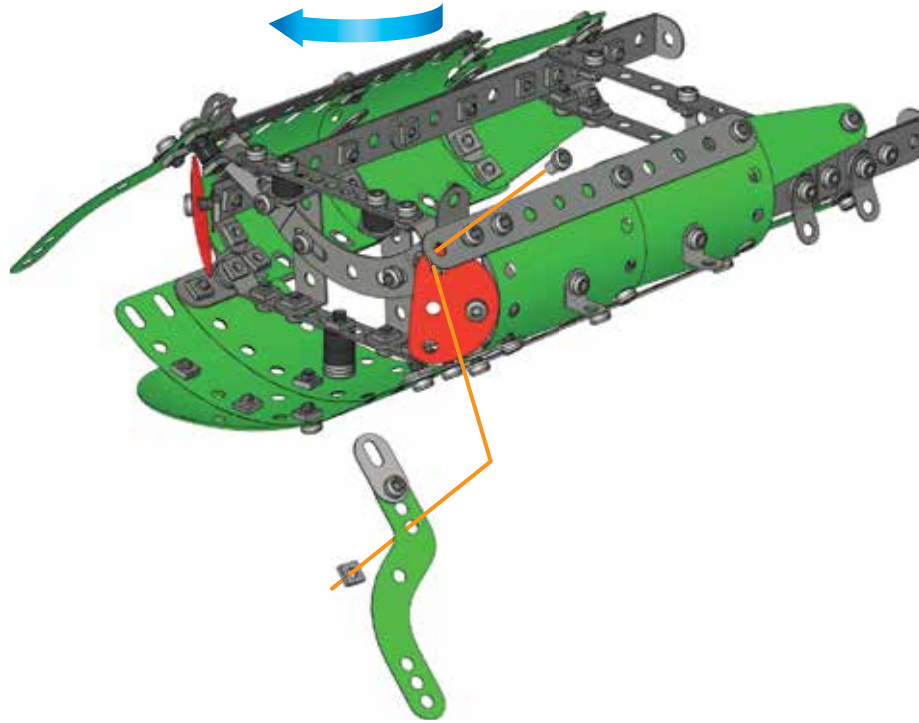

**59** 57 + 58 +

	5,8 mm 15/64"	<b>x1</b>
		<b>x1</b>

	<b>S1</b>	<b>1:1</b>
---	-----------	------------





**60**

	<b>x1</b>	
	<b>x4</b>	
	5,8 mm 15/64"	<b>x4</b>
	<b>x4</b>	

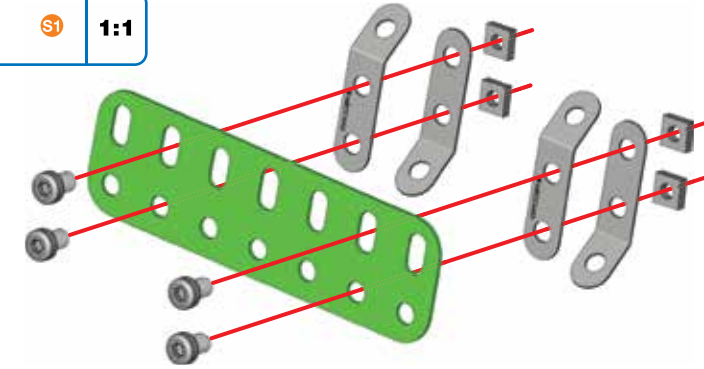
	<b>S1</b>	<b>1:1</b>
---	-----------	------------





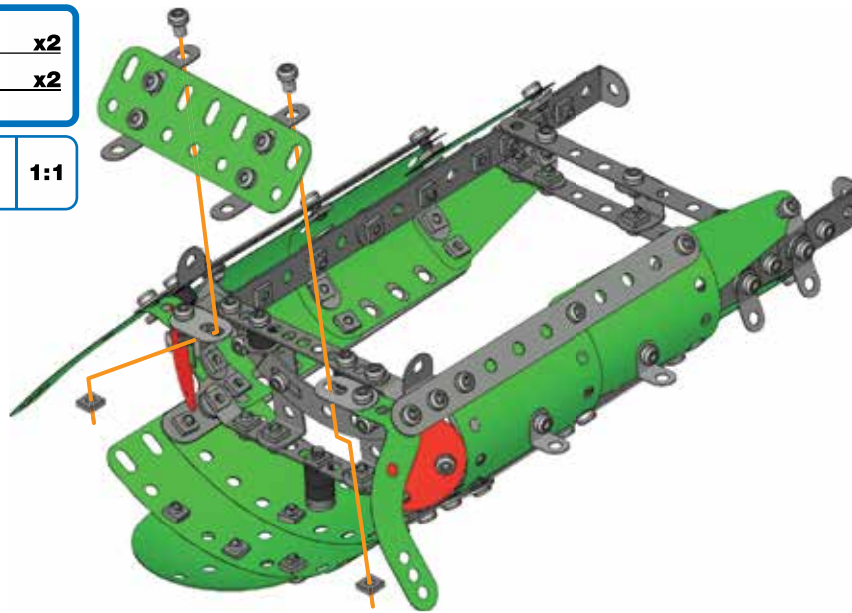

**61** 59 + 60 +

	5,8 mm 15/64"	<b>x2</b>
		<b>x2</b>

	<b>S1</b>	<b>1:1</b>
---	-----------	------------



**62**

	<b>x2</b>	
	<b>x1</b>	
	5,8 mm 15/64"	<b>x3</b>
	<b>x3</b>	

	<b>S1</b>	<b>1:1</b>
---	-----------	------------

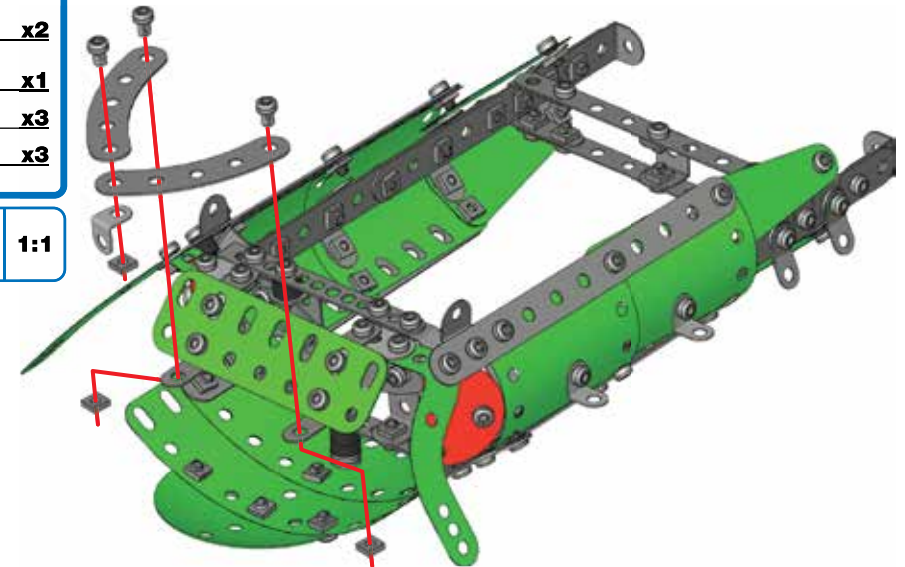



**63**

- x1
- x1
- x1
- 12 mm | 1/2" | x1
- x1

- 1:1
- 1:1

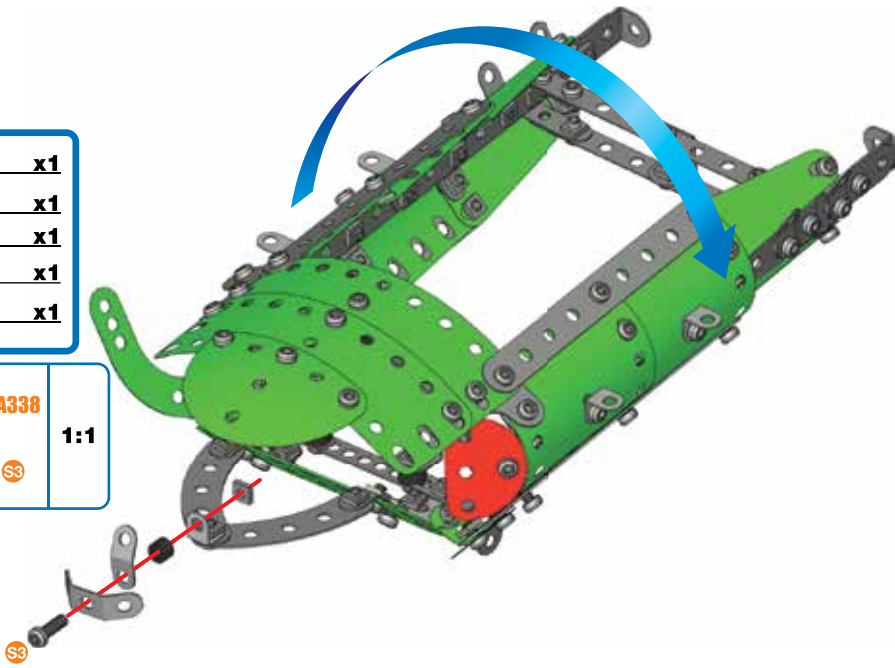

**64**

- x1
- 5,8 mm | 15/64" | x1
- x1

- 1:1

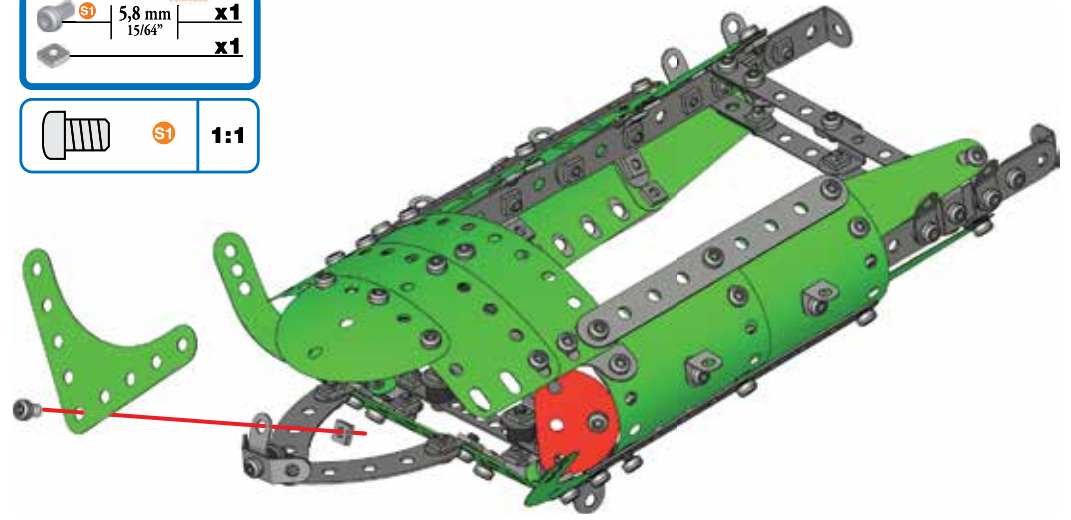

**65**

- x1
- x1
- 5,8 mm | 15/64" | x3
- x3

- 1:1

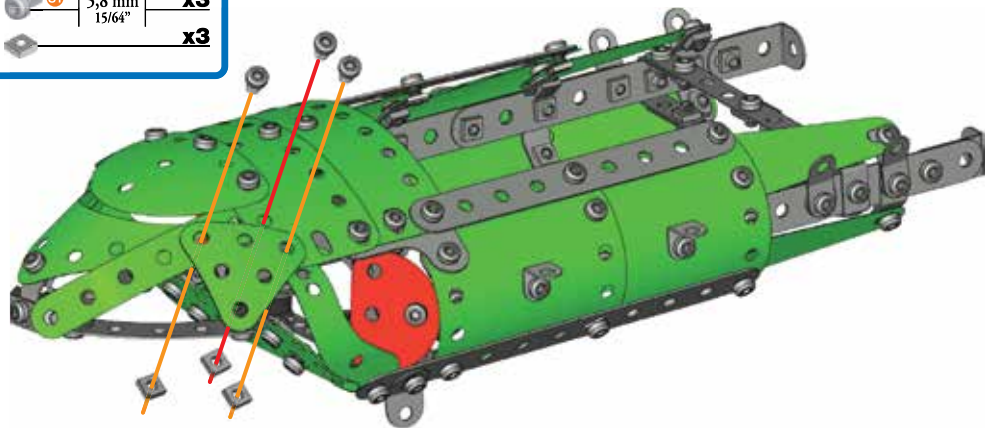

**66**

- x1
- x1
- 5,8 mm | 15/64" | x3
- x3

- 1:1

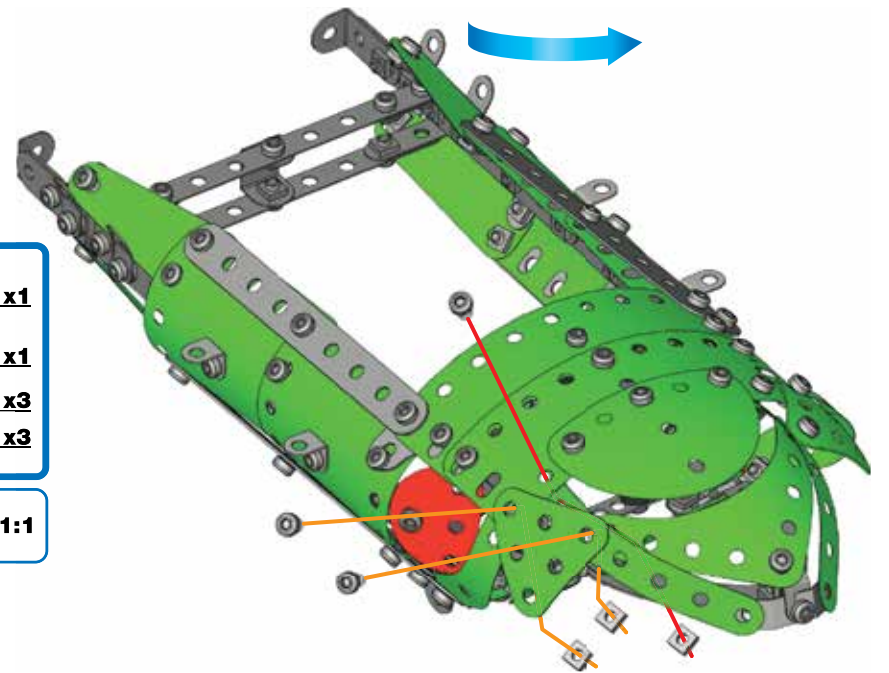

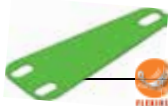

**67**

 **x1**

 **S1** | 5,8 mm | **x2**

 **x2**

 **S1** | **1:1**

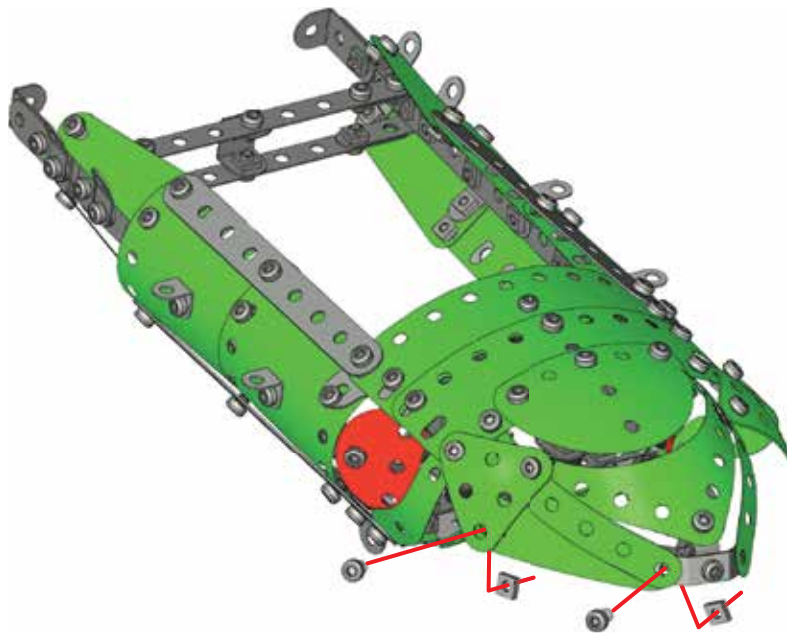

**68**

 **x1**

 **S1** | 5,8 mm | **x2**

 **x2**

 **S1** | **1:1**

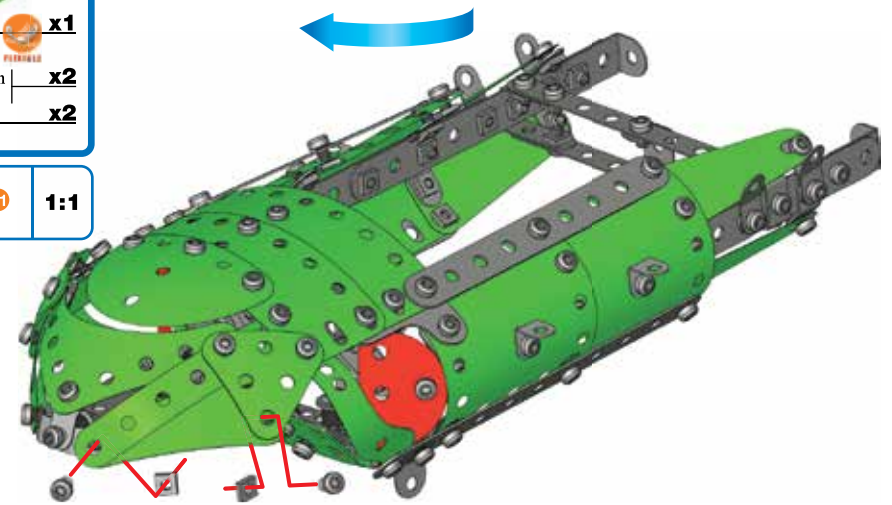

**69**

 **x2**

 **x2**

 **S3** | 12 mm | **x2**

 **x2**

 **S3** | **1:1**

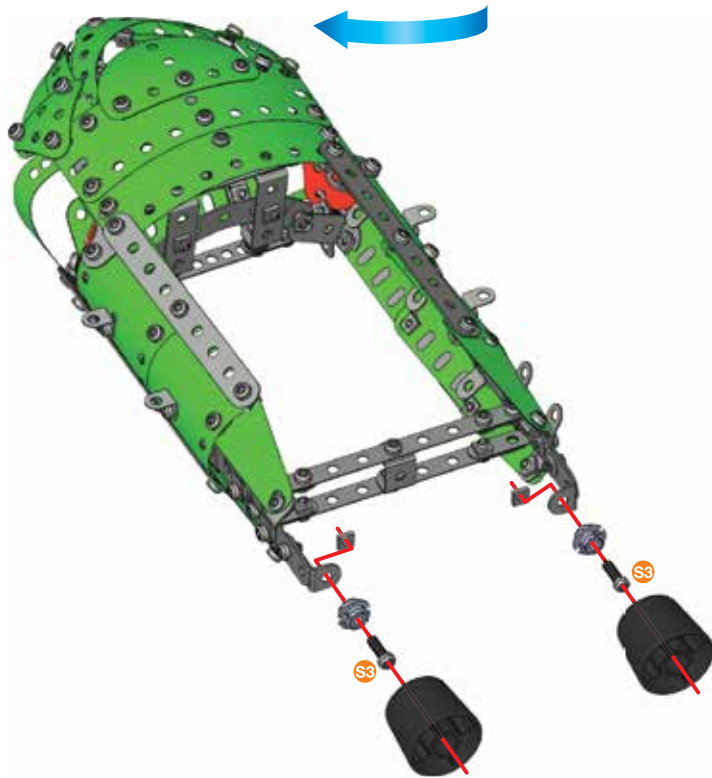

**70**

 **x1**

 **x2**

 **S3** | 12 mm | **x2**

 **x2**

  **A238** | **1:1**

 **S3**

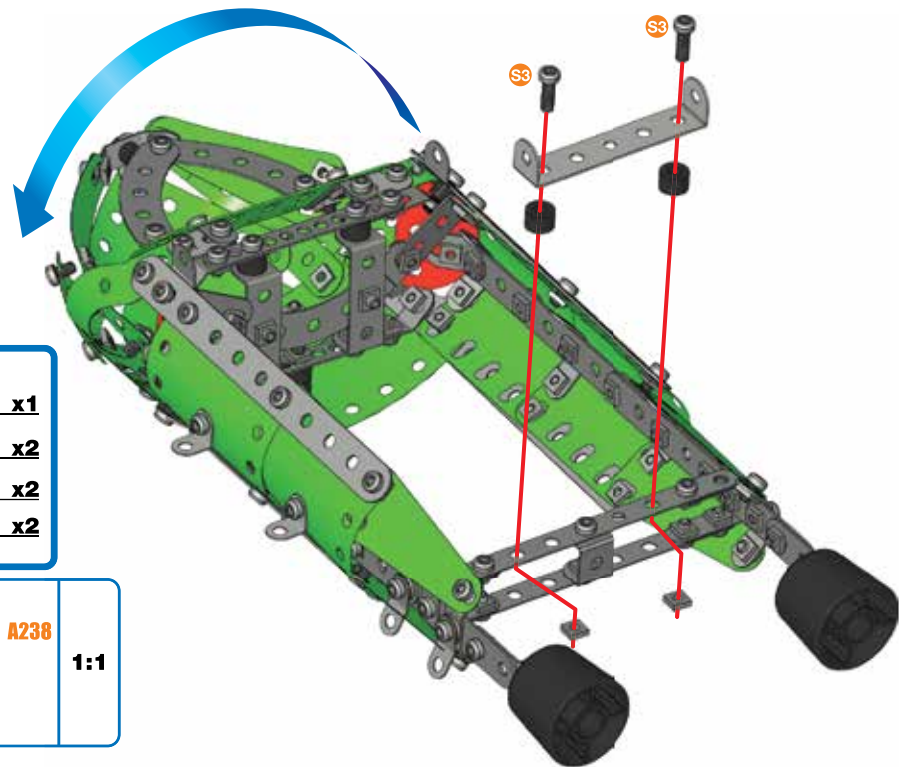

71

- x2
- x2
- 19 mm | 3/4" x2
- x2

- A238 1:1
- B2

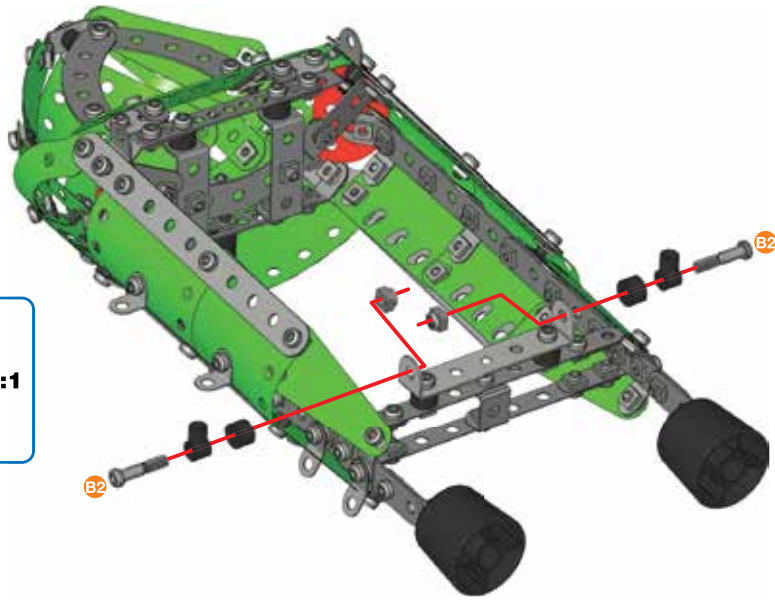
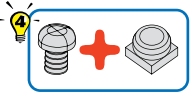

72

- x2
- 12 mm | 1/2" x2
- x2

- S3 1:1

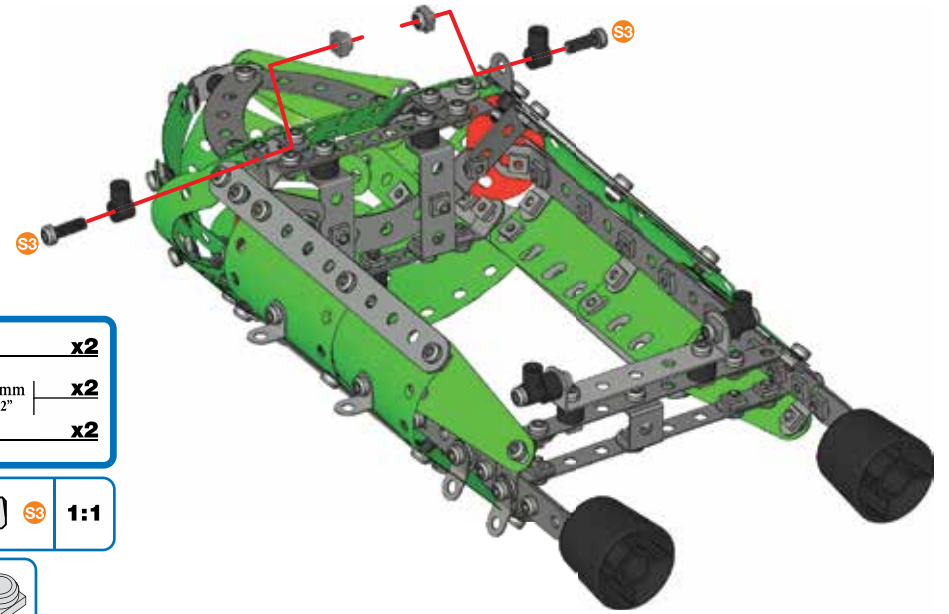
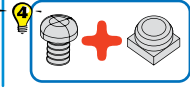

73

- x4
- x4
- 19 mm | 3/4" S4 x2
- 19 mm | 3/4" B2 x2

- S4 1:1
- B2

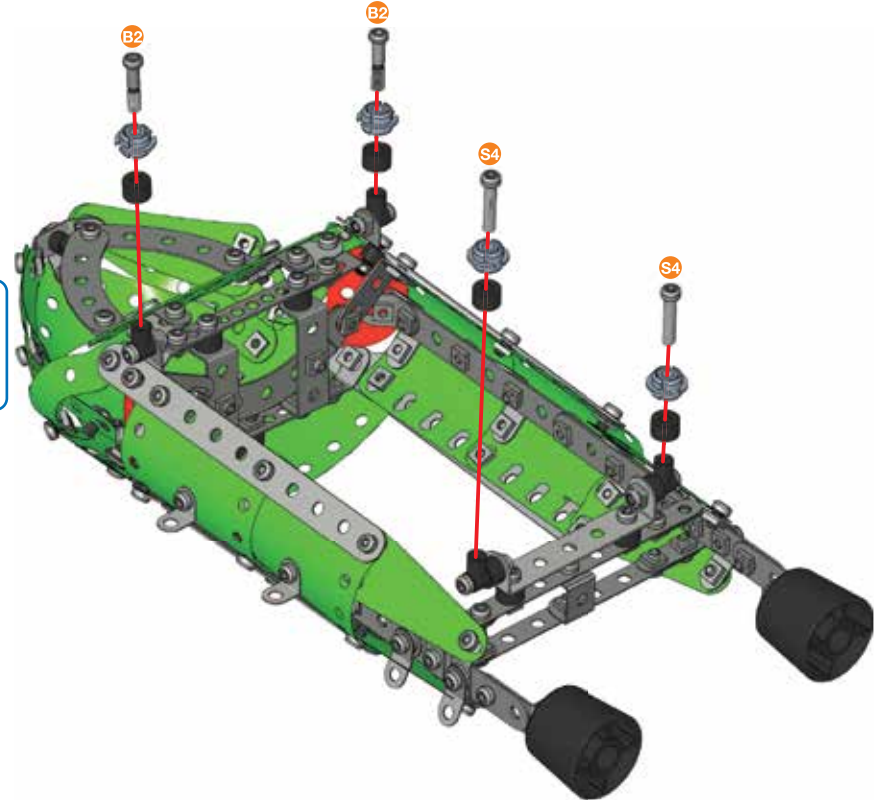

74

- 44,5 mm | 1 3/4" x4
- x4
- x4
- x4
- x4
- x4

- A238 1:1
- A338

- 1:1

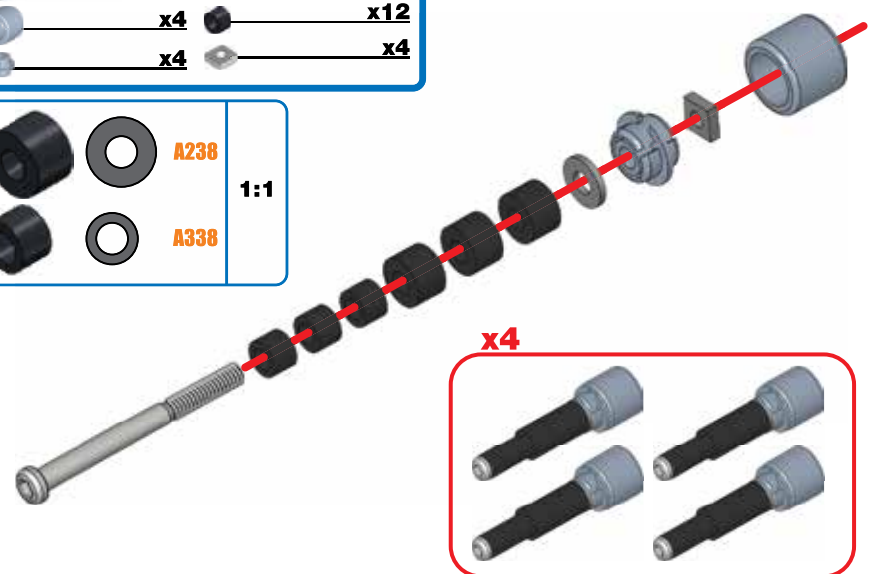



**75**  
 73 + 74 +

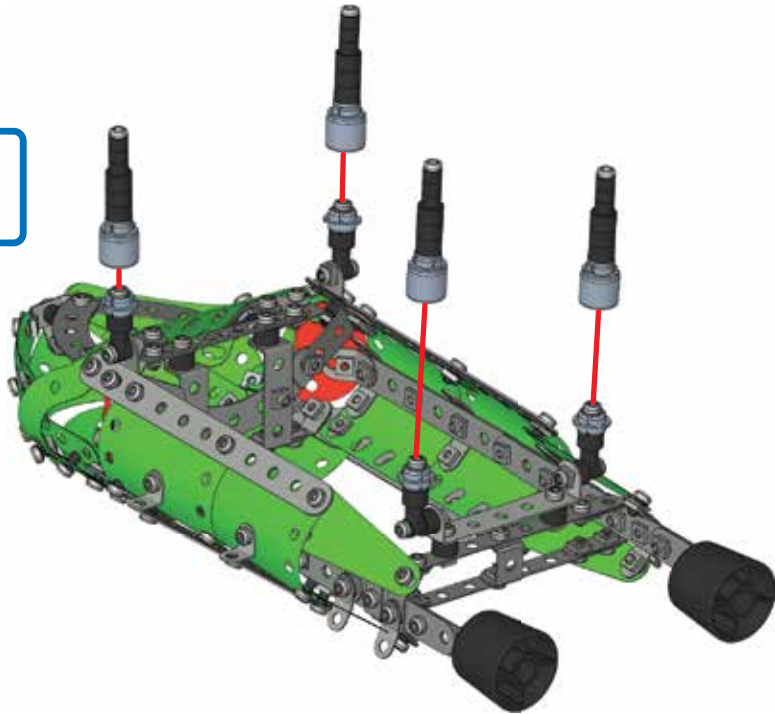

**76**  
 [Grey Technic Beam] x2  
 [Grey Pin S1] 5,8 mm 15/64" x2  
 [Grey Pin S1] x2  
 [Grey Pin S1] 1:1

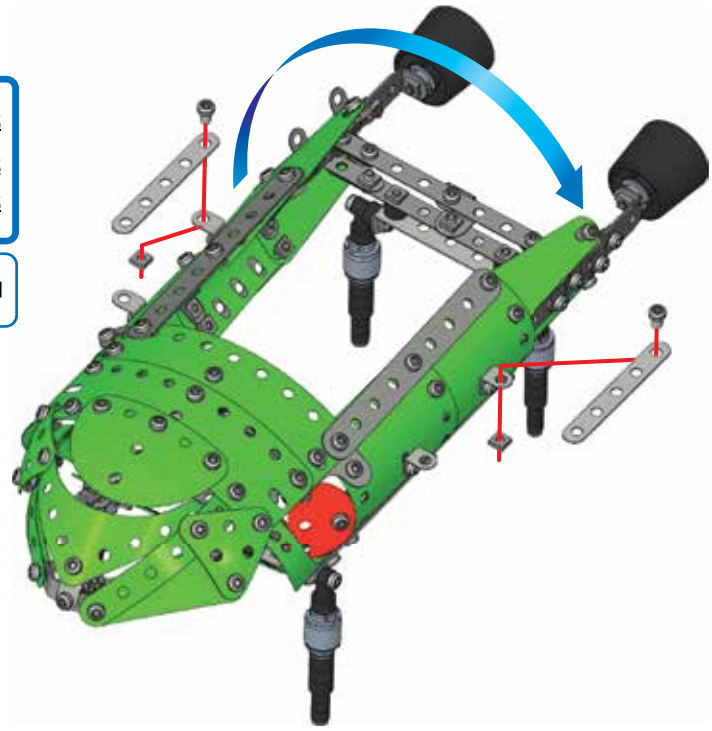

**77**  
 [Green Technic Plate] x2  
 [Grey Pin S1] 5,8 mm 15/64" x4  
 [Grey Pin S1] x4  
 [Grey Pin S1] 1:1

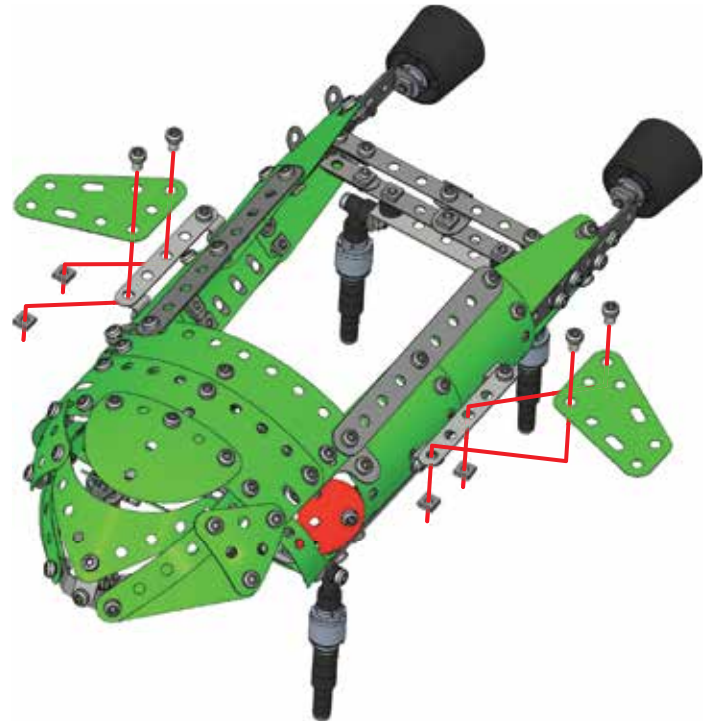



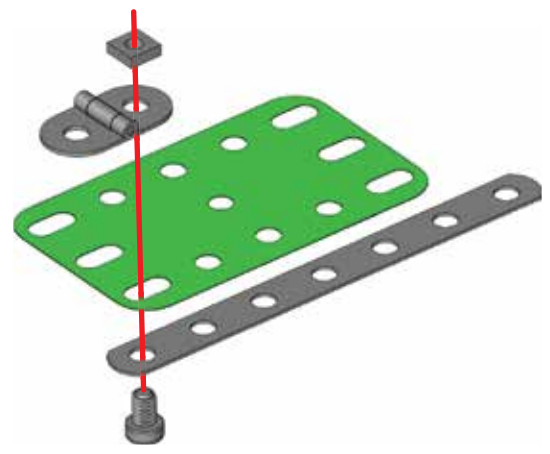

**78**  
 [Grey Technic Beam] x1  
 [Green Technic Plate] x1  
 [Grey Pin S1] x1  
 [Grey Pin S1] 5,8 mm 15/64" x1  
 [Grey Pin S1] x1  
 [Grey Pin S1] 1:1





**79**



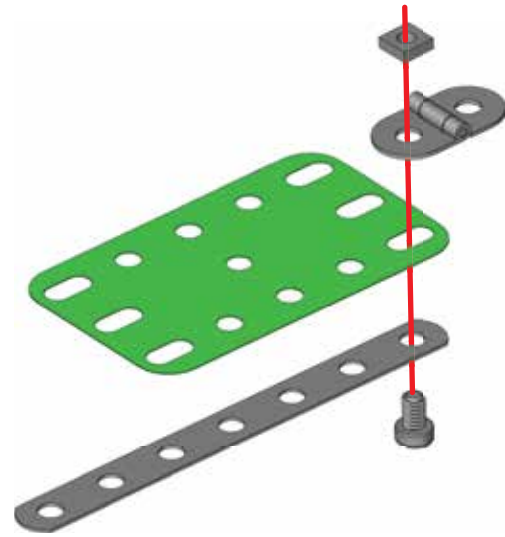

-  **x1**
-  **x1**
-  **x1**
-  **x1**
-  **x1**

-  **S1** **1:1**



**80**



**78 + 79 +**

-  **x1**
-  **x1**
-  **x2**
-  **x2**
-  **x2**

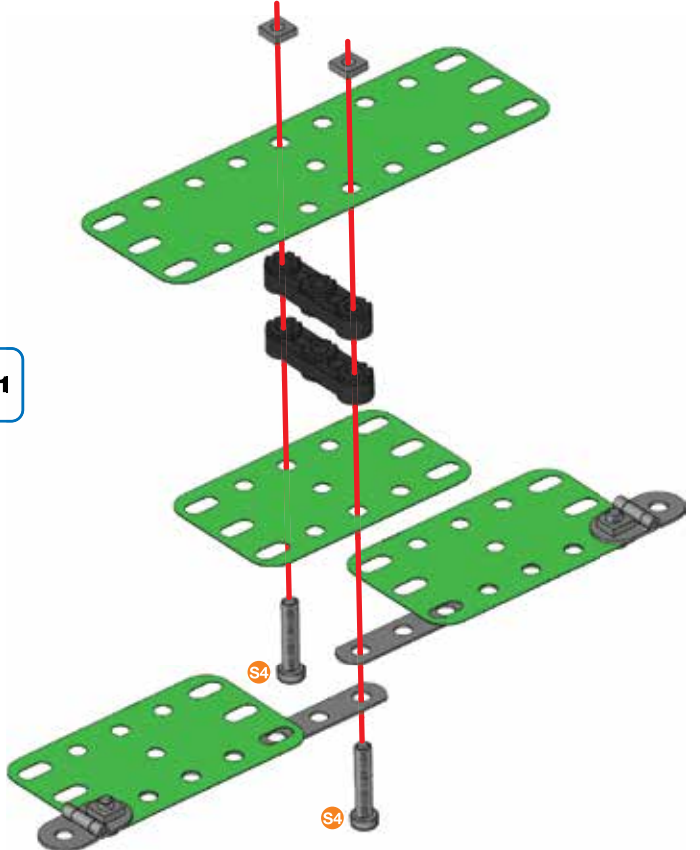
-  **S4** **1:1**





**81**

-  **x4**
-  **x4**
-  **x4**

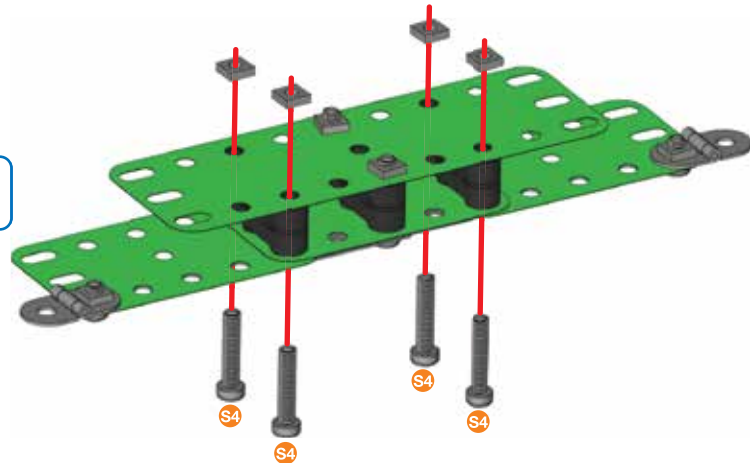
-  **S4** **1:1**





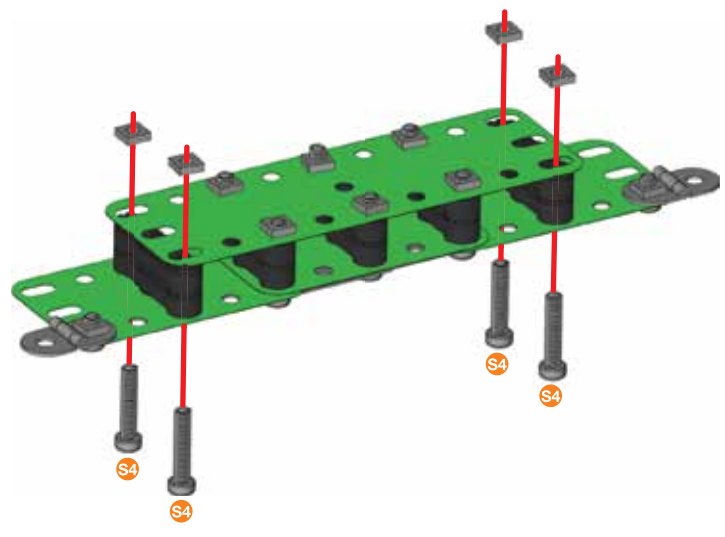

**82**

-  **x4**
-  **x4**
-  **x4**

-  **S4** **1:1**





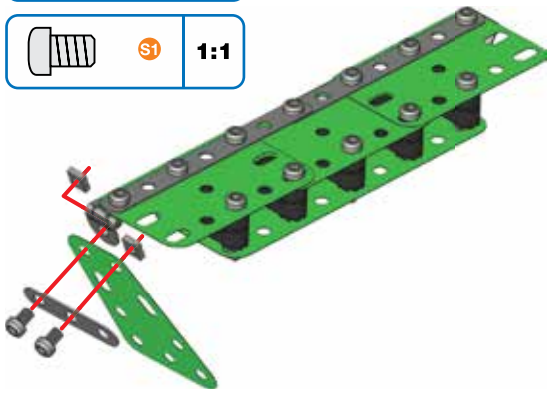

**83**

-  **x2**
-  **x2**
-  | 5,8 mm | **x4**
-  | 15/64" | **x4**

 **S1** | **1:1**





**84**

-  **x2**
-  **x2**
-  | 5,8 mm | **x4**
-  | 15/64" | **x4**

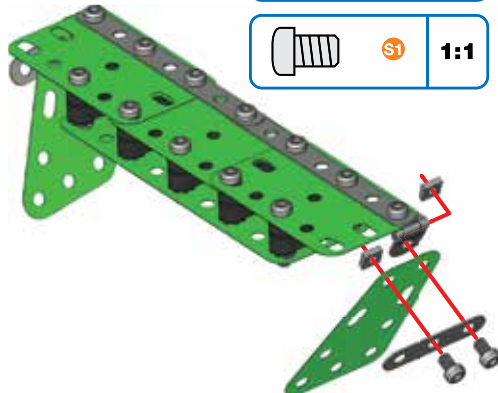
 **S1** | **1:1**





**85** **77** + **84** +

-  | 5,8 mm | **x2**
-  | 15/64" | **x2**

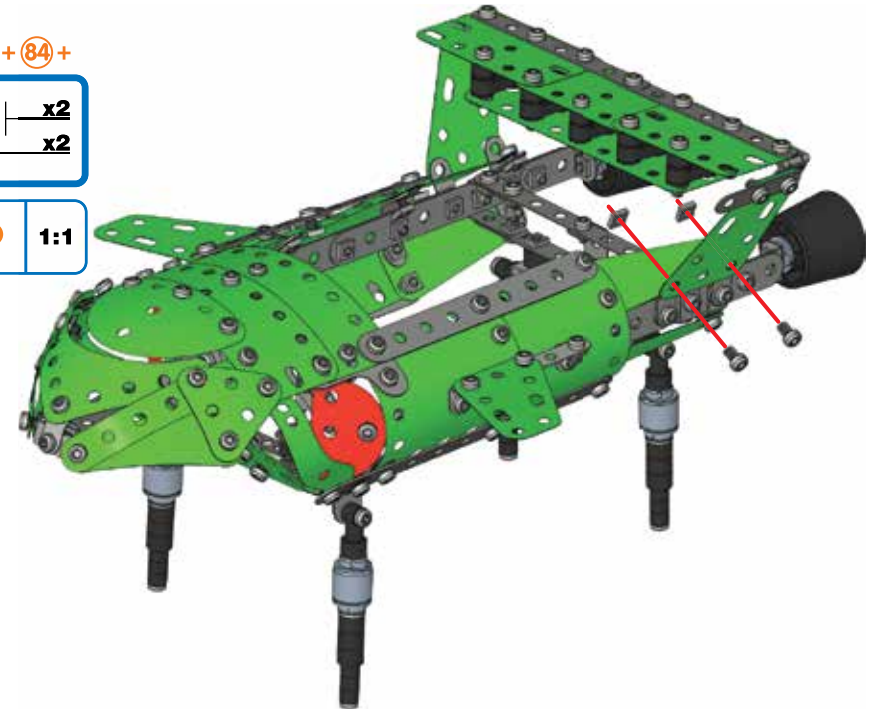
 **S1** | **1:1**



**86**

-  | 5,8 mm | **x2**
-  | 15/64" | **x2**

 **S1** | **1:1**

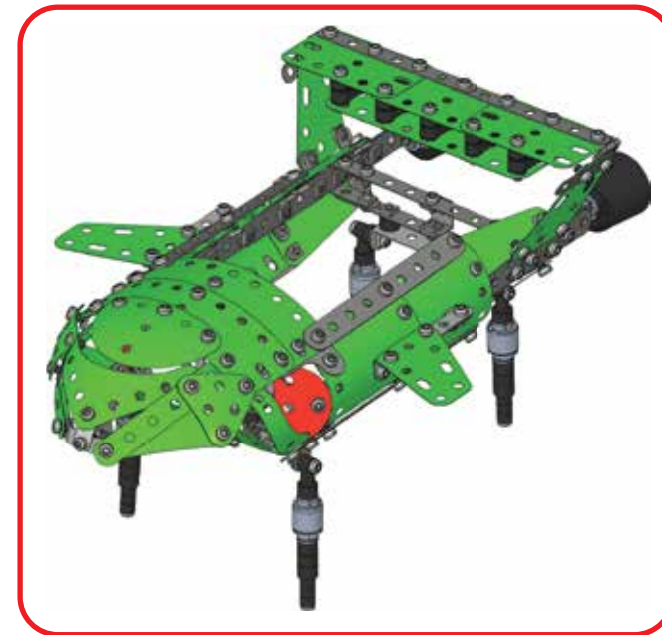
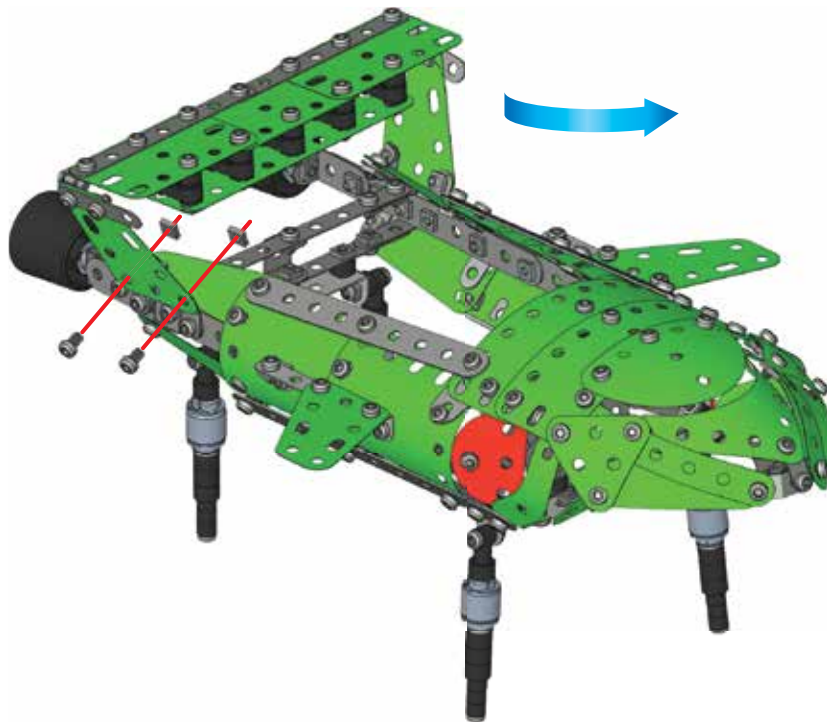



87

(21) + (86) +

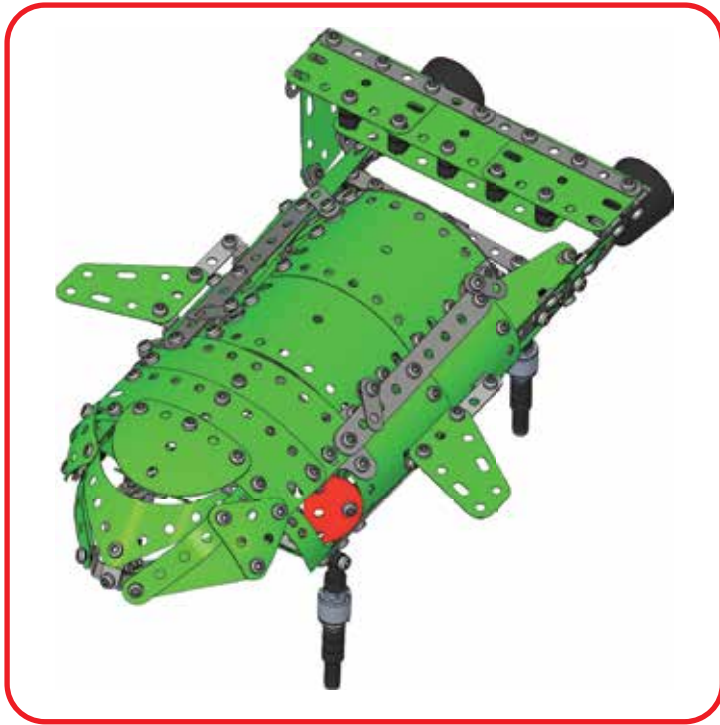
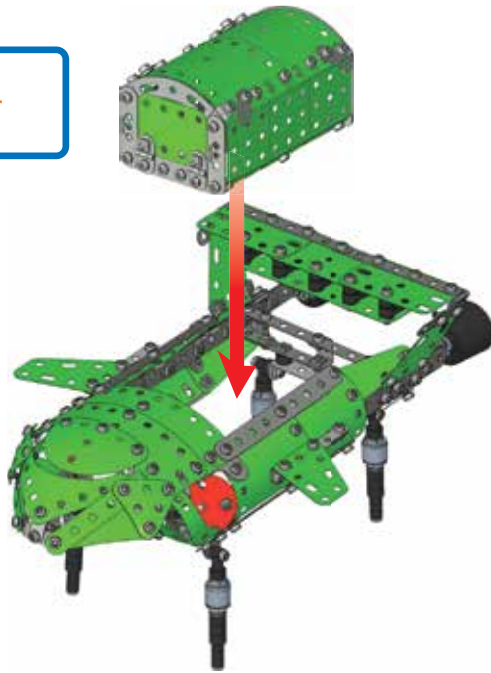

88

1  
 2  
 3  
 4 THUNDERBIRD 2 THUNDERBIRD 2 T2 T2  
 5 6 7 8  
 9 10 2 2 11  
 12 13 14  
 WARNING JET BLAST WARNING JET BLAST NO STEP NO STEP KEEP CLEAR

⚠ CAUTION: Stickers not intended to be placed on skin.  
 ⚠ MISE EN GARDE: Les autocollants ne sont pas destinés à être placés sur la peau.  
 ⚠ PRECAUCION: Las calcomanias no deben colocarse sobre la piel.

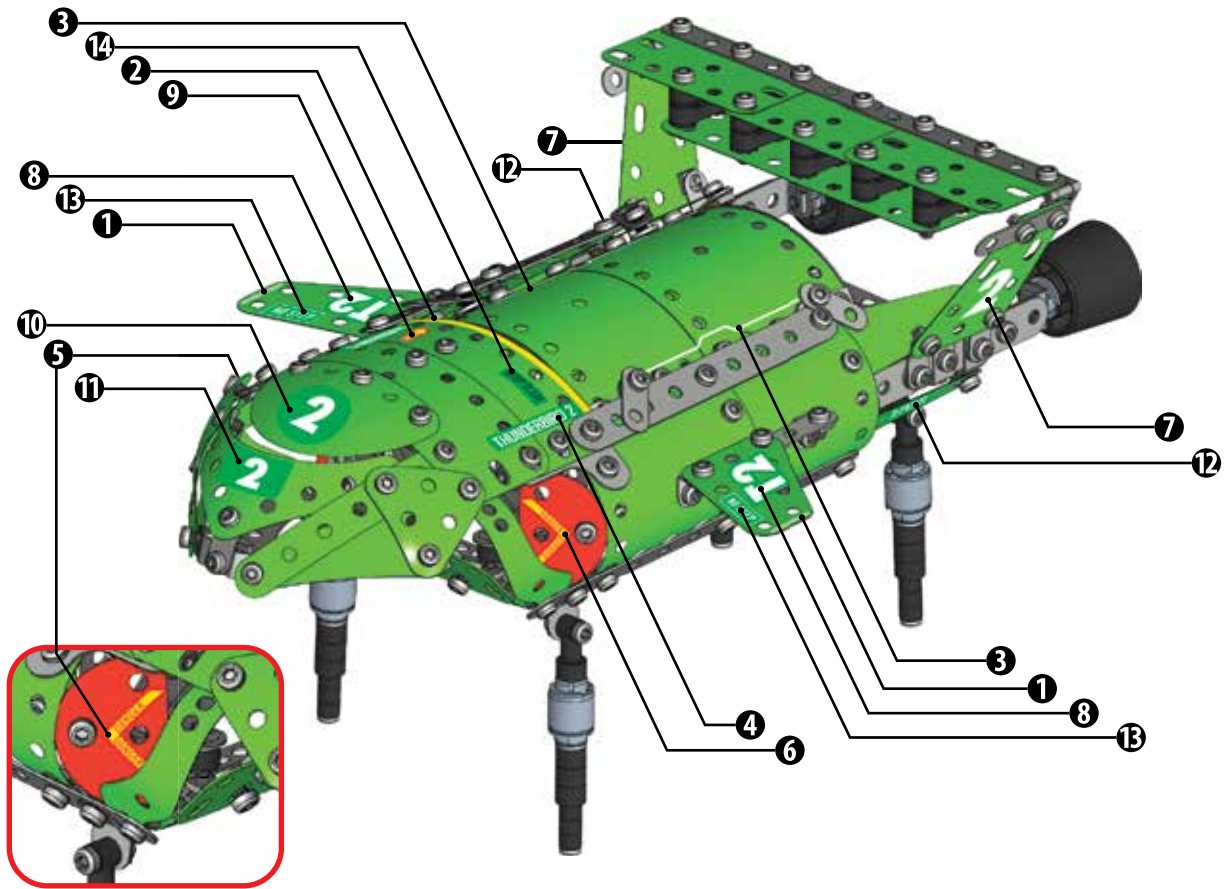
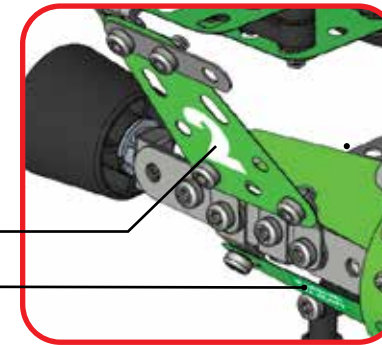



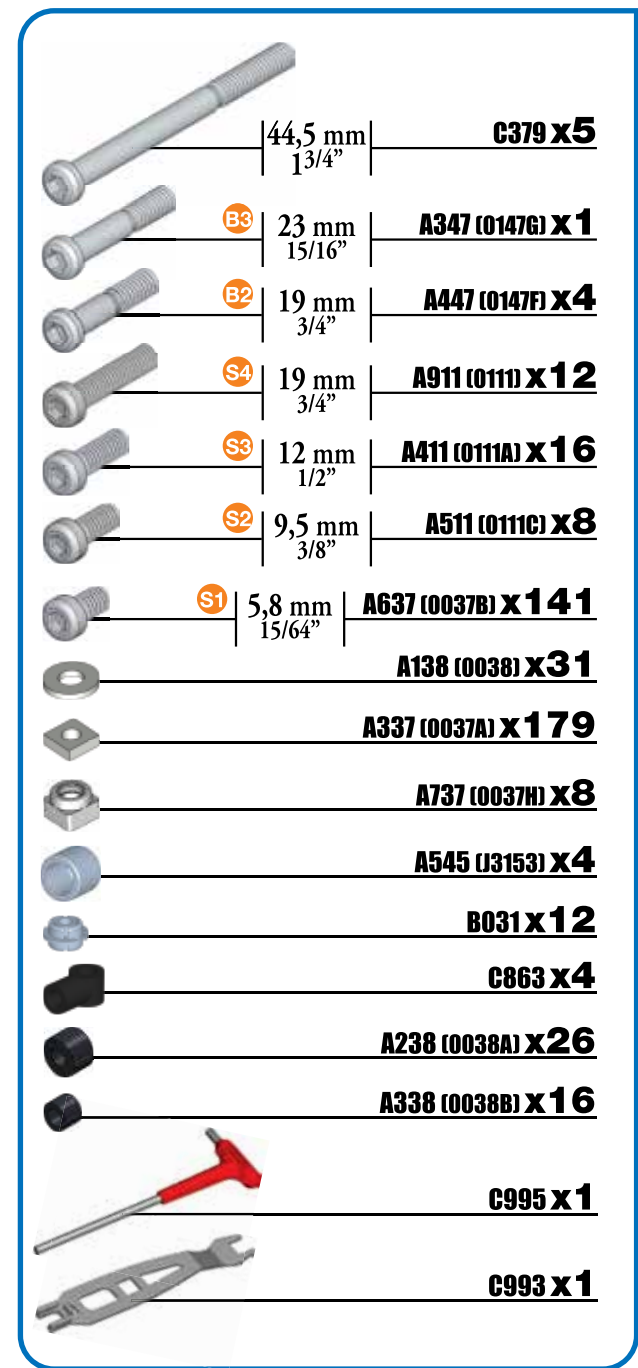
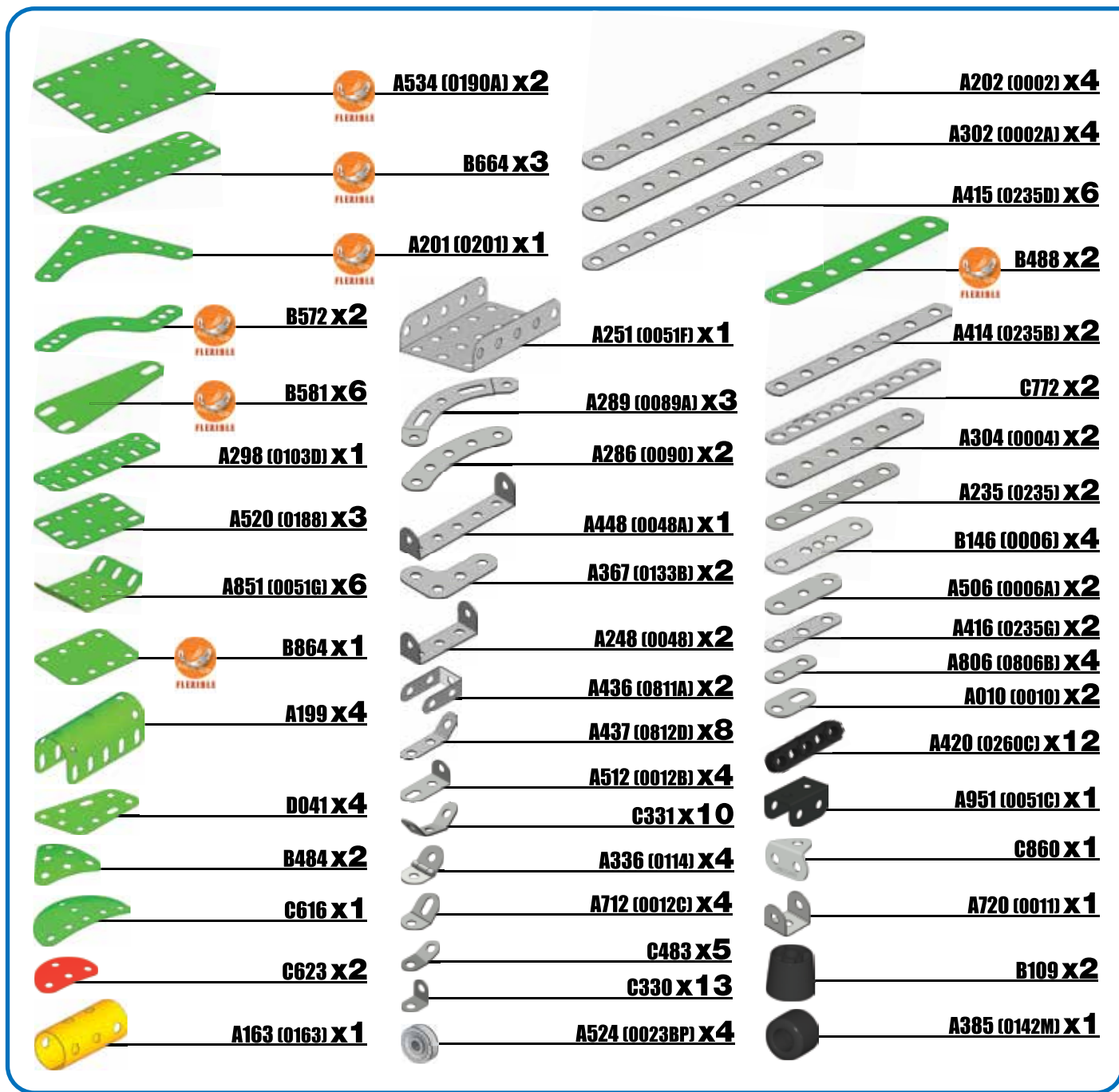

**GB.** Remove all packaging before use. Retain this information, addresses and phone numbers for future reference. Content may vary from pictures. Meccano reserves the right to discontinue the website [www.meccano.com](http://www.meccano.com) at any time. An adult should periodically check this toy to ensure no damage or hazard exist if so, remove from use. Children should be supervised during play.

**F.** Retirer tout l'emballage avant utilisation. Conserver les informations, adresses et numéros de téléphone pour consultation ultérieure. Le contenu peut différer des images. Meccano se réserve le droit de supprimer le site Internet [www.meccano.com](http://www.meccano.com) à tout moment. Un adulte doit régulièrement examiner ce jouet afin de s'assurer qu'il ne présente pas de dommage ni de risque. En cas de problème, ne plus l'utiliser. Les enfants doivent être surveillés lorsqu'ils jouent.

**E.** Retire todo el embalaje antes de utilizar el producto. Conserve toda la información, las direcciones y los números de teléfono para futuras referencias. El contenido del paquete puede no corresponder con las imágenes. Meccano se reserva el derecho a suspender el sitio web [www.meccano.com](http://www.meccano.com) en cualquier momento. Un adulto debe revisar de forma periódica el juguete para asegurarse de que no supone un riesgo o peligro para el niño; si así fuera el caso, interrumpa su uso. Supervise a los niños mientras juegan con el producto.

**D.** Entfernen Sie vor der Benutzung sämtliche Verpackungsmaterialien. Alle Informationen, Adressen und Telefonnummern bitte für mögliche Rückfragen aufbewahren. Der Packungsinhalt kann von den Bildern abweichen. Meccano behält sich das Recht vor, den Betrieb der Website [www.meccano.com](http://www.meccano.com) jederzeit einzustellen. Ein Erwachsener sollte regelmäßig sicherstellen, dass das Spielzeug keine Gefahr darstellt, und es gegebenenfalls entfernen. Kinder sollten beim Spielen beaufsichtigt werden.

**NL.** Verwijder de verpakking voor gebruik. Bewaar deze informatie, adressen en telefoonnummers voor toekomstig gebruik. Inhoud kan afwijken van illustraties. Meccano behoudt zich het recht voor de website [www.meccano.com](http://www.meccano.com) wanneer gewenst buiten gebruik te stellen. Een volwassene dient dit speelgoed regelmatig te controleren op schade en gevaren. Indien het speelgoed is beschadigd of indien er een gevaarlijke situatie kan ontstaan, dient het product te worden weggegooid. Houd toezicht als kinderen spelen.

**I.** Rimuovere l'imballo prima dell'uso. Conservare informazioni, indirizzi e numeri di telefono per riferimento futuro. Il prodotto potrebbe essere differente dalle immagini. Meccano si riserva il diritto di rimuovere il sito [www.meccano.com](http://www.meccano.com) in qualsiasi momento. È consigliabile un controllo periodico del giocattolo da parte di un adulto: in caso di danni o rischi interrompere l'uso. È richiesta la supervisione di un adulto durante il gioco.

**P.** Remova totalmente a embalagem antes de utilizar. Guarde todos os endereços, números de telefone e demais informações para consulta e referência. O conteúdo poderá ser diferente das ilustrações. A Meccano reserva-se o direito de descontinuar o sítio [www.meccano.com](http://www.meccano.com) a qualquer altura. Um adulto deve verificar o brinquedo periodicamente para garantir que ele não apresenta danos ou riscos. Se houver, é necessário que o brinquedo seja retirado de uso. Crianças devem ser supervisionadas enquanto brincam.

**R.** Снимите все упаковочные материалы перед использованием. Запишите указанные на упаковке адреса и номера телефонов, чтобы у вас была возможность связаться с нами. Содержимое упаковки может отличаться от иллюстрации. Компания Meccano оставляет за собой право прекратить использование сайта [www.meccano.com](http://www.meccano.com) в любое время. Регулярно проверяйте состояние игрушки на наличие повреждений и возможных рисков для ребенка. Если таковые имеются, игрушку не следует использовать. Во время игры за детьми следует присматривать.

- △ Warning: CHOKING HAZARD – Small parts.
- △ Attention ! RISQUE D'ETOUFFEMENT – Contient de petits éléments.
- △ Advertencia: PELIGRO DE ASFIXIA – Contiene piezas pequeñas No conveniente para niños menores de 3 años.
- △ Achtung: ERSTICKUNGSGEFAHR – Kleinteile.
- △ Waarschuwing: VERSTIKKINGSGEVAAR – Kleine onderdelen.
- △ Attenzione: RISCHIO DI SOFFOCAMENTO – Pezzi piccoli.
- △ Aviso: PERIGO DE ASFIXIA – Peças pequenas.
- △ Осторожно! ОПАСНОСТЬ УДУШЬЯ – Мелкие детали.

- △ CAUTION: Stickers not intended to be placed on skin.
- △ MISE EN GARDE : Les autocollants ne sont pas destinés à être placés sur la peau.
- △ PRECAUCIÓN: Las calcomanías no deben colocarse sobre la piel.
- △ ACHTUNG: Sticker sind nicht zum Aufkleben auf die Haut geeignet.
- △ VOORZICHTIG: Stickers zijn niet voor op de huid bedoeld.
- △ ATTENZIONE: Non applicare gli adesivi sulla pelle.
- △ ATENÇÃO: os autocolantes não devem ser colocados na pele.
- △ ОСТОРОЖНО: Стикеры не предназначены для приклеивания к коже.



SPIN MASTER LTD., 450 FRONT STREET WEST, TORONTO, ON M5V 1B6 CANADA.  
DISTRIBUTED IN EU BY SPIN MASTER INTERNATIONAL, S.A.R.L., 16 AVENUE PASTEUR, L-2310, LUXEMBOURG. [www.spinmaster.com](http://www.spinmaster.com)  
Made in France by / Fabriqué en France par / Hecho en Francia por  
Meccano : 363, avenue de Saint-Exupéry 62100 Calais - France



TM & © 2015 MECCANO for packaging, instructions and models built with this set.  
® MECCANO is an exclusive trademark of MECCANO. Spin Master logo is a trademark of Spin Master Ltd. All rights reserved. TM & © 2015 MECCANO pour l'emballage, les notices et modèles de ce coffret. ® MECCANO est une marque de commerce exclusive de MECCANO. Le logo de Spin Master est une marque de commerce de Spin Master Ltd. Tous droits réservés. Meets CPSC Safety Requirements. / Conforme aux exigences de sécurité de la CPSC. / Cumple con las normas de seguridad de la CPSC.

itv  
STUDIOS

© ITV Studios Limited / Pukeko Pictures LP 2015. All copyright in the original Thunderbirds™ series is owned by ITC Entertainment Group Limited.  
© ITV Studios Limited / Pukeko Pictures LP 2015. Les droits d'auteur de la série originale Thunderbirds™ sont détenus par ITC Entertainment Group Limited.

THUNDERBIRDS.COM

T91816\_0002\_20072515\_GML\_IB\_R1\_MEC\_Thunderbird2\_FR

UK – 0800 206 1191, [SERVICEUK@SPINMASTER.COM](mailto:SERVICEUK@SPINMASTER.COM)  
FRANCE – 0800 909 150, [SERVICEFR@SPINMASTER.COM](mailto:SERVICEFR@SPINMASTER.COM)  
ESPAÑA – [SERVICIO@SPINMASTER.COM](mailto:SERVICIO@SPINMASTER.COM)  
DEUTSCHLAND – 00800 0101 0222, [KUNDENSERVICE@SPINMASTER.COM](mailto:KUNDENSERVICE@SPINMASTER.COM)  
SCHWEIZ – 0800 561 350 • ÖSTERREICH – 0800 29 72 67  
NEDERLAND – 0800 022 36 83, [KLANTENSERVICE@SPINMASTER.COM](mailto:KLANTENSERVICE@SPINMASTER.COM)  
BELGIË/BELGIQUE – 0800 77 688 • LUXEMBOURG – 800 28 044  
ITALIA – 800 788 532, [SERVIZIO@SPINMASTER.COM](mailto:SERVIZIO@SPINMASTER.COM)  
MEXICO – 53.51.44.00  
[WWW.SPINMASTER.COM](http://WWW.SPINMASTER.COM)



NORTH AMERICA:  
AMÉRIQUE DU NORD: 1-800-622-8339 [customer@spinmaster.com](mailto:customer@spinmaster.com)