

# MECCANO™ TECH

MAKER SYSTEM

16402

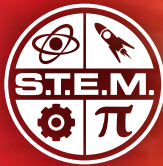

## MECCANOID 2.0™

PERSONAL ROBOT



10+

Instructions  
Notice de montage  
Instrucciones de construcción  
Bauanleitung  
Bouwinstructie  
Istruzioni  
Instruções  
Инструкции

- ⚠ **WARNING:** Cords could be a strangulation hazard. Not for use by children under 3 years of age.
- ⚠ **ATTENTION!** Les câbles peuvent présenter un risque de strangulation. Ne pas laisser à la portée des enfants de moins de 3 ans.

**4 x D/LR201, 5V**  
BATTERIES NOT INCLUDED / PILAS NO INCLUIDAS /  
FOURNIES / PILAS NO INCLUIDAS /  
BATTERIEN NICHT ENTHALTEN /  
BATTERIEN NIET INBEGREPEN /  
BATTERIE NON INCLUSE / PILHAS NÃO  
INCLUSAS / ЭЛЕМЕНТЫ ПИТАНИЯ НЕ  
ВХОДЯТ В КОМПЛЕКТ



**FCC Statement:** This device complies with Part 15 of the FCC rules. Operation is subject to the following two conditions:

(1) This device may not cause harmful interference, and (2) This device must accept any interference received, including interference that may cause undesired operation.

This equipment has been tested and found to comply with the limits for Class B digital devices pursuant to Part 15 of the FCC rules. These limits are designed to provide reasonable protection against harmful interference to radio communications. This equipment generates, uses and can radiate radio frequency energy and, if not installed and used in accordance with the instruction, may cause harmful interference to radio communication. However, there is no guarantee that interference will not occur in a particular installation. If this toy does cause interference to radio or television reception (you can check this by turning the toy off and on while listening for the interference), one or more of the following measures may be useful:

- Reorient or relocate the receiving antenna.
- Increase the separation between the toy and the radio or the TV.
- Consult the dealer or an experienced TV-radio technician for help.

**NOTE:** Changes, adjustments or modifications to this unit, including but not limited to, replacement of any transmitter component (crystal, semiconductor, etc) could result in a violation of FCC rules under part 15 and/or 95 and must be expressly approved by Spin Master Ltd. or they could void the user's authority to operate the equipment.

**Déclaration FCC :** Cet appareil est conforme à l'article 15 de la réglementation de la FCC. Son utilisation est soumise aux deux conditions suivantes :

(1) Cet appareil ne doit pas causer d'interférences nuisibles, et (2) Cet appareil doit tolérer toutes les interférences reçues, y compris celles pouvant entraîner un fonctionnement indésirable.

Cet équipement a été testé et jugé conforme aux limites de la classe B pour les équipements numériques en vertu de l'article 15 de la réglementation de la FCC. Ces limites ont été instaurées pour assurer une protection raisonnable contre toute interférence nuisible avec les communications radios. Cet équipement génère, utilise et peut émettre de l'énergie de fréquence radio. S'il n'est pas installé et utilisé selon le mode d'emploi, il peut causer des interférences nuisibles aux communications radios. Cependant, selon l'installation, des interférences peuvent être constatées. Si ce jouet cause des interférences à la réception radio ou télévisée (ce qui est vérifiable en l'éteignant, puis en le rallumant tout en écoutant s'il y a des interférences), suivre une ou plusieurs des recommandations suivantes :

- Réorienter ou déplacer l'antenne réceptrice.
- Augmenter la distance entre le jouet et la radio ou la télévision.
- Consulter le revendeur ou demander l'aide d'un technicien radio/TV expérimenté.

**REMARQUE :** tout changement, réglage ou modification de cet appareil, incluant mais ne se limitant pas au remplacement de tout composant du transmetteur (cristal, semi-conducteur, etc.), pourrait constituer une violation de l'article 15 et/ou 95 de la réglementation de la FCC, et doit être expressément approuvé par Spin Master Ltd., sous peine d'entraîner l'annulation du droit de l'utilisateur d'exploiter l'équipement.

**Declaración de la FCC:** Este aparato cumple con el artículo 15 de las normas de la FCC.

El funcionamiento está sujeto a las dos siguientes condiciones: (1) Este aparato no debe causar interferencias perjudiciales, y (2) Este aparato debe aceptar cualquier interferencia recibida, incluidas las que podrían causar un funcionamiento no deseado.

Este equipo se sometió a las pruebas debidas y se comprobó que cumple con los requisitos específicos para aparatos digitales de clase B en conformidad con el artículo 15 de las normas de la FCC. Estos requisitos están diseñados para proporcionar protección razonable contra interferencias perjudiciales en las comunicaciones por radio. Este juguete genera, utiliza y puede emitir energía de radiofrecuencia. Si no se instala y se utiliza de acuerdo con la guía de instrucciones, puede causar interferencias en las comunicaciones por radio. Sin embargo, en función de la instalación, pueden ocurrir interferencias. Si este juguete ocasiona interferencias perjudiciales en la recepción radio o televisiva (lo cual se puede comprobar encendiendo y apagando el juguete mientras se escucha la interferencia), seguir una o varias de las siguientes recomendaciones:

- Volver a orientar o ubicar la antena receptora.
- Aumentar la distancia entre el juguete y la radio o el televisor.
- Consultar al distribuidor o a un técnico especializado en radio y televisión.

**NOTA:** Los cambios, ajustes o modificaciones realizados sobre este aparato, incluidos pero no limitados al cambio de cualquier componente del transmisor (emisor de cristal, semiconductor, etc.) podrían constituir una violación del artículo 15 y/o 95 de las normas de la FCC y deberían ser expresamente aprobados por Spin Master Ltd., de lo contrario quedaría inválida la autoridad del usuario para usar el equipo.

**EN.** Content: 497 Parts, 1 MeccaBrain™, 1 LED module, 3 hand tools, 4 servos, 2 rear wheel assembly, 2 motor gear box assembly, 1 USB cable

**FR.** Contenu : 497 pièces, 1 MeccaBrain™, 1 module LED, 3 outils, 4 servomoteurs, assemblage 2 roues arrière, assemblage 2 moteurs et engrenages, 1 câble USB

**ES.** Contenido: 497 piezas, 1 MeccaBrain™, 1 módulo LED, 3 herramientas, 4 servos, ensamblaje para 2 ruedas traseras, ensamblaje con 2 motores y caja de engranajes, 1 cable USB

**DE.** Inhalt: 497 Teile, 1 MeccaBrain™, 1 LED-Modul, 3 Handwerkzeuge, 4 Servos, 2 Hinterräder zum Zusammenbauen, Box mit 2 Getriebenen und Motoren, 1 USB-Kabel

**NL.** Inhoud: 497 onderdelen, 1 MeccaBrain™, 1 LED-module, 3 stuks gereedschap, 4 servo's, 2 achterwielen, tandwielkast met 2 motoren, 1 USB-kabel

**IT.** Contenuto: 497 pezzi, 1 MeccaBrain™, 1 modulo a LED, 3 attrezzi, 4 servomotori, kit con 2 ruote posteriori, kit con 2 motori e cambi di velocità, 1 cavo USB

**PT.** Conteúdo: 497 partes, 1 MeccaBrain™, 1 módulo de LED, 3 ferramentas manuais, 4 servomotores, 2 rodas traseiras, caixa com 2 engrenagens e motor, 1 cabo USB

**RU.** В коробке: 497 деталей, 1 MeccaBrain™, 1 светодиодный модуль, 3 ручных инструмента, 4 сервопривода, комплект из 2 задних колес, комплект из 2 механизированных коробок передач, 1 USB-кабель

**EN.** Building instructions for model#2 are available at [www.meccano.com](http://www.meccano.com).

**FR.** La notice de montage du modèle 2 est disponible sur [www.meccano.com](http://www.meccano.com)

**ES.** Hay instrucciones de construcción disponibles para el modelo 2 en [www.meccano.com](http://www.meccano.com).

**DE.** Die Bauanleitung für Modell Nr. 2 ist auf [www.meccano.com](http://www.meccano.com) zu finden.

**NL.** Bouwinstructies voor model#2 zijn verkrijgbaar op [www.meccano.com](http://www.meccano.com).

**IT.** Le istruzioni di montaggio del modello 2 sono disponibili alla pagina [www.meccano.com](http://www.meccano.com).

**PT.** As instruções de montagem para o modelo 2 estão disponíveis em [www.meccano.com](http://www.meccano.com).









**RU.** Инструкции по сборке модели №2 можно найти на сайте [www.meccano.com](http://www.meccano.com).

## CAN ICES-3(B)/NMB-3(B)

**CANADIAN Class B statement:** This device complies with Industry Canada Licence-exempt RSS-210. Operation is subject to the following two conditions: (1) this device may not cause interference, and (2) this device must accept any interference, including interference that may cause undesired operation of the device.

**Déclaration CANADIENNE classe B :** Le présent appareil est conforme au CNR-210 d'Industrie Canada applicable aux appareils radio exempts de licence. L'utilisation est autorisée aux deux conditions suivantes : (1) l'appareil ne doit pas produire de brouillage, et (2) l'appareil doit accepter tout brouillage radioélectrique subi, même si le brouillage est susceptible d'en compromettre le fonctionnement.

Only one model can be built at a time./ Les pièces fournies ne permettent de monter qu'un seul modèle à la fois./ Solo es posible construir un modelo a la vez./ Jeweils nur eins der Modelle baubar./ Er kan maar een model tegelijk worden gebouwd./ Permette di realizzare un solo modello per volta./ Só é possível montar um modelo de cada vez./ Одновременно можно построить только одну модель.

- Ⓔ The product may have unexpected movement. User and third body should stay at least 30 cm away from the product to avoid unexpected impact. The toy is only to be connected to Class II equipment bearing the symbol:  **CAUTION Cut Hazard:** Product has functional sharp points. Contact may result in injury. Always keep points away from fingers and body. Handle with care. Use with adult supervision. All the wires should be well attached in the provided wire clip #M044 to avoid hazards caused by loose wire. Extra wire clips are provided in the package. Do not put the phone into the phone tray except in motion capture mode. Activate the product only when the area is appropriate for the intended use (free area, no obstacles). The product is intended to be played on the floor.
- Ⓕ Le produit peut effectuer des mouvements brusques. L'utilisateur et toute autre personne doivent se tenir à au moins 30 cm du produit pour éviter tout choc imprévu. Le jouet ne doit être branché qu'à des équipements de classe II portant le symbole suivant :  **MISE EN GARDE contre les coupures :** le produit présente des extrémités coupantes fonctionnelles. Éviter tout contact pour ne pas se blesser. Les extrémités doivent toujours rester à distance des doigts et du corps. Utiliser avec précaution. Utiliser sous la surveillance d'un adulte. Faire passer tous les fils dans l'attache de sécurité #M044 pour éviter tout risque de trébuchement. Des attaches supplémentaires sont fournies avec le produit. Ne pas insérer de téléphone dans l'espace prévu si le mode de capture de mouvement n'est pas sélectionné. Activer le produit uniquement si la zone est adaptée à l'utilisation prévue (zone bien dégagée). Le produit est destiné à une utilisation au sol.
- Ⓖ El producto podría hacer movimientos inesperados. El usuario y cualquier cuerpo extraño deben mantenerse al menos a unos 30 cm del producto para evitar cualquier impacto no deseado. El juguete solo se debe conectar a dispositivos de Clase II que lleven el símbolo:  **PRECAUCIÓN Riesgo de corte:** el producto contiene partes afiladas. El contacto con ellas podría provocar lesiones. Mantén estas partes afiladas lejos de los dedos y del cuerpo. Manipula el juguete con cuidado. Utilízalo bajo la supervisión de un adulto. Todos los cables deben estar bien sujetos con el clip para cables que se proporciona #M044 para evitar riesgos provocados por algún cable suelto. En la caja se incluyen clips para cables adicionales. Coloca el teléfono en la bandeja para teléfono únicamente en el modo de captura de movimiento. Activa el producto solo en áreas apropiadas para tal fin (zonas amplias, sin obstáculos). El producto se ha diseñado para usarlo en el suelo.
- Ⓓ Das Produkt kann unerwartete Bewegungen ausführen. Benutzer und Umstehende sollten mindestens 30 cm Abstand zum Produkt halten, um Zusammenstöße zu vermeiden. Das Spielzeug darf nur an Geräte der Schutzklasse II mit dem folgenden Symbol angeschlossen werden:  **ACHTUNG Schnittgefahr:** Das Produkt enthält funktionale scharfe Kanten. Kontakt kann zu Verletzungen führen. Scharfe Kanten von Fingern und anderen Körperteilen fernhalten. Mit Vorsicht handhaben. Unter Aufsicht eines Erwachsenen verwenden. Alle Kabel müssen mithilfe der mitgelieferten Kabelklemme #M044 gesichert werden, um Gefahr durch lose Kabel zu vermeiden. Zusätzliche Kabelklemmen sind im Lieferumfang enthalten. Das Telefon nur im Bewegungserkennungsmodus in die Telefonablage legen. Das Produkt nur in Bereichen aktivieren, die für die Nutzung des Produkts geeignet sind (offene Bereiche ohne Hindernisse). Das Produkt ist ausschließlich für das Spielen auf dem Boden vorgesehen.
- Ⓝ Dit product kan onverwachte bewegingen maken. De gebruiker en derden moeten op een afstand van ten minste 30 cm van het product blijven om een onverwachte botsing te voorkomen. Het speelgoed mag alleen worden verbonden met apparatuur van klasse II met het volgende symbool:  **LET OP Snijgevaar:** het product bevat scherpe punten. Contact daarmee kan resulteren in verwondingen. Houd de punten altijd uit de buurt van vingers en lichaam. Wees voorzichtig tijdens het gebruik van het speelgoed. Gebruik onder toezicht van een volwassene. Alle kabels dienen goed bevestigd te worden in de inbegrepen kabelklem #M044 om gevaar van losse kabels te voorkomen. Extra kabelklemmen zijn in de verpakking inbegrepen. Plaats de telefoon alleen in de telefoonhouder bij opnames van bewegingen. Activeer het product uitsluitend als het gebied geschikt is voor het beoogde gebruik (leeg gebied, geen obstakels). Dit product is bedoeld om op de vloer mee te spelen.
- Ⓜ Il prodotto potrebbe muoversi inaspettatamente. Si consiglia di rispettare una distanza di almeno 30 cm dal prodotto per evitare impatti improvvisi. Il giocattolo può essere collegato solo ad apparecchiature di Classe II che recano il simbolo:  **ATTENZIONE! Rischio di taglio:** il prodotto presenta elementi appuntiti. Il contatto potrebbe causare infortuni. Tenere sempre gli elementi appuntiti lontano dalle dita e dal corpo. Maneggiare con cura. Utilizzare con la supervisione di un adulto. Tutti i fili devono essere riuniti nel morsetto #M044 fornito in dotazione per evitare eventuali rischi causati da fili sciolti. Nella confezione sono inclusi morsetti aggiuntivi. Inserire il telefono nell'apposito supporto esclusivamente in modalità motion capture. Attivare il prodotto solamente nelle aree indicate per l'uso (spazio libero, senza ostacoli). Il prodotto va utilizzato posizionandolo a terra.
- Ⓟ O produto pode fazer movimentos inesperados. O usuário e qualquer outra pessoa deverão ficar pelo menos a 30 cm de distância do produto para evitar qualquer impacto inesperado. O brinquedo deve ser conectado somente a equipamentos de Classe II com o seguinte símbolo:  **CUIDADO risco de corte:** o produto contém pontas afiadas. O contato poderá causar lesões. Sempre mantenha as pontas longe dos dedos e do corpo. Manuseie com cuidado. Use sob a supervisão de um adulto. Todos os fios devem estar bem presos no clipe de fios #M044 incluso para evitar lesões causadas fios soltos. Clipes de fios extra inclusos no pacote. Não coloque o telefone na base, exceto no modo de captura de movimento. Ative o produto somente em uma área apropriada para o uso (área ampla, sem obstáculos). Este produto deve ser utilizado no chão.
- Ⓡ Игрушка может внезапно начать двигаться. Пользователь и окружающие должны находиться на расстоянии не менее 30 см от игрушки. Игрушка совместима только с оборудованием класса защиты II, отмеченным символом:  **ОСТОРОЖНО! Опасность пореза:** игрушка содержит острые детали. Прикосновение к ним может привести к травме. Не прикасайтесь к этим деталям пальцами и другими частями тела. Соблюдайте осторожность. Допускается использование только под присмотром взрослых. Все провода должны быть собраны зажимом для проводов, входящим в комплект #M044, чтобы избежать потенциальной угрозы от незакрепленного провода. В комплект входят несколько дополнительных зажимов для проводов. Телефон можно вставлять в подставку для телефона только в режиме записи движения. Активируйте игрушку только в подходящем месте (для игры требуется свободное пространство без препятствий). Игрушка предназначена для использования на полу.



## TABLE OF CONTENTS • SOMMAIRE • ÍNDICE • INHALTSVERZEICHNIS • INHOUD • INDICE • СОДЕРЖАНИЕ

1. ASSEMBLY .....	5-28
1.1 PLUG IN AND DOWNLOAD YOUR LANGUAGE.....	7
1.2 BUILD YOUR ROBOT.....	8-28
2. CONNECT THE ELECTRONICS .....	29
2.1 CONNECT THE ELECTRONICS.....	29-30
3. PLAY .....	31
3.1 LET'S PLAY.....	31
3.2 COMMAND CARD .....	32
3.3 VOICE COMMANDS .....	33
3.4 DOWNLOAD FREE APP .....	34
CONSUMER INFORMATION .....	41-44

1. ASSEMBLAGE.....	5-28
1.1 BRANCHEMENTS ET TÉLÉCHARGEMENT DE LA LANGUE.....	7
1.2 MONTAGE DU ROBOT .....	8-28
2 RÉALISATION DES BRANCHEMENTS.....	35
2.1 RÉALISATION DES BRANCHEMENTS.....	35-36
3. JEU.....	37
3.1 JOUONS! .....	37
3.2 LISTE DES COMMANDES.....	38
3.3 COMMANDES VOCALES .....	39
3.4 PROGRAMMATION VIA L'APPLICATION.....	40
INFORMATIONS DESTINÉES AU CONSOMMATEUR.....	41-44

1. MONTAJE • ZUSAMMENBAU • MONTAGE • MONTAGGIO • MONTAGEM • СБОРКА .....	5-28
1.1 CONÉCTALO Y DESCARGA TU IDIOMA • ANSCHLIESSEN UND DEINE SPRACHE HERUNTERLADEN • SLUIT AAN EN DOWNLOAD JE TAAL • COLLEGA E SCARICA LA TUA LINGUA • CONECTE E BAIXE SEU IDIOMA ПОДКЛЮЧЕНИЕ И ЗАГРУЗКА ЯЗЫКА.....	7
1.2 MONTA TU ROBOT • BAUE DEINEN ROBOTER ZUSAMMEN • BOUW JE EIGEN ROBOT • COSTRUISCI IL TUO ROBOT • MONTE SEU ROBÔ • СБОРКА РОБОТА .....	8-28
2. CONECTA LOS COMPONENTES ELECTRÓNICOS • ELEKTRONISCHE TEILE VERBINDEN • SLUIT DE ELEKTRONICA AAN • COLLEGA I COMPONENTI ELETTRONICI • CONECTE OS ELETRÔNICOS ПОДКЛЮЧЕНИЕ ЭЛЕКТРОННЫХ КОМПОНЕНТОВ .....	
2.1 CONECTA LOS COMPONENTES ELECTRÓNICOS • ELEKTRONISCHE TEILE VERBINDEN • SLUIT DE ELEKTRONICA AAN • COLLEGA I COMPONENTI ELETTRONICI • CONECTE OS ELETRÔNICOS ПОДКЛЮЧЕНИЕ ЭЛЕКТРОННЫХ КОМПОНЕНТОВ.....	Puedes consultar las instrucciones en tu idioma en <a href="http://www.meccano.com">www.meccano.com</a> • Eine Bedienungsanleitung in deiner Sprache findest du unter <a href="http://www.meccano.com">www.meccano.com</a> • Ga verder met instructies in je eigen taal op <a href="http://www.meccano.com">www.meccano.com</a> • Continua con le istruzioni nella tua lingua su <a href="http://www.meccano.com">www.meccano.com</a> • Continue a ler as instruções em seu idioma acessando <a href="http://www.meccano.com">www.meccano.com</a> • Найти інструкції на вашому мові можна на сайті <a href="http://www.meccano.com">www.meccano.com</a>
3. CÓMO JUGAR • SPIELEN • SPELEN • GIOCO • COMO JOGAR • КАК ИГРАТЬ.....	Puedes consultar las instrucciones en tu idioma en <a href="http://www.meccano.com">www.meccano.com</a> • Eine Bedienungsanleitung in deiner Sprache findest du unter <a href="http://www.meccano.com">www.meccano.com</a> • Ga verder met instructies in je eigen taal op <a href="http://www.meccano.com">www.meccano.com</a> • Continua con le istruzioni nella tua lingua su <a href="http://www.meccano.com">www.meccano.com</a> • Continue a ler as instruções em seu idioma acessando <a href="http://www.meccano.com">www.meccano.com</a> • Найти інструкції на вашому мові можна на сайті <a href="http://www.meccano.com">www.meccano.com</a>
3.1 VAMOS A JUGAR • SO WIRD GESPIELT • LATEN WE SPELEN • COMINCIAMO • VAMOS BRINCAR • ДАВАЙ ПОИГРАЕМ .....	Puedes consultar las instrucciones en tu idioma en <a href="http://www.meccano.com">www.meccano.com</a> • Eine Bedienungsanleitung in deiner Sprache findest du unter <a href="http://www.meccano.com">www.meccano.com</a> • Ga verder met instructies in je eigen taal op <a href="http://www.meccano.com">www.meccano.com</a> • Continua con le istruzioni nella tua lingua su <a href="http://www.meccano.com">www.meccano.com</a> • Continue a ler as instruções em seu idioma acessando <a href="http://www.meccano.com">www.meccano.com</a> • Найти інструкції на вашому мові можна на сайті <a href="http://www.meccano.com">www.meccano.com</a>
3.2 TARJETA DE COMANDOS • BEFEHLSKARTE • COMMANDO-KAART • SCHEDA DEI COMANDI • CARTÃO DE COMANDO • КАРТА КОМАНД .....	Puedes consultar las instrucciones en tu idioma en <a href="http://www.meccano.com">www.meccano.com</a> • Eine Bedienungsanleitung in deiner Sprache findest du unter <a href="http://www.meccano.com">www.meccano.com</a> • Ga verder met instructies in je eigen taal op <a href="http://www.meccano.com">www.meccano.com</a> • Continua con le istruzioni nella tua lingua su <a href="http://www.meccano.com">www.meccano.com</a> • Continue a ler as instruções em seu idioma acessando <a href="http://www.meccano.com">www.meccano.com</a> • Найти інструкції на вашому мові можна на сайті <a href="http://www.meccano.com">www.meccano.com</a>
3.3 COMANDOS DE VOZ • SPRACHBEFEHLE • SPRAAKOPDRACHTEN • COMANDI VOCALI • COMANDOS DE VOZ • ГОЛОСОВЫЕ КОМАНДЫ .....	Puedes consultar las instrucciones en tu idioma en <a href="http://www.meccano.com">www.meccano.com</a> • Eine Bedienungsanleitung in deiner Sprache findest du unter <a href="http://www.meccano.com">www.meccano.com</a> • Ga verder met instructies in je eigen taal op <a href="http://www.meccano.com">www.meccano.com</a> • Continua con le istruzioni nella tua lingua su <a href="http://www.meccano.com">www.meccano.com</a> • Continue a ler as instruções em seu idioma acessando <a href="http://www.meccano.com">www.meccano.com</a> • Найти інструкції на вашому мові можна на сайті <a href="http://www.meccano.com">www.meccano.com</a>
3.4 PROGRAMAR CON APLICACIÓN • ÜBER DIE APP PROGRAMMIEREN • PROGRAMMEERBAAR VIA APP • PROGRAMMA CON L'APP • PROGRAME COM O APLICATIVO ПРОГРАММИРОВАНИЕ С ПОМОЩЬЮ ПРИЛОЖЕНИЯ.....	Puedes consultar las instrucciones en tu idioma en <a href="http://www.meccano.com">www.meccano.com</a> • Eine Bedienungsanleitung in deiner Sprache findest du unter <a href="http://www.meccano.com">www.meccano.com</a> • Ga verder met instructies in je eigen taal op <a href="http://www.meccano.com">www.meccano.com</a> • Continua con le istruzioni nella tua lingua su <a href="http://www.meccano.com">www.meccano.com</a> • Continue a ler as instruções em seu idioma acessando <a href="http://www.meccano.com">www.meccano.com</a> • Найти інструкції на вашому мові можна на сайті <a href="http://www.meccano.com">www.meccano.com</a>

4	INFORMACION PARA EL CONSUMIDOR • VERBRAUCHERHINWEISE INFORMATIE VOOR GEBRUIKERS • INFORMAZIONI PER I CONSUMATORI • INFORMAÇÕES PARA O CONSUMIDOR ИНФОРМАЦИЯ ДЛЯ ПОТРЕБИТЕЛЕЙ.....	41-44
---	--	-------



# 1

## ASSEMBLY • ASSEMBLAGE • MONTAJE • ZUSAMMENBAU • MONTAGE • MONTAGGIO • MONTAGEM • СБОРКА

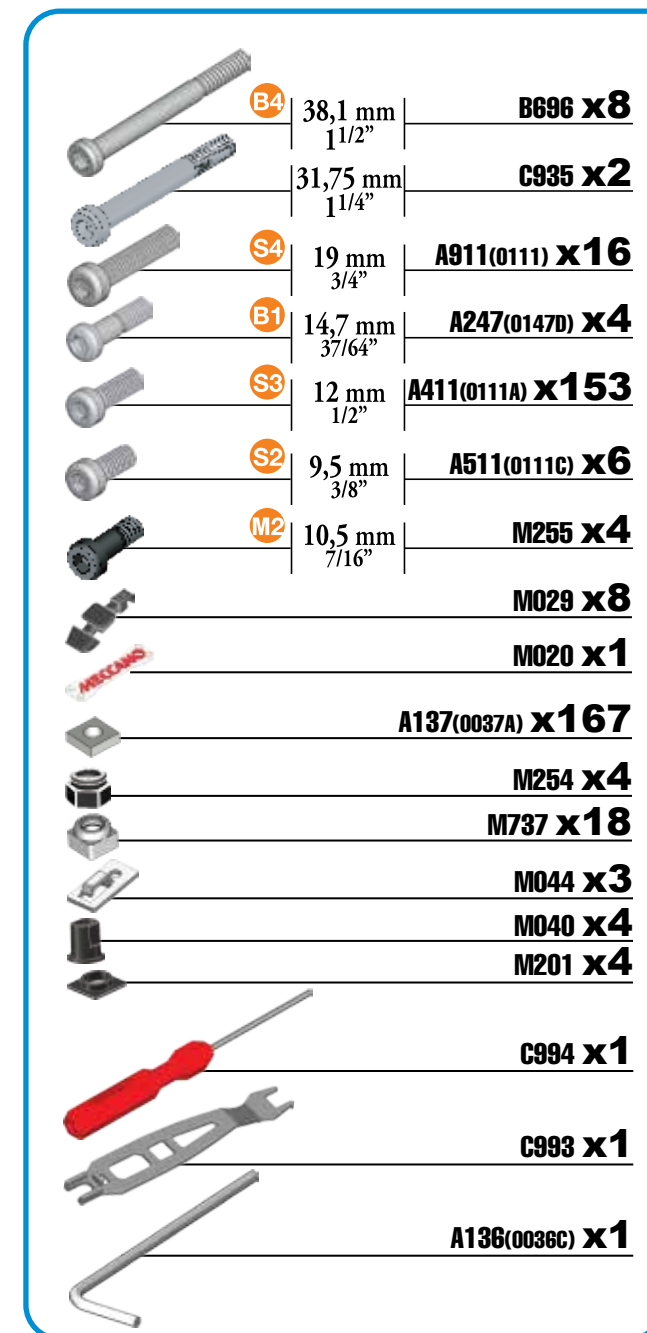
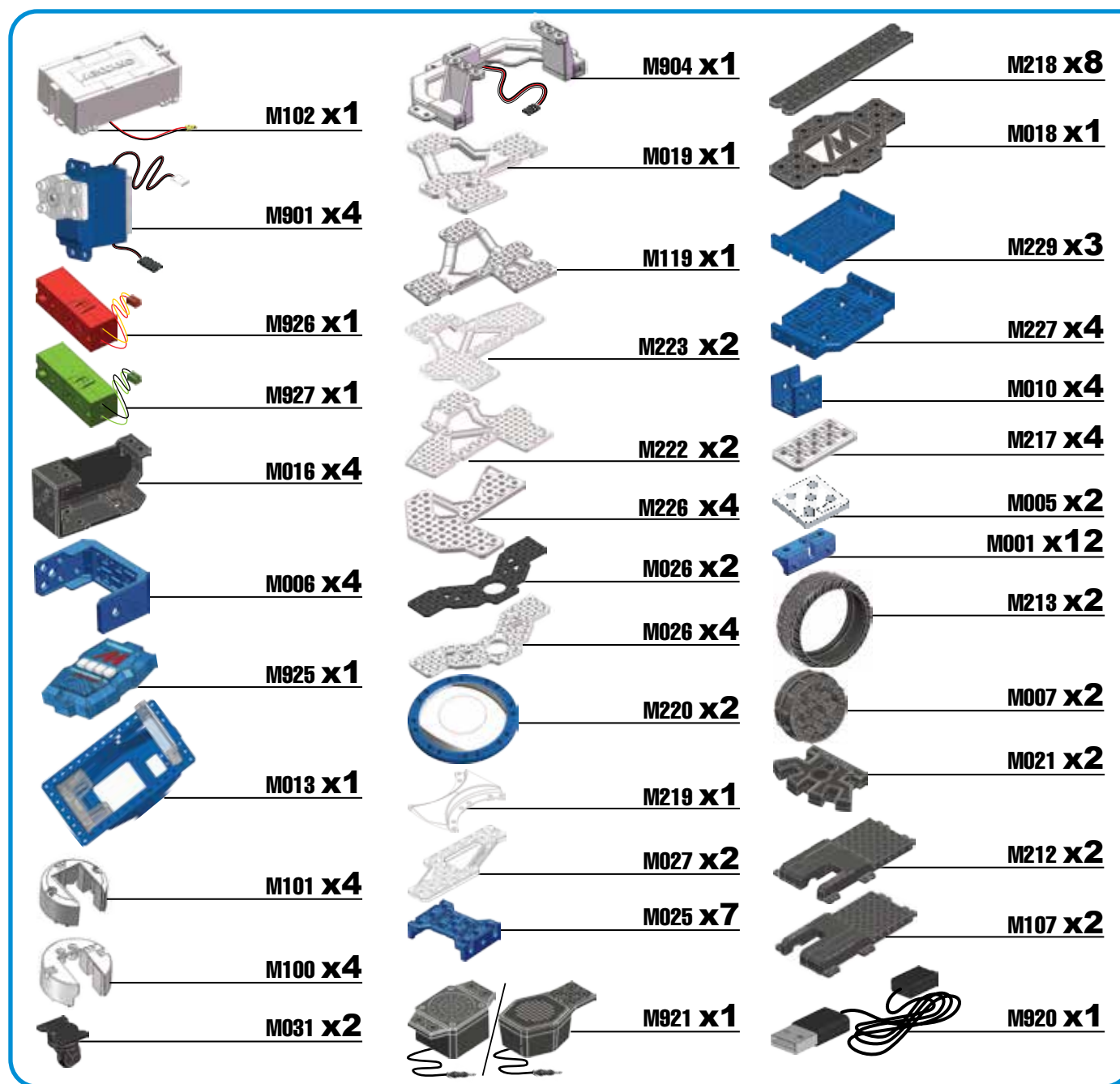



**CONSTRUCTION TIPS / ASTUCES DE CONSTRUCTION**  
TIPS DE CONSTRUCCIÓN / TIPPS ZUM BAUEN  
MONTAGETIPS / SUGGERIMENTI PER COSTRUIRE  
DICAS DE MONTAGEM / РЕКОМЕНДАЦІЇ ПО СБОРКЕ

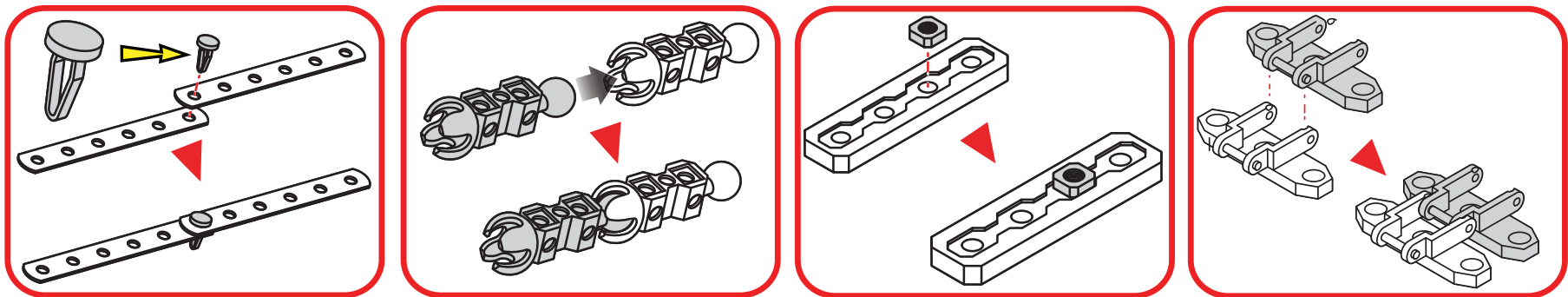
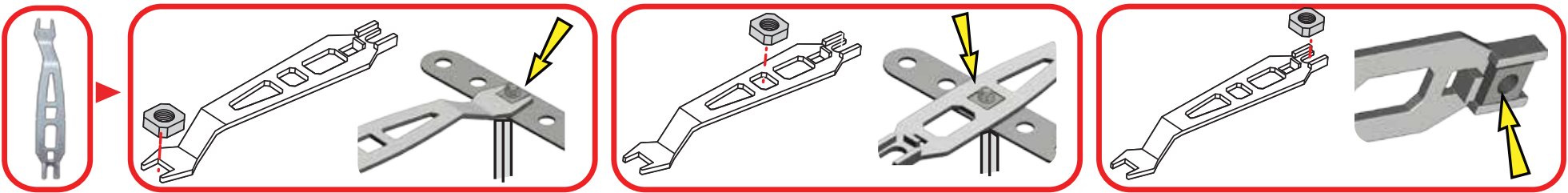
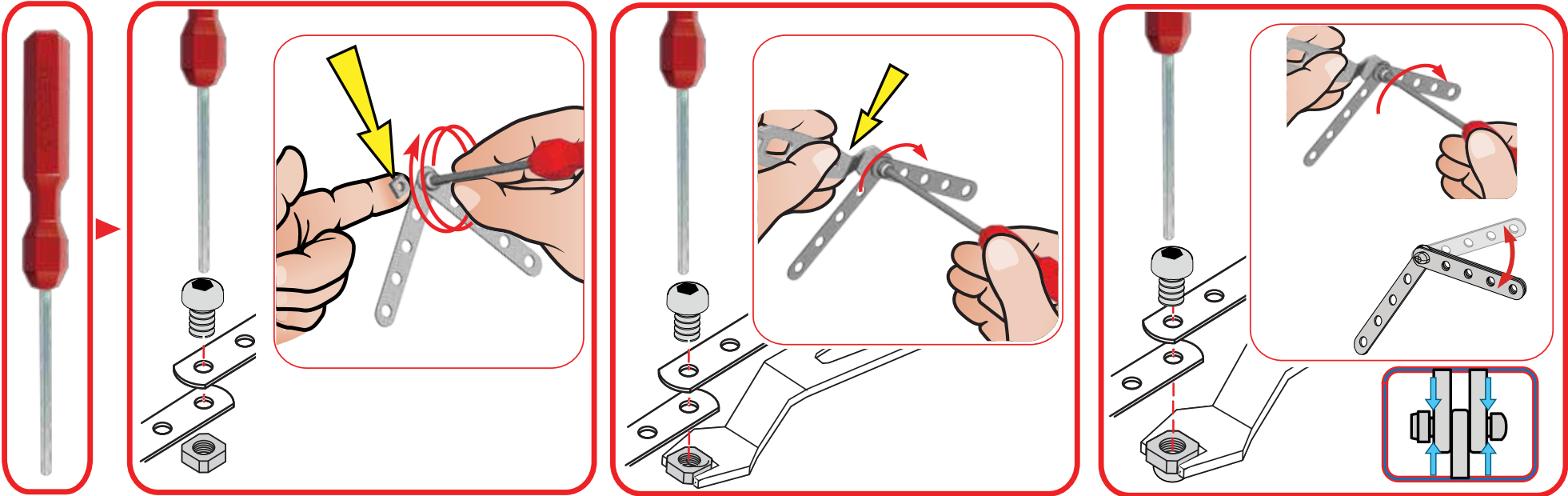

# CONNECT AND PLUG IN • BRANCHEMENTS ET CONNEXIONS • CONÉCTALO • VERBINDEN UND ANSCHLIESSEN • AANSLUITEN • COLLEGAMENTI • CONECTE • ПОДКЛЮЧЕНИЕ И УСТАНОВКА

## 1.1 PLUG IN AND DOWNLOAD YOUR LANGUAGE • BRANCHEMENTS ET TÉLÉCHARGEMENT DE LA LANGUE

For instructions in other languages, visit [www.meccano.com](http://www.meccano.com)

Pour télécharger les instructions dans une autre langue, rends-toi sur [www.meccano.com](http://www.meccano.com)

Para consultar las instrucciones en otros idiomas, visita [www.meccano.com](http://www.meccano.com)

Eine detaillierte Bedienungsanleitung in deutscher Sprache findest du auf [www.meccano.com](http://www.meccano.com)

Voor instructies in andere talen, bezoek [www.meccano.com](http://www.meccano.com)

Per le istruzioni in altre lingue, visitare il sito [www.meccano.com](http://www.meccano.com)

Para instruções em outros idiomas, acesse [www.meccano.com](http://www.meccano.com)

Инструкции на других языках можно найти на сайте [www.meccano.com](http://www.meccano.com)

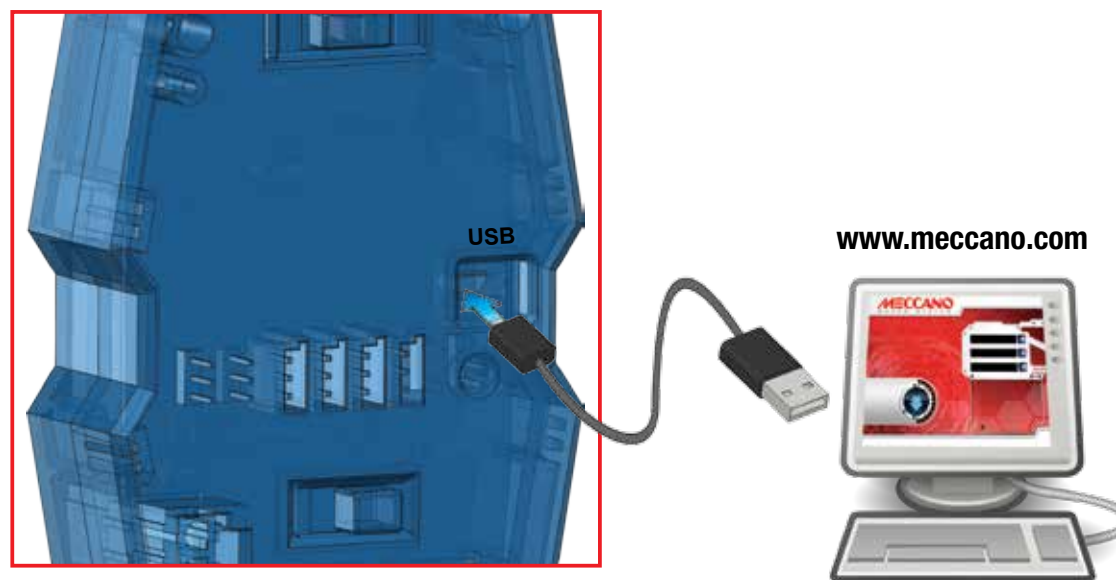

### (EN) Meccanoid must be updated before proceeding.

- To change my language, go to [www.meccano.com](http://www.meccano.com) and find your language.
- Download the Robot Update software
- Locate the included USB cable
- Connect USB cable to computer
- Insert micro USB end into the port on the MeccaBrain™

\*U.K. English also available.

### (ES) Se debe actualizar Meccanoid antes de continuar.

- Si quieres cambiar el idioma, ve a [www.meccano.com](http://www.meccano.com) y busca el tuyo.
- Descarga el software de actualización del robot
- Encuentra el cable USB (incluido)
- Conéctalo a la computadora
- Inserta el micro USB en el puerto del MeccaBrain™
- Puedes consultar las instrucciones en tu idioma en [www.meccano.com](http://www.meccano.com)

### (NL) Meccanoid moet worden bijgewerkt voordat u verdergaat.

- Om mijn taal te veranderen, ga je naar [www.meccano.com](http://www.meccano.com) en zoek je jouw taal.
- Download de updatesoftware van de robot
- Pak de meegeleverde USB-kabel
- Sluit de USB-kabel aan op de computer
- Steek het micro-USB-uiteinde in de poort van de MeccaBrain™
- Ga verder met instructies in je eigen taal op [www.meccano.com](http://www.meccano.com)

### (PT) O Meccanoid deve ser atualizado antes de prosseguir.

- Para mudar meu idioma, acesse [www.meccano.com](http://www.meccano.com) e encontre seu idioma.
- Faça download do software de atualização do robô
- Localize o cabo USB incluído
- Conecte o cabo USB ao computador
- Insira a extremidade micro do cabo USB na porta do MeccaBrain™
- Continue a ler as instruções em seu idioma acessando [www.meccano.com](http://www.meccano.com)

### (FR) Le Meccanoid doit d'abord être mis à jour.

- Pour me faire parler une autre langue de ton choix, rends-toi sur [www.meccano.com](http://www.meccano.com).
- Télécharge le logiciel de mises à jour du robot
- Munis-toi du câble USB inclus.
- Branche le câble USB sur ton ordinateur.
- Insère le connecteur mini USB du câble dans le port du MeccaBrain™
- Pour la suite des instructions en français, passe à la page 36.

### (DE) Meccanoid muss zunächst aktualisiert werden.

- Du findest deine Sprache als Softwarepaket auf [www.meccano.com](http://www.meccano.com).
- Software-Update für den Roboter herunterladen.
- Das mitgelieferte USB-Kabel zur Hand nehmen.
- USB-Kabel mit dem Computer verbinden.
- Den Micro-USB-Stecker in den Ladeanschluss von MeccaBrain™ stecken.
- Eine Bedienungsanleitung in deiner Sprache findest du unter [www.meccano.com](http://www.meccano.com).

### (IT) È necessario aggiornare Meccanoid prima di continuare.

- Per modificare la lingua, visita [www.meccano.com](http://www.meccano.com) e trova la tua lingua.
- Scarica il software di aggiornamento Robot
- Individua il cavo USB in dotazione
- Collega il cavo USB al computer
- Inserisci l'estremità micro USB nella porta del MeccaBrain™
- Continua con le istruzioni nella tua lingua su [www.meccano.com](http://www.meccano.com)

### (RU) Перед продолжением необходимо обновить Meccanoid.

- Чтобы изменить мой язык, перейдите на сайт [www.meccano.com](http://www.meccano.com) и найдите нужный язык.
- Загрузите программное обеспечение для обновления робота
- Возьмите USB-кабель (входит в комплект)
- Подключите USB-кабель к компьютеру
- Подключите разъем micro USB к порту на MeccaBrain™
- Найти инструкции на вашем языке можно на сайте [www.meccano.com](http://www.meccano.com)





**1**

**x1**

**x1**

**x2**

31,75 mm  
1 1/4"

**x2**

**1:1**

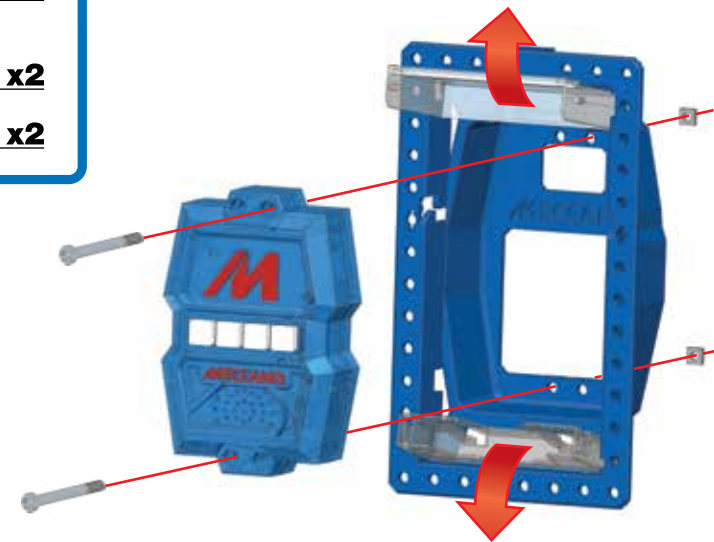
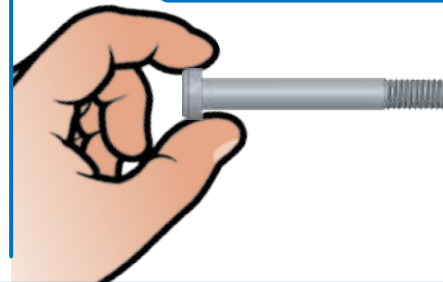

**2**

**x1**

**x1**

**x2**

**x8**

12 mm  
1/2"

**x8**

**1:1**

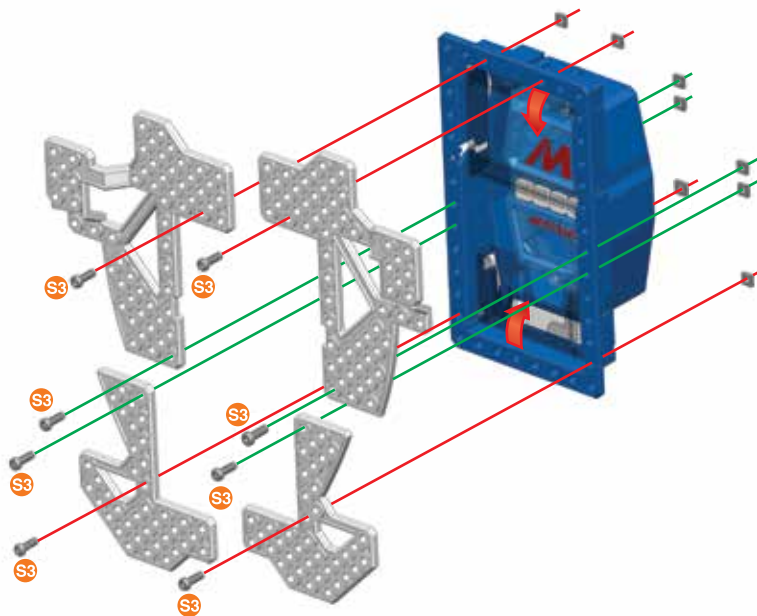

**3**

**x1**

**x2**

19 mm  
3/4"

**x2**

**1:1**

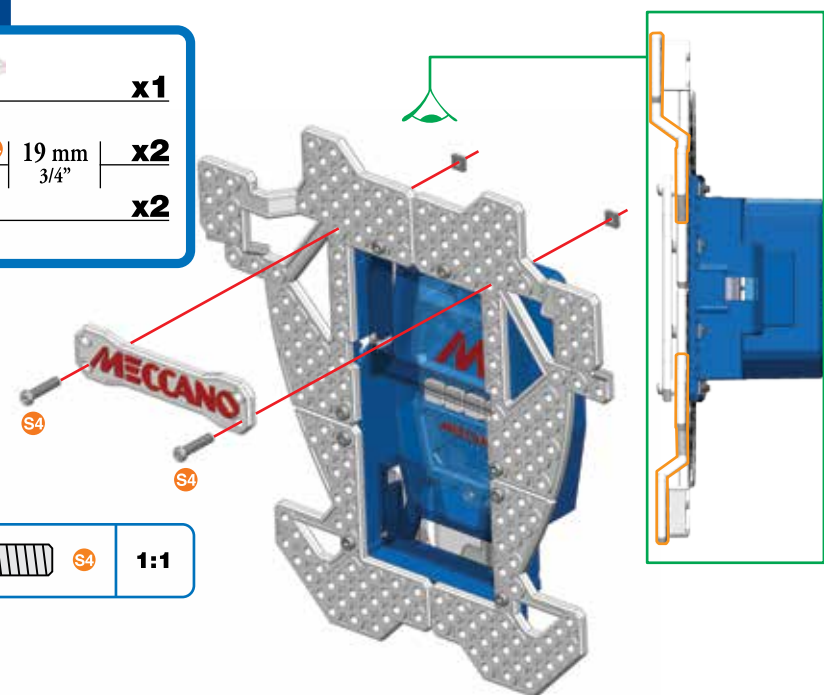

**4**

 **x2**

 **x2**

**x2**

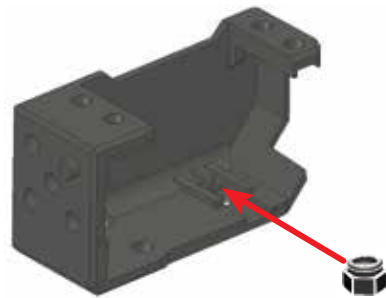

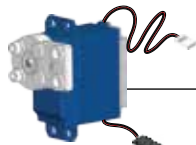

**5**

 **x2**

 **x2**

 **x2**

 **S3** **1:1**

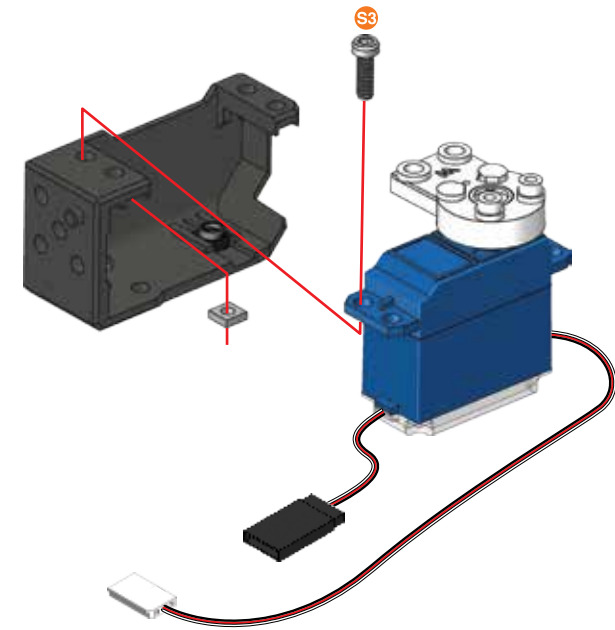



**6**

 **x2**

 **S3** **12 mm** **1/2"** **x4**

 **x2**

 **x2**

 **S3** **1:1**

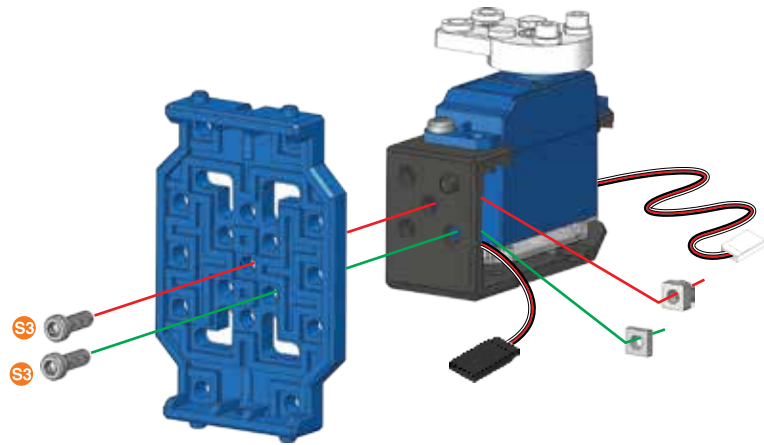

**7**

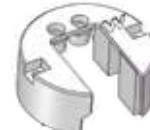
 **x2**

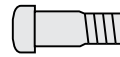

 **B1** **14,7 mm** **37/64"** **x2**

 **x2**

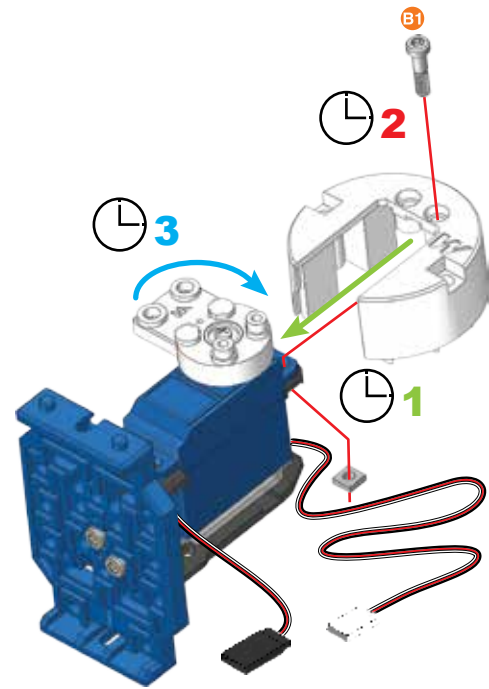
 **B1** **1:1**



**8**

	<b>x2</b>
	<b>x4</b>
	<b>x4</b>

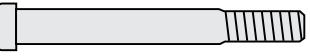
	<b>1:1</b>
---	------------

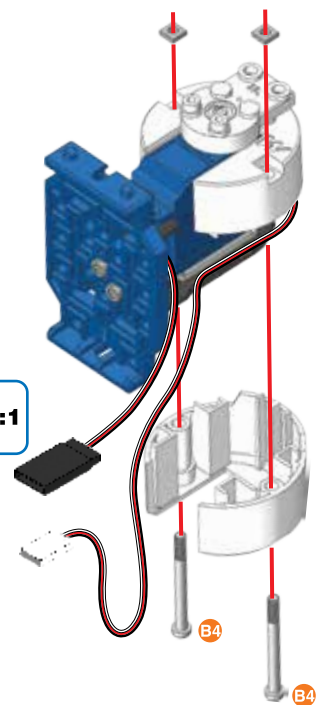
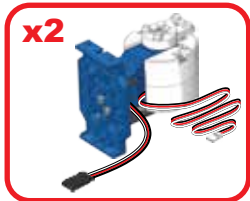



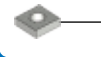

**9** ③+⑧+

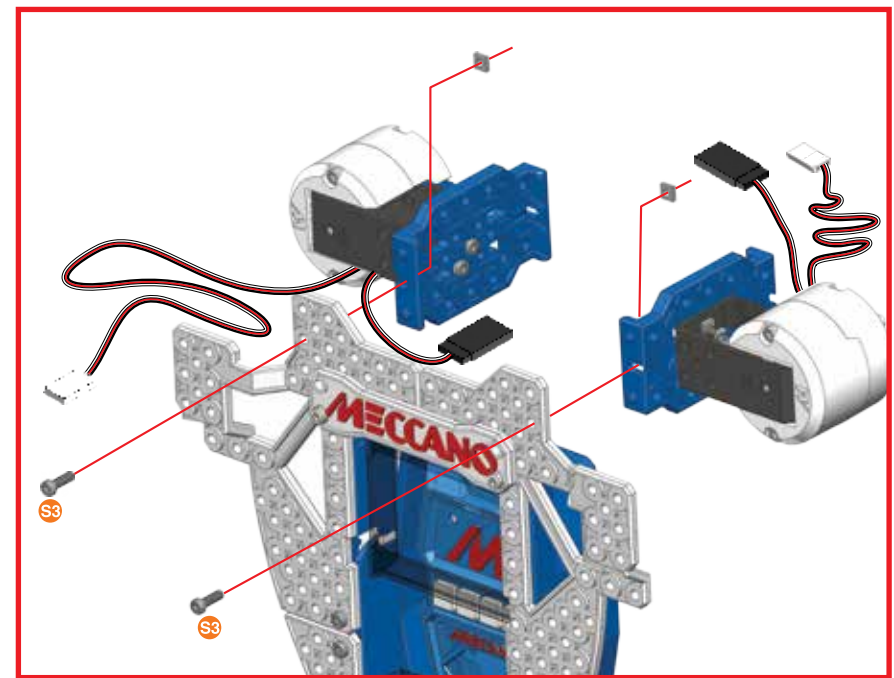
	<b>x2</b>
	<b>x2</b>

	<b>1:1</b>
--	------------

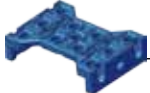



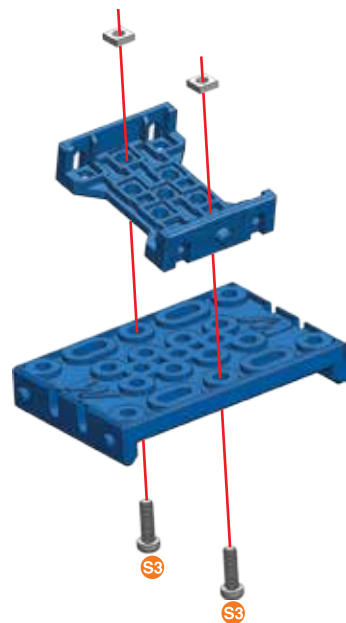

**10**

	<b>x1</b>
	<b>x1</b>
	<b>x2</b>
	<b>x2</b>

	<b>1:1</b>
--	------------

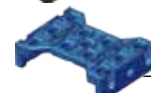

**11**

	<b>x1</b>
	<b>x2</b>
	<b>x1</b>
	<b>x8</b>
	<b>x8</b>

	<b>1:1</b>
--	------------

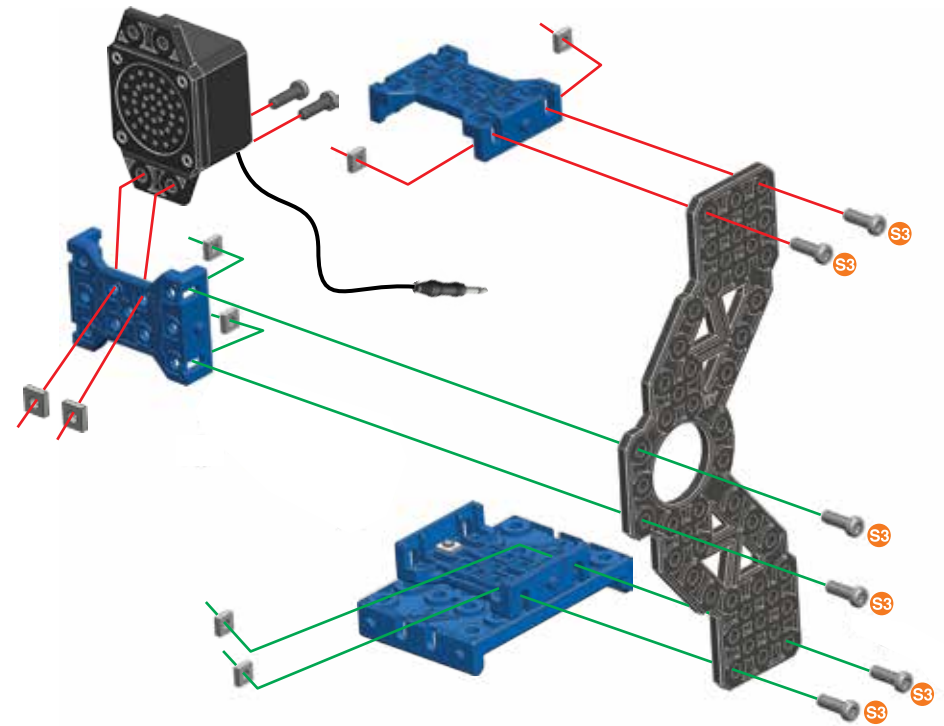



12



x1

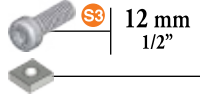

x6

x6

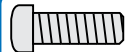

S3

1:1

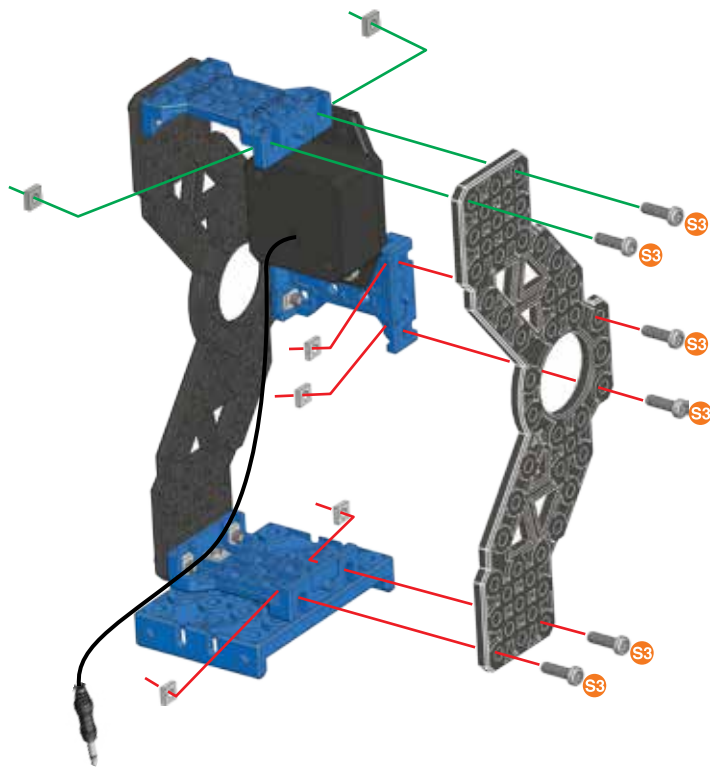

13

9+12+



x2



x2

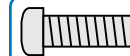

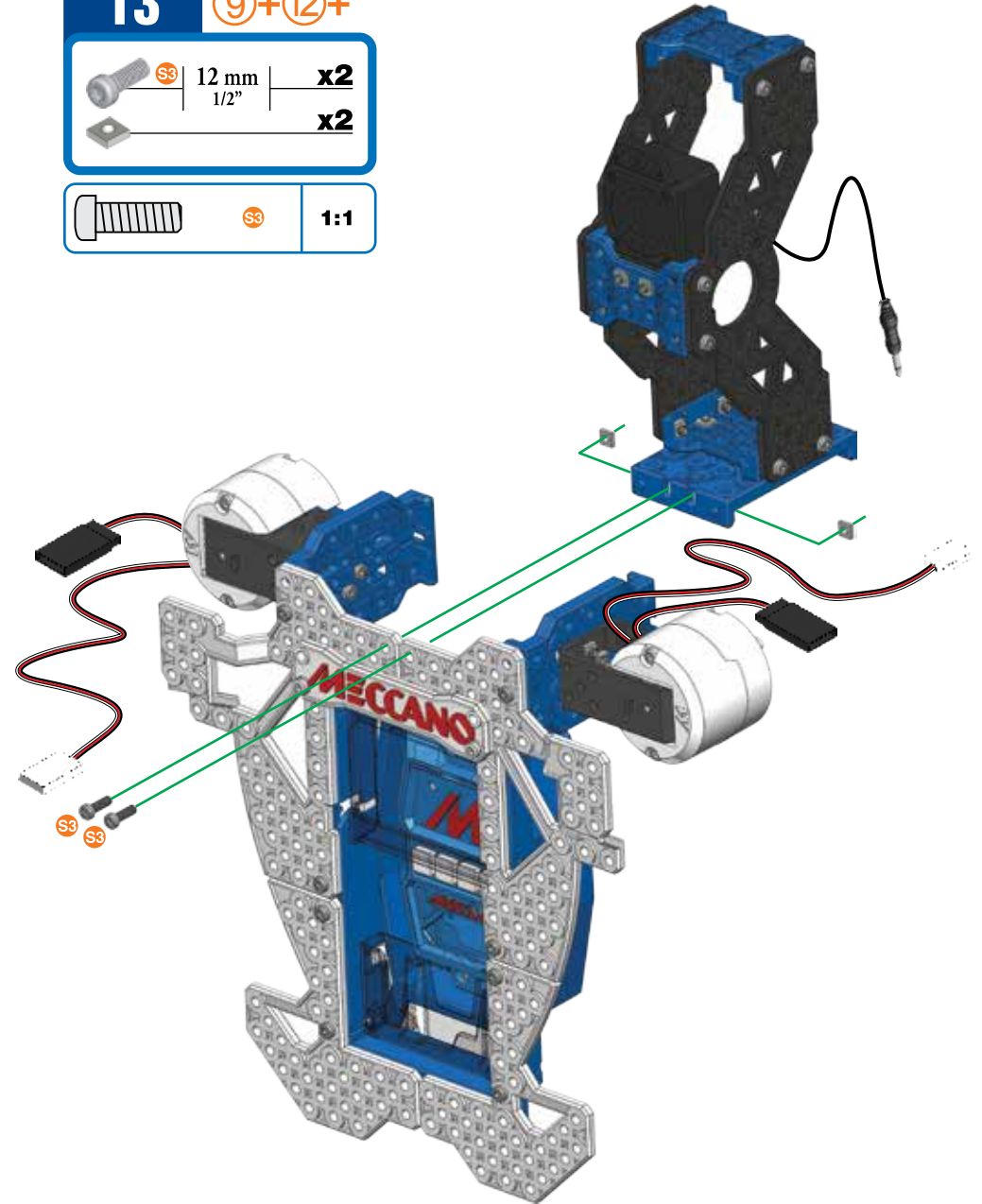

S3

1:1



14

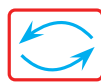

	12 mm 1/2"	<b>x4</b>
		<b>x4</b>
		<b>x2</b>

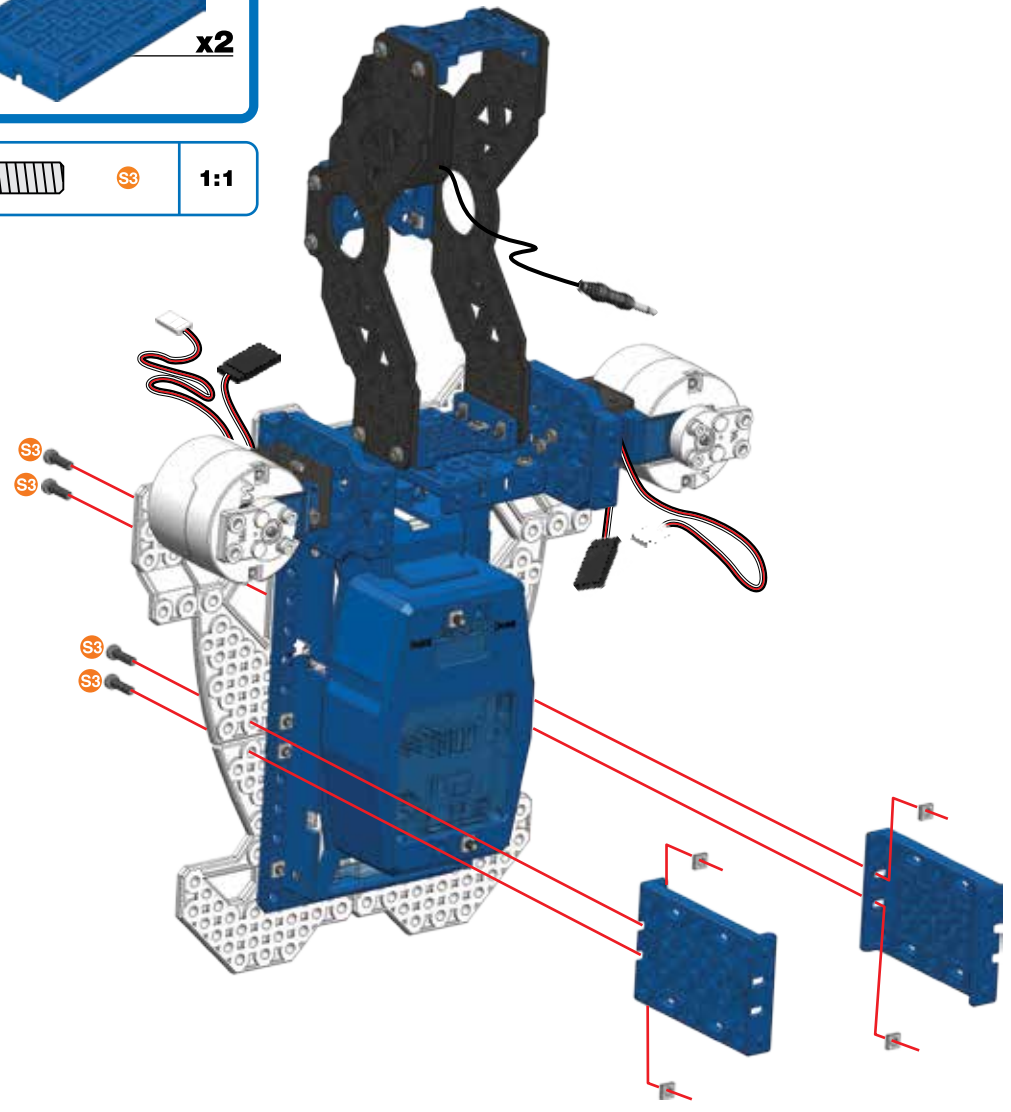

		<b>1:1</b>
---	---	------------





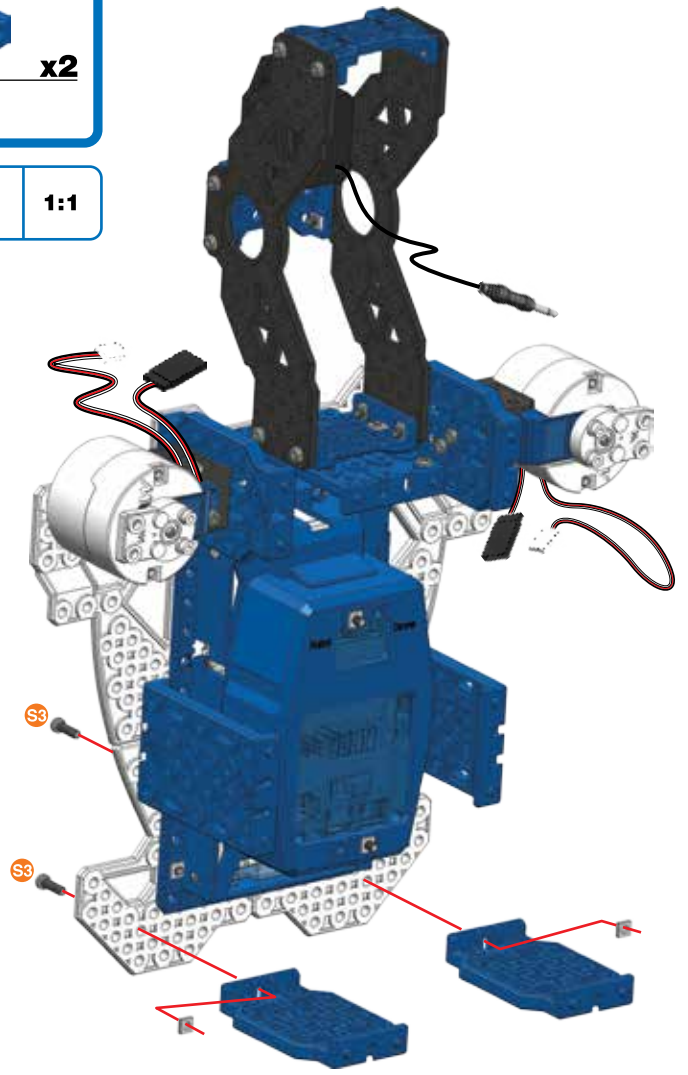

15

	12 mm 1/2"	<b>x2</b>
		<b>x2</b>
		<b>x2</b>

		<b>1:1</b>
---	---	------------





# 16

-  **x1**
-  **x1**
-  12 mm | **x4**
-  **x4**

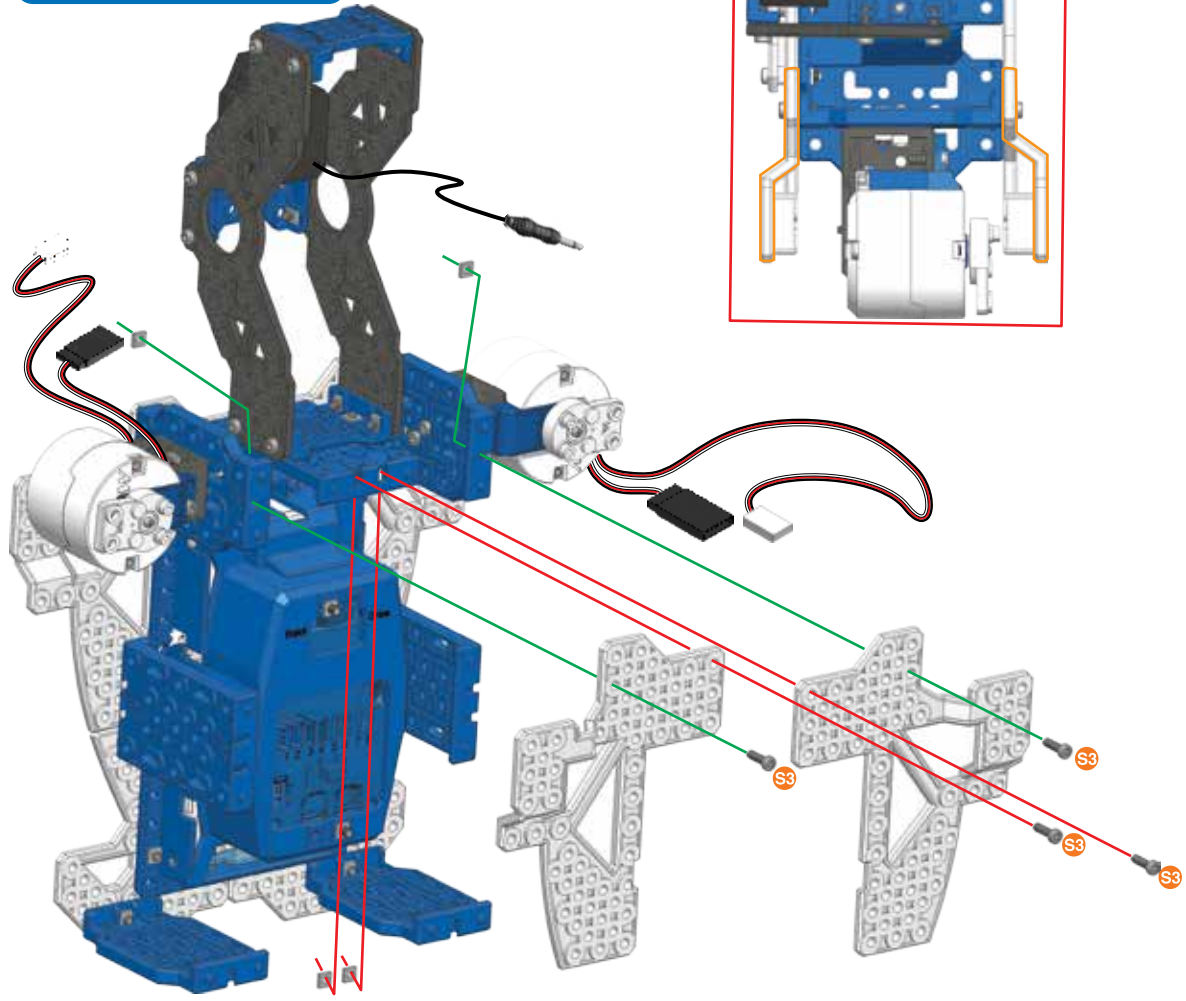
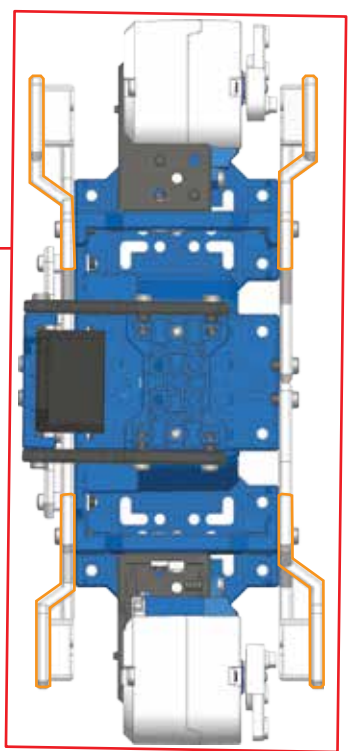
-  **S3** | **1:1**



# 17

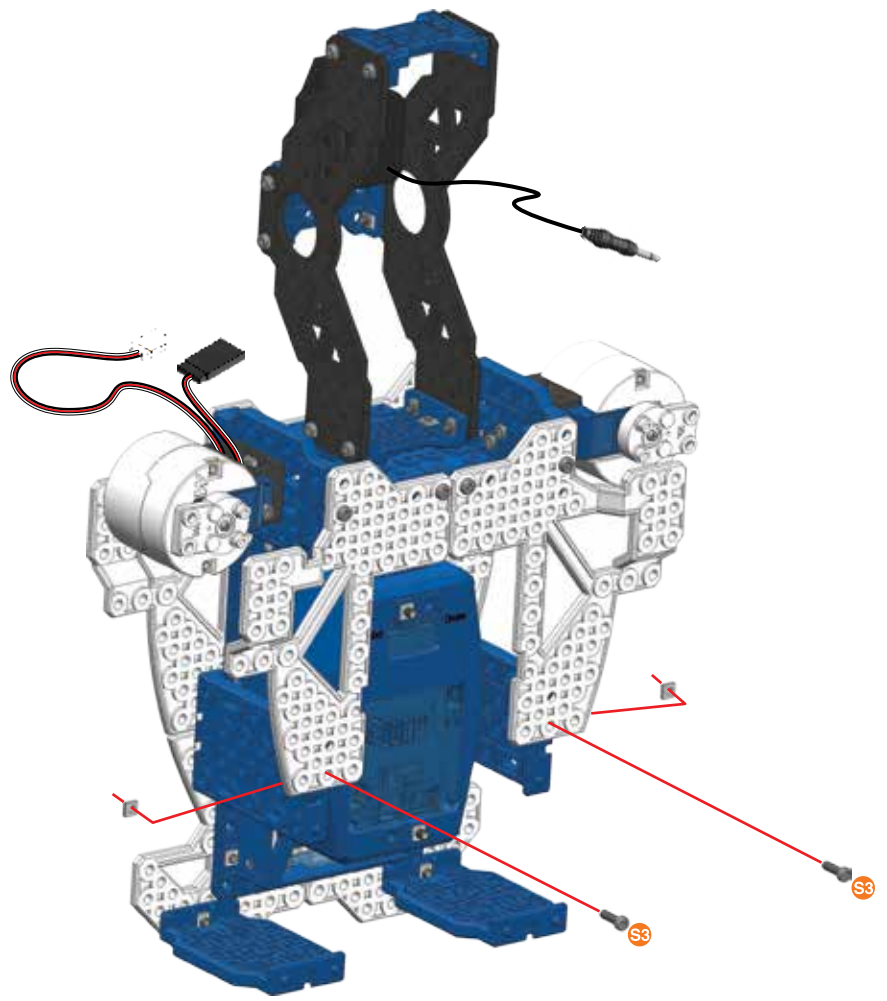

-  12 mm | **x2**
-  **x2**

-  **S3** | **1:1**





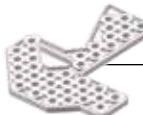

18

-  **x2**
-  12 mm | **x4**  
1/2"
-  **x4**

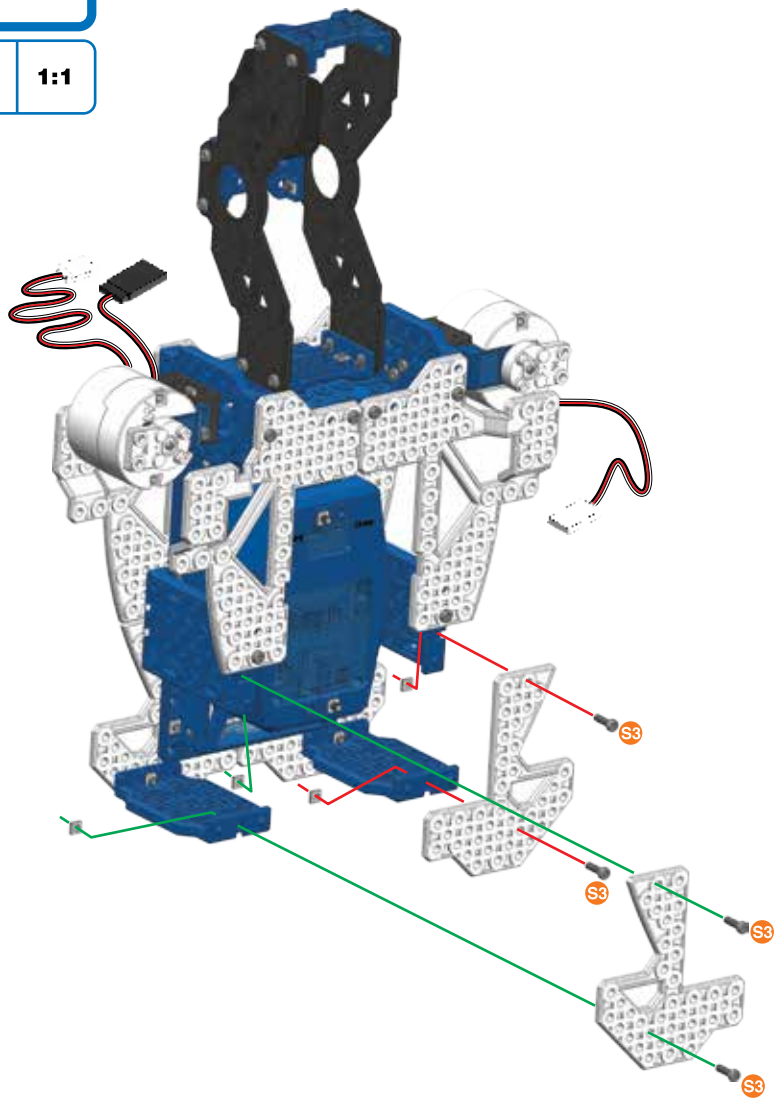
		<b>1:1</b>
---	---	------------

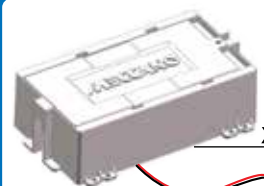

19

-  **x1**
-  12 mm | **x2**  
1/2"
-  **x2**

		<b>1:1</b>
---	---	------------

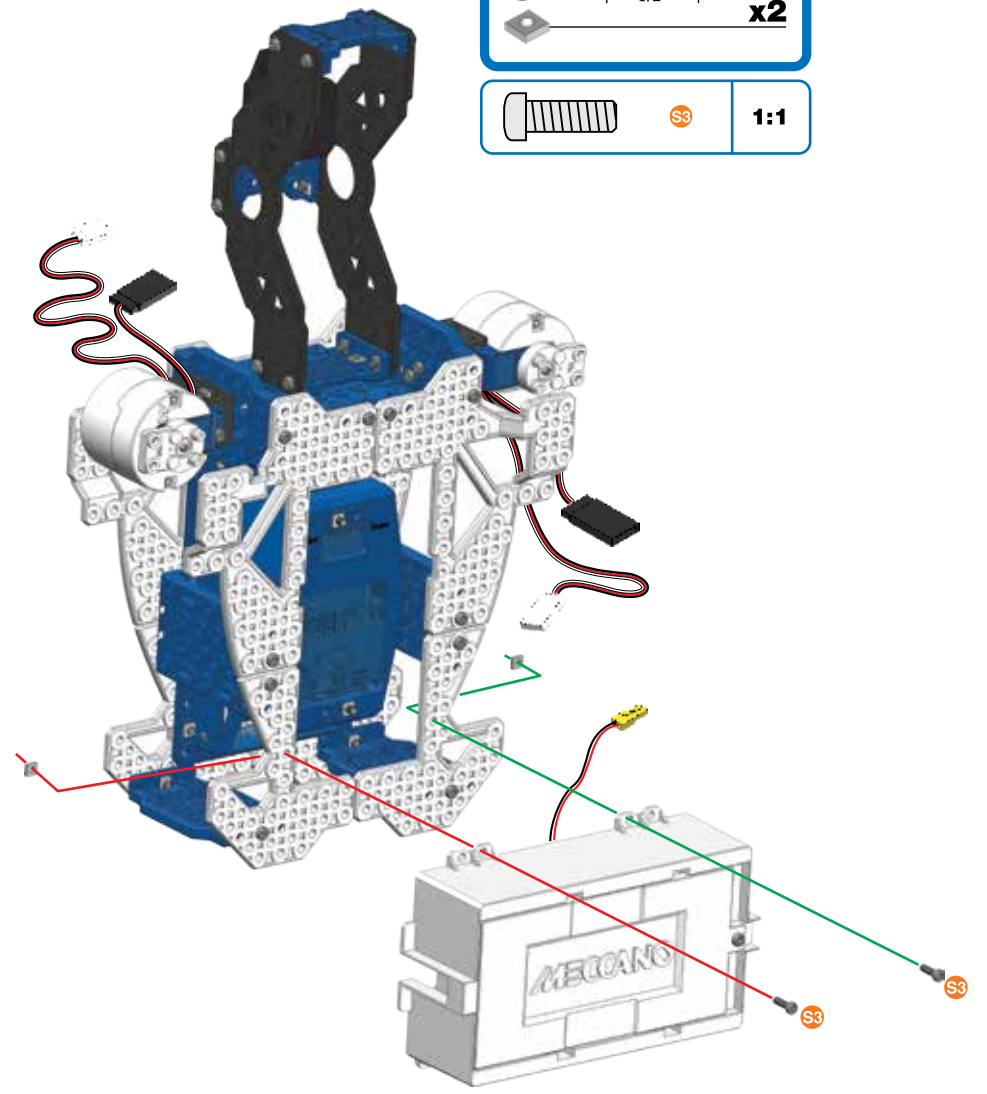



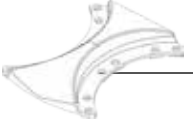

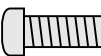
### 20

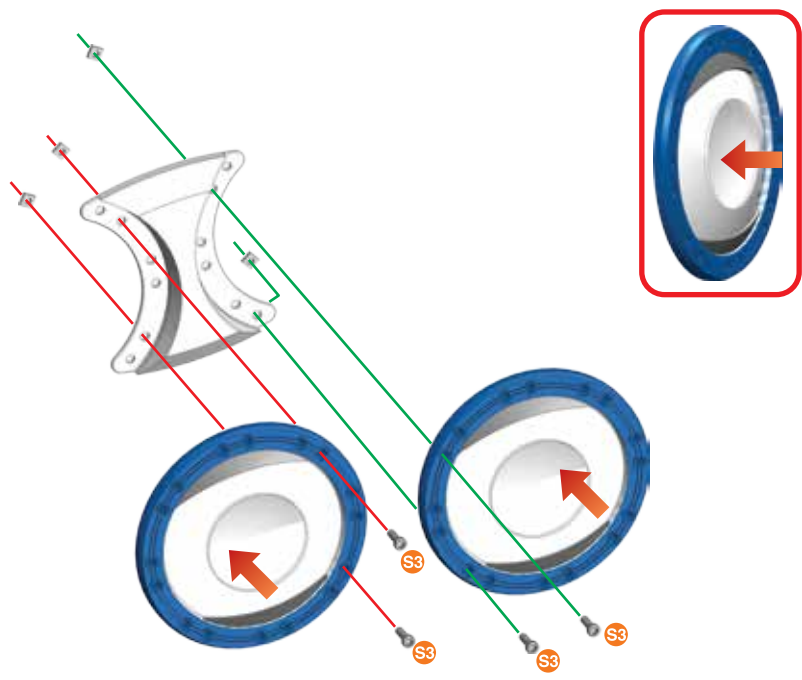
-  **x2**
-  **x1**
-  12 mm | **x4**  
1/2"
-  **x4**

	S3	1:1
---	----	-----



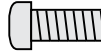

### 21

-  **x1**
-  **x2**
-  12 mm | **x3**  
1/2"
-  **x3**

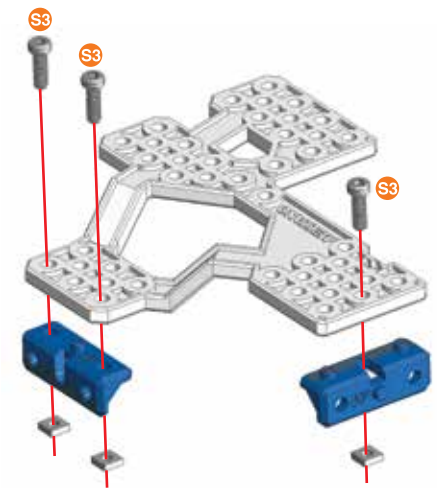
	S3	1:1
---	----	-----



### 22

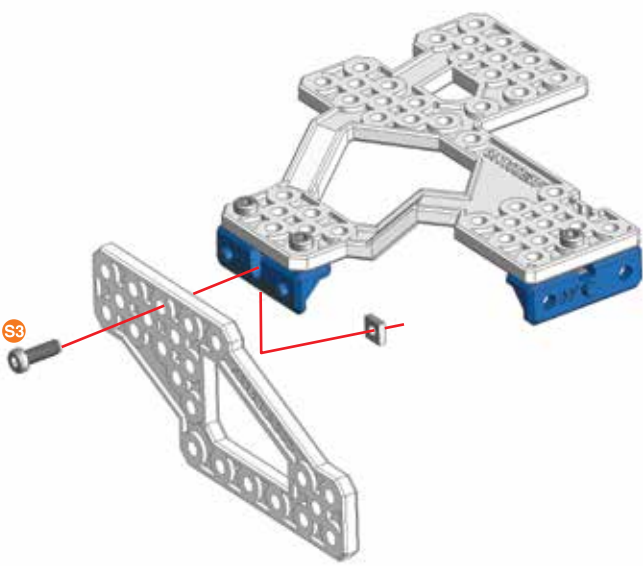

-  **x1**
-  12 mm | **x1**  
1/2"
-  **x1**

	S3	1:1
---	----	-----



### 23

Ⓜ20 + Ⓜ22 +

-  12 mm | **x1**  
1/2"
-  **x1**

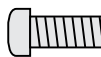
	S3	1:1
---	----	-----

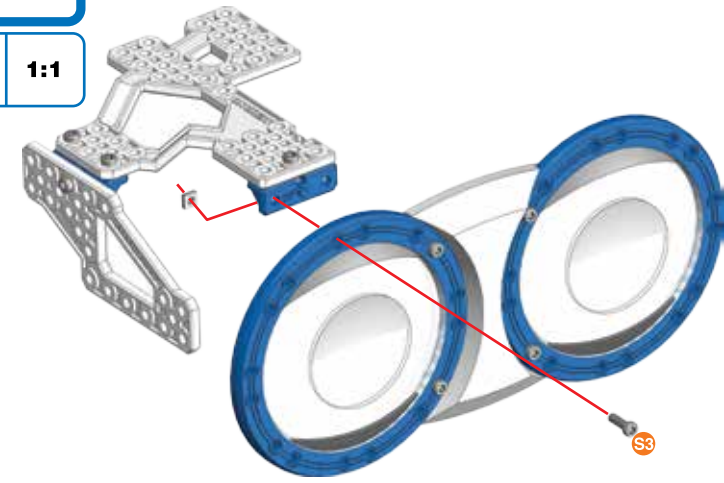

24



x1



x2



x3

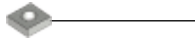

x3



S3

1:1

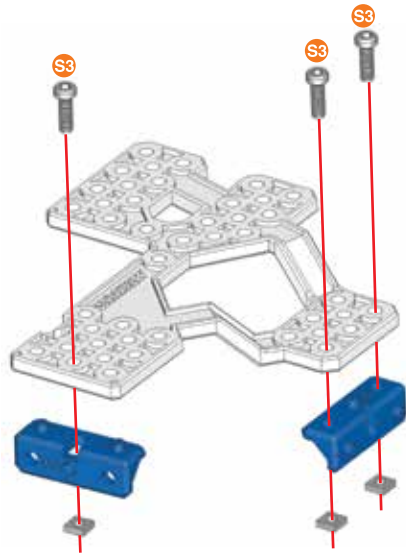

25



x1



12 mm 1/2" x1



x1

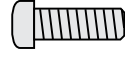

S3

1:1

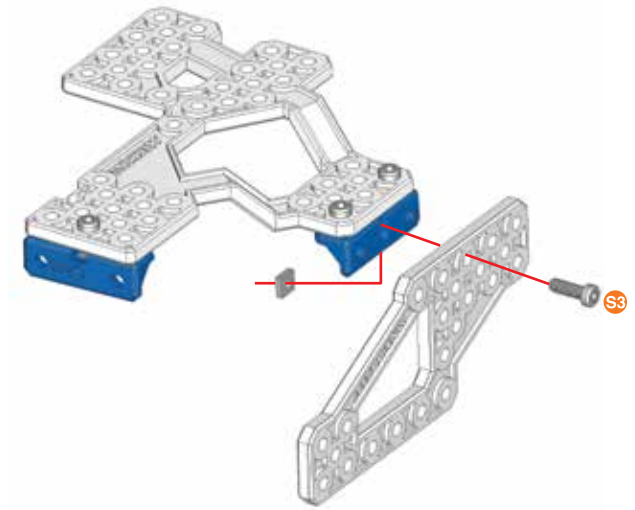

26

23+25+



x1



x1



S3

1:1

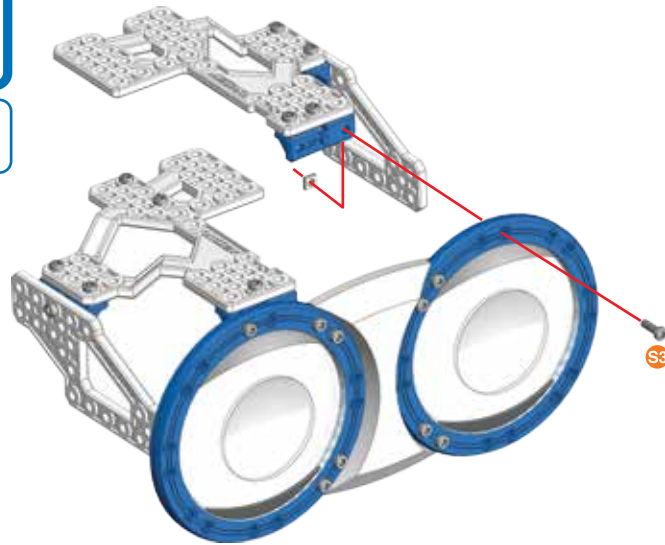

27

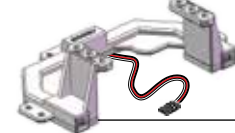

x1



12 mm 1/2" x4



x4

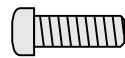

S3

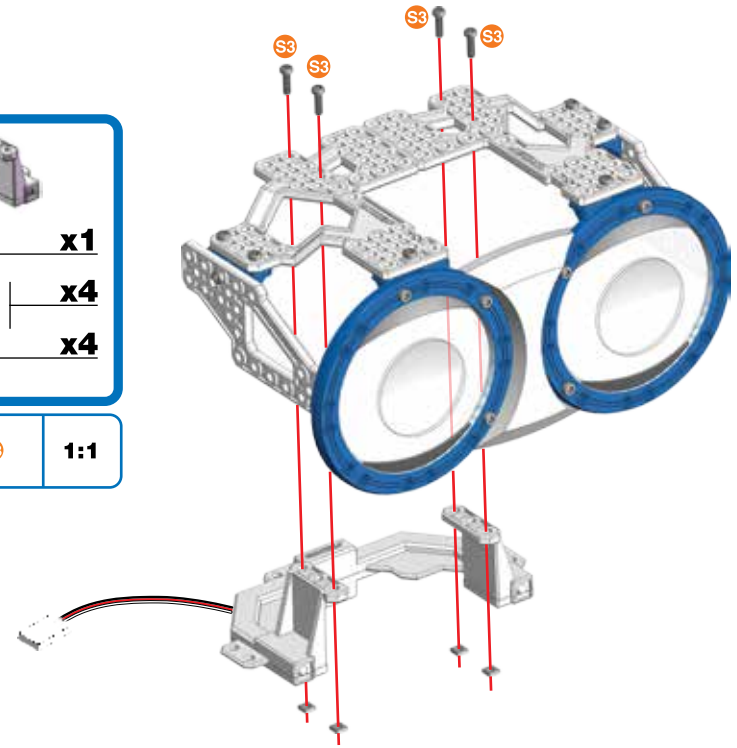

1:1





28



(19)+(27)+

-  12 mm 1/2" x4
-  x4

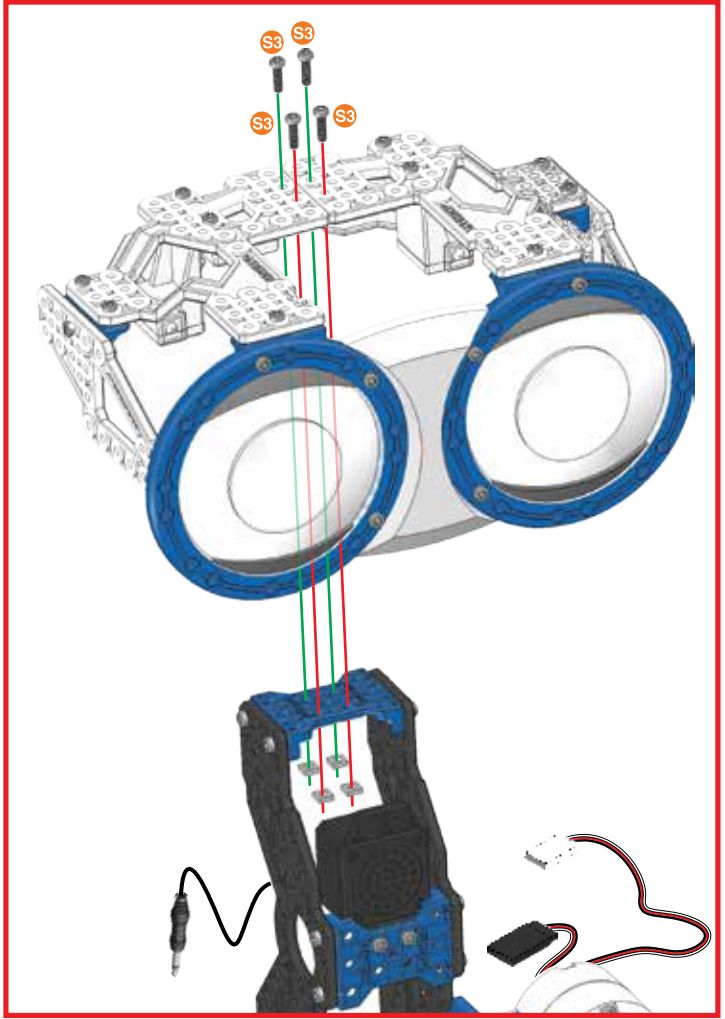
-  S3 1:1



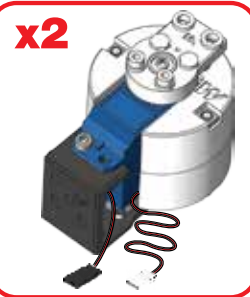
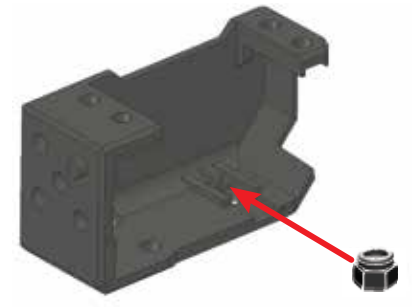

29

-  x2
-  x2

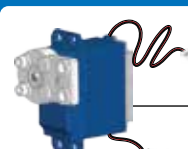

30

-  x2
-  12 mm 1/2" x2
-  x2

-  S3 1:1

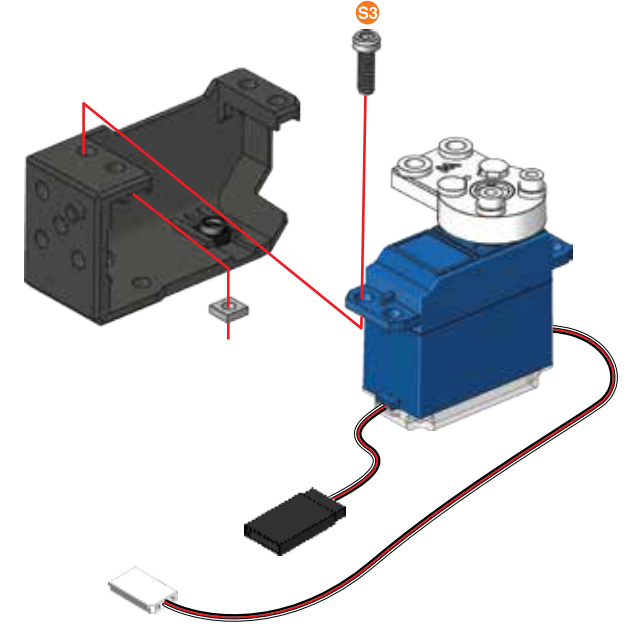

### 31

- x2**
- x2** | 14,7 mm | 37/64"
- x2**

**B1** | 1:1

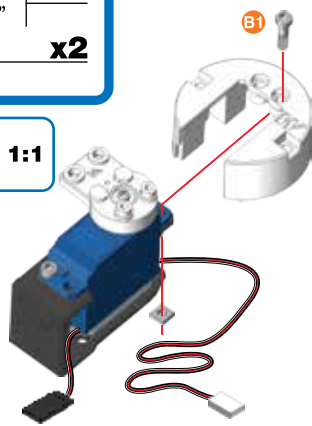

### 32

- x2**
- x4** | 38,1 mm | 1 1/2"
- x4**



**B4** | 1:1

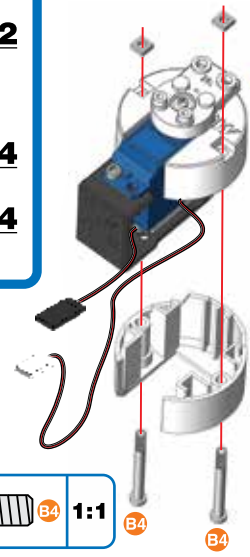

### 33

- x1**
- x1**
- x1** | 19 mm | 3/4"
- x1**

**S4** | 1:1

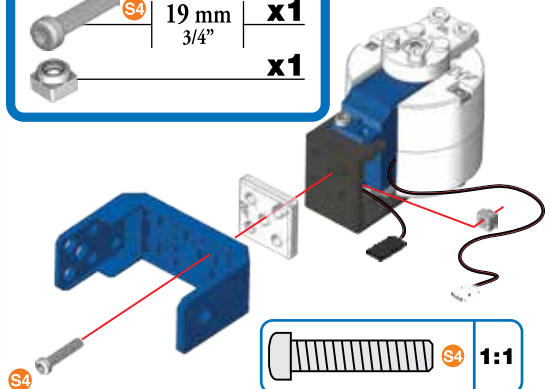

### 34

- x1**
- x1**
- x1** | 12 mm | 1/2"
- x1**

**S3** | 1:1

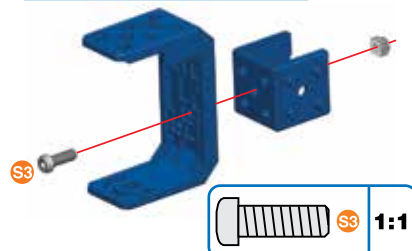

### 35

- x1**
- x4**

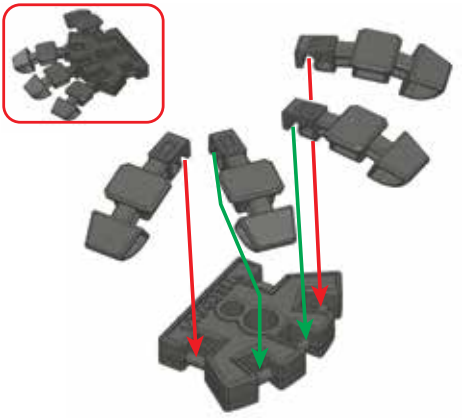

### 36

- x1**

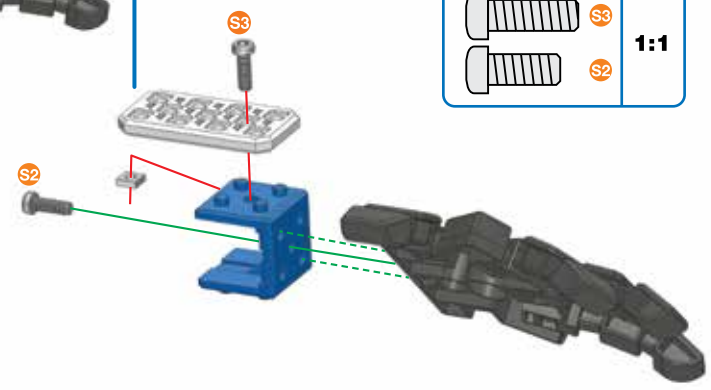

### 37

- x1**
- x1** | 12 mm | 1/2"
- x1** | 9,5 mm | 3/8"
- x1**

**S3** | 1:1

**S2** | 1:1

### 38



**34+37+**

- x1**
- x3** | 12 mm | 1/2"
- x3**

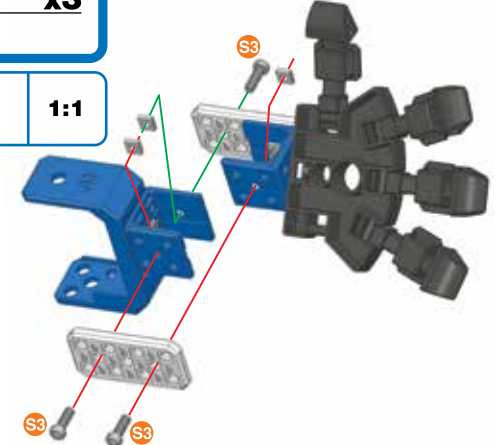
**S3** | 1:1



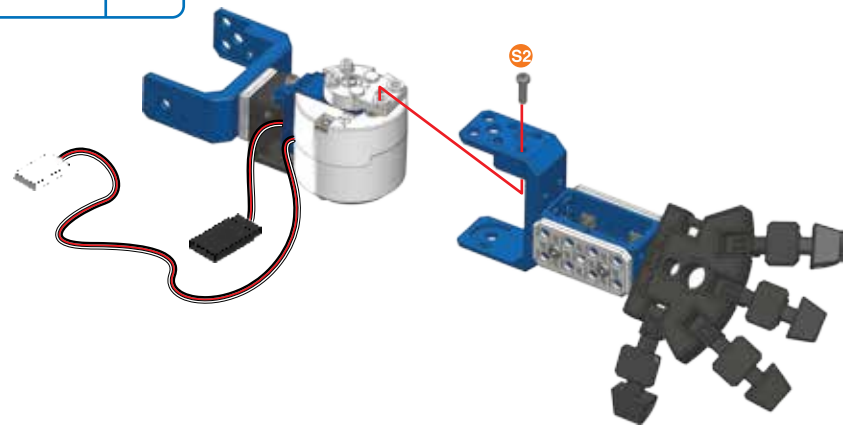

**39** (33)+(38)+

	S2	9,5 mm 3/8"	x1
	S2		1:1



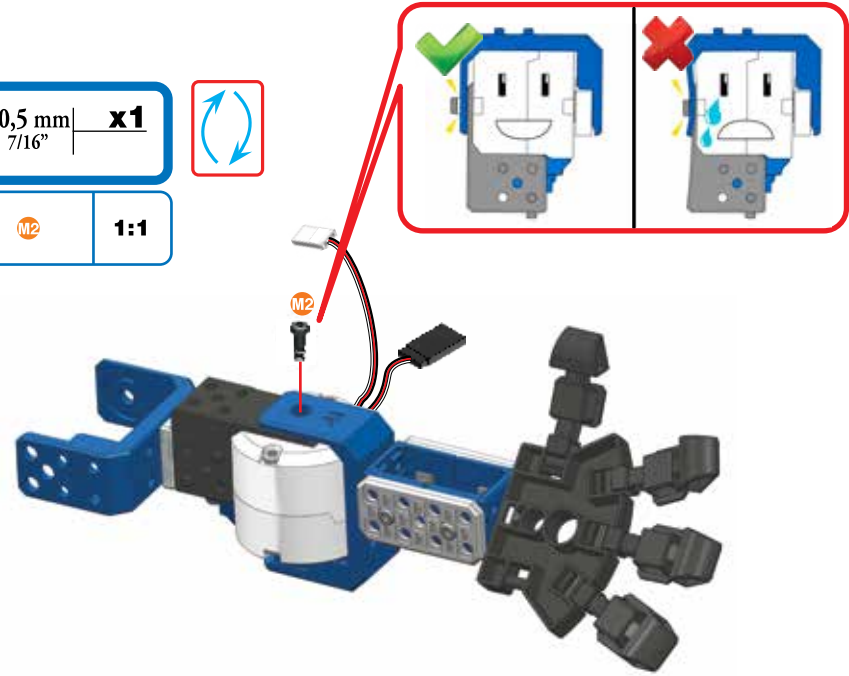

**40**

	M2	10,5 mm 7/16"	x1
	M2		1:1



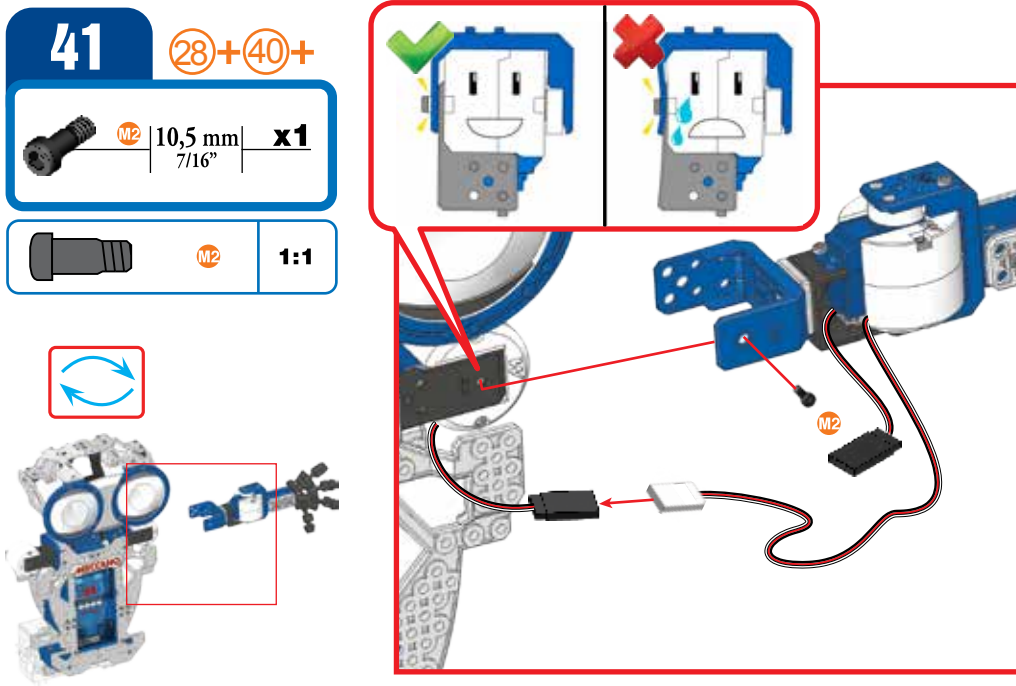

**41** (28)+(40)+

	M2	10,5 mm 7/16"	x1
	M2		1:1



**42**

	S2	9,5 mm 3/8"	x1
	S2		1:1

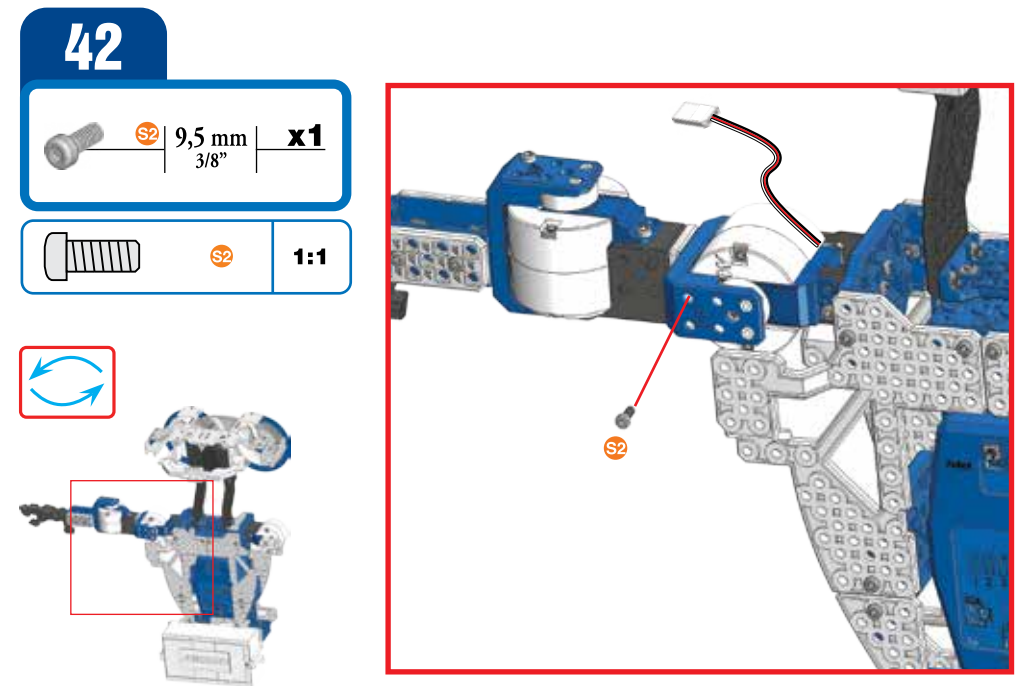





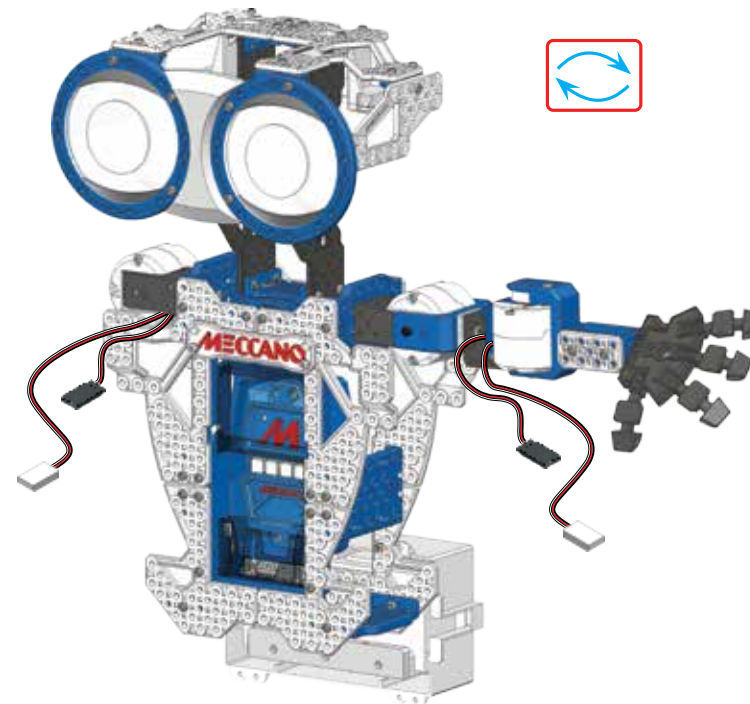
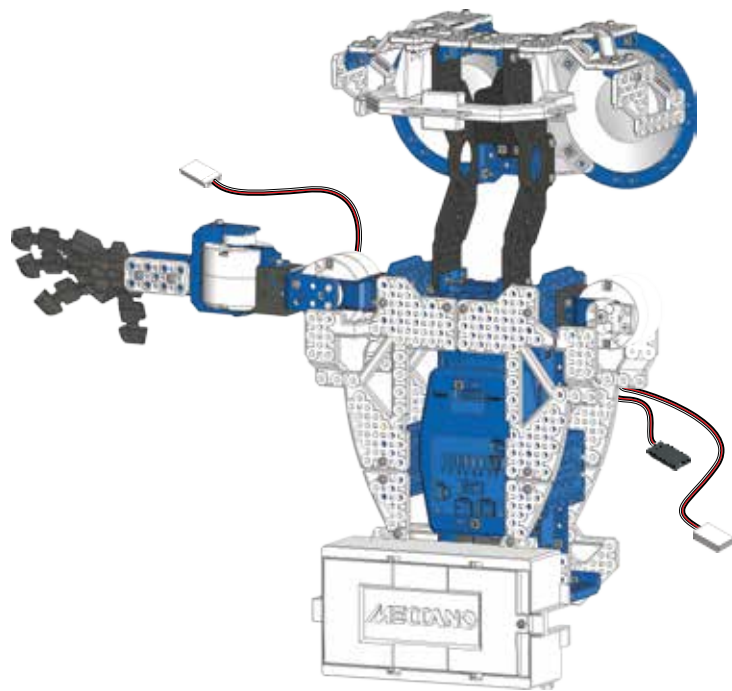

43



44

32+



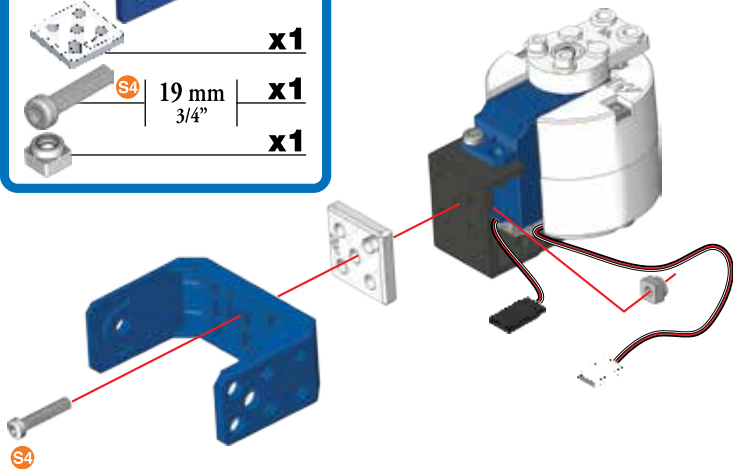

-  x1
-  x1
-  S4 19 mm | 3/4" x1
-  x1

-  S4 1:1



20

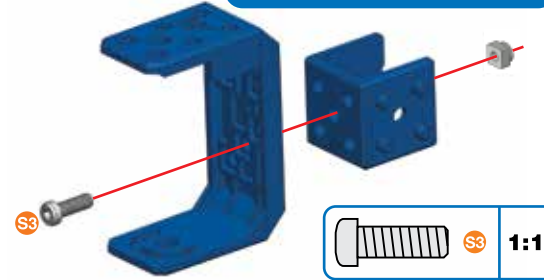

45

-  x1
-  x1
-  S3 12 mm | 1/2" x1
-  x1



-  S3 1:1

46

-  x1
-  x4

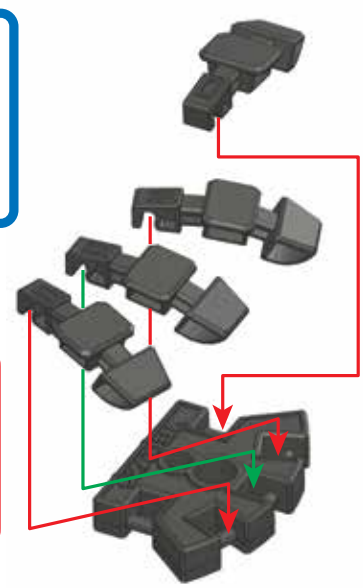

**47**

**x1**



**48**

**x1** **x1** **x1** **x1**

**x1** **x1** **x1**

**1:1**

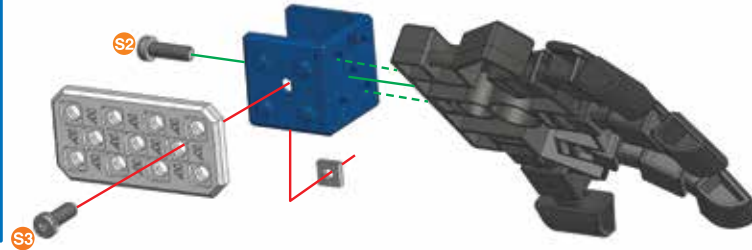

**49** (45)+(48)+

**x1** **x3** **x3**

**1:1**

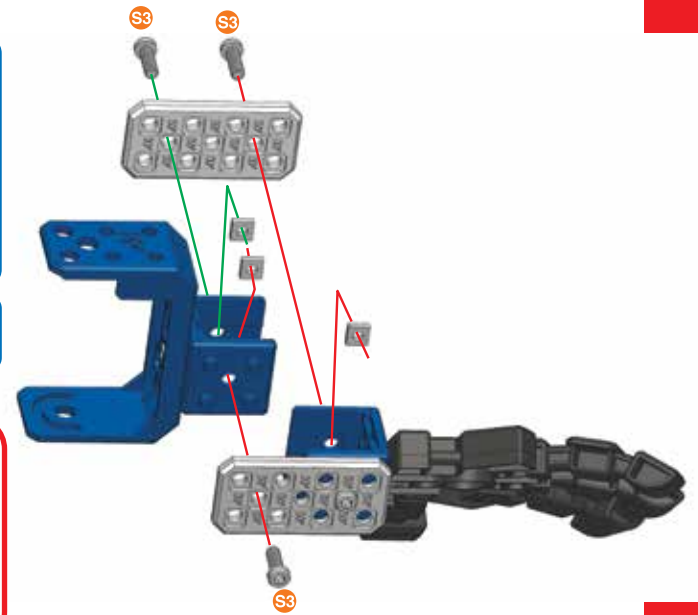

**50** (44)+(49)+

**x1**

**1:1**

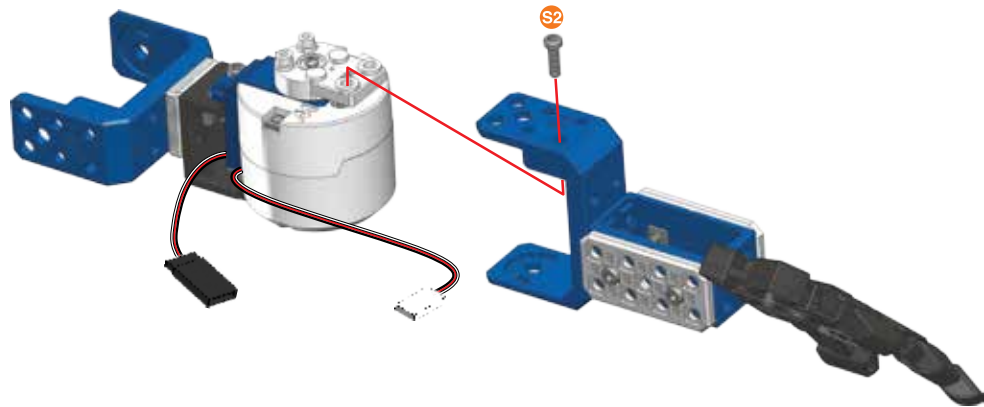

**51**

**x1**

**1:1**

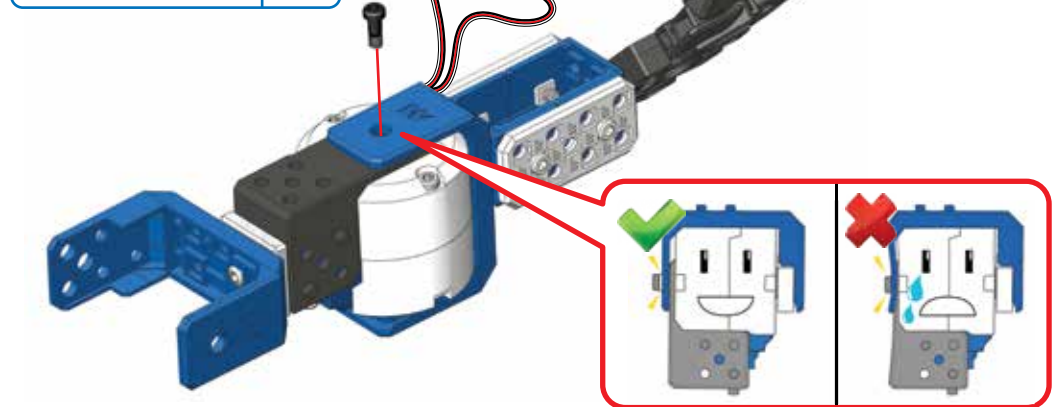

52

43+51+

- M2 10,5 mm 7/16" x1
- S2 9,5 mm 3/8" x1

- M2 1:1
- S2 1:1

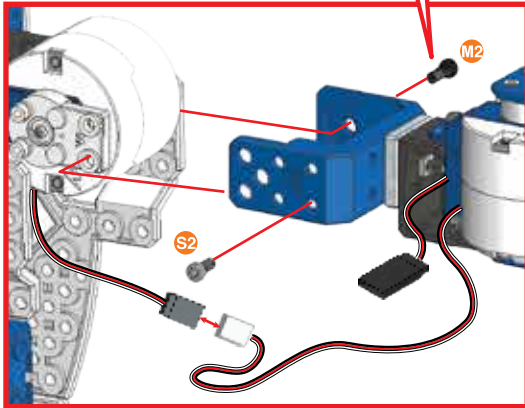
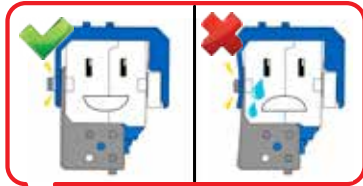

53

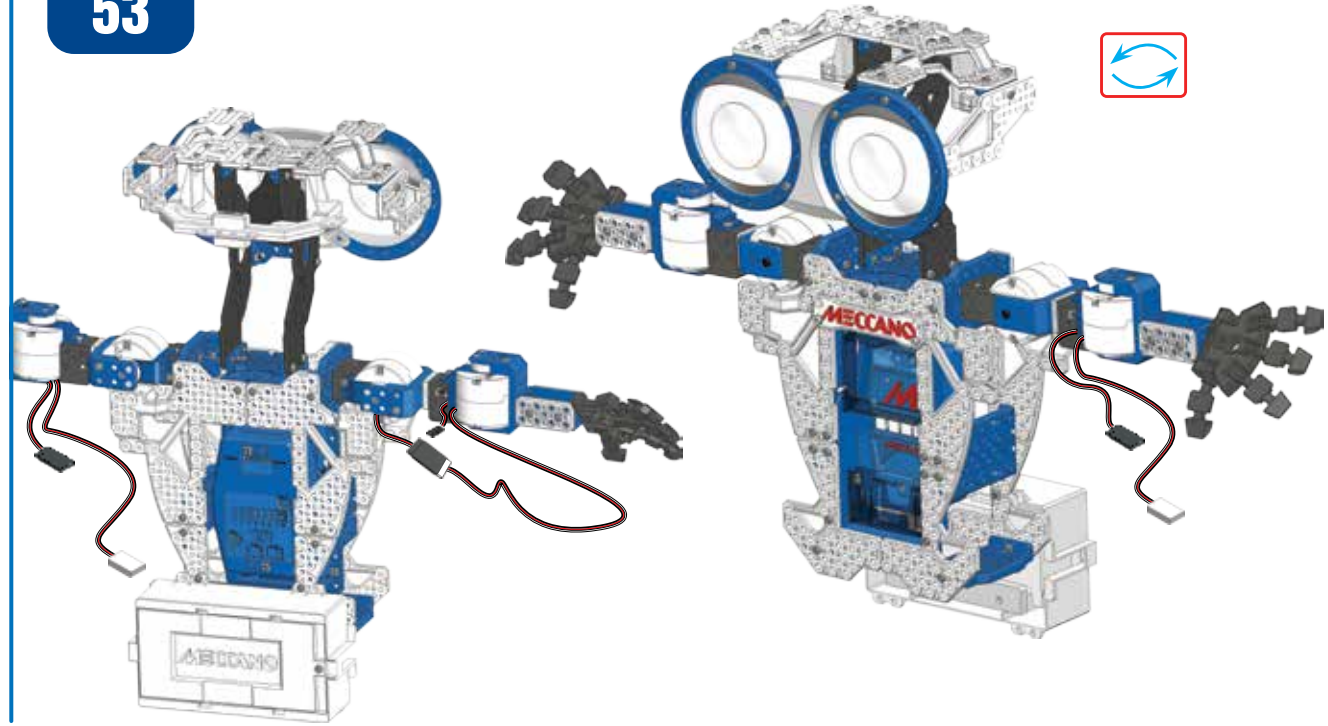

54

- x2
- x4
- S3 12 mm 1/2" x8
- x8

- S3 1:1

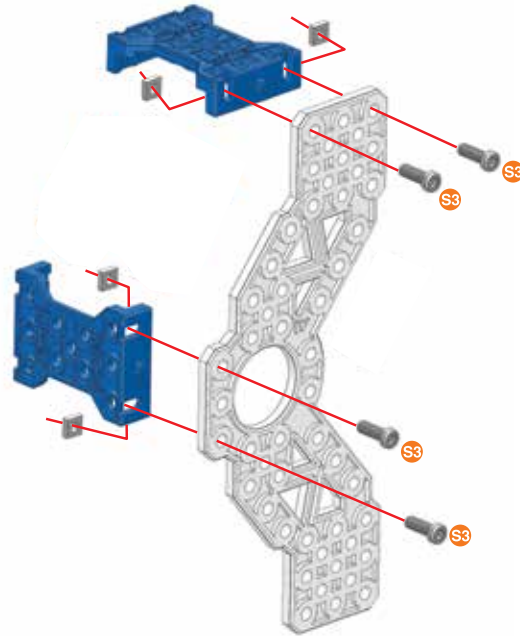

55

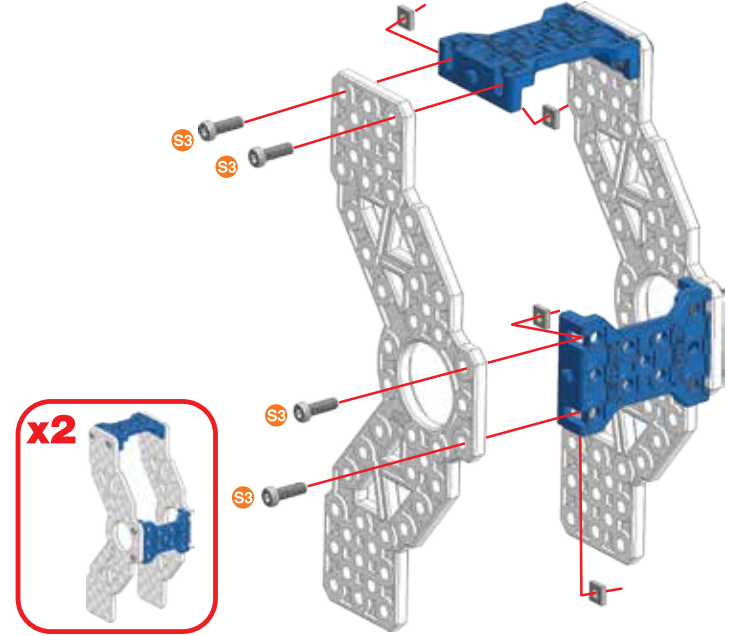

- x2
- S3 12 mm 1/2" x8
- x8

- S3 1:1







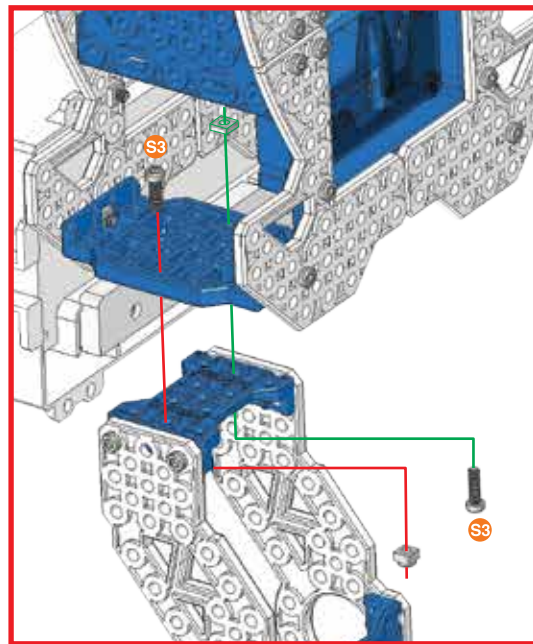
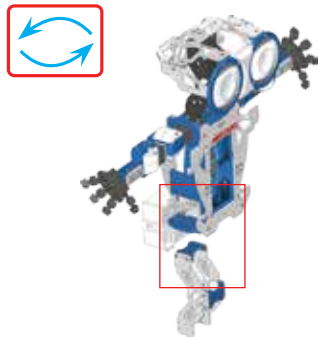

**56** (52)+(55)+

	12 mm 1/2"	<b>x2</b>
		<b>x1</b>
		<b>x1</b>

	<b>S3</b>	<b>1:1</b>
---	-----------	------------



**57** (55)+(56)+

	12 mm 1/2"	<b>x2</b>
		<b>x1</b>
		<b>x1</b>

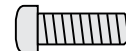

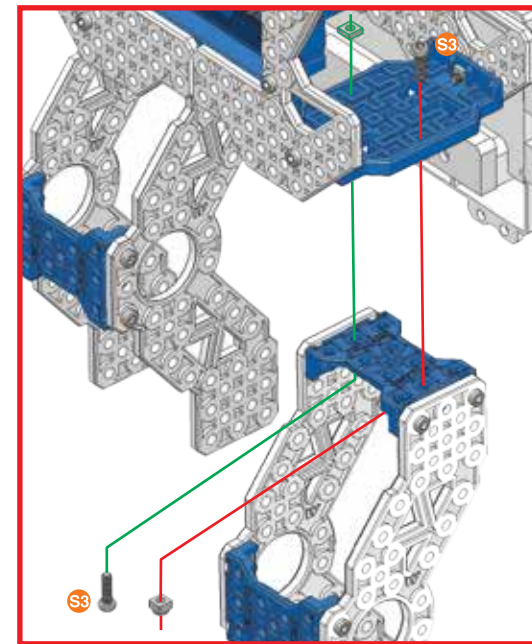
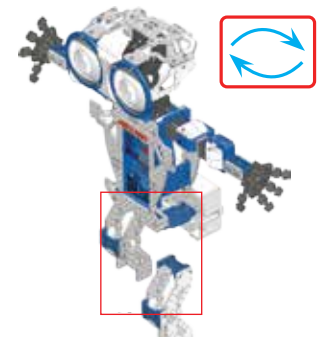

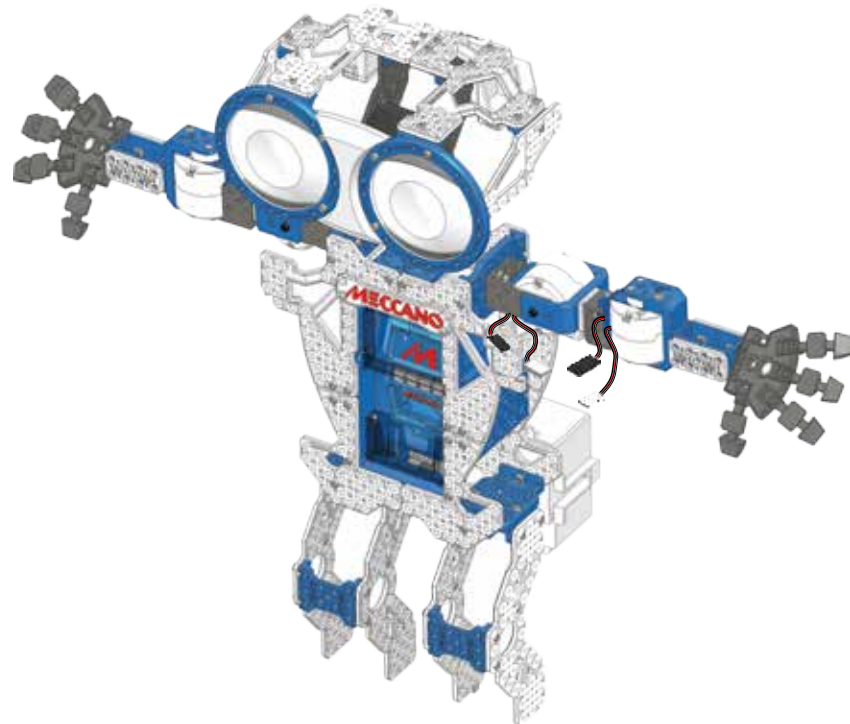

	<b>S3</b>	<b>1:1</b>
---	-----------	------------



**58**



**59**

		<b>x1</b>
		<b>x2</b>
		<b>x2</b>
	19 mm 3/4"	<b>x4</b>
		<b>x2</b>
		<b>x2</b>

	<b>S4</b>	<b>1:1</b>
---	-----------	------------

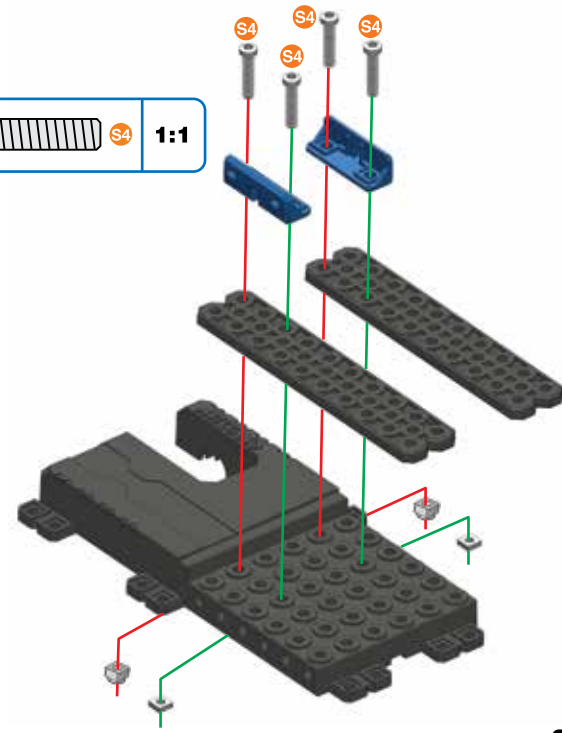

**60**

- 1x1 Technic Beam (Dark Grey)
- 2x S3 12 mm 1/2" Screws
- 2x Technic Washers

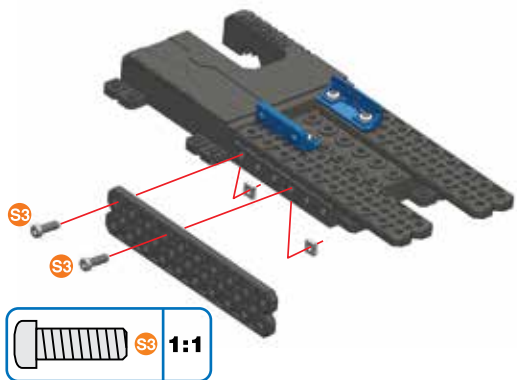

**61**

- 1x1 Technic Beam (Dark Grey)
- 2x S3 12 mm 1/2" Screws
- 2x Technic Washers

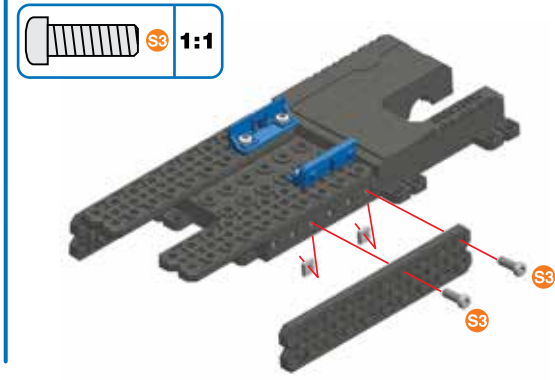

**62**

- 1x Blue Technic Connector
- 1x S3 12 mm 1/2" Screw
- 1x Technic Washer

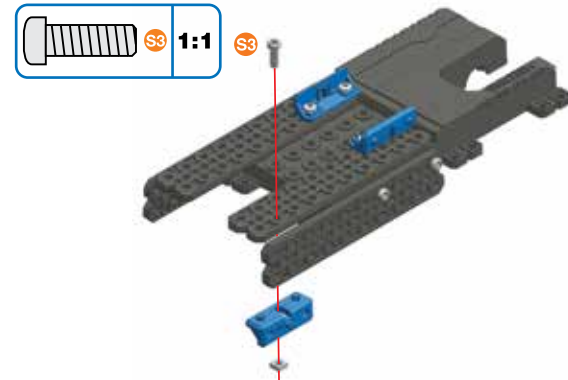

**63**

- 2x S3 12 mm 1/2" Screws
- 2x Technic Washers

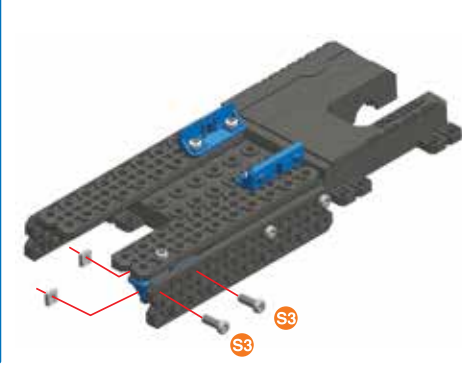

**64**

- 1x Blue Technic Connector
- 1x S3 12 mm 1/2" Screw
- 1x Technic Washer

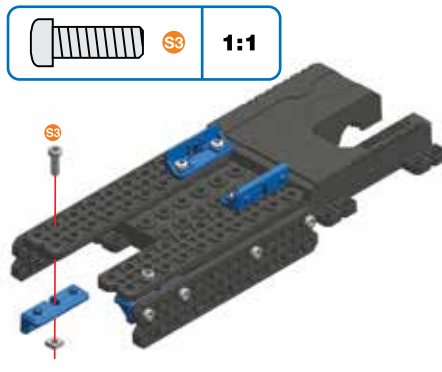

**65**

- 2x S3 12 mm 1/2" Screws
- 2x Technic Washers

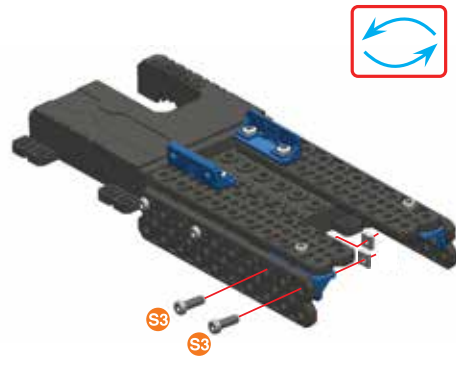

**66**

- 1x Grey Technic Bracket
- 2x S4 19 mm 3/4" Screws
- 1x Technic Washer
- 1x Nut

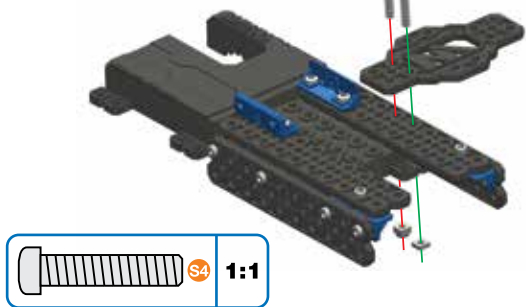



**67**

- 1x Red Motor
- 1x Grey Gear
- 2x Grey Gears
- 1x Grey Ring
- 2x Grey Washers
- 2x Grey Spacers





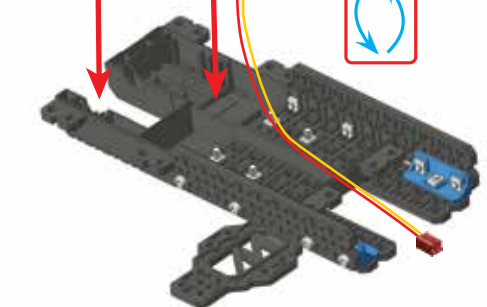

**68** (66)+(67)+

-  **x1**
-  **x1**





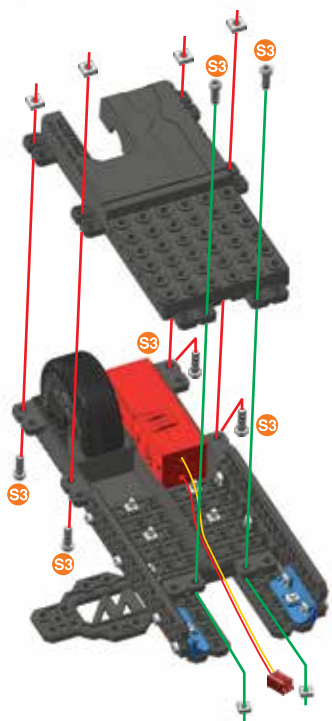

**69**

-  **x1**
-  **x6**
-  **x6**

 **S3** **1:1**







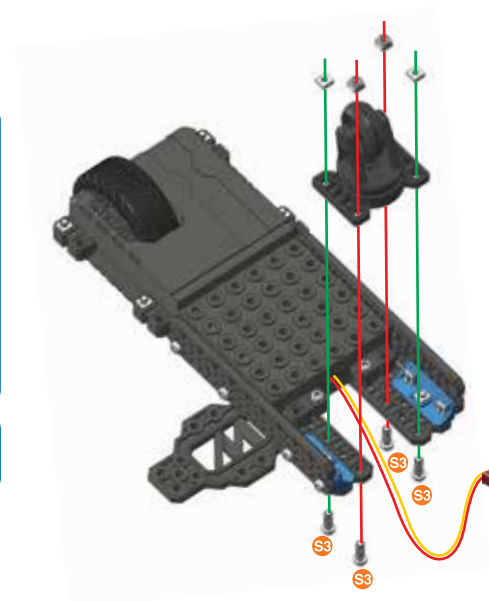

**70**

-  **x1**
-  **x4**
-  **x2**
-  **x2**

 **S3** **1:1**



**71**

-  **x1**
-  **x2**
-  **x2**
-  **x4**
-  **x2**
-  **x2**

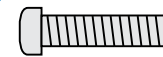
 **S4** **1:1**

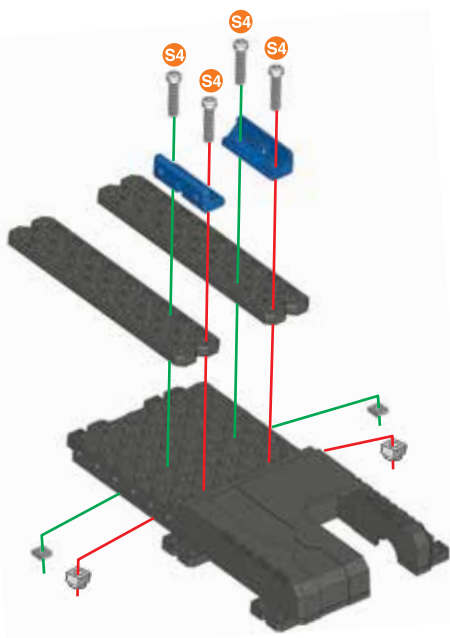

**72**

-  **x1**
-  **x2**
-  **x2**

 **S3** **1:1**

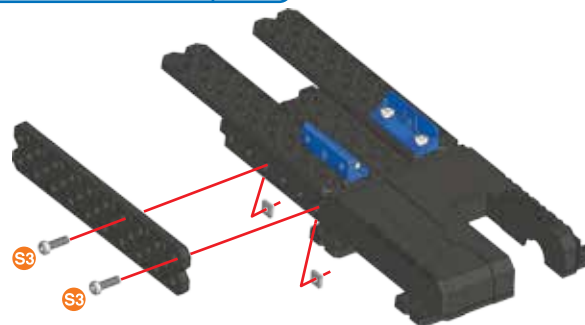

**73**

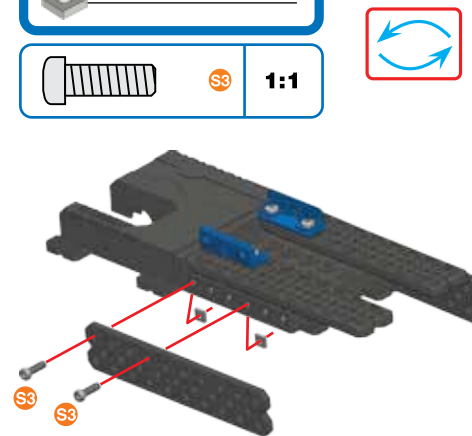

-  **x1**
-  **x2**
-  **x2**

 **S3** **1:1**





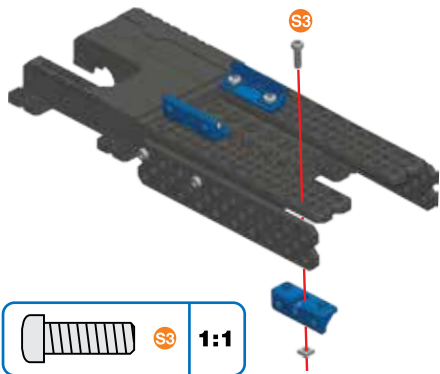

**74**

-  **x1**
-  12 mm | **x1**
-  **x1**



 **S3** | **1:1**



**75**

-  12 mm | **x2**
-  **x2**

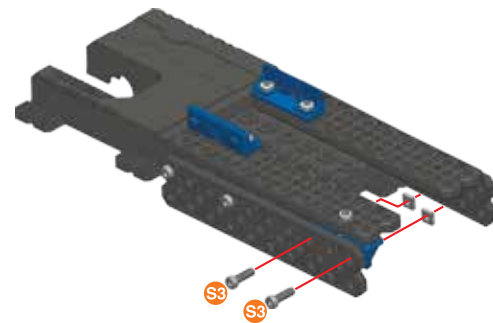
 **S3** | **1:1**





**76**

-  **x1**
-  12 mm | **x1**
-  **x1**

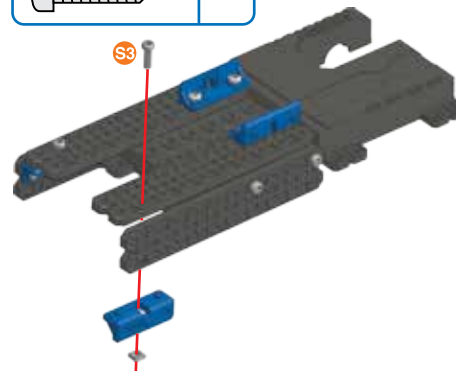
 **S3** | **1:1**





**77**

-  12 mm | **x2**
-  **x2**

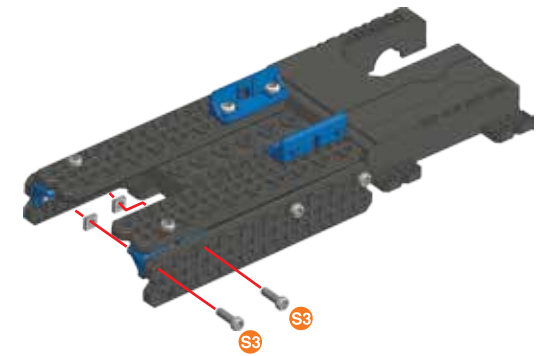
 **S3** | **1:1**





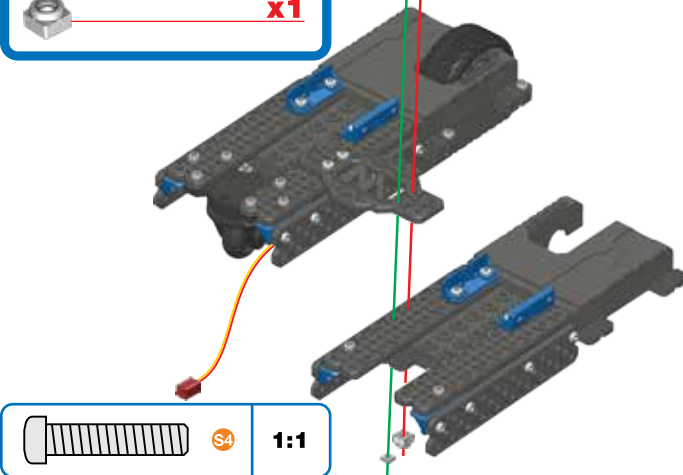

**78** (70)+(77)+

-  19 mm | **x2**
-  **x1**
-  **x1**





 **S4** | **1:1**

**79**

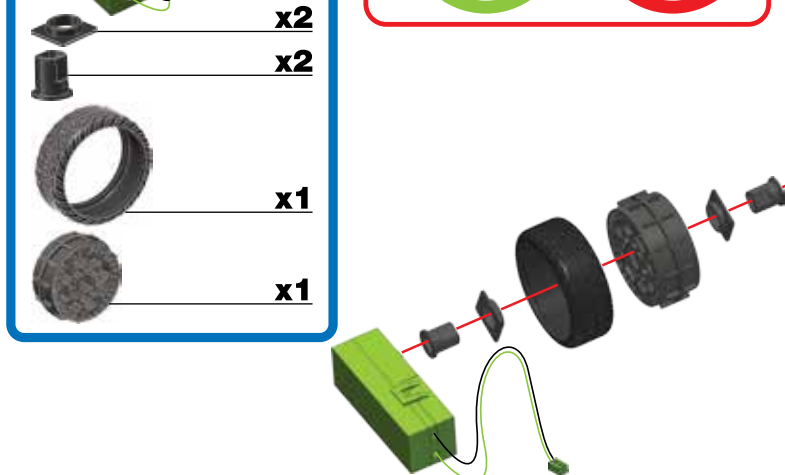
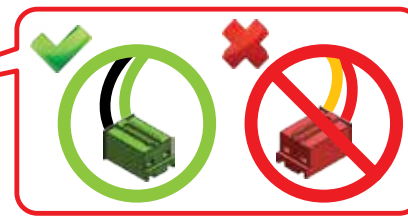
-  **x1**
-  **x2**
-  **x2**
-  **x1**
-  **x1**



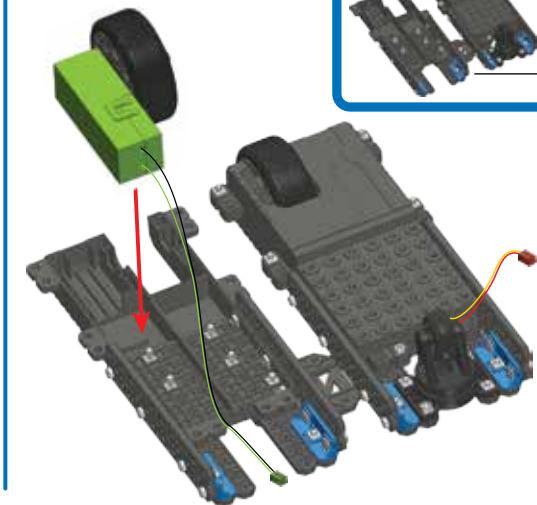

**80** (78)+(79)+

-  **x1**
-  **x1**





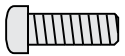

### 81

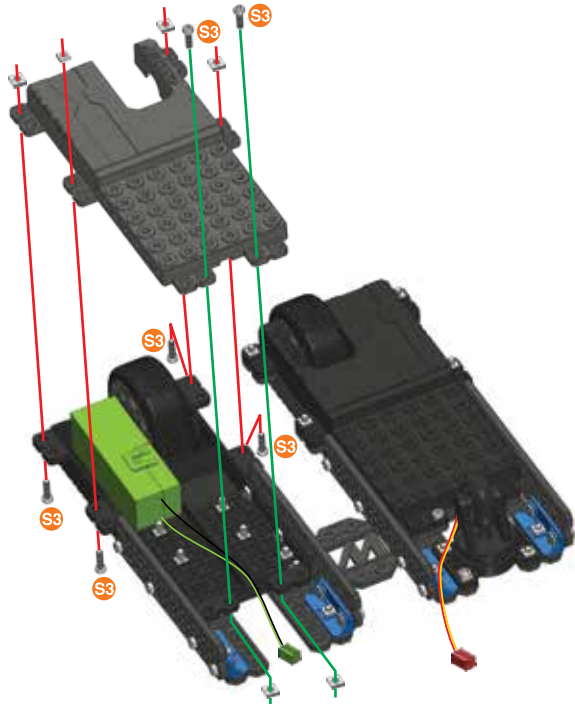
-  **x1**
-  **x6**
-  **x6**

 **1:1**



### 82

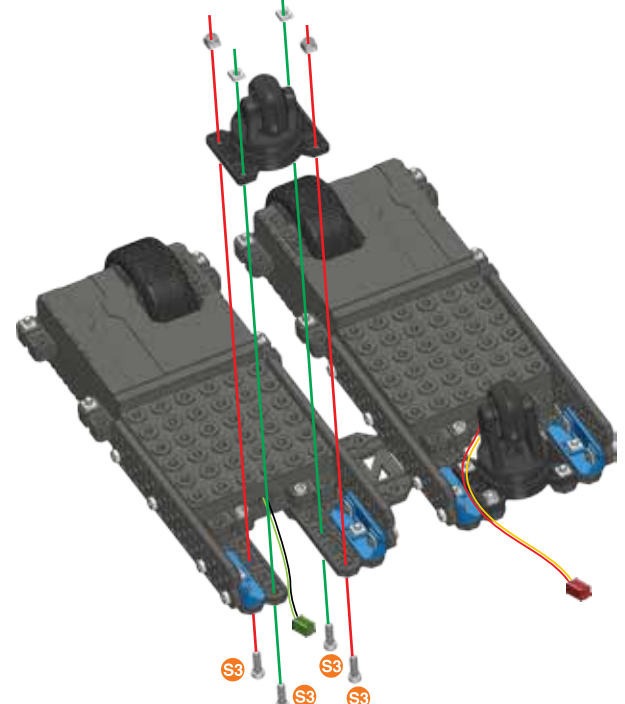

-  **x1**
-  **x4**
-  **x2**
-  **x2**

 **1:1**



### 83

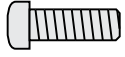

**(58) + (82) +**

-  **x4**
-  **x4**

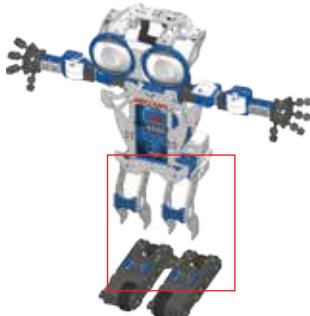
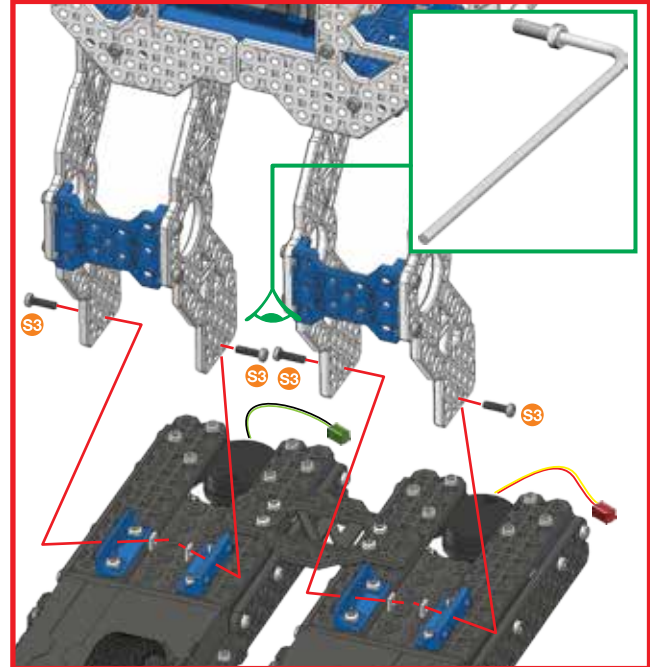
 **1:1**



### 84

-  **x3**
-  **x3**
-  **x3**

 **1:1**

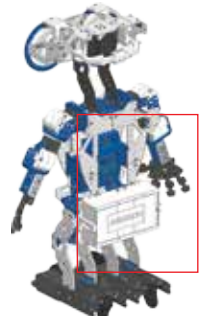
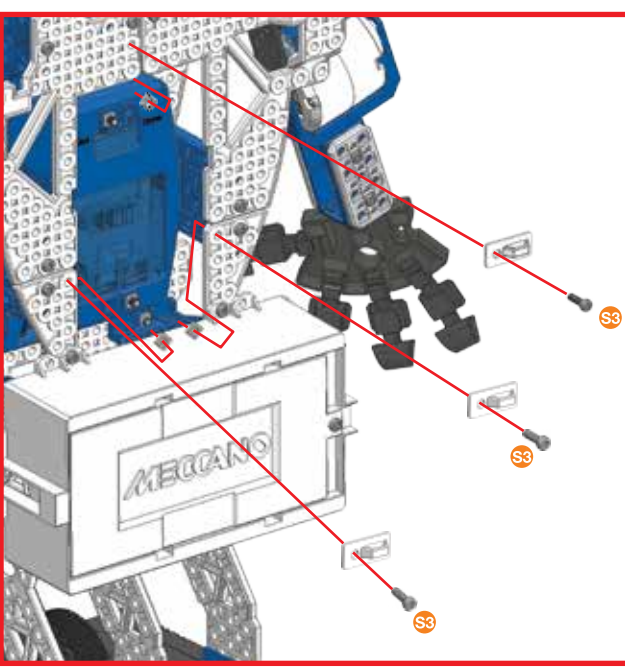



85

 B1 | 14,7 mm | x1  
37/64"

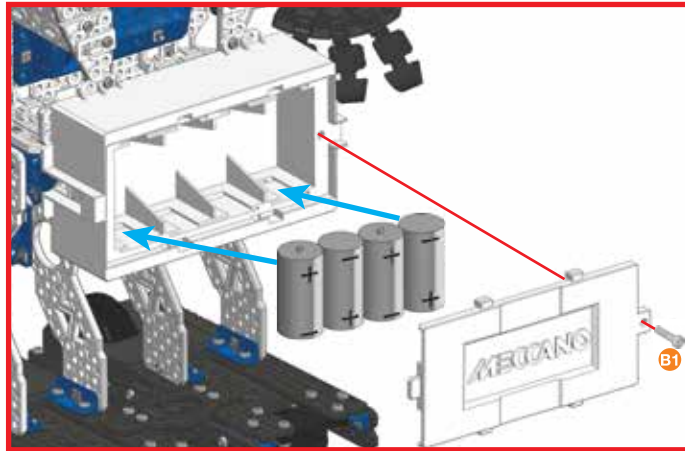
 B1 | 1:1
**(EN) HOW TO INSTALL BATTERIES**

1. Open the battery door with a Meccano tool. 2. If used batteries are present, remove these batteries from the unit by pulling up on one end of each battery. DO NOT remove or install batteries using sharp or metal tools. 3. Install new batteries as shown in the polarity diagram (+/-) inside the battery compartment. 4. Replace battery door securely. 5. Check your local laws and regulations for correct recycling and/or battery disposal.

**(FR) INSTALLATION DES PILES**

1. Ouvrir le compartiment des piles à l'aide d'un outil Meccano. 2. S'il contient des piles usagées, les retirer en les soulevant par l'une des extrémités. NE PAS utiliser d'objet coupant ou métallique pour retirer ou insérer des piles. 3. Insérer les nouvelles piles en respectant le schéma de polarité (+/-) dans le compartiment des piles. 4. Bien refermer le compartiment des piles. 5. Recycler ou jeter les piles usagées conformément à la législation locale.

**(ES) INSTALACIÓN DE LAS PILAS**

1. Abra la tapa del compartimento de las pilas con una herramienta de Meccano. 2. Si las pilas están gastadas, tire hacia arriba de uno de sus extremos para extraerlas. NO utilice herramientas metálicas o puntiagudas para instalar o extraer las pilas. 3. Instale las pilas nuevas como se muestra en el esquema de polaridad (+/-) dentro del compartimento de las pilas. 4. Vuelva a colocar la tapa del compartimento de las pilas. 5. Consulte la normativa local relativa al reciclaje y desecho de las pilas.

**(DE) EINLEGEN DER BATTERIEN**

1. Batteriefachabdeckung mit einem Meccano-Werkzeug öffnen. 2. Wenn sich gebrauchte Batterien darin befinden, diese einzeln herausziehen. Batterien NICHT mit scharfen oder metallenen Gegenständen entfernen oder einlegen. 3. Neue Batterien unter Beachtung des Polaritätsdiagramms (+/-) in das Batteriefach einlegen. 4. Batteriefachabdeckung wieder anbringen. 5. Örtliche Gesetze und Bestimmungen für das Recycling bzw. die Entsorgung von Altbatterien beachten.

**(NL) DE BATTERIJEN PLAATSEN**

1. Open het batterijdeksel met Meccano-gereedschap. 2. Verwijder eventueel gebruikte aanwezige batterijen uit de unit door één kant van elke batterij omhoog te trekken. Verwijder of plaats batterijen NIET met behulp van scherpe of metalen voorwerpen. 3. Plaats de nieuwe batterijen zoals weergegeven op het polariteitsdiagram (+/-) aan de binnenkant van het batterijvak. 4. Sluit het vak af met het batterijdeksel. 5. Lees de plaatselijke voorschriften en regelgeving om de batterijen op de juiste wijze te recyclen of af te voeren.

**(IT) COME INSTALLARE LE PILE**

1. Aprire lo scomparto pile con un attrezzo Meccano. 2. Se sono presenti pile usate, rimuoverle dall'unità sollevandole da un'estremità. NON usare oggetti metallici o appuntiti per rimuovere o installare le pile. 3. Inserire le nuove pile seguendo il diagramma della polarità (+/-) all'interno dello scomparto pile. 4. Riporre saldamente lo sportello dello scomparto pile. 5. Eliminare e/o riciclare le pile secondo quanto previsto dalle normative locali vigenti.

**(PT) COMO COLOCAR AS PILHAS**

1. Abra a tampa da bateria com uma ferramenta Meccano. 2. Se houver pilhas usadas, retire-as da unidade individualmente, puxando pela extremidade de cada uma. NÃO retire ou coloque pilhas com qualquer acessório pontiagudo ou metálico. 3. Instale pilhas novas seguindo o diagrama de polaridade (+/-) dentro do compartimento de pilhas. 4. Coloque de novo a porta do compartimento com cuidado. 5. Consulte as leis, as normas e os regulamentos locais de reciclagem e/ou descarte de pilhas e baterias.

**(RU) УСТАНОВКА ЭЛЕМЕНТОВ ПИТАНИЯ**

1. Откройте крышку отсека элементов питания инструментом Meccano. 2. Извлеките старые или истощенные элементы питания из отсека (при их наличии), подняв каждый элемент питания за край. ЗАПРЕЩАЕТСЯ извлекать или устанавливать батареи с помощью острых или металлических предметов. 3. Установите новые элементы питания внутри отсека, соблюдая полярность (+/-). 4. Надежно закройте крышку отсека. 5. Ознакомьтесь с законами и нормативами вашей страны, установленными в отношении правил переработки и/или утилизации элементов питания.

86

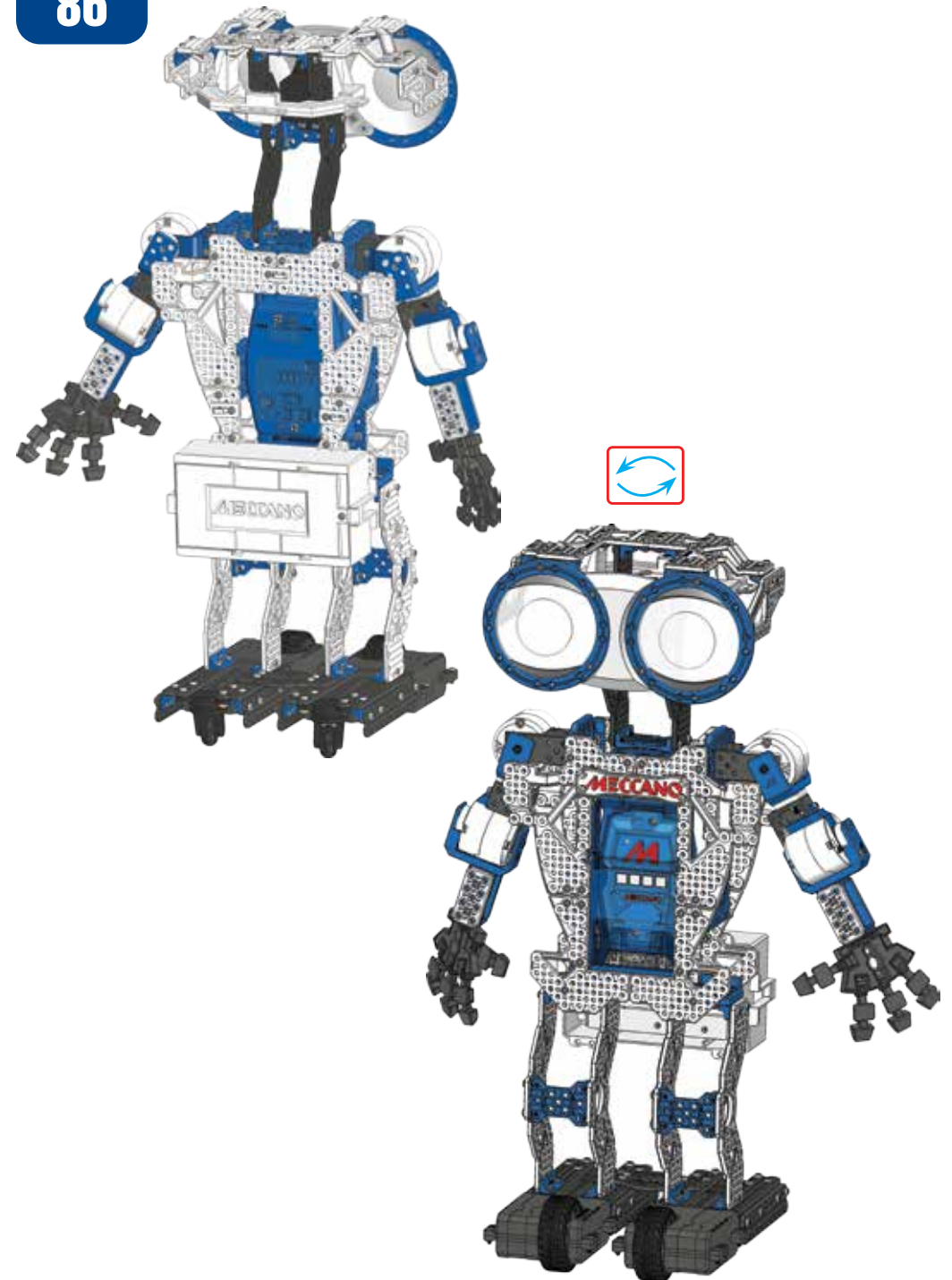



# 2

## 2.1 CONNECT THE ELECTRONICS

87

Plug in servos and LED module into ports 1, 2 and 3.

Right Arm Servo  
Head LEDs  
Left Arm Servo

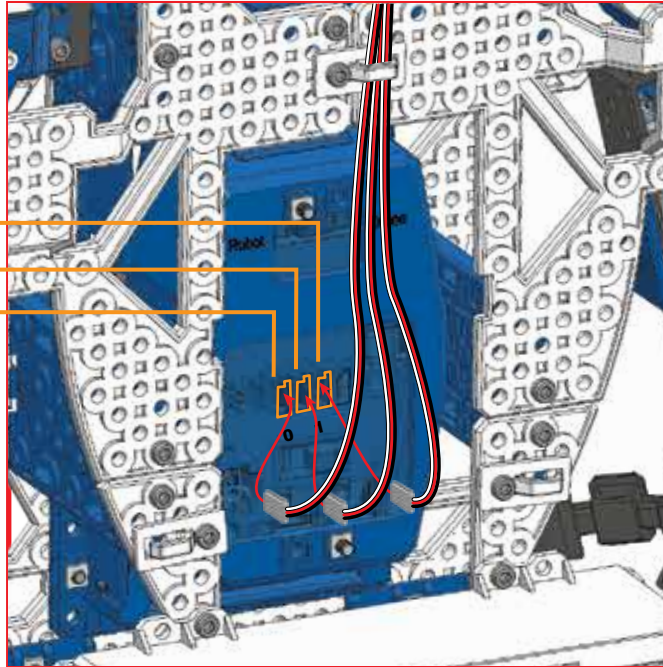

88

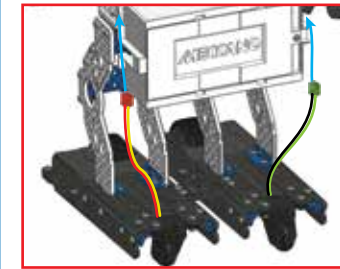

Left Foot Motor      Right Foot Motor

Plug in left foot motor  
and right foot motor.

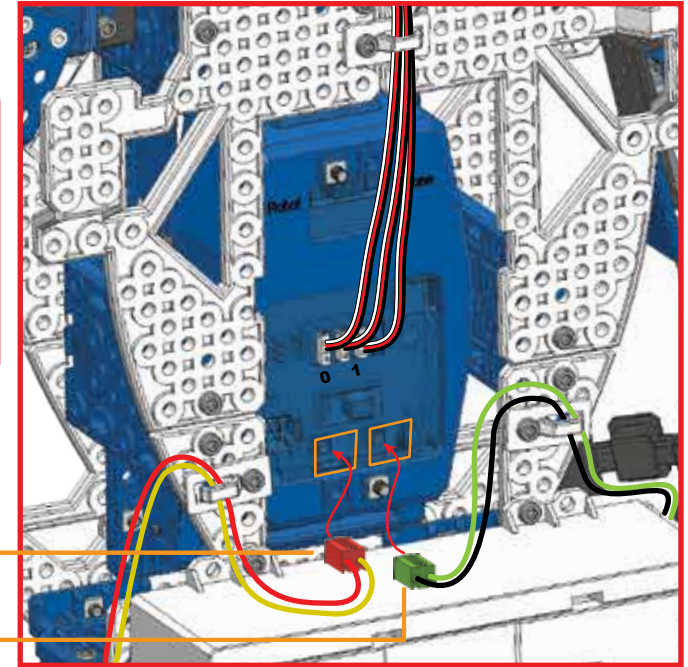

89

Plug in speaker.  
Plug in battery cable.

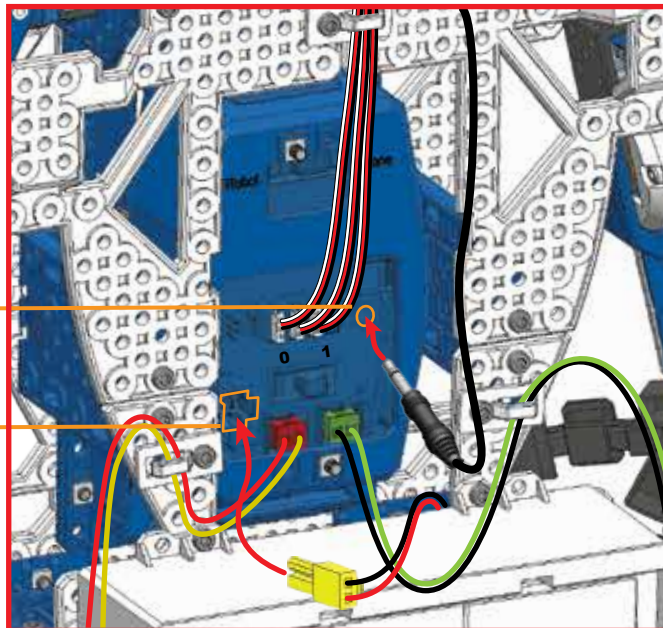

90

Make sure robot is in  
robot mode.

Turn robot on.

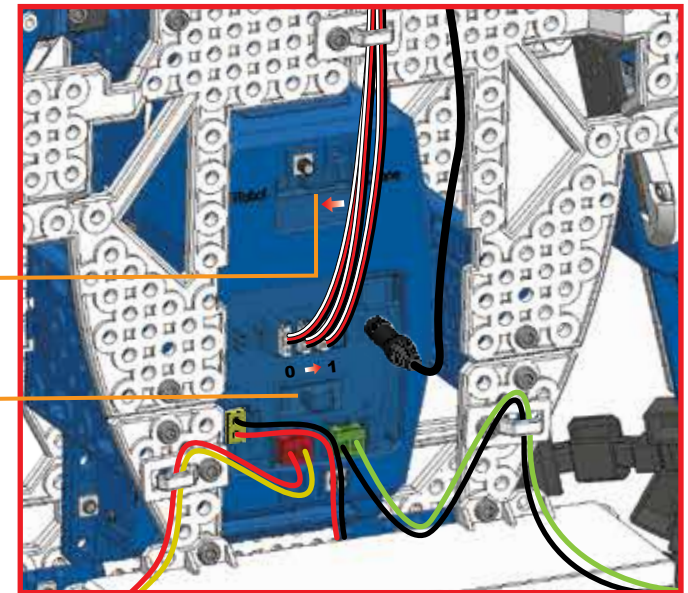

Well done, your  
build is complete.

# 2

## 2.1 CONNECT THE ELECTRONICS

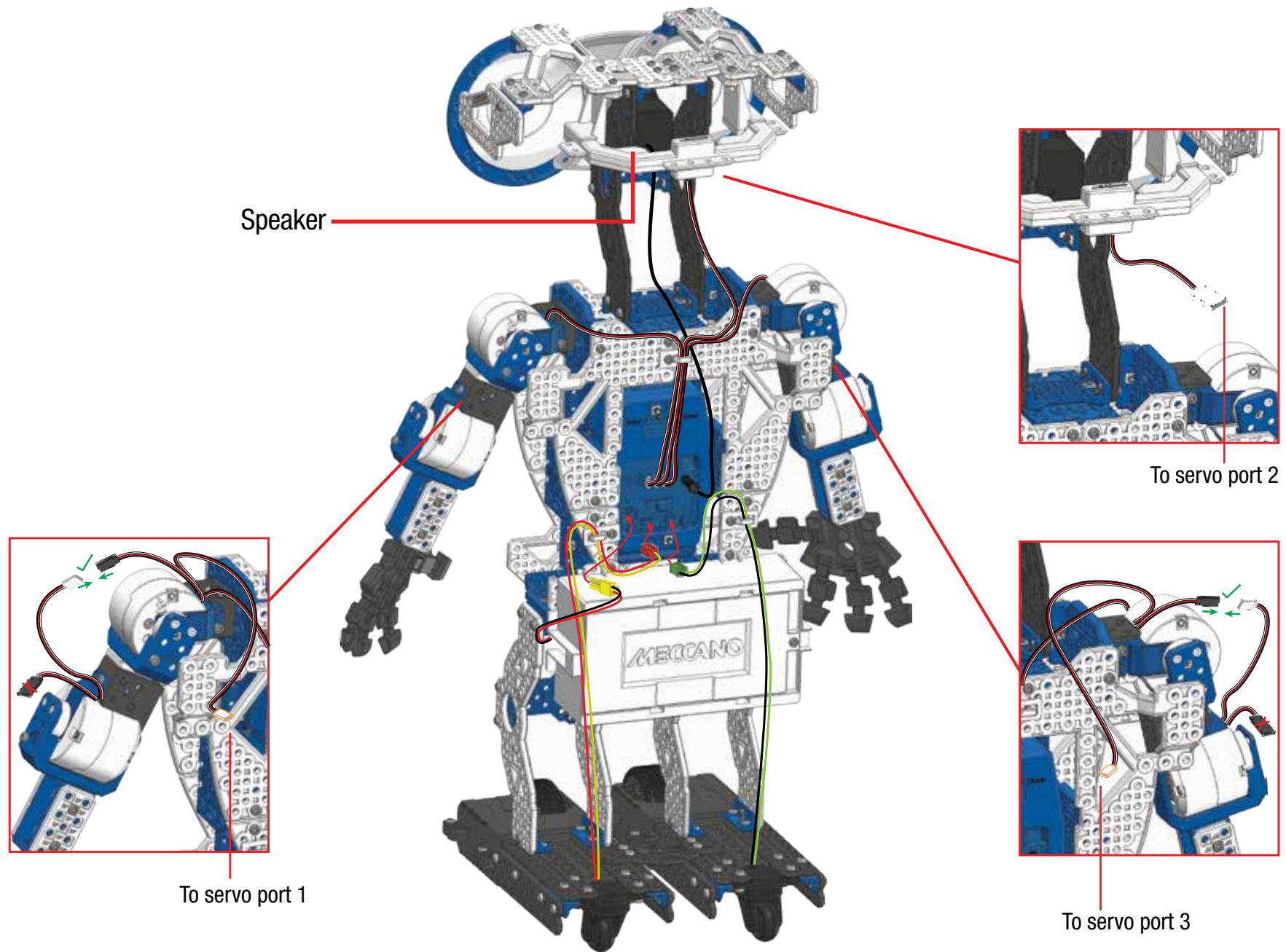



# 3

## PLAY

### 3.1 LET'S PLAY

- 1 Meccanoid will start speaking and do a systems check to verify connections.
- 2 If connections are correct, the robot will restart, and then introduce himself.  
Note: If connections are not correct, the robot will let you know. Return to step 88 and review connections.
- 3 Meccanoid will ask you to test its voice commands. Listen for the directions.

Eye colour communicates mode

Servo Motor

Motors

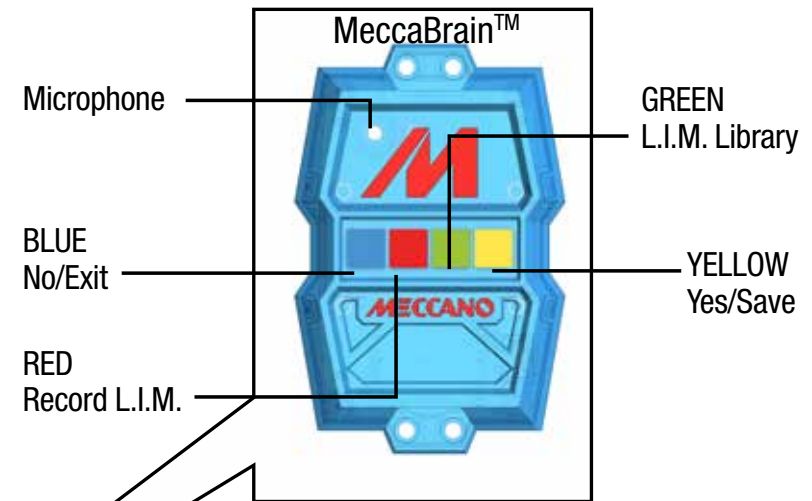

**TIP:** Press any button when they are all unlit for help. The robot will also tell you about its button functions.

**YOU ARE NOW READY TO PLAY!**

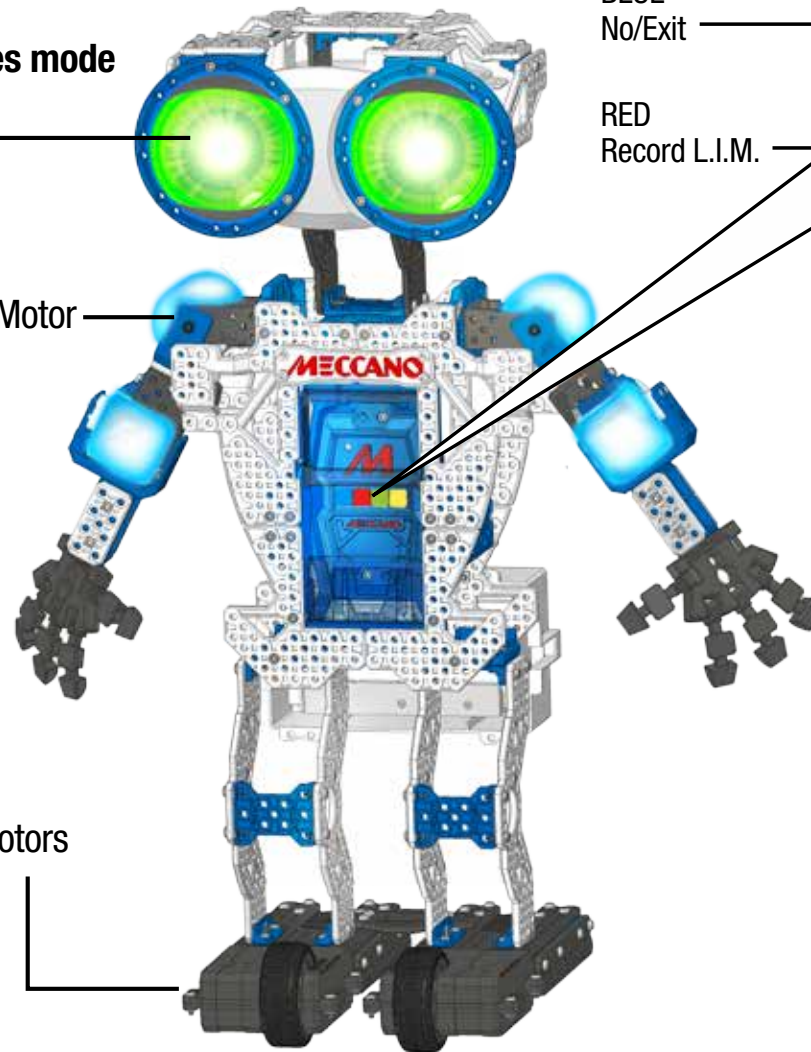





### 3.2 COMMAND CARD

#### VOICE CONTROL TIPS

- 1 Say "Main Menu", "Play a Game" or "Teach Me Something" to navigate between the voice command sections shown below.
- 2 Then you can say a voice command from the section that you have selected.
- 3 Speak clearly when giving a voice command. Not too fast, not too slow.

## COMMAND CARD

### MAIN MENU

- "ADJUST VOLUME"
- "DANCE WITH ME"
- "DO A DANCE"
- "DO KUNG FU"
- "EXCERCISE"
- "GIMME FIVE" 
- "GO TO SLEEP"
- "HUG ME"
- "INTRODUCE YOURSELF"
- "L.I.M. LIBRARY"
- "LIST COMMANDS"
- "PLAY A GAME" 
- "RECORD L.I.M."
- "SHAKE MY HAND"
- "SYSTEMS CHECK"
- "TEACH ME SOMETHING" 
- "TELL ME A JOKE"
- "TELL ME A STORY"
- "TURN AROUND"
- "LEFT TURN"
- "RIGHT TURN"
- "WALK FORWARD"
- "WALK BACKWARD"
- "WALK WITH ME"
- "WORDS OF WISDOM"

### PLAY A GAME

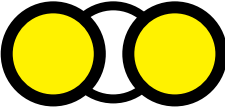
- "5 CLUES" 
- "CHARADES"
- "ROBO TRIVIA"
- "MAIN MENU"

SAY  
"MAIN MENU"  
TO GO BACK

### TEACH ME SOMETHING

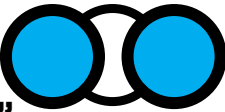
- "FUN FACTS" 
- "ROBOT HISTORY"
- "SCIENCE"
- "HOW DO YOU WORK"
- "MAIN MENU"

SAY  
"MAIN MENU"  
TO GO BACK

SAY "MECCANOID" TO INTERRUPT  
HIM AT ANY TIME

### BUTTON GUIDE



• NO  
• EXIT



• RECORD L.I.M.

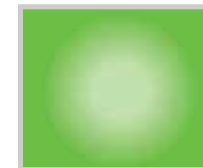

• L.I.M. LIBRARY



• YES  
• SAVE



### 3.3 VOICE COMMANDS



**Say: Introduce yourself\***



**Meccanoid will:** Introduce himself.



**Say: List commands**



**Meccanoid will:** List all voice commands available in the current mode.



**Say: Gimme five\***



**Meccanoid will:** Raise up his arm and ask for a high five.

Note: Gently but firmly push his hand back to give him a high five.



**Say: Tell me a Joke\***



**Meccanoid will:** Tell a joke.



**Say: Walk with me\***



**Meccanoid will:** Ask you to take his hand and lead him on a walk.

Note: Lift the robot's hand and he will start moving forward. When you are finished, drop Meccanoid's hand and he will stop.



**Say: L.I.M.™ library**



**Meccanoid will:** Allow you to play one of the recordings in your L.I.M. library.



**Say: Forward/ Backward**



**Meccanoid will:** Roll forwards or backwards.



**Say: Left Turn/ Right Turn**



**Meccanoid will:** Turn left or turn right.



**Say: Turn Around**



**Meccanoid will:** Turn around.



**Say: Do Kung Fu\***



**Meccanoid will:** Demonstrate karate moves, young grasshopper.



**Say: Exercise\***



**Meccanoid will:** Exercise! Grab a sweatband and follow his moves!



**Say: Do a Dance\***



**Meccanoid will:** Play his own music and show you a dance routine.



**Say: Systems Check\***



**Meccanoid will:** Make sure all servos and modules are plugged in and functioning correctly.



**Say: Adjust Volume**



**Meccanoid will:** Allow you to adjust his volume.



**Say: Shake my hand\***



**Meccanoid will:** Reach out his right hand and offer you a shake... don't leave him hangin'.



**Say: Record L.I.M.™**



**Meccanoid will:** Tell you how to program using Learned Intelligent Movement, or L.I.M.™

L.I.M.™ allows you to create animations by physically moving the robot which you can then name and store in the L.I.M.™ library.



**Say: Main Menu**



**Meccanoid will:** Exit to Main Menu.



**Say: Go to sleep**



**Meccanoid will:** Go to sleep. Note: press any button to wake up Meccanoid.



**Say: Play a Game\***



**Meccanoid will:** Prompt you to play one of his included games. Choose from Robo Trivia, 5 Clues, or Charades.



**Say: Robo Trivia\***



**Meccanoid will:** Guide you through the basic instructions of the game before starting. He can challenge your knowledge on a variety of different subjects such as Animals, Astronomy, Famous Humans, Famous Robots, Geography, Physics, Robotics, and Technology!



**Say: 5 Clues\***



**Meccanoid will:** Guide you through the instructions of the game. First choose how many teams you'll be playing against, then play best out of 5 rounds. The challenge is to guess the person, place, or thing that Meccanoid has in mind.



**Say: Charades\***



**Meccanoid will:** Guide you through the basic instructions of the Game. He will do his best impression of a person, place, or thing, then challenge you to guess what he is. Each game will consist of 10 questions. See how many you can get right!



**Say: Tell Me a Story\***



**Meccanoid will:** Tell you a story on a topic of your choosing. He will prompt you to choose a funny, scary or interesting story.



**Say: Hug Me\***



**Meccanoid will:** Reach out to you with open arms. Hug him, and he'll hug you back!



**Say: Teach me Something\***



**Meccanoid will:** Give you a fascinating lecture on a topic of your choosing. He can teach you about Robot History, Science, How he Works, and other Fun Facts!



**Say: Words of Wisdom\***



**Meccanoid will:** Give you his insights into the ways of the world. He's a very deep robot... or at least he tries to be.



**Say: Dance with Me\***



**Meccanoid will:** Offer his hand to dance. Lead him in a style of your choosing by moving his arms!

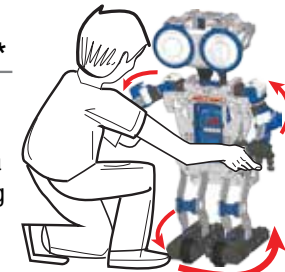

\* Please note that the voice commands with an asterisk (\*) beside them will not work in Drone mode. Drone mode is only for alternative builds and is not recommended for Meccanoid when assembled as shown in this instruction manual.

To enter Drone mode, slide the mode switch to DRONE MODE.

### 3.4 DOWNLOAD FREE APP

**DOWNLOAD  
FREE APP\***

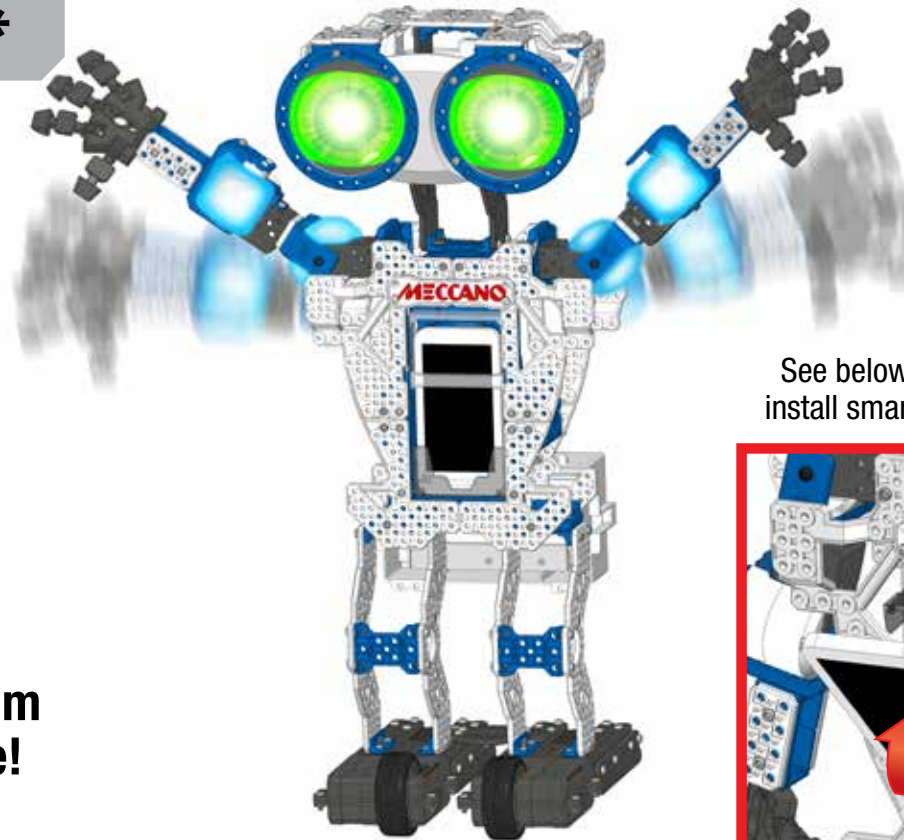

See below image for how to install smart device into cradle

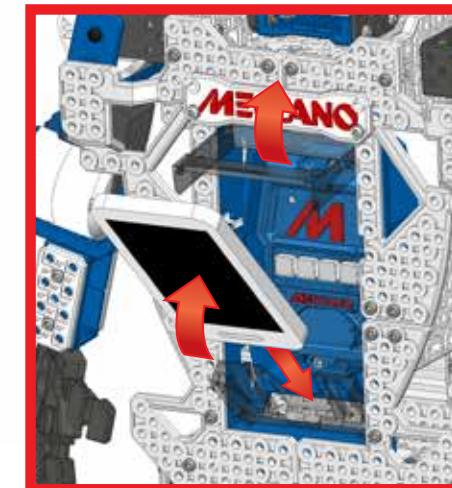

## MORE WAYS TO PLAY!

**Download the free app and program Meccanoid with your smart device!**

Program movements and/or sounds with:

1- Learned Intelligent Movement (L.I.M.™) 2- Ragdoll 3- Motion Capture powered by Extreme Reality ([www.xtr3d.com](http://www.xtr3d.com)) 4- Behavior Builder (2, 3 and 4 require smart device [not included])

Free app available at [www.meccano.com](http://www.meccano.com)

IMPORTANT! CHECK [WWW.MECCANO.COM](http://WWW.MECCANO.COM) TO SEE IF YOUR DEVICE IS COMPATIBLE. (MAY NOT WORK WITH ALL DEVICES\*)

\*COMPATIBLE WITH SELECT IOS AND SELECT ANDROID DEVICES (SOLD SEPARATELY). CHECK [WWW.MECCANO.COM](http://WWW.MECCANO.COM) FOR A LIST OF COMPATIBLE DEVICES AND SYSTEM REQUIREMENTS, TO DETERMINE IF YOUR DEVICE IS COMPATIBLE. SPIN MASTER RESERVES THE RIGHT TO WITHDRAW THE APPLICATION AT ANY GIVEN TIME AND WITHOUT NOTICE.



App Store is a service mark of Apple Inc.  
Google Play™ is a trademark of Google Inc.  
The Bluetooth® word mark is a registered trademark owned by Bluetooth SIG, Inc. and any use of such mark by Spin Master Ltd. is under license.

Meccanoid communicates with your smart device through Bluetooth®



Spin Master Inc., PMB #10053, 300 International Drive, Suite 100, Williamsville, NY 14221



# 2

## 2.1 RÉALISATION DES BRANCHEMENTS

87

Branche les servomoteurs et le module LED dans les ports 1, 2 et 3.

Servomoteur du bras droit  
LED de la tête  
Servomoteur du bras gauche

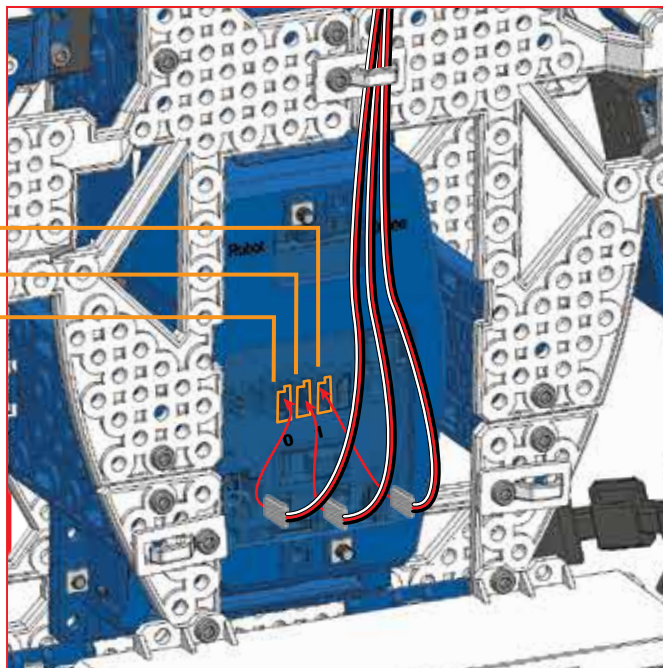

88

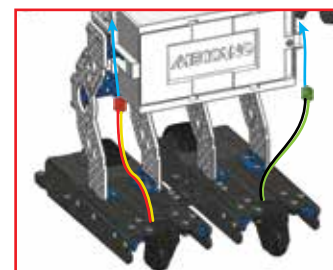

Moteur du pied gauche      Moteur du pied droit

Branche le moteur du pied gauche...  
et celui du pied droit.

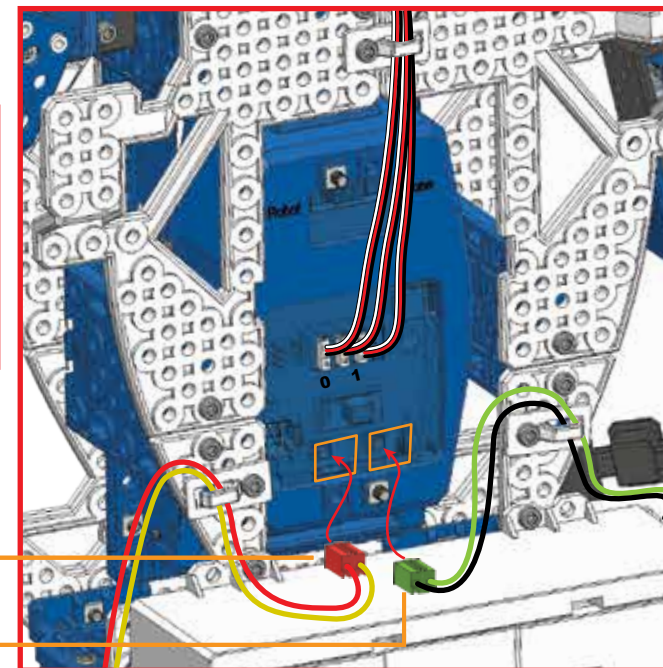

89

Branche le haut-parleur.  
Branche le câble d'alimentation.

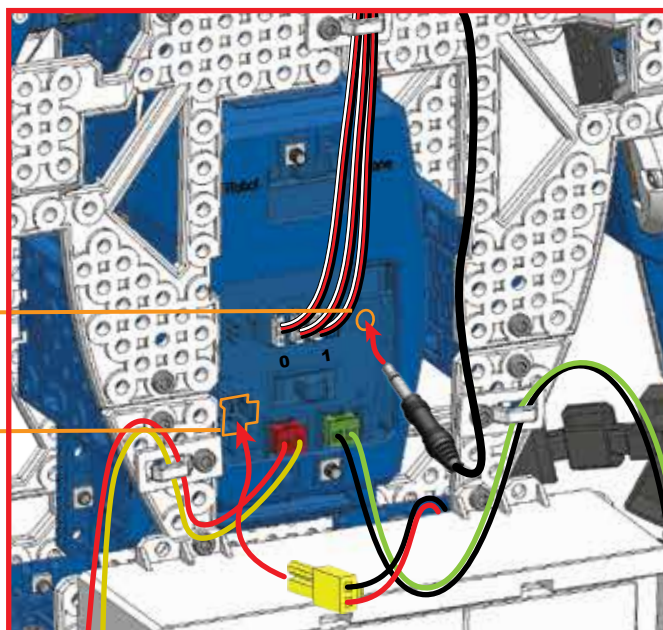

90

Vérifie que le robot est en mode robot.

Mets le robot en marche.

**Les branchements sont terminés, bien joué !**

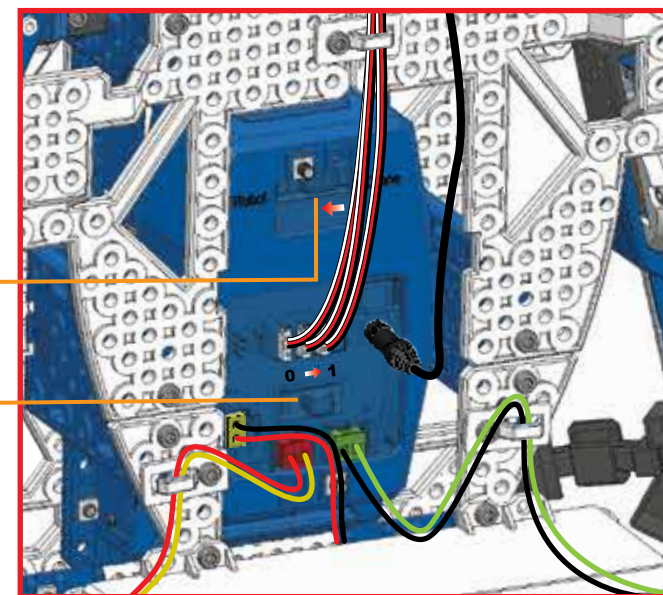

# 2

## 2.1 RÉALISATION DES BRANCHEMENTS

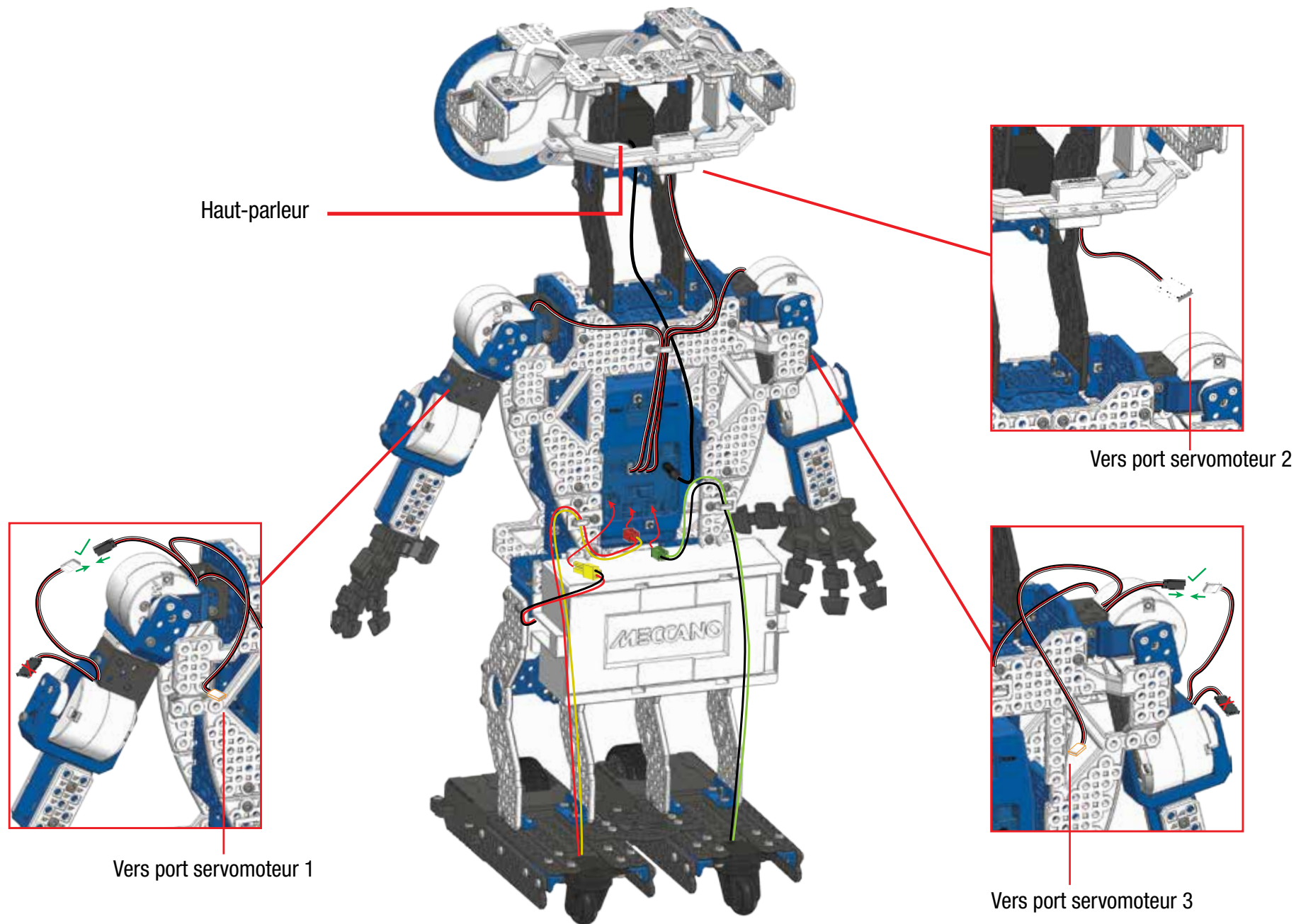



# 3

## JEU

### 3.1 JOUONS !

1 Meccanoid commence à parler et vérifie ses systèmes afin de détecter d'éventuels problèmes de branchements.

2 Si aucun problème n'est détecté, il redémarre, te demande ton nom, puis se présente à son tour.

Remarque : Le robot t'indiquera si des branchements sont incorrects. Reporte-toi à l'étape 88 et vérifie les branchements.

3 Meccanoid te demande de tester les commandes vocales. Attends ses consignes.

La couleur des yeux indique le mode

Servomoteur

Moteurs

ROUGE  
Enregistrer un  
mouvement L.I.M.<sup>™</sup>

BLEU  
Non/  
Quitter

Micro

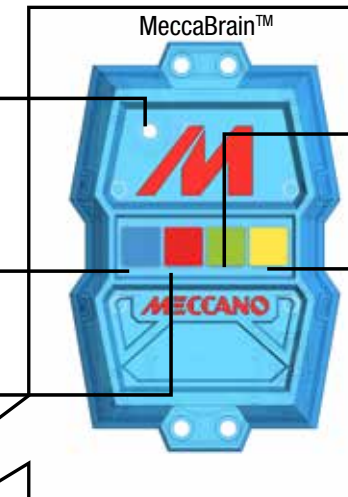

VERT  
Bibliothèque L.I.M.<sup>™</sup>

JAUNE  
Oui/Sauvegarder

**CONSEIL :** Lorsque tous les boutons sont éteints, appuie sur l'un d'entre eux pour obtenir de l'aide. Le robot te donnera aussi des informations sur les fonctionnalités des boutons.

MECCANOID EST PRÊT !



## 3.2 LISTE DES COMMANDES

### CONSEILS POUR L'UTILISATION DES COMMANDES VOCALES

- 1 Dis « Menu principal », « Jouons à un jeu » ou « Apprends-moi quelque chose » pour parcourir les commandes vocales indiquées ci-dessous.
- 2 Prononce alors l'une des commandes vocales de la catégorie que tu as choisie.
- 3 Parle clairement lorsque tu prononces une commande vocale ; ni trop vite, ni trop lentement.

### LISTE DES COMMANDES

#### MENU PRINCIPAL

- « RÉGLER LE VOLUME »
- « DANSE AVEC MOI »
- « FAIS UNE DANSE »
- « FAIS DU KUNG-FU »
- « FAIS DE L'EXERCICE »
- « TOPE LÀ »
- « PASSE EN MODE VEILLE »
- « FAIS-MOI UN CÂLIN »
- « PRÉSENTE-TOI »
- « BIBLIOTHÈQUE L.I.M. »
- « LISTE DES COMMANDES »
- « JOUONS À UN JEU »
- « ENREGISTRE UN MOUVEMENT L.I.M. »
- « SERRONS-NOUS LA MAIN »
- « VÉRIFICATION DES SYSTÈMES »
- « APPRENDS-MOI QUELQUE CHOSE »
- « RACONTE-MOI UNE BLAGUE »
- « RACONTE-MOI UNE HISTOIRE »
- « RETOURNE-TOI »
- « TOURNE À GAUCHE »
- « TOURNE À DROITE »
- « MARCHE AVANT »
- « MARCHE ARRIÈRE »
- « MARCHE AVEC MOI »
- « PAROLES DE SAGESSE »



### JOUONS À UN JEU

- « 5 INDICES »
- « IMITATIONS »
- « QUIZ ROBOT »
- « MENU PRINCIPAL »

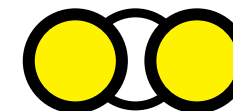

### APPRENDS-MOI QUELQUE CHOSE

- « FAITS AMUSANTS »
- « HISTOIRE DES ROBOTS »
- « SCIENCE »
- « COMMENT FONCTIONNES-TU ? »
- « MENU PRINCIPAL »



DIS « MECCANOÏD » POUR L'INTERROMPRE  
À TOUT MOMENT

### BOUTONS



•NON  
•QUITTER



•ENREGISTRER UN  
MOUVEMENT L.I.M.

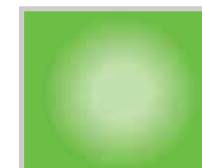

•BIBLIOTHÈQUE  
L.I.M.

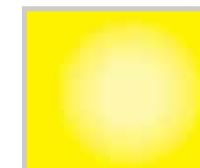

•OUI  
•SAUVEGARDER



### 3.3 COMMANDES VOCALES



**Dis : Présente-toi\***



**Meccanoid va :** Se présenter.



**Dis : Liste des commandes**



**Meccanoid va :** Répertorier toutes les commandes vocales disponibles dans le mode actuel.



**Dis : Tope là\***



**Meccanoid va :** Lever le bras et te demander de taper dans sa main.

Remarque : Pour « tope là », repousse la main du robot sans forcer, mais fermement.



**Dis : Raconte-moi une blague\***



**Meccanoid va :** Te raconter une blague.



**Dis : Marche avec moi\***



**Meccanoid va :** Te demander de lui prendre la main et de marcher à côté de lui.

Remarque : Soulève la main du robot pour le faire avancer. Quand vous êtes arrivés à destination, lâche sa main pour qu'il s'arrête.



**Dis : Bibliothèque L.I.M.™**



**Meccanoid va :** Reproduire l'un des enregistrements de ta bibliothèque L.I.M.™.



**Dis : Marche avant / Marche arrière**



**Meccanoid va :** Avancer ou reculer.



**Dis : Tourne à gauche/Tourne à droite**



**Meccanoid va :** Tourner à gauche ou à droite.



**Dis : Retourne-toi**



**Meccanoid va :** Se retourner.



**Dis : Fais du Kung-Fu\***



**Meccanoid va :** Montrer ses techniques de karaté, jeu de scarabée.



**Dis : Fais de l'exercice\***



**Meccanoid va :** Faire de l'exercice ! Prépare-toi et répète ses mouvements.



**Dis : Fais une danse\***



**Meccanoid va :** Effectuer une chorégraphie de danse sur sa propre musique.



**Dis : Vérification des systèmes\***



**Meccanoid va :** S'assurer que tous les servomoteurs et modules sont branchés et fonctionnent correctement.



**Dis : Régler le volume**



**Meccanoid va :** Régler son volume.



**Dis : Serrons-nous la main\***



**Meccanoid va :** Il t'offre une poignée de main avec la main droite... ne le laisse pas mariner.



**Dis : Enregistre un mouvement L.I.M.™**



**Meccanoid va :** T'expliquer comment le programmer en utilisant l'Apprentissage intelligent des mouvements (L.I.M.™).

L'apprentissage intelligent des mouvements (L.I.M.™) te permet de créer des animations en faisant bouger le robot. Tu peux nommer ces animations pour les stocker dans la bibliothèque L.I.M.™.



**Dis : Menu principal**



**Meccanoid va :** Revenir au menu principal.



**Dis : Passe en mode veille**



**Meccanoid va :** Passer en mode veille.

Remarque : Appuie sur n'importe quel bouton pour réveiller Meccanoid.



**Dis : Jouons à un jeu\***



**Meccanoid va :** T'inviter à jouer à l'un de ses jeux inclus : Quiz robot, 5 indices ou À mimer



**Dis : Quiz robot\***



**Meccanoid va :** Te présenter les règles de base du jeu avant de commencer. Il peut tester tes connaissances sur divers sujets, notamment : Animaux, Astronomie, Humains célèbres, Robots célèbres, Géographie, Physique, Robotique et Technologies !



**Dis : 5 indices\***



**Meccanoid va :** Te présenter les règles du jeu. Choisis le nombre d'équipes auxquelles tu te mesureras. La partie se dispute en 5 manches. Le but du jeu est de deviner la personne, l'endroit ou la chose que le Meccanoid a en tête.



**Dis : Imitations\***



**Meccanoid va :** Te présenter les règles de base du jeu. Il imitera une personne, un endroit ou une chose et tu devras deviner de qui ou quoi il s'agit. Chaque partie se compose de 10 questions. Combien de bonnes réponses obtiendras-tu ?



**Dis : Raconte-moi une histoire\***



**Meccanoid va :** Te raconter une histoire sur le sujet de ton choix. Il t'invitera à choisir une histoire drôle, effrayante ou intéressante.



**Dis : Fais-moi un câlin\***



**Meccanoid va :** T'accueillir à bras ouverts. Fais-lui un câlin, il fera un câlin en retour !



**Dis : Apprends-moi quelque chose\***



**Meccanoid va :** Te raconter une histoire passionnante sur le sujet de ton choix : Histoire des robots, Science, Comment il marche et C'est fou !



**Dis : Paroles de sagesse\***



**Meccanoid va :** Te faire part de ses perles de sagesse. C'est un robot très profond... du moins, qui essaie de l'être.



**Dis : Danse avec moi\***



**Meccanoid va :** Te tendre la main pour danser. Bouge ses bras pour mener la danse sur le style de ton choix !

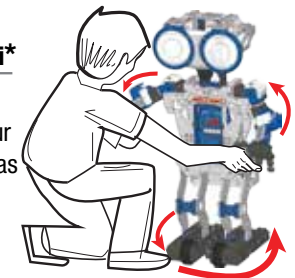

\* Attention, les commandes vocales suivies d'un astérisque (\*) ne fonctionneront pas si le mode Drone est sélectionné. Le mode Drone convient uniquement aux autres modèles ; ne le sélectionne pas si tu as construit Meccanoid selon les consignes de ce mode d'emploi. Règle l'interrupteur de changement de mode sur MODE DRONE si tu souhaites passer à ce mode.

### 3.4 PROGRAMMATION VIA L'APPLICATION

**TÉLÉCHARGE  
L'APPLICATION  
GRATUITE\***

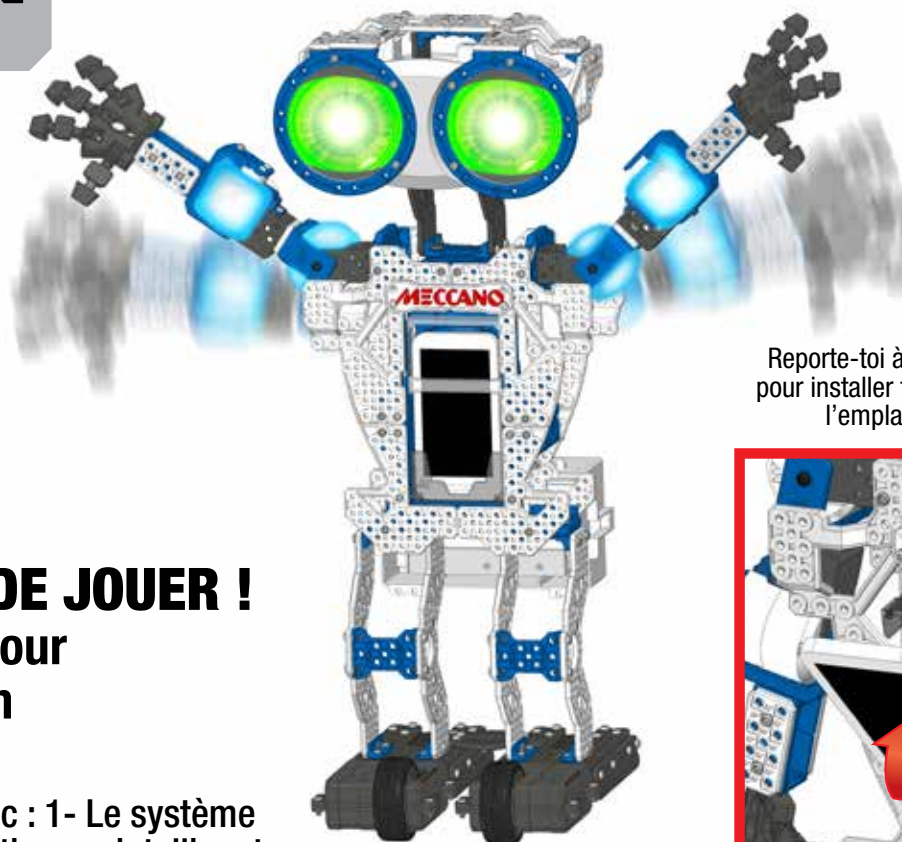

Reporte-toi à l'image ci-dessous pour installer ton appareil mobile à l'emplacement prévu.

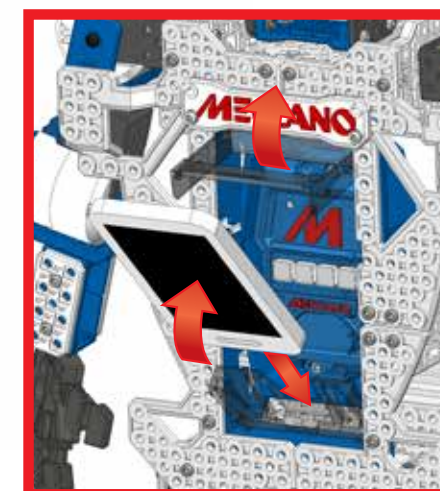

**IL EXISTE D'AUTRES FAÇONS DE JOUER !**  
Télécharge l'application gratuite pour programmer Meccanoid depuis ton appareil mobile !

Programme les mouvements et/ou les sons avec : 1- Le système L.I.M.<sup>TM</sup> (Learned Intelligent Movement, Apprentissage intelligent des mouvements) 2- Un avatar 3- La capture de mouvements optimisée par Extreme Reality ([www.xtr3d.com](http://www.xtr3d.com)) 4- Bâtisseur de comportement (Les solutions 2, 3 & 4 nécessitent un appareil mobile non fourni.)

Application gratuite disponible sur : [www.meccano.com](http://www.meccano.com)

IMPORTANT ! RENDS-TOI SUR [WWW.MECCANO.COM](http://WWW.MECCANO.COM) POUR VÉRIFIER SI TON APPAREIL EST COMPATIBLE. (PEUT NE PAS FONCTIONNER AVEC TOUS LES APPAREILS\*)

\*COMPATIBLE AVEC CERTAINS APPAREILS IOS ET ANDROID (VENDUS SÉPARÉMENT). LISTE DES APPAREILS COMPATIBLES ET DE LA CONFIGURATION REQUISE DISPONIBLE SUR [WWW.MECCANO.COM](http://WWW.MECCANO.COM). SPIN MASTER SE RÉSERVE LE DROIT DE RETIRER L'APPLICATION À TOUT MOMENT ET SANS PRÉAVIS.

Meccanoid communique avec les appareils mobiles en Bluetooth®



Spin Master Inc., PMB #10053, 300 International Drive, Suite 100, Williamsville, NY 14221



App Store est une marque de service d'Apple Inc.  
Google Play est une marque de commerce de Google Inc.  
Bluetooth® est une marque déposée de Bluetooth SIG, Inc. et toute utilisation de cette marque par Spin Master Ltd. est sous licence.



# CONSUMER INFORMATION • INFORMATIONS DESTINÉES AU CONSOMMATEUR • INFORMACION PARA EL CONSUMIDOR • VERBRAUCHERHINWEISE INFORMATIE VOOR GEBRUIKERS • INFORMAZIONI PER I CONSUMATORI • INFORMAÇÕES PARA O CONSUMIDOR • ИНФОРМАЦИЯ ДЛЯ ПОТРЕБИТЕЛЕЙ

## **(EN) BATTERY SAFETY INFORMATION:**

- Requires 4 x 1.5V D alkaline batteries (not included).
- Batteries are small objects.
- Replacement of batteries must be done by adults.
- Follow the polarity (+/-) diagram in the battery compartment.
- Promptly remove dead batteries from the toy.
- Dispose of used batteries properly.
- Remove batteries for prolonged storage.
- Only batteries of the same or equivalent type as recommended are to be used.
- DO NOT incinerate used batteries.
- DO NOT dispose of batteries in fire, as batteries may explode or leak.
- DO NOT mix old and new batteries or types of batteries (i.e. alkaline/standard).
- DO NOT use rechargeable batteries.
- DO NOT recharge non-rechargeable batteries.
- DO NOT short-circuit the supply terminals.

**IMPORTANT INFORMATION:** Remove all packaging before use. Retain this information, addresses and phone numbers for future reference. Content may vary from pictures. Meccano reserves the right to discontinue the website [www.meccano.com](http://www.meccano.com) at any time. Keep away from obstacles and electrical hazards.

**SAFETY PRECAUTIONS:** Parental guidance is recommended. Do not use Meccanoid on a table or near stairs; only use on the floor. Regularly examine for damage to the toy and sensors. In the event of any damage, remove from use. Keep hands, hair and loose clothing away from moving parts when power switch is turned ON. Turn OFF Meccanoid when not in use. During play, keep in sight so that you can supervise it all the time. Users should keep strict accordance with the instruction manual while operating the product.

**CARE AND MAINTENANCE:** This product is intended for indoor use only. Do not use outdoor - dirt, grass, cement will scratch the finish and/or block the sensors. Do not submerge the toy in water. Do not play around water as this is a hazard and can cause a malfunction or damage the electronic assemblies. Keep the sensors clean, wipe with a scratchless cloth. Do not put any foreign objects in the USB port or sensors. Do not pull hard on any part of the robot as this may cause damage.

**TROUBLE SHOOTING:** If normal function of the product is disturbed or interrupted, strong electro-magnetic interference may be causing the issue. To

reset product, turn it completely off, then turn it back on. If normal operation does not resume, move the product to another location and try again. To ensure normal performance, change the batteries, as low batteries may not allow full function.

## **(FR) INFORMATIONS DE SÉCURITÉ RELATIVES**

### **AUX PILES :**

- Fonctionne avec 4 piles alcalines D 1,5 V (non fournies).
- Les piles sont de petits objets.
- Le remplacement des piles doit être effectué par un adulte.
- Respecter le schéma de polarité (+/-) du compartiment des piles.
- Retirer immédiatement toute pile usagée du jouet.
- Jeter correctement les piles usagées.
- Retirer les piles du jouet en cas d'inutilisation prolongée.
- N'utiliser que des piles d'un même type ou d'un type équivalent à celui recommandé.
- NE PAS incinérer les piles usagées.
- NE PAS jeter les piles au feu ; elles pourraient exploser ou fuir.
- NE PAS mélanger des piles neuves et des piles usagées, ou des piles de types différents (ex : alcalines/standard).
- NE PAS utiliser de piles rechargeables.
- NE PAS recharger des piles non rechargeables.
- NE PAS court-circuiter les bornes d'alimentation.

**INFORMATIONS IMPORTANTES :** Retirer tout l'emballage avant utilisation. Conserver les informations, adresses et numéros de téléphone pour consultation ultérieure. Le contenu peut différer des images. Meccano se réserve le droit de supprimer le site Internet [www.meccano.com](http://www.meccano.com) à tout moment. Maintenir à l'écart de tout obstacle ou risque électrique.

**MESURES DE SÉCURITÉ :** L'aide d'un adulte est recommandée. Ne pas utiliser Meccanoid sur une table ou près d'escaliers. L'utiliser sur le sol uniquement. Vérifier régulièrement que le jouet et les capteurs ne sont pas endommagés. S'ils le sont, ne plus utiliser le jouet. S'assurer que les mains, cheveux et vêtements amples ne se trouvent pas à proximité des parties mobiles lorsque l'interrupteur est placé sur ON. ÉTEINDRE Meccanoid lorsqu'il n'est pas utilisé. Le jouet doit toujours être dans le champ de vision et surveillé à tout moment. Les utilisateurs doivent suivre rigoureusement les consignes de ce mode d'emploi lors de l'utilisation du jouet.

**ENTRETIEN ET MAINTENANCE :** Ce produit est conçu pour être utilisé en intérieur seulement. Ne pas utiliser en extérieur : tout contact avec de la terre, de l'herbe ou du béton peut érafler la peinture et/ou empêcher les capteurs de fonctionner. Ne pas plonger le jouet dans l'eau. Ne pas utiliser le jouet à proximité d'eau ; cela présente un danger et risquerait de provoquer un mauvais fonctionnement des assemblages électroniques ou de les endommager. Les capteurs doivent rester propres. Les nettoyer à l'aide d'un chiffon doux. Ne placer aucun objet étranger dans les capteurs ni dans le port USB. Ne pas tirer trop fort sur une partie du robot, car cela pourrait l'endommager.

**DÉPANNAGE :** de fortes interférences électromagnétiques peuvent perturber ou empêcher le fonctionnement du jouet. Pour réinitialiser le jouet, l'éteindre totalement, puis le rallumer. S'il ne fonctionne toujours pas correctement, le déplacer et réessayer. Pour assurer le fonctionnement normal du jouet, remplacer les piles. En effet, des piles faibles peuvent ne pas permettre un fonctionnement optimal.

## **(ES) INFORMACIÓN DE SEGURIDAD SOBRE LAS PILAS:**

- Requiere 4 pilas alcalinas D de 1,5 V (no incluidas).
- Las pilas son objetos pequeños.
- Las pilas deben ser sustituidas por un adulto.
- Siga las instrucciones de polaridad (+ / -) que aparecen en el compartimento de las pilas.
- Retire rápidamente las pilas usadas.
- Las pilas usadas deben desecharse de forma adecuada.
- Retire las pilas si va a guardar el juguete durante un período de tiempo prolongado.
- Utilice únicamente pilas del tipo recomendado o de un tipo equivalente.
- NO exponga las pilas usadas al fuego.
- NO deseche las pilas usadas quemándolas, ya que podrían explotar o desprender productos químicos.
- NO mezcle pilas nuevas y viejas, ni mezcle pilas de tipos distintos (p. ej. alcalinas y normales).
- NO utilice pilas recargables.
- NO intente recargar pilas no recargables.
- NO cause cortocircuitos en las terminales de corriente.

**INFORMACIÓN IMPORTANTE :** Retire todo el embalaje antes de utilizar el producto. Conserve toda la información, las direcciones y los números de teléfono para futuras referencias. El contenido del paquete puede no corresponder con las imágenes. Meccano se reserva el derecho a suspender el sitio web [www.meccano.com](http://www.meccano.com) en cualquier momento. Mantenga el producto alejado de obstáculos y riesgos eléctricos.

**MEDIDAS DE SEGURIDAD:** Se recomienda la supervisión

de un adulto. Coloca tu Meccanoid en el suelo cuando vayas a utilizarlo, nunca en una mesa ni cerca de las escaleras. Comprueba periódicamente si el juguete o los sensores han sufrido daños. En caso de que estén dañados, deja de utilizar el juguete. Mantén las manos, el pelo y la ropa alejados del juguete cuando el interruptor esté en posición de ENCENDIDO. APAGA tu Meccanoid cuando no vayas a utilizarlo. No lo pierdas de vista mientras lo estés usando; debe estar bajo control en todo momento. Los usuarios del producto deben seguir todas las recomendaciones de esta guía de instrucciones.

**CUIDADO Y MANTENIMIENTO:** este producto debe utilizarse únicamente en interiores. No lo utilices en exteriores, ya que la suciedad, la hierba y el cemento pueden arañar el acabado y bloquear los sensores. No sumerjas el juguete en agua. No utilices el juguete cerca del agua. Esto puede resultar muy peligroso ya que podría provocar un mal funcionamiento o dañar los componentes electrónicos. Mantén limpios los sensores; límpialos con un paño suave. No insertes objetos extraños en el puerto USB ni en los sensores. No tires con fuerza de ninguna parte del robot, ya que podrías dañarlo.

**RESOLUCIÓN DE PROBLEMAS:** si se interrumpe el funcionamiento normal del producto, es posible que se deba a interferencias electromagnéticas fuertes. Para reiniciarlo, apágalo y vuelve a encenderlo. Si el producto sigue sin funcionar normalmente, cambia la zona de uso y vuelve a intentarlo. Las pilas usadas pueden impedir que el producto funcione correctamente. Para conseguir un rendimiento óptimo, cambia las pilas.

## **(DE) SICHERHEITSHINWEISE ZU BATTERIEN:**

- Benötigt 4 x 1,5-V-Alkali-Babyzellen D (nicht enthalten).
- Batterien sind kleine Gegenstände.
- Batterien müssen von Erwachsenen ausgewechselt werden.
- Das Polaritätsdiagramm (+/-) im Batteriefach beachten.
- Leere Batterien sofort aus dem Spielzeug entfernen.
- Verbrauchte Batterien ordnungsgemäß entsorgen.
- Bei längerfristiger Lagerung Batterien vorher entfernen.
- Nur dieselben oder gleichwertige Batterien wie empfohlen verwenden.
- Verbrauchte Batterien NICHT verbrennen.
- Batterien NICHT in Feuer entsorgen, da sie explodieren oder auslaufen könnten.
- Alte und neue Batterien oder verschiedene Batterietypen (z. B. Alkali/Standard) NICHT zusammen einlegen.
- KEINE aufladbaren Batterien verwenden.
- Nicht-aufladbare Batterien NICHT aufladen.
- Batteriepole NICHT kurzschließen.

**WICHTIGE INFORMATIE:** Entfernen Sie vor der Benutzung sämtliche Verpackungsmaterialien. Alle Informationen, Adressen und Telefonnummern bitte für mögliche Rückfragen aufbewahren. Der Packungsinhalt kann von den Bildern abweichen. Meccano behält sich das Recht vor, den Betrieb der Website [www.meccano.com](http://www.meccano.com) jederzeit einzustellen. Nicht in der Nähe von Hindernissen und gefährlichen Stromquellen spielen.

**SICHERHEITSVORKEHRUNGEN:** Beaufsichtigung durch Erwachsene empfohlen. Meccanoid nicht auf Tischen oder in der Nähe von Treppen verwenden. Das Spielzeug ist ausschließlich für die Verwendung auf dem Boden gedacht. Das Spielzeug und die Sensoren regelmäßig auf Schäden untersuchen. Ist das Spielzeug beschädigt, darf es nicht länger verwendet werden. Hände, Haare und weite Kleidung von den beweglichen Teilen fernhalten, wenn das Spielzeug eingeschaltet ist. Meccanoid ausschalten, wenn das Spielzeug nicht verwendet wird. Kinder während des Spielens mit Meccanoid nicht unbeaufsichtigt lassen. Das Produkt sollte streng nach den Anweisungen in der Bedienungsanleitung verwendet werden.

**PFLGE UND WARTUNG:** Dieses Produkt ist nur zur Verwendung in Innenräumen vorgesehen. Nicht im Freien verwenden. Schmutz, Gras und Asphalt können die Oberfläche zerkratzen und/oder die Sensoren blockieren. Das Spielzeug nicht unter Wasser tauchen. Das Spielzeug nicht in der Nähe von Wasser verwenden. Dies ist nicht nur gefährlich, sondern kann auch zu einer Fehlfunktion oder zur Beschädigung der elektronischen Komponenten führen. Die Sensoren mit einem weichen Tuch sauber halten. Keine Fremdkörper in den USB-Anschluss oder die Sensoren einführen. Nicht an Roboterteilen zerran, denn das kann Schäden verursachen.

**FEHLERBEHEBUNG:** Wenn die normale Funktion des Produkts gestört oder unterbrochen wird, könnte starke elektromagnetische Strahlung der Grund dafür sein. Durch Aus- und wieder Einschalten des Produkts können die Einstellungen zurückgesetzt werden. Sollte dies die Fehlfunktion nicht beheben, das Produkt an einen anderen Ort bringen und dort erneut ausprobieren. Bei Bedarf die Batterien austauschen, da schwache Batterien die Leistungsfähigkeit beeinträchtigen können.

#### **(NL) VEILIGHEIDSMATERIE MET BETREKKING TOT DE BATTERIJEN:**

- Vereist 4 D alkalinebatterijen van 1,5 V (niet inbegrepen).
- Batterijen zijn kleine voorwerpen.
- Het vervangen van batterijen dient door volwassenen te worden gedaan.
- Houd je aan het polariteitsdiagram (+/-) in het batterijvak.
- Verwijder lege batterijen onmiddellijk uit het speelgoed.
- Zorg voor een milieuvriendelijke afvalverwerking van de batterijen.

**42**

- Verwijder de batterijen als het speelgoed voor langere tijd wordt opgeborgen.
- Alleen batterijen van het aanbevolen type of een equivalent daarvan mogen worden gebruikt.
- Steek gebruikte batterijen NOOIT in brand.
- Gooi batterijen NOOIT in vuur. Hierdoor kunnen deze ontploffen of gaan lekken.
- Gebruik oude en nieuwe batterijen of verschillende typen batterijen (bijv. alkaline/standaard) NOOIT door elkaar.
- Gebruik NOOIT oplaadbare batterijen.
- Laad niet-oplaadbare batterijen NOOIT op.
- Veroorzaak NOOIT kortsluiting tussen de contactpunten.

**BELANGRIJKE INFORMATIE:** Verwijder de verpakking voor gebruik. Bewaar deze informatie, adressen en telefoonnummers voor toekomstig gebruik. Inhoud kan afwijken van illustraties. Meccano behoudt zich het recht voor de website [www.meccano.com](http://www.meccano.com) wanneer gewenst buiten gebruik te stellen. Blijf uit de buurt van obstakels en voorwerpen die elektrische schokken kunnen veroorzaken.

**VEILIGHEIDSMATREGELEN:** Ouderlijk toezicht wordt aanbevolen. Gebruik Meccanoid niet op tafels of in de buurt van trappen. Gebruik Meccanoid alleen op de vloer. Controleer het speelgoed en de sensoren regelmatig op beschadigingen. In geval van schade, speelgoed niet meer gebruiken. Houd handen, haar en losvallende kleding uit de buurt van bewegende onderdelen als de stroomschakelaar op ON staat. Zet Meccanoid uit wanneer je hem niet gebruikt. Houd Meccanoid tijdens het spelen altijd in de gaten. Gebruikers dienen zich tijdens het gebruik van het product strikt aan de informatie in de gebruiksaanwijzing te houden.

**VERZORGING EN ONDERHOUD:** dit product is uitsluitend voor gebruik binnenshuis. Gebruik het product niet buitenshuis. Vuil, gras en cement zorgen voor krassen op de lak of blokkeren de sensoren. Dompel het speelgoed niet onder in water. Gebruik het speelgoed niet in de buurt van water, omdat dit gevaarlijk is en een elektronisch defect kan veroorzaken. Maak de sensoren schoon met een zachte doek. Plaats geen vreemde objecten in de USB-poort of de sensoren. Trek niet hard aan de onderdelen van de robot omdat dit schade kan veroorzaken.

**PROBLEMEN OPLOSSEN:** bij ontregeling of onderbreking van het normale functioneren van het product kan een sterke elektromagnetische storing de oorzaak van het probleem zijn. Reset het product door het volledig uit te schakelen en vervolgens weer in te schakelen. Functioneert het product dan nog niet naar behoren, reset het dan nogmaals in een andere ruimte. Controleer ook of de batterijen niet leeg zijn en vervang deze indien nodig. Lege batterijen kunnen een correcte werking verstoren.

#### **(IT) INFORMAZIONI DI SICUREZZA PER LE PILE:**

- Richiede 4 pile alcaline D da 1,5 V (non incluse).
- Le pile sono oggetti di piccole dimensioni.
- Le pile devono essere sostituite da adulti.
- Far riferimento allo schema delle polarità (+/-) all'interno dello scomparto pile.
- Estrarre tempestivamente le pile scariche.
- Eliminare le pile scariche con la dovuta cautela.
- Estrarre le pile se non si utilizza il prodotto per un periodo di tempo prolungato.
- Usare solo pile dello stesso tipo o equivalenti.
- NON bruciare le pile usate.
- NON gettare le pile nel fuoco, potrebbero esplodere o essere soggette a perdite di liquido.
- NON mischiare pile vecchie e nuove o tipi di pile diverse (ad esempio alcaline e standard).
- NON usare pile ricaricabili.
- NON ricaricare le pile non ricaricabili.
- NON cortocircuitare i terminali delle pile.

**INFORMAZIONI IMPORTANTI:** Rimuovere l'imballo prima dell'uso. Conservare informazioni, indirizzi e numeri di telefono per riferimento futuro. Il prodotto potrebbe essere differente dalle immagini. Meccano si riserva il diritto di rimuovere il sito [www.meccano.com](http://www.meccano.com) in qualsiasi momento. Tenere lontano da ostacoli, dispositivi elettrici e prese di corrente.

**PRECAUZIONI DI SICUREZZA:** È consigliata la supervisione dei genitori. Non usare Meccanoid su un tavolo o in prossimità di scale. Usare solo sul pavimento. Esaminare regolarmente il giocattolo e i sensori per verificare l'eventuale presenza di danni. Se danneggiato, il giocattolo non deve essere usato. Tenere le mani, i capelli e i capi di vestiario lontani dai componenti in movimento quando l'interruttore di alimentazione è acceso. Spegnerne Meccanoid quando non lo si sta usando. Durante il gioco, tenere Meccanoid™ in vista per poterlo controllare in ogni momento. Seguire attentamente la guida per l'uso.

**CONSERVAZIONE E MANUTENZIONE:** questo prodotto deve essere utilizzato esclusivamente in luoghi chiusi. Non utilizzare all'esterno: terra, erba e cemento potrebbero graffiare la superficie e/o potrebbero bloccare i sensori. Non immergere il giocattolo in acqua. Non utilizzare in prossimità di acqua per evitare il rischio di malfunzionamenti o danni ai componenti elettronici. Tenere puliti i sensori utilizzando un panno antigraffio. Non inserire corpi estranei nella porta USB o nei sensori. Non tirare troppo forte nessun componente del robot per evitare danni.

**RISOLUZIONE DEI PROBLEMI:** se il normale funzionamento del prodotto risultasse disturbato, ciò potrebbe essere causato da una forte interferenza elettromagnetica. Per resettare il prodotto, spegnerlo e riaccenderlo. Se non dovesse riprendere a funzionare

adeguatamente, spostarlo in una posizione diversa e riprovare. Per un funzionamento corretto, sostituire le pile poco cariche che possono compromettere il regolare funzionamento del prodotto.

#### **(PT) INFORMAÇÕES DE SEGURANÇA SOBRE AS PILHAS:**

- Requer 4 pilhas alcalinas tipo D de 1,5 V (não incluídas).
- Pilhas são objetos pequenos.
- A troca das pilhas deve ser realizada por adultos.
- Siga o diagrama de polaridade (+/-) no compartimento de pilhas.
- Retire as pilhas vazias do brinquedo.
- Descarte corretamente as pilhas usadas.
- Retire as pilhas para armazenamento prolongado.
- Recomenda-se que sejam usadas apenas pilhas iguais ou similares.
- NÃO incinere as pilhas usadas.
- NÃO jogue as pilhas no fogo, pois podem explodir ou vazar.
- NÃO misture pilhas novas com usadas, tampouco misture tipos de pilhas diferentes (pilhas alcalinas com pilhas regulares, por exemplo).
- NÃO use pilhas recarregáveis.
- NÃO recarregue pilhas não recarregáveis.
- NÃO permita que ocorra curto-circuito nos terminais do produto.

**IMPORTANTE:** emova totalmente a embalagem antes de utilizar. Guarde todos os endereços, números de telefone e demais informações para consulta e referência. O conteúdo poderá ser diferente das ilustrações. A Meccano reserva-se o direito de descontinuar o site [www.meccano.com](http://www.meccano.com) a qualquer altura. Mantenha distância de obstáculos e perigos elétricos.

**PRECAUÇÕES DE SEGURANÇA:** É recomendada a supervisão de um adulto. Não use o Meccanoid em mesas ou perto de escadas, apenas no chão. Verifique regularmente se há danos no brinquedo e nos sensores. Em caso de algum dano, suspenda o uso. Mantenha mãos, cabelos e roupas distantes do brinquedo quando a chave de liga/desliga estiver em "ON" ("LIGADO"). DESLIGUE o Meccanoid quando não estiver em uso. Ao brincar com o produto, mantenha-o sob sua supervisão em todos os momentos. Os usuários devem seguir todas as instruções do guia de instruções para usar o brinquedo.

**CUIDADOS E MANUTENÇÃO:** Este produto destina-se somente a uso interno. Não o use fora de casa - pó, grama e cimento arranharão o acabamento e/ou obstruirão os sensores. Não submerja o brinquedo em água. Não brinque perto da água, pois isso representa um risco e pode causar mau funcionamento ou danos aos componentes eletrônicos. Mantenha os sensores limpos

usando um tecido macio. Não insira objetos estranhos na porta USB ou nos sensores. Não puxe com muita força nenhuma parte do robô para não causar danos.

**SOLUÇÃO DE PROBLEMAS:** Se o funcionamento normal do produto for afetado ou interrompido, a causa pode ser uma interferência eletromagnética. Para reiniciar o produto, desligue-o completamente e ligue-o novamente. Se o funcionamento não voltar ao normal, desloque o produto para o outro local e tente novamente. Para garantir o funcionamento normal, troque as pilhas, já que as pilhas com carga baixa não possibilitam o funcionamento completo do produto.

**(RU) INFORMAÇÃO PO BEZOPASNOMU OBRASHENIU S ELEMENTAMI PITANIA:**

- Требуются 4 щелочных элемента питания типа D с напряжением 1,5 В (не входят в комплект).
- Элементы питания представляют собой миниатюрные предметы.
- Замену элементов питания должны выполнять взрослые.
- Соблюдайте полярность (+/-), указанную в отсеке элементов питания.
- Не оставляйте разрядившиеся элементы питания в игрушке.
- Утилизируйте элементы питания надлежащим образом.
- Извлекайте элементы питания, если игрушка не используется долгое время.
- Рекомендуется использовать элементы питания одного или эквивалентного типа.
- НЕ сжигайте использованные элементы питания.
- НЕ бросайте элементы питания в огонь. Это может привести к их утечке или взрыву.
- НЕ используйте новые элементы питания в сочетании с использованными или элементами питания разного типа (т.е. щелочные/обычные).
- НЕ используйте перезаряжаемые элементы питания.
- ЗАПРЕЩАЕТСЯ заряжать непозаряжаемые элементы питания.
- ИЗБЕГАЙТЕ короткого замыкания источников питания.

**ВАЖНАЯ ИНФОРМАЦИЯ:** Снимите все упаковочные материалы перед использованием. Запишите указанные на упаковке адреса и номера телефонов, чтобы у вас была возможность связаться с нами. Содержимое упаковки может отличаться от иллюстрации. Взрослым следует время от времени проверять игру и следить за тем, чтобы она не была сломана и не представляла опасности для ребенка. В противном случае ее не следует использовать. Во время игры дети должны находиться под присмотром взрослых.

Компания Мессано оставляет за собой право прекратить использование сайта [www.messano.com](http://www.messano.com) в любое время.

**МЕРЫ ПРЕДОСТОРОЖНОСТИ:** Рекомендуется присмотр взрослых. Не используйте игрушку Мессаноид на столе или рядом с лестницей — игрушка предназначена для использования на полу. Следует проводить регулярный осмотр на предмет повреждения игрушки и датчиков. Если таковые имеются, игрушку не следует использовать. Не прикасайтесь к игрушке руками и следите за тем, чтобы она находилась на безопасном расстоянии от волос и прилегающих элементов одежды, когда переключатель питания находится в положении "ВКЛ.". Выключите игрушку, когда она не используется. Во время использования игрушка всегда должна находиться в поле зрения. При управлении игрушкой необходимо строго следовать указаниям, приведенным в руководстве по эксплуатации.

**УХОД И ОБСЛУЖИВАНИЕ:** игрушка предназначена только для использования в помещении. Не используйте игрушку на улице — грязь, трава и бетон могут поцарапать покрытие и/или повредить датчики. Не погружайте игрушку в воду. Не используйте игрушку рядом с водой, так как это может привести к сбою в работе или повреждению электронных компонентов. Очистку датчиков следует выполнять мягкой тканью. Не помещайте посторонние предметы в USB-порт или датчики. Не подвергайте части тела робота сильному растяжению, поскольку это может привести к повреждению.

**УСТРАНЕНИЕ НЕИСПРАВНОСТЕЙ:** если устройство перестает работать или работает нестабильно, причиной могут быть сильные электромагнитные помехи. Чтобы восстановить работу устройства, полностью выключите его, а затем включите снова. Если устройство по-прежнему будет работать неисправно, повторите процедуру в другом месте комнаты. Для нормальной работы устройства замените элементы питания. При низком уровне заряда элементы питания могут быть неспособны обеспечить работу устройства в полнофункциональном режиме.

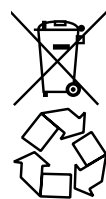

**(EN)** Requires 4 X1.5 V D alkaline batteries (not included). Batteries or battery packs must be recycled or disposed of properly. When this product has reached the end of its useful life it should not be disposed of with other household waste. The Waste Electrical and Electronic Equipment Regulations require it to be separately collected so that it can be treated using the best available recovery and recycling techniques. This will minimize the impact on the environment and human health from soil and water contamination by any hazardous substances, decrease the resources required to make new products and avoid using up landfill space. Please do your part by keeping this product out of the municipal waste stream! The "wheelie bin" symbol means that it should be collected as "waste electrical and electronic equipment". You can return an old product to your retailer when you buy a similar new one. For other options, please contact your local council.

**(FR)** Fonctionne avec 4 piles alcalines D 1,5 V (non fournies). Les piles et batteries doivent être recyclées ou mises au rebut conformément aux réglementations en vigueur. Lorsque ce produit a atteint la fin de sa durée de vie utile, il ne peut pas être jeté avec les ordures ménagères. La directive DEEE (déchets d'équipements électriques et électroniques) exige que le produit soit collecté séparément, afin qu'il puisse être traité en utilisant les meilleures techniques de valorisation et de recyclage disponibles. Cela réduira la contamination des eaux et du sol par des substances dangereuses pour l'Homme et l'environnement, les ressources nécessaires à la fabrication de nouveaux produits ainsi que les besoins de mise en décharge. Participez à ces efforts pour la planète, ne laissez pas ce produit entrer dans le flux des déchets municipaux. Le symbole représentant une poubelle indique que le produit doit être collecté en tant que déchet d'équipement électrique et électronique. Vous pouvez également rapporter un produit usagé chez votre détaillant lorsque vous achetez un produit similaire. Pour connaître les autres possibilités, veuillez contacter votre conseil municipal.

**(ES)** Requiere 4 pilas alcalinas D de 1,5 V (no incluidas). Las baterías o paquetes de baterías deben reciclarse, o desecharse de forma adecuada. Cuando este producto alcance el final de su vida útil, no lo deseche como residuo doméstico. La normativa de residuos de aparatos eléctricos y electrónicos exige que se recojan de forma separada, para que puedan tratarse con las mejores técnicas de recuperación y reciclaje disponibles. De esta forma, se minimizará el impacto que la contaminación del suelo y el agua, causada por sustancias peligrosas, tiene sobre el medio ambiente y la salud humana, se reducirán los recursos necesarios para fabricar nuevos productos y se evitará la saturación de los vertederos. ¡Colabore desechando este producto de forma adecuada! El símbolo del contenedor con ruedas significa que debe desecharse como "residuo de aparatos eléctricos y electrónicos".

Puede devolver un producto viejo en su establecimiento habitual cuando adquiera un producto nuevo similar. Si desea obtener más información, consulte con las autoridades locales.

**(DE)** Benötigt 4 x 1,5-V-Alkali-Batterien D (nicht enthalten). Batterien oder Akkus müssen recycelt oder ordnungsgemäß entsorgt werden. Ist das Gerät nicht mehr zu gebrauchen, darf es nicht über den Hausmüll entsorgt werden. Die Elektroaltgeräteverordnung sieht vor, dass das Gerät separat entsorgt wird, damit es so weit wie möglich recycelt werden kann. Dadurch lässt sich die Menge an umwelt- und gesundheitsschädlichen Substanzen, die über den Boden und das Grundwasser in den menschlichen Nahrungskreislauf gelangen könnten, minimieren sowie die für die Herstellung neuer Produkte erforderlichen Ressourcen reduzieren und Platz auf Mülldeponien sparen. Leisten Sie bitte Ihren Beitrag dazu, indem Sie das Gerät nicht über den Hausmüll entsorgen. Das Mülltonnen-Symbol bedeutet, dass das Gerät gemäß den Vorschriften für Elektro- und Elektronikgeräte entsorgt werden muss. Alte Geräte können oft beim Kauf eines neuen, ähnlichen Geräts im Einzelhandel zurückgegeben werden. Weitere Entsorgungsmöglichkeiten erfragen Sie bitte bei Ihrer Gemeindeverwaltung.

**(NL)** Vereist 4 D alkalinebatterijen van 1,5 V (niet inbegrepen). Batterijen en accu's dienen op de juiste wijze te worden gerecycled of afgevoerd. Wanneer dit product het einde van zijn levensduur heeft bereikt, mag het niet samen met ander huishoudelijk afval worden weggegooid. Volgens de wet moet het product afzonderlijk worden ingezameld zodat het kan worden behandeld met de best beschikbare hergebruik- en recycletechnieken. Op deze manier wordt de invloed op het milieu en de menselijke gezondheid van grond- en watervervuiling door gevaarlijke stoffen geminimaliseerd, hoeven er minder bronnen te worden gebruikt om nieuwe producten te maken en raken stortplaatsen minder snel vol. Draag je steentje bij door dit product uit de gemeentelijke afvalstroom te houden! Het afvalcontainersymbool betekent dat het product moet worden ingezameld als elektrische en elektronische afvalapparatuur. Je kunt een oud product inruilen bij de detailhandelaar wanneer je een vergelijkbaar nieuw product koopt. Neem voor andere opties contact op met de gemeente.

**(IT)** Richiede 4 pile alcaline D da 1,5 V (non incluse). Le batterie e le loro confezioni devono essere riciclate o smaltite correttamente. Non smaltire il prodotto assieme ai rifiuti generici. La direttiva per lo smaltimento di apparecchiature elettriche ed elettroniche prevede che tali rifiuti siano raccolti separatamente, in modo da essere smaltiti utilizzando le più efficaci tecniche di riciclo e di recupero disponibili. Ciò consente di contenere l'impatto sull'ambiente e sulla salute umana,



evitando che il terreno e l'acqua siano contaminati da sostanze nocive, di ridurre l'uso delle risorse necessarie alla realizzazione di nuovi prodotti e di limitare il ricorso a discariche. Non gettare il prodotto assieme ai rifiuti generici. Il simbolo del contenitore per i rifiuti indica che il prodotto deve essere smaltito come "apparecchiatura elettrica ed elettronica". In caso di acquisto di un giocattolo analogo, è possibile restituire il prodotto usato al rivenditore. Per ulteriori informazioni circa lo smaltimento del prodotto, contattare le autorità locali preposte al servizio.

**(PT)** Requer 4 pilhas alcalinas tipo D de 1,5 V (não inclusas). As baterias e as suas embalagens devem ser recicladas ou descartadas corretamente. Quando o produto alcançar o fim de sua vida útil, não o descarte com o lixo doméstico. As regulamentações para descarte de resíduos elétricos e eletrônicos solicitam que o produto seja recolhido para ser tratado usando as melhores técnicas de recuperação e reciclagem disponíveis. Isso minimizará os impactos no meio ambiente e na saúde humana pela contaminação do solo e da água por substâncias perigosas, diminuirá os recursos necessários para a produção de novos produtos e evitará o uso de aterros. Colabore! Mantenha este produto fora do fluxo de resíduos urbanos! O símbolo de reciclagem significa que tais produtos devem ser recolhidos como "descarte de equipamentos eletrônicos e elétricos". É possível devolver o produto antigo ao comerciante quando comprar um novo equivalente. Para outras opções, entre em contato com o conselho municipal.

**(RU)** Требуется 4 щелочных элемента питания типа D с напряжением 1,5 В (не входят в комплект). Элементы питания и комплекты элементов питания необходимо утилизировать надлежащим образом. По окончании срока эксплуатации не выбрасывайте игрушку вместе с бытовыми

отходами. Согласно закону об утилизации электрических и электронных устройств, ее необходимо утилизировать отдельным способом, с использованием наиболее подходящих технологий утилизации и переработки. Это позволит снизить негативные последствия для окружающей среды и здоровья человека, уменьшит загрязнение воды и почвы опасными веществами, а также снизит количество ресурсов, необходимых для изготовления новых игрушек и сократит объем мусора на городских свалках. Внесите свой вклад, сохранив город чистым. Значок с изображением перечеркнутой корзины означает, что игрушку следует утилизировать согласно закону об утилизации электрических и электронных устройств. При покупке новой игрушки вы можете вернуть старую в магазин. Чтобы узнать о других возможных вариантах утилизации, обратитесь в местную перерабатывающую организацию.

**EN.** Spin Master International SARL, hereby declares that this Meccanoid 2.0 is in compliance with the essential requirements and other relevant provisions of Directive 1999/5/EC. A copy of the declaration of conformity can be requested through [customercare@spinmaster.com](mailto:customercare@spinmaster.com) or SPIN MASTER INTERNATIONAL S.A.R.L., 16 Avenue Pasteur, L-2310, Luxembourg.

**FR.** Par la présente, Spin Master International SARL déclare que ce jouet Meccanoid 2.0 respecte les principales exigences ainsi que les dispositions pertinentes de la Directive 1999/5/EC. Une copie de la déclaration de conformité est disponible sur demande. Contactez-nous à l'adresse [customercare@spinmaster.com](mailto:customercare@spinmaster.com) ou SPIN MASTER INTERNATIONAL S.A.R.L., 16 Avenue Pasteur, L-2310, Luxembourg.

**ES.** Por la presente, Spin Master International SARL declara que este juguete Meccanoid 2.0 cumple con los requisitos esenciales y con otras provisiones relevantes de la Directiva 1999/5/EC. Se puede solicitar una copia de la declaración de conformidad en [customercare@spinmaster.com](mailto:customercare@spinmaster.com) o en SPIN MASTER INTERNATIONAL S.A.R.L., 16 Avenue Pasteur, L-2310, Luxembourg.

**DE.** Spin Master International SARL erklärt hiermit, dass Meccanoid 2.0 den grundlegenden Anforderungen und weiteren Bestimmungen der Richtlinie 1999/5/EG entspricht. Ein Exemplar der Konformitätserklärung kann per E-Mail an [customercare@spinmaster.com](mailto:customercare@spinmaster.com) oder bei SPIN MASTER INTERNATIONAL S.A.R.L., 16 Avenue Pasteur, L-2310, Luxemburg, angefordert werden.

**NL.** Spin Master International SARL verklaart hierbij dat deze Meccanoid 2.0 voldoet aan de noodzakelijke vereisten en andere voorwaarden in richtlijn 1999/5/EG. Je kunt een kopie van deze conformiteitsverklaring opvragen via [customercare@spinmaster.com](mailto:customercare@spinmaster.com) of SPIN MASTER INTERNATIONAL S.A.R.L., 16 Avenue Pasteur, L-2310, Luxemburg.

**IT.** Spin Master International SARL dichiara che questo Meccanoid 2.0 è in regola con i requisiti essenziali e altre clausole rilevanti della Direttiva 1999/5/EC. Una copia della dichiarazione di conformità può essere richiesta scrivendo a [customercare@spinmaster.com](mailto:customercare@spinmaster.com) o SPIN MASTER INTERNATIONAL S.A.R.L., 16 Avenue Pasteur, L-2310, Lussemburgo.

**PT.** A Spin Master International SARL declara por meio desta que o Meccanoid 2.0 está em conformidade com as exigências essenciais e outras disposições relevantes da Diretiva 1999/5/EC. Uma cópia da declaração de conformidade pode ser solicitada pelo e-mail [customercare@spinmaster.com](mailto:customercare@spinmaster.com) ou via missiva endereçada à SPIN MASTER INTERNATIONAL S.A.R.L., 16 Avenue Pasteur, L-2310, Luxembourg.

**RU.** Компания Spin Master International SARL настоящим заявляет, что данное устройство Meccanoid 2.0 соответствует основным требованиям и другим релевантным положениями Директивы 1999/5/EC. Копию декларации соответствия можно получить, отправив запрос на адрес [customercare@spinmaster.com](mailto:customercare@spinmaster.com) или обратившись по адресу SPIN MASTER INTERNATIONAL S.A.R.L., 16 Avenue Pasteur, L-2310, Luxembourg.

- ⚠ **WARNING:** CHOKING HAZARD – Small parts.
- ⚠ **ATTENTION ! RISQUE D'ÉTOUFFEMENT** – Contient de petits éléments.
- ⚠ **ADVERTENCIA:** PELIGRO DE ASFIXIA – Contiene piezas pequeñas. No conveniente para niños menores de 3 años.
- ⚠ **ACHTUNG:** ERSTICKUNGSGEFAHR – Kleinteile.
- ⚠ **WAARSCHUWING:** VERSTIKKINGSGEVAAR – Kleine onderdelen.
- ⚠ **ATTENZIONE:** RISCHIO DI SOFFOCAMENTO – Contiene pezzi di piccole dimensioni.
- ⚠ **AVISO:** RISCO DE ASFIXIA – Peças pequenas.
- ⚠ **ОСТОРОЖНО!** ОПАСНОСТЬ ДУШЬЯ – Мелкие детали.



- ⚠ **ADVERTENCIA:** El cable del adaptador de alimentación podría suponer un riesgo de estrangulación. No recomendado para niños menores de 3 años.
- ⚠ **ACHTUNG:** Beim Umgang mit dem Netzkabel besteht Strangulierungsgefahr. Nicht für Kinder unter 3 Jahren geeignet.
- ⚠ **WAARSCHUWING:** Het adapterkoord kan een verstikkingsgevaar vormen. Niet voor gebruik door kinderen onder de 3 jaar.
- ⚠ **ATTENZIONE:** Il cavo dell'adattatore può causare il rischio di strangolamento. Non adatto ai bambini di età inferiore a 3 anni.
- ⚠ **AVISO:** Tome cuidado com o cabo do adaptador, já que ele pode apresentar perigo de estrangulamento e asfixia. O equipamento não deve ser utilizado por crianças de 3 anos de idade ou menos.
- ⚠ **ПРЕДУПРЕЖДЕНИЕ:** Шнур адаптера является источником опасности удушья. Устройство не предназначено для использования детьми в возрасте младше 3 лет.

Bluetooth operates at: 2.4GHz  
Fréquence de fonctionnement du Bluetooth : 2,4 GHz  
La conexión Bluetooth funciona a: 2,4 GHz  
Bluetooth arbeitet mit einer Frequenz von: 2,4 GHz  
Bluetooth werkt op een frequentie van: 2,4 GHz  
Bluetooth funziona a: 2,4 GHz  
Bluetooth opera a: 2,4 GHz  
Сигнал Bluetooth действует на частоте: 2,4 ГГц

TM & © 2016 MECCANO for packaging, instructions and models built with this set. MECCANO® is an exclusive trademark of MECCANO. Spin Master logo is a trademark of Spin Master Ltd. All rights reserved. Patent Pending.

TM & © 2016 MECCANO pour l'emballage, les notices et modèles de ce coffret. MECCANO® est une marque de commerce exclusive de MECCANO. Le logo de Spin Master est une marque de commerce de Spin Master Ltd. Tous droits réservés. Brevet en instance.

SPIN MASTER LTD., 450 FRONT STREET WEST, TORONTO, ON M5V 1B6 CANADA.  
IMPORTED INTO EU BY SPIN MASTER INTERNATIONAL, S.A.R.L.,  
16 AVENUE PASTEUR, L-2310, Luxembourg. [www.spinmaster.com](http://www.spinmaster.com)

Spin Master Inc., PMB #10053, 300 International Drive, Suite 100, Williamsville, NY 14221

MADE IN CHINA / FABRIQUÉ EN CHINE / HECHO EN CHINA

T91763\_0011\_20074040/0012\_GML\_IB\_R2\_MEC\_Meccnoid G16\_CN\_F16



**NORTH AMERICA / AMÉRIQUE DU NORD**  
1-800-622-8339, [customercare@spinmaster.com](mailto:customercare@spinmaster.com)  
**UK** – 0800 206 1191, [serviceuk@spinmaster.com](mailto:serviceuk@spinmaster.com)  
**IRELAND** – 1800 992 249  
**FRANCE** – 0800 909 150, [servicefr@spinmaster.com](mailto:servicefr@spinmaster.com)  
**DEUTSCHLAND** – 0800 0101 0222, [Kundenservice@spinmaster.com](mailto:Kundenservice@spinmaster.com)  
**SCHWEIZ** – 0800 561 350 • **ÖSTERREICH** – 0800 297 267  
**NEDERLAND** – 0800 022 3683, [klantenservice@spinmaster.com](mailto:klantenservice@spinmaster.com)  
**BELGIË/BELGIQUE** – 0800 77 688 • **LUXEMBOURG** – 800 2 8044  
**ITALIA** – 800 788 532, [servizio@spinmaster.com](mailto:servizio@spinmaster.com)  
**MEXICO** – 55 4160 7947, [servicio@spinmaster.com](mailto:servicio@spinmaster.com)

**WWW.SPINMASTER.COM**

Meets CPSC safety standards / Conforme aux exigences de sécurité de la CPSC.  
Cumple con las normas de seguridad de la CPSC.