



*Huayra
Roadster*

17304



 **10+**

Instructions
Notice de montage
Instrucciones de construcción
Bauanleitung

Bouwinstructie
Istruzioni
Instruções
Инструкции

Instrukcja
Pokyny
Útmutató
Instrucțiuni





CONSTRUCTION TIPS / ASTUCES DE CONSTRUCTION

TIPS DE CONSTRUCCIÓN / TIPPS ZUM BAUEN / MONTAGETIPS / SUGGERIMENTI PER COSTRUIRE

DICAS DE MONTAGEM / РЕКОМЕНДАЦИИ ПО СБОРКЕ / WSKAZÓWKI BUDOWANIA

KONSTRUKČNÍ TIPY / TIPY NA MONTÁŽ / ÖSSZESZERELÉSI TIPPEK / SFATURI PENTRU CONSTRUIRE

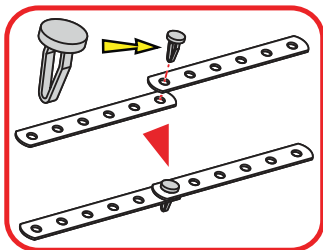
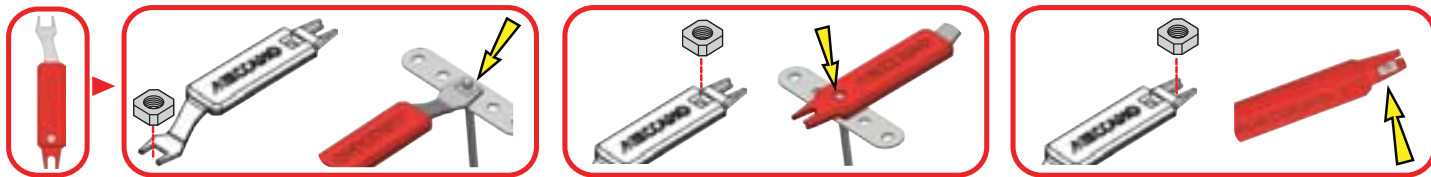
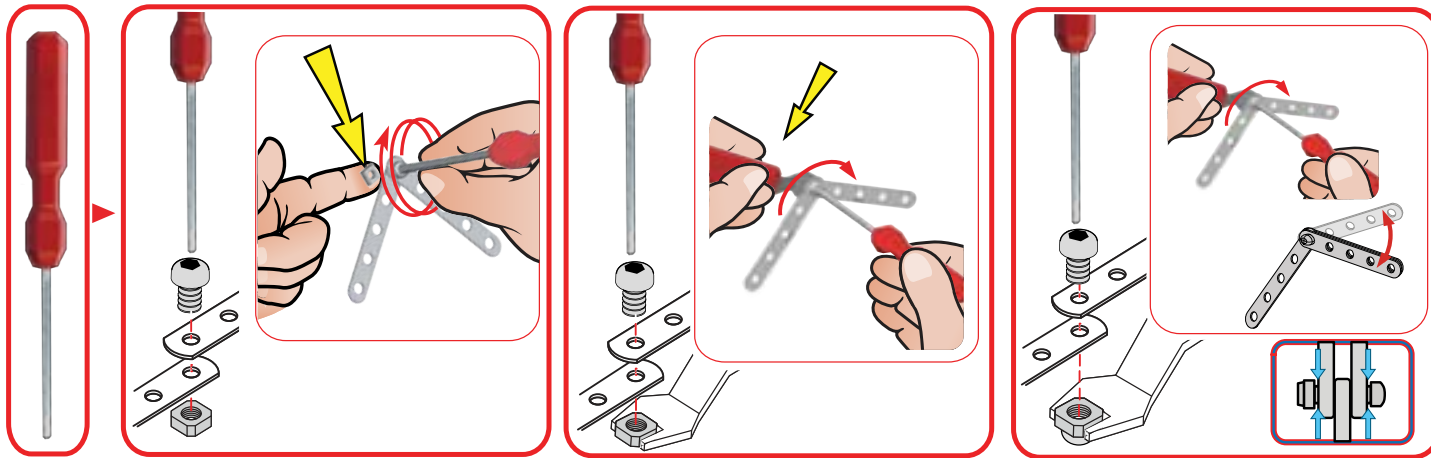

TABLE OF CONTENTS / SOMMAIRE

ÍNDICE / INHALTSVERZEICHNIS / INHOUD / INDICE / СОДЕРЖАНИЕ





SPIS TREŚCI / OBSAH / TARTALOMJEGYZÉK / CUPRINS



- EN.** Content: 295 parts, 2 real tools, 1 sticker sheet and 1 instruction sheet for 1 model.
FR. Contenu : 295 pièces, 2 vrais outils, 1 feuillet d'autocollants et 1 notice de montage pour 1 modèle.
ES. Contenido: 295 piezas, 2 herramientas reales, 1 hoja de calcomanías y 1 guía de instrucciones para 1 modelo.
DE. Inhalt: 295 Teile, 2 echte Werkzeuge, 1 Aufkleberbogen und 1 Bauanleitung für 1 Modell.
NL. Inhoud: 295 onderdelen, 2 stuks gereedschap, 1 stickervel en 1 bouw instructie voor 1 model.
IT. Contenuto: 295 pezzi, 2 attrezzi, 1 foglio di adesivi e 1 guida per l'uso per 1 modello.
PT. Conteúdo: 295 peças, 2 ferramentas reais, 1 folha de adesivos e 1 guia de instruções para 1 modelo.
RU. В комплекте: 295 деталей, 2 настоящих инструмента, 1 лист с наклейками и 1 инструкция по сборке 1 модели.
PL. Zawartość: 295 elementów, 2 prawdziwe narzędzia, 1 arkusz naklejek i 1 karta z instrukcjami dla 1 modelu.
CZ. Obsah: 295 dílů, 2 skutečné nástroje, 1 list se samolepkami a 1 list s pokyny pro 1 model.
SK. Obsah: 295 dielov, 2 skutočné nástroje, 1 hárok s nálepkami a 1 hárok s pokynmi pre 1 model.
KU. Tartalom: 295 db alkatrész, 2 db valódi szerszám, 1 db matricalap és 1 db 1 modellhez tartozó felhasználói útmutató.
RO. Conținut: 295 de piese, 2 instrumente reale, 1 foaie cu autocolante și 1 fișă cu instrucțiuni pentru 1 model.





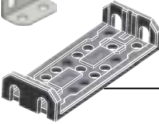

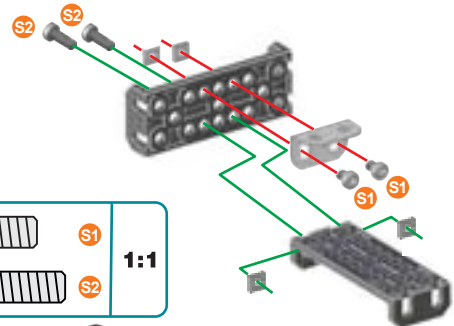
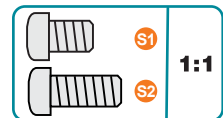
1

-  **S2** | 9.5 mm | **x2**
3/8"
-  **S1** | 5.8 mm | **x2**
15/64"
-  **x4**
-  **x1**
-  **x2**



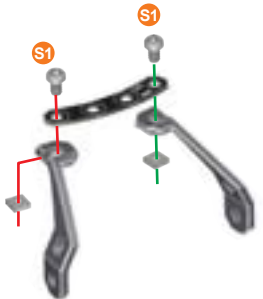

2

-  **S1** | 5.8 mm | **x2**
15/64"
-  **x2**
-  **x1**
-  **x1**
-  **x1**



3



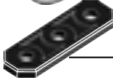

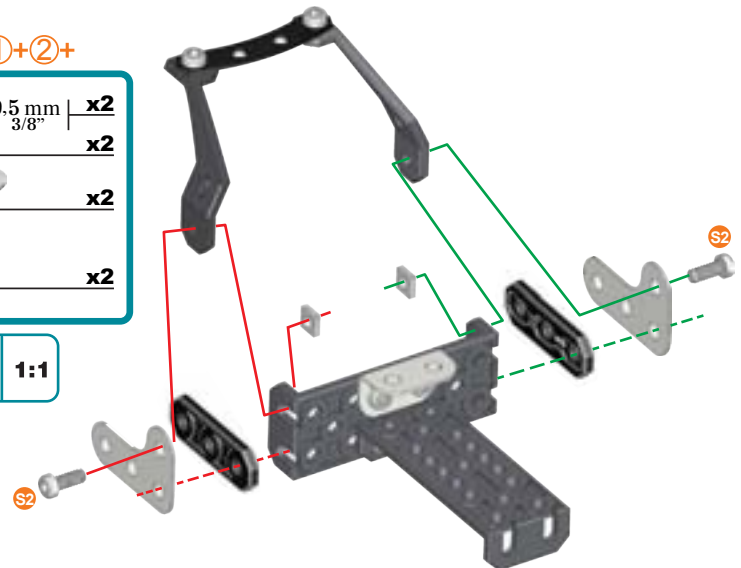
①+②+

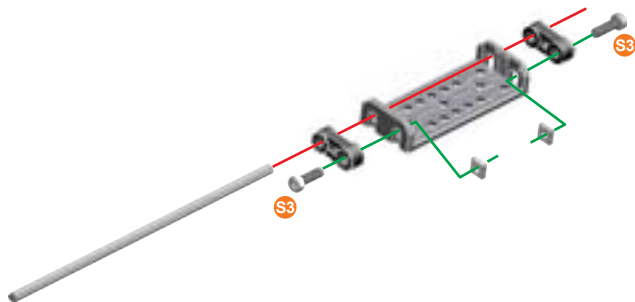
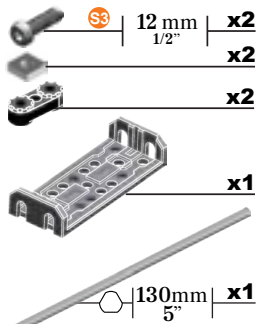
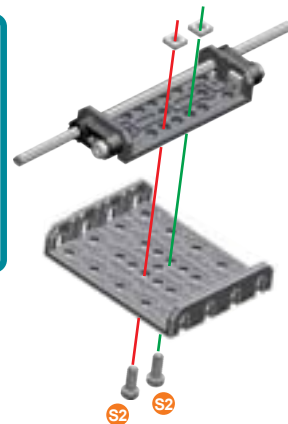
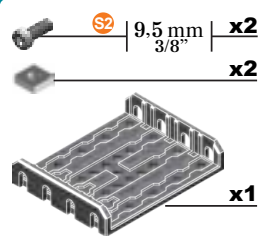
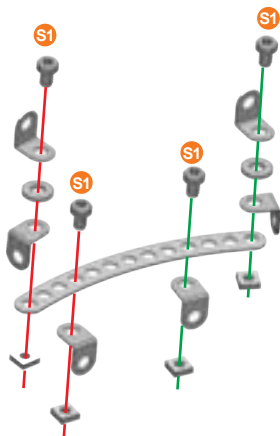
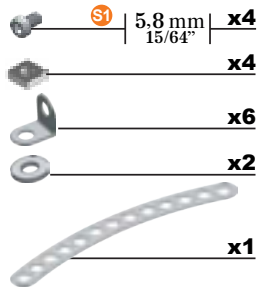
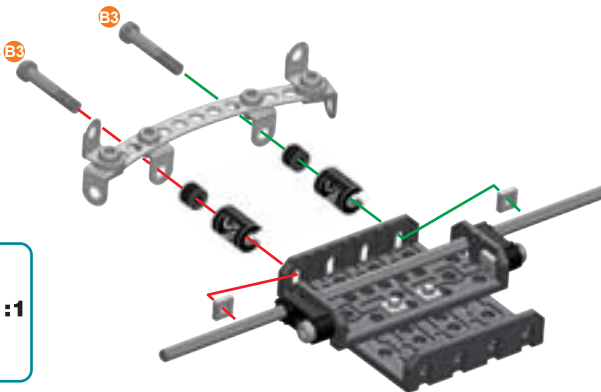
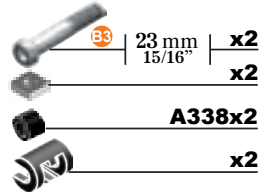

-  **S2** | 9.5 mm | **x2**
3/8"
-  **x2**
-  **x2**
-  **x2**

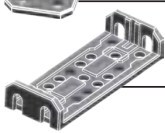

4**5****6****7****(5)+(6)+**

8



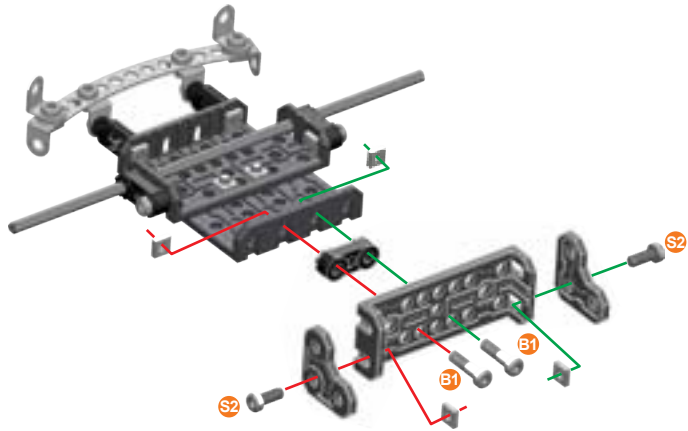

-  **S2** | 9.5 mm | **x2**
3/8"
-  **B1** | 14.7 mm | **x2**
37/64"
-  **x4**
-  **x1**
-  **x2**
-  **x1**

-  **S2**
 -  **B1**
- 1:1**



9

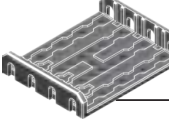

③+⑧+

-  **B1** | 14.7 mm | **x6**
37/64"
-  **x6**
-  **A338x6**
-  **x2**
-  **x1**

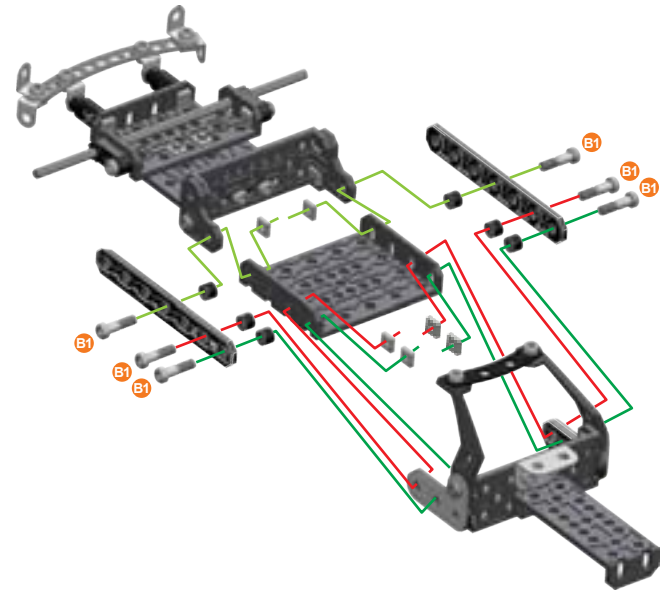
-  **A338**
 -  **B1**
- 1:1**





10

-  S1 | 5.8 mm | $\frac{15}{64}$ " | **x2**
-  **x2**
-  **x2**

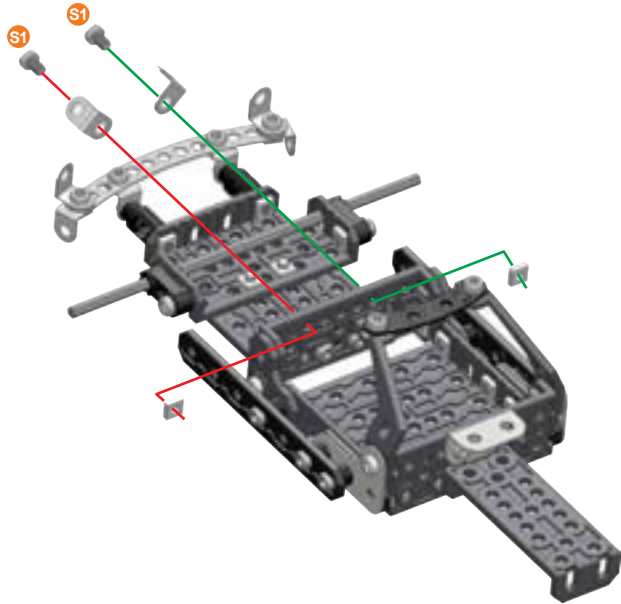
-  S1 | **1:1**





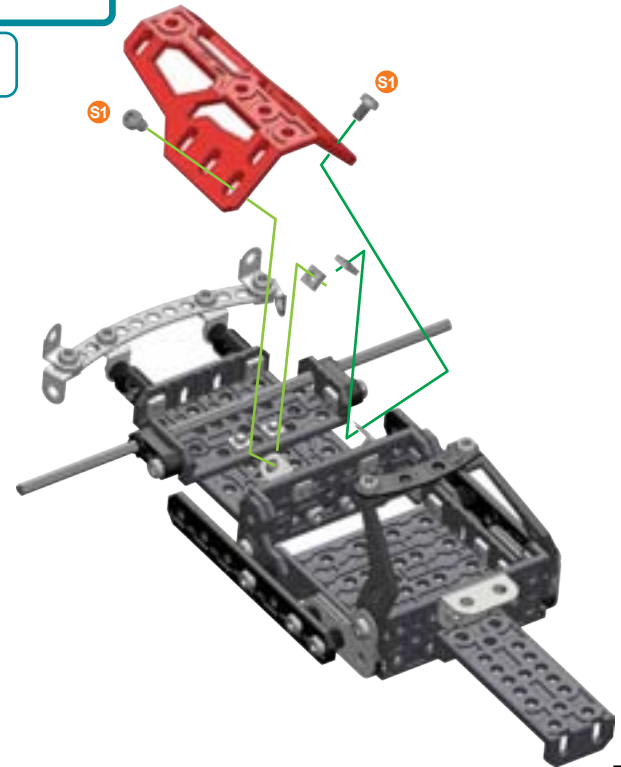

11

-  S1 | 5.8 mm | $\frac{15}{64}$ " | **x2**
-  **x2**
-  **x1**

-  S1 | **1:1**



12

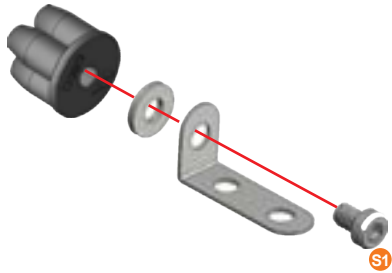

-  S1 | 5.8 mm | x1
15/64"
-  | x1
-  | x1
-  | x1

-  S1 | 1:1



13

(12)+

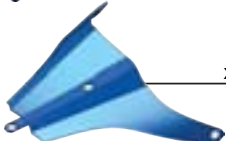
-  S2 | 9.5 mm | x1
3/8"
-  | x1
-  | x1
-  | x1

-  S2 | 1:1
-  D1 | 1:1

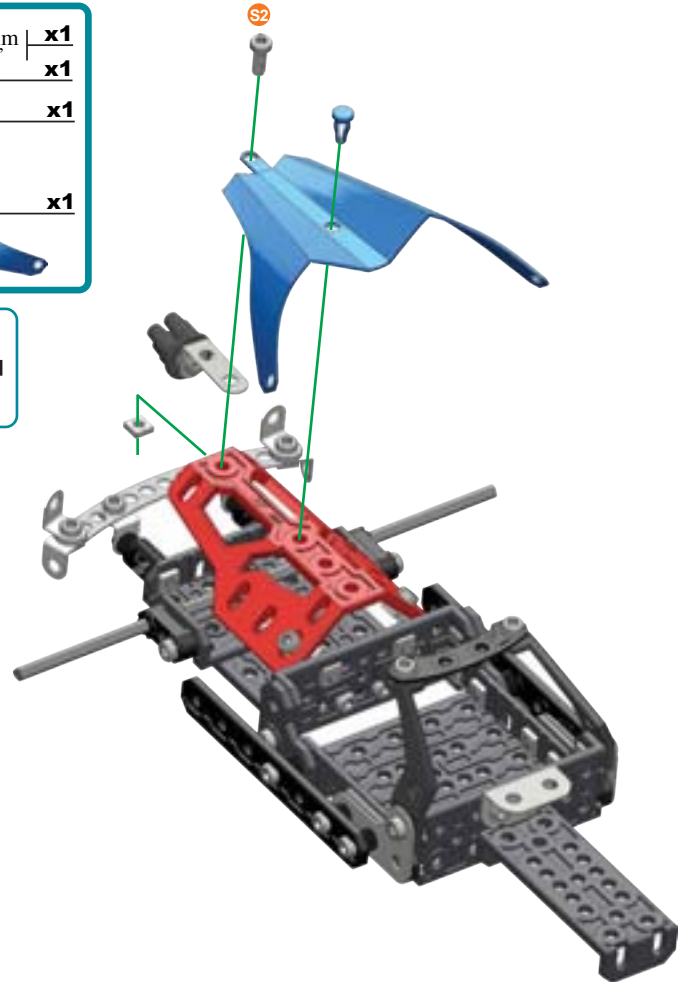

14

 S3 | 12 mm | x1
1/2"

 | x1

 A338 x1

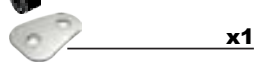
 | x1

 | x1

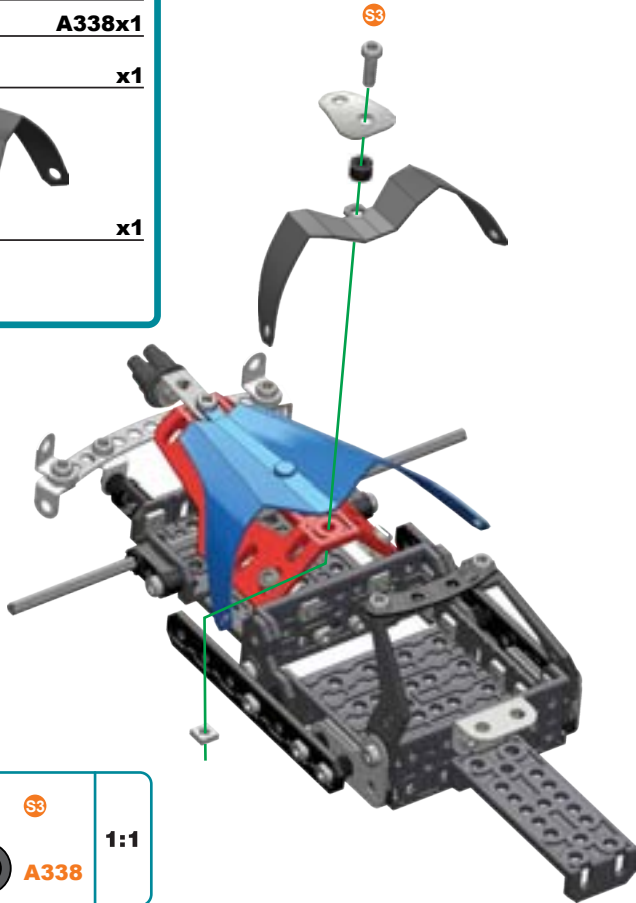

 S3 | 1:1

 A338

15





 S2 | 9.5 mm | x2
3/8"

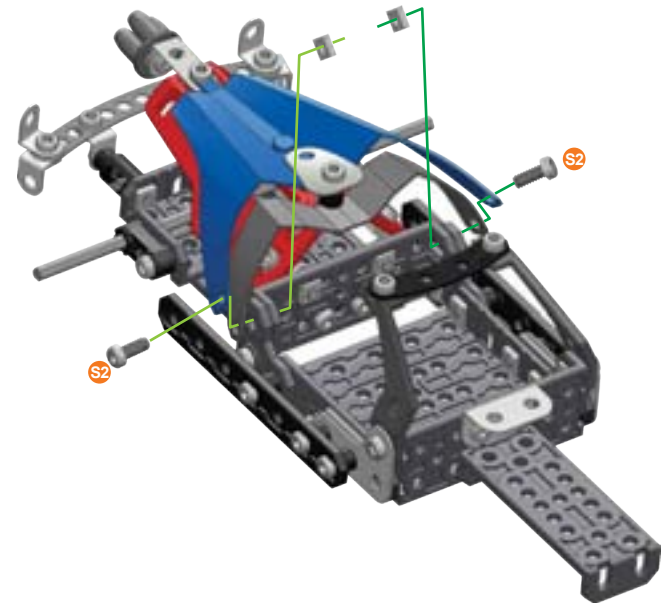

 | x2

 S2 | 1:1





16

-  S1 | 5.8 mm | x1
15/64"
-  x1
-  x1
-  x1
-  x1

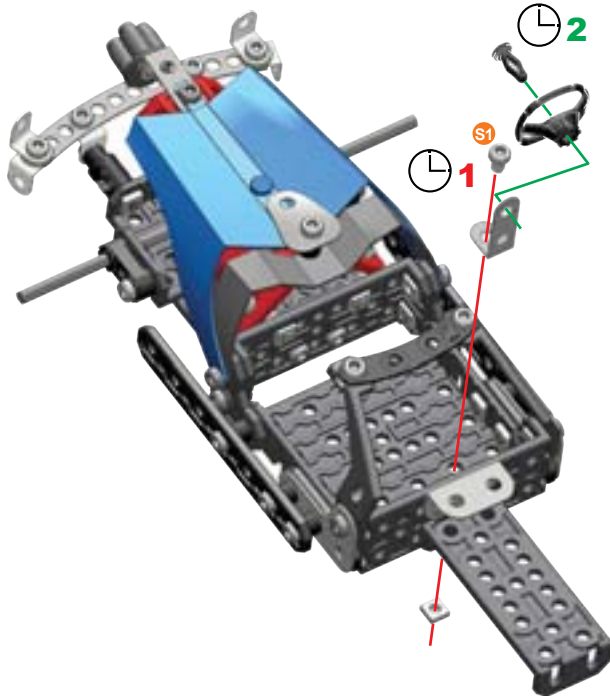
-  S1
-  D2
- 1:1





17

-  x2
-  x2
-  50mm | x1
2"

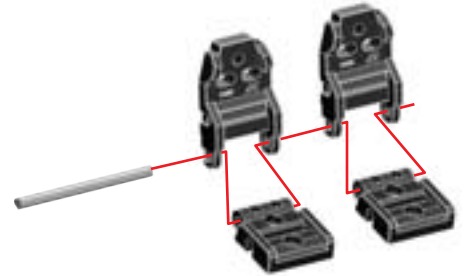
-  1:1









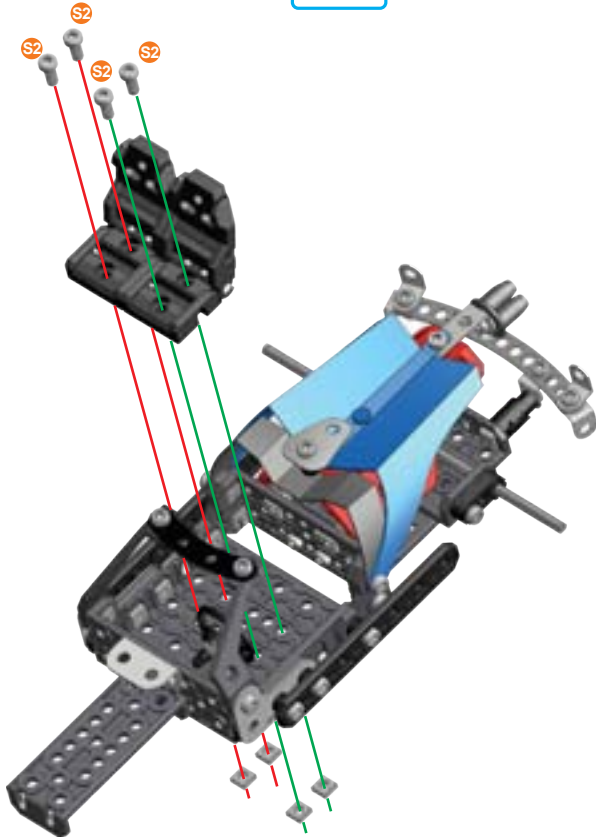

18**17+**





	S2	9.5 mm 3/8"	x4
			x4

	S2	1:1
--	----	-----

**19**





	S2	9.5 mm 3/8"	x2
	B1	14.7 mm 37/64"	x4
			x2
			x4
			x2
			x2
			x1
			x1
			x1

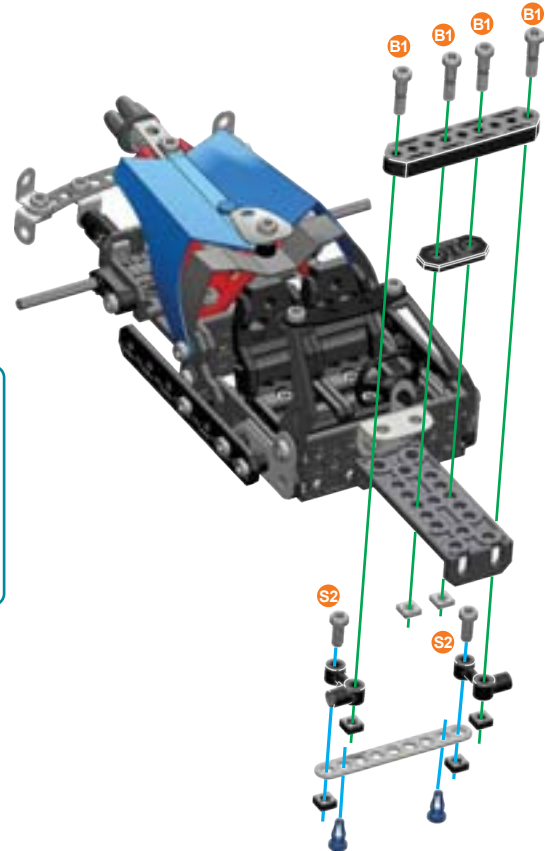

	B1	1:1
	S2	
	D1	
	D277	





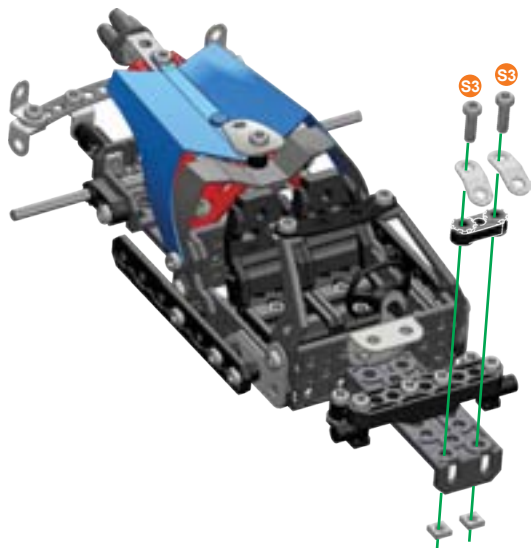

20

	S3 12 mm 1/2"	x2
		x2
		x1
		x2

	S3 1:1
--	-----------------



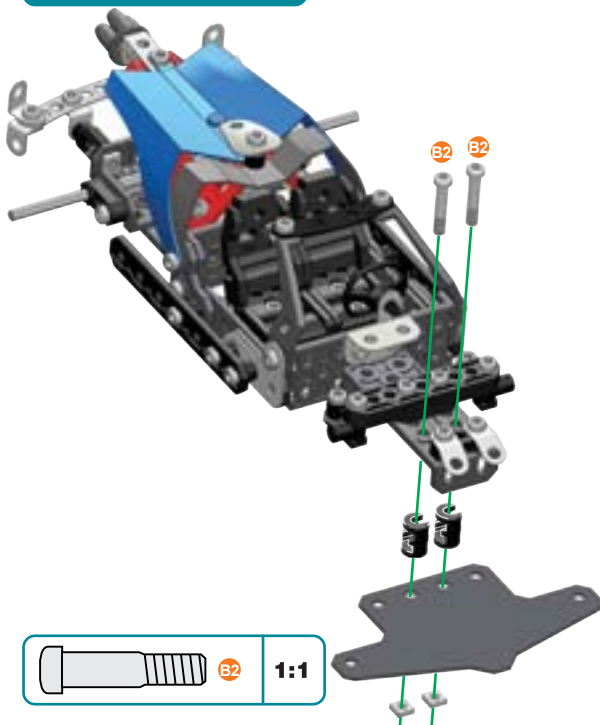

**21**

	B2 19 mm 3/4"	x2
		x2
		x2
		x1



	B2 1:1
--	-----------------

22



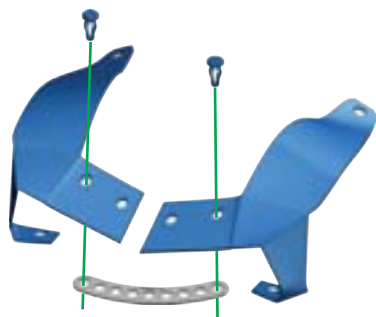

		x2
		x1
		x1
		x1

	D1 1:1
---	-----------------



23

⑳+㉑+

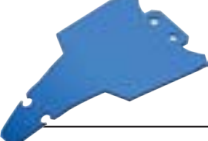
-  **S3** | 12 mm | **x2**
1 1/2"
-  **x2**
-  **x2**
-  **x1**
-  **x1**

-  **S3**
-  **D1**
- 1:1**

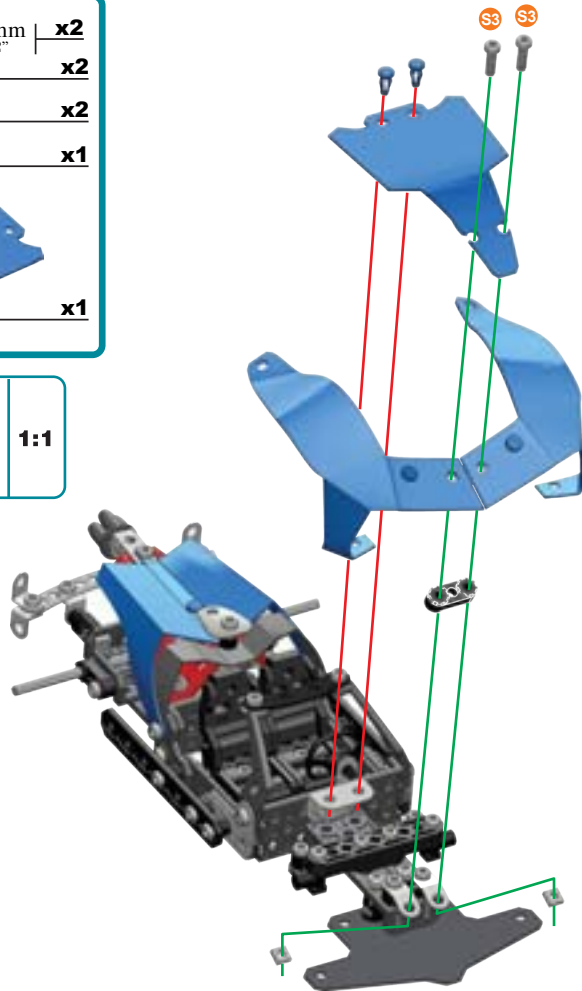

24

-  **x2**
-  **D1** | **1:1**

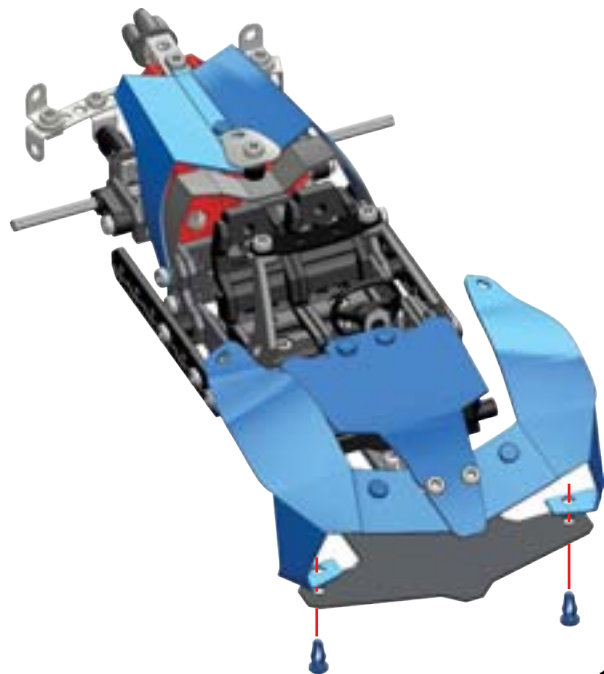

25

 **S2** | 9.5 mm | **x2**
3/8" | **x2**

 **x2**

 **x1**

 **S2** | **1:1**

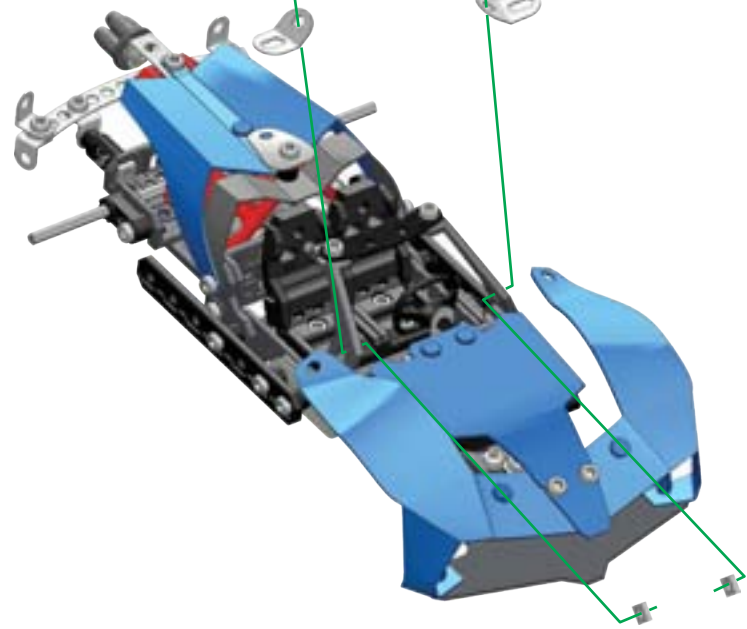
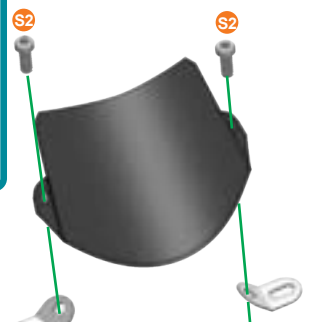

26

 **B1** | 14.7 mm | **x1**
37/64" | **x1**

 **S6** | 28 mm | **x1**
2 1/8" | **x1**

 **x2**

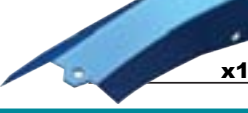

 **x2**

 **A238x2**

 **x1**

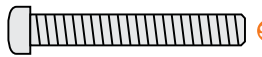

 **B1**



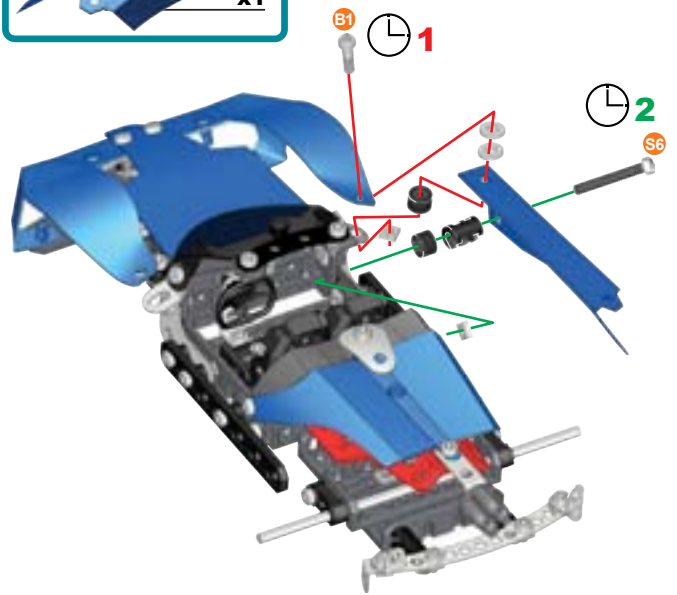
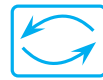

 **S6** | **1:1**

 **A238** 



27

-  **B1** | 14.7 mm | **x1**
37/64"
-  **S6** | 28 mm | **x1**
2 1/8"
-  **x2**
-  **x2**
- A238x2**
-  **x1**
-  **x1**
-  **x1**





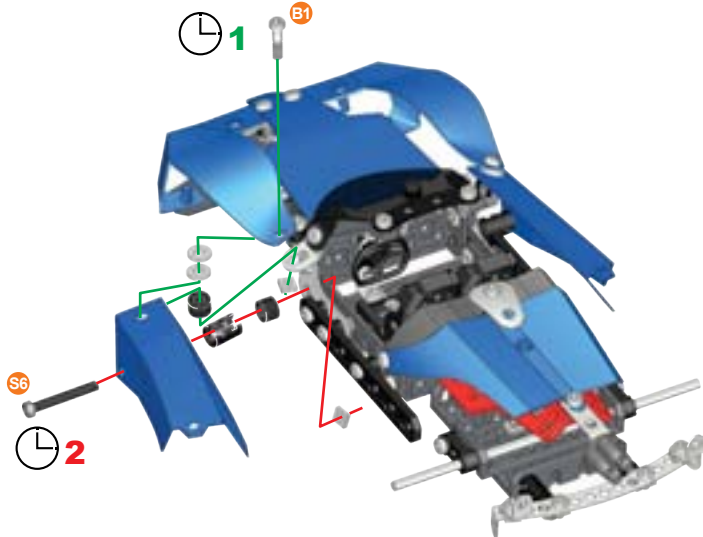

-  **B1**
-  **S6**
- 1:1**
-  **A238**
- 







⌚ 1



⌚ 2

28

-  **B3** | 23 mm | **x1**
15/16"
-  **S6** | 28 mm | **x1**
2 1/8"
-  **x2**
- A338x1**
- A238x1**
-  **x2**
-  **x1**
-  **x1**
-  **x1**

-  **B3**
-  **S6**
- 1:1**
-  **A338**
- 
-  **A238**
- 

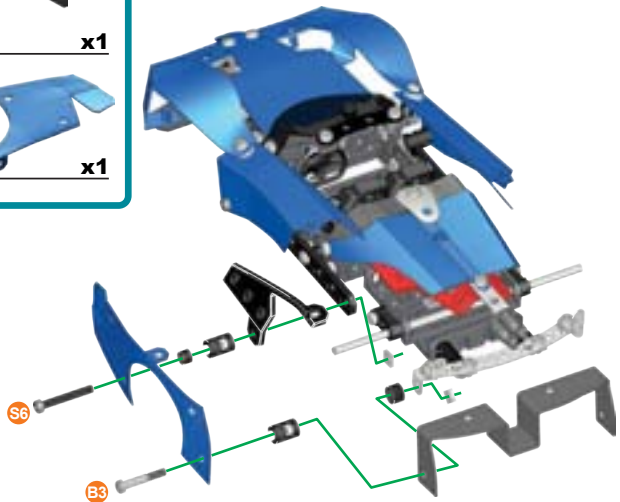

29

- S2 9.5 mm 3/8" x1
- S1 5.8 mm 15/64" x5
- x6
- A338x1

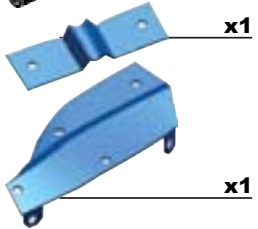

- S1
- S2
- 1:1
- A338

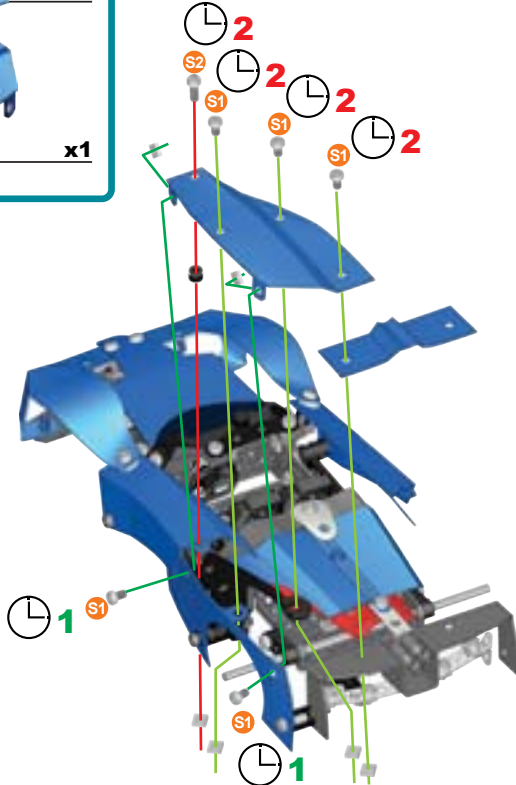



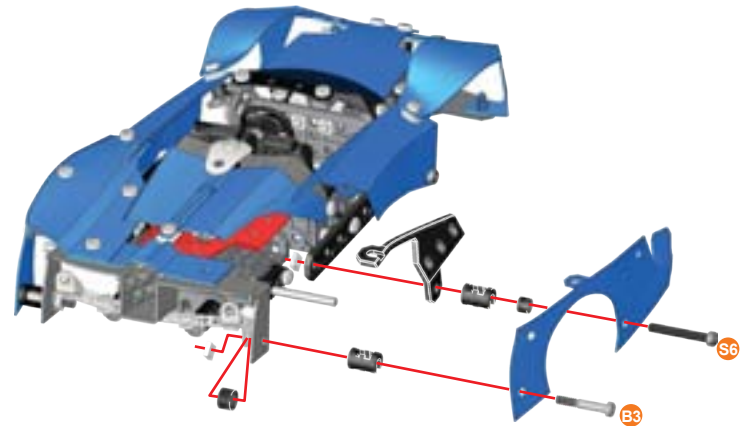

30

- B3 23 mm 15/16" x1
- S6 28 mm 2 1/8" x1
- x2
- A338x1
- A238x1
- x2
- x1
- x1

- B3
- S6
- 1:1
- A338
- A238



31

-  **S2** | 9.5 mm | **x1**
3/8"
-  **S1** | 5.8 mm | **x5**
15/64"
-  **x6**
-  **A338x1**

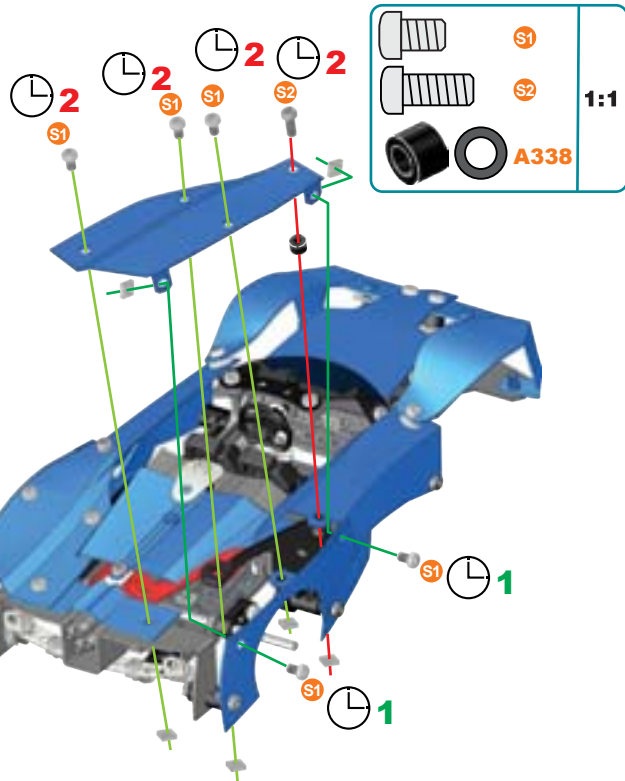
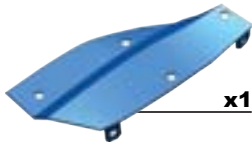

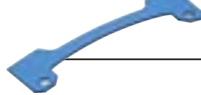

32

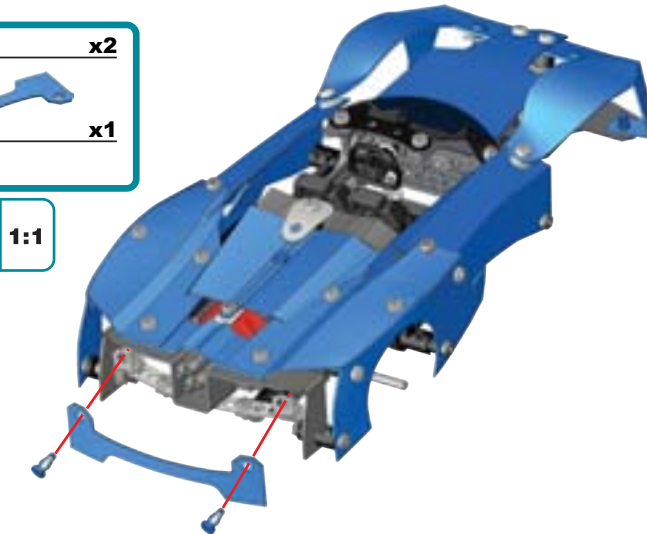
-  **x2**
-  **x1**



33

-  **x4**
-  **x4**

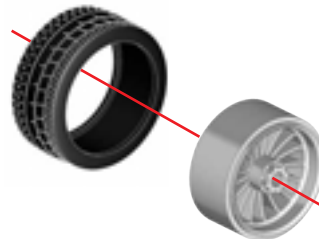
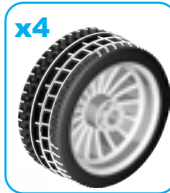

34

33+

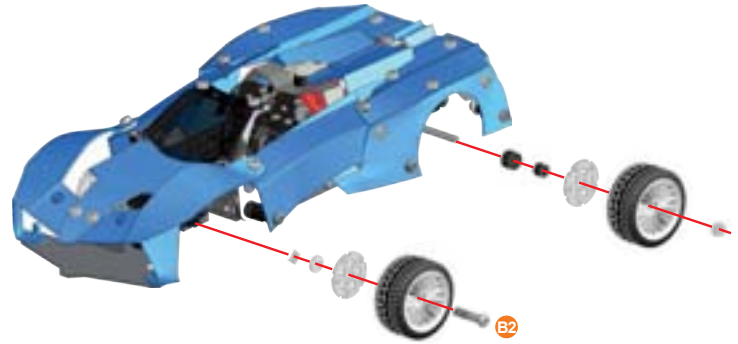
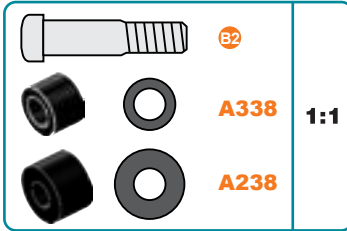
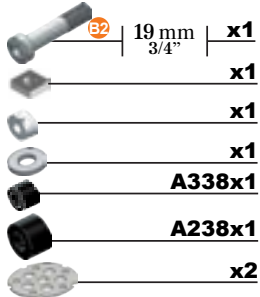





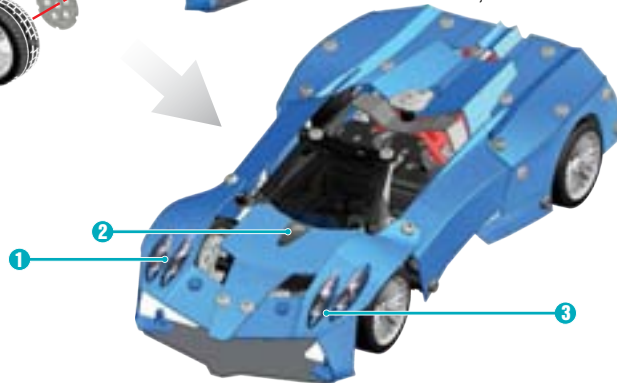
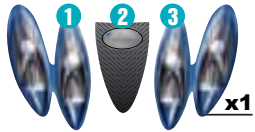
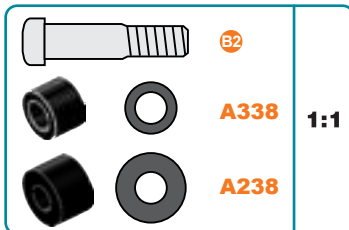
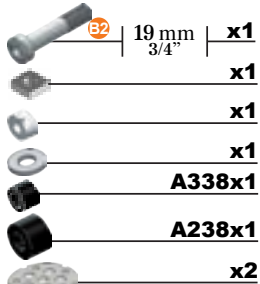



35









33+ 34+



















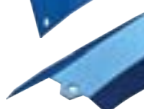











- △ CAUTION: Stickers not intended to be placed on skin.
- △ MISE EN GARDE: Les autocollants ne sont pas destinés à être placés sur la peau.
- △ PRECAUCIÓN: Las calcomanías no deben colocarse sobre la piel.
- △ ACHTUNG: Sticker sind nicht zum Aufkleben auf die Haut geeignet.
- △ VOORZICHTIG: Stickers zijn niet voor op de huid bedoeld.
- △ ATTENZIONE: Non applicare gli adesivi sulla pelle.
- △ CUIDADO: Não aplique os adesivos na pele.
- △ OSTRZEGNIENIE: Stikery nie przeznaczone do przyklewania k skórze.
- △ POZOR: Samolepky nejsou určeny k lepení na kůži.
- △ UPOZORNENIE: Nálepky nie sú určené na nalepenie na pokožku.
- △ VIGYÁZATI! A matricák nem alkalmasak a bőrre történő ragasztásra.
- △ ATENȚIE: Autocolantele nu sunt destinate lipirii pe piele.

-  **C330 x8**
-  **C483 x2**
-  **A712 x2**
-  **A309 x1**
-  **C323 x1**
-  **D291 x4**
-  **D292 x10**
-  **D373 x2**
-  **C868 x5**
-  **A423 x2**
-  **D048 x1**
-  **D049 x2**
-  **B051 x1**
-  **C771 x1**
-  **D249 x2**
-  **D229 x1**
-  **A812 x2**
-  **A367 x2**
-  **C777 x1**
-  **C779 x1**

-  **D383 x1**
-  **D304 x1**
-  **D422 x2**
-  **D423 x2**
-  **D454 x4**
-  **D452 x4**
-  **D369 x1**
-  **D370 x1**
-  **D367 x1**
-  **D368 x1**
-  **D353 x4**
-  **D349 x2**

-  **D037 x1**
-  **x1**
-  **D384 x1**
-  **x1**
-  **x1**
-  **x1**
-  **x1**
-  **x1**
-  **x1**

-  **x1**
-  **x1**
-  **x1**
-  **x1**
-  **x1**
-  **x1**
-  **x1**
-  **x1**
-  **x1**

-  **S1** | 5,8 mm | **A637 x24**
-  **S2** | 9,5 mm | **A511 x21**
-  **S3** | 12 mm | **A411 x7**
-  **B1** | 14,7 mm | **A247 x14**
-  **B2** | 19 mm | **A447 x4**
-  **B3** | 23 mm | **A347 x4**
-  **S6** | 28 mm | **A611 x4**
-  **x1** | 50mm | **A317 x1**
-  **x1** | 130mm | **A315 x1**
-  **D1** | **D005 x11**
-  **D2** | **D047 x1**
-  **x1** | **D277 x4**
-  **x1** | **A337 x73**
-  **x1** | **A259 x2**
-  **x1** | **A338 x15**
-  **x1** | **A238 x8**
-  **x1** | **A138 x9**
-  **x1** | **C994 x1**
-  **x1** | **D499 x1**

EN Remove all packaging before use. Retain this information, addresses and phone numbers for future reference. Content may vary from pictures. Meccano reserves the right to discontinue the website www.meccano.com at any time. An adult should periodically check this toy to ensure no damage or hazards exist, if so, remove from use. Children should be supervised during play.

FR Retirer tout l'emballage avant utilisation. Conserver les informations, adresses et numéros de téléphone pour consultation ultérieure. Le contenu peut différer des images. Meccano se réserve le droit de supprimer le site Internet www.meccano.com à tout moment. Un adulte doit régulièrement examiner ce jouet afin de s'assurer qu'il ne présente pas de dommage ni de risque. En cas de problème, ne plus l'utiliser. Les enfants doivent être surveillés lorsqu'ils jouent.

ES Retire todo el embalaje antes de utilizar el producto. Conserve toda la información, las direcciones y los números de teléfono para futuras referencias. El contenido del paquete puede no corresponder con las imágenes. Un adulto debe revisar de forma periódica el juguete para asegurarse de que no supone un riesgo para el niño; si así fuera el caso, interrumpa su uso. Supervise a los niños mientras juegan con el producto.

DE Entnehmen Sie vor der Benutzung sämtliche Verpackungsmaterialien. Alle Informationen, Adressen und Telefonnummern bitte für mögliche Rückfragen aufbewahren. Der Packungsinhalt kann von den Bildern abweichen. Ein Erwachsener sollte regelmäßig sicherstellen, dass das Spielzeug keine Gefahr darstellt, und es gegebenenfalls entfernen. Kinder sollten beim Spielen beaufsichtigt werden.

NL Verwijder de verpakking voor gebruik. Bewaar deze informatie, adressen en telefoonnummers voor toekomstig gebruik. Inhoud kan afwijken van illustraties. Een volwassene dient dit speelgoed regelmatig te controleren. In geval van schade of gevaren het speelgoed niet meer gebruiken. Houd toezicht als kinderen spelen.

IT Rimuovere l'imballo prima dell'uso. Conservare informazioni, indirizzi e numeri di telefono per riferimento futuro. Il prodotto potrebbe essere differente dalle immagini. Il giocattolo deve essere periodicamente controllato da un adulto per prevenire eventuali danni o rischi; in caso di danno, sospendere l'uso. I bambini devono essere sorvegliati durante il gioco.

PT Remova totalmente a embalagem antes de utilizar. Guarde todos os endereços, números de telefone e demais informações para consulta e referência. O conteúdo poderá ser diferente das ilustrações. Um adulto deve verificar o brinquedo periodicamente para garantir que não há danos ou riscos. Se houver, é necessário que o brinquedo seja retirado de uso. As crianças devem ser supervisionadas enquanto brincam.

RU Снимите все упаковочные материалы перед использованием. Запишите указанные на упаковке адреса и номера телефонов, чтобы у вас была возможность связаться с нами. Содержимое упаковки может отличаться от иллюстраций. Взрослым следует время от времени проверять игру и следить за тем, чтобы она не была сломана и не представляла опасности для ребенка. В противном случае ее не следует использовать. Во время игры дети должны находиться под присмотром.

PL Przed użyciem wyjąć zabawkę z opakowania. Zachować niniejsze informacje, adresy i numery telefonów na wypadek, gdyby były potrzebne w przyszłości. Zawartość opakowania może różnić się od zabawki przedstawionej na obrazkach. Osoba dorosła powinna regularnie sprawdzać zabawkę pod kątem uszkodzeń oraz zagrożeń. Jeśli takowe wystąpią, należy zaprzestać używania zabawki. Dzieci nie powinny bawić się bez nadzoru.

CZ Před použitím odstraňte veškeré balící materiály. Uložte si tyto informace, adresy a telefonní čísla pro budoucí použití. Obsah se může lišit od obrázků. Dospělá osoba by měla pravidelně kontrolovat, zda hračka není poškozená nebo zda nepředstavuje nebezpečí. Pokud ano, hračku vyhodte. Během hry nenechávejte děti bez dozoru.

SK Pred použitím odstráňte všetok obalový materiál. Tieto informácie, adresy a telefónne čísla si uchovajte na ďalšie použitie. Obsah sa môže líšiť od zobrazenia. Túto hračku musí pravidelne kontrolovať dospelá osoba, aby sa uistila, že nedošlo k jej poškodeniu a že nehrozí žiadne nebezpečenstvo. Ak áno, ukončíte jej používanie. Deti nesmú byť pri hre bez dozoru.

HU Használat előtt távolítson el minden csomagolóanyagot. A tudnivalókat, a címet és a telefonszámot őrizze meg későbbi használatra. A csomag tartalma eltérhet a képen látottaktól. A felnettéknak rendszeresen ellenőrizniük kell, hogy a játékon nincs-e sérülés, illetve nem jelent-e veszélyforrást. Ha igen, ki kell vonni a használatból. A gyermeknek játék közben felügyeletet igényelnek.

RO Îndepărtați toate ambalajele înainte de utilizare. Păstrați aceste informații, adresele și numerele de telefon pentru consultare ulterioară. Conținutul poate fi diferit de imaginea din fotografii. Această jucărie trebuie verificată periodic de un adult pentru a se asigura că nu există nicio deteriorare sau niciun pericol; dacă există, scoateți jucăria din uz. Copiii trebuie supravegheați în timp ce se joacă.



TM & © 2017 MECCANO for packaging, instructions and models built with this set. ©MECCANO is an exclusive trademark of MECCANO. Spin Master logo is a trademark of Spin Master Ltd. All rights reserved. / TM & © 2017 MECCANO pour l'emballage, les notices et modèles de ce coffret. ©MECCANO est une marque de commerce exclusive de MECCANO. Le logo de Spin Master est une marque de commerce de Spin Master Ltd. Tous droits réservés.

The trademarks PAGANI and Pagani Automobili and Huayra and Zonda are registered trademarks and used under license from HORACIO PAGANI S.P.A., Italy. Les marques de commerce PAGANI, Pagani Automobili, Huayra et Zonda sont des marques de commerce déposées utilisées sous licence de HORACIO PAGANI S.P.A., Italy.

Meets CPSC Safety Requirements.

Conforme aux exigences de sécurité de la CPSC.

Cumple con las normas de seguridad de la CPSC.



SPIN MASTER LTD., 450 FRONT STREET WEST, TORONTO, ON M5V 1B6 CANADA.

Imported into EU by/Importé dans l'UE par: SPIN MASTER INTERNATIONAL, S.A.R.L., 20 RUE DES PEUPLIERS, L-2328, LUXEMBOURG
www.spinmaster.com



Made in China / Fabriqué en Chine / Hecho en China

T91837_0012_20090446_GML_ISW_R1 (MEC_Pagani_Huayra_Cn)

UK – 0800 206 1191, serviceuk@spinmaster.com
IRELAND – 1800 992 249
FRANCE – 0800 909 150, servicefr@spinmaster.com
AUSTRALIA – 1800 316 982, customercare@spinmaster.com
DEUTSCHLAND – 0800 0101 0222, Kundenservice@spinmaster.com
SCHWEIZ – 0800 561 350 • ÖSTERREICH – 0800 297 267
NEDERLAND – 0800 022 3683, klantenservice@spinmaster.com
BELGIË/BELGIQUE – 0800 77 688 • LUXEMBOURG – 800 2 8044

ITALIA – 800 788 532, servizio@spinmaster.com
MEXICO – 55 4160 7947, servicio@spinmaster.com
POLSKA – 800080238, poland@spinmaster.com
ČESKÁ REPUBLIKA – 800550530, czechrepublic@spinmaster.com
SLOVENSKO – 0800232800, slovakia@spinmaster.com
MAGYARORSZÁG – 080 100 052, hungary@spinmaster.com
ROMÂNIA – 0800400015, romania@spinmaster.com

NORTH AMERICA • AMÉRIQUE DU NORD 1-800-622-8339, CUSTOMERCARE@SPINMASTER.COM

WWW.SPINMASTER.COM