

# EVOLUTION

**9+**  
**YEARS/ANS**  
Años/Jahre/Jaar/Anni  
Anos/Ετών/År  
Vuotta/Лет

Instructions  
Notice de montage  
Instrucciones de construcción  
Bauanleitung  
Handleiding  
Istruzioni  
Instruções  
Οδηγίες  
Instruktioner  
Monteringsinstruktioner  
Ohjeet  
Инструкции





**CONSTRUCTION TIPS**  
 LES ASTUCES DE CONSTRUCTION  
 KONSTRUKTIONS-TIPPS  
 LE ASTUZIE DELLA COSTRUZIONE  
 LOS INGENIOS DE LA CONSTRUCCIÓN  
 DICAS PARA A MONTAGEM  
 KOKOONPANON KIKAT  
 BYGGKNEPEN  
 ET PAR TIPS TIL BYGGEARBEJDET  
 DE FIJNE KNEEPJES VAN HET BOUWEN  
 Τα έξυπνα κόλπα κατασκευής  
 рекомендации по сборке

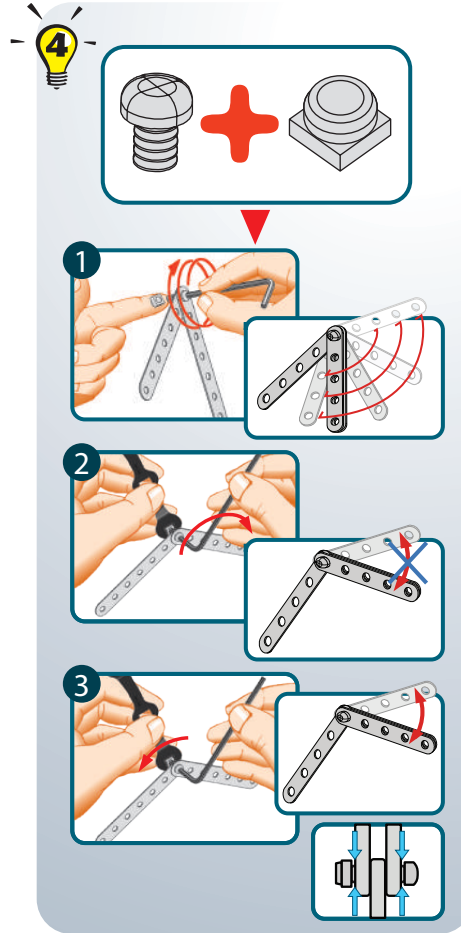
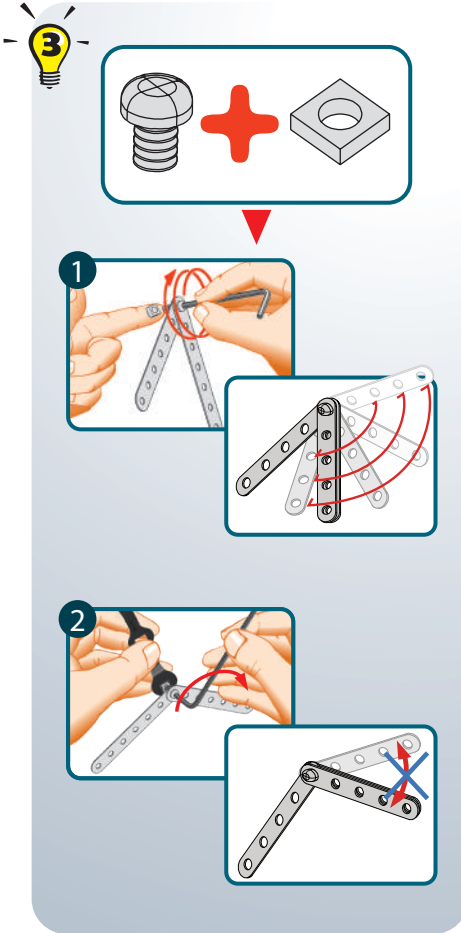
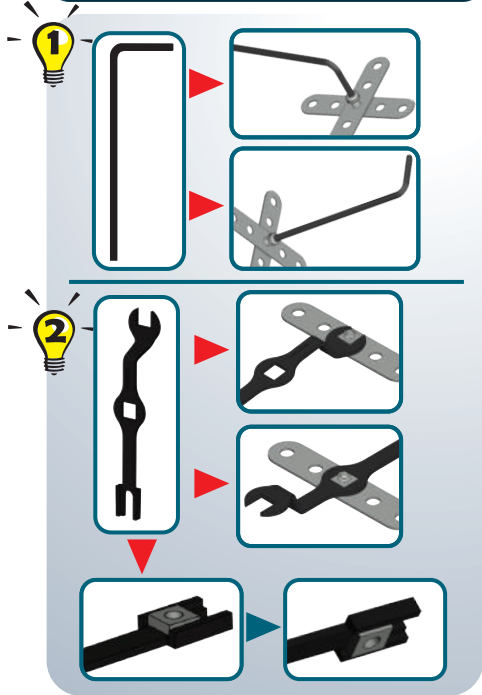

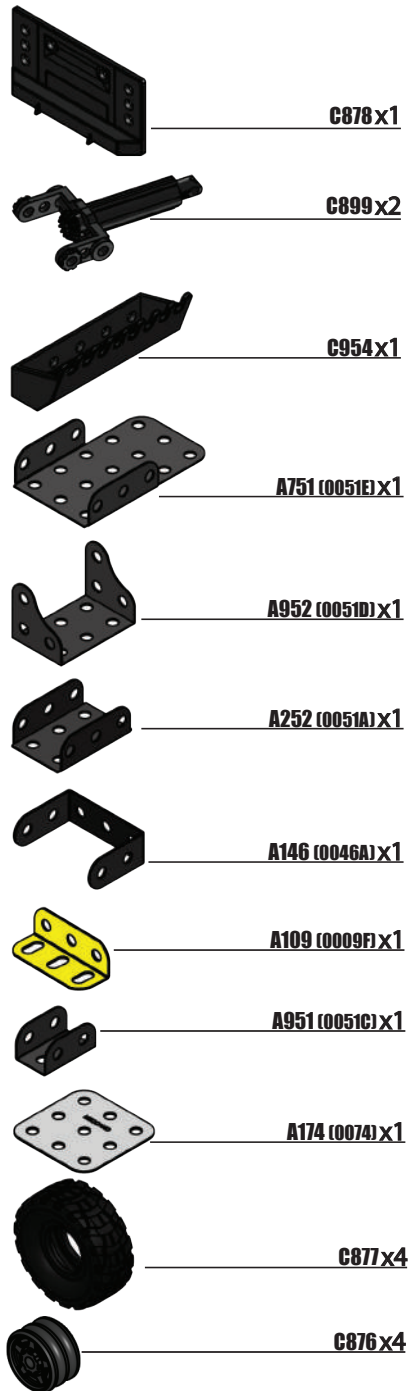

**C878** x1  
**C899** x2  
**C954** x1  
**A751 (0051E)** x1  
**A952 (0051D)** x1  
**A252 (0051A)** x1  
**A146 (0046A)** x1  
**A109 (0009F)** x1  
**A951 (0051C)** x1  
**A174 (0074)** x1  
**C877** x4  
**C876** x4

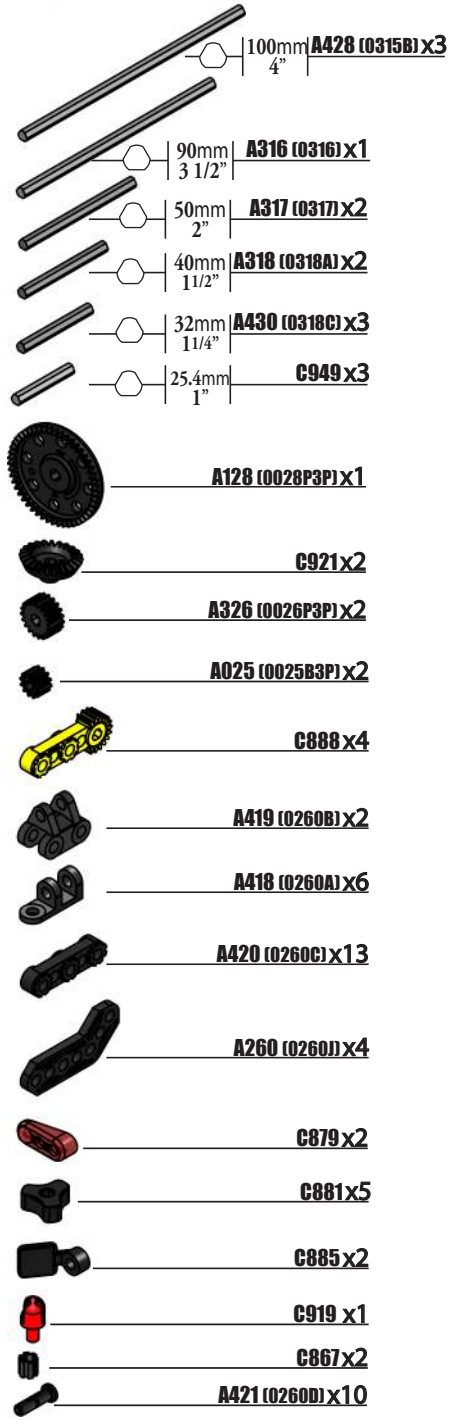

100mm **A428 (0315B)** x3  
 90mm **A316 (0316)** x1  
 50mm **A317 (0317)** x2  
 40mm **A318 (0318A)** x2  
 32mm **A430 (0318C)** x3  
 25.4mm **C949** x3  
**A128 (0028P3P)** x1  
**C921** x2  
**A326 (0026P3P)** x2  
**A025 (0025B3P)** x2  
**C888** x4  
**A419 (0260B)** x2  
**A418 (0260A)** x6  
**A420 (0260C)** x13  
**A260 (0260J)** x4  
**C879** x2  
**C881** x5  
**C885** x2  
**C919** x1  
**C867** x2  
**A421 (0260D)** x10

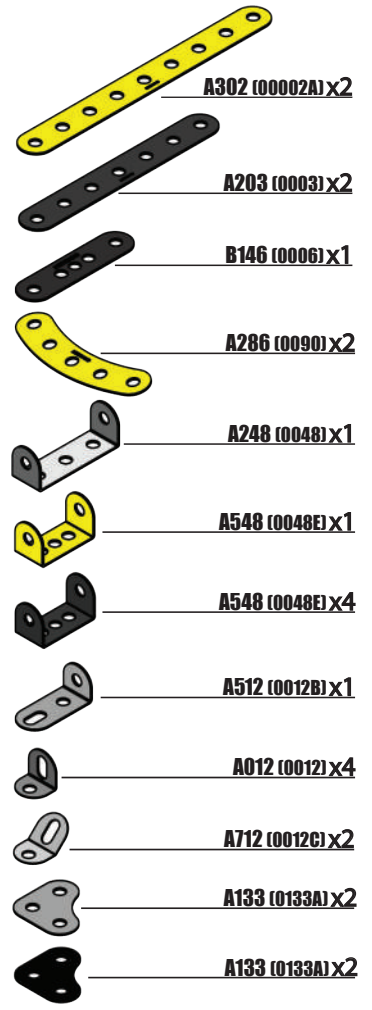

**A302 (00002A)** x2  
**A203 (0003)** x2  
**B146 (0006)** x1  
**A286 (0090)** x2  
**A248 (0048)** x1  
**A548 (0048E)** x1  
**A548 (0048E)** x4  
**A512 (0012B)** x1  
**A012 (0012)** x4  
**A712 (0012C)** x2  
**A133 (0133A)** x2  
**A133 (0133A)** x2

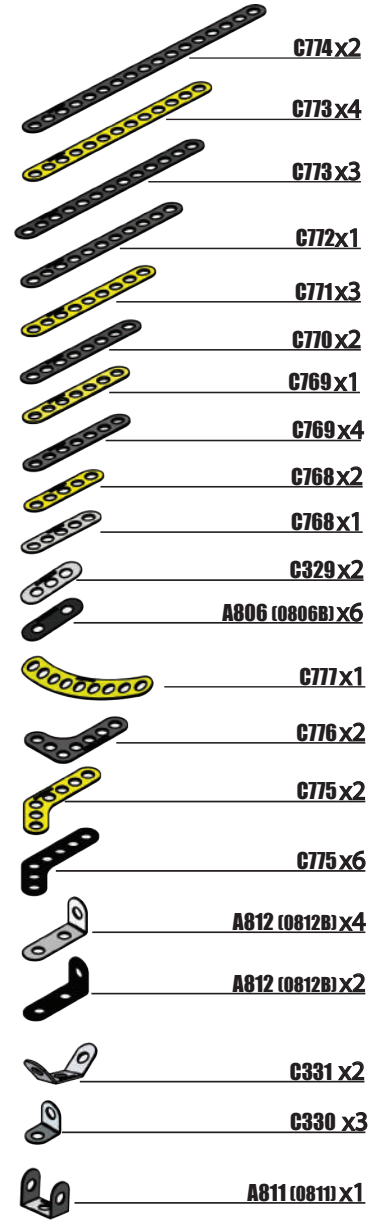

**C774** x2  
**C773** x4  
**C773** x3  
**C772** x1  
**C771** x3  
**C770** x2  
**C769** x1  
**C769** x4  
**C768** x2  
**C768** x1  
**C329** x2  
**A806 (0806B)** x6  
**C777** x1  
**C776** x2  
**C775** x2  
**C775** x6  
**A812 (0812B)** x4  
**A812 (0812B)** x2  
**C331** x2  
**C330** x3  
**A811 (0811)** x1

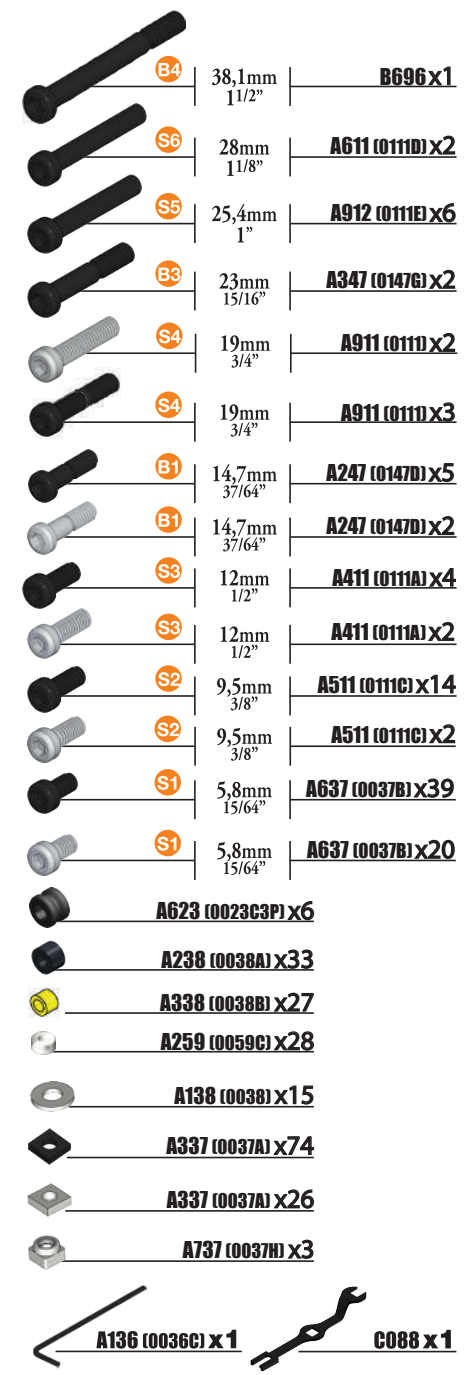

**B4** 38,1mm 1 1/2" **B696** x1  
**S6** 28mm 1 1/8" **A611 (0111D)** x2  
**S5** 25,4mm 1" **A912 (0111E)** x6  
**B3** 23mm 15/16" **A347 (0147G)** x2  
**S4** 19mm 3/4" **A911 (0111)** x2  
**S4** 19mm 3/4" **A911 (0111)** x3  
**B1** 14,7mm 37/64" **A247 (0147D)** x5  
**B1** 14,7mm 37/64" **A247 (0147D)** x2  
**S3** 12mm 1/2" **A411 (0111A)** x4  
**S3** 12mm 1/2" **A411 (0111A)** x2  
**S2** 9,5mm 3/8" **A511 (0111C)** x14  
**S2** 9,5mm 3/8" **A511 (0111C)** x2  
**S1** 5,8mm 15/64" **A637 (0037B)** x39  
**S1** 5,8mm 15/64" **A637 (0037B)** x20  
**A623 (0023C3P)** x6  
**A238 (0038A)** x33  
**A338 (0038B)** x27  
**A259 (0059C)** x28  
**A138 (0038)** x15  
**A337 (0037A)** x74  
**A337 (0037A)** x26  
**A737 (0037H)** x3

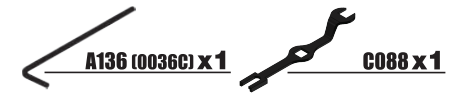

**A136 (0036C)** x1 **C088** x1

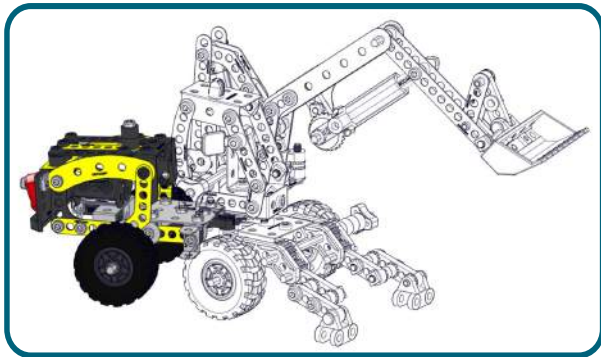

**1**

	<b>x1</b>
	<b>x2</b>
	<b>x2</b>
	<b>x2</b>

	<b>S1</b>	<b>1:1</b>
	Scale 1	Escala 1
	Echelle 1	Mittakaava 1
	Maßstab 1	Schaal 1
	Scala 1	Malesok 1
		Κλίμακα 1
		масштаб 1

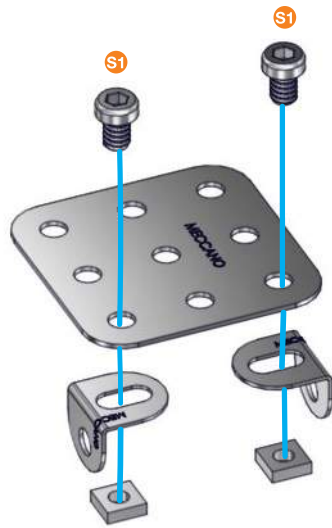

**2** ①+

	<b>x2</b>
	<b>x2</b>
	<b>x2</b>

	<b>S1</b>	<b>1:1</b>
--	-----------	------------

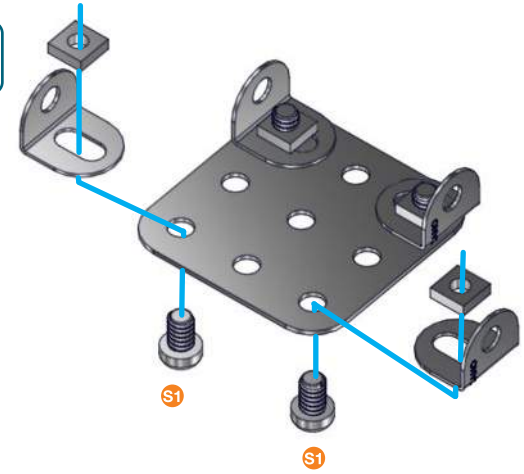

**3** (2)+

	x2
	x1
	x1
	x1
	x1
	x2

	B1	1:1
	S1	

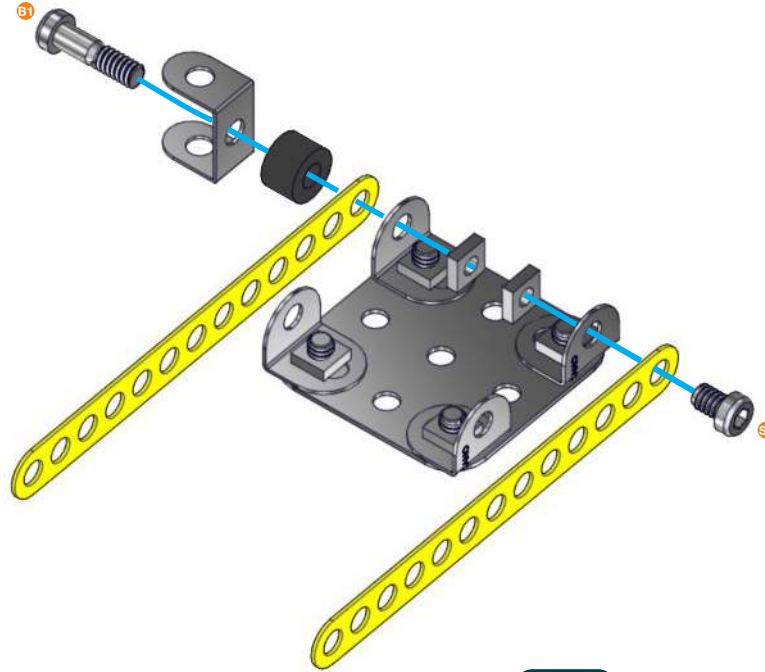

**4** (3)+

	x2
	x2
	x2

	S1	1:1
--	----	-----

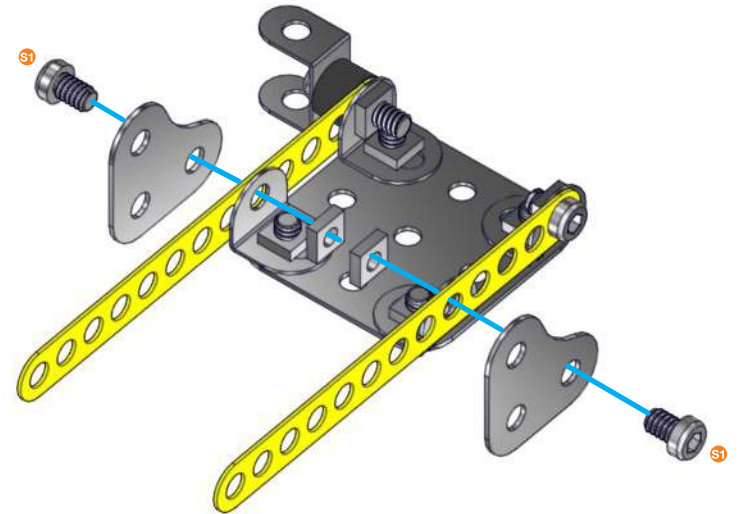

5 (4)+

	x2
5,8mm 15/64"	x4
	x4
	S1
	1:1

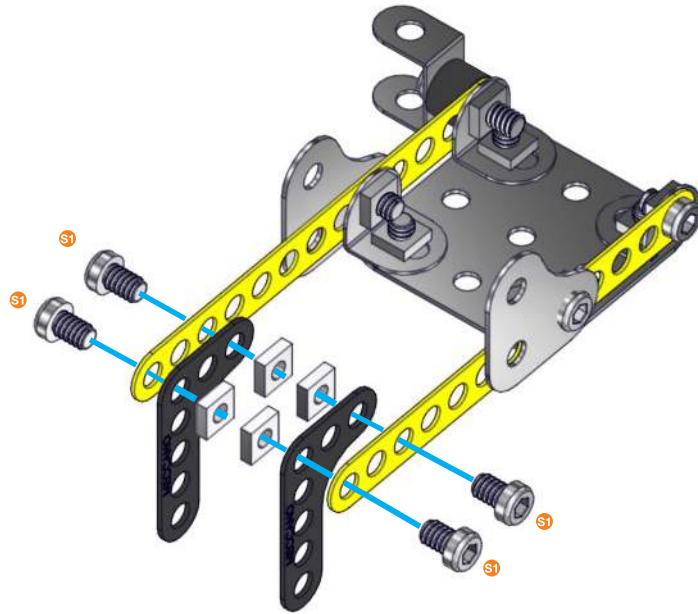

6 (5)+

	x2
	x2
5,8mm 15/64"	x2
	x2
	S1
	1:1

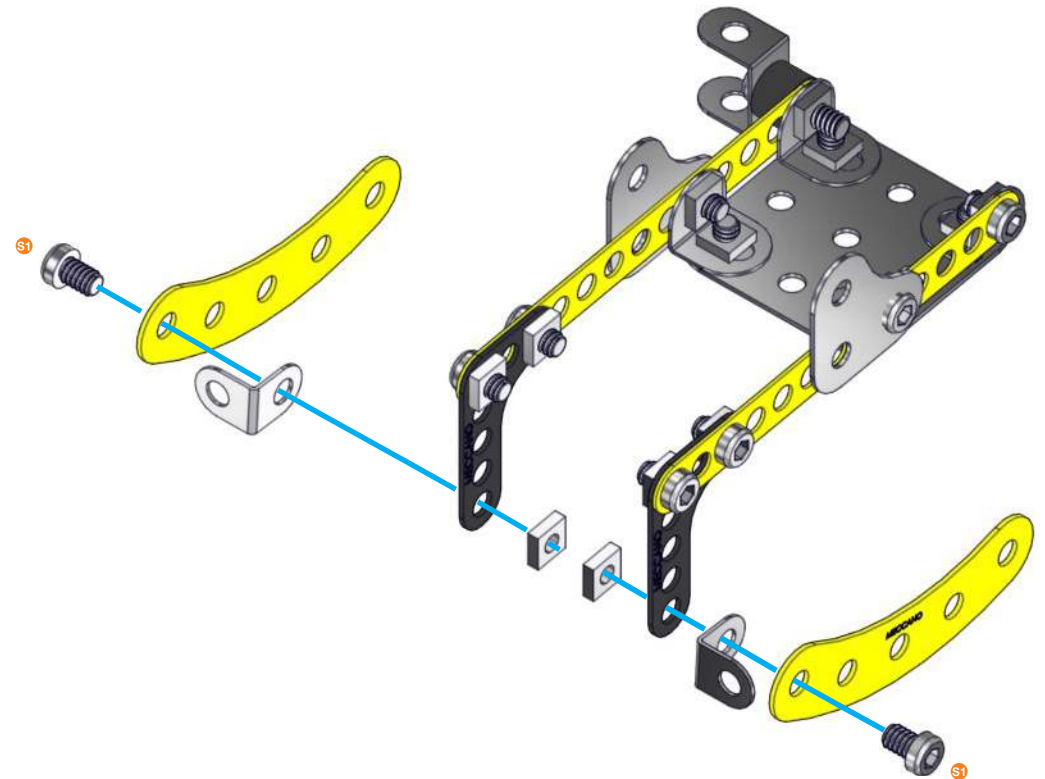



**7** (6)+

	x2
	x2
	x2

	(S1)	1:1
--	------	-----

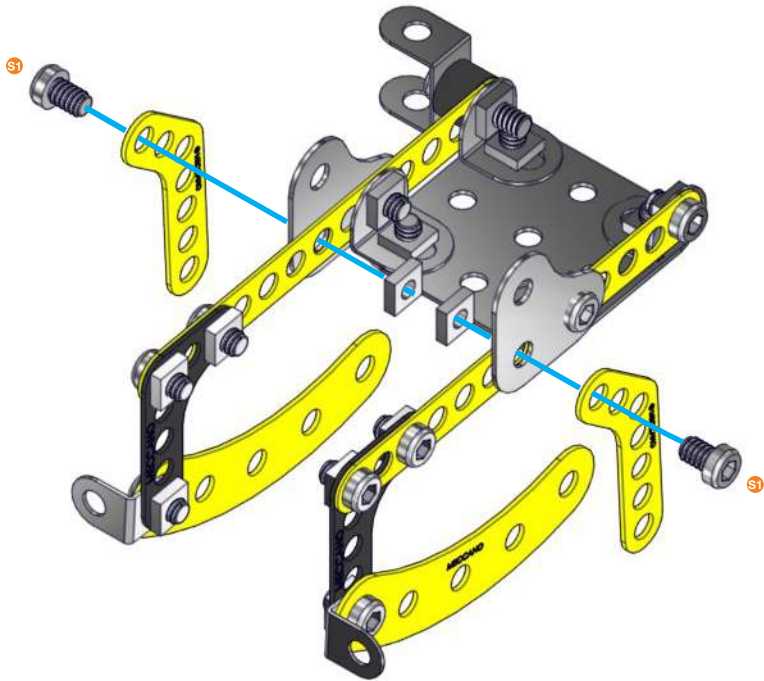

**8** (7)+

	x1
	x2
	x2

	(S1)	1:1
--	------	-----

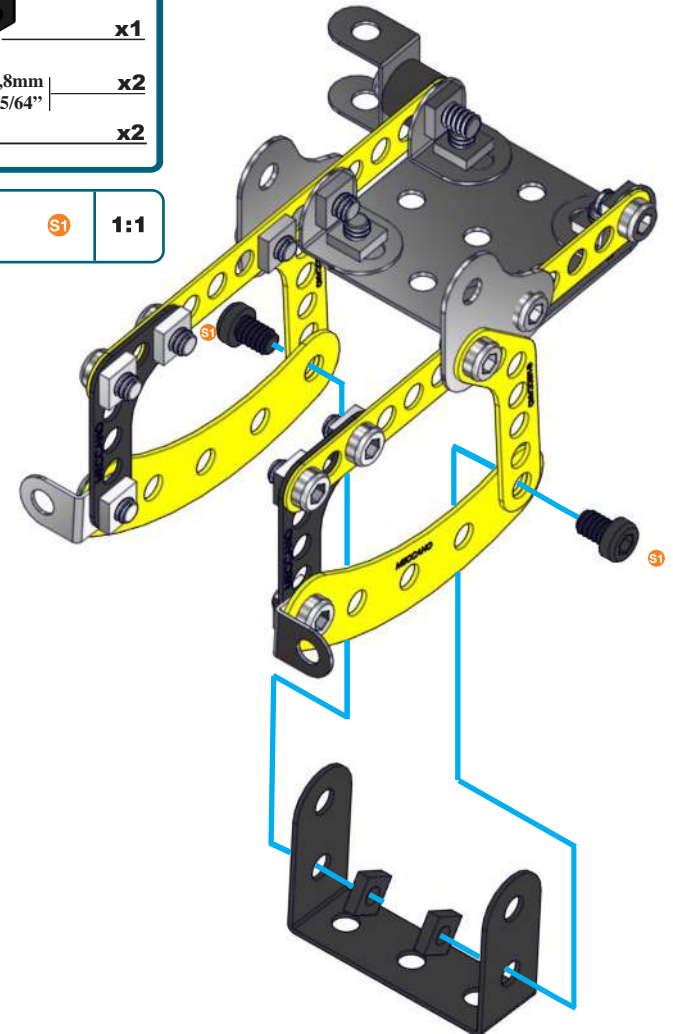

**9** **8+**

		<b>x1</b>
	9,5mm 3/8"	<b>x2</b>
		<b>x2</b>

	S2	<b>1:1</b>
--	----	------------









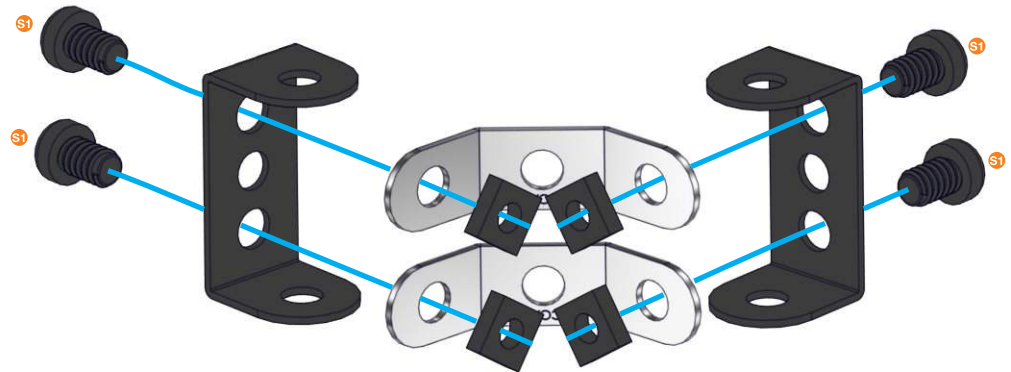

**10**

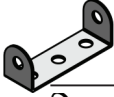

		<b>x2</b>
		<b>x2</b>
	5,8mm 15/64"	<b>x4</b>
		<b>x4</b>

	S1	<b>1:1</b>
--	----	------------





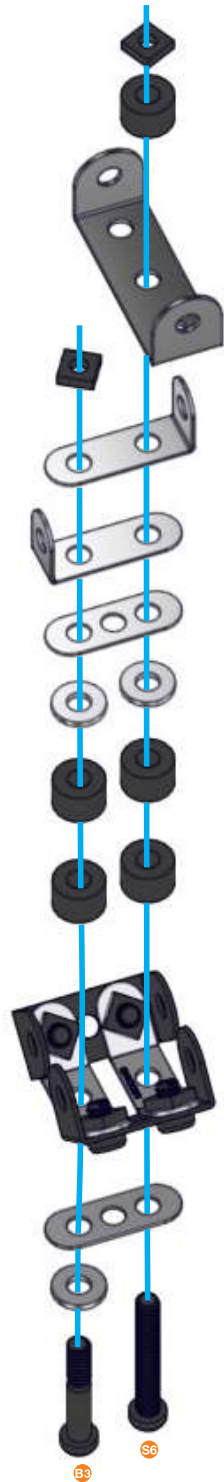

- 11** ⑩+
-  x1
  -  x2
  -  x2
  -  x3
  -  x5
  -  x1
  -  x1
  -  x2

-  **1:1**
-  **1:1**



- 12** ⑪+
-  x2
  -  x2
  -  **1:1**

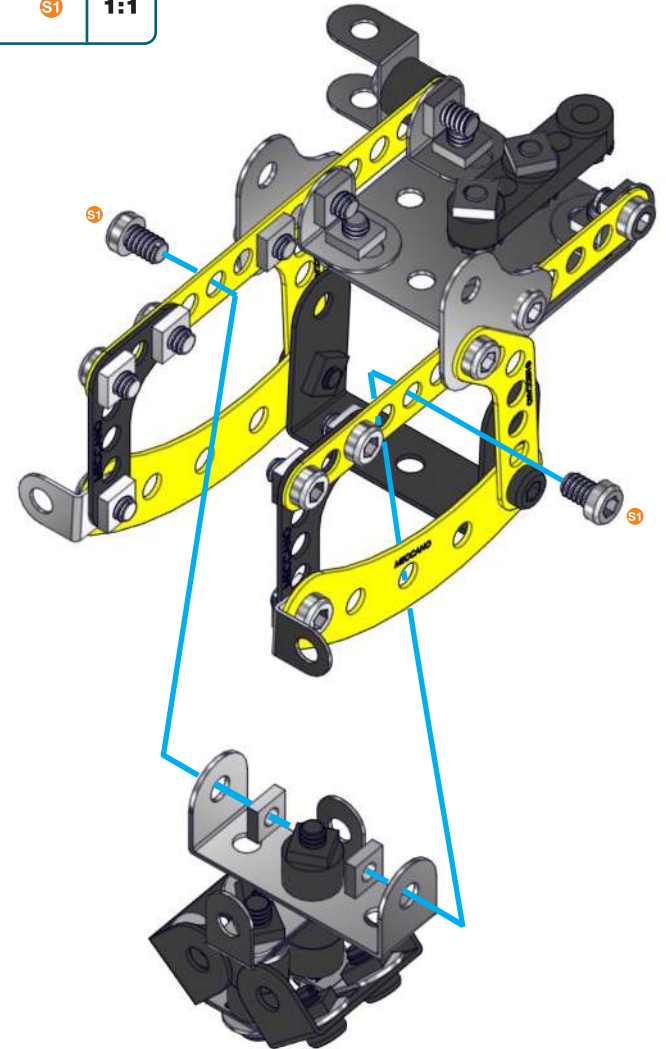

**13**

	x1
	x1
	x2
	x2

	S1	1:1
--	----	-----

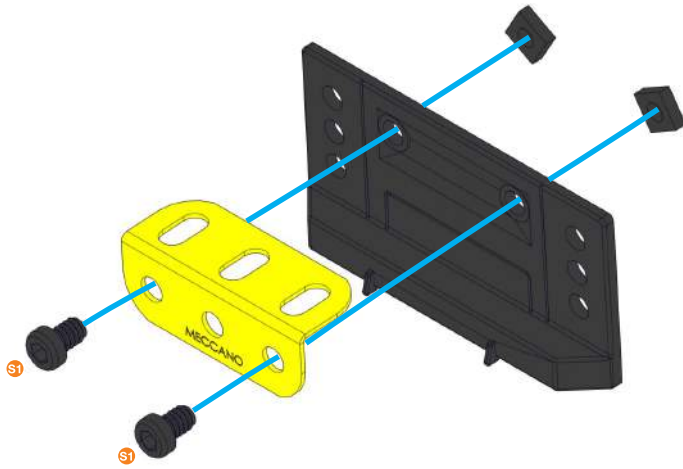

**14** (13+)

	x2
	x1
	x2
	x2

	S3	1:1
--	----	-----

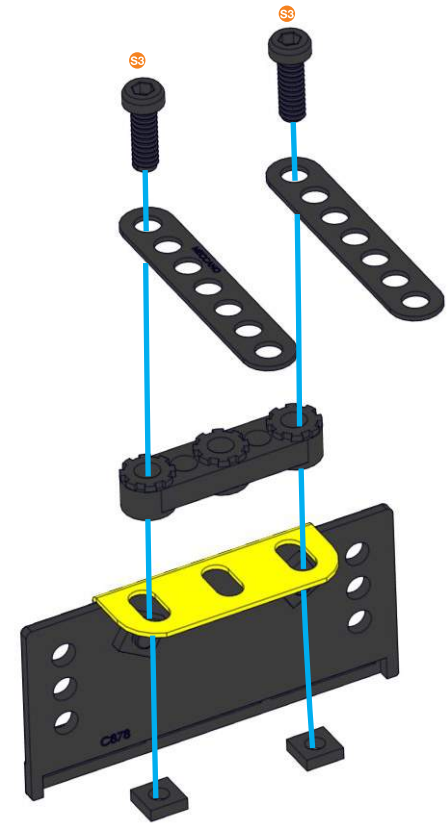

**15** (14+)

	x2
	x2
	x2

	S1	1:1
--	----	-----

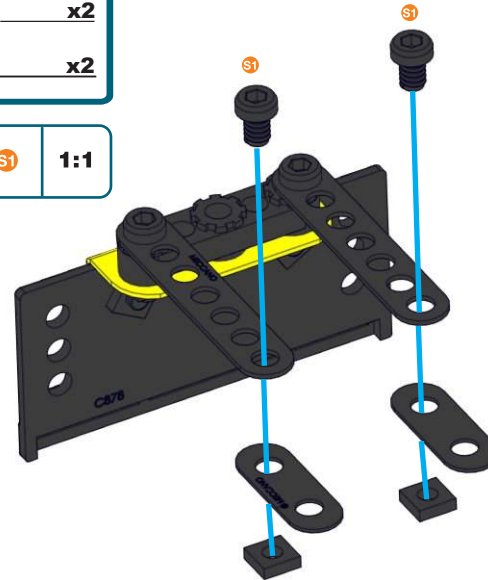

**16** (15) +

		<b>x1</b>
	12mm 1/2"	<b>x1</b>
		<b>x1</b>

	<b>S3</b>	<b>1:1</b>
--	-----------	------------

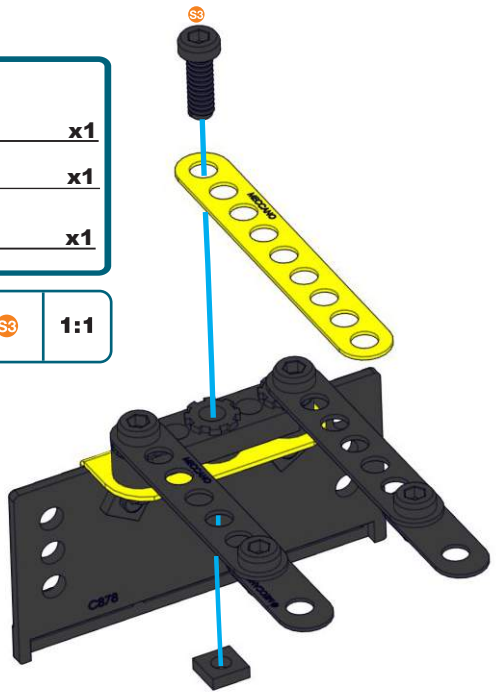

**17** (16) +

		<b>x2</b>
	19mm 3/4"	<b>x1</b>
		<b>x1</b>

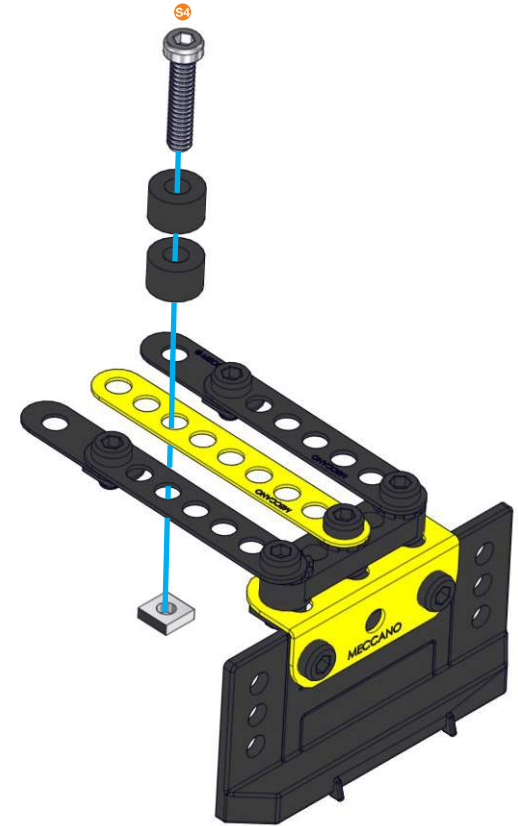

	<b>S4</b>	<b>1:1</b>
--	-----------	------------





18



12+17+

	x2
 12mm 1/2"	x2
	x2

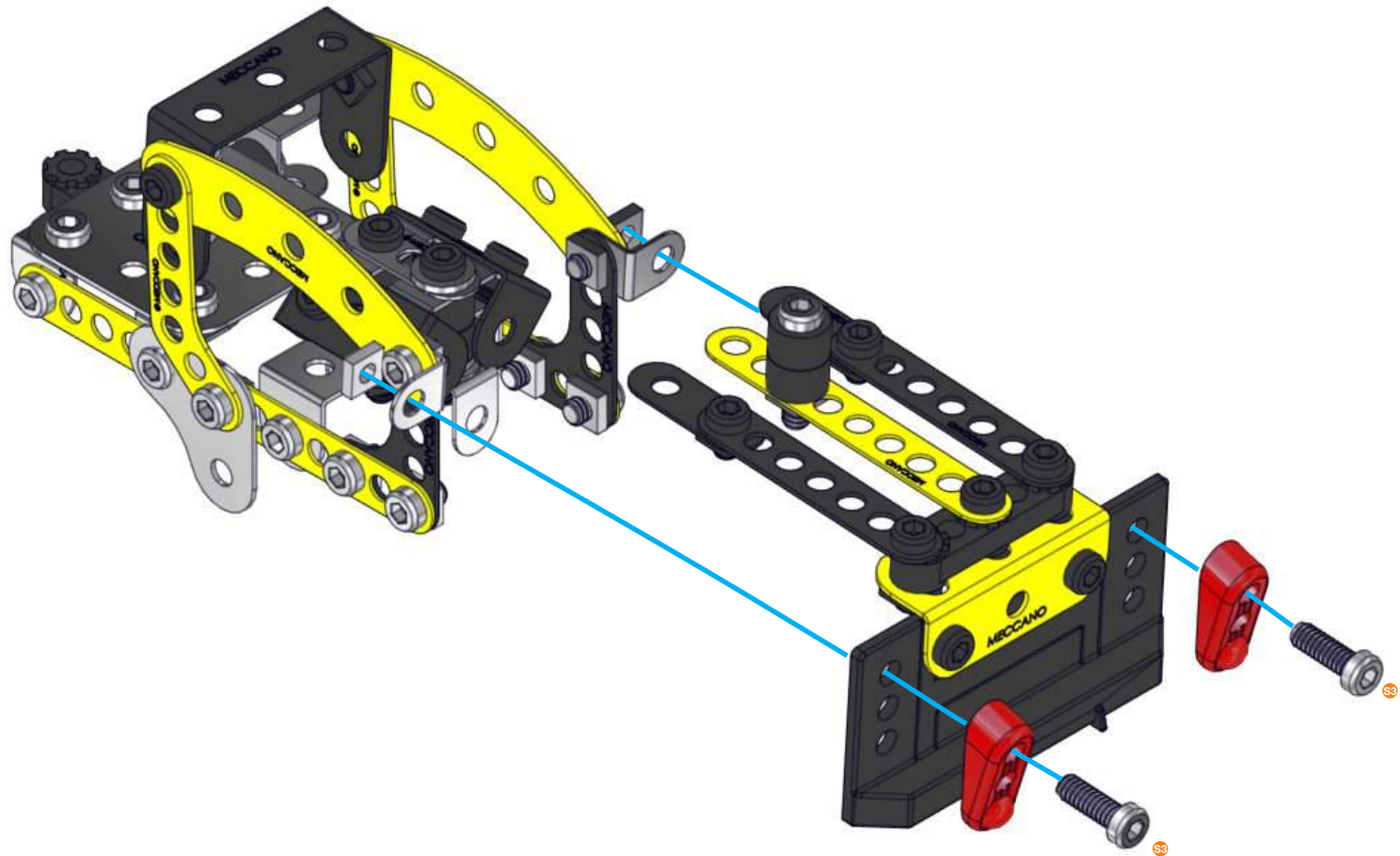
	1:1
---	-----



**19** (18) +

	<b>S1</b>   5,8mm   15/64"	<b>x3</b>
		<b>x3</b>

	<b>S1</b>	<b>1:1</b>
---	-----------	------------

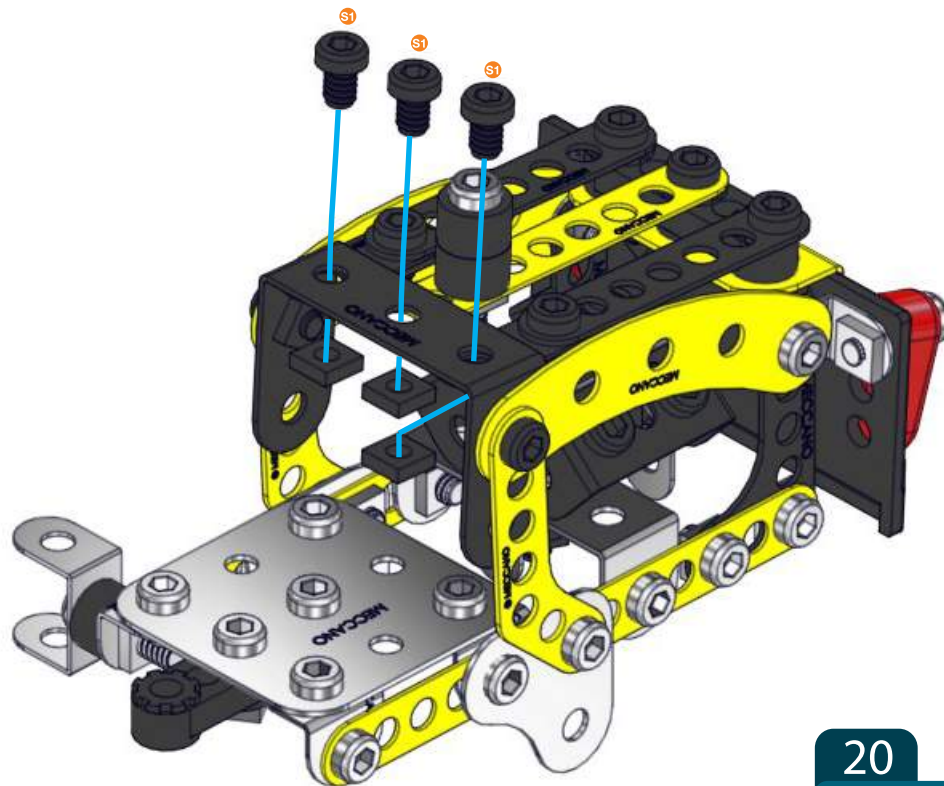

**20**

	<b>x4</b>
	<b>x4</b>



**x4**



21 19+20+

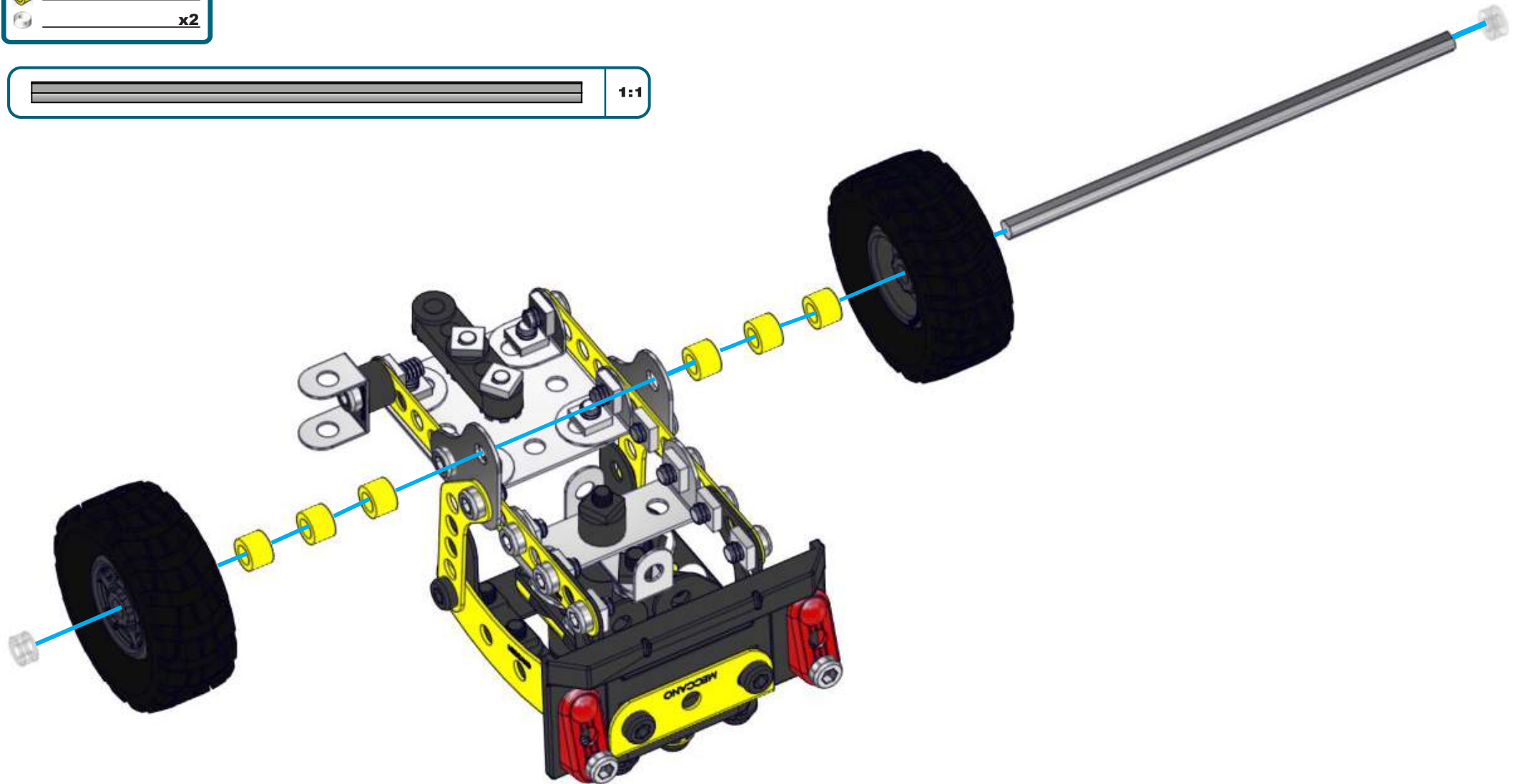
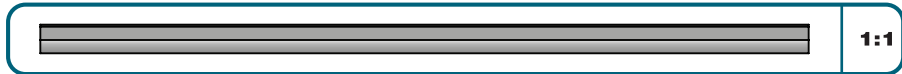
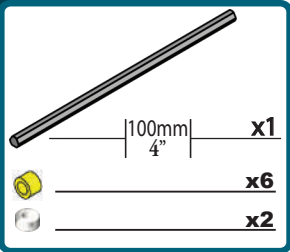





**22**

		<b>x1</b>
		<b>x2</b>
	9,5mm 3/8"	<b>x2</b>
		<b>x2</b>

	<b>S2</b>	<b>1:1</b>
--	-----------	------------

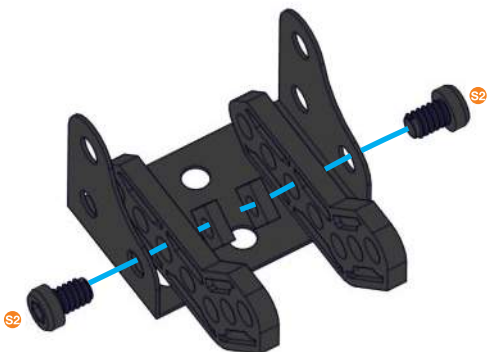

**23** (22) +

		<b>x2</b>
		<b>x2</b>
	19mm 3/4"	<b>x2</b>
		<b>x2</b>

	<b>S4</b>	<b>1:1</b>
--	-----------	------------



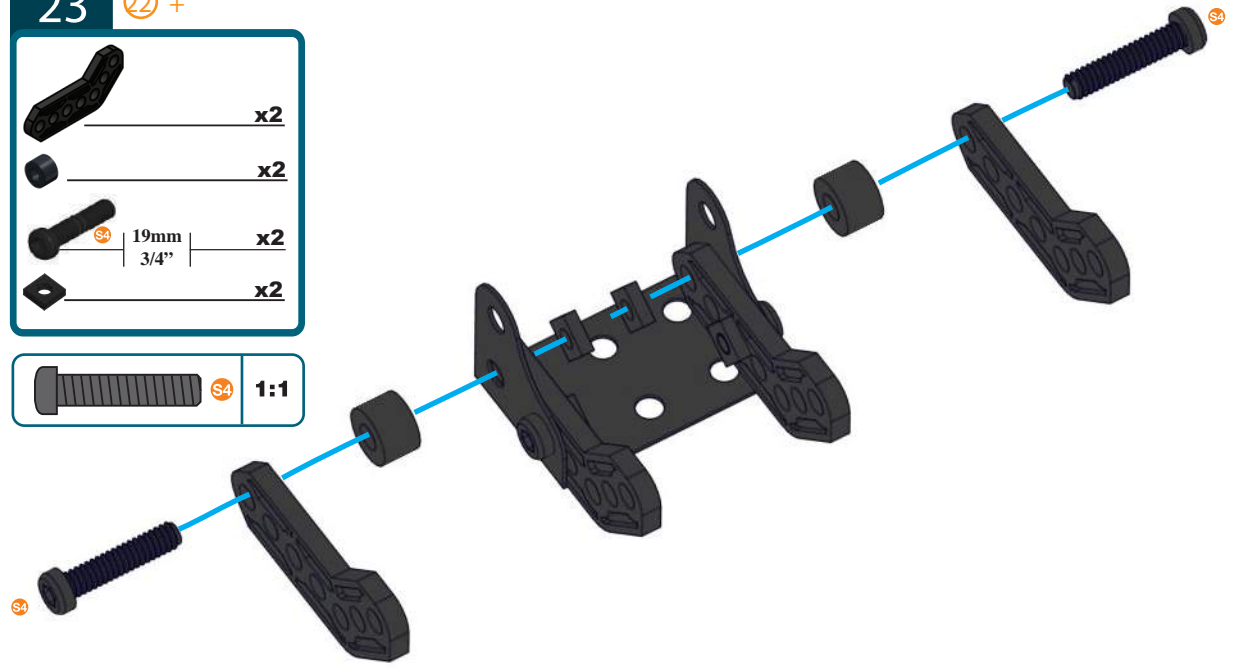

**24** 23 +

	<b>x3</b>
 23 mm 15/16"	<b>x1</b>
	<b>x1</b>

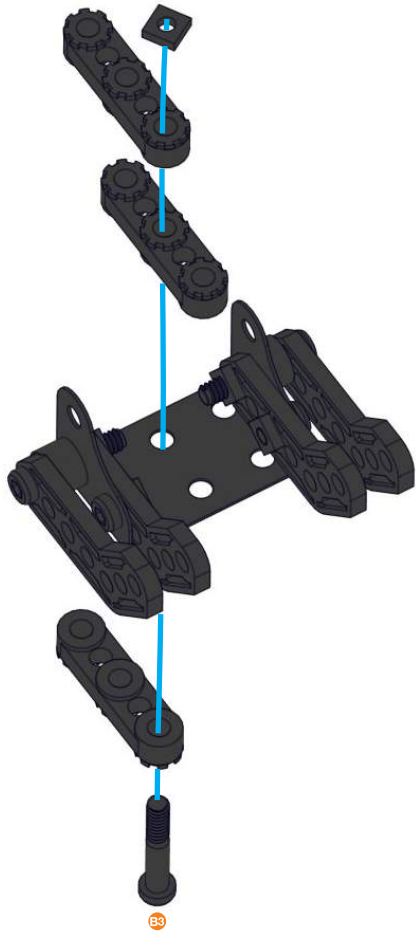
	<b>1:1</b>
---	------------







**25** 24 +

	9,5mm 3/8"	<b>x1</b>
		<b>x1</b>

	<b>1:1</b>
---	------------

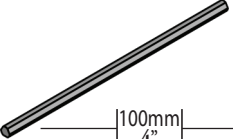

26 <sup>25</sup> +

-  100mm  $\frac{1}{4}$ " x1
-  x1
-  x2
-  x4
-  x2

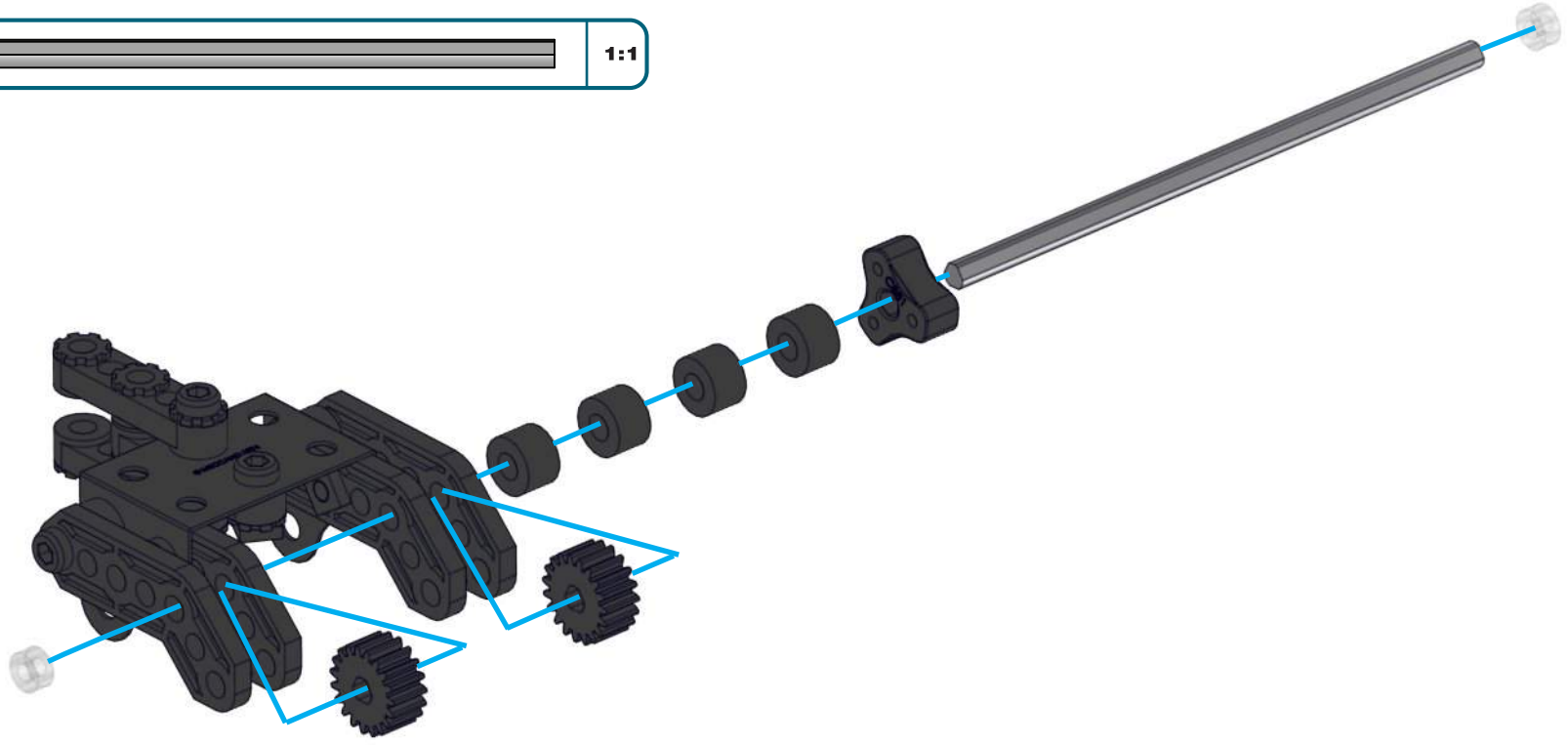



**27**

	x1
	x1
	x4
	x2
	x2

	SS	1:1
--	----	-----

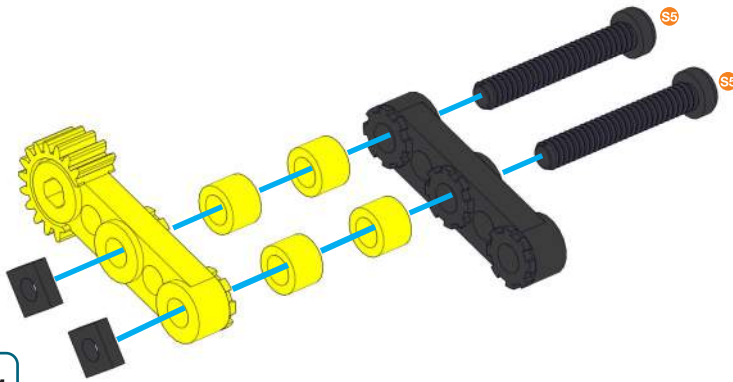

**28** (27) +

	x1
	x1

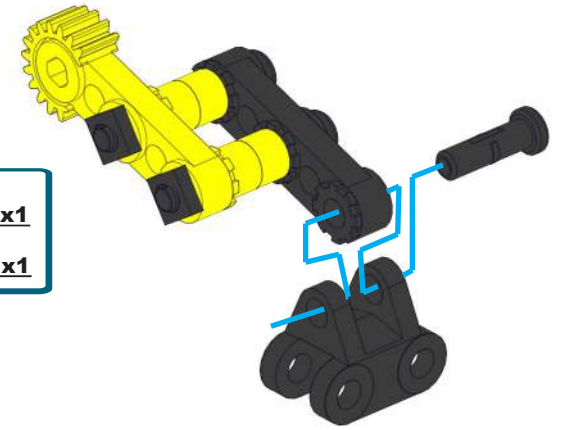

**29**

	x1
	x1
	x4
	x2
	x2

	SS	1:1
--	----	-----

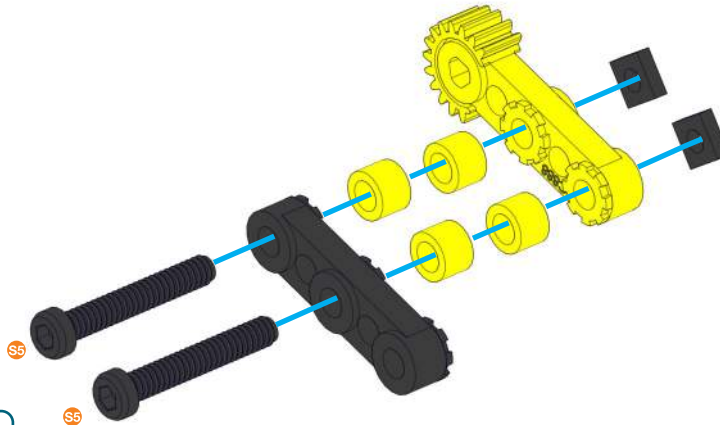

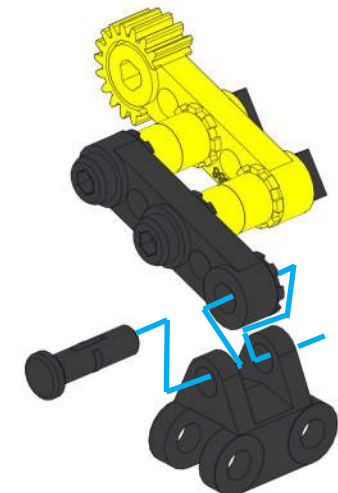

**30** (29) +

	x1
	x1





31 26+30+

	25,4 mm  1"	x1
		x2

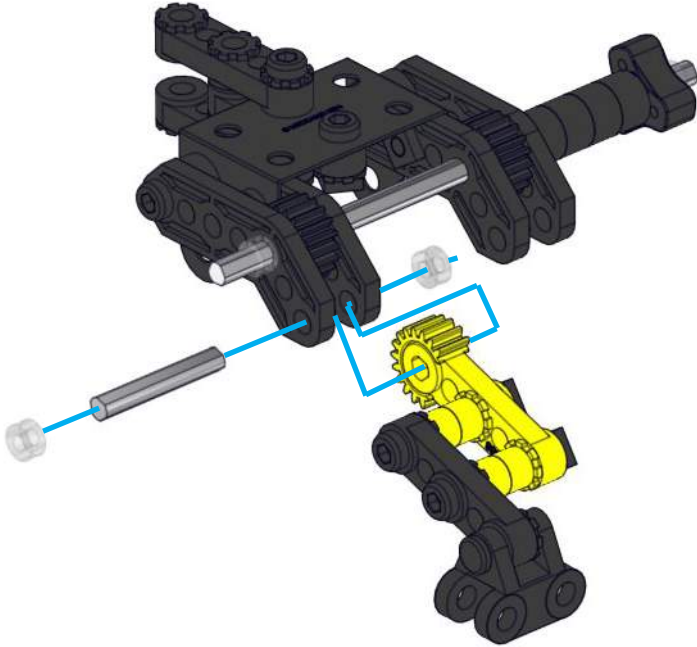
	1:1
---	-----



32 28+31+



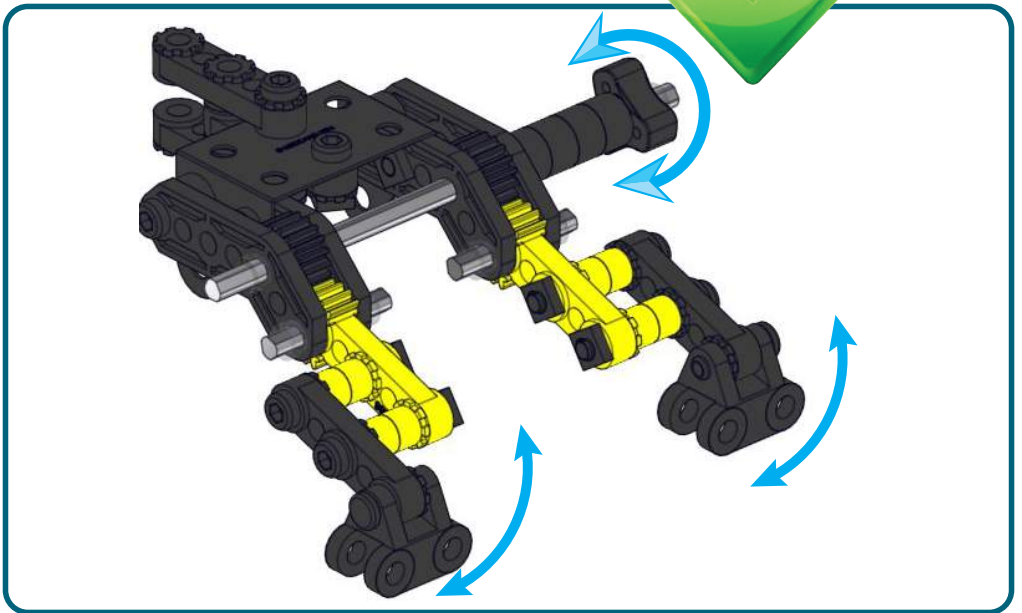
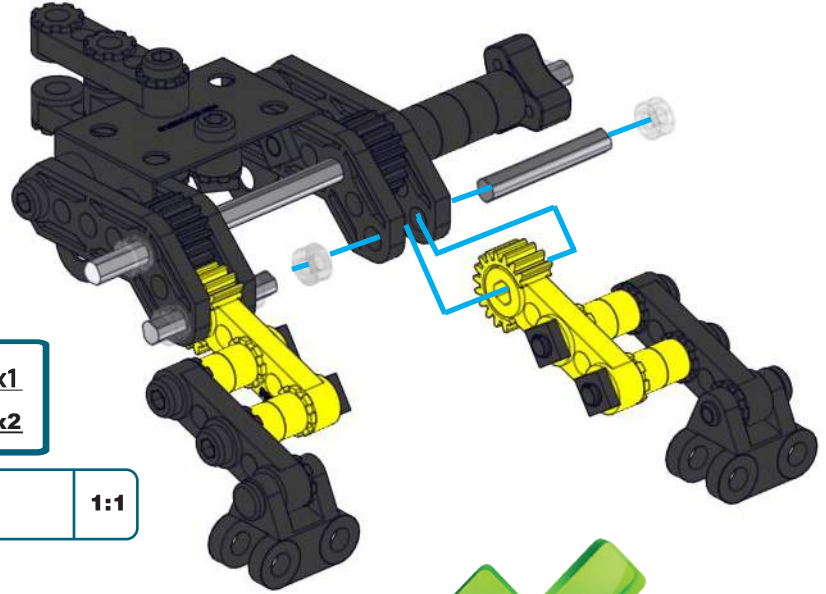

	25,4 mm  1"	x1
		x2

	1:1
---	-----

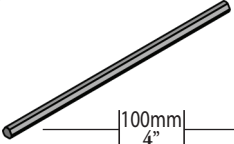

33

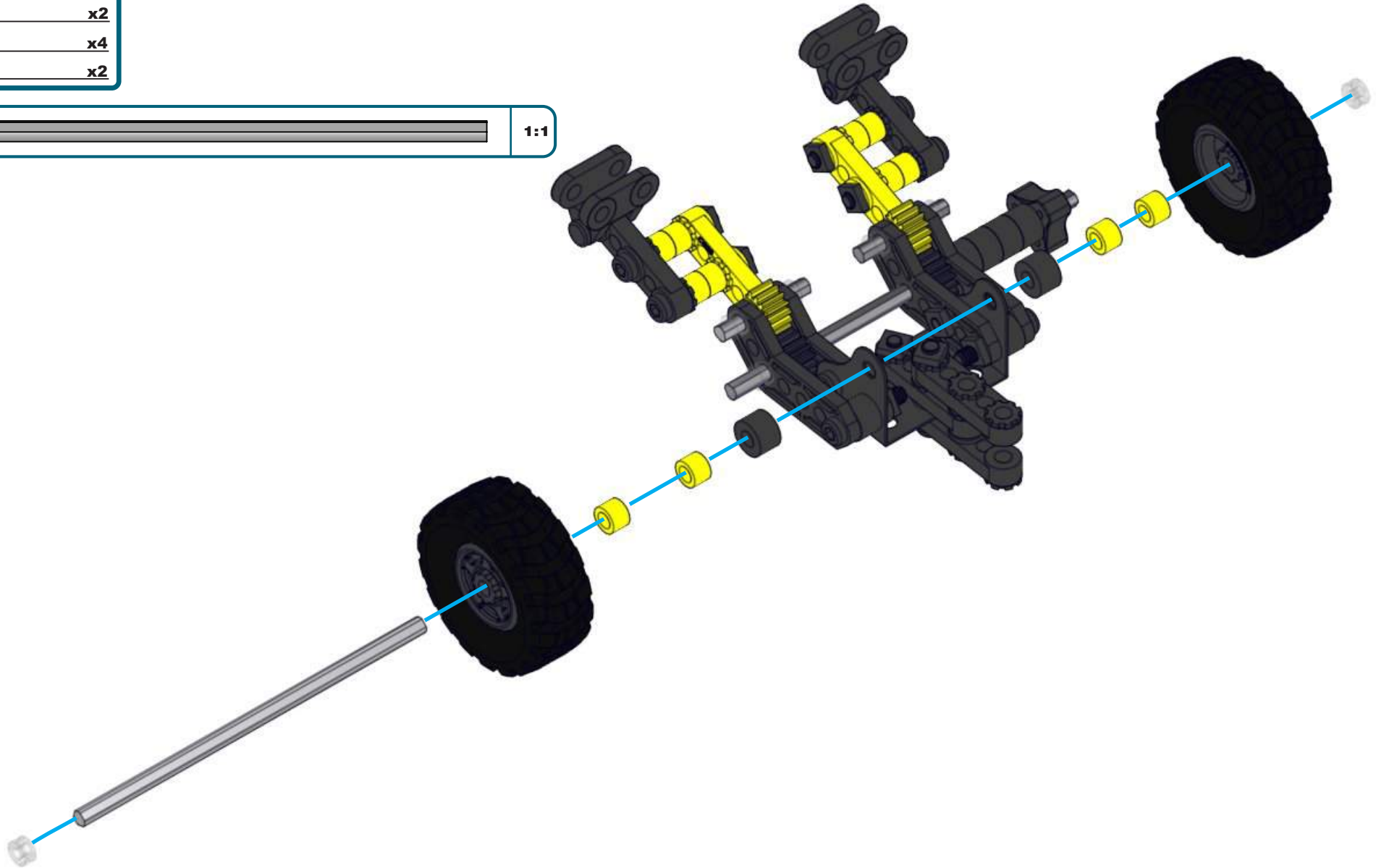

20+32+

	100mm 4"	x1
		x2
		x4
		x2









**34** (21)+(33)+

	25.4mm 1"	x1
		x1

	1:1
---	-----

  +  

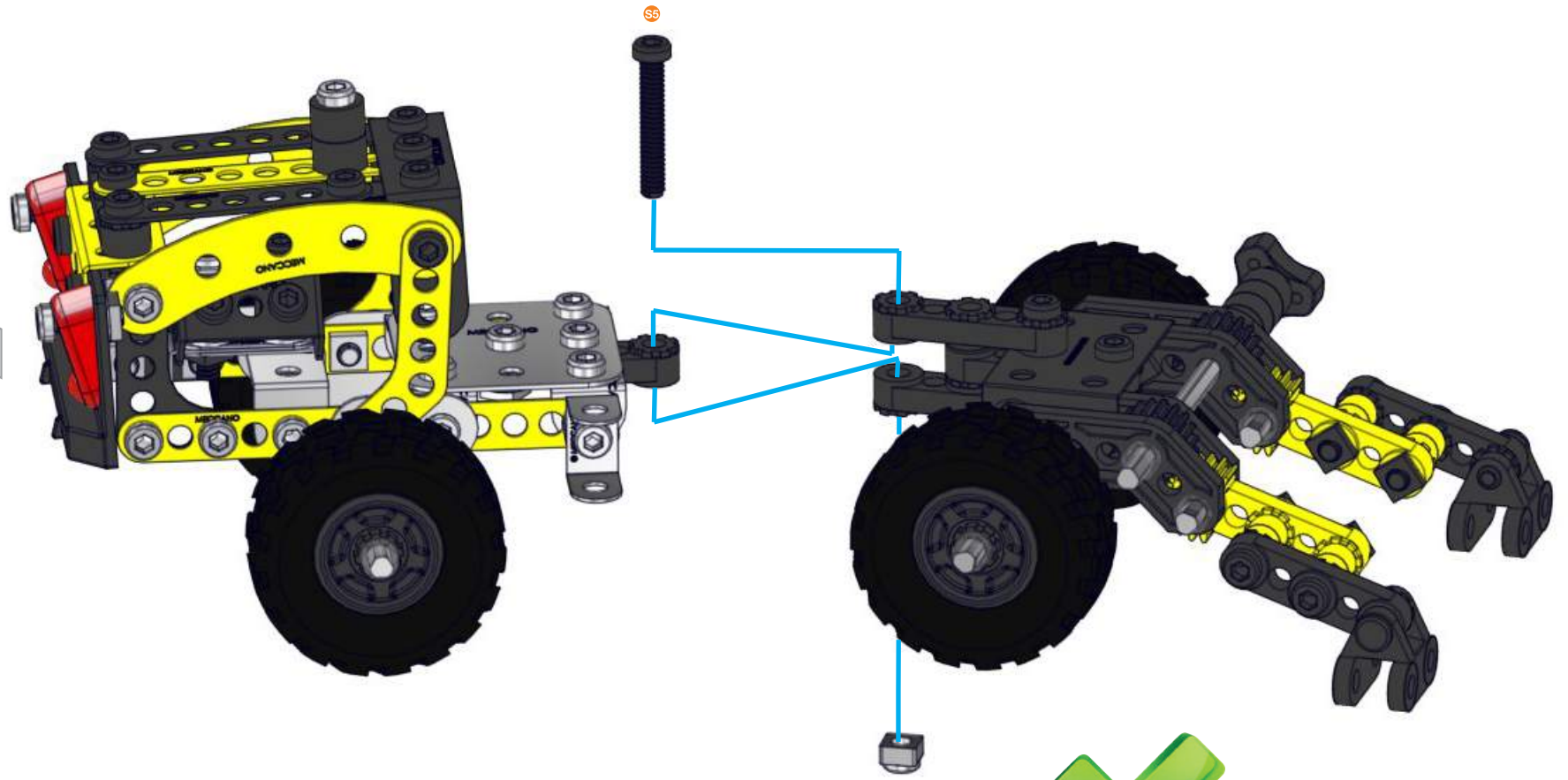

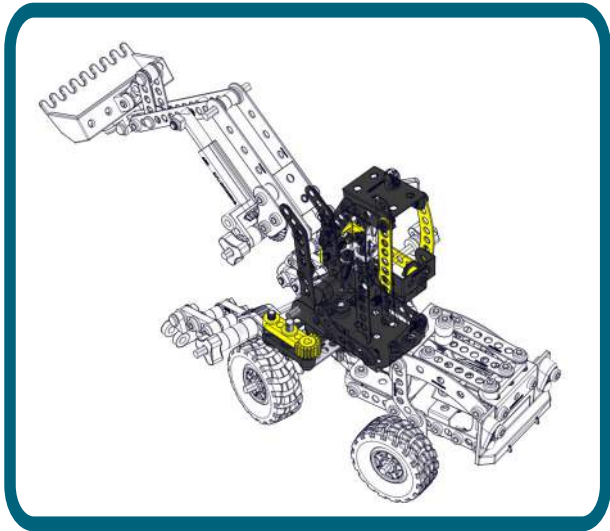

**35**

	x1
	x1
	x1
	x1

	S1	1:1
--	----	-----

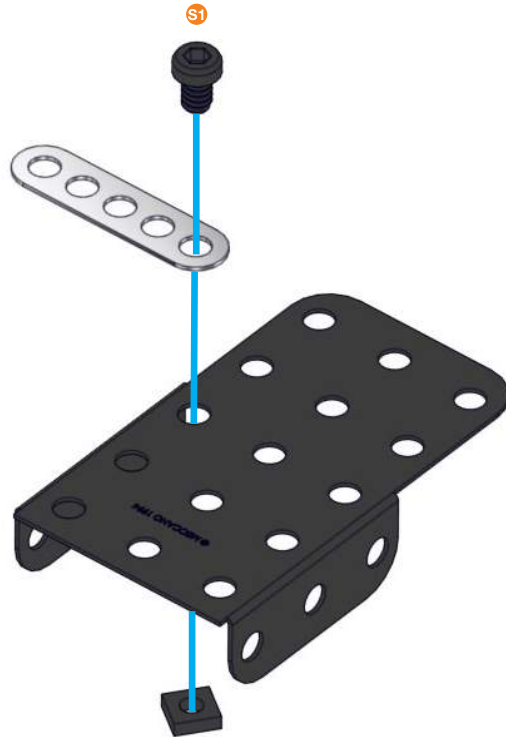

**36** <sup>35</sup> +

	x1
	x1
	x1
	x1

	S1	1:1
--	----	-----

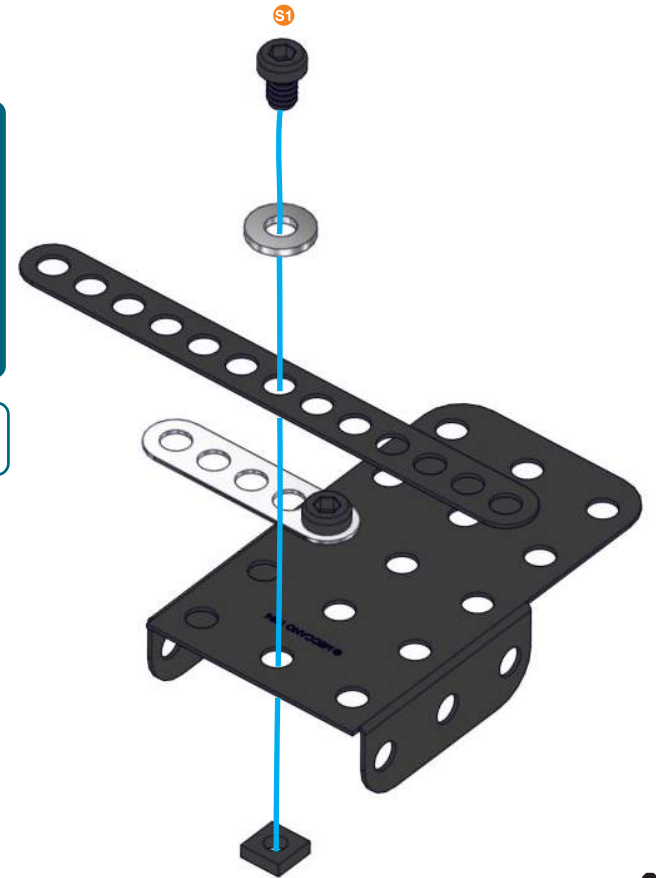

**37** 36 +

	<b>x1</b>
	<b>x2</b>
 <span style="border: 1px solid black; border-radius: 50%; padding: 2px;">S1</span>   14,7mm   37/64"	<b>x2</b>
	<b>x2</b>

 <span style="border: 1px solid black; border-radius: 50%; padding: 2px;">S1</span>	<b>1:1</b>
--	------------

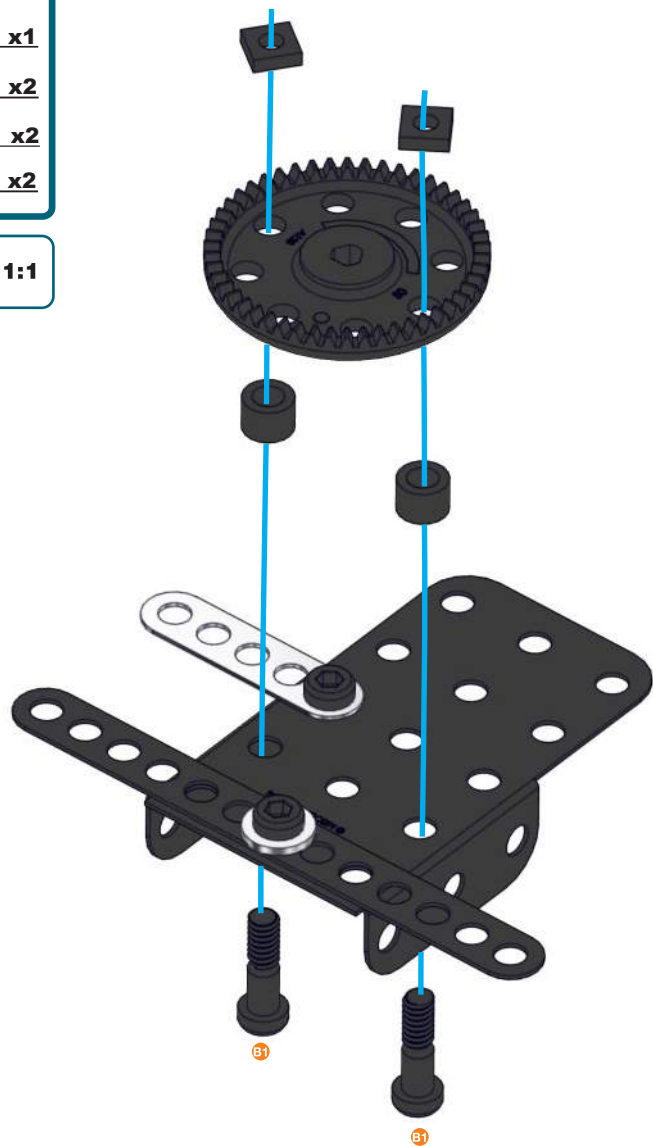

**38** 37 +

	<b>x2</b>
 <span style="border: 1px solid black; border-radius: 50%; padding: 2px;">S1</span>   5,8mm   15/64"	<b>x1</b>
	<b>x1</b>

 <span style="border: 1px solid black; border-radius: 50%; padding: 2px;">S1</span>	<b>1:1</b>
--	------------

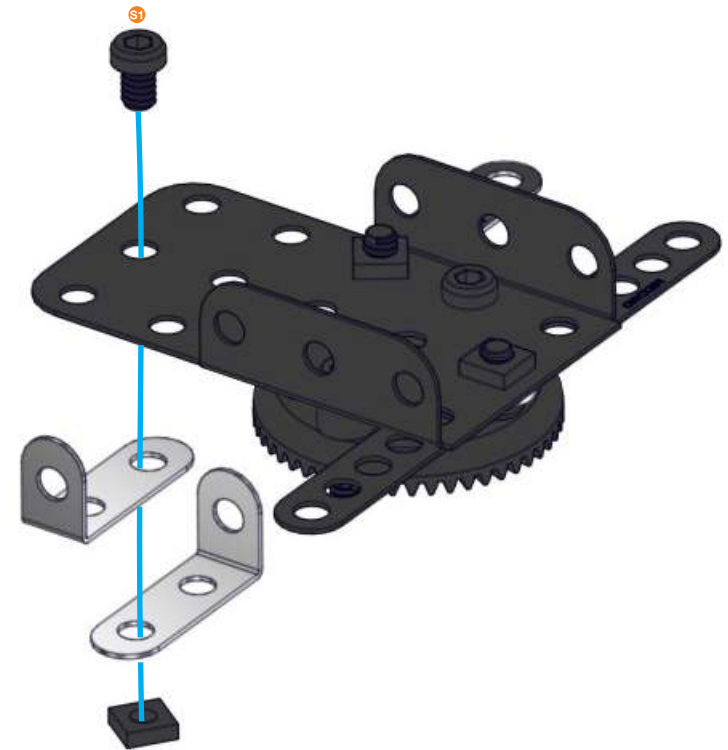

**39** 38+

	x1
	x2
	x2

	S1	1:1
--	----	-----

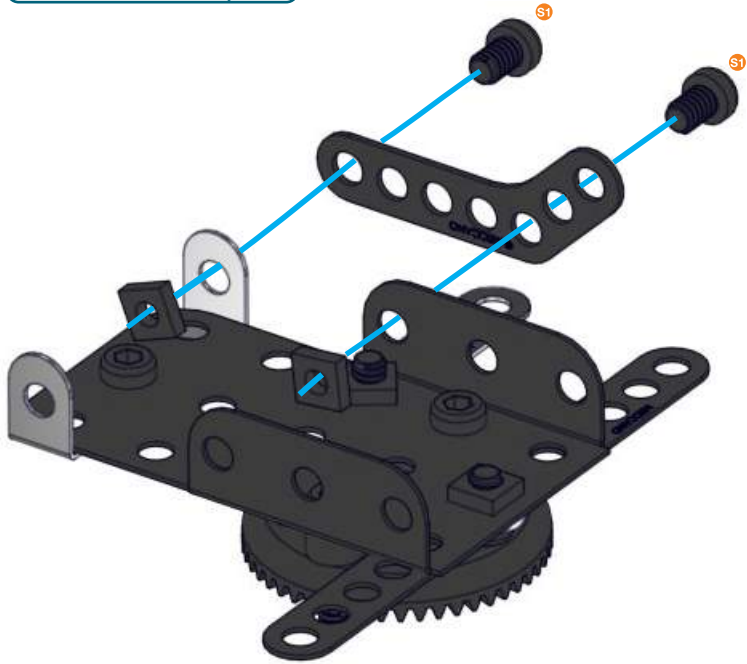

**40** 39+

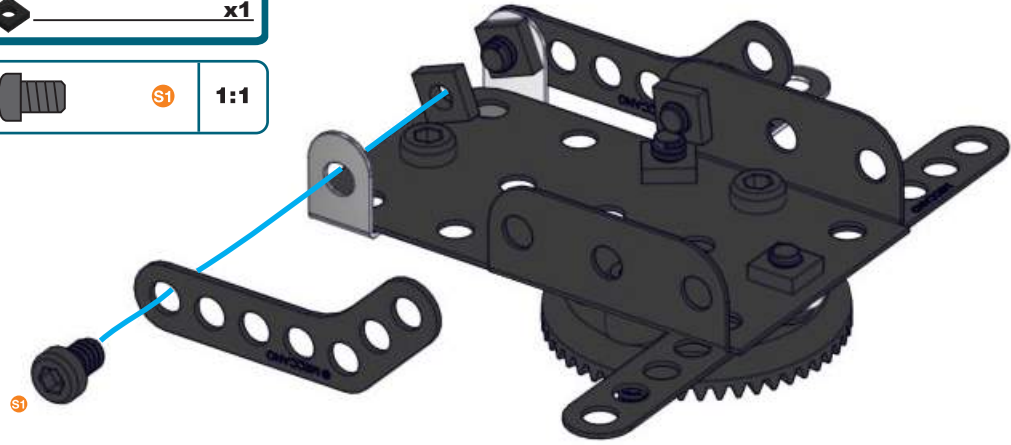

	x1
	x1
	x1

	S1	1:1
--	----	-----





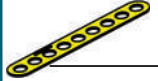

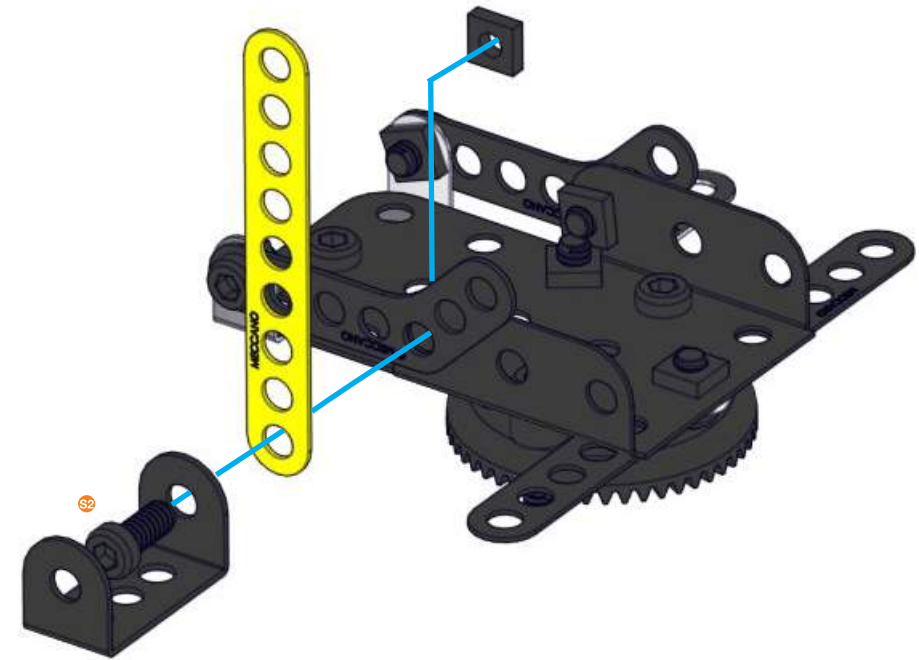

41 (40) +

	x1
	x1
 9,5mm 3/8"	x1
	x1

	S2	1:1
---	----	-----



42 (41) +

	x1
	x1
 5,8mm 15/64"	x1
	x1

	S1	1:1
---	----	-----

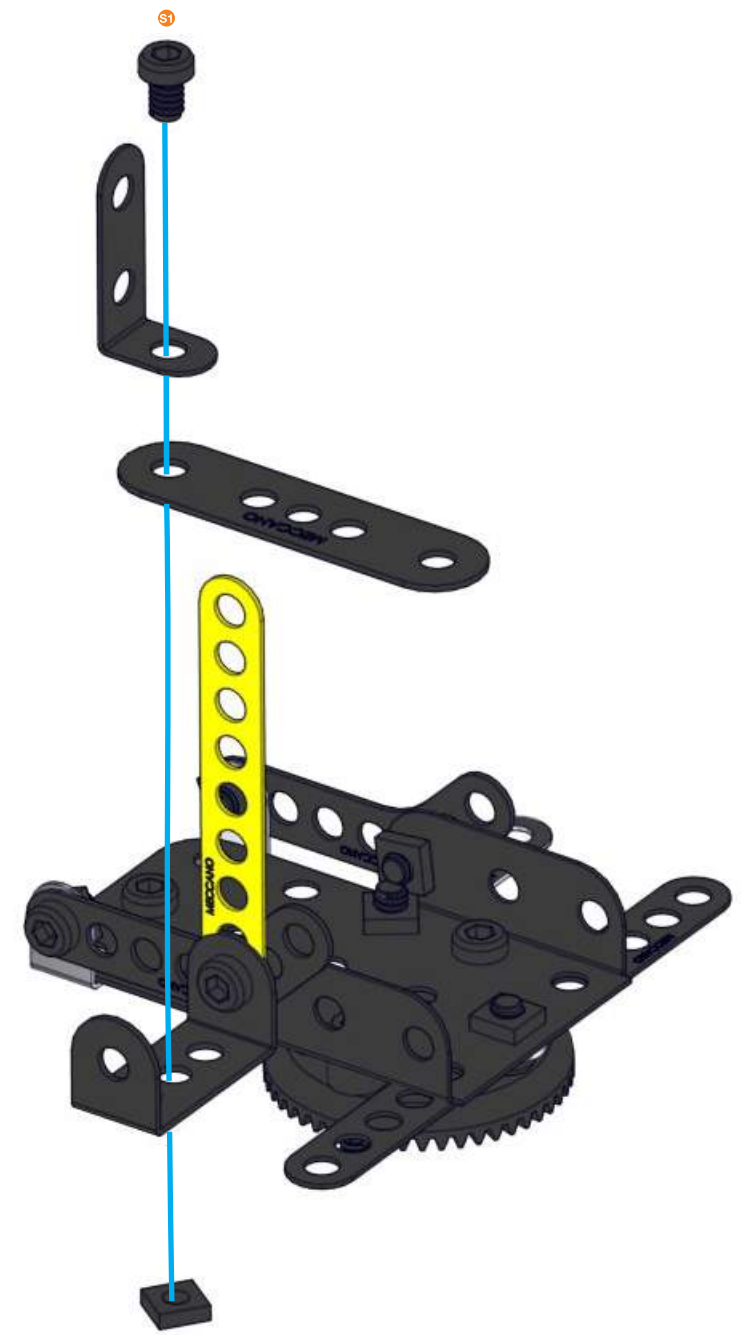

43

	x2
	x2
	x2
	x2

	1:1
--	-----

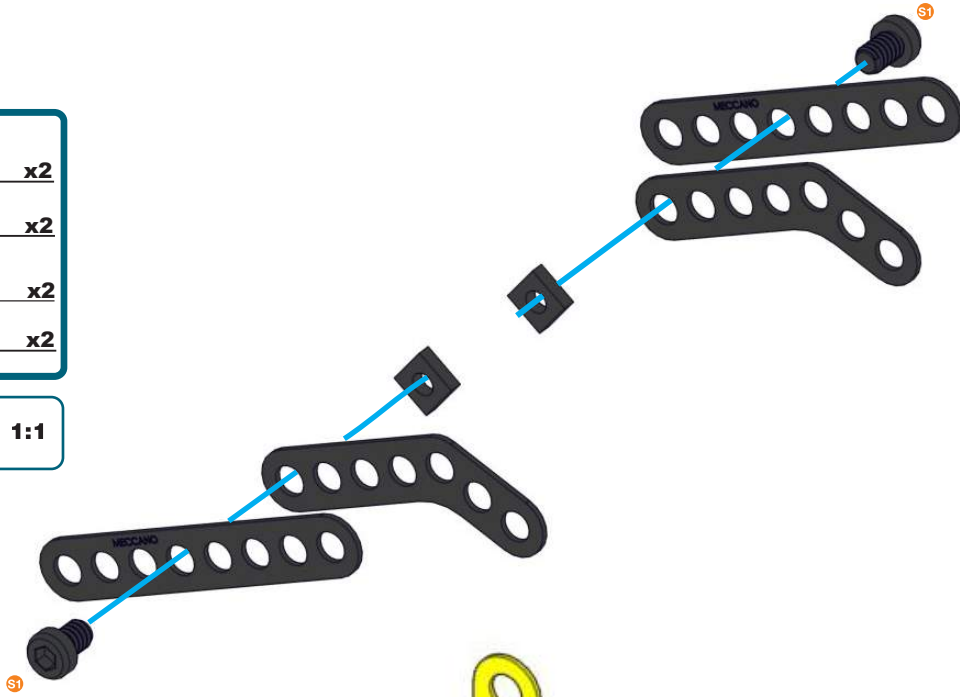

44

42+43+

	50mm 2"	x1
		x5
		x2

	1:1
--	-----

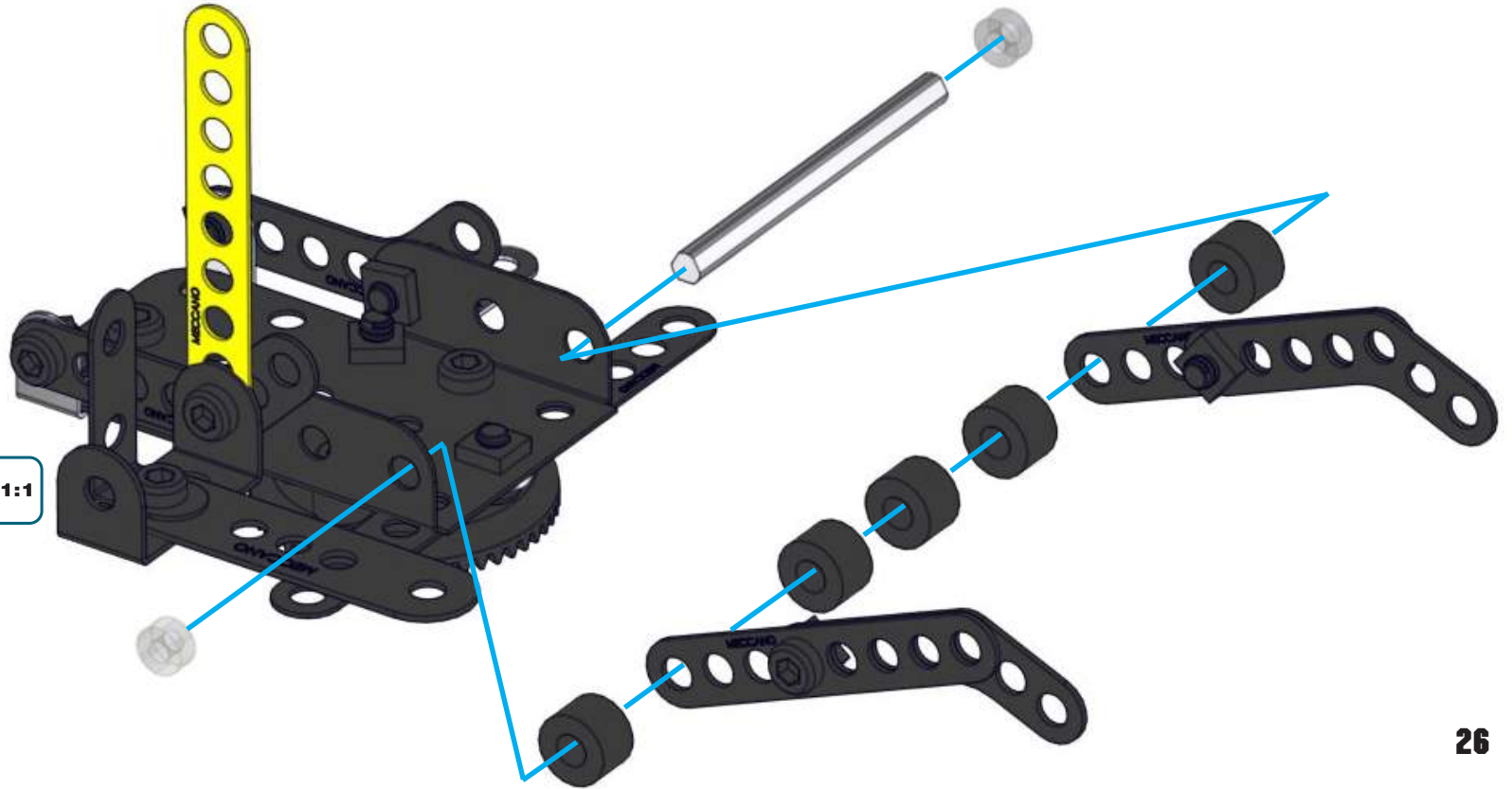

**45** (44) +

	x1
	x2
19mm / 3/4"	x1
	x1

	S4	1:1
--	----	-----

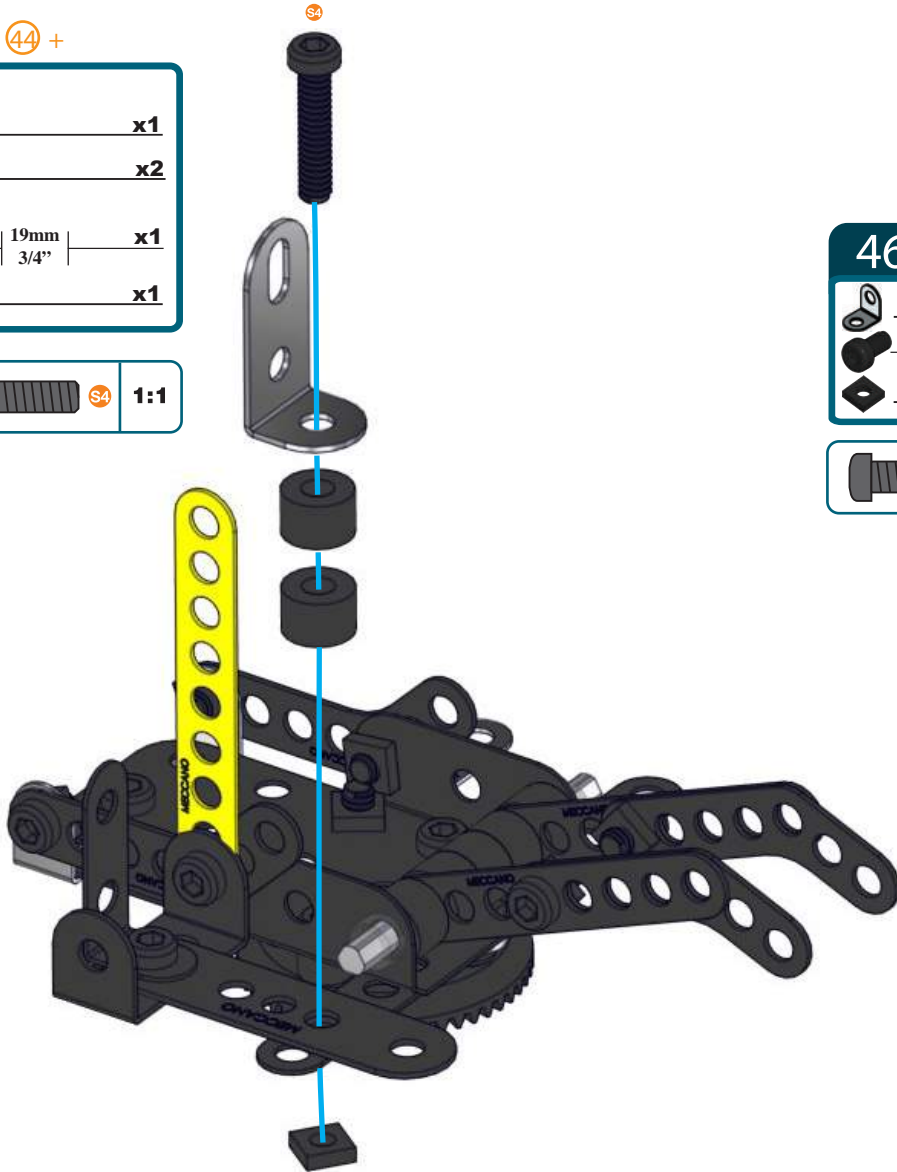

**46** (45) +

	x1
5,8mm / 15/64"	x1
	x1

	S1	1:1
--	----	-----

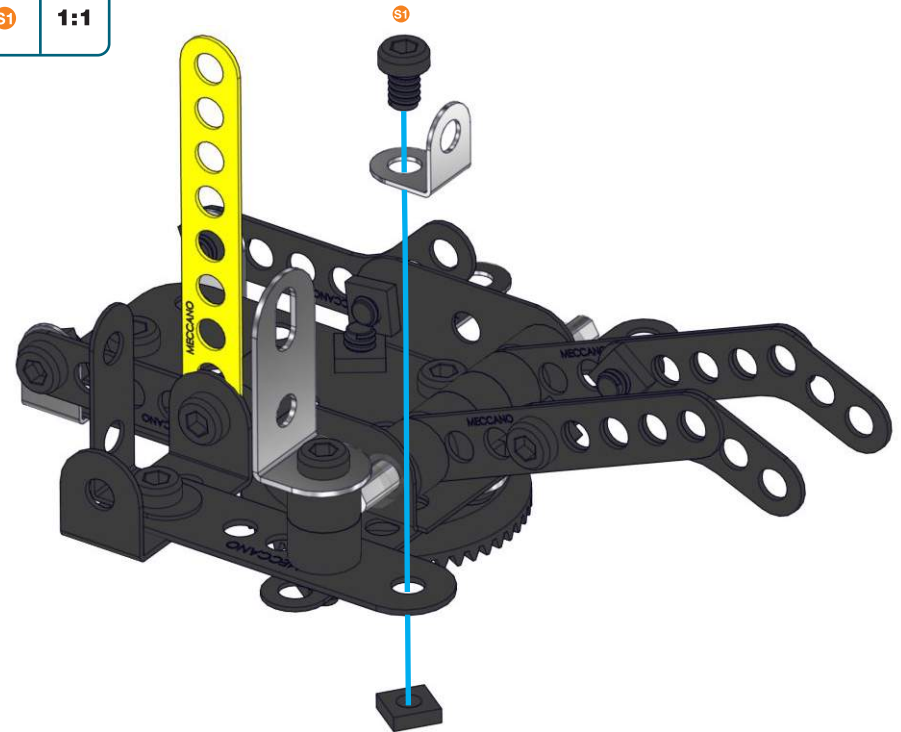

**47**

	x1
	x1
	x1
	x1

	<b>S1</b>	<b>1:1</b>
--	-----------	------------

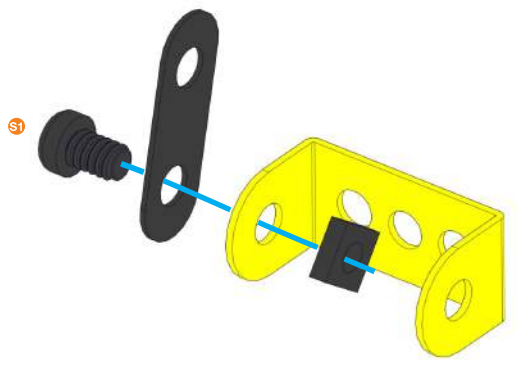

**48** (46)+(47)+

	<b>S1</b> 5,8mm   15/64"	x1
		x1

	<b>S1</b>	<b>1:1</b>
--	-----------	------------



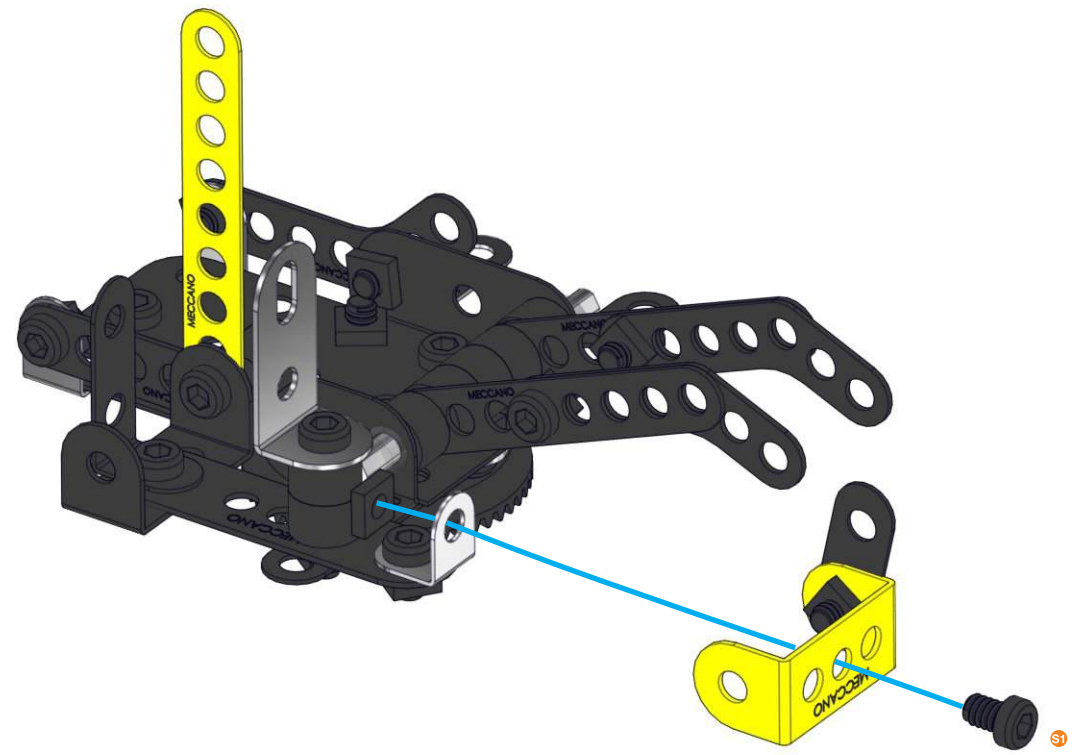

49

48 +

	x1
	x1
	x1

	1:1
--	-----

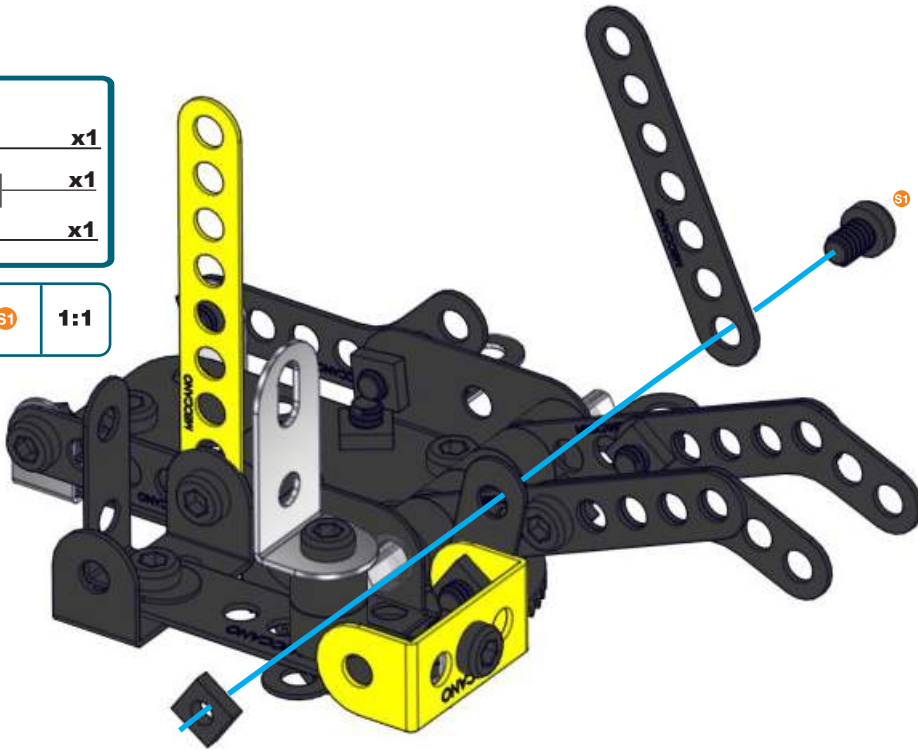



50

49 +

	x1
	x1
	x1

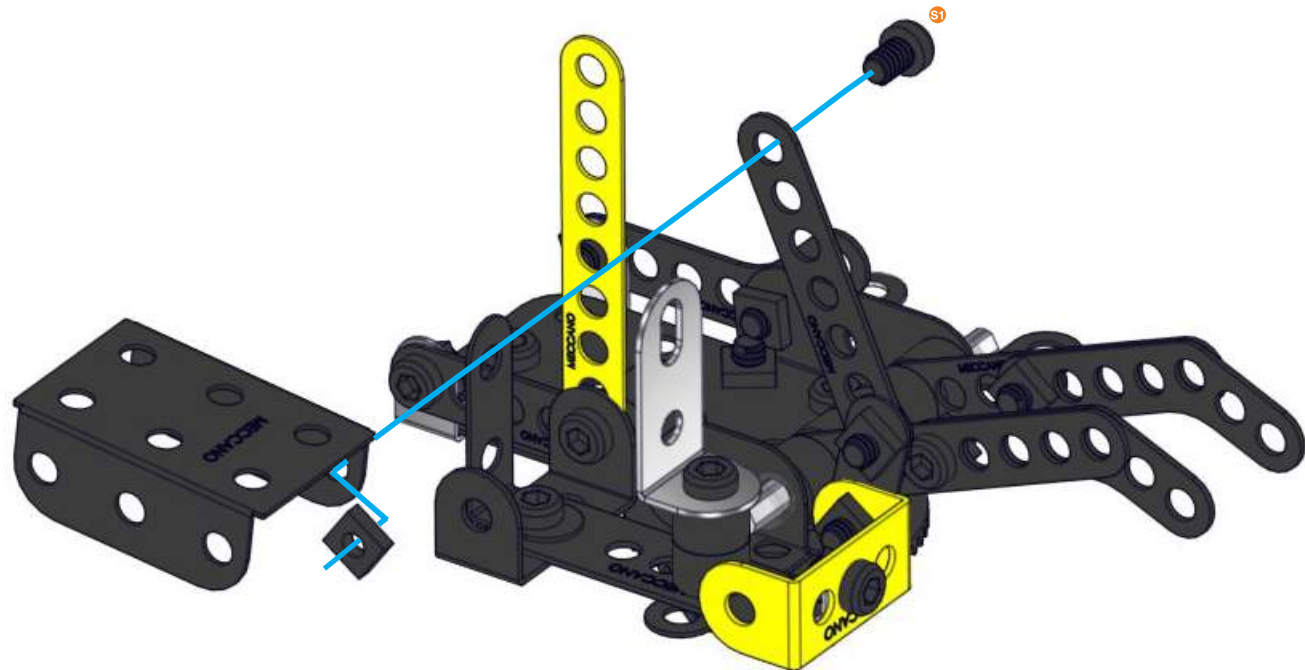
	1:1
--	-----



<b>51</b>		<b>50 +</b>	
	<b>5,8mm</b> <b>15/64"</b>	<b>x1</b>	
		<b>x1</b>	

	<b>1:1</b>
---	------------

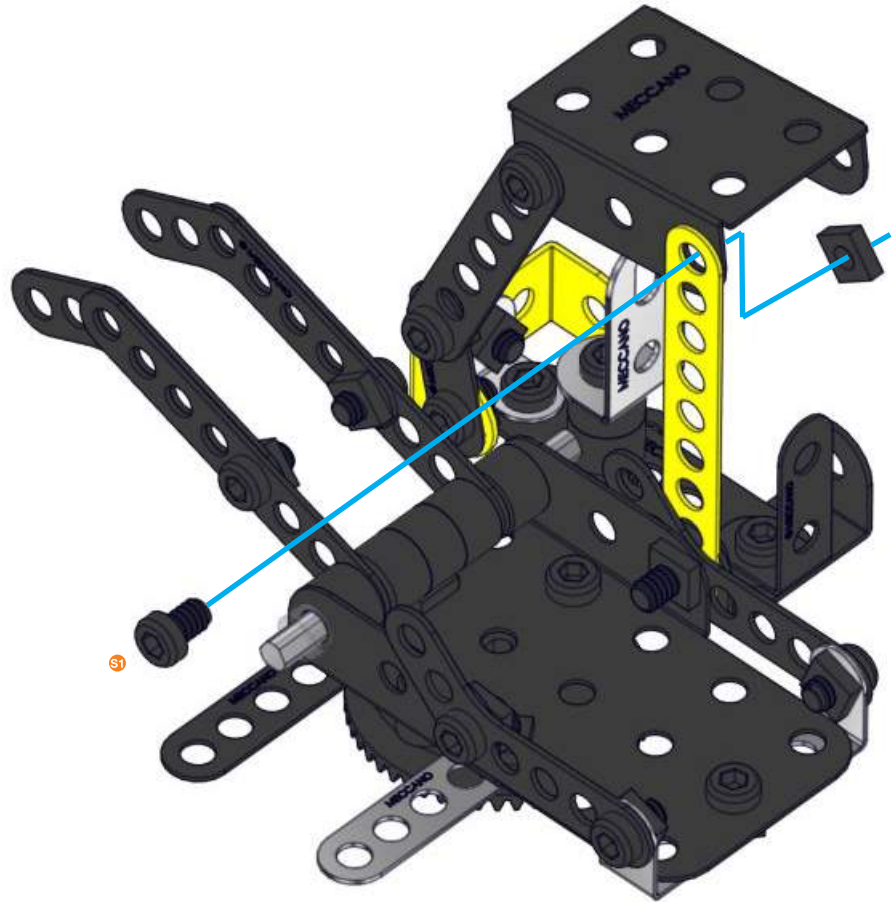

**52** (51) +

	x1	
	x1	
	x1	
	5,8mm 15/64"	x3
	x3	

	S1	1:1
--	----	-----

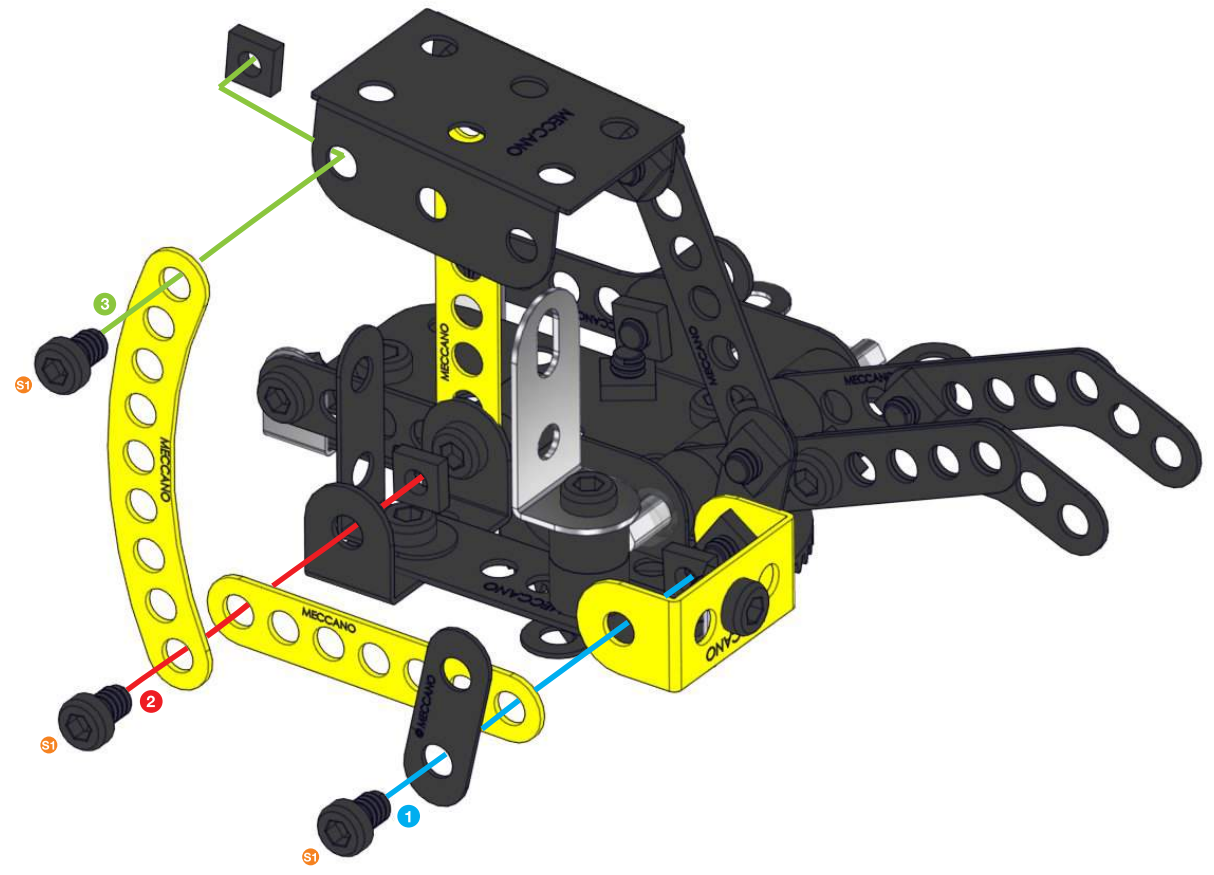

**53** (52) +

	x1
	x1
	x1
	x1

	(S2)	1:1
--	------	-----

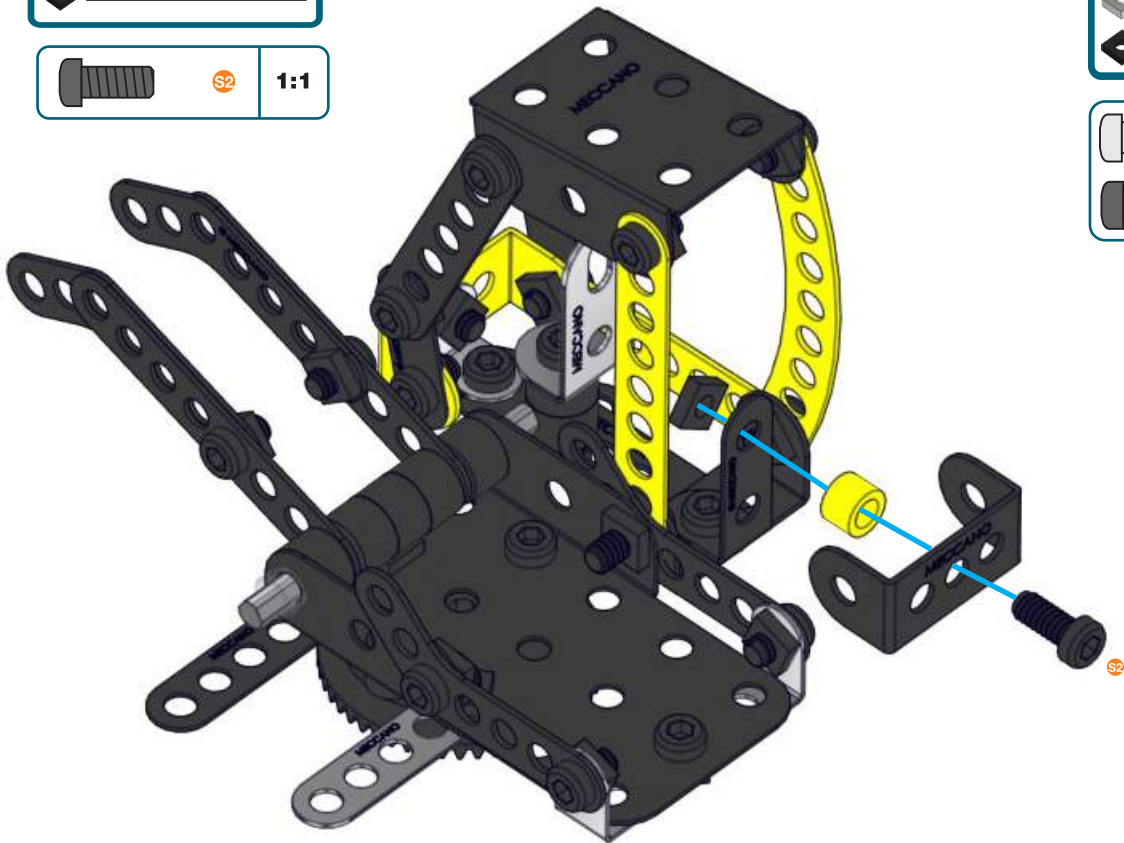

**54** (53) +

	x1
	(S4) 19mm 3/4" x1
	(S2) 9.5mm 3/8" x1
	x1
	x1



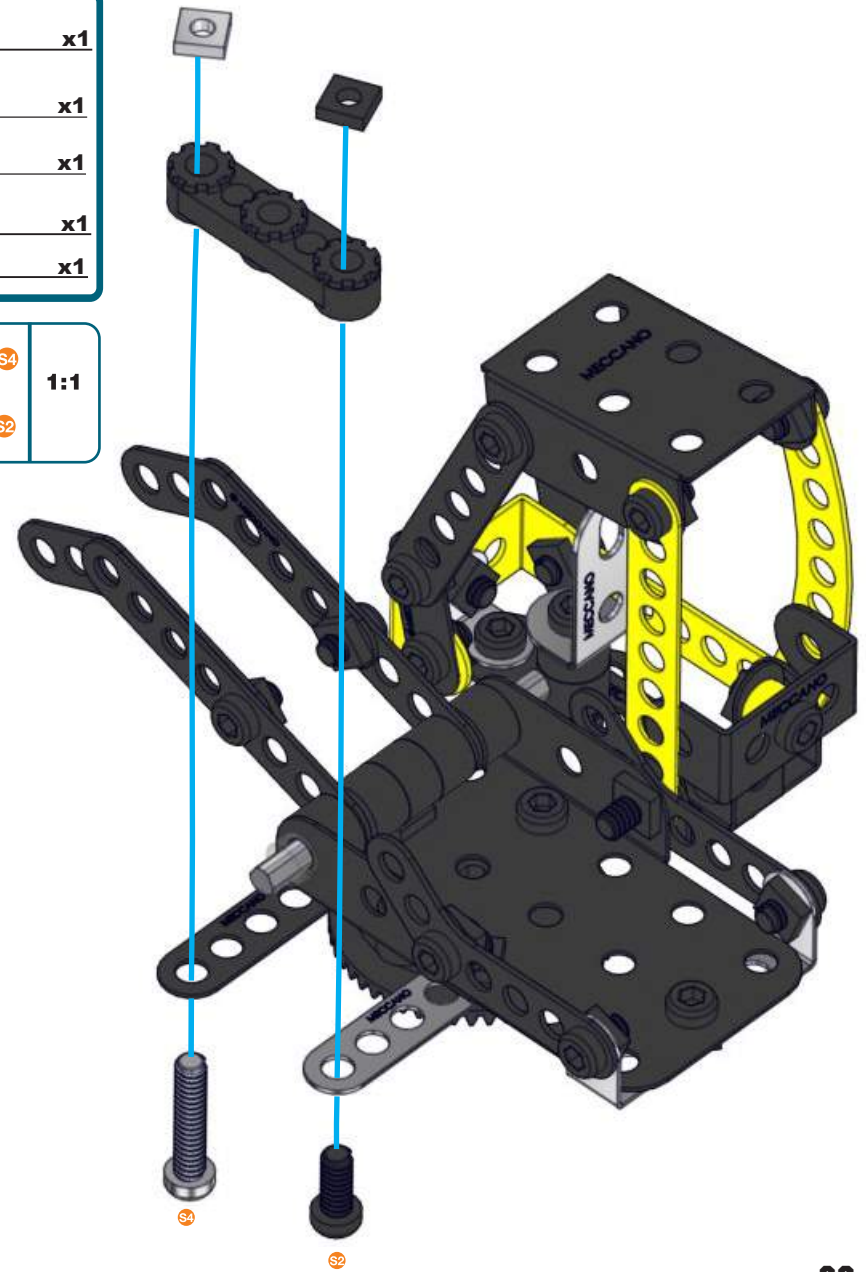

	(S4) 1:1
	(S2) 1:1





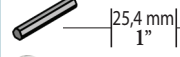

55 54 +

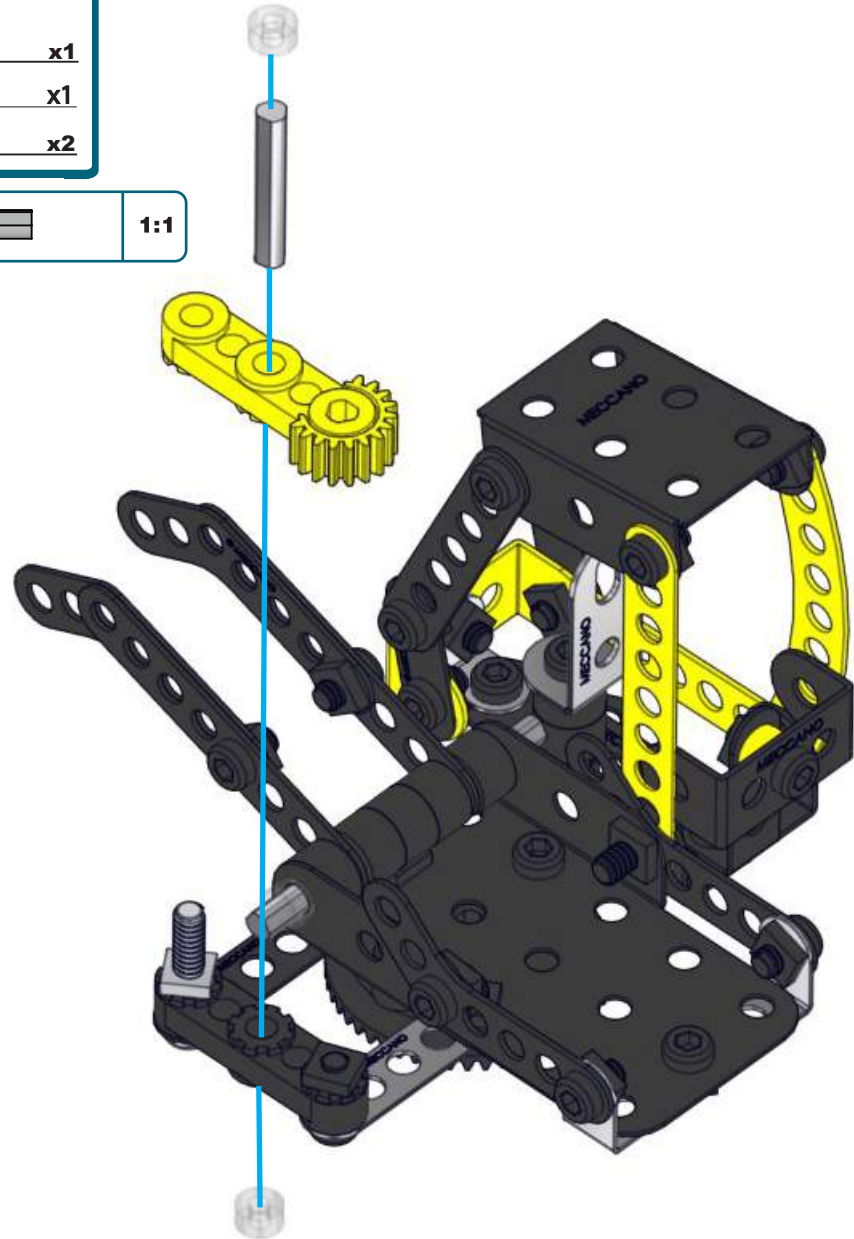
-  x1
-  x1
-  x2



56 55 +

-  x1
-  x1

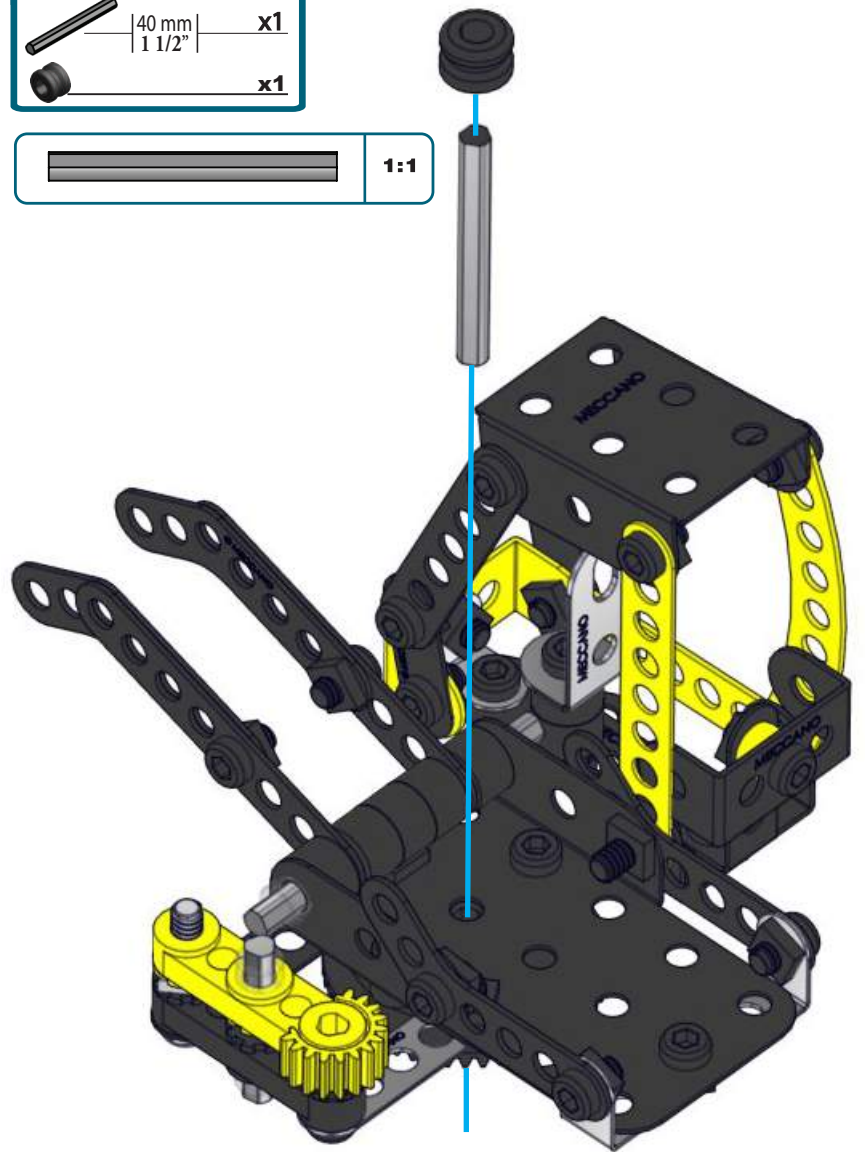
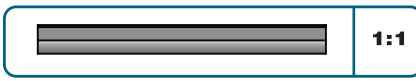

57

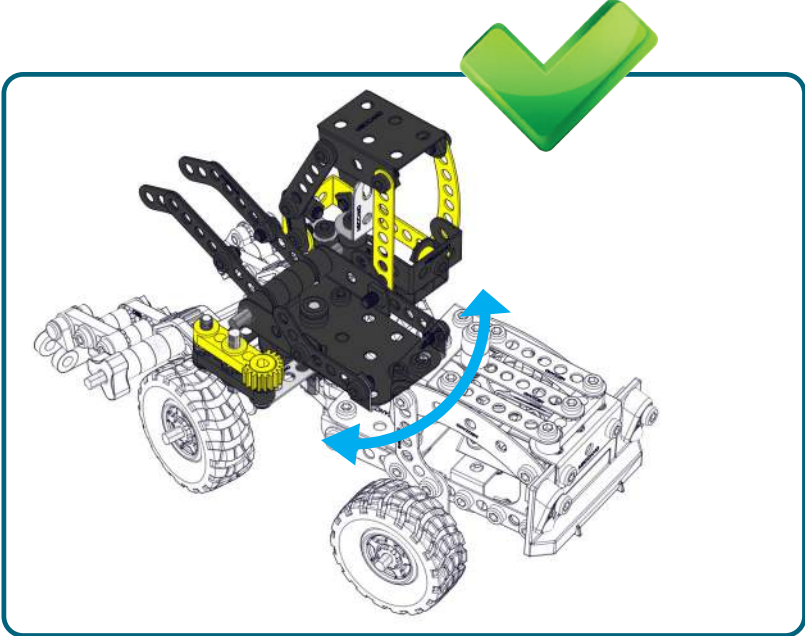
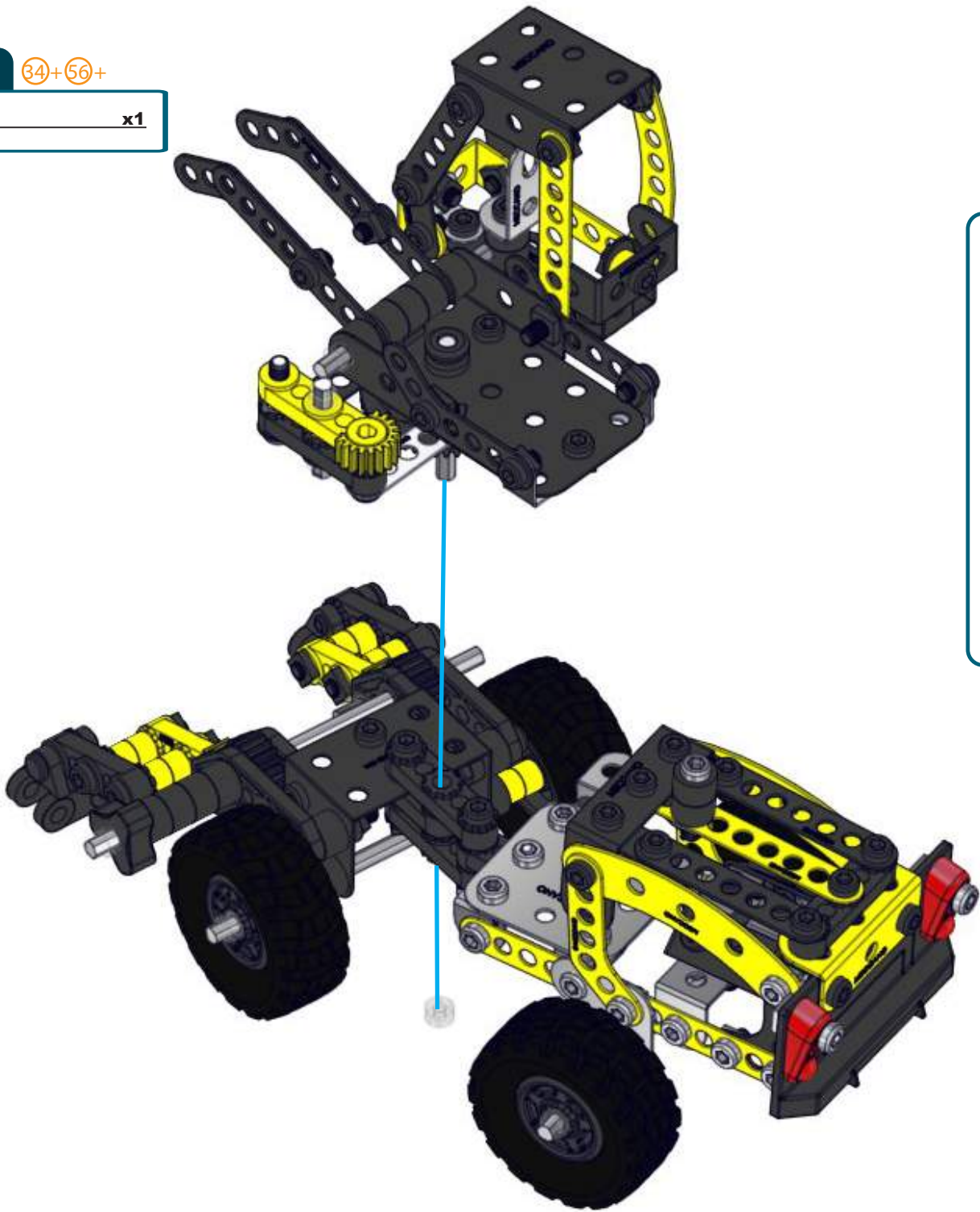

Ⓟ4+ Ⓟ6+

\_\_\_\_\_ x1



58

57+

		<b>x1</b>
	5,8mm 15/64"	<b>x2</b>
		<b>x2</b>

	S1	<b>1:1</b>
---	----	------------





59 58 +



	x1
	<span style="border: 1px solid orange; border-radius: 50%; padding: 2px;">S2</span> 9,5mm 3/8" x1
	x1

	<span style="border: 1px solid orange; border-radius: 50%; padding: 2px;">S2</span>	1:1
---	---	-----





60 59+

	x1
	x1

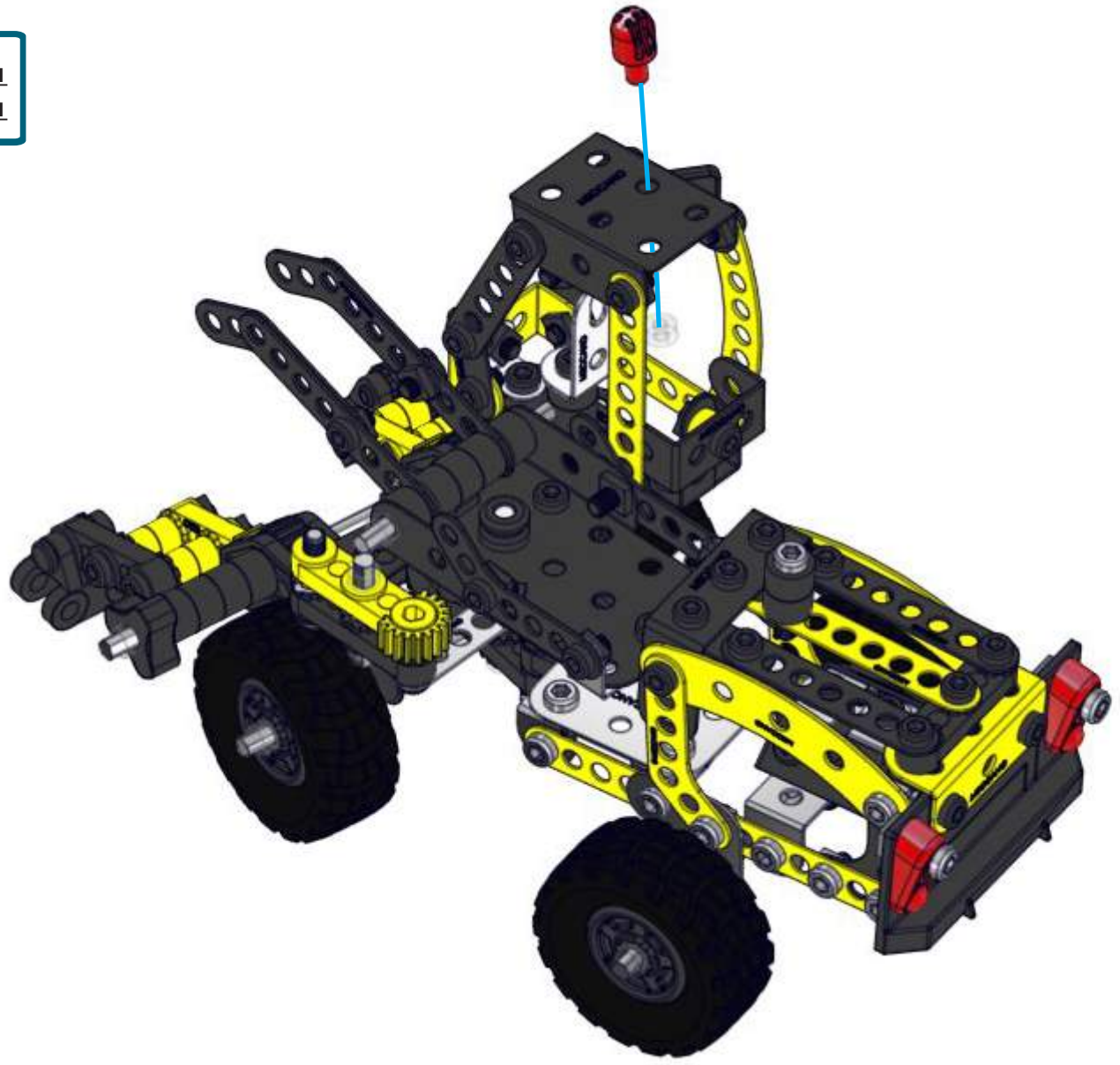



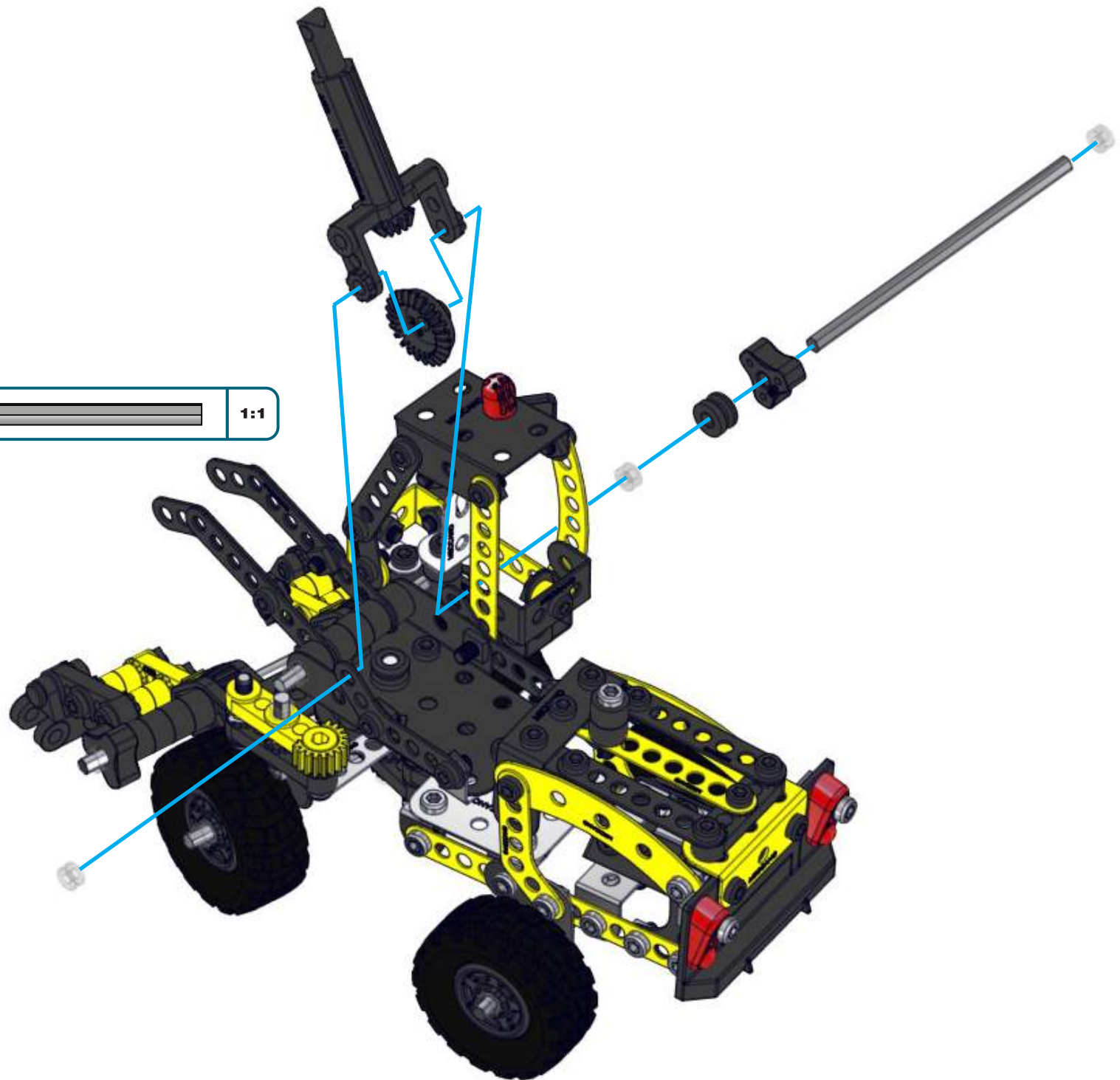

61

60+

-  90mm  
3 1/2" x1
-  x1
-  x1
-  x1
-  x1
-  x3

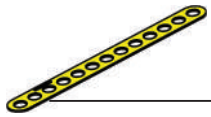

62 61+

	x1
	x1
	x1
	x1





63 62+

	x1
	x1
	x1
	x1

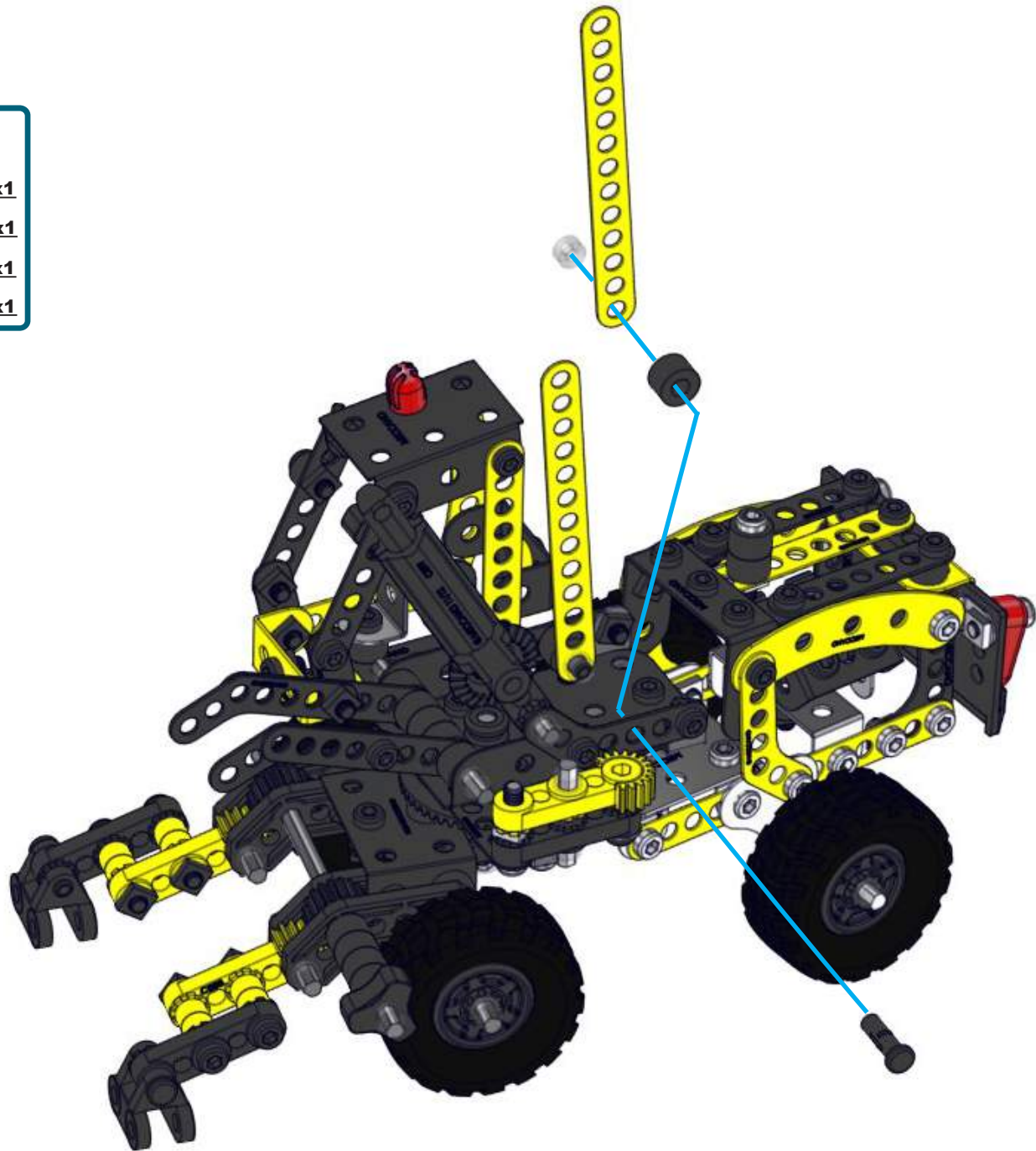



64

	x2
	x1
	x1
	x1

	S2	1:1
--	----	-----

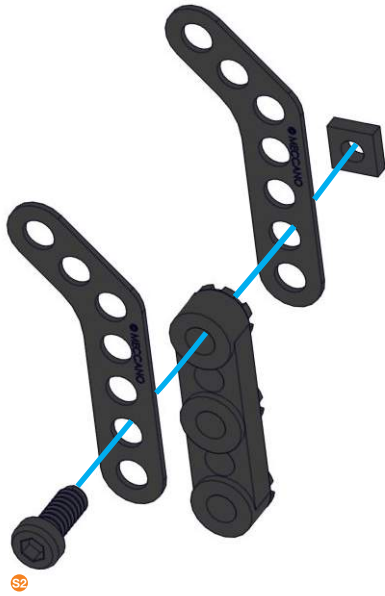

65



63+64+

	32mm 1 1/4"	x1
		x2
		x2

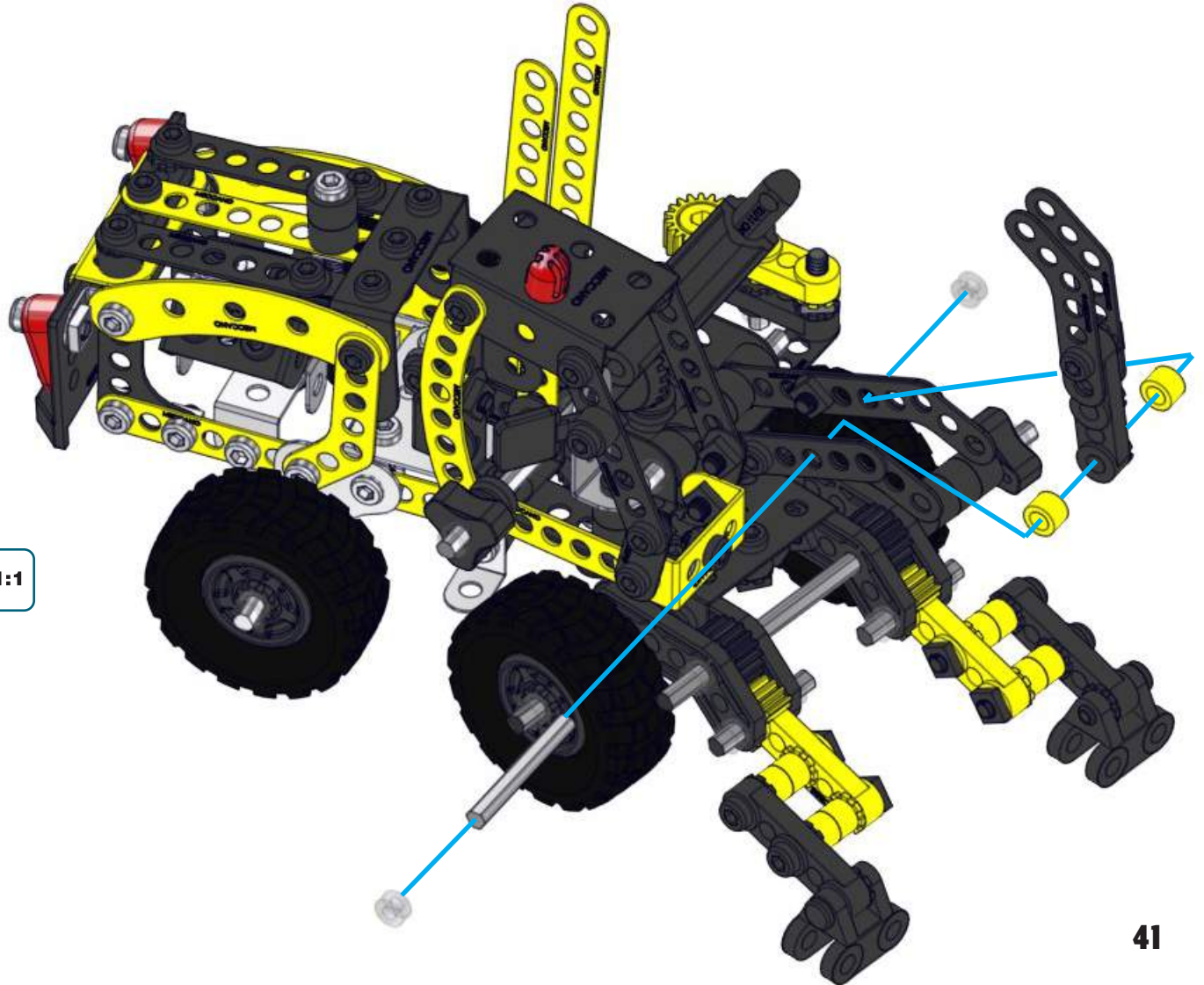
	1:1
--	-----



66 (65) +

	S6 28mm 1 1/8"	x1
		x2
		x1

	S6	1:1
---	----	-----

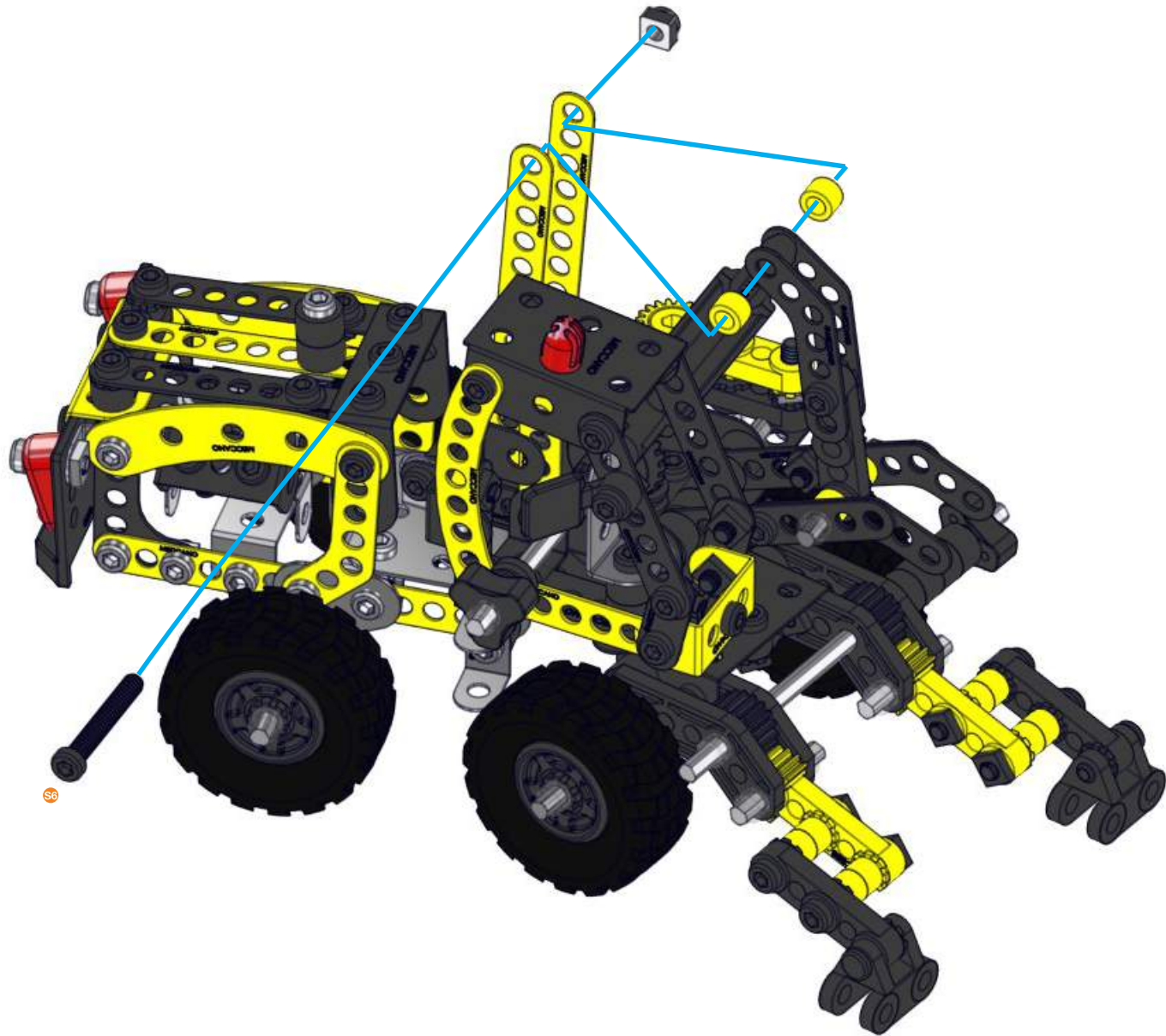
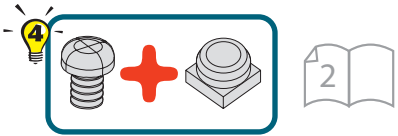

67 66 +



x2



5,8mm  
15/64"

x2



x2



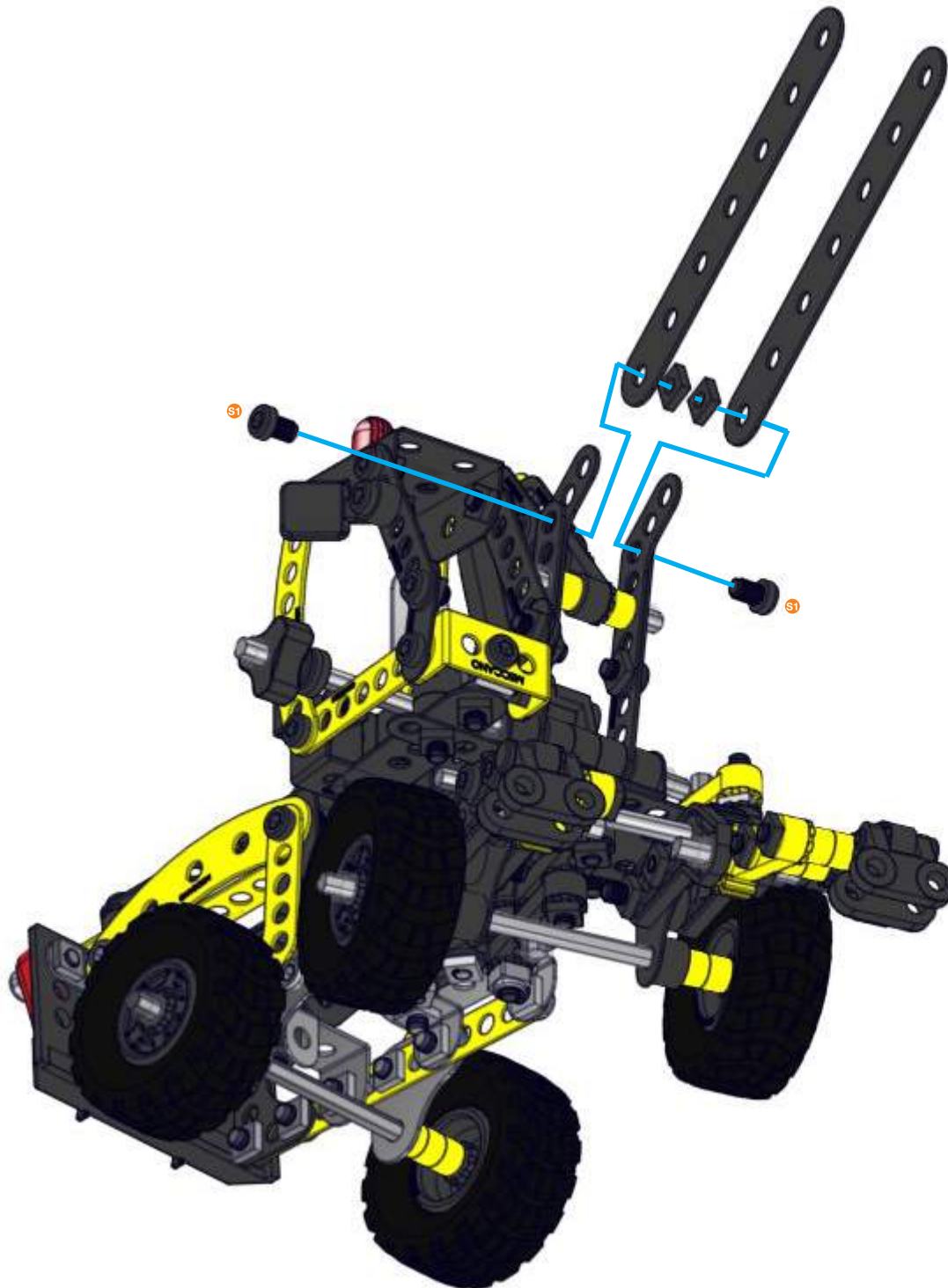

S1

1:1





68

-  x1
-  S1 5,8mm  
15/64" x1
-  x1

-  S1 1:1





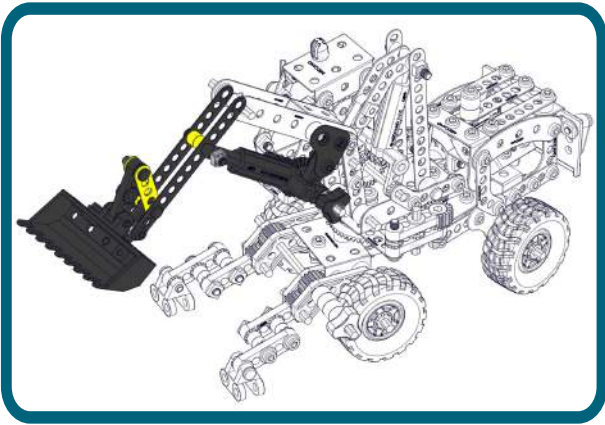

69

	x2
	x2
	x2

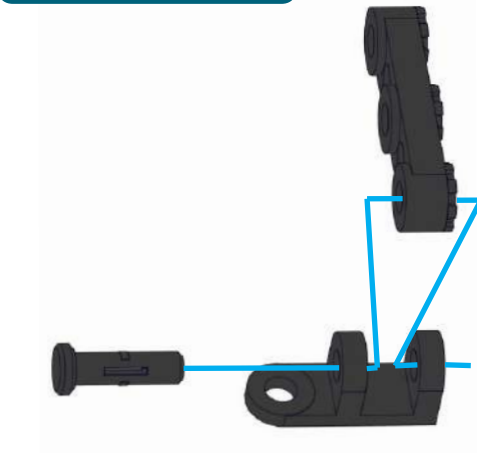

x2



70 <sup>69+</sup>

	x1
	x1
	x1

	S2	1:1
--	----	-----

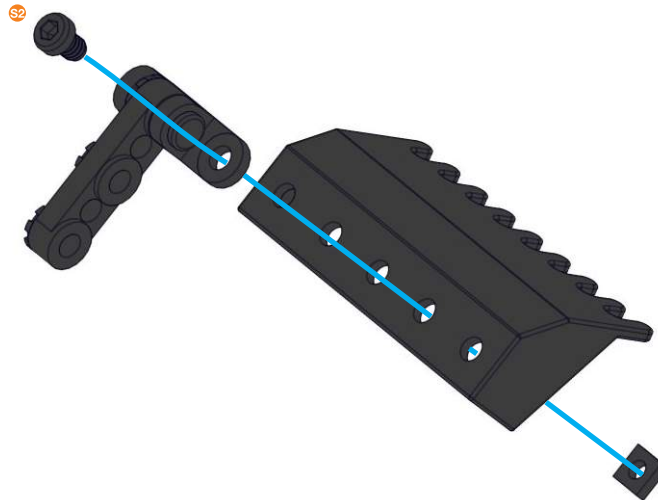



71 <sup>69+</sup> <sup>70+</sup>

	S2	9,5mm	x1
		3/8"	x1

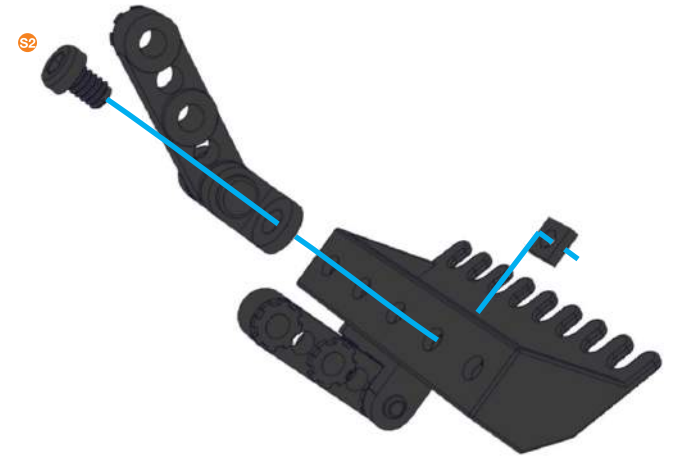
	S2	1:1
--	----	-----





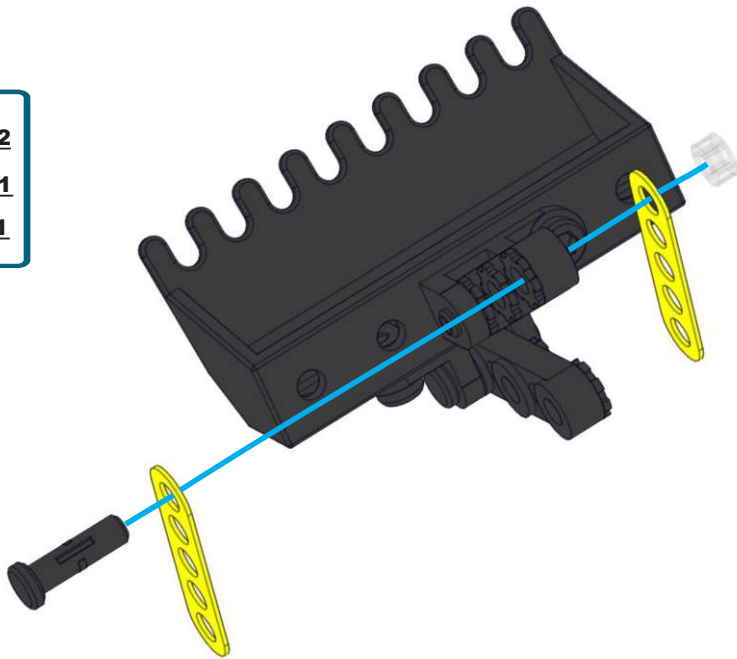

72 71+

	x2
	x1
	x1

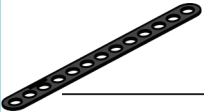



73 72+

	x2
	x2
	14,7mm 37/64" x1
	x1

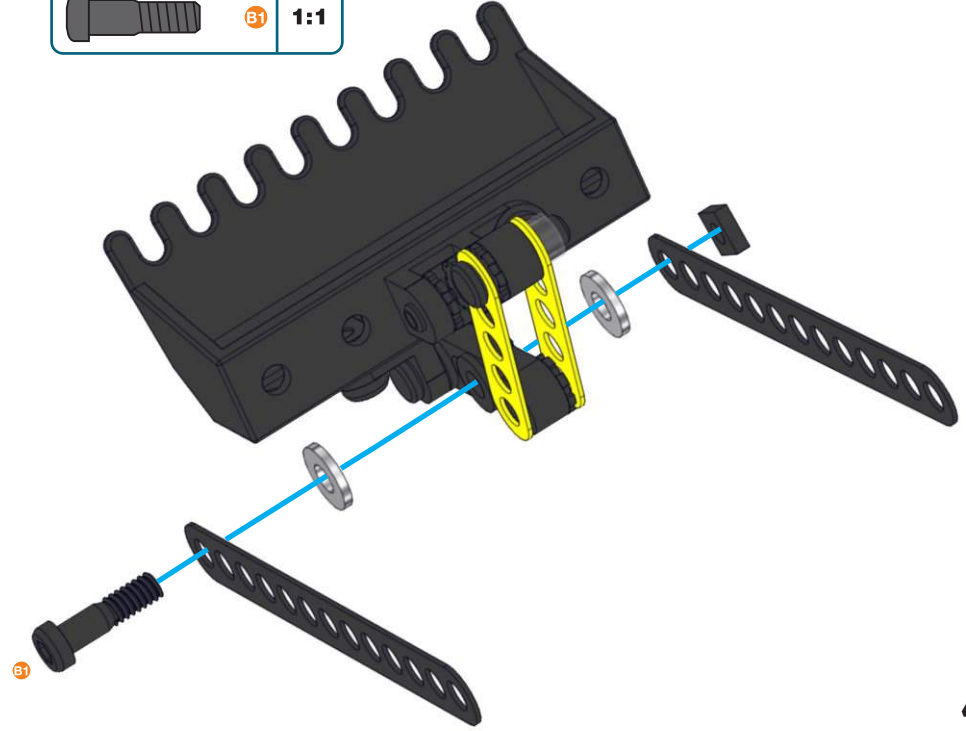
	B1 1:1
---	--------







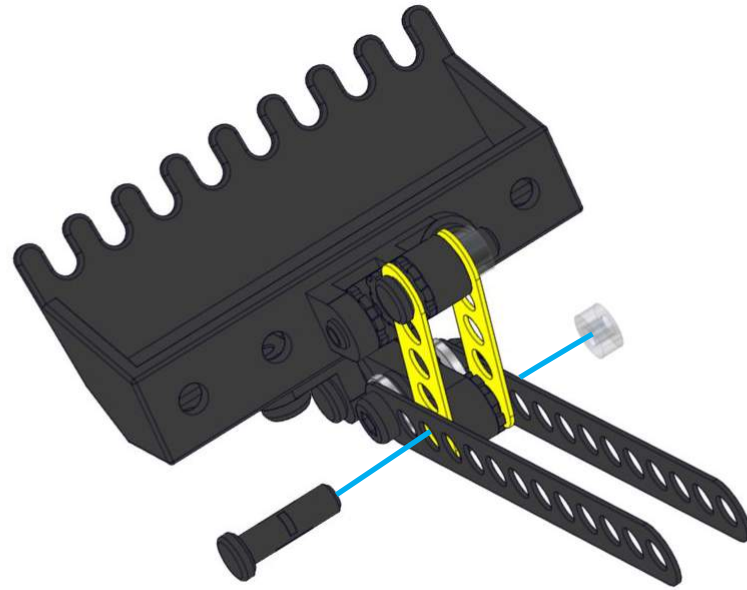



74 73 +

	x1
	x1





**75**

	50mm 2"	x1
		x1
		x1
		x1
		x1
		x2
		x1
		x3

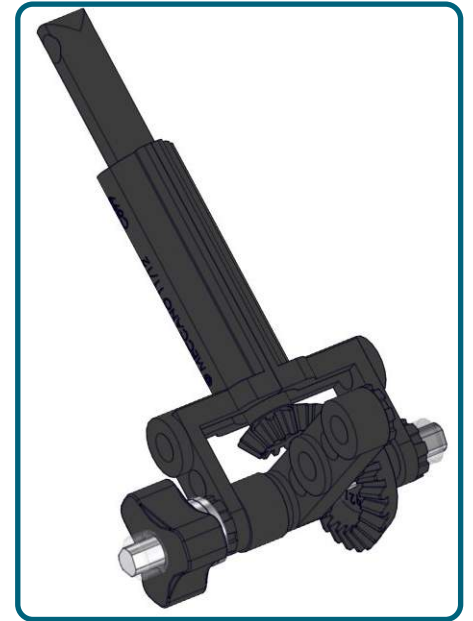
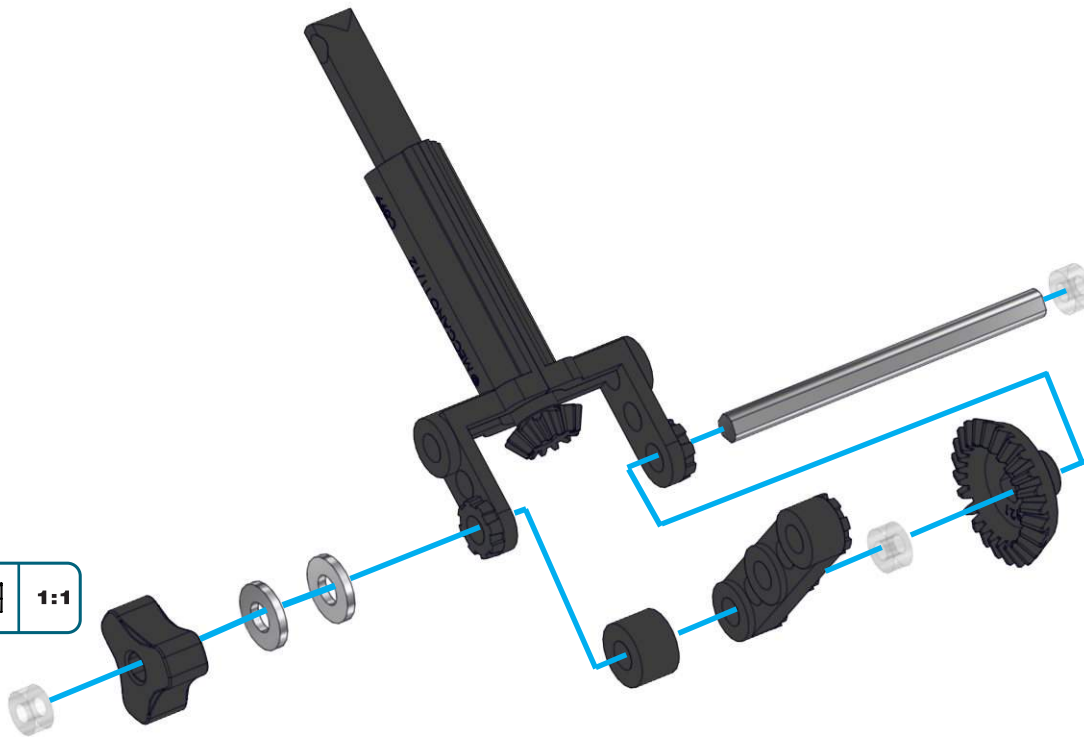
	1:1
---	-----



**76** (75+)

		x1
	S2 9,5mm 3/8"	x1
		x1

	S2	1:1
---	----	-----

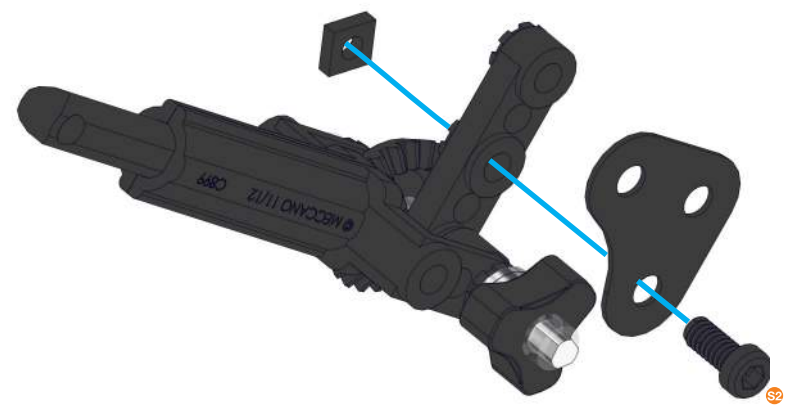



77

(74)+(76)+



	S5	25.4mm 1"	x1
			x2
			x1

	S5	1:1
--	----	-----

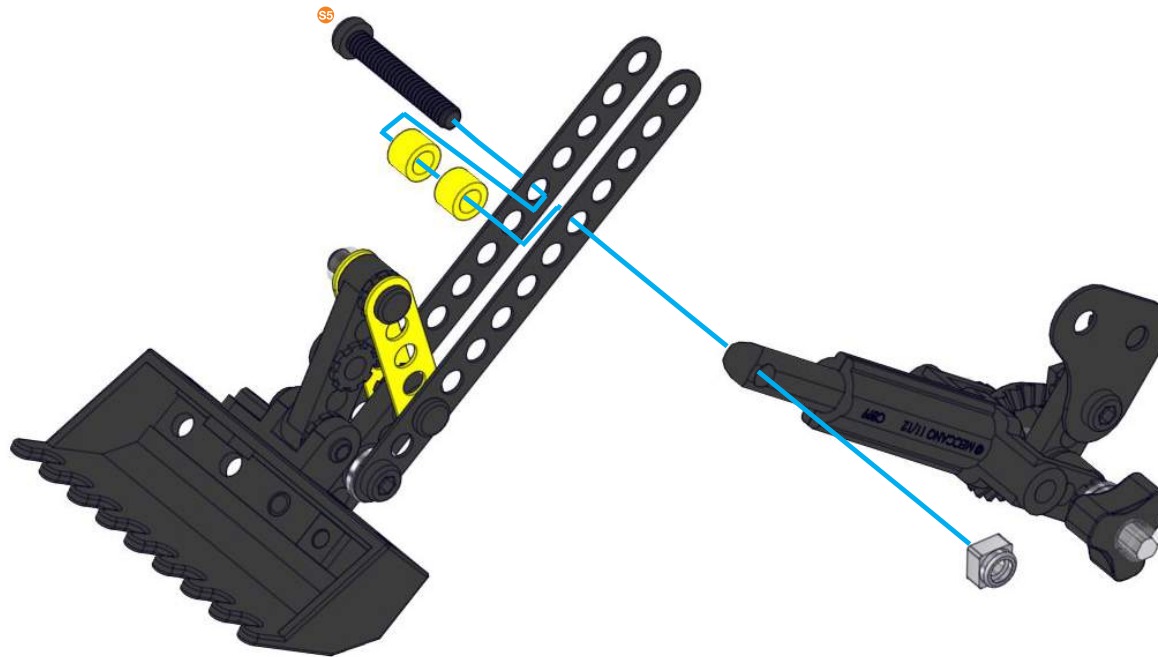
4 +



**78** 68+ 77+



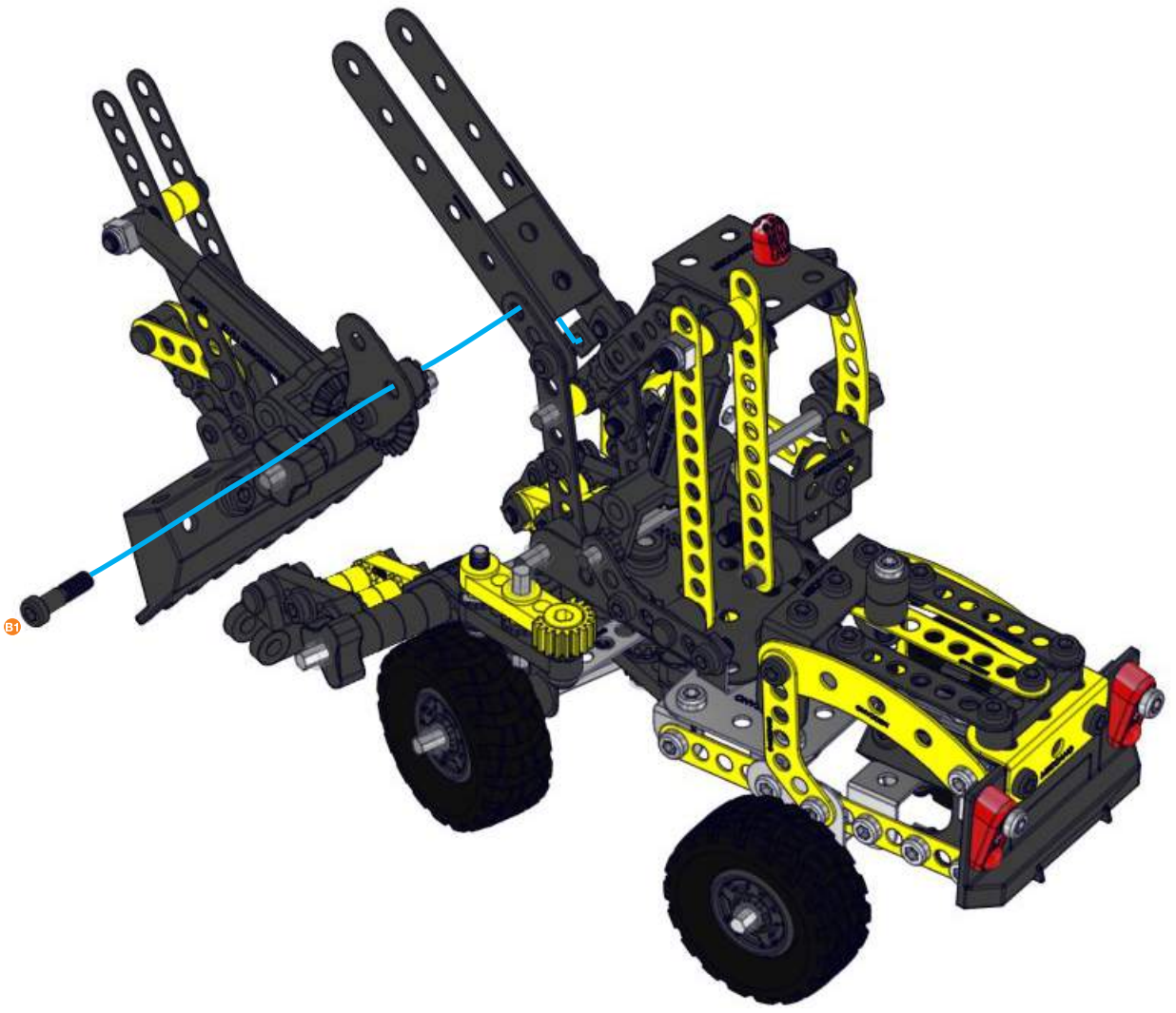

	61   14,7mm	x1
	37/64"	x1

	61	1:1
---	----	-----



79 78+





	_____	<b>x1</b>
	_____	<b>x1</b>
	<span style="border: 1px solid orange; border-radius: 50%; padding: 2px;">B1</span>   14,7mm   37/64"	<b>x1</b>
	_____	<b>x1</b>

	<span style="border: 1px solid orange; border-radius: 50%; padding: 2px;">B1</span>	<b>1:1</b>
---	---	------------



80

79+

	40 mm 1 1/2"	x1
		x2
		x2
		x2

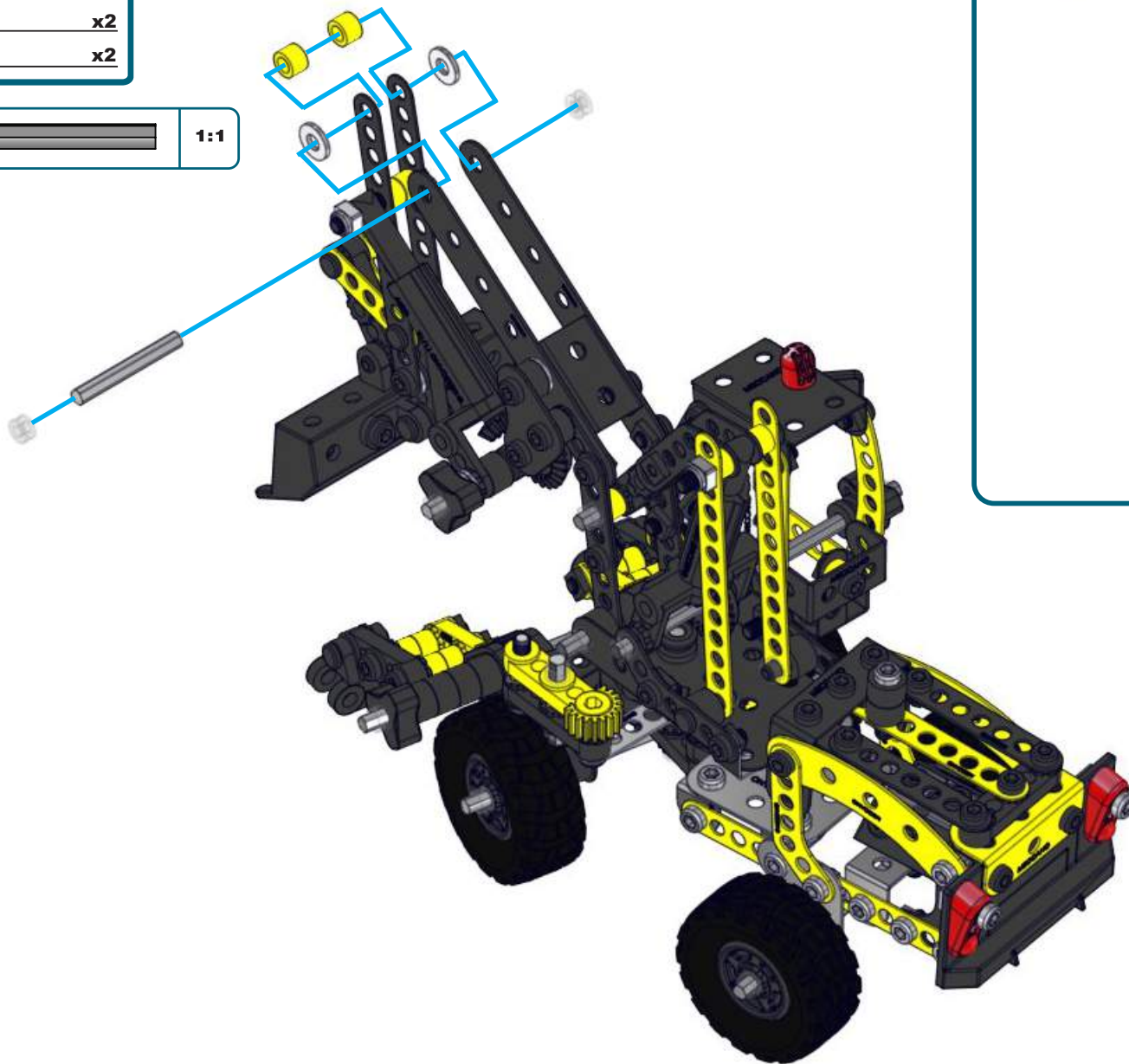
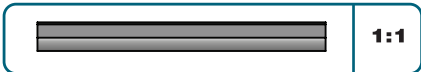



1	2	11
3	4	12
5	6	
7	EVO	
9	EVO	
10	EVO	







**GB.** Only one model can be built at a time. **F.** Les pièces fournies ne permettent de monter qu'un seul modèle à la fois. **E.** Solo es posible construir un modelo a la vez. **D.** Jeweils nur eins der Modelle baubar. **NL.** Er kan maar een model tegelijk worden gebouwd. **I.** Consente di realizzare un solo modello per volta. **P.** Só é possível montar um modelo de cada vez. **GR.** Μπορείτε να δημιουργείτε μόνο ένα μοντέλο κάθε φορά. **S.** Endast en modell kan byggas i taget. **DK.** Der kan kun bygges én model af gangen. **FIN.** Osista voidaan koota kerrallaan vain yksi malli. **R.** Одновременно можно построить только одну модель.



- GB** Content: 485 parts, 2 real tools, 1 sticker sheet and 1 instruction sheet for model#1.
- F** Contenu : 485 pièces, 2 vrais outils, 1 feuillet d'autocollants et 1 notice de montage pour le modèle 1.
- E** Contenido: 485 piezas, 2 herramientas reales, 1 hoja de calcomanías y 1 guía de instrucciones para el modelo 1.
- D** Inhalt: 485 Teile, 2 echte Werkzeuge, 1 Bogen mit Aufklebern und 1 Bedienungsanleitung für Modell Nr. 1.
- NL** Inhoud: 485 onderdelen, 2 stuks gereedschap, 1 stickervel en 1 gebruiksaanwijzing voor model 1.
- I** Contenuto: 485 pezzi, 2 attrezzi, 1 foglio di adesivi e 1 guida per l'uso per il modello 1.
- P** Conteúdo: 485 peças, 2 ferramentas reais, 1 cartela de adesivos e 1 folha de instruções para o modelo 1.
- GR** Περιεχόμενα : 485 κομμάτια, 2 Πραγματικά, 1 φύλλο αυτοκόλλητο εργαλεία 1 φυλλάδιο οδηγιών για το μοντέλο#1.
- S** Innehåll: 485 delar, 2 riktiga verktyg, 1 klistermärken täcker och 1 instruktionsblad för modell#1.
- DK** Indhold: 485 dele, 2 rigtige værktøjer, 1 klistermærke ark og 1 instruktionsark til model#1.
- FIN** Sisältö: 485 osaa, 2 aidot työkalut, 1 tarra-arkki ja 1 rakennusohje mallia 1 varten.
- RU** В коробке: 485 деталей, 2 настоящих инструмента, 1 лист с наклейками и 1 инструкция по сборке модели №1.



- GB** Building instructions for model#2 are available at [www.meccano.com](http://www.meccano.com).
- F** La notice de montage du modèle 2 est disponible sur [www.meccano.fr](http://www.meccano.fr)
- E** Hay instrucciones de construcción disponibles para el modelo 2 en [www.meccano.com](http://www.meccano.com).
- D** Die Bauanleitung für Modell Nr. 2 ist auf [www.meccano.com](http://www.meccano.com) zu finden.
- NL** Bouwinstructies voor model#2 zijn beschikbaar op [www.meccano.com](http://www.meccano.com).
- I** Le istruzioni di montaggio del modello 2 sono disponibili alla pagina [www.meccano.com](http://www.meccano.com).
- P** As instruções de montagem para o modelo 2 estão disponíveis em [www.meccano.com](http://www.meccano.com).
- GR** Οι οδηγίες κατασκευής για το μοντέλο#2 διατίθενται στη διεύθυνση [www.meccano.com](http://www.meccano.com).
- S** Bygginstruktioner för modell#2 finns på [www.meccano.com](http://www.meccano.com).
- DK** Byggevejledning til model#2 findes på [www.meccano.com](http://www.meccano.com).
- FIN** Mallin 2 rakennusohjeet ovat saatavilla osoitteesta [www.meccano.com](http://www.meccano.com).
- RU** Инструкции по сборке модели №2 можно найти на сайте [www.meccano.com](http://www.meccano.com).



**GB.** Share your build. See what the world is making! Become an Ultimate Builder and show the world your talent! Join a brand new MECCANO community site! Ask your parents before going on line. **F.** Partage ton modèle. Découvre les réalisations d'autres fans ! Deviens un pro de la construction et révèle ton talent au monde ! Rejoins la toute nouvelle communauté MECCANO en ligne ! Demande la permission à tes parents avant d'aller sur Internet. **E.** Comparte tus modelos. ¡Conoce lo que otros construyen! ¡Conviértete en un auténtico constructor y enséñale al mundo tu talento! Participa en el nuevo sitio web de la comunidad de MECCANO. Pide permiso a tus padres para conectarte a Internet. **D.** Teile deine Modelle mit anderen. Schau dir an, was auf der ganzen Welt gebaut wird! Werde zum ultimativen Konstrukteur und zeige der Welt, wie gut du bist! Mach mit bei der brandneuen MECCANO Community-Website! Bitte deine Eltern um Erlaubnis, bevor du online gehst. **NL.** Deel je creatie. Ontdek wat de rest van de wereld maakt! Word een uitmuntende bouwer en laat je talent zien! Word actief op een gloednieuwe MECCANO-communitysite! Vraag je ouders om toestemming voordat je online gaat. **I.** Condividi il tuo modello. Guarda i modelli realizzati dai giocatori di tutto il mondo! Diventa un esperto di costruzioni e mostra al mondo il tuo talento! Registrati al nuovo sito della comunità MECCANO! Chiedi ai tuoi genitori prima di andare online. **R.** Покажи свою модель. Посмотри на модели других игроков! Научись собирать отличные модели и продемонстрируй миру свои умения! Посети новый сайт сообщества MECCANO! Спроси разрешения у родителей, прежде чем выйти в Интернет.

**GB** Remove all packaging before use. Retain this information, addresses and phone numbers for future reference. Content may vary from pictures. Meccano reserves the right to discontinue the website [www.meccano.com](http://www.meccano.com) at any time. An adult should periodically check this toy to ensure no damage or hazard exist if so, remove from use. Children should be supervised during play.

**F** Retirer tout l'emballage avant utilisation. Conserver les informations, adresses et numéros de téléphone pour consultation ultérieure. Le contenu peut différer des images. Meccano se réserve le droit de supprimer le site Internet [www.meccano.fr](http://www.meccano.fr) à tout moment. Un adulte doit régulièrement examiner ce jouet afin de s'assurer qu'il ne présente pas de dommage ni de risque. En cas de problème, ne plus l'utiliser. Les enfants doivent être surveillés lorsqu'ils jouent.

**E** Retire todo el embalaje antes de utilizar el producto. Conserve toda la información, las direcciones y los números de teléfono para futuras referencias. El contenido del paquete puede no corresponder con las imágenes. Meccano se reserva el derecho a suspender el sitio web [www.meccano.com](http://www.meccano.com) en cualquier momento. Un adulto debe revisar de forma periódica el juguete para asegurarse de que no supone un riesgo o peligro para el niño; si así fuera el caso, interrumpa su uso. Supervise a los niños mientras juegan con el producto.

**D** Entfernen Sie vor der Benutzung sämtliche Verpackungsmaterialien. Alle Informationen, Adressen und Telefonnummern bitte für mögliche Rückfragen aufbewahren. Der Packungsinhalt kann von den Bildern abweichen. Meccano behält sich das Recht vor, den Betrieb der Website [www.meccano.com](http://www.meccano.com) jederzeit einzustellen. Ein Erwachsener sollte regelmäßig sicherstellen, dass das Spielzeug keine Gefahr darstellt, und es gegebenenfalls entfernen. Kinder sollten beim Spielen beaufsichtigt werden.

**GB** ⚠ CAUTION: Stickers not intended to be placed on skin.

**F** ⚠ MISE EN GARDE : Les autocollants ne sont pas destinés à être placés sur la peau.

**E** ⚠ PRECAUCIÓN: Las calcomanías no deben colocarse sobre la piel.

**D** ⚠ ACHTUNG: Sticker sind nicht zum Aufkleben auf die Haut geeignet.

**NL** ⚠ VOORZICHTIG: Stickers zijn niet voor op de huid bedoeld.

**I** ⚠ ATTENZIONE: Non applicare gli adesivi sulla pelle.

**P** ⚠ ATENÇÃO: os autocolantes não devem ser colocados na pele.

**GR** ⚠ ΠΡΟΣΟΧΗ: Μην κολλάτε τα αυτοκόλλητα στο δέρμα σας.

**S** ⚠ VARNING: Klistermärkena bör inte sättas på huden.

**DK** ⚠ ADVARSEL: Klistermærker er ikke beregnet til at sætte på huden.

**FIN** ⚠ VAROITUS: Tarjoja ei saa kiinnittää ihoon.

**RU** ⚠ ОСТОРОЖНО: Стикеры не предназначены для приклеивания к коже.

**NL** Verwijder de verpakking voor gebruik. Bewaar deze informatie, adressen en telefoonnummers voor toekomstig gebruik. Inhoud kan afwijken van illustraties. Meccano behoudt zich het recht voor de website [www.meccano.com](http://www.meccano.com) wanneer gewenst buiten gebruik te stellen. Een volwassene dient dit speelgoed regelmatig te controleren op schade en gevaren. Indien het speelgoed is beschadigd of indien er een gevaarlijke situatie kan ontstaan, dient het product te worden weggegooid. Ouderlijk toezicht is vereist als kinderen met dit speelgoed spelen.

**I** Rimuovere l'imballo prima dell'uso. Conservare informazioni, indirizzi e numeri di telefono per riferimento futuro. Il prodotto potrebbe essere differente dalle immagini. Meccano si riserva il diritto di rimuovere il sito [www.meccano.com](http://www.meccano.com) in qualsiasi momento. È consigliabile un controllo periodico del giocattolo da parte di un adulto: in caso di danni o rischi interrompere l'uso. È richiesta la supervisione di un adulto durante il gioco.

**P** Remova totalmente a embalagem antes de utilizar. Guarde estas informações, as moradas e os números de telefone para consulta futura. O conteúdo poderá ser diferente das ilustrações. A Meccano reserva-se o direito de descontinuar o site [www.meccano.com](http://www.meccano.com) a qualquer altura. Um adulto deve verificar o brinquedo periodicamente para garantir que ele não apresenta danos ou riscos. Se houver, é necessário que o brinquedo seja retirado de uso. Crianças devem ser supervisionadas enquanto brincam.

**GR** Πριν την χρήση αφαιρέστε όλα τα υλικά της συσκευασίας. Διατηρήστε αυτές τις πληροφορίες, τις διεύθυνσεις και τους αριθμούς τηλεφώνου για μελλοντική αναφορά. Το περιεχόμενο ενδέχεται να διαφέρει από τις εικόνες. Η Meccano διατηρεί το δικαίωμα να διακόψει τη λειτουργία της τοποθεσίας [www.meccano.com](http://www.meccano.com) ανά πάσα στιγμή. Ένας ενήλικας θα πρέπει να εξετάζει τακτικά αυτό το παιχνίδι και να διακόπτει τη χρήση του σε περίπτωση εντοπισμού βλαβών ή κινδύνων. Τα παιδιά θα πρέπει να παίζουν υπό επίτηρηση.

**GB** ⚠ Warning! CHOKING HAZARD - Small parts.

**F** ⚠ Attention ! RISQUE D'ÉTOUFFEMENT - Contient de petits éléments.

**E** ⚠ Advertencia: PELIGRO DE ASFIXIA - Contiene piezas pequeñas. No conveniente para niños menores de 3 años.

**D** ⚠ Achtung: ERSTICKUNGSGEFAHR - Kleinteile.

**NL** ⚠ Waarschuwing: VERSTIKKINGSGEVAAR - Kleine onderdelen.

**I** ⚠ Attenzione: RISCHIO DI SOFFOCAMENTO - Pezzi piccoli.

**P** ⚠ Aviso: PERIGO DE ASFIXIA - Peças pequenas.

**GR** ⚠ Προειδοποίηση: ΚΙΝΔΥΝΟΣ ΠΝΙΓΜΟΥ — Μικρά μέρη.

**S** ⚠ Varning: RISK FÖR KVÄVNING - Små delar.

**DK** ⚠ Advarsel: KVAELNINGSFARE - Små dele.

**FIN** ⚠ Varoitus: TUKEHTUMISVAARA - Pieniä osia.

**RU** ⚠ Осторожно! ОПАСНОСТЬ УДУШЬЯ - мелкие детали.

**S** Ta bort alla förpackningar före användning. Spara den här informationen, adresser och telefonnummer för framtida referens. Innehållet kan skilja sig från bilderna. Meccano förbehåller sig rätten att när som helst ta bort webbplatsen [www.meccano.com](http://www.meccano.com). En vuxen ska regelbundet undersöka den här leksaken för att säkerställa att det inte finns några skador eller faror rörande den. Om det finns några ska den inte användas längre. Barn ska hållas under uppsikt när de leker.

**DK** Fjern al emballage før brug. Gem disse oplysninger, adresser og telefonnumre for fremtidig brug. Indholdet kan være forskelligt fra billederne. Meccano forbeholder sig ret til at nedlægge hjemmesiden [www.meccano.com](http://www.meccano.com) til enhver tid. En voksen bør jævnligt tjekke dette legetøj for at sikre, at det ikke er beskadiget eller udgør nogen fare, i så fald, stop brugen af det. Børn bør overvåges, når de leger med det.

**FIN** Poista kaikki pakkausmateriaali ennen käyttöä. Säilytä nämä tiedot, osoitteet ja puhelinnumerot tulevia tarpeita varten. Sisältö saattaa poiketa kuvista. Meccano pidättää oikeuden lakkauttaa sivuston [www.meccano.com](http://www.meccano.com) milloin tahansa. Aikuisen tulee säännöllisesti tarkistaa, että lelu ei ole vaurioitunut ja muuttunut vaaralliseksi. Jos näin on käynyt, lelu tulee poistaa käytöstä. Lasten tulee leikkiä vain aikuisen valvonnassa.

**RU** Снимите все упаковочные материалы перед использованием. Запишите указанные на упаковке адреса и номера телефонов, чтобы у вас была возможность связаться с нами. Содержимое упаковки может отличаться от иллюстрации. Компания Meccano оставляет за собой право прекратить использование сайта [www.meccano.com](http://www.meccano.com) в любое время. Регулярно проверяйте состояние игрушки на наличие повреждений и возможных рисков для ребенка. Если таковые имеются, игрушку не следует использовать. Во время игры за детьми следует присматривать.



SPIN MASTER LTD., 450 FRONT STREET WEST,  
TORONTO, ON M5V 1B6 CANADA.  
Distributed in EU by SPIN MASTER INTERNATIONAL,  
S.A.R.L., 16 AVENUE PASTEUR,  
L-2310, LUXEMBOURG. [www.spinmaster.com](http://www.spinmaster.com)  
Meccano : 363, avenue de Saint-Exupéry 62100 Calais – France



T91716 0001 20066588 GML IB R1 W2

© 04 /2014 MECCANO for packaging, instructions and models built with this set. © 04/2014 MECCANO pour l'emballage, les notices et modèles de ce coffret. © MECCANO is an exclusive trademark of MECCANO. Spin Master logo is a trademark of Spin Master Ltd. © MECCANO est une marque de commerce exclusive de MECCANO. Le logo de Spin Master est une marque de commerce de Spin Master Ltd. All rights reserved. Tous droits réservés.



UK – 0800 206 1191, [SERVICEUK@SPINMASTER.COM](mailto:SERVICEUK@SPINMASTER.COM)  
FRANCE – 0800 909 150, [SERVICEFR@SPINMASTER.COM](mailto:SERVICEFR@SPINMASTER.COM)  
ESPAÑA – [SERVICIO@SPINMASTER.COM](mailto:SERVICIO@SPINMASTER.COM)  
DEUTSCHLAND – 00800 0101 0222, [KUNDENSERVICE@SPINMASTER.COM](mailto:KUNDENSERVICE@SPINMASTER.COM)  
SCHWEIZ – 0800 561 350 • ÖSTERREICH – 0800 29 72 67  
NEDERLAND – 0800 022 36 83, [KLANTENSERVICE@SPINMASTER.COM](mailto:KLANTENSERVICE@SPINMASTER.COM)  
BELGIË/BELGIQUE – 0800 77 688 • LUXEMBOURG – 800 28 04 4  
ITALIA – 800 788 532, [SERVIZIO@SPINMASTER.COM](mailto:SERVIZIO@SPINMASTER.COM)  
MEXICO – 53.51.44.00  
[WWW.SPINMASTER.COM](http://WWW.SPINMASTER.COM)

NORTH AMERICA:  
AMÉRIQUE DU NORD : 1-800-622-8339 [customer@spinmaster.com](mailto:customer@spinmaster.com)

867210104111