

MECCANOID G15KS

PERSONAL ROBOT

10+

Years/Ans/Años
Jahre/Jaar/Anni
Anos/Лет

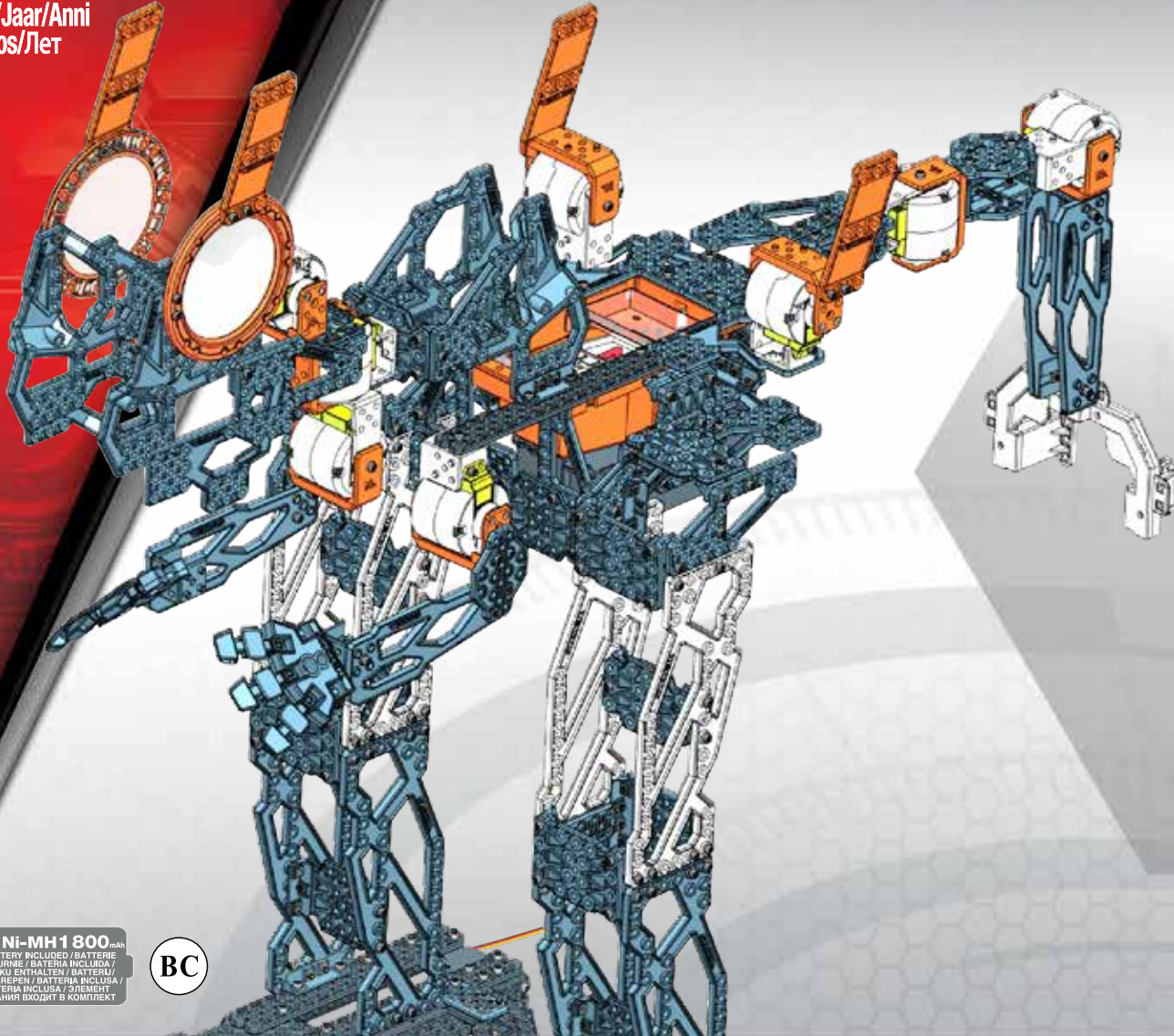

- INSTRUCTION GUIDE
- MODE D'EMPLOI
- GUÍA DE INSTRUCCIONES
- BEDIENUNGSANLEITUNG
- GEBRUIKSAANWIJZING
- GUIDA PER L'USO
- GUIA DE INSTRUÇÕES
- ИНСТРУКЦИЯ ПО ИСПОЛЬЗОВАНИЮ

⚠ **CAUTION - ELECTRIC TOY**
Not recommended for children under 10 years of age. As with all electric products, precautions should be observed during the handling and use to prevent shock.

⚠ **MISE EN GARDE : JOUET ÉLECTRIQUE**
Non recommandé pour des enfants de moins de 10 ans. Comme avec tous les autres produits électriques, des précautions s'imposent durant la manipulation et l'utilisation afin d'éviter les chocs électriques.

UK - 0800 206 1191, SERVICEUK@SPINMASTER.COM
FRANCE - 0800 909 150, SERVICEFR@SPINMASTER.COM
ESPAÑA - SERVICIO@SPINMASTER.COM
DEUTSCHLAND - 0800 0101 0222, KUNDENSERVICE@SPINMASTER.COM
SCHWEIZ - 0800 561 350 • ÖSTERREICH - 0800 29 72 67
NEDERLAND - 0800 022 36 83, KLANTENSERVICE@SPINMASTER.COM
BELGIË/BELGIQUE - 0800 77 688 • LUXEMBOURG - 800 28 044
ITALIA - 800 788 532, SERVIZIO@SPINMASTER.COM
MEXICO - (55) 5351-4400



NORTH AMERICA • AMÉRIQUE DU NORD
1-800-622-8339, CUSTOMERCARE@SPINMASTER.COM

⚠ **WARNING:** Adapter cord could be a strangulation hazard. Not for use by children under 3 years of age.

⚠ **ATTENTION !** Le cordon de l'adaptateur présente un risque de strangulation. Ne pas laisser à la portée des enfants de moins de 3 ans.

1 x Ni-MH 1800mAh
BATTERY INCLUDED / BATTERIE
FOURNIE / BATERIA INCLUSA /
AKKU ENTHALTEN / BATTERIJ/
INBEGREPEN / BATERIA INCLUSA /
BATERIA INCLUSA / ОБЪЕКТ
ПИТАНИЯ ВХОДИТ В КОМПЛЕКТ

BC

FCC Statement: This device complies with Part 15 of the FCC rules. Operation is subject to the following two conditions: (1) This device may not cause harmful interference, and (2) This device must accept any interference received, including interference that may cause undesired operation. This equipment has been tested and found to comply with the limits for Class B digital devices pursuant to Part 15 of the FCC rules. These limits are designed to provide reasonable protection against harmful interference to radio communications. This equipment generates, uses and can radiate radio frequency energy and, if not installed and used in accordance with the instruction, may cause harmful interference to radio communication. However, there is no guarantee that interference will not occur in a particular installation. If this toy does cause interference to radio or television reception (you can check this by turning the toy off and on while listening for the interference), one or more of the following measures may be useful: • Reorient or relocate the receiving antenna • Increase the separation between the toy and the radio or the TV • Consult the dealer or an experienced TV-radio technician for help. Shielded cables must be used with this unit to ensure compliance with the Class B FCC limits. Shielded cables must be used with this unit to ensure compliance with the Class B FCC limits. **NOTE:** Changes, adjustments or modifications to this unit, including but not limited to, replacement of any transmitter component (crystal, semiconductor, etc.), could result in a violation of FCC rules under part 15 and/or 95 and must be expressly approved by Spin Master Ltd., or they could void the user's authority to operate the equipment. Connect the equipment into an outlet on a circuit different from that to which the receiver is connected

Déclaration de la FCC : Le présent appareil est conforme à l'article 15 de la réglementation de la FCC. L'utilisation est autorisée aux deux conditions suivantes : (1) l'appareil ne doit pas produire de brouillage, et (2) l'appareil doit accepter tout brouillage radioélectrique subi, même si le brouillage est susceptible d'en compromettre le fonctionnement. Cet équipement a été testé et jugé conforme aux limites de la classe B pour les équipements numériques en vertu de l'article 15 de la réglementation de la FCC. Ces limites ont été instaurées pour assurer une protection raisonnable contre toute interférence nuisible avec les communications radio. Cet équipement génère, utilise et peut émettre de l'énergie de fréquence radio. S'il n'est pas installé et utilisé selon le mode d'emploi, il peut causer des interférences nuisibles aux communications radio. Cependant, il n'existe aucune garantie contre ces interférences dans le cas où l'installation ne serait pas conforme. Si ce jouet cause des interférences à la réception radio ou télévisée (ce qui est vérifiable en l'éteignant, puis en le rallumant tout en écoutant s'il y a des interférences), suivre une ou plusieurs des recommandations suivantes : • Réorienter ou déplacer l'antenne réceptrice • Augmenter la distance entre le jouet et la radio ou la télévision • Consulter le revendeur ou demander l'aide d'un technicien radio/T.V. expérimenté. Pour respecter les limites de la classe B de la réglementation de la FCC, cet appareil doit être utilisé avec des câbles blindés. **REMARQUE :** tout changement, réglage ou modification de cet appareil, incluant mais ne se limitant pas au remplacement de tout composant du transmetteur (cristal, semi-conducteur, etc.), pourrait constituer une violation de l'article 15 et/ou 95 de la réglementation de la FCC, et doit être expressément approuvé par Spin Master Ltd., sous peine d'entraîner l'annulation du droit de l'utilisateur d'exploiter l'équipement. Brancher l'équipement sur un autre circuit que celui utilisé par le récepteur.

Declaración de la FCC: Este dispositivo cumple con la sección 15 de la normativa de la FCC. El funcionamiento está sujeto a estas dos siguientes condiciones: (1) el dispositivo no debe causar interferencias dañinas, y (2) el dispositivo debe admitir la recepción de cualquier tipo de interferencia, incluidas aquellas que puedan causar un funcionamiento indeseado. Este equipo ha sido probado y cumple los límites para dispositivos de clase B digital establecidos en la sección 15 de la normativa de la FCC. Estos límites han sido diseñados para proporcionar una protección razonable contra la interferencia dañina en las comunicaciones por radio. Este equipo genera, utiliza y emite energía en forma de radiofrecuencias, por lo que si no se instala y utiliza como indican las instrucciones, podría provocar interferencias dañinas en comunicaciones de radio. No obstante, no se puede garantizar que no habrá interferencias en una instalación determinada. Si este juguete provoca interferencias en la recepción de radio o televisión (puede comprobarlo apagando y encendiendo el juguete mientras escucha si se producen interferencias), puede tomar alguna de las siguientes medidas: • Reorientar o cambiar de lugar la antena receptora • Aumentar la separación entre el juguete y la radio o el televisor • Consultar con el vendedor o un técnico de televisión y radio si necesita asistencia adicional. Para cumplir con los límites de la clase B de las normas FCC, este aparato se debe utilizar con cables blindados. **NOTA:** Los cambios, los ajustes o las modificaciones realizadas en este dispositivo, como, entre otros, la sustitución de cualquier componente transmisor (cristal, semiconductor, etc.) podría suponer la infracción de las secciones 15 ó 95 de la normativa de la FCC, y debe ser explícitamente aprobada por Spin Master Ltd.; en caso contrario, el usuario podría verse privado del derecho de operar el equipo. Conectar el equipo en una toma de un circuito diferente de aquel al que esta conectado el receptor.

GB Content: 1188 Parts, 1 AC/DC wall mount charger (10.4W), 1 Rechargeable Ni-MH battery 1800 mAh, 1 MeccaBrain™, 1 LED module, 2 hand tools, 8 servos, 2 rear wheel assembly, 2 motor gear box assembly, 1 USB cable

F Contenu : 1188 pièces, 1 chargeur mural CA/CC (10,4 W), 1 batterie Ni-MH 1 800 mAh rechargeable, 1 MeccaBrain™, 1 module LED, 2 outils, 8 servomoteurs, assemblage 2 roues arrière, assemblage 2 moteurs et engrenages, 1 câble USB

E Contenido: 1188 piezas, 1 cargador con toma de pared ca/cc (10,4 W), 1 batería Ni-MH recargable de 1800 mAh, 1 MeccaBrain™, 1 módulo LED, 2 herramientas, 8 servos, ensamblaje para 2 ruedas traseras, ensamblaje con 2 motores y caja de engranajes, 1 cable USB

D Inhalt: 1188 Teile, 1 WS/GS-Wand-Ladegerät (10,4 W), 1 aufladbarer Nickel-Metallhydrid-Akku 1.800 mAh, 1 MeccaBrain™, 1 LED-Modul, 2 Handwerkzeuge, 8 Servos, 2 Hinterräder zum Zusammenbauen, 2 Motorgetriebe, 1 USB-Kabel

NL Inhoud: 1188 onderdelen, 1 AC/DC-oplader (10,4 W), 1 oplaadbare Ni-MH-batterij van 1800 mAh, 1 MeccaBrain™, 1 LED-module, 2 stuks handgereedschap, 8 servo's 2 achterwielen, 2 motorkasten, 1 USB-Kabel

I Contenuto: 1188 pezzi, 1 caricabatteria da parete CA/CC (10,4 W), 1 batteria ricaricabile Ni-MH da 1800 mAh, 1 MeccaBrain™, 1 modulo a LED, 2 attrezzi, 8 servomotori, kit con 2 ruote posteriori, kit con 2 motori e cambi di velocità, 1 cavo USB

P Conteúdo: 1188 partes, 1 carregador AC/DC (10,4 W) de montagem na parede, 1 Bateria Ni-MH recarregável de 1800 mAh, 1 MeccaBrain™, 1 módulo de LED, 2 ferramentas manuais, 8 servomotores, 2 rodas traseiras, caixa com 2 engrenagens e motor, 1 cabo USB

R В коробке: 1188 деталей, 1 настенное зарядное устройство с универсальным питанием (10,4 Вт), 1 перезаряжаемый никель-металл-гидридный элемент питания 1800 мАч, 1 MeccaBrain™, 1 светодиодный модуль, 2 ручных инструмента, 8 сервоприводов, комплект из 2 задних колес, комплект из 2 механизированных коробок передач, 1 USB-кабель

CAN ICES-3 (B)/NMB-3(B)

CANADIAN Class B statement: This device complies with Industry Canada Licence-exempt RSS-210. Operation is subject to the following two conditions: (1) this device may not cause interference, and (2) this device must accept any interference, including interference that may cause undesired operation of the device.

Déclaration CANADIENNE classe B: Le présent appareil est conforme au CNR-210 d'Industrie Canada applicable aux appareils radio exempts de licence. L'utilisation est autorisée aux deux conditions suivantes : (1) l'appareil ne doit pas produire de brouillage, et (2) l'appareil doit accepter tout brouillage radioélectrique subi, même si le brouillage est susceptible d'en compromettre le fonctionnement.

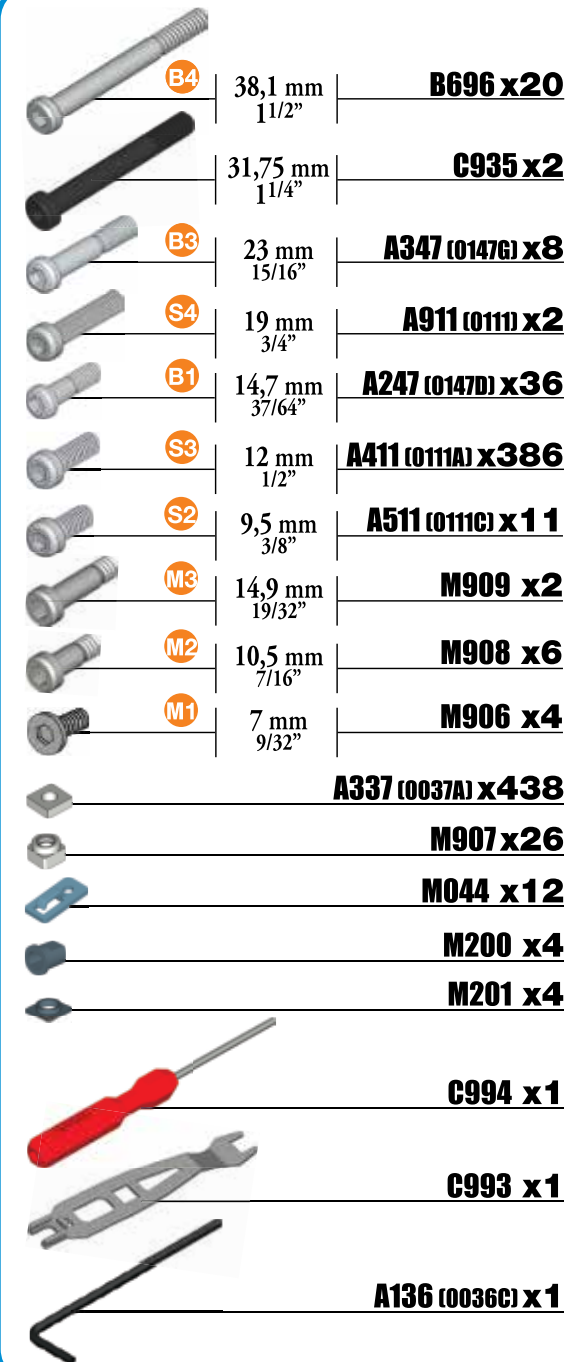
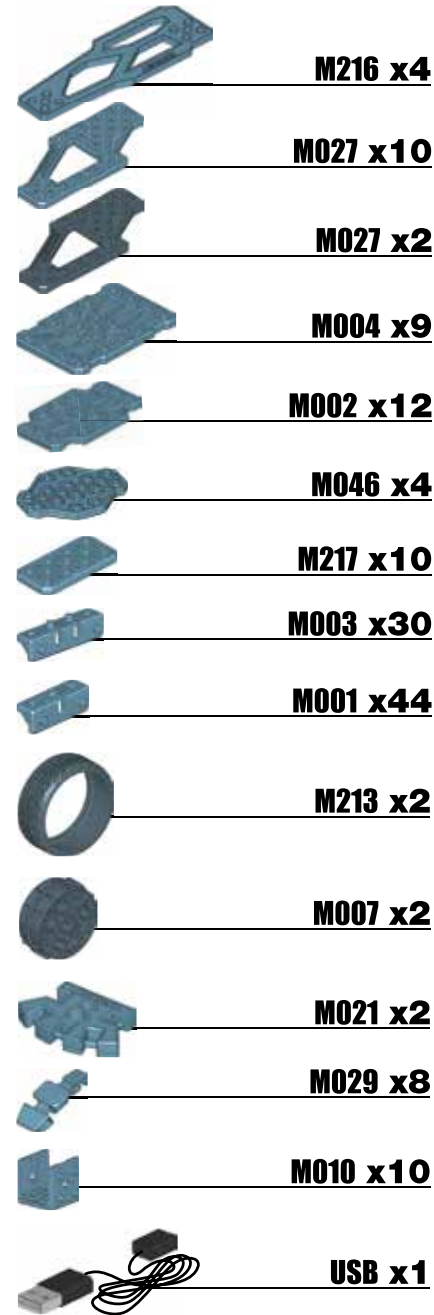
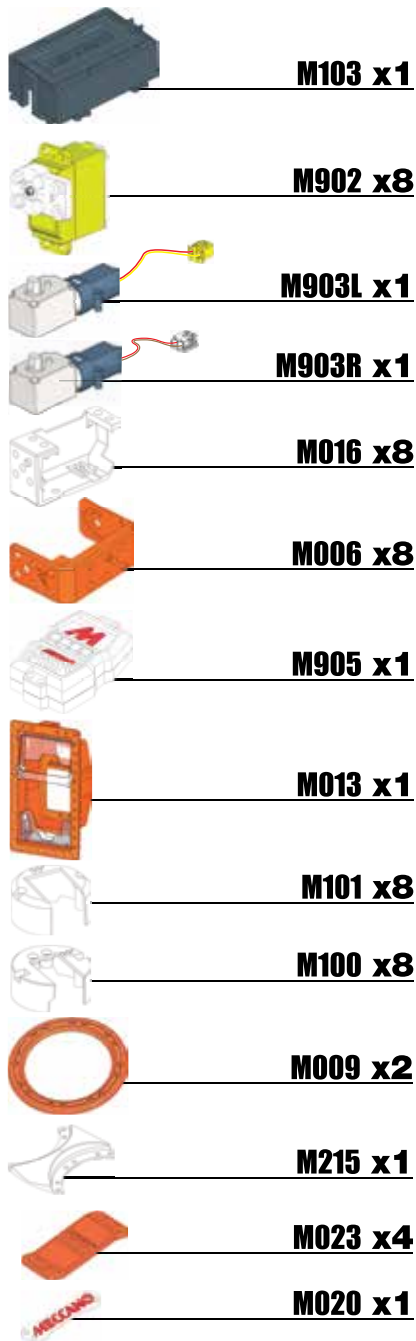

Only one model can be built at a time. / Les pièces fournies ne permettent de monter qu'un seul modèle à la fois. / Solo es posible construir un modelo a la vez. / Jeweils nur eins der Modelle baubar.

Er kan maar een model tegelijk worden gebouwd. Permette di realizzare un solo modello per volta. / Só é possível montar um modelo de cada vez. / Одновременно можно построить только одну модель.

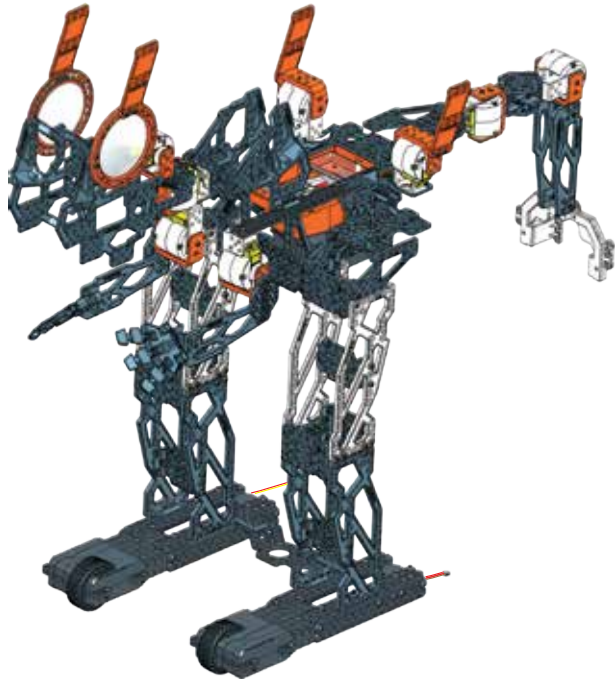



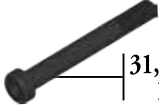

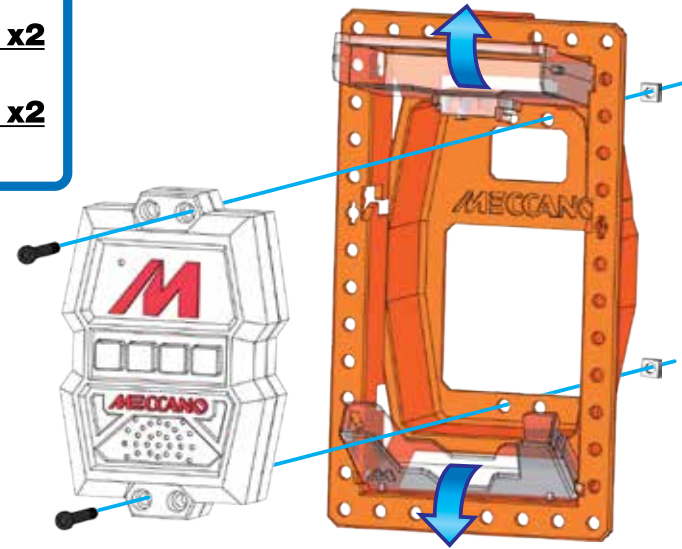

1

-  **x1**
-  $\left| \begin{array}{l} 31,75 \text{ mm} \\ 1\frac{1}{4}'' \end{array} \right|$ **x2**
-  **x1**
-  **x2**

-  **1:1**





2

-  **x1**
-  **x1**
-  $\left| \begin{array}{l} 12 \text{ mm} \\ 1/2'' \end{array} \right|$ **x4**
-  **x4**

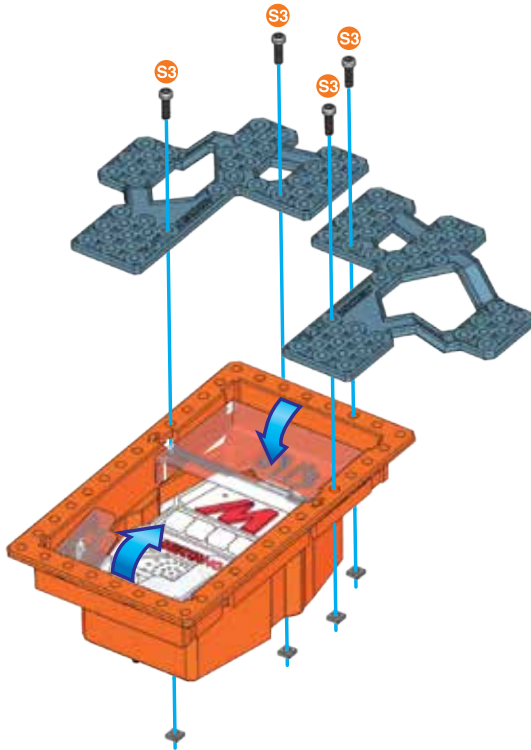
-  **1:1**





3

-  **x1**
-  $\left| \begin{array}{l} 12 \text{ mm} \\ 1/2'' \end{array} \right|$ **x2**
-  **x2**

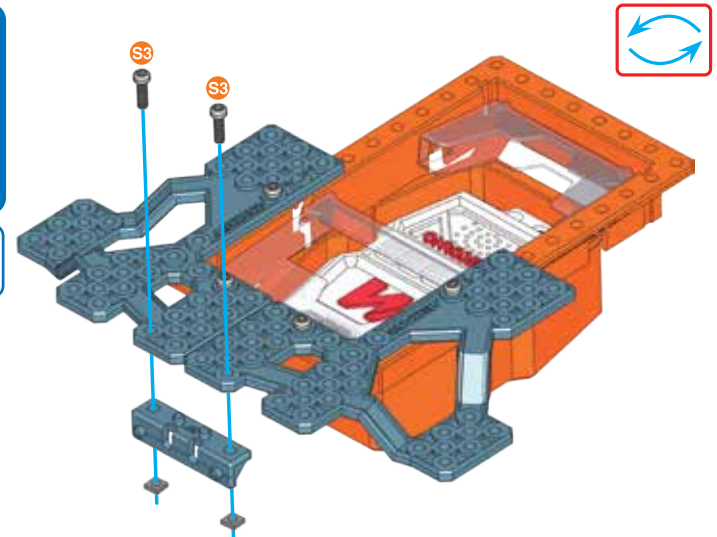
-  **1:1**





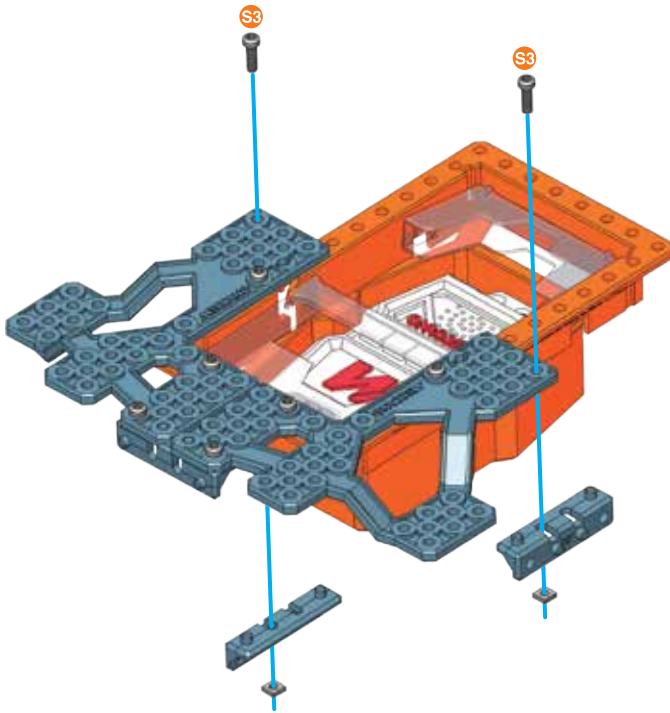

4

-  **x2**
-  12 mm | 1/2" **x2**
-  **x2**

-  **S3** **1:1**



5

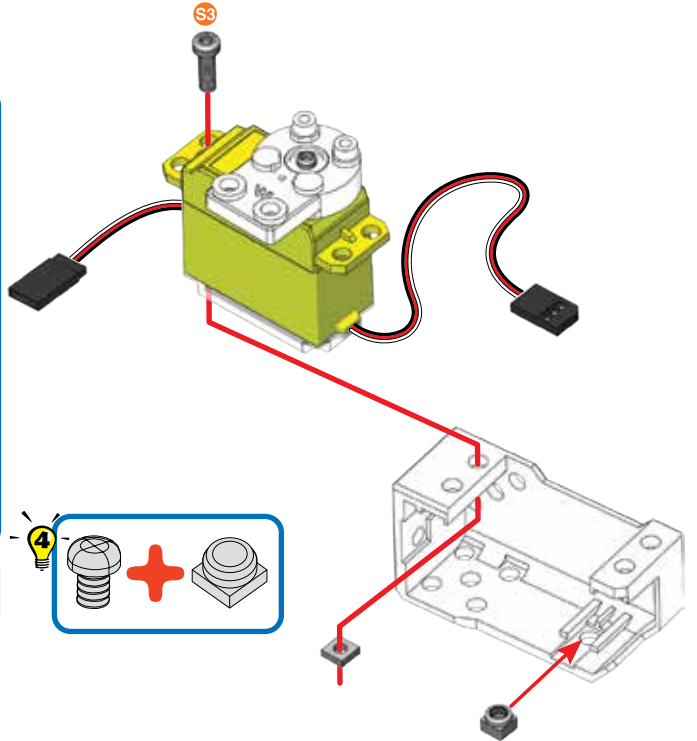

-  **x2**
-  **x2**
-  12 mm | 1/2" **x2**
-  **x2**
-  **x2**

-  **S3** **1:1**



2x

6

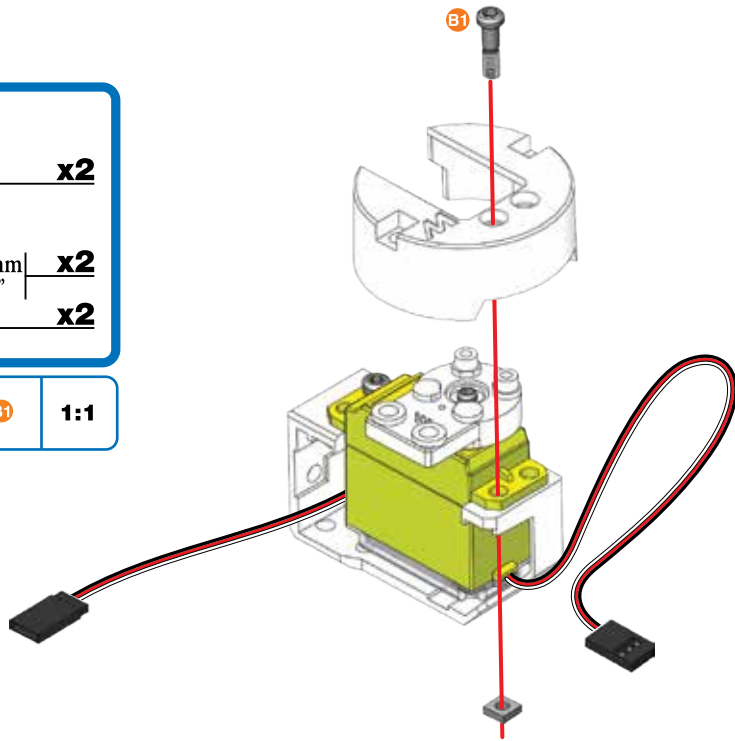

-  **x2**
-  14,7 mm | 37/64" **x2**
-  **x2**

-  **B1** **1:1**



2x

7

-  **x2**
-  38,1 mm | 1 1/2" **x4**
-  **x4**

-  **B4** **1:1**

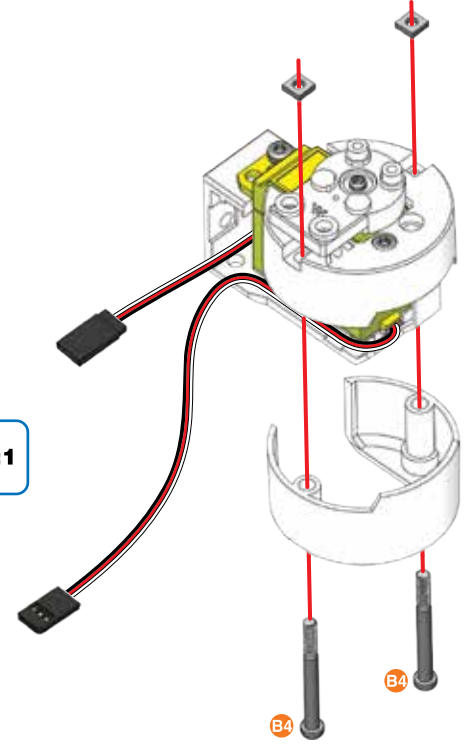

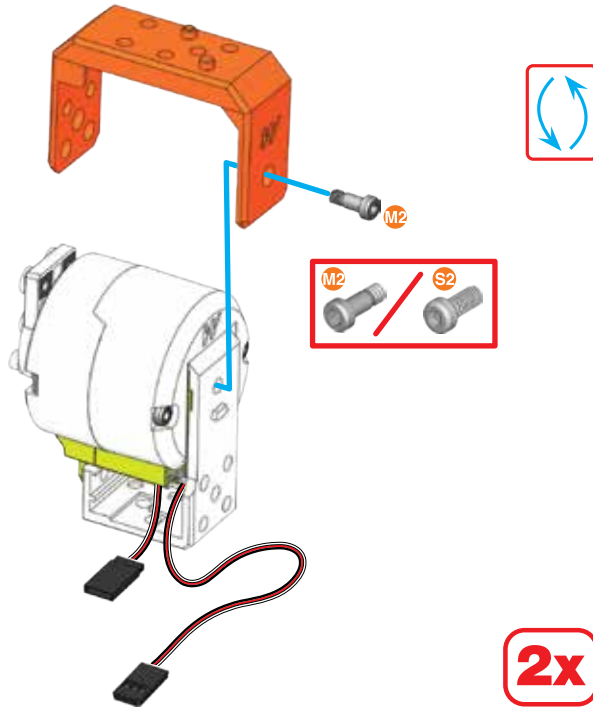
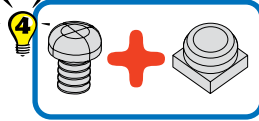
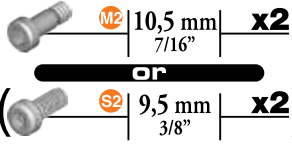
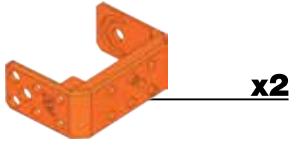
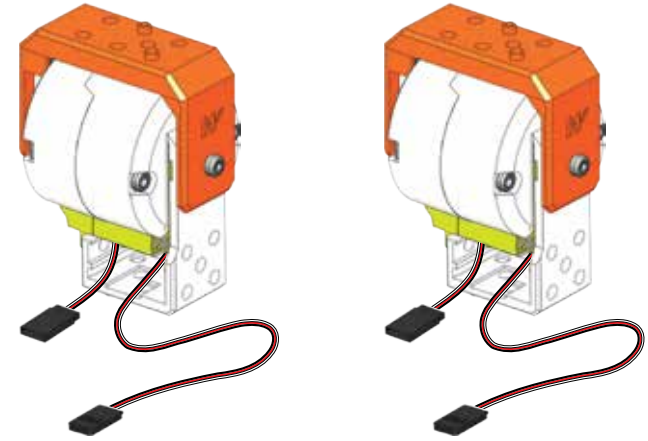
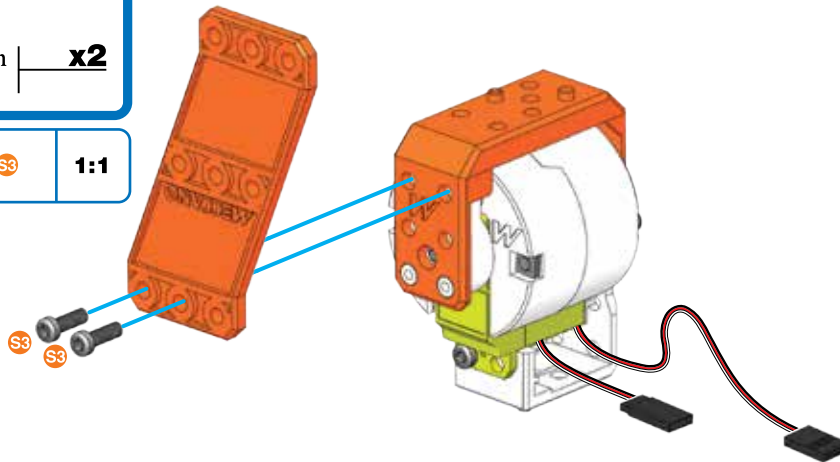
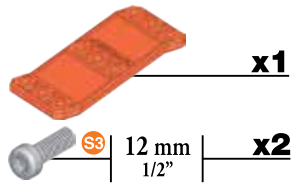
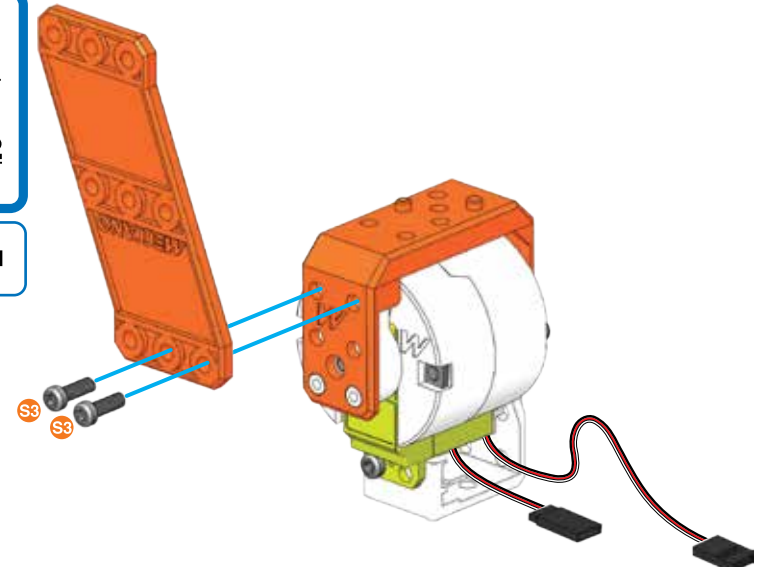
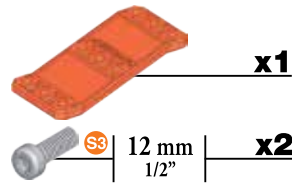

2x

8**9****5 ~ 8****10****9+****11****9+**

12

④ + ⑨ +

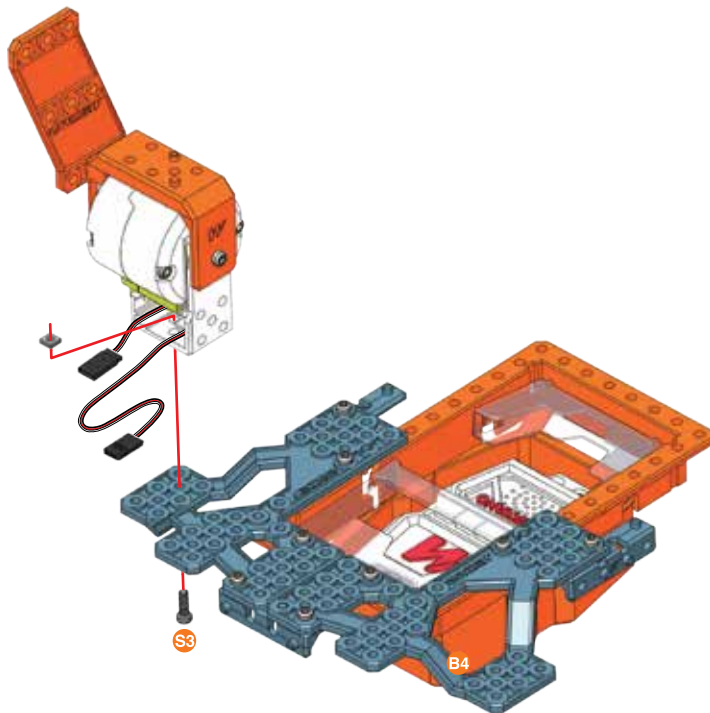

	12 mm	x1
	1/2"	x1

	S3	1:1
--	----	-----



13

⑪ + ⑫ +

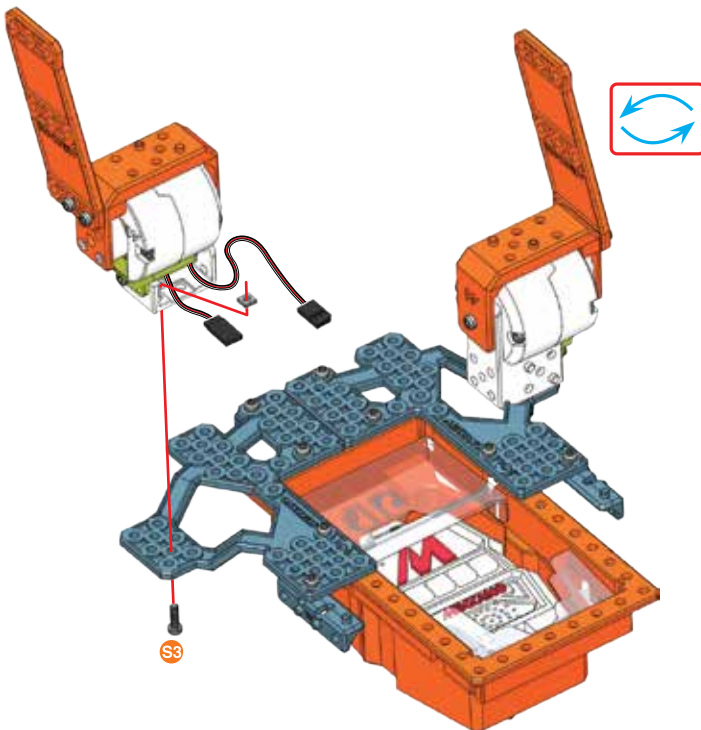

	12 mm	x1
	1/2"	x1

	S3	1:1
--	----	-----



14

	x2
---	----

	12 mm	x2
	1/2"	x2

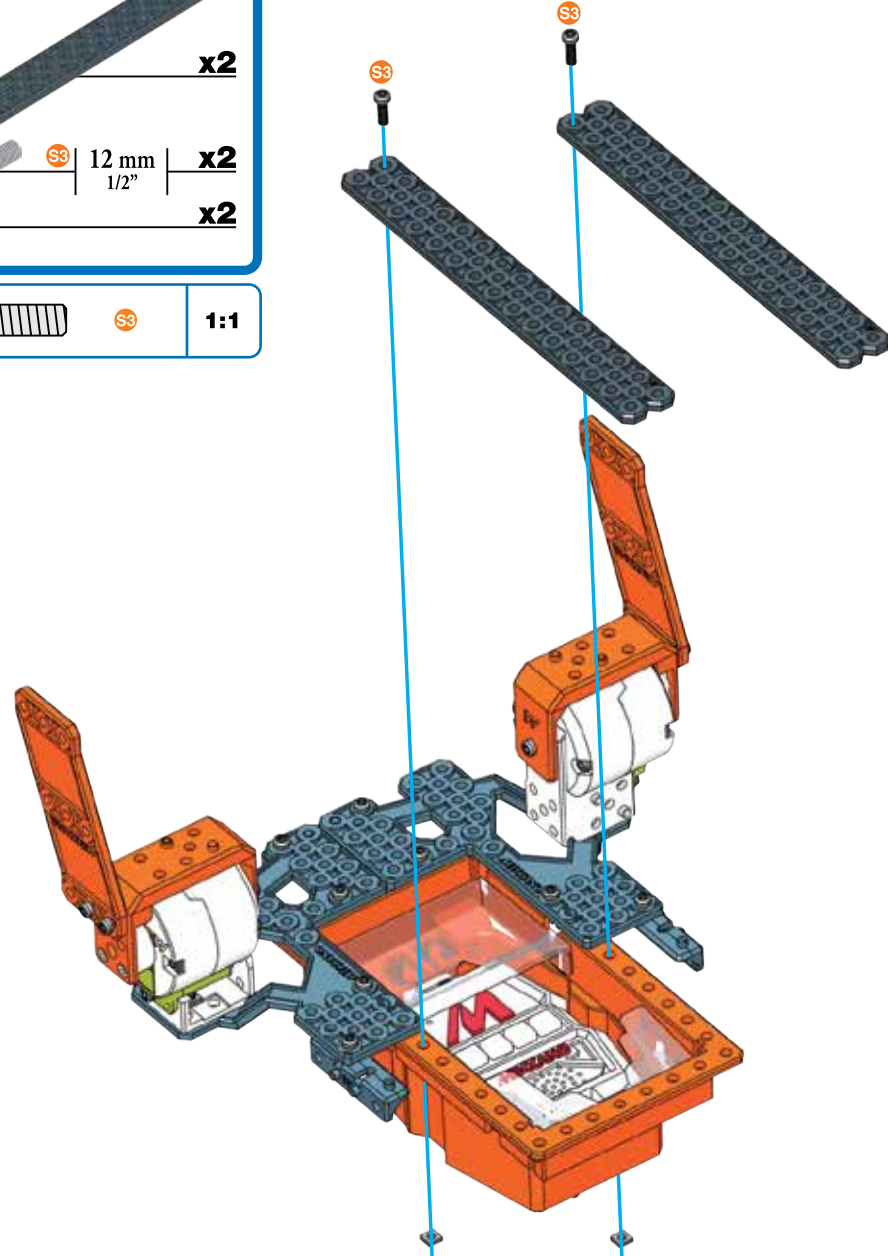

	S3	1:1
---	----	-----

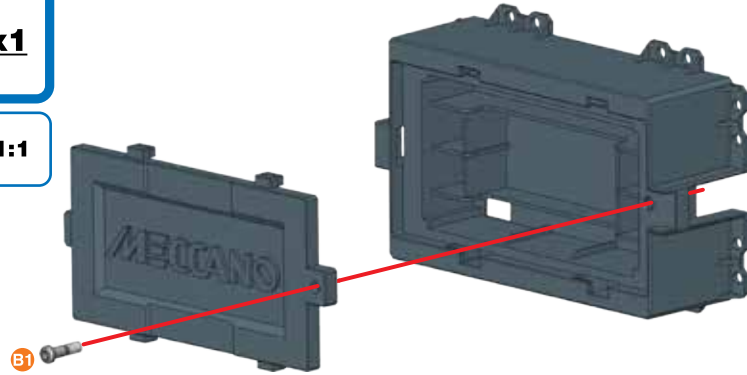
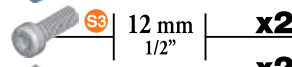
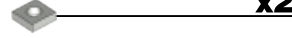
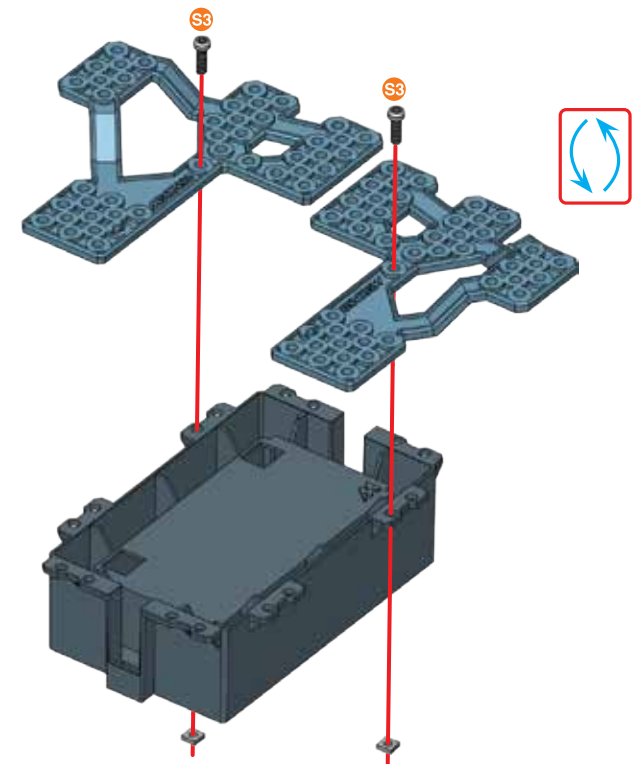
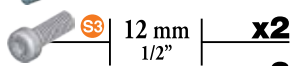
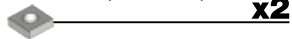
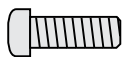
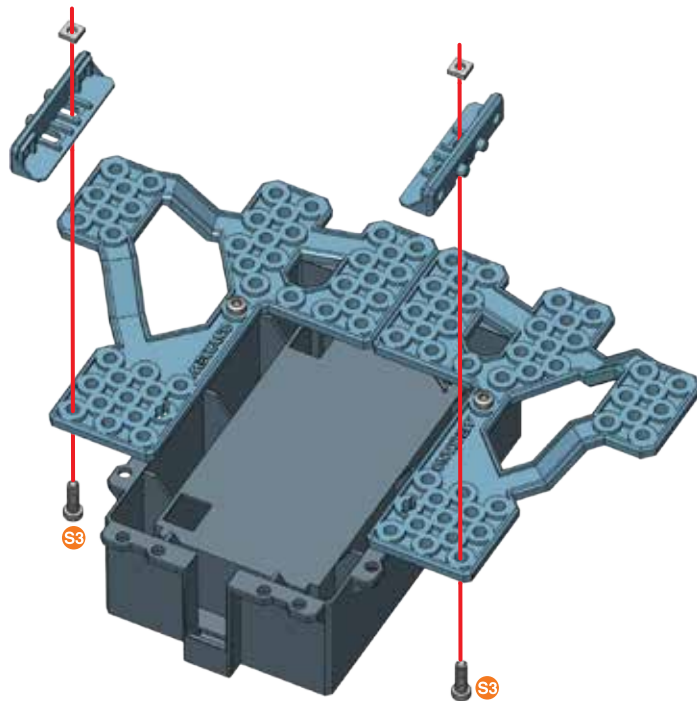
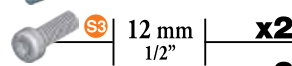
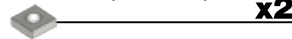
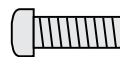
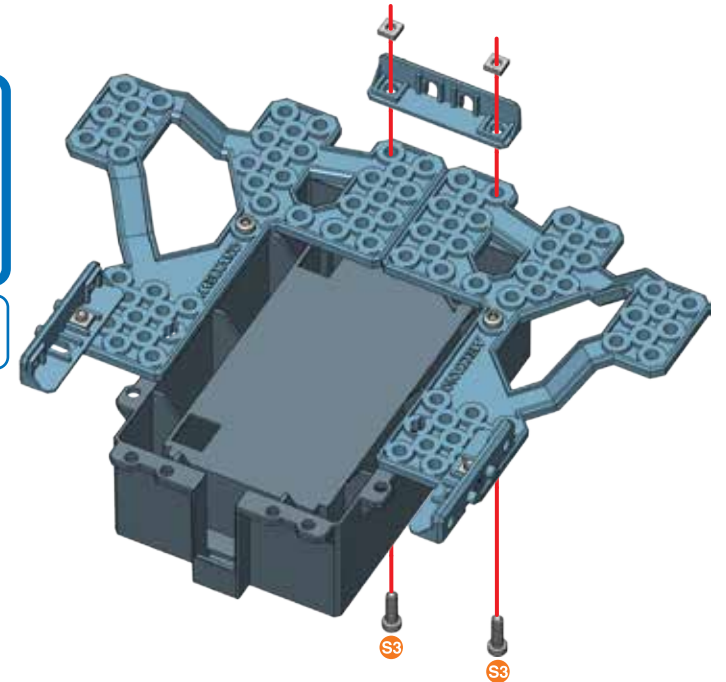

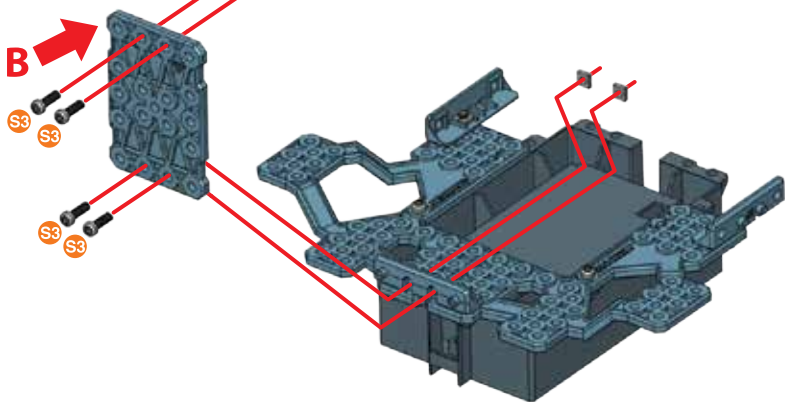
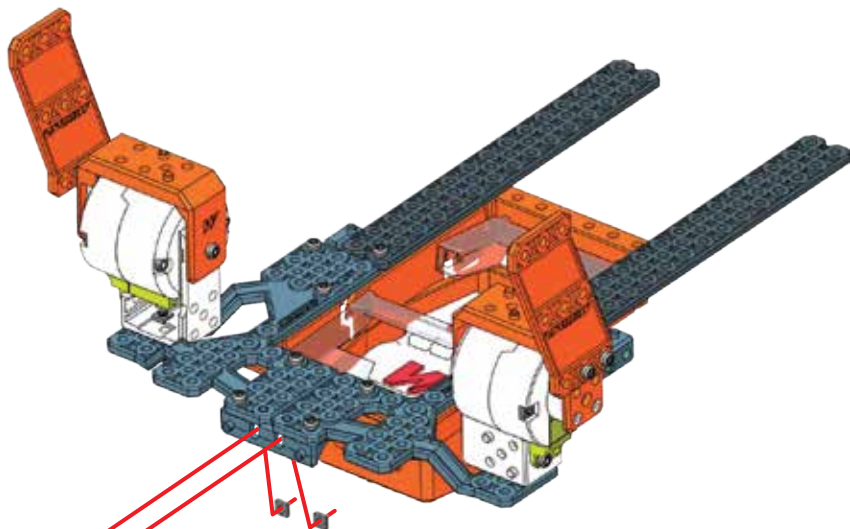
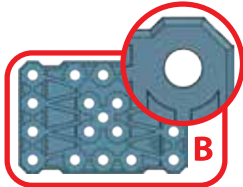
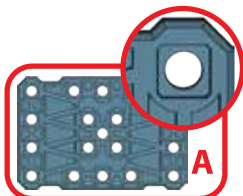
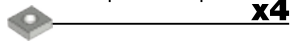
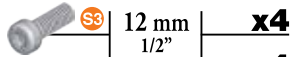
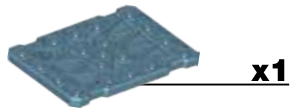
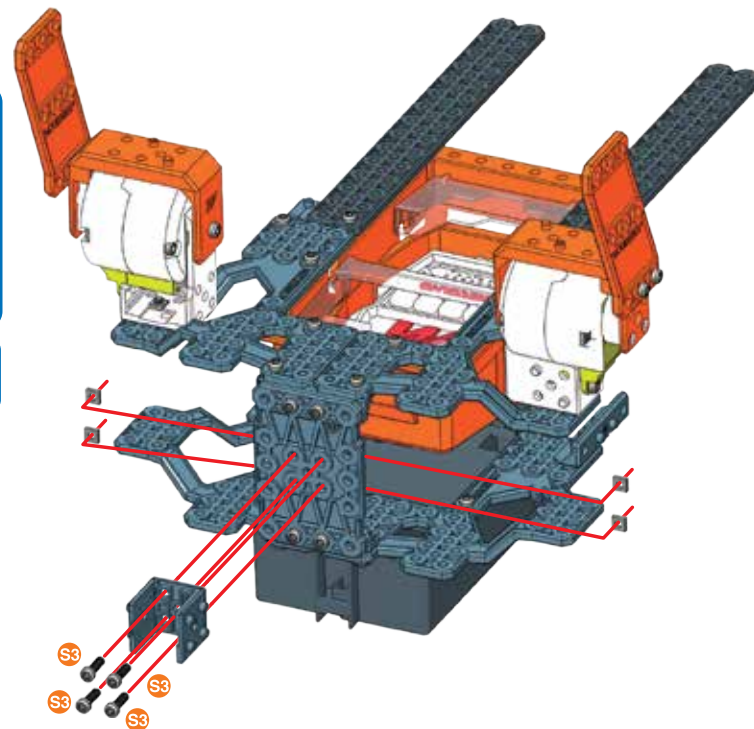
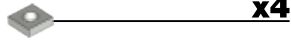
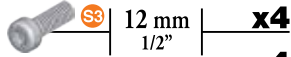
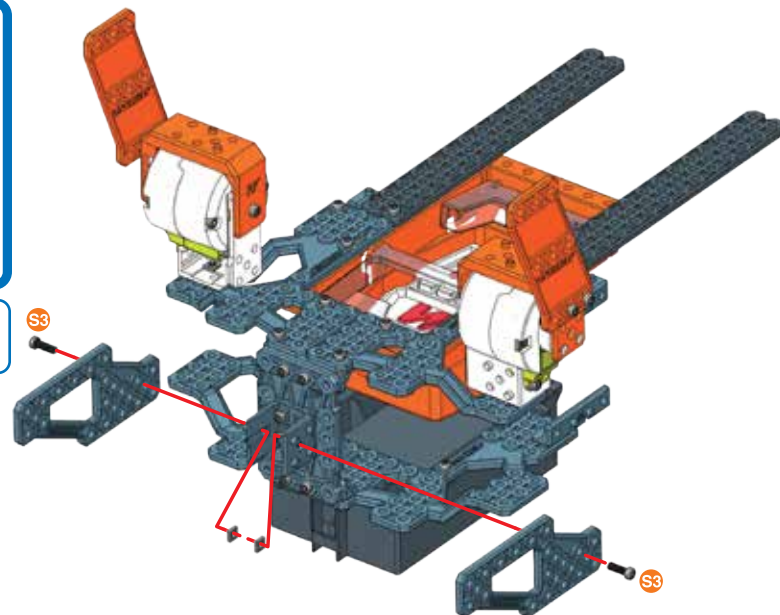
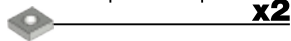
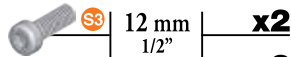
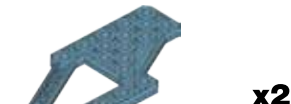
15**x1****x1****B1****1:1****16****x1****x1****x2****x2****S3****1:1****17****x2****x2****x2****S3****1:1****18****x1****x2****x2****S3****1:1**

19**(14) + (18) +****20****21**

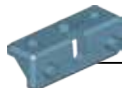

22

-  **x2**
-  | 12 mm | **x2**
1/2"
-  **x2**

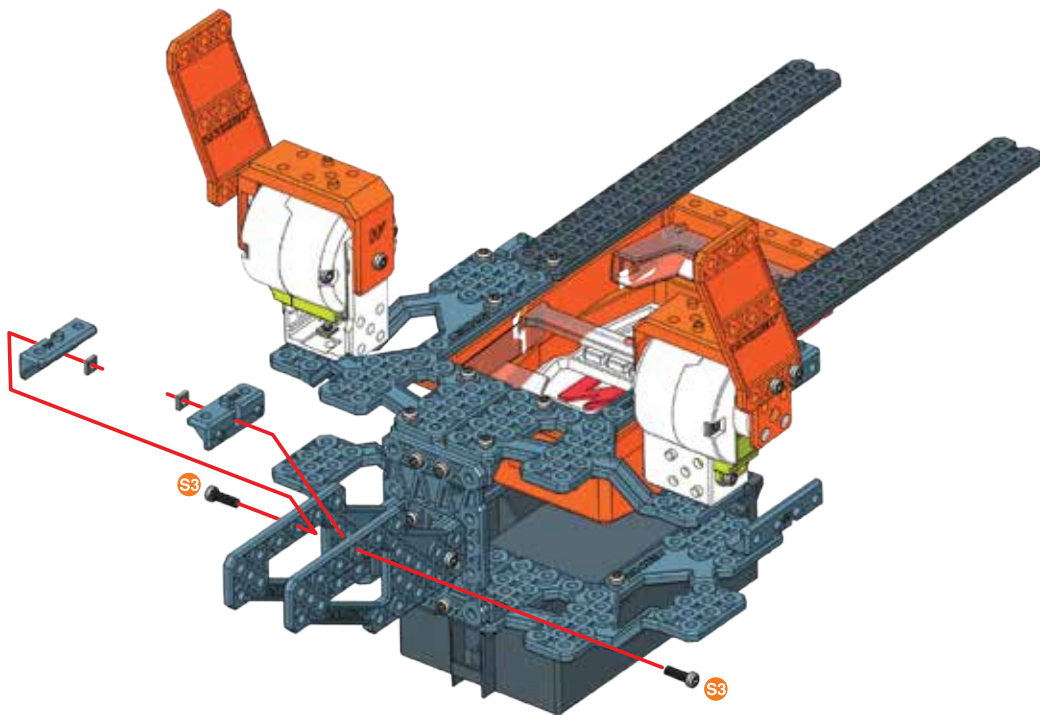
-  **S3** | **1:1**

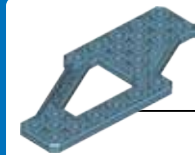

23

-  **x2**
-  | 12 mm | **x4**
1/2"
-  **x4**

-  **S3** | **1:1**

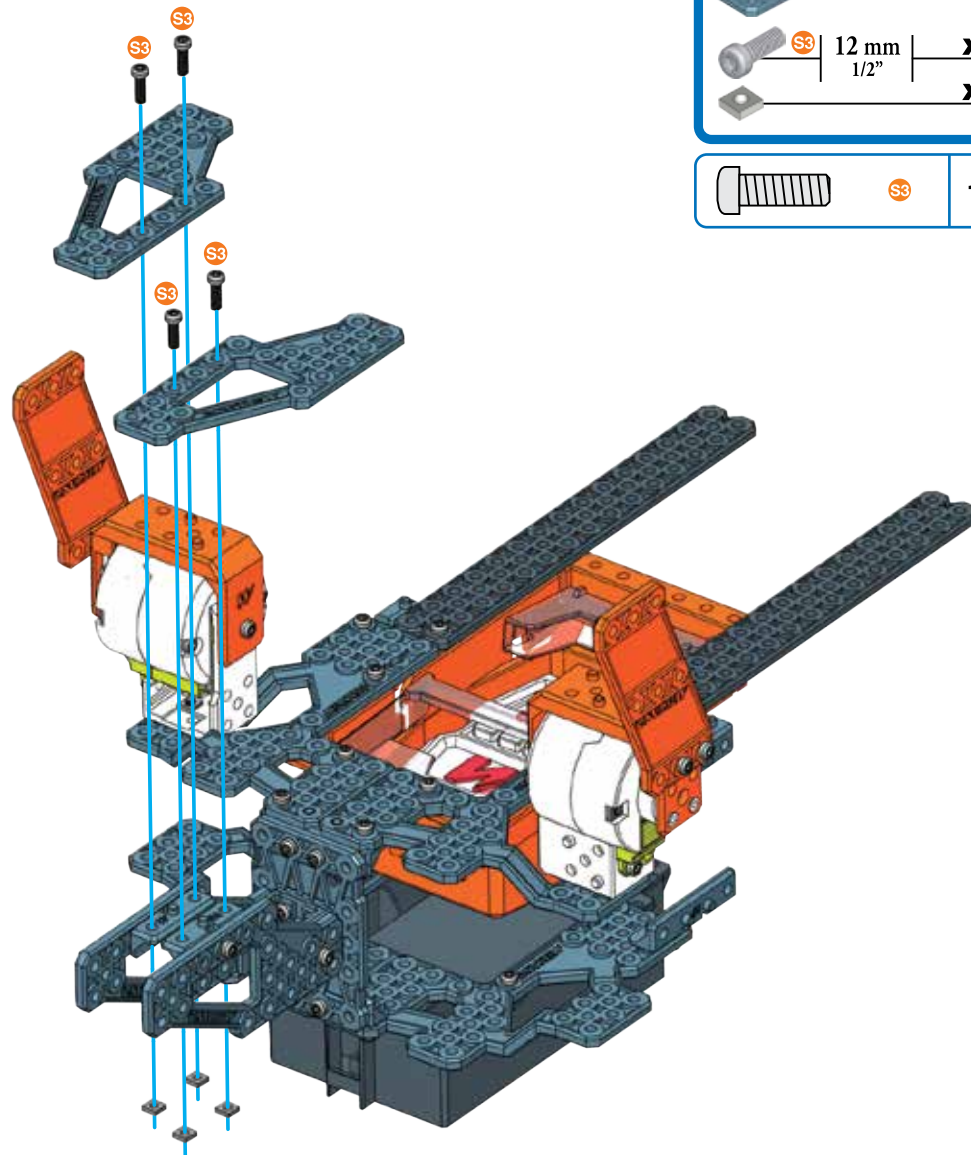

24

- x2
- x2
- 12 mm | 1/2" | x2
- x2
- x2

- 1:1

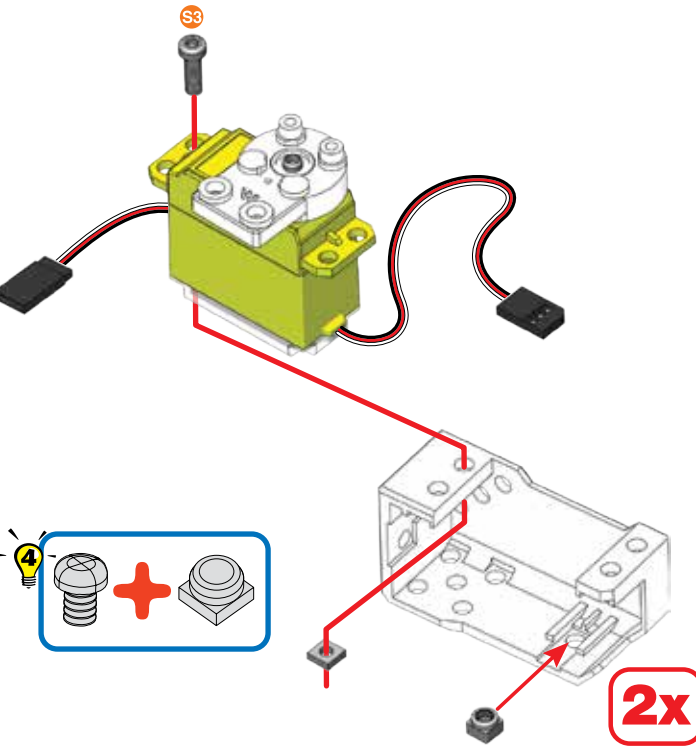

25

- x2
- 14,7 mm | 37/64" | x2
- x2

- 1:1

2x

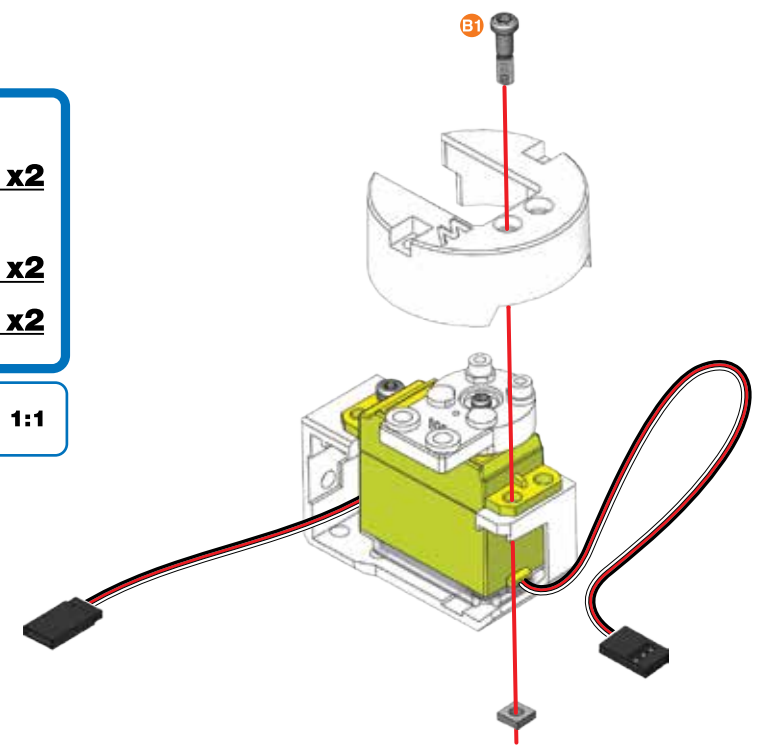

26

- x2
- 38,1 mm | 1 1/2" | x4
- x4

- 1:1

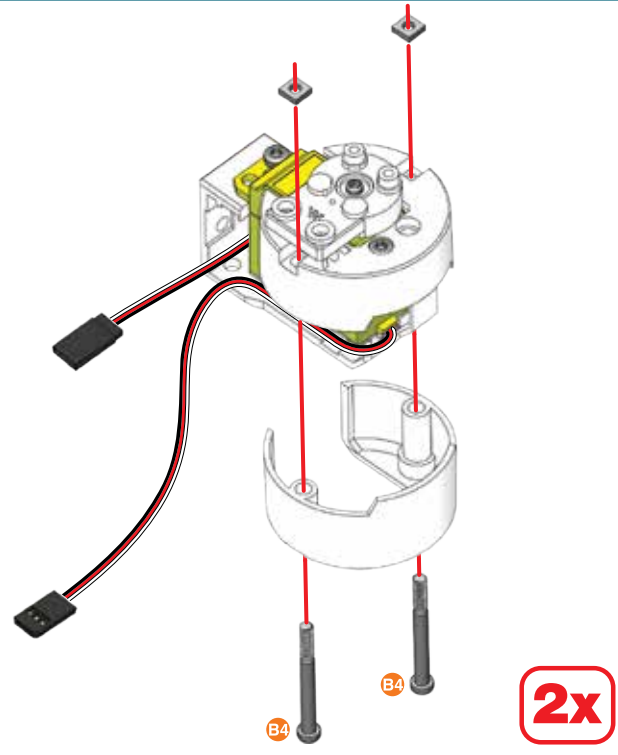

27



- x2
- x2
- 12 mm | 1/2" | x2
- x2

- 1:1

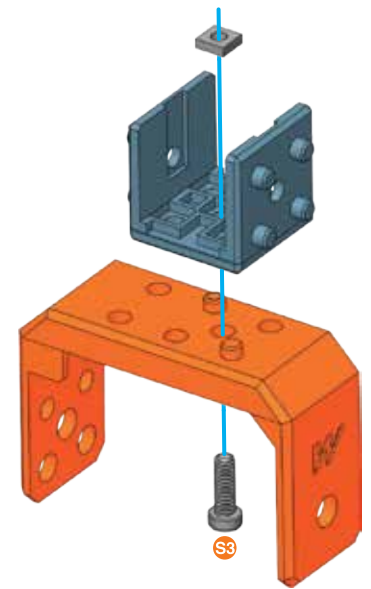
2x





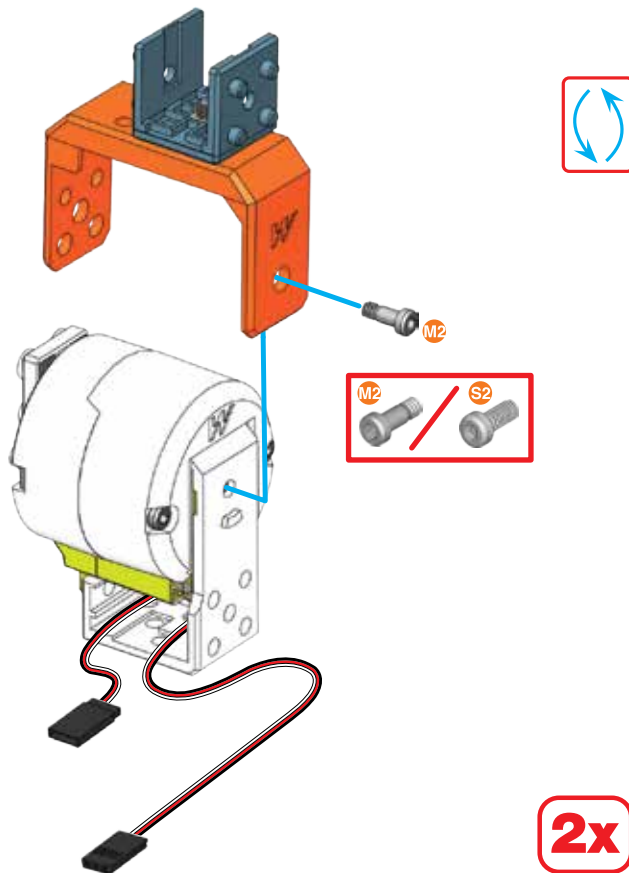
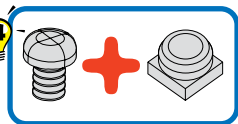

28**26 + 27 +**

	M2	10,5 mm 7/16"	x2
	S2	9,5 mm 3/8"	x2

	M2	1:1
	S2	

**29**

	x2		
	S3	12 mm 1/2"	x2
	x2		

	S3	1:1
---	----	------------

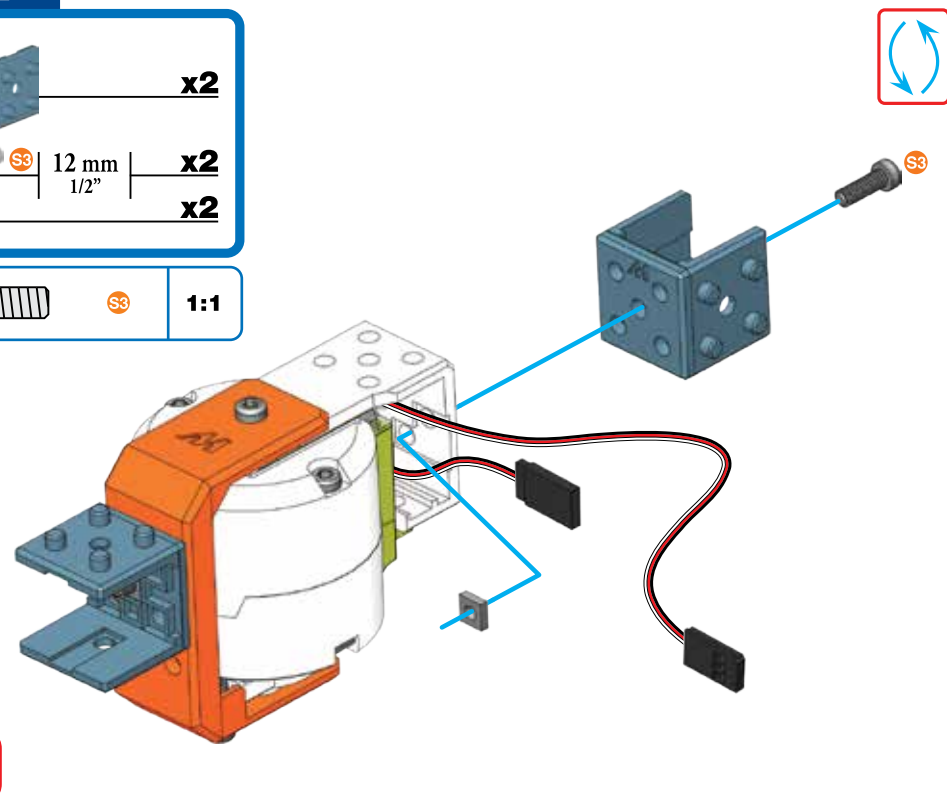
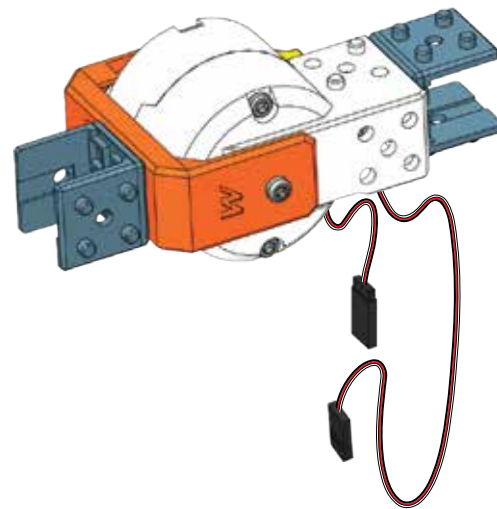
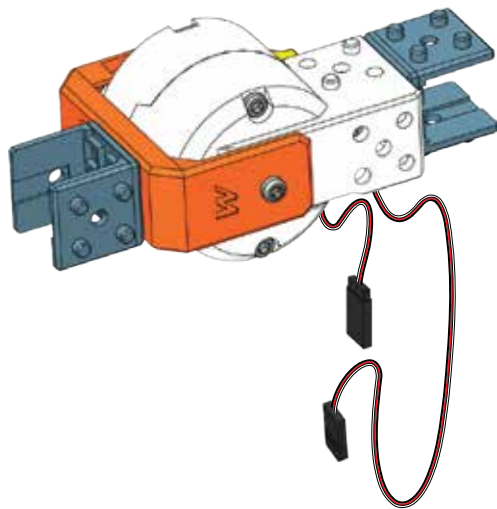
**30****24 ~ 29****2x**

31**(23) + (30) +**

	12 mm 1/2"	x2
		x2

	S3	1:1
--	-----------	------------

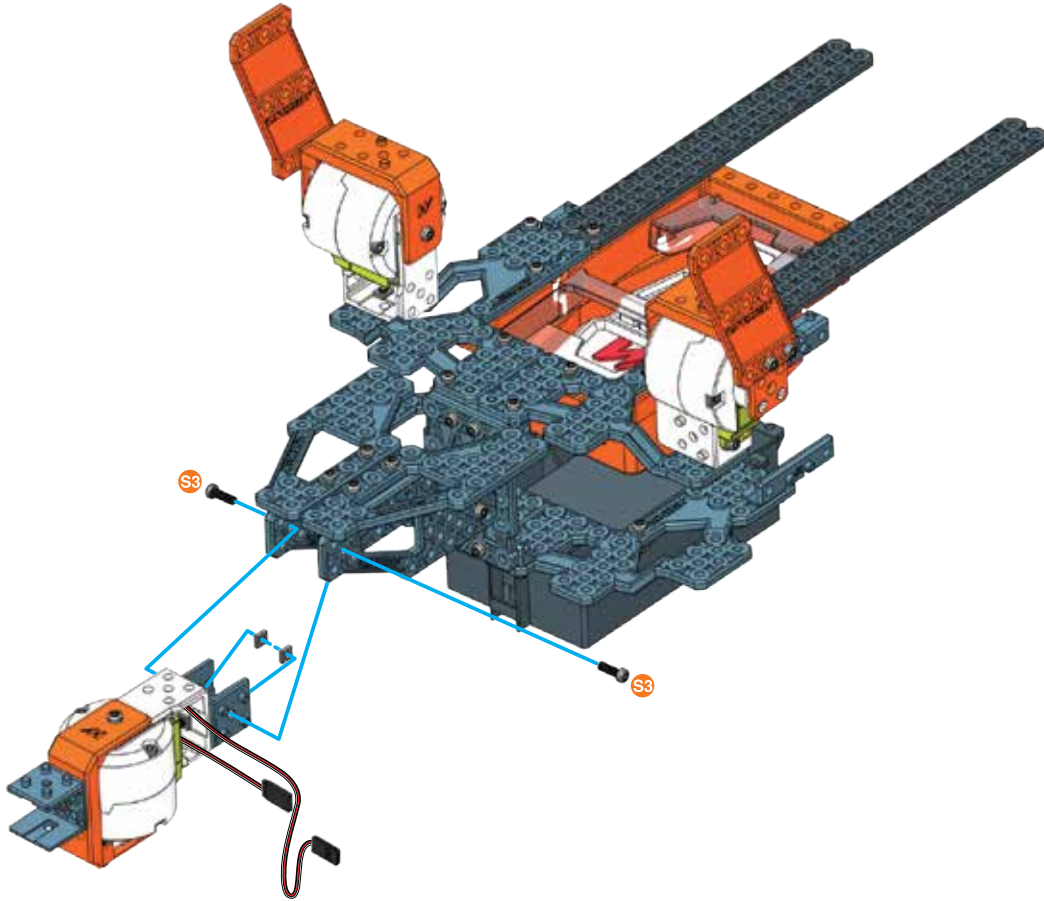

**32****(30) + (31) +**

	12 mm 1/2"	x2
		x2

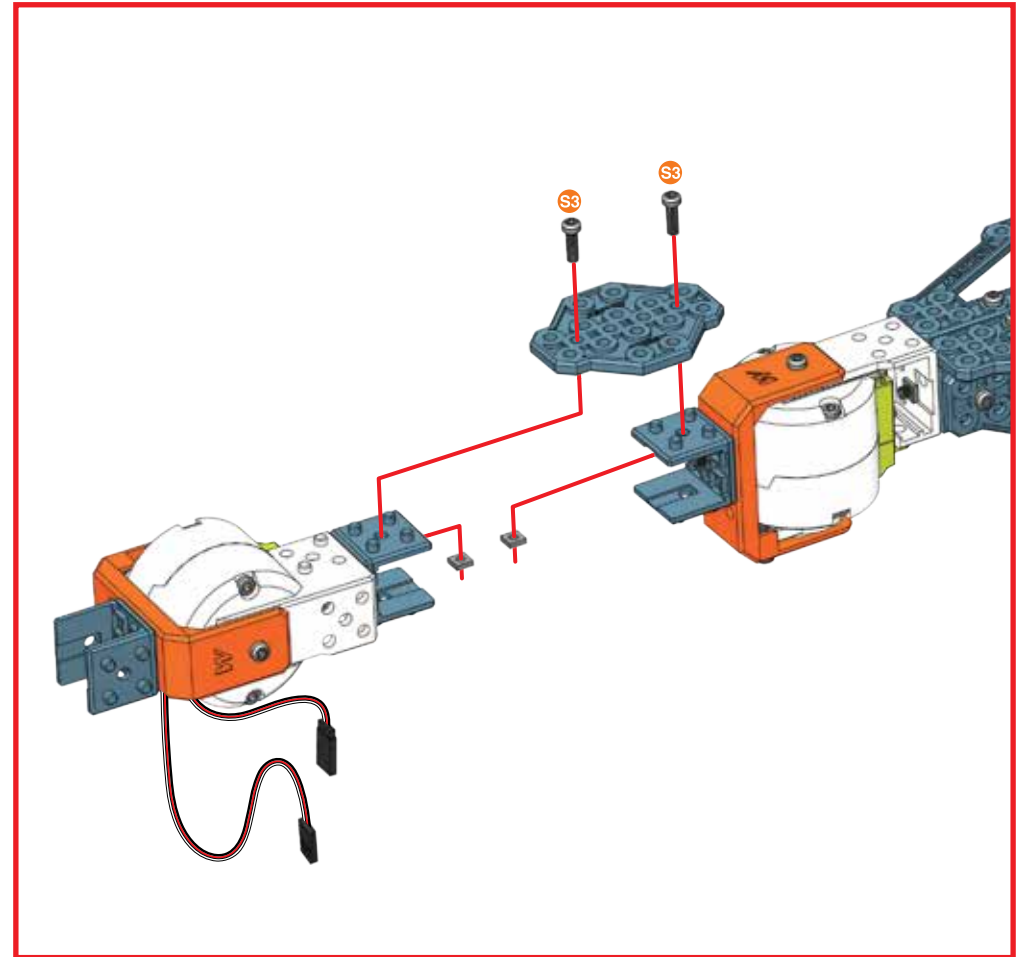
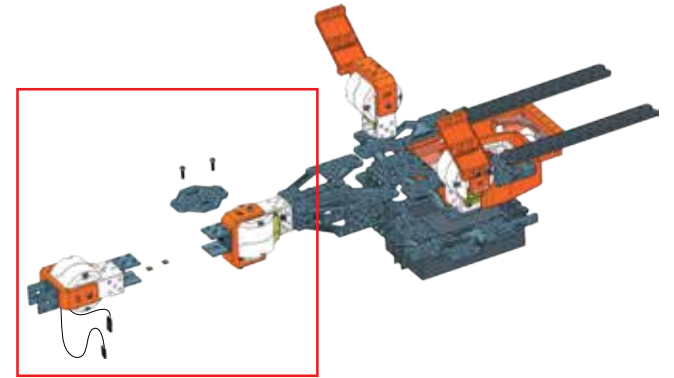
	S3	1:1
--	-----------	------------



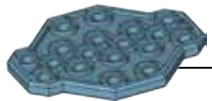

33

-  **x1**
-  | 12 mm | **x2**
-  **x2**

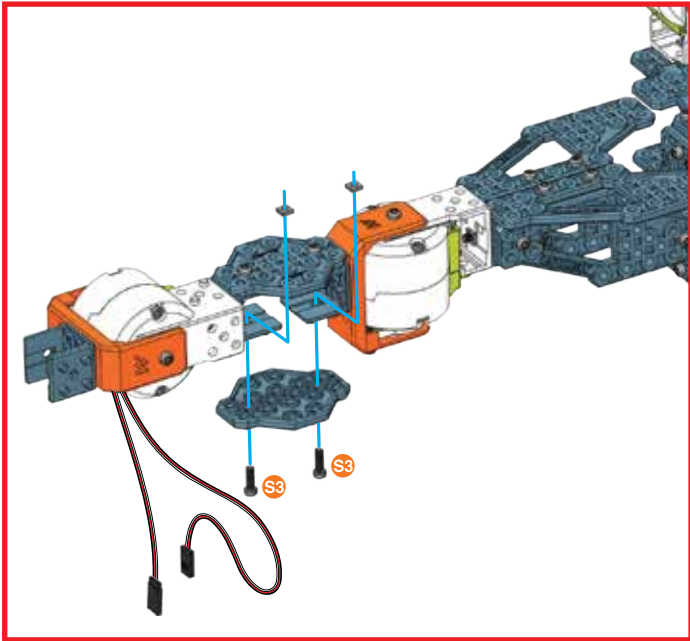
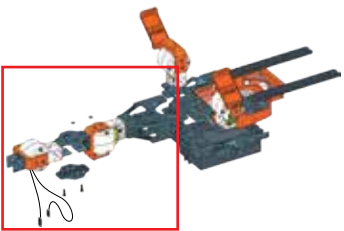
-  **S3** | **1:1**





34

-  **x2**
-  | 12 mm | **x2**
-  **x2**

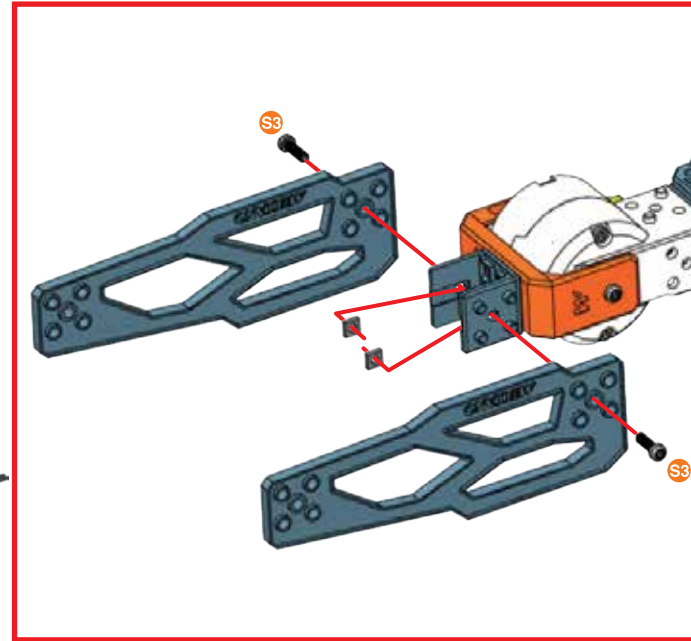
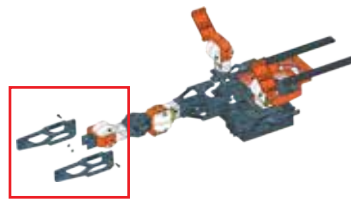
-  **S3** | **1:1**





35

-  **x1**
-  | 12 mm | **x2**
-  **x2**

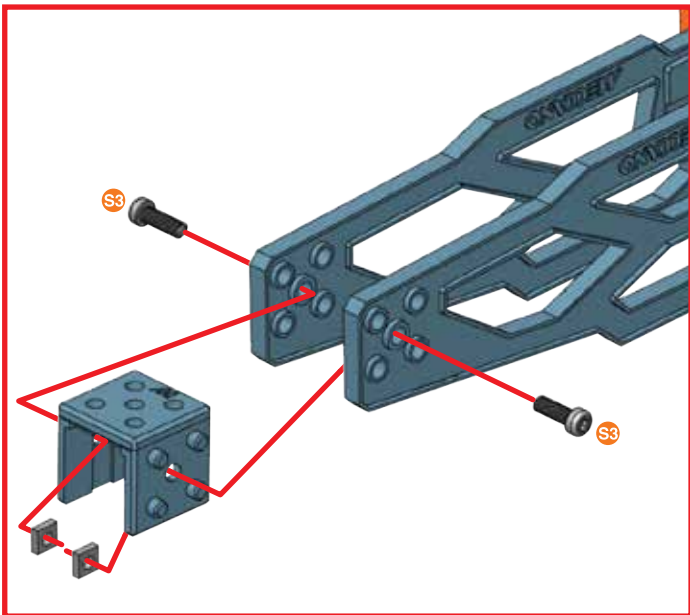
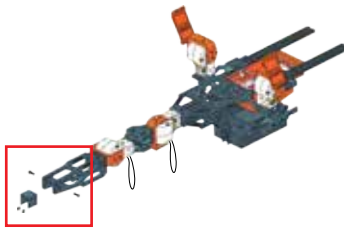
-  **S3** | **1:1**



36

-  **x1**
-  | 9,5 mm | **x2**
-  **x2**

-  **S2** | **1:1**

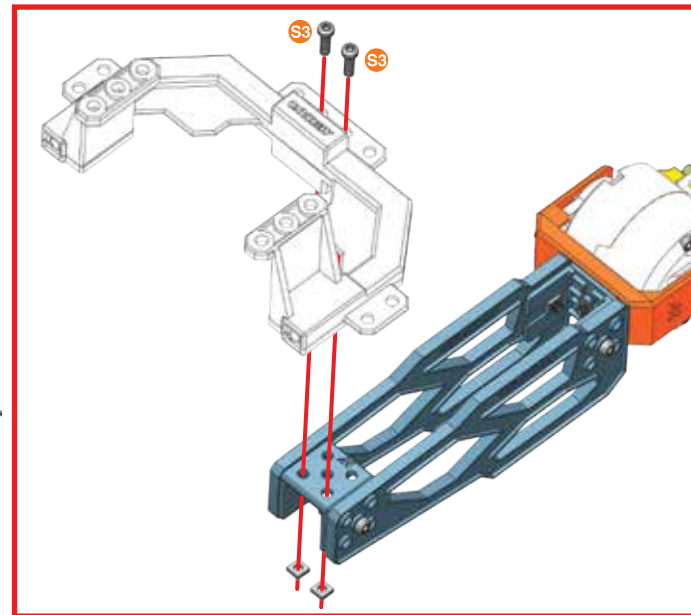

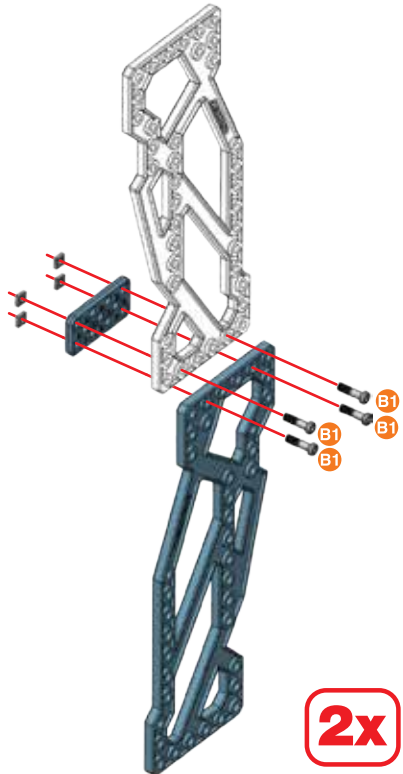
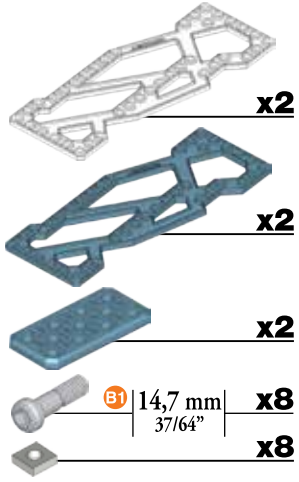
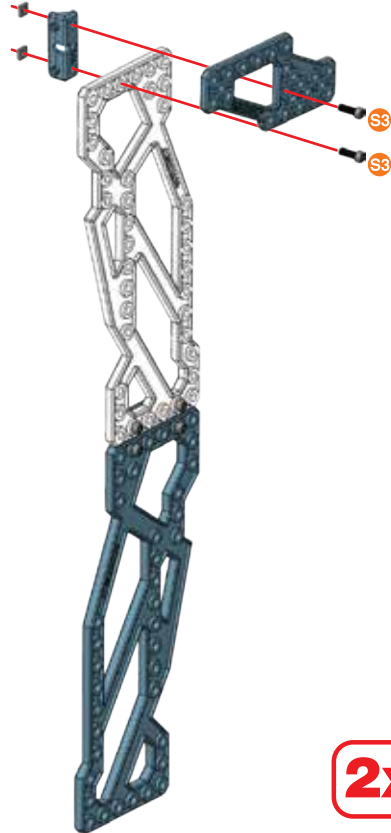
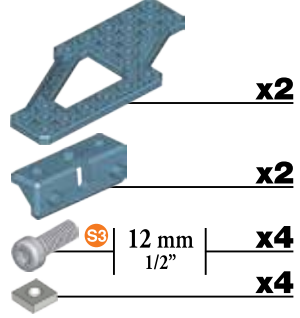
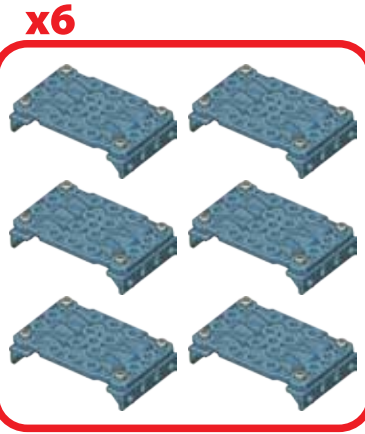
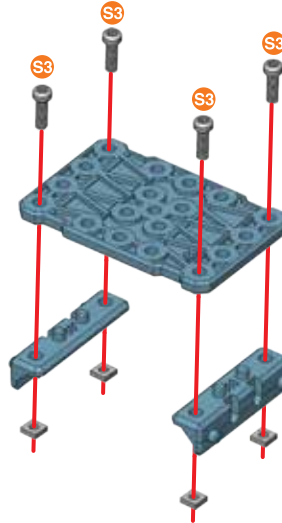
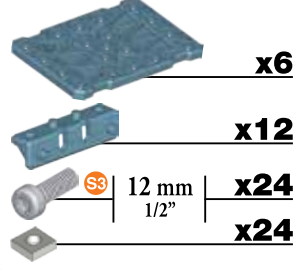
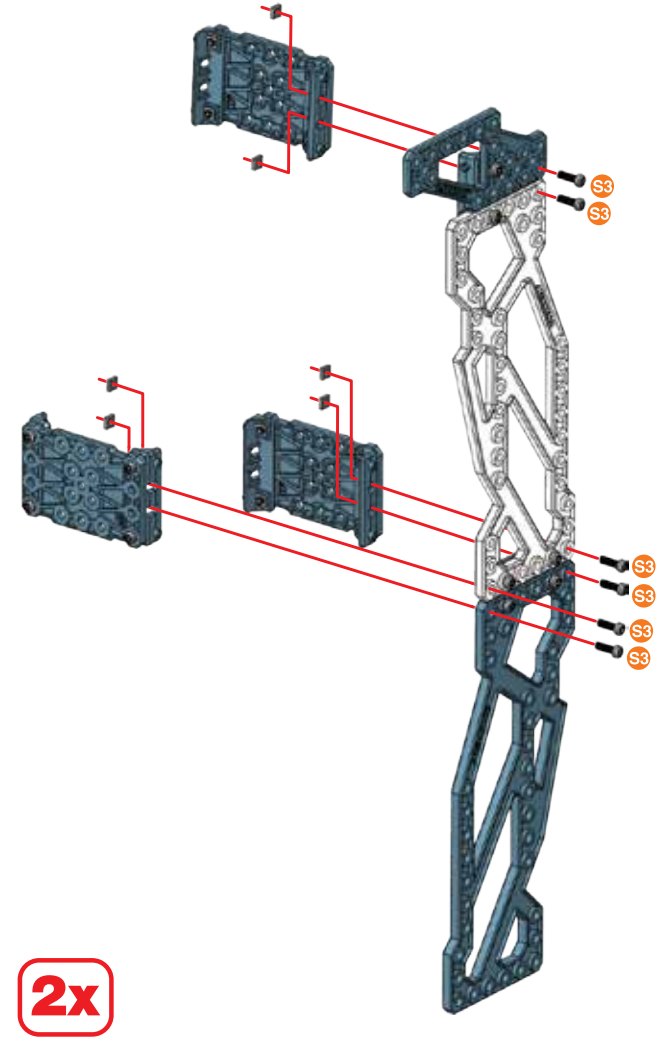
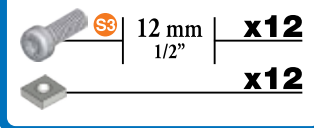
37**38****39****40****(38) + (39) +**

41



x6



x12

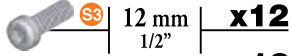

x12

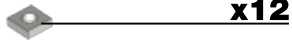

x12



S3

1:1

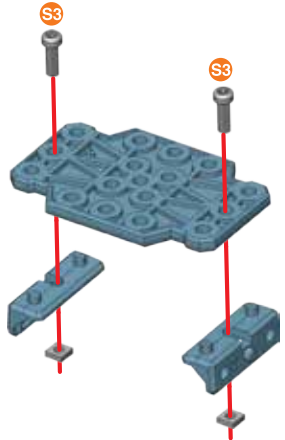

x6



6x

42

40 + 41 +

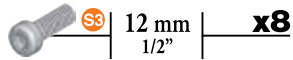

12 mm
1/2"

x8

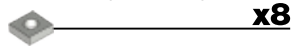

x8



S3

1:1

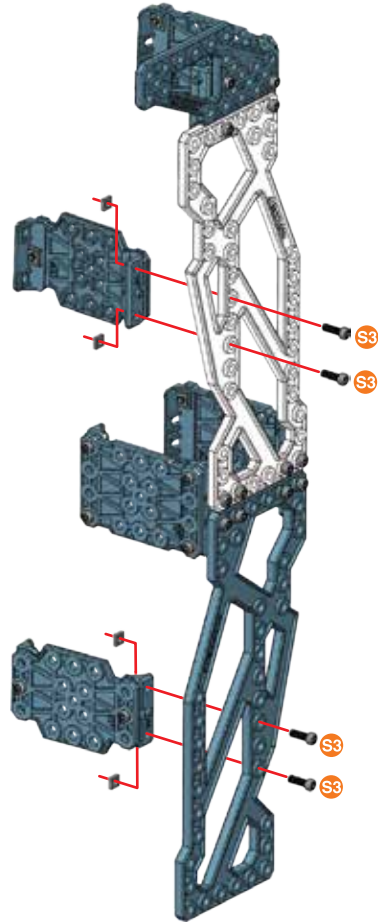

2x

43



x2

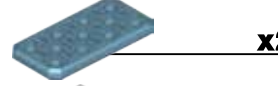

x2



B1

14,7 mm
37/64"

x4

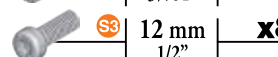

S3

12 mm
1/2"

x8

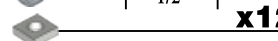

x12

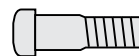

B1

1:1



S3

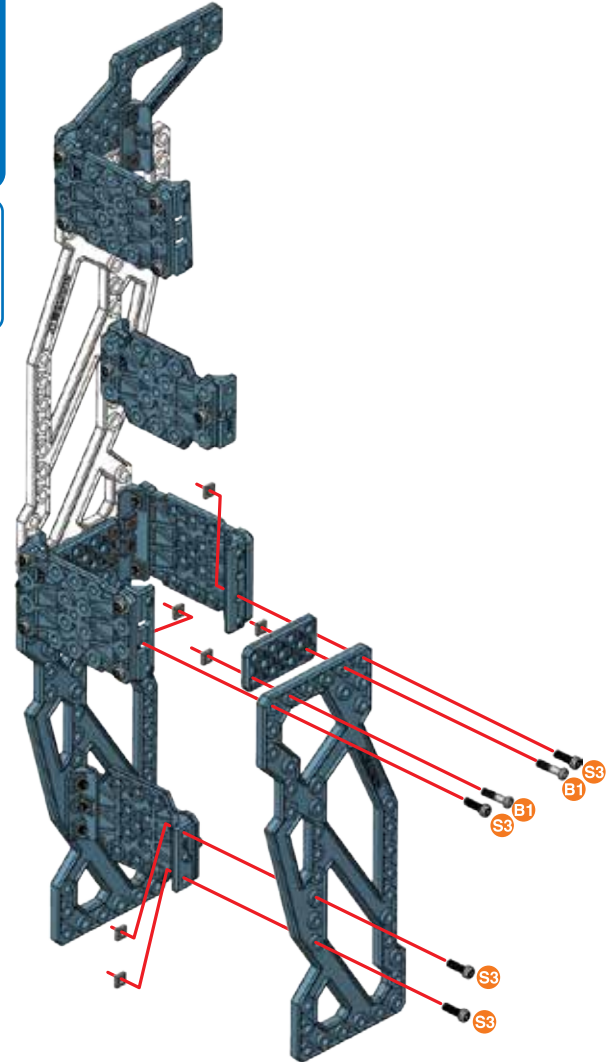



2x

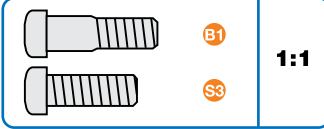
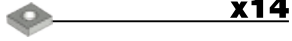
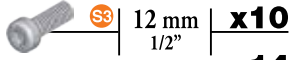
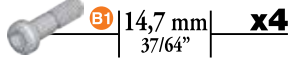
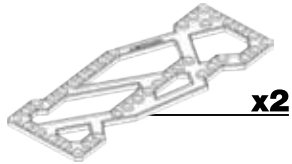
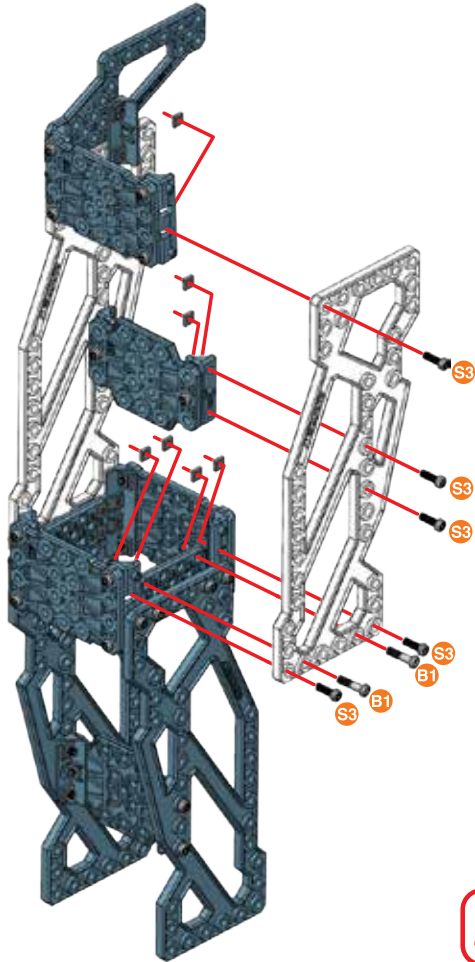
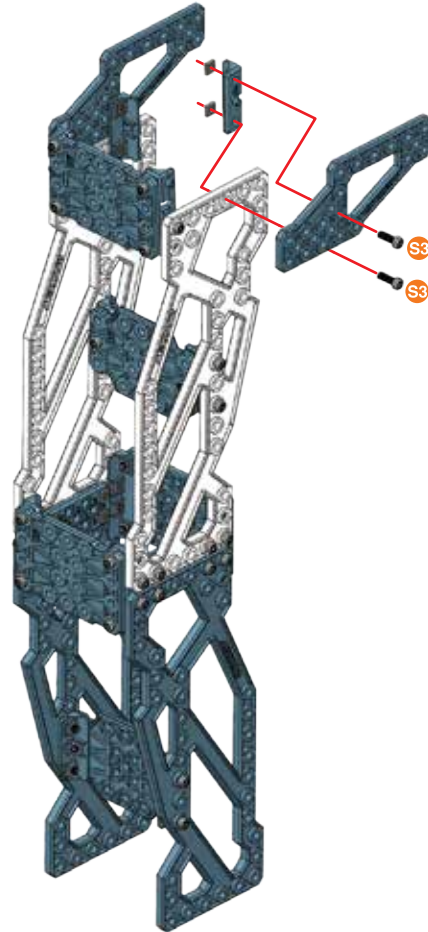
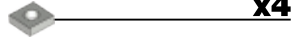
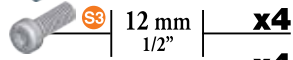
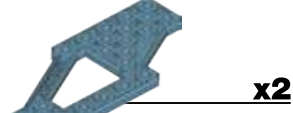
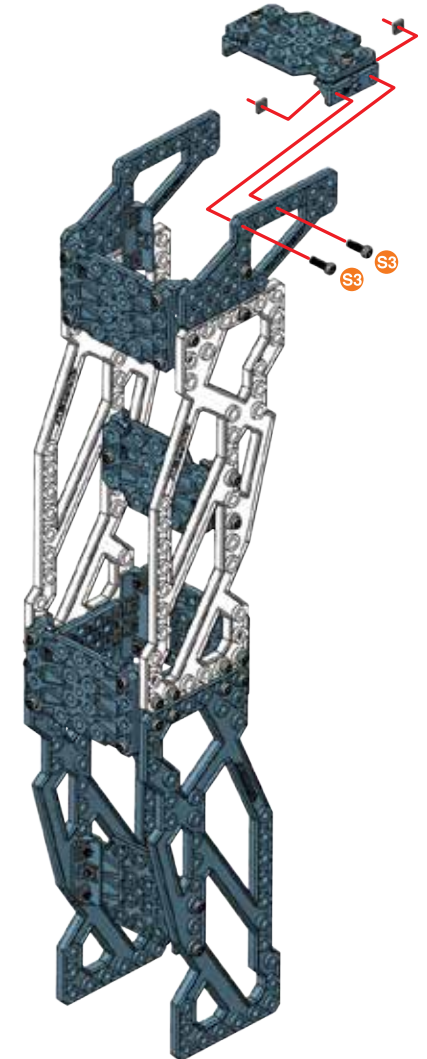
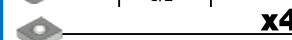
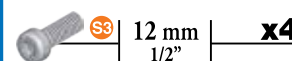

44**1:1****2x****45****2x****46****(41) + (45) +****2x**

47

-  12 mm | **x4**
-  1/2" | **x4**

-  **1:1**

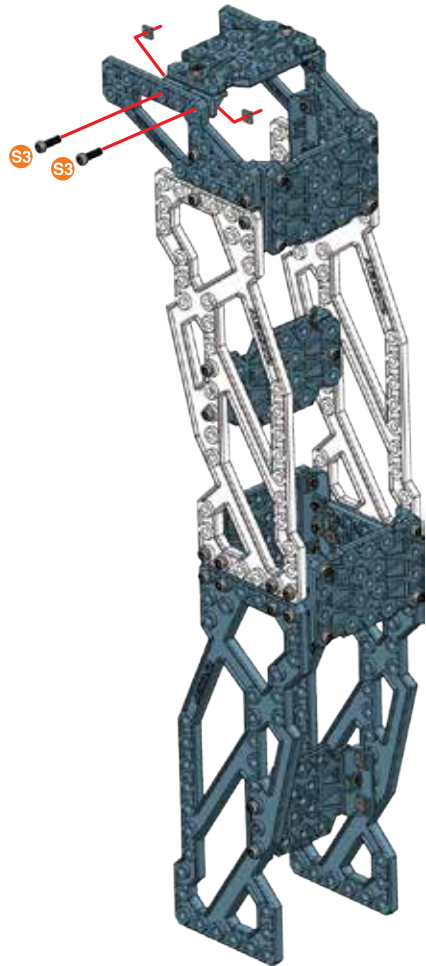

2x

48



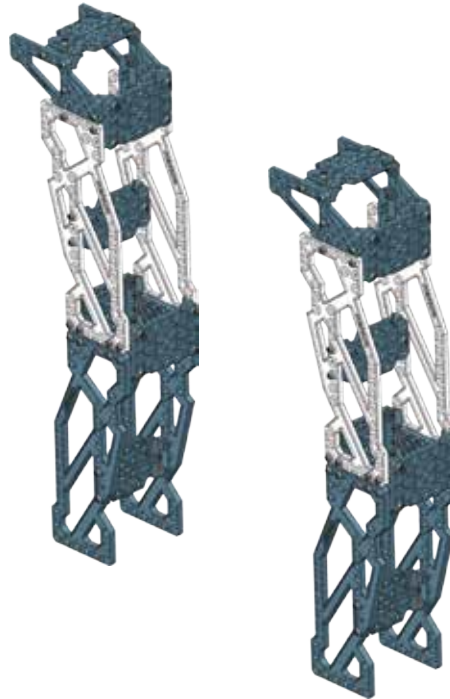

37 ~ 47

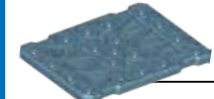

2x

49

48+



-  **x1**
-  19 mm | **x1**
2/4"
-  12 mm | **x2**
1/2"
-  **x3**

-  **1:1**
- 

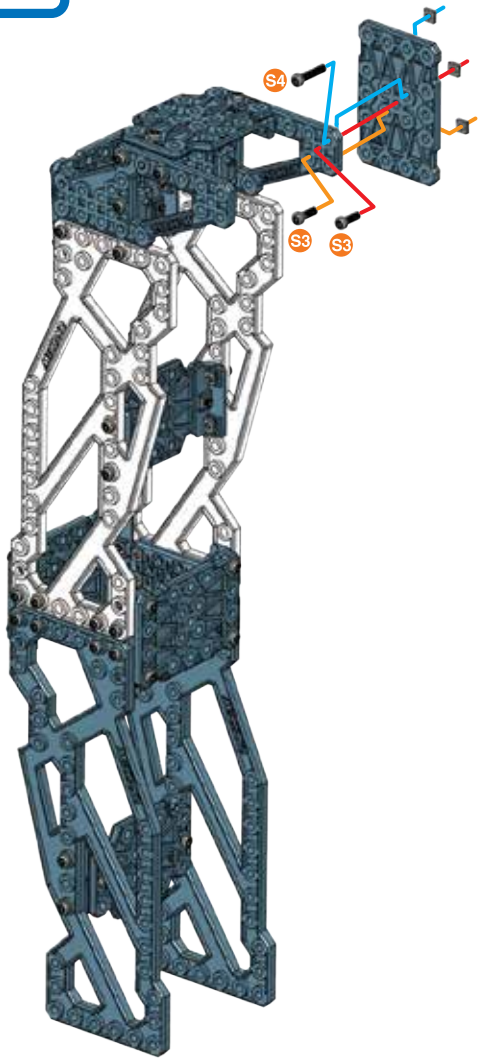
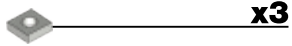
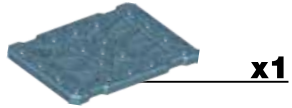
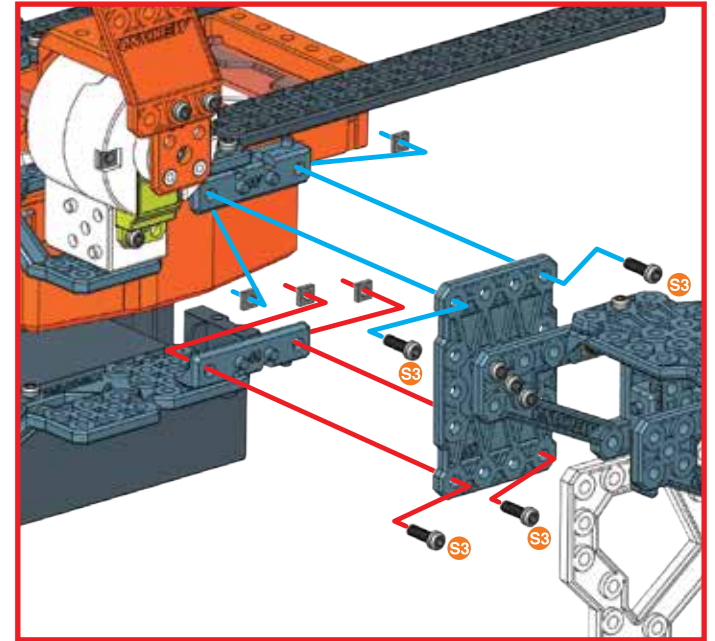
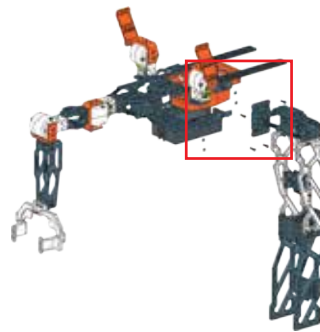
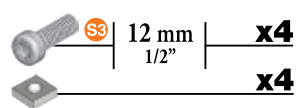
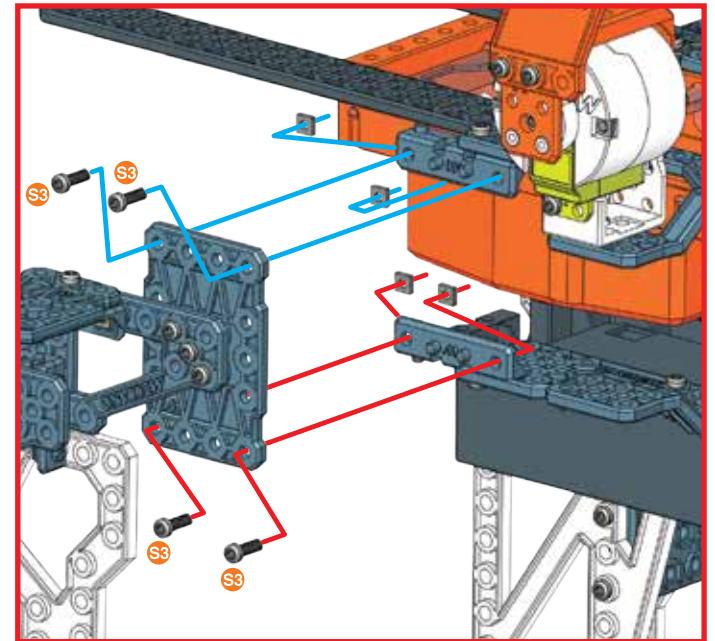
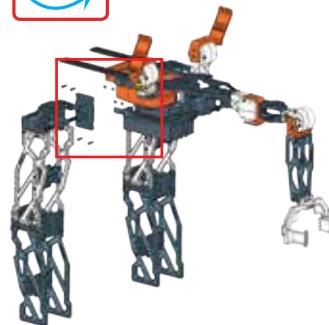
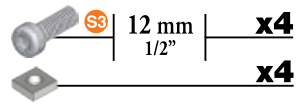

50**48+****51****36+49+****52****36+50+**



53

-  **x1**
-  | 12 mm | **x2**
1/2"
-  **x2**

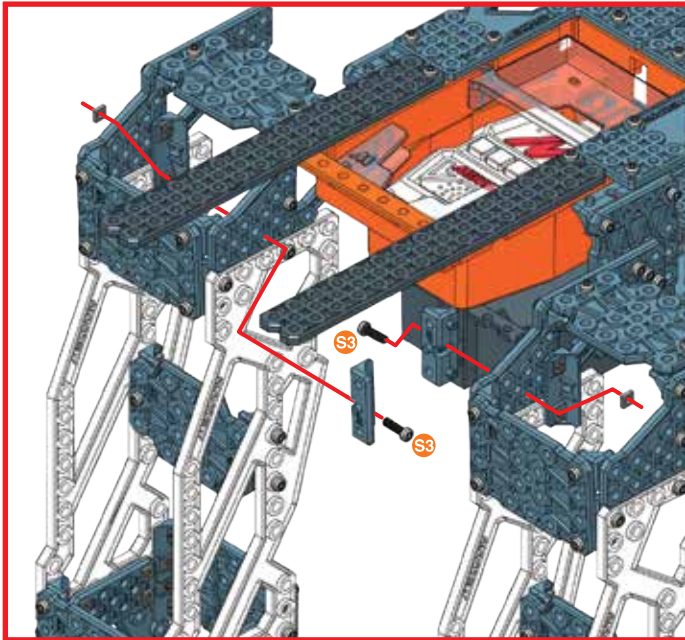
-  **1:1**



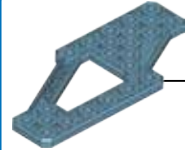

54

-  **x1**
-  | 12 mm | **x2**
1/2"
-  **x2**

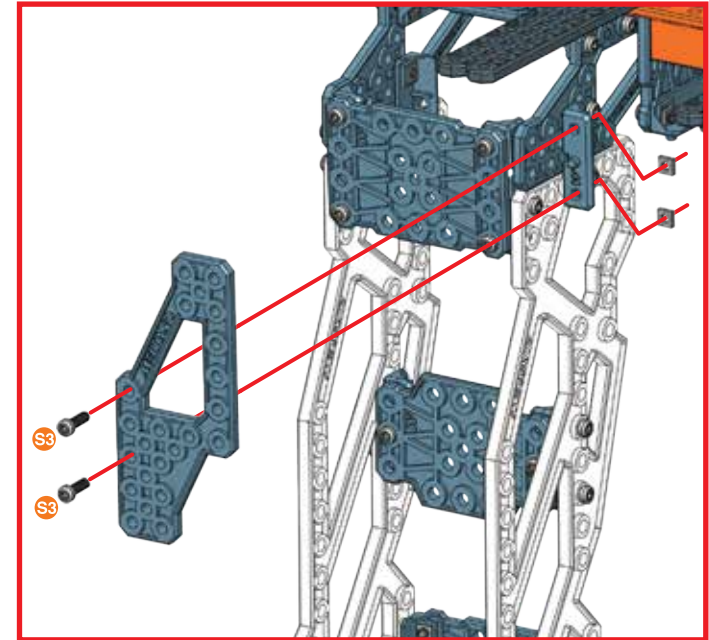
-  **1:1**



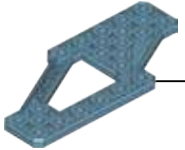

55

-  **x1**
-  | 12 mm | **x2**
1/2"
-  **x2**

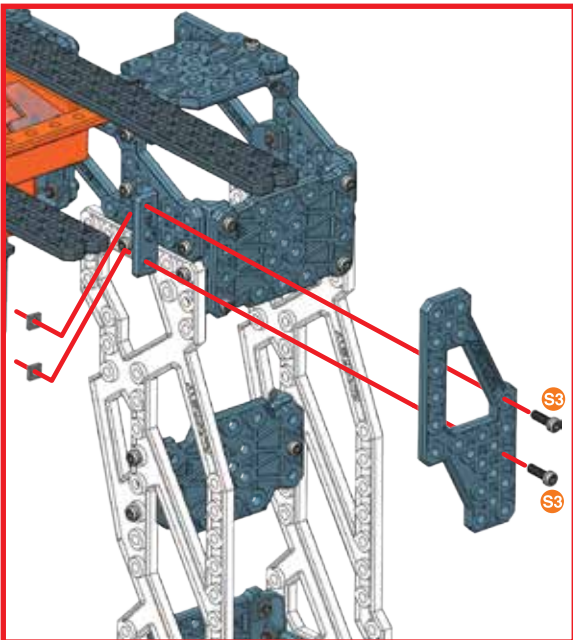
-  **1:1**



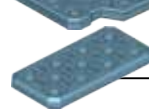

56

-  **x2**
-  **x1**
-  | 12 mm | **x8**
1/2"
-  **x8**

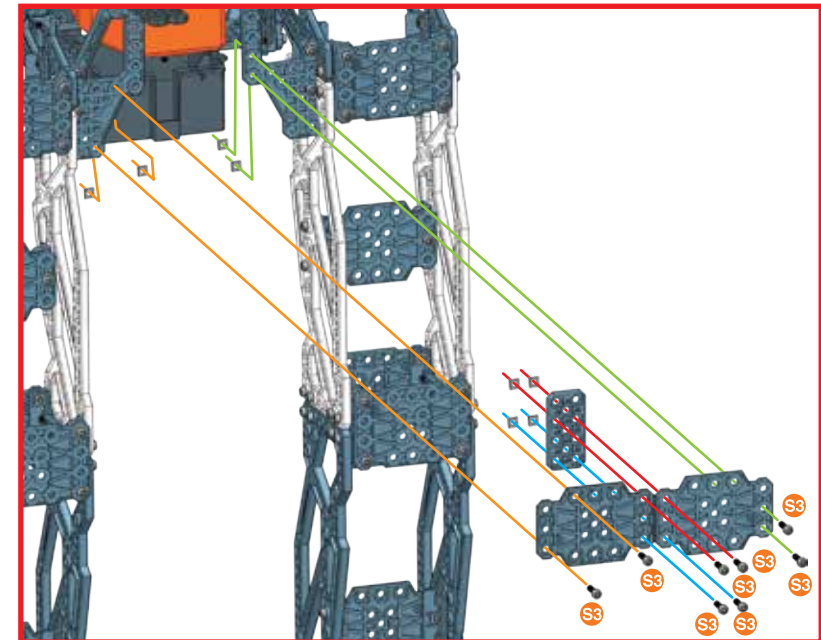
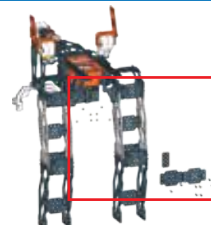
-  **1:1**





57

-  **x2**
-  **x1**
-  **x2**
-  **x2**

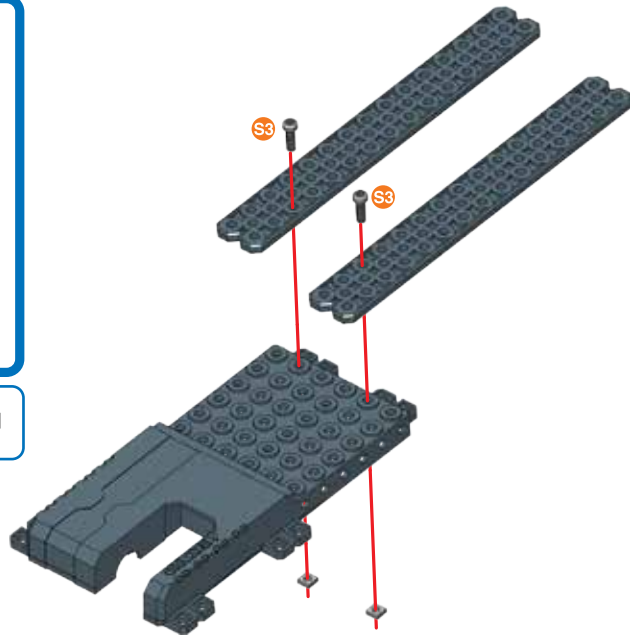
	S3	1:1
--	----	-----





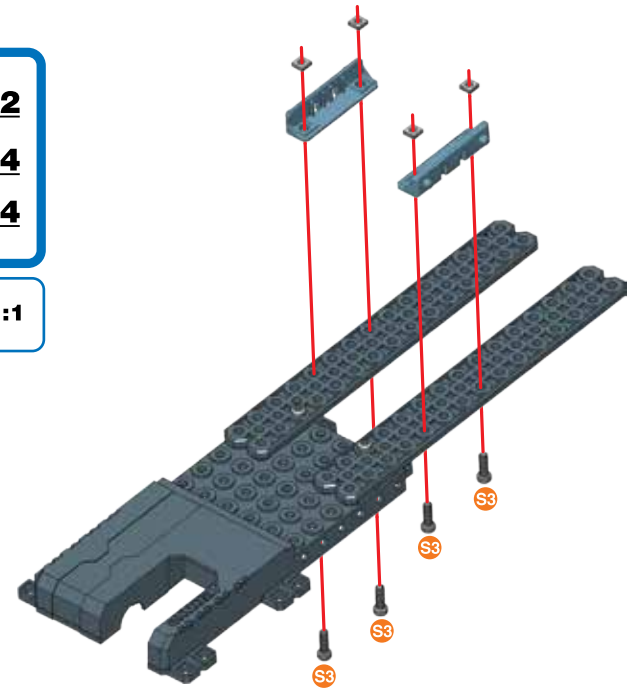

58

-  **x2**
-  **x4**
-  **x4**

	S3	1:1
---	----	-----





59

-  **x2**
-  **x1**
-  **x5**
-  **x5**

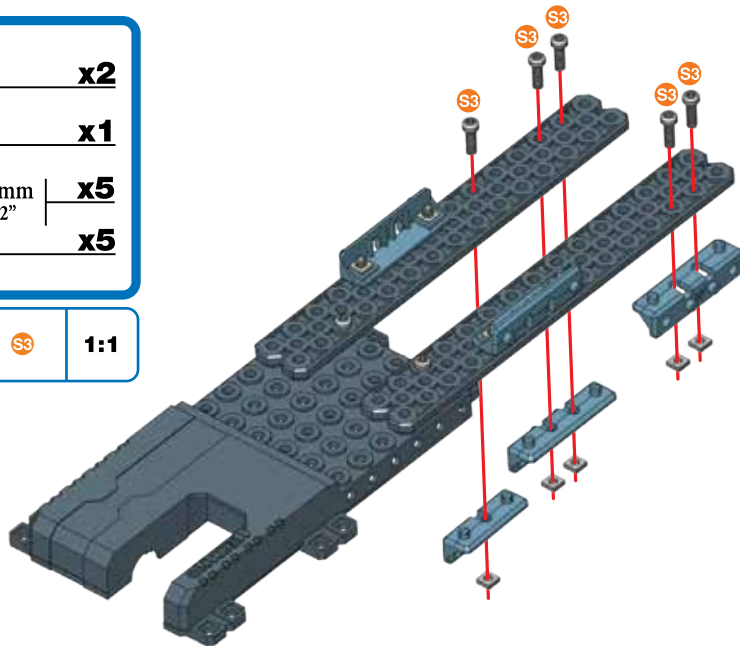
	S3	1:1
--	----	-----





60

-  **x1**
-  **x6**
-  **x6**

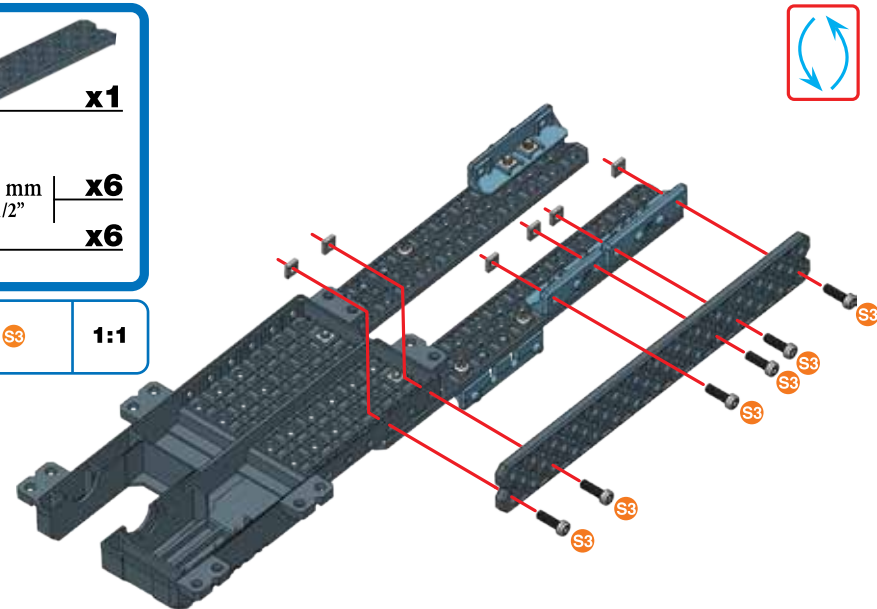
	S3	1:1
---	----	-----





61

-  x1
-  12 mm | 1/2" | x4
-  x4

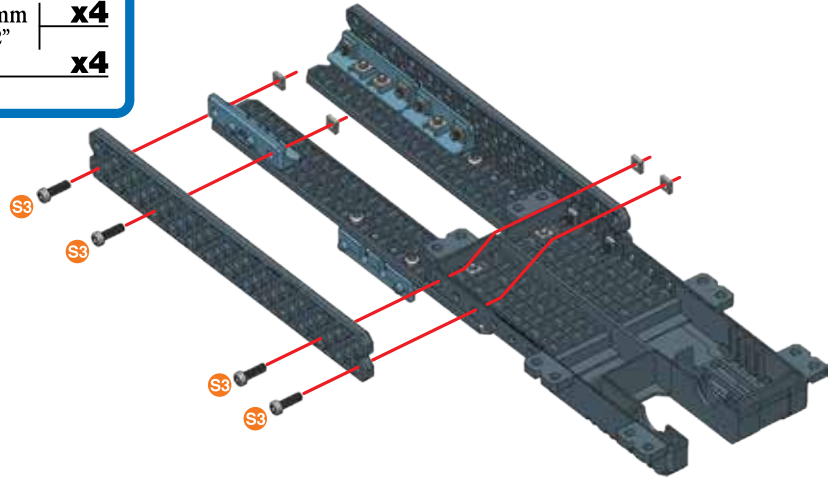
-  S3
- 1:1

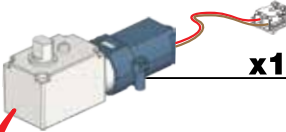

62

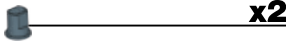
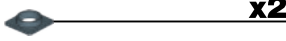
-  x1
-  x1
-  x2
-  x2

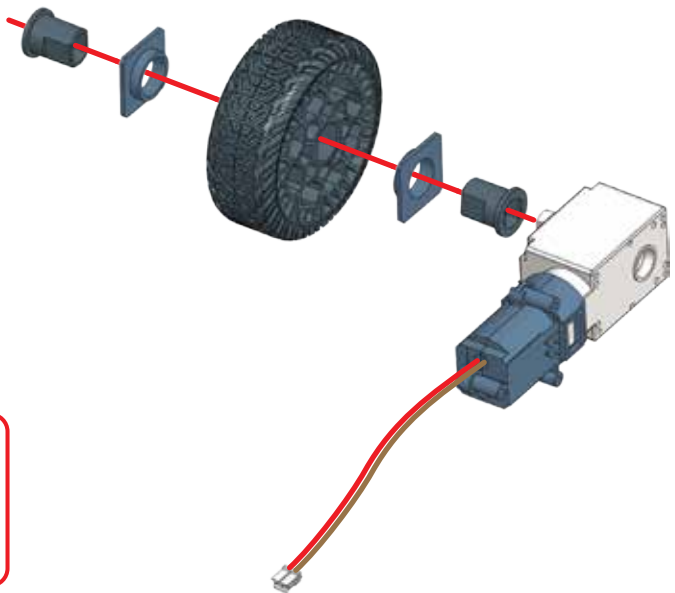

63

61 + 62

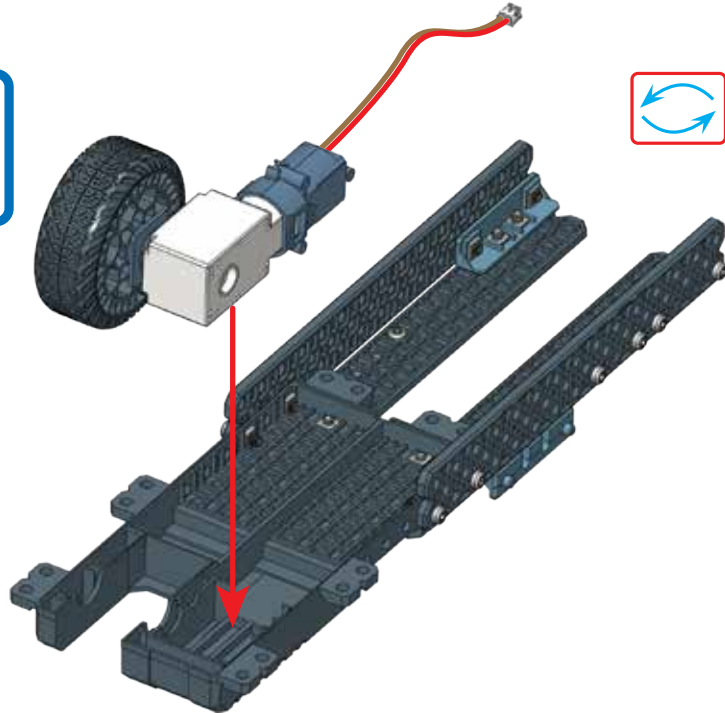

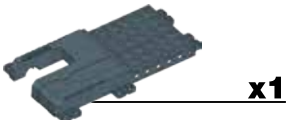
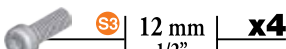
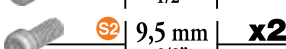
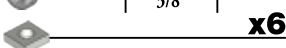

64

-  x1
-  12 mm | 1/2" | x4
-  9,5 mm | 3/8" | x2
-  x6

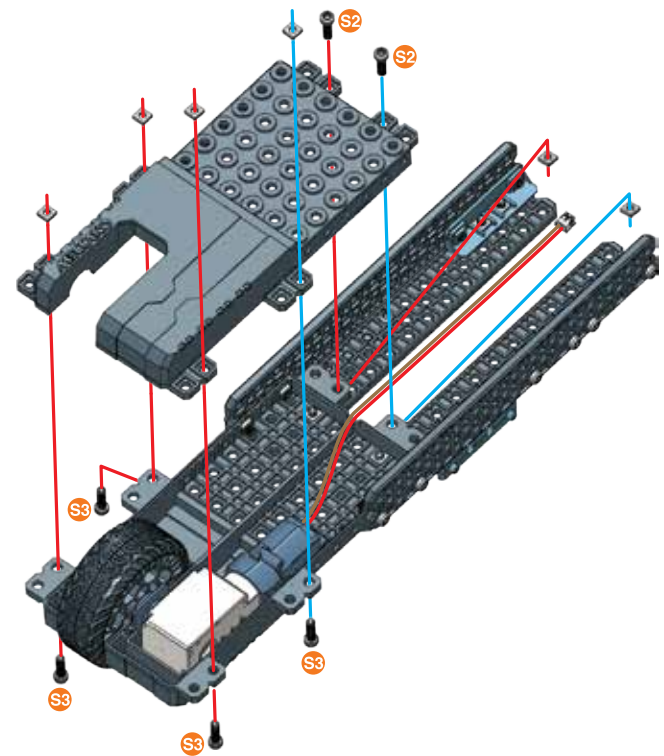
-  S3
-  S2
- 1:1





65

-  **x1**
-  | 12 mm | **x4**
-  **x4**

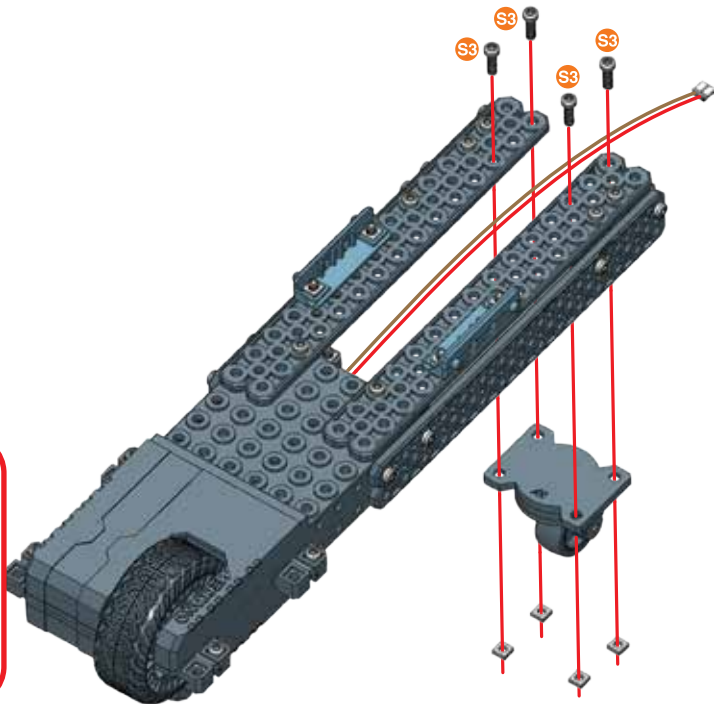
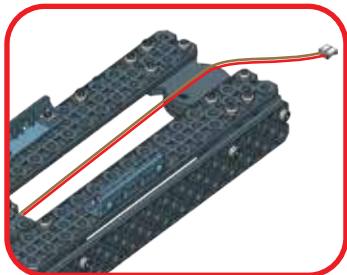
-  **S3** | **1:1**



66

-  **x1**
-  | 12 mm | **x2**
-  **x2**

-  **S3** | **1:1**

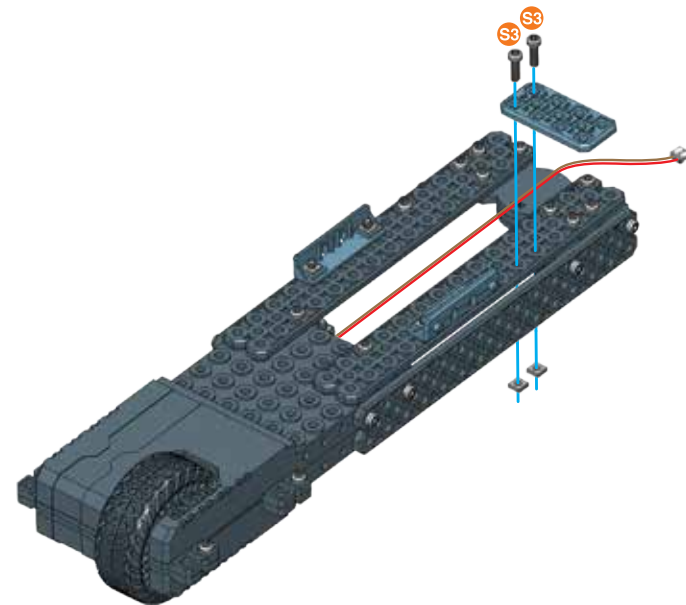



67

-  **x2**
-  **x1**
-  | 12 mm | **x2**
-  **x2**

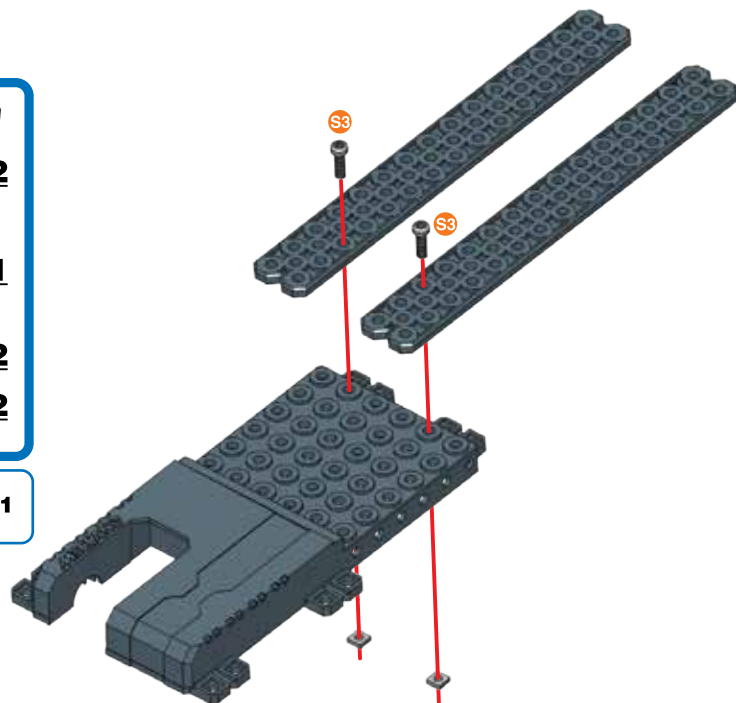
-  **S3** | **1:1**





68

-  **x2**
-  | 12 mm | **x4**
-  **x4**

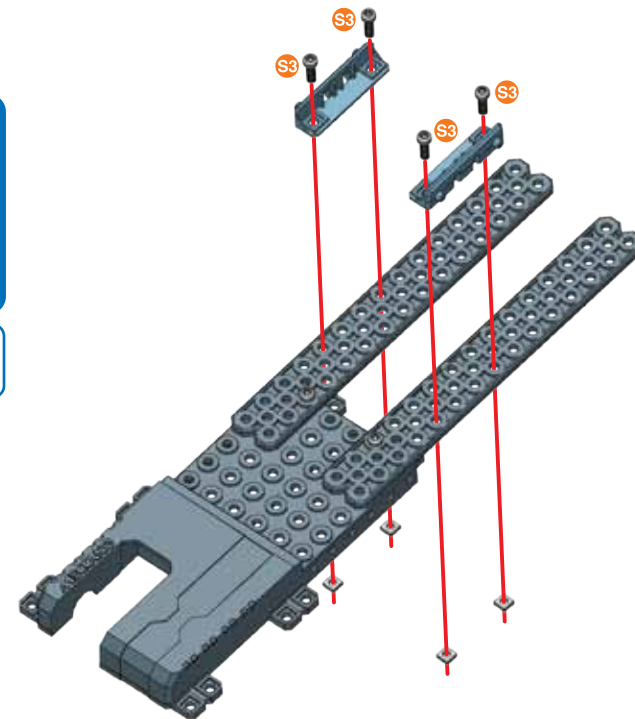
-  **S3** | **1:1**



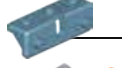

69

-  **x2**
-  **x1**
-  **x5**
-  **x5**

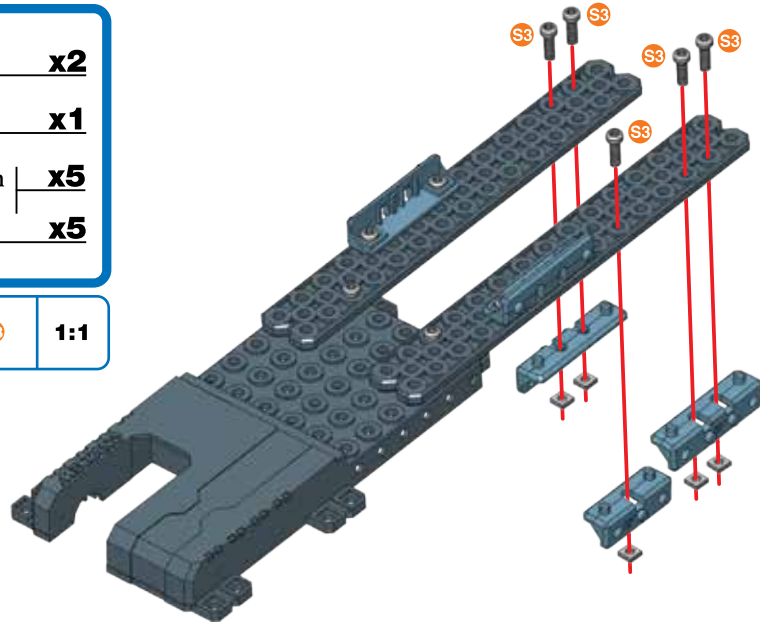

-  **S3** **1:1**

**70**

-  **x1**
-  **x4**
-  **x4**

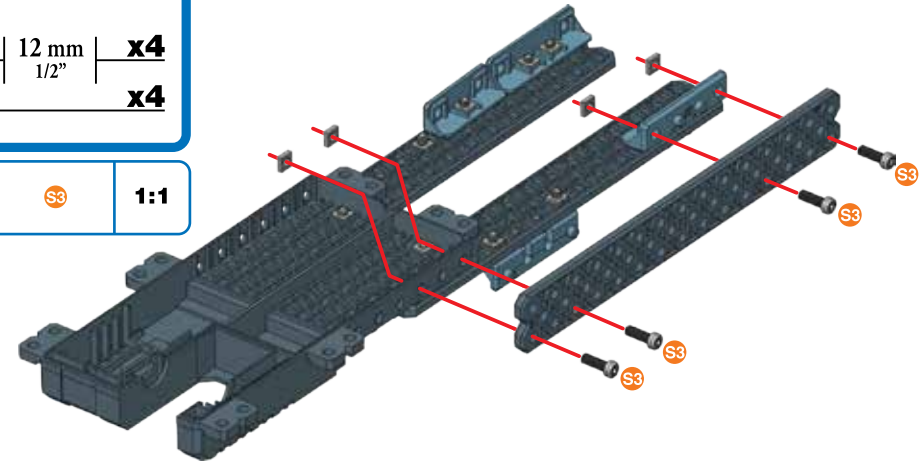

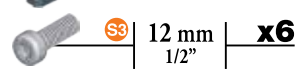

-  **S3** **1:1**

**71**

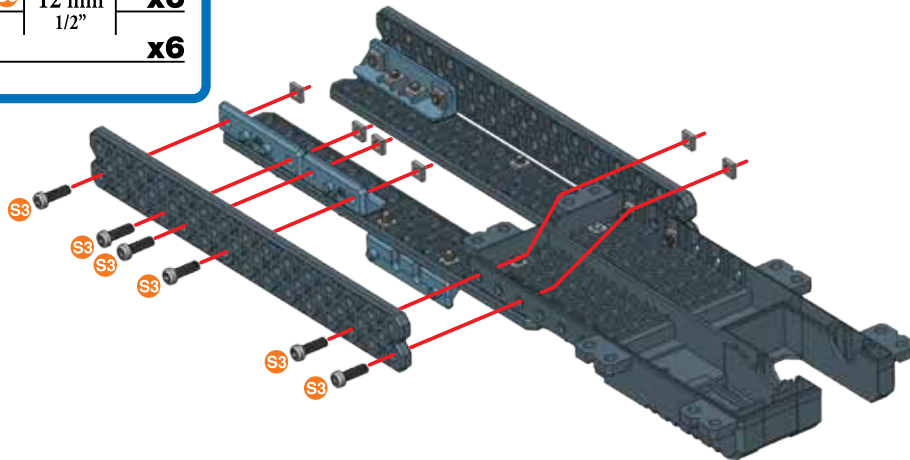
-  **x1**
-  **x6**
-  **x6**

-  **S3** **1:1**

**72**

-  **x1**
-  **x1**
-  **x2**
-  **x2**

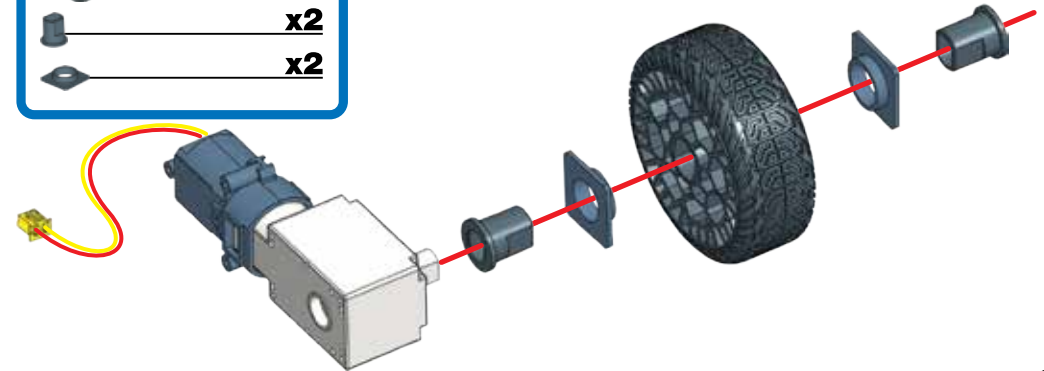
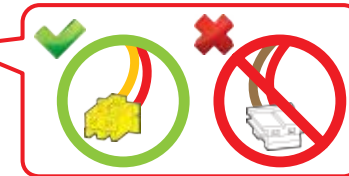



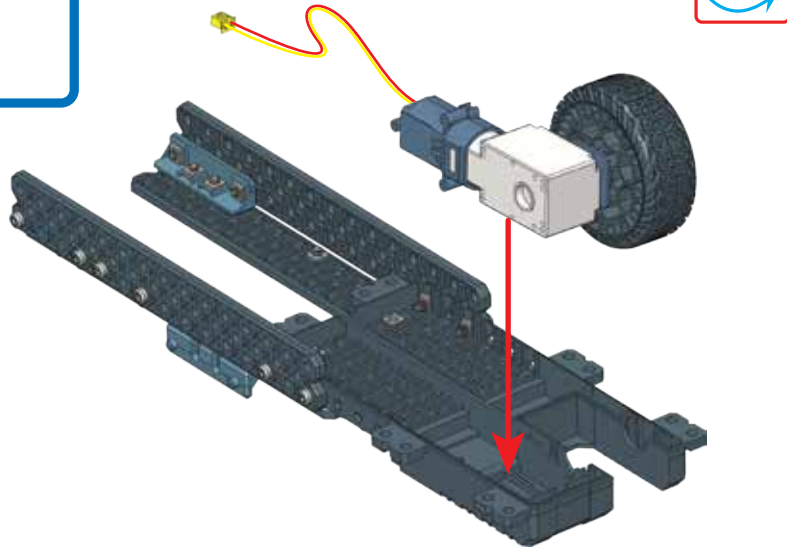

73

71 + 72





74

-  **x1**
-  S3 | 12 mm | **x4**
-  S2 | 9,5 mm | **x2**
-  **x6**

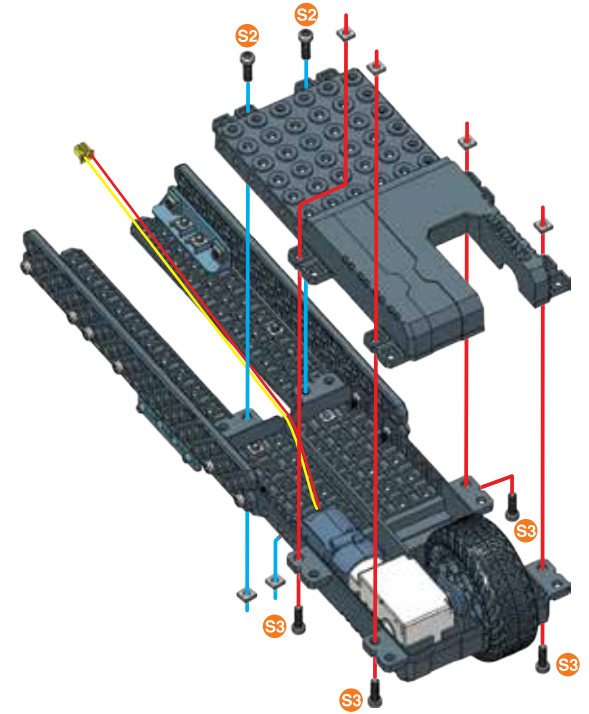
- | | | |
|---|----|------------|
|  | S3 | 1:1 |
|  | S2 | |





75

-  **x1**
-  S3 | 12 mm | **x4**
-  **x4**

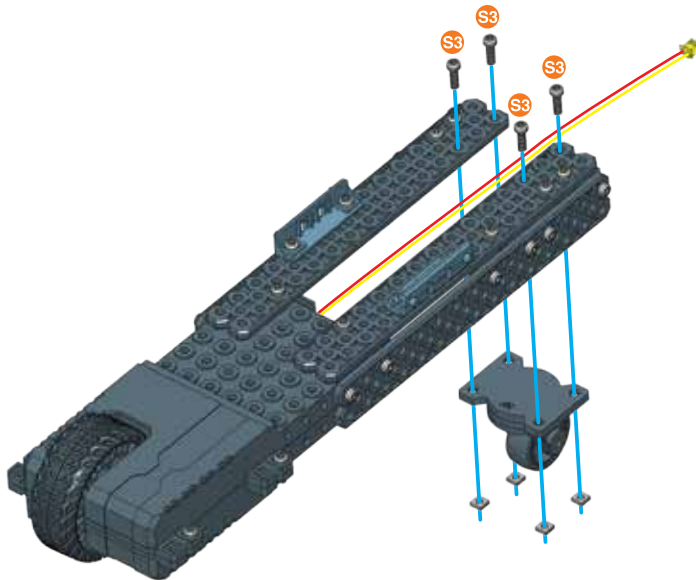
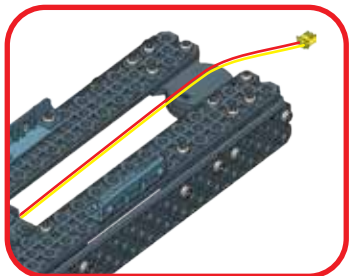
- | | | |
|--|----|------------|
|  | S3 | 1:1 |
|--|----|------------|



76

-  **x1**
-  S3 | 12 mm | **x2**
-  **x2**

- | | | |
|---|----|------------|
|  | S3 | 1:1 |
|---|----|------------|

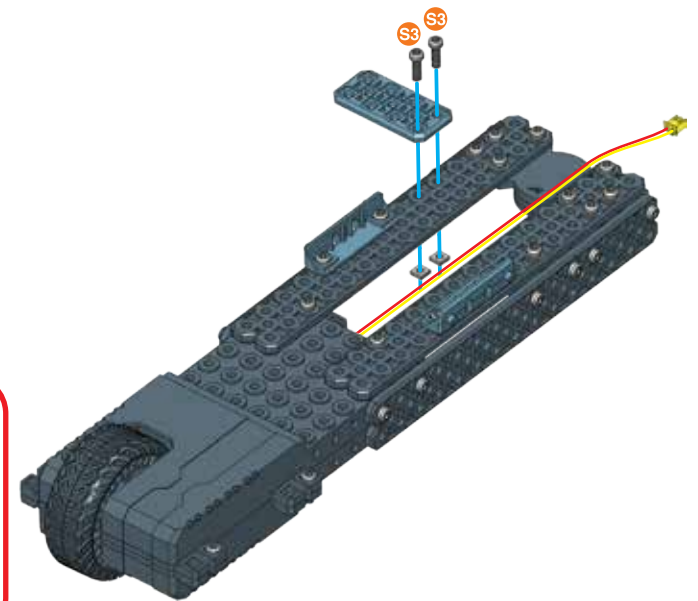

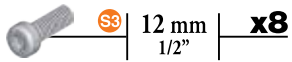
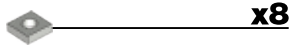
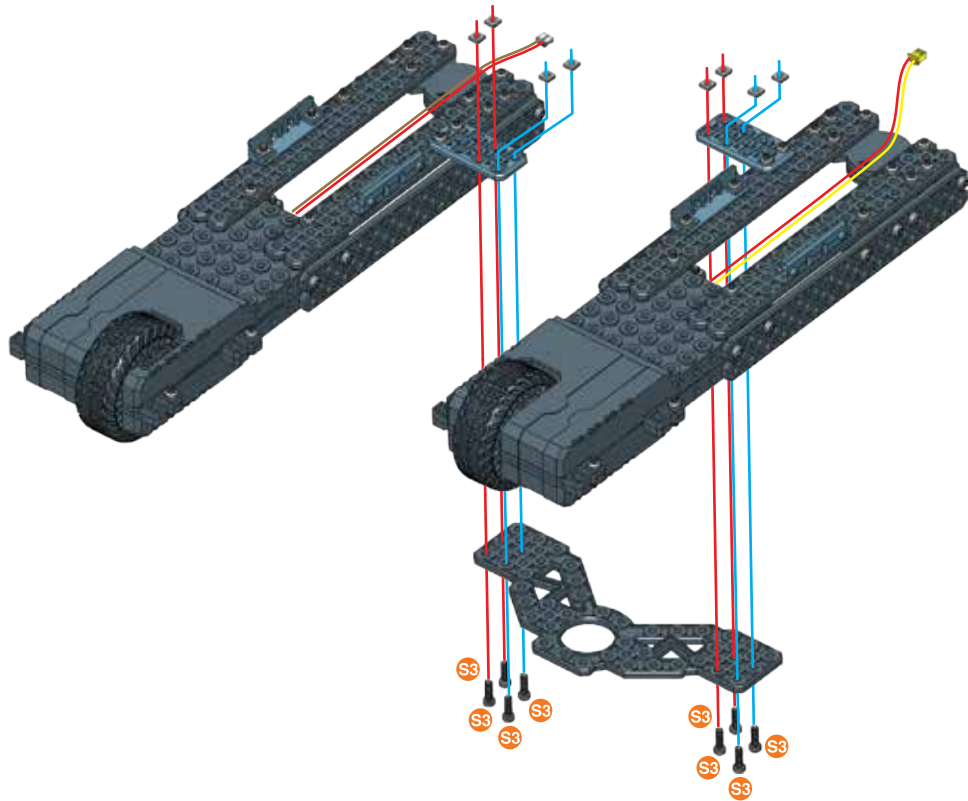
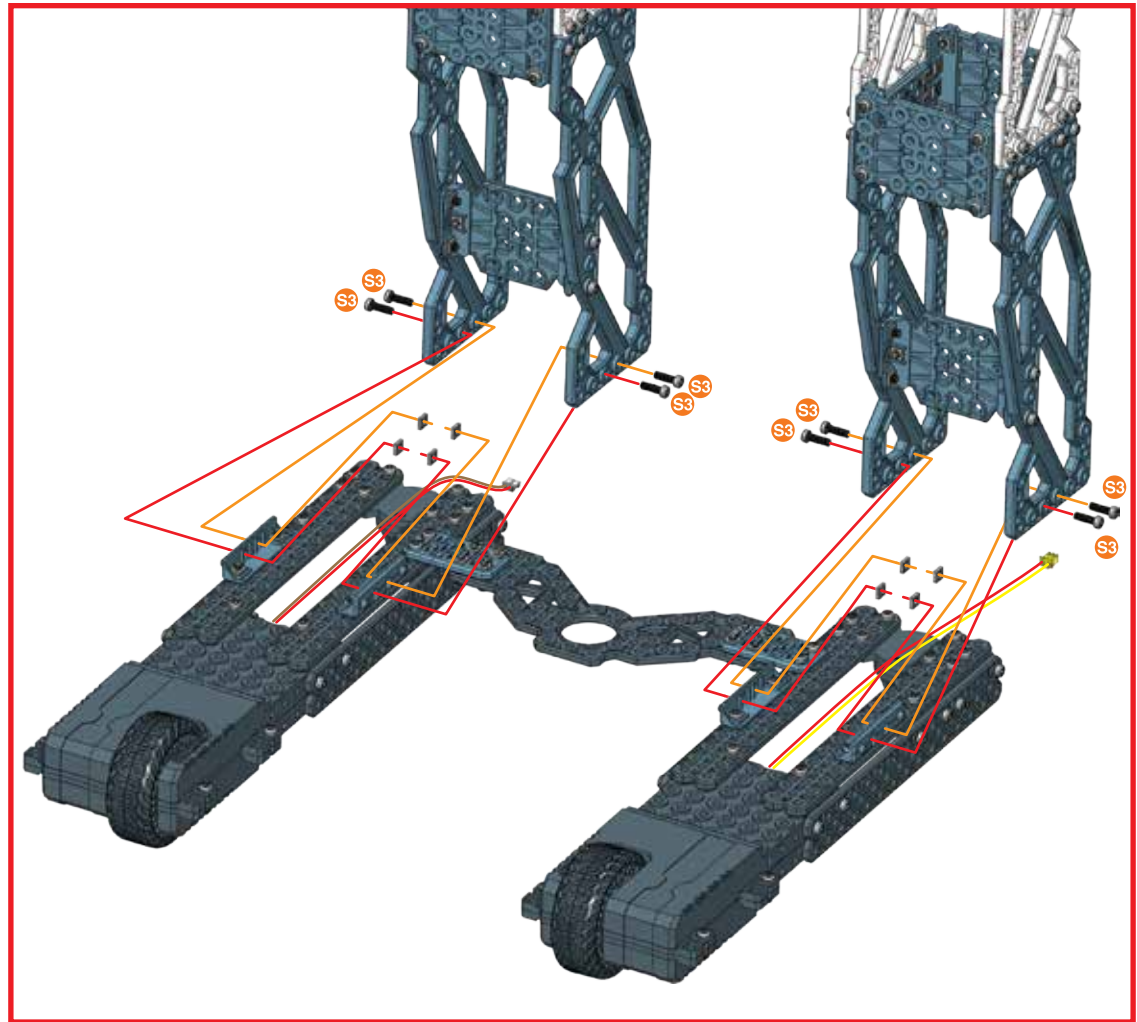
77**66 + 76 +****x1****x8****x8****S3****1:1****78****56 + 77 +****S3****12 mm****x8****1/2"****x8****S3****1:1**

79

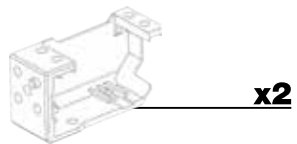

x2

x2

S3 12 mm 1/2" x2

x2

x2



1:1

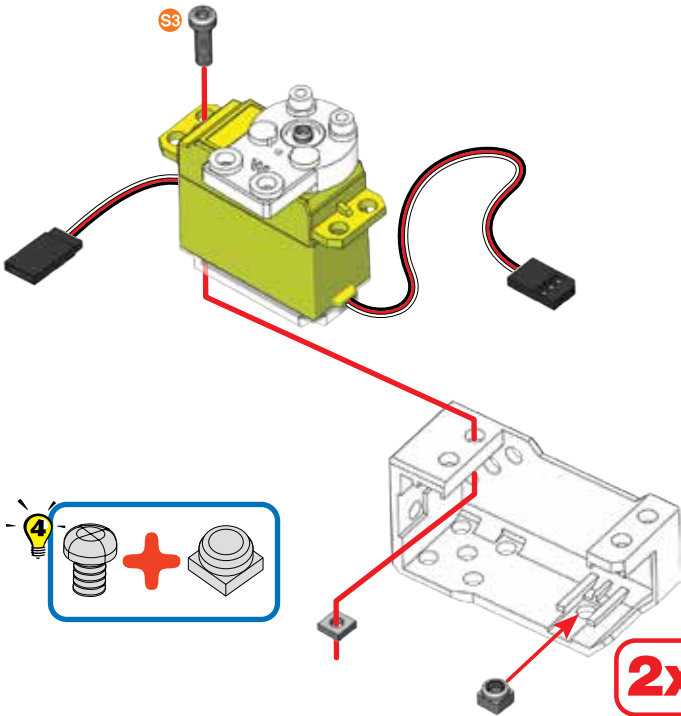
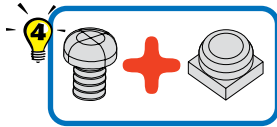

2x

80

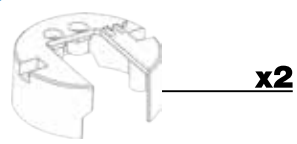

x2

B1 14,7 mm 37/64" x2

x2



1:1

2x

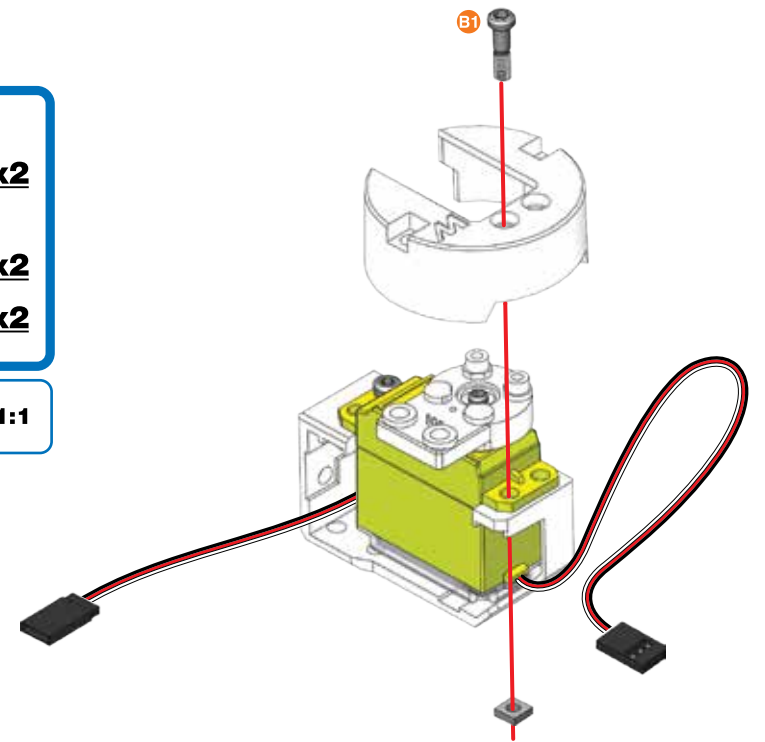

81

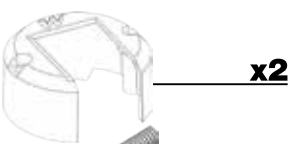

x2

B4 38,1 mm 1 1/2" x4

x4

x4

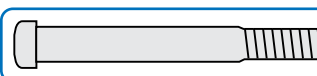

1:1

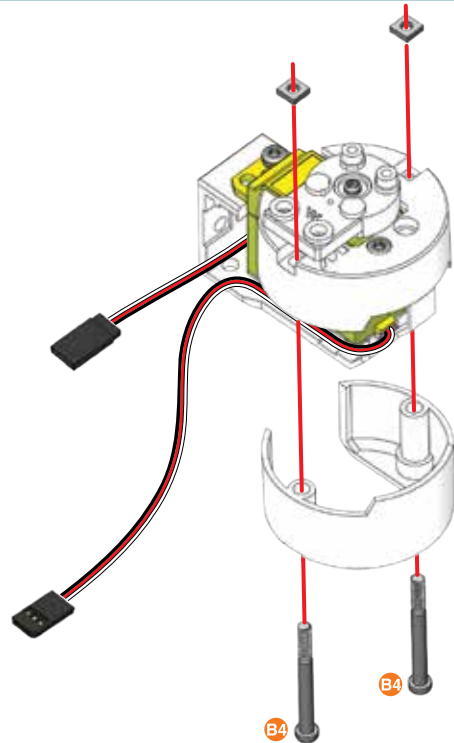

2x

82



x2

M2 10,5 mm 7/16" x2

x2

(S2 9,5 mm 3/8" x2)

x2



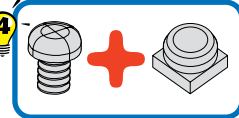

1:1

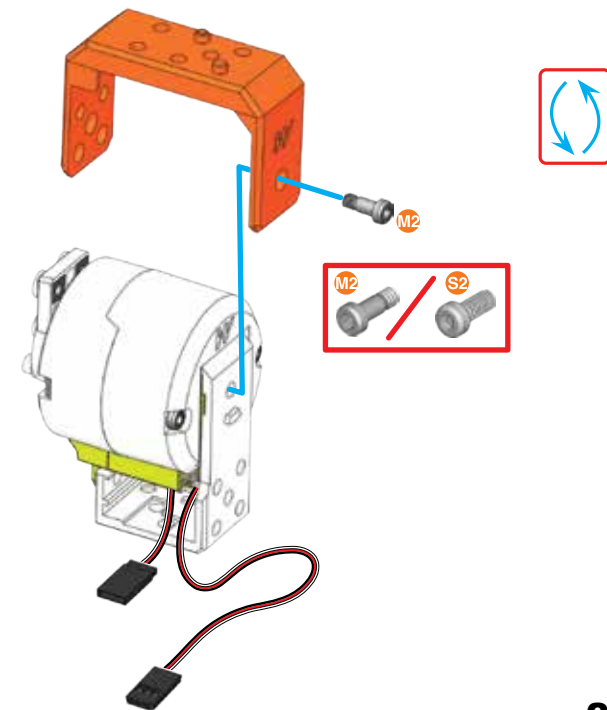

2x



83

 12 mm | $\frac{1}{2}$ " | **x2**
 **x2**

 **S3** | **1:1**

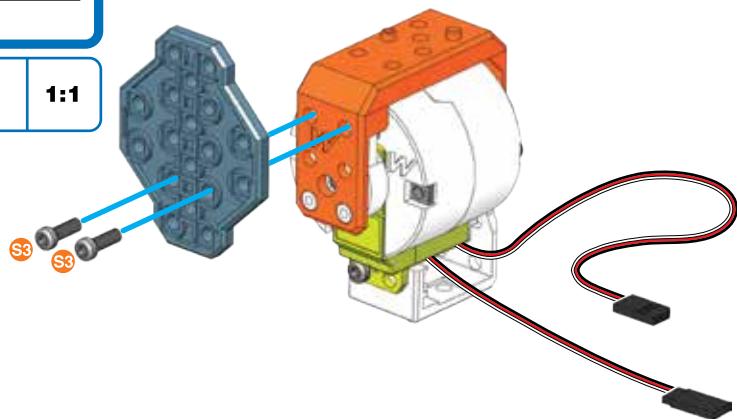

2x

84

79 ~ 83

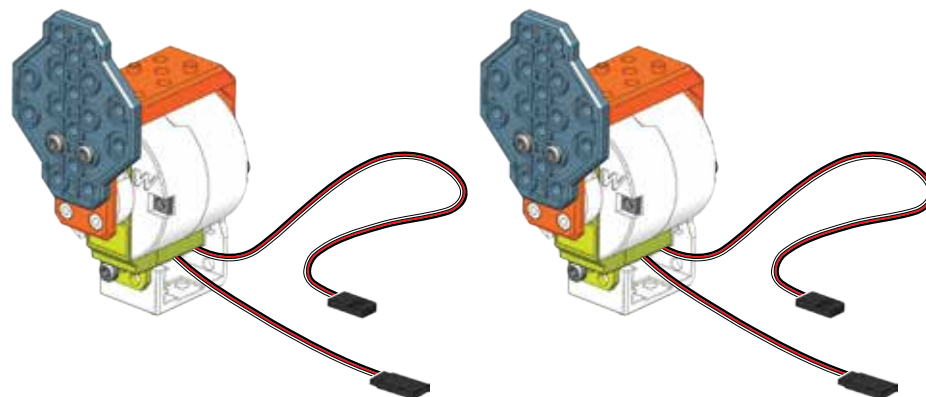



2x

85

84+

 **x1**

 12 mm | $\frac{1}{2}$ " | **x2**
 **x2**

 **S3** | **1:1**

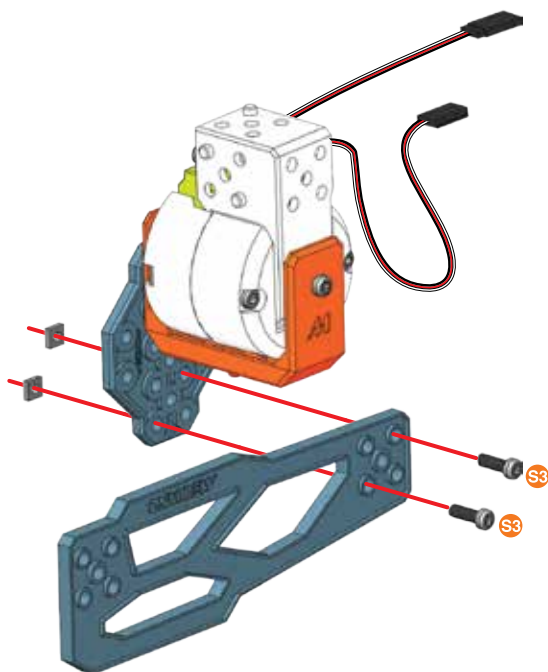

86

 **x1**

 **x3**

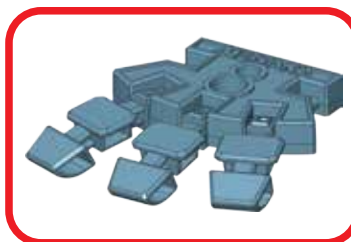

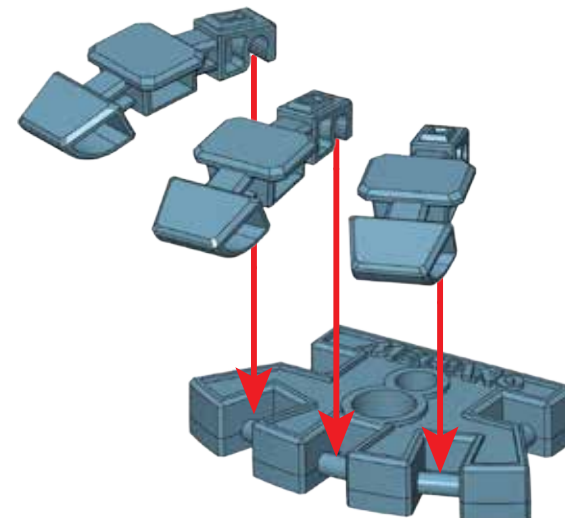

2x

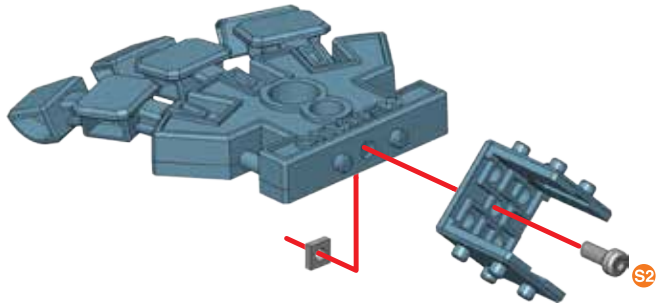
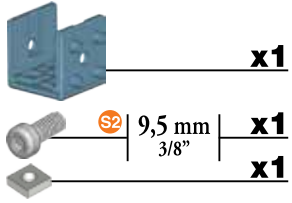
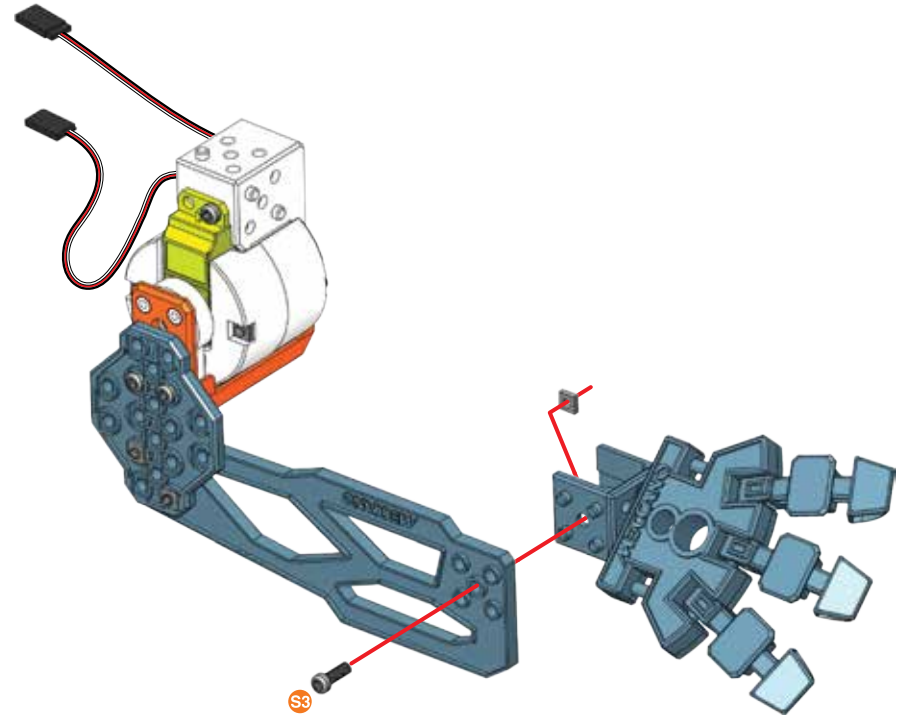
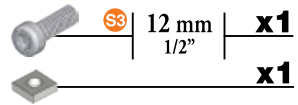
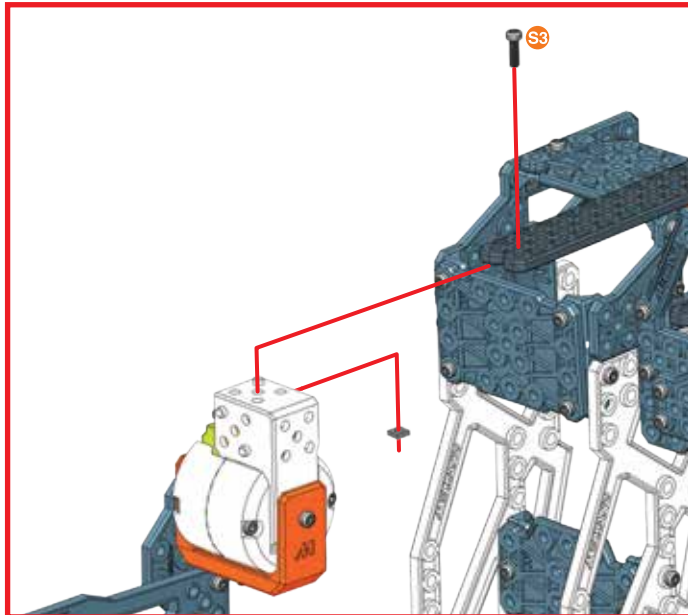
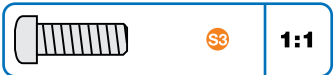
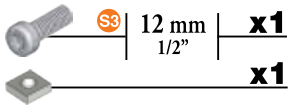
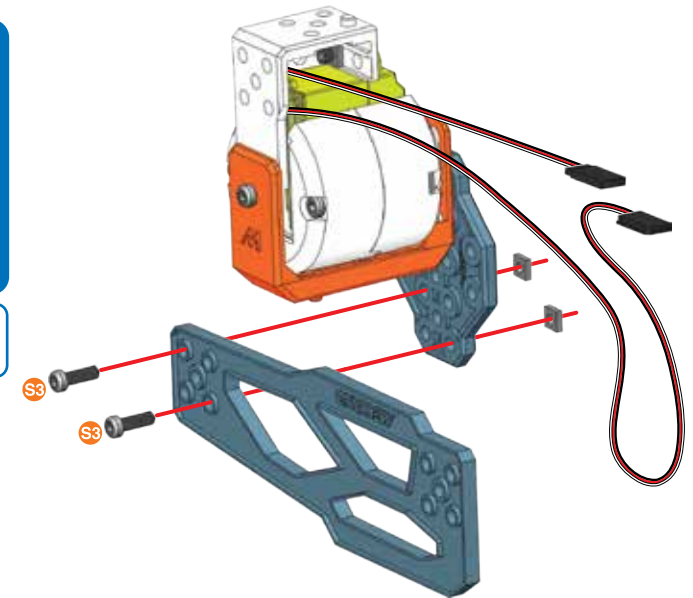
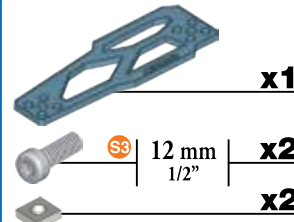

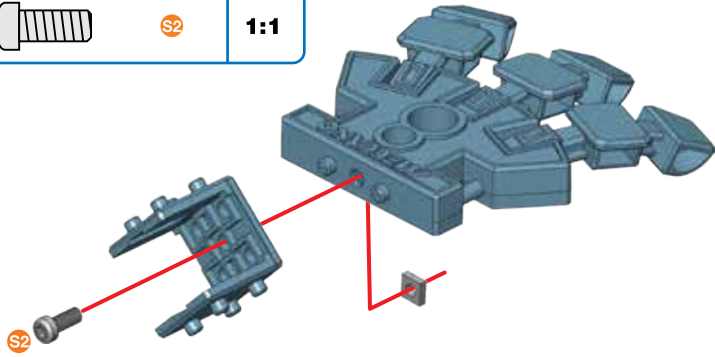
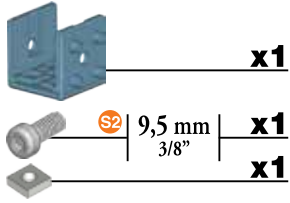
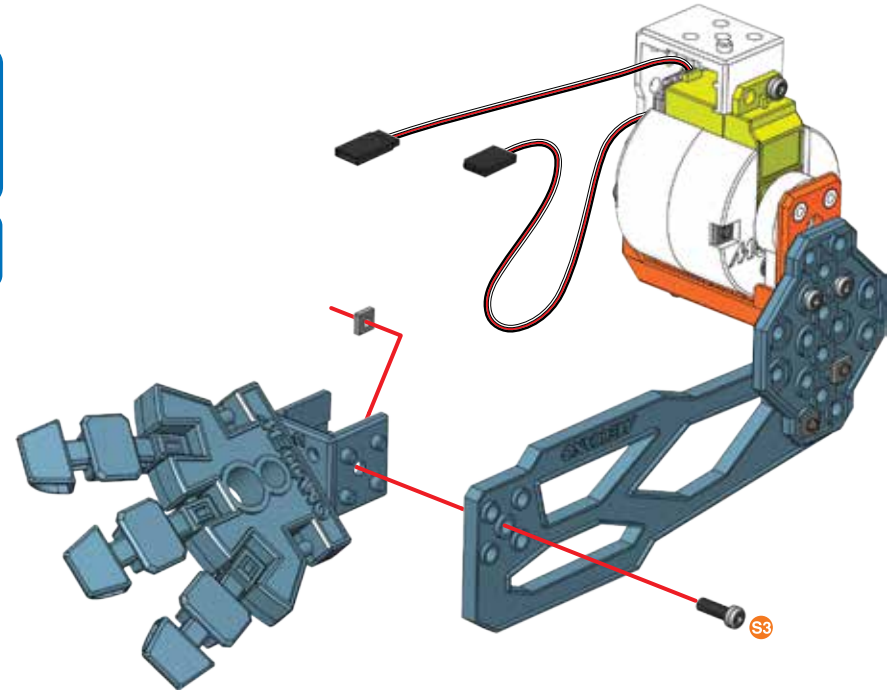
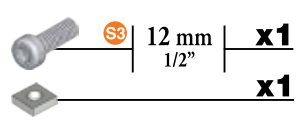
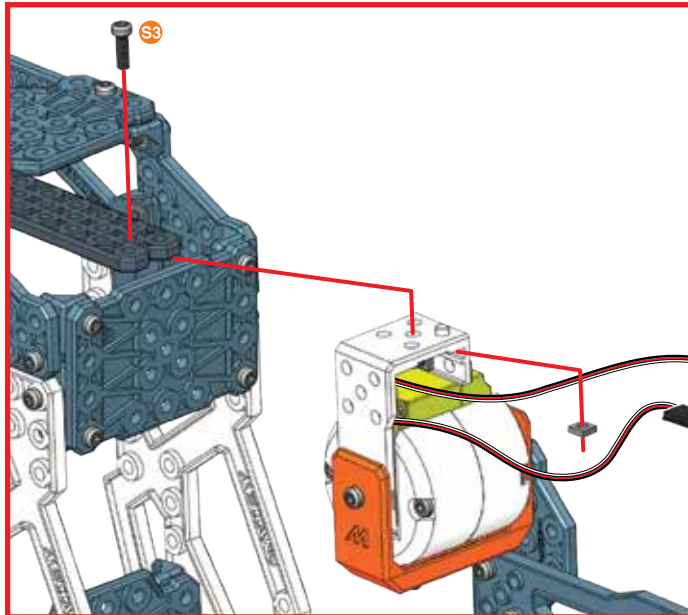
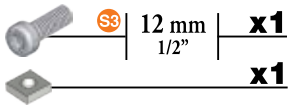
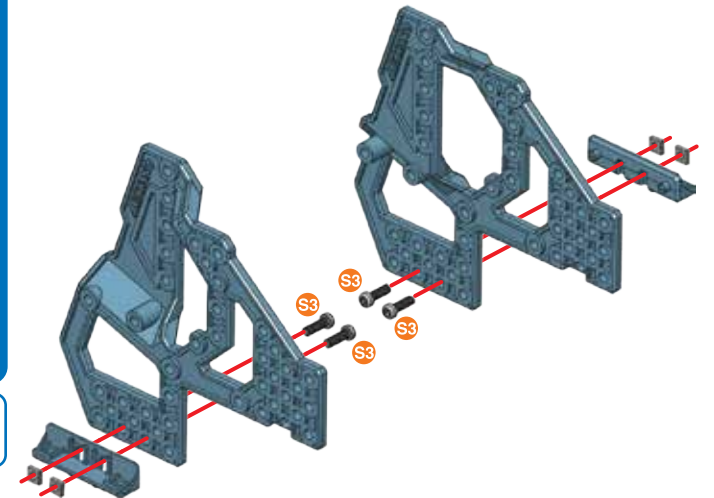
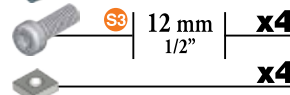
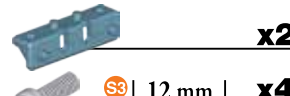
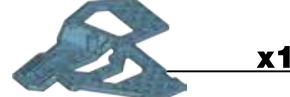
87**88****85 + 87****89****90****84 +**

91**92****90 + 91****93****89 + 92****94**



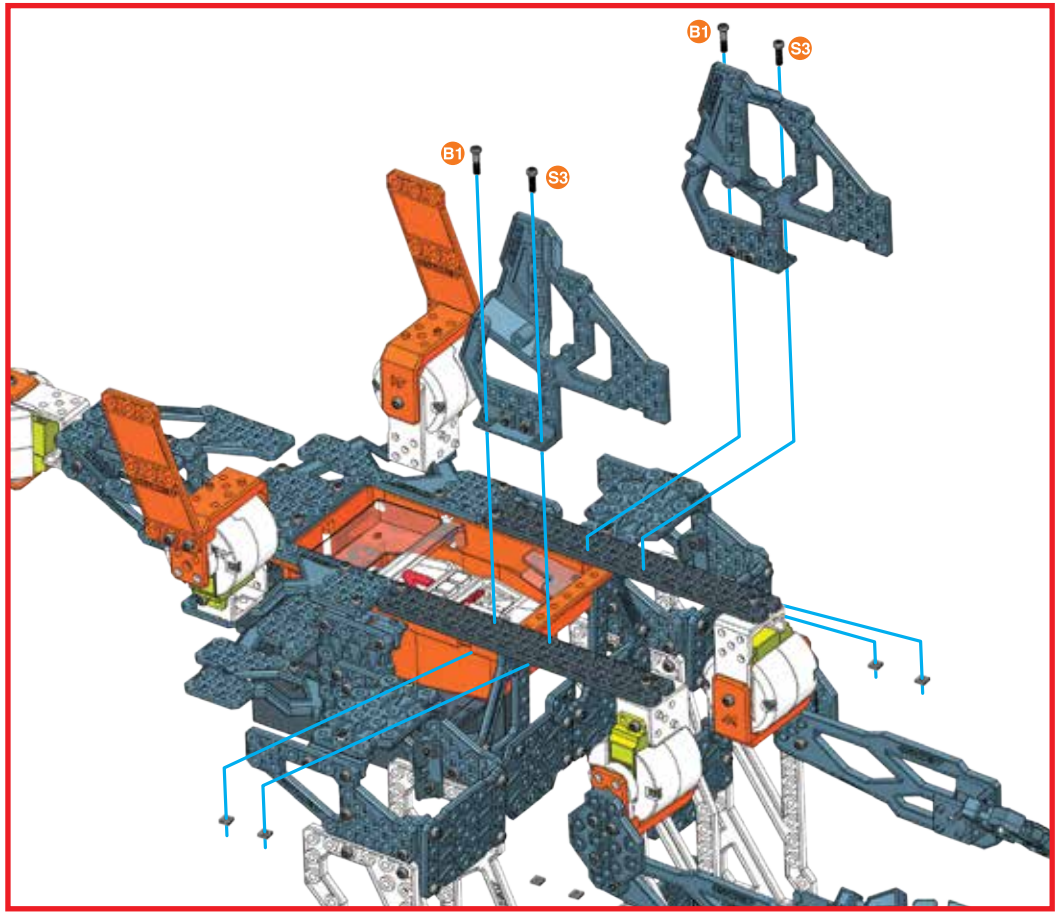

95

-  B1 | 14,7 mm | 37/64" | **x2**
-  S3 | 12 mm | 1/2" | **x2**
-  | **x4**

-  B1 | **1:1**
-  S3 | **1:1**





96

-  | **x1**
-  | **x1**
-  S3 | 12 mm | 1/2" | **x1**
-  | **x1**
-  | **x1**

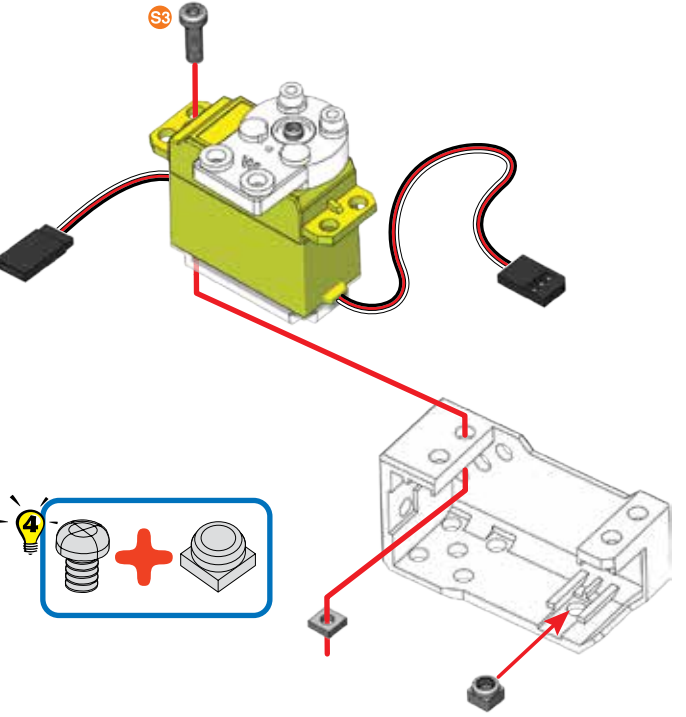
-  S3 | **1:1**



97

-  | **x1**
-  B1 | 14,7 mm | 37/64" | **x1**
-  | **x1**

-  B1 | **1:1**

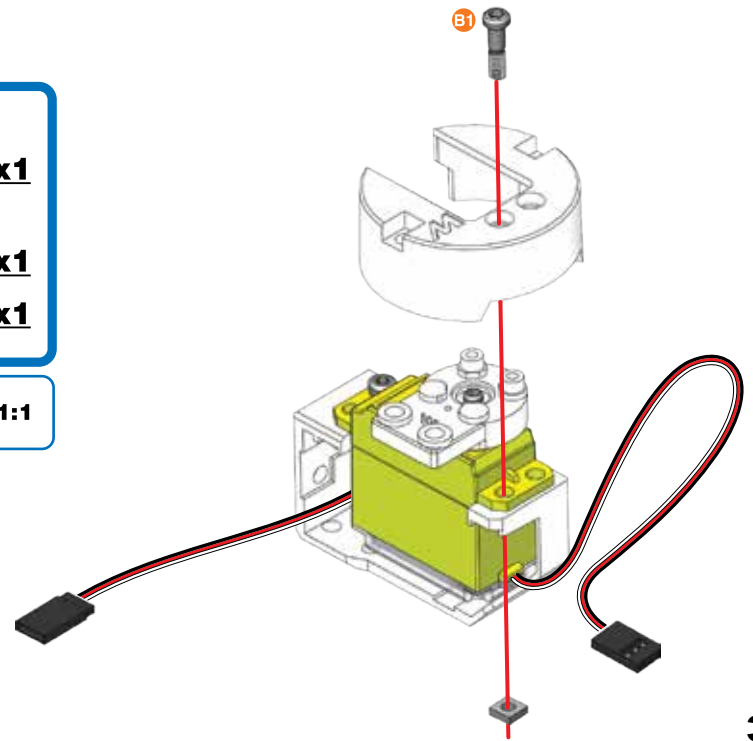

98

	x1
38,1 mm 1 1/2"	x2
	x2

	B4	1:1
--	-----------	------------

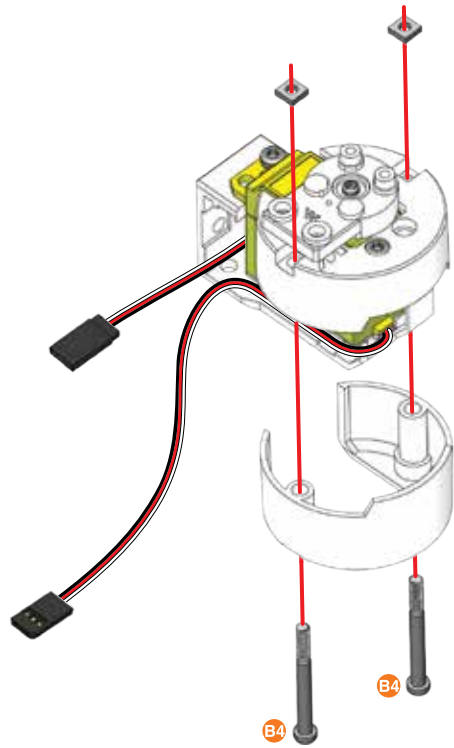

99

	x1
10,5 mm 7/16"	x1
9,5 mm 3/8"	x1

	M2	1:1
	S2	

--	--	--	--

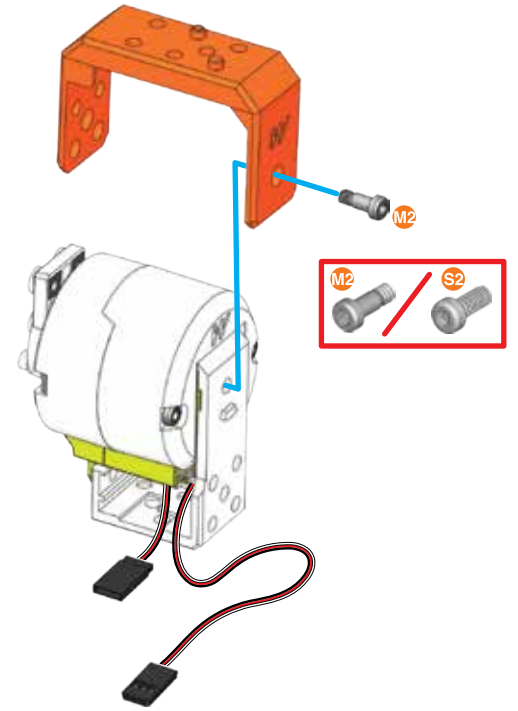

100

	x1
12 mm 1/2"	x2

	S3	1:1
--	-----------	------------

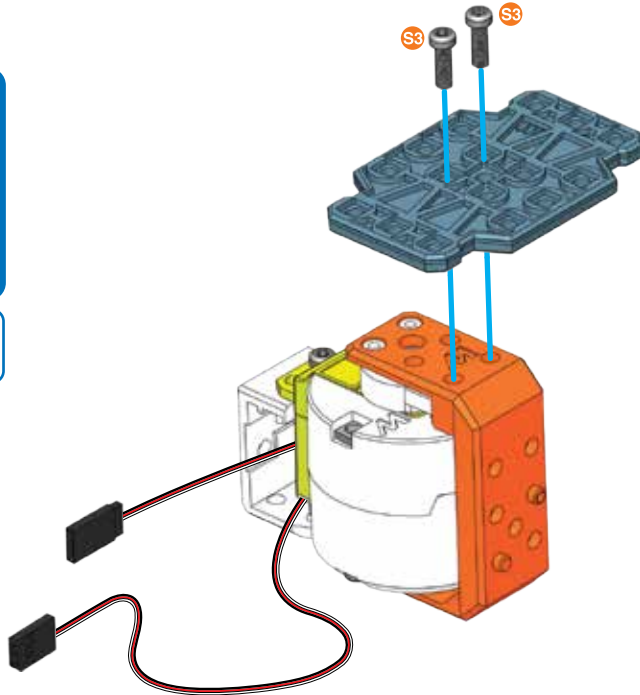



101

	x1
12 mm 1/2"	x1
	x1

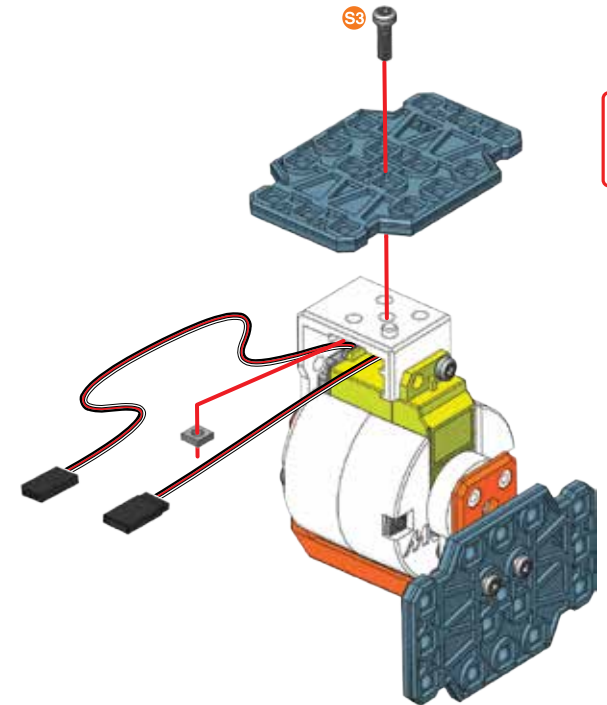
	S3	1:1
--	-----------	------------



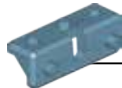

102

-  **x2**
-  **x4**
-  **x4**

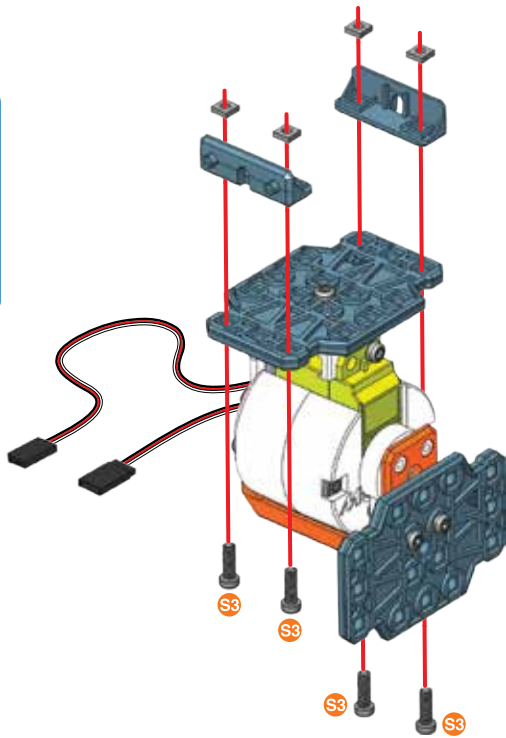
-  **S3** **1:1**



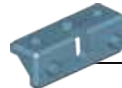

103

-  **x2**
-  **x2**
-  **x2**

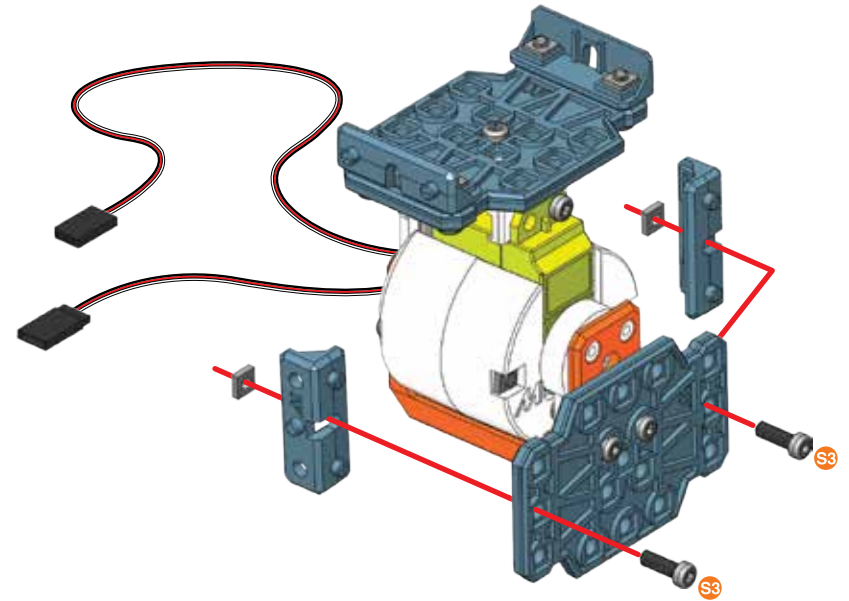
-  **S3** **1:1**





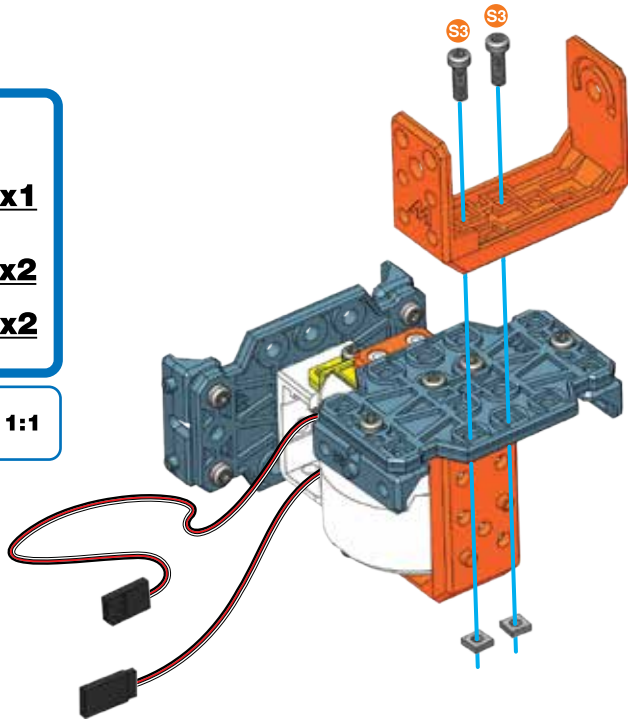

104

-  **x1**
-  **x2**
-  **x2**

-  **S3** **1:1**

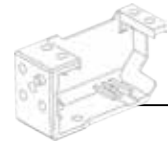

105

-  **x1**
-  **x1**
-  **x1**
-  **x1**
-  **x1**

-  **S3** **1:1**

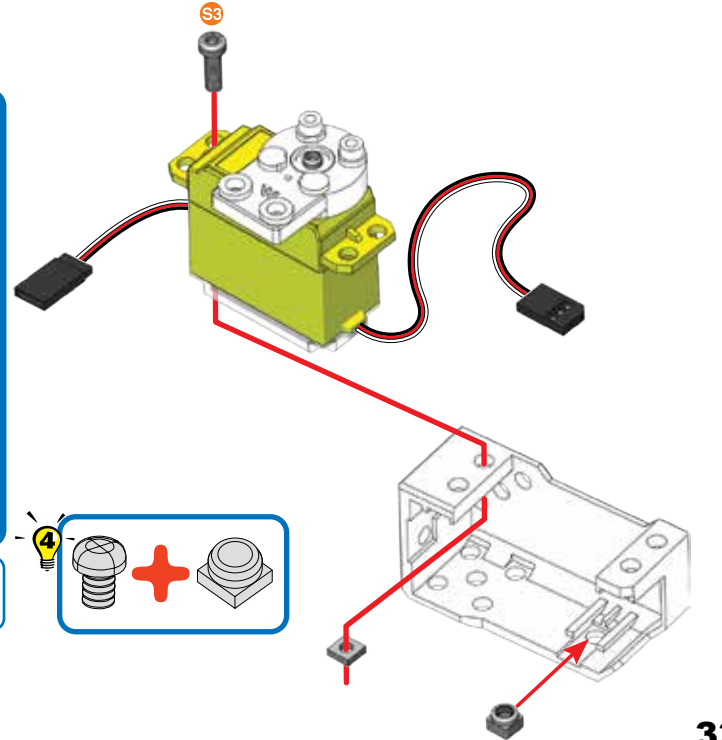

106

- x1
- 14,7 mm | 37/64" | x1
- x1

	B1	1:1
--	----	-----

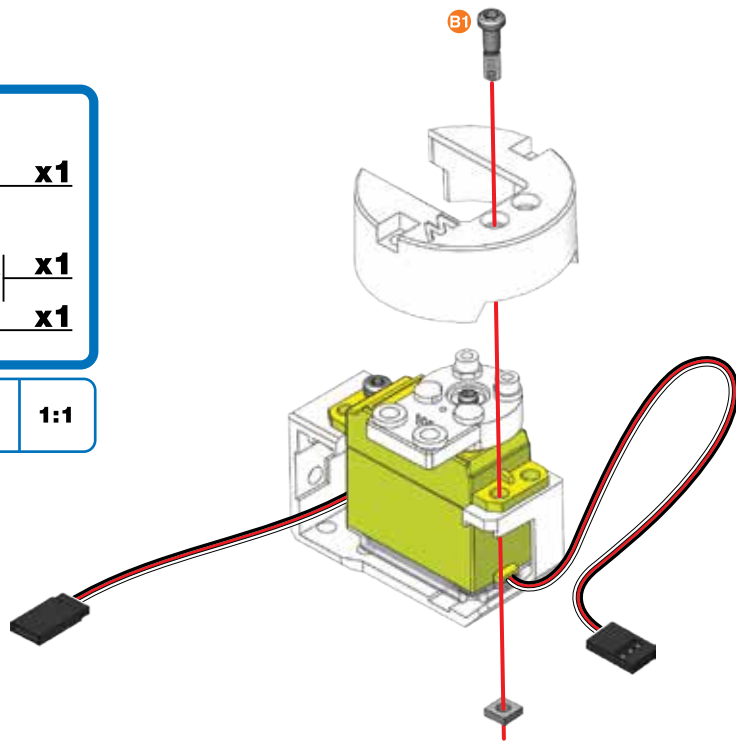

107

- x1
- 38,1 mm | 1 1/2" | x2
- x2

	B4	1:1
--	----	-----

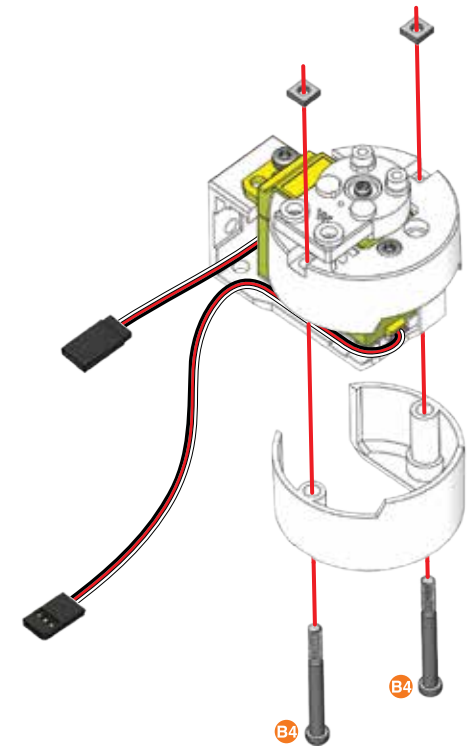

108

- x1
- 12 mm | 1/2" | x1
- x1

	S3	1:1
--	----	-----

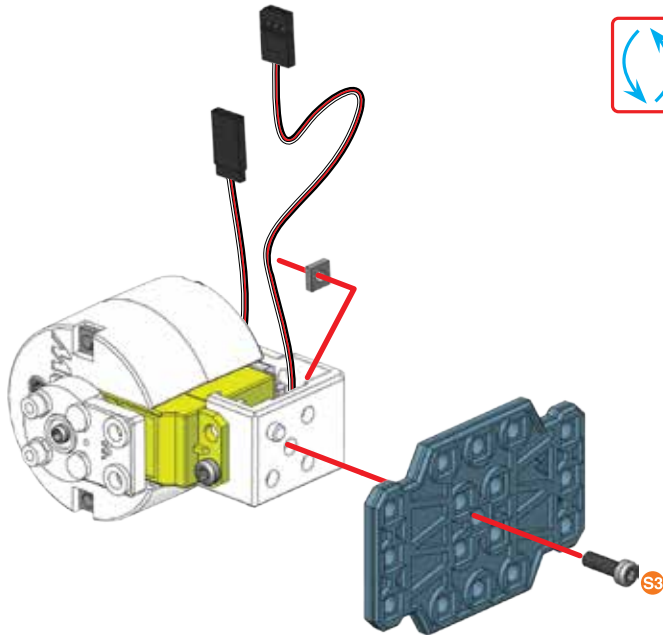

109

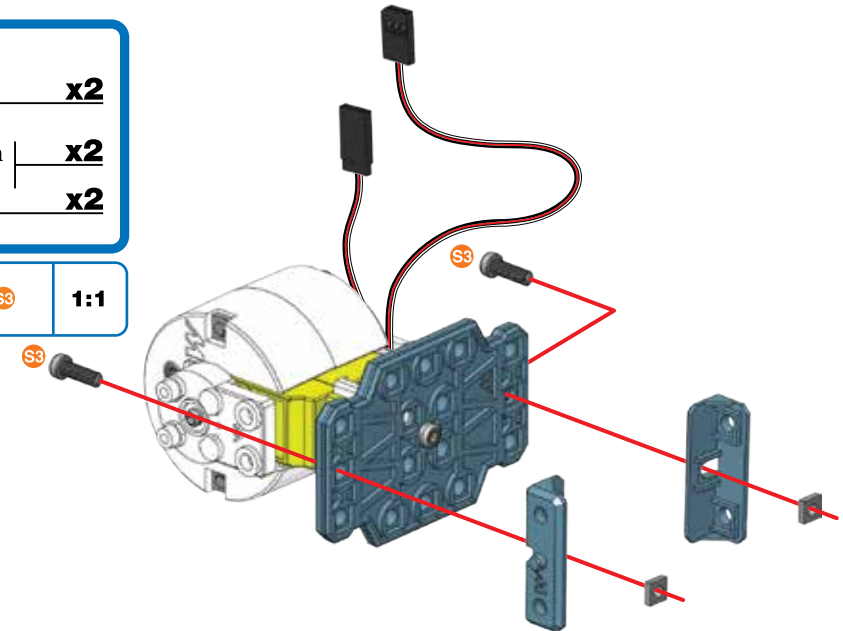

- x2
- 12 mm | 1/2" | x2
- x2

	S3	1:1
--	----	-----



110



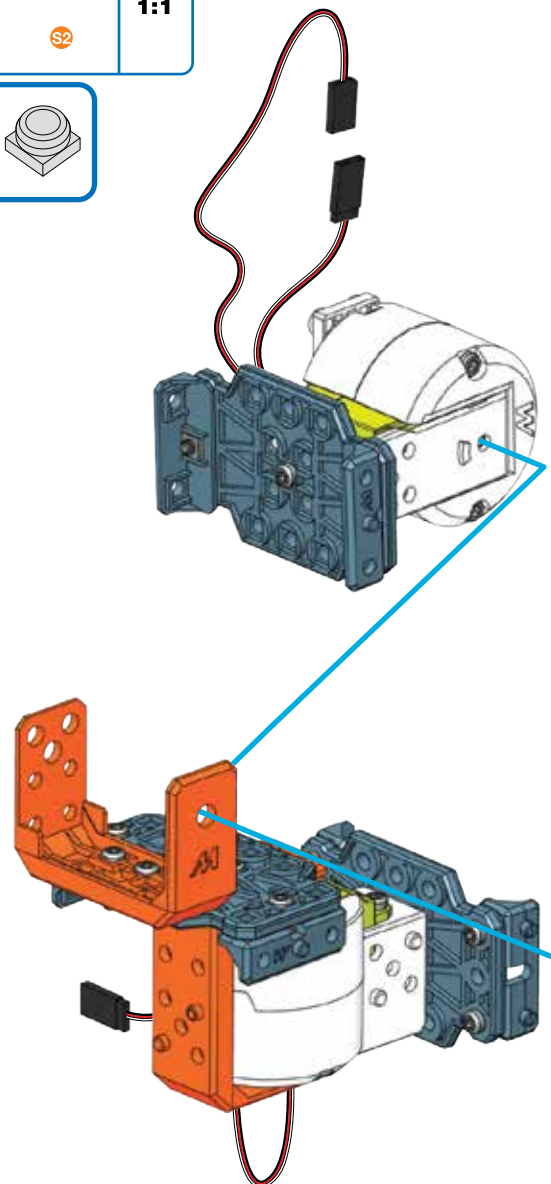
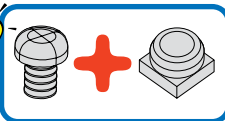

104 + 109 +

	M2	10,5 mm 7/16"	x1
	S2	9,5 mm 3/8"	x1

	M2	1:1
	S2	



111

	x1		
	x1		
	S3	12 mm 1/2"	x4
	x4		

	S3	1:1
--	----	-----

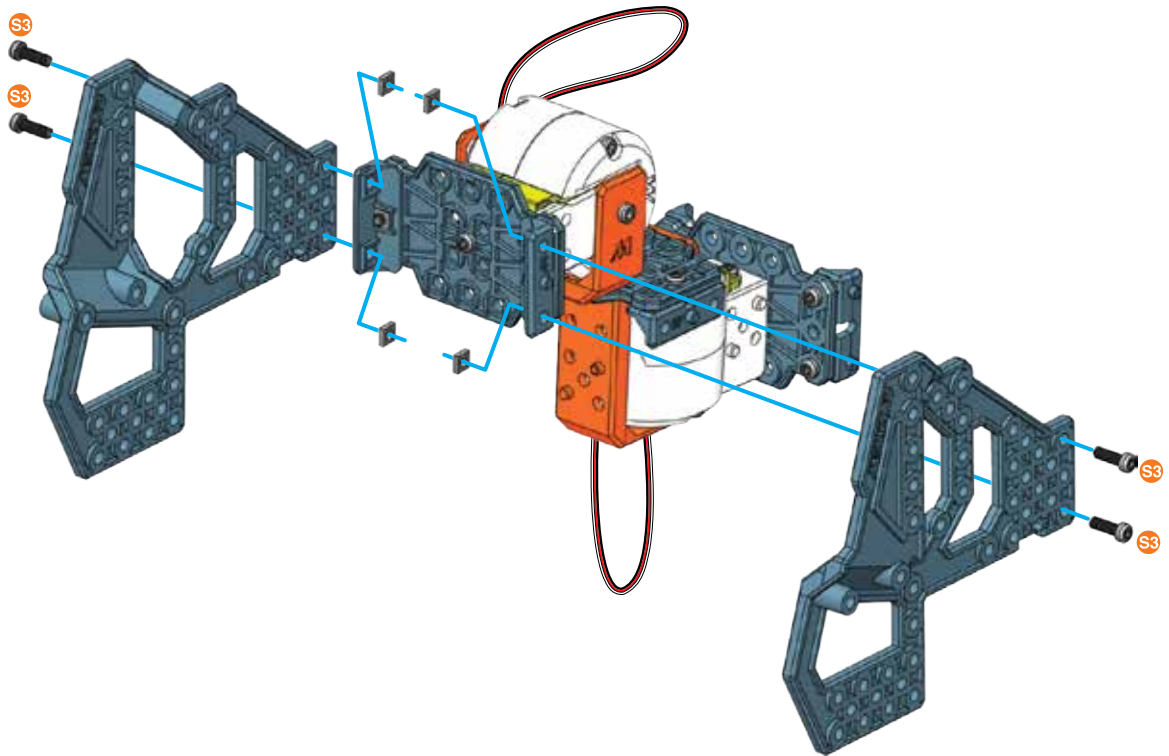

112



x1



x1



x4

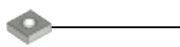

x4

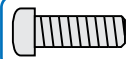

S3

1:1

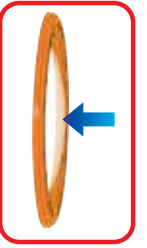
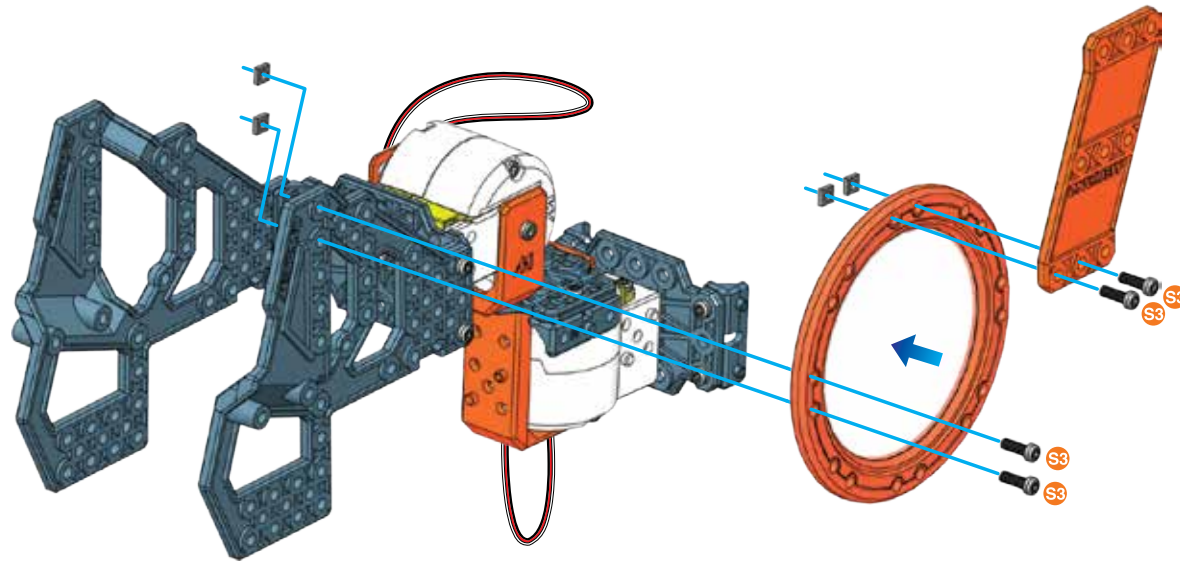

113



x1



x1



x4

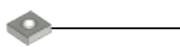

x4

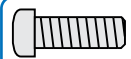

S3

1:1

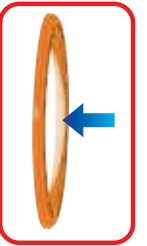
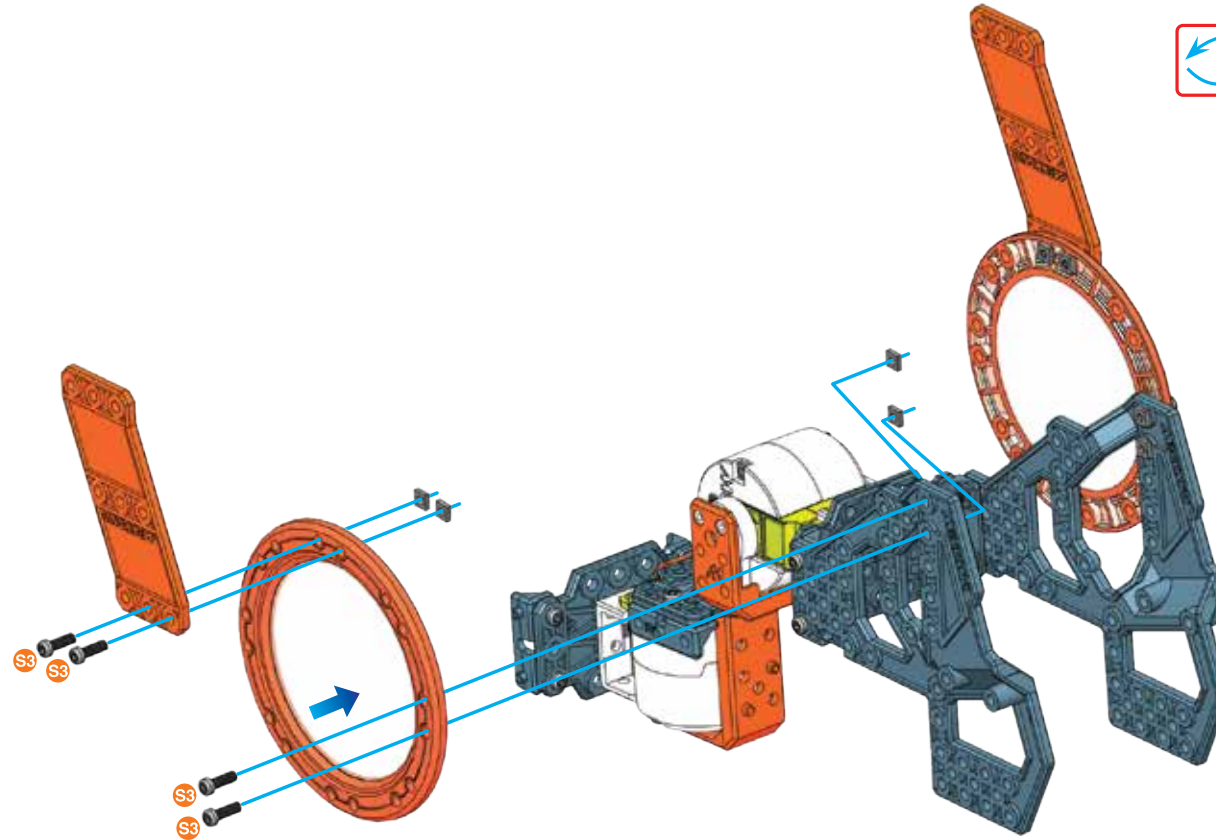

114

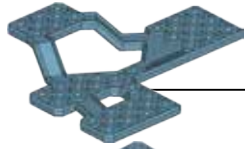

x1



x1



x3

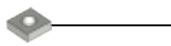

x3



S3

1:1

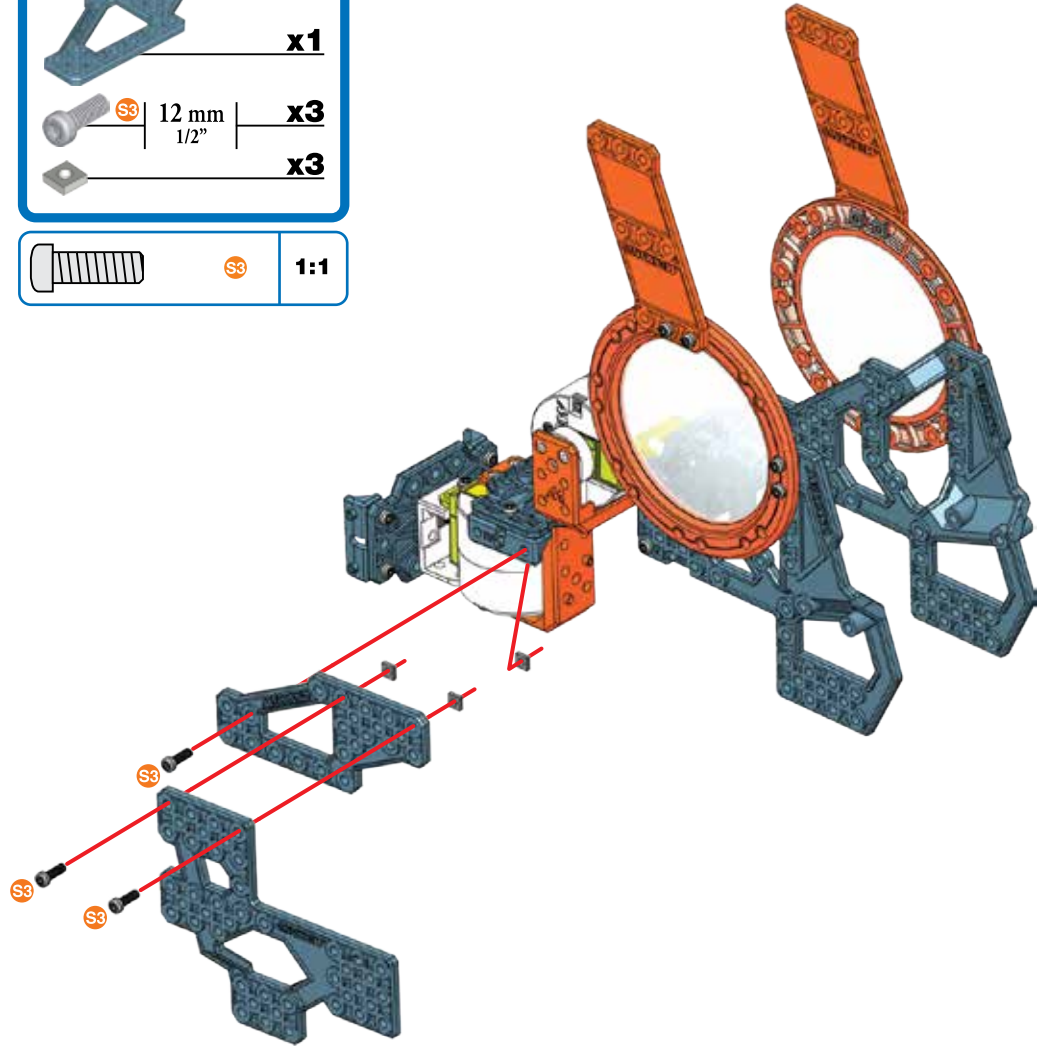

115

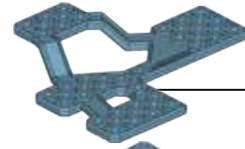

x1



x1



x3

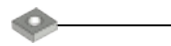

x3



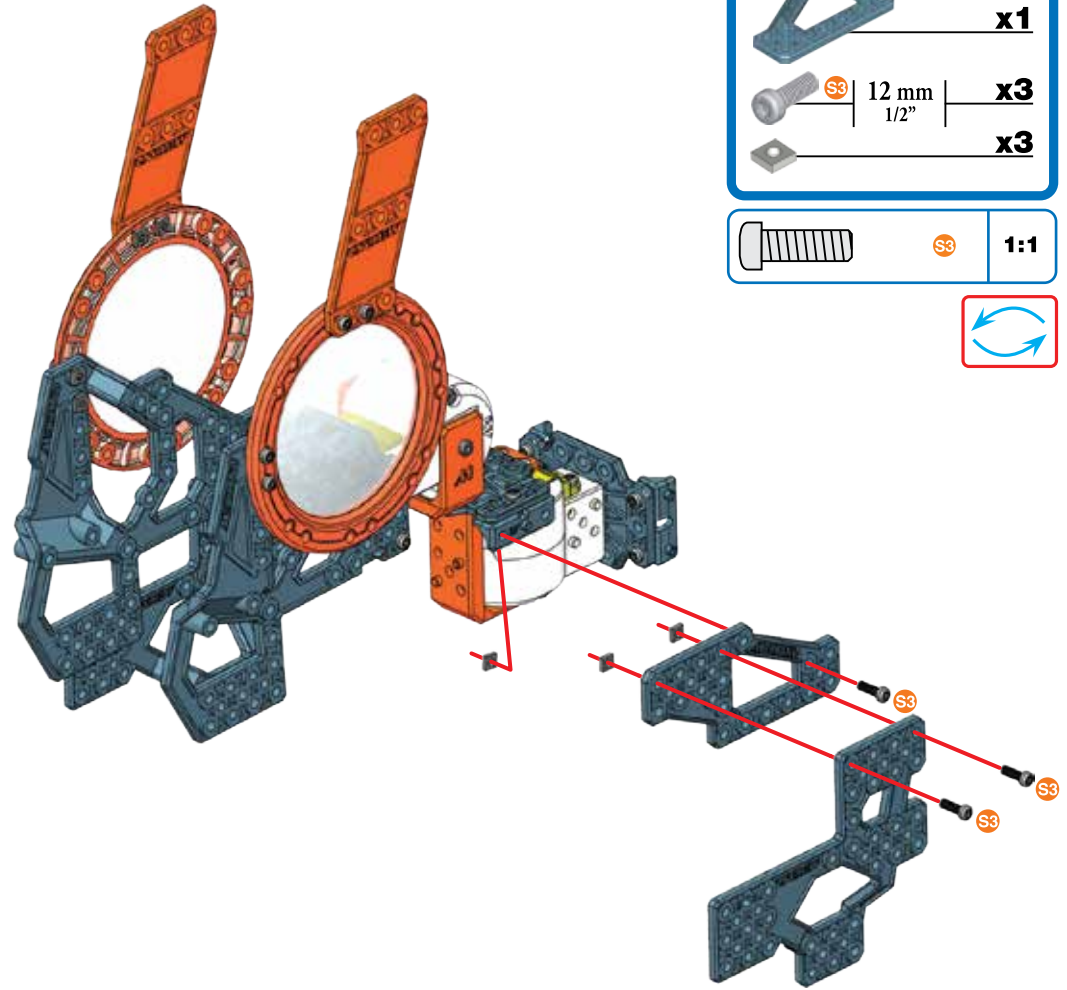

S3

1:1





116

 S3	12 mm 1/2"	x2
		x2

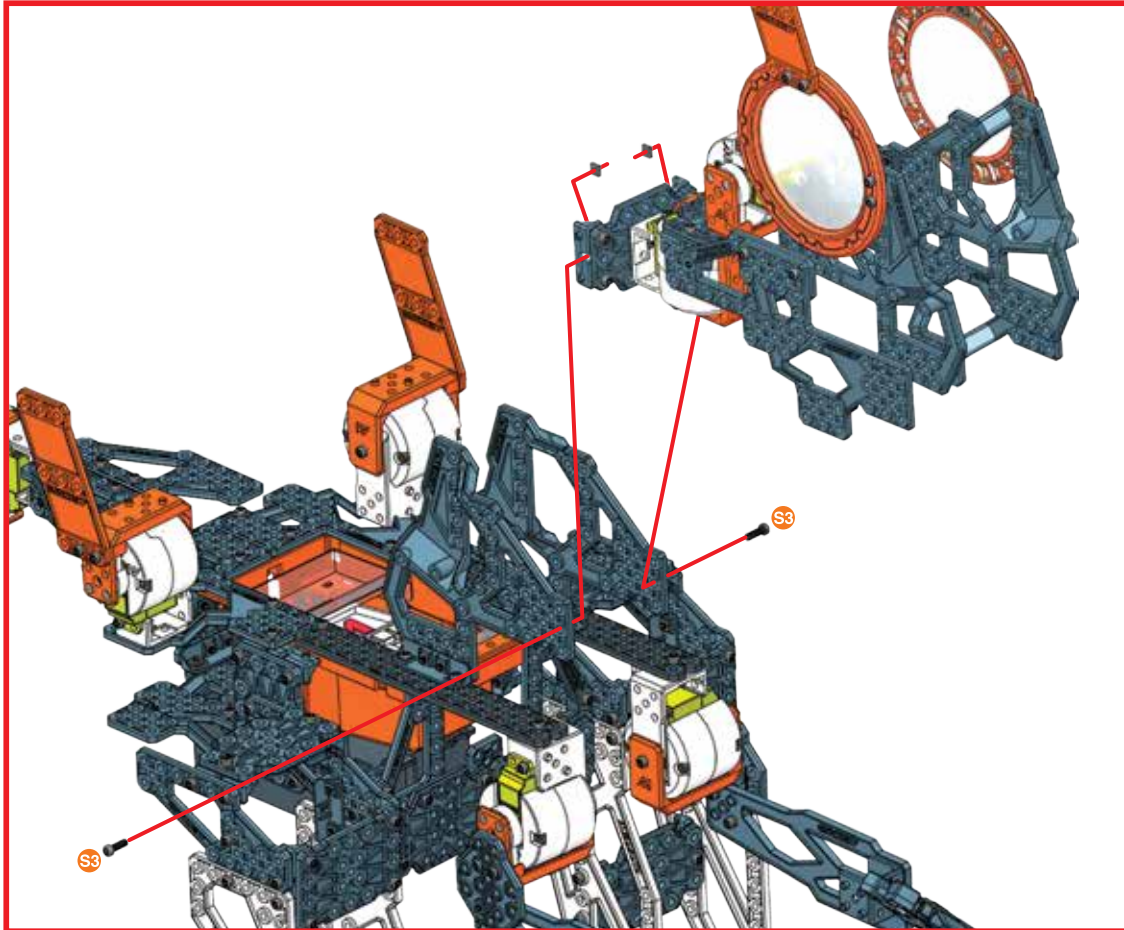
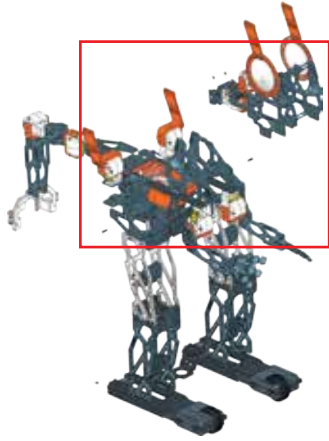
	S3	1:1
--	----	-----



117

	12 mm 1/2"	-2
		-2

	S3	1:1
--	----	-----

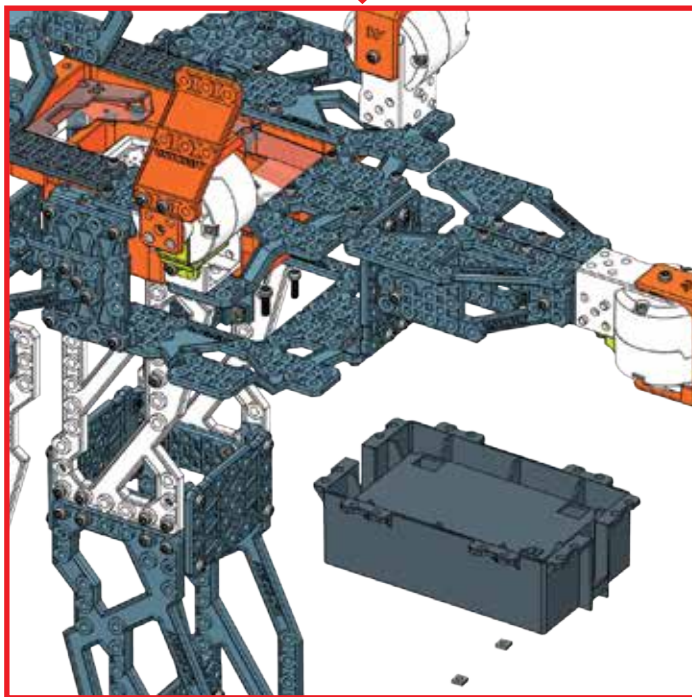
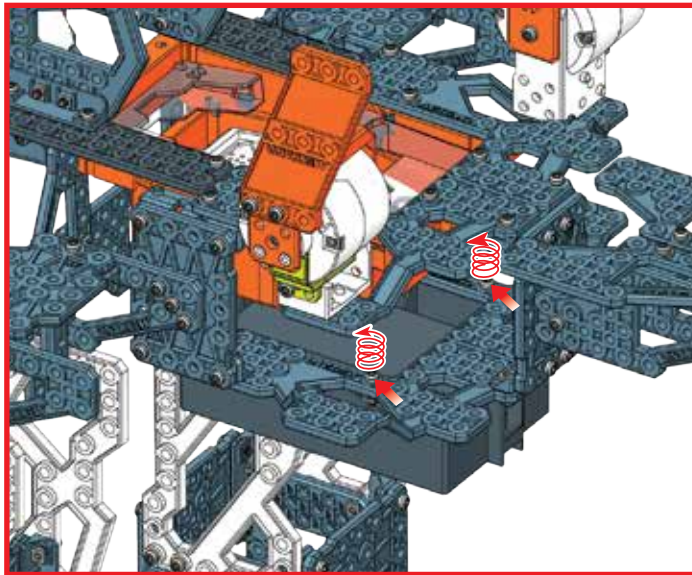
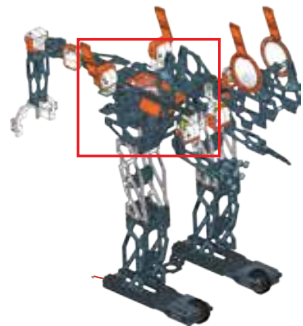

118

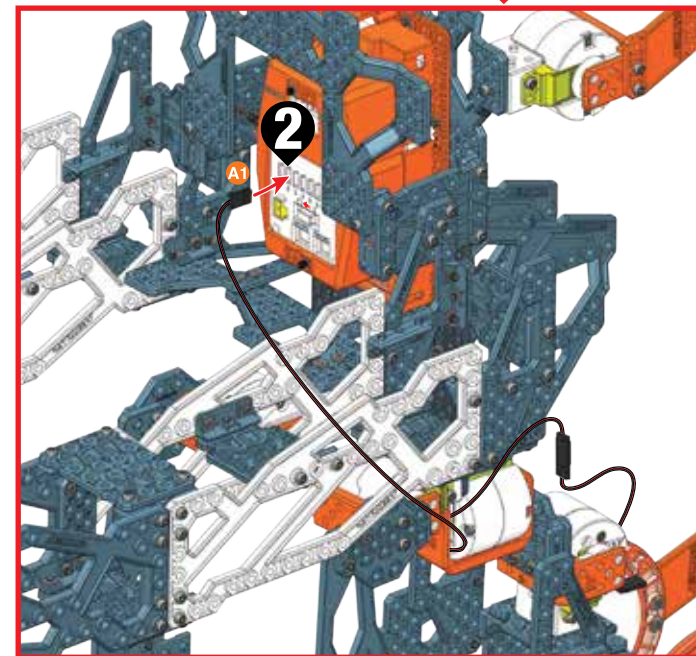
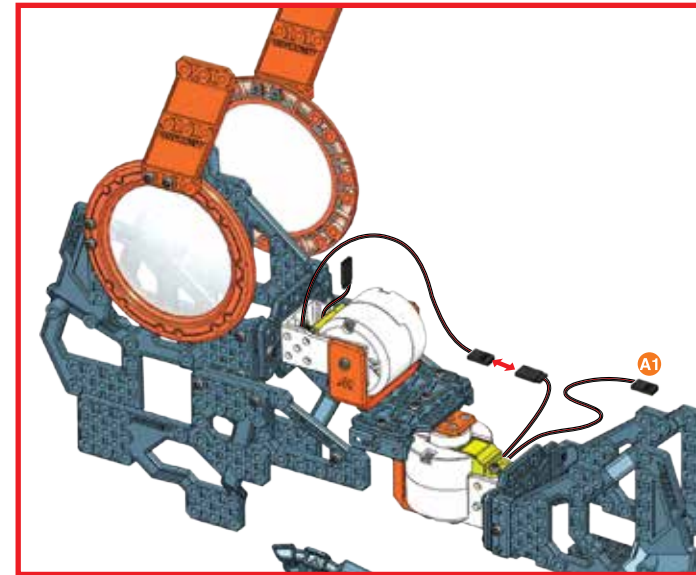
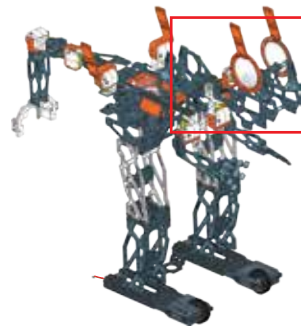

119

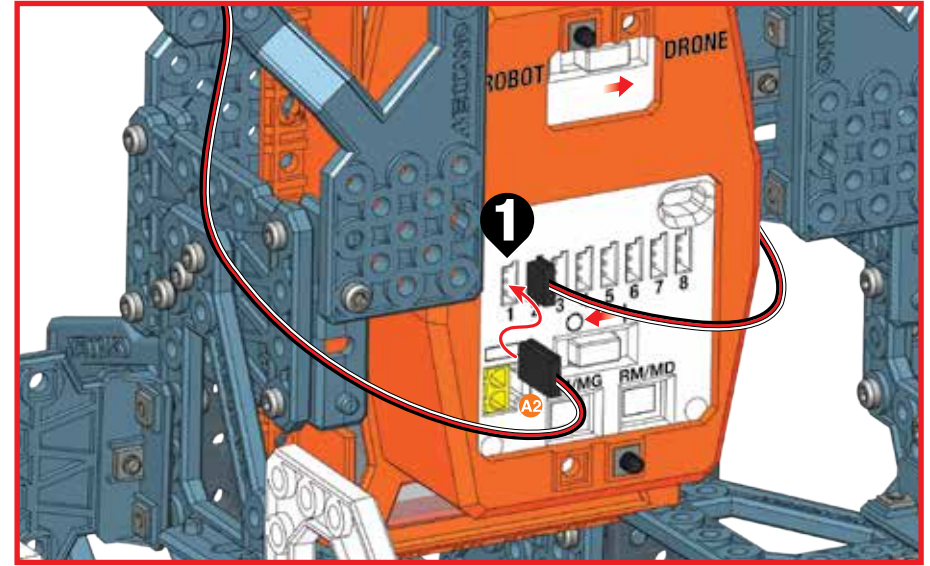
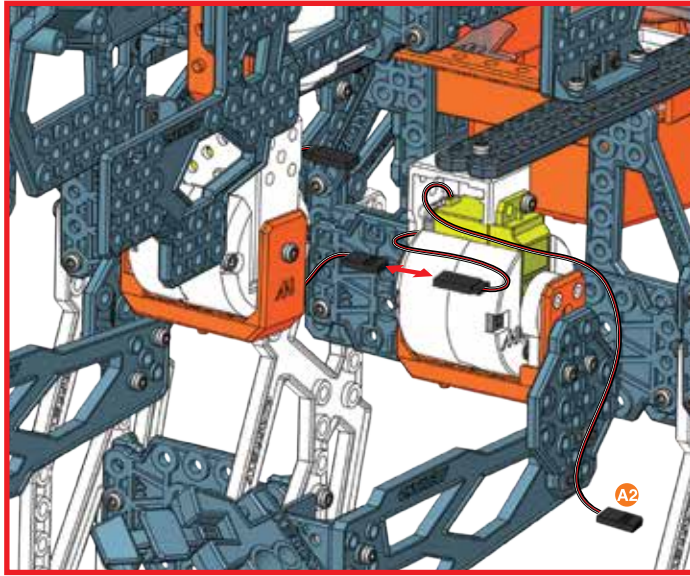
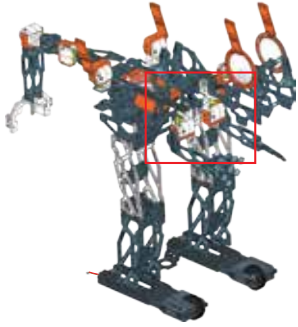

120

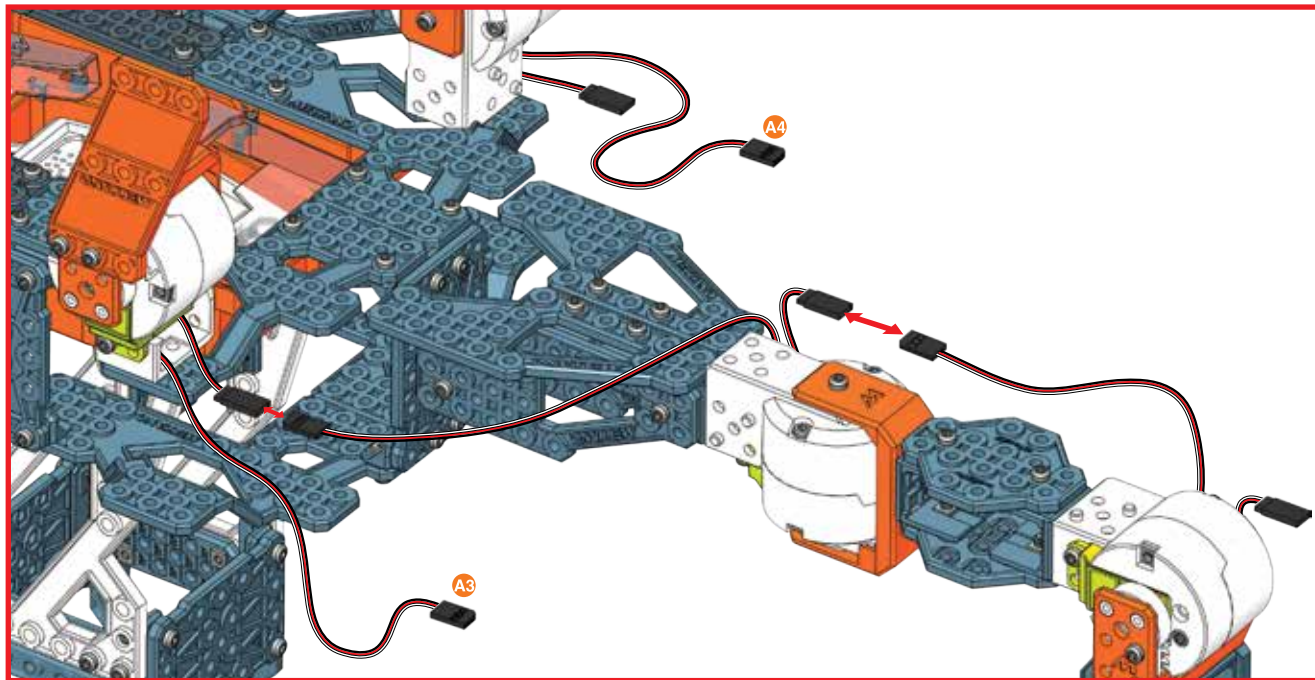
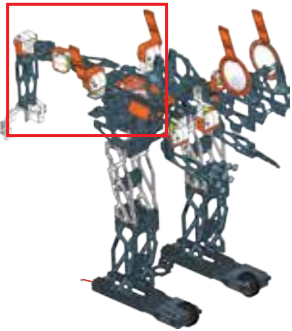

121

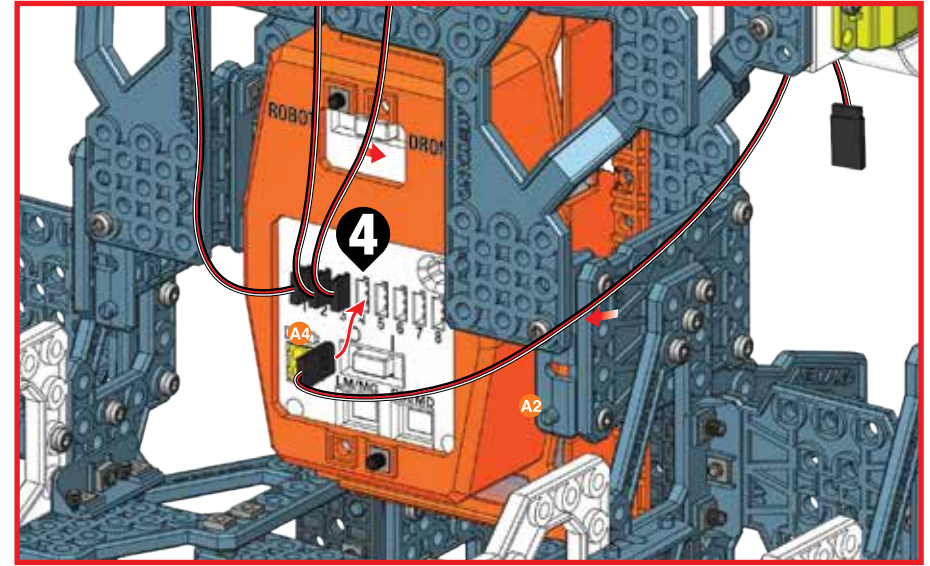
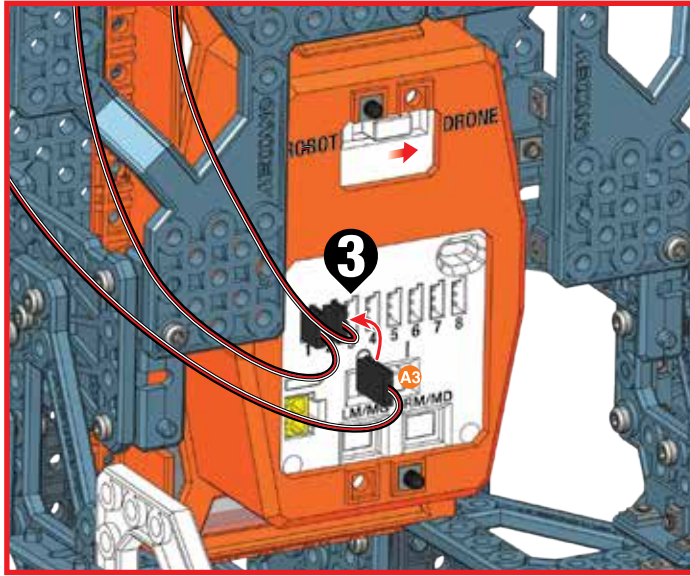
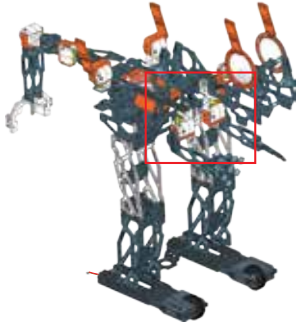

122

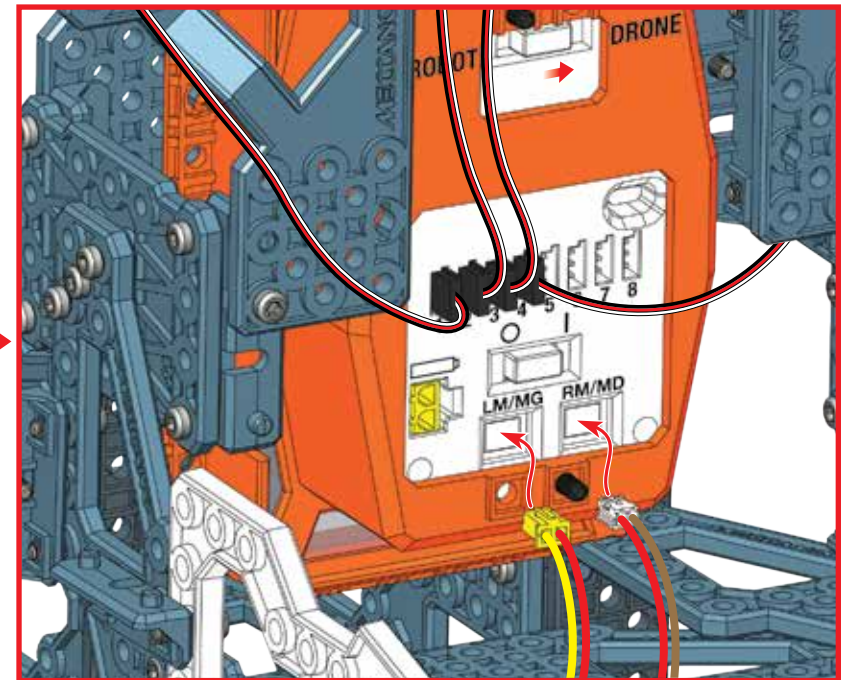
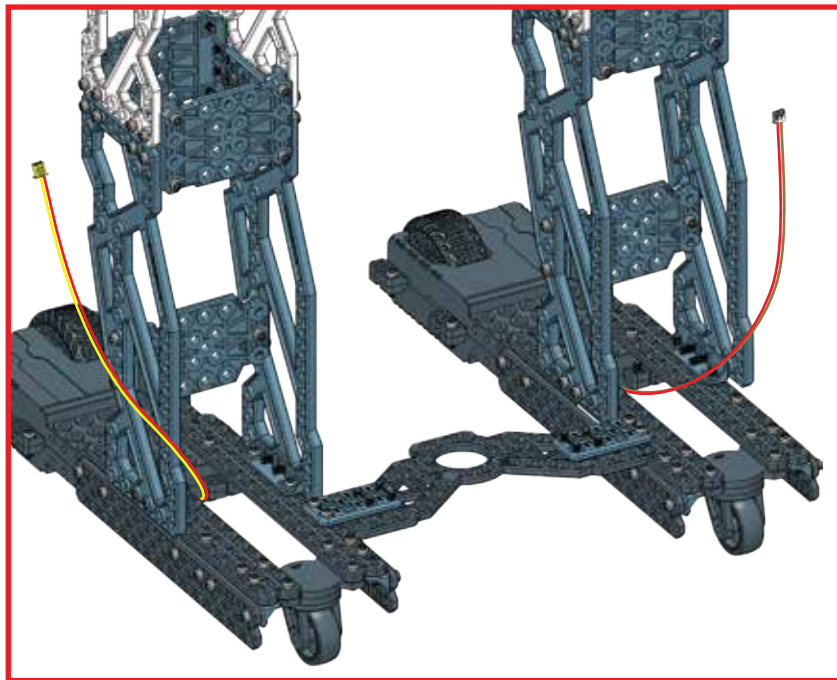

123

B1 14,7 mm | **x1**
37/64"

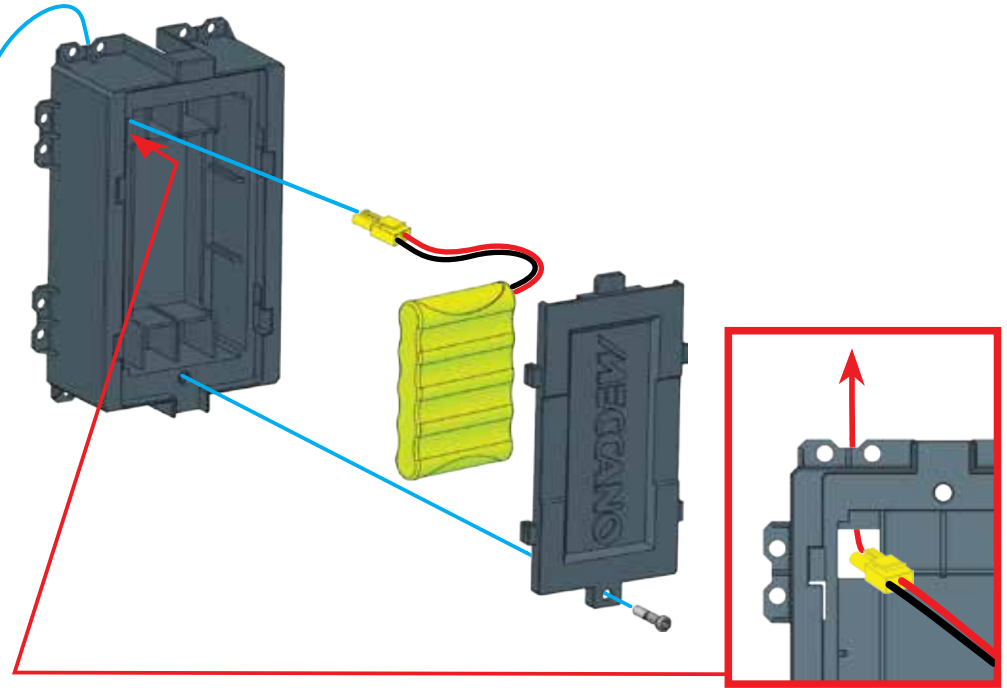
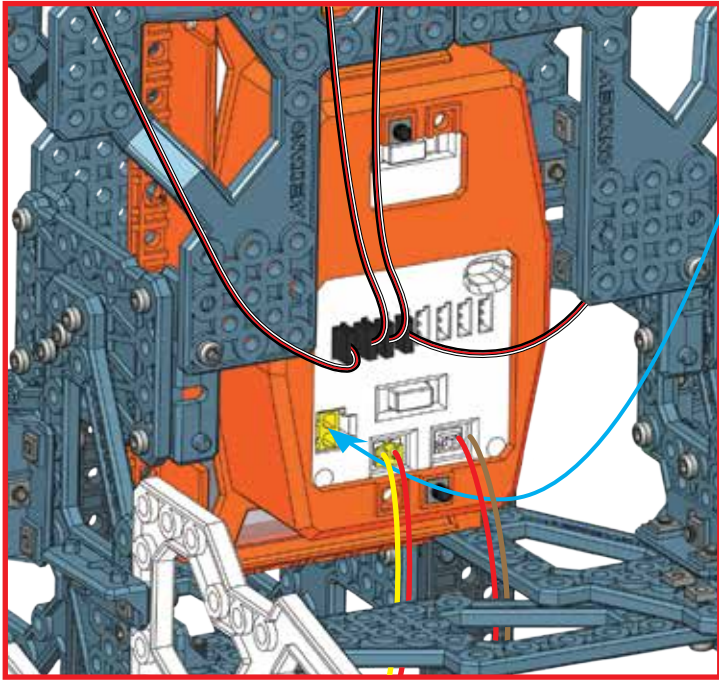
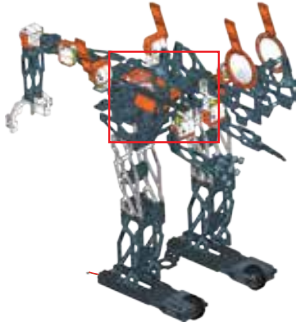
B1 1:1

GB HOW TO INSTALL BATTERIES

1. Open the battery door with a Meccano tool.
 2. **DO NOT** remove or install batteries using sharp or metal tools. 3. Install battery pack as shown. 4. Replace battery door securely. 5. Check your local laws and regulations for correct recycling and/or battery disposal.

F INSTALLATION DES PILES

1. Ouvrir le compartiment des piles à l'aide d'un outil Meccano. 2. **NE PAS** utiliser d'objet coupant ou métallique pour retirer ou insérer des piles. 3. Installer la batterie comme indiqué sur le schéma. 4. Bien refermer le compartiment des piles. 5. Recycler ou jeter les piles usagées conformément à la législation locale.

E INSTALACIÓN DE LAS PILAS

1. Abra la tapa del compartimento de las pilas con una herramienta de Meccano. 2. **NO** utilice herramientas metálicas o puntiagudas para instalar o extraer las pilas. 3. Instale la batería como se muestra. 4. Vuelva a colocar la tapa del compartimento de las pilas. 5. Consulte la normativa local relativa al reciclaje y desecho de las pilas.

D EINLEGEN DES AKKUS

1. Batteriefachabdeckung mit einem Meccano-Werkzeug öffnen. 2. Akkus **NICHT** mit scharfen oder metallenen Gegenständen entfernen oder einlegen. 3. Akku wie abgebildet einlegen. 4. Batteriefachabdeckung wieder anbringen. 5. Örtliche Gesetze und Bestimmungen für das Recycling bzw. die Entsorgung von Altbatterien beachten.

NL DE BATTERIJEN PLAATSEN

1. Open het batterijdeksel met Meccano-gereedschap.
 2. Verwijder of plaats batterijen **NIET** met behulp van scherpe of metalen voorwerpen. 3. Installeer de batterij zoals weergegeven. 4. Sluit het vak af met het batterijdeksel. 5. Lees de plaatselijke voorschriften en regelgeving om de batterijen op de juiste wijze te recyclen of af te voeren.

I COME INSTALLARE LE PILE

1. Aprire lo scomparto pile con un attrezzo Meccano.
 2. **NON** usare oggetti metallici o appuntiti per rimuovere o installare le pile. 3. Inserire la batteria come mostrato in figura. 4. Riporre saldamente lo sportello dello scomparto pile. 5. Eliminare e/o riciclare le pile secondo quanto previsto dalle normative locali vigenti.

P COMO COLOCAR AS PILHAS

1. Abra a tampa da bateria com uma ferramenta Meccano. 2. **NÃO** retire ou coloque pilhas com qualquer acessório pontiagudo ou metálico. 3. Instale o pacote de baterias conforme indicado. 4. Coloque de novo a porta do compartimento com cuidado. 5. Consulte as leis, as normas e os regulamentos locais de reciclagem e/ou descarte de pilhas e baterias.

R УСТАНОВКА ЭЛЕМЕНТОВ ПИТАНИЯ.

1 Откройте крышку отсека элементов питания инструментом Мессано. 2. Запрещается извлекать или устанавливать батареи с помощью острых или металлических предметов.
 3. Установите элементы питания, как показано на рисунке.
 4. Надежно закройте крышку отсека.
 5. Ознакомьтесь с законами и нормативами вашей страны, установленными в отношении правил переработки и/или утилизации элементов питания.

CONSUMER INFORMATION • INFORMATIONS DESTINÉES AU CONSOMMATEUR • INFORMACION PARA EL CONSUMIDOR • VERBRAUCHERHINWEISE INFORMATIE VOOR GEBRUIKERS • INFORMAZIONI PER I CONSUMATORI • INFORMAÇÕES PARA O CONSUMIDOR • ИНФОРМАЦИЯ ДЛЯ ПОТРЕБИТЕЛЕЙ

GB BATTERY SAFETY INFORMATION:

- Requires 1 x Ni-MH 1800mAh battery pack (included).
- Replacement of batteries must be done by adults.
- Promptly remove dead batteries from the toy.
- Dispose of used batteries properly.
- Remove batteries for prolonged storage.
- Only batteries of the same or equivalent type as recommended are to be used.
- DO NOT incinerate used batteries.
- DO NOT dispose of batteries in fire, as batteries may explode or leak.
- DO NOT recharge non-rechargeable batteries.
- DO NOT short-circuit the supply terminals.

SPECIAL Ni-MH BATTERY INSTRUCTIONS:

Requires 1 x Ni-MH 1800mAh battery pack. - Never charge battery unattended. - Charge battery in isolated area. Keep away from flammable materials. - Do not expose to direct sunlight. There is a risk of the batteries exploding, overheating, or igniting. - Do not disassemble, modify, heat, or short circuit the batteries. Do not place them in fires or leave them in hot places. - Do not drop or subject to strong impacts. - Do not allow the batteries or connectors to get wet. - Only charge the batteries with the specified Spin Master™ battery charger. - Only use the batteries in the device specified by Spin Master. - Carefully read the instruction guide and use the batteries correctly. - In the unlikely event of leakage or explosion use sand or a chemical fire extinguisher for the battery. - Batteries must be recycled or disposed of properly.

IMPORTANT INFORMATION: Remove all packaging before use. Retain this information, addresses and phone numbers for future reference. Content may vary from pictures. Meccano reserves the right to discontinue the website www.meccano.com at any time. Keep away from obstacles and electrical hazards.

SAFETY PRECAUTIONS: Parental guidance is recommended. Do not use Meccanoid on a table or near stairs; only use on the floor. Regularly examine for damage to the toy and sensors. In the event of any damage, remove from use. Keep hands, hair and loose clothing away from moving parts when power switch is turned ON. Turn OFF Meccanoid when not in use. During play, keep in sight so that you can supervise it all the time. Users should keep strict accordance with the instruction manual while operating the product.

CARE AND MAINTENANCE: This product is intended for indoor use only. Do not use outdoor - dirt, grass, cement will scratch the finish and/or block the sensors. Do not

submerge the toy in water. Do not play around water as this is a hazard and can cause a malfunction or damage the electronic assemblies. Keep the sensors clean, wipe with a scratchless cloth. Do not put any foreign objects in the USB port or sensors. Do not pull hard on any part of the robot as this may cause damage.

TROUBLE SHOOTING: If normal function of the product is disturbed or interrupted, strong electro-magnetic interference may be causing the issue. To reset product, turn it completely off, then turn it back on. If normal operation does not resume, move the product to another location and try again. To ensure normal performance, recharge the batteries, as low batteries may not allow full function.

F INFORMATIONS DE SÉCURITÉ RELATIVES AUX PILES :

- Fonctionne avec 1 batterie Ni-MH 1800mAh (fournie).
- Le remplacement des piles doit être effectué par un adulte.
- Retirer immédiatement toute pile usagée du jouet.
- Jeter correctement les piles usagées.
- Retirer les piles du jouet en cas d'inutilisation prolongée.
- N'utiliser que des piles d'un même type ou d'un type équivalent à celui recommandé.
- NE PAS incinérer les piles usagées.
- NE PAS jeter les piles au feu ; elles pourraient exploser ou fuir.
- NE PAS recharger des piles non rechargeables.
- NE PAS court-circuiter les bornes d'alimentation.

INSTRUCTIONS PROPRES À LA BATTERIE Ni-MH :

Contient 1 batterie 1 x Ni-MH 1800mAh. - Surveiller la batterie lors de la mise en charge. - Charger la batterie dans un endroit isolé. Tenir à distance de toute matière inflammable. - Protéger des rayons du soleil. Une batterie peut exploser, surchauffer, ou prendre feu. - Ne pas démonter, modifier, chauffer ou court-circuiter une batterie. Ne pas la mettre au feu ou la laisser dans un endroit chaud. - Ne pas laisser tomber une batterie ou la soumettre à des chocs. - Ne pas laisser une batterie ou ses connecteurs prendre l'eau. - N'utiliser que le chargeur indiqué par Spin Master™ pour recharger la batterie. - N'utiliser la batterie que dans l'appareil indiqué par Spin Master. - Lire attentivement le mode d'emploi et utiliser correctement la batterie. - Dans le cas peu probable d'une fuite ou d'une explosion, utiliser du sable ou un extincteur. - La batterie doit être recyclée ou jetée comme il convient.

INFORMATIONS IMPORTANTES : Retirer tout l'emballage avant utilisation. Conserver les informations, adresses et numéros de téléphone pour consultation ultérieure. Le contenu peut différer des images. Meccano se réserve le droit de supprimer le site Internet www.meccano.com à tout moment. Maintenir à l'écart de tout obstacle ou risque électrique.

MESURES DE SÉCURITÉ : L'aide d'un adulte est recommandée. Ne pas utiliser Meccanoid sur une table ou près d'escaliers. L'utiliser sur le sol uniquement. Vérifier régulièrement que le jouet et les capteurs ne sont pas endommagés. S'ils le sont, ne plus utiliser le jouet. S'assurer que les mains, cheveux et vêtements amples ne se trouvent pas à proximité des parties mobiles lorsque l'interrupteur est placé sur ON. ÉTEINDRE Meccanoid lorsqu'il n'est pas utilisé. Le jouet doit toujours être dans le champ de vision et surveillé à tout moment. Les utilisateurs doivent suivre rigoureusement les consignes de ce mode d'emploi lors de l'utilisation du jouet.

ENTRETIEN ET MAINTENANCE : Ce produit est conçu pour être utilisé en intérieur seulement. Ne pas utiliser en extérieur : tout contact avec de la terre, de l'herbe ou du béton peut érafler la peinture et/ou empêcher les capteurs de fonctionner. Ne pas plonger le jouet dans l'eau. Ne pas utiliser le jouet à proximité d'eau ; cela présente un danger et risquerait de provoquer un mauvais fonctionnement des assemblages électroniques ou de les endommager. Les capteurs doivent rester propres. Les nettoyer à l'aide d'un chiffon doux. Ne placer aucun objet étranger dans les capteurs ni dans le port USB. Ne pas tirer trop fort sur une partie du robot, car cela pourrait l'endommager.

DÉPANNAGE : De fortes interférences électromagnétiques peuvent perturber ou interrompre le fonctionnement normal du produit. Pour le réinitialiser, l'éteindre complètement et le rallumer. Si le produit ne fonctionne toujours pas normalement, changer de lieu d'utilisation et réessayer. Des piles ou une batterie faibles peuvent empêcher le produit de fonctionner correctement. Pour des performances optimales, changer les piles ou recharger complètement la batterie.

E INFORMACIÓN DE SEGURIDAD SOBRE LAS PILAS:

- Requiere 1 batería Ni-MH 1 800mAh (incluida).
- Las pilas deben ser sustituidas por un adulto.
- Retire rápidamente las pilas usadas.
- Las pilas usadas deben desecharse de forma adecuada.

- Retire las pilas si va a guardar el juguete durante un período de tiempo prolongado.
- Utilice únicamente pilas del tipo recomendado o de un tipo equivalente.
- NO exponga las pilas usadas al fuego.
- NO deseche las pilas usadas quemándolas, ya que podrían explotar o desprender productos químicos.
- NO intente recargar pilas no recargables.
- NO cause cortocircuitos en las terminales de corriente.

INSTRUCCIONES ESPECIALES SOBRE LA BATERÍA Ni-MH:

Requiere 1 batería Ni-MH 1 800mAh. - Nunca deje la batería cargándose sin supervisión. - Ponga a cargar la batería en un lugar despejado. Mantenga la batería alejada de materiales inflamables. - No exponga la batería a la luz directa del sol. De lo contrario, existe la posibilidad de que se recaliente, se incendie o estalle. - No desmonte, modifique, caliente ni cortocircuite la batería. No la exponga al fuego ni a altas temperaturas. - No someta la batería a caídas o golpes fuertes. - No exponga la batería a la humedad. - Utilice únicamente el cargador especificado por Spin Master™ para cargar la batería. - Utilice la batería únicamente con el dispositivo Spin Master para el que está diseñada. - Lea atentamente las instrucciones y asegúrese de usar la batería de forma correcta. - En el improbable caso de que la batería sufra una explosión o se produzca un escape de productos químicos, utilice arena o un extintor químico para contener el accidente. - Las pilas o paquetes de pilas deben reciclarse o desecharse de forma adecuada.

INFORMACIÓN IMPORTANTE : Retire todo el embalaje antes de utilizar el producto. Conserve toda la información, las direcciones y los números de teléfono para futuras referencias. El contenido del paquete puede no corresponder con las imágenes. Meccano se reserva el derecho a suspender el sitio web www.meccano.com en cualquier momento. Mantenga el producto alejado de obstáculos y riesgos eléctricos.

MEDIDAS DE SEGURIDAD: Se recomienda la supervisión de un adulto. Coloca tu Meccanoid en el suelo cuando vayas a utilizarlo, nunca en una mesa ni cerca de las escaleras. Comprueba periódicamente si el juguete o los sensores han sufrido daños. En caso de que estén dañados, deja de utilizar el juguete. Mantén las manos, el pelo y la ropa alejados del juguete cuando el interruptor esté en posición de ENCENDIDO. APAGA tu Meccanoid cuando no vayas a utilizarlo. No lo pierdas de

vista mientras lo estás usando; debe estar bajo control en todo momento. Los usuarios del producto deben seguir todas las recomendaciones de esta guía de instrucciones.

CUIDADO Y MANTENIMIENTO: este producto debe utilizarse únicamente en interiores. No lo utilices en exteriores, ya que la suciedad, la hierba y el cemento pueden arañar el acabado y bloquear los sensores. No sumerjas el juguete en agua. No utilices el juguete cerca del agua. Esto puede resultar muy peligroso ya que podría provocar un mal funcionamiento o dañar los componentes electrónicos. Mantén limpios los sensores; límpialos con un paño suave. No insertes objetos extraños en el puerto USB ni en los sensores. No tires con fuerza de ninguna parte del robot, ya que podría dañarlos.

RESOLUCIÓN DE PROBLEMAS: si se interrumpe el funcionamiento normal del producto, es posible que se deba a interferencias electromagnéticas fuertes. Para reiniciarlo, apágalo y vuelve a encenderlo. Si el producto sigue sin funcionar normalmente, cambia la zona de uso y vuelve a intentarlo. Las pilas usadas pueden impedir que el producto funcione correctamente. Para conseguir un rendimiento óptimo, cambia las pilas.

D SICHERHEITSHINWEISE ZU BATTERIEN:

- Benötigt 1 Ni-MH 1800mAh Akku (enthalten).
- Batterien müssen von Erwachsenen ausgetauscht werden.
- Leere Batterien sofort aus dem Spielzeug entfernen.
- Verbrauchte Batterien ordnungsgemäß entsorgen.
- Bei längerfristiger Lagerung Batterien vorher entfernen.
- Nur dieselben oder gleichwertige Batterien wie empfohlen verwenden.
- Verbrauchte Batterien NICHT verbrennen.
- Batterien NICHT in Feuer entsorgen, da sie explodieren oder auslaufen könnten.
- Nicht-aufladbare Batterien NICHT aufladen.
- Batteriepole NICHT kurzschließen.

HINWEISE FÜR DEN Ni-MH AKKU: Benötigt 1 Ni-MH 1800mAh Akku. - Den Akku nie unbeaufsichtigt aufladen. - Den Akku an einem isolierten Ort aufladen. Von entflammaren Materialien fernhalten. - Keinem direkten Sonnenlicht aussetzen. Der Akku könnte explodieren, sich überhitzen oder sich entzünden. - Den Akku nicht auseinandernehmen, die Temperatur verändern oder kurzschließen. Nicht in Feuer legen oder an heißen Orten lagern. - Nicht fallen lassen oder starken Stößen aussetzen. - Den Akku und die Anschlüsse nicht nass werden lassen. - Den Akku nur mit dem angegebenen Spin Master™- Ladegerät laden. - Den Akku nur in dem von Spin Master angegebenen Gerät verwenden. - Die Bedienungsanleitung sorgfältig durchlesen und den Akku ordnungsgemäß verwenden. - In dem unwahrscheinlichen Fall eines Lecks oder einer Explosion des Akkus, Sand oder einen chemischen Feuerlöscher verwenden. -

Batterien müssen recycelt oder ordnungsgemäß entsorgt werden.

WICHTIGE INFORMATIONEN: Entfernen Sie vor der Benutzung sämtliche Verpackungsmaterialien. Alle Informationen, Adressen und Telefonnummern bitte für mögliche Rückfragen aufbewahren. Der Packungsinhalt kann von den Bildern abweichen. Meccano behält sich das Recht vor, den Betrieb der Website www.meccano.com jederzeit einzustellen. Nicht in der Nähe von Hindernissen und gefährlichen Stromquellen spielen.

SICHERHEITSVORKEHRUNGEN: Beaufsichtigung durch Erwachsene empfohlen. Meccanoid nicht auf Tischen oder in der Nähe von Treppen verwenden. Das Spielzeug ist ausschließlich für die Verwendung auf dem Boden gedacht. Das Spielzeug und die Sensoren regelmäßig auf Schäden untersuchen. Ist das Spielzeug beschädigt, darf es nicht länger verwendet werden. Hände, Haare und weite Kleidung von den beweglichen Teilen fernhalten, wenn das Spielzeug eingeschaltet ist. Meccanoid ausschalten, wenn das Spielzeug nicht verwendet wird. Kinder während des Spielens mit Meccanoid nicht unbeaufsichtigt lassen. Das Produkt sollte streng nach den Anweisungen in der Bedienungsanleitung verwendet werden.

PFLEGE UND WARTUNG: Dieses Produkt ist nur zur Verwendung in Innenräumen vorgesehen. Nicht im Freien verwenden. - Schmutz, Gras und Asphalt können die Oberfläche zerkratzen und/oder die Sensoren blockieren. Das Spielzeug nicht unter Wasser tauchen. Das Spielzeug nicht in der Nähe von Wasser verwenden. Dies ist nicht nur gefährlich, sondern kann auch zu einer Fehlfunktion oder zur Beschädigung der elektronischen Komponenten führen. Die Sensoren mit einem weichen Tuch sauber halten. Keine Fremdkörper in den USB-Anschluss oder die Sensoren einführen. Nicht an Roboterteilen zerren, da dies Schäden verursachen kann.

FEHLERBEHEBUNG: Wenn die normale Funktion des Produkts gestört oder unterbrochen wird, könnte starke elektromagnetische Strahlung der Grund dafür sein. Durch Aus- und wieder Einschalten des Produkts können die Einstellungen zurückgesetzt werden. Sollte dies die Fehlfunktion nicht beheben, das Produkt an einen anderen Ort bringen und dort erneut ausprobieren. Bei Bedarf die Batterien austauschen, da schwache Batterien die Leistungsfähigkeit beeinträchtigen können.

(NL) VEILIGHEIDSINFORMATIE MET BETREKKING TOT DE BATTERIJEN:

- Vereist 1 Ni-MH 1800mAh (inbegrepen).
- Het vervangen van batterijen dient door volwassenen te worden gedaan.
- Verwijder lege batterijen onmiddellijk uit het speelgoed.
- Zorg voor een milieuvriendelijke afvalverwerking van de batterijen.

- Verwijder de batterijen als het speelgoed voor langere tijd wordt opgeborgen.
- Alleen batterijen van het aanbevolen type of een equivalent daarvan mogen worden gebruikt.
- Steek gebruikte batterijen NOOIT in brand.
- Gooi batterijen NOOIT in vuur. Hierdoor kunnen deze ontploffen of gaan lekken.
- NOOIT door elkaar.
- Laad niet-oplaadbare batterijen NOOIT op.
- Veroorzaak NOOIT kortsluiting tussen de contactpunten.

SPECIALE INSTRUCTIES VOOR DE Ni-MH-BATTERIJ:

Vereist 1 x Ni-MH-accu van 1800 mAh. - Laad de batterij nooit zonder toezicht op. - Laad de batterij op in een afgeschermd omgeving. - Houd de batterij uit de buurt van brandbare materialen. - Stel de batterij niet bloot aan direct zonlicht. De batterij kan dan mogelijk ontploffen, oververhit raken of vlam vatten. - Haal de batterij niet uit elkaar, wijzig en verhit deze niet en veroorzaak evenmin kortsluiting. - Plaats de batterij nooit in vuur en laat deze niet achter in warme omgevingen. - Laat de batterij niet vallen en stel deze niet bloot aan hevige schokken. - Voorkom dat de batterij of contactpunten nat worden. - Laad de batterij alleen op met de gespecificeerde Spin Master™-batterijlader. - Gebruik in het apparaat uitsluitend de door Spin Master gespecificeerde batterijen. - Lees de gebruiksaanwijzing zorgvuldig door en gebruik de batterijen op de juiste manier. - Gebruik in het onwaarschijnlijke geval van ontploffing of lekkage van of een chemische brandblusser voor de batterij. - Zorg voor een milieuvriendelijke afvalverwerking van de batterij.

BELANGRIJKE INFORMATIE: Verwijder de verpakking voor gebruik. Bewaar deze informatie, adressen en telefoonnummers voor toekomstig gebruik. Inhoud kan afwijken van illustraties. Meccano behoudt zich het recht voor de website www.meccano.com wanneer gewenst buiten gebruik te stellen. Blijf uit de buurt van obstakels en voorwerpen die elektrische schokken kunnen veroorzaken.

VEILIGHEIDSMATREGELEN: Ouderlijk toezicht wordt aanbevolen. Gebruik Meccanoid niet op tafels of in de buurt van trappen. Gebruik Meccanoid alleen op de vloer. Controleer het speelgoed en de sensoren regelmatig op beschadigingen. In geval van schade, speelgoed niet meer gebruiken. Houd handen, haar en losvallende kleding uit de buurt van bewegende onderdelen als de stroomschakelaar op ON staat. Zet Meccanoid uit wanneer je hem niet gebruikt. Houd Meccanoid tijdens het spelen altijd in de gaten. Gebruikers dienen zich tijdens het gebruik van het product strikt aan de informatie in de gebruiksaanwijzing te houden.

VERZORGING EN ONDERHOUD: dit product is uitsluitend voor gebruik binnenshuis. Gebruik het product niet buitenshuis. Vuil, gras en cement zorgen voor krassen op de lak of blokkeren de sensoren. Dompel het speelgoed niet onder in water. Gebruik het speelgoed niet in de buurt van water, omdat dit gevaarlijk is en een elektronisch defect kan veroorzaken. Maak de sensoren schoon met een zachte doek. Plaats geen vreemde objecten in de USB-poort of de sensoren. Trek niet hard aan de onderdelen van de robot omdat dit schade kan veroorzaken.

PROBLEMEN OPLOSSEN: bij ontregeling of onderbreking van het normale functioneren van het product kan een sterke elektromagnetische storing de oorzaak van het probleem zijn. Reset het product door het volledig uit te schakelen en vervolgens weer in te schakelen. Functioneert het product dan nog niet naar behoren, reset het dan nogmaals in een andere ruimte. Controleer ook of de batterijen niet leeg zijn en vervang ze indien nodig. Leg de batterijen kunnen een correcte werking verstoren.

(I) INFORMAZIONI DI SICUREZZA PER LE PILE:

- Richiede una batteria Ni-MH 1800mAh (includere).
- Le pile devono essere sostituite da adulti.
- Estrarre tempestivamente le pile scariche.
- Eliminare le pile scariche con la dovuta cautela.
- Estrarre le pile se non si utilizza il prodotto per un periodo di tempo prolungato.
- Usare solo pile dello stesso tipo o equivalenti.
- NON bruciare le pile usate.
- NON gettare le pile nel fuoco, potrebbero esplodere o essere soggette a perdite di liquido.
- NON ricaricare le pile non ricaricabili.
- NON cortocircuitare i terminali delle pile.

ISTRUZIONI SPECIALI PER LE BATTERIE Ni-MH

Richiede una batteria Ni-MH 1800mAh. - Non caricare mai le batterie senza supervisione. - Caricare le batterie in un'area isolata. Tenerle lontane da materiali infiammabili. - Non esporle alla luce solare diretta. Le batterie possono esplodere, surriscaldarsi o incendiarsi. - Non smontare, modificare, scaldare o mettere in cortocircuito le batterie. Non buttarle nel fuoco o lasciarle in luoghi caldi. - Non farle cadere o sottoporle a urti violenti. - Non lasciare che le batterie o i connettori si bagnino. - Caricare le batterie solo con il caricabatteria Spin Master™ specificato. - Usare le batterie solo nel dispositivo specificato da Spin Master. - Leggere attentamente le istruzioni e usare le batterie nel modo corretto. - Nel caso improbabile di perdite o esplosioni, usare sabbia o un estintore chimico per la batteria. - Le batterie devono essere riciclate o smaltite correttamente.

INFORMAZIONI IMPORTANTI: Rimuovere l'imballo prima dell'uso. Conservare informazioni, indirizzi e numeri di telefono per riferimento futuro. Il prodotto potrebbe essere differente dalle immagini. Meccano si riserva il diritto di rimuovere il sito www.meccano.com in qualsiasi momento. Tenere lontano da ostacoli, dispositivi elettrici e prese di corrente.

PRECAUZIONI DI SICUREZZA: È consigliata la supervisione dei genitori. Non usare Meccanoid su un tavolo o in prossimità di scale. Usare solo sul pavimento. Esaminare regolarmente il giocattolo e i sensori per verificare l'eventuale presenza di danni. Se danneggiato, il giocattolo non deve essere usato. Tenere le mani, i capelli e i capi di vestiario lontani dai componenti in movimento quando l'interruttore di alimentazione è acceso. Spegnerne Meccanoid quando non lo si sta usando. Durante il gioco, tenere Meccanoid in vista per poterlo controllare in ogni momento. Seguire attentamente la guida per l'uso.

CONSERVAZIONE E MANUTENZIONE: questo prodotto deve essere utilizzato esclusivamente in luoghi chiusi. Non utilizzare all'esterno: terra, erba e cemento potrebbero graffiare la superficie e/o potrebbero bloccare i sensori. Non immergere il giocattolo in acqua. Non utilizzare in prossimità di acqua per evitare il rischio di malfunzionamenti o danni ai componenti elettronici. Tenere puliti i sensori utilizzando un panno antigraffio. Non inserire corpi estranei nella porta USB o nei sensori. Non tirare troppo forte nessun componente del robot per evitare danni.

RISOLUZIONE DEI PROBLEMI: se il normale funzionamento del prodotto risultasse disturbato, ciò potrebbe essere causato da una forte interferenza elettromagnetica. Per resettare il prodotto, spegnerlo e riaccenderlo. Se non dovesse riprendere a funzionare adeguatamente, spostarlo in una posizione diversa e riprovare. Per prestazioni ottimali ricaricare le pile poiché pile poco cariche possono compromettere il regolare funzionamento.

INFORMAÇÕES DE SEGURANÇA SOBRE AS PILHAS:

- Requer 1 bateria Ni-MH 1800mAh (inclusa).
- A troca das pilhas deve ser realizada por adultos.
- Retire as pilhas vazias do brinquedo.
- Descarte corretamente as pilhas usadas.
- Retire as pilhas para armazenamento prolongado.
- Recomenda-se que sejam usadas apenas pilhas iguais ou similares.
- NÃO incinere as pilhas usadas.
- NÃO jogue as pilhas no fogo, pois podem explodir ou vazar.
- NÃO recarregue pilhas não recarregáveis.
- NÃO permita que ocorra curto-circuito nos terminais

do produto.

INSTRUÇÕES ESPECIAIS PARA A PILHA NI-MH:

Requer 1 bateria Ni-MH 1800mAh. - Supervisionar sempre o carregamento da pilha. - Carregar a pilha numa área isolada. Manter afastada de materiais inflamáveis. - Não expor a luz solar directa. A pilha poderá explodir, sobreaquecer ou entrar em ignição. - Não desmontar, modificar, aquecer ou provocar curto-circuito da pilha. Não colocar no fogo ou deixar em locais quentes. - Não deixar cair ou sujeitar a impactos fortes. - Não permitir que a pilha ou conectores se molhem. - Carregar a pilha apenas com o carregador Spin Master™ específico. - Usar a pilha apenas no dispositivo especificado pela Spin Master™. - Ler cuidadosamente o manual de instruções e usar a pilha correctamente. - Na eventualidade improvável de fuga ou explosão, usar areia ou um extintor químico. - A pilha deverá ser reciclada ou eliminada de forma adequada.

IMPORTANTE: emova totalmente a embalagem antes de utilizar. Guarde todos os endereços, números de telefone e demais informações para consulta e referência. O conteúdo poderá ser diferente das ilustrações. A Meccano reserva-se o direito de descontinuar o sítio www.meccano.com a qualquer altura. Mantenha distância de obstáculos e perigos elétricos.

PRECAUÇÕES DE SEGURANÇA: É recomendada a supervisão de um adulto. Não use o Meccanoid em mesas ou perto de escadas, apenas no chão. Verifique regularmente se há danos no brinquedo e nos sensores. Em caso de algum dano, suspenda o uso. Mantenha mãos, cabelos e roupas distantes do brinquedo quando a chave de liga/desliga estiver em "ON" ("LIGADO"). DESLIGUE o Meccanoid quando não estiver em uso. Ao brincar com o produto, mantenha-o sob sua supervisão em todos os momentos. Os usuários devem seguir todas as instruções do guia de instruções para usar o brinquedo.

CUIDADOS E MANUTENÇÃO: Este produto destina-se somente a uso interno. Não o use fora de casa - pó, grama e cimento arranhão o acabamento e/ou obstruirão os sensores. Não submerja o brinquedo em água. Não brinque perto da água, pois isso representa um risco e pode causar mau funcionamento ou danos aos componentes eletrônicos. Mantenha os sensores limpos usando um tecido macio. Não insira objetos estranhos na porta USB ou nos sensores. Não puxe com muita força nenhuma parte do robô para não causar danos.

SOLUÇÃO DE PROBLEMAS: Se o funcionamento normal

do produto for afetado ou interrompido, a causa pode ser uma interferência eletromagnética. Para reiniciar o produto, desligue-o completamente e ligue-o novamente. Se o funcionamento não voltar ao normal, desloque o produto para o outro local e tente novamente. Para garantir o funcionamento normal, troque as pilhas novamente, já que as pilhas com carga baixa não possibilitam o funcionamento completo do produto.

INFORMAÇÃO PO BEZOPASNOMU OBRASHENIU S ELEMENTAMI PITANIA:

- Requerem-se 1 elemento de alimentação tipo Ni-MH 1800mAh (entra no conjunto).
- A substituição dos elementos de alimentação deve ser feita por adultos.
- Não deixe os elementos de alimentação sobrecarregados no brinquedo.
- Utilize os elementos de alimentação corretamente.
- Evite os elementos de alimentação, se o brinquedo não estiver sendo usado por um longo período.
- Recomenda-se usar os elementos de alimentação de um ou de dois tipos equivalentes.
- Não queime os elementos de alimentação.
- Não jogue os elementos de alimentação no fogo. Isso pode causar explosão.
- É PROIBIDO carregar os elementos de alimentação.
- EVITE o curto-circuito dos terminais de alimentação.

INSTRUÇÕES PO EKSPLUATACII LITIIY-POLIMERNYKH ELEMENTOV PITANIA:

O conjunto contém um elemento de alimentação litio-polímero Ni-MH 1800mAh. - É proibido deixar o elemento de alimentação sozinho sem supervisão. - Carregue o elemento de alimentação em um local seguro. Mantenha o elemento de alimentação longe de materiais inflamáveis. - Não deixe o elemento de alimentação sobrecarregado. - Não exponha o elemento de alimentação ao fogo. - Não deixe o elemento de alimentação sob a luz solar direta. - Não permita que o elemento de alimentação seja molhado. - Não permita que o elemento de alimentação seja exposto a impactos fortes. - Não permita que o elemento de alimentação seja exposto a temperaturas altas. - Não permita que o elemento de alimentação seja exposto a temperaturas baixas. - Não permita que o elemento de alimentação seja exposto a umidade. - Não permita que o elemento de alimentação seja exposto a produtos químicos. - Não permita que o elemento de alimentação seja exposto a produtos inflamáveis. - Não permita que o elemento de alimentação seja exposto a produtos corrosivos. - Não permita que o elemento de alimentação seja exposto a produtos oxidantes. - Não permita que o elemento de alimentação seja exposto a produtos tóxicos. - Não permita que o elemento de alimentação seja exposto a produtos voláteis. - Não permita que o elemento de alimentação seja exposto a produtos inflamáveis. - Não permita que o elemento de alimentação seja exposto a produtos oxidantes. - Não permita que o elemento de alimentação seja exposto a produtos tóxicos. - Não permita que o elemento de alimentação seja exposto a produtos voláteis.

ВАЖНАЯ ИНФОРМАЦИЯ: Снимите все упаковочные материалы перед использованием. Запишите указанные на упаковке адреса и номера телефонов, чтобы у вас была возможность связаться с нами. Содержимое упаковки может отличаться от иллюстрации. Компания Meccano оставляет за собой право прекратить использование сайта www.meccano.com в любое время. Держите игрушку вдали от опасных электроприборов и объектов, мешающих игре.

МЕРЫ ПРЕДОСТОРОЖНОСТИ: Рекомендуется присмотр взрослых. Не используйте игрушку Meccanoid на столе или рядом с лестницей — игрушка предназначена для использования на полу. Следует проводить регулярный осмотр на предмет повреждения игрушки и датчиков. Если таковые имеются, игрушку не следует использовать. Не прикасайтесь к игрушке руками и следите за тем, чтобы она находилась на безопасном расстоянии от волос и неприлегающих элементов одежды, когда переключатель питания находится в положении "ВКЛ.". Выключите игрушку, когда она не используется. Во время использования игрушка всегда должна находиться в поле зрения. При управлении игрушкой необходимо строго следовать указаниям, приведенным в руководстве по эксплуатации. Компания Meccano оставляет за собой право прекратить использование сайта www.meccano.com в любое время.

УХОД И ОБСЛУЖИВАНИЕ: игрушка предназначена только для использования в помещении. Не используйте игрушку на улице — грязь, трава и бетон могут поцарапать покрытие и/или повредить датчики. Не погружайте игрушку в воду. Не используйте игрушку рядом с водой, так как это может привести к сбою в работе или повреждению электронных компонентов. Очистку датчиков следует выполнять мягкой тканью. Не помещайте посторонние предметы в USB-порт или датчики. Не подвергайте части тела робота сильному растяжению, поскольку это может привести к повреждению.

УСТРАНЕНИЕ НЕИСПРАВНОСТЕЙ: если устройство перестает работать или работает нестабильно, причиной могут быть сильные электромагнитные помехи. Чтобы восстановить работу устройства, полностью выключите его, а затем включите снова. Если устройство по-прежнему будет работать неисправно, повторите процедуру в другом месте комнаты. Для нормальной работы устройства замените элементы питания. При низком уровне заряда элементы питания могут быть неспособны обеспечить работу устройства в полнофункциональном режиме.

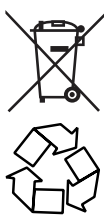

(GB) Requires 1 x Ni-MH 1800mAh battery pack (included). Batteries or battery packs must be recycled or disposed of properly. When this product has reached the end of its useful life it should not be disposed of with other household waste. The Waste Electrical and Electronic Equipment Regulations require it to be separately collected so that it can be treated using the best available recovery and recycling techniques. This will minimize the impact on the environment and human health from soil and water contamination by any hazardous substances, decrease the resources required to make new products and avoid using up landfill space. Please do your part by keeping this product out of the municipal waste stream! The “wheelie bin” symbol means that it should be collected as “waste electrical and electronic equipment”. You can return an symbol means that it should be collected as “waste electrical and electronic equipment”. You can return an old product to your retailer when you buy a similar new one. For other options, please contact you local council.

(F) Fonctionne avec 1 batterie Ni-MH 1800mAh (fournie). Les piles ou les batteries doivent être correctement recyclées ou éliminées. Lorsque ce produit arrive en fin de vie, il ne doit pas être jeté avec le reste des déchets ménagers. Conformément à la directive sur les Déchets des équipements électriques et électroniques (DEEE), il doit être collecté séparément afin d’être éliminé selon les meilleures techniques de récupération et de recyclage disponibles. Cette démarche réduit les risques de pollution du sol et des eaux, et permet ainsi de minimiser l’impact de toute substance nocive sur la santé et sur l’environnement. Cela diminue également la quantité de ressources nécessaires à la fabrication de nouveaux produits, et évite la saturation des sites d’enfouissement. Veuillez apporter votre contribution en ne jetant pas ce produit avec les déchets de votre commune. Le symbole de la « poubelle sur roues » signifie que ce produit doit faire l’objet d’une collecte respectant la directive sur les Déchets des équipements électriques et électroniques (DEEE). Vous pouvez également retourner les produits en fin de vie à votre détaillant lors de l’achat d’un produit similaire neuf. Pour plus d’informations, contactez votre commune.

(E) Requiere 1 batería Ni-MH 1 800mAh (incluida). Las pilas o las baterías deben ser recicladas o desechadas de manera apropiada. Cuando este producto alcance el final de su vida útil, no lo deseches como residuo doméstico. La normativa exige que se recoja de forma separada para que pueda tratarse con las mejores técnicas de recuperación y reciclaje disponibles. De esta forma, se minimizará el impacto que la contaminación del suelo y el agua causada por sustancias peligrosas tiene sobre el medio ambiente y la salud humana, se reducirán los recursos necesarios para fabricar nuevos

productos y se evitará la saturación de los vertederos. ¡Colabora desechando este producto de forma adecuada! El símbolo del contenedor con ruedas significa que debería recogerse como residuo de aparatos eléctricos y electrónicos. Puedes devolver un producto antiguo en tu establecimiento habitual cuando adquieras un producto nuevo similar. Si deseas obtener más información, consulta con las autoridades locales.

(D) Benötigt 1 Ni-MH 1800mAh Akku (enthalten). Batterien oder Akkus müssen recycelt oder ordnungsgemäß entsorgt werden. Ist das Gerät nicht mehr zu gebrauchen, darf es nicht über den Hausmüll entsorgt werden. Die Elektroaltgeräteverordnung sieht vor, dass das Gerät separat entsorgt wird, damit es so weit wie möglich recycelt werden kann. Dadurch lässt sich die Menge an umwelt- und gesundheitsschädlichen Substanzen, die über den Boden und das Grundwasser in den menschlichen Nahrungskreislauf gelangen könnten, minimieren sowie die für die Herstellung neuer Produkte erforderlichen Ressourcen reduzieren und Platz auf Mülldeponien sparen. Leisten Sie bitte Ihren Beitrag dazu, indem Sie das Gerät nicht über den Hausmüll entsorgen. Das Mülltonnen-Symbol bedeutet, dass das Gerät gemäß den Vorschriften für Elektro- und Elektronikgeräte entsorgt werden muss. Alte Geräte können oft beim Kauf eines neuen, ähnlichen Geräts im Einzelhandel zurückgegeben werden. Weitere Entsorgungsmöglichkeiten erfragen Sie bitte bei Ihrer Gemeindeverwaltung.

(NL) Vereist 1 Ni-MH 1800mAh (inbegrepen). Batterijen en accu's dienen op de juiste wijze te worden gerecycled of afgevoerd. Wanneer dit product het einde van zijn levensduur heeft bereikt, mag het niet samen met ander huishoudelijk afval worden weggegooid. Volgens de wet moet het product afzonderlijk worden ingezameld zodat het kan worden behandeld met de best beschikbare hergebruik- en recycletechnieken. Op deze manier wordt de invloed op het milieu en de menselijke gezondheid van grond- en watervervuiling door gevaarlijke stoffen geminimaliseerd, hoeven er minder bronnen te worden gebruikt om nieuwe producten te maken en raken stortplaatsen minder snel vol. Draag je steentje bij door dit product uit de gemeentelijke afvalstroom te houden! Het afvalcontainersymbool betekent dat het product moet worden ingezameld als elektrische en elektronische afvalapparatuur. Je kunt een oud product inruilen bij de detailhandelaar wanneer je een vergelijkbaar nieuw product koopt. Neem voor andere opties contact op met de gemeente.

(I) Richiede una batteria Ni-MH 1800mAh (inclusa). Le pile e le loro confezioni devono essere riciclate o smaltite correttamente. Non smaltire il prodotto assieme ai rifiuti generici. La direttiva per lo smaltimento di apparecchiature elettriche ed elettroniche prevede che tali rifiuti siano raccolti separatamente, in modo da essere smaltiti

utilizzando le più efficaci tecniche di riciclo e di recupero disponibili. Ciò consente di contenere l’impatto sull’ambiente e sulla salute umana, evitando che il terreno e l’acqua siano contaminati da sostanze nocive, di ridurre l’uso delle risorse necessarie alla realizzazione di nuovi prodotti e di limitare il ricorso a discariche. Non gettare il prodotto assieme ai rifiuti generici. Il simbolo del contenitore per i rifiuti indica che il prodotto deve essere smaltito come “apparecchiatura elettrica ed elettronica”. In caso di acquisto di un giocattolo analogo, è possibile restituire il prodotto usato al rivenditore. Per ulteriori informazioni circa lo smaltimento del prodotto, contattare le autorità locali preposte al servizio.

(P) Requer 1 batería Ni-MH 1800mAh (inclusa). As baterias e as suas embalagens devem ser recicladas ou descartadas corretamente. Quando o produto alcançar o fim de sua vida útil, não o descarte com o lixo doméstico. As regulamentações para o descarte de resíduos elétricos e eletrônicos solicitam que o produto seja recolhido para ser tratado usando as melhores técnicas de recuperação e reciclagem disponíveis. Isso minimizará os impactos no meio ambiente e na saúde humana pela contaminação do solo e da água por substâncias perigosas, diminuirá os recursos necessários para a produção de novos produtos e evitará o uso de aterros. Colabore! Mantenha este produto fora do fluxo de resíduos urbanos! O símbolo de reciclagem significa que tais produtos devem ser recolhidos como “descarte de equipamentos eletrônicos e elétricos”. É possível devolver o produto antigo ao comerciante quando comprar um novo equivalente. Para outras opções, entre em contato com o conselho municipal.

(R) Требуется 1 щелочных элемента питания типа Ni-MH 1800mAh (входит в комплект). Элементы питания и комплекты элементов питания необходимо утилизировать надлежащим образом. По окончании срока эксплуатации не выбрасывайте игрушку вместе с бытовыми отходами. Согласно закону об утилизации электрических и электронных устройств ее необходимо утилизировать отдельным способом, с использованием наиболее подходящих технологий утилизации и переработки. Это позволит снизить негативные последствия для окружающей среды и здоровья человека, уменьшит загрязнение воды и почвы опасными веществами, а также снизит количество ресурсов, необходимых для изготовления новых игрушек и сократит объем мусора на городских свалках. Внесите свой вклад, сохранив город чистым. Значок с изображением перечеркнутой корзины означает, что игрушку следует утилизировать согласно закону об утилизации электрических и электронных устройств. При покупке новой игрушки вы можете вернуть старую в магазин. Чтобы узнать о других возможных вариантах утилизации, обратитесь в местную перерабатывающую организацию.

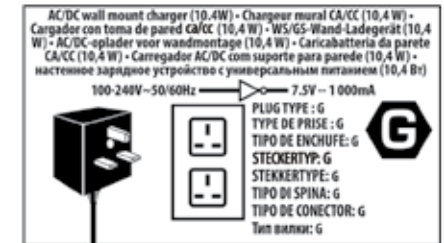
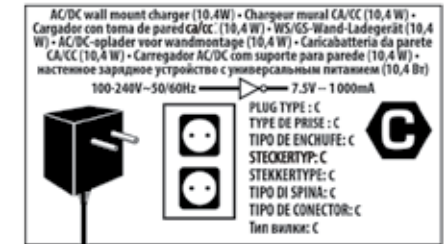
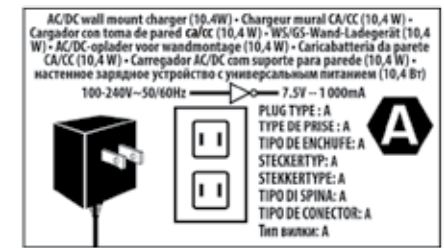

Bluetooth operates at:
Fréquence de fonctionnement du Bluetooth :
La conexión Bluetooth funciona a:
Bluetooth arbeitet mit einer Frequenz von:
Bluetooth werkt op een frequentie van:
Bluetooth funziona a:
O Bluetooth opera a:
Сигнал Bluetooth действует на частоте:

2.4GHz / 2,4 GHz

- ⚠ **WARNING:** CHOKING HAZARD – Small parts.
- ⚠ **ATTENTION !** RISQUE D'ÉTOUFFEMENT – Contient de petits éléments.
- ⚠ **ADVERTENCIA:** PELIGRO DE ASFIXIA – Contiene piezas pequeñas. No conveniente para niños menores de 3 años.
- ⚠ **ACHTUNG:** ERSTICKUNGSGEFAHR – Kleinteile.
- ⚠ **WAARSCHUWING:** VERSTIKKINGSGEVAAR – Kleine onderdelen.
- ⚠ **ATTENZIONE:** RISCHIO DI SOFFOCAMENTO - Contiene pezzi di piccole dimensioni.
- ⚠ **AVISO:** RISCO DE ASFIXIA — Peças pequenas.
- ⚠ **ОСТОРОЖНО!** - ОПАСНОСТЬ УДУШЬЯ - Мелкие детали.



- ⚠ **ADVERTENCIA:** El cable del adaptador de alimentación podría suponer un riesgo de estrangulación. No recomendado para niños menores de 3 años.
- ⚠ **ACHTUNG:** Beim Umgang mit dem Netzkabel besteht Strangulierungsgefahr. Nicht für Kinder unter 3 Jahren geeignet.
- ⚠ **WAARSCHUWING:** Het adapterkoord kan een verstikkingsgevaar vormen. Niet voor gebruik door kinderen onder de 3 jaar.
- ⚠ **ATTENZIONE:** Il cavo dell'adattatore può causare il rischio di strangolamento. Non adatto ai bambini di età inferiore a 3 anni.
- ⚠ **AVISO:** Tome cuidado com o cabo do adaptador, já que ele pode apresentar perigo de estrangulamento e asfixia. O equipamento não deve ser utilizado por crianças de 3 anos de idade ou menos.
- ⚠ **ПРЕДУПРЕЖДЕНИЕ:** Шнур адаптера является источником опасности удушья. Устройство не предназначено для использования детьми в возрасте младше 3 лет.

- ⚠ **PRECAUCIÓN:** JUGUETE ELÉCTRICO – No recomendado para niños menores de 10 años. Como sucede con todos los productos eléctricos, se deben tomar precauciones especiales durante su manipulación para evitar cualquier riesgo de descarga eléctrica.
- ⚠ **ACHTUNG –** ELEKTRONISCHES SPIELZEUG – Nicht empfohlen für Kinder unter 10 Jahren. Bitte wie bei allen elektrischen Geräten Vorsicht bei der Handhabung, um Stromschläge zu vermeiden.
- ⚠ **VOORZICHTIG –** ELEKTRISCH SPEELGOED – Niet aanbevolen voor kinderen onder de 10 jaar. Zoals met alle elektrische producten moeten tijdens de omgang met en het gebruik van het speelgoed de noodzakelijke voorzorgsmaatregelen in acht worden genomen om elektrische schokken te voorkomen.

- ⚠ **ATTENZIONE:** GIOCATTOLO ELETTRONICO – Sconsigliato per i bambini di età inferiore a 10 anni. Come tutti i prodotti elettronici, deve essere maneggiato e usato con attenzione per evitare scosse elettriche.
- ⚠ **CUIDADO -** BRINQUEDO ELETRÔNICO – Não recomendado para crianças de 10 anos de idade ou menos. Assim como ocorre com todos os produtos elétricos, alguns cuidados e precauções devem ser seguidos no manuseio e uso do equipamento para evitar choque elétrico.
- ⚠ **ОСТОРОЖНО!** ЭЛЕКТРИЧЕСКАЯ ИГРУШКА - Устройство не – рекомендуется к использованию детьми в возрасте младше 10 лет. Во избежание поражения электрическим током при эксплуатации следует соблюдать меры предосторожности, применимые к использованию любых других электрических устройств.

GB. Spin Master International SARL, hereby declares that this Meccanoid G15KS is in compliance with the essential requirements and other relevant provisions of Directive 1999/5/EC. A copy of the declaration of conformity can be requested through customercare@spinmaster.com or SPIN MASTER INTERNATIONAL S.A.R.L., 16 Avenue Pasteur, L-2310, Luxembourg.

F. Par la présente, Spin Master International SARL déclare que ce jouet Meccanoid G15KS™ respecte les principales exigences ainsi que les dispositions pertinentes de la Directive 1999/5/EC. Une copie de la déclaration de conformité est disponible sur demande. Contactez-nous à l'adresse customercare@spinmaster.com ou SPIN MASTER INTERNATIONAL S.A. R. L., 16 Avenue Pasteur, L-2310, Luxembourg.

E. Por la presente, Spin Master International SARL declara que este juguete Meccanoid G15KS™ cumple con los requisitos esenciales y con otras provisiones relevantes de la Directiva 1999/5/EC. Se puede solicitar una copia de la declaración de conformidad en customercare@spinmaster.com o en SPIN MASTER INTERNATIONAL S.A.R.L., 16 Avenue Pasteur, L-2310, Luxemburgo.

D. Spin Master International SARL erklärt hiermit, dass Meccanoid G15KS™ den grundlegenden Anforderungen und weiteren Bestimmungen der Richtlinie 1999/5/EG entspricht. Ein Exemplar der Konformitätserklärung kann per E-Mail an customercare@spinmaster.com oder bei SPIN MASTER INTERNATIONAL S.A.R.L., 16 Avenue Pasteur, L-2310, Luxemburg, angefordert werden.

NL. Spin Master International SARL verklaart hierbij dat deze Meccanoid G15KS™ voldoet aan de noodzakelijke vereisten en andere voorwaarden in richtlijn 1999/5/EG. U kunt een kopie van deze conformiteitsverklaring opvragen via customercare@spinmaster.com of SPIN MASTER INTERNATIONAL S.A.R.L., 16 Avenue Pasteur, L-2310, Luxemburg.

I. Spin Master International SARL dichiara che questo Meccanoid G15KS™ è in regola con i requisiti essenziali e altre clausole rilevanti della Direttiva 1999/5/EC. Una copia della dichiarazione di conformità può essere richiesta scrivendo a customercare@spinmaster.com o SPIN MASTER INTERNATIONAL S.A.R.L., 16 Avenue Pasteur, L-2310, Lussemburgo.

P. A Spin Master International SARL declara por meio desta que o Meccanoid G15KS™ está em conformidade com as exigências essenciais e outras disposições relevantes da Diretiva 1999/5/EC. Uma cópia da declaração de conformidade pode ser solicitada pelo e-mail customercare@spinmaster.com ou via missiva endereçada à SPIN MASTER INTERNATIONAL S.A.R.L., 16 Avenue Pasteur, L-2310, Luxemburgo.

R. Компания Spin Master International SARL настоящим заявляет, что данное устройство Meccanoid G15KS™ соответствует основным требованиям и другим релевантным положениями Директивы 1999/5/EC. Копию декларации соответствия можно получить, отправив запрос на адрес customercare@spinmaster.com или обратившись по адресу SPIN MASTER INTERNATIONAL S.A.R.L., 16 Avenue Pasteur, L-2310, Luxembourg.

Spin Master Inc., PMB #10053, 300 International Drive, Suite 100, Williamsville, NY 14221



UK – 0800 206 1191, SERVICEUK@SPINMASTER.COM
 FRANCE – 0800 909 150, SERVICEFR@SPINMASTER.COM
 ESPAÑA – SERVICIO@SPINMASTER.COM
 DEUTSCHLAND – 0800 0101 0222, KUNDENSERVICE@SPINMASTER.COM
 SCHWEIZ – 0800 561 350 • ÖSTERREICH – 0800 29 72 67
 NEDERLAND – 0800 022 36 83, KLANTENSERVICE@SPINMASTER.COM
 BELGIË/BELGIQUE – 0800 77 688 • LUXEMBOURG – 800 26 044
 ITALIA – 800 788 532, SERVIZIO@SPINMASTER.COM
 MEXICO - (55) 5351-4400

NORTH AMERICA • AMÉRIQUE DU NORD
1-800-622-8339, CUSTOMERCARE@SPINMASTER.COM

Meets CPSC safety standards.

Conforme aux exigences de sécurité de la CPSC.

Cumple con las normas de seguridad de la CPSC.

TM & © 2015 MECCANO for packaging, instructions and models built with this set. © MECCANO is an exclusive trademark of MECCANO. Spin Master logo is a trademark of Spin Master Ltd. All rights reserved. Patent pending.

TM et © 2015 MECCANO pour l'emballage, les notices et modèles de ce coffret. © MECCANO est une marque de commerce exclusive de MECCANO. Le logo de Spin Master est une marque de commerce de Spin Master Ltd. Tous droits réservés. Brevet en instance.

SPIN MASTER LTD., 450 FRONT STREET WEST, TORONTO, ON M5V 1B6 CANADA.

Imported into EU by Spin Master International S.A.R.L., 16 Avenue Pasteur L-2310, Luxembourg.
www.spinmaster.com



MADE IN CHINA / FABRIQUÉ EN CHINE / HECHO EN CHINA
 T91764_0002_20068868_GML_IB_R1 W1_MEC_Dino_CN