

14303



27.145 MHz

REMOTE CONTROL
RADIOCOMMANDÉ
CONTROL REMOTO



- Ⓕ Merci d'imprimer à échelle 1 sans les marges de l'imprimante.
- ⒼⓈ Please print at scale 1 without the printer margins.
- Ⓕ Den Maßstab 1 bitte randlos drucken.
- Ⓣ Stampare la scala 1 senza i margini della stampante.
- Ⓔ Imprimir a escala 1 sin los márgenes de la impresora.
- Ⓕ É favor imprimir escala 1 sem as margens da impressora.
- Ⓢ Skriv ut i skala 1 utan skrivarens marginaler.
- ⓇⓈ Portaiden painatuksen jälkeen reunat eivät saa näkyä.
- Ⓕ Udskriv venligst i målestoksforhold 1 uden printermargener.
- Ⓕ É favor imprimir escala 1 sem as margens da impressora.
- ⒼⓈ Σας παρακαλώ τυπώστε την κλίμακα 1 μέσα στα περιθώρια του εκτυπωτή.
- Ⓕ Пожалуйста, печатайте в масштабе 1:1 без отступов от края.

8+

Instructions
Notice de montage
Instrucciones de construcción
Bauanleitung

Bouwinstructie
Istruzioni
Instruções
Инструкции



CONSTRUCTION TIPS
ASTUCES DE CONSTRUCTION
TIPS DE CONSTRUCCIÓN
TIPPS ZUM BAUEN
MONTAGETIPS
SUGGERIMENTI PER COSTRUIRE
DICAS DE MONTAGEM
ΣΥΜΒΟΥΛΕΣ ΚΑΤΑΣΚΕΥΗΣ
BYGGTIPS
BYGGTIPS
КОКОАМІСОНІЕ
РЕКОМЕНДАЦІЇ ПО СБОРКЕ

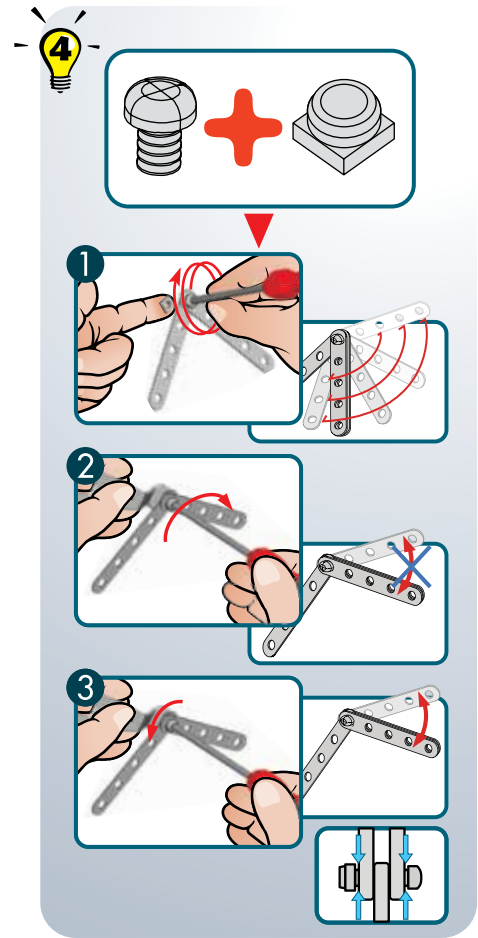
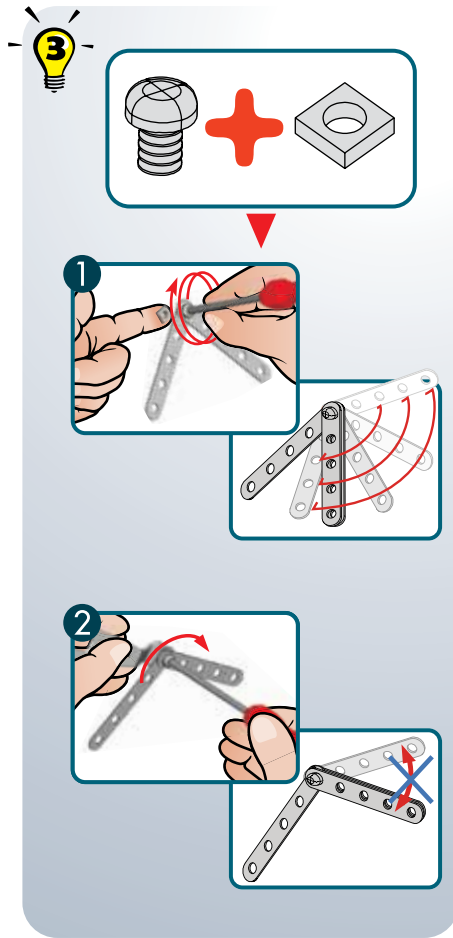
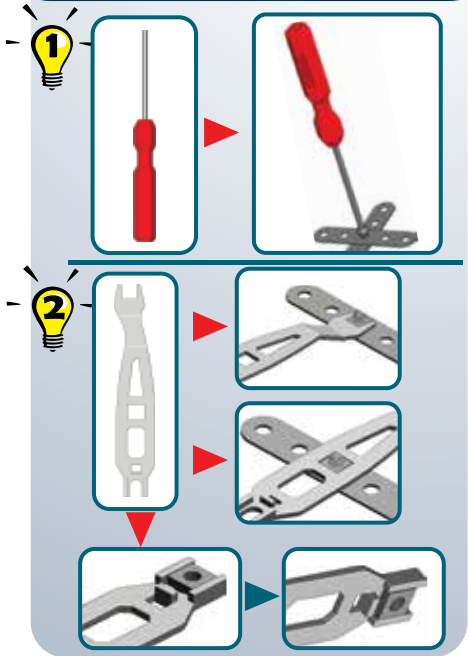

NEW TOOLS/NOUVEAUX OUTILS
NUEVAS HERRAMIENTAS/NEUE WERKZEUGE/NIEUW GEREEDSCHAP
NUOVI ATTREZZI/NOVAS FERRAMENTAS/NEA ΕΡΓΑΛΕΙΑ/NYA VERKTYG
NYE VÆRKTØJER/UUDET TŶÖKALUT/НОВЫЕ ИНСТРУМЕНТЫ

TABLE OF CONTENTS/SOMMAIRE

ÍNDICE/INHALTSVERZEICHNIS/INHOUD/INDICE/ΠΙΝΑΚΑΣ ΠΕΡΙΕΧΟΜΕΝΩΝ/ INNEHÅLLSFÖRTECKNING/INDHOLDSFORTEGNELSE/SISÄLLYSLUETTELO/СОДЕРЖАНИЕ



- GB** Content: 130 parts, 2 real tools, 1 remote controller, 1 RC Chassis, 1 Sticker sheet and 1 instruction sheet for model#1.
- F** Contenu : 130 pièces, 2 vrais outils, 1 radiocommande, 1 chassis R/C, 1 feuillet d'autocollants et 1 notice de montage pour le modèle 1.
- E** Contenido: 130 piezas, 2 herramientas reales, 1 control remoto, 1 chasis RC, 1 hoja de calcomanías y 1 guía de instrucciones para el modelo 1.
- D** Inhalt: 130 Teile, 2 echte Werkzeuge, 1 Fernsteuerung, 1 Fahrgestell mit ferngesteuertem Antrieb, 1 Bogen mit Aufklebern und 1 Bauanleitung für Modell Nr. 1.
- NL** Inhoud: 130 onderdelen, 2 stuks gereedschap, 1 afstandsbediening, 1 controller, 1 RC-chassis, 1 stickervel en 1 bouw instructie voor model 1.
- I** Contenuto: 130 pezzi, 2 attrezzi, 1 radiocomando, 1 telaio radiocomandato, 1 foglio di adesivi e 1 guida per l'uso per il modello 1.
- P** Conteúdo: 130 peças, 2 ferramentas reais, 1 controlo remoto, 1 chassis RC, 1 cartela de adesivos e 1 folha de instruções para o modelo 1.
- GR** Περιεχόμενα : 130 κομμάτια, 2 Πραγματικά, 1 τηλεχειριστήριο, 1 σασί RC, 1 φύλλο αυτοκόλλητο εργαλεία 1 φυλλάδιο οδηγιών για το μοντέλο#1.
- S** Innehåll: 130 delar, 2 riktiga verktyg, 1 fjärrkontroll, 1 RC-chassi, 1 klistermärken täcker och 1 instruktionsblad för modell#1.
- DK** Indhold: 130 dele, 2 rigtige værktøjer, 1 fjernbetjening, 1 RC-chassis, 1 klistermærke ark og 1 instruktionsark til model#1.
- FIN** Sisältö: 130 osaa, 2 aidot työkalut, 1 kauko-ohjain, 1 radio-ohjattava runko, 1 tarra-arkki ja 1 rakennusohje mallia 1 varten.
- R** В коробке: 130 деталей, 2 настоящих инструмента, 1 устройство дистанционного управления, 1 радиоуправляемое шасси, 1 лист с наклейками и 1 инструкция по сборке модели №1.

GB. Only one model can be built at a time. **F.** Les pièces fournies ne permettent de monter qu'un seul modèle à la fois. **E.** Solo es posible construir un modelo a la vez. **D.** Jeweils nur eins der Modelle baubar. **NL.** Er kan maar een model tegelijk worden gebouwd. **I.** Consente di realizzare un solo modello per volta. **P.** Só é possível montar um modelo de cada vez. **GR.** Μπορείτε να δημιουργείτε μόνο ένα μοντέλο κάθε φορά. **S.** Endast en modell kan byggas i taget. **DK.** Der kan kun bygges én model af gangen. **FIN.** Osista voidaan koota kerrallaan vain yksi malli. **R.** Одновременно можно построить только одну модель.



1



x1



x2



9,5 mm
3/8"

x2

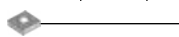

x2



S2

1:1

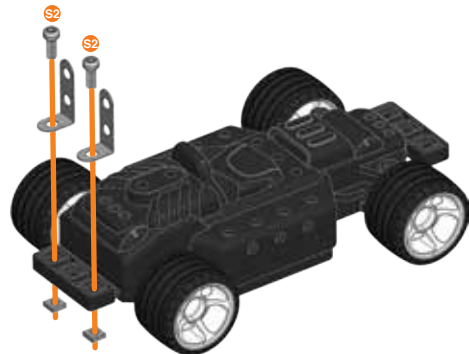

2



x1



x2



x2



14,7 mm
37/64"

x2



x2



A238

1:1



S1

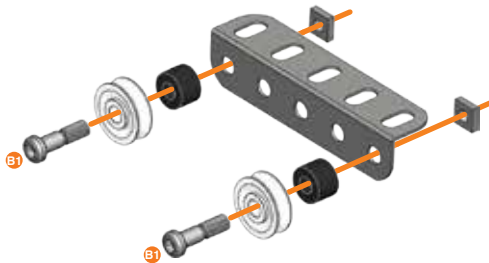

3

① + ② +

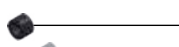

x1

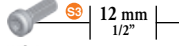

12 mm
1/2"

x1

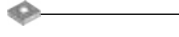

x1



A338

1:1





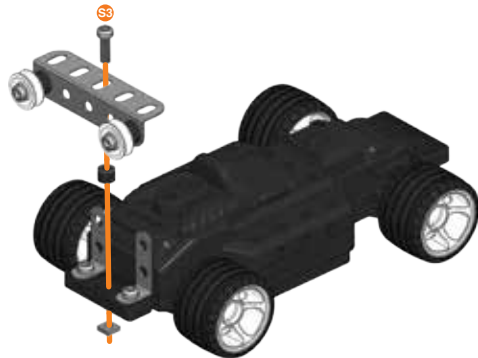

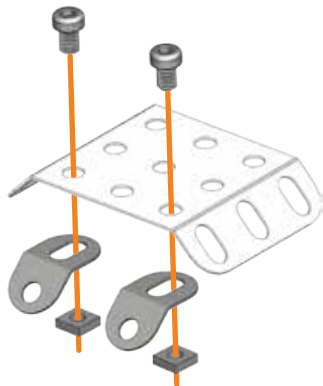
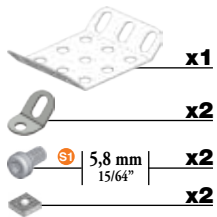
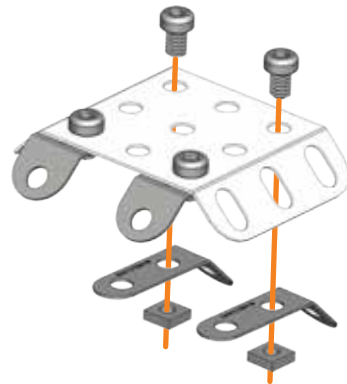
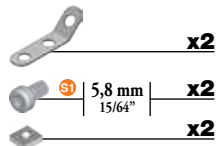
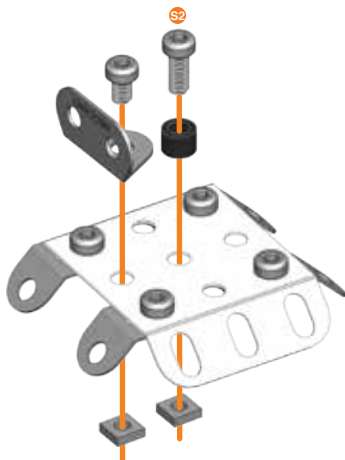
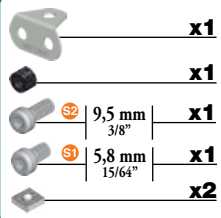
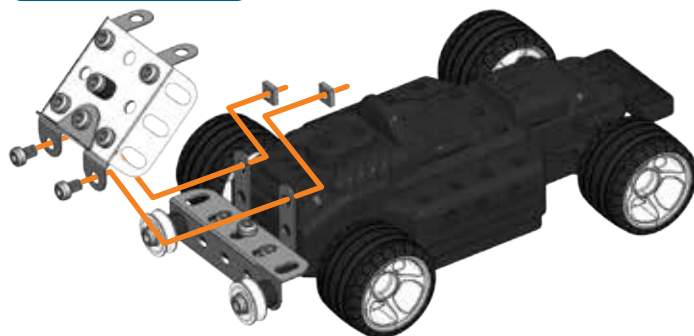
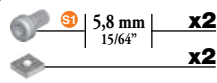
S3







4**5****6****7****③ + ⑥ +**

8

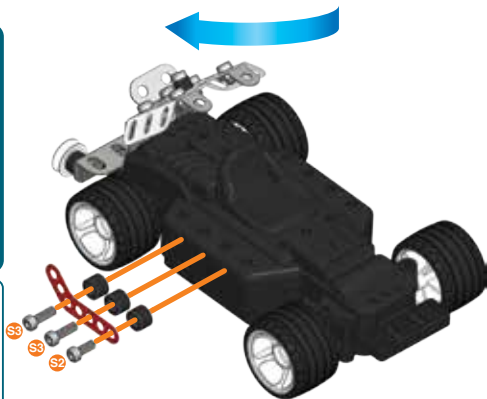
	x1
	x3
 12 mm	x2
 9,5 mm	x1



		A238	1:1
			

**9**

	x1
	x3
 12 mm	x2
 9,5 mm	x1

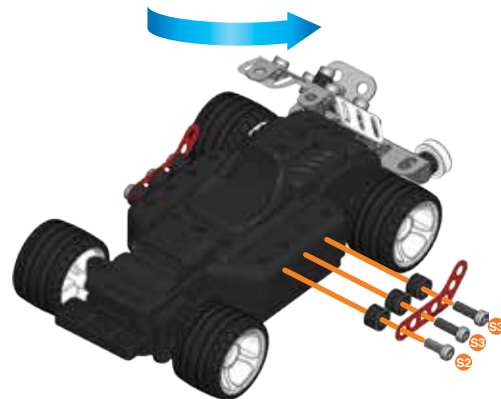



		A238	1:1
			

**10**

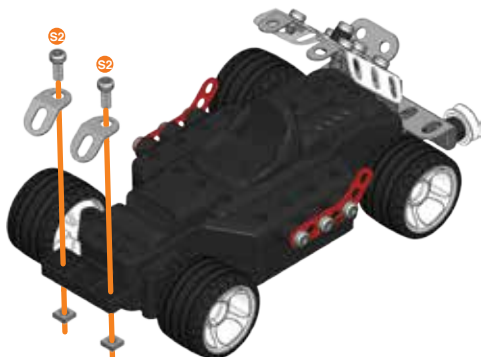
	x2
 9,5 mm	x2
	x2

	1:1
--	------------

**11**

	x1
	x2
 5,8 mm	x2
	x2

	1:1
---	------------

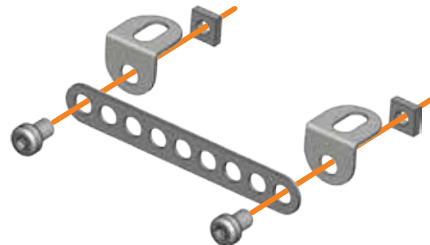

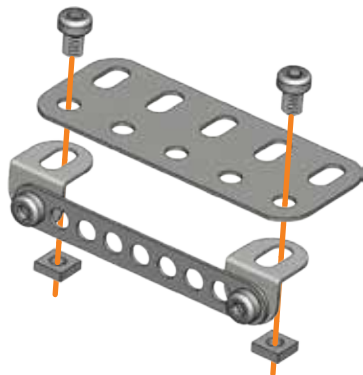
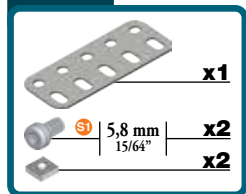
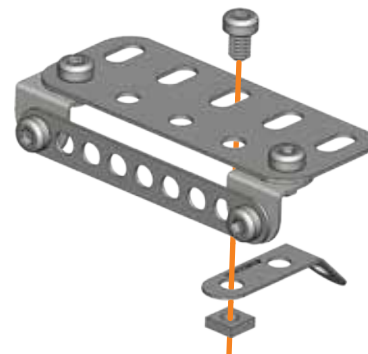
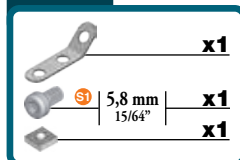
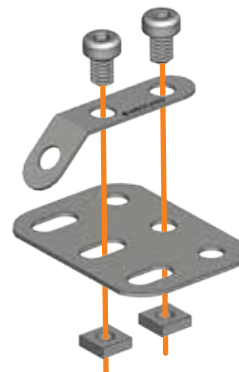
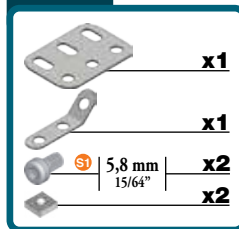
12**13****14****15**

16

	x2
S1	x2
	x2

	S1	1:1
--	-----------	------------

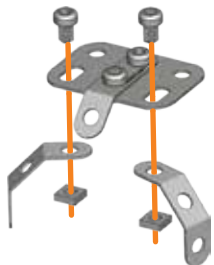
**17**

	x2
S1	x2
	x2

	S1	1:1
--	-----------	------------

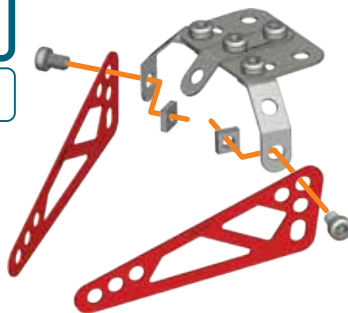
**18**

	x1
S1	x1
	x1

	S1	1:1
--	-----------	------------

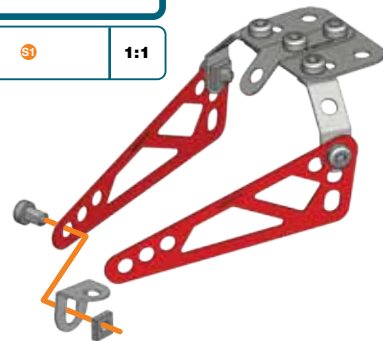
**19**

	x1
S1	x1
	x1

	S1	1:1
--	-----------	------------

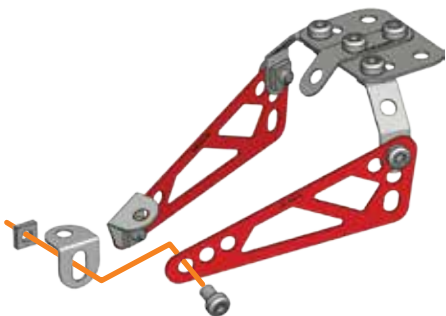
**20**

	x2
S1	x2
	x2

	S1	1:1
--	-----------	------------

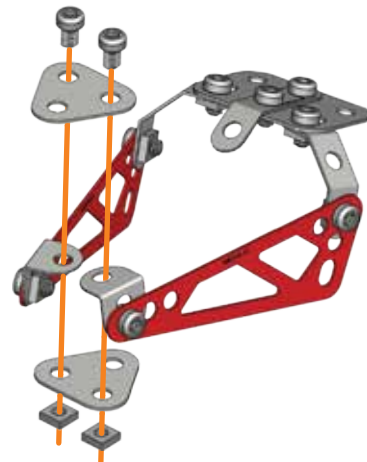

21

	x1
	x1
	x1
	x1



		1:1
--	--	-----

22**20 + 21 +**

	x1
	x1

		1:1
--	--	-----

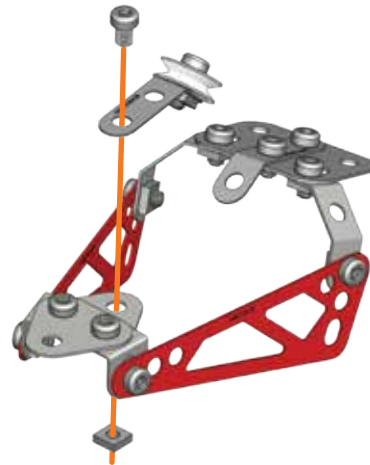
**23****14 + 22 +**

	x2
	x2

		1:1
--	--	-----

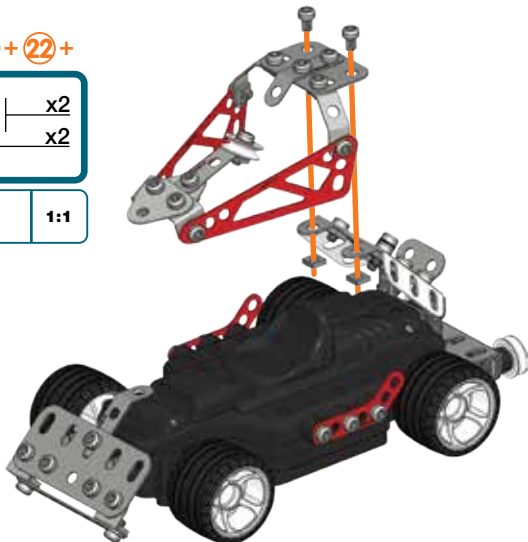
**24**

	x1
	x1

		1:1
--	--	-----

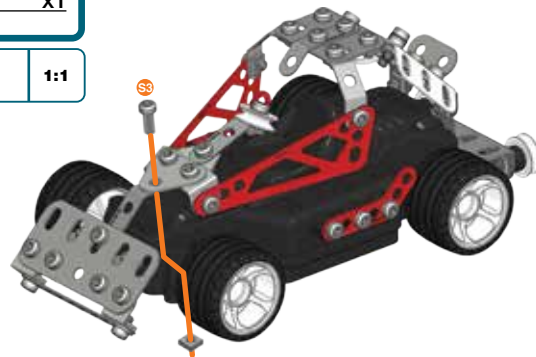

GB Remove all packaging before use. Retain this information, addresses and phone numbers for future reference. Content may vary from pictures. Meccano reserves the right to discontinue the website www.meccano.com at any time. An adult should periodically check this toy to ensure no damage or hazard exists so, remove from use. Children should be supervised during play.

F Retirez tout l'emballage avant utilisation. Conservez les informations, adresses et numéros de téléphone pour consultation ultérieure. Le contenu peut différer des images. Meccano se réserve le droit de supprimer le site Internet www.meccano.com à tout moment. Un adulte doit régulièrement examiner ce jouet afin de s'assurer qu'il ne présente pas de dommage ni de risque. En cas de problème, ne plus l'utiliser. Les enfants doivent être surveillés lorsqu'ils jouent.

E Retire todo el embalaje antes de utilizar el producto. Conserve toda la información, las direcciones y los números de teléfono para futuras referencias. El contenido del paquete puede no corresponder con las imágenes. Meccano se reserva el derecho a suspender el sitio web www.meccano.com en cualquier momento. Un adulto debe revisar de forma periódica el juguete para asegurarse de que no supone un riesgo o peligro para el niño; si así fuera el caso, interrumpa su uso. Supervise a los niños mientras juegan con el producto.

D Entfernen Sie vor der Benutzung sämtliche Verpackungsmaterialien. Alle Informationen, Adressen und Telefonnummern bitte für mögliche Rückfragen aufbewahren. Der Packungsinhalt kann von den Bildern abweichen. Meccano behält sich das Recht vor, den Betrieb der Website www.meccano.com jederzeit einzustellen. Ein Erwachsener sollte regelmäßig sicherstellen, dass das Spielzeug keine Gefahr darstellt, und es gegebenenfalls entfernen. Kinder sollten beim Spielen beaufsichtigt werden.

- ⚠ Warning! CHOKING HAZARD - Small parts.
- ⚠ Attention ! RISQUE D'ÉTOUFFEMENT - Contient de petits éléments.
- ⚠ Advertencia: PELIGRO DE ASFIXIA - Contiene piezas pequeñas. No conveniente para niños menores de 3 años.
- ⚠ Achtung: ERSTICKUNGSGEFAHR - Kleinteile.
- ⚠ Waarschuwing: VERSTIKKINGSGEVAAR - Kleine onderdelen.
- ⚠ Attenzione: RISCHIO DI SOFFOCAMENTO - Pezzi piccoli.
- ⚠ Aviso: PERIGO DE ASFIXIA - Peças pequenas.
- ⚠ Προειδοποίηση: ΚΙΝΔΥΝΟΣ ΠΝΙΓΜΟΥ — Μικρά μέρη.
- ⚠ Warning: RISK FÖR KVÄVNING - Små delar.
- ⚠ Advarsel: KVAELNINGSFARE - Små dele.
- ⚠ Varoitus: TUKEHTUMISVAARA - Pieniä osia.
- ⚠ Осторожно! ОПАСНОСТЬ УДУШЬЯ - мелкие детали.

NL Verwijder de verpakking voor gebruik. Bewaar deze informatie, adressen en telefoonnummers voor toekomstig gebruik. Inhoud kan afwijken van illustraties. Meccano behoudt zich het recht voor de website www.meccano.com wanneer gewenst buiten gebruik te stellen. Een volwassene dient dit speelgoed regelmatig te controleren op schade en gevaren. Ouderlijk toezicht is vereist als kinderen met dit speelgoed spelen.

I Rimuovere l'imballo prima dell'uso. Conservare informazioni, indirizzi e numeri di telefono per riferimento futuro. Il prodotto potrebbe essere differente dalle immagini. Meccano si riserva il diritto di rimuovere il sito www.meccano.com in qualsiasi momento. Il giocattolo deve essere periodicamente controllato da un adulto per prevenire eventuali danni o rischi; in caso di danno, sospendere l'uso. I bambini devono essere sorvegliati durante il gioco.

P Remova totalmente a embalagem antes de utilizar. Guarde estas informações, as moradas e os números de telefone para consulta futura. O conteúdo poderá ser diferente das ilustrações. A Meccano reserva-se o direito de descontinuar o site www.meccano.com a qualquer altura. Um adulto deve verificar o brinquedo periodicamente para garantir que ele não apresenta danos ou riscos. Se houver, é necessário que o brinquedo seja retirado de uso. Crianças devem ser supervisionadas enquanto brincam.

GR Πριν την χρήση αφαιρέστε όλα τα υλικά της συσκευασίας. Διατηρήστε αυτές τις πληροφορίες, τις διευθύνσεις και τους αριθμούς τηλεφώνου για μελλοντική αναφορά. Το περιεχόμενο ενδέχεται να διαφέρει από τις εικόνες. Η Meccano διατηρεί το δικαίωμα να διακόψει τη λειτουργία της ιστοσελίδας www.meccano.com ανά πάσα στιγμή. Ένας ενήλικας θα πρέπει να εξετάζει τακτικά αυτό το παιχνίδι και να διακόπτει τη χρήση του σε περίπτωση εντοπισμού βλαβών ή κινδύνου. Τα παιδιά θα πρέπει να παίζουν υπό επίτηρηση.

S Ta bort alla förpackning före användning. Spara den här informationen, adresser och telefonnummer för framtida referens. Innehållet kan skilja sig från bilderna. Meccano förbehåller sig rätten att när som helst ta bort webbplatsen www.meccano.com. En vuxen ska regelbundet undersöka den här leksaken för att säkerställa att det inte finns några skador eller faror rörande den. Bam ska hållas under uppsikt när de leker.

DK Fjern al emballage før brug. Gem disse oplysninger, adresser og telefonnumre for fremtidig brug. Indholdet kan være forskelligt fra billederne. Meccano forbeholder sig ret til at nedlægge hjemmesiden www.meccano.com til enhver tid. En voksen bør jævnligt tjekke dette legetøj for at sikre, at det ikke er beskadiget eller udgør nogen fare, i så fald, stop brugen af det. Børn bør overvåges, når de leger med det.

FIN Poista kaikki pakkausmateriaali ennen käyttöä. Säilytä nämä tiedot, osoitteet ja puhelinnumerot tulevia tarpeita varten. Sisältö saattaa poiketa kuvista. Meccano pidättää oikeuden lakkauttaa sivuston www.meccano.com milloin tahansa. Aikuisen tulee säännöllisesti tarkistaa, että lelu ei ole vaurioitunut ja muuttunut vaaralliseksi. Jos näin on käynyt, lelu tulee poistaa käytöstä. Lasten tulee leikkiä vain aikuisen valvonnassa.

RU Снимите все упаковочные материалы перед использованием. Запишите указанные на упаковке адреса и номера телефонов, чтобы у вас была возможность связаться с нами. Содержимое упаковки может отличаться от иллюстрации. Компания Meccano оставляет за собой право прекратить использование сайта www.meccano.com в любое время. Взрослым следует время от времени проверять игру и следить за тем, чтобы она не была сломана и не представляла опасности для ребенка. В противном случае ее не следует использовать. Во время игры за детьми следует присматривать.



SPIN MASTER LTD., 450 FRONT STREET WEST, TORONTO, ON M5V 1B6 CANADA.
Imported into EU by SPIN MASTER INTERNATIONAL, S.A.R.L.,
16 AVENUE PASTEUR, L-2310, LUXEMBOURG.
www.spinmaster.com



TM & © 2015 MECCANO for packaging, instructions and models built with this set. TM & © 2015 MECCANO pour l'emballage, les notices et modèles de ce coffret. © MECCANO is an exclusive trademark of MECCANO. Spin Master logo is a trademark of Spin Master Ltd. © MECCANO est une marque de commerce exclusive de MECCANO. Le logo de Spin Master est une marque de commerce de Spin Master Ltd. All rights reserved. Tous droits réservés.
T91780_0001_20070939_GML_IB_R1 W2_MEC_Auto Cross

 **UK – 0800 206 1191, SERVICEUK@SPINMASTER.COM**
FRANCE – 0800 909 150, SERVICEFR@SPINMASTER.COM
ESPAÑA – SERVICIO@SPINMASTER.COM
DEUTSCHLAND – 0800 0101 0222, KUNDENSERVICE@SPINMASTER.COM
SCHWEIZ – 0800 561 350 • ÖSTERREICH – 0800 29 72 67
NEDERLAND – 0800 022 36 83, KLANTENSERVICE@SPINMASTER.COM
BELGIË/BELGIQUE – 0800 77 688 • LUXEMBOURG – 800 28 044
ITALIA – 800 788 532, SERVIZIO@SPINMASTER.COM
MEXICO – 53.51.44.00
WWW.SPINMASTER.COM
NORTH AMERICA : 1-800-622-8339 customercare@spinmaster.com
AMÉRIQUE DU NORD :