

INSTRUCTION LOG BOOK

LIVRO DE BORDO PARA MONTAGEM

CARNET DE BORD DE MONTAGE

MONTÉRINGS-PROTOKOLL

BAJANLEITUNG

ASENUKSEN LOKIKIRJA

LIBRETTÒ DI BORDO PER IL MONTAGGIO

MONTAGE HEFTE

DIARIO DE A BORDO DE MONTAJE

ΣΗΜΕΙΩΜΑΤΑΡΙΟ ΣΥΝΑΡΜΟΛΟΓΗΣΗΣ

MONTAGEDAGBOEK

組み立て説明書

1

2

3

4

5

6

XR SHUTTLE  
XR SHUTTLE

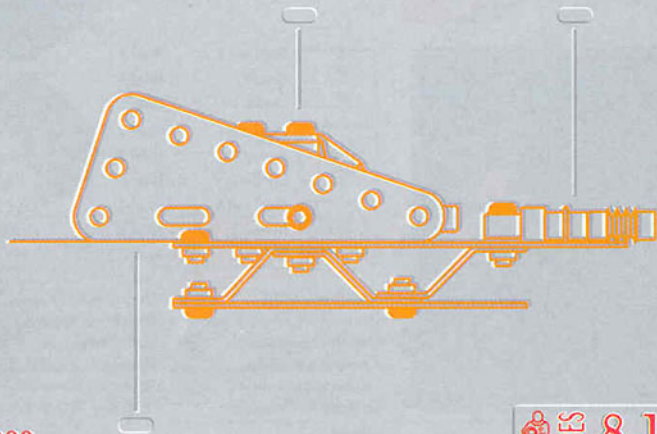

4800



AGES

8-12

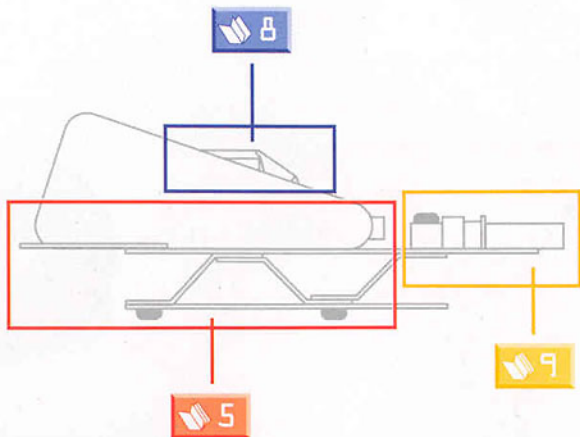

Skill Level 1  
Niveau 1  
Livello 1



Skill Level 2  
Niveau 2  
Livello 2



Skill Level 3  
Niveau 3  
Livello 3

Nível 1  
Nível 1  
Nivå 1

Nível 2  
Nível 2  
Nivå 2

Nível 3  
Nível 3  
Nivå 3

Taso 1  
Στάδιο 1  
Λεβελ 1

Taso 2  
Στάδιο 2  
Λεβελ 2

Taso 3  
Στάδιο 3  
Λεβελ 3

Models do not fly.  
Les modèles ne volent pas.  
Modelle fliegen nicht.  
I modelli non volano.  
Los modelos no vuelan.  
De modellen vliegen niet.

Os modelos não voam.  
Modellerna flyger ej.  
Mallit eivät lennä.  
Modellerne kan ikke flye.  
Το μοντέλο δεν πετούν.  
実際には飛びません。

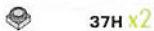
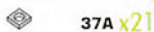
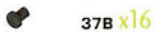
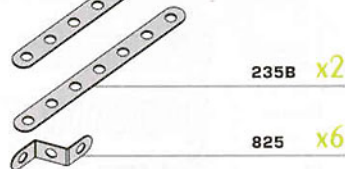
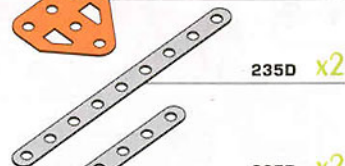
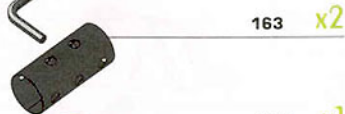
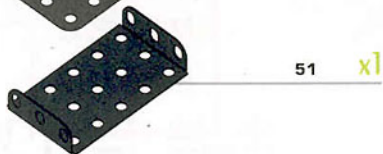

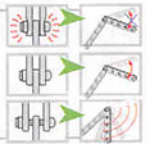
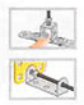

23 mm  
 $\frac{29}{32}$ "



19 mm  
 $\frac{3}{4}$ "

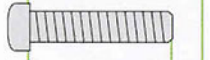

12 mm  
 $\frac{1}{2}$ "

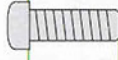

5,8 mm  
 $\frac{15}{64}$ "



Scale  
Echelle  
Maßstab  
Scala

Escala  
Schaal  
Escala  
Skala

Mittakaava  
Mälestok  
Käijaxo  
スケール

1:1



Cm

Inches

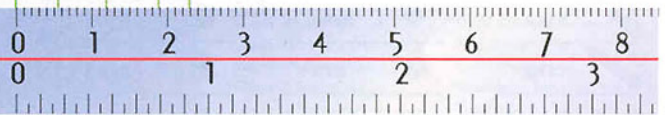

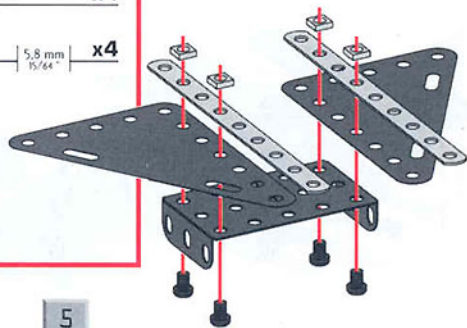
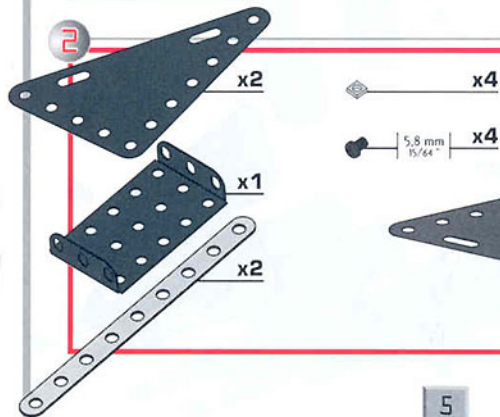
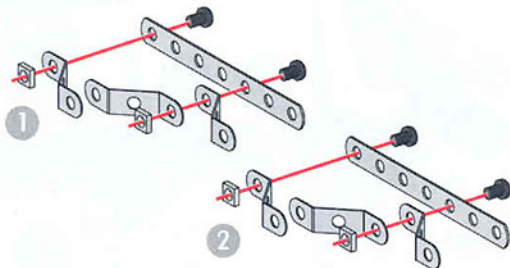
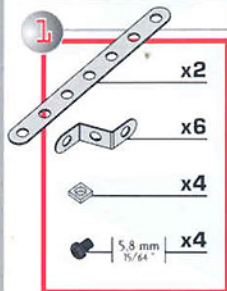
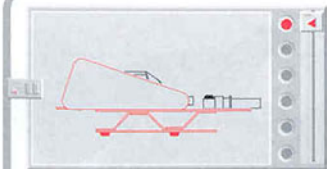

5

3



x2

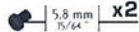

x2

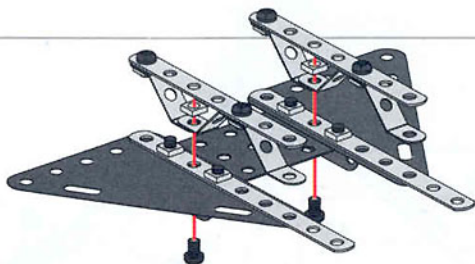

4



x2



x2

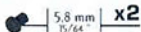

x2

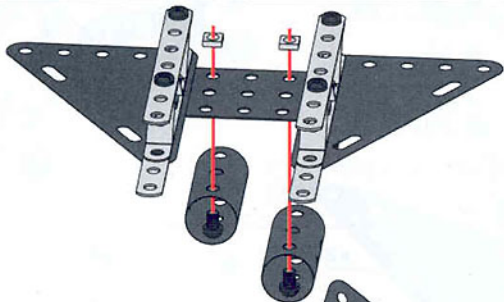

5

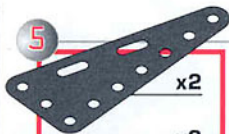

x2



x2

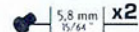

x2

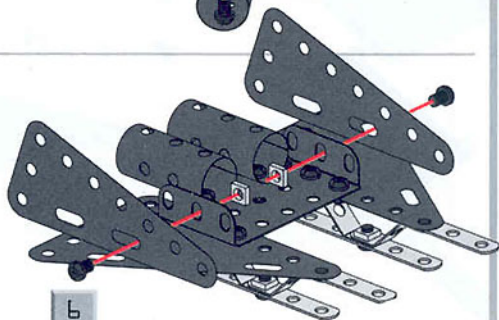

6

6

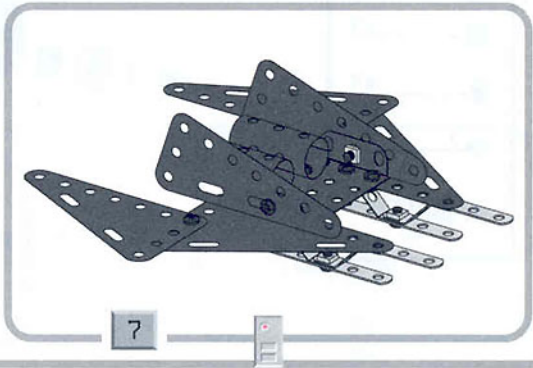
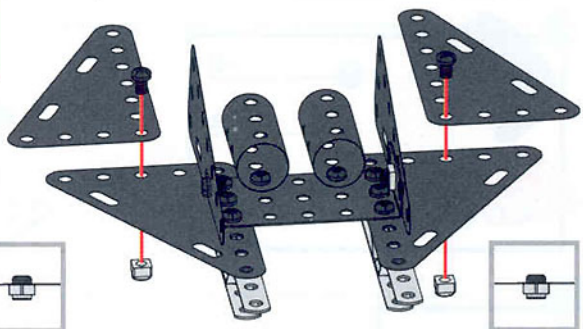
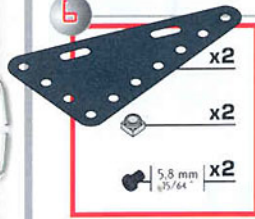

7

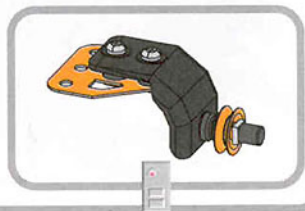
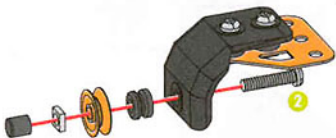
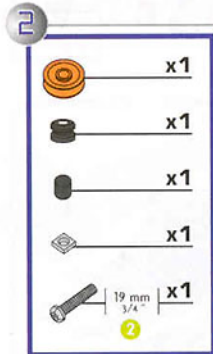
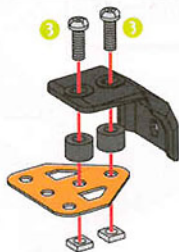
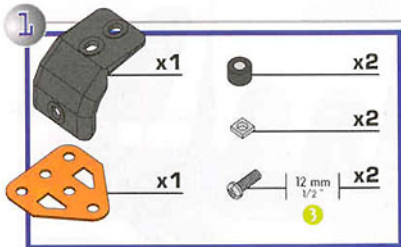
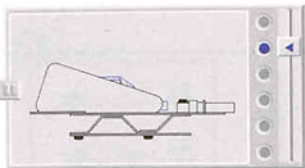



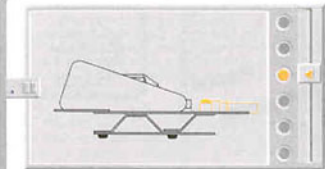

1



x1



x1



x1



x2



x1

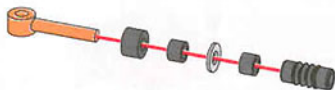





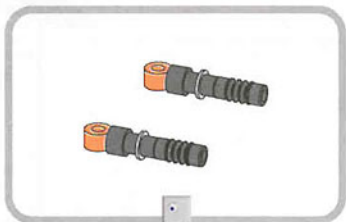

x2

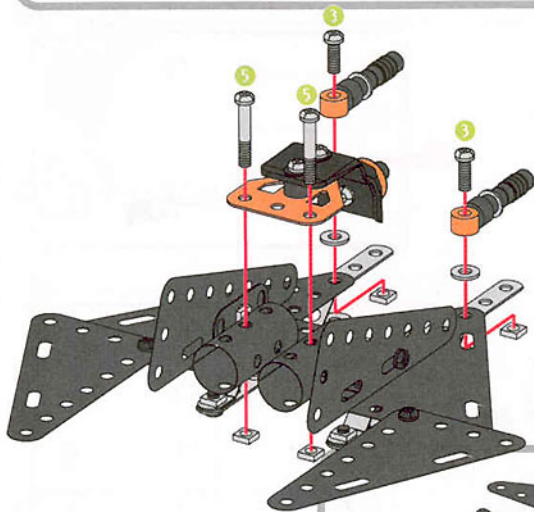
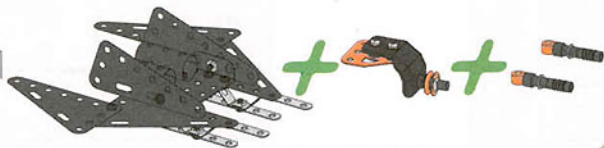

9





	x2
	x4
	23 mm 29/32"   x2
	5
	12 mm 1/2"   x2
	5

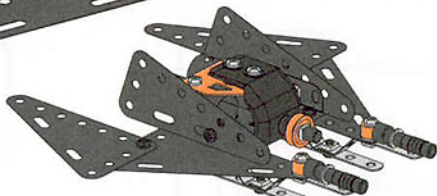

10

**GB** Many of the models and component parts are unique and original designs which are the property of MECCANO S.A. They are protected by national legislation as industrial designs, trademarks and/or copyrights throughout many countries. For detailed information, please contact MECCANO S.A. MECCANO takes no responsibility where instructions have not been followed, where pieces have been put to use other than those in the instructions, or have been modified for another use.

**F** De nombreux modèles et pièces sont des créations originales, propriétés de MECCANO S.A. et sont protégés par les législations nationales sur les dessins et modèles, marques et/ou droits d'auteurs. Pour toute information, merci de contacter : MECCANO S.A. MECCANO se dégage de toutes responsabilités en cas de non-respect des indications de montage, utilisation des pièces pour un autre usage que celui indiqué dans les notices et/ou modification des pièces.

**D** Zahlreiche Modelle und Teile sind Erfindungen und Eigentum der Firma MECCANO S.A. Sie sind durch Inland-Gesetze über Zeichnungen und Modelle sowie Warenzeichen und/oder Urheberrechte geschützt. Für zusätzliche Auskünfte wenden Sie sich bitte an: MECCANO S.A. MECCANO kann keine Haftung übernehmen, wenn die Anleitungen nicht befolgt oder wenn Teile anders als in den Anleitungen vorgesehen eingesetzt oder abgeändert werden.

**I** Numerosi modelli e pezzi sono creazioni originali della MECCANO S.A. e sono protetti dalle legislazioni nazionali su disegni e modelli, marchi e/o diritti d'autore. Per qualsiasi informazione, vogliate prendere contatto con MECCANO S.A. MECCANO non si assume alcuna responsabilità qualora le istruzioni non vengano seguite, le parti componenti vengano impiegate in modo diverso da quanto illustrato o siano state modificate per usi differenti dal montaggio dei modelli MECCANO.

**E** Numerosos modelos y piezas son creaciones originales, propiedades de MECCANO S.A. y están protegidos por las legislaciones nacionales en lo que concierne a los dibujos y modelos, marcas y/o derechos de autor. Para cualquier información, sírvase ponerse en contacto con: MECCANO S.A. MECCANO no se responsabilizará en aquellos casos en los que no se hayan seguido las instrucciones, las piezas se hayan usado con distinto fin al indicado en las instrucciones o bien se hayan modificado para otros usos.

**NL** Veel modellen en onderdelen zijn origineel ontworpen en eigendom van MECCANO S.A. en worden beschermd door de nationale wetgevingen op tekeningen en modellen, merken e/ou auteursrechten. Voor informatie gelieve contact op te nemen met MECCANO S.A. MECCANO sluit elke aansprakelijkheid uit ingeval van het niet opvolgen van de montage-instructies, het gebruik van onderdelen voor andere doeleinden dan omschreven in de instructies e/ou het modificeren van geleverde onderdelen.

**P** Vários modelos e peças são criações originais, propriedades da MECCANO S.A. e são protegidos pelas legislações nacionais relativas aos desenhos e modelos, às marcas e/ou aos direitos de autor. Para qualquer informação, é favor contactar: MECCANO S.A. A MECCANO não tem as responsabilidades, das peças serem utilizadas para outros fins que não os indicados nas instruções e/ou que tenham sido alteradas para outras utilizações.

**S** Många modeller och delar bildar en unik och originell formgivning vilken är MECCANO S.A. egendom. Dessa modeller och delar är skyddade genom lagstiftning såsom industriell formgivning, varumärke och/eller upphovs rättigheter i ett flertal länder. För mer detaljerad information, var vänlig och kontakta MECCANO S.A. MECCANO kan ej ta ansvar för något då instruktionerna ej har följts, då delar har använts till annat än vad instruktionerna anvisat eller att delarna har blivit modifierade till annan användning.

**FIN** Useat mallit ja osat ovat MECCANO S.A.:n omaisuutta olevaa suunnittelua. Useat mallit ja niiden osat ovat lailla suojattua teollista tuotantoa, tavaramerkkejä ja/tai kopiointioikeuksia useissa maissa. Tuotemerkki MECCANO on MECCANO S.A.:n omaisuutta oleva rekisteröity



tavaramerkki, jonka käyttö ilman lupaa on kielletty. Lisätietoja varten, ottakaa yhteyttä MECCANO S.A. MECCANO ei ota vastuuta, jos osia on käytetty muuhun kuin ohjeiden suosittelemaan käyttötarkoitukseen tai jos osia on itse muutettu.

**DK** Vore mange modeller og dele er originale fremstillinger og ejes af MECCANO S.A. Tegninger, modeller, fabrikmærker og ophavsret er lovbeskyttede i hvert land. Yderligere oplysninger kan fås hos: MECCANO S.A. MECCANO frastiger sig ethvert ansvar såfremt montageinstruktionerne ikke overholdes, hvis materialer bliver brugt til andre formål end det der står anført i instruktionerne, eller hvis der foretages ændringer af leddene.

**GR** Πολλά μοντέλα και ανταλλακτικά είναι αυθεντικά, ιδιοκτησία της MECCANO A.E. και προστατεύονται από τις εθνικές νομοθεσίες για τα μοντέλα, τις μαρκές ή τα διπλώματα ευρεσιτεχνίας. Για κάθε πληροφορία παρακαλώ απευθυνθείτε στη MECCANO A.E.. Η MECCANO δε φέρει καμία ευθύνη σε περίπτωση που δεν τηρηθούν οι οδηγίες συναρμολόγησης, σε περίπτωση που τα συναρμολογημένα κομμάτια χρησιμοποιούνται για άλλη χρήση ή αν εκείνη που αναφέρεται στις οδηγίες χρήσης και/ή σε περίπτωση που τροποποιηθούν.

**JPN** モデルもろびに部品は、その多くが MECCANO 社 所有のオリジナル・デザインで、意匠・商標および/または著作権に関する国内法によって保護されています。詳細については、当社 (MECCANO S.A.)までお問い合わせ願います。指定の組立方法に反する組み合わせや説明書にない用途に部品を用いた場合、また部品を改造した場合、MECCANO はその責任を一切負いません。

**USA** Many models and component parts incorporate original designs which are the property of MECCANO S.A. and are protected as design and/or utility patent and/or copyrights. For detailed information, please contact MECCANO S.A. Instruction booklets are solely to assist in construction of sets. MECCANO, Inc. shall have no responsibility for:

1. Failure to follow instructions.
2. Use of parts for any purpose other than as specified in the instruction booklets.
3. Any alteration of any parts or components.

Made in France by: / Fabriqué en France par: / Hecho en Francia :  
Meccano S.A. 363, avenue de Saint-Exupéry - F - 62100 LAZIS

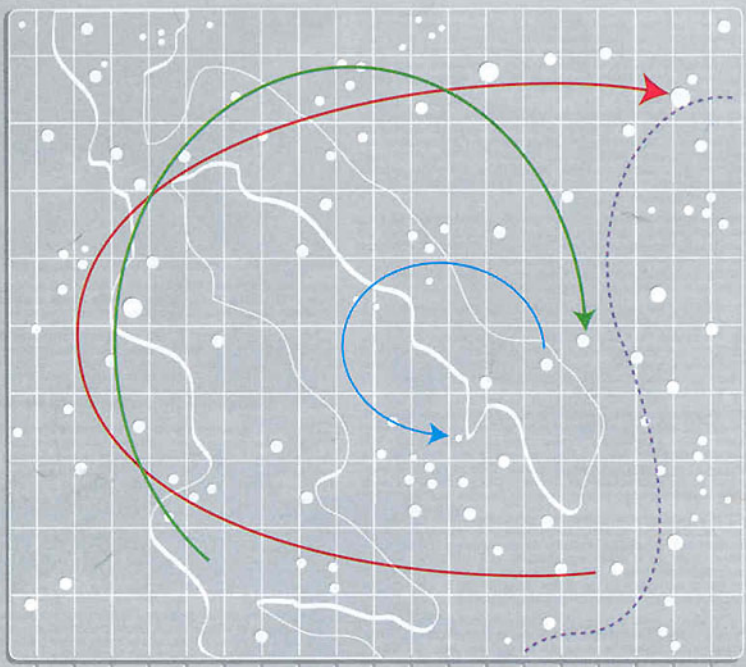

MECCANO

MECCANO® and ERECTOR® are exclusive trademarks of MECCANO S.A.

© Oct. / 1997 MECCANO S.A. 03 4800 104 111 10/97