

INSTRUCTION LOG BOOK

LIVRO DE BORDO PARA MONTAGEM

CARNET DE BORD DE MONTAGE

MONTERINGSPROTOKOLL

BAUANLEITUNG

ASENNUKSEN LOKIKIRJA

LIBRETTO DI BORDO PER IL MONTAGGIO

MONTAGE HAEFTE

DIARIO DE A BORDO DE MONTAJE

ΣΗΜΕΙΩΜΑΤΑΡΙΟ ΣΥΝΑΡΜΟΛΟΓΗΣΗΣ

MONTAGEDAGBOEK

組み立て説明書

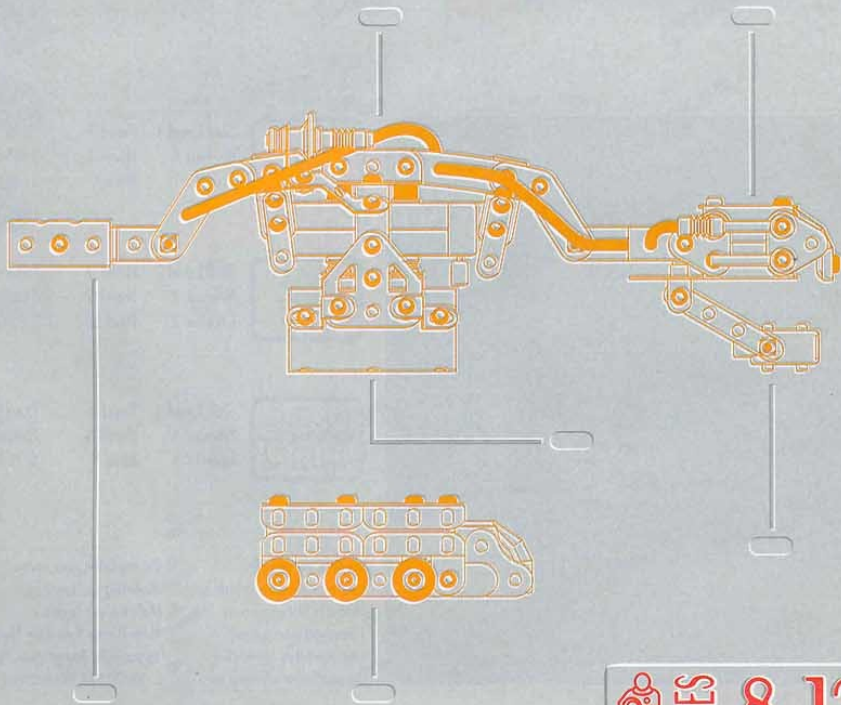

4831

 AGES 8-12



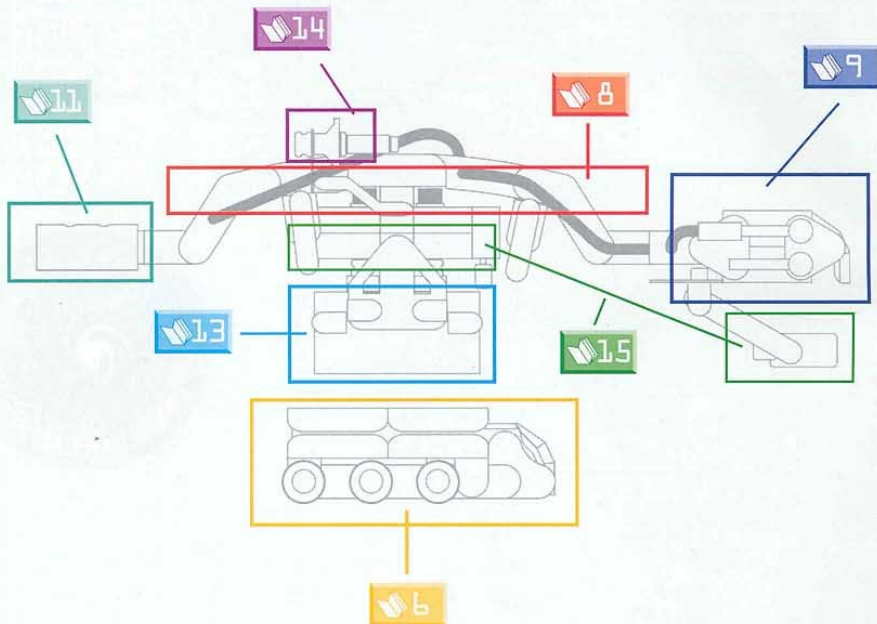

Skill Level 1 Niveau 1 Livello 1 Nivel 1 Nivà 1 Taso 1 Stádio 1 レベル 1



Skill Level 2 Niveau 2 Livello 2 Nivel 2 Nivà 2 Taso 2 Stádio 2 レベル 2



Skill Level 3 Niveau 3 Livello 3 Nivel 3 Nivà 3 Taso 3 Stádio 3 レベル 3

Models do not fly.  
 Les modèles ne volent pas.  
 Modelle fliegen nicht.  
 I modelli non volano.  
 Los modelos no vuelan.  
 De modellen vliegen niet.

Os modelos não voam.  
 Modellerna flyger ej.  
 Mallit eivät lennä.  
 Modellerne kan ikke flyve.  
 Τα μοντέλα δεν πετούν.  
 実際には飛びません。



51G x4



46A x2



34 x1



51E x1



48 x2



36C x1



51B x1



11A x2

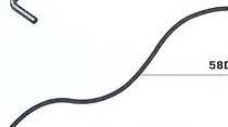

58D x1



74 x1



133C x4



16A x3



216A x2



12D x4



18B x1



163 x2



812D x4

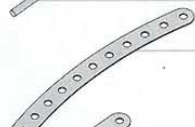

89 x2



324A x2



825 x1



3 x2



126A x2



825A x4



4 x1



126 x2



812B x1



215 x2



133A x2



811 x3



321 x1



77 x4



45 x2



753 x1

111 x5

147F x1

37A x71

38A x21

59B x3

111A x3

147D x2

37H x12

23C x12

120E x4

111C x10

111E x6

38 x36

38B x13

142M x6

147G x2

37B x53

213C x3

184G x4

537A x4



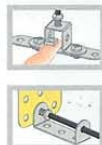
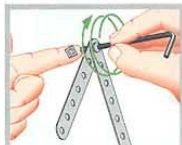
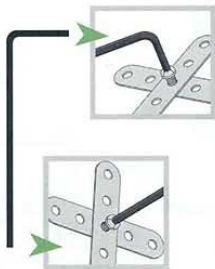

1

2

3

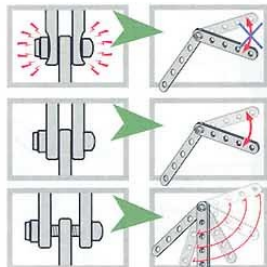
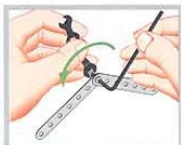

1

2

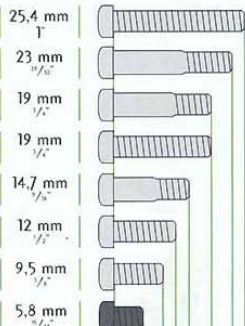

Scale  
Echelle  
Maßstab  
Scala

Escala  
Schaal  
Escala  
Skala

Mittakaava  
Maleskok  
Κλίμακα  
スケール

1:1

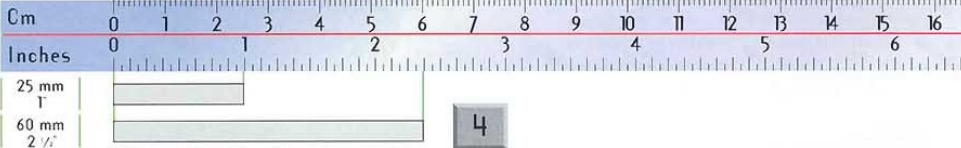

1



2

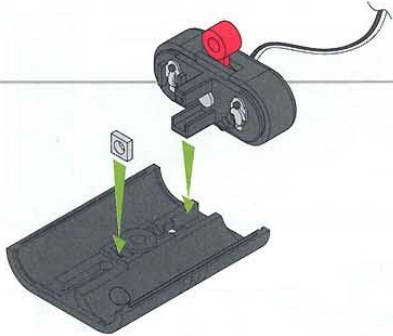

3

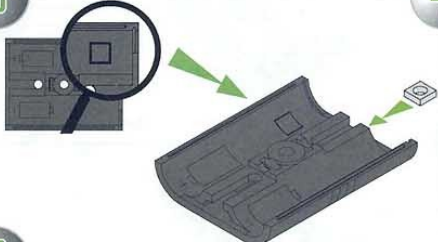

4



5

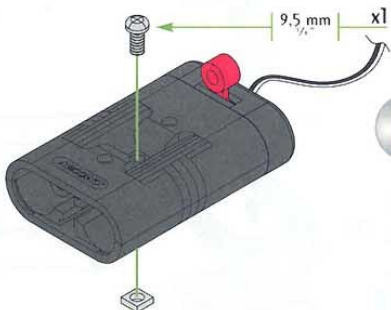

6

Do not mix old and new batteries. Do not mix alkaline, standard (carbon-zinc), or rechargeable (nickel-cadmium) batteries.



7

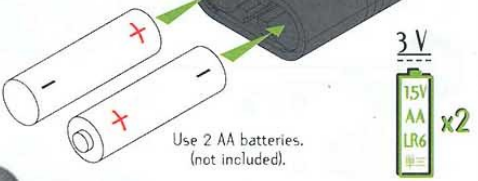

8

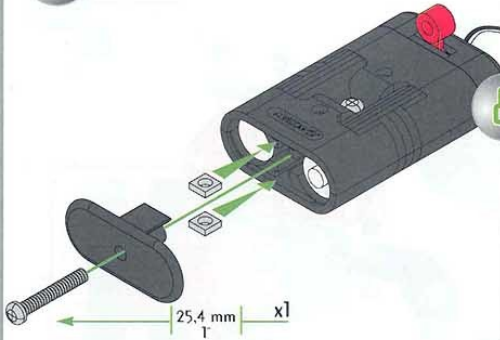

5



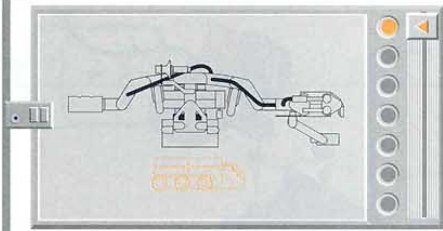

1

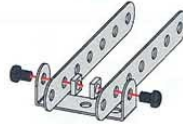
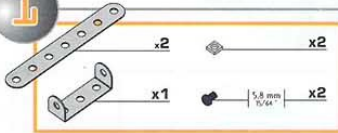

2

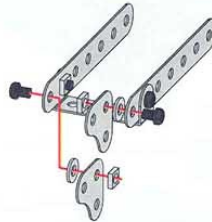
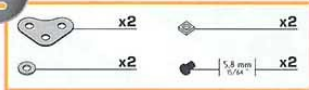

3

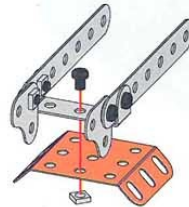
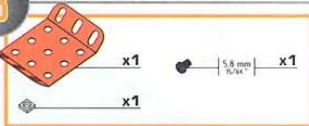

4

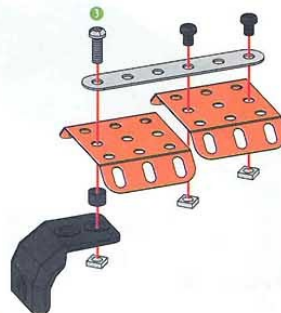
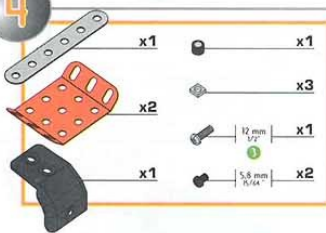

5

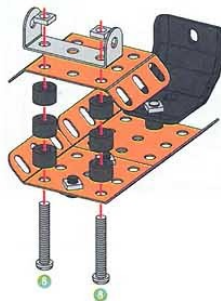
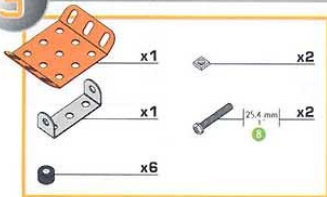

6

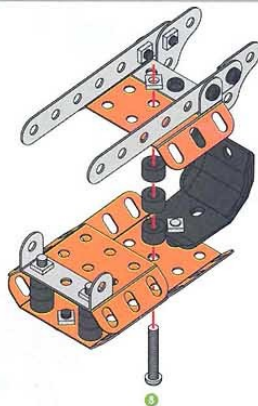
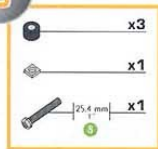

7

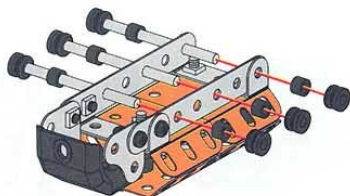
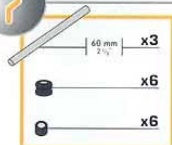

8

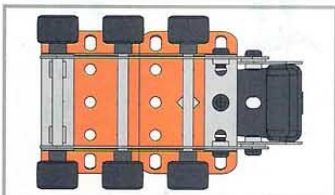
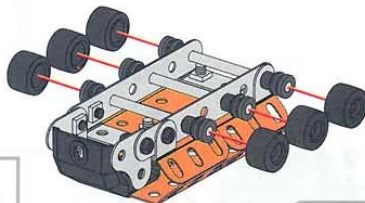
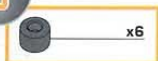

7

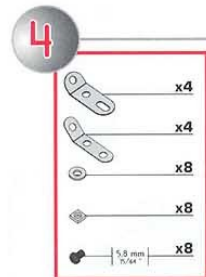
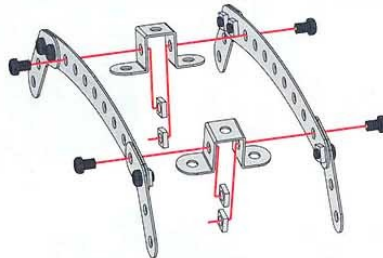
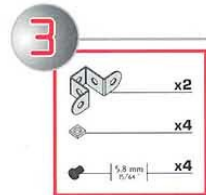
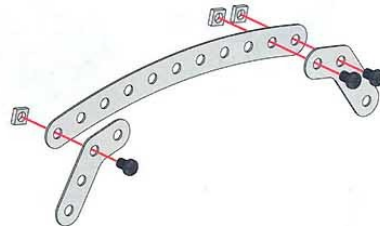
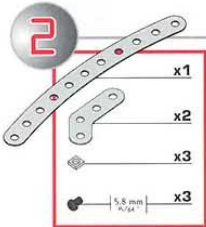
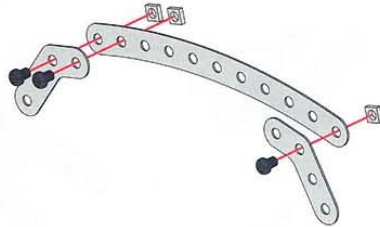
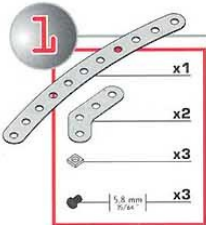
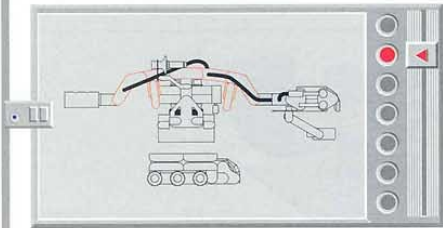



5

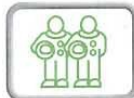
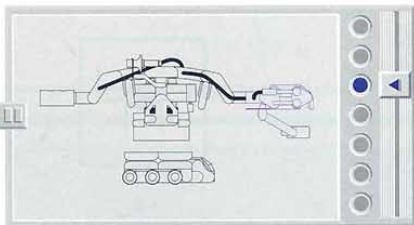
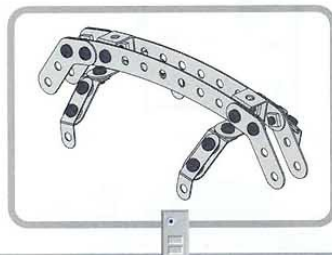
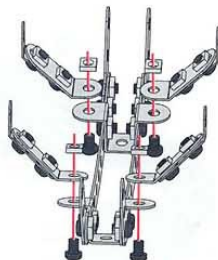
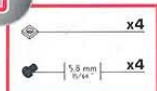

1

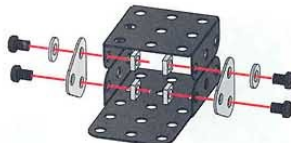
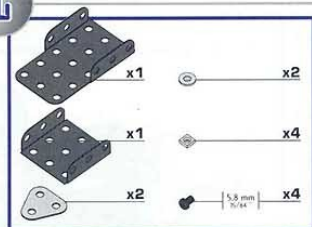

2

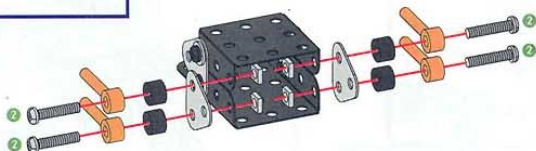
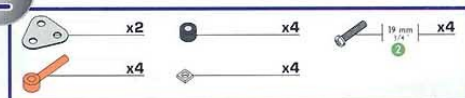



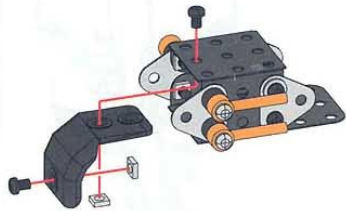

3

-  x1
-  x2
-  x2



4

-  x1
-  x2
-  x1
-  x1

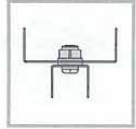
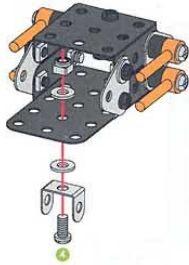



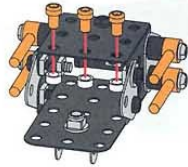

5

-  x3
-  x3





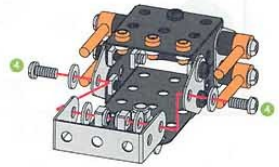
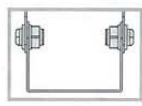

6

-  x1
-  x4
-  x2
-  x2





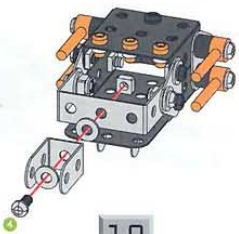

7

-  x1
-  x2
-  x1
-  x1







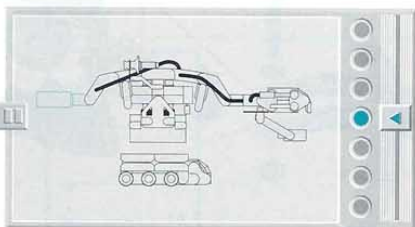
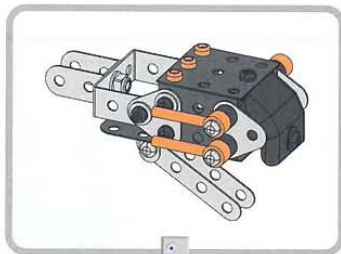
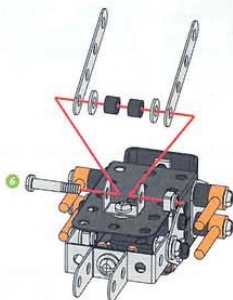

-  x2
-  x2
-  x2
-  x1
-  x1





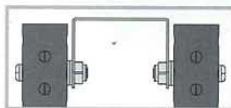
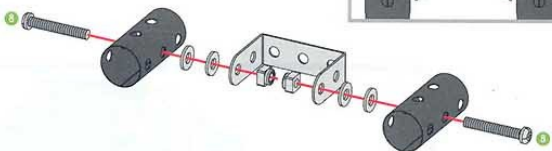

1

-  x1
-  x2
-  x2
-  x2
-  x4



2

-  x1
-  x2
-  x1
-  x1

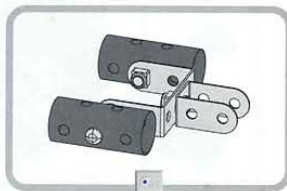
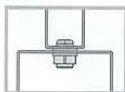
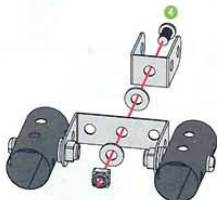

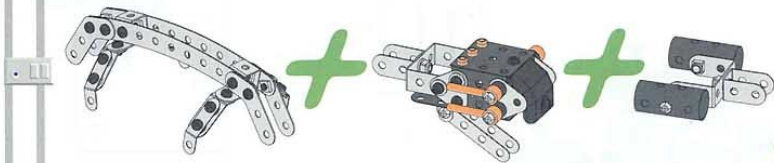

|  |    |
|--|----|
|  | x4 |
|  | x2 |
|  | x2 |
|  | x2 |

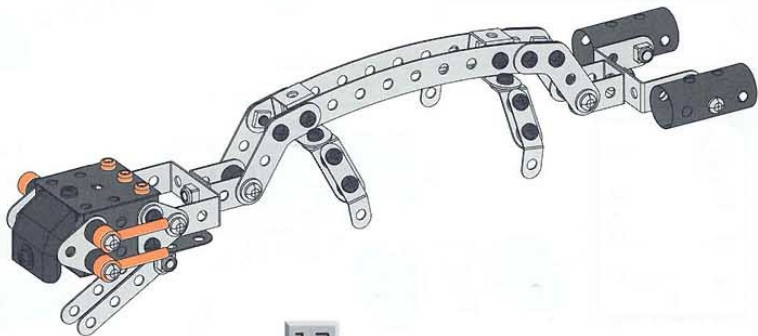
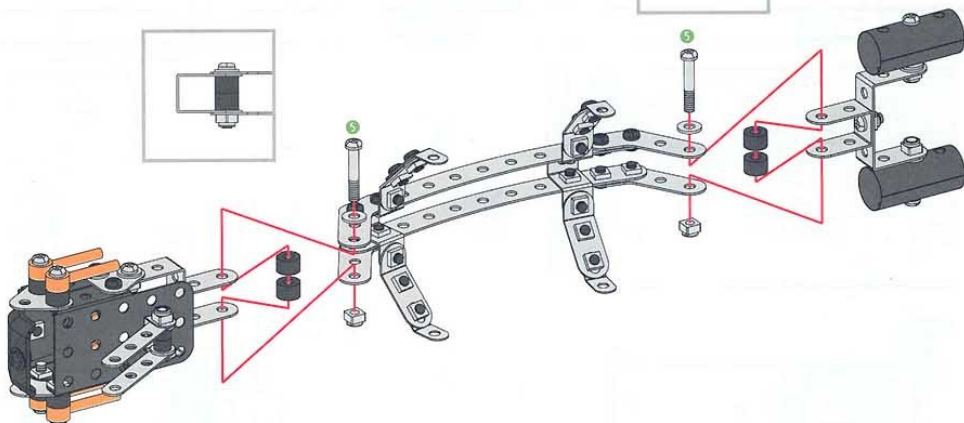

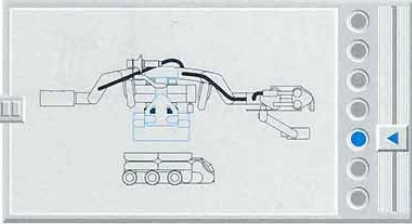
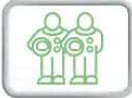

1

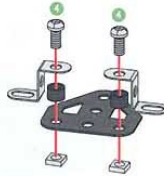
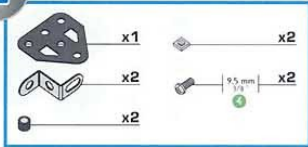

2

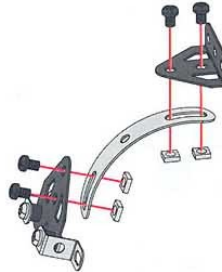

3

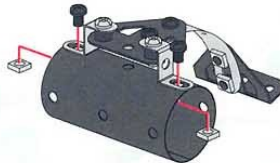

x2



13



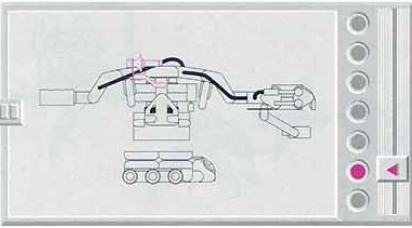

1

- x1
- x1
- x1
- x1



2

- x1
- x1
- x1
- x2
- x1

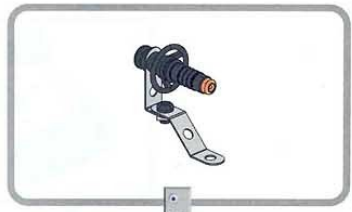

14

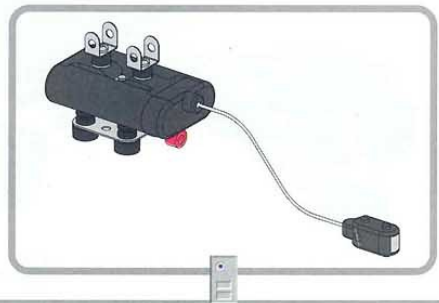
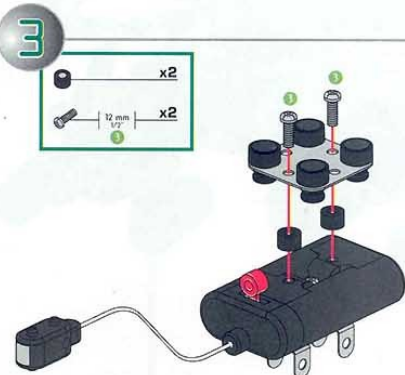
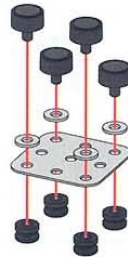
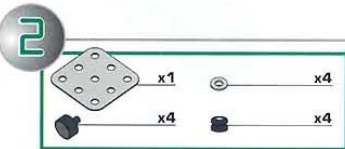
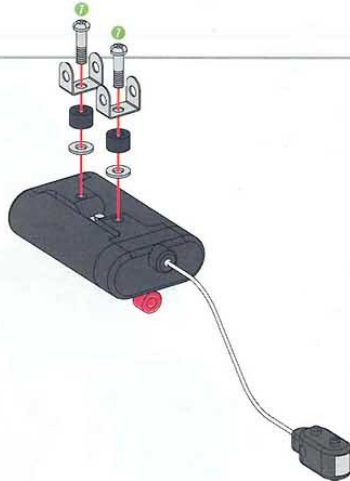
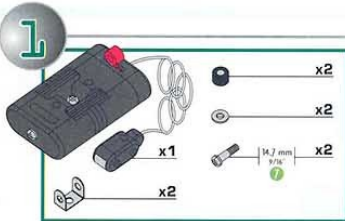
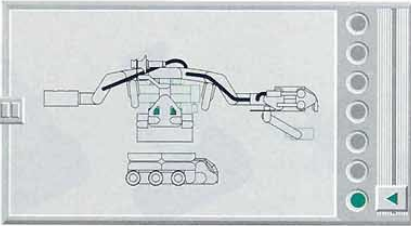

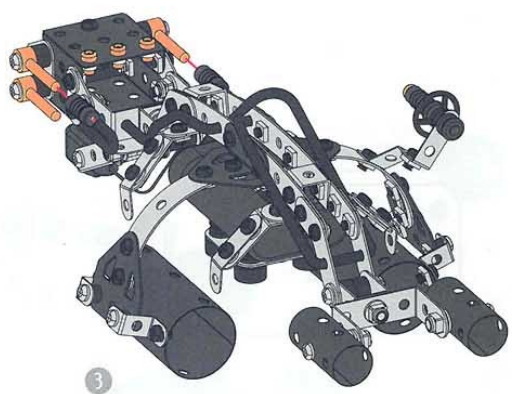
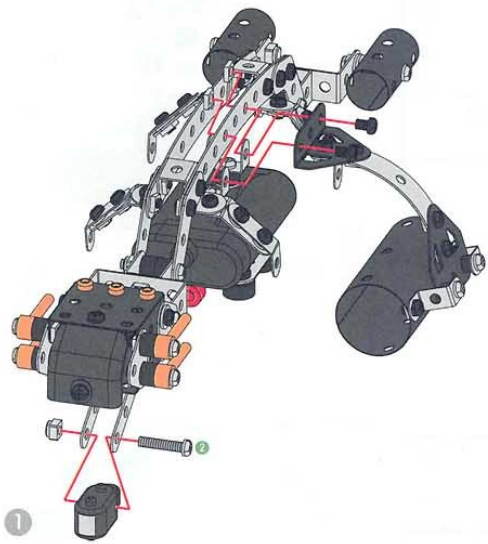
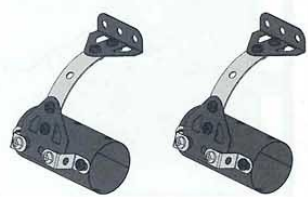
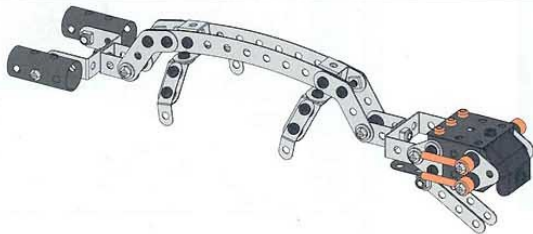



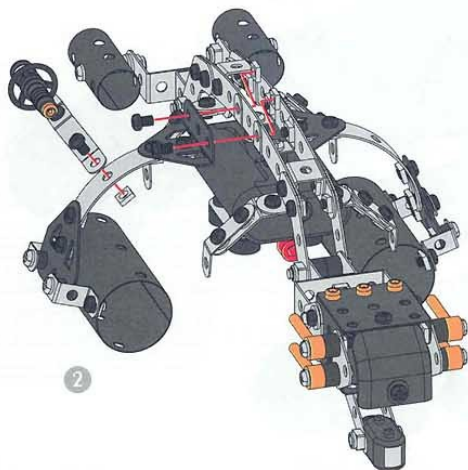
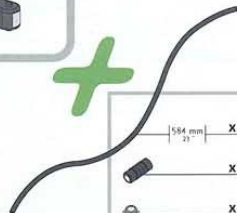
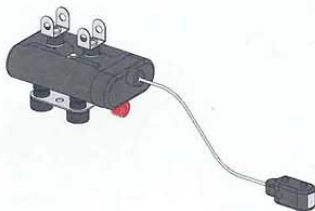

|  |                |    |
|--|----------------|----|
|  | 584 mm<br>21   | x1 |
|  |                | x2 |
|  |                | x1 |
|  |                | x5 |
|  | 19 mm<br>3/4   | x1 |
|  | 5,8 mm<br>5/32 | x5 |

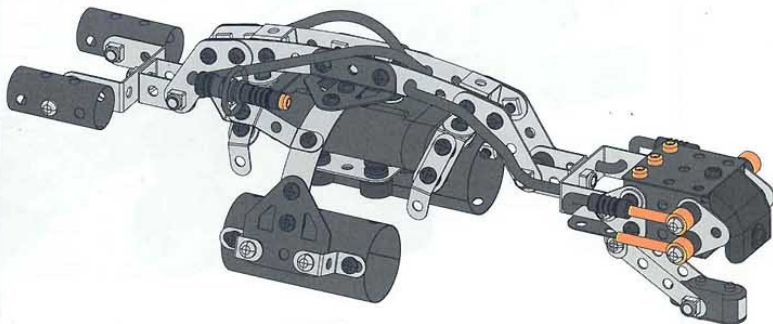

17

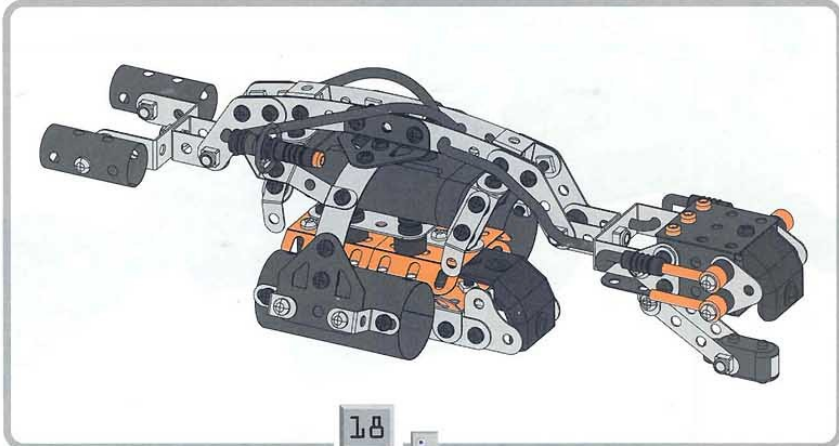
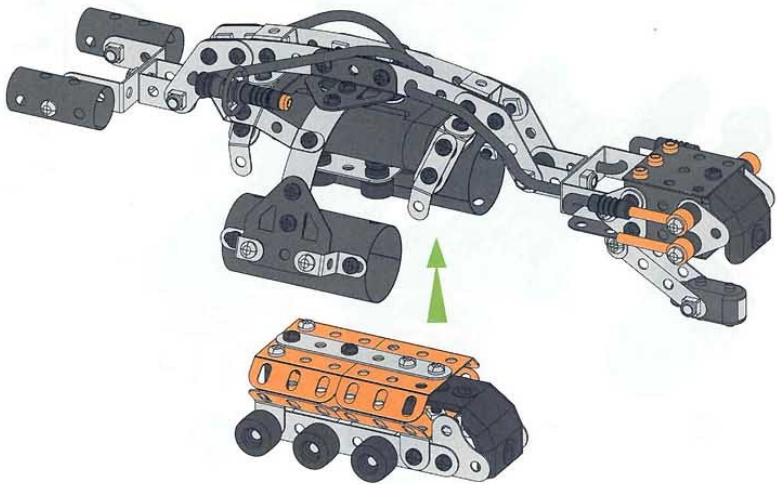
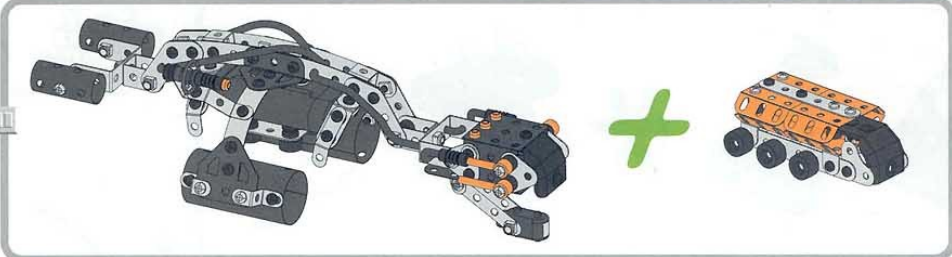



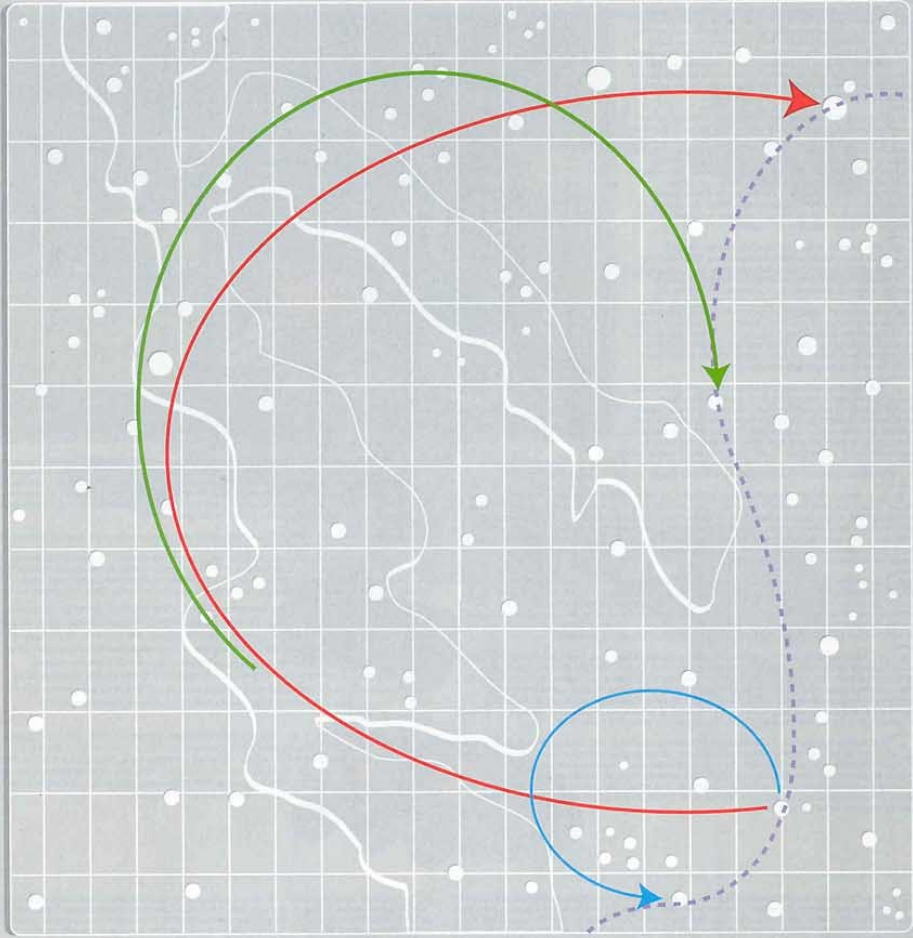

MECCANO