

Instructions
Notice de montage
Bauanleitung
istruzioni di montaggio
Instrucciones de montaje
Instruções de montagem
Monteringsanvisning
Kokoamisohje
Monterings instruktioner
Montagehandleiding
Οδηγίες συναρμολόγησης.
組立説明書

TUNING RADIO CONTROL



#6950

8+



P.6



P.11



B482 x2



B488 x3



B487 x1



B581 x2



B865 x8



A215 (0215) x1



A271 (0090A) x2



B684 x2



B863 x1



A520 (0188) x1



A535 (0193) x1



B864 x2



B584 x2



A286 (0090) x2



A286 (0090) x1



A105 (0005) x1



B146 (0006) x2



A506 (0006A) x2



A010 (0010) x2



A438 (0825A) x3



A713 (0012D) x1



A712 (0012C) x9



A012 (0012) x6



A338 (0038B) x2

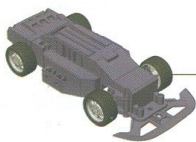

B889 x1



B890 x1



B905 x1



3

A411 (0111A) x2
12 mm
1/2"



4

A511 (0111C) x4
9,5 mm
3/8"



A637 (0037B) x45
5,8 mm
15/64"



A138 (0038) x2



A337 (0037A) x50



S084 x1



A134 (0034) x1



A136 (0036C) x1

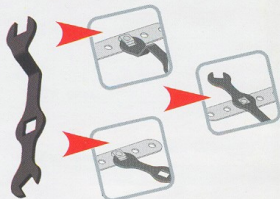
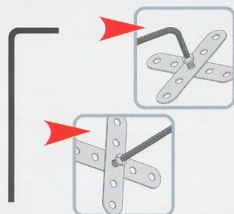

1

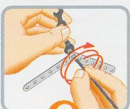

2



3

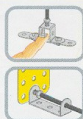

GB : Bend the spring steel parts, they will return to their original position.

F : Déformez les pièces en acier ressort, elles retrouvent leur position initiale.

D : Verbiege die Teile aus Federstahl, sie nehmen wieder ihre ursprüngliche Stellung ein.

I : Deformati i pezzi in acciaio elastico ritrovano la loro posizione iniziale.

E : Deforma las piezas de acero muelle, que recuperan su posición inicial.

JPN : 鋼鉄スプリングの部品を曲げてみてください。元の形に戻ります。

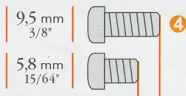

Scale
Echelle
Maßstab
Scala

Escala
Schaal
Escala
Skala

Mittakaava
Målestok
Κλίμακα
スケール

1:1





- GB USA** Refer to the USER GUIDE, included in the box, for information on operating the remote control.
- F** Pour le fonctionnement du module radio-commandé, se référer au GUIDE DE L'UTILISATEUR inclus dans la boîte.
- D** Die Funktion des funkgesteuerten Moduls ist in der beiliegenden GEBRAUCHSANWEISUNG erklärt.
- I** Per il funzionamento del modulo radiocomandato, far riferimento al MANUALE UTENTE incluso nella confezione.
- E** Para el funcionamiento del módulo radiocomandado, remitirse a la GUÍA DEL USUARIO incluida en la caja.
- P** Para o funcionamento do módulo radiocomandado, reporte-se ao GUIA DO UTILIZADOR incluído na caixa.
- S** För den radiostyrda modulens funktion, se ANVÄNDARGUDIEN som ingår i lädan.
- FIN** Katso radio-ohjattun moduulin käyttöohjeet mukana toimitetusta KÄYTTÄJÄN KÄSIKIRJASTA
- DK** Det radiostyrede moduls virkemåde er beskrevet i BRUGSVEJLEDNINGEN, der medfølger i æsken.
- NL** Voor de werking van de radiogestuurde module verwijzen we naar de GEBUIKERSGIDS die in de doos zit.
- GR** Για τη λειτουργία της τηλεχειριζόμενης μονάδας, ανατρέξτε στις ΟΔΗΓΙΕΣ ΧΡΗΣΗΣ που περιλαμβάνονται στη συσκευασία.
- JPN** リモコン操作に関する説明は、ボックスに入っている「ユーザーガイド」を参照してください。

CONSTRUCTION TIPS

ASTUCES DE CONSTRUCTION

KONSTRUKTIONS-TIPPES

LE ASTUZIE DELLA COSTRUZIONE

LOS INGENIOS DE LA CONSTRUCCION

DE FIJNE KNEEPJES VAN NET BOUWEN

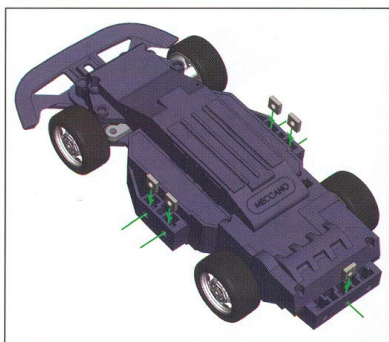
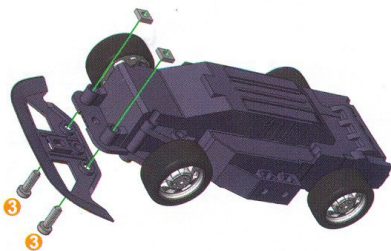

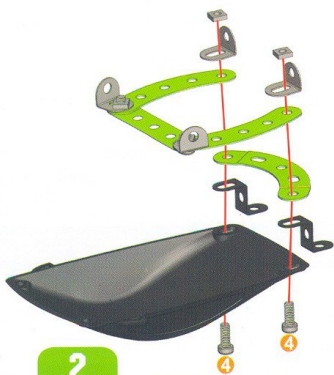

1

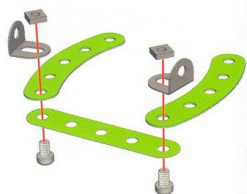

- | | | | |
|--|-----------|--|-----------|
| | x2 | | x2 |
| | x1 | | x2 |
| | | | x2 |

2

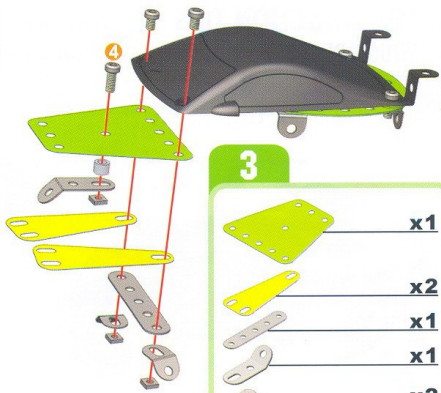

- | | |
|--|-----------|
| | x1 |
| | x1 |
| | x2 |
| | x2 |
| | x2 |
| | x2 |



3





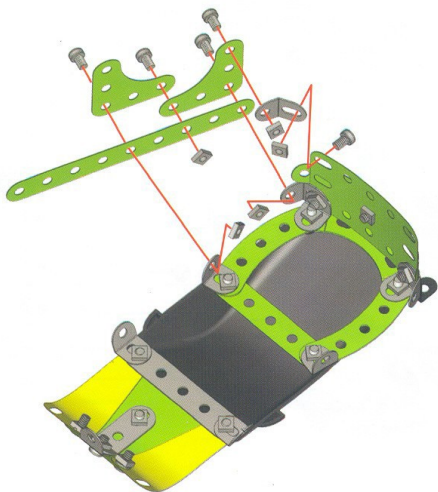
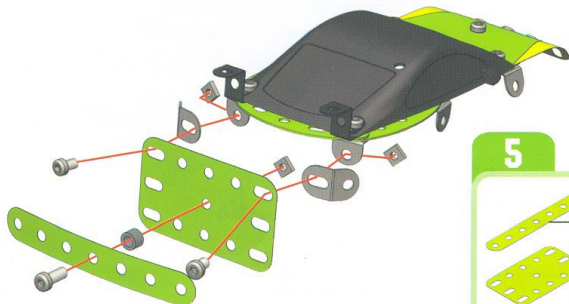
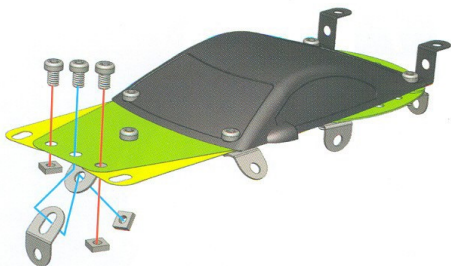

- | | |
|--|-----------|
| | x1 |
| | x2 |
| | x1 |
| | x1 |
| | x2 |
| | x1 |
| | x1 |
| | x2 |
| | x3 |

4





	_____	x1
	5,8 mm 15/64"	x3
	_____	x3

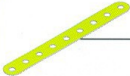

5

	_____	x1
	_____	x1
	_____	x2
	_____	x1
	4 9,5 mm 3/8"	x1
	5,8 mm 15/64"	x2
	_____	x3

6

	_____	x1
	_____	x2
	_____	x1
	5,8 mm 15/64"	x5
	_____	x5

7

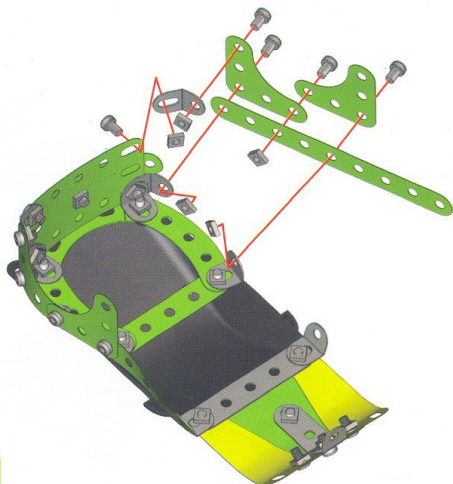
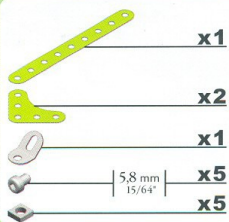

8

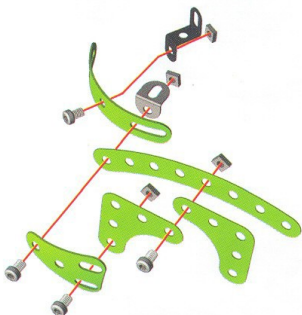
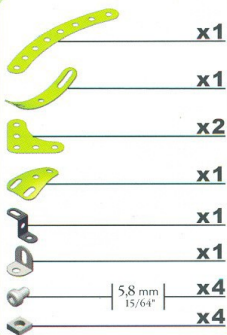



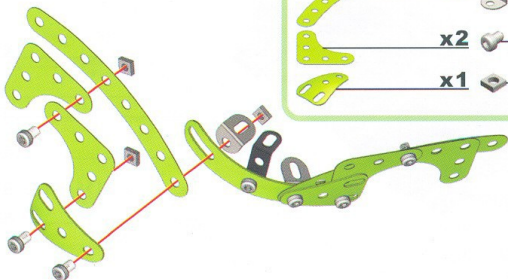
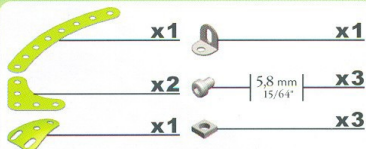

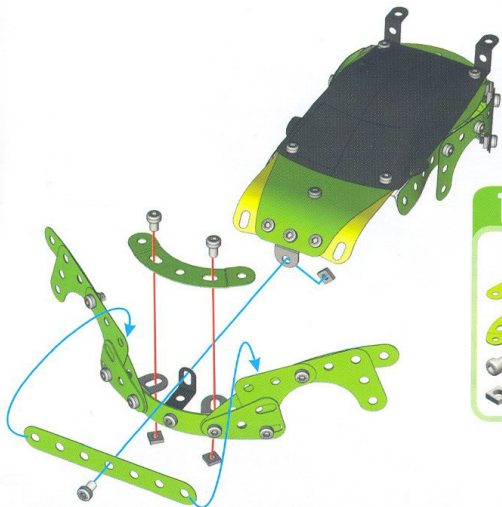
9





10 ⑦ + ⑨ +



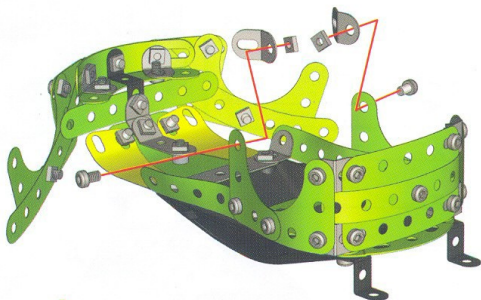

-  **x1**
-  **x1**
-  **x3**
-  **x3**

11

-  **x2**
-  **x2**
-  **x2**





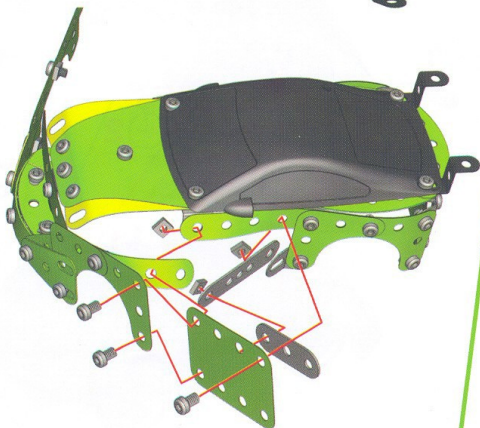

12

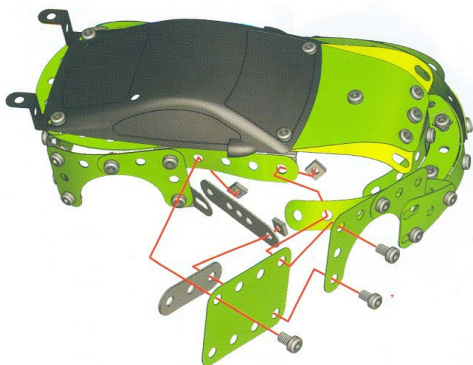
-  **x1**
-  **x1**
-  **x1**
-  **x3**
-  **x3**







13



-  x1
-  x1
-  x1
-  | 5,8 mm | x3
15/64"
-  x3

14

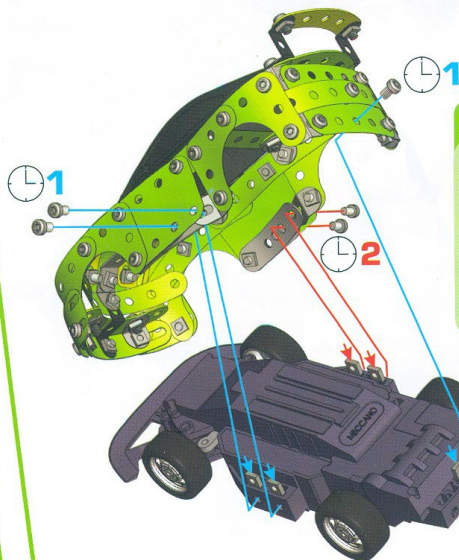
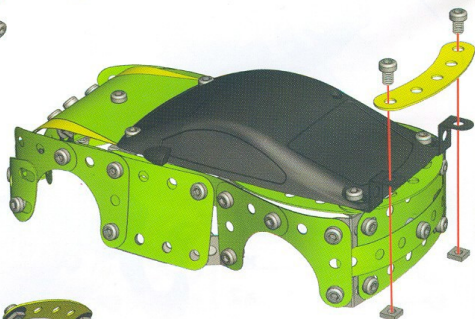
-  x1
-  | 5,8 mm | x2
15/64"
-  x2



15

-  x1
-  | 5,8 mm | x5
15/64"
-  x5

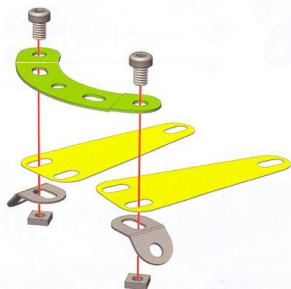

1

	x2		x2
	x1		x2
			x2

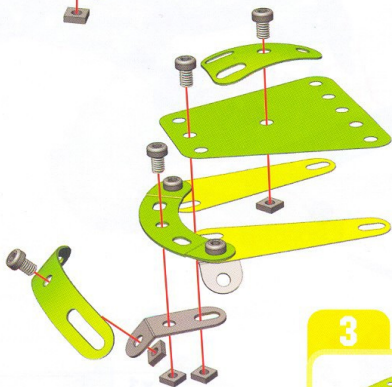

2

	x1
	x1
	x1
	x1
	x4
	x4

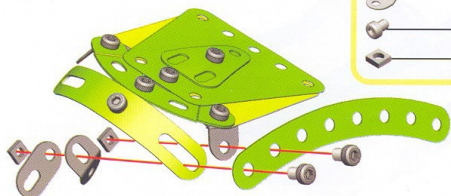

3

	x1
	x1
	x1
	x2
	x2

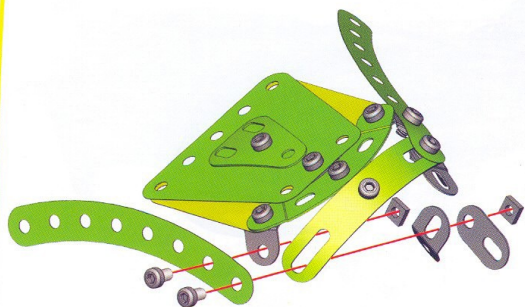

4

	x1
	x1
	x1
	x2
	x2

5

	x1
	x2
	x2

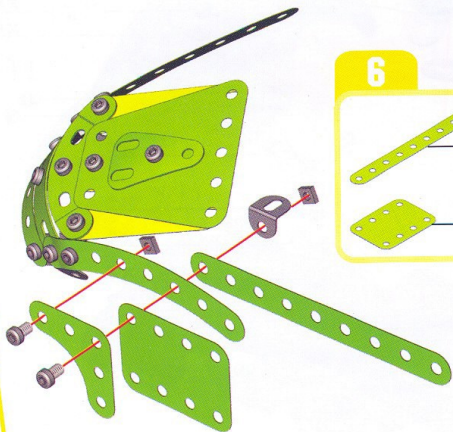
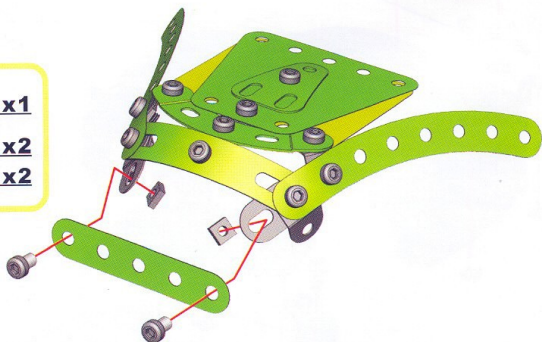

6

	x1		x1
	x1		x1
	x1		x2
			x2

7

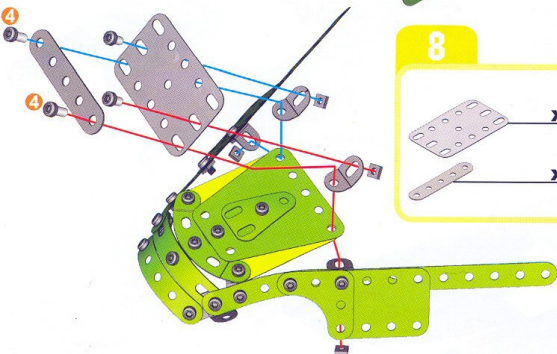
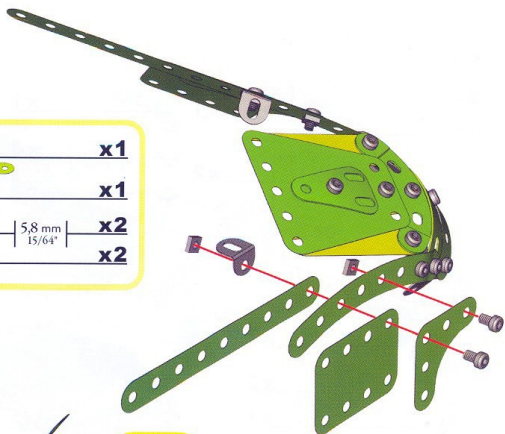
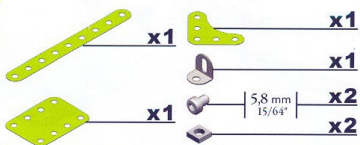

8

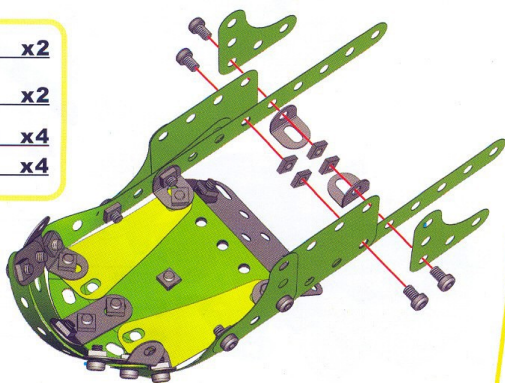
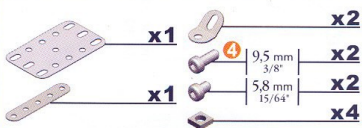

9

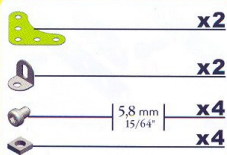

10

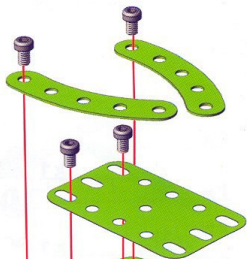
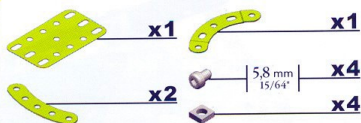

11

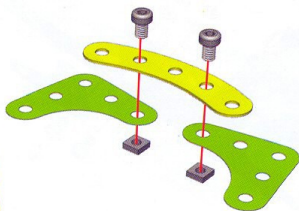
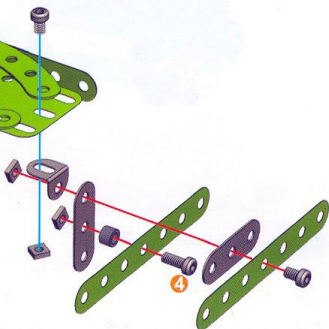
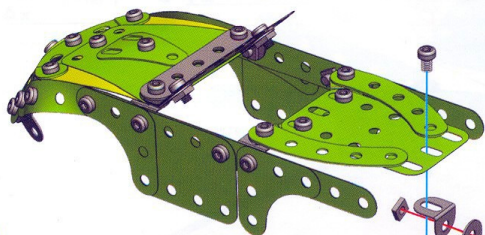
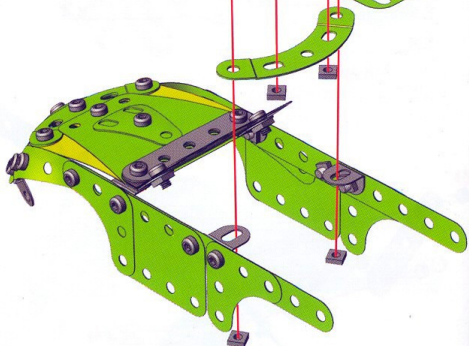
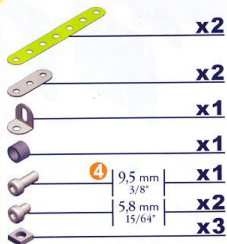

12

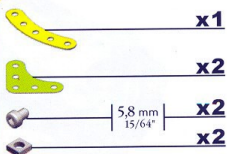

13

⑪ + ⑫ +

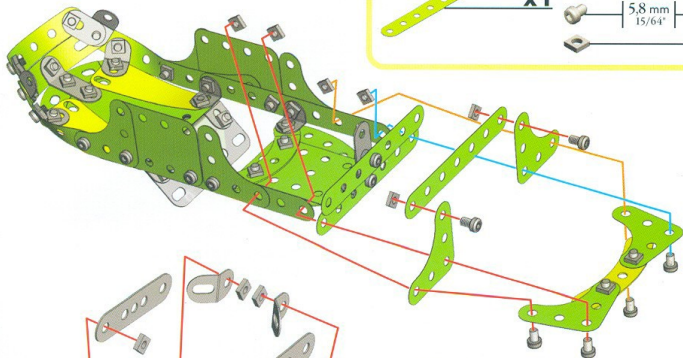

14

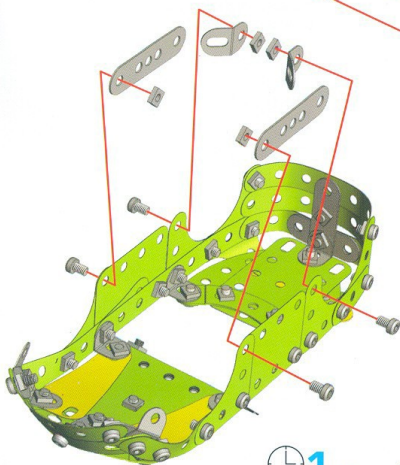
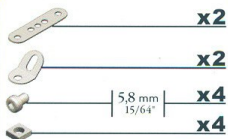

⌚ 1

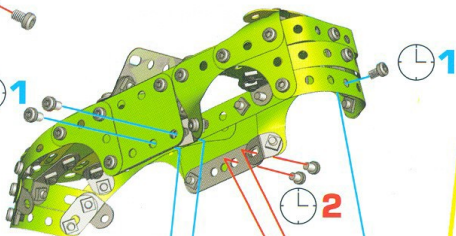

⌚ 2

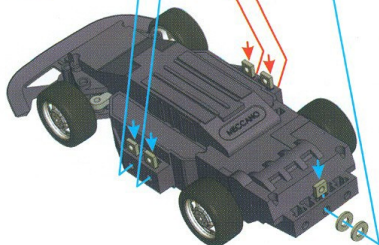

15

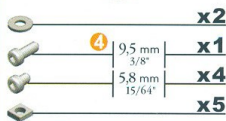

15

