

Instructions
Notice de montage
Bauanleitung
istruzioni di montaggio
Instrucciones de montaje
Instruções de montagem
Monteringsanvisning
Kokoamisohje
Monterings instruktioner
Montagehandleiding
Οδηγίες συναρμολόγησης.
組立説明書

TUNING RADIO CONTROL



#8952

8+

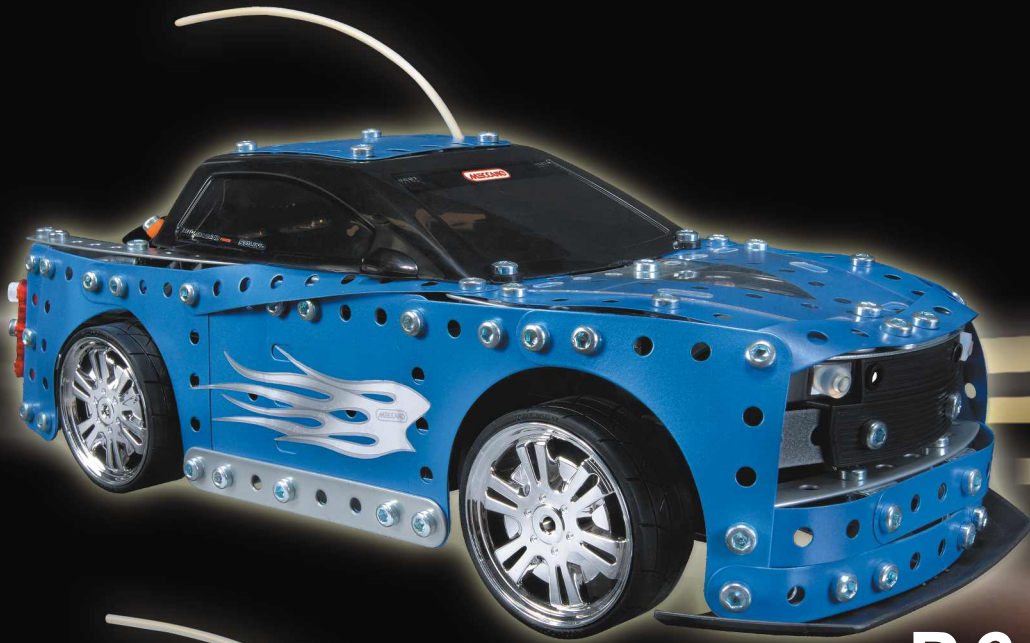

P.6



P.14

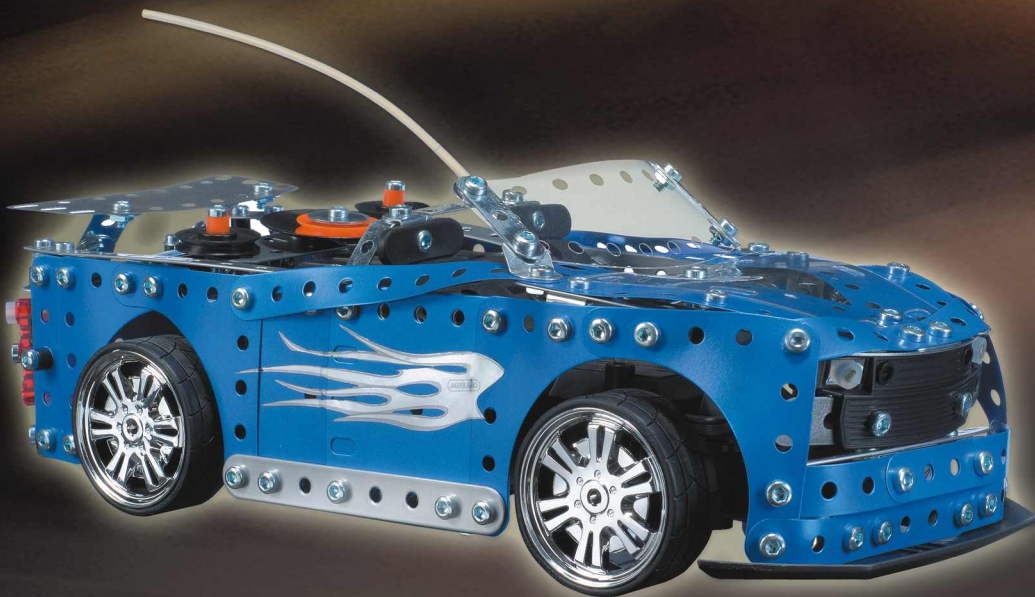

P.20

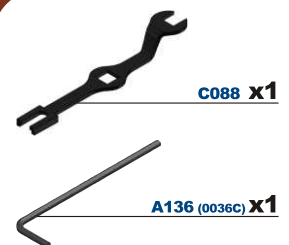
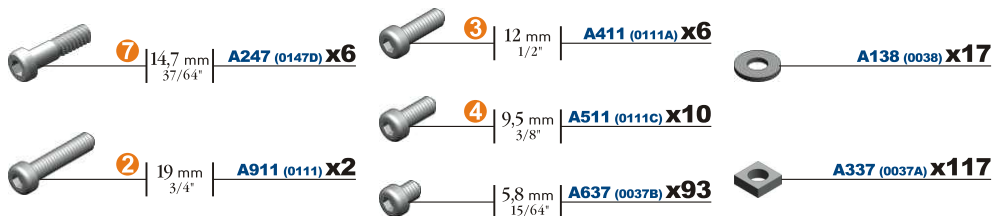
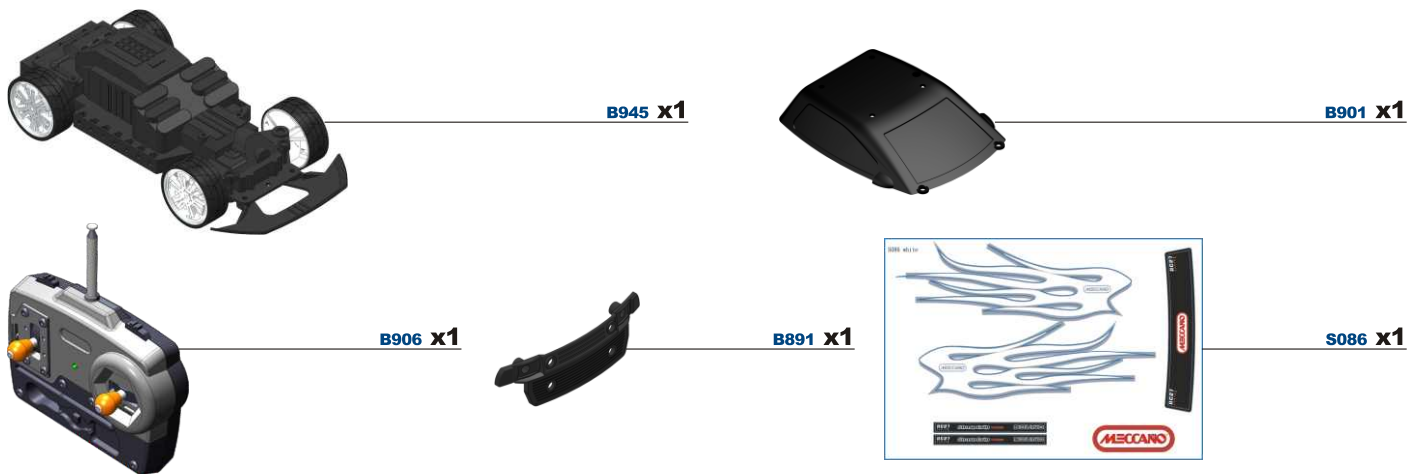
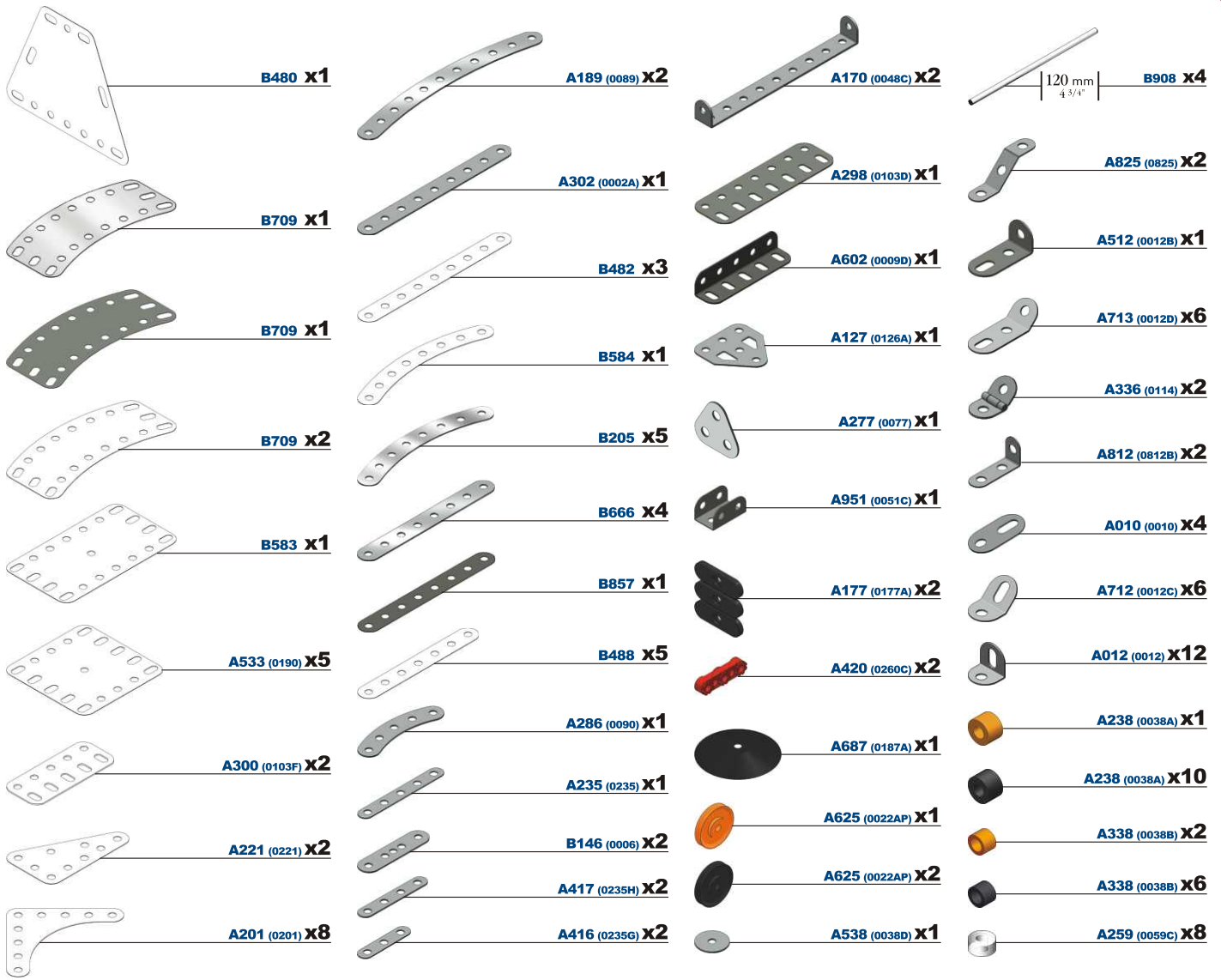

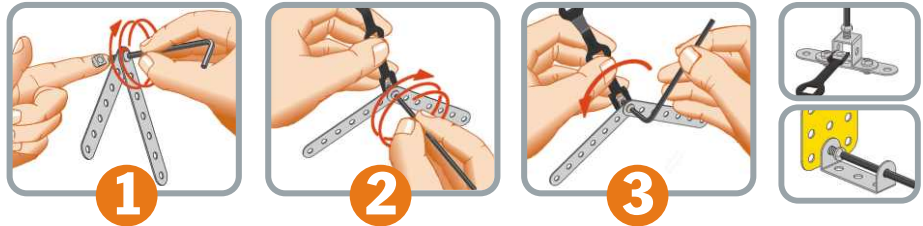
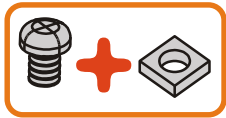
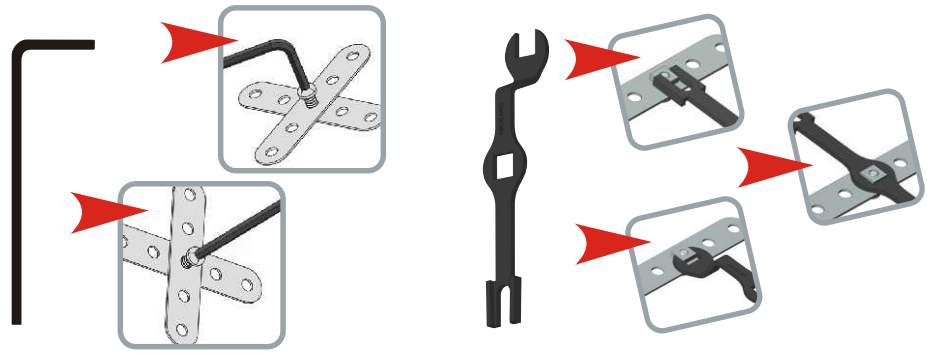
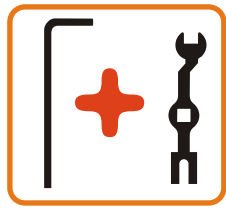

GB : Bend the spring steel parts, they will return to their original position.
F : Déformez les pièces en acier ressort, elles retrouvent leur position initiale.
D : Verbiege die Teile aus Federstahl, sie nehmen wieder ihre ursprüngliche Stellung ein.
I : Deformati i pezzi in acciaio elastico ritrovano la loro posizione iniziale.
E : Deforma las piezas de acero muelle, que recuperan su posición inicial.
JPN : 鋼鉄スプリングの部品を曲げてみてください。元の形に戻ります。

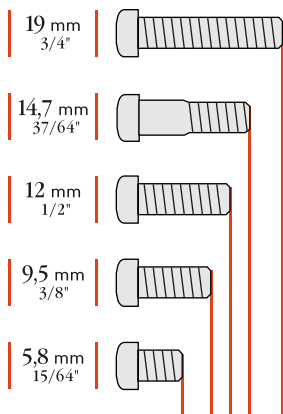

② Scale Escala Mittakaava
 Echelle Schaal Mällestok
 ⑦ Maßstab Escala Κλίμακα
 Scala Skala スケール

1:1





- Ⓒ^{GB} **USA** Refer to the USER GUIDE, included in the box, for information on operating the remote control.
- Ⓕ **F** Pour le fonctionnement du module radio-commandé, se référer au GUIDE DE L'UTILISATEUR inclus dans la boîte.
- Ⓖ **D** Die Funktion des funkgesteuerten Moduls ist in der beiliegenden GEBRAUCHSANWEISUNG erklärt.
- Ⓘ **I** Per il funzionamento del modulo radiocomandato, far riferimento al MANUALE UTENTE incluso nella confezione.
- Ⓔ **E** Para el funcionamiento del módulo radiocomandado, remitirse a la GUÍA DEL USUARIO incluida en la caja.
- Ⓖ **P** Para o funcionamento do módulo radiocomandado, reporte-se ao GUIA DO UTILIZADOR incluído na caixa.
- Ⓒ **S** För den radiostyrda modulens funktion, se ANVÄNDARGUDIEN som ingår i lådan.
- Ⓕ **FIN** Katso radio-ohjatus moduulin käyttöohjeet mukana toimitetusta KÄYTTÄJÄN KÄSIKIRJASTA
- Ⓕ **DK** Det radiostyrede moduls virkemåde er beskrevet i BRUGSVEJLEDNINGEN, der medfølger i æsken.
- Ⓕ **NL** Voor de werking van de radiogestuurde module verwijzen we naar de GEBRUIKERSGIDS die in de doos zit.
- Ⓕ **GR** Για τη λειτουργία της τηλεχειριζόμενης μονάδας, ανατρέξτε στις ΟΔΗΓΙΕΣ ΧΡΗΣΗΣ που περιλαμβάνονται στη συσκευασία.
- Ⓕ **JPN** リモコン操作に関する説明は、ボックスに入っている「ユーザーガイド」を参照してください。

CONSTRUCTION TIPS

ASTUCES DE CONSTRUCTION

KONSTRUKTIONSTIPPS

LE ASTUZIE DELLA COSTRUZIONE

LOS INGENIOS DE LA CONSTRUCCIÓN

DE FIJNE KNEEPJES VAN NET BOUWEN

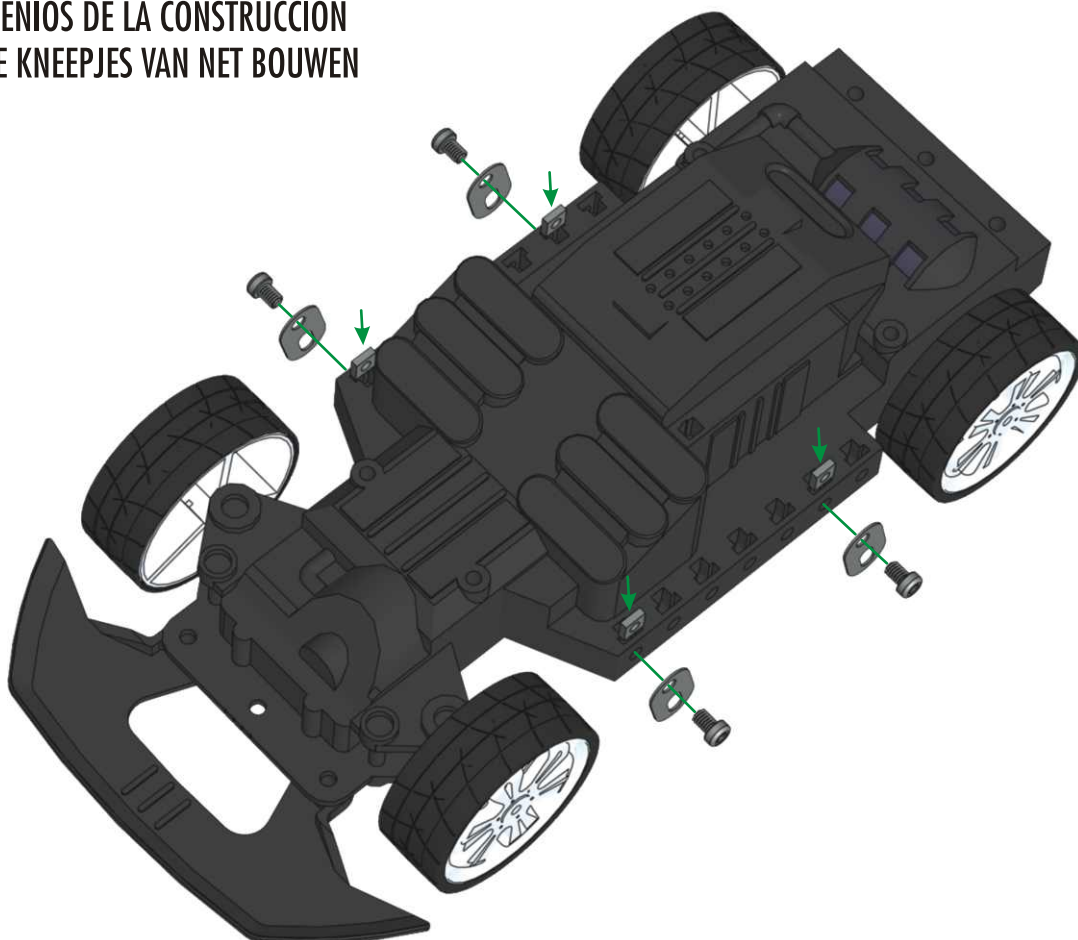

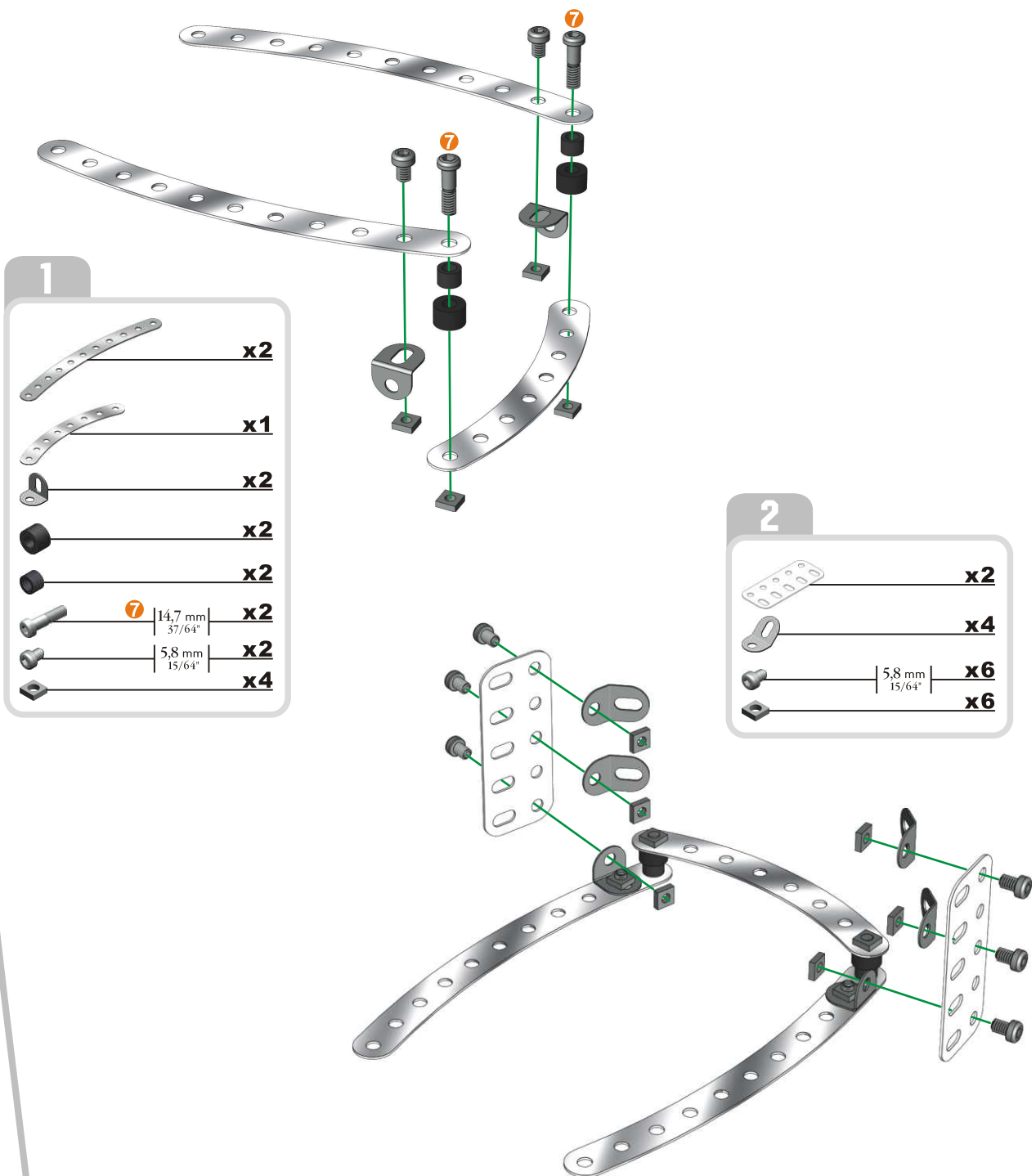





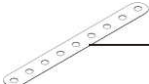

- 1**
- x2**
 - x1**
 - x2**
 - x2**
 - x2**
 - x2** | 14,7 mm | 37/64"
 - x2** | 5,8 mm | 15/64"
 - x4**



- 2**
- x2**
 - x4**
 - x6** | 5,8 mm | 15/64"
 - x6**

3

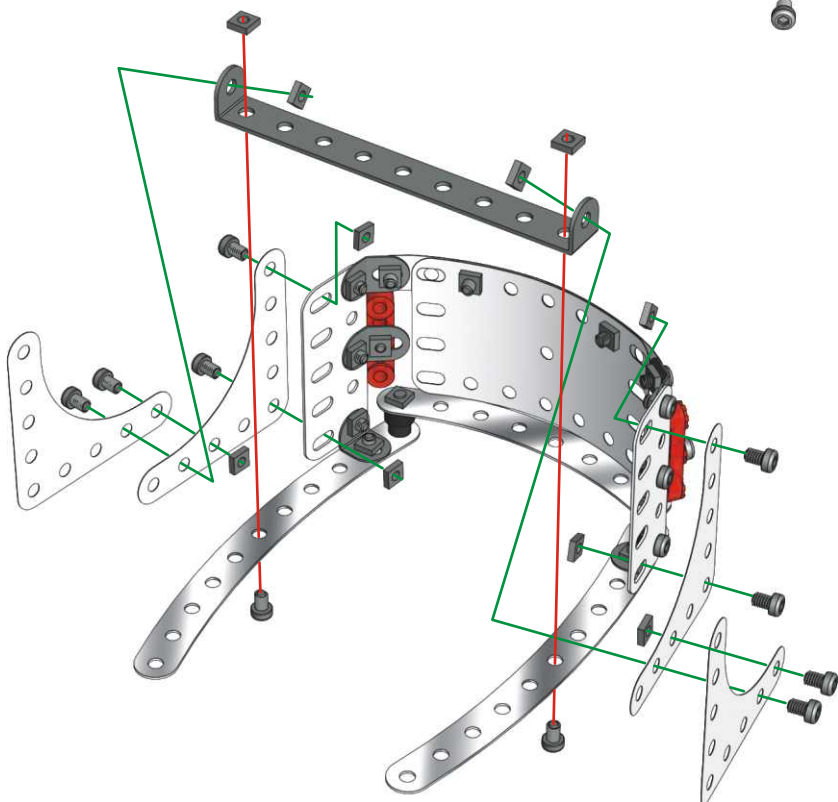
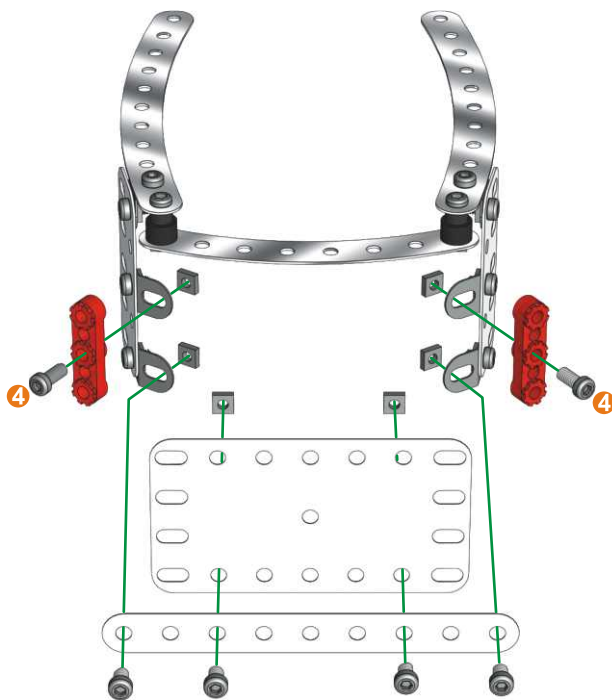



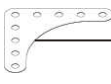





-  **x1**
-  **x1**
-  **x2**
-  9,5 mm **x2**
3/8"
-  5,8 mm **x4**
15/64"
-  **x6**



4

-  **x1**
-  **x4**
-  5,8 mm **x10**
15/64"
-  **x10**

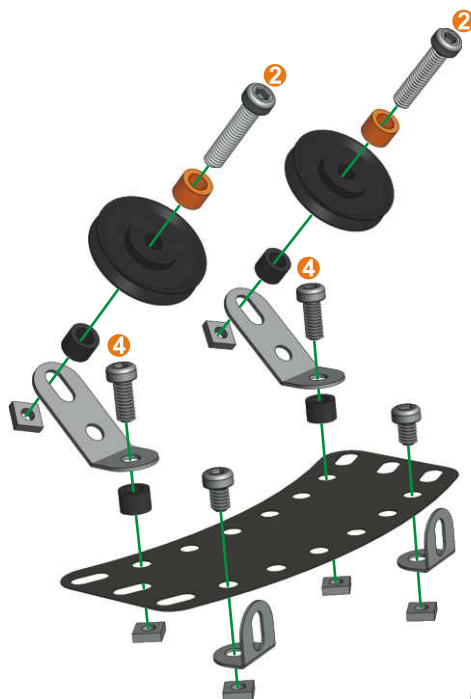

5

-  **x1**
-  **x2**
-  **x2**
-  **x2**
-  **x4**
-  **x2**
-  19 mm **x2**
3/4"
-  9,5 mm **x2**
3/8"
-  5,8 mm **x2**
15/64"
-  **x6**









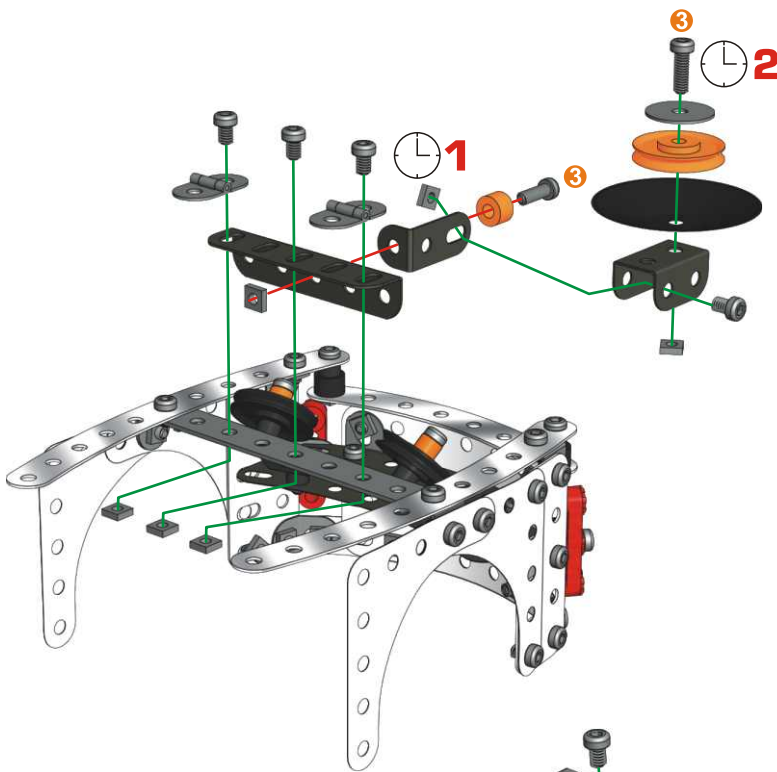
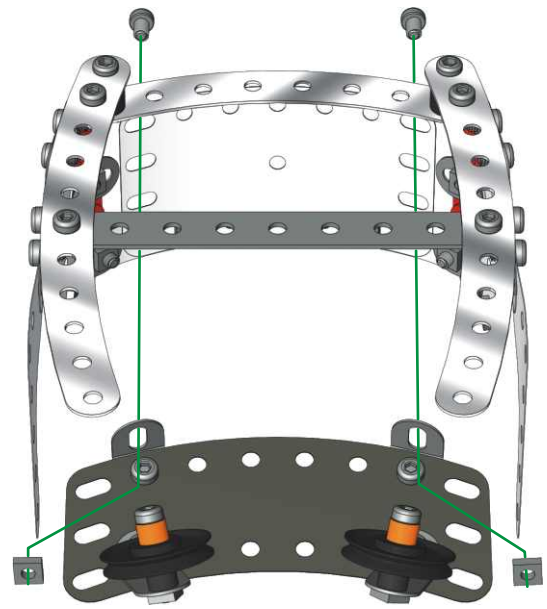





6

4 + 5 +





-  5,8 mm | 15/64" | **x2**
-  | **x2**



7

-  **x1**
-  **x1**
-  **x1**
-  **x1**
-  **x1**
-  **x1**
-  **x2**
-  **x1**
-  **x1**
-  **x2**
-  **x4**
-  **x6**

8

-  **x1**
-  **x2**
-  5,8 mm | 15/64" | **x6**
-  | **x6**

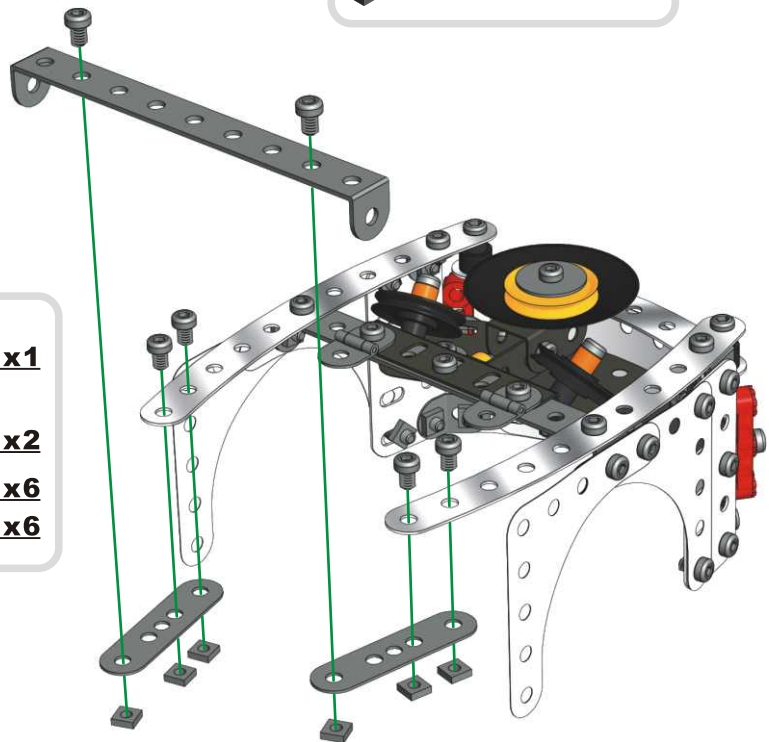

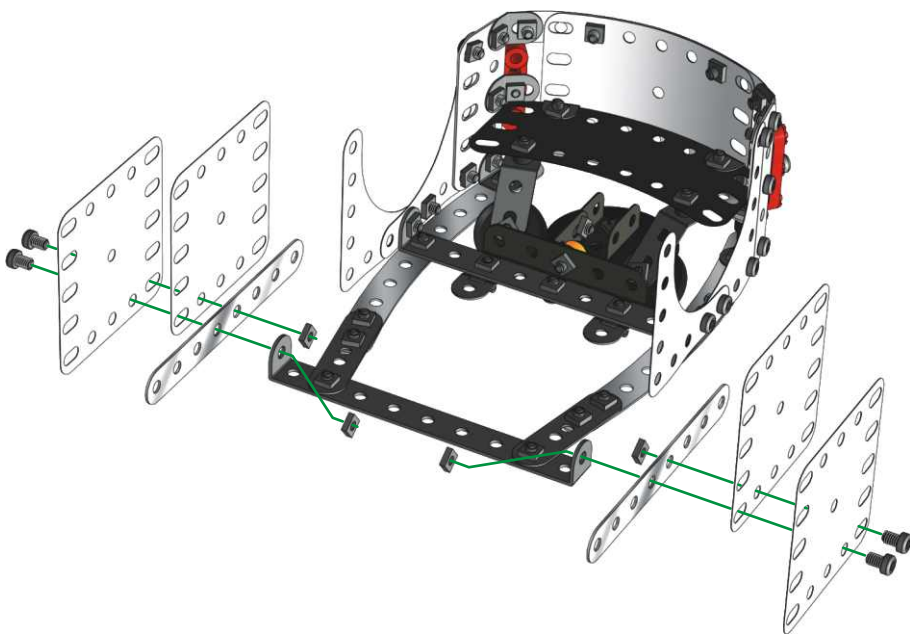

- 9**
- x2**
 - x4**
 - x4**
 - x4**

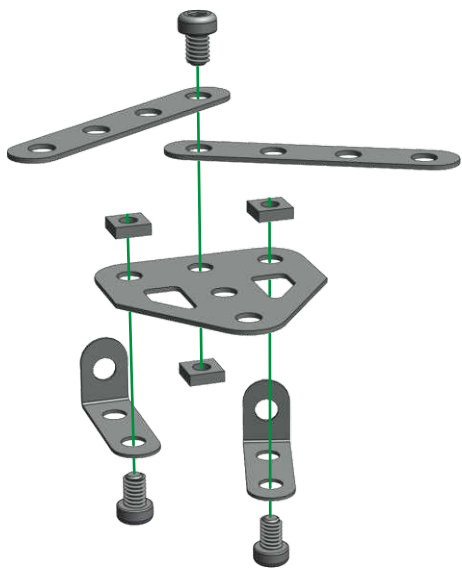



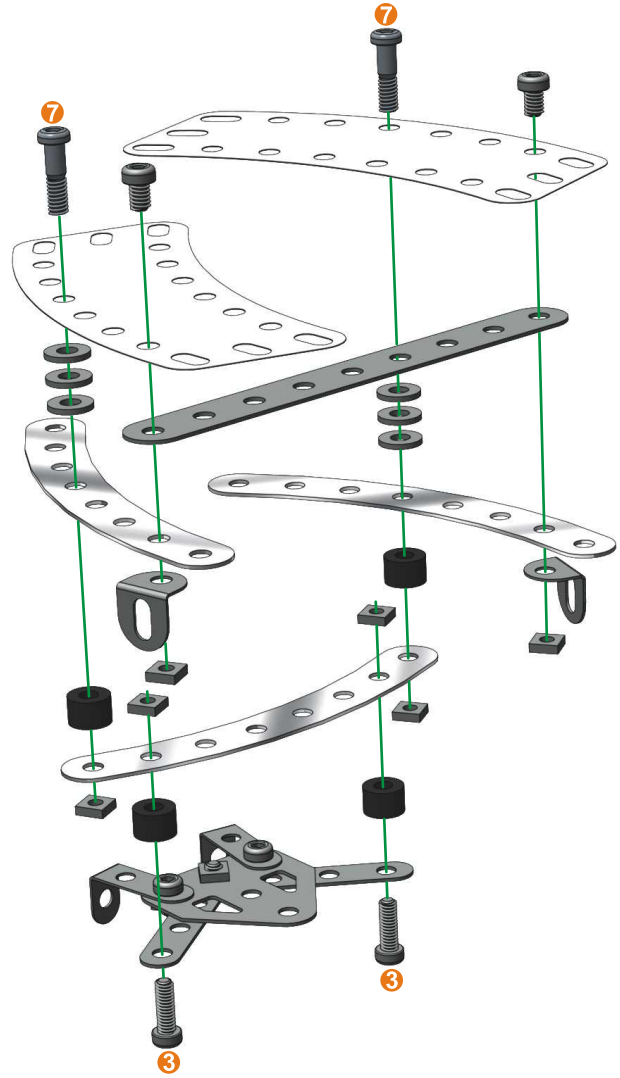

- 10**
- x2**
 - x1**
 - x2**
 - x3**
 - x3**

- 11**
- x1**
 - x2**
 - x3**
 - x2**
 - x4**
 - x6**
 - x2**
 - x2**
 - x2**
 - x6**



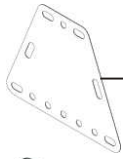





12



-  **x1**
-  **x1**
-  | 5,8 mm | **x2**
15/64"
-  **x2**

13

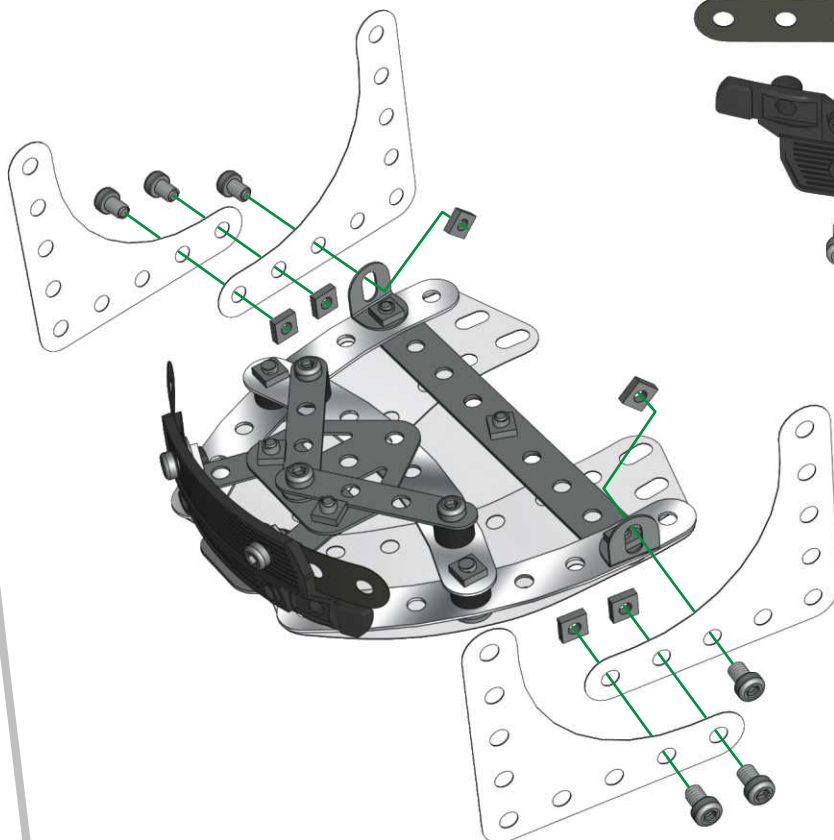
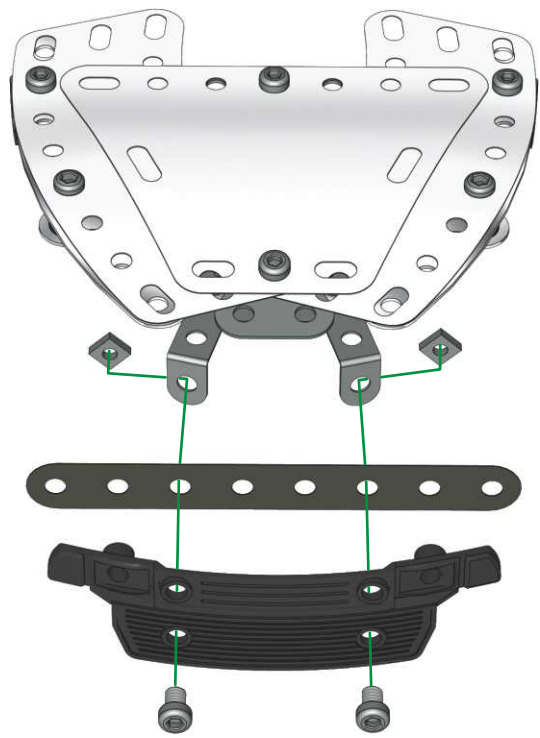

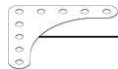

-  **x1**
-  **x1**
-  | 5,8 mm | **x2**
15/64"
-  **x2**



14

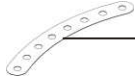

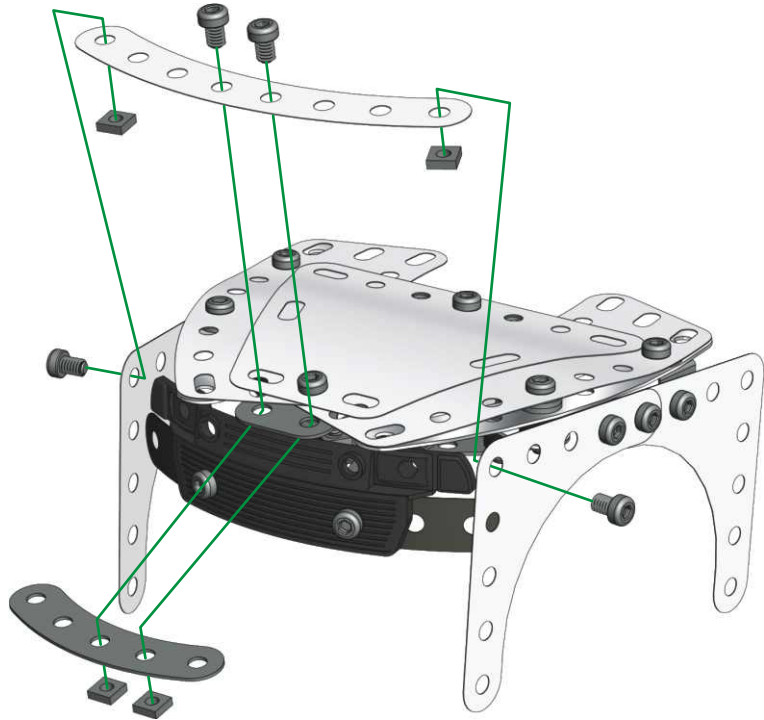

-  **x4**
-  | 5,8 mm | **x6**
15/64"
-  **x6**

15

-  **x1**
-  **x1**
-  **x4**
-  **x4**

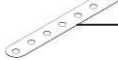





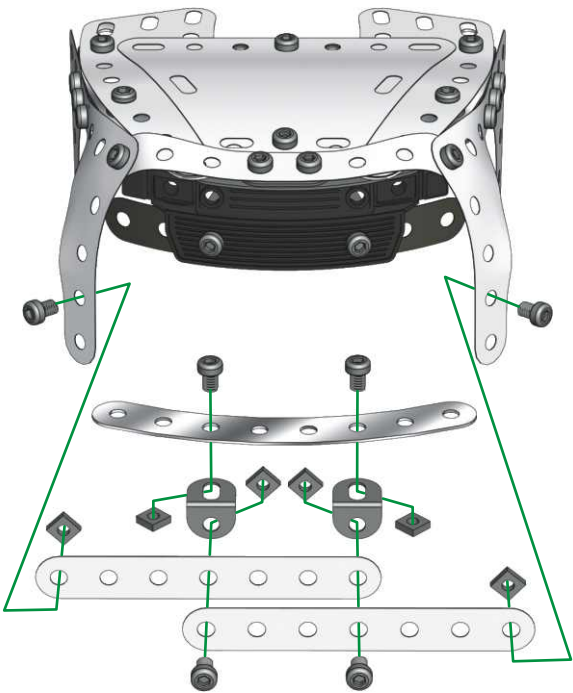

16

-  **x1**
-  **x2**
-  **x2**
-  **x6**
-  **x6**





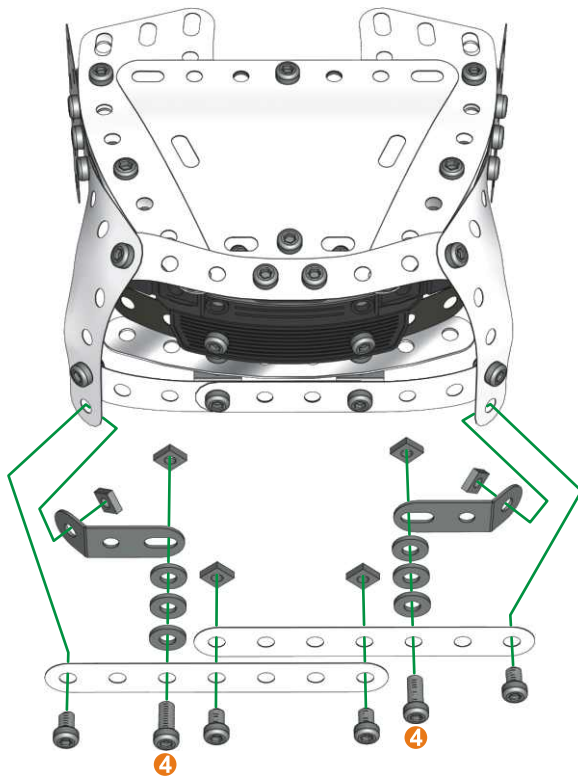

17

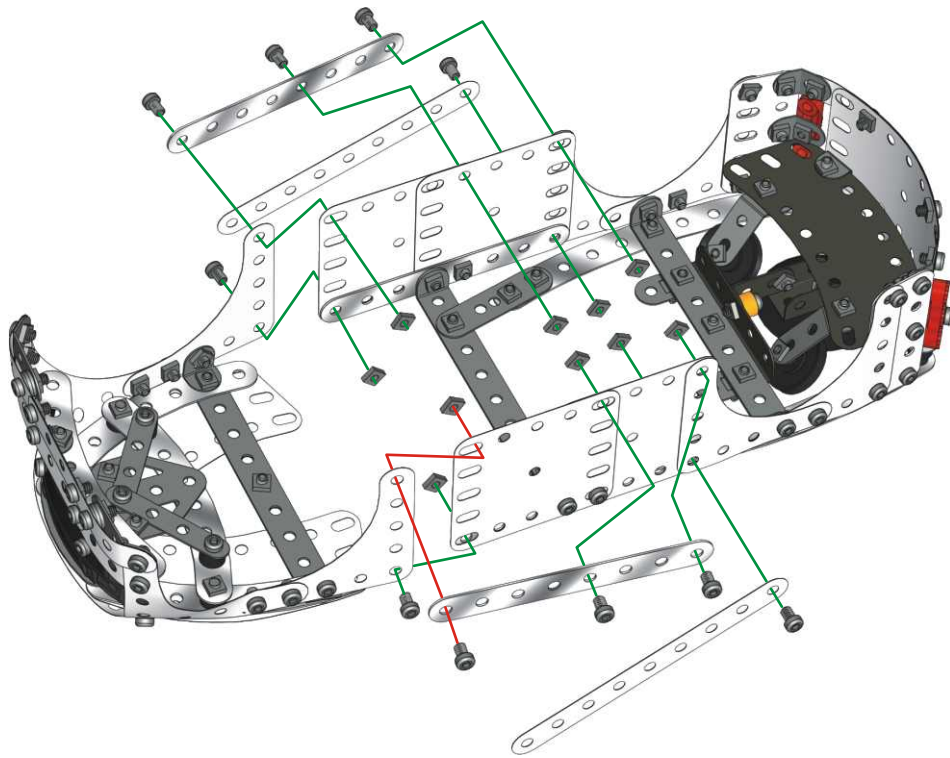
-  **x2**
-  **x2**
-  **x6**
-  **x2**
-  **x4**
-  **x6**



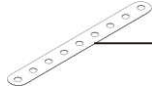

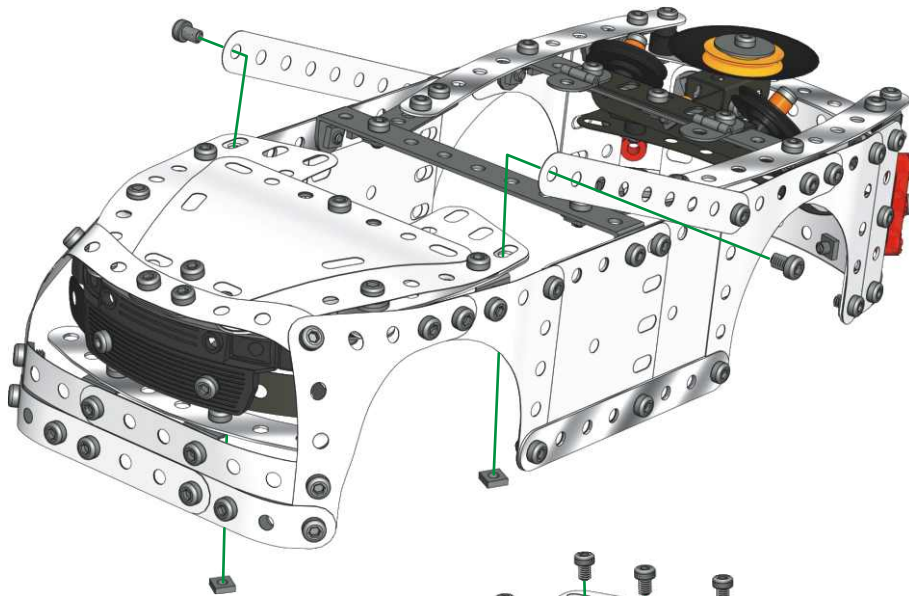

18 9 + 17 +

-  x2
-  x2
-  | 5,8 mm | x10
15/64"
-  x10





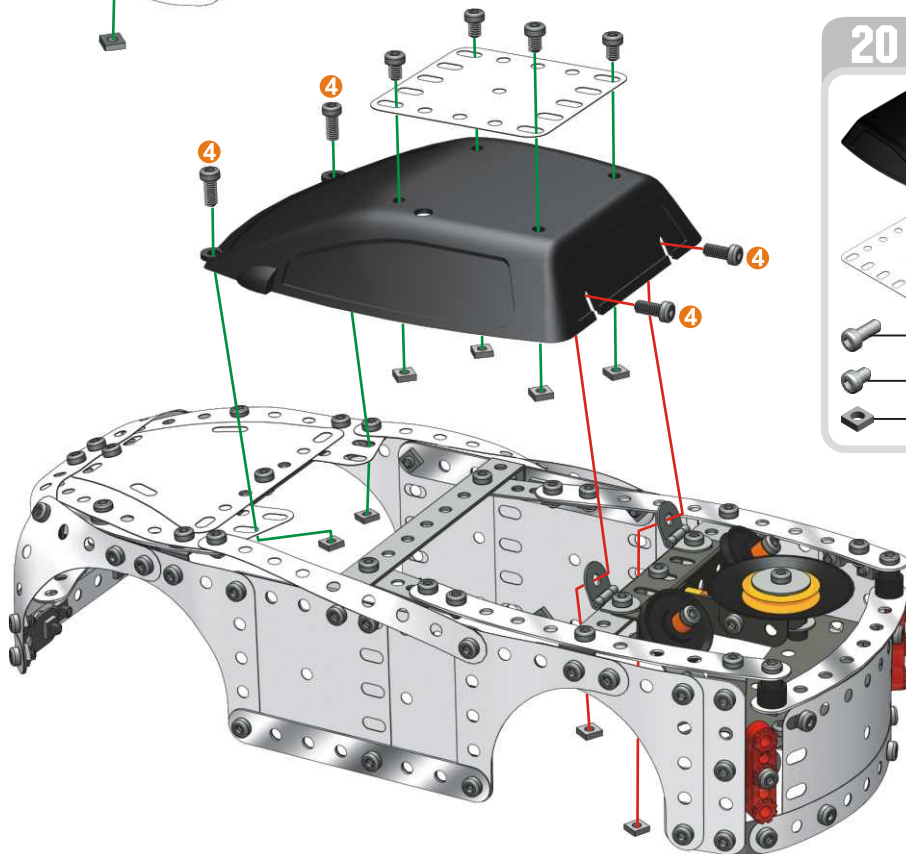

19

-  | 5,8 mm | x2
15/64"
-  x2

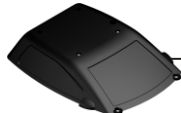



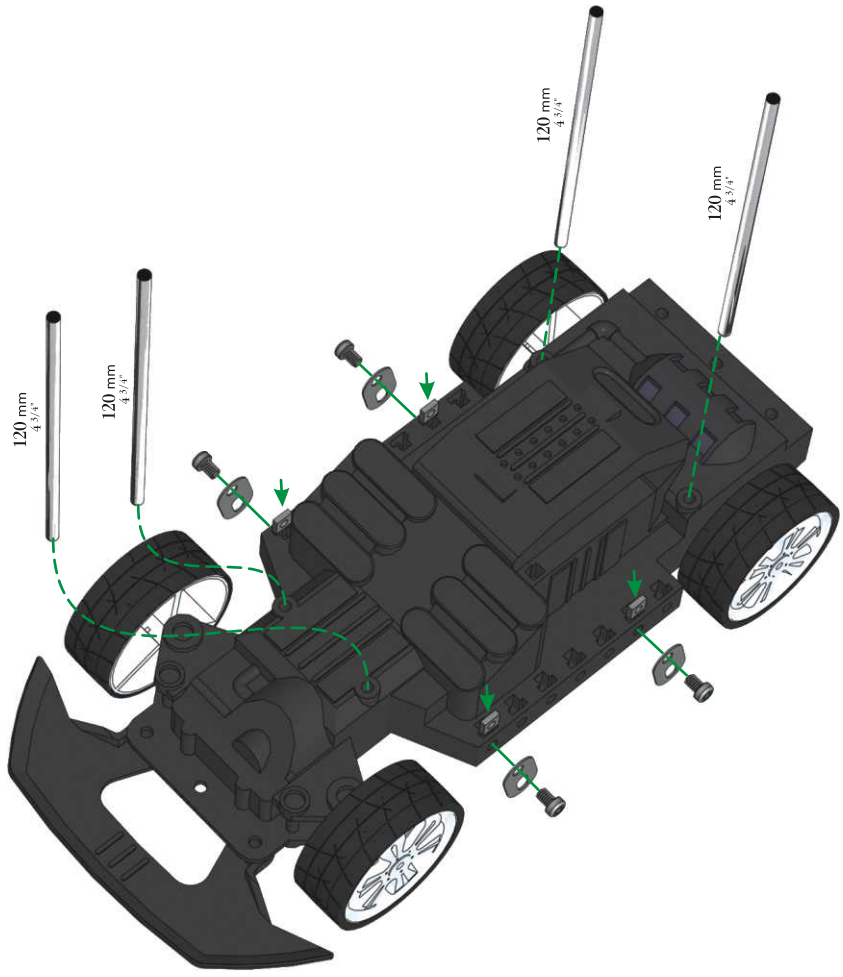

20

-  x1
-  x1
-  | 9,5 mm | x4
3/8"
-  | 5,8 mm | x4
15/64"
-  x8







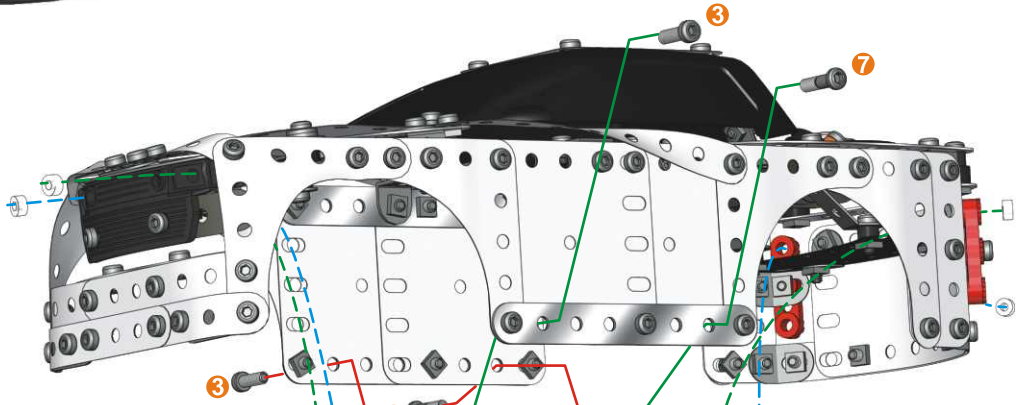

21

-  **x1**
-  | 120 mm | **x4**
4 3/4"
-  **x4**
-  | 5,8 mm | **x4**
15/64"
-  **x4**







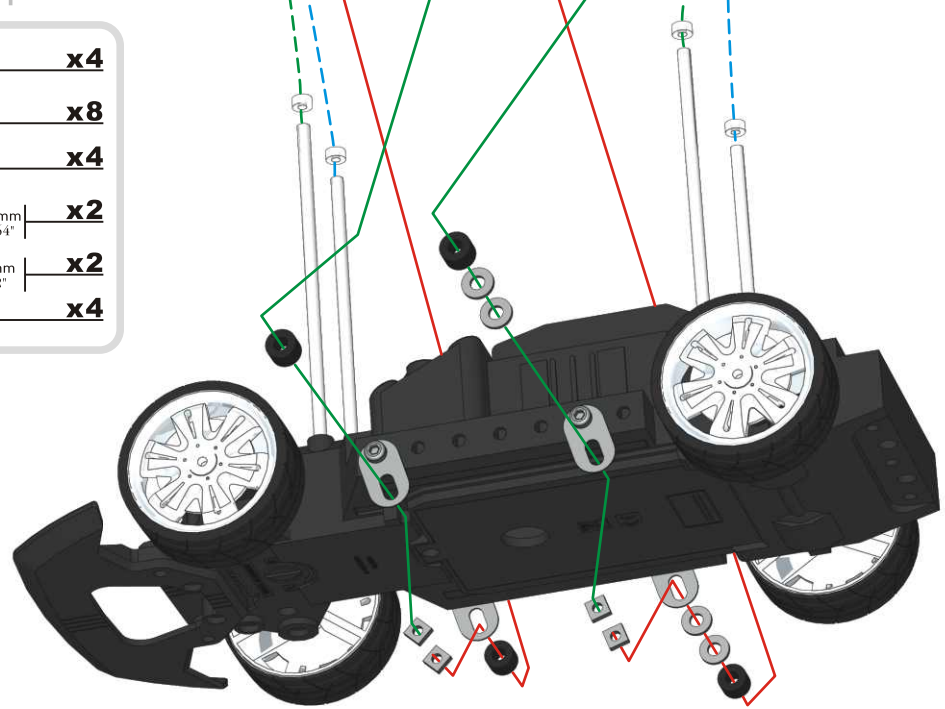

22 (20) + (21) +

-  **x4**
-  **x8**
-  **x4**
-  | 14,7 mm | **x2**
37/64"
-  | 12 mm | **x2**
1/2"
-  **x4**







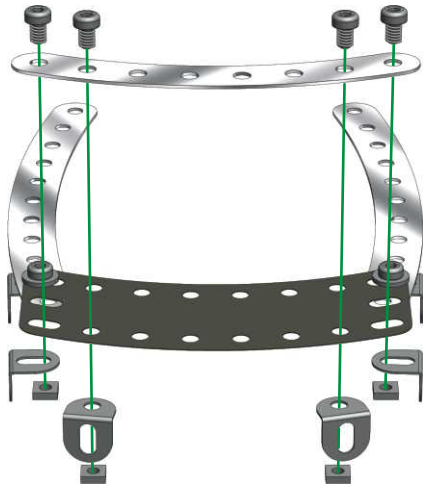
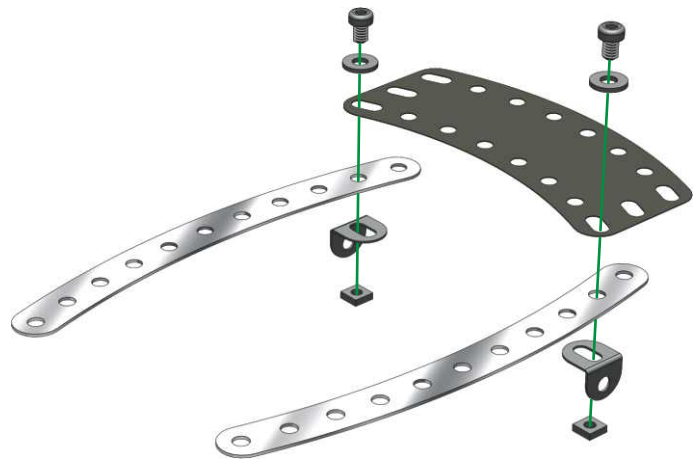

1

-  **x2**
-  **x1**
-  **x2**
-  **x2**
-  **x2**
5.8 mm | 15/64"
-  **x2**





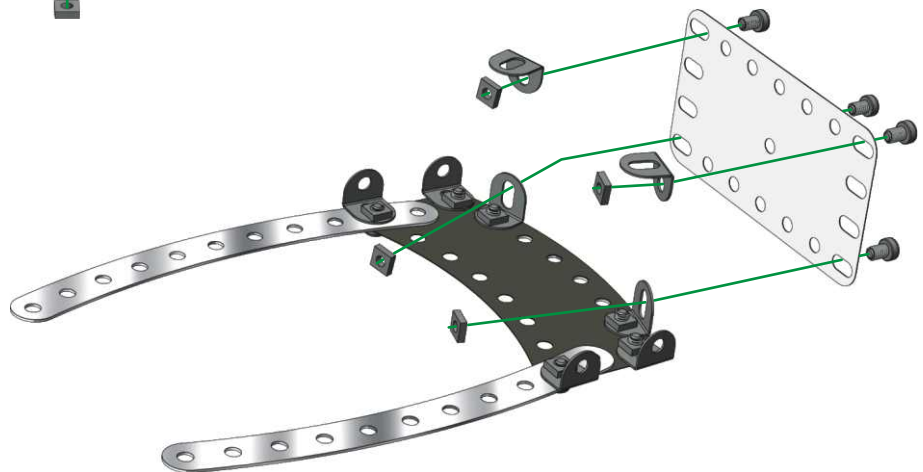

2





-  **x1**
-  **x4**
-  **x4**
5.8 mm | 15/64"
-  **x4**



3



-  **x1**
-  **x2**
-  **x4**
5.8 mm | 15/64"
-  **x4**

4

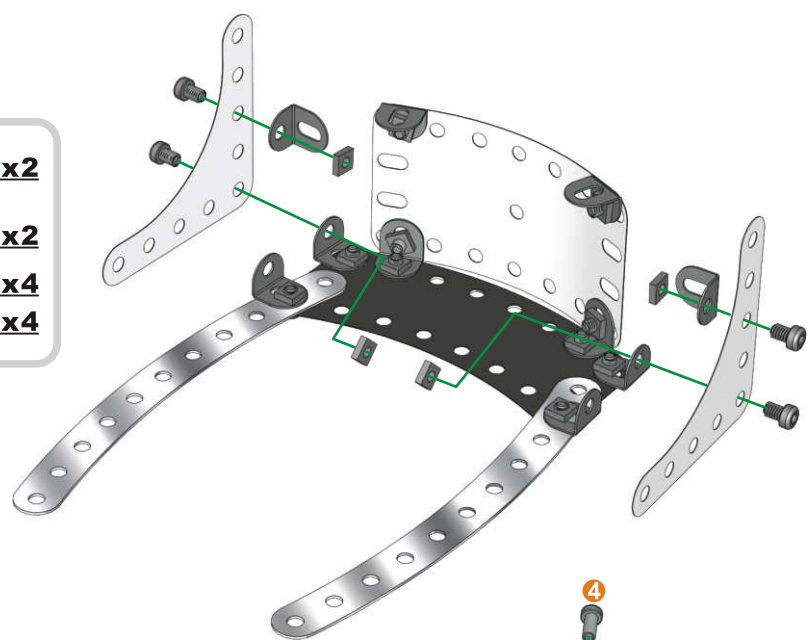
-  **x2**
-  **x2**
-  | 5,8 mm | **x4**
15/64"
-  **x4**



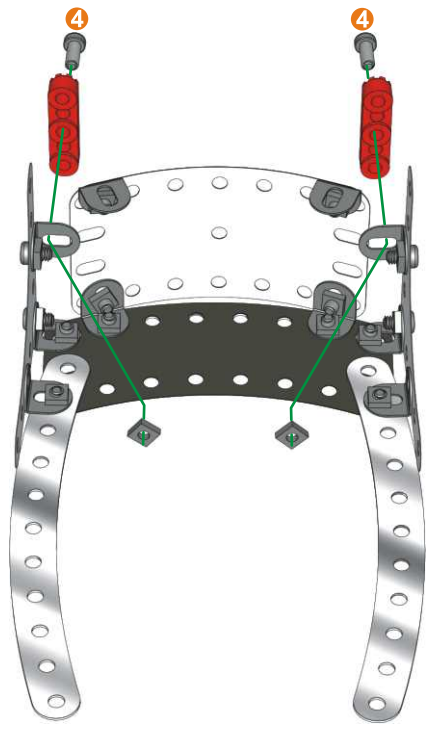

5

-  **x2**
-  | 9,5 mm | **x2**
3/8"
-  **x2**





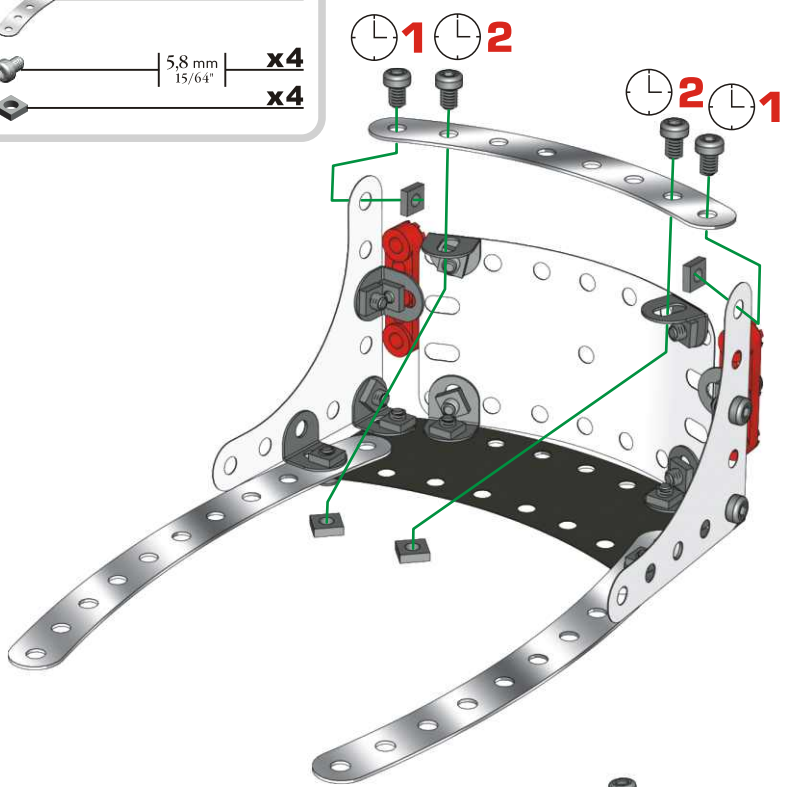

6

-  **x1**
-  | 5,8 mm | **x4**
15/64"
-  **x4**





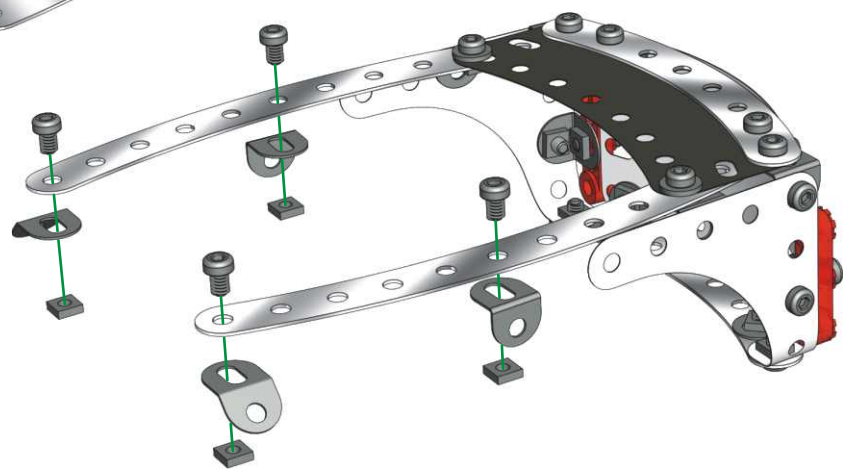

7

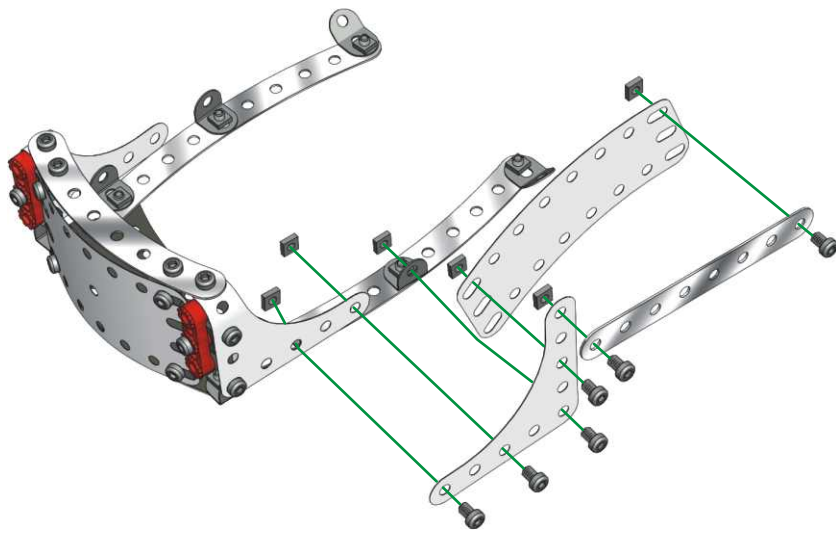
-  **x2**
-  **x2**
-  | 5,8 mm | **x4**
15/64"
-  **x4**



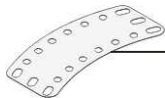

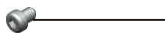



8

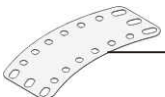

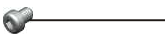

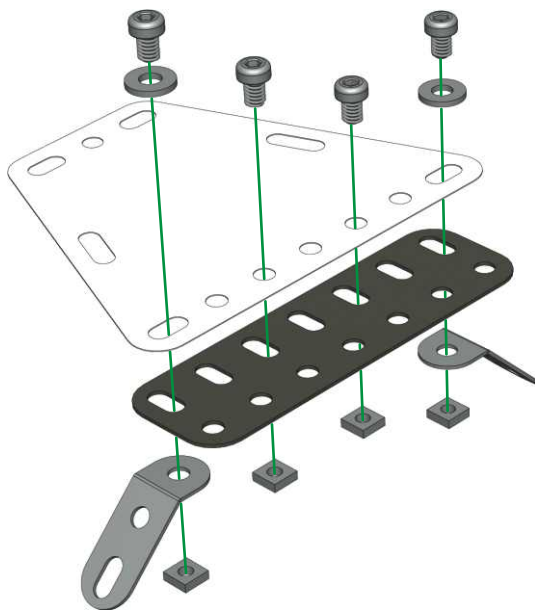
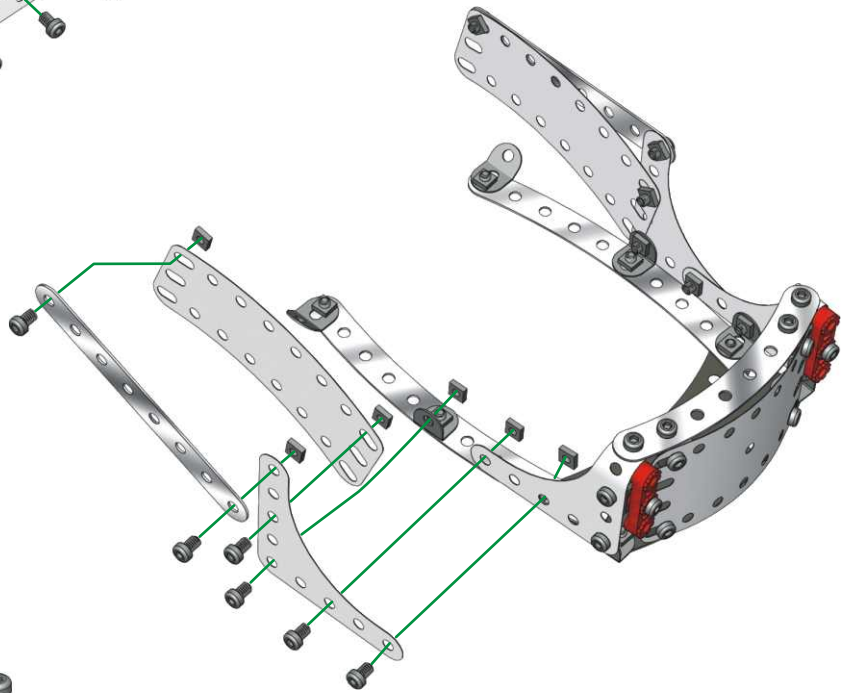

-  **x1**
-  **x1**
-  **x1**
-  **x6**
5,8 mm
15/64"
-  **x6**

9



-  **x1**
-  **x1**
-  **x1**
-  **x6**
5,8 mm
15/64"
-  **x6**



10

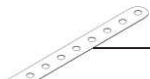
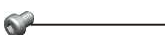

-  **x1**
-  **x1**
-  **x2**
-  **x2**
-  **x4**
5,8 mm
15/64"
-  **x4**

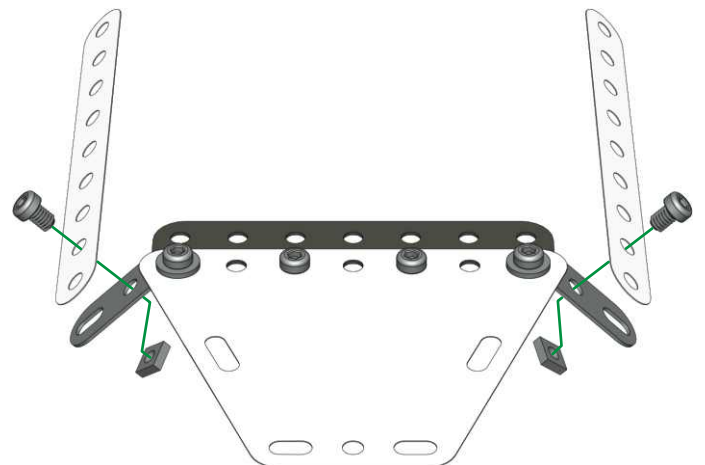

11

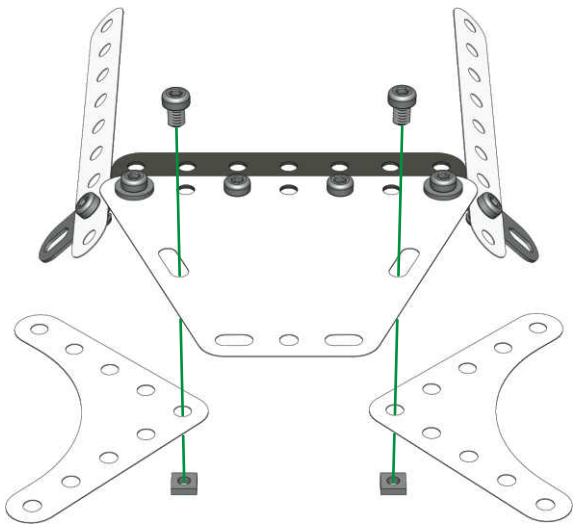
-  **x2**
-  **x2**
5,8 mm
15/64"
-  **x2**









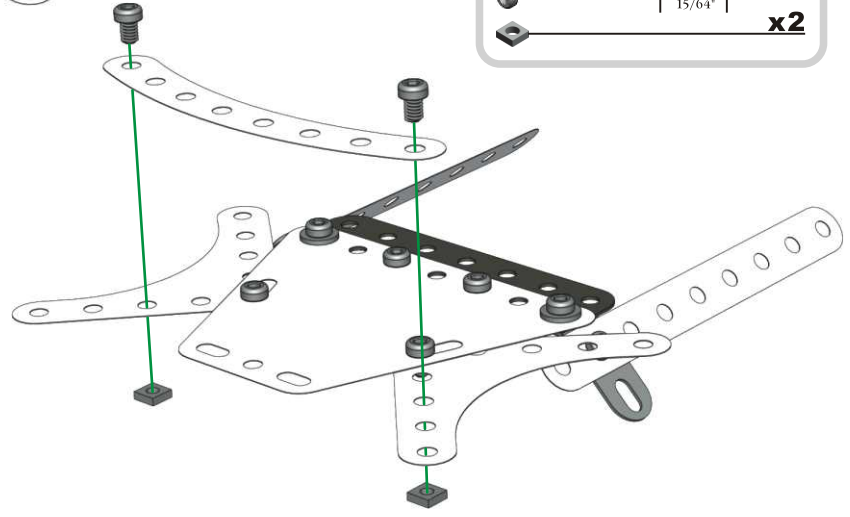

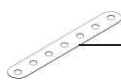



- 12**
-  **x2**
 -  | 5,8 mm | **x2**
15/64"
 -  **x2**

- 13**
-  **x1**
 -  | 5,8 mm | **x2**
15/64"
 -  **x2**

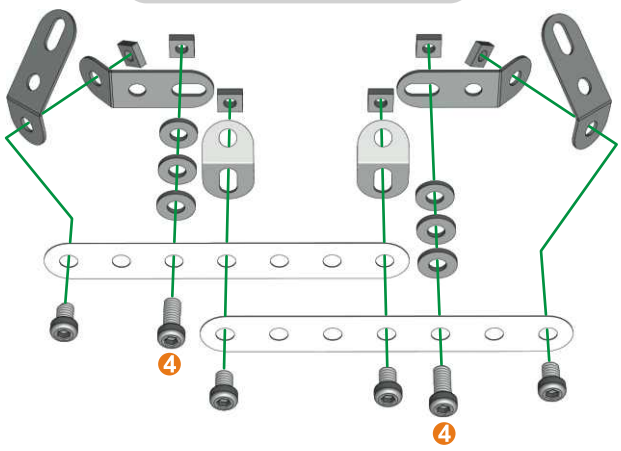



- 14**
-  **x2**
 -  **x4**
 -  **x2**
 -  **x6**
 -  | 9,5 mm | **x2**
3/8"
 -  | 5,8 mm | **x4**
15/64"
 -  **x6**



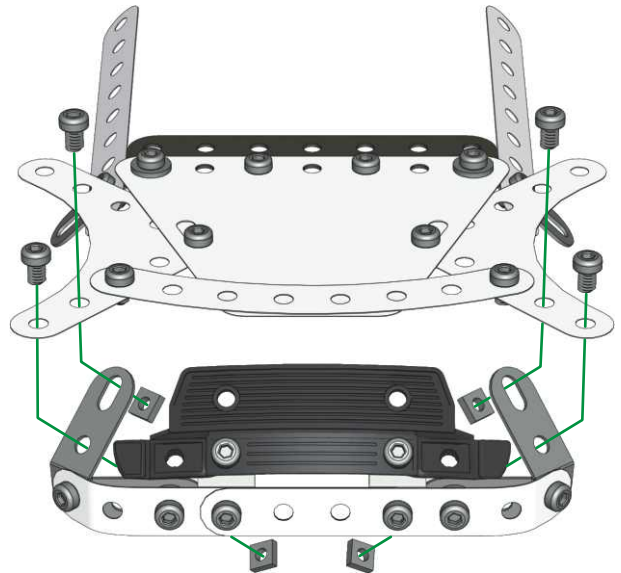
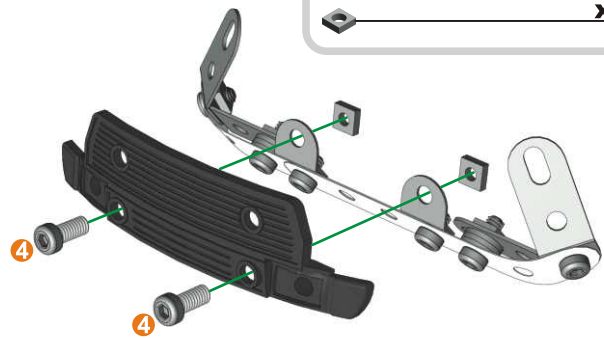



- 15**
-  **x1**
 -  | 9,5 mm | **x2**
3/8"
 -  **x2**





- 16** ⑬ + ⑮ +
-  | 5,8 mm | **x4**
15/64"
 -  **x4**

17

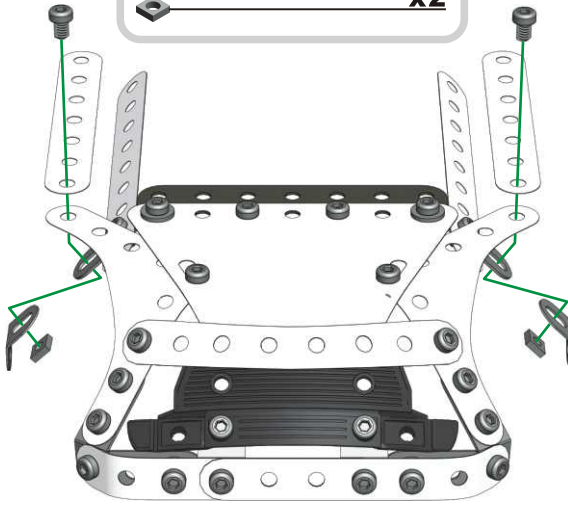
-  **x2**
-  **x2**
-  **x2**
-  **x2**



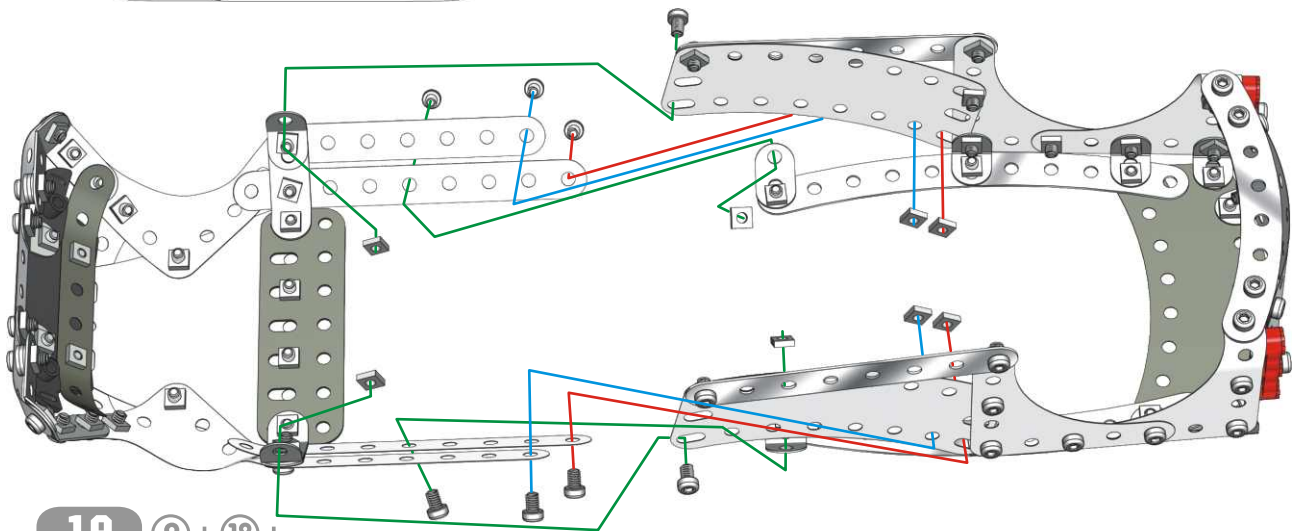
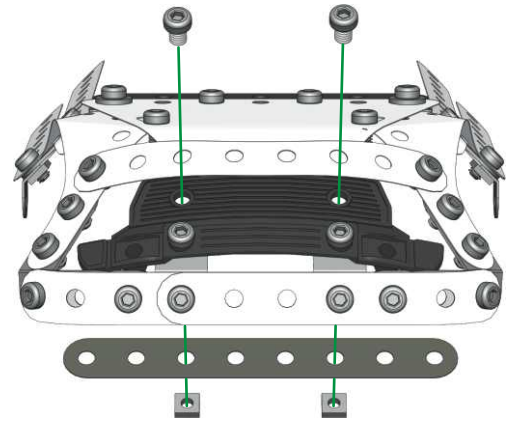

18

-  **x2**
-  **x2**
-  **x2**



19

9 + 18 +

-  **x8**
-  **x8**

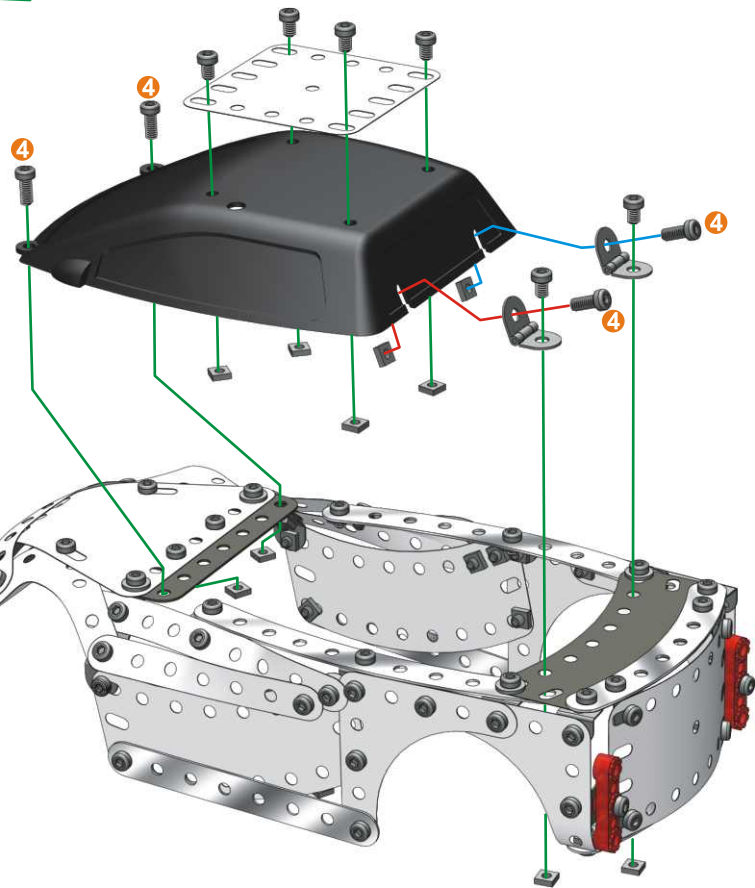

20

-  **x1**
-  **x1**
-  **x2**
-  **x4**
-  **x6**
-  **x10**

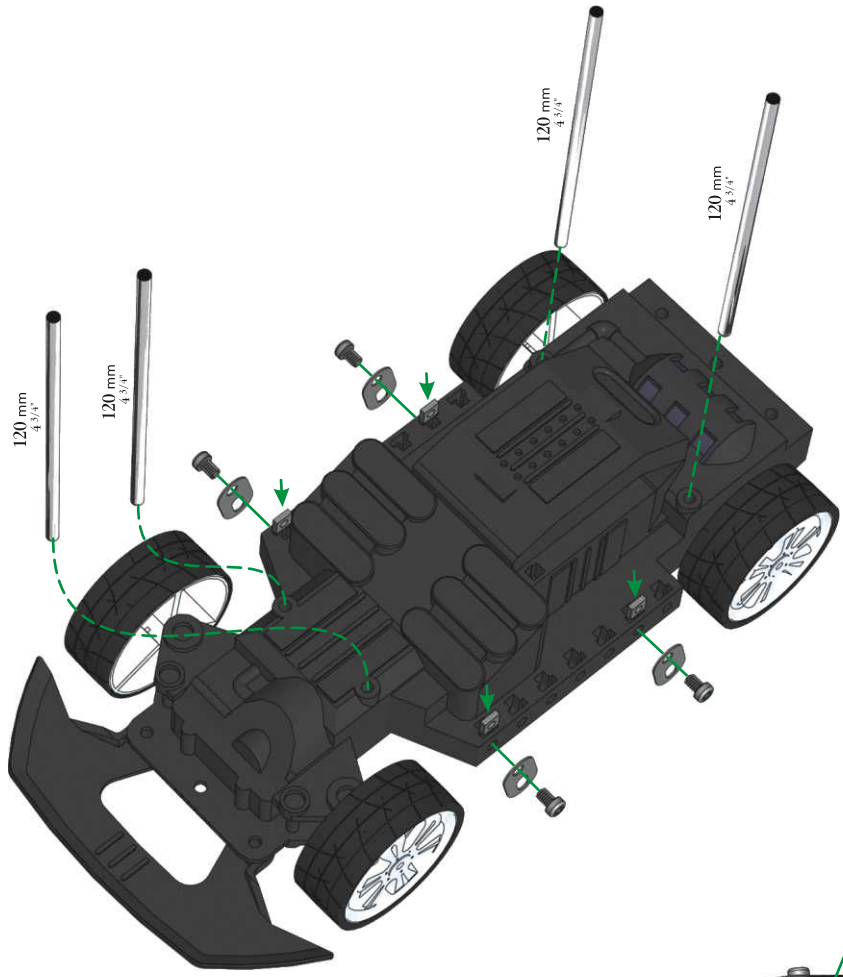

21

- x1**
- | 120 mm | **x4**
4 3/4"
- x4**
- | 5,8 mm | **x4**
15/64"
- x4**

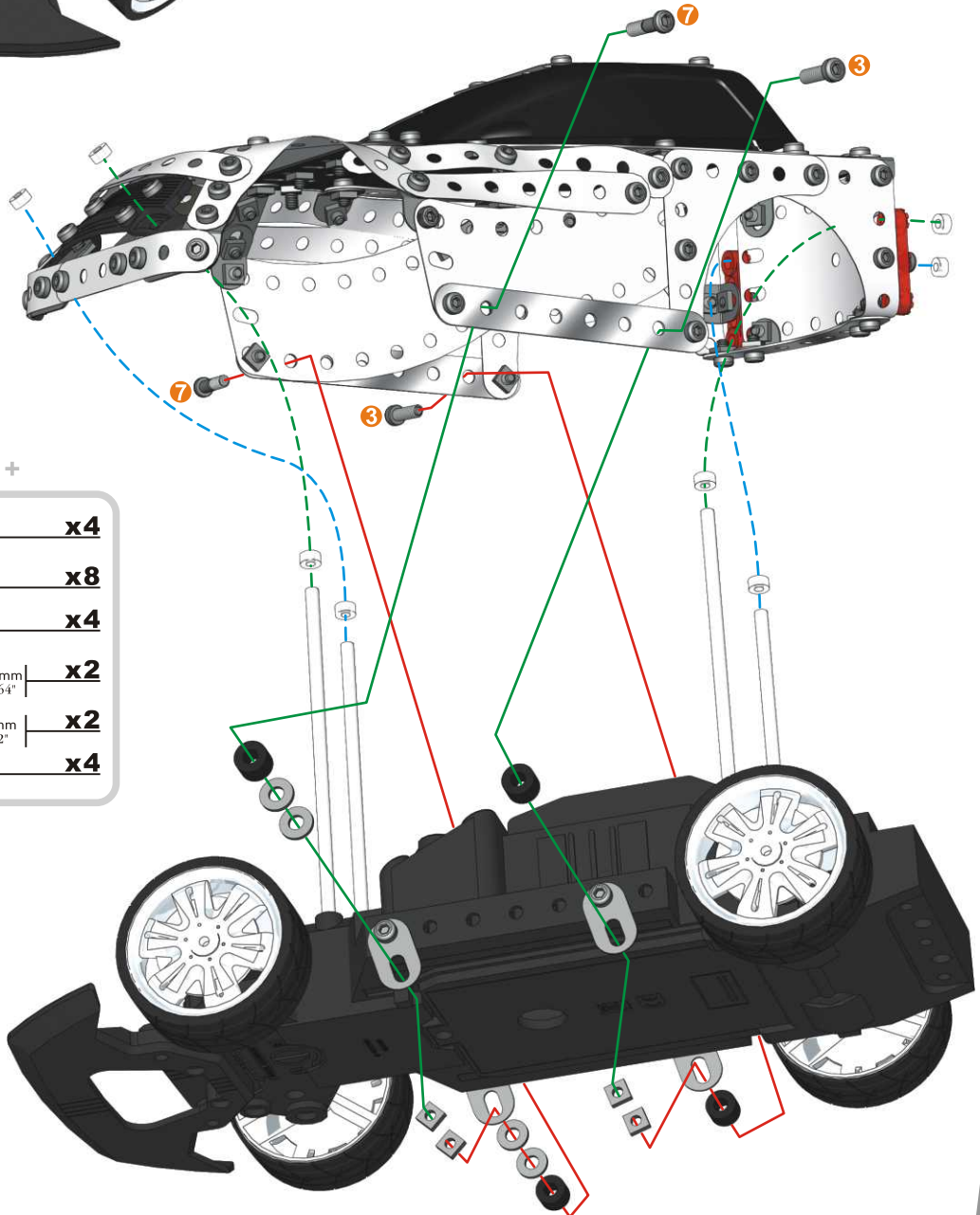

22 (20) + (21) +



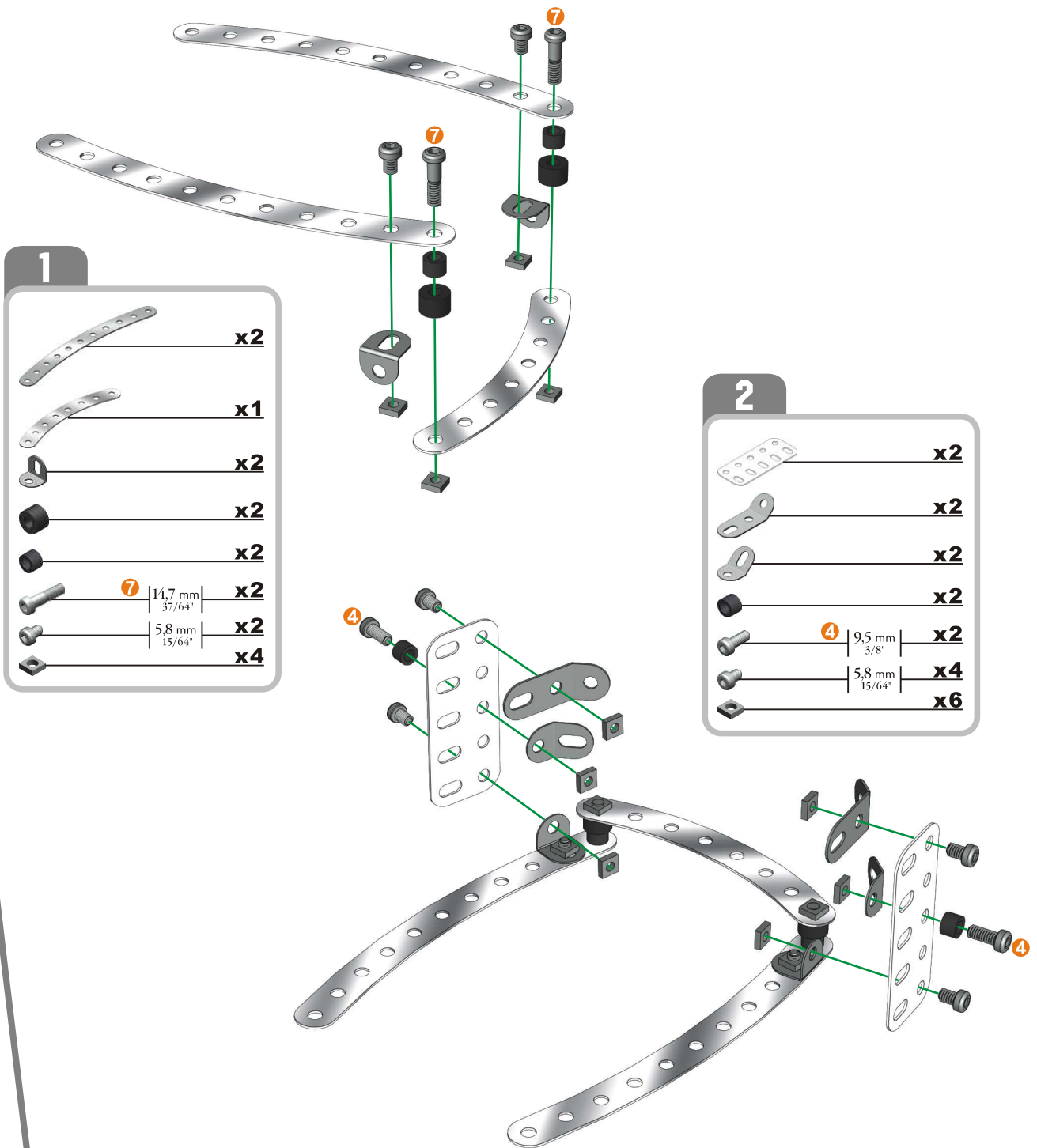



- x4**
- x8**
- x4**
- | 14,7 mm | **x2**
37/64"
- | 12 mm | **x2**
1/2"
- x4**



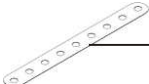





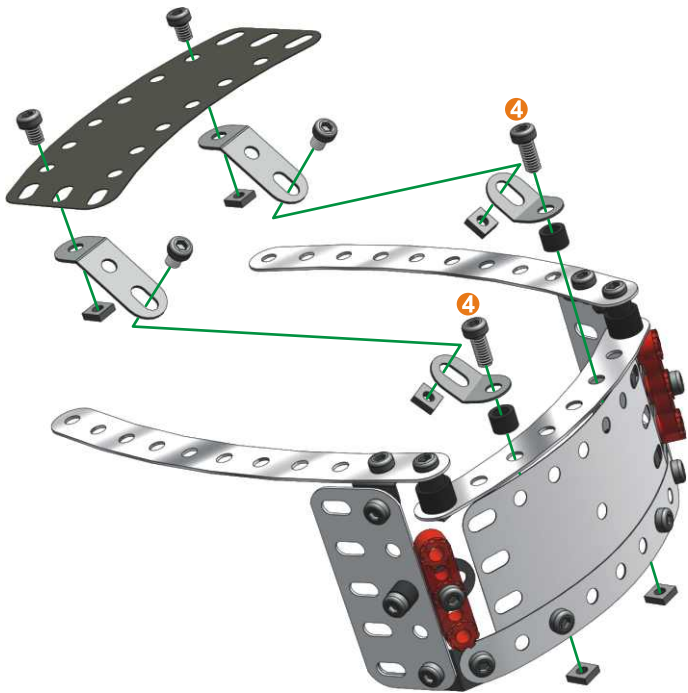
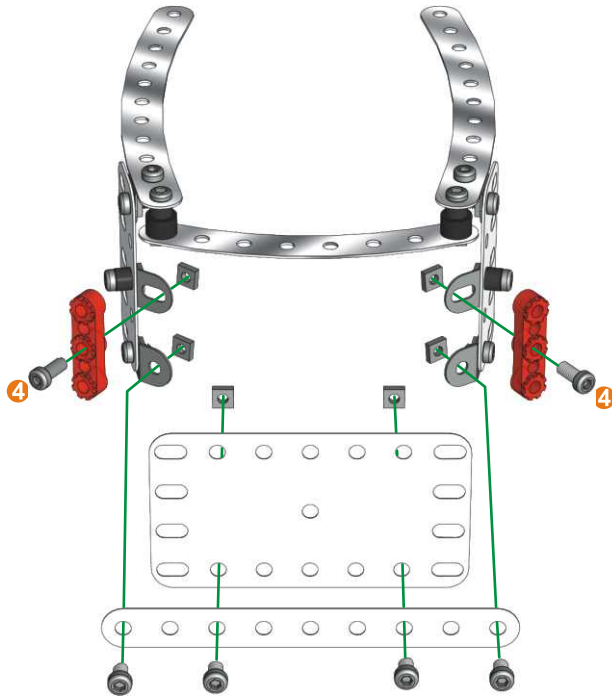

- 1**
- x2**
 - x1**
 - x2**
 - x2**
 - x2**
 - 7** | 14,7 mm | **x2**
37/64"
 - | 5,8 mm | **x2**
15/64"
 - x4**

- 2**
- x2**
 - x2**
 - x2**
 - x2**
 - 4** | 9,5 mm | **x2**
3/8"
 - | 5,8 mm | **x4**
15/64"
 - x6**



3

-  **x1**
-  **x1**
-  **x2**
-  **x2**
-  **x4**
-  **x6**

**4**

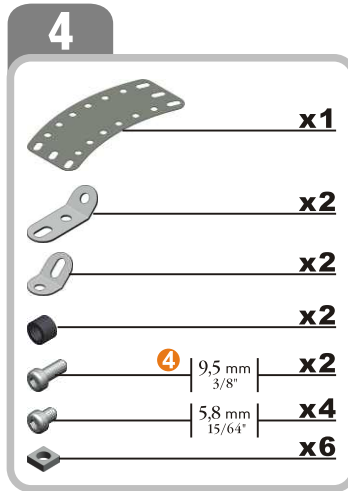
-  **x1**
-  **x2**
-  **x2**
-  **x2**
-  **x2**
-  **x4**
-  **x6**

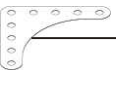
**5**

-  **x1**
-  **x4**
-  **x8**
-  **x8**

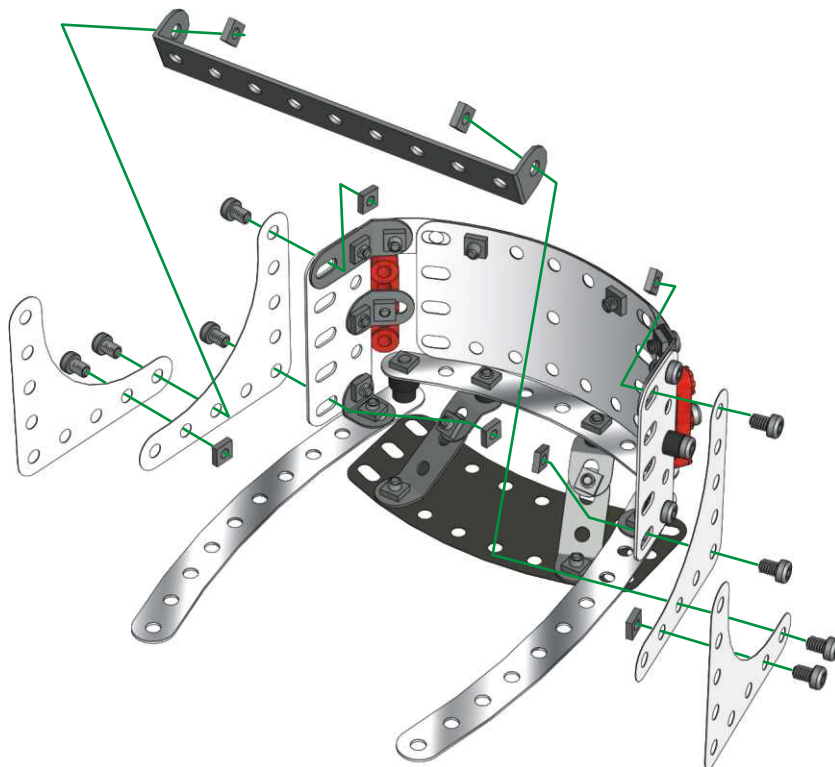

6

	x1
	x2
	x1
	x2
	x2

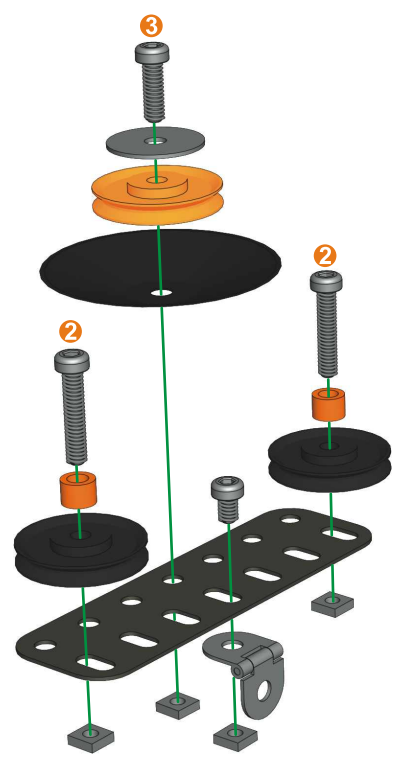
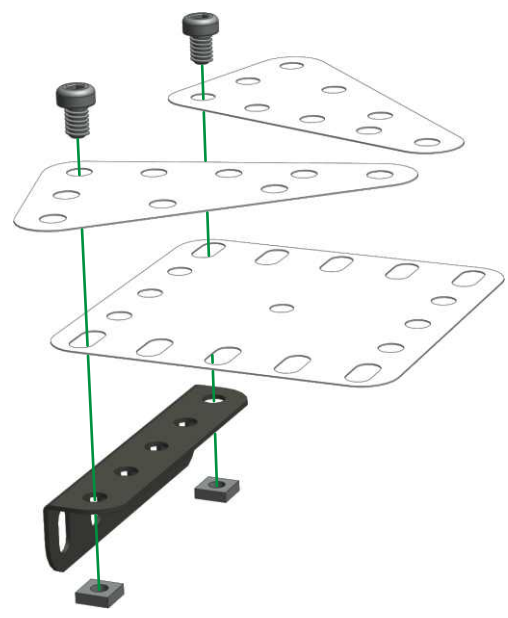

7





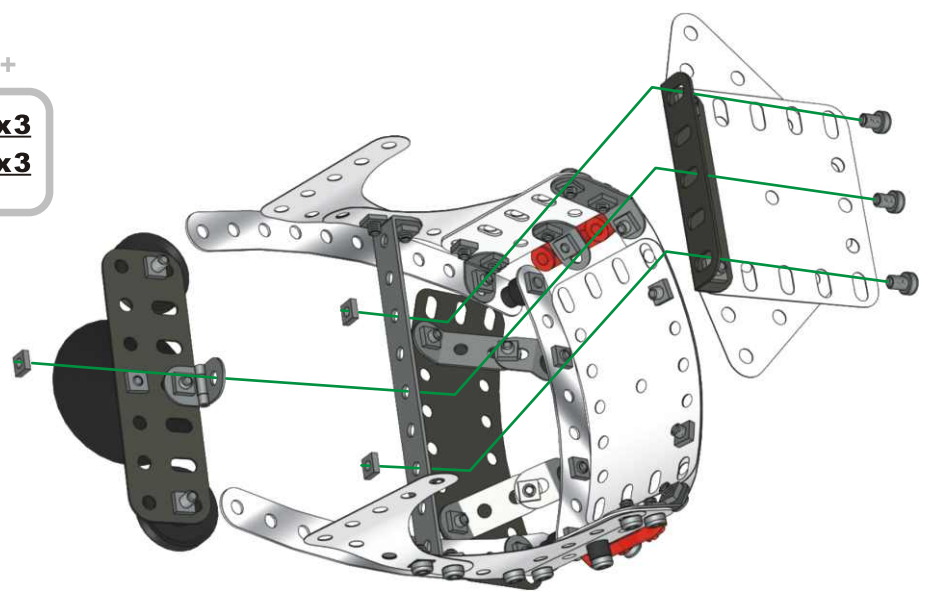

	x1
	x1
	x1
	x2
	x1
	x1
	x2
	x2
	x1
	x1
	x4

8 (5) + (6) + (7) +

	x3
	x3





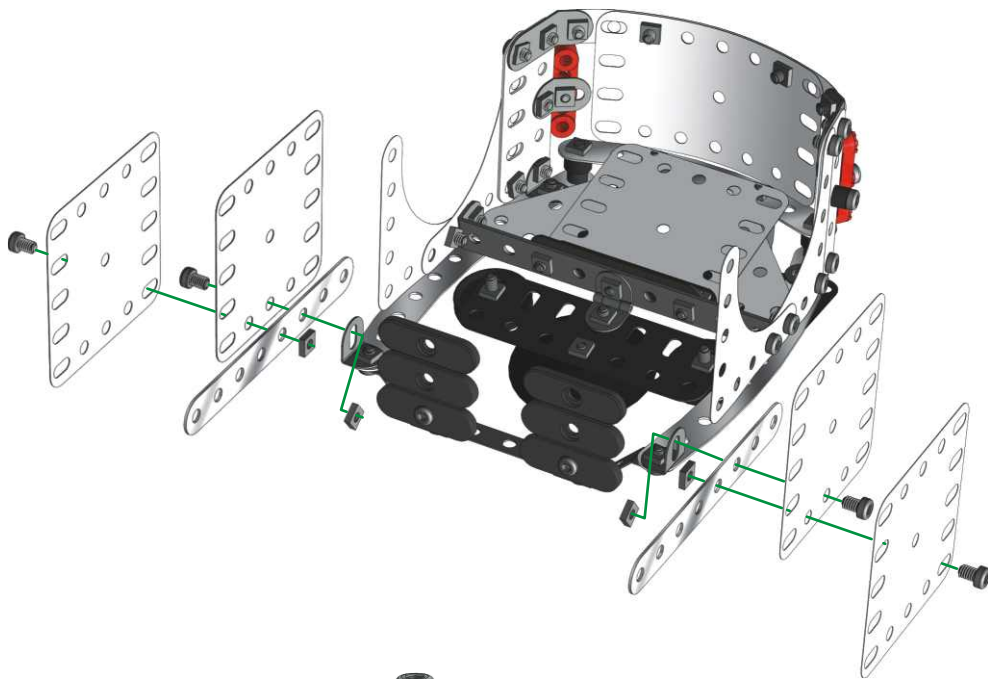
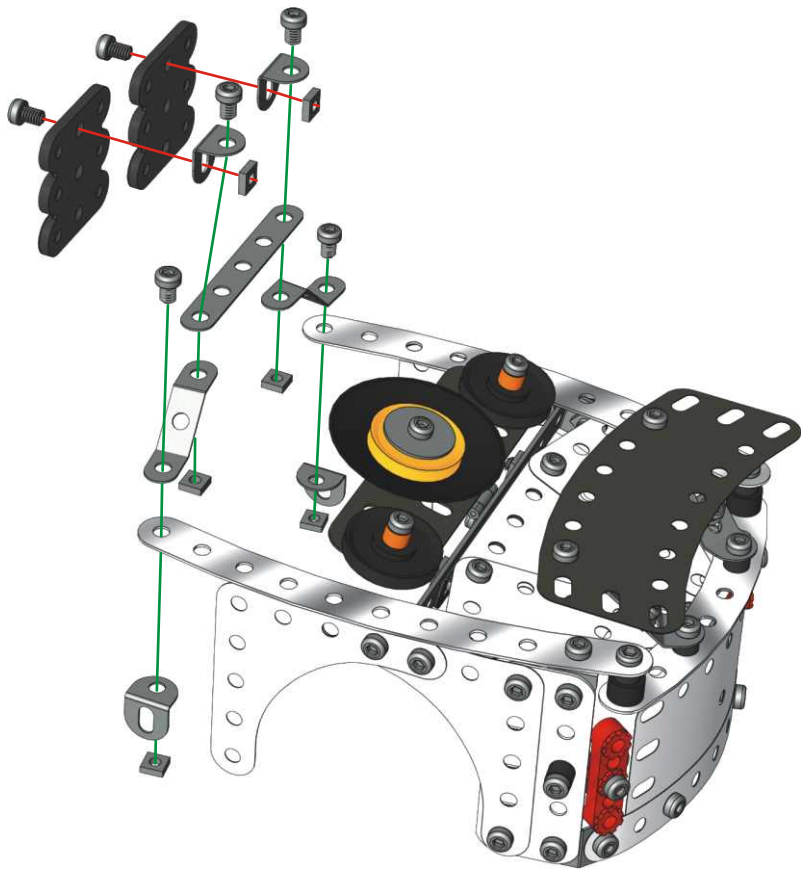

9

-  **x2**
-  **x1**
-  **x2**
-  **x4**
-  **x6**
-  **x6**





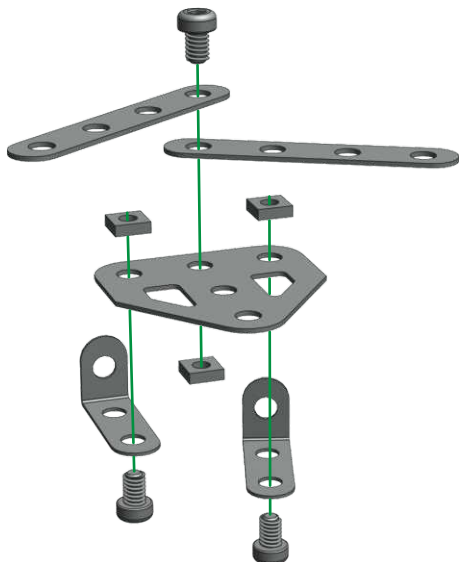

10



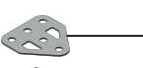





-  **x2**
-  **x4**
-  **x4**
-  **x4**



11



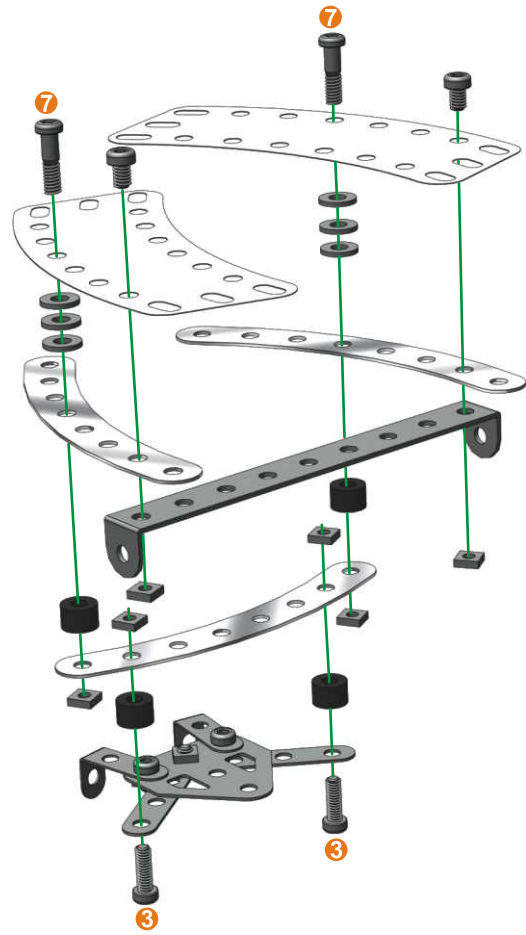

-  **x2**
-  **x1**
-  **x2**
-  **x3**
-  **x3**

12

-  **x1**
-  **x2**
-  **x3**
-  **x4**
-  **x6**
-  **x2**
-  **x2**
-  **x2**
-  **x6**

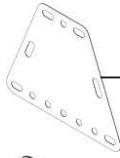



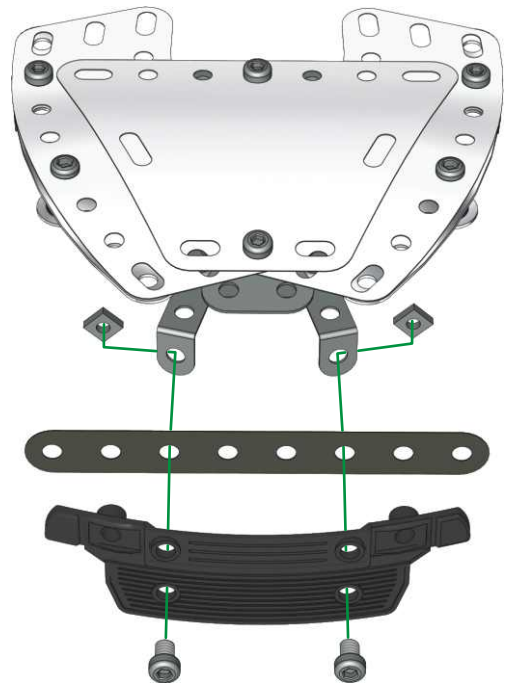

13



-  **x1**
-  **x1**
-  **x2**
-  **x2**



14



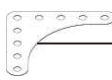

-  **x1**
-  **x1**
-  **x2**
-  **x2**

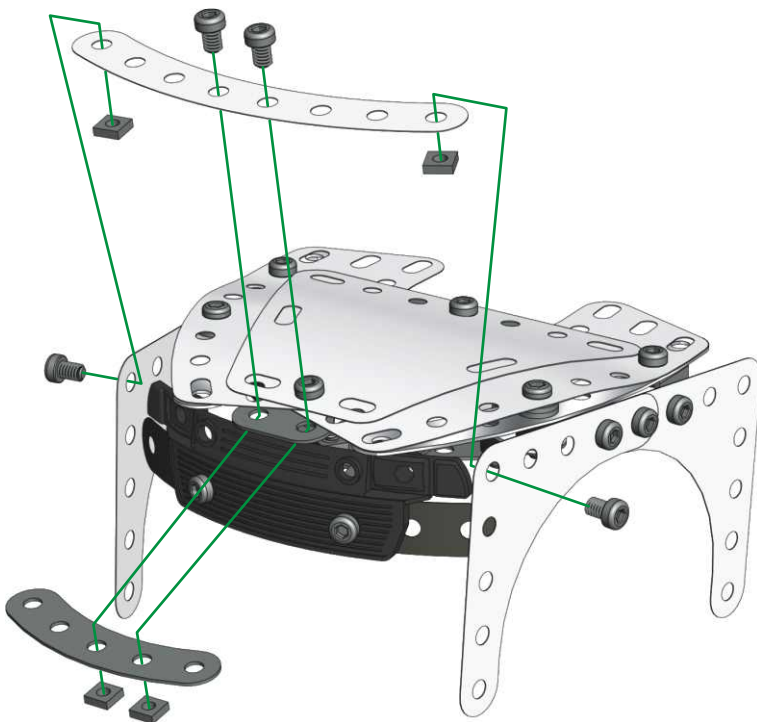
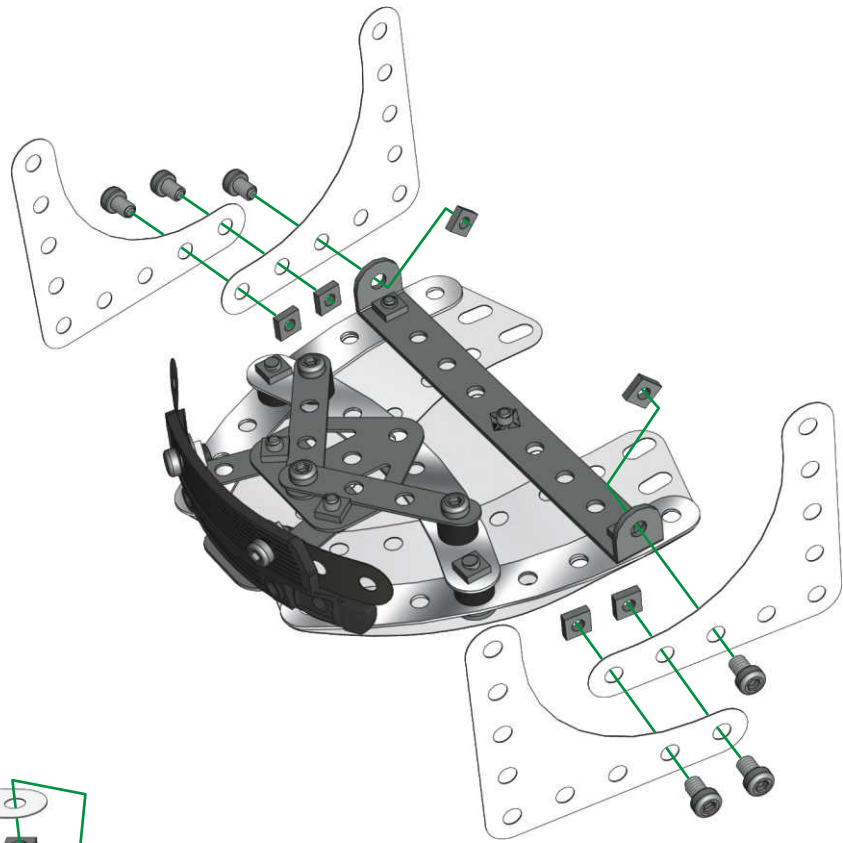
15

-  **x4**
-  | 5,8 mm | **x6**
-  | 15/64" | **x6**

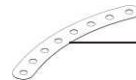



16

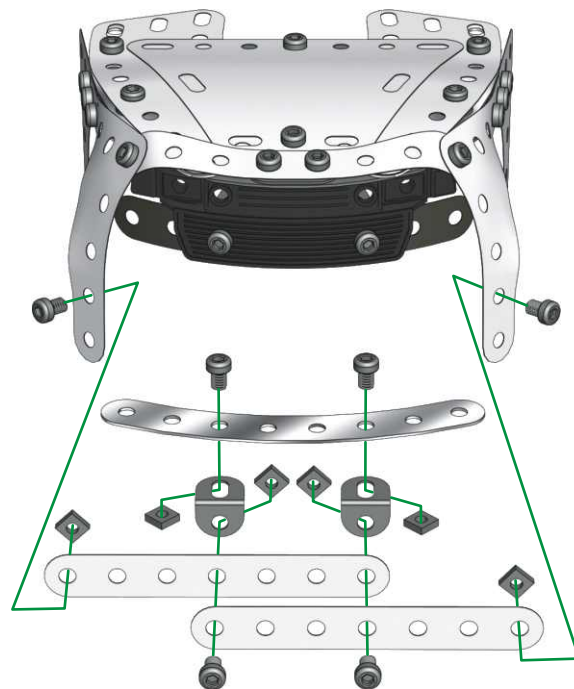



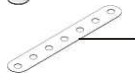
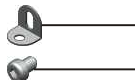

-  **x1**
-  **x1**
-  | 5,8 mm | **x4**
-  | 15/64" | **x4**

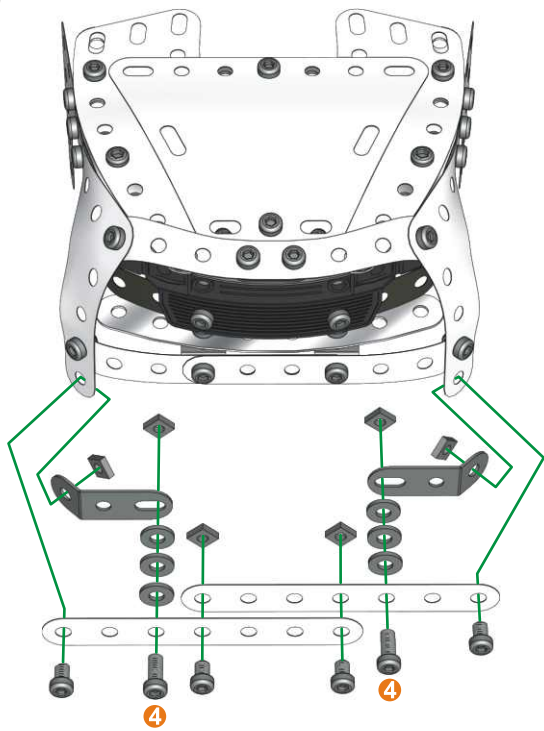





17





-  **x1**
-  **x2**
-  **x2**
-  | 5,8 mm | **x6**
-  | 15/64" | **x6**

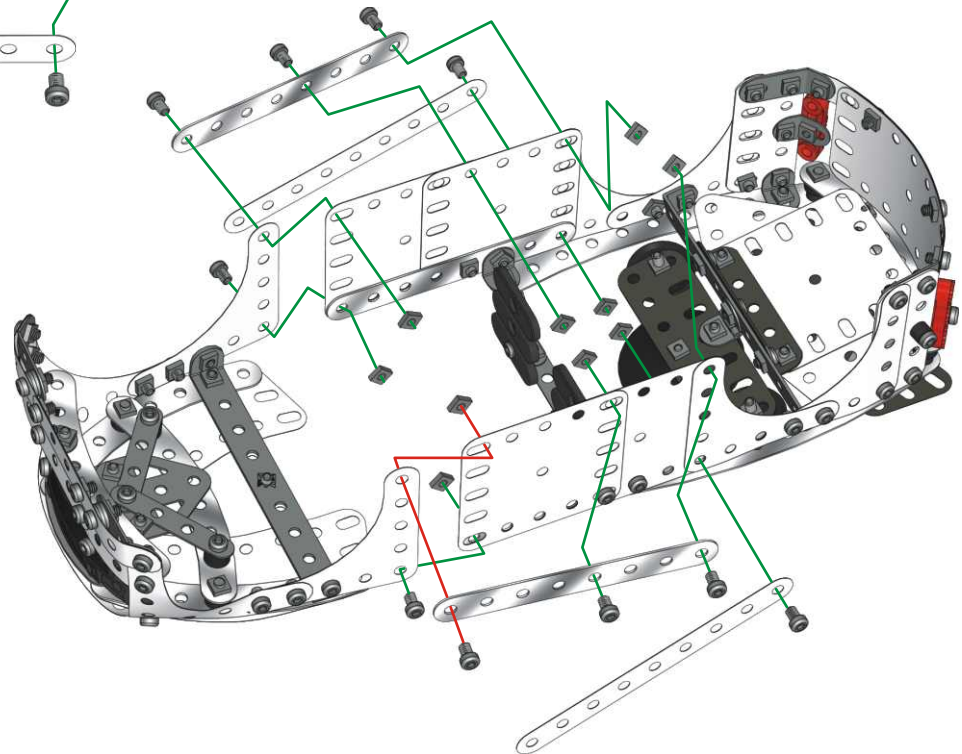

- 18**
-  **x2**
 -  **x2**
 -  **x6**
 -  **4** | 9,5 mm | **x2**
3/8"
 -  **x4**
5,8 mm | 15/64"
 -  **x6**

- 19** (10) + (18) +
-  **x2**
 -  **x2**
 -  **x8**
5,8 mm | 15/64"
 -  **x8**



- 20**
-  **x1**
 -  **x2**
 -  **x2**
 -  **x6**
5,8 mm | 15/64"
 -  **x6**

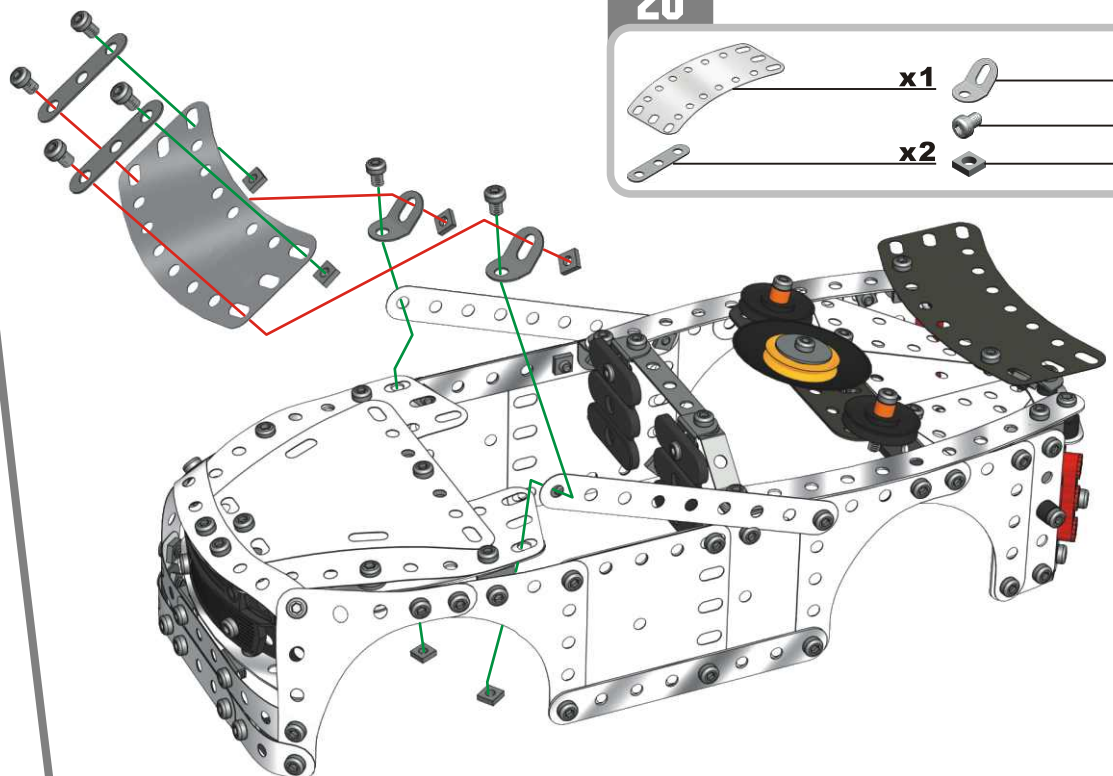

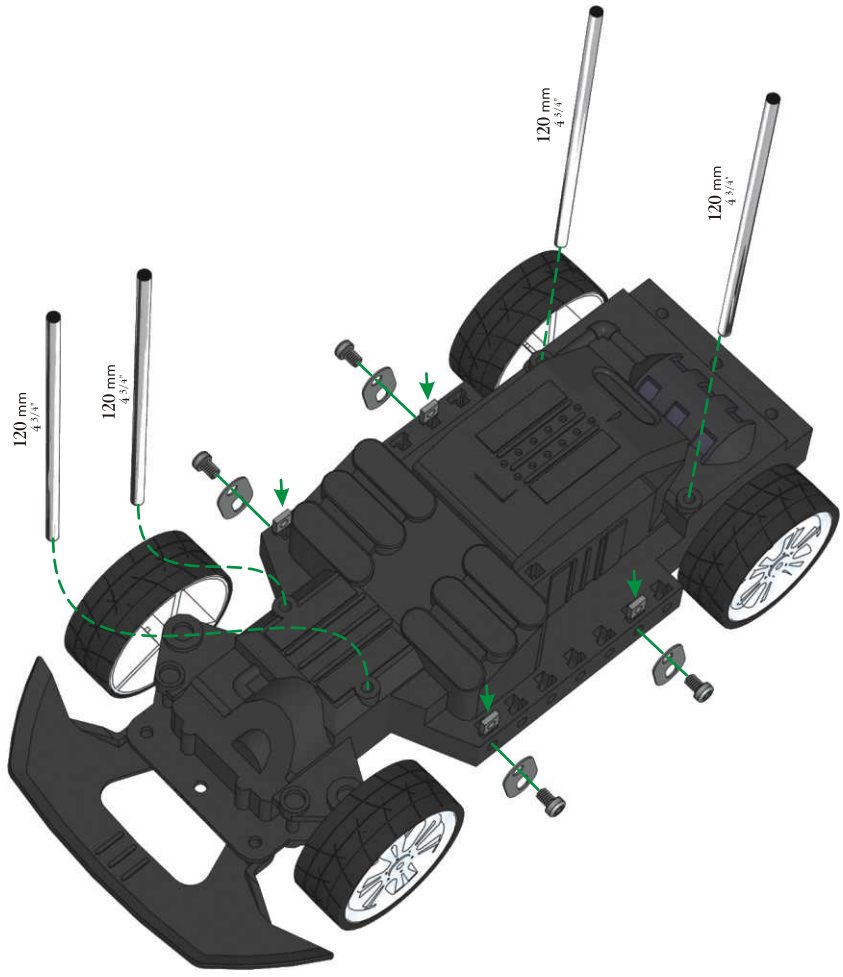

21

x1

x4

x4

x4

x4

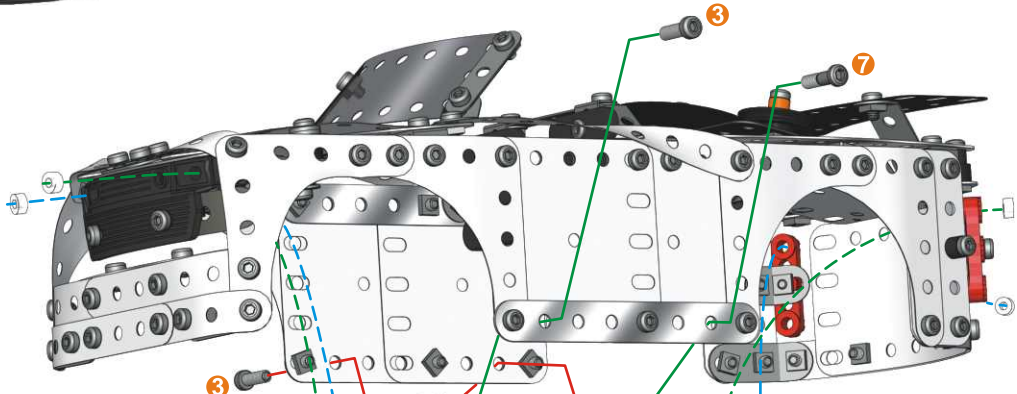

22 (20) + (21) +

x4

x8

x4

x2 7 | 14,7 mm | 37/64"

x2 3 | 12 mm | 1/2"

x4

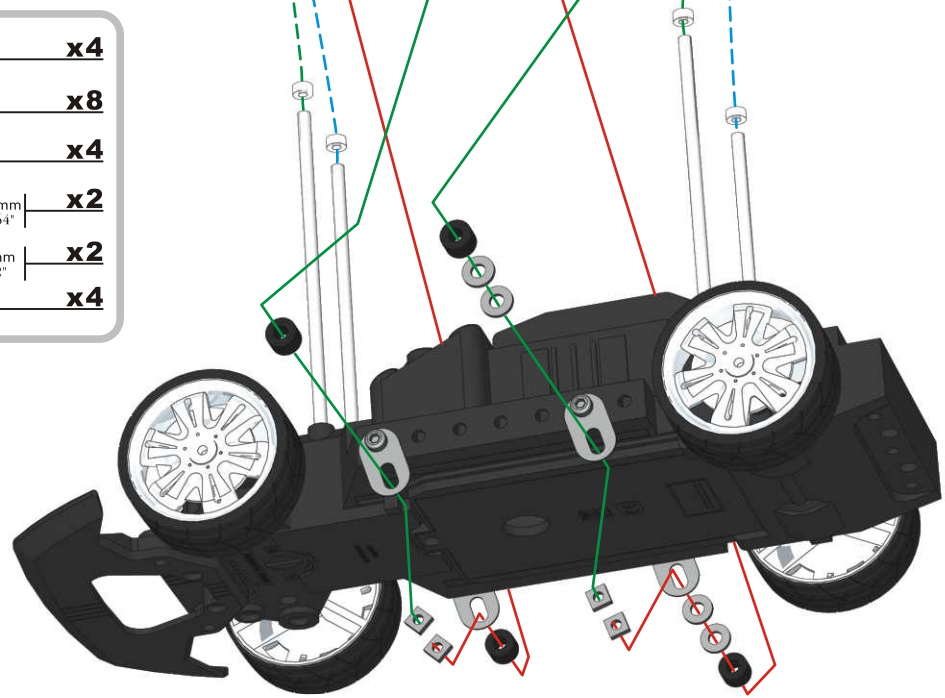

GB USA Many of the models and component parts are unique and original designs which are the property of MECCANO. They are protected by national legislation as industrial designs, trademarks and/or copyrights throughout many countries. For detailed information, please contact: MECCANO. Meccano shall have no responsibility for (I) failure to follow instructions, (II) use of parts for any purpose other than as specified in the instructions (III) any alteration of any parts or components. MECCANO respects children's safety: all models are tested by children.

F De nombreux modèles et pièces sont des créations originales, propriétés de MECCANO et sont protégés par les législations nationales sur les dessins et modèles, marques et/ou droits d'auteurs. Pour toute information, merci de contacter : MECCANO. La responsabilité de MECCANO ne saurait être engagée en cas d'accident survenu à la suite (I) du non respect des instructions de montage (II) d'une utilisation des pièces autre que celle proposée dans la notice (III) d'une altération ou de la modification des pièces. La société MECCANO respecte la sécurité des enfants : ses modèles sont testés par des enfants.

D Zahlreiche Modelle und Teile sind Erfindungen und Eigentum der Firma MECCANO. Sie sind durch Inland-Gesetze über Zeichnungen und Modelle sowie Warenzeichen und/oder Urheberrechte geschützt. Für zusätzliche Auskünfte wenden Sie sich bitte an : MECCANO. Die Firma Meccano haftet nicht für Unfälle, die aus der (I) Nichtbeachtung der Bauanleitung, der (II) Verwendung anderer als in der Bauanleitung angegebenen Teile oder der (III) Änderung oder Modifikation der Teile resultieren. Alle Modelle der Firma Meccano wurden von Kindern getestet und entsprechen den Sicherheitsnormen.

I Numerosi modelli e pezzi sono creazioni originali della MECCANO e sono protetti dalle legislazioni nazionali sui disegni e modelli, marche e/o diritti d'autore. Per qualsiasi informazione, vogliate prendere contatto con : MECCANO. Meccano declina ogni responsabilità in caso d'incidenti sopravvenuti in seguito (I) a: non rispetto delle istruzioni di montaggio (II) utilizzo dei pezzi per funzioni diverse da quelle previste nel manuale (III) alterazione e/o modifica dei pezzi. La società MECCANO rispetta la sicurezza dei bambini : i suoi modelli vengono testati dai bambini stessi.

E Numerosos modelos y piezas son creaciones originales, propiedades de MECCANO y están protegidos por las legislaciones nacionales en lo que concierne a los dibujos y modelos, marcas y/o derechos de autor. Para cualquier información, sírvase ponerse en contacto con : MECCANO. MECCANO carece de responsabilidad en caso de accidente debido a: (I) el incumplimiento de las instrucciones de montaje (II) una utilización de las piezas diferente a la que se indica en las instrucciones (III) una alteración o modificación de las piezas. La sociedad MECCANO respeta la seguridad de los niños : sus modelos están probados por niños.

P Vários modelos e peças são criações originais, propriedades da MECCANO e são protegidos pelas legislações nacionais relativas aos desenhos e modelos, às marcas e/ou aos direitos de autor. Para qualquer informação, é favor contactar : MECCANO. A Sociedade MECCANO não poderá ser responsabilizada pelos acidentes provocados: (I) pela falta de cumprimento das instruções de montagem (II) pelo uso indevido das peças ou (III) pela modificação ou alteração das peças. A Sociedade MECCANO respeita a segurança das crianças : os seus modelos foram testados por crianças.

GB USA Standard batteries must not be recharged. Rechargeable batteries must be removed from the toy before being recharged (if it is possible to remove them). Rechargeable batteries must only be recharged under adult supervision (if it is possible to remove them). Do not mix different types of batteries together or new with old rechargeable / non rechargeable batteries. Only batteries of the recommended type or a similar type should be used. Batteries must be fitted in accordance with their instructions. Remove used batteries from the toy. Battery terminals must not be short-circuited. Please keep instructions.

F Les piles ne doivent pas être rechargées. Les accumulateurs doivent être enlevés du jouet avant d'être chargés (s'ils peuvent être enlevés). Les accumulateurs ne doivent être chargés que sous la surveillance d'un adulte (s'ils peuvent être enlevés). Différents types de piles ou accumulateurs ou des piles ou accumulateurs neufs et usagés ne doivent pas être mélangés. Seuls des piles ou accumulateurs du type recommandé ou d'un type similaire doivent être utilisés. Les piles et accumulateurs doivent être mis en place en respectant la polarité. Les piles et accumulateurs usagés doivent être enlevés du jouet. Les bornes d'une pile ou d'un accumulateur ne doivent pas être mises en court-circuit. Indications à conserver.

D Die Batterien dürfen nicht wieder aufgeladen werden. Die Akkus müssen vor dem Nachladen aus dem Spielzeug genommen werden (wenn sie ausgebaut werden können). Die Akkus dürfen nur unter Aufsicht eines Erwachsenen nachgeladen werden (wenn sie ausgebaut werden können). Unterschiedliche Arten von Batterien und Akkus oder neue und gebrauchte Batterien bzw. Akkus dürfen nicht zusammen verwendet werden. Es dürfen nur Batterien bzw. Akkus der empfohlenen Art oder einer ähnlichen Art verwendet werden. Beim Einsetzen der Batterien bzw. Akkus auf die richtige Polung achten. Verbrauchte Batterien bzw. Akkus bitte aus dem Spielzeug entfernen. Die Klemmen der Batterien bzw. Akkus dürfen nicht kurzgeschlossen werden. Diese Anweisungen bitte aufbewahren.

I Le pile non devono essere ricaricate. Gli accumulatori devono essere tolti dal giocattolo prima di essere caricati (se è possibile toglierli). Gli accumulatori devono essere caricati solo sotto la sorveglianza di un adulto (se è possibile toglierli). Non possono essere mescolati tipi diversi di pile o di accumulatori oppure pile o accumulatori nuovi e usati. Si devono usare solo pile o accumulatori del tipo raccomandato o di un tipo simile. Le pile e gli accumulatori devono venire sistemati rispettando la polarità. Le pile e gli accumulatori usati devono essere tolti dal giocattolo. I morsetti di una pila o di un accumulatore non devono essere messi in cortocircuito. Conservare queste istruzioni.

E Las pilas no deberán recargarse. Habrá que retirar los acumuladores del juguete antes de proceder a recargarlos (si es que pueden retirarse). Los acumuladores sólo se recargarán bajo la vigilancia de una persona adulta (si es que pueden retirarse). No deberán mezclarse diferentes tipos de pilas o acumuladores o de pilas o acumuladores nuevos y usados. Sólo se utilizarán pilas o acumuladores del tipo recomendado o de un tipo similar. Las pilas y acumuladores deberán colocarse respetando la polaridad. Deberán retirarse del juguete las pilas y acumuladores usados. Lors bormes de una pila o de un acumulador ne deberán disponerse nunca en posición de cortocircuito. Conserve estas indicaciones.

P As pilhas não devem ser novamente carregadas. Os acumuladores devem ser removidos do brinquedo antes de serem carregados (caso possam ser removidos). Os acumuladores devem ser carregados apenas sob cuidados de um adulto (caso possam ser removidos). Diferentes tipos de pilhas ou acumuladores ou pilhas ou acumuladores novos já utilizados não devem ser misturados. Pilhas ou acumuladores do tipo recomendado ou de um tipo similar poderão ser utilizados. As pilhas e acumuladores devem ser inseridos, respeitando a polaridade. Devem ser removidos do brinquedo as pilhas e acumuladores já utilizados. Os pólos de uma pilha ou de um acumulador não devem ser curto-circuitados. Indicações a conservar.

S Många modeller och delar bildar en unik och originell formgivning vilken är MECCANO egendom. Dessa modeller och delar är skyddade genom lagstiftning såsom industriell formgivning, varumärke och/eller upphovsmannarätt i ett flertal länder. För mer detaljerad information, var vänlig och kontakta MECCANO. MECCANO fräntar sig allt ansvar i händelse av olycka till följd av (I) att monteringsinstruktionerna inte har respekterats (II) en annan användning av delarna än den som står i anvisningen (III) en förvanskning eller förändring av delarna. Företaget MECCANO respekterar barnsäkerheten : modellerna har testats av barn.

FIN Useat mallit ja osat ovat MECCANO: n omaisuutta olevaa alkuperäistä suunnittelua. Ne ovat kansallisilla lailla suojattuna teollista tuotantola, tavaramerkkejä ja/tai kopiointioikeuksia. Pyydämme ottamaan yhteyden MECCANO: han kaikissa asioissa liittyvissä kysymyksissä. MECCANO ei vastaa eikä kata seuraavista syistä sattuneita onnettomuuksia: (I) ohjeiden vastainen kokoaminen, (II) muiden kuin ohjeissa ehdotettujen osien käyttö, (III) osien muuntelu tai eri tarkoituksiin väärin käyttö. MECCANO-yhtiö huolehtii lasten turvallisuudesta: lapset ovat testanneet mallimme.

DK Vore mange modeller og dele er originale fremstillinger og ejes af MECCANO. Tegninger, modeller, fabrikmærker og ophavsret er lovbeskyttede i hvert land. Yderligere oplysninger kan fås hos: MECCANO. MECCANO frasiger sig ethvert ansvar, såfremt der er sket uheld forårsaget af (I) at monteringsinstruktionerne ikke er blevet overholdt, (II) at delene er blevet brugt til andre formål, end dem der er beskrevet i betjeningsvejledningen, (III) eller at delene er blevet beskadiget eller ændret, MECCANO overholder sikkerhedsreglerne for børn: Alle modeller testes af børn.

NL Veel modellen en onderdelen zijn originele ontwerpen en eigendom van MECCANO en worden beschermd door de nationale wetgevingen op tekeningen en modellen, merken en/of auteursrechten. Voor informatie gelieve contact op te nemen met MECCANO. De verantwoordelijkheid van MECCANO is uitgesloten in geval van ongevallen voortkomend uit het niet naleven van de montage-instructies (I), uit het gebruik van andere onderdelen dan die zoals vermeld in de handleiding (II) of uit het veranderen of modifieren van de onderdelen (III). De firma MECCANO neemt de veiligheid van de kinderen in acht : de modellen zijn door kinderen getest.

GR Πολλά μοντέλα και ανταλλακτικά είναι αυθεντικά, ιδιοκτησία της MECCANO και προστατεύονται από τις εθνικές νομοθεσίες για τα μοντέλα της μάρκας ή τα διπλώματα ευρεσιτεχνίας. Για κάθε πληροφορία Για κάθε πληροφορία παρακαλώ απευθυνθείτε στη MECCANO. Η ευθύνη της MECCANO δεν δεσμεύεται σε περίπτωση ατυχήματος που έγινε συνεχώς (I) μη σεβασμού των οδηγιών συναρμολόγησης (II) χρήσης των τμημάτων διαφορετικά από αυτήν που προτείνεται στις οδηγίες (III) καταστροφή ή αλλαγή των τμημάτων. Η εταιρεία MECCANO σεβεται την ασφάλεια των παιδιών: τα μοντέλα της δοκιμάζονται από παιδιά.

JPN モデルならびに部品は、その多くが MECCANO 社所有のオリジナル・デザインで、意匠・商標および/または著作権に関する国内法によって保護されています。詳細については、当社 (MECCANO) メカノ社は (I) 組立の注意事項を守らなかつた場合、(II) 使用説明書に記載されたもの以外の部品を使用した場合、(III) 部品を改変・改造した場合などに起きた事故については責任を負うことはできません。メカノ社の全モデルは事前に子供たちによりテストを行い、その安全性を確認されております。

S Batterierna skall inte laddas om. Akkumulatorbatterierna skall tas av från lleksken innan de laddas (om de kan tas av). Akkumulatorbatterierna skall endast laddas under uppsikt av en vuxen (om de kan tas av). Olika typer av batterier eller akkumulatorbatterier skall inte blandas. Nya och använd batterier eller akkumulatorbatterier skall inte blandas. Använd endast rekommenderade typer eller likartade typer av batterier eller akkumulatorbatterier. Batterierna och akkumulatorbatterier skall sättas i med hänsyn till polaritet. Använda batterier och akkumulatorbatterier skall tas av från lleksken. Kontakterna på ett batteri eller ett akkumulatorbatteri skall inte kortslutas. Bevåra anvisningarna.

FIN Paristoja ei saa ladata uudelleen. Akut on otettava ulos leikkikalusta ennen lataamista (jos se on mahdollista). Akut saa ladata vain aikuisen valvonnassa (jos ne voidaan ottaa ulos). Erityyppisiä paristoja tai akkuja ei saa käyttää yhdessä, samoin ei saa sekoittaa akkuja ja uusia ja vanhoja paristoja. Vain suositeltuja akku- tai paristotyyppjeä saa käyttää tai tyyppejä, jollin on samat ominaisuudet. Paristo ja akut on asetettava paikoilleen niin, että navat tulevat oikeisiin suuntiin. Loppuunkäytetyt paristot tai akut on otettava leikkikalusta ulos. Akun tai pariston napoja ei saa oikosulkea. Ohjeet on pidettävä tallalla.

DK Batterierne må ikke oplades. Akkumulatorbatterier skal tages ud af legetøjet, inden de lades op (hvis de kan tages ud). Akkumulatorbatterierne må kun lades op under opsyn af voksne (hvis de kan tages ud). Forskellige typer batterier og akkumulatorbatterier, eller nye og brugte batterier, må ikke blandes sammen. Der må kun anvendes batterier eller akkumulatorbatterier af den type der er anbefalet eller tilsvarende modeller. Batterier og akkumulatorbatterier skal vendes rigtigt (+/- poler). Brugte batterier og akkumulatorbatterier skal tages ud af legetøjet. Klemmerne på et batteri eller et akkumulatorbatteri må ikke kortsluttes. Disse instruktioner bør opbevares.

NL De batterijen mogen niet weer opgeladen worden. De accu's mogen voor het laden uit het speelgoed verwijderd worden (indien ze verwijderd kunnen worden). Gebruik geen verschillende typen batterijen of accu's of gebruikte en nieuwe batterijen of accu's door elkaar. Gebruik alleen batterijen of accu's van het aanbevolen type of van een gelijkwaardig type. Let bij het plaatsen van de batterijen en accu's goed op de juiste polariteit. De gebruikte batterijen en accu's dienen uit het speelgoed verwijderd te worden. De aansluitingen van een batterij of van een accu mogen niet kortgesloten worden. Aanwijzingen om te bewaren.

GR Οι μπαταρίες δεν πρέπει να επαναφορτίζονται. Οι συσσωρευτές πρέπει να αφαιρούνται από το παιχνίδι πριν τη φόρτιση (εάν μπορούν να αφαιρεθούν). Οι συσσωρευτές πρέπει να φορτίζονται μόνον υπό την επίβλεψη ενήλικα (εάν μπορούν να αφαιρεθούν). Δεν πρέπει να ανακατεύονται διάφοροι τύποι μπαταριών ή συσσωρευτών ή μπαταριών ή συσσωρευτών και παλιών. Πρέπει να χρησιμοποιούνται μόνον μπαταρίες ή συσσωρευτές του συνιστώμενου τύπου ή παρόμοιου τύπου. Οι μπαταρίες και οι συσσωρευτές πρέπει να τοποθετούνται σύμφωνα με τη σωστή πόλωση. Οι παλιές μπαταρίες και οι παλιοί συσσωρευτές πρέπει να αφαιρούνται από το παιχνίδι. Οι πόλοι μιας μπαταρίας ή ενός συσσωρευτή δεν πρέπει να βραχυκυκλώνονται. Διατηρήστε τις οδηγίες.

JPN 電池は充電しないで下さい。蓄電池は充電する前に玩具から取り外して下さい (玩具から取り外せるようになっていない場合)。蓄電池の充電は必ず大人のいるところで行って下さい (玩具から取り外せるようになっていない場合)。電池や蓄電池は、使用前、使用済、あるいは異なる種類のものなどを混ぜ合わせておかないで下さい。電池や蓄電池は、指定の種類・またはそれに類似したもの以外は使わないで下さい。電池や蓄電池をセットする際には、陽極と陰極の向きをよく確認します。使用済の電池や蓄電池は玩具から取り出して下さい。電池や蓄電池の極はショートしないよう取り扱いに注意して下さい。この説明書は保存しておいて下さい。

USA Do not mix old and new batteries. Do not mix alkaline, standard (carton-zinc), or rechargeable (nickel-cadmium) batteries.

Made in China for / Fabriqué en Chine pour / Fabricado en China para:



363, avenue de Saint Exupéry
62100 Calais - France
<http://www.meccano.com>
<http://www.erektor-set.com>
©05/2010 MECCANO

®MECCANO and EREKTOR are exclusive trademarks of MECCANO
All rights reserved



USER GUIDE

GUIDE DE L'UTILISATEUR

GEBRAUCHSANWEISUNG

GUIDA UTENTE

GUÍA DEL USUARIO

GEBRUIKERSGIDS

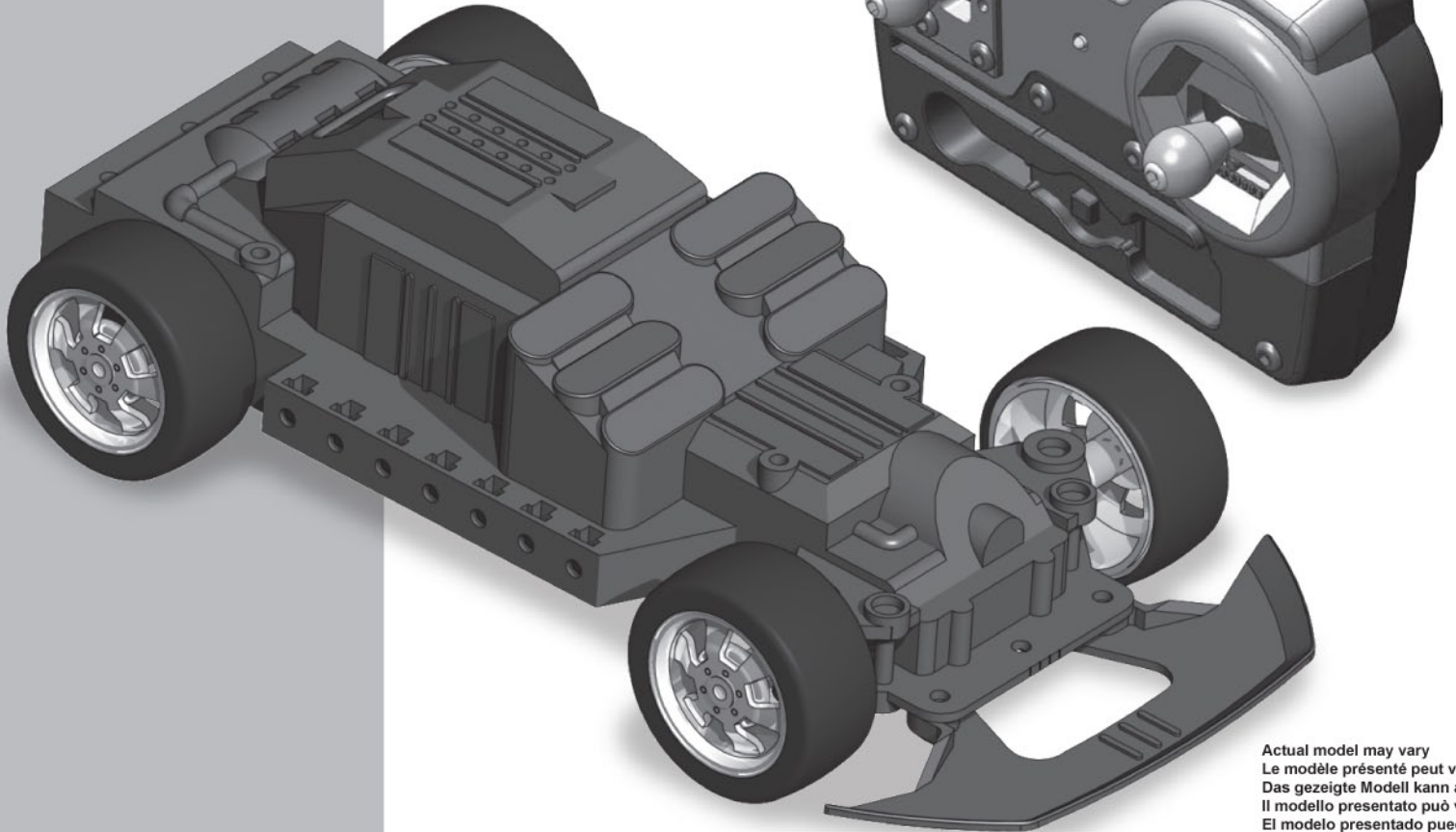

Actual model may vary
Le modèle présenté peut varier
Das gezeigte Modell kann abweichen
Il modello presentato può variare
El modelo presentado puede variar
Het voorgestelde model kan variëren

Warning: Changes or modifications to this unit not expressly approved by the party responsible for compliance could void the user's authority to operate the equipment.

NOTE: This equipment has been tested and found to comply with the limits for a Class B digital device, pursuant to Part 15 of the FCC Rules. These limits are designed to provide reasonable protection against harmful interference in a residential installation. This equipment generates, uses and can radiate radio frequency energy and, if not installed and used in accordance with the instructions, may cause harmful interference to radio communications.

However, there is no guarantee that interference will not occur in a particular installation. If this equipment does cause harmful interference to radio or television reception, which can be determined by turning the equipment off and on, the user is encouraged to try to correct the interference by one or more of the following measures:

- Reorient or relocate the receiving antenna.
- Increase the separation between the equipment and receiver.
- Connect the equipment into an outlet on a circuit different from that to which the receiver is connected.
- Consult the dealer or an experienced radio/TV technician for help.



INSERTING BATTERIES

- F MISE EN PLACE DE LA BATTERIE ET DE LA PILE
- D ANBRINGEN DER BATTERIE UND DER BABYZELLE
- I POSIZIONAMENTO DELLA BATTERIA E DELLA PILA
- E COLOCACIÓN DE LA BATERÍA Y DE LA PILA
- NL PLAATSING VAN DE ACCU EN BATTERIJ

- VEHICLE
- VEICOLO
- VEHICULE
- VEHÍCULO
- FAHRZEUG
- VOERTUIG

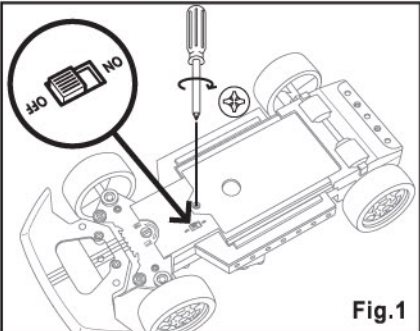

Fig.1

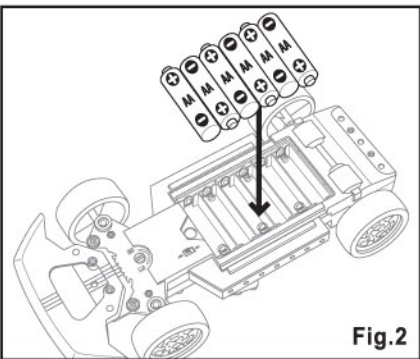

Fig.2

ADJUSTING THE DIRECTION

- F AJUSTEMENT DE LA DIRECTION
- D EINSTELLUNG DER LENKUNG
- I REGOLAZIONE DELLA DIREZIONE
- E AJUSTE DE LA DIRECCIÓN
- NL REGELEN VAN DE RIJRICHTING

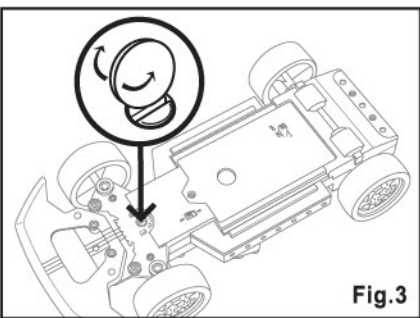

Fig.3

- TRANSMITTER
- TELECOMANDO
- TELECOMMANDE
- MANDO A DISTANCIA
- FERNSTEUERUNG
- AFSTANDSBEDIENING

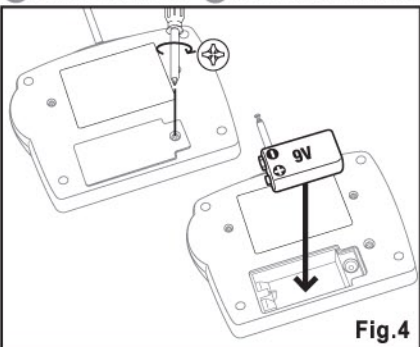

Fig.4

- PLAY
- SPIEL
- JUEGO
- JEU
- GIOCO
- SPELEN

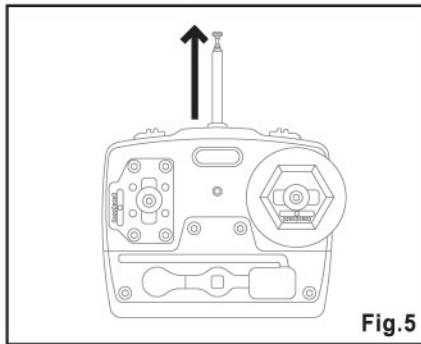

Fig.5

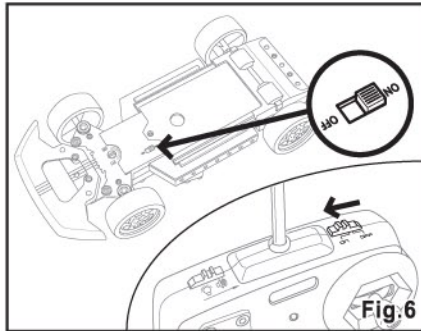

Fig.6

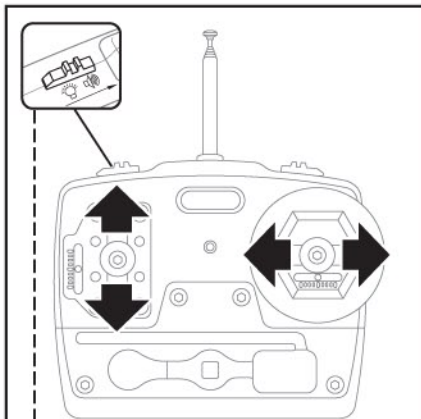

Fig.7



Fig.8

Fig.1

- 1. Check that the vehicle is switched to OFF before inserting the battery.
- 2. Remove the screw in the battery compartment using a Phillips screwdriver.
- F 1. Vérifier que l'interrupteur du véhicule est sur OFF lors de l'installation de la batterie.
- 2. Dévisser le couvercle du compartiment batterie à l'aide d'un tournevis cruciforme.
- D 1. Der Fahrzeugschalter muss beim Anbringen der Batterie auf OFF stehen.
- 2. Den Deckel des Batteriefachs mit einem Kreuzschraubenzieher abschrauben.
- I 1. Verificare che l'interruttore del veicolo si trovi su OFF durante l'installazione della batteria.
- 2. Allentare il coperchio del vano batteria per mezzo di un cacciavite a stella.
- E 1. Verificar que el interruptor del vehículo esta en OFF cuando se instale la batería.
- 2. Desatornillar la tapa del compartimento de batería con un destornillador cruciforme.
- NL 1. Controleren of de schakelaar van het voertuig wel op OFF staat bij de plaatsing van de accu.
- 2. Het deksel van het accuvak met een kruiskopschroevendraaier losschroeven.

Fig.2

- 3. Insert the batteries into the indicated compartment according to the correct polarities. Do not mix old and new batteries. Do not mix alkaline, standard (carbon-zinc) or rechargeable (nickel-cadmium) batteries.
- F 3. Insérer le pack batterie dans le compartiment prévu à cet effet en respectant les polarités.
- D 3. Den Batteriesatz im dafür vorgesehen Fach anbringen, dabei die Polaritäten beachten.
- I 3. Inserire il pack batteria nell'apposito vano rispettando le polarità.
- E 3. Insertar el pack de batería en el compartimento previsto con este objeto respetando las polaridades.
- NL 3. Het accublok in het hier toe voorzien vak aanbrengen en de polariteit respecteren.

Fig.3

- The direction may be adjusted using the adjustment screw on the underside of the chassis. Using a coin, turn the adjustment screw towards the right or left in order to correct the direction of the vehicle.
- F Avec l'aide d'une pièce de monnaie, tourner la vis de réglage vers la droite ou vers la gauche afin de corriger la direction du véhicule.
- D Die Lenkung kann mittels der Stellschraube auf der Unterseite des Chassis eingestellt werden. Die Stellschraube mit einer Münze nach rechts oder links drehen, um die Lenkung des Fahrzeugs zu korrigieren.
- I La direzione può essere regolata per mezzo della vite di regolazione posta sulla parte inferiore del telaio. Con una moneta, ruotare la vite di regolazione a destra o sinistra per correggere la direzione del veicolo.
- E La dirección se puede ajustar con el tornillo que se encuentra debajo del chasis. Con una moneda, gire el tornillo de ajuste hacia la derecha o hacia la izquierda para corregir la dirección del vehículo.
- NL De rijrichting kan bijgesteld worden dankzij de regeling aan de onderzijde van het chassis. Met een munstuk de regelschroef naar rechts of links draaien om de rijrichting van het voertuig bij te stellen.

Fig.4

- 1. Remove the cover of the remote control using a Phillips screwdriver.
- 2. Insert the battery according to the polarities shown. Dispose of used batteries separately from household waste.
- WARNING**
Leave the motor and the battery to cool for 20 minutes after removing the batteries.
- F 1. Dévisser le couvercle de la télécommande à l'aide d'un tournevis cruciforme.
- 2. Installer la pile en respectant les polarités. Jetez vos anciennes piles séparément des autres déchets.
- ATTENTION**
Laissez refroidir le moteur et la batterie pendant 20 mn après l'épuisement des piles
- D 1. Den Deckel der Fernsteuerung mit einem Kreuzschraubenzieher abschrauben.
- 2. Die Babyzelle unter Einhaltung der Polaritäten anbringen. Anmerkung: Abgenutzte Babyzellen separat vom Hausmüll entsorgen.
- VORSICHT**
Den Motor und die Batterie 20 Min. nach Entleerung der Babyzellen abkühlen lassen.

1. Allentare il coperchio del telecomando per mezzo di un cacciavite a stella.
2. Installare la pila rispettando le polarità.

Cettare le pile vecchie separatamente dagli altri rifiuti.

ATTENZIONE

Lasciate raffreddare il motore e la batteria per 20 minuti dopo la scarica delle pile.

1. Desatornillar la tapa del mando a distancia con un destornillador cruciforme.
2. Colocar la pila respetando las polaridades.

Las pilas usadas no deben tirarse con los demás residuos.

ATENCIÓN

Cuando se hayan agotado las pilas, deje enfriar el motor y la batería durante 20 minutos.

1. Het deksel van de afstandsbediening met een kruiskopschroevendraaier losschroeven.
2. De batterij plaatsen en de polariteit naleven.

Uw oude batterijen gescheiden van de rest van uw afval weggooiën.

OPGEPAST

De motor en accu gedurende 20 min. laten afkoelen nadat de batterijen leeg zijn.

Fig.5

1. Extend the antenna of the remote control.

1. Etendez l'antenne de la télécommande.

1. Die Antenne der Fernsteuerung ausziehen.

1. Dispiegare l'antenna del telecomando.

1. Estire la antena del mando a distancia.

1. De antenne van de afstandsbediening uittrekken.

Fig.6

1. Switch the remote control to ON.
2. Switch the vehicle to ON.

1. Mettez l'interrupteur de la télécommande sur ON.
2. Mettez l'interrupteur du véhicule sur ON.

1. Den Schalter der Fernsteuerung auf ON stellen.
2. Den Fahrzeugschalter auf ON stellen.

1. Posizionate l'interruttore del telecomando su ON.
2. Posizionate l'interruttore del veicolo su ON.

1. Ponga el interruptor del mando a distancia en ON.
2. Ponga el interruptor del vehículo en ON.

1. De schakelaar van de afstandsbediening op ON.
2. De schakelaar van het voertuig op ON zetten.

Fig.7

Move your vehicle in all directions using the levers on the remote control. Select your style! 5 different modes combining 2 music styles, sound and light effects.

Dirigez votre véhicule dans toutes les directions grâce aux manettes de la télécommande. Choisissez votre style! 5 modes différents combinant 2 styles de musiques, des bruitages et des lumières.

Das Fahrzeug mit Hilfe der Fernsteuerungshebel in alle Richtungen lenken. Wähle deinen Stil! 5 verschiedene Funktionsarten mit einer Kombination von 2 Musikstilen, Geräuschen und Licht!

Dirigete il vostro veicolo in tutte le direzioni grazie alle manopole del telecomando. Scegli il tuo stile! 5 modi diversi che combinano 2 stili di musica, effetti sonori e luci!

Dirija el vehículo en todas las direcciones con los mandos del mando a distancia. ¡Elige tu estilo! 5 modos diferentes que combinan 2 estilos de música, de efectos de ruidos y de luces.

Uw voertuig in alle mogelijke richtingen sturen d.m.v. de hendels op de afstandsbediening. Kies zelf je stijl! 5 verschillende modi waarin 2 muziekstijlen, achtergrondgeluiden en lichten gecombineerd worden!

Fig.8

1. After playing, switch the remote control and the vehicle to OFF.
2. After playing, remove the vehicle battery and the remote control battery to avoid any leakage.

1. Après le jeu mettez les interrupteurs de la télécommande et du véhicule sur OFF.
2. Après le jeu, retirez la batterie du véhicule et la pile de la télécommande pour éviter toute fuite.

1. Die Schalter der Fernsteuerung und des Fahrzeugs nach beendetem Spiel auf OFF stellen.
2. Nach beendetem Spiel die Batterie des Fahrzeugs und die Bayzelle der Fernsteuerung herausnehmen, um ein Auslaufen zu vermeiden.

1. Dopo il gioco, posizionate gli interruttori del telecomando e del veicolo su OFF.
2. Dopo il gioco, togliete la batteria dal veicolo e la pila dal telecomando al fine di evitare qualsiasi perdita delle stesse.

1. Después de jugar, ponga los interruptores del mando a distancia y del vehículo en OFF.
2. A continuación, retire la batería del vehículo y la pila del mando a distancia para evitar las fugas.

1. Na het spelen de schakelaars van de afstandsbediening en het voertuig op OFF zetten.
2. Na het spelen de accu uit het voertuig en de batterij uit de afstandsbediening verwijderen om lekken te vermijden.

GB USA

1. After playing, switch the remote control and the vehicle to OFF.
2. After playing, remove the vehicle battery and the remote control battery to avoid any leakage.

1. Après le jeu mettez les interrupteurs de la télécommande et du véhicule sur OFF.
2. Après le jeu, retirez la batterie du véhicule et la pile de la télécommande pour éviter toute fuite.

1. Die Schalter der Fernsteuerung und des Fahrzeugs nach beendetem Spiel auf OFF stellen.
2. Nach beendetem Spiel die Batterie des Fahrzeugs und die Bayzelle der Fernsteuerung herausnehmen, um ein Auslaufen zu vermeiden.

1. Dopo il gioco, posizionate gli interruttori del telecomando e del veicolo su OFF.
2. Dopo il gioco, togliete la batteria dal veicolo e la pila dal telecomando al fine di evitare qualsiasi perdita delle stesse.

1. Después de jugar, ponga los interruptores del mando a distancia y del vehículo en OFF.
2. A continuación, retire la batería del vehículo y la pila del mando a distancia para evitar las fugas.

1. Na het spelen de schakelaars van de afstandsbediening en het voertuig op OFF zetten.
2. Na het spelen de accu uit het voertuig en de batterij uit de afstandsbediening verwijderen om lekken te vermijden.

STANDARDS AND COMPLIANCE CERTIFICATE

1- MECCANO hereby declares that this car is made according to standard requirements and other regulations outlined in the 1999/5/EC directive. A copy of the original compliance declaration may be obtained from the following address: MECCANO, 363 avenue de Saint Exupéry 62100 Calais.

2- This product is for indoor use only.

SAFETY RULES

Choose a SAFE place in which to operate the vehicle. Not to be operated on the street. Avoid use on SAND or in puddles as this may damage its performance. Check the area in which the vehicle will be operated and carefully avoid obstacles.

The radio aerials of the vehicles and transmitters are delicate. Do not leave close to a HEAT source or in broad SUNLIGHT for long periods.

Avoid leaving the vehicle or transmitter OUTDOORS OVERNIGHT. NIGHT HUMIDITY IS HARMFUL TO THE INTERIOR MECHANISM.

MAINTENANCE

This toy requires regular cleaning and maintenance.

WARNING

Keep out of the reach of children under 36 months as they may be injured.

*ANY CHANGES OR MODIFICATIONS CARRIED OUT WITHOUT MANUFACTURER'S APPROVAL MAY REMOVE THE USER'S RIGHT TO OPERATE THIS TOY.

RADIO INTERFERENCE: Irregular behaviour or loss of control of the vehicle may result from proximity to high voltage wires, high voltage transformers, certain building types, concrete walls or narrow spaces in which RADIO SIGNALS from the transmitter MAY BE DIFFUSED, thus making it difficult for the vehicle to receive a GOOD RADIO SIGNAL. In the case of this behaviour or loss of control, MOVE TO ANOTHER PLAY AREA.

There will be INTERFERENCE if ANOTHER radio controlled vehicle or CB radio are operating in close proximity on the same FREQUENCY.

DO NOT RECHARGE NON RECHARGEABLE BATTERIES

If the power lead is damaged, it must be replaced by the manufacturer or its dealer, or by a qualified person, to avoid the risk of accidents.

Rechargeable batteries must be recharged under adult supervision only.

NORMES ET CERTIFICAT DE CONFORMITE

1- Par ceci, nous MECCANO déclarons que cette voiture est en règle avec les normes requises et autres réglementations relevantes de la directive 1999/5/EC. Une copie de la déclaration d'origine de conformité peut être obtenue à l'adresse suivante: MECCANO, 363 avenue de Saint Exupéry 62100 Calais.

2- Ce produit doit être utilisé à l'intérieur.

REGLES DE SECURITE

Choisir un lieu SUR pour faire fonctionner le véhicule. Ne pas le faire fonctionner dans la rue. Eviter de jouer sur le SABLE ou dans les flaques d'eau. Cela pourrait dégrader ses performances. Vérifier l'état de surface où évolue le véhicule et faire attention aux obstacles.

Les récepteurs radio du véhicules et de l'émetteur sont des instruments sensibles. Ne pas laisser le véhicule ou l'émetteur près d'une source de CHALEUR ou en PLEIN SOLEIL pendant longtemps.

Eviter de laisser le véhicule ou l'émetteur DEHORS PENDANT LA NUIT. L'HUMIDITE NOCTURNE EST NUISIBLE POUR LE MECANISME INTERIEUR.

ENTRETIEN ET MAINTENANCE

Ce jouet exige une maintenance et un nettoyage périodique.

ATTENTION

Conserver hors de portée des enfants de moins de 36 mois, ils pourraient être blessés.

* DES CHANGEMENTS OU MODIFICATIONS NON EXPRESSEMENT APPROUVES PAR LE FABRICANT POURRAIENT ANNULER LE DROIT A L'UTILISATEUR DE FAIRE FONCTIONNER CET APPAREIL.

INTERFERENCES RADIO: Un comportement irrégulier ou une perte de contrôle du véhicule peut être le résultat d'interférences provoquées par des fils à haute tension, des transformateurs haute tension, certains types d'immeubles, des murs de béton ou des espaces étroits dans lesquels les SIGNALS RADIO envoyés par l'émetteur PEUVENT ETRE DIFFUS, ce qui rend la réception d'un BON SIGNAL RADIO DIFFICILE pour le véhicule. En cas de comportement de ce type ou de perte de contrôle, CHANGER D'EMPLACEMENT DE JEU.

Il y aura des INTERFERENCES si un AUTRE véhicule radiocommandé ou une radio CB fonctionne à proximité sur la même FREQUENCE.

NE PAS RECHARGER DES BATTERIES NON RECHARGEABLES

Si le cordon d'alimentation est endommagé, il doit être remplacé par le fabricant ou son concessionnaire, ou encore par une personne qualifiée, de manière à éviter tout risque d'accident. Les batteries rechargeables doivent seulement être rechargées sous la supervision d'un adulte.

NORMEN UND KONFORMITÄTSBESCHENIGUNG

1- Wir, MECCANO, bescheinigen hiermit dass dieses Fahrzeug den vorgeschriebenen Normen und anderen Regeln der Richtlinie 1999/5/EC entspricht. Eine Kopie der ursprünglichen Konformitätserklärung kann bei folgender Adresse angefordert werden: MECCANO, 363 avenue de Saint Exupéry 62100 Calais.

2- Dieses Produkt muss im Haus verwendet werden.

SICHERHEITSGESAMT

Einen SICHEREN Ort zur Verwendung des Fahrzeugs wählen. Nicht auf der Straße verwenden. Vermeiden, auf SAND oder in Wasserpfützen zu spielen, denn dies könnte seine Leistungen beeinträchtigen. Zustand der Fläche kontrollieren, auf der das Fahrzeug fährt und auf Hindernisse achten.

Die Funkempfänger des Fahrzeugs und der Emitter sind empfindliche Geräte. Das Fahrzeug oder den Emitter nicht zu lange in der Nähe einer WARMEQUELLE oder in der Sonne lassen.

Vermeiden, das Fahrzeug oder den Emitter DIE NACHT ÜBER IM FREIEN ZU LASSEN. DIE NÄCHTLICHE FEUCHTIGKEIT IST SCHÄDLICH FÜR DEN INNENMECHANISMUS.

PFLEGE UND WARTUNG

Diese Spielzeug erfordert eine regelmäßige Wartung und Reinigung.

VORSICHT

Von Kindern unter 36 Monaten fernhalten, sie könnten verletzt werden.

*NICHT VOM HERSTELLER AUSDRÜCKLICH GENEHMIGTE ÄNDERUNGEN ODER UMBARBEITUNGEN KÖNNEN DEM BENUTZER DAS RECHT ENTZIEHEN, DIESES GERÄT ZU BETRIEBEN. FREQUENZSTÖRUNGEN: Ein unregelmäßiges Verhalten oder ein Verlust der Fahrzeugkontrolle kann auf Frequenzstörungen zurückzuführen sein, die durch Hochspannungsleitungen, Hochspannungsstrassen, bestimmte Gebäudearten, Betonmauern oder enge Räume verursacht werden können, in denen die vom Emitter gesendeten Funksignale GESTREUT WERDEN KÖNNEN, was den Empfang eines GUTEN FUNKSIGNALS für das Fahrzeug SCHWIERIG machen kann. Bei einem derartigen Verhalten oder Kontrollverlust DEN SPIELORT WECHSELN.

STÖRUNGEN treten ebenfalls auf, wenn ein ANDERES funktionsfähiges Fahrzeug oder ein CB Radio auf der gleichen Frequenz in der Nähe funktioniert.

EINWEGBATTERIEN NICHT WIEDER AUFLADEN

Falls die Anschlusschneur beschädigt ist, muss sie vom Hersteller, seinem Konzipienten oder einer befähigten Person ausgetauscht werden, damit jedes Unfallrisiko ausgeschlossen ist. Die wiederaufladbaren Batterien dürfen nur unter Aufsicht eines Erwachsenen aufgeladen werden.

NORME E CERTIFICATO DI CONFORMITA'

1- Con la presente, MECCANO dichiara che questa macchina è in regola con le norme richieste e le altre normative previste dalla direttiva 1999/5/EC. Una copia della dichiarazione d'origine di conformità può essere ottenuta scrivendo a: MECCANO, 363 avenue de Saint Exupéry 62100 Calais.

2- Questo prodotto deve essere utilizzato all'interno.

NORME DI SICUREZZA

Scegliere un luogo SICURO per azionare il veicolo. Non utilizzarlo nelle strade. Evitare di giocare sulla SABBIA o nelle pozzanghere. Ciò potrebbe alterare le prestazioni dello stesso. Verificare lo stato della superficie sul quale evolve il veicolo e far attenzione agli ostacoli.

I ricevitori radio del veicolo e dell'emettitore sono strumenti sensibili. Non lasciare troppo a lungo il veicolo o l'emettitore accanto ad una fonte di CALORE o in PIENO SOLE.

Evitare di lasciare il veicolo o l'emettitore ALL'ESTERNO DURANTE LA NOTTE. L'UMIDITA' NOTTURNA POTREBBE DANNEGGIARE IL MECCANISMO INTERNO.

PULIZIA E MANUTENZIONE

Questo giocattolo richiede manutenzione e pulizia periodiche.

ATTENZIONE

Conservare fuori dalla portata dei bambini di meno di 36 mesi in quanto potrebbero ferirsi.

*CAMBIAMENTI O MODIFICHE NON ESPRESSAMENTE APPROVATI DAL FABBRICANTE POTREBBERO ANNULARE IL DIRITTO DELL'UTENTE A FAR FUNZIONARE QUESTO APPARECCHIO.

INTERFERENZE RADIO: Un comportamento irregolare o una perdita di controllo del veicolo possono essere causati da interferenze provocate da fili di alta tensione, trasformatori alta tensione, da muri di edifici, muri in calcestruzzo o spazi ridotti nei quali i SEGNALI RADIO inviati dall'emettitore POSSONO VENIR DISTURBATI, il che impedisce la corretta ricezione del SEGNALE RADIO da parte del veicolo. In caso si verichino eventi di questo tipo o di perdita di controllo, CAMBIARE IL LUOGO DEL GIOCO.

Potranno verificarsi INTERFERENZE qualora un ALTRO veicolo radioguidato o una radio CB sia attivato in prossimità, sulla stessa FREQUENZA.

NON TENTARE DI RICARICARE BATTERIE NON RICARICABILI

Se il cordone di alimentazione è danneggiato, deve essere sostituito dal fabbricante, dal concessionario dello stesso o da una persona qualificata al fine di evitare qualsiasi rischio di incidente. Le batterie ricaricabili devono essere ricaricate soltanto sotto la supervisione di un adulto.

NORMAS Y CERTIFICADO DE CONFORMIDAD

1- Nosotros MECCANO declaramos que este coche es conforme a las normas requeridas y demás regulaciones contempladas por la directiva 1999/5/EC. Se puede obtener una copia de la declaración de origen de conformidad en la siguiente dirección: MECCANO, 363 avenue de Saint Exupéry 62100 Calais, Francia.

2- Este producto debe utilizarse en el interior.

REGLAS DE SEGURIDAD

Poner el vehículo en funcionamiento en un lugar SEGURO. No jugar con él en la calle. Evitar jugar sobre la ARENA, o en charcos de agua, ya que podrían degradarse sus prestaciones. Comprobar el estado de la superficie por la que se mueve el vehículo y prestar atención a los obstáculos.

Los receptores de radio del vehículo y del emisor son instrumentos sensibles. No dejar el vehículo o el emisor cerca de una fuente de CALOR o a PLENO SOL durante mucho tiempo.

Evitar dejar el vehículo o el emisor FUERA DURANTE LA NOCHE. LA HUMEDAD NOCTURNA ES PERJUDICIAL PARA EL MECANISMO INTERIOR.

LIMPIEZA Y MANTENIMIENTO

Este juguete requiere una limpieza y un mantenimiento periódicos.

ATENCIÓN

Manténgase fuera del alcance de niños menores de 36 meses, podrían herirse.

*LOS CAMBIOS O MODIFICACIONES NO APROBADOS EXPRESAMENTE POR EL FABRICANTE, PODRIAN ANULAR EL DERECHO DEL USUARIO A PONER EN FUNCIONAMIENTO ESTE APARATO.

INTERFERENCIAS DE RADIO: Un comportamiento irregular o una pérdida de control del vehículo puede ser resultado de las interferencias provocadas por cables de alta tensión, transformadores de alta tensión, algunos tipos de inmuebles, muros de hormigón o espacios estrechos en los que las SEÑALES DE RADIO enviadas por el emisor PUEDEN SER DIFUSAS, lo que dificulta al vehículo una buena recepción de la SEÑAL DE RADIO. Si se produce un comportamiento de este tipo o una pérdida de control, JUGAR EN OTRO LUGAR.

Pueden producirse INTERFERENCIAS si OTRO vehículo radiocomandado o una radio CB funciona cerca en la misma FRECUENCIA.

NO CARGAR BATERÍAS NO RECHARGEABLES

Si el cable de alimentación está deteriorado, debe ser cambiado por el fabricante o su concesionario o por una persona cualificada, para evitar todo riesgo de accidentes.

Las baterías recargables deben cargarse únicamente bajo la supervisión de un adulto.

NORMEN EN GELUKKIGHEIDSCERTIFICATIE

1- Hiermee verklaren wij, MECCANO, dat dit voertuig voldoet aan de vereiste normen en andere relevante bepalingen van richtlijn 1999/5/EC. Een kopie van de originele gelukkigheidscertificatie is verkrijgbaar op volgend adres: MECCANO, 363 avenue de Saint Exupéry 62100 Calais.

2- Dit product is bestemd voor gebruik binnenshuis.

VEILIGHEIDSGESAMT

Een VEILIGE plaats kiezen om het voertuig te laten werken. Het niet op straat gebruiken. Vermijden om op ZAND of in waterplassen te spelen. Dit zou de prestaties negatief kunnen beïnvloeden. De toestand controleren van het oppervlak waarop het voertuig rijdt en aandachtig zijn voor hindernissen.

De radio-ontvangers van het voertuig en de zender zijn gevoelige instrumenten. Het voertuig of de zender niet gedurende lange tijd in de buurt van een WARMEbron of in de VOLLE ZON laten staan.

Vermijden dat het voertuig of de zender 'S NACHTS BIJTEN GELATEN WORDEN. DE NACHTELIJKE VOCHT IS SCHADELIJK VOOR HET INTERNE MECHANISME.

ONDERHOUD EN REINIGING

Dit speelgoed vergt een regelmatig onderhoud en periodieke reiniging.

OPGEPAST

Buiten het bereik van kinderen jonger dan 36 maanden houden, ze zouden zich kunnen kneten.

*AANPASSINGEN OF WIJZIGINGEN DIE NIET UITDRUKKELIJK DOOR DE FABRIKANT GOEDGEKEURD ZIJN, KUNNEN HET RECHT VAN DE GEBRUIKER OM HET SPEELGOED TE BEDIENEN DOEN VERVALLEN.

RADIO-INTERFERENTIES: Een onregelmatig gedrag of het controleverlies van het voertuig kan het resultaat zijn van interferenties die veroorzaakt worden door hoogspanningslijnen, hoogspanningstransformators, bepaalde types van gebouwen, betonnen muren of enge ruimten waarin de RADIO-SIGNALLEN die door de zender verstuurd worden DIFFUUS KUNNEN ZIJN, wat de ontvangst van een GOED RADIO-SIGNAAL voor het voertuig BEMOELIJKT. Bij dergelijke gedragingen of bij controleverlies, onmiddellijk van SPEELZONE VERANDEREN.

Er zullen INTERFERENTIES optreden wanneer een ANDER radiogestuurd voertuig of een CB-radio in de buurt op dezelfde FREQUENTIE werkt.

NIET-HEROPLAATBARE ACCU'S OOK NOOIT HEROPLAATEN

Wanneer het netsnoer beschadigd is, moet dit door de fabrikant of zijn concessiehouder, of een bekwaam persoon, vervangen worden zodat elke kans op een ongeluk verminderd wordt. De heropladbare accu's mogen enkel onder toezicht van een volwassene heropladen worden.

GB USA Many of the models and component parts are unique and original designs which are the property of MECCANO. They are protected by national legislation as industrial designs, trademarks and/or copyrights throughout many countries. For detailed information, please contact: MECCANO. Meccano shall have no responsibility for (I) failure to follow instructions, (II) use of parts for any purpose other than as specified in the instructions (III) any alteration of any parts or components. MECCANO respects children's safety: all models are tested by children.

F De nombreux modèles et pièces sont des créations originales, propriétés de MECCANO et sont protégés par les législations nationales sur les dessins et modèles, marques et/ou droits d'auteurs. Pour toute information, merci de contacter : MECCANO. La responsabilité de MECCANO ne saurait être engagée en cas d'accident survenu à la suite (I) du non respect des instructions de montage (II) d'une utilisation des pièces autre que celle proposée dans la notice (III) d'une altération ou de la modification des pièces. La société MECCANO respecte la sécurité des enfants : ses modèles sont testés par des enfants.

D Zahlreiche Modelle und Teile sind Erfindungen und Eigentum der Firma MECCANO. Sie sind durch Inland-Gesetze über Zeichnungen und Modelle sowie Warenzeichen und/oder Urheberrechte geschützt. Für zusätzliche Auskünfte wenden Sie sich bitte an : MECCANO. Die Firma Meccano haftet nicht für Unfälle, die aus der (I) Nichteinhaltung der Bauanleitung, der (II) Verwendung anderer als in der Bauanleitung angegebenen Teile oder der (III) Änderung oder Modifikation der Teile resultieren. Alle Modelle der Firma Meccano wurden von Kindern getestet und entsprechen den Sicherheitsnormen.

I Numerosi modelli e pezzi sono creazioni originali della MECCANO e sono protetti dalle legislazioni nazionali sui disegni e modelli, marche e/o diritti d'autore. Per qualsiasi informazione, vogliate prendere contatto con : MECCANO. Meccano declina ogni responsabilità in caso d'incidenti sopravvenuti in seguito (I) a: non rispetto delle istruzioni di montaggio (II) utilizzo dei pezzi per funzioni diverse da quelle previste nel manuale (III) alterazione e/o modifica dei pezzi. La società MECCANO rispetta la sicurezza dei bambini : i suoi modelli vengono testati dai bambini stessi.

E Numerosos modelos y piezas son creaciones originales, propiedades de MECCANO y están protegidos por las legislaciones nacionales en lo que concierne a los dibujos y modelos, marcas y/o derechos de autor. Para cualquier información, sírvase ponerse en contacto con : MECCANO. MECCANO carece de responsabilidad en caso de accidente debido a: (I) el incumplimiento de las instrucciones de montaje (II) una utilización de las piezas diferente a la que se indica en las instrucciones (III) una alteración o modificación de las piezas. La sociedad MECCANO respeta la seguridad de los niños : sus modelos están probados por niños.

P Vários modelos e peças são criações originais, propriedades da MECCANO e são protegidos pelas legislações nacionais relativas aos desenhos e modelos às marcas e/ou aos direitos de autor. Para qualquer informação, é favor contactar : MECCANO. A Sociedade MECCANO não poderá ser responsabilizada pelos acidentes provocados: (I) pela falta de cumprimento das instruções de montagem (II) pelo uso indevido das peças ou (III) pela modificação ou alteração das peças. A Sociedade MECCANO respeita a segurança das crianças : os seus modelos foram testados por crianças.

S Många modeller och delar bildar en unik och originell formgivning vilken är MECCANO egendom. Dessa modeller och delar är skyddade genom lagstiftning såsom industriell formgivning, varumärke och/eller upphovsmannarätt i ett flertal länder. För mer detaljerad information, var vänlig och kontakta MECCANO. MECCANO fräntar sig allt ansvar i händelse av olycka till följd av (I) att monteringsinstruktionerna inte har respekterats (II) en annan användning av delarna än den som står i anvisningen (III) en förvanskning eller förändring av delarna. Företaget MECCANO respekterar barnsäkerheten : modellerna har testats av barn.

GB USA Standard batteries must not be recharged. Rechargeable batteries must be removed from the toy before being recharged (if it is possible to remove them). Rechargeable batteries must only be recharged under adult supervision (if it is possible to remove them). Do not mix different types of batteries together or new with old rechargeable / non rechargeable batteries. Only batteries of the recommended type or a similar type should be used. Batteries must be fitted in accordance with their instructions. Remove used batteries from the toy. Battery terminals must not be short-circuited. Please keep instructions.

F Les piles ne doivent pas être rechargées. Les accumulateurs doivent être enlevés du jouet avant d'être chargés (s'ils peuvent être enlevés). Les accumulateurs ne doivent être chargés que sous la surveillance d'un adulte (s'ils peuvent être enlevés). Différents types de piles ou accumulateurs ou des piles ou accumulateurs neufs et usagés ne doivent pas être mélangés. Seuls des piles ou accumulateurs du type recommandé ou d'un type similaire doivent être utilisés. Les piles et accumulateurs doivent être mis en place en respectant la polarité. Les piles et accumulateurs usagés doivent être enlevés du jouet. Les bornes d'une pile ou d'un accumulateur ne doivent pas être mises en court-circuit. Indications à conserver.

D Die Batterien dürfen nicht wieder aufgeladen werden. Die Akkus müssen vor dem Nachladen aus dem Spielzeug genommen werden (wenn sie ausgebaut werden können). Die Akkus dürfen nur unter Aufsicht eines Erwachsenen nachgeladen werden (wenn sie ausgebaut werden können). Unterschiedliche Arten von Batterien und Akkus oder neue und gebrauchte Batterien bzw. Akkus dürfen nicht zusammen verwendet werden. Es dürfen nur Batterien bzw. Akkus der empfohlenen Art oder einer ähnlichen Art verwendet werden. Beim Einsetzen der Batterien bzw. Akkus auf die richtige Polung achten. Verbrauchte Batterien bzw. Akkus bitte aus dem Spielzeug entfernen. Die Klemmen der Batterien bzw. Akkus dürfen nicht kurzgeschlossen werden. Diese Anweisungen bitte aufbewahren.

I Le pile non devono essere ricaricate. Gli accumulatori devono essere tolti dal giocattolo prima di essere caricati (se è possibile toglierli). Gli accumulatori devono essere caricati solo sotto la sorveglianza di un adulto (se è possibile toglierli). Non possono essere mescolati tipi diversi di pile o di accumulatori oppure pile o accumulatori nuovi e usati. Si devono usare solo pile o accumulatori del tipo raccomandato o di un tipo simile. Le pile e gli accumulatori devono venire sistemati rispettando la polarità. Le pile e gli accumulatori usati devono essere tolti dal giocattolo. I morsetti di una pila o di un accumulatore non devono essere messi in cortocircuito. Conservare queste istruzioni.

E Las pilas no deberán recargarse. Habrá que retirar los acumuladores del juguete antes de proceder a recargarlos (si es que pueden retirarse). Los acumuladores sólo se recargarán bajo la vigilancia de una persona adulta (si es que pueden retirarse). No deberán mezclarse diferentes tipos de pilas o acumuladores o de pilas o acumuladores nuevos y usados. Sólo se utilizarán pilas o acumuladores del tipo recomendado o de un tipo similar. Las pilas y acumuladores deberán colocarse respetando la polaridad. Deberán retirarse del juguete las pilas y acumuladores usados. Lors bornes de una pila o de un acumulador no deberán disponerse nunca en posición de cortocircuito. Conserve estas indicaciones.

P As pilhas não devem ser novamente carregadas. Os acumuladores devem ser removidos do brinquedo antes de serem carregados (caso possam ser removidos). Os acumuladores devem ser carregados apenas sob cuidados de um adulto (caso possam ser removidos). Diferentes tipos de pilhas ou acumuladores ou pilhas ou acumuladores novos já utilizados não devem ser misturados. Pilhas ou acumuladores do tipo recomendado ou de um tipo similar poderão ser utilizados. As pilhas e acumuladores devem ser inseridos, respeitando a polaridade. Devem ser removidos do brinquedo as pilhas e acumuladores já utilizados. Os pólos de uma pilha ou de um acumulador não devem ser curto-circuitados. Indicações a conservar.

FIN Useat mallit ja osat ovat MECCANO: n omaisuutta olevaa alkuperäistä suunnittelua. Ne ovat kansallisilla lailla suojattua teollista tuotantoa, tavaramerkkejä ja/tai kopiointioikeuksia. Pyydämme ottamaan yhteyden MECCANO: han kaikissa asiaan liittyvissä kysymyksissä. MECCANO ei vastaa eikä kata seuraavista syistä sattuneita onnettomuuksia: (I) ohjeiden vastainen kokoaminen, (II) muiden kuin ohjeissa ehdotettujen osien käyttö, (III) osien muuntelu tai eri tarkoitukseen käyttö. MECCANO-yhtiö huolehtii lasten turvallisuudesta: lapset ovat testanneet mallimme.

DK Vore mange modeller og dele er originale fremstillinger og ejes af MECCANO. Tegninger, modeller, fabrikanter og mærker er beskyttet af lovgivningen i hvert land. Yderligere oplysninger kan fås hos: MECCANO. Meccano frsiger sig ethvert ansvar, sftredt der er sket uheld forrsaget af (I) at monteringsinstruktionerne ikke er blevet overholdt, (II) at delene er blevet brugt til andre formål, end dem der er beskrevet i betjeningsvejledningen, (III) eller at delene er blevet beskadiget eller ændret, MECCANO overholder sikkerhedsreglerne for børn: Alle modeller testes af børn.

NL Veel modellen en onderdelen zijn originele ontwerpen en eigendom van MECCANO en worden beschermd door de nationale wetgevingen op tekeningen en modellen, merken en/of auteursrechten. Voor informatie gelieve contact op te nemen met MECCANO. De verantwoordelijkheid van MECCANO is uitgesloten in geval van ongevalen voortvloeiend uit het niet naleven van de montage-instructies (I), uit het gebruik van andere onderdelen dan die zoals vermeld in de handleiding (II) of uit het veranderen of modificeren van de onderdelen (III). De firma MECCANO neemt de veiligheid van de kinderen in acht : de modellen zijn door kinderen getest.

GR Πολλά μοντέλα και ανταλλακτικά είναι αυθεντικά, ιδιοκτησία της MECCANO και προστατεύονται από τις εθνικές νομοθεσίες για τα μοντέλα της μάρκας ή τα διπλώματα ευρεσιτεχνίας. Για κάθε πληροφορία παρακαλώ απευθυνθείτε στη MECCANO. Η ευθύνη της MECCANO δεν δεσμεύεται σε περίπτωση ατυχήματος που έγινε συνεχώς (I) μη σεβασμού των οδηγιών συναρμολόγησης (II) χρήσης των τεμαχίων διαφορετική από αυτήν που προτείνεται στις οδηγίες (III) καταστροφής ή αλλαγής των τεμαχίων. Η εταιρεία MECCANO σέβεται την ασφάλεια των παιδιών: τα μοντέλα της δοκιμάζονται από παιδιά.

JPN モデルならびに部品は、その多くが MECCANO 社 所有のオリジナル・デザインで、意匠・商標および/または著作権に関する国内法によって保護されています。詳細については、当社 (MECCANO) メカノ社は (I) 組立の注意事項を守らなかった場合、(II) 使用説明書に記されたもの以外の部品を使用した場合、(III) 部品を改変・改造した場合などに起きた事故については責任を負うことはできません。メカノ社の全モデルは事前に子供たちによりテストを行い、その安全性を確認されております。

S Batterierna skall inte laddas om. Ackumulatorbatterierna skall tas av från leksaken innan de laddas (om de kan tas av). Ackumulatorbatterierna skall endast laddas under uppsikt av en vuxen (om de kan tas av). Olika typer av batterier eller ackumulatorbatterier skall inte blandas. Nya och använda batterier eller ackumulatorbatterier skall inte blandas. Använd endast rekommenderade typer eller likartade typer av batterier eller ackumulatorbatterier. Batterierna och ackumulatorbatterierna skall sättas i med hänsyn till polerna. Använda batterier och ackumulatorbatterier skall tas av från leksaken. Kontaktterna på ett batteri eller ett ackumulatorbatteri skall inte kortslutas. Bevara anvisningarna.

FIN Paristoja ei saa ladata uudelleen. Akut on otettava ulos leikkikalusta ennen lataamista (jos se on mahdollista). Akut saa ladata vain aikuisen valvonnassa (jos ne voidaan ottaa ulos). Erityyisiä paristoja tai akkuja ei saa käyttää yhdessä, samoin ei saa sekoittaa akkuja ja uusia ja vanhoja paristoja. Vain suositeltuja akku- tai paristotyyppijä saa käyttää tai tyyppejä, joilla on samat ominaisuudet. Paristo ja akut on asetettava paikoilleen niin, että navat tulevat oikeisiin suuntiin. Loppuunkäytetyt paristot tai akut on otettava leikkikalusta ulos. Akun tai pariston napoja ei saa oikosulkea. Ohjeet on pidettävä tullessa.

DK Batterierne må ikke oplades. Akkumulatorbatterier skal tages ud af legetøjet, inden de lades op (hvis de kan tages ud). Akkumulatorbatterierne må kun lades op under opsyn af voksne (hvis de kan tages ud). Forskellige typer batterier og akkumulatorbatterier, eller nye og brugte batterier, må ikke blandes sammen. Der må kun anvendes batterier eller akkumulatorbatterier af den type der er anbefalet eller tilsvarende modeller. Batterier og akkumulatorbatterier skal vendes rigtigt (+/- polar). Brugte batterier og akkumulatorbatterier skal tages ud af legetøjet. Klemmerne på et batteri eller et akkumulatorbatteri må ikke kortsluttes. Disse instruktioner bør opbevares.

NL De batterijen mogen niet weer opgeladen worden. De accu's moeten voor het laden uit het speelgoed verwijderd worden (indien ze verwijderd kunnen worden). Gebruik geen verschillende typen batterijen of accu's of gebruikte en nieuwe batterijen of accu's door elkaar. Gebruik alleen batterijen of accu's van het aanbevolen type of van een gelijkwaardig type. Let bij het plaatsen van de batterijen en accu's goed op de juiste polariteit. De verbruikte batterijen en accu's dienen uit het speelgoed verwijderd te worden. De aansluitingen van een batterij of van een accu mogen niet kortgesloten worden. Aanwijzingen om te bewaren.

GR Οι μπαταρίες δεν πρέπει να επαναφορτίζονται. Οι συσσωρευτές πρέπει να αφαιρούνται από το παιχνίδι πριν τη φόρτιση (εάν μπορούν να αφαιρεθούν). Οι συσσωρευτές πρέπει να φορτίζονται μόνον υπό την επίβλεψη ενήλικα (εάν μπορούν να αφαιρεθούν). Δεν πρέπει να ανακατεύονται διάφοροι τύποι μπαταριών ή συσσωρευτών ή μπαταριών ή συσσωρευτών καινούριων και παλιών. Πρέπει να χρησιμοποιούνται μόνον μπαταρίες ή συσσωρευτές του συνιστώμενου τύπου ή παρόμοιοι τύποι. Οι μπαταρίες και οι συσσωρευτές πρέπει να τοποθετούνται σύμφωνα με τη σωστή πόλωση. Οι παλιές μπαταρίες και οι παλιοί συσσωρευτές πρέπει να αφαιρούνται από το παιχνίδι. Οι πόλοι μιας μπαταρίας ή ενός συσσωρευτή δεν πρέπει να βραχυκυκλώνονται. Διατηρήστε τις οδηγίες.

JPN 電池は充電しないで下さい。蓄電池は充電する前に玩具から取り外して下さい (玩具から取り外せるようになっている場合)。蓄電池の充電は必ず大人のいるところで行って下さい (玩具から取り外せるようになっている場合)。電池や蓄電池は、使用済、使用済、あるいは異なる種類のものなどを混ぜ合わせておかないで下さい。電池や蓄電池は、指定の種類、またはそれに類似したもの以外は使わないで下さい。電池や蓄電池をセットする時には、極性と陰極の向きをよく確認します。使用済の電池や蓄電池は玩具から取り外して下さい。電池や蓄電池の極はショートしないよう取り扱いに注意して下さい。この説明書は保存しておいて下さい。

USA Do not mix old and new batteries. Do not mix alkaline, standard (carbon-zinc), or rechargeable (nickel-cadmium) batteries.

C € 0359

Made in China for / Fabriqué en Chine pour / Fabricado en China por:



363, avenue de Saint Exupéry 62100 Calais - France
<http://www.meccano.com> <http://www.erecator-sets.com>

© 03/2009 MECCANO

® MECCANO and ERECTOR are exclusive trademarks of MECCANO
All rights reserved