

Model No. S.31.

Australia 6d.

Steam Excavator

OR MECHANICAL DIGGER

A VERY important branch of modern engineering work might be described as "digging holes in the ground." In this category are such undertakings as canals, tunnels, reservoirs and the sinking of deep foundations of very large buildings. Years ago big excavation works involved the employment of vast numbers of men because little or no machinery was available and all the work had to be done by manual labour. This state of affairs continued to a considerable extent until comparatively recent times. To-day, however, although

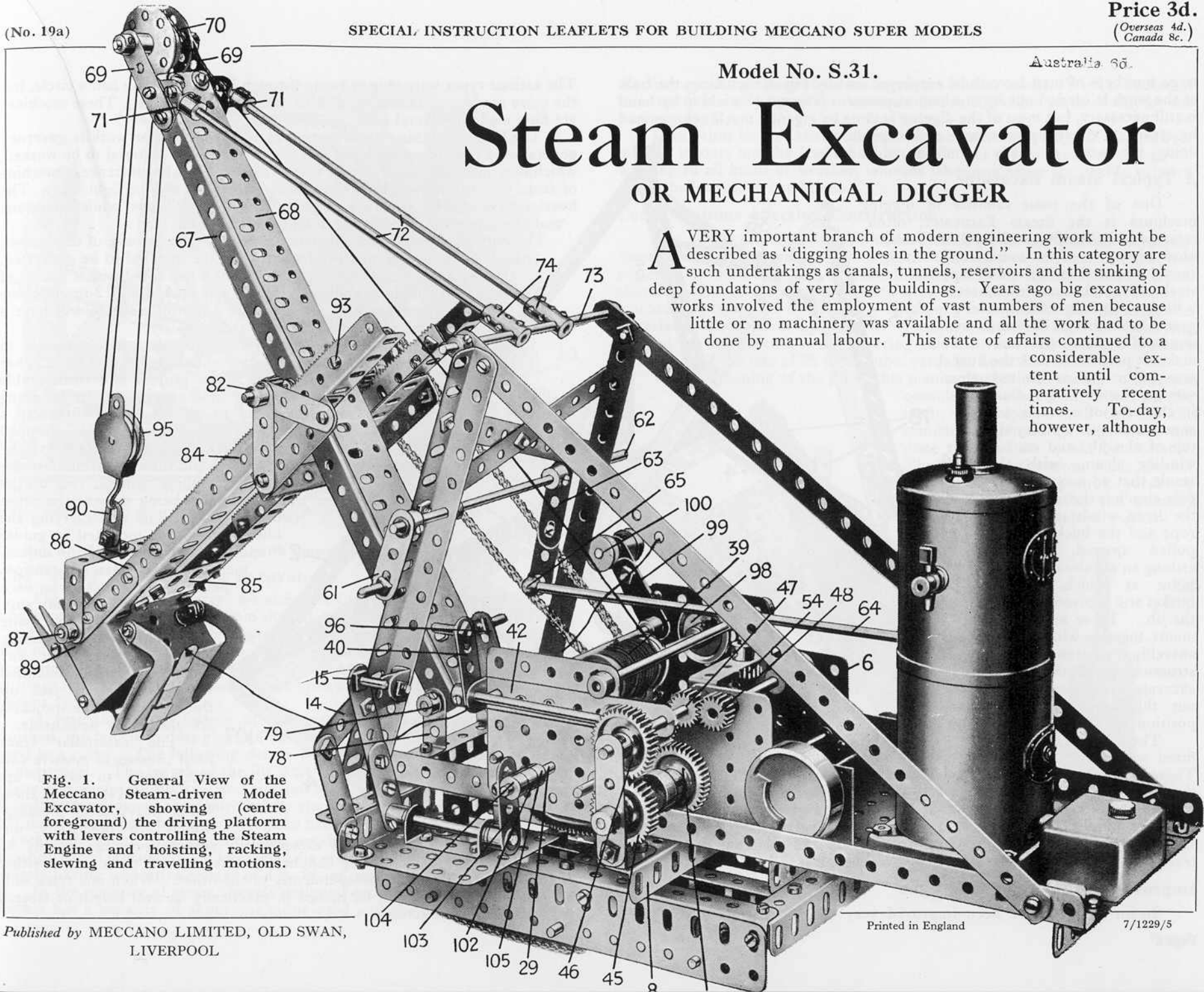

Fig. 1. General View of the Meccano Steam-driven Model Excavator, showing (centre foreground) the driving platform with levers controlling the Steam Engine and hoisting, racking, slewing and travelling motions.

large numbers of men have to be employed on any big undertaking, the bulk of the work is carried out by mechanical power. The spade wielded by hand is still necessary, but most of the digging is done by gigantic machines operated by steam or electric power, and each capable of doing the work of many hundreds of men.

A Typical Steam Excavator

One of the most familiar of digging machines is the Steam Excavator, often referred to as the Steam Shovel or Mechanical Navy. This consists of a huge shovel mounted on the end of a powerful steel arm that, in turn, is connected with a jib by two long racks meshing with gear wheels driven by steam engines mounted on the shovel frame. This makes it possible to rack the bucket arm in or out as desired, thus varying the working radius. As in the case of a crane, a wire rope passes over a pulley at the top of the jib, and on to a winding drum, with the result that so soon as the gear clutch is thrown in the drum winds in the rope and the bucket is pulled upward, describing an arc about the point at which the bucket arm is pivoted to the jib. These movements, together with the swivelling of the superstructure, enable the bucket to excavate a considerable area without the necessity of altering the position of the base of the machine.

The leading edge of the digger bucket is fitted with a cutting lip armed with a number of teeth. These are made of the hardest steel, and dig their way into the material to be removed. In most machines, the jib is attached to a swivelling framework, in which the gears, engines and boiler, etc., are housed. The whole revolving superstructure is mounted on an under carriage and this runs on rails, the travelling motion being taken from the main engines.

Improvements in Modern Designs

Steam navvies have been improved very considerably in recent years.

The earliest types were able to swing through little more than half a circle, but the more modern machines are able to complete a full circle. These machines are now made in several sizes.

The size of machine to be employed on any particular work is governed generally by the output required and the nature of the material to be worked, which determine also the "cutting effort" to be used. For instance, a machine of from 4 to 6 tons weight is suitable for working earth or light clay. The heavier clays require machines weighing from 10 to 20 tons, whilst limestone and iron-ore require machines of 30 tons, or more.

The output of the machine depends principally on the size of the bucket, which again is governed by the nature of the material to be excavated. Usually a 6-ton machine is most efficient when fitted with a bucket of a capacity of about one cubic yard. The bucket of a 12-ton machine holds about twice as much, whilst a 20-ton machine will have a bucket of about 3 to 4 cubic yards capacity.

Sometimes during the course of excavation it is necessary to move a steam excavator over soft boggy land and at other times over hard uneven rocky ground and considerable difficulty was for a long time experienced in designing a machine adaptable to all occasions. Recently a type of machine has been designed that is equipped with "caterpillar" travelling gear. Four "track" sprockets are fitted and these are secured to the axles of the travelling wheels, two of the "track" supports being driven, the other two being idle. The axle carrying the idler sprockets is mounted in guides and fitted with screws for adjustment of the "track" tension.

Between the sprockets on each side are the rollers for supporting the track, these being carried on a separate framing and so situated that any roller can be dismantled without having to jack up the machine. The sprockets are also easily detachable.

The "caterpillar" track itself consists of massive cast steel links to which are secured mild steel pads, these being heavy steel pressings which are practically un-

breakable, and if bent through exceptionally severe usage can readily be straightened. Separate driving clutches are fitted to each track so that either of them may be operated independently of the other. When one track only is driven the machine can be turned in practically its own length or steered with ease in any direction.

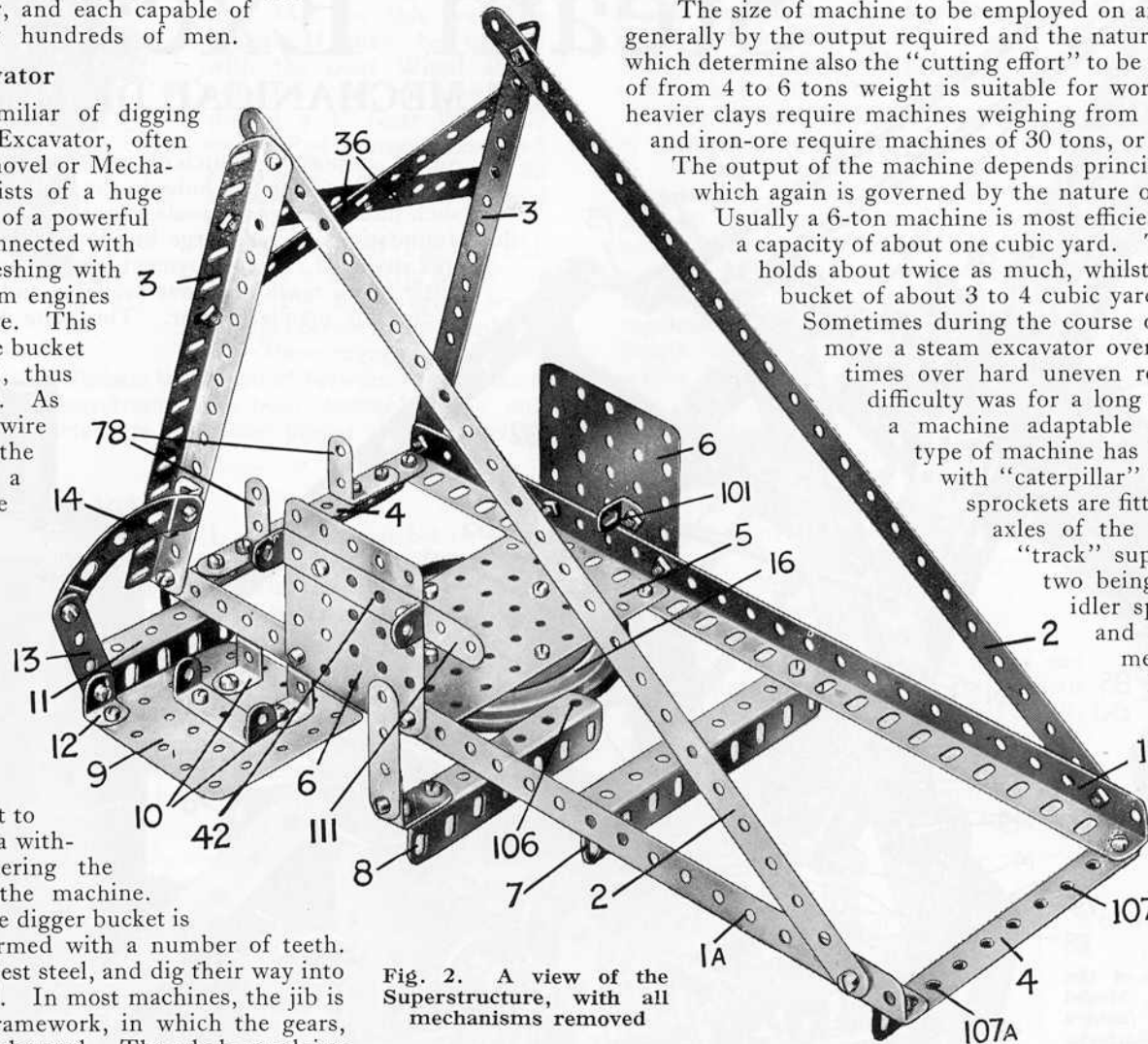

Fig. 2. A view of the Superstructure, with all mechanisms removed

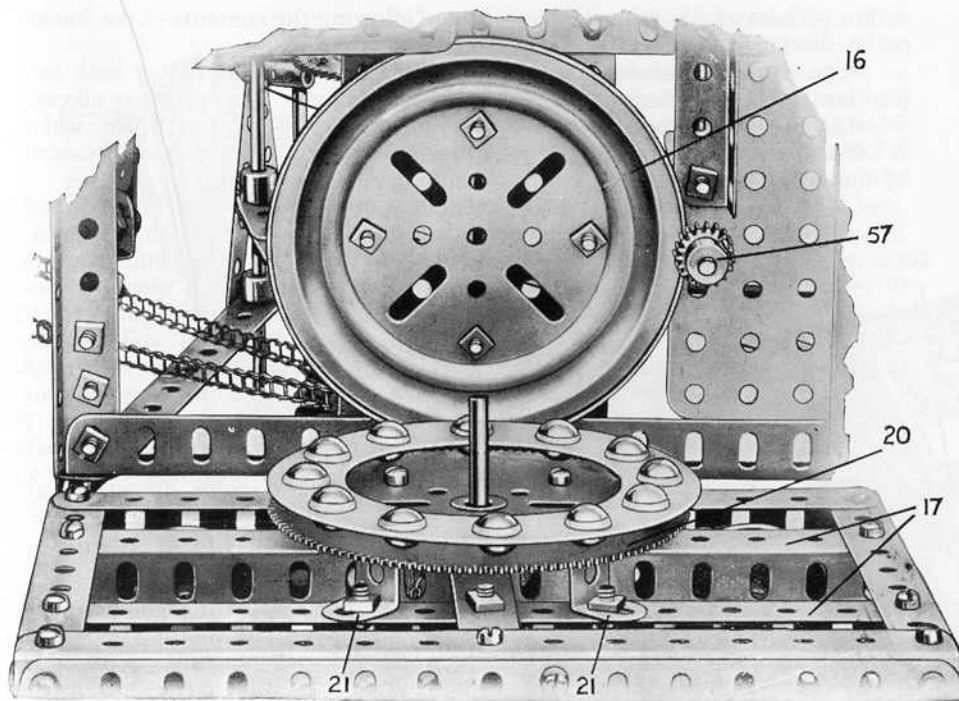

Fig. 3. The Ball Bearing unit, with upper Race raised to show details

The "Berry" 8-ton Steam Excavator

Fig. 4 illustrates a "Berry" 8-ton Steam Crane Excavator, a machine that may be accepted as typical of steam shovels generally. It will be seen from the illustration that the Meccano model is a close reproduction of this machine. It is of the type used by contractors for many kinds of excavating work, such as trenching for the foundations of large buildings, reservoirs, and narrow cuttings for railways. It is used also at brickworks and quarries where a large output is required.

A very interesting feature of this machine is that after excavating is finished, the bucket and its gear can be removed from the jib and the machine used as a crane. The following details will give some idea of its mechanical construction. The length of the jib is 24 ft., and it is made from mild steel plates and angles, firmly tied and rivetted together. The lifting, turning and travelling movements are controlled by the main engines while the depth of cut may be regulated by a pair of engines fixed on the jib and working through a rack and pinion. Lifting is carried out by means of wire rope, and the hoisting barrel is grooved. The machine is provided with two sets of travelling wheels having respective gauges of 4 ft. 8½ ins. and 7 ft. 8 ins.

In the majority of steam shovels designed especially for clayworking the bucket has a capacity of about one cubic yard and the engine is capable of

exerting a cutting effort of 6 tons upon the bucket teeth. With a bucket of this type it is easily possible to excavate 250 to 300 cubic yards of clay in one working day!

It will thus be seen that a mechanical excavator has many advantages over manual labour, not the least of which is the fact that a machine will go on working in all kinds of weather, whereas labourers often are unable to work under bad weather conditions.

Considerations affecting Construction

One of the principal considerations affecting both the size and constructional details of excavating machines is the distance from the machine that it is required to discharge the excavated material. For instance, many steam shovels discharge the excavated material at distances of up to 32 ft. from the machine centres, and by adding a longer jib it is possible to discharge the material at distances of up to 60 ft. Such machines are used for quarrying mineral buried beneath a top covering of earth, and will excavate ordinary soil or clay at the rate of 25 to 50 cubic yards an hour.

The lengthening of the jib in this manner makes it necessary to decrease considerably the cutting effort on the teeth, as compared with that on the standard machine. If this were not done the machine would be unstable. The bucket is therefore made smaller and handles only 1¼ cubic yards, or roughly about a quarter the quantity handled by the standard bucket.

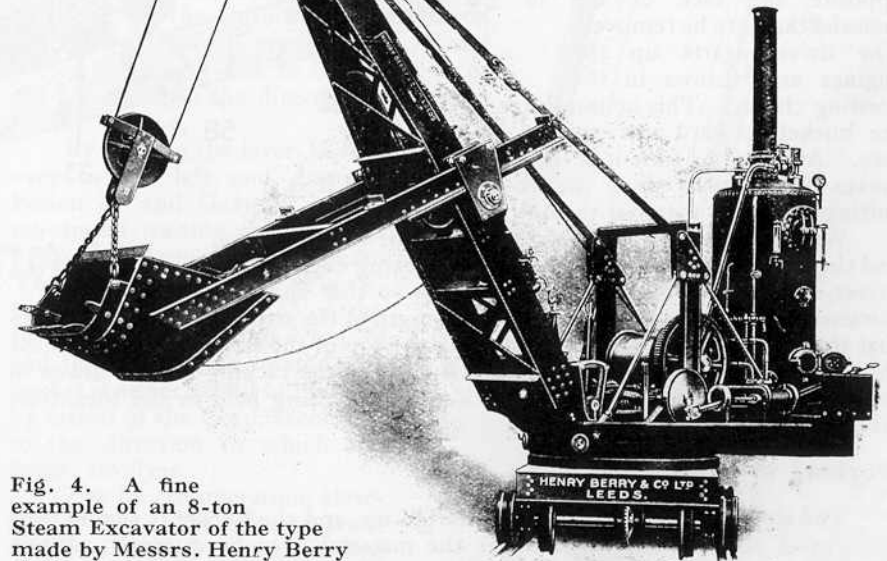

Fig. 4. A fine example of an 8-ton Steam Excavator of the type made by Messrs. Henry Berry & Co., Ltd., Leeds

On the radius over which the machine effectively operates depends also the depth to which it is able to cut. Modified machines, such as are referred to above, will excavate soil, etc., to a depth of 15 to 20 ft. and deposit it at points up to 60 ft. distance. If it is desired to excavate to a greater depth than this, machines with even longer reaches must be constructed.

If the material to be excavated is heavier than soil or clay, very powerful machines must be used. Some large machines now in use are equipped with rock-loading buckets having capacities of $3\frac{1}{2}$ cubic yards. Although naturally slower in operation than the lighter types, they are able to complete a cycle of operations in about a minute! They can eat their way through 300 cubic yards of material in an hour and discharge their loads at any given point over a radius of 100 ft.!

Controlling the Machinery

Having seen something of the construction of these giant shovels we may consider for a moment how a machine of the standard type is operated.

When commencing operations, the bucket hangs in a vertical position, with the teeth resting on the ground opposite the face of the material that is to be removed. The driver starts up the engines and throws in the hoisting clutch. This action drags the bucket forward and upward, to the face. At the same time it is thrust outwards by means of the racks along the bucket arm until it is cutting away the material to the required depth.

With one hand on the control-lever of the main engines, and the other on the control-lever of the racking engines, the driver is able to control the depth of cut so that an equal thickness is taken throughout the whole length of the stroke. He thus ensures that the bucket is completely filled when the top of the stroke is reached. At this stage, the hoisting clutch is thrown out and the racking motion draws in the bucket until it is clear of the working face, being held in the meantime on the free drum by means of the brake.

Working at High Speed

The slewing mechanism is then started up, and the bucket is swung over the wagon, or over the point where the material is to be dumped. When the correct position is reached, the driver pulls a cord by his side, and this

action withdraws a bolt on the bucket door, allowing the contents of the bucket to be discharged.

The slewing motion is then reversed and the bucket is swung back into position to take the next cut from the working face. The bucket is allowed to return to the bottom of the stroke by releasing the winding drum, which is loose upon its shaft. When free of the clutch it is under the driver's control by means of a foot-brake.

All these operations take place almost as quickly as they can be described, the actual time depending on the size of the machine and the length of the jib. As an illustration may be

mentioned a special test of a steam shovel capable of dealing with about 150 cubic yards of soil or clay per hour, or from 60 to 100 yards of iron-ore per hour. In the tests referred to, it regularly completed the cycle of operations in from 25 to 35 seconds!

Building the Meccano Model

This fascinating model performs all the motions of which the actual machine is capable. Provided that the following instructions are followed carefully no boy should experience difficulty with its construction. Care should be taken whilst building the model to see that all gears and rods work freely, so as to ensure successful working when it is completed.

The framework of the superstructure is shown in Fig. 2 and should be proceeded with first. The illustration indicates the method of construction very clearly. The side members 1 and 1a are $12\frac{1}{2}$ " Angle

Girders; 2 are two $12\frac{1}{2}$ " Strips; 3, two $7\frac{1}{2}$ " Angle Girders braced by two $5\frac{1}{2}$ " crossed Strips; 4, two $4\frac{1}{2}$ " Angle Girders; 5, a $4\frac{1}{2}$ " \times $2\frac{1}{2}$ " Plate; 6, two $2\frac{1}{2}$ " \times $2\frac{1}{2}$ " Plates; 7, a further $4\frac{1}{2}$ " Angle Girder; 8, a $3\frac{1}{2}$ " Angle Girder; 9 is a $2\frac{1}{2}$ " \times $2\frac{1}{2}$ " Plate that is secured to the Angle Girder 1a by two Reversed Angle Brackets 10. To a $2\frac{1}{2}$ " Angle Girder 11 is secured a 2" Strip, to the end of which a $2\frac{1}{2}$ " Curved Strip 14 is bolted. This latter forms the quadrant for the lever 15 (Fig. 1). The upper disc of a Ball Race 16 (Fig. 2) is secured to the Plate 5. The 3" Strip 111 and $2\frac{1}{2}$ " \times $\frac{1}{2}$ " Double Angle Strip 42 are both secured by the same bolts to the Plate 6.

After completing the superstructure framework, the base frame (Fig. 5) should be built. Four $7\frac{1}{2}$ " Angle Girders 17 and 17a are secured to two

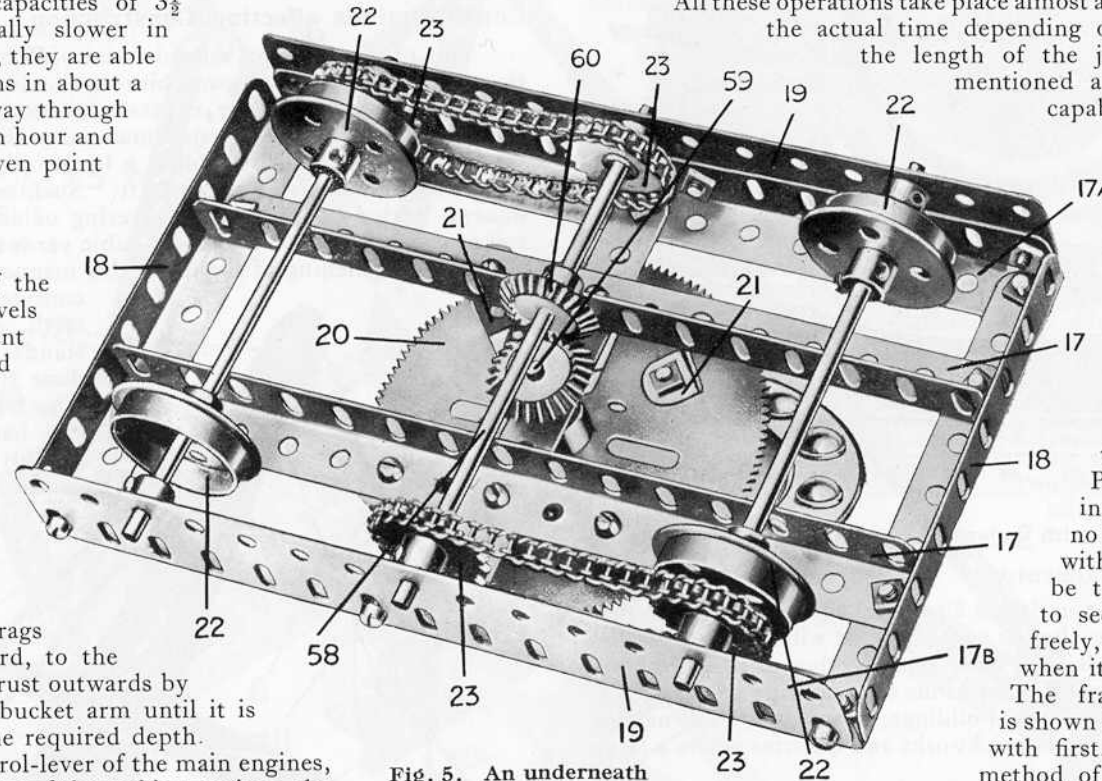

Fig. 5. An underneath view of the Chassis

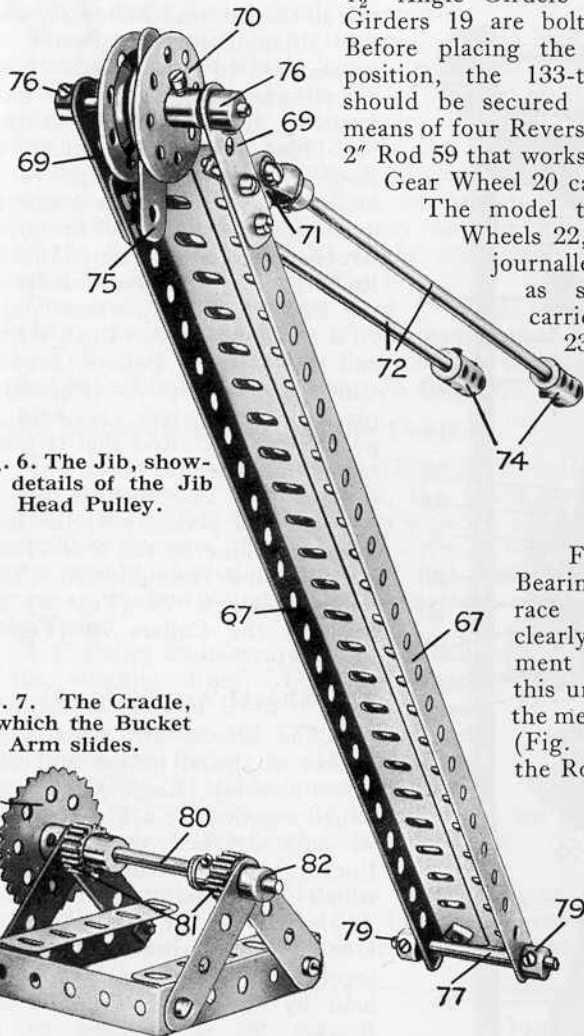
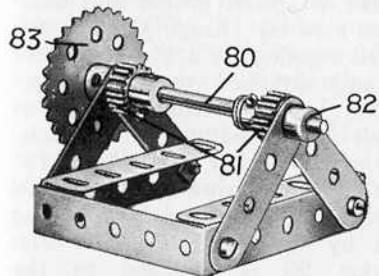

Fig. 6. The Jib, showing details of the Jib Head Pulley.

Fig. 7. The Cradle, in which the Bucket Arm slides.



4 1/2" Angle Girders 18, while two 7 1/2" Flat Girders 19 are bolted to the Girders 17a. Before placing the running wheels 22 in position, the 133-teeth Gear Wheel 20 should be secured to the Girders 17 by means of four Reversed Angle Brackets 21. A 2" Rod 59 that works freely in the boss of the Gear Wheel 20 carries a 7/8" Bevel Wheel.

The model travels on the Flanged Wheels 22, the axles of which are journalled in the Flat Girders 19 as shown. The Rod 58 carries two Sprocket Wheels 23 that are connected by Sprocket Chain with two further Sprockets 23 secured to the axles of the wheels 22. The Rod 58 is driven via a Bevel 60 from the Bevel on Rod 59.

Fig. 3 shows the Ball Bearing unit with the upper race raised, and illustrates clearly the general arrangement of the various parts of this unit. Before assembling the mechanism, the framework (Fig. 2) may be placed on the Rod 59 of the base frame, which passes through the centre hole of the Plate 5 (Fig. 2) and is secured in position by the 1 1/2" Bevel Gear 33 (Fig. 9).

Assembling the Mechanism

The drive from the engine is transmitted through a 1/2" Pinion 51 (Fig. 9) that engages the 57-teeth Gear 52, on the Rod of which a 1" Gear 24 is secured. The Gear 24 engages a further 1" Gear 25 on the Rod 26, at one end of which is a 3/4" diameter 3/4" wide Pinion 27 that transmits the drive through the 50-teeth Gear 28 to the slidable gear change Rod on which the Pinion 31 and the Bevel 30 are secured.

From this Rod the drive may be transmitted, through one of three different gear trains to produce the following movements—traversing, racking of the digger arm, and the raising or lowering of the bucket. Any of these movements

may be brought into operation by means of the lever 15 (Fig. 1) that controls the sliding of the Rod.

The arrangement of the lever is shown fairly clearly in the illustration. The Collar 102, which is placed between Collars 104 and 105 secured to Rod 29, is connected pivotally by a Bolt inserted in its set-screw hole, to a Crank secured to the Rod of the lever 15. Hence, by moving the lever 15 the Rod 29 is caused to slide longitudinally in its bearings. The Collar 102 is of course free on the Rod 29, the bolt that is passed through the Crank 103 being screwed into the Collar sufficiently to allow locking it by a nut but without securing the Collar to the Rod. This type of gear change lever forms the subject of Standard Mechanism No. 78.

The traversing motion is effected by pushing the lever 15 hard over to the left (as seen in Fig. 9), thus bringing the Bevel 30 into engagement with the Bevel 33. This movement throws the Pinion 31 clear of the 50-teeth Gear 35. The Bevel 33 is mounted on a Rod 59 (Fig. 5), on the lower end of which is a 26-teeth Bevel Gear engaging a similar Bevel Gear 60 that imparts motion to the running wheels 22 through the Sprockets and Chains 23.

The digger arm is brought into operation by moving the lever 15 slightly over to the right, thus throwing the Pinion 31 into engagement with the 57-teeth Gear Wheel 34 and disengaging the Bevels 30 and 33. A 3/4" Sprocket Wheel 36, secured on the Rod of Gear 34, transmits the drive by Sprocket Chain 38 to the Sprocket Wheel 83 on the side of the jib cradle (Fig. 7) and causes the digger arm to be drawn in or out according to the direction of rotation of the engine.

By moving the lever 15 slightly over to the left and disengaging Pinion 31 and Gear 34, the third movement, raising or lowering the bucket, is brought into operation. The driving Pinion 31 (Fig. 9) now engages the Gear 35 on the Rod 94 of the winding drum 39 and the latter being rotated, the bucket is either raised or lowered by means of the Cord, according to the direction in which the drum revolves.

The fourth operation, slewing of the jib, is effected from the lever 40 that controls a Dog Clutch 44a and 44b. The Strip

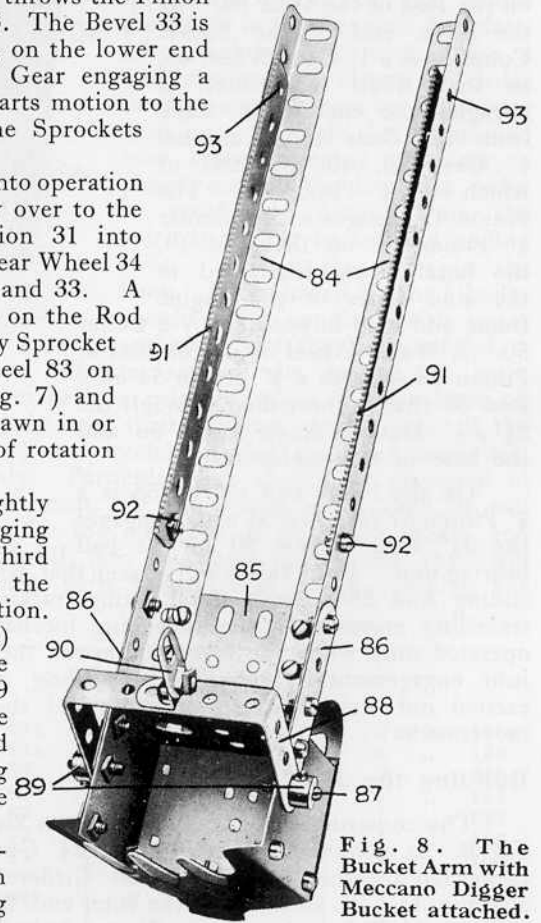

Fig. 8. The Bucket Arm with Meccano Digger Bucket attached.

forming the lever is secured to a 3" Rod 41 that carries a Crank 43 in the arm of which a Threaded Pin is held. The Rod is journalled in a 2½" × ½" Double Angle Strip 42.

The Threaded Pin of the Crank 43 engages the groove of a slidable Socket Coupling 44 (part No. 171) to one end of which is secured the male dog clutch member 44a. The female dog clutch section 44b is secured on the Rod of the Gear 52. At the other end of the Socket Coupling is a 1" Gear Wheel 45, so that when the clutch is engaged the motion is taken from the Gear 45 to another 1" Gear 46, on the Rod of which is a ½" Pinion 47. The Pinion 47 engages with a similar ½" Pinion 48 on the Rod 49, the latter being journalled in the side plates of the engine frame and held in position by a Collar 50. A Worm Wheel 53 on the Rod of Pinion 48 engages a ½" Pinion 54 on a Rod 55 that is journalled through the 2½" × ½" Double Angle Strip 56 and the base of the engine frame.

On the lower end of rod 55 is a ½" Pinion 57 (see Fig. 3) which engages the 3½" Gear Wheel 20 of the ball bearing unit. From this it will be seen that, whilst the sliding Rod 26 controls the hoisting, racking, and travelling movements, the swivelling mechanism is operated only when the lever 40 throws the clutch into engagement. Hence the swivelling may be carried out simultaneously with any of the other movements.

Building the Jib

The construction of the jib is shown clearly in Fig. 6. It comprises essentially two 12½" Girders 67 connected together by a 12½" Flat Girder 68 (see also Fig. 1). To each side of the outer end, 2" Strips 69 and 1" Triangular Plates 71 are bolted. The

Fig. 9. Plan view of the superstructure, showing arrangement of the Gear Box and Controls, etc.

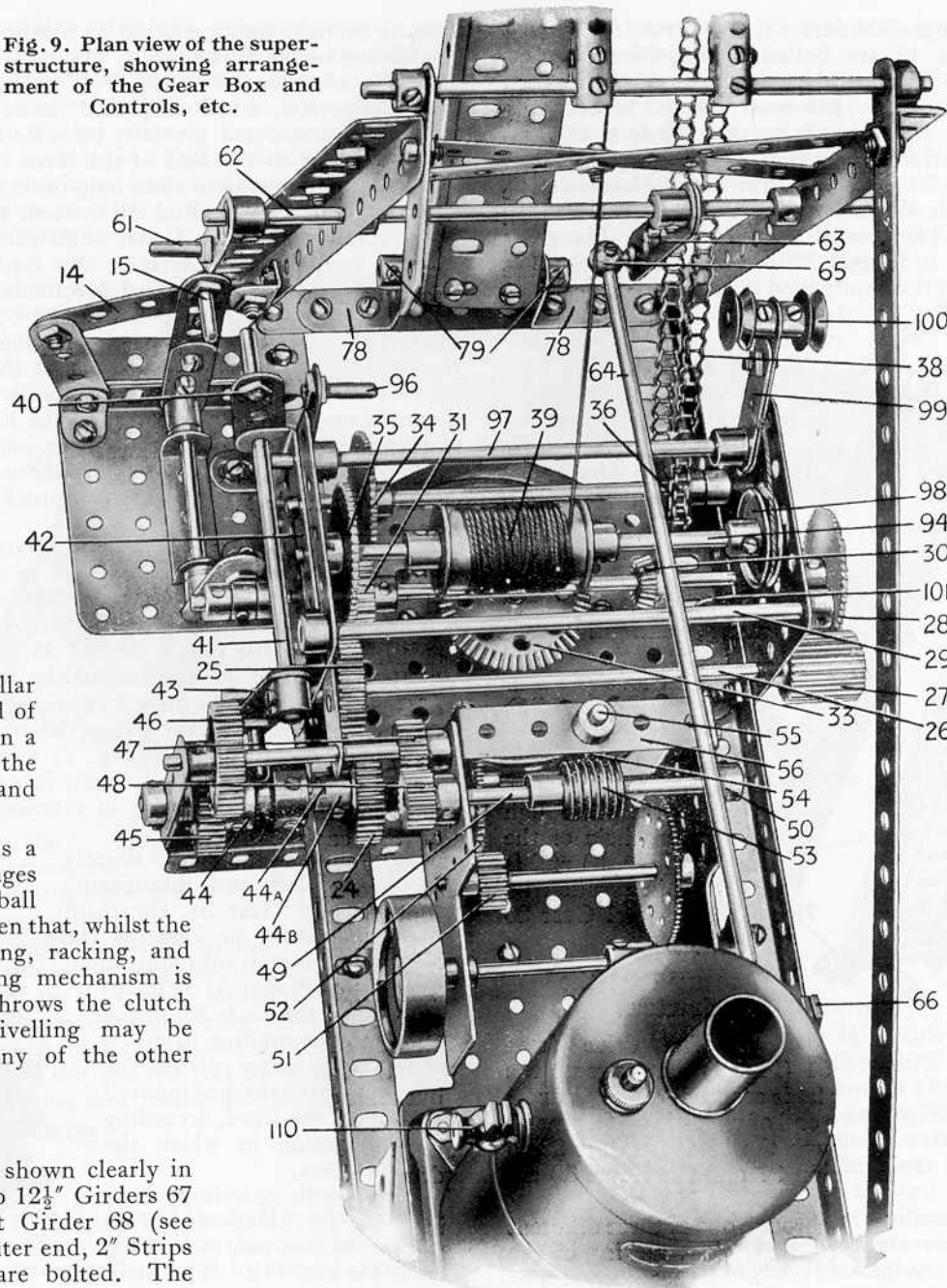

Strips form the bearings for the axle of the jib head Pulley 70, while the Triangular Plates serve for connections to the 8" Rods 72, the actual connection to the jib being made by Small Fork Pieces (part No. 116a). The other ends of the Rods 72 carry Couplings 74 by means of which they are connected to the Rod 73 (Fig. 1) of the superstructure. It is to be noted that the Rods 72 are mounted loosely on the Rod 73. The jib head pulley 70 is formed from two Bush Wheels and two 1" loose Pulleys, between which a 2" Strip 75 (Fig. 6) is placed. The whole is held in position on a 2" Rod that is maintained in the jib head by the Collars 76. The foot of the jib is connected pivotally to the body of the machine by the Rod 77 that is journalled through two 1" × 1" Angle Brackets 78 (Fig. 2) and held by the Collars 79 (Figs. 1 and 6).

The Shovel Arm (Fig. 8)

The shovel arm carries the bucket or shovel proper and comprises two 9½" Angle Girders 84, joined together by a 2" Flat Girder 85 and attached to the Digger Bucket by 2½" Strips 86, one of which is placed on either side. The arms, Bucket, and a 2½" × 1½" Double Angle Strip 88 are assembled together on Threaded Pins 87 and held by Collars 89. The Flat Bracket 90 is attached to the Double Angle Strip 88 by an Angle Bracket, and both are lock-nutted together to form the connection to the hook of the hoisting cord.

Two 6½" Rack Strips 91 are secured to the inside faces of the Girders 84 by bolts 92. At a later stage the arm will be threaded through the cradle (Fig. 7), after

which two further bolts are secured in the holes 93 to hold the Rack Strips firmly in position.

The shovel arm slides in the cradle shown in Fig. 7, the construction of which does not need description. The cradle is connected to the jib by the Rod 80 that is journaled through the centre holes of the jib and held in position by the Collar 82 and the $1\frac{1}{2}$ " Sprocket Wheel 83. The two $\frac{1}{2}$ " Pinions 81 carried by the Rod 80 engage the teeth of the Rack Strips. A length of Sprocket Chain 38 (Fig. 9) may now be passed round the Sprocket Wheel 83 of the cradle and the Sprocket Wheel 36, as indicated in Fig. 1.

One end of the hoisting cord (Figs. 1 and 9) is fixed to the winding drum 39 and passes over one of the Pulleys at the jib head, then through the block 95, and is tied finally to the Strip 75 (Fig. 6)

Brake Mechanism and Engine Control

The brake control lever 96 (Fig. 1) comprises a Crank carrying a Threaded Pin, the Crank being secured to the 5" Rod 97 (Fig. 9) on which is a second Crank 99 to the arm of which a 2" Strip is bolted to carry a weight consisting of two $\frac{1}{2}$ " fast Pulleys 100 that are secured on a Rod passed through the end hole of the Strip.

A 1" Pulley 98 is secured to the Rod 94 of the winding drum. The brake band comprises a piece of Cord that is connected to the Angle Bracket 101 (Fig. 2) and then carried over the Pulley 98 and tied to the Crank 99 (Fig. 9). The pressure of the Cord round the Pulley 98 should be slackened by moving the lever 96 when hoisting operations are commenced.

The working of the Meccano Steam Engine is controlled by the lever 61 (Fig. 1) that is formed from a Crank and Threaded Pin secured to a Rod 62.

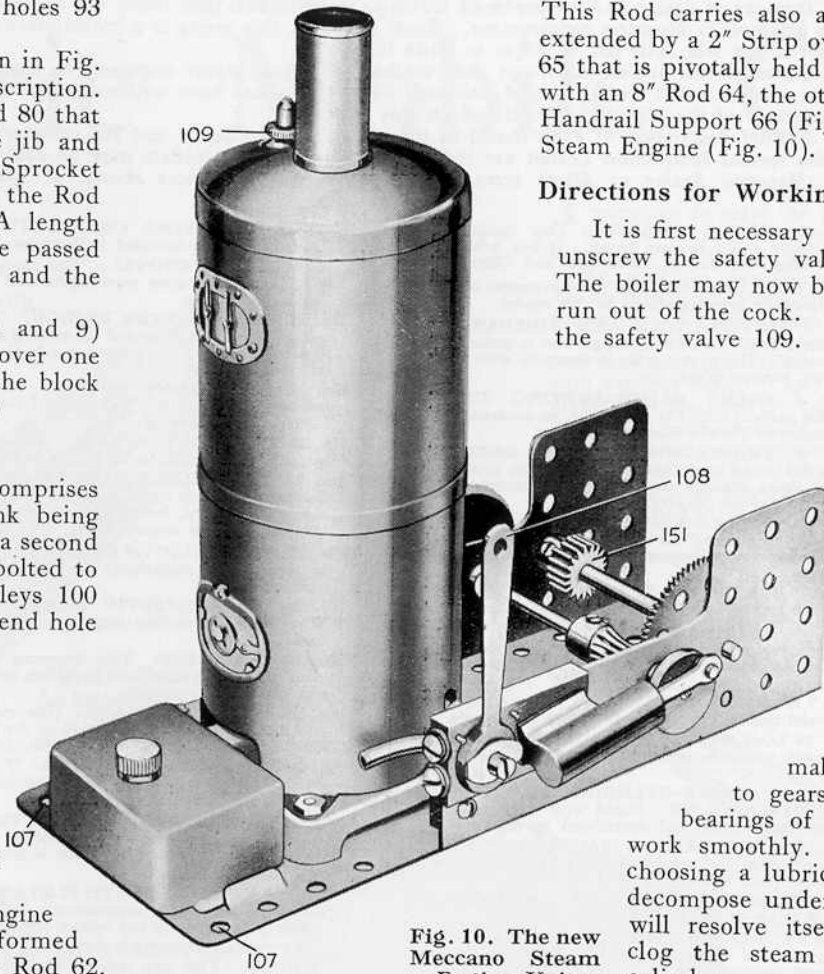

Fig. 10. The new Meccano Steam Engine Unit

This Rod carries also a second Crank 63, the arm of which is extended by a 2" Strip overlapped as shown. A Handrail Support 65 that is pivotally held in the end hole of the 2" Strip connects with an 8" Rod 64, the other end of which is connected by a further Handrail Support 66 (Fig. 9) to the steam throttle lever 108 of the Steam Engine (Fig. 10).

Directions for Working the Steam Engine

It is first necessary to fill the boiler with water. To do this unscrew the safety valve 109 and open the cock 110 (Fig 9). The boiler may now be filled with water until it commences to run out of the cock. Now turn off the cock 110 and replace the safety valve 109. The lamp is to be filled with methylated spirit and placed in the guides provided in the engine bedplate. After lighting the wick allow a few minutes to elapse in order to raise ample steam to commence working. It might be mentioned here that the spirit container is placed outside the boiler in order to avoid any danger from the spirit becoming heated and boiling over. When the spirit in the lamp is exhausted the boiler should be re-supplied with water as before and the lamp refilled.

Before setting the engine to work make it a rule always to apply a little oil to gears and shafts, piston, guides, and all the bearings of the model, so that the mechanism will work smoothly. Particular care should be exercised in choosing a lubricant. If the wrong oil is used, it will decompose under the influence of heat and steam and will resolve itself into vegetable substances that will clog the steam parts and prevent steam reaching the cylinder.

Parts required to build the Meccano Steam Excavator :—

2 of No. 1	1 of No. 9b	1 of No. 16a	1 of No. 25	4 of No. 31	2 of No. 48a	1 of No. 95a	2 of No. 116a
2 " 2	3 " 9d	3 " 16b	1 " 25a	1 " 32	1 " 53a	4 " 96	6 " 125
1 " 2a	1 " 10	3 " 17	6 " 26	125 " 37	24 " 59	1 " 96a	2 " 136
1 " 4	3 " 12	1 " 18b	3 " 27	3 " 37a	8 " 62	1 " 103b	1 " 144
4 " 5	3 " 12a	4 " 20	1 " 27a	21 " 38	2 " 63	1 " 103g	1 " 152
9 " 6	3 " 13a	2 " 20b	1 " 27b	1 " 40	3 " 72	2 " 103k	1 " 163
4 " 8	3 " 14	1 " 22	2 " 30	1 " 46	2 " 77	2 " 110a	1 " 168a
2 " 8a	7 " 15	2 " 22a	1 " 30a	1 " 47	1 " 90	2 " 111a	1 " 168c
6 " 8b	1 " 15a	2 " 23a	1 " 30c	1 " 48	1 " 94	7 " 115	1 " 169
5 " 9a	3 " 16	2 " 24					1 " 171

MECCANO SUPER MODELS

Our expert designers have produced for us 34 super models that reach the highest pinnacle ever attained in Meccano construction. Each model in this series is a masterpiece and there is not a boy who will not be eager to build them all.

These models are so important that we have engaged expert engineers to describe them and a special leaflet with beautiful half-tone illustrations has been written for each of them. A selection of the leaflets is illustrated on this page.

A brief description of each model in the series is given below and the number and price of the special Instruction Leaflet are indicated. Copies of the leaflets may be obtained from any Meccano dealer or direct from us, post free, at the prices shown at foot.



No. 6 Leaflet.



No. 3 Leaflet.

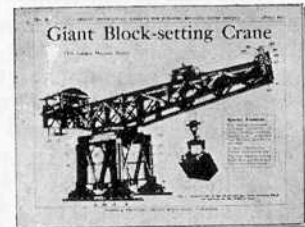

No. 4 Leaflet.



No. 8 Leaflet.

No. 1 MOTOR CHASSIS. This model runs perfectly under its own power. It has Ackermann Steering, Differential, Gear Box and Clutch, etc.

No. 2 SHIP COALER. All the movements of a real ship-coaler are reproduced in this model.

No. 3 MOTOR-CYCLE AND SIDECAR. The sidecar is of stream-line design and is mounted on springs. The motor-cycle is complete with lamps, horn, exhaust pipes, etc.

No. 4 GIANT BLOCK-SETTING CRANE. This realistic model is fitted with an accurate reproduction of Fidler's block-setting gear.

No. 5 TRAVELLING BUCKET DREDGER. In this model trucks and wagons can run underneath the chute through which falls the material raised by the dredger buckets.

No. 6 STIFF-LEG DERRICK. This model has many interesting movements, including hoisting, luffing and swivelling, which are controlled by suitable levers.

No. 7 PLATFORM SCALES. This model will weigh articles up to 4½ lbs. with remarkable accuracy.

No. 8 ROUNDABOUT. This model is most attractive when in motion. As the roundabout rotates the cars spin round and the horses rise and fall.

No. 9 BAGATELLE TABLE. This is an interesting model that will give hours of fun to the players.

No. 10 LOG SAW. In this model the saw is driven rapidly to and fro while the work table travels beneath it.

No. 11 SINGLE-CYLINDER HORIZONTAL STEAM ENGINE. Fitted with balanced crank-shaft, crosshead, and centrifugal governor.

No. 12 STONE SAWING MACHINE. The model is equipped with adjustable work table and overhead trolley with self-sustaining chain hoist.

No. 13 MECCANOGRAPH. This wonderful model will draw hundreds of beautiful designs.

No. 14 GRANDFATHER CLOCK. A practical example of Meccano model-building. The model keeps accurate time.

No. 15 BALTIC TANK LOCOMOTIVE. The driving wheels are operated by an Electric Motor. An accurate reproduction of Walschaerts' Valve Gear is fitted.

No. 16 LOOM. This is perhaps the greatest Meccano success. The model weaves beautiful material.

No. 17 PLANING MACHINE. Fitted with quick-return motion.

No. 18 REVOLVING CRANE. This model is fitted with screw-operated luffing gear.

No. 19 STEAM SHOVEL. This model embodies travelling and rotating mechanisms and jib hoisting and lowering gear.

No. 21 TRANSPORTER BRIDGE. The carriage automatically travels to and fro as long as the motor is driven, pausing for a few seconds at each end of its travel.

No. 22 TRACTION ENGINE. A remarkably realistic model that will pull a boy of average weight. Fitted with two speeds.

No. 23 VERTICAL LOG SAW. While the saws are in motion, the logs are fed slowly to them.

No. 24 TRAVELLING GANTRY CRANE. The movements of this model comprise the traversing of the entire gantry, hoisting and lowering, and the traversing of the crane trolley.

No. 25 HYDRAULIC CRANE. The hydraulic ram is represented realistically by a powerful screw mechanism.

No. 26 TWIN-ELLIPTIC HARMONOGRAPH. Many beautiful designs may be produced with this model.

No. 27 DRAGLINE. This imposing model of a giant excavator is fitted with travelling, luffing, slewing and dragging movements.

No. 28 PONTOON CRANE. The movements of this model include the operation of the two hoisting blocks, slewing of the entire crane, and luffing.

No. 29 HAMMERHEAD CRANE. This is a very realistic and powerful model, comprising traversing, hoisting and slewing motions.

No. 30 BREAKDOWN CRANE. This model is equipped with travelling, slewing, luffing, and hoisting motions, and also is fitted with laminated springs, brakes, out-riggers, etc.

No. 31 WAREHOUSE WITH ELEVATORS. The two cages are driven automatically and work alternately, pausing at top and bottom positions.

No. 32 TWO-CYLINDER STEAM ENGINE AND BOILER. This is a realistic working model of a complete steam plant, equipped with valve gear, governor, balanced cranks, etc.

No. 33 SINGLE AND DOUBLE FLYBOATS. These two models represent popular pleasure-fair attractions.

No. 34 THREE-ENGINE BIPLANE. This is a realistic model of an "Argosy" machine, and is fitted with ailerons elevators and rudders.



No. 19 Leaflet.

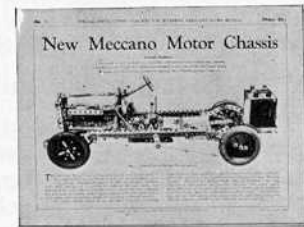

No. 1 Leaflet

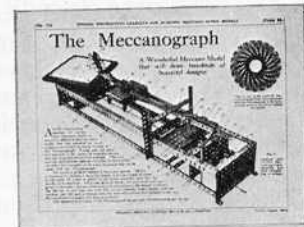

No. 13 Leaflet.

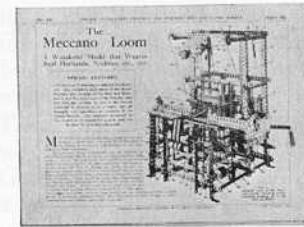

No. 16 Leaflet.

INSTRUCTION LEAFLET PRICES.

Leaflet Nos. 3 5 6 7 8 9 10 11 12 17 18 19 21 22 23 24 25 26 28 29—United Kingdom 2d., Overseas 3d., Canada 5 cents.

Leaflet Nos. 1 2 13 14 15 16 27 30 31 32 33 34—United Kingdom 3d., Overseas 4d., Canada 8 cents.

Leaflet No. 4—United Kingdom 6d., Overseas 8d. Canada 15 cents.

MECCANO LIMITED - Old Swan - LIVERPOOL