

# Mechanics Made Easy

PRELIMINARY MODELS FOR YOUNG CHILDREN



## A Constructional Mechanical Toy

THIS INVENTION HAS FOR ITS OBJECT THE  
TRAINING OF THE YOUNG IN  
MECHANICAL CONSTRUCTION

PATENTED IN ENGLAND AND ABROAD

---

May be obtained from the leading Toy Dealers.

COPYRIGHT

E. & H., LIVERPOOL

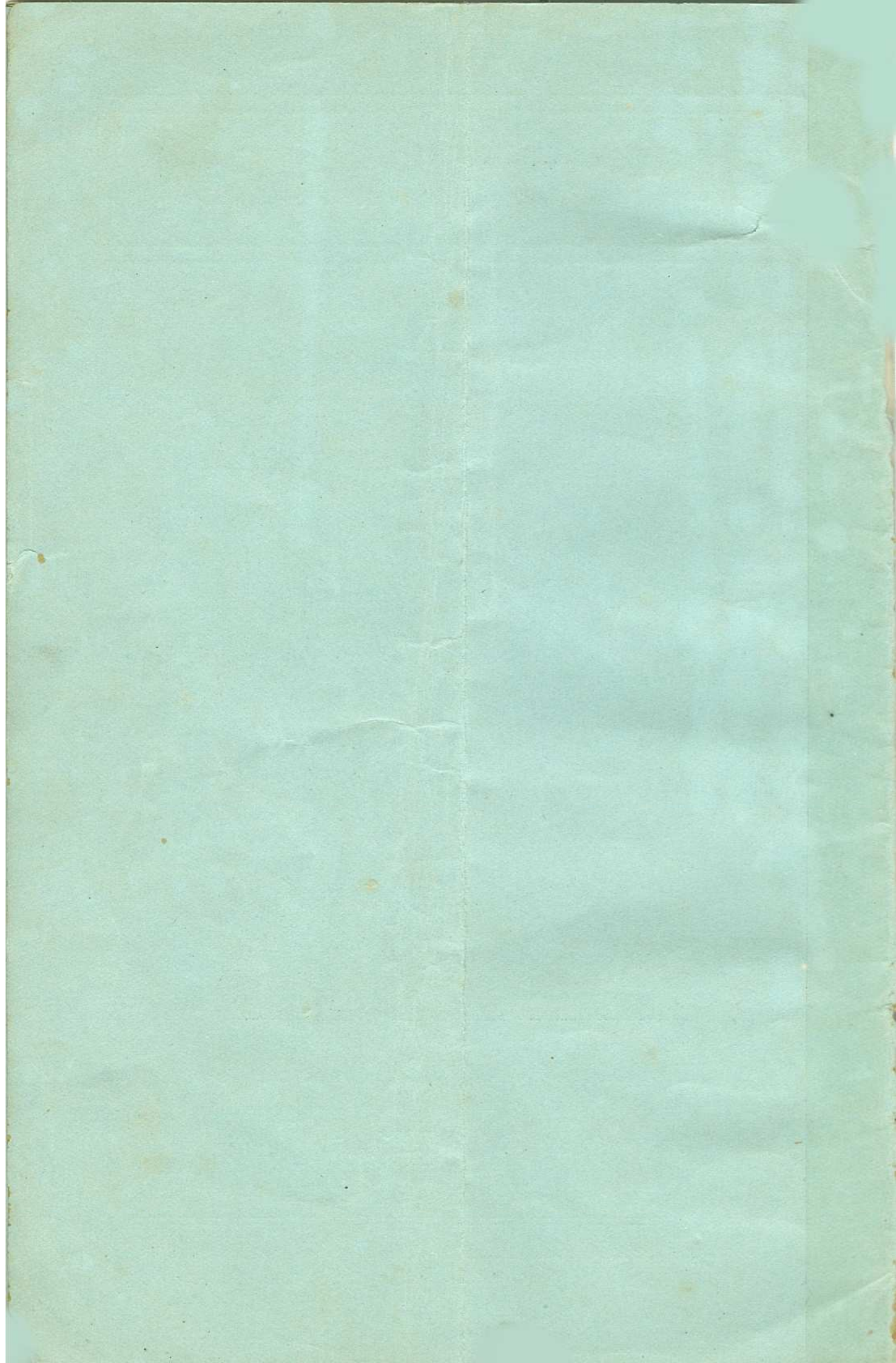

# Mechanics Made Easy

---

## A CONSTRUCTIONAL MECHANICAL TOY.

---

THIS Toy comprises a variety of mechanical parts which, by the aid of the drawings and directions furnished, are adapted to be built up into a number of interesting working models and structures, such as WAGONS, RAILWAYS, TRUCKS, CRANES, BRIDGES, ELEVATORS, TOWERS, and the like objects of interest. No tools are necessary beyond the appliances supplied, and no turning or machining is necessary, so that the toy is well adapted for parlour use.

The natural bent of most children's minds is constructional—to make something, especially **something which will work**, is one of their chief pleasures; most of the toys they have are already made, and too frequently the only way in which children can exercise their ingenuity is in the negative manner of trying to take the toy to pieces—usually with disastrous results.

Building blocks to some extent meet the child's need, but the structures made with bricks are not portable, and, above all, they do not **work**, and at the best, the exercise given is in one direction only, viz., building with bricks. The present toy, however, comprises all the main mechanical parts used in machines, such as levers, beams, wheels, axles, pulleys, wormwheels, screws, bolts, keys, &c., and the graduated series of examples given are designed to gradually train the child's mind in the mechanical principles involved in various machines and structures.

It is believed that not only is the knowledge gained in this way useful, but that educationally the training thus afforded is most valuable in developing the reasoning faculties, and tending in quite a pleasurable way to cultivate ingenuity, resourcefulness, and method.

All parts are made to gauge, and the necessity for accuracy of work is clearly taught.

An almost endless variety of models may be built ; the parts are of metal and almost unbreakable ; and when one structure is finished the same parts can be used repeatedly for different structures.

A board 6ft. long, 9in. wide, and  $\frac{3}{4}$ in. thick, should be obtained upon which to work. This will be found very useful in the construction of models which require to be securely fastened.

Parents will find co-operation with the children an interesting and stimulating exercise, and in many instances a pleasant mode of exercising their own inventive faculties.

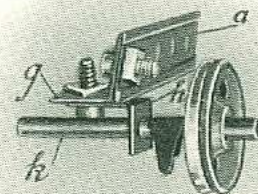
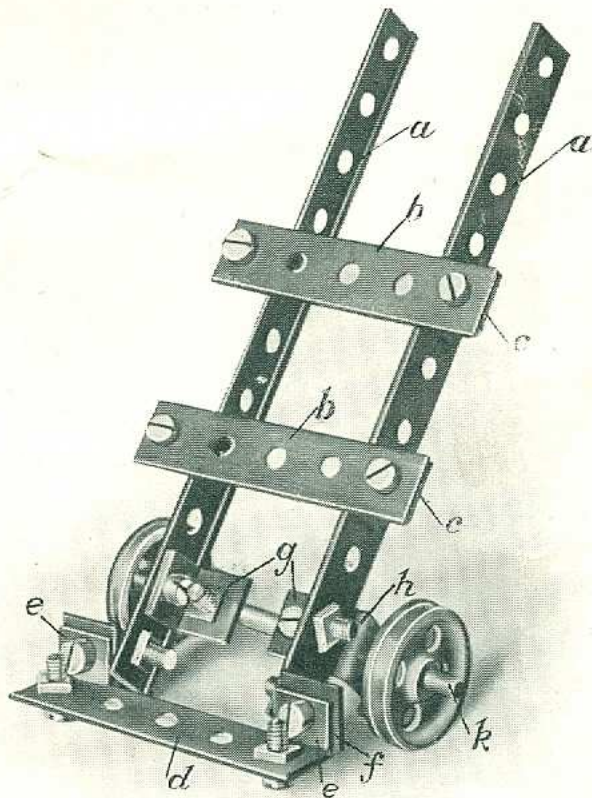

### No. 1. LUGGAGE TRUCK.

In constructing this example, the two side frames *a* should, in the first place, be connected to the cross pieces *b* by means of four angle pieces *c*, advantage being taken of the slots in the latter to give a slight splay to the frames as indicated in the drawing. The lowest cross piece *d* may then be carried from the end holes of the frames *a* by a combination of the two angle pieces *e f* at each end, and the bearings for the wheel axle are each somewhat similarly constructed of two angle pieces *g h*, as will be readily understood by referring to the small detail view. When these are in place the axle *k* is inserted, keys *l* put over the ends, and the wheels secured thereon.

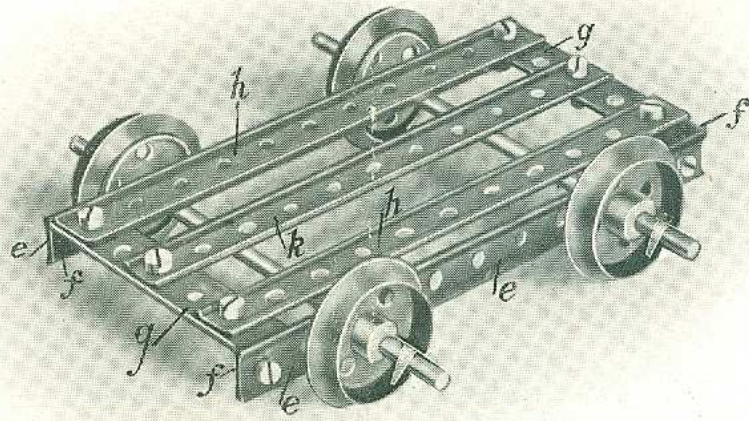

## No. 2. TRUCK.

To construct this design, take a  $5\frac{1}{2}$ in. strip *e* and attach, by means of screws and nuts, an angle piece *f* at each end. Then take a second  $5\frac{1}{2}$ in. strip, and in the same way attach angle pieces at each end of it. These strips are to form the sides of the truck in which the axles of the wheels run. Now connect each end pair of angle pieces with two  $2\frac{1}{2}$ in. strips *g* at right angles to the  $5\frac{1}{2}$ in. strips forming the sides, and over these short strips *g* lay two  $5\frac{1}{2}$ in. strips *h*, fastening each corner of the truck, where the ends of the strips *h* and *g* overlay the angle pieces *f*, by means of screws and nuts. Now attach the  $5\frac{1}{2}$ in. piece *k* at each end to the centre hole of the strips *g*. This, with the two pieces *h*, forms the bottom of the truck. Next insert two axles, as shown, through the third holes from the ends of the side pieces *e*. Then push on the four wheels, and secure them in position by the keys by pushing the feather of the key along the groove in the axle and through the key-way in the wheels. These feathers serve to keep the wheels in position.

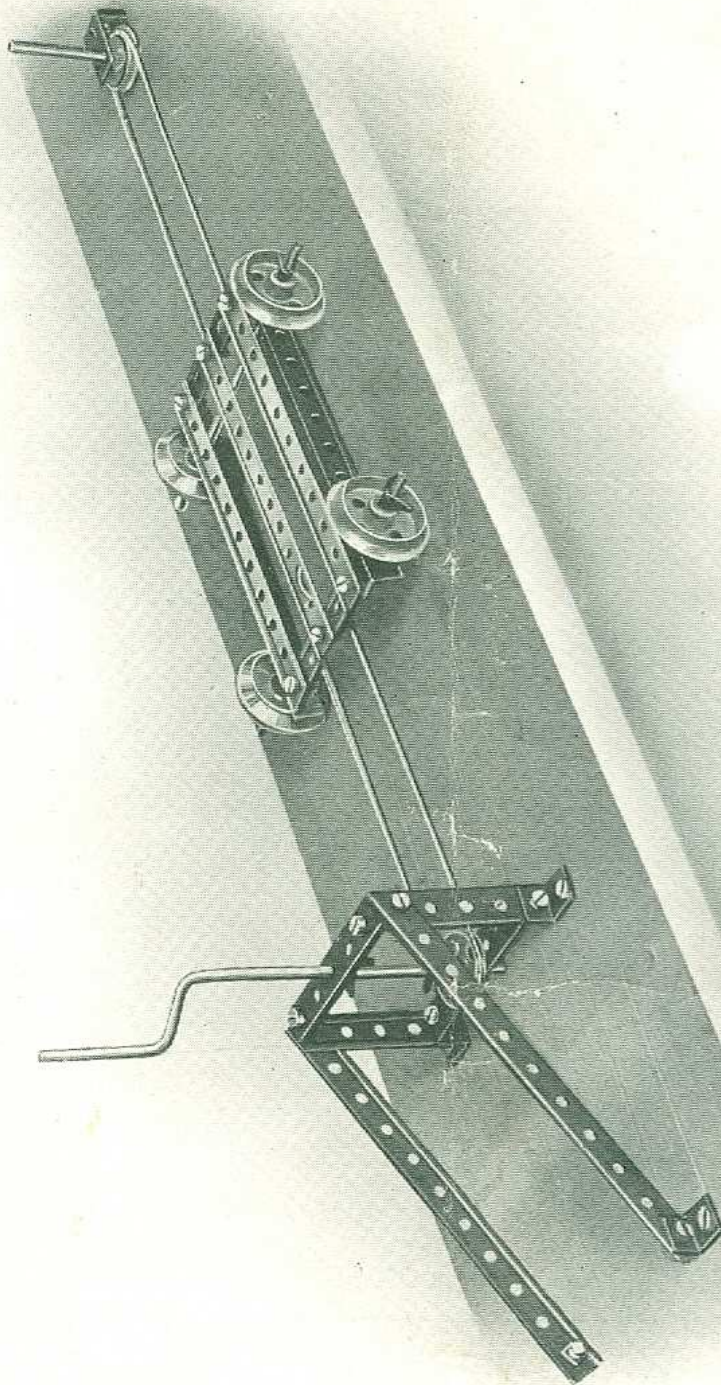

### No. 3. ENDLESS ROPE RAILWAY.

In this example, the truck made according to the previous design is used, and it is connected to an endless cord which passes from a pulley attached to the board to another pulley and shaft carried on the bracket shown. In the illustration, this bracket is shown close to the pulley to

No. 3.—*continued.*

save space, but it may, of course, be placed at any distance desired.

The bracket is constructed as follows: Two vertical  $2\frac{1}{2}$ in. side pieces are connected together at the top and bottom by two more  $2\frac{1}{2}$ in. pieces attached by angle pieces as shown. From the angle pieces at the top, two  $5\frac{1}{2}$ in. pieces are carried down to two angle pieces screwed to the board, as shown, and angle pieces are placed at the feet of the uprights, which are also screwed to the board. The pulley is keyed to the vertical spindle, which is threaded through the central holes of the two  $2\frac{1}{2}$ in. cross pieces, and a second pulley, attached to a U shaped piece as shown, is screwed opposite to the bracket.

A piece of string is then formed into an endless rope running over the two pulleys, and the truck is attached to one side of the string, so that by rotating the handle in one direction or another, the truck is moved as desired.



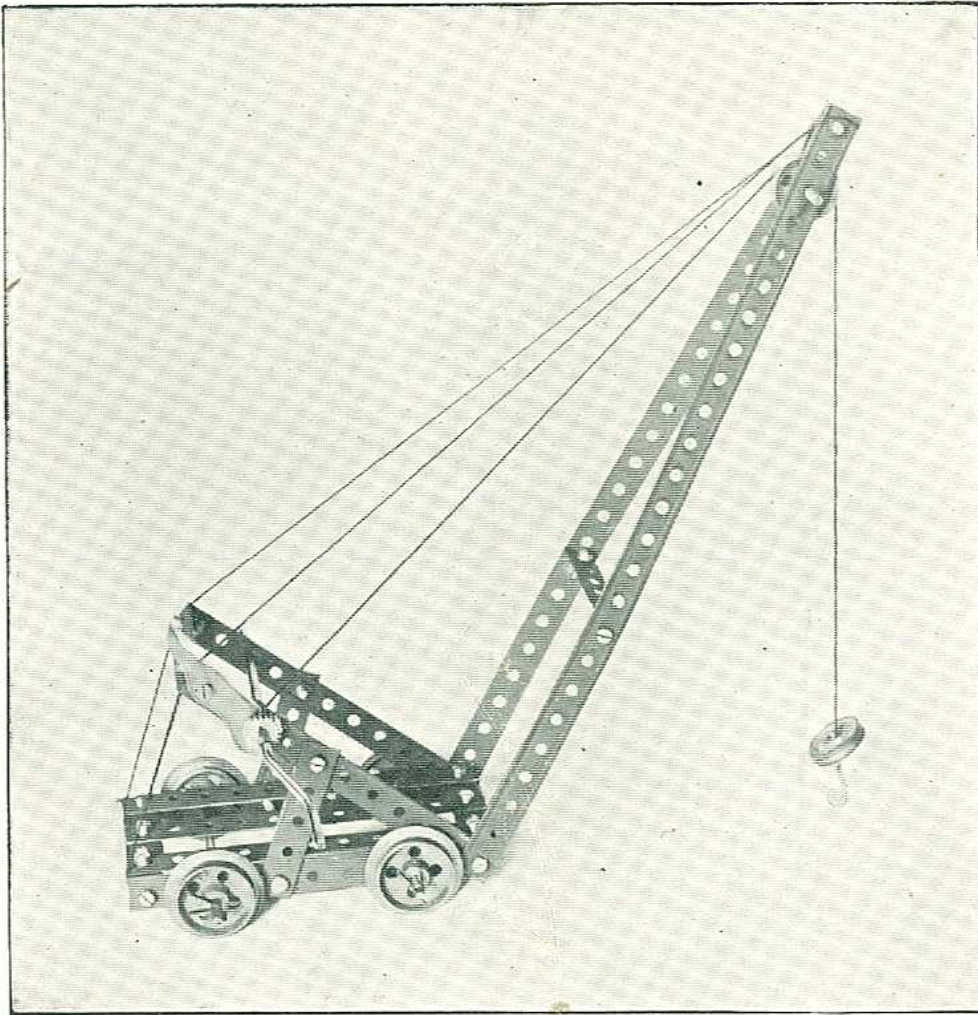

#### No. 4. TRAVELLING JIB CRANE.

The truck of Example 2 is used in the construction of the crane, with the following additions:—

Two  $5\frac{1}{2}$ in. strips sloping back to carry the spindle, and two  $12\frac{1}{2}$ in. strips to form the jib, are attached by the same screws to the end holes of the truck; the two  $5\frac{1}{2}$ in. strips being braced to the truck by the two  $2\frac{1}{2}$ in. strips as shown, and being connected together at their ends by a  $2\frac{1}{2}$ in. strip and angle pieces.

The spindle to which the pinion is keyed is carried in the third pair of holes in the  $5\frac{1}{2}$ in. strips as shown, and the pawl is pivoted on the screw which holds the angle piece in position.

The jib is braced by a  $2\frac{1}{2}$ in. strip and angles at the ninth hole from the end, and the two sides are bolted together at the top hole, and the short spindle carrying the pulley is carried in the third hole from the top, over which pulley the string is passed and tied to the pinion spindle; the whole structure is braced by tie rods formed of strings attached to the ends of the truck, the  $5\frac{1}{2}$ in. strips, and the jib.

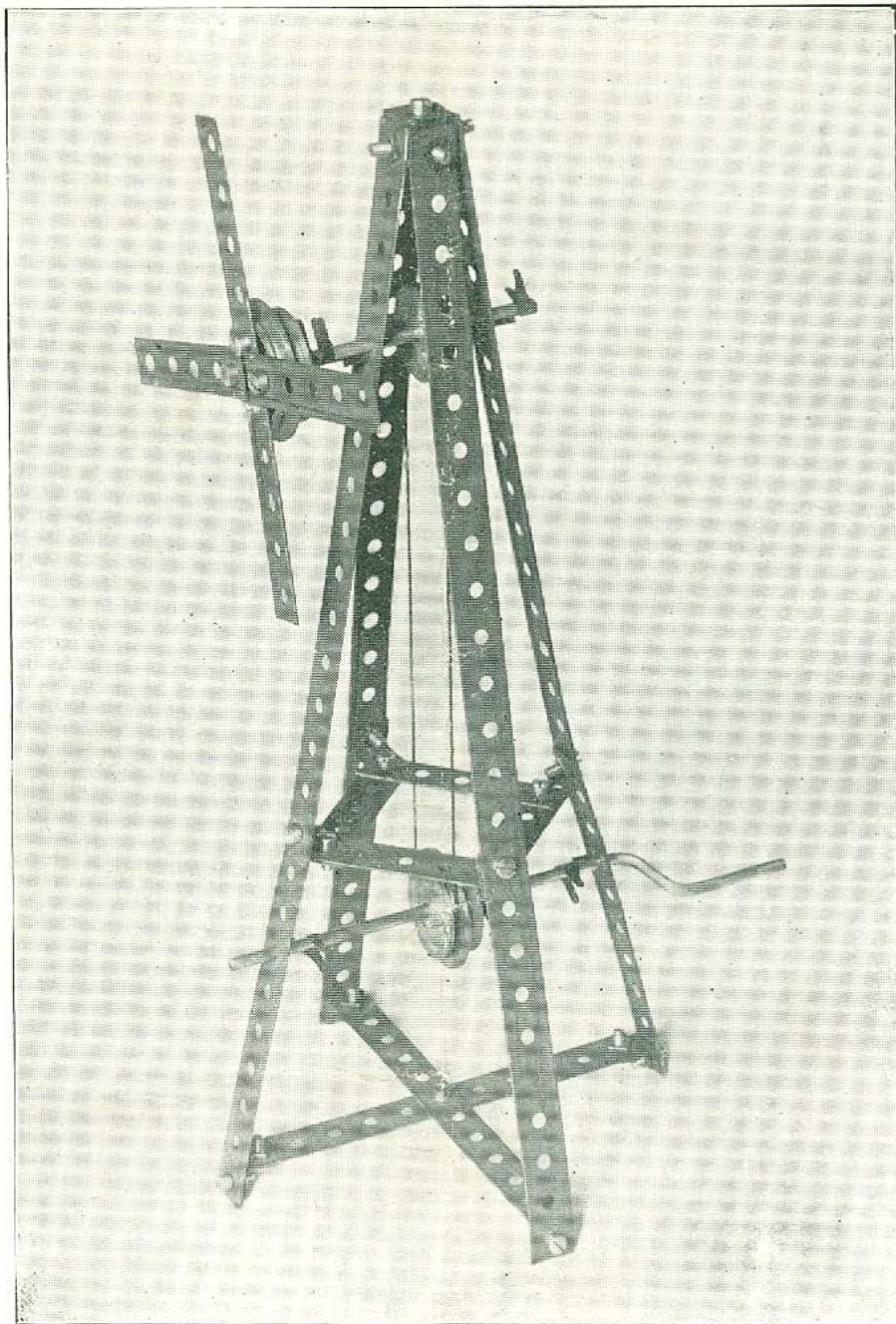

### No. 5. WINDMILL.

This model will not be described quite so fully as the preceding ones, in order that its construction may be a test for the young model-maker, and may be of use for developing his faculties for constructional work.

It will suffice to say that the four  $12\frac{1}{2}$ in. strips are formed at the top by four angle pieces, and are stiffened lower down by the four  $2\frac{1}{2}$ in. strips formed into a square, the corners of which are connected by angle pieces to the  $12\frac{1}{2}$ in. strips.

The wind sails are made by attaching four  $2\frac{1}{2}$ in. strips to the flanged wheel, and keying the latter to the spindle. NOTE.—This spindle has a second pulley on the frame connected by the string band to the pulley on the spindle below.

This model may be driven by a model engine if a straight spindle be used instead of a cranked one, in which case a grooved pulley is keyed to it, and connected by an endless string band to the engine.

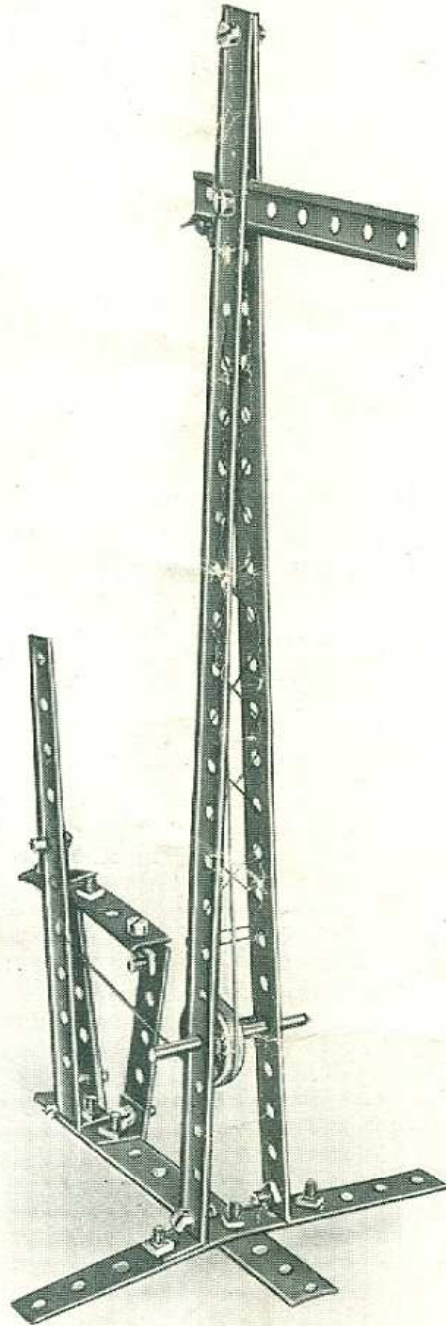

### No. 6. RAILWAY SIGNAL.

Very little difficulty will be found in constructing this model after Model 5 has been accomplished. It will therefore form another test for the young model-maker.

In fixing the lever to the angle bracket at the bottom, lock the nuts so as to prevent the screw from working out.

Fig. 1.

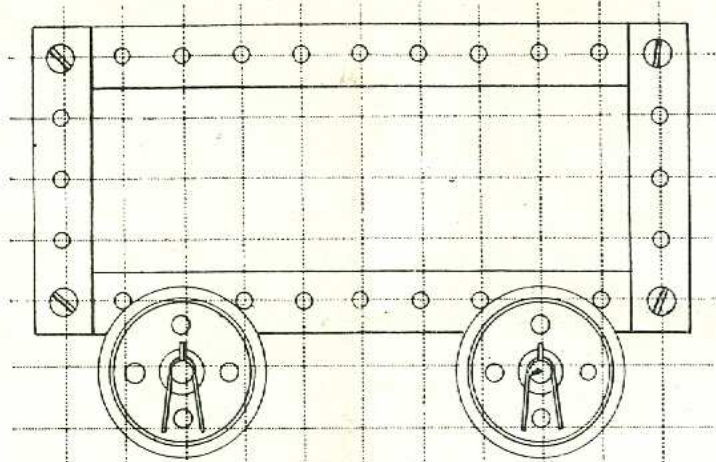

Fig. 2.

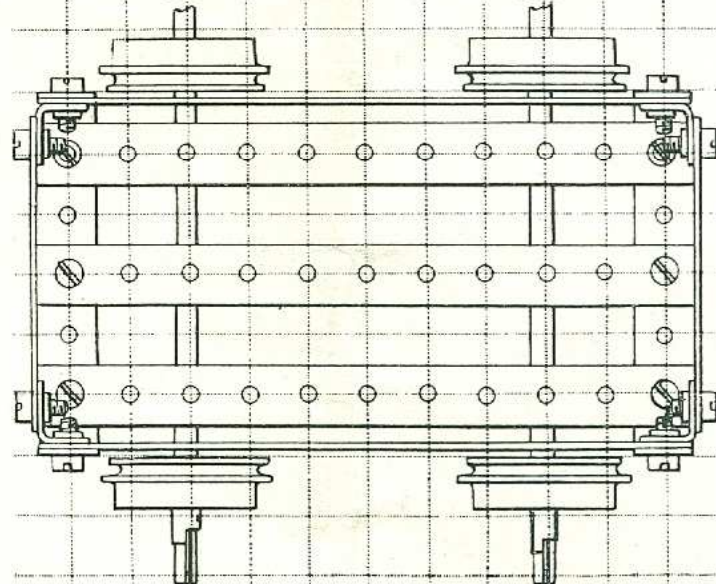
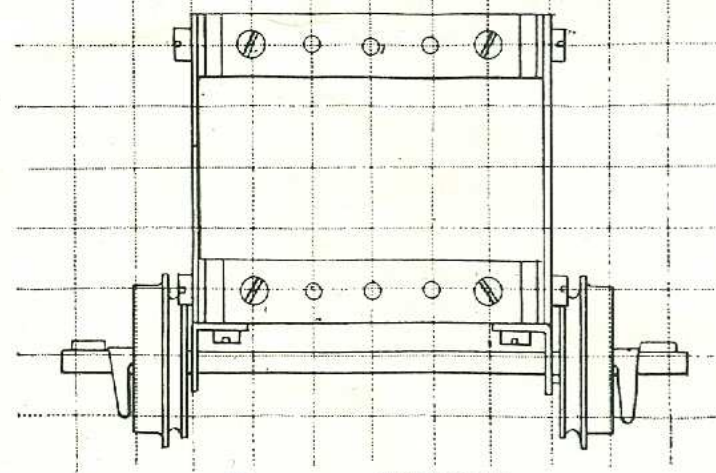
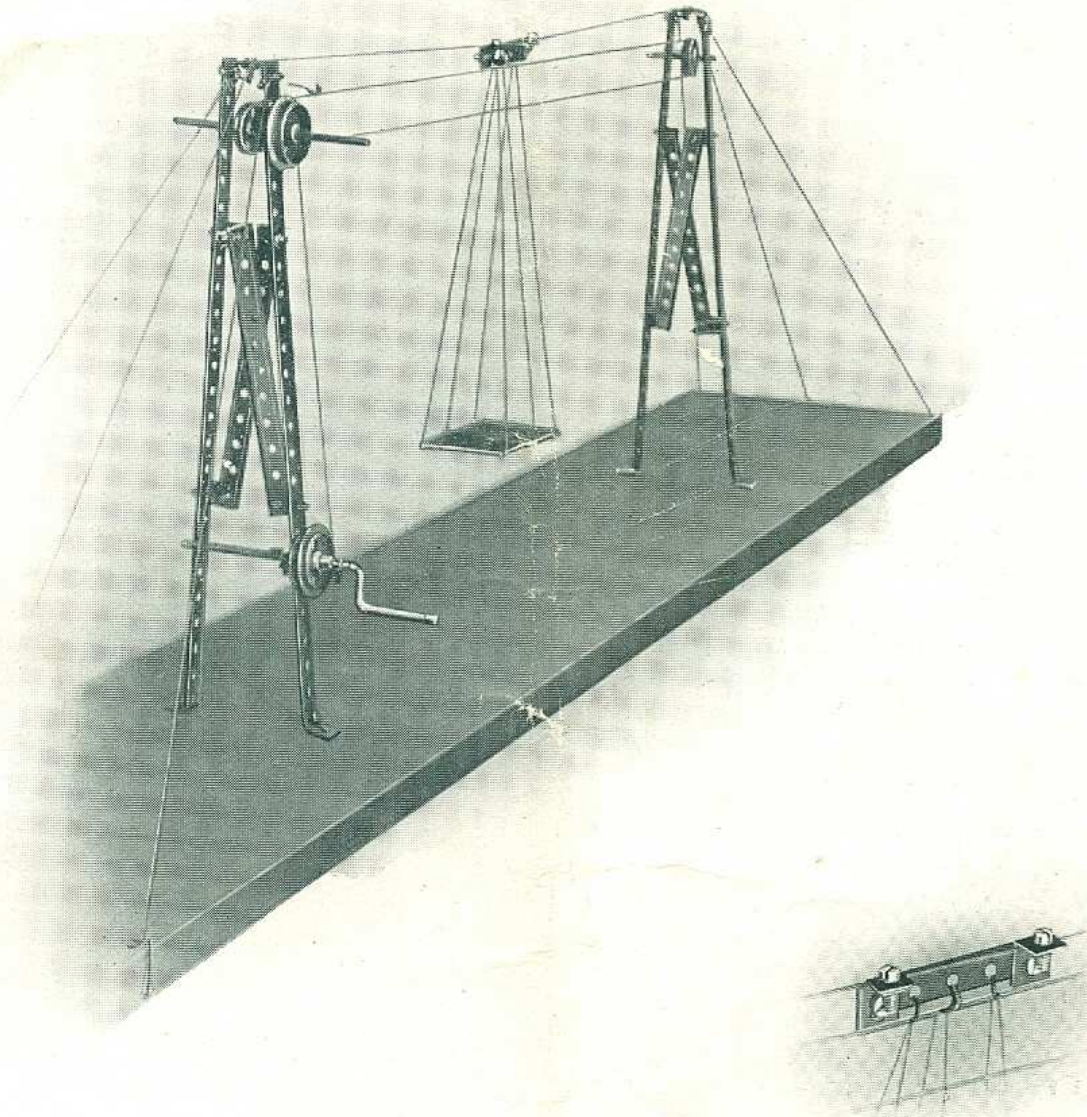

Fig. 3.



**No. 7. TRUCK.**

This illustration is of a truck constructed in a similar manner to the foregoing models. It is intended in this to give an example of the actual kind of drawing that an engineer would make to represent such a model. Fig. 1 would be called an elevation, Fig. 2 a plan, and Fig. 3 an end view of the truck. It will be noticed that the views are on squared paper, and the elevation and plan are projected from each other, as should be the case with all views on an engineering drawing.



**No. 8. MODEL OF TELPHER SPAN.**

The construction of this model will be facilitated if the standards are screwed down before connecting the cords.

The crank pulley cord should be wound twice around the pulleys so as to ensure a better grip.

## MECHANICS MADE EASY

### Separate Parts and Prices

6	Perforated Strips ...	No. 1, 12½ ins. long	... 1/- per doz.
10	" " ...	No. 2, 5½ ins. "	... 6d. "
1	" " ...	No. 3, 3½ ins. "	... 5d. "
	" " ...	No. 4, 3 ins. "	... 5d. "
12	" " ...	No. 5, 2½ ins. "	... 4d. "
	" " ...	No. 6, 2 ins. "	... 4d. "
	Angle Girders ...	No. 9, 12 ins. "	... 1/6 "
18	Angle Brackets ...	No. 12, in bundles of 18	6d. per bdl.
	Axle Rod ...	No. 13, 11 ins. long	... 3d. each.
	" " ...	No. 14, 6 ins. "	... 2d. "
2	" " ...	No. 15, 5 ins. "	... 1d. "
1	" " ...	No. 16, 3½ ins. "	... 1d. "
1	" " ...	No. 17, 2 ins. "	... ½d. "
1	Crank Handle ...	No. 19	... 3d. "
4	Flanged & Grooved Wheel ...	No. 20	... 5d. "
	Pulley Wheel ...	No. 21, 1½ ins. diam.	... 4d. "
2	" " ...	No. 22, 1 in. "	... 3d. "
	" " ...	No. 23, ½ in. "	... 2d. "
	Bush Wheel ...	No. 24	... 3d. "
	Pinion Wheel ...	No. 25, ¾ in. diam.	... 6d. "
1	" " ...	No. 26, ½ in. "	... 4d. "
	Gear Wheel ...	No. 27, 1½ ins. "	... 10d. "
	Contrite Wheel ...	No. 28, 1½ ins. "	... 1/3 "
	" " ...	No. 29, ¾ in. "	... 1/- "
	Worm Wheel... ..	No. 32	... 9d. "
1	Pawl ... ..	No. 33	... 3d. "
	Spanner ... ..	No. 34	... 3d. "
12	Keys ... ..	No. 35	... 6d. per doz.
1	Turn Screws ... ..	No. 36	... 3d. each.
	Nuts and Bolts ...	No. 37	... 5d. per doz.
	Boxes containing—		
	50 Nuts and Bolts,	No. 38	... 1/9 each.
	12 Keys, 1 Hook.)		
1	Balls Cord (special)	No. 39	... 2d. "
1	Hanks Cord ... ..	No. 40	... 1d. "

# Separate Parts.

---



No. 21.

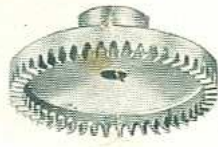

No. 28.



No. 27



No. 1.



No. 9.



No. 23.



No. 33.

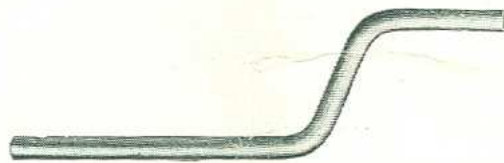

No. 19.



No. 35.



No. 25.



No. 32.



No. 12.



No. 34.



No. 13.



No. 20.



No. 24.

CONTENTS OF BOX.		Parts required for Models.							
NO.	DESCRIPTION OF PARTS.	1	2	3	4	5	6	7	8
6	12½ in. Perforated Strips				2	4	2		
10	5½ in. „ „	2	5	7	7	2	3	7	4
1	3½ in. „ „						1		
12	2½ in. „ „	3	2	6	6	8	3	10	1
18	Angle Pieces ... ..	12	4	13	8	12	8	16	16
2	5 in. Grooved Rods ...		2	2	2		1	2	1
1	¾ in. „ „ ...	1				1			
1	2 in. „ „ ...			1	1				1
1	Crank Handle ... ..			1	1	1			1
4	Flanged and Grooved Wheels ... ..		4	4	4	2		4	2
2	1 in. Pulley Wheels ...	2		2	2	1	1		2
1	½ in. Pinion „ ...				1				
1	Pawl ... ..				1				
30	Nuts and Screws ...	18	10	21	23	25	19	20	30
5	Wood Screws ... ..			5					4
1	Hook ... ..				1				
12	Keys ... ..	2	4	6	8	6	1	4	5
1	Driver ... ..								
1	Hank Cord ... ..								
1	Ball Cord ... ..								
1	Bent Strip ... ..			1					



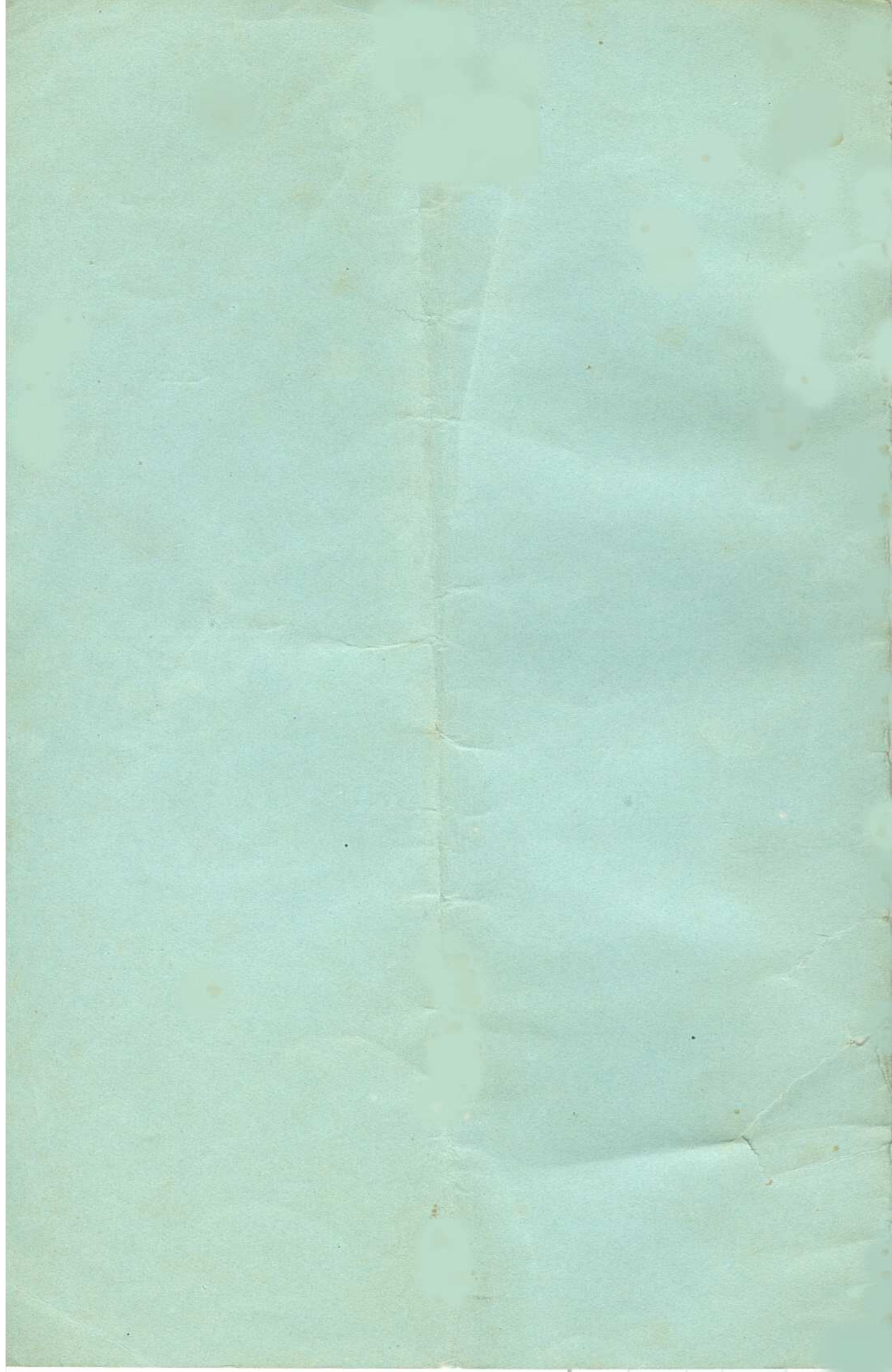

"Guardian" General Printing Works  
Manchester, Reddish, and  
London.