

MECCANO



(MECHANICS MADE EASY)

MANUAL OF INSTRUCTIONS

For the whole series of Models, comprising
eleven progressive outfits

6^d
net

Copyright by **MECCANO LIMITED. LIVERPOOL,** throughout the world

MECCANO. (COPYRIGHTED.)

DURING the years which "Meccano" has been on the market its progress has been extensive and rapid, and it now holds a warm place in the affections of many thousands of boys and parents. Each year we have enlarged its scope and improved our Models, and "Meccano" now holds an unrivalled and, we believe, an unassailable position in the land of Toys and Hobbies. A "Meccano" working Model is a thing which commands the absorbed interest of the parent, and fills the youthful mind with pleasure. Every requisite for making the various Models which we illustrate is provided in our series of Outfits, and the building up of these working Toys, with the aid of the bright nickel-plated and accurately fitting strips, and neatly turned and beautifully finished wheels and pulleys, has proved a source of pleasure to many thousands of boys and girls.

This year we have introduced several new Models, which we feel sure will please both present and prospective users of "Meccano." We should like to again emphasize the fact that all our Models are built on sound and standard engineering principles, and that the parts employed represent the main mechanical parts used in machinery, such as levers, beams, wheels, axles, pulleys, wormwheels, screws, bolts, keys, &c., so that, as an introduction to the serious study of mechanics, the value of this hobby is very great indeed.

Each Model may, of course, be taken to pieces, and the same parts may be used to make up other Models. Additional parts may be purchased at any time from your dealer, or direct from us.

We have illustrated a large and varied selection of Models which can be made with "Meccano," but these by no means represent its full possibilities. Both parents and children will find the designing of new Models an interesting and stimulating exercise, and in many instances a pleasant mode of exercising their inventive faculties. Some of our new Models have been designed entirely or suggested to us by users of "Meccano," in various parts of the country, whom we have never seen, and we gratefully acknowledge our indebtedness to them. We are at all times glad to correspond with users of "Meccano," and to assist them by suggestions, or criticism, when difficulties occur with new Models.

To the beginner we would suggest that the simple designs be proceeded with first, and skill gradually acquired in following the designs, and correctly connecting the parts together. The strips are perforated with holes equi-distant, and successive lengths may be united together by means of one, or where a very rigid connection is required, two bolts. The axles fit any of the holes, and their position in the various designs can always be ascertained by counting the holes.

Additional parts may be purchased either separately or in complete connecting Outfits, as set out on pages 63 and 64. Thus, by purchasing a No. 1A Accessory Outfit, sufficient parts may be obtained to convert a No. 1 into a No. 2 "Meccano" Outfit. The No. 2A Accessory Outfit contains all the parts necessary to convert a No. 2 into a No. 3 Outfit, and so on.

Figure No. 1. Luggage Truck

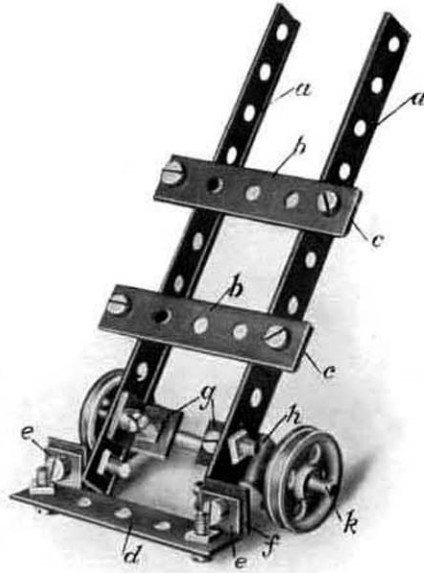

PARTS REQUIRED.

2	5½"	Perforated Strips
3	2½"	" "
12		Angle Brackets.
1	3½"	Rod.
2		Wheels.
18		Nuts and Bolts.
2		Keys.

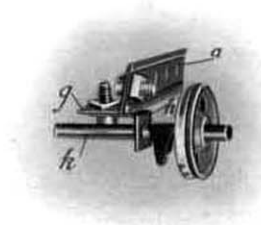

This is a simple and neat little model, very easily constructed. Commence by screwing the two cross pieces B to the two side frames A, four angle brackets and eight nuts and bolts are required for this. The lowest cross piece D may then be carried from the end holes of the frames A by a combination of the two angle pieces E F at each end, and the bearings for the wheel axle are each somewhat similarly constructed of two angle pieces G H, as will be readily understood by referring to the small detail view. When these are in place the axle K is inserted, keys L put over the ends, and the wheels secured thereon.

Fig. No. 2. Truck.

(MADE WITH MECCANO OUTFIT NO. I.)

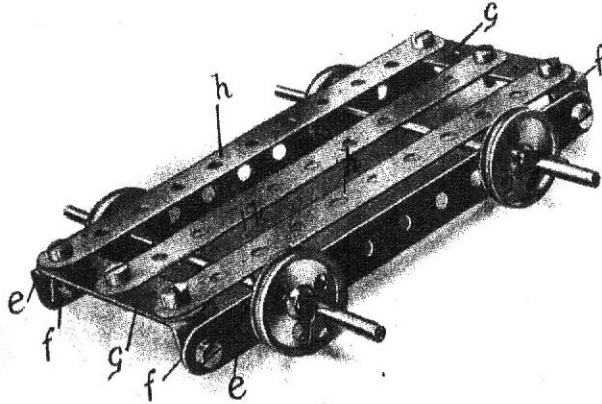

PARTS REQUIRED.

5	5½" Perforated Strips.
2	2½" " "
4	Angle Brackets.
2	5" Rods.
4	1" Pulley Wheels.
10	Nuts and Bolts.
4	Keys.

This is an interesting model, which can easily be constructed by means of the following instructions :—

To construct this design, take a 5½" strip E and attach by means of screws and nuts an angle piece F at each end. Then take a second 5½" strip, and in the same way attach angle pieces at each end of it. These strips are to form the sides of the truck in which the axles of the wheels run. Now connect each end pair of angle pieces with two 2½" strips G at right angles to the 5½" strips forming the sides, and over these short strips G lay two 5½" strips H, fastening each corner of the truck, where the ends of the strips H and G overlay the angle pieces F, by means of screws and nuts. Now attach the 5½" piece K at each end to the centre hole of the strips G. This with the two pieces H forms the bottom of the truck. Next insert two axles, as shown, through the third holes from the ends of the side pieces E, then push on the four wheels and secure them in position by the keys.

Fig. No. 3. Endless Rope Railway.

(MADE WITH MECCANO OUTFIT NO. I.)

PARTS REQUIRED.

7	5½" Perforated Strips.
11	2½" " " "
18	Angle " Brackets. "
2	5" Rods.
1	3½" Rod.
1	Crank Handle.
6	1" Pulley Wheels.
30	Nuts and Bolts.
8	Wood Screws.
11	Keys.

This is an attractive little combination working model, which will well repay a little trouble in making.

The truck made according to the previous design is used, and it is connected to an endless cord which passes from a pulley attached to a bracket at one end to another pulley carried on the crank handle shown. In the illustration, the two pulleys are shown close together to save space, but they may, of course, be placed at any distance desired.

The main bracket is constructed as follows: Two vertical 2½" side pieces are connected together at the top and half-way down by two more 2½" pieces attached by angle pieces as shown. From the angle pieces at the top, two 5½" pieces are carried down to two angle pieces screwed to the board as shown, and angle pieces are placed at the feet of the uprights, which are also screwed to the board. The pulley is keyed to the vertical spindle, which is threaded through the central holes of the two 2½" cross pieces, and a second pulley is attached to the opposite bracket, as shown in the illustration.

A piece of string is then formed into an endless rope running over the two pulleys, and the truck is attached to one side of the string, so that by rotating the handle in one direction or another, the truck is moved as desired.

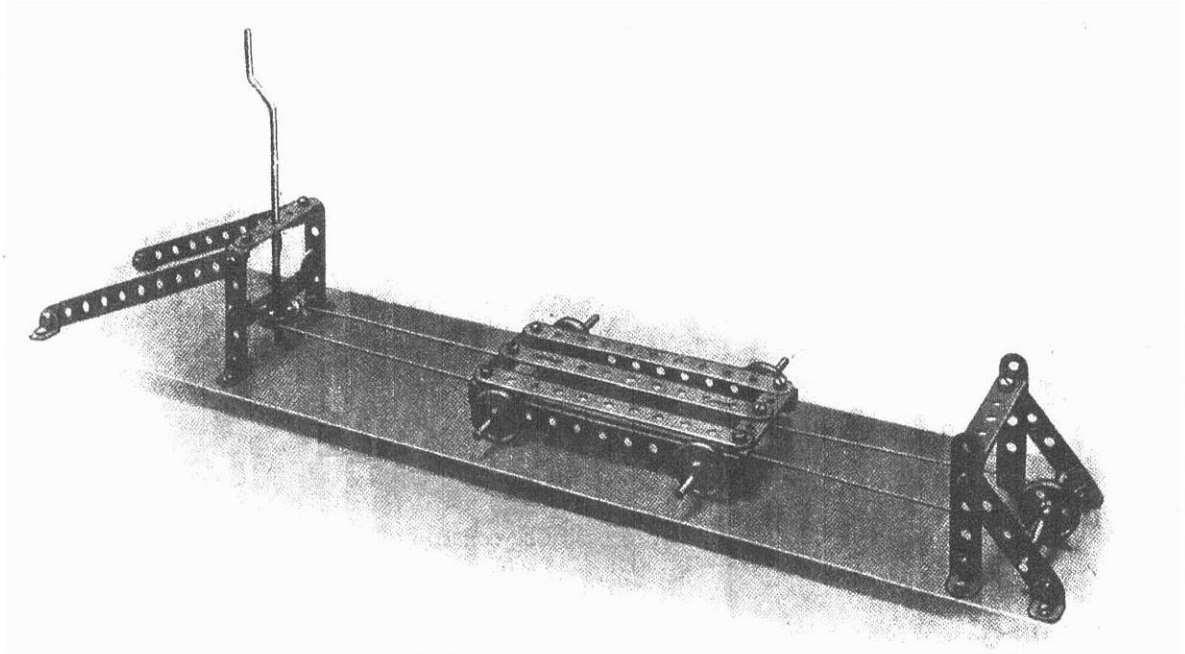

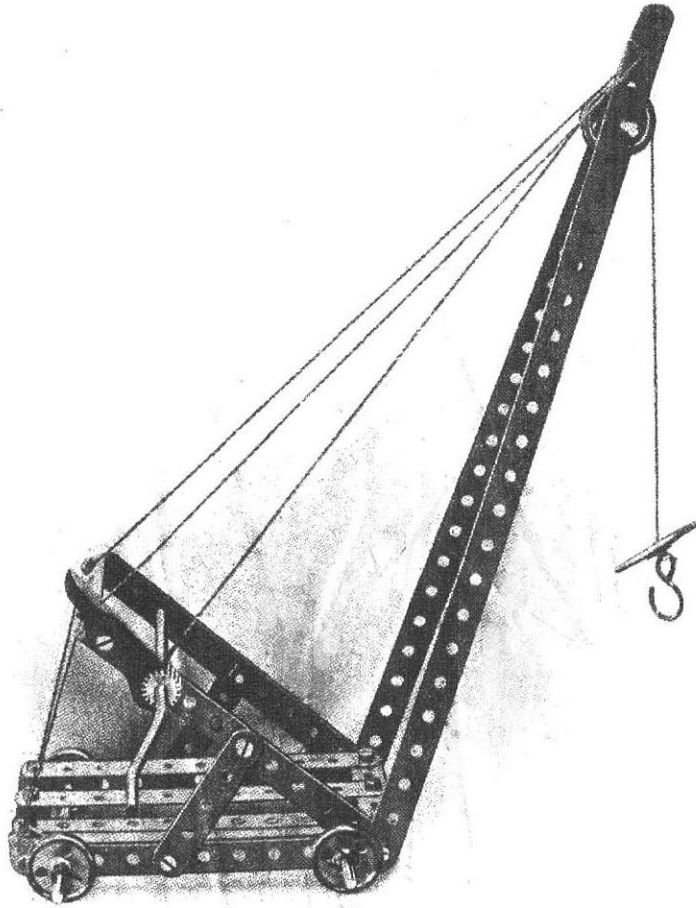

Fig. No. 4. Travelling Jib Crane.

(MADE WITH MECCANO OUTFIT NO. 1.)

PARTS REQUIRED.

2	12½"	Perforated Strips.	5	1"	Pulley Wheels.
7	5½"	" "	1		Bush Wheel.
5	2½"	" "	1	½"	Pinion.
6		Angle Brackets.	1		Pawl.
2	5"	Rods.	19		Nuts and Bolts
1	2"	Rod.	1		Hook.
1		Crank Handle.	7		Keys.

A very fine model which cannot fail to interest and instruct the budding mechanic. It is designed on thoroughly scientific lines, and it will teach a boy more about the principles of a crane's action than hours of book study.

The truck of Example 2 is used in the construction of the crane, with the following additions:—

Two 5½" strips sloping back to carry the spindle, and two 12½" strips to form the jib, are attached by the same screws to the end holes of the truck; the two 5½" strips being braced to the truck by the two 2½" strips as shown, and being connected together at their ends by a 2½" strip and angle pieces.

The spindle, to which the pinion is keyed, is carried in the third pair of holes in the 5½" strips as shown, and the pawl is pivoted on the screw which holds the angle piece in position.

The two sides of the jib are bolted together at the top hole, and the short spindle carrying the pulley is carried in the fourth hole from the top, over which pulley the string is passed and tied to the pinion spindle; the whole structure is braced by tie rods formed of strings attached to the ends of the truck, the 5½" strips, and the jib.

Fig. No. 5. Windmill.

(MADE WITH MECCANO OUTFIT NO. 1)

PARTS REQUIRED.	
.6	12½" Perforated Strips,
7	5½" " "
11	2½" " "
12	Angle Brackets,
1	5" Rod.
1	Crank Handle.
2	1" Pulley Wheels.
1	Bush Wheel.
30	Nuts and Bolts.
8	Keys.

An effective model which calls for no special instructions to construct.

It will not be described quite so fully as the preceding ones, in order that its construction may be a test for the young model-maker, and may be of use in developing his faculties for constructional work.

It will suffice to say that the wind sails are made by attaching four 5½" strips to the bush wheel, and keying the latter to the spindle. To this spindle is keyed a pulley, which is connected by a string band to the spindle of the handle.

This model may be driven by a small engine or other suitable motive power.

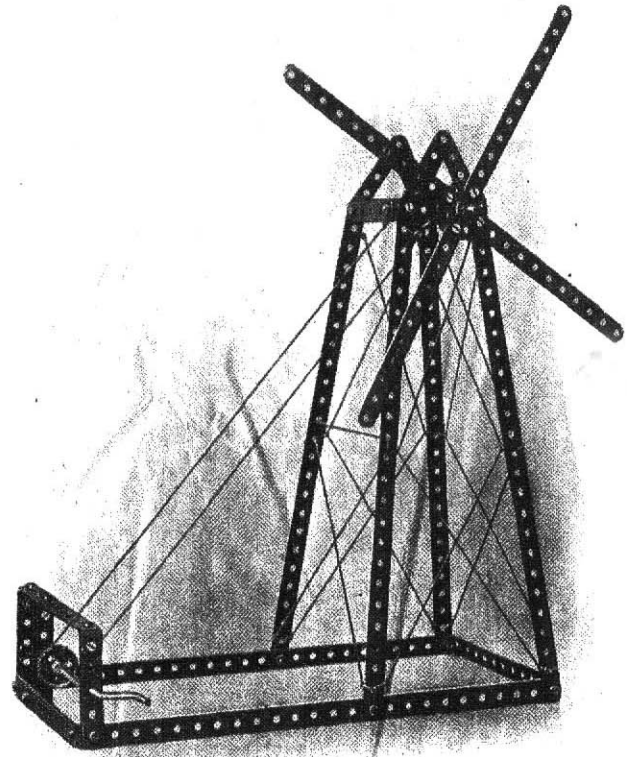
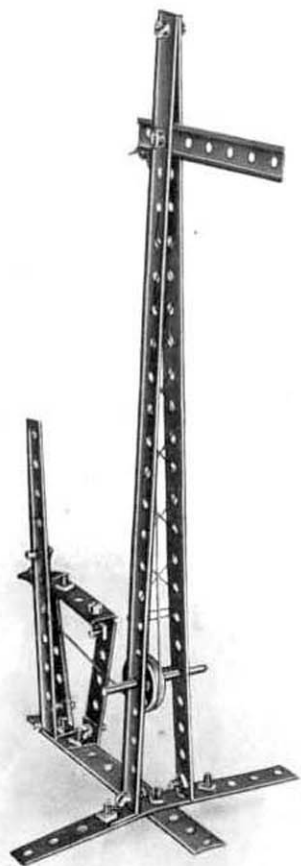

Fig. No. 6. Railway Signal



PARTS REQUIRED.

2	12 $\frac{1}{2}$ "	Perforated Strips.
3	5 $\frac{1}{2}$ "	" "
1	3 $\frac{1}{2}$ "	" "
3	2 $\frac{1}{2}$ "	" "
8		Angle Brackets.
2	2"	Rods.
1		Wheel.
19		Nuts and Bolts.
1		Key.

A simple model which explains itself.

Very little difficulty will be found in constructing it after Model 5 has been accomplished. It will therefore form another test for the young model-maker.

In fixing the lever to the angle bracket at the bottom, lock the nuts so as to prevent the screw from working out.

Fig. No. 7. Truck.

(MADE WITH MECCANO OUTFIT NO. 1)

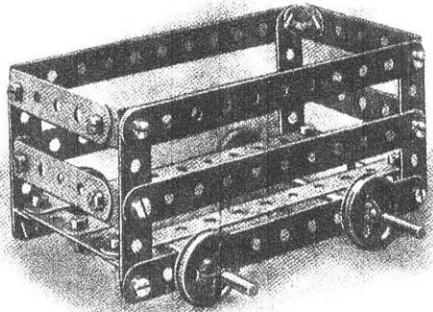

PARTS REQUIRED.

9	5½"	Perforated Strips.
10	2½"	" "
12		Angle Brackets.
2	5"	Rods.
4	1"	Pulley Wheels.
26		Nuts and Bolts.
4		Keys.

This model is constructed in precisely the same way as preceding models, and we confidently leave our young friend to make it up for himself.

Fig. No. 8. Model of Telpher Span.

(MADE WITH MECCANO OUTFIT NO. 1)

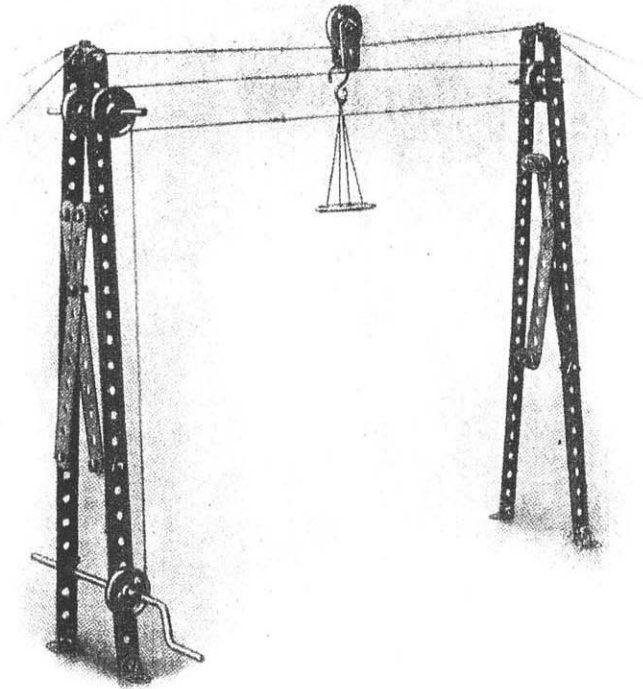

PARTS REQUIRED.

4	12½" Perforated Strips.
4	5½" " "
16	Angle Brackets.
1	3½" Rod.
1	2" " "
1	Crank Handle.
5	1" Pulley Wheels.
1	Push Wheel.
29	Nuts and Bolts.
4	Wood Screws.
8	Keys.

For the information of our young friends we may say that Telpher is the name of the man who invented this device. It was designed to overcome the difficulty of transporting goods over hilly and difficult country. Its construction cannot fail to fix in the mind the principles on which it works.

We recommend that the standards be screwed down before connecting the cords. The crank-pulley cord may be wound twice around the pulleys to ensure a better grip.

Fig. No. 9. Luggage Truck.

Fig. No. 10. Luggage Truck.

(MADE WITH MECCANO OUTFIT NO. 1)

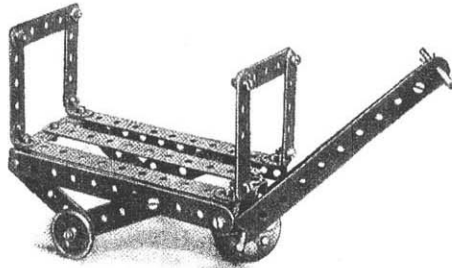

PARTS REQUIRED.

7	5½" Perforated Strips.	1	Bush Wheel.
12	2½" " "	2	1" Pulley Wheels.
8	Angle Brackets.	22	Nuts and Bolts.
1	3½" Rod.	6	Keys.
2	2" Rods.	1	Bent Strip.

PARTS REQUIRED.

5	5½" Perforated Strips.	2	1" Pulley Wheels.
13	2½" " "	20	Nuts and Bolts.
6	Angle Brackets.	2	Keys.
1	3½" Rod.		

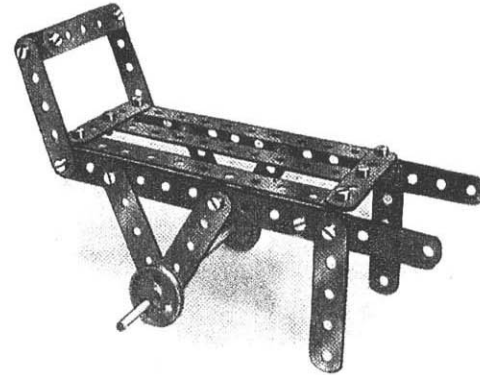
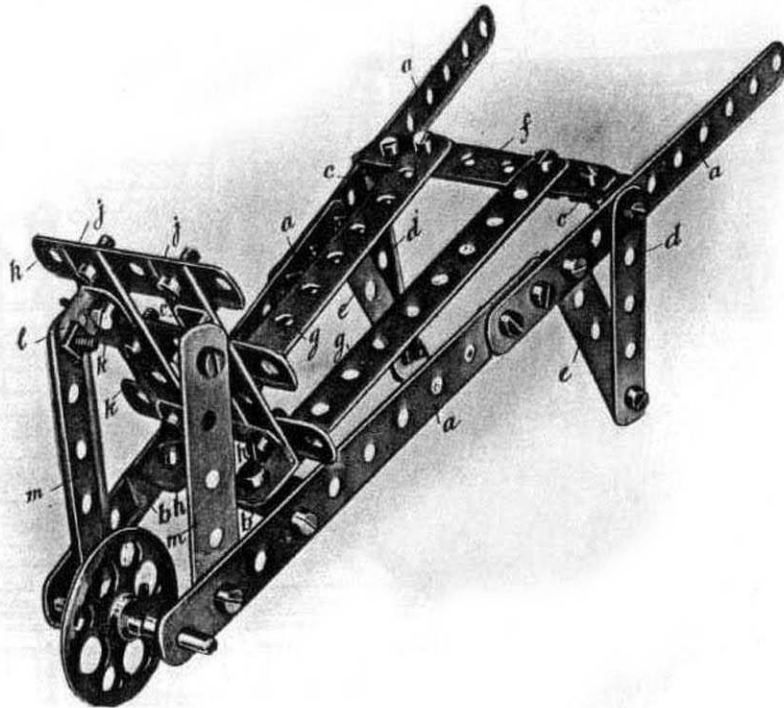

Fig. No. 13. Luggage Barrow.

(MADE WITH MECCANO OUTFIT NO. 2 OR NO. 1 AND NO. 1A)



PARTS REQUIRED.

6	5½" Perforated Strips.
13	2½" " "
8	Angle Brackets.
1	2" Rod.
1	Bush Wheel.
30	Nuts and Bolts.
2	Keys.

*Parts required in addition to
Outfit No. 1.*

1	2½" Perforated Strip.
---	-----------------------

Our illustration clearly shows how this model is built up, and no difficulty should be experienced with it. The two angle pieces C are connected together by two overlapping 2½" strips in F. The wheel is held in place by two keys which have their feathers turned *away* from the wheel, thus forming collars between which the wheel rotates.

Fig. No. 14. Revolver Truck.

(MADE WITH MECCANO OUTFIT NO. 2 OR NO. 1 AND NO. 1A)

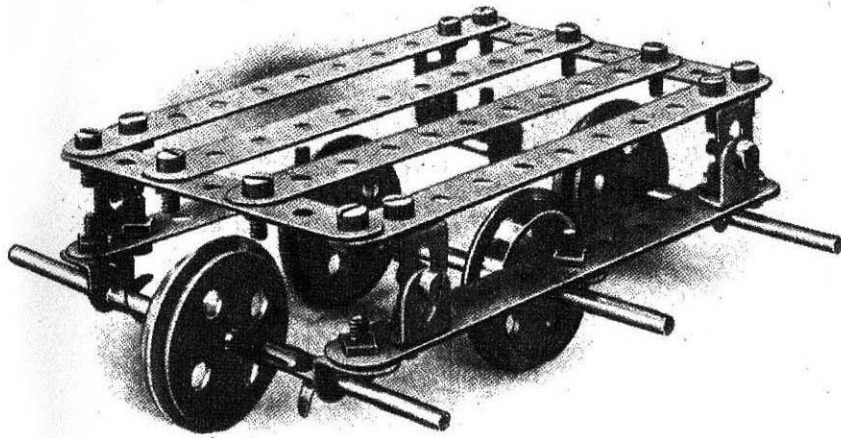

PARTS REQUIRED.	
6	5½" Perforated Strips.
2	3½" "
12	Angle Brackets.
3	5" Rods.
4	Flanged Wheels.
26	Nuts and Bolts.
10	Keys.

Parts required in addition to Outfit No. 1.

4	Flanged Wheels.
1	5" Rod.

In a Revolver Truck the two end wheels are always raised just a little higher than the two centre wheels. This enables the truck to be quickly revolved upon the centre wheels. The construction of this model is clearly shown in our illustration.

Fig. No. 15. Railway Wagon.

(MADE WITH MECCANO OUTFIT NO. 2 OR NO. 1 AND NO. 1A)

PARTS REQUIRED.			
5	5½" Perforated Strips.	2	5" Rods.
2	3½" " "	4	Flanged Wheels.
5	2½" " "	23	Nuts and Bolts.
10	Angle Brackets.	4	Keys.
	1		Double Bent Strip.
<i>Parts required in addition to Outfit No. 1.</i>			
1	3½" Perforated Strip.	4	Flanged Wheels.
	1		Double Bent Strip.

A very simple and attractive working model. The front swivelling support, of which a separate view is given, is formed from a 2½" strip bent to the shape indicated in the drawing. The rear axle frame is formed from a 2½" strip, and is held to the platform by two pairs of angle pieces. Both axles are carried in inverted angle pieces.

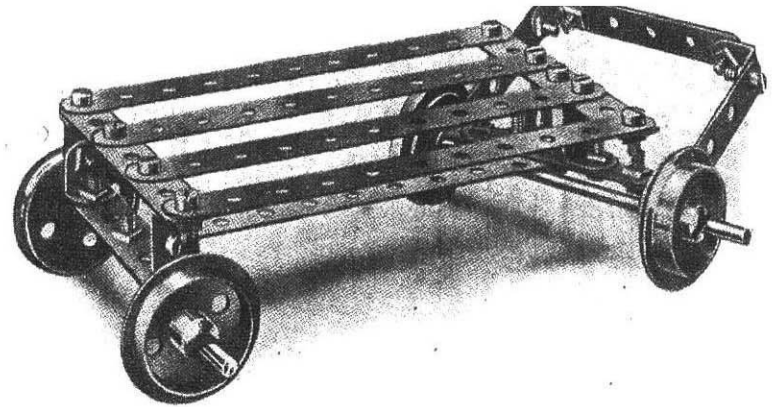
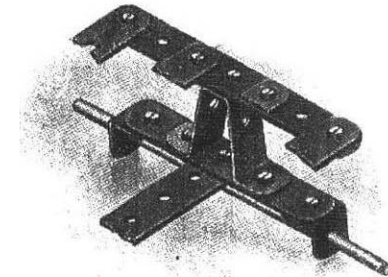
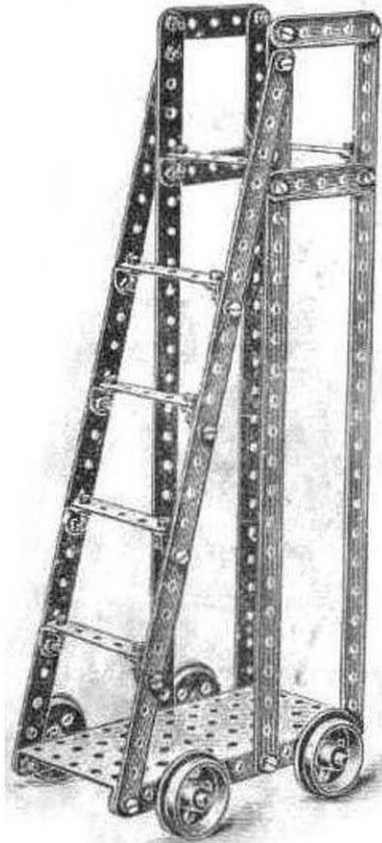

Fig. No. 16. Ladder on Wheels.

Fig. No. 17. Bath Chair.

(MADE WITH MECCANO OUTFIT NO. 2 OR NO. 1 AND NO. 1A)



PARTS REQUIRED.

- 6 12½" Perforated Strips.
- 2 5½" " "
- 13 2½" " "
- 18 Angle Brackets.
- 2 5" Rods.
- 4 Flanged Wheels.
- 48 Nuts and Bolts.
- 4 Keys.

*Parts required in addition to
Outfit No. 1.*

- 1 2½" Perforated Strip.
- 18 Nuts and Bolts
- 4 Flanged Wheels.

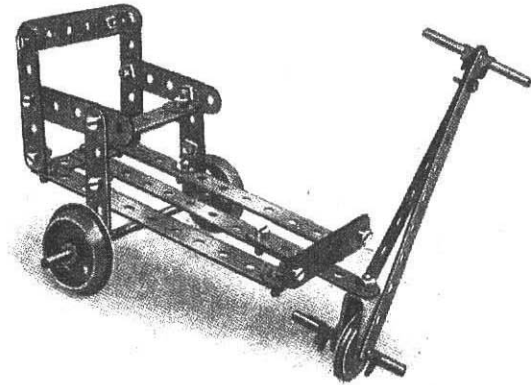

PARTS REQUIRED.

- 5 5½" Perforated Strips.
- 11 2½" " "
- 11 Angle Brackets.
- 1 5" Rod.
- 2 2" Rods,
- 2 Flanged Wheels.
- 1 1" Pulley Wheel.
- 29 Nuts and Bolts.
- 6 Keys.
- 1 Single Bent Strip.

*Parts required in addition to
Outfit No. 1.*

- 2 Flanged Wheels.

Fig. No. 18. Travelling Jib Crane.

(MADE WITH MECCANO OUTFIT NO. 2 OR NO. 1 AND NO. 1A)

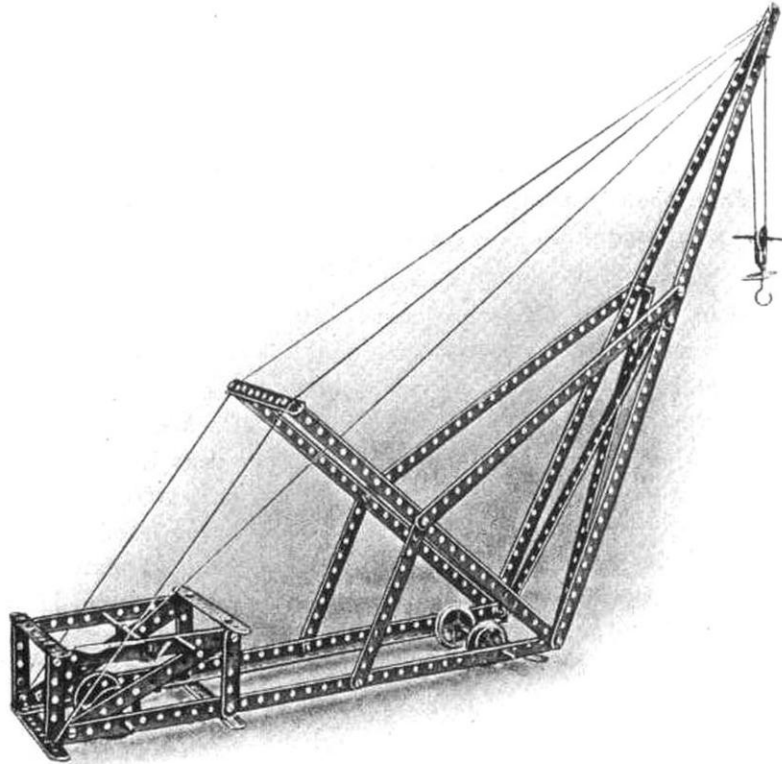

PARTS REQUIRED.

10	12½"	Perforated Strips.
14	5½"	" "
5	2½"	" "
2		Angle Girders.
16		Angle Brackets.
2	5"	Rods.
2	2"	" "
1		Crank Handle.
4		Flanged Wheels.
2	1"	Pulley Wheels.
1		Bush Wheel.
1	½"	Pinion.
1		Pawl.
38		Nuts and Bolts.
1		Hook.
10		Keys.
1		Single Bent Strip.

Parts required in addition to Outfit No. 1.

4	12½"	Perforated Strips.
4	5½"	" "
8		Nuts and Bolts.
2		Angle Girders.
4		Flanged Wheels.

This is so important a model that we have thought it best to give a detailed description of it, making use of engineering terms. It can be erected from a study of the illustration alone, but we strongly recommend our enthusiastic young friend to carefully read our instructions, and to make himself familiar with the correct technical description and terms. This model will well repay the time expended on a close and careful study.

The lower horizontal sides of the crane should first be put together. Each side consists of an angle

girder and a $5\frac{1}{2}$ " strip joined together, three holes overlapping. The winch frame at the end is formed of four $2\frac{1}{2}$ " strips secured to the side frames and connected together at their tops by two $5\frac{1}{2}$ " strips, the sides so constructed being united together by four $5\frac{1}{2}$ " strips connected to the angle pieces as shown at the third hole from each end; a fifth transverse $5\frac{1}{2}$ " strip is used to connect the other ends of the horizontal sides together as shown, and the wheel axles are inserted through appropriate holes in the ends of the horizontal frame.

The bearings for the winch handle are formed by two $5\frac{1}{2}$ " top strips of the winch frame; the winch handle has a pinion, and a ratchet is pivoted to the right-hand diagonal, and a brake wheel and lever may be added if desired.

Each side of the jib is constructed of two $12\frac{1}{2}$ " strips, jointed together by overlapping; at the top where the sides meet a pulley is fixed on a short length of spindle, and at the bottom the two sides are respectively screwed to the two ends of the horizontal base.

The jib is braced by two diagonally arranged $12\frac{1}{2}$ " strips attached to the sides of the jib by angle pieces.

From each side of the jib two $12\frac{1}{2}$ " strips are carried to a truss member, formed of two $12\frac{1}{2}$ " strips united together, secured at one end to the screws at the base of the jib, and united at their other ends by a $5\frac{1}{2}$ " strip; the connection being made at the third hole from the end, as in the case of the other $5\frac{1}{2}$ " transverse strips. The truss frame is connected to the horizontal base by two $5\frac{1}{2}$ strips as shown.

The rope by which the weight is raised has one end fixed to the end of the jib; it is then passed round the pulley block, then over the jib pulley, and finally connected to the winch handle.

The crane is further strengthened by strings to represent tie rods, which connect the ends of the jib, the truss frame, and the winch frame as shown.

If possible, the joint between the truss frame, the side frame, and the jib, should be made with a single pair of screws, which should also carry the angle pieces for the cross bracing of the crane.

Fig. No. 19. Windmill.

(MADE WITH MECCANO OUTFIT NO. 2 OR NO. 1 AND NO. 1A)

PARTS REQUIRED.

10	12½"	Perforated Strips.
18	5½"	" "
2	3½"	" "
3	2½"	" "
4		Angle Girders.
9		Angle Brackets.
1	5"	Axle Rod.
1		Crank Handle.
2	1"	Pulley Wheels.
1		Bush Wheel.
45		Nuts and Screws.
9		Keys.

Parts required in addition to Outfit No. 1.

4	12½"	Perforated Strips.
8	5½"	" "
1	3½"	" "
4		Angle Girders.
15		Nuts and Screws.

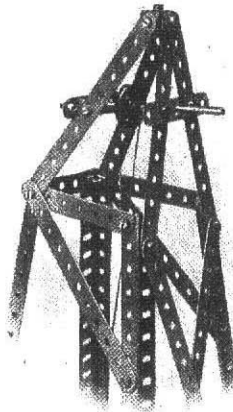

This model requires no special instructions. We would, however, say that with the assistance of the parts contained in the succeeding outfits a more elaborate mechanism may be arranged to enable it to be driven by an engine or other suitable motive power.

This model also lends itself to further decorations by means of coloured ribbons used in the place of the cord lacings; or as streamers.

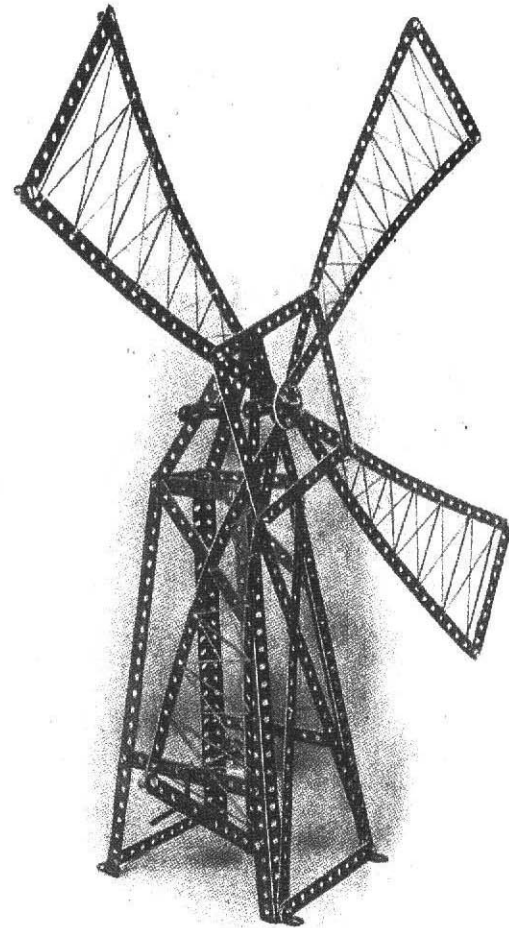
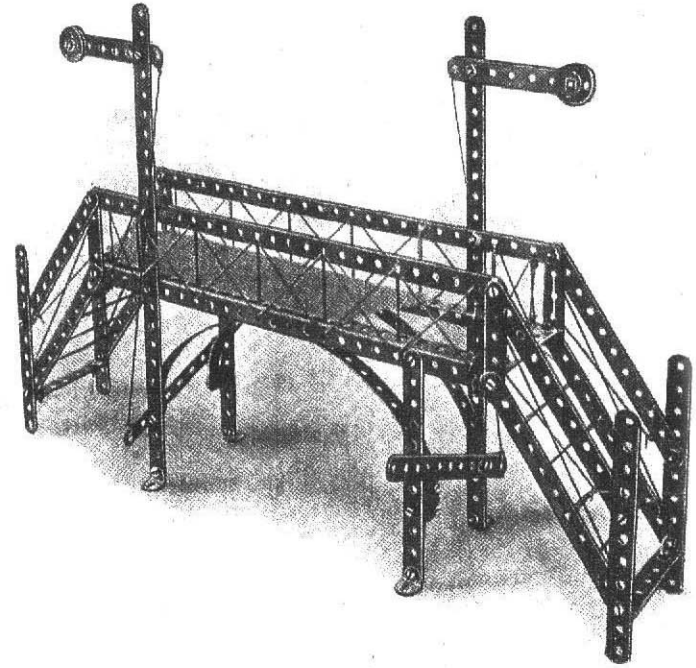
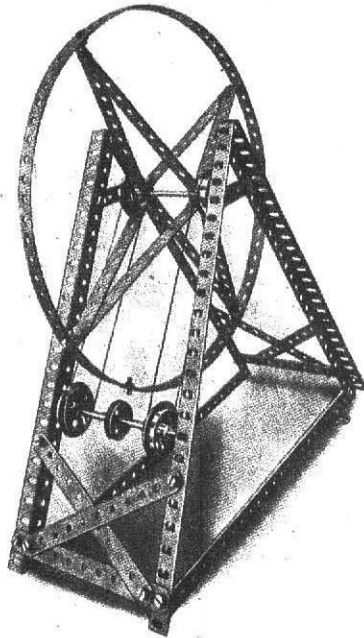

Fig. No. 20. Wheel.

Fig. No. 21. Bridge with Signals.

(MADE WITH MECCANO OUTFIT NO. 2 OR NO. 1 AND NO. 1A)



PARTS REQUIRED.				
5	12 1/2"	Perforated Strips.	4	Flanged Wheels.
14	5 1/2"	" "	1	1" Pulley Wheel.
2	2 1/2"	" "	48	Nuts and Bolts.
4		Angle Girders.	4	Wood Screws.
16		" Brackets.	6	Keys.
2	5"	Rods.		

Parts required in addition to Outfit No. 1.

4	5 1/2"	Perforated Strips.	4	Angle Girders.	18	Nuts and Bolts,
			4	Flanged Wheels.		

PARTS REQUIRED.				<i>Parts required in addition to Outfit No. 1.</i>	
6	12 1/2"	Perforated Strips	—
16	5 1/2"	" "	6
2	3 1/2"	" "	1
8	2 1/2"	" "	—
2		Angle Girders	2
8		" Brackets	—
2	1"	Pulley Wheels	—
50		Nuts and Bolts	20

Fig. No. 30. Cable Railway.

(MADE WITH MECCANO OUTFIT NO. 3 OR NO. 2 AND NO. 2A)

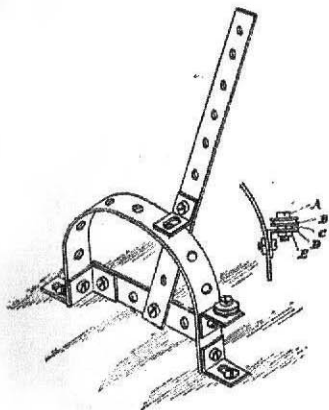

FIG. 30C.

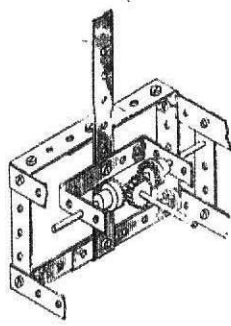

FIG. 30A.

Parts required in addition to Outfits

PARTS REQUIRED.

11	5 1/2"	Perforated Strips.
6	3 1/2"	" "
14	2 1/2"	" "
2		Angle Girders.
22		" Brackets.
6	5"	Rods.
1	1 1/2"	Pulley.
2	1"	Pulleys.
4		Flanged Wheels.
2	3/4"	Pinions.
1		Gear Wheel.
2	3/4"	Contrate Wheels.
54		Nuts and Bolts.
12		Wood Screws.
17		Keys.
1		Large Bent Strip.

No. 1	No. 2
1	—
5	4
2	—
2	4
4	3
1	1
—	—
4	—
2	2
1	1
2	2
24	4
4	4
5	—
1	1

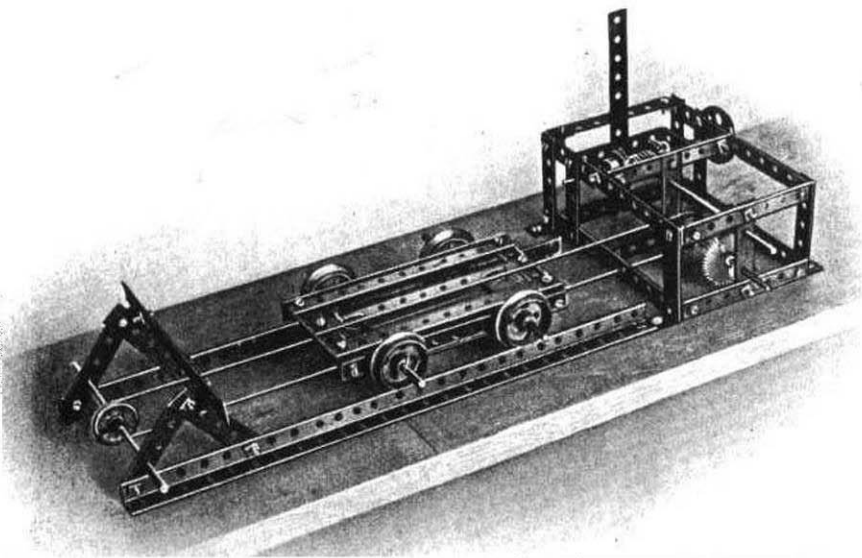

FIG. 30B.

Our illustration hardly does this excellent model justice, owing to the parts having to be so crowded together. This is a very fine model, both instructive and highly interesting.

The driving power is received at the outer 1 1/2" pulley, and is transmitted through the clutch mechanism (of which a separate detail is given) and the pinion and gear wheels to the lower spindle on which the driving pulley is fixed, the driving rope passing round this pulley and the second pulley at the end of the rails, all as shown in the drawing.

In fixing the lever for operating the clutch mechanism, the nuts should be locked to prevent the screw working out. Only one section of rails is shown in the design, but they may be extended as desired.

Figure No. 30c is an example of a lever for operating signals at a distance. The bracket D is gripped between the top facing nut C and the lower locking nut E, which are threaded on the bolt A so as to leave sufficient play for the guide pulley B to rotate easily.

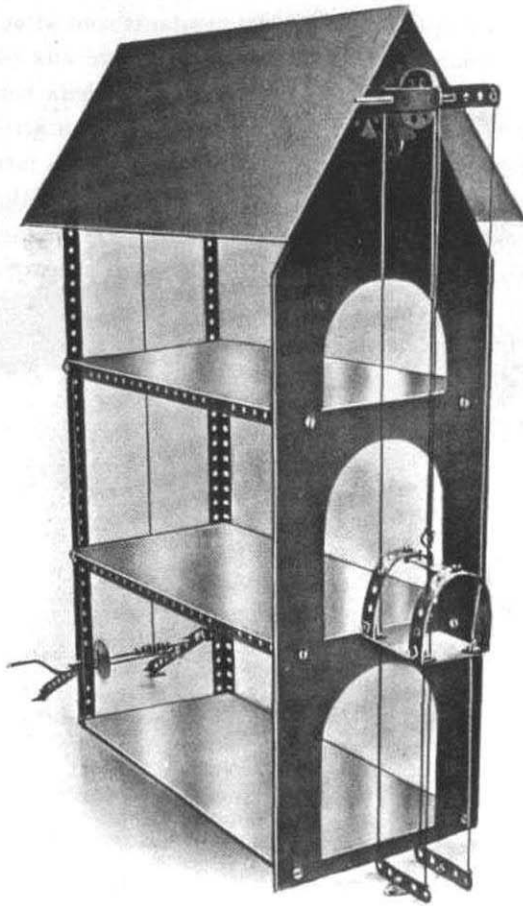

Fig. No. 31. Warehouse with Elevator.

(MADE WITH MECCANO OUTFIT NO. 3 OR WITH
NO. 2 AND NO. 2A)

*Parts required in
addition to Outfits*

PARTS REQUIRED.		No. 1
9	12½" Perforated Strips.	3
16	5½" " "	5
4	3½" " "	3
16	2½" " "	4
4	Angle Girders.	4
42	" Brackets.	24
1	5" Rod.	—
1	3½" "	—
1	2" "	1
1	Crank Handle.	—
2	Pulley Wheels.	—
1	¾" Pinion.	1
1	Gear Wheel.	1
1	Pawl.	—
68	Nuts and Bolts.	38
10	Wood Screws.	5
9	Keys.	—

Fig. No. 31. Warehouse with Elevator.

Fig. No. 32. Swing Bridge.

(MADE WITH MECCANO OUTFIT No. 3 OR No. 2 AND No. 2A)

Parts required in addition
to Outfits

PARTS REQUIRED.	
4	12½" Perforated Strips.
16	5½" " "
4	3½" " "
10	2½" " "
4	Angle Girders.
34	" Brackets.
1	5" Rod.
1	Crank Handle.
1	Bush Wheel.
1	½" Pinion.
1	Worm Wheel.
78	Nuts and Bolts.
6	Keys.

No. 1	No. 2
—	—
6	—
3	2
—	—
4	—
16	16
—	—
—	—
—	—
—	—
—	—
1	1
48	28
—	—

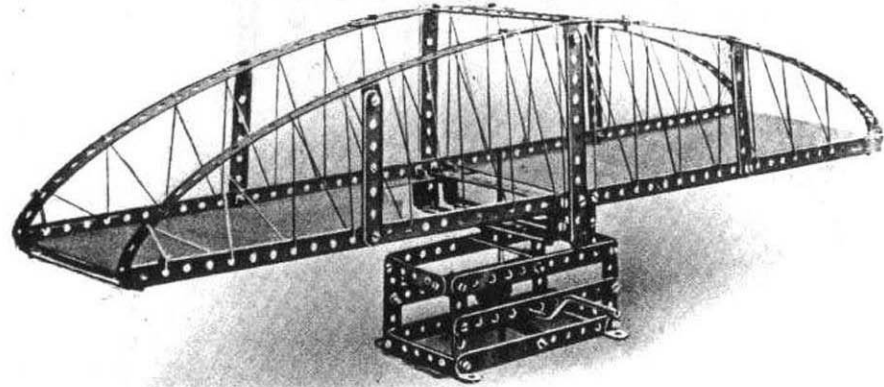

This is a fine engineering model of [the highest value to the young student, and any thought and care expended on its construction will be well repaid.

The base portion containing the perpendicular axle actuated by the worm and pinion should be constructed first. This, as will be seen by the illustration, is formed by connecting three 5½" strips in alternate holes to two 2½" strips, with an angle bracket at each corner to form one side. The other side is constructed in a similar manner. These two sides are then connected together by a 2½" strip at each end, top and bottom. A 2½" strip is then connected by two angle brackets to the two bottom 5½" strips in the centre hole, and one in a similar position to the two top 5½" strips. These carry the perpendicular axle upon which the bridge swings. A ½" pinion is keyed to this axle, which is operated by the horizontal spindle upon which is keyed a worm wheel. The platform is constructed by connecting two angle girders in the third holes, then bending two 12½" strips and one 5½" strip to form the top side, which is connected to each end of the angle girders. This is further strengthened by attaching two 3½" strips and one 5½" strip as shown in the illustration, thus forming one side. The other side is formed similarly, and both are connected together by 5½" strips at each end. The upper platform, it will be noticed, has, besides the framework forming the continuous floor, a secondary and shorter lower framework formed by two 5½" strips connected at each end by two angle brackets. Into the centre of this lower framework is built the bush wheel upon which the platform rotates.

Fig. No. 33. Tower Wagon.

(MADE WITH MECCANO OUTFIT NO. 3 OR NO. 2 AND NO. 2A)

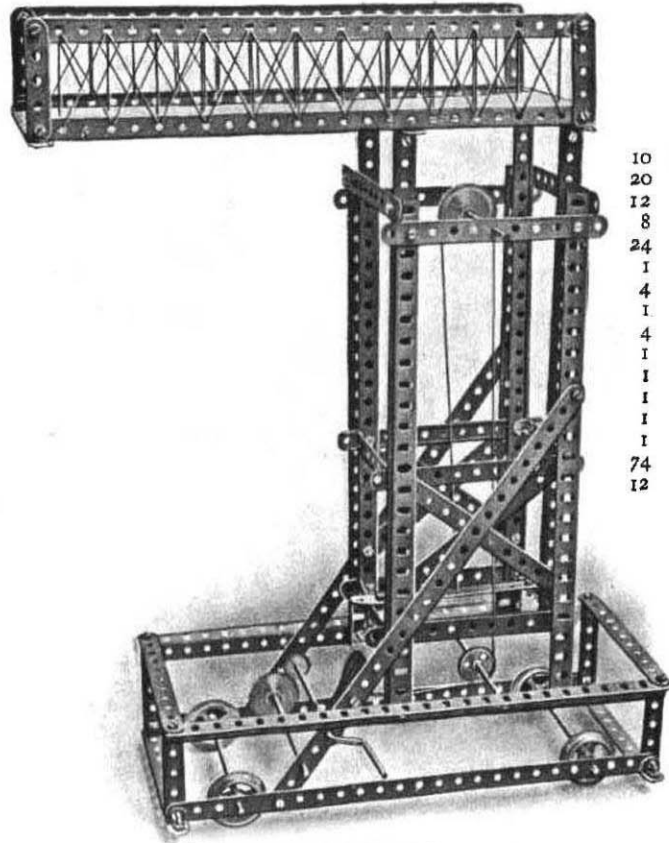

*Parts required in addition
to Outfits*

PARTS REQUIRED.		No. 1	No. 2
10	12 $\frac{1}{2}$ " Perforated Strips.	4	—
20	5 $\frac{1}{2}$ " " "	10	2
12	2 $\frac{1}{2}$ " " "	—	—
8	Angle Girders.	8	4
24	" Brackets.	6	6
1	6" Rod.	1	1
4	5" Rods.	2	1
1	Crank Handle.	—	—
4	Flanged Wheels.	4	—
1	1 $\frac{1}{2}$ " Pulley.	1	1
1	1" "	—	—
1	$\frac{3}{4}$ " Pinion.	1	1
1	Gear Wheel.	1	1
1	Pawl.	—	—
74	Nuts and Bolts.	44	24
12	Keys.	—	—

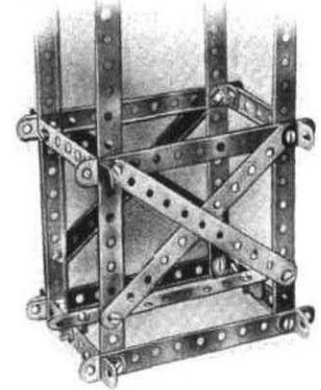

This is a representation of a wagon used for repairing overhead electrical wires carrying the current for street cars. Each part is shown clearly in our illustration, and little difficulty will be experienced in its construction.

Fig. No. 34. Swivelling and Luffing Jib Crane.

(MADE WITH MECCANO OUTFIT NO. 3 OR NO. 2 AND NO. 2A)

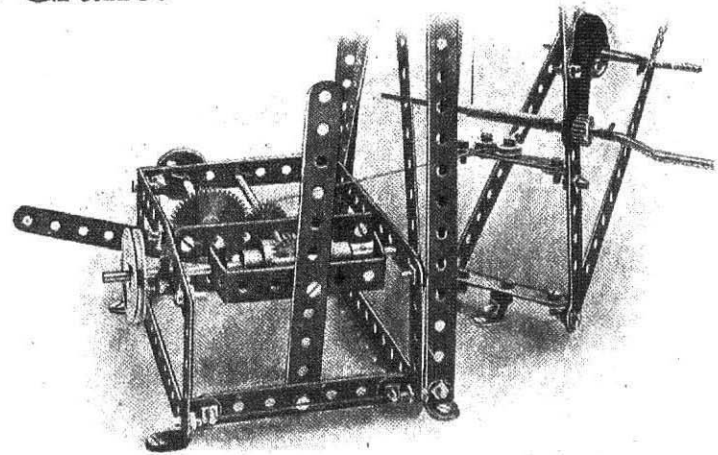
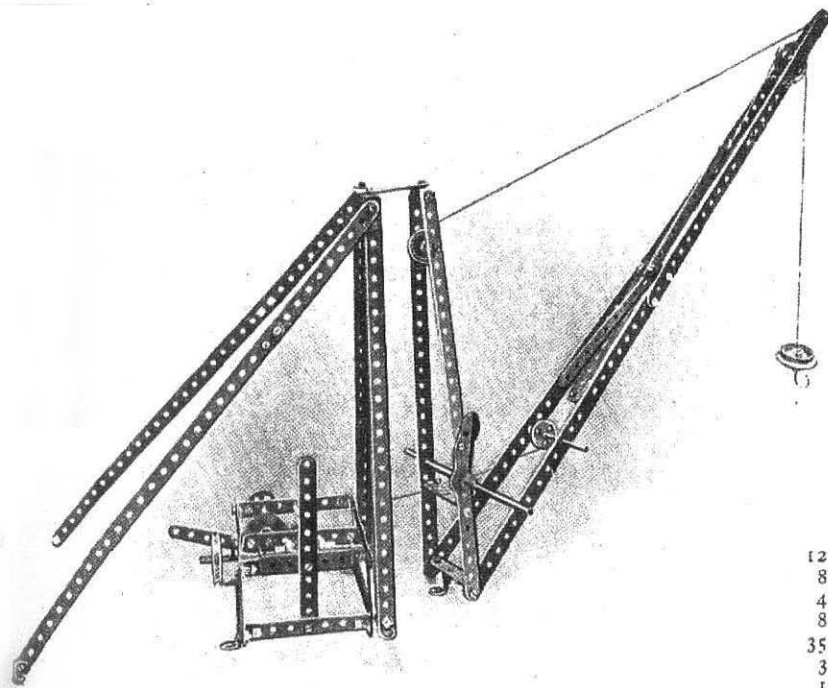

PARTS REQUIRED.	Parts required in addition to Outfits		PARTS REQUIRED.	Parts required in addition to Outfits	
	No. 1	No. 2		No. 1	No. 2
12 12½" Perforated Strips.	6	2	3 1" Pulleys.	—	1
8 5½" " "	—	—	2 1½" " "	2	2
4 3½" " "	3	2	2 1½" Pinions.	2	2
8 2½" " "	—	—	1 1½" " "	—	—
35 Angle Brackets.	17	17	1 Gear Wheel.	1	1
3 5" Rods.	1	—	2 ¾" Contrates.	2	2
1 3½" " "	—	—	1 Pawl.	—	—
2 2" " "	—	—	71 Nuts and Bolts.	41	21
1 Crank Handle.	—	—	5 Wood Screws.	—	—
1 1½" Pulley.	1	1	1 Hook.	—	—
1 Large Bent Strip.	1	1	19 Keys.	7	1

This model is interesting as affording an example of a crane used to transport the load from, say, a ship's deck on to a quay, by "luffing" or altering the angle of the jib. The apparatus consists of two parts, a fixed frame and a swivelling and luffing jib. The construction of the fixed frame with the reversing frame and lever should present no difficulties.

The two 12½" uprights are braced together as shown, and are held in vertical position by the two 12½" connected to two 5½" strips rearwardly sloping pieces, and from the structure so formed the reversing frame is carried.

The swivelling piece of the jib consists of two $12\frac{1}{2}$ " pieces bent as shown, connected at the bottom by a $2\frac{1}{2}$ " piece. This $2\frac{1}{2}$ " piece is provided with a screw in the centre hole, which fits in a double angle bracket screwed to the bench, and this forms the lower pivot; the upper pivot is formed with an angle bracket, having a screw, carried in the triangle formed of $2\frac{1}{2}$ " pieces attached to the fixed frame.

The jib itself consists of two pairs of $12\frac{1}{2}$ " pieces connected and braced together as shown. The jib luffs about its connection to the swivelling frame, and is thus capable of two motions—a swivelling motion and a luffing motion.

The luffing motion is effected by the luffing rope, which is coiled round the handle shown, and then passes round the pulley at the top of the swivelling frame, the other end being attached to the head of the jib. In order to keep the hoisting rope in position when the crane is swivelled, the two guide rollers carried on the swivelling frame are provided. These are attached by screws to two angle brackets connected with a $2\frac{1}{2}$ " piece as shown.

By operating the luffing handle the jib may be put at any angle from nearly horizontal to nearly vertical, the crane thus acting as a transporter of the load.

Fig. No. 35. Pit Headgear.

(MADE WITH MECCANO OUTFIT NO. 3 OR NO. 2 AND NO. 2A)

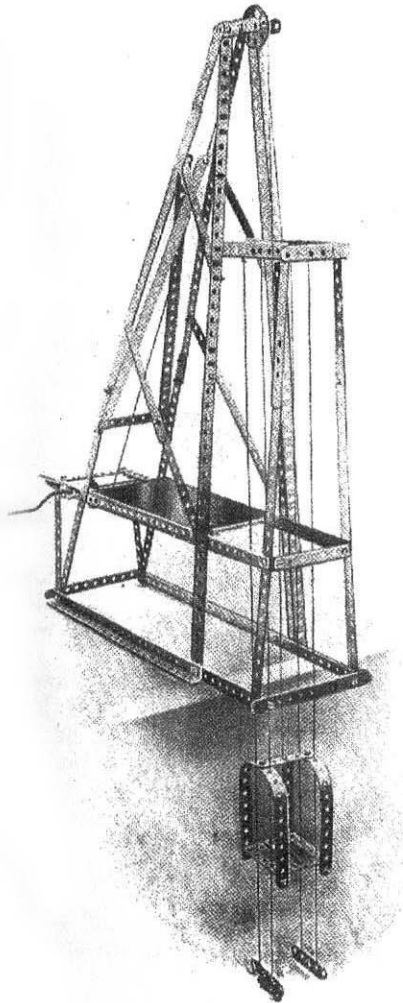

PARTS REQUIRED.		Parts required in addition to Outfits		PARTS REQUIRED.		Parts required in addition to Outfits	
		No. 1	No. 2			No. 1	No. 2
10	12 1/2" Perforated Strips.	4	—	1	Crank Handle.	—	—
20	5 1/2" " "	10	2	1	1 1/2" Pulley.	1	1
4	3 3/4" " "	3	2	1	3/4" Pinion.	1	1
1	3" " "	1	1	1	" "	—	—
10	2 1/2" " "	—	—	1	Gear Wheel.	1	1
8	Angle Girders.	8	4	1	Pawl.	—	—
20	" Brackets.	2	2	76	Nuts and Bolts.	46	26
1	5" Rod.	—	—	6	Keys.	—	—
1	2" "	—	—				

This is a most interesting model, showing the principle upon which minerals are raised from below the ground.

The front main uprights are formed by two angle girders overlapped in the third hole. Each of these two uprights are fastened together at the top by two angle brackets. Two 2 1/2" strips are bolted horizontally at the top to carry the wheel over which the winding rope runs, and to connect the diagonal stays. To stiffen the structure one 5 1/2" strip is fixed on each side connected in the eighteenth hole down on the upright, and the eleventh hole down on the stays. Two more 5 1/2" strips are bolted together, and fastened on each side lower down.

The framework in which the cage moves is formed by connecting a 5 1/2" strip with a 12 1/2" strip in the fourth hole to form the uprights. These are connected by 5 1/2" strips to the main uprights. The framework takes the same angle as the main uprights, and is connected in the front at the top by a 3" strip bolted one hole from the end on each side of the strip. The next lower down is a 3 1/2" strip bolted at the extreme holes of the strip, and the bottom is a 5 1/2" strip.

The cage is formed by bending two 12 1/2" strips, and connecting them at the bottom by five 2 1/2" strips to form the floor, and one 2 1/2" strip to connect them at the top. The guide ropes are connected to the cross pieces at the top of the framework, passed through the holes at each side of the cage, and connected with two 2 1/2" strips screwed to the floor.

The hoisting mechanism is operated by the crank handle, upon which is keyed a 3/4" pinion engaging a gear wheel connected with the spindle over which the hoisting rope is wound.

Fig. No. 36. Level Crossing Gates.

(MADE WITH MECCANO OUTFIT NO. 3 OR NO. 2 AND NO. 2A)

Parts required in addition
to Outfits

PARTS REQUIRED.

		No. 1	No. 2
18	5½" Perforated Strips.	8	—
4	3½" " "	3	2
17	2½" " "	5	1
6	Angle Girders.	6	2
32	Brackets.	14	14
4	1" Pulley Wheels.	—	2
75	Nuts and Bolts.	45	25

This model, if constructed with care, is a most admirable one, as the gates are opened simultaneously by the operation of one lever.

To construct it, commence by taking two angle girders and connecting them together in the second hole at each end with a 5½" strip placed perpendicularly between them to form the supports of one pair of gates as shown in Figure A. The supports for the other pair of gates are arranged in a similar manner. These two structures are connected by two other angle girders, and braced by four 3½" cross pieces as shown in the illustration.

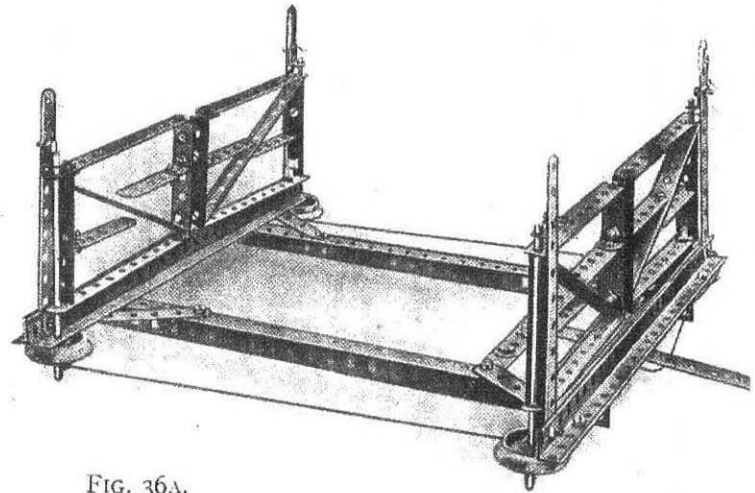

FIG. 36A.

The gates are formed by connecting two 5½" strips with a 2½" strip and angle brackets in the end holes at one side. At the other side the 2½" strip is connected in the second holes from the end to permit the axle rod to pass through upon which the gate swings.

Figure 36B is an inverted perspective view showing the arrangement of operating cord 1 which is passed from the operating lever 2, around the corner pulleys 3, and back to the lever 2. In order to obtain a better grip on the pulleys, it is desirable to wind the operating cord twice around them. It is to be noted that the cord 1 is wound in opposite directions around the diagonal pairs of pulleys 3.

Figure C is a side detail showing the method in which the operating pulley 3 is keyed upon the spindle 4 by the key 5. The gate 6 rests upon the angle bracket 7, and a pinching screw 8 is fitted in the inner side to grip it to the spindle 4, so that all rotate together.

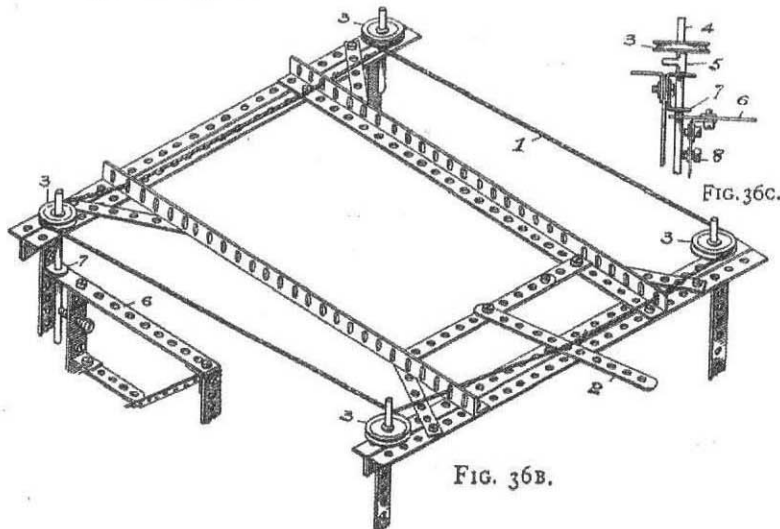

FIG. 36B.

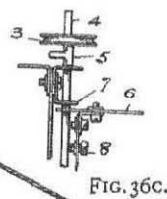

FIG. 36C.

Fig. No. 37. Fire Escape.

(MADE WITH MECCANO OUTFIT NO. 3 OR NO. 2 AND NO. 2A)

*Parts required in addition
to Outfits*

PARTS REQUIRED.		No. 1	No. 2
2	12½" Perforated Strips.	—	—
4	5½" " "	—	—
3	3½" " "	2	1
2	3" " "	2	2
5	2½" " "	—	—
4	Angle Girders.	4	—
25	" Brackets.	7	7
2	5" Axle Rods.	—	—
3	3½" " "	2	2
2	Crank Handles.	1	1
4	Flanged and Grooved Wheels.	4	—
3	1" Pulley Wheels.	—	1
1	½" Pulley Wheel.	1	1
2	Pinions.	1	1
2	Pawls.	1	1
50	Nuts and Screws.	20	—
19	Keys.	7	1

In constructing this model, take two angle girders and tie these together with 3½" strips at top and bottom. A 5½" strip is then attached at right angles to one end of the frame, diagonal stays tying these short strips to the angle brackets attached to the frame. The sliding frame is constructed from two angle girders reversed to those of the main frame, the angle girders of the sliding frame being tied together by two 2½" strips, and being retained and guided in the main carriage by the short angle brackets which act as clips. The framework of the running truck is very simply constructed, and is pivotally attached by angle brackets to the main frame.

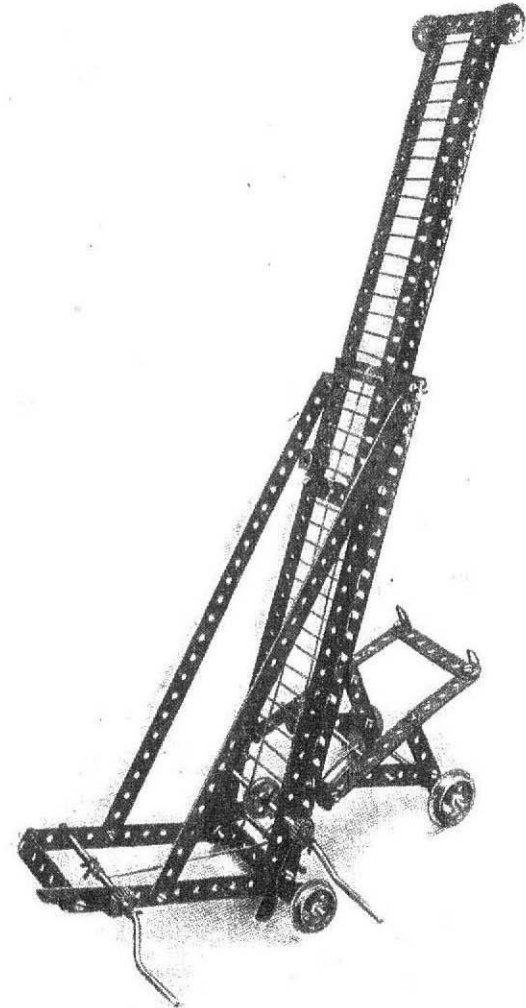
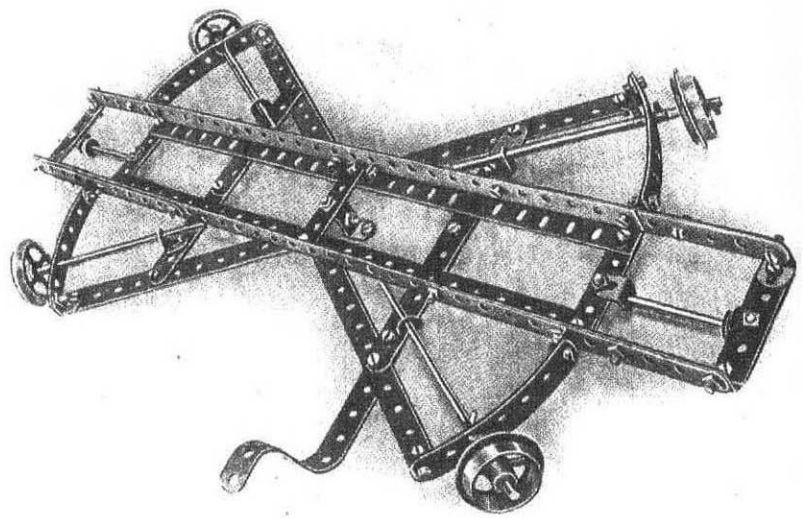
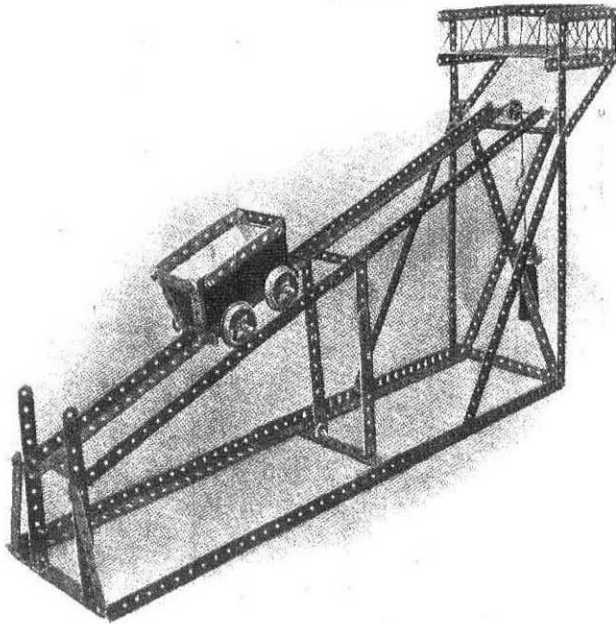

Fig. No.38. Inclined Delivery Shoot.

Fig.No.39. Loco Turntable.

(MADE WITH MECCANO OUTFIT NO. 3 OR WITH NO. 2. AND NO. 2A)



Parts required in addition to Outfits.		PARTS REQUIRED.		PARTS REQUIRED.		Parts required in addition to Outfits	
No.1	No.2			No.1	No.2		
—	—	6	12½" Perforated Strips.	28	—	10	10
9	1	19	5½" " "	2	3½" Angle Brackets.	1	1
5	4	6	3½" " "	4	3½" Rods.	4	—
2	2	2	3" " "	1	1" Flanged Wheels.	—	—
—	—	12	2½" " "	80	1" Pulley Wheel	—	—
8	4	8	Angle Girders	1	Nuts and Bolts.	50	30
				8	Hook.	—	—
					Keys.	—	—

The model furnishes an illustration of the inclined plane. The loading platform at the extreme right delivers a load into the truck, which, being now heavier than the balance weight, runs down the incline, and when at the bottom discharges its load by tipping. The weight immediately overcoming the empty truck returns it quickly to the loading platform.

Parts required in addition to Outfits.		PARTS REQUIRED.		PARTS REQUIRED.		Parts required in addition to Outfits.	
No.1	No.2			No.1	No.2	No.1	No.2
—	—	9	5½" Perforated Strips.	4	5" Rods.	—	—
5	4	6	3½" " "	2	2" " "	—	—
2	2	2	3" " "	4	Flanged Wheels.	4	—
—	—	9	2½" " "	2	½" Pulley Wheels.	2	2
2	—	2	Angle Girders.	61	Nuts and Bolts.	31	11
4	4	22	" Brackets	12	Keys.	—	—

This is an extremely simple yet interesting model to construct. The shafts carrying the running wheels are disposed so as to converge to the central bolt in the middle cross-bar of the apparatus, so that it may rotate accurately thereon, and the short shafts parallel to the track rails are each provided with small pulleys to take the weight of the train as it enters upon the turntable.

Fig. No. 40. Flying Machine.

(MADE WITH MECCANO OUTFIT
NO. 4 OR NO. 3 AND NO. 3A)

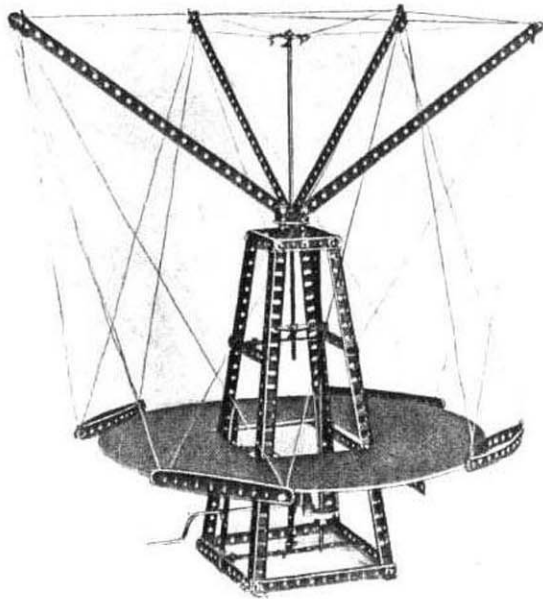

PARTS REQUIRED.		Parts required in addition to Outfits.		
		No. 1	No. 2	No. 3
8	12½" Perforated Strips.	2	—	—
15	5½" " "	5	—	—
3	3½" " "	2	1	—
4	2½" " "	—	—	—
4	Angle Girders.	4	—	—
18	" Brackets.	—	—	—
2	11½" Rods.	2	1	1
1	Crank Handle.	—	—	—
2	Bush Wheels.	1	1	1
2	Pinions.	2	2	—
1	Gear Wheel.	1	1	—
1	1½" Contrite.	1	1	1
72	Nuts and Bolts.	42	22	—
4	Wood Screws.	—	—	—
8	Keys.	—	—	—

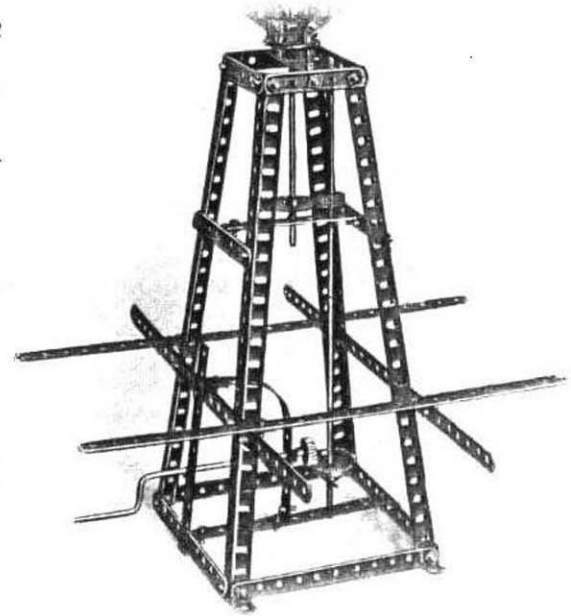

FIG. 40A.

Most boys will have seen the Maxim Flying Machine at work, and will hardly fail to be interested in constructing a working model of it.

The main frame is composed of four angle girders connected at the bottom by four 5½" strips and at the top by four 2½" strips. Across the centre at the top of the frame is connected a 2½" strip, and a 3½" strip is attached on opposite sides in the ninth hole down connected in the centre of each of these by another 3½" strip. This transverse 2½" and 3½" strip carry the perpendicular spindle upon which the upper structure revolves. A bush wheel is keyed to this spindle to support the four arms, which are attached by four angle brackets. The outer ends of the arms are supported by means of tie rods formed of string to a bush wheel keyed on the top of the spindle, and the boats are connected to these by string arranged as shown in the illustration. The platform is supported by four 12½" strips as shown in Figure 40A.

Figure 40A also illustrates the manner of constructing the mechanism to operate the model.

Fig. No. 41. Travelling Crane.

(MADE WITH MECCANO OUTFIT NO. 4 OR NO. 3 AND NO. 3A)

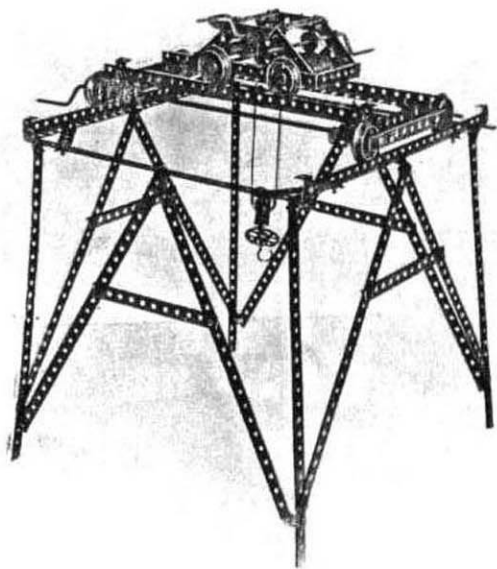

Parts required
in addition
to Outfits.

No. 1	No. 2	No. 3	PARTS REQUIRED.
8	4	2	14 12 1/2" Perforated Strips
—	—	—	10 5 1/2" " "
4	4	2	4 3 3/4" " "
—	—	—	8 2 3/4" " "
4	—	4	Angle Girders.
16	16	—	34 " Brackets.
1	—	—	1 1 1/2" Rod.
—	—	—	2 " "
1	1	—	3 1/2" " "
2	2	1	3 Crank Handles.

Parts required
in addition
to Outfits.

PARTS REQUIRED.		No. 1	No. 2	No. 3
8	Flanged Wheels.	8	4	4
1	1" Pulley.	—	—	—
1	Bush Wheel.	—	—	—
1	Pinion.	1	1	—
5	3/4" Gear Wheel.	4	4	3
1	Pawl.	1	1	—
1	Nuts and Bolts.	—	—	—
82	Hook.	52	32	2
1	Keys.	—	—	—
18		6	—	—

Separate views are given of three distinct parts composing the travelling crane. The first view, Fig. 41A, shows the braced gantry structure carrying a rail at each side. The two pairs of running wheels in the travelling gantry, Fig. 41B, must be keyed on the small axles, so as to fit the gauge of these rails. The gantry is caused to travel to and fro on these rails by rotating the cranked axle. The winch, Fig. 41C, again, is arranged to run on the gantry rails of Fig. 41B, and is provided with a hoisting axle, and one for traversing the winch.

Fig. 41 shows a general arrangement of the complete model.

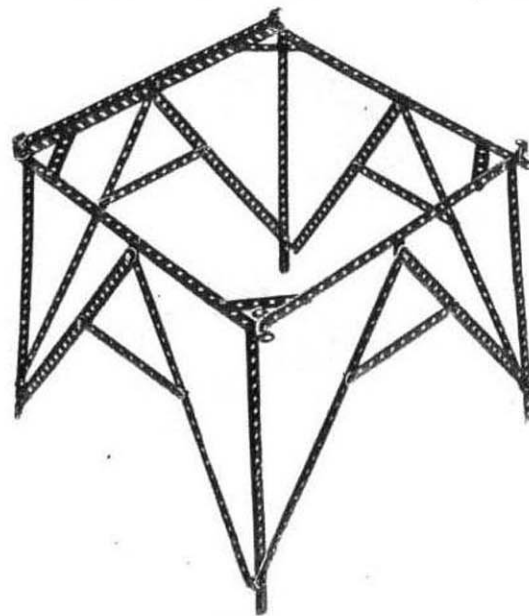

FIG. 41A.

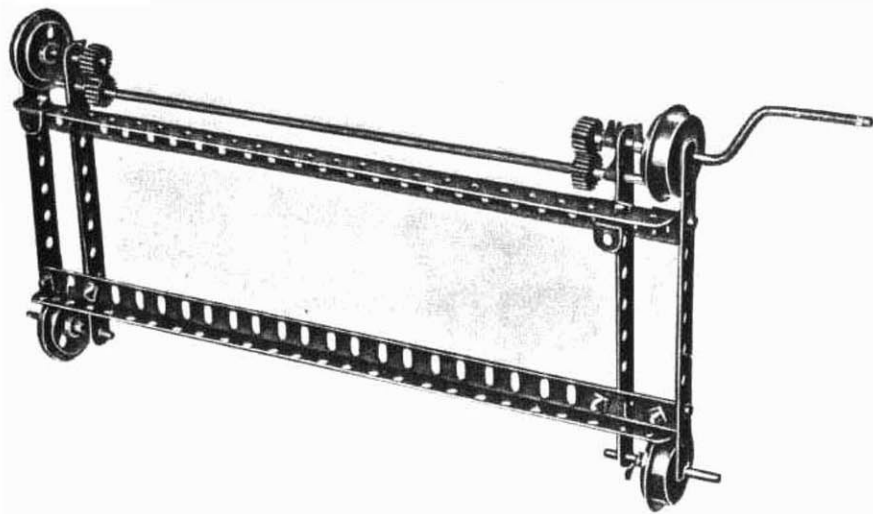

FIG. 41B.

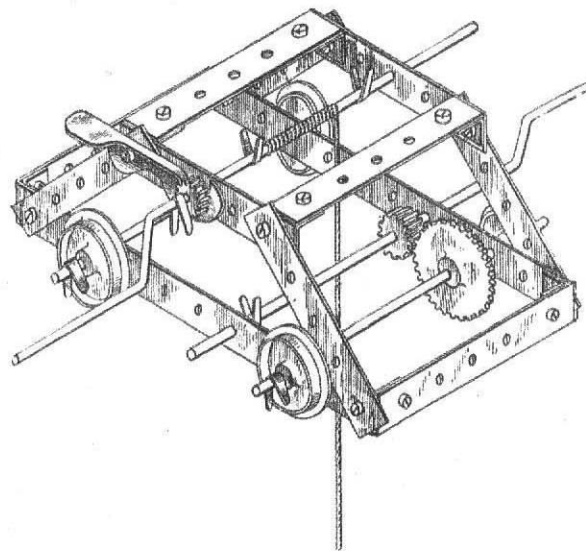
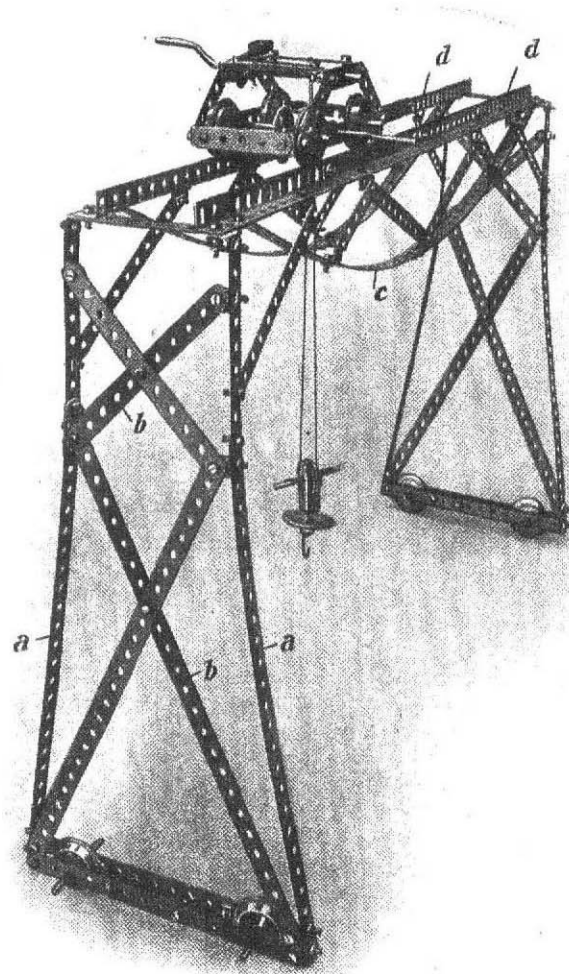

FIG. 41C.

Fig. No. 42. Travelling Crane.

(MADE WITH MECCANO OUTFIT NO. 4 OR WITH NO. 3 AND NO. 3A)



The side frames of this model are each similarly constructed. Two edge strips (*a*) of $12\frac{1}{2}$ " and $5\frac{1}{2}$ " overlapped in three holes and diagonal bracings (*b*) being attached to these edge strips (*a*) by angle brackets.

The side frames are connected together by two bowstring rail girders (*c*) also diagonally braced, as shown in Fig. No. 42A. The rail members (*d*) are composed of two angle girders butted together, and overlapped by a strengthening girder, in the central portion of which diagonal bracings are secured.

The construction of the carriage is shown in Fig. No. 41C, with the exception that the flanged wheels need to be fitted inside the carriage to suit the gauge of the rails.

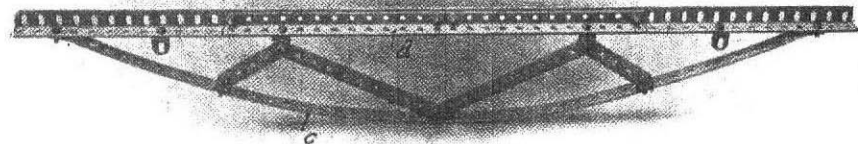

Parts required in addition to Outfits

PARTS REQUIRED.		No. 1	No. 2	No. 3
12	$12\frac{1}{2}$ " Perforated Strips	6	2	—
22	$5\frac{1}{2}$ " " "	12	4	1
6	$3\frac{1}{2}$ " " "	5	4	—
14	$2\frac{1}{2}$ " " "	2	—	—
6	Angle Girders	6	2	—
46	" Brackets	28	28	1
2	$3\frac{1}{2}$ " Rods	1	1	—
5	$2\frac{1}{2}$ " " "	3	3	2
2	Crank Handles	1	1	—
8	Flanged Wheels	8	4	4
1	1" Pulley Wheel	—	—	—
1	Bush Wheel	—	—	—
1	$\frac{3}{4}$ " Pinion	1	1	—
1	" "	—	—	—
1	Gear Wheel	1	1	—
1	Pawl	—	—	—
123	Nuts and Bolts	92	72	42
1	Hook	—	—	—
20	Keys	8	2	—
1	Single Bent Strip	—	—	—

Fig. No. 43. Elevated Jib Crane.

(MADE WITH MECCANO OUTFIT NO. 4 OR NO. 3 AND NO. 3A)

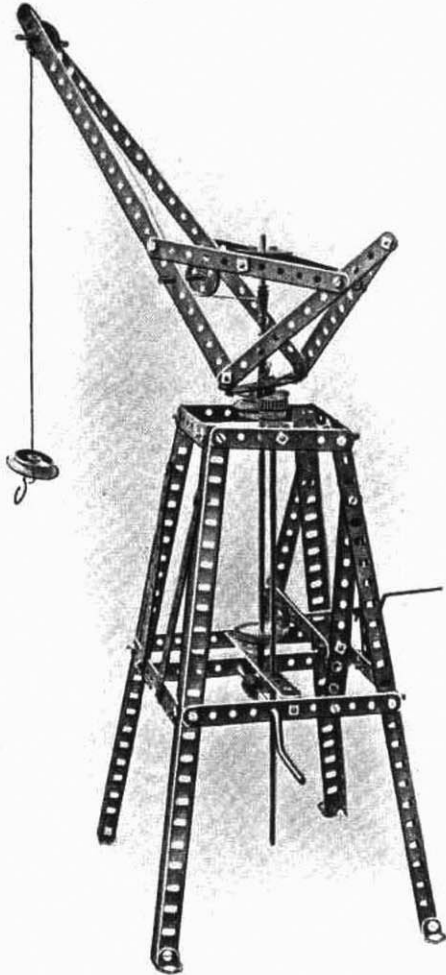

*Parts required in addition
to Outfits*

PARTS REQUIRED.		No. 1	No. 2	No. 3
2	12½" Perforated Strips.	—	—	—
15	5½" " "	5	—	—
6	3½" " "	5	4	—
2	2½" " "	—	—	—
4	Angle Girders.	4	—	—
16	" Brackets.	—	—	—
2	11½" Rods.	2	1	1
1	3½" " "	—	—	—
1	2" " "	—	—	—
2	Crank Handles.	1	1	—
2	Flanged Wheels.	2	—	—
2	1" Pulleys.	—	—	—
1	¾" Pinion.	1	1	—
1	" "	—	—	—
1	Gear Wheel.	1	1	—
1	1½" Contrate.	1	1	1
1	Worm Wheel.	1	1	—
63	Nuts and Bolts.	33	13	—
1	Hook.	—	—	—
13	Keys.	1	—	—

The general construction of this crane will be understood from the photograph, Fig. 43, which shows the different parts of the structure assembled ready for use. The details of the hoisting and swivelling gear are shown in the separate views, Fig. 43A and Fig. 43B.

It is desirable that the model should be fixed in position, and for this purpose the four angle brackets at the bottom of the uprights are provided. These may be attached by screwing to a wood base, or where no damage is likely to result they may be screwed directly to a bench or the like.

The main frame on which the jib rests is composed of four angle girders forming the main uprights, braced together by four 3½" strips at the top, and four 5½" strips at the fourteenth hole down. The structure is further stiffened by 5½" strips placed diagonally as shown in Fig. 43.

The hoisting arrangement is operated by the upper handle, upon which is keyed a $\frac{1}{2}$ " pinion, engaging a $1\frac{1}{2}$ " contra-rotate wheel keyed on to the centre spindle. One end of the winding rope is carried under a 1" pulley on the jib and fastened to the spindle, so that by turning the handle the rope is wound round the spindle, and the load raised.

The mechanism for swinging the jib is operated by the lower handle, upon which is fixed a worm wheel geared into a $\frac{1}{2}$ " pinion keyed to a second spindle. On the upper end of this spindle is keyed a $\frac{3}{4}$ " pinion engaging a gear wheel bolted securely to the base of the jib, but revolving freely on the centre spindle. Between the gear wheel and a $3\frac{1}{2}$ " strip fastened across the top of the pedestal is a flanged wheel which raises the gear wheel high enough to engage the $\frac{3}{4}$ " pinion as shown in Fig. 43B.

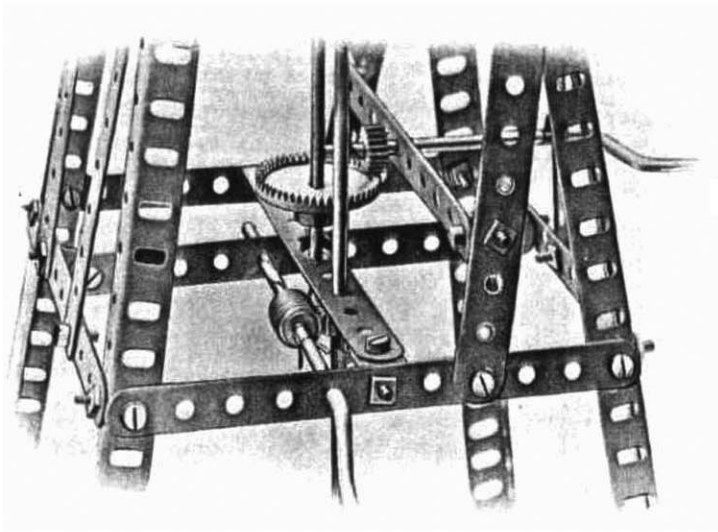

FIG. 43A.

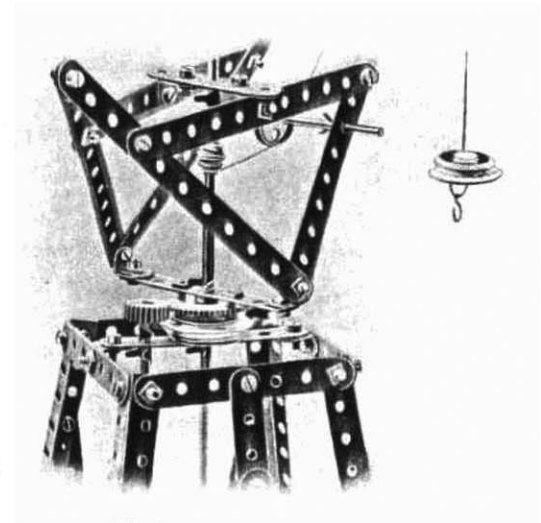
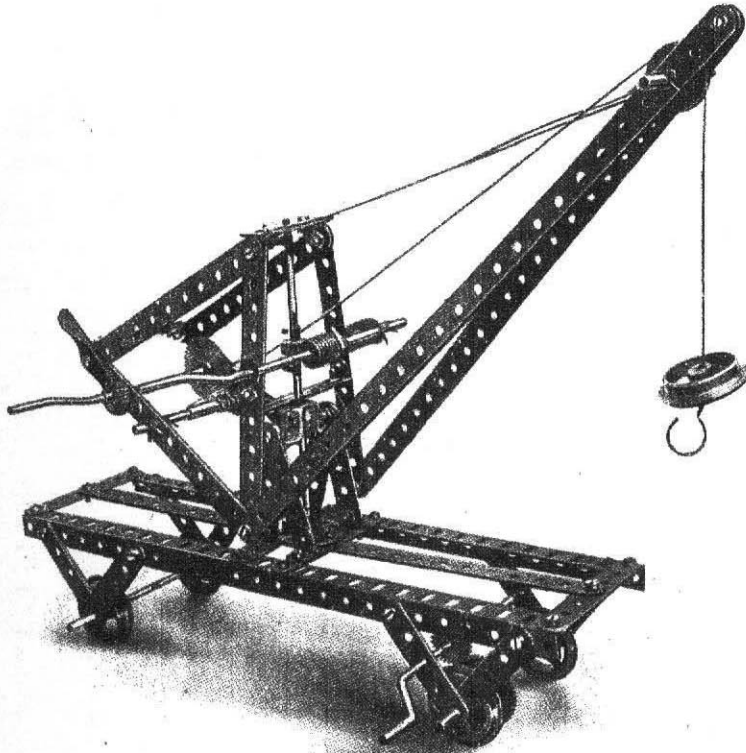

FIG. 43B.

Fig. No. 44. Trolley Crane.

(MADE WITH MECCANO OUTFIT NO. 4 OR NO. 3 AND NO. 3A)



*Parts required in addition
to Outfits.*

PARTS REQUIRED.		No. 1	No. 2	No. 3
3	12½" Perforated Strips.	—	—	—
6	5½" " "	—	—	—
4	3½" " "	3	2	—
15	2½" " "	3	—	—
2	Angle Girders.	2	—	—
16	" Brackets.	—	—	—
1	6" Rod.	1	1	—
2	5" Rods.	—	—	—
1	3½" Rod.	—	—	—
1	2" "	—	—	—
3	Crank Handles.	2	2	1
5	Flanged Wheels.	5	1	1
1	1" Pulley Wheel.	—	—	—
1	Bush Wheel.	—	—	—
1	¾" Pinion Wheel.	1	1	—
2	½" " Wheels.	1	1	1
1	Gear Wheel.	1	1	—
1	Worm "	1	1	—
1	Pawl.	—	—	—
51	Nuts and Bolts.	21	1	—
17	Keys.	5	—	—
1	Double Bent Strip.	1	—	—

Fig. No. 50. Tower.

(MADE WITH MECCANO OUTFIT NO. 5 OR NO. 4 AND NO. 4A)

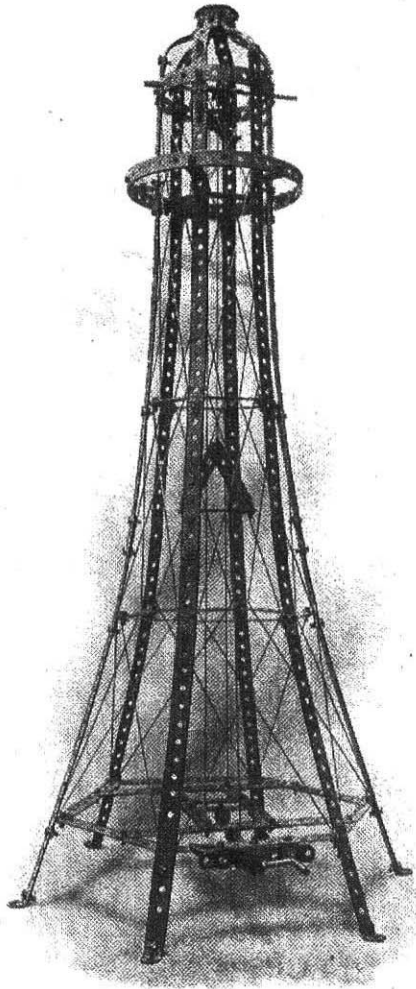

*Parts required in addition
to Outfits*

PARTS REQUIRED.			<i>Parts required in addition to Outfits</i>			
			No. 1	No. 2	No. 3	No. 4
14	12½"	Perforated Strips.	8	4	2	—
18	5½"	" "	8	—	—	—
17	3½"	" "	16	15	11	11
12	2½"	" "	—	—	—	—
6	2"	" "	6	6	6	6
53		Angle Brackets.	35	35	8	—
1	5"	Rod.	—	—	—	—
1		Crank Handle.	—	—	—	—
1	1"	Pulley Wheel.	—	—	—	—
1		Bush Wheel.	—	—	—	—
1	½"	Pinion Wheel.	—	—	—	—
1		Pawl.	—	—	—	—
132		Nuts and Screws.	102	82	52	10
6		Wood Screws.	—	—	—	—
8		Keys.	—	—	—	—

A few particulars may be given regarding the construction of the main features of this model, without going into details.

Begin by constructing the lowest platform, which is made by bolting together six 5½in. strips to form a hexagon, attaching at the same time an angle bracket to each corner. The other three platforms are constructed in a similar manner by 3½in., 2½in., and 2in. strips respectively. The main upright corner strips forming the tower are then bolted to these angle brackets, care being taken to bend the strips so as to follow the curvature indicated in the illustration.

Fig. No. 51. Tower Bridge.

(MADE WITH MECCANO OUTFIT NO. 5 OR NO. 4
AND NO. 4A)

*Parts required in addition
to Outfits*

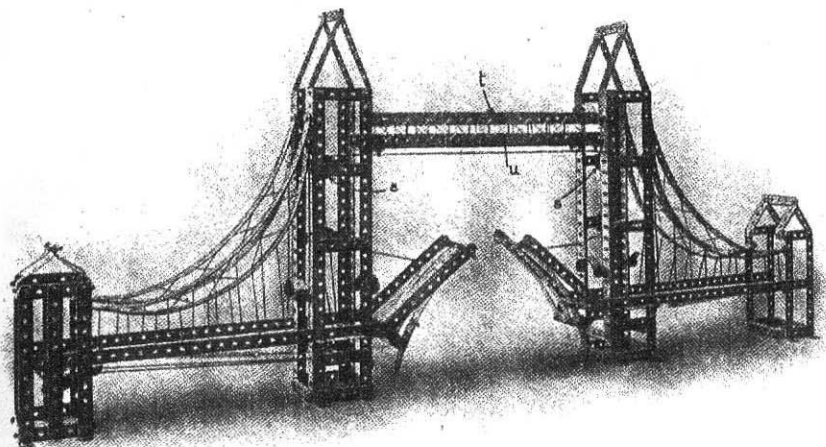

PARTS REQUIRED.		No.	No.	No.	No.
		1	2	3	4
16	12½" Perforated Strips.	10	6	4	—
30	5½" " "	20	12	9	2
77	2½" " "	65	61	53	49
4	2" " "	4	4	4	4
10	Angle Girders.	10	6	2	2
92	" Brackets.	74	74	47	38
6	3½" Rods.	5	5	3	3
1	Crank Handle.	—	—	—	—
6	1" Pulley Wheels.	—	4	2	2
1	¾" Pinion Wheel.	1	1	—	—
1	¾" " "	—	—	—	—
1	1" Gear Wheel.	1	1	—	—
1	Pawl.	—	—	—	—
231	Nuts and Screws.	201	181	151	109
16	Wood Screws.	8	8	4	4
22	Keys.	10	4	—	—
2	Springs.	2	2	2	1

Begin by making the two main towers. The construction of one of these is shown in Fig. 51A. The four upright angle girders (*a*) being connected with the side bracings (*b*), the guide pulleys and its shaft (*c*) are then keyed into position. The top gable (*d*) may then be fixed to the uprights. The two shorter end towers (*e*) may then be constructed, consisting of side frames which carry the bascule operating gear (*f*). This gear consists of a crank shaft carrying the pinion engaging the upper gear wheel (*g*), the spindle of which acts as the winding drum for the operating cord. The roadway girder (*h*) is now constructed and inserted into position in the towers, the transverse strips (*k*) being bolted through to the outer strip (*l*). The catenary member (*m*) is now built up from two curved $12\frac{1}{2}$ in. strips, which are bolted to the vertical angle girders of the higher tower, and by angle brackets to the shorter tower. Each bascule is provided with a bent $2\frac{1}{2}$ in. strip (*n*), which bears against the main tower, and acts as a stop when the bascules are horizontal. The bascules are hinged by fixing the bolts (*o*) in the end holes (*p*) of the side frames (*l*). The spring (*r*) is connected to the lower part of the bascule and the short towers, which acts to always return the bascules to the closed position. The operating cord passes from the winding spindle (*g*) round the lower right pulley (*c*) and over the upper guide pulleys (*s*) in the main towers to the outer ends of the bascules. The upper gangway (*t*) is built up of two side frames, the lower members of which are formed of angle girders (*u*), which are secured to angle brackets (*v*) on the main towers. The catenary girders and the upper gangway are then laced with cord, to represent the chains and diagonal bracing respectively.

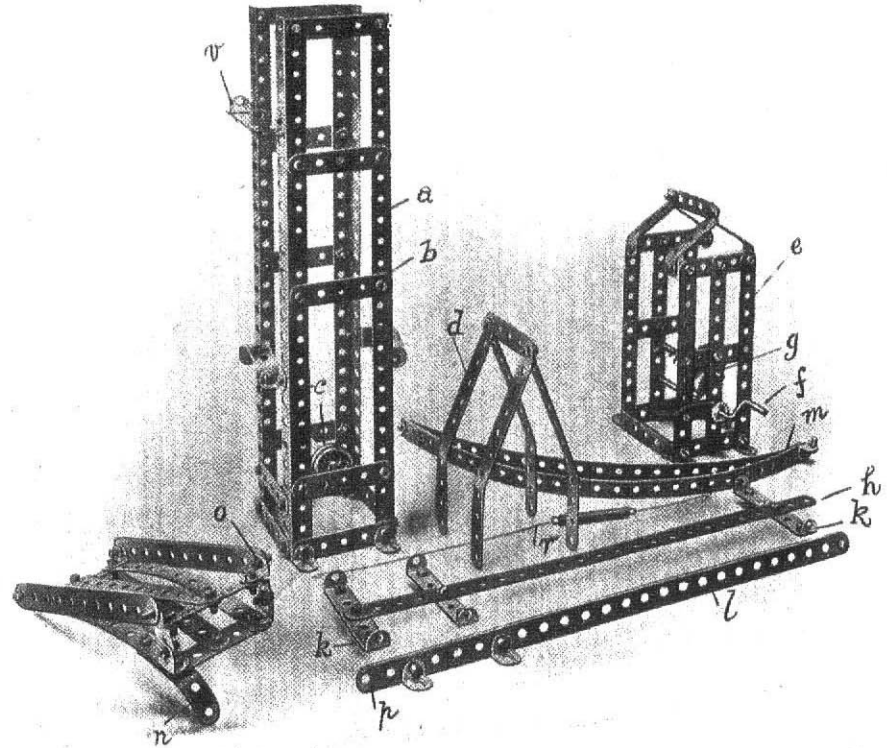

Fig. 51A.

Fig. No. 52. Big Wheel

PARTS REQUIRED.		<i>List of Parts required in addition to Meccano No. 1.</i>	
46	12 $\frac{1}{4}$ " Perforated Strips.	40	12 $\frac{1}{4}$ " Perforated Strips.
38	5 $\frac{1}{2}$ " " "	28	5 $\frac{1}{2}$ " " "
4	3 $\frac{1}{2}$ " " "	3	3 $\frac{1}{2}$ " " "
18	3" " "	18	3" " "
26	2 $\frac{1}{2}$ " " "	16	2 $\frac{1}{2}$ " " "
8	Angle Girders.	8	Angle Girders.
96	" Brackets.	78	" Brackets.
4	11 $\frac{1}{2}$ " Rods.	1	6" Rod.
1	6" "	6	Flanged Wheels.
6	Flanged Wheels.	1	1 $\frac{1}{2}$ " Pulley.
1	1 $\frac{1}{2}$ " Pulley.	3	Bush Wheels.
4	Bush Wheels.	1	2" Pinion.
1	2" Pinion.	1	Gear Wheel.
1	Gear Wheel.	235	Nuts and Bolts.
268	Nuts and Bolts.	3	Wood Screws.
23	Keys.	11	Keys.
1	Length of Chain.	1	Length of Chain.
8	Wood Screws.	4	11 $\frac{1}{2}$ " Rods.

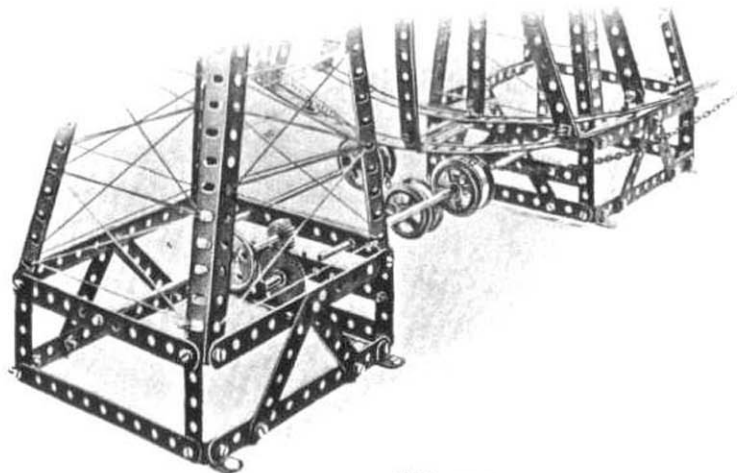

FIG. 52A.

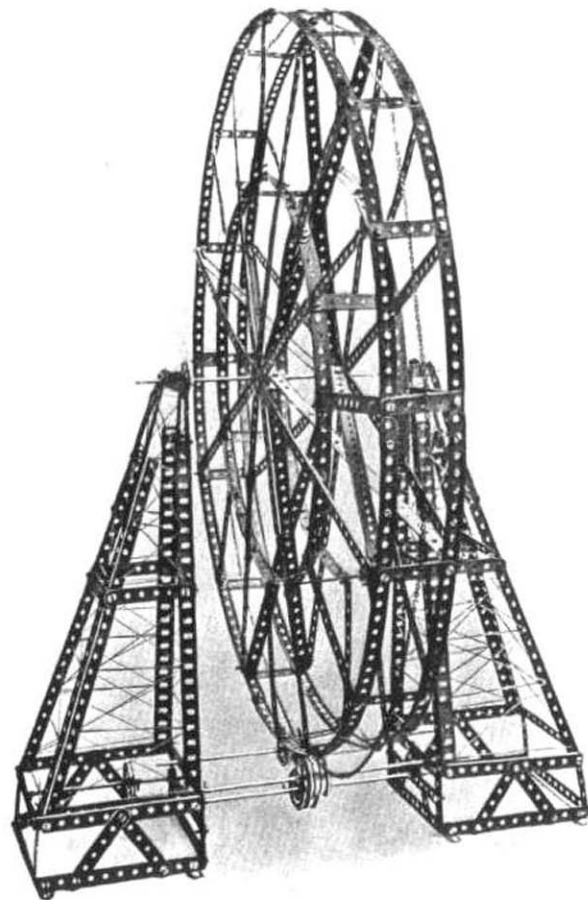

Fig. No. 53. Transporter

PARTS REQUIRED.

20	12½"	Perforated Strips.
38	5½"	" "
2	3½"	" "
33	2½"	" "
12		Angle Girders.
32		" Brackets.
1	5"	Rod.
1	3½"	"
1		Crank Handle.
2	1½"	Pulley Wheels.
2	1"	" "
4	½"	" "
167		Nuts and Bolts.
7		Keys.

List of Parts required in addition to Meccano No. 1.

14	12½"	Perforated Strips.
28	5½"	" "
1	3½"	" "
21	2½"	" "
12		Angle Girders.
14		" Brackets.
2	1½"	Pulley Wheels.
4	½"	" "
137		Nuts and Bolts.

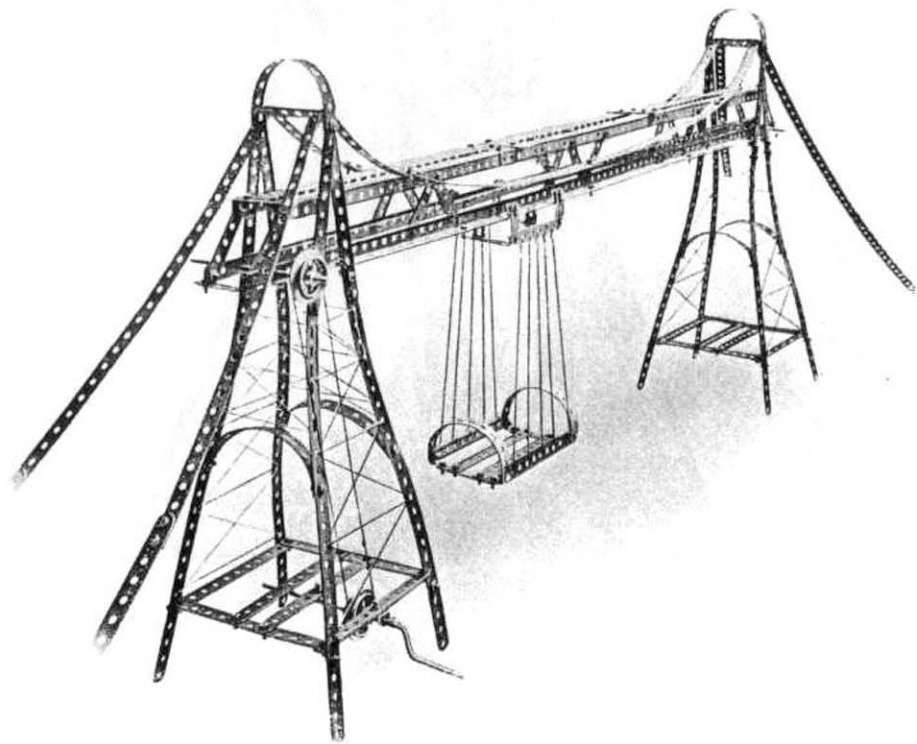
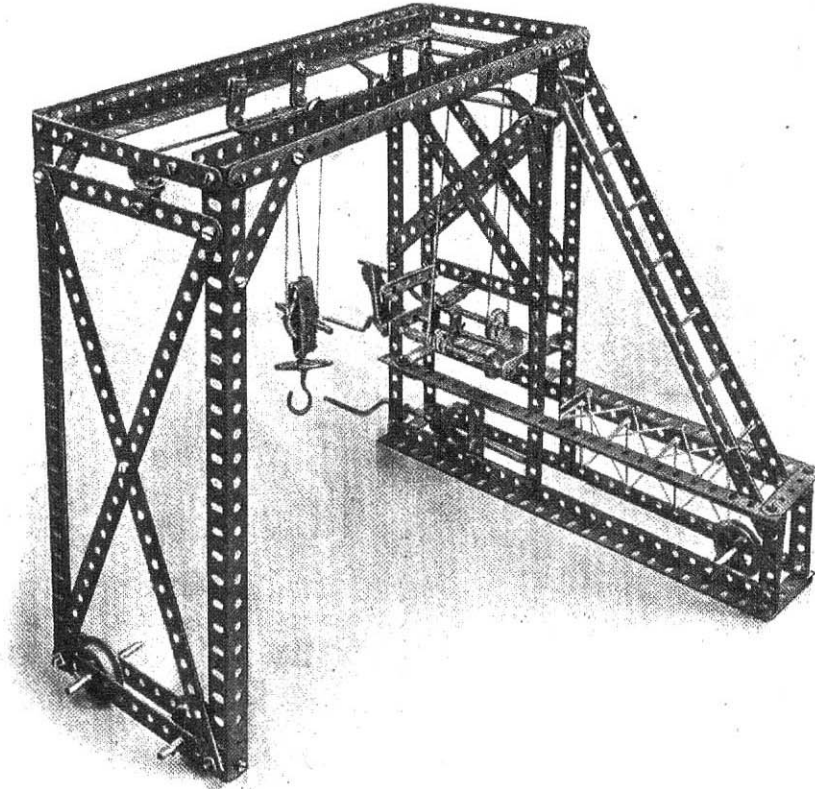

Fig. No. 54. Travelling Gantry.

(MADE WITH MECCANO OUTFIT NO. 5 OR NO. 4 AND NO. 4A)



A most interesting Model to the student of mechanics. If carefully constructed the mechanism will be found to work with the utmost precision and smoothness, and much instruction can be gained by a study of its parts.

The construction is quite straightforward, and hardly needs any description. Care should be taken as to the construction of the clutch mechanism, which is clearly shown in the illustration.

As regards the Cord for operating the travelling carriage, care must be taken to wind this Cord twice around the pulley on the spindle of the traversing handle.

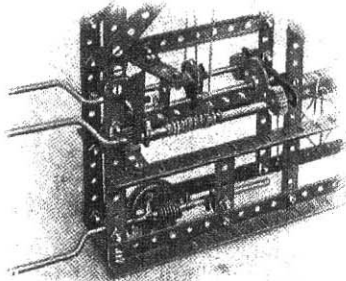
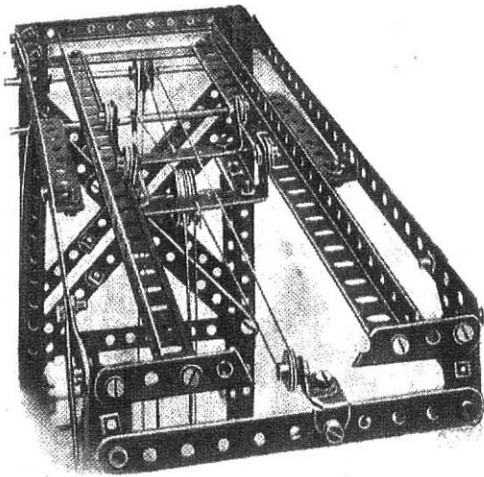

PARTS REQUIRED.

*Parts required in addition
to the following Outfits.*

	No. 1	No. 2	No. 3	No. 4
12 12 $\frac{1}{2}$ " Perforated Strips.	6	2	—	—
15 5 $\frac{1}{2}$ " " "	5	—	—	—
4 3" " "	4	4	2	—
13 2 $\frac{1}{2}$ " " "	1	—	—	—
8 Angle Girders.	8	4	—	—
29 Angle Brackets.	11	11	—	—
2 6" Rods.	2	2	1	—
1 5" Rod.	—	—	—	—
6 2" Rods.	4	4	3	1
3 Crank Handles.	2	2	1	—
4 Flanged and Grooved Wheels.	4	—	—	—
6 1" Pulleys.	—	4	2	2
6 $\frac{1}{2}$ " " "	6	6	4	4
1 Bush Wheel.	—	—	—	—
2 $\frac{3}{4}$ " Pinion Wheels.	2	2	—	—
2 $\frac{1}{2}$ " " "	1	1	—	—
1 Gear Wheel.	1	1	—	—
1 Worm Wheel.	1	1	—	—
125 Nuts and Screws.	95	75	45	3
1 Pawl.	—	—	—	—
1 Hook.	—	—	—	—
33 Keys.	21	15	11	5
2 Single Bent Strips	1	1	1	1

Fig. No. 55. Coal Tip.

(MADE WITH MECCANO OUTFIT
No. 5, OR No. 4 AND No. 4A)

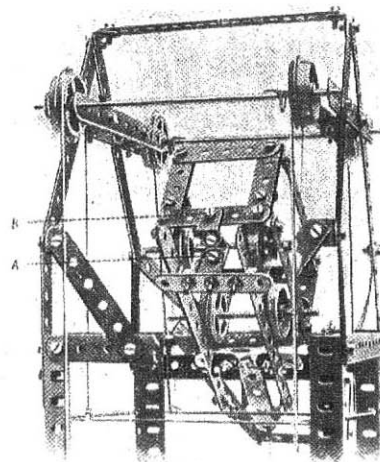
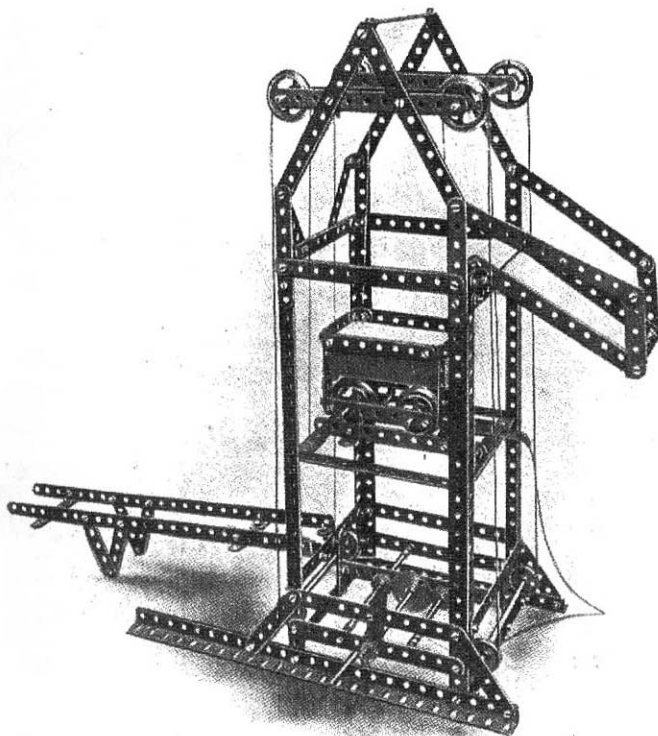

PARTS REQUIRED.

2	12 1/2"	Perforated Strips.	—	—	—	—
34	5 1/2"	" "	24	16	13	6
8	3 1/2"	" "	7	6	2	2
6	3"	" "	6	6	4	2
20	2 1/2"	" "	8	4	—	—
6		Angle Girders.	6	2	—	—
53		Brackets.	35	35	8	—
4	6"	Rods.	4	4	3	2
3	5"	" "	1	—	—	—
2	3 1/2"	" "	1	1	—	—
1		Crank Handle.	—	—	—	—
8		Flanged Wheels.	8	4	4	—
4	1"	Pulley "	—	2	—	—
2	3/4"	Pinion "	2	2	—	—
1	1"	" Wheel "	—	—	—	—
1		Gear Wheel.	1	1	—	—
1		Pawl.	—	—	—	—
149		Nuts and Bolts.	119	99	69	27
23		Keys.	11	5	1	—

*Parts required in addition
to Outfits*

No. 1	No. 2	No. 3	No. 4
—	—	—	—
24	16	13	6
7	6	2	2
6	6	4	2
8	4	—	—
6	2	—	—
35	35	8	—
4	4	3	2
1	—	—	—
1	1	—	—
—	—	—	—
8	4	4	—
—	2	—	—
2	2	—	—
—	—	—	—
1	1	—	—
—	—	—	—
119	99	69	27
11	5	1	—

Fig. No. 56. Revolving Aeroplane.

(MADE WITH MECCANO OUTFIT NO. 5 OR NO. 4 AND NO. 4A)

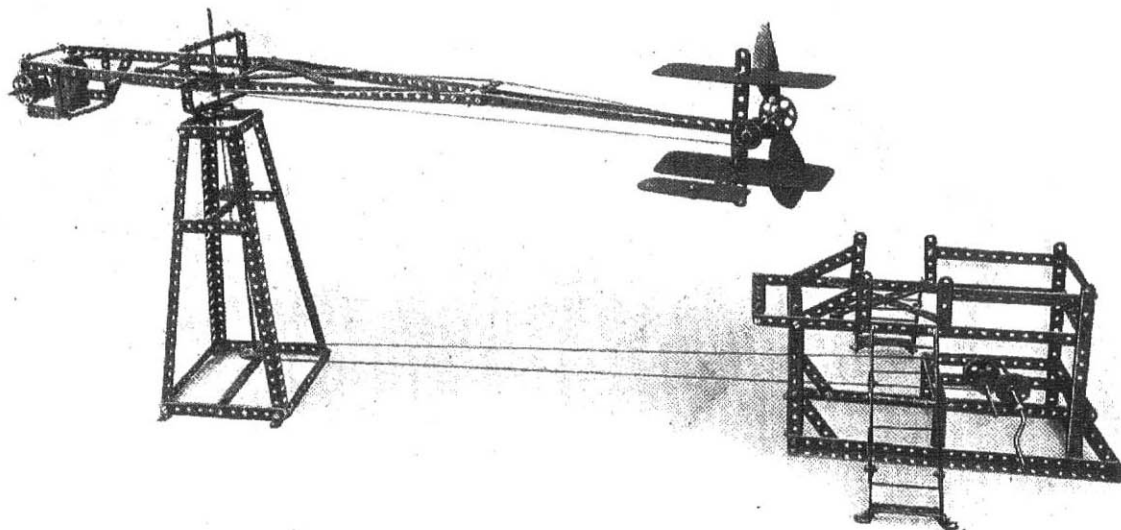

Parts required in addition to Outfits

PARTS REQUIRED.		No. 1	No. 2	No. 3	No. 4
8	12 $\frac{1}{2}$ " Perforated Strips.	2	—	—	—
25	5 $\frac{1}{2}$ " " "	15	7	4	—
15	3 $\frac{1}{2}$ " " "	14	13	9	9
6	3 " "	6	6	4	2
26	2 $\frac{1}{2}$ " " "	14	10	2	—
6	Angle Girders.	6	2	—	—
54	Angle Brackets.	36	36	9	—
2	11 $\frac{1}{2}$ " Rods.	2	1	1	—
4	5 " "	2	1	—	—
2	3 $\frac{1}{2}$ " " "	1	1	—	—
1	2 Rod.	—	—	—	—
2	Large Bent Strips	2	2	1	1

Parts required in addition to Outfits

PARTS REQUIRED.		No. 1	No. 2	No. 3	No. 4
1	Crank Handle.	—	—	—	—
1	Flanged Wheel.	1	—	—	—
1	1 $\frac{1}{2}$ " Pulley Wheel.	1	1	—	—
3	1 " " "	—	1	—	—
1	Bush Wheel.	—	—	—	—
3	$\frac{3}{4}$ " Pinions.	3	3	1	1
2	Gear Wheels.	2	2	1	—
1	$\frac{3}{4}$ " Contrate Wheel.	1	1	—	—
162	Nuts and Bolts.	132	112	82	40
26	Keys.	14	8	4	—
2	Propeller Blades.	2	2	2	2

As regards the construction of the detailed portion shown in Fig. 56A, the pulley wheel (*a*) and the pinion (*b*) are both keyed on the short spindle (*c*) in the following manner: The pulley wheel (*a*) is first inserted on the spindle (*c*), after the latter has been passed through the outer strip (*d*). It is then keyed on the spindle, and the $5\frac{1}{2}$ in. strip (*e*), which is loose on both the spindles (*f*) is then slid on the spindles (*f*) and the spindle (*c*) close against the pulley wheel (*a*). The pinion (*b*) is then inserted on the spindle (*c*), and keyed in place. During this operation it is necessary to have the swinging arm and the square frame (*g*) drawn off the main vertical spindle (*h*), so as to give room for the keying up of the pulley (*a*) and pinion (*b*), after which the frame (*g*) may be dropped into place over the spindle (*h*).

The balance weight is made up of a series of short strips or wheels threaded over the spindles in the shorter arm, and by this means the weight can be adjusted to any nicety.

The driving gear is operated from the crank handle (shown on the right in the sketch), and drives the vertical spindle (*h*) in the pedestal on the left, upon which a $\frac{3}{4}$ in. contrate wheel is keyed, engaging the $\frac{3}{4}$ in. pinion (*b*). At the upper end of this spindle is mounted the balanced swinging arm carrying the propeller and aeroplane on its longer limb, and a balance weight on the short one. The operation of the crank will cause the propeller to revolve, and the aeroplane to rise during its travel, sufficient play being allowed at the spindle to enable the arm to rise.

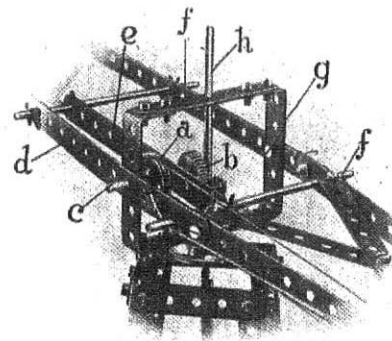
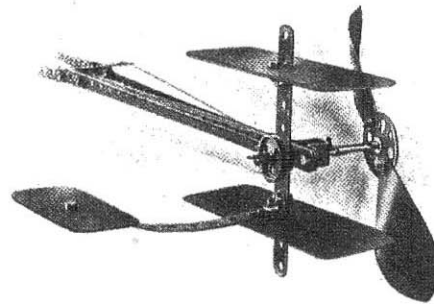

FIG. 56A.

Fig. No. 57. Signal Gantry.

(MADE WITH MECCANO OUTFIT NO. 5 OR NO. 4 AND NO. 4A)

Parts required in addition
to Outfits

PARTS REQUIRED.

5	12½"	Perforated Strips.
38	5½"	" "
8	3½"	" "
12	3"	" "
30	2½"	" "
4	2"	" "
8		Angle Girders.
55		Angle Brackets.
1	6"	Rod
2	3½"	Rods
6	1"	Pulley Wheels.
203		Nuts and Bolts.
6		Keys.

No. 1	No. 2	No. 3	No. 4
—	—	—	—
28	20	17	10
7	6	2	2
12	12	10	8
18	14	6	2
4	4	4	4
8	4	—	—
37	37	10	1
1	1	—	—
1	1	—	—
—	4	2	2
173	153	123	81
—	—	—	—

In this model begin by constructing the lower base frame, the long side frames of which are made up of two 12½ in. angle girders butted together and jointed by a 3 in. strip. The diagonal strips (*a*) must also be connected up to prevent racking. The pedestal (*b*) of the signal pillar is then built up as shown in the detailed view.

The operating lever frame is then proceeded with, the guides for the levers being made from bent 5½ in. strips, carried on cross strips (*c*) which are bolted to the top strips (*d*) of the framework, beneath which is secured an additional strip (*e*) 3½ in. long to strengthen the frames. Operating levers (*f*) are fitted with angle brackets, each pair of levers rotating round the curved strip; the angle bracket on one lever riding on the top of the curved strip, and the angle bracket on the other lever riding below the strip. In this way they can freely pass each other. The lever frame is bolted to the angle brackets (*g*) on the base frame.

The top cage of the model illustrated in Fig. 57c is built up in rectangular fashion from a series of flat strips, the vertical signal standards being carried from the centre of the cage.

The cords operating the signals are carried from the lower ends of the levers around a 6 in. rod (*h*) in the lever frame and under two 3½ in. rods in the lower base frame to the signals.

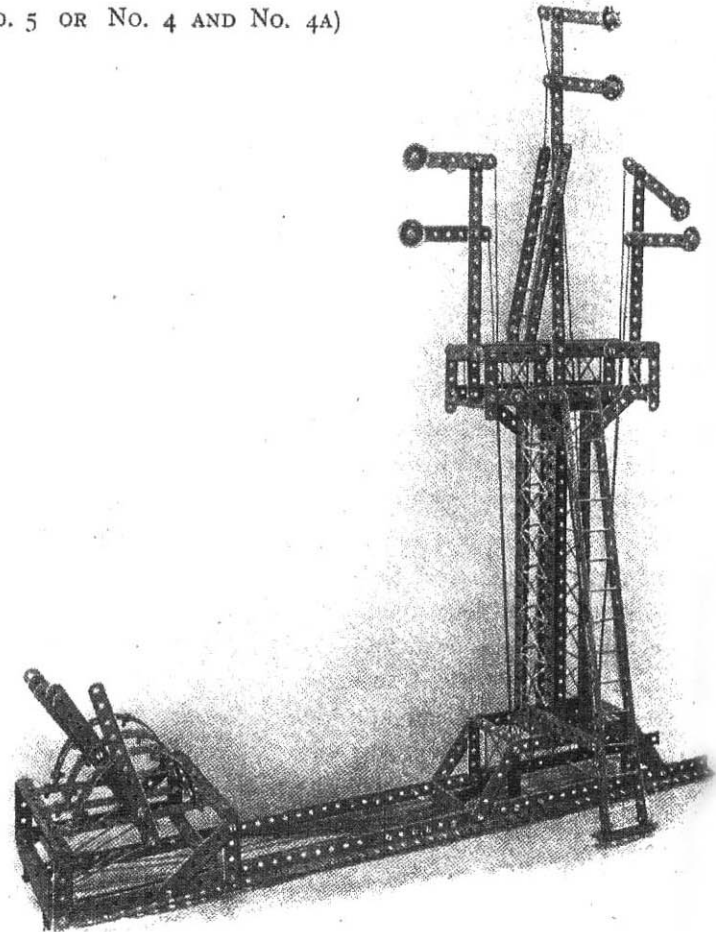

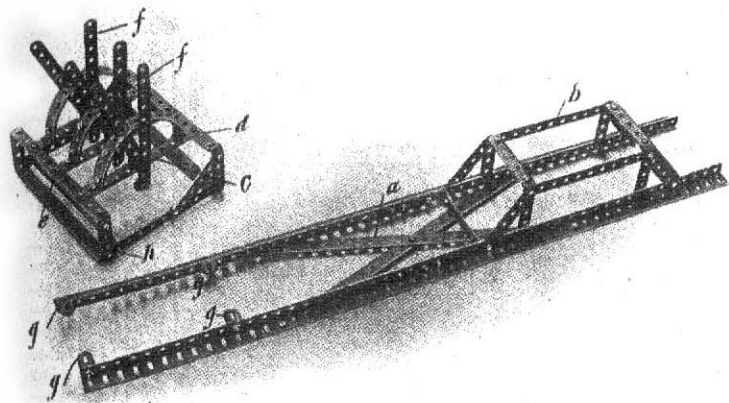

FIG. 57B.

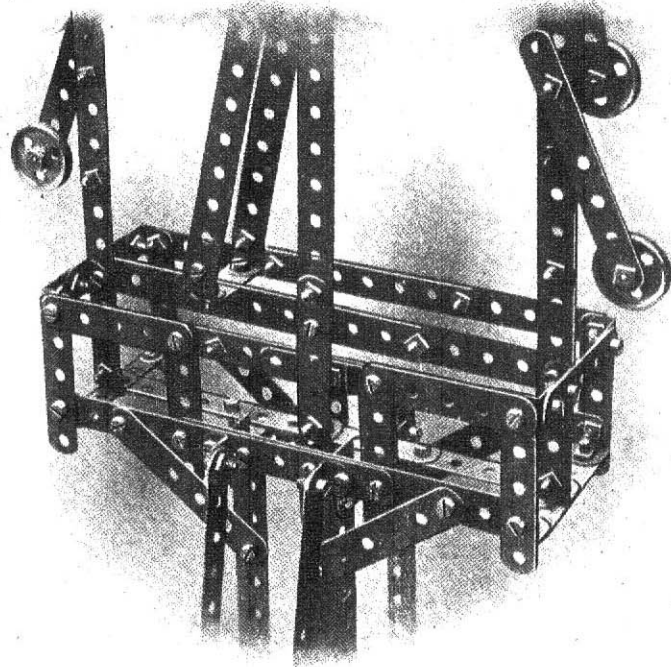
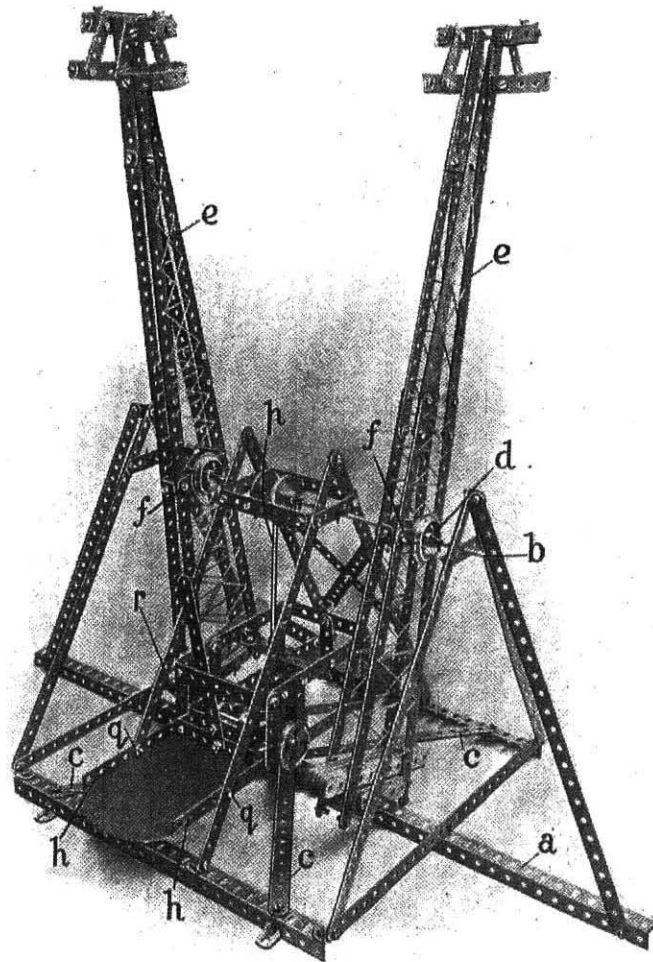

FIG. 57C.

Fig. No. 60. Flip Flap. (MADE WITH MECCANO OUTFIT NO. 6 OR NO. 5 AND NO. 5A)



PARTS REQUIRED.		Parts required in addition to the following Outfits.				
No.		No. 1	No. 2	No. 3	No. 4	No. 5
30	12 1/2" Perforated Strips	24	20	18	10	—
11	5 1/2" " "	1	—	—	—	—
16	3 1/2" " "	15	14	10	10	—
5	3" " "	5	5	3	1	—
26	2 1/2" " "	14	10	2	—	—
8	2" " "	8	8	8	8	—
4	1 1/2" " "	4	4	4	4	4
4	Angle Girders.	4	—	—	—	—
80	Brackets.	62	62	35	26	—
1	8" Rod.	1	1	1	1	1
1	6" " "	1	1	—	—	—
5	5" Rods.	3	2	—	—	—
4	2" " "	2	2	1	—	—
4	Flanged and Grooved Wheels.	4	—	—	—	—
1	1 1/2" Pulley Wheel.	1	1	—	—	—
3	3/4" Pinion Wheels.	3	3	1	1	—
2	1/2" " "	1	1	—	—	—
2	Gear Wheels.	2	2	1	—	—
2	1 1/2" Contribute Wheels.	2	2	2	1	—
2	3/4" " "	2	2	—	—	—
1	Worm Wheel.	1	1	—	—	—
225	Nuts and Bolts.	195	175	145	103	—
24	Keys.	12	6	2	—	—
4	Wood Screws	—	—	—	—	—

The construction of the arms and the main body of the supporting frame is clearly shown in the illustration. Care must be taken, however, when constructing the main frame that the main longitudinal rib of the base (a), which is made up from two angle girdles, is butt-jointed, and not overlapped, the butt joint being strengthened with a 3in. strip, bolted through in every hole to the angle pieces. By this means of butt-jointing the true alignment of the main axle (b) is secured.

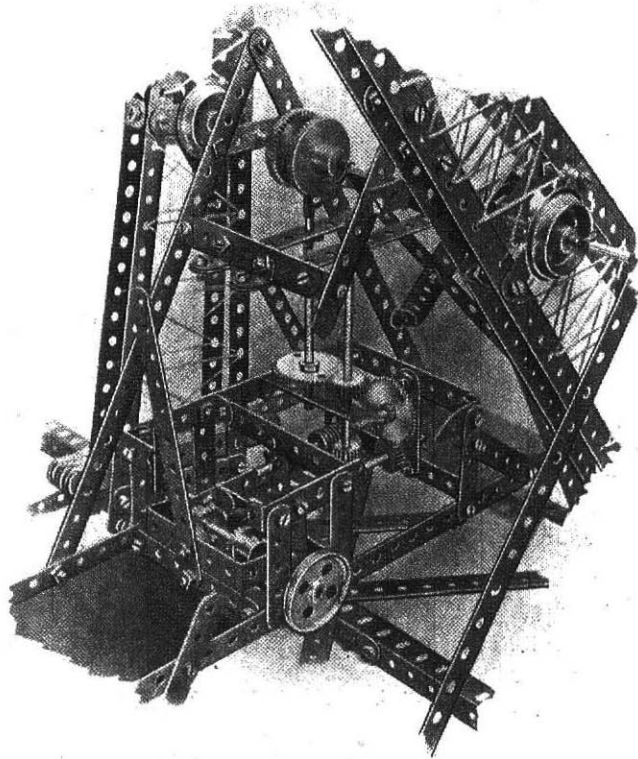

FIG. 60A.

The cross diagonal pieces (*c*) of the base are formed by joining together $12\frac{1}{2}$ in. and $5\frac{1}{2}$ in. strips and overlapping them together for five holes.

The axle (*b*) is gripped to the arms (*e*) by means of the keyed wheels (*d*) on either side of the arms, which are in turn secured to the arms by means of a pair of screws and nuts in the holes in the wheels, the nuts binding against the short $2\frac{1}{2}$ in. cross strips (*f*) on the arms.

Having constructed the main body of the supporting frame as above described, the operating gear cage is now proceeded with. This is built up of a rectangular framing (*g*) bolted on two angle girders (*h*). The clutch mechanism (*j*) is identical with that shown in Fig. 30A; the lower driving spindle (*k*) being connected by the pinion and gear wheel (*l*) to the worm shaft (*m*), which drives the vertical spindle (*n*), the pinion of which meshes with the gear wheel (*o*) on the main vertical spindle (*p*). The angle girders (*h*) of this gear box are then bolted at (*q*) to the inclined supports (*r*), which carry the central bearings of the axle (*b*).

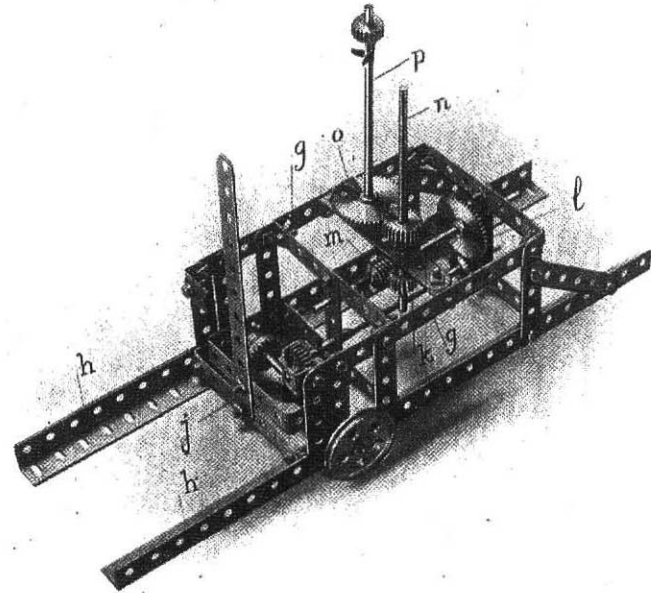
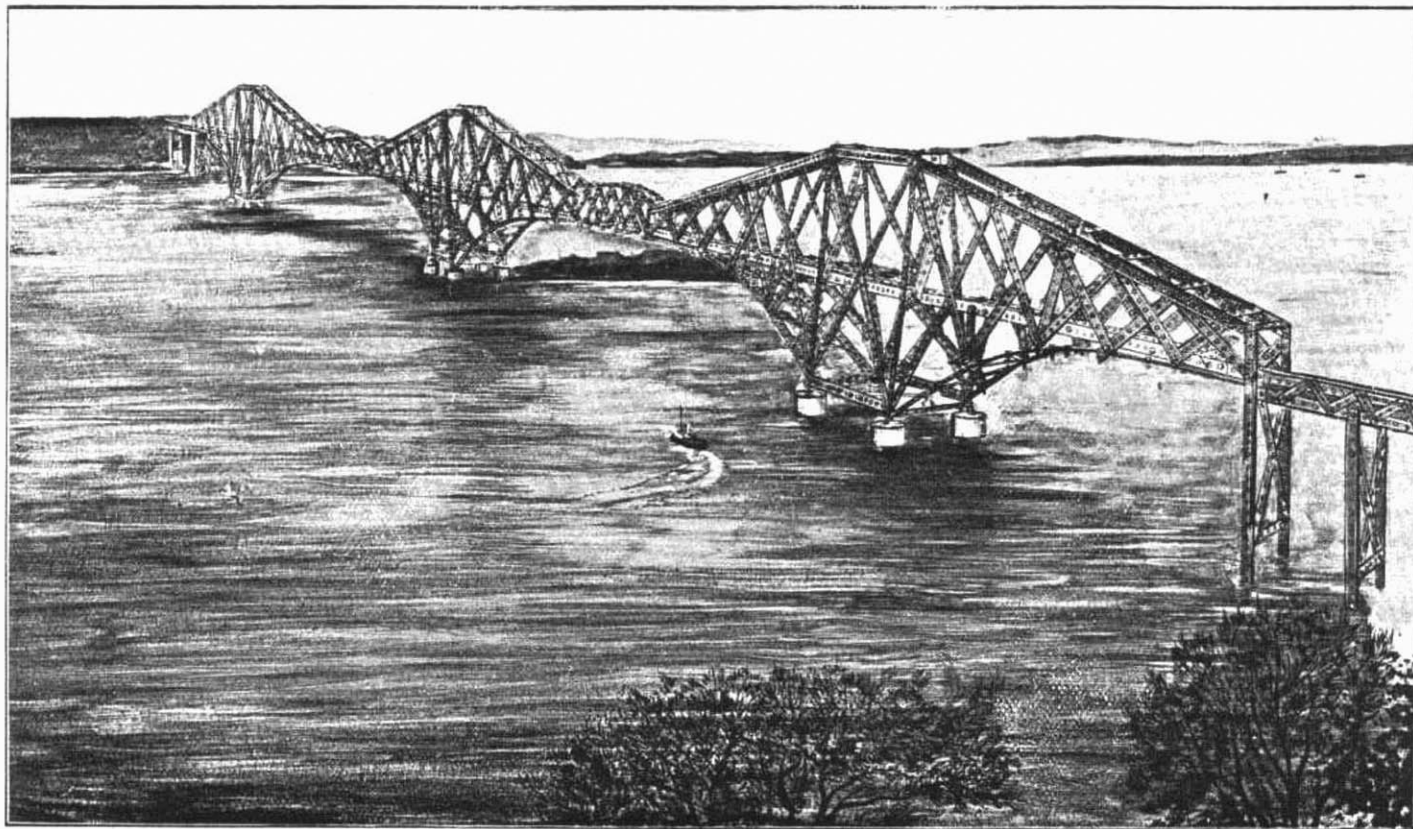

FIG. 60B.

Fig. No. 61. Forth Bridge.
 (MADE WITH MECCANO OUTFIT NO. 6 OR NO. 5 AND NO. 5A)



PARTS REQUIRED.

164	12 $\frac{1}{2}$ "	Perforated Strips.
204	5 $\frac{1}{2}$ "	" "
122	3 $\frac{1}{2}$ "	" "
112	2 $\frac{1}{2}$ "	" "
248		Angle Brackets.
850		Nuts and Bolts.

Parts required in addition to Outfits.

No. 1	No. 2	No. 3	No. 4	No. 5
158	154	152	144	116
254	246	243	236	224
121	120	116	116	98
100	96	88	84	24
230	230	203	194	128
820	800	770	728	580

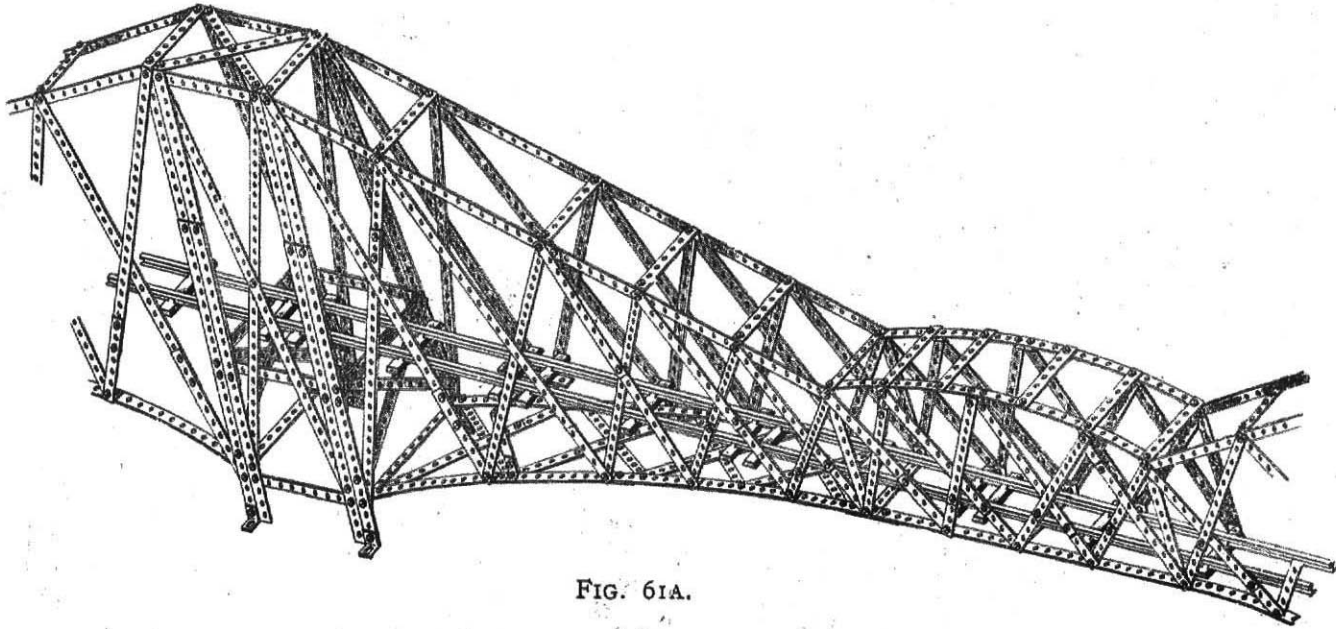

FIG. 61A.

This is one of the most interesting models which can be made with this apparatus. When completed, its length is 16 feet, and it forms a most realistic representation of the great Forth Bridge, and illustrates very clearly the cantilever principle used in its construction.

Fig. No. 62. The Meccano Model Aeroplane.

(MADE WITH MECCANO OUTFIT NO. 6 OR WITH NO. 5 AND NO. 5A)

The Wright Brothers have acquired fame as the inventors of the most practical and satisfactory Aeroplane yet constructed, and, thanks to their genius, aviation promises soon to become a universal and safe means of rapid transit. Their famous Aeroplane has attracted world-wide interest; its principles have proved to be sound, and there is no doubt that they will be embodied in all future successful Flying Machines. Users of "Meccano" can now construct for themselves an almost exact copy of the Wright Aeroplane, capable of demonstrating all its movements, and to all our customers we recommend this as one of our most important and successful models.

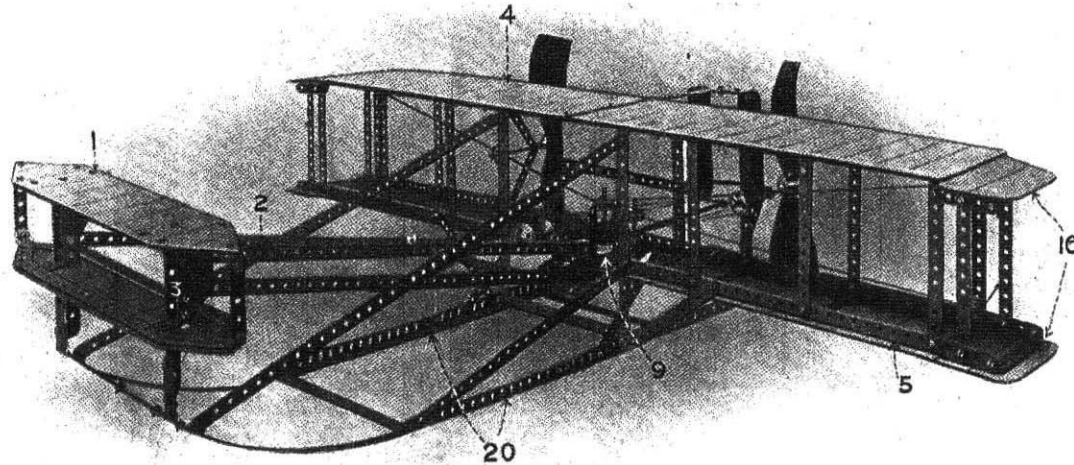

(Designed on the lines of the famous Wright Aeroplane)

To add to the interest which we have no doubt our friends will take in the "Meccano" Model Aeroplane, we have indicated the various working parts, and we append a short description of these. A little study of same will be of material assistance in following the future progress of this new and wonderful science.

- 1—Elevating planes.
- 2—Lever arm.
- 3—Lever crank.
- 4—Upper supporting plane.
- 5—Lower supporting plane.
- 6—Lever for elevating planes.
- 7—Lever for turning rudder.

- 8—Lever crank of rudder.
- 9—Seat.
- 10—Cords operating rudder.
- 11—Pivot of rudder.
- 12—Rudder.
- 13—Propellers.
- 14—Axle of propellers.

- 15—Pulley wheels and cord (representing chains and sprocket wheels).
- 16—Flexible ends.
- 17—Lever rod for turning upright arm.
- 18—Upright arm operating flexible ends.
- 19—Cords connecting pivot with flexible ends.
- 20—Runners.
- 21—Foot rest.

Fig. No. 62. The Meccano Model Aeroplane.

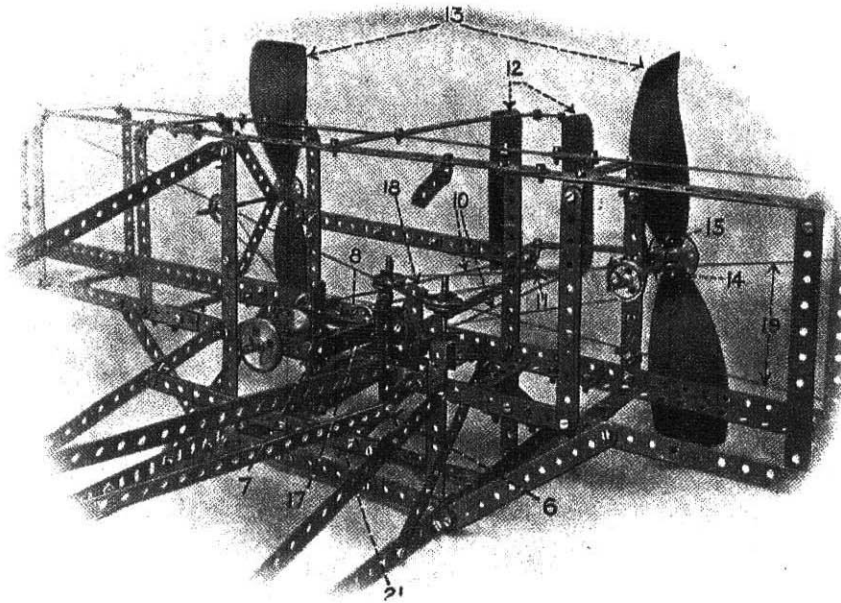

Parts required in addition to Outfits

PARTS REQUIRED.		No. 1	No. 2	No. 3	No. 4	No. 5
22	12½" Perforated Strips	16	12	10	2	—
59	5½" " "	49	41	38	31	19
16	3½" " "	15	14	10	10	—
7	3" " "	7	7	5	3	—
28	2½" " "	16	12	4	—	—
2	2" " "	2	2	2	2	—
10	Angle Girders	10	6	2	2	—
91	" Brackets	73	73	46	37	—
3	5" Rods	1	—	—	—	—
4	3½" " "	3	3	1	1	—
1	1½" Pulley Wheel	1	1	—	—	—
6	1" " Wheels	—	4	2	2	—
6	½" " "	6	6	4	4	—
2	Bush Wheels	1	1	1	—	—
2	¾" Pinion	2	2	—	—	—
1	Gear Wheel	1	1	—	—	—
350	Nuts and Bolts	320	300	270	228	80
28	Keys	16	10	6	—	—
4	Propeller Blades	4	4	4	4	2
1	Double Bent Strip	1	—	—	—	—

In building this model proceed by constructing the main frame, to which the upper and lower supporting planes are attached, the lower portion being formed of six Angle Girders, three on each side, overlapped in the third hole. At each end and in the centre they are connected together by 3½" strips, but between these 5½" strips are used both top and bottom overhanging four holes in order to support the upper and lower planes. The uprights are formed of 5½" strips, and the two front centre struts are formed by connecting two 5½" strips together, overlapped in the fifth hole, and attached at the bottom to the runners. The two struts immediately behind these are formed in the same way.

The axles of the propellers are supported by three 3" strips, with angle brackets attached to these at the outer ends to form a bearing, whilst the inner bearing is formed by the upright 5½" strip on the main frame.

The rudder swivels on two 12½" strips, one attached to the upper portion of the frame, and the other to the lower.

The manner of constructing the struts connecting the elevating planes with the main structure should present no difficulties, as they are clearly shown in the views.

Wherever the bolts act as the pivots of movable parts, lock nuts should be fitted over the ordinary nuts.

Separate detail views are given of the elevating planes and the main operating gear.

Contents of Outfits.

Description of Parts.	1	1A	2	2A	3	3A	4	4A	5	5A	6
12 1/2" Perforated Strips	6	4	10	2	12	8	20	28	48	120	168
5 1/2" " "	10	8	18	3	21	7	28	12	40	224	264
3 3/8" " "	1	1	2	4	6	—	6	18	24	98	122
3" " "	—	—	—	2	2	2	4	20	24	36	60
2 1/2" " "	12	4	16	8	24	4	28	60	88	112	200
2" " "	—	—	—	—	—	—	—	8	8	—	8
1 1/2" " "	—	—	—	—	—	—	—	—	—	4	4
Angle Girders	—	4	4	4	8	—	8	4	12	12	24
" " Brackets	18	—	18	27	45	9	54	66	120	132	252
11 1/2" Rods	—	1	1	—	1	1	2	2	4	2	6
8" " "	—	—	—	—	1	1	2	2	4	—	4
6" " "	—	—	—	—	1	1	2	2	4	—	4
5" " "	2	1	3	3	6	—	6	—	6	—	6
3 1/2" " "	1	—	1	2	3	—	3	3	6	—	6
3" " "	2	—	2	1	3	2	5	1	6	—	6
Crank Handles	1	—	1	1	2	2	4	—	4	—	4
Flanged and Grooved Wheels	—	4	4	—	4	4	8	—	8	—	8
1 1/2" Pulley Wheels	—	—	—	1	1	—	1	1	2	—	2
1" " "	6	—	2	2	4	—	4	2	6	—	6
3/4" " "	—	—	—	2	2	—	2	4	6	—	6
Bush Wheels	1	—	1	—	1	1	2	2	4	1	5
3/4" Pinion Wheels	—	—	—	2	2	—	2	1	3	—	3
" " "	1	—	1	1	2	3	5	—	5	—	5
Gear Wheels	—	—	—	1	1	1	2	1	3	—	3
1 1/2" Contrate Wheels	—	—	—	—	—	1	1	1	2	—	2
" " "	—	—	—	2	2	—	2	—	2	—	2
Worm Wheels	—	—	—	1	1	—	1	—	1	—	1
Pawl	1	—	1	1	2	—	2	—	2	—	2
Spanner	—	1	1	—	1	—	1	1	2	—	2
Nuts and Bolts	30	20	50	30	80	42	122	148	270	680	950
Wood Screws	8	—	8	4	12	—	12	12	24	—	24
Hook	1	—	1	—	1	—	1	—	1	1	2
Keys	12	6	18	4	22	6	28	6	34	6	40
Screw Driver	1	—	1	—	1	—	1	—	1	—	1
Propeller Blades	—	—	—	—	—	—	—	2	2	2	4
Hank Cord	1	1	2	—	2	2	4	2	6	—	6
Ball Cord	1	—	1	—	1	1	2	—	2	—	2
Manual of Instruction	1	—	1	—	1	—	1	—	1	—	1
Length of Chain	—	—	—	—	—	—	—	1	1	—	1
Single Bent Strips	1	—	1	—	1	—	1	2	3	—	3
Double " "	—	1	1	—	1	—	1	—	1	—	1
Large " "	—	—	—	—	1	—	1	1	1	—	2
Spring	—	—	—	—	—	1	1	1	2	—	2

Separate Parts.

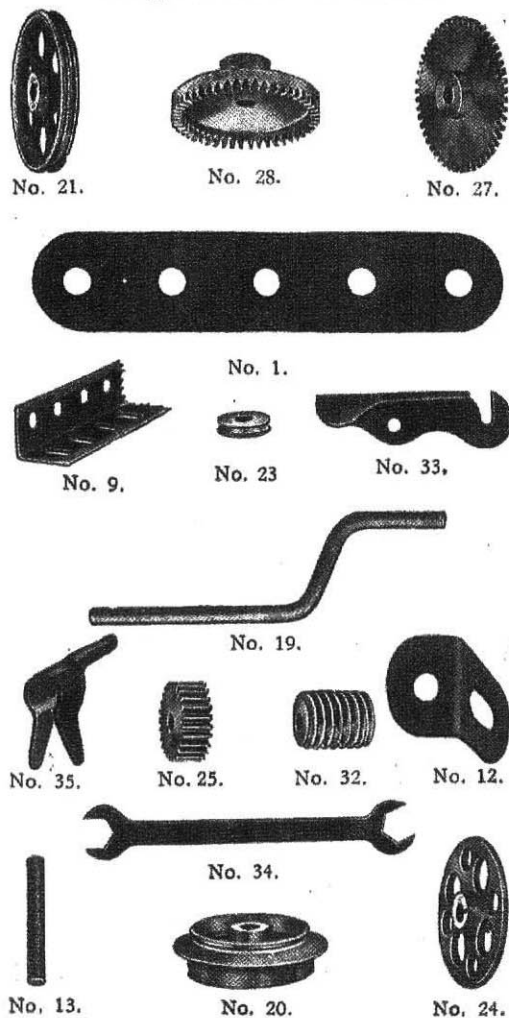

Price List of Additional Parts.

				s.	d.
1.—Perforated Strips	12½" long	per ½ doz.	0 9
2.—	" "	5½"	0 4
3.—	" "	3½"	0 3
4.—	" "	3"	0 3
5.—	" "	2½"	0 3
6.—	" "	2"	0 3
9.—Angle Girders,	12½" long	1 0
12.—Angle Brackets	per dozen	0 6
13.—Axle Rod,	11½" long each	0 3
14.—	" "	6"	0 2
15.—	" "	5"	0 2
16.—	" "	3½"	0 2
17.—	" "	2"	0 1
19.—Crank Handle	0 3
20.—Flanged and Grooved Wheel	0 9
21.—Pulley Wheel,	1½" diameter	0 6
22.—	" "	1"	0 4
23.—	" "	½"	0 2
24.—Bush Wheel	0 6
25.—Pinion Wheel,	¾" diameter	0 9
26.—	" "	½"	0 6
27.—Gear Wheel,	1½" diameter	0 10
28.—Contrate Wheel,	1½" diameter	1 3
29.—	" "	¾"	1 0
32.—Worm Wheel	0 9
33.—Pawl	0 3
34.—Spanner	0 3
35.—Keys	per dozen	0 6
36.—Screw Driver each	0 3
37.—Nuts and Bolts	per 2 dozen	1 0
39.—Ball Cord (Special) each	0 2
40.—Hank Cord	0 1
41.—Propeller Blades	per pair	0 6
42.—Chain	12 ft. lengths, each	2 0
43.—Spring each	0 2
44.—Single Bent Strip	0 2
45.—Double	" "	0 2
46.—Large	" "	0 3

Price List.

No. 1.	Meccano Outfit	5/-
No. 2.	”	”	10/-
No. 3.	”	”	15/-
No. 4.	”	”	25/-
No. 5.	”	Presentation Outfit		63/-
				Packed in well made walnut stained box with lock and key.				
No. 6.	”	”	”	Ditto.	ditto.			126/-
No. 1A	”	Accessory Outfit		(containing sufficient parts to convert a No. 1 into a No. 2 Outfit) ...				5/6
No. 2A	”	”	”	(containing sufficient parts to convert a No. 2 into a No. 3 Outfit) ...				6/-
No. 3A	”	”	”	(containing sufficient parts to convert a No. 3 into a No. 4 Outfit) ...				11/-
No. 4A	”	”	”	(containing sufficient parts to convert a No. 4 into a No. 5 Outfit) ...				38/-
				Packed in well made walnut stained box with lock and key.				
No. 5A	”	”	”	(containing sufficient parts to convert a No. 5 into a No. 6 Outfit) ...				63/-
				Packed in well made walnut stained box with lock and key.				

