

MECCANO



(PATENTED)

INSTRUCTIONS

For the whole series of Models,
comprising eleven progressive outfits

BOOK **6**^{d.}_{net}

Copyright by **MECCANO LIMITED, LIVERPOOL,** throughout the World



HOW TO MAKE MODELS AND TOYS WITH MECCANO

THE first piece of advice we would give to the beginner in "Meccano" is that he commences with Model No. 1, and that he erects every model in turn up to the capacity of his outfit. By that time he will have grown so familiar with the various parts of "Meccano," and will see its possibilities so clearly, that he will with little difficulty be able to build many other models of his own invention.

The charm of "Meccano" lies greatly in its endless variety, and until the user has commenced to apply his own inventive faculties to the hobby, he is not getting the enjoyment out of it which he should.

Every part of the outfit should first be taken from its box, examined, and its name committed to memory, so that the instructions in the Manual may be followed easily and rapidly.

The parts are all standardised, and are interchangeable, and they will be found to fit together easily and without forcing. The holes in the strips are of equal distance apart. The axles fit any of the holes, and their position in the various designs may be ascertained by counting the holes.

All the models shown are built upon sound and standard engineering principles, and the parts employed represent the main mechanical parts used in machinery, such as levers, beams, wheels, axles, pulleys, worm wheels, screws, bolts, keys, &c., so that as an introduction to the serious study of Mechanics the value of "Meccano" is very great indeed.

Each model may be taken in pieces, and the same parts may be used to make up other models. Additional parts can always be purchased from your dealer or from us.

We are at all times glad to correspond with users of "Meccano," and to assist them by suggestions or criticisms when difficulties occur with new models.

For the convenience of users of Meccano we have compiled a series of standard details frequently occurring in the construction of our models; and we would particularly draw attention to the illustrations of these on pages 2 and 3.

Standard Details for use in the Construction of Models on the Meccano Principle

A Brake Mechanism suitable for controlling winding or similar spindles

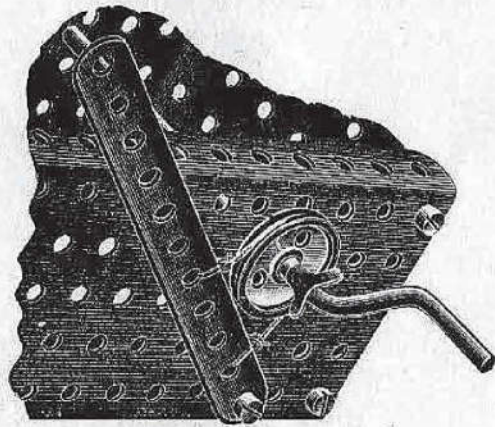

FIG. 1.

Method of locking swivelling connections with double nuts

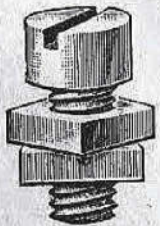

FIG. 4.

Pawl and Pinion or Ratchet Gear; used also as a brake

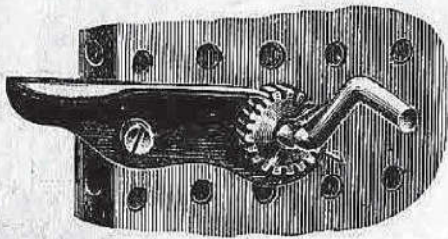

FIG. 5.

Type of Reversing Gear

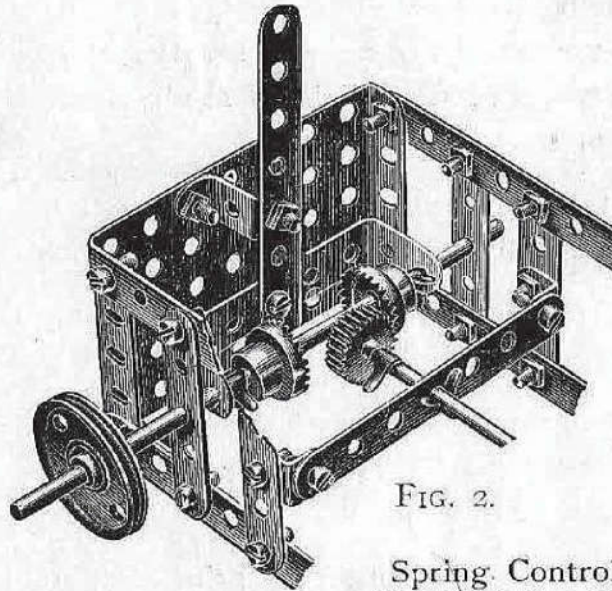

FIG. 2.

Spring Controlled Band Friction Brake

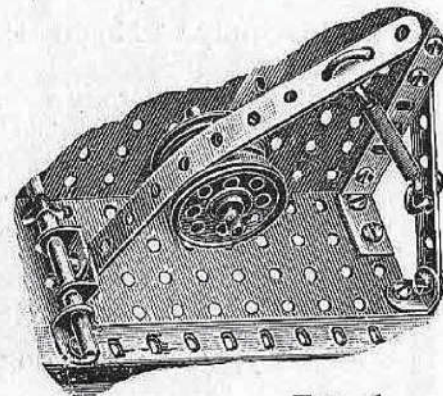

FIG. 6.

Worm and Worm Gear

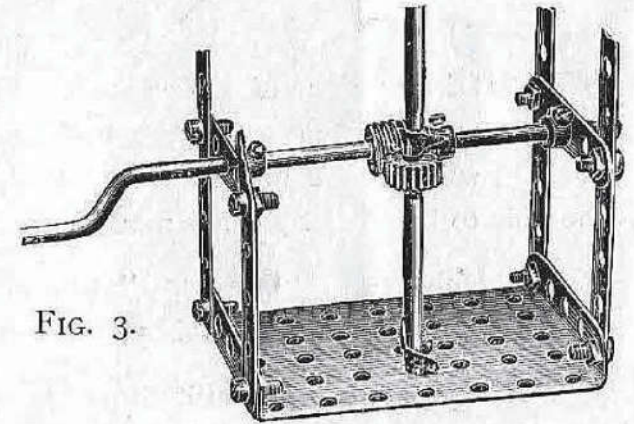

FIG. 3.

Method of operating a fast and loose pulley with a belt drive, one of the flanged wheels on the main shaft being keyed whilst the other runs freely

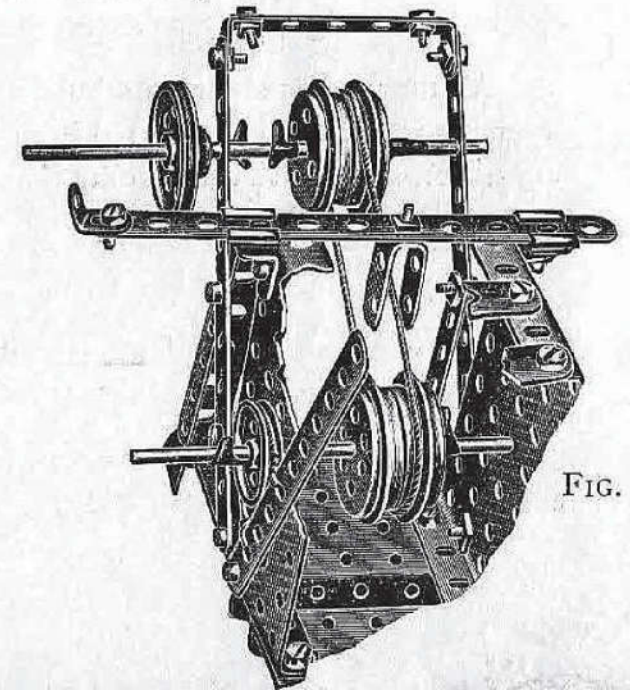
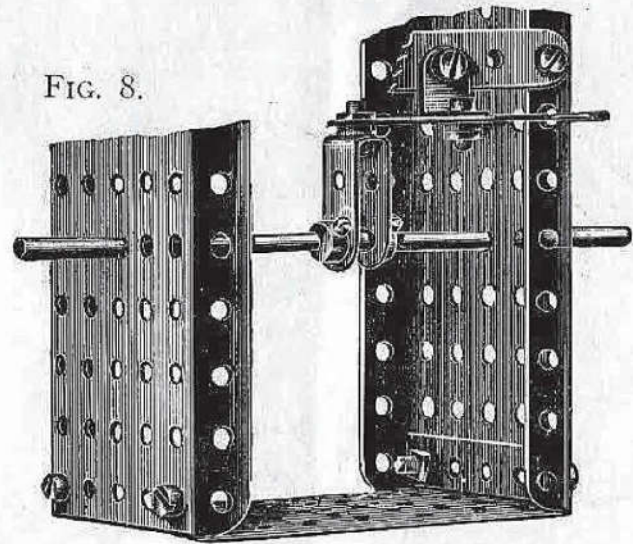
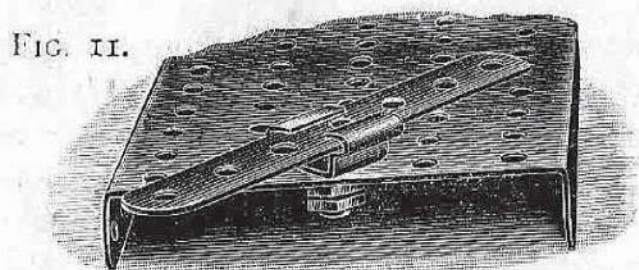

FIG. 7.

Simple Extended Bearing suitable for longitudinal or rotary movement of spindles



Swivel Bearing providing for combined sliding and oscillating movement of a strip



Crank formed with flanged wheel and strip, lock-nutted

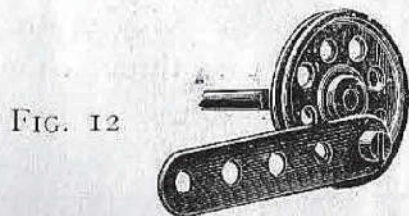

Gear Connection for coupling two shafts at right angles

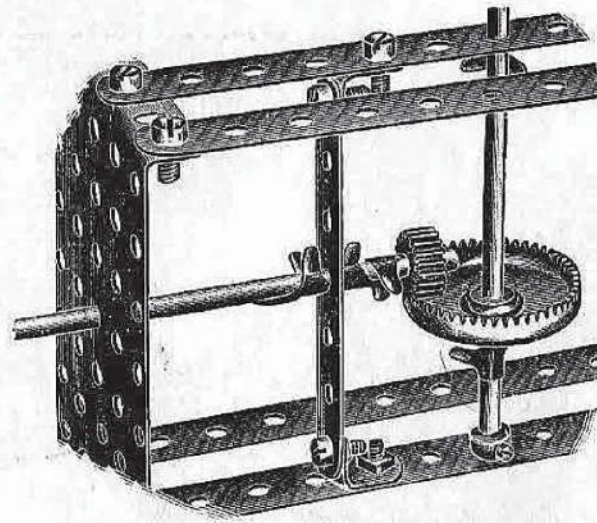

FIG. 9.

Jockey Pulley Arrangement for increasing grip in a driving band

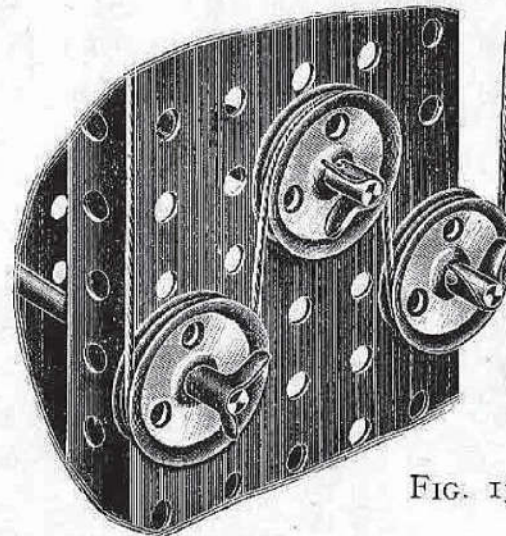

FIG. 13.

... 3 ...

Purchase Pulley

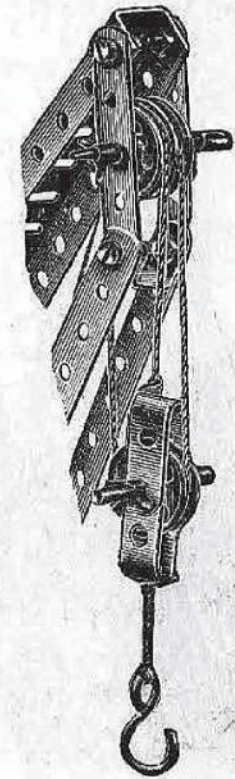

FIG. 10.

Reinforced Bearing for spindles

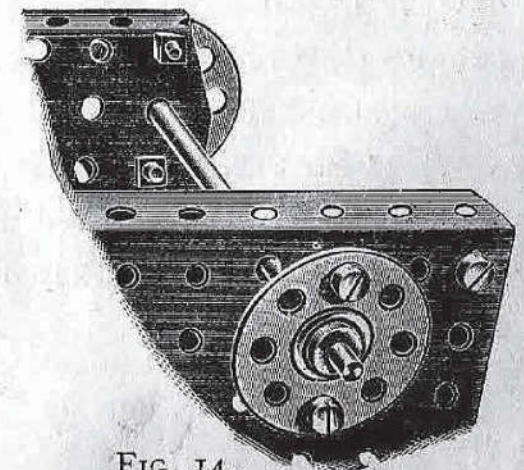
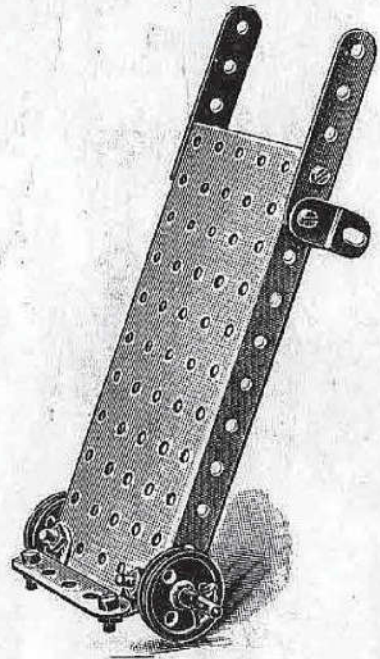

FIG. 14.

Model No. 1. Luggage Truck



(MADE WITH MECCANO)
OUTFIT NO. 1.)

PARTS REQUIRED.

- 3 2½" Perforated Strips.
- 6 Angle Brackets.
- 1 4½" Rod.
- 2 1" Pulley Wheels.
- 10 Nuts and Bolts.
- 2 Keys.
- 1 Large Rectangular Plate.

1A.



The body of the Truck is made of a rectangular plate, two 2½" strips being bolted through angle brackets 1A. to the upper end to form shafts. The lip of the Truck consists of a 2½" strip bolted to the plate by angle brackets. On an axle passed through the end holes of the flanges are keyed a pair of 1" pulley wheels.

Model No. 2. Seesaw

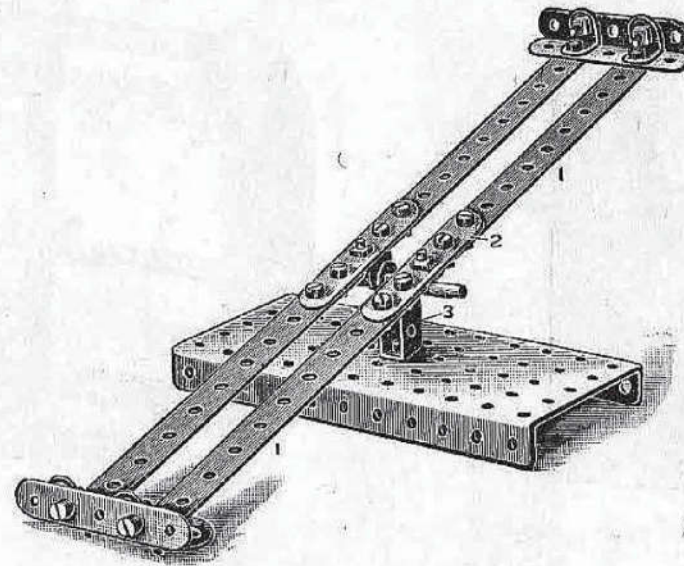

(MADE WITH MECCANO)
OUTFIT NO. 1.)

PARTS REQUIRED.

- 4 5½" Perforated Strips.
- 6 2½" " " "
- 6 Angle Brackets.
- 1 2" Rod.
- 10 Nuts and Bolts.
- 2 Keys.
- 1 Single Bent Strip.
- 1 Large Rectangular Plate.

Make the Seesaw first. Commence with one side by connecting two 5½" strips (1) together with a 2½" strip (2), as shown in the illustration. An angle bracket is then bolted to the central hole of the short strip on its under side to form a bearing for the spindle. It is to be noted that the angle bracket is bolted with the head of the bolt downward, to clear the spindle. The other side of the Seesaw is formed in a similar manner.

Now connect these two together at each end by two 2½" strips and two angle brackets. Next bolt the single bent strip (3) to the centre of the rectangular plate; bring the two centre brackets on the underside of the Seesaw in line with the top holes in the bent strip, and pass through the short rod, fixing a key on each side to keep it in position.

Model No. 3. Revolver Truck

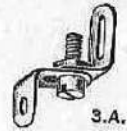
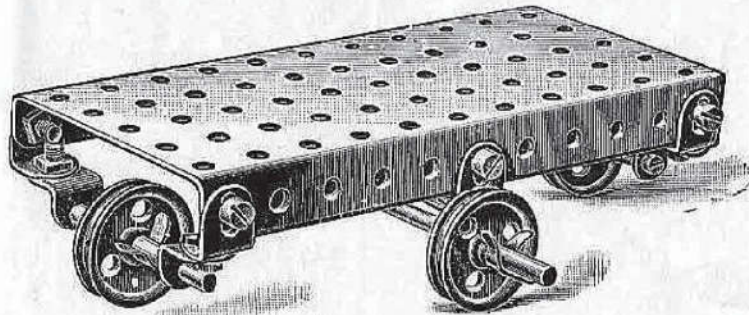

FIG. 3A.



FIG. 3B.

(MADE WITH MECCANO
OUTFIT NO. 1.)

PARTS REQUIRED.

- 12 Angle Brackets.
- 1 $4\frac{1}{2}$ " Rod.
- 2 2" "
- 4 1" Pulley Wheels.
- 12 Nuts and Bolts.
- 6 Keys.
- 1 Large Rectangular Plate.

In a Revolver Truck the two end wheels are always raised just a little higher than the two centre wheels, so that the Truck may be quickly revolved upon the centre wheels.

The bearings for the end axles are formed by connecting two angle brackets together, as shown in Fig. 3A, and bolting them in each end hole at the sides of the plate.

The two centre bearings are formed as shown in Fig. 3B, and bolted in the centre holes of each flanged side of the plate.

It will be noted that the elongated holes of the bearings are bolted on the outside of the plate flanges. This enables the end wheels to be raised and the centre wheels to be lowered for the purpose already mentioned.

The axles and wheels are then placed in position and secured by the keys.

Model No. 4. Truck

(MADE WITH MECCANO OUTFIT NO. 1.)

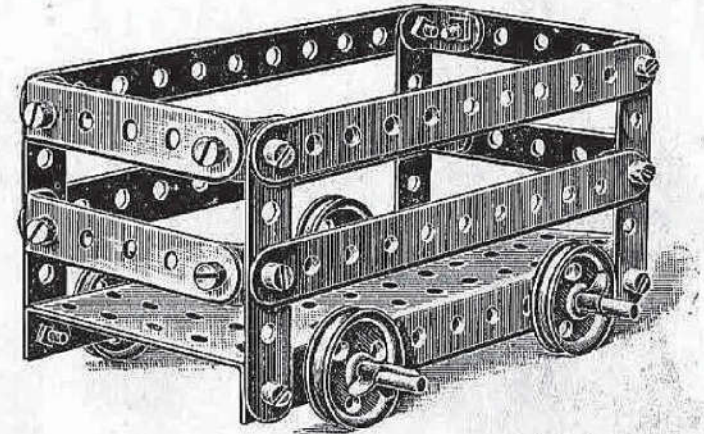

PARTS REQUIRED.

- | | |
|---------------------------------------|----------------------------|
| 4 $5\frac{1}{2}$ " Perforated Strips. | 4 1" Pulley Wheels. |
| 8 $2\frac{1}{2}$ " " " | 20 Nuts and Bolts. |
| 8 Angle Brackets. " | 4 Keys. |
| 2 $4\frac{1}{2}$ " Rods. | 1 Large Rectangular Plate. |

Fix the four upright $2\frac{1}{2}$ " strips at each corner of the plate first; then attach the end and side strips to the uprights by means of angle brackets. Insert two axles through the third holes from each end of the plate; push on the wheels, and secure them in position by the keys, with the tongue turned outward.

This is a very neat little model, and very simple to make.

Model No. 5. Luggage Truck

(MADE WITH MECCANO OUTFIT No. 1.)

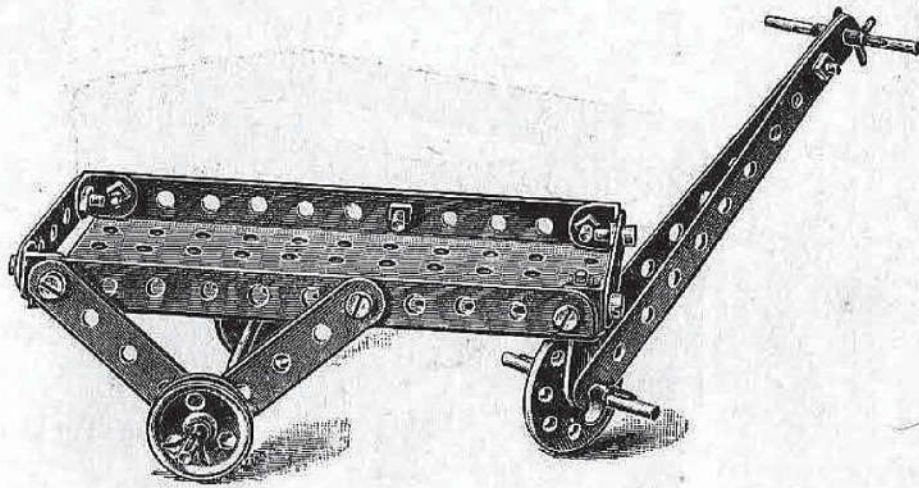

PARTS REQUIRED.

- | | |
|---------------------------|---------------------|
| 2 5½" Perforated Strips | 2 1" Pulley Wheels |
| 6 2½" " " | 1 Bush Wheel |
| 4 Angle Brackets | 13 Nuts and Bolts |
| 1 4½" Rod | 6 Keys |
| 2 2" " " | 1 Single Bent Strip |
| 1 Large Rectangular Plate | |

In connection with the construction of this Model, it will only be necessary to state that the front swivelling support is formed by connecting loosely a single bent strip in the centre end hole of the plate, by a bolt with two nuts on the upper side, locked, to prevent it from working out, and that the axle carrying the hind wheels is passed through the end holes of the 2½" diagonal side strips which form the bearings.

Model No. 6. Bath Chair

(MADE WITH MECCANO OUTFIT No. 1.)

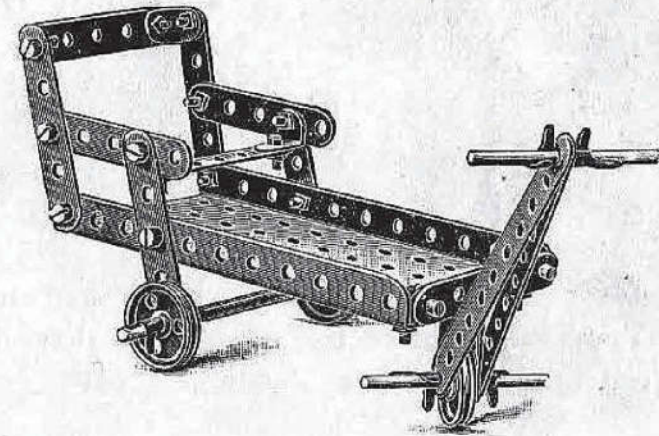

PARTS REQUIRED.

- | | |
|-------------------------|---------------------------|
| 2 5½" Perforated Strips | 3 1" Pulley Wheels |
| 9 2½" " " | 20 Nuts and Bolts |
| 6 Angle Brackets | 6 Keys |
| 1 4½" Rod | 1 Single Bent Strip |
| 2 2" " " | 1 Large Rectangular Plate |

After Model No. 5 has been accomplished, no difficulty will be experienced in the construction of this model.

Model No. 7. Go Chair

Model No. 8. Luggage Truck

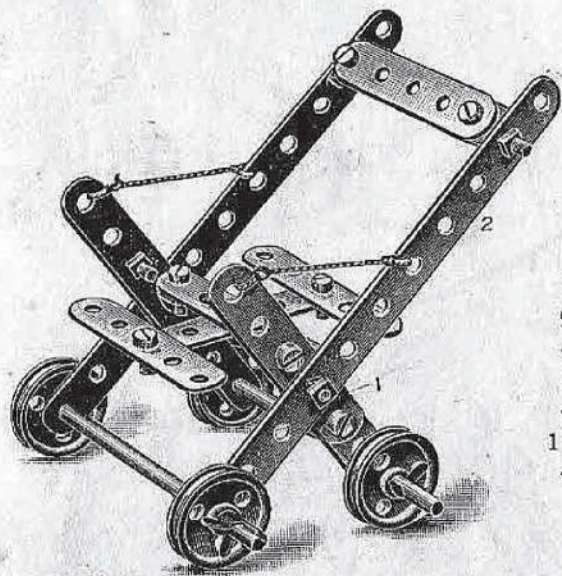

(MADE WITH
MECCANO OUTFIT
NO. 1.)

- PARTS REQUIRED.
- 2 5½" Perforated Strips.
 - 9 2½" " " "
 - 4 Angle Brackets. "
 - 2 4½" Rods.
 - 4 1" Pulley Wheels.
 - 17 Nuts and Bolts.
 - 4 Keys.

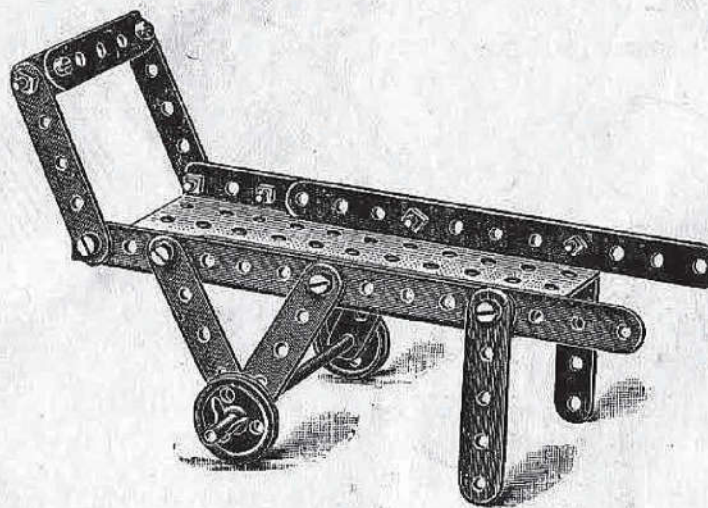

(MADE WITH MECCANO
OUTFIT NO. 1.)

- PARTS REQUIRED.
- 2 5½" Perforated Strips.
 - 9 2½" " " "
 - 2 Angle Brackets.
 - 1 4½" Rod
 - 2 1" Pulley Wheels.
 - 12 Nuts and Bolts.
 - 2 Keys.
 - 1 Large Rectangular Plate.

Proceed to construct one side of this Model first by taking two 2½" strips (1) and bolting them together overlapped in three holes; after which attach diagonally a 5½" strip (2) in the fourth hole from the bottom, and with the same bolt, an angle bracket on the inside, with the elongated hole outward to take the seat. The other side is constructed in a similar manner.

The seat is then formed by bolting together at right angles two 2½" strips and a further 2½" strip at each end of one of the strips. The sides are then brought together, and connected by bolting the seat to the side brackets.

The back is formed by connecting a 2½" strip by means of angle brackets in the second hole from the top of the two 5½" side strips. Two axle rods are then passed through the bottom holes, and the wheels placed in position, and secured by the special keys.

This is very similar to Model No. 5, and requires no explanation.

Model No. 9. Luggage Barrow

(MADE WITH MECCANO OUTFIT NO. 1.)

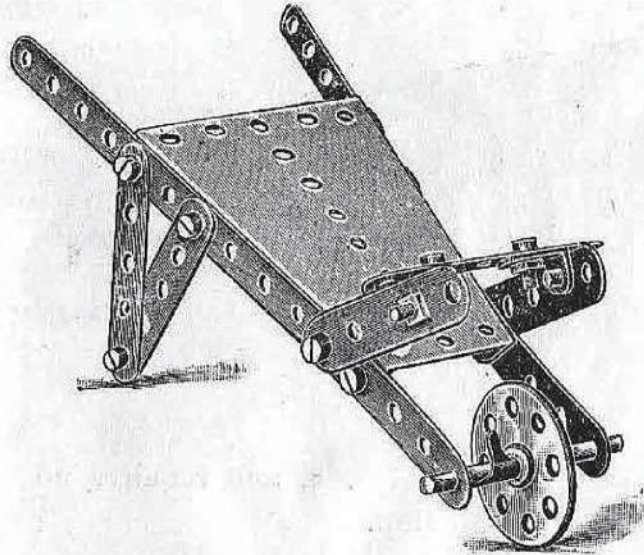

PARTS REQUIRED.

- 2 $5\frac{1}{2}$ " Perforated Strips.
- 9 $2\frac{1}{2}$ " " "
- 2 Angle Brackets.
- 1 2" Rod.
- 1 Bush Wheel.
- 14 Nuts and Bolts.
- 2 Keys.
- 1 Sector Plate.

The only point to be noted in this Model, is that the floor plate of the Barrow is made from a sector plate, to the sides of which the arm strips are secured, made up from two $5\frac{1}{2}$ " strips bolted on the inside of the sector plate ; the $2\frac{1}{2}$ " strips carrying the wheel axle being bolted on the outside of the sector plate.

Model No. 10. Truck

(MADE WITH MECCANO OUTFIT NO. 1.)

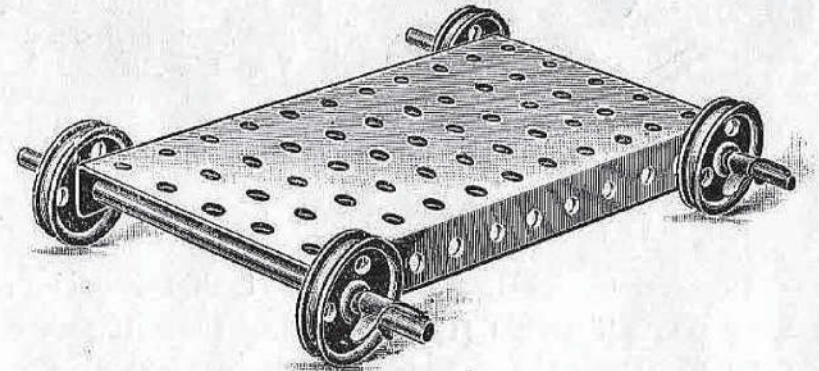

PARTS REQUIRED.

- | | |
|--------------------------|----------------------------|
| 2 $4\frac{1}{2}$ " Rods. | 4 Keys. |
| 4 1" Pulley Wheels. | 1 Large Rectangular Plate. |

Model No. 11. Endless Rope Railway

(MADE WITH MECCANO OUTFIT NO. 1.)

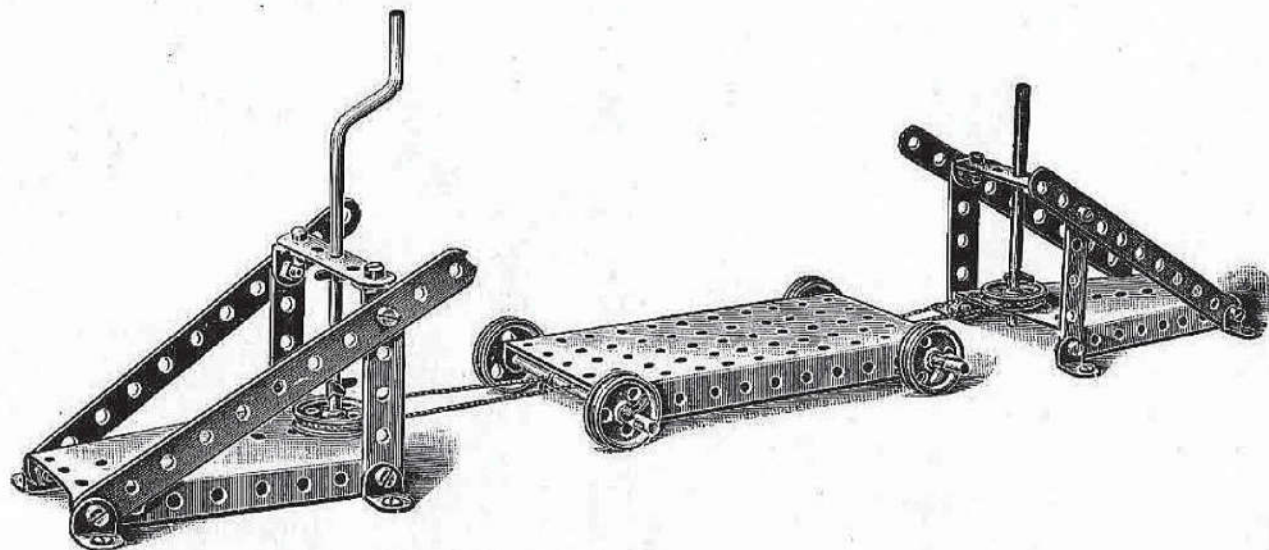

PARTS REQUIRED.

4	5½" Perforated Strips.	16	Nuts and Bolts.
6	2½" " "	8	Wood Screws.
12	Angle Brackets.	8	Keys.
3	4½" Rods.	1	Large Rectangular Plate.
1	Crank Handle.	2	Sector Plates.
6	1" Pulley Wheels.		

This is an attractive little combination working model, which will well repay a little trouble in making.

The truck is connected to an endless cord which passes from a pulley attached to a bracket at one end to another pulley carried on the crank handle shown. In the illustration the two pulleys are shown close together to save space, but they may, of course, be placed at any distance desired.

A piece of string is formed into an endless rope running over the two pulleys, and the truck is attached to one side of the string, so that by rotating the handle in one direction or another the truck is moved as desired.

Model No. 12

Windmill

(MADE WITH MECCANO OUTFIT NO. 1.)

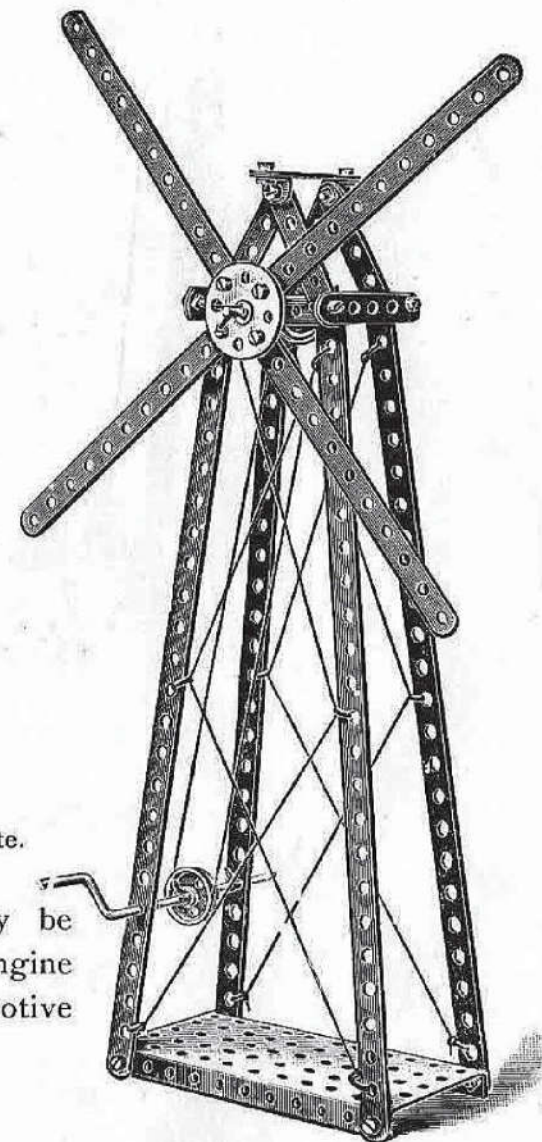

PARTS REQUIRED.

4	12½" Perforated Strips
4	5½" " "
9	2½" " "
6	Angle Brackets.
1	4½" Rod.
1	Crank Handle.
2	1" Pulley Wheels.
1	Bush Wheel.
20	Nuts and Bolts.
9	Keys.
1	Large Rectangular Plate.

This model may be driven by a small engine or other suitable motive power.

Model No. 13. Swing

(MADE WITH MECCANO OUTFIT NO. 1.)

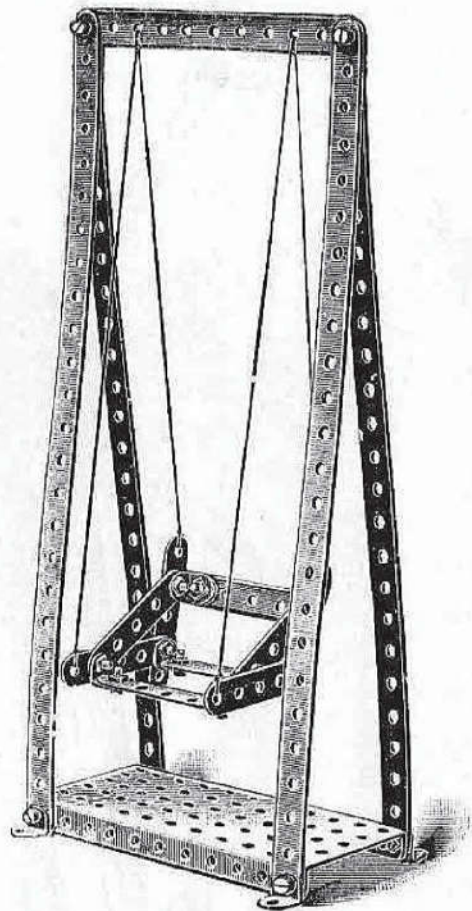

PARTS REQUIRED.

- | | | | | | |
|---|--------------------|--------------------|----|-----------------|--------------------------|
| 4 | 12 $\frac{1}{2}$ " | Perforated Strips, | 10 | Angle Brackets. | |
| 1 | 5 $\frac{1}{2}$ " | " " | 18 | Nuts and Bolts. | |
| 9 | 2 $\frac{1}{2}$ " | " " | 4 | Wood Screws. | |
| | | | | 1 | Large Rectangular Plate. |

Model No. 14. Railway Signal

(MADE WITH MECCANO OUTFIT NO. 1.)

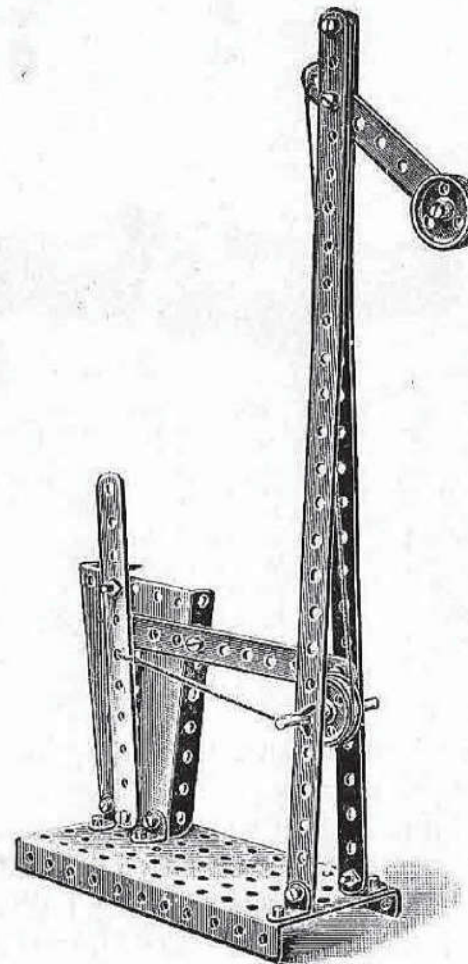

PARTS REQUIRED.

- | | | |
|----|--------------------------|--------------------|
| 2 | 12 $\frac{1}{2}$ " | Perforated Strips, |
| 2 | 5 $\frac{1}{2}$ " | " " |
| 1 | 3 $\frac{1}{2}$ " | " " |
| 6 | Angle Brackets. | |
| 1 | 2" Rod. | |
| 2 | 1" Pulley Wheels. | |
| 18 | Nuts and Bolts. | |
| 2 | Keys. | |
| 1 | Large Rectangular Plate. | |
| 1 | Sector Plate. | |

In fixing the lever to the sector plate at the bottom, lock the nuts so as to prevent the screw from working out.

Model No. 15. Model of Telpher Span.

(MADE WITH MECCANO OUTFIT NO. 1.)

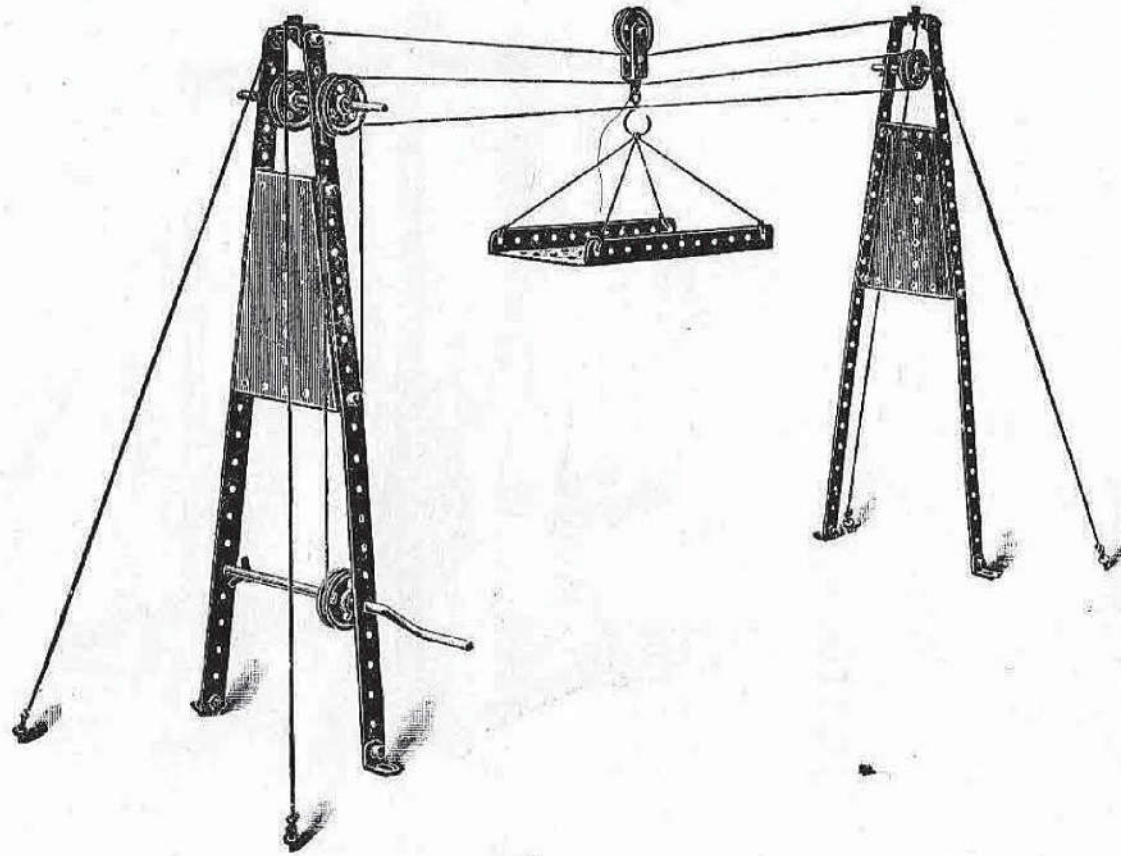

PARTS REQUIRED.

- 4 12½" Perforated Strips.
- 8 Angle Brackets.
- 1 4½" Rod.
- 1 2" "
- 1 Crank Handle.
- 5 1" Pulley Wheels.
- 19 Nuts and Bolts.
- 4 Wood Screws.
- 1 Hook.
- 9 Keys.
- 1 Single Bent Strip.
- 1 Large Rectangular Plate.
- 2 Sector Plates.

There are two separate cord drives in this model. The crank pulley cord passes round the nearer one of the two upper pulleys in the left standard, and the traversing drive cord passes round the further one of the two upper pulleys, and the single pulley in the opposite standard. The top cord is merely a stationary tension rail upon which runs the pulley of the carrier. The crank pulley cord should be wound twice round the pulleys to ensure a better grip. We recommend that the standards be screwed down before connecting up the cords.

Model No. 16. Travelling Jib Crane

(MADE WITH MECCANO OUTFIT NO. 1.)

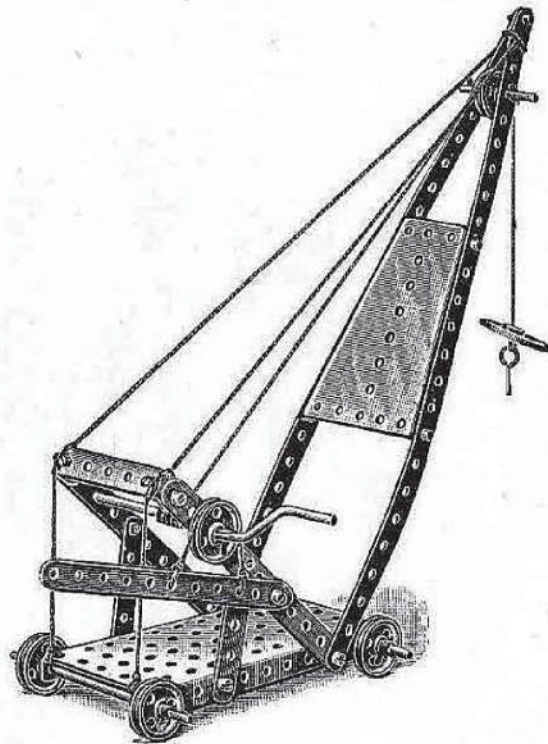

PARTS REQUIRED.

2 12½" Perforated Strips.	6 1" Pulley Wheels.
3 5½" " "	1 Bush Wheel.
3 2½" " "	17 Nuts and Bolts.
2 Angle Brackets.	1 Hook.
2 4½" Rods.	8 Keys.
1 2" Rod.	1 Large Rectangular Plate.
1 Crank Handle.	1 Sector Plate.

Model No. 17. Scales

(MADE WITH MECCANO OUTFIT NO. 1.)

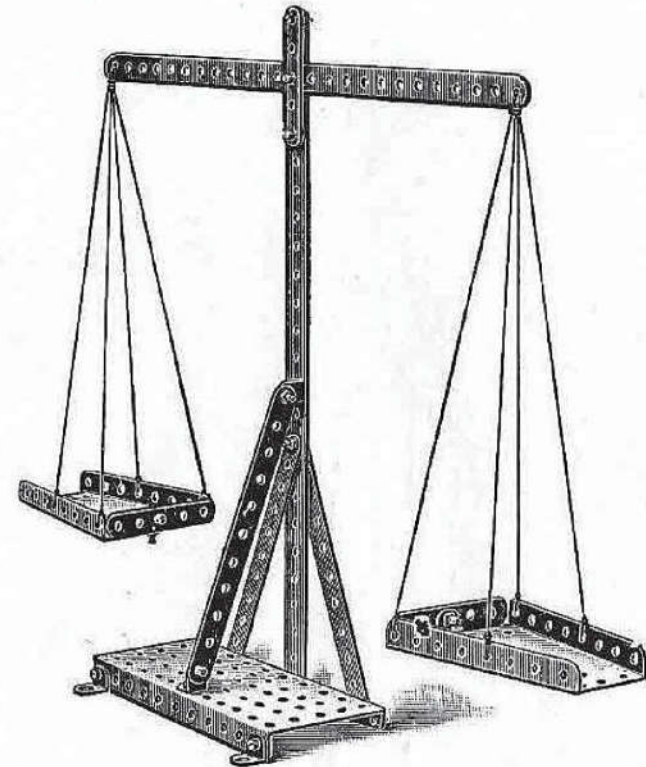

PARTS REQUIRED.

2 12½" Perforated Strips.	19 Nuts and Bolts.
3 5½" " "	4 Wood Screws.
3 2½" " "	1 Large Rectangular Plate.
8 Angle Brackets.	2 Sector Plates.

Model No. 18. Travelling Ladder

(MADE WITH MECCANO OUTFIT NO. 1.)

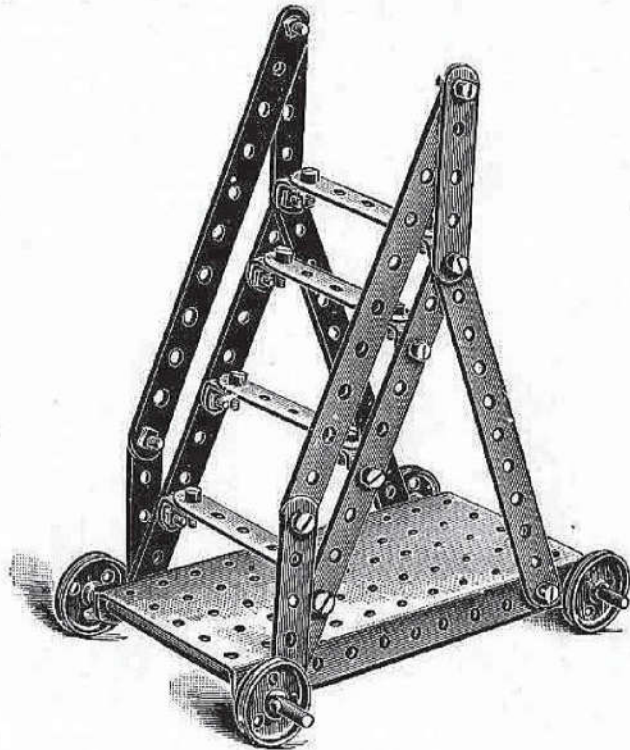

PARTS REQUIRED.

- | | |
|---------------------------------------|----------------------------|
| 6 $5\frac{1}{2}$ " Perforated Strips. | 4 1" Pulley Wheels. |
| 8 $2\frac{1}{2}$ " " " | 24 Nuts and Bolts. |
| 8 Angle Brackets. | 4 Keys. |
| 2 $4\frac{1}{2}$ " Rods. | 1 Large Rectangular Plate. |

Model No. 19. High Level Bridge

(MADE WITH MECCANO OUTFIT NO. 1.)

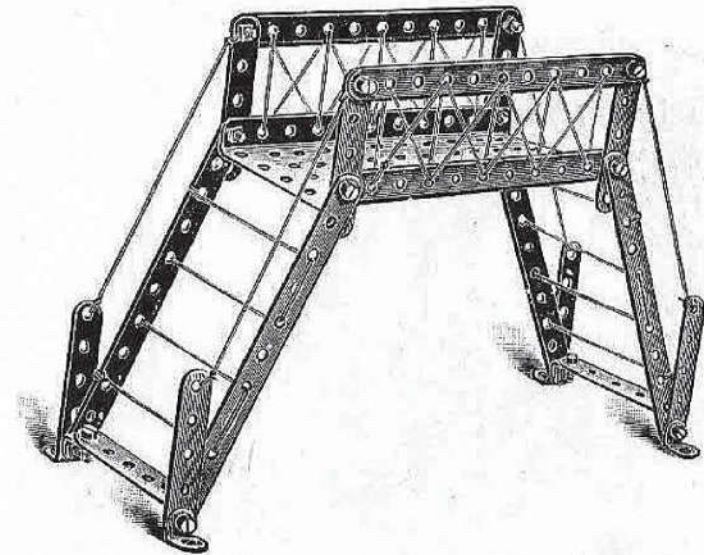

PARTS REQUIRED.

- | | |
|---------------------------------------|----------------------------|
| 6 $5\frac{1}{2}$ " Perforated Strips. | 16 Nuts and Bolts. |
| 10 $2\frac{1}{2}$ " " " | 1 Large Rectangular Plate. |
| 8 Angle Brackets. | |

Model No. 20. Tip Wagon

(MADE WITH MECCANO OUTFIT NO. 1.)

PARTS REQUIRED,

- 1 5½" Perforated Strip,
- 8 2½" " "
- 9 Angle Brackets,
- 3 4½" Rods,
- 4 1" Pulley Wheels,
- 21 Nuts and Bolts,
- 6 Keys,
- 1 Large Rectangular Plate.

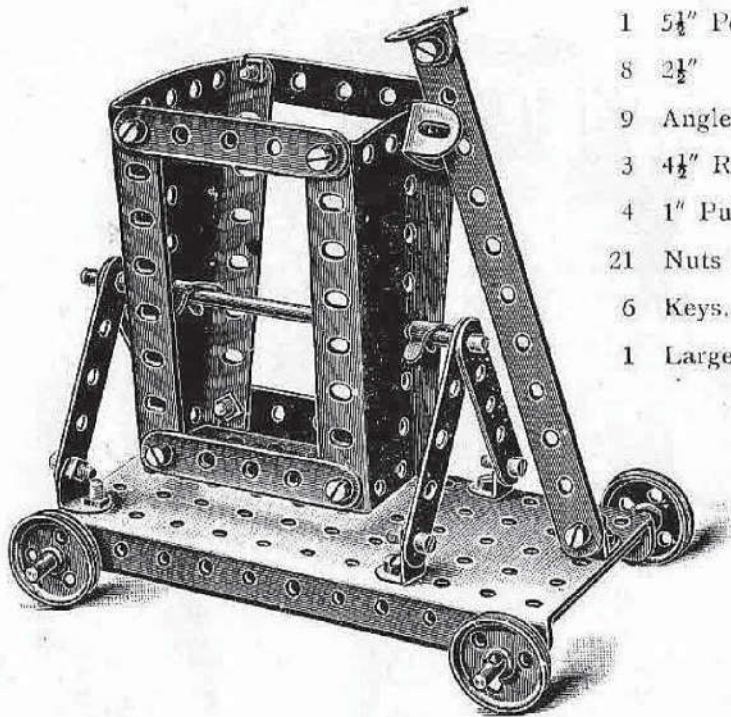

FIG. 20A.

This interesting Model represents a Tip Wagon, such as is used on constructional or embankment work for carrying loads of earth, &c., along a track in such manner that the load may be readily tipped to one side or the other at any required position.

The sides of the Tip consist of sector plates connected at the top and bottom by 2½" strips. The pivoted lever strip at the end engages between a pair of inclined angle brackets, see Fig. 20A, to lock the Tip. By releasing the lever, the tip may be swung to either side. To enable the Model to hold material, a bent piece of cardboard may be inserted, resting on the axle.

This completes the Models which may be made with "Meccano" No. 1. By purchasing a No. 1A Accessory Outfit at a cost of 5/6, Models Nos. 25 to 33 shown on the following pages may be made, or the necessary additional parts may be purchased separately at the prices shown on page 78. We recommend the Accessory Outfit, as the parts are contained in a neat cardboard box, in which they may be kept when not in use.

Model No. 25. Ladder on Wheels

(MADE WITH MECCANO OUTFIT NO. 2, OR NO. 1 AND NO. 1A.)

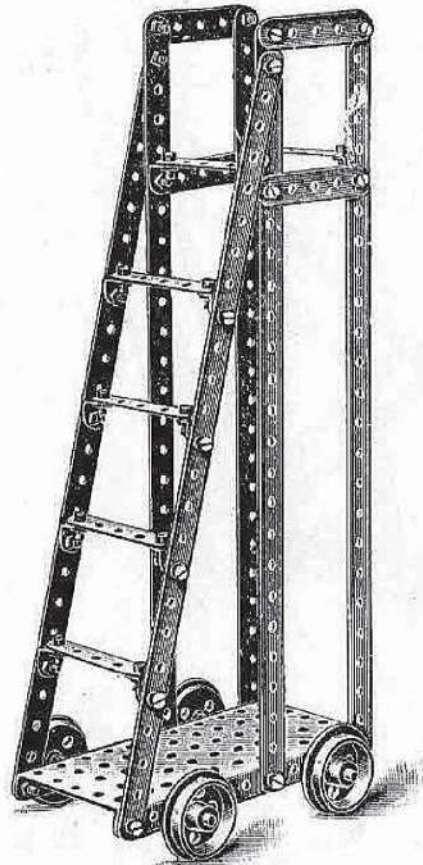

PARTS REQUIRED.

- 6 12 $\frac{1}{2}$ " Perforated Strips.
- 10 2 $\frac{1}{2}$ " " "
- 12 Angle Brackets.
- 2 5" Rods.
- 4 Flanged Wheels.
- 36 Nuts and Bolts.
- 4 Keys.
- 1 Large Rectangular Plate.

Parts required in addition to Outfit No. 1.

- 2 12 $\frac{1}{2}$ " Perforated Strips.
- 2 5" Rods.
- 4 Flanged Wheels.
- 11 Nuts and Bolts.

Model No. 26. Tipping Motor Wagon

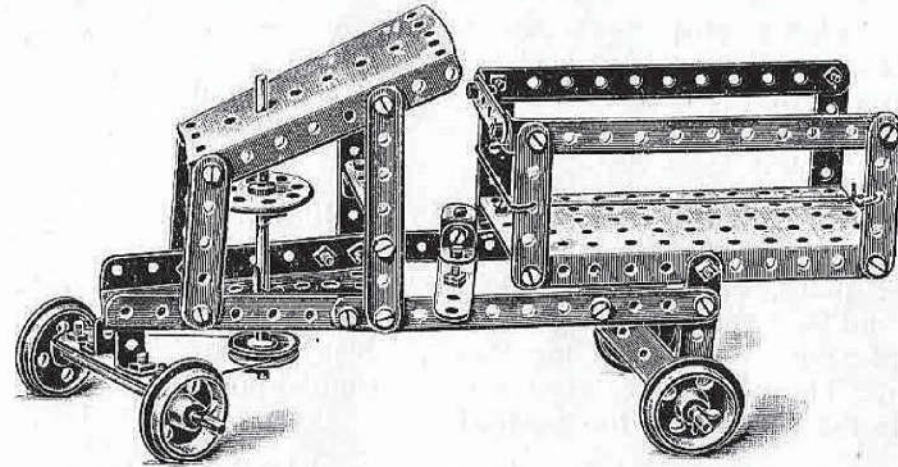

PARTS REQUIRED.

- 4 5 $\frac{1}{2}$ " Perforated Strips.
- 2 3 $\frac{1}{2}$ " " "
- 14 2 $\frac{1}{2}$ " " "
- 11 Angle Brackets.
- 3 5" Rods.
- 4 Flanged Wheels.
- 1 1" Pulley.
- 1 Bush Wheel.
- 45 Nuts and Bolts.
- 11 Keys.
- 1 Double Bent Strip.
- 1 Large Rectangular Plate.
- 2 Sector Plates.

Parts required in addition to Outfit No. 1.

- 1 3 $\frac{1}{2}$ " Perforated Strip.
- 4 2 $\frac{1}{2}$ " " "
- 3 5" Rods.
- 4 Flanged Wheels.
- 20 Nuts and Bolts.
- 2 Keys.
- 1 Double Bent Strip.

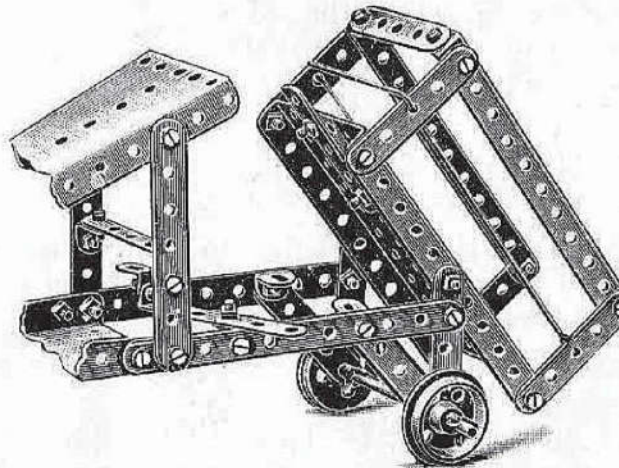

Model No. 27. Travelling Jib Crane

(MADE WITH MECCANO OUTFIT NO. 2 OR NO. 1 AND NO. 1A.)

This is so important a model that we have thought it best to give a detailed description of it, making use of engineering terms. It can be erected from a study of the illustration alone, but we strongly recommend our enthusiastic young friend to carefully read our instructions, and to make himself familiar with the correct technical description and terms. This model will well repay the time expended on a close and careful study.

The lower horizontal sides of the crane should first be put together. Each side consists of an angle girder joined to a rectangular plate, two holes overlapping. The winch frame at the end is formed of two sector plates bolted to the rectangular plate and connected together at their tops by two $2\frac{1}{2}$ " strips. The wheel axles are inserted through appropriate holes in the ends of the horizontal frame.

The bearings for the winch handle are formed by two holes in the sector plates; the winch handle has a pinion, and a ratchet is pivoted to the right-hand sector plate. A brake wheel and lever may be added if desired.

Each side of the jib is constructed of two $12\frac{1}{2}$ " strips, jointed together by overlapping; at the top where the sides meet a pulley is fixed on a short length of spindle, and at the bottom the two sides are respectively screwed to the two ends of the horizontal base.

The jib is braced by two diagonally arranged $12\frac{1}{2}$ " strips attached to the sides of the jib by angle pieces.

From each side of the jib two $12\frac{1}{2}$ " strips are carried to a truss member, formed of two $12\frac{1}{2}$ " strips united together, secured at one end to the screws at the base of the jib, and united at their other ends by a $2\frac{1}{2}$ " strip. The truss frame is connected to the horizontal base by two $5\frac{1}{2}$ " strips as shown.

The rope by which the weight is raised has one end fixed to the end of the jib; it is then passed round the pulley block, then over the jib pulley, and finally connected to the winch handle.

The crane is further strengthened by strings to represent tie rods, which connect the ends of the jib, the truss frame, and the winch frame as shown. If possible, the joint between the truss frame, the side frame, and the jib, should be made with a single pair of screws which should also carry the angle pieces for the cross bracing of the crane.

PARTS REQUIRED.	
10	$12\frac{1}{2}$ " Perforated Strips
2	$5\frac{1}{2}$ " " "
4	$2\frac{1}{2}$ " " "
2	Angle Girders
6	Angle Brackets
2	5" Rods
2	2" " "
1	Crank Handle
4	Flanged Wheels
2	1" Pulley Wheels
1	Bush Wheel
1	$\frac{1}{2}$ " Pinion
1	Pawl
35	Nuts and Bolts
1	Hook
10	Keys
1	Single Bent Strip
1	Large Rectangular Plate
2	Sector Plates

*Parts required in addition to
Outfit No. 1*

6	$12\frac{1}{2}$ " Perforated Strips
2	Angle Girders
2	5" Rods
4	Flanged Wheels
1	$\frac{1}{2}$ " Pinion
1	Pawl
10	Nuts and Bolts
1	Key

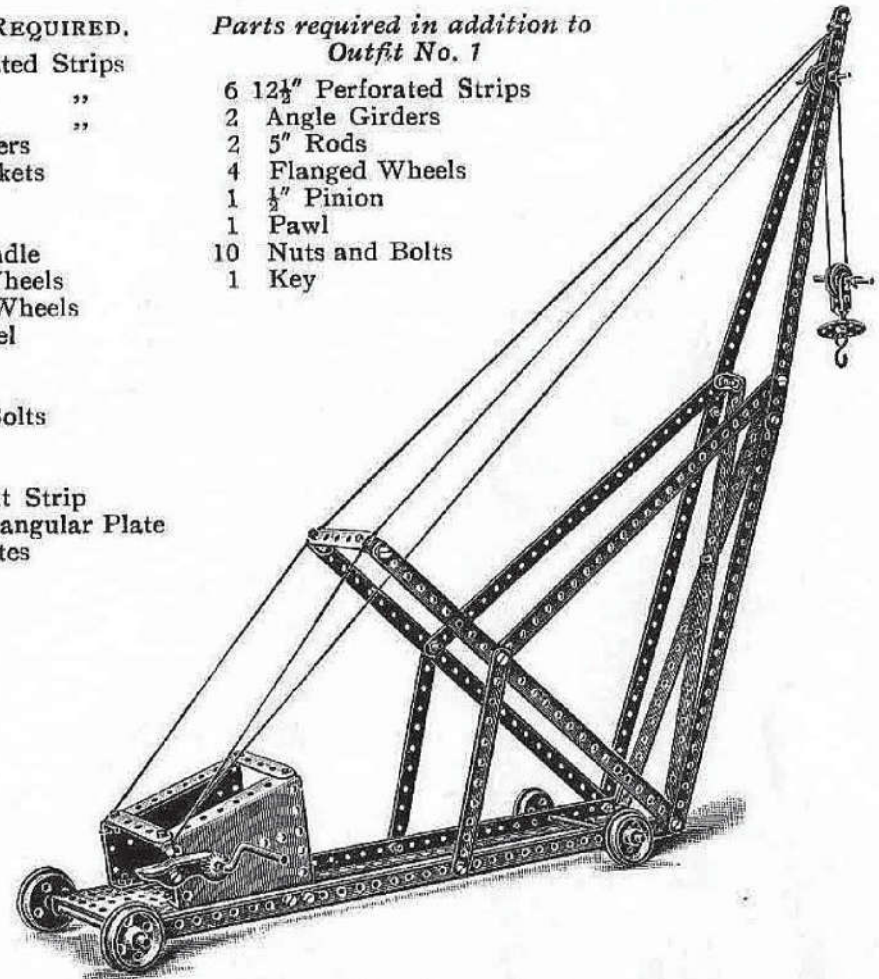

Model No. 28. Windmill

(MADE WITH MECCANO OUTFIT NO. 2 OR NO. 1 AND NO. 1A.)

PARTS REQUIRED.

10	12½" Perforated Strips.	1	Crank Handle.
13	5½" " "	2	1" Pulley Wheels.
2	3½" " "	1	Bush Wheel.
2	2½" " "	45	Nuts and Bolts.
4	Angle Girders.	10	Keys.
8	Angle Brackets.	2	Sector Plates.
1	5" Rod.		

Parts required in addition to Outfit No. 1.

6	12½" Perforated Strips.
7	5½" " "
4	Angle Girders.
1	5" Rod.
20	Nuts and Bolts.

This model requires no special instructions. We would, however, say that with the assistance of the parts contained in the succeeding outfits a more elaborate mechanism may be arranged to enable it to be driven by an engine or other suitable motive power.

This model also lends itself to further decorations by means of coloured ribbons used in the place of the cord lacings; or as streamers.

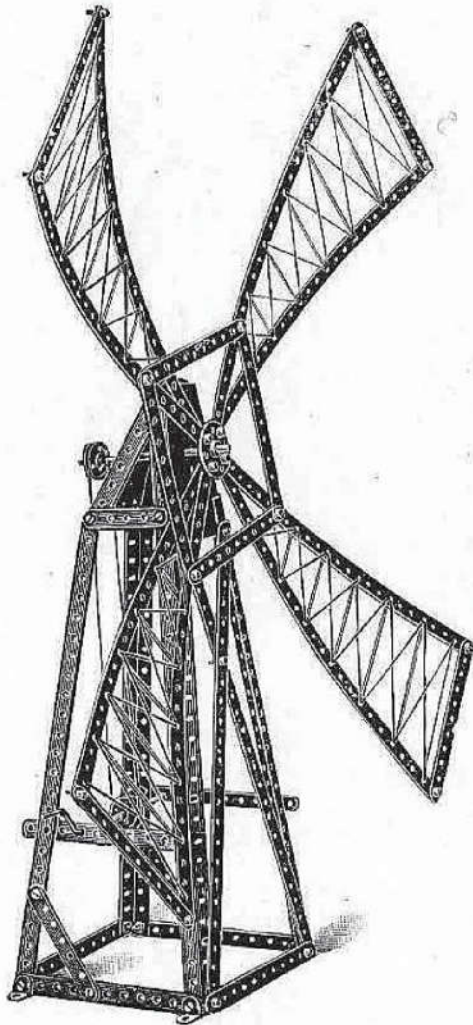

Model No. 29. Wheel

PARTS REQUIRED.

5	12½" Perforated Strips.
14	5½" " "
2	2½" " "
4	Angle Girders.
16	Angle Brackets.
2	5" Rods.
4	Flanged Wheels.
1	1" Pulley Wheel.
48	Nuts and Bolts.
6	Keys.

Parts required in addition to Outfit No. 1.

1	12½" Perforated Strip.
8	5½" " "
4	Angle Brackets.
2	5" Rods.
4	Angle Girders.
4	Flanged Wheels.
23	Nuts and Bolts.

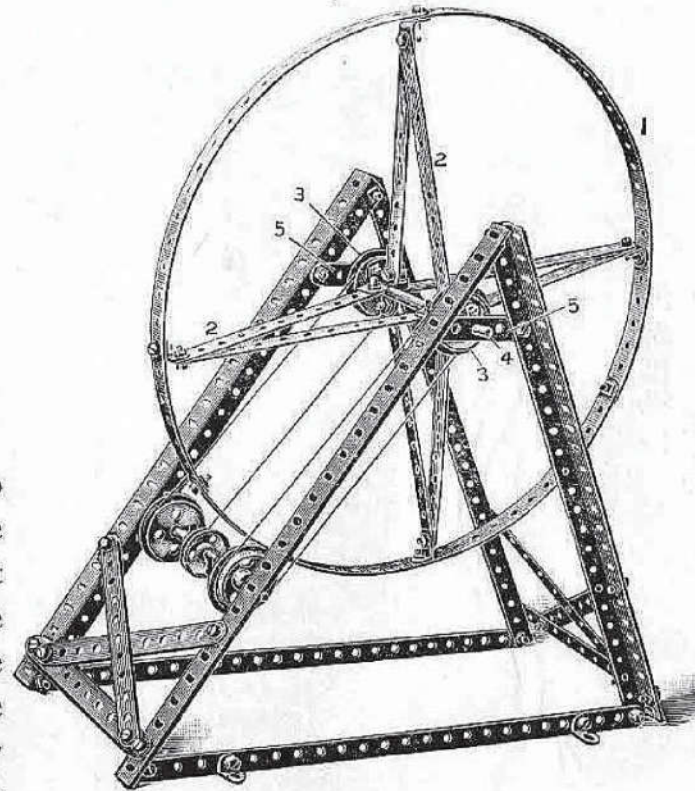

The only point calling for description in this model which is otherwise very clearly shown, is the wheel. This is made from three 12½" strips to form the outer hoop (1), the spokes being made from pairs of 5½" strips (2), bolted by angle brackets to flanged wheels (3) mounted on a spindle (4). These wheels are keyed in their splayed position on the spindle by keys inserted between the strips (5) and the flanged wheels, the tongues of the keys pointing towards the flanged wheels, so that when the latter are pressed on the tongues, they retain the wheels in position.

Model No. 30. Swing Bridge

(MADE WITH MECCANO NO. 2 OR NO. 1 AND NO. 1A.)

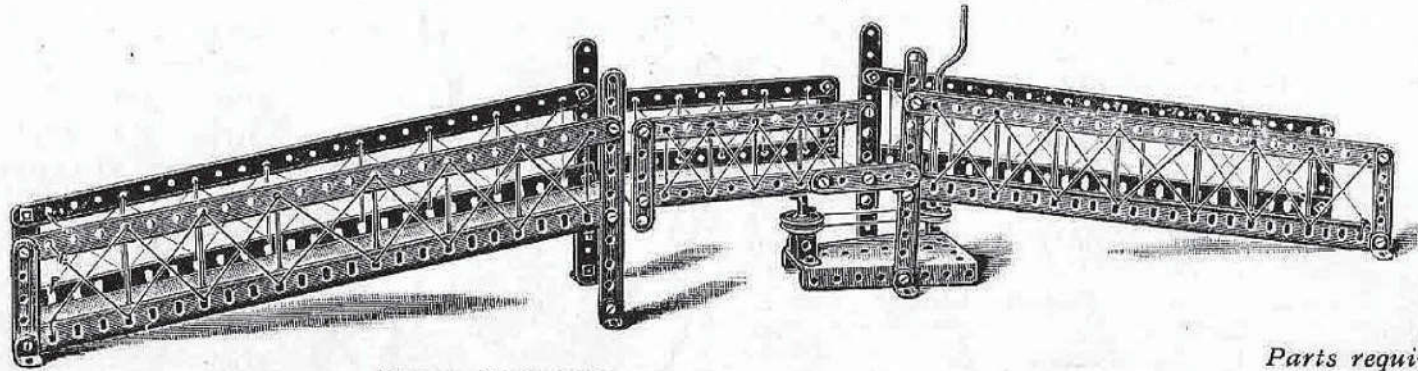

PARTS REQUIRED.		
4 12" Perforated Strips.	1 2" Rod.	4 Keys.
6 5½" " "	1 Crank Handle.	1 Double Bent Strip.
13 2½" " "	2 1" Pulley Wheels.	1 Large Rectangular Plate.
4 Angle Girders.	1 Bush Wheel.	1 Sector Plate.
8 Angle Brackets.	41 Nuts and Bolts.	

Parts required in addition to Outfit No. 1.

- 3 2½" Perforated Strips.
- 4 Angle Girders.
- 16 Nuts and Bolts.
- 1 Double Bent Strip.

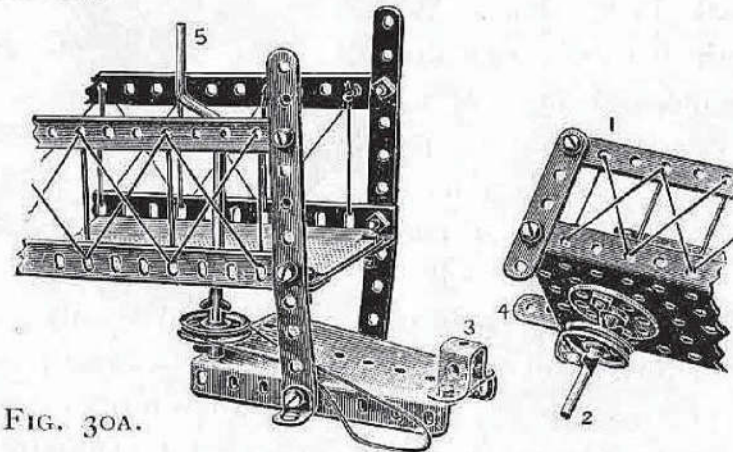

FIG. 30A.

The action for swinging the middle section of the Bridge will be made clearer by the detail Fig. 30A, the middle section (1) being fitted with a spindle (2) journalled in the double bent strip (3); the upper end of the spindle being keyed to a bush wheel.

A short strip (4) acts as a stop against the middle section of the Bridge swinging past the central position.

The operating cord passes round pulleys on the spindles (2) and crank handle (5).

Model No. 31. Bridge with Signals

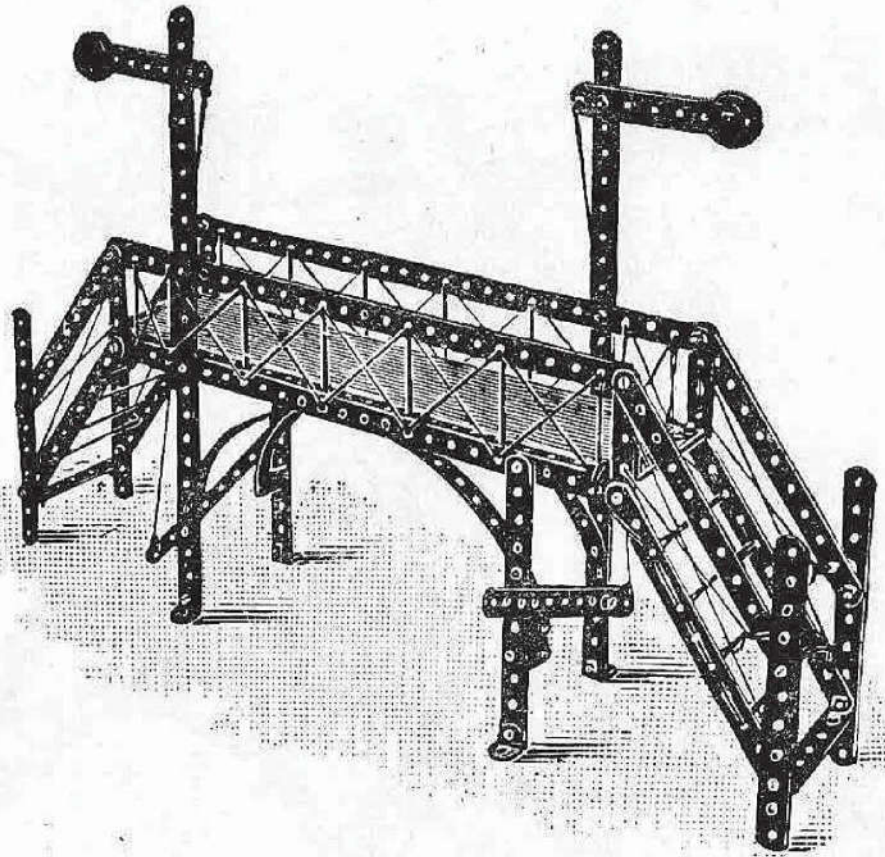

PARTS REQUIRED.

6	12 $\frac{1}{2}$ "	Perforated Strips.	2	Angle Girders.
16	5 $\frac{1}{2}$ "	" "	8	Angle Brackets.
2	3 $\frac{1}{2}$ "	" "	2	1" Pulley Wheels.
8	2 $\frac{1}{2}$ "	" "	50	Nuts and Bolts.

*Parts required in addition to
Outfit No. 1.*

2	12 $\frac{1}{2}$ "	Perforated Strips.	2	Angle Girders.
10	5 $\frac{1}{2}$ "	" "	25	Nuts and Bolts.
1	3 $\frac{1}{2}$ "	" "		

Model No. 32.

Roundabout Seesaw

(MADE WITH MECCANO OUTFIT NO. 2 OR NO. 1 AND NO. 1A.)

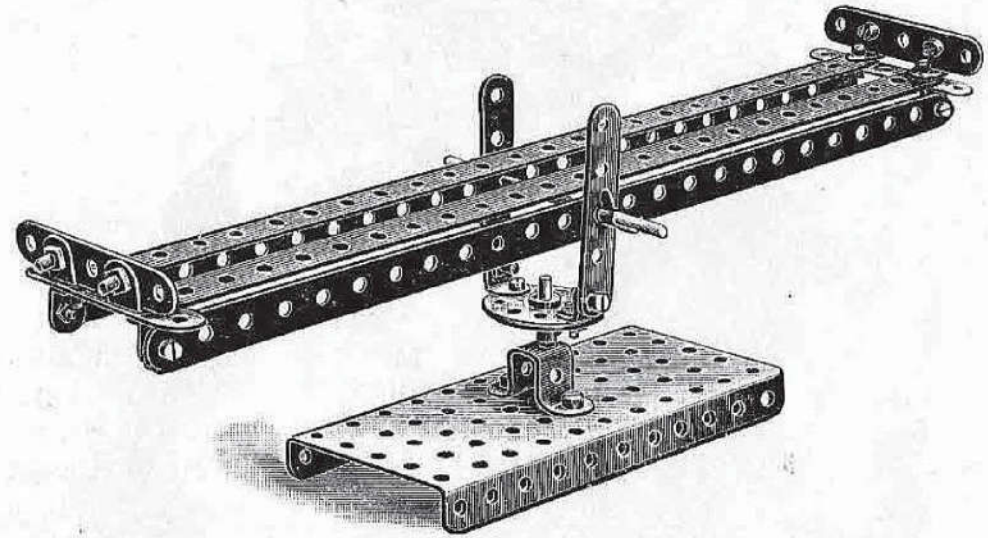

PARTS REQUIRED.

4	12 $\frac{1}{2}$ "	Perforated Strips.	18	Nuts and Bolts.
6	2 $\frac{1}{2}$ "	" "	2	Keys.
10	Angle Brackets.		1	Double Bent Strip.
1	4 $\frac{1}{2}$ " Rod.		1	Large Rectangular Plate.
1	Bush Wheel.			

Parts required in addition to Outfit No. 1.

1 Double Bent Strip.

Model No. 33. Motor Van

(MADE WITH MECCANO OUTFIT NO. 2 OR NO. 1 AND NO. 1A.)

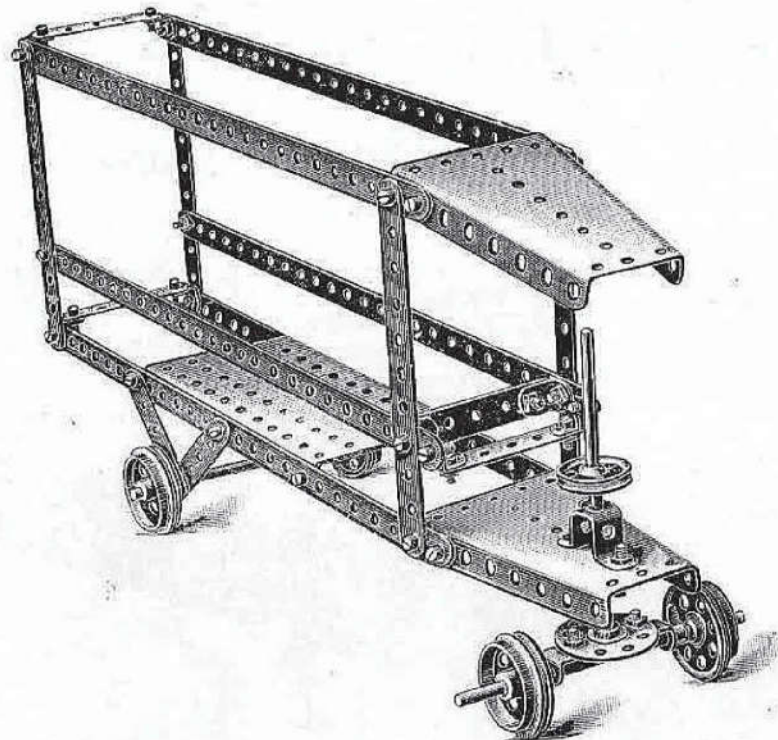

The only portion of this Model calling for a description is the steering gear. The steering shaft, to which is keyed the steering handle, passes through a double bent strip bolted to the steering platform, consisting of a sector plate. The arrangement of the gear beneath the platform is shown in Fig. 33A. A 1" pulley wheel is keyed on the spindle immediately below the platform, and a bush wheel affixed by a separate key below this on the end of the spindle. Two angle brackets bolted to the bush wheel form the bearings for the spindle of the running wheels. By fitting the 1" pulley below the platform, the running wheels are maintained at a requisite distance, to give clearance from the platform flanges.

PARTS REQUIRED.

6 12 $\frac{1}{2}$ " Perforated Strips.
 4 5 $\frac{1}{2}$ " " "
 8 2 $\frac{1}{2}$ " " "
 10 Angle Brackets.
 3 4 $\frac{1}{2}$ " Rods.
 4 Flanged Wheels.
 2 1" Pulley Wheels.

1 Bush Wheel.
 36 Nuts and Bolts.
 7 Keys.
 1 Double Bent Strip.
 1 Large Rectangular Plate.
 2 Sector Plates.

Parts required in addition to Outfit No. 1.

2 12 $\frac{1}{2}$ " Perforated Strips.
 1 4 $\frac{1}{2}$ " Rod.
 4 Flanged Wheels,
 11 Nuts and Bolts.
 1 Double Bent Strip.

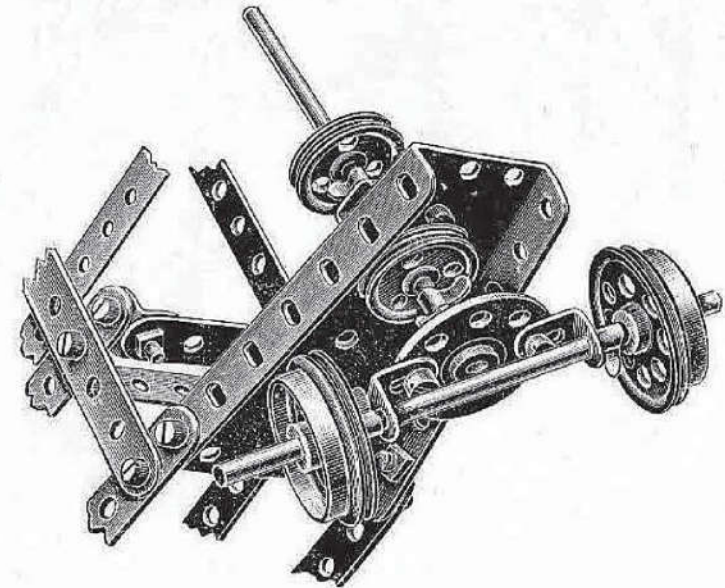
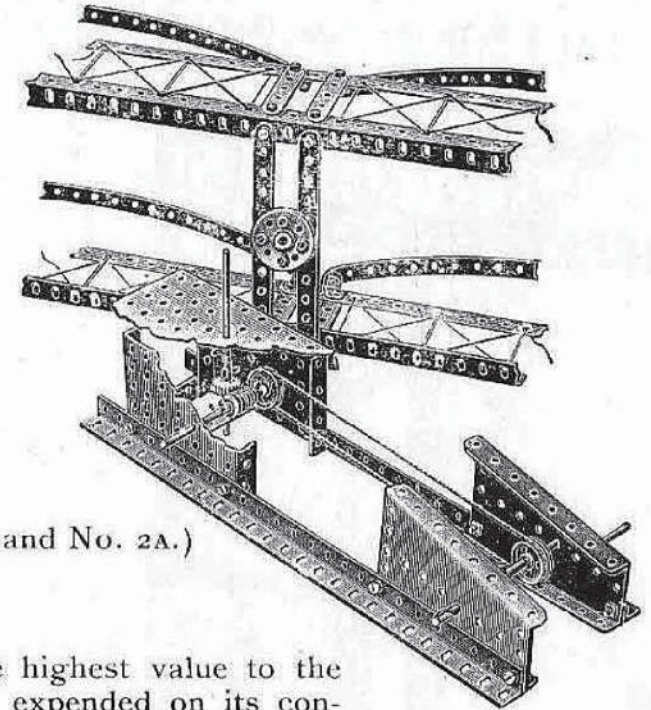
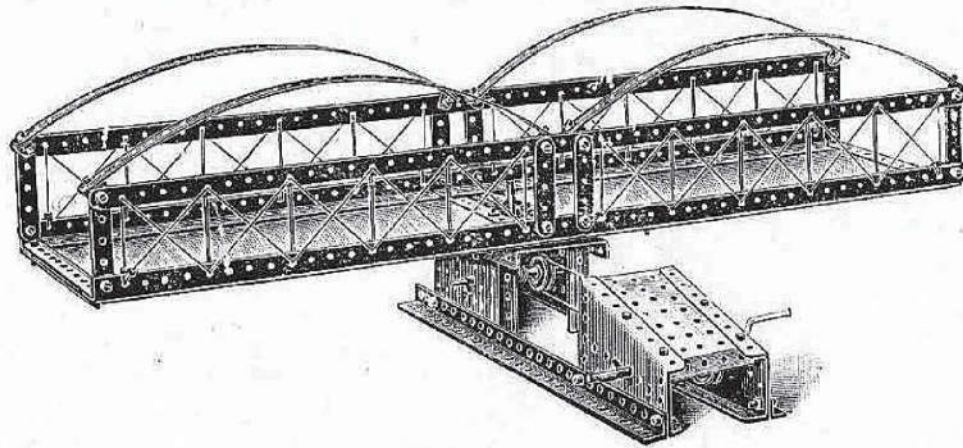

FIG. 33A.

This completes the Models which may be made with "Meccano" No. 2. By purchasing a No. 2A Accessory Outfit at a cost of 6/-, Models Nos. 42 to 50 shown on the following pages may be made, or the necessary additional parts may be purchased separately at the prices as shown on page 78. We recommend the Accessory Outfit, as the parts are contained in a neat cardboard box, in which they may be kept when not in use.

Model No. 42. Swing Bridge



Parts required in addition to Outfits

(MADE WITH MECCANO OUTFIT No. 3 or No. 2 and No. 2A.)

PARTS REQUIRED.	No. 1	No. 2
8 12½" Perforated Strips	4	—
4 5½" " "	—	—
9 2½" " "	—	—
6 Angle Girders	6	2
10 Angle Brackets	—	—
2 4½" Rods	—	—
1 Crank Handle	—	—
2 1" Pulleys	—	—
1 Bush Wheel	—	—
1 ½" Pinion	1	—
1 Worm Wheel	1	1
60 Nuts and Bolts	35	10
11 Keys	2	—
2 Collars and Set Screws	2	2
1 Large Rectangular Plate	—	—
3 Small " "	3	3
2 Sector Plates	—	—

This is a fine engineering model of the highest value to the young student, and any thought and care expended on its construction will be well repaid.

The base portion containing the perpendicular axle actuated by the worm and pinion should be constructed first. This, as will be seen by the illustration, is formed by connecting a small rectangular plate to an angle girder three holes from one end and a sector plate at the other end to form one side of the base. The other side is constructed in a similar manner. These two sides are then connected together at one end by a large rectangular plate containing the spindle, upon which the bridge swings, and at the other by a small rectangular plate. A 2½" strip is connected by two angle brackets to the angle girders to carry the lower portion of the perpendicular axle upon which the bridge swings. A ½" pinion is keyed to this axle, which is operated by the horizontal spindle upon which is keyed a worm wheel. A pulley wheel is also keyed to this spindle around which a driving rope passes from the pulley at the other end of the base keyed to a crank handle as shown in the illustration.

The platform is constructed by connecting two angle girders in the third holes. Two 2½" strips are attached to these in the centre and one at each end, with two 12½" strips along the top. Two 12½" strips are curved and connected by four angle brackets to form one side of the bridge. The other side is formed in a similar manner, and both are connected together by 5½" strips at the end and in the centre. Attached to the two 5½" strips in the centre is a bush wheel upon which the platform rotates.

Model No. 43. Tower Wagon

(MADE WITH MECCANO OUTFIT NO. 3 OR NO. 2 AND NO. 2A.)

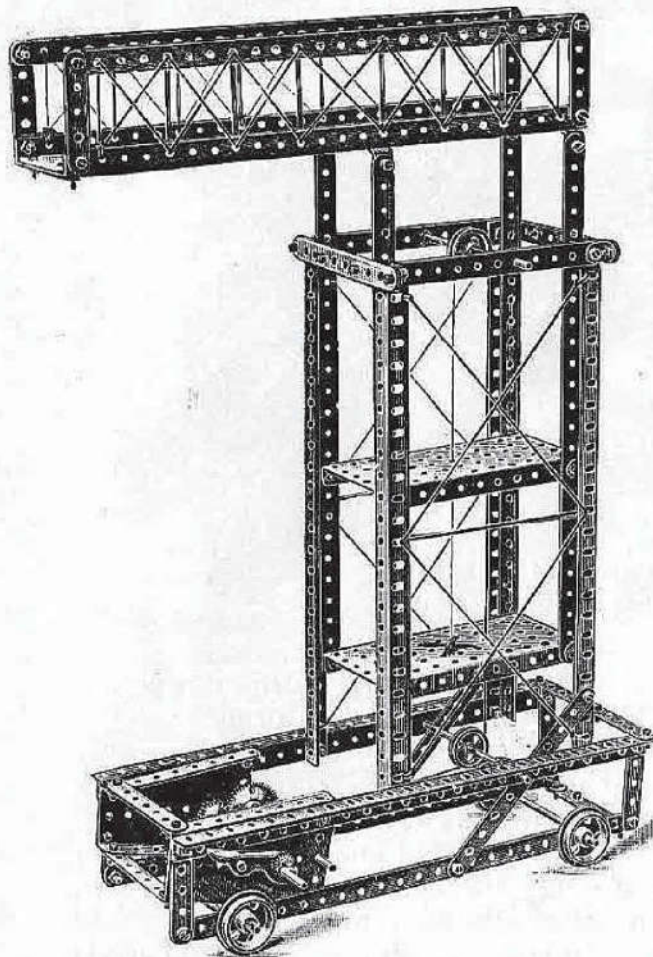

PARTS REQUIRED.	
8	12½" Perforated Strips.
4	5½" " "
6	3½" " "
2	3" " "
13	2½" " "
8	Angle Girders
18	Angle Brackets
2	5" Rods
3	4½" " "
1	Crank Handle
4	Flanged Wheels
2	1" Pulleys
1	¾" Pinion
1	1" " "
1	Gear Wheel
1	Pawl
69	Nuts and Bolts
18	Keys
2	Large Rectangular Plates
2	Sector Plates

This is a representation of a wagon used for repairing overhead electrical wires carrying the current for street cars. Each part is shown clearly in our illustration, and little difficulty will be experienced in its construction.

Model No. 44. Pile Driver

(MADE WITH MECCANO OUTFIT NO. 3 OR NO. 2 AND NO. 2A.)

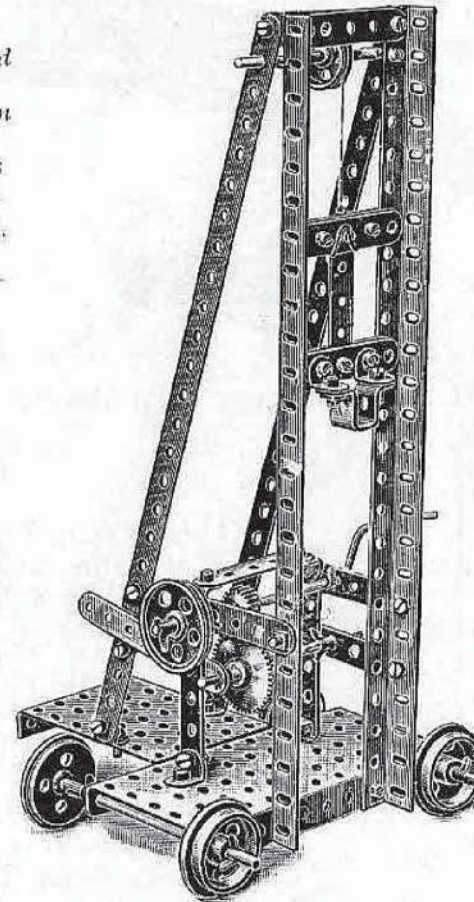

PARTS REQUIRED.		No.	No.
		1	2
2	12½" Perforated Strips	—	—
1	3½" " "	—	—
2	3" " "	2	2
10	2½" " "	—	—
2	Angle Girders	2	—
8	Angle Brackets	—	—
2	5" Rods	2	—
2	4½" " "	—	—
1	Crank Handle	—	—
4	Flanged Wheels	4	—
1	1½" Pulley Wheel	1	1
1	1" " "	—	—
1	¾" Pinion	1	1
1	Gear Wheel	1	1
42	Nuts and Bolts	17	—
16	Keys	7	5
1	Double Bent Strip	1	1
1	Large Rectangular Plate	—	—
1	Small Rectangular Plate	1	1

This illustration shows a model pile driver in which the pile head is guided on the two vertical angle girders. The raising of the pile head is controlled from the main driving shaft through the pinion and gear wheel. This latter being mounted on the end of the pivoted lever, and in order to drop the pile head the lever is raised to free the gear wheel. A grooved pulley is fitted on the pinion shaft to enable the model to be driven from an engine.

Model No. 45. Cake Walk

(MADE WITH MECCANO NO. 3 OR NO. 2 AND NO. 2A.)

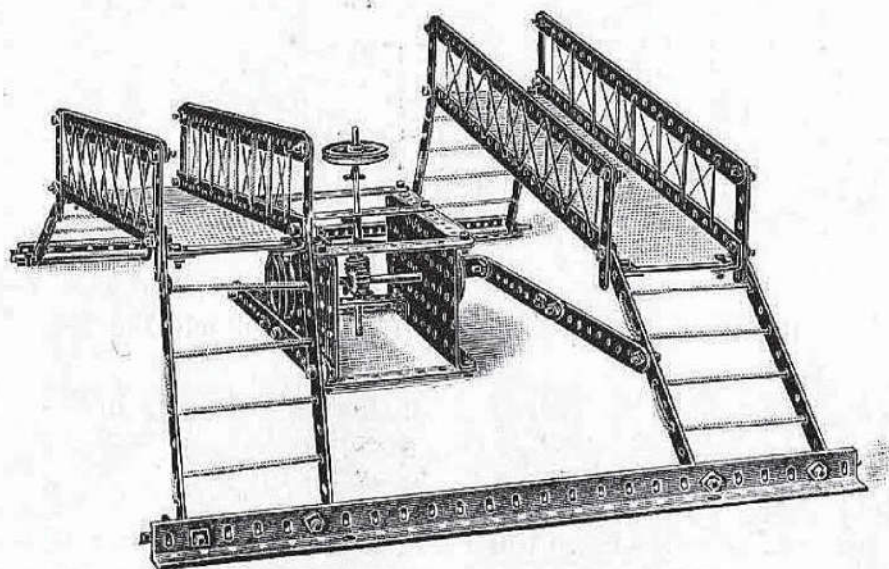

Parts required in addition to Outfits

PARTS REQUIRED.	No. 1	No. 2
4 12 $\frac{1}{2}$ " Perforated Strips	—	—
12 5 $\frac{1}{2}$ " " "	6	—
5 3 $\frac{1}{2}$ " " "	4	3
13 2 $\frac{1}{2}$ " " "	3	—
6 12 $\frac{1}{2}$ " Angle Girders	6	2
10 Angle Brackets	—	—
4 5" Rods	4	1
2 4 $\frac{1}{2}$ " "	—	—
2 Flanged Wheels	2	—
1 1 $\frac{1}{2}$ " Pulley Wheel	1	1
1 $\frac{1}{2}$ " Pinion	1	—
1 Worm Wheel	1	1
66 Nuts and Bolts	41	16
15 Keys	6	4
2 Collars and Set Screws	2	2
2 Large Rectangular Plates.	1	1

This model comprises two side platforms carried upon strips pivotted to the platforms, and to the angle girders forming the base. The strips, where connected to the platforms, are lock-nutted to allow for free movement, and at their lower ends engage a rod secured to the base girders.

The platforms are rocked by coupling strips, the outer ends of which are lock-nutted, and the inner ends connected to flanged wheels also lock-nutted forming cranks. These cranked wheels are mounted upon a common spindle carrying a pinion operated by a worm on the vertical spindle.

Model No. 46. Pit Headgear

(MADE WITH MECCANO OUTFIT NO. 3 OR NO. 2 AND 2A.)

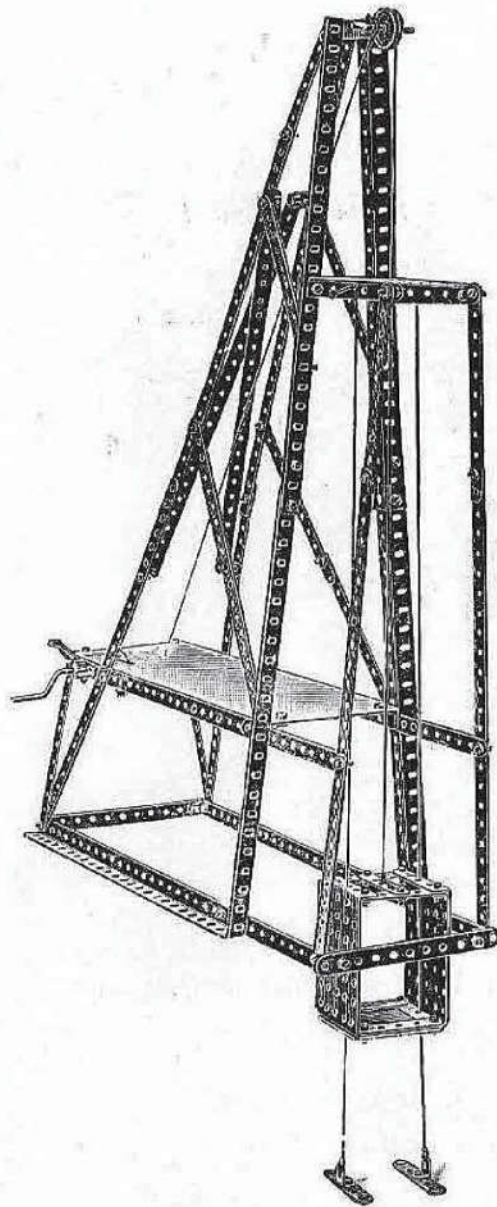

Parts required in addition to Outfits

PARTS REQUIRED.	PARTS REQUIRED.	
	No. 1	No. 2
8 12 $\frac{1}{2}$ " Perforated Strips	4	—
18 5 $\frac{1}{2}$ " " "	12	2
2 3 $\frac{1}{2}$ " " "	1	—
9 2 $\frac{1}{2}$ " " "	—	—
8 Angle Girders	8	4
14 Angle Brackets	2	—
1 4 $\frac{1}{2}$ " Rod	—	—
1 2" Rod	—	—
1 Crank Handle	—	—

Parts required in addition to Outfits

PARTS REQUIRED.	PARTS REQUIRED.	
	No. 1	No. 2
1 1" Pulley	—	—
1 $\frac{3}{4}$ " Pinion	1	1
1 $\frac{1}{2}$ " " "	1	—
1 Gear Wheel	1	1
1 Pawl	1	—
70 Nuts and Bolts	45	20
6 Keys	—	—
3 Small Rectangular Plates	3	3

This is a most interesting model, showing the principle upon which minerals are raised from below the ground.

The front main uprights are formed by two angle girders overlapped in the third hole. Each of these two uprights are fastened together at the top by two angle brackets. Two 2 $\frac{1}{2}$ " strips are bolted horizontally at the top to carry the wheel over which the winding rope runs, and to connect the diagonal stays. To stiffen the structure one 5 $\frac{1}{2}$ " strip is fixed on each side connected in the eighteenth hole down on the upright, and the eleventh hole down on the stays. Two more 5 $\frac{1}{2}$ " strips are bolted together, and fastened on each side lower down.

The framework in which the cage moves is formed by connecting a 5 $\frac{1}{2}$ " strip with a 12 $\frac{1}{2}$ " strip in the second hole to form the uprights. These are connected by 5 $\frac{1}{2}$ " strips to the main uprights. The framework takes the same angle as the main uprights, and is connected at the top by a small rectangular plate and two angle brackets, and at the bottom by a 5 $\frac{1}{2}$ " strip.

The cage is formed by connecting two small rectangular plates by two 2 $\frac{1}{2}$ " strips at the top and bottom. Another 2 $\frac{1}{2}$ " strip is bolted in the centre at the top, to which is attached the hoisting rope.

The guide ropes are connected to the small rectangular plate at the top of the framework, passed through the holes at each side of the cage, and connected with two 2 $\frac{1}{2}$ " strips screwed to the floor.

The hoisting mechanism is operated by the crank handle, upon which is keyed a $\frac{3}{4}$ " pinion engaging a gear wheel connected with the spindle over which the hoisting rope is wound.

Model No. 47. Level Crossing Gates

(MADE WITH MECCANO OUTFIT NO. 3 OR NO. 2 AND NO. 2A.)

Parts required in addition to Outfits

PARTS REQUIRED.	No. 1	No. 2
9 $5\frac{1}{2}$ " Perforated Strips	3	—
4 $3\frac{1}{2}$ " " "	3	2
2 3" " "	2	2
10 $2\frac{1}{2}$ " " "	—	—
6 Angle Girders	6	2
24 Angle Brackets	12	8
4 5" Rods	4	1
4 1" Pulley Wheels	—	2
54 Nuts and Bolts	29	4
4 Keys	—	—
2 Large Rectangular Plates	1	1

This model, if constructed with care, is a most admirable one, as the gates are opened simultaneously by the operation of one lever.

To construct it, commence by taking two angle girders and connecting them together at each end with a $5\frac{1}{2}$ " strip placed perpendicularly between them to form the supports of one pair of gates as shown in Figure 47. The supports for the

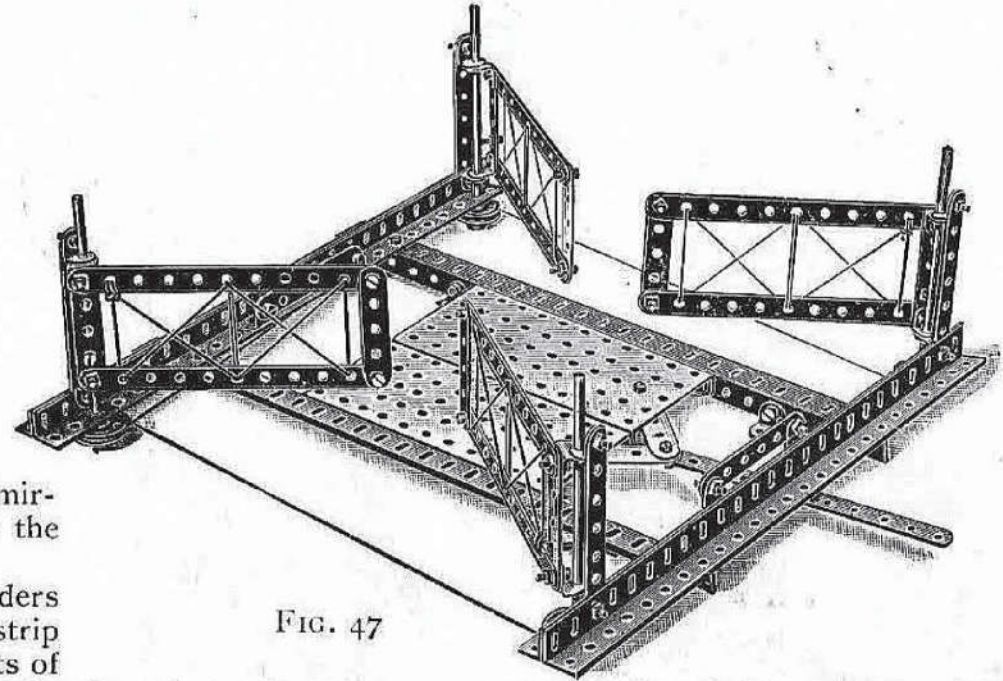

FIG. 47

other pair of gates are arranged in a similar manner. These two structures are connected by two other angle girders and two rectangular plates, as shown in the illustration.

The gates are formed by connecting two $5\frac{1}{2}$ " strips with two $2\frac{1}{2}$ " strips at one side of the gates; two angle brackets are attached to permit the axle rods to pass through upon which the gates swing.

Figure 47A is an inverted view showing the arrangement of operating cord 1 which is passed from the operating lever 2, around the corner pulleys 3, and back to the lever 2. In order to obtain a better grip on the pulleys, it is desirable to wind the operating cord twice around them. It is to be noted that the cord 1 is wound in opposite directions around the diagonal pairs of pulleys 3.

Pinching screws 4 are fitted in the inner sides of the gates to grip them to the spindles 5 so that all rotate together.

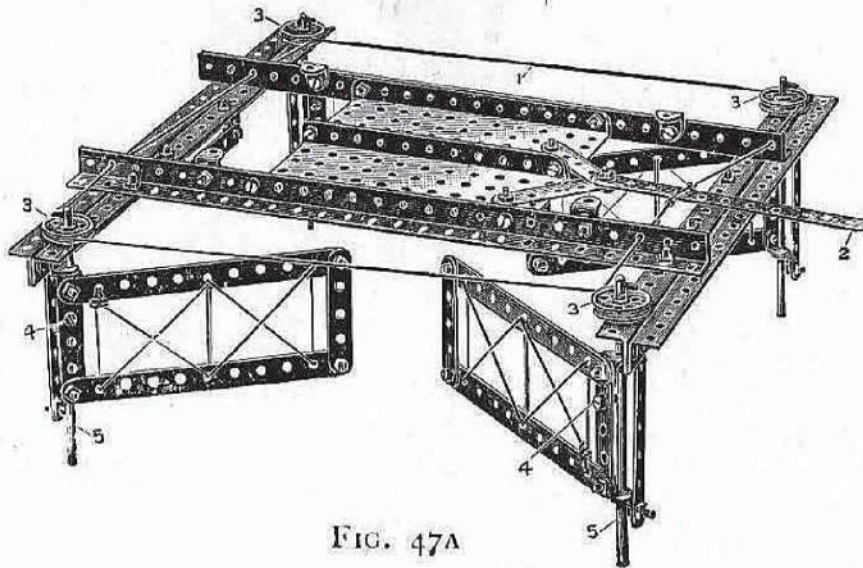
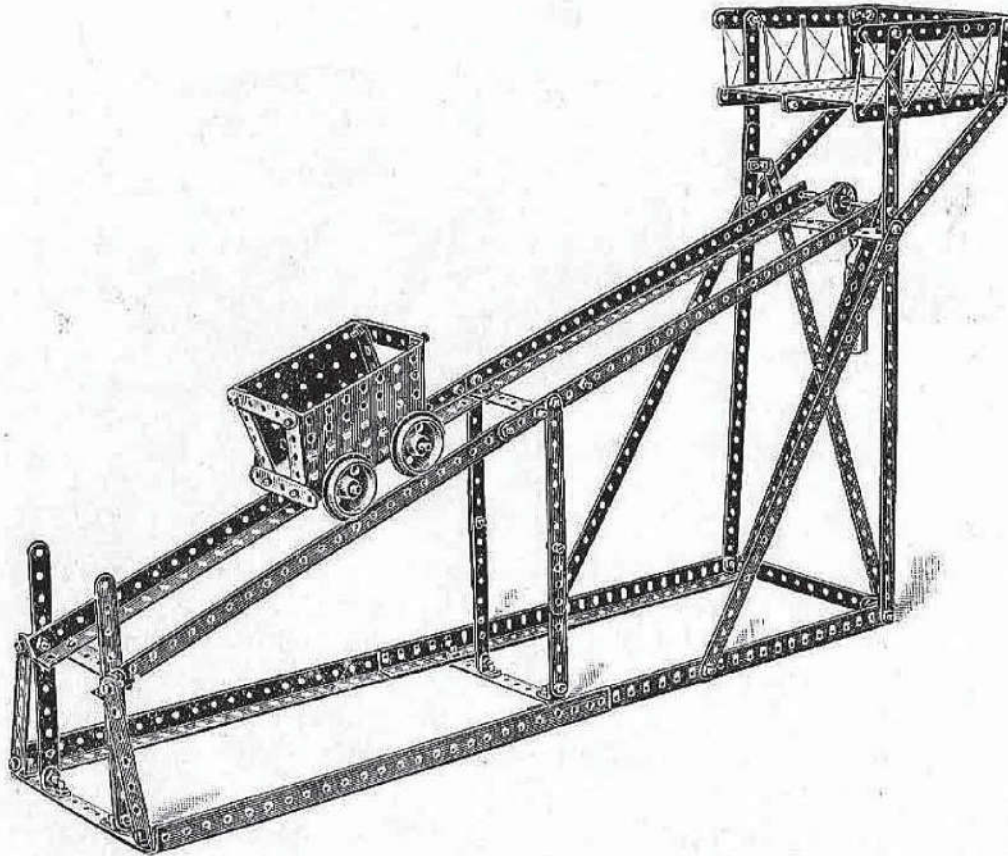

FIG. 47A

Model No. 48. Inclined Delivery Shoot

(MADE WITH MECCANO OUTFIT NO. 3 OR WITH NO. 2 AND NO. 2A.)



Parts required in addition to Outfits

PARTS REQUIRED.		No. 1	No. 2
6	12 $\frac{1}{2}$ " Perforated Strips	2	—
16	5 $\frac{1}{2}$ " " "	10	—
4	3 $\frac{1}{2}$ " " "	3	2
2	3" " "	2	2
8	2 $\frac{1}{8}$ " " "	—	—
8	Angle Girders	8	4
16	Angle Brackets	4	—
3	4 $\frac{1}{2}$ " Rods	—	—
4	Flanged Wheels	4	—
1	1" Pulley Wheel	—	—
70	Nuts and Bolts	45	20
1	Hook	—	—
8	Keys	—	—
2	Large Rectangular Plates	1	1
2	Small " "	2	2

The model furnishes an illustration of the inclined plane. The loading platform at the extreme right delivers a load into the truck, which being now heavier than the balance weight, runs down the incline, and when at the bottom discharges its load by tipping. The weight immediately overcoming the empty truck returns it quickly to the loading platform.

Model No. 49. Fire Escape

(MADE WITH MECCANO OUTFIT NO. 3 OR NO. 2 AND NO. 2A.)

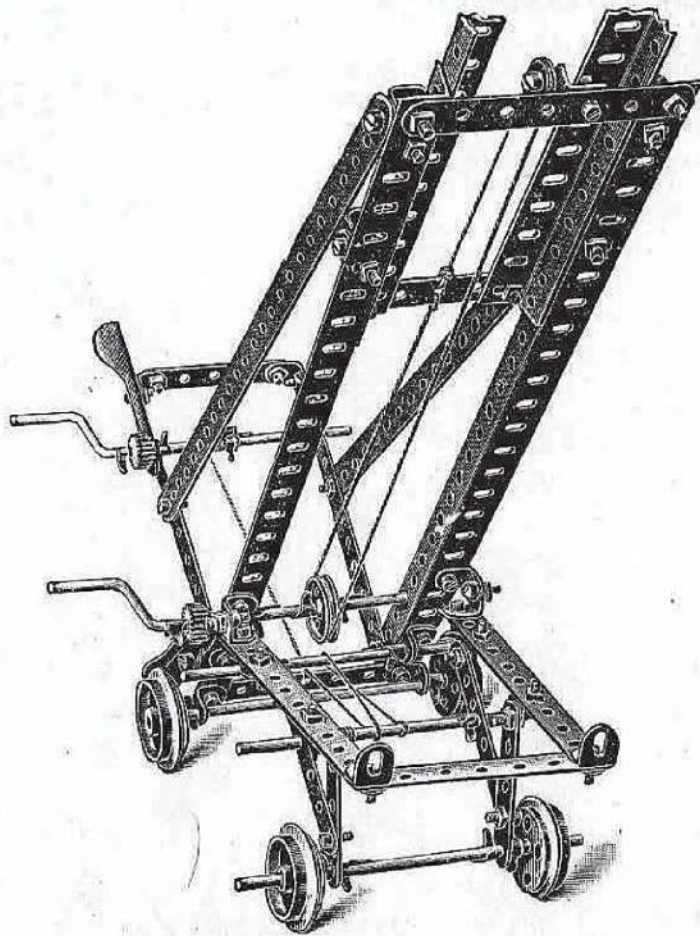

Parts required in addition to Outfits

PARTS REQUIRED.	No. 1		No. 2	
	No. 1	No. 2	No. 1	No. 2
2 12½" Perforated Strips	—	—	—	—
4 5½" " "	—	—	—	—
3 3½" " "	2	1	—	—
2 3" " "	2	2	—	—
5 2½" " "	—	—	—	—
4 Angle Girders	4	—	—	—
25 Angle Brackets	13	9	—	—
2 5" Rods	2	—	—	—
3 4½" " "	—	—	—	—
2 Crank Handles	1	1	—	—
4 Flanged Wheels	4	—	—	—
3 1" Pulley Wheels	—	1	—	—
1 ½" " "	1	1	—	—
2 ½" Pinions	2	1	—	—
2 Pawls	2	1	—	—
50 Nuts and Screws	25	—	—	—
19 Keys	10	8	—	—

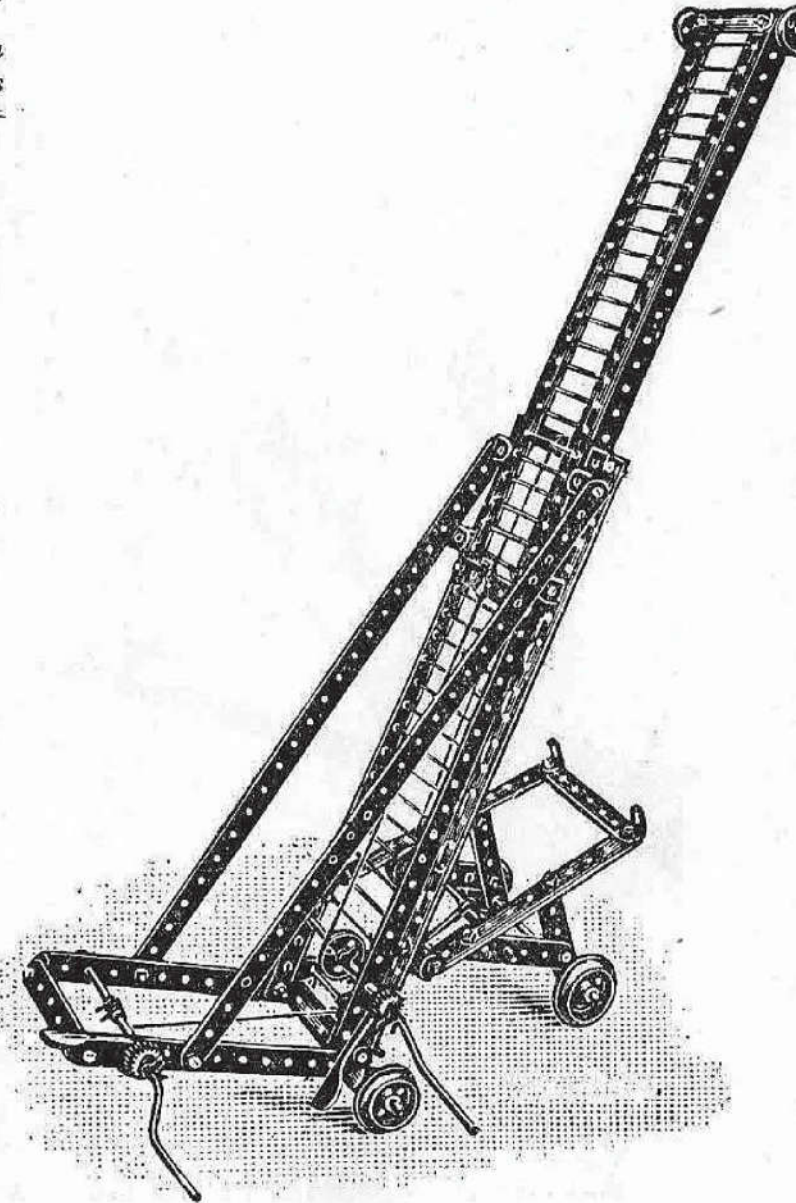

In constructing this model, take two angle girders and tie these together with 3½" strips at top and bottom. A 5½" strip is then attached at right angles to one end of the frame, diagonal stays tying these short strips to the angle brackets attached to the frame. The sliding frame is constructed from two angle girders reversed to those of the main frame, the angle girders of the sliding frame being tied together by two 2½" strips, and being retained and guided in the main carriage by the short angle brackets which act as clips. The framework of the running truck is very simply constructed, and is pivotally attached by angle brackets to the main frame.

Model No. 50. Rotating Crane

(MADE WITH MECCANO OUTFIT NO. 3 OR NO. 2 AND NO. 2A.)

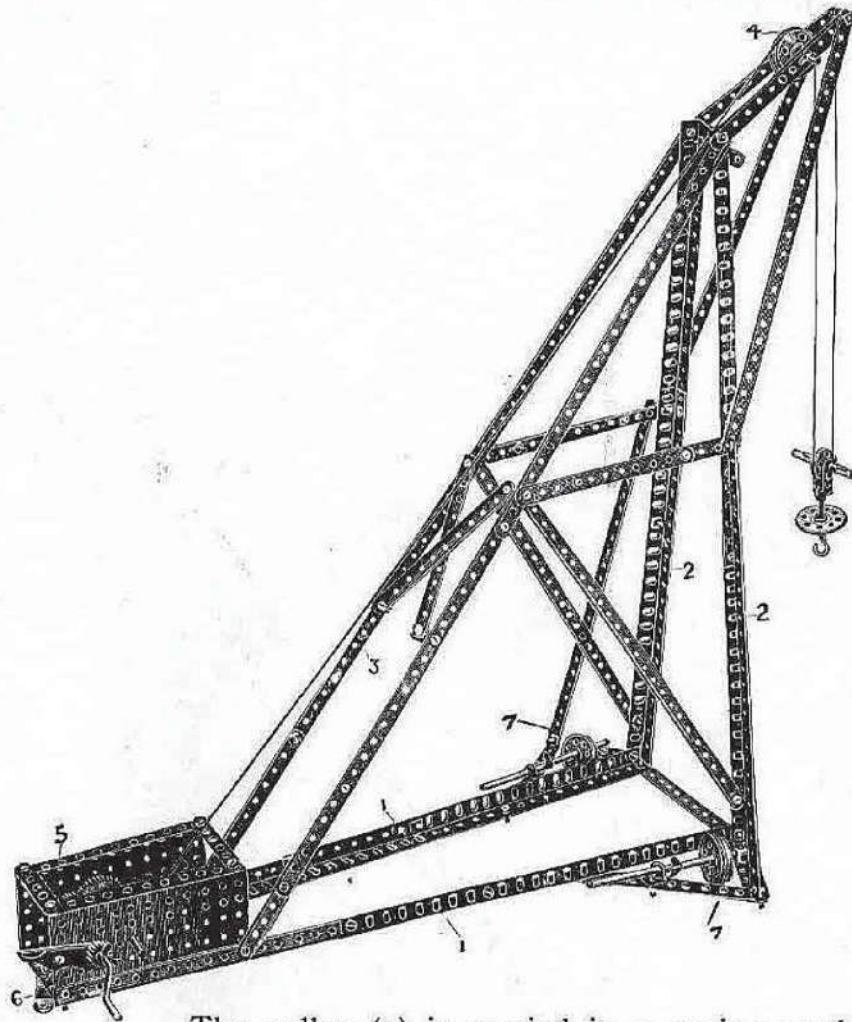

Parts required
in addition to
Outfits

PARTS REQUIRED.		No. 1	No. 2
10	12½" Perforated Strips	6	—
13	5½" " "	7	—
3	3½" " "	2	1
1	3" " "	1	1
5	2½" " "	—	—
8	12½" Angle Girders	8	4
14	Angle Brackets	2	—
2	5" Rods	2	—
1	4½" Rod	—	—
2	2" Rods	—	—
1	Crank Handle	—	—
2	Flanged Wheels	2	—
1	1½" Pulley Wheel	1	1
1	1" " "	—	—
1	Bush " "	—	—
1	¾" Pinion " "	1	1
1	½" " "	1	1
1	Gear " Wheel	1	1
1	Pawl	1	—
14	Keys	5	3
62	Nuts and Bolts	37	12
1	Hook	—	—
1	Single Bent Strip	—	—
1	Double " "	1	—
2	Large Rectangular Plates	1	1

The lower horizontal ribs (1) and main vertical members (2) are made of angle girders overlapping nine holes; and the diagonal ties (3) of two 12½" strips, and one 5½" strip, the 12½" strips being overlapped three holes, and the lower 5½" strip seven holes.

The pulley (4) is carried in a nosing made of two 5½" strips, and two 12½" strips connected at their apex by angle brackets. The rear swivel point of the crane is made by bolting the gear box (5) to a double bent strip (6) secured to the floor. The crane runs on the flanged wheels (7).

This completes the Models which may be made with "Meccano" No. 3. By purchasing a No. 3A Accessory Outfit at a cost of 11/-, Models Nos. 60 to 68 shown on the following pages may be made, or the necessary additional parts may be purchased separately, at the prices shown on page 78. We recommend the Accessory Outfit, as the parts are contained in a neat cardboard box, in which they may be kept when not in use.

Model No. 60. Flying Machine

(MADE WITH MECCANO OUTFIT NO. 4 OR NO. 3 AND NO. 3A.)

Parts required in addition to Outfits

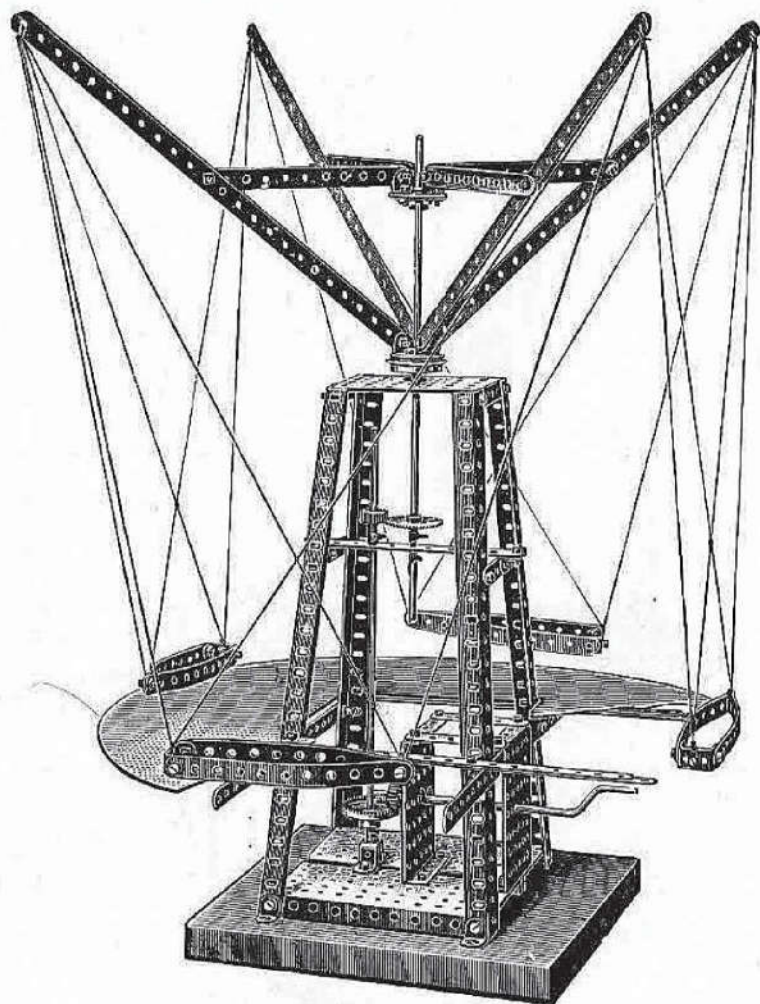

PARTS REQUIRED.		No. 1	No. 2	No. 3
10	12 $\frac{1}{2}$ " Perforated Strips	6	—	—
13	5 $\frac{1}{2}$ " " "	7	—	—
2	3 $\frac{1}{2}$ " " "	1	—	—
2	2 $\frac{1}{2}$ " " "	—	—	—
4	Angle Girders	4	—	—
26	Angle Brackets	14	10	—
2	11 $\frac{1}{2}$ " Rods	2	2	2
1	Crank Handle	—	—	—
1	Flanged Wheel	1	—	—
1	Bush Wheel	—	—	—
2	$\frac{3}{4}$ " Pinions	2	2	1
1	Gear Wheel	1	1	—
1	1 $\frac{1}{2}$ " Contrite	1	1	1
74	Nuts and Bolts	49	24	4
11	Keys	2	—	—
1	Collar and Set Screw	1	1	—
1	Double Bent Strip	1	—	—
2	Large Rectangular Plates	1	1	—
3	Small " "	3	3	—

Most boys will have seen the Maxim Flying Machine at work, and will hardly fail to be interested in constructing a working model of it.

The main frame is composed of four angle girders connected at the bottom by two large rectangular plates separated one hole apart and connected together by two small rectangular plates carrying the crank handle, and at the top by a small rectangular plate. Across the centre on opposite sides in the ninth hole down is attached a 3 $\frac{1}{2}$ " strip connected together by a 5 $\frac{1}{2}$ " strip. These transverse 3 $\frac{1}{2}$ " and 5 $\frac{1}{2}$ " strips and the small rectangular plate at the top carry the perpendicular spindle upon which the upper structure revolves. A flanged wheel is keyed to this spindle to support the four arms, which are attached by four angle brackets. The arms are supported by means of 5 $\frac{1}{2}$ " strips connected to a bush wheel keyed on to the spindle, and the boats are connected to these by string arranged as shown in the illustration. The platform is supported by four 12 $\frac{1}{2}$ " strips attached to the sides of the main framework. The manner of constructing the mechanism for operating the model is clearly shown in the illustration.

Model No. 61. Travelling Crane

(MADE WITH MECCANO OUTFIT NO. 4 OR NO. 3 AND NO. 3A.)

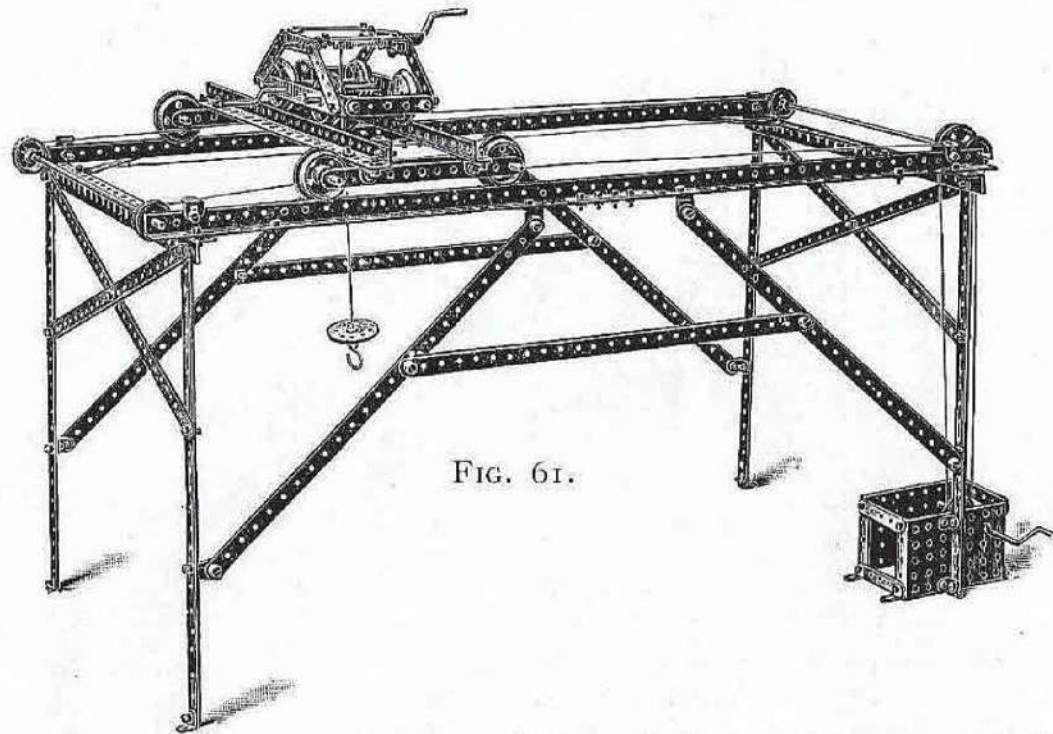

FIG. 61.

Separate views are given of two distinct parts composing the travelling crane. Fig. 61 is a complete view of the structure showing the braced gantry carrying a rail at each side. The rails are formed by angle girders butt-jointed. FIG. 61A shows the construction of the travelling gantry with two pairs of wheels so arranged as to fit the gauge of the rails. The gantry is caused to travel to and fro on the rails by a cord which is connected to the gantry by a nut and bolt (r), and passes over a pulley at each end of the rail, keyed to the rod. On one of these rods is keyed a $1\frac{1}{2}$ " pulley carrying the driving cord, which passes over a pulley wheel keyed to the crank handle. The winch Fig. 61B again is arranged to run on the gantry rails of 61A, and is provided with a hoisting axle and one for traversing the winch.

Parts required in addition to Outfits

PARTS REQUIRED.		No. 1	No. 2	No. 3
14	$12\frac{1}{2}$ " Perforated Strips	10	4	4
6	$5\frac{1}{2}$ " " "	—	—	—
4	3" " "	4	4	2
16	$2\frac{1}{2}$ " " "	6	2	—
8	Angle Girders	8	4	—
39	Angle Brackets	27	23	13
2	$11\frac{1}{2}$ " Rods	2	2	2
2	$4\frac{1}{2}$ " " "	—	—	—
4	2" " "	2	2	1
3	Crank Handles	2	2	1
8	Flanged Wheels	8	4	4
1	$1\frac{1}{2}$ " Pulley Wheel	1	1	—
5	1" Pulleys	—	3	1
1	Bush Wheel	—	—	—
1	$\frac{3}{4}$ " Pinion	1	1	—
1	$\frac{1}{2}$ " " "	1	—	—
1	Gear Wheel	1	1	—
1	Pawl	1	—	—
105	Nuts and Bolts	80	55	35
1	Hook	—	—	—
22	Keys	13	11	—
2	Small Rectangular Plates	2	2	—

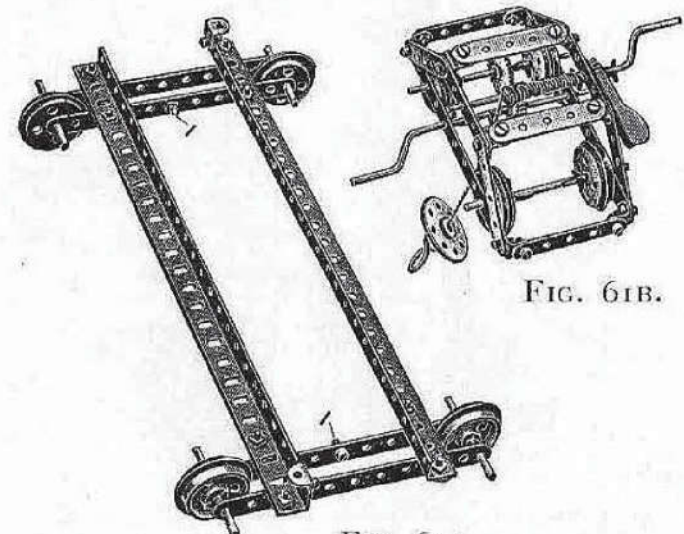
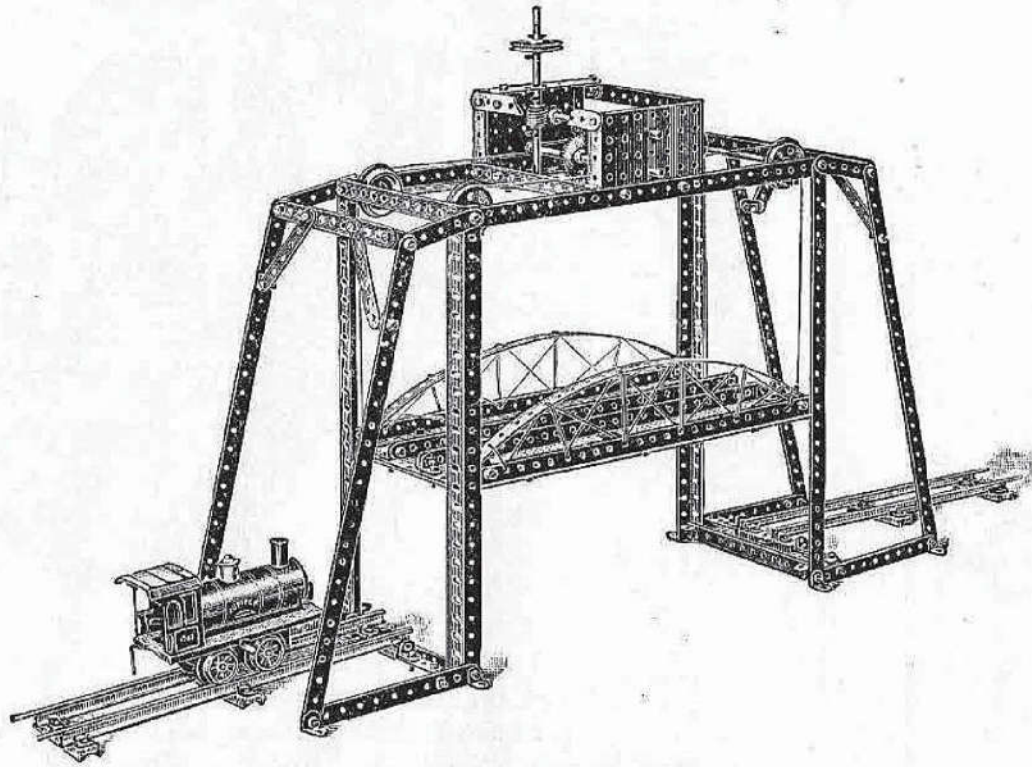

FIG. 61B.

FIG. 61A.

Model No. 62. Viaduct Bridge

(MADE WITH MECCANO OUTFIT NO. 4 OR NO. 3 AND NO. 3A.)



Parts required in addition to Outfits

PARTS REQUIRED.		No. 1	No. 2	No. 3
8	12½" Perforated Strips	4	—	—
19	5½" " "	13	3	1
2	3½" " "	1	—	—
4	3" " "	4	4	2
4	2½" " "	—	—	—
8	Angle Girders	8	4	—
44	Angle Brackets	32	28	18
2	6" Rods	2	2	2
3	5" " "	3	—	—
4	Flanged Wheels	4	—	—
1	¾" Pinion	1	1	—
1	½" " "	1	—	—
1	Gear Wheel	1	1	—
1	Worm Wheel	1	1	—
102	Nuts and Bolts	77	52	32
15	Keys	6	4	—
2	Collars and Set Screws	2	2	—
2	Small Rectangular Plates	2	2	—

This model shows the construction of a suspended viaduct bridge, the central girder platform when lowered permitting the locomotive to pass along the continuous track, and is raised to enable ships to pass along the waterway beneath the gantry. The central movable girder platform is suspended from the corner cords, passing over the four pulley wheels, and is raised or lowered by the operation of the gear mechanism in the gear box on the top of the gantry. The grooved pulley wheel on the vertical driving shaft may be operated from an engine. The shaft carrying a worm gearing with a ½" pinion on a transverse shaft and a ¾" pinion which in turn gears with a gear wheel on the winding spindle, operates the lifting cords. The operating cords are led on to the winding spindle in opposite directions so that when the spindle is being continuously driven in one direction all four cords wind on or off simultaneously.

The side rails and locomotive shown in the illustration are not included in the Outfit.

Model No. 63. Elevated Jib Crane

(MADE WITH MECCANO OUTFIT NO. 4 OR NO. 3 AND NO. 3A.)

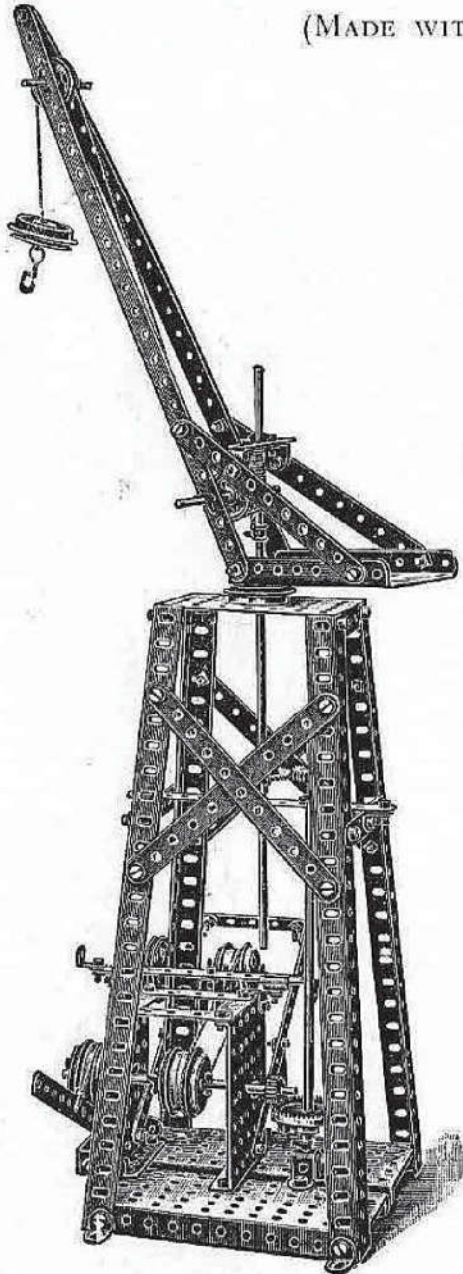

Parts required in addition to Outfits

PARTS REQUIRED.

2	12½"	Perforated Strips
11	5½"	" "
2	3½"	" "
4	2½"	" "
4		Angle Girders
13		Angle Brackets
2	11½"	Rods
2	5"	"
1	4½"	"
1	2"	"
8		Flanged Wheels
2		1" Pulleys
1		¾" Pinion
1		½" "
1		Gear Wheel
1		1½" Contrate
67		Nuts and Bolts
1		Hook
21		Keys
1		Collar and Set Screw
1		Single Bent Strip
1		Double Bent Strip
1		Large Bent Strip
2		Large Rectangular Plates
3		Small Rectangular Plates
1		Sector Plate
2		Eye Pieces
1		Rubber Band

No. 1	No. 2	No. 3
—	—	—
5	—	—
1	—	—
—	—	—
4	—	—
6	2	—
2	2	2
2	—	—
—	—	—
—	—	—
8	4	4
—	—	—
1	1	—
1	—	—
1	1	—
1	1	1
42	17	—
—	—	—
12	10	—
1	1	—
—	—	—
1	—	—
1	1	—
1	1	—
3	3	—
—	—	—
2	2	2
1	1	1

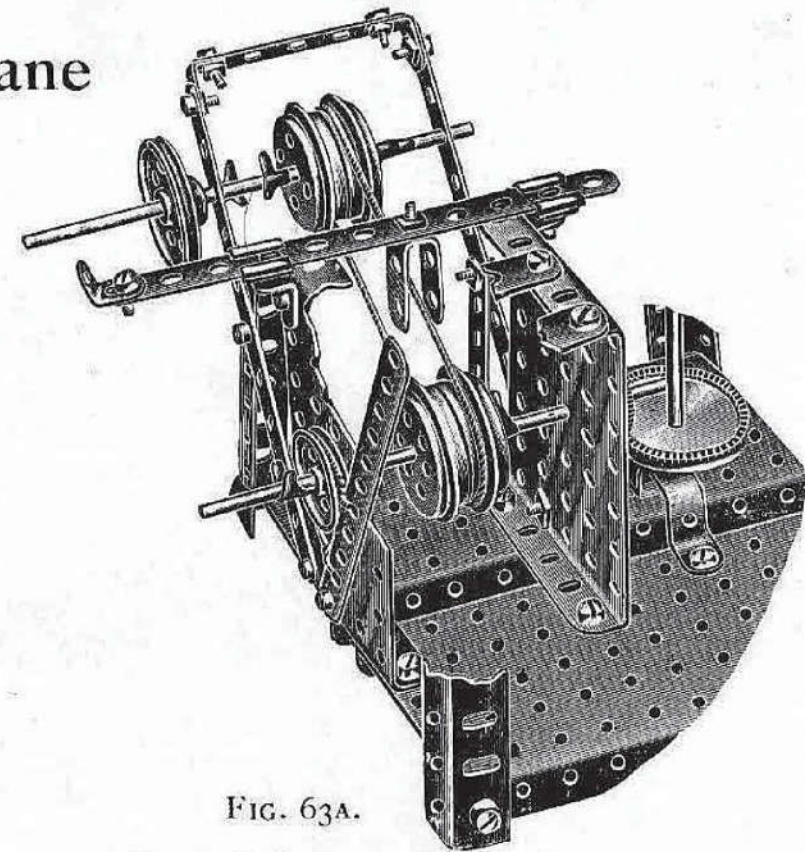

FIG. 63A.

The main framework is similar to Model 60, and the vertical winding spindle for hoisting is supported and driven from the lower pinion and contrate wheel in the same manner as in Model 60.

The main shaft is fitted with fast and loose pulleys, flanged wheels being used for this purpose.

The driving power is received at the outer 1½" pulley on the main driving shaft, as shown in the illustration. The means for striking the belt from the fast to the loose pulley is clearly brought out in the illustration.

Model No. 64. Suspension Bridge

(MADE WITH MECCANO NO. 4 OR NO. 3 AND NO. 3A.)

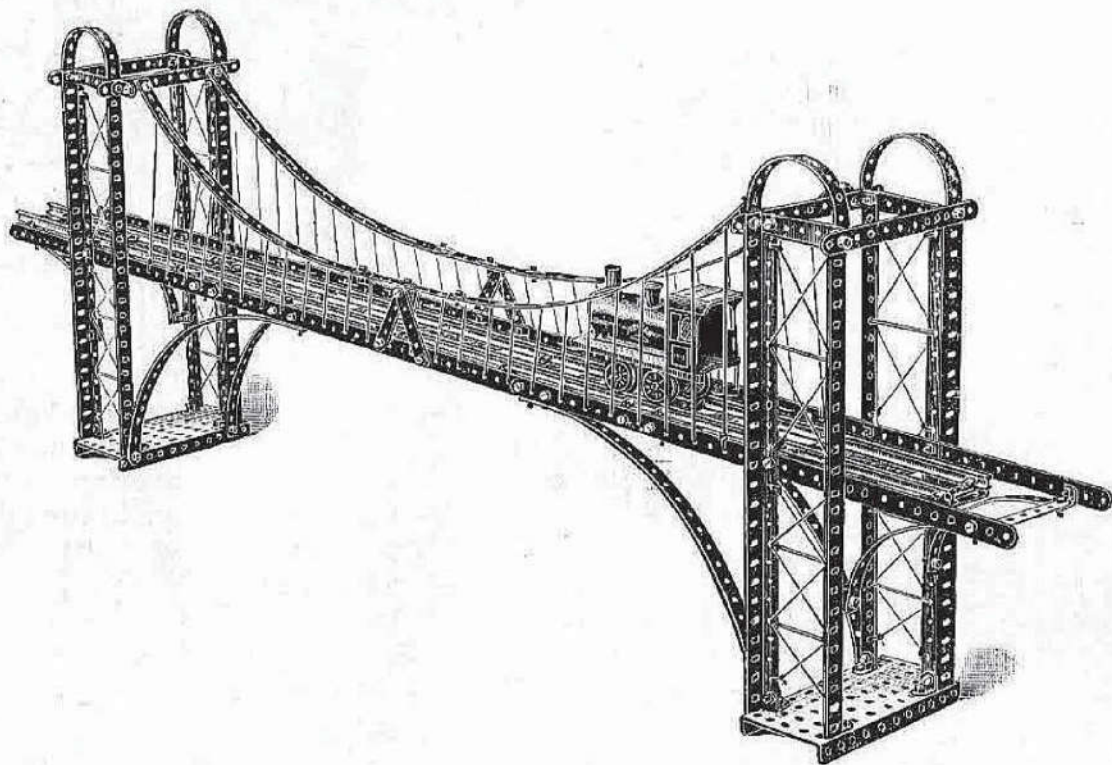

Parts required in addition to Outfits.

PARTS REQUIRED.		No. 1	No. 2	No. 3
14	12 $\frac{3}{8}$ " Perforated Strips	10	4	—
18	5 $\frac{1}{2}$ " " "	12	2	—
4	3 $\frac{1}{2}$ " " "	3	2	—
8	2 $\frac{1}{2}$ " " "	—	—	—
8	Angle Girders	8	4	—
30	Angle Brackets	18	14	4
103	Nuts and Bolts	78	53	33
2	Large Rectangular Plates	1	1	—
3	Small Rectangular Plates	3	3	—

The end towers of this model are built up from four angle girders carried from large rectangular plates at the base.

The rail track platform is coupled to the towers by small rectangular plates. A third small rectangular plate being disposed at the centre of the track platform. Two 3 $\frac{1}{2}$ " strips are connected to the side strips of the girder platform between the end and middle rectangular plates and one at each end. Any suitable track rails may be laid across the girder platform.

The engine and rails shown in the illustration are not included in the outfit, and are merely shown for purposes of illustration.

Model No. 65. Warehouse with Elevator

(MADE WITH MECCANO OUTFIT No. 4 OR WITH No. 3 AND No. 3A.)

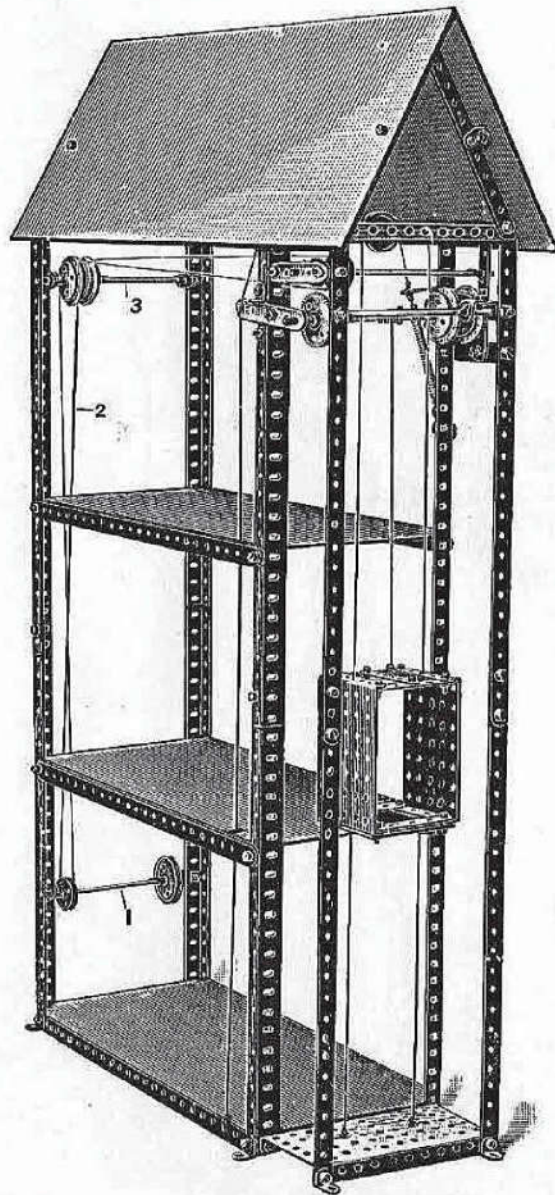

PARTS REQUIRED.

13	12½"	Perforated Strips	9	—	—
8	5½"	" "	2	—	—
2	3½"	" "	1	—	—
1	3"	" "	1	1	—
7	2½"	" "	—	—	—
8		Angle Girders	8	4	—
29		Angle Brackets	17	13	—
2	6"	Rods	2	2	1
2	5"	" "	2	—	—
1	4½"	" "	—	—	—
2	2"	" "	—	—	—
4		Flanged Wheels	4	—	—
1	1½"	Pulley Wheel	1	1	—
4	1"	" "	—	2	—
1	¾"	Pinion	1	1	—
1		Gear Wheel	1	1	—
86		Nuts and Bolts	61	36	16
1		Hook	—	—	—
19		Keys	10	8	—
1		Spring	1	1	1
2		Large Rectangular Plates	1	1	—
3		Small " "	3	3	—

geared with the gear wheel 6 by operating the cord 7 controlling the lever 8 which carries the wheel spindle. The cord 7 is extended over pulleys at 7a and connected to a brake band 9 engaging the brake driven pulley 10 mounted on the winding spindle. The one operation of throwing the gear wheel 6 into engagement with the driving pinion 5, simultaneously releases the brake 9 and enables the cage to be hoisted. By only partially releasing the operating cord 7 the gears 5 and 6 are disconnected without the brake 9 being engaged, the cage is then allowed to descend freely.

Parts required in addition to Outfits

No. 1	No. 2	No. 3
9	—	—
2	—	—
1	—	—
1	1	—
—	—	—
8	4	—
17	13	—
2	2	1
2	—	—
—	—	—
—	—	—
4	—	—
1	1	—
—	2	—
1	1	—
1	1	—
61	36	16
—	—	—
10	8	—
1	1	1
1	1	—
3	3	—

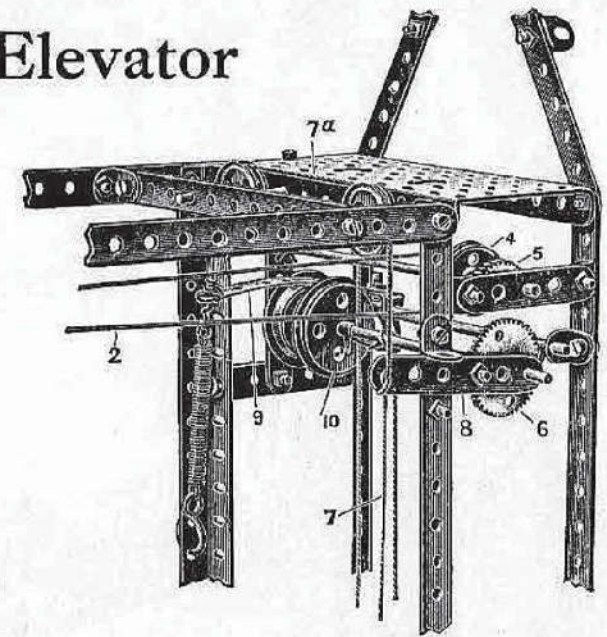

The structure of the warehouse is built up of corner members made from pairs of angle girders overlapped three holes and bolted together in the middle hole. These are connected at the sides by 12½" strips, and at the ends, top and bottom, by 5½" strips, and a large rectangular plate to form the floor for the elevator arrangement.

The driving shaft 1 is connected to the grooved pulley 4 by belt 2 passing over loose pulleys and shaft 3. The shaft carrying the pulley 4 is fitted with a ¾" pinion 5, and is adapted to be

Model No. 66. Cable Railway

(MADE WITH MECCANO OUTFIT NO. 4 OR NO. 3 AND NO. 3A.)

Parts required in addition to Outfits.

PARTS REQUIRED.	No. 1	No. 2	No. 3
3 5½" Perforated Strips	—	—	—
2 3" " "	2	2	—
1 2½" " "	—	—	—
2 Angle Girders	2	—	—
6 Angle Brackets	—	—	—
3 5" Rods	3	—	—
3 4½" "	—	—	—
4 Flanged Wheels	4	—	—
1 1½" Pulley Wheel	1	1	—
2 1" " "	—	—	—
2 ¾" Pinions	2	2	1
1 Gear Wheel	1	1	—
2 ¾" Contrate Wheels	2	2	2
28 Nuts and Bolts	3	—	—
18 Keys	9	7	—
1 Large Bent Strip	1	1	—
2 Large Rectangular Plates	1	1	—
3 Small " "	3	3	—
2 Sector Plates	—	—	—

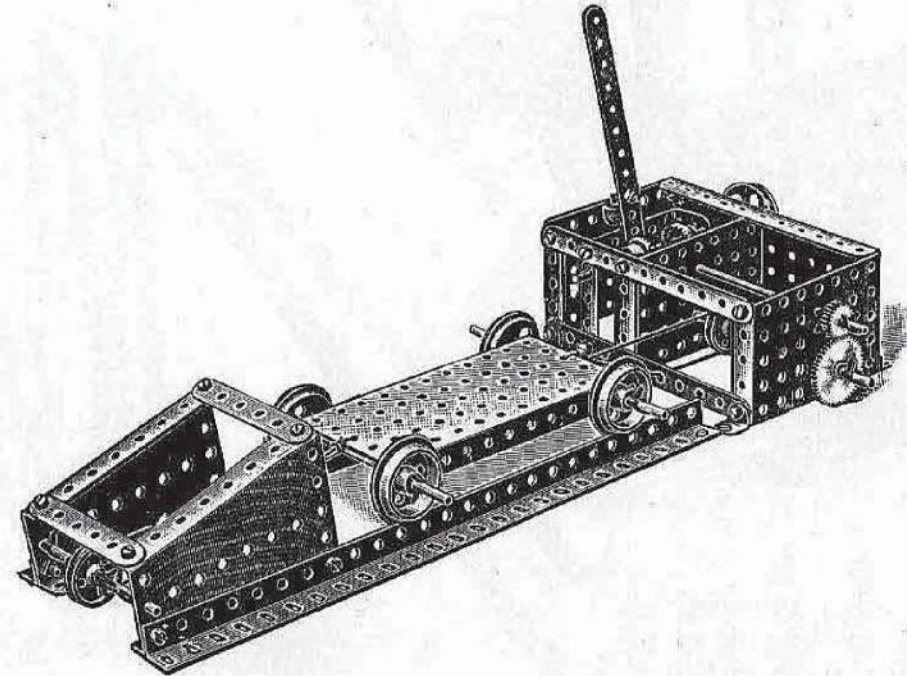

Our illustration hardly does this excellent model justice, owing to the parts having to be so crowded together. This is a very fine model, both instructive and highly interesting.

The driving power is received at the outer 1½" pulley, and is transmitted through the clutch mechanism and the pinion and gear wheels to the lower spindle on which the driving pulley is fixed, the driving rope passing round this pulley and the second pulley at the end of the rails, all as shown in the drawing.

In fixing the lever for operating the clutch mechanism, the nuts should be locked to prevent the screw working out. Only one section of rails is shown in the design, but they may be extended as desired.

Model No. 67. Swivelling & Luffing Jib Crane

(MADE WITH MECCANO NO. 4 OR NO. 3 AND NO. 3A.)

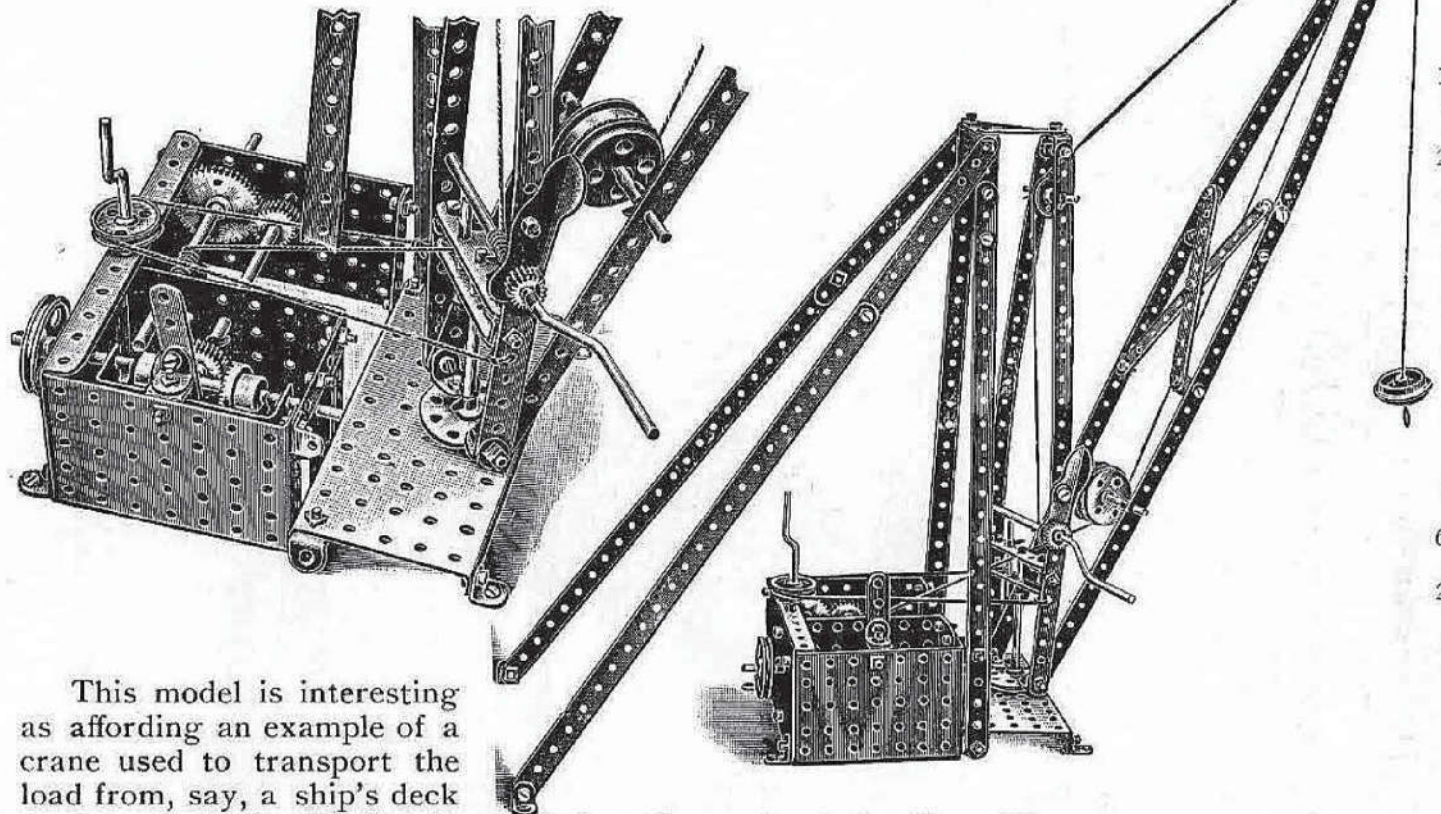

This model is interesting as affording an example of a crane used to transport the load from, say, a ship's deck on to a quay, by "luffing" or altering the angle of the jib. The apparatus consists of two parts, a fixed frame and a swivelling and luffing jib. The construction of the fixed frame with the reversing frame and lever should present no difficulties.

The two 12 1/2" upright strips are braced together as shown, and are held in vertical position by the two 12 1/2" connected to two 5 1/2" strips rear-wardly sloping pieces, and from the structure so formed the reversing frame is carried.

The swivelling piece of the jib consists of two 12 1/2" strips bent as shown, connected at the bottom by a bush wheel and at the sixth hole up by two 2 1/2" strips. A 4 1/2" rod is passed through the centre hole of these 2 1/2" strips, and the bush wheel into the bottom plate to form the lower pivot; the upper pivot is formed with an angle bracket, having a screw, carried in the triangle formed of 2 1/2" strips attached to the fixed frame.

The jib itself consists of two pairs of 12 1/2" strips connected and braced together as shown. The jib luffs about its connection to the swivelling frame, and is thus capable of two motions—a swivelling motion and a luffing motion.

The luffing motion is effected by the luffing rope, which is coiled round the handle shown, and then passes round the pulley at the top of the swivelling frame, the other end being attached to the head of the jib. In order to keep the hoisting rope in position when the crane is swivelled, the two guide rods carried on the swivelling frame are provided.

By operating the luffing handle the jib may be put at any angle from nearly horizontal to nearly vertical, the crane thus acting as a transporter of the load.

Parts required in addition to Outfits

PARTS REQUIRED.		No. 1	No. 2	No. 3
10	12 1/2" Perforated Strips	6	—	—
4	5 1/2" " "	—	—	—
9	2 1/2" " "	—	—	—
24	Angle Brackets	12	8	—
3	5" Rods	3	—	—
2	4 1/2" " "	—	—	—
3	2" " "	1	1	—
2	Crank Handles	1	1	—
3	Flanged Wheels	3	—	—
1	1 1/2" Pulley	1	1	—
3	1" " "	—	1	—
1	Bush Wheel	—	—	—
2	3/4" Pinions	2	2	1
1	1 1/2" " "	1	—	—
1	Gear Wheel	1	1	—
2	3/4" Contrate Wheels	2	2	2
1	Pawl	1	—	—
69	Nuts and Bolts	44	19	—
1	Hook	—	—	—
22	Keys	13	11	—
1	Large Bent Strip	1	1	—
2	Large Rectangular Plates	1	1	—
3	Small " "	3	3	—

Model No. 68. Drilling Machine

(MADE WITH MECCANO OUTFIT NO. 4 OR NO. 3 AND NO. 3A.)

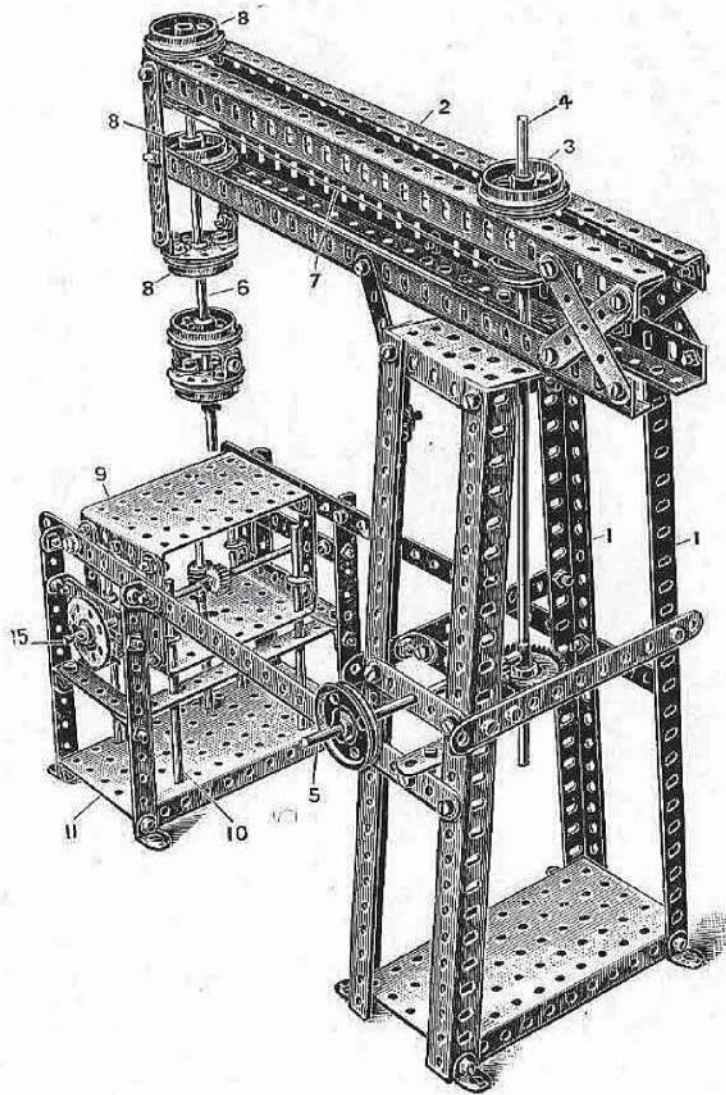

The main tower built up of top and bottom perforated plates with angle girder corner pieces, supports the driller arm made up of four angle brackets (2). The lower angle girders of the arm (2) are bolted to the top perforated plate, and a flanged wheel (3) bolted to the top angle girders forms the upper bearing for the driving shaft (4), driven from the main shaft (5) through a pinion and contrate wheel.

The drive from the shaft (4) is conveyed to the drilling spindle (6) by cord (7) passing round grooved pulleys on the spindles (4) and (6). The spindle (6) is journalled in flanged wheels (8) carried from the arm (2).

The drilling table (9) is arranged to rise and fall on the vertical spindles (10), Fig. 68A. These spindles (10) being held in the perforated plate (11), and framing strips (12), and passing through the end holes in the perforated plate (9A) of the table and guide angle brackets (13) bolted to the table walls. The vertical movement of the table is effected by the pinion (14) keyed to the operating shaft (15) meshing with the worm wheel (16) carried on a spindle (17) rigidly keyed to the table, the worm (16) acting as a rack.

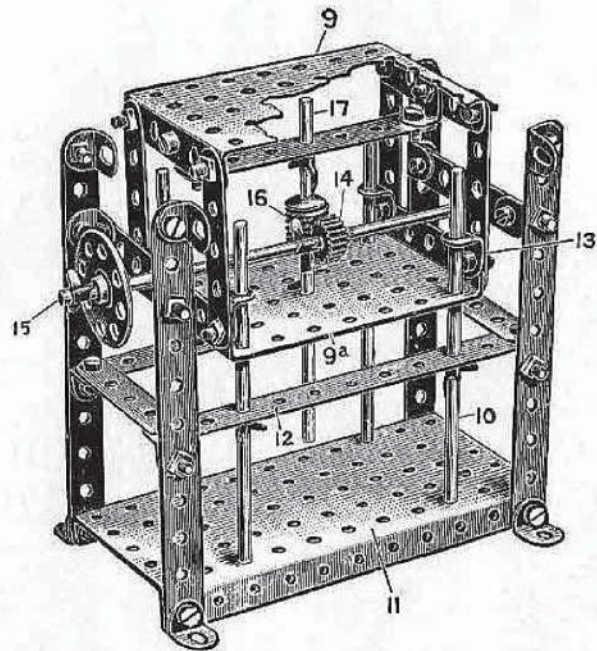

FIG. 68A.

Parts required in addition to Outfits.

PARTS REQUIRED.		No. 1	No. 2	No. 3
2	12 $\frac{1}{2}$ " Perforated Strips	—	—	—
9	5 $\frac{1}{2}$ " " "	3	—	—
3	3 $\frac{1}{2}$ " " "	2	1	—
2	3" " "	2	2	—
14	2 $\frac{1}{2}$ " " "	4	—	—
8	12 $\frac{1}{2}$ " Angle Girders	8	4	—
38	Angle Brackets	26	22	12
1	11 $\frac{1}{2}$ " Rod	1	1	1
2	6" "	2	2	2
4	5" "	4	1	—
2	4 $\frac{1}{2}$ " "	—	—	—
1	2" "	—	—	—
6	Flanged Wheels	6	2	2
1	1 $\frac{1}{2}$ " Pulley Wheel	1	1	—
2	1" " "	—	—	—
1	Bush " "	—	—	—
2	$\frac{1}{2}$ " Pinion " "	2	1	—
1	1 $\frac{1}{2}$ " Contrate " "	1	1	1
1	Worm " "	1	1	—
102	Nuts and Bolts	77	52	32
20	Keys	11	9	—
2	Collars and Set Screws	2	2	—
2	Large Rectangular Plates	1	1	—
3	Small " "	3	3	—

This completes the Models which may be made with "Meccano" No. 4. By purchasing a No. 4A Accessory Outfit at a cost of 14/- in cardboard box, or 35/- in walnut stained box with lock and key, Models No. 71 to 79 shown on the following pages may be made, or the necessary additional parts may be purchased separately at the prices shown on page 78.

We recommend the Accessory Outfit, as the parts are contained in a neat box, in which they may be kept when not in use.

Model No. 71. Travelling Crane

(MADE WITH MECCANO OUTFIT NO. 5 OR WITH NO. 4 AND NO. 4A.)

Parts required in addition to Outfits,

PARTS REQUIRED.

	No. 1	No. 2	No. 3	No. 4
12 12½" Perforated Strips	8	2	—	—
22 5½" " "	16	6	4	2
6 3½" " "	5	4	—	—
14 2½" " "	4	—	—	—
6 Angle Girders	6	2	—	—
46 Angle Brackets	34	30	20	2
2 3½" Rods	1	—	—	—
5 2" " "	3	3	2	1
2 Crank Handles	1	1	—	—
8 Flanged Wheels	8	4	4	—
1 1" Pulley Wheel	—	—	—	—
1 Bush Wheel	—	—	—	—
1 ¾" Pinion	1	1	—	—
1 ½" " "	1	—	—	—
1 Gear Wheel	1	1	—	—
1 Pawl	1	—	—	—
122 Nuts and Bolts	77	72	52	12
1 Hook	—	—	—	—
20 Keys	11	9	—	—
1 Single Bent Strip	—	—	—	—

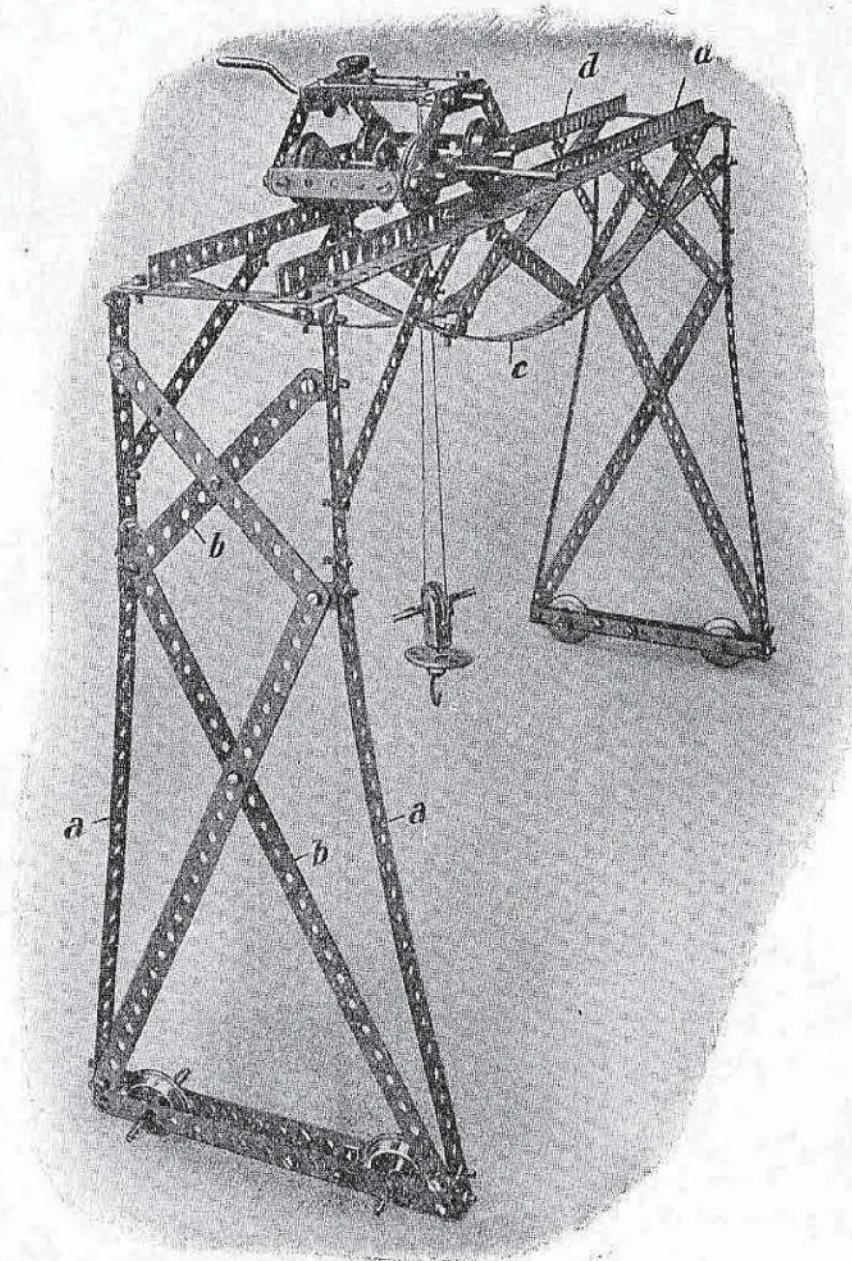

The side frames of this model are each similarly constructed. Two edge strips (*a*) of 12½" and 5½" overlapped in three holes and diagonal bracings (*b*) being attached to these edge strips (*a*) by angle brackets.

The side frames are connected together by two bowstring rail girders (*c*) also diagonally braced, as shown in Fig. No. 71A. The rail members (*d*) are composed of two angle girders butted together, and overlapped by a strengthening girder, in the central portion of which diagonal bracings are secured.

The construction of the carriage is shown in Fig. No. 61B.

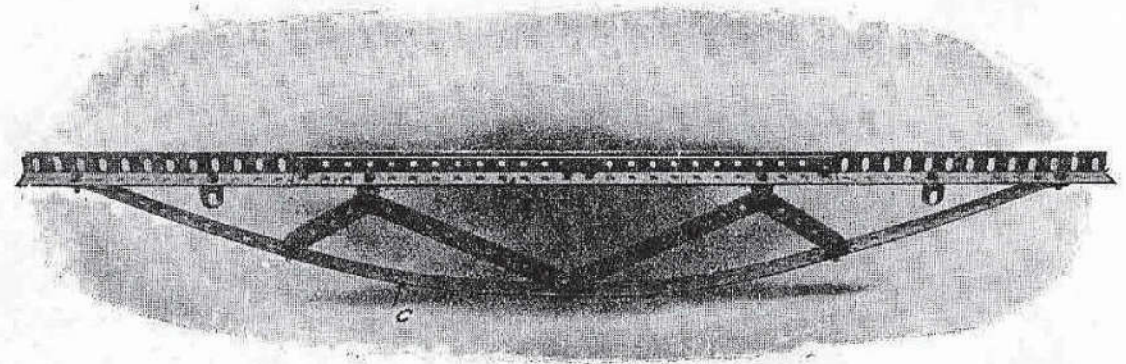

Model No. 72. Planing Machine

(MADE WITH MECCANO OUTFIT No. 5 OR No. 4 AND No. 4A.)

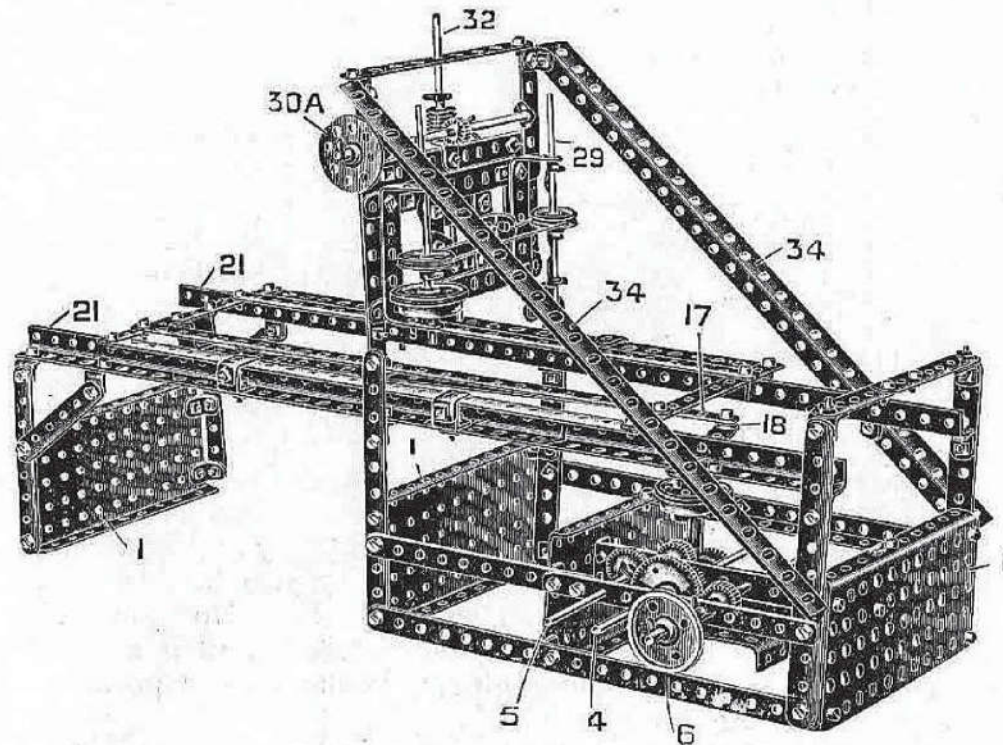

Parts required in addition to Outfits.

PARTS REQUIRED.		No. 1	No. 2	No. 3	No. 4
3	12 1/2" Perforated Strips	—	—	—	—
24	5 1/2" " "	18	8	6	4
3	3 1/2" " "	2	1	—	—
4	3" " "	4	4	2	—
6	2 1/2" " "	—	—	—	—
3	2" " "	3	3	3	3
8	12 1/2" Angle Girders	8	4	—	—
45	Angle Brackets	33	29	19	1
1	6" Rod	1	1	1	—
2	5" Rods	2	—	—	—
3	4 1/2" " "	—	—	—	—
2	3 1/2" " "	2	2	2	2
1	2" Rod	—	—	—	—
2	Flanged Wheels	2	—	—	—
1	1 1/2" Pulley Wheel	1	1	—	—
2	1" " "	—	—	—	—
1	1/2" " "	1	1	—	—
1	Bush Wheel	—	—	—	—
2	3/4" Pinion	2	2	1	—
2	1/2" " "	2	1	—	—
2	Gear Wheels	2	2	1	1
1	1 1/2" Contrate Wheel	1	1	1	—
1	Worm Wheel	1	1	—	—
133	Nuts and Bolts	118	83	63	23
27	Keys	18	16	5	5
2	Collars and Set Screws	2	2	—	—
1	Double Bent Strip	1	—	—	—
2	Large " "	2	2	1	1
4	Large Rectangular Plates	3	3	2	2
1	Small " "	1	1	—	—

Begin by constructing the gear box Fig. 72A, consisting of three large rectangular plates (1) joined by pairs of 5 1/2" strips (2) overlapped three holes. The strips (2) form bearings for the spindles (3) (4) and (5). The spindle (3) on which is the driving pulley (6) carries pinion (7) meshing with the gear wheel (8) keyed with the pinion (9) on the spindle (4). This pinion (9) meshes with the gear wheel (10) on the spindle (5) which also carries pinion (11) engaging the contrate wheel (12) on the vertical spindle (13). A crank is formed on the flanged wheel (14) by means of two angle brackets, bolted thereon. This crank is pivotally connected to the link (16) Fig. 72B, the other

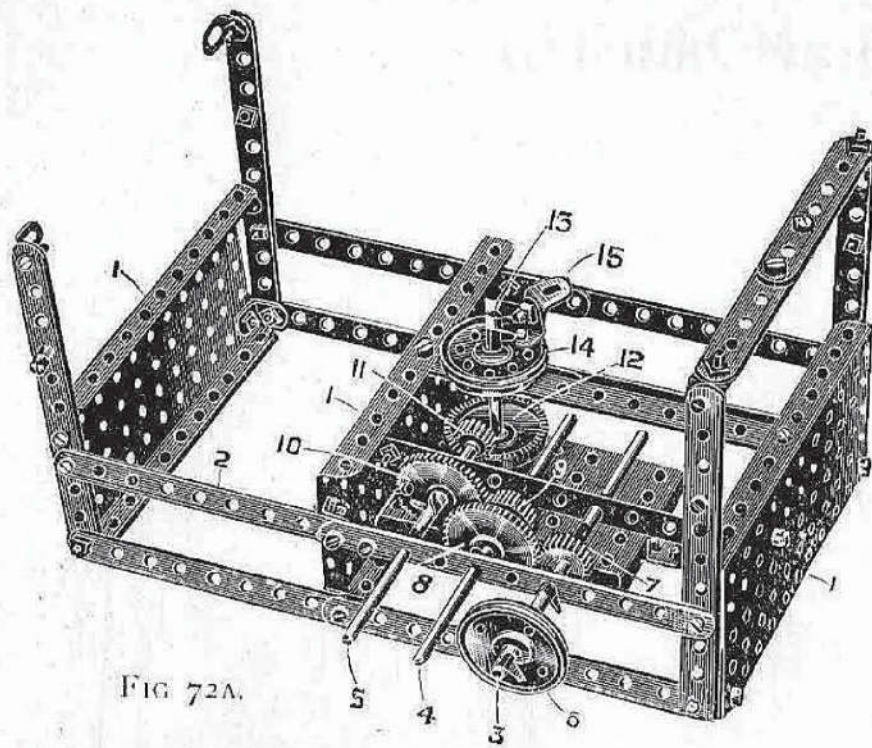

FIG. 72A.

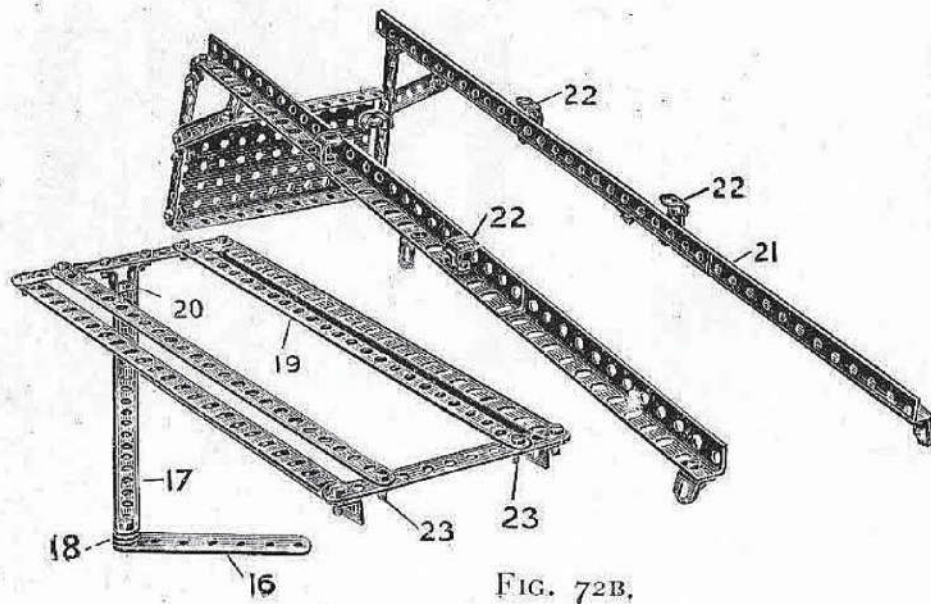

FIG. 72B.

extremity of which is pivotally connected to the connecting rod (17) by a lock-nutted attachment (18). The rod (17) is coupled to the table (19) by the double bent strip (20). The table (19) runs upon the angle girders (21). The angle brackets (22) forming guides for the table are first bolted in position, and the end nuts and bolts (23) of the table removed to enable the table to pass under the angle brackets initially.

Fig. 72c illustrates the mechanism for controlling the traversing and vertical movement of the tool (24). The tool is carried in the plate (25) to which are secured angle brackets (26) from which the operating cord (27) controlled by the flanged wheel (28A) passes round the pulleys (28) on the spindles (29). The vertical movement of the plate is regulated through the bush wheel (30A) by means of the pinion (30) engaging the worm (31) here acting as a rack, and keyed to the vertically moving spindle (32) guided in the strip (33). The tool head is stayed to the rear plate (1) by the diagonal girders (34).

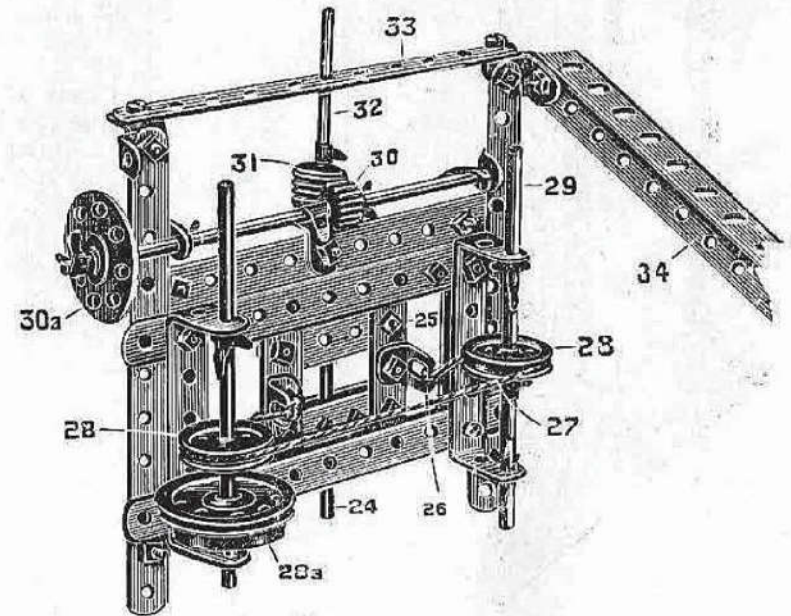
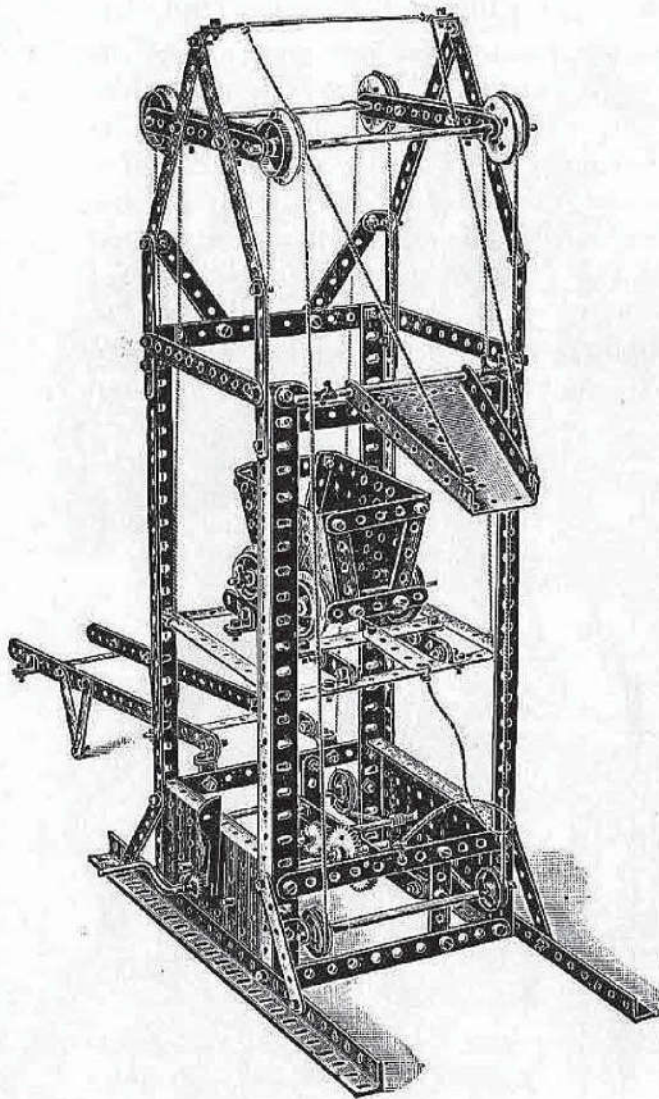

FIG. 72C.

Model No. 73. Coal Tip

(MADE WITH MECCANO OUTFIT NO. 5 OR NO. 4 AND NO. 4A.)



Parts required in addition to Outfits.

PARTS REQUIRED.

2	12½"	Perforated Strips
24	5½"	" "
8	3½"	" "
6	3"	" "
11	2½"	" "
6		Angle Girders
37		Angle Brackets
4	6"	Rods
3	5"	"
2	3½"	"
1		Crank Handle
8		Flanged Wheels
4	1"	Pulley Wheels
2	¾"	Pinion Wheels
1	½"	" "
1		Gear Wheel "
1		Pawl
124		Nuts and Bolts
28		Keys
2		Small Rectangular Plates
1		Sector Plate

No. 1	No. 2	No. 3	No. 4
—	—	—	—
18	8	6	4
7	6	2	2
6	6	4	2
1	—	—	—
6	2	—	—
25	21	11	—
4	4	4	2
3	—	—	—
2	2	2	2
—	—	—	—
8	4	4	—
—	2	—	—
2	2	1	—
1	—	—	—
1	1	—	—
1	—	—	—
99	74	54	14
19	17	6	—
2	2	—	—
—	—	—	—

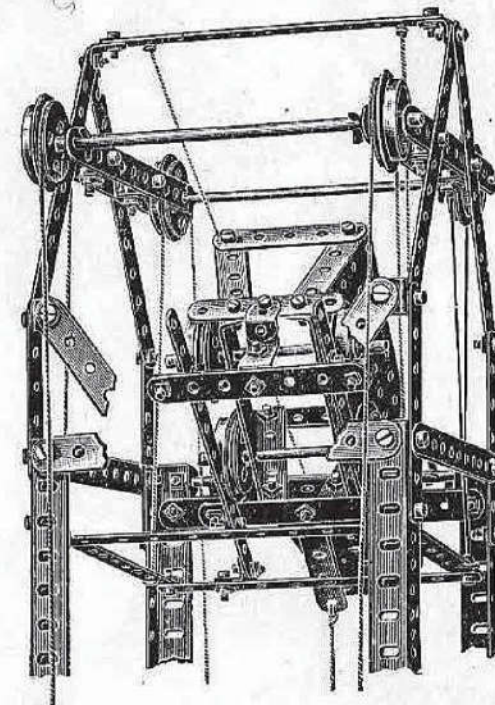

Model No. 74. Telpher Line

(MADE WITH MECCANO OUTFIT No. 5 OR No. 4 AND No. 4A.)

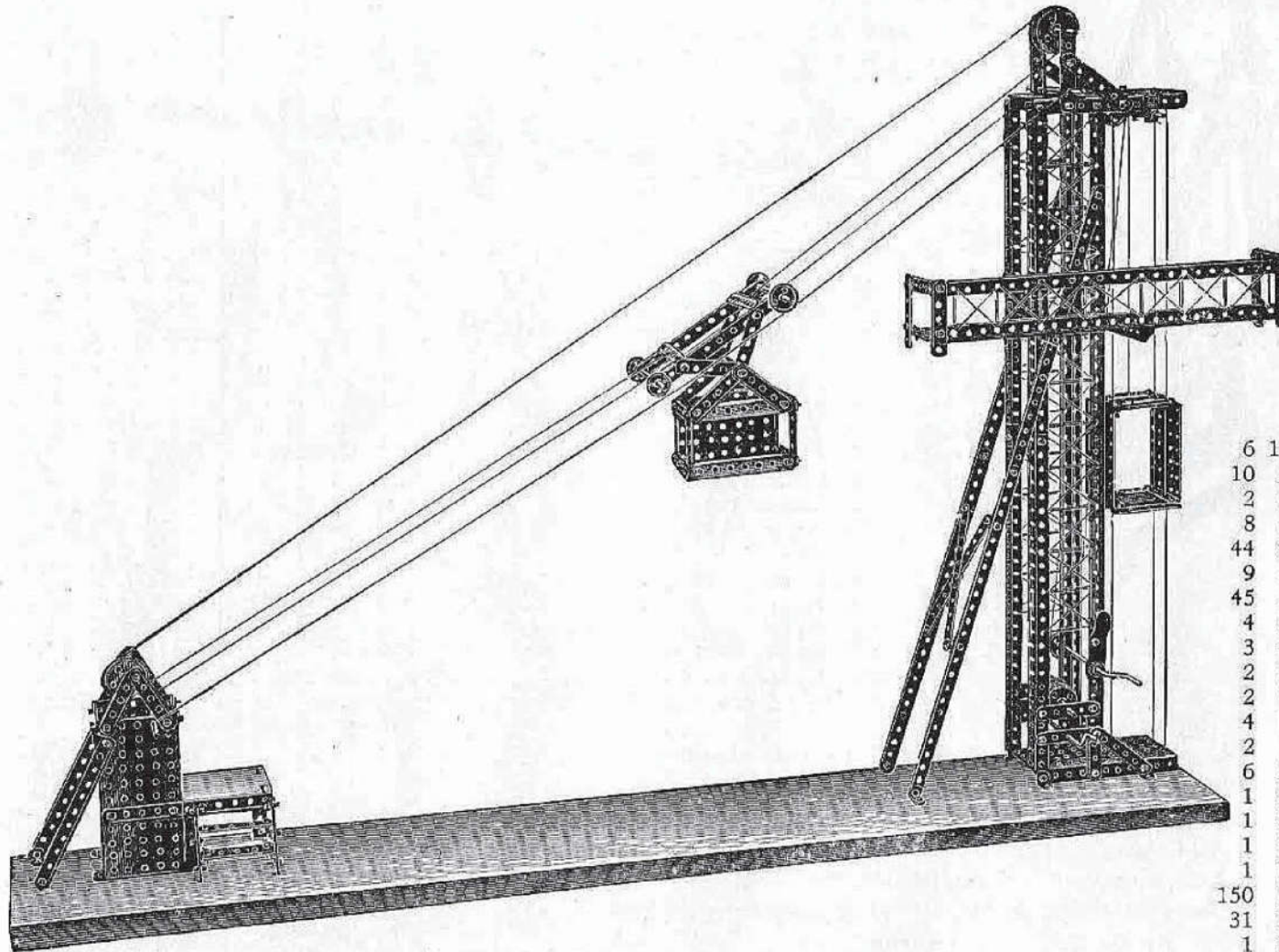

This figure represents a Telpher Line such as is used in hilly countries for transporting loads across intervening valleys.

Parts required in addition to Outfits

PARTS REQUIRED.		No. 1	No. 2	No. 3	No. 4
6	12 $\frac{1}{8}$ " Perforated Strips	2	—	—	—
10	5 $\frac{1}{2}$ " " "	4	—	—	—
2	3 $\frac{1}{2}$ " " "	1	—	—	—
8	3" " "	8	8	6	4
44	2 $\frac{1}{2}$ " " "	34	30	30	26
9	Angle Girders	9	5	1	1
45	Angle Brackets	33	29	19	1
4	5" Rods	4	1	—	—
3	4 $\frac{1}{2}$ " " "	—	—	—	—
2	3 $\frac{1}{2}$ " " "	2	2	2	2
2	Crank Handles	1	1	—	—
4	Flanged & Grooved Wheels	4	—	—	—
2	1 $\frac{1}{2}$ " Pulley Wheels	2	2	1	1
6	1" " "	—	4	2	1
1	$\frac{3}{4}$ " Pinion Wheel	1	1	—	—
1	$\frac{1}{2}$ " " "	1	—	—	—
1	Gear Wheel	1	1	—	—
1	Pawl	1	—	—	—
150	Nuts and Bolts	125	100	80	40
31	Keys	22	20	9	9
1	Large Bent Strip	1	1	—	—
4	Large Rectangular Plates	3	3	2	2
3	Small Rectangular Plates	3	3	—	—

Model No. 75. Travelling Gantry

(MADE WITH MECCANO OUTFIT NO. 5 OR NO. 4 AND NO. 4A.)

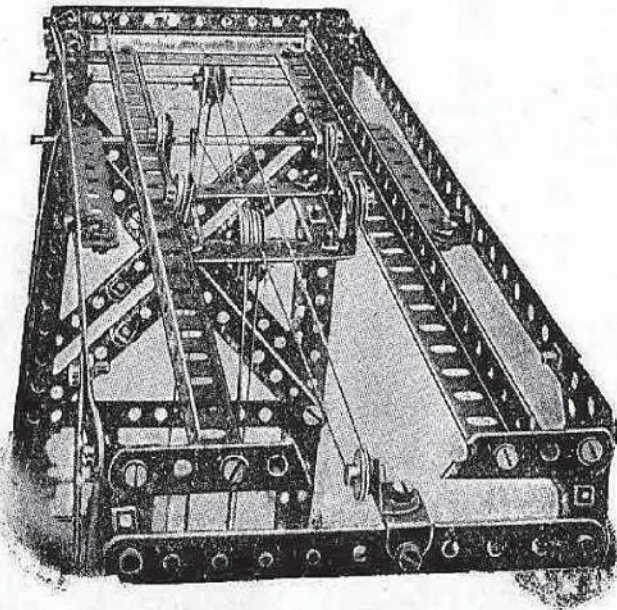
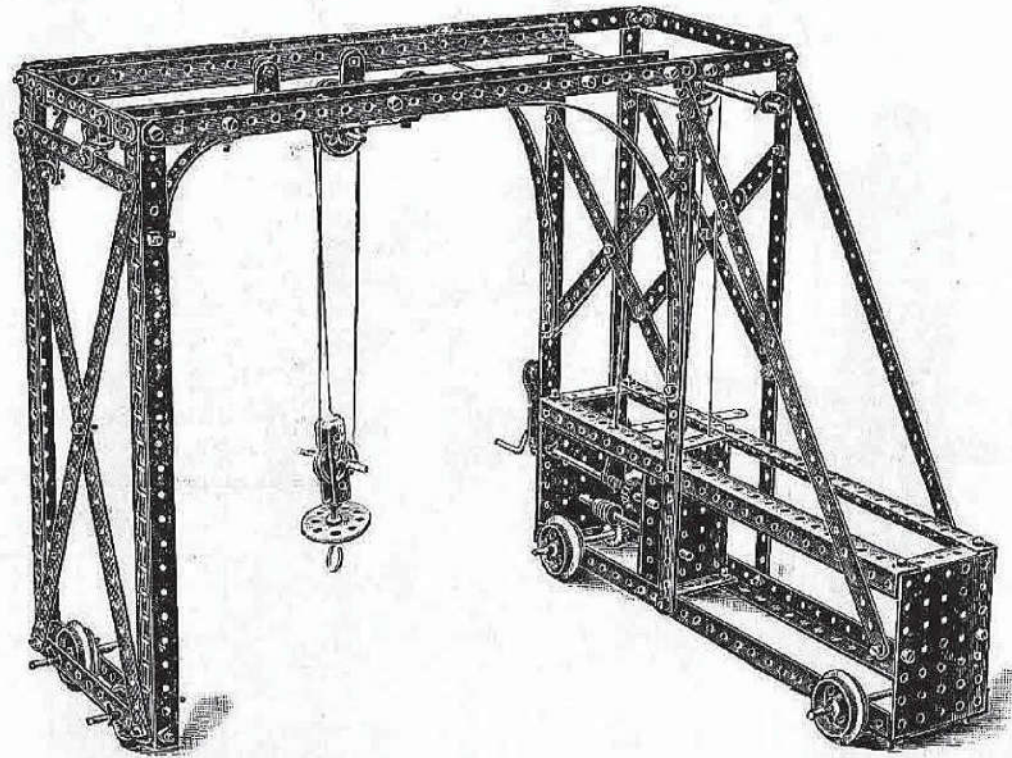

PARTS REQUIRED.

12	12 $\frac{3}{4}$ "	Perforated Strips	8	2	—	—
16	5 $\frac{1}{2}$ "	" "	10	—	—	—
1	3 $\frac{1}{2}$ "	" "	—	—	—	—
2	3"	" "	2	2	—	—
3	2 $\frac{1}{2}$ "	" "	—	—	—	—
8		Angle Girders	8	4	—	—
26		Angle Brackets	14	10	—	—
2	6"	Rods	2	2	2	—
1	5"	"	1	—	—	—
2	4 $\frac{1}{2}$ "	"	—	—	—	—
4	2"	"	2	2	1	—
3		Crank Handles	2	2	1	—
6		Flanged and Grooved Wheels	6	2	2	—
6	1"	Pulleys	—	4	2	1
6	$\frac{1}{2}$ "	"	6	6	5	5
1		Bush Wheel	—	—	—	—
2	$\frac{3}{4}$ "	Pinion Wheels	2	2	1	—
2	$\frac{1}{2}$ "	"	2	1	—	—
1		Gear Wheel "	1	1	—	—
1		Worm Wheel	1	1	—	—
109		Nuts and Bolts	84	59	39	—
1		Pawl	1	—	—	—
1		Hook	—	—	—	—
33		Keys	24	22	11	11
4		Collars and Set Screws	4	4	—	—
2		Single Bent Strips	1	1	1	1
2		Large Bent Strips	2	2	1	1
3		Small Rectangular Plates	3	3	—	—

Parts required in addition to Outfits

No. 1	No. 2	No. 3	No. 4
8	2	—	—
10	—	—	—
—	—	—	—
2	2	—	—
—	—	—	—
8	4	—	—
14	10	—	—
2	2	2	—
1	—	—	—
—	—	—	—
2	2	1	—
2	2	1	—
6	2	2	—
—	4	2	1
6	6	5	5
—	—	—	—
2	2	1	—
2	1	—	—
1	1	—	—
1	1	—	—
84	59	39	—
1	—	—	—
—	—	—	—
24	22	11	11
4	4	—	—
1	1	1	1
2	2	1	1
3	3	—	—

A most interesting model to the student of mechanics. If carefully constructed, the mechanism will be found to work with the utmost precision and smoothness, and much instruction can be gained by a study of its parts.

The construction is quite straightforward, and hardly needs any description. Care should be taken as to the construction of the clutch mechanism, which is clearly shown in the illustration.

As regards the Cord for operating the travelling carriage, care must be taken to wind this cord twice around the pulley on the spindle of the traversing handle.

...44...

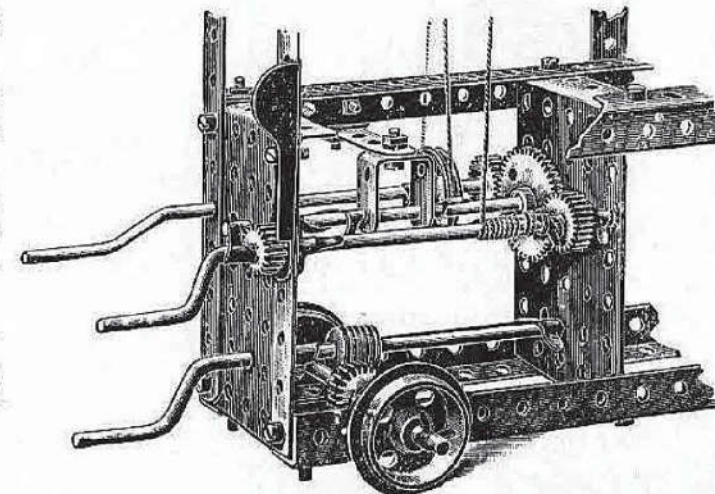

Model No. 76. Revolving Aeroplane

(MADE WITH MECCANO OUTFIT No. 5 OR No. 4 AND No. 4A.)

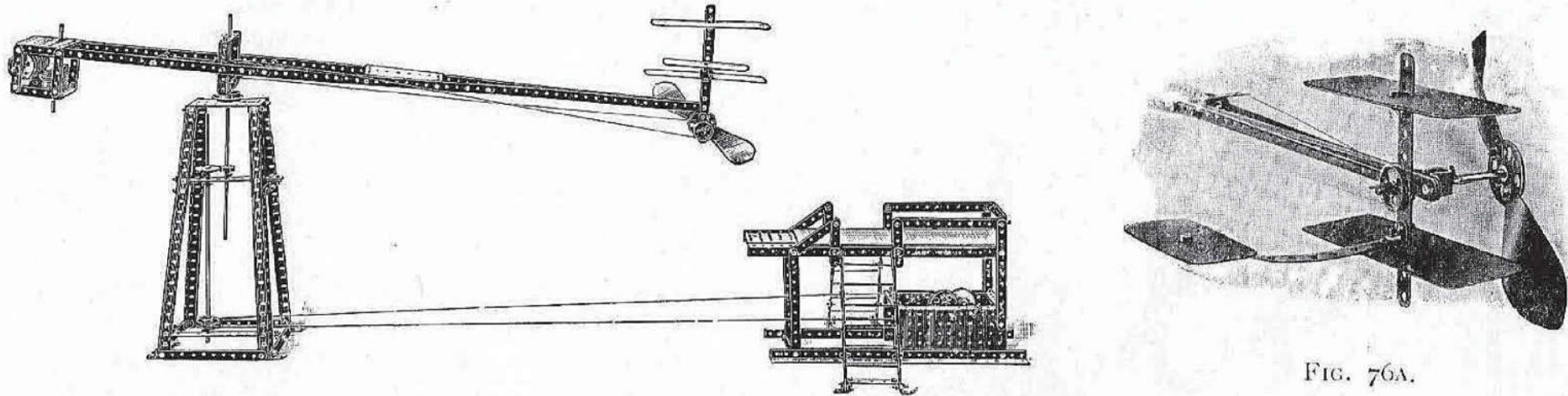

FIG. 76A.

Parts required in addition to Outfits.

Parts required in addition to Outfits.

PARTS REQUIRED.	No. 1	No. 2	No. 3	No. 4
6 12 $\frac{1}{2}$ " Perforated Strips	2	—	—	—
23 5 $\frac{1}{2}$ " " "	17	7	5	3
10 3 $\frac{1}{2}$ " " "	9	8	4	4
2 3" " "	2	2	—	—
11 2 $\frac{1}{2}$ " " "	1	—	—	—
8 Angle Girders	8	4	—	—
28 Angle Brackets	16	12	2	—
2 11 $\frac{1}{2}$ " Rods	2	2	2	—
4 5" "	4	1	—	—
1 4 $\frac{1}{2}$ " "	—	—	—	—
1 3 $\frac{1}{2}$ " "	1	1	—	—
1 2" "	—	—	—	—
1 Crank Handle	—	—	—	—
1 Flanged Wheel	1	—	—	—
2 1 $\frac{1}{2}$ " Pulley Wheels	2	2	1	1

PARTS REQUIRED.	No. 1	No. 2	No. 3	No. 4
2 1" Pulley Wheels	—	—	—	—
6 $\frac{1}{2}$ " " "	6	6	5	5
1 Bush Wheel	—	—	—	—
3 $\frac{3}{4}$ " Pinions	3	3	2	1
2 Gear Wheels	2	2	1	1
1 $\frac{3}{4}$ " Contra Wheel	1	1	1	—
128 Nuts and Bolts	103	78	58	18
27 Keys	18	16	5	5
2 Propeller Blades	2	2	2	2
1 Double Bent Strip	1	—	—	—
2 Large Bent Strips	2	2	1	1
2 Large Rectangular Plates	1	1	—	—
4 Small Rectangular Plates	4	4	1	1
1 Sector Plate	—	—	—	—

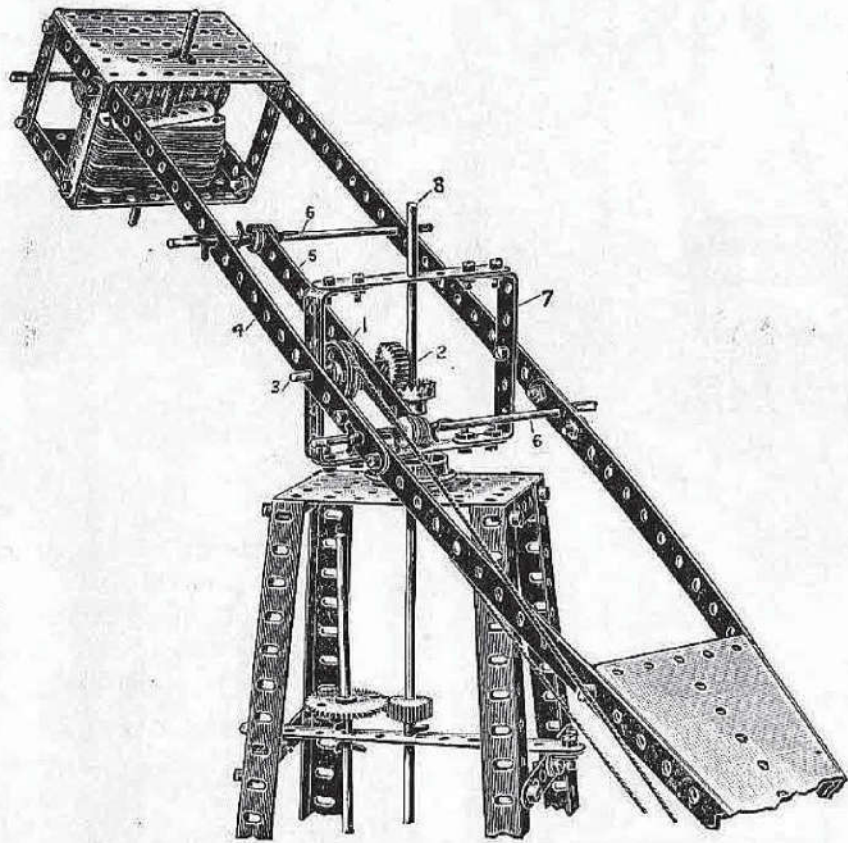

FIG. 76B.

As regards the construction of the detailed portion shown in Fig. 76B, the pulley wheel (1) and the pinion (2) are both keyed on the short spindle (3) in the following manner : The pulley wheel (1) is first inserted on the spindle (3), after the latter has been passed through the outer strip (4). It is then keyed on the spindle, and the $5\frac{1}{2}$ " strip (5), which is loose on both the spindles (6), is then slid on the spindles (6) and the spindle (3) close against the pulley wheel (1). The pinion (2) is then inserted on the spindle (3), and keyed in place. During this operation it is necessary to have the swinging arm and the square frame (7) drawn off the main vertical spindle (8), so as to give room for the keying up of the pulley (1) and pinion (2), after which the frame (7) may be dropped into place over the spindle (8).

The balance weight is made up of a series of short strips or wheels threaded over the spindles in the shorter arm, and by this means the weight can be adjusted to any nicety.

The driving gear is operated from the crank handle (shown on the right in the sketch), and drives the vertical spindle (8) in the pedestal on the left, upon which a $\frac{3}{4}$ " contrate wheel is keyed, engaging the $\frac{3}{4}$ " pinion (2). At the upper end of this spindle is mounted the balanced swinging arm carrying the propeller and aeroplane on its longer limb, and a balance weight on the short one. The operation of the crank will cause the propeller to revolve, and the aeroplane to travel.

Model No. 77.

Signal Gantry

(MADE WITH MECCANO OUTFIT No. 5 OR NO. 4 AND NO. 4A.)

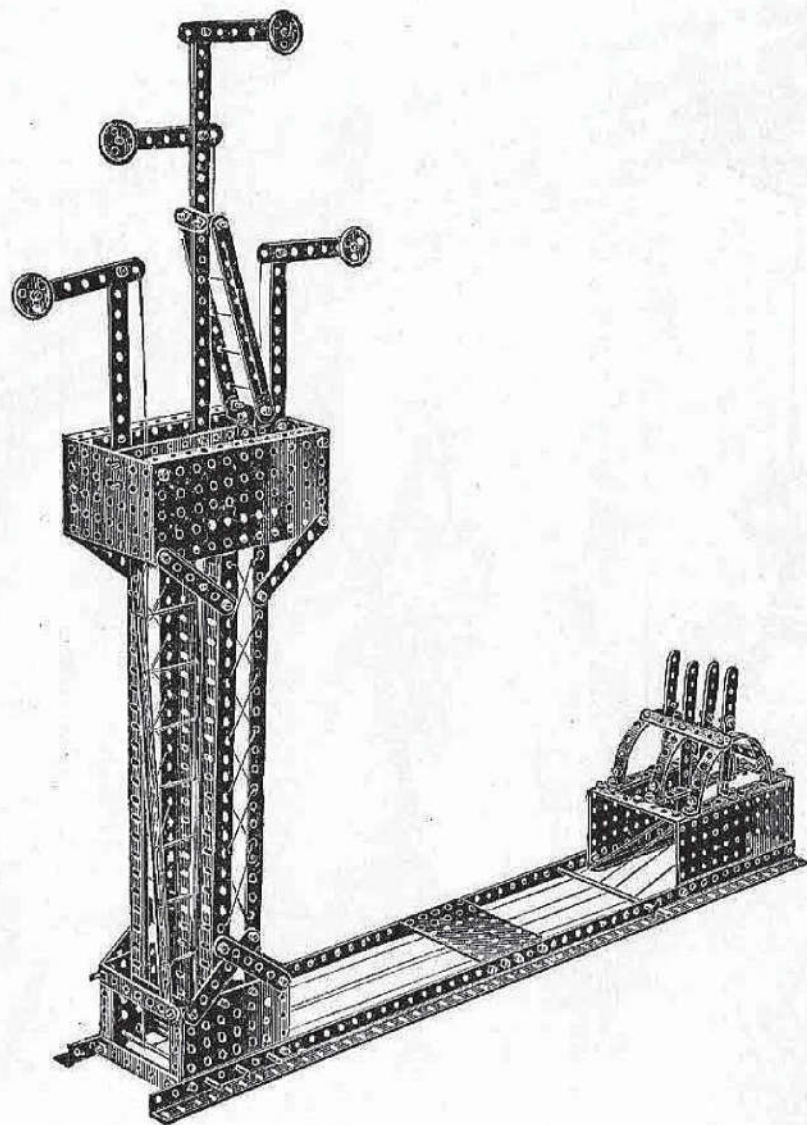

*Parts required in addition
to Outfits*

PARTS REQUIRED.

3	12½"	Perforated Strips	—	—	—	—
13	5½"	" "	7	—	—	—
16	3½"	" "	15	14	10	10
8	3"	" "	8	8	6	4
8		Angle Girders	8	4	—	—
33		Angle Brackets	21	17	7	—
1	5"	Rod	1	—	—	—
3	4½"	Rods	—	—	—	—
4	1"	Pulley Wheels	—	2	—	—
138		Nuts and Bolts	113	88	68	28
8		Keys	—	—	—	—
4		Large Rectangular Plates	3	3	2	2
5		Small Rectangular Plates	5	5	2	2

No. 1	No. 2	No. 3	No. 4
—	—	—	—
7	—	—	—
15	14	10	10
8	8	6	4
8	4	—	—
21	17	7	—
1	—	—	—
—	—	—	—
—	2	—	—
113	88	68	28
—	—	—	—
3	3	2	2
5	5	2	2

Model No. 78. Extended Tip

(MADE WITH MECCANO OUTFIT NO. 5 OR NO. 4 AND NO. 4A.)

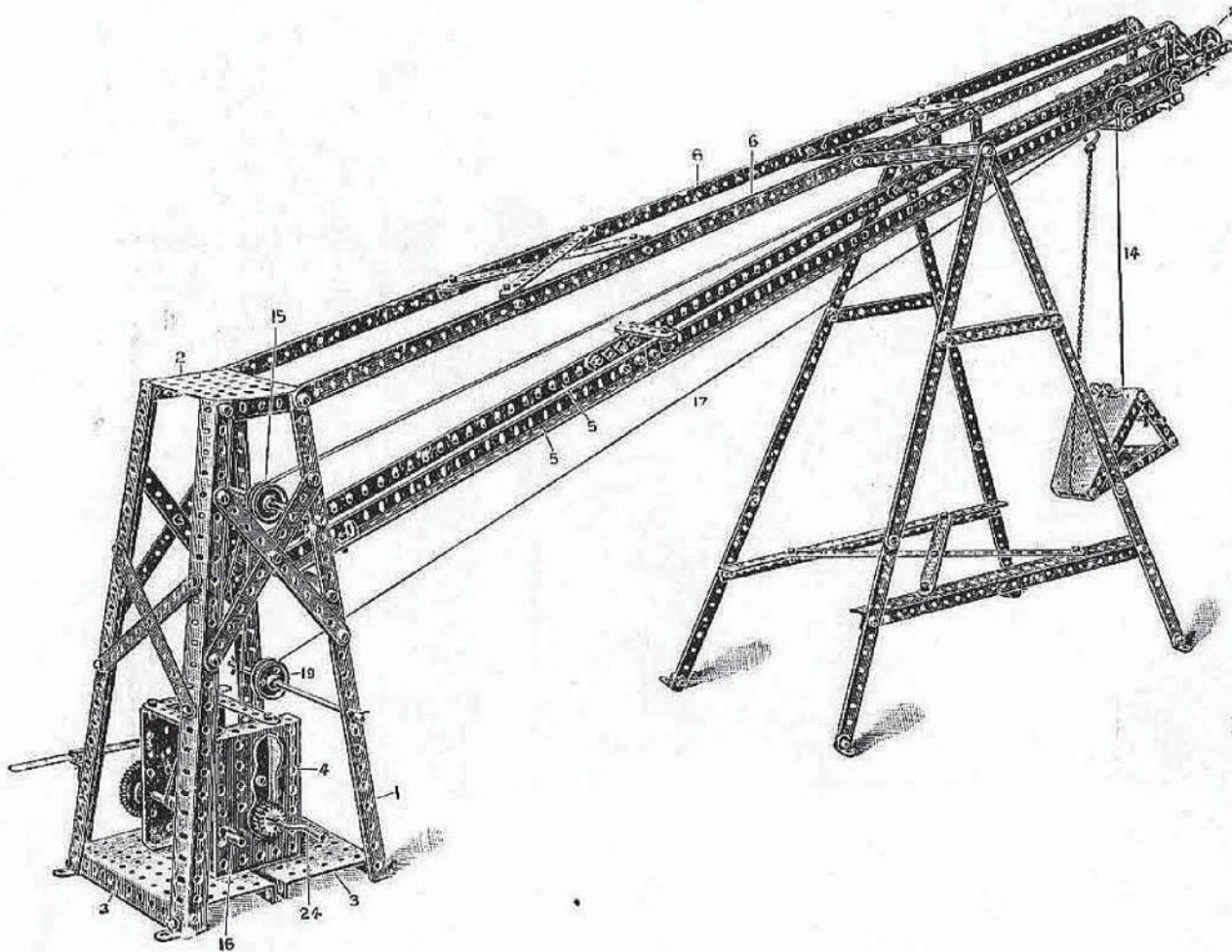

PARTS REQUIRED.

14	12 $\frac{1}{2}$ "	Perforated Strips
17	5 $\frac{1}{2}$ "	" "
7	3 $\frac{1}{2}$ "	" "
2	3"	" "
8	2 $\frac{1}{2}$ "	" "
6	2"	" "
12	12 $\frac{1}{2}$ "	Angle Girders
28		Angle Brackets
2	6"	Rods
1	5"	Rod
1	4 $\frac{1}{2}$ "	"
2	3 $\frac{1}{2}$ "	Rods
2	2"	"
1		Crank Handle
1	1 $\frac{1}{2}$ "	Pulley Wheel
5	1"	Pulley Wheels
4	1 $\frac{1}{2}$ "	" "
1	1 $\frac{3}{4}$ "	Pinion Wheel
1	1 $\frac{1}{2}$ "	" "
2		Gear Wheels
1		Pawl
149		Nuts and Bolts
26		Keys
2		Collars and Set Screws
1		Small Chain
2		Single Bent Strips
2		Large " "
2		Large Rectangular Plates
3		Small " "
1		Eye Piece

Parts required in addition to Outfits.

No. 1	No. 2	No. 3	No. 4
10	4	4	—
11	1	—	—
6	5	1	1
2	2	—	—
—	—	—	—
6	6	6	6
12	8	4	4
16	12	2	—
2	2	2	—
1	—	—	—
—	—	—	—
2	2	2	2
—	—	—	—
1	1	—	—
—	3	1	—
4	4	3	3
1	1	—	—
1	—	—	—
2	2	1	1
1	—	—	—
124	99	79	39
17	15	4	4
2	2	—	—
1	1	1	1
1	1	1	1
2	2	1	1
1	1	—	—
3	3	—	—
1	1	1	—

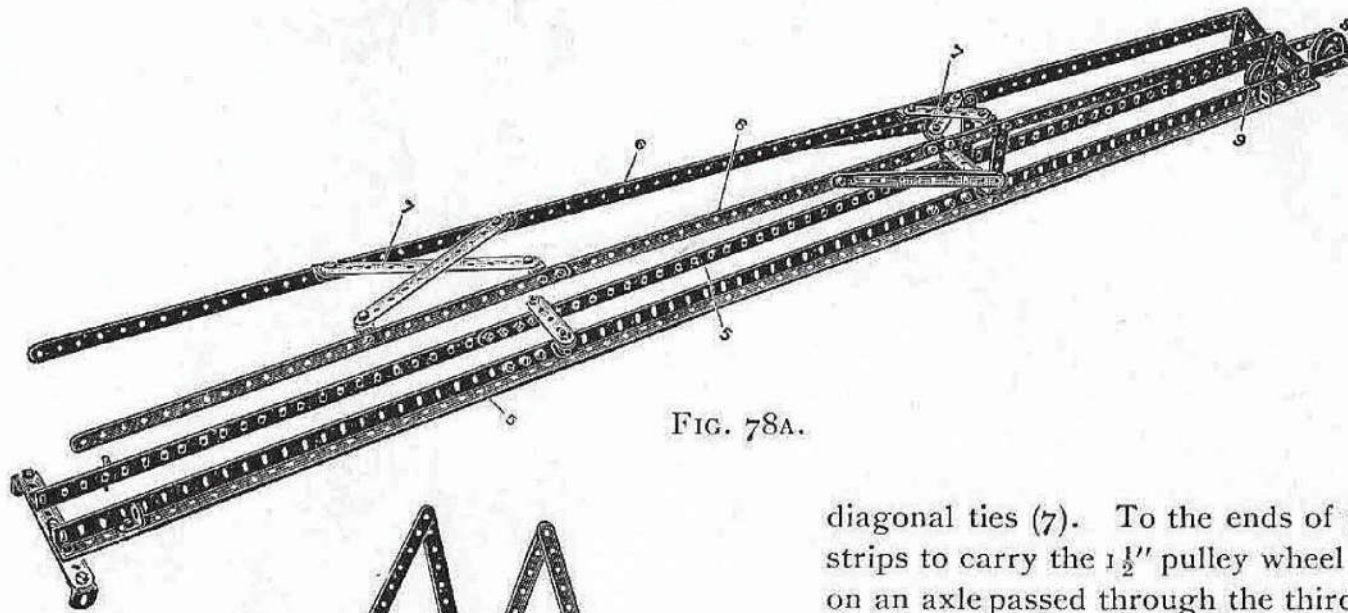

FIG. 78A.

The main tower of the tip is made from four $12\frac{1}{2}$ " angle girders (1) bolted at the top to a small rectangular plate (2) and at the bottom to two large plates (3); the side plates (4) of the gear box being bolted to the rectangular base plates.

The jib, Fig 78A is made from sets of angle girders (5) butted together and coupled by strips, a pair of members (6) being formed from $12\frac{1}{2}$ " strips strengthened by

diagonal ties (7). To the ends of the angle girders (5) are bolted two $3\frac{1}{2}$ " strips to carry the $1\frac{1}{2}$ " pulley wheel (8) and the 1" pulley wheel (9) is carried on an axle passed through the third holes from the end of the angle girders.

The support for the jib is shown in Fig. 78B, and the jib is connected to this support by a $3\frac{1}{2}$ " perforated strip attached by angle brackets to the support and to the angle girders (5).

The trolley Fig. 78C carrying the tip bucket is made from two large bent strips (10) in the upper ends of which are lock-nutted $\frac{1}{2}$ " pulley wheels, the bent ends of the strips being connected by 3" strips (11) in one of the central holes of which is the axle (12) carrying the pulley (13) for the operating cord (14) of the tip bucket. This cord passes round the inner end pulley (9) and back to one of the pulleys (15) and then to the winding shaft (16). The cord (17) for traversing the trolley along the rails is continuous, being given a complete turn round the spindle (18) Fig. 78D, then round the pulley (19) to the trolley, and again from the trolley round the outer pulley (8) back over one of the pulleys (15) to the winding spindle (18).

The tip bucket as will be seen from Fig. 78C is made from two sector plates (20) bolted together at their lower edges, and coupled by $2\frac{1}{2}$ " strips at their upper ends; the bucket is supported by a single bent strip (21) engaging the axle passed through the strips. A slack chain (22) connects

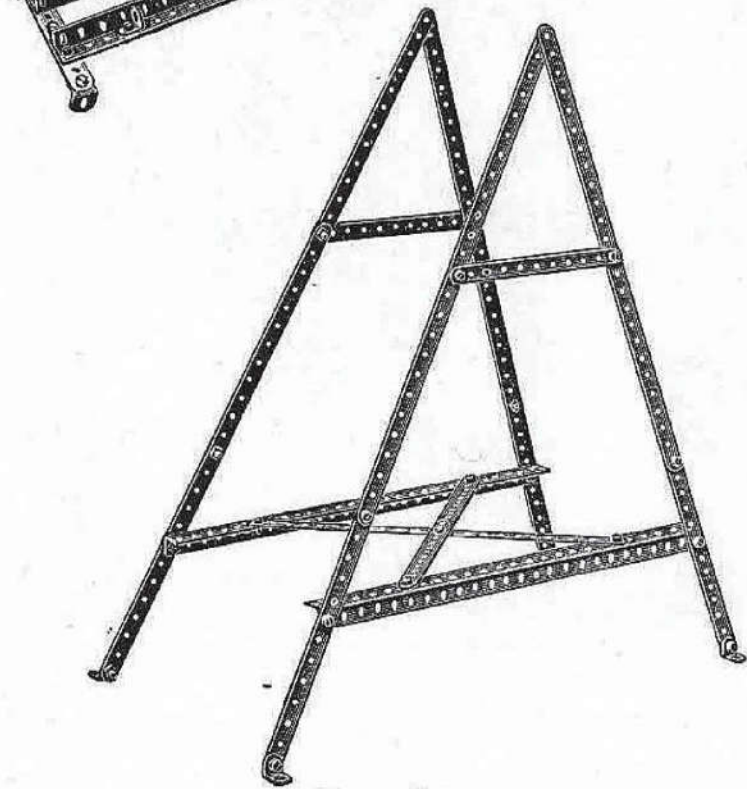

FIG. 78B.

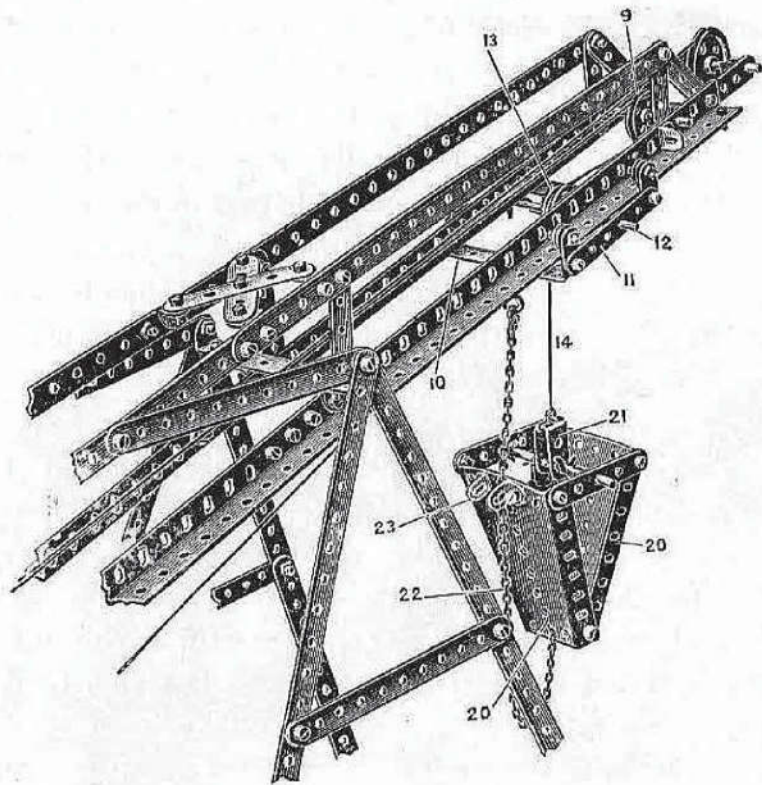

FIG. 78C.

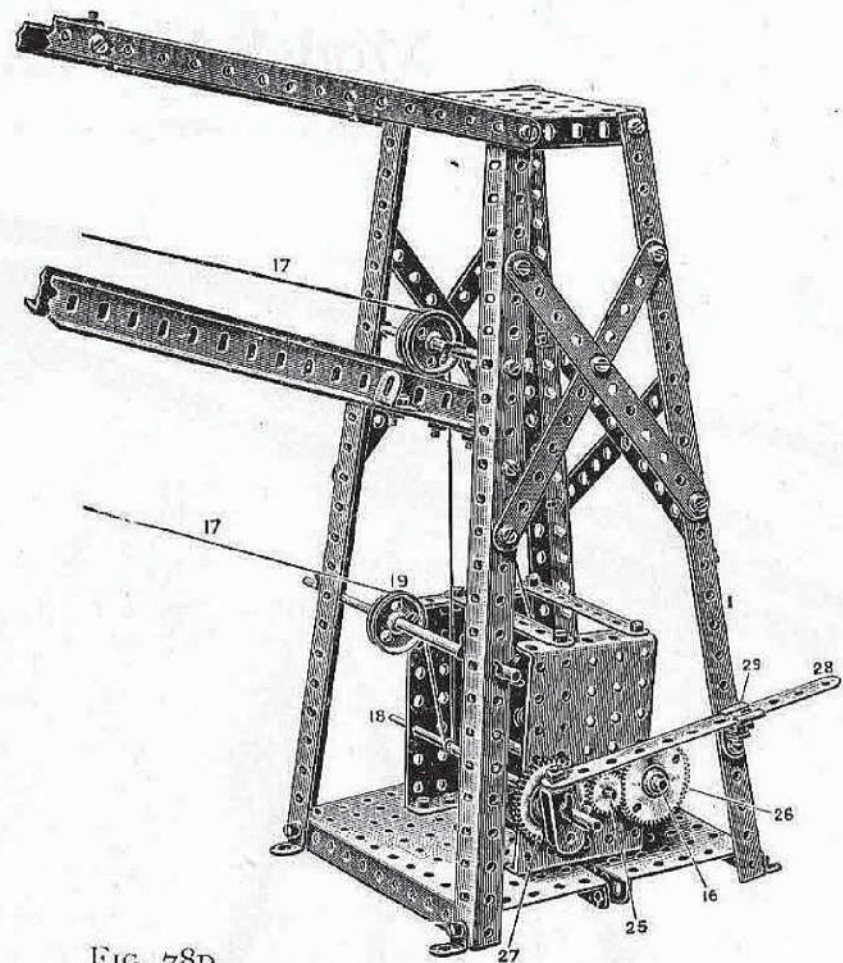

FIG. 78D.

the lower end of the tip bucket to a hook on the trolley, the chain passing between angle bracket girders (23).

To tip the bucket, the cord (14) is lowered until the chain (22) becomes taut, further lowering of the cord (14) then allowing the bucket to swing over.

The cranked spindle (24) is provided at its opposite end with a pinion (25) which is permanently in gear with a $1\frac{1}{2}$ " gear wheel (26) on the spindle (16) controlling the hoisting cord (14). Another $1\frac{1}{2}$ " gear wheel (27) is mounted on the spindle (18) and is so controlled by the lever (28) that it may be thrown in or out of gear with the pinion (25). The lever (28) is supported in an eye piece (29) carried from the corner girder (1).

To cause the bucket trolley to traverse the rails without raising or lowering the bucket, the gear wheel (27) is engaged with the pinion (25), but to lift or lower the bucket, the gear wheel (27) is disengaged, the hoisting wheel (26) only being operated.

Model No. 79. Turn-table Crane

(MADE WITH MECCANO OUTFIT NO. 5 OR NO. 4 AND NO. 4A.)

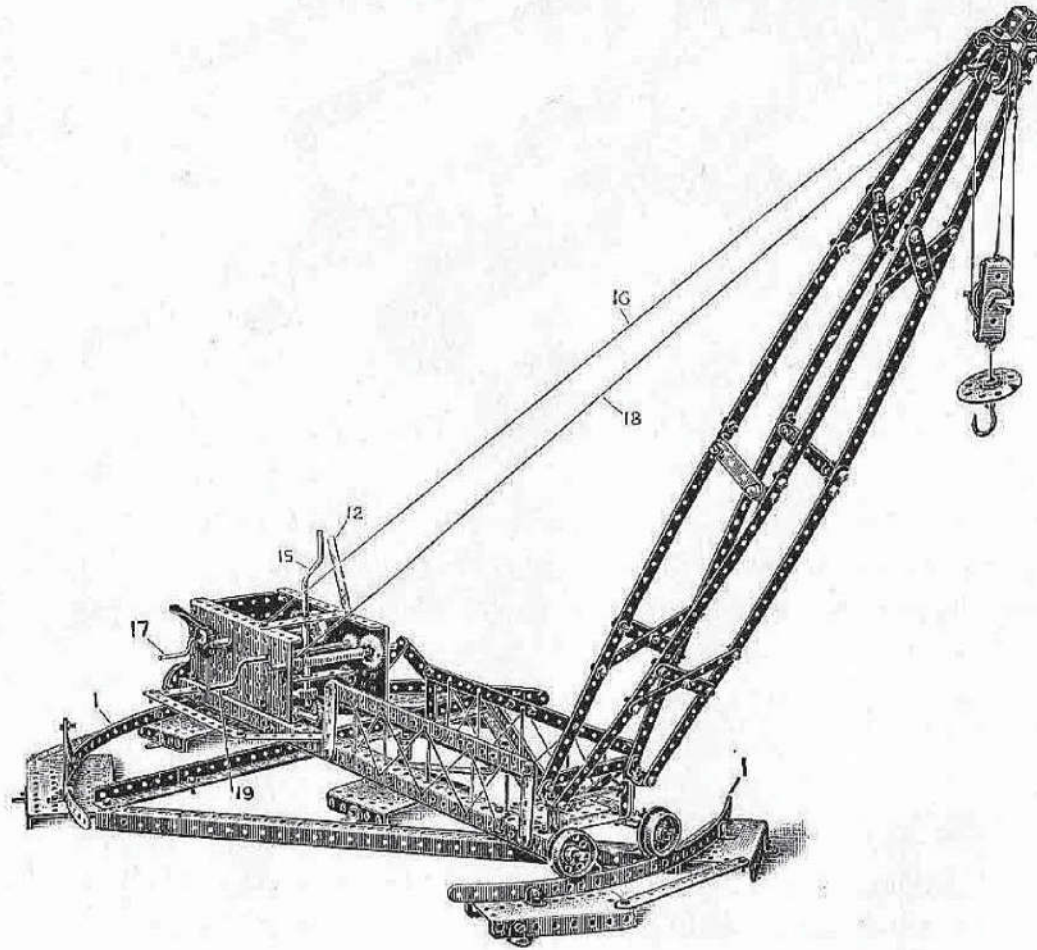

*Parts required
in addition to Outfits.*

PARTS REQUIRED.		No. 1	No. 2	No. 3	No. 4
11	12½" Perforated Strips	7	1	1	—
11	5½" " "	5	—	—	—
7	3½" " "	6	5	1	1
1	3" " "	1	1	—	—
14	2½" " "	4	—	—	—
3	2" " "	3	3	3	3
10	12½" Angle Girders	10	6	2	2
49	Angle Brackets	37	33	23	5
1	6" Rod	1	1	1	—
4	5" Rods	4	1	—	—
2	4½" " "	—	—	—	—
1	3½" " "	1	1	1	1
2	2" " "	—	—	—	—
3	Crank Handles	2	2	1	—
5	Flanged Wheels	5	1	1	—
4	1" Pulley Wheels	—	2	—	—
1	Bush Wheel	—	—	—	—
2	¾" Pinion Wheels	2	2	1	—
2	½" " "	2	1	—	—
2	Gear Wheels	2	2	1	1
1	1½" Contrate Wheel	1	1	1	—
1	Pawl	—	—	—	—
30	Keys	21	19	8	8
156	Nuts and Bolts	131	106	86	45
1	Hook	—	—	—	—
2	Single Bent Strips	1	1	1	1
1	Double Bent Strip	1	—	—	—
1	Large " "	1	1	—	—
4	Large Rectangular Plates	3	3	2	2
5	Small " "	5	5	2	2
2	Sector Plates	—	—	—	—

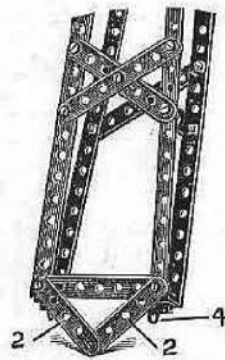

FIG. 79A.

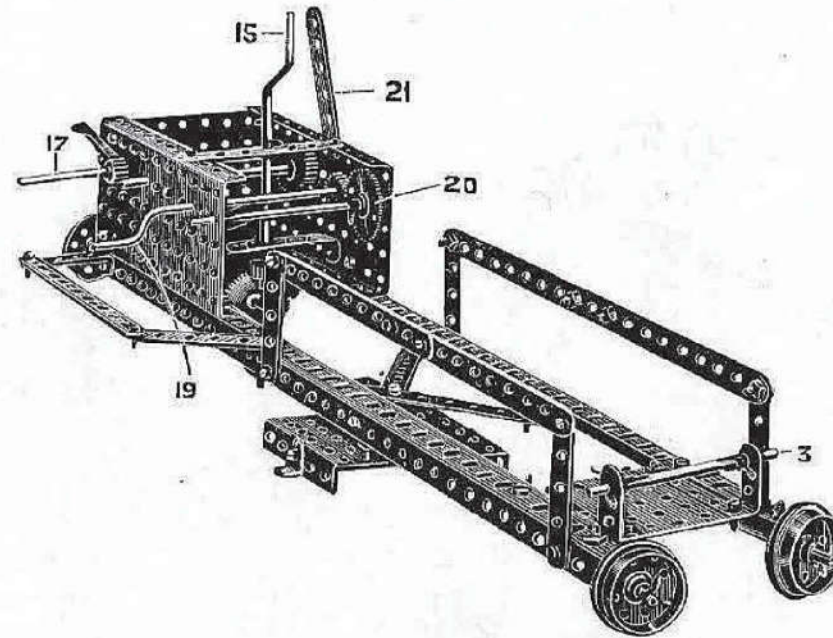

FIG. 79B.

This crane, the jib of which is carried from a turn-table, swivels on the rails (1). The jib is braced as shown clearly in the general illustration, the lower part being fitted with diagonal strips (2) Fig. 79A, which act as a stop to limit the elevational movement of the jib, which swivels on the extremities of a $3\frac{1}{2}$ " axle rod (3) Fig. 79B, engaged by angle brackets (4) on the jib.

The circular rails (1) made of curved $12\frac{1}{2}$ " strips, Fig. 79C, supported on perforated plates (4) braced by angle girders (5) overlapped as shown.

The construction of the turn-table is shown in the inverted view, Fig. 79D, the side angle girders (6) being connected by perforated plates (7), and diagonal strips (8). The central hole of these strips (8) is pivotally connected by a bolt to the yoke piece (9) made of a large bent strip, the up-turned ends of which are bolted by angle brackets to a perforated plate (10). The platform swivels about this pivotal connection. The running flanged wheels (11) are mounted on radially placed rods (12) being carried in angle brackets bolted to the plates (7).

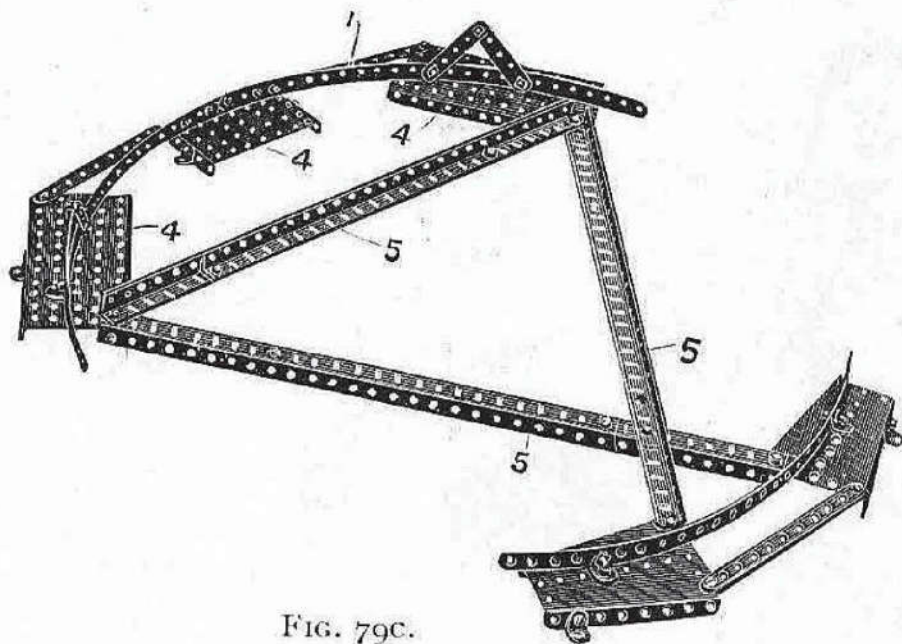

FIG. 79C.

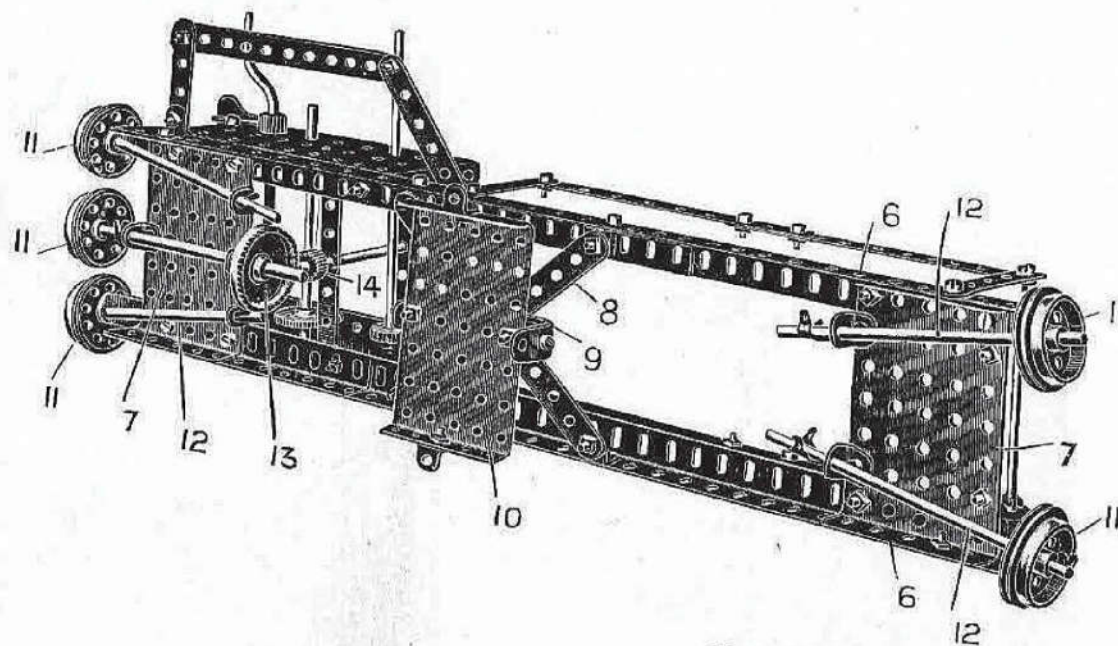

FIG. 79D.

The central flanged wheel (11) is driven by the contrate wheel (13) engaged by the pinion (14) mounted on the cranked handle (15), see Fig. 79B. The jib is elevated by the operating cord (16) controlled by the crank handle (17); and the hoisting gear by the cord (18) controlled by the cranked handle (19) meshing by a $\frac{3}{4}$ " pinion with a gear wheel (20) on the winding spindle. The brake gear, the handle (21) of which is shown in the illustration is similar to that shown in Standard Details 1.

This completes the Models which may be made with "Meccano" No. 5. By purchasing a No. 5A Accessory Outfit at a cost of 50/-, all the Models contained in this book may be made, or the necessary additional parts may be purchased separately, at the prices shown on page 78.

We recommend the Accessory Outfit, as the parts are contained in a neat box, in which they may be kept when not in use.

Model No. 81. Tower Bridge

(MADE WITH MECCANO OUTFIT NO. 6 OR NO. 5 AND NO. 5A.)

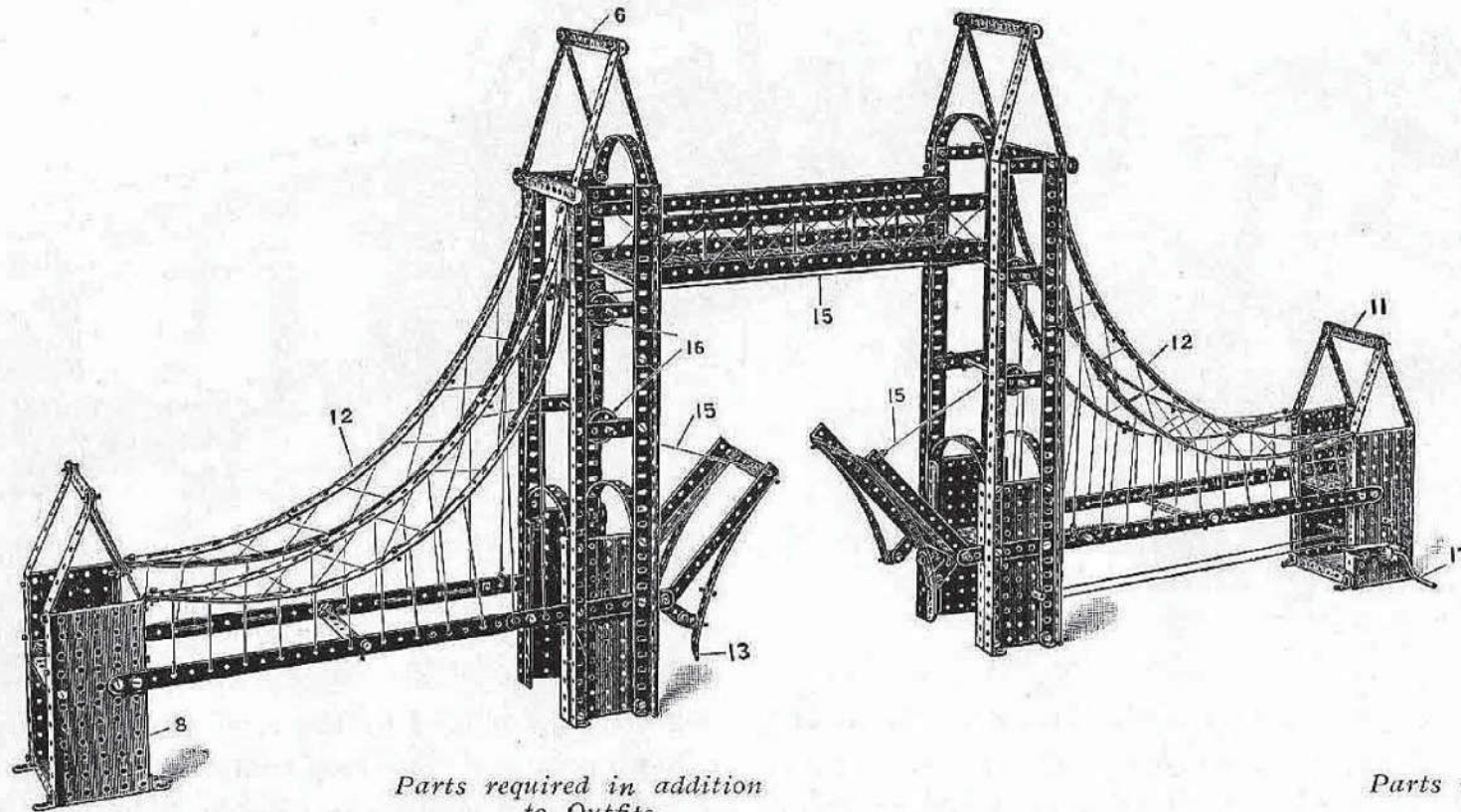

Parts required in addition to Outfits

Parts required in addition to Outfits

PARTS REQUIRED.

22	12 $\frac{1}{2}$ "	Perforated Strips
34	5 $\frac{1}{2}$ "	" "
12	3 $\frac{1}{2}$ "	" "
12	2 $\frac{1}{2}$ "	" "
10	12 $\frac{1}{2}$ "	Angle Girders
12	5 $\frac{1}{2}$ "	" "
28		Angle Brackets
4	5"	Rods
2	4 $\frac{1}{2}$ "	" "
1		Crank Handle
6	1"	Pulley Wheels

No. 1	No. 2	No. 3	No. 4	No. 5
18	12	12	8	8
38	18	16	14	10
11	10	6	6	—
2	—	—	—	—
10	6	2	2	1
12	12	12	12	12
16	12	2	—	—
4	1	—	—	—
—	—	—	—	—
—	—	—	—	—
—	4	2	1	—

PARTS REQUIRED.

1	3"	Pinion Wheel
1	1 $\frac{1}{2}$ "	" "
1		Gear Wheel "
1		Pawl
183		Nuts and Bolts
18		Keys
2		Large Bent Strips
2		Springs
8		Large Rectangular Plates
4		Small " "

No. 1	No. 2	No. 3	No. 4	No. 5
1	1	—	—	—
1	—	—	—	—
1	1	—	—	—
1	—	—	—	—
158	133	113	73	23
9	7	—	—	—
2	2	1	1	—
2	2	2	1	1
7	7	6	6	4
4	4	1	1	—

Tower Bridge

Begin by making the two main towers, the construction of one of which is shown in figure 81A. The four uprights (1) are made of angle girders, connected at their lower extremities by large rectangular plates (2) and transverse strips (3). The sides of the tower are connected together by a small rectangular plate (4) across the top of which, and at the top of the tower, are bolted bent $5\frac{1}{2}$ " strips.

The top gable (6) constructed as shown, is then bolted at its lower edges (7) to the top of the uprights.

The short end towers, one of which is shown to the right of the figure, are built up from two large rectangular plates (8) connected together by a small rectangular plate (9) and two $3\frac{1}{2}$ " strips (10), the gable (11) being then bolted on top.

The catenary member (12) is built up from four curved $12\frac{1}{2}$ " strips overlapped, the lower member by 12 holes and the upper member by 15 holes, so as to produce a longer sweep in the lower member, and are bolted to the vertical angle girders of the higher towers, and by angle brackets to the shorter towers.

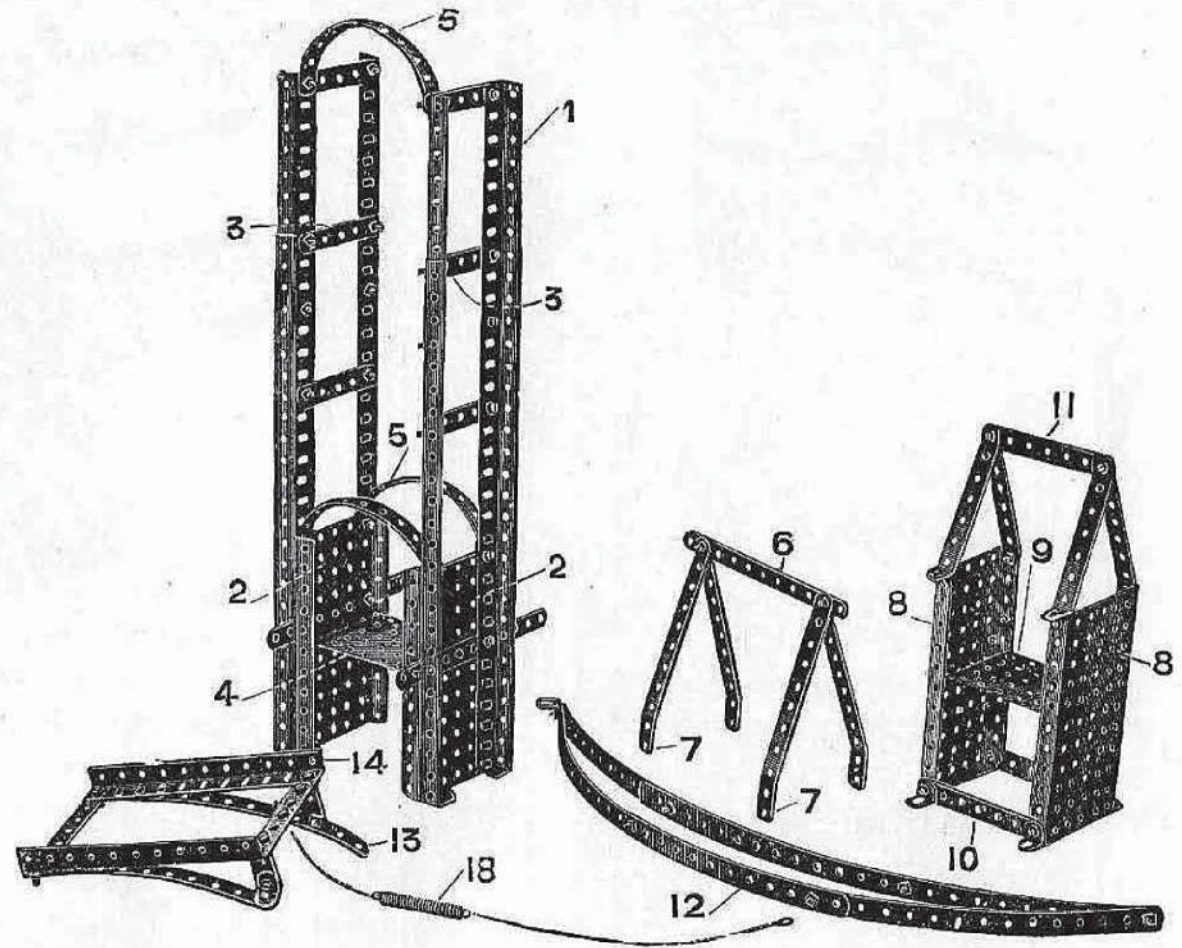

FIG. 81A.

The bascules as illustrated in the left-hand corner of the picture are built up of two $5\frac{1}{2}$ " angle girders braced with transverse $3\frac{1}{2}$ " strips, and reinforced with bent $5\frac{1}{2}$ " strips, one of which is provided with a projecting $2\frac{1}{2}$ " strip (13), which bears against the main tower and acts as a stop when the bascules are horizontal. The bascules are hinged by fixing bolts in the end holes (14). The bascules are opened by the cords (15) passing over the guide pulleys (16), and are controlled by the extension spring (18), which normally acts to return them to their closed position. In the right smaller tower is the operating handle (17), on which is keyed a pinion meshed with a worm wheel on the spindle, on to which the operating cords (15) are wound.

Model No. 82. Rotating Crane

(MADE WITH MECCANO OUTFIT NO. 6 OR NO. 5 AND NO. 5A.)

*Parts required in addition
to Outfits*

PARTS REQUIRED.

4	12 $\frac{1}{2}$ "	Perforated Strips
37	5 $\frac{1}{2}$ "	" "
18	3 $\frac{1}{2}$ "	" "
11	3"	" "
18	2 $\frac{1}{2}$ "	" "
1	2"	" "
16	12 $\frac{1}{2}$ "	Angle Girders
2	5 $\frac{1}{2}$ "	" "
47		Angle Brackets
1	6"	Axle Rod
3	4 $\frac{1}{2}$ "	" "
5	2"	" "
3		Crank Handles
8		Flanged Wheels
2	1 $\frac{1}{2}$ "	Pulley Wheels
6	1"	" "
1		Bush Wheel
1	3 $\frac{1}{4}$ "	Pinion Wheel
2	1 $\frac{1}{2}$ "	" "
1		Gear Wheel
1		Worm Wheel
1		Pawl
174		Nuts and Bolts
1		Hook
32		Keys
2		Single Bent Strips
1		Large " "
1		Length of Chain
5		Small Rectangular Plates

No. 1	No. 2	No. 3	No. 4	No. 5
—	—	—	—	—
31	20	19	17	13
17	16	12	12	1
11	11	9	7	3
8	4	4	—	—
1	1	1	1	—
16	12	8	8	7
2	2	2	2	2
35	31	21	3	—
1	1	1	—	—
—	—	—	—	—
3	3	2	—	—
2	2	1	—	—
8	4	4	—	—
2	2	1	1	—
—	4	2	1	—
—	—	—	—	—
1	1	—	—	—
2	1	—	—	—
1	1	—	—	—
1	1	—	—	—
1	—	—	—	—
149	124	104	64	14
—	—	—	—	—
23	21	10	10	—
1	1	—	—	—
1	1	—	—	—
1	1	1	1	1
5	5	2	2	—

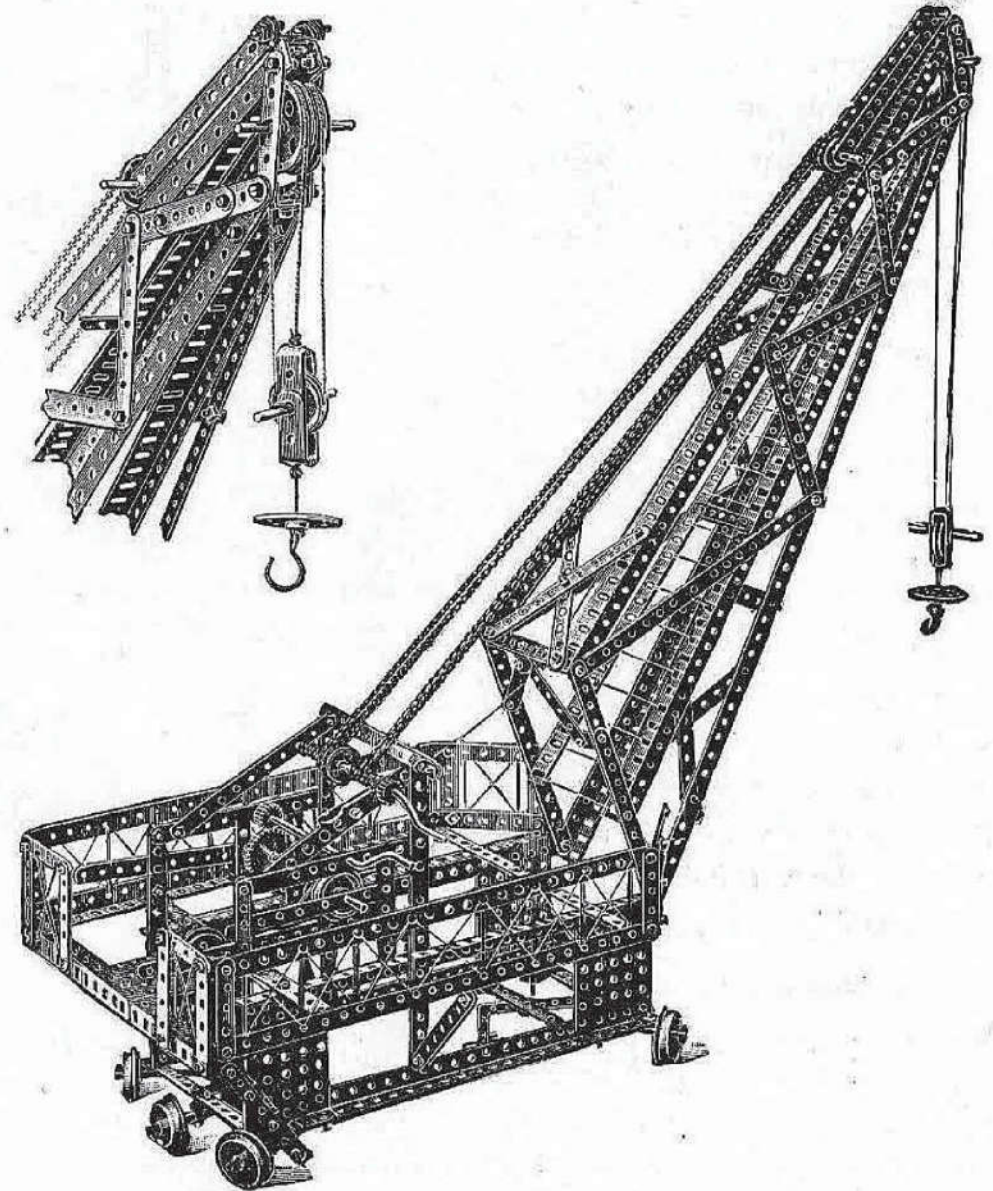

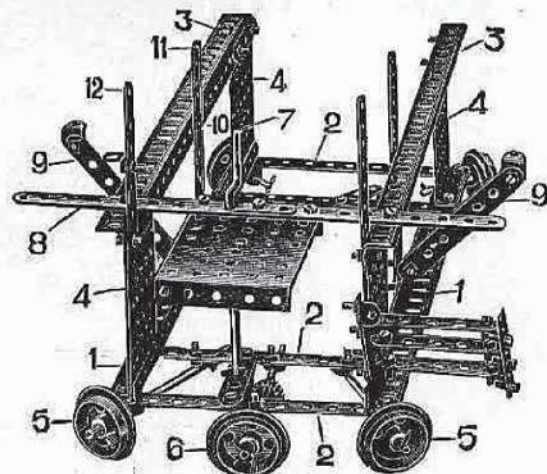

FIG. 82A

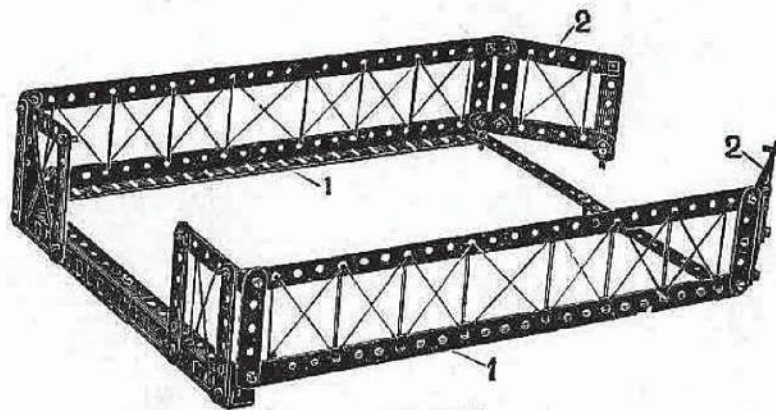

FIG. 82B

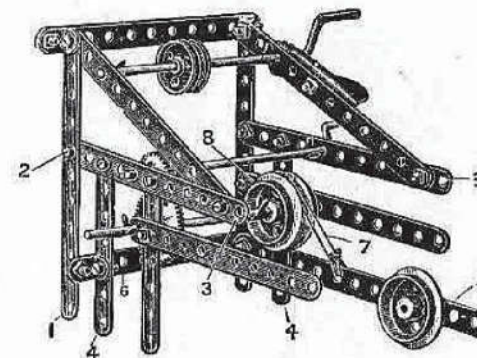

FIG. 82C

In constructing this model, begin by building up the lower wheel carriage (Figure 82A). As will be seen, this consists of two main angle girders (1) connected by four $5\frac{1}{2}$ " cross strips (2), the superstructure made from the upper angle girders (3) and vertical small rectangular plates (4) being then bolted to the lower girders (1). The extreme bolts in these lower girders carry two reverse angle brackets, which form the bearing for the spindles of the flanged wheels (5), the flanged pulley (6) running in bearings formed by angle brackets on the end cross strips being driven from the operating handle (7), carrying a worm engaging the pinion on the spindle of the driven wheel (6). Two $5\frac{1}{2}$ " strips (8) overlapped three holes form with the inclined $3\frac{1}{2}$ " strips (9) supports for the outer gallery frame (Figure 82B). The outer ends of the inclined strips (9) and the cross strips (8) are bolted to the gallery frame.

The gallery frame (Figure 82B) is built up of two $12\frac{1}{2}$ " angle girders (1) braced at one end with two $5\frac{1}{2}$ " angle girders overlapped three holes, and at the other end with two $5\frac{1}{2}$ " strips similarly overlapped. The end wings (2) are bolted in the extreme holes to the angle girders (3) in Figure 82A.

The gear frame mechanism (Figure 82C) may now be proceeded with, the framework of which is clearly shown in the illustration. The holes (1 and 2) are bolted to the corresponding holes (10 and 11) in the upright strips (Figure 82A), the holes (3) being bolted to the top holes of the strips (12) in Figure 82A. The lower holes (4) are bolted to the angle girders (3) in Figure 82A.

The brake mechanism is effected by means of the weighted lever (5) pivoted in an angle bracket carried from the cross piece (6), the lever being provided with the brake cord (7) which passes over a pair of flanged pulleys (8) keyed together on the winding spindle,

Model No. 83. Flip Flap

(MADE WITH MECCANO OUTFIT NO. 6 OR NO. 5 AND NO. 5A.)

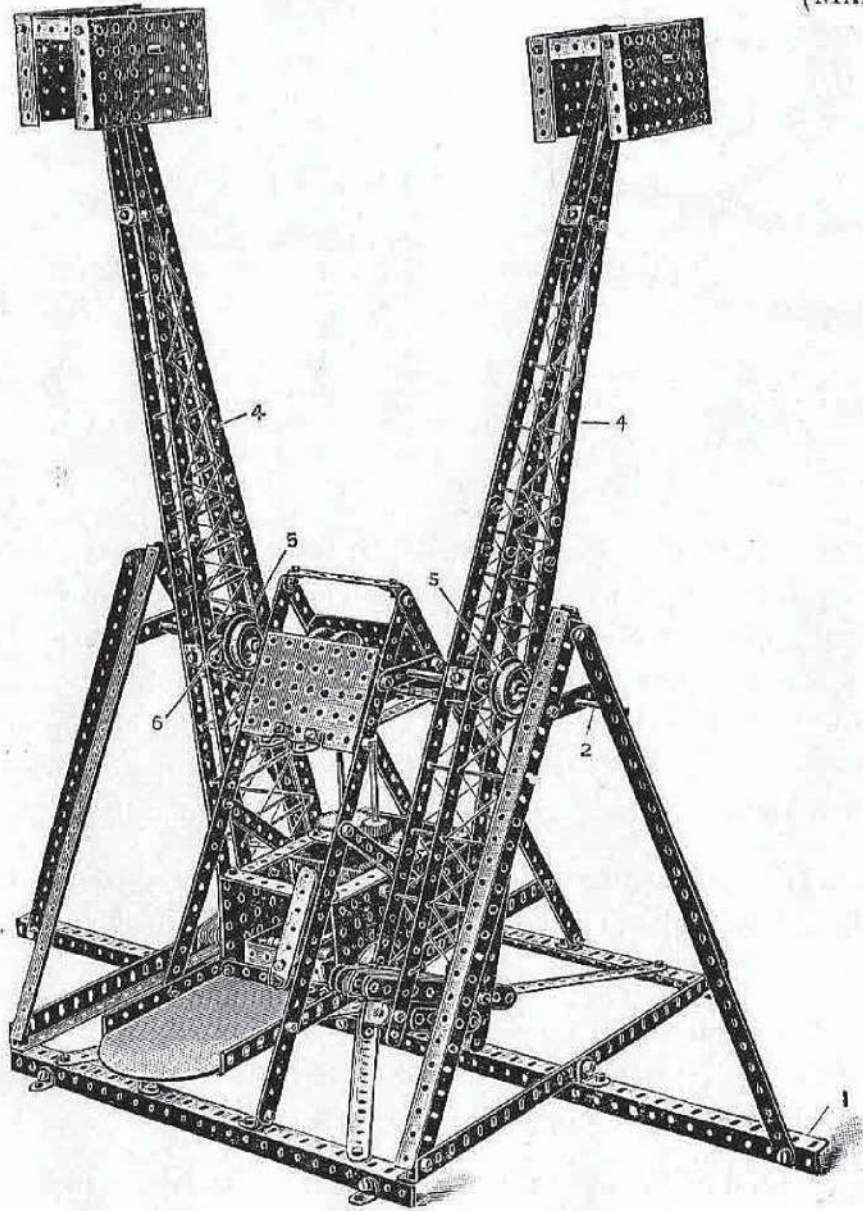

*Parts required in addition to
Outfits.*

PARTS REQUIRED.

24	12½"	Perforated Strips
4	5½"	" "
10	3½"	" "
12	2½"	" "
10	12½"	Angle Girders
1	5½"	" "
44		Angle Brackets
1	8"	Rod
2	6"	Rods
4	5"	"
2	3½"	"
4		Flanged Wheels
1	1½"	Pulley Wheel
3	¾"	Pinion Wheels
2	1"	" "
2		Gear Wheels
2	1½"	Contrate Wheels
2	¾"	" "
1		Worm Wheel
161		Nuts and Bolts
30		Keys
4		Collars and Set Screws
1		Large Bent Strip
2		Large Rectangular Plates
8		Small Rectangular Plates

No. 1	No. 2	No. 3	No. 4	No. 5
20	14	14	10	10
—	—	—	—	—
9	8	4	4	—
2	—	—	—	—
10	6	2	2	—
1	1	1	1	—
32	28	18	—	—
1	1	1	1	1
2	2	2	—	—
4	1	—	—	—
2	2	2	2	—
4	—	—	—	—
1	1	—	—	—
3	3	2	1	—
2	1	—	—	—
2	2	1	1	—
2	2	2	1	1
2	2	2	—	—
1	1	—	—	—
136	111	91	51	—
21	19	8	8	—
4	4	—	—	—
1	1	—	—	—
1	1	—	—	—
8	8	5	5	3

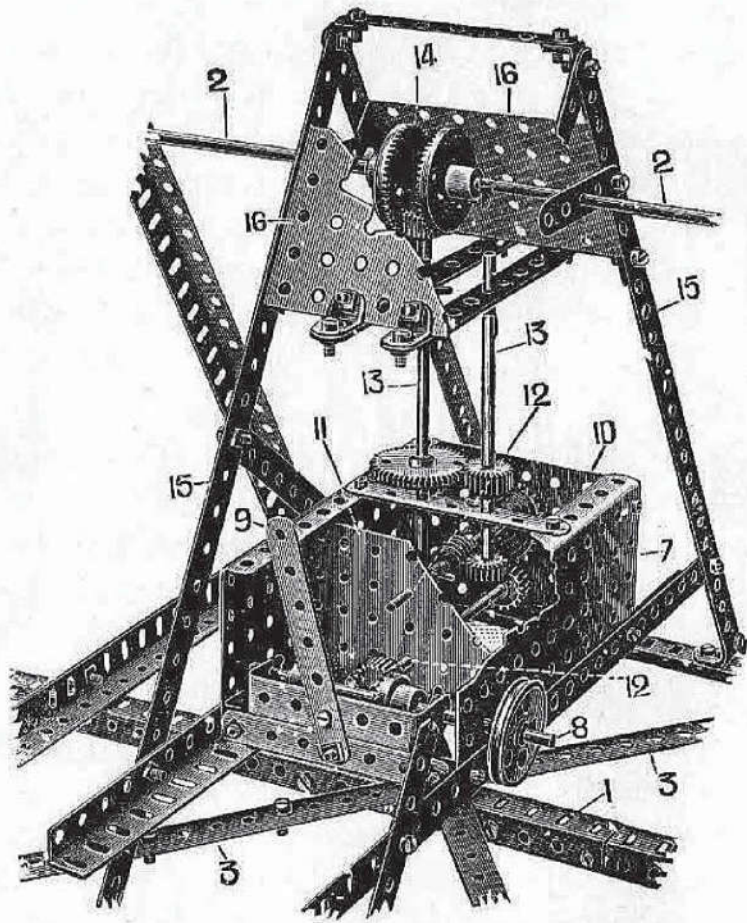

The construction of the arms and the main body of the supporting frame is clearly shown in the illustration. The main longitudinal rib (1) is made up from two angle girders butt jointed, not overlapped, the joint being strengthened with a 3" strip bolted through in every hole to the angle girders. By this means of butt-jointing the true alignment of the main axle (2) is secured.

The cross diagonal strips (3) of the base are formed by joining together 12½" and 5½" strips and overlapping them together for five holes.

The axle (2) is gripped to the arms (4) by means of the keyed wheels (5) on either side of the arms, which are in turn secured to the arms by means of a pair of nuts and bolts in the wheels, the nuts binding against the short 2½" cross strip (6) on the arms.

Having constructed the main body of the supporting frame as above described, the operating gear cage is now proceeded with. This is built up of large rectangular plates (7) forming a bearing for the driving spindle (8) operated by the clutch handle (9) and connected together by a small rectangular plate (10) and a similar mid plate (11). These two latter plates form bearings for the longitudinal spindle (12). The vertical spindles (13) drive the 1½" contrate wheels (14) on the main axles (2), the inclined 12½" strips (15) being connected near the contrate wheels by the small rectangular plates (16).

Model No. 84. Transporter Bridge

(MADE WITH MECCANO OUTFIT NO. 6 OR
NO. 5 AND NO. 5A).

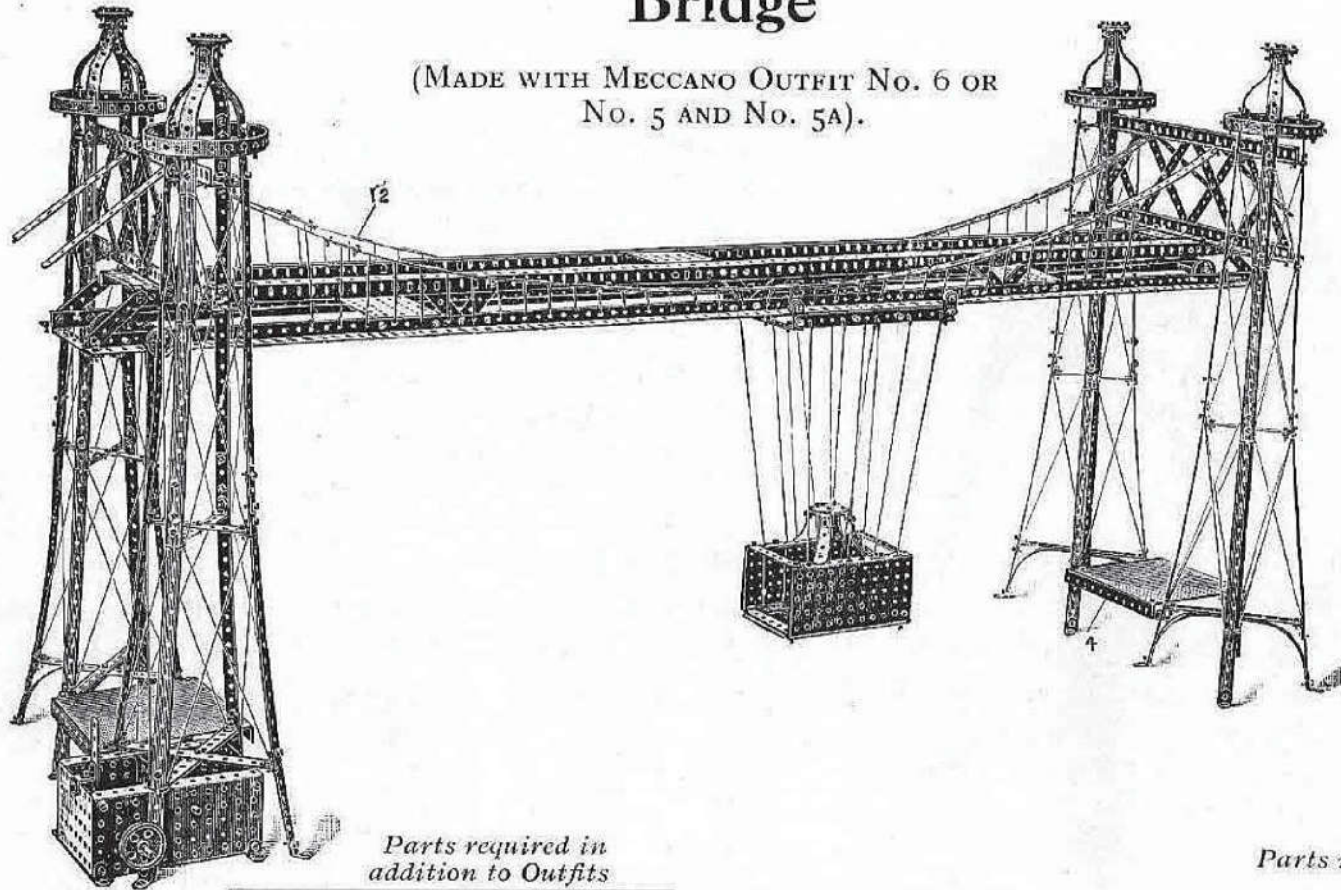

Parts required in addition to Outfits

PARTS REQUIRED.		No. 1	No. 2	No. 3	No. 4	No. 5
46	12 $\frac{1}{2}$ " Perforated Strips	42	32	36	32	32
44	5 $\frac{1}{2}$ " " "	38	24	26	24	20
29	3 $\frac{1}{2}$ " " "	28	27	23	23	12
8	3" " "	8	8	6	4	—
36	2 $\frac{1}{2}$ " " "	26	22	22	18	—
20	12 $\frac{1}{2}$ " Angle Girders	20	16	12	12	11
10	5 $\frac{1}{2}$ " " "	10	10	10	10	10
150	Angle Brackets	138	134	124	106	97
1	6" Rod	1	1	1	—	—
2	5" Rods	2	—	—	—	—
3	4 $\frac{1}{2}$ " " "	—	—	—	—	—
1	1 $\frac{1}{2}$ " Pulley Wheel	1	1	—	—	—
4	1" " "	—	2	—	—	—
4	$\frac{1}{2}$ " " "	4	4	3	3	—

...60...

Parts required in addition to Outfits

PARTS REQUIRED.		No. 1	No. 2	No. 3	No. 4	No. 5
5	Bush Wheels	4	4	4	4	4
2	$\frac{3}{4}$ " Pinion Wheels	2	2	1	—	—
1	$\frac{1}{2}$ " " "	1	—	—	—	—
1	Gear Wheel	1	1	—	—	—
2	$\frac{3}{4}$ " Contrate Wheels	2	2	2	—	—
1	Worm Wheel	1	1	—	—	—
473	Nuts and Bolts	448	423	403	363	313
28	Keys	19	17	6	6	—
1	Large Bent Strip	1	1	—	—	—
4	Large Rectangular Plates	3	3	2	2	—
8	Small " "	8	8	5	5	3

In the construction of this model begin by taking two $5\frac{1}{2}$ " strips to form the base portion of each tower. Four curved $5\frac{1}{2}$ " strips are now bolted to the centre of the cross, and bent down to form an attachment for the vertical members (1). At the top of the first $12\frac{1}{2}$ " strips forming the vertical brace, cross strips $3\frac{1}{2}$ " long are now connected by angle brackets. Further $12\frac{1}{2}$ " strips are overlapped on the lower strips, which carries the construction to the crown (2) of the tower, which is made of $3\frac{1}{2}$ " curved strips. The gallery is formed of a $12\frac{1}{2}$ " strip, bent round and secured by angle brackets to the uprights.

The towers are connected at their base by $5\frac{1}{2}$ " angle girders (4) bolted to the angle brackets (3) and at their upper parts by the braced girders (5). The $12\frac{1}{2}$ " angle girders (6) are bolted to the cross strips (7) on the towers in the third hole from the end.

The construction of the main girder is as follows :—

The side frames are built up of four $12\frac{1}{2}$ " angle girders (8) butted together and reinforced at the joints by $5\frac{1}{2}$ " angle girders. The upper elements are constructed of four $12\frac{1}{2}$ " angle girders (9) each overlapped two holes. Small rectangular plates (10) and upper small rectangular plates (11) are bolted to the lower and upper elements respectively.

The end upper plates (11) are bolted to the lower angle girders of the braced elements (5).

Figure 84D shows the construction of the cage, which is built up of side rectangular plates (1) connected across by four $3\frac{1}{2}$ " strips (2). The carrier frame (Figure 84E) is made of two $5\frac{1}{2}$ " strips overlapped eight holes and bent up to form the brackets on which the trolley wheels are bolted. The runners (3) carried in the bent-up ends of the end members (4) are made to run freely on the shank of the bolts by providing lock nuts on the inside and outside of the turned-up ends of the strips (4).

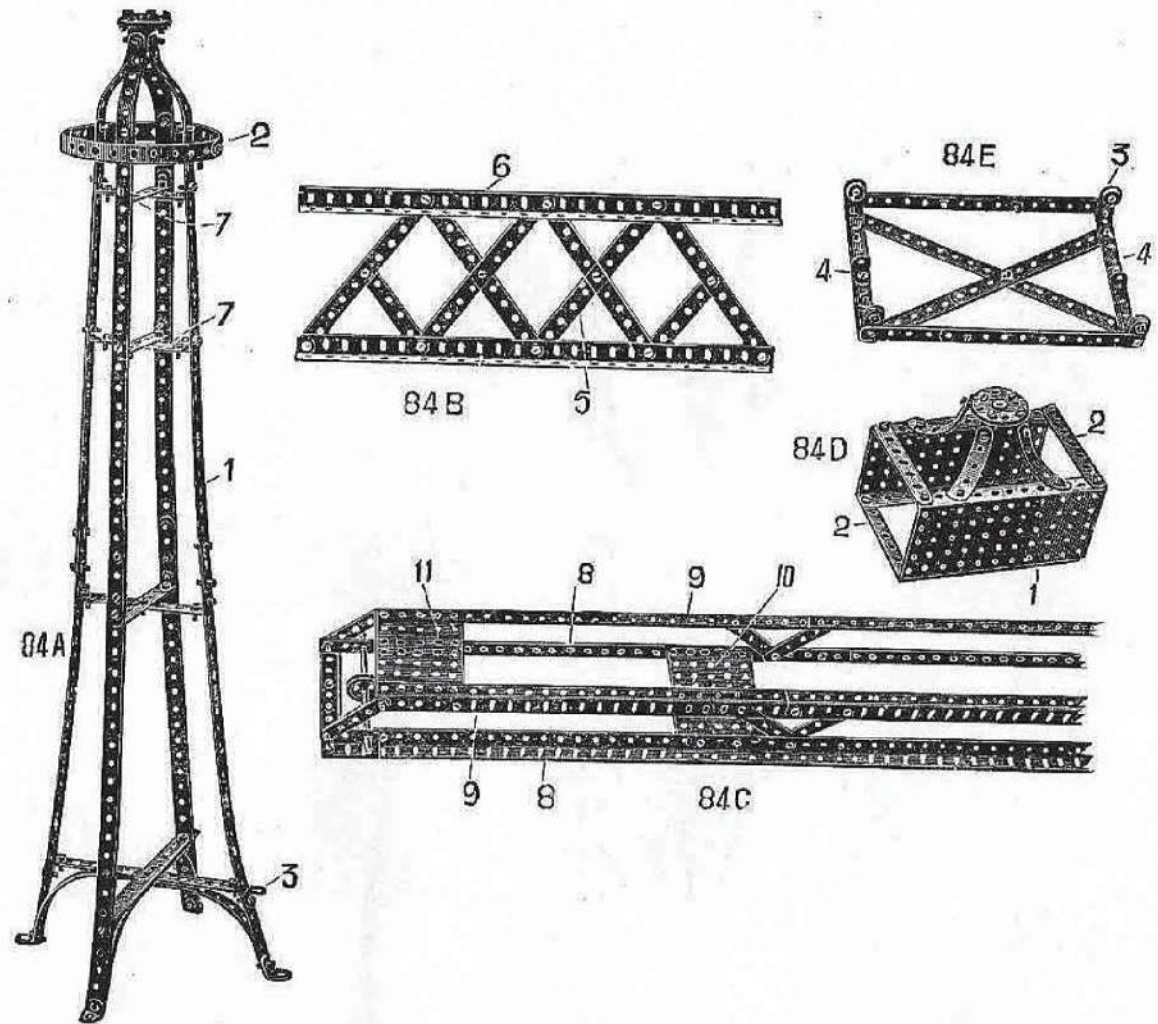

Model No. 85. Transporter Bridge

(MADE WITH MECCANO OUTFIT NO. 6 OR NO. 5 AND NO. 5A.)

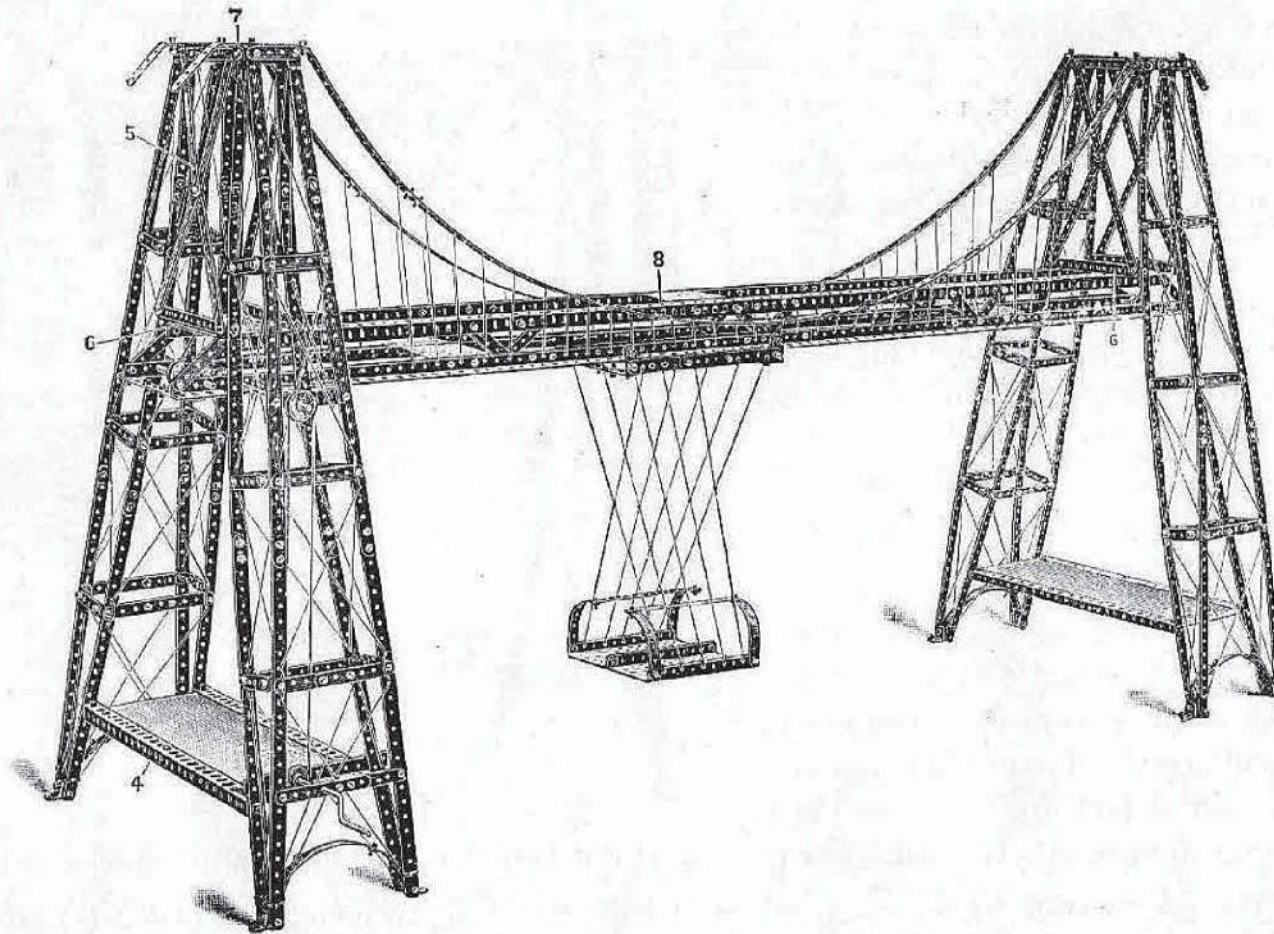

*Parts required in addition
to Outfits.*

PARTS REQUIRED.		No. 1	No. 2	No. 3	No. 4	No. 5
42	12½" Perforated Strips	36	32	32	28	28
56	5½" " "	50	40	38	36	32
12	3½" " "	11	10	6	6	—
23	3" " "	23	23	21	19	15
32	2½" " "	22	18	18	14	—
24	2" " "	24	24	24	24	18
20	12½" Angle Girders	20	16	12	12	11
11	5½" " "	11	11	11	11	11
120	Angle Brackets	108	104	94	76	67
1	11½" Rod	1	1	1	—	—
2	4½" Rods	—	—	—	—	—
1	Crank Handle	—	—	—	—	—
4	1" Pulley Wheels	—	2	—	—	—
4	½" " "	4	4	3	3	—
1	¾" Pinion Wheel	1	1	—	—	—
1	Gear Wheel	1	1	—	—	—
397	Nuts and Bolts	372	347	327	287	237
15	Keys	6	4	—	—	—
2	Large Rectangular Plates	1	1	—	—	—
5	Small " "	5	5	2	2	—

The main girder in this model calls for no particular description, being constructed similarly to that previously described.

The end towers are each made up of a pair of side girders composed of perforated strips (1) bowed at the centres and distanced by the short strips (2) and traverse strips (3). These side girders are connected at their lower ends by 12½" angle girders (4) and at their upper parts by the inclined 5½" strips (5), transverse 5½" angle girders (6) and upper 5½" strips (7). The end rectangular plates of the main girder (8) are bolted to the angle girders (6) of the towers.

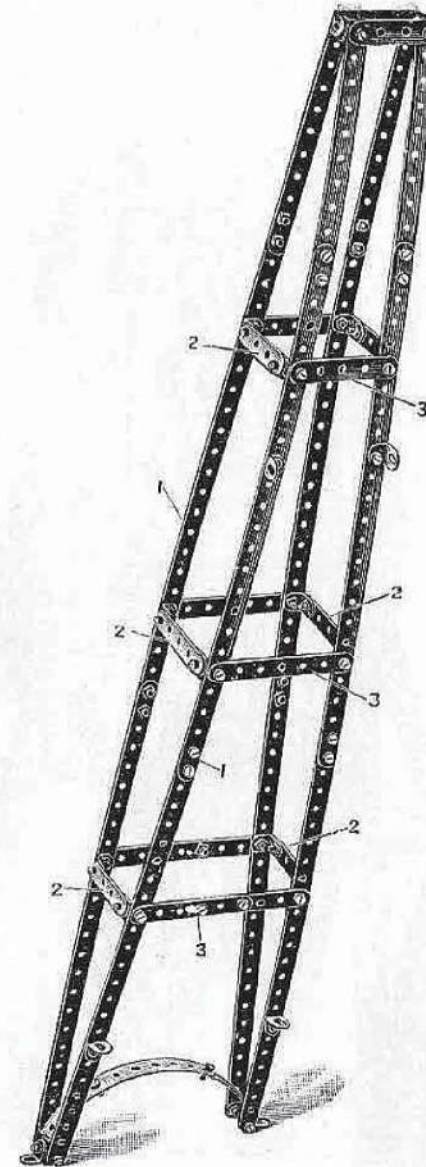

Model No. 86. Big Wheel

(MADE WITH MECCANO OUTFIT NO. 6 OR NO. 5 AND NO. 5A.)

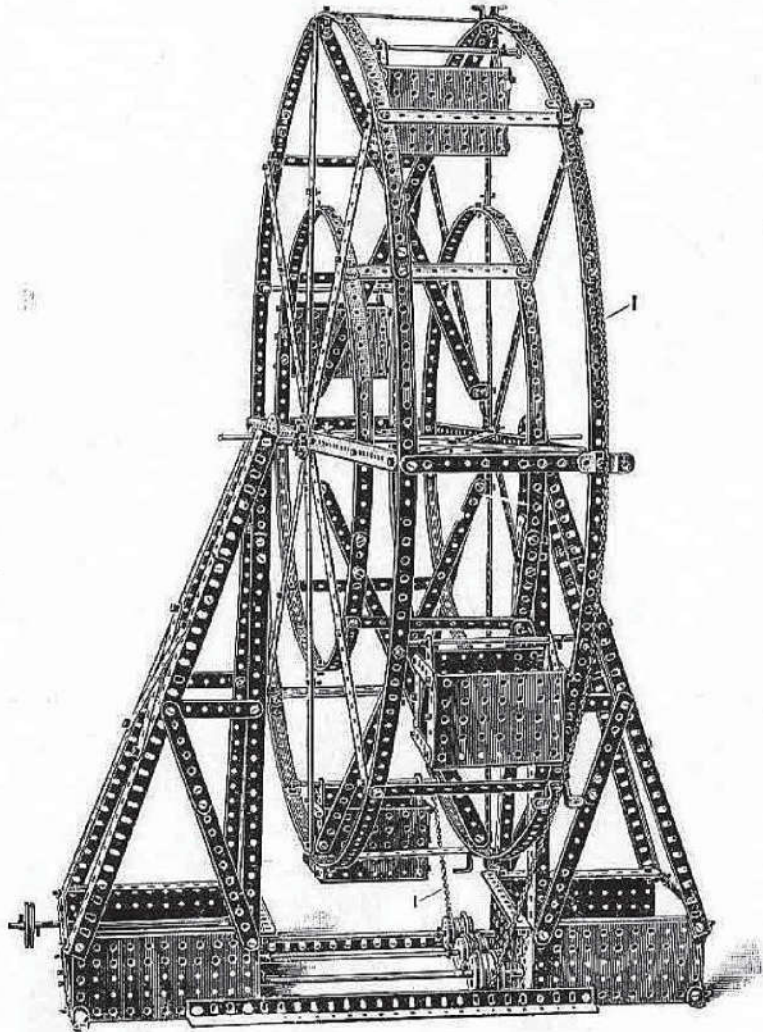

PARTS REQUIRED.

46	12 $\frac{1}{2}$ "	Perforated Strips
24	5 $\frac{1}{2}$ "	" "
4	3 $\frac{1}{2}$ "	" "
4	3"	" "
34	2 $\frac{1}{2}$ "	" "
10	12 $\frac{1}{2}$ "	Angle Girders
4	5 $\frac{1}{2}$ "	" "
60		Angle Brackets
4	11 $\frac{1}{2}$ "	Rods
1	8"	Rod
1	6"	"
4	5"	Rods
6		Flanged Wheels
1	1 $\frac{1}{2}$ "	Pulley Wheel
4		Bush Wheels
2	$\frac{3}{4}$ "	Pinion Wheels
2		Gear Wheels
292		Nuts and Bolts
27		Keys
1		Length of Chain
8		Double Bent Strips
6		Large Rectangular Plates
8		Small " "
2		Sector Plates

*Parts required in addition to
Outfits.*

No. 1	No. 2	No. 3	No. 4	No. 5
42	36	36	32	32
18	8	6	4	—
3	2	—	—	—
4	4	2	—	—
24	20	20	16	—
10	6	2	2	1
4	4	4	4	4
48	44	34	16	7
4	4	4	2	2
1	1	1	1	1
1	1	1	—	—
4	1	—	—	—
6	2	2	—	—
1	1	—	—	—
4	3	3	3	3
2	2	1	—	—
2	2	1	1	—
292	242	222	182	132
27	16	5	5	—
1	1	1	1	1
8	7	7	7	7
6	5	4	4	2
8	8	5	5	3
—	—	—	—	—

In constructing this model advantage is taken of the new rectangular perforated plates now issued with the Meccano Outfits to form the sides and inner part of the base of the side pedestals and also to form the suspended cages on the wheel.

The driving chain is conveniently kept in position around the periphery of one of the side elements of the wheel by a series of double bent strips bolted on the ends of the spokes.

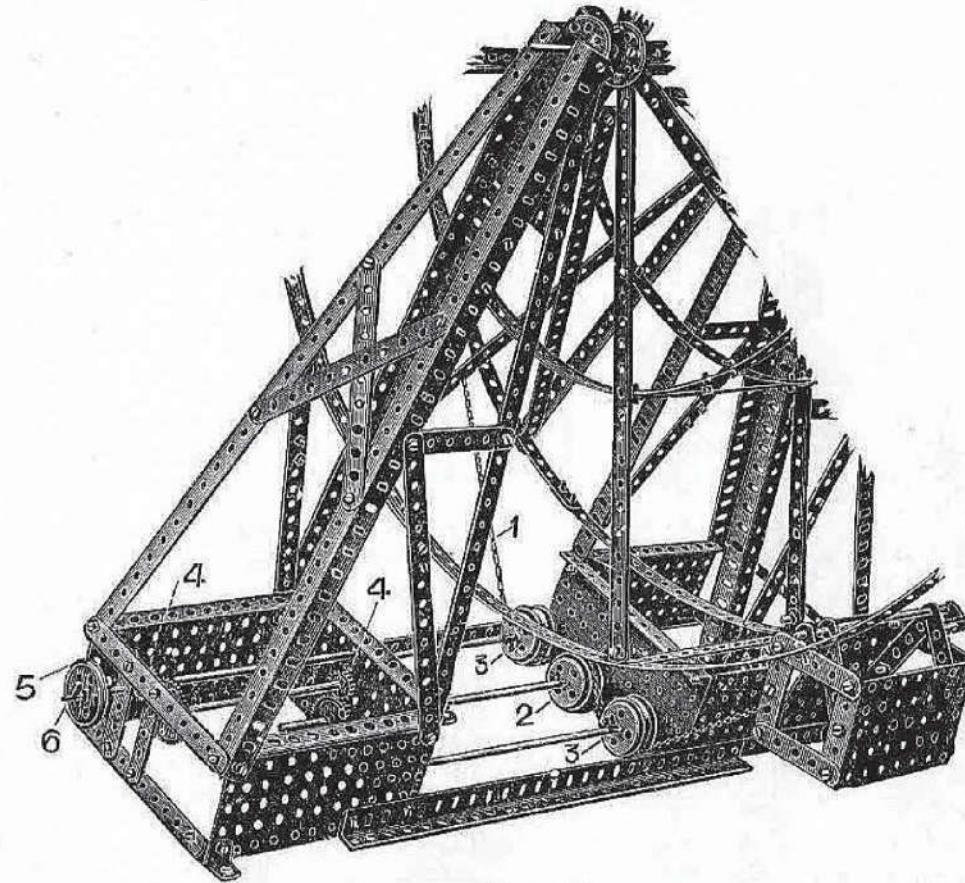

FIG. 86A.

In Figure 86A is shown how the driving chain (1), passing around the driving wheel (2), is held around the circumference thereof by the guide wheels (3). The driving wheel (2) being driven through the gear wheel (4) from a $1\frac{1}{2}$ " pulley wheel (5) carried on the spindle (6).

Model No. 87.

Parts required in addition to Outfits.

Funicular Railway

(MADE WITH MECCANO OUTFIT
No. 6 OR NO. 5 AND NO. 5A.)

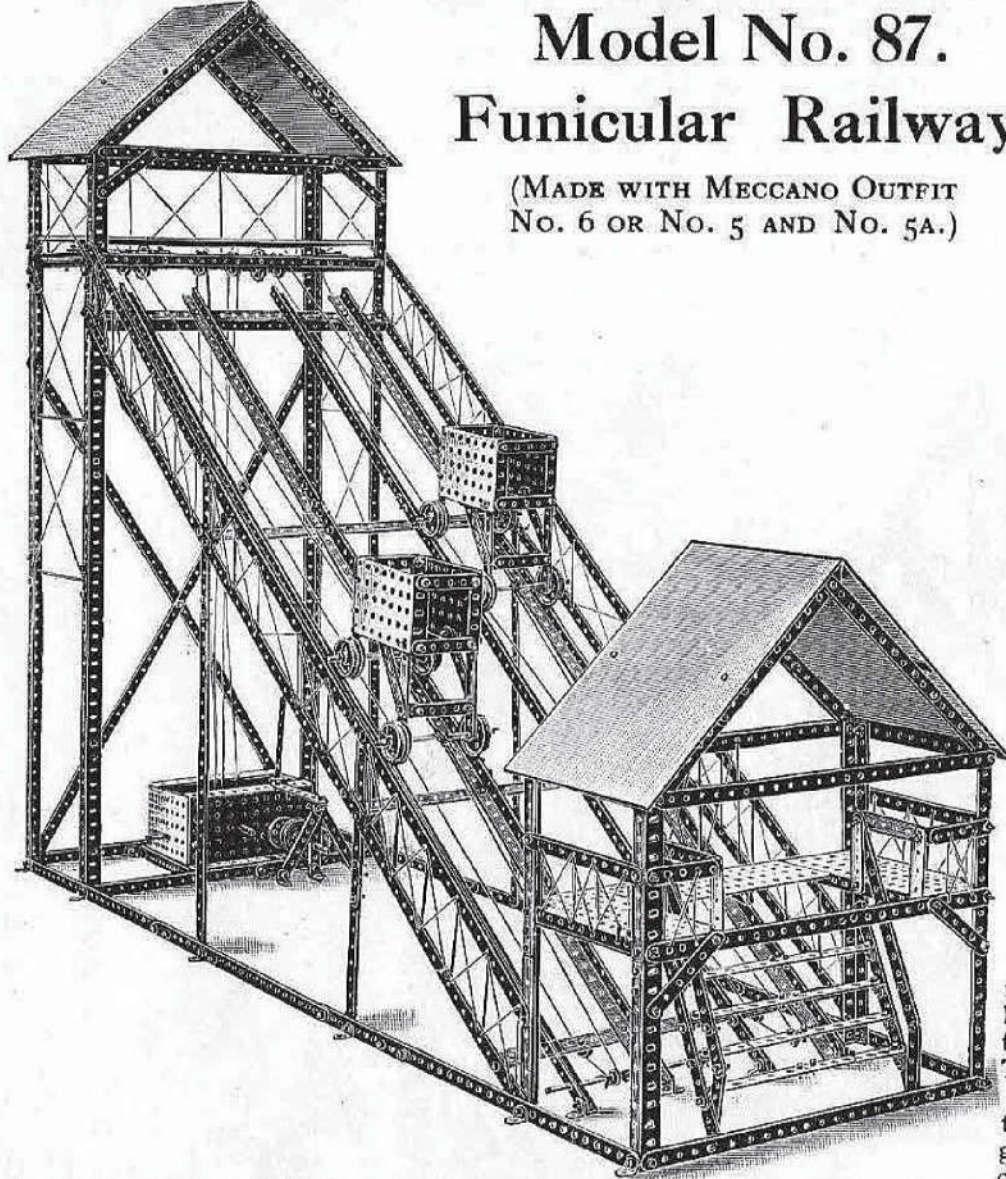

PARTS REQUIRED.

	NO. 1	NO. 2	NO. 3	NO. 4	NO. 5
38 12 $\frac{1}{2}$ " Perforated Strips	34	28	28	24	24
49 5 $\frac{1}{2}$ " " "	43	33	31	29	25
17 3 $\frac{1}{2}$ " " "	16	15	11	11	—
23 3" " "	23	23	21	19	15
16 2 $\frac{1}{2}$ " " "	6	2	2	—	—
23 12 $\frac{1}{2}$ " Angle Girders	23	19	15	15	11
12 5 $\frac{1}{2}$ " " "	12	12	12	12	12
88 Angle Brackets	76	72	62	44	35
1 11 $\frac{1}{2}$ " Rod	1	1	1	—	—
1 8" " "	1	1	1	1	1
4 6" Rods	4	4	4	2	—
2 5" " "	2	—	—	—	—
4 4 $\frac{1}{2}$ " " "	1	1	1	1	1
8 Flanged Wheels	8	4	4	—	—
1 1 $\frac{1}{2}$ " Pulley Wheel	1	1	—	—	—
6 1" " "	—	4	2	1	—
4 1" " "	4	4	3	3	—
3 Bush Wheels	2	2	2	2	2
3 3" Pinion Wheels	3	3	2	1	—
1 1" " "	1	—	—	—	—
2 Gear Wheels	2	2	1	1	—
2 3" Contrate Wheels	2	2	2	—	—
1 Worm Wheel	1	1	—	—	—
417 Nuts and Bolts	392	367	347	307	257
39 Keys	30	28	17	17	6
2 Collars and Set Screws	2	2	—	—	—
1 Double Bent Strip	1	—	—	—	—
1 Large " "	1	1	—	—	—
6 Large Rectangular Plates	5	5	4	4	2
8 Small " "	8	8	5	5	3

Begin by constructing the main tower Fig. 87A, the corner pillars (2) of which are made from two 12 $\frac{1}{2}$ " angle girders and a 5 $\frac{1}{2}$ " angle girder; the 12 $\frac{1}{2}$ " overlapped three holes and the 5 $\frac{1}{2}$ " girders two holes. The long tie strips (1) are 12 $\frac{1}{2}$ ", and the short side tie strips (3) 5 $\frac{1}{2}$ ". The rear diagonal ties (4) are made from 12 $\frac{1}{2}$ " strips overlapped. The roof rafters (5) consist of 5 $\frac{1}{2}$ " strips overlapped five holes.

The arrangement of the gear in the upper platform of this tower is well shown in the detail Fig. 87F. The inclined rails (5) Fig. 87B are made from 4 sets of 12 $\frac{1}{2}$ " angle girders, butted together and connected by 3" strips. The rails rest on three upper crossing 12 $\frac{1}{2}$ " angle girders (6), and a lower 12 $\frac{1}{2}$ " strip (7) to the ends of which are

bolted the latticed side rails (8) supported by the vertical members (9). The 3" pulleys (10) are bolted to the lower strip (7) and on the transverse spindle (11) opposite these pulleys are keyed further 1" pulleys (12). The ropes for hauling the wagons pass round these lower pulleys (10) and (11), and the pulleys (13) in the upper gear platform of the tower Fig. 87A. The loading platform Fig. 87C is built up from 12 $\frac{1}{2}$ " girder strips (14) to which are bolted side rectangular plates (15) which are again connected by two small rectangular plates (16). The other constructional details of this loading tower should present no trouble.

The main tower Fig. 87A; inclined rails Fig. 87B; and loading platform Fig. 87C are now coupled together by a series of horizontal 12 $\frac{1}{2}$ " strips (16) overlapped as shown.

The wagons Fig. 87D are made as follows:—Two small rectangular plates (17) connected top and bottom by 2 $\frac{1}{2}$ " strips (18). The journals for the front axle (19) are made by two 3 $\frac{1}{2}$ " strips bolted inside the rectangular plates, the axle being threaded through their lower projecting holes. The rear axle journals are made by carrying down two 3 $\frac{1}{2}$ " strips (20) bolted in their upper holes to the rectangular plates, and braced with the diagonal strips (21) to the sides of the wagon. The axle (22) is again threaded through the lowest holes. One end of the operating cord (23) as shown in this view is secured to this rear axle; the other end, after passing round the pulleys as previously explained, being secured to the front axle (19). The gear box for operating the main hauling shaft (24) is very fully shown in Fig. 87E; the operating cords from the pulleys (25) passing up round the pulleys (26).

The Gear Box is mounted on two perforated plates (27), the angle brackets on which are bolted to the transverse strips (28) at the base of the tower Fig. 87A.

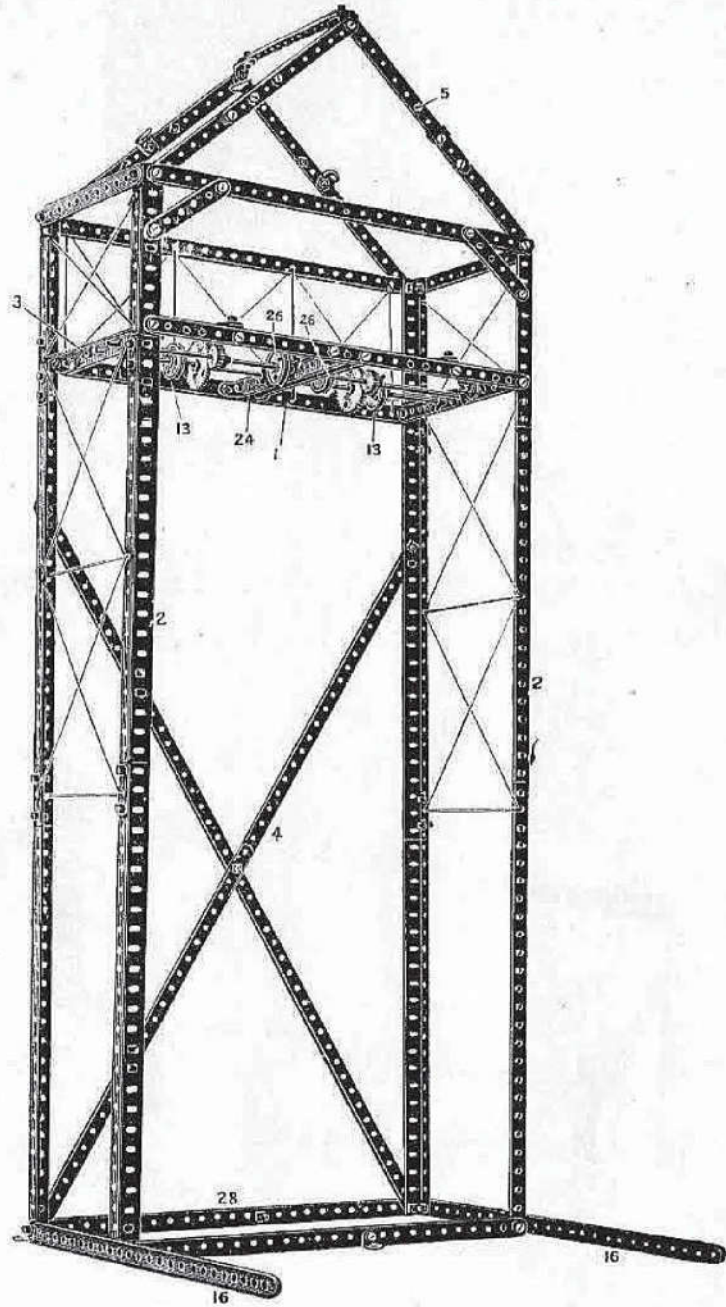

FIG. 87A.

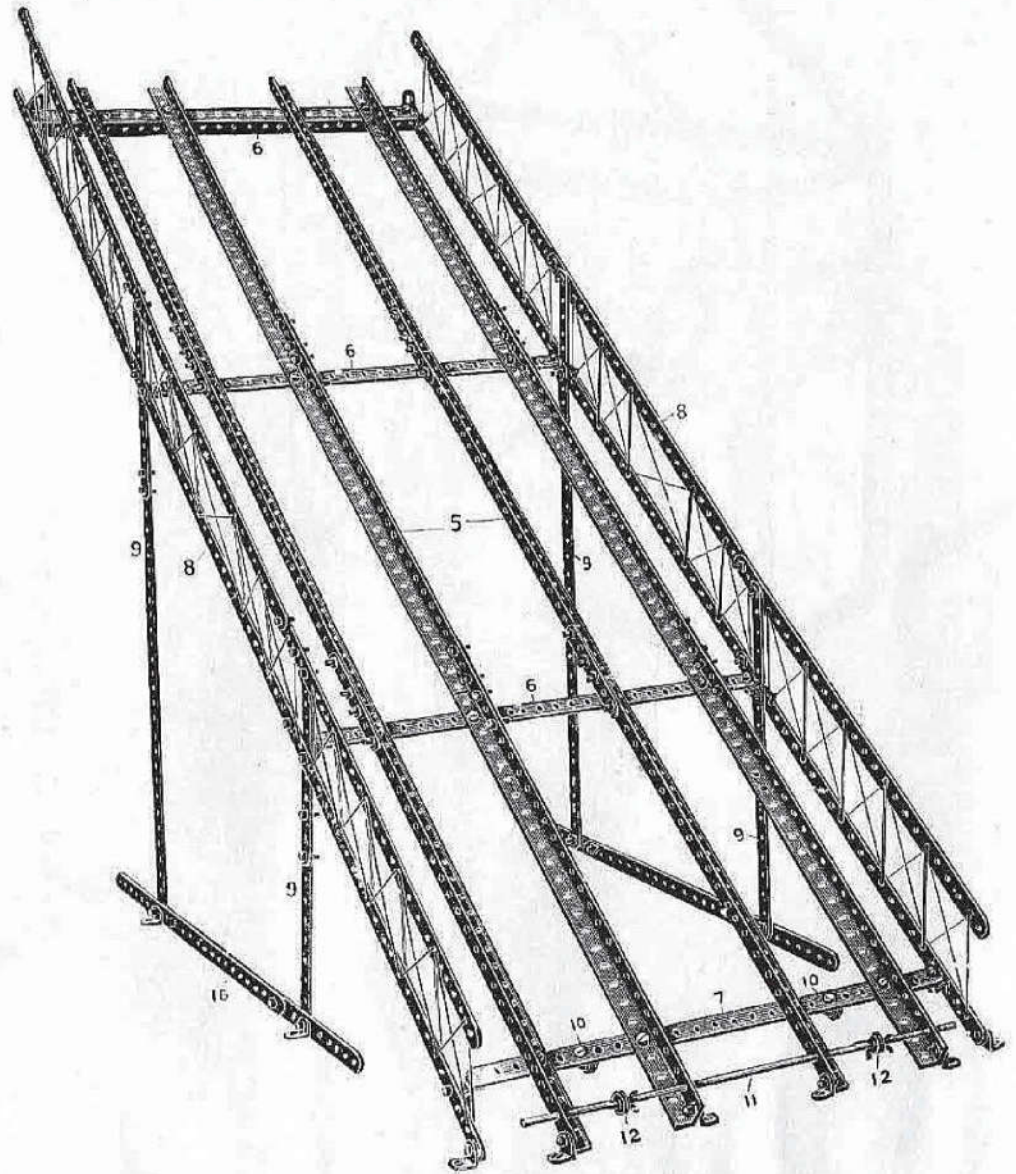

FIG. 87B.

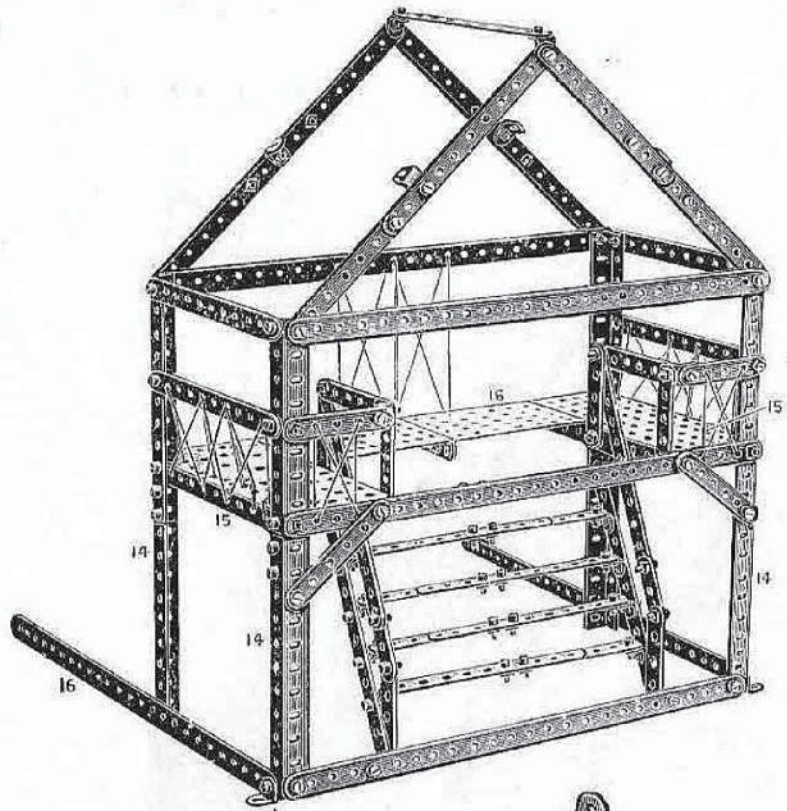

FIG. 87C.

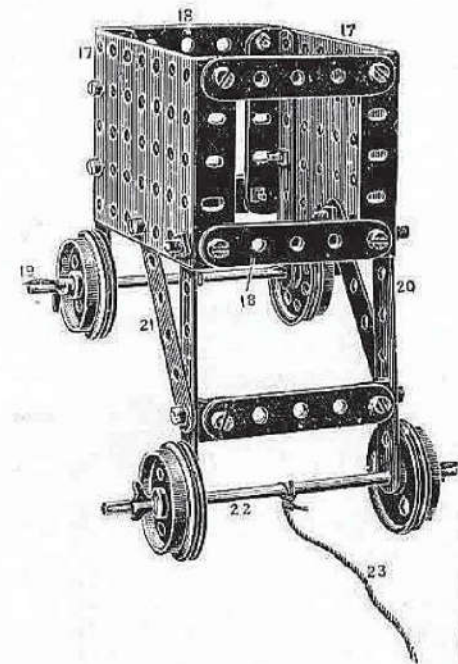

FIG. 87D.

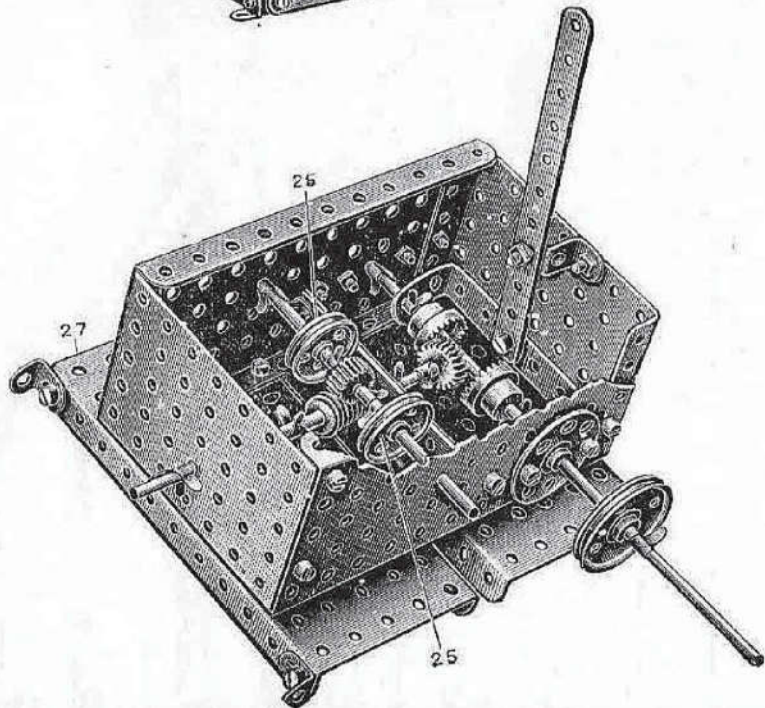

FIG. 87E.

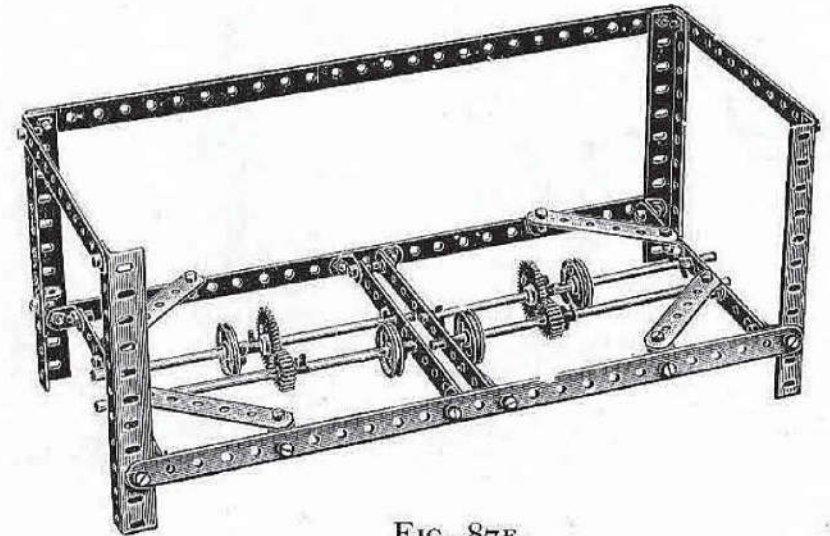
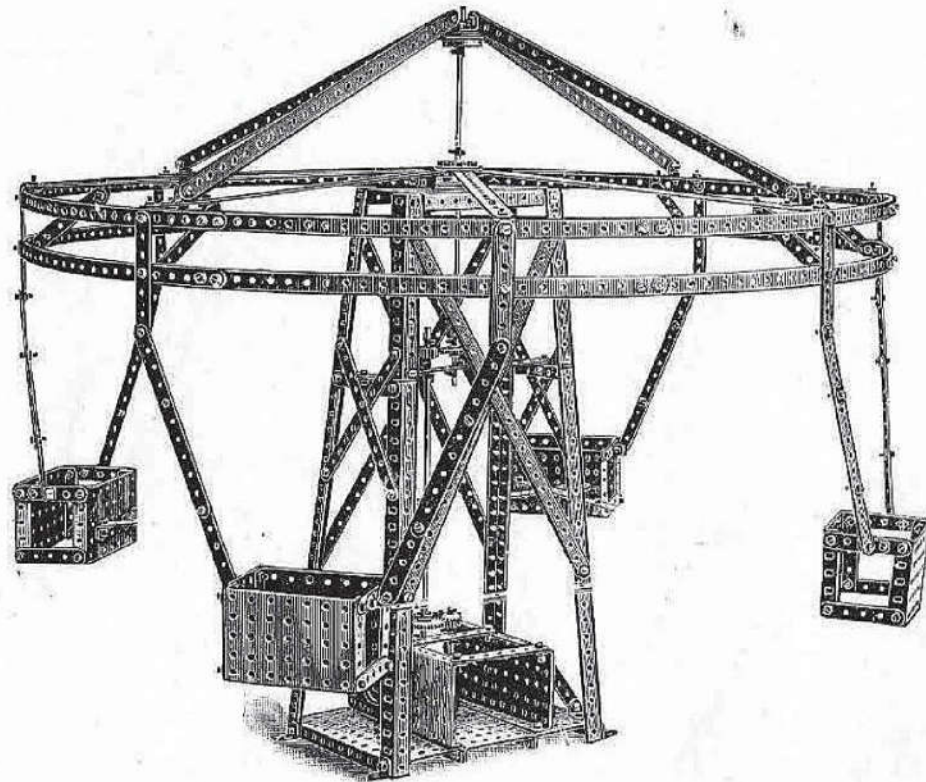

FIG. 87F.

Model No. 88. Roundabout

(MADE WITH MECCANO OUTFIT NO. 6 OR NO. 5 AND NO. 5A.)



*Parts required in addition to
Outfits.*

PARTS REQUIRED.

38	12 $\frac{1}{2}$ "	Perforated Strips
22	5 $\frac{1}{2}$ "	" "
13	3 $\frac{1}{2}$ "	" "
8	3"	" "
16	2 $\frac{1}{2}$ "	" "
4	12 $\frac{1}{2}$ "	Angle Girders
4	5 $\frac{1}{2}$ "	" "
56		Angle Brackets
2	11 $\frac{1}{2}$ "	Rods
1	6"	"
1	4 $\frac{1}{2}$ "	"
2		Flanged Wheels
1	1 $\frac{1}{2}$ "	Pulley Wheel
1		Bush Wheel
2	$\frac{3}{4}$ "	Pinion Wheels
1	$\frac{1}{2}$ "	" "
2		Gear Wheels
1		Worm Wheel
255		Nuts and Bolts
19		Keys
2		Collars and Set Screws
6		Large Rectangular Plates
8		Small Rectangular Plates

No 1	No. 2	No. 3	No. 4	No. 5
34	28	28	24	24
16	6	4	2	—
12	11	9	9	—
8	8	6	4	—
6	2	2	—	—
4	—	—	—	—
4	4	4	4	4
44	40	30	12	3
2	2	2	—	—
1	1	1	—	—
—	—	—	—	—
2	—	—	—	—
1	1	—	—	—
—	—	—	—	—
2	2	1	—	—
1	—	—	—	—
2	2	1	1	—
1	1	—	—	—
230	205	185	145	95
10	8	—	—	—
2	2	—	—	—
5	5	4	4	2
8	8	5	5	3

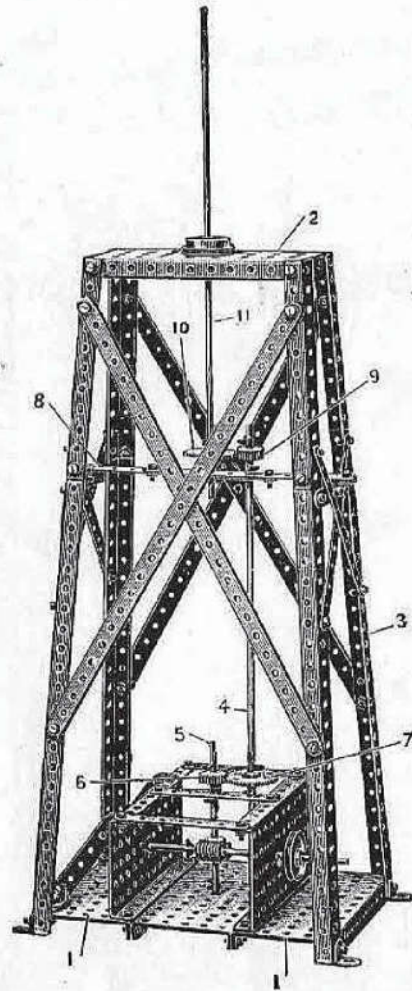

FIG. 88A.

Begin by constructing the central tower Fig. 88A, the base of which consists of three large rectangular plates (1) bolted at their flanges, and the top of one large rectangular plate (2), the corners (3) being each made of a $12\frac{1}{2}$ " angle girder and a $5\frac{1}{2}$ " angle girder overlapped two holes.

The side walls of the lower gear boxes also consist of large rectangular plates, connected across the top by $3\frac{1}{2}$ " strips, the middle one of which forms the bearings for the vertical spindles (4) and (5) connected by a $\frac{3}{4}$ " pinion and gear wheel (6) and (7). The upper end of spindle (4) is journalled in a cross strip (8) and coupled by a $\frac{3}{4}$ " pinion (9) to a gear wheel (10) keyed to the spindle (11).

The cross strip (8) is formed by two $5\frac{1}{2}$ " strips overlapped seven holes, and supported at each side of the tower by $3\frac{1}{2}$ " strips.

The ringed frame is made of seven $12\frac{1}{2}$ " strips overlapped two holes, and assembled together quite straight, the outer ends being then bolted together and overlapped three holes. The strips will assume a perfectly circular shape without special bending. The diagonal strips (12) are then bolted to the ringed frame in the third hole from the edge, and a flanged wheel keyed on the spindle (11).

The cages (13) are made from small rectangular plates connected across by $2\frac{1}{2}$ " strips, and are supported from the ringed frame by overlapped $5\frac{1}{2}$ " strips (14) as shown.

The other constructional details of the model are very clearly brought out in the illustration.

Model No. 89. Eiffel Tower

(MADE WITH MECCANO OUTFIT No. 6 OR No. 5 AND No. 5A.)

*Parts required in addition
to Outfits.*

*Parts required in addition
to Outfits.*

PARTS REQUIRED.	No. 1 No. 2 No. 3 No. 4 No. 5					PARTS REQUIRED.	No. 1 No. 2 No. 3 No. 4 No. 5				
	45 12½" Perforated Strips	41	35	35	31		31	5 1" Pulley Wheels	—	3	1
56 5½" " "	50	40	38	36	32	1 Bush Wheel	—	—	—	—	—
36 3½" " "	35	34	30	30	19	3 ¾" Pinion Wheels	3	3	2	1	—
20 3" " "	20	20	18	16	12	1 ½" " "	1	—	—	—	—
46 2½" " "	36	32	32	28	2	2 Gear Wheels	2	2	1	1	—
6 2" " "	6	6	6	6	—	2 ¾" Contrate Wheels	2	2	2	—	—
4 12½" Angle Girders	4	—	—	—	—	1 Worm Wheel	1	1	—	—	—
12 5½" " "	12	12	12	12	12	404 Nuts and Bolts	379	354	334	294	244
89 Angle Brackets	77	73	63	45	36	38 Keys	29	27	16	16	5
1 6" Rod	1	1	1	—	—	2 Collars and Set Screws	2	2	—	—	—
1 5" " "	1	—	—	—	—	1 Double Bent Strip	1	—	—	—	—
3 4½" " "	—	—	—	—	—	1 Large " "	1	1	—	—	—
4 3½" " "	4	4	4	4	2	3 Large Rectangular Plates	2	2	1	1	—
1 1½" Pulley Wheel	1	1	—	—	—	6 Small " "	6	6	3	3	1

Begin by constructing the four platforms Fig. 89A, which are then assembled and connected to the vertical ribs (1) Fig. 89B by means of angle brackets. The position of these angle brackets should be carefully noted on Fig. 89A.

The base of the Tower is made from a number of small frames (2) Fig. 89c, which are bolted to the angle brackets (3) Fig. 89A.

The gallery (4) of the Tower, Fig. 89c, is then constructed as clearly shown in the illustration, being composed of three 12½" strips, bolted together in the first holes to form the top ring, the bottom ring being formed in a similar manner and bolted to angle brackets (5) by the inclined strips (6).

The crown (7) Fig. 89c of the Tower is next built up, the lower strips (8) being bolted to the upper ends (9) of the ribs (1).

The cages (10) Fig. 89c are made of rectangular plates connected by 2½" strips, the upper pulley wheel case (11) being reversed and bolted over the top to the upper platform (12) Fig. 89A.

The hoisting gear box, the construction of which is clearly brought out in Fig. 89D, is then bolted by bolts (13) to the angle girders (14) in such position that the cords rising from the pulleys (15) pass up through orifices (16) in the lower platform, over the pulleys (23) Fig. 89c. The drive is from the spindle (17) through a clutch gear to a transverse spindle (18) carrying a worm engaging a ½" pinion on the shaft (20), from which the drive is taken through a gear train to a spindle (21) carrying a pulley (22) round which, and the other pulleys (15) a continuous cord is passed, and connected to the top and bottom of the cages.

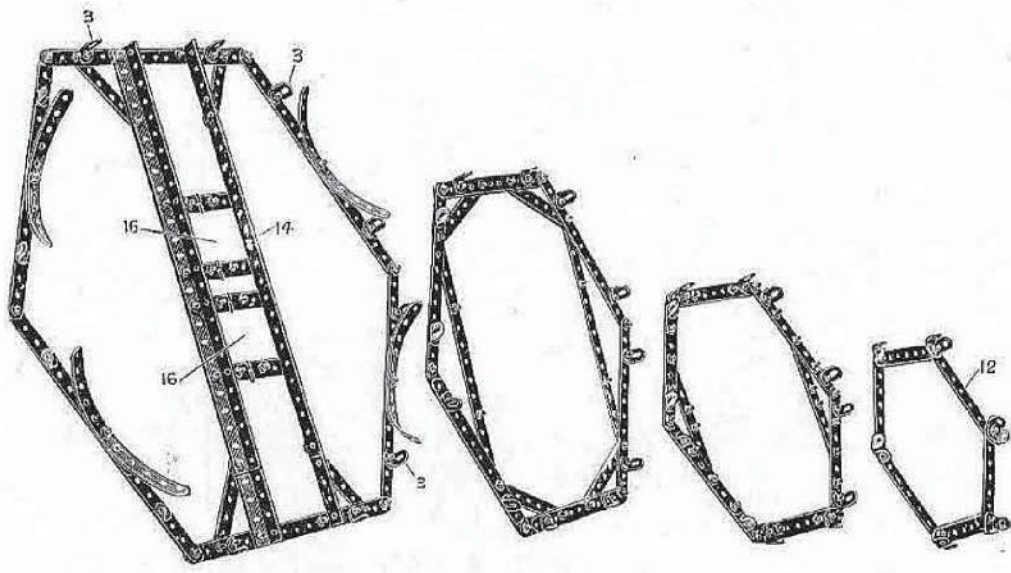

FIGS. 89A.

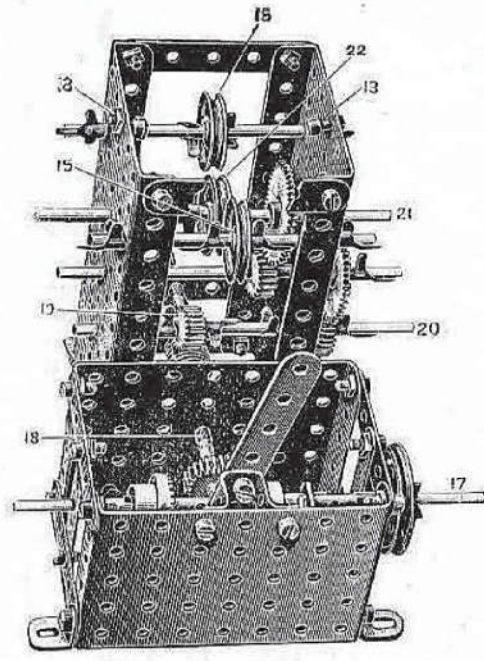

FIG. 89D.

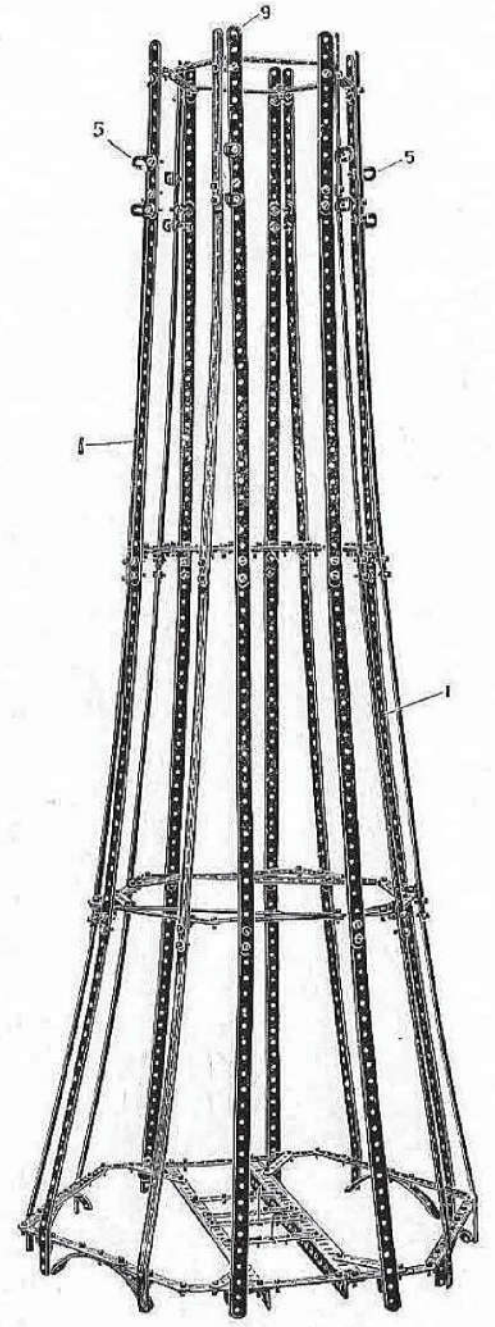
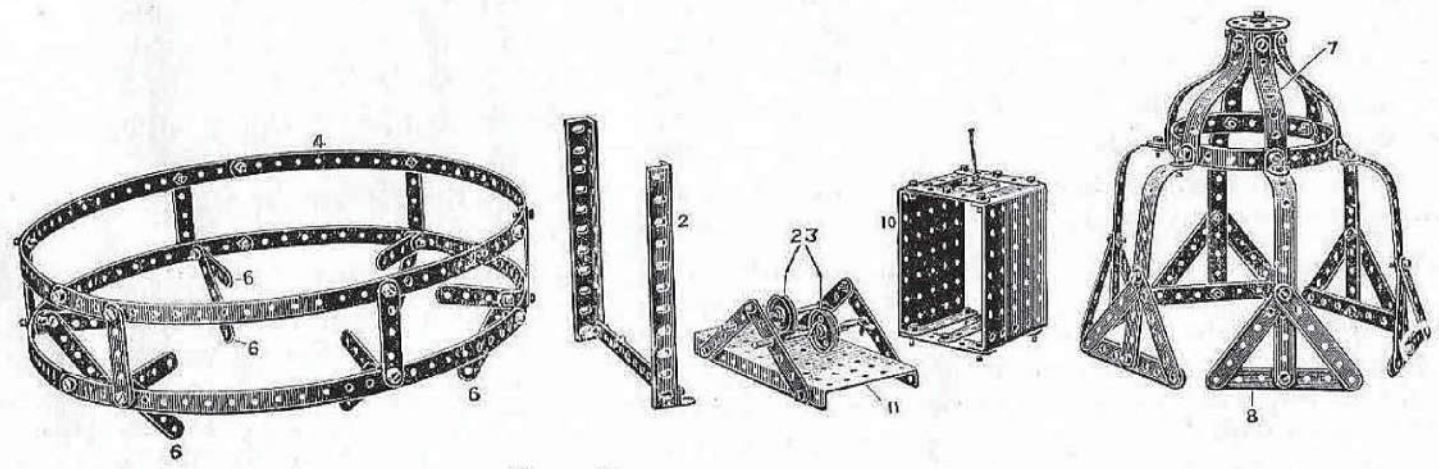

FIG. 89B.



FIGS. 89C.

Model No. 90. Mechanical Navy

(MADE WITH MECCANO OUTFIT NO. 6 OR NO. 5 AND NO. 5A.)

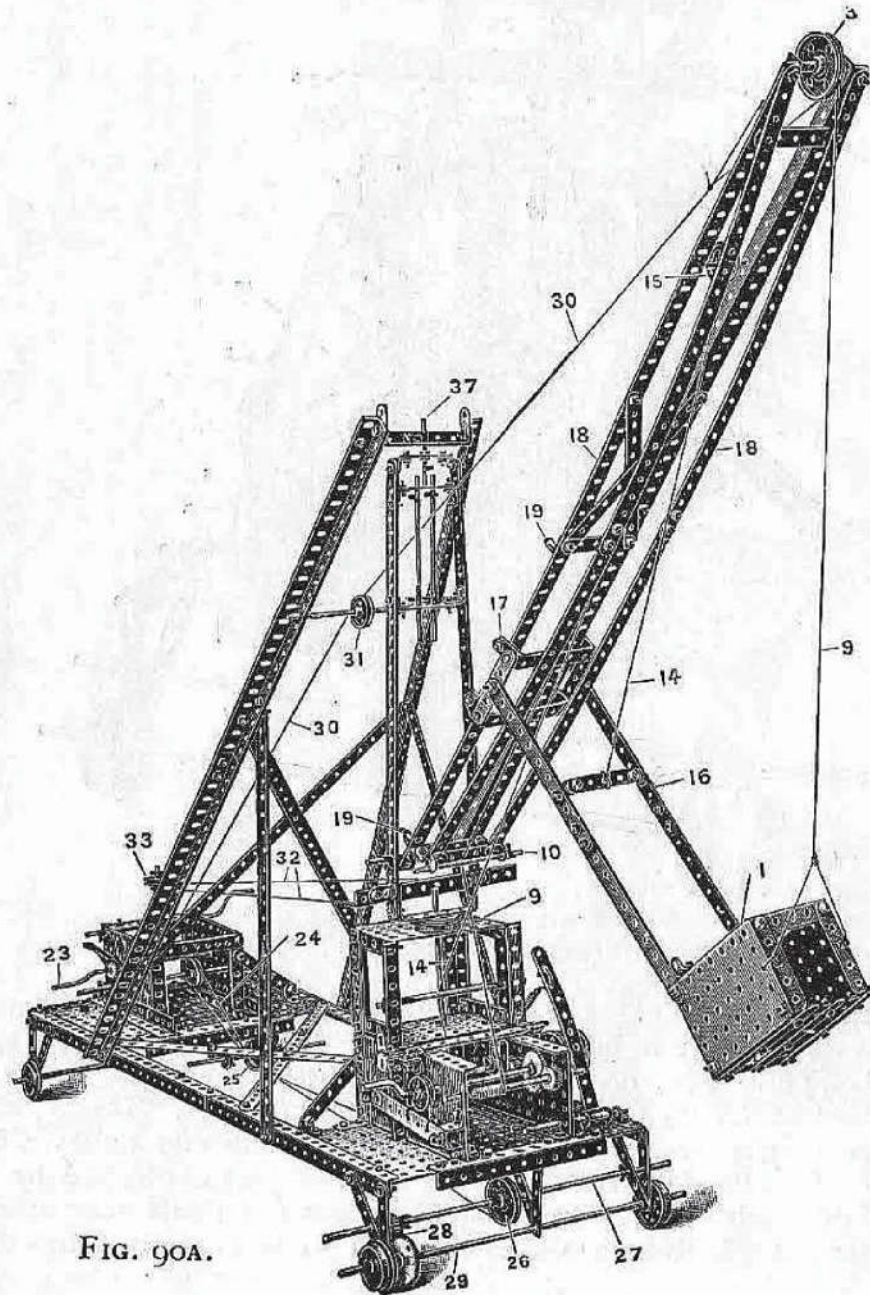

FIG. 90A.

Parts required in addition
to Outfits.

PARTS REQUIRED.		No. 1	No. 2	No. 3	No. 4	No. 5
12	12 1/2" Perforated Strips	8	2	2	—	—
8	5 1/2" " "	2	—	—	—	—
3	3 1/2" " "	2	1	—	—	—
11	3" " "	11	11	9	7	3
22	2 1/2" " "	12	8	8	4	—
2	2" " "	2	2	2	2	—
12	12 1/2" Angle Girders	12	8	4	4	—
12	5 1/2" " "	12	12	12	12	12
44	Angle Brackets	32	28	18	—	—
3	11 1/2" Rods	3	3	3	1	1
1	8" Rod	1	1	1	1	1
1	6" " "	1	1	1	—	—
4	5" Rods	4	1	—	—	—
4	4 1/2" " "	1	1	1	1	1
2	3 1/2" " "	2	2	2	2	—
3	2" " "	1	1	—	—	—
4	Crank Handles	3	3	2	1	—
7	Flanged Wheels	7	3	3	—	—
2	1 1/2" Pulley Wheels	2	2	1	1	—
6	1" " "	—	4	2	1	—
4	1/2" " "	4	4	3	3	—
1	Bush Wheel	—	—	—	—	—
3	3/4" Pinion Wheels	3	3	2	1	—
2	1 1/2" " "	2	1	—	—	—
2	Gear Wheels	2	2	1	1	—
1	Worm Wheel	1	1	—	—	—
1	Pawl	1	—	—	—	—
48	Keys	39	37	26	26	15
2	Collars and Set Screws	2	2	—	—	—
223	Nuts and Bolts	198	173	153	113	63
2	Hooks	1	1	1	1	1
1	Spring	1	1	1	—	—
1	Single Bent Strip	—	—	—	—	—
1	Double " "	1	—	—	—	—
4	Large Bent Strips	4	4	3	3	2
8	Large Rectangular Plates	7	7	6	6	4
7	Small " "	7	7	4	4	2
2	Eye Pieces	2	2	2	—	—

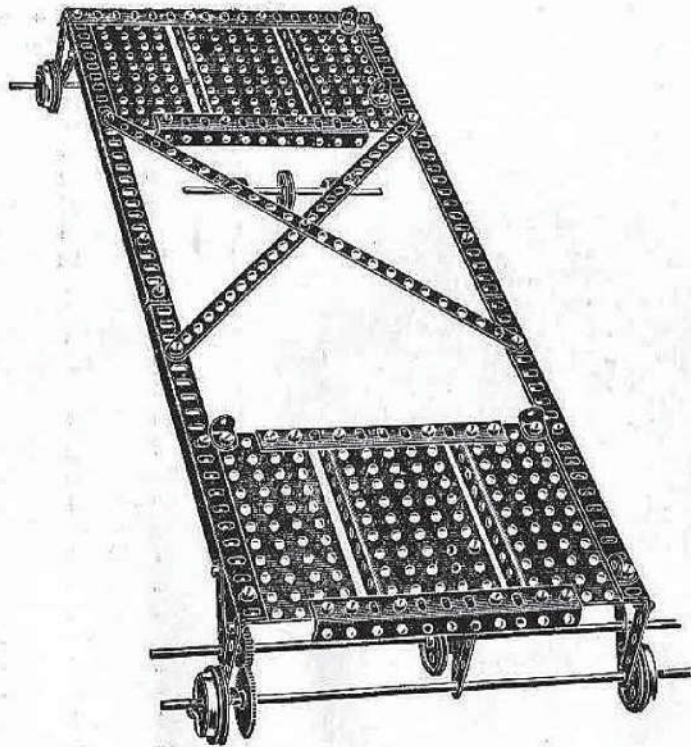

FIG. 90A.

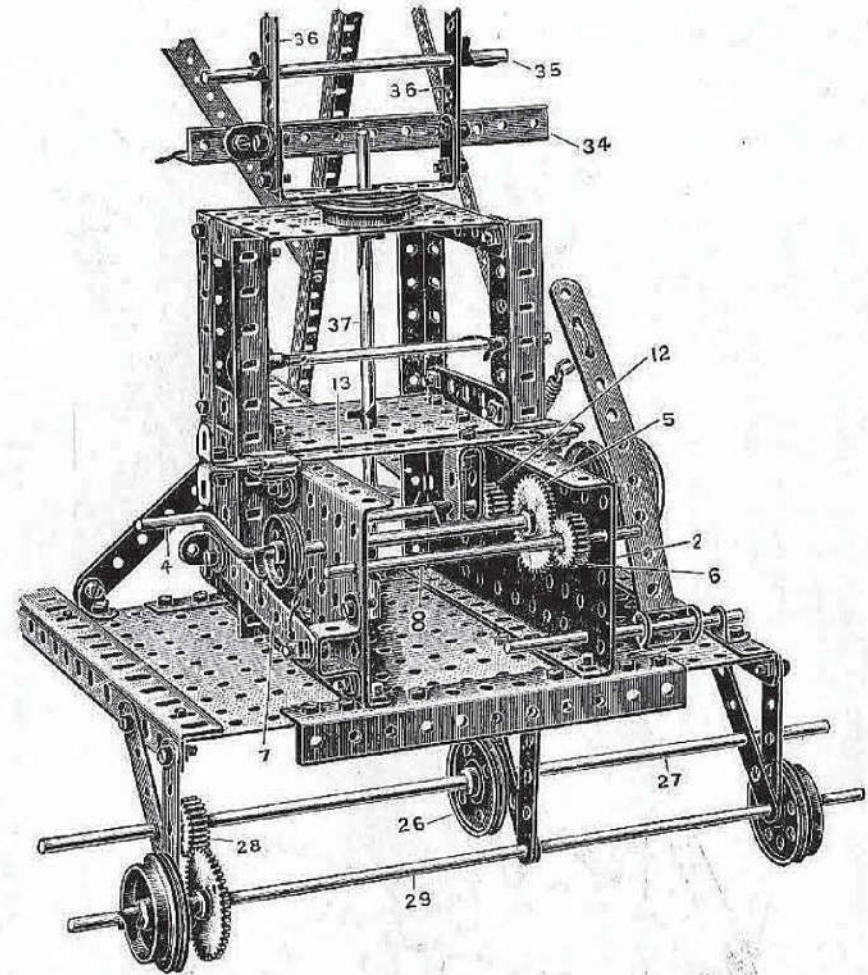

FIG. 90B.

With this Model, proceed first by constructing the bed frame Fig. 90A. On the front portion of the bed frame is now mounted the gear box Fig. 90B, which controls the movements of the bucket (1). The side walls of the gear box (2) consist of two large rectangular plates bolted on the bed plate Fig. 90A; the crank handle (4) carries the large gear wheel (5) meshing with the $\frac{3}{4}$ " pinion (6). A friction brake mechanism (7) controls the crank handle (4). The winding spindle (8) driven from the crank handle, carries the cord (9) passing round the spindle (10) and the jib end pulley wheel (11) to control the swinging movement of the bucket (1). The rear spindle (11) carrying a $\frac{3}{4}$ " pinion (12) controlled by the (3) to control the swinging movement of the bucket (1). The cord (14) passes from this rear spindle (11) round the jib pulley (15) back to the bucket arm. When, therefore, both spindles (8) and (11) are in gear with the crank

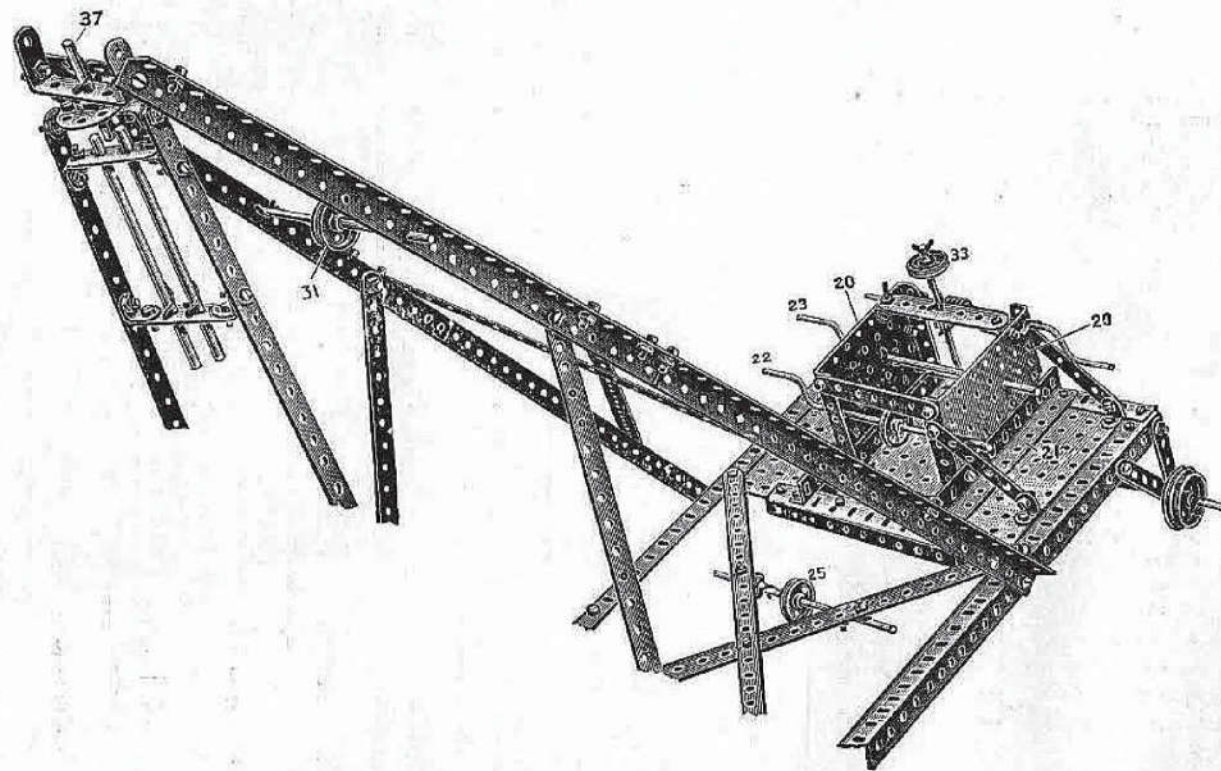

FIG. 90C.

handle (4) the bucket partakes of a combined swinging and vertical travelling movement up the jib, the bucket arm (16) being pivotted to a light trolley (17) riding on the edge girders (18) of the jib between stops (19) consisting of angle brackets.

Proceed next with the gear box on the rear platform shown in Fig. 90c. This again consists of two small rectangular plates, bolted by angle girders (21) to the bed frame, and carrying two cranked spindles (22) and (23). The spindle (22) carries a 1" pulley wheel round which passes the cord (24), for causing traversing movement of the bed frame. This cord passes under the pulley wheel (25) and round the front pulley wheel (26), which latter is keyed on a spindle (27) geared at (28) to the flanged wheel spindle (29).

The cord (30) for elevating the jib, passes round the pulley wheel (31) and on to the rear cranked spindle (23). The cord (32) for luffing the jib, passes round the pulley wheel (33) on the vertical spindle of the gear box, and is connected to the outer ends of the yoke piece (34). The jib of the crane pivots about the spindle (35) mounted in the standard (36), which in turn swivels about the spindles (37).

Contents of Outfits

DESCRIPTION OF PARTS.	0	0A	1	1A	2	2A	3	3A	4	4A	5	5A	6
12 $\frac{1}{8}$ " Perforated Strips ...	—	4	4	6	10	—	10	4	14	—	14	34	48
5 $\frac{1}{2}$ " " " ...	4	2	6	10	16	2	18	2	20	4	24	36	60
3 $\frac{1}{2}$ " " " ...	—	1	1	1	2	4	6	—	6	11	17	19	36
3" " " ...	—	—	—	—	—	2	2	2	4	4	8	16	24
2 $\frac{1}{2}$ " " " ...	9	1	10	4	14	—	14	4	18	26	44	4	48
2" " " ...	—	—	—	—	—	—	—	—	—	6	6	18	24
12 $\frac{1}{2}$ " Perforated Angle Girders ...	—	—	—	4	4	4	8	—	8	4	12	12	24
5 $\frac{1}{2}$ " " " ...	—	—	—	—	—	—	—	—	—	—	—	12	12
Angle Brackets ...	12	—	12	4	16	10	26	18	44	9	53	115	168
11 $\frac{1}{4}$ " Rods ...	—	—	—	—	—	—	—	2	2	—	2	2	4
8" " " ...	—	—	—	—	—	—	—	—	—	—	—	1	1
6" " " ...	—	—	—	—	—	—	—	2	2	2	4	—	4
5" " " ...	—	—	—	3	3	1	4	—	4	—	4	—	4
4 $\frac{1}{2}$ " " " ...	2	1	3	—	3	—	3	—	3	—	3	1	4
3 $\frac{1}{2}$ " " " ...	—	—	—	—	—	—	—	—	—	2	2	2	4
2" " " ...	2	—	2	—	2	1	3	1	4	1	5	1	6
Crank Handles ...	1	—	1	—	1	1	2	1	3	1	4	—	4
Flanged, and Grooved Wheels ...	—	—	—	4	4	—	4	4	8	—	8	—	8
1 $\frac{1}{2}$ " Pulley Wheels ...	—	—	—	—	—	1	1	—	1	1	2	—	2
1" " " ...	4	2	6	—	2	2	4	1	5	1	6	—	6
$\frac{1}{2}$ " " " ...	1	—	—	—	—	1	1	—	1	5	6	—	6
Bush Wheels ...	1	—	1	—	1	—	1	—	1	—	1	4	5
$\frac{3}{4}$ " Pinion Wheels ...	—	—	—	—	—	1	1	1	2	1	3	—	3
$\frac{1}{2}$ " " " ...	—	—	—	1	1	1	2	—	2	—	2	—	2
Gear Wheels ...	—	—	—	—	—	1	1	—	1	1	2	—	2
1 $\frac{1}{2}$ " Contrate Wheels ...	—	—	—	—	—	—	—	1	1	—	1	1	2
$\frac{3}{4}$ " " " ...	—	—	—	—	—	—	—	2	2	—	2	—	2
Worm Wheel ...	—	—	—	—	—	1	1	—	1	—	1	—	1
Pawl ...	—	—	—	1	1	1	2	—	2	—	2	—	2
Spanner ...	—	—	—	1	1	—	1	1	2	—	2	—	2
Keys ...	7	2	9	2	11	11	22	—	22	11	33	15	48
Collar and Set Screw ...	—	—	—	—	—	4	4	—	4	—	4	—	4
Screw Driver ...	1	—	1	—	1	—	1	—	1	—	1	—	2
Nuts and Bolts ...	20	5	25	25	50	20	70	40	110	50	160	340	500
Wood Screws ...	—	8	8	—	8	—	8	—	8	4	12	12	24
Hook ...	1	—	1	—	1	—	1	—	1	—	1	1	2
Hanks Cord ...	—	1	1	1	2	1	3	1	4	2	6	—	6
Cards Cord ...	1	—	1	—	1	—	1	—	1	1	2	1	3
Propeller Blades ...	—	—	—	—	—	—	—	—	—	2	2	2	4
Chain ...	—	—	—	—	—	—	—	—	—	1	1	—	1
Springs ...	—	—	—	—	—	—	—	1	1	—	1	1	2
Single Bent Strips ...	1	—	1	—	1	—	1	—	1	1	2	1	3
Double " " ...	—	—	—	1	1	—	1	—	1	—	1	7	8
Large " " ...	—	—	—	—	—	1	1	—	1	1	2	2	4
Large Rectangular Plates ...	1	—	1	—	1	1	2	—	2	2	4	4	8
Small Rectangular Plates ...	—	—	—	—	—	3	3	—	3	2	5	3	8
Sector Plates ...	1	1	2	—	2	—	2	—	2	—	2	2	4
Eye Pieces... ...	—	—	—	—	—	—	—	—	—	—	—	—	—
Rubber Bands ...	—	—	—	—	—	—	—	1	1	1	2	2	4
Manual of Instructions ...	1	1	1	—	1	—	1	—	1	—	1	—	1

Separate Parts



No. 1.

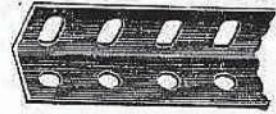

No. 8



No. 12.



No. 32.



No. 44.



No. 51.



No. 37.



No. 35.



No. 13.



No. 19.



No. 20.

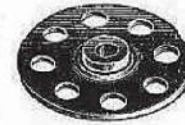

No. 24.



No. 25.

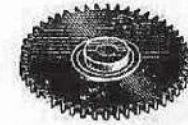

No. 27.



No. 59.



No. 33.



No. 34.

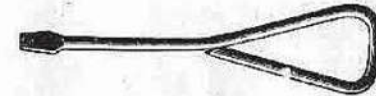

No. 36.



No. 21.



No. 28.

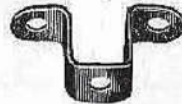

No. 45.

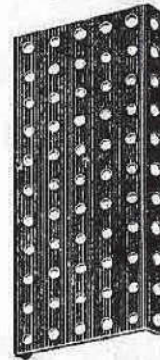

No. 52.



No. 43.



No. 41.

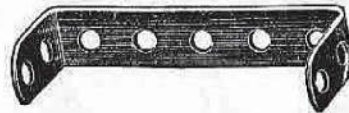

No. 46.

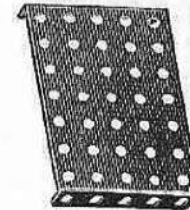

No. 53.

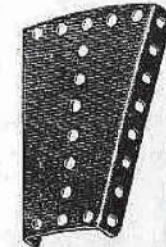

No. 54.

Price List of Additional Parts

			s.	d.
1.—Perforated Strips, 12 $\frac{1}{2}$ " long	...	per bdl. ($\frac{1}{2}$ doz.)	0	9
2.— " " 5 $\frac{1}{2}$ " "	...	" "	0	4
3.— " " 3 $\frac{1}{2}$ " "	...	" "	0	3
4.— " " 3" "	...	" "	0	3
5.— " " 2 $\frac{1}{2}$ " "	...	" "	0	3
6.— " " 2" "	...	" "	0	3
8.—Angle Girders, 12 $\frac{1}{2}$ " long	...	" "	1	0
9.— " " 5 $\frac{1}{2}$ " "	...	" "	0	6
12.—Angle Brackets	...	(dozen)	0	6
13.—Axle Rod, 11 $\frac{1}{2}$ " long each	0	3
14.— " 6" " "	0	2
15.— " 5" or 4 $\frac{1}{2}$ " long "	0	2
16.— " 3 $\frac{1}{2}$ " long "	0	1
17.— " 2" " "	0	1
19.—Crank Handle	0	3
20.—Flanged and Grooved Wheel	0	9
21.—Pulley Wheel, 1 $\frac{1}{2}$ " diameter	0	6
22.— " " 1" "	0	4
23.— " " $\frac{1}{2}$ " "	0	2
24.—Bush Wheel	0	6
25.—Pinion Wheel, $\frac{3}{4}$ " diameter	0	9
26.— " " $\frac{1}{2}$ " "	0	6
27.—Gear Wheel, 1 $\frac{1}{2}$ " "	0	10
28.—Contrate Wheel, 1 $\frac{1}{2}$ " diameter	1	3

			s.	d.
29.—Contrate Wheel, $\frac{3}{4}$ " diameter each	1	0
32.—Worm Wheel	0	9
33.—Pawl	0	3
34.—Spanner	0	3
35.—Keys	...	per box (dozen)	0	6
36.—Screw Driver each	0	3
37.—Nuts and Bolts	...	per box (1 dozen)	0	6
39.—Card Cord (Special) each	0	1
40.—Hank Cord	0	1
41.—Propeller Blades	...	per pair	0	6
42.—Chain 12ft. lengths, each	2	0
43.—Spring each	0	2
44.—Single Bent Strip	0	2
45.—Double " "	0	2
46.—Large " "	0	3
51.—Eye Piece	0	2
52.—Perforated Rectangular Plate, Large...	0	4
53.— " " " Small...	0	3
54.—Perforated Sector Plate, Small	0	3
55.—Rubber Bands	0	1
56.—Book of Instructions	0	6
57.—Hook	0	1
58.—Wood Screws	...	per doz.	0	2
59.—Collar and Set Screw each	0	2

Price List

No. 0.	Meccano (Royal)	3/-
No. 1.	Meccano Outfit	5/-
No. 2	”	”	10/-
No. 3.	”	”	15/-
No. 4.	”	”	25/-
No. 5.	”	Presentation Outfit	55/-
Packed in well made walnut stained box with lock and key.									
No. 6.	”	”	”	Ditto	ditto	ditto	ditto	ditto	100/-

No. 0A	Meccano Accessory Outfit	(containing sufficient parts to convert a Meccano Royal into a No. 1 Outfit)						2/9	
No. 1A	”	”	”	(containing sufficient parts to convert a No. 1 into a No. 2 Outfit) ...				5/6	
No. 2A	”	”	”	(containing sufficient parts to convert a No. 2 into a No. 3 Outfit) ...				6/-	
No. 3A	”	”	”	(containing sufficient parts to convert a No. 3 into a No. 4 Outfit) ...				11/-	
No. 4A	”	”	”	(containing sufficient parts to convert a No. 4 into a No. 5 Outfit) ...				14/-	
Do.	”	”	”	Packed in neat cardboard box.				35/-	
No. 5A	”	”	”	(containing sufficient parts to convert a No. 5 into a No. 6 Outfit) ...				50/-	
Packed in well made walnut stained box with lock and key.									

The Hornby System of Mechanical Demonstration.

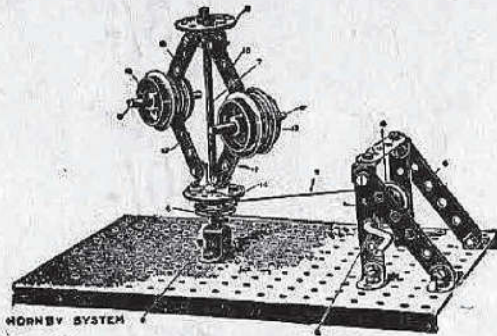

Centrifugal Governor.

We have recently introduced, in conjunction with Meccano, the "Hornby" System of Mechanical Demonstration, which provides an economical and yet very effective series of apparatus for demonstrating the main elementary fundamentals of mechanics and mechanical science. The scheme is intended to cover the requirements of ordinary elementary schools, though it is by no means limited to such an application. The present models used in the teaching of mechanical science such as those in use in Evening and Secondary Schools are very costly. In such models one piece of apparatus is employed to teach a given lesson and that one only, the consequence being that to cover anything like a proper ground the cost of the apparatus required is very heavy.

With the "Hornby" System a model may be taken to pieces, and the parts utilised to construct other models; again, the student by making his own model develops his constructive faculties, and instead of merely using an already highly finished piece of apparatus, he makes his apparatus from standard parts, his skill in the putting together of the parts being to some extent a measure of the success of his subsequent experiments with the apparatus. Experimental models constructed from "Hornby" System parts will be found to be of quite as high a degree of accuracy as apparatus costing many times as much.

Every care has been taken in designing these models to make each one both simple in construction and effective as a demonstration of some important principle.

We have introduced three separate Outfits to meet the requirements of the three higher standards of elementary day schools. "A" section relates mainly to constructional work, and is designed to bring out such ideas as bracing, girder construction, the building up of roof trusses, the joining of plates, and so on. "B" section embodies a series of simple movable parts in engines; whilst the "C" section is designed to afford scope for the teaching of the elementary laws of mechanics.

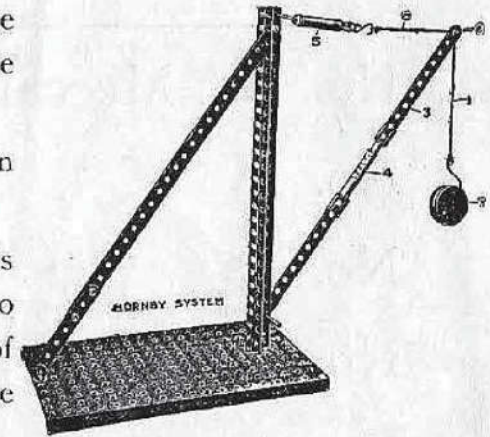

Jib Crane.

No. A.	"Hornby" System Outfit	10/-	No. AA. Accessory Outfit	Containing sufficient parts to convert a No. A into a No. B.	27/6	
No. B.	"	"	"	35/-	No. BA. Do. do.	No. B into a No. C	37/6	
No. C.	"	"	"	70/-				
No. MSB.	Containing sufficient parts in conjunction with a No. 3 Meccano Outfit to demonstrate A and B Sections						...	10/-
No. MSC.	Do.	do.	do.	do.	do.	A, B, and C Sections	30/-	



