

MECCANO



(PATENTED)

(TRADE MARK 12633)

INSTRUCTIONS

For the No. 0 Outfit

6^d.

Copyright 1914 by

MECCANO LIMITED, LIVERPOOL, ENG.

No. 140

Colonial Edition

HOW TO MAKE MODELS AND TOYS WITH MECCANO

THE first piece of advice we would give to the beginner in Meccano is that he commences with Model No. 1, and that he erects every model in turn up to the capacity of his outfit. By that time he will have grown so familiar with the various parts of Meccano, and will see its possibilities so clearly, that he will with little difficulty be able to build many other models of his own invention.

The charm of Meccano lies greatly in its endless variety, and until the user has commenced to apply his own inventive faculties to the hobby, he is not getting the enjoyment out of it which he should.

Every part of the outfit should first be taken from its box, examined, and its name and number, as contained in the illustrations of Meccano parts over leaf, committed to memory. The standard details shown at the end of the Manual should also be carefully studied, so that the instructions for making the various models may be followed easily and rapidly.

The parts are all standardised, and are interchangeable, and they will be found to fit together easily and without forcing. The holes in the strips are of equal distance apart. The axles fit any of the holes, and their position in the various designs may be ascertained by counting the holes.

All the models shown are built upon sound and standard engineering principles, and the parts employed represent the main mechanical parts used in machinery, such as levers, beams, wheels, axles, pulleys, worm wheels, screws, bolts, &c., so that as an introduction to the serious study of Mechanics the value of Meccano is very great indeed.

Each model may be taken to pieces, and the same parts may be used to make up other models. Additional parts can always be purchased from your dealer or from us.

We are at all times glad to correspond with users of Meccano, and to assist them by suggestions or criticisms when difficulties occur with new models.

Trucks and Luggage Carts

MODEL No. 1



The body of the Truck is made of a flanged plate, two $2\frac{1}{2}$ " strips being bolted through flat brackets to the upper end to form shafts. The lip of the Truck consists of a $2\frac{1}{2}$ " strip bolted to the plate by angle brackets. On an axle passed through the end holes of the flanges are secured a pair of 1" pulley wheels, with set screws.

MODEL No. 2

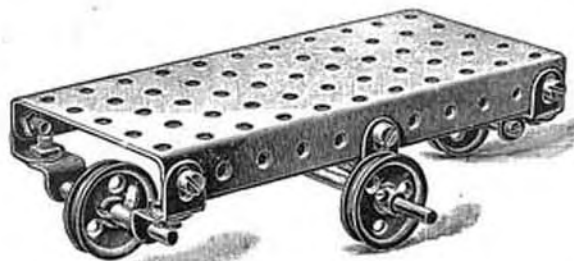

Fig. 2A.

In a Revolver Truck the two end wheels are always raised just a little higher than the two centre wheels with a moderate amount of play on the axles, so that the Truck may be quickly revolved upon the centre wheels.

The bearings for the end axles are formed by connecting two angle brackets together, as shown in Fig. 2A, and bolting them in each end hole at the sides of the plate.

The two centre bearings are formed of flat brackets, and bolted in the centre holes of each flanged side of the plate.

It will be noted that the elongated holes of the bearings are bolted on the outside of the plate flanges. This enables the end wheels to be raised and the centre wheels to be lowered for the purpose already mentioned.

The axle carrying the two centre wheels is then placed in position, and the wheels having set screws are secured to this axle, while the two end wheels run freely on the rods, the latter being held in position by clips.

Trucks and Luggage Carts—(continued)

MODEL No. 3

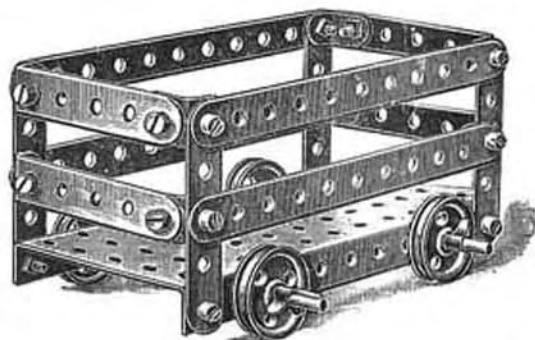

Fix the four upright $2\frac{1}{2}$ " strips at each corner of the plate first; then attach the $2\frac{1}{2}$ " bent strips and $5\frac{1}{2}$ " side strips to the uprights by means of nuts and bolts. Insert two axles through the third holes from each end of the plate; push on the wheels, and secure them in position by the set screws.

This is a very neat little model, and very simple to make.

MODEL No. 4

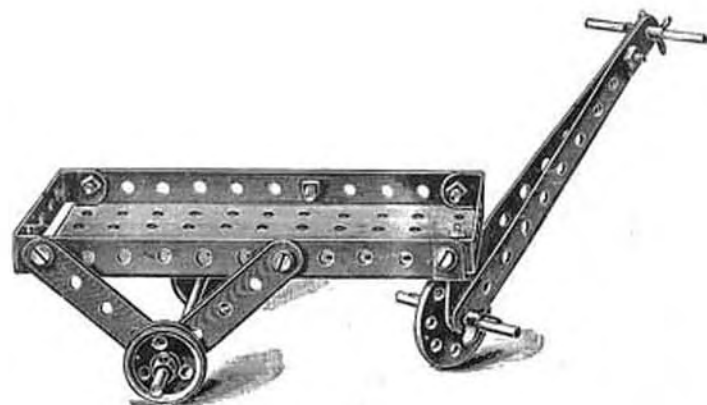

In connection with the construction of this Model, it will only be necessary to state that the front swivelling support is formed by connecting loosely a cranked bent strip in the centre end hole of the plate, by a bolt with two nuts on the upper side, locked, to prevent it from working out, and that the axle carrying the hind wheels is passed through the end holes of the $2\frac{1}{2}$ " diagonal side strips which form the bearings.

Trucks and Luggage Carts—*(continued)*

MODEL No. 6

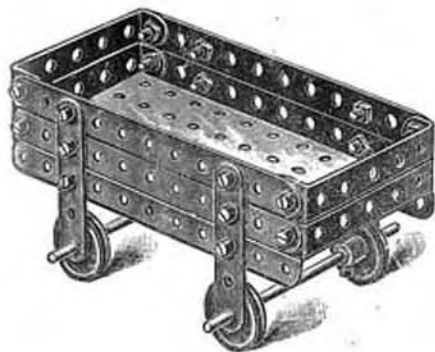

MODEL No. 5

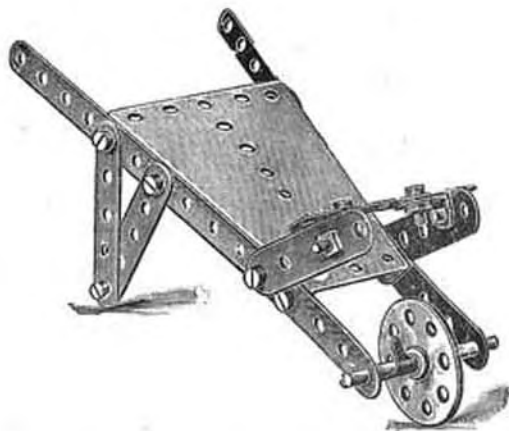

MODEL No. 8

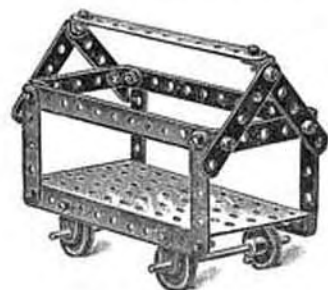

MODEL No. 7



MODEL No. 9

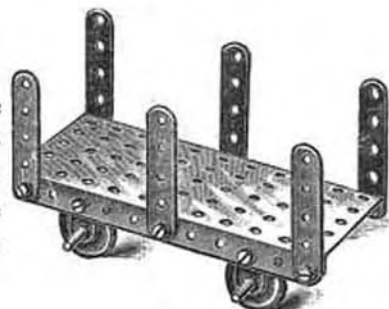

The only point to be noted in this Model is that the floor plate of the Barrow is made from a sector plate, to the sides of which the arm strips are secured, made up from two $5\frac{1}{2}$ " strips bolted on the inside of the sector plate; the $2\frac{1}{2}$ " strips carrying the wheel axle being bolted on the outside of the sector plate.

Trucks and Luggage Carts—(continued)

MODEL No. 10

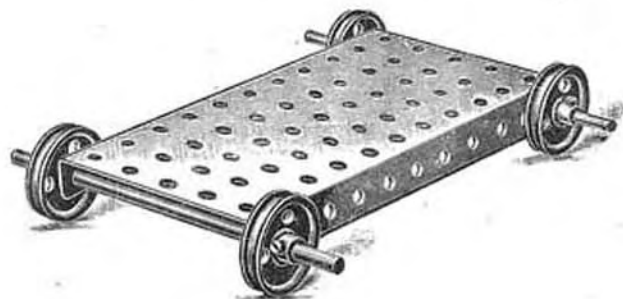

MODEL No. 11

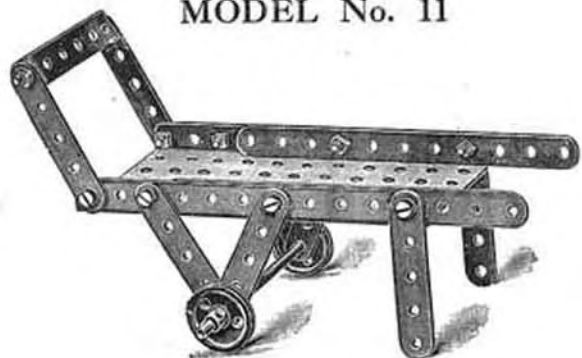

MODEL No. 12

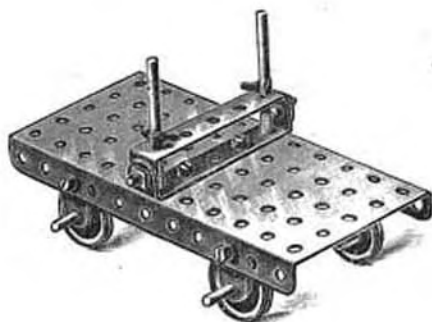

MODEL No. 13. Well Windlass

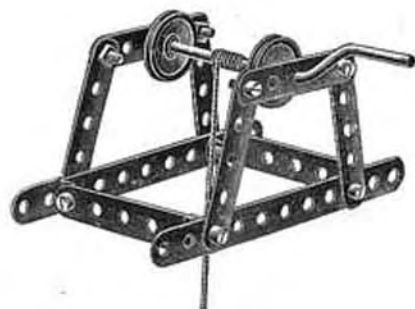

Seesaw

MODEL No. 14

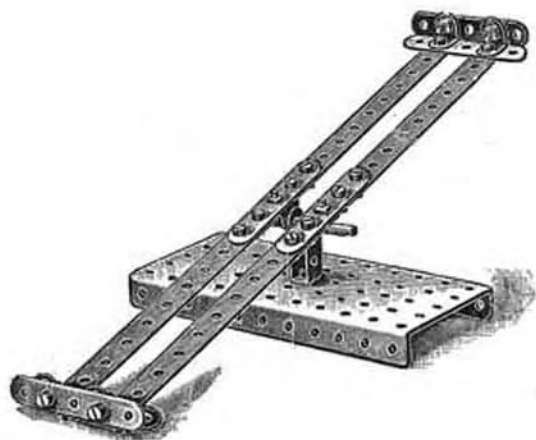

Bath Chair

MODEL No. 15

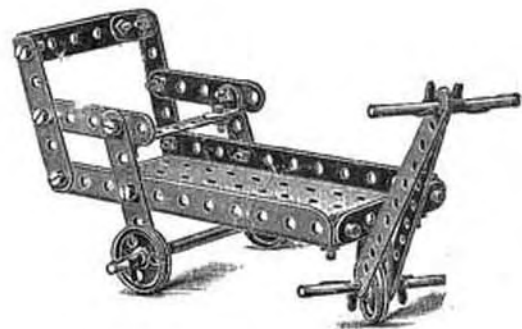

Make the Seesaw first. Commence with one side by connecting two $5\frac{1}{2}$ " strips 1 together with a $2\frac{1}{2}$ " strip 2, as shown in the illustration. An angle bracket is then bolted to the central hole of the short strip on its under side to form a bearing for the spindle. It is to be noted that the angle bracket is bolted with the head of the bolt downward, to clear the spindle. The other side of the Seesaw is formed in a similar manner.

Now connect these two together at each end by two $2\frac{1}{2}$ " strips and two angle brackets. Next bolt the cranked bent strip 3 to the centre of the flanged plate; bring the two centre brackets on the under side of the Seesaw in line with the top holes in the bent strip, and pass through the short rod, fixing a clip on each side to keep it in position.

Go Chair

MODEL No. 16



Proceed to construct one side of this Model first by taking two $2\frac{1}{2}$ " strips and bolting them together overlapped three holes; after which attach diagonally a $5\frac{1}{2}$ " strip in the fourth hole from the bottom, and with the same bolt a $2\frac{1}{2}$ " bent strip on the inside. The other side is constructed in a similar manner. The sides are then brought together and connected by the $2\frac{1}{2}$ " bent strip.

The seat is then formed by bolting a $2\frac{1}{2}$ " strip at right angles with the central $2\frac{1}{2}$ " bent strip, and a further $2\frac{1}{2}$ " strip at each end.

The back is formed by connecting a $2\frac{1}{2}$ " bent strip in the second hole from the top of the two $5\frac{1}{2}$ " side strips. Two axle rods are then passed through the bottom holes, and the wheels placed in position, and secured by clips.

Cot

MODEL No. 17

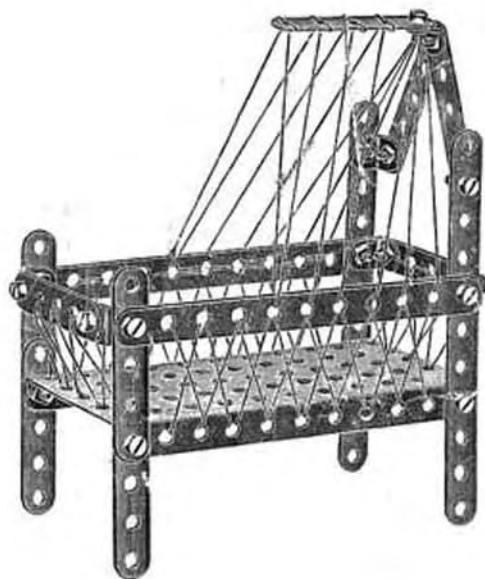

In the construction of this Model it will only be necessary to say that the two front uprights are formed by $2\frac{1}{2}$ " strips overlapped two holes.

MODEL No. 21. Potters's Wheel

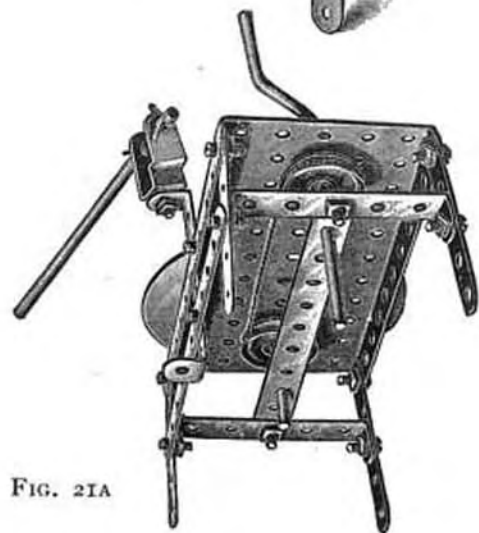
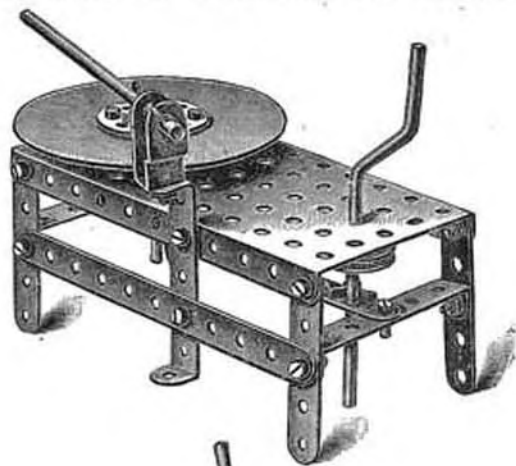
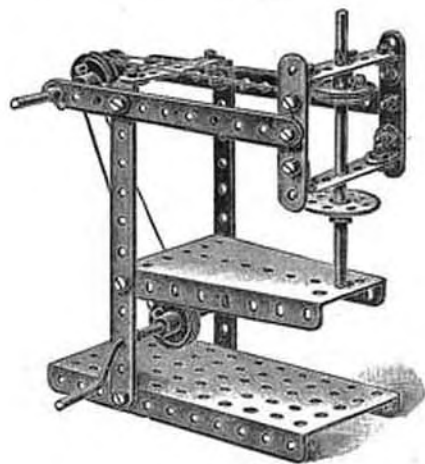

FIG. 21A

MODEL No. 22. Drilling Machine



MODEL No. 23. Lathe



Hoisting Block

MODEL No. 24



Gangway

MODEL No. 25

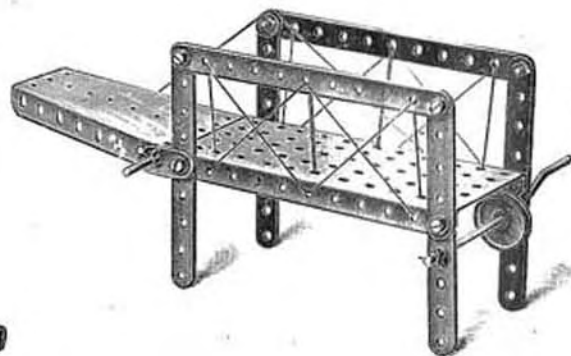

Tower Wagon

MODEL No. 26

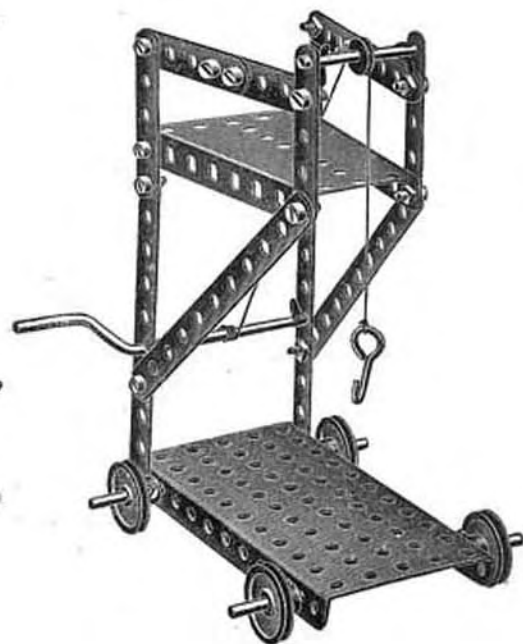

Drop Stamp

MODEL No. 27

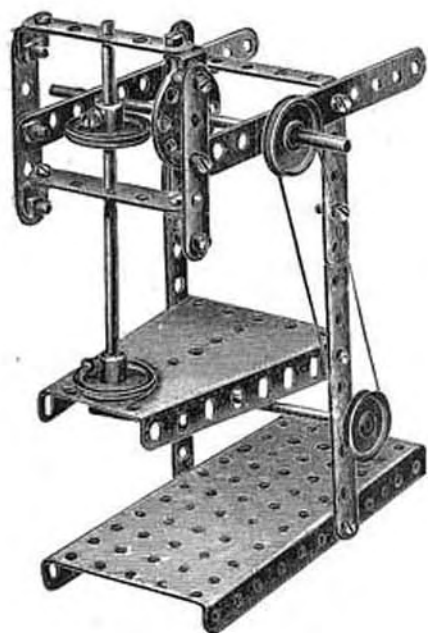

The stamp of this model is raised and dropped by a $2\frac{1}{2}$ " strip attached to a bush wheel.

Swivelling Crane

MODEL No. 28



The sector plate of the Crane in this model is pivoted to the base.

Level Crossing Barrier

MODEL No. 29

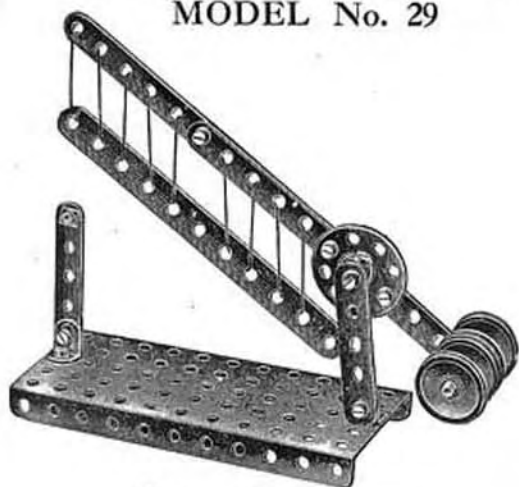

Polishing Spindle

MODEL No. 30

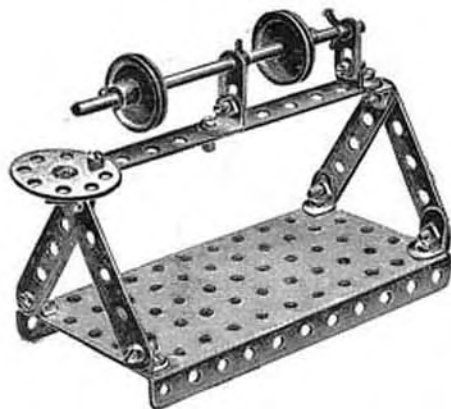

Ore Crusher

MODEL No. 31

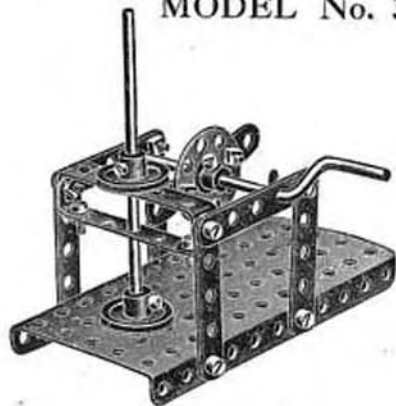

Buffing Spindle

MODEL No. 32

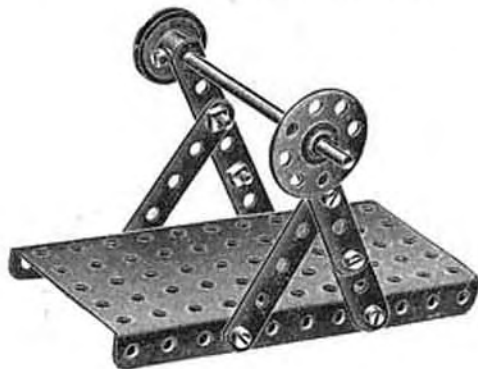

Model No. 33—RAILWAY SIGNAL

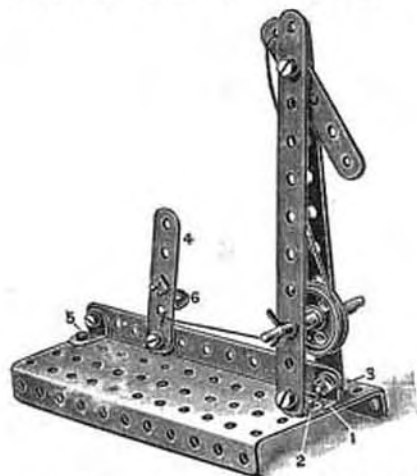

Model No. 35—PULLEY SHAFT

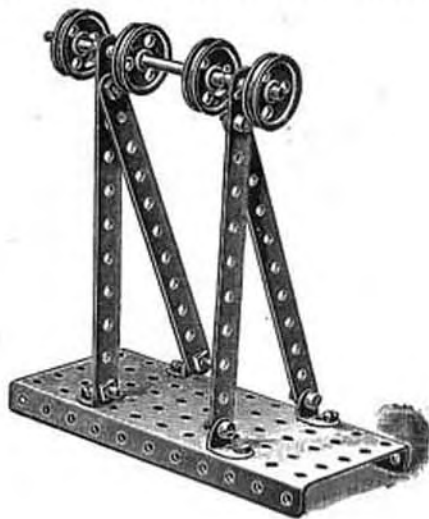

Model No. 34—AEROPLANE

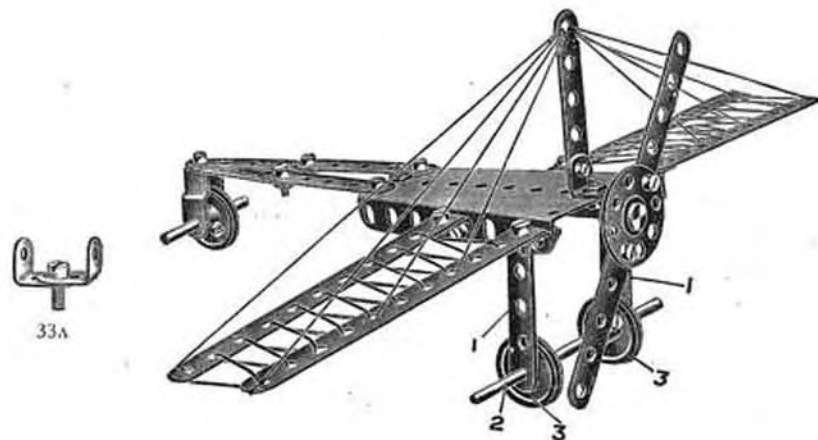

Begin by connecting two $5\frac{1}{2}$ " strips on each side of the sector plate by angle brackets to form the wings. The tail plane consists of four $2\frac{1}{2}$ " strips attached as shown. $2\frac{1}{2}$ " strips 1 are then bolted vertically to the sector plate in the second hole, and a rod 2 passed through the lowest holes to carry the wheels 3. Angle brackets are then bolted at each end of the sector plate and in the centre on the under side, and a rod $4\frac{1}{2}$ " is threaded through these angle brackets to carry the shaft upon which the Bush Wheel and $2\frac{1}{2}$ " strip are attached, forming the propeller.

Jib Crane MODEL No. 37

Windmill

MODEL No. 36

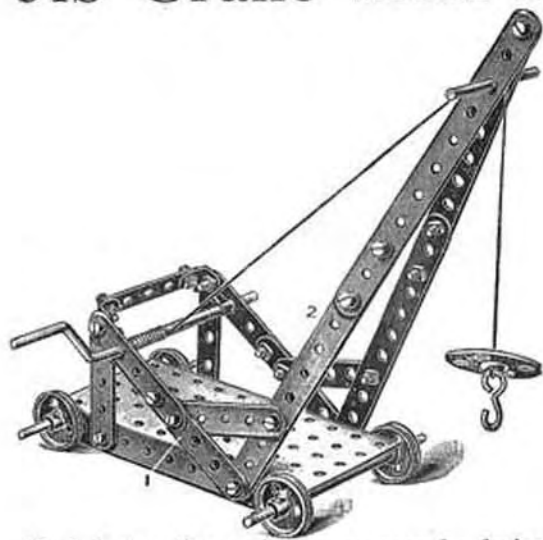
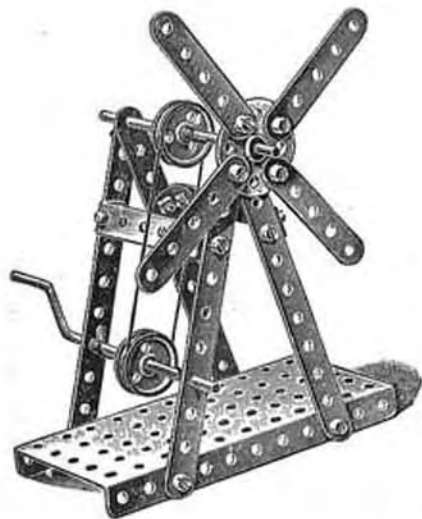

Swing

MODEL No. 38

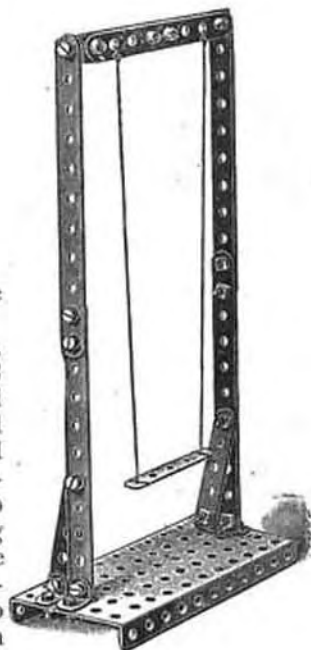

Much instruction and pleasure may be derived from the construction of this model.

Two $2\frac{1}{2}$ " strips 1 bolted together, overlapped two holes, sloping back to carry the winding spindle, and two $5\frac{1}{2}$ " strips 2 overlapped three holes to form one side of the jib, are attached by the same screw in the third hole from the end on the flanged side of the rectangular plate. These parts are then braced together by a further $2\frac{1}{2}$ " strip connected, as shown in the illustration, to give rigidity. At the upper end of the sloping strip is connected an angle bracket and a $2\frac{1}{2}$ " strip, the latter being bolted to the third hole in the plate. The other side of the crane is constructed in a similar manner, and both sides connected across the back by a $2\frac{1}{2}$ " strip, and at the top of the jib by a bolt. A short rod carrying the jib pulley is carried in the third hole from the top, the cord is passed over the pulley and tied to the spindle. Insert two axles through the end holes and push on the four wheels, securing them in position.

Telpher Span

MODEL No. 39

Many hours of enjoyment can be obtained from this model. The illustration shows just how it is worked. The cords may be made to any length, and the load carried from one side of the room to the other. In order to give a better grip, the operating cord should be wound twice round the crank handle pulley. The body of the telpher should be screwed down on to a solid base with ordinary wood screws, and the pulley bracket screwed in a suitable position on the opposite side of the room.

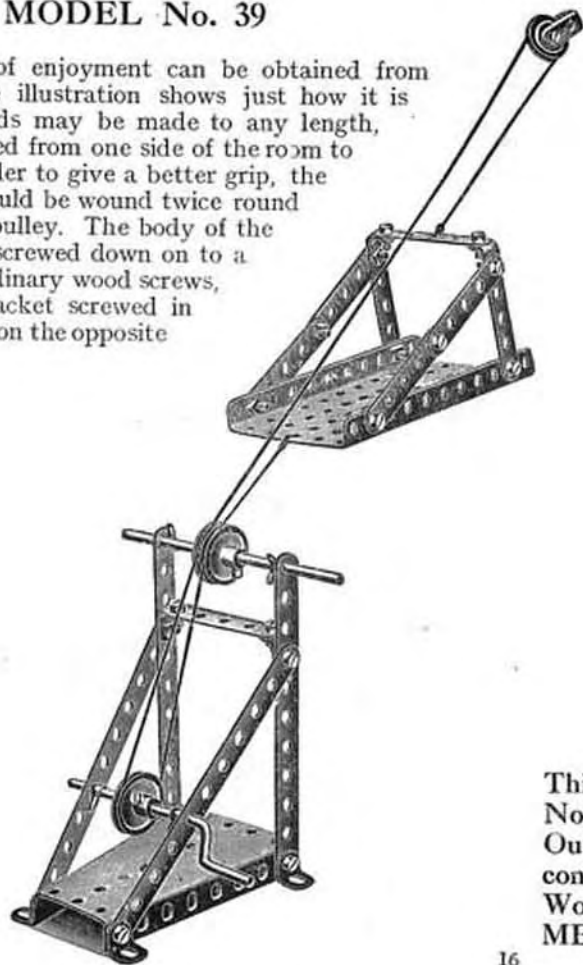

Swivelling Crane

MODEL No. 40

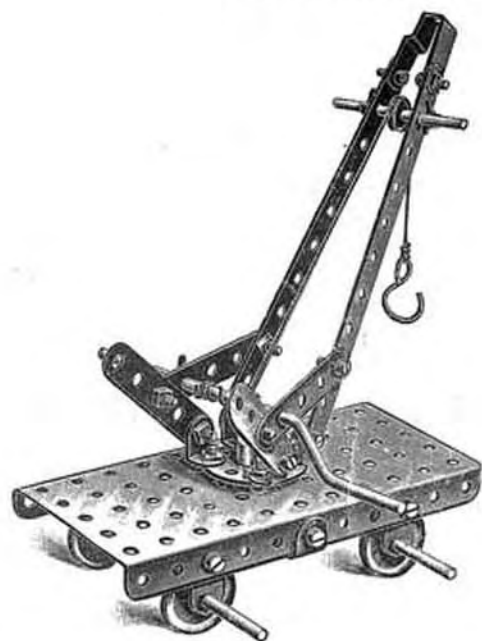

HOW TO CONTINUE

This completes the Models made with MECCANO No. 0. To make further models a No. 0a Accessory Outfit should now be purchased (see page 20.) This contains the full Book of Instructions illustrating 133 Working Models which may all be made with MECCANO.

Meccano Motors (Patent Pending).

One of the principal merits of Meccano is that all the models which it makes are *working* models. No greater pleasure for any boy can be imagined, than for him to take a number of elementary parts, piece them together with his own hands and in his own way, and then to see the results of his efforts and skill move and work in a precise and scientific way. The Meccano Motors will encourage this very natural pleasure. They have been designed on Meccano lines, and solely to work Meccano models, to each one of which they give life and movement. They are built into and become part of each model. To such models as Cranes, Wagons, Windmills, Roundabouts, &c., they are an indispensable addition to Meccano. They are driven by a powerful spring, and are quite free from the dangers and disadvantages of steam or electrically driven motors.

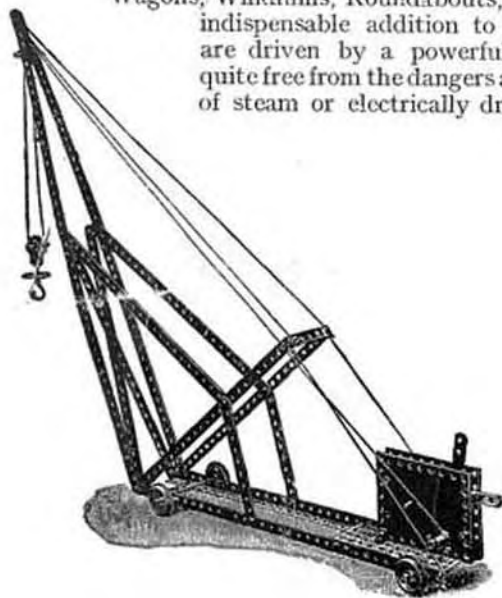

This illustration shows just how a No. 1 Meccano Motor is used in connection with a Travelling Jib Crane. Full instructions accompany each Motor, and there is no difficulty in using it.

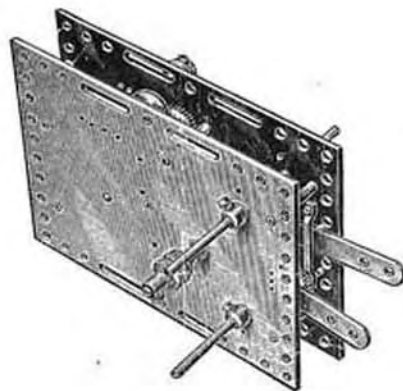

The No. 2 Meccano Motor.

The No. 1 Motor may be used in connection with Outfits Nos. 0 to 3. It has a stopping and starting motion, and the movement can be reversed.

PRICE \$2.00

The No. 2 Motor is suitable for driving models made with Outfits Nos. 4 to 6. There are three driving spindles, one of which has a clutch movement, and each can be worked independently. It has also a starting button and a reversing movement.

PRICE \$6.00

Meccano is more than a Toy

IT is important to remember that when a boy is playing with MECCANO he is using engineering parts in miniature, and that these parts act in precisely the same way as the corresponding engineering elements would do in actual practice. No other system of model construction could, therefore, be correct. Other toys which attempt the same object by other methods must avail themselves of other constructive elements which are not correct engineering elements. Consequently, though a boy may succeed in building playthings with them, they are merely toys and nothing else, and his mind, as regards proper mechanical construction and methods, is distorted instead of instructed. He thus learns wrong principles, and, when his ambition tempts him to invent or construct more elaborate models, he will be stopped by the deficiencies of his non-mechanical system.

Contents of No. 0 Outfit.

No.	Quantity.
2. 5½" perforated strips	4
5. 2½" " "	9
10. Flat brackets	4
12. Angle brackets	8
15A. 4½" rods	2
17. 2" rods	2
19. Small crank handle	1
22. 1" pulley wheels (fast)	4
23. ½" pulley wheel	1
24. Bush wheel	1
35. Spring clips	4
36. Combined screwdriver	1
37. Nuts and bolts	25
40. Hank cord	1
44. Cranked bent strip	1
52. Perforated flanged plate, 5½ × 2½	1
54. Perforated sector plate	1
56. Manual of instructions	1
57. Hook	1
60. 2½" bent strip	1

Price List

No. 0.	Meccano Outfit	5/-
No. 1.	” ”	8/6
No. 2.	” ”	16/6
No. 3.	” ”	25/-
No. 4.	” ”	40/-
No. 5.	” ”	70/-
Do.	Presentation Outfit	90/-
No. 6.	” ”	”	”	Ditto	ditto			160/-
No. 0A.	Meccano Accessory Outfit			(containing sufficient parts to convert a Meccano No. 0 into a No. 1 Outfit)				4/6
No. 1A.	” ”	”	”	(containing sufficient parts to convert a No. 1 into a No. 2 Outfit)	...			9/6
No. 2A.	” ”	”	”	(containing sufficient parts to convert a No. 2 into a No. 3 Outfit)	...			10/6
No. 3A.	” ”	”	”	(containing sufficient parts to convert a No. 3 into a No. 4 Outfit)	...			18/6
No. 4A.	” ”	”	”	(containing sufficient parts to convert a No. 4 into a No. 5 Outfit)	...			24/-
Do.	” ”	”	”	Packed in neat and well-made cardboard box				58/6
No. 5A.	” ”	”	”	(containing sufficient parts to convert a No. 5 into a No. 6 Outfit)	...			58/6
Do.	” ”	”	”	Packed in neat and well-made cardboard box				82/6