

MECCANO



(TRADE MARK 296321)

INSTRUCTIONS

FOR OUTFITS Nos. 1 to 3.

1/-

Copyright by MECCANO LIMITED, LIVERPOOL, throughout the World

No. 19A

ENGLISH EDITION

MECCANO

Hornby's Original System, First Patented 1901

PATENTS & DESIGNS,
GREAT BRITAIN:

577,272

577,207

648,958

22,962-13

20,535-13

21,117-12

4564-15

2085-11

4183-14

3869-14

103,537-17

PATENTED THROUGHOUT THE WORLD

To Meccano Boys



YOUR Meccano Outfit contains a number of accurately made and finished engineering parts, which enable you to duplicate any and every movement known to mechanism.

The value of a constructional system does not lie in the number of parts which it contains, but entirely in the uses to which the various parts can be put. It is a sweeping statement to make, but a perfectly true one, that Meccano will do all and more than all other constructional toys put together, and that no other system will do the same as Meccano. Every other metal constructional toy is an imitation of Meccano, which was the first toy of its kind. *The genius and knowledge and experience are in the Meccano parts.* Each part will fill a hundred different purposes in a perfect manner, and there is no limit to the uses to which they can be applied.

Meccano is sold as a children's toy, to give them fun, interest them, and instruct them in the fascinating wonders of engineering, but every day sees a fresh use for it. Engineers and architects use it for designing models and inventing movements. Professors and teachers in technical schools use it to demonstrate mechanical principles to their students. We have received enthusiastic letters from inventors who have designed practical commercial machines with Meccano parts for weaving and other purposes. It is largely used in institutions for the blind, for teaching patients, and in very many children's hospitals it brings happiness and relief to thousands of afflicted ones.

To Meccano Boys—(continued).

There is no hard work attached to building Meccano models. All the work and thought have been put into the parts when they were designed, and all you have to do is to follow the instructions, and screw the parts together.

Bright boys are inventing new Meccano models every day, and sending them in to win prizes in our big competitions. These new models will be included in subsequent editions which we shall publish from time to time, and which you should look out for and secure as they are published. Notification of these will be made in the **Meccano Magazine** and through your dealers. If you are not already a Subscriber to the **Meccano Magazine**, we strongly recommend that you write us at once to have your name placed on our list so that you may not miss any of the pleasures of Meccano.

MECCANO PRIZE COMPETITIONS

MONEY AND FAME FOR MECCANO BOYS. Each year there is a big Meccano Prize Competition, in which we offer big prizes in money, and new Meccano Outfits to clever boys, who are able to design new models. Send your own ideas in, and get your share of the prize money. Be sure to ask your dealer for full particulars and entry forms. If you have any difficulty send us a postcard, and we will see that you get what you want. There are no entrance fees or restrictions of any kind.

IMPORTANT NOTICE.—In some of the models throughout this manual we have made use of the Meccano Braced Girder, large wheels, sprocket wheels and chain, etc., which are only supplied in the Inventor's Accessory Outfit, or as separate parts. We have employed these parts, as they improve the appearance and working of the models, and they also form a suggestion for the use of the Inventor's Accessory Outfit, but in every case the same models may be effectively built with the parts contained in the regular Meccano outfits.

Types of Trucks and Luggage Carts

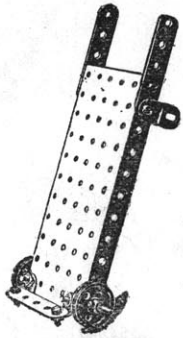

Model
No. 1

Parts Required:

3 of No. 5	1 of No. 15A
2 " " 10	2 " " 22
2 " " 12	8 " " 37
	1 of No. 52

Model No. 2

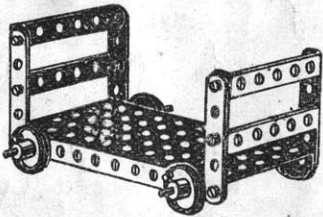

Parts
Required:

4 of No. 5
4 " " 60
2 " " 15A
4 " " 22
12 " " 37
1 " " 52

Model No. 3

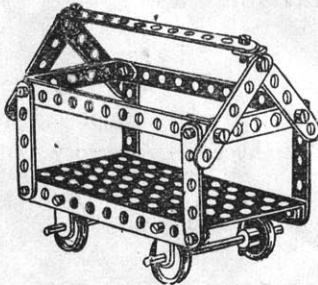

Parts
Required:

3 of No. 2
8 " " 5
2 " " 60
4 " " 10
2 " " 12
2 " " 15A
4 " " 22
20 " " 37
1 " " 52

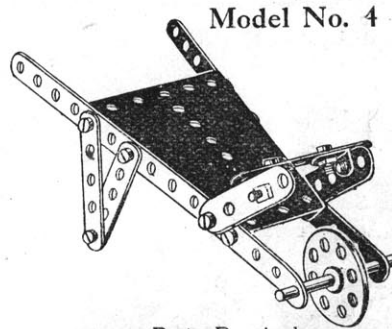

Model No. 4

Parts Required:

2 of No. 2	1 of No. 24
9 " " 5	2 " " 35
2 " " 12	14 " " 37
1 " " 17	1 " " 54

Model
No. 5

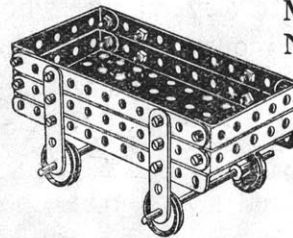

Parts Required:

4 of No. 2	4 of No. 22
4 " " 5	20 " " 37
4 " " 60	1 " " 52
2 " " 15A	

Model
No. 6

Parts
Required:

4 of No. 2
4 " " 5
4 " " 60
2 " " 15A
4 " " 22
12 " " 37
1 " " 52

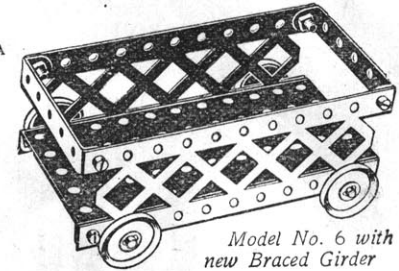
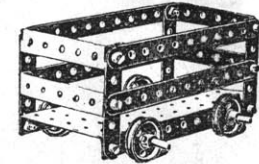

Model No. 6 with
new Braced Girder

Model No. 7

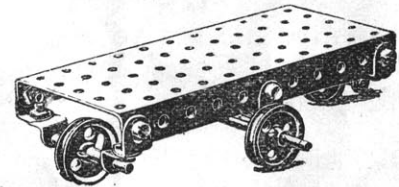

Parts
Required:

2 of No. 10	2 of No. 22A
8 " " 12	4 " " 35
1 " " 15A	10 " " 37
2 " " 17	1 " " 52
2 " " 22	

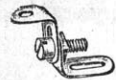
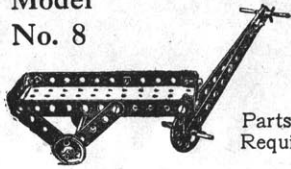

Fig. 7A

Model No. 8



Parts Required :

2 of No. 2	1 of No. 24
4 " " 5	9 " " 37
1 " " 15A	4 " " 35
2 " " 17	1 " " 44
2 " " 22	1 " " 52
2 of No. 60	

Types of Trucks and Luggage Carts (continued)

Model No. 11

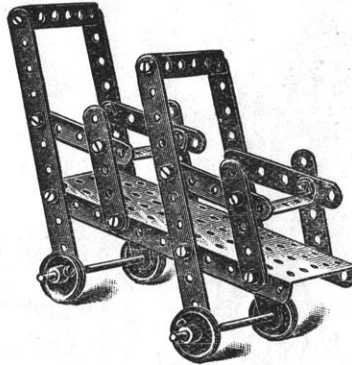

Parts Required :

4 of No. 2
8 " " 5
2 " " 15A
4 " " 22
20 " " 37
1 " " 52
4 " " 60

Model No. 13

Parts Required :

2 of No. 15A
4 " " 22
1 " " 52

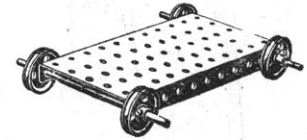

Model No. 9

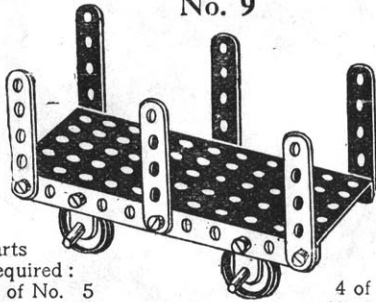

Parts Required :

6 of No. 5
4 " " 10
2 " " 15A

4 of No. 22
10 " " 37
1 " " 52

Model No. 14

Parts Required :

6 of No. 2
8 " " 5
2 " " 10
4 " " 12
3 " " 15A
4 " " 22
2 " " 35
20 " " 37
1 " " 52
4 " " 60

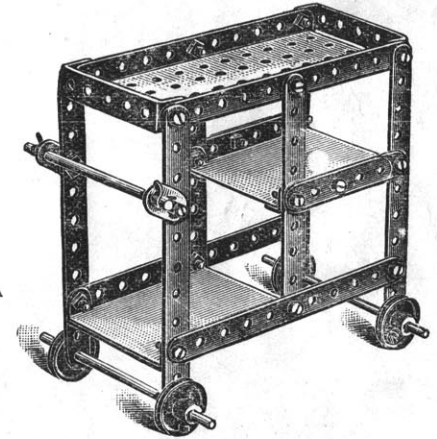

Model No. 10

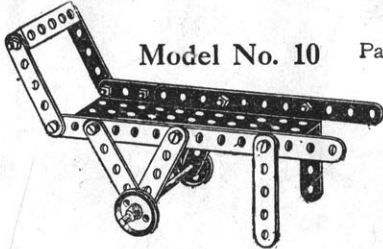

Parts Required :

2 of No. 2
8 " " 5
1 " " 15A
2 " " 22
10 " " 37
1 " " 52
1 " " 60

Model No. 12

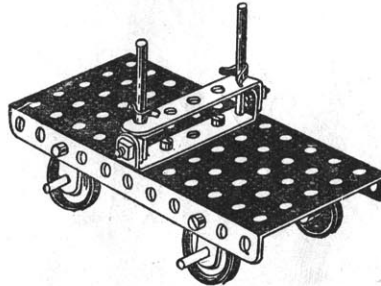

Parts Required :

4 of No. 10	4 of No. 22
2 " " 15A	2 " " 35
2 " " 17	8 " " 37
	1 " " 52
	2 " " 60

The two lower platforms are constructed out of pieces of ordinary cardboard, their outer edges resting on $2\frac{1}{2}$ " bent strips and their inner edges on angle brackets.

These Models Can be Made with MECCANO Outfit No. 1



Model No. 15
Swing

Parts	Required:
4 of No. 1	
1 " " 2	
6 " " 5	
4 " " 12	
12 " " 37	
1 " " 52	
3 " " 60	

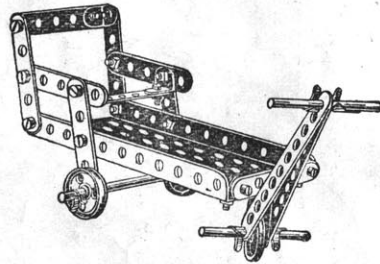

Model No. 16 Bath Chair

2 of No. 2	4 of No. 35
6 " " 5	14 " " 37
1 " " 15A	1 " " 44
2 " " 17	1 " " 52
3 " " 22	3 " " 60

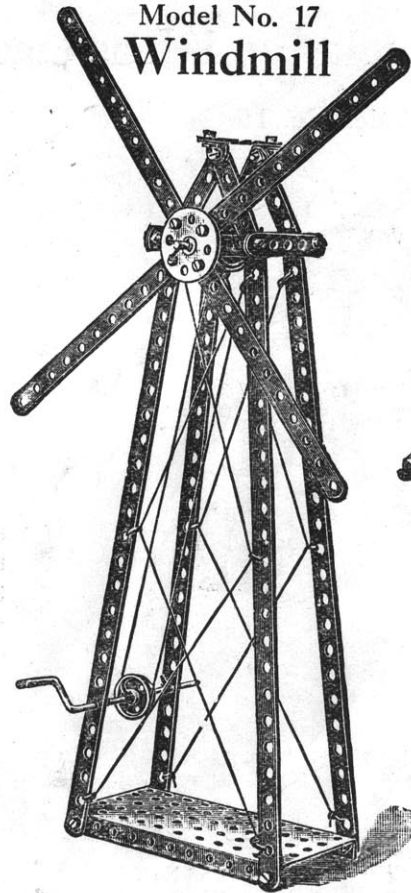

Model No. 17
Windmill

Parts Required:		
4 of No. 1	1 of No. 15A	4 of No. 35
4 " " 2	1 " " 19	20 " " 37
7 " " 5	2 " " 22	1 " " 52
2 " " 12	1 " " 24	2 " " 60

Model No. 18
Well Windlass

2 of No. 2
8 " " 5
4 " " 12
1 " " 19
2 " " 22
12 " " 37

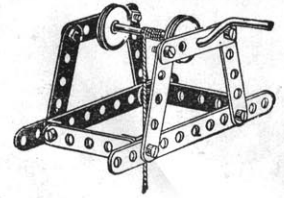

Model No. 19

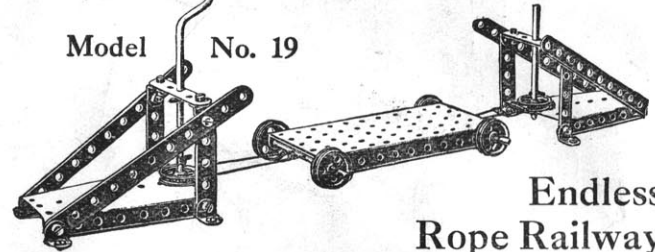

Endless
Rope Railway

4 of No. 2	1 of No. 19	12 of No. 37
4 " " 5	4 " " 22	1 " " 52
8 " " 12	2 " " 22A	2 " " 54
3 " " 15A	4 " " 35	2 " " 60

Model No. 20 Seesaw

Parts Required:

4 of No. 2	2 of No. 35
6 " " 5	19 " " 37
6 " " 12	1 " " 44
1 " " 17	1 " " 52

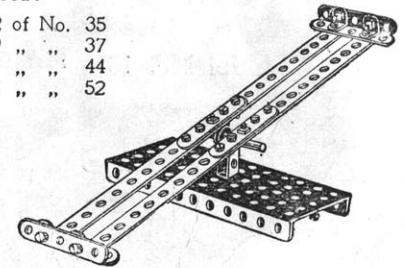

Model No. 21

Travelling Ladder

Parts Required:

- 6 of No. 2
- 4 " " 5
- 2 " " 15A
- 4 " " 22
- 16 " " 37
- 1 " " 52
- 4 " " 60

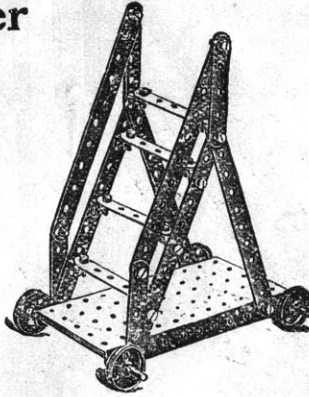

Model No. 22

Step Ladder

Parts Required:

- | | |
|------------|-------------|
| 4 of No. 2 | 2 of No. 12 |
| 3 " " 5 | 12 " " 37 |
| | 4 " " 60 |

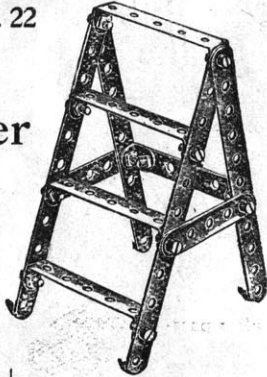

Model No. 23 Telpher Span

Parts Required:

- | | | |
|------------|-------------|--------------|
| 2 of No. 1 | 1 of No. 17 | 20 of No. 37 |
| 2 " " 2 | 1 " " 19 | 1 " " 44 |
| 6 " " 5 | 3 " " 22 | 1 " " 52 |
| 4 " " 12 | 2 " " 22A | 2 " " 54 |
| 2 " " 15A | 6 " " 35 | 3 " " 60 |

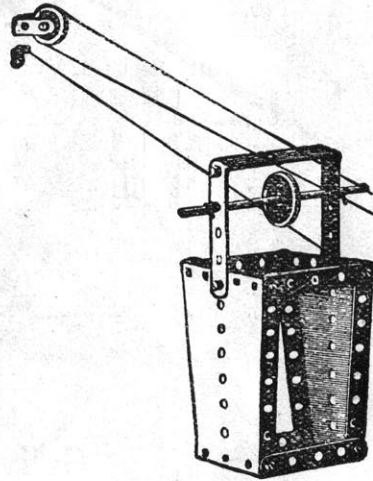

Many hours of enjoyment can be obtained from this model. The illustration shows just how it is worked. The cords may be made to any length, and the load carried from one side of the room to the other. In order to give a better grip, the operating cord should be wound twice round the crank handle pulley. The open sides of the bucket may be filled in with cardboard, so that it can be loaded with marbles, or beads, etc. The body of the Telpher should be screwed down on to a solid base with ordinary wood screws, and the pulley bracket, and that to which is secured the cord on which the bucket travels, are screwed in a suitable position on the opposite side of the room.



Model No. 24 Travelling Jib Crane

Parts Required:

2 of No.	1
3 " "	2
2 " "	5
2 " "	15A
1 " "	17
1 " "	19
4 " "	22
2 " "	22A
1 " "	24
5 " "	35
15 " "	37
1 " "	52
1 " "	54
1 " "	57
1 " "	60

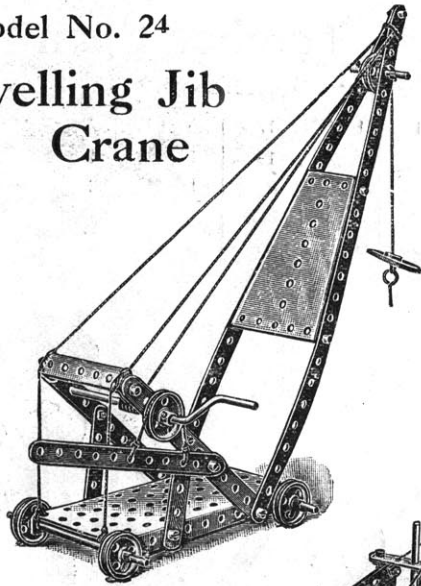

Types of Cranes

Model No. 25 Jib Crane

Parts Required:

4 of No.	1	4 of No.	35
6 " "	2	20 " "	37
1 " "	3	1 " "	52
1 " "	11	2 " "	54
2 " "	12	1 " "	57
1 " "	15A	2 " "	60
2 " "	17		
1 " "	19		
4 " "	22		
2 " "	22A		
1 " "	24		

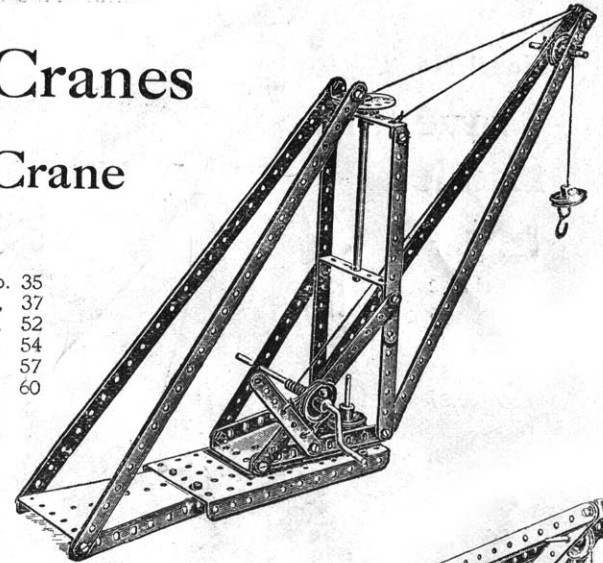

Model No. 26 Overhead Crane

Parts Required:

2 of No.	1	2 of No.	22A
6 " "	2	1 " "	24
9 " "	5	6 " "	35
4 " "	10	20 " "	37
4 " "	12	1 " "	44
3 " "	15	1 " "	52
1 " "	17	2 " "	54
1 " "	19	1 " "	57
4 " "	22	2 " "	60

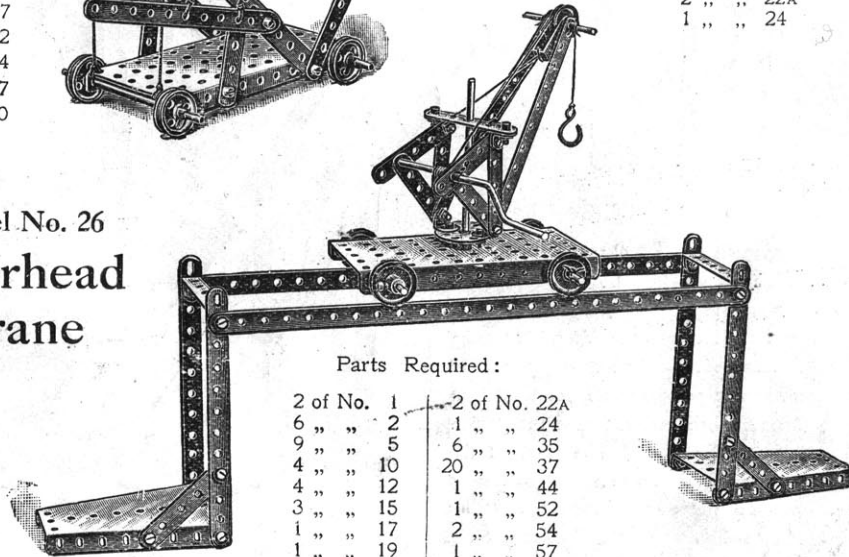

Model No. 27 Swivelling Crane

Parts Required:

2 of No.	1	2 of No.	22A
6 " "	2	1 " "	24
1 " "	3	4 " "	35
4 " "	5	18 " "	37
1 " "	11	1 " "	44
1 " "	15A	1 " "	52
2 " "	17	2 " "	54
1 " "	19	1 " "	57
4 " "	22	3 " "	60

The hoisting cord after passing over the pulley at the end of the jib, passes over a pulley running in a cranked bent strip secured by a nut and bolt to the 2 1/2" bent strip at the back of the jib.

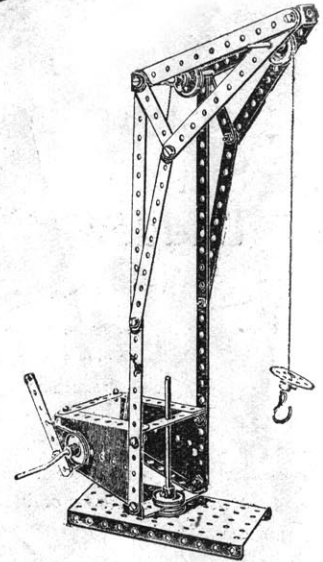

Model No. 28

Swivelling Jib Crane

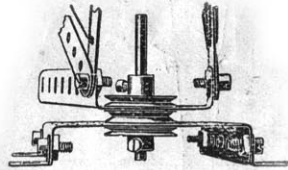
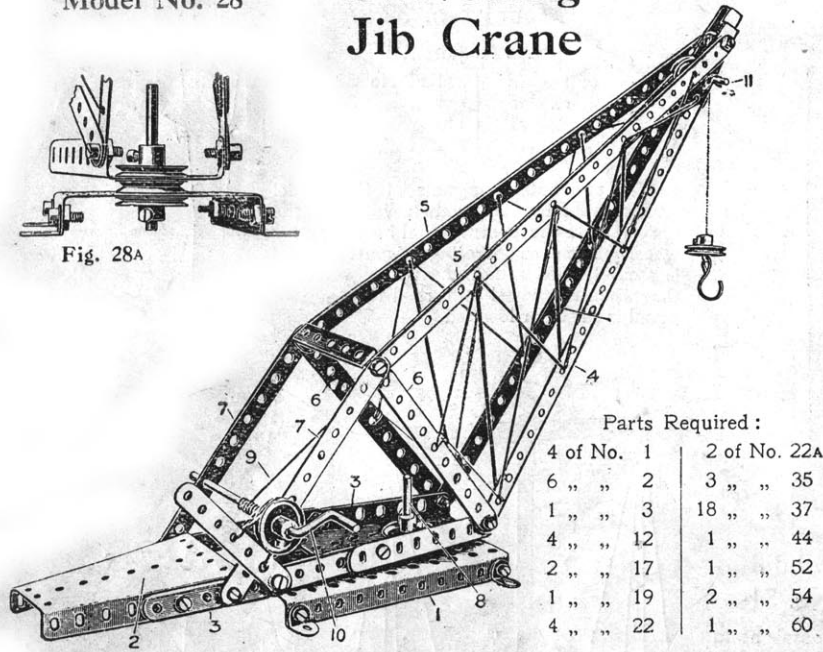

Fig. 28A



Parts Required :

4 of No. 1	2 of No. 22A
6 " " 2	3 " " 35
1 " " 3	18 " " 37
4 " " 12	1 " " 44
2 " " 17	1 " " 52
1 " " 19	2 " " 54
4 " " 22	1 " " 60

The fixed base of this Crane is a perforated flanged plate 1, and the swivelling base of the Crane is formed by two sector plates 2 and 3. The jib is formed from two 12½" strips 4 bolted to the ends of the sector plate 3, two other 12½" strips 5 being bolted to the top of the strips 4 and to cross strips 6, the outer ends of these latter strips being stayed by strips 7 bolted to the other sector plate. The upper structure of the Crane swivels about a rod 8, and is secured as shown in Fig. 28A. The winding rope 9 is operated by the crank handle 10 and passes over a pulley in the head of the Crane on a short rod 11.

Model No. 29 Turntable Gangway

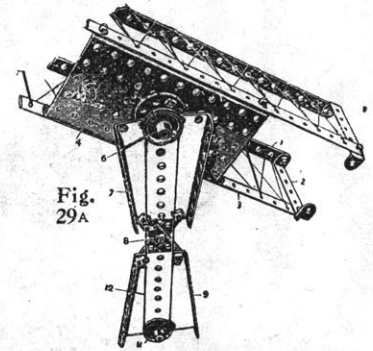
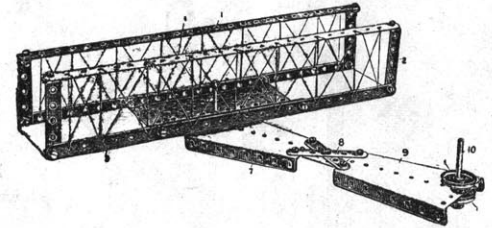

Fig. 29A

Parts Required :

4 of No. 1	19 of No. 37
2 " " 5	1 " " 52
2 " " 17	2 " " 54
3 " " 22	4 " " 60
1 " " 24	

The side frames of the gangway are made of 12½" strips 1 bolted by means of 2½" bent strips 2 to lower strips 3, the strips 3 and 1 being set at right angles to each other, and the side frames being connected by a perforated flanged plate 4. A bush wheel 5 is bolted to the underside of the flanged plate and fitted with a rod on which is mounted a 1" pulley 6, the rod passing through one of the end holes of a sector plate 7. This sector plate 7 is connected by diagonal strips 8 to another sector plate 9, through the end hole of which a rod 10 is threaded carrying two 1" pulleys 11. An operating cord 12 passes from the pulley 11 to the pulley 6. In this way the gangway may be rotated by operating the spindle 10.

Types of Railway Signals

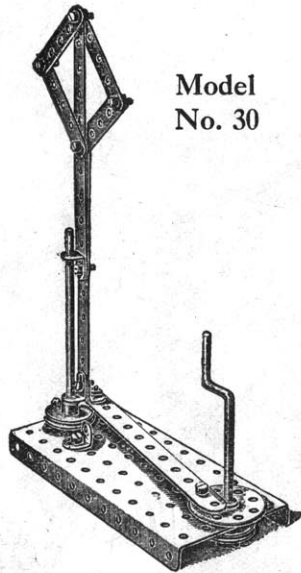

Model No. 30

Parts Required:

3 of No. 2	3 of No. 22
4 " " 5	1 " " 24
4 " " 12	14 " " 37
1 " " 15A	1 " " 52
1 " " 19	

**Model No. 33
Scales**

Parts Required:

4 of No. 2	2 of No. 22A
8 " " 5	4 " " 35
1 " " 11	19 " " 37
2 " " 12	1 " " 52
2 " " 17	2 " " 54

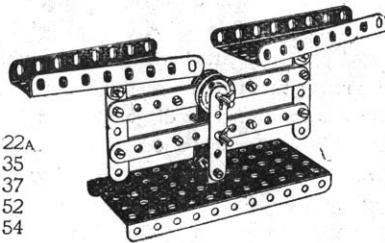

Model No. 31
In fixing the lever to the lower end of the sector plate, lock the nuts, so as to prevent the screw from working out.

Parts Required:

2 of No. 1
2 " " 2
1 " " 3
4 " " 12
1 " " 17
2 " " 22
19 " " 37
2 " " 35
1 " " 52
1 " " 54

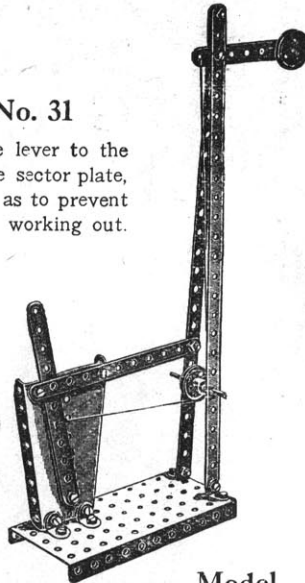

Model No. 34

The scale beam of this model is pivoted in a slot at the top of the upright standard. This slot is formed by bolting a 2½ in. strip to the standard, nuts being placed between the strip and the standard before screwing up. These nuts hold the strip and the standard at the required distance apart to give the beam free play.

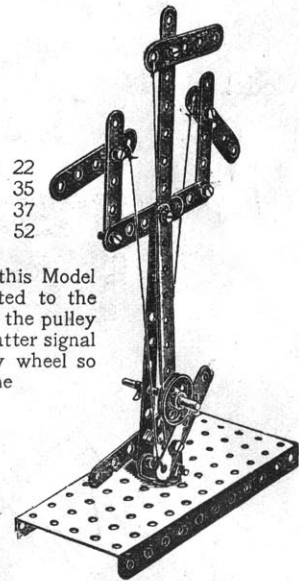
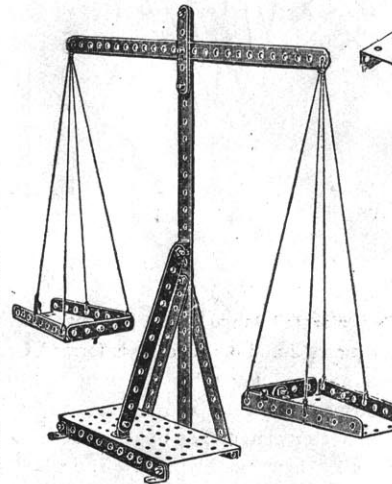

Model No. 32

Parts Required:

3 of No. 2	1 of No. 22
9 " " 5	1 " " 35
1 " " 11	16 " " 37
1 " " 17	1 " " 52

The two outside signals of this Model are operated by the levers pivoted to the upright, and the centre signal by the pulley wheel. The cord operating this latter signal is securely tied round the pulley wheel so that when the wheel is turned the signal is raised or lowered.

Scales

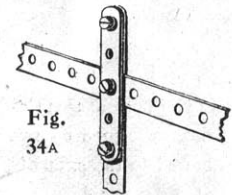

Parts Required:

2 of No. 1	19 of No. 37
3 " " 2	1 " " 52
1 " " 5	2 " " 54
4 " " 12	2 " " 60

Model No. 35 Joy Wheel

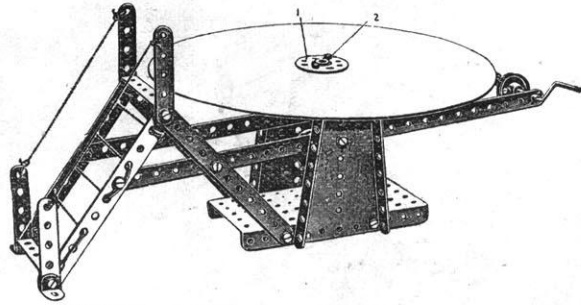

Parts Required:

2 of No. 1	3 of No. 22
4 " " 2	1 " " 24
4 " " 5	3 " " 35
2 " " 12	20 " " 37
1 " " 15A	1 " " 52
1 " " 19	2 " " 54
	3 " " 60

The driving mechanism and construction of the framework of this model are clearly brought out in Fig. 35A. Cut out a circular piece of cardboard, 8" in diameter, and in the centre of the disc fix a bush wheel 1 by nuts and bolts 2. The eye of the bush wheel is then threaded over the top of the vertical spindle 3, and secured by its set-screw. The rotating table is cut out of a piece of ordinary cardboard.

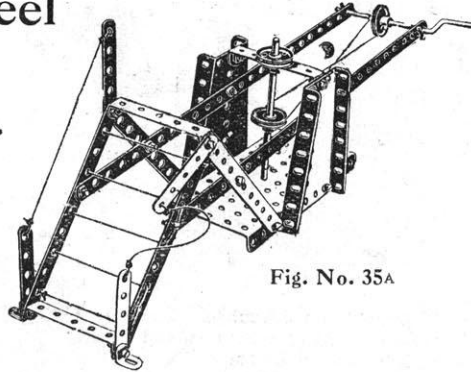

Fig. No. 35A

Model No. 36 Go Chair

Parts

Required:

2 of No. 2
7 " " 5
2 " " 15A
4 " " 22
13 " " 37
2 " " 60

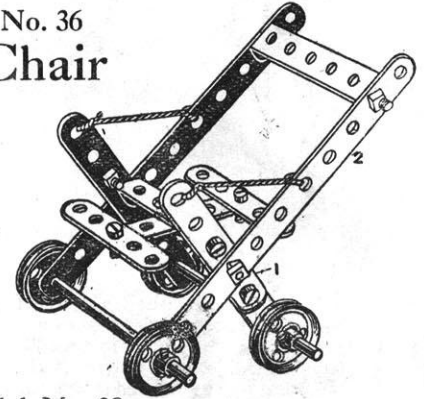

Model No. 38 Cot on Wheels

Parts Required:

4 of No. 2	4 of No. 22
6 " " 5	17 " " 37
2 " " 12	3 " " 60

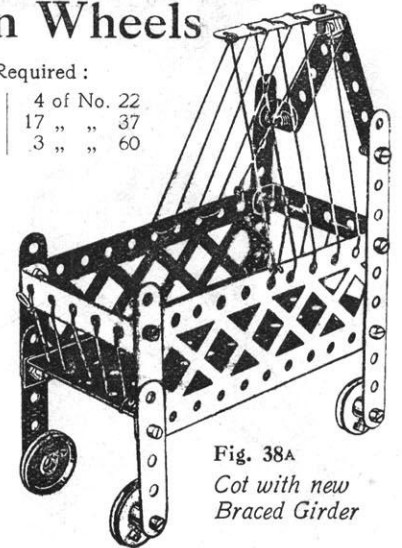

Fig. 38A
Cot with new
Braced Girder

Model No. 37

Roundabout

Parts Required:

4 of No. 1
4 " " 2
6 " " 5
4 " " 10
2 " " 15A
1 " " 17
1 " " 19
3 " " 22
1 " " 24
5 " " 35
20 " " 37
1 " " 52
2 " " 54
4 " " 60

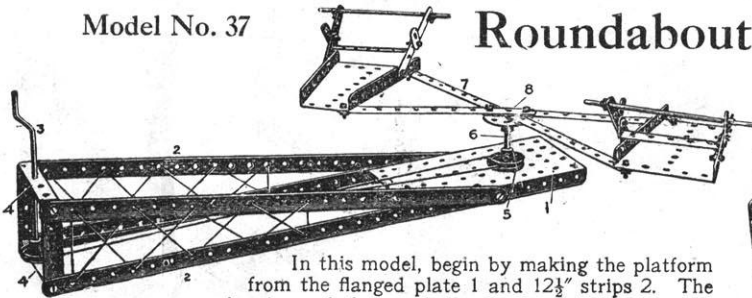

In this model, begin by making the platform from the flanged plate 1 and 12½" strips 2. The bearings of the crank handle 3 are formed in .2½" bent strips 4. The drive from the pulley on the crank is taken to a 1" pulley 5, fast on the spindle 6, another similar pulley being secured to the spindle beneath the flanged plate. The arms 7, formed of four 5½" strips, are bolted to a bush wheel 8 fast on the spindle 6.

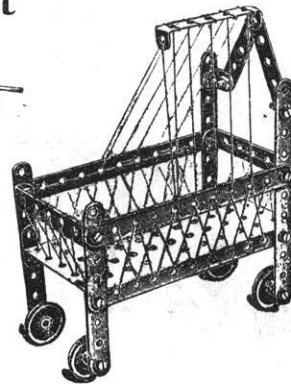

Model No. 39 Snow Plough

Fig. No. 39A

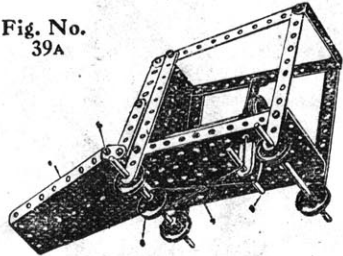

Parts Required:

6 of No. 2	2 of No. 22A
3 " " 5	1 " " 24
2 " " 60	4 " " 35
2 " " 10	19 " " 37
1 " " 12	1 " " 44
3 " " 15A	1 " " 52
1 " " 17	2 " " 54
4 " " 22	

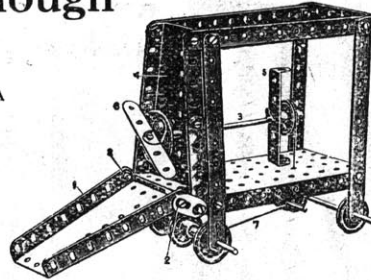

The construction of the framework of this Model presents no difficulty. The sector plate 1 forming the plough is loosely pivoted on the bolts 2. The axle 3 is mounted in the front sector plate 4 and the 2½" bent strip 5. A 2½" strip 6 is bolted by angle brackets to a bush wheel on the front of the axle and forms a dispersing propeller for the snow after it rises up the inclined sector plate 1. A continuous cord 7 is passed round a 1" pulley wheel 8 and round a short axle 9 and a 1" pulley wheel on the propeller axle. In this way, as the plough is moved along the track, the propeller is revolved.

Model No. 40 Motor Cart

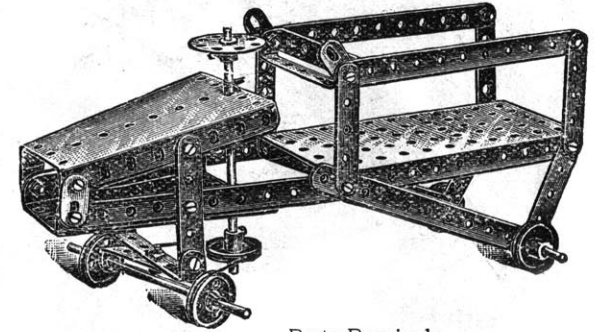

Parts Required:

6 of No. 2	1 of No. 24
8 " " 5	3 " " 35
4 " " 10	20 " " 37
3 " " 15A	1 " " 52
3 " " 22	2 " " 54
2 " " 22A	4 " " 60

Model No. 41

Monoplane

Fig. No. 41A

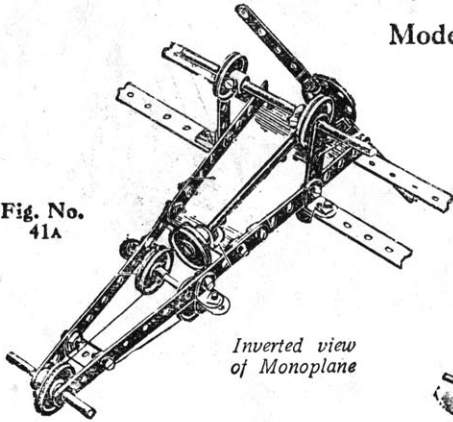

Inverted view of Monoplane

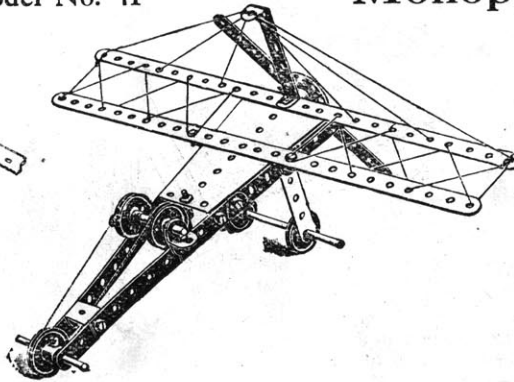

Parts Required:

2 of No. 1
2 " " 2
4 " " 5
1 " " 11
8 " " 12
2 " " 15A
1 " " 17
4 " " 22
2 " " 22A
1 " " 24
2 " " 35
18 " " 37
1 " " 54
1 " " 60

Fig. No. 41B

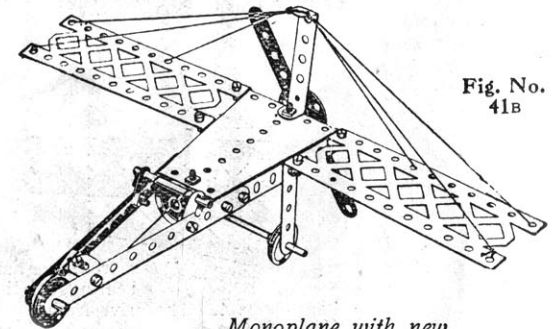

Monoplane with new Meccano Braced Girder

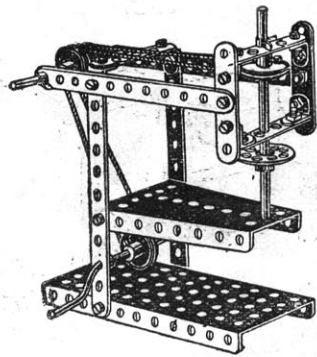

Model No. 42
Drilling Machine

Parts Required:

4 of No.	2
5	5
6	12
2	15A
1	19
4	22
1	24
4	35
18	37
1	52
1	54

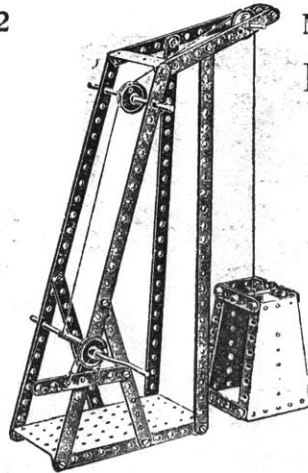

Model No. 43
Pit Headgear

Parts Required:

4 of No.	1
4	2
1	3
4	5
1	11
1	15A
1	17
1	19
3	22
2	35
24	37
1	52
2	54

Model No. 44
Hoisting Block

Parts Required:

4 of No.	2
3	5
8	12
1	17
1	22
1	24
22	37
1	52
1	57
1	60

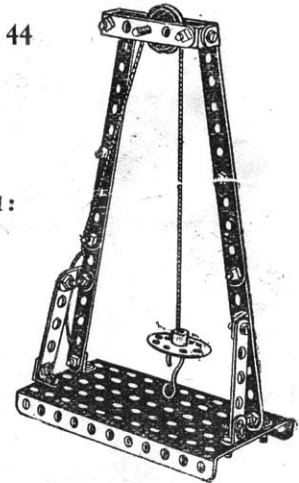

Model No. 45
Churn

Parts Required:

6 of No.	2
4	5
2	12
2	15
1	19
2	22
2	22A
1	24
5	35
19	37
1	52
2	54
3	60

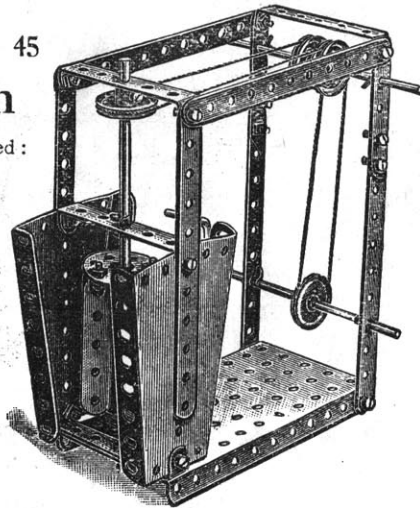

Model No. 46 Potter's Wheel

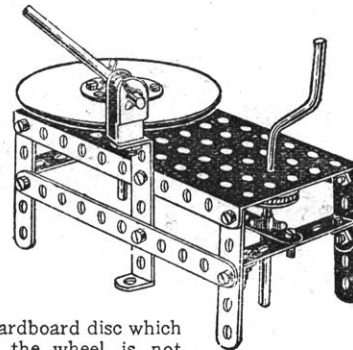

The cardboard disc which forms the wheel is not provided in the outfit.

Parts Required:

2 of No.	2
4	5
1	15A
1	17
1	19
2	22
1	24
3	35
16	37
1	44
1	52
3	60

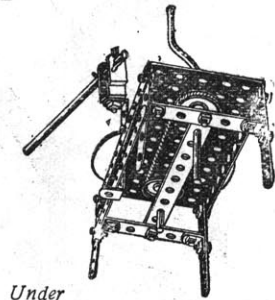

Under View of Potter's Wheel

Fig. 46A

These Models Can be Made with MECCANO Outfit No. 1

Model No. 47

Torpedo Destroyer

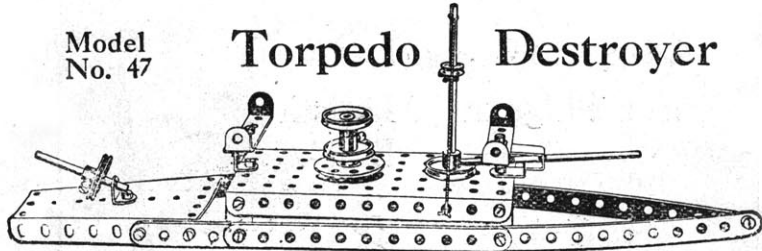

Parts Required:	4 of No. 2	1 of No. 17	19 of No. 37
	2 " " 5	4 " " 22	1 " " 44
	4 " " 10	1 " " 23	1 " " 52
	1 " " 11	1 " " 24	1 " " 54
	1 " " 12	3 " " 35	2 " " 60
	2 " " 15A		

Model No. 48 Drop Stamp

Parts Required:

4 of No. 2	4 of No. 22
7 " " 5	1 " " 24
4 " " 12	2 " " 35
2 " " 15A	20 " " 37
1 " " 19	1 " " 52
	1 " " 60

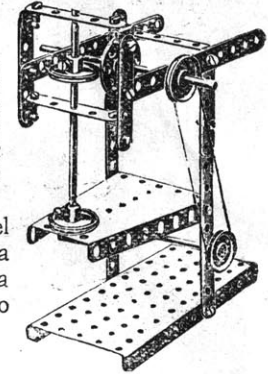

The stamp of this model is raised and dropped by a 2½" strip attached to a bush wheel similar to Model No. 55.

Model No. 49

Tower Wagon

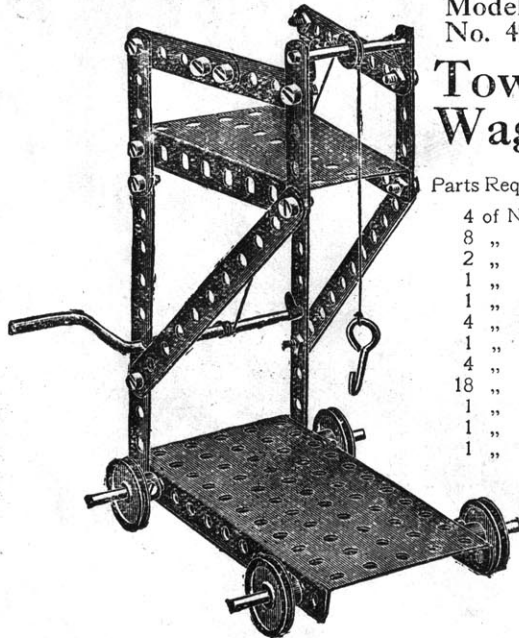

Parts Required:

4 of No. 2
8 " " 5
2 " " 15A
1 " " 17
1 " " 19
4 " " 22
1 " " 23
4 " " 35
18 " " 37
1 " " 52
1 " " 54
1 " " 57

Model No. 50 Automatic Dial Press

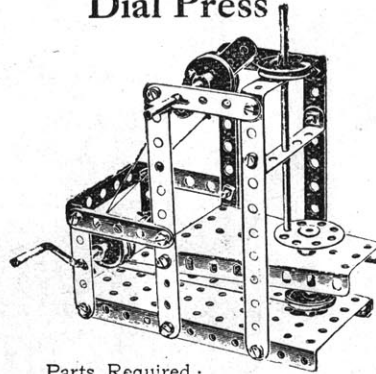

Parts Required:

4 of No. 2	2 of No. 22A
7 " " 5	1 " " 24
2 " " 15A	6 " " 35
1 " " 17	18 " " 37
1 " " 19	1 " " 52
4 " " 22	1 " " 54
	3 " " 60

Model No. 51

Tip Wagon

Parts Required:

1 of No. 2
4 " " 5
5 " " 12
3 " " 15A
4 " " 22
15 " " 37
2 " " 35
1 " " 52
2 " " 54
2 " " 60

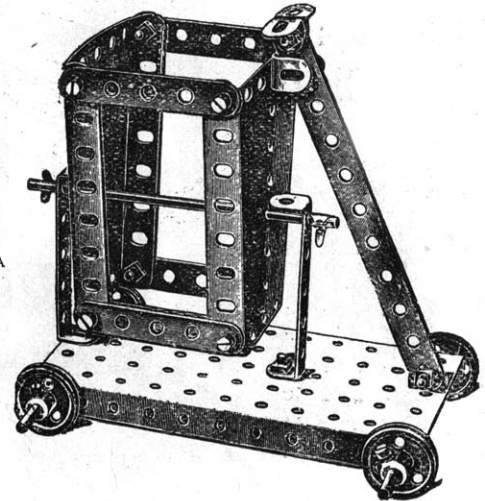

Model No. 52 Polishing Spindle

Parts

Required:

- 1 of No. 2
- 4 " " 5
- 2 " " 10
- 8 " " 12
- 1 " " 15A
- 2 " " 22
- 1 " " 24
- 2 " " 35
- 15 " " 37
- 1 " " 52

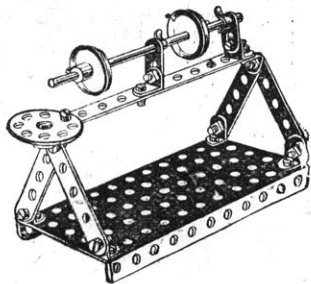

Model No. 53 High Level Bridge

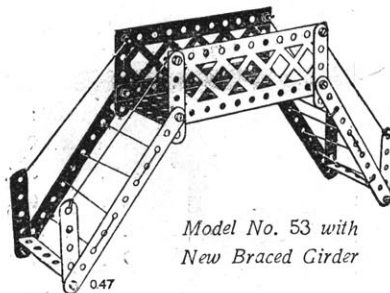

Model No. 53 with
New Braced Girder

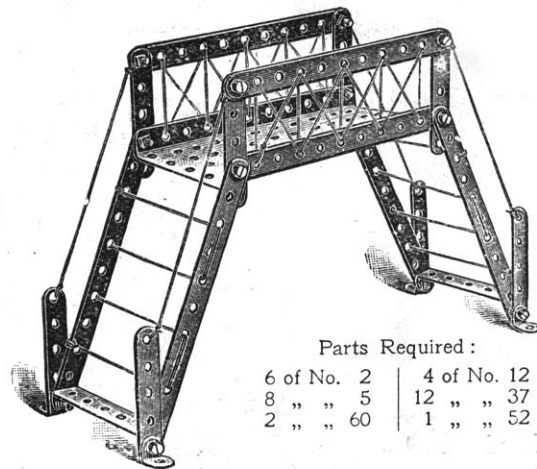

Parts Required:

- | | |
|------------|-------------|
| 6 of No. 2 | 4 of No. 12 |
| 8 " " 5 | 12 " " 37 |
| 2 " " 60 | 1 " " 52 |

Model No. 54 Level Crossing

Parts

Required:

- 3 of No. 2
- 2 " " 5
- 2 " " 12
- 1 " " 17
- 4 " " 22
- 1 " " 24
- 9 " " 37
- 1 " " 52

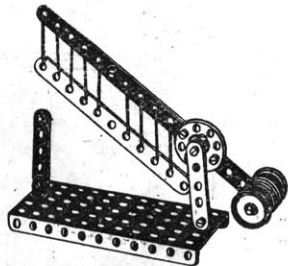

Model No. 55 Ore Crusher

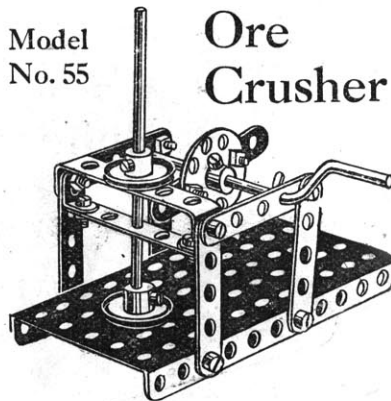

Parts Required:

- | | | |
|------------|-------------|-------------|
| 8 of No. 5 | 1 of No. 19 | 2 of No. 35 |
| 2 " " 12 | 2 " " 22 | 12 " " 37 |
| 1 " " 15A | 1 " " 24 | 1 " " 52 |
| | | 1 " " 60 |

Model No. 56 Buffing Spindle

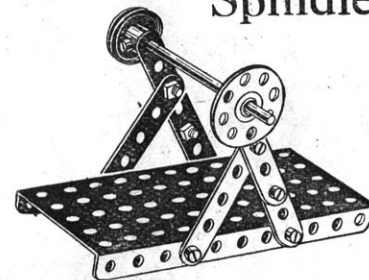

Parts Required:

- | | |
|------------|-------------|
| 6 of No. 5 | 1 of No. 24 |
| 1 " " 15A | 8 " " 37 |
| 1 " " 22 | 1 " " 52 |

Model No. 57 Metal Saw

Parts Required:

4 of No. 2	1 of No. 19
5 " " 5	2 " " 22
1 " " 10	1 " " 24
8 " " 12	2 " " 35
1 " " 17	23 " " 37
2 " " 60	

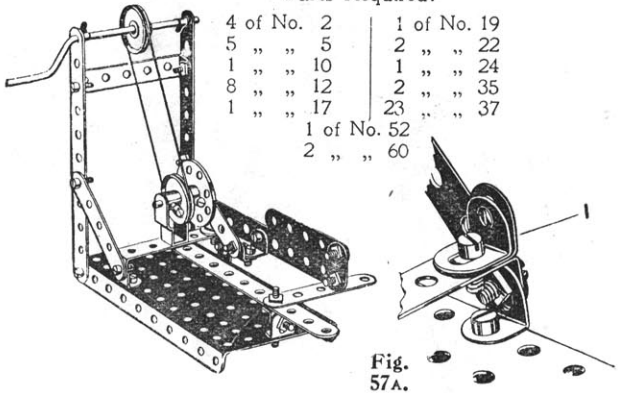
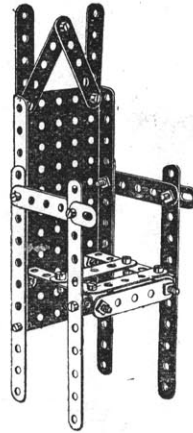

Fig. 57A.

Model No. 58 Coronation Chair

Parts Required:

4 of No. 2
9 " " 5
2 " " 10
2 " " 12
19 " " 37
1 " " 52



Model No. 59 Gangway

Parts Required:

2 of No. 2	8 " " 5
2 " " 10	1 " " 15A
1 " " 19	1 " " 22
1 " " 22	1 " " 22A
3 " " 35	8 " " 37
1 " " 52	1 " " 54



With new MECCANO Braced Girder

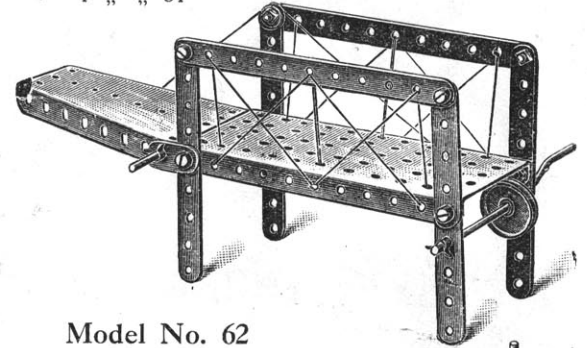

Model No. 60 Lathe

Parts Required:

6 of No. 2
2 " " 60
4 " " 12
1 " " 17
1 " " 19
3 " " 22
1 " " 24
17 " " 37
1 " " 44
1 " " 52

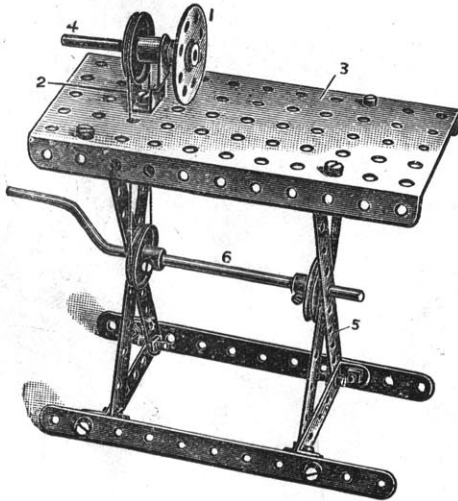

Model No. 61 Buffers

Parts Required:

2 of No. 2	4 of No. 35
2 " " 5	6 " " 37
2 " " 17	1 " " 52
2 " " 22	2 " " 60

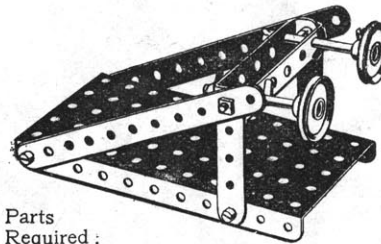

Model No. 62 Stamping Mill

Parts Required:

1 of No. 2	18 of No. 37
1 " " 3	1 " " 52
12 " " 12	2 " " 54
2 " " 15A	
1 " " 19	
4 " " 22	
1 " " 24	
2 " " 35	

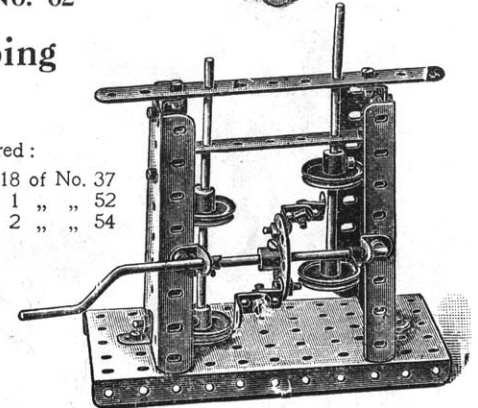

Model No. 63 **Ticca Gharry**

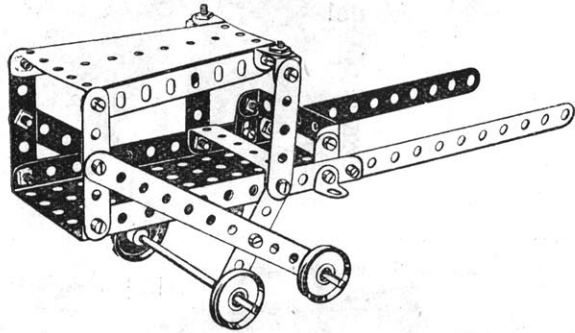

Parts Required:	4 of No. 2	4 of No. 22
	6 " " 5	20 " " 37
	2 " " 10	1 " " 52
	6 " " 12	1 " " 54
	2 " " 15A	2 " " 60

Model No. 66

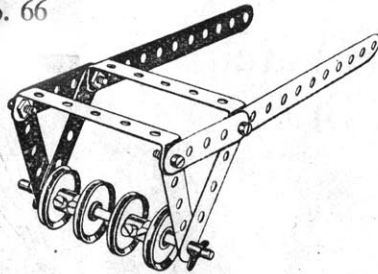

Furrowing Roller

Parts Required:	2 of No. 2	2 of No. 35
	6 " " 5	4 " " 37
	1 " " 15A	2 " " 60
	4 " " 22	

Model No. 64 **Sharpshooter Gun**

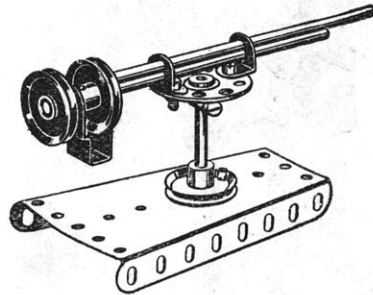

Parts Required:

2 of No. 12
2 " " 15A
1 " " 17
4 " " 22
1 " " 24
2 " " 37
1 " " 44
1 " " 54

Model No. 67 **Anti-Aircraft Gun**

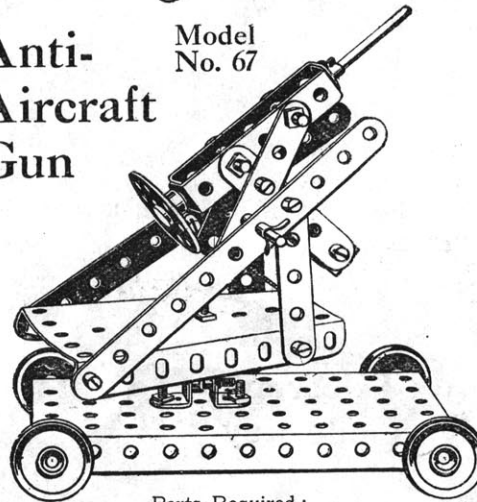

Parts Required:

2 of No. 2	4 of No. 22	1 of No. 44
6 " " 5	1 " " 24	1 " " 52
4 " " 12	5 " " 35	1 " " 54
2 " " 15A	23 " " 37	2 " " 60

Model No. 65 **Sleigh**

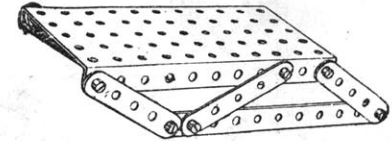

Parts Required:

2 of No. 2
6 " " 5
12 " " 37
1 " " 52

Stamping Machine

Model No. 68

Parts Required:

4 of No. 2
8 " " 5
2 " " 12
2 " " 15A
1 " " 19
4 " " 22
1 " " 24
3 " " 35
20 " " 37
1 " " 52
2 " " 60

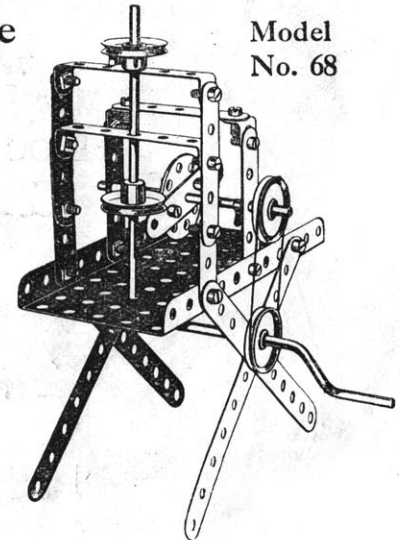

Model No. 69 Timber Drag

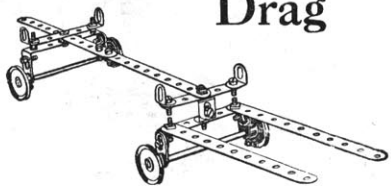

Parts Required :	4 of No. 2	4 of No. 22
	4 " " 10	18 " " 37
	6 " " 12	3 " " 60
	2 " " 15A	

Steering Truck

Model No. 70

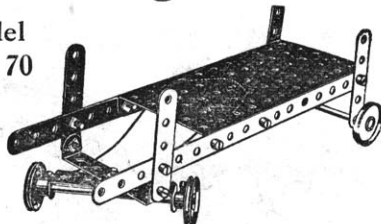

Parts Required :	2 of No. 2	11 of No. 37
	4 " " 5	1 " " 52
	2 " " 15A	2 " " 60
	4 of No. 22	

Boiler Truck

Model No. 71

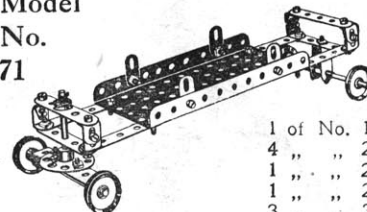

Parts Required :	8 of No. 5	1 of No. 17
	4 " " 10	4 " " 22
	8 " " 12	1 " " 23
	2 " " 15A	1 " " 24
		3 " " 35
		23 " " 37
		1 " " 44
		1 " " 52
		1 " " 60

Model No. 73 Lurry

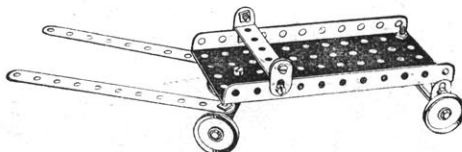

Parts Required :	2 of No. 2	13 of No. 37
	4 " " 10	1 " " 24
	2 " " 12	1 " " 52
	2 " " 15A	2 " " 60
	4 of No. 22	

Model No. 74 Watch Stand



Parts Required :	4 of No. 2	1 of No. 35
	1 " " 17	8 " " 37
	1 " " 22	1 " " 52
	1 " " 23	1 " " 57
	1 " " 24	1 " " 60

Model No. 72 Rocking Chair



Parts Required :	4 of No. 2	18 of No. 37
	9 " " 5	1 " " 52
	2 " " 12	1 " " 60

Model No. 75 Telegraph Code Key

Parts Required :	3 of No. 2	1 of No. 22
	1 " " 10	12 " " 37
	5 " " 12	1 " " 52

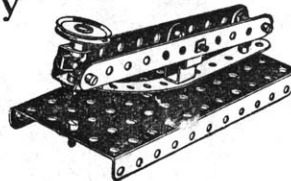

Model
No. 76

Drop Hammer

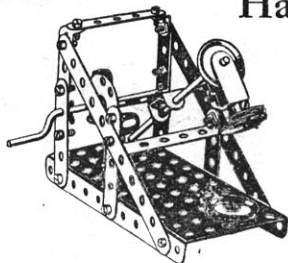

Parts Required:	2 of No. 2	3 of No. 22
	7 " " 5	1 " " 24
	6 " " 12	23 " " 37
	1 " " 15A	1 " " 44
	1 " " 19	1 " " 52
	2 of No. 60	

Model
No. 79

Double- Drop Hammer

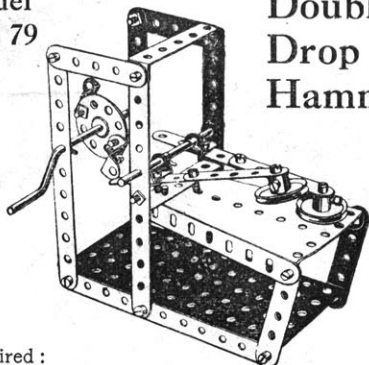

Parts Required:	4 of No. 2	1 of No. 19	22 of No. 37
	8 " " 5	2 " " 22	1 " " 52
	8 " " 12	1 " " 24	1 " " 54
	1 " " 15A	4 " " 35	2 " " 60

Model
No. 77

Roulette Wheel

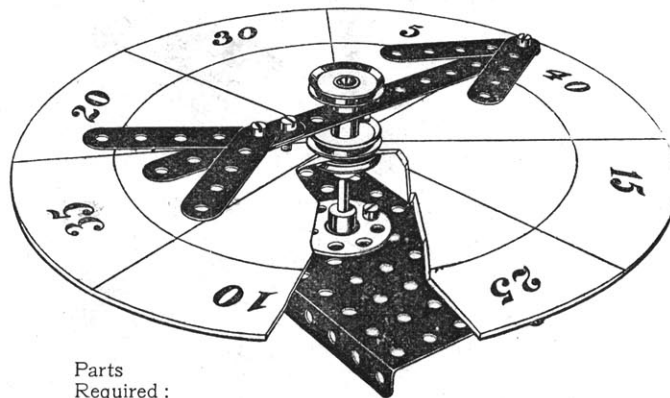

Parts
Required:

1 of No. 2
5 " " 5
1 " " 15A
3 " " 22
1 " " 24
5 " " 37
1 " " 52

Cut out a circular piece of cardboard and mark as shown to form scoring board. This is clamped between two 1" pulley wheels. The pointer revolves freely on the upright spindle and is held in position by another 1" pulley wheel.

Model No. 80

Bogey Truck

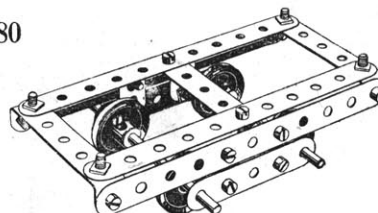

Parts
Required:

4 of No. 2	4 of No. 22
3 " " 5	18 " " 37
4 " " 10	2 " " 60
2 " " 15A	

Model
No. 78

Spinning Top

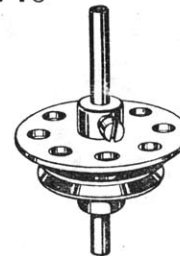

Parts Required:	1 of No. 17
	1 " " 22
	1 " " 24

Band Saw

Model
No. 81

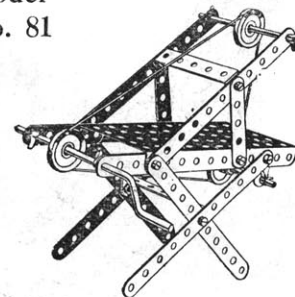

Parts
Required:

6 of No. 2	3 of No. 22
4 " " 5	6 " " 35
2 " " 10	10 " " 37
2 " " 15A	1 " " 52
1 " " 19	2 " " 60

Gong

Model No. 82

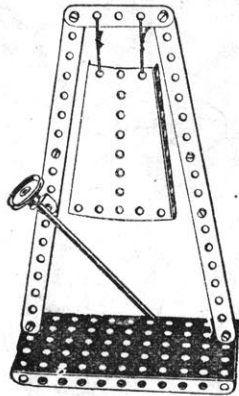

- Parts Required:
- 2 of No. 2
 - 1 " " 5
 - 3 " " 12
 - 1 " " 15A
 - 1 " " 22
 - 10 " " 37
 - 1 " " 52
 - 1 " " 54

Model No. 83 Horse Sleigh

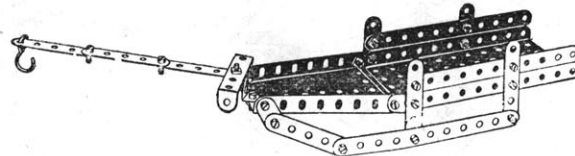

- Parts Required:
- | | |
|------------|--------------|
| 4 of No. 2 | 25 of No. 37 |
| 9 " " 5 | 1 " " 52 |
| 4 " " 10 | 1 " " 54 |
| 2 " " 12 | 1 " " 57 |

Model No. 84

Motor Van

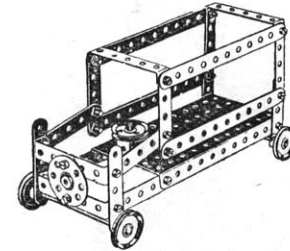

- Parts Required:
- | | | |
|------------|--------------|--------------|
| 6 of No. 2 | 2 of No. 15A | 22 of No. 37 |
| 1 " " 3 | 4 " " 22 | 1 " " 52 |
| 9 " " 5 | 1 " " 22A | 4 " " 60 |
| 1 " " 11 | 1 " " 24 | |

Model No. 85 Rock Drill

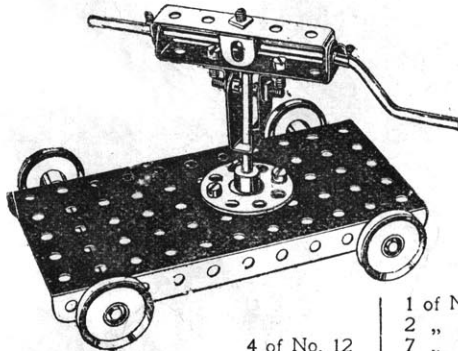

- Parts Required:
- | | |
|-------------|-------------|
| 4 of No. 12 | 1 of No. 24 |
| 1 " " 15A | 2 " " 35 |
| 1 " " 19 | 7 " " 37 |
| 1 " " 22 | 1 " " 44 |
| | 1 " " 52 |
| | 2 " " 60 |

Model No. 86 Bed Table

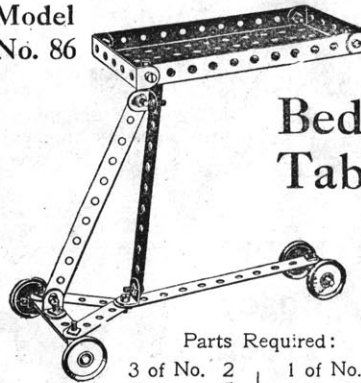

- Parts Required:
- | | |
|------------|-------------|
| 3 of No. 2 | 1 of No. 17 |
| 2 " " 5 | 4 " " 22 |
| 1 " " 11 | 15 " " 37 |
| 4 " " 12 | 1 " " 52 |
| 1 " " 15A | 3 " " 60 |

Model No. 87 Motor Lurry

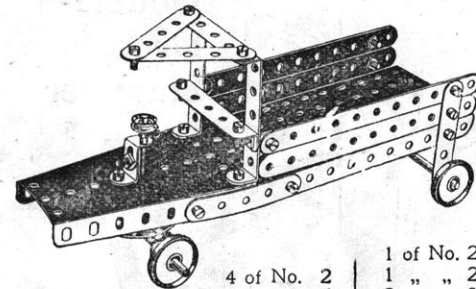

- Parts Required:
- | | |
|------------|-------------|
| 4 of No. 2 | 1 of No. 23 |
| 8 " " 5 | 1 " " 24 |
| 8 " " 12 | 2 " " 35 |
| 2 " " 15A | 25 " " 37 |
| 1 " " 17 | 1 " " 52 |
| 4 " " 22 | 1 " " 54 |
| | 2 " " 60 |

Model No. 88 Lawn Mower

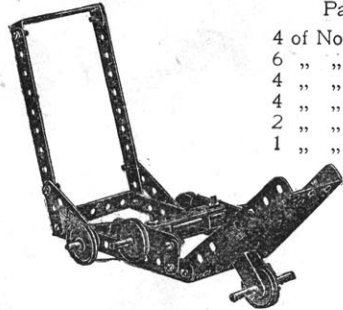

Parts Required:

4 of No. 2	4 of No. 22
6 " " 5	21 " " 37
4 " " 10	1 " " 44
4 " " 12	1 " " 54
2 " " 15A	2 " " 60
1 " " 17	

Model No. 89 Foot Cycle

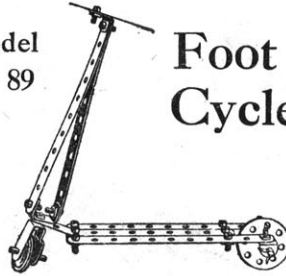

Parts Required:

5 of No. 2	1 of No. 22
1 " " 5	1 " " 24
4 " " 10	4 " " 35
1 " " 11	15 " " 37
3 " " 12	1 " " 44
2 " " 17	

Model No. 90 Cart

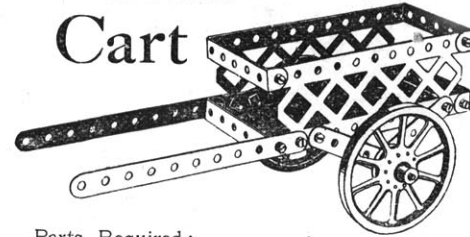

Parts Required:

4 of No. 2	2 of No. 22	2 of No. 59
4 " " 5	15 " " 37	4 " " 60
1 " " 15	1 " " 44	2 " " 100
2 " " 19A	1 " " 52	

Model No. 91 Deck Chair



Parts Required:

4 of No. 1	1 of No. 15A
4 " " 2	30 " " 37
1 " " 3	1 " " 52
6 " " 5	2 " " 60
6 " " 12	

Model No. 92 Invalid Chair

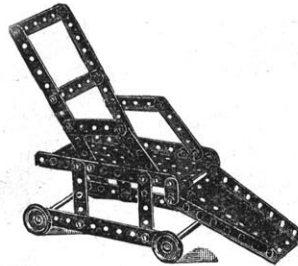

Parts Required:

4 of No. 2	22 of No. 37
8 " " 5	1 " " 52
2 " " 10	1 " " 54
2 " " 15A	2 " " 60
4 " " 22	

Forge Bellows Model No. 93

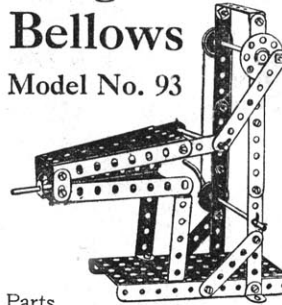

Parts Required:

4 of No. 2	1 of No. 19
1 " " 3	2 " " 22
2 " " 5	1 " " 24
2 " " 10	5 " " 35
1 " " 11	25 " " 37
2 " " 12	1 " " 52
2 " " 15A	2 " " 54
1 " " 17	3 " " 60

Model No. 94 Coster's Barrow

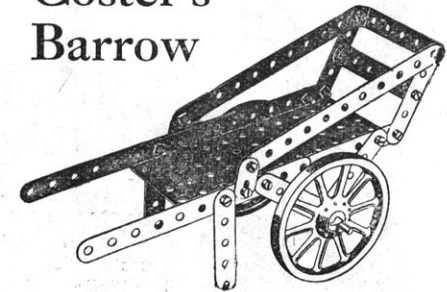

Parts Required:

4 of No. 2	4 of No. 35
8 " " 5	16 " " 37
2 " " 10	1 " " 52
1 " " 15A	2 " " 60
2 " " 19A	

Sighting Rule

Model No. 95

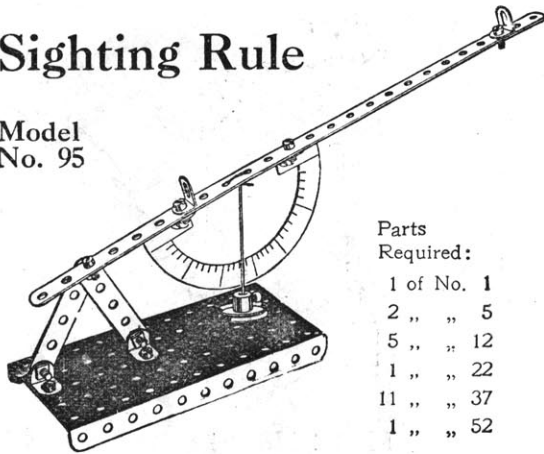

- Parts Required:
- 1 of No. 1
 - 2 " " 5
 - 5 " " 12
 - 1 " " 22
 - 11 " " 37
 - 1 " " 52

Devil Wall

Model No. 96

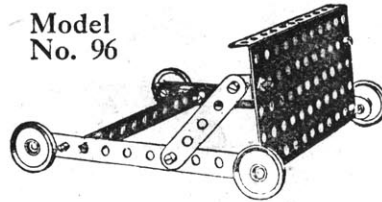

- Parts Required:
- | | |
|------------|-------------|
| 3 of No. 2 | 4 of No. 22 |
| 2 " " 5 | 18 " " 37 |
| 6 " " 12 | 1 " " 52 |

Model No. 97

Hatchet

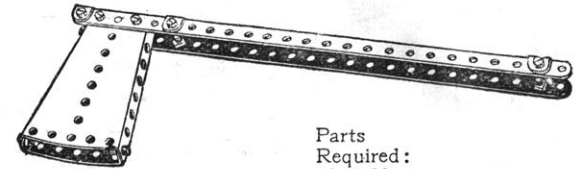

- Parts Required:
- 3 of No. 1
 - 6 " " 12
 - 15 " " 37
 - 2 " " 54

Model No. 98

Mail Bag Hanger

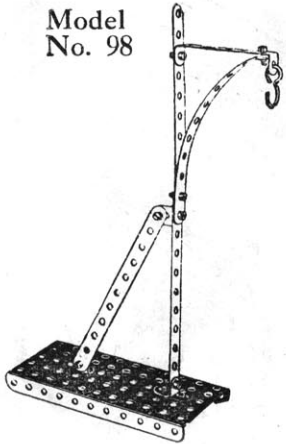

- Parts Required:
- 4 of No. 2
 - 4 " " 12
 - 10 " " 37
 - 1 " " 52
 - 1 " " 57
 - 1 " " 60

Model No. 99

Music Stand

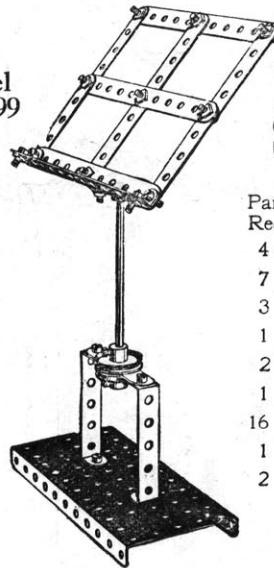

- Parts Required;
- 4 of No. 2
 - 7 " " 5
 - 3 " " 12
 - 1 " " 15A
 - 2 " " 22
 - 1 " " 24
 - 16 " " 37
 - 1 " " 52
 - 2 " " 60

Punching Machine

Model No. 100

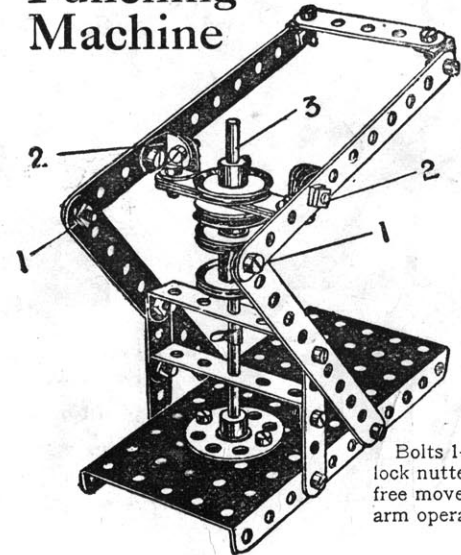

- Parts Required:
- 4 of No. 2
 - 7 " " 5
 - 6 " " 12
 - 1 " " 15A
 - 4 " " 22
 - 1 " " 24
 - 1 " " 35
 - 22 " " 37
 - 1 " " 52
 - 2 " " 60

Bolts 1—1 and 2—2 are lock nutted so as to permit free movement of the lever arm operating the punch 3.

Anchor

Model No. 101

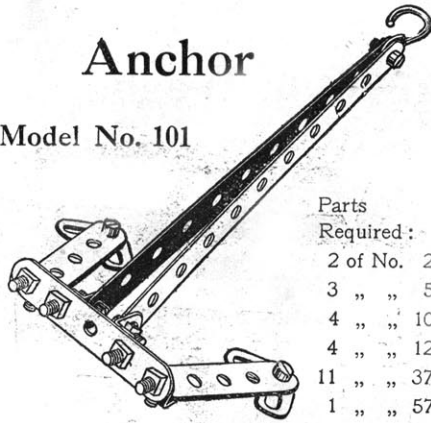

Parts Required:

2 of No. 2
3 " " 5
4 " " 10
4 " " 12
11 " " 37
1 " " 57

Model No. 102 Invalid Chair

Parts Required:

4 of No. 2	1 of No. 44
2 " " 5	2 " " 60
2 " " 15A	
1 " " 18	
3 " " 22	
1 " " 24	
2 " " 35	
13 " " 37	

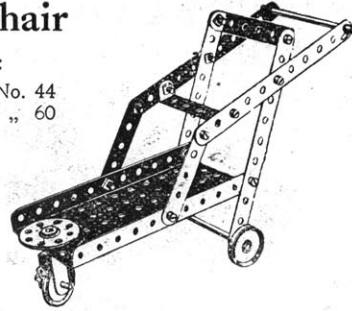

Model No. 105 Jib Crane

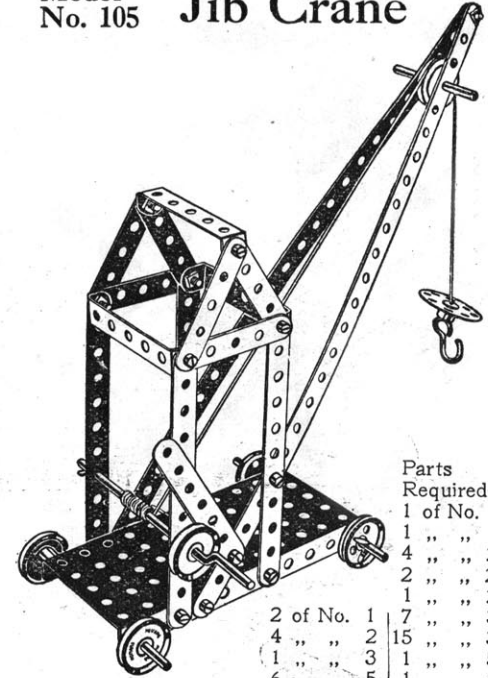

Parts Required:

1 of No. 17
1 " " 19
4 " " 22
2 " " 22A
1 " " 24
7 " " 35
15 " " 37
1 " " 52
5 " " 57
3 " " 60
2 of No. 1
4 " " 2
1 " " 3
6 " " 5
2 " " 15A

Model No. 103

Grill

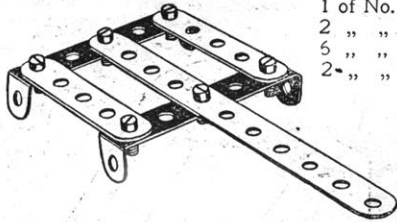

Parts Required:

1 of No. 2
2 " " 5
5 " " 37
2 " " 60

Model No. 104

Mountain Transport

Parts Required:

2 of No. 1	3 of No. 5	4 of No. 22
2 " " 2	4 " " 12	18 " " 37
	2 " " 15A	1 " " 52
		1 " " 54
		2 " " 60

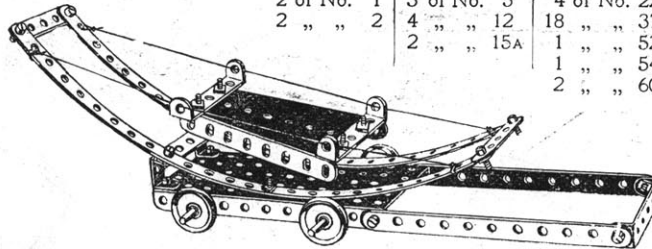

HOW TO CONTINUE

This completes the Models which may be made with Meccano Outfit No. 1. The next Models are a little more advanced, requiring a number of extra parts to construct them. The necessary parts are all contained in a No. 1A Accessory Outfit, the cost of which will be found in the Price List at the end of the Manual.

Model No. 106

Motor Van

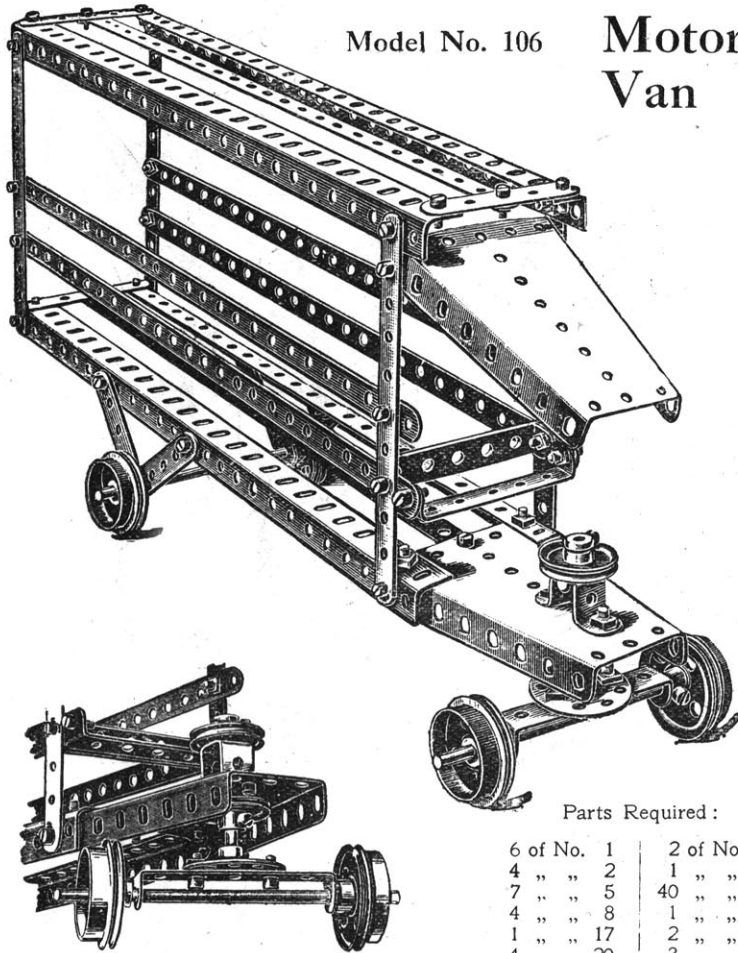

Fig. 106A

Parts Required :

6 of No. 1	2 of No. 22
4 " " 2	1 " " 24
7 " " 5	40 " " 37
4 " " 8	1 " " 45
1 " " 17	2 " " 54
4 " " 20	3 " " 60
2 " " 15	

Tipping Motor Wagon

Model No. 107

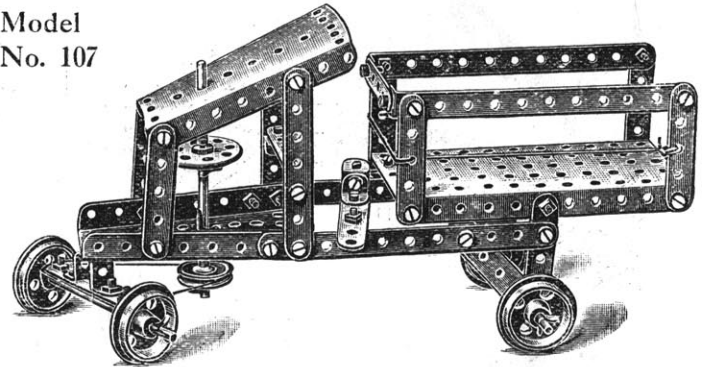

Parts Required :

4 of No. 2
2 " " 3
12 " " 5
5 " " 12
3 " " 15
4 " " 20
1 " " 22
1 " " 24
38 " " 37
1 " " 45
1 " " 52
2 " " 54
3 " " 60

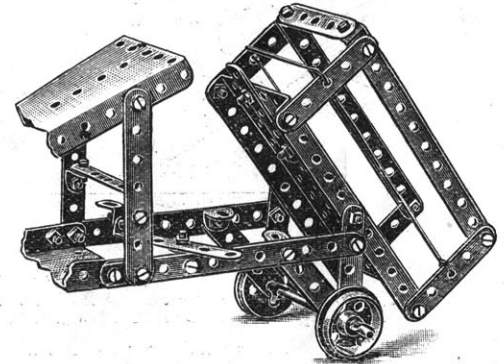
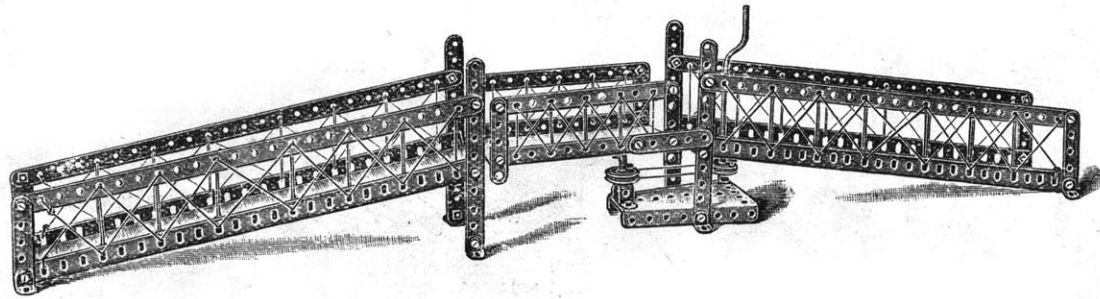

Fig. 107A

Model No. 108 Swing Bridge



Ladder on Wheels

Model No. 109

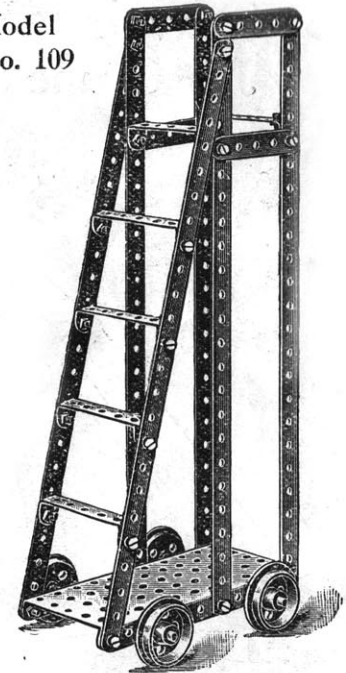
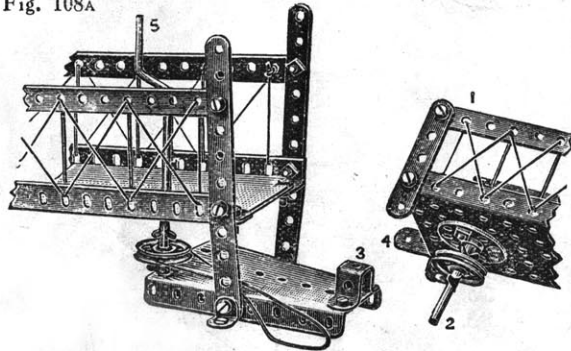

Fig. 108A



Parts Required :

4 of No. 1	1 of No. 24
6 " " 2	1 " " 35
9 " " 5	31 " " 37
4 " " 8	1 " " 45
8 " " 12	1 " " 52
1 " " 17	1 " " 54
1 " " 19	4 " " 60
2 " " 22	

The action for swinging the middle section of the Bridge will be made clearer by the detail Fig. 108A, the middle section 1 being fitted with a spindle 2 journalled in the double bent strip 3; the upper end of the spindle being secured to a bush wheel.

A short strip 4 acts as a stop against the middle section of the Bridge swinging past the central position.

The operating cord passes round pulleys on the spindles 2 and crank handle 5.

Parts Required :

6 of No. 1	24 of No. 37
4 " " 5	1 " " 52
2 " " 15	6 " " 60
4 " " 20	

Model No. 110
**Travelling
 Jib Crane**

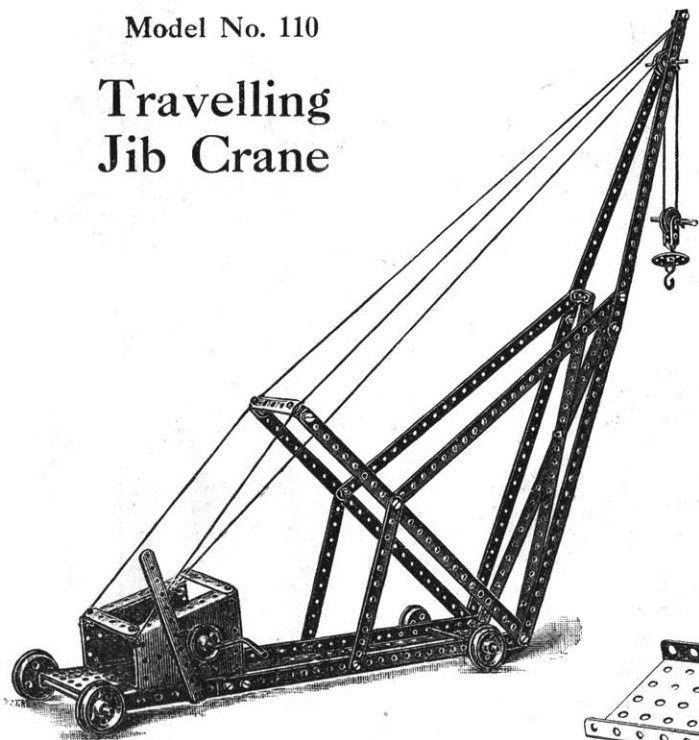

Parts Required :

10 of No. 1	2 of No. 15A	1 of No. 24
3 " " 2	2 " " 17	35 " " 37
3 " " 5	1 " " 19	1 " " 57
1 " " 60	4 " " 20	5 " " 35
2 " " 8	2 " " 22	1 " " 44
4 " " 12	1 " " 22A	1 " " 52
		2 " " 54

Model No. 111
**Roundabout
 Seesaw**

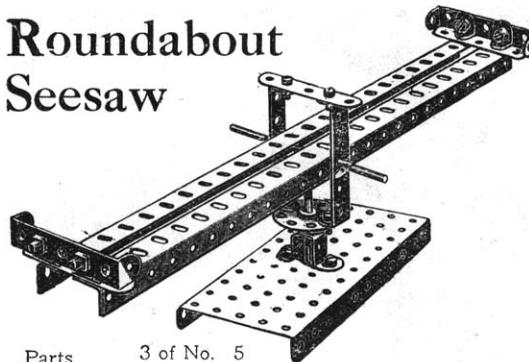

Parts Required :

3 of No. 5	14 of No. 37
2 " " 8	1 " " 45
4 " " 12	1 " " 52
1 " " 15	4 " " 60
1 " " 24	
2 " " 35	

Model No. 112 **Carrier Tricycle**

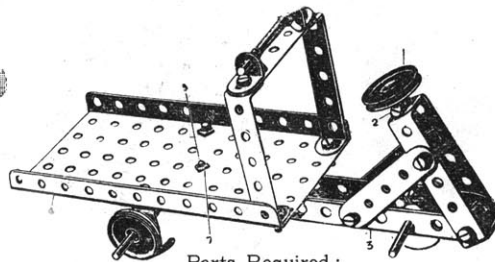

Parts Required :

2 of No. 2	3 of No. 22
3 " " 5	1 " " 24
1 " " 11	2 " " 35
2 " " 12	16 " " 37
1 " " 15	1 " " 52
2 " " 17	5 " " 60

Fig. 112A

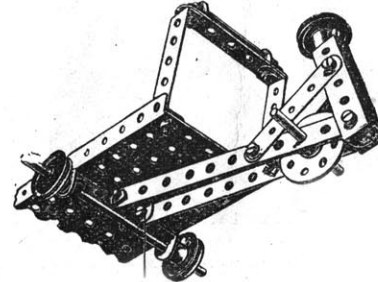

Types of Windmills

Model No. 113

Three-arm Signal

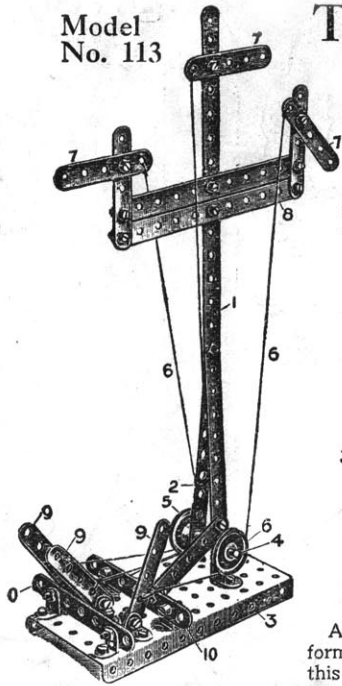

Parts Required :

- 1 of No. 1
- 3 " " 2
- 2 " " 3
- 9 " " 5
- 10 " " 12
- 1 " " 17
- 2 " " 22
- 37 " " 37
- 1 " " 52

A flanged plate forms the base of this model, a 12½" strip 1 being bolt-

ed to a 5½" strip 2, the feet of both these strips being connected to the flanged plate 3 by angle brackets. A rod 4 is passed through the lower holes of the strips 1 and 2 and is fitted with guide pulleys 5 leading the actuating cords 6 to the signal arms 7. The cord operating the central arm is run under the rod 4. The signal arms 7 are carried from transverse strips 8. The operating cords 6 are led to three strips 9, pivoted to angle brackets bolted to the flanged plate, and transverse strips 10 are bolted to the perforated plate in the front and rear of the pivoted strips 9 to limit their movement.

Model No. 114

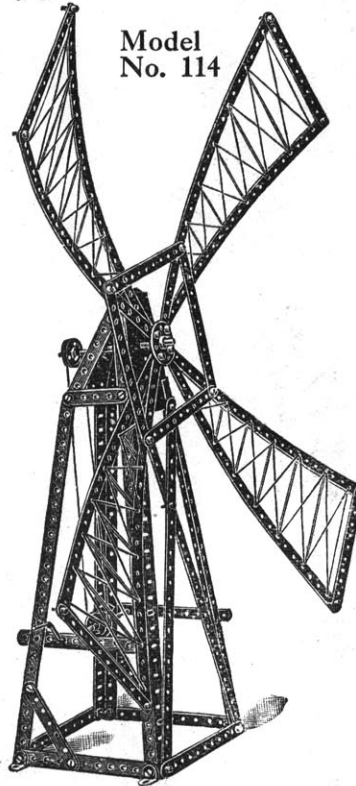

Parts Required :

- | | |
|-------------|-------------|
| 10 of No. 1 | 1 of No. 19 |
| 13 " " 2 | 2 " " 22 |
| 2 " " 3 | 1 " " 24 |
| 2 " " 5 | 4 " " 35 |
| 4 " " 8 | 45 " " 37 |
| 4 " " 12 | 2 " " 54 |
| 1 " " 15 | |

Model No. 115

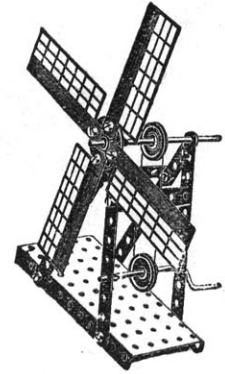

Parts Required :

- 4 of No. 2
- 2 " " 60
- 1 " " 15
- 1 " " 19
- 2 " " 22
- 1 " " 24
- 12 " " 37
- 3 " " 35
- 1 " " 52
- 4 " " 61

Model No. 116

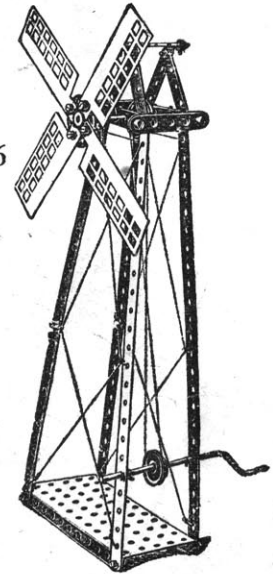

Parts Required :

- 4 of No. 1
- 7 " " 5
- 2 " " 60
- 2 " " 12
- 1 " " 15
- 1 " " 19
- 2 " " 22
- 1 " " 24
- 20 " " 37
- 4 " " 35
- 1 " " 52
- 4 " " 61

Model No. 117 Monoplane

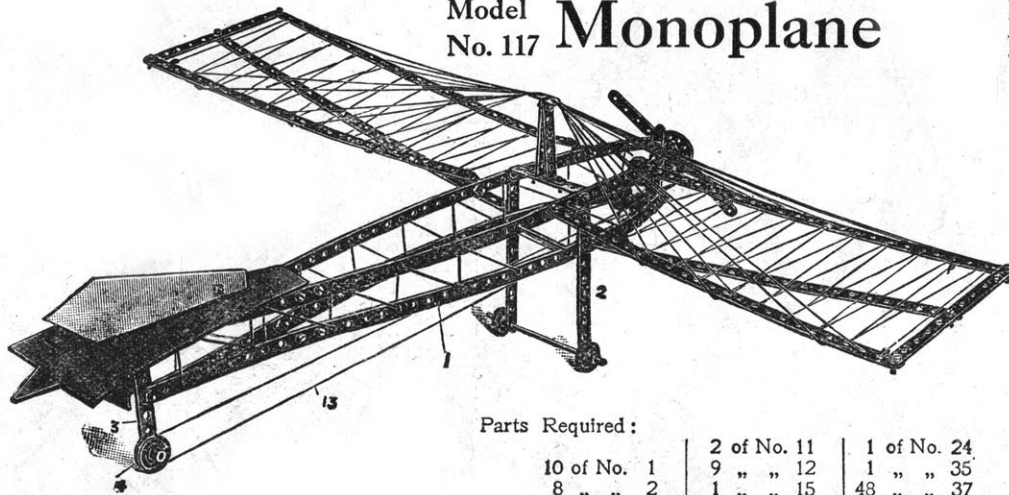
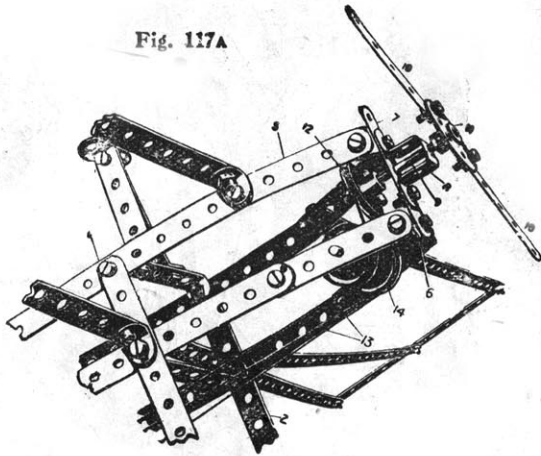

Fig. 117A

Parts Required:

10 of No. 1	2 of No. 11	1 of No. 24
8 " " 2	9 " " 12	1 " " 35
1 " " 3	1 " " 15	48 " " 37
7 " " 5	1 " " 17	1 " " 45
	4 " " 22	4 " " 60
	2 " " 22A	

Model No. 119 Wheel



Parts Required:

5 of No. 1
12 " " 2
2 " " 5
4 " " 8
4 " " 11
2 " " 15
3 " " 20
2 " " 22
44 " " 37

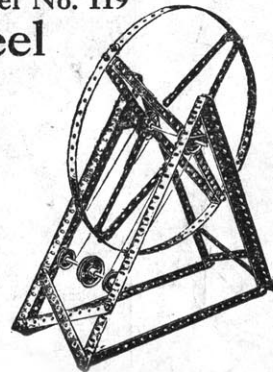

Model No. 118 Ferry Gangway

The vertical standard is built up from two angle girders, the slotted holes overlapped to form a channel section girder.

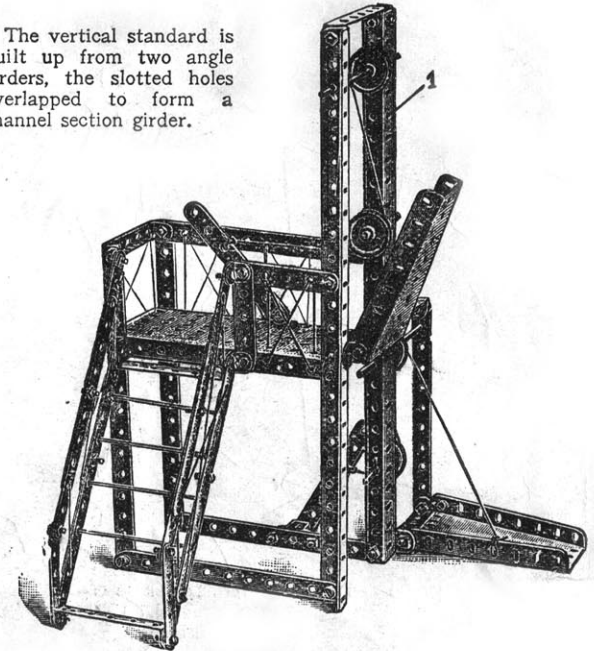

Parts Required:

14 of No. 2	2 of No. 15	50 of No. 37
2 " " 3	2 " " 17	1 " " 45
6 " " 5	2 " " 22	1 " " 52
3 " " 8	2 " " 22A	2 " " 54
2 " " 10	6 " " 35	6 " " 60
7 " " 12		

Model No. 120

Roundabout

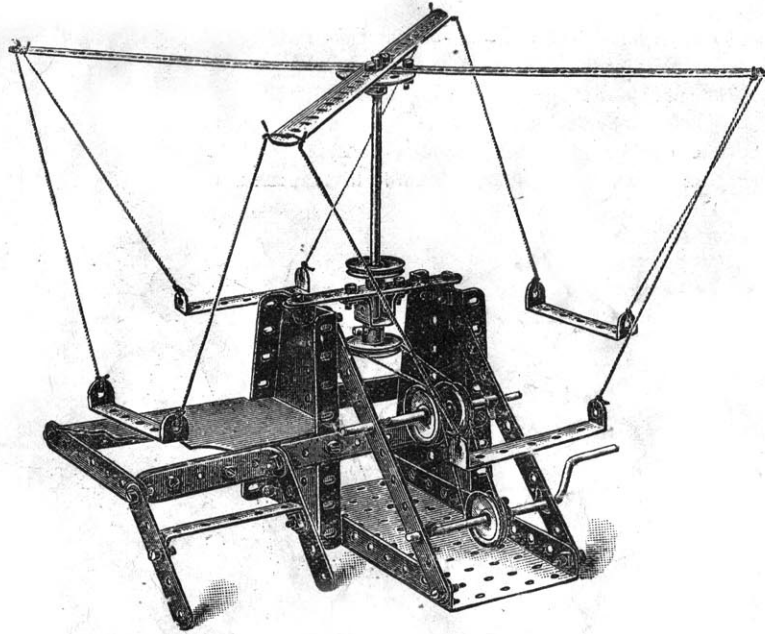

Parts Required :	2 of No. 1	2 of No. 22A
	4 " " 2	1 " " 24
	2 " " 3	4 " " 35
	4 " " 5	33 " " 37
	3 " " 12	1 " " 45
	1 " " 15	1 " " 52
	1 " " 16	2 " " 54
	1 " " 19	6 " " 60
	3 " " 22	

Railway Foot Bridge and Signals

Model No. 121

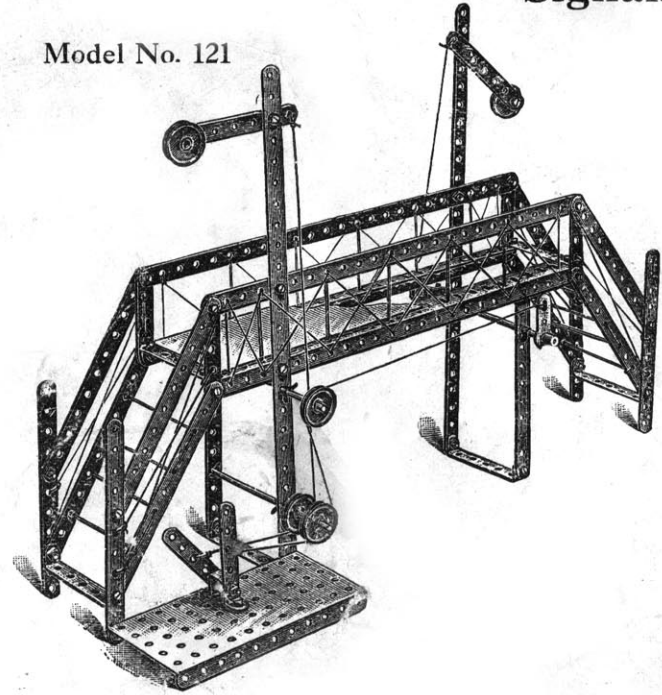

	4 of No. 1	2 of No. 8	6 of No. 35
	14 " " 2	2 " " 22A	1 " " 45
	2 " " 3	3 " " 22	4 " " 60
	8 " " 5	43 " " 37	2 " " 62
	3 " " 15	1 " " 52	

Model No. 122 Extending Ladder on Running Carriage

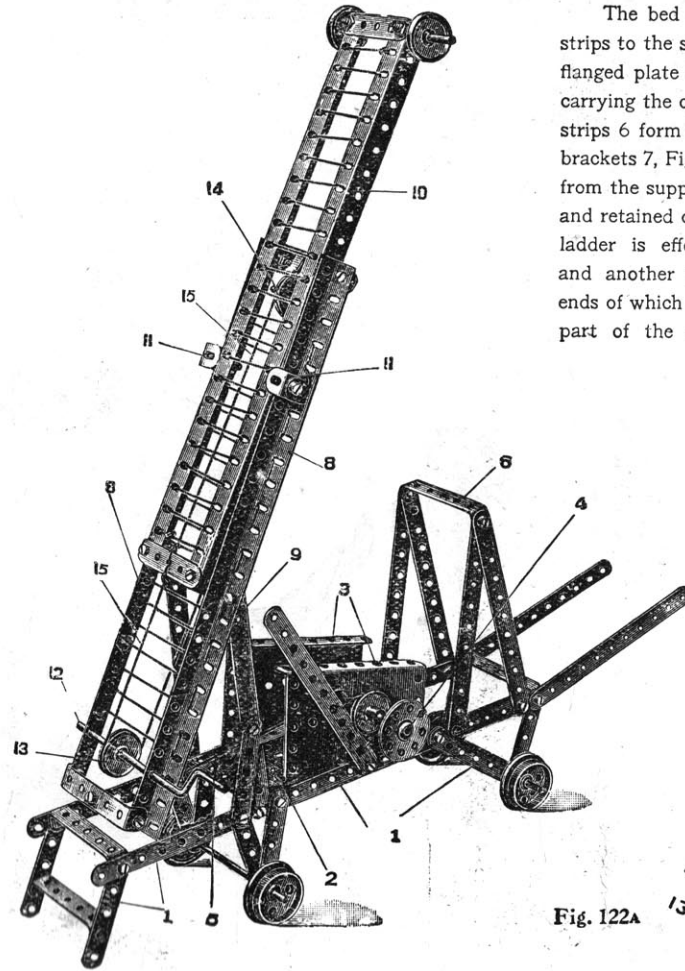

Fig. 122A

The bed of the lower carriage framework 1 is formed by bolting two 12½" strips to the sides of a large flanged plate 2, and two sector plates 3 bolted to the flanged plate by their flanges to form the sides, and a bearing for the spindle 4 carrying the operating cord 5 to raise the ladder from a horizontal position. The strips 6 form a support for the ladder when in this horizontal position. Angle brackets 7, Fig. 122A, form pivots for the lower part 8 of the ladder, and are carried from the supports 9. The upper part of the ladder 10, Fig. 122B, is slidably guided and retained on the lower ladder 8 by double brackets 11. The extension of the ladder is effected by the cranked spindle 12, round a pulley 13, on which and another 14, carried as shown in Fig. 122A, the cord 15 is passed, the ends of which are secured to the lower part of the movable ladder 10.

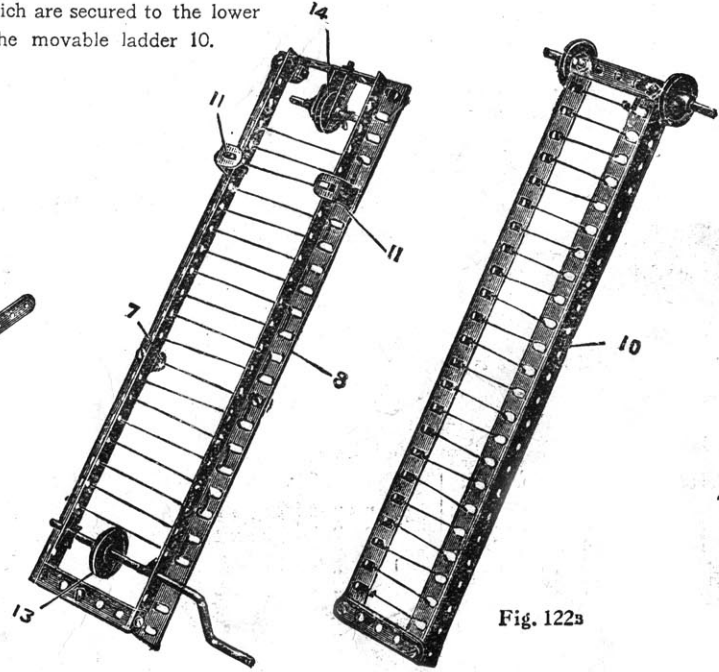
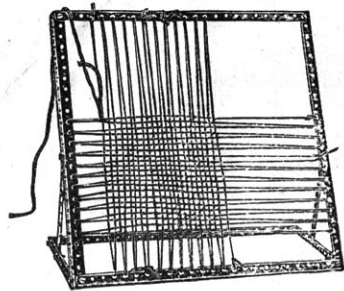

Fig. 122B

Parts Required:

2	of No. 1
9	" " 2
2	" " 3
12	" " 5
4	" " 8
2	" " 11
4	" " 12
3	" " 15
1	" " 15A
1	" " 19
4	" " 20
4	" " 22
1	" " 22A
1	" " 24
6	" " 35
47	" " 37
1	" " 44
1	" " 52
2	" " 54
5	" " 60

Model No. 123 Mat Frame



	1 of No. 1
Parts	4 " " 2
Required :	4 " " 8
	2 " " 12
	14 " " 37

Model No. 124 Coaster

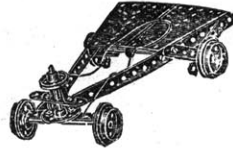

Parts Required :

2 of No. 2	1 of No. 22
5 " " 5	1 " " 24
1 " " 15	12 " " 37
1 " " 16	1 " " 45
1 " " 17	2 " " 54
4 " " 20	1 " " 60

Model No. 125 Locomotive

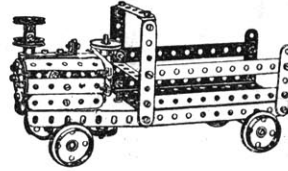

Parts Required :

4 of No. 2	1 of No. 16	46 of No. 37
2 " " 3	1 " " 17	1 " " 45
7 " " 5	4 " " 20	1 " " 52
4 " " 10	4 " " 22	1 " " 54
1 " " 11	1 " " 23	6 " " 60
8 " " 12	1 " " 24	2 " " 62
2 " " 15A	3 " " 35	

Model No. 126 Embossing Machine

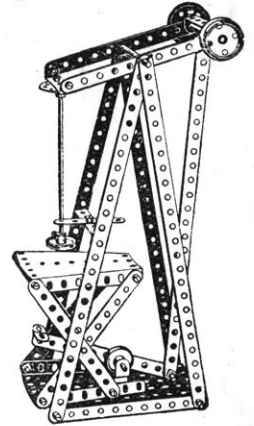

Parts Required :

5 of No. 1
7 " " 2
1 " " 5
1 " " 15
2 " " 15A
1 " " 18
2 " " 20
2 " " 22
1 " " 24
4 " " 35
23 " " 37
1 " " 44
1 " " 52
2 " " 54
3 " " 60

Model No. 127 Motor Van

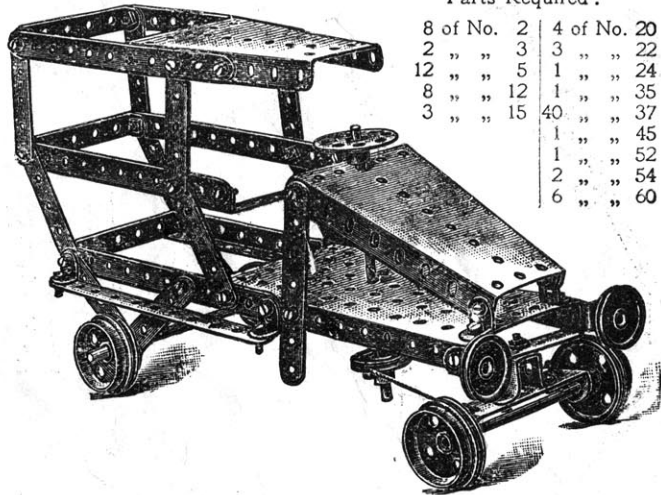

Parts Required :

8 of No. 2	4 of No. 20
2 " " 3	3 " " 22
12 " " 5	1 " " 24
8 " " 12	1 " " 35
3 " " 15	40 " " 37
	1 " " 45
	1 " " 52
	2 " " 54
	6 " " 60

Model No. 128 Try-your-Strength Machine

Parts Required :

2 of No. 1
3 " " 2
2 " " 5
2 " " 8
4 " " 12
1 " " 16
2 " " 17
1 " " 18
4 " " 22
1 " " 24
29 " " 37
1 " " 44
1 " " 45
1 " " 52
1 " " 54
4 " " 60
1 " " 62

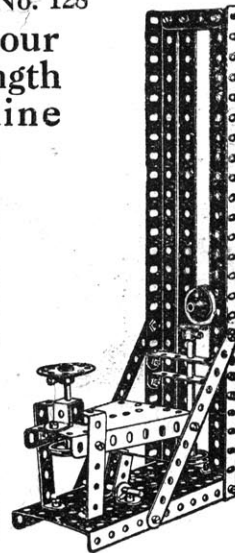

Model No. 129 Mechanical Hammer

Parts Required :

6 of No. 1
11 " " 2
1 " " 3
7 " " 5
2 " " 8
3 " " 12
2 " " 15A
4 " " 22
1 " " 24
4 " " 35
48 " " 37
1 " " 45
1 " " 52
1 " " 54
2 " " 60

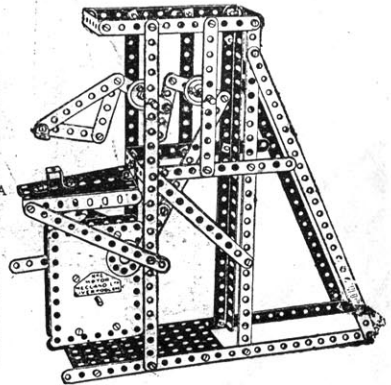

Model No. 130 Designing Machine

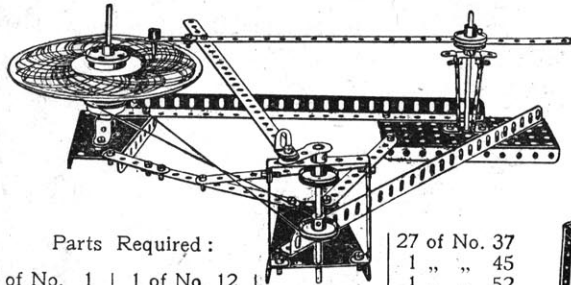

Parts Required :

2 of No. 1	1 of No. 12	27 of No. 37
3 " " 2	2 " " 15A	1 " " 45
2 " " 8	1 " " 16	1 " " 52
1 " " 11	1 " " 20	2 " " 54
	4 of No. 22	5 " " 60
	1 " " 24	2 " " 62
	1 " " 35	

Model No. 131 Crossbow

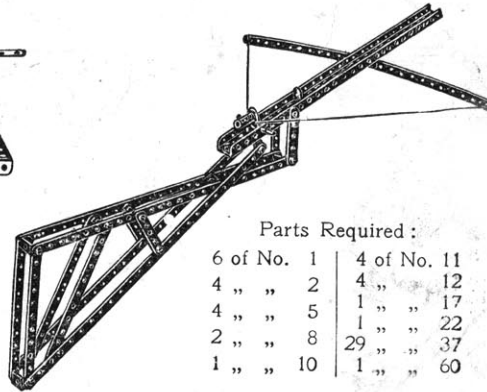

Parts Required :

6 of No. 1	4 of No. 11
4 " " 2	4 " " 12
4 " " 5	1 " " 17
2 " " 8	1 " " 22
1 " " 10	29 " " 37
	1 " " 60

Model No. 132 Lathe

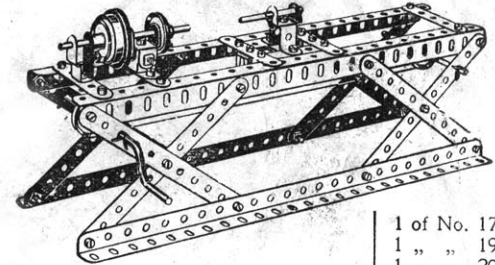

Parts Required :

		1 of No. 17
		1 " " 19
		1 " " 20
		4 " " 22
		6 " " 35
4 of No. 8		41 " " 37
3 " " 11		1 " " 44
4 " " 12		1 " " 45
8 of No. 2	1 " " 15A	
7 " " 5	1 " " 16	

Model No. 133 Dwarf Derrick

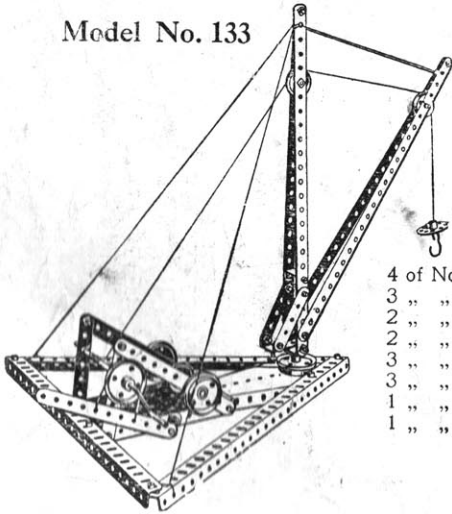

Parts Required :

1 of No. 19	
4 " " 20	
2 " " 22	
2 " " 23A	
1 " " 23	
4 of No. 1	1 " " 24
3 " " 2	4 " " 35
2 " " 3	39 " " 37
2 " " 5	1 " " 45
3 " " 8	1 " " 52
3 " " 11	1 " " 54
1 " " 15A	1 " " 57
1 " " 17	1 " " 62

Model No. 134 Potato Reaper

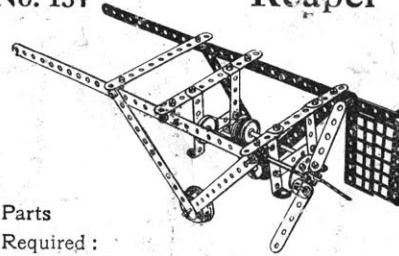

Parts Required :

2 of No. 1	1 of No. 15A	5 of No. 35
8 " " 2	2 " " 20	31 " " 37
4 " " 5	2 " " 22	4 " " 60
10 " " 12	2 " " 22A	2 " " 61
2 " " 15	1 " " 24	

Model No. 135 Elevator

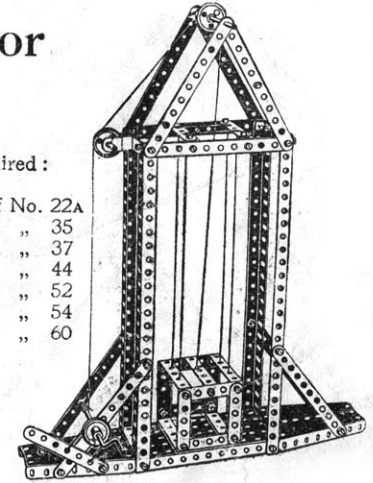

Parts Required :

1 of No. 1	2 of No. 22A
10 " " 2	5 " " 35
1 " " 3	44 " " 37
10 " " 5	1 " " 44
4 " " 8	1 " " 52
4 " " 12	2 " " 54
1 " " 15A	5 " " 60
1 " " 17	
1 " " 19	
1 " " 22	

Model
No. 136

Maize Sheller

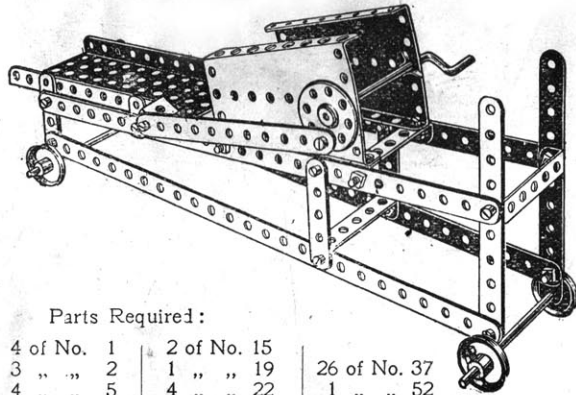

Parts Required:

4 of No. 1	2 of No. 15	
3 " " 2	1 " " 19	26 of No. 37
4 " " 5	4 " " 22	1 " " 52
2 " " 10	1 " " 24	2 " " 54
1 " " 11	2 " " 35	4 " " 60

Model No. 137

Hay Stacker

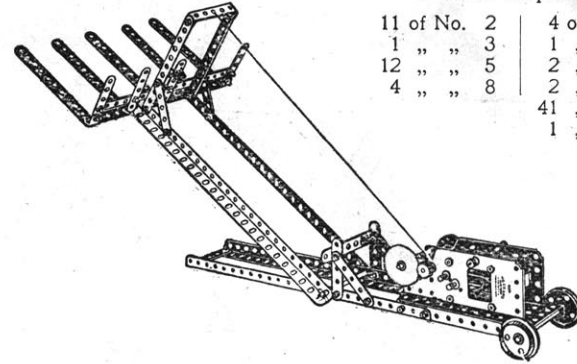

Parts Required:

11 of No. 2	4 of No. 12
1 " " 3	1 " " 16
12 " " 5	2 " " 20
4 " " 8	2 " " 35
	41 " " 37
	1 " " 52

Model
No. 139

Beam Scales

Model No. 138

Candy Puller

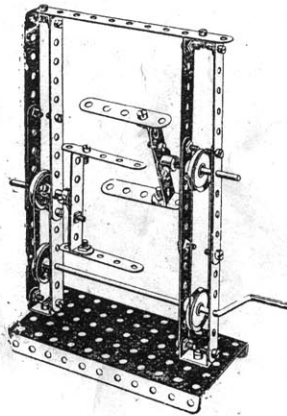

Parts
Required:

9 of No. 2
4 " " 5
4 " " 11
2 " " 17
1 " " 19
4 " " 22
2 " " 35
26 " " 37
1 " " 52
2 " " 60
2 " " 62

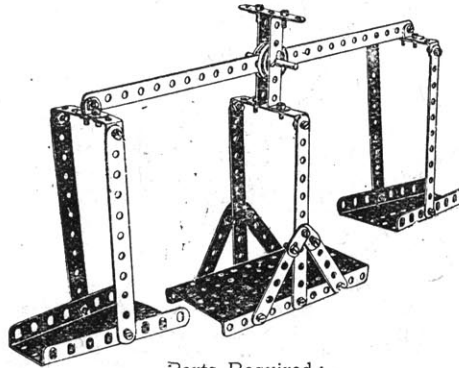

Parts Required:

1 of No. 1	4 of No. 12	32 of No. 37
6 " " 2	1 " " 17	1 " " 52
5 " " 5	2 " " 22A	2 " " 54
4 " " 10	2 " " 35	5 " " 60

Model No. 140

Baby Chair

Parts
Required:

8 of No. 2
2 " " 3
10 " " 5
6 " " 12
2 " " 17
4 " " 22
32 " " 37
6 " " 60

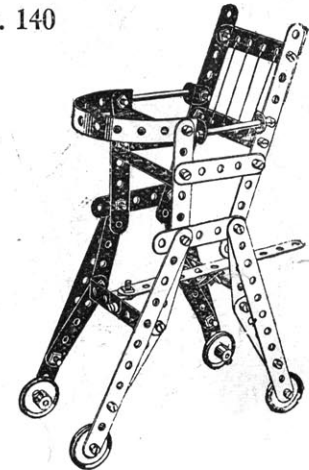

Hay Tedder

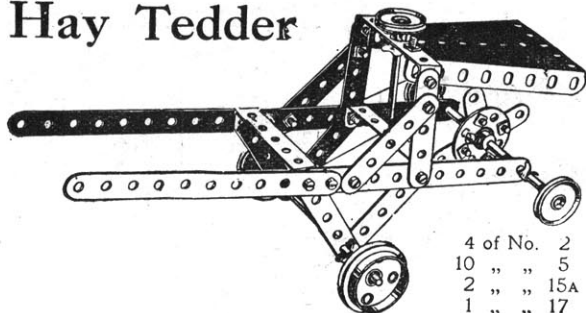

4 of No. 2
10 " " 5
2 " " 15A
1 " " 17

Model No. 141

Parts
Required :

2 of No. 20
3 " " 22
1 " " 24
5 " " 35
18 " " 37
1 " " 54
3 " " 60

Model No. 142 Ducking Chair

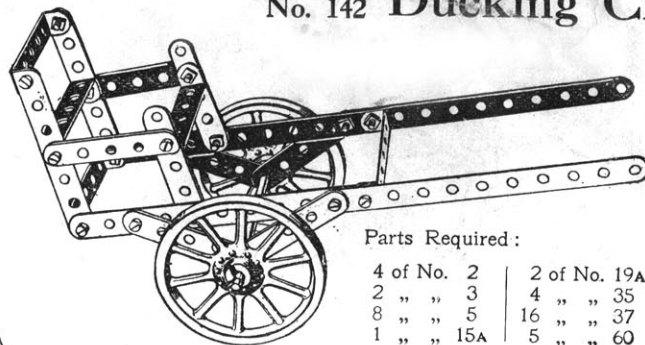

Parts Required :

4 of No. 2	2 of No. 19A
2 " " 3	4 " " 35
8 " " 5	16 " " 37
1 " " 15A	5 " " 60

Model No. 143 Needlework Basket

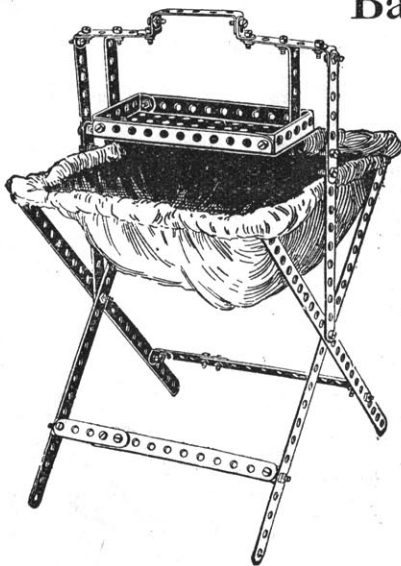

Parts
Required :

4 of No. 1
6 " " 2
2 " " 3
6 " " 5
12 " " 12
46 " " 37
1 " " 52
3 " " 60

Model No. 144

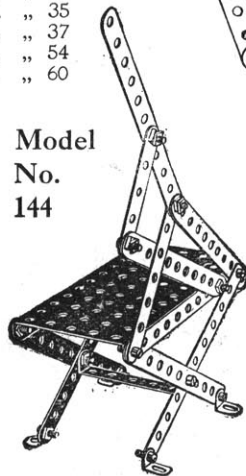

Cutting Machine

Parts
Required :

8 of No. 2
1 " " 3
1 " " 5
4 " " 12
20 " " 37
1 " " 52

Model No. 145 Dinner Gong

Parts
Required :

6 of No. 1
4 " " 2
2 " " 5
2 " " 8
2 " " 11
1 " " 15
1 " " 22
27 " " 37
1 " " 54

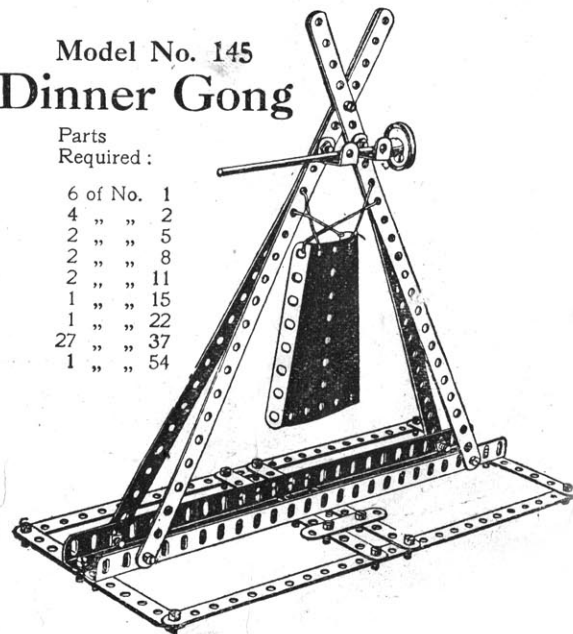

Model No. 146 Seashore Aeroplage

Parts
Required :

3 of No.	1
1 " "	2
3 " "	5
4 " "	12
2 " "	15
1 " "	16
4 " "	22
2 " "	22A
1 " "	24
6 " "	35
15 " "	37
1 " "	44
1 " "	52
1 " "	54
2 " "	60

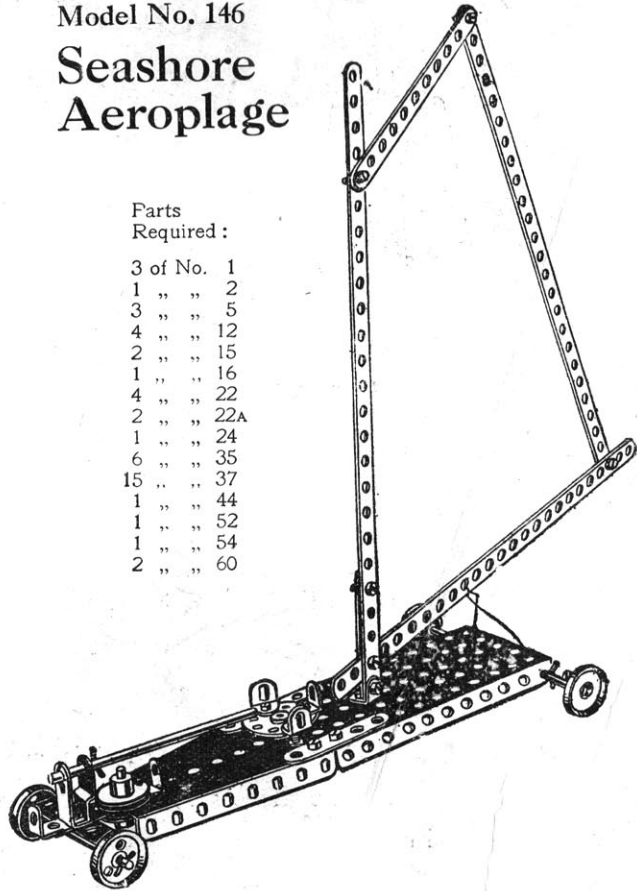

Model No. 147 Mechanical Hammer

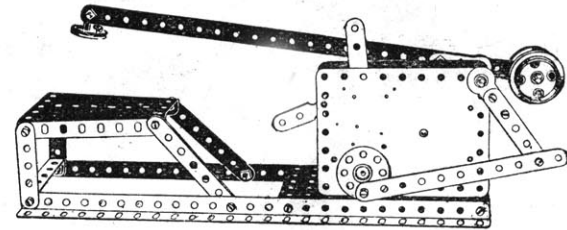

Parts Required :	1 of No. 1	4 of No. 12	26 of No. 37
	1 " " 2	1 " " 17	1 " " 52
	2 " " 3	2 " " 20	1 " " 54
	2 " " 5	1 " " 22	1 " " 60
	2 " " 8	1 " " 24	2 " " 62

Model No. 148

Coal Shaker

Parts
Required :

7 of No.	2	5 of No. 35
2 " "	3	30 " "
8 " "	5	1 " "
4 " "	8	1 " "
2 " "	15A	1 " "
1 " "	19	1 " "
1 " "	24	1 " "

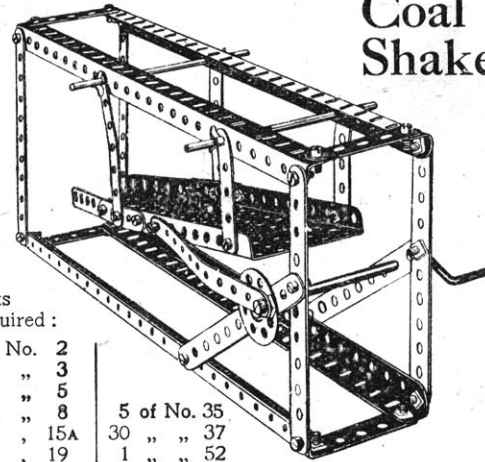

Model No. 149 Sifter

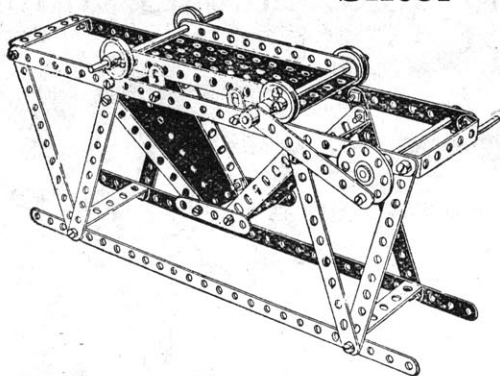

Parts Required:	
4 of No.	1
6 "	2
1 "	3
2 "	5
4 "	10
2 "	15A
1 "	19
4 "	22
1 "	24
4 "	35
26 "	37
1 "	52
2 "	54
4 "	60

Model No. 150 Spinning Top

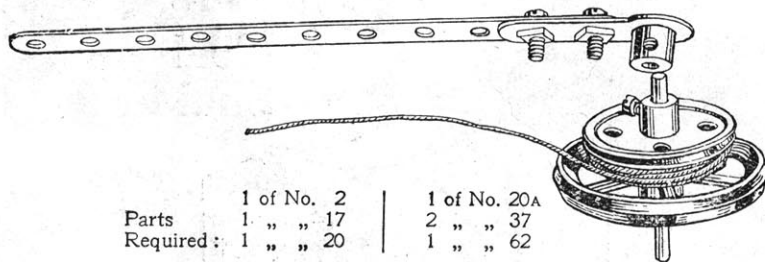

Parts Required:	1 of No. 2	1 of No. 20A
	1 " " 17	2 " " 37
	1 " " 20	1 " " 62

Model No. 151 Easel

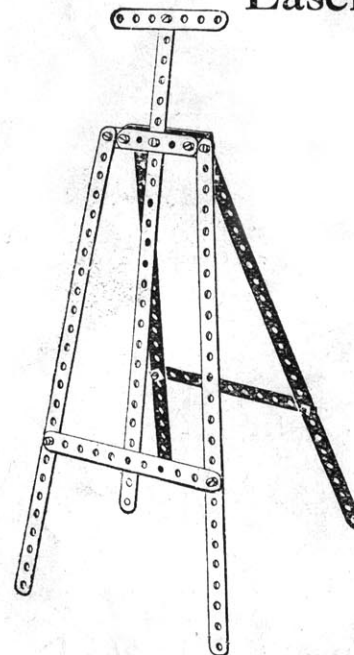

Parts
Required:

5 of No.	1
2 "	2
2 "	3
1 "	5
2 "	12
14 "	37
1 "	60

HOW TO CONTINUE

This completes the Models which may be made with MECCANO Outfit No. 2. The next Models are a little more advanced, requiring a number of extra parts to construct them. The necessary parts are all contained in a No. 2A Accessory Outfit, the cost of which will be found in the Price List at the end of the Manual.

Model No. 152 Swing Bridge

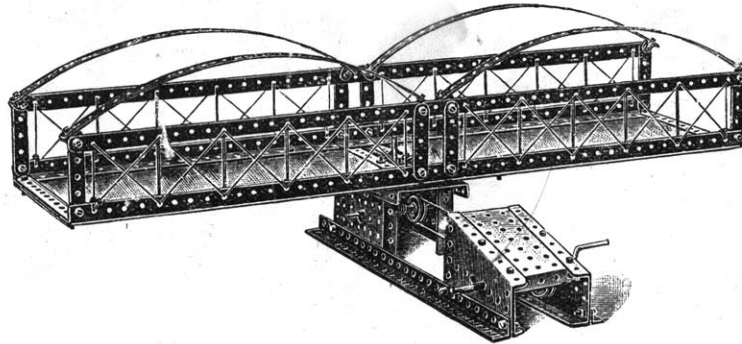

Parts Required:

8 of No. 1	1 of No. 19	60 of No. 37
4 " " 2	2 " " 22	1 " " 52
8 " " 5	1 " " 24	3 " " 53
6 " " 8	1 " " 26	2 " " 54
10 " " 12	1 " " 32	2 " " 59
2 " " 15	3 " " 35	1 " " 60

This is a fine engineering model of the highest value to the young student, and any thought and care expended on its construction will be well repaid.

The base portion containing the perpendicular axle actuated by the worm and pinion should be constructed first. This, as will be seen by the illustration, Fig. 152A, is formed by connecting a small flanged plate to an angle girder three holes from one end and a sector plate at the other end to form one side of the base. The other side is constructed in a similar manner. These two sides are then connected together at one end by a large flanged plate containing the spindle, upon which the bridge swings, and at the other by a small flanged plate. A $2\frac{1}{2}$ " bent strip is connected to the angle girders to carry the lower portion of the perpendicular axle upon which the bridge swings. A $\frac{1}{2}$ " pinion is secured to this axle, which is operated by the horizontal spindle upon which is secured a worm wheel. A pulley wheel is also secured to this spindle around which a driving rope passes from the pulley at the other end of the base secured to a crank handle, as shown in the illustration.

The platform is constructed by connecting two angle girders in the third holes. Two $2\frac{1}{2}$ " strips are attached to these in the centre and one at each end, with two $12\frac{1}{2}$ " strips along the top. Two $12\frac{1}{2}$ " strips are curved and connected by four angle brackets to form one side of the bridge. The other side is formed in a similar manner, and both are connected together by $5\frac{1}{2}$ " strips at the end and in the centre. Attached to the two $5\frac{1}{2}$ " strips in the centre is a bush wheel upon which the platform rotates.

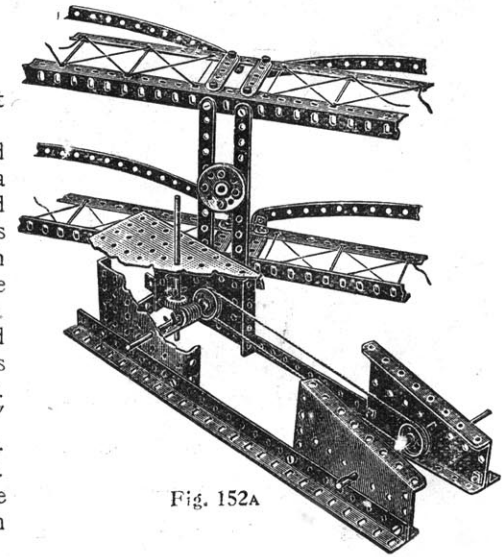

Fig. 152A

Model No. 153 Cake Walk

Parts Required :

8 of No. 1	1 of No. 32
12 " " 2	8 " " 35
9 " " 5	62 " " 37
6 " " 8	2 " " 52
8 " " 12	2 " " 53
4 " " 15	3 " " 59
2 " " 15A	6 " " 60
1 " " 22	2 " " 62
1 " " 26	

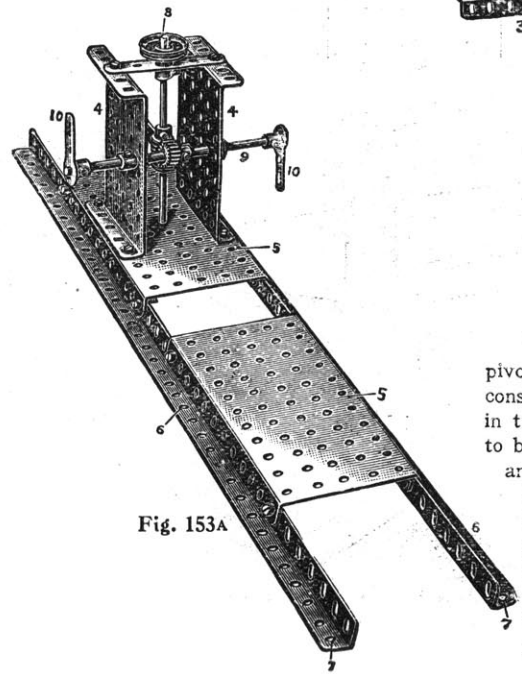
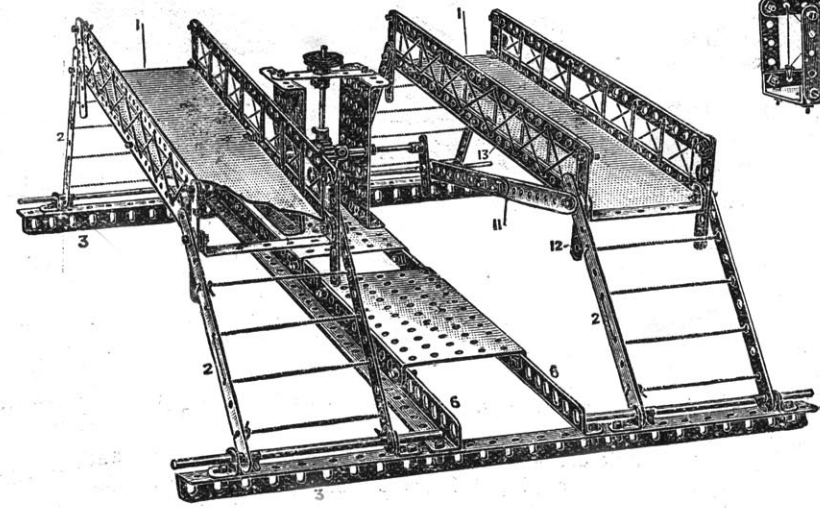
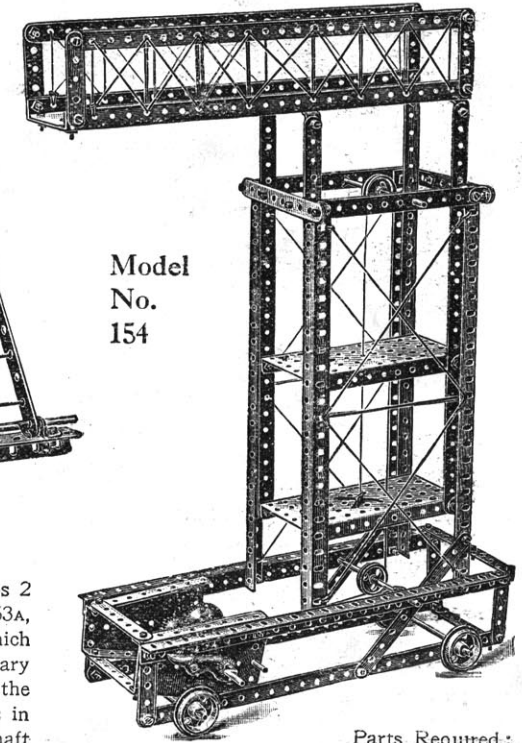

Fig. 153A

This model comprises two side platforms 1 carried upon 5½" strips 2 pivoted to angle brackets bolted to angle girders 3. The gear box, Fig. 153A, consists of small flanged plates 4 bolted to a large flanged plate 5, which in turn is bolted to angle girders 6 overlapped 14 holes. It is necessary to bolt the flanges to the flanged plate 5 outside the vertical parts of the angle girders 6 so that the end holes 7 shall register with the holes in the angle girders 3. The platforms 1 are rocked from a vertical shaft 8 gearing with a shaft 9 by a worm and pinion, the ends of the shaft 9 being fitted with cranks 10 pivotally bolted to connecting rods 11 formed of two 5½" strips overlapped two holes. The strips 11 are also pivotally bolted to the end strips 2, a vertical 2½" strip 12, and the lower end hole of the lower strip 13 of each side platform, so as to give free rocking movement.

Tower Wagon



Model No. 154

Parts Required :

8 of No. 1	4 of No. 15	1 of No. 33
4 " " 2	1 " " 15A	6 " " 35
6 " " 3	1 " " 19	69 " " 37
2 " " 4	4 " " 20	2 " " 52
11 " " 5	2 " " 22	2 " " 54
8 " " 8	2 " " 26	2 " " 60
14 " " 12	1 " " 27A	

Model No. 155 Level Crossing Gate

Parts Required:		
9 of No. 2	6 of No. 8	4 of No. 22
4 " " 3	16 " " 12	54 " " 37
2 " " 4	4 " " 15	2 " " 52
6 " " 5		4 " " 60

This Model, if constructed with care, is a most admirable one, as the gates are opened simultaneously by the operation of one lever.

To construct it, commence by taking two angle girders and connecting them together in the second hole from each end with a $3\frac{1}{2}$ " strip placed perpendicularly between them to form the supports of one pair of gates as shown in Fig. 155. The supports for the other pair of gates are arranged in a similar manner. These two structures are connected by two other angle girders and two flanged plates, as shown in the illustration.

The gates are formed by connecting two $5\frac{1}{2}$ " strips with a $2\frac{1}{2}$ " strip at the outer end of the gate and a $2\frac{1}{2}$ " bent strip at the inner end, to permit the axle rods to pass through upon which the gates swing.

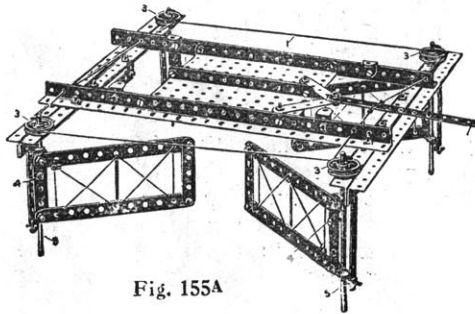

Fig. 155A

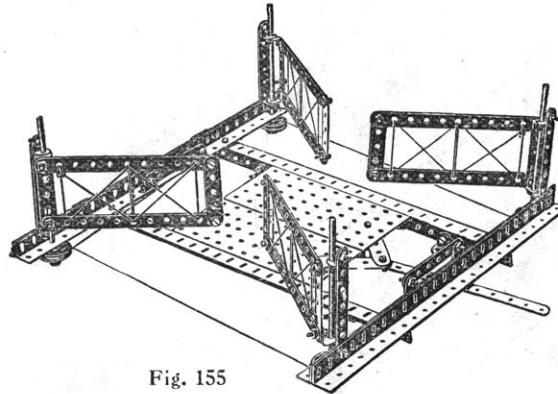

Fig. 155

Fig. 155A is an inverted view showing the arrangement of operating cord 1 which is passed from the operating lever 2, around the corner pulleys 3, and back to the lever 2. In order to obtain a better grip on the pulleys it is desirable to wind the operating cord twice around them. It is to be noted that the cord 1 is wound in opposite directions around the diagonal pairs of pulleys 3.

Pinching screws 4 are fitted in the inner sides of the gates to grip them to the spindles 5 so that all rotate together.

Pile Driver

Model No. 156

Parts Required:	
2 of No. 1	1
1 " " 3	3
2 " " 4	4
8 " " 5	5
2 " " 8	8
4 " " 12	12
4 " " 15	15
1 " " 19	19
4 " " 20	20
1 " " 21	21
1 " " 22	22
1 " " 26	26
1 " " 27A	27A
4 " " 35	35
40 " " 37	37
1 " " 45	45
1 " " 52	52
1 " " 53	53
2 " " 60	60

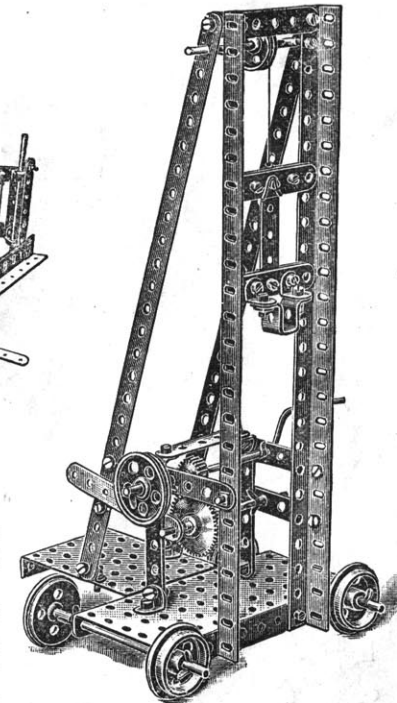

This illustration shows a model pile driver in which the pile head is guided on the two vertical angle girders. The raising of the pile head is controlled from the main driving shaft through the pinion and gear wheel. This latter is mounted on the end of the pivoted lever, and in order to drop the pile head the lever is raised to free the gear wheel. A grooved pulley is fitted on the pinion shaft to enable the model to be driven from an engine.

Model No. 157 Rotating Crane

		Parts Required:	
10 of No.	1	2 of No.	20
13 " "	2	1 " "	21
3 " "	3	1 " "	22
1 " "	4	1 " "	24
5 " "	5	2 " "	26
8 " "	8	1 " "	27A
1 " "	11	1 " "	33
12 " "	12	4 " "	35
3 " "	15	61 " "	37
2 " "	17		
1 " "	19	1 of No.	44
		1 " "	45
		2 " "	52
		1 " "	57
		4 " "	59

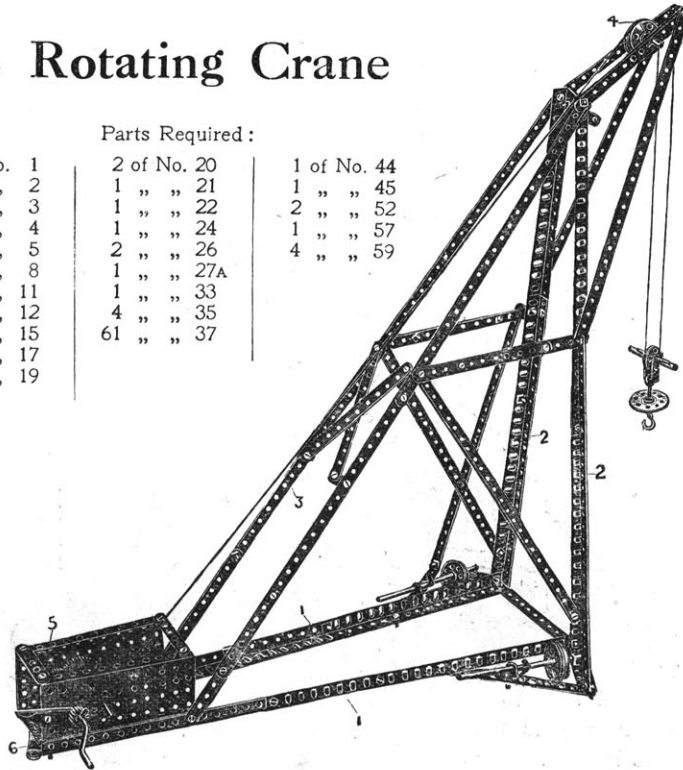

The lower horizontal ribs 1 and main vertical members 2 are made of angle girders overlapping nine holes; and the diagonal ties 3 of two $12\frac{1}{2}$ " strips and one $5\frac{1}{2}$ " strip, the $12\frac{1}{2}$ " strips being overlapped three holes, and the lower $5\frac{1}{2}$ " strip seven holes.

The pulley 4 is carried in a nosing made of two $5\frac{1}{2}$ " strips and two $12\frac{1}{2}$ " strips connected at their apex by angle brackets. The rear swivel point of the crane is made by bolting the gear box 5 to a double bent strip 6 secured to the floor. The crane runs on the flanged wheels 7, the spindles of which are secured in their position by collars and set-screws.

Inclined Delivery Chute

Model No. 158

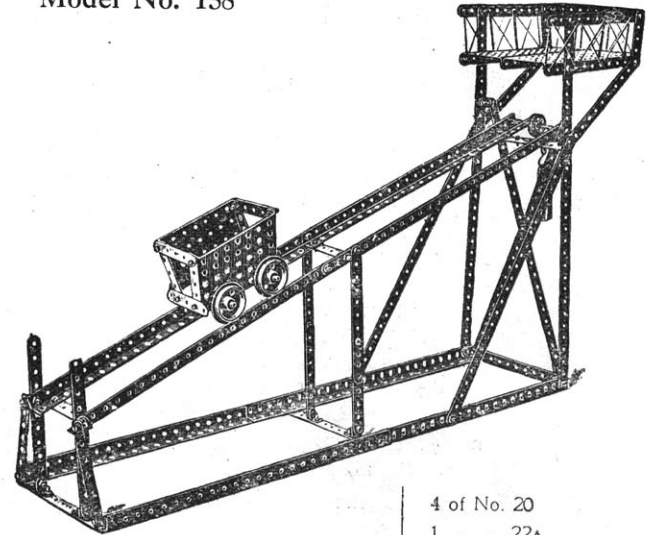

		Parts Required:	
4 of No.	20	2 of No.	4
1 " "	22A	8 " "	5
2 " "	35	8 " "	8
70 " "	37	16 " "	12
2 " "	52	4 " "	3
2 " "	53	3 " "	15
1 " "	57		

This model furnishes an illustration of the inclined plane. The loading platform at the extreme right delivers a load into the truck, which being now heavier than the balance weight, runs down the incline, and when at the bottom discharges its load by tipping. The weight immediately overcoming the empty truck returns it quickly to the loading platform.

Model No. 159 Fire Escape

Parts Required:

2 of No. 1	1 of No. 15A
4 " " 2	2 " " 19
3 " " 3	4 " " 20
2 " " 4	3 " " 22
4 " " 5	1 " " 23
4 " " 8	2 " " 26
2 " " 11	2 " " 33
18 " " 12	8 " " 35
4 " " 15	43 " " 37
	1 " " 60

In constructing this model, take two angle girders 1 and tie these together with $3\frac{1}{2}$ " strips 2 at top and bottom. $5\frac{1}{2}$ " strips 3 are then attached at right angles to one end of the frame, diagonal stays 4 tying these short strips to the angle brackets attached to the frame. The sliding ladder, Fig. 159B, is constructed from two angle girders reversed to those of the main frame, the angle girders of the sliding ladder being tied together by two $2\frac{1}{2}$ " strips, and being retained and guided in the main carriage by the short angle brackets 5 which act as clips. The framework of the running truck, Fig. 159A, is very simply constructed, and is pivotally attached by angle brackets 6 to the main frame.

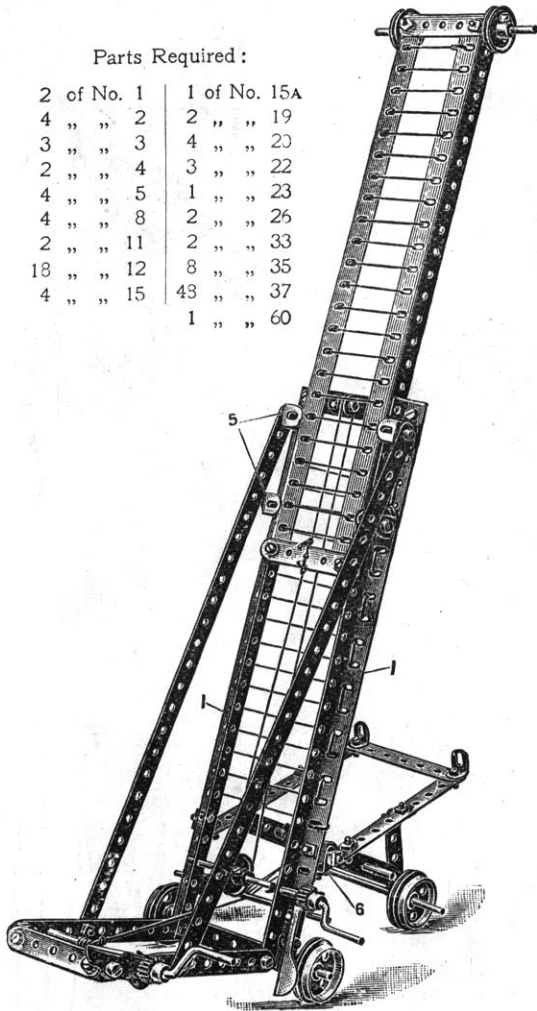

Fig. No. 159A

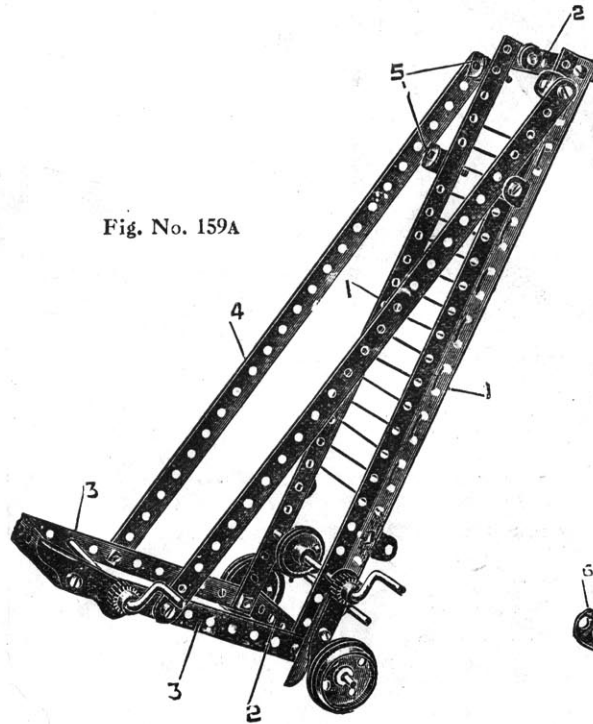
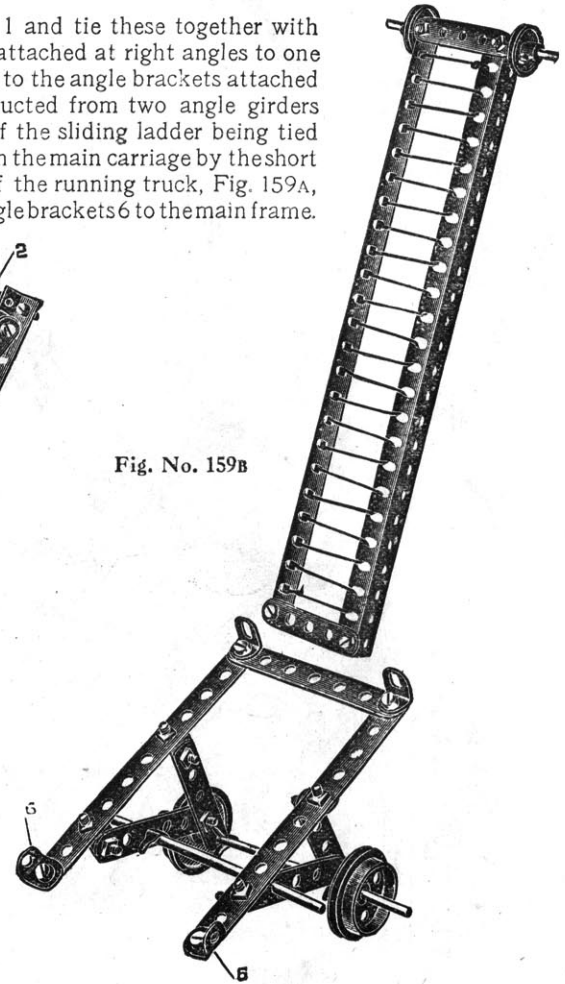

Fig. No. 159B



Model No. 160

Railway Wagon Swivel Crane

The swivelling action of this model is obtained as follows: The spindle 1 is fixed against rotation in a bush wheel 2 bolted to a cross $2\frac{1}{2}$ " bent strip 3 beneath the wagon. The pinion 4 on the spindle 1 is therefore fixed, and when the worm 5 is rotated by the cranked handle the whole crane rotates about the pinion.

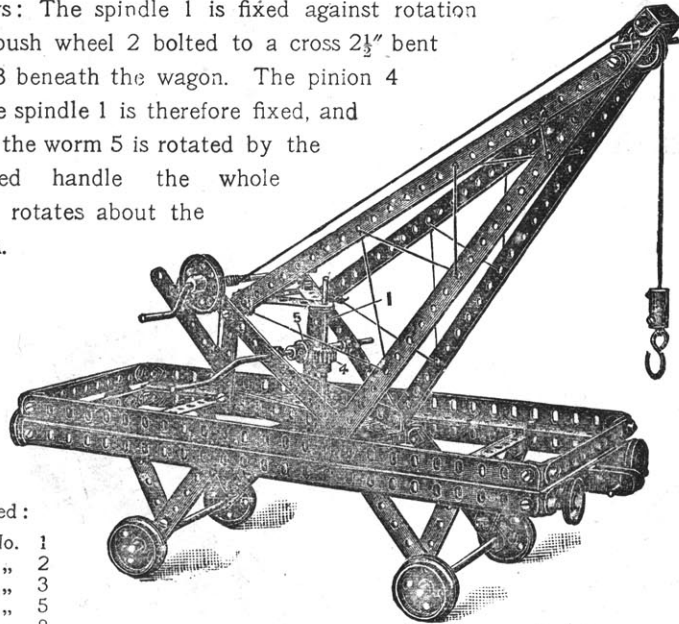

Parts Required:

4	of No.	1	
8	"	"	2
5	"	"	3
9	"	"	5
4	"	"	8
1	"	"	11
16	"	"	12
3	"	"	15
2	"	"	17
2	"	"	19
4	"	"	20
1	"	"	21
4	"	"	22
1	"	"	22A
1	"	"	24
1	"	"	26
1	"	"	32
			5 of No. 35
			69 " " 37
			1 " " 44
			1 " " 45
			1 " " 52
			1 " " 54
			1 " " 57
			2 " " 59
			2 " " 60

Parts Required:

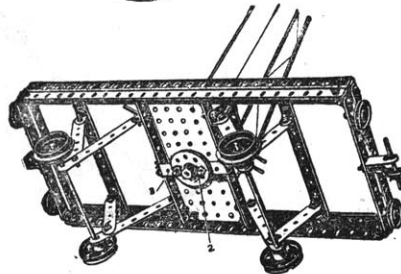
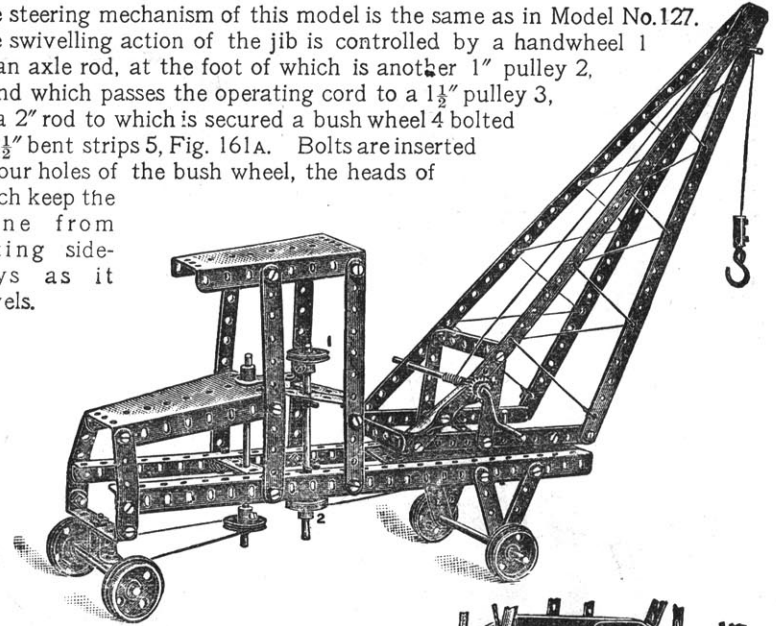

Fig. 160A

Model No. 161

Travelling Swivel Crane

The steering mechanism of this model is the same as in Model No.127. The swivelling action of the jib is controlled by a handwheel 1 on an axle rod, at the foot of which is another 1" pulley 2, round which passes the operating cord to a $1\frac{1}{2}$ " pulley 3, on a 2" rod to which is secured a bush wheel 4 bolted to $2\frac{1}{2}$ " bent strips 5, Fig. 161A. Bolts are inserted in four holes of the bush wheel, the heads of which keep the crane from tilting sideways as it swivels.



Parts Required:

4	of No.	1	2	of No.	17	6	of No.	35	
6	"	"	2	1	"	19	51	"	37
2	"	"	3	4	"	20	1	"	45
11	"	"	5	1	"	21	1	"	52
2	"	"	8	3	"	22	2	"	54
1	"	"	11	1	"	22A	1	"	57
2	"	"	12	1	"	24	6	"	60
3	"	"	15	1	"	26	1	"	62
1	"	"	16	1	"	33	1	"	63

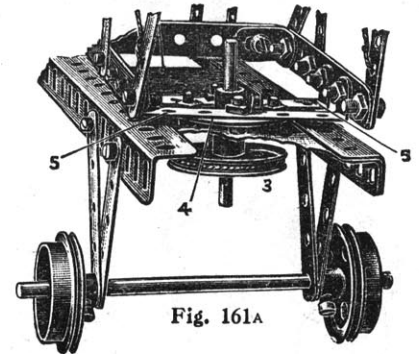

Fig. 161A

Model No. 162 Pile Driver

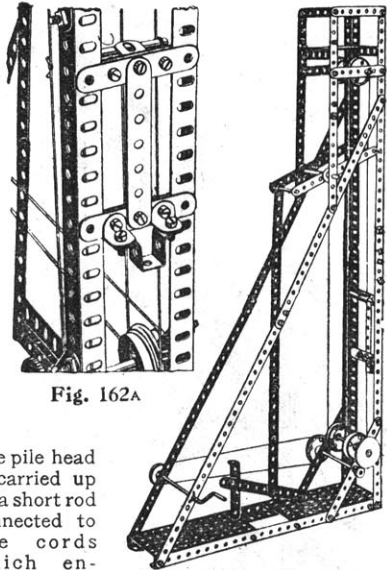

Fig. 162A

The pile head is carried up by a short rod connected to the cords which engages a catch on the head formed by an angle bracket. The short rod is disengaged from the angle bracket, being drawn away by a fixed cross rod as the short rod travels upward, and the pile head is thus released.

Parts Required:

5 of No. 1	3 of No. 15A	6 of No. 35
10 " " 2	2 " " 17	69 " " 37
6 " " 3	1 " " 19	1 " " 45
2 " " 4	4 " " 20	2 " " 52
4 " " 5	1 " " 21	1 " " 53
6 " " 8	1 " " 22	1 " " 60
6 " " 12	1 " " 26	2 " " 62
2 " " 15	1 " " 27A	

Model No. 163 Bob Sleigh

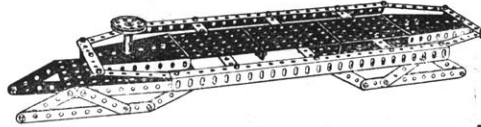

Parts Required:

7 of No. 2	1 of No. 24
6 " " 3	59 " " 37
12 " " 5	1 " " 45
2 " " 8	2 " " 52
2 " " 11	3 " " 53
1 " " 17	2 " " 54
1 " " 21	1 " " 63

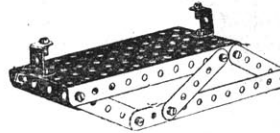
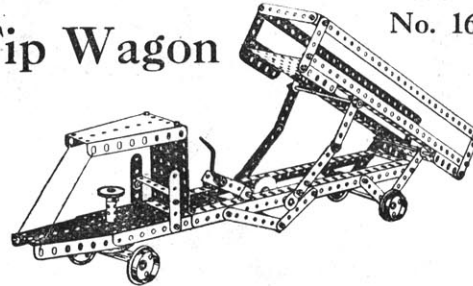

Fig. 163A

Tip Wagon



Model No. 165

Parts Required:

2 of No. 1	2 of No. 16	1 of No. 32	4 of No. 59
6 " " 3	1 " " 17	2 " " 35	4 " " 60
2 " " 4	1 " " 19	54 " " 37	2 " " 62
12 " " 5	4 " " 20	1 " " 45	1 " " 63
4 " " 8	1 " " 22	1 " " 52	
6 " " 12	1 " " 24	3 " " 53	
3 " " 15A	1 " " 27	2 " " 54	

Model No. 164

Tower Wagon

The lazy tongs are collapsed by the action of a spring 1 fixed at one end to a cross rod, and at the other to the axle rod passing through the foot of the lazy tongs which slide in the grooves.

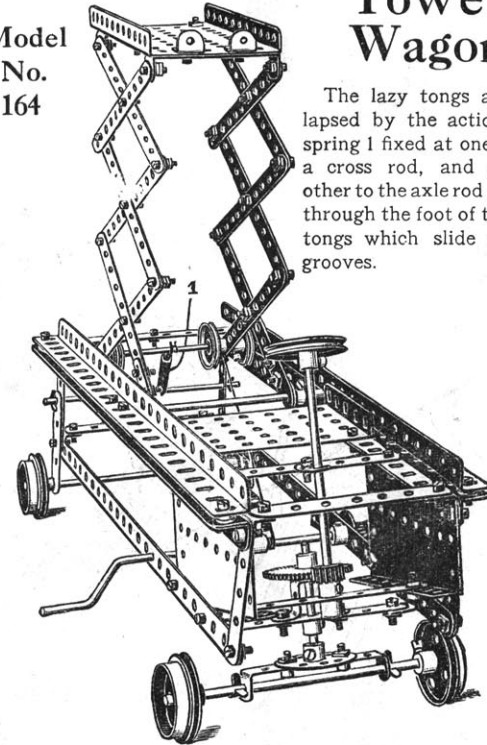

Parts Required:

2 of No. 1	3 of No. 15	4 of No. 22	1 of No. 45
12 " " 2	2 " " 15A	1 " " 24	1 " " 52
6 " " 3	1 " " 17	2 " " 26	1 " " 53
2 " " 4	1 " " 19	1 " " 27	2 " " 54
4 " " 8	4 " " 20	1 " " 33	4 " " 59
1 " " 10	1 " " 21	65 " " 37	2 " " 62
4 " " 12			

Model No. 166

Parts Required:

1 of No. 2	
2 " " 3	
8 " " 8	
3 " " 15	
3 " " 15A	
4 " " 20	4 of No. 35
1 " " 21	27 " " 37
1 " " 22	2 " " 52
1 " " 24	3 " " 53
1 " " 26	4 " " 59
1 " " 27	1 " " 62

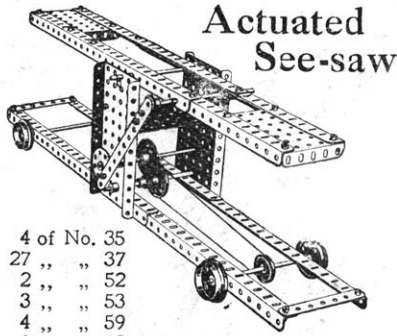

Actuated See-saw

Model No. 167 Coffee Grinder

Parts Required:

1 of No. 1	2 of No. 17
2 " " 2	1 " " 24
6 " " 3	2 " " 26
2 " " 4	28 " " 37
4 " " 5	2 " " 54
4 " " 12	4 " " 59
1 " " 15	2 " " 62
1 " " 16	

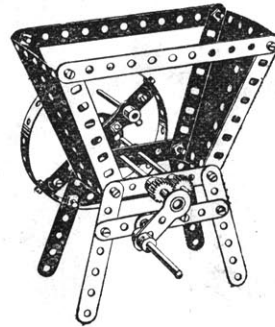

Demonstration Scales

Model No. 168

Parts Required:

5 of No. 1
10 " " 2
6 " " 3
12 " " 5
4 " " 8
2 " " 11
5 " " 12
1 " " 16
2 " " 20
1 " " 24
49 " " 37
2 " " 52
3 " " 53
2 " " 54

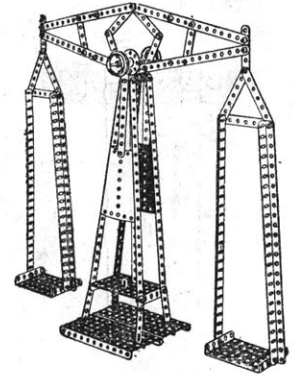

Model No. 169

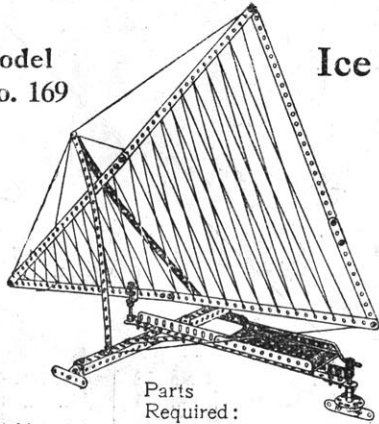

Ice Boat

Parts Required:

7 of No. 1	3 of No. 11	39 of No. 37
1 " " 2	6 " " 12	1 " " 52
2 " " 3	2 " " 17	3 " " 59
3 " " 5	1 " " 19	2 " " 62
2 " " 8	1 " " 24	1 " " 63
2 " " 10		

Model No. 170

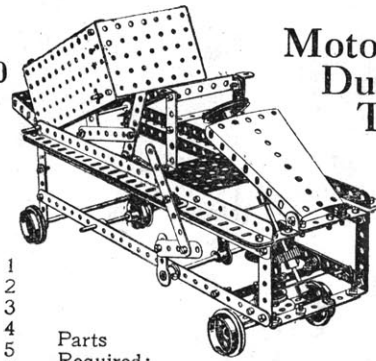

Motor Dump Truck

2 of No. 1
1 " " 2
6 " " 3
2 " " 4
11 " " 5
4 " " 8
9 " " 12
4 " " 15
2 " " 15A
1 " " 16
1 " " 17
4 " " 20
1 " " 21

Parts Required:

3 of No. 22	1 of No. 45
1 " " 23	2 " " 52
1 " " 24	3 " " 53
1 " " 26	1 " " 54
1 " " 27	4 " " 59
4 " " 35	6 " " 60
65 " " 37	2 " " 62

Model No. 171

Lawn Swing

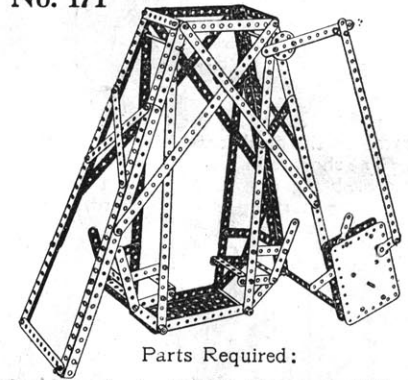

Parts Required:

9 of No. 1	2 of No. 15A	1 of No. 52
9 " " 2	2 " " 16	4 " " 59
6 " " 3	1 " " 24	6 " " 60
12 " " 5	6 " " 35	2 " " 62
8 " " 8	65 " " 37	1 " " 63

Model No. 172 Letter Balance

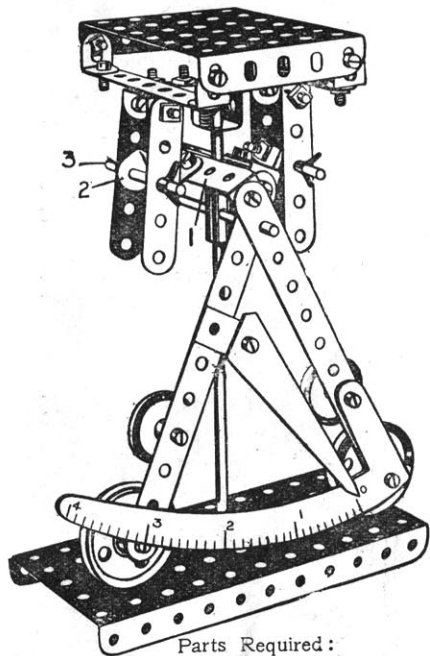

Parts Required:

2 of No. 2	2 of No. 20
2 " " 3	2 " " 22
5 " " 5	8 " " 35
2 " " 10	31 " " 37
4 " " 11	1 " " 45
4 " " 12	1 " " 52
1 " " 15	1 " " 53
1 " " 16	4 " " 60
2 " " 17	1 " " 63

Strip 1 is bolted by an angle bracket to a double bent strip 2, which forms the pivot round the rod 3.

Model No. 173 Flax Cleaner

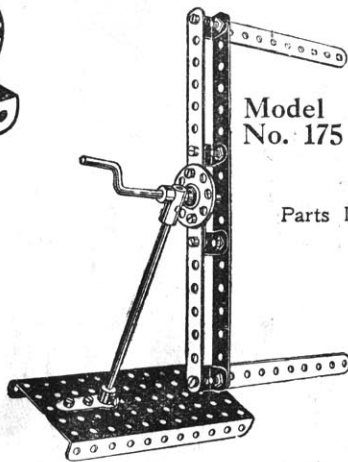
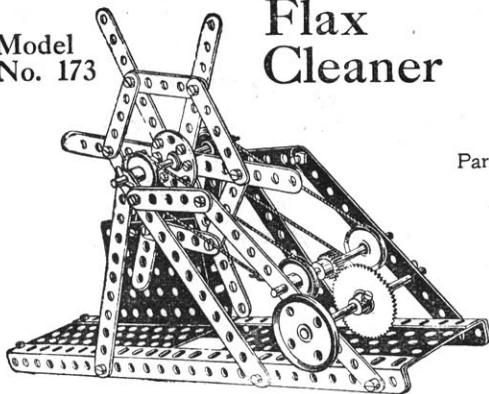

Model No. 175 Lace Jennier

Parts Required:

8 of No. 2
4 " " 11
1 " " 15
1 " " 19
1 " " 24
14 " " 37
1 " " 52
1 " " 59
1 " " 62
1 " " 63

Model No. 174 Oscillating Steam Engine

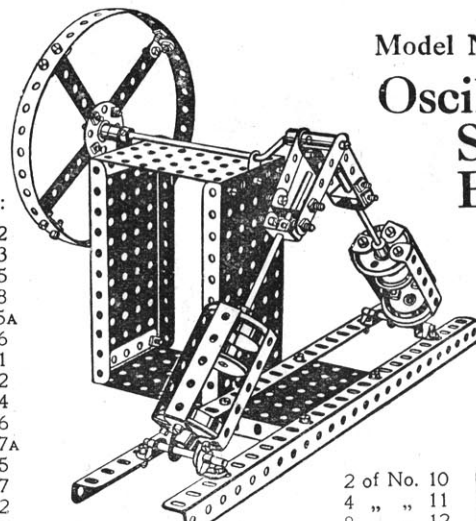

Parts Required:

6 of No. 2	2
6 " " 3	3
8 " " 5	5
2 " " 8	8
1 " " 15A	15A
2 " " 16	16
1 " " 21	21
4 " " 22	22
1 " " 24	24
1 " " 26	26
1 " " 27A	27A
3 " " 35	35
28 " " 37	37
2 " " 52	52

Parts Required:

4 of No. 20	20
2 " " 22	22
1 " " 24	24
54 " " 37	37
2 " " 52	52
3 " " 53	53
4 " " 59	59
6 " " 60	60
1 " " 63	63

2 of No. 10	10
4 " " 11	11
8 " " 12	12
2 " " 15	15
2 " " 17	17
2 " " 8	8

Perambulator

Model No. 176

Parts Required:

3 of No. 1	1	1 of No. 16
10 " " 2	2	4 " " 19A
12 " " 5	5	2 " " 22
2 " " 10	10	10 " " 35
12 " " 12	12	45 " " 37
3 " " 15A	15A	1 " " 52
		3 " " 60

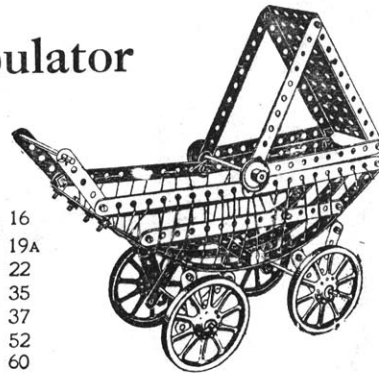

Model No. 177 "Drop the Nigger"

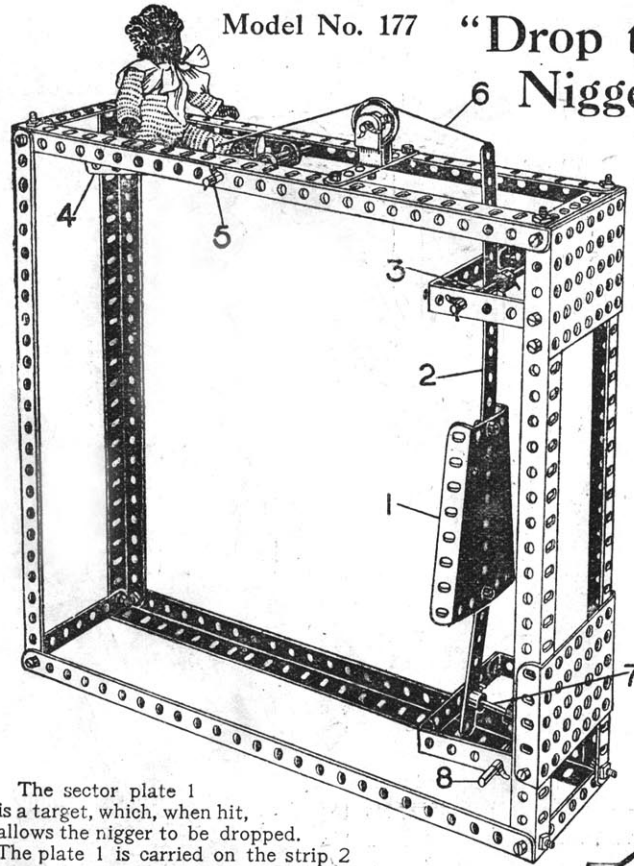

Parts Required:

1 of No.	1
6 "	3
8 "	8
1 "	12
3 "	15A
1 "	17
1 "	22
6 "	35
33 "	37
1 "	44
2 "	53
2 "	54
3 "	59
4 "	60
1 "	63

The sector plate 1 is a target, which, when hit, allows the nigger to be dropped. The plate 1 is carried on the strip 2 pivoted at 3, and the weight of the nigger supported on another sector plate 4 pivoted at 5 by means of the cord 6 keeps the lower end of the strip 2 hard against a short rod 7 pivoted at 8. When the target is hit and knocked back the rod 7 is released and falls about its pivot allowing the sector plate 4, with the nigger, to drop.

Model No. 178 Newton's Disc

This is a model to show that white light is made up of the three primary colours—red, yellow, blue. Sectors of these three colours are mounted or painted on the disc, which, if then quickly rotated, shows as white.

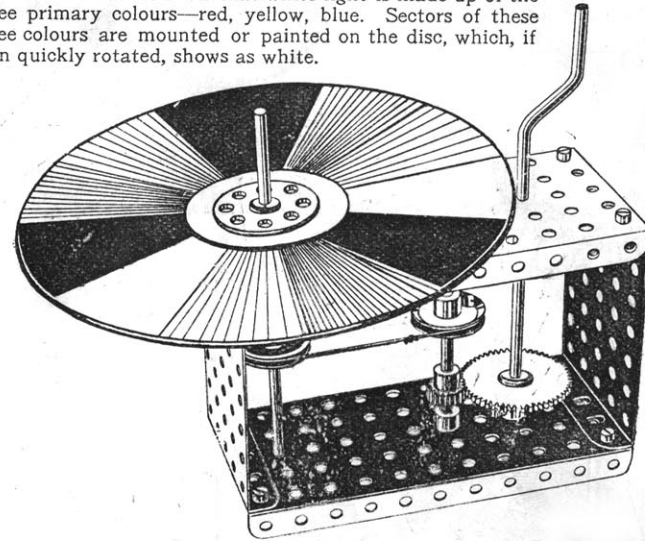

Parts Required:

1 of No.	15
1 "	15A
1 "	19
2 "	22
1 "	24
1 "	26
1 "	27
2 "	35
8 "	37
2 "	52
2 "	53
4 "	59

Model No. 179

Parts Required:

2 of No.	2
1 "	3
10 "	5
3 "	11
10 "	12

Wire Rope Maker

3 of No.	15	2 of No.	26	2 of No.	52
2 "	15A	1 "	27A	3 "	53
2 "	19	2 "	35	4 "	59
4 "	20	38 "	37	2 "	60
1 "	24	1 "	45	2 "	62

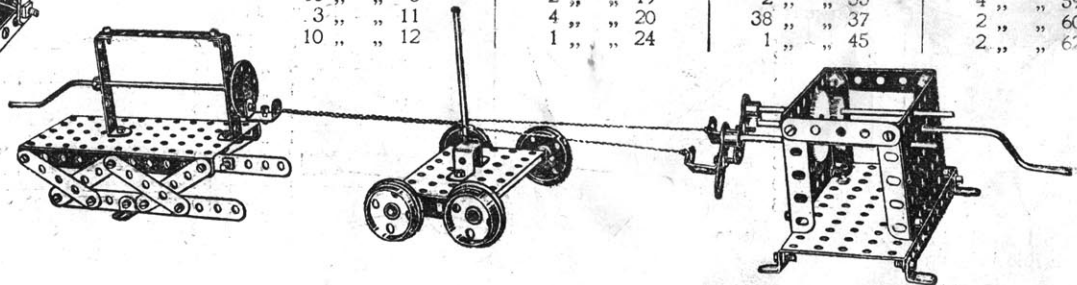

Model No. 180 Roundabout

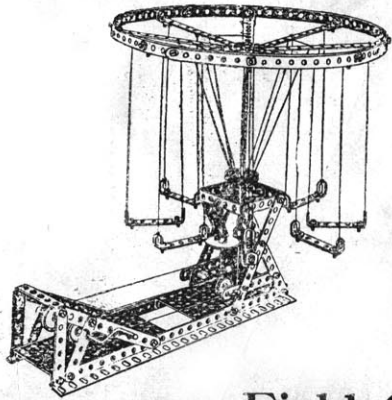

Parts Required:

3 of No. 1	4 of No. 22
14 " " 2	2 " " 26
2 " " 3	1 " " 27
2 " " 4	1 " " 32
12 " " 5	68 " " 37
2 " " 8	2 " " 52
24 " " 12	4 " " 59
3 " " 15	4 " " 60
1 " " 16	1 " " 63
1 " " 19	12 " " 38
1 " " 21	

Model No. 181 Trunk Hesister

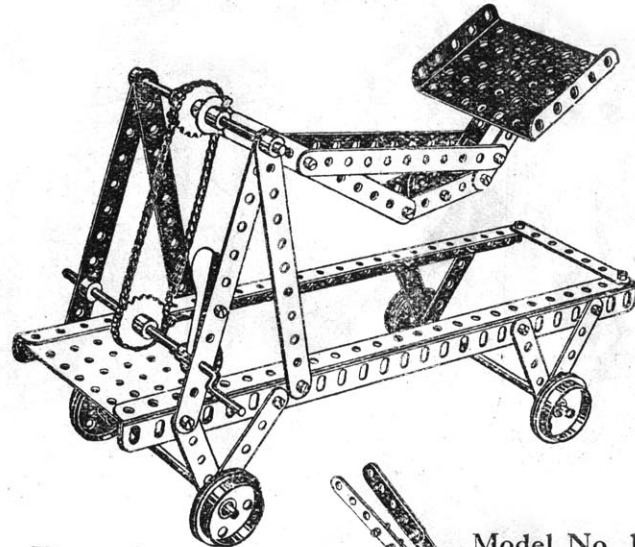

Parts Required:

8 of No. 2
1 " " 3
12 " " 5
2 " " 8
2 " " 11
2 " " 15
1 " " 15A
1 " " 19
4 " " 20
1 " " 26
1 " " 33
13 " " 37
2 " " 53
3 " " 59
2 " " 62
2 " " 96

Model No. 182 Field Gun and Carriage

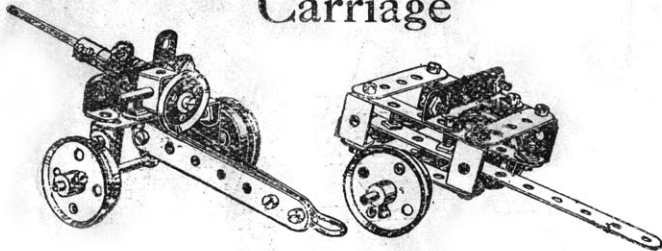

Parts Required:

1 of No. 2	2 of No. 15A	27 of No. 37
5 " " 3	1 " " 16	1 " " 45
12 " " 5	1 " " 17	1 " " 57
2 " " 10	4 " " 20	2 " " 59
4 " " 11	1 " " 22	2 " " 60
5 " " 12	1 " " 32	1 " " 63

Model No. 183 Rattle

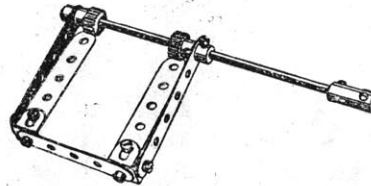

Parts Required:

2 of No. 4	2 of No. 26
3 " " 5	6 " " 37
4 " " 12	2 " " 59
1 " " 15	1 " " 63

Model No. 184 Scarifier

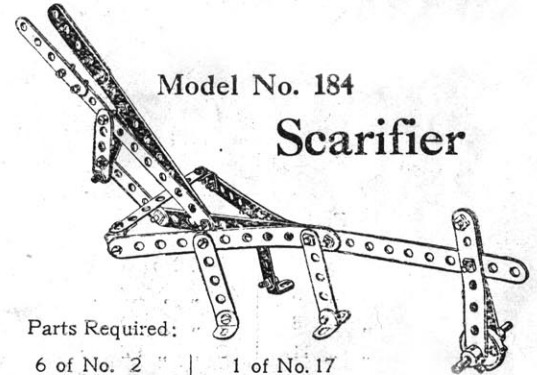

Parts Required:

6 of No. 2	1 of No. 17
3 " " 3	1 " " 22
10 " " 5	22 " " 37
6 " " 12	2 " " 59

Model
No. 185 **Swing**

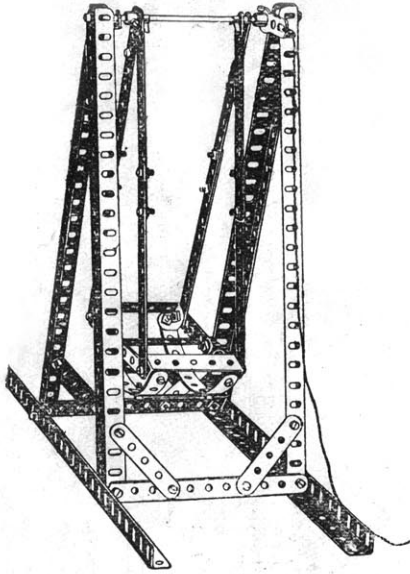

Parts Required :

12 of No. 2	1 of No 15
10 " " 5	45 " " 37
6 " " 8	4 " " 60
2 " " 11	2 " " 62
4 " " 12	

Model
No. 186 **Automatic
Swing Boat**

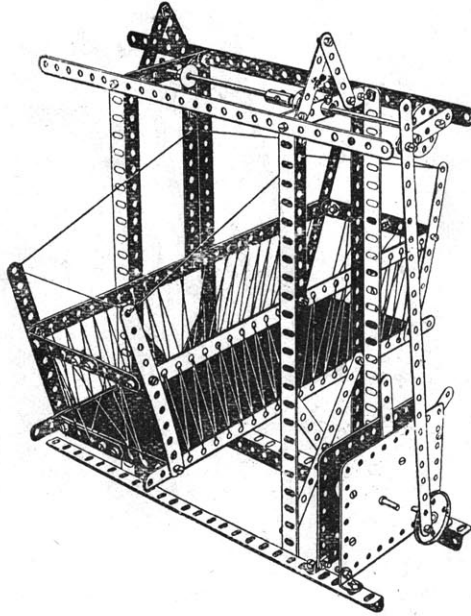

Parts Required :

7 of No. 1	1 of No. 21
10 " " 2	1 " " 24
3 " " 3	66 " " 37
12 " " 5	2 " " 59
4 " " 8	2 " " 62
12 " " 12	1 " " 63
2 " " 15	

Model
No. 187 **Swing**

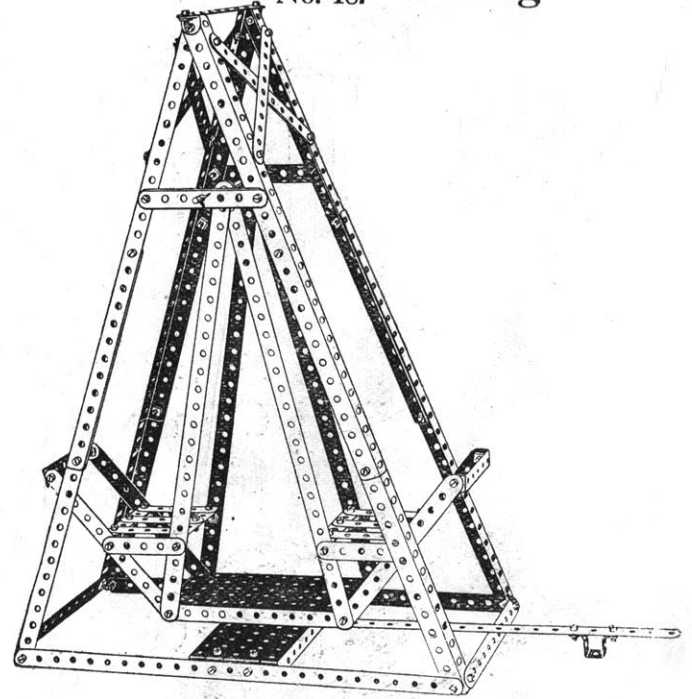

Parts Required :

7 of No. 1	1 of No. 15
11 " " 2	6 " " 35
2 " " 3	67 " " 37
10 " " 5	1 " " 45
8 " " 8	2 " " 52
6 " " 12	6 " " 60

Model No. 188 Pit Head Gear

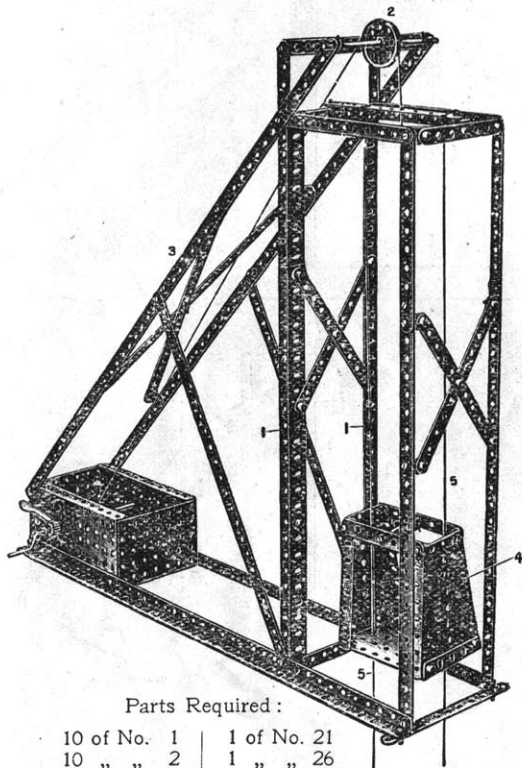

Parts Required :

10 of No. 1	1 of No. 21
10 " " 2	1 " " 26
6 " " 3	1 " " 33
4 " " 5	6 " " 35
8 " " 8	76 " " 37
1 " " 11	2 " " 52
14 " " 12	3 " " 53
1 " " 15	2 " " 54
1 " " 17	1 " " 59
1 " " 19	

Model No. 189 Locomotive Crane

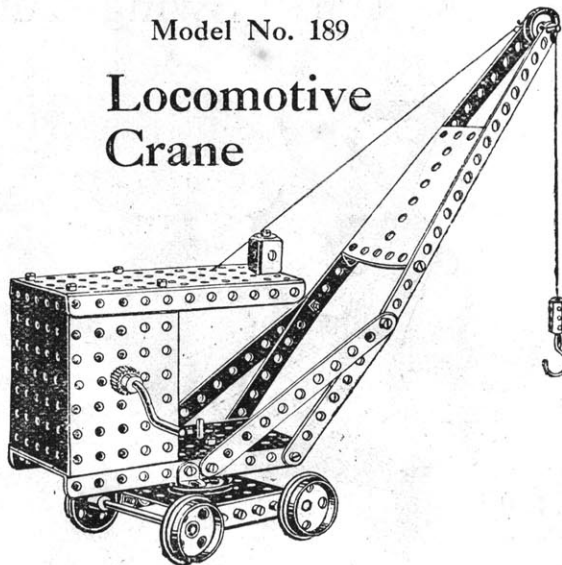

Parts Required :

2 of No. 1	1 of No. 24
2 " " 2	1 " " 26
2 " " 3	1 " " 33
3 " " 11	2 " " 35
2 " " 12	38 " " 37
2 " " 15A	2 " " 52
1 " " 17	3 " " 53
1 " " 18	1 " " 54
1 " " 19	1 " " 57
4 " " 20	2 " " 59
1 " " 21	5 " " 60
1 " " 22	1 " " 63

Model No. 190 Crane

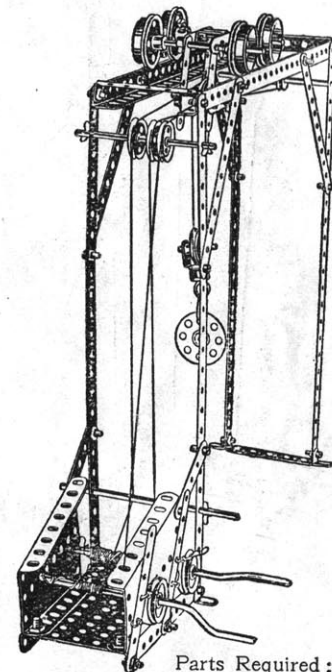

Parts Required :

4 of No. 1	4 of No. 20
6 " " 2	1 " " 21
2 " " 3	4 " " 22
10 " " 5	2 " " 22A
2 " " 8	1 " " 23
3 " " 11	1 " " 24
4 " " 12	12 " " 35
1 " " 15	32 " " 37
3 " " 15A	1 " " 44
1 " " 16	1 " " 52
1 " " 17	2 " " 54
1 " " 18	1 " " 57
2 " " 19	3 " " 60

Model No. 191

Band Saw

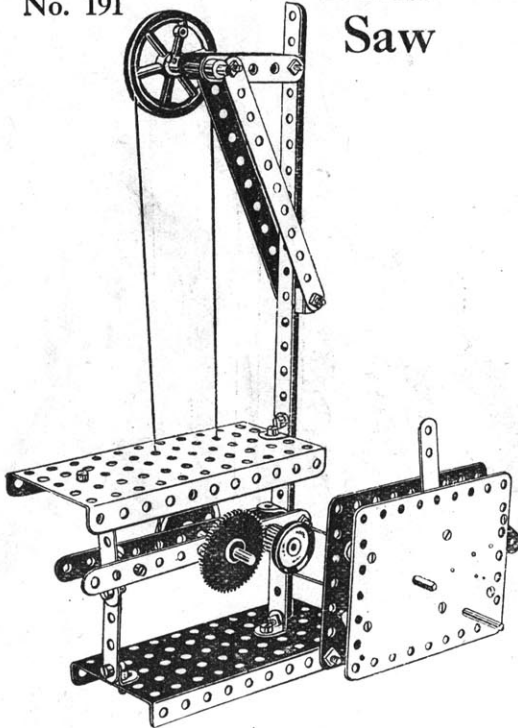

Parts Required :

4 of No. 2	2 of No. 17	1 of No. 27A
4 " " 5	1 " " 20A	21 " " 37
1 " " 8	1 " " 21	2 " " 52
3 " " 11	1 " " 22	2 " " 59
3 " " 12	1 " " 26	1 " " 60
1 " " 16		

Model No. 192 Swing Cot

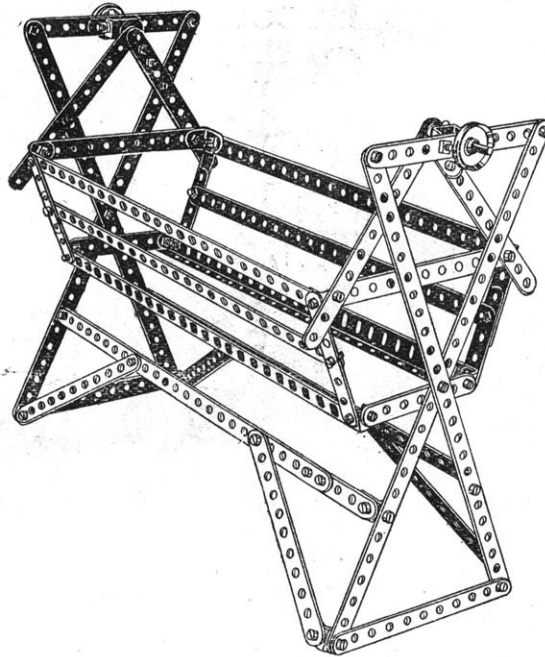

Parts Required :

10 of No. 1	20 of No. 12
14 " " 2	2 " " 17
2 " " 3	2 " " 22
8 " " 5	62 " " 37
2 " " 8	2 " " 62
2 " " 11	

Model No. 193

Hand-Punch

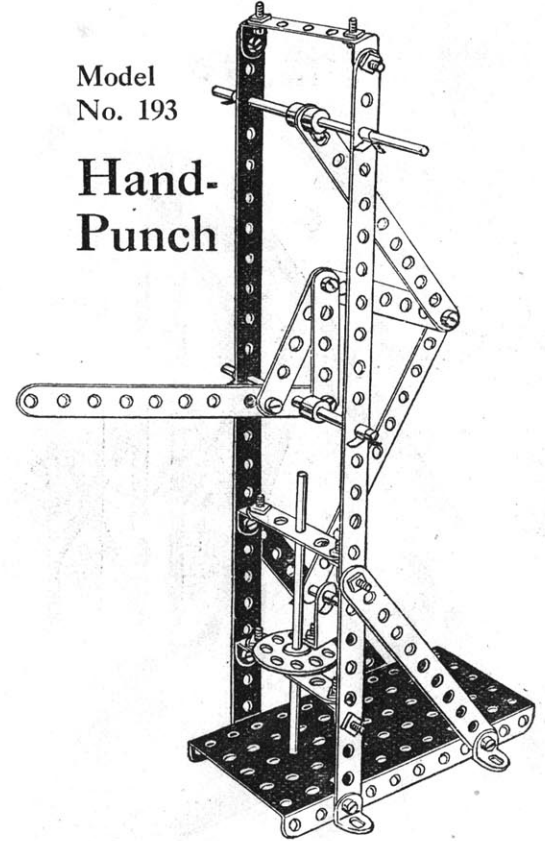

Parts Required :

2 of No. 1	1 of No. 15	23 of No. 37
5 " " 2	2 " " 16	1 " " 44
1 " " 3	1 " " 18	1 " " 52
2 " " 5	1 " " 24	4 " " 59
8 " " 12	6 " " 35	3 " " 60

Model
No. 194 **Hand Car**

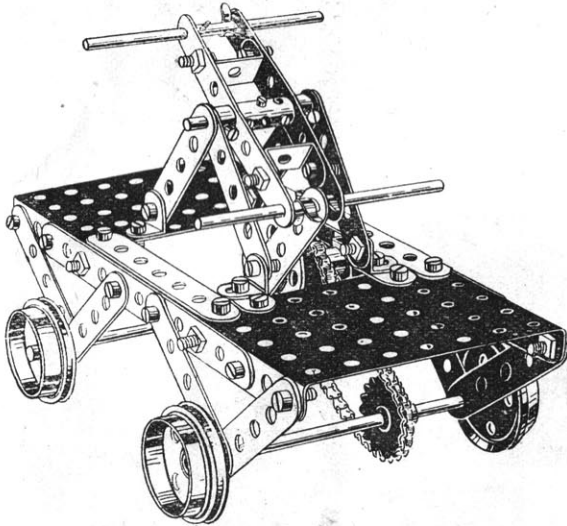

Parts Required :

2 of No. 2	2 of No. 15A	34 of No. 37
5 " " 3	2 " " 16	1 " " 45
12 " " 5	2 " " 17	2 " " 53
2 " " 10	4 " " 20	4 " " 59
2 " " 11	1 " " 24	1 " " 63
4 " " 12	4 " " 35	2 " " 96

Model
No. 195 **Oil Cake
Chopper**

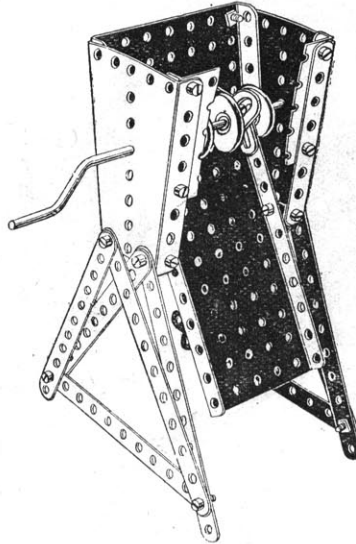

Parts Required :

10 of No. 2	20 of No. 37
4 " " 10	1 " " 52
4 " " 12	2 " " 53
1 " " 19	2 " " 54
4 " " 22	

Model
No. 196 **Rocking
Chair**

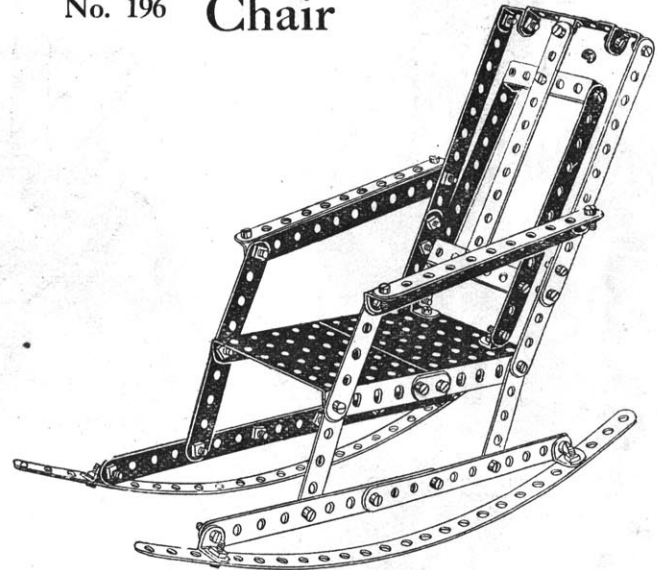

Parts Required :

2 of No. 1	2 of No. 10	48 of No. 37
13 " " 2	2 " " 11	2 " " 53
8 " " 5	11 " " 12	3 " " 60

HOW TO CONTINUE

This completes the Models which may be made with MECCANO Outfit No. 3. The next Models are a little more advanced, requiring a number of extra parts to construct them. The necessary parts are all contained in a No. 3A Accessory Outfit, the cost of which will be found in the Price List at the end of the Manual.

Standard Details for use in the Construction of Models on the Meccano Principle

A—A Brake Mechanism suitable for controlling winding or similar spindles.

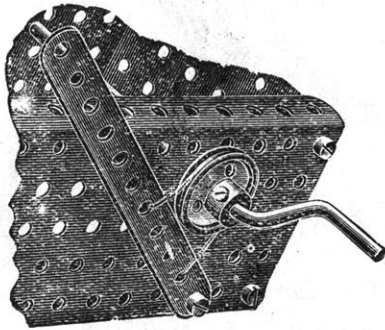

B—Type of Reversing Gear.

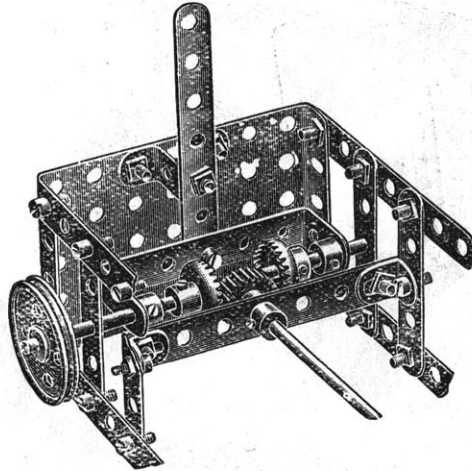

C—Worm and Worm Gear.

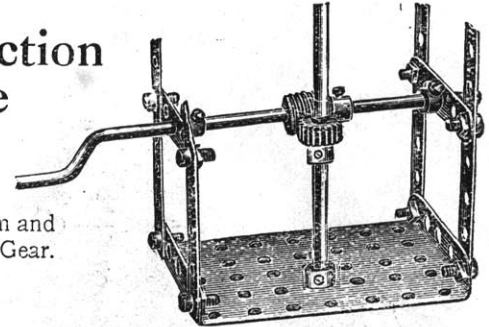

G—Method of operating a fast and loose pulley with a belt drive, one of the flanged wheels on the main shaft being secured whilst the other runs freely.

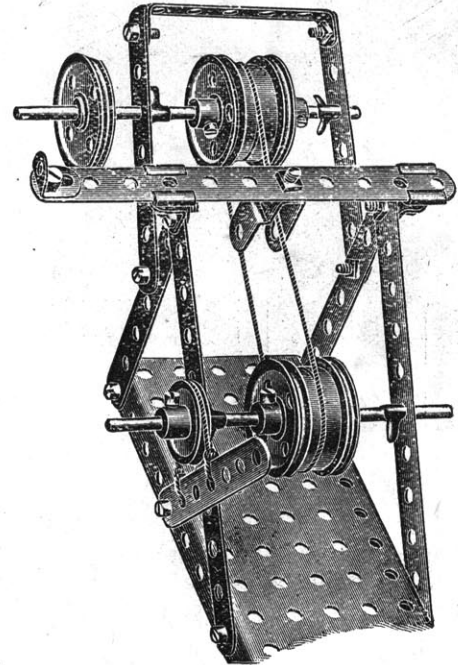

D—Method of locking swivelling connections with double nuts.

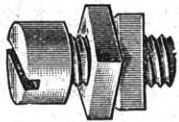

E—Pawl and Pinion or Ratchet Gear; used also as a brake.

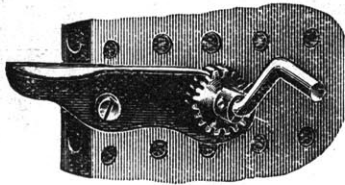

F—Spring controlled Band Friction Brake.

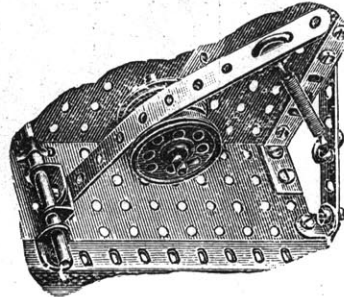

H—Simple Extended Bearing suitable for longitudinal or rotary movement of spindles.

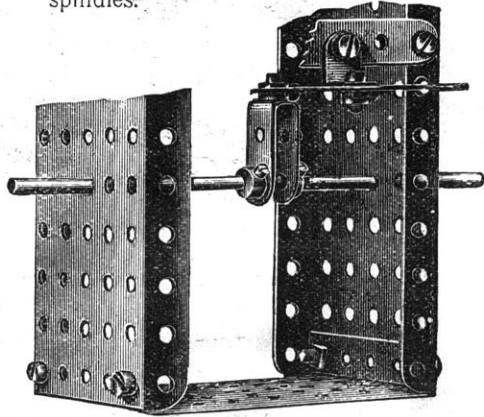

I—Gear Connection for coupling two shafts at right angles.

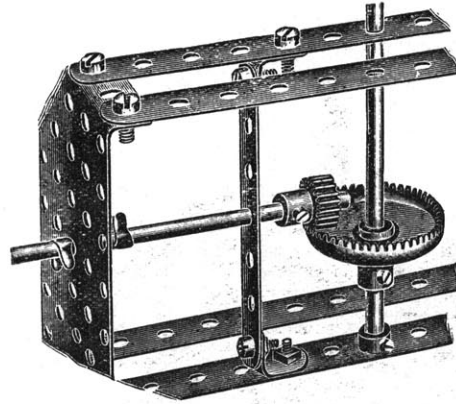

J—Purchase Pulley.

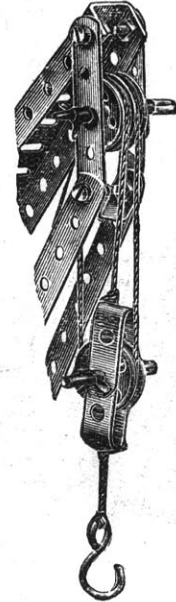

K—Swivel Bearing providing for combined sliding and oscillating movement of a strip

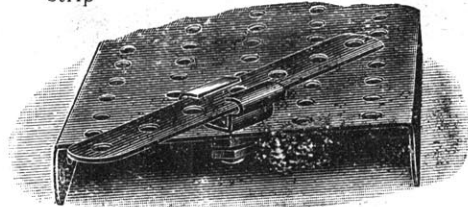

L—Jockey Pulley Arrangement for increasing grip in a driving band.

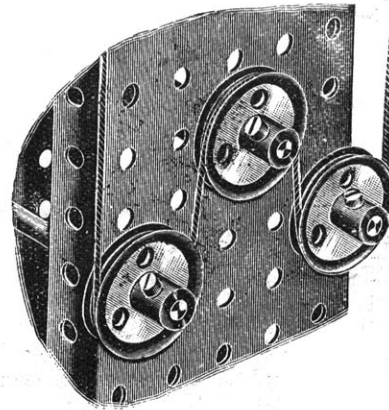

N—Crank formed with $1\frac{1}{2}$ " pulley wheel and strip, lock-nutted. (See detail D.)

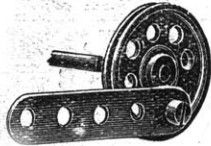

M—Reinforced Bearing for spindles.

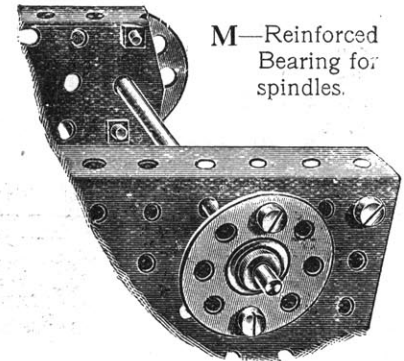

O—Extended bearing for a spindle formed by a double bent strip bolted to a perforated plate.

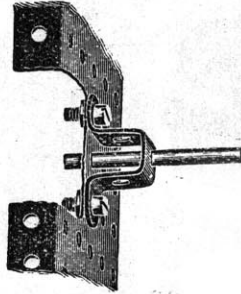

P—Footstep bearing for a vertical spindle formed by bolting a double bent strip to a perforated plate.

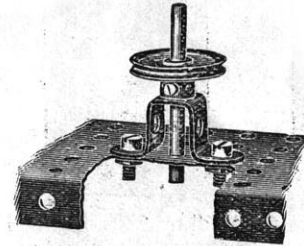

Q—Overhung support for $\frac{1}{2}$ " pulley. The bolt spindle for the pulley is nutted on each side of the angle bracket.

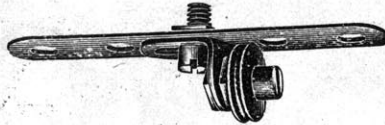

R—Overhung support for larger pulley. The screwed end of the bolt is entered in the wheel boss and nipped by the set screw.



The Meccano Electric Motor

This is the Meccano Electric Motor—the most powerful and reliable toy electric motor made. It runs Elevators, Sawmills, Lathes, or any other Meccano models. It has been tested to lift 30lbs. dead weight when properly geared. Two or three dry batteries will run it but accumulators are more satisfactory. Direct shaft drive; positive and powerful. Interchangeable gearing. It puts action into Meccano models; makes them operate like real machinery.

The Meccano Spring Motor

THE MECCANO SPRING MOTOR contains its own motive power in a simple and convenient form. It can be built into, and becomes part of, the model it drives.

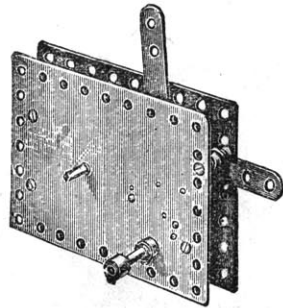

The No. 1 Meccano Spring Motor may be used in connection with a very large number of Meccano models. It has a stopping and starting motion, and the movement can be reversed. Price 12/6

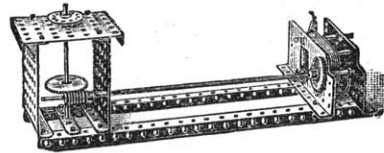

Showing the application of the Electric motor to such models as the Roundabout, Maxim Flying Machine, &c.

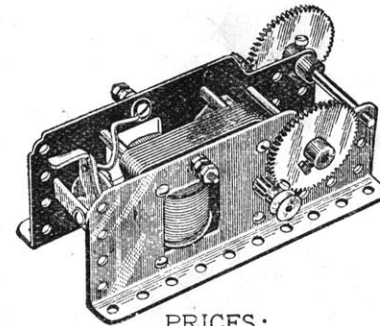

PRICES:

Without reversing mechanism .. 10/-
With reversing mechanism .. 15/-

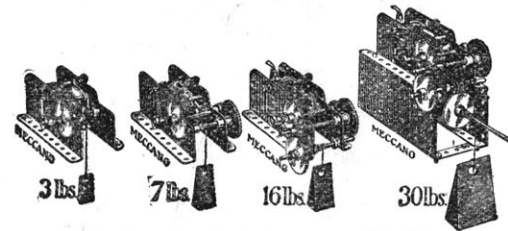

This illustration shows a combination of gears built from Meccano parts on to the Electric Motor itself, the drive being direct from the Armature Spindle. Note how a slow drive and substantial lifting power are secured. In this case three dry batteries (approximately four volts) were used.

Just a hint on the use of the non-reversing electric motor. When it is fitted to a crane or an elevator it is a good plan to secure a collar to the shaft, on the inside of the plate nearest the large gear wheel, allowing about $\frac{1}{4}$ in. play. When the load has reached the top the rod may be slid along sufficiently to throw the big gear wheel out of gear with the pinion, thus allowing the load to be released.

Particulars and Prices of Meccano Parts

			
No.		s.	d.
1.	Perforated Strips, 12 $\frac{1}{2}$ " long ..	$\frac{1}{2}$ doz.	1 3
2.	" " 5 $\frac{1}{2}$ " " ..	"	0 9
3.	" " 3 $\frac{1}{2}$ " " ..	"	0 5
4.	" " 3" " ..	"	0 4
5.	" " 2 $\frac{1}{2}$ " " ..	"	0 4
6.	" " 2" " ..	"	0 4
6A.	" " 1 $\frac{1}{2}$ " " ..	"	0 3

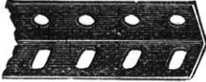
			
8.	Angle Girders, 12 $\frac{1}{2}$ " long ..	$\frac{1}{2}$ doz.	2 3
9.	" " 5 $\frac{1}{2}$ " " ..	"	1 3

			
10.	Flat Brackets	$\frac{1}{2}$ doz.	0 3

			
11.	Double Brackets	each	0 1



			
12.	Angle Brackets	doz.	0 6

			
13.	Silver Steel Axle Rods, 11 $\frac{1}{2}$ " long, each		0 5
13A.	Axle Rods 8" long	"	0 3
14.	" 6" "	"	0 2
15.	" 5" "	"	0 2
15A.	" 4 $\frac{1}{2}$ " "	"	0 2
16.	" 3 $\frac{1}{2}$ " "	"	0 1
17.	" 2 $\frac{1}{2}$ " "	"	0 1
18.	" 1" "	"	0 1

			
19.	Crank Handles	each	0 3

			
No.		s.	d.
19A.	Wheels, 3" diam.	each	0 8
19B.	Pulley Wheels, 3in. diam. with set screw	each	1 3

			
20.	Flanged Wheels	each	0 9

			
			
	Pulley Wheels.		
20A.	2" diam., with set screw ..	each	1 0
21.	1 $\frac{1}{2}$ " " " " ..	"	0 9
22.	1" " " " ..	"	0 6
22A.	1" " without " ..	"	0 3
23.	$\frac{1}{2}$ " " " " ..	"	0 2
23A.	$\frac{1}{2}$ " " with " ..	"	0 6

			
24.	Bush Wheels	each	0 8

			
25.	Pinion Wheels, $\frac{3}{8}$ " diam. ..	each	1 3
26.	" " $\frac{1}{2}$ " " ..	"	0 9

			
	Gear Wheels.		
27.	50 teeth to gear with $\frac{3}{8}$ " pinion ..	each	0 10
27A.	56 " " " $\frac{1}{2}$ " " ..	"	1 0

			
No.		s.	d.
28.	Contrate Wheels, 1 $\frac{1}{2}$ " diam. ...	each	1 3
29.	" " $\frac{1}{4}$ " " ..	"	1 0

			
32.	Worm Wheels	each	0 10

			
33.	Pawls	each	0 3





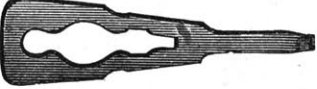

			
34.	Spanners	each	0 3





			
35.	Spring Clips	per box (doz.)	0 6



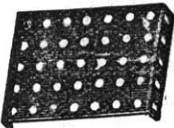
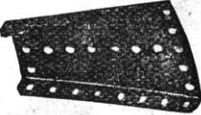
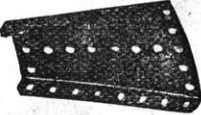

			
36.	Screw Drivers	each	0 3
36A.	" " special	"	1 3

			
37.	Nuts and Bolts	per box (doz.)	0 6
37A.	Nuts	"	0 3
38.	Washers	doz.	0 2
40.	Hanks of Cord	two for	0 3

Particulars and Prices of Meccano Parts (continued)

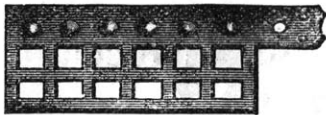
No.		s	d.
41.	 Propeller Blades per pair	0	6
43.	 Springs each	0	2
44.	 Cranked Bent Strips each	0	2
45.	 Double Bent Strips each	0	2
46.	 Large Bent Strips each	0	3
47A.	 Dynamometers (tension) each	2	6
50.	 Eye Pieces each	0	2

No.		s	d.
52.	 Perforated Flanged Plates, 5½" x 2½" each	0	6
53.	 Perforated Flanged Plates, 3½" x 2½" each	0	5
54.	 Perforated Sector Plates .. each	0	5
56.	Instruction Manuals "	2	6
56A.	" " No. 2 "	1	3
57.	 Hooks each	0	1
57A.	" (scientific) "	0	1
58.	 Spring Cord per length	1	0
59.	 Collars with Set Screws .. each	0	3
60.	 Bent Strips, 2½" long .. per ½ doz.	0	9

No.		s	d.
61.	 Windmill Sails each	0	3
62.	 Cranks each	0	6
63.	 Couplings each	0	9
65.	Centre Forks "	0	3
66.	Weights, 50 gramme "	0	6
67.	" 25 "	0	4
68.	Wood Screws, ½" doz.	0	3
69.	Set Screws "	0	4
69A.	Grub Screws "	0	4
94.	Sprocket Chain per yard	1	0
95.	 Sprocket Wheels, 2" diam. .. each	0	6
96.	" " 1" "	0	4
97.	 Braced Girders, 3½" long .. ½ doz.	0	9
98.	" " 2½" "	0	6
99.	" " 12½" "	1	9
100.	" " 5½" "	1	0
101.	Healds, for Looms .. doz.	0	9
102.	Single Bent Strips .. each	0	2
103.	5½" Flat Girders "	0	2
104.	Shuttles.. "	1	0
105.	Reed Hooks "	0	3
106.	Rollers "	0	6
107.	Tables, for Designing Machines ..	1	0

Price List

No. 0.	Meccano Outfit	6/-
No. 1.	”	”	10/-
No. 2.	”	”	20/-
No. 3.	”	”	30/-
No. 4.	”	”	50/-
No. 5.	”	”	70/-
Do.	”	Presentation Outfit					Packed in neat and well-made cardboard box	100/-
No. 6.	”	”	”				Ditto ditto ditto	180/-
No. 0A.	Meccano Accessory Outfit						(containing sufficient parts to convert a Meccano No. 0 Outfit into a No. 1)	5/-
No. 1A.	”	”	”				(containing sufficient parts to convert a No. 1 Outfit into a No. 2)	11/-
No. 2A.	”	”	”				(containing sufficient parts to convert a No. 2 Outfit into a No. 3)	12/-
No. 3A.	”	”	”				(containing sufficient parts to convert a No. 3 Outfit into a No. 4)	22/-
No. 4A.	”	”	”				(containing sufficient parts to convert a No. 4 Outfit into a No. 5)	17/6
No. 5A.	”	”	”				(containing sufficient parts to convert a No. 5 Outfit into a No. 6)	65/-
Do.	”	”	”				Packed in neat and well-made cardboard box	95/-
	Meccano Inventors' Accessory Outfit						Packed in superior oak cabinet with lock and key	10/-

Contents of Outfits

No.	DESCRIPTION OF PARTS.	0	0A	1	1A	2	2A	3	3A	4	4A	5	5A	6
1	Perforated Strips, 12 $\frac{1}{2}$ "	4	4	6	10	..	10	4	14	..	14	34	48
2	" " 5 $\frac{1}{2}$ " ..	4	2	6	10	16	2	18	4	22	4	26	34	60
3	" " 3 $\frac{1}{2}$ "	1	1	1	2	4	6	..	6	11	17	19	36
4	" " 3"	2	2	2	4	6	10	14	24
5	" " 2 $\frac{1}{2}$ " ..	9	..	9	3	12	..	12	8	20	24	44	4	48
6	" " 2"	6	6	18	24
8	Perforated Angle Girders, 12 $\frac{1}{2}$ "	4	4	4	8	..	8	4	12	12	24
9	" " 5 $\frac{1}{2}$ "	16	16
10	Flat Brackets ..	4	..	4	..	4	..	4	4	8	..	8	8	16
11	Double Brackets	1	1	3	4	..	4	4	4	..	4	12	16
12	Angle Brackets ..	8	4	12	..	12	..	24	12	36	17	53	67	120
13	Rods, 11 $\frac{1}{2}$ "	2	2	..	2	2	4
13A	" " 8"	2	2
14	" " 6"	2	2	..	2	6	8
15	" " 5"	3	3	1	4	..	4	..	4	4	4
15A	" " 4 $\frac{1}{2}$ "	3	3	1	3	..	3	..	3	1	4
16	" " 3 $\frac{1}{2}$ " ..	2	1	3	1	1	1	2	2	4	..	4	4	4
17	" " 2" ..	2	..	2	..	2	..	2	2	4	..	4	3	7
18	" " 1"	1	1	..	1	1	2	1	2	..	2	2	2
19	Crank Handles ..	1	..	1	..	1	..	1	1	3	..	3	1	4
20	Flanged Wheels	4	4	..	4	4	8	..	8	8	8
21	Pulley Wheels, 1 $\frac{1}{2}$ "	4	..	4	..	1	1	1	1	2	1	2
22	" " 1" (fast) ..	4	..	4	..	4	..	4	..	4	..	4	1	5
22A	" " 1" (loose)	2	2	..	2	..	2	..	2	..	2	1	3
23	" " $\frac{3}{8}$ " ..	1	..	1	..	1	..	1	..	1	..	1	3	5
24	Bush Wheels	2	6
25	Pinion Wheels, $\frac{3}{8}$ "	2	5
26	" " $\frac{1}{2}$ "	2	5
27	Gear Wheels, 50 teeth	2	2	..	2	1	3	2	5
27A	" " 56 teeth	1	1	..	1	1	2	1	2
28	Contrate Wheels, 1 $\frac{1}{2}$ "	2	2	..	2	1	2
29	" " $\frac{3}{4}$ "	1	2
32	Worm Wheels	2
33	Fawls	2	2	..	2	..	2	..	2
34	Spanners	1	1	..	1	..	1	1	2	..	2	..	2
35	Spring Clips ..	4	2	6	..	6	6	12	6	18	..	18	6	24
36	Screwdrivers ..	1	..	1	..	1	..	1	..	1	..	1	1	2
37	Nuts and Bolts ..	25	5	30	25	55	25	80	50	130	45	175	290	465
40	Hanks of Cord	1	1	1	2	1	3	1	4	..	6	..	6
41	Propeller Blades	2
43	Springs	1	1	1	1	1	2
44	Cranked Bent Strips ..	1	..	1	..	1	..	1	1	1	1	2	1	2
45	Double Bent Strips	1	1	..	1	1	2	..	2	2	4
46	Large Bent Strips	1	1	2	3	1	4
50	Eye Pieces	1	1	1	2	1	2	2	4	4	8
52	Perforated Flanged Plates, 5 $\frac{1}{2}$ " x 2 $\frac{1}{2}$ " ..	1	..	1	..	1	3	3	1	4	1	5	3	8
53	" " 3 $\frac{1}{2}$ " x 2 $\frac{1}{2}$ "	1	1	3	3	1	4
54	" " Sector Plates ..	1	1	2	..	2	..	2	1	3	..	3	1	4
56	Manual of Instructions ..	1	1	1	..	1	..	1	..	1	..	1	1	2
57	Hooks	2
58	Spring Cord	1
59	Collars with Set Screws	4	4	4	8	..	8	10	18
60	Bent Strips, 2 $\frac{1}{2}$ " ..	2	2	4	2	6	4	6	2	8	1	9	7	16
61	Windmill Sails	4	4	..	4	4	4	..	4	2	3
62	Cranks	2	2	..	2	..	2	..	2	1	8
63	Couplings	1	1	..	1	..	1	1	1
65	Centre Fork	1
94	Sprocket Chain (length)	1

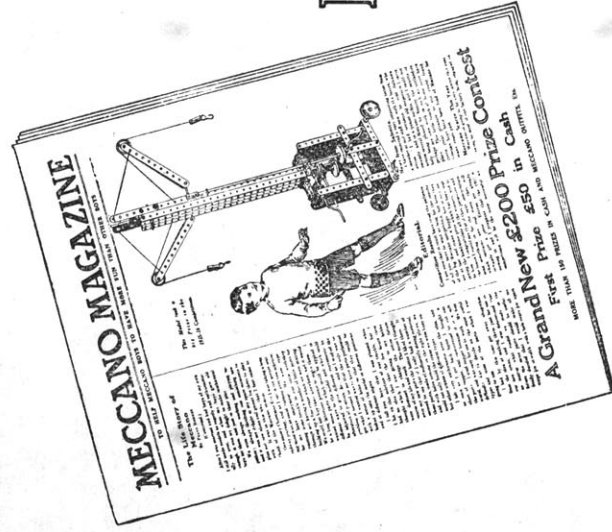

More Fun for you, Boys!

IF you are not a regular reader of the Meccano Magazine, you are not enjoying building with Meccano as much as you should. It is a splendid, brightly-written publication, in which Mr. Frank Hornby, the inventor of Meccano, is now writing the life story of the hobby which has become famous all over the world. It also contains illustrations of fine new Meccano prize models which every boy wants to build; articles by well-known writers; essays by Meccano boys, with their photographs; announcements and results of the various Meccano competitions which are always running, and which every Meccano boy should enter; helps and hints to Meccano boys, with replies to their letters by the Editor. Your first copy will be sent to you free on receipt of a request from you, but if you wish to receive it regularly you should send 2d. in stamps to the Editor, Meccano Works, Binns Road, Liverpool, for postage on the next four issues. A double subscription of 4d. will, of course, insure you receiving the next eight issues.

THE EDITOR OF THE MECCANO MAGAZINE IS
WAITING FOR A LETTER FROM YOU

MECCANO IS MORE THAN A TOY

It is important to remember that when a boy is playing with Meccano he is using engineering parts in miniature, and that these parts act in precisely the same way as the corresponding engineering elements would do in actual practice. No other system of model construction could, therefore, be correct. Other toys which attempt the same object by other methods must avail themselves of other constructive elements which are not correct engineering elements. Consequently, though a boy may succeed in building playthings with them, they are merely toys, and nothing else, and his mind, as regards proper mechanical construction and methods, is distorted instead of instructed. He thus learns wrong principles, and when his ambition tempts him to invent or construct more elaborate models he will be stopped by the deficiencies of his non-mechanical system.

**No Outfit is genuine unless it bears the
trade mark MECCANO**