

# MECCANO



(TRADE MARK 296321)

## INSTRUCTIONS

BOOK No. 2.

Price 1/3.

Copyright by MECCANO LIMITED, LIVERPOOL, throughout the World

No. 20

ENGLISH EDITION

No 1	Messico	100
No 2	"	100
No 3	"	100
No 4	"	100
No 5	"	100
No 6	"	100
No 7	"	100
No 8	"	100
No 9	"	100
No 10	"	100
No 11	"	100
No 12	"	100
No 13	"	100
No 14	"	100
No 15	"	100
No 16	"	100
No 17	"	100
No 18	"	100
No 19	"	100
No 20	"	100
No 21	"	100
No 22	"	100
No 23	"	100
No 24	"	100
No 25	"	100
No 26	"	100
No 27	"	100
No 28	"	100
No 29	"	100
No 30	"	100
No 31	"	100
No 32	"	100
No 33	"	100
No 34	"	100
No 35	"	100
No 36	"	100
No 37	"	100
No 38	"	100
No 39	"	100
No 40	"	100
No 41	"	100
No 42	"	100
No 43	"	100
No 44	"	100
No 45	"	100
No 46	"	100
No 47	"	100
No 48	"	100
No 49	"	100
No 50	"	100
No 51	"	100
No 52	"	100
No 53	"	100
No 54	"	100
No 55	"	100
No 56	"	100
No 57	"	100
No 58	"	100
No 59	"	100
No 60	"	100
No 61	"	100
No 62	"	100
No 63	"	100
No 64	"	100
No 65	"	100
No 66	"	100
No 67	"	100
No 68	"	100
No 69	"	100
No 70	"	100
No 71	"	100
No 72	"	100
No 73	"	100
No 74	"	100
No 75	"	100
No 76	"	100
No 77	"	100
No 78	"	100
No 79	"	100
No 80	"	100
No 81	"	100
No 82	"	100
No 83	"	100
No 84	"	100
No 85	"	100
No 86	"	100
No 87	"	100
No 88	"	100
No 89	"	100
No 90	"	100
No 91	"	100
No 92	"	100
No 93	"	100
No 94	"	100
No 95	"	100
No 96	"	100
No 97	"	100
No 98	"	100
No 99	"	100
No 100	"	100

PLATE 121

# MECCANO

Hornby's Original System, First Patented 1901

PATENTS & DESIGNS,  
GREAT BRITAIN:

577,272

577,207

648,958

22,962-13

20,535-13

21,117-12

4564-15

2085-11

4183-14

3869-14

103,537-17

PATENTED THROUGHOUT THE WORLD



## 100 New Meccano Models

THIS book contains an entirely new series of Meccano Models, and it forms a splendid addition to the regular 140 page Meccano Manual, with its 326 models. Many of the new models have been designed by our own staff of skilled model builders, who are experimenting with new parts and models all the time; others have been suggested by men whose profession is engineering, and whose hobby is Meccano model building; many of them are the pick of the models which have been sent in to compete for the big prizes in the Grand

## 100 New Meccano Models—continued

Meccano Competitions. We have hundreds more new models which are being perfected, and all Meccano boys should look out for these in future editions of the Meccano Manual.

### MECCANO FOR SCIENTIFIC BOYS

The scientific and educational side of Meccano is going ahead at a great pace. Boys everywhere are using Meccano to make experiments in mechanical problems, and teachers are finding in it an easy and effective means of imparting engineering knowledge to students. We are illustrating in this manual a few choice scientific examples which any boy will find pleasure in constructing, whether he is interested in mechanics or not.

### THE MECCANO MAGAZINE



If you are not a regular reader of the *Meccano Magazine*, you are missing a lot of the fun of the Meccano hobby. It contains all kinds of useful "tips" to Meccano boys on model-building, essays and letters from Meccano boys, useful articles written specially for boys, announcements of new competitions and lists of prize-winners. It is a live magazine for live boys. Write to the Editor, *Meccano Magazine*, Binns Road, Liverpool, for a specimen copy, which will be sent to you free. The next eight issues will be sent to you gratis on receipt of 8d. in stamps to cover postage.

**IMPORTANT NOTICE.**—In some of the models throughout this manual we have made use of the Meccano Braced Girder, large wheels, sprocket wheels and chain, etc., which are only supplied in the Inventor's Accessory Outfit, or as separate parts. We have employed these parts, as they improve the appearance and working of the models, and they also form a suggestion for the use of the Inventor's Accessory Outfit; but in every case the same models may be effectively built with the parts contained in the regular Meccano outfits.

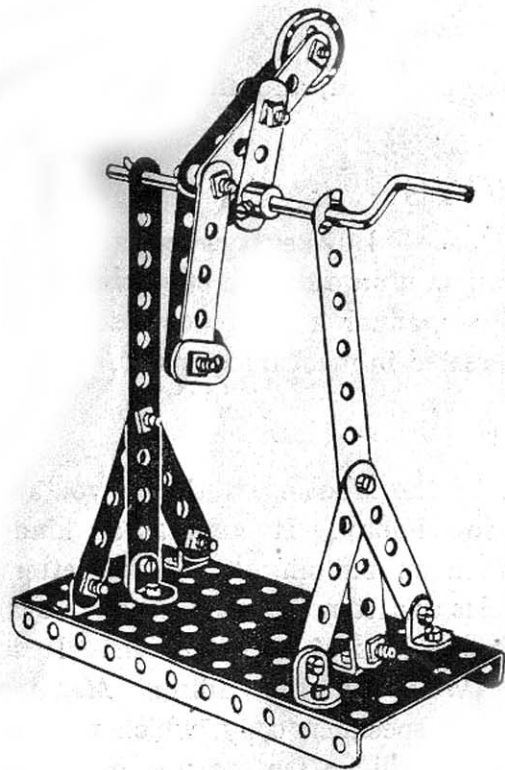

Model No. 327

## The Acrobat

(Outfit No. 3)

Parts Required:

2 of No. 2	1 of No. 19	21 of No. 37
8 " " 5	1 " " 22A	1 " " 52
2 " " 10	2 " " 35	2 " " 62
6 " " 12		

Model No. 328

## The Wrestlers

(Outfit No. 6)

Parts Required:

1 of No. 2	2 of No. 18A
2 " " 3	2 " " 22
2 " " 4	8 " " 35
8 " " 6	24 " " 37
2 " " 8	1 " " 52
4 " " 10	4 " " 59
8 " " 12	4 " " 60
2 " " 17	

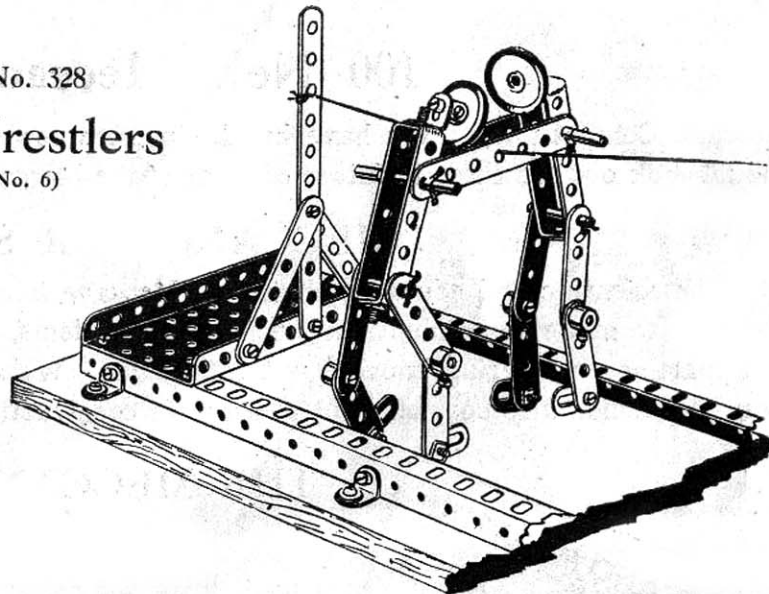

Boys will at once recognise this familiar toy. When the cord, which should be about 4ft. long, is held fairly tight, and manipulated, the figures will wrestle in a most realistic manner. The model should be mounted on a board, to keep it steady.

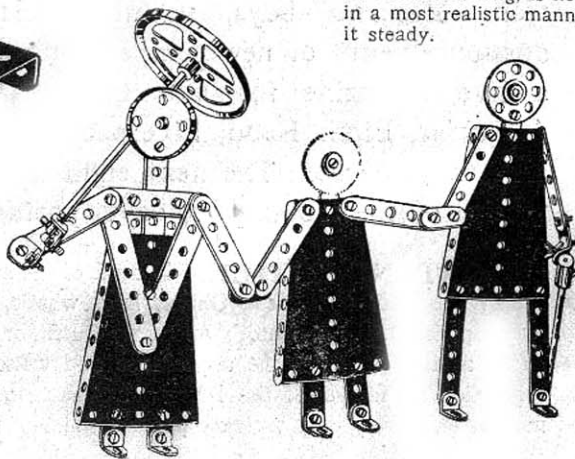

Model No. 329

## The Meccano

## Family

(Outfit No. 4)

Parts Required:

1 of No. 2	1 of No. 15	1 of No. 27A
2 " " 3	1 " " 15A	3 " " 35
2 " " 4	1 " " 18A	36 " " 37
12 " " 5	1 " " 19B	3 " " 54
7 " " 10	1 " " 21	1 " " 63
9 " " 12	1 " " 24	

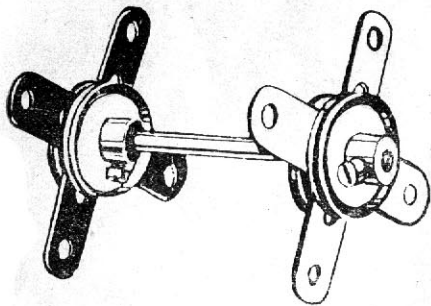

**Model No. 330**  
**Cutlery Rest**  
 (Outfit No. 0)

Parts 4 of No. 5  
 Required: 1 .. .. 15A  
 4 .. .. 22

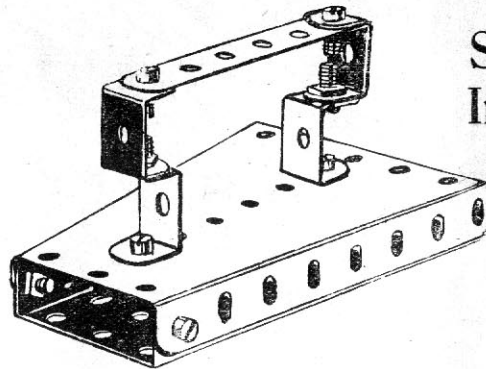

**Model No. 332**  
**Smoothing Iron**  
 (Outfit No. 3)

Parts 1 of No. 4  
 Required: 4 .. .. 11  
 8 .. .. 37  
 2 .. .. 54

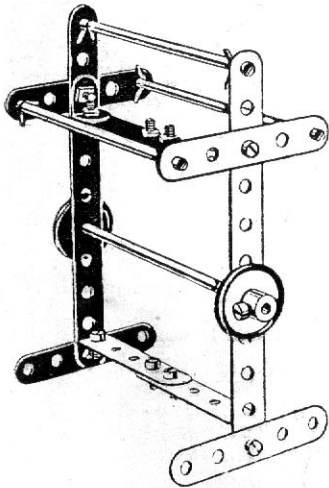

**Model No. 331**  
**Towel Rail**  
 (Outfit No. 2)

Parts Required:  
 2 of No. 2 | 3 of No. 15A  
 8 .. .. 5 | 2 .. .. 22  
 4 .. .. 12 | 6 .. .. 35  
 1 .. .. 15 | 12 .. .. 37

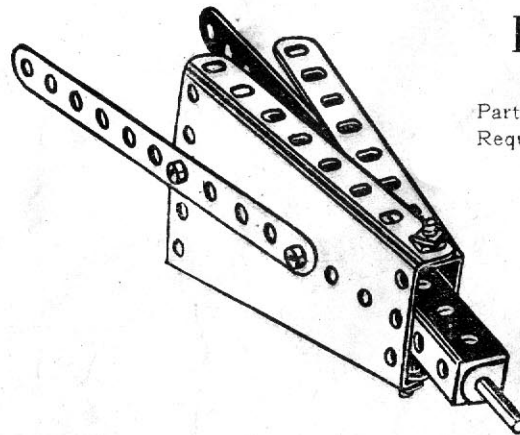

**Model No. 333**  
**Bellows**  
 (Outfit No. 1)

Parts 2 of No. 2  
 Required: 1 .. .. 17  
 9 .. .. 37  
 2 .. .. 54  
 4 .. .. 60

Model No. 334

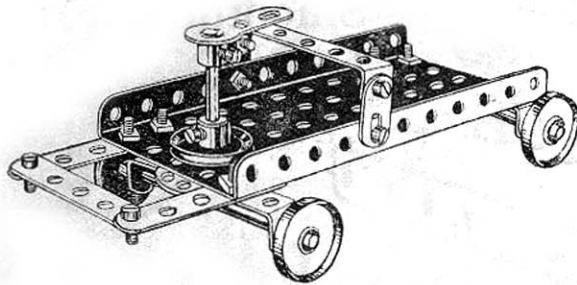
**Motor Van** (Outfit No. 2)Parts  
Required:

3 of No. 5
2 " " 10
2 " " 15A
3 " " 22
2 " " 22A
1 " " 24
2 " " 35
14 " " 37
1 " " 52
2 " " 60
1 " " 62

Model No. 335

**Chair for Wounded Soldier** (Outfit No. 2)Parts  
Required:

6 of No. 2
2 " " 3
10 " " 5
2 " " 11
2 " " 15A
4 " " 20
22 " " 37
1 " " 52
2 " " 60

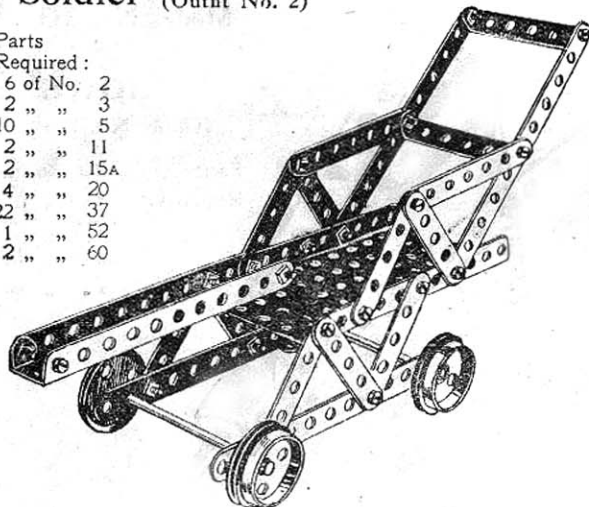

Model No. 336

**Stretcher**

(Outfit No. 1)

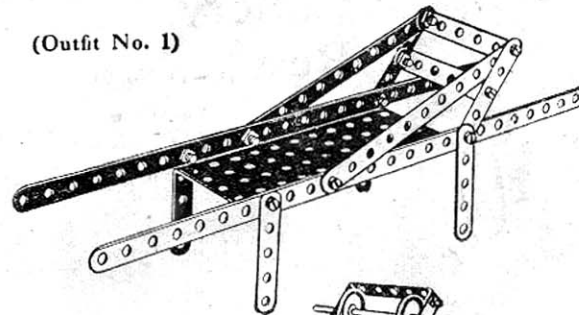
Parts  
Required:

2 of No. 1
2 " " 2
6 " " 5
10 " " 37
1 " " 52
2 " " 60

Model No. 337

**Double Action Crane**

(Outfit No. 1)

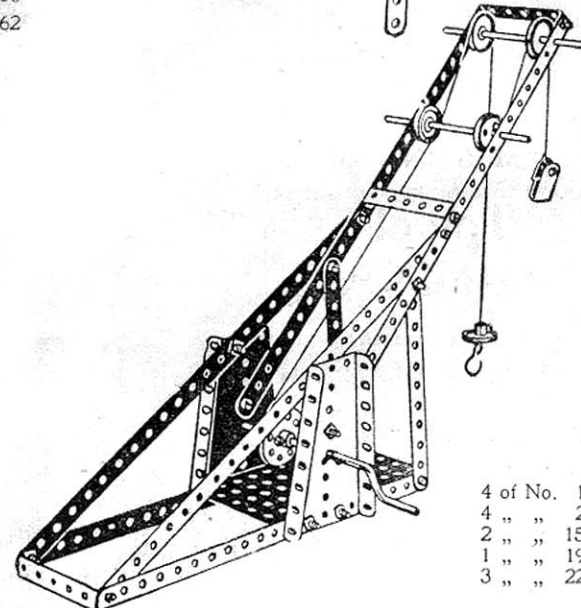

Parts Required:

4 of No. 1	2 of No. 22A	1 of No. 52
4 " " 2	1 " " 24	2 " " 54
2 " " 15A	6 " " 35	1 " " 57
1 " " 19	22 " " 37	3 " " 60
3 " " 22	1 " " 44	

A feature of this crane is that, by the arrangement of the cords on the crank handle, one load may be raised whilst the other is being lowered.



**Model No. 338**  
**Gondola**

(Outfit No. 2)

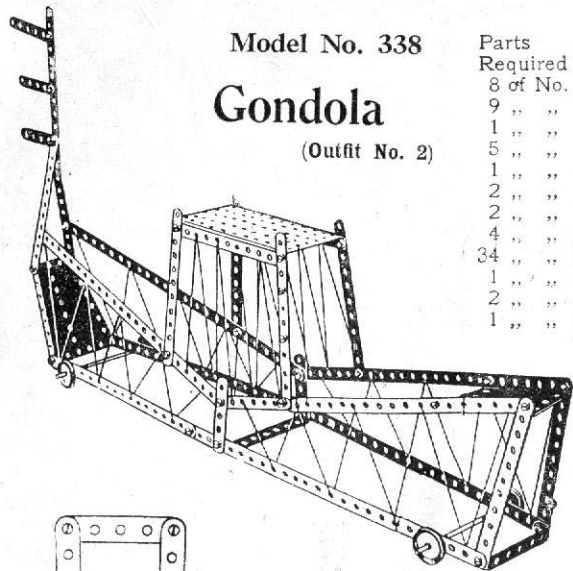

Parts Required:

8 of No.	1
9 " "	2
1 " "	3
2 " "	5
5 " "	10
1 " "	12
2 " "	15
4 " "	22
34 " "	37
1 " "	52
2 " "	54
1 " "	60

**Model No. 340**  
**Submarine**

(Outfit No. 4)

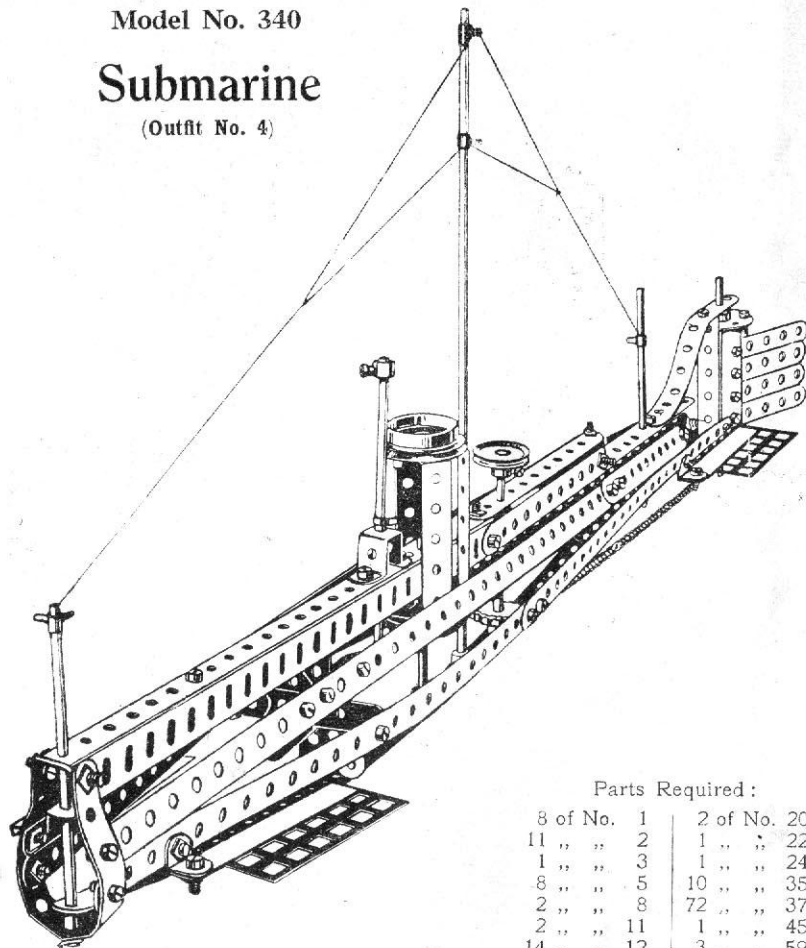

Parts Required:

8 of No.	1	2 of No.	20
11 " "	2	1 " "	22
1 " "	3	1 " "	24
8 " "	5	10 " "	35
2 " "	8	72 " "	37
2 " "	11	1 " "	45
14 " "	12	3 " "	59
1 " "	13	6 " "	60
2 " "	15	4 " "	61
3 " "	15A	2 " "	94
1 " "	16	2 " "	96

**Model No. 339**

**Croix de Guerre**

(Outfit No. 4)

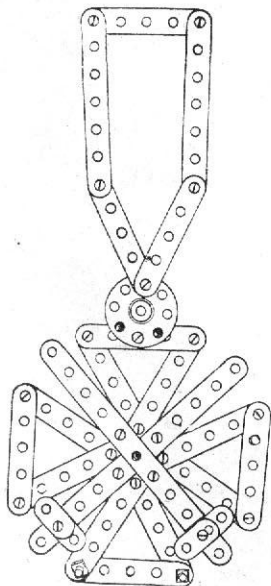

Parts Required:

2 of No.	2
2 " "	3
15 " "	5
4 " "	10
2 " "	24
24 " "	37

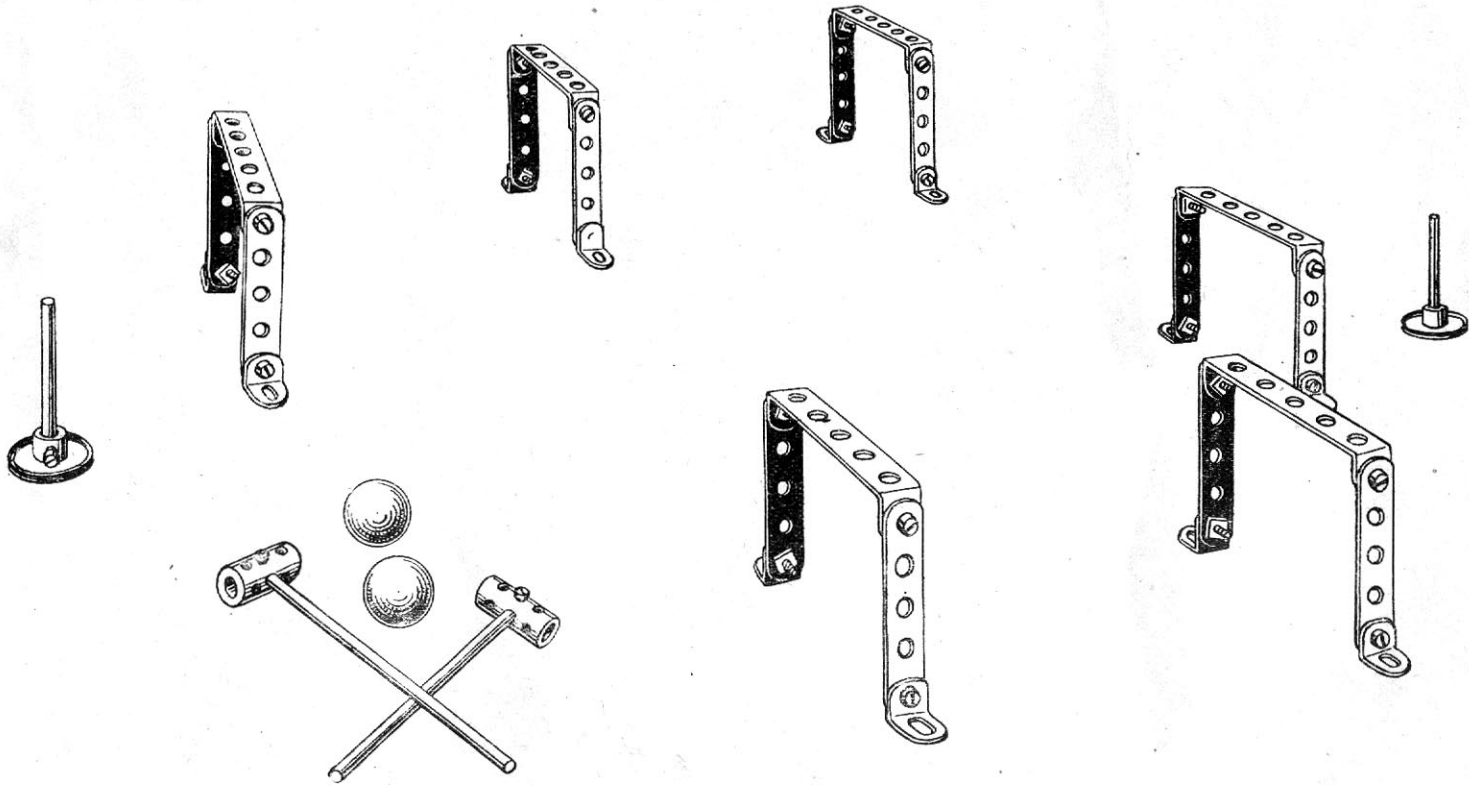

Model No. 341 **Table Croquet** (Outfit No. 4)

Parts Required:

12 of No. 5	2 of No. 22
12 .. .. 12	24 .. .. 37
2 .. .. 16	2 .. .. 63
2 .. .. 17	

A most diverting game. Coloured marbles should be used for the balls. Full instructions for playing croquet may be obtained from any sports or games dealer.

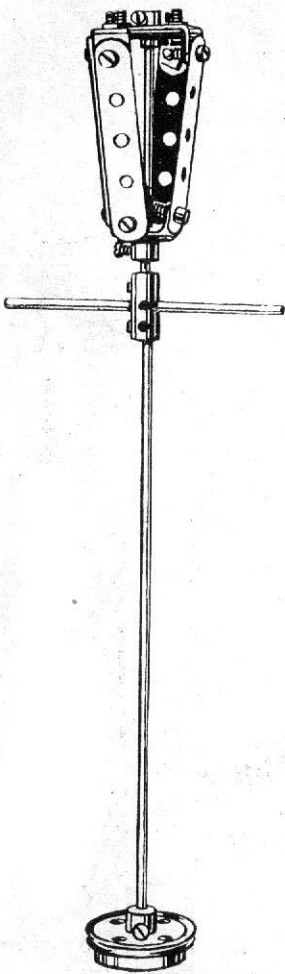

Model No. 342

# Street Lamp

(Outfit No. 4)

Parts Required:

4 of No. 5	1 of No. 20
2 " " 11	1 " " 24
4 " " 12	12 " " 37
1 " " 13	1 " " 59
2 " " 16	1 " " 63

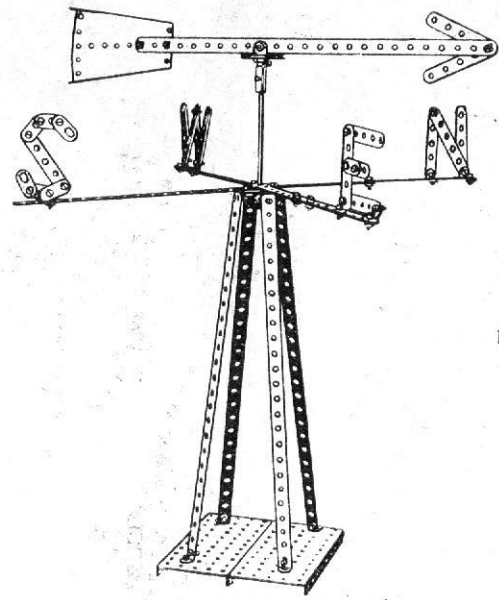

Model No. 343

# Weather Vane

(Outfit No. 4)

Parts Required:

7 of No. 1	8 of No. 10	50 of No. 37
2 " " 2	17 " " 12	2 " " 52
1 " " 4	1 " " 15	1 " " 54
12 " " 5	1 " " 21	1 " " 63
	1 " " 24	

# Bullock Cart

(Outfit No. 2)

Parts Required:

3 of No. 2	1 of No. 16
1 " " 3	2 " " 19B
10 " " 5	21 " " 37
	1 " " 52

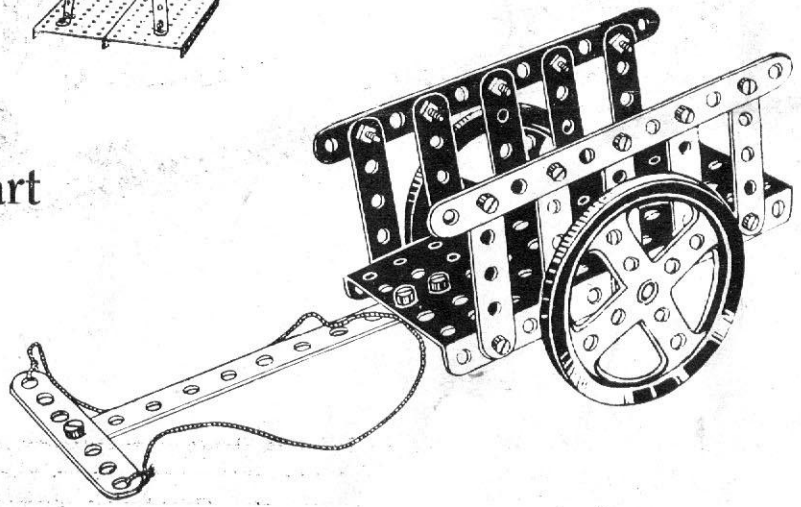

# Model No. 345 St. Malo Transporter Bridge (Outfit No. 6)

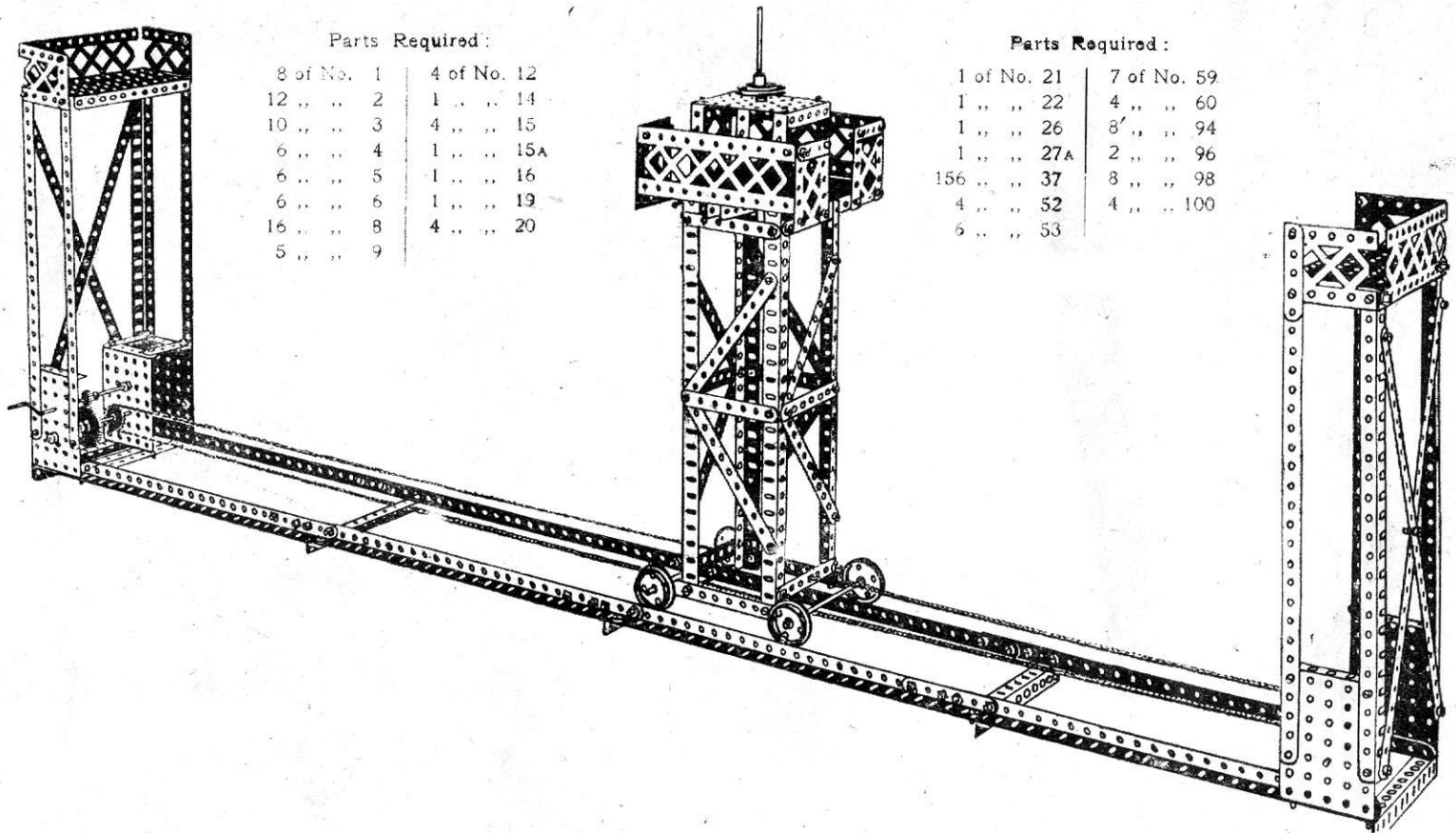

### Parts Required :

8 of No. 1	4 of No. 12
12 .. .. 2	1 .. .. 14
10 .. .. 3	4 .. .. 15
6 .. .. 4	1 .. .. 15A
6 .. .. 5	1 .. .. 16
6 .. .. 6	1 .. .. 19
16 .. .. 8	4 .. .. 20
5 .. .. 9	

### Parts Required :

1 of No. 21	7 of No. 59
1 .. .. 22	4 .. .. 60
1 .. .. 26	8 .. .. 94
1 .. .. 27A	2 .. .. 96
156 .. .. 37	8 .. .. 98
4 .. .. 52	4 .. .. 100
6 .. .. 53	

This is an excellent representation of the Rolling Bridge which conveys passengers from St. Malo to St. Servan. It is much less costly to construct than a transporter bridge of the Newport type, on page 40, but of course it can only be used over marshy land with shallow water, over which a solid track can be laid. The clever Meccano boy will know how to add little decorations to the transporter and the landing platforms, in the way of flags, &c., and make a first-class toy of this fine model.

Model No. 347

# Diplodocus

(Outfit No. 4)

This is a most extraordinary effort sent in by a young French boy to compete for one of the big prizes in our Meccano Contest. We could scarcely class it as an engineering model, but any boy with a brain clever enough and an imagination lively enough to conceive and construct such an animal as this from Meccano parts, deserved a good prize, so we awarded him one. Screw the nuts and bolts up tightly because he looks most dejected when he droops.

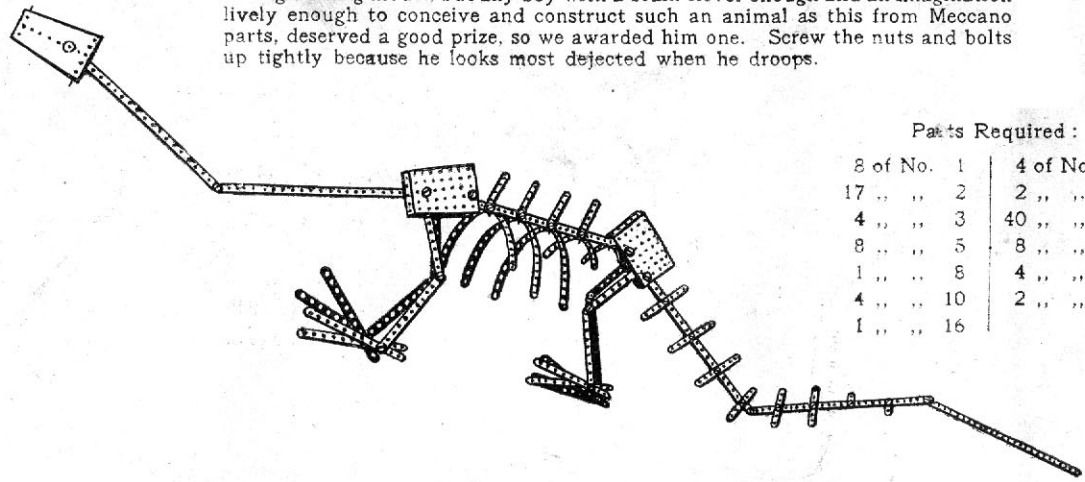

Parts Required :

8 of No. 1	4 of No. 17
17 .. .. 2	2 .. .. 22
4 .. .. 3	40 .. .. 37
8 .. .. 5	8 .. .. 59
1 .. .. 8	4 .. .. 53
4 .. .. 10	2 .. .. 54
1 .. .. 16	

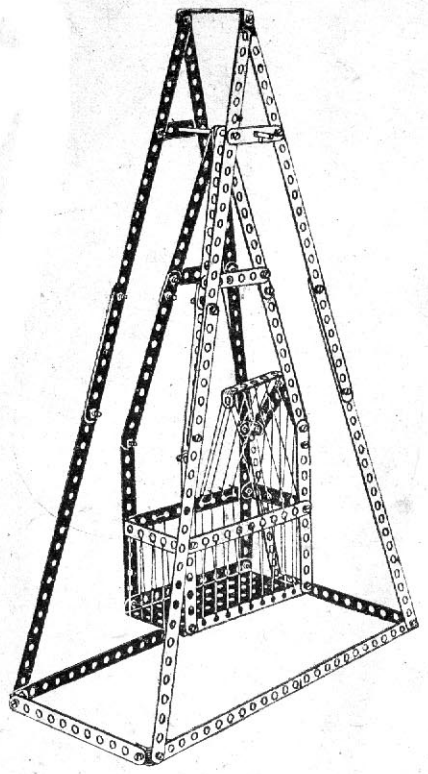

Model No. 346

# Swinging Cot

(Outfit No. 2)

Parts Required :

10 of No. 1	6 of No. 12	51 of No. 37
16 .. .. 2	1 .. .. 15A	1 .. .. 52
6 .. .. 5	4 .. .. 35	4 .. .. 60

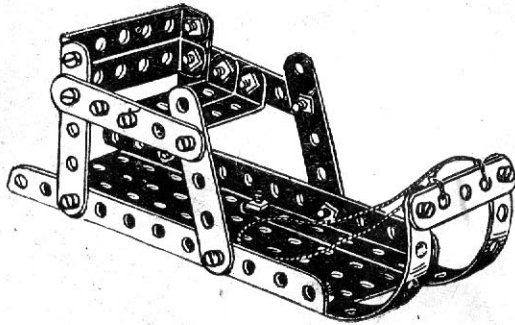

Model No. 348

# Toboggan

(Outfit No. 1)

Parts Required :

2 of No. 2	1 of No. 52
7 .. .. 5	4 .. .. 60
20 .. .. 37	

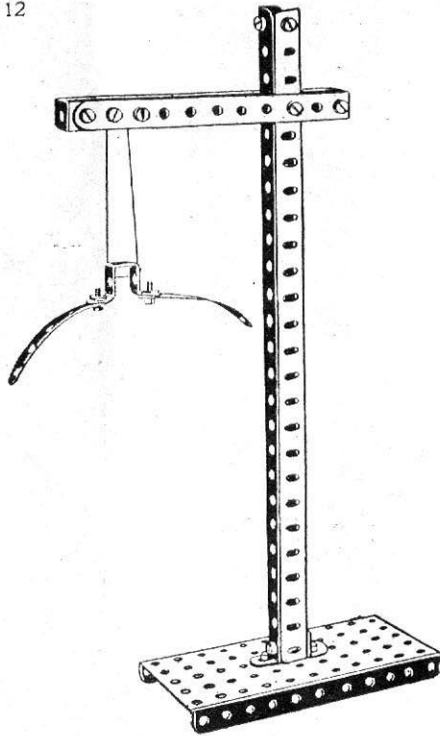

Model No. 349

## Railway Gauge

(Outfit No. 2)

Parts Required:

2 of No. 2	2 of No. 12
2 " " 5	18 " " 37
2 " " 8	1 " " 45
4 " " 11	1 " " 52

Model No. 350

## Auto Steering Car

(Outfit No. 3)

Parts Required:

2 of No. 2	1 of No. 24
1 " " 3	1 " " 26
3 " " 5	1 " " 32
3 " " 11	20 " " 37
1 " " 12	4 " " 59
2 " " 15	2 " " 62
2 " " 15A	1 " " 95
2 " " 19B	1 " " 96
2 " " 20	

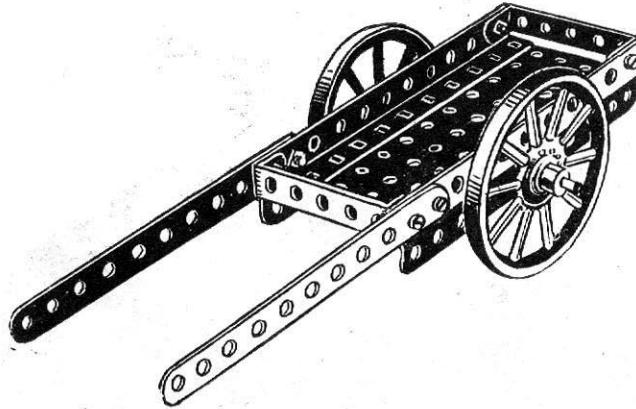
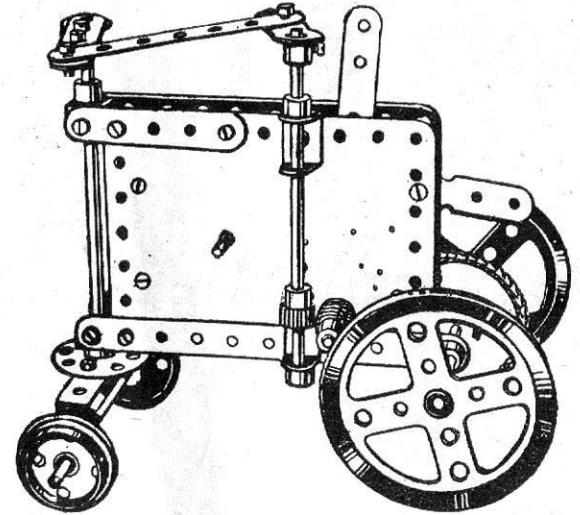

Model No. 351

## Station Cart

(Outfit No. 0)

Parts Required:

4 of No. 2	10 of No. 37
4 " " 12	1 " " 52
1 " " 15A	2 " " 60
3 " " 19B	

Model No. 352

# Revolving Book Case

(Outfit No. 6)

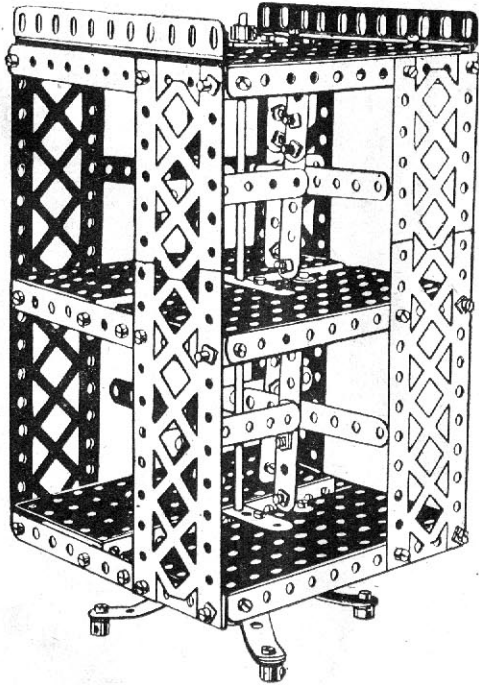

Parts Required :

10 of No. 2	1 of No. 13
8 " " 3	2 " " 24
8 " " 4	122 " " 37
2 " " 5	6 " " 52
8 " " 6	4 " " 59
2 " " 9	1 " " 63
36 " " 12	8 " " 100

See Notice Page 3.

Model No. 353

# Post Card Stand

(Outfit No. 3)

Parts  
Required :

8 of No. 1
16 " " 2
8 " " 5
4 " " 8
2 " " 11
1 " " 15
1 " " 35
36 " " 37
1 " " 45
1 " " 52
1 " " 59

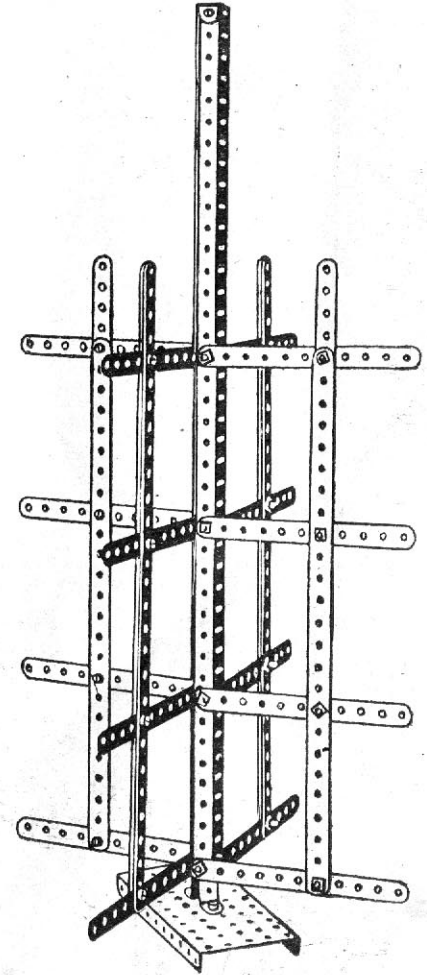

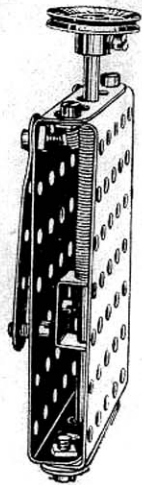

Model No. 354

## Conductor's Punch

(Outfit No. 4)

Parts  
Required :

3 of No. 5
1 " " 11
1 " " 15A
1 " " 22
9 " " 37
1 " " 43
2 " " 53

This is just the thing for your younger brother, and he only needs a strap to hang it over his shoulder with to make him into a regular tram conductor. Note the 2½ in. strip at the bottom, spaced a little away from the body of the punch, to allow the ticket to pass in to be punched.

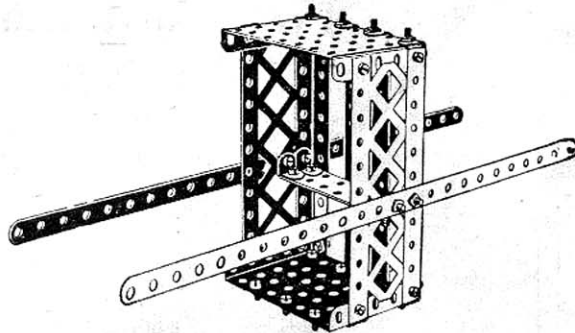

Model No. 356

## Chinese Palanquin

(Outfit No. 3)

Parts Required :

2 of No. 1	35 of No. 37
4 " " 2	2 " " 53
2 " " 3	2 " " 100
12 " " 12	

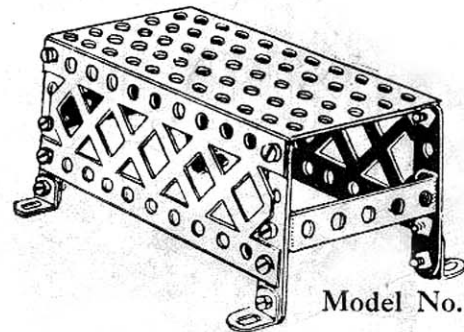

Model No. 357

## Fire Stand

(Outfit No. 0)

Parts Required :

4 of No. 5	1 of No. 52
4 " " 12	2 " " 60
16 " " 37	2 " " 100

Model No. 355

## Ship Yard Bogey

(Outfit No. 0)

Parts Required :

2 of No. 2	2 of No. 22
5 " " 5	10 " " 37
1 " " 12	1 " " 52
1 " " 15A	1 " " 60

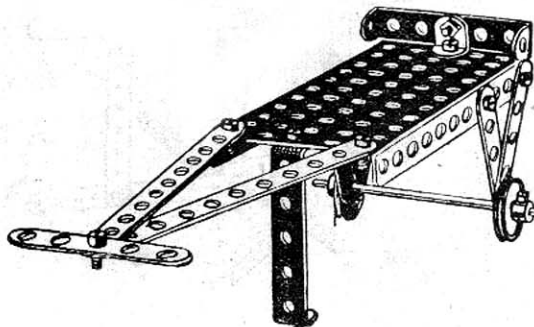



Model No. 358  
**Silhouettograph**

(Outfit No. 6)

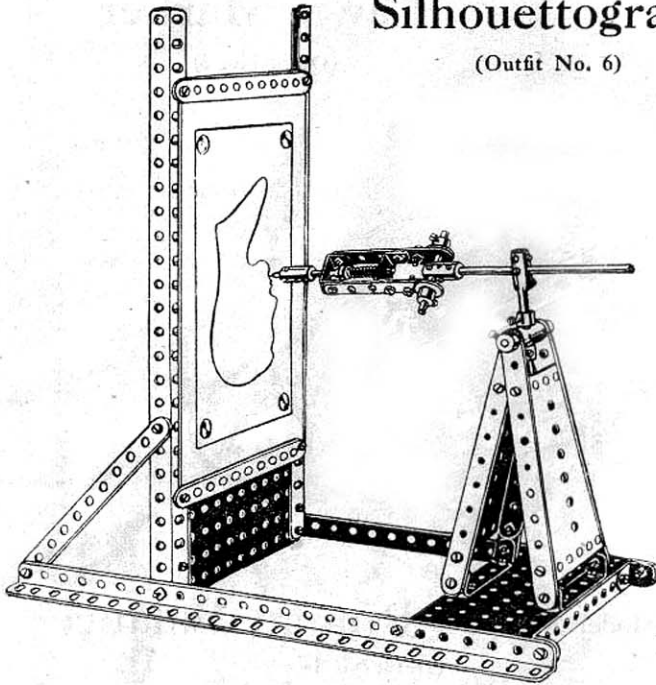

Parts Required :

8 of No. 2	4 of No. 12	2 of No. 18A	2 of No. 54
2 " " 4	3 " " 13	42 " " 37	5 " " 59
4 " " 8	1 " " 16	1 " " 43	2 " " 62
2 " " 11	2 " " 17	2 " " 52	6 " " 63

The writing arm should be about 3ft. long. The person to be silhouetted should sit with his profile exactly opposite the centre of the writing board, upon which a sheet of plain paper has been fixed. The writing arm is then passed smoothly round the profile.

Model No. 359  
**Drafting Machine**

(Outfit No. 3)

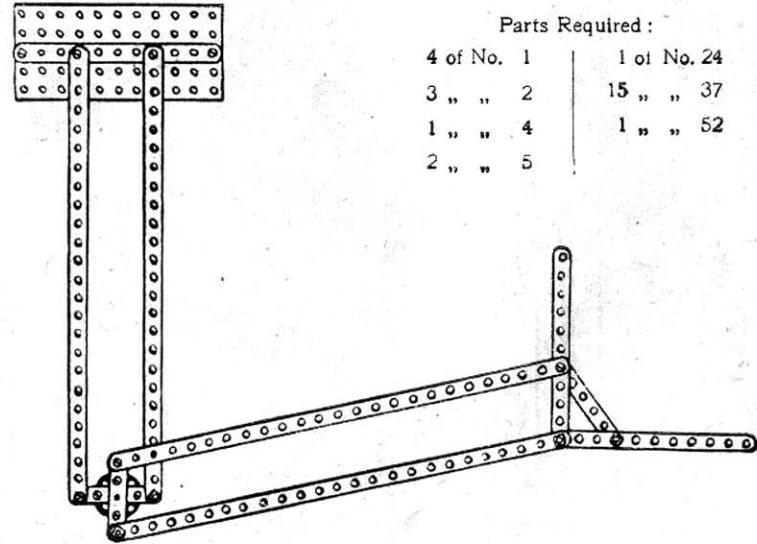

Parts Required :

4 of No. 1	1 of No. 24
3 " " 2	15 " " 37
1 " " 4	1 " " 52
2 " " 5	

This is an instrument used by draughtsmen for drawing straight lines at any angle and in any part of the board, also for producing series of horizontal and vertical parallel lines.

Model No. 360

**Breast Drill**

(Outfit No. 4)

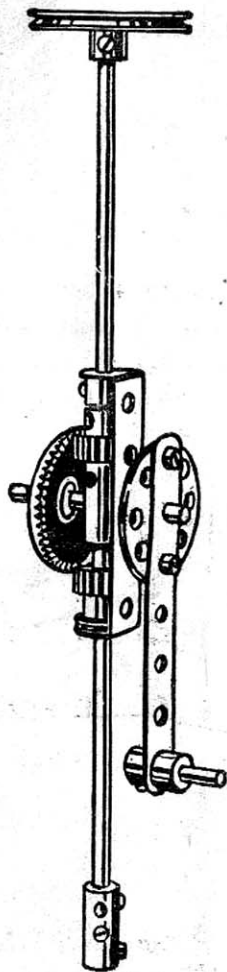
Parts  
Required:

1 of No. 3
2 " " 15
1 " " 17
1 " " 18A
1 " " 21
1 " " 23
1 " " 24
2 " " 26
1 " " 28
2 " " 37
3 " " 59
1 " " 60
2 " " 63

Model No. 361

**Lawn Marker**

(Outfit No. 3)

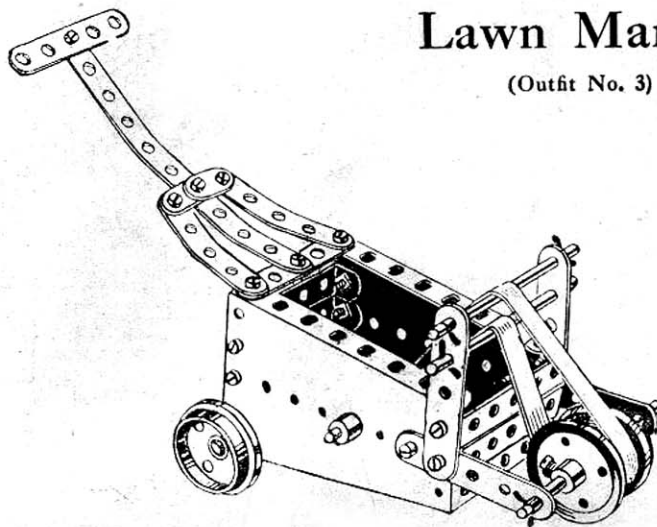
Parts  
Required:

1 of No. 2
8 " " 5
2 " " 10
3 " " 15A
4 " " 20
6 " " 35
23 " " 37
1 " " 53
2 " " 54
2 " " 59
5 " " 60

Model No. 362 **Roman Balance**

(Outfit No. 1)

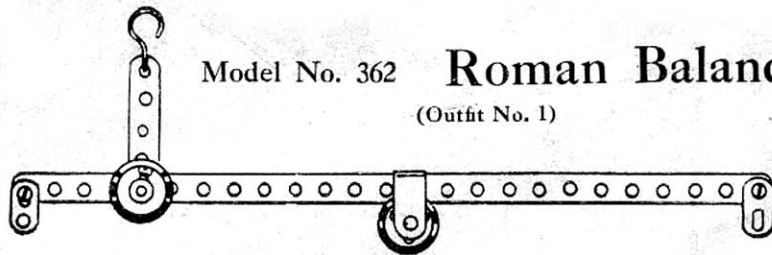

Parts Required:

1 of No. 1	2 of No. 22	1 of No. 44
2 " " 5	1 " " 22A	1 " " 57
2 " " 10	4 " " 37	

# Model No. 363 Search Light

(Outfit No. 6)

A splendid model which any boy with an electric flash lamp will enjoy making and playing with. The light can be quickly manoeuvred in any direction and the enemy aircraft can be spotted at once.

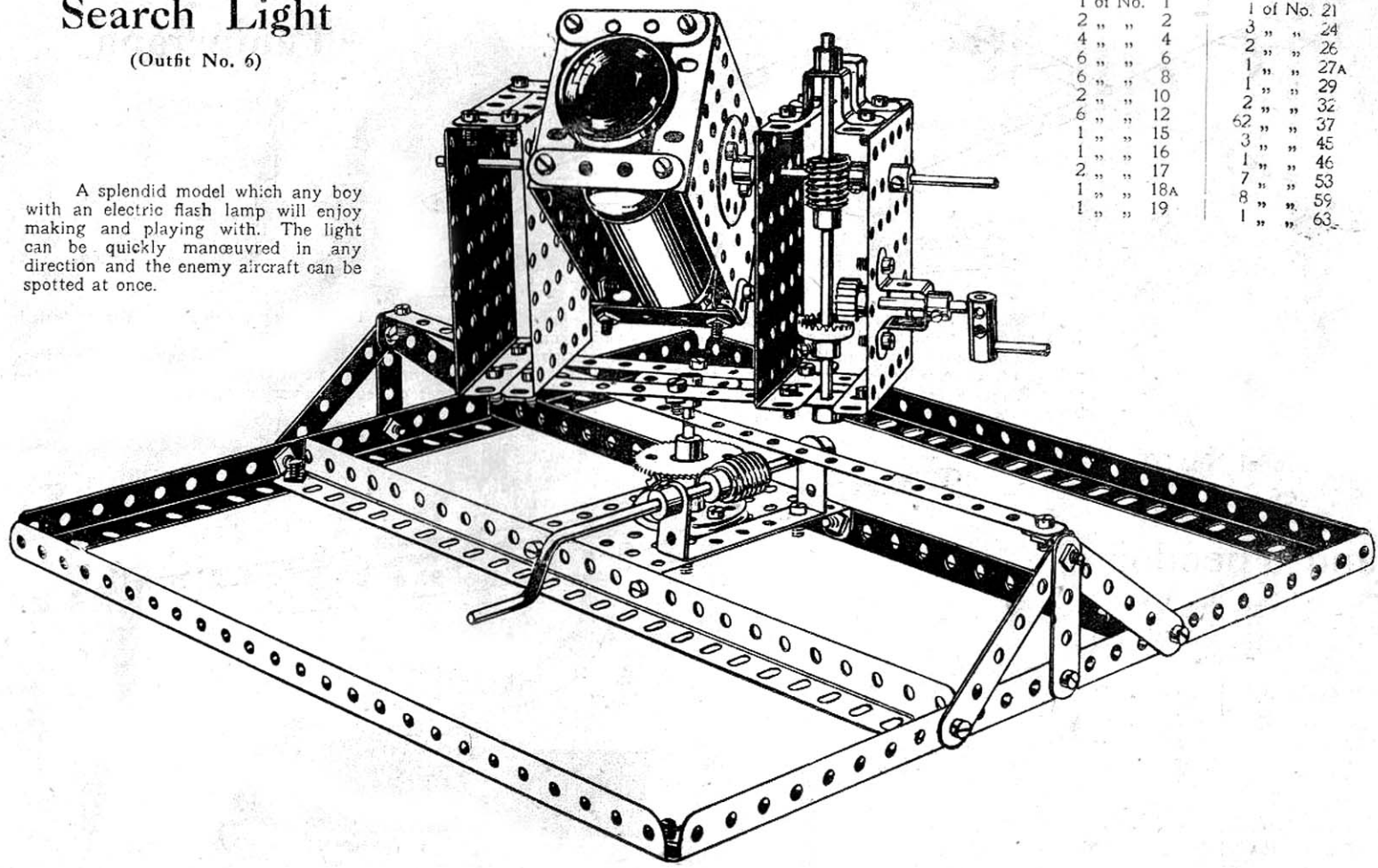

### Parts Required

1 of No.	1	1 of No.	21
2 "	2	3 "	24
4 "	4	2 "	26
6 "	6	1 "	27A
6 "	8	1 "	29
2 "	10	2 "	32
6 "	12	62 "	37
1 "	15	3 "	45
1 "	16	1 "	46
2 "	17	7 "	53
1 "	18A	8 "	59
1 "	19	1 "	63

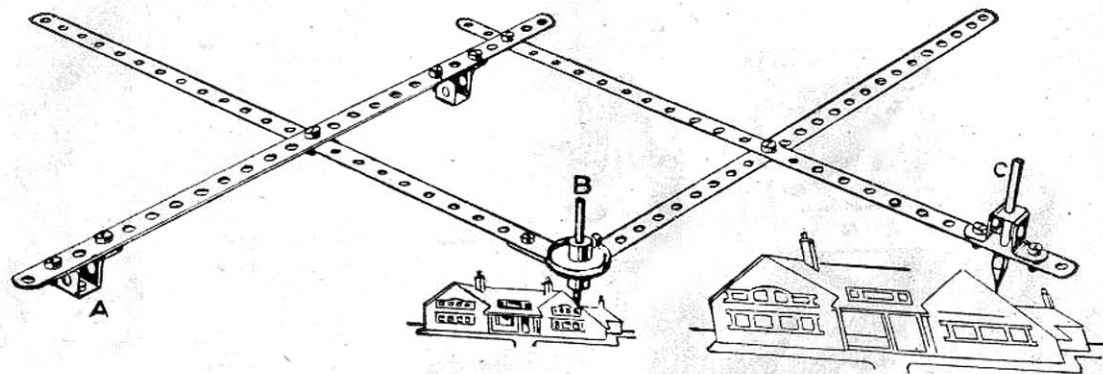

Model No. 364

## Pantograph

(Outfit No. 6)

Parts Required :

4 of No. 1	10 of No. 37
1 " " 17	3 " " 45
1 " " 22	1 " " 62

Most boys have heard of the Pantograph, but not many have had an opportunity of seeing its principles demonstrated. It is an instrument for copying plans, &c., on the same or on a reduced or enlarged scale.

The apparatus is fixed at the point A. If an enlarged sketch is to be made, the point B is traced round the outlines, the writing point C reproducing the sketch on a larger scale. When a reduced drawing is to be made, the point B reproduces the sketch on a smaller scale. The degree of enlargement or reduction varies according to the position in which point C is fixed on the perforated arm.

## Model No. 365 Sextant and Theodolite

(Outfit No. 4)

Parts Required :

1 of No. 1	1 of No. 21
2 " " 2	1 " " 22
2 " " 11	8 " " 37
2 " " 12	1 " " 52
1 " " 16	4 " " 59
1 " " 17	3 " " 63
2 " " 18A	1 " " 65

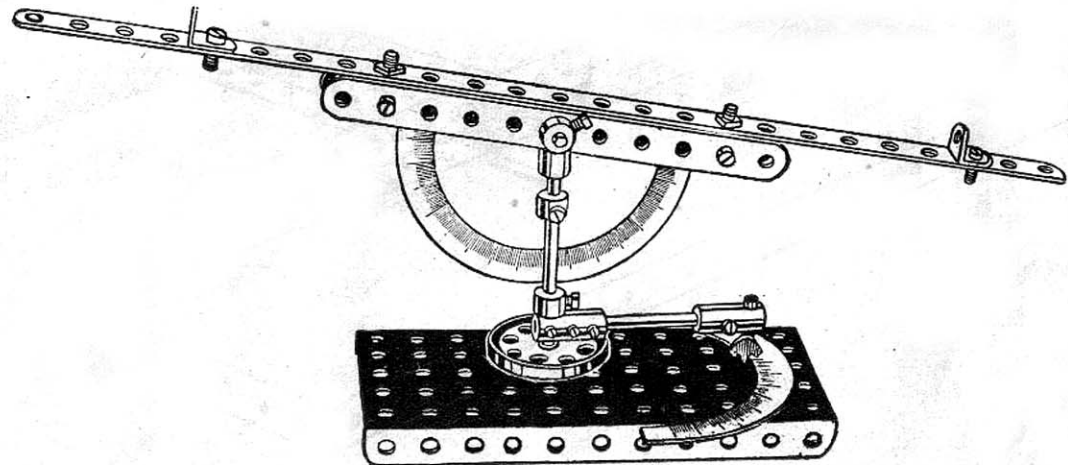

Model No. 366

# Pastry Designer

(Outfit No. 3)

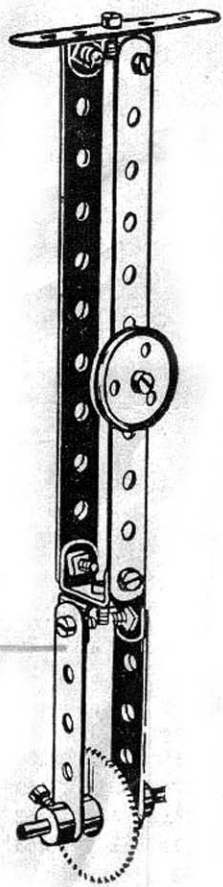

- Parts Required:
- 2 of No. 2
  - 3 " " 5
  - 3 " " 11
  - 1 " " 17
  - 1 " " 22A
  - 1 " " 27A
  - 9 " " 37
  - 2 " " 59

Model No. 367

# Fire Alarm

(Outfit No. 1)

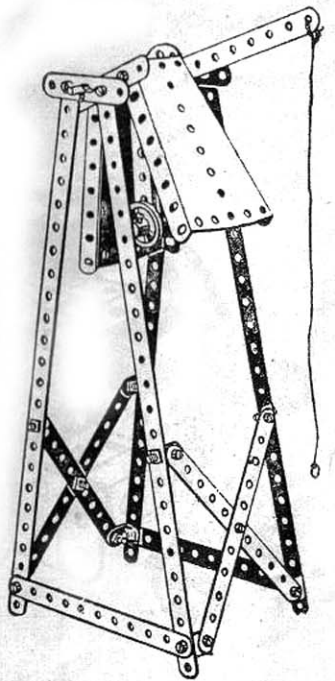

- Parts Required:
- |            |             |
|------------|-------------|
| 4 of No. 1 | 1 of No. 22 |
| 7 " " 2    | 1 " " 24    |
| 1 " " 3    | 4 " " 35    |
| 3 " " 5    | 27 " " 37   |
| 8 " " 12   | 2 " " 54    |
| 1 " " 15A  |             |

Model No. 368

# Child's Joy Wheel

(Outfit No. 4)

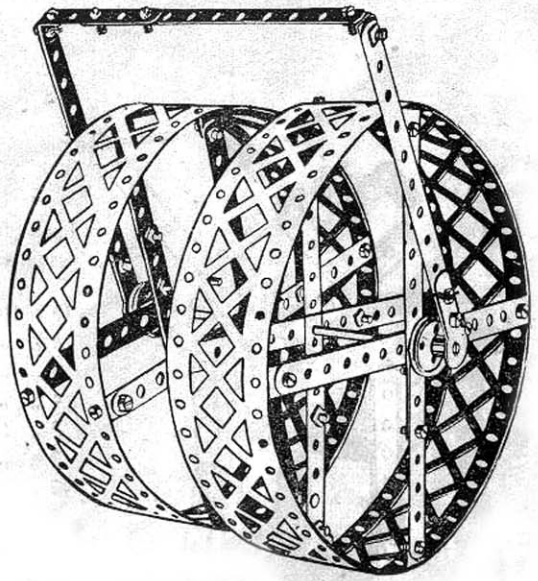

- Parts Required:
- |             |              |              |
|-------------|--------------|--------------|
| 11 of No. 2 | 18 of No. 12 | 54 of No. 37 |
| 4 " " 3     | 1 " " 14     | 2 " " 62     |
| 5 " " 5     | 2 " " 22     | 4 " " 99     |
|             | 2 " " 22A    |              |

This makes a splendid toy for your young brother or sister. It can be decorated by threading coloured ribbons through the holes, or with coloured streamers.

Model No. 369  
**Bale Press**  
 (Outfit No. 3)

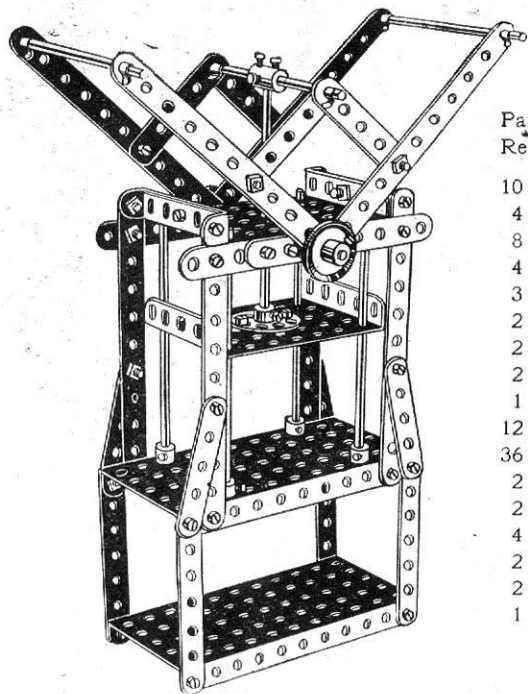

Parts  
 Required:

10 of No.	2
4 " "	3
8 " "	5
4 " "	15
3 " "	15A
2 " "	17
2 " "	18A
2 " "	22
1 " "	24
12 " "	35
36 " "	37
2 " "	52
2 " "	53
4 " "	59
2 " "	60
2 " "	62
1 " "	63

Model No. 370  
**Potato Reaper**  
 (Outfit No. 4)

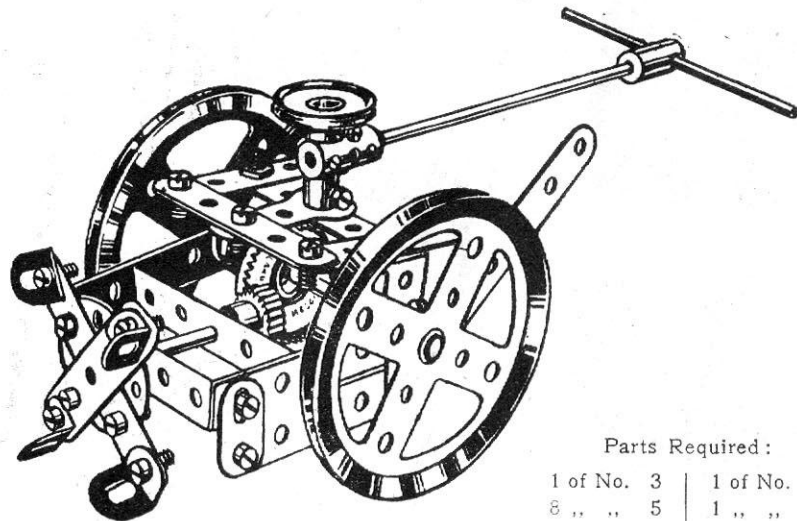

Parts Required:

1 of No.	3	1 of No.	24
8 " "	5	1 " "	26
2 " "	10	1 " "	28
4 " "	12	19 " "	37
1 " "	15	1 " "	46
2 " "	16	1 " "	59
1 " "	17	2 " "	60
1 " "	18A	1 " "	62
2 " "	19B	2 " "	63
1 " "	22		

Model No. 371

# Clothes Horse

(Outfit No. 1)

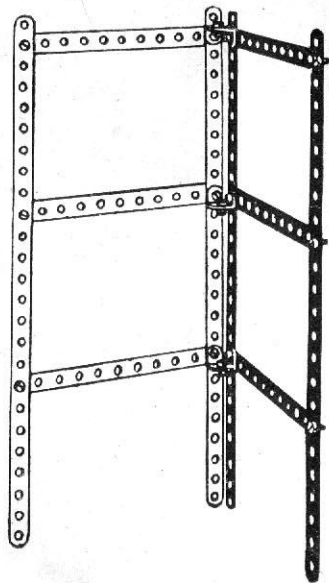

Parts Required:

4 of No. 1	6 of No. 12
6 " " 2	15 " " 37

Model No. 372

# Settee

(Outfit No. 0)

Parts Required:

2 of No. 2	15 of No. 37
8 " " 5	1 " " 52
3 " " 10	2 " " 60

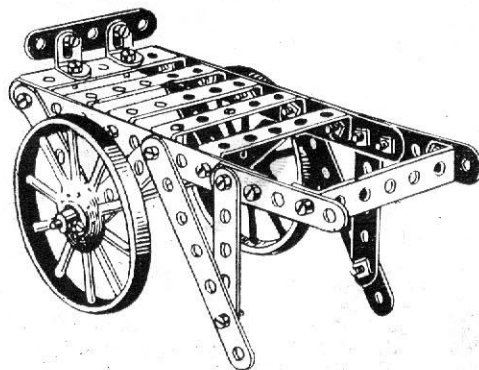
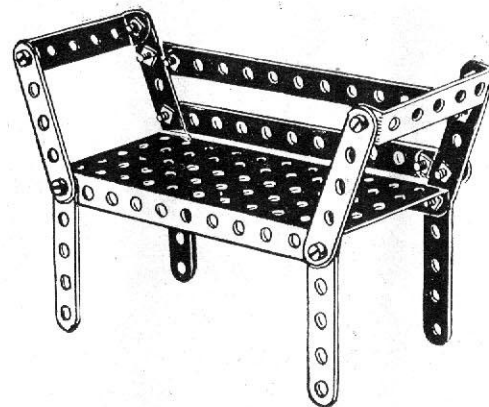

Model No. 373

# Market Gardener's Truck

(Outfit No. 2)

Parts Required:

2 of No. 2	2 of No. 12	2 of No. 35
2 " " 3	1 " " 15A	22 " " 37
9 " " 5	2 " " 19A	6 " " 60

## Model No. 374 Aeroplage

(Outfit No. 4)

Parts Required :

4 of No. 1	4 of No. 19 <sup>B</sup>
3 " " 2	1 " " 21
3 " " 3	1 " " 22
13 " " 5	1 " " 24
3 " " 8	54 " " 37
2 " " 11	2 " " 52
12 " " 12	1 " " 54
1 " " 13	7 " " 59
2 " " 15	1 " " 60
1 " " 16	1 " " 63
2 " " 17	

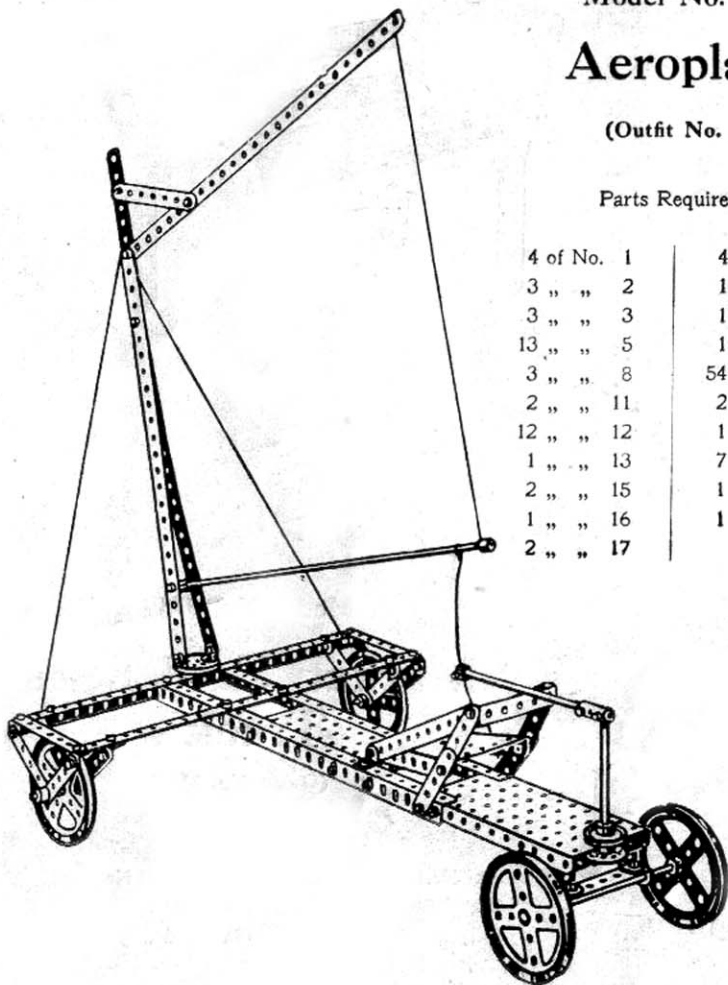

## Model No. 375 Heliograph

(Outfit No. 6)

Parts  
Required :

9 of No. 2
3 " " 3
5 " " 4
1 " " 5
2 " " 6
8 " " 8
4 " " 10
3 " " 12
1 " " 15A
1 " " 17
1 " " 18A
2 " " 24
64 " " 37
1 " " 52
3 " " 53
3 " " 59
2 " " 60
3 " " 62

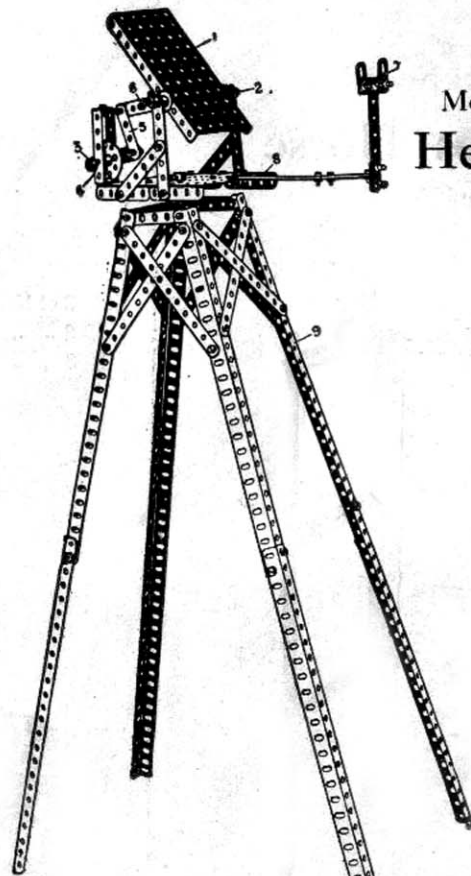

A large rectangular plate 1 is rocked about its pivots 2 by a lever 3, pivoted at 4 and connected by a 2" strip 5 to the outer end of a crank 6, to which is connected a 2" strip. The rectangular plate 1 should be fitted with a mirror, and a sighting aperture 7 is mounted in front, the operator bringing one of the perforations in the plate 1 in line with the aperture 7, while signalling, so that he can see the opposite instrument in the distance. The platform 8 is pivotally mounted on the standard 9 so that it may be swung round to any position, a bush wheel being bolted to the top of the standard in which the pivot works. The platform is made of two small rectangular plates butted together and connected on each side by strips.



Model No. 376  
**Bale Lifter**

(Outfit No. 3)

Parts Required:

2 of No. 1	1 of No. 19
6 " " 2	2 " " 20
6 " " 3	4 " " 22
2 " " 4	1 " " 23
2 " " 5	1 " " 26
4 " " 8	1 " " 33
4 " " 11	6 " " 35
6 " " 12	40 " " 37
2 " " 15	1 " " 52
2 " " 16	2 " " 59
2 " " 18A	1 " " 63

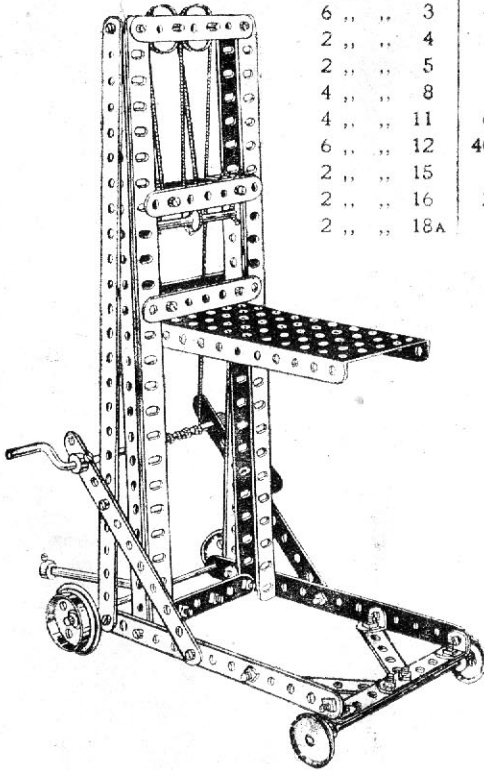

Model No. 377

**Scales**

(Outfit No. 3)

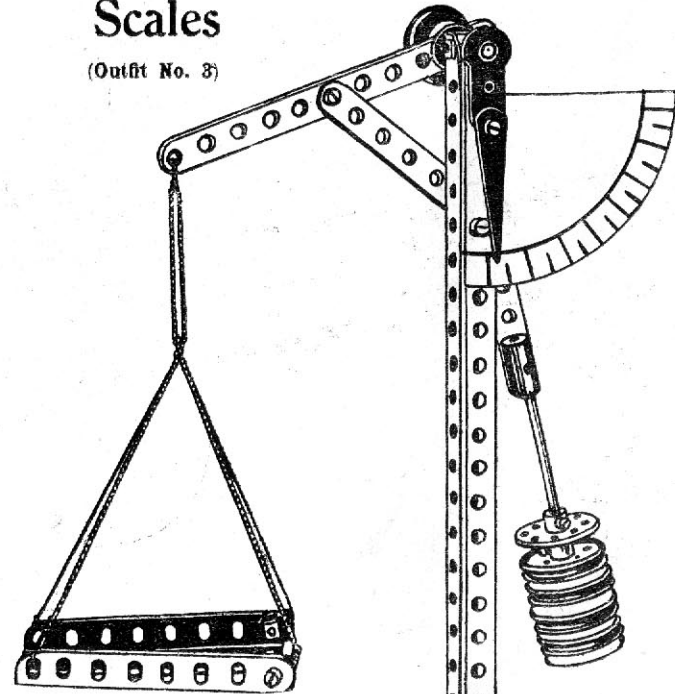

Parts Required:

2 of No. 2	2 of No. 22
1 " " 3	1 " " 24
2 " " 4	21 " " 37
2 " " 8	2 " " 52
1 " " 11	1 " " 54
1 " " 15	1 " " 60
1 " " 17	2 " " 62
4 " " 20	1 " " 63

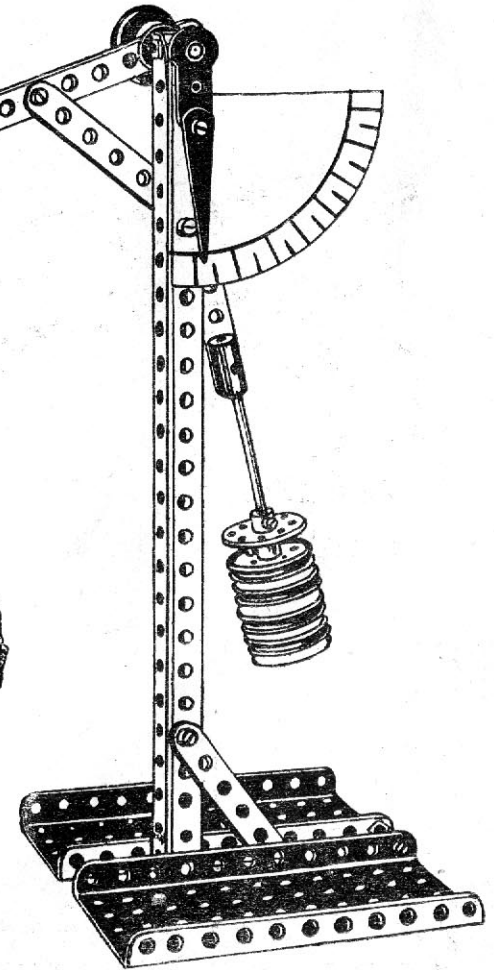

Model No. 378

**Brewer's Dray**

(Outfit No. 4)

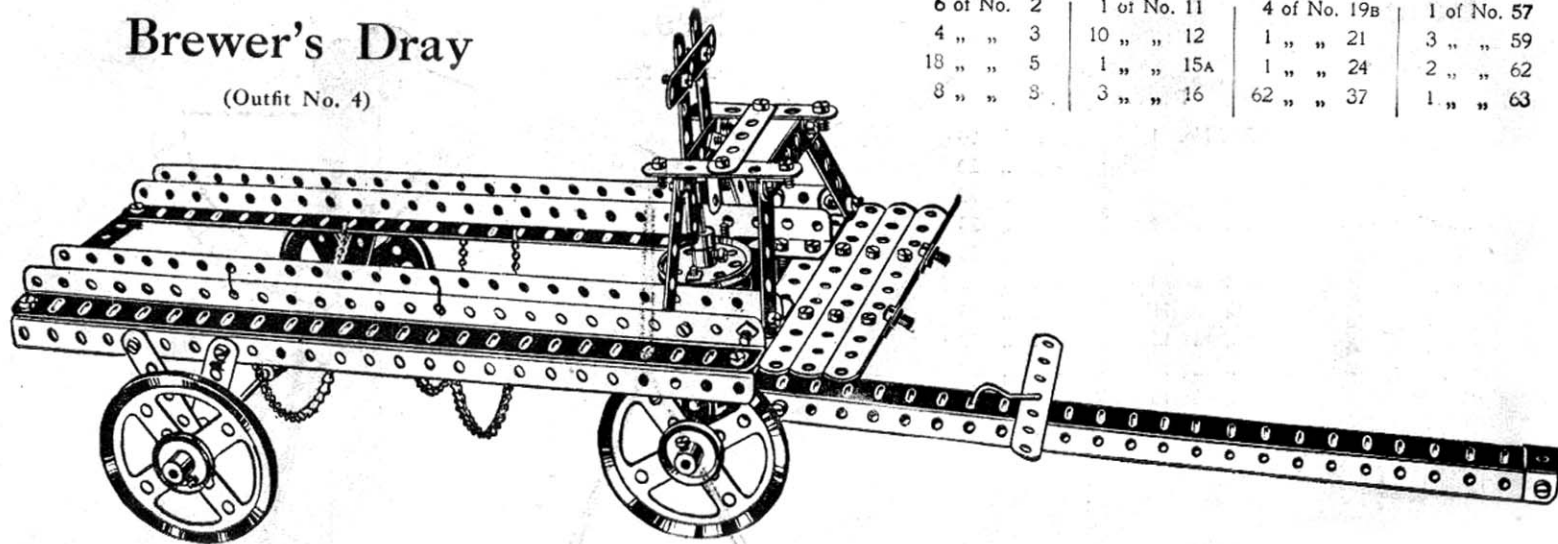

Parts Required:

6 of No. 2	1 of No. 11	4 of No. 19B	1 of No. 57
4 " " 3	10 " " 12	1 " " 21	3 " " 59
18 " " 5	1 " " 15A	1 " " 24	2 " " 62
8 " " 8	3 " " 16	62 " " 37	1 " " 63

Model No. 379

**Skate**

(Outfit No. 4)

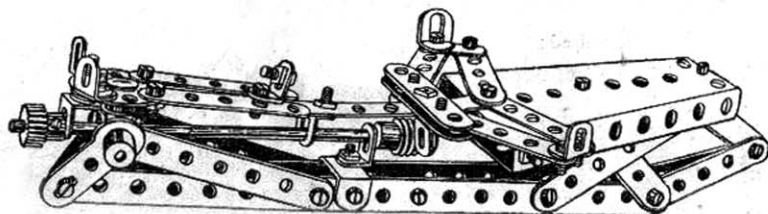

Parts Required:

5 of No. 2	1 of No. 11	1 of No. 26	1 of No. 54
4 " " 3	16 " " 12	1 " " 32	1 " " 60
12 " " 5	1 " " 14	42 " " 37	2 " " 62
5 " " 10	1 " " 24	5 " " 38	

# Model No. 380 Cantilever Bridge

(Outfit No. 6)

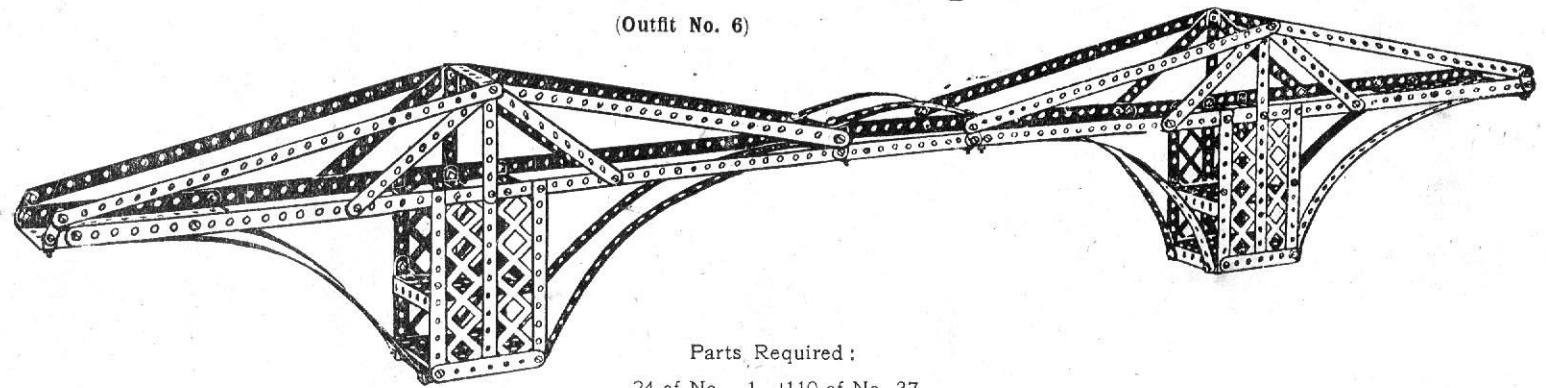

Parts Required :

24 of No.	1	110 of No.	37
10 " "	2	3 " "	52
8 " "	3	4 " "	53
8 " "	10	8 " "	60
22 " "	12	8 " "	100

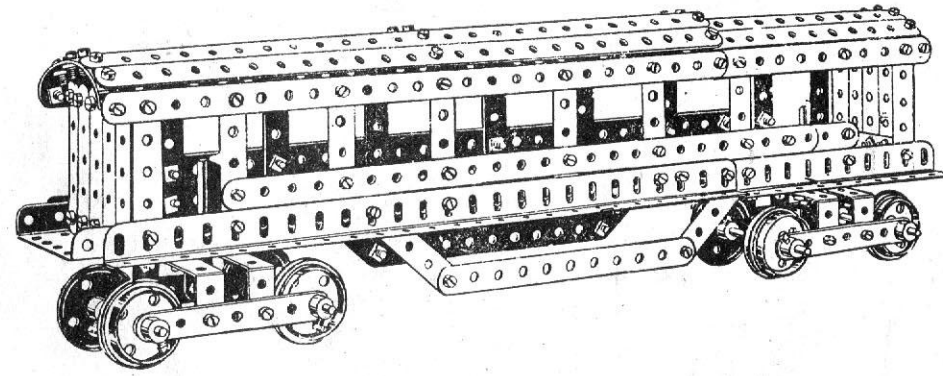

# Model No. 381 Pullman Car

(Outfit No. 5)

Parts Required :

9 of No.	1	4 of No.	8	8 of No.	20	4 of No.	46
9 " "	2	4 " "	16	2 " "	21	3 " "	52
8 " "	3	2 " "	17	116 " "	37	10 " "	59
34 " "	5						

Model No. 382

# Anti-Aircraft Gun

(Outfit No. 3)

Parts  
Required :

2 of No. 2
9 " " 5
2 " " 11
2 " " 15
1 " " 16
1 " " 17
1 " " 19
1 " " 21
4 " " 22
1 " " 24
2 " " 26
1 " " 27A
1 " " 32
26 " " 37
1 " " 52
3 " " 53
4 " " 59
2 " " 60
1 " " 63

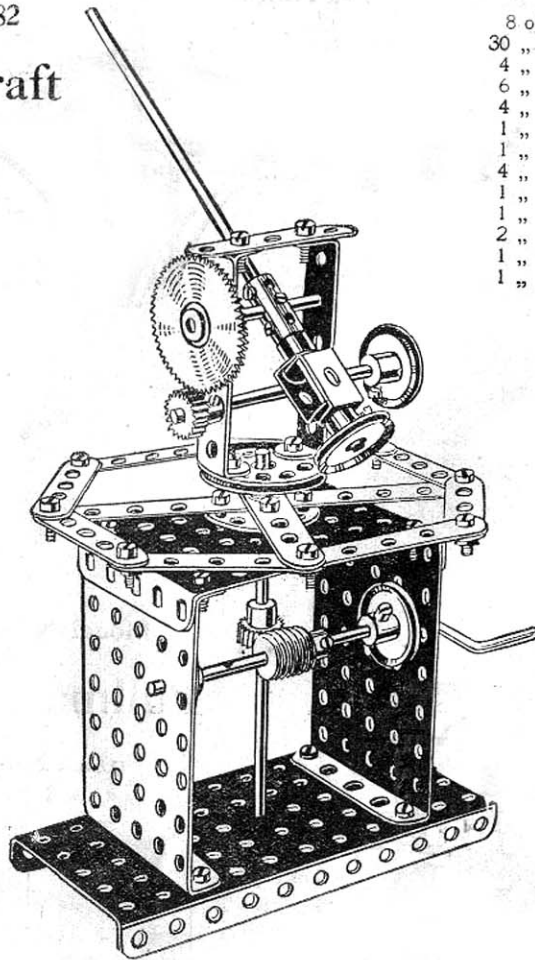

Parts Required :

8 of No. 1	16 of No. 35
30 " " 2	86 " " 37
4 " " 3	2 " " 52
6 " " 8	4 " " 53
4 " " 11	5 " " 59
1 " " 13	12 " " 60
1 " " 14	1 " " 70
4 " " 15	2 " " 94
1 " " 15A	1 " " 95
1 " " 21	1 " " 96
2 " " 24	2 " " 99
1 " " 27A	3 " " 100
1 " " 32	

Model No. 383

# Fly Boats

(Outfit No. 6)

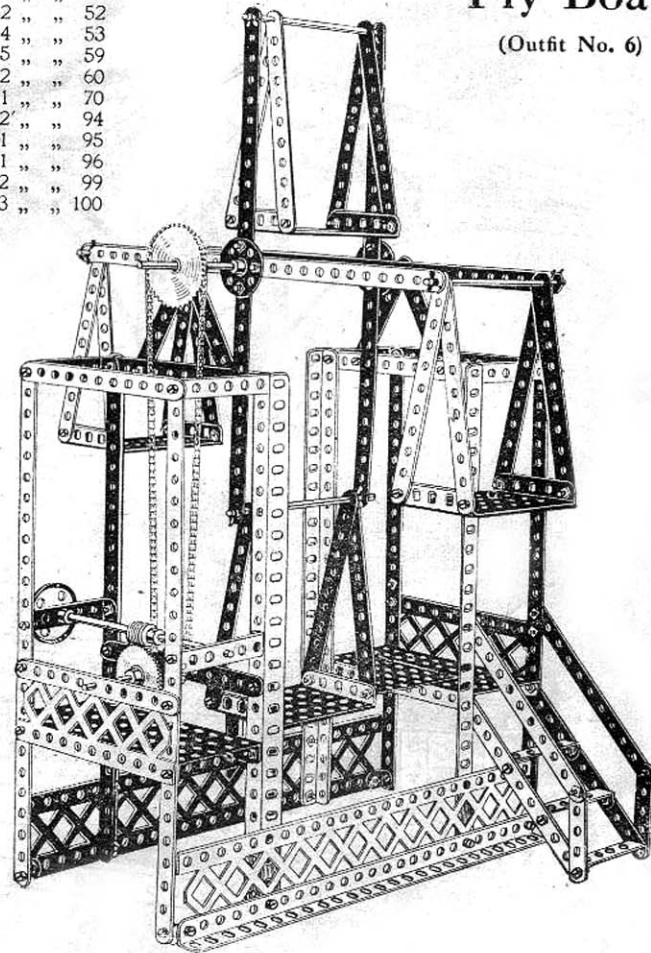

Model No. 384

(Outfit No. 4)

## Apparatus for Transforming a Circular Movement into a Rectilinear Movement

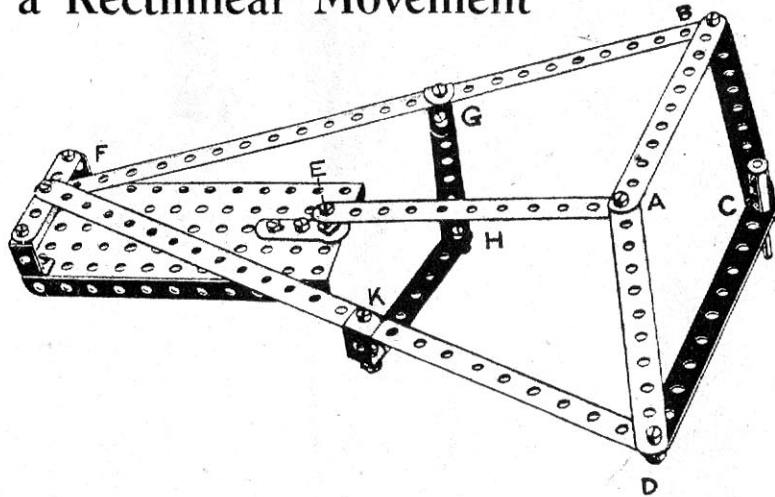

This most ingenious model was designed by M. Pierre-Th. Dufour, who used it in his Thesis presented to the Faculty of Science in Paris, to obtain his title of Doctor of the University of Paris. He required an instrument which would transform a circular movement into a movement rigorously rectilinear, and he states in his published work that he was able to do this "with the aid of Meccano parts which permit of making experiments so easily in mechanisms of the most varied types."

The point F is fixed, and is situated at a distance from the fixed point E, equal to AE, the two arms FB and FD being together equal to the four sides of the lozenge ABCD. The trajectory of the point C is then at right angles to EF, the point A is describing a circle round the fixed point E.

Every Meccano boy should make up this very interesting model, and experiment with it.

Parts  
Required:

2 of No.	1
5 " "	2
2 " "	3
1 " "	5
4 " "	11
1 " "	17
16 " "	37
1 " "	52
7 " "	59
1 " "	62
1 " "	63

Model No. 385

## Magic Sector Plates

(Outfit No. 2)

Parts  
Required:

2 of No.	11
1 " "	17
2 " "	35
6 " "	37
2 " "	54

When the cord is held vertically the magic sector plates will fall or stop at the bidding of the owner. If the cord is held without tension the plates will fall, but the instant the cord is tightened they will stop dead. The cord is wrapped once around the rod which passes through the centre holes of the Sector Plates.

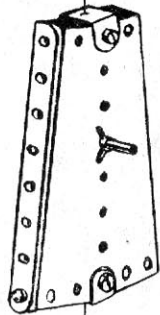

# Aeroscope

(Special Model)

The general construction of the model is clearly shown in the illustrations. The carriage rotates upon a series of wheels 1, upon the board 2, on which is fixed a circular rail 3, which is connected up to the wire 4A from the electric battery. A collector shoe 5 for picking up the current from the rail is guided in a 2½" bent strip 6, so that it rests lightly in contact, and the top of the rod is connected by a wire to a terminal on the motor.

The other terminal 4 from the battery is carried under the wooden base and brought up and -16 connected to a centre pivot screw 22, about which the carriage rotates, as shown in the detail view, Fig. 386B. The motor is thus driven as the carriage rotates on the wheels 1.

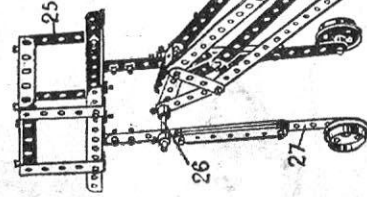

Parts

Required :

50 of No.	1	190 of No.	37
40 "	2	1 "	45
20 "	3	1 "	46
6 "	4	5 "	52
4 "	5	1 "	53
8 "	6	24 "	59
2 "	7	15 "	60
19 "	8	1 "	63
1 "	9	2 "	94
5 "	10	1 "	95
1 "	11	3 "	96
2 "	12	2 "	100
5 "	13		
10 "	14		
1 "	15		
2 "	16		
5 "	17		
20 "	18		
1 "	19		
1 "	20		
2 "	21		
4 "	22		
2 "	23		
1 "	24		
1 "	25		
1 "	26		
1 "	27		
1 "	28		
1 "	29		
1 "	30		
1 "	31		
1 "	32		

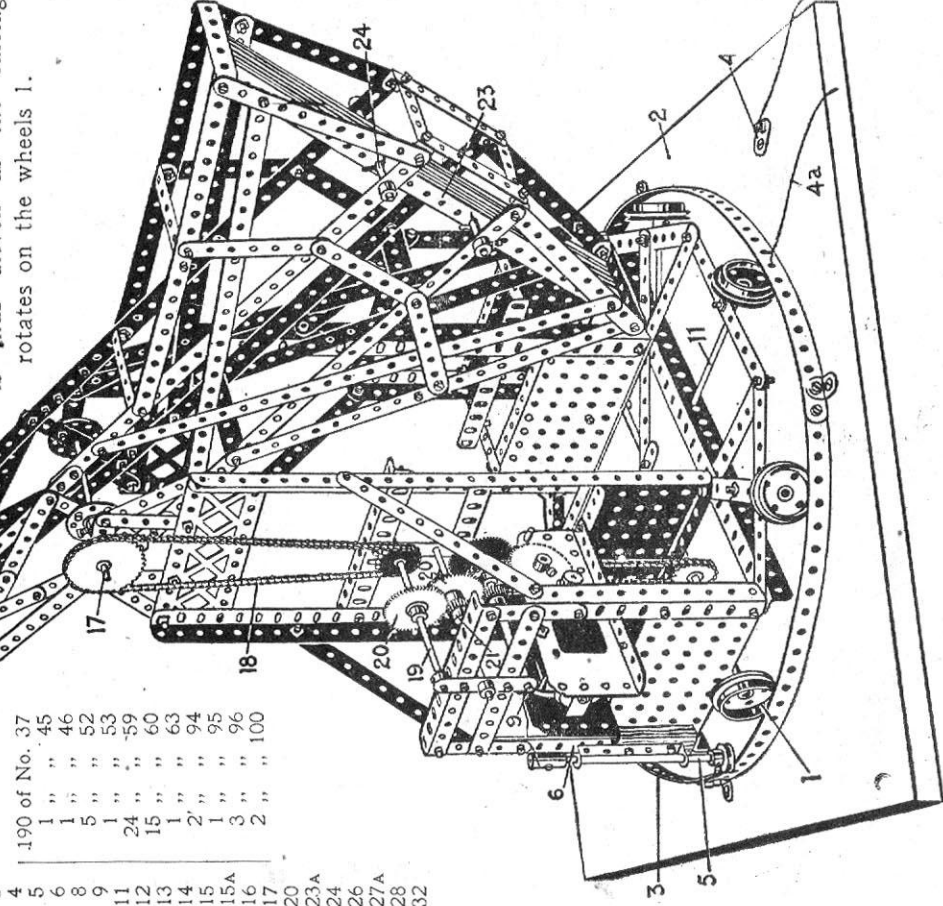

## Model No. 386 *Aeroscope* (contd.)

The rotation of the carriage is effected from the pinion 7, which gears with and drives a gear wheel on the spindle 8, on which latter is a worm gearing with a gear wheel 9, the spindle of which latter drives through the sprocket chain 10 and rod 11 on the outer ends of which are fixed flanged pulley wheels 12.

The wheels 12 at each end of the rod 11 are caused to rotate in opposite directions by means of the gear shown in Fig. 386B, the rod 11 being divided, and two pinions 13 and 14, secured on the separate parts of the rod, gearing with a contrate wheel 15, so that the flanged wheels at each end rotate in opposite directions. The end of one part of rod 11 is entered into the bore of the pinion 14, which is secured on the other part of the rod, the pinion 14 thus supporting the end of the other part of the rod 11.

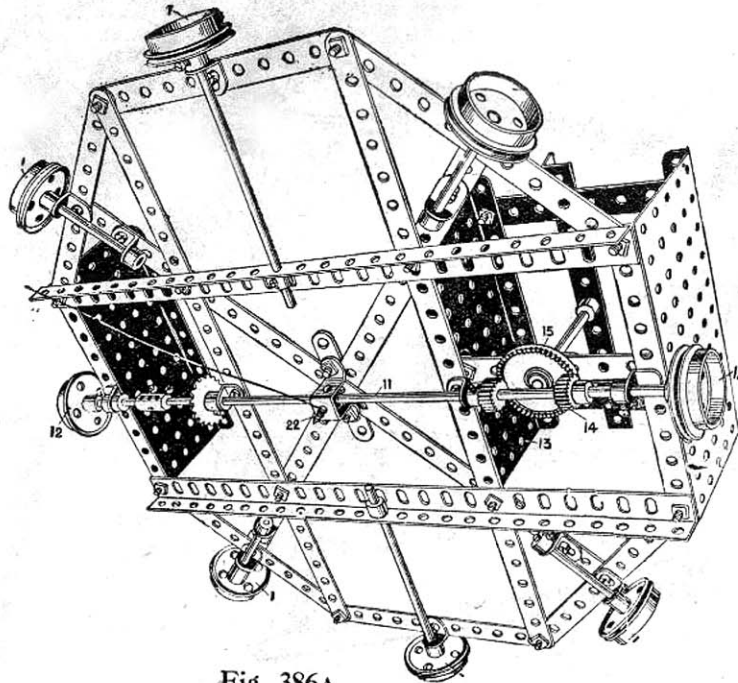

Fig. 386A

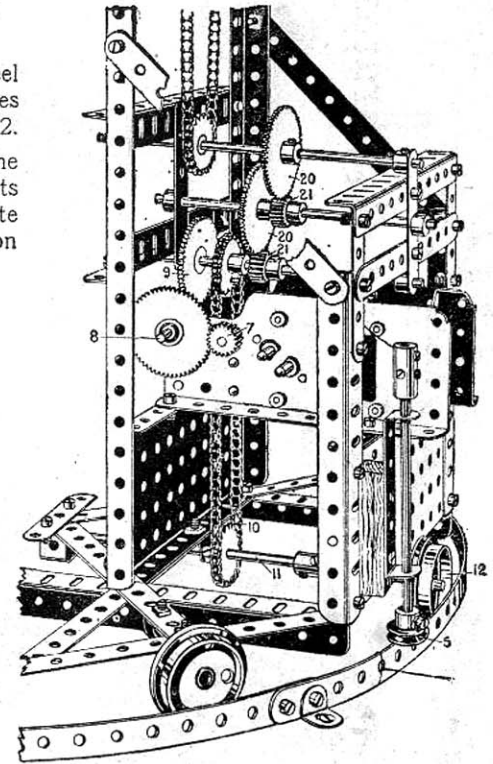

Fig. 386B

The weighted arm 16 is caused to swing about its pivot rod 17 by means of chain and sprocket gear 18 driven from a spindle 19 through a train of gears 20 and pinions 21 from the spindle 9. The arm 16 is balanced by a number of  $12\frac{1}{2}$ " strips 23, threaded on rods 24, secured to the framework. At the opposite end of the arm, the carriage 25 is pivoted on a rod 26, which passes through strips 27, which are suitably weighted by a number of strips and flanged wheels, so that the carriage always remains vertical while the arm swings over.

Model No. 387

# Well Boring Apparatus

Special Model

Parts Required:

4 of No.	1 of No.	28
14	1	32
16	5	37
10	8	38
4	9	45
4	11	46
1	13	52
1	15A	53
8	16	59
4	17	60
1	20A	62
2	21	63
1	22	65
1	25	94
2	26	95
1	27	96
2	27A	

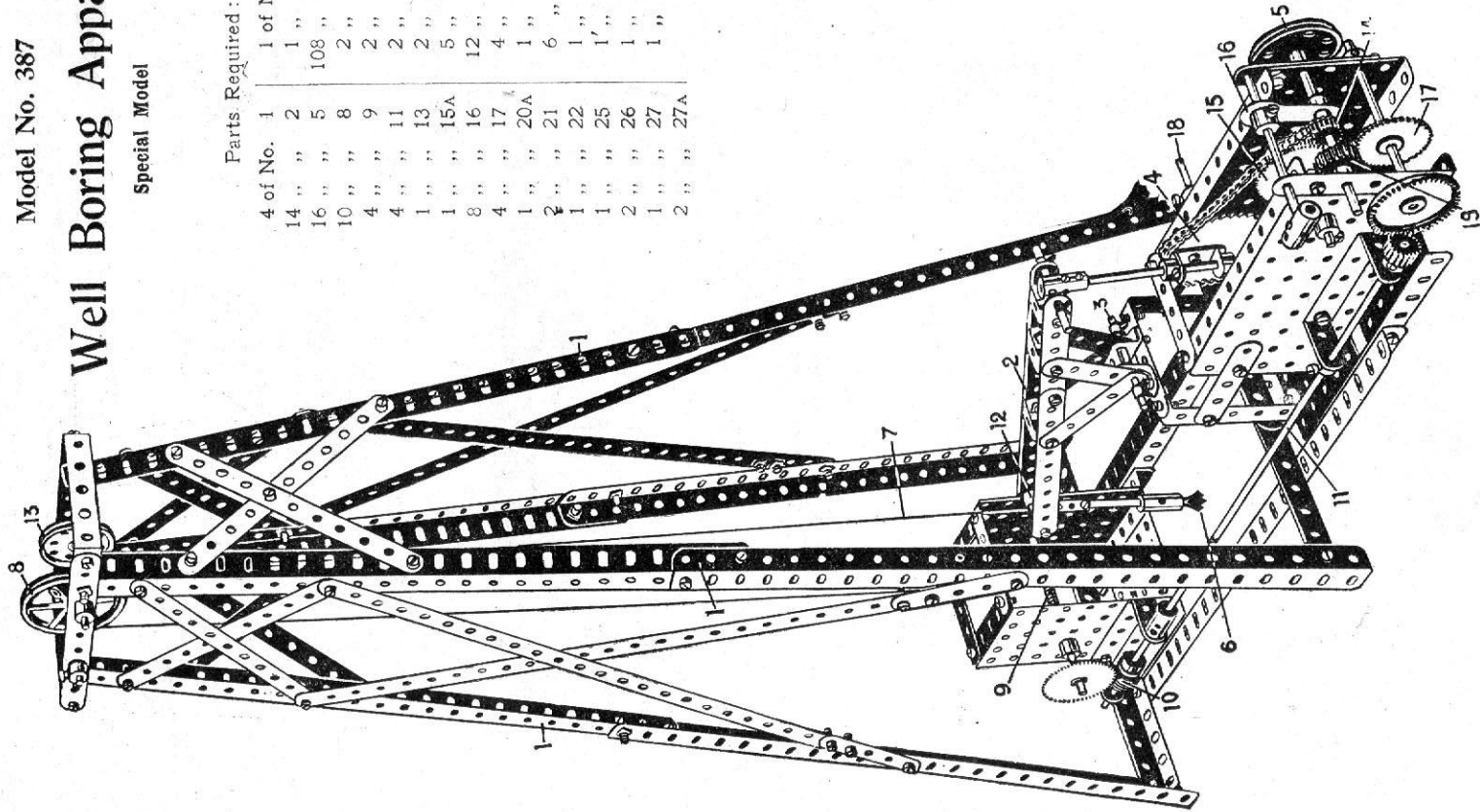



Model No. 387

## Well Boring Apparatus (continued)

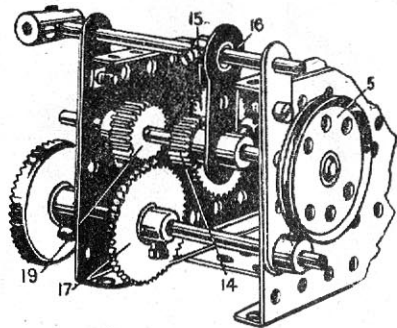

Fig. A

The bracing of the derrick 1 and its construction is well shown in the illustration. The "walking" beam 2 pivoted at 3 is driven with a quick see-saw motion from the 2" sprocket wheel 4 operated through a train of gears from the driving pulley 5, the pinion 14 being engaged with the 57-toothed gear wheel 15 by the crank 16 acting as a clutch. The walking beam carries the drill 6 by which the well is sunk. The cord 7 passes over the large pulley 8 and is paid out as required from the winding axle 9 driven by worm gearing 10 from the shaft 11 and is secured in the outer end 12 of the walking beam 2. As the hole is sunk the connection at 12 of the cord 7 is released and a further stretch of cord 7 passed through the grip 12 and again secured, this further stretch of cord being released from axle 9 by clutching the pinion 19 with the gear wheel 17. In this way additional lengths of cord 7 are paid out as the well sinks. In actual well boring apparatus, when drilling is commenced, the cord 7 is not connected to the walking beam, but a rope fastened to the crank on the sprocket wheel 4 is passed over the smaller pulley 13 at the top. A double bent strip is bolted on the side of the perforated plate to form an extended bearing for the spindle 18 (Fig. B).

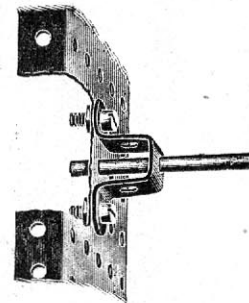
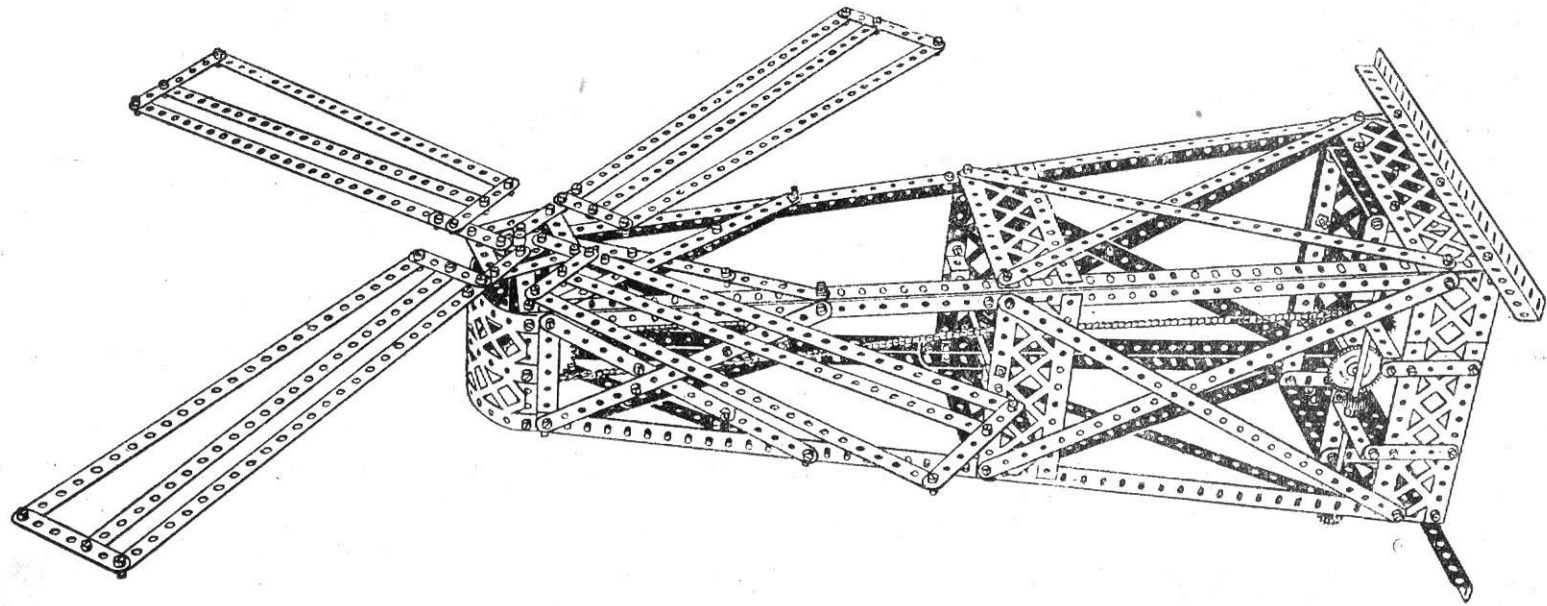

Fig. B

Model No. 388

# Windmill

(Outfit No. 6)



Parts  
Required:

20 of No.	1
24 " "	2
10 " "	3
14 " "	5
10 " "	8
2 " "	13A
2 " "	14
1 " "	15
1 " "	24
1 " "	26
1 " "	27A
1 " "	28
1 " "	32
2 " "	35
134 " "	37
4 " "	38
2 " "	45
2 " "	53
5 " "	59
2 " "	60
1 " "	62
4 " "	94
1 " "	95
1 " "	96
14 " "	100

## Model No. 389 Vertical Drill

(Outfit No. 6)

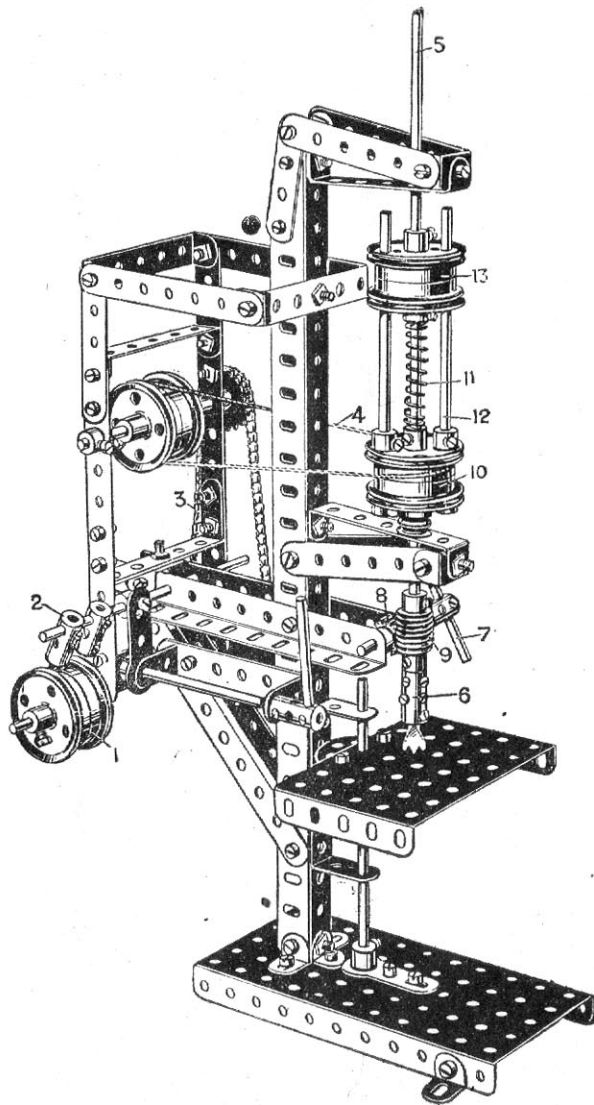

### Parts Required:

4 of No. 2	1 of No. 13	1 of No. 26	7 of No. 60
2 .. " 3	2 .. " 15	1 .. " 32	2 .. " 62
5 .. " 4	3 .. " 15A	55 .. " 37	5 .. " 63
2 .. " 5	2 .. " 16	2 .. " 46	1 .. " 65
2 .. " 6	3 .. " 17	1 .. " 52	1' .. " 94
2 .. " 8	8 .. " 20	1 .. " 53	1 .. " 95
2 .. " 9	2 .. " 23	8 .. " 59	1 .. " 96
2 .. " 11	1 .. " 24		

The fast and loose pulleys 1 fitted with a belt-shifting gear 2 drive through the sprocket chain 3 and cord 4 the drilling spindle 5. The drill chuck 6 is brought down on the work by turning a short rod 7 which rotates a pinion 8 gearing into a worm 9 on the drill spindle, the worm acting as a rack, rods 12 on the flanged wheels 10 sliding in the holes in the upper flanged wheels 13, the latter being secured to the spindle 5, a spring 11 normally keeping the drill on to the work.

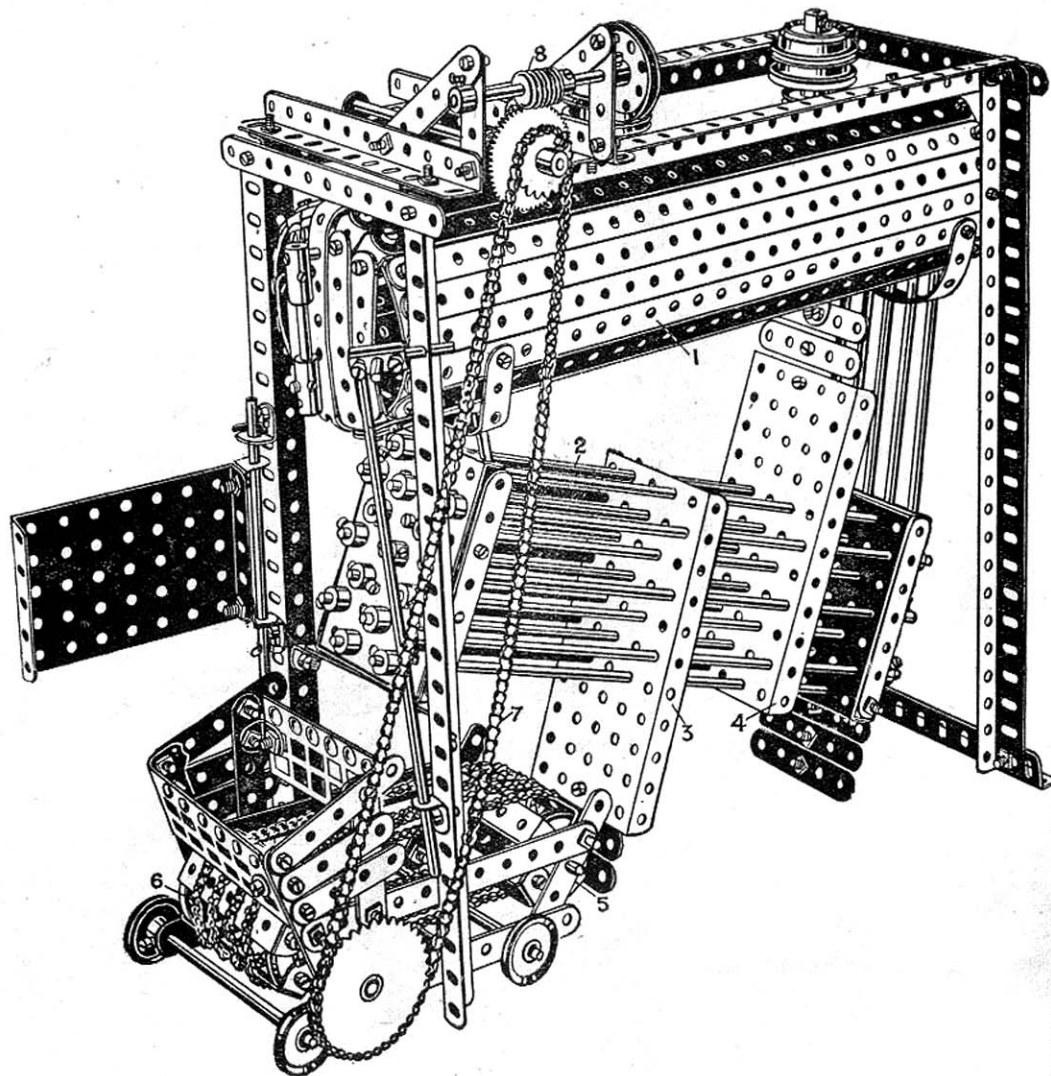

Model No. 390

# Babcock and Willcox Boiler

(Special Model)

Parts Required :

22 of No. 1	1	2 of No. 14	14
9 " " 2	2	8 " " 20	20
7 " " 3	3	1 " " 21	21
3 " " 4	4	8 " " 22	22
15 " " 5	5	1 " " 27A	27A
6 " " 6	6	1 " " 32	32
3 " " 6A	6A	21 " " 35	35
6 " " 8	8	140 " " 37	37
3 " " 9	9	2 " " 52	52
11 " " 12	12	4 " " 53	53
17 " " 13	13	24 " " 59	59
1 " " 13A	13A	9 " " 60	60
3 " " 15	15	2 " " 61	61
5 " " 15A	15A	5 " " 94	94
4 " " 16	16	1 " " 95	95
2 " " 17	17	1 " " 96	96
5 " " 18A	18A		

The upper steam drum 1 is made, as shown, of a number of perforated strips and the water tubes 2 are represented by rods passing through rectangular plates 3, 4, the plate 3 being set down and the plate 4 set up to produce the usual curved path for the furnace gases. The movable furnace 5 of the chain grate type consists of a number of chains 6 passing round drums made of short strips and is driven by the chain and sprocket gear 7 from the worm 8. The rest of the construction is clearly brought out in the illustration.

Model No. 391

Orrery (Special Model)

Apparatus for showing the rotation and revolution of the earth.

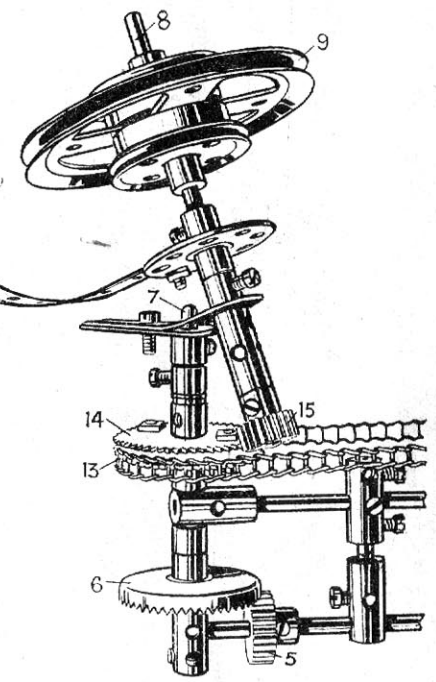
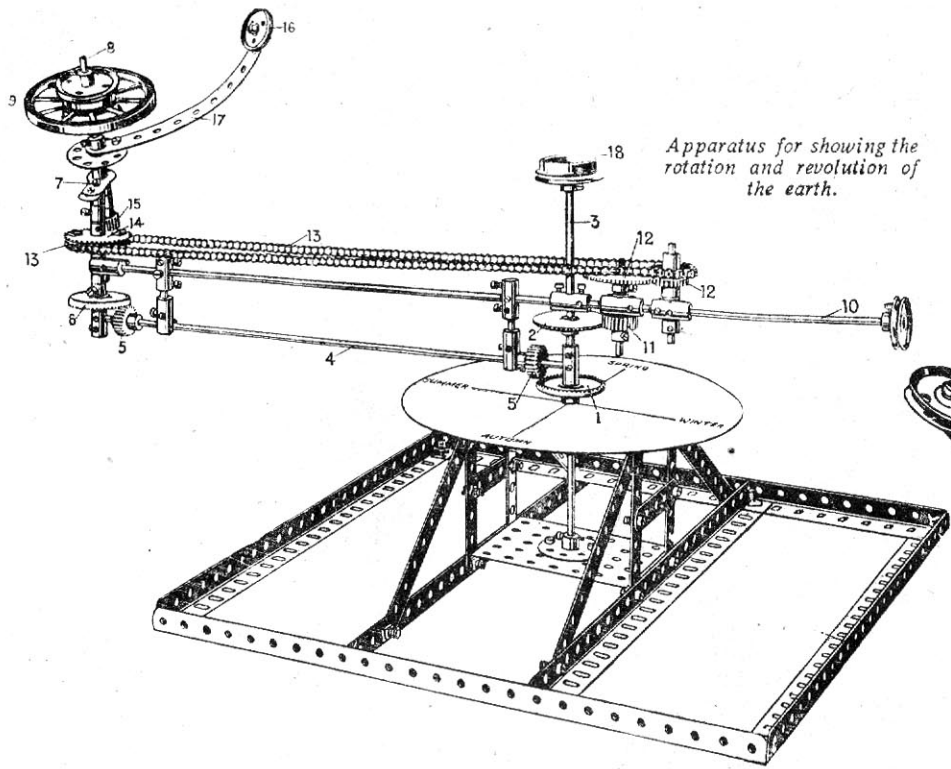

Parts Required :

5 of No.	2
4 " "	3
2 " "	5
6 " "	8
2 " "	13
1 " "	13A
1 " "	15
1 " "	15A
2 " "	16
1 " "	17
4 " "	18A
1 " "	19B
3 " "	20
1 " "	22
1 " "	22A
2 " "	24
4 " "	25
1 " "	26
4 " "	27A
2 " "	28
30 " "	37
10 " "	38
2 " "	53
5 " "	59
2 " "	62
11 " "	63
2 1/2 " "	94
1 " "	96

This is an excellent educational model. The contrate wheel 1 and gear wheel 2 are fixed on the vertical spindle 3 which does not rotate. The lower horizontal rod 4 rotates, and by means of the pinions 5 and contrate wheel 6 provides a compensating movement during revolution for the spindle 7, from which the rod 8 is carried at an inclination corresponding to the inclination of the earth's axis to the plane of the ecliptic. As the earth, represented by the large wheel 9 which is clamped by a flanged wheel on each side, is revolved round the spindle 3 by the horizontal rod 10 the direction of the axis 8 remains constant therefore. The rotational movement of the earth about its axis is effected from the pinion 11 engaging the fixed gear 2 and driving through the gear wheels 12 the chain and sprocket gear 13 loose on the spindle 7. Fixed to and rotating with the sprocket wheel 13 (wheel 13 is a 57-toothed gear wheel used as a sprocket wheel) is an upper gear wheel 14 which is engaged by a pinion 15 on the lower end of the rod 8. When, therefore, the system is revolved about the spindle 3 the earth wheel 9 is rotated about its axis 8 and owing to the compensating movement given by the rod 4 the direction of the axis is maintained. The moon wheel 16 is mounted on a bent strip 17 which is secured to a bush wheel which revolves loosely about the axle rod 8. A candle may be supported in the flanged wheel 18 to represent the sun, and a ball fixed on the rod to represent the earth, in place of the wheel 9, and the day and night effect at the four seasons clearly illustrated.

Model No. 392

## Drop Hammer

(Outfit No. 6)

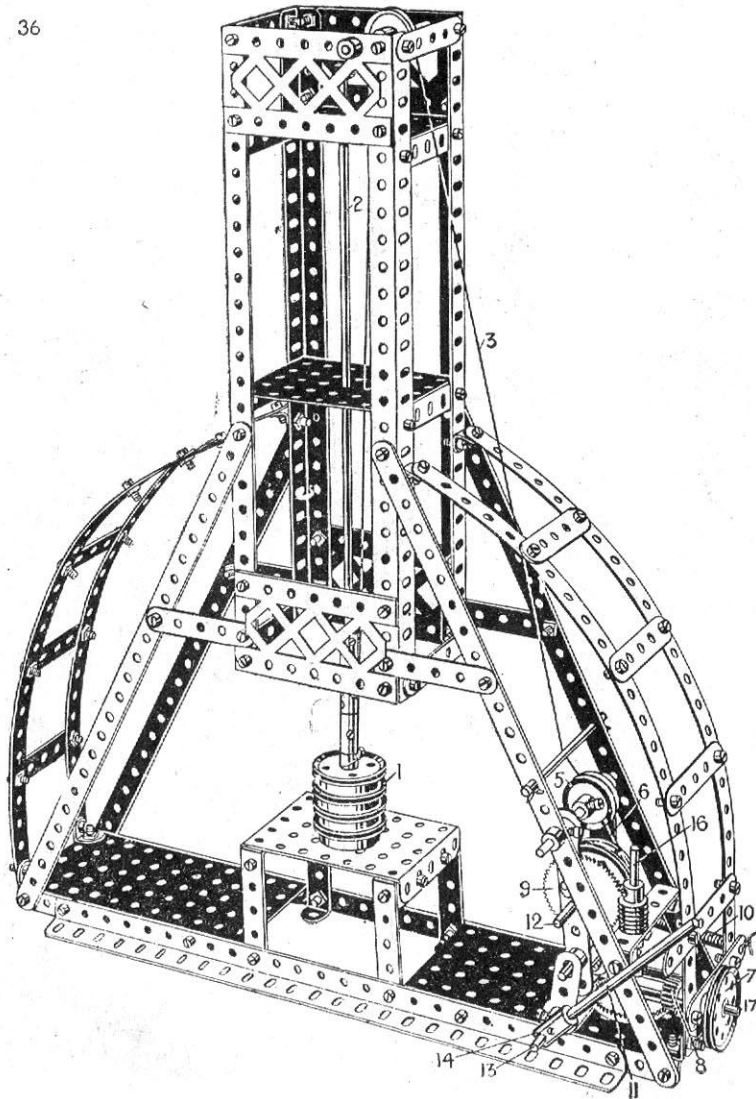

## Parts Required :

8 of No.	1	4 of No.	16	2 of No.	35
3 "	3	3 "	17	112 "	37
3 "	4	5 "	20	1 "	43
13 "	5	1 "	21	2 "	52
6 "	8	3 "	22	3 "	53
2 "	11	1 "	24	8 "	59
8 "	12	1 "	26	8 "	60
1 "	13	1 "	27A	3 "	62
1 "	15	1 "	28	6 "	63
2 "	15A	1 "	32	4 "	97

The weighted hammer head 1 is fixed at the end of the slidabie rod 2 and lifted by a cord 3 connected to the head and passing over a pulley and between guide pulleys 5 on to a winding drum of two flanged wheels 6. The driving pulley 7 is geared by a pinion 8 to a contrate wheel, on the spindle of which is a worm gearing with a 57-toothed gear wheel 9 by which the cord is operated. The coupling 15 is threaded on the upright spindle 16 and forms a bearing for the axle 17. The gear wheel 9 and flanged wheels 6 are held in engagement with the worm by the pull of a spring 10 when raising the hammer, but may be disengaged, in order to drop the hammer, by the handle-rod 11 secured to the rod 12 about which the geared wheel 9 pivots. To the rod 13 a crank is secured on each side of the winding-drum mechanism, to which also is secured the coupling 14 and a corresponding coupling at the other end of the rod to which the spring 10 is attached. This rod is pivotally attached to a 2½" bent strip bolted to the base plate:

Model No. 393

## Punching Press

(Outfit No. 6)

## Parts Required:

1 of No. 2	29 of No. 37
2 " " 3	22 " " 38
4 " " 4	1 " " 45
7 " " 5	1 " " 52
2 " " 6	2 " " 53
1 " " 14	2 " " 54
2 " " 16	15 " " 59
5 " " 17	2 " " 60
2 " " 19B	2 " " 62
2 " " 26	2 " " 63
2 " " 27A	

The rod 2 carrying the flywheels 1 is journaled in cranks 3, pinions 4 driving the large gear wheels 5 on short rods 6. The cranks by which the punch rods 7 are operated consist of couplings 8 secured at their middle holes to the ends of the short rods 6, the strips 9 operating the punch rods 7 being connected by screws 10 to one of the outer holes of the coupling.

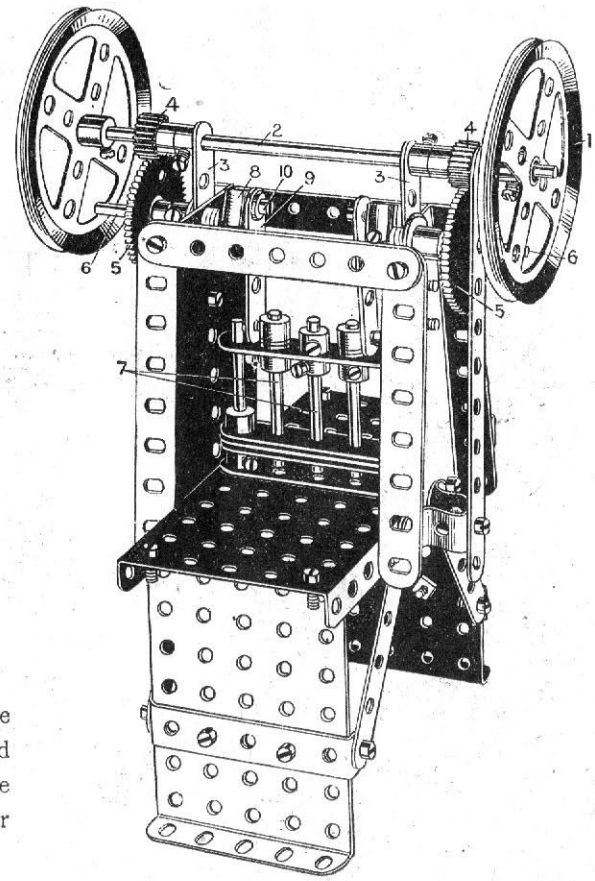

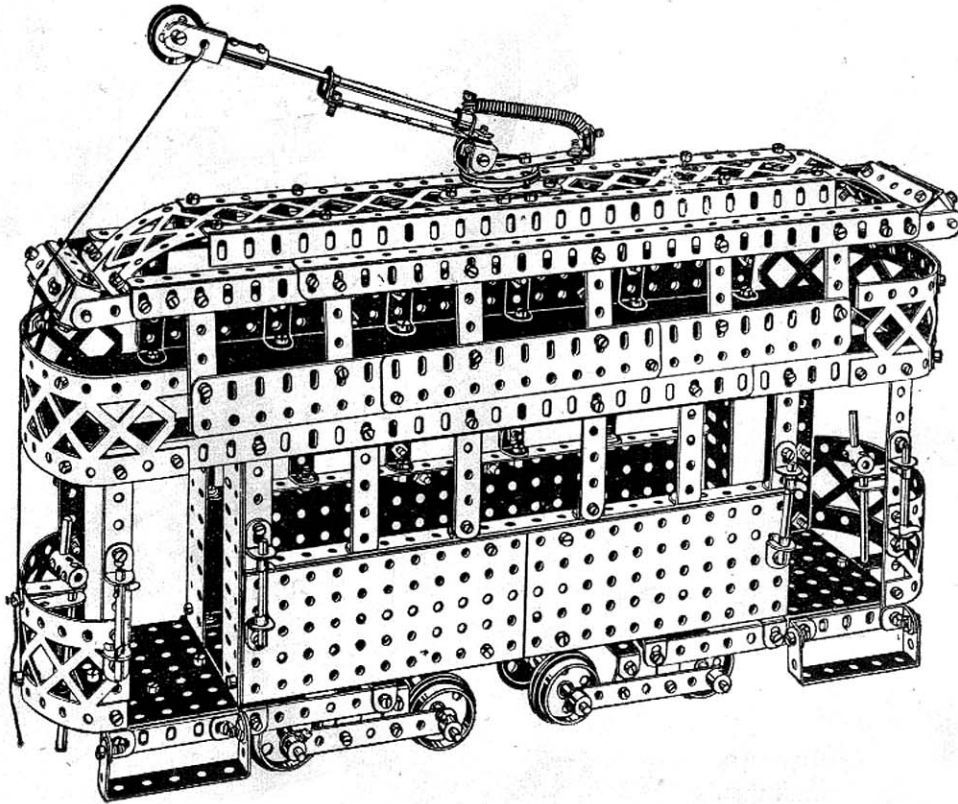

## Parts Required:

8 of No. 2	21 of No. 35
11 " " 3	225 " " 37
2 " " 4	1 " " 43
17 " " 5	3 " " 44
8 " " 8	4 " " 46
2 " " 9	4 " " 52
10 " " 11	2 " " 53
49 " " 12	12 " " 59
1 " " 15	24 " " 60
8 " " 16	1 " " 63
8 " " 17	2 " " 99
5 " " 18A	6 " " 100
10 " " 20	6 " " 103
1 " " 21	
1 " " 22A	



# Model No. 395 Punching Machine

(Outfit No. 6)

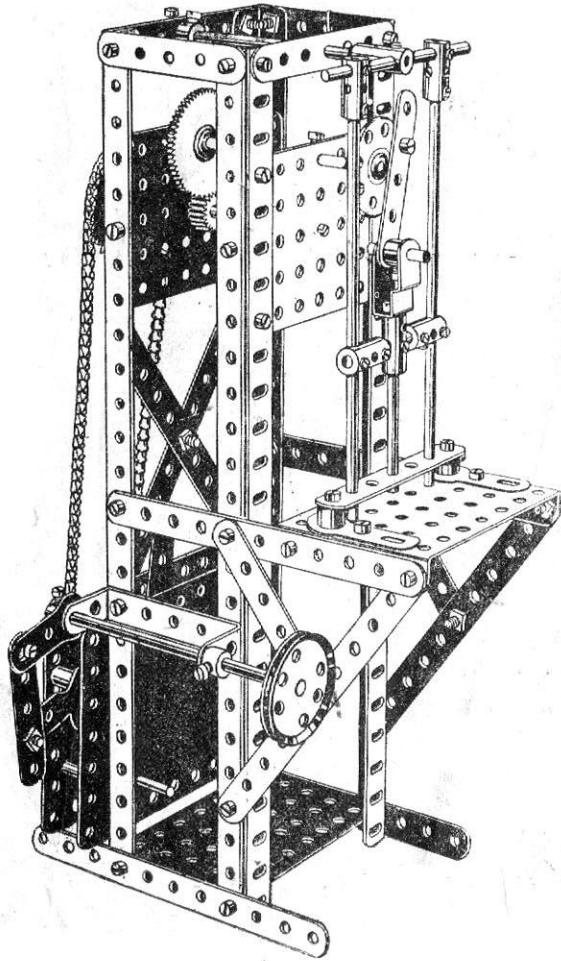

Parts  
Required:

- 8 of No. 2
- 3 " " 3
- 2 " " 4
- 4 " " 5
- 4 " " 8
- 2 " " 14
- 2 " " 15A
- 2 " " 16
- 2 " " 17
- 1 " " 18A
- 1 " " 21
- 1 " " 24
- 1 " " 26
- 1 " " 27A
- 50 " " 37
- 2 " " 38
- 1 " " 44
- 1 " " 46
- 4 " " 53
- 6 " " 59
- 3 " " 62
- 6 " " 63
- 2 " " 94
- 1 " " 95
- 1 " " 96

# Model No. 396 Butter Churn

(Outfit No. 4)

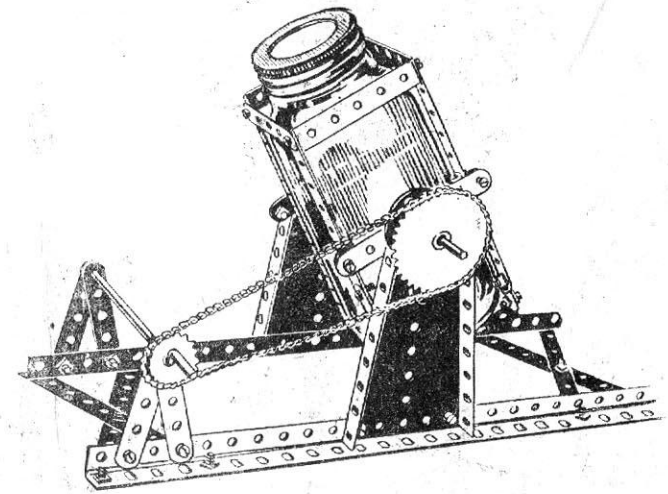

Parts Required:

- |            |             |             |             |
|------------|-------------|-------------|-------------|
| 2 of No. 2 | 4 of No. 12 | 2 of No. 24 | 4 of No. 60 |
| 2 " " 3    | 1 " " 17    | 50 " " 37   | 2 " " 62    |
| 2 " " 4    | 1 " " 18A   | 2 " " 54    | 1 " " 95    |
| 10 " " 5   | 1 " " 19    | 2 " " 59    | 1 " " 96    |
| 2 " " 8    |             |             |             |

See Notice Page 3.

Model No. 397

# Transporter Bridge

(Special Model)

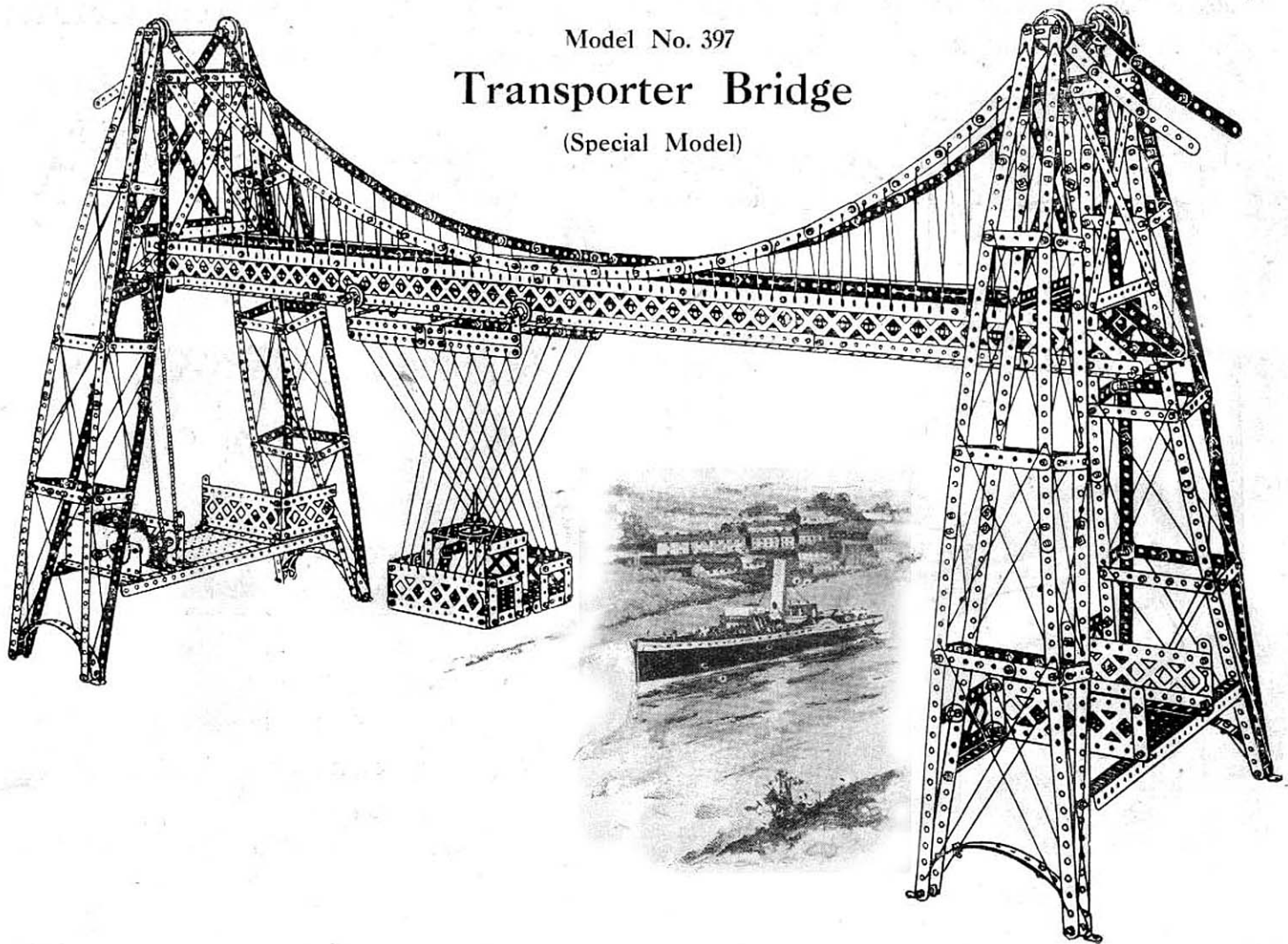

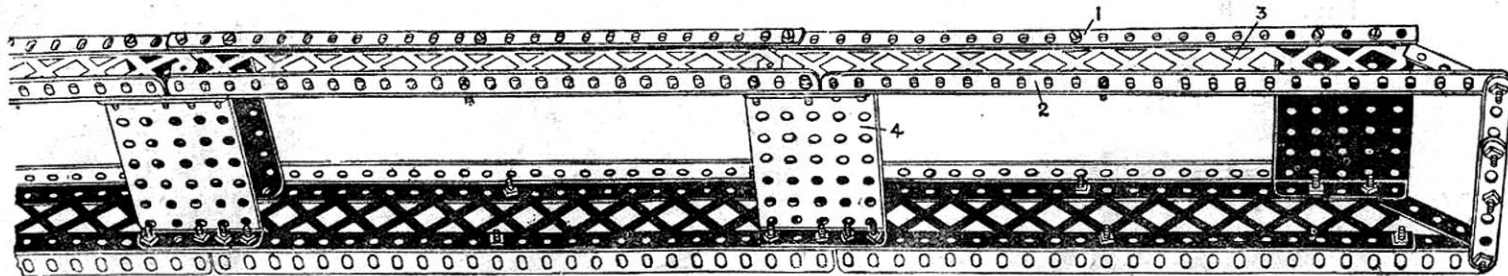

Fig. 397A—Girder Section

Model No. 397  
**Transporter**  
*(contd.)*

Parts Required:

32 of No. 1	4 of No. 20
52 " " 2	1 " " 21
8 " " 3	5 " " 22
32 " " 4	1 " " 26
120 " " 5	1 " " 27A
32 " " 6	507 " " 37
4 " " 7	6 " " 52
20 " " 8	7 " " 53
8 " " 9	15 " " 59
4 " " 10	10 " " 60
10 " " 11	10 " " 94
89 " " 12	4 " " 96
3 " " 14	3 " " 97
2 " " 15A	8 " " 99
1 " " 17	6 " " 100
4 " " 18A	

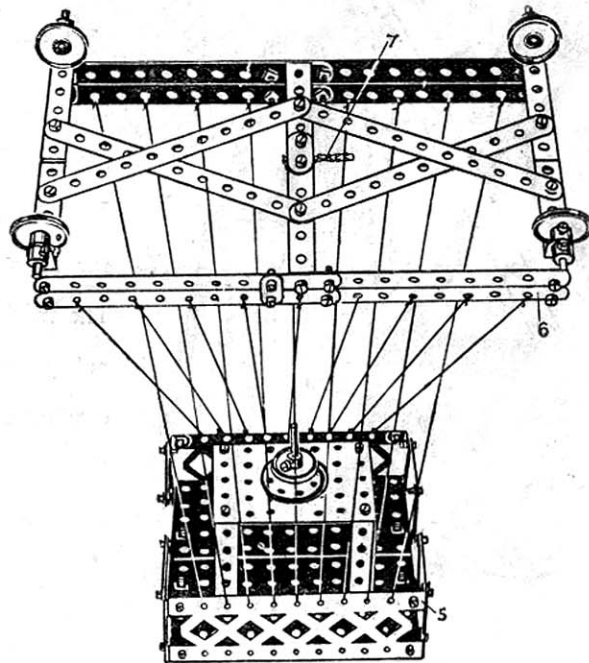
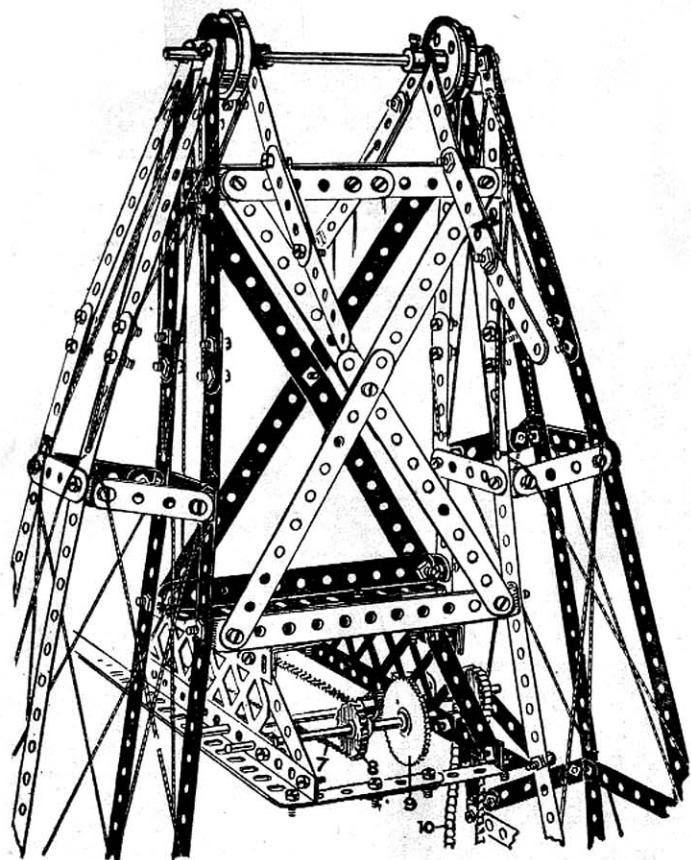

Fig. 397C—Travelling Platform

Fig. 397B



Model No. 397

## Transporter—*continued*

The main girder is built up of side pieces, Fig. 397A consisting of top and bottom angle girders 1, 2, reversed, and connected together by braced girderstrip 3. The sides are connected across by small rectangular plates 4. The ends of the main girder are supported from the end towers, as shown in Fig. 397B. The travelling platform 5, Fig. 397c, supported from the carriage 6, runs on 1" pulleys, which travel along the outer edges of the lower angle girders 2. The carriage 6 is moved by a sprocket chain 7 passing round wheels 8 supported in the main girder and operated from the pinion and 56-toothed gear wheel 9 by the sprocket chain 10 driven by the motor.

Model No. 398

**Yacht**

(Outfit No. 6)

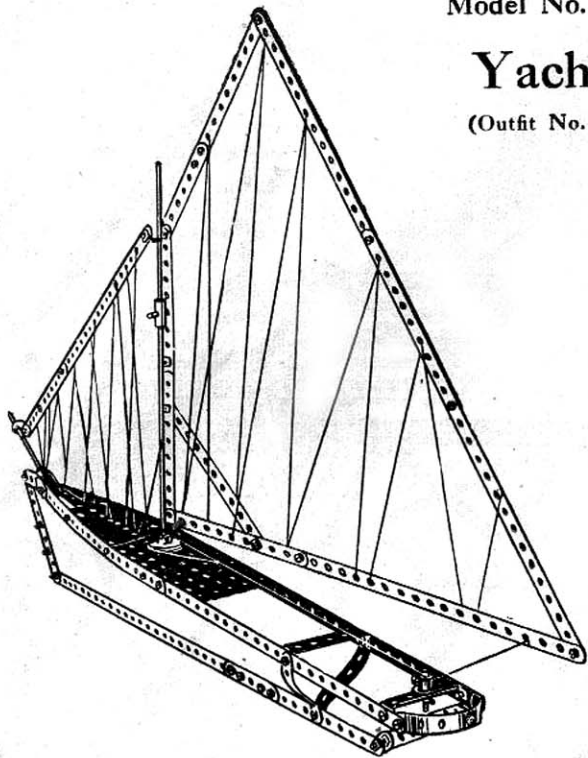

Parts Required :

9 of No. 1	5 of No. 12	1 of No. 44
7 " " 2	1 " " 13A	1 " " 52
4 " " 3	2 " " 15	1 " " 54
2 " " 4	2 " " 18A	2 " " 60
2 " " 5	1 " " 22	1 " " 63
1 " " 10	51 " " 37	

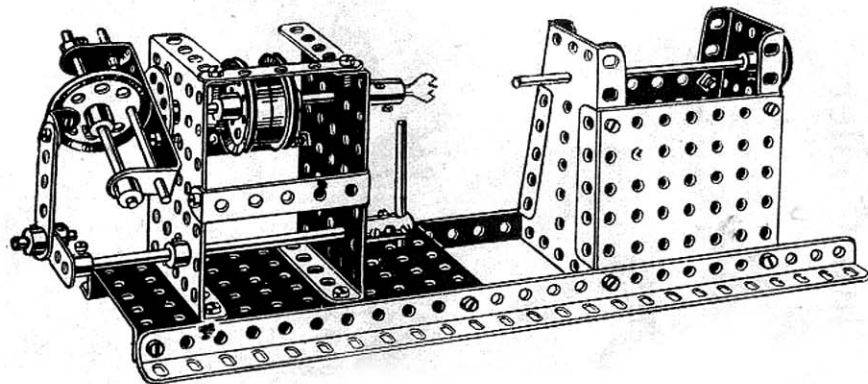

Model No. 399

**Elliptic Lathe**

(Outfit No. 4)

Parts Required :

2 of No. 5	2 of No. 20	4 of No. 53
2 " " 8	1 " " 21	2 " " 54
1 " " 12	1 " " 22	8 " " 59
2 " " 15	1 " " 24	2 " " 60
1 " " 15A	2 " " 35	1 " " 62
2 " " 16	26 " " 37	2 " " 63
1 " " 17	1 " " 46	1 " " 65
1 " " 18A	1 " " 52	

# Model No. 400 High-Speed Ship Coaler

(Special Model)

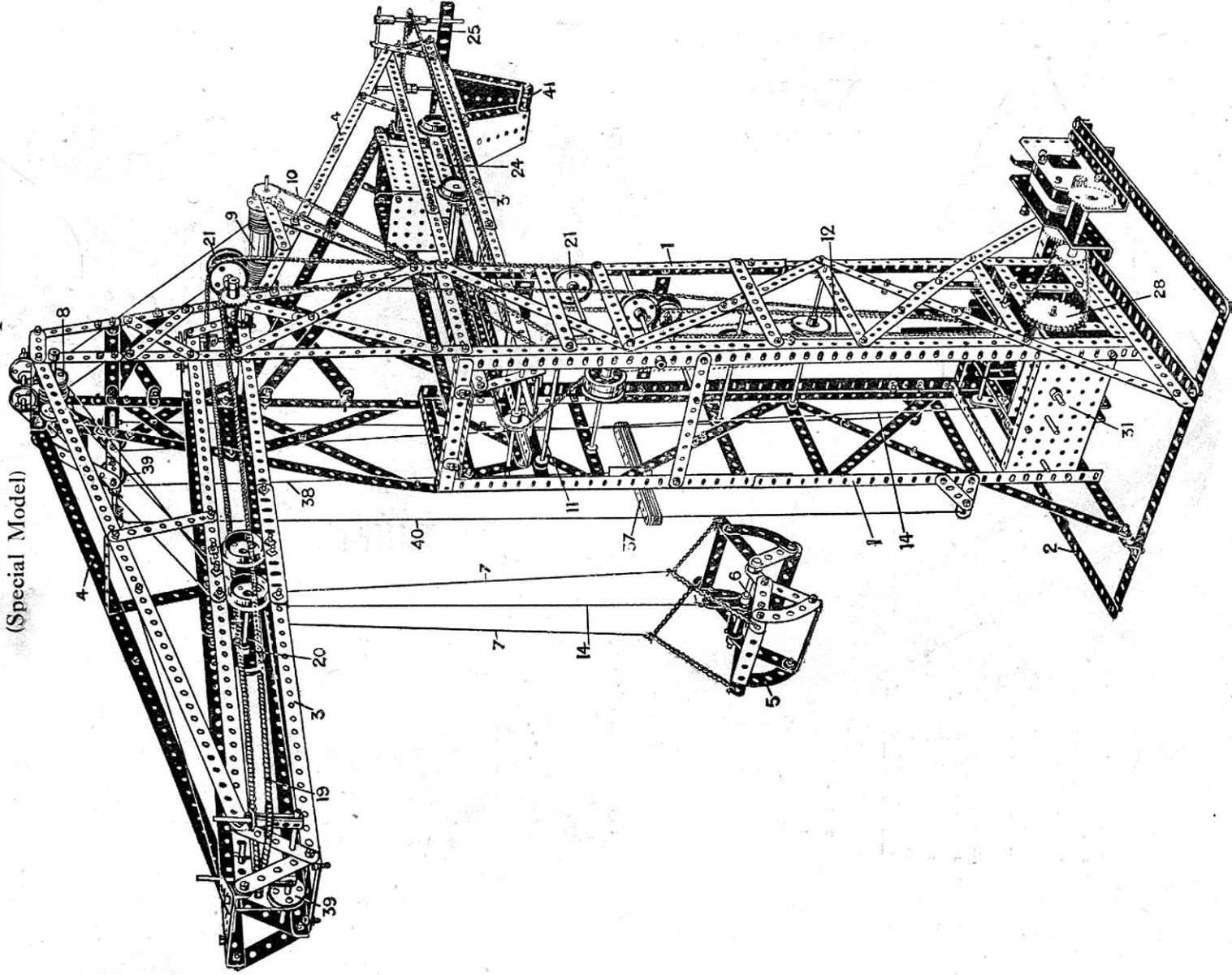

# Model No. 400 High-Speed Ship Coaler (contd.)

Parts Required:

24 of No. 1	11 of No. 16	1 of No. 46
63 " " 2	3 " " 17	4 " " 52
23 " " 3	19 " " 20	2 " " 53
6 " " 4	9 " " 22A	2 " " 54
26 " " 5	4 " " 23	34 " " 59
13 " " 6	1 " " 23A	6 " " 60
5 " " 7	5 " " 24	3 " " 62
21 " " 8	1 " " 25	7 " " 63
8 " " 9	3 " " 26	1 " " 70
5 " " 10	1 " " 27	2 " " 72
7 " " 11	1 " " 27A	4 " " 90
35 " " 12	2 " " 29	24 " " 94
1 " " 13A	1 " " 32	1 " " 95
8 " " 14	12 " " 35	17 " " 96
7 " " 15	353 " " 37	2 " " 106
4 " " 15A	3 " " 43	

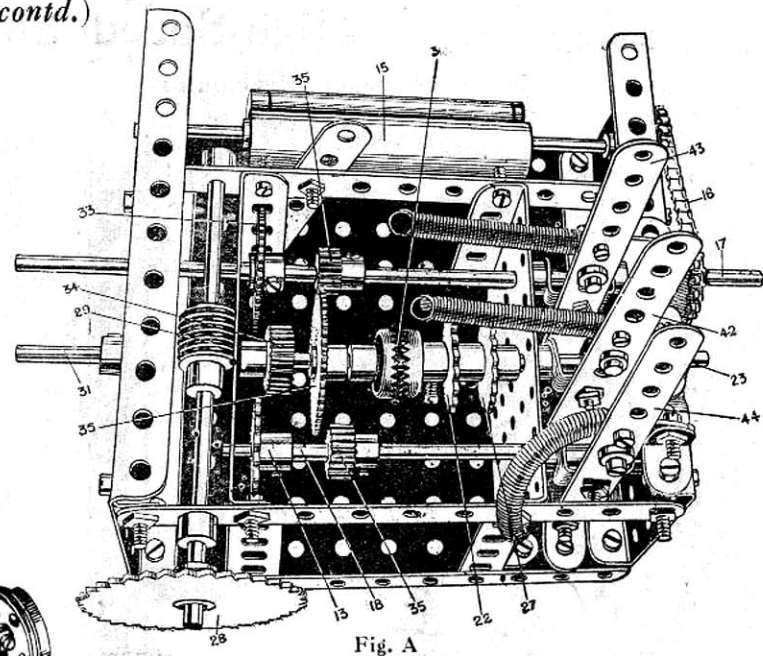

Fig. A

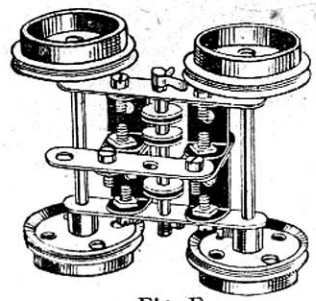

Fig. E

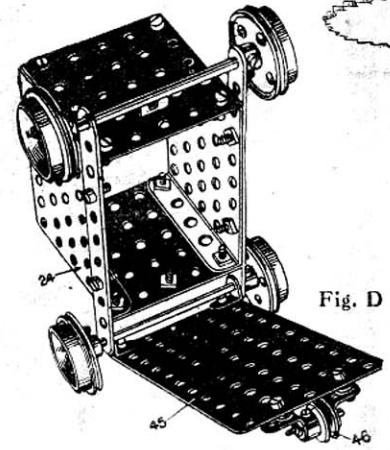

Fig. D

# Model No. 400 High-Speed Ship Coaler (Continued)

Fig. B—Sprocket Mechanism

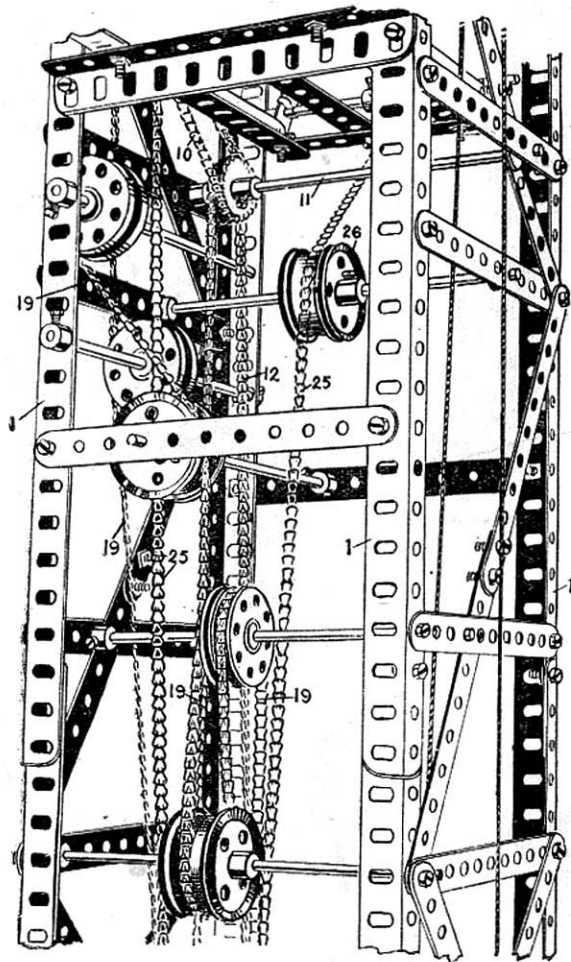
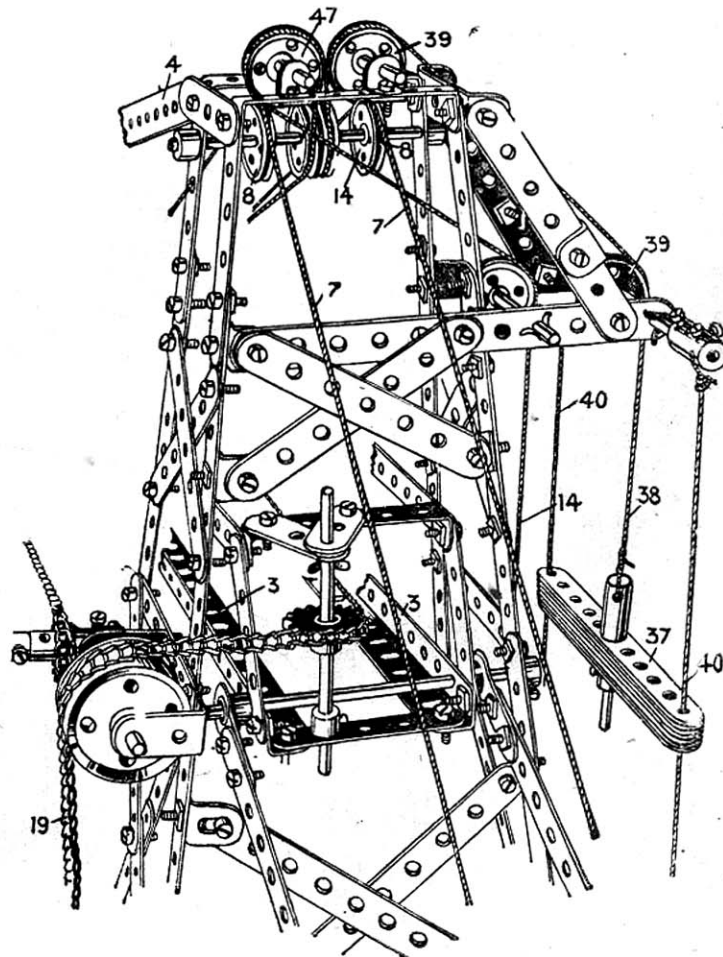

Fig. C





## Model No. 400 High-Speed Ship Coaler (Continued)

Fig. 400A is a detail view of the main driving mechanism.

Fig. 400B shows the chain and sprocket mechanism, Fig. 400C is a top view of the head. Fig. 400D is an underneath view of the wagon, showing the hinged bottom, and Fig. 400E is an underneath view of the running carriage.

The main upright framework is built up as shown from the corner angle girders 1, overlapping three holes and bolted to a base frame 2. The runways are also built of angle girders 3, which form the rails and are braced by strips 4 to the head frame. The grab 5 is built of two jaws pivoted on the rod 6, the outer ends of which are connected to operating cords 7, which pass over pulleys 8 in the head, and on to a wooden roller 9, which is driven by chain and sprocket gear 10 from a spindle 11 driven in turn by chain and sprocket gear 12 from a sprocket wheel 13 on the spindle 18. The grab jaws are closed by the raising of the centre cord 14, which passes round a pulley 47 at the head, and winds on another wooden roller 15 driven by chain and sprocket gear 16 from the spindle 17.

The grab 5 is traversed along the arm 3 by a chain 19 connected to the running carriage 20, and passing round pulleys 21 to a sprocket wheel 22 on the centre spindle 23 of the main gear box, Fig. 400A. The wagon 24 (Fig. 400D) on the other arm 3 is traversed along its rails by a sprocket chain 25 passing round pulleys 26 on to another sprocket 27 on the same spindle 23. The gear box is actuated from the motor by chain and sprocket gear 28, driving a worm 29 gearing with a  $\frac{1}{2}$ " pinion on the centre spindle 31, and a clutch mechanism 30 operated by a clutch lever 42 is provided for throwing the traversing chains 19 and 25 out of, or in, gear. In this way the grab and bucket move in unison outward along the arms, or inward, according to the direction of rotation of the centre spindle 31, which is controlled by the lever switch of the motor.

The opening and closing action of the grab is effected by throwing out of gear the sprocket chain mechanism 10 and 12 controlling the drum 9 by means of the lever 43, spindle 17 being in engagement, and driving from the centre spindle 31. On a downward movement of the grab the jaws will open; but on an upward movement the jaws will close, the outer operating cords 7 from the drum 9 being stationary, and only the inner cord 14 from the drum 15 being operated. When the grabjaws are open or closed, as desired, the lever 44 is then operated to clutch the outer spindle 18 to the centre spindle 31, the three operating cords 7 and 14 of the grab then winding on or off the drums, according as the grab is being raised or lowered.

For grabbing the load, the larger gear 33 and pinion 34 are brought in mesh by the lever 43, and in raising or lowering the load the gears 35 are brought in mesh by the levers 43 and 44. The weight of the grab and its load would tend to thrust the carriage 20 inward, and in order to counteract this, a balance weight 37, formed of a number of  $5\frac{1}{2}$ " strips, is connected by a cord 38 round the pulley 39 to the outer end of the carriage 20, the balance weight 37 rising and falling on the guide cords 40 as the carriage 20 moves in or out along the arm 3. In operation, the load, being raised by the grab, is then traversed into the centre of the machine, the wagon 24 moving in simultaneously until the grab is above the wagon, when the load is dumped into the wagon, and on the next outward movement of the grab the wagon moves outward until it arrives over the chute 41, the pivoted bottom 45 of the wagon falling and permitting the contents to discharge down the chute. The bottom of the wagon falls by reason of the front pulley 46 running down a curved rail which is bent down the inclined side of the chute 41.

# Eiffel Tower

(Special Model)

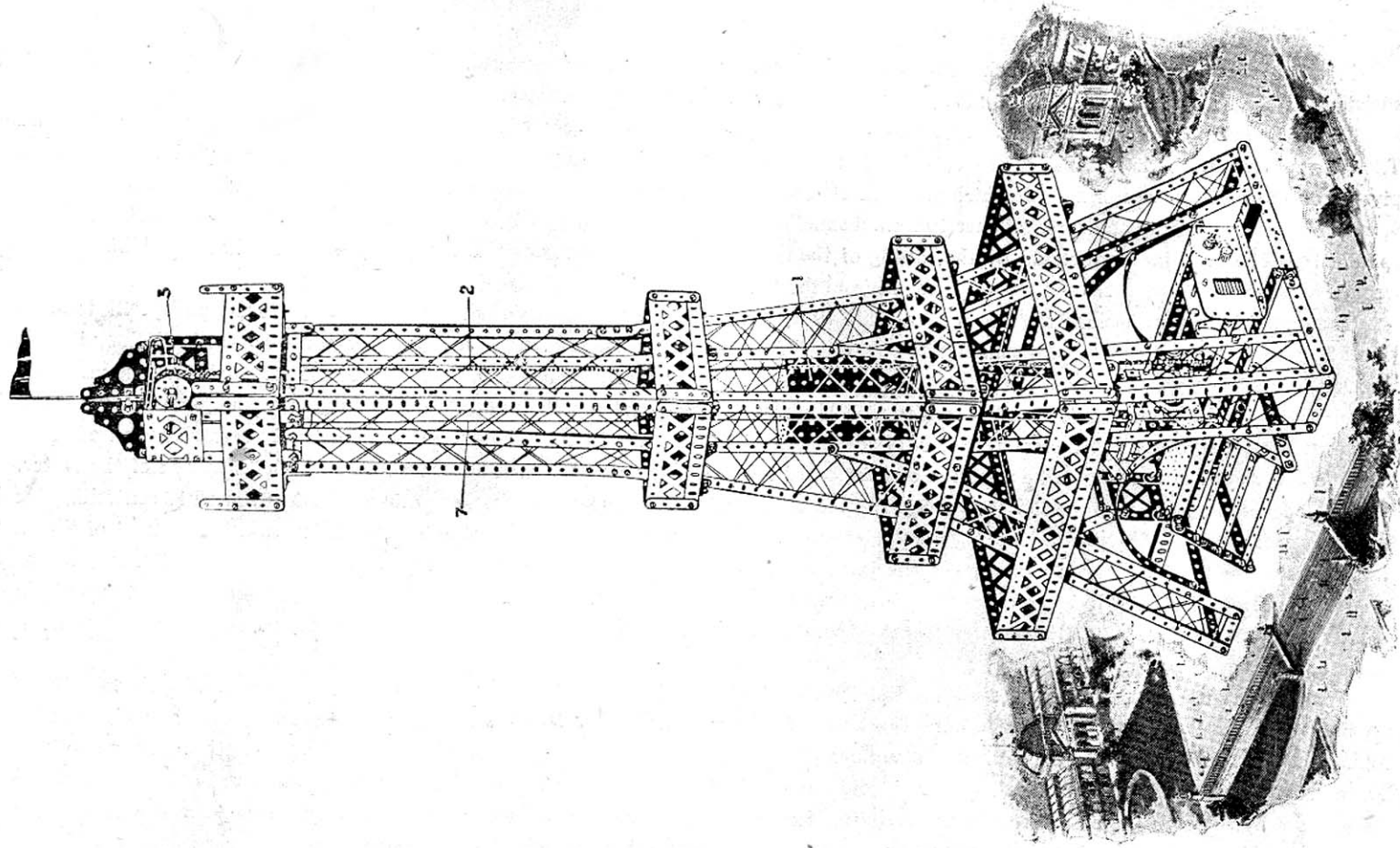

# Model No. 401 Eiffel Tower (Continued)

## Parts Required:

22 of No.	1
27 " "	2
6 " "	3
12 " "	4
14 " "	5
24 " "	6
20 " "	8
16 " "	9
72 " "	12
4 " "	12A
1 " "	13
1 " "	15
2 " "	15A
1 " "	16
1 " "	20
1 " "	24
1 " "	27A
1 " "	32
337 " "	37
1 " "	46
3 " "	52
3 " "	53
6 " "	59
4 " "	60
2 " "	72
8 " "	94
1 " "	95
4 " "	99
16 " "	100
4 " "	108

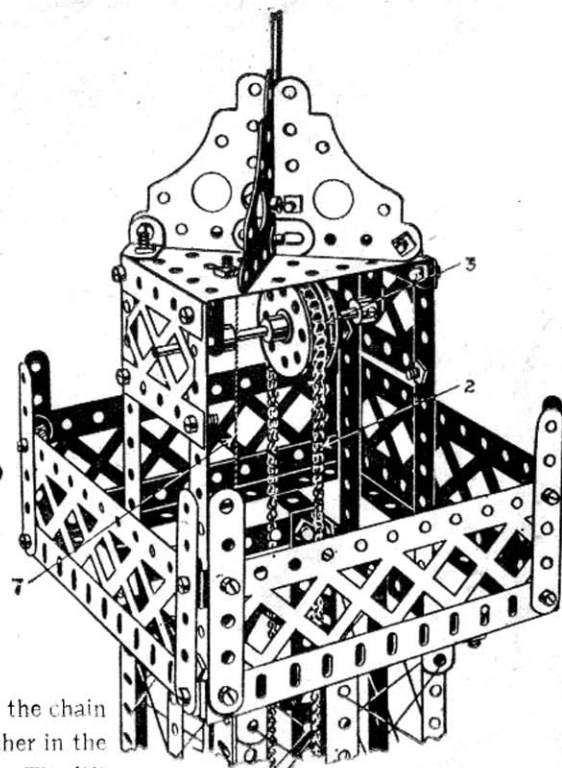
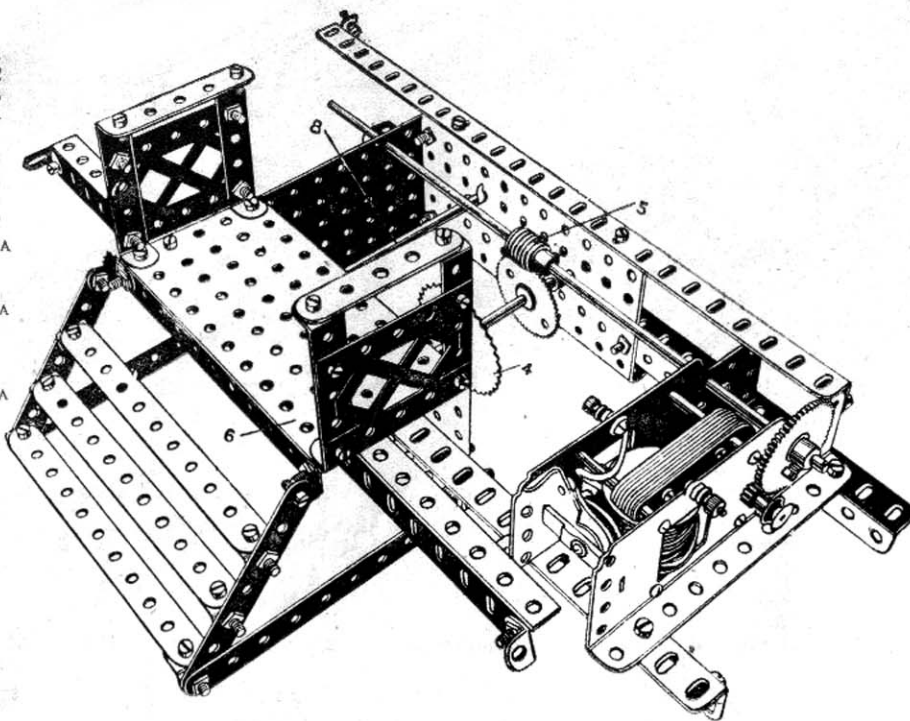

No description is necessary of the tower itself. The lift carriage 1 is raised and lowered by the chain 2 which passes over a pulley wheel 3 formed by butting a flanged wheel and a bush wheel together in the top, and a 2" sprocket wheel 4 in the bottom, driven by the worm gearing 5 from the motor. The lift carriage is brought to rest at the platform 6, and is guided by the cord 7 passing through the holes in the perforated plates of the lift carriages, the cord being secured to the top of the tower and to the rod 8 at the bottom.

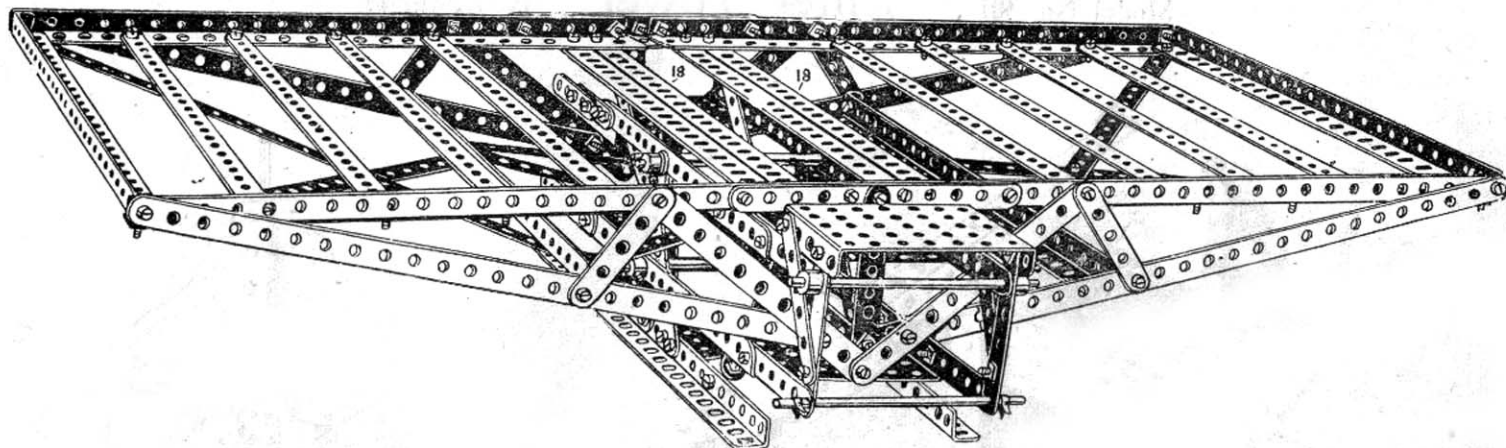

Parts  
Required :

22 of No.	1
12 "	2
6 "	3
6 "	4
8 "	5
14 "	8
12 "	12
4 "	15
2 "	15A
2 "	35
130 "	37
6 "	53
10 "	59
1 "	60

Begin the construction of this model by making the weigh beam, Fig. 402A. The side strips 1 are bolted to the base angle girders 2, and in the strips 1 are journaled the rods 3 which form the fixed pivots of the weigh beam. The upper and lower rods 4 are journaled in the strips 5 and form the moving pivots of the beam. All the rods 3 and 4 pass through perforations in the upper and lower strips 6 of the beam. Next construct the platform, Fig. 402B, leaving the strips at one side unconnected, as shown. The platform is then passed between the upper and lower parts of the weigh beam, and the unconnected strips then bolted, as follows. The ends 7 are bolted to the lowest hole 8, and the ends 9 to the angle bracket 10, and the end of the angle girder 11 is overlapped five holes of the strip 12 and bolted in the hole 13. The outer holes 14 of the 12½" crossed strips, Fig. 402A, are then bolted to the same holes 15 in the angle girders 16 as the strips 17. The double angle girders 18 are then bolted in position, and the outer holes 19, Fig. 402A, are bolted to the angle girders 18 in the centre holes and the holes 20, Fig. 402A, to the angle girders 18 at the fifth hole from the girder ends. The load to be weighed rests on the main platform, and the weights are placed on the small rectangular plate 21 at the end of the weigh beam.

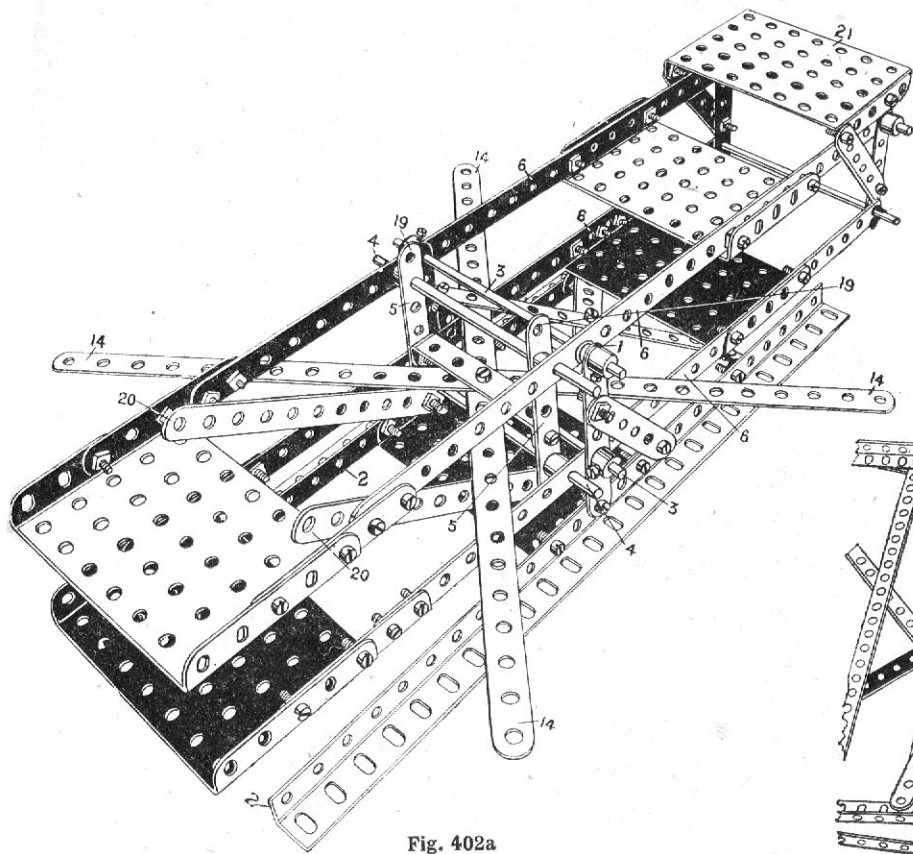

Fig. 402a

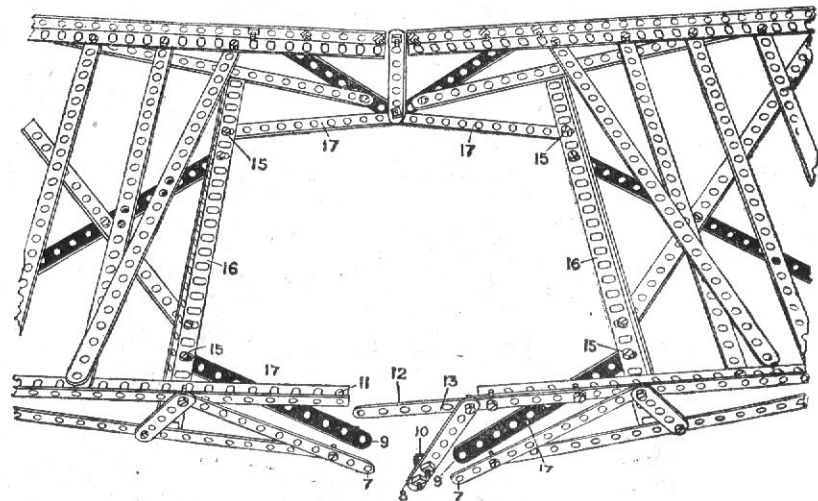
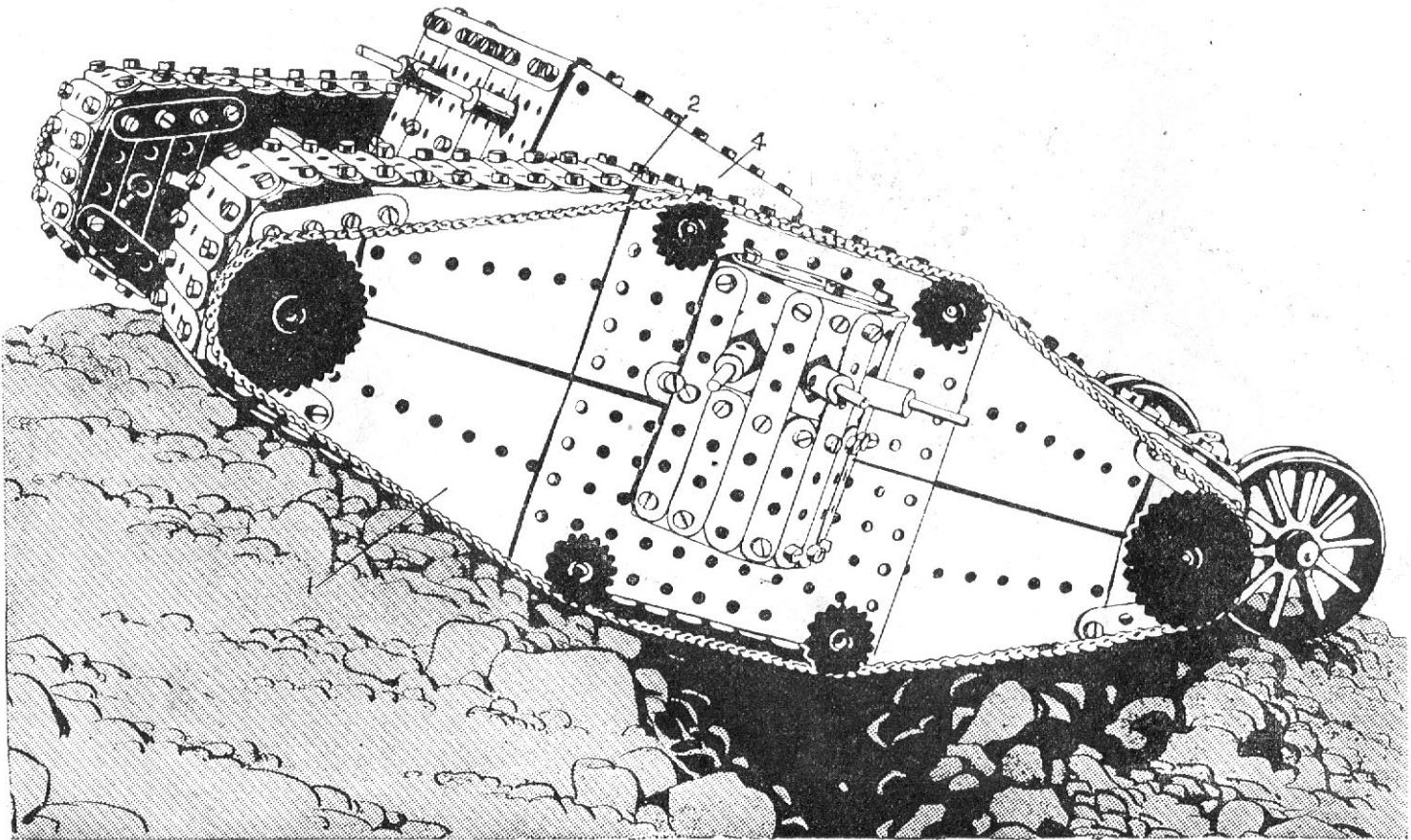

Fig. 402b

Model No. 403

## Tank or Travelling Land Fort

(Special Model)



Model No. 403

# Tank or Travelling Land Fort *(Continued)*

## Parts Required :

6 of No. 2	461 of No. 37
10 " " 3	1 " " 45
27 " " 5	13 " " 52
152 " " 6	18 " " 54
2 " " 6A	9 " " 59
4 " " 9	1 " " 62
30 " " 12	14 " " 63
1 " " 13	8 " " 90
1 " " 14	2yds. " 94
4 " " 16	4 " " 95
7 " " 17	8 " " 96
1 " " 18	2 " " 97
4 " " 19A	4 " " 100
2 " " 20A	

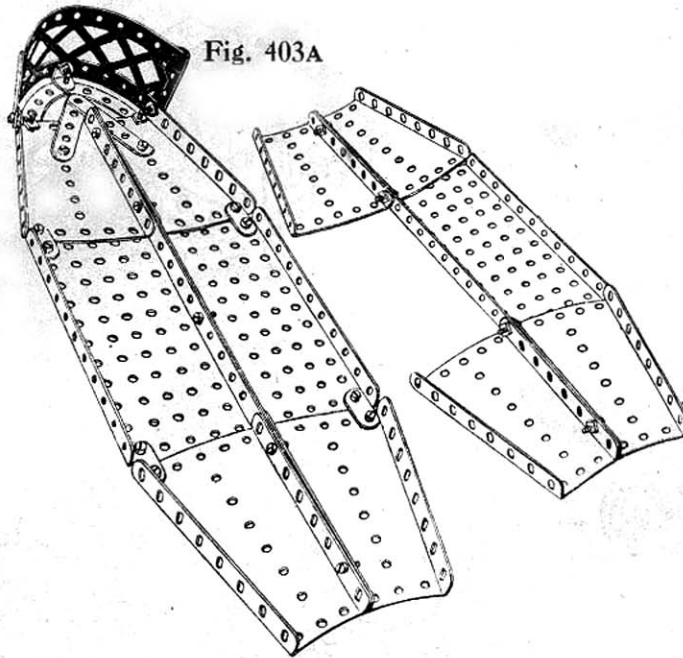

Fig. 403A

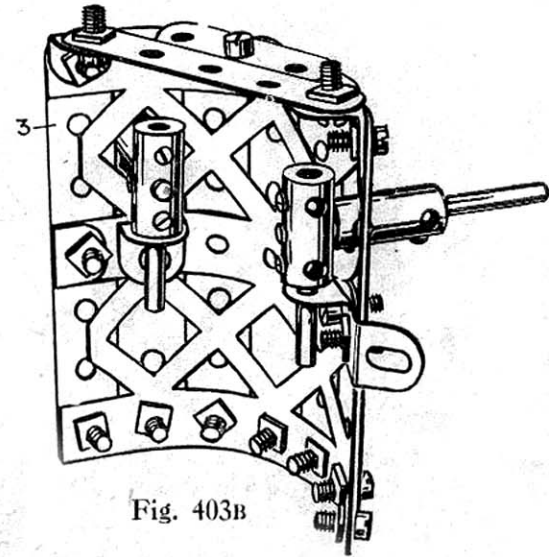
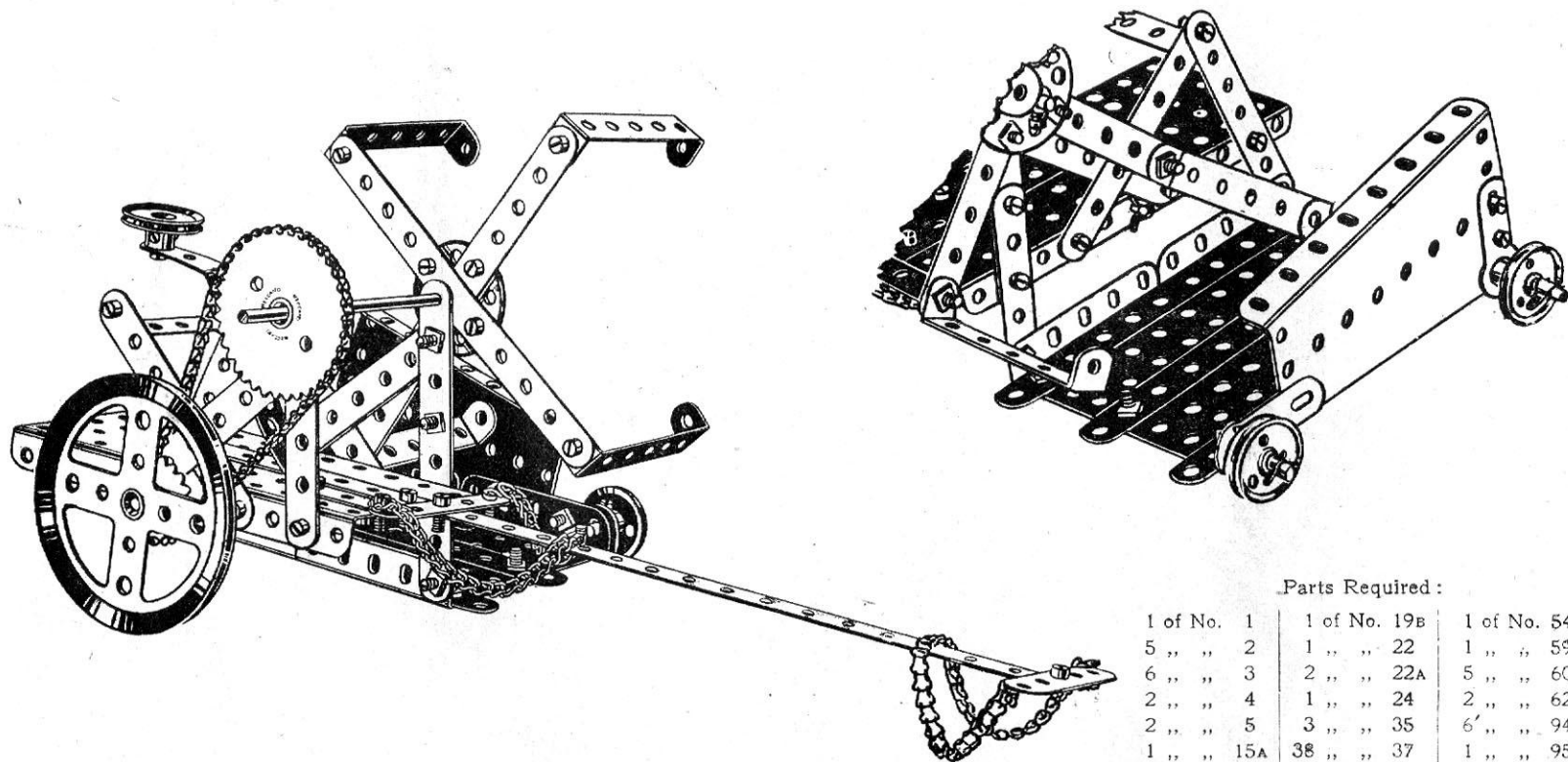

Fig. 403B

The sides of the Tank, Fig. 403A, are built up of rectangular and sector plates connected at each end as shown in the drawing, the two series of plates being then connected across by their flanged ends by a number of 2" strips 2. The gun turrets 3, Fig. 403B, are built up of 3½" braced girders bent round and bolted on the outside with vertical 3½" strips, and bolted on the sides of the tank. The sides of the tank are connected together by the compartment 4, made of rectangular plates bolted together.

# Model No. 404 Binder

(Outfit No. 3)



### Parts Required :

1 of No. 1	1 of No. 19B	1 of No. 54
5 " " 2	1 " " 22	1 " " 59
6 " " 3	2 " " 22A	5 " " 60
2 " " 4	1 " " 24	2 " " 62
2 " " 5	3 " " 35	6 " " 94
1 " " 15A	38 " " 37	1 " " 95
1 " " 16	1 " " 52	1 " " 96
2 " " 18A	2 " " 53	



Model No. 405

## Mangling Machine

(Outfit No. 4)

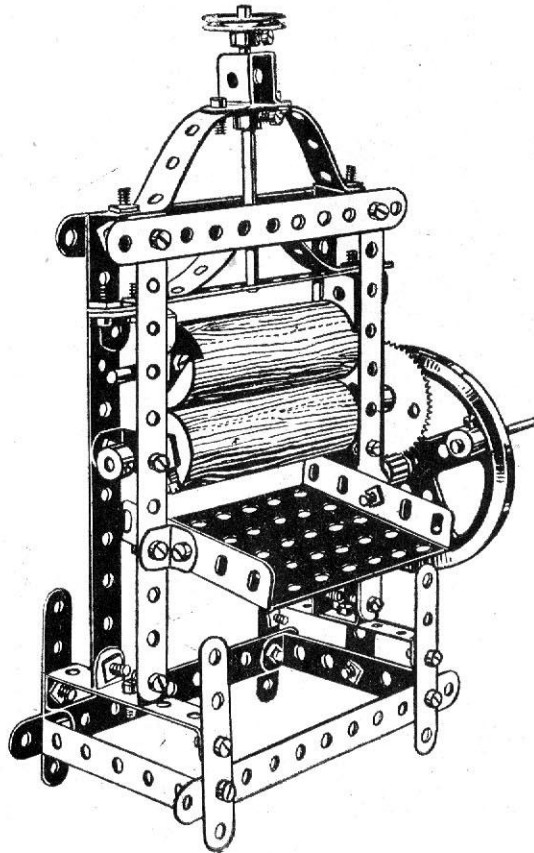

## Parts Required :

10 of No. 2	1 of No. 26
1 " " 3	1 " " 27A
6 " " 5	38 " " 37
4 " " 11	3 " " 38
6 " " 12	1 " " 45
2 " " 12A	1 " " 53
2 " " 15	5 " " 59
1 " " 16	4 " " 60
2 " " 17	1 " " 62
1 " " 19B	1 " " 106
1 " " 22	

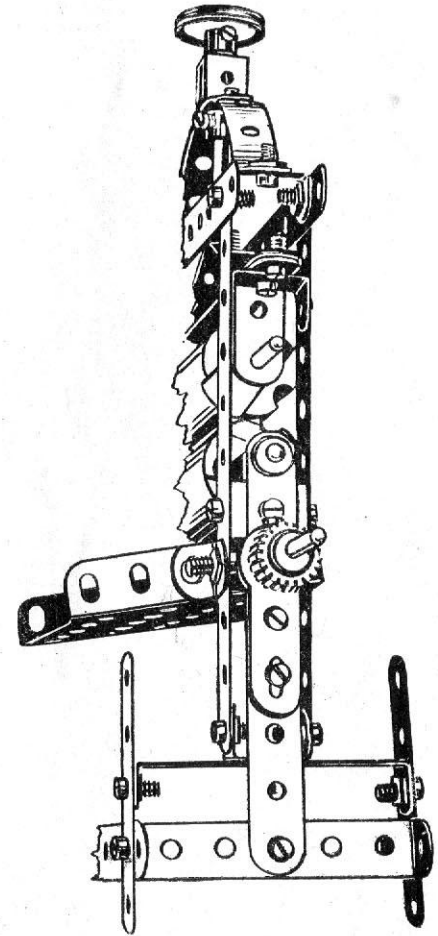

# Model No. 406 Portable Crane

(Outfit No. 6)

Parts Required:

14 of No. 2	1 of No. 15	4 of No. 22A	2 of No. 38
2 " " 3	4 " " 16	1 " " 24	1 " " 53
4 " " 4	5 " " 17	2 " " 26	1 " " 57
15 " " 5	3 " " 18A	1 " " 27A	11 " " 59
2 " " 6	1 " " 19	1 " " 33	4 " " 60
2 " " 9	1 " " 21	6 " " 35	2 " " 62
1 " " 11	4 " " 22	85 " " 37	2 " " 63
17 " " 12			

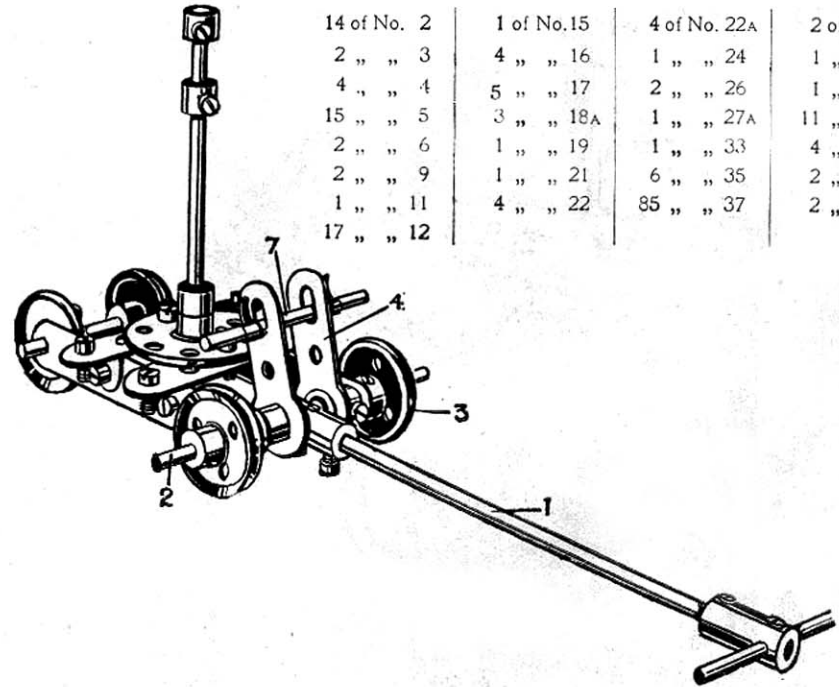
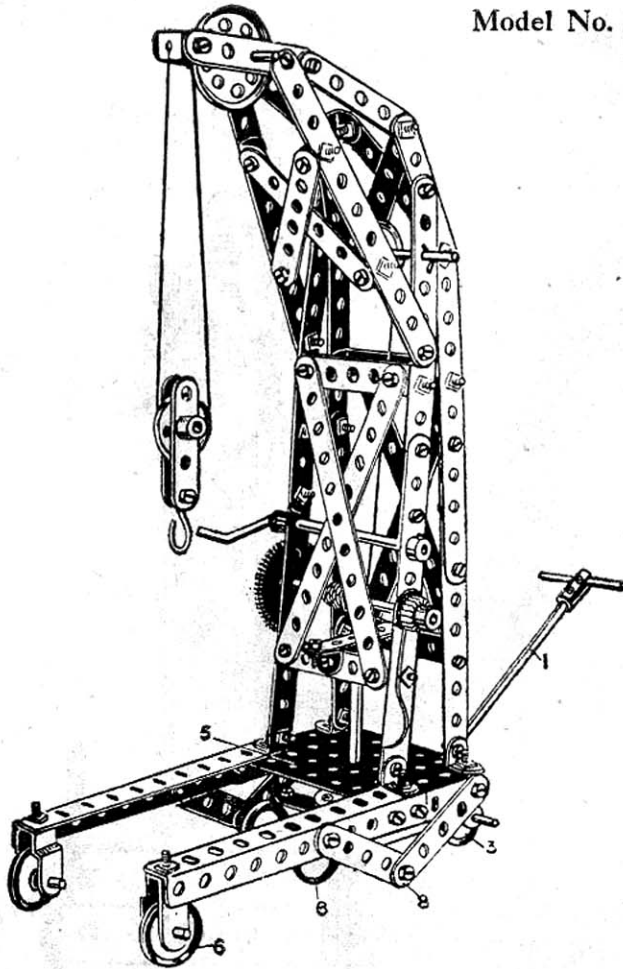

cranks 4 when the handle 1 is depressed engage an angle engagement with the plate 5. When the crane is brought to rest its weight forces down the cranks 4 which raises the handle 1, and the tips 8 of the strips together with the front wheels 6 then support the crane.

The construction of the tower is quite clear from the illustration. The crane is moved about by depressing the handle 1 carrying an axle 2 for the 1" loose pulley wheels 3, which are secured in position by collars and set screws. A pair of cranks 4 are secured to the axle 2 and are arranged when the handle is depressed to bear against the underface of the small rectangular plate 5 and lift the crane so that it then runs on the wheels 3 and 6. The tips of the bracket to stop the spindle 7 from coming completely away from

# Model No. 407 Sighting Apparatus

(Outfit No. 5)

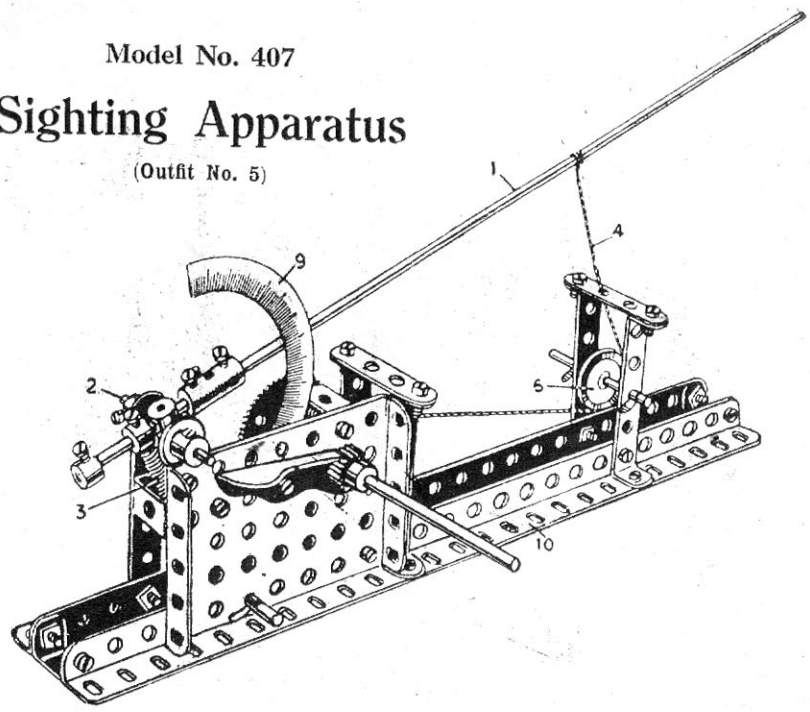

Parts Required :

1 of No. 5	1 of No. 33
2 " " 6	2 " " 35
2 " " 8	24 " " 37
4 " " 11	1 " " 43
1 " " 13	1 " " 53
4 " " 17	3 " " 59
1 " " 19	5 " " 60
1 " " 22	2 " " 62
2 " " 26	2 " " 63
1 " " 27A	

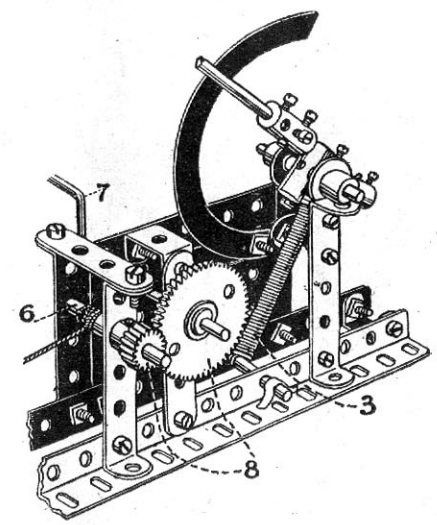

This model is for determining the heights of buildings, towers, etc. The pointer 11 1/2" rod 1 is pivoted on the 2" rod 2 and controlled by a spring 3, the pointer 1 being adjusted by the cord 4 which passes round a guide pulley 5 and on to the axle 6 upon which it is wound by the crank handle 7 which operates the gear wheel and pinion 8. A graduated scale of degrees 9 made of cardboard, or a protractor, is mounted in order to read off the angle of inclination of the pointer.

In finding the height of a building, measure out a number of feet or yards from the foot of the building, and set this out to some scale corresponding to the line *a, b*, in the diagram. then, standing at the point *a* furthest from the building, and keeping the angle girders 10 horizontal, move the pointer 1 until it is directed towards the top of the building. Then read off the angle on the scale 9, and draw a line *a, c*, making the angle *b a c* equal to the angle read off. Then draw a vertical line *b c* from the point *b*, and with the same scale used for setting off the distance *a b* measure the height *b c*, which will be the height of the building.

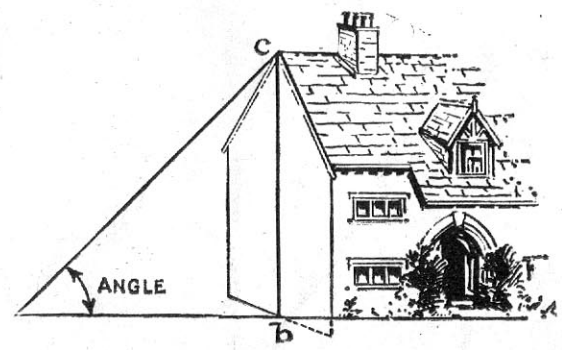

Model No. 408

**Mouse Trap**

(Outfit No. 5)

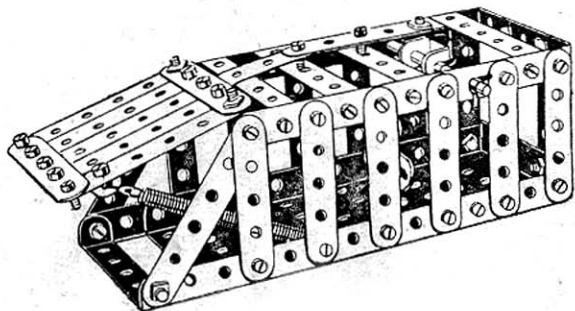
Parts  
Required :

5 of No. 2  
 7 " " 4  
 17 " " 5  
 5 " " 10  
 1 " " 11  
 6 " " 12  
 1 " " 16  
 4 " " 35  
 59 " " 37  
 5 " " 38  
 1 " " 43  
 1 " " 52  
 8 " " 60

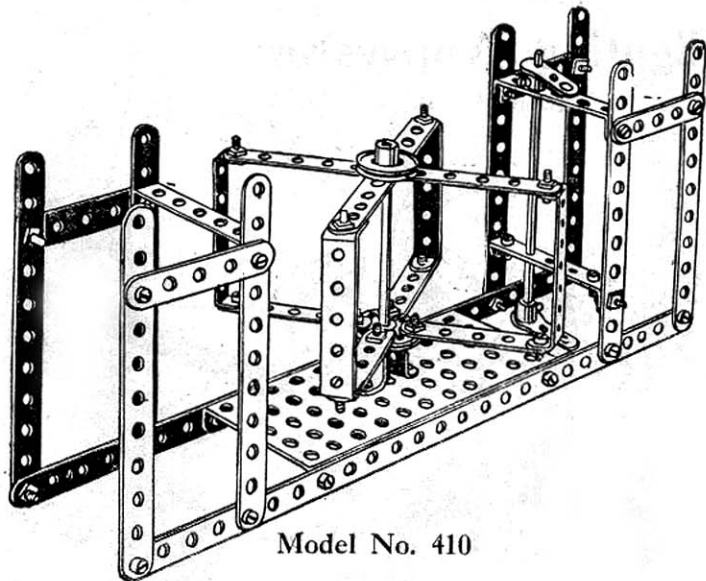

Model No. 410

**Turnstile**

(Outfit No. 2)

Parts Required :

2 of No. 1	1 of No. 24
10 " " 2	1 " " 35
9 " " 5	38 " " 37
2 " " 12	1 " " 45
1 " " 15	1 " " 52
1 " " 15A	6 " " 60
2 " " 22	2 " " 62

Model No. 409

**Pen Rack**

(Outfit No. 1)

Parts  
Required :

5 of No. 2  
 4 " " 5  
 4 " " 10  
 2 " " 12  
 20 " " 37  
 1 " " 52  
 2 " " 60

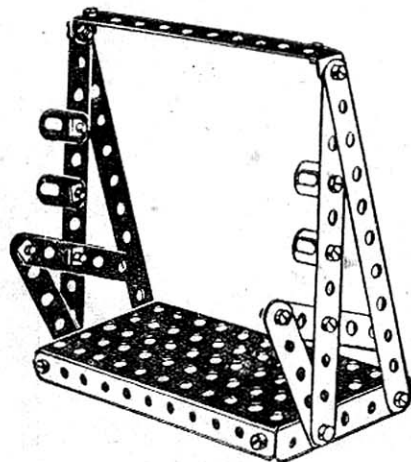

Model No. 411

# Vegetable Chopper

(Outfit No. 1)

Parts Required:

- 2 of No. 1
- 6 " " 5
- 19 " " 37
- 3 " " 60

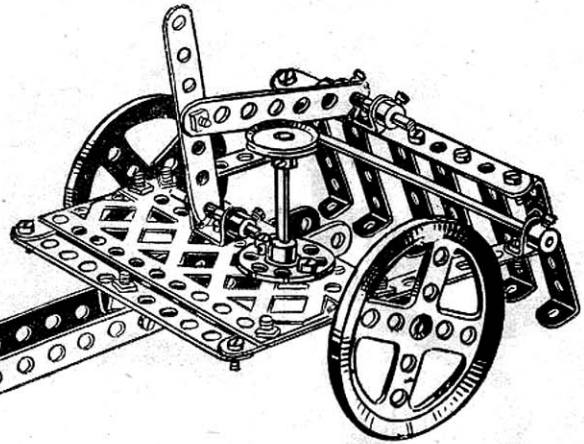
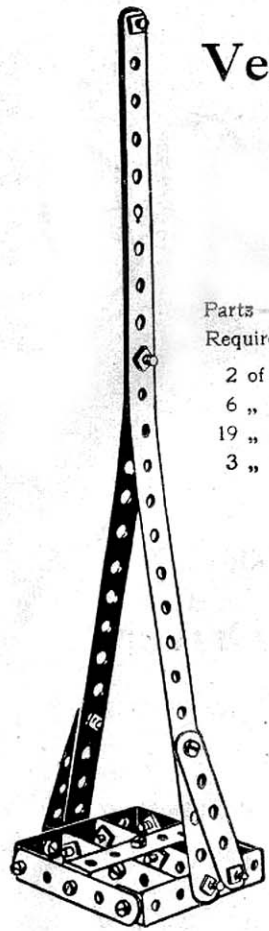

Model No. 412

# Horse Rake

(Outfit No. 4)

Parts Required:

- |            |              |
|------------|--------------|
| 2 of No. 1 | 2 of No. 153 |
| 5 " " 2    | 1 " " 22     |
| 3 " " 3    | 1 " " 24     |
| 3 " " 11   | 27 " " 37    |
| 6 " " 12   | 6 " " 59     |
| 2 " " 14   | 6 " " 60     |
| 3 " " 17   | 1 " " 100    |

Model No. 413

# Jumping Jack

(Outfit No. 2)

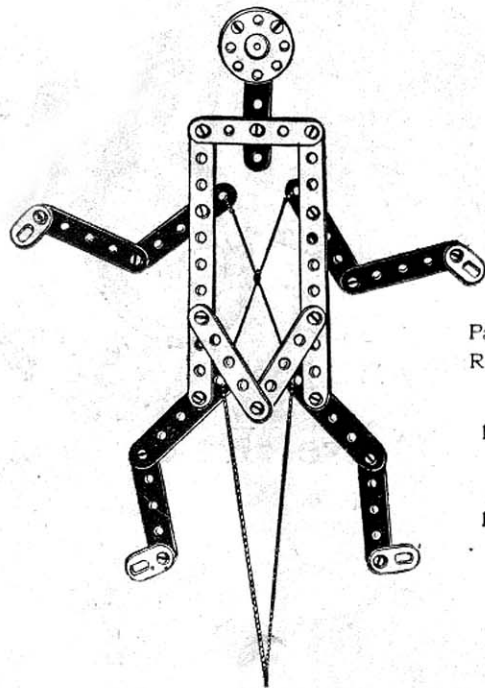
Parts  
Required:

2 of No. 2  
 12 " " 5  
 4 " " 10  
 1 " " 24  
 18 " " 37

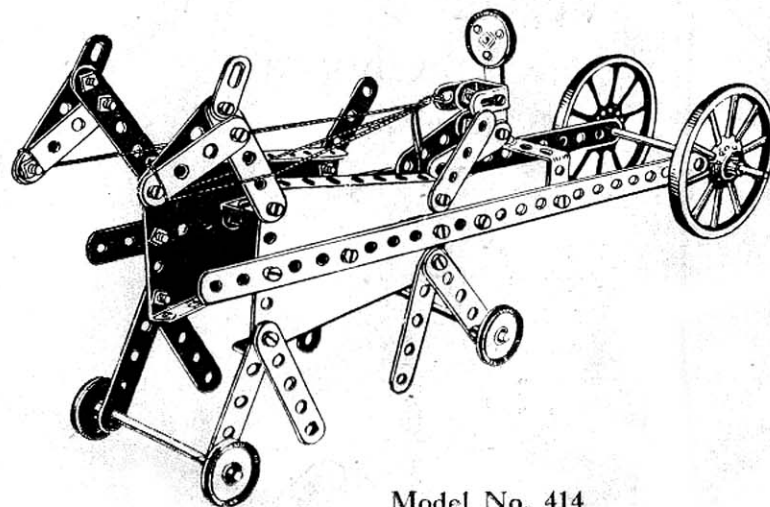

Model No. 414

# Sulky and Driver

(Outfit No. 6)

Parts Required:

2 of No. 1	1 of No. 12	32 of No. 37
10 " " 5	3 " " 15A	1 " " 46
9 " " 6	2 " " 19A	2 " " 54
4 " " 10	4 " " 22	2 " " 60
2 " " 11	1 " " 22A	

Model No. 415

# Speedometer

(Outfit No. 4)

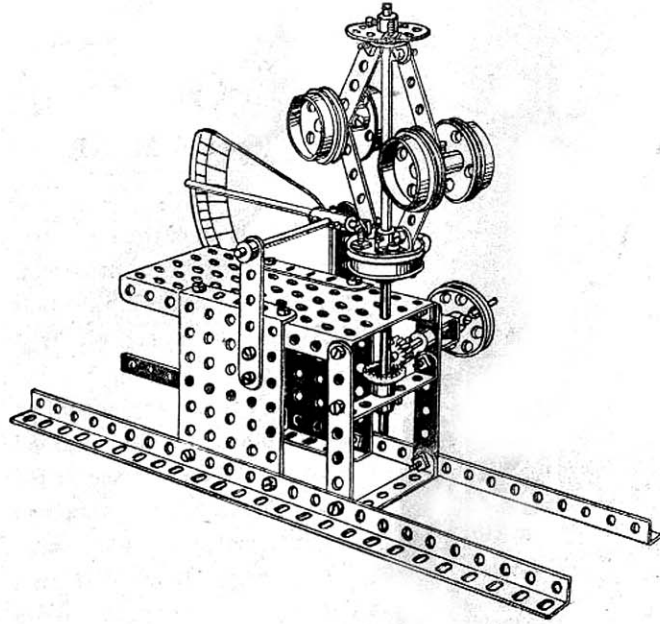

Parts Required:

2 of No. 3	1 of No. 26
2 " " 4	1 " " 29
4 " " 5	32 " " 37
2 " " 8	2 " " 38
4 " " 12	1 " " 48
1 " " 13A	1 " " 52
3 " " 16	2 " " 53
2 " " 18A	5 " " 59
5 " " 20	3 " " 60
1 " " 21	1 " " 63
2 " " 24	

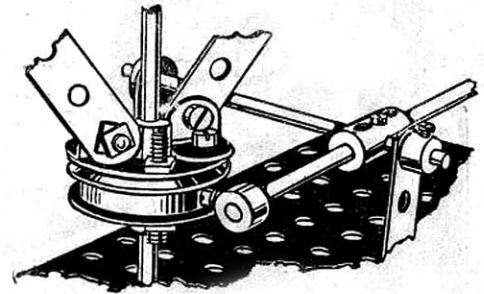

Model No. 416

# Boat Launching Gear

(Special Model)

## Parts Required :

7 of No. 2	1 of No. 28
8 " " 3	3 " " 29
2 " " 6	2 " " 32
2 " " 8	4 " " 35
4 " " 10	94 " " 37
10 " " 12	2 " " 44
1 " " 13	2 " " 52
1 " " 15	5 " " 53
2 " " 15A	2 " " 57
4 " " 16	8 " " 59
1 " " 19	4 " " 60
6 " " 23	2 " " 63
6 " " 26	4 " " 100
2 " " 27A	

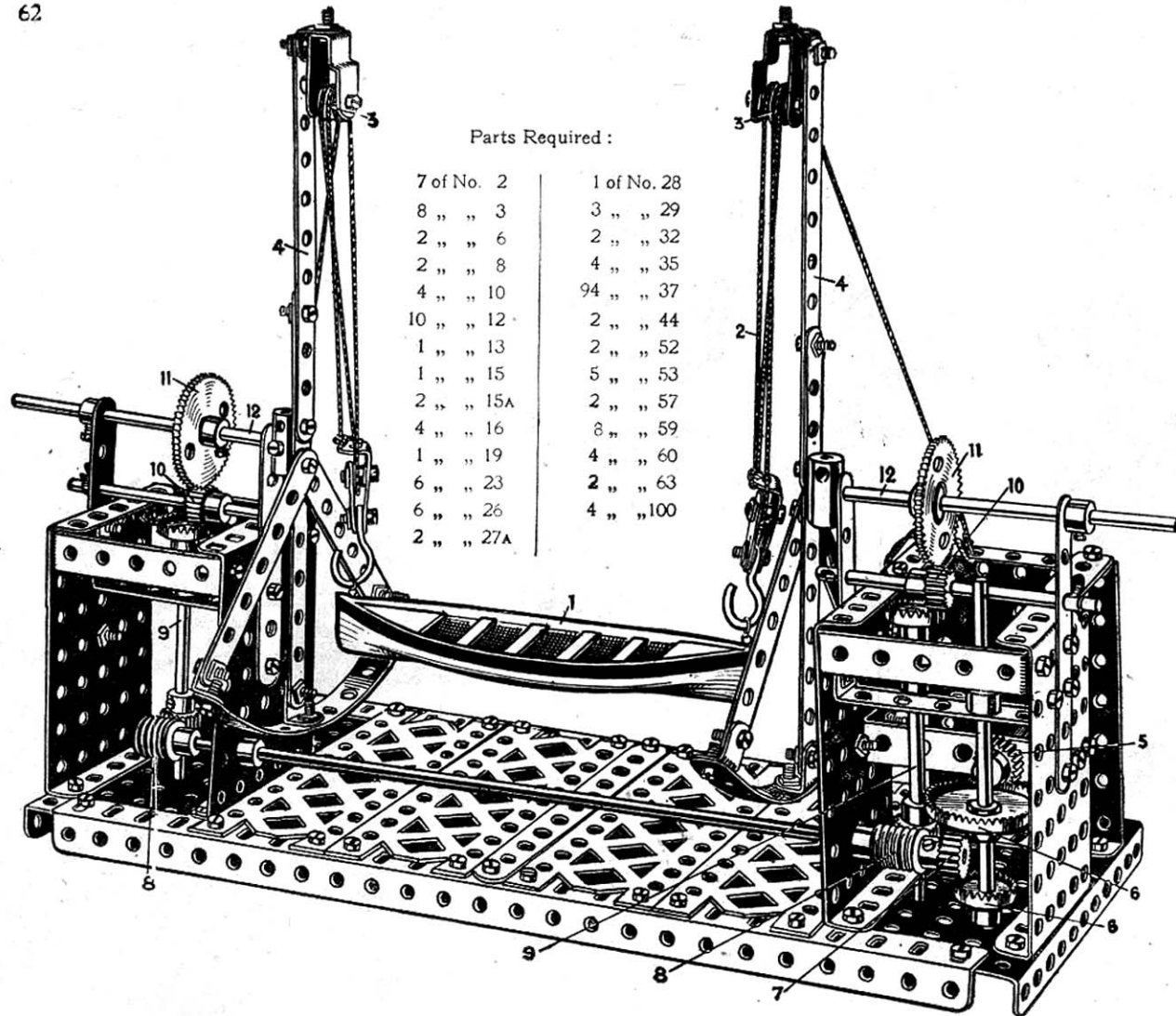

This is an extremely interesting model to construct. The boat 1 carried in the falls 2 from the upper blocks 3 composed of  $\frac{1}{2}$ " pulleys is swung outboard or inboard by the rotation of the weighted arms 4. The movement of the arms is effected from a cranked handle not shown, a  $\frac{1}{2}$ " pinion 5 on the end of which drives a  $1\frac{1}{2}$ " and a  $\frac{3}{4}$ " contrate wheel 6 and a  $\frac{1}{2}$ " pinion 7 on a shaft carrying worms 8 which drive vertical spindles 9 and through  $\frac{1}{2}$ " pinions 10 and 56-toothed gear wheels 11 the axle rods 12 upon which the arms 4 are pivotally supported.



Model No. 417

## A Gay Start

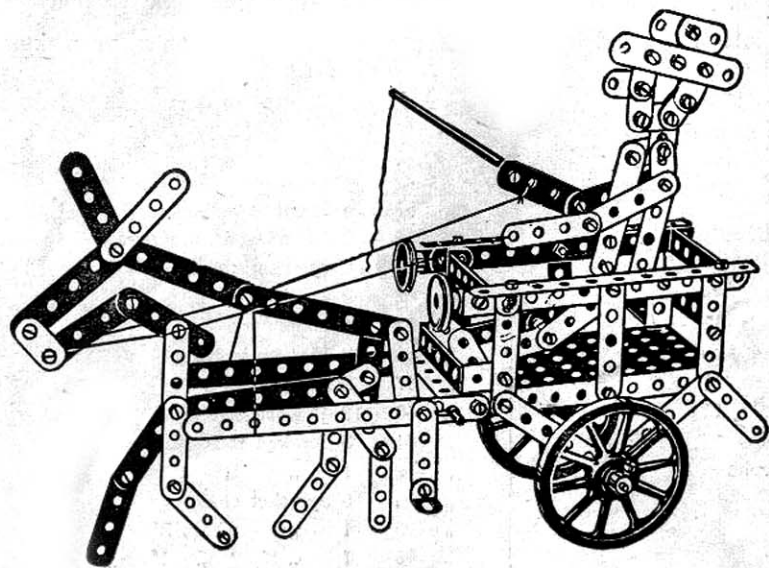

Model No. 418

The End of a  
Perfect DayParts  
Required:

6 of No.	2
2 "	3
5 "	4
10 "	5
24 "	6
23 "	10
8 "	12
1 "	15
1 "	15A
1 "	16
2 "	19B
2 "	22
2 "	35
71 "	37
2 "	46
1 "	52
3 "	60

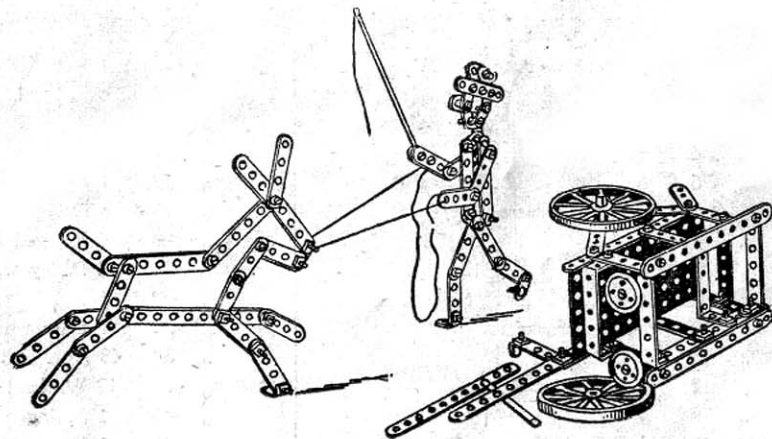

## Interesting Experiments in Applied Mechanics with Meccano

Few boys know what an important part the science of "Applied Mechanics" plays in everything which they see around them. It is this science which enables engineers to design machines, so that they will withstand all kinds of strains. It enables bridge builders to make their constructions so that they are able to guarantee them to bear certain weights. When an engineer builds a crane and guarantees it to lift a load of so many tons, "Applied Mechanics" tells him where the strain will come, exactly what strength of materials he must use, and how his crane ought to be designed.

Of course "Applied Mechanics" is a big subject, and you can only grasp its principles thoroughly after a lot of study; but it is a very fascinating subject, and some of the elementary principles are most interesting and novel and not at all difficult to understand. To simplify the working out of the examples which will be found on the following pages, we have introduced a standard frame work so that the various examples may be easily and quickly set up. Any boy can get lots of fun and learn a lot of useful points in mechanics, by making these experiments.

The following is a list of the parts required to build all the Scientific Examples illustrated here:—

No. 1	2 Perforated strips, $12\frac{1}{2}"$	No. 13A	1 Rod, 8"	No. 52	3 Perforated flanged plates, $5\frac{1}{2}" \times 2\frac{1}{2}"$
" 2	12 " " $5\frac{1}{2}"$	" 15	6 " " 5"	" 57A	6 Scientific hooks
" 3	6 " " $3\frac{1}{2}"$	" 16	1 " " $3\frac{1}{2}"$	" 59	12 Collars and set screws
" 4	6 " " 3"	" 17	6 " " 2"	" 60	6 $2\frac{1}{2}"$ bent strips
" 5	6 " " $2\frac{1}{2}"$	" 19	1 Crank handle	" 62	2 Cranks
" 7	4 Angle girders, $24\frac{1}{2}"$	" 19B	6 Pulley wheels, 3"	" 63	4 Couplings
" 7A	4 " " $18\frac{1}{2}"$	" 20	4 Flanged and grooved wheels	" 66	12 50-gram weights
" 8	6 " " $12\frac{1}{2}"$	" 21	2 Pulley wheels, $1\frac{1}{2}"$	" 67	2 25 " "
" 9	1 " " $5\frac{1}{2}"$	" 22	1 " " 1"	" 68	12 $\frac{1}{2}"$ wood screws
" 10	24 Flat brackets	" 24	1 Bush wheel	" 81	3 Screwed rods, 2"
" 11	2 Double "	" 37	48 Nuts and bolts	" 82	1 " " 1"
" 12	12 Angle "	" 38	12 Washers	" 94	5' Sprocket chain
" 12A	4 " " 1"	" 43	1 Spring	" 95	1 " " wheel, 2"
" 13	1 Rod, $11\frac{1}{2}"$	" 47A	1 Dynameter	" 96	1 " " 1"
					1 Board, $12\frac{1}{2}" \times 11\frac{1}{2}" \times \frac{1}{2}"$

Model No. 419

## Triangle of Forces

Little difficulty will be experienced in constructing the Meccano Demonstration Frame from this illustration. It may be well to mention, however, that the rear uprights, which consist of  $18\frac{1}{2}$ " angle girders, are secured to the sides of the board shown in the illustration by ordinary wood screws. The  $24\frac{1}{2}$ " girder at the top is secured in the same manner, as is also the  $12\frac{1}{2}$ " girder at the bottom. The board is used for pinning on sheets of paper, upon which the diagrams are drawn.

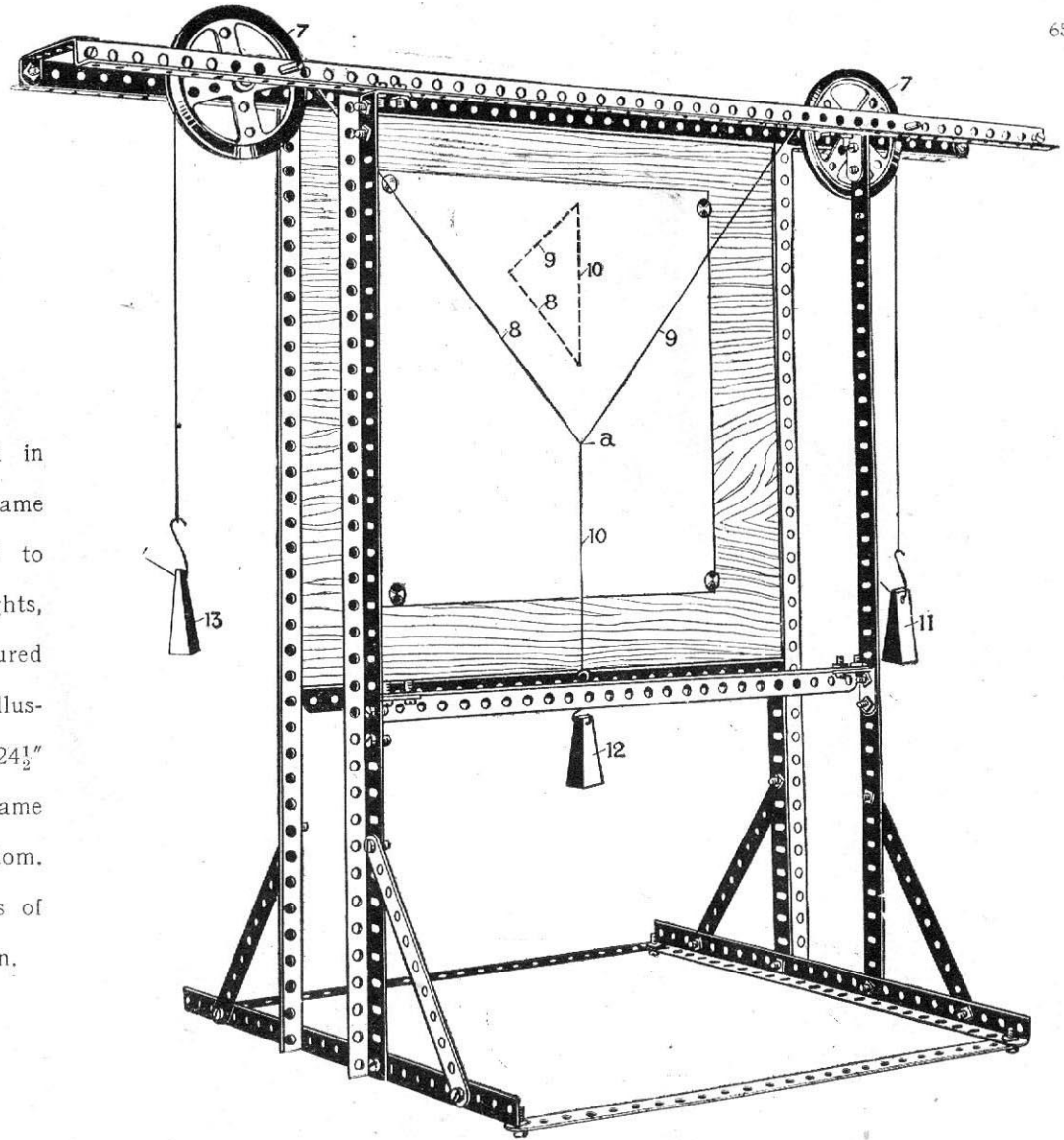

## Triangle of Forces *(continued)*

The first example is called the "Triangle of Forces." Briefly, if three forces meet at a point and balance each other, and we know one of the forces, we can find out the other two by drawing a triangle, making each side parallel to the direction of one of the forces. To demonstrate this, two large pulleys 7 are carried on rods in the top rails, and cords 8, 9, passed over these pulleys and their ends joined to another cord 10. Weights 11, 12, and 13 are then hung on the ends of the cords 8, 9, and 10, and when the point of junction (a) of the three cords has come to rest, lines in the direction of the cords are drawn on the sheet of paper, which is afterwards removed and a triangle drawn, as shown in the illustration, with its sides 8, 9, and 10 parallel to the directions of the three cords. This triangle is shown in dotted lines. If the sides of the triangle are measured it will be found that they are in the same proportion as the weights 11, 12, and 13. For instance, if the weight 12 were 15 units and the weight 13 were 9 units, and the weight 11 were 7 units, the lengths of the sides of the triangle would be 15, 9, and 7 units. By this experiment, therefore, we demonstrate that when three forces meet at a point, and we know their direction, and the value in grammes or pounds of one of the forces, if we construct a triangle, making that side of the triangle which corresponds to the known force equal to a number of units of length, each unit representing a gramme or pound of the known force, then by scaling off the other two sides of the triangle we can determine the values of the other two forces in grammes or pounds. Several experiments with different weights should be tried and triangles drawn, and the accuracy of the apparatus for different weights tested.

As an example of the triangle of forces, when a boy pulls a bow to shoot an arrow, if we know the force he pulls with, we can find the pull along each part A and B of the string by measuring the angle which the string forms.

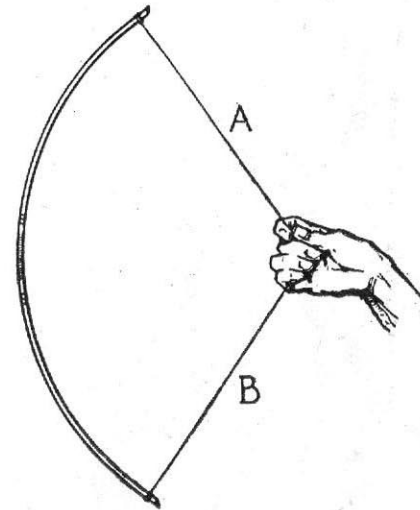

## Model No. 420 Pulleys

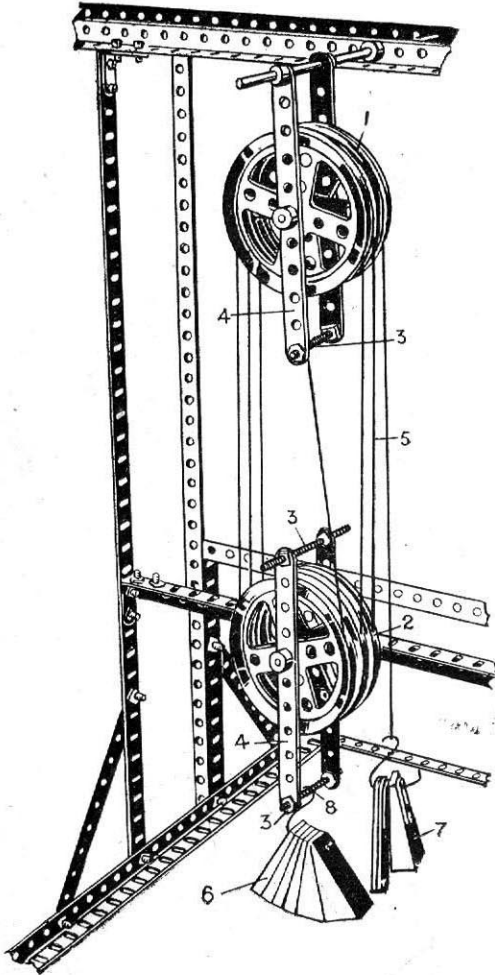

In this model the principle of a purchase pulley block is demonstrated. In engineering shops and other places where heavy weights are required to be lifted by hand, it is necessary to provide some means so that the ordinary power that a man can exert is multiplied to such an extent as to enable him to lift much heavier weights than would otherwise be possible without a pulley block. Whenever an apparatus for this purpose is used, what is gained in power is lost in speed. The pulley block shown consists of three 3" pulley wheels 1 in the upper block and a similar number of wheels 2 in the lower block. The construction of these blocks may be seen from the illustration, the rods 3 being screwed throughout their length, and the side strips 4 held thereon by nuts on the rods 3 inside and outside of the strips. The upper block 1 is fixed from the top girders of the frame, but the lower pulley block 2 is supported on the loops of the cord 5 and rises and falls carrying with it the weights 6 suspended from the lower block. The weights 6 represent the load to be lifted and the smaller weight 7 represents the power applied such as the pull of a man. If there were no such thing as friction in the bearings of the pulleys, then the proportion of the weight 7 necessary to balance or just raise the weights 6 would be as 1 is to 6. Of course the weight 7 moves six times the distance that the load 6 is lifted or lowered, so that although the heavy load 6 is overcome by a light power 7 the distance the power weight 7 has to move is considerably greater, in fact it is six times as great. In order to ascertain the amount of friction to be overcome, it is necessary in the first place to attach small weights to the hook 7, sufficient to counterbalance the weight of the lower block to the point when it commences to move. After the weights have been added as indicated above, that is, in the proportion of 1 to 6, the amount of friction can be ascertained by again adding small weights to the point when it commences to move, the weights added representing the amount of friction.

Different load weights 6 should be hung on the lower pulley, and it should be noted what are the corresponding power weights 7 required just to overcome the load weights.—These results should be tabulated like the following, which were obtained by experiment :

Power.	Load.	Friction.
25 + 3.3 = 28.3 grammes	150 grammes	2.2 per cent.
50 + 6.6 = 56.6 "	300 "	2.2 "
75 + 8.8 = 83.8 "	450 "	1.9 "

## Levers

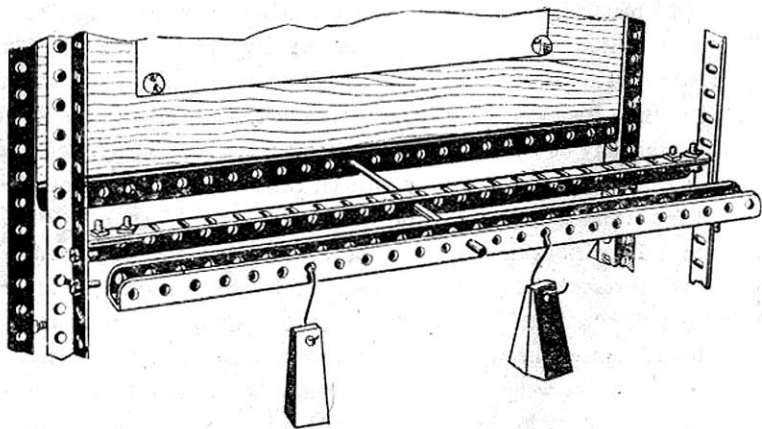

If we have a lever 6" long and pivoted 4" from one end, the arms of the lever will be 4" and 2", and if we hang a 2lb. weight at the end of the 2" arm, we say that the moment of the force of the 2lb. weight about the pivot is equal to the weight in pounds multiplied by the length of the arm in inches. In this case the moment, therefore, would be  $2 \times 2 = 4$ , and this would be called a moment of 4 inch-lbs. Similarly if a weight of 1lb. were hung at the end of the 4" arm of the lever we would say that the moment of that weight would be 1lb. multiplied by the length of the arm,  $1 \times 4 = 4$ , and we would call this 4 inch-lbs. Now when the moments of a lever obtained in this way are equal, the lever is balanced. Levers are of various kinds; they may be straight levers

or bell-crank levers, that is to say, where one of the arms is at right angles to the other. A straight lever is shown in this Model and a bell crank lever in Model No. 422. Now we will demonstrate the principle of moments in the case of the straight lever. This is made up of two  $1\frac{1}{2}$ " angle girders bolted together as shown, and pivoted on a short rod. The holes in the Meccano strips are all at a standard distance of  $\frac{1}{2}$ " apart, so that we can easily fix the lengths of the lever arms in inches by counting the holes. If we hang two weights of 50 grammes (that is 100 grammes) from the third hole, or  $1\frac{1}{2}$ " from the pivot at one side, the moment of that weight will be  $100 \times 1\frac{1}{2} = 150$  inch-grammes. Now if we hang a single weight of 50 grammes on the other side at six holes or 3" from the pivot the moment will be  $50 \times 3 = 150$  inch-grammes, and as the moments are equal the lever will balance, though the weights themselves are unequal.

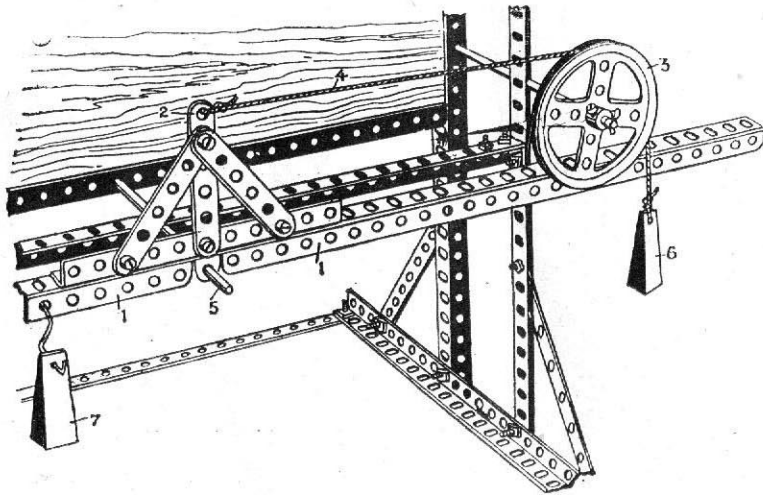

This Model is made up of two  $12\frac{1}{2}$ " angle girders 1 braced to a vertical strip 2, pivoted through a double bracket. A large wheel 3 is mounted on a rod in the side girders, care being taken that the cord 4 coming over the top of the pulley is parallel to the angle girders 1 of the lever. The arms of this lever are the left angle girder 1 and the vertical strip 2, and in order that this lever may balance about its pivot 5, the moment of the forces about the pivot must be equal, as we have previously described. Supposing, therefore, we hang a weight 6 of 50 grammes on the end of the cord 4 round the pulley 3, and connect the cord 4 to the strip 2 at 6 holes or 3" distance from the pivot 5, then the moment of the force will be the weight 50 multiplied by 3 = 150. The lever will be kept balanced if we hang an equal weight 7 of 50 grammes on the angle girder 1 at 6 holes or 3" distance from the pivot 5, because the moments,  $50 \times 3 = 150$  inch-grammes, are then equal. If on the other hand we hang two weights 6 of 50 grammes each on the end of the cord 4, the lever will be balanced by one 50 gramme weight 7 at 12 holes or 6" distance from the pivot.

A good example of a lever is a steelyard.

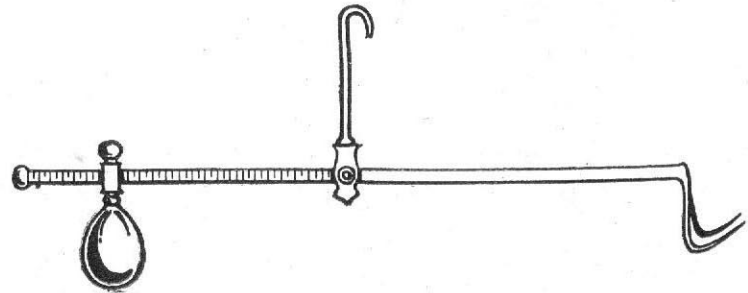

# Inclined Plane

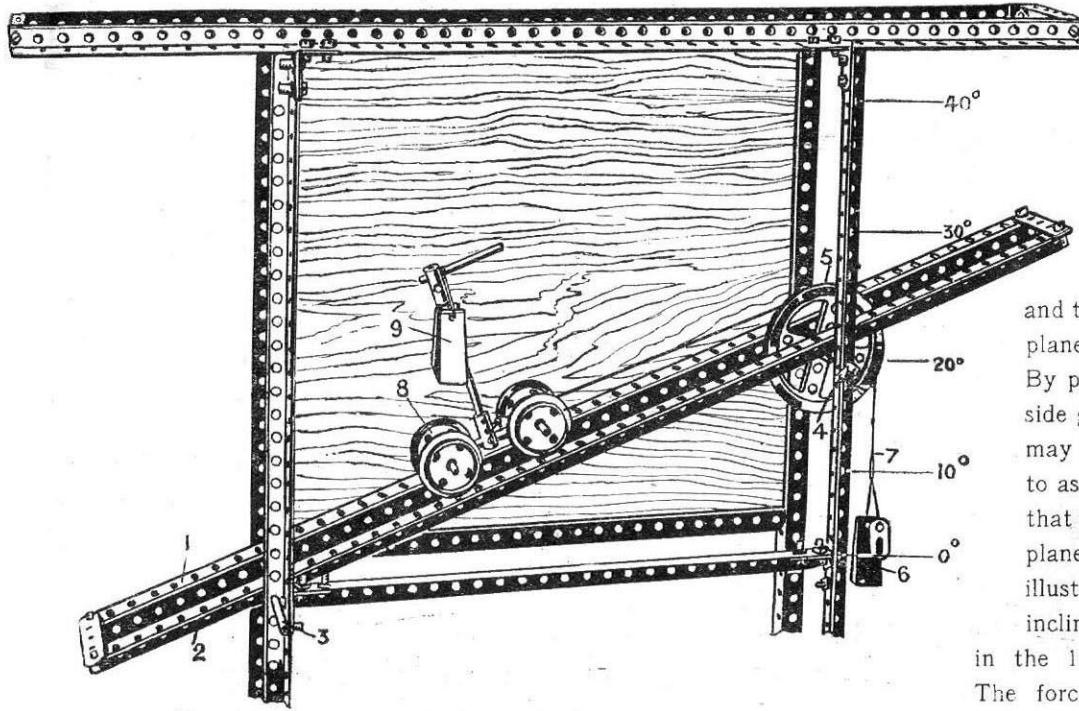

Another interesting principle which may be demonstrated on this apparatus is that known as the Inclined Plane. The force required to raise a body up an inclined plane varies according to the angle of the plane, that is to say, the slope. The plane is made of two angle girders 1, 2, connected together at each end by  $2\frac{1}{2}$ " strips and fixed on a rod 3 passed through holes in the vertical girders of the frame and the girders of the plane, and the other end of the plane rests on a rod 4 which carries a 3" pulley wheel 5. By putting the rod 4 through different holes in the side girders the slope or angle of the inclined plane may be varied. To obviate the need of a protractor to ascertain the slope of the plane it may be stated that if the rod 4 be placed in the fourth hole with the plane pivotally mounted on rod 3 as shown in the illustration, the surface of the plane will represent an incline of  $10^\circ$ , if placed in the 9th hole  $20^\circ$ , if in the 15th hole  $30^\circ$ , and if in the 21st hole  $40^\circ$ . The force or weight 6 on the cord 7 is arranged to act parallel to the plane, and the cord is connected to the carriage 8 so that the latter may roll up the plane.

The bearings for the axles of the wheels are formed of couplings and connected by a 2" rod.

Before commencing the experiment, weights should be hung on the cord 7, which are just sufficient to balance the carriage 8. If a weight 9 be then hung on the carriage it should be noted what additional weight is required to be hung on the end of the cord 7 just to make the carriage slowly ascend the plane. The weight 9 should then be varied and the alteration in the weight 6 on the cord 7 to make the carriage ascend the plane noted, and these results should be tabulated.



Model No. 424

## Inclined Plane

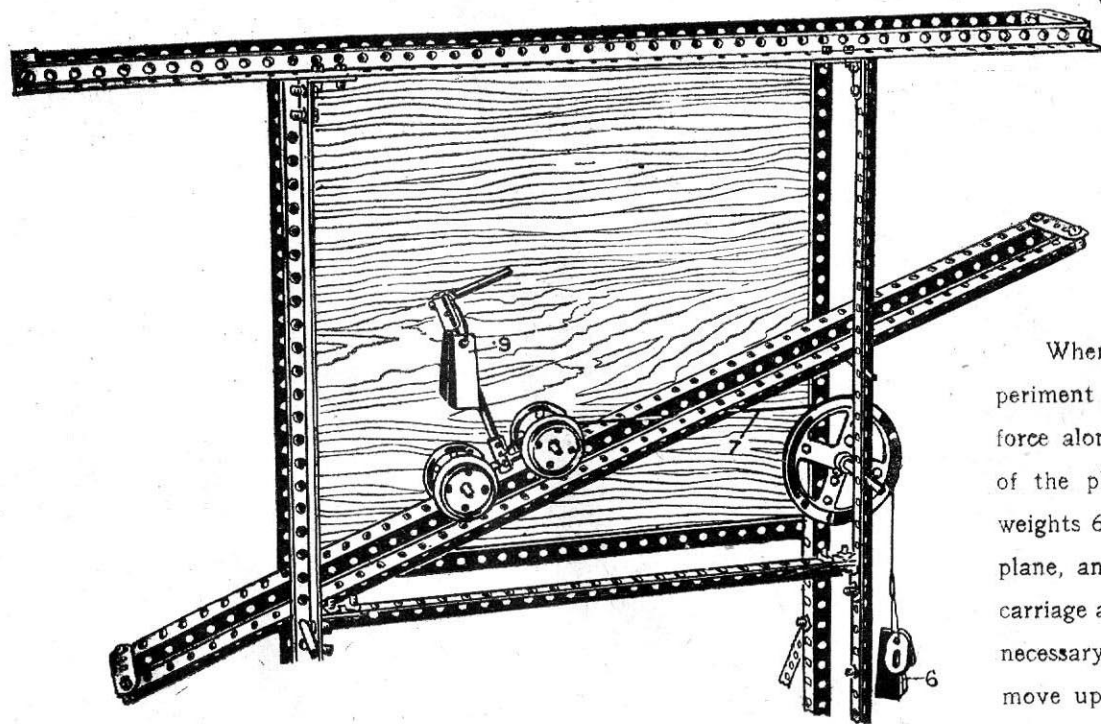

When the student has finished the preceding experiment he should try this example, where the force along the cord 7 is not parallel to the slope of the plane, but is horizontal, first hanging on weights 6 until the carriage is just balanced on the plane, and then hanging different weights 9 on the carriage and noting what additional weights at 6 are necessary just to cause the carriage to begin to move up the plane. These results should also be tabulated.

## Inclined Plane (continued)

Experiments made with the apparatus have yielded the following results:—

When forces are parallel to the plane:

	FORCE 6.	WEIGHT 9
At	Grammes.	Grammes.
10°	22.2	100
20°	40.54	100
30°	58.8	100
40°	70	100

When forces are horizontal:

	FORCE 6.	WEIGHT 9.
At	Grammes.	Grammes.
10°	23.31	100
20°	43.87	100
30°	63.2	100
40°	89.43	100

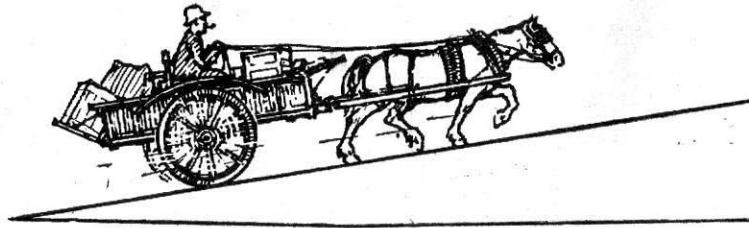

A good example of an inclined plane is a horse pulling a cart up a slope, the horse being the force and the cart the weight

## Centrifugal Governor

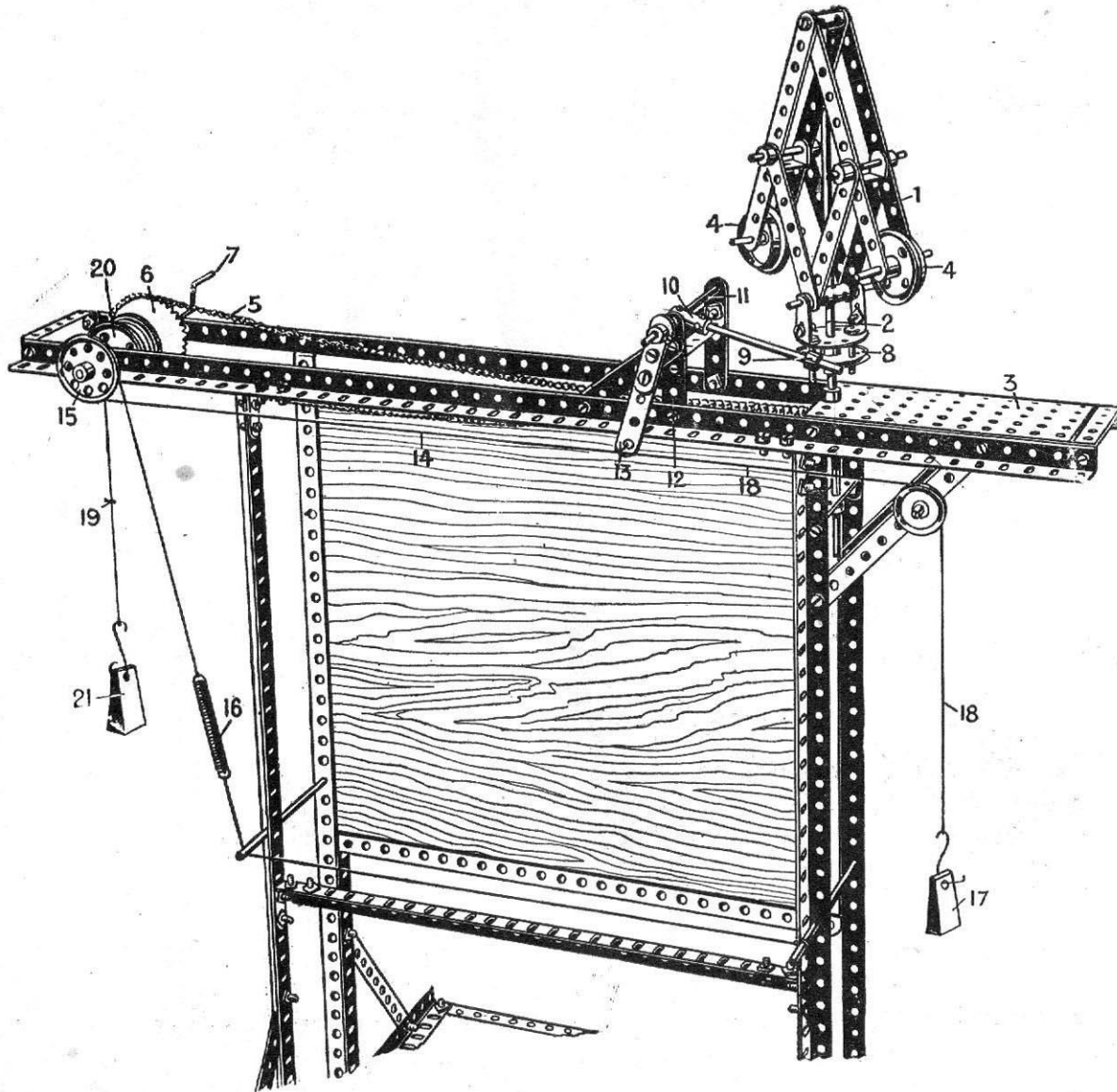

In this model an apparatus is shown for demonstrating the controlling effect of a governor. A governor is a device which is fitted on an engine in order to make its speed constant. In the case of an engine driving a works for instance, if all the machinery in the shop were running, the engine would be driving a heavy load and would be using a certain amount of steam. If a great portion of the machinery were stopped and the engine were allowed to take the same amount of steam, owing to the lightness of the load then on the engine it would race at great speed and probably be damaged. To prevent this engineers fit a governor device which, as the load on the engine is lightened, automatically shuts off the steam, or throttles it, and which, as the load comes again on the engine, permits it to take more steam. The governor thus arranges

## Model No. 425 *continued*

# Centrifugal Governor

(Continued)

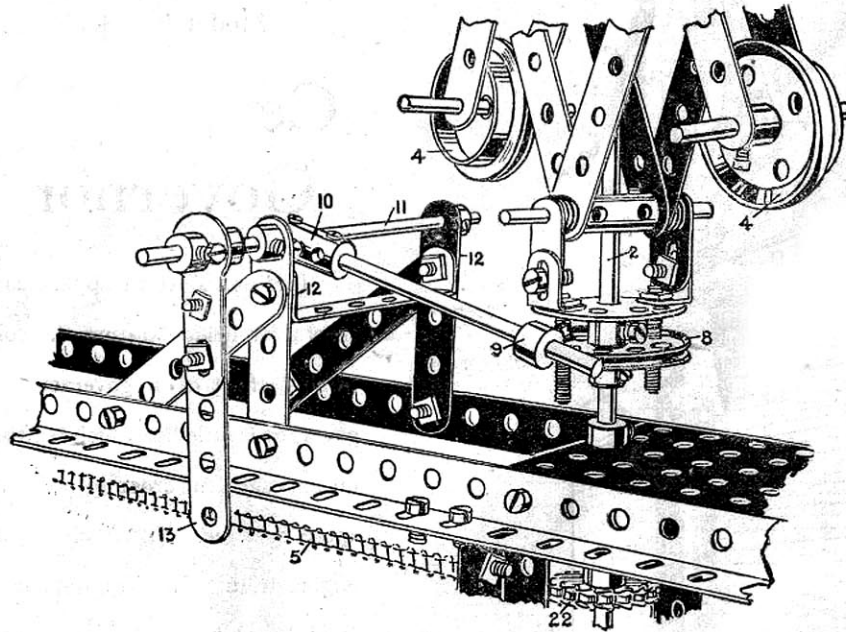

Fig. 425A

The governor 1, the construction of which is quite clear from the illustration, is mounted on a spindle 2 in a rectangular plate 3 fitted in the top girders. The flanged pulley wheels 4 represent the ball weights of the governor. Below the rectangular plate 3 and on the spindle 2 is a sprocket wheel 22, Fig. 425A, connected by the chain 5 to another sprocket wheel 6 on the cranked axle 7.

A bush wheel and a  $1\frac{1}{2}$ " pulley wheel 8 are fixed on the spindle of the governor a slight distance apart, and the head of a bolt in the collar 9 engages between the wheels 8. The collar 9 is connected by a coupling 10 to a rod 11 pivoted in the strips 12. The near end of the rod carries a

then on the engine it would race at great speed and probably be damaged. To prevent this engineers fit a governor device which, as the load on the engine is lightened, automatically shuts off the steam, or throttles it, and which, as the load comes again on the engine, permits it to take more steam. The governor thus arranges the steam supply to the engine to be suitable for the load which the engine bears and to drive it at a constant speed. Most governors are of the centrifugal ball type, that is to say, they have a pair of ball weights which are spun round by the engine. As the engine's speed increases, the ball weights fly out and this flying out or centrifugal action is arranged to shut off the steam.

strip 13, clamped between two cranks, to which is connected a cord 14 passed once round the  $1\frac{1}{2}$ " pulley 15 and connected to the spring 16. The cord 14 acts as a brake on the pulley 15, another cord 18 connected to the strip 13 carries a weight 17, and another cord 19, which is wound on the flanges of two reversed flanged and grooved wheels, is loaded with different weights 21 in order to conduct the experiments. The weights 21 correspond to the driving force of the engine, and the governor controls this varying driving force by applying the brake which is the cord 14. Different weights 21 should be hung on the cord 19, and the cord then wound up to the top by the crank axle 7. The time taken for different weights 21 to fall should be noted, and if the apparatus has been properly adjusted the different weights 21 should take nearly the same time to fall to the floor. If heavy weights are hung on, the governor ball weights 4 fly out and raise the discs 8 which swing the strip 13 and apply the brake thus retarding the fall of the weights. The student should tabulate his results, using different weights and noting the variation in seconds taken for the weights to fall. The following are examples:—

Weight.				Time in falling.
75 grammes	..	..	..	12 Secs.
100	..	..	..	11 ..
200	..	..	..	10 ..

Model No. 426

# Roof Truss

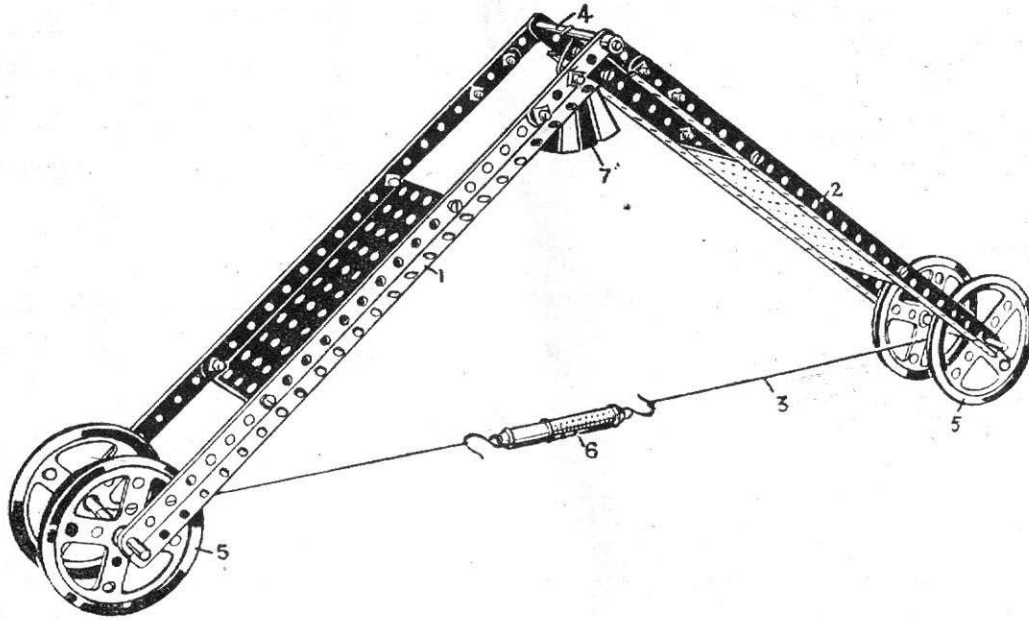

This is an apparatus for finding out the stresses in a roof-truss. The material in the inclined girders 1, 2, of any roof-truss frame are in compression, but the tie rod represented by the cord 3 is in tension, that is to say it is being pulled apart. The compression members in such a roof-truss are, therefore, made rigid so that they will not bend, but the tie rod 3 being in tension could not possibly bend, and is usually, therefore, made of thin bar or rod. The two compression members are pivotally connected at the apex by a rod 4 and large wheels 5 are fitted at the feet.

The cord 3 connects across to the axles of the wheels 5 and a spring balance 6 for registering the pull is inserted. Various weights 7 should be hung on the rod 4 and the different pulls registered by the spring balance 6 should be noted, and these results should be tabulated by the student. When this has been done for a number of weights the angle between the compression girders 1 and 2 should be altered by shortening or lengthening the string 3 and a new series of experiments with different weights 7 should be conducted and the results tabulated.

# Roof Truss (continued)

The student should note that the same weight *W* will give quite a different reading for the pull in the tie rod 3 when the angle of the roof truss girders 1 and 2 is altered.

The following are the results of one series of experiments:

Weight on Truss.	Pull in Tie Rod.
100 grammes ..	40 grammes.
200 " ..	80 "
300 " ..	120 "

For the purpose of experimenting, the following Meccano parts may be used as supplementary weights:—

- The weight of either an angle bracket or a flat bracket is 1.1 grammes.
- 2½" perforated strip weighs 4.35 grammes.
- 5" " " " 10 "

We recommend that great care be taken to see that all parts of the apparatus are oiled and work smoothly before commencing to experiment.

## Model Pulley Blocks

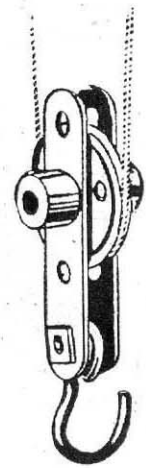

Model No. 427

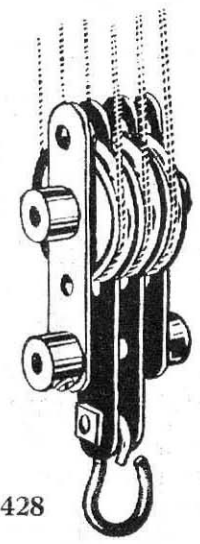

Model No. 428

# The Meccano Electric Motor

## The Meccano Spring Motor

THE MECCANO SPRING MOTOR contains its own motive power in a simple and convenient form. It can be built into, and becomes part of, the model it drives

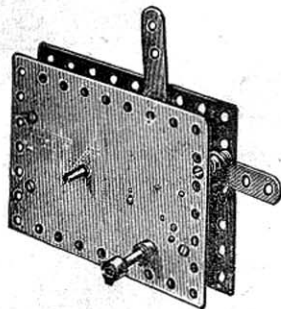

The Meccano Spring Motor may be used in connection with a very large number of Meccano models. It has a stopping and starting motion, and the movement can be reversed. Price 12/6



This is the Meccano Electric Motor—the most powerful and reliable toy electric motor made. It runs Elevators, Sawmills, Lathes, or any other Meccano models. It has been tested to lift 30lbs. dead weight when properly geared. Two or three dry batteries will run it but accumulators are more satisfactory. Direct shaft drive; positive and powerful. Interchangeable gearing. It puts action into Meccano models; makes them operate like real machinery.

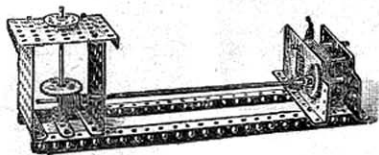

Showing the application of the Electric motor to such models as the Roundabout, Maxim Flying Machine, &c.

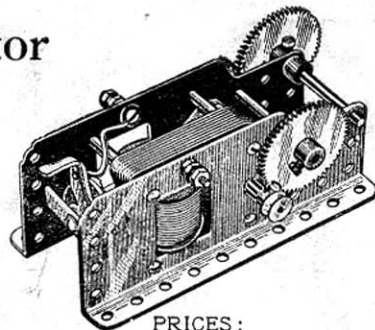

PRICES:  
Without reversing mechanism  
With reversing mechanism

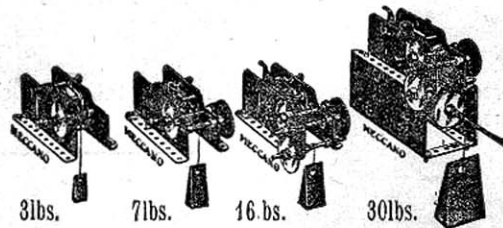

This illustration shows a combination of gears built from Meccano parts on to the Electric Motor itself, the drive being direct from the Armature Spindle. Note how a slow drive and substantial lifting power are secured. In this case three dry batteries (approximately four volts) were used.

Just a hint on the use of the non-reversing electric motor. When it is fitted to a crane or an elevator it is a good plan to secure a collar to the shaft, on the inside of the plate nearest the large gear wheel, allowing about  $\frac{1}{4}$  in. play. When the load has reached the top the rod may be slid along sufficiently to throw the big gear wheel out of gear with the pinion, thus allowing the load to be released.

## The Block Accumulator—4 volts ... 6 ampere hours

This is a new and excellent type of accumulator. We have subjected it to most severe tests, and we believe it to be most suitable for use with any type of toy electric motor. It is non-spillable, cannot be spoiled through short circuiting, and it will retain its charge for many months. Subjecting to any serious extent cannot occur, and if neglected or left in inexperienced hands, no serious harm can be done. Has remarkable recuperative powers, and will keep on working when nominally exhausted. A boon to any Meccano user who possesses a Meccano Electric Motor. Full instructions. Price, 21/-



# Particulars and Prices of Meccano Parts

No.	Description	Price
1.	Perforated Strips, 12 $\frac{1}{2}$ " long ... $\frac{1}{2}$ doz.	1 3
2.	" " 5 $\frac{1}{2}$ " " " " " "	0 9
3.	" " 3 $\frac{1}{2}$ " " " " " "	0 5
4.	" " 3" " " " " "	0 4
5.	" " 2 $\frac{1}{2}$ " " " " " "	0 4
6.	" " 2" " " " " "	0 4
6A.	" " 1 $\frac{1}{2}$ " " " " " "	0 3



7.	Angle Girders, 24 $\frac{1}{2}$ " long ...	each 0 9
7A.	" " 18 $\frac{1}{2}$ " " " " "	0 7
8.	" " 12 $\frac{1}{2}$ " " " " "	$\frac{1}{2}$ doz. 2 3
9.	" " 5 $\frac{1}{2}$ " " " " "	1 3



10.	Flat Brackets ...	$\frac{1}{2}$ doz. 0 3
-----	-------------------	------------------------



11.	Double Brackets ...	each 0 1
-----	---------------------	----------



12.	Angle Brackets...	doz. 0 6
-----	-------------------	----------



12A.	Angle Brackets, 1" ...	each 0 2
------	------------------------	----------



13.	Axle Rods, 11 $\frac{1}{2}$ " long ...	each 0 5
13A.	" " 8" " " " " "	0 3
14.	" " 6" " " " " "	0 2
15.	" " 5" " " " " "	0 2
15A.	" " 4 $\frac{1}{2}$ " " " " " "	0 2
16.	" " 3 $\frac{1}{2}$ " " " " " "	0 1
17.	" " 2 $\frac{1}{2}$ " " " " " "	0 1
18A.	" " 1" " " " " "	0 1



19.	Crank Handles...	each 0 3
-----	------------------	----------



No.	19A. Wheels, 3" diam. with set screws, each	s. d. 0 9
-----	---	-----------



20.	Flanged Wheels ...	each 0 9
-----	--------------------	----------

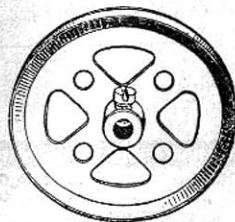

No.	19a. 3" diam. with centre boss and set screw, each	s. d. 1 0
20A.	2" " " " " " "	0 9



21.	1 $\frac{1}{2}$ " diam. with centre boss and set screw, each	0 9
22.	1" " " " " " "	0 6
22A.	1" " without " " " "	0 3
23.	1" " " " " " "	0 2
23A.	1" " with " " " "	0 6



24.	Bush Wheels ...	each 0 8
-----	-----------------	----------



25.	Pinion Wheels, $\frac{3}{4}$ " diam. ...	each 1 3
26.	" " $\frac{1}{2}$ " " " " "	0 9



No.	Description	Price
27.	50 teeth to gear with $\frac{1}{2}$ " pinion	each 0 10
27A.	56 " " " " "	1 0



28.	Contra Wheels, 1 $\frac{1}{2}$ " diam. ...	each 1 3
29.	" " " " " " "	1 0
30.	Bevel Gears ...	1 6



31.	Gear Wheels, 1", 40 teeth ...	each 1 9
-----	-------------------------------	----------



32.	Worm Wheels ...	each 0 10
-----	-----------------	-----------



33.	Pawls ...	each 0 3
-----	-----------	----------



34.	Spanners ...	each 0 3
-----	--------------	----------



35.	Spring Clips ...	per box (doz.) 0 6
-----	------------------	--------------------

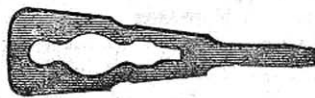

36.	Screw Drivers ...	each 0 3
36A.	" " (Special) ...	1 9



No.	37. Nuts and Bolts ...	per box (doz.) 0 6
37A.	Nuts ...	0 3
37B.	Bolts ...	0 4
38.	Washers ...	0 2
40.	Hanks of Cord ...	2" for 0 3



41.	Propeller Blades ...	per pair 0 6
-----	----------------------	--------------



43.	Springs ...	each 0 2
-----	-------------	----------



44.	Cranked Bent Strips ...	each 0 2
-----	-------------------------	----------



45.	Double Bent Strips ...	each 0 2
-----	------------------------	----------



46.	Double Angle Strips, 2 $\frac{1}{2}$ " x 1" ...	each 0 3
-----	---	----------



50.	Eye Pieces ...	each 0 2
-----	----------------	----------

## Particulars and Prices of Meccano Parts (continued)

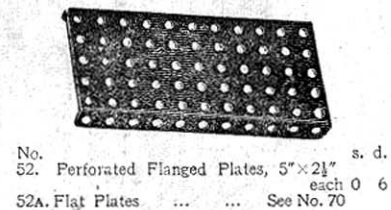

No. 52. Perforated Flanged Plates, 5"×2½" s. d.  
each 0 6  
52A. Flat Plates ... See No. 70

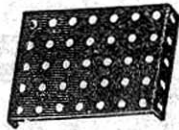

No. 53. Perforated Flanged Plates, 3½"×2½" s. d.  
each 0 5  
53A. Flat Plates ... See No. 70



No. 54. Perforated Flanged Sector Plates, s. d. 0 5  
56. Instruction Manual, No. 1 ... " 2 6  
56A. Instruction Manual, No 2 ... " 1 3



No. 57. Hooks ... each 0 1  
57A. " (scientific) ... " 0 1



No. 58. Spring Cord ... per length 1 0



No. 59. Collars with Set Screws ... each 0 3



No. 60A. Double Angle Strips, 1½"×1" each 0 1  
60. " " " 2½"×1" " 0 1½  
60B. " " " 3"×1" " 0 2  
60C. " " " 5"×1" " 0 3



No. 61. Windmill Sails ... s. d. each 0 3



No. 62. Cranks ... each 0 6

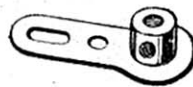

No. 62A. Threaded Cranks ... each 0 6



No. 63. Couplings ... each 0 9



No. 63A. Octagonal Couplings ... each 0 9



No. 63a. Strip Couplings ... each 0 9



No. 64. Threaded Bosses ... each 0 3  
65. Centre Forks ... " 0 3  
66. Weights, 50 grammes ... " 0 6  
67. " 25 " ... " 0 4  
68. Woodscrews, 1in. ... doz. 0 3  
69. Set Screws ... " 0 4  
69A. Grub Screws ... " 0 4

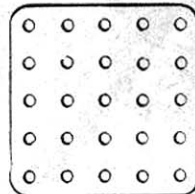

No. 70. Flat Plates each  
5½"×2½"... 5d.  
72 Flat Plates  
2½"×2½"... 3d.  
52A. Flat Plates  
5½"×3½"... 5d.  
53A. Flat Plates  
4½"×2½"... 4d.

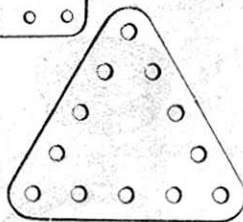

No. 76. Triangular Plates ... s. d. each 0 2  
77. " " " " " " 0 1½



No. 80. Screwed Rods, 5" ... each 0 6  
81. " " 2" ... " 0 3



No. 89. Curved Strips, 5½" ... each 0 2  
90. " " 2½" ... " 0 1  
94. Sprocket Chain... per yard 1 0



No. 95. Sprocket Wheels, 2" diam. ... each 0 6  
96. " " 1" ... " 0 4



No. 97. Braced Girders, 3½" long ... 1 doz. 0 9  
98. " " 2½" " ... " 0 8  
99. " " 12½" " ... " 1 0  
100. " " 5½" " ... " 1 0  
101. Healds ... for Looms ... doz. 0 9  
102. Single Bent Strips ... each 0 2  
103. Flat Girders, 5½" long ... " 0 2  
104. Shuttles ... " 1 0  
105. Reed Hooks ... " 0 3  
106. Wooden Rollers for Looms.

(One of each required in a Loom.)  
Cloth Rollers ... each 0 6  
Sand ... " 0 9  
107. Tables for Designing Machines ... 1 0

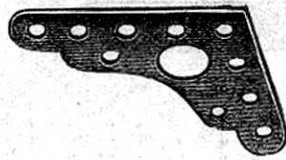

No. 108. Architraves ... s. d. each 0 3

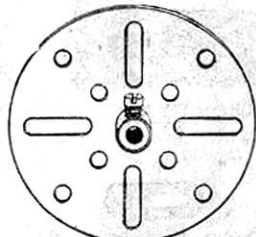

No. 109. Face Plates, 2½" diam. ... each 0 6

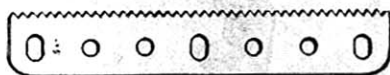

No. 110. Rack Strips, 3½" ... each 0 3



No. 111. Bolts, 3" ... each 0 1



No. 112. Double Angle Strips, 2½"×1½" each 0 3

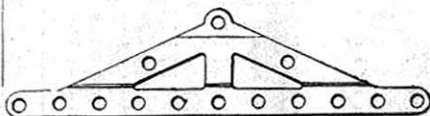

No. 113. Girder Frames ... each 0 4  
114. Hinges ... per pair 0 7  
115. Threaded Pins ... each 0 2  
120. Buffers ... " 0 2  
121. Train Couplings ... " 0 6

## Price List

No. 0.	Meccano Outfit	...	...	...	...	...	...	6/-
No. 1.	"	"	...	...	...	...	...	10/-
No. 2.	"	"	...	...	...	...	...	20/-
No. 3.	"	"	...	...	...	...	...	30/-
No. 4.	"	"	...	...	...	...	...	50/-
No. 5.	"	"	...	...	...	...	...	70/-
Do.	"	Presentation Outfit					Packed in neat and well-made cardboard box	100/-
No. 6.	"	"	"				Ditto ditto ditto	180/-
<hr/>								
No. 0A.	Meccano Accessory Outfit						(containing sufficient parts to convert a Meccano No. 0 Outfit into a No. 1)	5/-
No. 1A.	"	"	"				(containing sufficient parts to convert a No. 1 Outfit into a No. 2)	11/-
No. 2A.	"	"	"				(containing sufficient parts to convert a No. 2 Outfit into a No. 3)	12/-
No. 3A.	"	"	"				(containing sufficient parts to convert a No. 3 Outfit into a No. 4)	22/-
No. 4A.	"	"	"				(containing sufficient parts to convert a No. 4 Outfit into a No. 5)	17/6
No. 5A.	"	"	"				(containing sufficient parts to convert a No. 5 Outfit into a No. 6)	65/-
Do.	"	"	"				Packed in neat and well-made cardboard box	95/-
							Packed in superior oak cabinet with lock and key	10/-
	Meccano Inventors' Accessory Outfit A	...	...	...	...	...		10/-
	"	"	"	"	B	...	...	25/-

№	Мессия	Описание	№
1	Мессия	...	100
2	Мессия	...	100
3	Мессия	...	100
4	Мессия	...	100
5	Мессия	...	100
6	Мессия	...	100
7	Мессия	...	100
8	Мессия	...	100
9	Мессия	...	100
10	Мессия	...	100
11	Мессия	...	100
12	Мессия	...	100
13	Мессия	...	100
14	Мессия	...	100
15	Мессия	...	100
16	Мессия	...	100
17	Мессия	...	100
18	Мессия	...	100
19	Мессия	...	100
20	Мессия	...	100
21	Мессия	...	100
22	Мессия	...	100
23	Мессия	...	100
24	Мессия	...	100
25	Мессия	...	100
26	Мессия	...	100
27	Мессия	...	100
28	Мессия	...	100
29	Мессия	...	100
30	Мессия	...	100
31	Мессия	...	100
32	Мессия	...	100
33	Мессия	...	100
34	Мессия	...	100
35	Мессия	...	100
36	Мессия	...	100
37	Мессия	...	100
38	Мессия	...	100
39	Мессия	...	100
40	Мессия	...	100
41	Мессия	...	100
42	Мессия	...	100
43	Мессия	...	100
44	Мессия	...	100
45	Мессия	...	100
46	Мессия	...	100
47	Мессия	...	100
48	Мессия	...	100
49	Мессия	...	100
50	Мессия	...	100

Риски Риски

№ 6 М 7 6 М

No 1	Messico	100
No 2	"	100
No 3	"	100
No 4	"	100
No 5	"	100
No 6	"	100
No 7	"	100
No 8	"	100
No 9	"	100
No 10	"	100
No 11	"	100
No 12	"	100
No 13	"	100
No 14	"	100
No 15	"	100
No 16	"	100
No 17	"	100
No 18	"	100
No 19	"	100
No 20	"	100
No 21	"	100
No 22	"	100
No 23	"	100
No 24	"	100
No 25	"	100
No 26	"	100
No 27	"	100
No 28	"	100
No 29	"	100
No 30	"	100
No 31	"	100
No 32	"	100
No 33	"	100
No 34	"	100
No 35	"	100
No 36	"	100
No 37	"	100
No 38	"	100
No 39	"	100
No 40	"	100
No 41	"	100
No 42	"	100
No 43	"	100
No 44	"	100
No 45	"	100
No 46	"	100
No 47	"	100
No 48	"	100
No 49	"	100
No 50	"	100

PLATE 121

## MECCANO IS MORE THAN A TOY

---

**I**T is important to remember that when a boy is playing with Meccano he is using engineering parts in miniature, and that these parts act in precisely the same way as the corresponding engineering elements would do in actual practice. No other system of model construction could, therefore, be correct. Other toys which attempt the same object by other methods must avail themselves of other constructive elements which are not correct engineering elements. Consequently, though a boy may succeed in building playthings with them, they are merely toys, and nothing else, and his mind, as regards proper mechanical construction and methods, is distorted instead of instructed. He thus learns wrong principles, and when his ambition tempts him to invent or construct more elaborate models he will be stopped by the deficiencies of his non-mechanical system.

No Outfit is genuine unless it bears the  
trade mark MECCANO