



# MECCANO



ELECTRICAL OUTFIT

An accessory outfit enabling those who have a Meccano outfit, a Meccano Electric Motor, and electric current to make interesting experiments with

ELECTRIC LOCOMOTIVES  
SIGNALLING APPARATUS  
LAMP STANDARDS

MAGNETIC CRANES  
INDUCTION COILS  
MOTOR STARTER, Etc.

## INSTRUCTIONS

Price 45 Cents

MECCANO COMPANY, Inc., NEW YORK

# MECCANO

## Electrical Accessory Outfit

### FOREWORD

**T**HE Meccano electrical outfit is an accessory outfit, designed to give extra entertainment to those who already own a Meccano outfit. It contains the electrical parts only for building electric locomotives, magnetic cranes, Morse signalling apparatus, induction coils, electric lamp standards, etc.

Instructions for building certain types of these are given in this book, but the young Meccano builder will readily think of many further things he can build, and additional experiments he can make. Among the models shown are several which can be built with the smaller Meccano outfits. If the purchaser of the Electrical Accessory Outfit has not sufficient Meccano parts to build the models exactly as pictured, he can make modifications of them. For instance a Morse key, railroad signal or light standard can be built with the smallest outfit by using the parts contained in the outfit for those shown in this Manual. If he has a motor he can build an electric locomotive round it with just such parts as he has. Cranes Nos. 24, 25, or 28 in the large Meccano Manual can be equipped electrically just as easily as model No. 5 in the Electrical Manual. On page 12 there are types of railroad signals which can be built with a No. 1 Meccano outfit. These can be made to work electrically along the lines described on page 6 of the Electrical Manual. On page 27 of this book are illustrated a number of models suitable for experiments by the boy who has a Meccano Electrical Outfit.

Do not forget that it is always possible to purchase single parts required to complete any idea the young builder may have. The possessor of an electrical outfit will therefore be in a position to make any model in the electrical Manual, either from the Meccano set he has or by purchasing any separate parts which may be necessary. A full list of Meccano parts is given at end of this book.

# MECCANO ELECTRIFIED

**N**OT many boys realise the tremendous part which electricity plays in our every-day life these days. We use the electric light, electric trains, telephone and telegraph, without thinking much of the wonderful power which gives us these great facilities, what this power is, or how it operates. The study of electricity is extremely fascinating and it is our desire that all Meccano boys shall have a good insight into the subject and derive both pleasure and knowledge from it. A very large number of Meccano models may be operated by electricity, and in this manual we show you how easily this may be done.

No one has yet been able to define electricity or tell us just what it is, and all we can say is that it is a natural force capable of unlimited uses. A long treatise might be written on the phenomena of electricity, but it is only necessary here to deal with it so far as it applies to engineering.

Before commencing to make the models in this manual it is very necessary that a boy should know the meaning of the general terms used in Electricity, so that he may understand them whenever they are referred to.

**VOLT.** The practical unit of Electro-Motive Force (E.M.F.) is termed a Volt, and this represents the force of Electricity passing round a circuit. The more force there is the greater the voltage.

**RESISTANCE OR OHMS.** This means resistance to the current passing along a wire. Apart from silver, copper wire offers the least resistance to the current passing along it. If another class of wire were used, made from such metals as Zinc, Iron, Tin or Lead, which possess less conductivity, the resistance would be greater, consequently less current would be transmitted. The resistance of a Conductor increases as the length increases.

**AMPERES.** This means the rate at which Electricity flows around a circuit. The thicker the wire the more current may be transmitted.

**WATT.** This is the unit of Electrical Power and equals 0.7373 foot pounds per second, equal to 1/746 of a horse power. The number of watts is ascertained by multiplying the volts by the amperes. Thus, if the E.M.F. is four volts and the current two amperes, the power transmitted would be 8 watts.

**SHORT CIRCUIT.** This is the term used when the current takes a shorter course than the one intended. This would arise for instance if some other wire came into contact with the conductor and diverted the current along a shorter course. The usual result of this is either damage to the cell which gives off the current, or heating or fusing the wire on the shorter circuit

**B.A.** When referred to in the Manual means British Association Standard Threads, whether bolts or nuts, and not the Meccano nuts and bolts.

**S.C.C.** Applied to wire, means Single Cotton Covered.

The preceding terms will be better understood if we compare the wire transmitting the current to a water pipe.

The volts would represent the force of water flowing through the pipe, and the resistance, or ohms would correspond to the friction of the bore of the pipe. The amperage or rate of flow would represent the result obtained by the force acting on the resistance of the pipe.

NOTE—Wherever instructions are given in this Manual to connect models to an accumulator, either dry cells or transformer can also be used.

## THE MECCANO TRANSFORMER

For 110 Volts A. C. 60 Cycles only

Where house current is available a transformer is much more satisfactory than dry cells for supplying current to operate models and motors. There are no adjustments or moving parts to get out of order, it is entirely enclosed. A strong, reliable instrument which will give excellent service for years. Complete with cord and plug. Screw this into the light socket, and a steady supply of current properly reduced for operating the Meccano motor, is always available. Designed especially for use with the Meccano motor, but may be used wherever a low voltage current is desired.

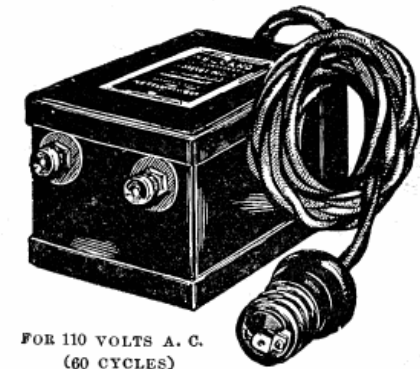

FOR 110 VOLTS A. C.  
(60 CYCLES)

## THE MECCANO ELECTRIC MOTOR

The Meccano Electric motor may be employed for any purpose for which a 4-volt motor is suitable, but it is specially adapted for running Meccano models. The holes in the side plates and flanges are the standard equidistant Meccano perforations, enabling the motor to be connected to Meccano perforated plates, strips, or angle girders, simply by using the regular Meccano nuts and bolts. A wide range of power and speed may be obtained by various combinations of gears.

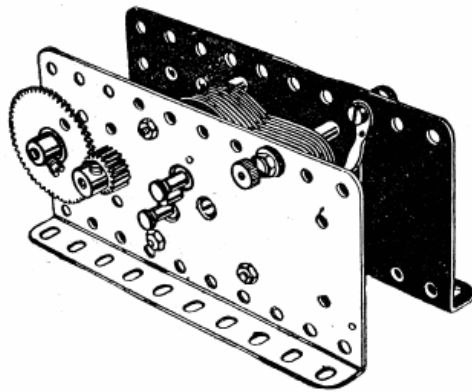

E-1 is a one way motor . . . . . \$3.00

E-2 has reverse and extra gears . . . . \$4.50

# TAPPER KEY MODEL No. 1

This is a most useful key, and may be used in conjunction with practically all the models. The base is a  $5\frac{1}{2}$ " by  $2\frac{1}{2}$ " flanged plate. At one end, and in the centre is fixed a single bent strip 10 on the top of which rests a  $5\frac{1}{2}$ " strip 12. The single bent strip and strip 12 are bolted to the flanged plate by  $\frac{3}{4}$ " Meccano screws and nuts 11. At the opposite end of the plate is bolted an insulated 6 B.A. screw 15. Two terminals 13, 14, are fixed at the end of the plate, one of these 14 is insulated and the other 13 bolted direct to the plate.

The key knob (threaded boss) 16 is fixed at the end of the strip by a Meccano bolt. The head of this bolt should only make contact with the bolt head 15 when the knob is pressed. A piece of No. 23 insulated wire connects the terminal 14 to the screw 15.

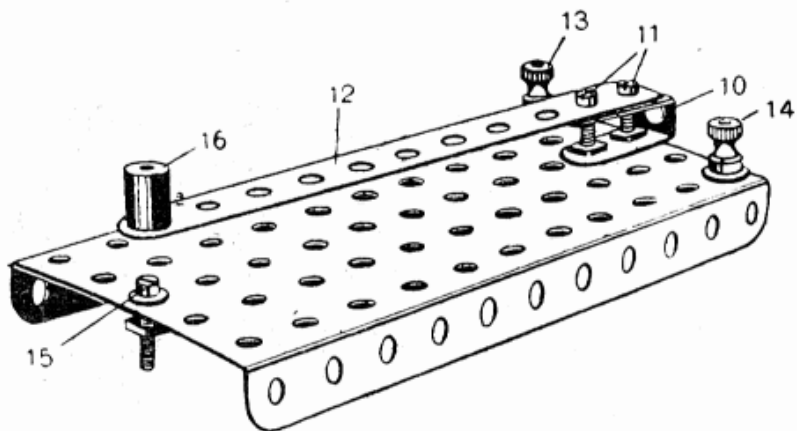

Fig. 1

## Parts required.

1	No.	2
6	"	37A
1	"	52
1	"	64
1	"	102
2	"	111
2	"	302
2	"	303
3	"	304
4	"	305
2	"	306
6"	"	314

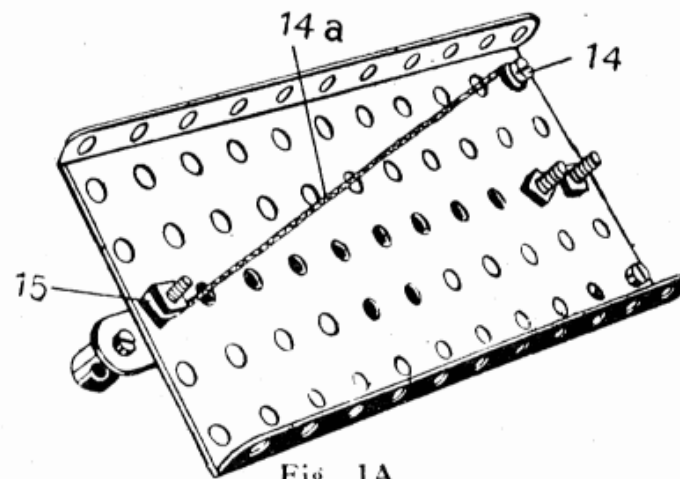

Fig. 1A

# SWITCH MODEL No. 2

This consists of a square plate 1 to which are connected two terminals 2, 3, insulated from the plate. A 3" strip 4 which forms the switch arm is pivotally bolted to and insulated from the plate at 5. Three other bolts 6 are also insulated from the plate and the bolt 6A is connected at the back by a short wire to the terminal 2 and the pivotal bolt by another wire to the terminal 3. Two other bolts 7 are secured in the holes as shown and stand up more from the plate than the bolt heads 6, so that although the arm 4 may pass across the bolt heads 6 it is stopped by the bolt heads 7. The bolts 7 are also insulated from the plate. When the switch is to be used the terminals 2, 3 are connected to the required wires, and on moving the arm 4 to the position shown the current is switched on, but by moving the arm against the other stop the current is shut off.

## Parts required.

1	No.	4	9	No.	302	12	No.	305
1	"	72	8	"	303	2	"	306
1	"	115	8	"	304	3"	"	314

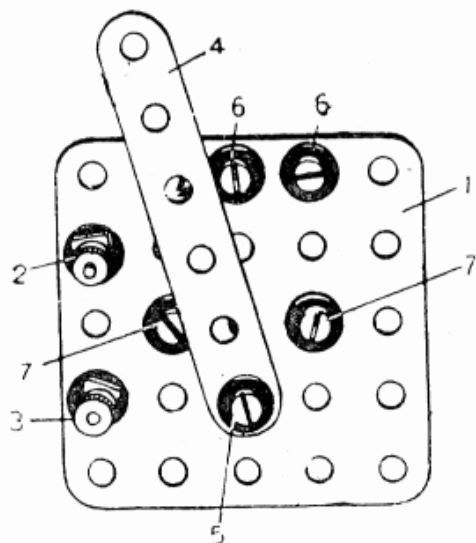

Fig. 2

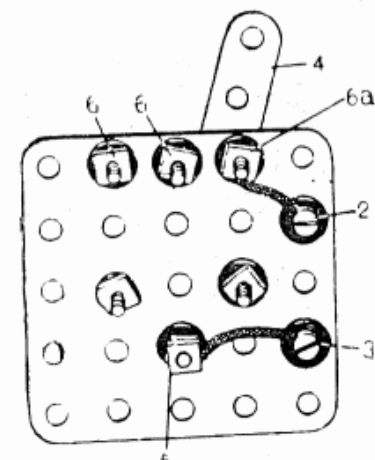

Fig. 2A

# COIL WINDER MODEL No. 3

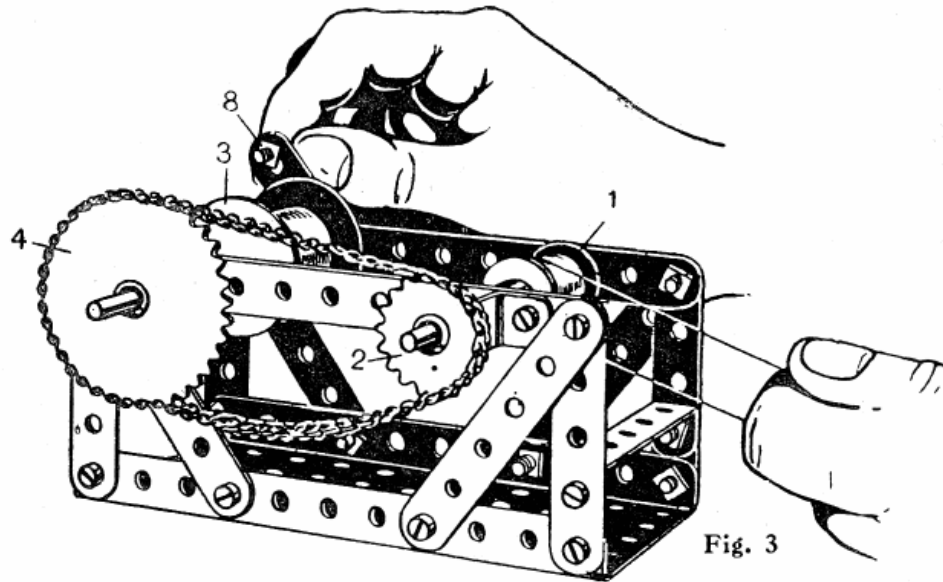
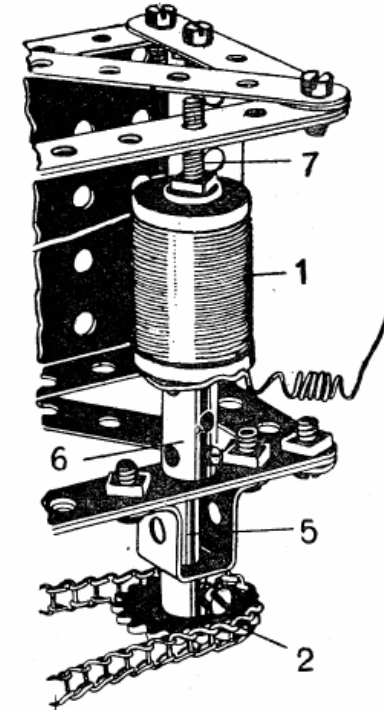

Fig. 3

Parts required.		
4	No.	2
4	"	4
4	"	5
1	"	15A
1	"	17
2	"	37A
18	"	37
1	"	45
1	"	52
1	"	59
2	"	60
1	"	62
1	"	63
1	"	81
12"	"	94
1	"	95
1	"	96
1	"	115

Fig. 3A



As will be seen from the illustration, the coil winder is easy to construct. The part which will need attention is the shaft on which the bobbin 1 to be wound is fastened. This shaft is composed of a 2" rod 5, a coupling 6, and a 2" screwed rod 7.

One end of the 2" rod enters the coupling half-way, and is screwed up. The other end carries a 1" sprocket wheel 2. The 2" screwed rod has one end fixed in the coupling, the other end running in one of the holes in the 5½" strip at the side. The 2" screwed rod also carries a nut.

To fix the bobbin in position for winding:—Unscrew the grub screw in the coupling 6 which holds the end of the screwed rod. Take out the screwed rod, and slide on the bobbin. The nut must be at the opposite end of the screwed rod to allow the bobbin to go on.

Now place the end of the screwed rod back in the coupling, and tighten up the grub screw.

Bring the end of the bobbin to the face of the coupling, then screw up the nut on the rod until it comes up tightly against the other end of the bobbin so as to prevent it from turning around.

After the coil is wound, unscrew the grub screw in the coupling, slide the rod to one side and take off the wound coil.

The wire for winding the Meccano bobbins is supplied on reels.

The required reel 3 must be placed on the 4½" rod which carries the 2" sprocket wheel 4.

Unscrew the grub screw on the crank 8, draw out the rod, slip on the reel, then replace the rod and crank.

Having fixed the reel of wire, also the bobbin in position, the winding may be commenced. Take the end of the wire, drawing it under the bobbin 1 and thread it through the hole in the bobbin cheek nearest to the shaft. Allow 6" or more if necessary of wire to project from the outside of the cheek.

Guide the wire on to the bobbin by holding it between the thumb and forefinger of the left hand, turning the handle of the winder with the right hand. Wind the wire evenly, making each turn to lie closely together; after a little practice your hand will guide the wire correctly.

When the correct number of layers have been wound, which will depend on the model for which the bobbin is to be used, cut the wire, and thread the end through the hole nearest to the edge in the bobbin cheek.

# ELECTRIC RAILWAY SIGNAL MODEL No. 4

The building of this model should not be difficult, though care must be taken that the movable parts work freely.

The signal arm 1 is balanced by a crank 2 fastened to a  $4\frac{1}{2}$ " rod 3.

The bearings for the rod consist of a large bent strip 4 in the centre of which is bolted a 1" angle bracket.

With the signal in its normal position, *i.e.*, at right angles with the main support 5, the crank should rest on the 1" angle bracket.

At the side of the  $5\frac{1}{2}$ " by  $2\frac{1}{2}$ " flanged plate 6 and near one end should be fixed two terminals 7, 8. One of these terminals must be insulated from the plate by means of an insulating bush and washer.

Wind the Meccano bobbin with the No. 26 wire until you have wound on nine layers.

When wound, the bobbin 9 is tied to the main support, allowing the top of the  $4\frac{1}{2}$ " rod to enter the hole in the centre of the bobbin half way. The rod 3 must work perfectly free through the centre of the bobbin.

Bring the two wires from the coil down to the terminals 7, 8, take off the cotton covering each end for  $\frac{1}{2}$ ", and connect the bare wires, one to each terminal, by means of a 6 B.A. nut.

The signal is operated from the battery 10 by a taper key described in Model No. 1. One wire 16 from the battery is connected to the terminal 7 and the other wire 17 to the terminal 13, while a third wire 18 connects the terminal 14 to the terminal 8. If the strip 12 is pressed down the bobbin 9 is electrified and draws up the rod 3 allowing the signal arm 1 to fall.

### Parts required.

No.	Quantity	Description
1	1	Signal arm
2	1	Crank
3	1	$4\frac{1}{2}$ " rod
4	1	Bent strip
5	1	Main support
6	1	Flanged plate
7	1	Terminal
8	1	Terminal
9	1	Meccano bobbin
10	1	Battery
11	1	Angle bracket
12	1	Taper key
13	1	Terminal
14	1	Terminal
15	15 yds.	Wire
16	1	Wire
17	1	Wire
18	1	Wire
12A	1	Terminal
15A	1	Terminal
23	1	Terminal
37	1	Terminal
46	1	Terminal
52	1	Terminal
62	1	Terminal
301	1	Terminal
302	1	Terminal
303	1	Terminal
304	2	Terminal
305	4	Terminal
306	2	Terminal
313	15 yds.	Wire

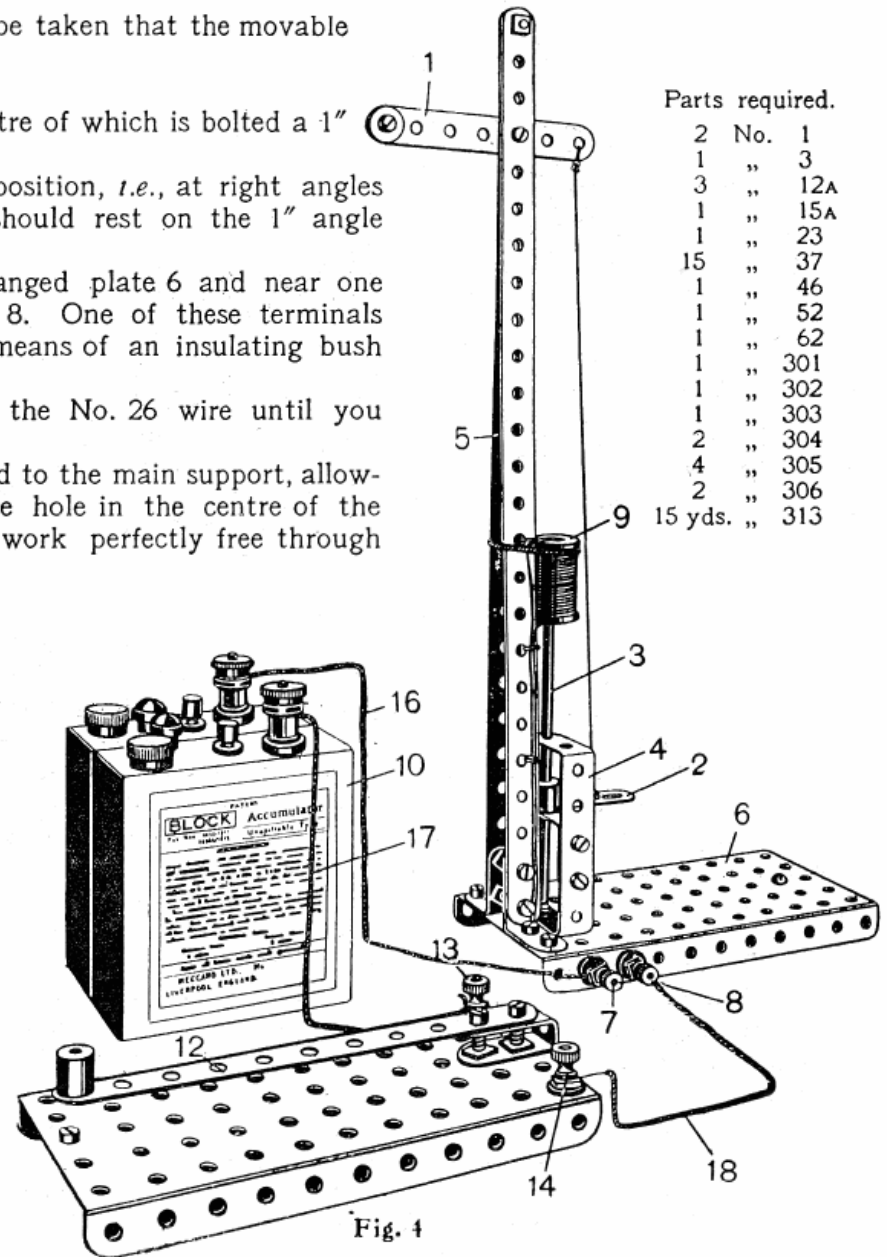
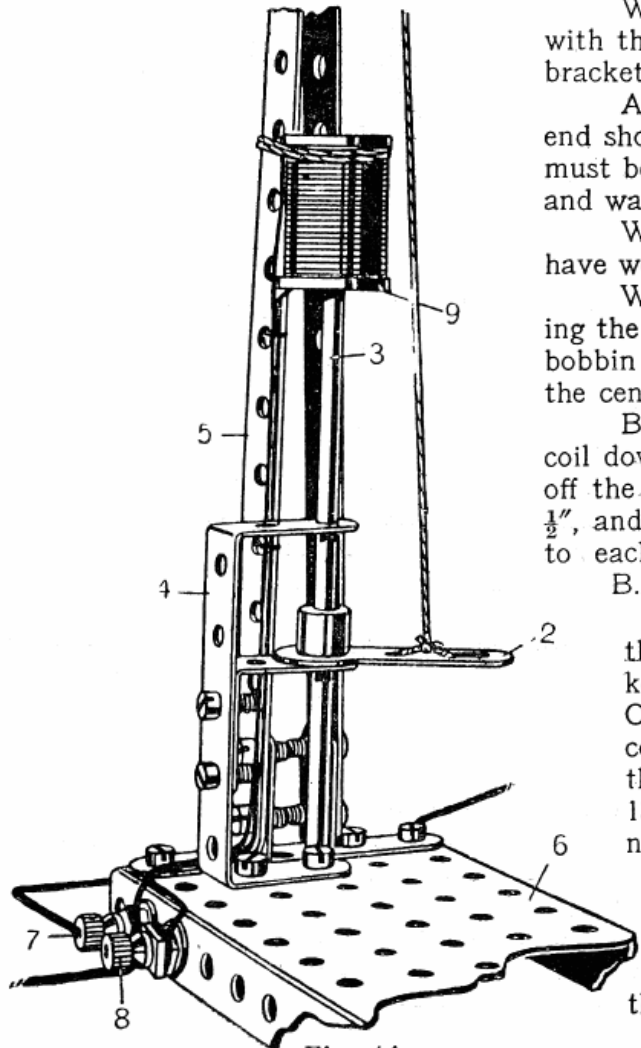

Fig. 4A

Fig. 4

# TRAVELLING JIB CRANE WITH ELECTRIC LIFTING MAGNETS MODEL No. 5

The base of the crane has its sides made of angle girders 1 connected at the ends by architraves 2, the top consisting of two 5½" by 3½" plates 3, spaced apart at the centre, and with

Parts required.

4	No. 1	7	No. 35
3	" 2	76	" 37
4	" 3	4	" 37A
5	" 4	16	" 38
3	" 6A	1	" 44
4	" 8	1	" 45
2	" 9	3	" 52A
4	" 12	5	" 59
1	" 13A	2	" 60A
2	" 14	3	" 60
1	" 16	2	" 99
2	" 17	6	" 100
1	" 18A	4	" 108
1	" 19B	2	" 301
6	" 20	10	" 302
1	" 22A	9	" 303

9	No. 304
13	" 305
1	" 306
2	" 308
20 yds.	" 313
2	" 314

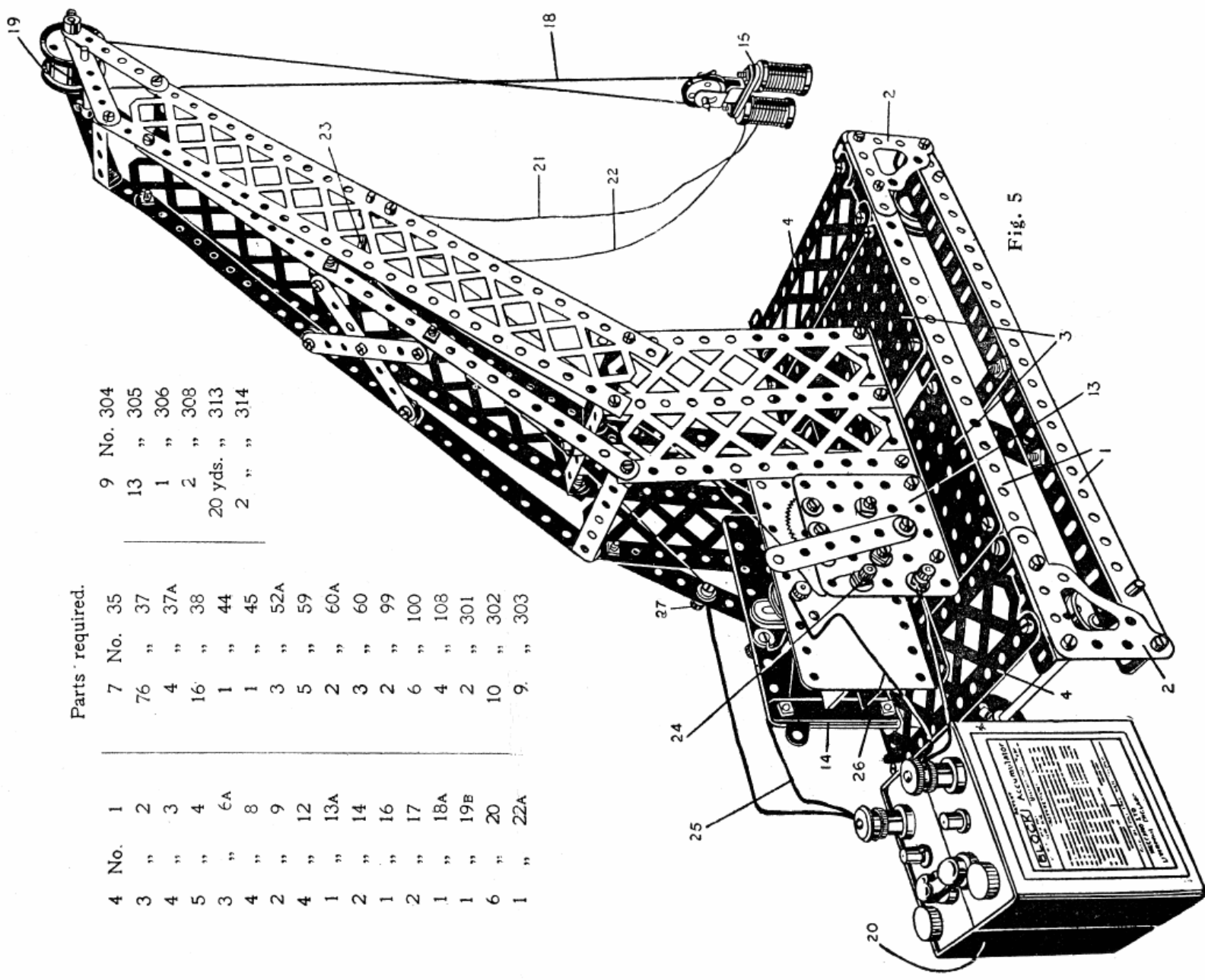



a  $5\frac{1}{2}$ " braced girder strip 4 at each end. The central pivot rod 5 is fitted with a collar 6 between the double bent strip 7 and the cross  $5\frac{1}{2}$ " strip 8. The revolving jib has a 3" pulley wheel 9 bolted to the  $5\frac{1}{2}$ " by  $3\frac{1}{2}$ " plate forming the base of the jib. Beneath the bolt heads are placed single washers so that the nuts 10 and ends of the bolts do not protrude below the flanges of the wheel thus enabling the jib to swivel freely. The rod 5 passes through the hole 11 in the upper strip 12 of the jib, and a collar is fitted at the top of the rod 5. The switch 13 is made as previously described (see Model 2), and is bolted to the  $5\frac{1}{2}$ " angle girders on the base plate of the jib. The motor 14 is bolted to the base plate.

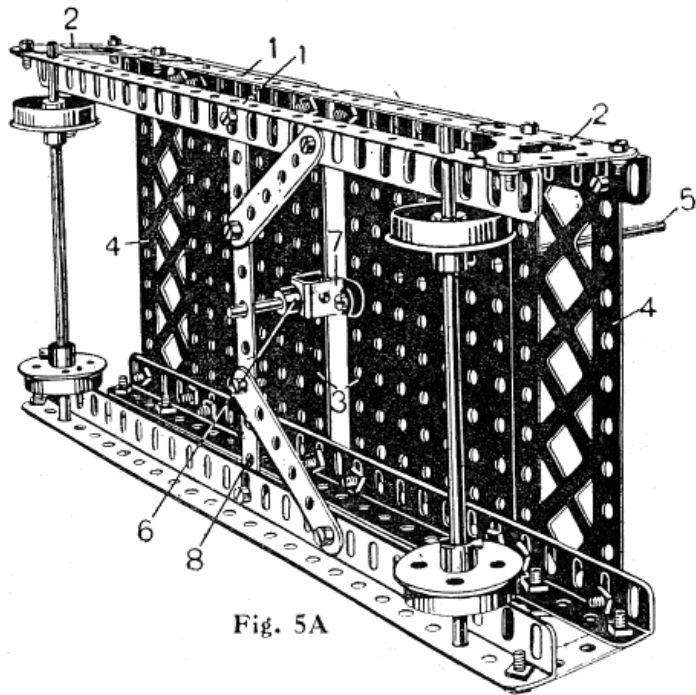

Fig. 5A

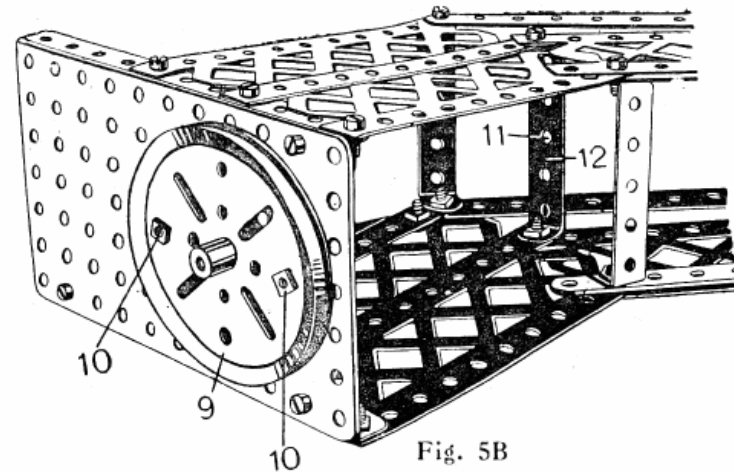

Fig. 5B

Wind two bobbins with seven layers of No. 26 wire on each, and fix a soft-iron core through the centre of each (Fig. 5D), secured with nuts at the bottom, and three  $1\frac{1}{2}$ " strips at the top, as shown in 5c. These  $1\frac{1}{2}$ " strips form the yoke 15 of the magnet. The cranked bent strip 16 is bolted at the top and in the centre holes of the  $1\frac{1}{2}$ " strip.

Take off the insulation from the ends of the inside wires at the bottoms of the coils, scrape clean, and twist the two wires, 17, tightly together. These wires should not project below the face of the two nuts on the core.

The magnet may now be slung by means of the cord 18 passing over the loose pulley wheel 19, as shown in the illustration.

An insulated terminal 27 must now be fixed on the strip at the side of the jib in the position shown Fig. 5E.

Take 30" of the No. 26 wire for 21, and a similar length for 22, bare the ends about 1" and fasten one wire to each of the free ends of your magnet coils. See that the connections are good and the wires twisted tightly.

It will be noticed that a  $3\frac{1}{2}$ " rod 23 has been placed about half-way up the jib. Bring the two wires to this rod, leaving enough loose wire to allow the magnet to work up and down. Give each wire two or three turns round the rod, then lead one to the terminal 27 and the other to the terminal 24 of the switch, and connect neatly.

The crane is now complete. Connect your 4-volt battery 20 to the terminals 27 and 24, and you will find that the magnet will pick up an iron or steel load when the switch is closed, and allow it to be raised or lowered.

To operate the motor connect the accumulator by the wires 25, 26 to the usual motor terminals.

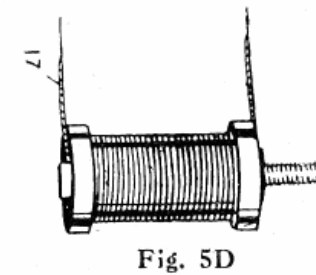
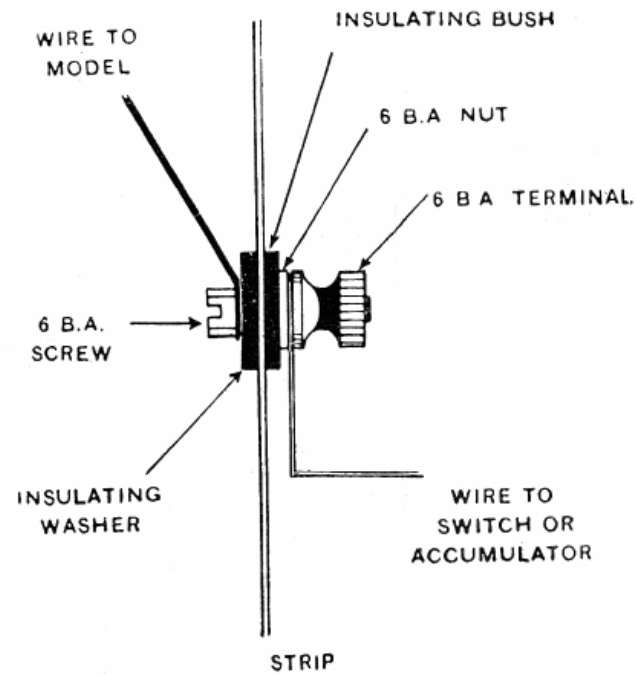
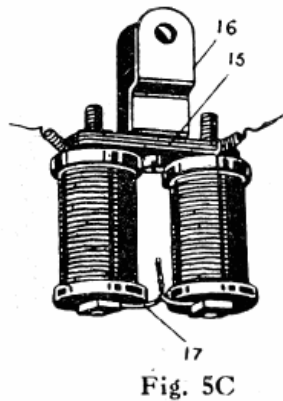

## ELECTRIC BUZZER MODEL No. 6

This buzzer works with the same action as an ordinary electric bell, and the note emitted may be varied by adjusting the contact screws 5.

Build the framework as shown with two terminals 1, 2, on the end of the  $5\frac{1}{2}$ "  $\times$   $2\frac{1}{2}$ " flanged plate near the coil.

One of these terminals 2 must be insulated from the plate, using an insulated bush and washer as described in the previous model. The other terminal must not be insulated, but screwed with a 6 B.A. nut and bolt directly on to the plate.

The coil 3 is wound with 10 layers of No. 26 wire, and a core inserted through the centre of the bobbin. (See Model 3.) Place two nuts on the longer end of the core thread when screwing up the coil to the plate.

When the coil is secured to the flanged plate, connect the wire 4 from the base of the coil to the insulated terminal 2.

The contact screws supplied with the outfit have tips of non-oxidising metal inserted in the ends. These screws should only be used for make and break contacts and not for bolting any of the parts together.

The thread on the contact screws 5 are 6 B. A. and takes the 6 B. A. nut.

The thread on the contact screws 5 are 6 B. A. and takes the 6 B. A. nut.

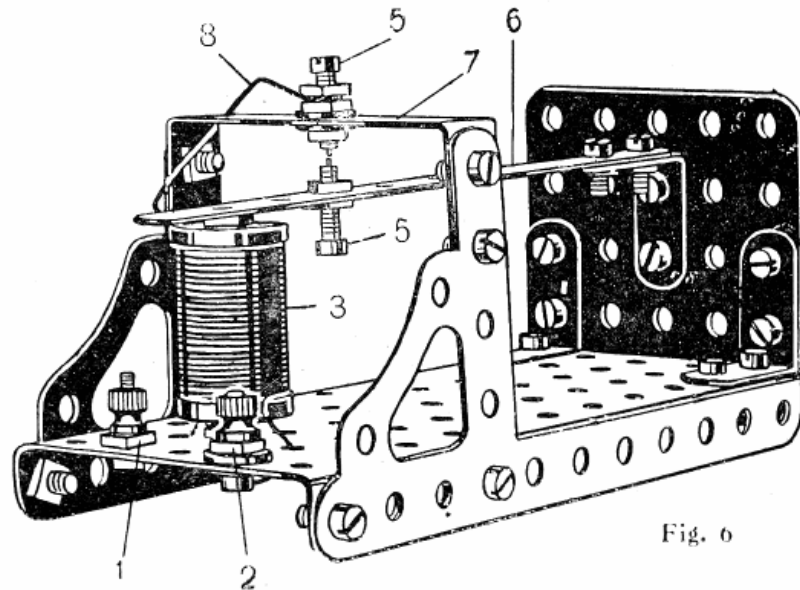

Fig. 6

Parts required.	
1	No. 2
3	" 12A
20	" 37
1	" 46
1	" 52
1	" 72
2	" 108
1	" 301
2	" 302
2	" 303
2	" 304
6	" 305
2	" 306
2	" 307
1	" 308
15 yds.	" 313

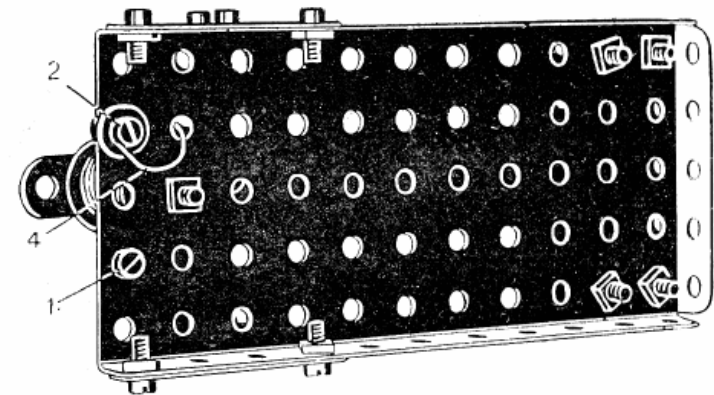

Fig. 6A

Two contact screws are used on this buzzer. One is bolted in the  $5\frac{1}{2}$ " strip 6 the fourth hole from the end without insulators, as this screw must be in electrical connection with the  $5\frac{1}{2}$ " strip.

Directly above this contact screw, and bolted in the centre of the  $2\frac{1}{2}$ " bent strip 7 is the second contact screw, which must be insulated. When the  $5\frac{1}{2}$ " strip is in its proper position the tips of the contact screws should just touch.

The top contact screw should be so adjusted as to press down the strip 6 to within a very short distance of the top of the coil core. The wire 8 from the top of the coil is connected between the nut and insulator to the top contact screw.

The buzzer works well with a 4-volt battery connected to the terminals 1, 2, giving a clear note. Connected up with the tapper key Model 1, the Morse code may be transmitted by depressing the key for long or short intervals as required to make the different lengths of sound to represent the letters.

## MORSE KEY MODEL No. 7

This key is used for telegraphic purposes, allowing signals to be sent in either direction between two stations along one pair of wires. In constructing the key, first bolt two 1" angle brackets 1 in the centre of the 5½" × 2½" flanged plate 2. The two insulated 6 B.A. screws 3, 4, should next be fitted with two 6 B.A. nuts lock nutted at the top of each for contact with the key arm 5.

The key arm is made of two superimposed 5½" strips, in the centre of which, and on either side, is bolted a 1½" strip 6.

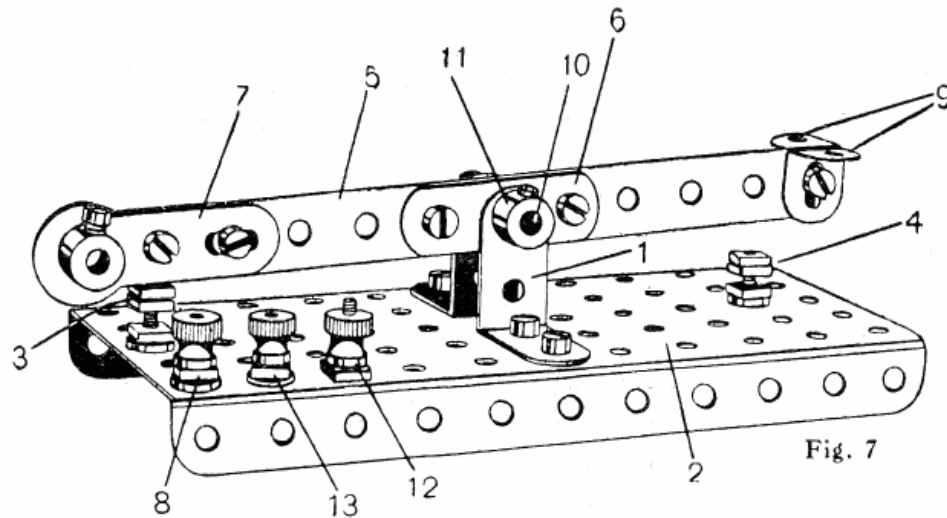

Fig. 7

Collars 11 are fixed at each end of the rod to keep the arm in position. These should be adjusted so that the arm works freely, but not so as to allow it too much side play.

In its normal position, the end of the key arm, which carries the crank, should rest on the rear insulated screw 3.

Three terminals are required, 8, 13, and 12, as shown in Fig. 7a, which is a near view of the key.

Terminals 8 and 13 are insulated, terminal 12 has no insulators, but is bolted direct to the plate.

The insulated terminal 8 must be connected to the insulated screw 3 in the centre of the plate, using the No. 23 wire, and the insulated terminal 13 to the insulated screw 4 at the other end of the plate.

### Parts required.

No.	No.
2	2
2	6A
2	12A
2	12
9	37
6	38
1	52
2	59
1	62
4	302
4	303
5	304
9	305
3	306
8"	314

At one end a crank 7 is fastened for bringing down the key arm to make contact on the rear screw 3.

At the other end of the 5½" strips two angle brackets 9 are bolted. These act as a rest for the finger when working the key.

The key arm is pivoted centrally in the top holes of the angle brackets, by means of a 1" rod 10. To fill in the space between the arm and the angle brackets, three washers are placed on each side of the arm on the 1" rod.

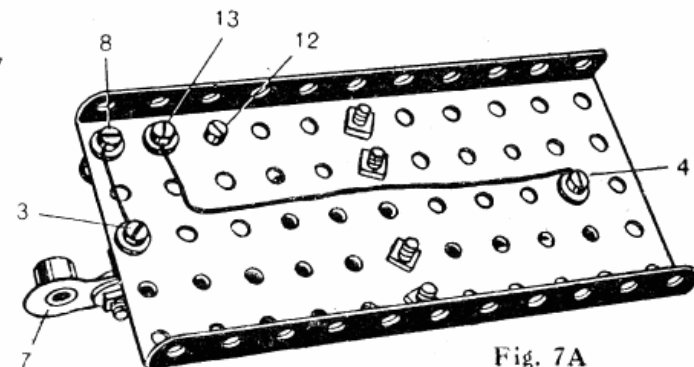

Fig. 7A

# SIGNALLING IN ONE DIRECTION WITH BUZZER AND TAPPER KEY MODEL No. 8

The Morse Code may be signalled by using the buzzer (Model 6), and tapper key (Model 1). Connections are shown on the circuit drawing. The Wires passing through the dotted lines may be extended to any length. Use wire No. 23 for the wires A and B.

The Morse Code is as follows: -

Alphabet.

A	. -
B	. . . .
C	- . - .
D	- . . .
E	.
F	. . . -
G	- . - .
H	. . . .
I	. . .
J	. - - -
K	- . - -
L	. . . .
M	- -
N	- .
O	- - -
P	. - . -
Q	- . - -
R	. - . .
S	. . . .
T	-
U	. . -
V	. . . -
W	. - - -
X	- . . -
Y	- . - -
Z	- - . .

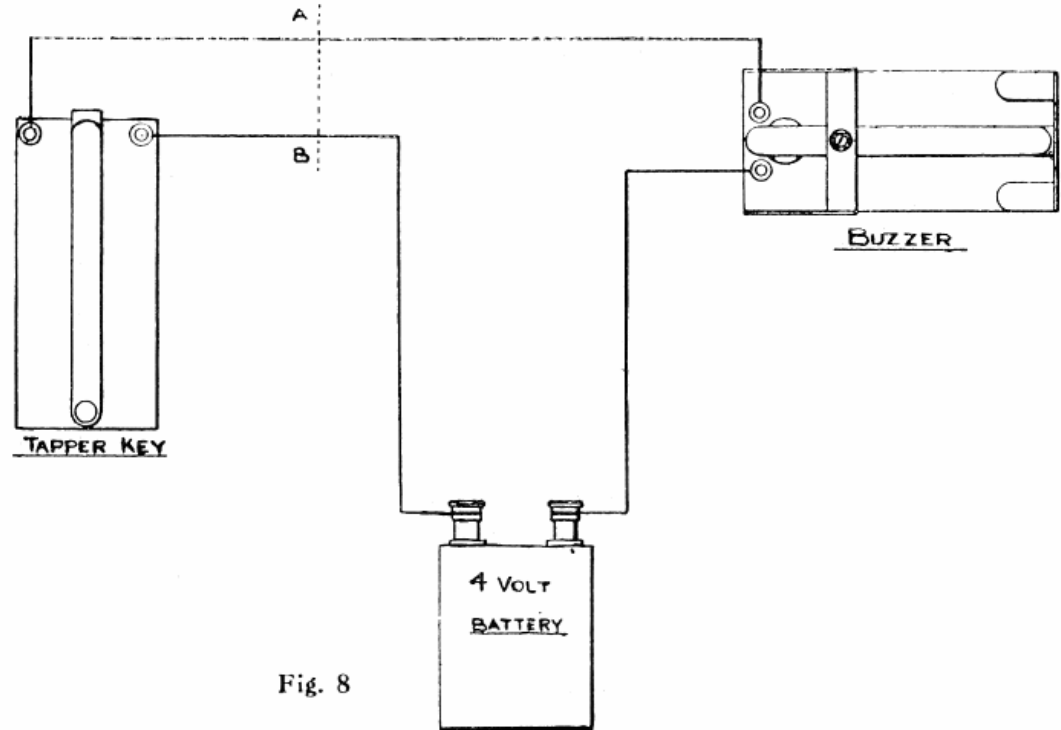

Fig. 8

Numerals.

1	. - - -	5	. . . . .
2	. . - -	6	- . . . .
3	. . . -	7	- - . . .
4	. . . .	8	- - - . .
		9	- - - . .
		0	- - - - -

To transmit a dot, press the Tapper Key for part of a second, then release. For a dash, press key for a second, and release. Allow about two seconds between each letter.

## TO SIGNAL IN BOTH DIRECTIONS OVER ONE PAIR OF WIRES MODEL No. 9

The Morse Key (Model 7) must be used to signal in either direction over one pair of wires. Full connections for two stations are given on the circuit drawing.

The wires passing through the dotted line may be extended to any length.

A Morse key, buzzer and accumulator are required at each station, using wire No. 23 for lines A and B.

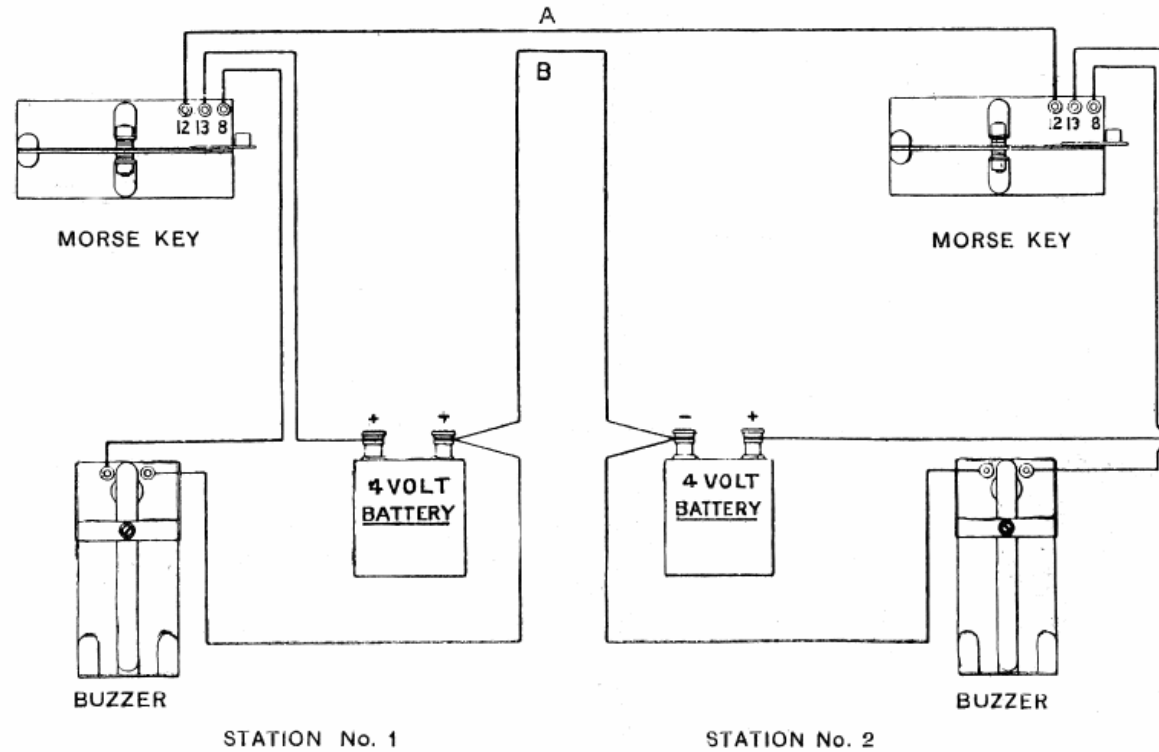

Fig. 9

All wires should be tightly screwed to the terminals to make good connections.

## ELECTRIC SMOOTHING IRON MODEL No. 10

This is a departure from the models described previously, but it will be interesting to construct, and at the same time give some idea of electric heating.

All metals conduct electricity, some more readily than others. Those metals that do not conduct so well are said to offer a resistance to the flow of the current.

Wherever there is resistance in a circuit, heat is developed when a current passes through.

In this electric iron there is used two feet of bare iron wire, No. 27. This iron wire has a certain amount of resistance.

The bottom sector plate 1 or sole of the iron must first have two layers of brown paper nicely fitted inside. This is to insulate the bare wire from the metal plate.

Referring to Fig. 10a, one end of the iron wire is fastened with a Meccano nut and bolt 2 in hole 1 on the left hand side of the sector plate.

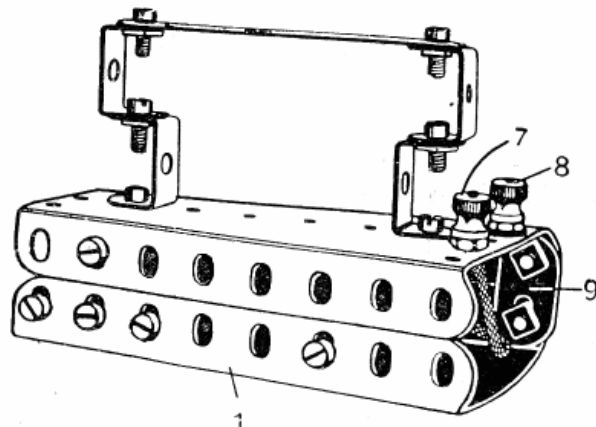

Fig. 10

Bend the wire 4 as shown in Fig. 10a and connect the other end to an insulated 6 B.A. bolt and nut 3 in hole 7 on the right-hand side. The iron wire should be made to lie flat and even on the brown paper after the ends have been connected.

On the insulated screw 3 another nut 5 is placed, and a short piece of insulated copper wire 6 fastened under this nut and then connected to the insulated terminal 8 on the top of the iron, Fig. 10.

### Parts required.

1	No.	4
1	"	6
1	"	6A
2	"	10
4	"	11
4	"	12
15	"	37
2	"	54
2	"	302
2	"	303
3	"	304
4	"	305
2	"	306
24"	"	312
3"	"	314

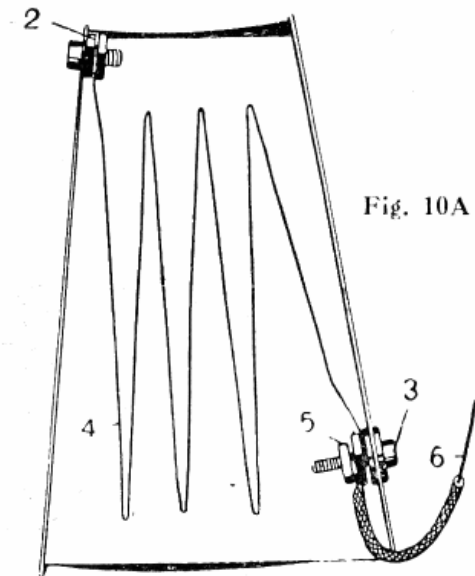

Fig. 10A

To hold the iron wire 4 in position, cut two more layers of brown paper to fit in the sole and completely cover up the wire 4.

In the third and sixth holes on each side of the sole are bolted angle brackets, and under these are placed strips which press down the top paper.

The top part of the iron should now be built. Fix two terminals, 7, 8, in the position shown, one, 8, is insulated, the other is not. The copper wire 6 from the sole is connected to the insulated terminal 8. The top is fastened to the sole by means of flat brackets 9 using the second hole on the left-hand side, and hole 8 on the right-hand side.

Connect the terminals 7, 8 to your 4-volt accumulator, and in about ten minutes the iron will be warm.

# INDUCTION OR SHOCKING COIL MODEL No. 11

This is an interesting model to build, and good fun may be obtained with the coil when complete.

The core of the coil is built of five  $3\frac{1}{2}$ " strips on which are placed the two cheeks A and B. At each end of the  $3\frac{1}{2}$ " strips bolt double brackets 1 and allow the cheeks to butt tight up to them, Fig. 11b.

In between the two cheeks and on the  $3\frac{1}{2}$ " strips wrap tightly two layers of paper, and gum down the edge to insulate the strip from the wire.

At one end of the core, under the head of the screw that bolts the core and double bracket together, place a short piece of No. 26 wire 2, with the cotton covering taken off. Bring the wire round the end of the core and fasten it under the nut, and screw up tightly.

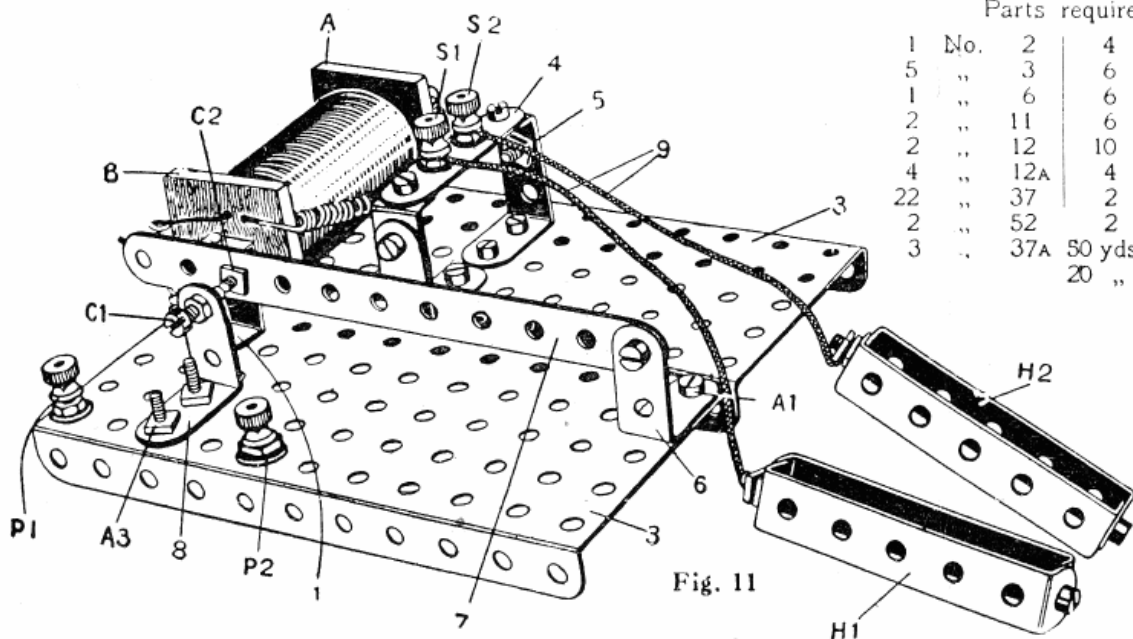

Fig. 11

### Parts required.

1	No.	2	4	No.	60
5	"	3	6	"	302
1	"	6	6	"	303
2	"	11	6	"	304
2	"	12	10	"	305
4	"	12A	4	"	306
22	"	37	2	"	307
2	"	52	2	"	309
3	"	37A	50 yds.	"	313
			20 "	"	314

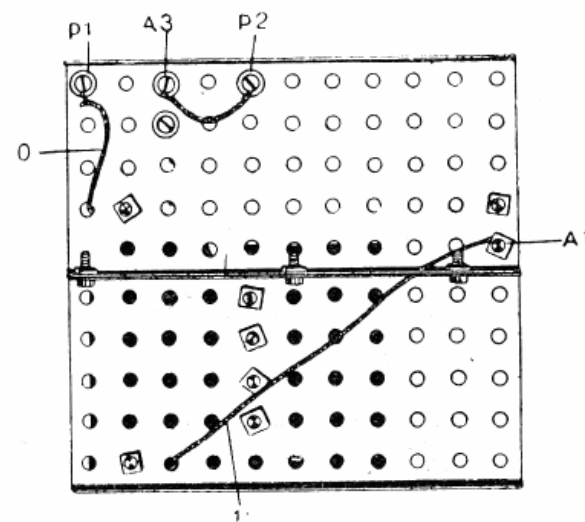

Fig. 11A

Induction coils have two separate coils wound on the core. The first or Primary coil consists of a few layers of thick wire: the second or Secondary coil has a good many layers of fine wire.

The Primary coil is the first to be wound on the core. Use No. 23 wire, and thread one end of the wire through one of the holes in the cheek A nearest the core, leaving 12" of wire outside the cheek, then wind the layers on by hand, winding evenly and straight, until there are three layers wound on. Next thread the free end of the wire through the corresponding hole in the cheek B, and leave 12" of wire projecting.

Over the Primary coil wind another layer of paper, gumming down the edge to insulate the two coils.

When starting the Secondary coil, thread the end of the wire through the next hole in the cheek A. This coil is wound on top of the Primary coil and consists of nine layers of No. 26 wire. Wind by hand as before, keeping the layers straight and even. Between



each two layers of wire place a layer of paper, and when all the layers are on, thread the other end through the topmost hole in the cheek B. Leave 12" of wire also at the end of the Secondary coil cheek B.

The base of the coil consists of two  $5\frac{1}{2} \times 2\frac{1}{2}$  flanged plates 3 bolted together.

The coil is screwed to the base by the double brackets 1 at each end as shown in Fig. 11b.

In front of the coil is fixed a 2" strip 4 with two insulated terminals S1 and S2 in the centre. The strip is raised from the base by means of two angle brackets and two 1" angle brackets.

The ends of the Secondary coil are brought to these terminals S1 and S2 and connected on the under side.

The armature 7 and contact pillar 8 are fitted next. The 1" angle bracket 6 is screwed to the base. To this bracket is bolted a  $5\frac{1}{2}$ " strip 7 which acts as the armature.

The contact pillar 8 is another 1" angle bracket. This must be insulated from the base by using insulating bushes and washers. Place the washers between the 1" angle bracket and base, as the two must not be in electrical connection. The 6 B.A. screws and nuts are to be used for bolting down bracket 8.

Two insulated terminals are screwed to the base at P1 and P2. These are connected to the battery when the coil is complete.

Two contact screws C1 and C2 are required; one is bolted in the contact pillar 8, the other in the  $5\frac{1}{2}$ " strip 7.

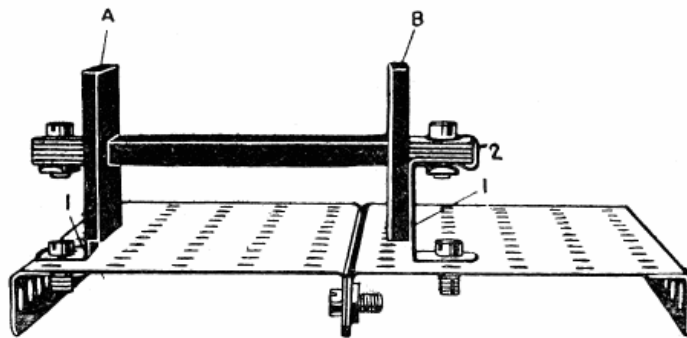

Fig. 11B

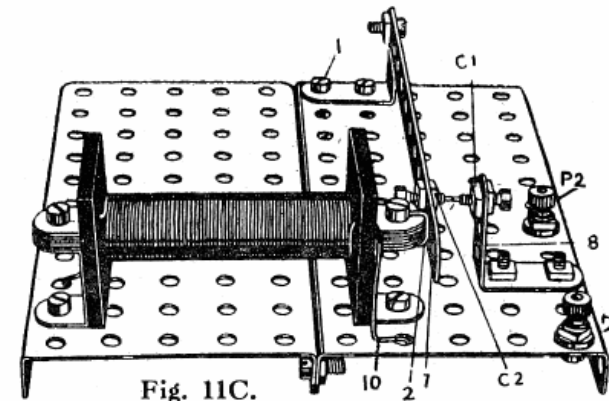

Fig. 11C.

The contacts of these two screws must come directly opposite each other, and be so fixed that the strip 7 is pressed to within a very short distance of the copper wire 2 on the end of the core.

In their normal position the contacts must touch, but when the  $5\frac{1}{2}$ " strip is attracted to the core due to the current going through the Primary coil, the contact points must separate, thus breaking the circuit.

The wires from the Primary coil may now be connected. Fig. 11a shows the Primary connections only for clearness. The end of the Primary wire 10 Fig. 11a coming out of the cheek B, is taken to the terminal P1, and connected underneath. The other end of the Primary wire 11 is taken to the angle bracket 6 and connected to one of the bolts A1 by means of a nut. Connect a piece of insulated wire underneath terminal P2, see Fig. 11a, and take the other end to the underside of the insulated screw A3.

Two handles H1 and H2 should be made as shown, by means of  $2\frac{1}{2}$ " bent strips. Connect these two handles to the brass terminals S1 and S2 by two insulated copper wires 9 each 18" long.

The coil is now complete. Connect your battery to the brass terminals P1 and P2 and if the instructions given have been carefully followed, the coil should give a gentle shock when the handles H1 and H2 are grasped.

## MOTOR STARTER MODEL No. 12

The construction of this model will show that by inserting a resistance in series with your motor the speed will be reduced. By gradually cutting out the resistance the speed will increase.

The front of the starter is a  $5\frac{1}{2}'' \times 2\frac{1}{2}''$  flanged plate 1. In the second row of holes from the top bolt five insulated 6 B.A. screws, 2, 3, 4, 5 and 6. The Meccano bolts and nuts 7 are fixed at the side and are used only for stops. The two terminals 8 and 9 are fixed as shown, 8 is insulated and 9 is not. A piece of No. 23 wire is taken along at the back of the plate from terminal 8 to screw 2.

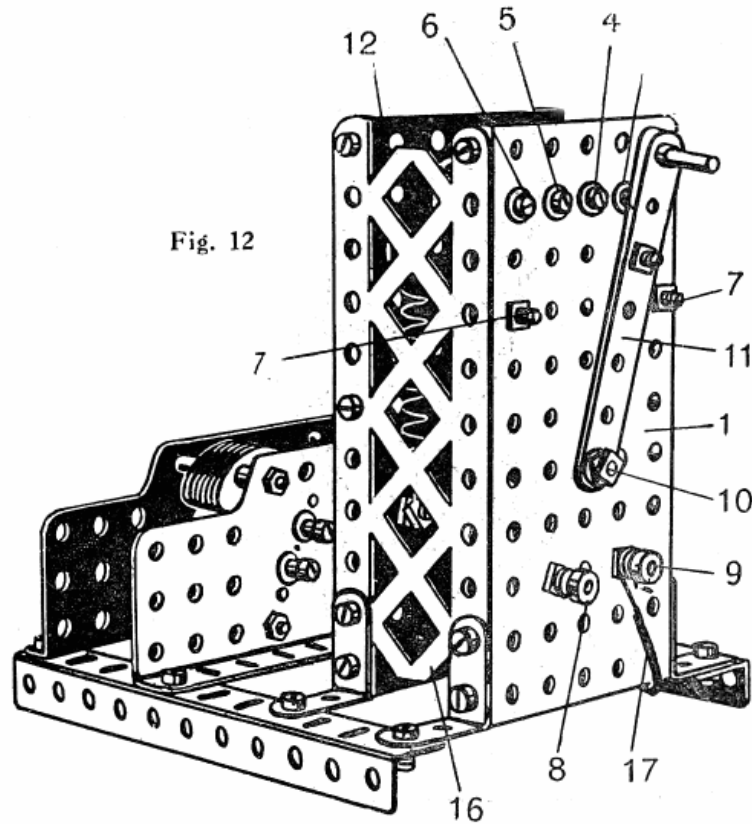

Fig. 12

### Parts required.

2	No.	3
2	"	9
4	"	12A
24	"	37
3	"	37A
2	"	52
2	"	100
1	"	115
12	"	302
12	"	303
13	"	304
29	"	305
2	"	306
30"	"	312
24"	"	311

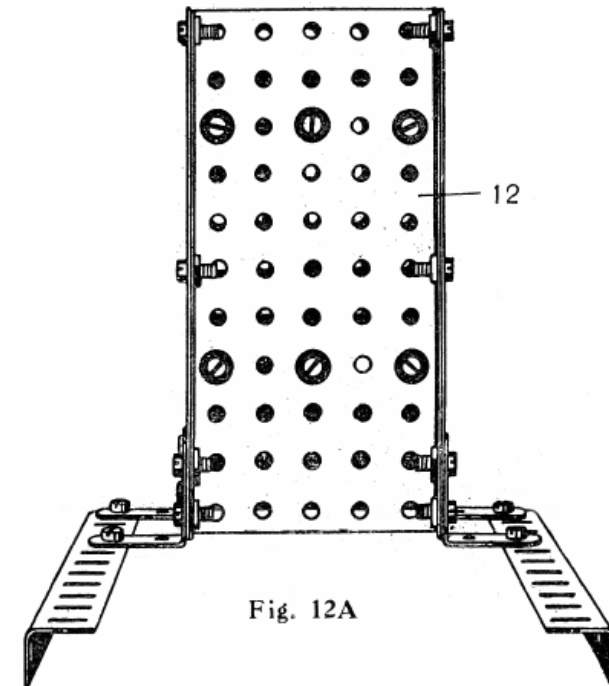

Fig. 12A

The movable arm 11 is secured by the bolt 10 which forms the pivot. The bolt and nut 10 being first screwed tightly to the front plate, after which the arm is placed on the bolt, then a washer, and two nuts locked tightly but with sufficient play to allow the arm to be moved.

The back plate 12 of the starter is also a  $5\frac{1}{2}'' \times 2\frac{1}{2}''$  flanged plate. Six insulated 6 BA screws 13 are bolted in the third and eighth row of holes from the top.

The resistances A.B.C: each consist of 8'' of bare iron wire No. 27.

To make the resistances, cut three pieces of this wire 8'' long. Coil each piece of wire in a close spiral around a Meccano rod, so that when finished it is like a compressed spring, stretch the resistances out and connect them by means of nuts to the insulated screws 13. Care must be taken that the wire does not touch the metal plate 12.

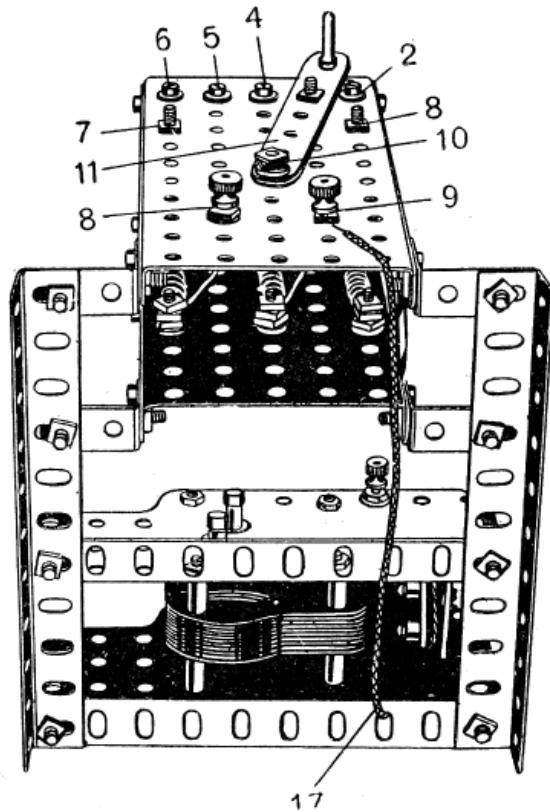

Fig. 12B

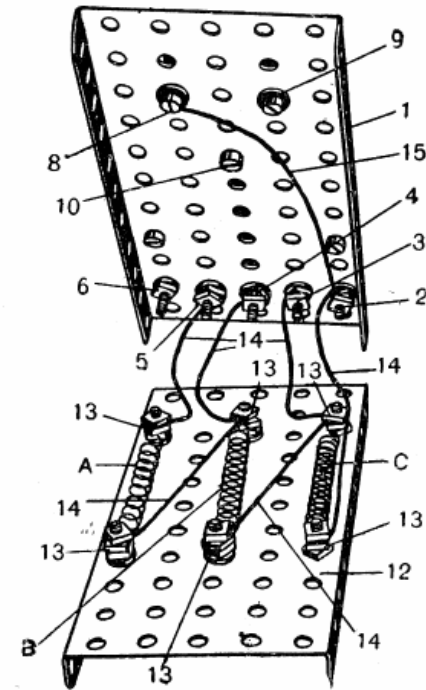

Fig. 12C

Insulated copper wires 14 No. 23 are connected by means of nuts to each of the insulated 6 BA screws 13, a view of the connections is shown in Fig. 12c. The wires 14 should project 2'' above the top of the plate 12.

No wire is connected to the screw 6, it being an off position, and the connections of the wires 14 are clearly shown in Fig. 12c. The terminal 8 is also connected to the screw 2 by a wire 15.

Fasten the two plates together by means of braced girders 16 and the starter is complete.

The starter is connected in series with motor and accumulator as shown in Fig. 12d. Take a wire from + or positive on the accumulator to the terminal 8 on the starter. Terminal 9 on the starter is connected by wire 17 to one terminal of the motor. The other terminal on the motor is connected to the negative — pole of the accumulator.

The length of the resistances, wire A, B and C, may be altered to suit requirements. If the starter is used for dimming lamps, the resistances should be cut longer. The lamp or lamps would be connected in series with the accumulator and starter, instead of the motor,

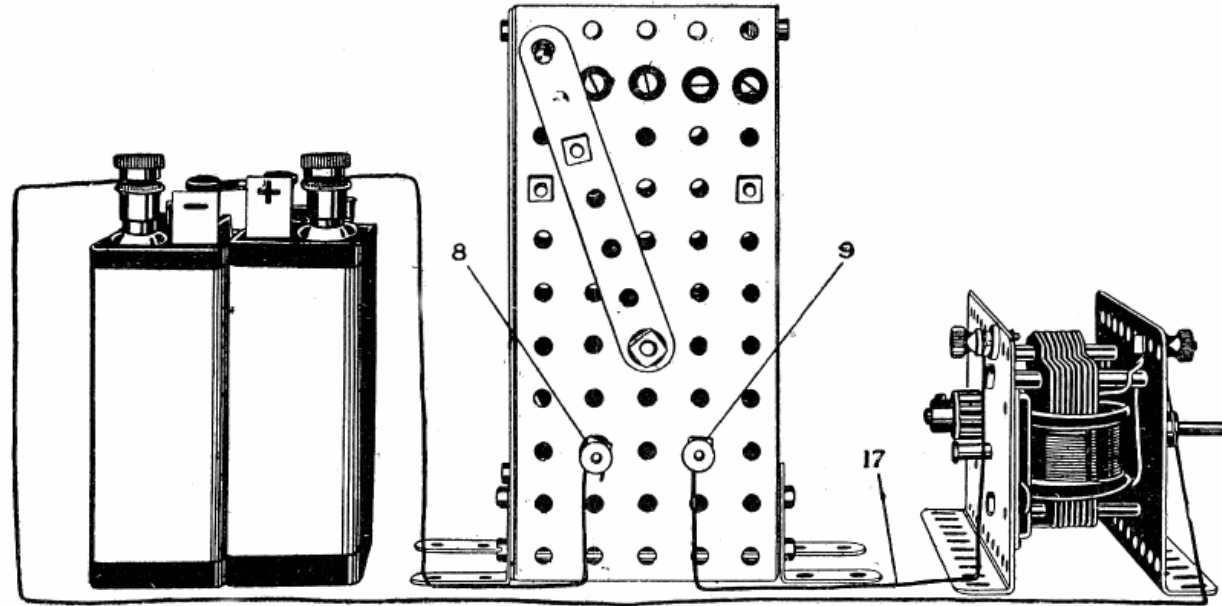

Fig. 12D

and would be fully incandescent with the arm on the screw 2. This arm is made of two  $3\frac{1}{2}$ " strips bolted together as shown in Fig. 12. At the top of the arm is bolted a threaded pin to act as the handle. As the arm is pushed over the other screws 3, 4 and 5, more resistance is inserted; consequently the lamps grow dim.

When the arm is on the "OFF" screw 6 the lamps are out.

# ELECTRIC LOCO. MODEL No. 13

This model is extremely interesting to construct. Begin as shown in Fig. 13a by connecting together a 2½" square flat plate, and two 2½"×1" double angle strip 1 by two 3½" strips across the underside as shown in the illustration. After which connect four 3½" strips 3 to the angle strips 1 in the end holes. The lower ends of these are bolted to the four sector plates 4. The side plates of the motor are bolted by their flanges to the flanges of the sector plates 4. (See Fig. 13b.) The flanged wheels 5 are fitted on a 3½" axle rod 6 with a 1" sprocket wheel between and journalled in a double angle strip 2½"×1" 7.

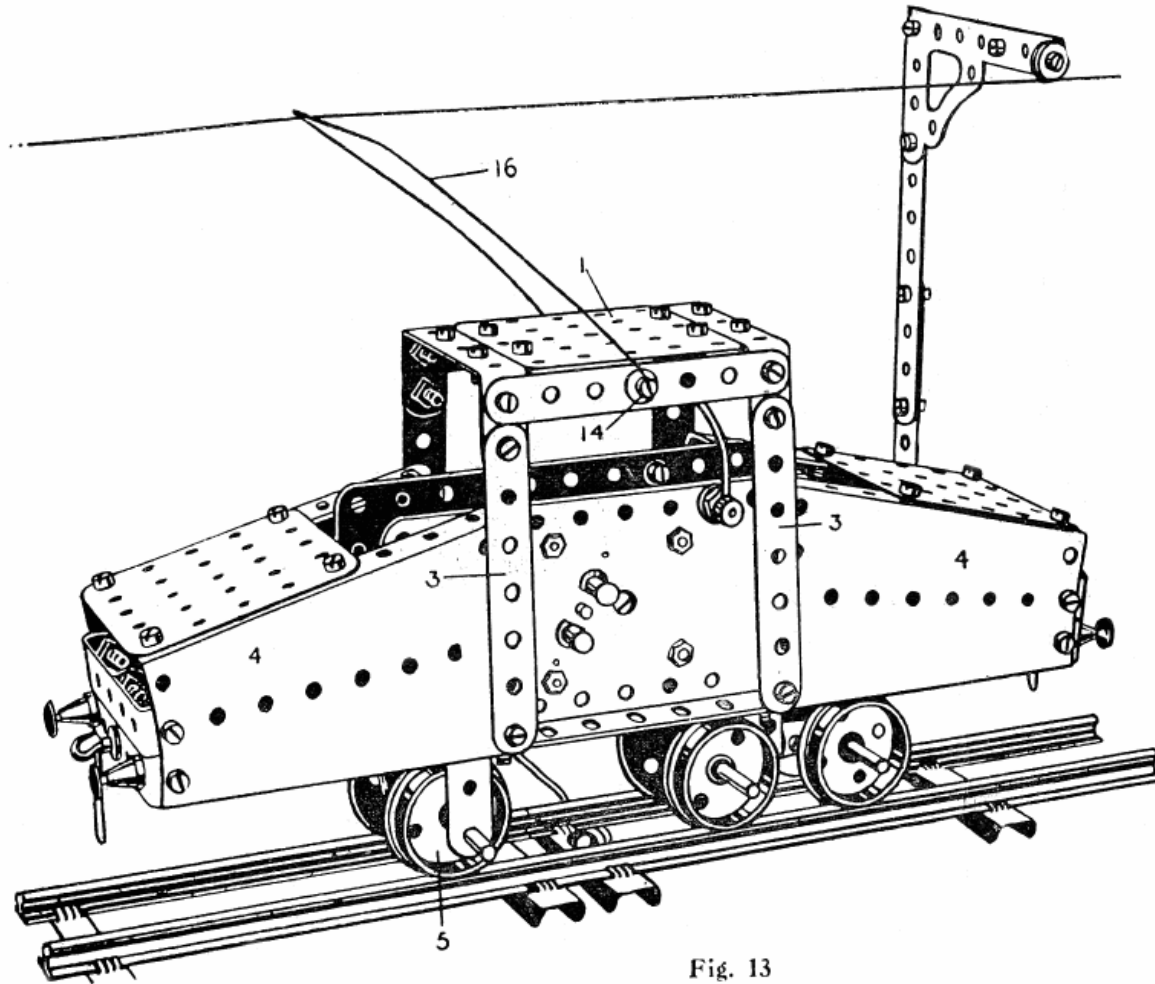

Fig. 13

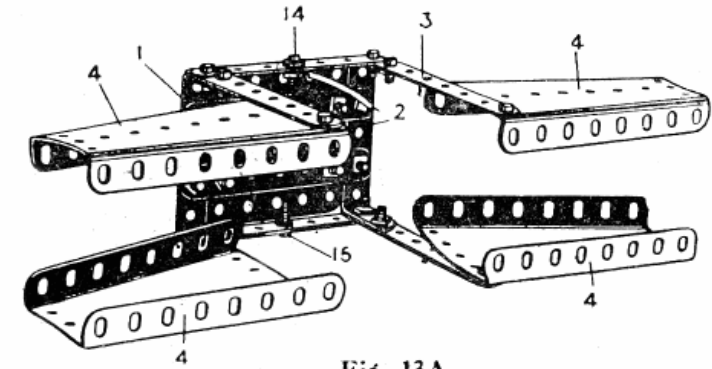

Fig. 13A

Parts required.								
	8	No.	3			4	No.	60
	1	"	5			3	"	63
	1	"	16			3	"	72
	2	"	17			12"	"	94
	2	"	18A			2	"	96
	6	"	20			4	"	120
	1	"	22A			2	"	121
	44	"	37			2	"	302
	6	"	37A			2	"	303
	3	"	46			2	"	304
	4	"	54			3	"	305
	3	"	59			9"	"	315

A  $2\frac{1}{2}$ " strip 8 is bolted across the other sector plates and the central hole 9 forms the bearing for the pivot rod 10 of the bogie. A pulley wheel 11 is placed between the strip 8 and the bogie, and a collar 12 is nipped on the rod 10 above the strip 8. A short sprocket chain 13—Figs. 13b and 13c—couples the sprocket wheel on the motor to the sprocket wheel on the axle 6.

After the model is constructed the electrical connections are made in the following manner :—

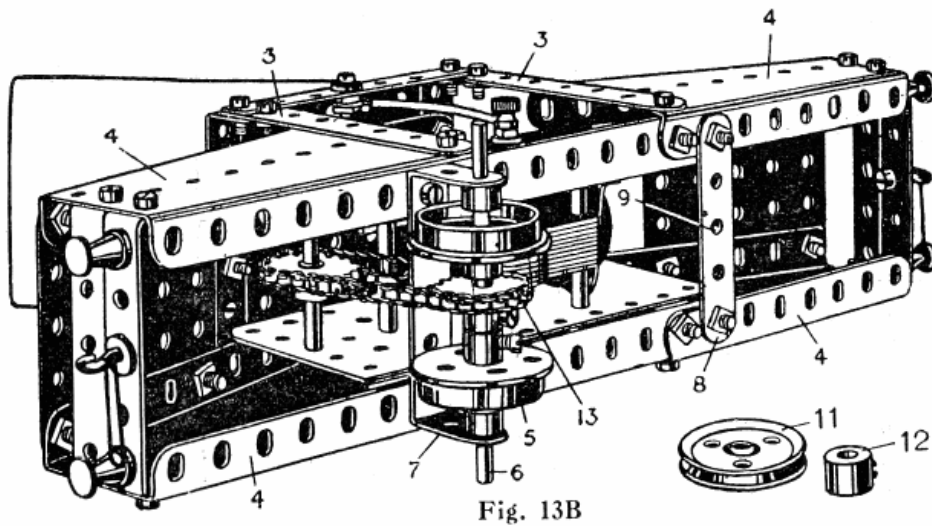

Fig. 13B

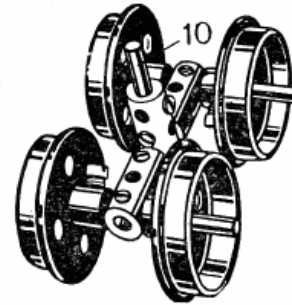

Fig. 13C

A 6 BA screw with insulated washers is fixed to each side of the cab at holes 14 and 15. Under the heads of these screws is secured the trolley-arm 16, which is made of No. 22 wire bent squarely. A short piece of No. 23 wire is attached to screw 14 and the insulated terminal of the motor

The current for operating the motor is conveyed by a wire No. 23 from the positive + terminal on the accumulator to one of the cross-ties of the track, and thence through the motor, trolley arm and overhead line, back to the negative of the accumulator. Various types of standards are illustrated in Figs. 14, 14a, 14b, 14c and 14d.

The railway tracks used in this model are No. 0 gauge used with the regular clockwork toy train sets. They are not supplied with the outfit but may be purchased from your regular toy dealer.

# TROLLEY WIRE STANDARDS MODELS Nos. 14, 14A, 14B, 14C, 14D.

The various forms of standards shown in the illustrations are suitable for carrying the wire by means of which electric current is conveyed to the electric locomotive shown in Fig. 13. In Fig. 14 the wire 1 is passed through the end holes of the perforated strip 2, and behind the end of the bolt 3 on the coupling 4 supported as shown from the vertical rod 5, the foot of which is held in the pulley

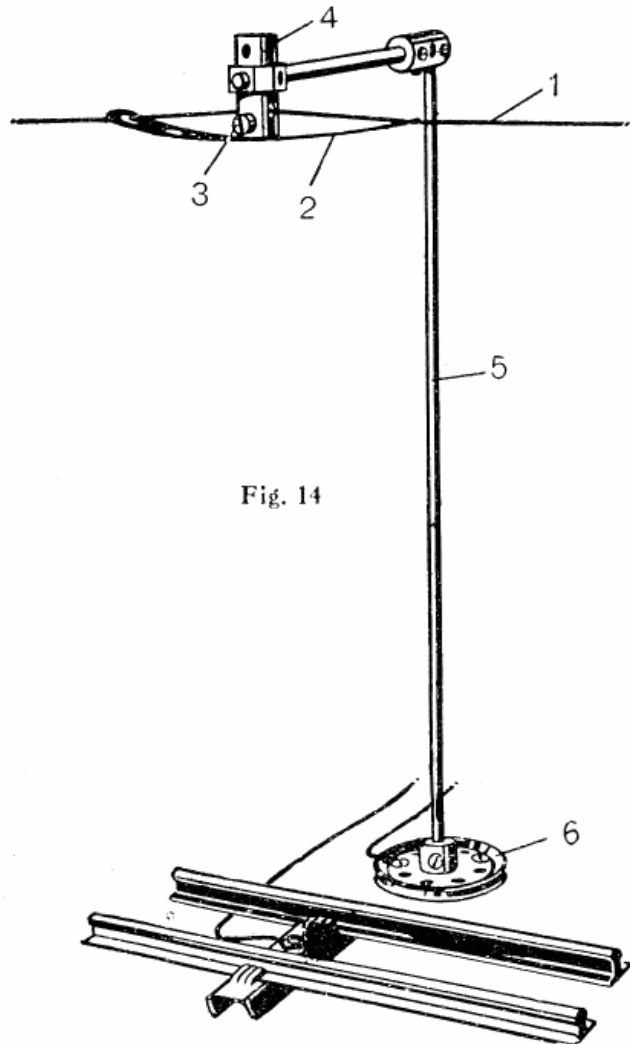

Fig. 14

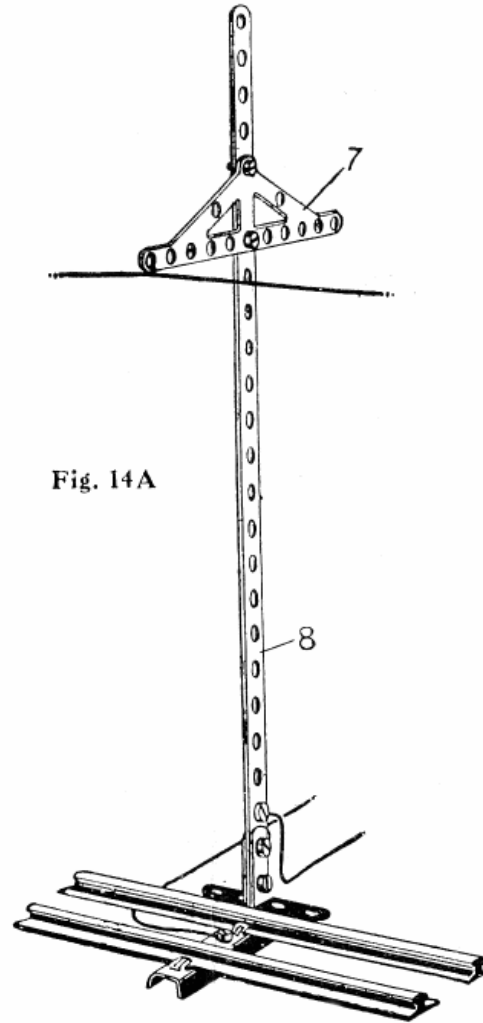

Fig. 14A

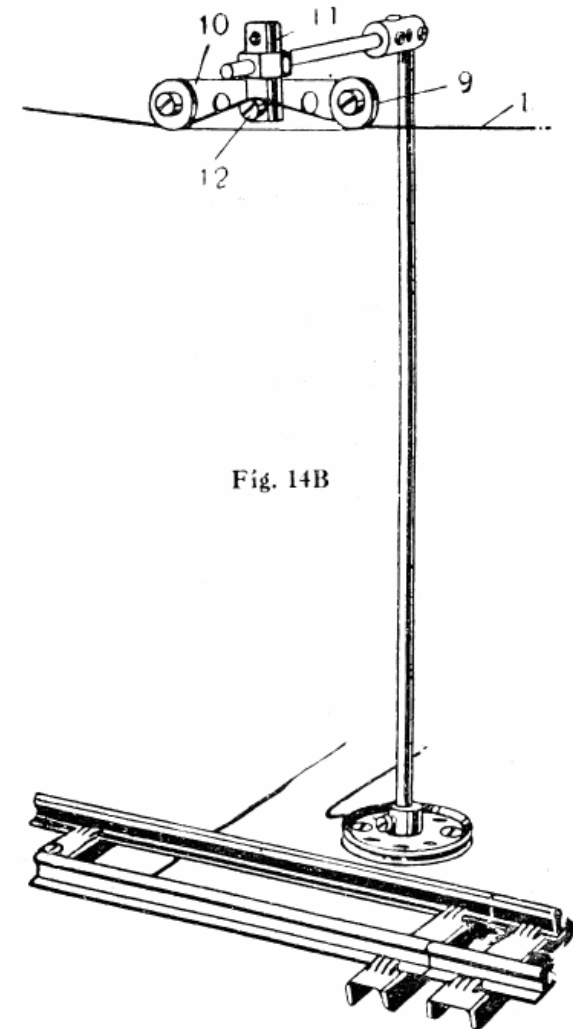

Fig. 14B

wheel 6. In Fig. 14A a girder frame 7 is bolted to the strip 8 and the wire 1 tied by wire to the outer hole in the frame. In Fig 14B the two pulley wheels 9 are bolted in the end holes of the strip 10 which is held in a strip coupling 11. The wire 1 is passed beneath the pulley wheels 9 and over the bolt 12, which holds the strip in the coupling 10. In Fig. 14c an architrave 13 is bolted to the top of two

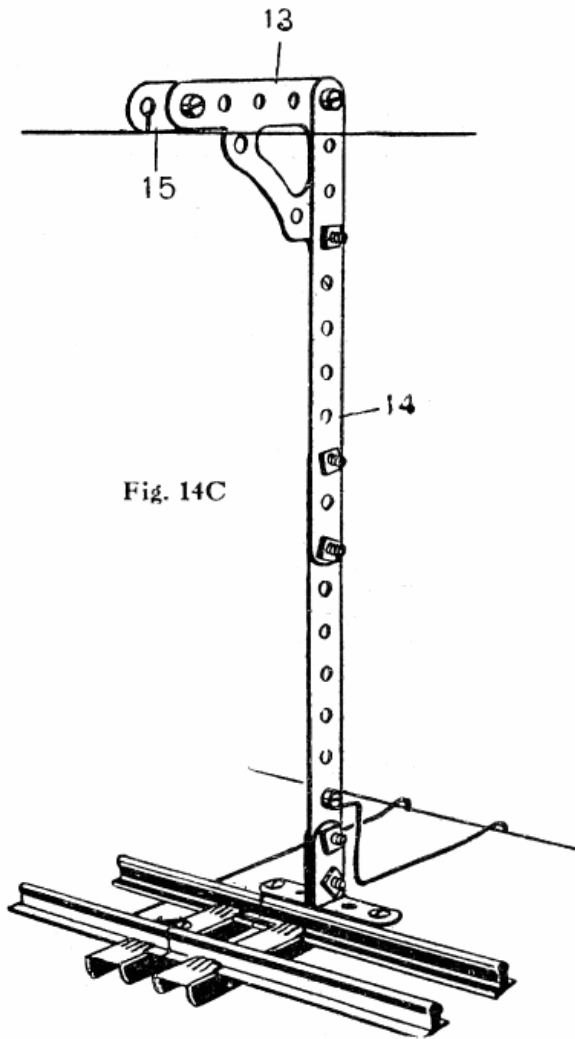

Fig. 14C

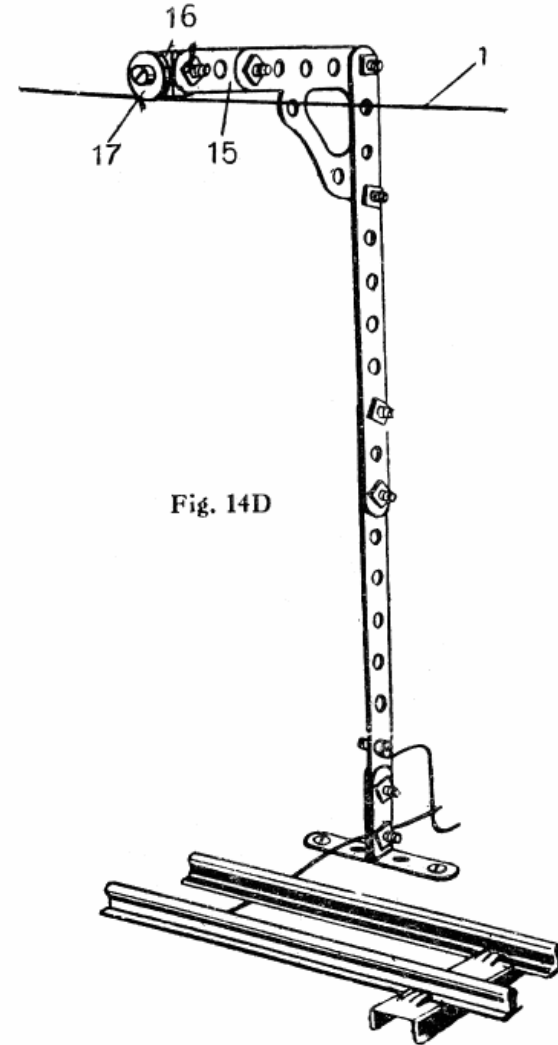

Fig. 14D

5½" strips overlapped 14 and a 3" strip 15 bolted at the outer end of the architrave, the wire 1 being looped through the outer hole of the strip. In the form shown in Fig. 14D, which is somewhat similar to Fig. 14c, an angle bracket 16 is bolted to the end of the strip 15 and a small pulley wheel 17 to the angle bracket. The wire 1 is given one complete turn round the pulley wheel.



# WAREHOUSE

## MODEL No. 15

Commence this model by building the frame-work. 24½" angle girders are used to form the corner uprights 1 with 5½" angle girders overlapped three holes at the top. Two 24½" angle girders 2 are also used to carry the front portion of the warehouse floors, the latter being bolted to two 5½" angle girders 3 overlapped eight holes and connected across to the two inner angle girders 2. Two similar 5½" angle girders are bolted to the back of the frame-work, to carry the other end of each of the floors. The floor is formed of four 5½" x 3½" flat plates butted together and bolted in the centre to a 5½" double flat strip on the under side—the two outer ends being bolted to the angle girders 3.

The horizontal side-strips are formed of 12½" strips to which are bolted the braced girder strips.

Fig 15a shows the construction of the Car This is guided by bolt heads

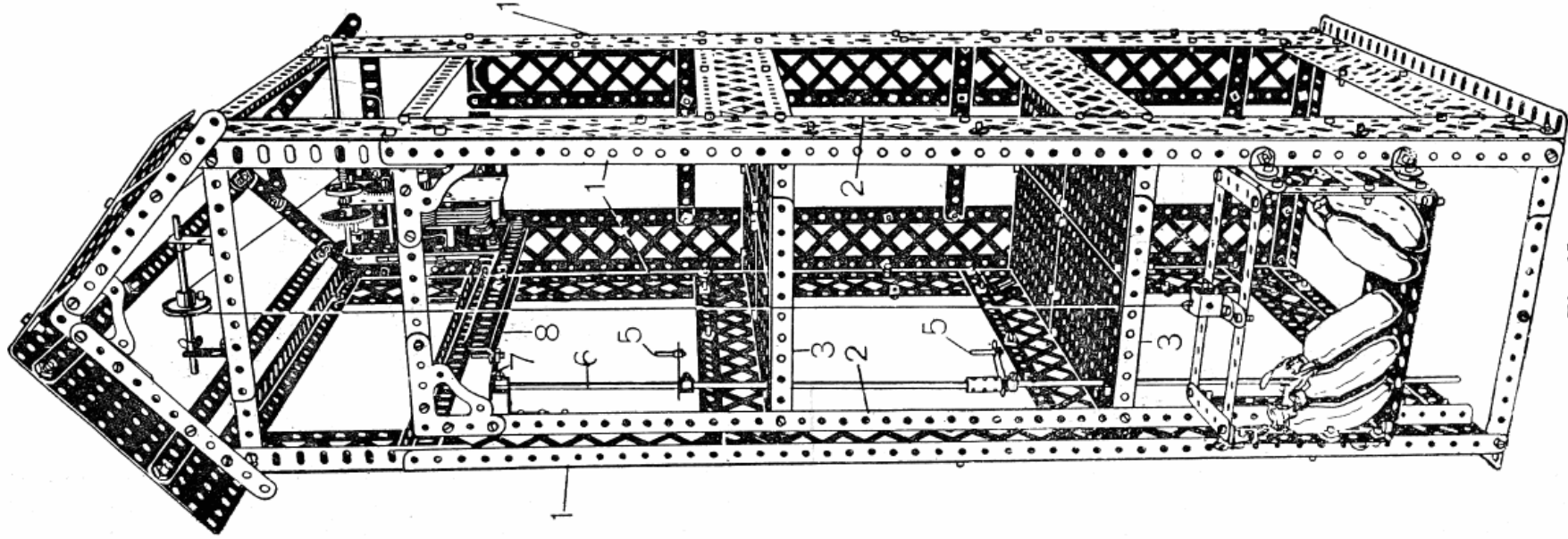

Fig. 15

Parts required.		No.	No.
18	1	2	35
21	2	240	37
9	5	30	38
1	6	1	45
4	6A	1	46
6	7	8	52A
6	8	1	59
23	9	4	62
16	12	1	63
2	12A	3	70
2	13	18	99
1	14	4	100
1	16	2	103
3	22	4	108
		4	115

4 at each side riding along the inwardly turned flanges of the angle girders 2. The bolts are attached to angle brackets which are secured to a  $1\frac{1}{2}$ " strip, this latter being secure to the side-strips of the Car, spaced with three washers to take up the play between the Car and the upright girders 2.

Fig. 15b shows the position of the motor, and this may be started and stopped from the control crank handles 5 one on each floor of the warehouse. These crank handles are fixed on a vertical rod 6 composed of two  $11\frac{1}{2}$ " rods connected by a coupling

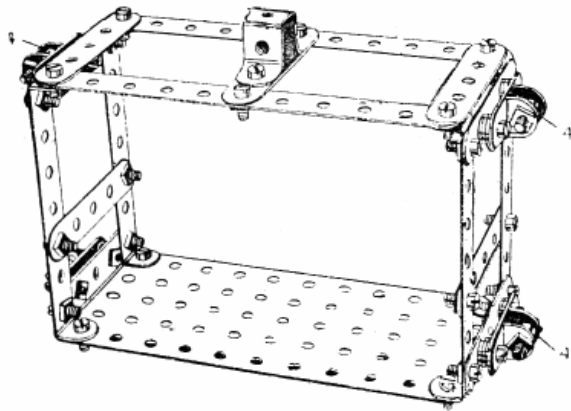

Fig. 15A

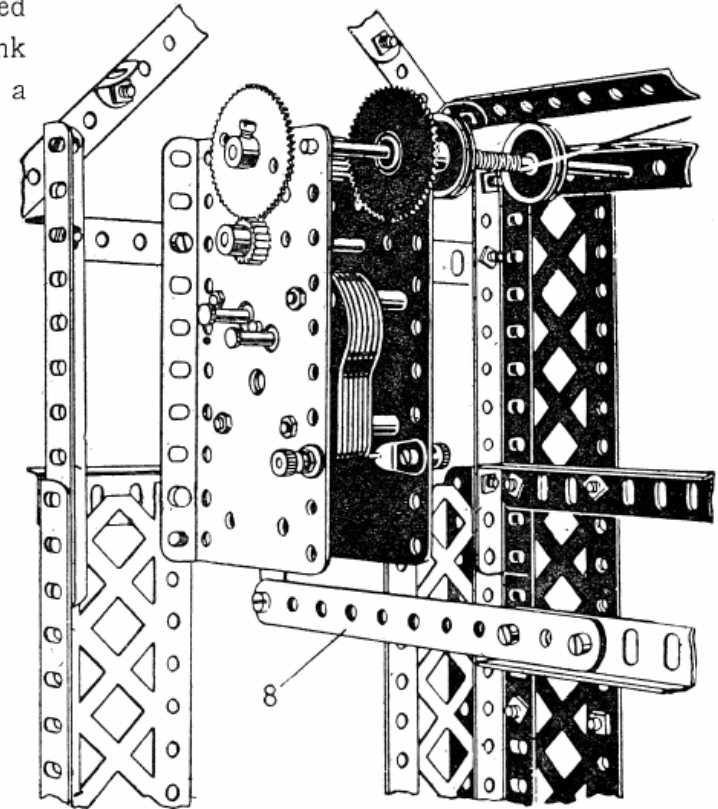

Fig. 15B

A crank 7 is secured to the upper end of this rod and is connected by a  $5\frac{1}{2}$ " angle girder and strip 8 to the operating lever of the motor.

One inch brackets secured to the sides of the Warehouse by strips form the bearings for the upper and lower ends of the vertical rod. When the motor is wired up to the accumulator, the elevator is ready to be operated.

# ELECTRIC LIGHT STANDARD MODEL No. 16

This is made by bolting an architrave 1 between two 12½" strips 2. At the outer end a strip coupling 3 is bolted, and in the end of this a double bent strip 4 is bolted to which the screwed lamp holder 5 is secured. Two terminals 6 and 7 are bolted at the base of the standard; the terminal one, 6, is insulated but the other is not. The terminal 6 is connected by a piece of No. 23 wire 8 to the screw 9.

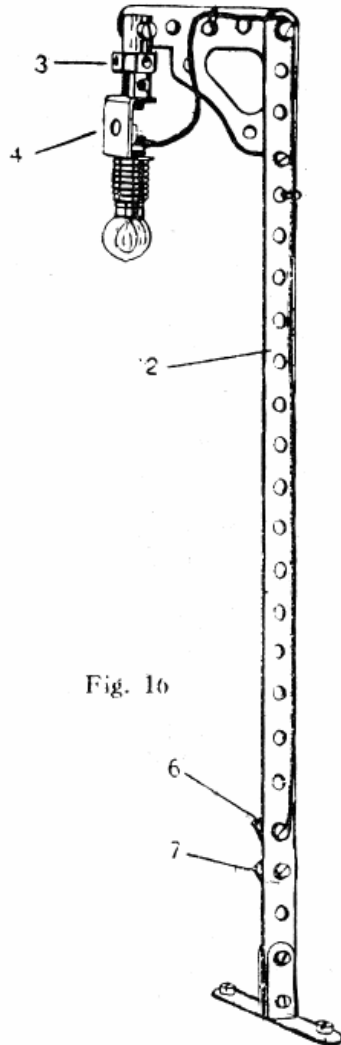

Fig. 16

When the accumulator is connected to the terminals 6 and 7 the current flows from the terminal 6 along the wire 8 to the screw 9 through the lamp and returns by the standard to the terminal 7.

The screw 9 securing the lamp holder 5 to the double bent strip 4 should be insulated by fixing a bush between a double bent strip and the two nuts between which the wire 8 is connected.

### Parts required.

2	No.	1	3	No.	302
1	"	11	3	"	304
2	"	12A	4	"	305
6	"	37	2	"	306
3	"	38	1	"	310
1	"	63B	1	"	311
1	"	108	12"	"	314

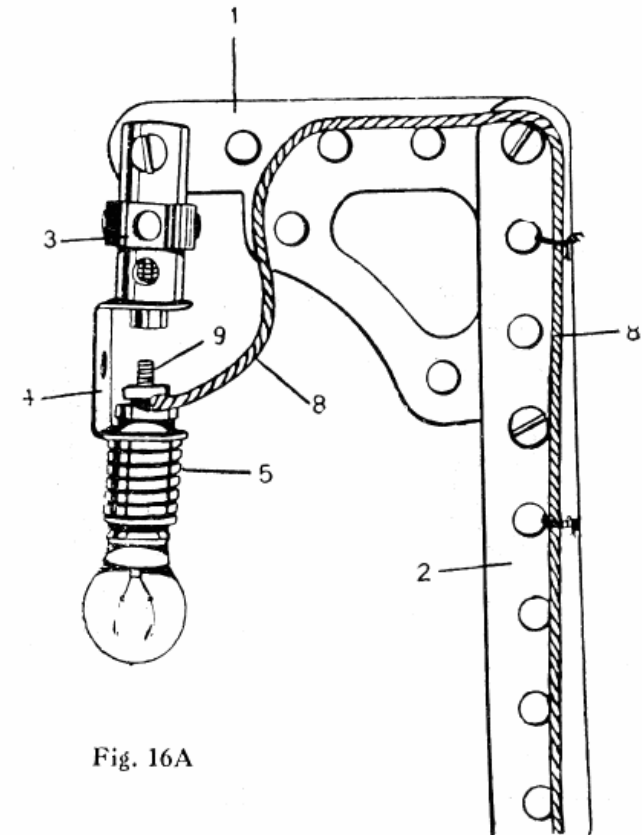

Fig. 16A