

MECCANO

(TRADE MARKS 296321, 12633, 10274, 55/13476, 884/25, 2913)

INSTRUCTIONS

FOR OUTFITS Nos. 00 to 3

2/3

Copyright by MECCANO LIMITED, LIVERPOOL, throughout the world

A TALK WITH NEW MECCANO BOYS



MECCANO OUTFITS contain accurately-made and highly-finished engineering parts with which any known mechanical movement may be reproduced in model form. With Meccano you can accomplish more than with any other constructional toy, for no other system has its possibilities. No study is needed to enable you to build models with Meccano—the genius is in the Meccano parts.

Recently The New Meccano has been introduced, with many parts richly enamelled in colour. With these coloured parts you can make your models even more realistic and at the same time satisfy your artistic taste. The parts can be used for hundreds of models and to all they bring a delightful charm, enhancing the appearance of even the simplest models.

A complete list of Meccano parts, both coloured and nickelled, is to be found on pages 3 and 4.

You never come to the end of Meccano fun. There is always more ahead—always some new, ingenious and interesting model to build. Each one, as it is completed, “tuned up,” and set going, brings a joy and satisfaction beyond anything that you have ever previously experienced.

As you progress in Meccano you obtain a greater variety of parts, Gear-Wheels, Pulley-Wheels, Worm-Wheels, Couplings, Cranks, and all manner of perfectly-made real engineering parts. These enable you to construct complicated mechanical movements without any difficulty. The most wonderful feature of Meccano is that it is *real engineering*; it is fascinating and delightful and yet so simple that even an inexperienced boy may join in the fun without first having to study or learn anything.

HOW TO BUILD WITH MECCANO

FOLLOW the instructions closely at first, and build the models just as you see them. Then take each model and try to improve our design. Every model can be made in a dozen different ways. Screw up all the nuts and bolts firmly and you will find that you can play with the trucks, cranes, signals, etc., and obtain many hours of fun.

For convenience Meccano parts are sold in nine Outfits of varying size, numbered 00 to 7. The quality and finish of the parts are of the same high standard throughout the series, but as the Outfits increase in size they contain larger quantities and greater varieties of parts. Each Outfit may be converted into the one next higher by the purchase of an Accessory Outfit (see page 62). Thus, if a No. 2 is the first Outfit bought, it may be converted into a No. 3 by adding to it a No. 2A. A No. 3A would then convert it into a No. 4 and so on up to No. 7. In this way, no matter with what Outfit you commence, you may build it up by degrees to a No. 7.

The separate Meccano parts may be bought at any time in any quantity (see price list on pages 3 and 4).

“MECCANO STANDARD MECHANISMS”

THERE are a number of Meccano movements that have to a certain extent become standardised; that is to say, they may be applied to more than one model—in most cases without any alteration, but in some few instances with only slight alterations to the original movement. These have been collected and classified, and may now be obtained in the form of a new Manual entitled “Meccano Standard Mechanisms.” This publication consists of 48 pages, 9½” x 6½”, and contains over 140 illustrations in half-tone. The various devices have been arranged so that immediate reference may be made to any particular motion that it is desired to incorporate in a model. No keen Meccano boy who wishes to embody correct engineering principles in his new structures will consider his equipment complete without a copy of “Meccano Standard Mechanisms.”

It will be observed that “Standard Mechanisms” are frequently mentioned in the instructions for building the larger models contained in this book. The “S.M.” Manual is included in Outfits 4A, 5, 6 and 7, and on referring to the details indicated the reader should have no difficulty whatever in understanding the construction of even the most intricate models. Although the Manual is not used in the smaller sets, all owners of Meccano Outfits should find it invaluable in assisting them in their model-building.





MECCANO GUILD
MEMBER'S CERTIFICATE.

THE MECCANO GUILD

THE MECCANO GUILD is an organisation for boys, started at the request of boys and conducted as far as possible by boys. The Guild is a great fraternal organisation of which all Meccano boys should become members, for its primary object is to bring them together. The Guild makes these boys feel that they are all members of a great brotherhood, each trying to help the other to get the very best out of life and it cannot fail to have a profound effect for good on the lives of its members.

MECCANO CLUBS

MECCANO CLUBS are founded and established under the guidance of the Guild Secretary at Headquarters and at the present time there are active Clubs in over one hundred towns and villages in the United Kingdom and in many countries Overseas. Each Club has its Leader, Secretary, Treasurer, and other officials all of whom, with the exception of the Leader, are boys. Write for information how to form a club, if there is no club near you.

Special awards are given to Club members for good work in connection with their Club and medallions are awarded in connection with the Recruiting Campaign, full particulars of which will be sent on request.



SPECIAL MERIT MEDALLIONS.



RECRUITING MEDALLION.

THE LIFE OF A MECCANO BOY

A MECCANO boy is the happiest boy in the world. He builds models from the Meccano Instruction books ; invents new models ; joins the Meccano Guild and a Meccano Club and by wearing the Guild badge proclaims himself to be the friend of millions of other Meccano boys all over the world. He reads the *Meccano Magazine* regularly and corresponds with his friend the Editor when he feels like it. Time never hangs heavily on his hands and he is too busy and happy to grumble.

The *Meccano Magazine* is the Meccano boy's newspaper. It tells him of the latest Meccano models ; what Meccano Clubs are doing ; how to correspond with other Meccano boys ; the Competitions that are running, etc. It contains interesting articles on engineering and electrical subjects, and deals with many other topics of interest to boys, including suggestions from Meccano boys for new Meccano parts and correspondence columns in which the Editor replies to his readers' enquiries. Write to the Editor, *Meccano Magazine*, Binns Road, Liverpool, enclosing 6d. in stamps. He will then forward a specimen copy, post free. The *Meccano Magazine* is sent regularly to subscribers at the rate of 4/- for six issues or 8/- for twelve issues, post free.

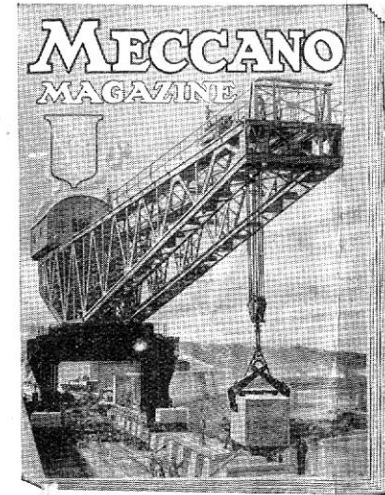

STRIPS, GIRDERS AND BRACKETS

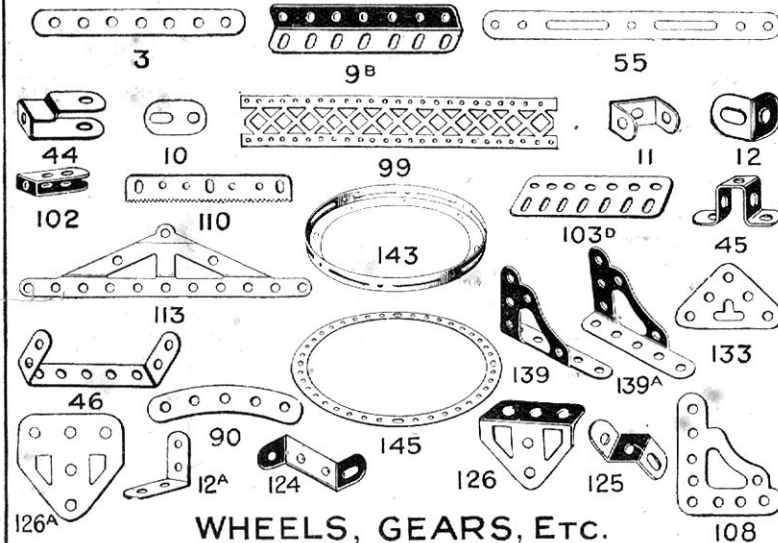

WHEELS, GEARS, ETC.

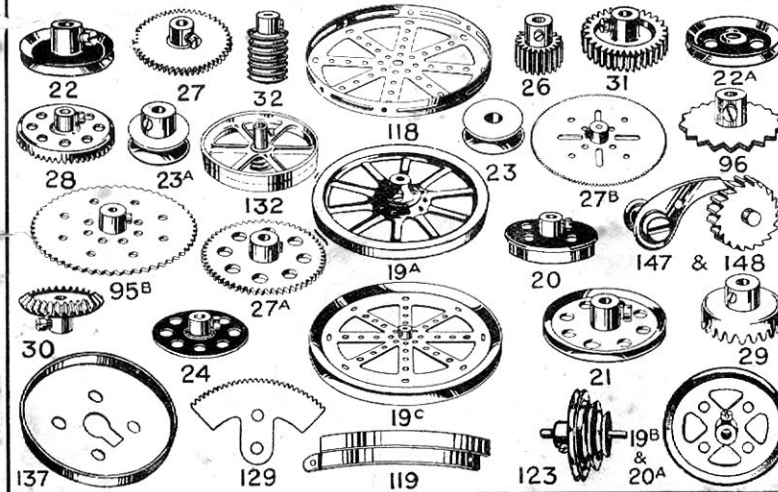

Particulars and Prices of Meccano Parts

No.	Description	Quantity	Price	No.	Description	Quantity	Price	
1.	Perforated Strips, 12 $\frac{1}{2}$ " long	... 1 doz.	1 6	31.	Gear Wheels, 1", 38 teeth	... each	1 6	
1a.	" "	9 $\frac{1}{2}$ "	1 3	32.	Worm Wheels	... each	0 9	
1b.	" "	7 $\frac{1}{2}$ "	1 0	34.	Spanners	... each	0 3	
2.	" "	5 $\frac{1}{2}$ "	0 9	34a.	" Combined	... each	0 3	
2a.	" "	4 $\frac{1}{2}$ "	0 8	34b.	Box Spanners	... each	0 5	
3.	" "	3 $\frac{1}{2}$ "	0 6	35.	Spring Clips	... per box (doz.)	0 5	
4.	" "	3"	0 5	36.	Screw Drivers	... each	0 9	
5.	" "	2 $\frac{1}{2}$ "	0 5	36a.	" Extra Long	... each	0 9	
6.	" "	2"	0 5	37.	Nuts and Bolts, 7/32"	... per box (doz.)	0 9	
6a.	" "	1 $\frac{1}{2}$ "	0 5	37a.	Nuts	... each	0 5	
7.	Angle Girders, 24 $\frac{1}{2}$ " long	... each	1 0	37b.	Bolts, 7/32"	... each	0 5	
7a.	" "	18 $\frac{1}{2}$ "	0 9	38.	Washers	... each	0 2	
8.	" "	12 $\frac{1}{2}$ "	0 9	40.	Hanks of Cord	... each	0 3	
8a.	" "	9 $\frac{1}{2}$ "	0 9	*41.	Propeller Blades	... per pair	0 6	
8b.	" "	7 $\frac{1}{2}$ "	0 9	43.	Springs	... each	0 3	
9.	" "	5 $\frac{1}{2}$ "	1 6	44.	Cranked Bent Strips	... each	0 2	
9a.	" "	4 $\frac{1}{2}$ "	1 2	45.	Double Bent Strips	... each	0 2	
9b.	" "	3 $\frac{1}{2}$ "	1 0	46.	Double Angle Strips, 2 $\frac{1}{2}$ " x 1"	... 1 doz.	0 9	
9c.	" "	3"	1 0	47.	" "	2 $\frac{1}{2}$ " x 1 $\frac{1}{2}$ "	1 3	
9d.	" "	2 $\frac{1}{2}$ "	1 0	47a.	" "	3" x 1 $\frac{1}{2}$ "	1 6	
9e.	" "	2"	0 9	48.	" "	1 $\frac{1}{2}$ " x 1 $\frac{1}{2}$ "	0 6	
9f.	" "	1 $\frac{1}{2}$ "	0 9	48a.	" "	2 $\frac{1}{2}$ " x 1 $\frac{1}{2}$ "	0 8	
10.	Flat Brackets	...	0 3	48b.	" "	3 $\frac{1}{2}$ " x 1 $\frac{1}{2}$ "	0 9	
11.	Double Brackets	... each	1 1	48c.	" "	4 $\frac{1}{2}$ " x 1 $\frac{1}{2}$ "	1 3	
12.	Angle Brackets, 1" x 1"	... doz.	0 9	48d.	" "	5 $\frac{1}{2}$ " x 1 $\frac{1}{2}$ "	1 3	
12a.	" "	1" x 1"	each	0 1 1	50.	Eye Pieces	... each	0 3
12b.	" "	1" x 1"	each	0 1 1	*51.	Perforated Flanged Plates, 5 $\frac{1}{4}$ " x 2 $\frac{1}{4}$ "	0 8	
13.	Axle Rods, 11 $\frac{1}{4}$ " long	...	0 5	*52a.	Flat Plates, 5 $\frac{1}{4}$ " x 3 $\frac{1}{2}$ "	...	0 8	
13a.	" "	8"	0 5	*53.	Perforated Flanged Plates, 3 $\frac{1}{2}$ " x 2 $\frac{1}{2}$ "	...	0 5	
14.	" "	6 $\frac{1}{2}$ "	0 3	*53a.	Flat Plates, 4 $\frac{1}{2}$ " x 2 $\frac{1}{2}$ "	...	0 5	
15.	" "	5 $\frac{1}{2}$ "	0 3	*54.	Perforated Flanged Sector Plates	...	0 5	
15a.	" "	5"	0 2	55.	Perforated Strips, slotted, 5 $\frac{1}{4}$ " long	...	0 3	
16.	" "	4 $\frac{1}{2}$ "	0 2	55a.	" "	2"	0 2	
16a.	" "	2 $\frac{1}{2}$ "	0 2	56.	Instruction Manuals, Complete	...	3 6	
16b.	" "	3"	0 2	56a.	" " No. 0-3	...	1 6	
17.	" "	2"	0 2	56b.	" " No. 0	...	0 6	
18a.	" "	1 $\frac{1}{2}$ "	0 2	57.	Hooks	...	0 2	
18b.	" "	1"	0 1 1	57a.	" (scientific)	...	0 2	
19.	Crank Handles	...	0 5	57b.	" Loaded	...	0 8	
19a.	Wheels, 3" diam., with set screws	...	1 0	58.	Spring Cord	... per length	1 3	
20.	Flanged Wheels	...	0 9	59.	Collars with Set Screws	... each	0 3	
Pulley Wheels.				59.	Windmill Sails	...	0 3	
19b.	3" dia. with centre boss and set screw	...	1 0	62.	Cranks	...	0 5	
19c.	6"	...	3 9	62a.	Threaded Cranks	...	0 6	
20a.	2"	...	0 9	63.	Couplings	...	0 9	
21.	1 $\frac{1}{2}$ "	...	0 9	63a.	Octagonal Couplings	...	1 0	
22.	1"	...	0 6	63b.	Strip Couplings	...	1 0	
22a.	1"	without	0 6	63c.	Threaded Couplings	...	0 9	
22a.	1"	without	0 3	64.	Threaded Bosses	...	0 3	
23.	" "	" "	0 3	65.	Centre Forks	...	0 3	
24.	Bush Wheels	...	0 9	66.	Weights, 50 grammes	...	1 6	
25.	Pinion Wheels, 1 $\frac{1}{2}$ " diam.	...	0 9	67.	" 25	...	1 6	
26.	" "	...	0 6	68.	Wood screws, 1"	... doz.	0 5	
Gear Wheels.				69.	Set Screws	...	0 6	
27.	50 teeth to gear with 3" pinion	...	1 3	69a.	Grub Screws, 5/32"	...	0 6	
27a.	57	...	1 3	69b.	" 7/32"	...	0 9	
27b.	133	...	2 3	*70.	Flat Plates, 5 $\frac{1}{4}$ " x 2 $\frac{1}{4}$ "	... each	0 5	
28.	Contrate Wheels, 1 $\frac{1}{2}$ " diam.	...	1 3	*72.	2 $\frac{1}{2}$ " x 2 $\frac{1}{2}$ "	...	0 3	
29.	" "	...	0 9	*76.	Triangular Plates, 2 $\frac{1}{2}$ "	...	0 3	
30.	Bevel Gears	...	1 3					

IMPORTANT.—All Meccano parts marked thus * are available with either red or nickel finish and all marked thus † are available with either green or nickel finish. When ordering nickelled parts quote only the numbers now shown in the list. When coloured parts are required add letter X to the distinguishing numbers under which they are listed. Thus part No. 99 would be ordered as 99x ; part No. 99a as 99ax and so on.

Trucks and Luggage Carts

**Model No. 1
Flat Truck**

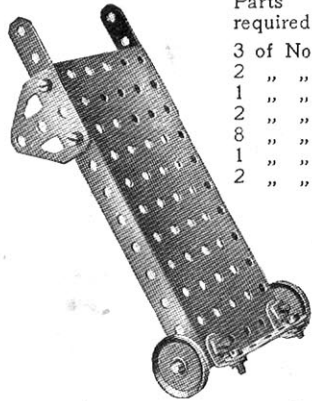

Parts
required:

3 of No.	5
2 " "	12
1 " "	16
2 " "	22
8 " "	37
1 " "	52
2 " "	126A

**Model No. 2
Truck with Sides**

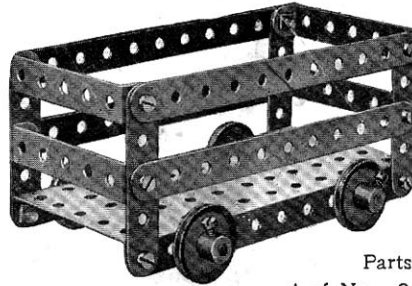

Parts required:

4 of No.	2	4 of No.	22
4 " "	5	12 " "	37
2 " "	16	4 " "	48A
		1 of No.	52

**Model No. 3
Luggage Cart**

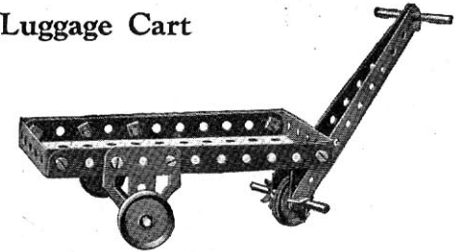

Parts required:

2 of No.	2	9 of No.	37
1 " "	16	1 " "	44
2 " "	17	2 " "	48A
3 " "	22	1 " "	52
4 " "	35	2 " "	126A

**Model No. 4
Truck**

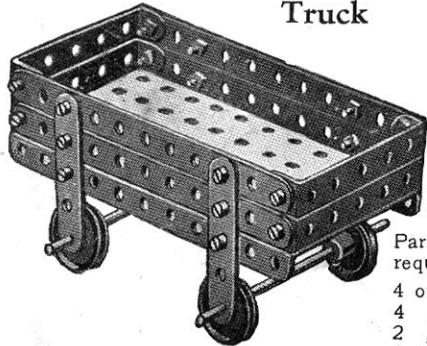

Parts
required:

4 of No.	2
4 " "	5
2 " "	16
4 " "	22
16 " "	37
4 " "	48A
1 " "	52

**Model No. 5
Bogie Truck**

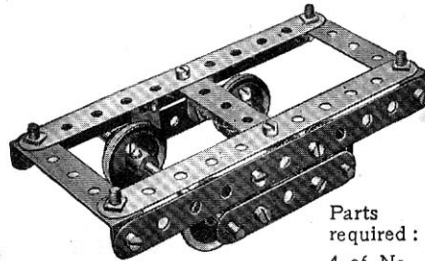

Parts
required:

4 of No.	2
3 " "	5
4 " "	10
2 " "	16
4 " "	22
18 " "	37
2 " "	48A

Model No. 6 Ticca Gharry

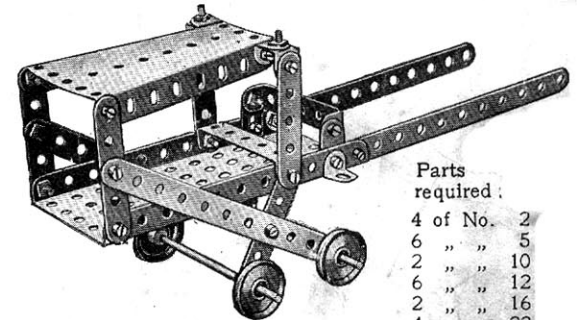

Parts
required:

4 of No.	2
6 " "	5
2 " "	10
6 " "	12
2 " "	16
4 " "	22
22 " "	37
1 " "	52
1 " "	54

Model No. 7
Covered Truck

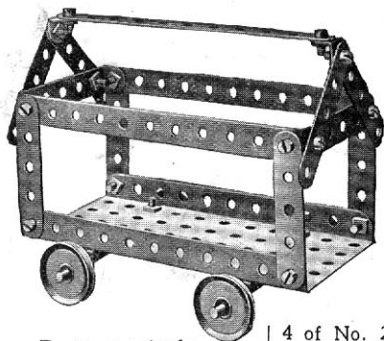

Parts required:	4 of No. 22
	20 " " 37
3 of No. 2	2 of No. 12
4 " " 5	2 " " 16
	4 " " 48A
	1 " " 52

Model No. 10 Shipyard Bogie

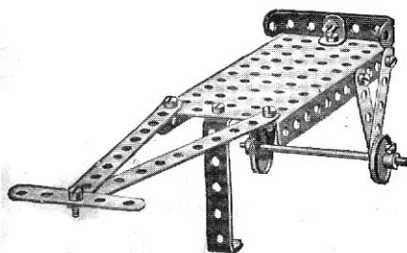

Parts required:	2 of No. 2
	5 " " 5
	1 " " 12
	1 " " 16
	2 " " 22
	10 " " 37
	2 " " 48A
	1 " " 52

Model No. 13 Coster's Barrow

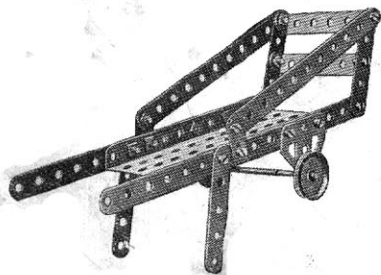

Parts required:	4 of No. 2
	4 " " 5
	1 " " 16
	2 " " 22
	16 " " 37
	2 " " 48A
	1 " " 52
	2 " " 126A

Trucks and Luggage Carts (continued)

Model No. 8 Timber Truck

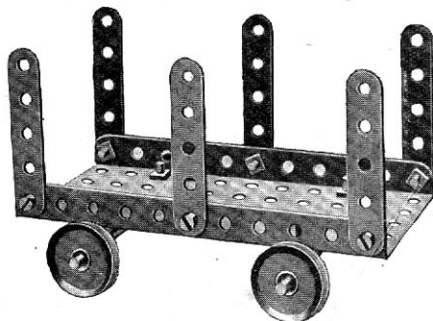

Parts required:	6 of No. 5	10 of No. 37
	2 " " 16	2 " " 48A
	4 " " 22	1 " " 52

Model No. 11 Timber Truck

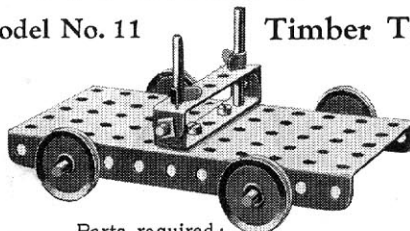

Parts required:	2 of No. 16	4 of No. 35
	2 " " 17	4 " " 37
	4 " " 22	2 " " 48A
	1 of No. 52	

Model No. 14 Timber Drag

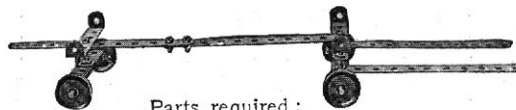

Parts required:	4 of No. 2	2 of No. 16	8 of No. 37
	2 " " 11	4 " " 22	4 " " 48A

Model No. 9
Flat Truck

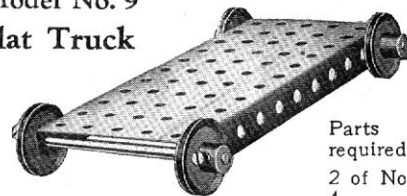

Parts required:	2 of No. 16
	4 " " 22
	1 " " 52

Model No. 12
Lurry

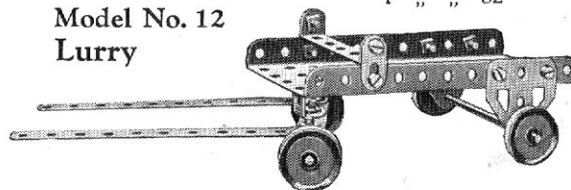

Parts required:	2 of No. 2	2 of No. 16	2 of No. 48A
	2 " " 10	4 " " 22	1 " " 52
	1 " " 11	12 " " 37	2 " " 126A

Model No. 15 Go Chair

Parts required:

2 of No. 2	4 of No. 22
7 " " 5	11 " " 37
2 " " 16	2 " " 48A

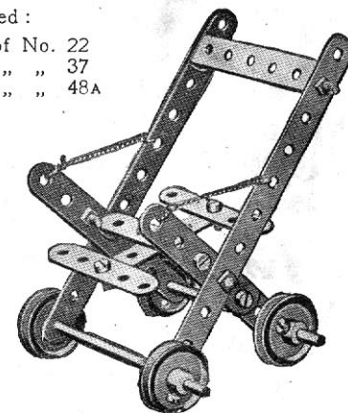

Model No. 16 Rock Drill

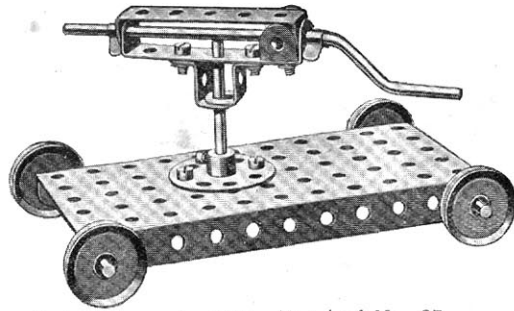

Parts required:	1 of No. 19	4 of No. 37
	4 " " 22	2 " " 48A
	2 of No. 16	1 " " 24
	1 " " 17	2 " " 35
		1 " " 52
		2 " " 125

Model No. 17 Travelling Crane

The jib 1 is pivoted to the flat trunnions 2, which are bolted at 3 to angle brackets secured to a bush wheel. The latter is nipped to a 2" rod 4 passing through the plate 5 and further supported in a double angle strip 6. A washer and spring clip mounted on the rod 4 below the strip 6 secure the crane to the carriage. The jib is supported by means of cords 7 tied to 2½" strips 8, the holes of which engage the shank of a bolt passed through the sector plate 9, and its elevation may be altered by inserting this bolt in different holes in the strips 8. The cord 10 of the brake lever is wound once round the crank handle, between two washers.

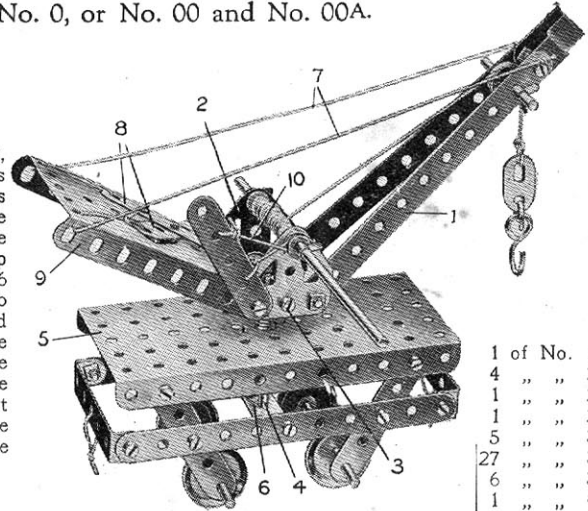

1 of No. 19
4 " " 22
1 " " 23A
1 " " 24
5 " " 35
27 " " 37
6 " " 38
1 " " 44
3 " " 48A
1 " " 52
1 " " 54
1 " " 57
2 " " 126A

Parts required:

4 of No. 2	2 of No. 12
7 " " 5	2 " " 16
1 " " 10	2 " " 17

Model No. 18 Railway Signal

Parts required:

3 of No. 2
7 " " 5
2 " " 10
2 " " 11
2 " " 12
2 " " 17
2 " " 22
1 " " 23
4 " " 35
21 " " 37
1 " " 52
1 " " 126A

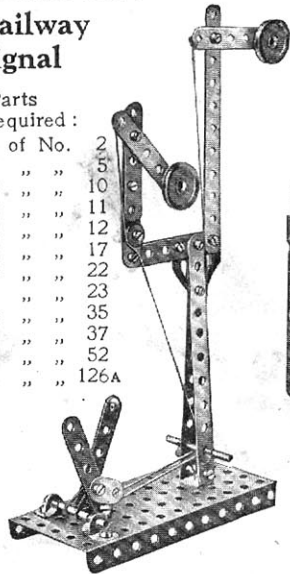

Model No. 19 Potter's Wheel

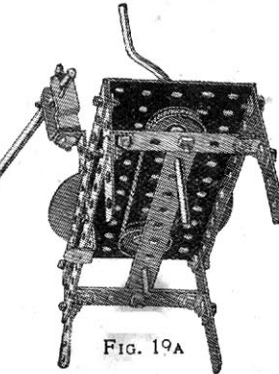
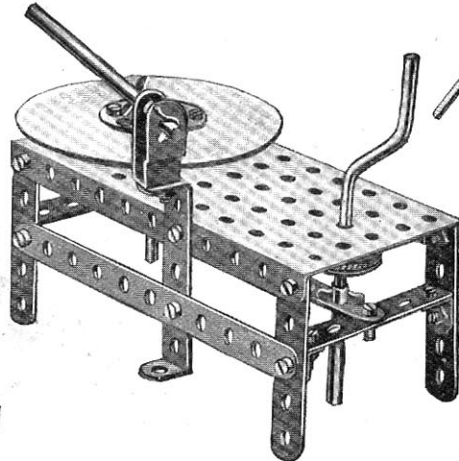
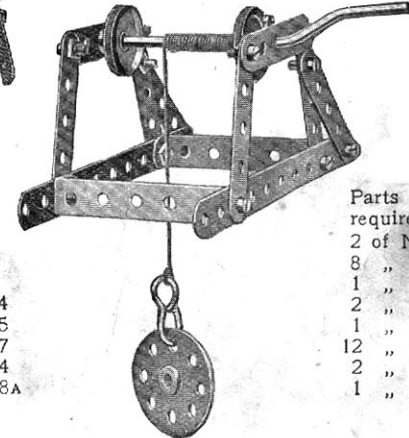

FIG. 19A

Parts required:

3 of No. 2	1 of No. 24
4 " " 5	2 " " 35
1 " " 16	17 " " 37
1 " " 19	1 " " 44
2 " " 22	3 " " 48A
	1 of No. 52

Model No. 20 Well Windlass



Parts required:

2 of No. 2	2
8 " " 5	5
1 " " 19	19
2 " " 22	22
1 " " 24	24
12 " " 37	37
2 " " 48A	48A
1 " " 57	57

These Models can be made with MECCANO Outfit No. 0, or No. 00 and No. 00A.

Model No. 21 Scales

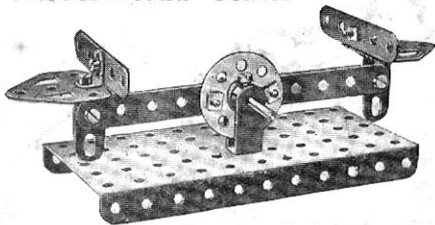

Parts required :

1 of No. 2	2 of No. 12	1 of No. 44
2 " " 5	1 " " 17	1 " " 52
2 " " 10	1 " " 24	2 " " 126A
	9 " " 37	

Model No. 22
Gangway

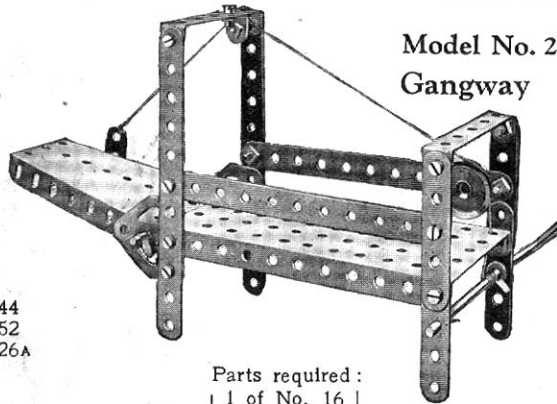

Parts required :

4 of No. 2	1 of No. 16	2 of No. 48A
4 " " 5	1 " " 19	1 " " 52
1 " " 10	1 " " 22	1 " " 54
1 " " 12	1 " " 23	2 " " 126A
	4 " " 35	
	18 " " 37	

Model No. 23
Level
Crossing
Barrier

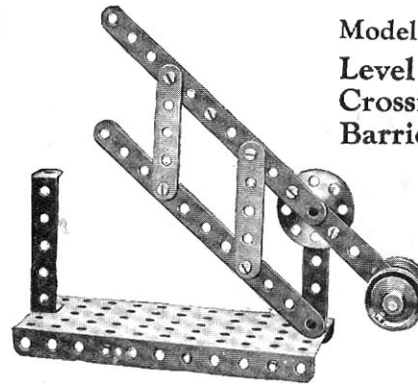

Parts required :

3 of No. 2	
2 " " 5	
1 " " 17	
4 " " 22	
1 " " 24	
10 " " 37	
2 " " 48A	
1 " " 52	

Model No. 24 Tower Wagon

Parts required :

4 of No. 2
8 " " 5
2 " " 16
1 " " 17
1 " " 19
4 " " 22
1 " " 23
4 " " 35
24 " " 37
1 " " 52
1 " " 54
1 " " 57
2 " " 126A

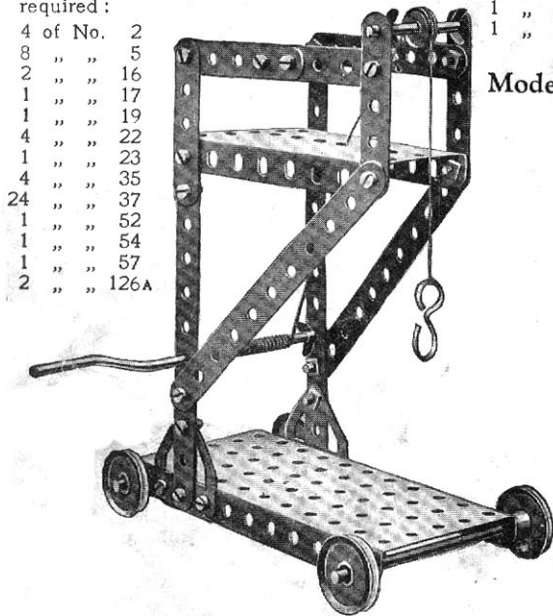

Model No. 25 Pulley Shaft

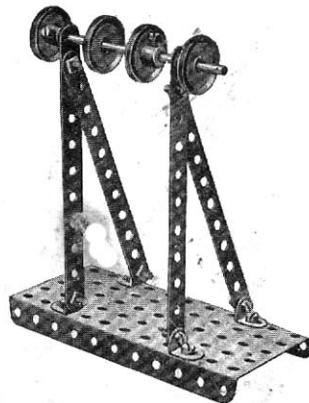

Parts required :

4 of No. 2	10 of No. 37
4 " " 12	2 " " 38
1 " " 16	1 " " 52
4 " " 22	

Model No. 26
Hoisting Block

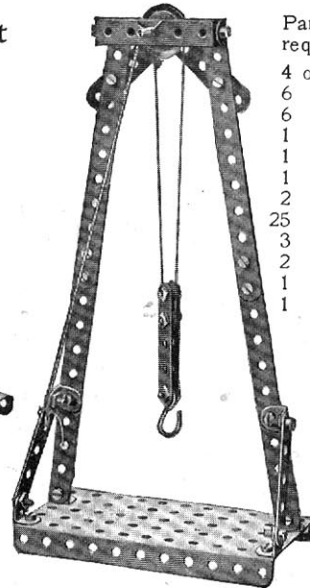

Parts required :

4 of No. 2
6 " " 5
6 " " 12
1 " " 17
1 " " 22
1 " " 23
2 " " 35
25 " " 37
3 " " 38
2 " " 48A
1 " " 52
1 " " 57

Model No. 27
Railway
Signal

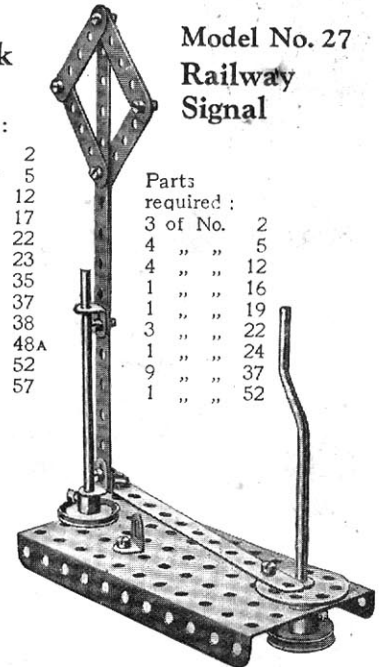

Parts required :

3 of No. 2
4 " " 5
4 " " 12
1 " " 16
1 " " 19
3 " " 22
1 " " 24
9 " " 37
1 " " 52

Model No. 28 Drilling Machine

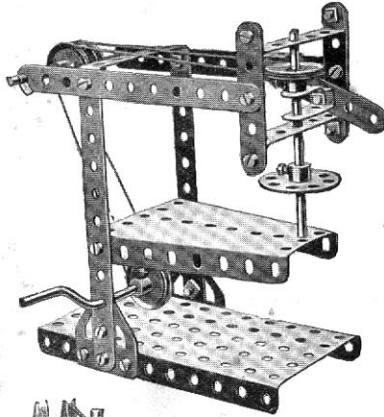

Parts required :

4 of No.	2
3 "	5
1 "	11
2 "	16
1 "	19
4 "	22
1 "	24
4 "	35
19 "	37
1 "	44
3 "	48A
1 "	52
1 "	54
2 "	126A

Model No. 29 Mechanical Saw

The strip 9 represents the saw. The crank handle drives through a belt 1 a short rod journalled in a double bracket 2 and carrying a bush wheel 3. The latter imparts a reciprocating motion to the saw frame 4 through a 2 1/4" strip 5 loosely mounted on bolts secured to the bush wheel and to an angle bracket bolted to the saw frame. This frame slides on a 3 1/4" rod 6, which acts as a guide, passing through the frame and supported in a reversed angle bracket 7. A washer is placed on the bolt 8 behind the bracket 7. A vice to secure the objects in position for cutting consists of a flat bracket 10 mounted on a bolt 11, a few turns of which causes the flat bracket to grip the object 12. The bolt 11 enters a nut held between the flat trunnion 13 and 5 1/8" strip 14, which are spaced apart for the purpose by washers placed on the two bolts holding the trunnion in position. The saw frame rests on the stop 15 when not in use. A 1" pulley secured to the top of the frame acts as a weight and helps to steady the saw.

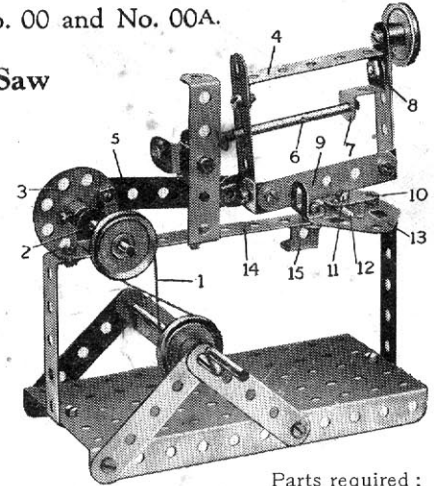

Parts required :

1 of No.	2	1 of No.	17	4 of No.	38
8 "	5	1 "	19	1 "	44
1 "	10	3 "	22	4 "	48A
1 "	11	1 "	24	1 "	52
4 "	12	3 "	35	2 "	125
1 "	16	22 "	37	1 "	126A

Model No. 31 Swing

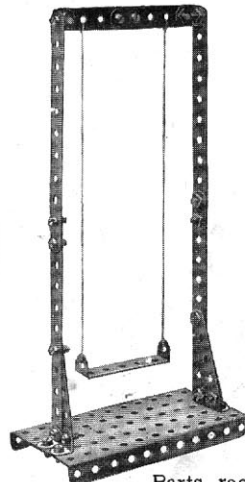

Parts required :

4 of No.	2	20 of No.	37
4 "	5	1 "	48A
6 "	12	1 "	52

Model No. 32 Ore Crusher

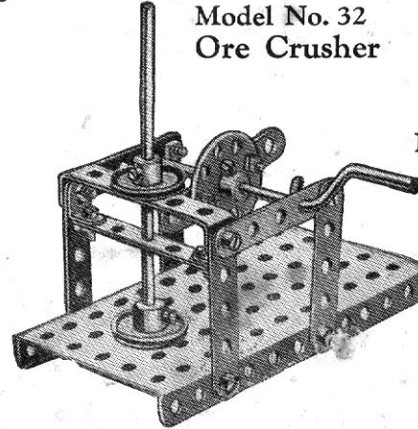

Parts required :

6 of No.	5	1 of No.	24
2 "	10	2 "	35
1 "	16	10 "	37
1 "	19	2 "	48A
2 "	22	1 "	52

Model No. 33 Jib Crane

Parts required :

4 of No.	2	1 of No.	23
9 "	5	1 "	24
2 "	16	4 "	35
1 "	17	17 "	37
1 "	19	1 "	48A
4 "	22	1 "	52
		1 of No.	57

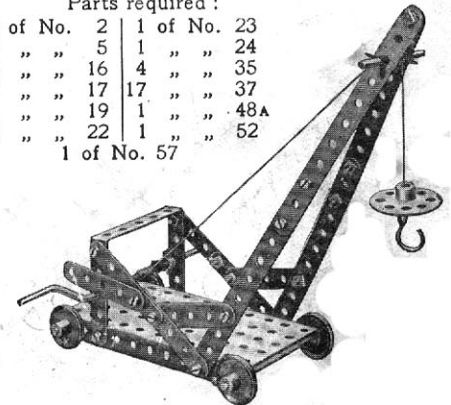
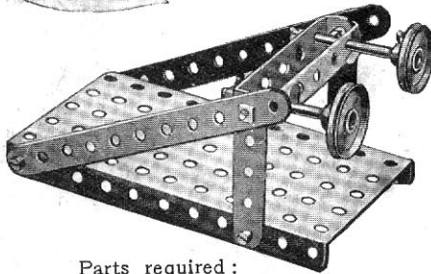

FIG. 28A
(Detail of
Drilling
Machine)

Model No. 30 Buffers



Parts required :

2 of No.	2	2 of No.	35
2 "	5	6 "	37
2 "	17	2 "	48A
2 "	22	1 "	52

Model No. 34 Telfer Span

Many hours of enjoyment may be obtained from this model. The illustration shows exactly how it is worked. The cords may be made to any length, and the load carried from one side of the room to the other. In order to give a better grip, the operating cord should be wound twice round the crank handle pulley. The body of the telfer should be screwed down to a solid base with ordinary wood screws, and the pulley bracket screwed in a suitable position on the opposite side of the room.

Parts required:

4	of No.	2
6	" "	5
4	" "	12
1	" "	16
1	" "	17
1	" "	19
4	" "	22
6	" "	35
14	" "	37
1	" "	44
2	" "	48A
1	" "	52
1	" "	54

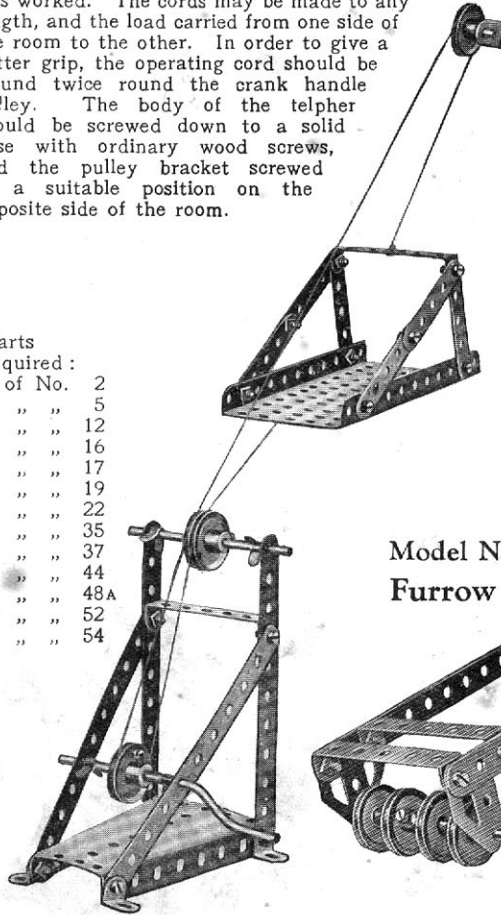

Model No. 35 Windmill

Parts required:

4	of No.	2
4	" "	5
1	" "	16
1	" "	19
2	" "	22
1	" "	24
4	" "	35
12	" "	37
2	" "	48A
1	" "	52

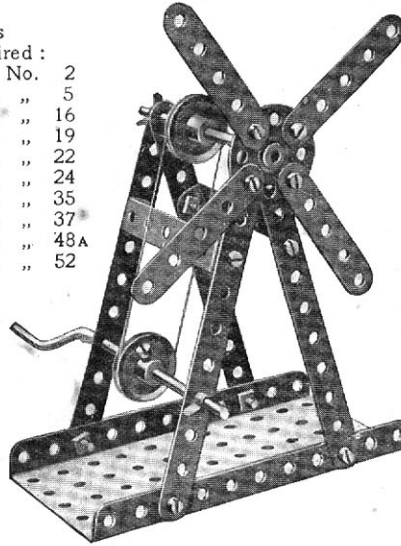

Model No. 36 Swivelling Crane

Parts required:

2	of No.	2	1	of No.	24
4	" "	5	4	" "	35
4	" "	12	18	" "	37
2	" "	16	4	" "	38
2	" "	17	1	" "	44
1	" "	19	2	" "	48A
4	" "	22	1	" "	52
1	" "	23	1	" "	57
		1 of No.		125	

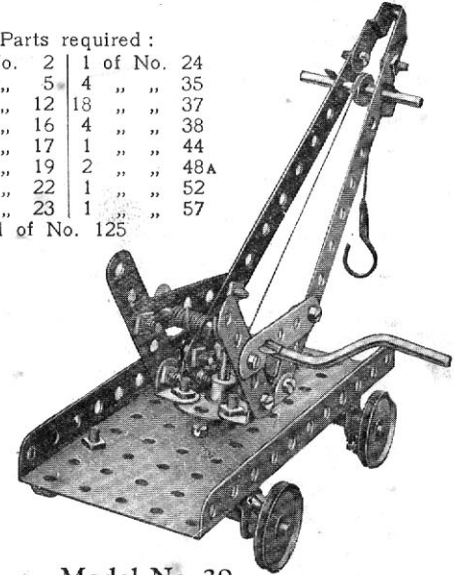

Model No. 37 Furrow Roller

Parts required:

2	of No.	2
1	" "	16
4	" "	22
4	" "	37
2	" "	48A
2	" "	126A

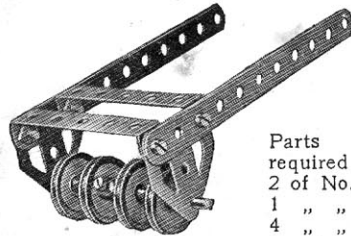

Model No. 38 Lawn Mower

Parts required:

4	of No.	2	1	of No.	17
7	" "	5	4	" "	22
2	" "	11	19	" "	37
2	" "	16	1	" "	44
		3 of No.		48A	

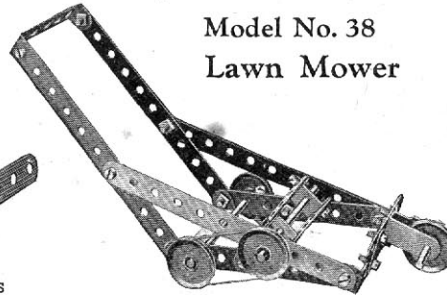

Model No. 39 Quick-Firing Gun

Parts required:

2	of No.	12	1	of No.	24
2	" "	16	4	" "	37
1	" "	17	1	" "	44
2	" "	22	1	" "	54

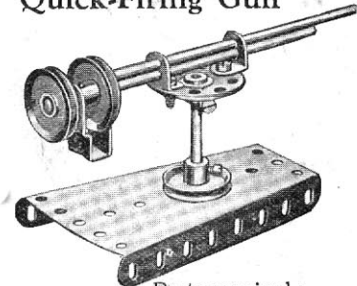

Model No. 40 Swivelling Crane

Parts required:	
4 of No. 2	1 of No. 44
7 " " 5	1 " " 48A
2 " " 12	1 " " 52
2 " " 17	1 " " 54
1 " " 19	1 " " 57
4 " " 22	2 " " 126A
1 " " 23	
2 " " 35	
21 " " 37	
3 " " 38	

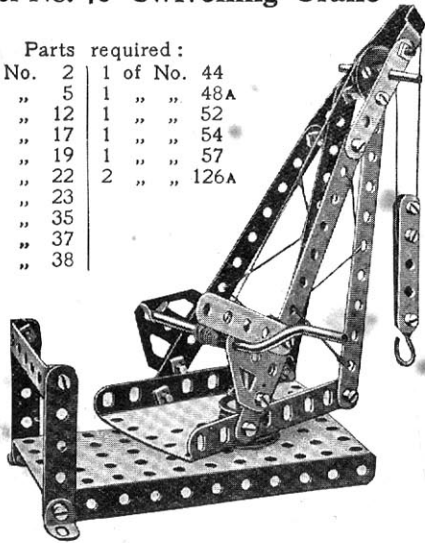

The sector plate of the Crane in this model is pivoted to the base with a fast pulley above and below.

Model No. 41 Hand Loom

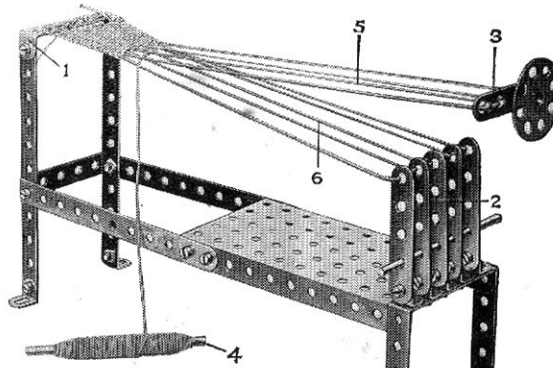

Parts required:	
4 of No. 2	1 of No. 24
6 " " 5	5 " " 37
7 " " 12	4 " " 48A
2 " " 16	1 " " 52

The warp threads are tied at one end to a double angle strip 1, whilst their other ends are secured alternately to the tops of the upright strips 2, and the 2 1/2" strip 3. The "shedding" movement of the warp is obtained by moving the strip 3 up or down each time the shuttle—a 3 1/2" rod 4—is passed between the two layers of warp 5 and 6. Wool or similar material is particularly suited to this apparatus. The strands 6 should be kept very taut, and the weft threads may be closed up with the woven portion by means of an ordinary comb each time the shuttle passes.

Model No. 42 Watch Stand

Watch Stand

Parts required:	
2 of No. 2	
1 " " 23	
10 " " 37	
1 " " 52	
1 " " 57	
1 " " 125	
2 " " 126A	

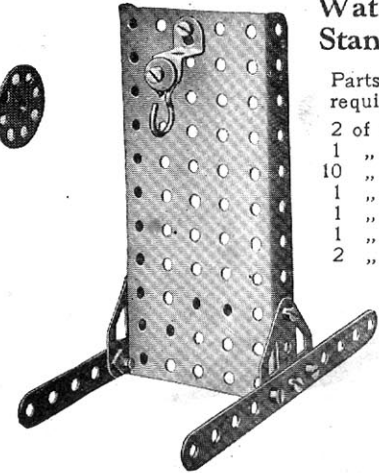

Model No. 43

Sawing Machine

Parts required:	
4 of No. 2	
3 " " 5	
4 " " 12	
1 " " 17	
1 " " 19	
2 " " 22	
1 " " 24	
2 " " 35	
23 " " 37	
1 " " 44	
2 " " 48A	
1 " " 52	
2 " " 126A	

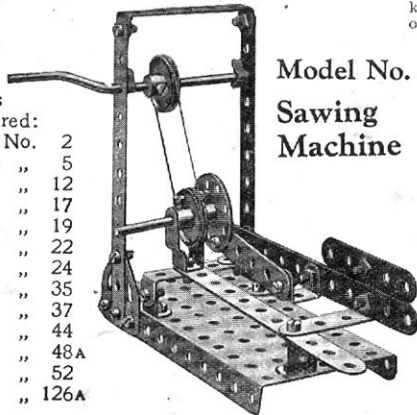

Model No. 44

Telegraph Key

Parts required:	
3 of No. 2	1 of No. 22
1 " " 10	11 " " 37
2 " " 11	1 " " 44
1 " " 12	1 " " 52

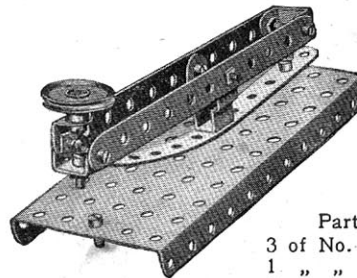

Model No. 45

Gong

Parts required:	
4 of No. 2	
1 " " 5	
3 " " 12	
1 " " 16	
1 " " 22	
7 " " 37	
1 " " 52	
1 " " 54	

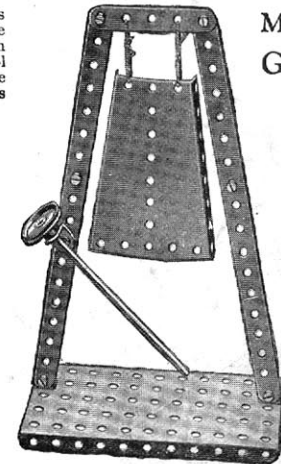

Model No. 46 Racing Motor Car

Parts required:

3 of No. 2	4 of No. 35
4 " " 5	25 " " 37
4 " " 10	3 " " 38
2 " " 11	1 " " 44
8 " " 12	4 " " 48A
2 " " 16	1 " " 126A
1 " " 19	
4 " " 22	
1 " " 23A	
1 " " 24	

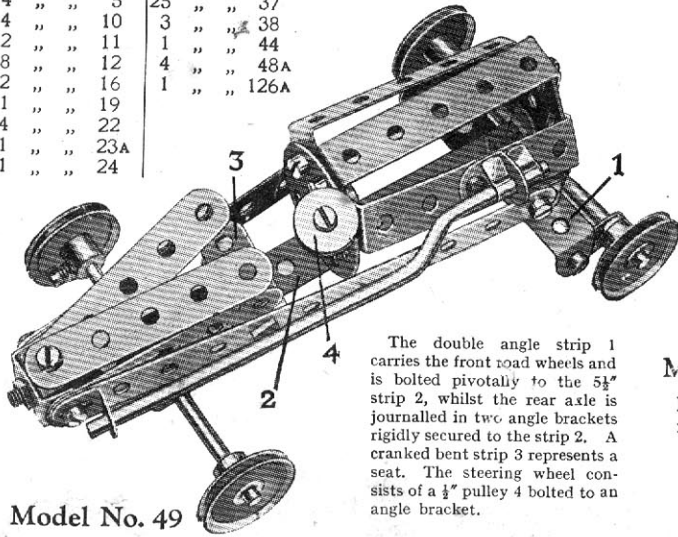

The double angle strip 1 carries the front road wheels and is bolted pivotally to the 5 1/2" strip 2, whilst the rear axle is journalled in two angle brackets rigidly secured to the strip 2. A cranked bent strip 3 represents a seat. The steering wheel consists of a 1/4" pulley 4 bolted to an angle bracket.

Model No. 49 Anchor

Parts required:

2 of No. 2
3 " " 5
4 " " 10
4 " " 12
11 " " 37
1 " " 57

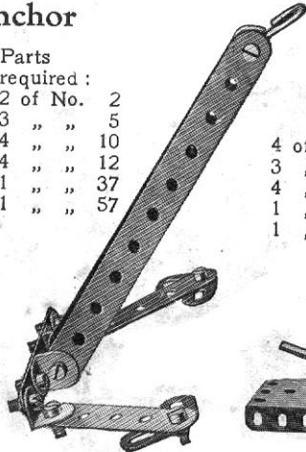

Model No. 50 Battleship

Parts required:

4 of No. 2	2 of No. 17	1 of No. 44
3 " " 5	4 " " 22	2 " " 48A
4 " " 10	1 " " 23	1 " " 52
4 " " 12	1 " " 24	1 " " 54
1 " " 16	3 " " 35	1 " " 125
	19 " " 37	

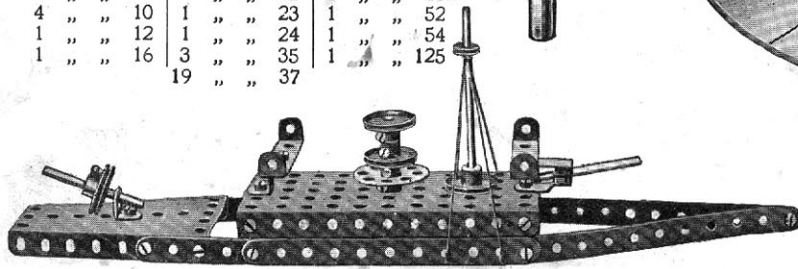

Model No. 47 Cutlery Rest

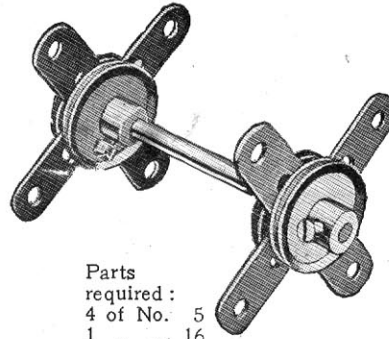

Parts required:

4 of No. 5
1 " " 16
4 " " 22

Model No. 48 Mechanical Hammer

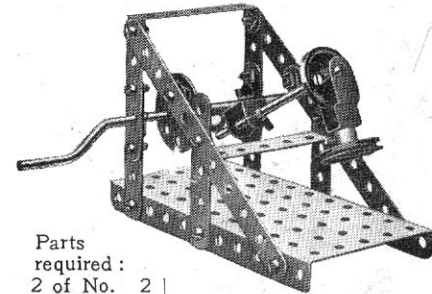

Parts required:

2 of No. 2	1 of No. 19	18 of No. 37
6 " " 5	2 " " 22	1 " " 44
1 " " 11	1 " " 24	3 " " 48A
1 " " 12	4 " " 35	1 " " 52
1 " " 16		

Model No. 51 Spinning Top

Parts required:

1 of No. 17
1 " " 22
1 " " 24

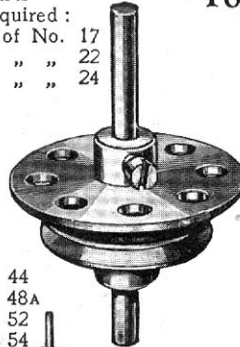

Model No. 52 Roulette Wheel

Parts required:

5 of No. 5	1 of No. 24
1 " " 16	5 " " 37
1 of No. 2	3 " " 22
	1 " " 52

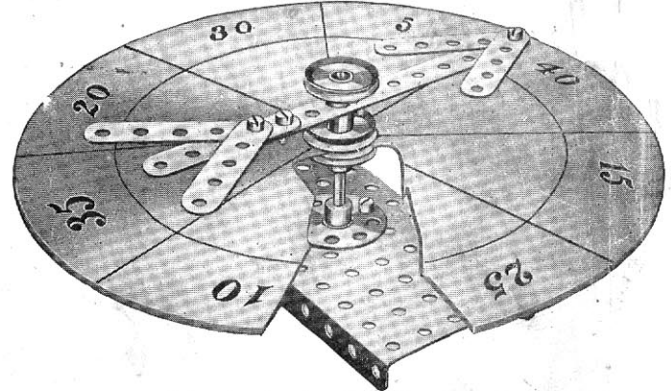

Cut out a circular piece of cardboard, and mark as shown to form scoring board. This is clamped between two 1" pulley wheels. The pointer revolves freely on the upright spindle and is held in position by another 1" pulley wheel.

Model No. 53 Invalid's Chair

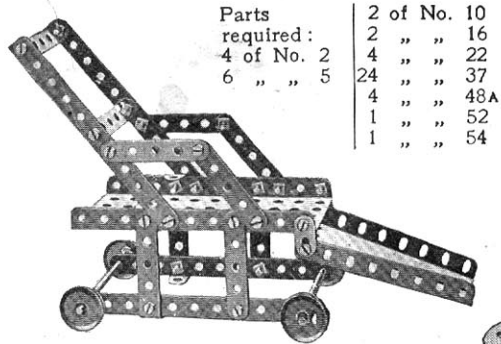

Parts required:	2 of No. 10
4 of No. 2	2 " " 16
6 " " 5	4 " " 22
	24 " " 37
	4 " " 48A
	1 " " 52
	1 " " 54

Model No. 54 Rotating Crane

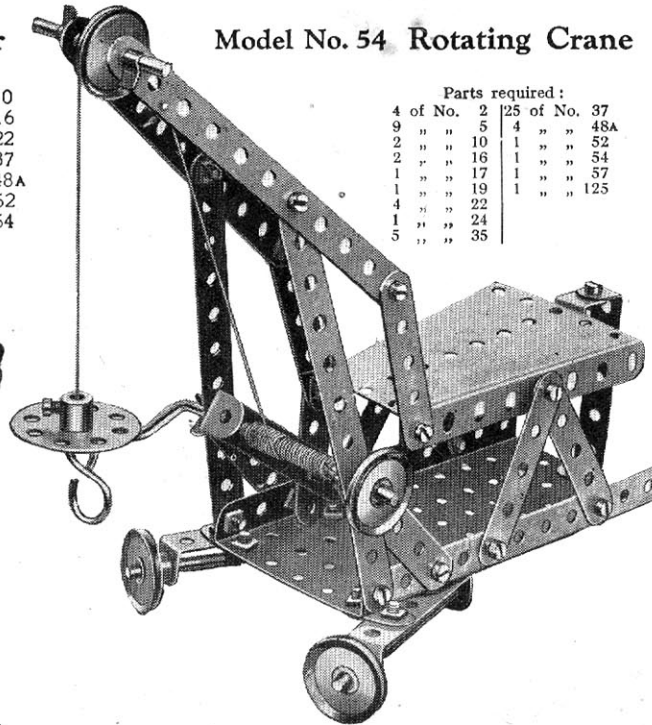

Parts required:		
4 of No. 2	25 of No. 37	
9 " " 5	4 " " 48A	
2 " " 10	1 " " 52	
2 " " 16	1 " " 54	
1 " " 17	1 " " 57	
1 " " 19	1 " " 125	
4 " " 22		
4 " " 24		
1 " " 35		

Model No. 55 Devil Wall

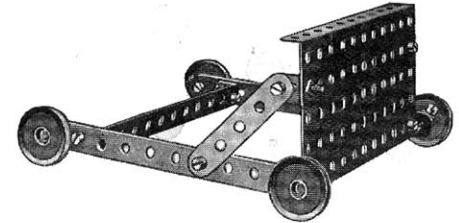

Parts required:	
3 of No. 2	4 of No. 22
2 " " 5	18 " " 37
6 " " 12	1 " " 52

Model No. 56 Stamping Machine

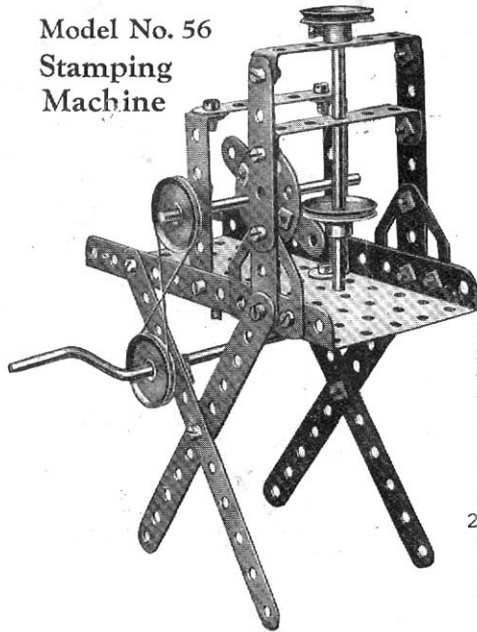

Parts required:	
4 of No. 2	
4 " " 5	
1 " " 16	
1 " " 19	
4 " " 22	
1 " " 24	
2 " " 35	
2 " " 37	
4 " " 48A	
1 " " 52	
2 " " 126A	

Model No. 57 Punching Machine

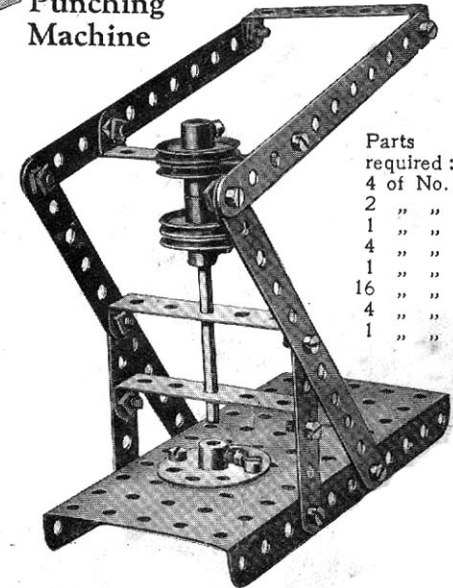

Parts required:	
4 of No. 2	
2 " " 5	
1 " " 16	
4 " " 22	
1 " " 24	
16 " " 37	
4 " " 48A	
1 " " 52	

The running wheels of this crane are journaled in double angle strips bolted to the base plate and secured at an angle by means of flat brackets. The rear of the base plate is supported on a double bracket. The jib is bolted loosely to the supporting $5\frac{1}{2}$ " strips and is connected by $2\frac{1}{2}$ " strips to the sector plate which pivots about its supporting bolts. By moving this sector plate the elevation of the jib may be altered as desired. The movement is controlled by a double angle strip mounted on the crank handle and connected pivotally to the plate by means of a $2\frac{1}{2}$ " strip. A reversed angle bracket bolted to an upright double angle strip in the rear of the model serves to restrict the movement of the sector plate.

These Models can be made with MECCANO Outfit No. 0, or No. 00 and No. 00A.

Model No. 58
Sailing Boat

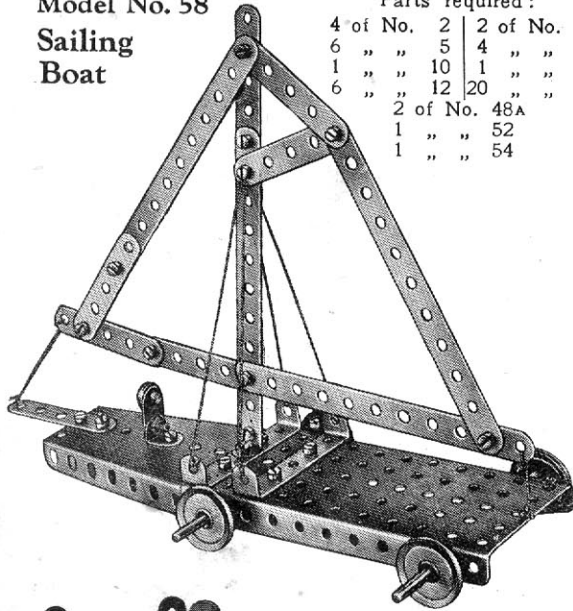

Parts required:

4 of No.	2	2 of No.	16
6 "	5	4 "	22
1 "	10	1 "	23
6 "	12	20 "	37
		2 of No.	48A
		1 "	52
		1 "	54

Model No. 59
Roman Balance

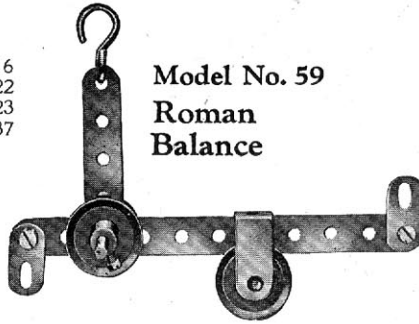

Parts required:

1 of No.	2	3 of No.	22
1 "	5	3 "	37
2 "	10	1 "	44
1 "	17	1 "	57

Model No. 60
Vegetable Chopper

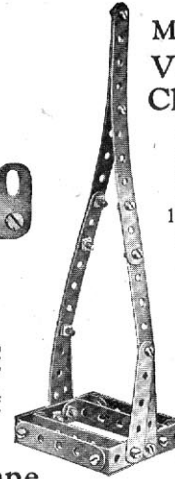

Parts required:

4 of No.	2
4 "	5
18 "	37
4 "	48A

Model No. 61
Mail-Bag Hanger

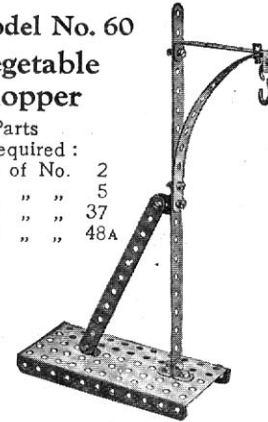

Parts required:

4 of No.	2
4 "	12
10 "	37
1 "	48A
1 "	52
1 "	57

Model No. 63
Aeroplane

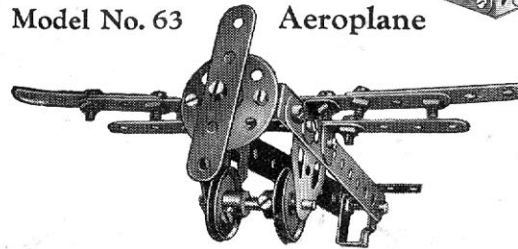

Parts required:

* 4 of No.	2	6 of No.	17	20 of No.	37
4 "	5	1 "	12	1 "	44
1 "	11	2 "	22	2 "	126A
		1 "	24		

Model No. 64
Pen Rack

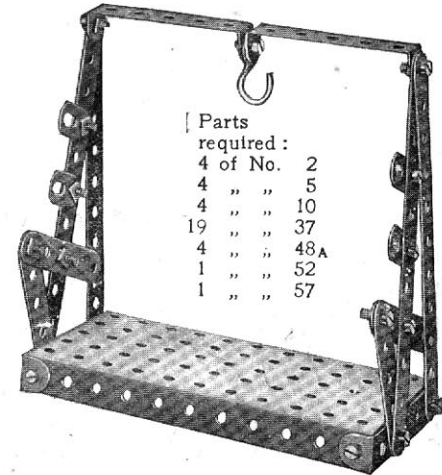

Parts required:

4 of No.	2
4 "	5
4 "	10
19 "	37
4 "	48A
1 "	52
1 "	57

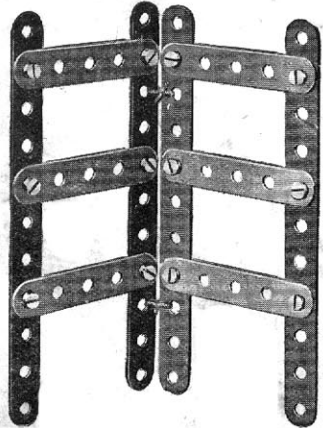

Model No. 62
Clothes Horse

Parts required:

4 of No.	2
6 "	5
12 "	37

HOW TO CONTINUE

This completes the Models which may be made with MECCANO Outfit No. 0. The next Models are a little more advanced, requiring a number of extra parts to construct them. The necessary parts are all contained in a No. 0A Accessory Outfit, the price of which will be found in the list at the end of the Manual.

**Model No. 101
Tandem Car**

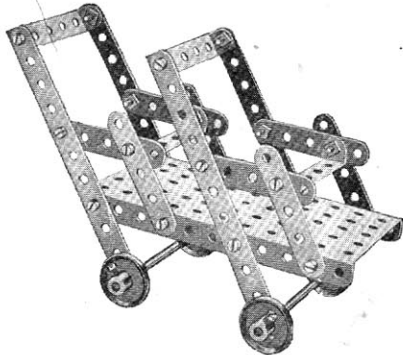

Parts required :

4 of No. 2	20 of No. 37
8 " " 5	4 " " 48A
2 " " 16	1 " " 52
4 " " 22	

Model No. 102 Swing

Parts required :

4 of No. 1
1 " " 2
6 " " 5
4 " " 12
12 " " 37
3 " " 48A
1 " " 52

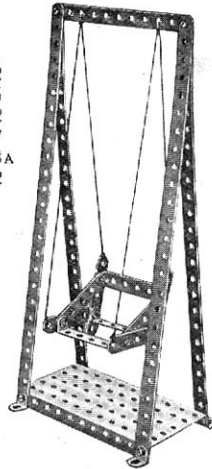

**Model No. 103
Bed Table**

Parts required :

3 of No. 2
1 " " 3
1 " " 5
1 " " 11
5 " " 12
2 " " 16
1 " " 17
4 " " 22
1 " " 24
21 " " 37
4 " " 48A
1 " " 52
1 " " 126A

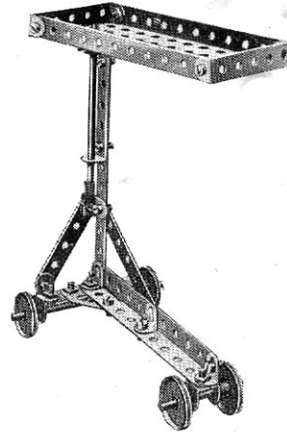

**Model No. 104
Swivelling Crane**

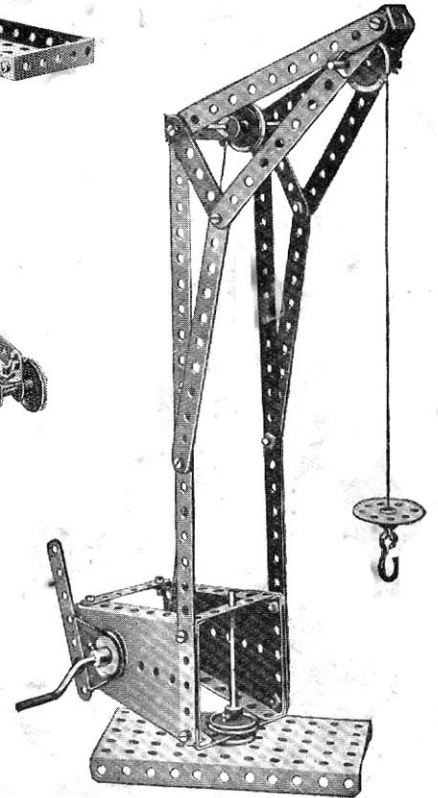

**Model No. 105
Travelling
Jib Crane**

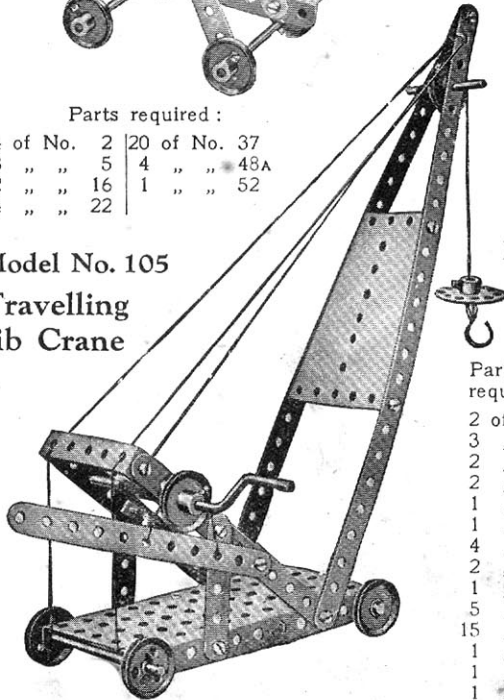

Model No. 106 Travelling Ladder

Parts required :

2 of No. 1
3 " " 2
2 " " 5
2 " " 16
1 " " 17
1 " " 19
4 " " 22
2 " " 22A
1 " " 24
5 " " 35
15 " " 37
1 " " 48A
1 " " 52
1 " " 54
1 " " 57

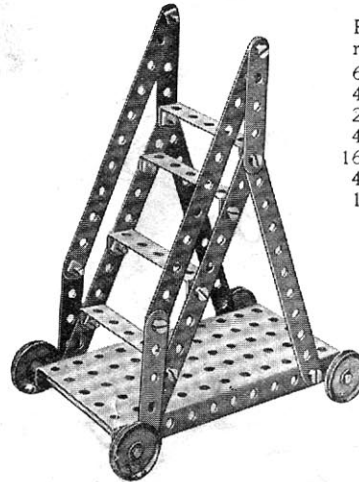

Parts required :

6 of No. 2
4 " " 5
2 " " 16
4 " " 22
16 " " 37
4 " " 48A
1 " " 52

Parts required :

2 of No. 1	1 of No. 11	2 of No. 22A	3 of No. 48A
6 " " 2	1 " " 16	1 " " 24	1 " " 52
1 " " 3	2 " " 17	4 " " 35	2 " " 54
4 " " 5	1 " " 19	18 " " 37	1 " " 57
	4 " " 22	1 " " 44	

These Models can be made with MECCANO Outfit No. 1, or No. 0 and No. 0A.

Model No. 107
Automatic
Dial Press

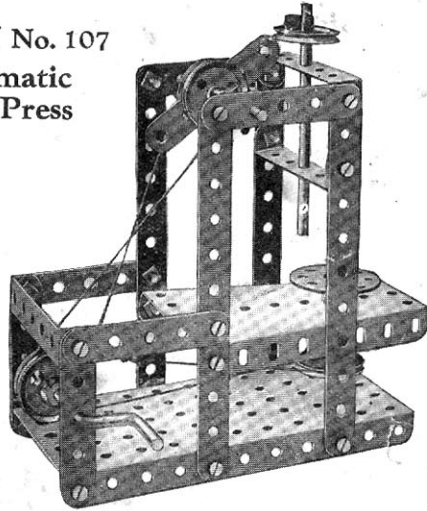

Parts required :

4 of No. 2	1 of No. 19	18 of No. 37
7 " " 5	4 " " 22	3 " " 48A
2 " " 16	2 " " 22A	1 " " 52
1 " " 17	1 " " 24	1 " " 54
	7 " " 35	

Model No. 109 **Endless Rope**
Railway

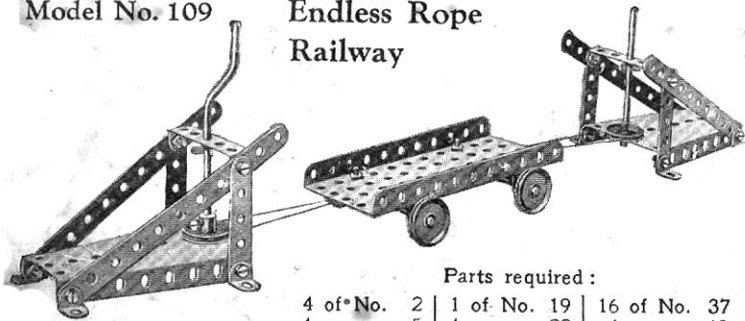

Parts required :

4 of No. 2	1 of No. 19	16 of No. 37
4 " " 5	4 " " 22	4 " " 48A
8 " " 12	2 " " 22A	1 " " 52
3 " " 16	4 " " 35	2 " " 54

Model No. 108
Telpher Span

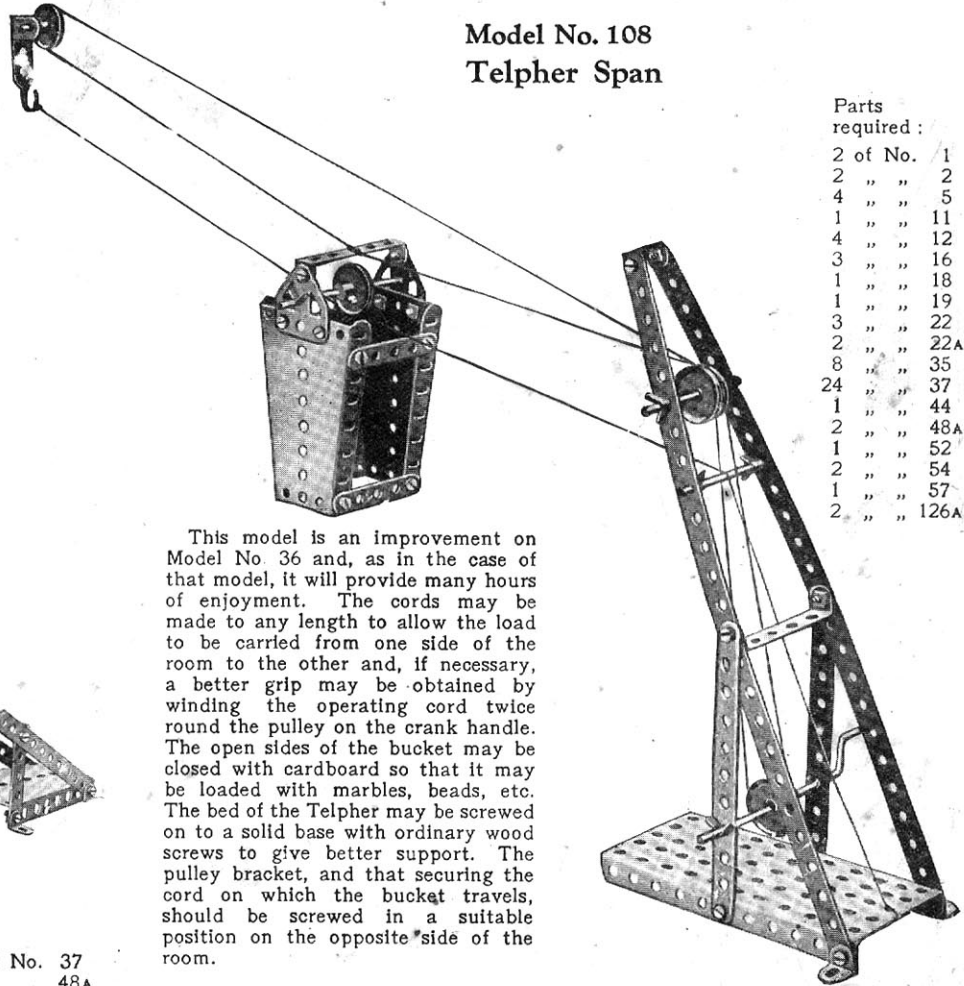

Parts required :

2 of No. 1
2 " " 2
4 " " 5
1 " " 11
4 " " 12
3 " " 16
1 " " 18
1 " " 19
3 " " 22
2 " " 22A
8 " " 35
24 " " 37
1 " " 44
2 " " 48A
1 " " 52
2 " " 54
1 " " 57
2 " " 126A

This model is an improvement on Model No 36 and, as in the case of that model, it will provide many hours of enjoyment. The cords may be made to any length to allow the load to be carried from one side of the room to the other and, if necessary, a better grip may be obtained by winding the operating cord twice round the pulley on the crank handle. The open sides of the bucket may be closed with cardboard so that it may be loaded with marbles, beads, etc. The bed of the Telpher may be screwed on to a solid base with ordinary wood screws to give better support. The pulley bracket, and that securing the cord on which the bucket travels, should be screwed in a suitable position on the opposite side of the room.

Model No. 110 Snow Plough

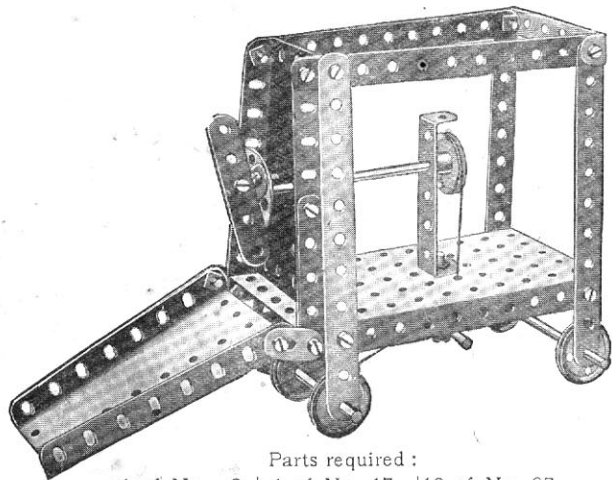

Parts required :

6 of No. 2	1 of No. 17	19 of No. 37
3 " " 5	4 " " 22	1 " " 44
2 " " 10	2 " " 22A	2 " " 48A
1 " " 12	1 " " 24	1 " " 52
3 " " 16	4 " " 35	2 " " 54

Model No. 112 Roundabout

The vertical spindle of the Roundabout is secured in place in the base plate by means of a 1" fast pulley bolted on either side of the plate. Washers should be placed beneath these pulleys in order to obtain freedom of movement.

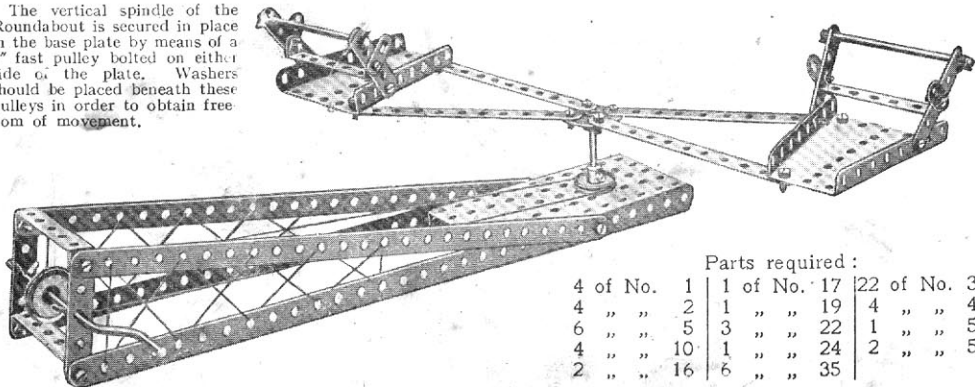

Parts required :

4 of No. 1	1 of No. 17	22 of No. 37
4 " " 2	1 " " 19	4 " " 48A
6 " " 5	3 " " 22	1 " " 52
4 " " 10	1 " " 24	2 " " 54
2 " " 16	6 " " 35	

FIG. 110A

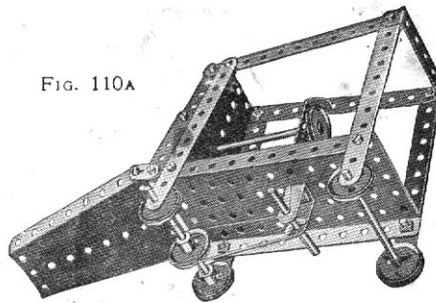

The construction of the framework of this model presents no difficulty. The sector plate forming the plough is loosely pivoted to the model. The plough shaft is mounted in the front sector plate and the 2½" double angle strip. A 2½" strip is bolted by angle brackets to a bush wheel on the front of the shaft and forms a dispersing propeller for the snow after it has risen up the inclined sector plate. A continuous cord is passed round a 1" pulley on the propeller shaft and round the short axle shown beneath the model (Fig. 110A) and a 1" pulley on the leading axle. In this way, as the plough is moved along the ground, the propeller is rotated.

Model No. 111 Dinner Wagon

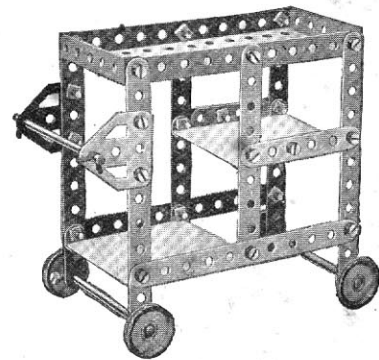

Parts required :

6 of No. 2	2 of No. 35
8 " " 5	22 " " 37
4 " " 12	4 " " 48A
3 " " 16	1 " " 52
4 " " 22	2 " " 126A

The two lower platforms are constructed out of pieces of ordinary cardboard, their outer edges resting on 2½" bent strips and their inner edges on angle brackets.

Model No. 113 Scooter

Parts required :

5 of No. 2	1 of No. 22
1 " " 10	1 " " 24
1 " " 11	14 " " 37
3 " " 12	2 " " 38
1 " " 17	1 " " 44
1 " " 18	1 " " 48A
2 of No. 126A	

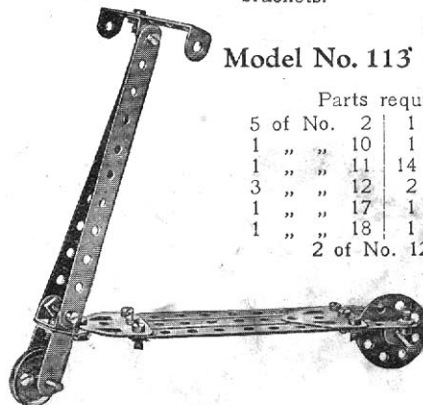

Model No. 114 Swivelling Jib Crane

Parts required:

4 of No. 1	4 of No. 12	20 of No. 37
6 " " 2	2 " " 17	3 " " 38
1 " " 3	1 " " 19	1 " " 48A
2 " " 5	3 " " 22	1 " " 52
1 " " 10	1 " " 22A	2 " " 54
1 " " 11	1 " " 23	1 " " 57
	3 " " 35	

The fixed base in this model consists of a 5 1/4" x 2 1/4" flanged plate, and the swivelling base of the superstructure is formed by two sector plates. The latter swivel about a short vertical rod secured in position by means of 1" fixed pulleys.

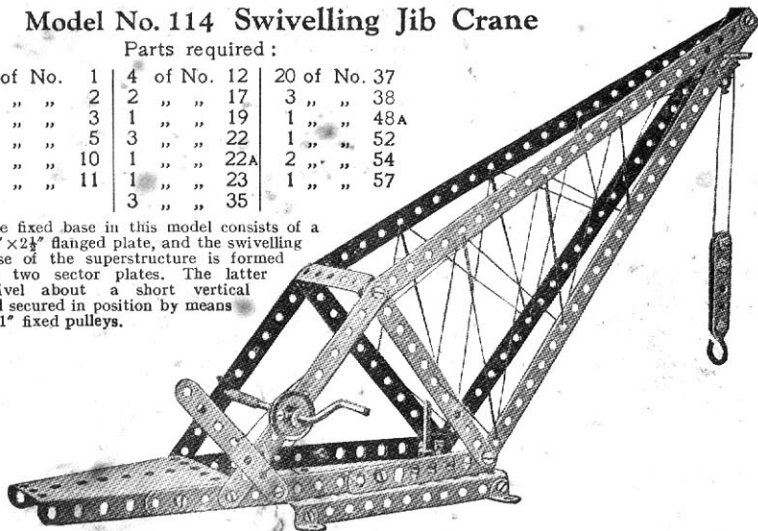

Model No. 117 Giant Foundry Ladle

This represents a device used in handling molten metal in foundry operations. The metal is poured from the converter into the bucket-like container which consists in our model of two sector plates bolted together at the top by 2 1/2" strips and at the bottom by flat brackets. The container swings about a central pivot so that it may be brought into position over the moulds that receive the metal. The bucket may be tipped on rotation of the crank handle 1 on each end of which cords 2 are wound two or three times between a pair of spring clips. The bucket is secured to the axle 3 by means of spring clips placed upon the axle and pressing against either side of each of the two sector plates.

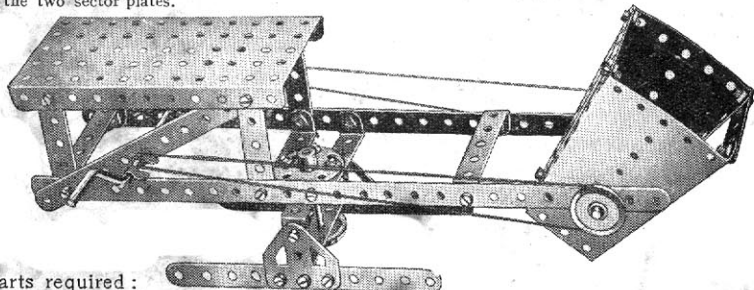

Parts required:

2 of No. 1	1 of No. 16	1 of No. 22A	2 of No. 38	2 of No. 54
4 " " 2	1 " " 17	1 " " 24	1 " " 40	2 " " 126A
6 " " 5	1 " " 19	8 " " 35	6 " " 48A	
2 " " 10	3 " " 22	30 " " 37	1 " " 52	

Model No. 115 Band Saw

Parts required:

6 of No. 2	
4 " " 5	
2 " " 10	
2 " " 16	
1 " " 19	
3 " " 22	
6 " " 35	
2 " " 37	
2 " " 48A	
1 " " 52	

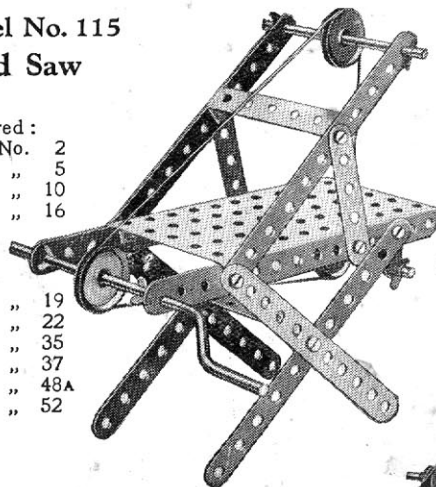

Model No. 116 Hatchet

Parts required:

3 of No. 1
6 " " 12
15 " " 37
2 " " 54

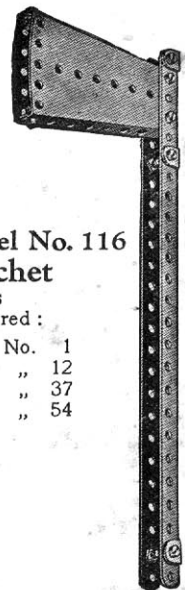

Model No. 118 Overhead Crane

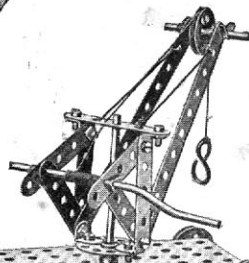

Parts required:

2 of No. 1	2 of No. 22A
6 " " 2	1 " " 24
9 " " 5	6 " " 35
4 " " 10	24 " " 37
4 " " 12	1 " " 44
3 " " 16	2 " " 48A
1 " " 17	1 " " 52
1 " " 19	2 " " 54
4 " " 22	1 " " 57

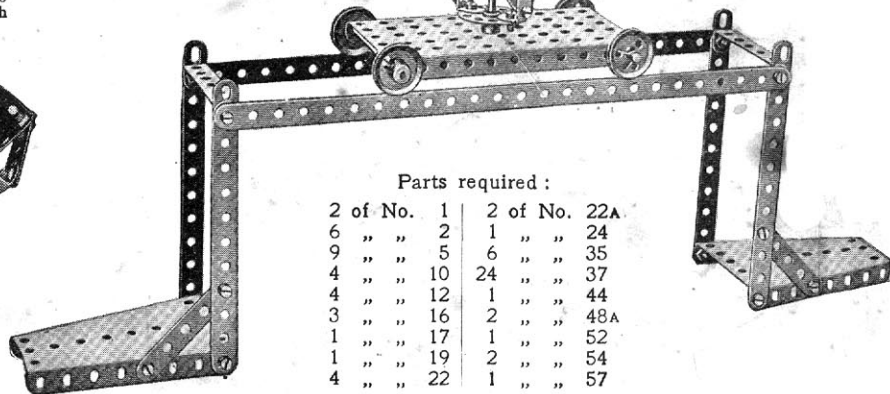

Model No. 119 Windmill

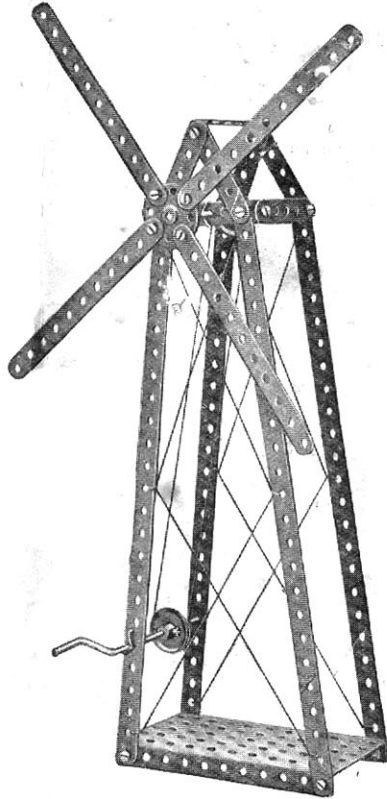

Parts required :

4 of No. 1	2 of No. 22
4 " " 2	1 " " 24
7 " " 5	4 " " 35
2 " " 12	20 " " 37
1 " " 16	3 " " 48A
1 " " 19	1 " " 52

Model No. 120 Deck Chair

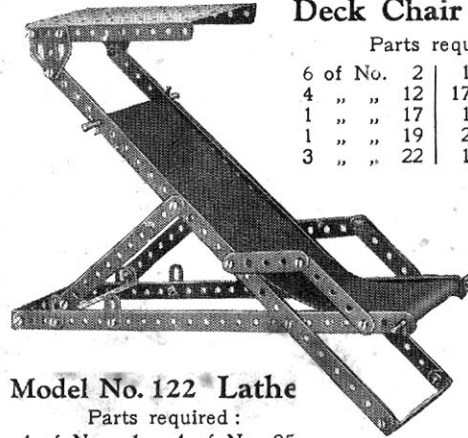

Parts required :

6 of No. 2	1 of No. 24
4 " " 12	17 " " 37
1 " " 17	1 " " 44
1 " " 19	2 " " 48A
3 " " 22	1 " " 52

Model No. 122 Lathe

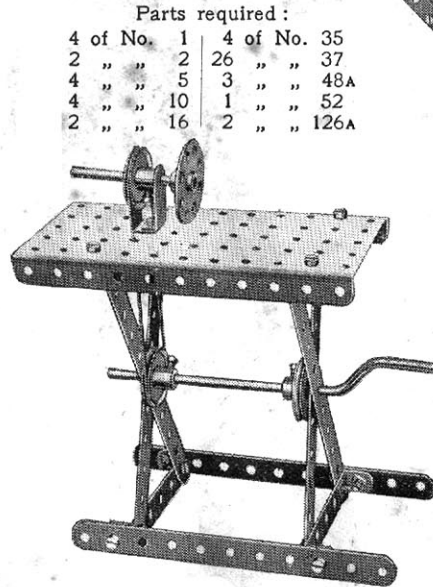

Parts required :

4 of No. 1	4 of No. 35
2 " " 2	26 " " 37
4 " " 5	3 " " 48A
4 " " 10	1 " " 52
2 " " 16	2 " " 126A

Model No. 121 Jib Crane

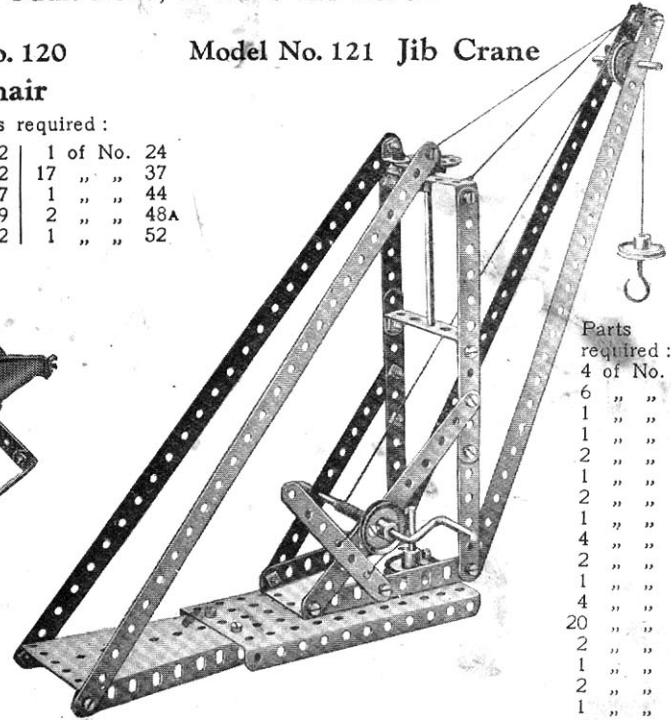

Parts required :

4 of No. 1	1
6 " " 2	3
1 " " 3	2
1 " " 11	11
2 " " 12	16
1 " " 16	17
2 " " 17	19
1 " " 19	22
4 " " 22	22A
2 " " 22A	24
1 " " 24	35
4 " " 35	37
20 " " 37	48A
2 " " 48A	52
1 " " 52	54
2 " " 54	57
1 " " 57	

Model No. 123 Invalid Chair

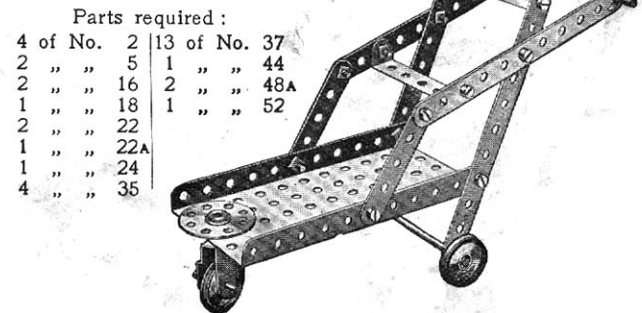

Parts required :

4 of No. 2	13 of No. 37
2 " " 5	1 " " 44
2 " " 16	2 " " 48A
1 " " 18	1 " " 52
2 " " 22	
1 " " 22A	
1 " " 24	
4 " " 35	

Model No. 124 Drop Stamp

Parts required :

4 of No. 2	1 of No. 19	3 of No. 48A
6 " " 5	4 " " 22	1 " " 52
3 " " 10	1 " " 24	1 " " 54
2 " " 16	2 " " 35	2 " " 126A
	27 " " 37	

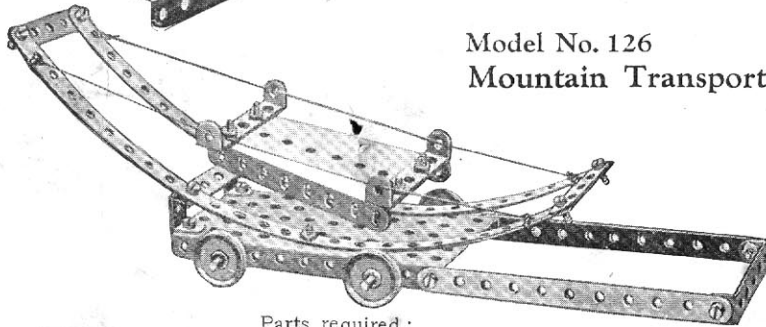
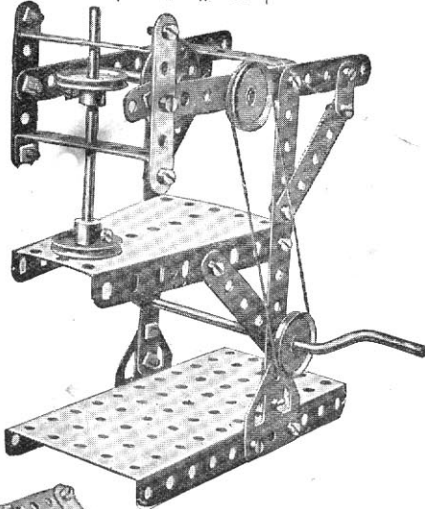

Parts required :

2 of No. 1	3 of No. 5	2 of No. 16	18 of No. 37	1 of No. 52
2 " " 2	4 " " 12	4 " " 22	2 " " 48A	1 " " 54

Model No. 125 Sewing Machine

Parts required :

3 of No. 2	1 of No. 16	2 of No. 22	1 of No. 44
6 " " 5	2 " " 17	1 " " 24	4 " " 48A
3 " " 10	1 " " 18A	3 " " 35	1 " " 52
2 " " 11	1 " " 19	2 " " 37	1 " " 54
3 " " 12	2 " " 21	3 " " 38	2 " " 125

The handle 1 carries a 1" pulley 2, which drives by means of a cord a similar pulley on a 2" rod 3 journalled in a cranked bent strip bolted to the sector plate. Two double brackets 4 are secured together by a bolt 5, the shank of which presses very tightly on the rod 3. This locks the double brackets in position, and they revolve with the rod 3. The outer double bracket carries a 1 1/2" rod 6, the end of which lies between two strips 7, arranged at a short distance apart from each other and bolted to two flat brackets. These are secured to a further strip 8 bolted pivotally to a transverse double angle strip. As the shaft 3 rotates, the rod 6 slides between the strips 7 and so rocks the strip 8 from side to side. This represents the movement of the shuttle.

The bush wheel 9 carries two angle brackets placed together in the form of a double bracket, with their elongated holes overlapping, and in such a position that an imaginary line drawn through their opposite round holes, would intercept the centre of the bush wheel. A flat bracket is bolted to the inner angle bracket in a line with the crank handle and forms a lever which engages a 1" pulley 10 mounted on a vertical sliding rod 11. This rod is journalled in a double angle strip bolted between the lower holes of the two flat trunnions and is further supported by two 1/2" reversed angle brackets secured to the angle strip. As the bush wheel rotates, the flat bracket imparts to the rod 11 a movement corresponding to the action of the needle.

The outer angle bracket on the bush wheel strikes once in every revolution the end of a double angle strip 12. This is pivotally mounted by a bolt passed through its second hole from the bush wheel end to the centre hole of the flat trunnion on that side of the model. The resulting movement of the strip 12 represents the apparatus by which the cotton is paid out from the reel to the needle.

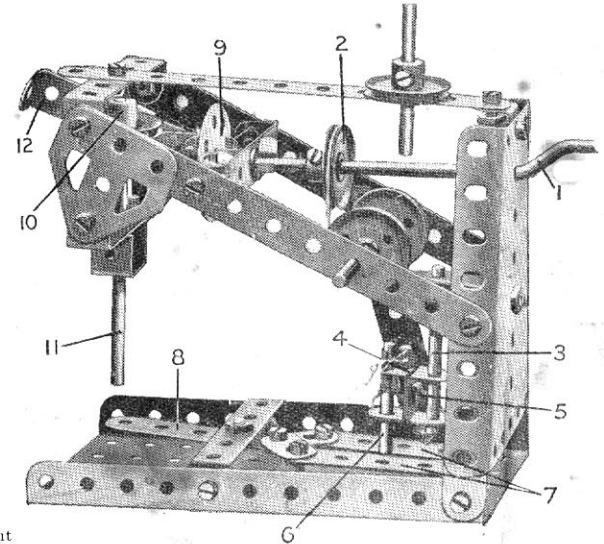

Model No. 127 Motor Lorry

Parts required :

4 of No. 2	
8 " " 5	
4 " " 12	
2 " " 16	
1 " " 17	
3 " " 22	
2 " " 22A	
1 " " 24	
2 " " 35	
25 " " 37	1 of No. 52
3 " " 38	1 " " 54
3 " " 48A	2 " " 125

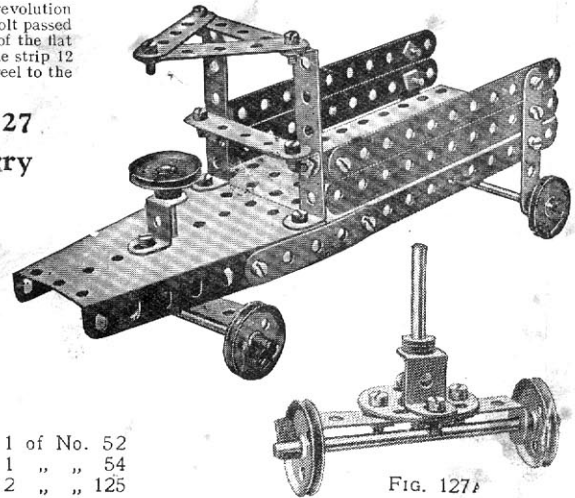
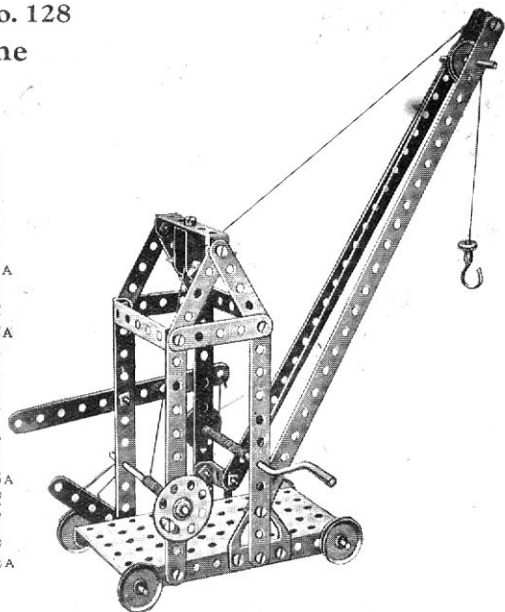

FIG. 127A

Model No. 128 Jib Crane

Parts required :

2	of No.	1
5	" "	2
7	" "	5
1	" "	11
3	" "	16
1	" "	17
1	" "	18A
1	" "	19
4	" "	22
2	" "	22A
1	" "	23
1	" "	24
6	" "	35
22	" "	37
2	" "	38
1	" "	44
3	" "	48A
1	" "	52
1	" "	57
2	" "	125
2	" "	126A



Model No. 129 Double Action Crane

A feature of this crane is that, by the arrangement of the cords on the crank handle, one load may be raised whilst the other is being lowered.

Parts required :

4	of No.	1	3	of No.	48A
4	" "	2	2	" "	52
2	" "	16	2	" "	54
1	" "	19	1	" "	57
3	" "	22			
2	" "	22A			
1	" "	24			
6	" "	35			
22	" "	37			
1	" "	44			

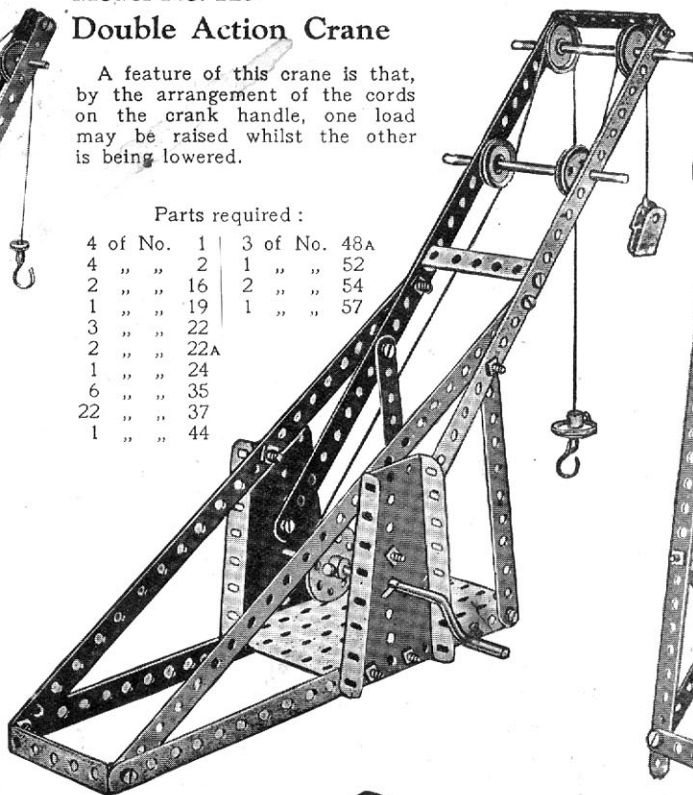

Model No. 130 Fire Alarm

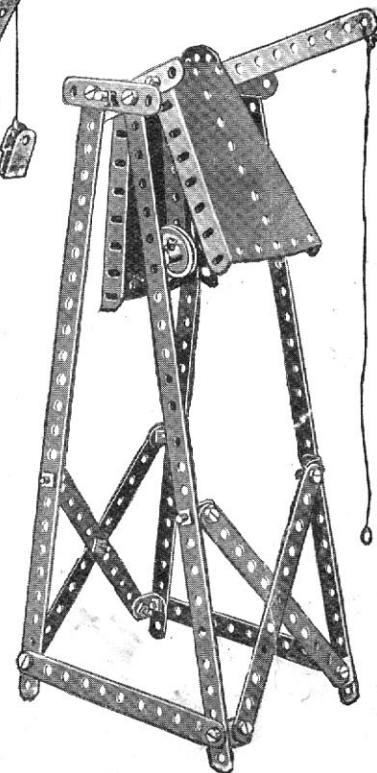

Model No. 131 Rowing Boat

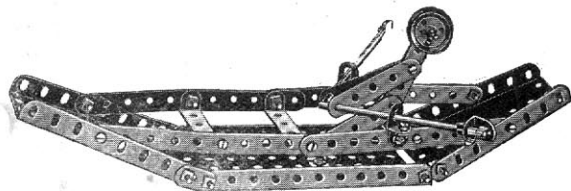

4	of No.	2	2	of No.	16	4	of No.	38
5	" "	5	1	" "	18A	3	" "	48A
4	" "	10	2	" "	22A	1	" "	52
7	" "	12	4	" "	35	2	" "	54
			24	" "	37			

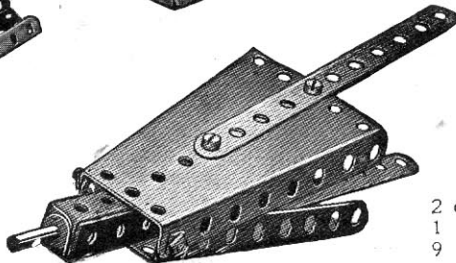

Model No. 132 Bellows

Parts required :

2	of No.	2	4	of No.	48A
1	" "	17	2	" "	54
9	" "	37			

Parts required :

4	of No.	1	1	of No.	22
7	" "	2	1	" "	24
1	" "	3	4	" "	35
3	" "	5	27	" "	37
8	" "	12	2	" "	54
1	" "	16			

**Model No. 133
Gantry Crane**

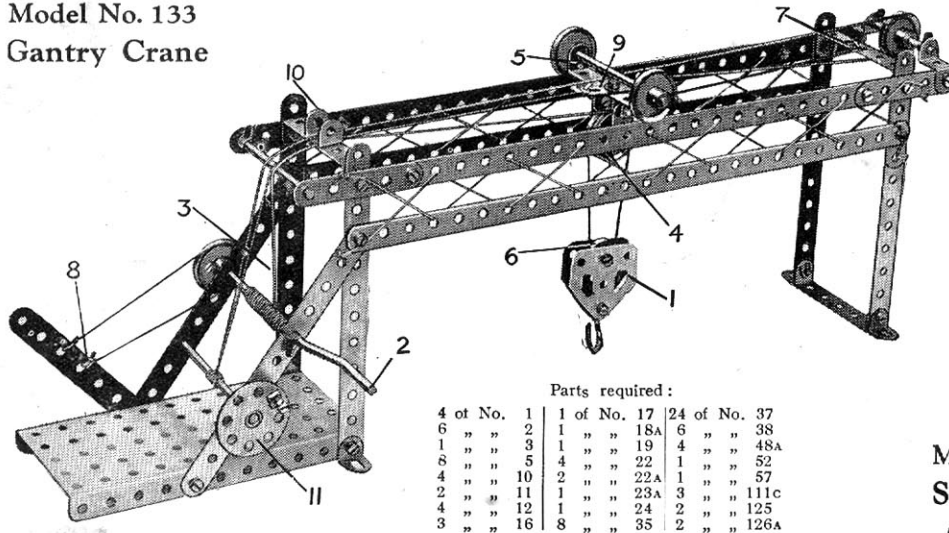

Parts required :

4 of No.	1	1 of No.	17	24 of No.	37
6 "	2	1 "	18A	6 "	38
1 "	3	1 "	19	4 "	48A
6 "	5	4 "	22	1 "	52
4 "	10	2 "	22A	1 "	57
2 "	11	1 "	23A	3 "	111c
4 "	12	1 "	24	2 "	125
3 "	16	8 "	35	2 "	126A

The pulley-block 1 is operated by means of the crank handle 2, on which a cord 3 is wound. This cord passes over one of the two loose 1" pulleys 4 carried on a short rod which is journalled in the ends of flat brackets suspended by means of a double bracket beneath the double angle strip 5 forming the frame of the trolley. The cord then passes round the 1" pulley wheel 6 in the pulley block and round the second of the pulleys 4, and is finally fixed to the model at 7. A friction brake, consisting of a 3 1/2" strip 8 and cord engaging a 1" pulley on the crank handle, is provided to control the hoisting movement.

The traversing movement of the trolley is effected as follows:—A length of cord tied to one of the two flat brackets 9 is passed round the 1" pulley wheel at the outer end of the gantry, and then led back under the axle of the trolley, over the guide 10 (consisting of a double bracket) and wound on to a 3 1/2" axle rod. The latter may be operated by a hand wheel 11, formed from a bush wheel and 3/8" bolt. After passing several times round the 3 1/2" rod the cord is returned over the double bracket 10, and its end is secured to the second of the two flat brackets 9, which are bolted to the centre of the double angle strip 5.

Model No. 134 Forge Bellows

Parts required :

4 of No.	2	1 of No.	19
1 "	3	2 "	22
2 "	5	1 "	24
2 "	10	5 "	35
1 "	11	25 "	37
2 "	12	3 "	48A
2 "	16	1 "	52
1 "	17	2 "	54

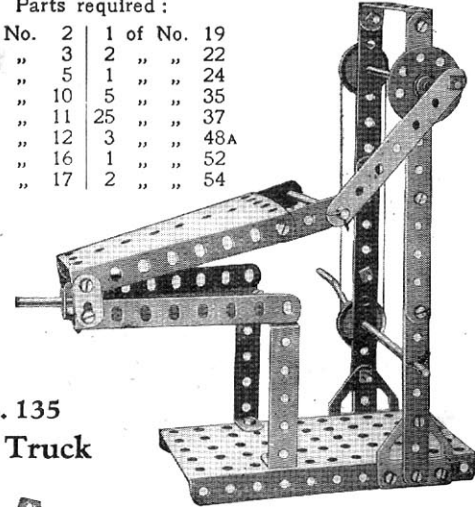

**Model No. 135
Steering Truck**

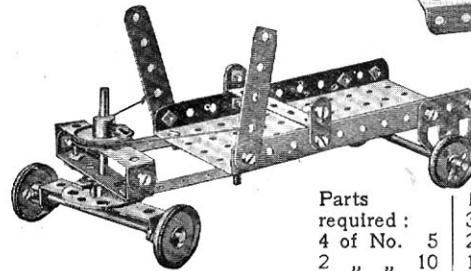

Parts required :

1 of No.	17	18 of No.	37
3 "	22	2 "	38
4 of No.	22A	4 "	48A
2 "	24	1 "	52
2 "	35	2 "	126A

HOW TO CONTINUE

This completes the Models which may be made with MECCANO Outfit No. 1. The next Models are a little more advanced, requiring a number of extra parts to construct them. The necessary parts are all contained in a No. 1A Accessory Outfit, the price of which will be found in the List at the end of the Manual.

Model No. 201
Truck

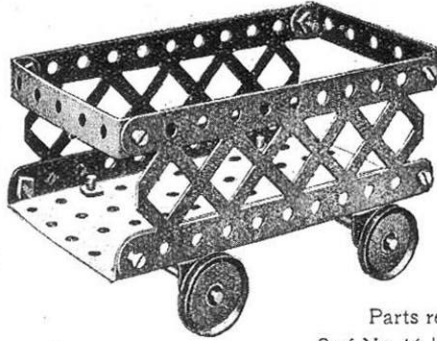

Parts required :

2 of No. 16	4 of No. 48A
4 " " 22	1 " " 52
12 " " 37	2 " " 100

Model No. 202
Revolving Truck

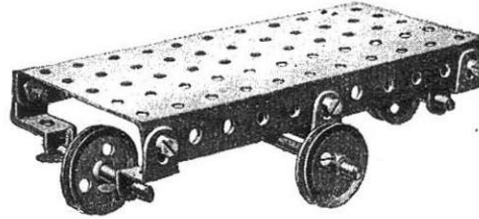

Parts required :

2 of No. 10	2 of No. 22	6 of No. 37
1 " " 16	2 " " 22A	1 " " 52
2 " " 17	4 " " 35	4 " " 125

Model No. 203—Lathe

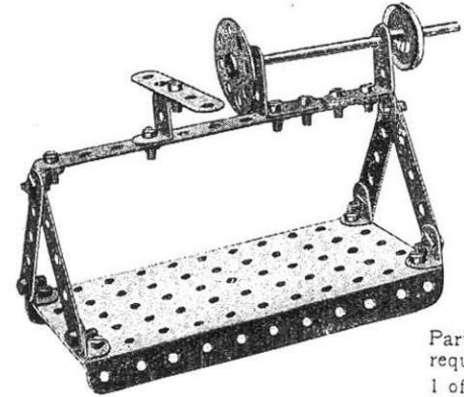

Parts required :

1 of No. 2
5 " " 5
6 " " 12
2 " " 12A
1 " " 16
1 " " 22
1 " " 24
17 " " 37
1 " " 52
1 " " 125

Model No. 204—Turntable Gangway

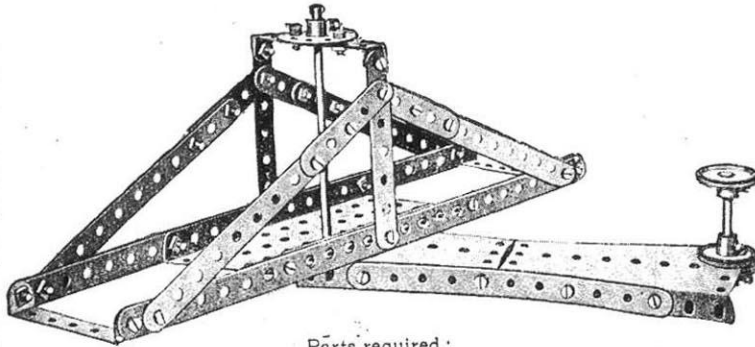

Parts required :

2 of No. 1	4 of No. 22
6 " " 2	1 " " 24
2 " " 3	34 " " 37
4 " " 5	3 " " 48A
1 " " 15A	1 " " 52
1 " " 17	2 " " 54

FIG. 204A
(underneath view)

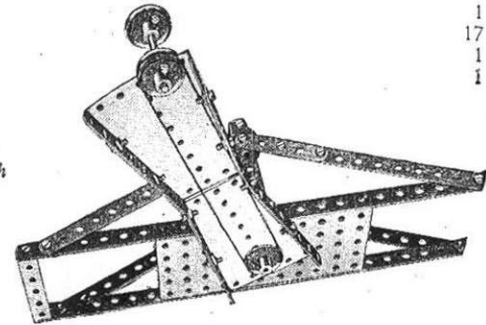

The side frames of the gangway are made of 12½" strips bolted by means of 2½" bent strips to parallel strips below. The side frames are connected by a perforated flanged plate to the underside of which is bolted a bush wheel fitted with a rod on which is mounted a 1" pulley (See Fig. 204A.) The rod passes through one of the end holes of the sector plate which is connected by diagonal strips to another sector plate. Through the end hole of the latter a rod is threaded carrying two 1" pulleys from one of which an operating cord passes through the pulley mounted on the under side of the flange plate. In this way the Gangway may be rotated by an operating spindle.

Model No. 205—Scales

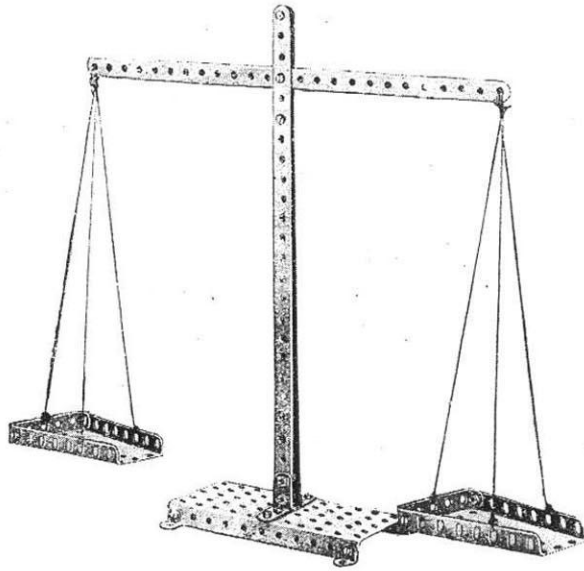

Parts required :

3 of No. 1	4 of No. 38
4 " " 12	2 " " 48A
2 " " 12A	1 " " 52
19 " " 37	2 " " 54

The slot is formed by inserting 2 washers in the bolts above and below the beam. These washers hold the strips composing the standard at the required distance apart to give the beam free play.

Model No. 206—Joy Wheel

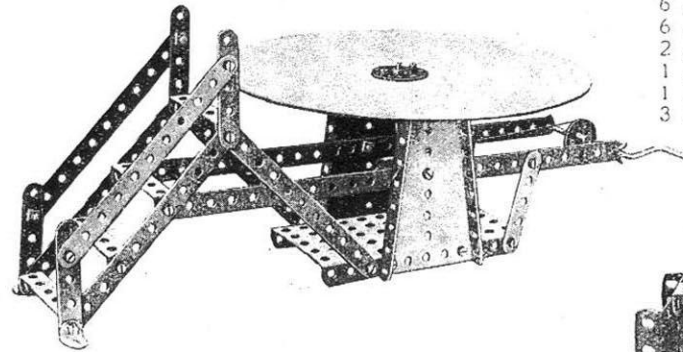

The driving mechanism and construction of the framework of this model are clearly brought out in Fig. 206A. Cut out a circular piece of cardboard, 8" in diameter, and in the centre of the disc fix a bush wheel by nuts and bolts. The eye of the bush wheel is then threaded over the top of a vertical spindle, and secured by its set-screw.

Parts required :

2 of No. 1	1 of No. 22A
6 " " 2	1 " " 24
6 " " 5	2 " " 35
2 " " 12	23 " " 37
1 " " 15A	5 " " 48A
1 " " 19	1 " " 52
3 " " 22	2 " " 54

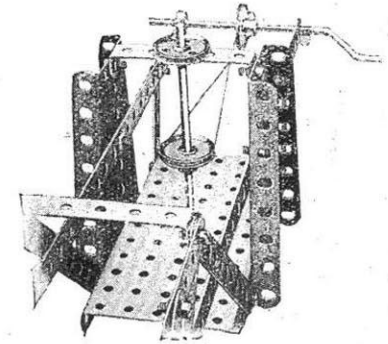
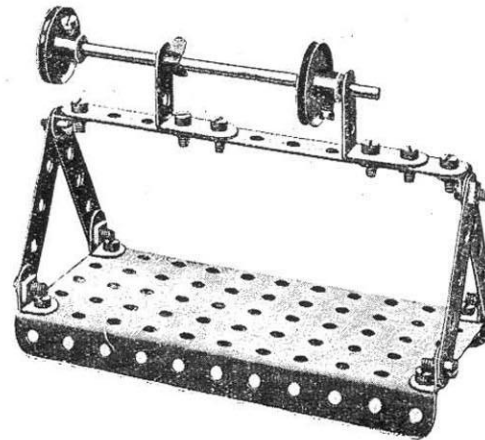

Fig. 206A.

Model No. 207
Polishing Spindle

Parts required :

1 of No. 2	1 of No. 15A
4 " " 5	2 " " 22
6 " " 12	1 " " 35
2 " " 12A	16 " " 37
	1 " " 52

Model No. 208 Pit Head Gear

Parts required:

4	of No.	1
5	"	2
2	"	3
2	"	5
2	"	12
1	"	16
1	"	19
3	"	22
2	"	35
25	"	37
5	"	48A
1	"	52
2	"	54

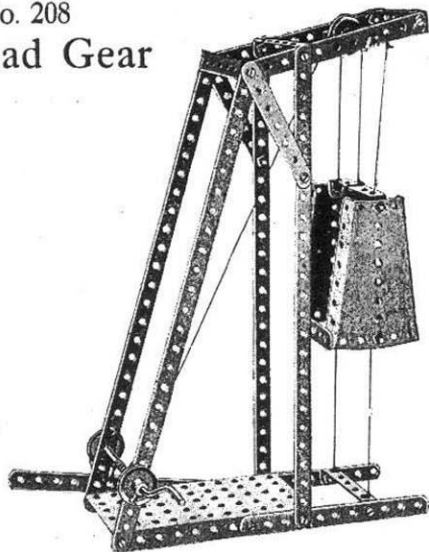

Model No. 209 Gangway

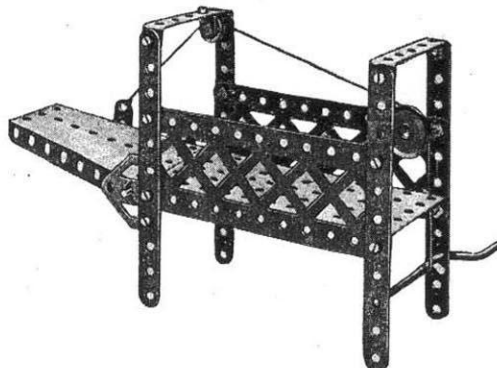

Parts required:

4	of No.	2	1	of No.	22	1	of No.	52
1	"	10	1	"	23	1	"	54
1	"	12	4	"	35	2	"	100
1	"	16	17	"	37	2	"	126A
1	"	19	2	"	48A			

Model No. 211—Motor Truck

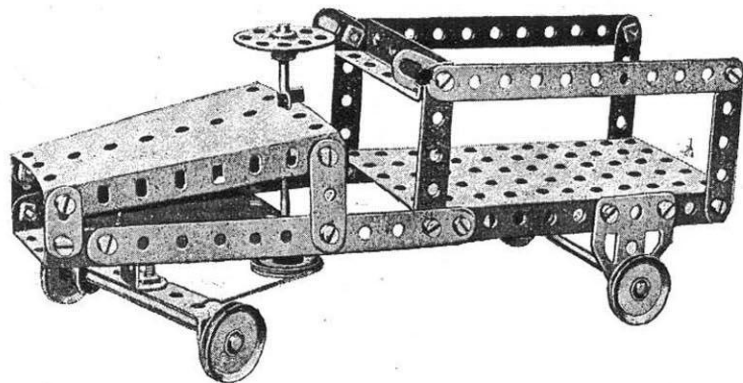

Parts required:

4	of No.	2
4	"	5
2	"	6A
4	"	10
1	"	11
3	"	16
3	"	22
2	"	22A
1	"	24
3	"	35
26	"	37
3	"	48A
1	"	52
2	"	54
2	"	126A

Model No. 210 Ladder on Wheels

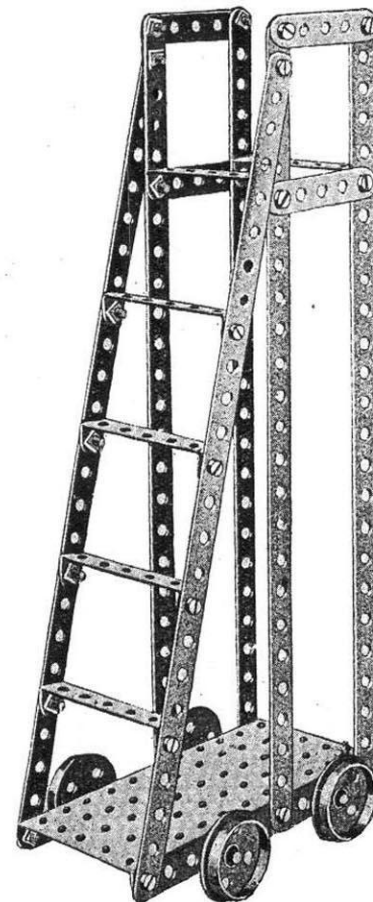

Parts required:

6	of No.	1	24	of No.	37
4	"	5	6	"	48A
2	"	16	1	"	52
4	"	20			

Model No. 212
Cot on Wheels

- Parts
required:
2 of No. 2
7 " " 5
3 " " 12
4 " " 22
18 " " 37
2 " " 48^A
2 " " 100

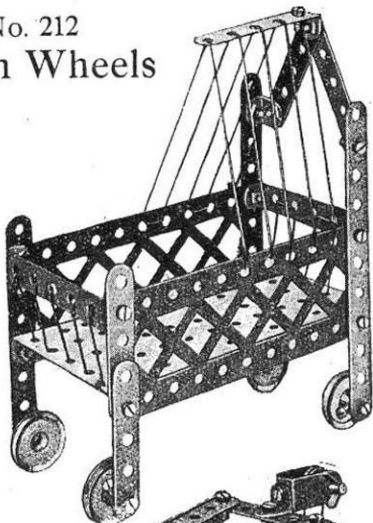

Model No 213
Monoplane

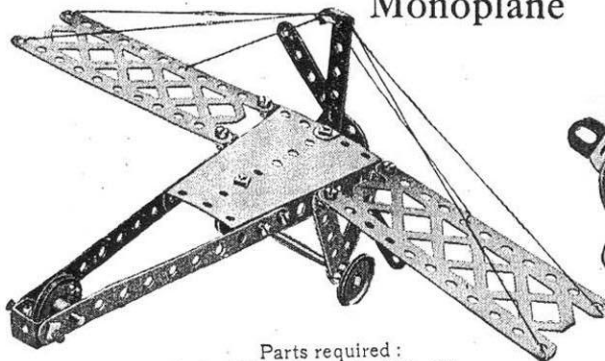

- Parts required:
- | | | |
|------------|-----------------------|-----------------------|
| 2 of No. 2 | 6 of No. 12 | 1 of No. 35 |
| 6 " " 5 | 2 " " 16 | 18 " " 37 |
| 1 " " 11 | 1 " " 18 ^A | 1 " " 48 ^A |
| | 3 " " 22 | 1 " " 54 |
| | 1 " " 24 | 2 " " 100. |

Model No. 214
Double Drop
Hammer

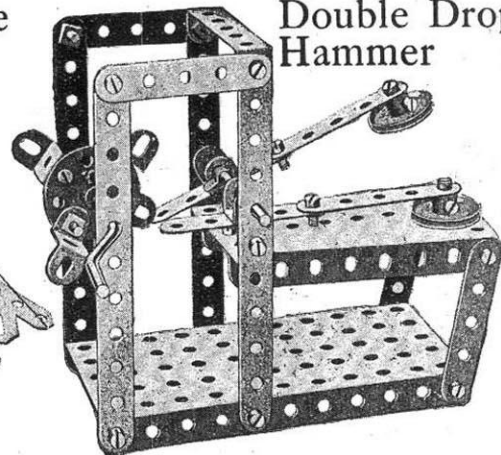

- Parts
required:
- | | | |
|------------|-------------|-----------------------|
| 4 of No. 2 | 1 of No. 16 | 25 of No. 37 |
| 8 " " 5 | 1 " " 19 | 2 " " 48 ^A |
| 2 " " 11 | 2 " " 22 | 1 " " 52 |
| | 1 " " 24 | 1 " " 54 |
| | 6 " " 35 | 4 " " 125 |

Model No. 215
Tipping
Motor
Wagon

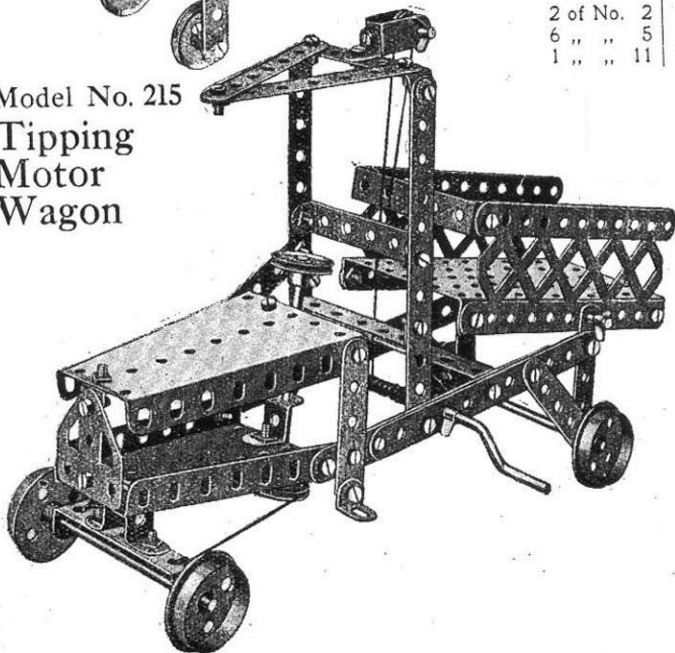

- Parts required:
- | | |
|------------------------|-----------------------|
| 6 of No. 2 | 2 " " 3 |
| 2 " " 5 | 7 " " 5 |
| 4 " " 12 | 1 " " 10 |
| 4 " " 16 | 4 " " 12 |
| 1 " " 18 ^A | 4 " " 16 |
| 1 " " 19 | 1 " " 18 ^A |
| 4 " " 20 | 1 " " 19 |
| 2 " " 22 | 4 " " 20 |
| 1 " " 23 | 2 " " 22 |
| 7 " " 35 | 1 " " 23 |
| 43 " " 37 | 7 " " 35 |
| 2 " " 38 | 2 " " 37 |
| 1 " " 44 | 2 " " 38 |
| 1 " " 45 | 1 " " 44 |
| 6 " " 48 ^A | 1 " " 45 |
| 1 " " 52 | 6 " " 48 ^A |
| 2 " " 54 | 1 " " 52 |
| 2 " " 100 | 2 " " 54 |
| 2 " " 125 | 2 " " 100 |
| 1 " " 126 ^A | 2 " " 125 |

Model No. 216
Roundabout
Seesaw

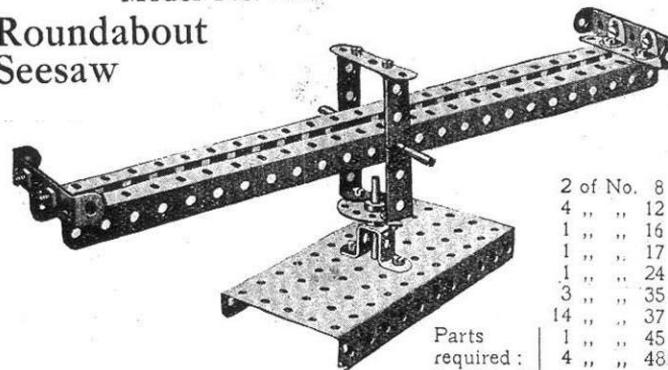

- Parts
required:
- | |
|-----------------------|
| 2 of No. 8 |
| 4 " " 12 |
| 1 " " 16 |
| 1 " " 17 |
| 1 " " 24 |
| 3 " " 35 |
| 14 " " 37 |
| 1 " " 45 |
| 4 " " 48 ^A |
| 3 of No 5 |
| 1 " " 52 |

Model No. 217—Monoplane

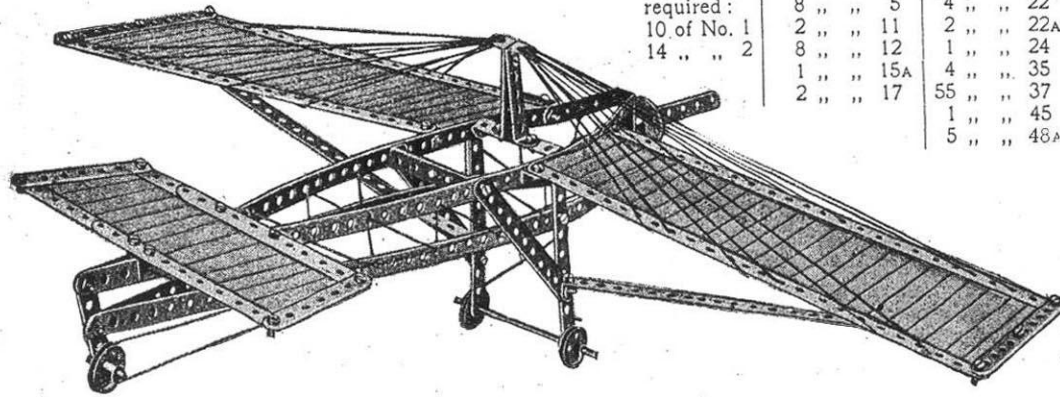

Parts required:	2 of No. 3	1 of No. 18A
10 of No. 1	8 " " 5	4 " " 22
14 " " 2	2 " " 11	2 " " 22A
	8 " " 12	1 " " 24
	1 " " 15A	4 " " 35
	2 " " 17	55 " " 37
		1 " " 45
		5 " " 48A

Model No. 218 Travelling Jib Crane

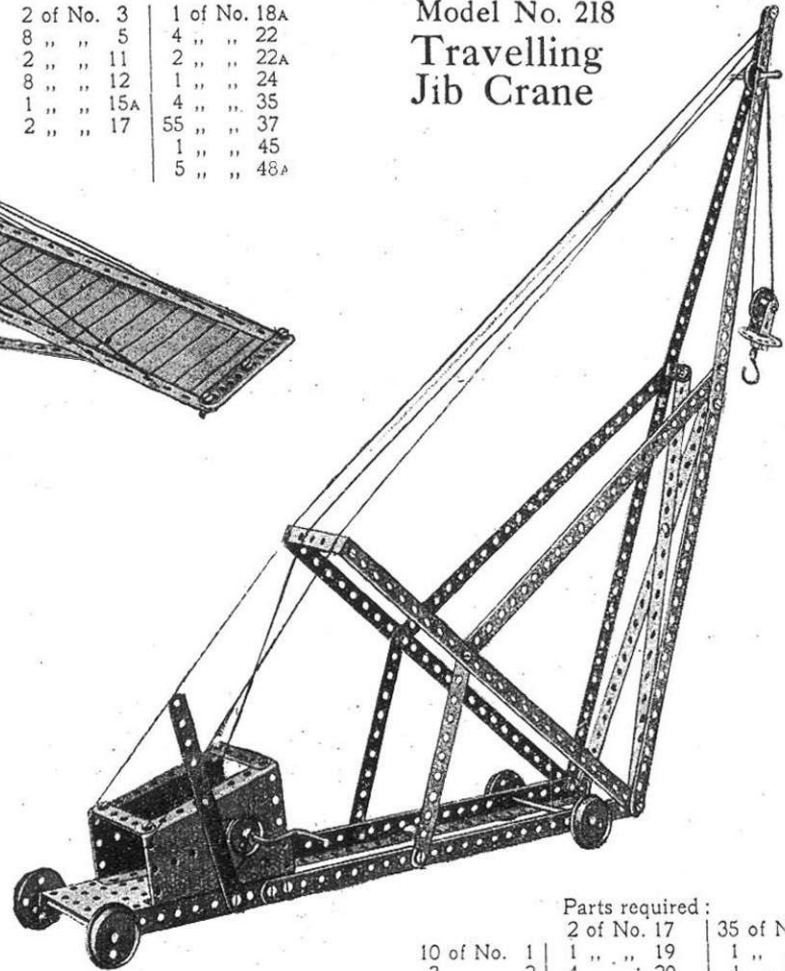

Parts required:	2 of No. 17	35 of No. 37
10 of No. 1	1 " " 19	1 " " 44
3 " " 2	4 " " 20	1 " " 48A
3 " " 5	2 " " 22	1 " " 52
2 " " 8	1 " " 22A	2 " " 54
4 " " 12	1 " " 24	1 " " 57
2 " " 16	5 " " 35	

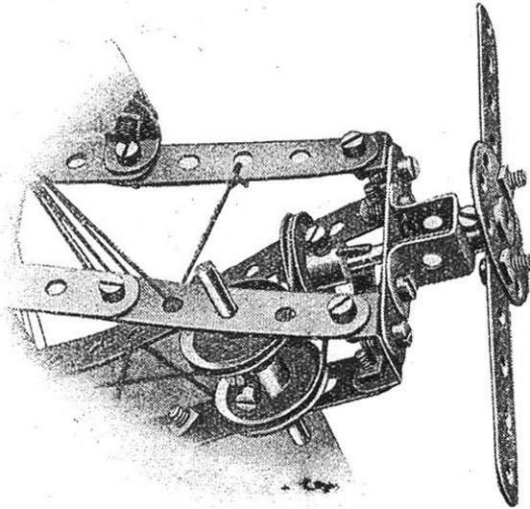
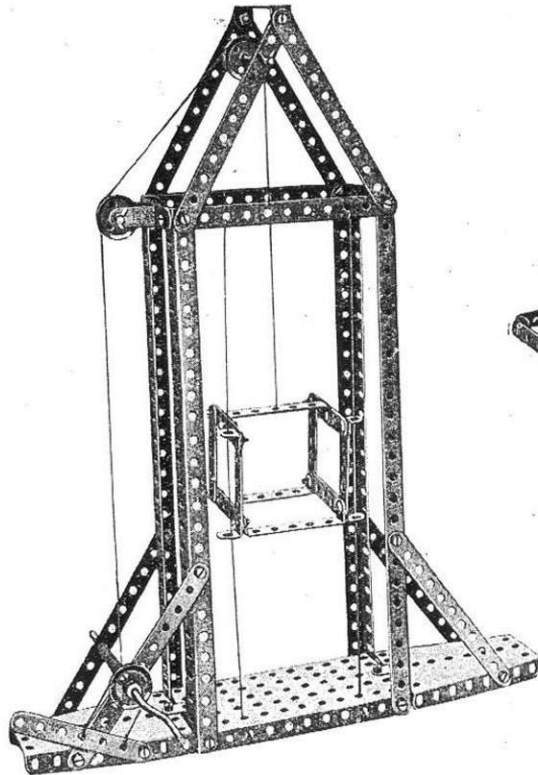

FIG. 217A

Model No. 219
Elevator



Parts required :		
10 of No. 2	1 of No. 16	38 of No. 37
1 " " 3	1 " " 18A	1 " " 44
10 " " 5	1 " " 19	4 " " 48A
4 " " 8	1 " " 22	1 " " 52
2 " " 10	2 " " 22A	1 " " 52
4 " " 12	5 " " 35	2 " " 54

Model No. 220
Mat Frame

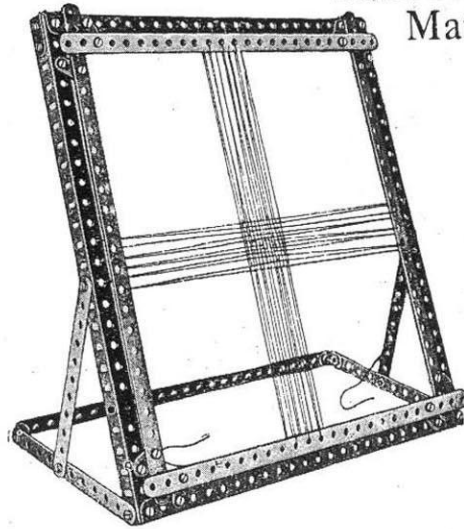

Parts required :

5 of No. 1	
4 " " 2	
4 " " 8	
8 " " 10	
2 " " 12	
2 " " 12A	
36 " " 37	

Model No. 221
Windmill

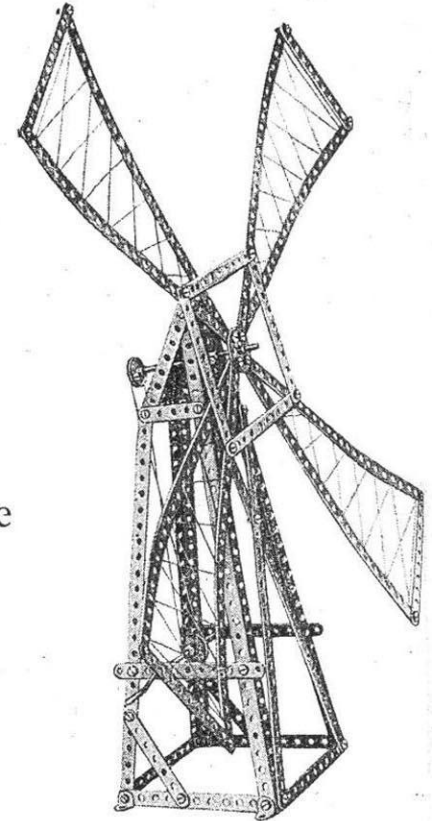

Parts required :

10 of No. 1	4 of No. 8	1 of No. 24
14 " " 2	4 " " 12	4 " " 35
2 " " 3	1 " " 15	45 " " 37
2 " " 5	1 " " 19	2 " " 54
	2 " " 22	

Model No. 222 High level
Bridge

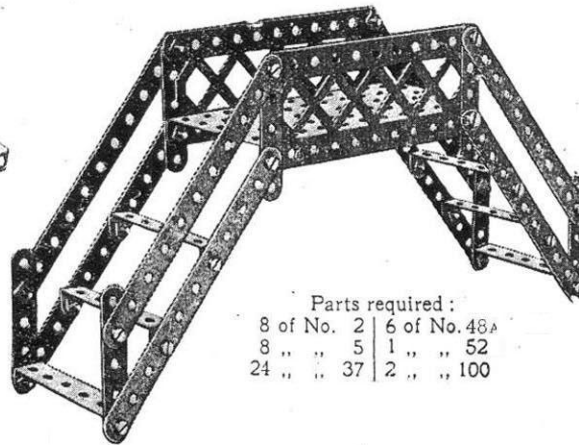

Parts required :

8 of No. 2	6 of No. 48A
8 " " 5	1 " " 52
24 " " 37	2 " " 100

Model No. 223--Coal Sifter

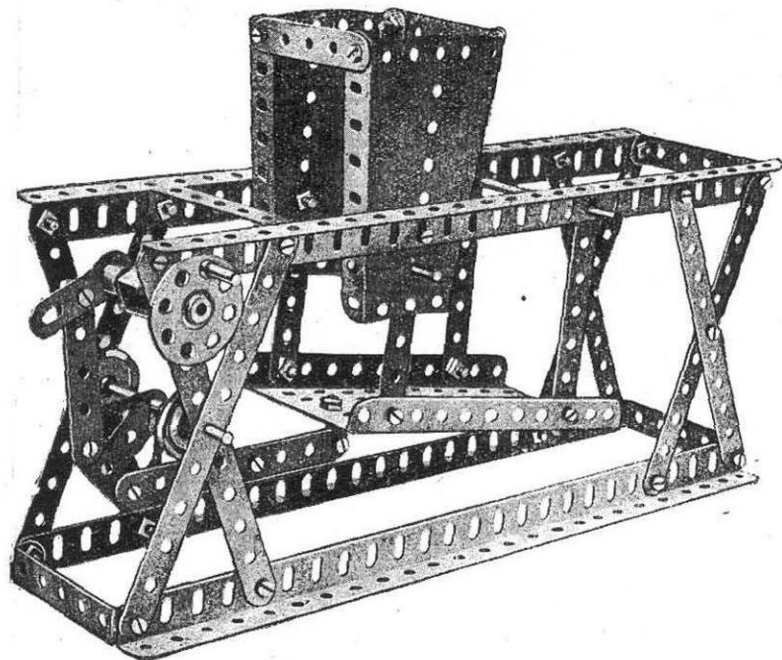

Parts
required :

8 of No.	2
2 " "	3
7 " "	5
4 " "	8
1 " "	12
3 " "	16
1 " "	17
2 " "	22
1 " "	24
6 " "	35
38 " "	37
1 " "	45
4 " "	48A
1 " "	52
2 " "	54
1 " "	62
1 " "	115
1 " "	126A

Model No. 224 Try-your-strength Machine

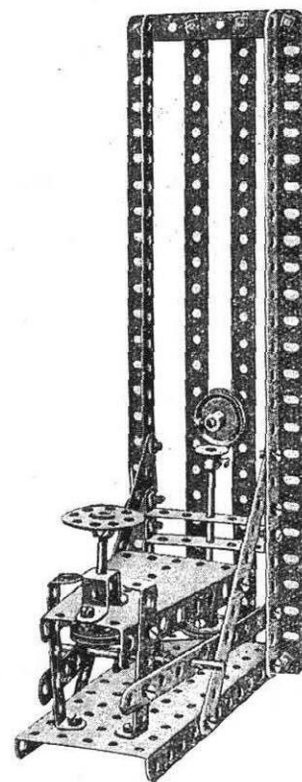

Parts required :

2 of No.	1	1 of No.	17	12 of No.	38
5 " "	2	1 " "	18A	1 " "	45
2 " "	3	4 " "	22	4 " "	48A
2 " "	8	1 " "	24	1 " "	52
1 " "	11	4 " "	35	1 " "	54
2 " "	16	30 " "	37	1 " "	126A

Model No. 225--Locomotive

Parts required :

4 of No.	2	1 of No.	24
2 " "	3	2 " "	35
6 " "	5	47 " "	37
3 " "	10	1 " "	45
7 " "	12	6 " "	48A
3 " "	16	1 " "	52
1 " "	17	1 " "	54
4 " "	20	1 " "	62
4 " "	22	2 " "	125
1 " "	23	2 " "	126A

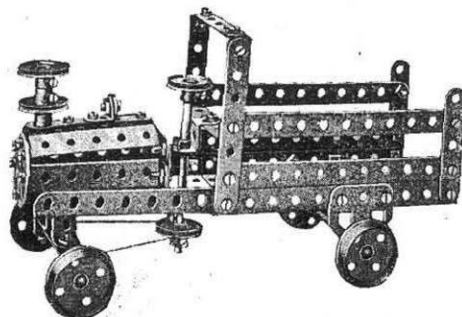

Model No. 226
Candy Puller

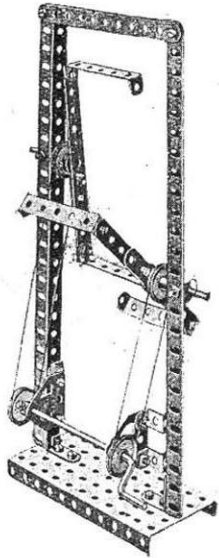

Parts required:

3 of No.	2
2 " "	8
2 " "	12
2 " "	12A
2 " "	17
1 " "	19
4 " "	22
2 " "	35
26 " "	37
10 " "	38
4 " "	48A
1 " "	52
2 " "	62
4 " "	125
2 " "	126

Model No. 227—Carrier Tricycle

Parts required:

2 of No.	2
3 " "	5
1 " "	11
2 " "	12
1 " "	16
1 " "	17
1 " "	18A
3 " "	22
1 " "	24
2 " "	35
15 " "	37
5 " "	48A
1 " "	52

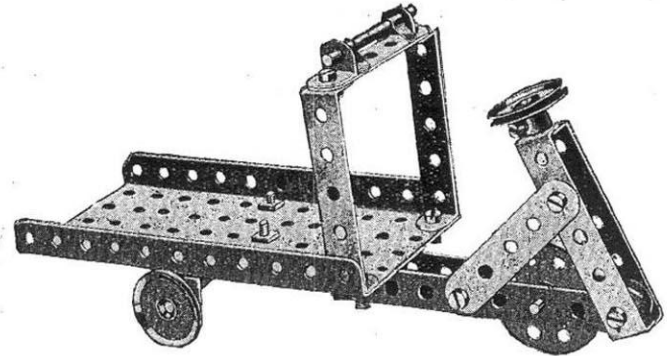

Model No. 229
Baby Chair

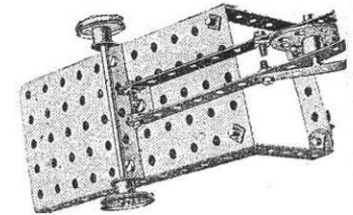
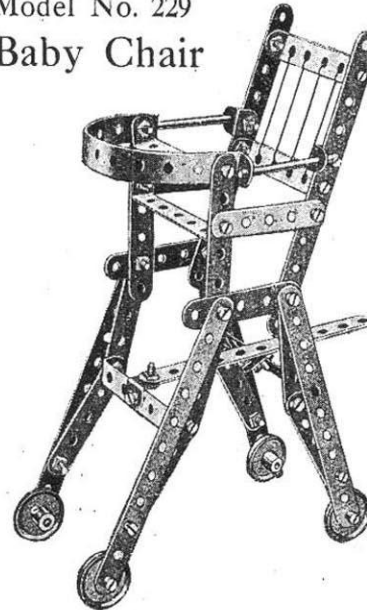

FIG. 227A

Carrier Tricycle, underneath view

Parts required:

8 of No.	2
2 " "	3
12 " "	5
6 " "	12
2 " "	17
4 " "	22
31 " "	37
6 " "	48A

Model No. 228
Hay Tedder

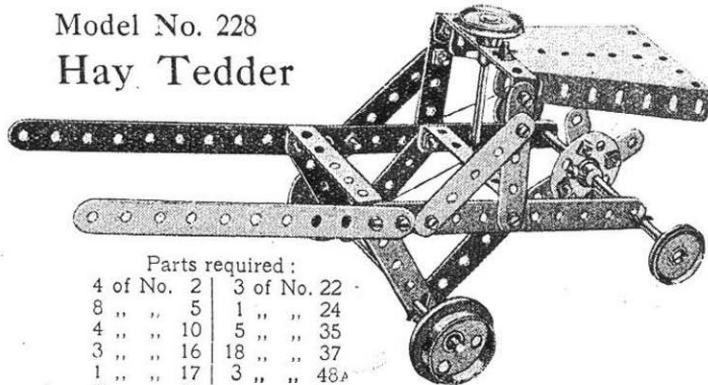

Parts required:

4 of No.	2	3 of No.	22
8 " "	5	1 " "	24
4 " "	10	5 " "	35
3 " "	16	18 " "	37
1 " "	17	3 " "	48A
2 " "	20	1 " "	54

Model No. 230—Motor Van

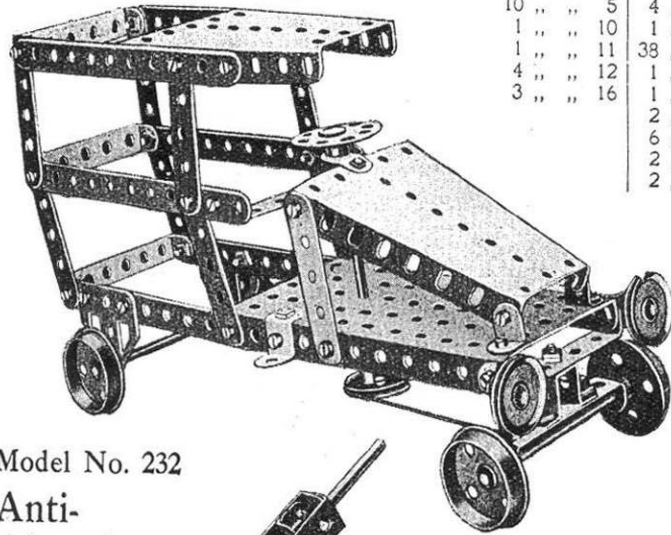

Parts required:

6 of No. 2	4 of No. 20
10 " " 5	4 " " 22
1 " " 10	1 " " 24
1 " " 11	38 " " 37
4 " " 12	1 " " 44
3 " " 16	1 " " 52
	2 " " 54
	6 " " 48A
	2 " " 125
	2 " " 126A

Model 231
Stamping Mill

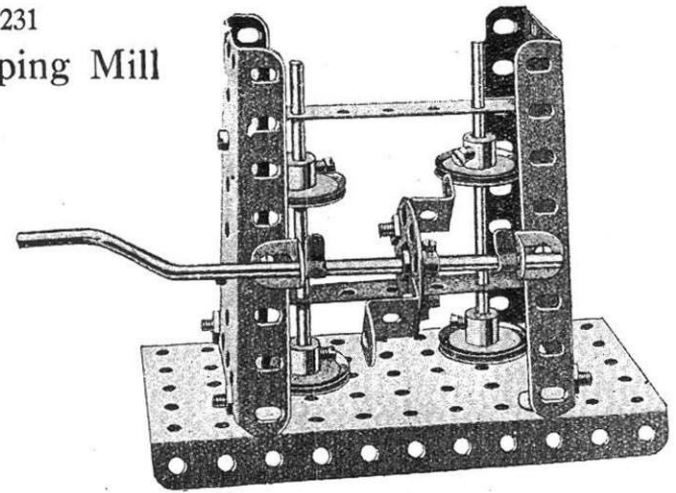

Parts required:

2 of No. 3	4 of No. 22	1 of No. 52
10 " " 12	1 " " 24	2 " " 54
2 " " 16	2 " " 35	2 " " 125
1 " " 19	16 " " 37	

Model No. 232
Anti-Aircraft
Gun

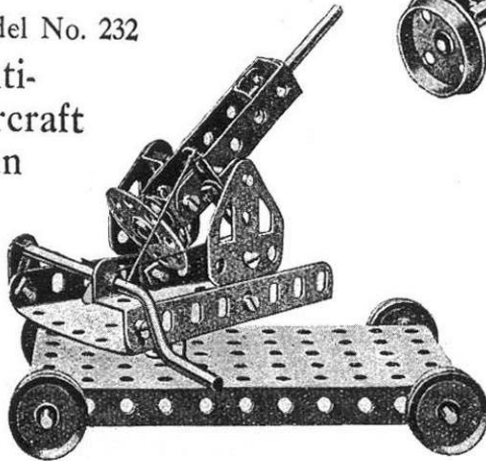

Parts required:

5 of No. 10	4 of No. 22	1 of No. 52
2 " " 11	1 " " 24	1 " " 54
2 " " 16	4 " " 35	4 " " 125
2 " " 17	12 " " 37	2 " " 126A
1 " " 19	2 " " 48A	

Model No. 233
Smoothing Iron

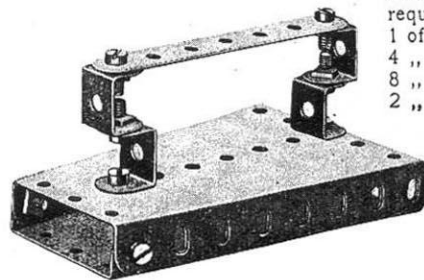

Parts required:

1 of No. 3
4 " " 11
8 " " 37
2 " " 54

Model No. 234
Coaster

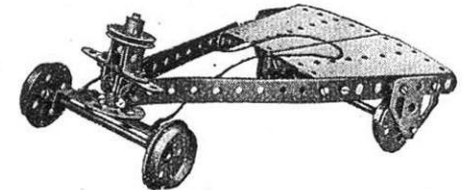

Parts required:

2 of No. 2	1 of No. 17	6 of No. 38
1 " " 5	4 " " 20	1 " " 45
2 " " 12	1 " " 22	1 " " 48A
1 " " 15	1 " " 24	2 " " 54
1 " " 16	16 " " 37	2 " " 126A

These Models can be made with MECCANO Outfit No. 2, or No. 1 and No. 1A

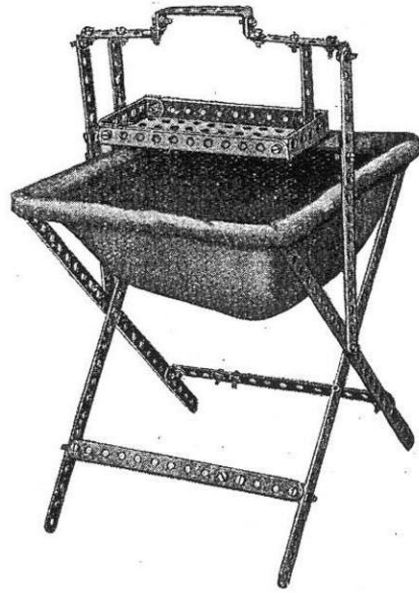

Model No. 235
Needlework
Basket

Parts required:

6 of No.	1
6 " "	2
2 " "	3
6 " "	5
12 " "	12
46 " "	37
3 " "	48 ^A
1 " "	52

Model No. 236 -Sifter

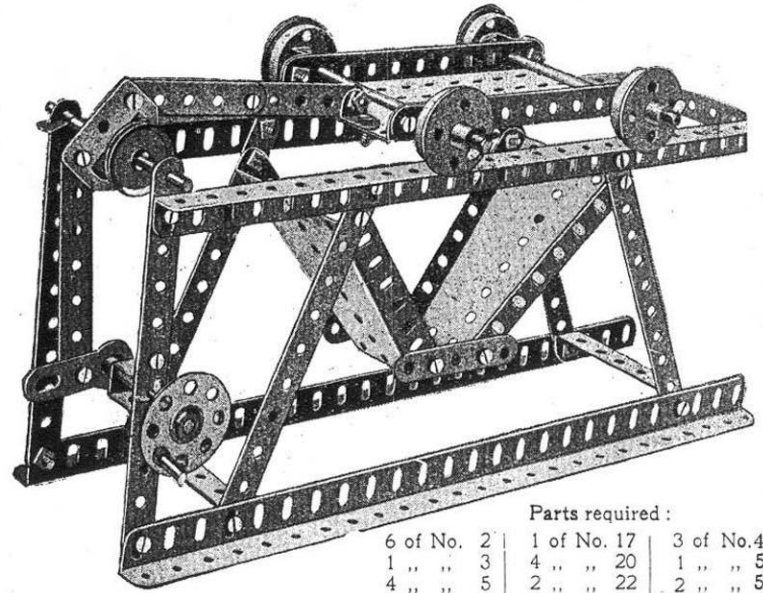

Parts required:

6 of No.	2	1 of No.	17	3 of No.	48 ^A
1 " "	3	4 " "	20	1 " "	52
4 " "	5	2 " "	22	2 " "	54
4 " "	8	1 " "	24	1 " "	62
1 " "	12	7 " "	35	1 " "	115
2 " "	15	34 " "	37	4 " "	125
1 " "	16	1 " "	45	1 " "	126 ^A

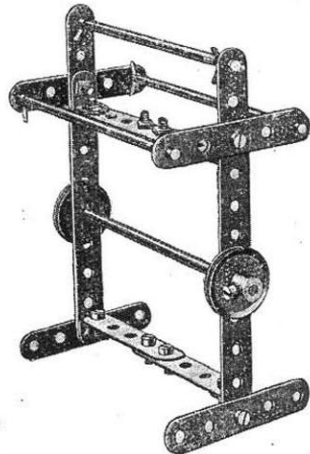

Model No. 237
Towel Rail

Parts required:

2 of No.	2
8 " "	5
4 " "	12
1 " "	15
4 " "	16
2 " "	22
6 " "	35
12 " "	37

Model No. 238—Spinning Top

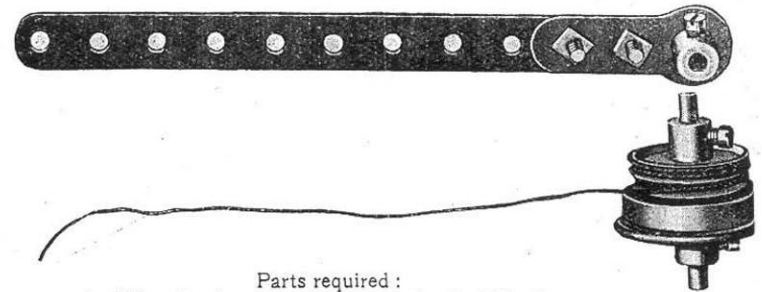

1 of No.	2	Parts required:	1 of No.	20	2 of No.	37
1 " "	17		2 " "	22	1 " "	62

Model No. 239—Seashore Aeroplane

Model No. 240—

Model No. 241—Dinner Gong

Embossing Machine

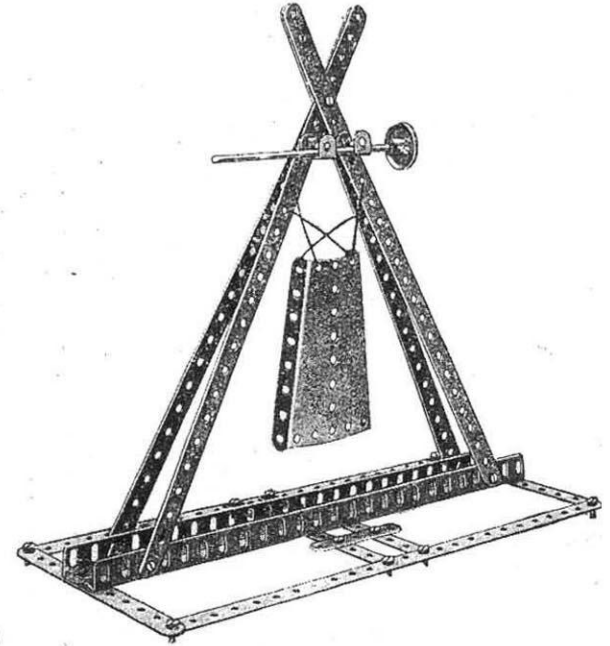
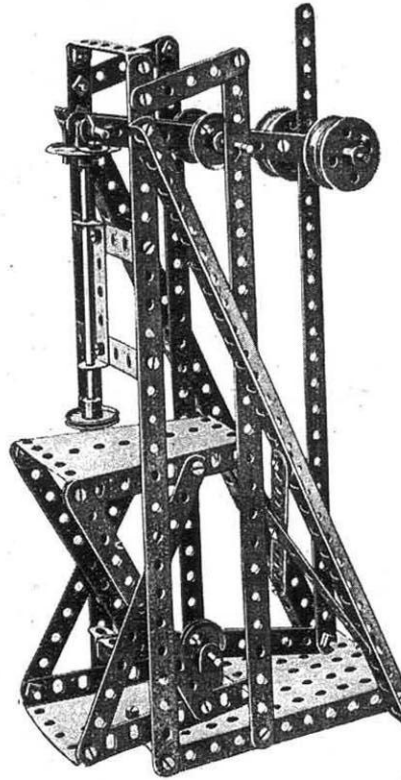
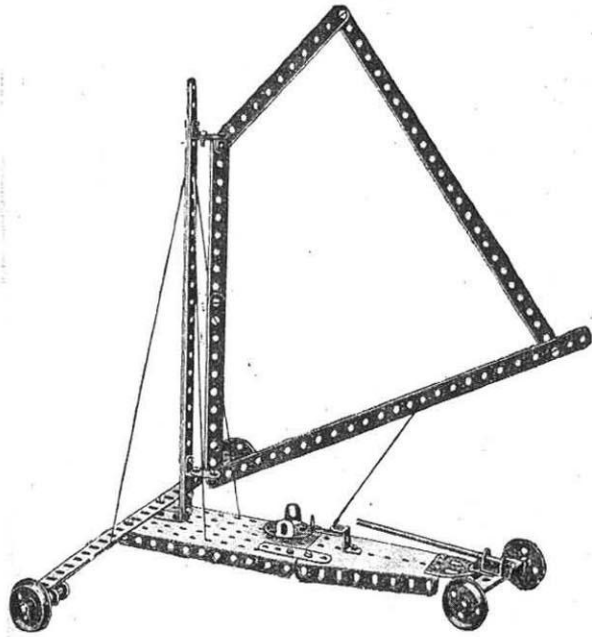

Parts required :

4 of No. 1	1 of No. 12A	33 of No. 37
3 " " 2	1 " " 15	1 " " 38
2 " " 5	1 " " 16	1 " " 48A
1 " " 8	2 " " 17	1 " " 52
3 " " 10	4 " " 20	1 " " 54
3 " " 11	1 " " 24	1 " " 125
7 " " 12	6 " " 35	1 " " 126A

Parts required :

5 of No. 1	2 of No. 16	44 of No. 37
9 " " 2	1 " " 17	1 " " 44
2 " " 5	1 " " 18A	4 " " 48A
2 " " 8	4 " " 20	1 " " 52
2 " " 11	4 " " 22	2 " " 54
4 " " 12	1 " " 24	
1 " " 15	4 " " 35	

Parts required :

6 of No. 1	1 of No. 15
4 " " 2	1 " " 22
2 " " 5	27 " " 37
2 " " 8	1 " " 54
2 " " 11	

Model No. 242
Dwarf
Derrick

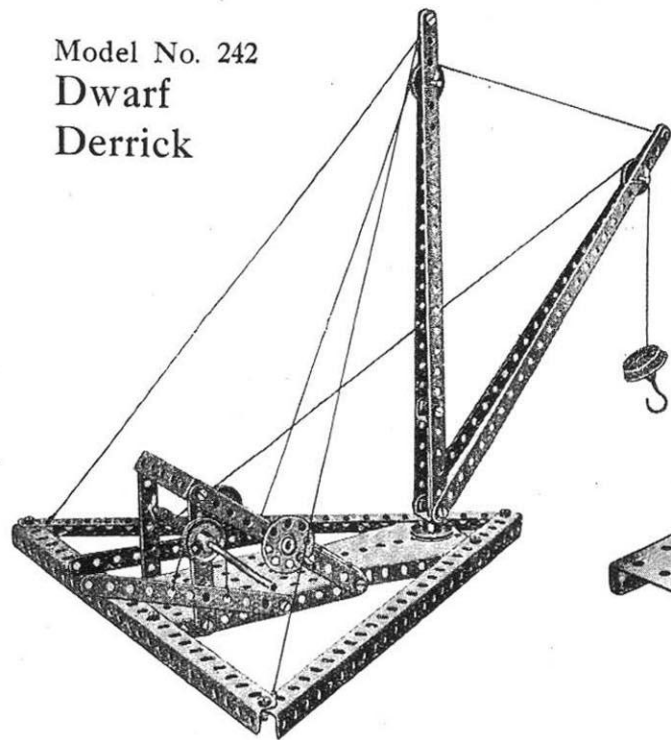

Parts required :

4 of No. 1	2 of No. 22A
4 " " 2	1 " " 24
2 " " 3	6 " " 35
3 " " 8	23 " " 37
2 " " 11	4 " " 38
2 " " 16	1 " " 48A
2 " " 18A	1 " " 52
1 " " 19	1 " " 54
1 " " 20	1 " " 57
4 " " 22	1 " " 115

Model No. 243
Mechanical
Hammer

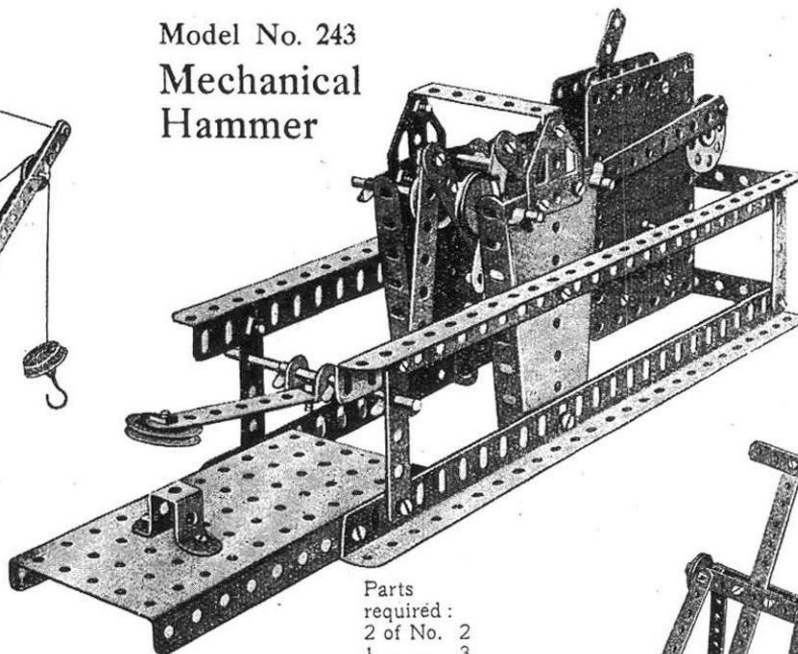

Parts required :

2 of No. 2	
1 " " 3	
6 " " 5	
4 " " 8	
1 " " 11	
1 " " 12	
3 " " 16	
4 " " 22	
1 " " 22A	
1 " " 24	
8 " " 35	
32 " " 37	
1 " " 45	
3 " " 48A	
1 " " 52	
2 " " 54	
2 " " 126A	

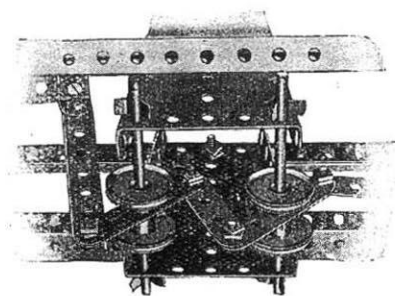

Clockwork Motor.

Model No. 244
Easel

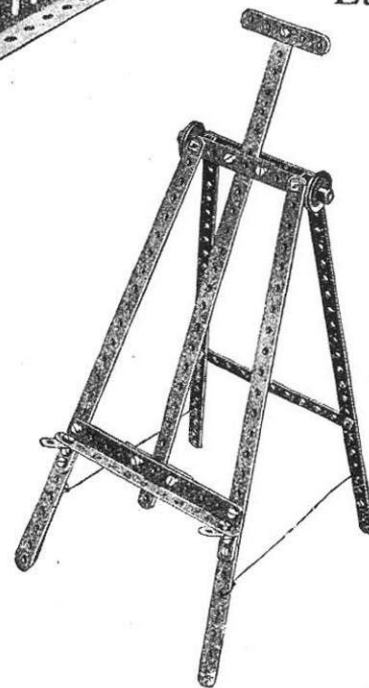

Parts required :

5 of No. 1	
3 " " 2	
2 " " 3	
3 " " 5	
4 " " 12	
2 " " 12	
1 " " 15	
2 " " 22	
19 " " 37	
4 " " 38	

FIG. 243A.

Model No. 245 Extending Ladder on Running Carriage

Parts
required:

2	of No.	1
8	" "	2
1	" "	3
7	" "	5
4	" "	8
5	" "	12
4	" "	16
1	" "	18A
1	" "	19
4	" "	20
4	" "	22
1	" "	22A
1	" "	24
6	" "	35
47	" "	37
2	" "	38
1	" "	44
1	" "	45
7	" "	48A
1	" "	52
2	" "	54
1	" "	115
2	" "	125
2	" "	126A

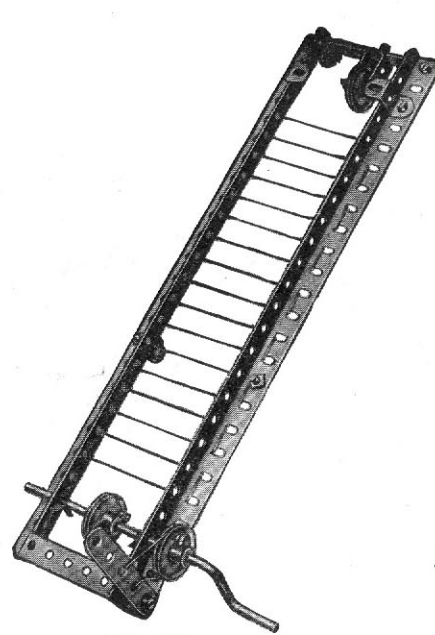
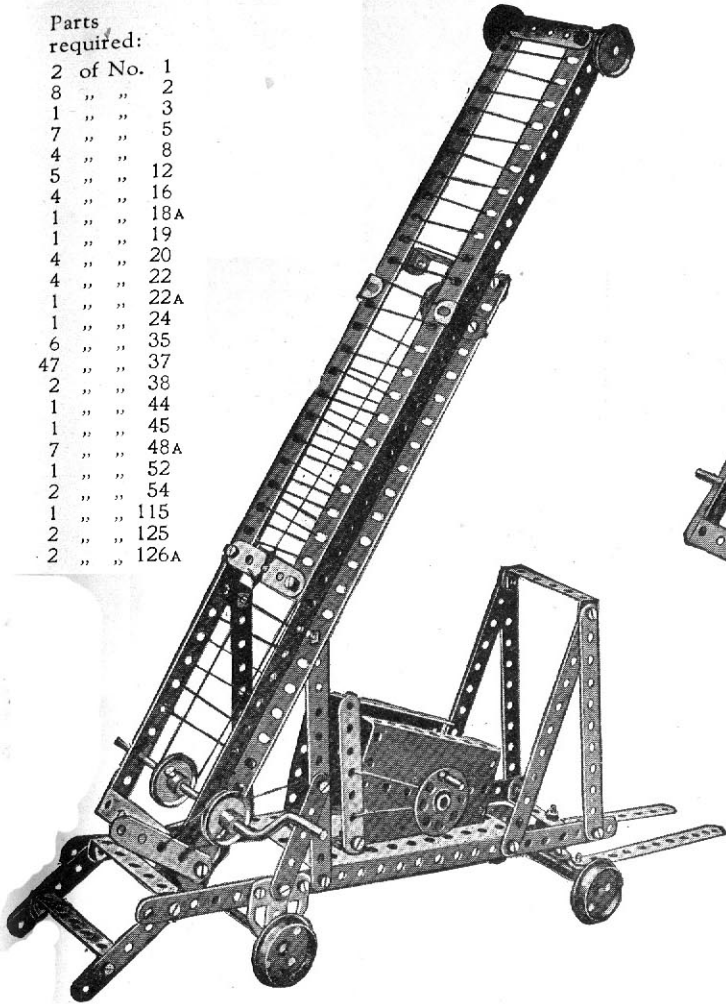

FIG. 245A

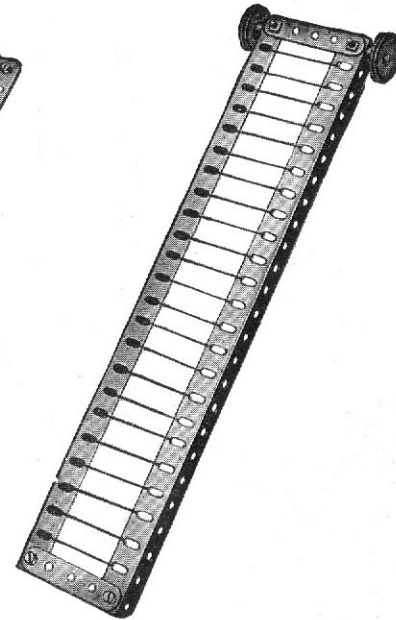
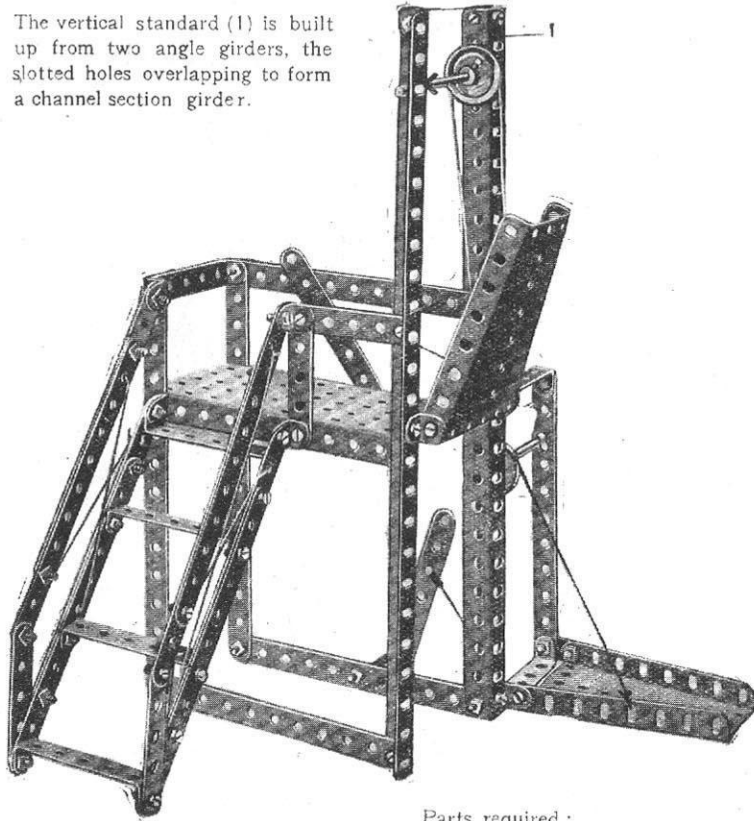

FIG. 245B

The bed of the lower carriage framework is formed by bolting two 12½" strips to the sides of a large flanged plate, and two sector plates bolted to the flanged plate by their flanges to form the sides, and a bearing for the spindle carrying the operating cord attached to the bottom of the ladder to raise it from a horizontal position; and the strips 1 form a support for the ladder when in this horizontal position. Angle brackets 2, Fig. 245A, form pivots for the lower part of the ladder, and are carried from the supports 3. The upper part of the ladder, Fig. 245, is slideably guided and retained on the lower ladder by reversed brackets 4. The extension of the ladder is effected by the cranked spindle round a pulley on which (and another pulley at the top of the framework) the cord is passed, the ends being secured to the lower part of the slideable ladder.

Model No. 246 Ferry Gangway

The vertical standard (1) is built up from two angle girders, the slotted holes overlapping to form a channel section girder.



Parts required :

14 of No. 2	6 of No. 12	1 of No. 45
2 " " 3	2 " " 16	8 " " 48A
6 " " 5	2 " " 22	1 " " 52
3 " " 8	2 " " 35	2 " " 54
2 " " 10	54 " " 37	

Model No. 247 The Acrobat

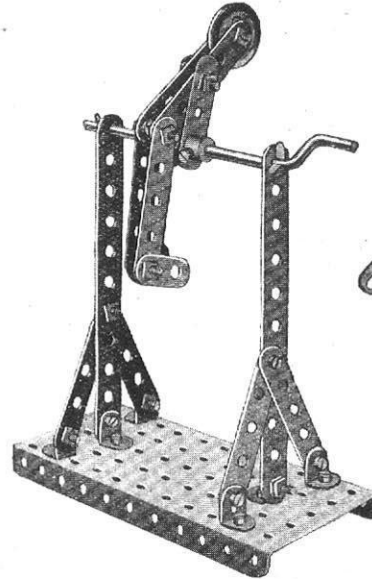

Parts required

2 of No. 2	1 of No. 22A
8 " " 5	2 " " 35
2 " " 10	21 " " 37
6 " " 12	1 " " 52
1 " " 19	2 " " 62

Model No. 248 Jumping Jack

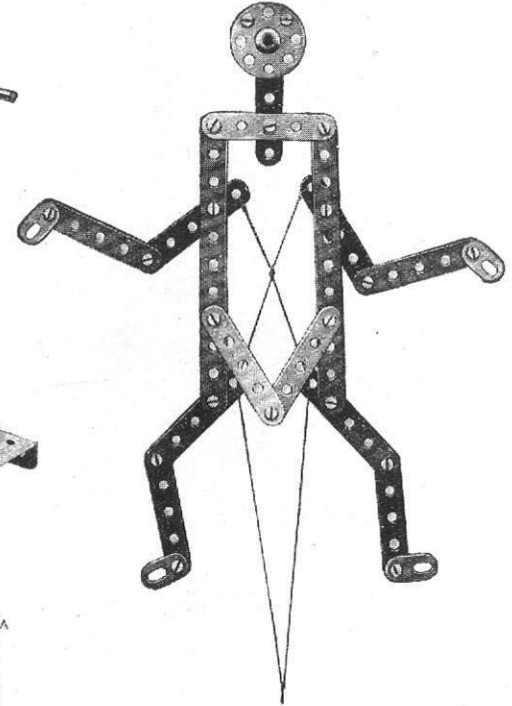

Parts
required :

2 of No. 2
12 " " 5
4 " " 10
1 " " 24
18 " " 37

Model No. 249 Turnstile

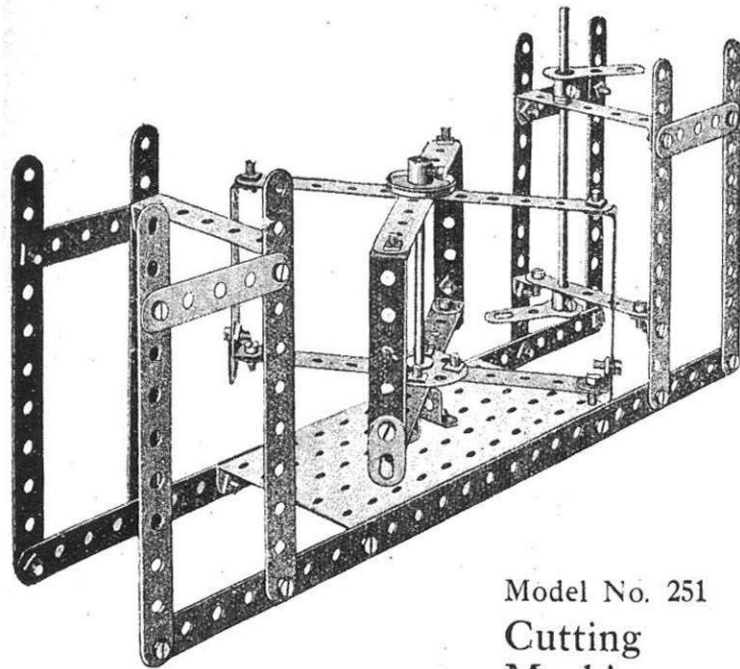

Parts required :

2 of No. 1	1 of No. 24
10 " " 2	42 " " 37
9 " " 5	2 " " 33
4 " " 10	1 " " 45
2 " " 12	6 " " 48A
1 " " 15	1 " " 52
1 " " 15A	2 " " 62
2 " " 22	

Model No. 251 Cutting Machine

Parts required :

7 of No. 2
1 " " 3
1 " " 5
4 " " 12
14 " " 37
1 " " 48A
1 " " 52

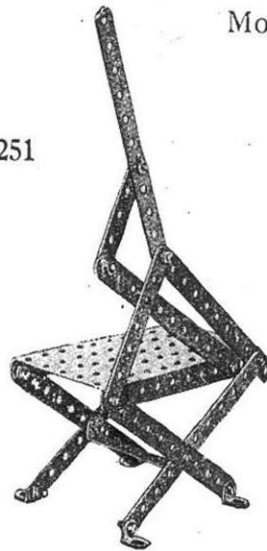

Model No. 250 Chair for Wounded

Parts required :

6 of No. 2
2 " " 3
10 " " 5
2 " " 11
2 " " 16
4 " " 22
21 " " 37
2 " " 48A
1 " " 52



Model No. 252

Magic Sector Plates

Parts required :

2 of No. 11
1 " " 17
2 " " 35
6 " " 37
2 " " 54



When the cord is held vertically the magic sector plates will fall or stop at the bidding of the owner. If the cord is held without tension the plates will fall, but the instant the cord is tightened they will stop dead. The cord is wrapped once around the rod which passes through the centre holes of the sector plates.

Model No. 253 Railway Foot Bridge and Signals

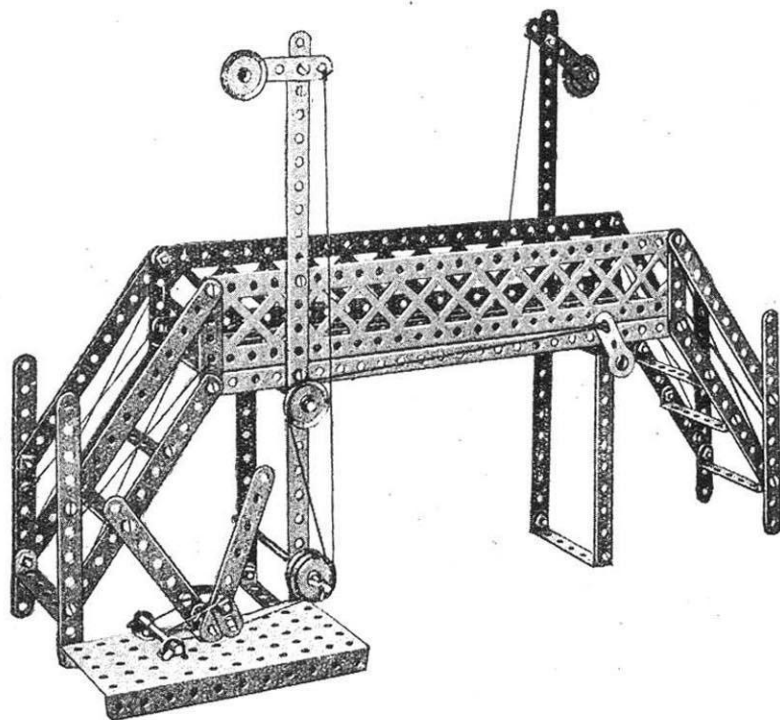

Parts required :

4 of No. 1	1 of No. 11	2 of No. 22A
14 " " 2	2 " " 12	6 " " 35
2 " " 3	1 " " 15A	50 " " 37
8 " " 5	2 " " 16	8 " " 48A
2 " " 8	1 " " 17	1 " " 52
2 " " 10	3 " " 22	1 " " 62

Model No. 254 Motor Van

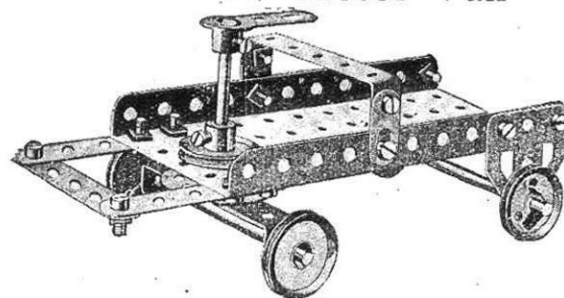

Parts required :

3 of No. 5	2 of No. 22A	2 of No. 48A
2 " " 10	1 " " 24	1 " " 52
2 " " 16	2 " " 35	1 " " 62
1 " " 17	16 " " 37	2 " " 126A
3 " " 22	2 " " 38	

Model No. 255 Gondola

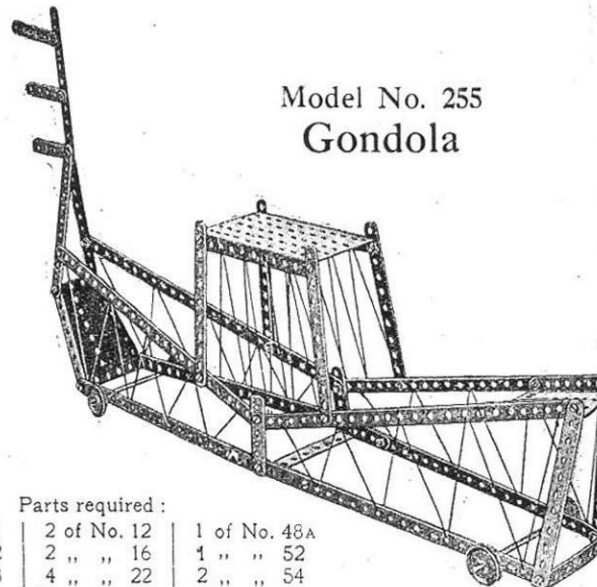

Parts required :

8 of No. 1	2 of No. 12	1 of No. 48A
9 " " 2	2 " " 16	1 " " 52
1 " " 3	4 " " 22	2 " " 54
5 " " 5	29 " " 37	

Model No. 256 Roundabout

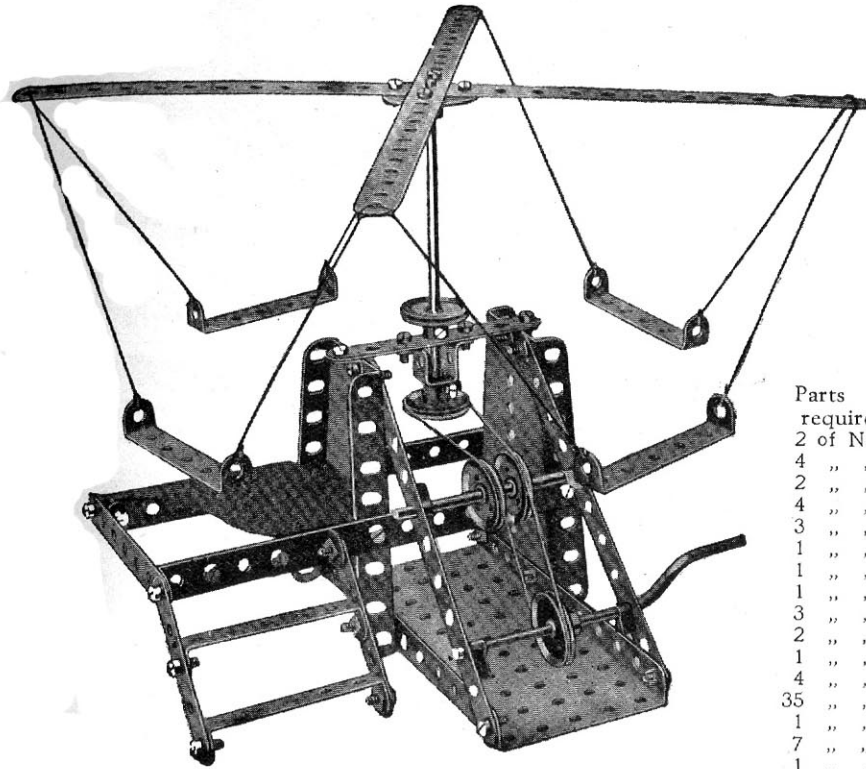

Parts required:

2	of No.	1
4	" "	2
2	" "	3
4	" "	5
3	" "	12
1	" "	15
1	" "	16
1	" "	19
3	" "	22
2	" "	22A
1	" "	24
4	" "	35
35	" "	37
1	" "	45
7	" "	48A
1	" "	52
2	" "	54

Model No. 257 Beam Scales



Parts required:

5	of No.	1	6	of No.	12	5	of No.	48A
6	" "	2	2	" "	17	1	" "	52
7	" "	5	2	" "	22A	2	" "	54
4	" "	8	6	" "	35	2	" "	126A
			48	" "	37			

HOW TO CONTINUE

This completes the Models which may be made with MECCANO Outfit No. 2. The next Models are a little more advanced, requiring a number of extra parts to construct them. The necessary parts are all contained in a No. 2A Accessory Outfit, the price of which will be found in the List at the end of the Manual.

Model No. 301 Rotating Crane

The lower horizontal ribs 1 and main vertical members 2 are made of angle girders overlapping nine holes, and the diagonal ties 3 of two 12½" strips and one 5½" strip, the 12½" strips being overlapped three holes and the lower 5½" strip seven holes. The pulley 4 is carried in a nosing made of two 5½" strips and two 12½" strips connected at their apex by a double bracket. The rear swivel point of the crane is made by bolting the gear box 5 to a double bent strip 6 secured to the floor. The crane runs on the flanged wheels 7 and is rotated by means of the worm 8 which engages a pinion 9 on the spindle of one of the flanged wheels and is rotated by the hand wheel 10.

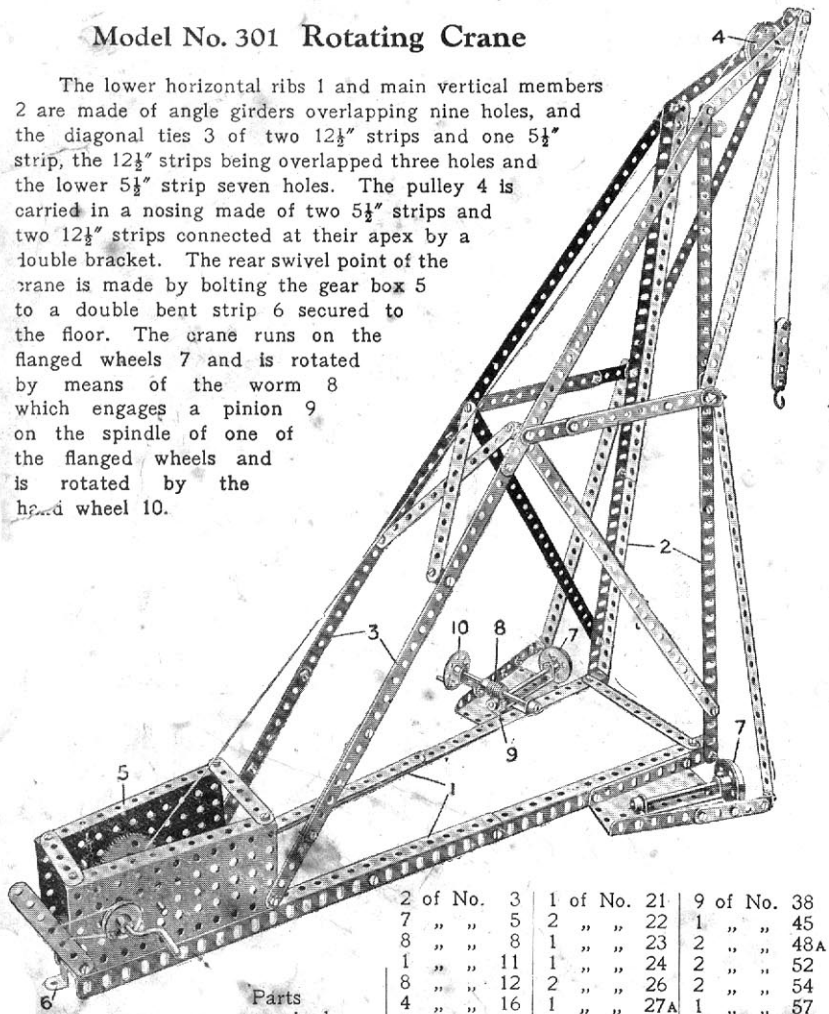

2 of No.	3	1 of No.	21	9 of No.	38
7 "	5	2 "	22	1 "	45
8 "	8	1 "	23	2 "	48A
1 "	11	1 "	24	2 "	52
8 "	12	2 "	26	2 "	54
4 "	16	1 "	27A	1 "	57
1 "	17	1 "	32	4 "	59
10 of No.	1	1 "	35	1 "	115
11 "	2	2 "	37	2 "	125

Model No. 302 Toboggan

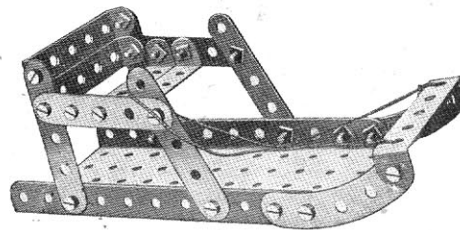

Parts required:	
6 of No.	5
20 "	37
5 "	48A
1 "	52
2 "	90

Model No. 303 Horse Sleigh

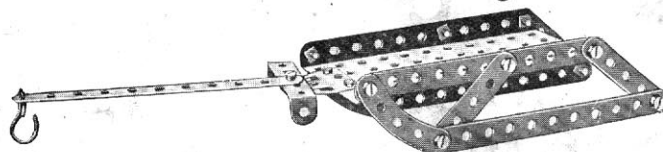

3 of No.	2	13 of No.	37	1 of No.	57
4 "	5	1 "	48A	2 "	90
1 "	23	1 "	52	1 "	126A

Model No. 304 Lathe

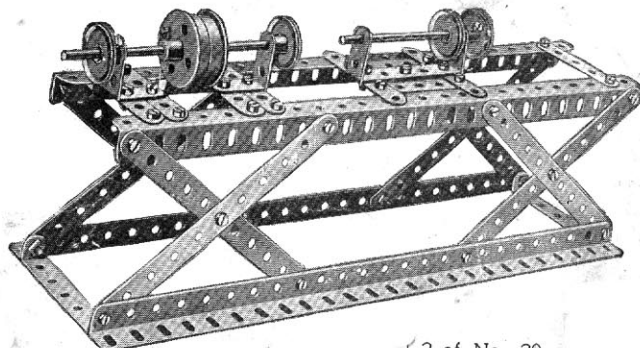

Parts required:	4 of No.	8	2 of No.	20
	2 "	12A	1 "	22
8 of No.	2	15A	41 "	37
10 "	5	16	1 "	46
			2 "	43A

Model No. 305 Tower Wagon

Parts
required :

6	of No.	1
2	" "	4
10	" "	5
8	" "	8
2	" "	12
2	" "	15A
4	" "	16
4	" "	20
1	" "	22A
1	" "	24
1	" "	26
1	" "	32
4	" "	35
72	" "	37
8	" "	38
10	" "	48A
2	" "	52
3	" "	59
1	" "	98
2	" "	100
1	" "	115
2	" "	126A

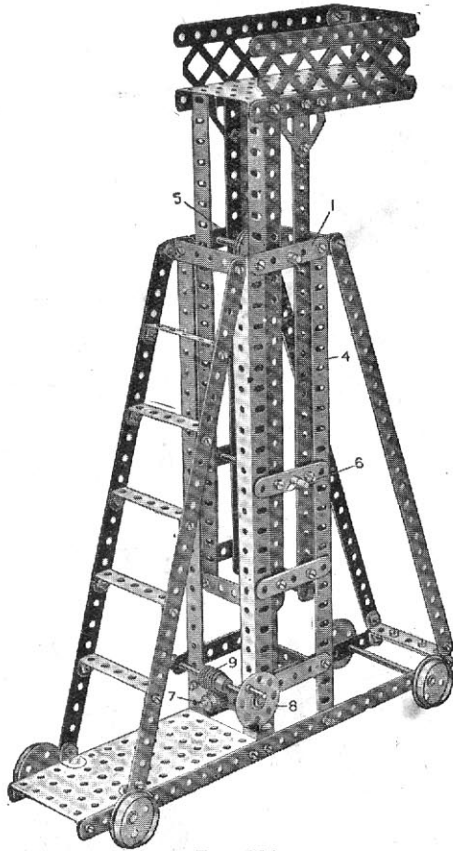

FIG. 305

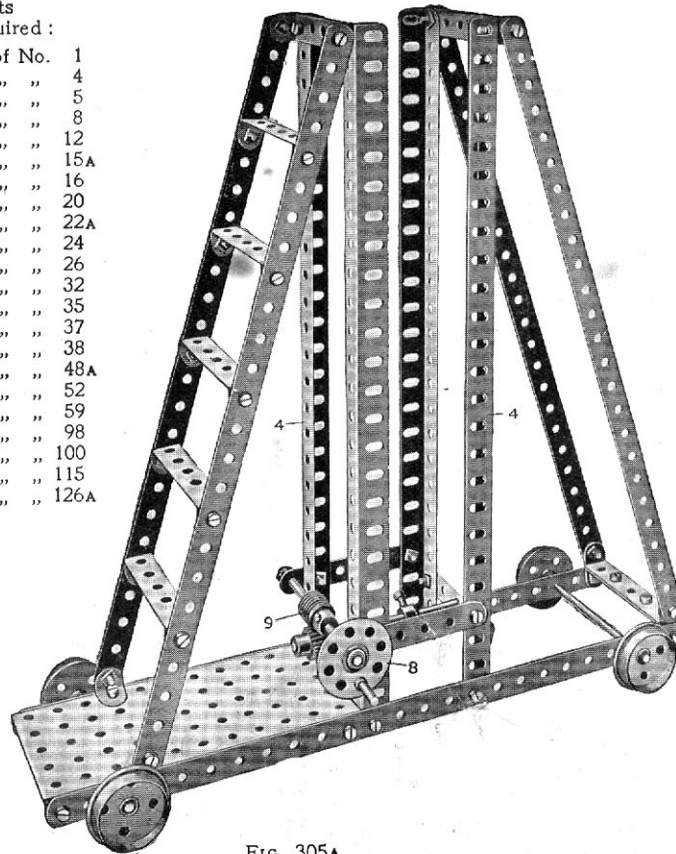

FIG. 305A

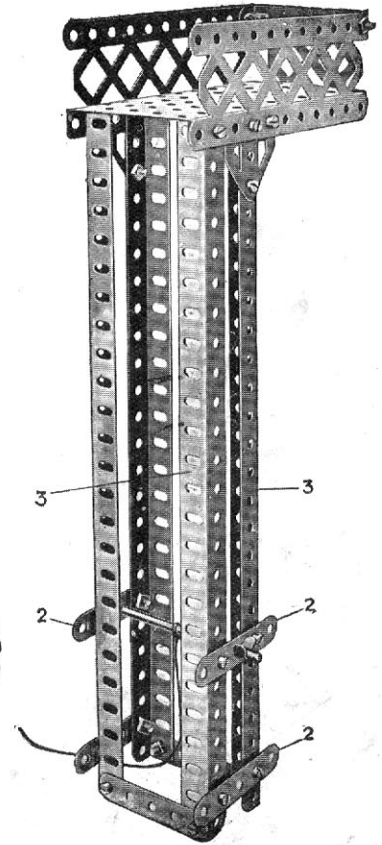
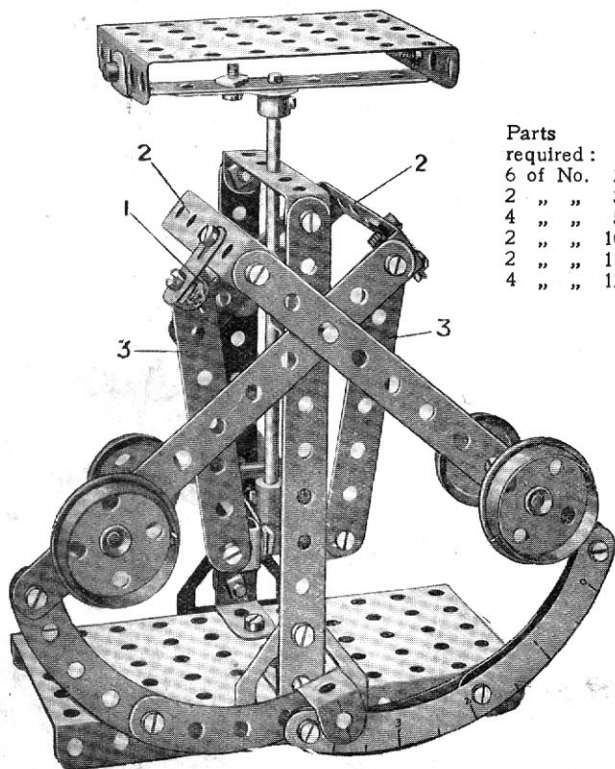

FIG. 305B

Begin the construction of this model by building up the platform. Fig. 305A, the tie strips 1 being left off as shown in order to be able to insert the rising and falling tower, Fig. 305B. The strips are then bolted on. The guide strips 2 are bolted to the girder 3 of the tower with washers beneath the strips. This gives the necessary clearance and enables the strips to rise easily up the faces of the girders 4 of the fixed lower part of the tower. The tower is raised by means of a cord which passes over a pulley 5 and is fastened to a rod 6, the other end of the cord winding on a rod 7 rotated by a hand wheel 8 on the spindle of the worm 9.

Model No. 306 Letter Balance



Parts
required:
6 of No. 2
2 " " 3
4 " " 5
2 " " 10
2 " " 11
4 " " 12

The connection at 1 of the rocking arms 2 to the thrust strips 3 is locknuttred to give a free pivotal action, and similarly the pivotal connections 5 of the strips 3 to the lever strips 4 are locknuttred to give free play.

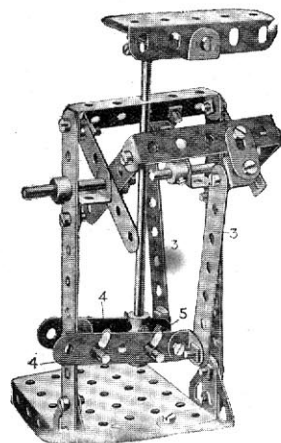
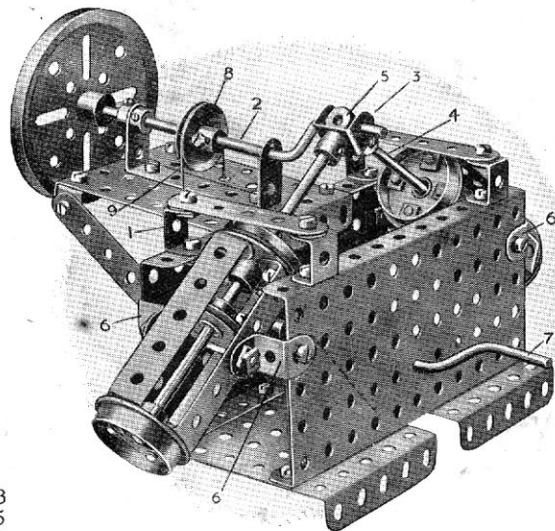

FIG. 306A

2 of No. 12A
1 " " 15
2 " " 17
2 " " 18A
2 " " 20
2 " " 22
4 " " 35
40 " " 37
6 " " 38
3 " " 48A
1 " " 48B
1 " " 52
1 " " 53
4 " " 59
1 " " 62
1 " " 63
4 " " 90
2 " " 126
2 " " 125A

Parts
required:
2 of No. 3
2 " " 5
4 " " 11
4 " " 12
2 " " 12A
2 " " 15
2 " " 19
1 " " 19B
4 " " 20
4 " " 22
3 " " 35
50 " " 37
6 " " 48A
2 " " 52
3 " " 53
2 " " 59
1 " " 63
1 " " 102
1 " " 116
4 " " 125

Model No. 307 Oscillating Steam Engine



The piston rod 1 of one cylinder is pivotally connected to the crank rod 2 by means of a fork piece 3, and the piston rod 4 of the other cylinder is pivoted to the crank rod by a coupling 5. The cylinders consisting of four strips are enclosed by flanged wheels at the ends, and are pivoted on $\frac{1}{2}$ " reversed brackets 6. The model is operated from the handle rod 7, a pulley on the rear end of which is coupled to the pulley 8 by a cord 9.

Model No. 308 Railway Wagon Swivel Crane

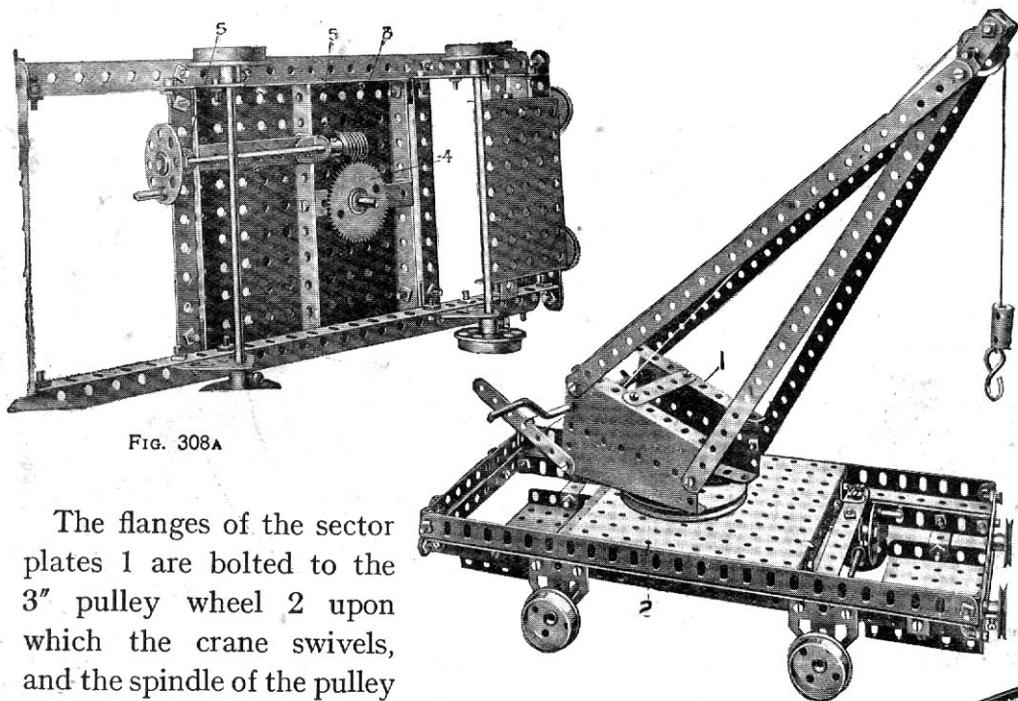

FIG. 308A

The flanges of the sector plates 1 are bolted to the 3" pulley wheel 2 upon which the crane swivels, and the spindle of the pulley wheel is rotated by the worm 3 engaging the gear wheel 4 on the spindle. In order to bring the worm centrally over the teeth of the gear wheel 4, washers are placed between the angle brackets 5 in which the spindle of the worm is journaled.

Parts required :

4 of No.	1	1 of No.	19	2 of No.	38
6 "	2	1 "	19B	2 "	48A
1 "	3	4 "	20	2 "	52
2 "	5	4 "	22	2 "	53
4 "	8	1 "	22A	2 "	54
1 "	11	1 "	24	1 "	57
14 "	12	1 "	27A	3 "	59
2 "	15	1 "	32	1 "	63
1 "	15A	3 "	35	1 "	115
2 "	17	70 "	37	4 "	125
				4 "	126A

Model No. 309 Crossbow

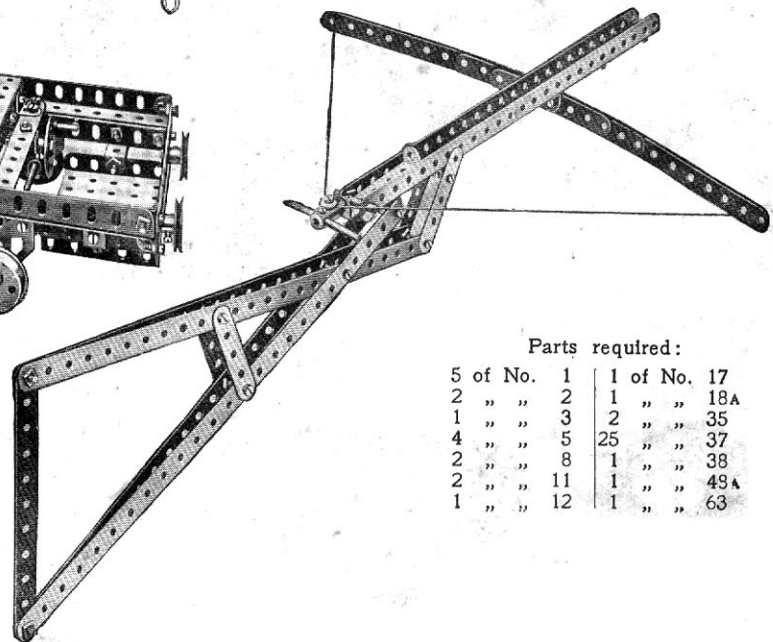

Parts required :

5 of No.	1	1 of No.	17
2 "	2	1 "	18A
1 "	3	2 "	35
4 "	5	25 "	37
2 "	8	1 "	38
2 "	11	1 "	49A
1 "	12	1 "	63

Model No. 310 Kinetograph

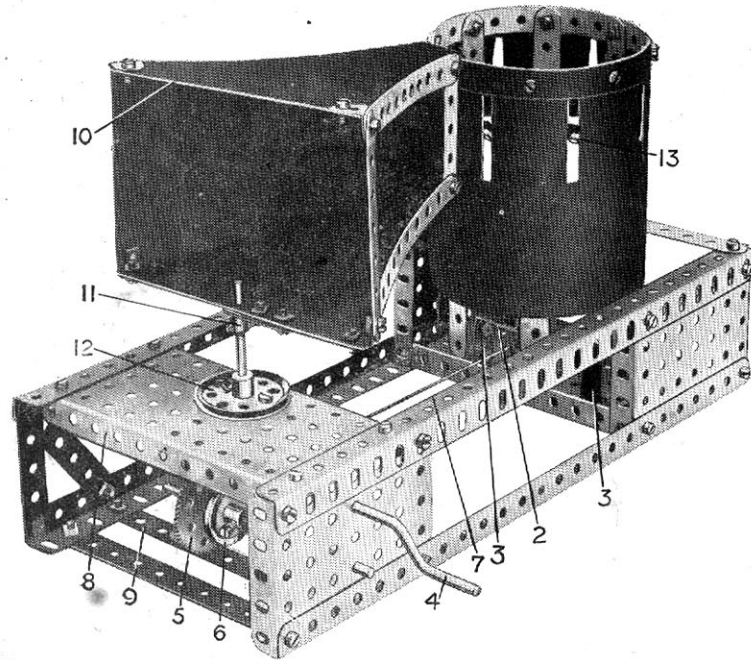

Most Meccano boys are probably aware of the principles of the Kinetograph, but for the benefit of those who have not seen one in action, we may mention that it is a device which imparts an appearance of animation to a series of pictures, each differing slightly from the other and passed in rapid succession before the eyes. In this respect it resembles the remarkable principle upon which the modern cinematograph is based.

In constructing the Meccano model the following details will prove useful:—The drum consists of a $12\frac{1}{2}$ " strip bent to form a circle, with its ends overlapping one hole, and bolted to eight vertical $5\frac{1}{2}$ " strips forming the sides. Two pairs of opposite $5\frac{1}{2}$ " strips are connected by $3\frac{1}{2}$ " strips and angle brackets bolted in the third holes from their lower ends. The $3\frac{1}{2}$ " strips cross at right angles to one another and are bolted in the centre to a bush wheel, in the boss of which is secured a short rod forming the pivot of the revolving drum. This rod is journalled in a double bent strip bolted to a $2\frac{1}{2}$ " \times 1 " double angle strip 2. This, in turn, is secured to the base of the model by two 1 " \times 1 " angle brackets 3. A further bearing for the short rod consists of a crank bolted in the base of the model.

The drum is rotated from the crank handle 4, on which is mounted a $\frac{1}{2}$ " pinion engaging a 57-teeth gear wheel 5 secured to a $3\frac{1}{2}$ " rod carrying a pulley wheel 6. The latter is connected by means of a cord 7 to a similar wheel nipped to the vertical spindle of the drum. Bearings are provided for the inner ends of the crank handle and $3\frac{1}{2}$ " rod by a double angle strip bolted between the plate 8 and $5\frac{1}{2}$ " strip 9. The sighting box 10 is built up from a framework of strips and is secured by means of a crank 11 to a short vertical rod rigidly mounted in the boss of the $1\frac{1}{2}$ " pulley 12. The four sides of the framework 10 are covered with some black material; stiff black paper suitable for this purpose may be obtained from any stationers. The drum is enclosed in the same way, but the covering paper should be cut in a strip measuring $12\frac{1}{2}$ " \times $4\frac{1}{2}$ " and pierced with slots spaced $1\frac{1}{2}$ " apart (from centre to centre) so that they fall exactly between the upright $5\frac{1}{2}$ " strips. The slots should measure $1\frac{1}{2}$ " \times $\frac{1}{8}$ ".

The type of drawing suitable for use in this model is shown in Fig. 310a, and the dimensions indicated therein should be followed carefully. No doubt Meccano boys will be able to devise numerous amusing pictures of a similar kind for themselves. The strip of stout white paper carrying the sketches is inserted in the bottom of the drum, as indicated at 13. The model is now ready for operation. Placing the frame 10 over the eyes, the line of vision is directed through the narrow end, where the strips are held apart by means of double brackets, and through the slots in the drum. The latter should be rotated rapidly by operating the handle 4, and as it revolves, the little dog shown in Fig. 310a will be seen jumping over the fence with a most realistic and amusing action.

Parts required:			
1 of No. 1	1 of No. 15A	12 of No. 38	
17 " " 2	2 " " 16	1 " " 45	
6 " " 3	1 " " 19	1 " " 46	
1 " " 4	1 " " 21	1 " " 48A	
3 " " 5	2 " " 22	2 " " 52	
4 " " 8	1 " " 24	3 " " 53	
2 " " 11	1 " " 26	4 " " 59	
12 " " 12	1 " " 27A	2 " " 62	
2 " " 12A	82 " " 37		

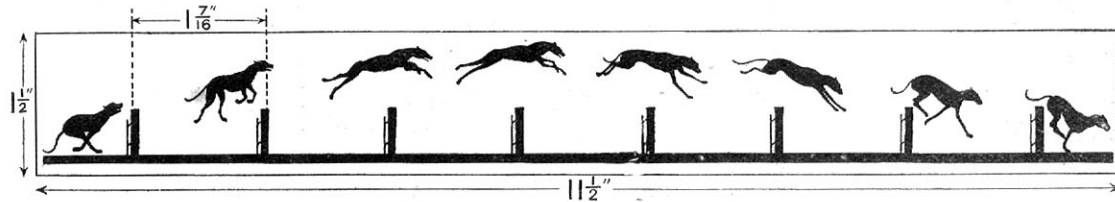
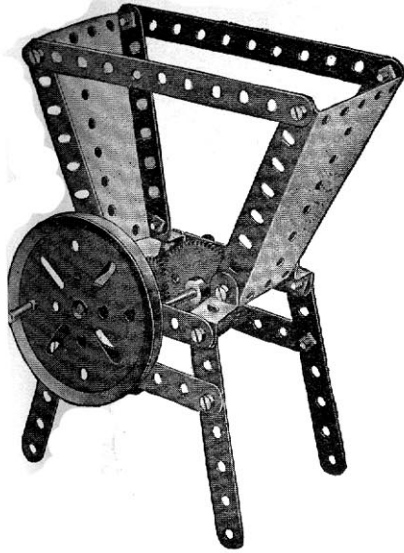

FIG. 310A

Model No. 311 Coffee Grinder



Parts required:

2	of No.	2
6	" "	3
2	" "	4
2	" "	16
1	" "	19B
1	" "	26
1	" "	27A
16	" "	37
2	" "	54
3	" "	59
1	" "	115
4	" "	125

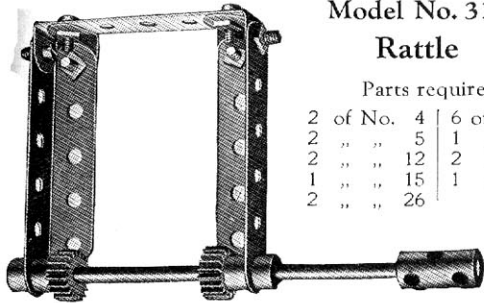

Model No. 313 Rattle

Parts required:

2	of No.	4	6	of No.	37
2	" "	5	1	" "	48A
2	" "	12	2	" "	59
1	" "	15	1	" "	63
2	" "	26			

Model No. 312 Demonstration Scales

Parts required:

3	of No.	1
4	" "	2
6	" "	3
1	" "	4
2	" "	5
8	" "	8
4	" "	11
6	" "	12
2	" "	12A
2	" "	17
1	" "	18A
1	" "	22
2	" "	35
58	" "	37
1	" "	44
2	" "	52
2	" "	53
2	" "	59
2	" "	62
4	" "	90
1	" "	125
3	" "	126A

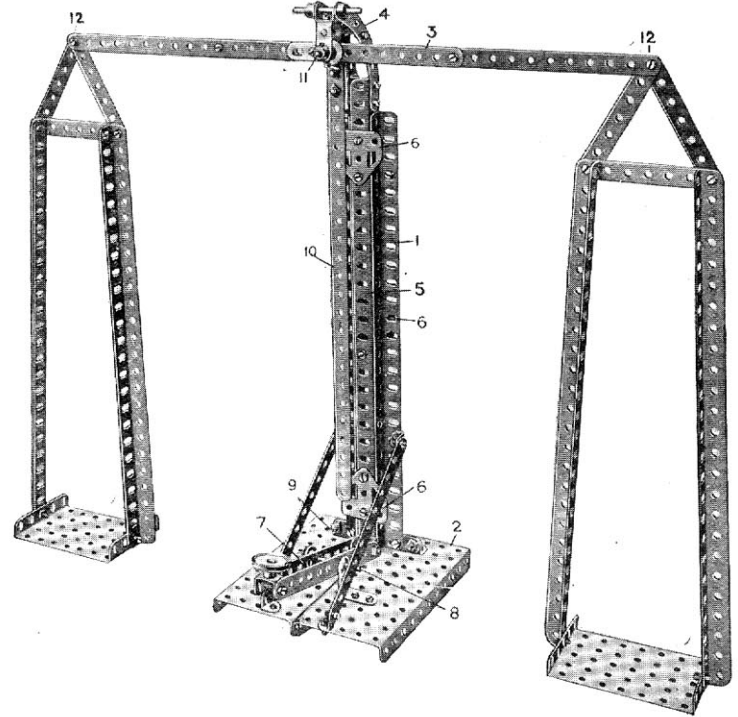

The only feature of this model which needs description is the standard, which is built up of two angle girders 1 bolted to the base 2 by angle brackets and spaced apart at the top by a $2\frac{1}{2}$ " strip obliquely disposed. The balance lever 3 is pivotally carried in curved strips 4 bolted to the top of two angle girders 5 sliding between the girders 1. The girders 5 are themselves bolted together and in order to guide them as they slide vertically flat trunnions 6 are bolted at the front and rear. The balance is raised by depressing the lever 8 pivoted at 9 and pivotally connected at 11 to the vertically sliding girders 5. The indicator 10 is bolted to a crank at the rear, the boss of which is fitted on the pivot rod 11. The connections at 12 are lock-nutted to allow free action.

Model No. 314—Drop the Nigger

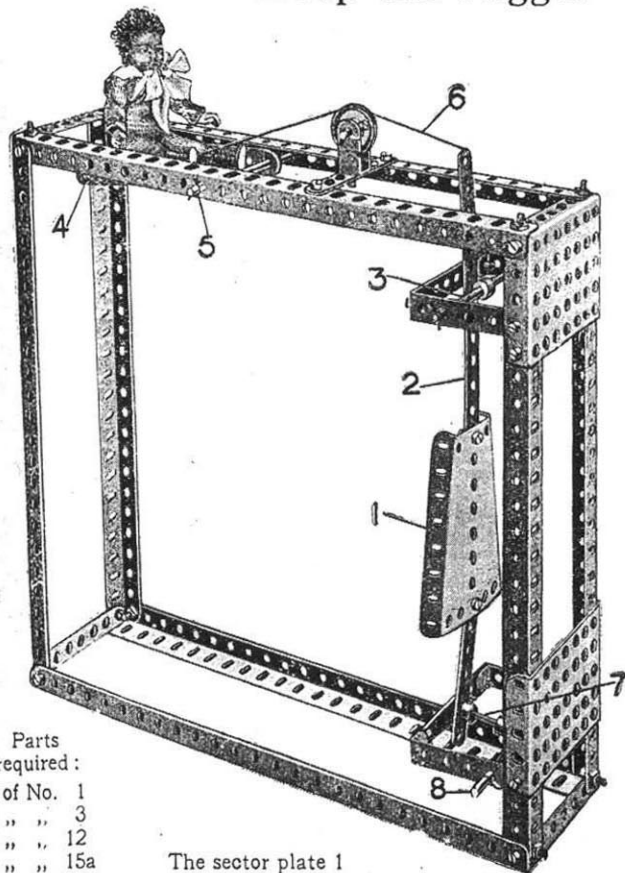

Parts
required:

1 of No. 1
6 " " 3
1 " " 12
3 " " 15a
1 " " 17
1 " " 22
6 " " 35
33 " " 37
1 " " 44
2 " " 53
2 " " 54
3 " " 59
4 " " 60
1 " " 63

The sector plate 1 is a target, which, when hit, allows the nigger to be dropped. The plate 1 is carried on the strip 2 pivoted at 3, and the weight of the nigger supported on another sector plate 4 pivoted at 5 by means of the cord 6 keeps the lower end of the strip 2 hard against a short rod 7 pivoted at 8. When the target is hit and knocked back the rod 7 is released and falls about its pivot, allowing the sector plate 4, with the nigger to drop.

Model No. 315—Newton's Disc

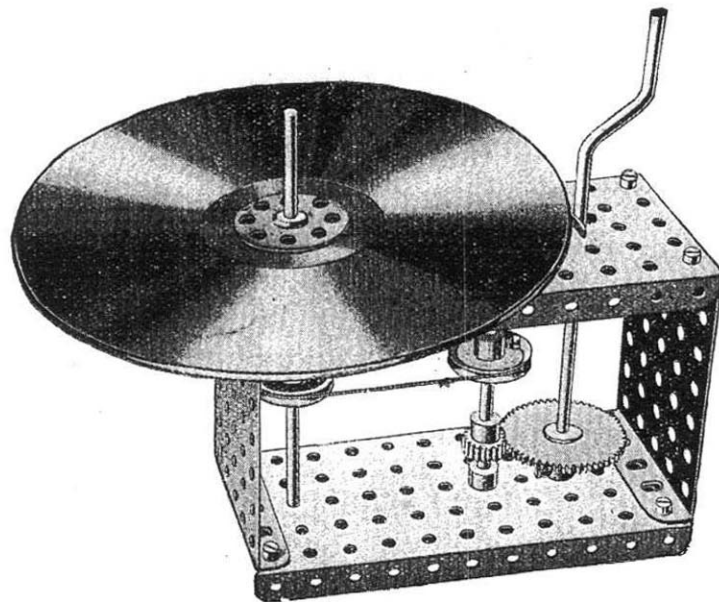

Parts required:

1 of No. 15	1 of No. 24	8 of No. 37
1 " " 15A	1 " " 26	2 " " 52
1 " " 19	1 " " 27A	2 " " 53
2 " " 22	2 " " 35	4 " " 59

This is a model to show that white light is made up of the three primary colours—red, yellow, blue. Sectors of these three colours are mounted or painted on the disc, which, if then quickly rotated, shows as white.

Model No. 316 Railway Breakdown Crane

Parts required :		
2 of No. 1	1 of No. 23	1 of No. 54
4 " " 2	1 " " 24	1 " " 57
4 " " 11	1 " " 26	2 " " 59
1 " " 12	1 " " 32	1 " " 63
3 " " 15A	4 " " 35	1 " " 115
1 " " 16	36 " " 37	4 " " 126A
2 " " 17	5 " " 38	1 " " 147A
1 " " 19	2 " " 48A	1 " " 147B
1 " " 19B	2 " " 48B	1 " " 148
4 " " 20	2 " " 52	
1 " " 22A	3 " " 53	

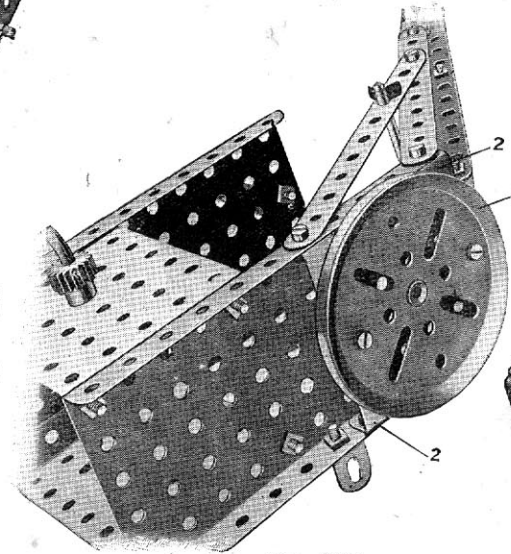
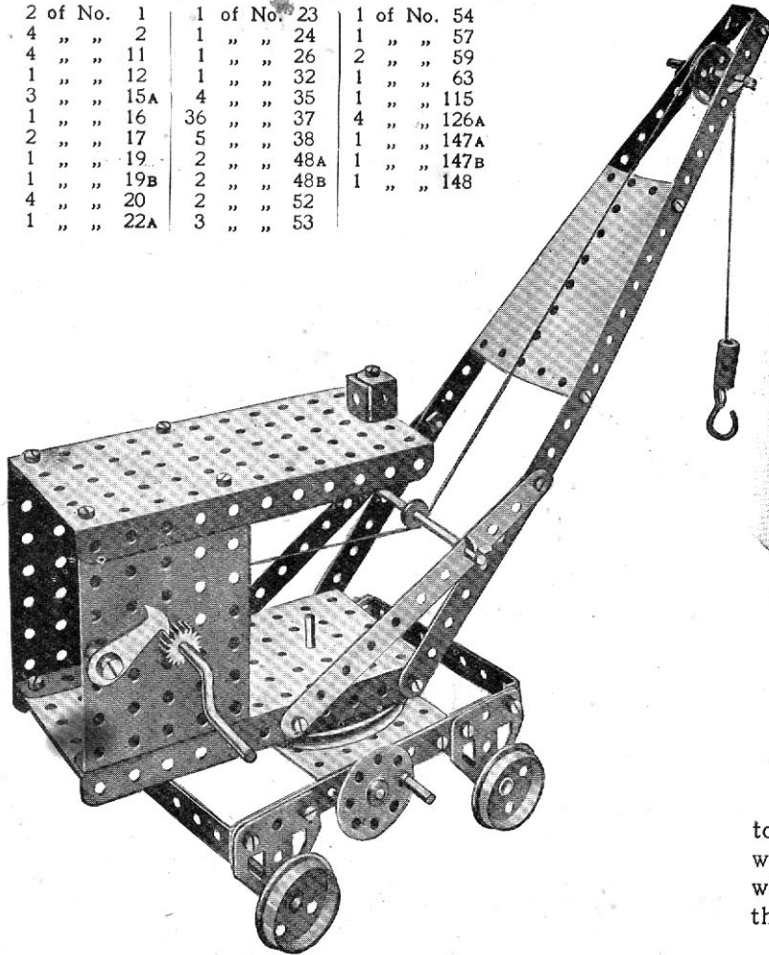

FIG. 316A

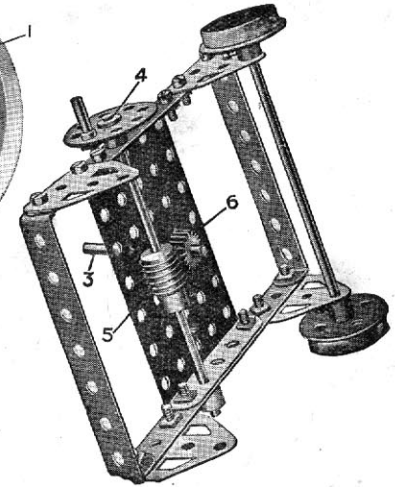

FIG. 316B

The swivelling action is obtained by bolting a 3" pulley 1 to double angle strips 2 on the jib frame. The boss of this wheel fits over the rod 3 and is secured to the rod. The hand wheel 4 rotates the worm 5, engaging the pinion 6 to swivel the jib.

Model No. 317 Pit Head Gear

Parts required :

10	of No.	1	6	of No.	35
10	"	"	74	"	"
4	"	"	2	"	"
2	"	"	3	"	"
8	"	"	2	"	"
10	"	"	3	"	"
1	"	"	1	"	"
3	"	"	2	"	"
1	"	"			
1	"	"			
1	"	"			
1	"	"			
1	"	"			
1	"	"			
1	"	"			

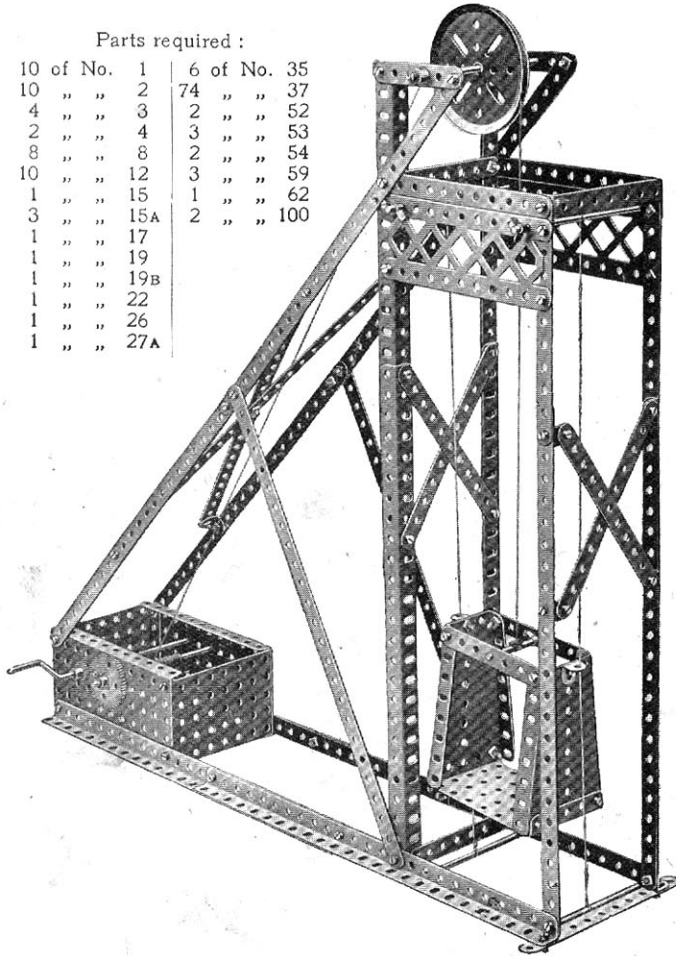

Model No. 318 Swing

Parts required :

7	of No.	1
13	"	"
12	"	"
8	"	"
4	"	"
1	"	"
6	"	"
69	"	"
4	"	"
6	"	"
1	"	"
1	"	"

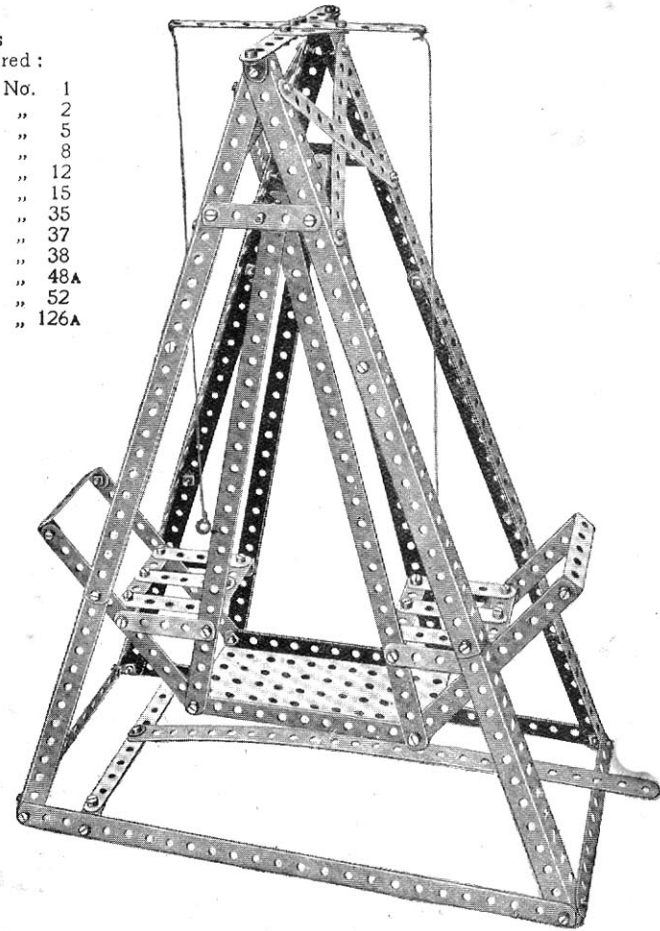

Model No. 319
Drilling Machine

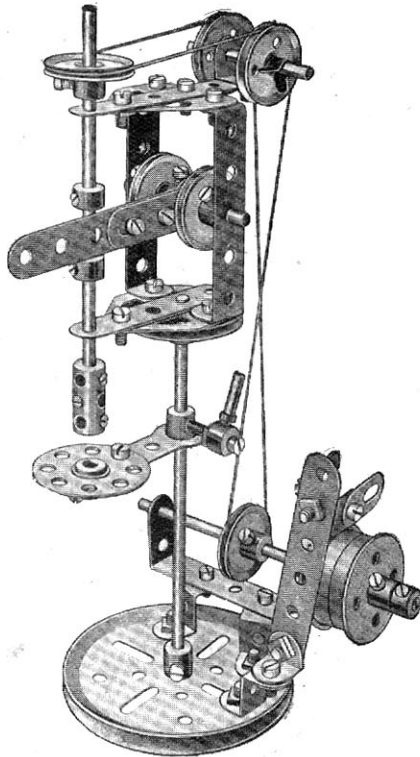

Parts required :

2 of No. 4	2 of No. 20	2 of No. 48A
2 " " 5	1 " " 21	5 " " 59
2 " " 10	4 " " 22	2 " " 62
2 " " 11	2 " " 22A	1 " " 63
1 " " 12	1 " " 24	1 " " 111
1 " " 15	2 " " 35	1 " " 115
2 " " 15A	21 " " 37	3 " " 125
2 " " 17	1 " " 44	2 " " 126A
2 " " 19B	1 " " 46	

Model No. 320 Strip-Bending Machine

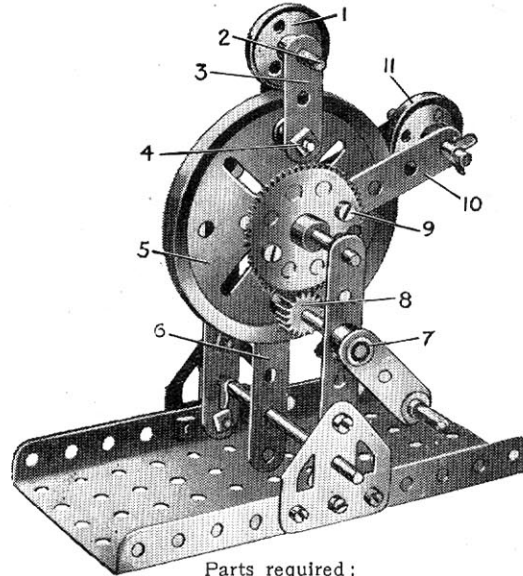

Parts required :

1 of No. 2	2 of No. 18B	10 of No. 38
2 " " 3	1 " " 19B	1 " " 52
1 " " 4	2 " " 22A	4 " " 59
1 " " 5	1 " " 26	1 " " 62
1 " " 6A	1 " " 27A	1 " " 111
2 " " 16	6 " " 35	1 " " 115
1 " " 17	10 " " 37	2 " " 126A

This model represents a device for bending bars or rods of metal to circular form, and may be put to practical purpose in shaping strips of tin or similar material. A loose pulley 1 is spaced by a collar and washers in the centre of the short rod 2 journalled in a 1 1/2" strip 3. The latter is secured to the end of a 1/2" bolt 4 and spaced away from the 3" pulley 5 by means of a number of washers. The opposite end of the rod is supported by a 5 1/2" strip 6. The handle 7 is secured to a 3 1/2" rod carrying a 1/2" pinion 8. This engages with a 57-teeth gear wheel 9 mounted on another 3 1/2" rod which is free to revolve in the boss of the wheel 5. The gear wheel 9 carries a 3" strip 10 forming one of the bearings for a short rod carrying a second 1" loose pulley 11. The latter is also spaced by means of a collar and washers so that it lies immediately above the groove of the pulley wheel 5. The material to be shaped is passed between the two loose pulleys at the top of the wheel 5, and on rotation of the handle 7 the arm 10 is caused to move downward, so forcing the object to the same curvature as the circumference of the wheel.

Model No. 321 Swing

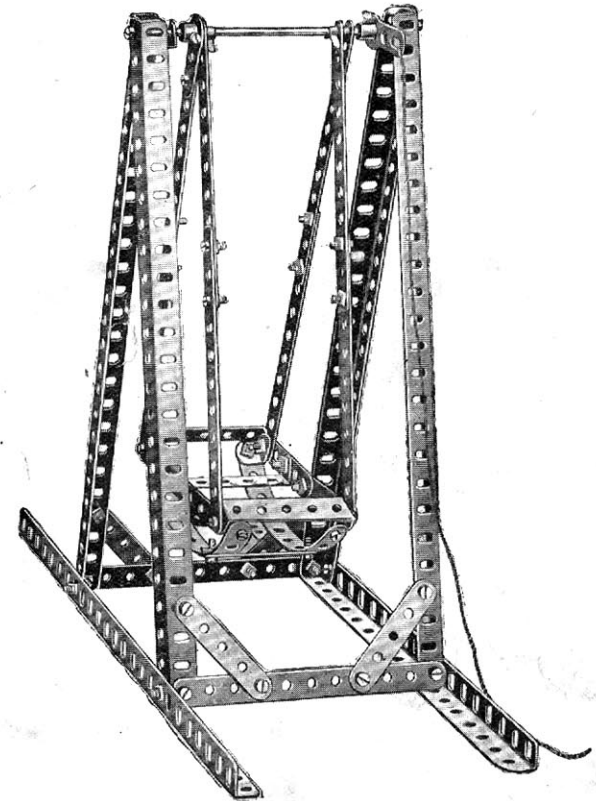

Parts required :

12 of No. 2	1 of No. 15
9 " " 5	2 " " 35
6 " " 8	43 " " 37
2 " " 11	4 " " 48A
4 " " 12	2 " " 62

Model No. 322 Railway Gauge

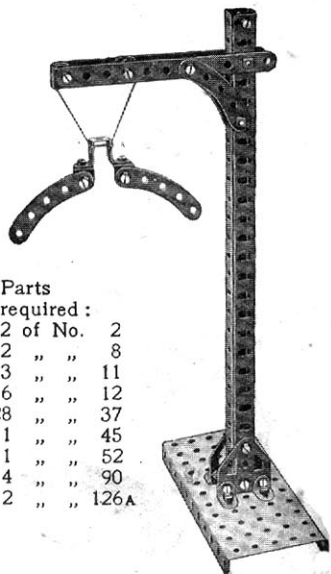

Parts required:

2 of No.	2
2 "	8
3 "	11
6 "	12
28 "	37
1 "	45
1 "	52
4 "	90
2 "	126A

Parts required:

6 of No.	2
1 "	3
2 "	5
2 "	8
3 "	11
12 "	12
2 "	15
3 "	15A
2 "	19
4 "	20
1 "	24
2 "	26
1 "	27A
3 "	35
50 of No.	37
1 "	45
2 "	48A
2 "	52
3 "	53
4 "	59
2 "	62
4 "	126A

Model No. 323 Scarifier



Parts required:

7 of No.	2	1 of No.	10
1 "	3	14 "	12
4 "	5	1 "	18A
		2 "	22
		31 "	37
		2 "	38
		2 "	90
		1 "	126A

Model No. 325 Wire Rope Maker

The strands are twisted from both ends by the handles 1 and 2 of the fixed parts. The handle 1 rotates through a large gear wheel 3 two pinions 4 on the rods 5 carrying cranks to which the strands are attached. The other ends of the strands are connected to a double bent strip 6 on a bush wheel which is rotated in the opposite direction by a crank handle 2. The carriage 7 runs on rails and the vertical rod 8 is kept just at the formation of the twisted rope and so controls the tightness of the twist.

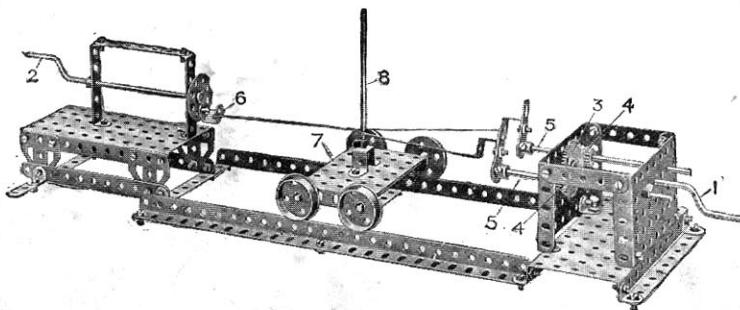

Parts required:

3 of No.	2	4 of No.	20	2 of No.	48B
6 "	3	1 "	22	1 "	52
5 "	5	2 "	22A	1 "	53
2 "	8	3 "	35	4 "	59
2 "	11	38 "	37	1 "	62
2 "	15	1 "	46	1 "	63
2 "	16	2 "	48A		

Model No. 324 Boring Machine

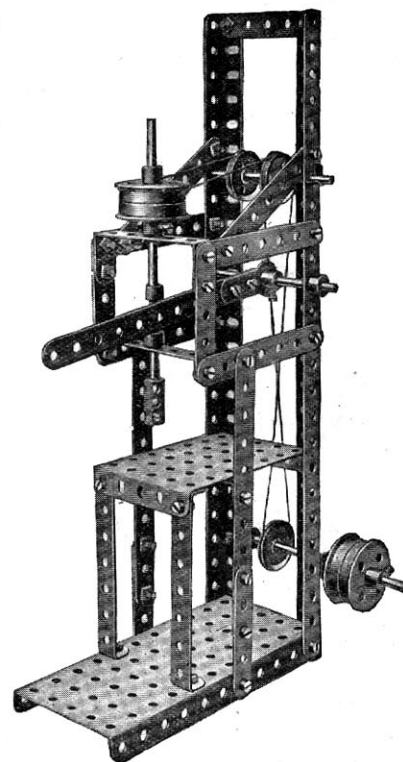

Model No. 326 Lawn Swing

Model No. 327 Oil Cake Chopper

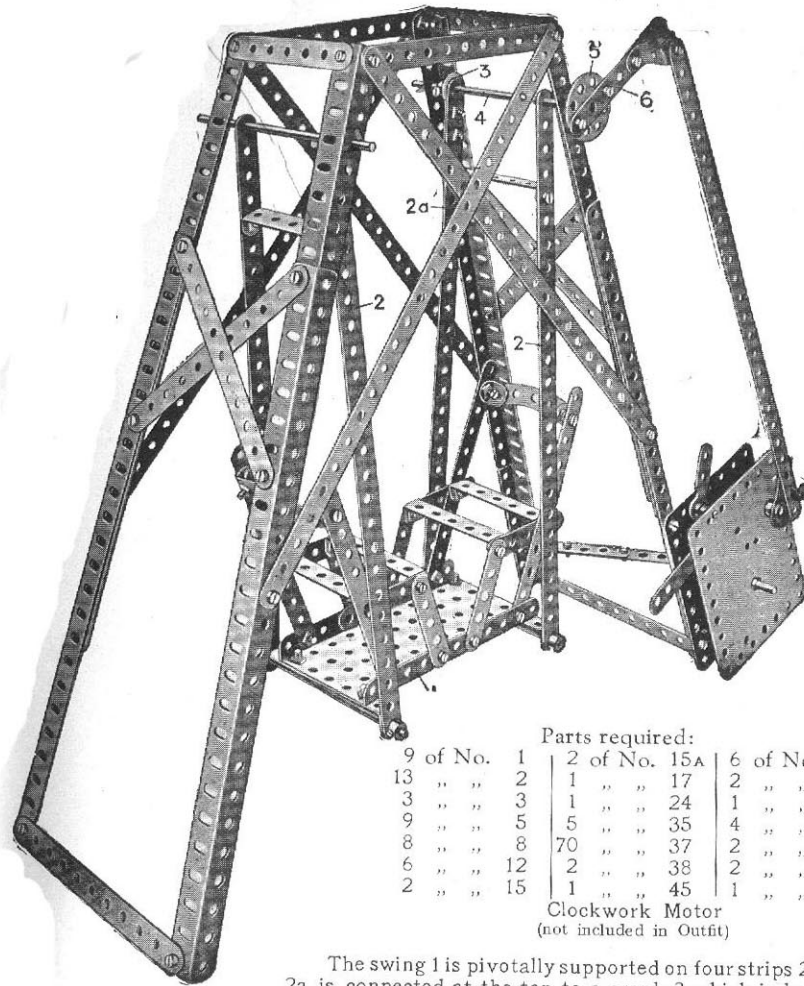

Parts required:

9 of No.	1	2 of No.	15A	6 of No.	48A
13 "	2	1 "	17	2 "	48B
3 "	3	1 "	24	1 "	52
9 "	5	5 "	35	4 "	59
8 "	8	70 "	37	2 "	62
6 "	12	2 "	38	2 "	90
2 "	15	1 "	45	1 "	115

Clockwork Motor
(not included in Outfit)

The swing 1 is pivotally supported on four strips 2, the far strip 2a is connected at the top to a crank 3 which is bolted to a rod 4 and at the front end of this rod is a wheel 5 to which is bolted a strip 6 to the motor spindle.

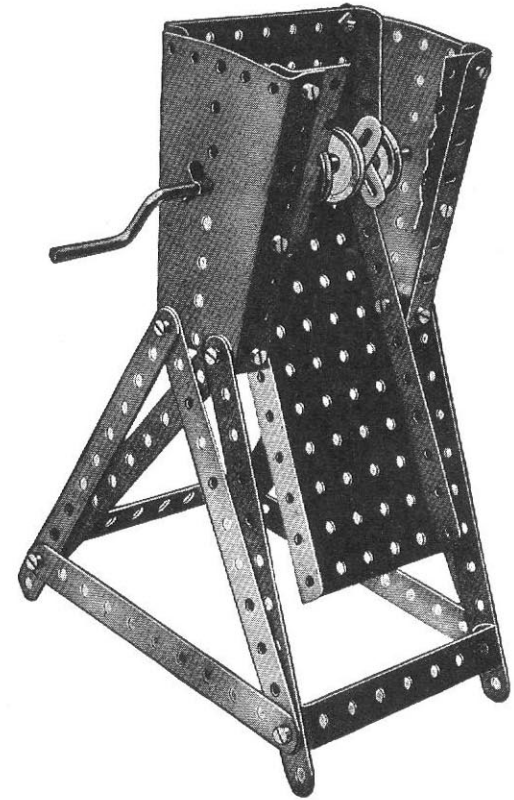

Parts required:

10 of No.	2	2 of No.	35
4 "	10	20 "	37
2 "	12	2 "	48B
1 "	19	1 "	52
4 "	22	2 "	53
	2 of No.		54

These Models can be made with MECCANO Outfit No. 3, or No. 2 and No. 2A

Model No. 328—Swinging Cot

Parts
required:
1 of No. 1
2 " " 2
5 " " 5
1 " " 12
1 " " 15A
1 " " 35
1 " " 37
1 " " 52
1 " " 60

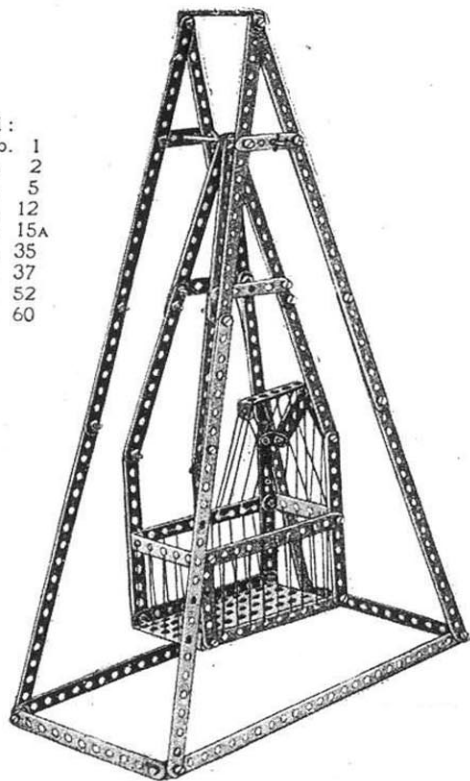

Model No. 329—Drafting Machine

Parts required:

4 of No. 1	1 of No. 24
3 " " 2	15 " " 37
1 " " 4	1 " " 52
2 " " 5	

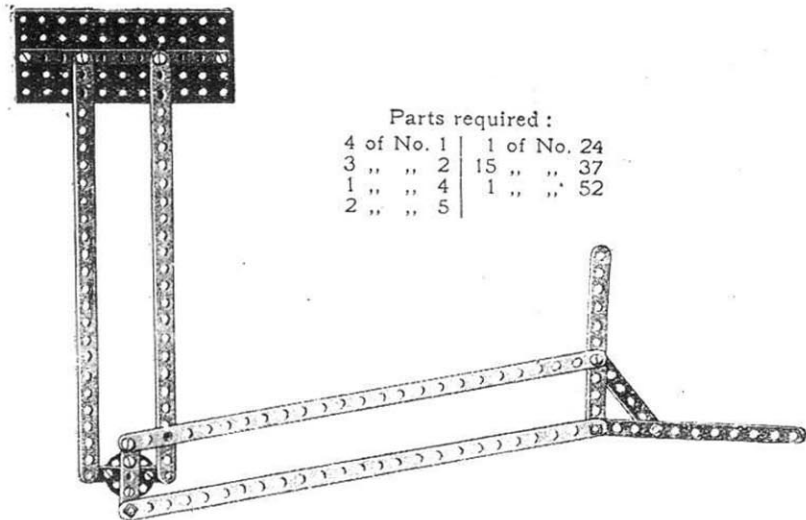

Model No. 330—Lawn Marker

Parts
required:
1 of No. 2
6 " " 5
1 " " 15A
4 " " 16
4 " " 20
6 " " 35
21 " " 37
1 " " 53
2 " " 54
2 " " 59
4 " " 60
1 " " 126A

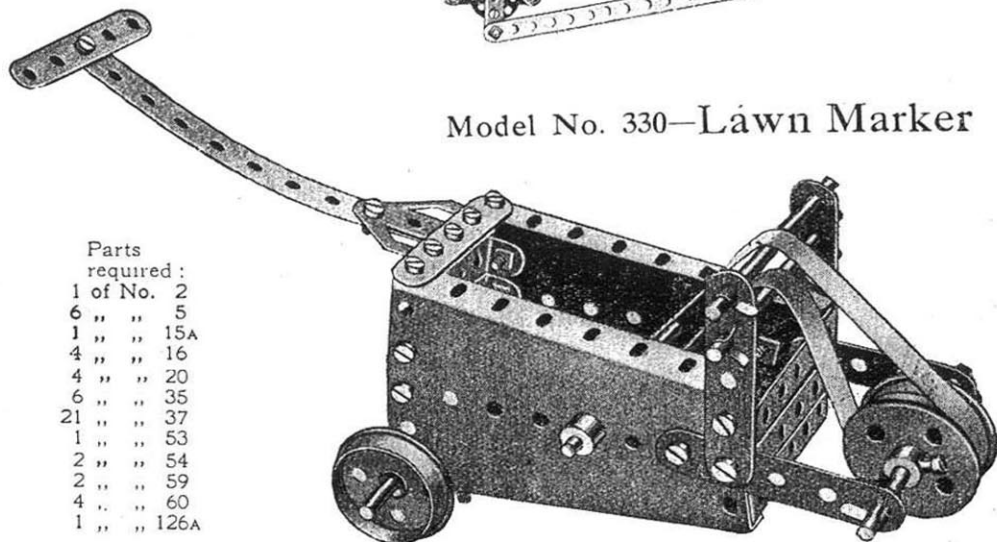

**Model No. 331
Lace Jennier**

Parts required :

8 of No.	2
4 " "	11
1 " "	15
1 " "	19
1 " "	24
14 " "	37
1 " "	52
1 " "	59
1 " "	62
1 " "	63

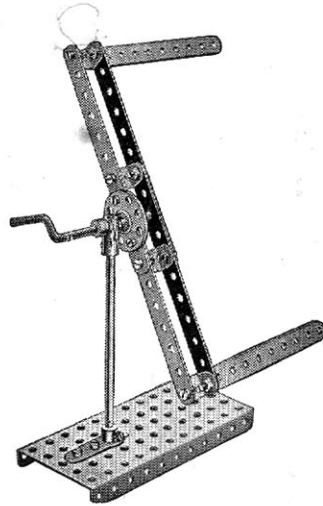

Model No. 333 Ice Boat

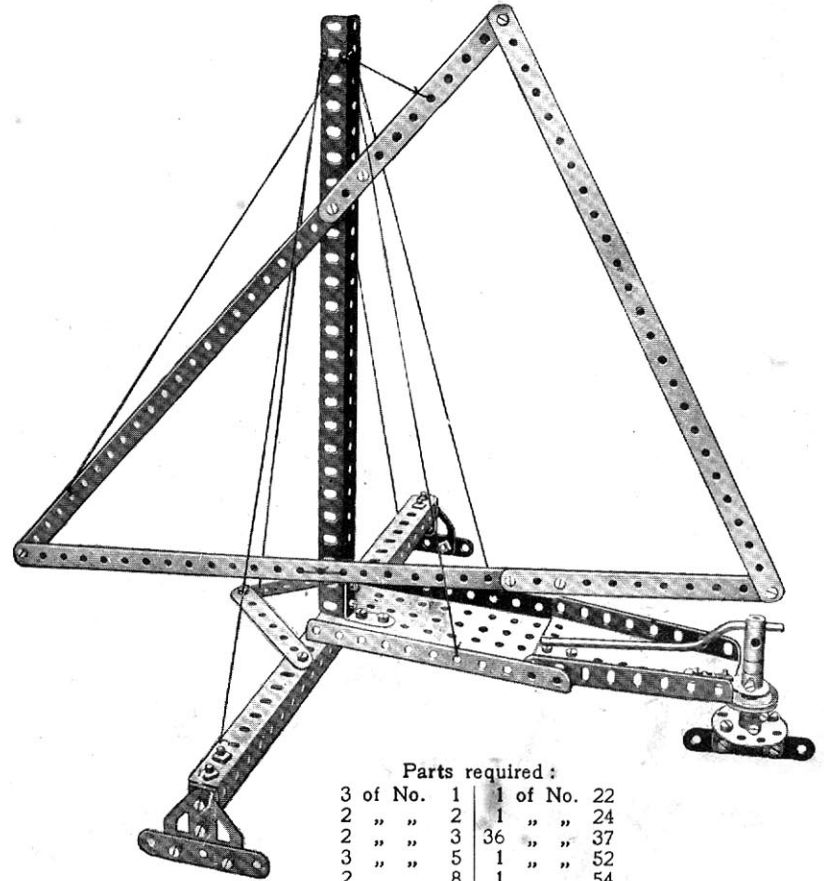

Parts required :

3 of No.	1	1 of No.	22
2 " "	2	1 " "	24
2 " "	3	36 " "	37
3 " "	5	1 " "	52
2 " "	8	1 " "	54
2 " "	12	1 " "	59
3 " "	12A	1 " "	62
1 " "	17	1 " "	63
1 " "	19	2 " "	126A

Model No. 332 Flax Cleaner

Parts required :

6 of No.	2	4 of No.	22
6 " "	3	1 " "	24
8 " "	5	1 " "	26
2 " "	8	1 " "	27A
1 " "	12	4 " "	35
1 " "	15A	26 " "	37
2 " "	16	2 " "	52
1 " "	21	1 " "	53

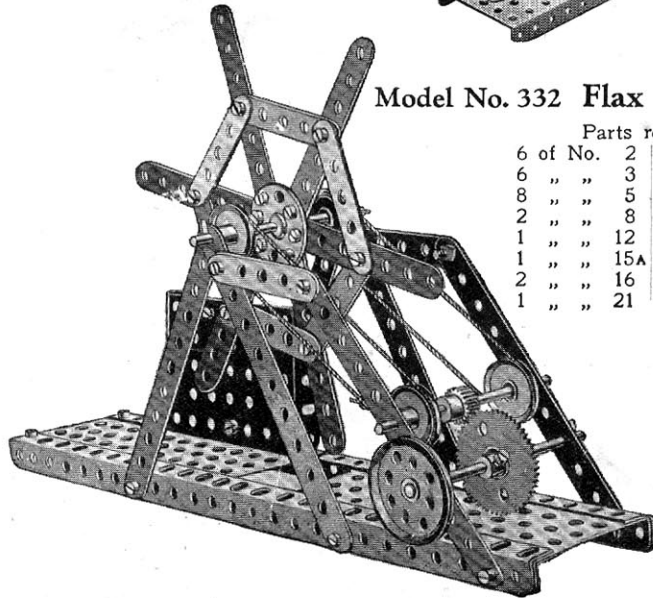

Model No. 334 Roundabout

Parts
required:

4 of No.	1
14 "	2
2 "	3
7 "	5
2 "	8
10 "	12
2 "	15
1 "	15A
1 "	16
1 "	19
1 "	21
4 "	22
1 "	24
2 "	26
1 "	27A
1 "	32
54 "	37
10 "	48A
2 "	52
3 "	59
1 "	63
2 "	126A

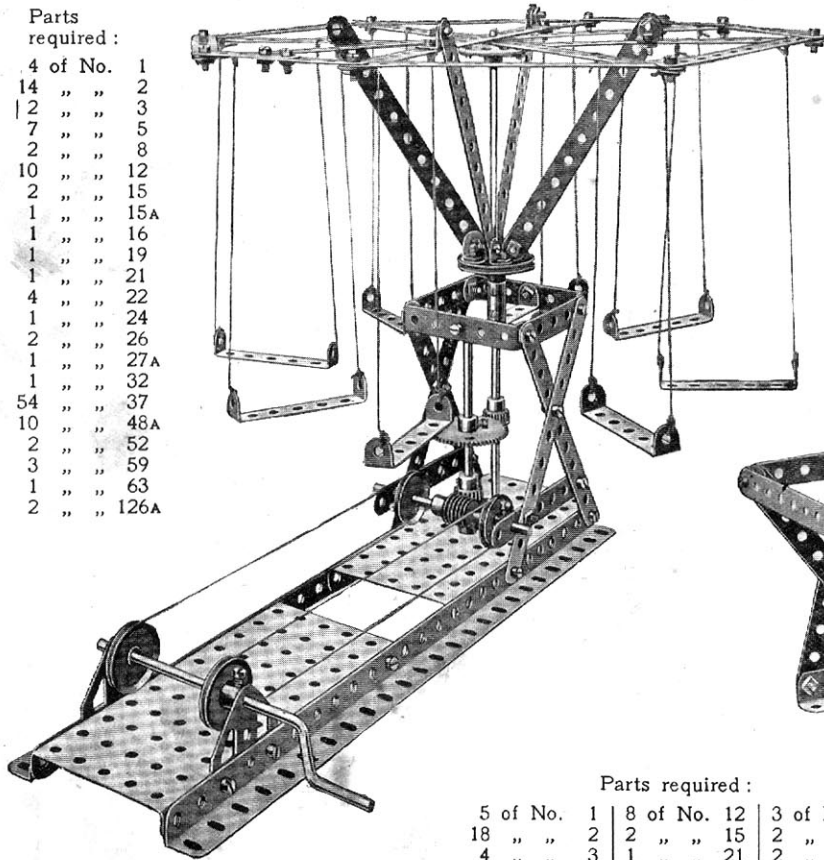

Model No. 335 Automatic Swing Boat

Parts required:

5 of No.	1	8 of No.	12	3 of No.	38
18 "	2	2 "	15	2 "	59
4 "	3	1 "	21	2 "	62
9 "	5	1 "	24	1 "	63
8 "	8	84 "	37	2 "	126A

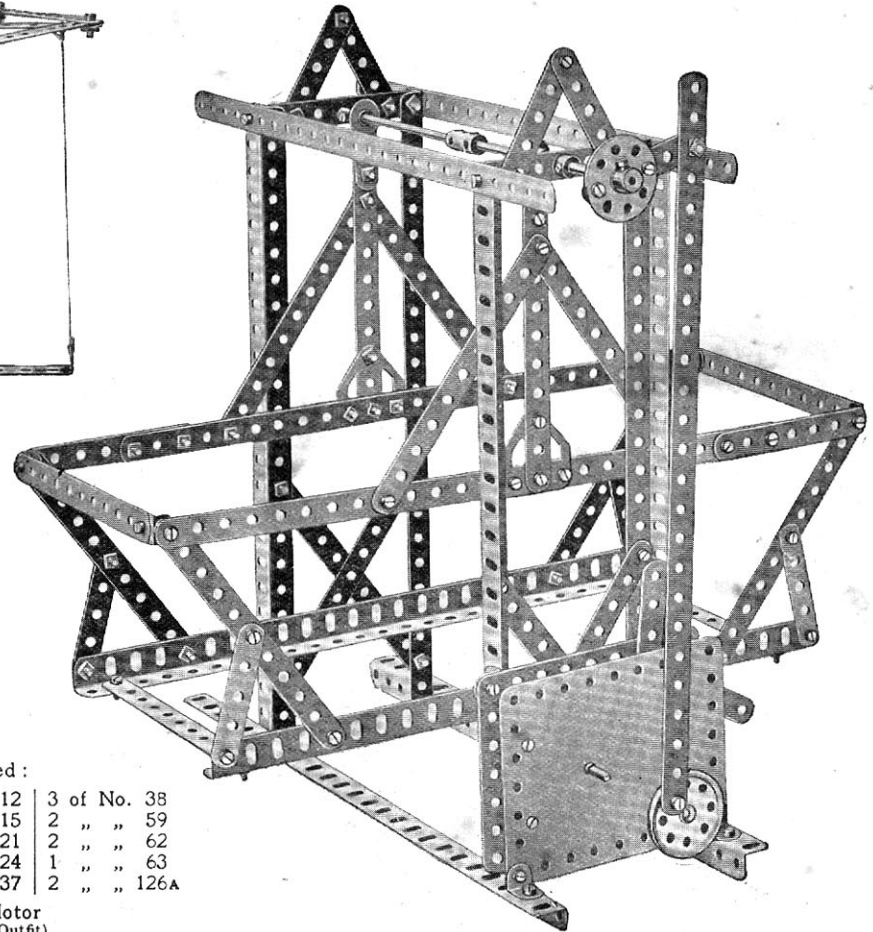
Clockwork Motor
(not included in Outfit)

Model No. 336 Fire Escape

The main frame 1 is pivotally connected to the running truck 2 about the rod 3. Ordinarily the frame 1 rests on the running truck 2 when the escape is being transported. In order to raise the main frame about the pivot rod 3 the handle 4 winds up the cord 5 the outer end of which is connected to the running truck axle. To raise or lower the ladder 6 the handle 7 is turned in one or other direction, the cord 8 passing over the pulleys 9 and being connected to the sliding ladder.

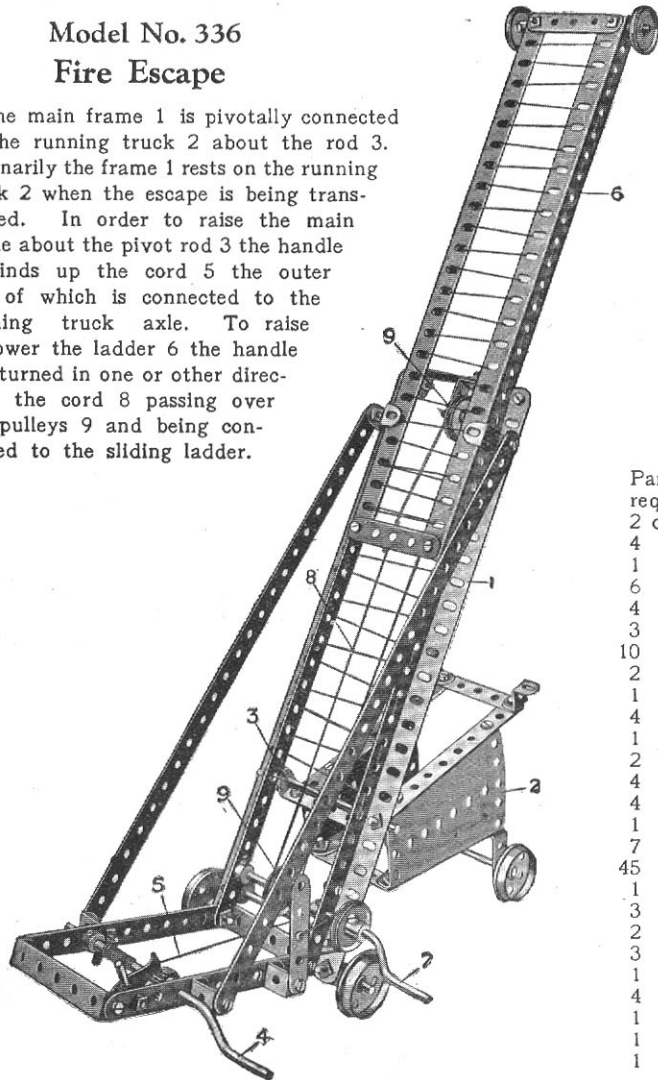

Parts required:

2 of No.	1
4 " "	2
1 " "	3
6 " "	5
4 " "	8
3 " "	11
10 " "	12
2 " "	12A
1 " "	15A
4 " "	16
1 " "	18A
2 " "	19
4 " "	20
4 " "	22
1 " "	22A
7 " "	35
45 " "	37
1 " "	44
3 " "	48A
3 " "	54
3 " "	59
1 " "	115
4 " "	125
1 " "	147A
1 " "	147B
1 " "	148

Model No. 337 Actuated See-Saw

The sea-sawing is actuated by the travelling action of the wheels 1. The spindle of the wheels is connected by the cord 2 to the pulley 3 on the spindle of the pinion 4 which drives a gear wheel on the spindle of the bush wheel 5. A threaded pin 6 on this wheel engages the strip 7 coupled to a lever strip 8 pivoted at 9 which rocks the pivot rod 10 of the see-saw 11.

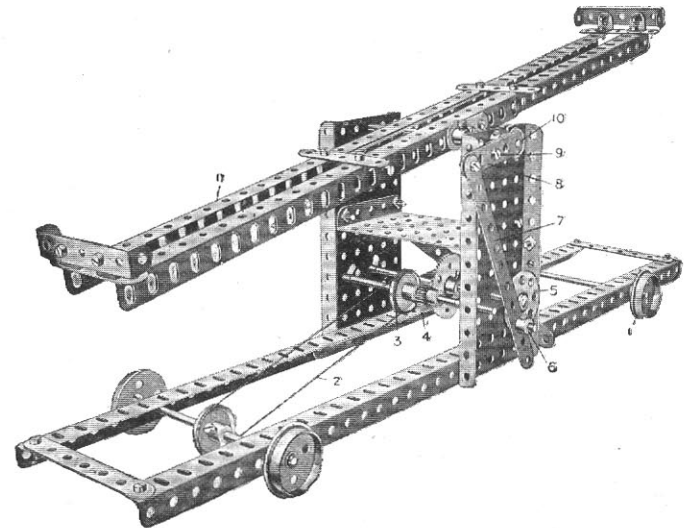

Parts required:

3 of No.	2	4 of No.	20	2 of No.	48A
2 " "	3	2 " "	22	2 " "	52
5 " "	5	1 " "	24	1 " "	53
8 " "	8	1 " "	26	3 " "	59
4 " "	12	1 " "	27A	2 " "	62
2 " "	15	4 " "	35	1 " "	115
3 " "	15A	36 " "	37		

Model No. 338 Hand Trolley

The trolley is caused to travel by working the rocking lever 1 which is connected by a strip 2 to a crank shaft 3 a gear wheel 4 which meshes a pinion 5 on a rod coupled by a cord 6 to an axle rod 7 of the travelling wheels 8.

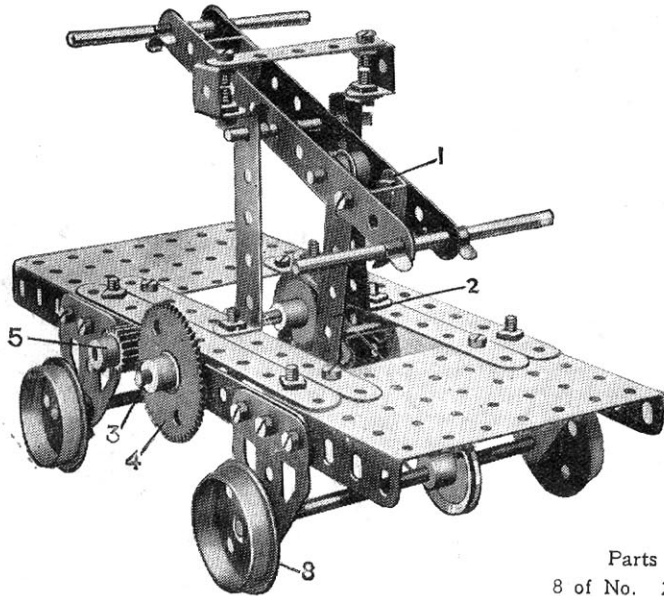

Parts required :

8 of No.	2	2 of No.	22
1 "	4	1 "	26
1 "	5	1 "	27A
4 "	11	6 "	35
3 "	15A	30 "	37
2 "	16	2 "	48A
1 "	17	2 "	53
1 "	18A	4 "	59
4 "	20	4 "	126A
		1 of No.	134

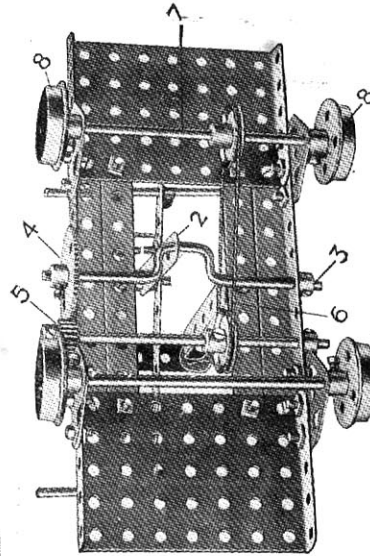

Model No. 339 Pile Driver

Parts required :

2 of No.	1
2 "	2
10 "	5
2 "	8
2 "	10
2 "	12
2 "	15A
3 "	16
1 "	19
4 "	20
3 "	22
1 "	26
1 "	27A
2 "	35
26 "	37
4 "	38
1 "	45
3 "	48A
1 "	52
4 "	59
1 "	115
3 "	126A

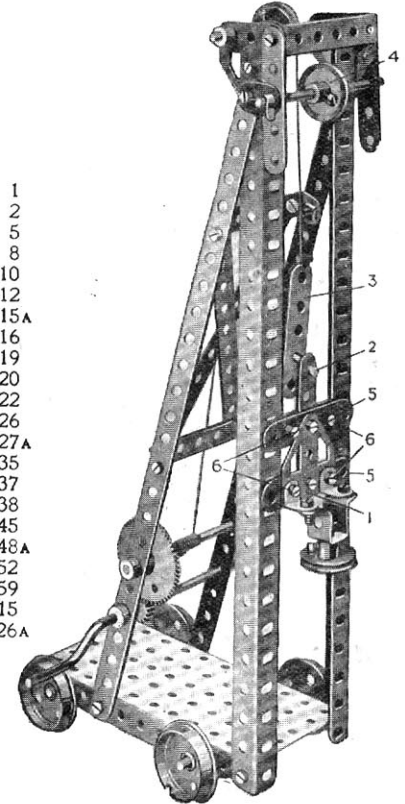

The driving head 1 is raised by means of a threaded pin 2 on two 2½" strips 3, the pin engaging in the first hole of the driving head. As the head is raised, the strip 3 makes contact with a pulley 4 and the latter pushes the strip rearwardly, disengaging the pin from the hole on the driving head, permitting it to fall. The cross strips 5 of the driving head are duplicated behind, spacing washers being inserted between them on the bolts 6 to allow free movement up and down the guide girders.

Model No. 340 Swing Cot

Parts required :

4 of No. 1	1 of No. 27
10 " " 2	42 " " 37
4 " " 5	2 " " 38
6 " " 8	2 " " 48B
4 " " 12	4 " " 59
2 " " 17	4 " " 90
1 " " 24	

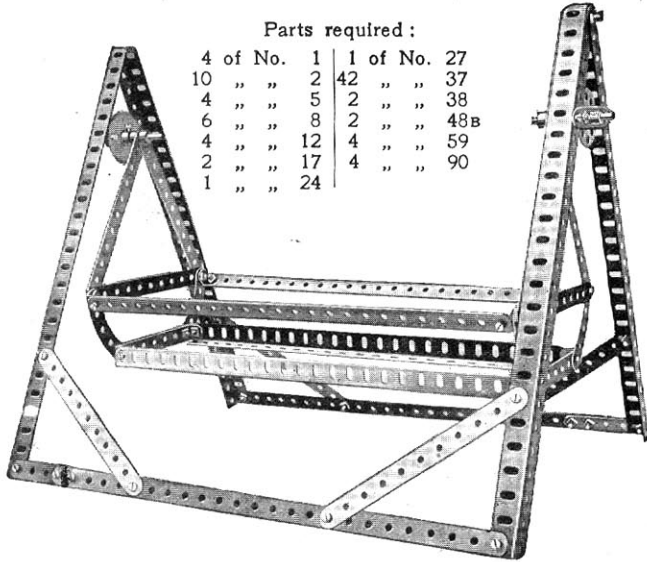

Model No. 341 Pastry Designer

Parts required :

2 of No. 2	1 of No. 17	9 of No. 37
3 " " 5	1 " " 22A	2 " " 59
3 " " 11	1 " " 27A	

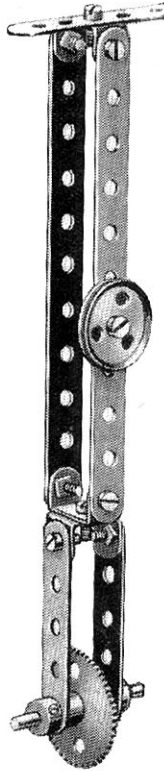

Model No. 342 Scales

Parts required :

2 of No. 2	2
1 " " 3	3
2 " " 4	4
1 " " 5	5
2 " " 8	8
1 " " 11	11
1 " " 15	15
1 " " 17	17
4 " " 20	20
1 " " 22	22
1 " " 24	24
15 " " 37	37
1 " " 48A	48A
2 " " 52	52
1 " " 54	54
2 " " 62	62
1 " " 63	63
1 " " 90	90

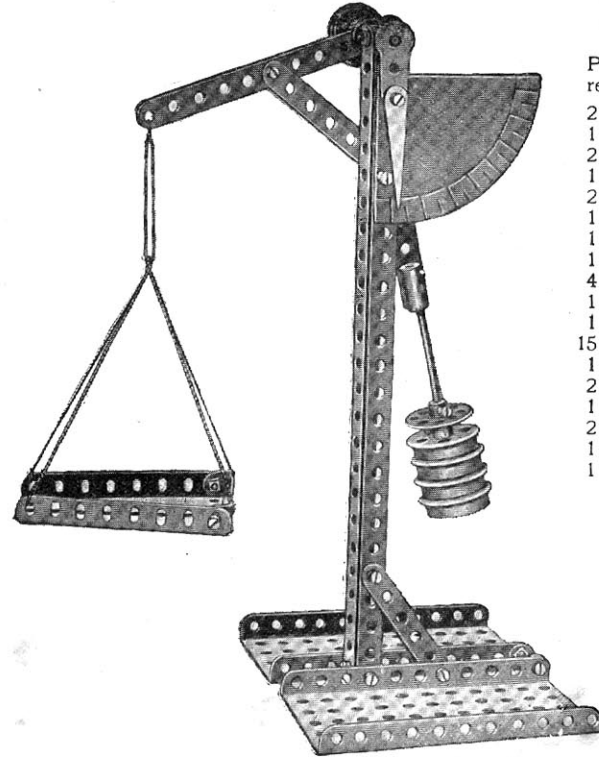

HOW TO CONTINUE

This completes the Models which may be made with MECCANO Outfit No. 3. The next Models are a little more advanced, requiring a number of extra parts to construct them. The necessary parts are all contained in a No. 3A Accessory Outfit, the price of which will be found in the List at the end of the Manual.

MECCANO ACCESSORY OUTFITS AND MOTORS



Meccano Accessory Outfits

Our illustration shows one of the Meccano Accessory Outfits. As has already been explained, these Outfits connect the main Outfits from No. 00 to No. 7, making it possible for a boy who commences with one of the earlier Outfits to build up his equipment by easy stages, until he is the possessor of parts that cover the entire system.

Electrical Outfit

All Meccano boys are fascinated by electricity and never become tired of learning more about this wonderful subject. The application of electricity to the Meccano system adds a further and wonderful charm, and the joys of model-building are now increased by the fascinating pastime of carrying out delightful electrical experiments.

The Meccano Electrical Outfit contains a number of specially designed electrical parts which may be used in conjunction with any of the regular Outfits.

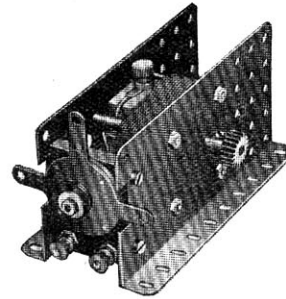

Electric Motor No. 1
(4-Volt)

The 4-volt Motor is specially designed to build into Meccano models. It may be run by a 4-volt Accumulator, or, by employing a suitable transformer, direct from the main. It is fitted with reversing motion, provided with stopping and starting controls, and the gearing is interchangeable.

Electric Motor No. 2
(100-250-Volt AC or DC)

This Electric Motor may be employed for any purpose for which a small motor is suitable, but it is specially adapted for driving Meccano models. The side plates are perforated with standard equidistant holes, thus allowing the motor to be built into any Meccano model. The motor is specially designed for connection with the electric-light main. It is supplied for 100-120-volts or 200-250-volts (alternating or direct), and is fitted with 6 ft. length of flex, an insulated plug for connection with the motor terminals, and an adapter for connection with an ordinary lamp socket.

A suitable resistance is required when the motor is run with a 200-250-volt current, and this is supplied by connecting a 60-watt lamp in series with the motor. A board on which are mounted a suitable lamp-holder (lamp not included) and a switch is provided separately.

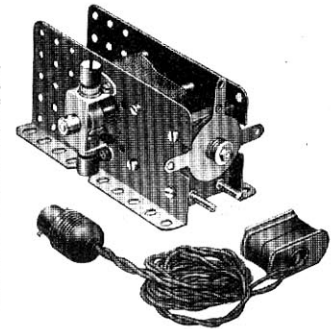

4-Volt Accumulators

These new and excellent types of Accumulators have been adapted to drive the Electric Motor No. 1. They have been subjected to the severest tests and have proved themselves to be the most suitable accumulators for use with any type of electric motor. They are non-spillable, have remarkable recuperative powers, and will continue to supply current when nominally exhausted.



Clockwork Motor

How splendid it is, after spending hours in building a model, to be able to set it in motion with a motor, just as do real engineers! The Meccano Clockwork Motor is specially made for this purpose and is a fine piece of mechanism—simple, powerful, and reliable. It is fitted with starting and stopping levers, and has a reversing movement.

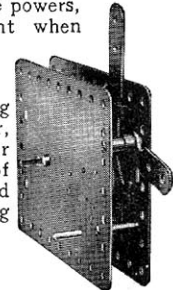

For prices of the above see price list at end of Manual

HORNBY CLOCK WORK TRAINS

59

HORNBY TRAINS are manufactured by Meccano Limited, and they are made from the finest materials obtainable. A most valuable feature of the Loco is that all the parts are standardised and any lost or damaged units may be replaced with new ones.

Each Train is a beautiful piece of workmanship with perfect mechanism, ensuring smooth running. A guarantee of efficiency is furnished with each Loco.

A HORNBY TRAIN LASTS FOR EVER!

Series M, No. 1 Passenger Set

This set contains Loco, Tender, two Pullman Coaches and set of Rails. One of the latter is a brake rail by means of which the train may be braked from the track. Richly coloured and well finished; fitted with brake mechanism; non-reversing. Gauge 0.

Series M, No. 2 Passenger Set

Similar in every way to the above excepting that it has three Pullman Coaches instead of two, and additional rails.

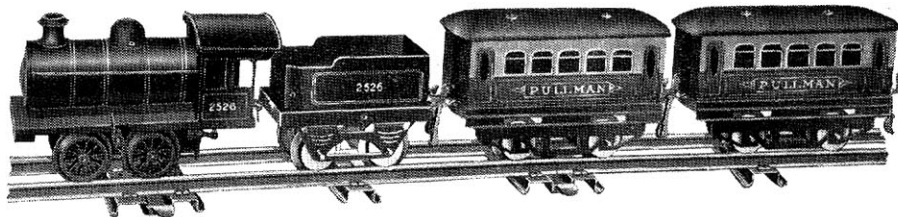

M, No. 1 PASSENGER SET

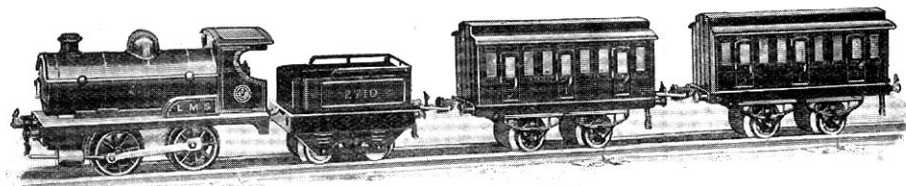

No. 1 PASSENGER SET

No. 1 Passenger Set

Each set contains Loco, Tender, and two Coaches, with Rails to form either a circle 2 ft. in diameter or an oval 2 ft. in width by 2 ft. 10 in. in length. One of the curved rails is a brake rail by means of which the train may be braked from the track. The Loco is fitted with reversing gear and brake mechanism. In colours to represent the principal British Railway Companies' rolling stock. The doors of the Coaches open. Gauge 0.

No. 1 Goods Set

This set is similar in every way to No. 1 Passenger Set, except that it contains one Wagon in place of Coaches. Gauge 0.

No. 2 Pullman Set

This set includes Loco and Tender of a larger type, measuring 17 in. in length. The Coaches are beautiful both in colour and finish. Each set includes Loco, Tender, and two Pullman Coaches, with set of Rails making a 4 ft. diameter circle. The rails include one brake rail by means of which the train may be both braked and reversed from the track. In colours to represent the principal British Railway Companies' rolling stock. The Loco is fitted with reversing gear and brake mechanism. Gauge 0.

No. 2 Goods Set

This set contains Loco, Tender, and Rails as in No. 2 Pullman Set, and two Wagons. Gauge 0.

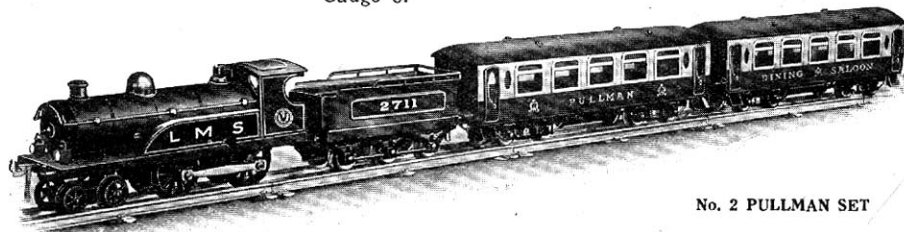

No. 2 PULLMAN SET

For prices of the above see price list at end of Manual.

HORNBY CLOCK WORK TRAINS

The following Hornby Tank Goods and Passenger Sets are very realistic models and are valuable additions to the popular range of Hornby Trains. Each set contains one of the famous Hornby Tank Locos with attractive rolling stock.

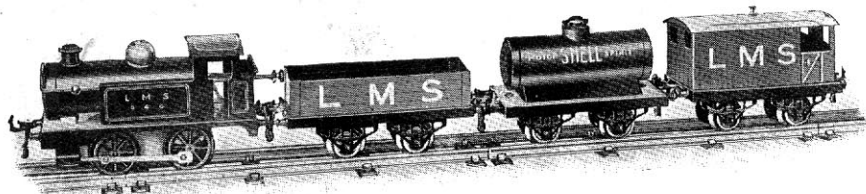

No. 1 TANK GOODS SET

No. 1 Tank Goods Set

This set contains a No. 1 Hornby Tank Loco, Hornby Wagon, Petrol Tank Wagon, Brake Van and set of Rails to form either a circle 2 ft. in diameter or an oval 2 ft. in width by 2 ft. 10 in. in length. One of the curved rails is a brake rail by means of which the train may be braked from the track.

Gauge 0, in colours to represent the principal British Railway Companies' rolling stock. The Loco is fitted with reversing gear and brake mechanism.

No. 2 Tank Goods Set

The famous No. 2 Hornby Tank Loco is included in this set. It is 10½ in. in length and is fitted at both ends with a four-wheeled bogie. In addition the set includes a Hornby Wagon, a Petrol Tank Wagon, a No. 1 Cattle Truck and a Brake Van, with a set of Rails to form a circle 4 ft. in diameter. The rails include one brake rail by means of which the train may be both braked and reversed from the track.

Gauge 0, in colours to represent the principal British Railway Companies' rolling stock. The Loco is fitted with reversing gear and brake mechanism.

No. 2 Tank Passenger Set

This set contains a No. 2 Hornby Tank Loco and Rails as in the No. 2 Goods Set, but three Passenger Coaches and one Guard's Van are included in place of the Wagons and Vans.

Gauge 0, in colours to represent the principal British Railway Companies' rolling stock.

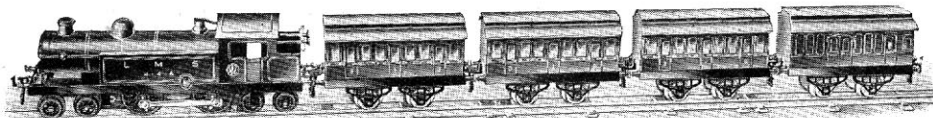

No. 2 TANK PASSENGER SET

The Riviera "Blue" Train Set

These splendid Train Sets are models of the famous express that runs regularly between Calais and the Mediterranean Coast. The Loco is coloured brown with yellow lining and the Coaches are coloured blue with white roofs. Two types are available, one with Clock-work Loco and the other with Electric Loco.

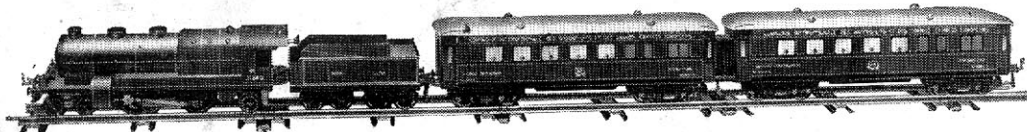

For prices of the above see price list at end of Manual.

ROLLING STOCK AND ACCESSORIES

(HORNBY SERIES)



BRAKE VAN
Finished in grey, with opening doors. Price 6/6

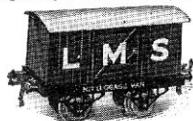

***No. 1 LUGGAGE VAN**
With opening doors. Price 6/6



SECCOTINE WAGON
Beautifully finished in blue, with opening doors. Price 6/6



CRAWFORD'S BISCUIT VAN
Finished in red, with opening doors ... Price 6/6

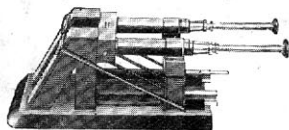

HYDRAULIC BUFFER STOP
Price 10/6



TELEGRAPH POLE
Price 4/6

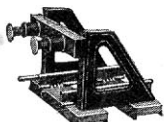

SPRING BUFFER STOP
Price 2/3



DOUBLE LAMP STANDARD
Four-volt bulbs may be fitted into the globes. Price 7/-



SIGNAL
Price 4/9

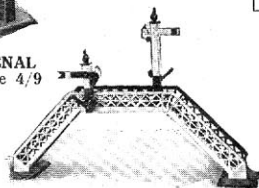

FOOTBRIDGE
No. 1. With detachable Signals Price 12/6
No. 2. Without Signals .. 8/-
Signals only .. per pair 4/9



ISLAND PLATFORM
Length 32½-in., height 6½-in., width 3-in. The ramps at either end are detachable, and if desired the platform may be connected to the main station. Attractively coloured in green, blue and white. Price 12/6

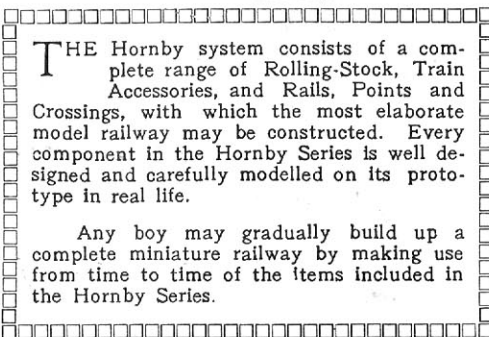

THE Hornby system consists of a complete range of Rolling-Stock, Train Accessories, and Rails, Points and Crossings, with which the most elaborate model railway may be constructed. Every component in the Hornby Series is well designed and carefully modelled on its prototype in real life.

Any boy may gradually build up a complete miniature railway by making use from time to time of the items included in the Hornby Series.



***TROLLEY WAGON**
Finished in grey and red. Suitable for 2-ft. radius rails only ... Price 9/-

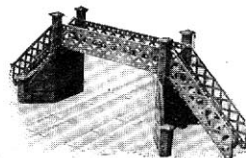

LATTICE GIRDER BRIDGE
Constructional type. Strong and well proportioned. Price 17/6

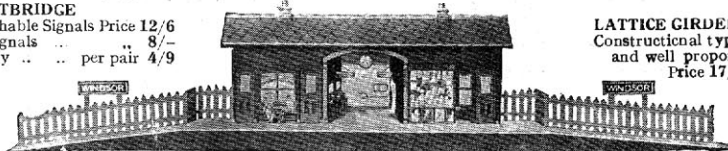

RAILWAY STATION. Excellent model, beautifully designed and finished. Dimensions: Length 2-ft. 9-in., breadth 6-in., height 7-in. Price 22/6

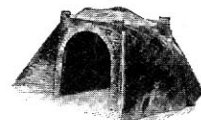

TUNNEL
Realistic and finished in colours ... Price 15/-



FUNCTION SIGNAL
Signal arms operated by levers at base. Very realistic model standing 14-in. in height. Price 11/6

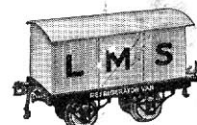

***REFRIGERATOR VAN**
Enamelled in white, with opening doors. Price 6/6

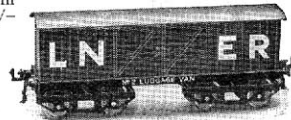

***No. 2 LUGGAGE VAN**
Finished in blue and green. Fitted with double doors. Suitable for 2-ft. radius rails only ... Price 10/6

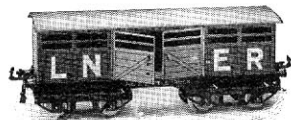

***No. 2 CATTLE TRUCK**
Splendid model fitted with double doors. Suitable for 2-ft. radius rails only ... Price 10/6

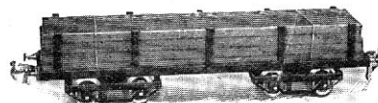

No. 2 TIMBER WAGON
Suitable for 2-ft. radius rails only Price 7/-

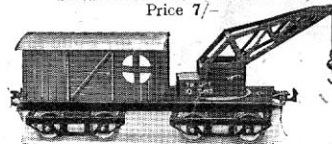

***BREAKDOWN VAN AND CRANE**
Beautifully coloured in grey and black, with opening doors. Suitable for 2-ft. radius rails only ... Price 11/6

There are now over 60 items of Rolling Stock and Accessories in the Hornby Series, some of which are illustrated and described above. Send for a complete illustrated price list.

* Lettered L.M.S., L.N.E.R. or G.W.

Meccano Price List

MECCANO OUTFITS

No. 00	Meccano Outfit	5/-
" 0	" "	" " " " " "	7/6
" 1	" "	" " " " " "	12/6
" 2	" "	" " " " " "	23/-
" 3	" "	" " " " " "	35/-
" 4	" "	" " " " " "	60/-
" 5*	" " (Carton)	" " " " " "	80/-
" 5*	" Presentation Outfit	" " " " " "	125/-
" 6*	" Outfit (Carton)	" " " " " "	155/-
" 6*	" Presentation Outfit	" " " " " "	210/-
" 7	" "	" " " " " "	540/-

ACCESSORY OUTFITS

No. 00A	Meccano Outfit	2/6
" 0A	" "	" " " " " "	6/-
" 1A	" "	" " " " " "	11/6
" 2A	" "	" " " " " "	13/-
" 3A	" "	" " " " " "	26/-
" 4A	" "	" " " " " "	20/-
" 5A*	" " (Carton)	" " " " " "	75/-
" 5A*	" " (Wood)	" " " " " "	120/-
" 6A	" "	" " " " " "	300/-
	Meccano Clockwork Motor	" " " " " "	10/6
	Meccano Electric Motor No. 1 (4-Volt)	" " " " " "	27/6
	" " " " " " 2 (100-120 or 200-250-Volt)	" " " " " "	60/-
	Lamp Board (with lamp-holder and switch)	" " " " " "	7/6
	Meccano Electrical Outfit X2	" " " " " "	70/-
	Meccano Accumulator, 4-Volt 8 amp.	" " " " " "	30/-
	" " 4-Volt 20 amp.	" " " " " "	42/-

* Outfits Nos. 5, 5A and 6 are supplied in neat and well-made cardboard boxes (cartons) or in superior oak cabinets, with lock and key.

Hornby Train Sets Price List

Series M, No. 1	Passenger Set	12/6
" "	2 Passenger Set	" " " " " "	15/6
" "	3 Goods Set	" " " " " "	25/-
Hornby No. 0	Goods Set	" " " " " "	30/-
" "	0 Passenger Set	" " " " " "	37/6
" "	1 Goods Set	" " " " " "	35/-
" "	1 Passenger Set	" " " " " "	42/6
" "	2 Goods Set	" " " " " "	57/6
" "	2 Pullman Set	" " " " " "	90/-
" "	2 Pullman Set fitted for Hornby Control	" " " " " "	97/6

Hornby No. 1	Tank Goods Set	40/-
" "	2 Tank Goods Set	" " " " " "	70/-
" "	2 Tank Passenger Set	" " " " " "	72/6
* "	2 Tank Passenger Set fitted for Hornby Control	" " " " " "	80/-
	Metropolitan Train Set No. 2 (4-Volt Electric)	" " " " " "	140/-
	*Metropolitan Train Set No. 3 (Clockwork)	" " " " " "	85/-
	Riviera "Blue" Train Set No. 1 (4-Volt Electric)	" " " " " "	127/6
	*Riviera "Blue" Train Set No. 2 (Clockwork)	" " " " " "	105/-

* All boys who make a hobby of Hornby Miniature Railway construction will welcome the latest development—the Hornby Control System. This system enables you to manipulate the Signals and Points, and to control the starting and stopping of the train entirely by the levers in the Signal Cabin. A folder is now available entitled "The Hornby Control System" which gives full details and a copy will be sent, post free, on request.

CONTENTS OF OUTFITS

N.O.	DESCRIPTION OF PART.	00	00A	0	0A	1	1A	2	2A	3	3A	4	4A	5	5A	6	6A	7
1	Perforated Strips, 12 $\frac{1}{2}$ "				4	4	6			10	2	12	4	16	32	48	2	50
1A	" " 9 $\frac{1}{2}$ "				3	7	7	14		18	3	21	5	26	24	50	10	12
1B	" " 7 $\frac{1}{2}$ "			4	3	1	1	2	4	6	2	6	2	4	8	8	2	14
2	" " 5 $\frac{1}{2}$ "																	
2A	" " 4 $\frac{1}{2}$ "																	
3	" " 3 $\frac{1}{2}$ "																	
4	" " 2 $\frac{1}{2}$ "			9	1	9	3	12	2	12	4	18	4	12	24	24	86	120
5	" " 2"																	
6	" " 1 $\frac{1}{2}$ "																	
6A	" " 1 $\frac{1}{4}$ "																	
7	Angle Girders, 14 $\frac{1}{2}$ "																	
7A	" " 12 $\frac{1}{2}$ "																	
8	" " 12"																	
8A	" " 10 $\frac{1}{2}$ "																	
8B	" " 7 $\frac{1}{2}$ "																	
9	" " 5 $\frac{1}{2}$ "																	
9A	" " 4 $\frac{1}{2}$ "																	
9B	" " 3 $\frac{1}{2}$ "																	
9C	" " 2 $\frac{1}{2}$ "																	
9D	" " 2"																	
9E	" " 1 $\frac{1}{2}$ "																	
9F	" " 1 $\frac{1}{4}$ "																	
10	Flat Brackets					5	3	8		8		8	4	12	4	16	4	24
11	Double Brackets			4	1	5	2	2	4	2	2	4	4	4	4	4	8	4
12	Angle Brackets, 3 $\frac{1}{2}$ " x 3 $\frac{1}{2}$ "			6	2	8	4	12	2	14	1	8	3	8	12	48	48	96
12A	" " 2 $\frac{1}{2}$ " x 2 $\frac{1}{2}$ "																	
12B	" " 1 $\frac{1}{2}$ " x 1 $\frac{1}{2}$ "																	
13	Axle Rods, 11 $\frac{1}{2}$ "																	
13A	" " 8 $\frac{1}{2}$ "																	
14	" " 6 $\frac{1}{2}$ "																	
15	" " 5 $\frac{1}{2}$ "																	
15A	" " 4 $\frac{1}{2}$ "																	
16	" " 3 $\frac{1}{2}$ "																	
16A	" " 2 $\frac{1}{2}$ "																	
16B	" " 2"																	
17	" " 1 $\frac{1}{2}$ "																	
18	" " 1 $\frac{1}{4}$ "																	
18A	" " 1"																	
18B	" " 8 $\frac{1}{2}$ "																	
19	Crank Handles																	
19A	Wheels, 3"																	
19B	Pulley Wheels, 3"																	
20	Flanged Wheels																	
20A	Pulley Wheels, 2"																	
21	" " 1 $\frac{1}{2}$ "																	
22	" " 1" (Fast)																	
22A	" " 1" (Loose)																	
23	" " $\frac{3}{4}$ " (Loose)																	
23A	" " $\frac{3}{8}$ " (Fast)																	
24	Bush Wheels																	
25	Fanion Wheels, 3 $\frac{1}{2}$ "																	
26	" " 3"																	
27	Gear Wheels, 50 Teeth																	
27A	" " 57																	
28	Contrate Wheels, 1 $\frac{1}{2}$ "																	
28A	" " 1 $\frac{1}{4}$ " (3 $\frac{1}{2}$ " diam.)																	
29	Bevel Gears																	
30	Gear Wheels, 17, 38 Teeth																	
31	Worm Wheels																	
32	Spanners																	
33	Spring Clips																	
34	Screw Drivers																	
35	Nuts and Bolts, 7/32"																	
36	" " 1/8"																	
37	Washers																	
38	Hanks of Cord																	
40	Propeller Blades																	
41	Spring Strips																	
43	Cranked Bent Strips																	
44	Double Bent Strips																	
45	Double Angle Strips, 2 $\frac{1}{2}$ " x 1 $\frac{1}{2}$ "																	
46	" " 2 $\frac{1}{2}$ " x 1 $\frac{1}{4}$ "																	
47	" " 1 $\frac{1}{2}$ " x 1 $\frac{1}{4}$ "																	
47A	" " 1 $\frac{1}{4}$ " x 1 $\frac{1}{4}$ "																	
48	" " 1 $\frac{1}{2}$ " x 3/8"																	
48A	" " 1 $\frac{1}{4}$ " x 3/8"																	
48B	" " 3/8" x 3/8"																	
48C	" " 4 $\frac{1}{8}$ " x 3/8"																	
48D	" " 5 $\frac{1}{8}$ " x 3/8"																	
50	Eye Pieces																	
52	Perforated Flanged Plates, 5 $\frac{1}{2}$ " x 2 $\frac{1}{2}$ "																	
52A	Flat Plates, 5 $\frac{1}{2}$ " x 3 $\frac{1}{2}$ "																	
53	Perforated Flanged Plates, 3 $\frac{1}{2}$ " x 2 $\frac{1}{2}$ "																	
53A	Flat Plates, 4 $\frac{1}{2}$ " x 2 $\frac{1}{2}$ "																	
54	Perforated Flanged Plates (Sector)																	
56	Instruction Manuals																	
	Meccano Standard Mechanisms Manual																	
	Hooks																	
57	" (Scientific)																	
57A	" (Loaded)																	
57B	Spring Cord, 40" length																	
58	Collars with Set Screws																	
59	Windmill Sails																	
61	Cranks																	
62	Threaded Cranks																	
63	Couplings																	
63A	Octagonal Couplings																	
63B	Strip Couplings																	
64	Threaded Bosses																	
65	Centre Forks																	

[CONTINUED OVERLEAF

MECCANO

Hornby's Original System, First Patented 1901

PATENTS AND DESIGNS

GREAT BRITAIN :

3,869/14	139,125	671,485	682,934
4,183/14	177,430	671,534	683,011
4,564/15	577,207	671,790	686,112
20,535/13	577,272	680,416	698,054
21,117/12	648,958	682,208	699,653
22,962/13	671,484	682,209	699,654

AUSTRALIA :

13,460/19
14,388/14
15,136/14

Meccano is more than a Toy

IT is important to remember that when a boy is playing with MECCANO he is using engineering parts in miniature, and that these parts act in precisely the same way as do the corresponding engineering elements in actual practice. No other system of model construction can be correct, and other toys which attempt the same object by other methods must avail themselves of constructive elements which are not correct engineering elements. Consequently, though a boy may succeed in building playthings with them, they are merely toys and nothing else, and his mind, as regards proper mechanical construction and methods, is distorted instead of instructed. He thus learns wrong principles, and when his ambition tempts him to invent or construct more elaborate models, he will find that he cannot do so because of the deficiencies of his non-mechanical system.

No Outfit is genuine unless it bears the Trade Mark MECCANO