



MECCANO



(TRADE MARKS 296321, 12633, 10274, 55/13476, 884/25, 2913)

INSTRUCTIONS

BOOK No. 1

3/6

Copyright by MECCANO LIMITED, LIVERPOOL, throughout the world

No. 27

AUSTRALIAN EDITION

A TALK WITH NEW MECCANO BOYS



MECCANO OUTFITS contain accurately-made and highly-finished engineering parts with which any known mechanical movement may be reproduced in model form. With Meccano you can accomplish more than with any other constructional toy, for no other system has its possibilities. No study is needed to enable you to build models with Meccano—the genius is in the Meccano parts.

Recently The New Meccano has been introduced, with many parts richly enamelled in colour. With these coloured parts you can make your models even more realistic and at the same time satisfy your artistic taste. The parts can be used for hundreds of models and to all they bring a delightful charm, enhancing the appearance of even the simplest models.

A complete list of Meccano parts, both coloured and nickelled, is to be found on pages 3 and 4.

You never come to the end of Meccano fun. There is always more ahead—always some new, ingenious and interesting model to build. Each one, as it is completed, “tuned up,” and set going, brings a joy and satisfaction beyond anything that you have ever previously experienced.

As you progress in Meccano you obtain a greater variety of parts, Gear-Wheels, Pulley-Wheels, Worm-Wheels, Couplings, Cranks, and all manner of perfectly-made real engineering parts. These enable you to construct complicated mechanical movements without any difficulty. The most wonderful feature of Meccano is that it is *real engineering*; it is fascinating and delightful and yet so simple that even an inexperienced boy may join in the fun without first having to study or learn anything.

HOW TO BUILD WITH MECCANO

FOLLOW the instructions closely at first, and build the models just as you see them. Then take each model and try to improve our design. Every model can be made in a dozen different ways. Screw up all the nuts and bolts firmly and you will find that you can play with the trucks, cranes, signals, etc., and obtain many hours of fun.

For convenience Meccano parts are sold in nine Outfits of varying size, numbered 00 to 7. The quality and finish of the parts are of the same high standard throughout the series, but as the Outfits increase in size they contain larger quantities and greater varieties of parts. Each Outfit may be converted into the one next higher by the purchase of an Accessory Outfit (see page 62). Thus, if a No. 2 is the first Outfit bought, it may be converted into a No. 3 by adding to it a No. 2A. A No. 3A would then convert it into a No. 4 and so on up to No. 7. In this way, no matter with what Outfit you commence, you may build it up by degrees to a No. 7.

The separate Meccano parts may be bought at any time in any quantity (see price list on pages 3 and 4).

“MECCANO STANDARD MECHANISMS”

THERE are a number of Meccano movements that have to a certain extent become standardised; that is to say, they may be applied to more than one model—in most cases without any alteration, but in some few instances with only slight alterations to the original movement. These have been collected and classified, and may now be obtained in the form of a new Manual entitled “Meccano Standard Mechanisms.” This publication consists of 48 pages, $9\frac{1}{2} \times 6\frac{1}{2}$ ”, and contains over 140 illustrations in half-tone. The various devices have been arranged so that immediate reference may be made to any particular motion that it is desired to incorporate in a model. No keen Meccano boy who wishes to embody correct engineering principles in his new structures will consider his equipment complete without a copy of “Meccano Standard Mechanisms.”

It will be observed that “Standard Mechanisms” are frequently mentioned in the instructions for building the larger models contained in this book. The “S.M.” Manual is included in Outfits 4A, 5, 6 and 7, and on referring to the details indicated the reader should have no difficulty whatever in understanding the construction of even the most intricate models. Although the Manual is not used in the smaller sets, all owners of Meccano Outfits should find it invaluable in assisting them in their model-building.



THE MECCANO GUILD

THE MECCANO GUILD is an organisation for boys, started at the request of boys and conducted as far as possible by boys. The Guild is a great fraternal organisation of which all Meccano boys should become members, for its primary object is to bring them together. The Guild makes these boys feel that they are all members of a great brotherhood, each trying to help the other to get the very best out of life and it cannot fail to have a profound effect for good on the lives of its members.



MECCANO GUILD
MEMBER'S CERTIFICATE.

MECCANO CLUBS

MECCANO CLUBS are founded and established under the guidance of the Guild Secretary at Headquarters and at the present time there are active Clubs in over one hundred towns and villages in the United Kingdom and in many countries Overseas. Each Club has its Leader, Secretary, Treasurer, and other officials all of whom, with the exception of the Leader, are boys. Write for information how to form a club, if there is no club near you.

Special awards are given to Club members for good work in connection with their Club and medallions are awarded in connection with the Recruiting Campaign, full particulars of which will be sent on request.

THE LIFE OF A MECCANO BOY

A MECCANO boy is the happiest boy in the world. He builds models from the Meccano Instruction books; invents new models; joins the Meccano Guild and a Meccano Club and by wearing the Guild badge proclaims himself to be the friend of millions of other Meccano boys all over the world. He reads the *Meccano Magazine* regularly and corresponds with his friend the Editor when he feels like it. Time never hangs heavily on his hands and he is too busy and happy to grumble.

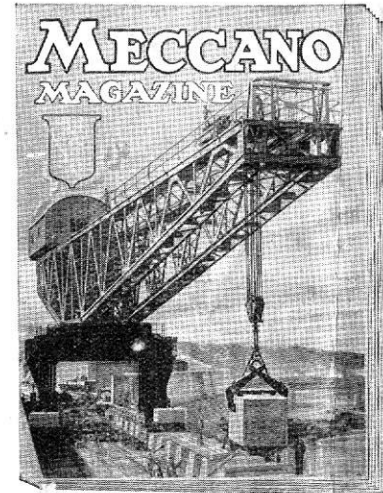
The *Meccano Magazine* is the Meccano boy's newspaper. It tells him of the latest Meccano models; what Meccano Clubs are doing; how to correspond with other Meccano boys; the Competitions that are running, etc. It contains interesting articles on engineering and electrical subjects, and deals with many other topics of interest to boys, including suggestions from Meccano boys for new Meccano parts and correspondence columns in which the Editor replies to his readers' enquiries. Write to the Editor, *Meccano Magazine*, Binns Road, Liverpool, enclosing 6d. in stamps. He will then forward a specimen copy, post free. The *Meccano Magazine* is sent regularly to subscribers at the rate of 4/- for six issues or 8/- for twelve issues, post free.



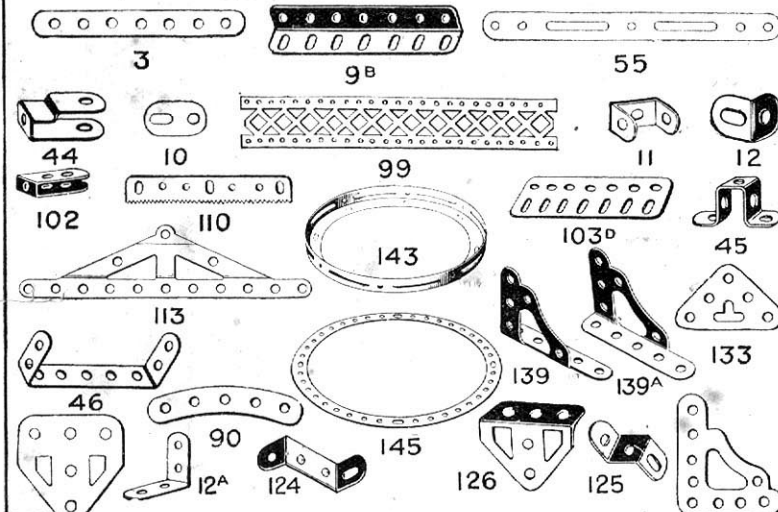
SPECIAL MERIT MEDALLIONS.



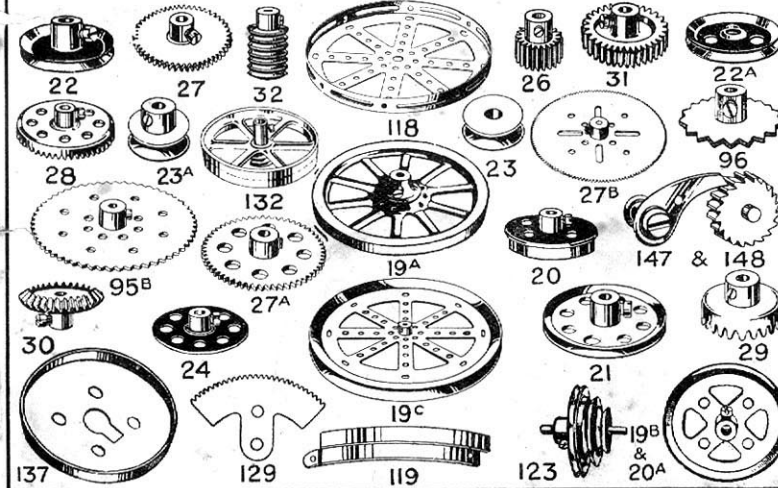
RECRUITING MEDALLION.



STRIPS, GIRDERS AND BRACKETS



WHEELS, GEARS, ETC.



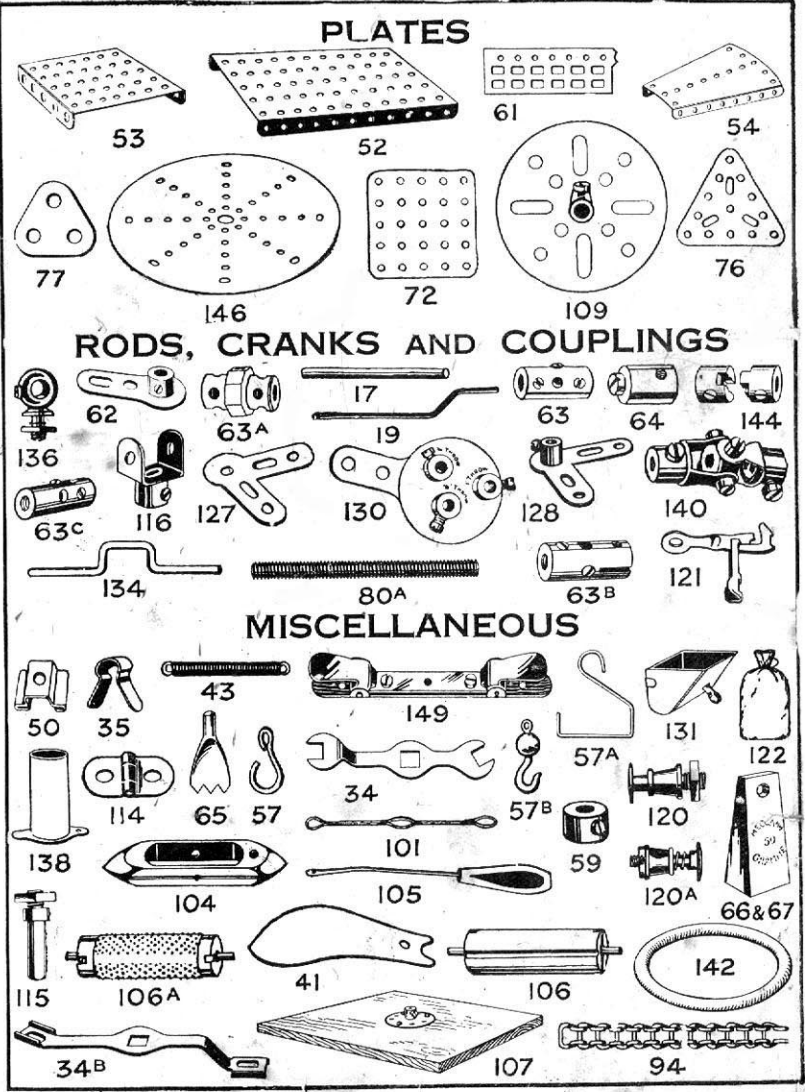
Particulars and Prices of Meccano Parts

No.	Description	Quantity	Price	No.	Description	Quantity	Price
1.	Perforated Strips, 12 $\frac{1}{2}$ " long	... 1 doz.	1 6	31.	Gear Wheels, 1", 38 teeth	... each	1 6
1a.	" " " 9 $\frac{1}{2}$ " "	" " "	1 3	32.	Worm Wheels	" " "	0 9
1b.	" " " 7 $\frac{1}{2}$ " "	" " "	1 0	34.	Spanners	" " "	0 3
2.	" " " 5 $\frac{1}{2}$ " "	" " "	0 9	34a.	" Combined	" " "	0 3
2a.	" " " 4 $\frac{1}{2}$ " "	" " "	0 8	34b.	Box Spanners	" " "	0 5
3.	" " " 3 $\frac{1}{2}$ " "	" " "	0 6	35.	Spring Clips	... per box (doz.)	0 5
4.	" " " 3"	" " "	0 5	36.	Screw Drivers	" " "	0 9
5.	" " " 2 $\frac{1}{2}$ " "	" " "	0 5	36a.	" Extra Long	" " "	0 9
6.	" " " 2"	" " "	0 5	37.	Nuts and Bolts, 7/32"	... per box (doz.)	0 9
6a.	" " " 1 $\frac{1}{2}$ " "	" " "	0 5	37a.	Nuts	" " "	0 5
7.	Angle Girders, 24 $\frac{1}{2}$ " long	... each	1 0	37b.	Bolts, 7/32"	" " "	0 5
7a.	" " " 18 $\frac{1}{2}$ " "	" " "	0 9	38.	Washers	" " "	0 2
8.	" " " 12 $\frac{1}{2}$ " "	" " "	0 9	40.	Hanks of Cord	" " "	0 3
8a.	" " " 9 $\frac{1}{2}$ " "	" " "	2 0	*41.	Propeller Blades	... per pair	0 6
8b.	" " " 7 $\frac{1}{2}$ " "	" " "	1 9	43.	Springs	" " "	0 3
9.	" " " 5 $\frac{1}{2}$ " "	" " "	1 6	44.	Cranked Bent Strips	" " "	0 2
9a.	" " " 4 $\frac{1}{2}$ " "	" " "	1 2	45.	Double Bent Strips	" " "	0 2
9b.	" " " 3 $\frac{1}{2}$ " "	" " "	1 0	46.	Double Angle Strips, 2 $\frac{1}{2}$ " x 1 $\frac{1}{2}$ "	... 1 doz.	0 9
9c.	" " " 3"	" " "	1 0	47.	" " " 2 $\frac{1}{2}$ " x 1 $\frac{1}{2}$ "	" " "	1 3
9d.	" " " 2 $\frac{1}{2}$ " "	" " "	1 0	47a.	" " " 3" x 1 $\frac{1}{2}$ "	" " "	1 6
9e.	" " " 2"	" " "	0 9	48.	" " " 1 $\frac{1}{2}$ " x 1 $\frac{1}{2}$ "	" " "	0 6
9f.	" " " 1 $\frac{1}{2}$ " "	" " "	0 9	48a.	" " " 2 $\frac{1}{2}$ " x 1 $\frac{1}{2}$ "	" " "	0 8
10.	Flat Brackets	" " "	0 3	48b.	" " " 3 $\frac{1}{2}$ " x 1 $\frac{1}{2}$ "	" " "	0 9
11.	Double Brackets	" " "	1 1	48c.	" " " 4 $\frac{1}{2}$ " x 1 $\frac{1}{2}$ "	" " "	1 3
12.	Angle Brackets, 1 $\frac{1}{2}$ " x 1 $\frac{1}{2}$ "	... each	0 9	48d.	" " " 5 $\frac{1}{2}$ " x 1 $\frac{1}{2}$ "	" " "	1 3
12a.	" " " 1" x 1"	" " "	0 9	50.	Eye Pieces	" " "	0 3
12b.	" " " 1" x 1"	" " "	1 1	*51.	Perforated Flanged Plates, 5 $\frac{1}{2}$ " x 2 $\frac{1}{2}$ "	" " "	0 8
13.	Axle Rods, 11 $\frac{1}{2}$ " long	" " "	0 5	*52a.	Flat Plates, 5 $\frac{1}{2}$ " x 3 $\frac{1}{2}$ "	" " "	0 8
13a.	" " " 8"	" " "	0 5	*53.	Perforated Flanged Plates, 3 $\frac{1}{2}$ " x 2 $\frac{1}{2}$ "	" " "	0 5
14.	" " " 6 $\frac{1}{2}$ " "	" " "	0 3	*53a.	Flat Plates, 4 $\frac{1}{2}$ " x 2 $\frac{1}{2}$ "	" " "	0 5
15.	" " " 5 $\frac{1}{2}$ " "	" " "	0 3	*54.	Perforated Flanged Sector Plates	" " "	0 5
15a.	" " " 4 $\frac{1}{2}$ " "	" " "	0 2	55.	Perforated Strips, slotted, 5 $\frac{1}{2}$ " long	" " "	0 3
16.	" " " 4"	" " "	0 2	55a.	" " "	" " "	0 2
16a.	" " " 3 $\frac{1}{2}$ " "	" " "	0 2	56.	Instruction Manuals, Complete	" " "	3 6
16b.	" " " 3"	" " "	0 2	56a.	" " No. 0-3	" " "	1 6
17.	" " " 2 $\frac{1}{2}$ " "	" " "	0 2	56b.	" " No. 0	" " "	0 6
18a.	" " " 1 $\frac{1}{2}$ " "	" " "	0 2	57.	Hooks	" " "	0 2
18b.	" " " 1"	" " "	0 1	57a.	" (scientific)	" " "	0 2
19.	Crank Handles	" " "	0 5	57b.	" Loaded	" " "	0 8
19a.	Wheels, 3" diam., with set screws	" " "	1 0	58.	Spring Cord	... per length	1 3
20.	Flanged Wheels	" " "	0 9	59.	Collars with Set Screws	" " "	0 3
	Pulley Wheels.			*61.	Windmill Sails	" " "	0 3
19b.	3" dia. with centre boss and set screw	" " "	1 0	62.	Cranks	" " "	0 5
19c.	6"	" " "	3 9	62a.	Threaded Cranks	" " "	0 6
20a.	2"	" " "	0 9	63.	Couplings	" " "	0 9
21.	1 $\frac{1}{2}$ "	" " "	0 9	63a.	Octagonal Couplings	" " "	1 0
22.	1"	" " "	0 6	63b.	Strip Couplings	" " "	1 0
22a.	" without	" " "	0 6	63c.	Threaded Couplings	" " "	0 9
22a.	" without	" " "	0 3	64.	Threaded Bosses	" " "	0 3
23.	" " "	" " "	0 3	65.	Centre Forks	" " "	0 3
24.	Bush Wheels	" " "	0 9	66.	Weights, 50 grammes	" " "	1 6
25.	Pinion Wheels, 1 $\frac{1}{2}$ " diam.	" " "	0 9	67.	" 25	" " "	1 6
26.	" " "	" " "	0 6	68.	Wood Screws, 1"	... doz.	0 5
	Gear Wheels.			69.	Set Screws	" " "	0 6
27.	50 teeth to gear with 3" pinion	" " "	1 3	69a.	Grub Screws, 5/32"	" " "	0 6
27a.	57	" " "	1 3	69b.	" 7/32"	" " "	0 9
27b.	133	" " "	2 3	*70.	Flat Plates, 5 $\frac{1}{2}$ " x 2 $\frac{1}{2}$ "	... each	0 5
28.	Contrate Wheels, 1 $\frac{1}{2}$ " diam.	" " "	1 3	*72.	2 $\frac{1}{2}$ " x 2 $\frac{1}{2}$ "	" " "	0 3
29.	" " "	" " "	0 9	*76.	Triangular Plates, 2 $\frac{1}{2}$ "	" " "	0 3
30.	Bevel Gears	" " "	1 3				

IMPORTANT.—All Meccano parts marked thus * are available with either red or nickel finish and all marked thus † are available with either green or nickel finish. When ordering nickelled parts quote only the numbers now shown in the list. When coloured parts are required add letter X to the distinguishing numbers under which they are listed. Thus part No. 99 would be ordered as 99x; part No. 99a as 99ax and so on.

Particulars and Prices of Meccano Parts (continued)

No.		s.	d.	No.		s.	d.
*77.	Triangular Plates, 1"	each	0 2	111a.	Bolts, 1/2"	2 for	0 1 1/2
78.	Screwed Rods, 1 1/2"	"	0 9	111c.	" 3/8"	doz.	0 6
79.	" " 8"	"	0 8	113.	Girder Frames	each	0 3
79a.	" " 6"	"	0 6	114.	Hinges	per pair	0 6
80.	" " 5"	"	0 5	115.	Threaded Pins	each	0 3
80a.	" " 3 1/2"	"	0 5	116.	Fork Pieces	"	0 5
80b.	" " 4 1/2"	"	0 5	117.	Steel Balls, 5/8" diam.	doz.	0 9
81.	" " 2"	"	0 3	*118.	Hub Discs, 5 1/2" diam.	each	1 9
82.	" " 1"	"	0 2	*119.	Channel Segments (8 to circle, 1 1/2" diam.)	"	0 6
89.	Curved Strips, 5 1/2"	"	0 3	120.	Buffers	"	0 3
90.	" " 2 1/2" large radius	"	0 2	120a.	Spring Buffers	per pair	1 0
*90a.	" " 2 1/2" small radius	"	0 2	121.	Train Couplings	each	0 3
94.	Sprocket Chain	per 40" length	0 9	122.	Miniature Loaded Sacks	"	0 3
95.	Sprocket Wheels, 2" diam.	each	0 8	123.	Cone Pulleys	"	2 0
95a.	" " 1 1/2" "	"	0 6	124.	Reversed Angle Brackets, 1"	1/2 doz.	1 3
95b.	" " 3" "	"	0 9	125.	" " "	"	0 9
96.	" " 1" "	"	0 5	*126.	Trunnions	each	0 4
96a.	" " 3" "	"	0 5	*126a.	Flat Trunnions	"	0 3
*97.	Braced Girders, 3 1/2" long	1/2 doz.	1 3	127.	Simple Bell Cranks	"	0 4
*97a.	" " 3" "	"	1 0	128.	Boss Bell Cranks	"	0 6
*98.	" " 2 1/2" "	"	0 9	129.	Rack Segments, 3" diam.	"	0 9
*99.	" " 1 2 1/2" "	"	2 9	130.	Triple Throw Eccentrics	"	2 0
*99a.	" " 9 1/2" "	"	2 6	*131.	Dredger Buckets	"	0 3
*99b.	" " 7 1/2" "	"	2 0	132.	Flywheels, 2 3/4" diam.	"	3 6
†100.	" " 5 1/2" "	"	1 6	*133.	Corner Brackets	"	0 5
†100a.	" " 4 1/2" "	"	1 6	134.	Crank Shafts, 1" stroke	"	0 5
101.	Heads, for looms	doz.	1 3	135.	Theodolite Protractors	"	0 4
102.	Single Bent Strips	each	0 2	136.	Handrail Supports	"	0 5
103.	Flat Girders, 5 1/2" long	1/2 doz.	1 6	137.	Wheel Flanges	"	0 6
103a.	" " 9 1/2" "	"	2 3	138.	Ship's Funnels	"	0 6
103b.	" " 12 1/2" "	"	3 0	*139.	Flanged Brackets (right)	"	0 3
103c.	" " 4 1/2" "	"	1 3	*139a.	" (left)	"	0 3
103d.	" " 3 1/2" "	"	1 0	140.	Universal Couplings	"	1 3
103e.	" " 3" "	"	0 9	141.	Wire Lines (for suspending clock weights)	"	1 0
103f.	" " 2 1/2" "	"	0 8	142.	Rubber Rings	"	0 6
103g.	" " 2" "	"	0 6	142a.	Dunlop Tyre, 2"	"	0 6
103h.	" " 1 1/2" "	"	0 5	142b.	" 3" "	"	0 9
103k.	" " 7 1/2" "	"	2 0	*143.	Circular Girders, 5 1/2" diam.	"	1 6
104.	Shuttles, for looms	each	6 0	144.	Dog Clutches	"	0 9
105.	Reed Hooks, for looms	"	0 6	*145.	Circular Strips, 7" diam. over all	"	1 6
106.	Wood Rollers	"	2 0	*146.	" Plates, 6"	"	1 9
106a.	Sand Rollers	"	2 3	147.	Pawls, with pivot bolt and nuts	"	0 5
107.	Tables for Designing Machines	"	1 6	147a.	Pawls	"	0 3
*108.	Architraves	"	0 3	147b.	Pivot Bolt with nuts	"	0 3
*109.	Face Plates, 2 1/2" diam.	"	0 6	148.	Ratchet Wheels	"	1 3
110.	Rack Strips, 3 1/2"	"	0 3	149.	Collecting Shoes, for Electric Locos	"	2 3
111.	Bolts, 3/4"	"	0 1 1/2				

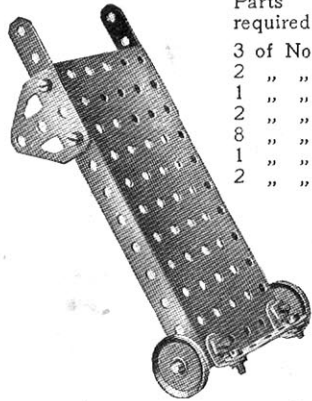


IMPORTANT.—All Meccano parts marked thus * are available with either red or nickel finish and all marked thus † are available with either green or nickel finish. When ordering nickelled parts quote only the numbers now shown in the list. When coloured parts are required add letter X to the distinguishing numbers under which they are listed. Thus part No. 99 would be ordered as 99X; part No. 99a as 99aX and so on.

As new parts are frequently added to the Meccano system the foregoing list is not necessarily complete. The latest illustrated list should be obtained from your dealer, or from Meccano Ltd., Liverpool, England.

Trucks and Luggage Carts

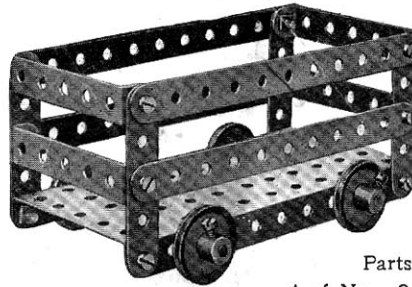
**Model No. 1
Flat Truck**



Parts
required:

3 of No.	5
2 " "	12
1 " "	16
2 " "	22
8 " "	37
1 " "	52
2 " "	126A

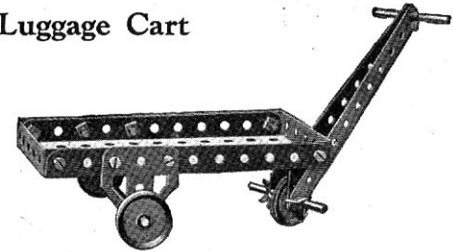
**Model No. 2
Truck with Sides**



Parts required:

4 of No.	2	4 of No.	22
4 " "	5	12 " "	37
2 " "	16	4 " "	48A
		1 of No.	52

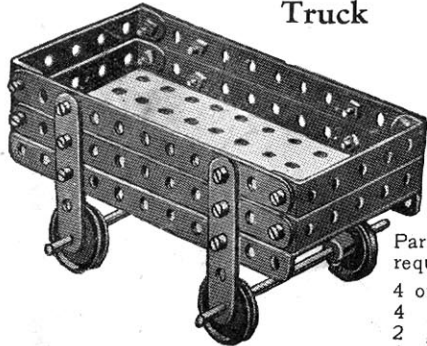
**Model No. 3
Luggage Cart**



Parts required:

2 of No.	2	9 of No.	37
1 " "	16	1 " "	44
2 " "	17	2 " "	48A
3 " "	22	1 " "	52
4 " "	35	2 " "	126A

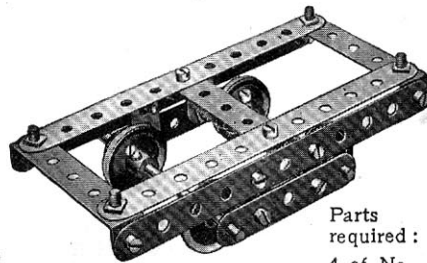
**Model No. 4
Truck**



Parts
required:

4 of No.	2
4 " "	5
2 " "	16
4 " "	22
16 " "	37
4 " "	48A
1 " "	52

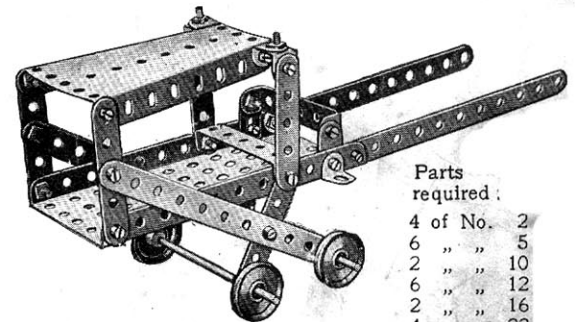
**Model No. 5
Bogie Truck**



Parts
required:

4 of No.	2
3 " "	5
4 " "	10
2 " "	16
4 " "	22
18 " "	37
2 " "	48A

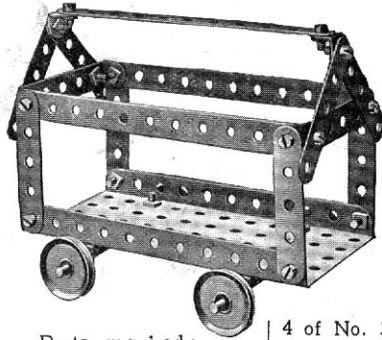
Model No. 6 Ticca Gharry



Parts
required:

4 of No.	2
6 " "	5
2 " "	10
6 " "	12
2 " "	16
4 " "	22
22 " "	37
1 " "	52
1 " "	54

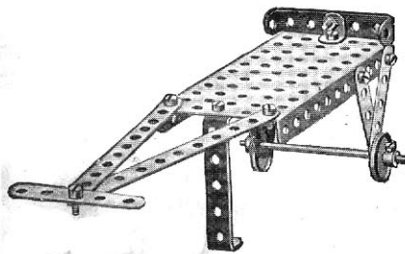
Model No. 7
Covered Truck



Parts required:

4 of No. 22	20 " " 37
3 of No. 2	2 of No. 12
4 " " 48A	1 " " 52

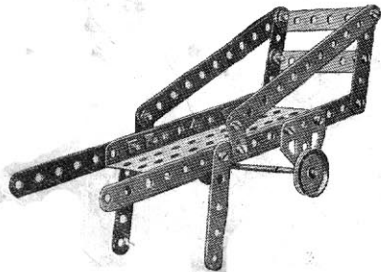
Model No. 10 Shipyard Bogie



Parts required:

2 of No. 2	5 " " 5	1 " " 12	2 " " 22	10 " " 37	2 " " 48A	1 " " 52
------------	---------	----------	----------	-----------	-----------	----------

Model No. 13 Coster's Barrow

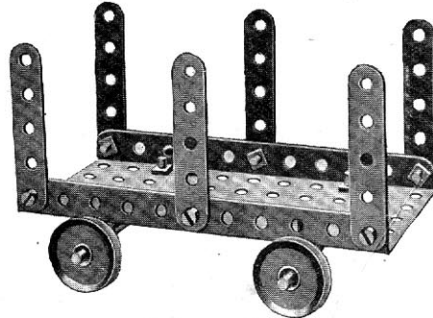


Parts required:

4 of No. 2	4 " " 5	1 " " 16	2 " " 22	16 " " 37	2 " " 48A	1 " " 52	2 " " 126A
------------	---------	----------	----------	-----------	-----------	----------	------------

Trucks and Luggage Carts *(continued)*

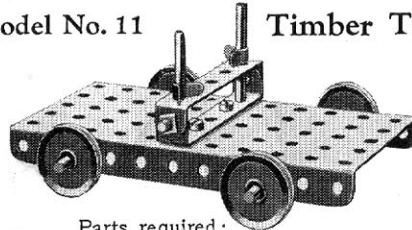
Model No. 8 Timber Truck



Parts required:

6 of No. 5	10 of No. 37
2 " " 16	2 " " 48A
4 " " 22	1 " " 52

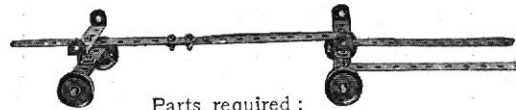
Model No. 11 Timber Truck



Parts required:

2 of No. 16	4 of No. 35
2 " " 17	4 " " 37
4 " " 22	2 " " 48A
1 of No. 52	

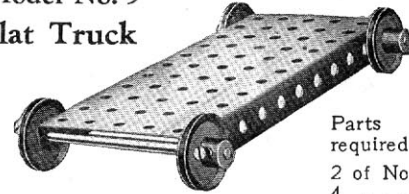
Model No. 14 Timber Drag



Parts required:

4 of No. 2	2 of No. 16	8 of No. 37
2 " " 11	4 " " 22	4 " " 48A

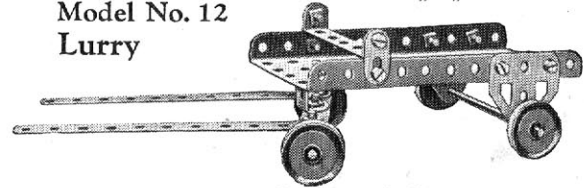
Model No. 9
Flat Truck



Parts required:

2 of No. 16
4 " " 22
1 " " 52

Model No. 12
Lurry



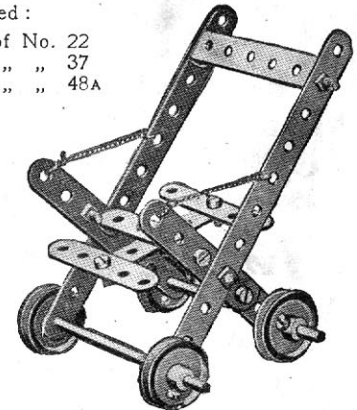
Parts required:

2 of No. 2	2 of No. 16	2 of No. 48A
2 " " 10	4 " " 22	1 " " 52
1 " " 11	12 " " 37	2 " " 126A

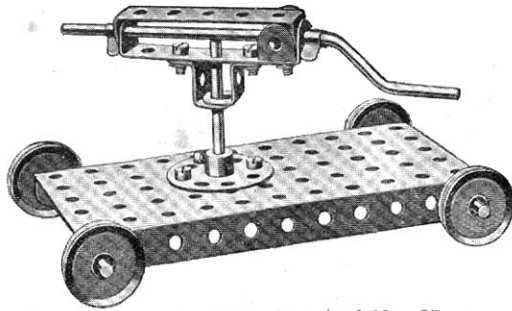
Model No. 15 Go Chair

Parts required:

2 of No. 2	4 of No. 22
7 " " 5	11 " " 37
2 " " 16	2 " " 48A



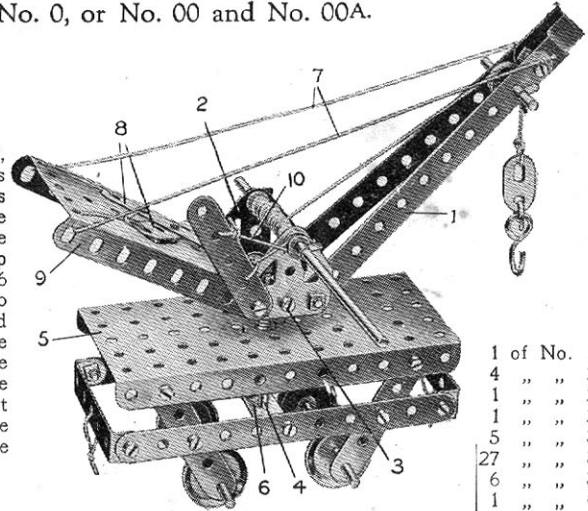
Model No. 16 Rock Drill



Parts required:	1 of No. 19	4 of No. 37
	4 " " 22	2 " " 48A
	2 of No. 16	1 " " 24
	1 " " 17	2 " " 35
		1 " " 52
		2 " " 125

Model No. 17 Travelling Crane

The jib 1 is pivoted to the flat trunnions 2, which are bolted at 3 to angle brackets secured to a bush wheel. The latter is nipped to a 2" rod 4 passing through the plate 5 and further supported in a double angle strip 6. A washer and spring clip mounted on the rod 4 below the strip 6 secure the crane to the carriage. The jib is supported by means of cords 7 tied to 2 1/2" strips 8, the holes of which engage the shank of a bolt passed through the sector plate 9, and its elevation may be altered by inserting this bolt in different holes in the strips 8. The cord 10 of the brake lever is wound once round the crank handle, between two washers.



	1 of No. 19
	4 " " 22
	1 " " 23A
	1 " " 24
	5 " " 35
	27 " " 37
	6 " " 38
	1 " " 44
	3 " " 48A
	1 " " 52
	1 " " 54
	1 " " 57
	2 " " 126A

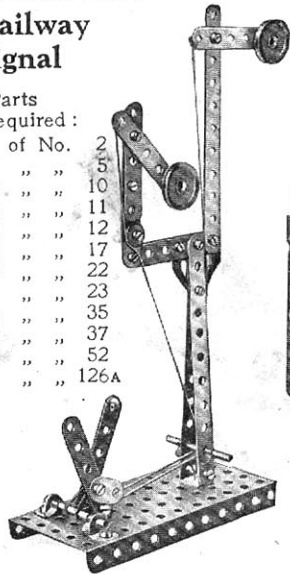
Parts required:

4 of No. 2	2 of No. 12
7 " " 5	2 " " 16
1 " " 10	2 " " 17

Model No. 18 Railway Signal

Parts required:

3 of No. 2
7 " " 5
2 " " 10
2 " " 11
2 " " 12
2 " " 17
2 " " 22
1 " " 23
4 " " 35
21 " " 37
1 " " 52
1 " " 126A



Model No. 19 Potter's Wheel

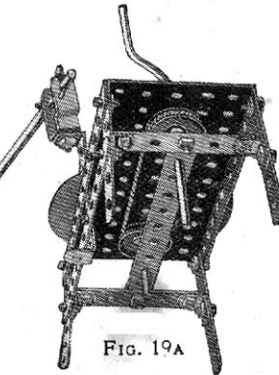
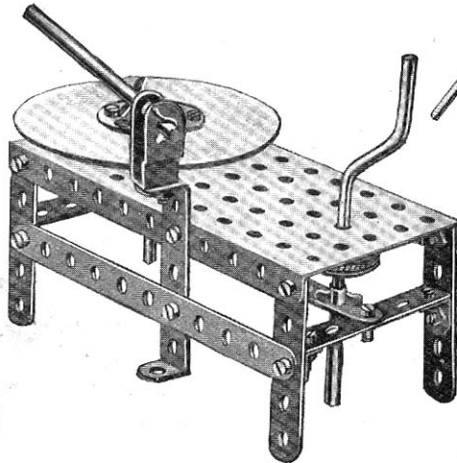
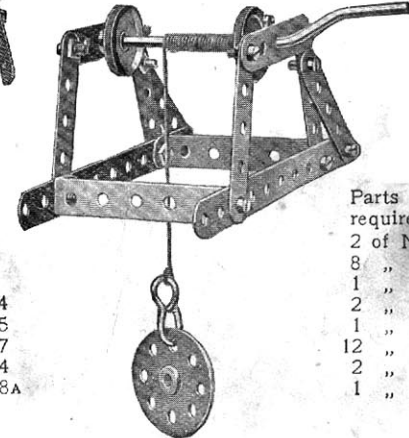


FIG. 19A

Parts required:

3 of No. 2	1 of No. 24
4 " " 5	2 " " 35
1 " " 16	17 " " 37
1 " " 19	1 " " 44
2 " " 22	3 " " 48A
	1 of No. 52

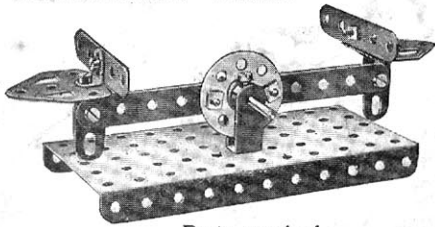
Model No. 20 Well Windlass



Parts required:

2 of No. 2
8 " " 5
1 " " 19
2 " " 22
1 " " 24
12 " " 37
2 " " 48A
1 " " 57

Model No. 21 Scales



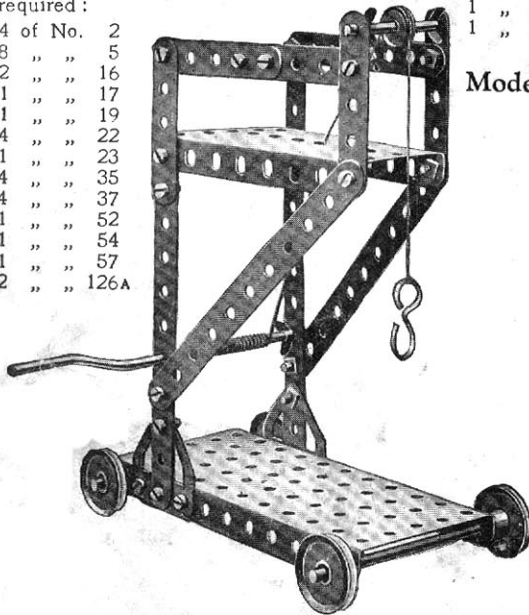
Parts required :

1 of No. 2	2 of No. 12	1 of No. 44
2 " " 5	1 " " 17	1 " " 52
2 " " 10	1 " " 24	2 " " 126A
	9 " " 37	

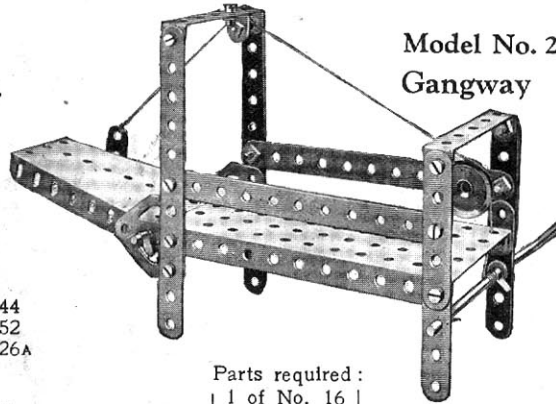
Model No. 24 Tower Wagon

Parts required :

4 of No. 2	8 " " 5
2 " " 16	1 " " 17
1 " " 19	4 " " 22
1 " " 23	4 " " 35
24 " " 37	1 " " 52
1 " " 54	1 " " 57
2 " " 126A	



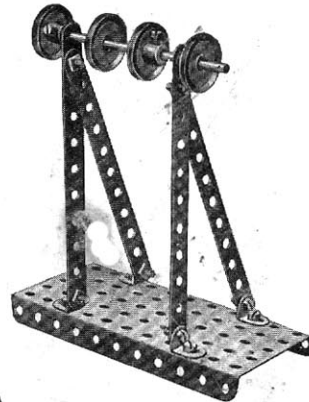
Model No. 22 Gangway



Parts required :

4 of No. 2	1 of No. 16	2 of No. 48A
4 " " 5	1 " " 19	1 " " 52
1 " " 10	1 " " 22	1 " " 54
1 " " 12	1 " " 23	2 " " 126A
	4 " " 35	
	18 " " 37	

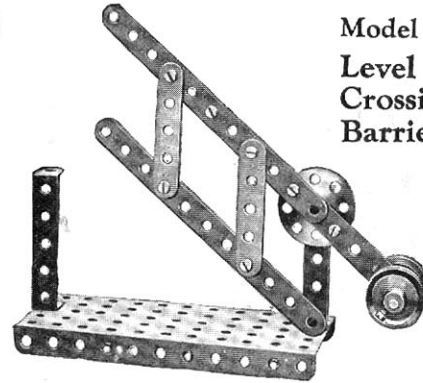
Model No. 25 Pulley Shaft



Parts required :

4 of No. 2	10 of No. 37
4 " " 12	2 " " 38
1 " " 16	1 " " 52
4 " " 22	

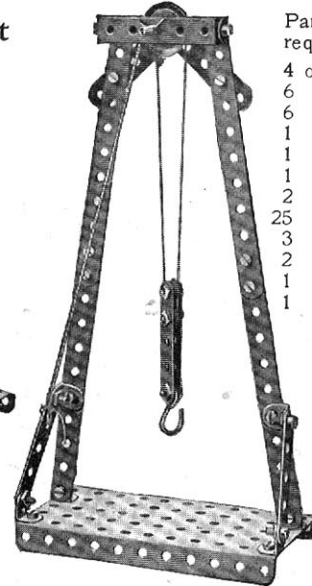
Model No. 23 Level Crossing Barrier



Parts required :

3 of No. 2	
2 " " 5	
1 " " 17	
4 " " 22	
1 " " 24	
10 " " 37	
2 " " 48A	
1 " " 52	

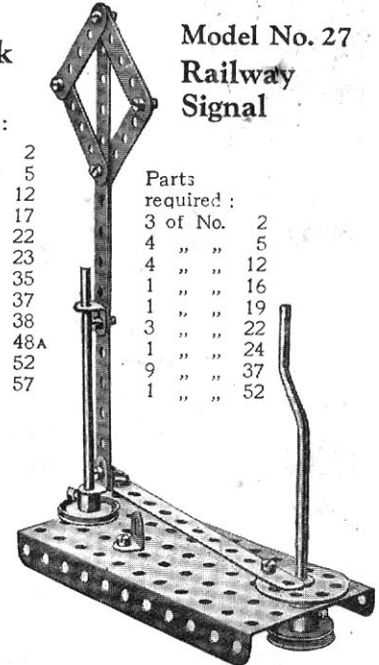
Model No. 26 Hoisting Block



Parts required :

4 of No. 2	6 " " 5
6 " " 12	6 " " 17
1 " " 22	1 " " 23
1 " " 23	2 " " 35
2 " " 35	25 " " 37
3 " " 38	3 " " 48A
2 " " 48A	1 " " 52
1 " " 52	1 " " 57

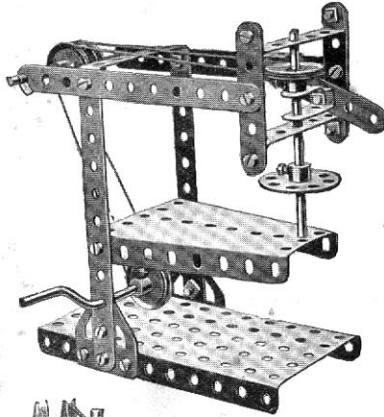
Model No. 27 Railway Signal



Parts required :

3 of No. 2	
4 " " 5	
4 " " 12	
1 " " 16	
1 " " 19	
3 " " 22	
1 " " 24	
9 " " 37	
1 " " 52	

Model No. 28 Drilling Machine

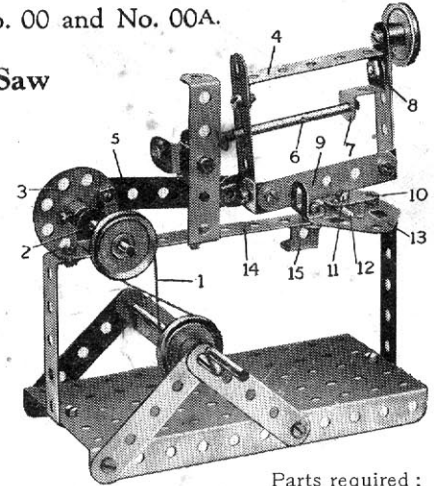


Parts required :

4 of No.	2
3 "	5
1 "	11
2 "	16
1 "	19
4 "	22
1 "	24
4 "	35
19 "	37
1 "	44
3 "	48A
1 "	52
1 "	54
2 "	126A

Model No. 29 Mechanical Saw

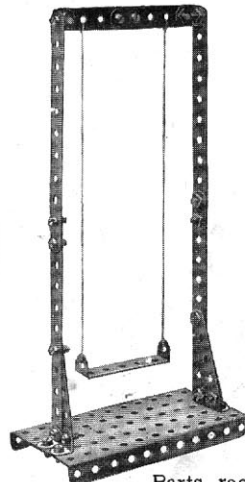
The strip 9 represents the saw. The crank handle drives through a belt 1 a short rod journalled in a double bracket 2 and carrying a bush wheel 3. The latter imparts a reciprocating motion to the saw frame 4 through a 2 1/4" strip 5 loosely mounted on bolts secured to the bush wheel and to an angle bracket bolted to the saw frame. This frame slides on a 3 1/4" rod 6, which acts as a guide, passing through the frame and supported in a reversed angle bracket 7. A washer is placed on the bolt 8 behind the bracket 7. A vice to secure the objects in position for cutting consists of a flat bracket 10 mounted on a bolt 11, a few turns of which causes the flat bracket to grip the object 12. The bolt 11 enters a nut held between the flat trunnion 13 and 5 1/4" strip 14, which are spaced apart for the purpose by washers placed on the two bolts holding the trunnion in position. The saw frame rests on the stop 15 when not in use. A 1" pulley secured to the top of the frame acts as a weight and helps to steady the saw.



Parts required :

1 of No.	2	1 of No.	17	4 of No.	38
8 "	5	1 "	19	1 "	44
1 "	10	3 "	22	4 "	48A
1 "	11	1 "	24	1 "	52
4 "	12	3 "	35	2 "	125
1 "	16	22 "	37	1 "	126A

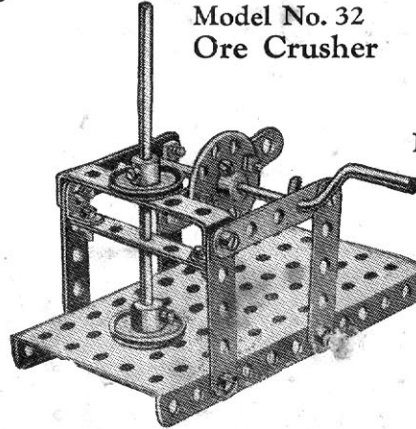
Model No. 31 Swing



Parts required :

4 of No.	2	20 of No.	37
4 "	5	1 "	48A
6 "	12	1 "	52

Model No. 32 Ore Crusher



Parts required :

6 of No.	5	1 of No.	24
2 "	10	2 "	35
1 "	16	10 "	37
1 "	19	2 "	48A
2 "	22	1 "	52

Model No. 33 Jib Crane

Parts required :

4 of No.	2	1 of No.	23
9 "	5	1 "	24
2 "	16	4 "	35
1 "	17	17 "	37
1 "	19	1 "	48A
4 "	22	1 "	52
		1 of No.	57

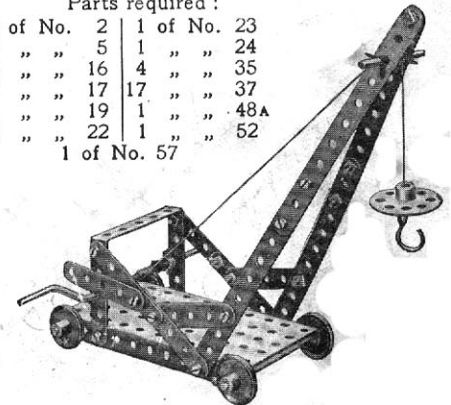
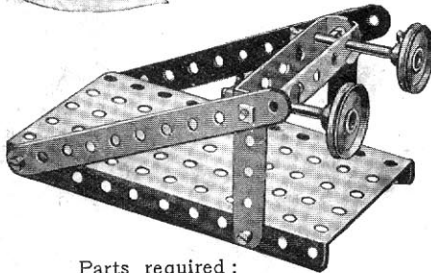


FIG. 28A
(Detail of
Drilling
Machine)

Model No. 30 Buffers



Parts required :

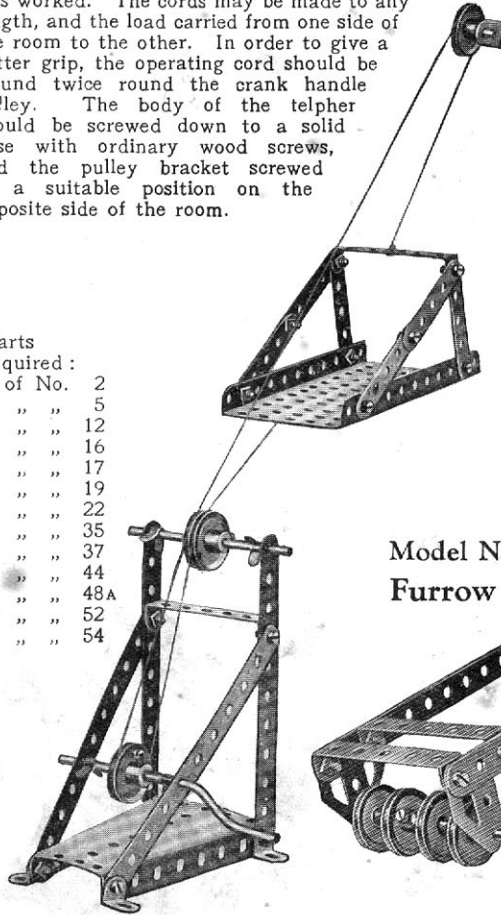
2 of No.	2	2 of No.	35
2 "	5	6 "	37
2 "	17	2 "	48A
2 "	22	1 "	52

Model No. 34 Telfer Span

Many hours of enjoyment may be obtained from this model. The illustration shows exactly how it is worked. The cords may be made to any length, and the load carried from one side of the room to the other. In order to give a better grip, the operating cord should be wound twice round the crank handle pulley. The body of the telfer should be screwed down to a solid base with ordinary wood screws, and the pulley bracket screwed in a suitable position on the opposite side of the room.

Parts required:

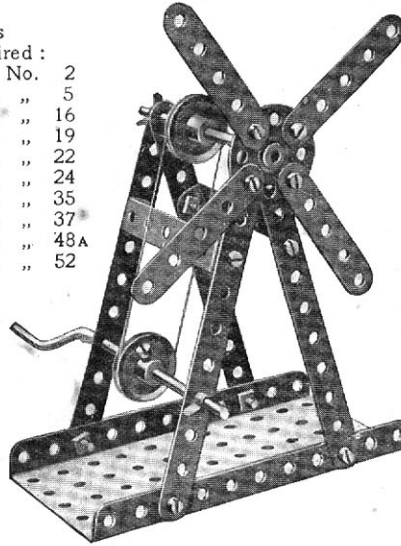
4	of No.	2
6	" "	5
4	" "	12
1	" "	16
1	" "	17
1	" "	19
4	" "	22
6	" "	35
14	" "	37
1	" "	44
2	" "	48A
1	" "	52
1	" "	54



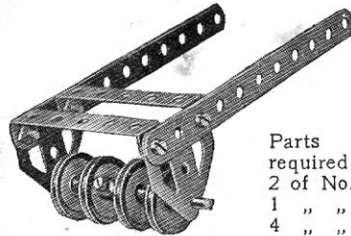
Model No. 35 Windmill

Parts required:

4	of No.	2
4	" "	5
1	" "	16
1	" "	19
2	" "	22
1	" "	24
4	" "	35
12	" "	37
2	" "	48A
1	" "	52



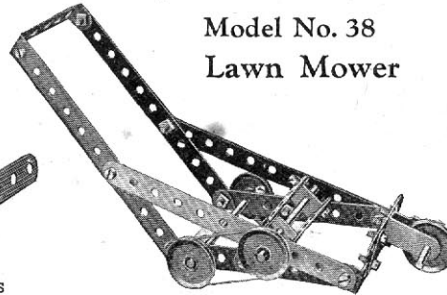
Model No. 37 Furrow Roller



Parts required:

2	of No.	2
1	" "	16
4	" "	22
4	" "	37
2	" "	48A
2	" "	126A

Model No. 38 Lawn Mower



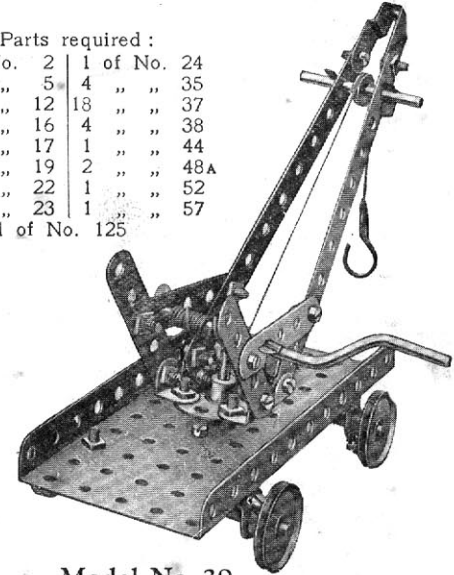
Parts required:

4	of No.	2	1	of No.	17
7	" "	5	4	" "	22
2	" "	11	19	" "	37
2	" "	16	1	" "	44
			3	of No.	48A

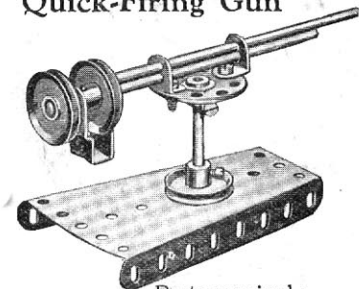
Model No. 36 Swivelling Crane

Parts required:

2	of No.	2	1	of No.	24
4	" "	5	4	" "	35
4	" "	12	18	" "	37
2	" "	16	4	" "	38
2	" "	17	1	" "	44
1	" "	19	2	" "	48A
4	" "	22	1	" "	52
1	" "	23	1	" "	57
			1	of No.	125



Model No. 39 Quick-Firing Gun

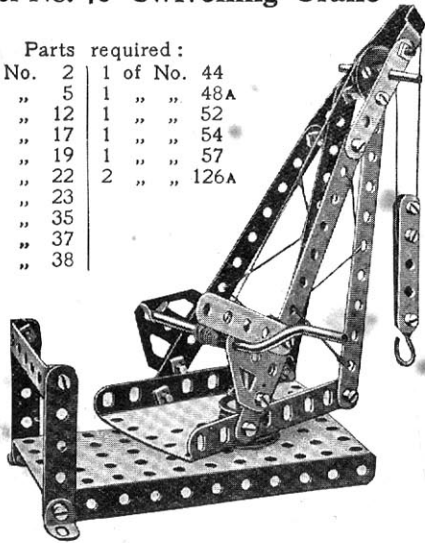


Parts required:

2	of No.	12	1	of No.	24
2	" "	16	4	" "	37
1	" "	17	1	" "	44
2	" "	22	1	" "	54

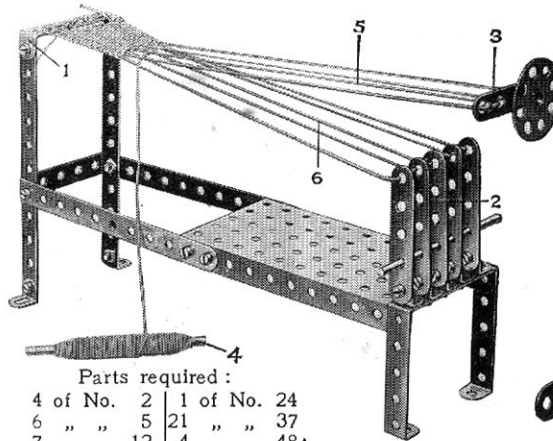
Model No. 40 Swivelling Crane

Parts required:			
4 of No.	2	1 of No.	44
7 "	5	1 "	48A
2 "	12	1 "	52
2 "	17	1 "	54
1 "	19	1 "	57
4 "	22	2 "	126A
1 "	23		
2 "	35		
21 "	37		
3 "	38		



The sector plate of the Crane in this model is pivoted to the base with a fast pulley above and below.

Model No. 41 Hand Loom



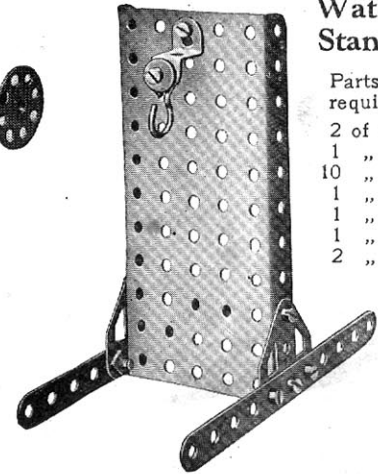
Parts required:			
4 of No.	2	1 of No.	24
6 "	5	21 "	37
7 "	12	4 "	48A
2 "	16	1 "	52

The warp threads are tied at one end to a double angle strip 1, whilst their other ends are secured alternately to the tops of the upright strips 2, and the 2 1/2" strip 3. The "shedding" movement of the warp is obtained by moving the strip 3 up or down each time the shuttle—a 3 1/2" rod 4—is passed between the two layers of warp 5 and 6. Wool or similar material is particularly suited to this apparatus. The strands 6 should be kept very taut, and the weft threads may be closed up with the woven portion by means of an ordinary comb each time the shuttle passes.

Model No. 42 Watch Stand

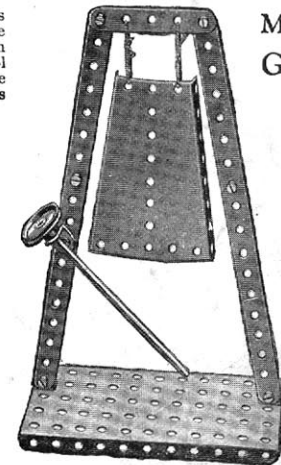
Watch Stand

Parts required:			
2 of No.	2		
1 "	23		
10 "	37		
1 "	52		
1 "	57		
1 "	125		
2 "	126A		



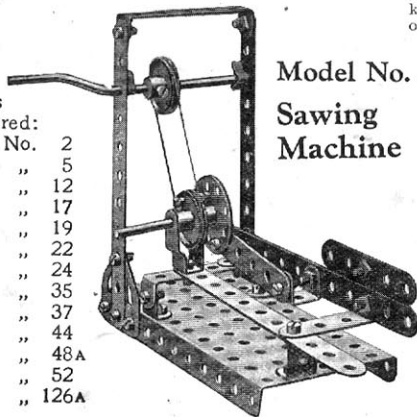
Model No. 45 Gong

Parts required:			
4 of No.	2		
1 "	5		
3 "	12		
1 "	16		
1 "	22		
7 "	37		
1 "	52		
1 "	54		



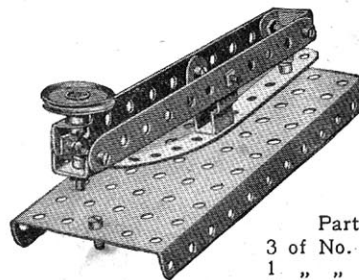
Model No. 43 Sawing Machine

Parts required:			
4 of No.	2		
3 "	5		
4 "	12		
1 "	17		
1 "	19		
2 "	22		
1 "	24		
2 "	35		
23 "	37		
1 "	44		
2 "	48A		
1 "	52		
2 "	126A		



Model No. 44 Telegraph Key

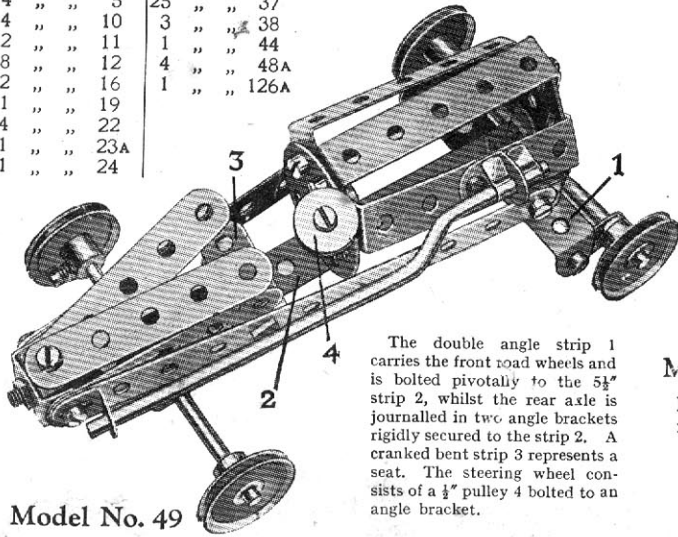
Parts required:			
3 of No.	2	1 of No.	22
1 "	10	11 "	37
2 "	11	1 "	44
1 "	12	1 "	52



Model No. 46 Racing Motor Car

Parts required:

3 of No. 2	4 of No. 35
4 " " 5	25 " " 37
4 " " 10	3 " " 38
2 " " 11	1 " " 44
8 " " 12	4 " " 48A
2 " " 16	1 " " 126A
1 " " 19	
4 " " 22	
1 " " 23A	
1 " " 24	

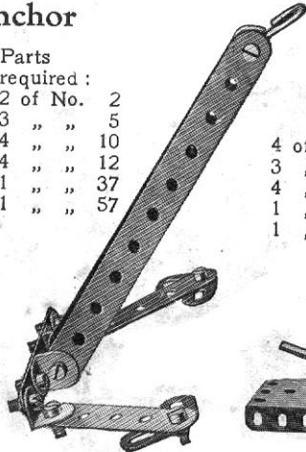


The double angle strip 1 carries the front road wheels and is bolted pivotally to the 5 1/2" strip 2, whilst the rear axle is journalled in two angle brackets rigidly secured to the strip 2. A cranked bent strip 3 represents a seat. The steering wheel consists of a 1/4" pulley 4 bolted to an angle bracket.

Model No. 49 Anchor

Parts required:

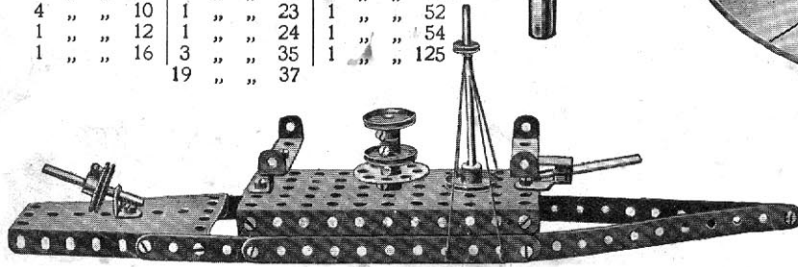
2 of No. 2
3 " " 5
4 " " 10
4 " " 12
11 " " 37
1 " " 57



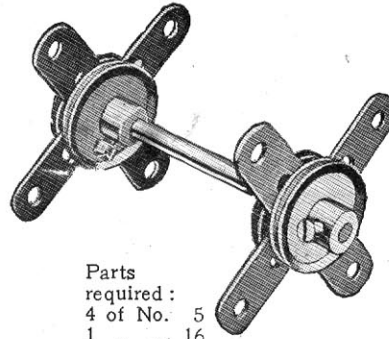
Model No. 50 Battleship

Parts required:

4 of No. 2	2 of No. 17	1 of No. 44
3 " " 5	4 " " 22	2 " " 48A
4 " " 10	1 " " 23	1 " " 52
4 " " 12	1 " " 24	1 " " 54
1 " " 16	3 " " 35	1 " " 125
	19 " " 37	



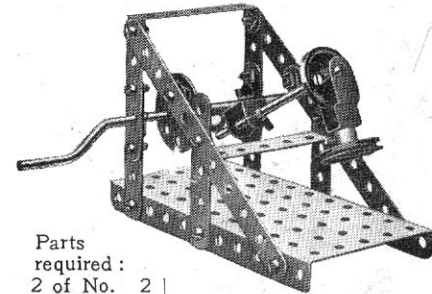
Model No. 47 Cutlery Rest



Parts required:

4 of No. 5
1 " " 16
4 " " 22

Model No. 48 Mechanical Hammer



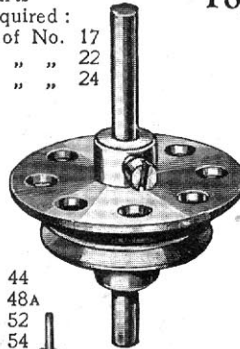
Parts required:

2 of No. 2	1 of No. 19	18 of No. 37
6 " " 5	2 " " 22	1 " " 44
1 " " 11	1 " " 24	3 " " 48A
1 " " 12	4 " " 35	1 " " 52
1 " " 16		

Model No. 51 Spinning Top

Parts required:

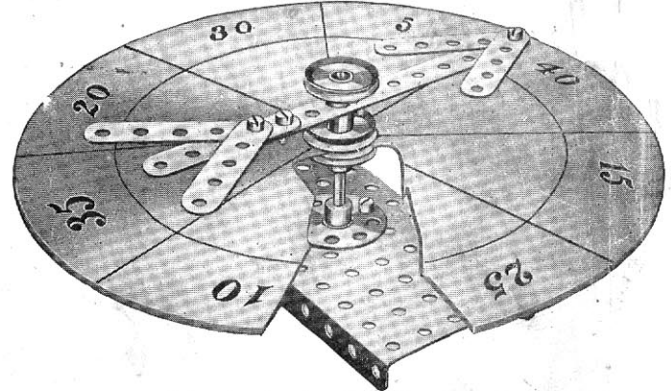
1 of No. 17
1 " " 22
1 " " 24



Model No. 52 Roulette Wheel

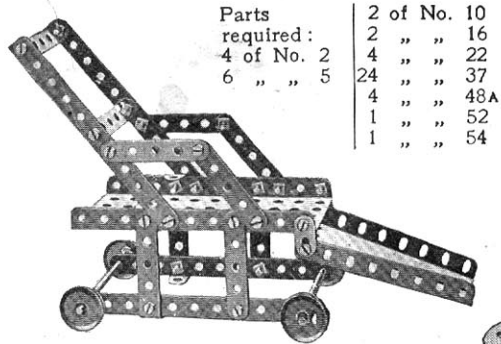
Parts required:

5 of No. 5	1 of No. 24
1 " " 16	5 " " 37
1 of No. 2	3 " " 22
	1 " " 52



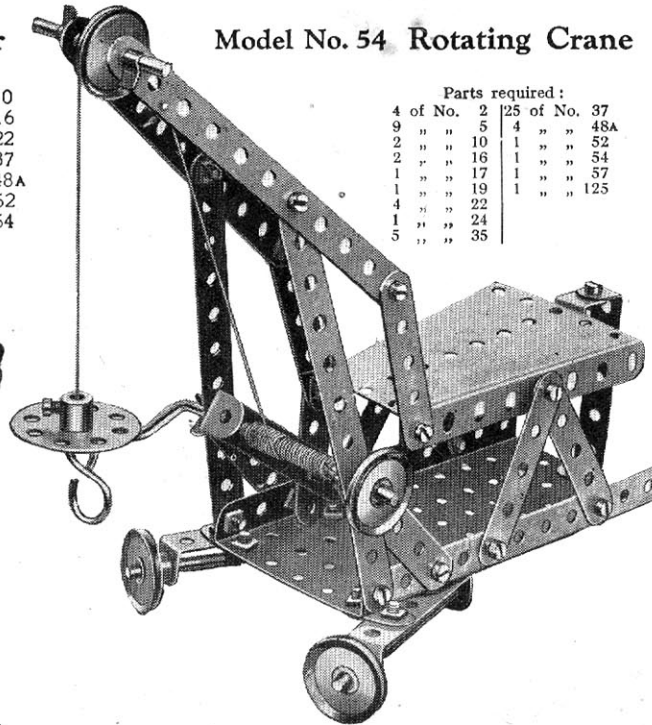
Cut out a circular piece of cardboard, and mark as shown to form scoring board. This is clamped between two 1" pulley wheels. The pointer revolves freely on the upright spindle and is held in position by another 1" pulley wheel.

Model No. 53 Invalid's Chair



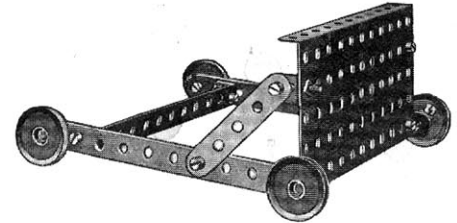
Parts required:	2 of No. 10
4 of No. 2	2 " " 16
6 " " 5	4 " " 22
	24 " " 37
	4 " " 48A
	1 " " 52
	1 " " 54

Model No. 54 Rotating Crane



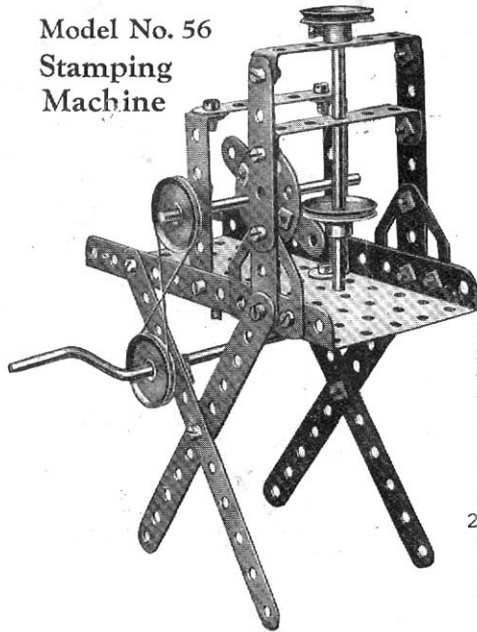
Parts required:		
4 of No. 2	25 of No. 37	
9 " " 5	4 " " 48A	
2 " " 10	1 " " 52	
2 " " 16	1 " " 54	
1 " " 17	1 " " 57	
1 " " 19	1 " " 125	
4 " " 22		
4 " " 24		
1 " " 35		

Model No. 55 Devil Wall



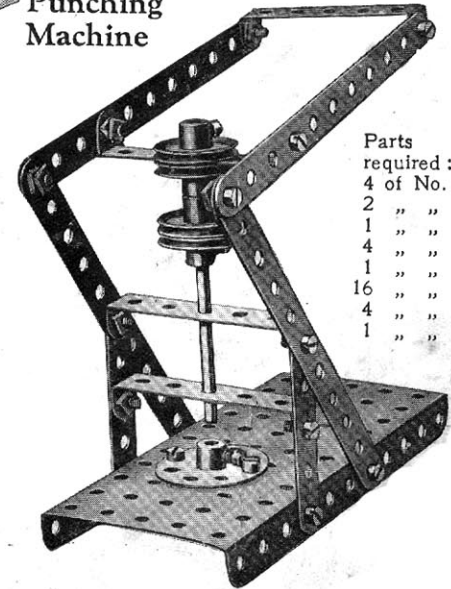
Parts required:	
3 of No. 2	4 of No. 22
2 " " 5	18 " " 37
6 " " 12	1 " " 52

Model No. 56 Stamping Machine



Parts required:	
4 of No. 2	
4 " " 5	
1 " " 16	
1 " " 19	
4 " " 22	
1 " " 24	
2 " " 35	
2 " " 37	
4 " " 48A	
1 " " 52	
2 " " 126A	

Model No. 57 Punching Machine

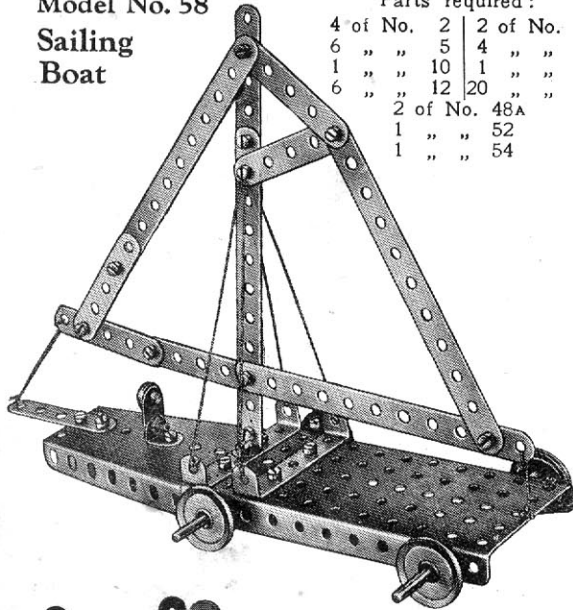


Parts required:	
4 of No. 2	
2 " " 5	
1 " " 16	
4 " " 22	
1 " " 24	
16 " " 37	
4 " " 48A	
1 " " 52	

The running wheels of this crane are journaled in double angle strips bolted to the base plate and secured at an angle by means of flat brackets. The rear of the base plate is supported on a double bracket. The jib is bolted loosely to the supporting $5\frac{1}{2}$ " strips and is connected by $2\frac{1}{2}$ " strips to the sector plate which pivots about its supporting bolts. By moving this sector plate the elevation of the jib may be altered as desired. The movement is controlled by a double angle strip mounted on the crank handle and connected pivotally to the plate by means of a $2\frac{1}{2}$ " strip. A reversed angle bracket bolted to an upright double angle strip in the rear of the model serves to restrict the movement of the sector plate.

These Models can be made with MECCANO Outfit No. 0, or No. 00 and No. 00A.

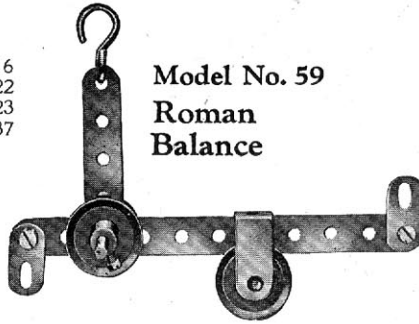
Model No. 58
Sailing Boat



Parts required:

4 of No.	2	2 of No.	16
6 "	5	4 "	22
1 "	10	1 "	23
6 "	12	20 "	37
		2 of No.	48A
		1 "	52
		1 "	54

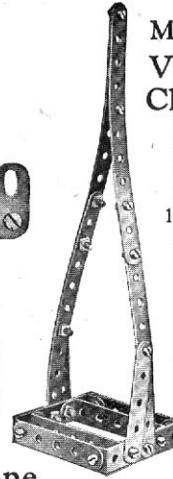
Model No. 59
Roman Balance



Parts required:

1 of No.	2	3 of No.	22
1 "	5	3 "	37
2 "	10	1 "	44
1 "	17	1 "	57

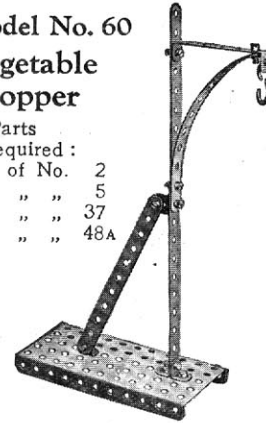
Model No. 60
Vegetable Chopper



Parts required:

4 of No.	2
4 "	5
18 "	37
4 "	48A

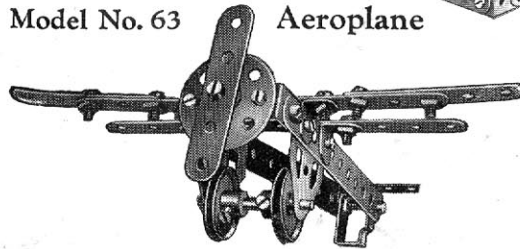
Model No. 61
Mail-Bag Hanger



Parts required:

4 of No.	2
4 "	12
10 "	37
1 "	48A
1 "	52
1 "	57

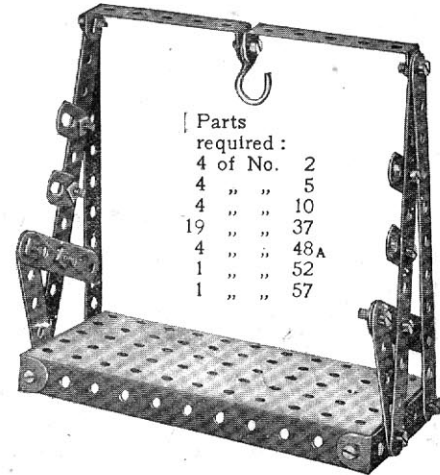
Model No. 63 **Aeroplane**



Parts required:

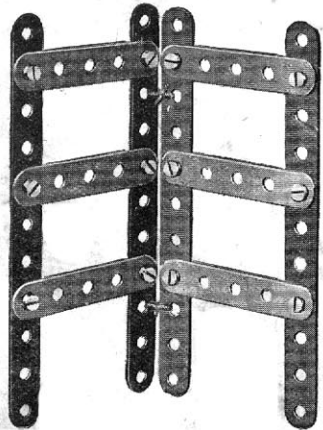
* 4 of No.	2	6 of No.	17	20 of No.	37
4 "	5	1 "	12	1 "	44
1 "	11	2 "	22	2 "	126A
		1 "	24		

Model No. 64
Pen Rack



Parts required:

4 of No.	2
4 "	5
4 "	10
19 "	37
4 "	48A
1 "	52
1 "	57



Model No. 62
Clothes Horse

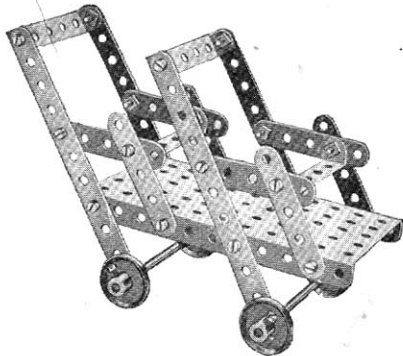
Parts required:

4 of No.	2
6 "	5
12 "	37

HOW TO CONTINUE

This completes the Models which may be made with MECCANO Outfit No. 0. The next Models are a little more advanced, requiring a number of extra parts to construct them. The necessary parts are all contained in a No. 0A Accessory Outfit, the price of which will be found in the list at the end of the Manual.

**Model No. 101
Tandem Car**



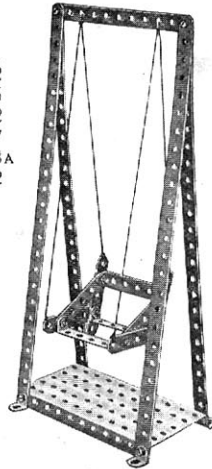
Parts required :

4 of No. 2	20 of No. 37
8 " " 5	4 " " 48A
2 " " 16	1 " " 52
4 " " 22	

Model No. 102 Swing

Parts required :

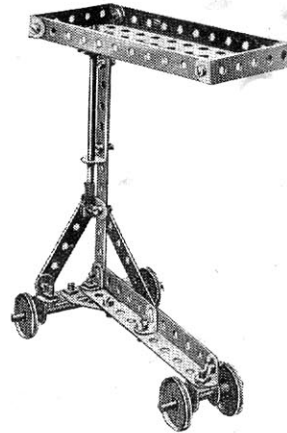
4 of No. 1
1 " " 2
6 " " 5
4 " " 12
12 " " 37
3 " " 48A
1 " " 52



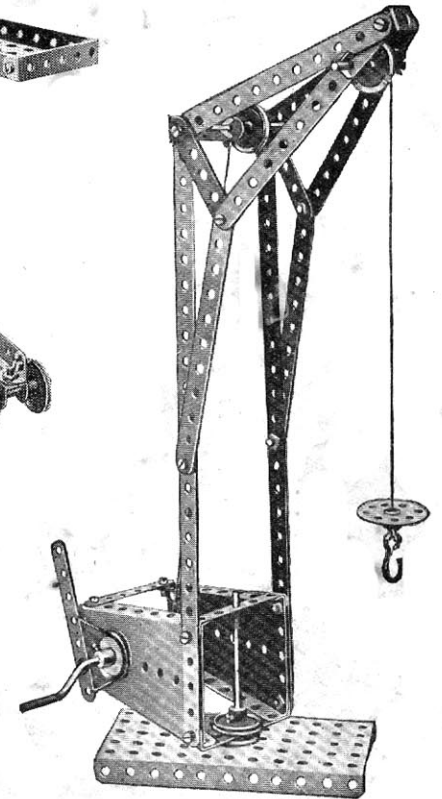
**Model No. 103
Bed Table**

Parts required :

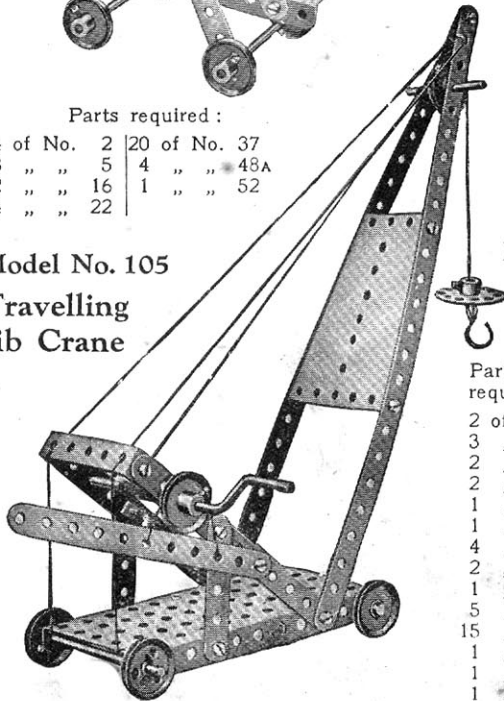
3 of No. 2
1 " " 3
1 " " 5
1 " " 11
5 " " 12
2 " " 16
1 " " 17
4 " " 22
1 " " 24
21 " " 37
4 " " 48A
1 " " 52
1 " " 126A



**Model No. 104
Swivelling Crane**



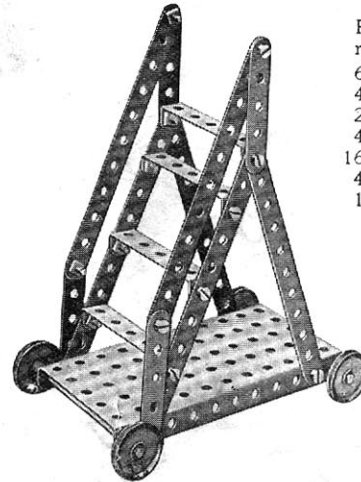
**Model No. 105
Travelling
Jib Crane**



Model No. 106 Travelling Ladder

Parts required :

2 of No. 1
3 " " 2
2 " " 5
2 " " 16
1 " " 17
1 " " 19
4 " " 22
2 " " 22A
1 " " 24
5 " " 35
15 " " 37
1 " " 48A
1 " " 52
1 " " 54
1 " " 57



Parts required :

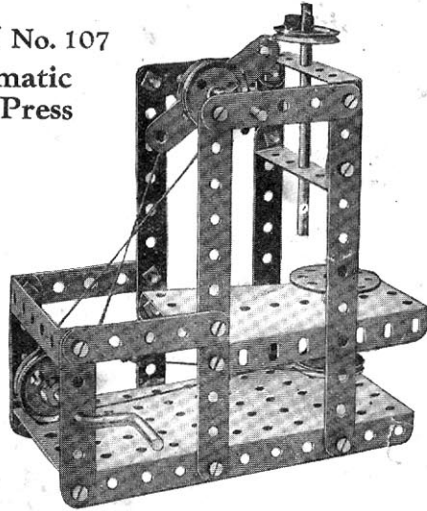
6 of No. 2
4 " " 5
2 " " 16
4 " " 22
16 " " 37
4 " " 48A
1 " " 52

Parts required :

2 of No. 1	1 of No. 11	2 of No. 22A	3 of No. 48A
6 " " 2	1 " " 16	1 " " 24	1 " " 52
1 " " 3	2 " " 17	4 " " 35	2 " " 54
4 " " 5	1 " " 19	18 " " 37	1 " " 57
	4 " " 22	1 " " 44	

These Models can be made with MECCANO Outfit No. 1, or No. 0 and No. 0A.

Model No. 107
Automatic
Dial Press

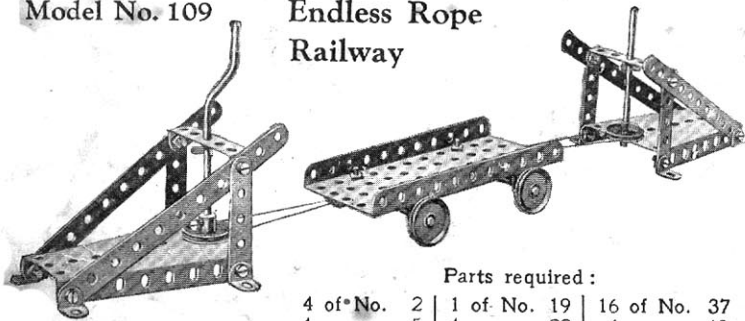


Parts required :

4 of No. 2	1 of No. 19	18 of No. 37
7 " " 5	4 " " 22	3 " " 48A
2 " " 16	2 " " 22A	1 " " 52
1 " " 17	1 " " 24	1 " " 54
	7 " " 35	

Model No. 109

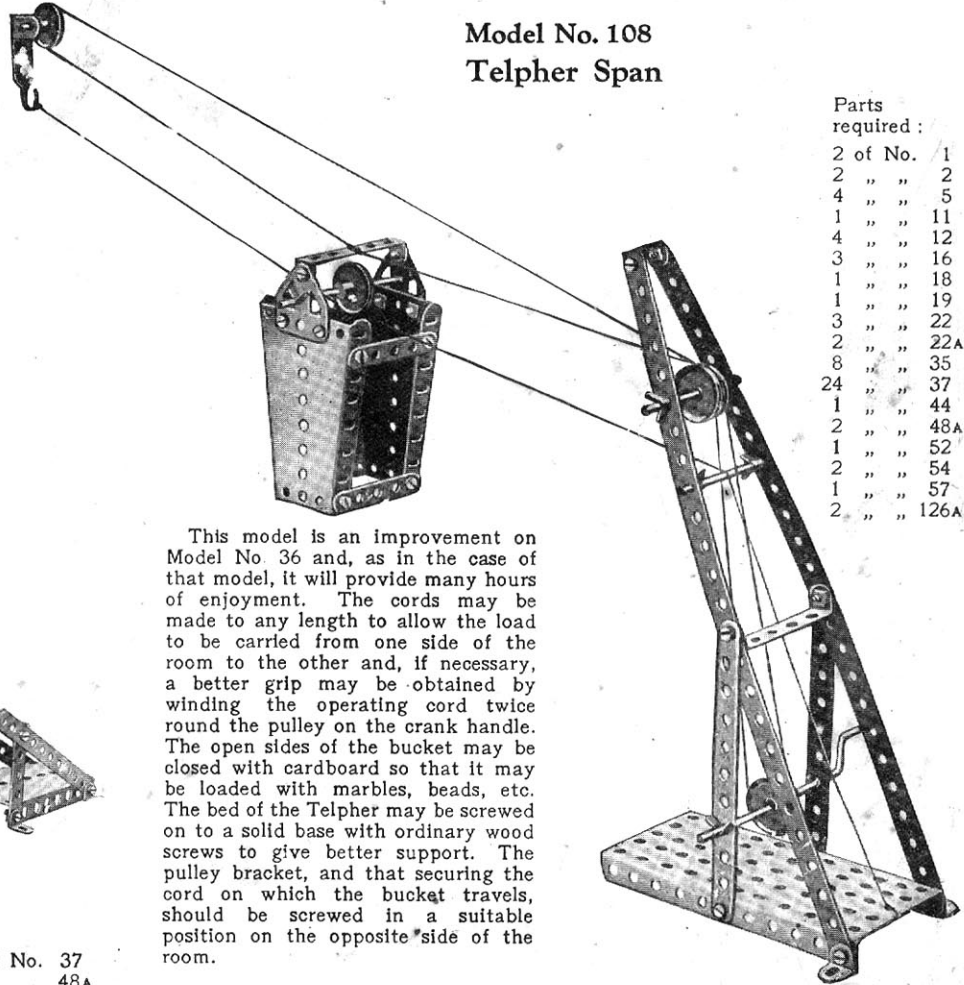
Endless Rope
Railway



Parts required :

4 of No. 2	1 of No. 19	16 of No. 37
4 " " 5	4 " " 22	4 " " 48A
8 " " 12	2 " " 22A	1 " " 52
3 " " 16	4 " " 35	2 " " 54

Model No. 108
Telpher Span

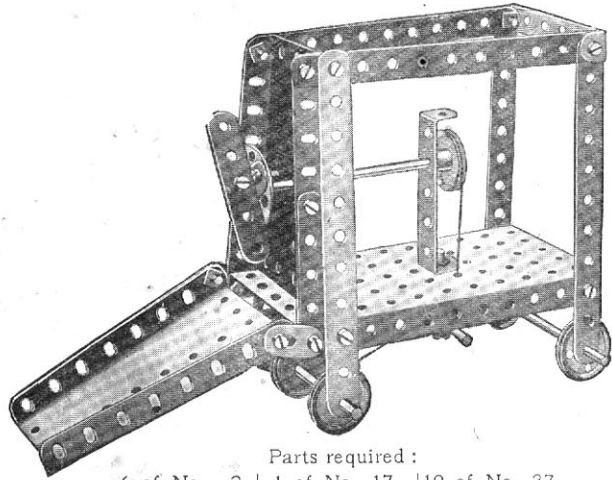


Parts required :

2 of No. 1
2 " " 2
4 " " 5
1 " " 11
4 " " 12
3 " " 16
1 " " 18
1 " " 19
3 " " 22
2 " " 22A
8 " " 35
24 " " 37
1 " " 44
2 " " 48A
1 " " 52
2 " " 54
1 " " 57
2 " " 126A

This model is an improvement on Model No 36 and, as in the case of that model, it will provide many hours of enjoyment. The cords may be made to any length to allow the load to be carried from one side of the room to the other and, if necessary, a better grip may be obtained by winding the operating cord twice round the pulley on the crank handle. The open sides of the bucket may be closed with cardboard so that it may be loaded with marbles, beads, etc. The bed of the Telpher may be screwed on to a solid base with ordinary wood screws to give better support. The pulley bracket, and that securing the cord on which the bucket travels, should be screwed in a suitable position on the opposite side of the room.

Model No. 110 Snow Plough

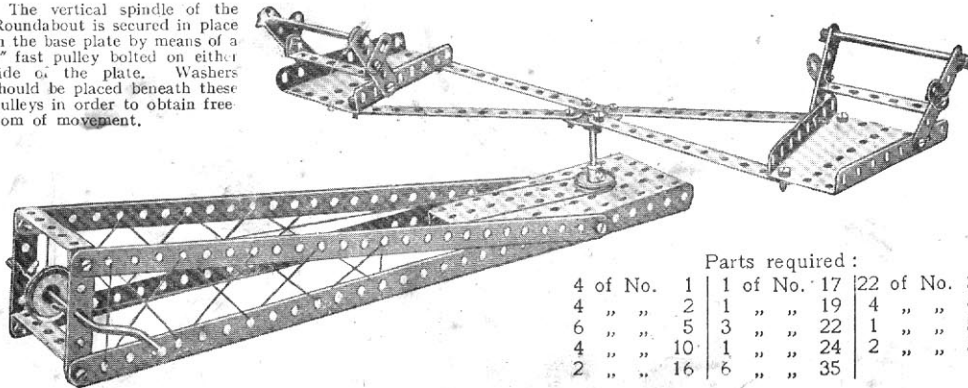


Parts required :

6 of No. 2	1 of No. 17	19 of No. 37
3 " " 5	4 " " 22	1 " " 44
2 " " 10	2 " " 22A	2 " " 48A
1 " " 12	1 " " 24	1 " " 52
3 " " 16	4 " " 35	2 " " 54

Model No. 112 Roundabout

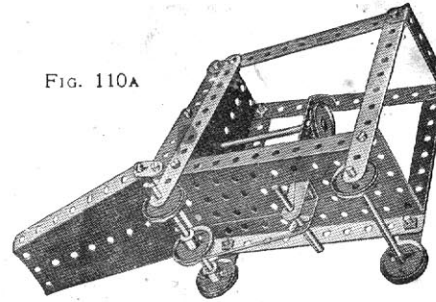
The vertical spindle of the Roundabout is secured in place in the base plate by means of a 1" fast pulley bolted on either side of the plate. Washers should be placed beneath these pulleys in order to obtain freedom of movement.



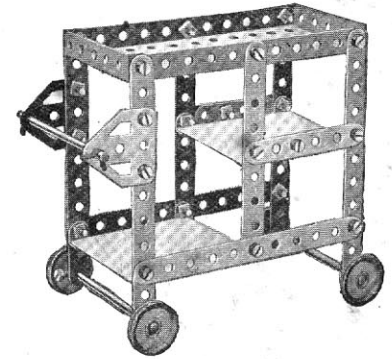
Parts required :

4 of No. 1	1 of No. 17	22 of No. 37
4 " " 2	1 " " 19	4 " " 48A
6 " " 5	3 " " 22	1 " " 52
4 " " 10	1 " " 24	2 " " 54
2 " " 16	6 " " 35	

FIG. 110A



Model No. 111 Dinner Wagon



Parts required :

6 of No. 2	2 of No. 35
8 " " 5	22 " " 37
4 " " 12	4 " " 48A
3 " " 16	1 " " 52
4 " " 22	2 " " 126A

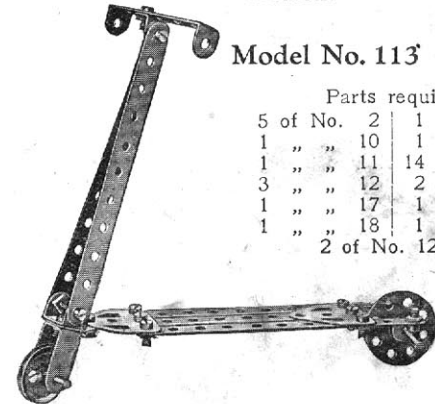
The construction of the framework of this model presents no difficulty. The sector plate forming the plough is loosely pivoted to the model. The plough shaft is mounted in the front sector plate and the 2½" double angle strip. A 2½" strip is bolted by angle brackets to a bush wheel on the front of the shaft and forms a dispersing propeller for the snow after it has risen up the inclined sector plate. A continuous cord is passed round a 1" pulley on the propeller shaft and round the short axle shown beneath the model (Fig. 110A) and a 1" pulley on the leading axle. In this way, as the plough is moved along the ground, the propeller is rotated.

The two lower platforms are constructed out of pieces of ordinary cardboard, their outer edges resting on 2½" bent strips and their inner edges on angle brackets.

Model No. 113 Scooter

Parts required :

5 of No. 2	1 of No. 22
1 " " 10	1 " " 24
1 " " 11	14 " " 37
3 " " 12	2 " " 38
1 " " 17	1 " " 44
1 " " 18	1 " " 48A
2 of No. 126A	

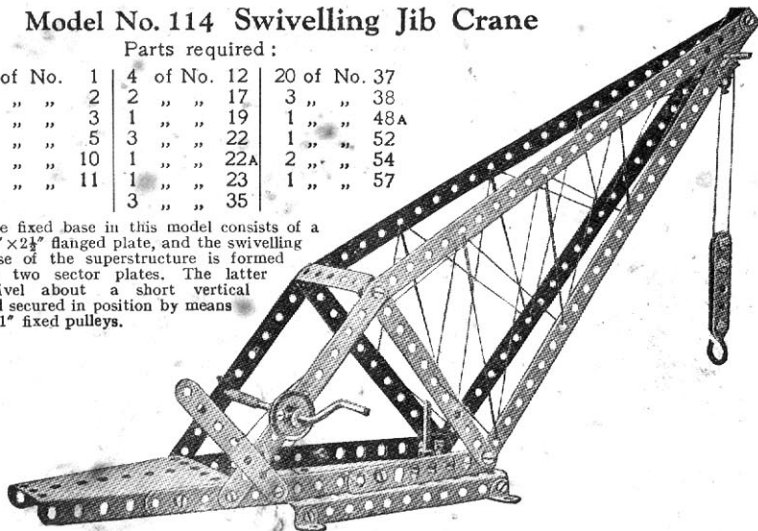


Model No. 114 Swivelling Jib Crane

Parts required:

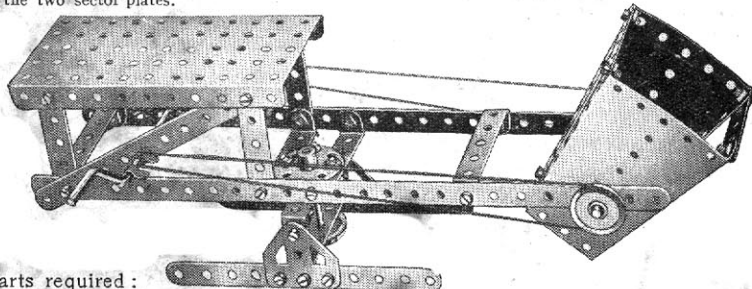
4 of No. 1	4 of No. 12	20 of No. 37
6 " " 2	2 " " 17	3 " " 38
1 " " 3	1 " " 19	1 " " 48A
2 " " 5	3 " " 22	1 " " 52
1 " " 10	1 " " 22A	2 " " 54
1 " " 11	1 " " 23	1 " " 57
	3 " " 35	

The fixed base in this model consists of a 5 1/4" x 2 1/4" flanged plate, and the swivelling base of the superstructure is formed by two sector plates. The latter swivel about a short vertical rod secured in position by means of 1" fixed pulleys.



Model No. 117 Giant Foundry Ladle

This represents a device used in handling molten metal in foundry operations. The metal is poured from the converter into the bucket-like container which consists in our model of two sector-plates bolted together at the top by 2 1/2" strips and at the bottom by flat brackets. The container swings about a central pivot so that it may be brought into position over the moulds that receive the metal. The bucket may be tipped on rotation of the crank handle 1 on each end of which cords 2 are wound two or three times between a pair of spring clips. The bucket is secured to the axle 3 by means of spring clips placed upon the axle and pressing against either side of each of the two sector plates.



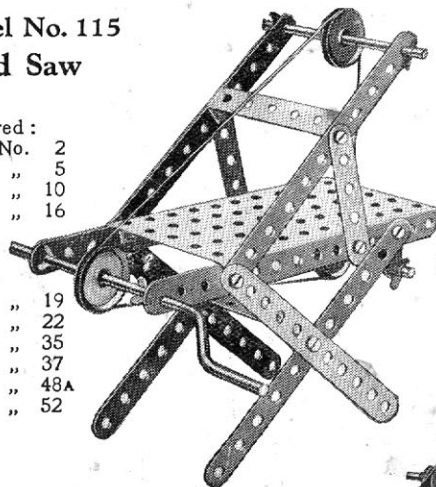
Parts required:

2 of No. 1	1 of No. 16	1 of No. 22A	2 of No. 38	2 of No. 54
4 " " 2	1 " " 17	1 " " 24	1 " " 40	2 " " 126A
6 " " 5	1 " " 19	8 " " 35	6 " " 48A	
2 " " 10	3 " " 22	30 " " 37	1 " " 52	

Model No. 115 Band Saw

Parts required:

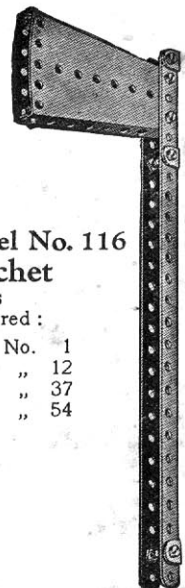
6 of No. 2	
4 " " 5	
2 " " 10	
2 " " 16	
1 " " 19	
3 " " 22	
6 " " 35	
2 " " 37	
2 " " 48A	
1 " " 52	



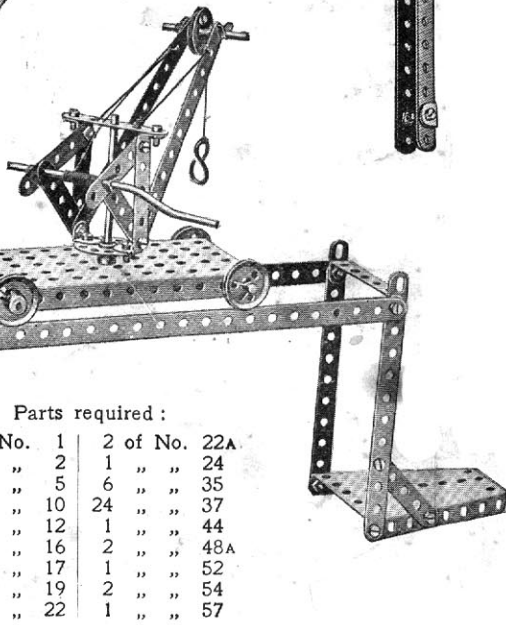
Model No. 116 Hatchet

Parts required:

3 of No. 1
6 " " 12
15 " " 37
2 " " 54



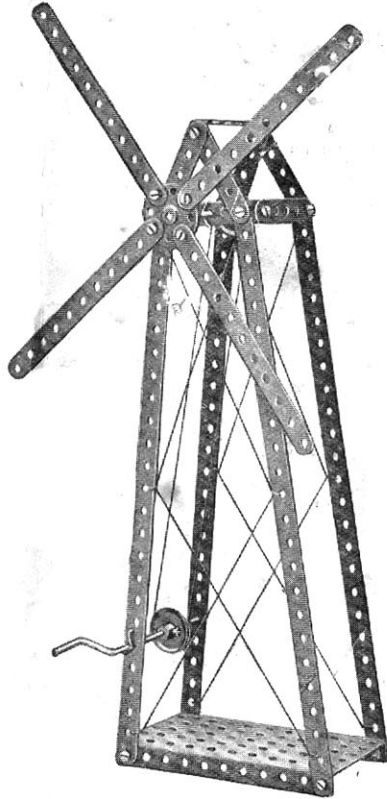
Model No. 118 Overhead Crane



Parts required:

2 of No. 1	2 of No. 22A
6 " " 2	1 " " 24
9 " " 5	6 " " 35
4 " " 10	24 " " 37
4 " " 12	1 " " 44
3 " " 16	2 " " 48A
1 " " 17	1 " " 52
1 " " 19	2 " " 54
4 " " 22	1 " " 57

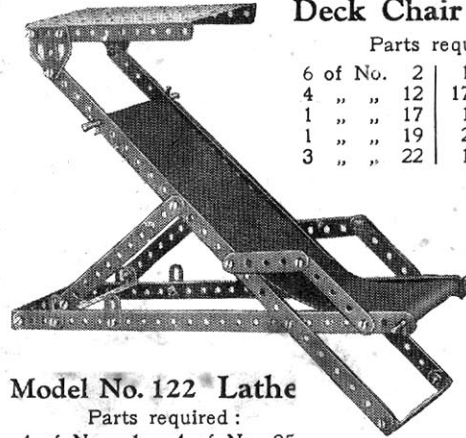
Model No. 119 Windmill



Parts required :

4 of No. 1	2 of No. 22
4 " " 2	1 " " 24
7 " " 5	4 " " 35
2 " " 12	20 " " 37
1 " " 16	3 " " 48A
1 " " 19	1 " " 52

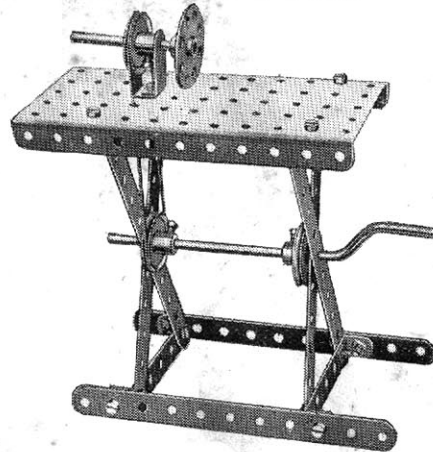
Model No. 120 Deck Chair



Parts required :

6 of No. 2	1 of No. 24
4 " " 12	17 " " 37
1 " " 17	1 " " 44
1 " " 19	2 " " 48A
3 " " 22	1 " " 52

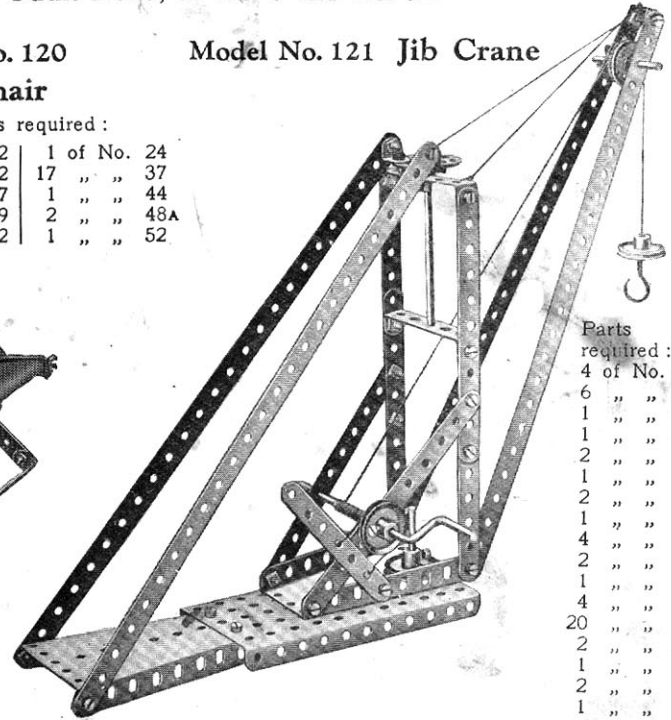
Model No. 122 Lathe



Parts required :

4 of No. 1	4 of No. 35
2 " " 2	26 " " 37
4 " " 5	3 " " 48A
4 " " 10	1 " " 52
2 " " 16	2 " " 126A

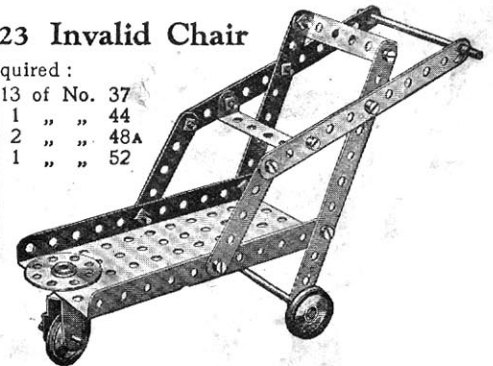
Model No. 121 Jib Crane



Parts required :

4 of No. 1	1
6 " " 2	2
1 " " 3	3
1 " " 11	11
2 " " 12	12
1 " " 16	16
2 " " 17	17
1 " " 19	19
4 " " 22	22
2 " " 22A	22A
1 " " 24	24
4 " " 35	35
20 " " 37	37
2 " " 48A	48A
1 " " 52	52
2 " " 54	54
1 " " 57	57

Model No. 123 Invalid Chair



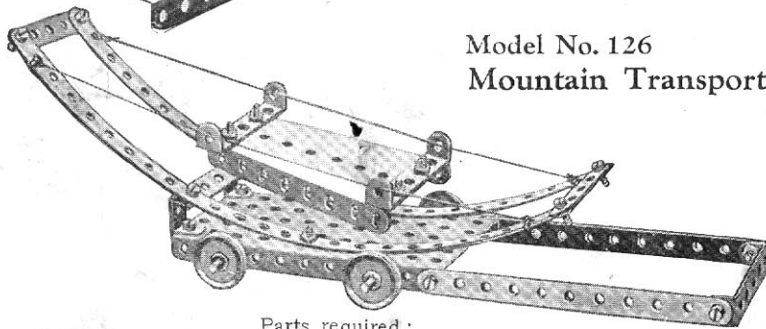
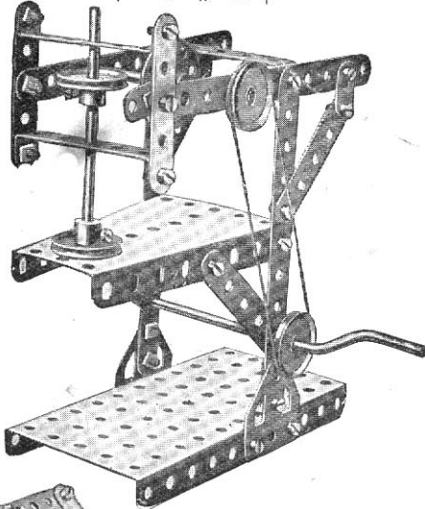
Parts required :

4 of No. 2	13 of No. 37
2 " " 5	1 " " 44
2 " " 16	2 " " 48A
1 " " 18	1 " " 52
2 " " 22	
1 " " 22A	
1 " " 24	
4 " " 35	

Model No. 124 Drop Stamp

Parts required :

4 of No. 2	1 of No. 19	3 of No. 48A
6 " " 5	4 " " 22	1 " " 52
3 " " 10	1 " " 24	1 " " 54
2 " " 16	2 " " 35	2 " " 126A
	27 " " 37	



Parts required :

2 of No. 1	3 of No. 5	2 of No. 16	18 of No. 37	1 of No. 52
2 " " 2	4 " " 12	4 " " 22	2 " " 48A	1 " " 54

Model No. 125 Sewing Machine

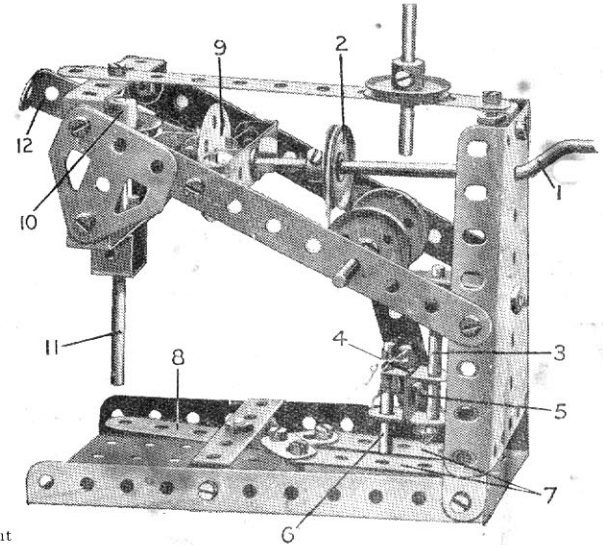
Parts required :

3 of No. 2	1 of No. 16	2 of No. 22	1 of No. 44
6 " " 5	2 " " 17	1 " " 24	4 " " 48A
3 " " 10	1 " " 18A	3 " " 35	1 " " 52
2 " " 11	1 " " 19	2 " " 37	1 " " 54
3 " " 12	2 " " 21	3 " " 38	2 " " 125

The handle 1 carries a 1" pulley 2, which drives by means of a cord a similar pulley on a 2" rod 3 journalled in a cranked bent strip bolted to the sector plate. Two double brackets 4 are secured together by a bolt 5, the shank of which presses very tightly on the rod 3. This locks the double brackets in position, and they revolve with the rod 3. The outer double bracket carries a 1 1/2" rod 6, the end of which lies between two strips 7, arranged at a short distance apart from each other and bolted to two flat brackets. These are secured to a further strip 8 bolted pivotally to a transverse double angle strip. As the shaft 3 rotates, the rod 6 slides between the strips 7 and so rocks the strip 8 from side to side. This represents the movement of the shuttle.

The bush wheel 9 carries two angle brackets placed together in the form of a double bracket, with their elongated holes overlapping, and in such a position that an imaginary line drawn through their opposite round holes, would intercept the centre of the bush wheel. A flat bracket is bolted to the inner angle bracket in a line with the crank handle and forms a lever which engages a 1" pulley 10 mounted on a vertical sliding rod 11. This rod is journalled in a double angle strip bolted between the lower holes of the two flat trunnions and is further supported by two 1/2" reversed angle brackets secured to the angle strip. As the bush wheel rotates, the flat bracket imparts to the rod 11 a movement corresponding to the action of the needle.

The outer angle bracket on the bush wheel strikes once in every revolution the end of a double angle strip 12. This is pivotally mounted by a bolt passed through its second hole from the bush wheel end to the centre hole of the flat trunnion on that side of the model. The resulting movement of the strip 12 represents the apparatus by which the cotton is paid out from the reel to the needle.



Model No. 127 Motor Lorry

Parts required :

4 of No. 2	
8 " " 5	
4 " " 12	
2 " " 16	
1 " " 17	
3 " " 22	
2 " " 22A	
1 " " 24	
2 " " 35	
25 " " 37	1 of No. 52
3 " " 38	1 " " 54
3 " " 48A	2 " " 125

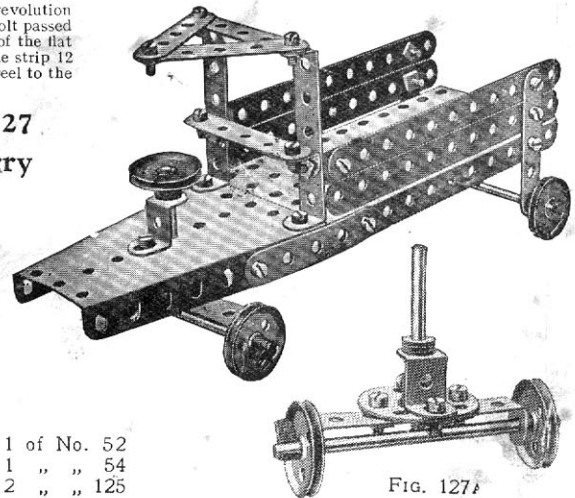
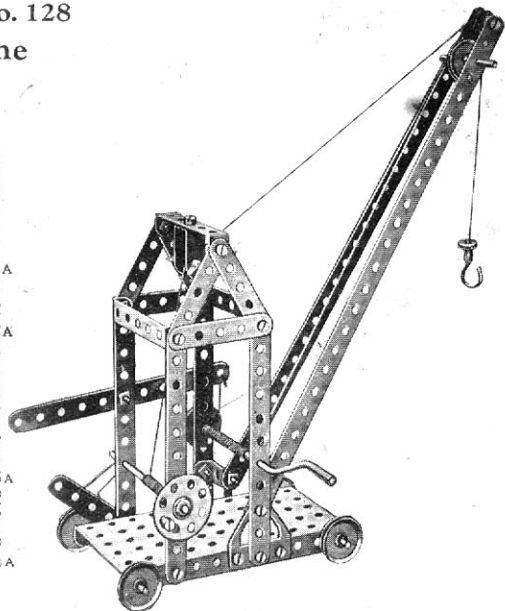


FIG. 127A

Model No. 128
Jib Crane

Parts required :

2	of No.	1
5	" "	2
7	" "	5
1	" "	11
3	" "	16
1	" "	17
1	" "	18A
1	" "	19
4	" "	22
2	" "	22A
1	" "	23
1	" "	24
6	" "	35
22	" "	37
2	" "	38
1	" "	44
3	" "	48A
1	" "	52
1	" "	57
2	" "	125
2	" "	126A

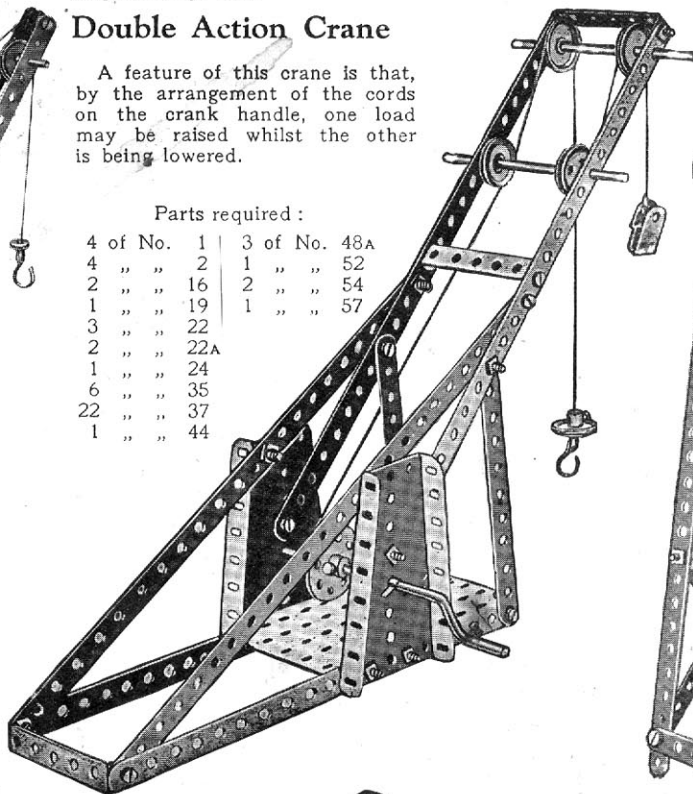


Model No. 129
Double Action Crane

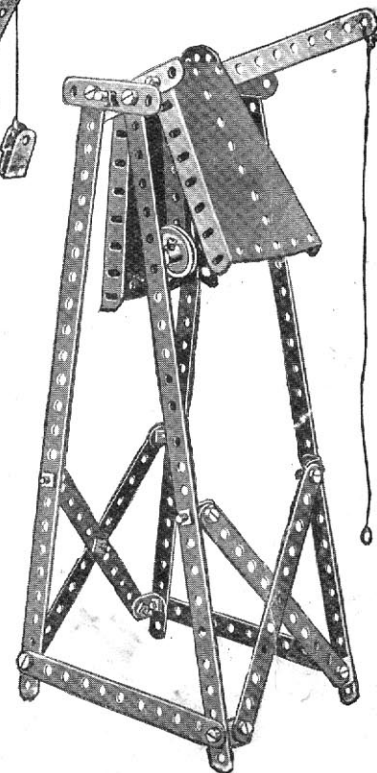
A feature of this crane is that, by the arrangement of the cords on the crank handle, one load may be raised whilst the other is being lowered.

Parts required :

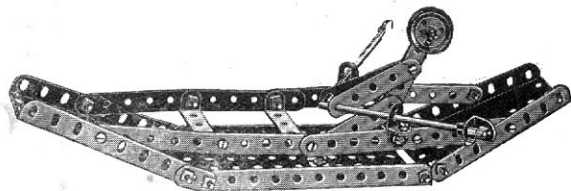
4	of No.	1	3	of No.	48A
4	" "	2	2	" "	52
2	" "	16	2	" "	54
1	" "	19	1	" "	57
3	" "	22			
2	" "	22A			
1	" "	24			
6	" "	35			
22	" "	37			
1	" "	44			



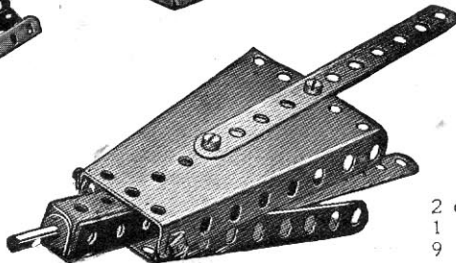
Model No. 130
Fire Alarm



Model No. 131 Rowing Boat



4	of No.	2	2	of No.	16	4	of No.	38
5	" "	5	1	" "	18A	3	" "	48A
4	" "	10	2	" "	22A	1	" "	52
7	" "	12	4	" "	35	2	" "	54
			24	" "	37			



Model No. 132
Bellows

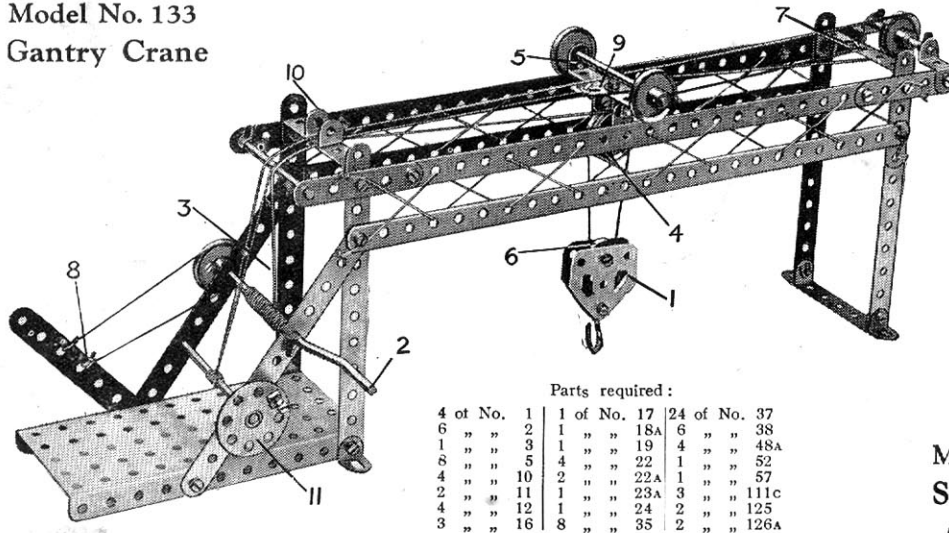
Parts required :

2	of No.	2	4	of No.	48A
1	" "	17	2	" "	54
9	" "	37			

Parts required :

4	of No.	1	1	of No.	22
7	" "	2	1	" "	24
1	" "	3	4	" "	35
3	" "	5	27	" "	37
8	" "	12	2	" "	54
1	" "	16			

**Model No. 133
Gantry Crane**



Parts required :

4 of No.	1	1 of No.	17	24 of No.	37
6 "	2	1 "	18A	6 "	38
1 "	3	1 "	19	4 "	48A
6 "	5	4 "	22	1 "	52
4 "	10	2 "	22A	1 "	57
2 "	11	1 "	23A	3 "	111c
4 "	12	1 "	24	2 "	125
3 "	16	8 "	35	2 "	126A

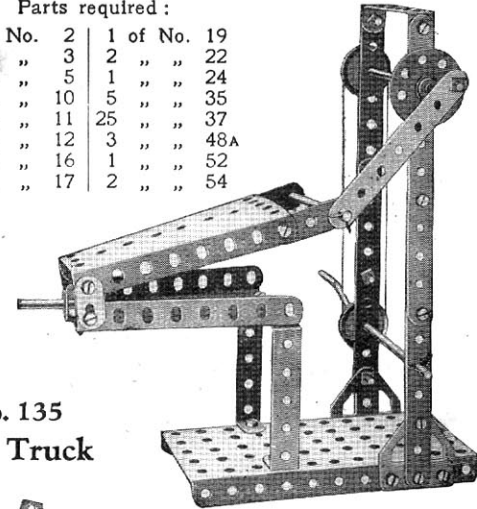
The pulley-block 1 is operated by means of the crank handle 2, on which a cord 3 is wound. This cord passes over one of the two loose 1" pulleys 4 carried on a short rod which is journalled in the ends of flat brackets suspended by means of a double bracket beneath the double angle strip 5 forming the frame of the trolley. The cord then passes round the 1" pulley wheel 6 in the pulley block and round the second of the pulleys 4, and is finally fixed to the model at 7. A friction brake, consisting of a 3 1/2" strip 8 and cord engaging a 1" pulley on the crank handle, is provided to control the hoisting movement.

The traversing movement of the trolley is effected as follows:—A length of cord tied to one of the two flat brackets 9 is passed round the 1" pulley wheel at the outer end of the gantry, and then led back under the axle of the trolley, over the guide 10 (consisting of a double bracket) and wound on to a 3 1/2" axle rod. The latter may be operated by a hand wheel 11, formed from a bush wheel and 3/8" bolt. After passing several times round the 3 1/2" rod the cord is returned over the double bracket 10, and its end is secured to the second of the two flat brackets 9, which are bolted to the centre of the double angle strip 5.

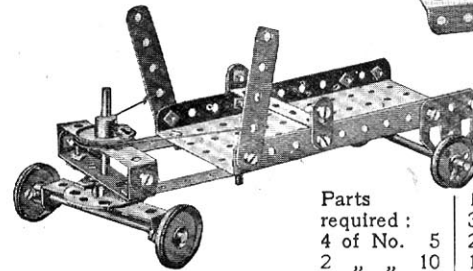
Model No. 134 Forge Bellows

Parts required :

4 of No.	2	1 of No.	19
1 "	3	2 "	22
2 "	5	1 "	24
2 "	10	5 "	35
1 "	11	25 "	37
2 "	12	3 "	48A
2 "	16	1 "	52
1 "	17	2 "	54



**Model No. 135
Steering Truck**



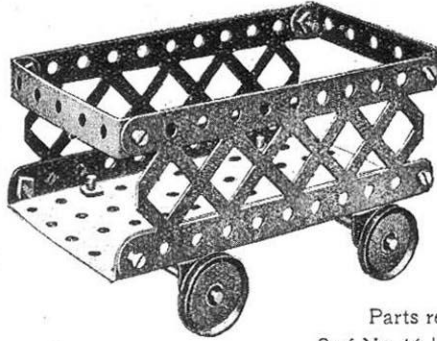
Parts required :

1 of No.	17	18 of No.	37
3 "	22	2 "	38
4 of No.	22A	4 "	48A
2 "	24	1 "	52
2 "	35	2 "	126A

HOW TO CONTINUE

This completes the Models which may be made with MECCANO Outfit No. 1. The next Models are a little more advanced, requiring a number of extra parts to construct them. The necessary parts are all contained in a No. 1A Accessory Outfit, the price of which will be found in the List at the end of the Manual.

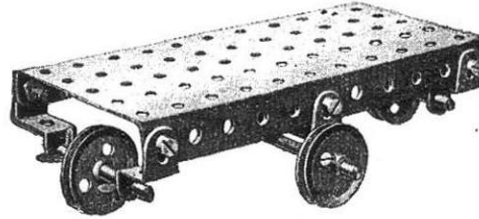
Model No. 201
Truck



Parts required :

2 of No. 16	4 of No. 48A
4 " " 22	1 " " 52
12 " " 37	2 " " 100

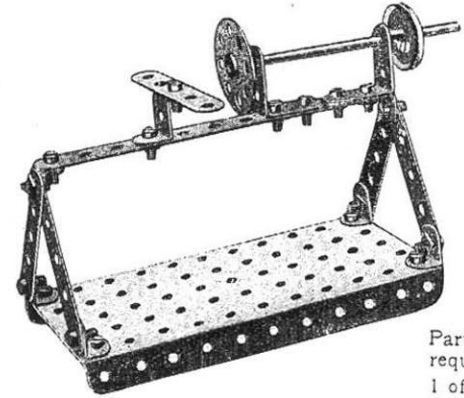
Model No. 202
Revolving Truck



Parts required :

2 of No. 10	2 of No. 22	6 of No. 37
1 " " 16	2 " " 22A	1 " " 52
2 " " 17	4 " " 35	4 " " 125

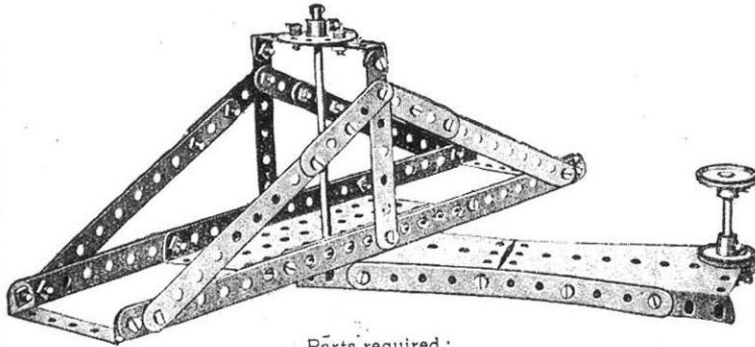
Model No. 203—Lathe



Parts required :

1 of No. 2
5 " " 5
6 " " 12
2 " " 12A
1 " " 16
1 " " 22
1 " " 24
17 " " 37
1 " " 52
1 " " 125

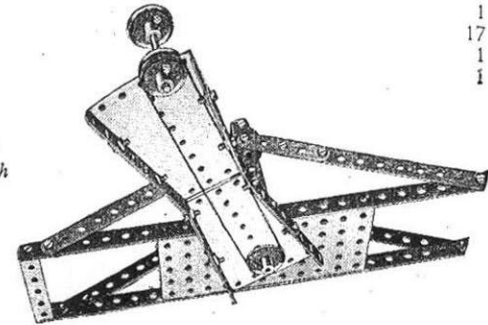
Model No. 204—Turntable Gangway



Parts required :

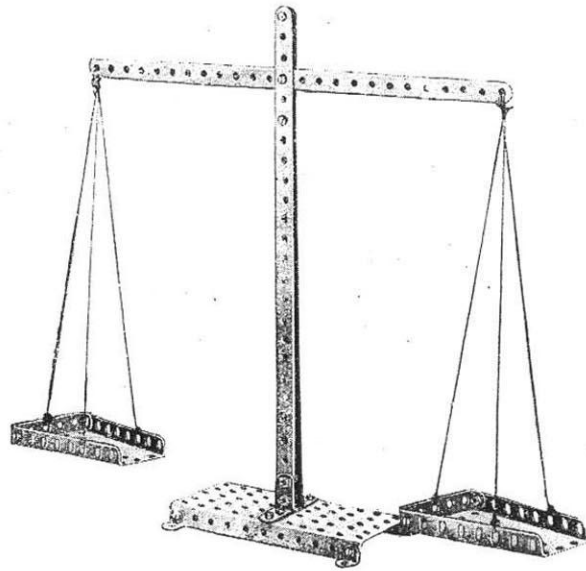
2 of No. 1	4 of No. 22
6 " " 2	1 " " 24
2 " " 3	34 " " 37
4 " " 5	3 " " 48A
1 " " 15A	1 " " 52
1 " " 17	2 " " 54

FIG. 204A
(underneath view)



The side frames of the gangway are made of 12½" strips bolted by means of 2½" bent strips to parallel strips below. The side frames are connected by a perforated flanged plate to the underside of which is bolted a bush wheel fitted with a rod on which is mounted a 1" pulley (See Fig. 204A.) The rod passes through one of the end holes of the sector plate which is connected by diagonal strips to another sector plate. Through the end hole of the latter a rod is threaded carrying two 1" pulleys from one of which an operating cord passes through the pulley mounted on the under side of the flange plate. In this way the Gangway may be rotated by an operating spindle.

Model No. 205—Scales

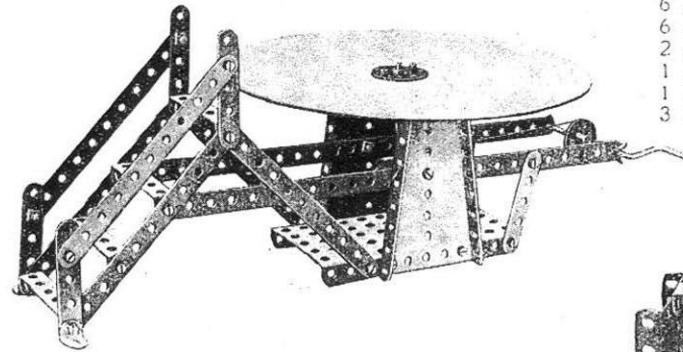


Parts required :

3 of No. 1	4 of No. 38
4 " " 12	2 " " 48A
2 " " 12A	1 " " 52
19 " " 37	2 " " 54

The slot is formed by inserting 2 washers in the bolts above and below the beam. These washers hold the strips composing the standard at the required distance apart to give the beam free play.

Model No. 206—Joy Wheel



The driving mechanism and construction of the framework of this model are clearly brought out in Fig. 206A. Cut out a circular piece of cardboard, 8" in diameter, and in the centre of the disc fix a bush wheel by nuts and bolts. The eye of the bush wheel is then threaded over the top of a vertical spindle, and secured by its set-screw.

Parts required :

2 of No. 1	1 of No. 22A
6 " " 2	1 " " 24
6 " " 5	2 " " 35
2 " " 12	23 " " 37
1 " " 15A	5 " " 48A
1 " " 19	1 " " 52
3 " " 22	2 " " 54

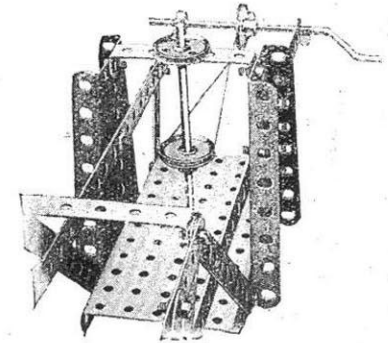
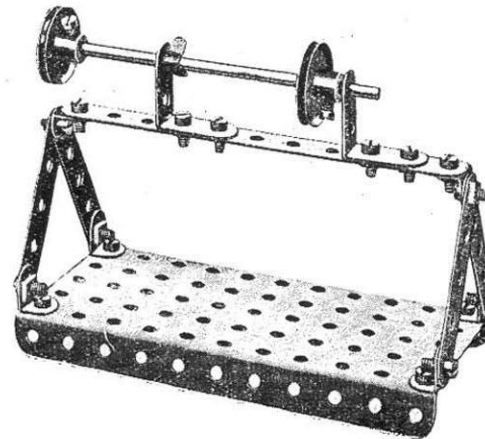


Fig. 206A.

Model No. 207
Polishing Spindle

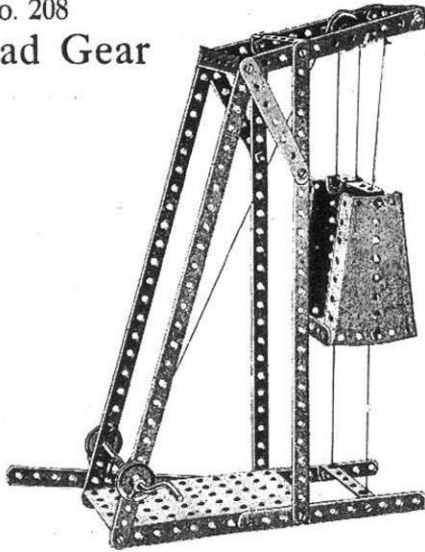
Parts required :

1 of No. 2	1 of No. 15A
4 " " 5	2 " " 22
6 " " 12	1 " " 35
2 " " 12A	16 " " 37
	1 " " 52

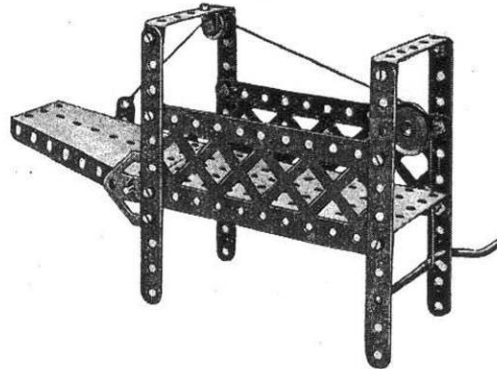
Model No. 208 Pit Head Gear

Parts required:

4	of No.	1
5	"	2
2	"	3
2	"	5
2	"	12
1	"	16
1	"	19
3	"	22
2	"	35
25	"	37
5	"	48A
1	"	52
2	"	54



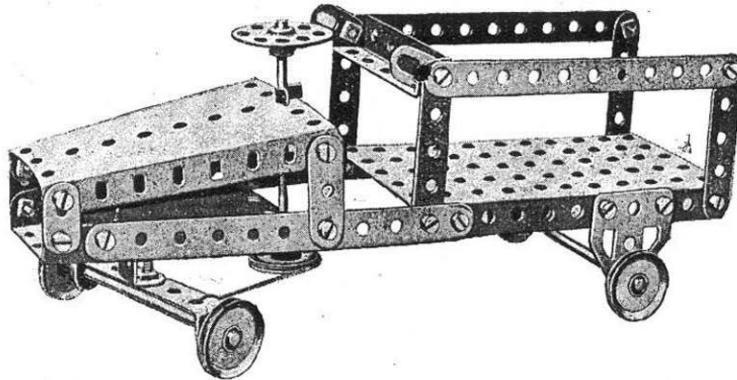
Model No. 209 Gangway



Parts required:

4	of No.	2	1	of No.	22	1	of No.	52
1	"	10	1	"	23	1	"	54
1	"	12	4	"	35	2	"	100
1	"	16	17	"	37	2	"	126A
1	"	19	2	"	48A			

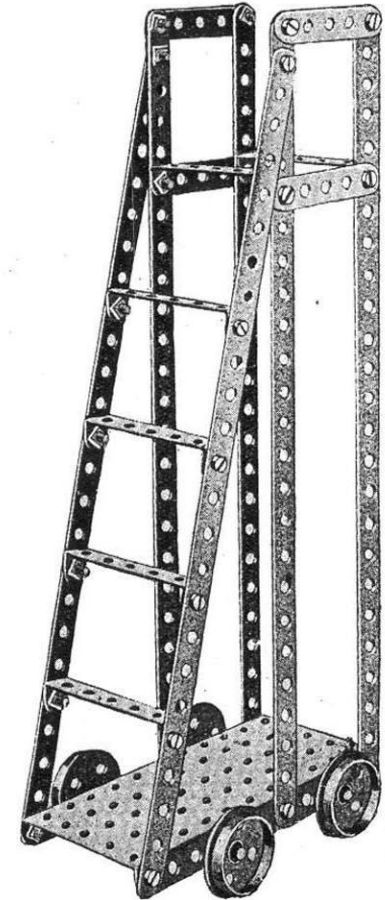
Model No. 211—Motor Truck



Parts required:

4	of No.	2
4	"	5
2	"	6A
4	"	10
1	"	11
3	"	16
3	"	22
2	"	22A
1	"	24
3	"	35
26	"	37
3	"	48A
1	"	52
2	"	54
2	"	126A

Model No. 210 Ladder on Wheels



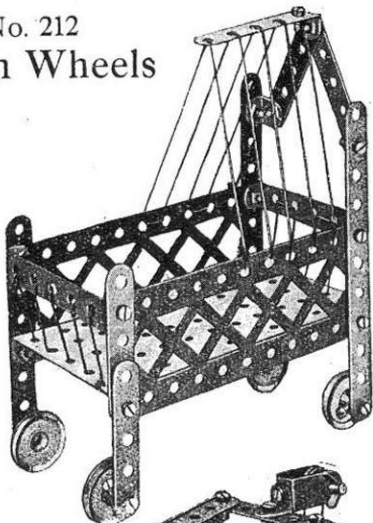
Parts required:

6	of No.	1	24	of No.	37
4	"	5	6	"	48A
2	"	16	1	"	52
4	"	20			

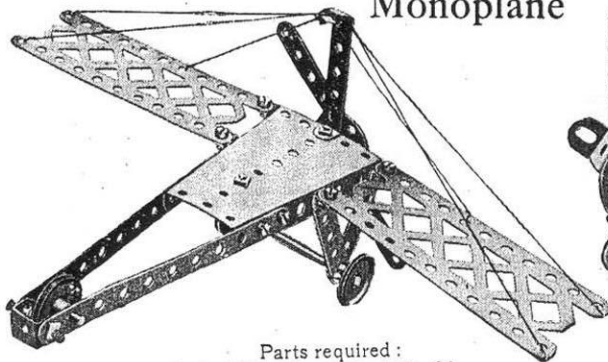
These Models can be made with MECCANO Outfit No. 2, or No. 1 and No. 1A

Model No. 212
Cot on Wheels

- Parts
required:
2 of No. 2
7 " " 5
3 " " 12
4 " " 22
18 " " 37
2 " " 48A
2 " " 100

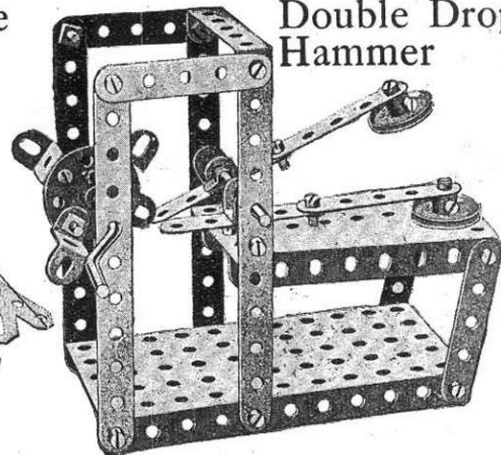


Model No 213
Monoplane



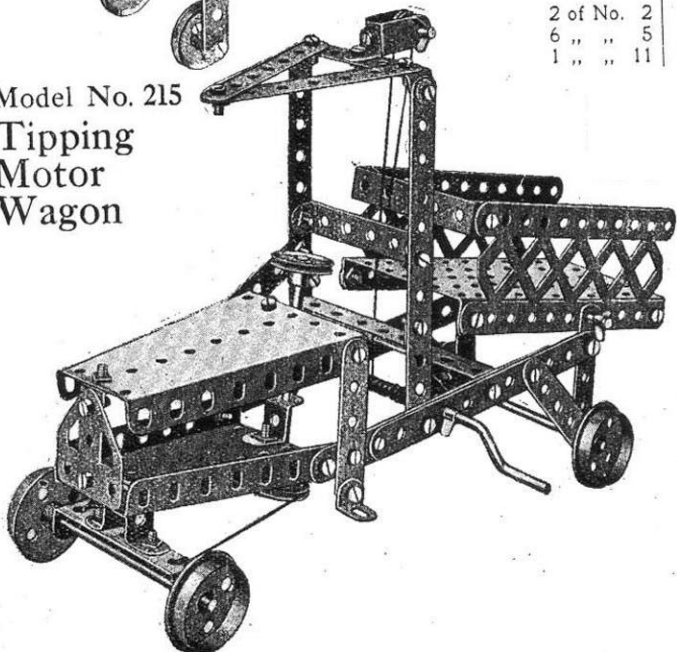
- Parts required:
- | | | |
|------------|-------------|-------------|
| 2 of No. 2 | 6 of No. 12 | 1 of No. 35 |
| 6 " " 5 | 2 " " 16 | 18 " " 37 |
| 1 " " 11 | 1 " " 18A | 1 " " 48A |
| | 3 " " 22 | 1 " " 54 |
| | 1 " " 24 | 2 " " 100. |

Model No. 214
Double Drop Hammer



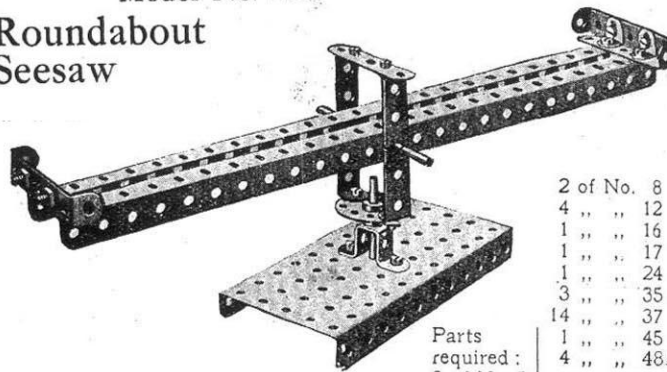
- Parts required:
- | | | |
|------------|-------------|--------------|
| 4 of No. 2 | 1 of No. 16 | 25 of No. 37 |
| 8 " " 5 | 1 " " 19 | 2 " " 48A |
| 2 " " 11 | 2 " " 22 | 1 " " 52 |
| | 1 " " 24 | 1 " " 54 |
| | 6 " " 35 | 4 " " 125 |

Model No. 215
Tipping Motor Wagon



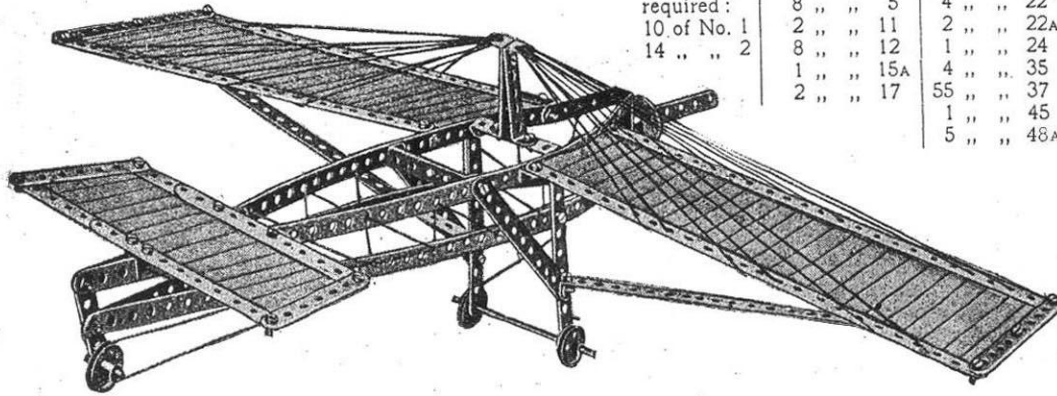
- Parts required:
- | |
|------------|
| 6 of No. 2 |
| 2 " " 3 |
| 7 " " 5 |
| 1 " " 10 |
| 4 " " 12 |
| 4 " " 16 |
| 1 " " 18A |
| 1 " " 19 |
| 4 " " 20 |
| 2 " " 22 |
| 1 " " 23 |
| 7 " " 35 |
| 43 " " 37 |
| 2 " " 38 |
| 1 " " 44 |
| 1 " " 45 |
| 6 " " 48A |
| 1 " " 52 |
| 2 " " 54 |
| 2 " " 100 |
| 2 " " 125 |
| 1 " " 126A |

Model No. 216
Roundabout Seesaw



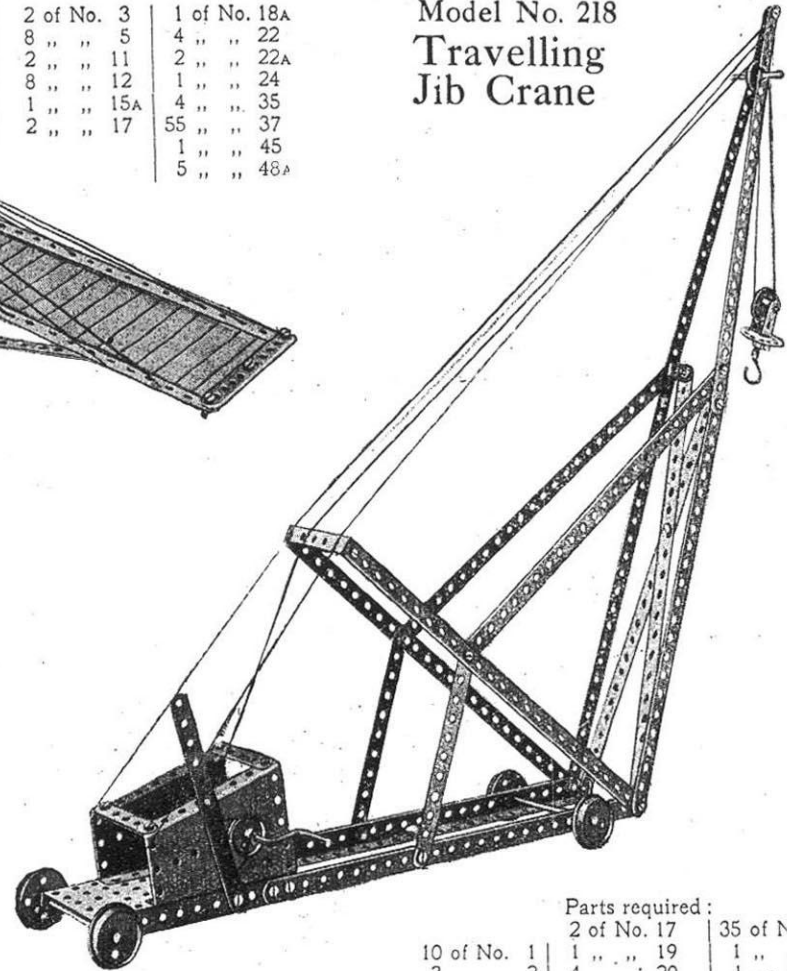
- Parts required:
- | |
|------------|
| 2 of No. 8 |
| 4 " " 12 |
| 1 " " 16 |
| 1 " " 17 |
| 1 " " 24 |
| 3 " " 35 |
| 14 " " 37 |
| 1 " " 45 |
| 4 " " 48A |
| 3 of No 5 |
| 1 " " 52 |

Model No. 217—Monoplane



Parts required:	2 of No. 3	1 of No. 18A
10 of No. 1	8 " " 5	4 " " 22
14 " " 2	2 " " 11	2 " " 22A
	8 " " 12	1 " " 24
	1 " " 15A	4 " " 35
	2 " " 17	55 " " 37
		1 " " 45
		5 " " 48A

Model No. 218 Travelling Jib Crane



Parts required:	2 of No. 17	35 of No. 37
10 of No. 1	1 " " 19	1 " " 44
3 " " 2	4 " " 20	1 " " 48A
3 " " 5	2 " " 22	1 " " 52
2 " " 8	1 " " 22A	2 " " 54
4 " " 12	1 " " 24	1 " " 57
2 " " 16	5 " " 35	

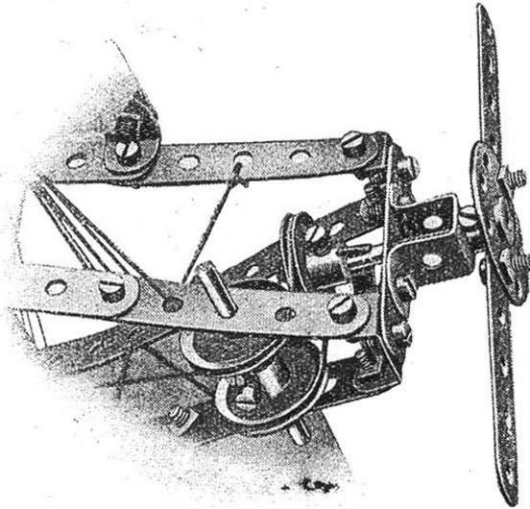
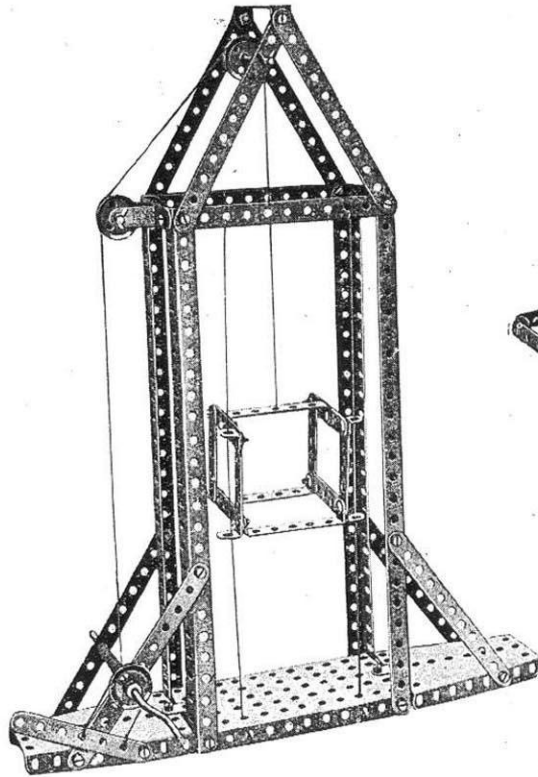


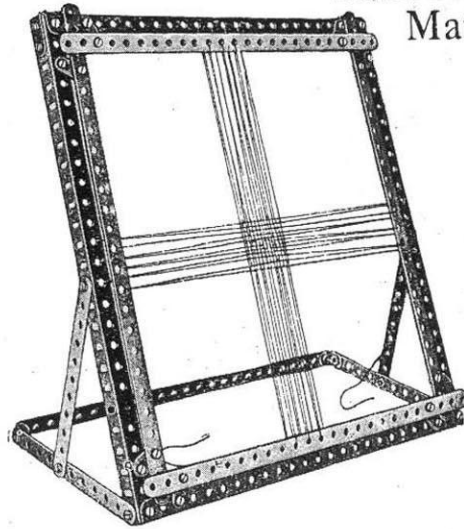
FIG. 217A

Model No. 219
Elevator



Parts required :		
10 of No. 2	1 of No. 16	38 of No. 37
1 " " 3	1 " " 18A	1 " " 44
10 " " 5	1 " " 19	4 " " 48A
4 " " 8	1 " " 22	1 " " 52
2 " " 10	2 " " 22A	1 " " 52
4 " " 12	5 " " 35	2 " " 54

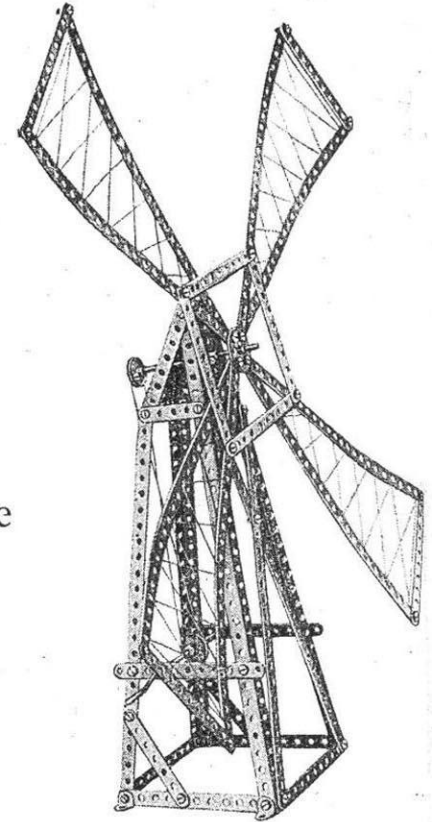
Model No. 220
Mat Frame



Parts required :

5 of No. 1	
4 " " 2	
4 " " 8	
8 " " 10	
2 " " 12	
2 " " 12A	
36 " " 37	

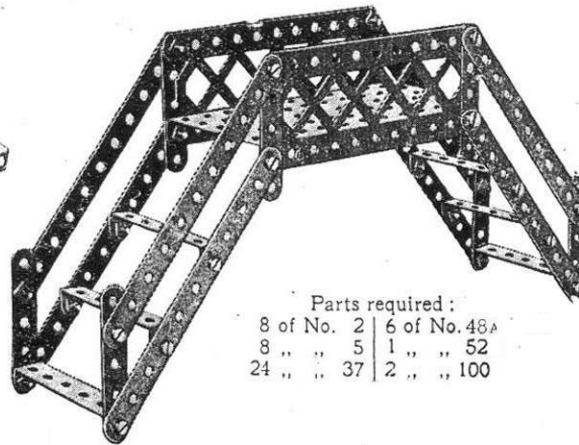
Model No. 221
Windmill



Parts required :

10 of No. 1	4 of No. 8	1 of No. 24
14 " " 2	4 " " 12	4 " " 35
2 " " 3	1 " " 15	45 " " 37
2 " " 5	1 " " 19	2 " " 54
	2 " " 22	

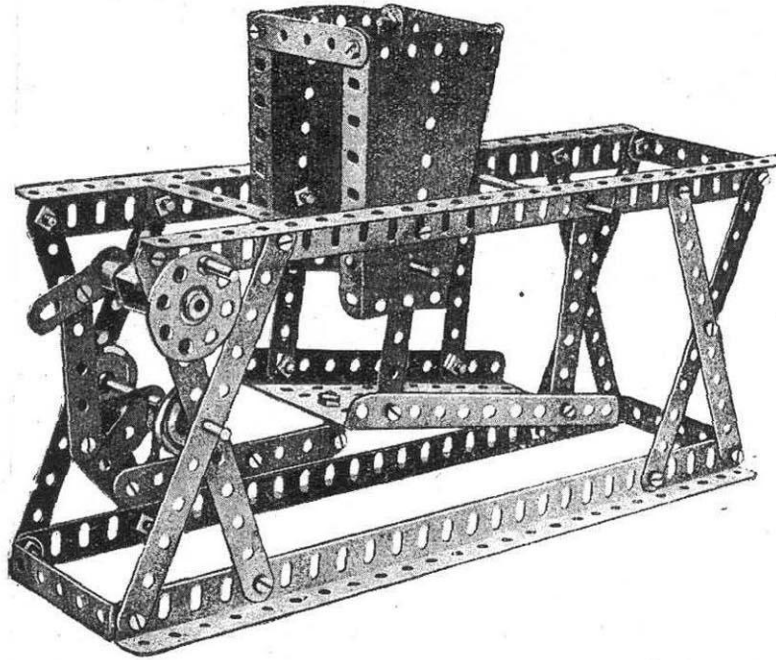
Model No. 222 High level
Bridge



Parts required :

8 of No. 2	6 of No. 48A
8 " " 5	1 " " 52
24 " " 37	2 " " 100

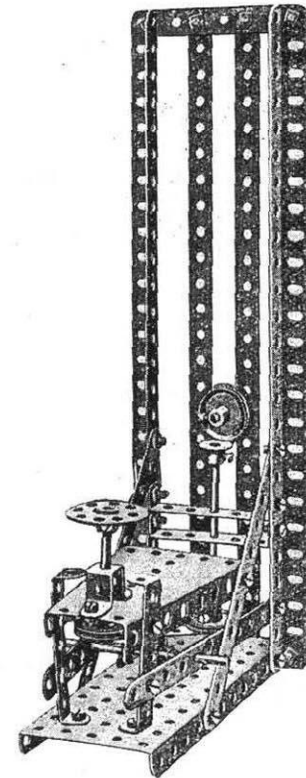
Model No. 223--Coal Sifter



Parts
required :

8 of No.	2
2 " "	3
7 " "	5
4 " "	8
1 " "	12
3 " "	16
1 " "	17
2 " "	22
1 " "	24
6 " "	35
38 " "	37
1 " "	45
4 " "	48 ^A
1 " "	52
2 " "	54
1 " "	62
1 " "	115
1 " "	126 ^A

Model No. 224 Try-your-strength Machine



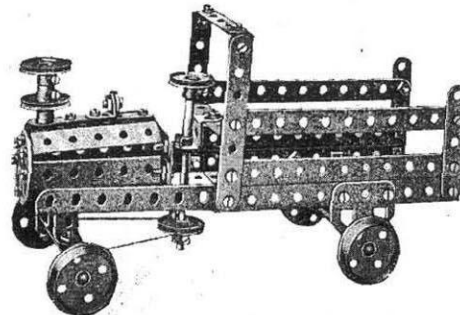
Parts required :

2 of No.	1	1 of No.	17	12 of No.	38
5 " "	2	1 " "	18 ^A	1 " "	45
2 " "	3	4 " "	22	4 " "	48 ^A
2 " "	8	1 " "	24	1 " "	52
1 " "	11	4 " "	35	1 " "	54
2 " "	16	30 " "	37	1 " "	126 ^A

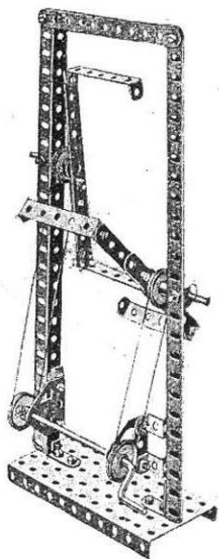
Model No. 225--Locomotive

Parts required :

4 of No.	2	1 of No.	24
2 " "	3	2 " "	35
6 " "	5	47 " "	37
3 " "	10	1 " "	45
7 " "	12	6 " "	48 ^A
3 " "	16	1 " "	52
1 " "	17	1 " "	54
4 " "	20	1 " "	62
4 " "	22	2 " "	125
1 " "	23	2 " "	126 ^A

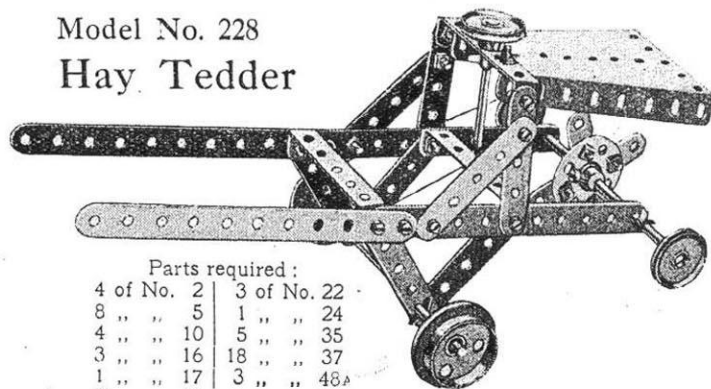


Model No. 226 Candy Puller



Parts required:	
3 of No.	2
2 " "	8
2 " "	12
2 " "	12A
2 " "	17
1 " "	19
4 " "	22
2 " "	35
26 " "	37
10 " "	38
4 " "	48A
1 " "	52
2 " "	62
4 " "	125
2 " "	126

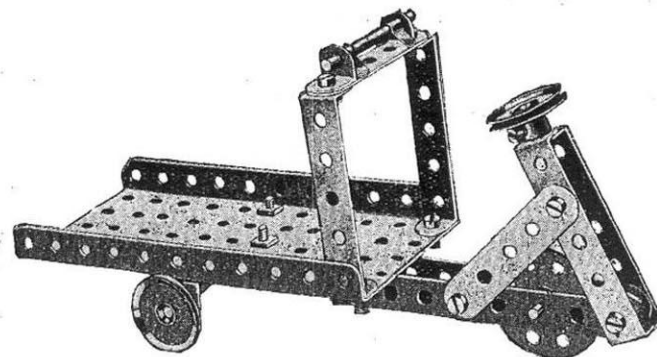
Model No. 228 Hay Tedder



Parts required:	
4 of No. 2	3 of No. 22
8 " " 5	1 " " 24
4 " " 10	5 " " 35
3 " " 16	18 " " 37
1 " " 17	3 " " 48A
2 " " 20	1 " " 54

Model No. 227—Carrier Tricycle

Parts required:	
2 of No.	2
3 " "	5
1 " "	11
2 " "	12
1 " "	16
1 " "	17
1 " "	18A
3 " "	22
1 " "	24
2 " "	35
15 " "	37
5 " "	48A
1 " "	52



Model No. 229 Baby Chair

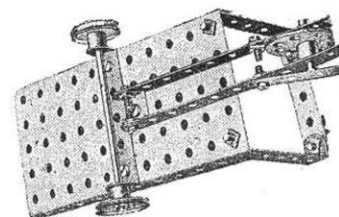
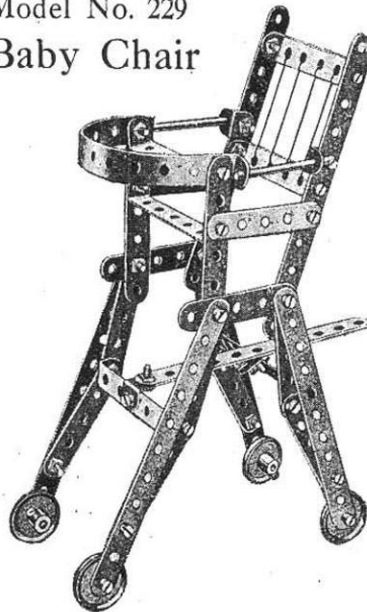
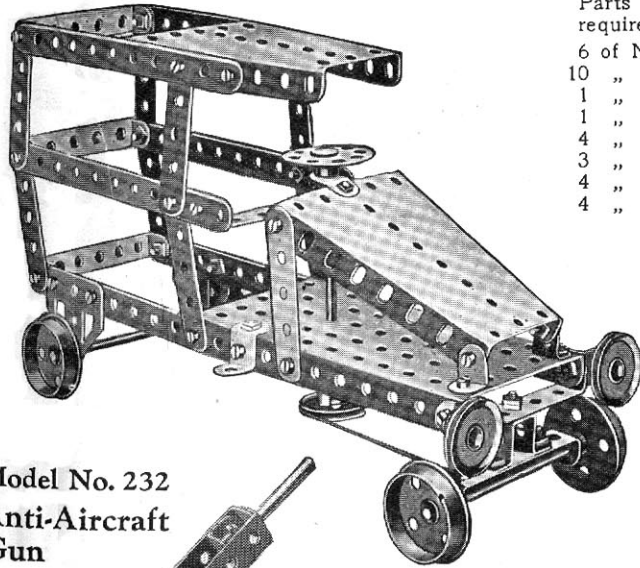


FIG. 227A

Carrier Tricycle, underneath view

Parts required:	
8 of No.	2
2 " "	3
12 " "	5
6 " "	12
2 " "	17
4 " "	22
31 " "	37
6 " "	48A

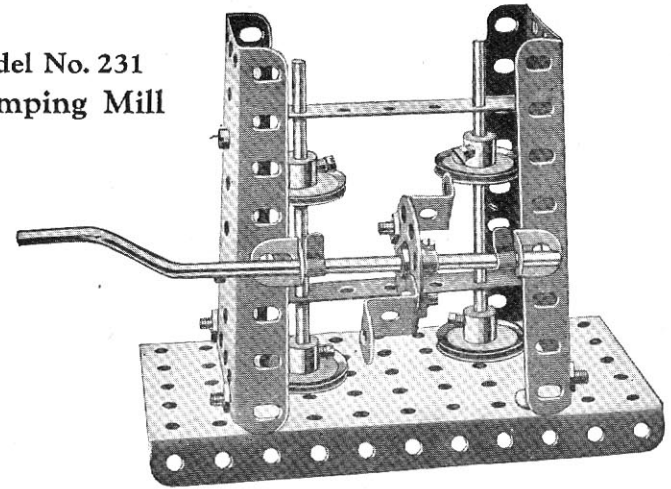
Model No. 230 Motor Van



Parts required:

6 of No.	2
10 " "	5
1 " "	10
1 " "	11
4 " "	12
3 " "	16
4 " "	20
4 " "	22
1 of No.	24
38 " "	37
1 " "	44
6 " "	48A
1 " "	52
2 " "	54
2 " "	125
2 " "	126A

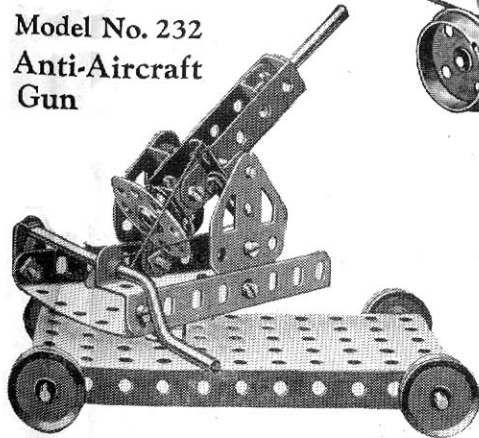
Model No. 231 Stamping Mill



Parts required:

2 of No.	3	4 of No.	22	1 of No.	52
10 " "	12	1 " "	24	2 " "	54
2 " "	16	2 " "	35	2 " "	125
1 " "	19	16 " "	37		

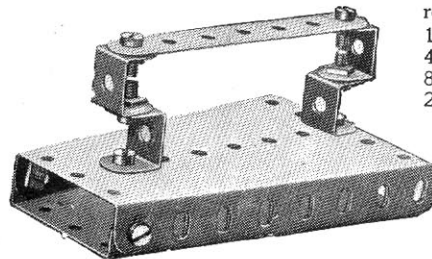
Model No. 232 Anti-Aircraft Gun



Parts required:

5 of No.	10	4 of No.	22	1 of No.	52
2 " "	11	1 " "	24	1 " "	54
2 " "	16	4 " "	35	4 " "	125
2 " "	17	12 " "	37	2 " "	126A
1 " "	19	2 " "	48A		

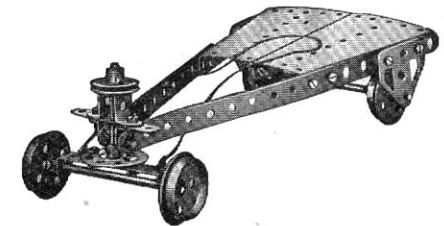
Model No. 233 Smoothing Iron



Parts required:

1 of No.	3
4 " "	11
8 " "	37
2 " "	54

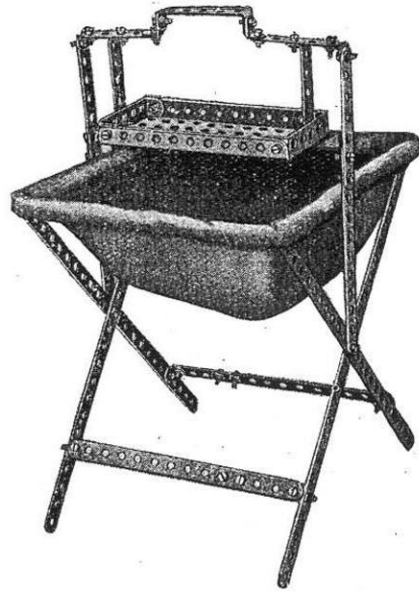
Model No. 234 Coaster



Parts required:

2 of No.	2	1 of No.	17	6 of No.	38
1 " "	5	4 " "	20	1 " "	45
2 " "	12	1 " "	22	1 " "	48A
1 " "	15	1 " "	24	2 " "	54
1 " "	16	16 " "	37	2 " "	126A

These Models can be made with MECCANO Outfit No. 2, or No. 1 and No. 1A

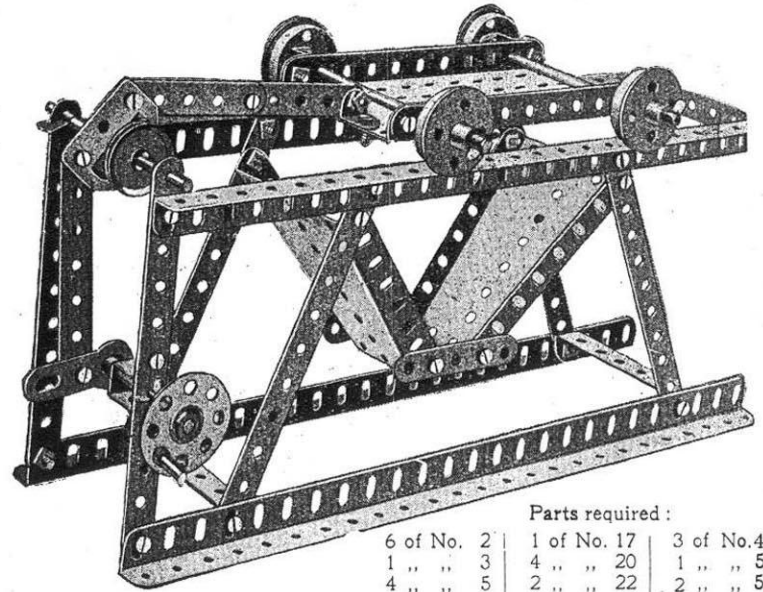


Model No. 235
Needlework
Basket

Parts required :

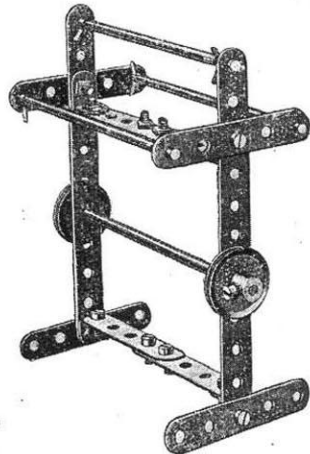
6 of No.	1
6 " "	2
2 " "	3
6 " "	5
12 " "	12
46 " "	37
3 " "	48 ^A
1 " "	52

Model No. 236 -Sifter



Parts required :

6 of No.	2	1 of No.	17	3 of No.	48 ^A
1 " "	3	4 " "	20	1 " "	52
4 " "	5	2 " "	22	2 " "	54
4 " "	8	1 " "	24	1 " "	62
1 " "	12	7 " "	35	1 " "	115
2 " "	15	34 " "	37	4 " "	125
1 " "	16	1 " "	45	1 " "	126 ^A

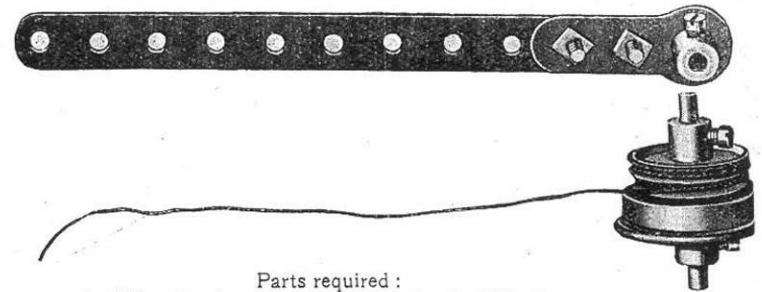


Model No. 237
Towel Rail

Parts required :

2 of No.	2
8 " "	5
4 " "	12
1 " "	15
4 " "	16
2 " "	22
6 " "	35
12 " "	37

Model No. 238—Spinning Top



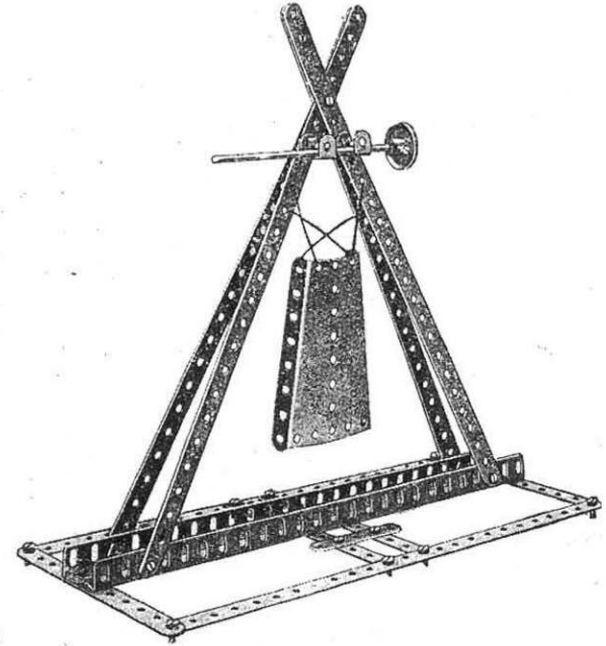
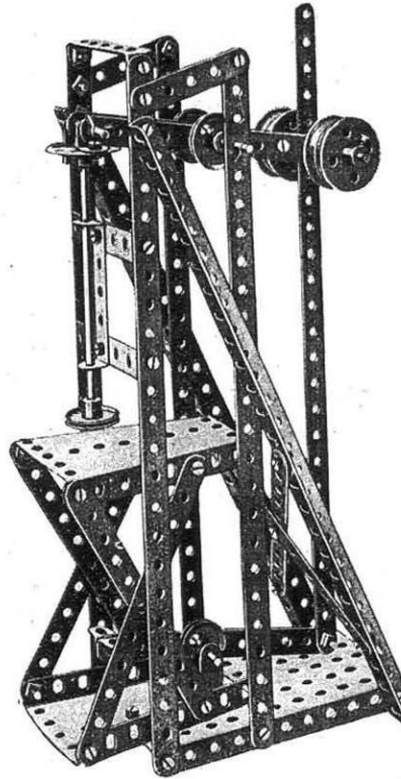
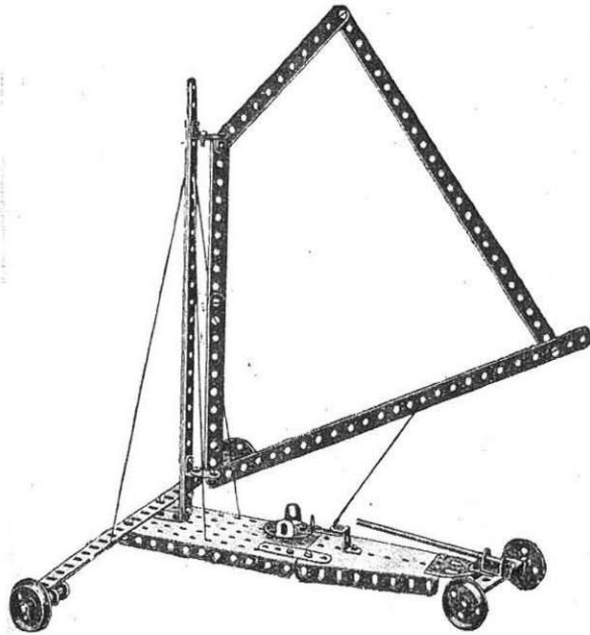
1 of No.	2	Parts required :	1 of No.	20	2 of No.	37
1 " "	17		2 " "	22	1 " "	62

Model No. 239—Seashore Aeroplane

Model No. 240—

Model No. 241—Dinner Gong

Embossing Machine



Parts required :

4 of No. 1	1 of No. 12A	33 of No. 37
3 " " 2	1 " " 15	1 " " 38
2 " " 5	1 " " 16	1 " " 48A
1 " " 8	2 " " 17	1 " " 52
3 " " 10	4 " " 20	1 " " 54
3 " " 11	1 " " 24	1 " " 125
7 " " 12	6 " " 35	1 " " 126A

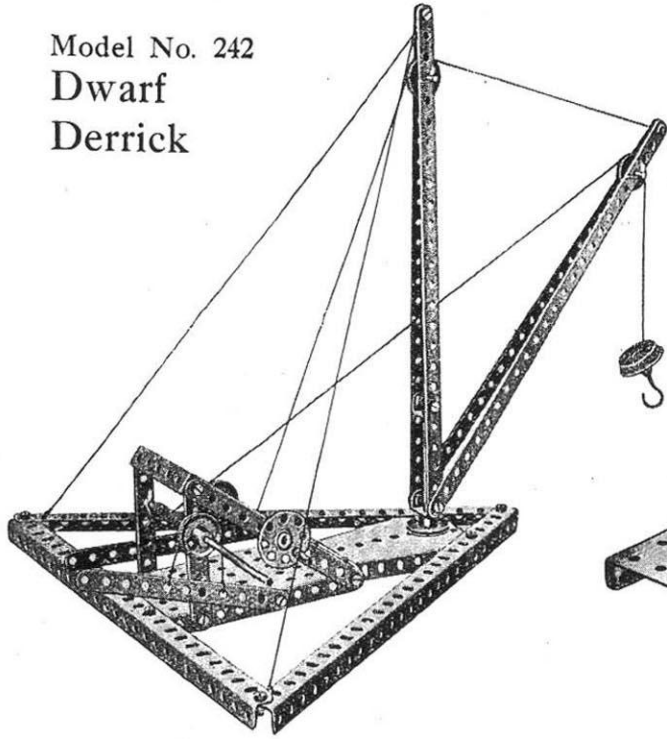
Parts required :

5 of No. 1	2 of No. 16	44 of No. 37
9 " " 2	1 " " 17	1 " " 44
2 " " 5	1 " " 18A	4 " " 48A
2 " " 8	4 " " 20	1 " " 52
2 " " 11	4 " " 22	2 " " 54
4 " " 12	1 " " 24	
1 " " 15	4 " " 35	

Parts required :

6 of No. 1	1 of No. 15
4 " " 2	1 " " 22
2 " " 5	27 " " 37
2 " " 8	1 " " 54
2 " " 11	

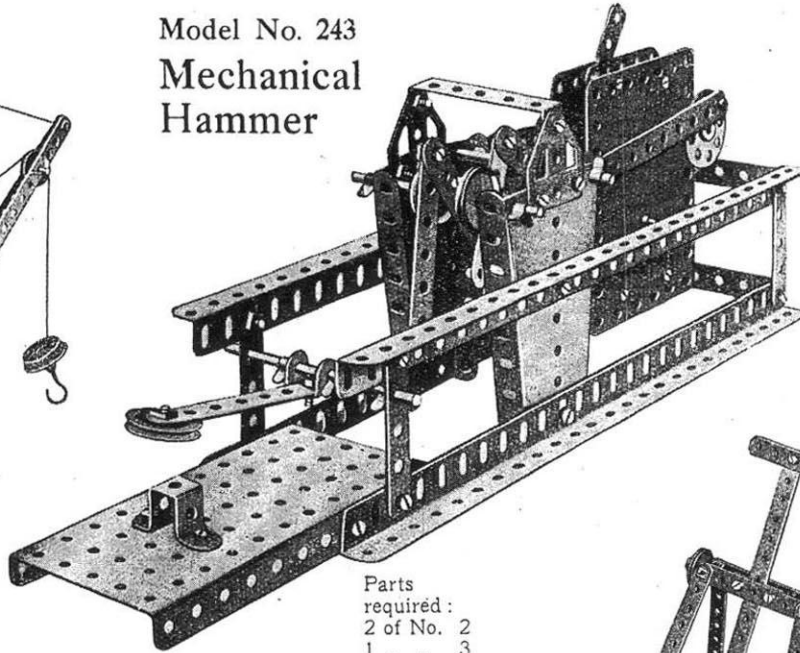
Model No. 242
Dwarf
Derrick



Parts required :

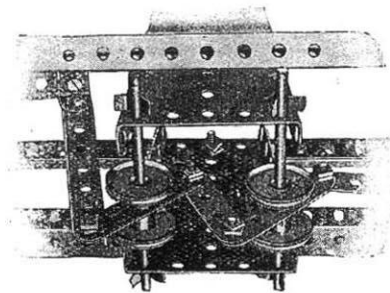
4 of No. 1	2 of No. 22A
4 " " 2	1 " " 24
2 " " 3	6 " " 35
3 " " 8	23 " " 37
2 " " 11	4 " " 38
2 " " 16	1 " " 48A
2 " " 18A	1 " " 52
1 " " 19	1 " " 54
1 " " 20	1 " " 57
4 " " 22	1 " " 115

Model No. 243
Mechanical
Hammer



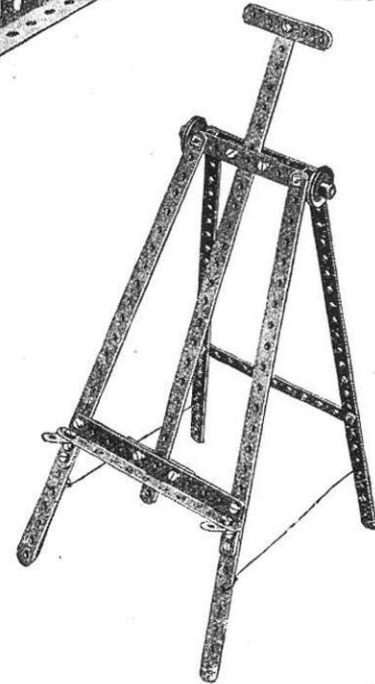
Parts required :

2 of No. 2	2
1 " " 3	3
6 " " 5	5
4 " " 8	8
1 " " 11	11
1 " " 12	12
3 " " 16	16
4 " " 22	22
1 " " 22A	22A
1 " " 24	24
8 " " 35	35
32 " " 37	37
1 " " 45	45
3 " " 48A	48A
1 " " 52	52
2 " " 54	54
2 " " 126A	126A



Clockwork Motor.

Model No. 244
Easel



Parts required :

5 of No. 1	1
3 " " 2	2
2 " " 3	3
3 " " 5	5
4 " " 12	12
2 " " 12	12
1 " " 15	15
2 " " 22	22
19 " " 37	37
4 " " 38	38

FIG. 243A.

Model No. 245 Extending Ladder on Running Carriage

Parts
required:

2	of No.	1
8	" "	2
1	" "	3
7	" "	5
4	" "	8
5	" "	12
4	" "	16
1	" "	18A
1	" "	19
4	" "	20
4	" "	22
1	" "	22A
1	" "	24
6	" "	35
47	" "	37
2	" "	38
1	" "	44
1	" "	45
7	" "	48A
1	" "	52
2	" "	54
1	" "	115
2	" "	125
2	" "	126A

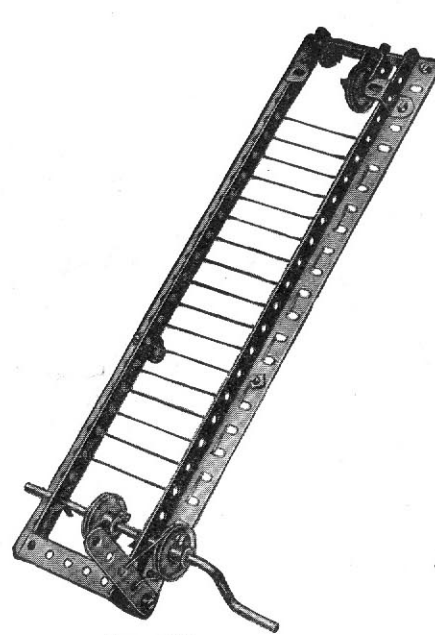
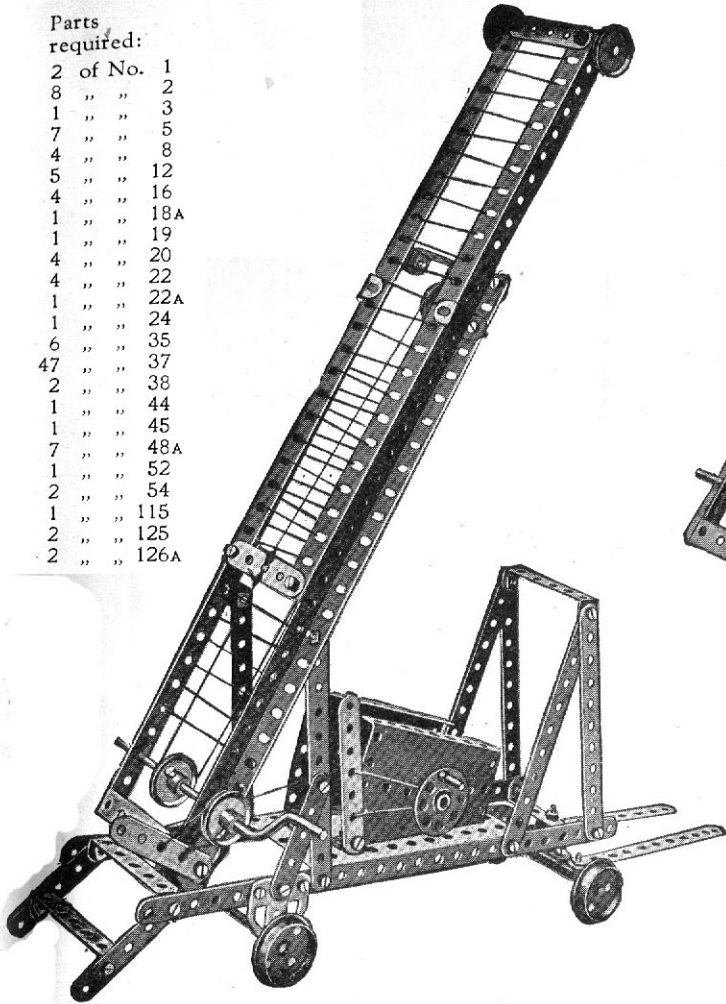


FIG. 245A

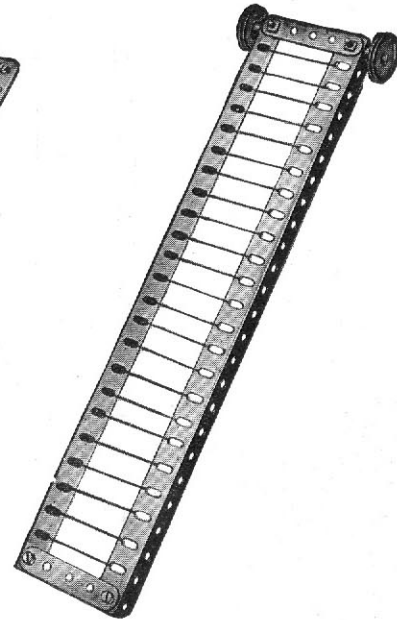
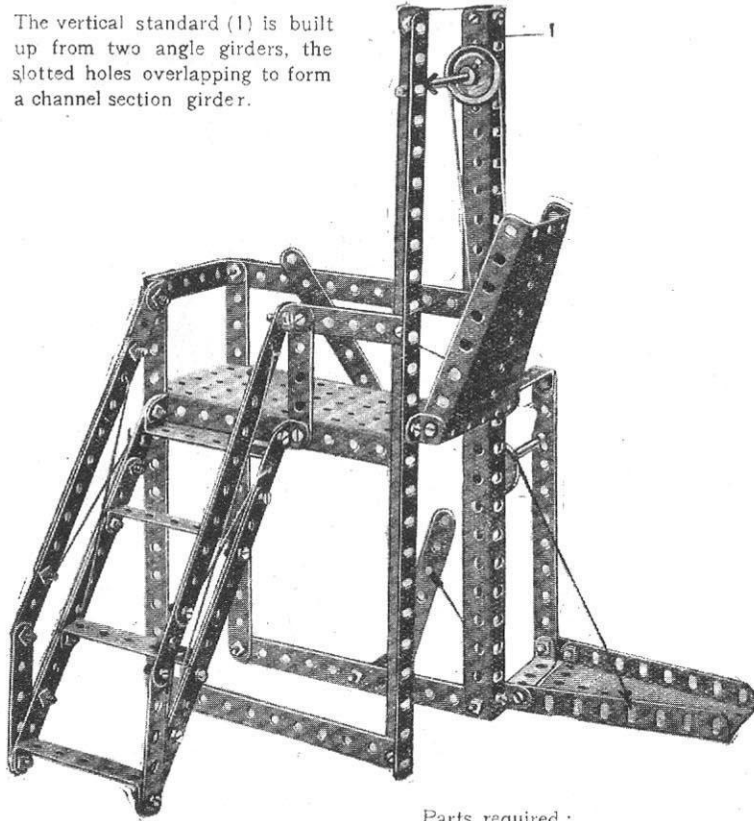


FIG. 245B

The bed of the lower carriage framework is formed by bolting two 12½" strips to the sides of a large flanged plate, and two sector plates bolted to the flanged plate by their flanges to form the sides, and a bearing for the spindle carrying the operating cord attached to the bottom of the ladder to raise it from a horizontal position; and the strips 1 form a support for the ladder when in this horizontal position. Angle brackets 2, Fig. 245A, form pivots for the lower part of the ladder, and are carried from the supports 3. The upper part of the ladder, Fig. 245, is slideably guided and retained on the lower ladder by reversed brackets 4. The extension of the ladder is effected by the cranked spindle round a pulley on which (and another pulley at the top of the framework) the cord is passed, the ends being secured to the lower part of the slideable ladder.

Model No. 246 Ferry Gangway

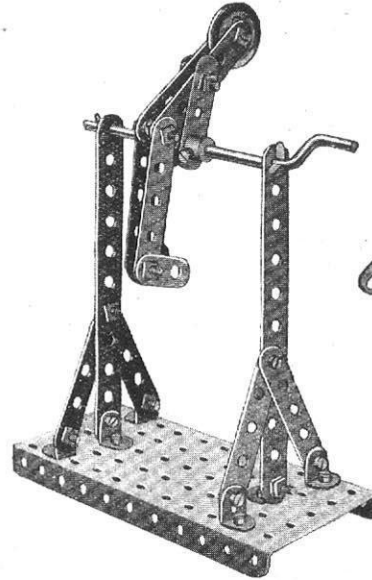
The vertical standard (1) is built up from two angle girders, the slotted holes overlapping to form a channel section girder.



Parts required :

14 of No. 2	6 of No. 12	1 of No. 45
2 " " 3	2 " " 16	8 " " 48A
6 " " 5	2 " " 22	1 " " 52
3 " " 8	2 " " 35	2 " " 54
2 " " 10	54 " " 37	

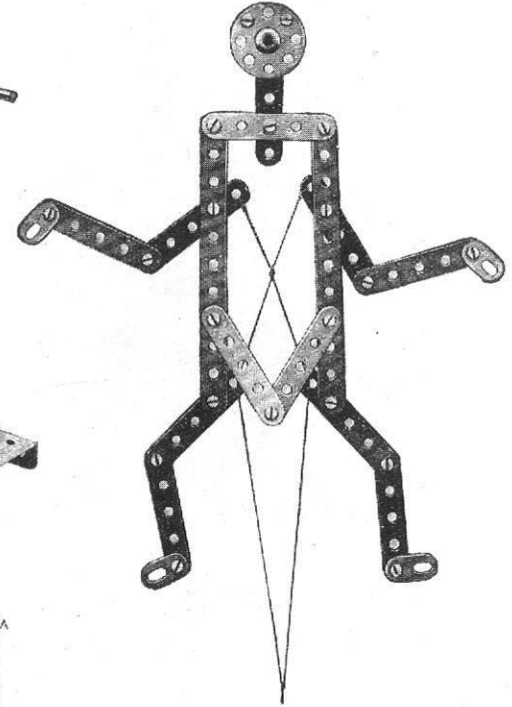
Model No. 247 The Acrobat



Parts required

2 of No. 2	1 of No. 22A
8 " " 5	2 " " 35
2 " " 10	21 " " 37
6 " " 12	1 " " 52
1 " " 19	2 " " 62

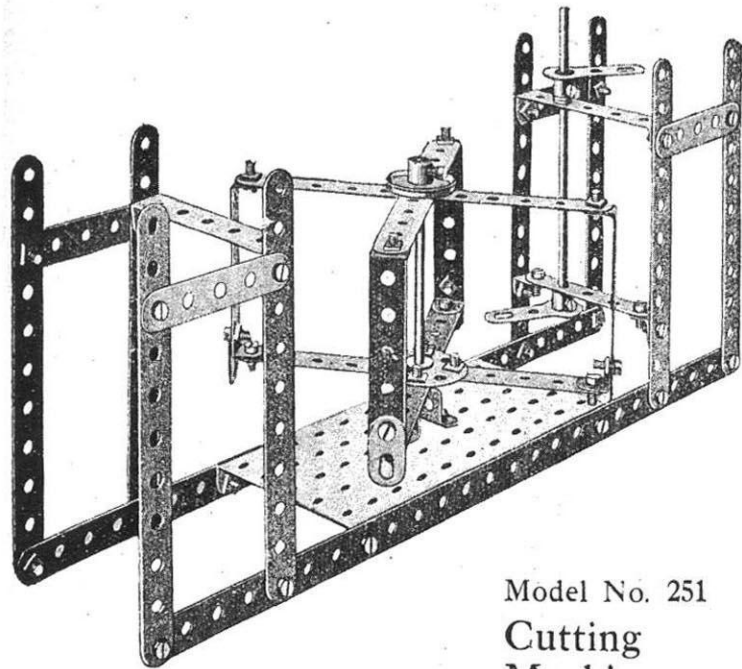
Model No. 248 Jumping Jack



Parts
required :

2 of No. 2
12 " " 5
4 " " 10
1 " " 24
18 " " 37

Model No. 249 Turnstile



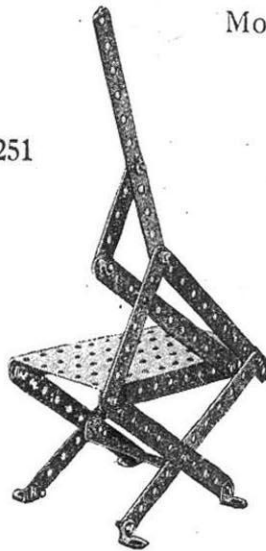
Parts required :

2 of No. 1	1 of No. 24
10 " " 2	42 " " 37
9 " " 5	2 " " 33
4 " " 10	1 " " 45
2 " " 12	6 " " 48A
1 " " 15	1 " " 52
1 " " 15A	2 " " 62
2 " " 22	

Model No. 251
Cutting
Machine

Parts
required :

7 of No. 2
1 " " 3
1 " " 5
4 " " 12
14 " " 37
1 " " 48A
1 " " 52



Model No. 250
Chair for
Wounded

Parts
required :

6 of No. 2
2 " " 3
10 " " 5
2 " " 11
2 " " 16
4 " " 22
21 " " 37
2 " " 48A
1 " " 52

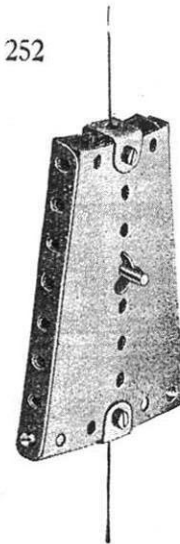


Model No. 252

Magic Sector
Plates

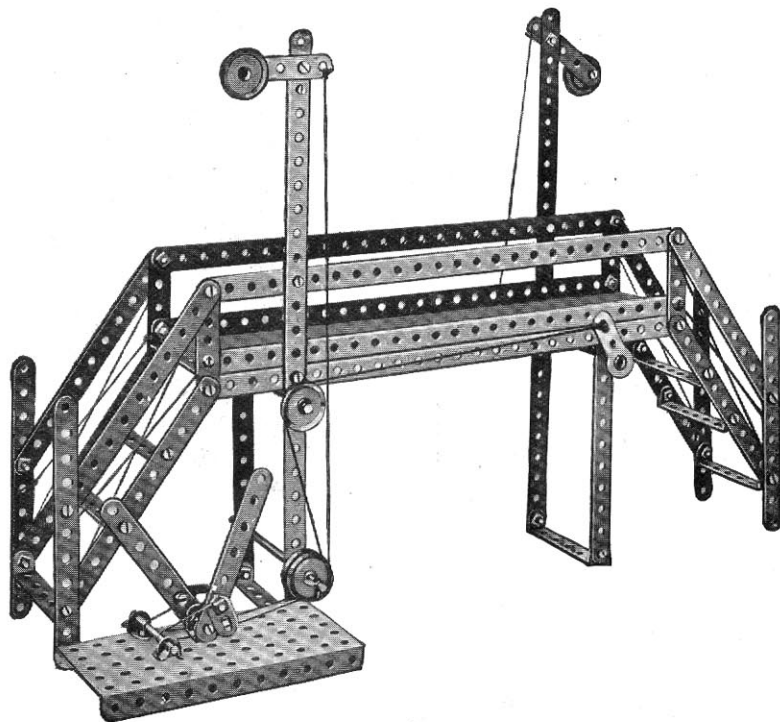
Parts
required :

2 of No. 11
1 " " 17
2 " " 35
6 " " 37
2 " " 54



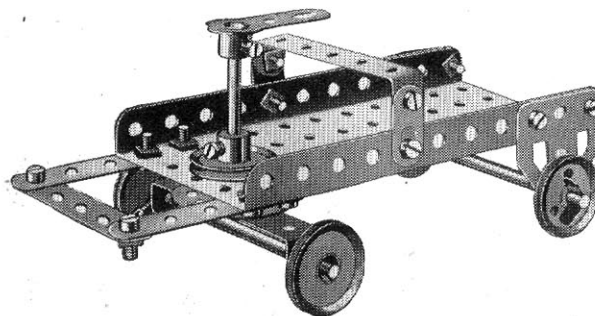
When the cord is held vertically the magic sector plates will fall or stop at the bidding of the owner. If the cord is held without tension the plates will fall, but the instant the cord is tightened they will stop dead. The cord is wrapped once around the rod which passes through the centre holes of the sector plates.

Model No. 253
Railway Foot Bridge and Signals



Parts required :			
4 of No. 1	1 of No. 11	2 of No. 22A	
14 " " 2	2 " " 12	6 " " 35	
2 " " 3	1 " " 15A	50 " " 37	
8 " " 5	2 " " 16	8 " " 48A	
2 " " 8	1 " " 17	1 " " 52	
2 " " 10	3 " " 22	1 " " 62	

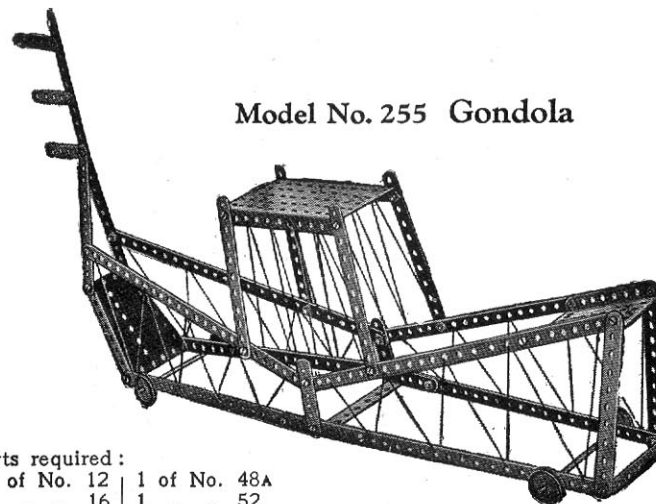
Model No. 254 Motor Van



Parts required :

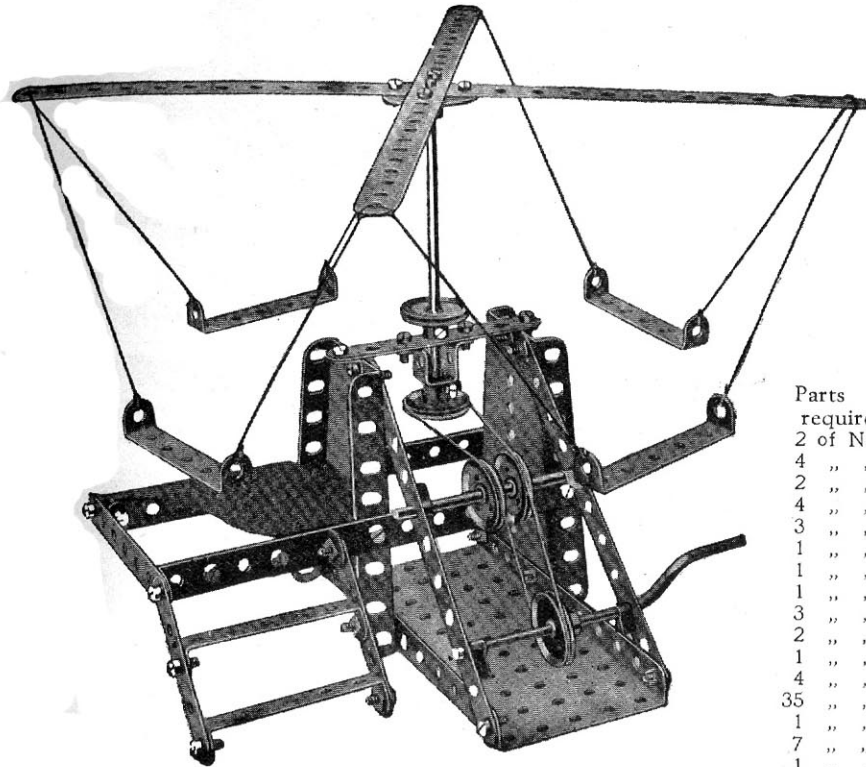
3 of No. 5	2 of No. 22A	2 of No. 48A
2 " " 10	1 " " 24	1 " " 52
2 " " 16	2 " " 35	1 " " 62
1 " " 17	16 " " 37	2 " " 126A
3 " " 22	2 " " 38	

Model No. 255 Gondola



Parts required :			
8 of No. 1	2 of No. 12	1 of No. 48A	
9 " " 2	2 " " 16	1 " " 52	
1 " " 3	4 " " 22	2 " " 54	
5 " " 5	29 " " 37		

Model No. 256 Roundabout



Parts required:

2	of No.	1
4	" "	2
2	" "	3
4	" "	5
3	" "	12
1	" "	15
1	" "	16
1	" "	19
3	" "	22
2	" "	22A
1	" "	24
4	" "	35
35	" "	37
1	" "	45
7	" "	48A
1	" "	52
2	" "	54

Model No. 257 Beam Scales



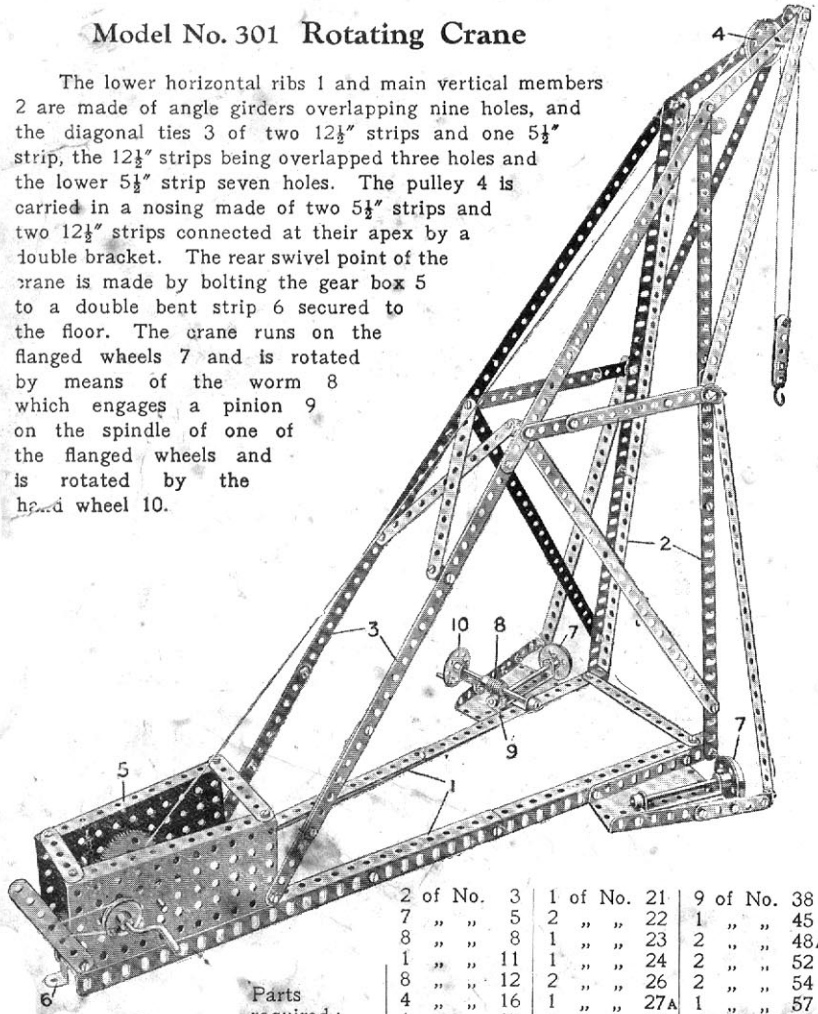
Parts required:		
5	of No.	1
6	" "	2
7	" "	5
4	" "	8
6	of No.	12
2	" "	17
2	" "	22A
6	" "	35
48	" "	37
5	of No.	48A
1	" "	52
2	" "	54
2	" "	126A

HOW TO CONTINUE

This completes the Models which may be made with MECCANO Outfit No. 2. The next Models are a little more advanced, requiring a number of extra parts to construct them. The necessary parts are all contained in a No. 2A Accessory Outfit, the price of which will be found in the List at the end of the Manual.

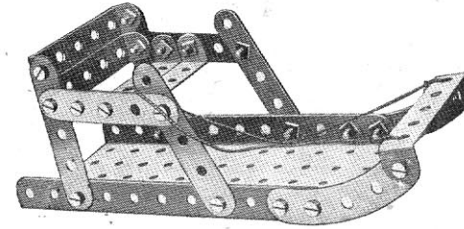
Model No. 301 Rotating Crane

The lower horizontal ribs 1 and main vertical members 2 are made of angle girders overlapping nine holes, and the diagonal ties 3 of two 12½" strips and one 5½" strip, the 12½" strips being overlapped three holes and the lower 5½" strip seven holes. The pulley 4 is carried in a nosing made of two 5½" strips and two 12½" strips connected at their apex by a double bracket. The rear swivel point of the crane is made by bolting the gear box 5 to a double bent strip 6 secured to the floor. The crane runs on the flanged wheels 7 and is rotated by means of the worm 8 which engages a pinion 9 on the spindle of one of the flanged wheels and is rotated by the hand wheel 10.



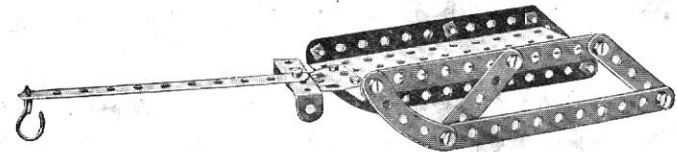
2 of No.	3	1 of No.	21	9 of No.	38
7 "	5	2 "	22	1 "	45
8 "	8	1 "	23	2 "	48A
1 "	11	1 "	24	2 "	52
8 "	12	2 "	26	2 "	54
4 "	16	1 "	27A	1 "	57
1 "	17	1 "	32	4 "	59
10 of No.	1	1 "	35	1 "	115
11 "	2	2 "	37	2 "	125

Model No. 302 Toboggan



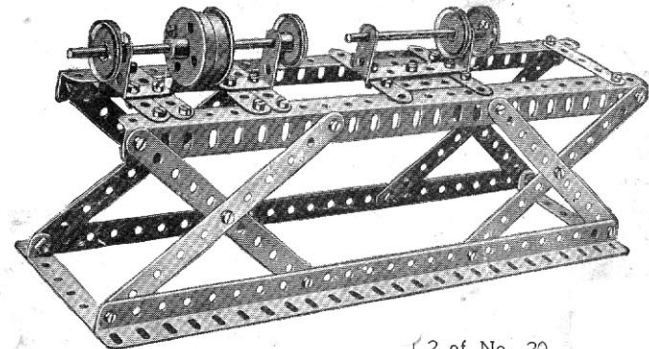
Parts required:	
6 of No.	5
20 "	37
5 "	48A
1 "	52
2 "	90

Model No. 303 Horse Sleigh



Parts required:					
3 of No.	2	13 of No.	37	1 of No.	57
4 "	5	1 "	48A	2 "	90
1 "	23	1 "	52	1 "	126A

Model No. 304 Lathe



Parts required:			
4 of No.	8	2 of No.	20
2 "	12A	1 "	22
8 of No.	15A	41 "	37
10 "	16	1 "	46
		2 "	43A

Model No. 305 Tower Wagon

Parts
required :

6	of No.	1
2	" "	4
10	" "	5
8	" "	8
2	" "	12
2	" "	15A
4	" "	16
4	" "	20
1	" "	22A
1	" "	24
1	" "	26
1	" "	32
4	" "	35
72	" "	37
8	" "	38
10	" "	48A
2	" "	52
3	" "	59
1	" "	98
2	" "	100
1	" "	115
2	" "	126A

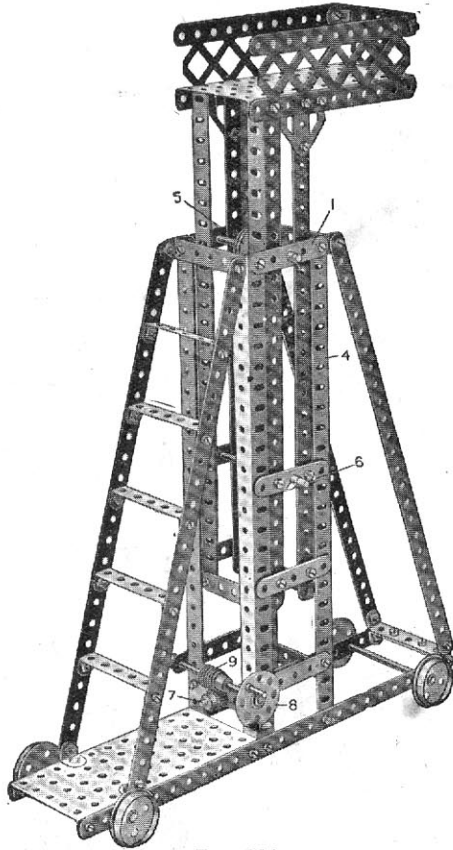


FIG. 305

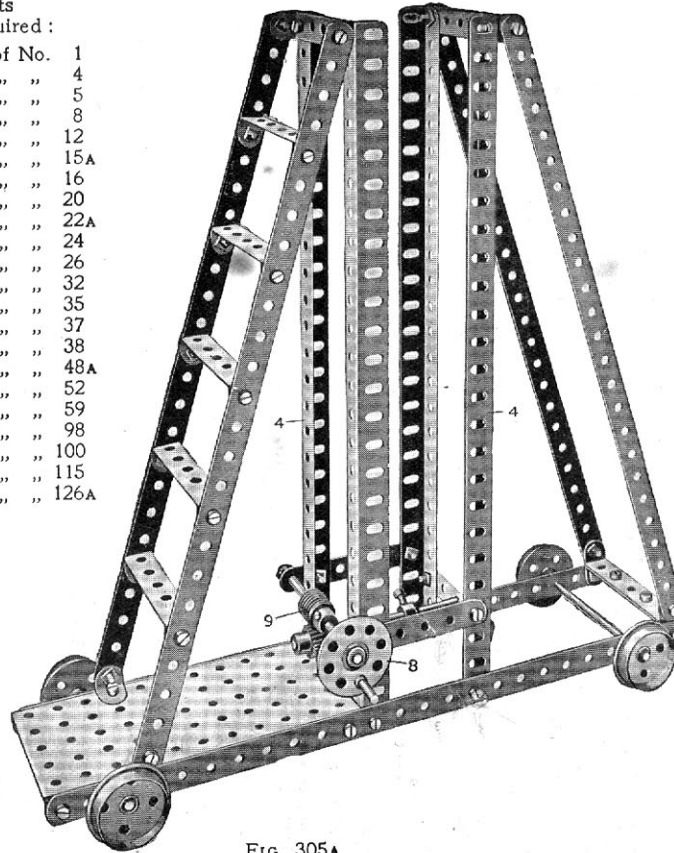


FIG. 305A

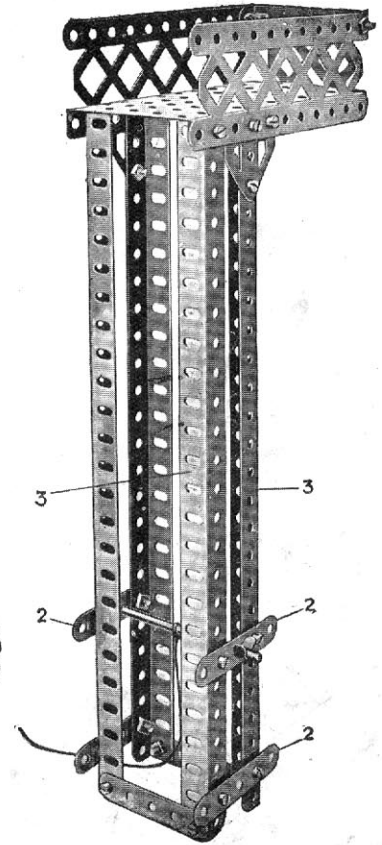
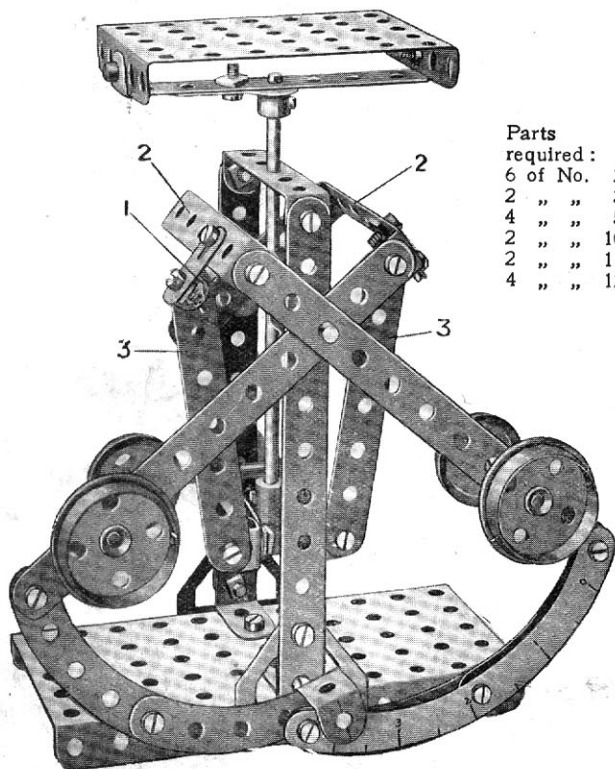


FIG. 305B

Begin the construction of this model by building up the platform. Fig. 305A, the tie strips 1 being left off as shown in order to be able to insert the rising and falling tower, Fig. 305B. The strips are then bolted on. The guide strips 2 are bolted to the girder 3 of the tower with washers beneath the strips. This gives the necessary clearance and enables the strips to rise easily up the faces of the girders 4 of the fixed lower part of the tower. The tower is raised by means of a cord which passes over a pulley 5 and is fastened to a rod 6, the other end of the cord winding on a rod 7 rotated by a hand wheel 8 on the spindle of the worm 9.

Model No. 306 Letter Balance



Parts
required:
6 of No. 2
2 " " 3
4 " " 5
2 " " 10
2 " " 11
4 " " 12

The connection at 1 of the rocking arms 2 to the thrust strips 3 is locknuttred to give a free pivotal action, and similarly the pivotal connections 5 of the strips 3 to the lever strips 4 are locknuttred to give free play.

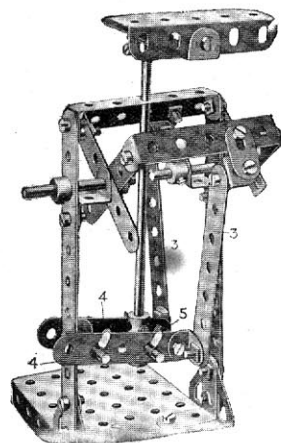
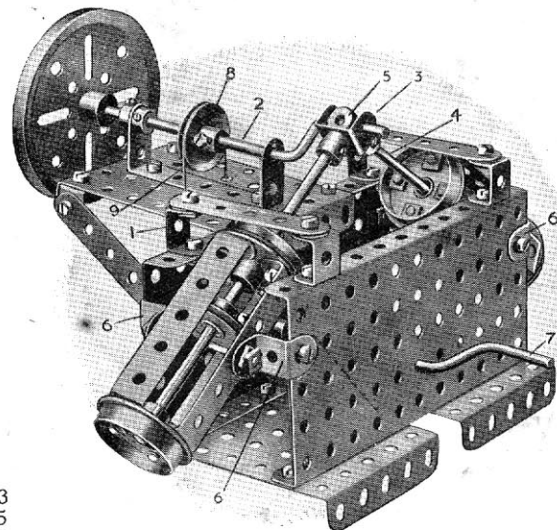


FIG. 306A

2 of No. 12A
1 " " 15
2 " " 17
2 " " 18A
2 " " 20
2 " " 22
4 " " 35
40 " " 37
6 " " 38
3 " " 48A
1 " " 48B
1 " " 52
1 " " 53
4 " " 59
1 " " 62
1 " " 63
4 " " 90
2 " " 126
2 " " 125A

Parts
required:
2 of No. 3
2 " " 5
4 " " 11
4 " " 12
2 " " 12A
2 " " 15
2 " " 19
1 " " 19B
4 " " 20
4 " " 22
3 " " 35
50 " " 37
6 " " 48A
2 " " 52
3 " " 53
2 " " 59
1 " " 63
1 " " 102
1 " " 116
4 " " 125

Model No. 307 Oscillating Steam Engine



The piston rod 1 of one cylinder is pivotally connected to the crank rod 2 by means of a fork piece 3, and the piston rod 4 of the other cylinder is pivoted to the crank rod by a coupling 5. The cylinders consisting of four strips are enclosed by flanged wheels at the ends, and are pivoted on $\frac{1}{8}$ " reversed brackets 6. The model is operated from the handle rod 7, a pulley on the rear end of which is coupled to the pulley 8 by a cord 9.

Model No. 308 Railway Wagon Swivel Crane

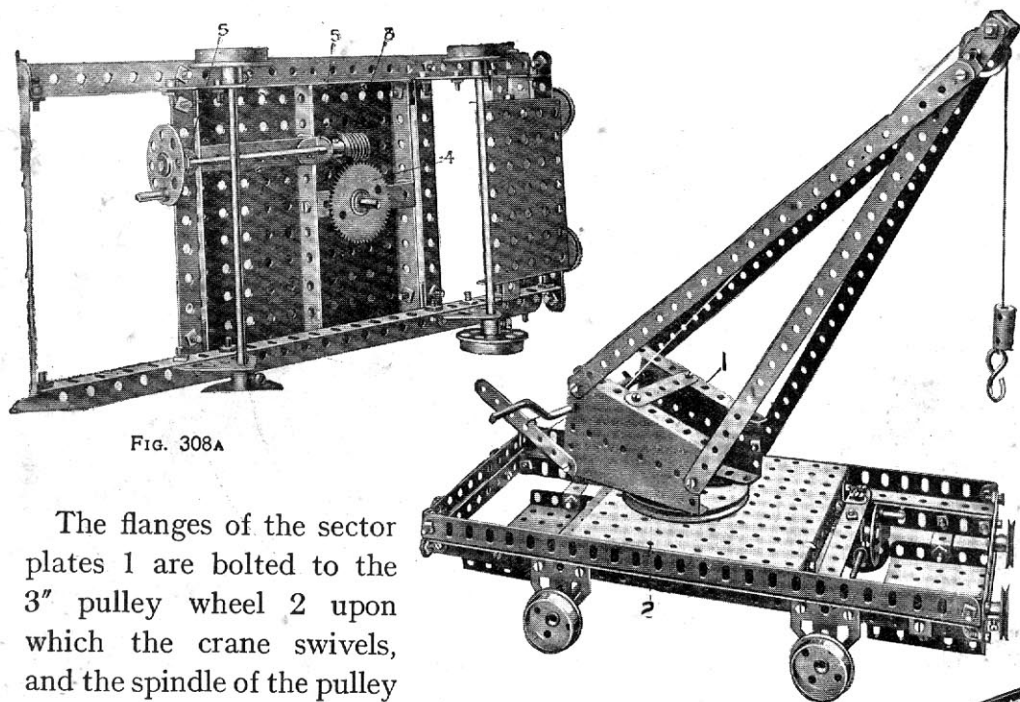


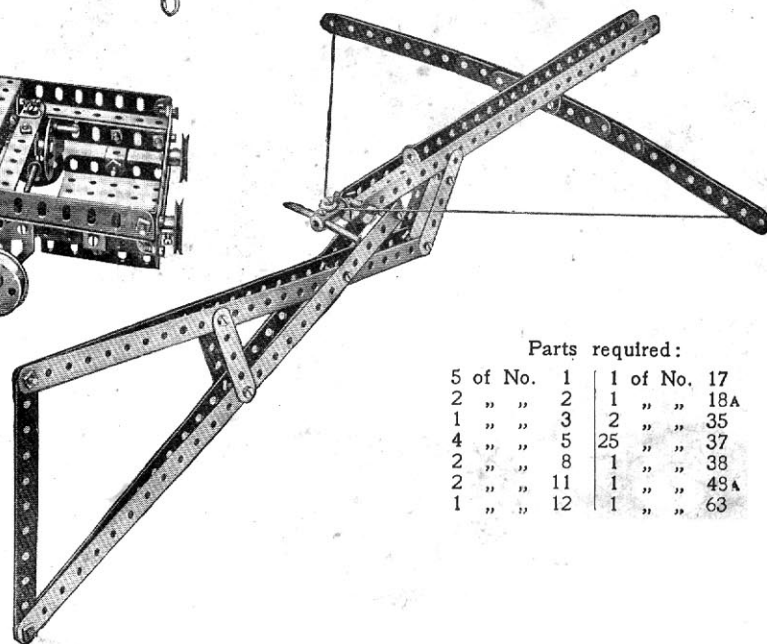
FIG. 308A

The flanges of the sector plates 1 are bolted to the 3" pulley wheel 2 upon which the crane swivels, and the spindle of the pulley wheel is rotated by the worm 3 engaging the gear wheel 4 on the spindle. In order to bring the worm centrally over the teeth of the gear wheel 4, washers are placed between the angle brackets 5 in which the spindle of the worm is journaled.

Parts required :

4 of No.	1	1 of No.	19	2 of No.	38
6 "	2	1 "	19B	2 "	48A
1 "	3	4 "	20	2 "	52
2 "	5	4 "	22	2 "	53
4 "	8	1 "	22A	2 "	54
1 "	11	1 "	24	1 "	57
14 "	12	1 "	27A	3 "	59
2 "	15	1 "	32	1 "	63
1 "	15A	3 "	35	1 "	115
2 "	17	70 "	37	4 "	125
				4 "	126A

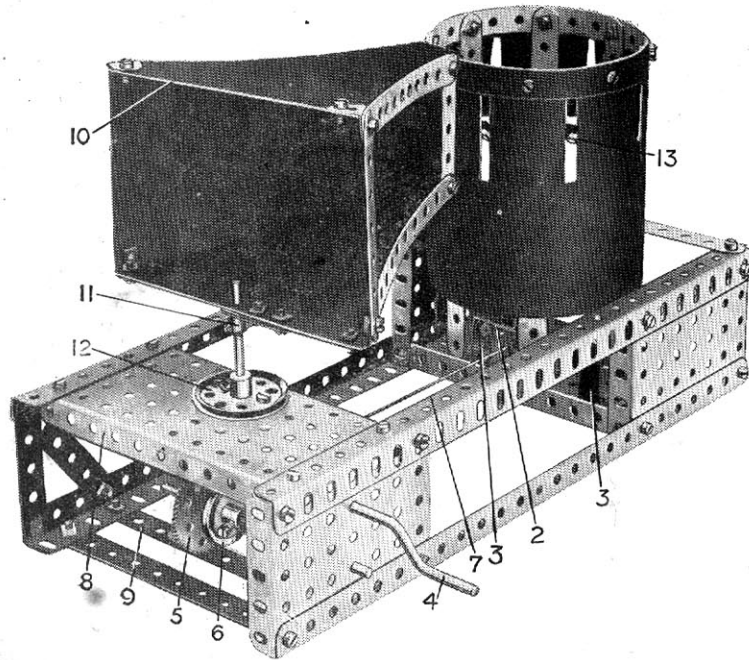
Model No. 309 Crossbow



Parts required :

5 of No.	1	1 of No.	17
2 "	2	1 "	18A
1 "	3	2 "	35
4 "	5	25 "	37
2 "	8	1 "	38
2 "	11	1 "	49A
1 "	12	1 "	63

Model No. 310 Kinetograph



Most Meccano boys are probably aware of the principles of the Kinetograph, but for the benefit of those who have not seen one in action, we may mention that it is a device which imparts an appearance of animation to a series of pictures, each differing slightly from the other and passed in rapid succession before the eyes. In this respect it resembles the remarkable principle upon which the modern cinematograph is based.

In constructing the Meccano model the following details will prove useful:—The drum consists of a $12\frac{1}{2}$ " strip bent to form a circle, with its ends overlapping one hole, and bolted to eight vertical $5\frac{1}{2}$ " strips forming the sides. Two pairs of opposite $5\frac{1}{2}$ " strips are connected by $3\frac{1}{2}$ " strips and angle brackets bolted in the third holes from their lower ends. The $3\frac{1}{2}$ " strips cross at right angles to one another and are bolted in the centre to a bush wheel, in the boss of which is secured a short rod forming the pivot of the revolving drum. This rod is journalled in a double bent strip bolted to a $2\frac{1}{2}$ " \times 1 " double angle strip 2. This, in turn, is secured to the base of the model by two 1 " \times 1 " angle brackets 3. A further bearing for the short rod consists of a crank bolted in the base of the model.

The drum is rotated from the crank handle 4, on which is mounted a $\frac{1}{2}$ " pinion engaging a 57-teeth gear wheel 5 secured to a $3\frac{1}{2}$ " rod carrying a pulley wheel 6. The latter is connected by means of a cord 7 to a similar wheel nipped to the vertical spindle of the drum. Bearings are provided for the inner ends of the crank handle and $3\frac{1}{2}$ " rod by a double angle strip bolted between the plate 8 and $5\frac{1}{2}$ " strip 9. The sighting box 10 is built up from a framework of strips and is secured by means of a crank 11 to a short vertical rod rigidly mounted in the boss of the $1\frac{1}{2}$ " pulley 12. The four sides of the framework 10 are covered with some black material; stiff black paper suitable for this purpose may be obtained from any stationers. The drum is enclosed in the same way, but the covering paper should be cut in a strip measuring $12\frac{1}{2}$ " \times $4\frac{1}{2}$ " and pierced with slots spaced $1\frac{1}{2}$ " apart (from centre to centre) so that they fall exactly between the upright $5\frac{1}{2}$ " strips. The slots should measure $1\frac{1}{2}$ " \times $\frac{1}{8}$ ".

The type of drawing suitable for use in this model is shown in Fig. 310a, and the dimensions indicated therein should be followed carefully. No doubt Meccano boys will be able to devise numerous amusing pictures of a similar kind for themselves. The strip of stout white paper carrying the sketches is inserted in the bottom of the drum, as indicated at 13. The model is now ready for operation. Placing the frame 10 over the eyes, the line of vision is directed through the narrow end, where the strips are held apart by means of double brackets, and through the slots in the drum. The latter should be rotated rapidly by operating the handle 4, and as it revolves, the little dog shown in Fig. 310a will be seen jumping over the fence with a most realistic and amusing action.

Parts required:

1 of No. 1	1 of No. 15A	12 of No. 38
17 " " 2	2 " " 16	1 " " 45
6 " " 3	1 " " 19	1 " " 46
1 " " 4	1 " " 21	1 " " 48A
3 " " 5	2 " " 22	2 " " 52
4 " " 8	1 " " 24	3 " " 53
2 " " 11	1 " " 26	4 " " 59
12 " " 12	1 " " 27A	2 " " 62
2 " " 12A	82 " " 37	

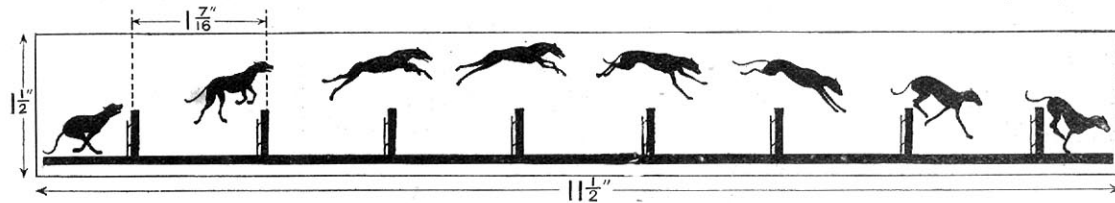
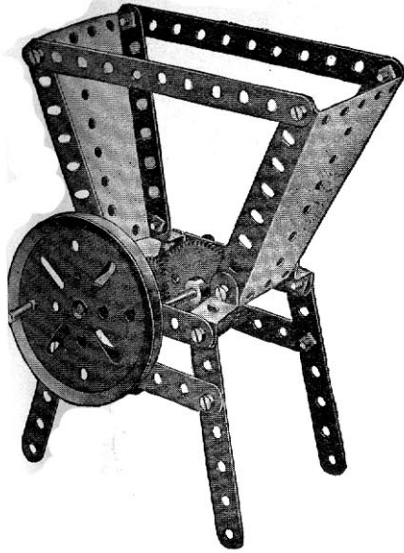


FIG. 310A

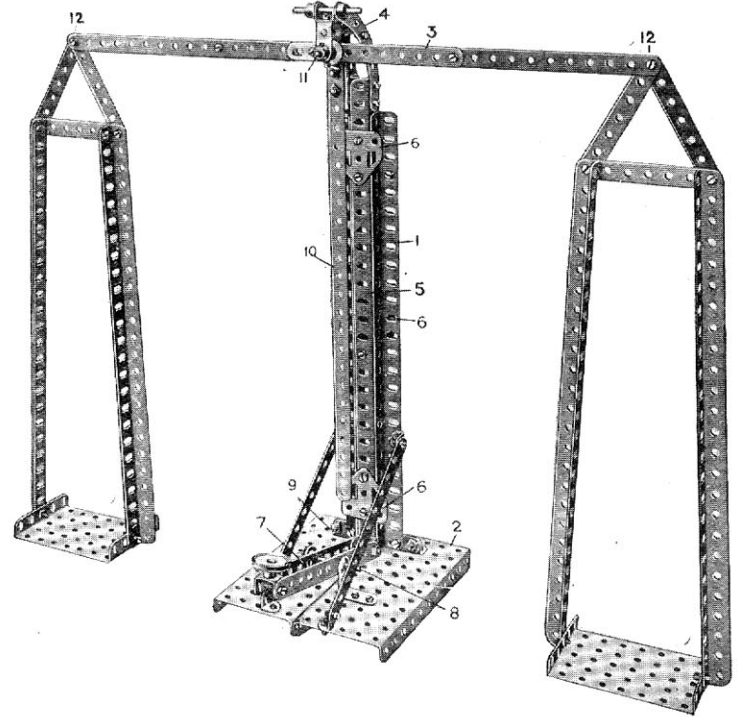
Model No. 311 Coffee Grinder



Parts required:

2	of No.	2
6	" "	3
2	" "	4
2	" "	16
1	" "	19B
1	" "	26
1	" "	27A
16	" "	37
2	" "	54
3	" "	59
1	" "	115
4	" "	125

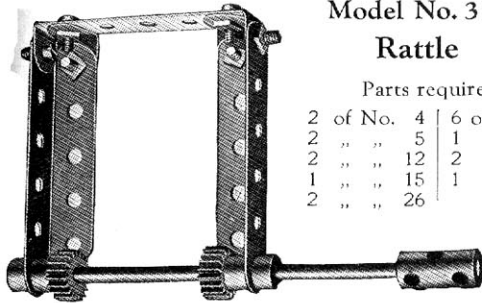
Model No. 312 Demonstration Scales



Parts required:

3	of No.	1
4	" "	2
6	" "	3
1	" "	4
2	" "	5
8	" "	8
4	" "	11
6	" "	12
2	" "	12A
2	" "	17
1	" "	18A
1	" "	22
2	" "	35
58	" "	37
1	" "	44
2	" "	52
2	" "	53
2	" "	59
2	" "	62
4	" "	90
1	" "	125
3	" "	126A

Model No. 313 Rattle

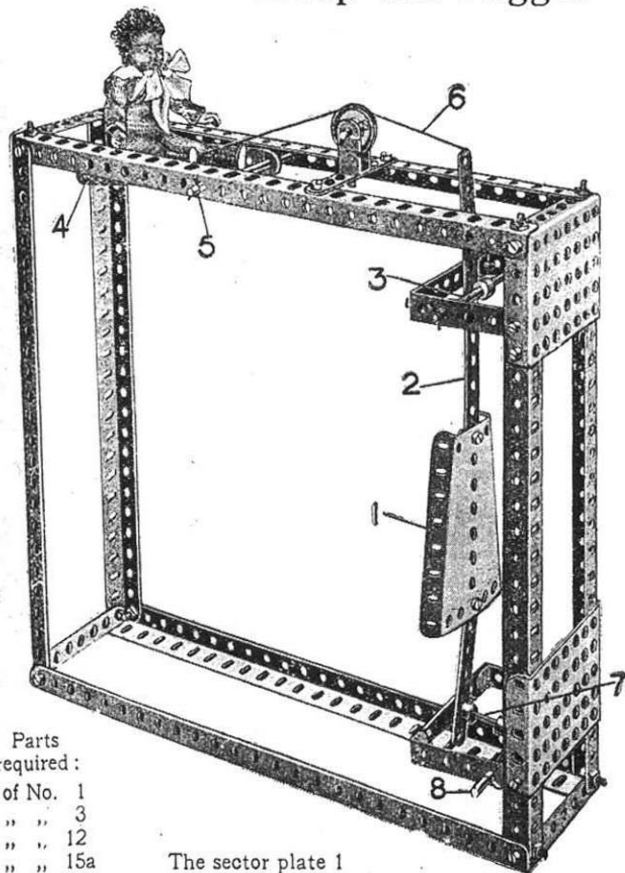


Parts required:

2	of No.	4	6 of No.	37
2	" "	5	1	48A
2	" "	12	2	59
1	" "	15	1	63
2	" "	26		

The only feature of this model which needs description is the standard, which is built up of two angle girders 1 bolted to the base 2 by angle brackets and spaced apart at the top by a $2\frac{1}{2}$ " strip obliquely disposed. The balance lever 3 is pivotally carried in curved strips 4 bolted to the top of two angle girders 5 sliding between the girders 1. The girders 5 are themselves bolted together and in order to guide them as they slide vertically flat trunnions 6 are bolted at the front and rear. The balance is raised by depressing the lever 8 pivoted at 9 and pivotally connected at 11 to the vertically sliding girders 5. The indicator 10 is bolted to a crank at the rear, the boss of which is fitted on the pivot rod 11. The connections at 12 are lock-nutted to allow free action.

Model No. 314—Drop the Nigger

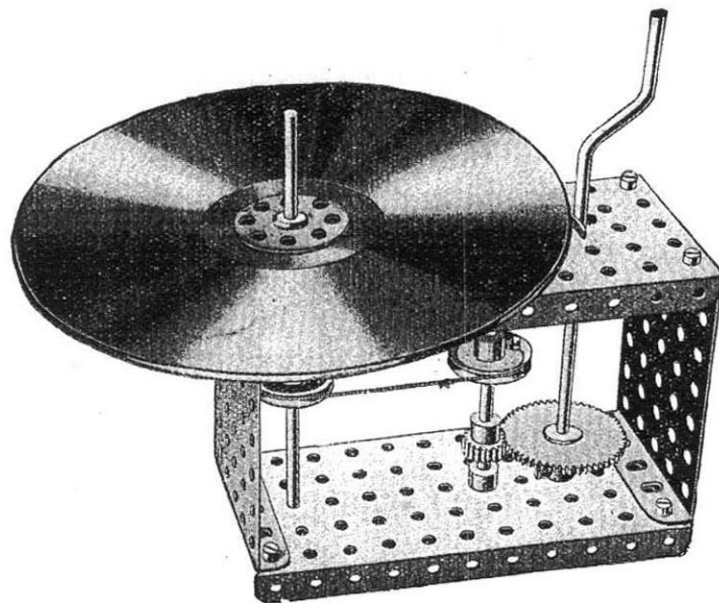


Parts
required:

1 of No. 1
6 " " 3
1 " " 12
3 " " 15a
1 " " 17
1 " " 22
6 " " 35
33 " " 37
1 " " 44
2 " " 53
2 " " 54
3 " " 59
4 " " 60
1 " " 63

The sector plate 1 is a target, which, when hit, allows the nigger to be dropped. The plate 1 is carried on the strip 2 pivoted at 3, and the weight of the nigger supported on another sector plate 4 pivoted at 5 by means of the cord 6 keeps the lower end of the strip 2 hard against a short rod 7 pivoted at 8. When the target is hit and knocked back the rod 7 is released and falls about its pivot, allowing the sector plate 4, with the nigger to drop.

Model No. 315—Newton's Disc



Parts required:

1 of No. 15	1 of No. 24	8 of No. 37
1 " " 15A	1 " " 26	2 " " 52
1 " " 19	1 " " 27A	2 " " 53
2 " " 22	2 " " 35	4 " " 59

This is a model to show that white light is made up of the three primary colours—red, yellow, blue. Sectors of these three colours are mounted or painted on the disc, which, if then quickly rotated, shows as white.

Model No. 316 Railway Breakdown Crane

Parts required :		
2 of No. 1	1 of No. 23	1 of No. 54
4 " " 2	1 " " 24	1 " " 57
4 " " 11	1 " " 26	2 " " 59
1 " " 12	1 " " 32	1 " " 63
3 " " 15A	4 " " 35	1 " " 115
1 " " 16	36 " " 37	4 " " 126A
2 " " 17	5 " " 38	1 " " 147A
1 " " 19	2 " " 48A	1 " " 147B
1 " " 19B	2 " " 48B	1 " " 148
4 " " 20	2 " " 52	
1 " " 22A	3 " " 53	

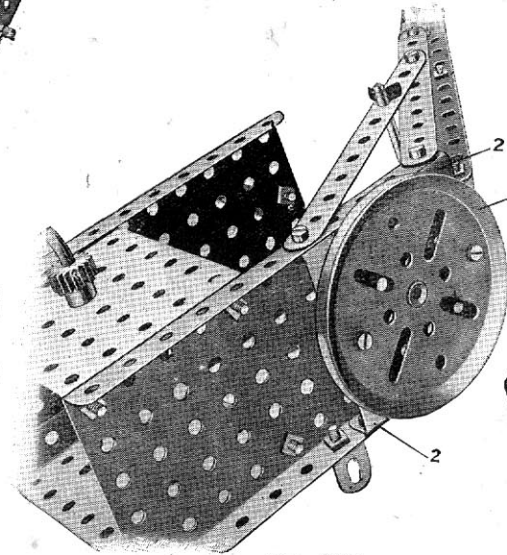
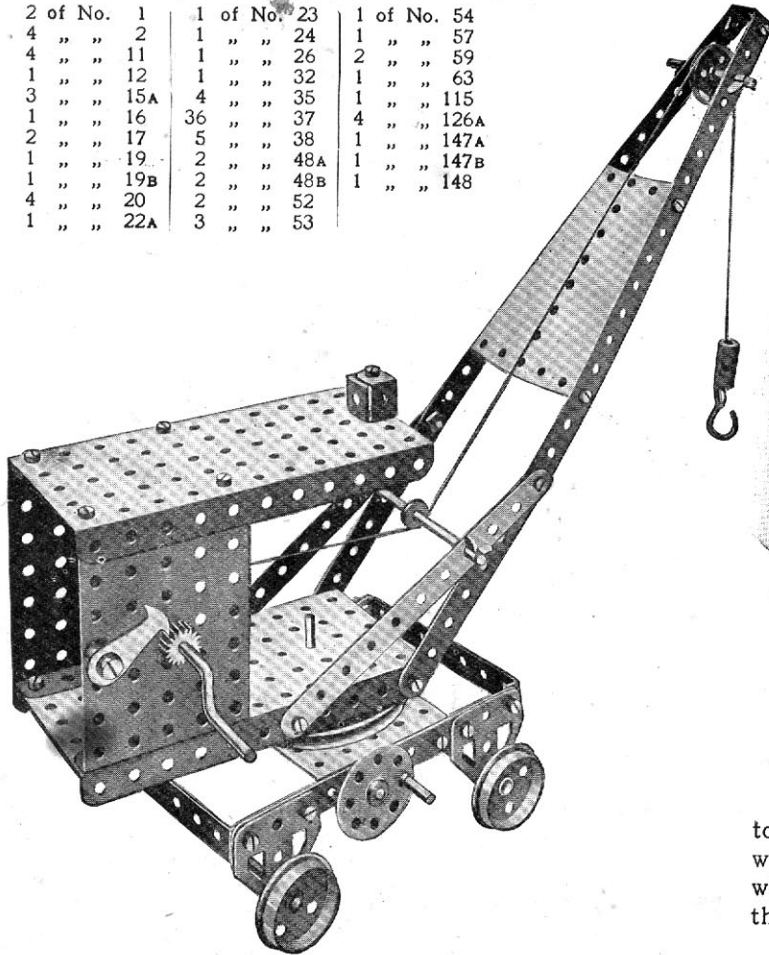


FIG. 316A

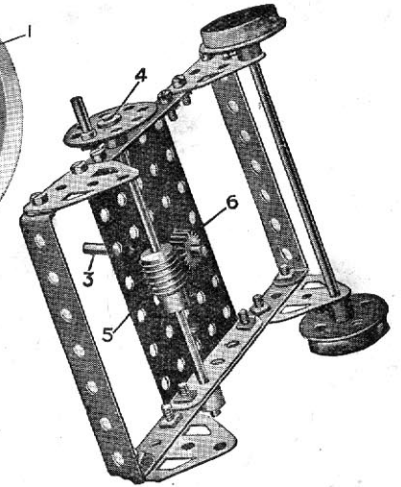


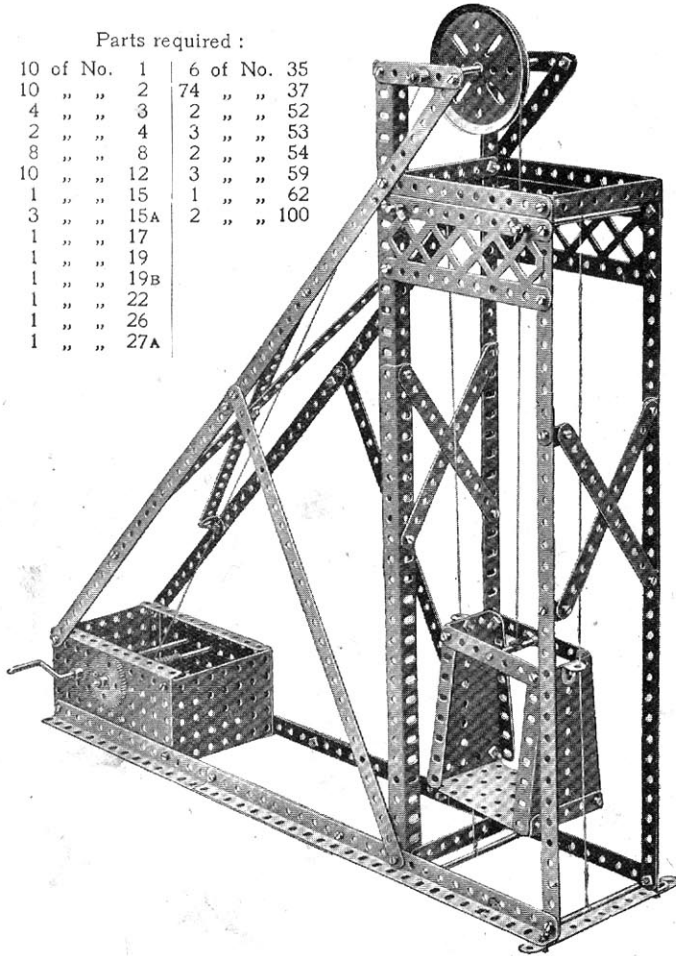
FIG. 316B

The swivelling action is obtained by bolting a 3" pulley 1 to double angle strips 2 on the jib frame. The boss of this wheel fits over the rod 3 and is secured to the rod. The hand wheel 4 rotates the worm 5, engaging the pinion 6 to swivel the jib.

Model No. 317 Pit Head Gear

Parts required :

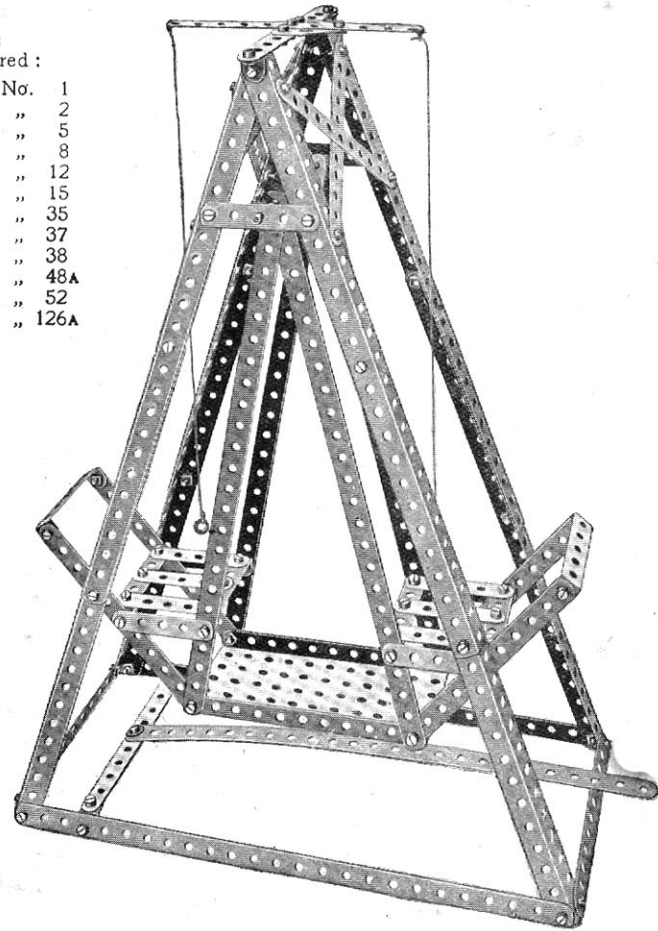
10	of No.	1	6	of No.	35	
10	"	"	74	"	"	37
4	"	"	2	"	"	52
2	"	"	3	"	"	53
8	"	"	2	"	"	54
10	"	"	3	"	"	59
1	"	"	1	"	"	62
3	"	"	2	"	"	100
1	"	"				
1	"	"				
1	"	"				
1	"	"				
1	"	"				
1	"	"				



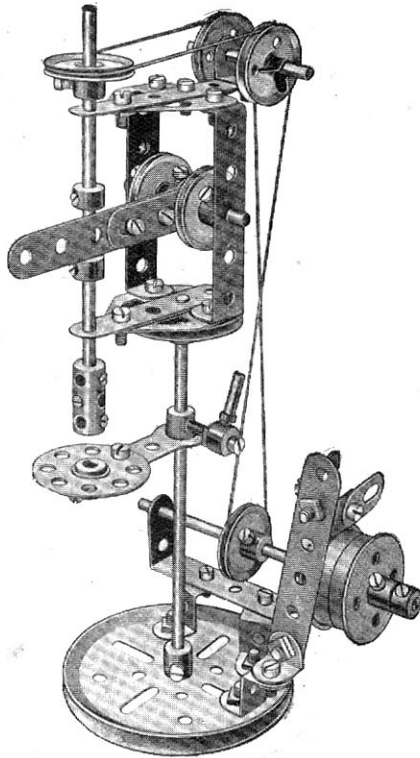
Model No. 318 Swing

Parts required :

7	of No.	1	
13	"	"	2
12	"	"	5
8	"	"	8
4	"	"	12
1	"	"	15
6	"	"	35
69	"	"	37
4	"	"	38
6	"	"	48A
1	"	"	52
1	"	"	126A



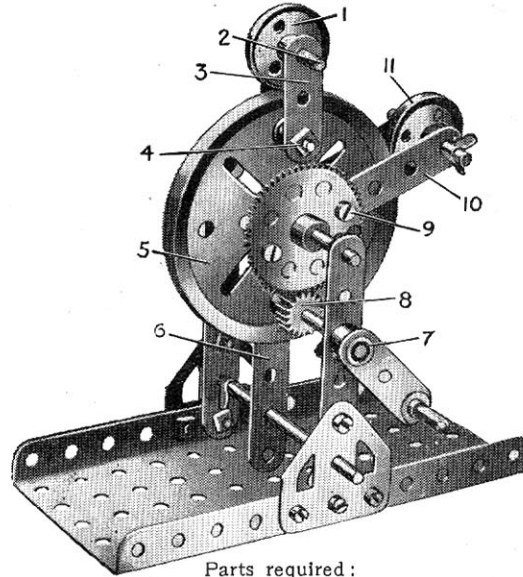
Model No. 319
Drilling Machine



Parts required :

2 of No. 4	2 of No. 20	2 of No. 48A
2 " " 5	1 " " 21	5 " " 59
2 " " 10	4 " " 22	2 " " 62
2 " " 11	2 " " 22A	1 " " 63
1 " " 12	1 " " 24	1 " " 111
1 " " 15	2 " " 35	1 " " 115
2 " " 15A	21 " " 37	3 " " 125
2 " " 17	1 " " 44	2 " " 126A
2 " " 19B	1 " " 46	

Model No. 320 Strip-Bending Machine

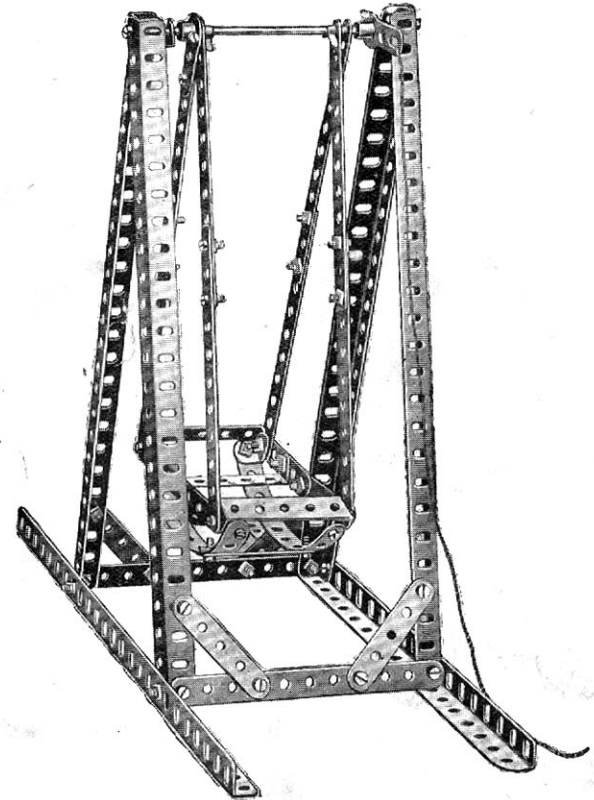


Parts required :

1 of No. 2	2 of No. 18B	10 of No. 38
2 " " 3	1 " " 19B	1 " " 52
1 " " 4	2 " " 22A	4 " " 59
1 " " 5	1 " " 26	1 " " 62
1 " " 6A	1 " " 27A	1 " " 111
2 " " 16	6 " " 35	1 " " 115
1 " " 17	10 " " 37	2 " " 126A

This model represents a device for bending bars or rods of metal to circular form, and may be put to practical purpose in shaping strips of tin or similar material. A loose pulley 1 is spaced by a collar and washers in the centre of the short rod 2 journalled in a 1 1/2" strip 3. The latter is secured to the end of a 1/2" bolt 4 and spaced away from the 3" pulley 5 by means of a number of washers. The opposite end of the rod is supported by a 5 1/2" strip 6. The handle 7 is secured to a 3 1/2" rod carrying a 1/2" pinion 8. This engages with a 57-teeth gear wheel 9 mounted on another 3 1/2" rod which is free to revolve in the boss of the wheel 5. The gear wheel 9 carries a 3" strip 10 forming one of the bearings for a short rod carrying a second 1" loose pulley 11. The latter is also spaced by means of a collar and washers so that it lies immediately above the groove of the pulley wheel 5. The material to be shaped is passed between the two loose pulleys at the top of the wheel 5, and on rotation of the handle 7 the arm 10 is caused to move downward, so forcing the object to the same curvature as the circumference of the wheel.

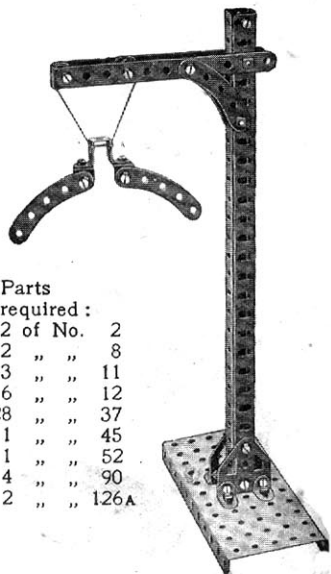
Model No. 321 Swing



Parts required :

12 of No. 2	1 of No. 15
9 " " 5	2 " " 35
6 " " 8	43 " " 37
2 " " 11	4 " " 48A
4 " " 12	2 " " 62

Model No. 322 Railway Gauge



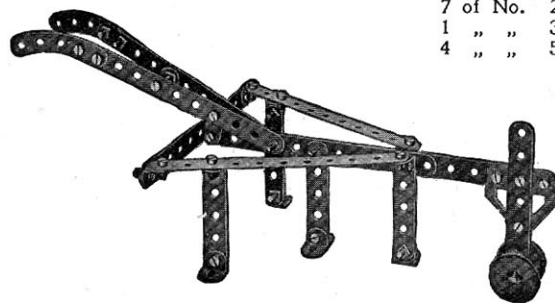
Parts required:

2 of No.	2
2 "	8
3 "	11
6 "	12
28 "	37
1 "	45
1 "	52
4 "	90
2 "	126A

Parts required:

6 of No.	2
1 "	3
2 "	5
2 "	8
3 "	11
12 "	12
2 "	15
3 "	15A
2 "	19
4 "	20
1 "	24
2 "	26
1 "	27A
3 "	35
50 of No.	37
1 "	45
2 "	48A
2 "	52
3 "	53
4 "	59
2 "	62
4 "	126A

Model No. 323 Scarifier

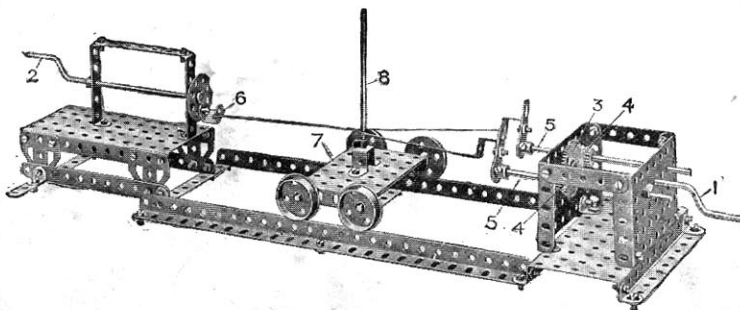


Parts required:

7 of No.	2	1 of No.	10
1 "	3	14 "	12
4 "	5	1 "	18A
		2 "	22
		31 "	37
		2 "	38
		2 "	90
		1 "	126A

Model No. 325 Wire Rope Maker

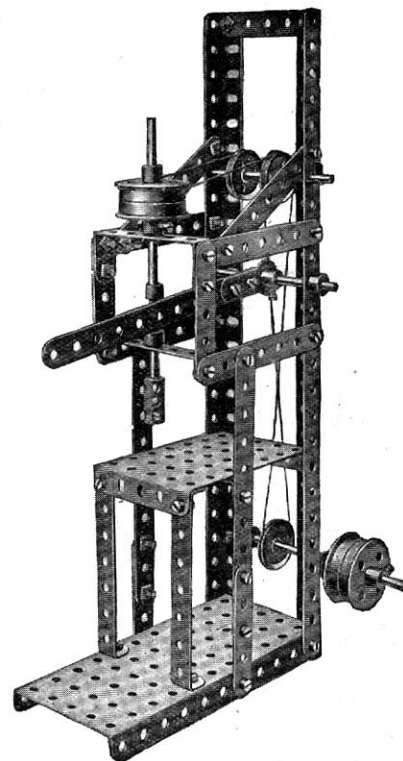
The strands are twisted from both ends by the handles 1 and 2 of the fixed parts. The handle 1 rotates through a large gear wheel 3 two pinions 4 on the rods 5 carrying cranks to which the strands are attached. The other ends of the strands are connected to a double bent strip 6 on a bush wheel which is rotated in the opposite direction by a crank handle 2. The carriage 7 runs on rails and the vertical rod 8 is kept just at the formation of the twisted rope and so controls the tightness of the twist.



Parts required:

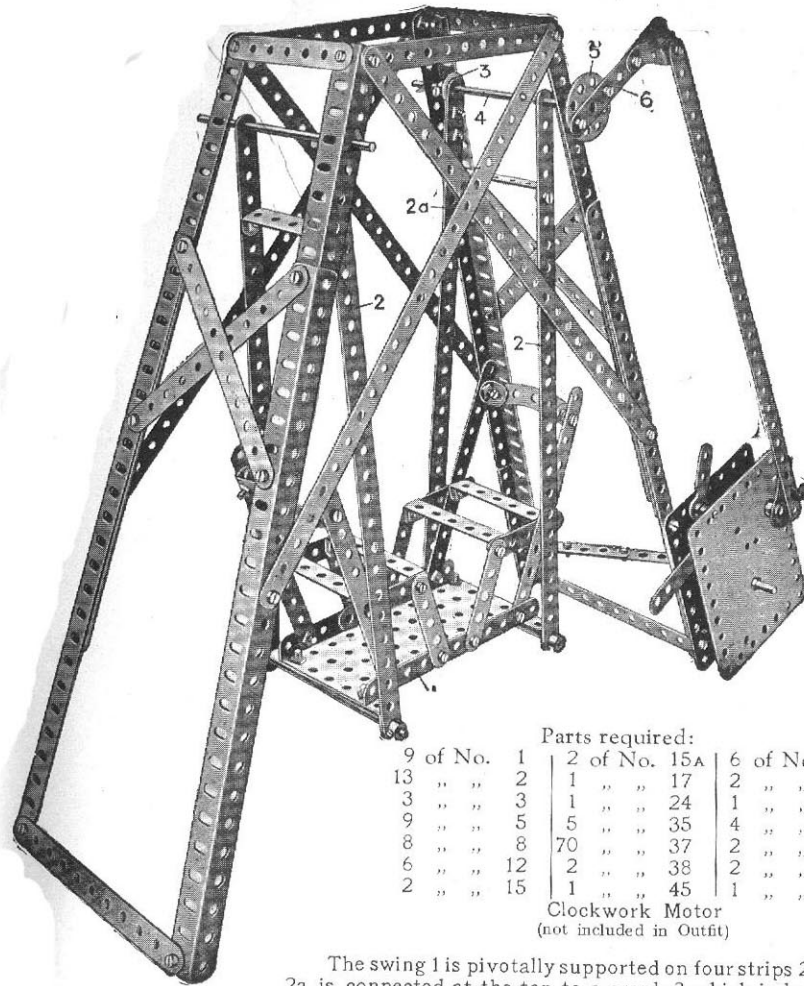
3 of No.	2	4 of No.	20	2 of No.	48B
6 "	3	1 "	22	1 "	52
5 "	5	2 "	22A	1 "	53
2 "	8	3 "	35	4 "	59
2 "	11	38 "	37	1 "	62
2 "	15	1 "	46	1 "	63
2 "	16	2 "	48A		

Model No. 324 Boring Machine



Model No. 326 Lawn Swing

Model No. 327 Oil Cake Chopper

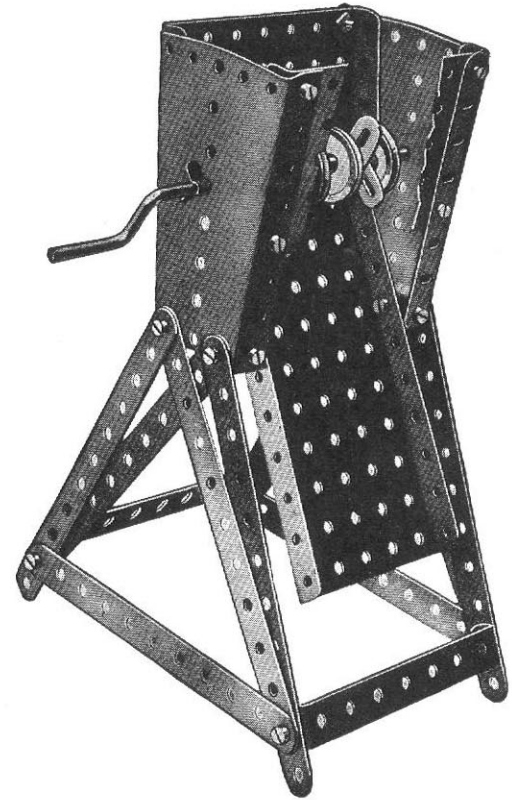


Parts required:

9 of No.	1	2 of No.	15A	6 of No.	48A
13 " "	2	1 " "	17	2 " "	48B
3 " "	3	1 " "	24	1 " "	52
9 " "	5	5 " "	35	4 " "	59
8 " "	8	70 " "	37	2 " "	62
6 " "	12	2 " "	38	2 " "	90
2 " "	15	1 " "	45	1 " "	115

Clockwork Motor
(not included in Outfit)

The swing 1 is pivotally supported on four strips 2, the far strip 2a is connected at the top to a crank 3 which is bolted to a rod 4 and at the front end of this rod is a wheel 5 to which is bolted a strip 6 to the motor spindle.



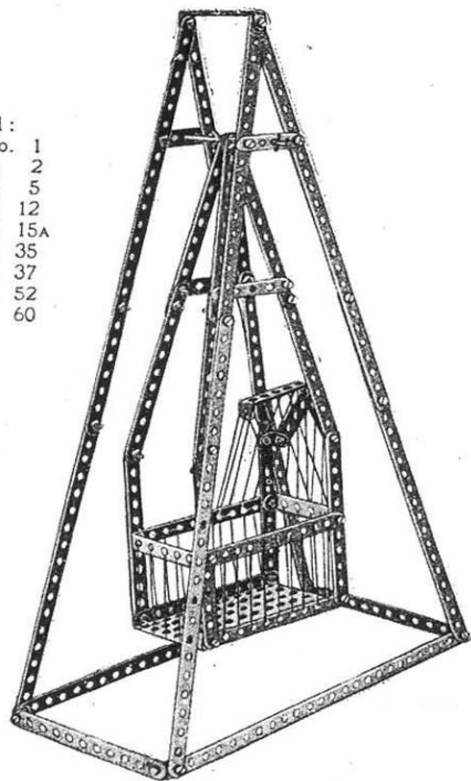
Parts required:

10 of No.	2	2 of No.	35
4 " "	10	20 " "	37
2 " "	12	2 " "	48B
1 " "	19	1 " "	52
4 " "	22	2 " "	53
	2 of No.		54

These Models can be made with MECCANO Outfit No. 3, or No. 2 and No. 2A

Model No. 328—Swinging Cot

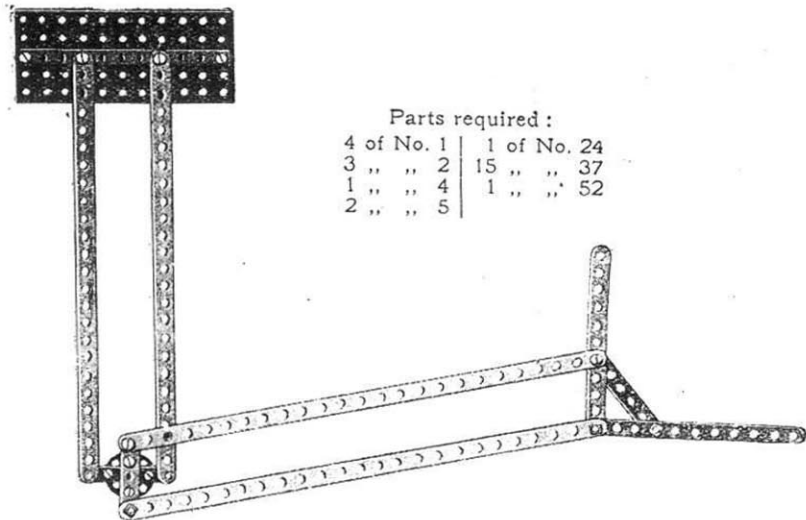
Parts
required:
1 of No. 1
2 " " 2
5 " " 5
1 " " 12
1 " " 15A
1 " " 35
1 " " 37
1 " " 52
1 " " 60



Model No. 329—Drafting Machine

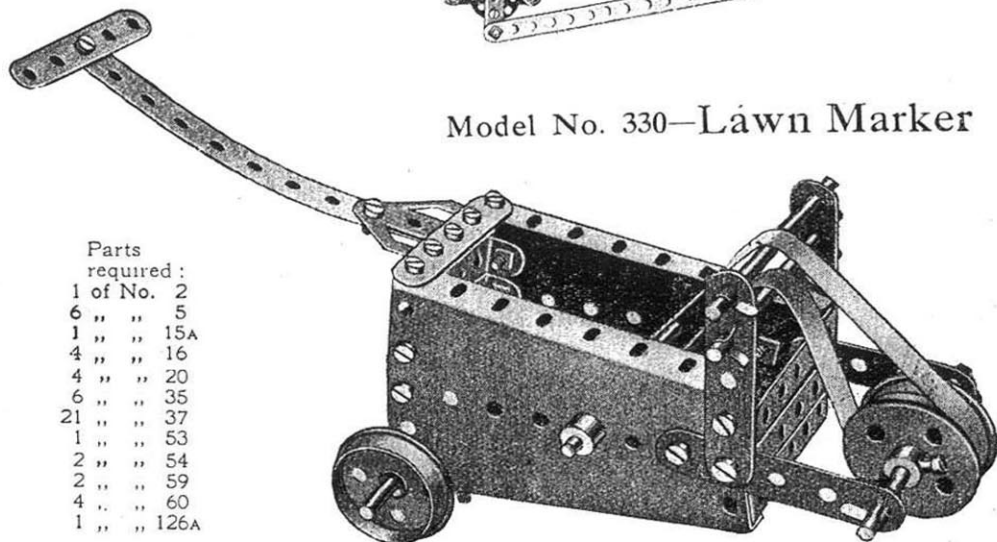
Parts required:

4 of No. 1	1 of No. 24
3 " " 2	15 " " 37
1 " " 4	1 " " 52
2 " " 5	



Model No. 330—Lawn Marker

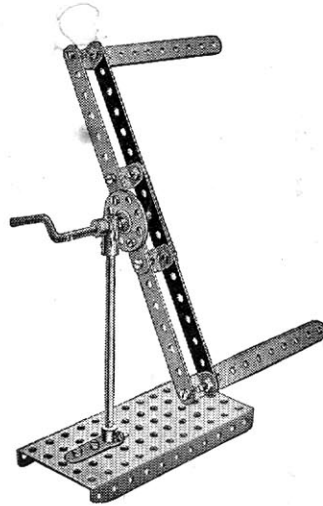
Parts
required:
1 of No. 2
6 " " 5
1 " " 15A
4 " " 16
4 " " 20
6 " " 35
21 " " 37
1 " " 53
2 " " 54
2 " " 59
4 " " 60
1 " " 126A



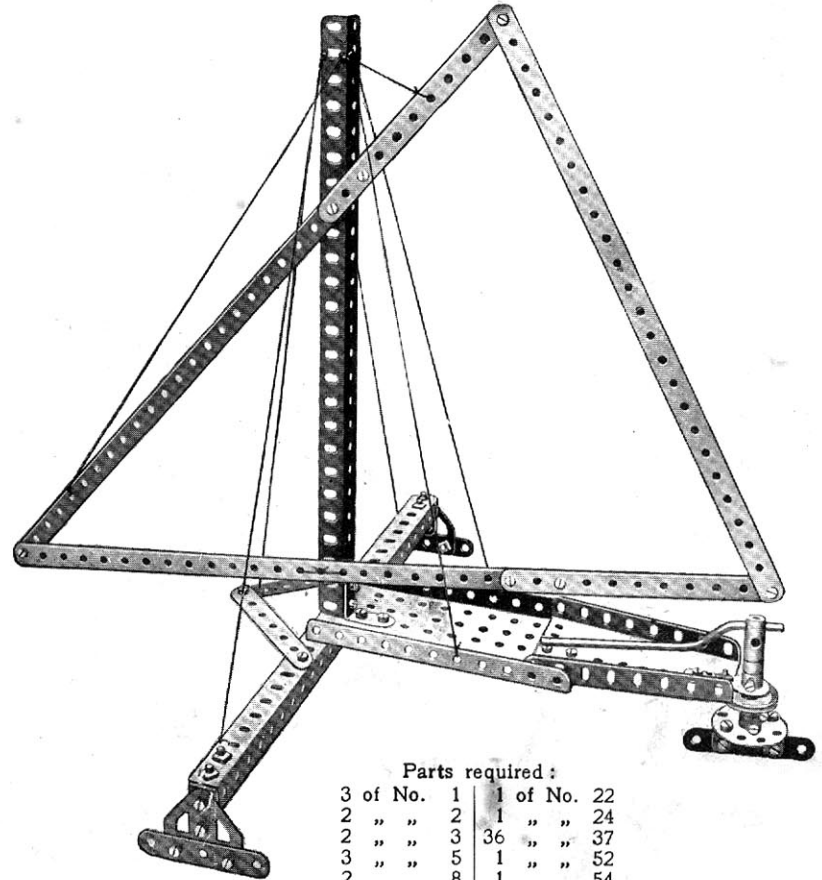
**Model No. 331
Lace Jennier**

Parts required :

8 of No.	2
4 " "	11
1 " "	15
1 " "	19
1 " "	24
14 " "	37
1 " "	52
1 " "	59
1 " "	62
1 " "	63



Model No. 333 Ice Boat



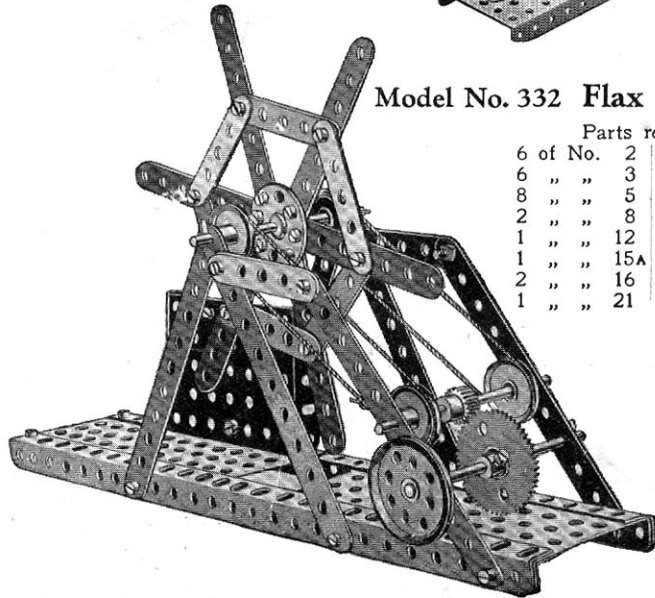
Parts required :

3 of No.	1	1 of No.	22
2 " "	2	1 " "	24
2 " "	3	36 " "	37
3 " "	5	1 " "	52
2 " "	8	1 " "	54
2 " "	12	1 " "	59
3 " "	12A	1 " "	62
1 " "	17	1 " "	63
1 " "	19	2 " "	126A

Model No. 332 Flax Cleaner

Parts required :

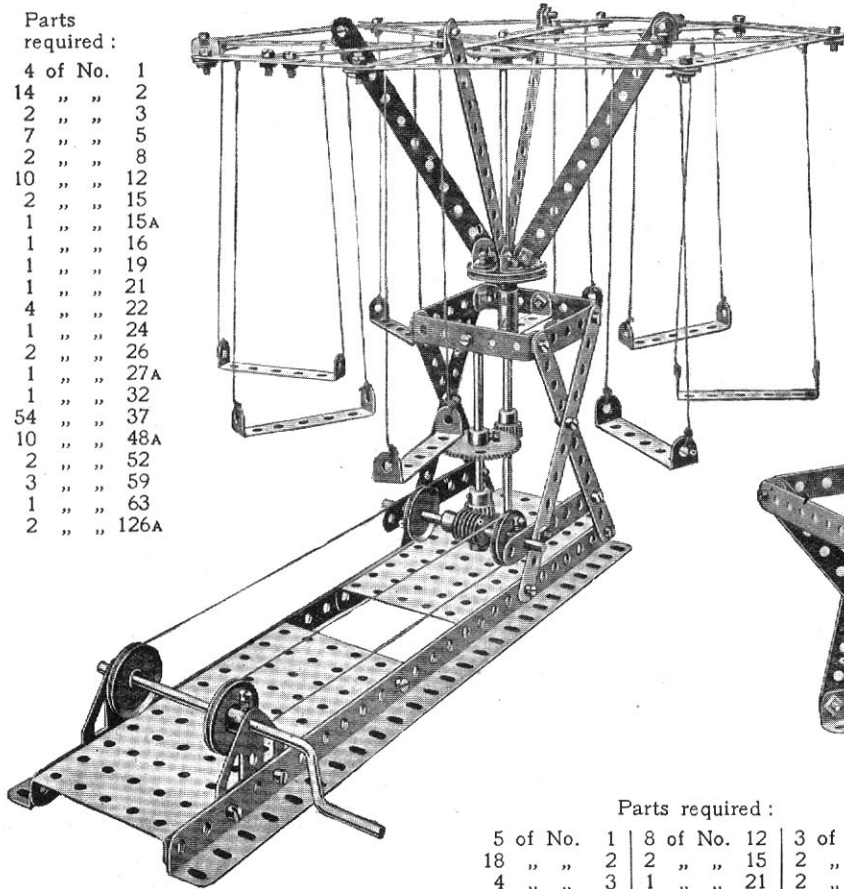
6 of No.	2	4 of No.	22
6 " "	3	1 " "	24
8 " "	5	1 " "	26
2 " "	8	1 " "	27A
1 " "	12	4 " "	35
1 " "	15A	26 " "	37
2 " "	16	2 " "	52
1 " "	21	1 " "	53



Model No. 334 Roundabout

Parts
required :

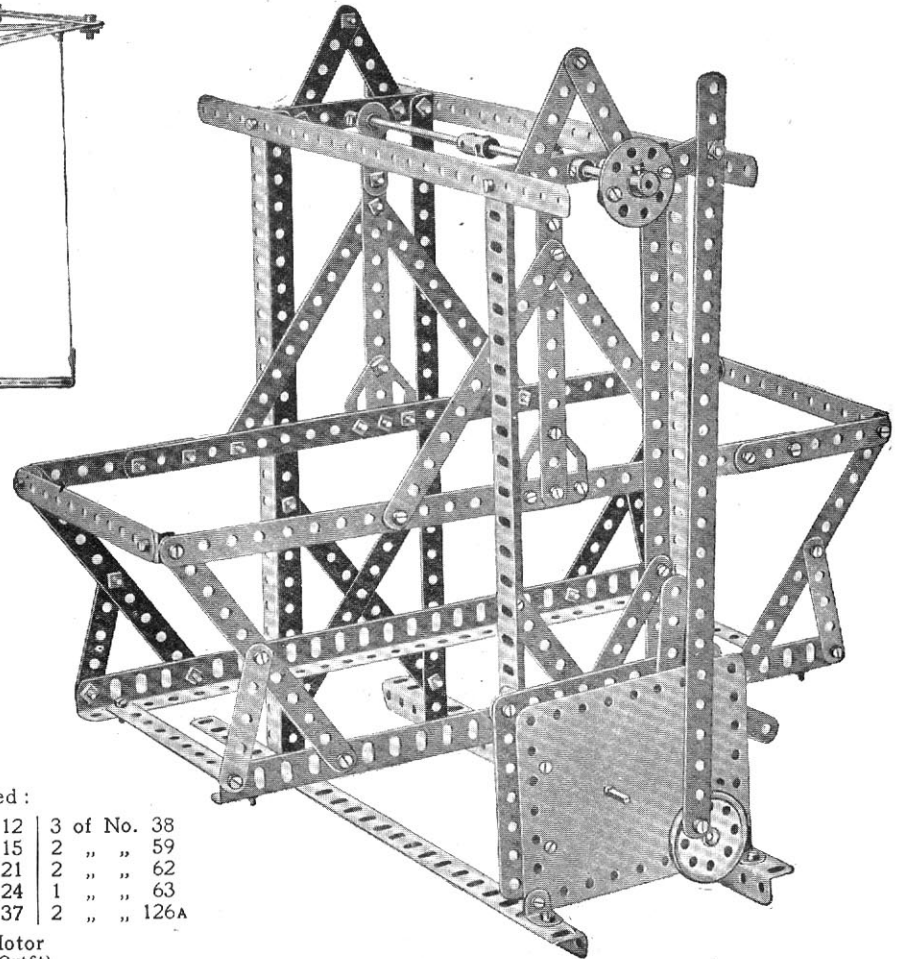
4	of	No.	1
14	"	"	2
2	"	"	3
7	"	"	5
2	"	"	8
10	"	"	12
2	"	"	15
1	"	"	15A
1	"	"	16
1	"	"	19
1	"	"	21
4	"	"	22
1	"	"	24
2	"	"	26
1	"	"	27A
1	"	"	32
54	"	"	37
10	"	"	48A
2	"	"	52
3	"	"	59
1	"	"	63
2	"	"	126A



Model No. 335 Automatic Swing Boat

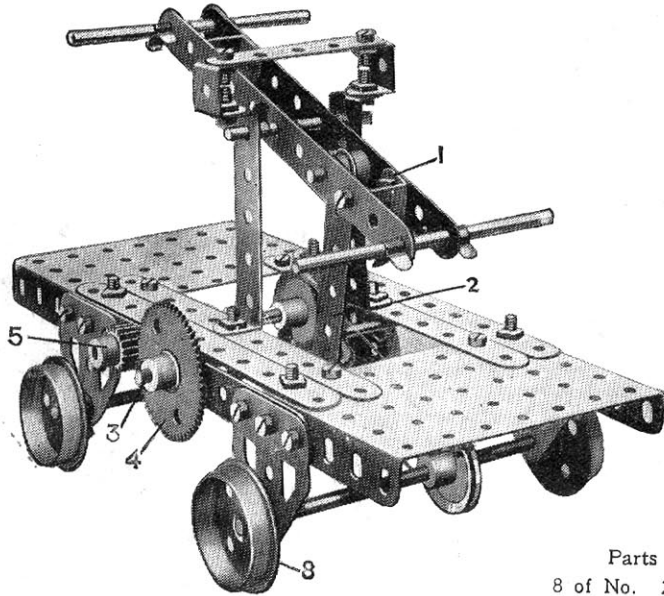
Parts required :

5	of	No.	1	8	of	No.	12	3	of	No.	38
18	"	"	2	2	"	"	15	2	"	"	59
4	"	"	3	1	"	"	21	2	"	"	62
9	"	"	5	1	"	"	24	1	"	"	63
8	"	"	8	84	"	"	37	2	"	"	126A

Clockwork Motor
(not included in Outfit)

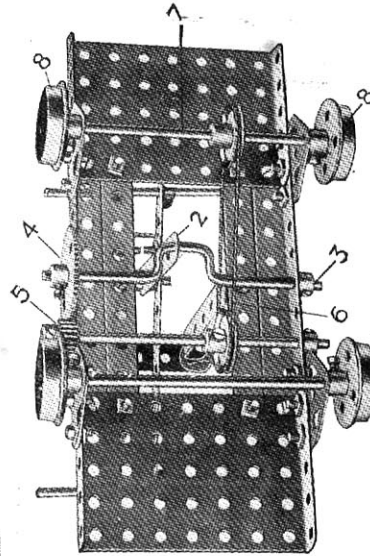
Model No. 338 Hand Trolley

The trolley is caused to travel by working the rocking lever 1 which is connected by a strip 2 to a crank shaft 3 a gear wheel 4 which meshes a pinion 5 on a rod coupled by a cord 6 to an axle rod 7 of the travelling wheels 8.



Parts required :

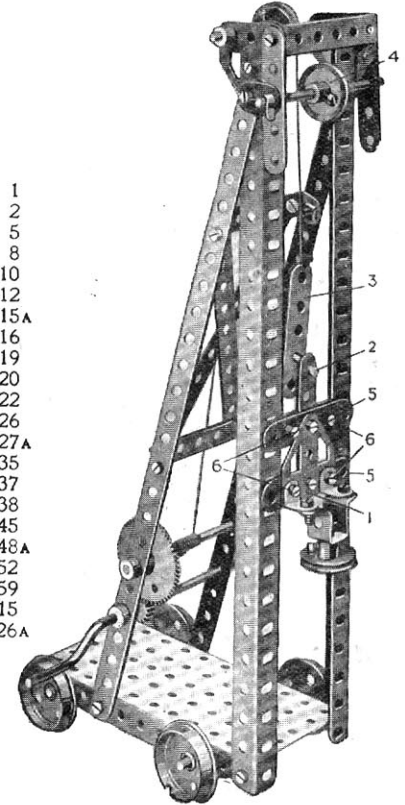
8 of No.	2	2 of No.	22
1 "	4	1 "	26
1 "	5	1 "	27A
4 "	11	6 "	35
3 "	15A	30 "	37
2 "	16	2 "	48A
1 "	17	2 "	53
1 "	18A	4 "	59
4 "	20	4 "	126A
		1 of No.	134



Model No. 339 Pile Driver

Parts required :

2 of No.	1
2 "	2
10 "	5
2 "	8
2 "	10
2 "	12
2 "	15A
3 "	16
1 "	19
4 "	20
3 "	22
1 "	26
1 "	27A
2 "	35
26 "	37
4 "	38
1 "	45
3 "	48A
1 "	52
4 "	59
1 "	115
3 "	126A

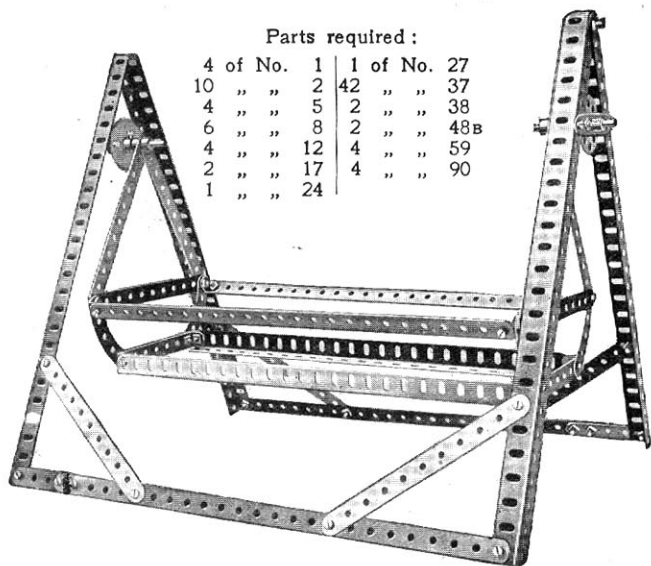


The driving head 1 is raised by means of a threaded pin 2 on two 2 1/2" strips 3, the pin engaging in the first hole of the driving head. As the head is raised, the strip 3 makes contact with a pulley 4 and the latter pushes the strip rearwardly, disengaging the pin from the hole on the driving head, permitting it to fall. The cross strips 5 of the driving head are duplicated behind, spacing washers being inserted between them on the bolts 6 to allow free movement up and down the guide girders.

Model No. 340 Swing Cot

Parts required :

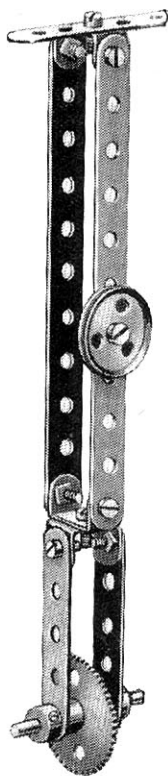
4 of No. 1	1 of No. 27
10 " " 2	42 " " 37
4 " " 5	2 " " 38
6 " " 8	2 " " 48B
4 " " 12	4 " " 59
2 " " 17	4 " " 90
1 " " 24	



Model No. 341 Pastry Designer

Parts required :

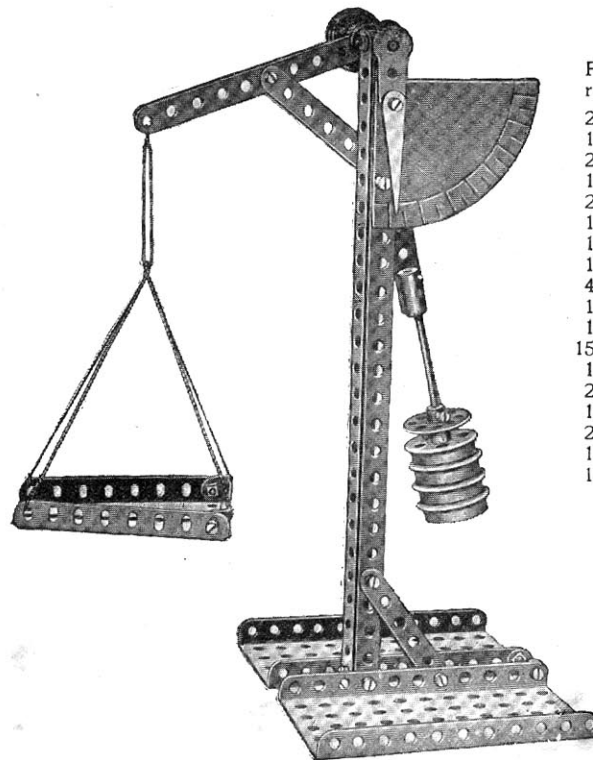
2 of No. 2	1 of No. 17	9 of No. 37
3 " " 5	1 " " 22A	2 " " 59
3 " " 11	1 " " 27A	



Model No. 342 Scales

Parts required :

2 of No. 2	2
1 " " 3	3
2 " " 4	4
1 " " 5	5
2 " " 8	8
1 " " 11	11
1 " " 15	15
1 " " 17	17
4 " " 20	20
1 " " 22	22
1 " " 24	24
15 " " 37	37
1 " " 48A	48A
2 " " 52	52
1 " " 54	54
2 " " 62	62
1 " " 63	63
1 " " 90	90



HOW TO CONTINUE

This completes the Models which may be made with MECCANO Outfit No. 3. The next Models are a little more advanced, requiring a number of extra parts to construct them. The necessary parts are all contained in a No. 3A Accessory Outfit, the price of which will be found in the List at the end of the Manual.

Model No. 401 Elevated Jib Crane

The gear-box 1 is secured to a 3" pulley wheel 2 (the boss 3 of which stands up), by means of 2 $2\frac{1}{2} \times \frac{1}{2}$ " double angle strips 4. The $1\frac{1}{2}$ " rod 5 passes up through the boss 3, a collar 6 being positioned on top of the boss within, the contrate wheel 7 being secured to the top of the rod 5. A $\frac{1}{2}$ " pinion 8 engages the contrate wheel 7 and also a 57-toothed wheel 9 on the rod 14 on which latter the hoisting cord 10 is wound, passing over the 1" pulley 12 to the hook 13. The rod 5 is actuated from the crank handle 15 by the pinion 16 engaging a $\frac{3}{4}$ " contrate wheel 17 and through the gear wheels 7, 8, and 9, and operates the cord 10 to raise or lower the load. The jib 18 is swivelled from the crank handle 19, a continuous cord 20 being wound twice round the flange wheel 21, against which is butted a bush wheel 22 to make it into a double flange pulley. A cord 20 passes round 1" guide pulleys 23 round the 3" pulley wheel 2. By turning the handle 19 the jib is swivelled.

Alternative Construction. In order to make the jib swivel more freely, a ball-race, Fig. 401b, may be fitted. This is made by bolting to the top of the frame a 3" pulley wheel 24 by bolts 25 which also secure in the pulley wheel 24 a wheel flange 26. This provides a circular groove for the reception of the ball bearings 27. The pulley wheel 2 which is bolted to the gear-box 1 is then placed over the rod 5 and rests on the ball bearings 27 to form a race.

(N.B.—The wheel flange and the balls for the bearing are not provided in this Outfit but can be bought separately. See parts list page).

Parts required :

4	of No. 1	1	of No. 22
10	" "	2	" "
1	" "	3	" "
7	" "	5	" "
4	" "	8	" "
4	" "	11	" "
12	" "	12	" "
3	" "	12A	" "
2	" "	14	85
5	" "	16	2
1	" "	18A	5
2	" "	19	1
1	" "	19B	6
6	" "	20	1
	4 of No. 125		

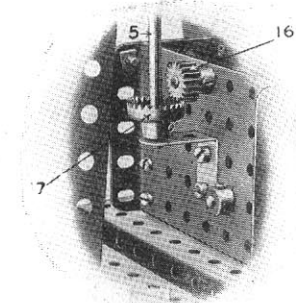
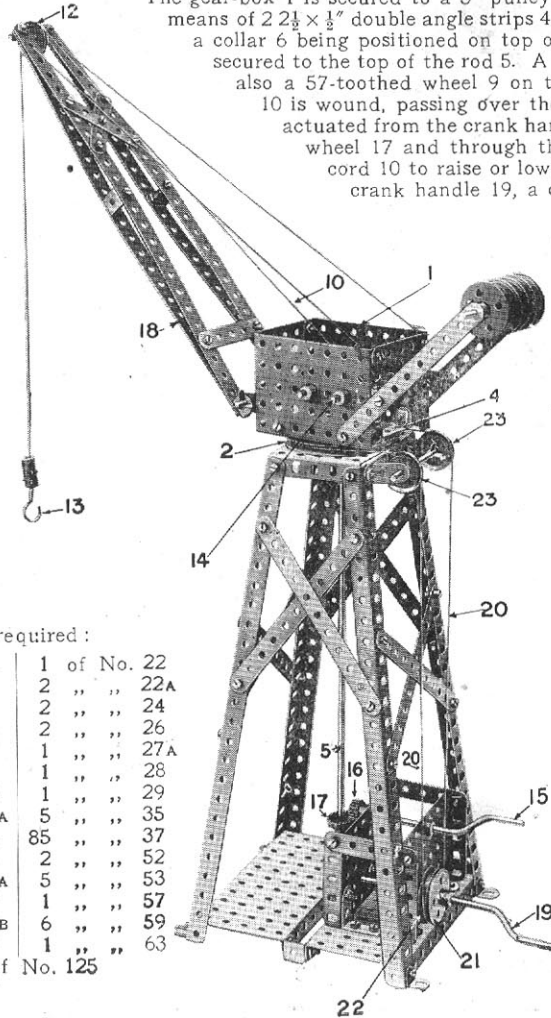


FIG. A.

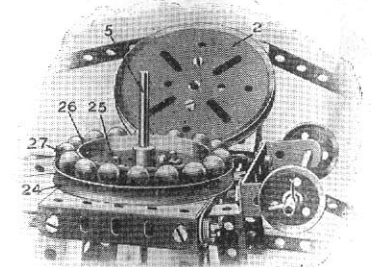


FIG. B.

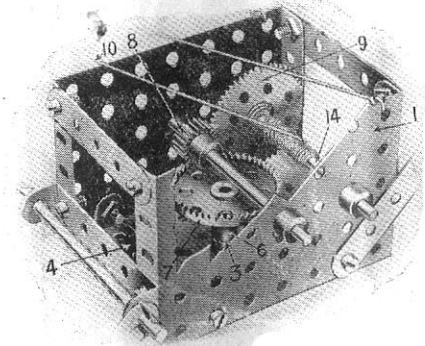


FIG. C.

Model No. 402

Alternating Swing

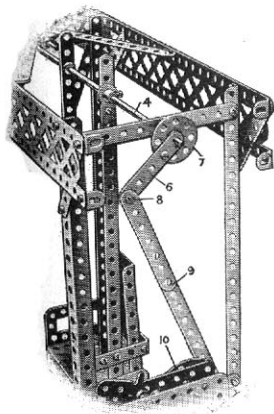
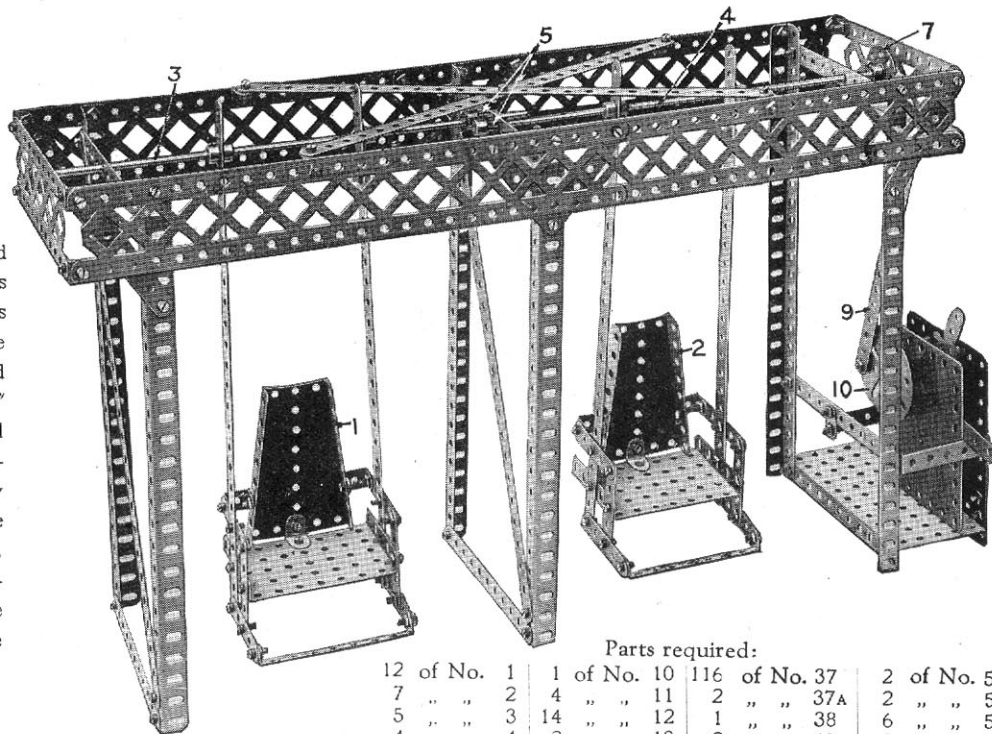


FIG. 402A

The chairs 1, 2, are pivoted on $11\frac{1}{2}$ " rods 3, 4, these rods being geared together by pinions 5, so that they turn in opposite directions. The rod 4 is turned to and fro by means of a $2\frac{1}{2}$ " strip 6 is pivotally connected at 8 to a $7\frac{1}{2}$ " strip 9 loosely bolted to a face plate 10 on the driven spindle 11 of the motor. As the spindle 11 rotates continuously in one direction, the swings are rocked in opposite directions.

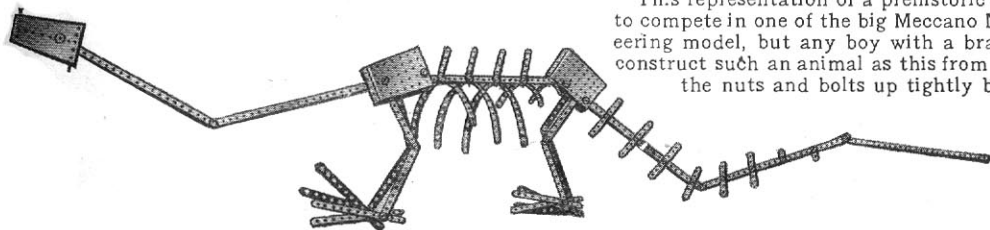


Parts required:

12 of No. 1	1 of No. 10	116 of No. 37	2 of No. 53
7 " " 2	4 " " 11	2 " " 37A	2 " " 54
5 " " 3	14 " " 12	1 " " 38	6 " " 59
4 " " 4	2 " " 13	2 " " 48A	2 " " 62
15 " " 5	1 " " 24	2 " " 48B	4 " " 99
6 " " 8	2 " " 26	1 " " 52	2 " " 100
	1 of No. 109		

Clockwork Motor (not included in Outfit)

Model No. 403 Diplodocus



This representation of a prehistoric animal is a most extraordinary effort sent in by a young French boy to compete in one of the big Meccano Model Building Competitions. We could scarcely class it as an engineering model, but any boy with a brain clever enough and an imagination lively enough to conceive and construct such an animal as this from Meccano parts deserved a good prize, so we awarded him one. Screw the nuts and bolts up tightly because the Diplodocus looks most dejected when he droops.

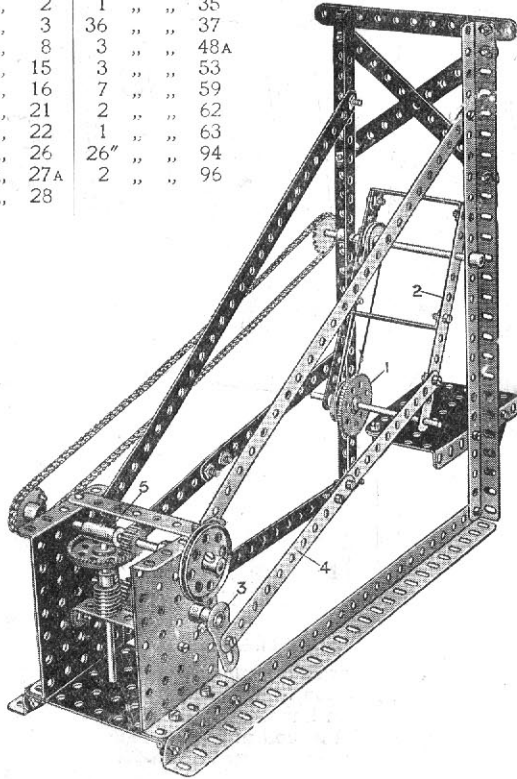
Parts required:

1 of No. 1	1 of No. 8	40 of No. 37
7 " " 2	4 " " 10	4 " " 53
4 " " 3	1 " " 16	2 " " 54
8 " " 5	4 " " 17	8 " " 59
	2 " " 22	

Model No. 404 Swinging Hot Saw

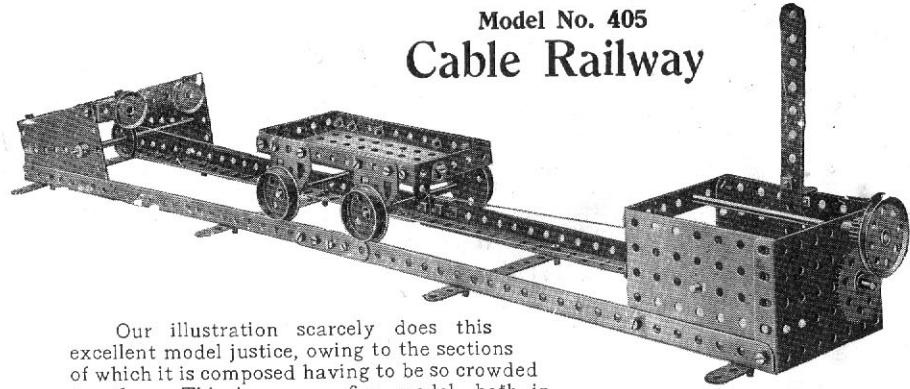
Parts required :

2	of No. 1	1	of No. 32	
9	" "	1	" "	35
1	" "	3	" "	37
4	" "	8	" "	48A
2	" "	15	" "	53
3	" "	16	" "	59
1	" "	21	" "	62
2	" "	22	" "	63
2	" "	26	" "	94
1	" "	27A	" "	96
1	" "	28	" "	



The swinging frame 2 carrying the circular saw 1 is rocked to and fro by a continuous rotary movement of the crank 3 through the connecting strips 4. The coupling 5 is loose on the sprocket wheel spindle and forms a bearing for the spindle of the worm.

Model No. 405 Cable Railway



Our illustration scarcely does this excellent model justice, owing to the sections of which it is composed having to be so crowded together. This is a very fine model, both instructive and highly interesting.

The driving power is received at the outer $1\frac{1}{2}$ " pulley, and is transmitted through the clutch mechanism and the pinion and gear wheels to the lower spindle on which the driving pulley is fixed, the driving rope passing round this pulley and the second pulley at the end of the rails, all as shown in the drawing.

In fixing the lever for operating the clutch mechanism, the nuts should be locked to prevent the screw working out. Only one section of rails is shown in the design but they may be extended as desired.

Parts required :

5	of No. 2	1	of No. 27A	
3	" "	2	" "	29
2	" "	5	" "	35
4	" "	8	" "	37
1	" "	15	" "	38
2	" "	15A	" "	46
2	" "	16	" "	48A
1	" "	17	" "	48c
4	" "	20	" "	52
1	" "	21	" "	53
3	" "	22	" "	54
1	" "	22A	" "	59
2	" "	26	" "	125
				4 of No. 126A

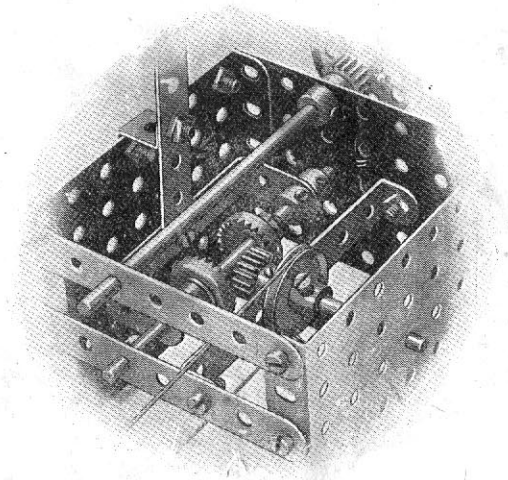
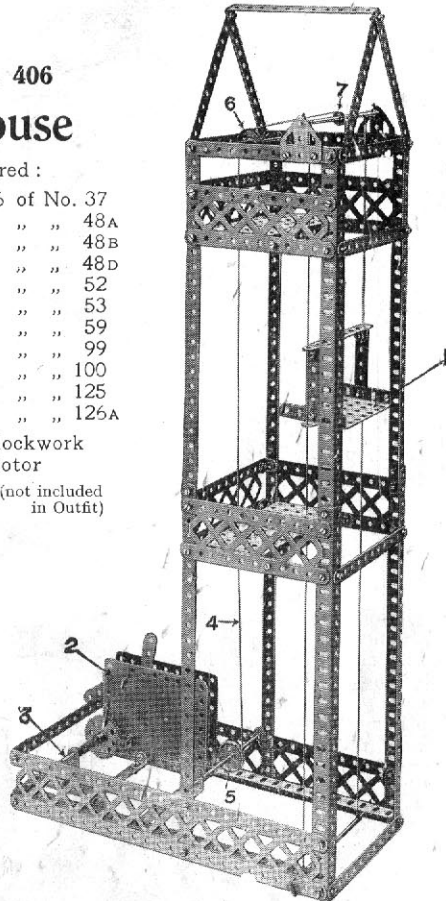


FIG. A

Model No. 406
Warehouse

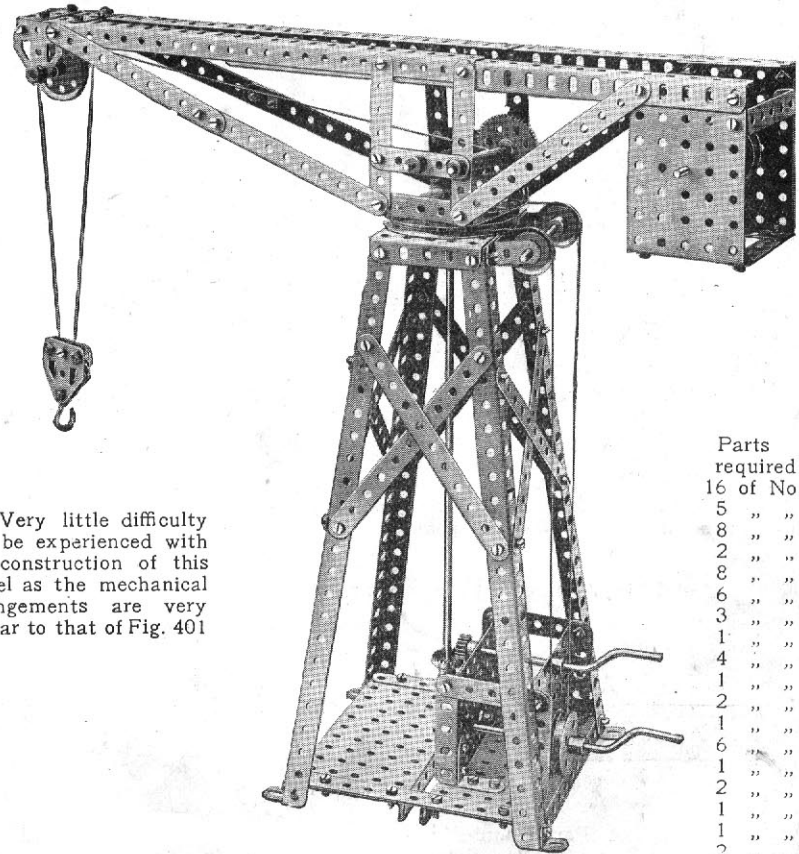
Parts required:

4 of No. 1	126 of No. 37
18 " " 2	2 " " 48A
2 " " 4	1 " " 48B
6 " " 8	2 " " 48D
4 " " 11	2 " " 52
14 " " 12	1 " " 53
1 " " 12A	2 " " 59
3 " " 14	2 " " 99
1 " " 15	6 " " 100
1 " " 16	2 " " 125
1 " " 17	2 " " 126A
2 " " 22A	Clockwork
1 " " 23	Motor
1 " " 26	(not included
1 " " 27A	in Outfit)
10 " " 35	



The cage 1 is raised or lowered to the several floors from the motor 2 driving a rod 3 from which passes the hoisting cord 4 round a 1" pulley 5 and another 6 at the top, and thence over a 1/2" pulley 7 to the cage 1. The construction of the floors and frame should be clear from the illustration.

Model No. 407 **Girder Crane**



Very little difficulty will be experienced with the construction of this model as the mechanical arrangements are very similar to that of Fig. 401

Parts required:

16 of No. 2
5 " " 3
8 " " 5
2 " " 6A
8 " " 8
6 " " 12
3 " " 12A
1 " " 13
4 " " 16
1 " " 17
2 " " 19
1 " " 19B
6 " " 20
1 " " 21
2 " " 22
1 " " 23
1 " " 24
2 " " 26
1 " " 27A

1 of No. 28	10 of No. 38	2 of No. 52	9 of No. 59
1 " " 29	1 " " 46	5 " " 53	1 " " 115
92 " " 37	3 " " 48A	1 " " 57	4 " " 126A

Model No. 408 Tower Wagon

Parts required :

16 of No. 2	78 of No. 37
2 " " 4	22 " " 37A
4 " " 5	24 " " 38
2 " " 8	1 " " 45
2 " " 15	4 " " 48A
5 " " 15A	6 " " 48B
1 " " 16	1 " " 52
2 " " 17	2 " " 53
4 " " 20	2 " " 54
1 " " 21	3 " " 59
3 " " 22	2 " " 62
1 " " 22A	2 " " 77
1 " " 24	2 " " 100
2 " " 26	2 " " 103
1 " " 27A	1 " " 115
1 " " 32	2 " " 125
2 " " 35	4 " " 126A

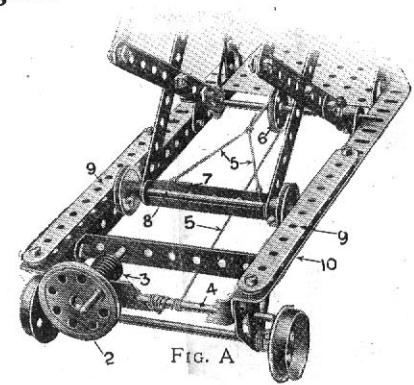
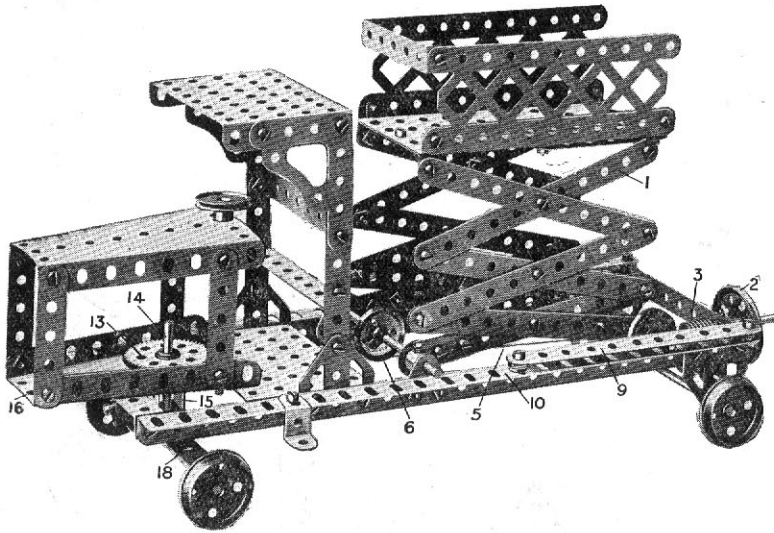
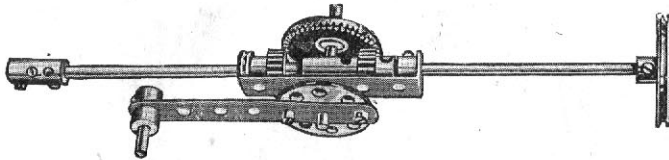


FIG. A

The Lazy Tongs 1 are extended by turning the hand wheel 2, a worm 3 on which engages a $\frac{1}{2}$ " pinion, not shown, on the rod 4. On this rod winds a cord 5 which passes round a pulley 6 and is secured to a $2\frac{1}{2}$ " \times $\frac{1}{2}$ " double angle strip 7 on the rod 8, the ends of which slide in guides on either side formed by the strips 9 spaced by washers and the angle girders 10 of the carriage. The Lazy Tongs collapse by their own weight. The steering is effected from the rod 11, a pinion 12 on which engages a 57-toothed gear wheel 13, the 2" rod 14 of which passes through a double bent strip 15 bolted to the under-side of the sector plate 16. The rod 14 is secured to the bush wheel 17 which carries the double angle strip $3\frac{1}{2}$ " \times $\frac{1}{2}$ " 18.

Model No. 409 Breast Drill



1 of No. 3	1 of No. 21	1 of No. 28
2 " " 15	1 " " 23	2 " " 37
2 " " 17	1 " " 24	1 " " 48A
1 " " 18A	2 " " 26	3 " " 59
	2 " " 63	

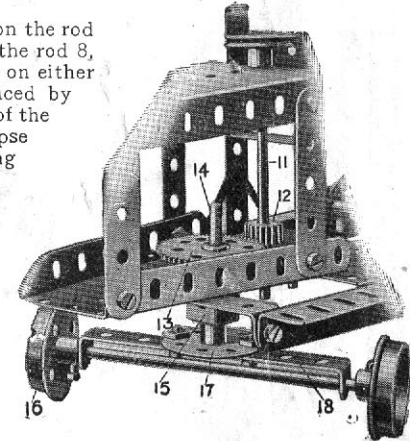
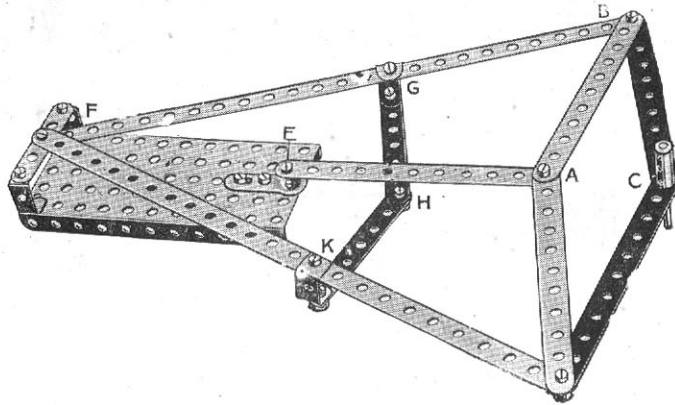


FIG. B

Model No. 410 Geometrical Apparatus



This most ingenious model for transforming a circular movement into a rectilinear movement was designed by M. Pierre-Th. Dufour, who used it in his Thesis (presented to the Faculty of Science in Paris) to obtain his degree of Doctor of the University of Paris. He required an instrument which would transform a circular movement into a movement rigorously rectilinear and he states in his published work that he was able to do this "with the aid of Meccano parts, which permit of making experiments so easily in mechanisms of the most varied types."

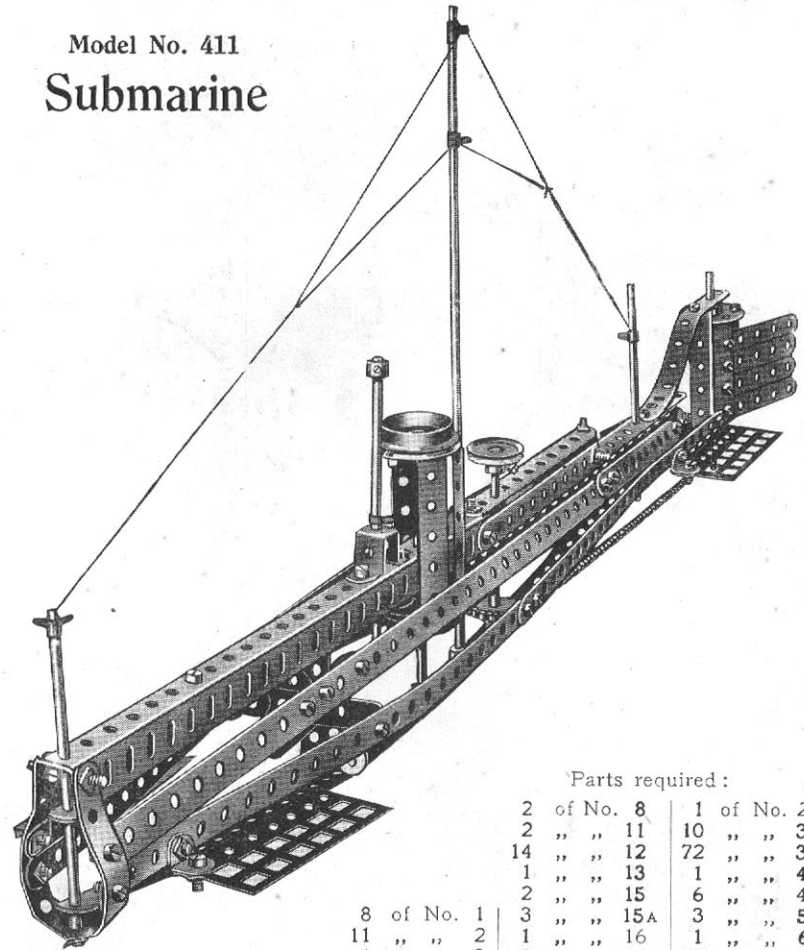
The point F is fixed, and is situated at a distance from the fixed point E, equal to AE, the two arms FB and FD being together equal to the four sides of the lozenge ABCD. The trajectory of the point C is then at right angles to EF. It will be found that whilst the point C is moving in a straight line at right angles to EF, the point A is describing a circle round the fixed point E.

Every Meccano boy should make up this very interesting model and experiment with it.

Parts required:

2	of No.	1
5	" "	2
2	" "	3
1	" "	5
4	" "	11
1	" "	17
16	" "	37
1	" "	52
7	" "	59
1	" "	62
1	" "	63

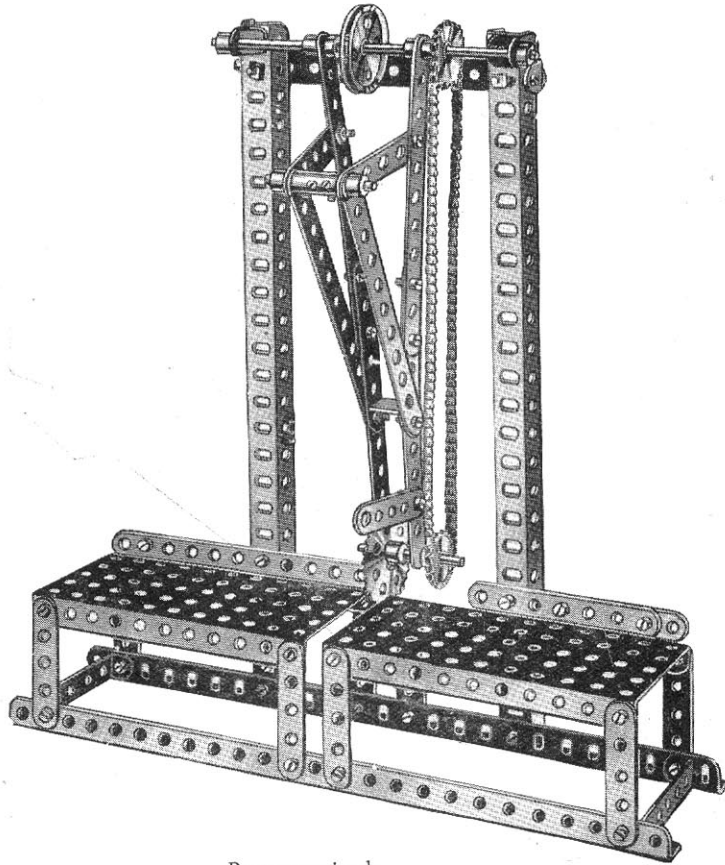
Model No. 411 Submarine



Parts required:

2	of No.	8	1	of No.	24
2	" "	11	10	" "	35
14	" "	12	72	" "	37
1	" "	13	1	" "	45
2	" "	15	6	" "	48A
8	of No.	1	3	" "	59A
11	" "	2	1	" "	16
1	" "	3	2	" "	20
8	" "	5	1	" "	22
			3	" "	59
			1	" "	61
			26"	" "	94
			2	" "	96

Model No. 412 Swing Saw



Parts required:

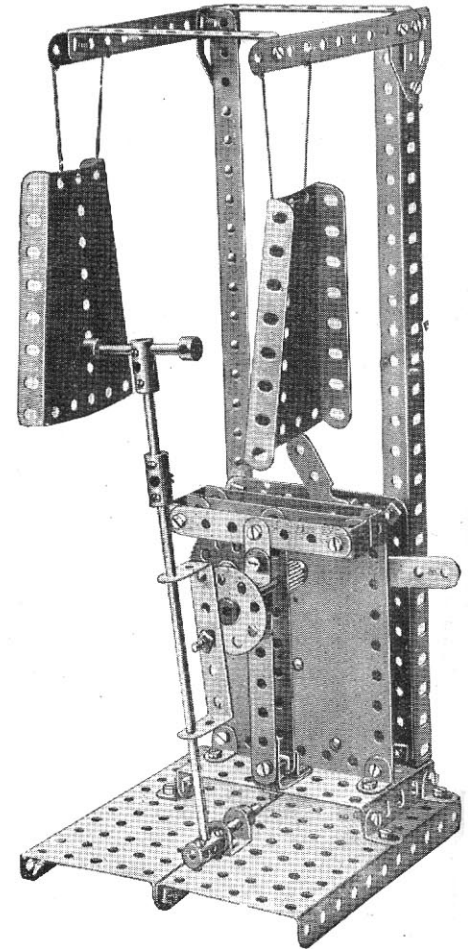
8 of No. 2	1 of No. 11	45 of No. 37	22" of No. 94
1 " " 3	4 " " 12	2 " " 48A	1 " " 95
12 " " 5	1 " " 14	2 " " 52	2 " " 96
6 " " 8	2 " " 17	8 " " 59	
1 " " 10	1 " " 21	1 " " 63	

Model No. 413 Automatic Gong

Parts required:

2 of No. 2
2 " " 2A
2 " " 3
2 " " 8
5 " " 11
9 " " 12
1 " " 12A
1 " " 14
5 " " 17
1 " " 24
1 " " 26
1 " " 27A
43 " " 37
2 " " 37A
2 " " 38
1 " " 45
1 " " 46
2 " " 48B
2 " " 52
1 " " 53
2 " " 54
3 " " 59
3 " " 63
1 " " 111
2 " " 126A

Clockwork Motor
(not included in Outfit)



Model No. 414 Wire Rope-making Machine

Parts required:

21 of No. 2	1 of No. 13	4 of No. 17	1 of No. 22	104 of No. 37	2 of No. 53	1 of No. 95
4 " " 3	2 " " 14	1 " " 19	2 " " 24	16 " " 38	2 " " 54	1 " " 96
8 " " 5	1 " " 15	1 " " 19 _B	2 " " 26	1 " " 45	4 " " 59	1 " " 109
6 " " 8	1 " " 15 _I	8 " " 20	1 " " 27 _A	4 " " 48 _A	2 " " 63	4 " " 126 _A
3 " " 12	1 " " 16	1 " " 21	1 " " 28	2 " " 52	16 " " 94	

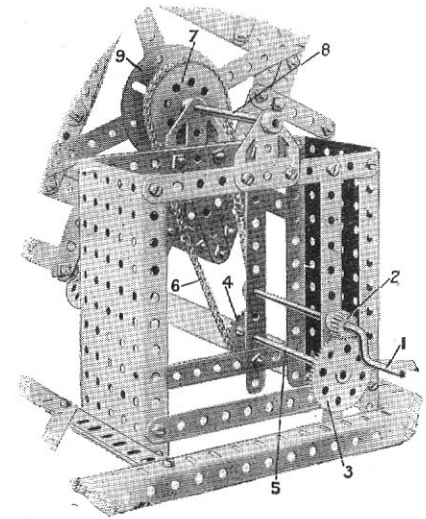
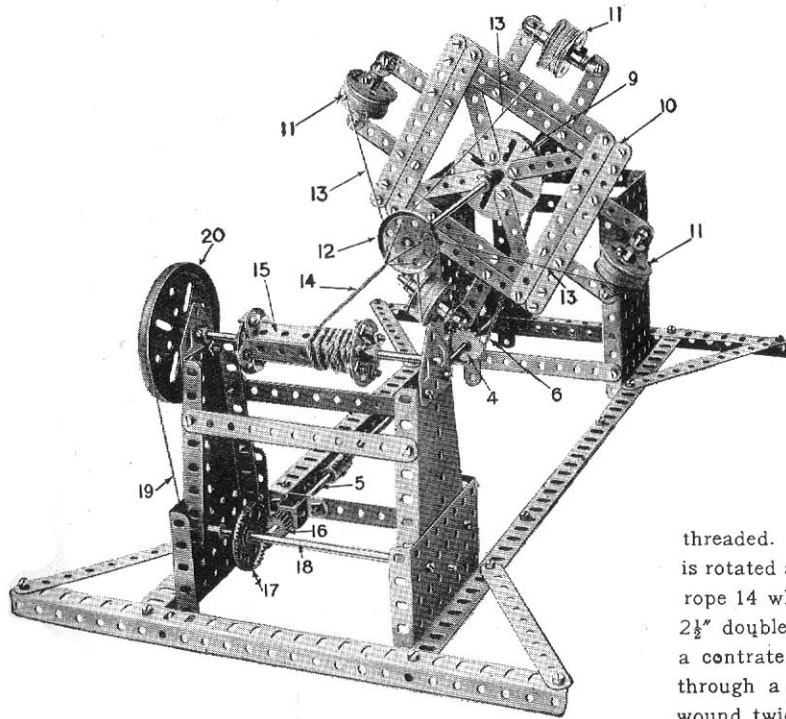


FIG. A

The machine is operated from the crank handle 1, a pinion 2 on which engages a 57-toothed wheel 3. A 1" sprocket wheel 4 on the rod 5 of the toothed wheel 3 drives through a chain 6 a 2" sprocket wheel 7, bolted on the rod 8. To this rod is bolted a face plate 9 which carries a framework 10 in which are mounted the wire spools 11, made from two flanged pulley wheels. At the front of the rod is bolted a 1½" pulley wheel 12, through alternate holes in which the wires 13 from the spools 11 are threaded. By operating the handle 1 the frame 10 is rotated and the wires stranded to form a twisted rope 14 which is taken up on a drum formed of 4 2½" double angle strips 15. This drum is rotated from the rod 5 by a pinion 16 engaging a contrate wheel 17 on the rod 18 of which a 1" pulley wheel, not shown, drives through a cord 19 a 3" pulley wheel 20, on the drum spindle. The cord 19 may be wound twice round the smaller pulley wheel to get a better grip.

Model No. 415

Swivelling and Luffing Jib Crane

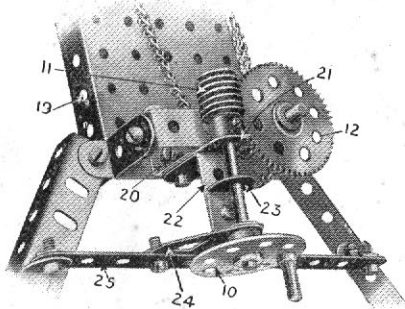


FIG. A

In this model three separate actions are provided, for raising the load, raising the jib, and swivelling the jib. The load is raised by means of a crank handle 1 on which the cord 2 is wound and passes over the 1" pulley 3, thence round the $\frac{1}{2}$ " pulley in the block 4 (spacing washers being used

to give clearance to the $\frac{1}{2}$ " pulley), the end of the cord 2 being made fast to the top of the jib. By turning the handle 1 the load is raised or lowered. The jib itself is raised or lowered by the operation of the crank handle 5 on the rod of which a cord is wound, and passes over one of two pulleys 7 to and round another 1" pulley 8 in the jib, whence it returns to and passes round the other pulley 7, being finally made fast to the double bracket 9 bolted to the jib.

As the handle 5 is turned the cord 6 is wound round the pulleys and the angle of the jib varied. The jib is swivelled by the hand-wheel 10, a worm 11 on which engages a 57-toothed wheel 12 on the rod of which a 1" sprocket wheel 13 is mounted. A sprocket chain 14 passes round this wheel 13 and round a 2" sprocket wheel 15 secured to the standard 16 of the crane. The bearing for the rod of the worm 11 is made by bolting a 1" angle bracket 20 to the rectangular plate 19, and to the angle bracket 20 is secured a $1\frac{1}{2}$ " strip 21 and a 1" bracket 22. To the bracket 22 is bolted a double bracket 23. A flat trunnion 24 is bolted to the $5\frac{1}{2}$ " strip 25 which forms with the bracket 23 the front bearing for the rod. The standard is built up of 2 $12\frac{1}{2}$ " girders 16 which are connected at the base by a $1\frac{1}{2}$ " double angle strip 17 which is bolted to the 2" sprocket wheel 15. The 1" rod 18 is secured in the bush of the sprocket wheel 15 and fitted with a collar below the rectangular plate 19, Fig. 415B.

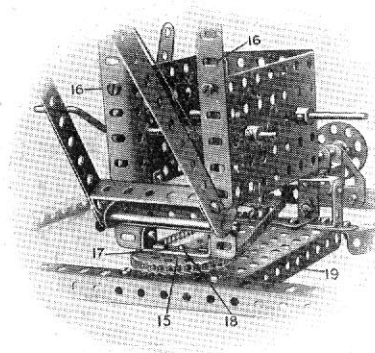
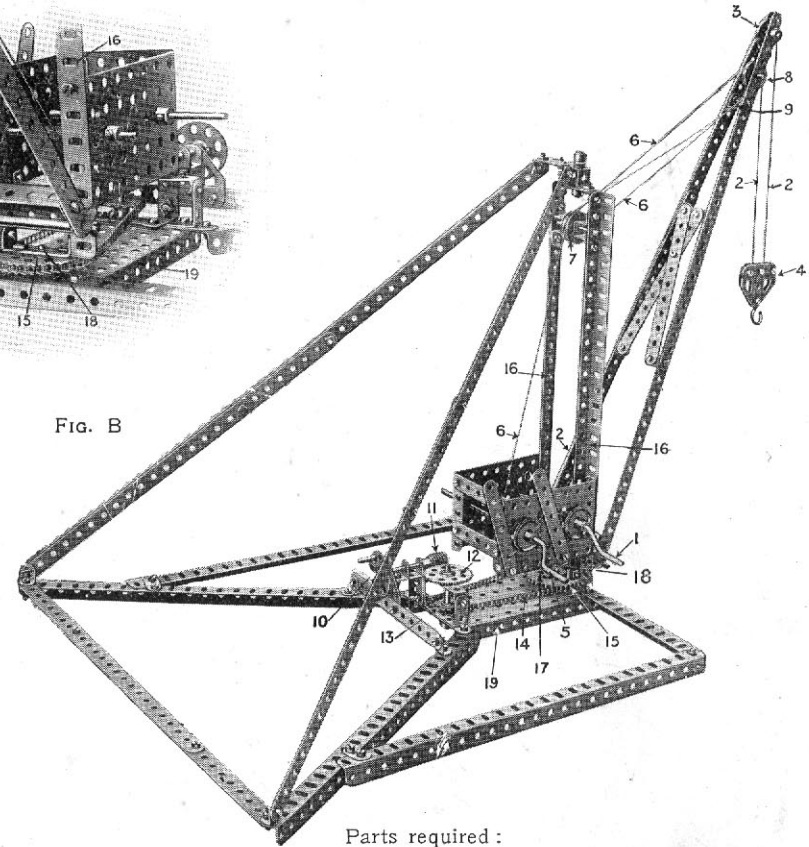


FIG. B

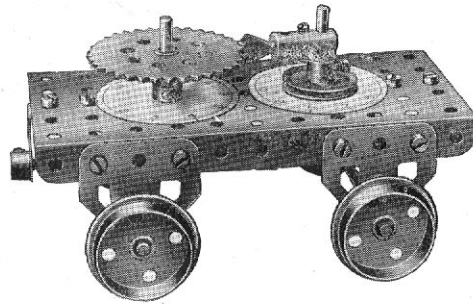


Parts required :

10 of No. 1	2 of No. 12A	1 of No. 27A	3 of No. 48A
3 " " 2	1 " " 16	1 " " 32	2 " " 52
3 " " 3	3 " " 17	2 " " 35	2 " " 53
2 " " 5	4 " " 18A	80 " " 37	1 " " 57
1 " " 6A	2 " " 19	2 " " 37A	8 " " 59
7 " " 8	3 " " 22	13 " " 38	1 " " 95
2 " " 10	3 " " 22A	3 " " 45	1 " " 96
2 " " 11	1 " " 23	1 " " 46	1 " " 115
10 " " 12	1 " " 24	2 " " 48	4 " " 126A

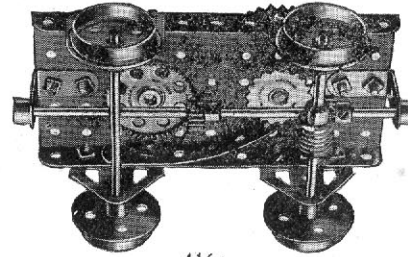
Model No. 416 Distance Indicator

Model No. 417 Band Saw

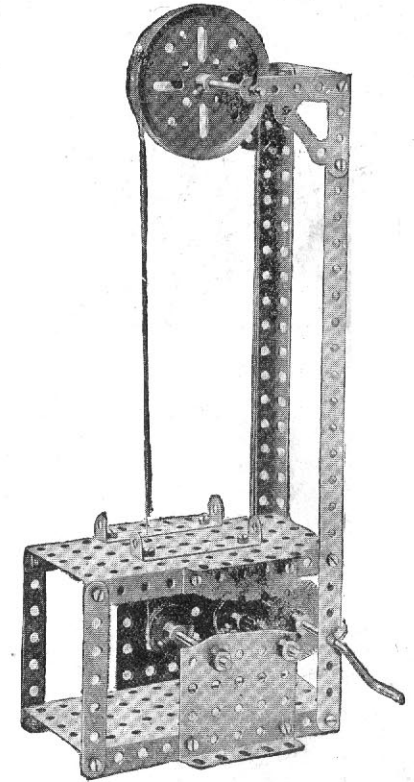


Parts required:

1 of No. 4	1 of No. 37A
4 " " 10	3 " " 38
2 " " 12	1 " " 52
1 " " 15	3 " " 59
2 " " 16	2 " " 62
2 " " 17	1 " " 63
4 " " 19A	1 " " 65
2 " " 26	1 " " 95
1 " " 28	1 " " 96
1 " " 32	4 " " 126A
16 " " 37	

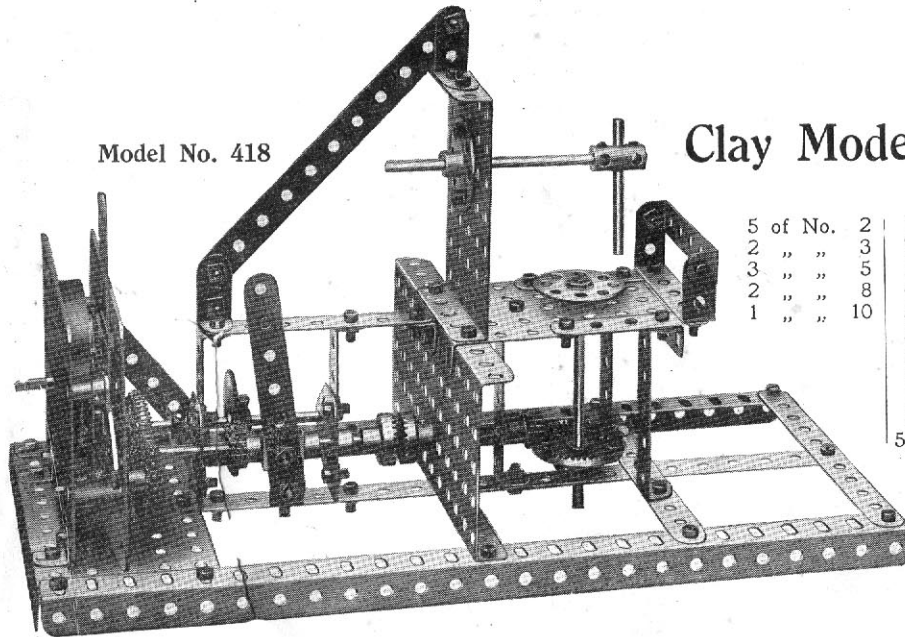


416A



Model No. 418

Clay Modelling Machine



Parts required:

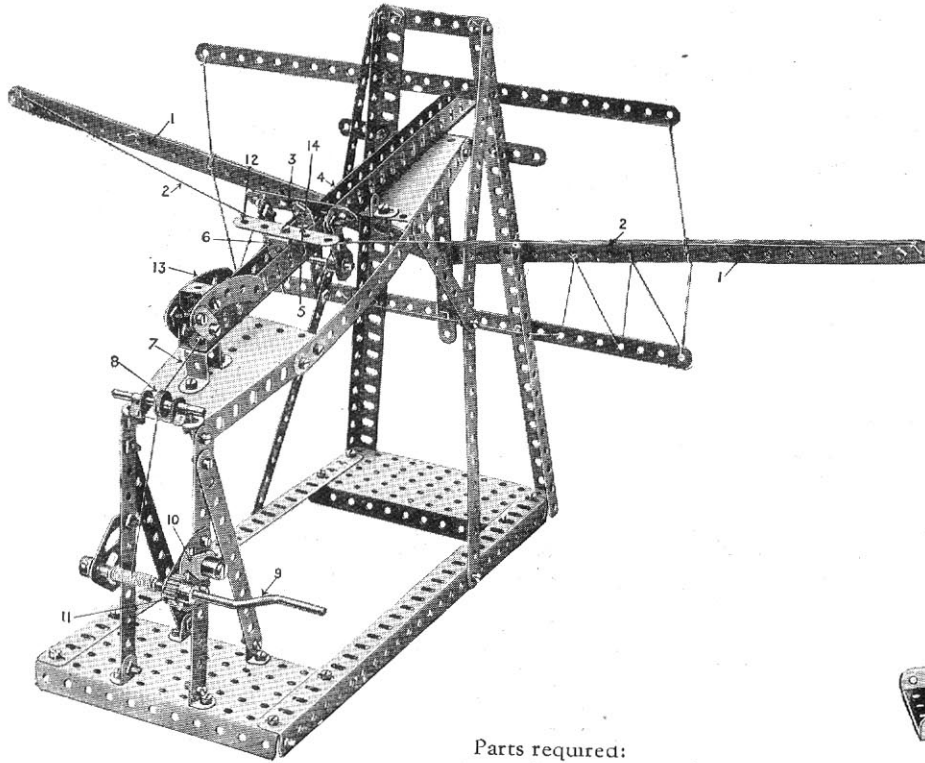
5 of No. 2	1 of No. 11	2 of No. 37A
2 " " 3	7 " " 12	2 " " 38
3 " " 5	1 " " 12A	1 " " 46
2 " " 8	4 " " 16	6 " " 48A
1 " " 10	2 " " 17	2 " " 52
	2 " " 24	2 " " 53
	2 " " 26	4 " " 59
	1 " " 27A	1 " " 63
	1 " " 28	6 " " 94
	2 " " 29	2 " " 96
	55 " " 37	2 " " 126A

Clockwork Motor
(not included in Outfit).

Parts required:

2 of No. 3	2 of No. 22	2 of No. 52
1 " " 5	1 " " 26	2 " " 53
2 " " 8	1 " " 27A	4 " " 59
3 " " 16	4 " " 35	2 " " 108
1 " " 19	26 " " 37	
1 " " 19B	2 " " 48A	

Model No. 419 Mechanical Cross Bow



Parts required:										
	10	of No.	1	12	of No.	12	2	of No.	54	
	8	"	"	2	"	"	17	1	"	59
	2	"	"	3	"	"	19	2	"	62
	3	"	"	5	"	"	23	2	"	90
	4	"	"	8	"	"	35	1	"	111
	3	"	"	10	"	"	37	2	"	126A
	3	"	"	11	"	"	37A	1	"	147A
	3	"	"		"	"	45	1	"	147B
	3	"	"		"	"	52	1	"	148

The only part of this model that requires description is the release of the bow. This is obtained by the following mechanism: the bow is made of three $12\frac{1}{2}$ " strips, 1, on each side, from the outer ends of which the cords 2 of the bow are connected to a frame 3, sliding on the angle girders 4. To this frame is bolted a double bracket 5 and a flat bracket 14, and this is engaged by another double bracket 6, forming the trigger. A cord 7 is connected to the double bracket 6 and passes over the pulley wheel 8 to the winding handle 9, controlled by a pawl 10 engaging a pinion 11. As the handle 9 is turned to bend the bow, the double bracket 6 is drawn back, and eventually the cross strip 12 engages and rides up the curved strips 13, disengaging the bracket 6 from the bracket 5 and releasing the bow.

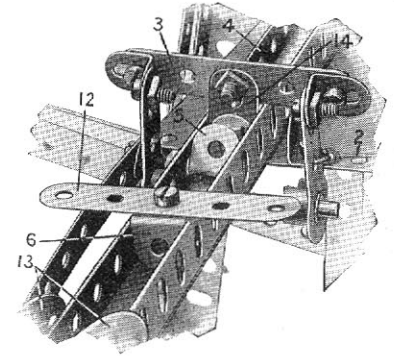
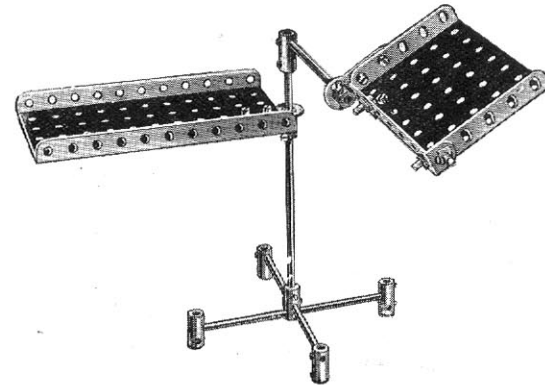


FIG. 419A

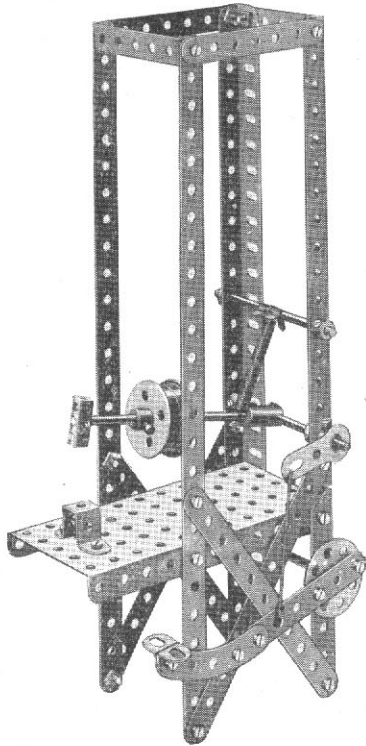
Model No. 420 Bed Table



Parts required:	
1	of No. 3
1	" " 12
1	" " 14
2	" " 15A
1	" " 16
8	" " 37
1	" " 52
1	" " 53
2	" " 62
6	" " 66

Model No. 421

Treadle Hammer



Parts required :

2 of No. 1	3 of No. 16	1 of No. 45
4 " " 2	2 " " 20	1 " " 48A
3 " " 3	1 " " 24	1 " " 52
1 " " 5	2 " " 35	5 " " 59
2 " " 8	23 " " 37	1 " " 62
2 " " 12	2 " " 38	2 " " 63
1 " " 15A	1 " " 43	1 " " 90

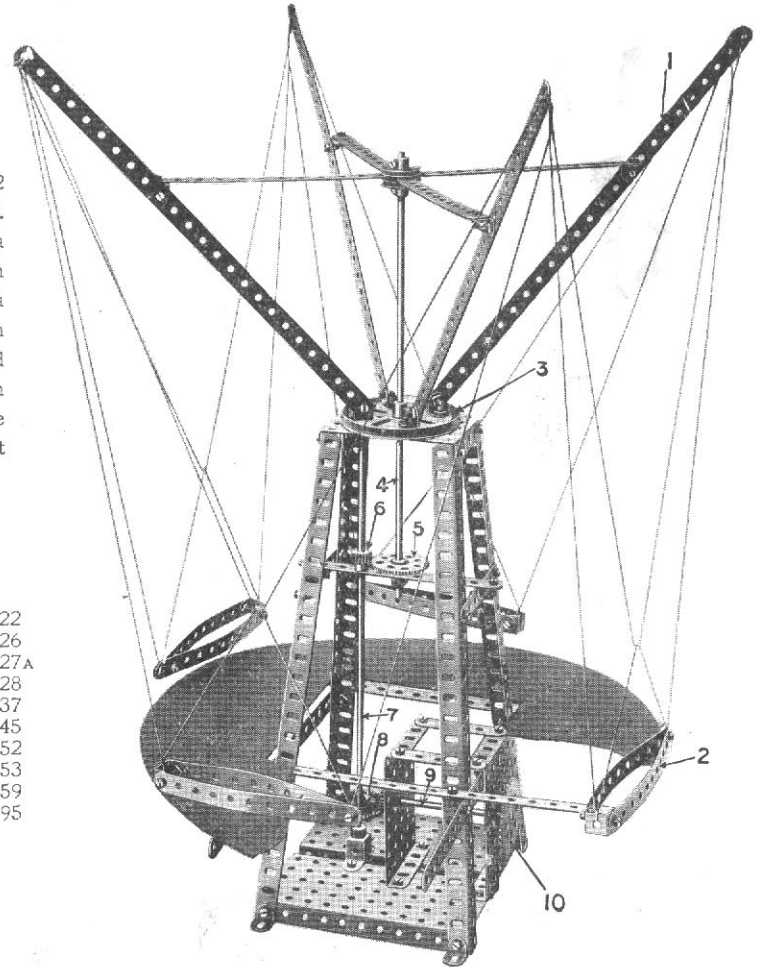
Model No. 422

Flying Machine

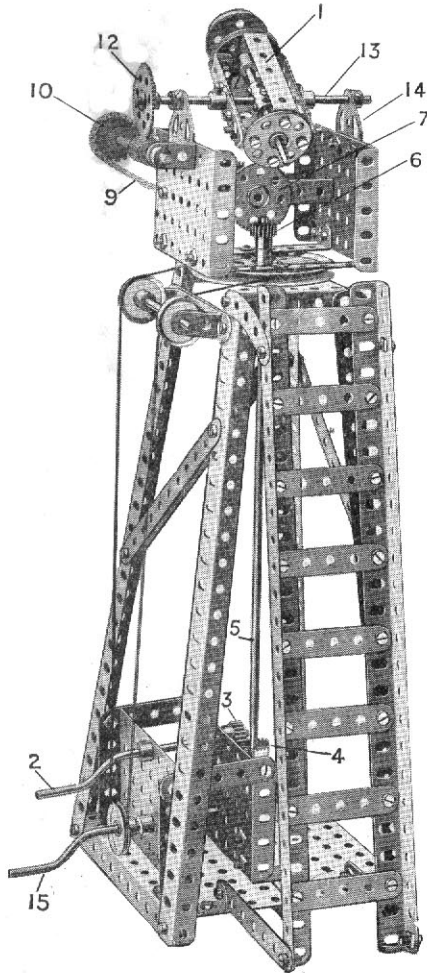
The arms 1 carrying the boats 2 are driven from the 3" pulley 3. This is connected by the rod 4 to a gear wheel 5 driven by a pinion 6 on a rod 7. At the foot of this rod is a contrate wheel 8 driven by a pinion on the end of another rod 9. This rod carries the sprocket wheel 10 driven by a chain from the motor. As the arms 1 rotate the boats 2 fly out centrifugally.

Parts required :

10 of No. 1	2 of No. 22
9 " " 2	2 " " 26
2 " " 3	1 " " 27A
2 " " 5	1 " " 28
4 " " 8	66 " " 37
4 " " 11	1 " " 45
22 " " 12	2 " " 52
2 " " 13	3 " " 53
1 " " 16	2 " " 59
1 " " 19B	1 " " 95



Model No. 423 Searchlight Tower



The elevation of the search-light 1 is obtained through the crank handle 2 a pinion 3 on which engages a $\frac{3}{4}$ " contrate wheel 4 on an $1\frac{1}{2}$ " rod 5 at the top of which a $\frac{1}{2}$ " pinion 6 engages a $1\frac{1}{2}$ " contrate wheel 7. On the rod of this contrate wheel at the rear end a 1" sprocket wheel 8 drives through a chain 9 another sprocket wheel 10. A worm 11 on the rod of the latter sprocket engages and drives a 57-toothed gear wheel 12, bolted to a 5" rod 13 which forms the pivot of the search-light 1. The rod 13 is journalled in two flat brackets 14. The search-light is swivelled from a crank handle 15 in the same manner as Model No. 401.

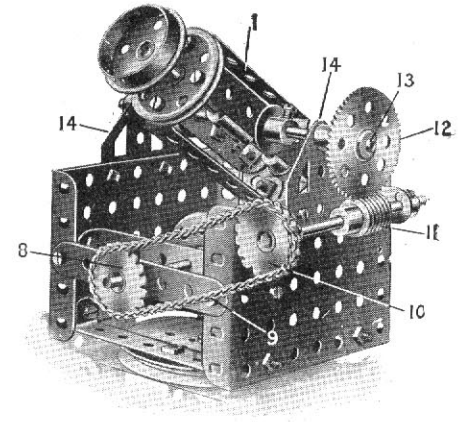
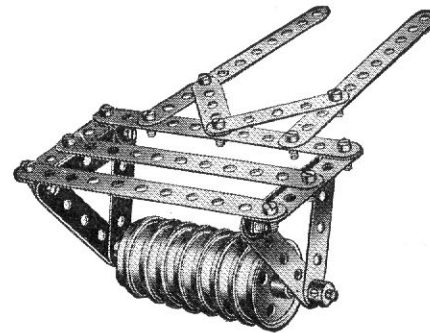


FIG. A

Parts required :

3 of No.	2	2 of No.	26
4 "	3	1 "	27A
10 "	5	1 "	28
6 "	8	1 "	29
4 "	12	1 "	32
3 "	12A	88 "	37
1 "	13	4 "	38
1 "	15	2 "	46
2 "	16	4 "	48A
3 "	17	3 "	48B
2 "	19	2 "	52
1 "	19B	5 "	53
1 "	20	6 "	59
1 "	21	2 "	62
3 "	22	1 "	63
1 "	22A	2 "	90
1 "	24	2 "	126A

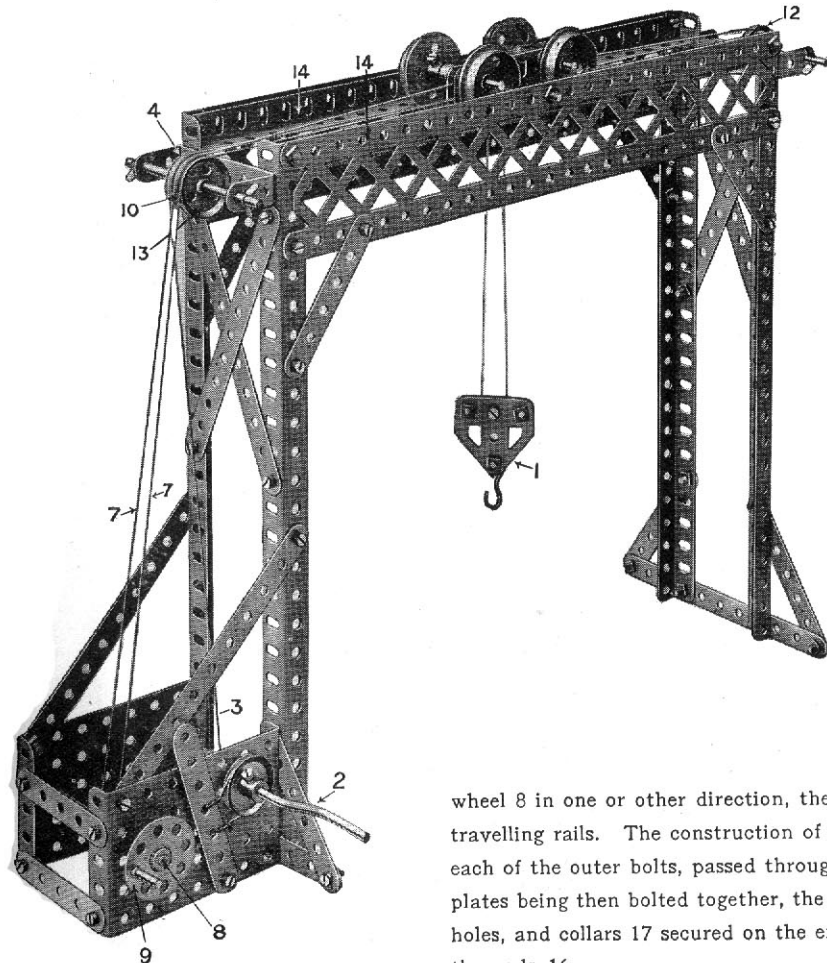
Model No. 424 Field Roller



Parts required :

5 of No.	2
10 "	5
4 "	12
1 "	15
8 "	20
15 "	37
4 "	59

Model No. 425 Gantry



Parts required:

2	of No.	1	1	of No.	24
8	"	2	6	"	35
3	"	3	59	"	37
6	"	4	1	"	37A
2	"	5	12	"	38
6	"	8	2	"	46
3	"	16	2	"	53
2	"	17	1	"	57
1	"	19	4	"	59
4	"	20	2	"	103F
3	"	22	1	"	115
2	"	22A	2	"	126A
3	"	23			

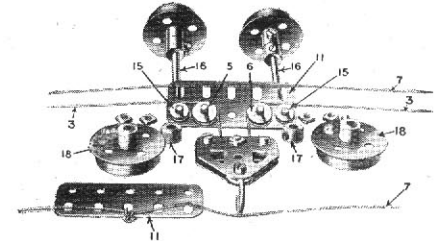
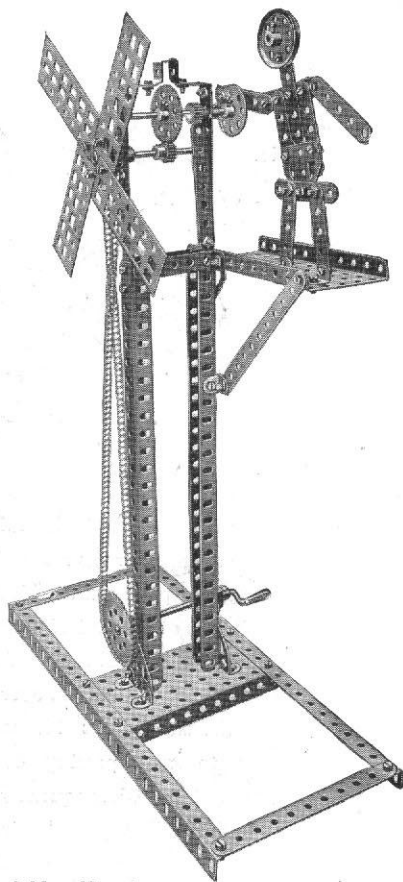


FIG. 425A

The pulley 1 is capable of being hoisted to raise the load, or traversed. In order to raise the load the crank handle 2 is operated, which winds the cord 3 passing over the rear pulley wheel 4 round the $\frac{1}{2}$ " pulley 5 and a corresponding pulley in the block, thence round another $\frac{1}{2}$ " pulley 6 and is made fast at the end of the gantry. For traversing, a continuous cord 7 is wound several turns on the $3\frac{1}{2}$ " rod 8 to which is secured a hand wheel 9. The cord passes over the pulley wheel 10 and is secured to one of the side plates 11, and continues round the pulley 12 returning to and passing over the nearest pulley wheel 13 back to the rod 8. Consequently by turning the hand wheel 8 in one or other direction, the carriage is traversed to and fro along the top angle girders 14, which form the travelling rails. The construction of the travelling carriage is shown in Fig. 425A, three washers 15 being placed on each of the outer bolts, passed through the two plates 11; and $\frac{1}{2}$ " pulley wheels 5, 6, on the inner bolts. The outer plates being then bolted together, the rods 16 of the flange wheels are passed through both plates in the end elongated holes, and collars 17 secured on the exterior. After which the remaining flange wheels 18 are secured on the ends of the rods 16.

Model No. 426
**Windmill
Scare**



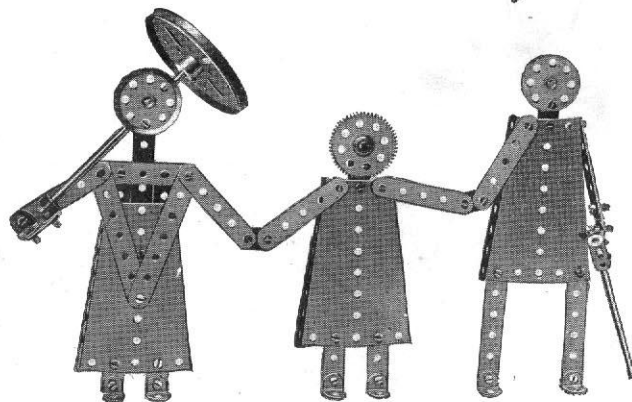
Parts
required :

5	of No.	2				
1	" "	3				
11	" "	5				
6	" "	8				
8	" "	12				
2	" "	12A				
5	" "	16				
1	" "	19				
1	" "	21	2 of No.	37A		
2	" "	24	3 " "	38	1 of No.	95
2	" "	26	1 " "	45	1 " "	96
1	" "	27A	2 " "	52	1 " "	115
61	" "	37	4 " "	59	2 " "	125
			20" "	94	3 " "	126A

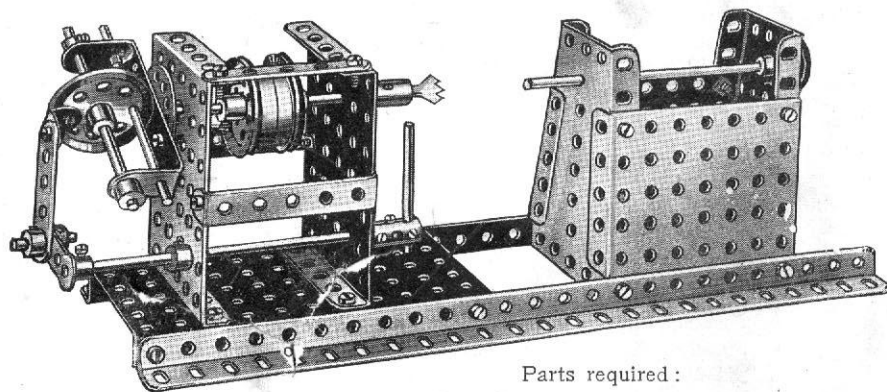
Model No. 427 **The Meccano Family**

Parts required :

1	of No.	2	1	of No.	19B
2	" "	3	1	" "	21
2	" "	4	1	" "	24
12	" "	5	1	" "	27A
7	" "	10	3	" "	35
9	" "	12	36	" "	37
1	" "	15	3	" "	54
1	" "	15A	1	" "	63
1	" "	18A			



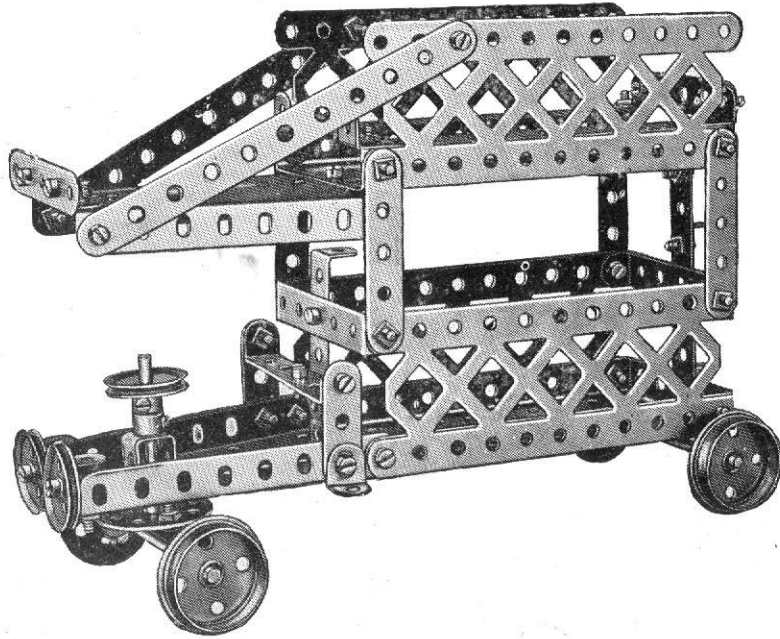
Model No. 428 **Elliptic Lathe**



Parts required :

2	of No.	5	1	of No.	17	2	of No.	35	2	of No.	54
2	" "	8	1	" "	18A	26	" "	37	8	" "	59
1	" "	12	2	" "	20	1	" "	46	1	" "	62
2	" "	15	1	" "	21	2	" "	48A	2	" "	63
1	" "	15A	1	" "	22	1	" "	52	1	" "	65
2	" "	16	1	" "	24	4	" "	53			

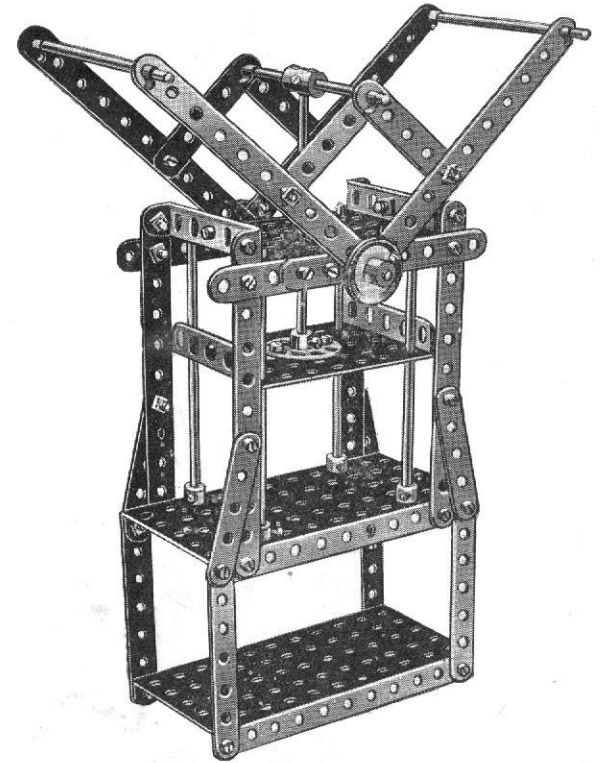
Model No. 429 Motor 'Bus



Parts required :

2 of No. 2	12 of No. 12	2 of No. 22A	2 of No. 52
1 " " 3	2 " " 16	1 " " 24	1 " " 54
6 " " 5	1 " " 17	48 " " 37	1 " " 59
2 " " 6A	4 " " 20	1 " " 45	4 " " 100
3 " " 11	1 " " 22	7 " " 48A	

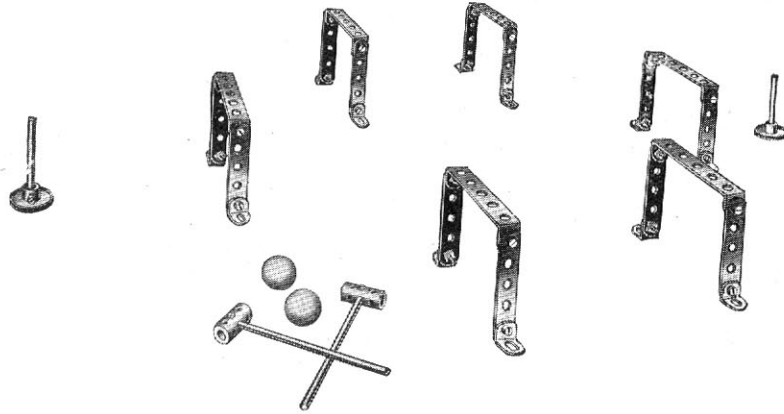
Model No. 430 Bale Press



Parts required :

10 of No. 2	1 of No. 15A	44 of No. 37	2 of No. 52
4 " " 3	2 " " 17	14 " " 37A	2 " " 53
8 " " 5	1 " " 24	2 " " 38	4 " " 59
4 " " 15	8 " " 35	2 " " 48A	1 " " 63
		2 of No. 111	

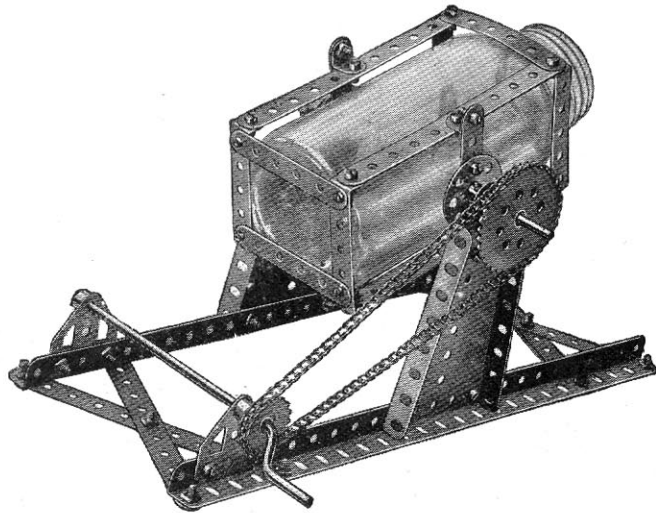
Model No. 431 Table Croquet



A most diverting game. Coloured marbles may be used for the balls. Full instructions for playing croquet may be obtained from any sports or games dealer.

Parts required:

12 of No. 5	2 of No. 22
12 " " 12	24 " " 37
2 " " 16	2 " " 63
2 " " 17	



Model No. 433 Butter Churn

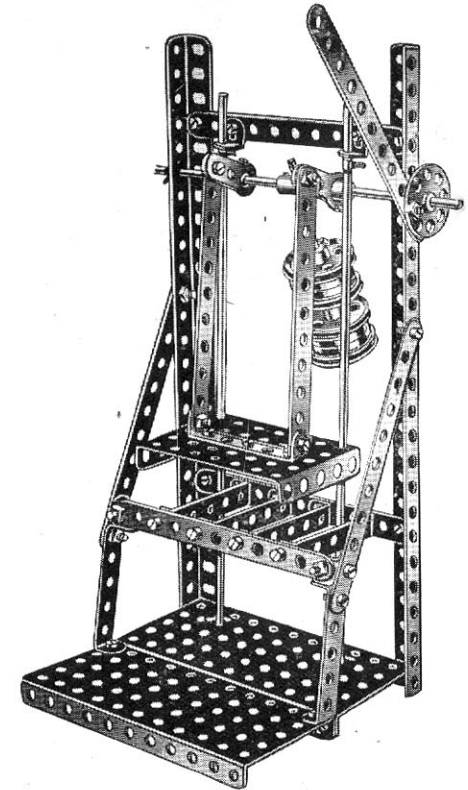
Parts required:

8 of No. 2	1 of No. 19	2 of No. 62
2 " " 3	2 " " 24	16" " " 94
4 " " 4	42 " " 37	1 " " " 95
2 " " 8	4 " " 48A	1 " " " 96
4 " " 12	2 " " 54	2 " " " 126A
2 " " 17	3 " " 59	

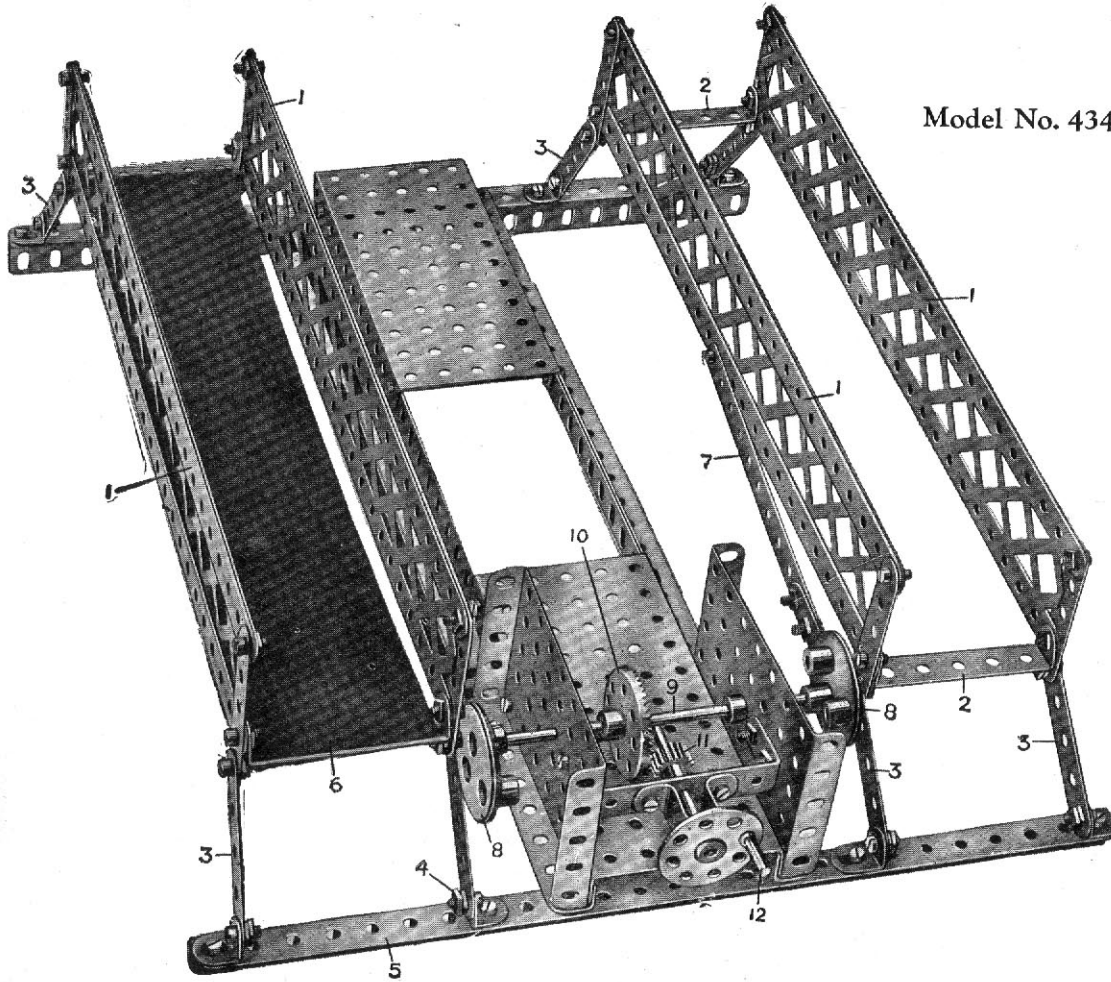
Model No. 432 Potato Chopper

Parts required:

8 of No. 2	1 of No. 24
2 " " 8	5 " " 35
4 " " 12	38 " " 37
2 " " 13	6 " " 48A
1 " " 15A	2 " " 52
2 " " 16	1 " " 53
4 " " 20	1 " " 63



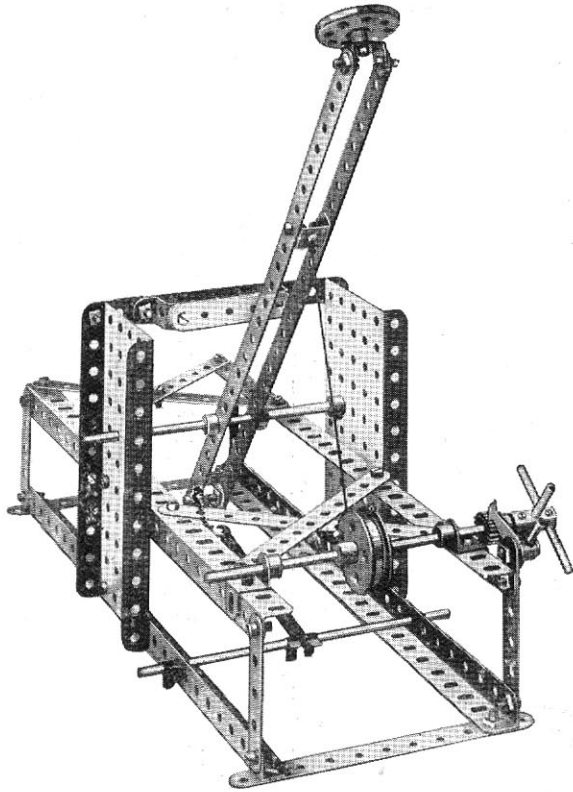
Model No. 434 Cake Walk



Parts required:	
8	of No. 1
2	" " 2
16	" " 5
6	" " 8
1	" " 10
8	" " 12
1	" " 15
1	" " 24
1	" " 26
1	" " 28
66	" " 37
1	" " 38
1	" " 45
1	" " 46
4	" " 48A
2	" " 52
2	" " 53
2	" " 59
1	" " 77
4	" " 99
1	" " 115
2	" " 130

The rocking platforms are built up of braced girders 1 connected by the end strips 2 and pivotally bolted and lock-nutted to the strips 3 forming rocking links. These latter are bolted and lock-nutted at 4 to the angle girders 5. Strips 6 of cardboard are secured to the end strips 2. The platforms are rocked by means of strips 7 one of which is connected to each rocking platform and to eccentrics 8 fixed on the rod 9 on which is secured a contrate wheel 10 driven by a pinion 11 from the handle 12. As the handle 12 is turned the platforms are rocked to and fro on the strips 3. The eccentrics 8 should be so arranged that the platforms rock in opposite directions.

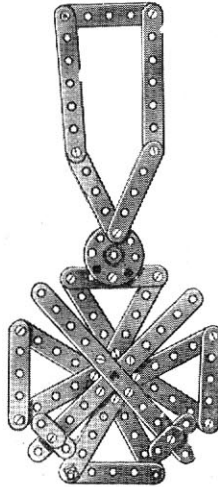
Model No. 435 Catapult



Parts required:

2 of No. 1	3 of No. 14	44 of No. 37	1 of No. 115
7 " " 2	2 " " 17	1 " " 43	4 " " 125
1 " " 4	1 " " 20	2 " " 52	1 " " 147A
6 " " 5	1 " " 24	1 " " 57	1 " " 147B
4 " " 8	1 " " 28	6 " " 59	1 " " 148
3 " " 11	4 " " 35	1 " " 62	

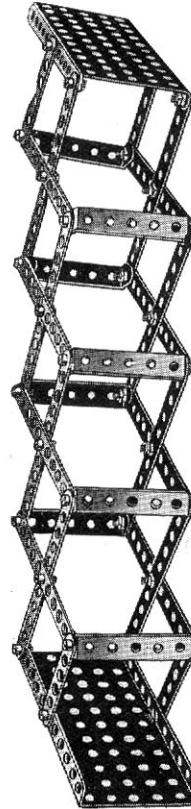
Model No. 436 Croix de Guerre



Parts required:

2 of No. 2	2
2 " " 3	3
15 " " 5	5
4 " " 10	10
2 " " 24	24
24 " " 37	37

Model No. 437 Periscope

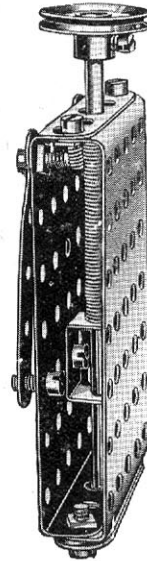


Parts required:

16 of No. 2	2
4 " " 4	4
32 " " 37	37
8 " " 48A	48A
2 " " 52	52

Small pieces of looking glass should be inserted in the top and bottom plates.

Model No. 438 Conductor's Punch



Parts required:

3 of No. 5	9 of No. 37
1 " " 11	1 " " 43
1 " " 15A	2 " " 53
1 " " 22	

This is just the thing for your younger brother, and he only needs a strap to hang it over his shoulder with to make him into a tram conductor. Note the 2½" strip at the bottom, spaced a little away from the body of the punch to allow the ticket to pass in to be punched.

Model No. 439
Speed Indicator

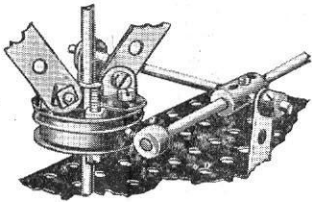
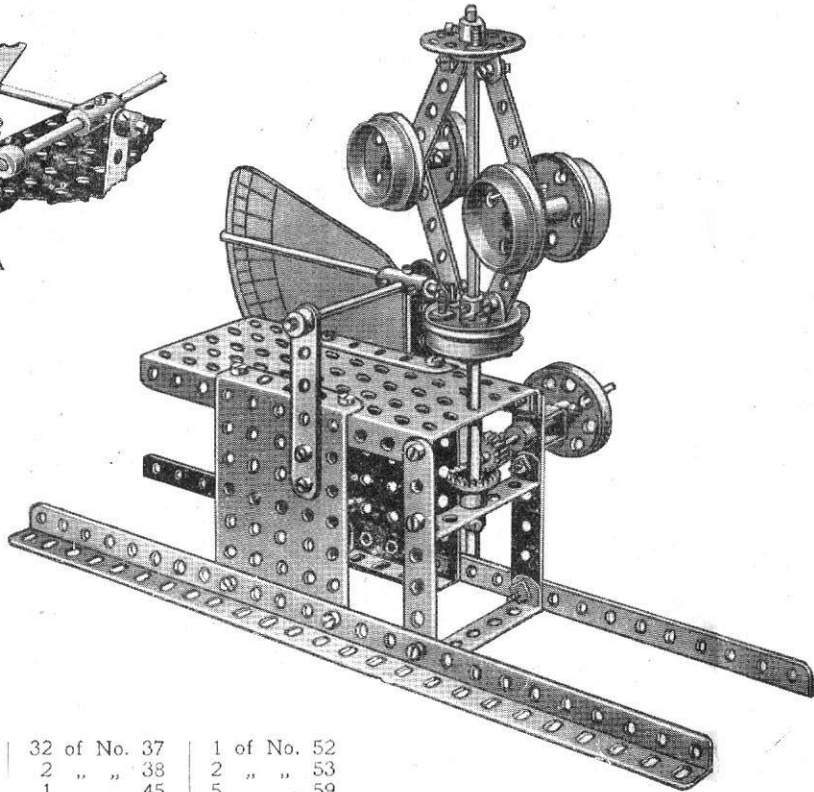


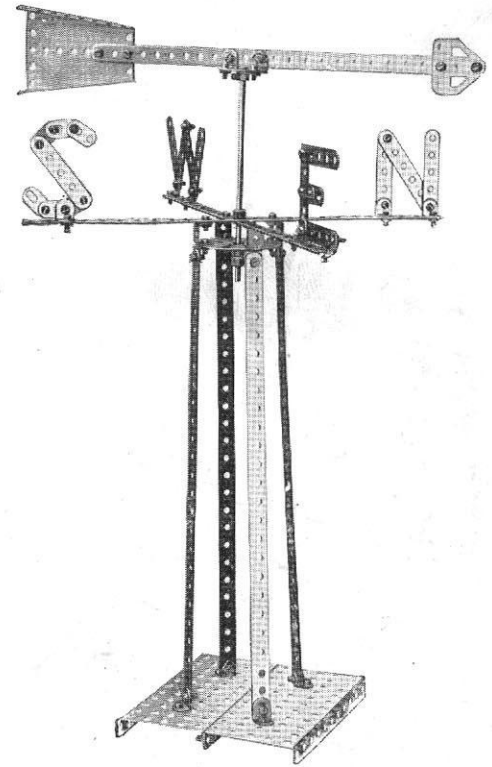
Fig. 439A



Parts
required :

2	of No. 3		
2	" "	4	
4	" "	5	
2	" "	8	
4	" "	12	
1	" "	13A	
3	" "	16	
2	" "	18A	
5	" "	20	
1	" "	21	
2	" "	24	
1	" "	26	
1	" "	29	
	32 of No. 37	1 of No. 52	
	2 " " 38	2 " " 53	
	1 " " 45	5 " " 59	
	3 " " 48A	1 " " 63	

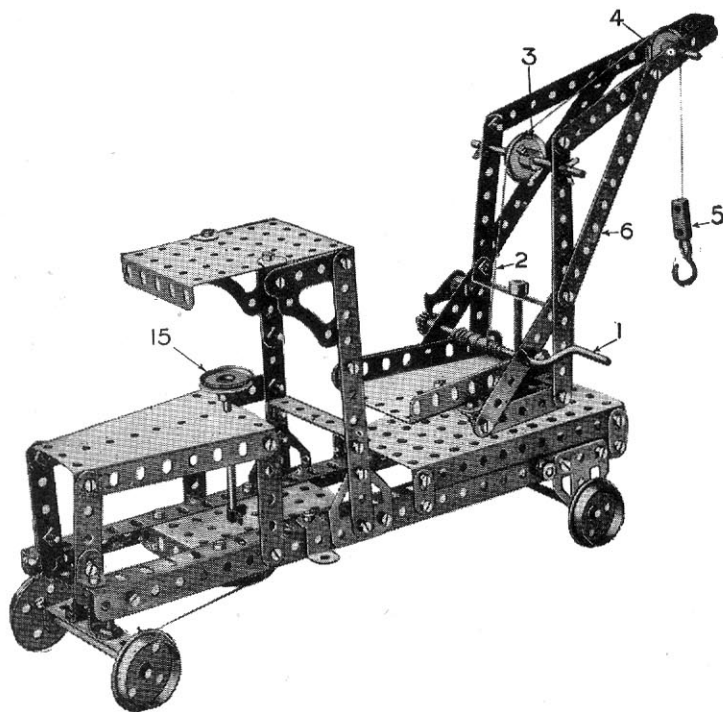
Model No. 440 Weather Vane



Parts required :

7 of No. 1	1 of No. 14	1 of No. 54
11 " " 5	1 " " 24	2 " " 59
8 " " 10	54 " " 37	1 " " 109
4 " " 11	2 " " 38	1 " " 126A
17 " " 12	2 " " 52	

Model No. 441 Travelling Swivel Crane



The load is raised from the crank handle 1, a cord 2 winding on which passes over the 1" pulleys 3 and 4 to the block 5. The jib 6 is swivelled from the hand-wheel 7 on the rod of which is a worm 8 engaging a pinion 9 bolted to a vertical rod 10, to which is secured beneath the platform 11 a 1" pulley wheel 12 and a 57-toothed wheel 13 which carries the swivel platform 14. The steering of the crane is effected from the 1" pulley wheel 15 in the same way as Model No. 230.

Parts required:

8 of No.	2	6 of No.	35
2 "	3	69 "	37
9 "	5	3 "	37A
2 "	8	1 "	45
4 "	10	5 "	48A
1 "	11	1 "	52
8 "	12	2 "	53
2 "	15A	2 "	54
4 "	16	1 "	57
1 "	17	3 "	59
1 "	19	1 "	63
4 "	20	2 "	108
1 "	21	1 "	115
4 "	22	1 "	125
1 "	24	4 "	126A
1 "	26	1 "	147A
1 "	27A	1 "	147B
1 "	32	1 "	148

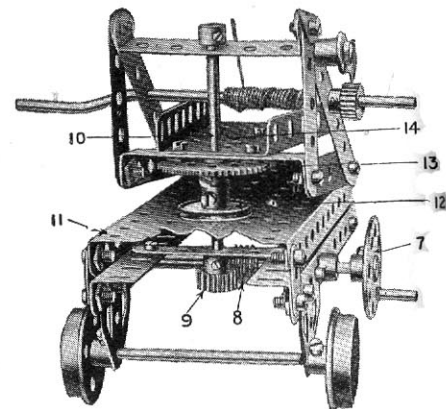
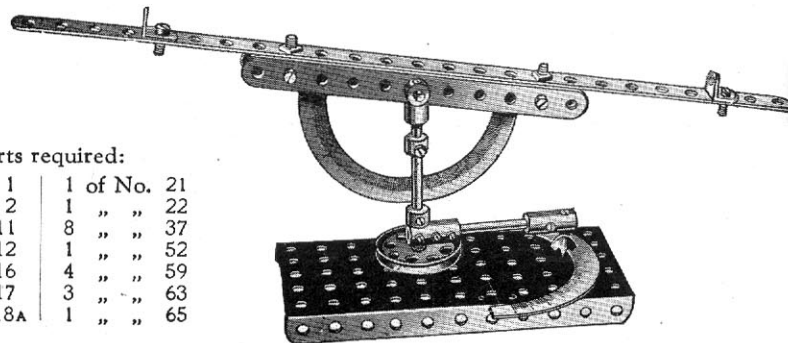


FIG. 441A

Model No. 442 Sextant and Theodolite



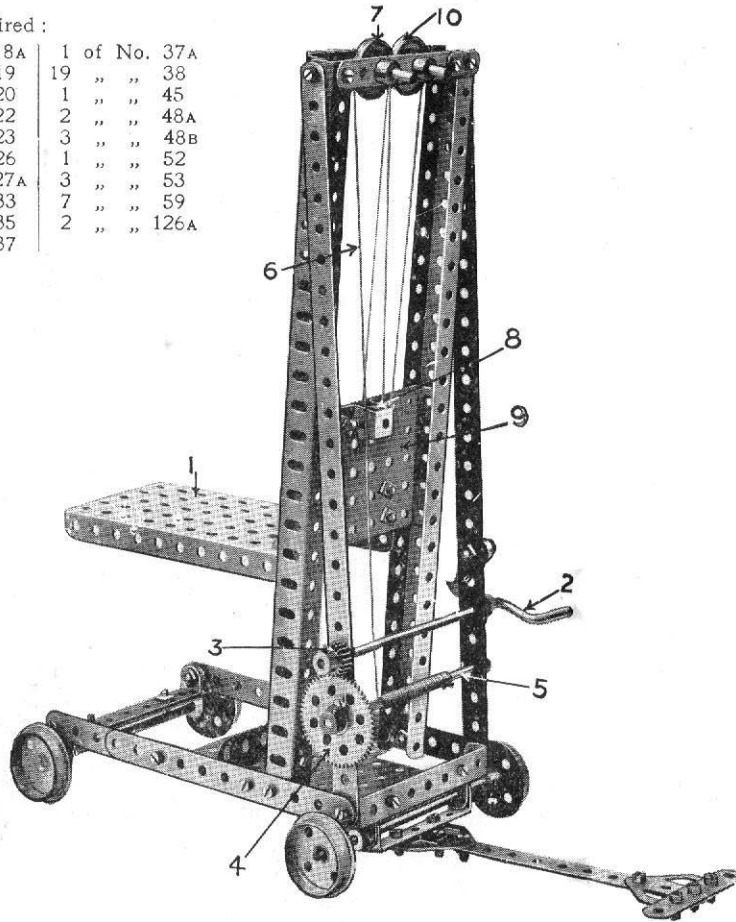
Parts required:

1 of No.	1	1 of No.	21
2 "	2	1 "	22
2 "	11	8 "	37
2 "	12	1 "	52
1 "	16	4 "	59
1 "	17	3 "	63
2 "	18A	1 "	65

Model No. 443 Bale-lifter

		Parts required :			
2 of No.	1	1 of No.	18A	1 of No.	37A
5 "	2	1 "	"	19 "	"
2 "	3	4 "	"	20 "	"
1 "	5	2 "	"	22 "	48A
4 "	8	1 "	"	23 "	48B
3 "	10	2 "	"	26 "	52
2 "	12A	1 "	27A	3 "	53
1 "	15	1 "	"	7 "	59
2 "	15A	2 "	"	2 "	126A
2 "	17	46 "	"	37 "	

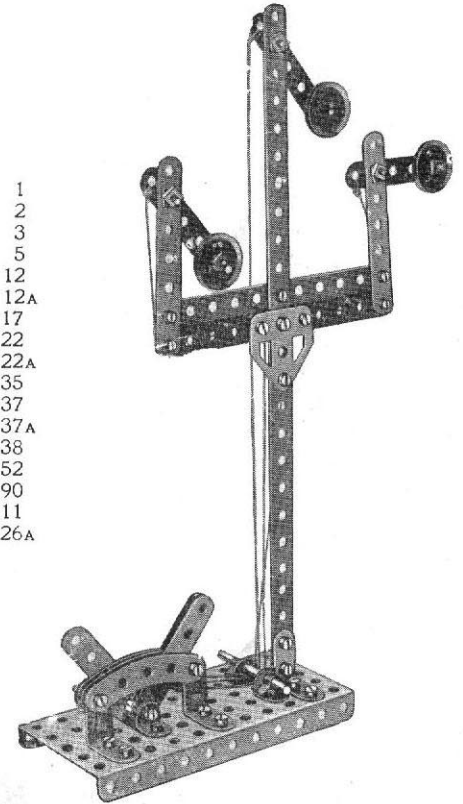
The bale platform 1, consisting of a large rectangular plate, is raised by operating a crank handle 2, a pinion 3 on which engages a 57-toothed wheel 4 on a rod 5, upon which is wound a cord 6, passing over a pulley 7, in the head of the framework, round a $\frac{1}{2}$ " pulley 8, pivoted in a double bent strip bolted to the plate 9, up over another pulley 10, and made fast to the plate 9. The rectangular plate 1 is connected to the plate 9 by 1" angle brackets, and the plates 1 and 9 thus slide together in the vertical framework formed by 12 $\frac{1}{2}$ " angle girders doubled.



Model No. 444 Three-arm Signal

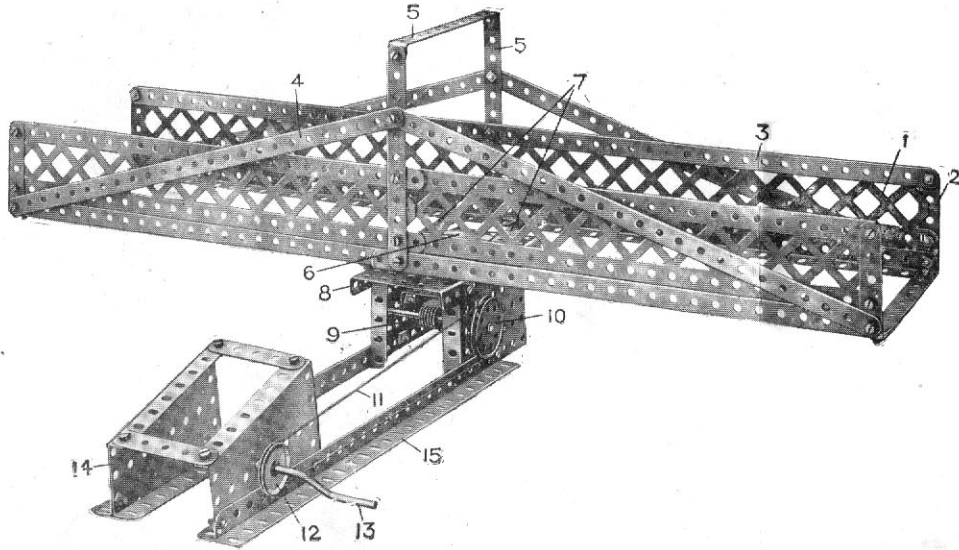
Parts required :

1 of No.	1
3 "	2
2 "	3
6 "	5
4 "	12
23 "	12A
1 "	17
1 "	22
2 "	22A
2 "	35
7 "	37
26 "	37A
3 "	38
1 "	52
4 "	90
3 "	111
1 "	126A



Model No. 445

Swing Bridge



Parts required :

8 of No. 1	1 of No. 17	1 of No. 27A	1 of No. 52
6 " " 2	1 " " 19	1 " " 32	2 " " 53
6 " " 5	1 " " 19B	50 " " 37	2 " " 54
6 " " 8	1 " " 21	1 " " 48A	2 " " 59
1 " " 16	1 " " 22	1 " " 48D	4 " " 99

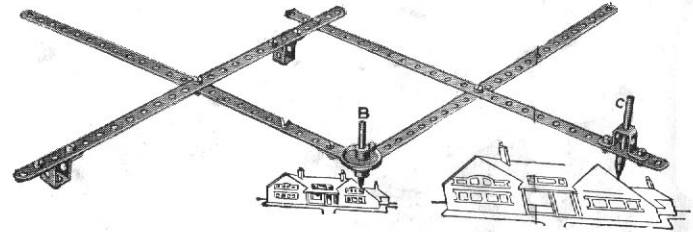
The sides of this model, as shown in the illustration, are made of the braced girders 1 secured to the upright strips 2 and reinforced by the inner strips 3. Other diagonal strips 4 brace the side girders to the top structure 5 forming a stay for the sides 1. The swing base of the bridge is composed of a 3" pulley wheel 6 which is bolted to two cross 5½" strips 7 which in turn are secured to the main base side girders. The bridge swings on the perforated plate 8 on a short rod, on the lower end of which is secured a gear wheel engaged and driven by a worm 9 on the spindle of which is the grooved pulley 10 driven by the cord 11 which is operated from the smaller grooved pulley 12 on the crank handle 13. The crank handle is journalled in two sector plates 14 secured to the base angle girder 15.

Model No. 446

Pantograph

Parts required :

4 of No. 1	10 of No. 37
2 " " 17	3 " " 45
1 " " 22	2 " " 62

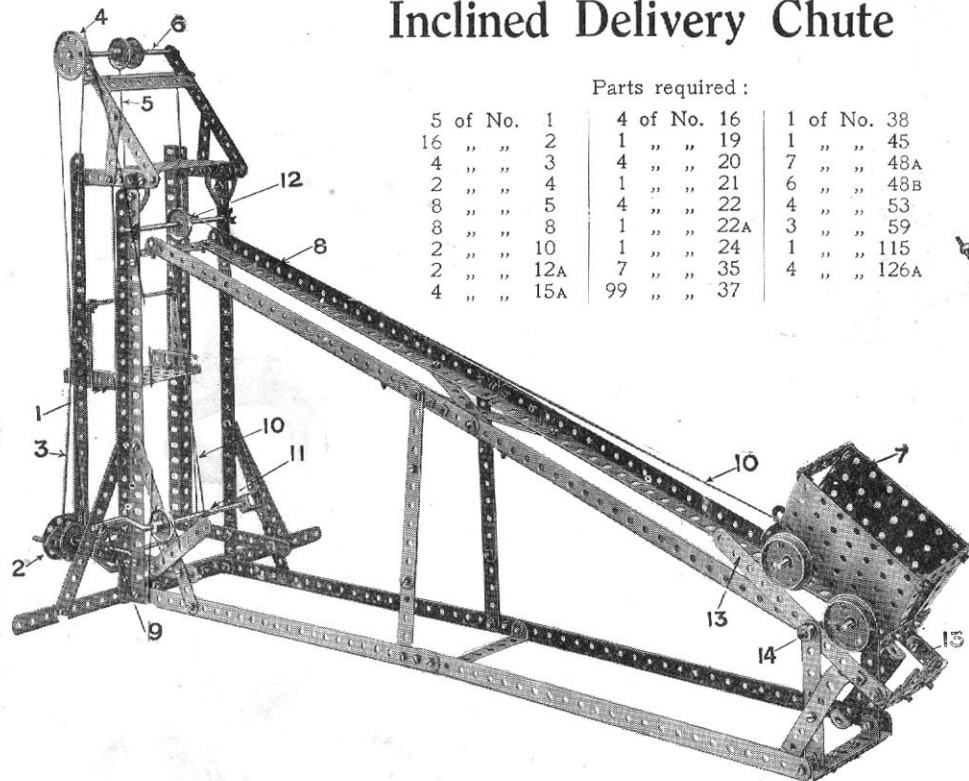


Most boys have heard of the Pantograph but not many have had an opportunity of seeing its principles demonstrated. It is an instrument for copying plans, etc., on the same or on a reduced or enlarged scale.

The apparatus is fixed at the point A. If an enlarged sketch is to be made, the point B is traced round the outlines, the writing point C reproducing the sketch on a larger scale. When a reduced drawing is to be made, the point C traces the outline, whilst the point B reproduces the sketch on a smaller scale. The degree of enlargement or reduction varies according to the position in which point C is fixed on the perforated arm.

Model No. 447

Inclined Delivery Chute

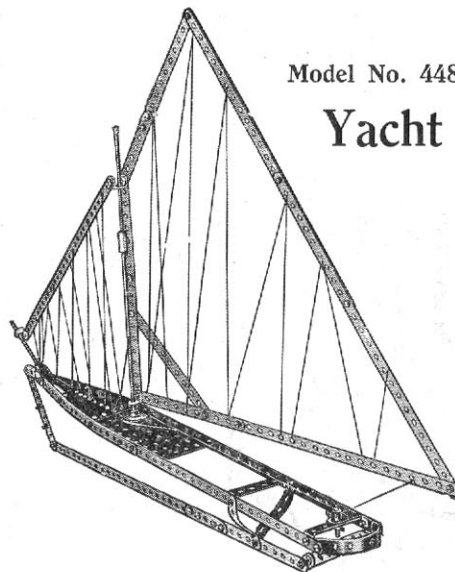


Parts required :

5 of No.	1	4 of No.	16	1 of No.	38
16 " "	2	1 " "	19	1 " "	45
4 " "	3	4 " "	20	7 " "	48A
2 " "	4	1 " "	21	6 " "	48B
8 " "	5	4 " "	22	4 " "	53
8 " "	8	1 " "	22A	3 " "	59
2 " "	10	1 " "	24	1 " "	115
2 " "	12A	7 " "	35	4 " "	126A
4 " "	15A	99 " "	37		

Model No. 448

Yacht



Parts required :

9 of No.	1	2 of No.	18A
7 " "	2	1 " "	22
4 " "	3	51 " "	37
2 " "	4	1 " "	44
2 " "	5	2 " "	48A
1 " "	10	1 " "	52
5 " "	12	1 " "	54
1 " "	13A	1 " "	63
2 " "	15		

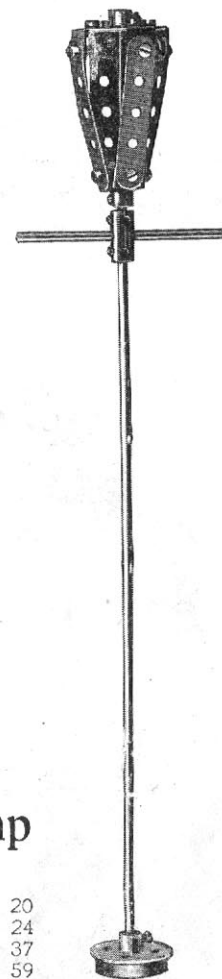
Model No. 449

Street Lamp

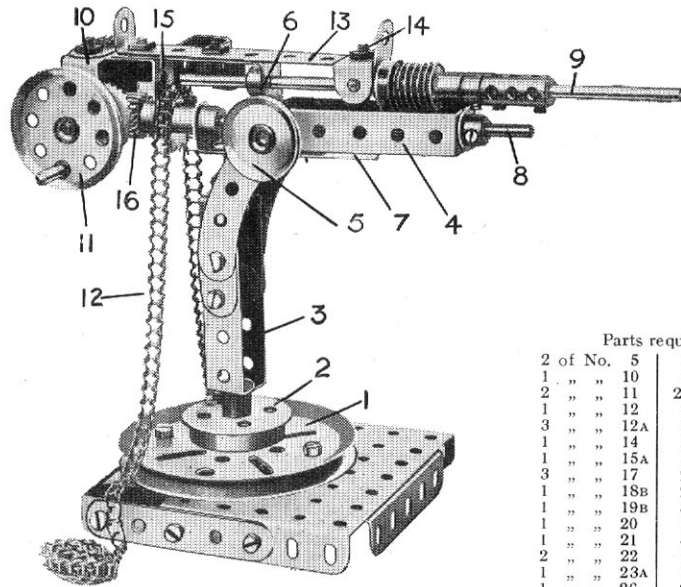
Parts required :

4 of No.	5	1 of No.	20
2 " "	11	1 " "	24
4 " "	12	12 " "	37
1 " "	13	1 " "	59
2 " "	16	1 " "	63

The cage 1 is raised from the hand-wheel 2 by means of an endless cord 3 which passes over the upper $1\frac{1}{2}$ " pulley 4. A cord 5 winding on rod 6 between two $1\frac{1}{2}$ " fast pulleys raises or lowers the cage. The truck 7 is raised or lowered along the inclined rails 8 by a crank handle 9, a cord 10 being wound on the rod 11, passing over a pulley 12, and connected to the truck 7. When the truck reaches the end of the inclined rails 10 it rests upon two $5\frac{1}{2}$ " strips 13 pivoted at 14, the weight of the truck depressing these pivoted strips and tipping the load.



Model No. 450 Naval Quick-firing Gun

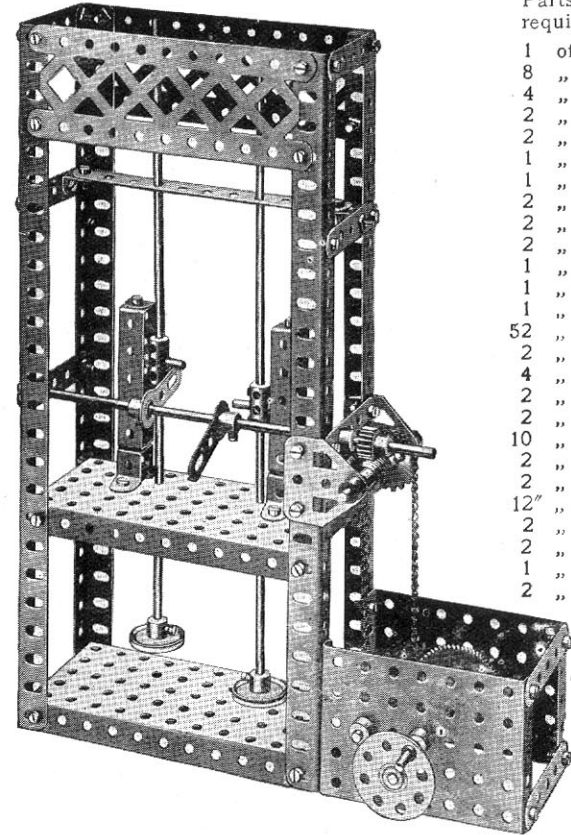


Parts required :

2 of No. 5	1 of No. 32
1 " " 10	2 " " 35
2 " " 11	24 " " 37
1 " " 12	2 " " 38
3 " " 12A	1 " " 45
1 " " 14	1 " " 46
1 " " 15A	5 " " 48A
3 " " 17	2 " " 48B
1 " " 18B	2 " " 53
1 " " 19B	8 " " 59
1 " " 20	1 " " 63
1 " " 21	4 " " 90
2 " " 22	1 " " 94
1 " " 23A	1 " " 96A
1 " " 26	2 " " 111A
1 " " 29	1 " " 115
	1 of No. 125

A 3" pulley wheel 1 provides a bearing for the vertical $4\frac{1}{2}$ " rod forming the axis about which the gun pivots. The rod is secured to the base by a flanged wheel 2 and a 1" pulley wheel attached to it beneath the larger wheel 1. Two double angle strips 3, spaced apart by a double bracket, are mounted upon this vertical rod and held in place by a collar secured to its upper end. Two $2\frac{1}{2}$ " curved strips overlapped 4 holes are bolted to each of the double angle strips 3, and their upper holes form bearings for a short rod passing through the ends of further double angle strips 4 and carrying a hand wheel 5. Two spring clips are mounted on this rod inside the strips 4 to secure it to the pivoting portion of the gun, the elevation of which may be altered on turning the wheel 5. The strips 4 are bolted to the end of a double angle strip 6, and the same bolt secures an angle bracket which in turn is bolted to the double angle strip 7. The rod 8 passes through the end holes of the strips 4 and 7 and is held in place by two collars. On the top of the strip 6 is bolted a $3\frac{1}{2}$ " double angle strip 13, the upturned ends of which form the sighting apertures. The bolt 14 secures a double bracket and an angle bracket, the latter together with one of the holes in the strip 6 forming bearings for the barrel 9. A 1" angle bracket 15, bolted beneath the strip 6, and the end of the strip 7 provide bearings for the short rod carrying a $\frac{3}{4}$ " sprocket wheel and $\frac{1}{2}$ " pinion 16. Two $1\frac{1}{2} \times 1\frac{1}{2}$ " angle brackets 10 form bearings for a 2" rod carrying the hand wheel 11. This rod is fitted with a $\frac{3}{4}$ " conrate wheel which engages with the pinion 16. On rotation of the wheel 11, the small sprocket wheel actuates the sprocket chain 12 which represents the cartridge belt.

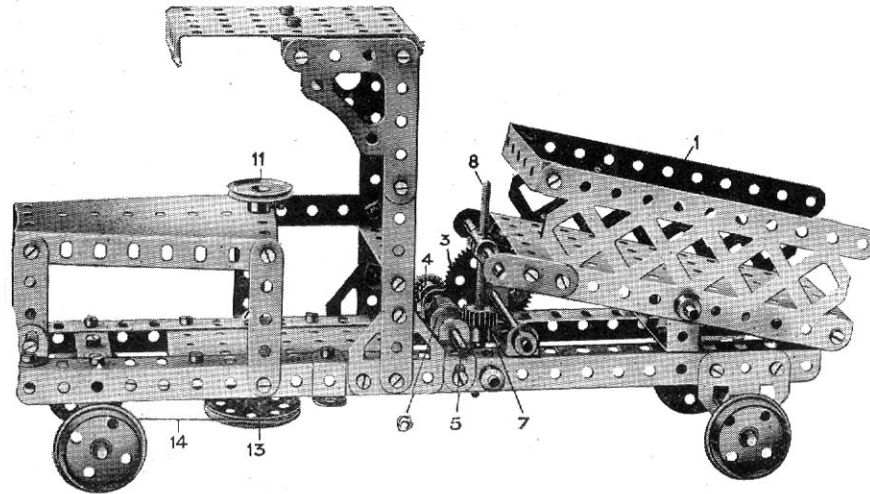
Model No. 451 Trip Hammer



Parts required :

1 of No. 2
8 " " 5
4 " " 8
2 " " 12
2 " " 13
1 " " 13A
1 " " 15A
2 " " 16
2 " " 18A
2 " " 22
1 " " 24
1 " " 27A
1 " " 32
52 " " 37
2 " " 45
4 " " 48A
2 " " 52
2 " " 53
10 " " 59
2 " " 62
2 " " 63
12" " " 94
2 " " 96
1 " " 100
1 " " 115
2 " " 126A

Model No. 452 Tip Wagon



The tipping of the wagon 1 is effected by the handle 2 secured on a 57-toothed wheel 3 which engages a $\frac{1}{2}$ " pinion 4 mounted on the rod 5. On the same rod is secured a worm 6 which engages a $\frac{1}{2}$ " pinion 7 secured to the upright threaded rod 8. The threaded rod 8 revolves freely in the coupling 9, being retained in position by the collar 10. As the handle 2 is operated, the wagon 1 is tipped or restored to its original position. The steering is effected by a $\frac{1}{2}$ " pulley wheel 11 on a rod 12, at the lower end of which is secured a $1\frac{1}{2}$ " pulley wheel 13, a cord 14, wound twice round this pulley wheel, being connected to a double angle strip 15 in which the steering axle 16 is journalled.

Parts
required:

2	of No.	2
1	" "	3
9	" "	5
2	" "	6A
2	" "	8
10	" "	12
5	" "	16
1	" "	19
4	" "	27
1	" "	21
1	" "	22
1	" "	24
1	" "	26
1	" "	27A
2	" "	35
59	" "	37
2	" "	37A
1	" "	38
4	" "	48A
1	" "	52
2	" "	53
1	" "	54
3	" "	59
2	" "	62
1	" "	63
1	" "	80A
2	" "	100
2	" "	108
1	" "	125
4	" "	126A

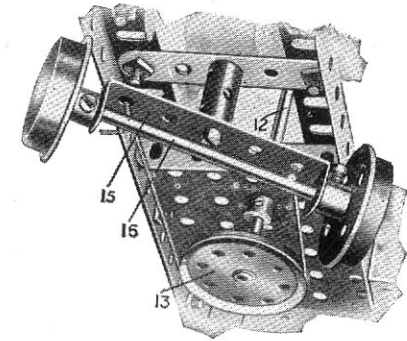


FIG. 452A

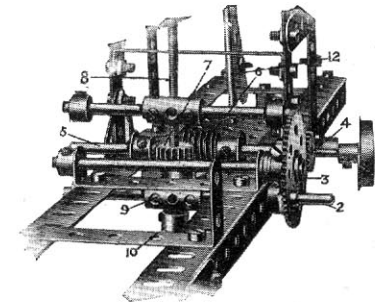
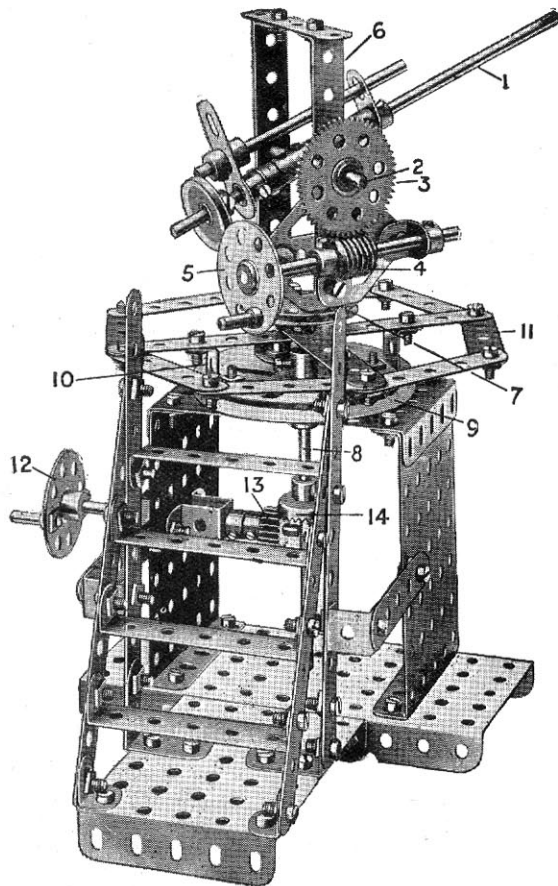


FIG. 452B

This Model can be made with MECCANO Outfit No. 4, or No. 3 and No. 3A.



Model No. 453 Anti-Aircraft Gun

The gun represented by the rod 1 is pivoted upon a transverse rod 2 which passes through a coupling on the rod 1. A 57-toothed wheel 3 on the pivot rod 2 is engaged by a worm 4 operated from the hand-wheel 5. By turning this wheel 5 the gun is lifted or lowered. The two vertical strips forming the framework for the pivot rod 2 are bolted to a $1\frac{1}{2}$ " pulley 7 which is secured on a vertical rod 8. A 3" pulley wheel 9 is also bolted to a rod 8 and from the pulley wheel is carried by reversed angle brackets 10 a framework 11. The rod 8 with the framework is rotated from the hand-wheel 12, a pinion 13 on the spindle of which engages a $\frac{3}{4}$ " contrate wheel 14 on the rod 8. By turning the wheel 12 the gun is swivelled round.

Parts required :

6 of No. 2	4 of No. 16	1 of No. 29	4 of No. 53
11 " " 5	1 " " 17	1 " " 32	8 " " 59
1 " " 10	1 " " 19B	64 " " 37	1 " " 62
2 " " 11	1 " " 21	12 " " 38	2 " " 63
4 " " 12	2 " " 22	2 " " 45	2 " " 115
2 " " 12A	2 " " 24	4 " " 48A	4 " " 125
1 " " 15	1 " " 26	2 " " 48B	2 " " 126A
1 " " 15A	1 " " 27A	1 " " 52	

HOW TO CONTINUE

This completes the Models which may be made with MECCANO Outfit No. 4. The next Models are a little more advanced, requiring a number of extra parts to construct them. The necessary parts are all contained in a No. 4A Accessory Outfit, the price of which will be found in the List at the end of the Manual.

Model No. 501 Beam Scales

Parts required:

7 of No.	1	2 of No.	22
8 "	2	88 "	37
8 "	3	2 "	44
2 "	4	1 "	46
10 "	5	5 "	48A
8 "	8	1 "	50
2 "	10	2 "	52
9 "	12	2 "	53
2 "	15	2 "	54
4 "	15A	2 "	57
2 "	16	8 "	59
7 "	20		

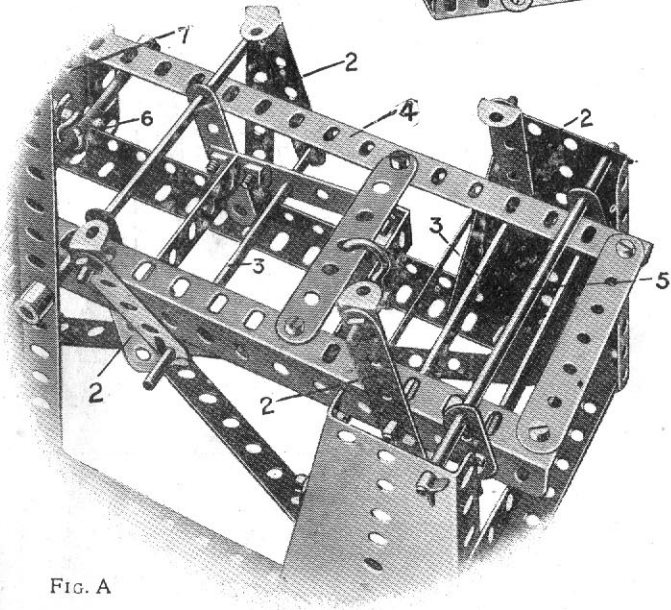
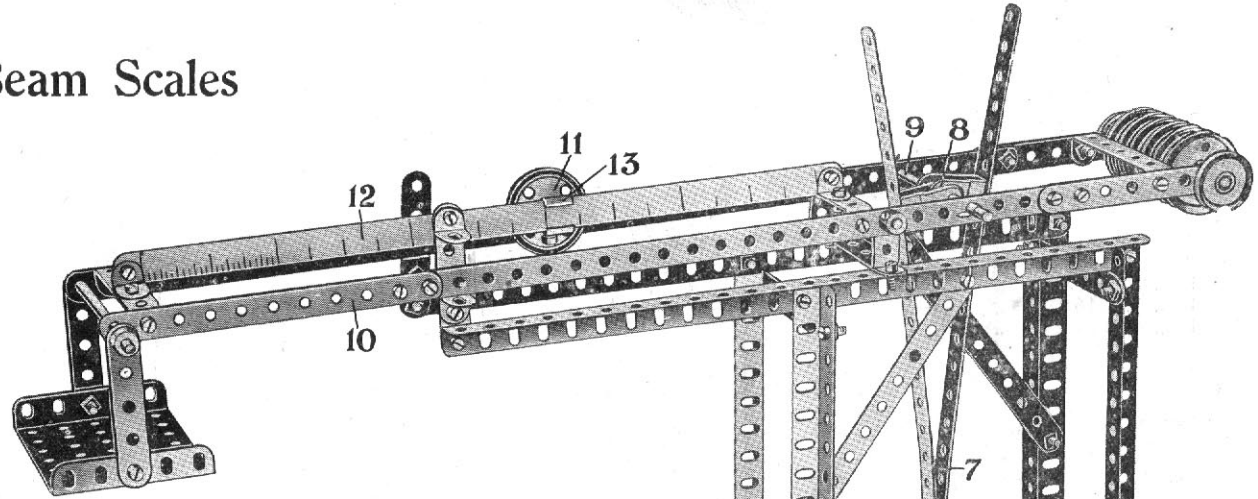
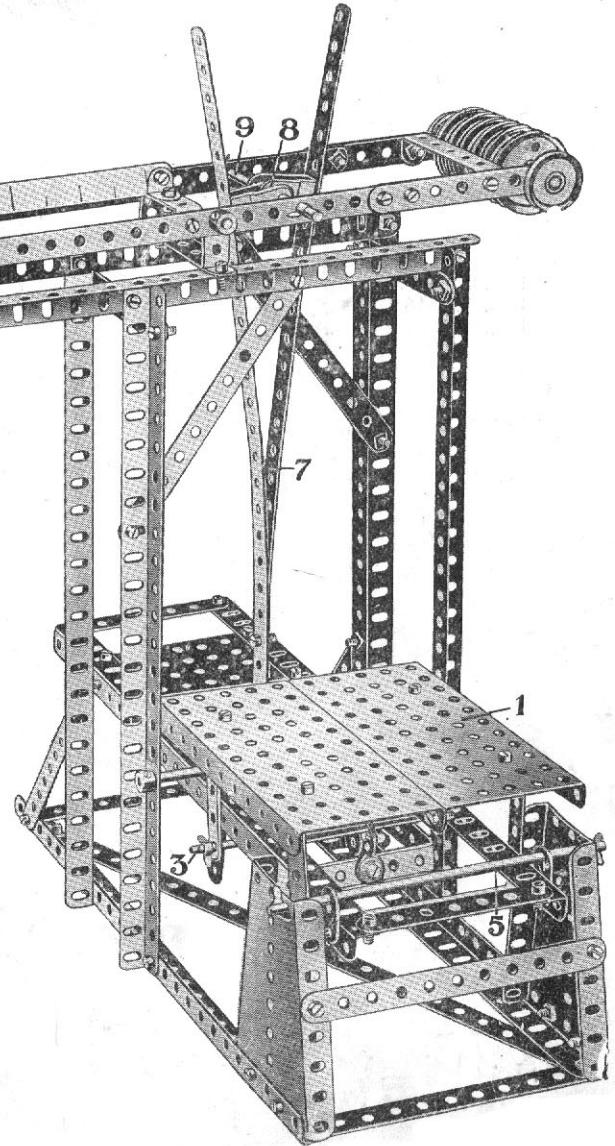


FIG. A

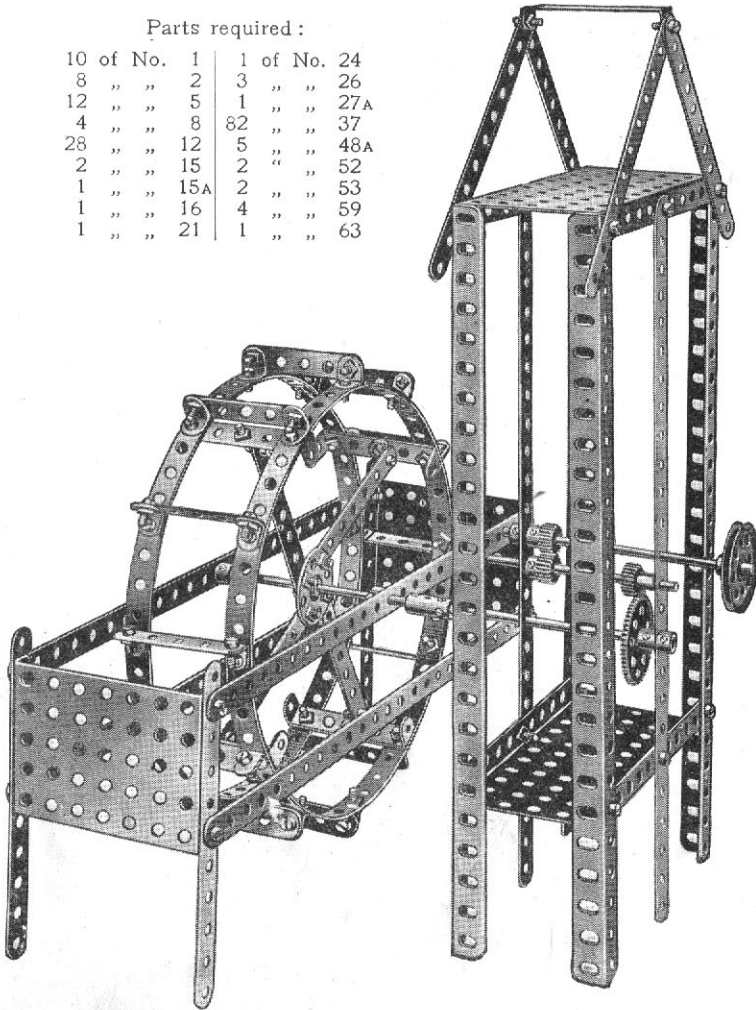
The weighing platform 1 is bolted to the four uprights 2, which engage over transverse rods 3, to permit of a parallel movement. The frame 4 of the platform is pivotally slung by flat brackets from the rod 5, and is coupled by hook 6, pull rods 7, which are connected by a pair of cranked bent strips 8 to a rod 9, passing through the side strips 10 to the main weight beam. The sliding weight 11 is adjustable on the graduated arm by an eye piece 13.



Model No. 502 Belgian Water Wheel

Parts required :

10 of No.	1	1 of No.	24
8 " "	2	3 " "	26
12 " "	5	1 " "	27A
4 " "	8	82 " "	37
28 " "	12	5 " "	48A
2 " "	15	2 " "	52
1 " "	15A	2 " "	53
1 " "	16	4 " "	59
1 " "	21	1 " "	63



Model No. 503 Hand Car

Parts required :

4 of No.	2	1 of No.	26
2 " "	6A	1 " "	27A
2 " "	8	32 " "	37
1 " "	9D	4 " "	37A
4 " "	11	2 " "	45
2 " "	14	1 " "	46
1 " "	15A	7 " "	59
1 " "	16	2 " "	63
1 " "	17	1 " "	70
4 " "	19A	2 " "	126A
2 " "	24		

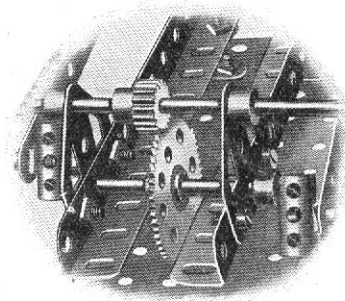
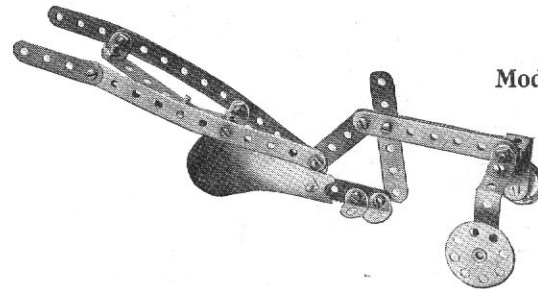
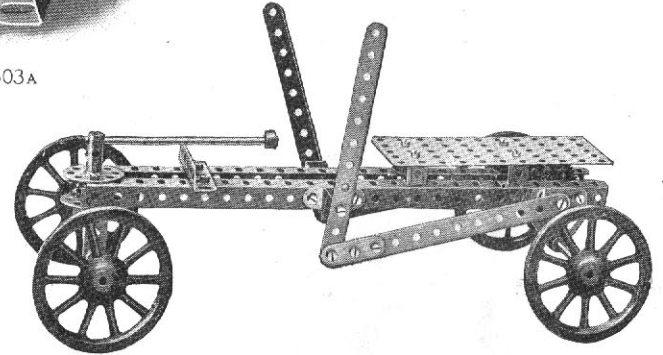


FIG. 503A

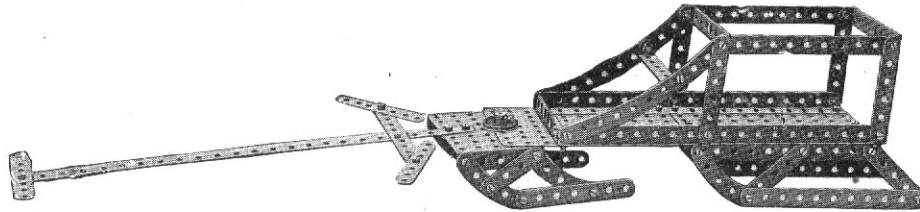


Model No. 504 Plough

Parts required :

2 of No.	2	1 of No.	22
4 " "	3	1 " "	24
1 " "	4	19 " "	37
3 " "	6	1 " "	41
1 " "	10	1 " "	47
8 " "	12		

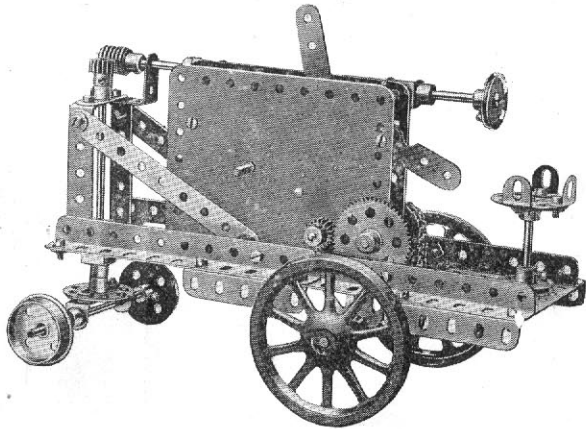
Model No. 505 Bob Sleigh



Parts required :

1 of No. 1	2 of No. 22
5 " " 2	50 " " 37
5 " " 3	3 " " 48B
4 " " 4	1 " " 52
4 " " 5	2 " " 52A
2 " " 6	1 " " 53
2 " " 8A	2 " " 89
1 " " 9D	6 " " 90
1 " " 18A	

Model No. 506 Farm Tractor

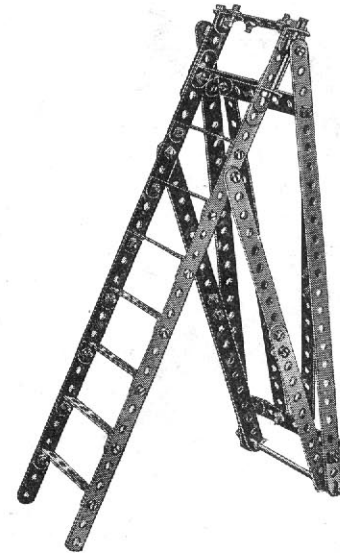


Parts required :

2 of No. 2A	1 of No. 27A
1 " " 3	1 " " 32
1 " " 6A	38 " " 37
4 " " 9	6 " " 38
2 " " 11	1 " " 45
7 " " 12	1 " " 48
1 " " 12A	2 " " 48A
1 " " 13A	2 " " 53
1 " " 15	9 " " 59
1 " " 15A	6" " " 94
2 " " 17	2 " " 96
2 " " 19A	2 " " 126A
2 " " 20	
2 " " 22	Clockwork
2 " " 24	Motor
2 " " 26	(not included
	in Outfit)

Model No. 507

Step Ladder



Parts
required :

4 of No. 1	i
8 " " 2	2
2 " " 3	3
3 " " 5	5
2 " " 10	10
8 " " 12	12
1 " " 16	16
2 " " 17	17
10 " " 35	35
44 " " 37	37
9 " " 48A	48A
2 " " 59	59

Model No. 508 Sighting Apparatus

This model is for determining the heights of buildings, towers, etc. The pointer $11\frac{1}{2}$ " rod 1 is pivoted on the 2" rod 2 and controlled by a spring 3, the pointer 1 being adjusted by the cord 4 which passes round a guide pulley 5 and on to the axle 6 upon which it is wound by the crank handle 7 which operates the gear wheel and pinion 8. A graduated scale of degrees 9 made of cardboard, or a protractor, is mounted in order to read off the angle of inclination of the pointer.

In finding the height of a building, measure out a number of feet or yards from the foot of the building, and set this out to some scale corresponding to the line *ab* (Fig. B). Then standing at the point *a* furthest from the building, and keeping the angle girders 10 horizontal, move the pointer 1 until it is directed towards the top of the building. Then read off the angle on the scale 9, and draw a line *ac*, making the angle *bac* equal to the angle read off. Then draw a vertical line *bc* from the point *b*, and with the same scale used for setting off the distance *ab* measure the height *bc*, which will be the height of the building.

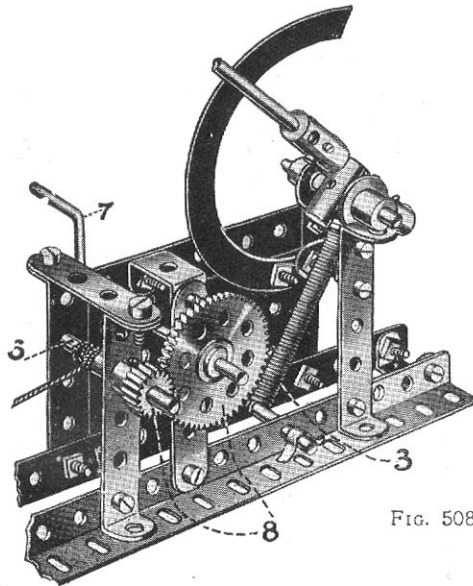


FIG. 508A

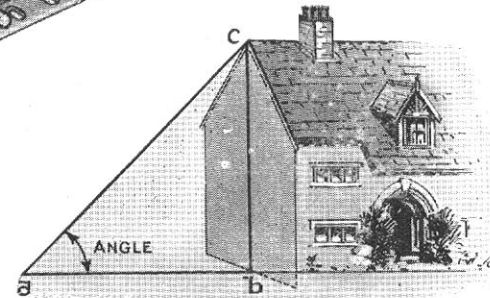
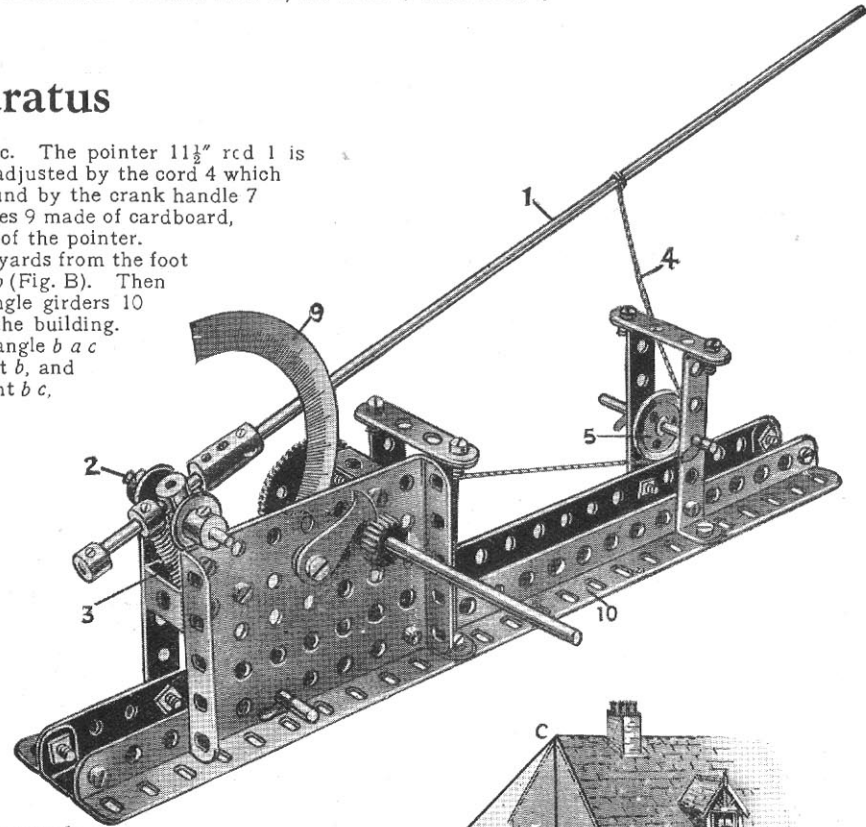


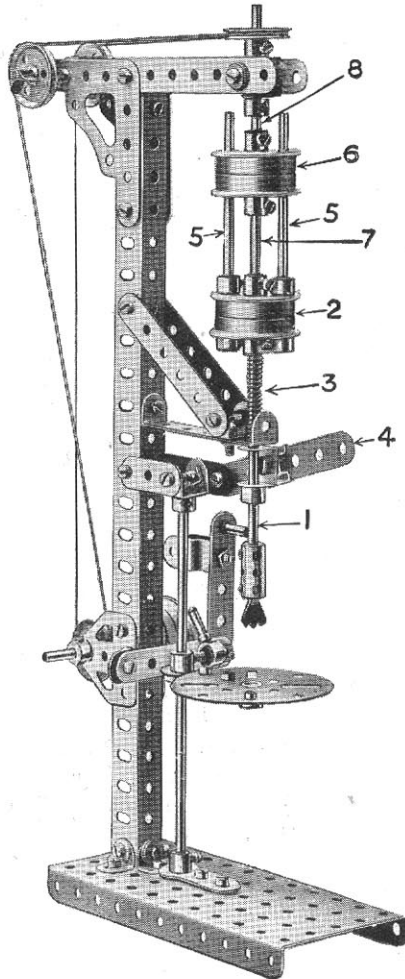
FIG. 508B

Parts required:

1 of No. 5	24 of No. 37
2 " " 6	1 " " 43
2 " " 8	5 " " 48A
4 " " 11	1 " " 53
1 " " 13	3 " " 59
4 " " 17	2 " " 62
1 " " 19	2 " " 63
1 " " 22	1 " " 147A
1 " " 26	1 " " 147B
1 " " 27A	1 " " 148
2 " " 35	

Model No. 510 Fret Saw

Model No. 509 Vertical Drill

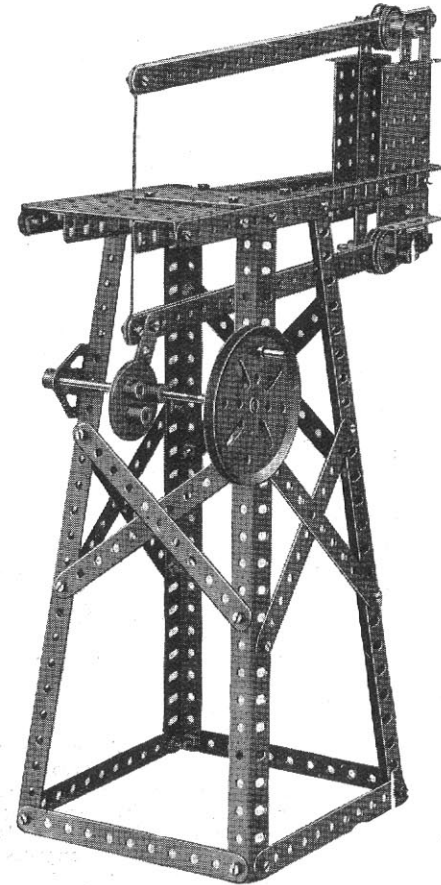


Parts required:

2 of No. 2	4 of No. 16	1 of No. 48A
3 " " 4	1 " " 17	1 " " 50
2 " " 5	6 " " 20	10 " " 59
1 " " 6	2 " " 21	2 " " 62
1 " " 6A	2 " " 22A	1 " " 65
2 " " 8	4 " " 35	2 " " 108
5 " " 11	39 " " 37	1 " " 109
6 " " 12	6 " " 38	1 " " 111
1 " " 14	1 " " 43	2 " " 115
1 " " 15A	1 " " 44	2 " " 126A

The drill rod 1 is connected to the boss of the lower pair of flanged wheels 2 which are reversed, a spring 3 round the rod raising the drill after it has been depressed by the handle strip 4. Bolted in the wheels 2 are two outer rods 5 which slide in the upper flanged wheels 6. The central rod 7 is bolted in the upper wheels and slides in the centre bosses of the lower wheels 2. The upper wheels 6 are bolted to the driving spindle 8 and consequently the drill is driven by the rods 5 when the drill is depressed by the handle 4 against the spring.

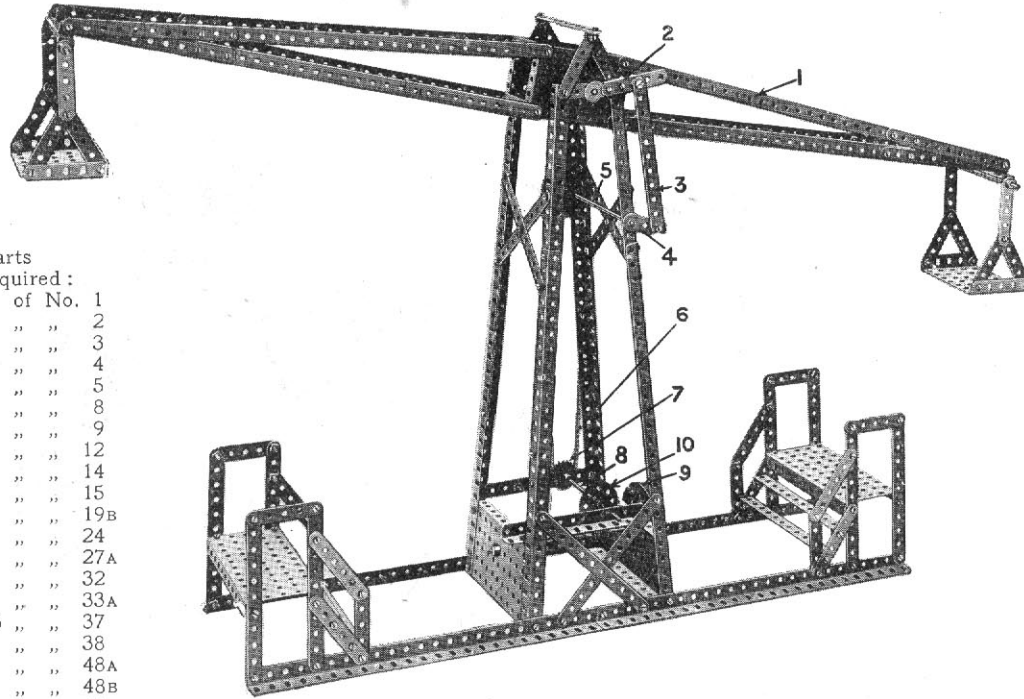
See also "Meccano Standard Mechanisms," under Locking Device (S.M. 137) and Variable Drive (Section XIII.)



Parts
required:

4 of No.	1
17 " "	2
6 " "	8
1 " "	15
2 " "	17
1 " "	19B
4 " "	22
53 " "	37
4 " "	53
5 " "	59
1 " "	115
2 " "	126A
1 " "	130

Model No. 511 Giant Auto Swing



Parts required :

8	of No.	1
26	" "	2
2	" "	3
8	" "	4
31	" "	5
12	" "	8
1	" "	9
18	" "	12
2	" "	14
4	" "	15
1	" "	19B
1	" "	24
1	" "	27A
1	" "	32
1	" "	33A
165	" "	37
2	" "	38
2	" "	48A
2	" "	48B
4	" "	48D
4	" "	52
4	" "	53
9	" "	59
2	" "	62
28"	" "	94
1	" "	95
1	" "	96

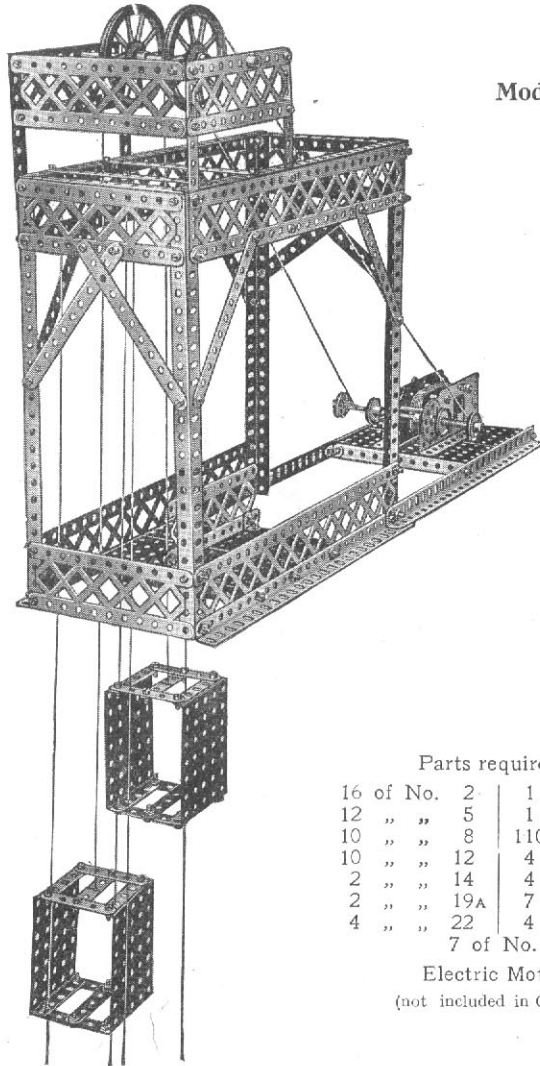
The beam 1 is rocked by means of a crank 2 secured on the end of a rod which forms the beam pivot and which is bolted in a bush wheel secured to the beam. This crank 2 is connected by a strip 3 to another crank 4 on a rod 5. On the end of this is a large sprocket wheel driven by a chain 6 from a small sprocket wheel 7 on a rod 8. This rod is driven by means of a worm on the rod of the 3" pulley 9 which worm engages and drives the gear wheel 10 on the rod 8. As the crank 4 continuously rotates the link 3 causes the upper crank 2 to oscillate and also the beam 1,

Model No. 512 Rocking Chair



Parts required :

9	of No.	2	2	of No.	48A
8	" "	5	1	" "	48B
2	" "	10	2	" "	53
3	" "	12	4	" "	89
44	" "	37			



Model No. 513

Pit Head Gear

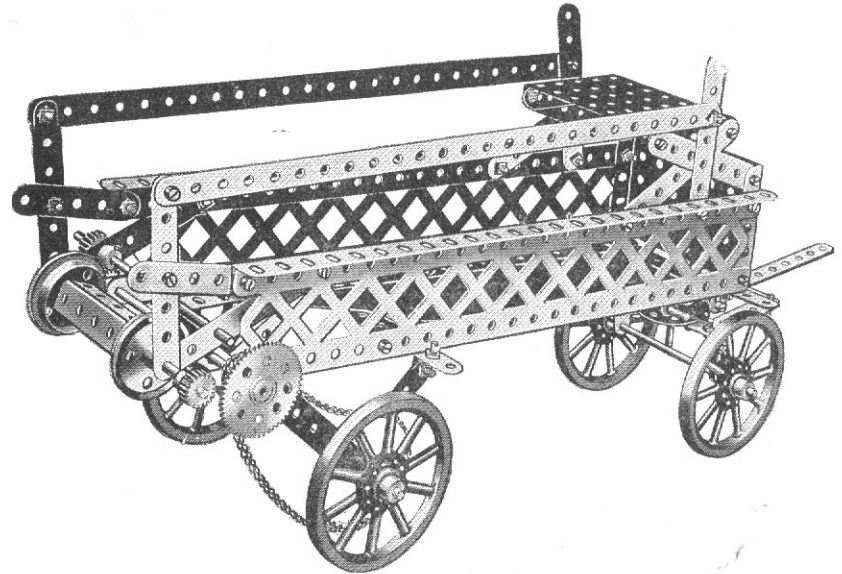
Parts required :

16 of No. 2	1 of No. 26
12 " " 5	1 " " 27
10 " " 8	110 " " 37
10 " " 12	4 " " 52
2 " " 14	4 " " 53
2 " " 19A	7 " " 59
4 " " 22	4 " " 99
7 of No. 100	

Electric Motor
(not included in Outfit).

Model No. 514

Manure Distributing Cart



Parts required :

2 of No. 1	3 of No. 15	3 of No. 26	2 of No. 53
3 " " 2	2 " " 15A	1 " " 27A	8 " " 59
10 " " 3	2 " " 17	4 " " 35	1 " " 94
9 " " 5	4 " " 19A	57 " " 37	1 " " 95
4 " " 8	2 " " 20	1 " " 46	1 " " 96
6 " " 12	1 " " 24	4 " " 48A	2 " " 99
1 " " 14			

Model No. 515 Travelling Gantry Crane

The travelling gantry 1 is traversed along the rails by a hand wheel 2, a sprocket chain 3 driving the rod 4 round the pulleys 5 on which pass the cords 6 which are connected to the travelling gantry. The load is raised or lowered by operating the crank handle 7 on which a cord 8 is wound, passing round a $\frac{1}{2}$ " pulley in the block 9 and being secured to a rod 10. The winch is traversed along the rails of the gantry 1 by means of the crank handle 11, a pinion 12 on which engages a 57-toothed gear wheel 13, on the axle of the travelling wheels. The travelling gantry is built up of the rails of the angle girders 1 bolted at each end to two $5\frac{1}{2}$ " angle girders 14 butted together. The flange wheels 15 are carried upon their axles 16 passed through the end holes of the angle girders 14.

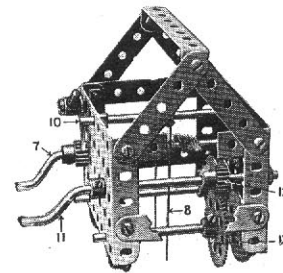
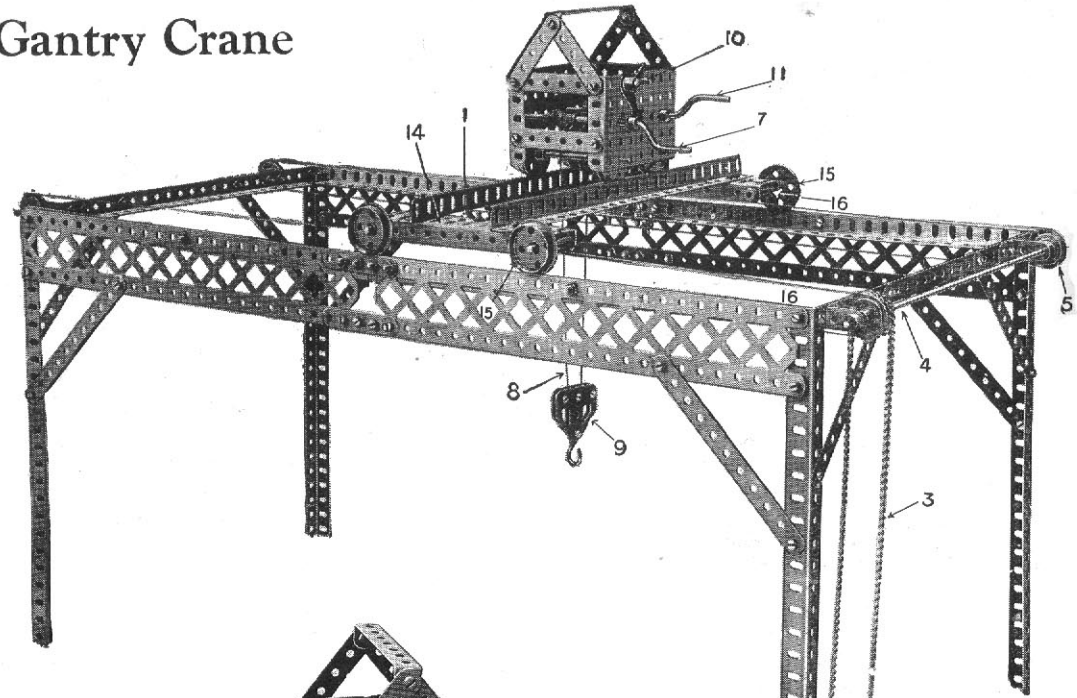
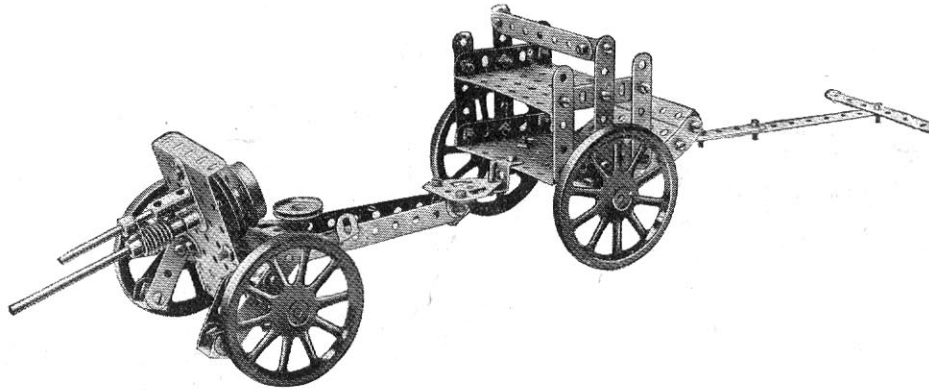


Fig. 515A

Parts required:

4	of No. 1	8	of No. 20	1	of No. 57
8	" "	4	" "	8	" "
4	" "	1	" "	24"	" "
10	" "	1	" "	2	" "
12	" "	1	" "	4	" "
4	" "	1	" "	4	" "
2	" "	2	" "	2	" "
4	" "	26	" "	3	" "
2	" "	6	" "	1	" "
3	" "	1	" "	1	" "
5	" "	1	" "	1	" "
2	" "	2	" "		

Model No. 516 Field Gun and Carriage



Parts required :

4 of No. 2	1 of No. 22
2 " " 3	1 " " 24
2 " " 4	1 " " 32
6 " " 5	62 " " 37
2 " " 6A	2 " " 38
3 " " 10	3 " " 48A
3 " " 11	2 " " 48B
14 " " 12	2 " " 53
2 " " 15	3 " " 59
1 " " 15A	1 " " 62
1 " " 16	1 " " 63
1 " " 18A	2 " " 90
4 " " 19A	1 " " 115
1 " " 20	2 " " 125
1 " " 21	2 " " 126A

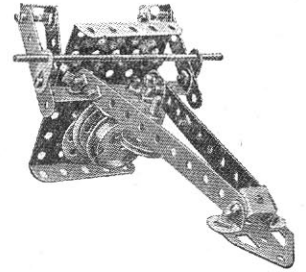
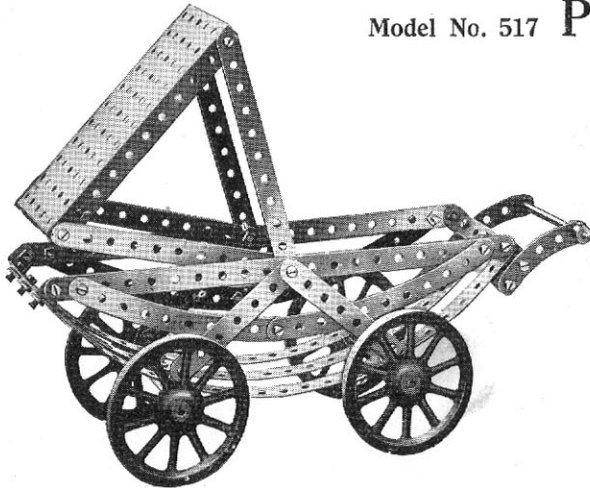


FIG. 516A

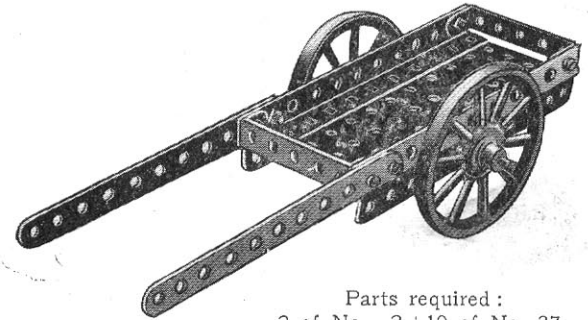
Model No. 517 Perambulator



Parts required :

3 of No. 1	37 of No. 37
8 " " 2	5 " " 48A
4 " " 3	1 " " 52
6 " " 12	2 " " 59
3 " " 16	4 " " 89
4 " " 19A	2 " " 90

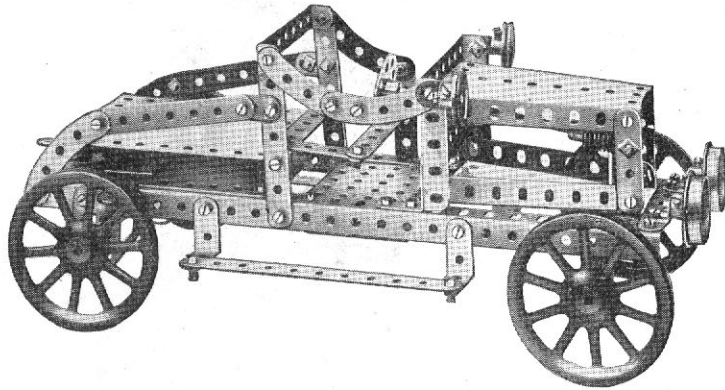
Model No. 518 Station Cart



Parts required :

2 of No. 2	10 of No. 37
2 " " 9	2 " " 48A
1 " " 15A	1 " " 52
2 " " 19A	

Model No. 519 Motor Car

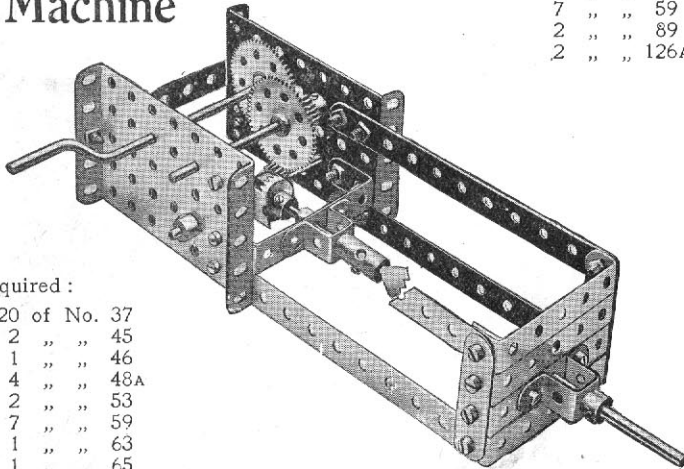


Parts required:

2	of No.	2
8	" "	3
1	" "	5
4	" "	6
2	" "	8
2	" "	10
8	" "	12
6	" "	12A
1	" "	14
2	" "	15
1	" "	16A
4	" "	19A
2	" "	20
2	" "	22
2	" "	24
2	" "	26
1	" "	28
1	" "	32
75	" "	37
4	" "	38
3	" "	48B
2	" "	53
2	" "	54
7	" "	59
2	" "	89
2	" "	126A

Model No. 520

Spooling Machine



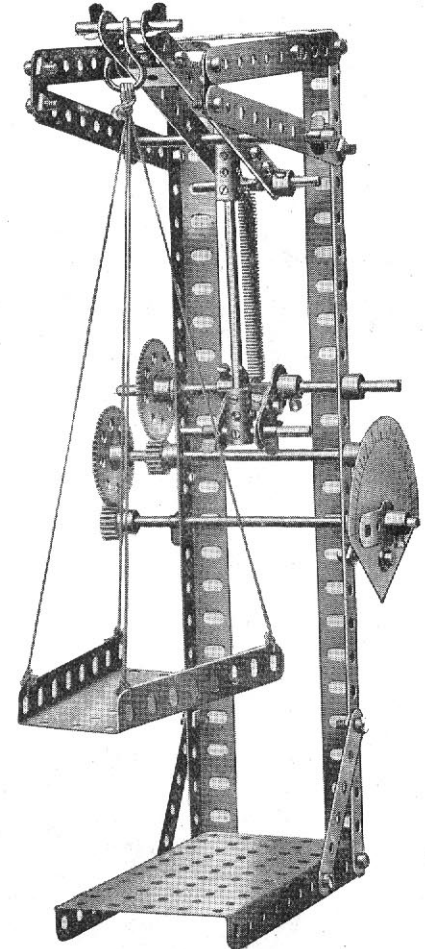
Parts required:

4	of No.	2	20	of No.	37
1	" "	3	2	" "	45
3	" "	16	1	" "	46
1	" "	17	4	" "	48A
1	" "	19	2	" "	53
2	" "	26	7	" "	59
2	" "	27A	1	" "	63
1	" "	29	1	" "	65

Model No. 521 Spring Scales

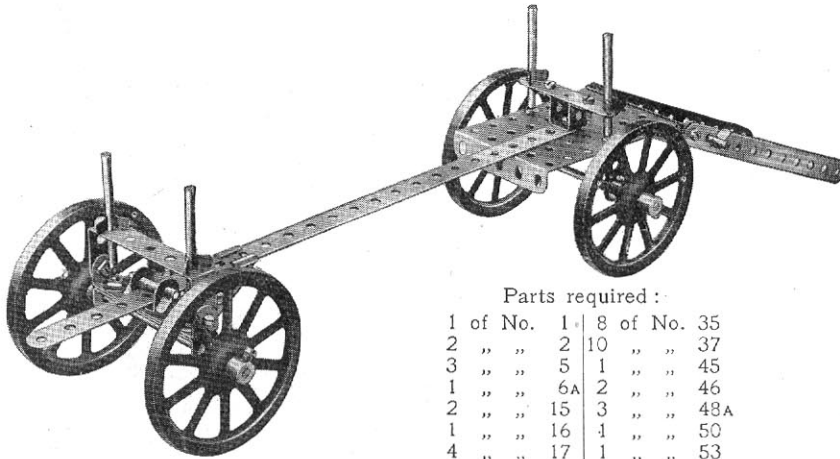
Parts required:

6	of No.	2
2	" "	4
2	" "	8
2	" "	10
3	" "	11
2	" "	15
1	" "	15A
2	" "	16
2	" "	17
1	" "	18A
2	" "	26
2	" "	27A
23	" "	37
1	" "	43
1	" "	48A
1	" "	52
1	" "	54
1	" "	57
2	" "	59
2	" "	62
2	" "	63



The Scale beam 1 is made of two $5\frac{1}{2}$ " strips distanced by double bent strips. The vertical rod 2 is connected to the beam which is pivoted on the rod 3. The cranks 4 are gripped on an axle 5 on which is secured the gear wheel 6 actuating through a gear train the pointer 7. A spring 8 connected to a rod 5 and another rod in the end hole of the beam acts as the spring balance.

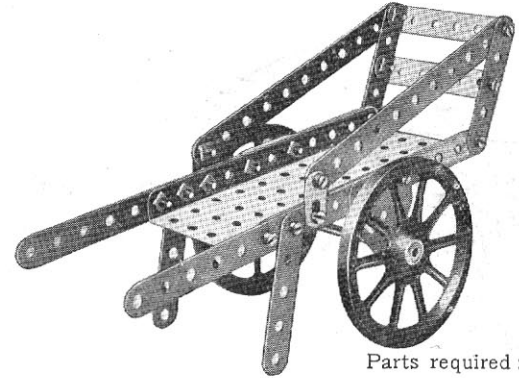
Model No. 522 **Timber Carriage**



Parts required :

1	of No.	1	8	of No.	35
2	" "	2	10	" "	37
3	" "	5	1	" "	45
1	" "	6A	2	" "	46
2	" "	15	3	" "	48A
1	" "	16	1	" "	50
4	" "	17	1	" "	53
1	" "	18B	4	" "	59
4	" "	19A	1	" "	111

Model No. 523 **Coster's Barrow**



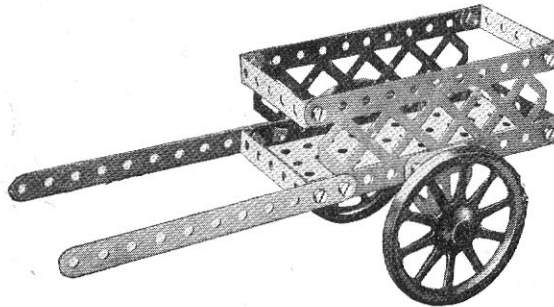
Parts required :

4	of No.	2	18	of No.	37
4	" "	5	2	" "	48A
2	" "	10	1	" "	52
1	" "	16	2	" "	126A
2	" "	19A			

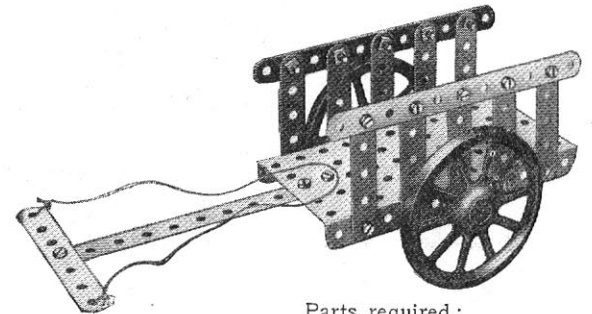
Model No. 524 **Cart**

Parts required :

2	of No.	2
1	" "	16
2	" "	19A
14	" "	37
4	" "	48A
1	" "	52
2	" "	100
2	" "	126A



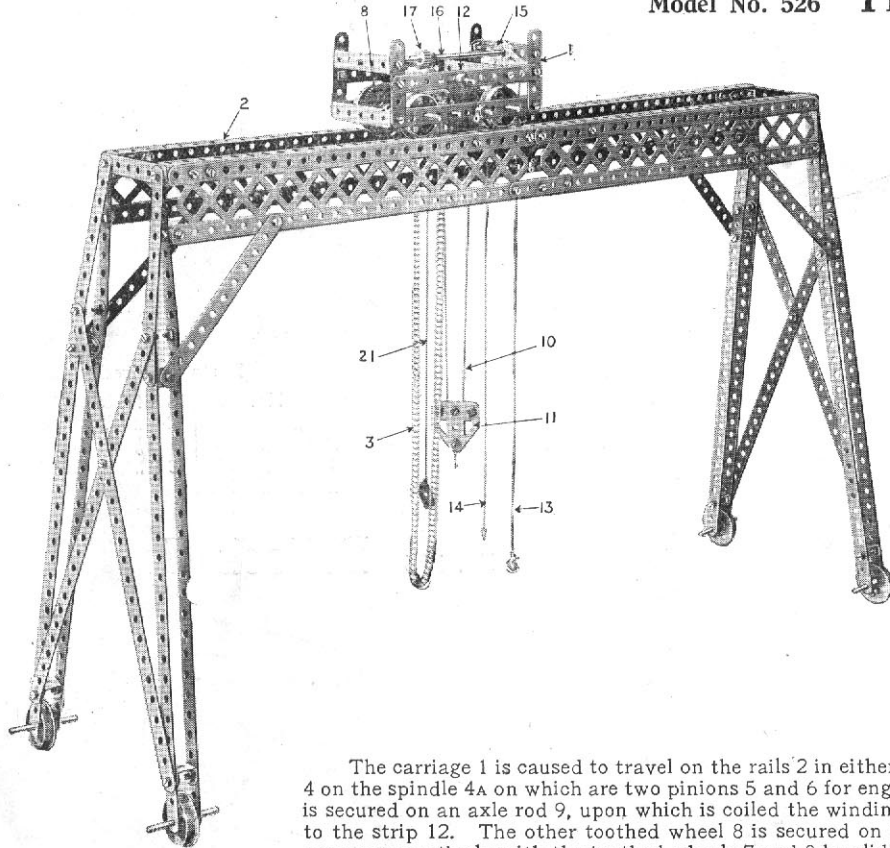
Model No. 525 **Bullock Cart**



Parts required :

3	of No.	2	2	of No.	19A
1	" "	3	21	" "	37
10	" "	5	1	" "	52
1	" "	16			

Model No. 526 Travelling Crane



Parts required :

16	of No. 1	2	of No. 27A
16	" "	1	" "
6	" "	86	" "
4	" "	8	" "
2	" "	2	" "
8	" "	5	" "
4	" "	1	" "
1	" "	1	" "
4	" "	30"	" "
8	" "	1	" "
1	" "	4	" "
1	" "	2	" "
3	" "	1	" "
			32
			37
			38
			47A
			48A
			57
			59
			62
			63
			94
			96
			99
			126A
			128

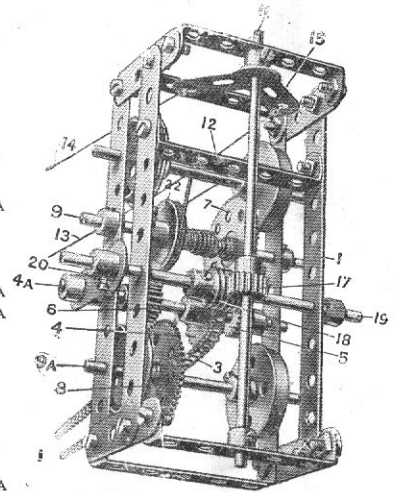
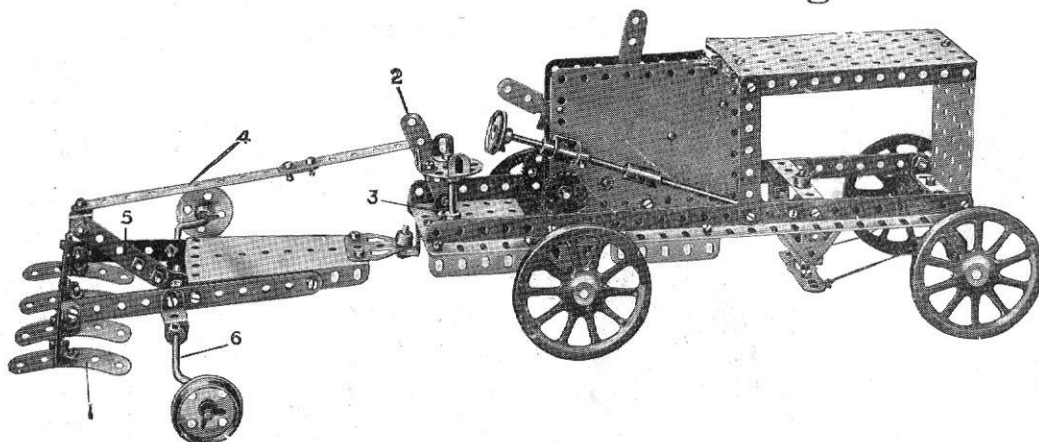


FIG. A

The carriage 1 is caused to travel on the rails 2 in either direction by the sprocket chain 3, which passes over a 1" sprocket wheel 4 on the spindle 4A on which are two pinions 5 and 6 for engagement respectively with toothed wheels 7 and 8. The toothed wheel 7 is secured on an axle rod 9, upon which is coiled the winding cord 10 passing round a $\frac{1}{2}$ " pulley in the block 11, and being made fast to the strip 12. The other toothed wheel 8 is secured on the axle of the travelling wheels 9A. The pinions 5 and 6 are caused to engage respectively with the toothed wheels 7 and 8 by sliding the pinion axle 4A in the carriage frame 1. This is effected by means of two cords 13 and 14 connected to a boss bell crank 15 on a rod 16, a pinion 17 which engages a worm 18 in the manner of a rack. This worm is secured to a rod 19, which is connected by a crank piece 20 to the pinion rod 4A. The latter revolving freely in the crank 20, being held in position by a collar on each side of the crank. Consequently, by pulling on one or other of the cords 13, 14, the bell crank is racked and the pinions caused to engage with one or other of the toothed wheels 7 or 8. When engaging the toothed wheel 7 the load may be raised or lowered by pulling the sprocket chain 3, but when the pinion 6 engages the toothed wheel 8, the carriage travels on the rails. The cord 21 passes round a pulley 22 on the winding axle and acts as a brake.

Model No. 527 Motor Plough



The ploughshares 1 are raised or lowered by the handle 2 pivoted to an angle bracket on the far side of the seat pillar, and connected by strips 4 to a crank 5 secured on the bent axle 6 of the wheels formed by crank handles. The plough is driven by a Meccano Clockwork Motor.

Parts required :		
5 of No. 2	2 of No. 26	1 of No. 54
3 " " 3	1 " " 27A	9 " " 59
3 " " 5	1 " " 29	1 " " 62
2 " " 8	4 " " 35	2 " " 63
2 " " 10	24 " " 37	4 " " 90
1 " " 11	6 " " 38	6 " " 94
19 " " 12	1 " " 45	2 " " 96
3 " " 15A	1 " " 46	1 " " 115
1 " " 16	4 " " 48A	3 " " 125
3 " " 17	1 " " 52	5 " " 126A
2 " " 19	3 " " 53	
4 " " 19A		
2 " " 20		
3 " " 22		
1 " " 24		

Clockwork Motor
(not included in Outfit)

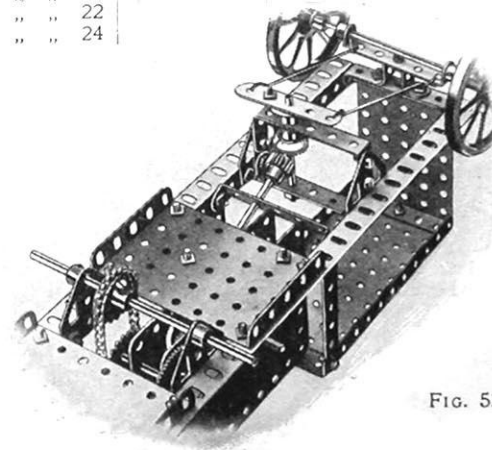
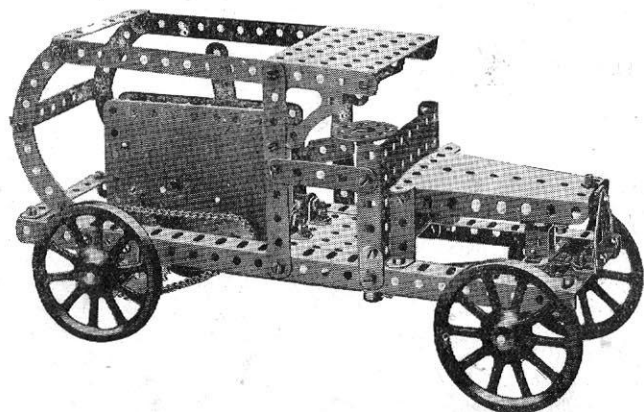


FIG. 527A

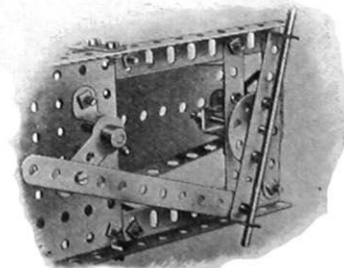
Model No. 528 Motor Car



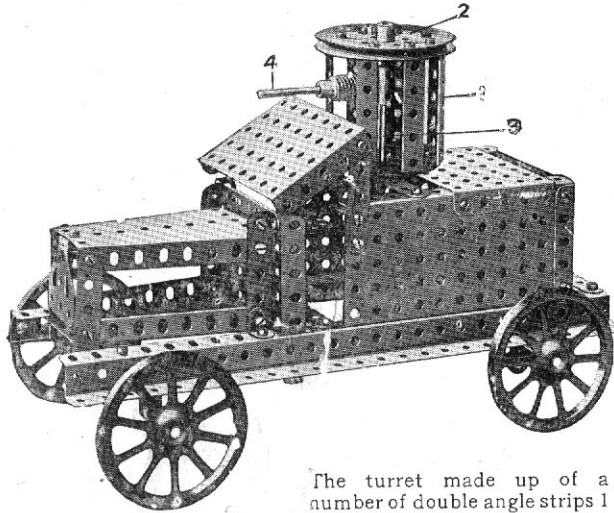
Parts required :	
3 of No. 2	2 of No. 45
4 " " 3	2 " " 48
5 " " 5	2 " " 48B
2 " " 8	3 " " 53
2 " " 10	1 " " 54
11 " " 12	3 " " 59
2 " " 15A	1 " " 62
1 " " 16	4 " " 90
1 " " 17	12" " 94
4 " " 19A	1 " " 95
2 " " 24	1 " " 96
63 " " 37	2 " " 108
2 " " 38	1 " " 125
	3 of No. 126A

Clockwork Motor
(not included in Outfit).

FIG. 528A



Model No. 529 Armoured Motor Car

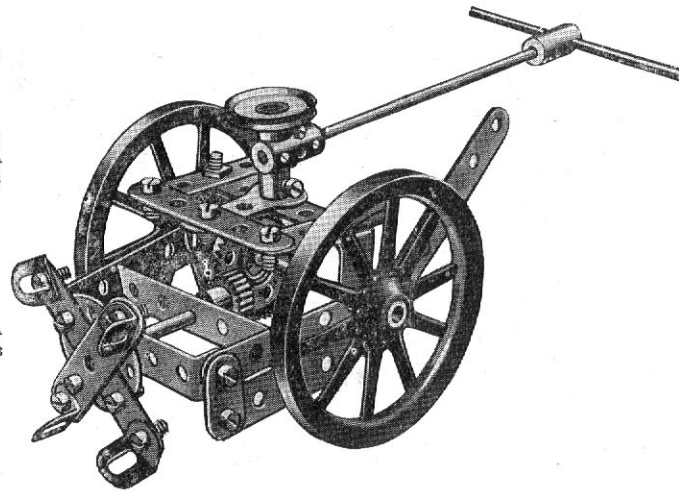


The turret made up of a number of double angle strips 1 bolted at the top to a 3" pulley 2 and below to a face plate is bolted on a rod 3 passing up the centre which forms the pivot of the turret so that it may freely turn. The gun 4 is bolted in a coupling on this pivot rod.

Parts required :

5	of No.	3
6	" "	5
4	" "	8
5	" "	12
1	" "	12A
2	" "	14
1	" "	15
2	" "	16
2	" "	18A
4	" "	19A
1	" "	19B
2	" "	22
2	" "	24
1	" "	32
77	" "	37
2	" "	38
2	" "	45
7	" "	48A
1	" "	48B
2	" "	52
4	" "	53
2	" "	54
8	" "	59
1	" "	63
1	" "	109
3	" "	126A

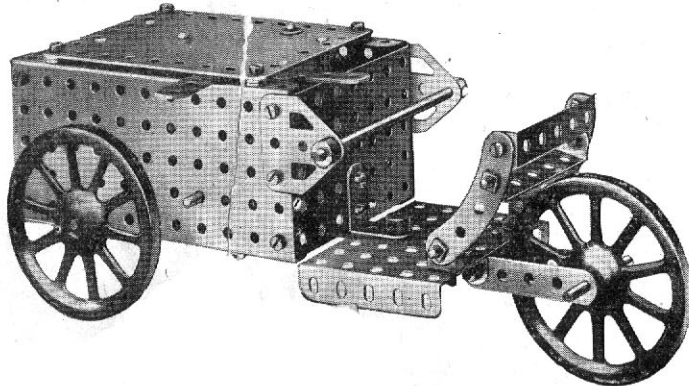
Model No. 530 Potato Reaper



Parts required :

1	of No.	3
8	" "	5
2	" "	10
4	" "	12
1	" "	15
2	" "	16
1	" "	17
1	" "	18A
2	" "	19B
1	" "	22
1	" "	24
1	" "	26
1	" "	28
19	" "	37
1	" "	46
2	" "	48A
1	" "	59
1	" "	62
2	" "	63

Model No. 531 Delivery Van



Parts required :

1	of No.	3	1	of No.	28
3	" "	5	31	" "	37
4	" "	12	9	" "	38
1	" "	12A	2	" "	48A
1	" "	15	2	" "	52
2	" "	15A	3	" "	53
1	" "	17	7	" "	59
1	" "	18A	2	" "	90
3	" "	19A	9"	" "	94
1	" "	26	2	" "	95

2 of No. 126A
Clockwork Motor
(not included in Outfit)

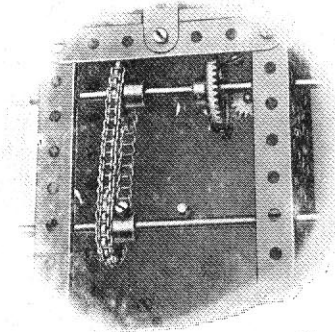
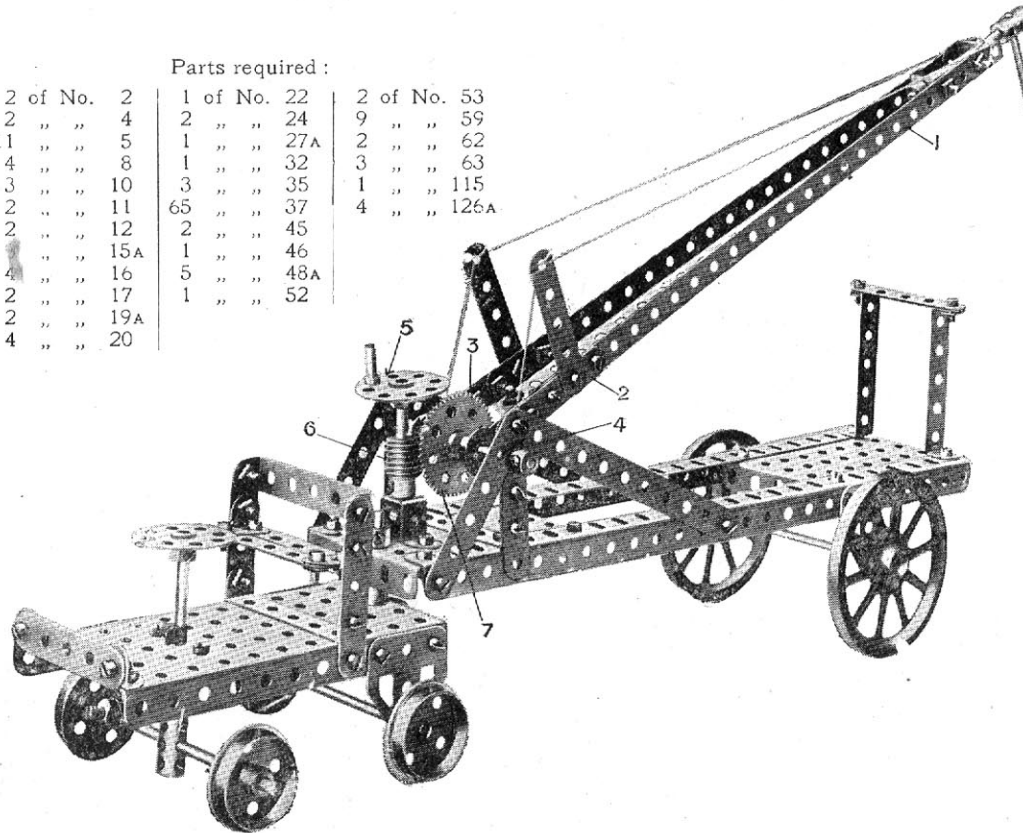


FIG 531A

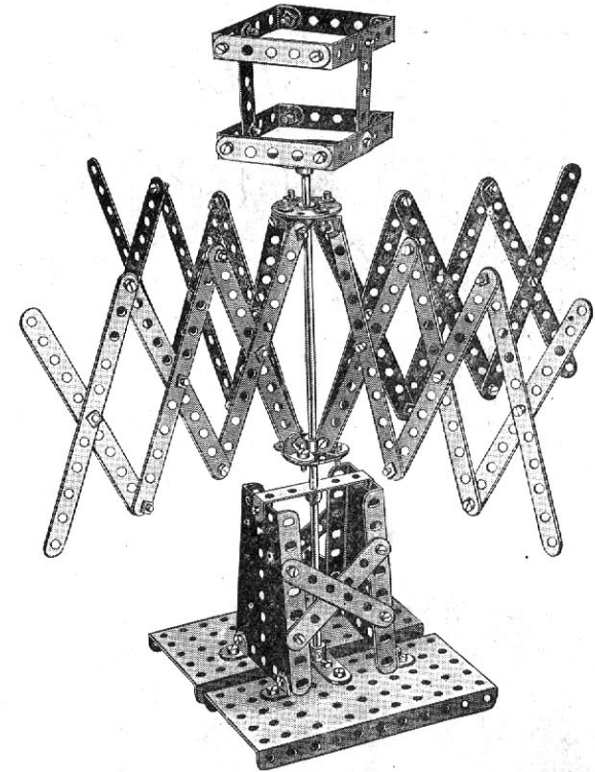
Model No. 532 Fire Watertower

Parts required :		
2 of No. 2	1 of No. 22	2 of No. 53
2 " " 4	2 " " 24	9 " " 59
11 " " 5	1 " " 27A	2 " " 62
4 " " 8	1 " " 32	3 " " 63
3 " " 10	3 " " 35	1 " " 115
2 " " 11	65 " " 37	4 " " 126A
2 " " 12	2 " " 45	
2 " " 15A	1 " " 46	
4 " " 16	5 " " 48A	
2 " " 17	1 " " 52	
2 " " 19A		
4 " " 20		



This is an apparatus for raising a water-hose and directing the nozzle towards high buildings. The hose is led along the support 1, formed of two $12\frac{1}{2}$ " angle girders, secured by strips 2 and cranks 3 to the rod 4, forming a pivot for the support. The support is raised or lowered about the pivot by turning the hand-wheel 5, a worm 6 on the spindle of which engages a 57-toothed wheel 7 on the rod 4.

Model No. 533 Skein Winder



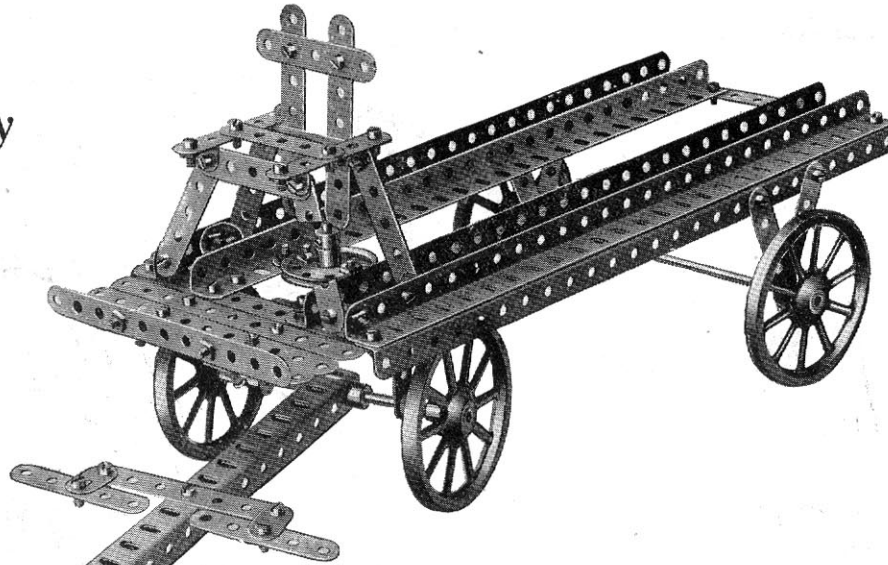
Parts required :			
24 of No. 2	2 of No. 24		
4 " " 4	86 " " 37		
7 " " 5	5 " " 48A		
8 " " 12	2 " " 52		
1 " " 13	2 " " 54		
1 " " 21	2 " " 59		

Model No. 534.

Brewer's Dray

Parts required:

6	of No.	2
3	" "	3
19	" "	5
8	" "	8
2	" "	10
1	" "	11
10	" "	12
1	" "	14
1	" "	15
1	" "	18A
4	" "	19A
1	" "	21
1	" "	24
62	" "	37
1	" "	47
6	" "	59



Model No. 535 Measuring Machine

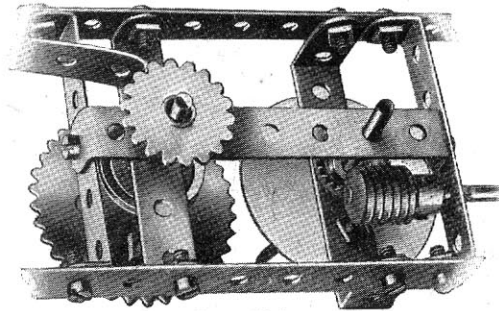
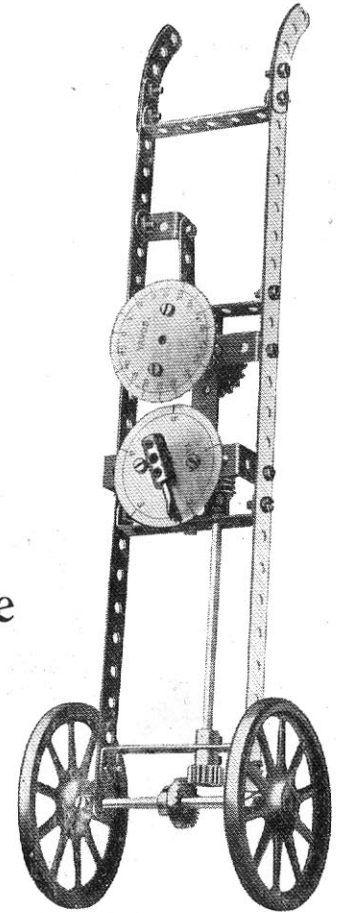


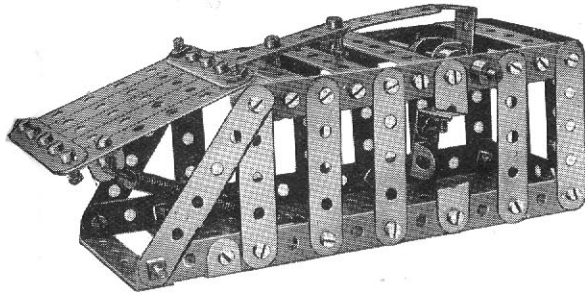
FIG. 535A

Parts required:

2	of No.	1		
1	" "	5		
1	" "	15		
1	" "	16		
2	" "	17		
2	" "	19A		
1	" "	22		
1	" "	26		
2	" "	29		
1	" "	32	1 of No. 48B	2 of No. 90
22	" "	37	1 " " 59	1 " " 95
1	" "	46	1 " " 63	1 " " 96
5	" "	48A	1 " " 65	1 " " 125



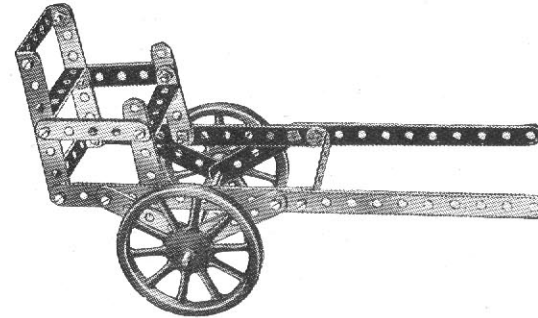
Model No. 536 Mouse Trap



Parts required:

3 of No.	2
8 " "	4
18 " "	5
1 " "	10
1 " "	11
4 " "	12
1 " "	16
59 " "	37
5 " "	38
1 " "	43
1 " "	48
9 " "	48A
1 " "	52
4 " "	59

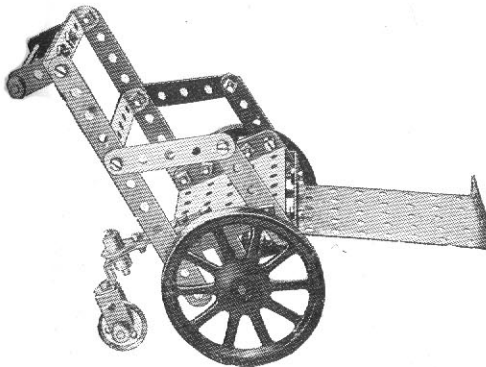
Model No. 537 Ducking Chair



Parts required:

4 of No.	2
2 " "	3
8 " "	5
1 " "	15A
2 " "	19A
4 " "	35
16 " "	37
5 " "	48A

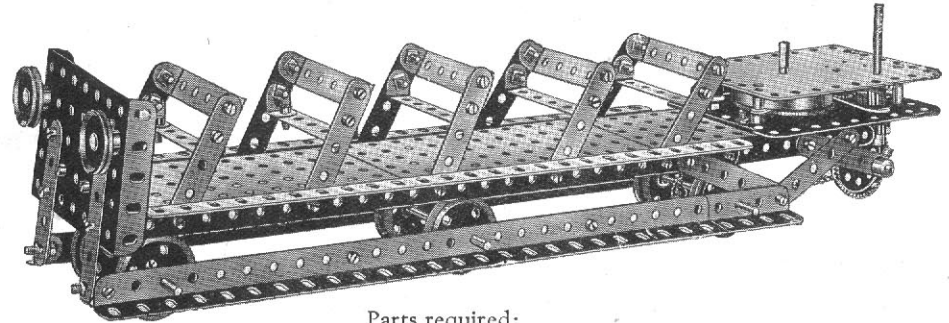
Model No. 538 Invalid Chair



Parts required:

2 of No.	2
5 " "	5
1 " "	10
1 " "	15A
1 " "	16
2 " "	18A
2 " "	19A
1 " "	22A
25 " "	37
5 " "	38
1 " "	46
3 " "	48B
2 " "	53
5 " "	59
1 " "	62
1 " "	102
1 " "	125
2 " "	126A

Model No. 539 Touring Tram Car



Parts required:

20 of No. 5	6 of No. 20	8 of No. 48A
6 " " 8	2 " " 22	3 " " 52
8 " " 12	1 " " 26	1 " " 53
4 " " 16	1 " " 28	2 " " 59
	64 " " 37	

Clockwork Motor
(not included in Outfit)

Model No. 540 Motor Car

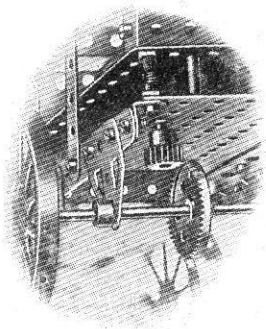
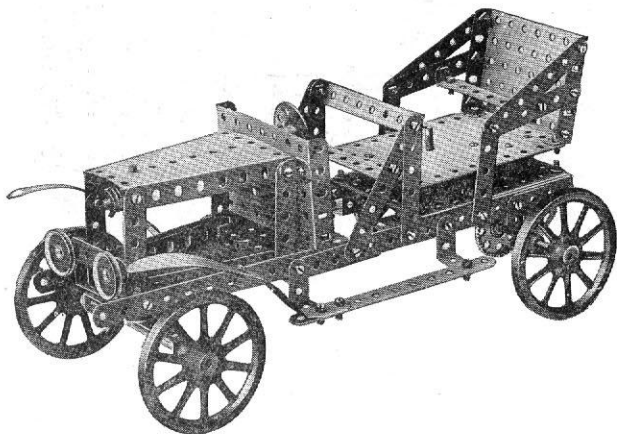


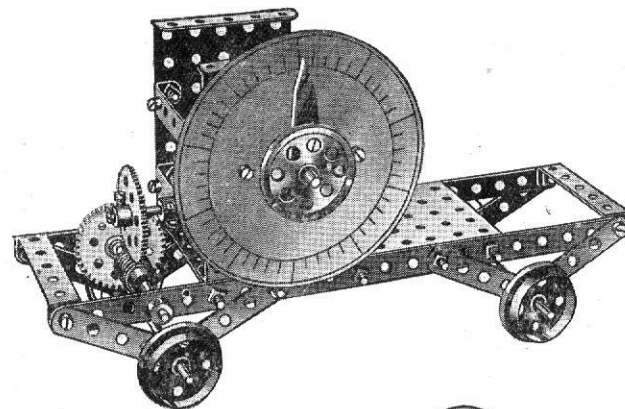
Fig. 540A

Parts required :

2 of No.	1	2 of No.	24
2 "	2	2 "	26
7 "	3	1 "	28
4 "	4	1 "	32
7 "	5	67 "	37
2 "	9	3 "	38
9 "	12	2 "	41
4 "	12A	1 "	48A
1 "	14	3 "	48B
2 "	15	3 "	53
1 "	16	2 "	54
4 "	19A	7 "	59
2 "	22	2 "	126A

Clockwork Motor
(not included in Outfit)

Model No. 541 Distance Indicator



Parts required :

4 of No.	2
4 "	3
8 "	5
10 "	12
2 "	15
2 "	15A
1 "	16
1 "	17
4 "	20
1 "	21
2 "	22
1 "	24
2 "	26
2 "	27A
1 "	28
1 "	32
38 "	37
2 "	48A
1 "	52
2 "	53
6 "	59

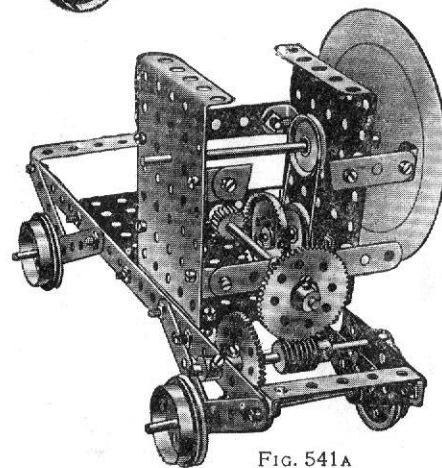


Fig. 541A

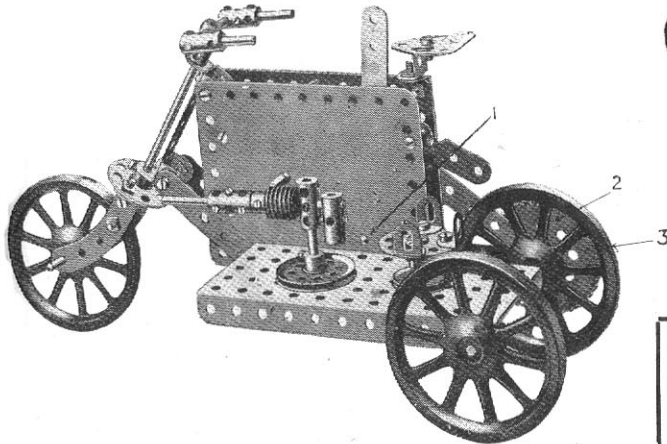
Model No. 542

Armoured Motor Tricycle

Parts required:

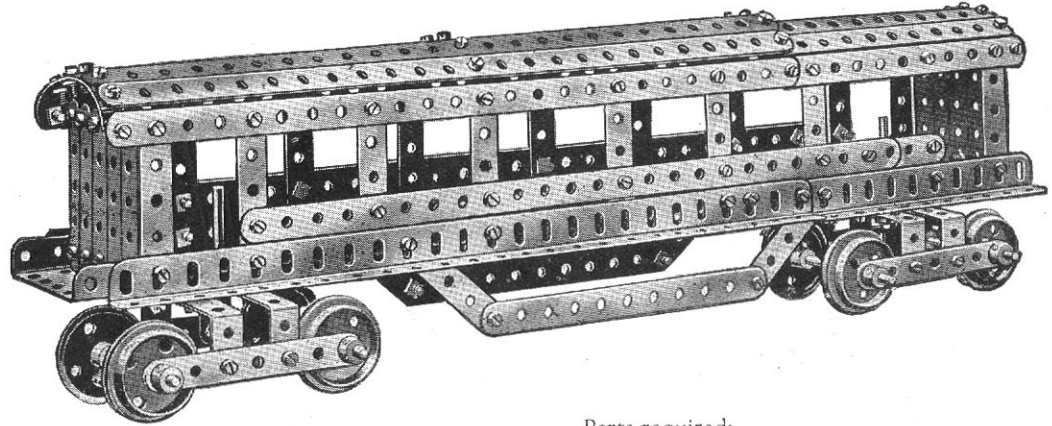
2 of No. 2	4 of No. 18A	1 of No. 52
2 " " 5	3 " " 19A	1 " " 59
1 " " 9D	1 " " 21	6 " " 63
2 " " 11	3 " " 22	2 " " 90
4 " " 12	2 " " 24	1 " " 95
2 " " 12A	1 " " 32	1 " " 96
1 " " 15A	22 " " 37	1 " " 125
2 " " 16	10 " " 38	1 " " 126A
2 " " 17	1 " " 48A	

Clockwork Motor
(not included in Outfit)



This is driven from the motor spindle 1, a small sprocket wheel at the rear, not shown in the illustration, being geared by a chain to the larger sprocket wheel 2 bolted on the axle rod of the rear wheels 3.

Model No. 543 Pullman Car



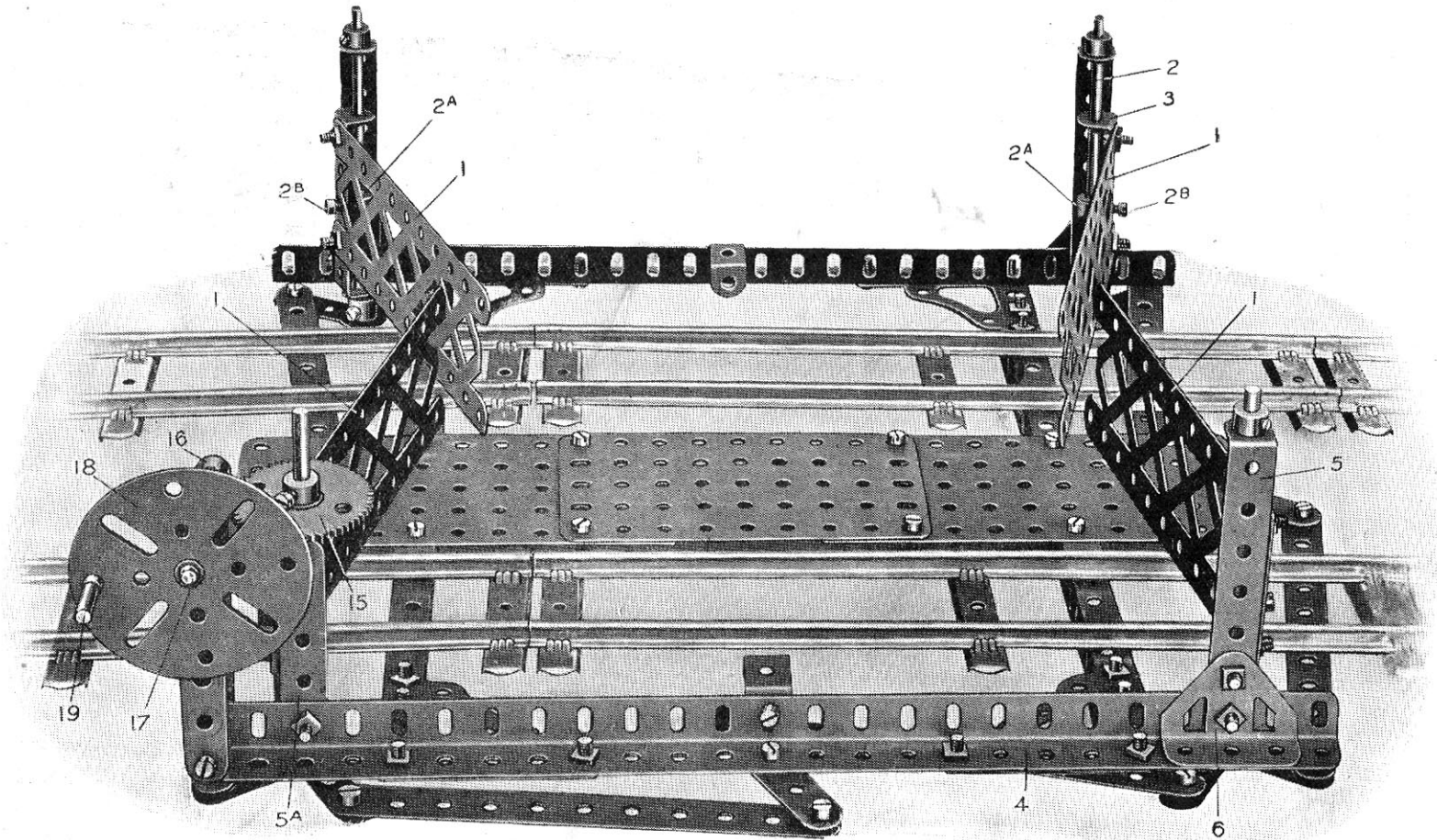
Parts required:

9 of No. 1	4 of No. 8	116 of No. 37
9 " " 2	4 " " 16	4 " " 46
8 " " 3	2 " " 17	3 " " 52
34 " " 5	8 " " 20	10 " " 59
	2 " " 21	

HOW TO CONTINUE

This completes the Models which may be made with MECCANO Outfit No. 5. The next Models are a little more advanced, requiring a number of extra parts to construct them. The necessary parts are all contained in a No. 5A Accessory Outfit, the price of which will be found in the List at the end of the Manual.

Model No. 601 Level Crossing Gates



Model No. 601 Level Crossing Gates (continued)

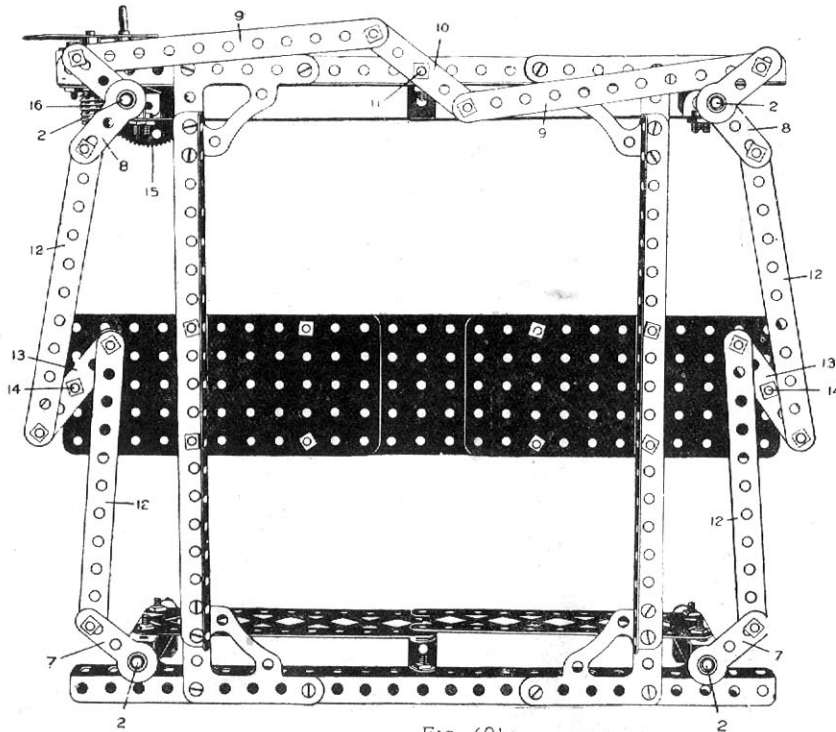


Fig. 601A

Parts required :

6	of No.	2
2	" "	4
3	" "	5
1	" "	6A
2	" "	8
2	" "	8A
4	" "	11
4	" "	15A
1	" "	17
1	" "	27A
1	" "	32
53	" "	37
16	" "	37A
4	" "	48A
3	" "	48B
1	" "	53A
7	" "	59
2	" "	62
3	" "	70
4	" "	100
4	" "	108
1	" "	109
1	" "	115
3	" "	126
2	" "	128

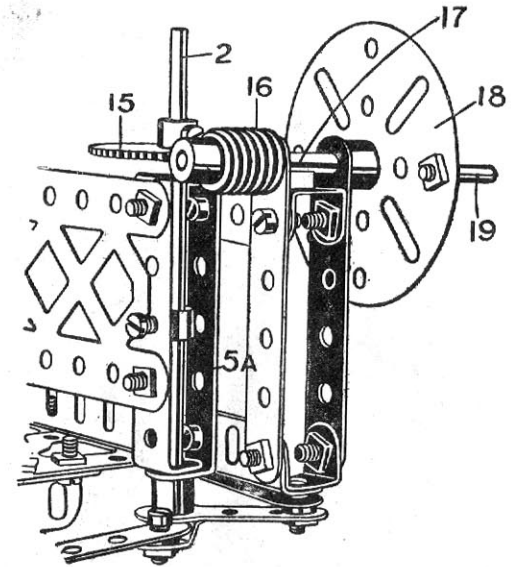


Fig. 601B

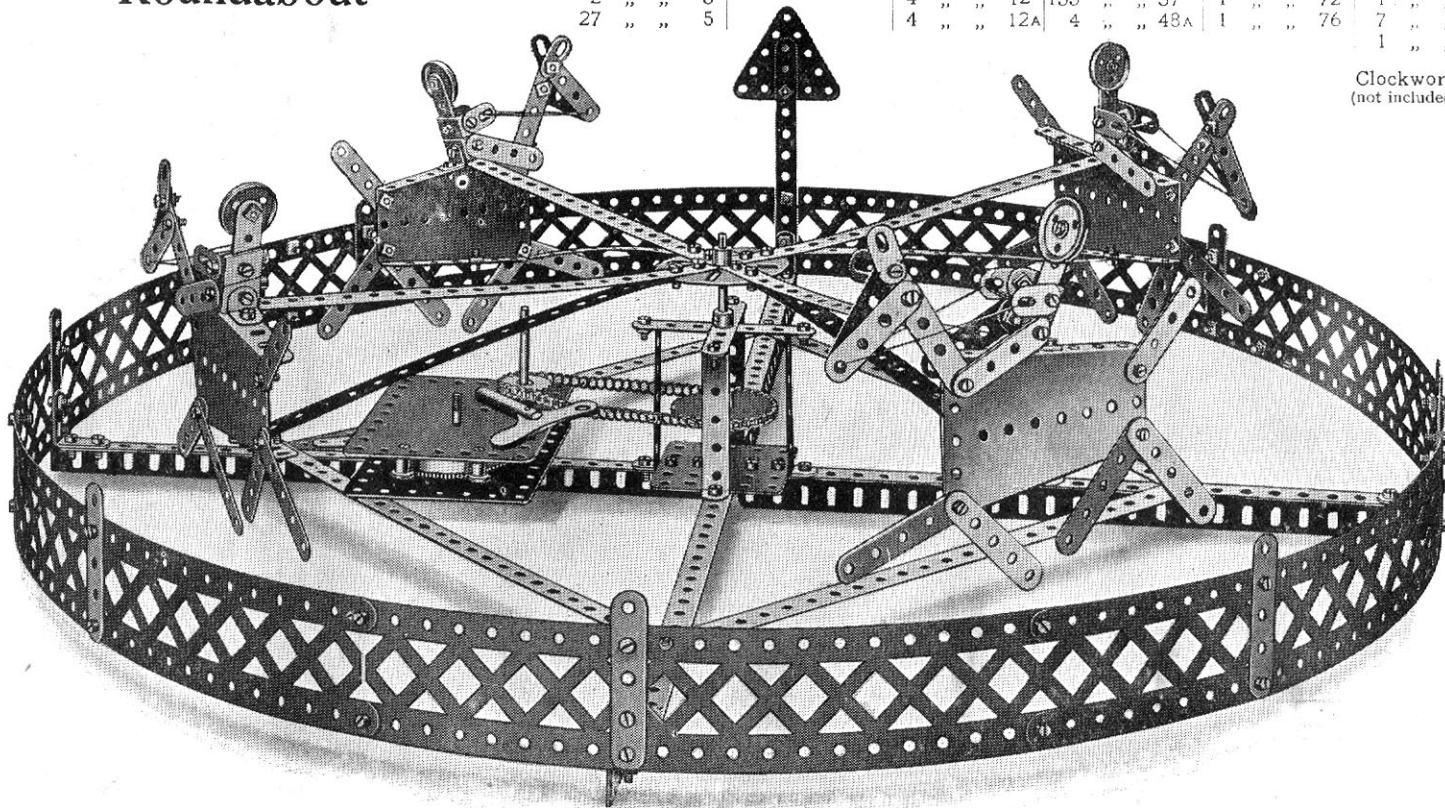
The gates consist of $5\frac{1}{2}$ " braced girders 1 and are pivotally carried on the rods 2 being bolted to $2\frac{1}{2}$ " by $\frac{1}{2}$ " double angle strips 3. On each rod 2 is threaded a collar 2A, Fig. 601, and a bolt 2B is passed through the centre hole of the double angle strips 3 and screwed into the thread hole of the collar 2A, nipping the collar to the rod 2, thus ensuring that the braced girders 1 shall turn with the rods 2. Three of the rods 2 are carried from the lower angle girders 4 in $3\frac{1}{2}$ " by $\frac{1}{2}$ " double angle strips 5, and one in a $2\frac{1}{2}$ " by $\frac{1}{2}$ " double angle strip 5A, the feet of the strips 5 being reinforced to the angle girders 4 by the trunnions 6. The rods 2 are coupled together by cranks 7 on the rear rods, and bell cranks 8 on the other rods, the ends of the two bell cranks being connected by strips 9 to $2\frac{1}{2}$ " strip 10 pivoted on the bolt 11, Fig. 601A, while the bell cranks 8 are connected to the cranks 7 by other strips 12, pivotally connected to $2\frac{1}{2}$ " strips 13, pivoted on the bolts 14. Consequently, all the rods 2 are inter-connected. As will be seen from the Figs. 601 and 601B, a 56-toothed gear wheel 15 is secured on one of the rods 2, and is engaged by a worm 16 on a rod 17 to which is secured a face plate 18, fitted with a threaded pin 19, as an operating handle. By turning the face plate 18 the spindles 2 are all rotated, and the gates caused to open or close.

Model No. 602

Roundabout

		Parts required:											
12 of No.	1	24 of No.	6	16 of No.	10	1 of No.	15	4 of No.	54	14" of No.	94		
1	" "	2	4	8	" "	11	4	" "	22A	2	" "	59	
2	" "	3	8	4	" "	12	135	" "	37	1	" "	72	
27	" "	5		4	" "	12A	4	" "	48A	1	" "	76	
											1	" "	95
											1	" "	96
											7	" "	99
											1	" "	109

Clockwork Motor
(not included in Outfit).



In this model the animals, built up from sector plates and short strips to represent the limbs, are carried from $9\frac{1}{2}$ " strips bolted to a face plate, which is rotated from the centre rod by means of a chain and a 1" sprocket wheel connected to the spring motor.

The centre rod, by means of which the rotating figures are driven, is supported below the face plate by a light framing to give rigidity.

The model is surrounded by braced girder strips bolted together, and strengthened by $12\frac{1}{2}$ " cross angle girders, connected in the centre by a $2\frac{1}{2}$ " by $2\frac{1}{2}$ " flat plate. The centre hole of this plate carries the lower end of the vertical rod upon which the animals are mounted.

Model No. 603 Portable Crane

Parts required:

12 of No. 2	16 of No. 12	1 of No. 21	1 of No. 40
3 " " 3	1 " " 15	5 " " 22	2 " " 44
6 " " 5	5 " " 16	2 " " 22A	1 " " 45
2 " " 9	4 " " 17	2 " " 23	1 " " 48
	2 " " 18A	1 " " 24	2 " " 48A
	1 " " 19	1 " " 26	1 " " 53
		1 " " 27A	1 " " 57
		74 " " 37	10 " " 59
		16 " " 38	2 " " 62
			2 " " 63
			2 " " 89
			2 " " 90
			4 " " 126A

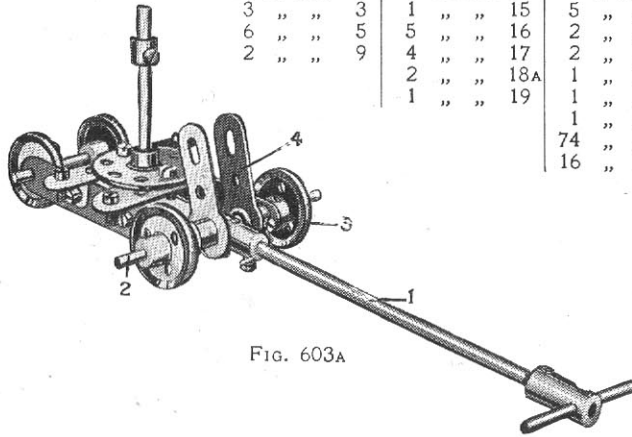
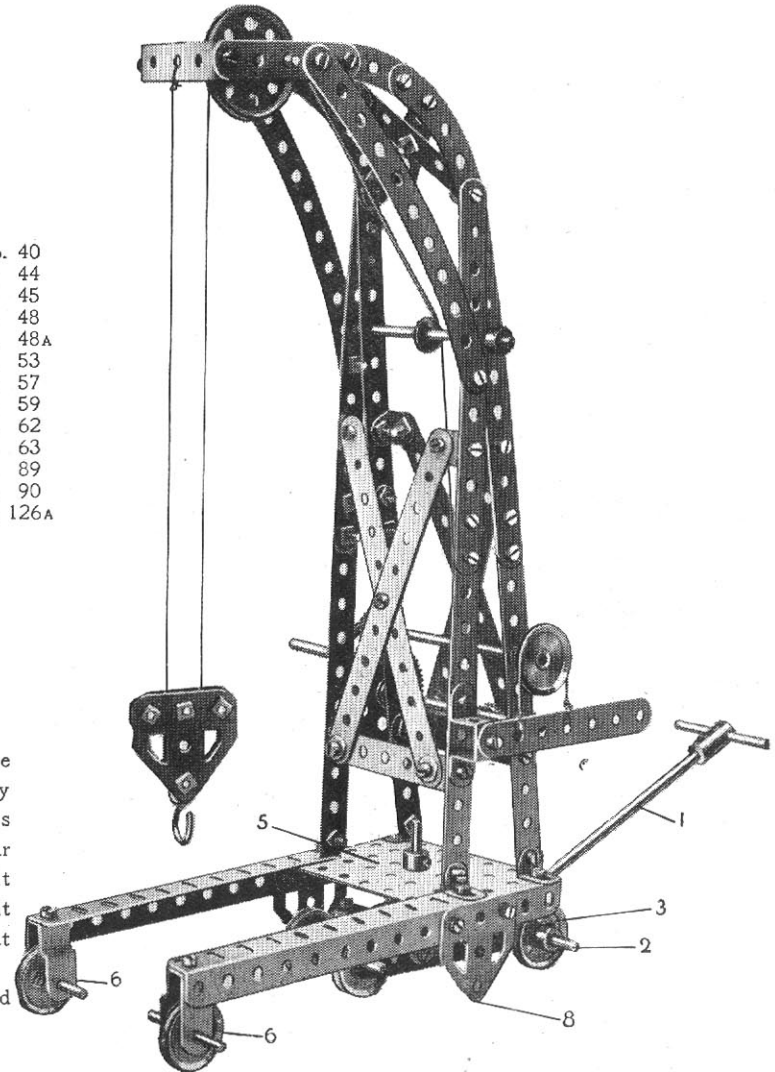


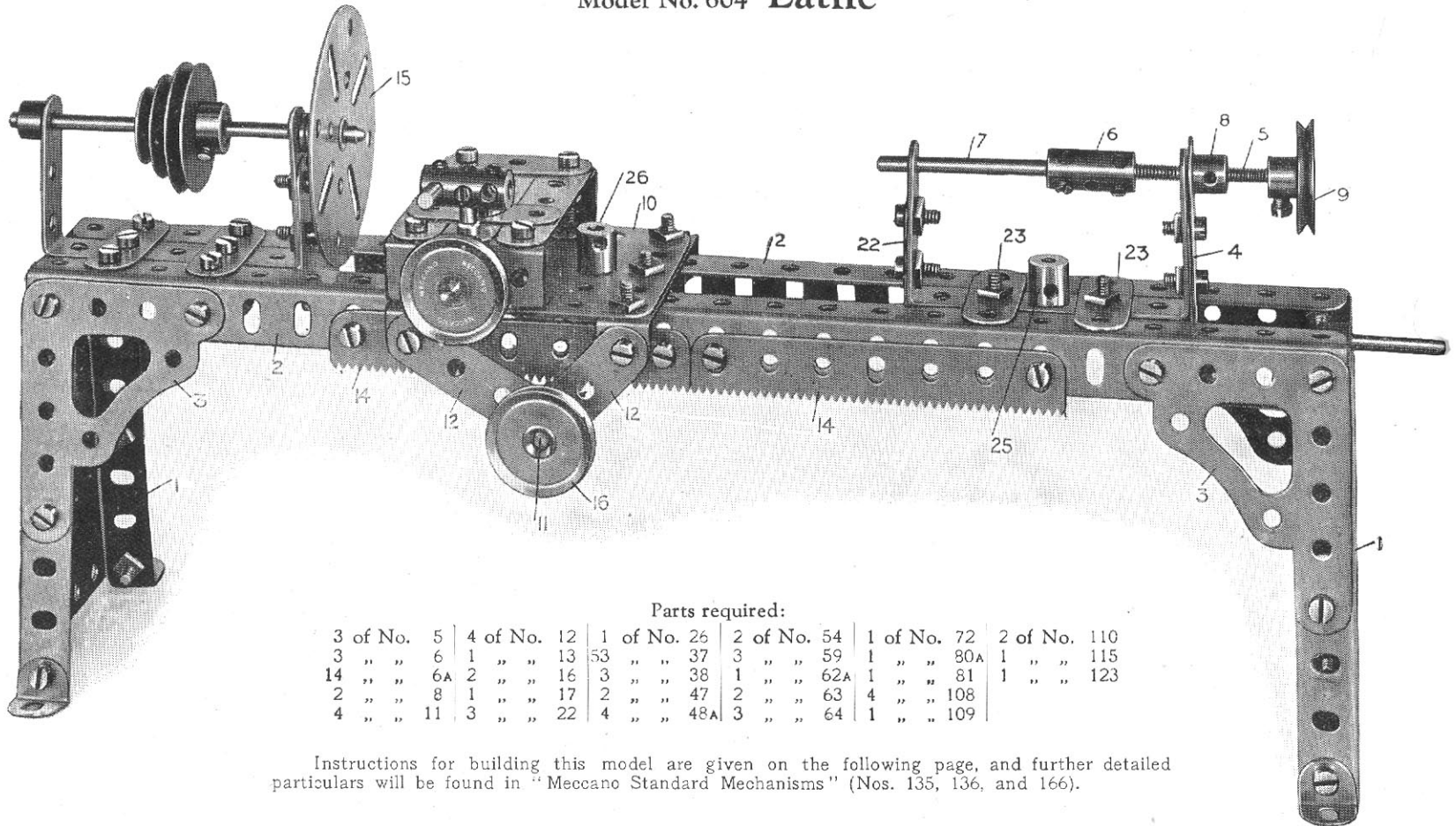
FIG. 603A

The construction of the tower is quite clear from the illustration. The crane is moved about by depressing the handle 1 carrying an axle 2 for the 1" loose pulley wheels 3, which are secured in position by collars and set screws. A pair of cranks 4 are secured to the axle 2 and are arranged when the handle is depressed to bear against the underface of the small rectangular plate 5 and lift the crane so that it then runs on the wheels 3 and 6. When the crane is brought to rest its weight forces down the cranks 4 which raises the handle 1, and the tips 8 of the flat trunnions together with front wheels 6 then support the crane.

The load is controlled by a strap and lever brake (see "Meccano Standard Mechanisms," detail No. 81).



Model No. 604 Lathe



Parts required:

3 of No. 5	4 of No. 12	1 of No. 26	2 of No. 54	1 of No. 72	2 of No. 110
3 " " 6	1 " " 13	53 " " 37	3 " " 59	1 " " 80A	1 " " 115
14 " " 6A	2 " " 16	3 " " 38	1 " " 62A	1 " " 81	1 " " 123
2 " " 8	1 " " 17	2 " " 47	2 " " 63	4 " " 108	
4 " " 11	3 " " 22	4 " " 48A	3 " " 64	1 " " 109	

Instructions for building this model are given on the following page, and further detailed particulars will be found in "Meccano Standard Mechanisms" (Nos. 135, 136, and 166).

Model No. 604 Lathe (continued)

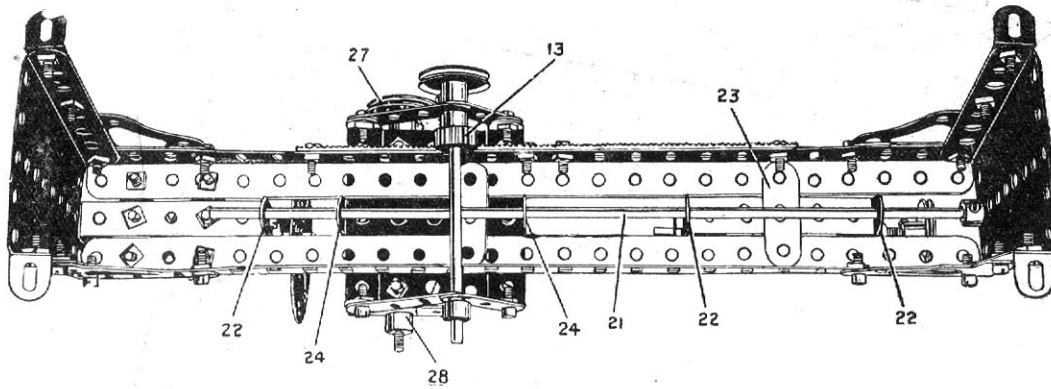


FIG. 604A

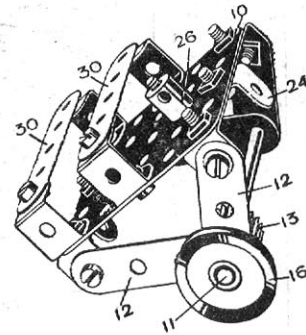


FIG. 604B

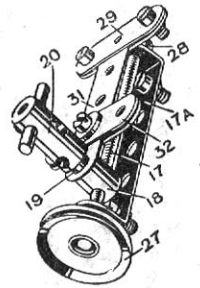


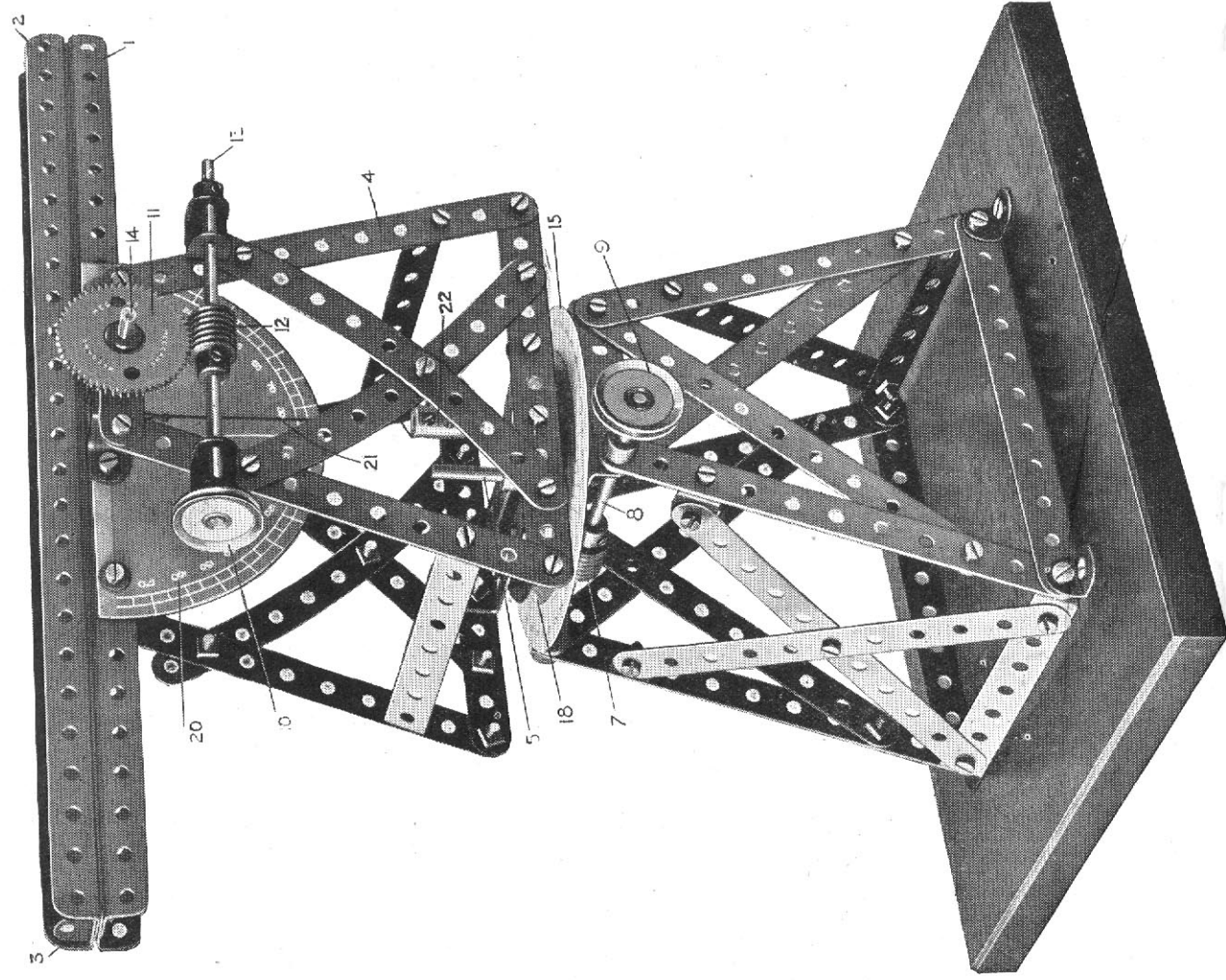
FIG. 604C

The lathe frame is built up from sector plates 1, at each end bolted to $1\frac{1}{2}$ " angle girders 2, forming the bed, by means of architraves 3. The tail stock 4, slides between the angle girders 1, and has a screw adjustment 5, the screw of which is connected by the threaded coupling 6 to the rod 7; the screw 5 is threaded into a threaded crank 8, and is operated by the 1" pulley wheel 9. The tail stock is locked by turning the threaded boss 25, which engages the bolt holding the underneath cross strip 23, thus gripping it beneath the lathe bed. The saddle 10, consisting of a $2\frac{1}{2}$ " by $2\frac{1}{2}$ " flat plate, carries the rod 11, journalled in the strips 12, and carries a pinion 13, Fig. 604B, which engages the racks 14, so that the saddle may be moved to or from the face plate 15, by turning the pulley wheel 16. The traversing movement is obtained by means of the screw 17, which engages a threaded boss 18, into the end of which is screwed a threaded pin 19, carrying the coupling 20, which forms the tool post. The saddle is locked by the threaded boss 26, similar to the tail stock. The screwed rod 17, is held against end movement in the $2\frac{1}{2}$ " by $\frac{1}{2}$ " bent strip 17A, by the pulley wheel 27 at one side and the collar 28 on the other.

The construction of the saddle is shown in Figs. 604B and 604C, where the $1\frac{1}{2}$ " strips 29, of Fig. 604C are shown removed from Fig. 604B; these strips 29 are bolted at the end of the guide strips 30, Fig. 604B, and form guides for the $2\frac{1}{2}$ " strip 31, carrying the tool post. They are spaced apart by the thickness of the strips 30, and the $1\frac{1}{2}$ " strips 32, bolted to the strip 31, slide on the strips 30. As will be seen from the underneath view, Fig. 604A, a guide rod 21, is fixed beneath the bed plates, and is engaged by the end holes of the $1\frac{1}{2}$ " strips 22, secured to the sides of the head and tail stocks; $1\frac{1}{2}$ " strips 23, being bolted above and below to retain the tail stock in position. The saddle engages the rod 21 by means of a $2\frac{1}{2}$ " by $\frac{1}{2}$ " double angle strip 24.

This Model can be made with MECCANO Outfit No. 6, or No. 5 and No. 5A.

Model No. 605 Theodolite



Model No. 605 Theodolite (continued)

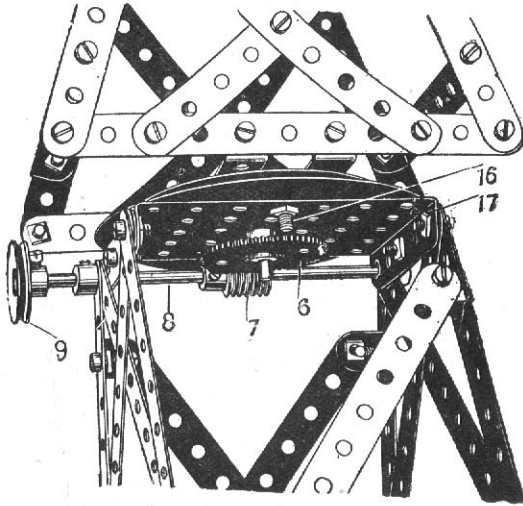


FIG. 605A

Parts required:	
20 of No.	
2	5
6	6A
4	8
2	11
10	12
3	15
1	17
1	19B
2	22
2	27A
2	32
60	37
1	45
6	48B
1	53
6	59
1	62
1	63
4	89
1	135

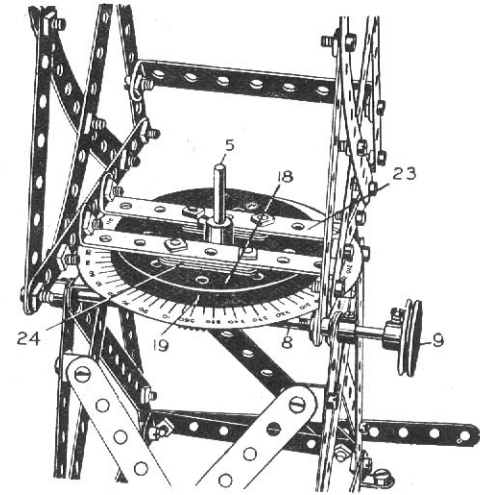


FIG. 605B

The Theodolite is represented by two reverse pairs of angle girders 1 and 2, which form a "sighting arm," an angle bracket 3 being bolted at one end to form an eye piece. A small piece of gummed paper is fastened over the aperture in the angle bracket, and a fine pin-hole made in the paper at the centre of the aperture. Two crossed threads are gummed across the aperture of the angle bracket bolted at the other end of the sighting arm.

The upper framework 4 swivels horizontally with the vertical spindle 5 as a pivot. On the lower end of this rod is a gear wheel 6, Fig. 605A, engaged by a worm 7 on a rod 8, operated by the 1" pulley 9. This gives the horizontal traverse of the upper frame 4, in which the sighting arm is pivotally mounted upon a rod 14, on which is a gear wheel 11 engaged by a worm 12 on a rod 13 operated by a 1" pulley 10. This mechanism gives the vertical traverse or inclination of the sighting arm.

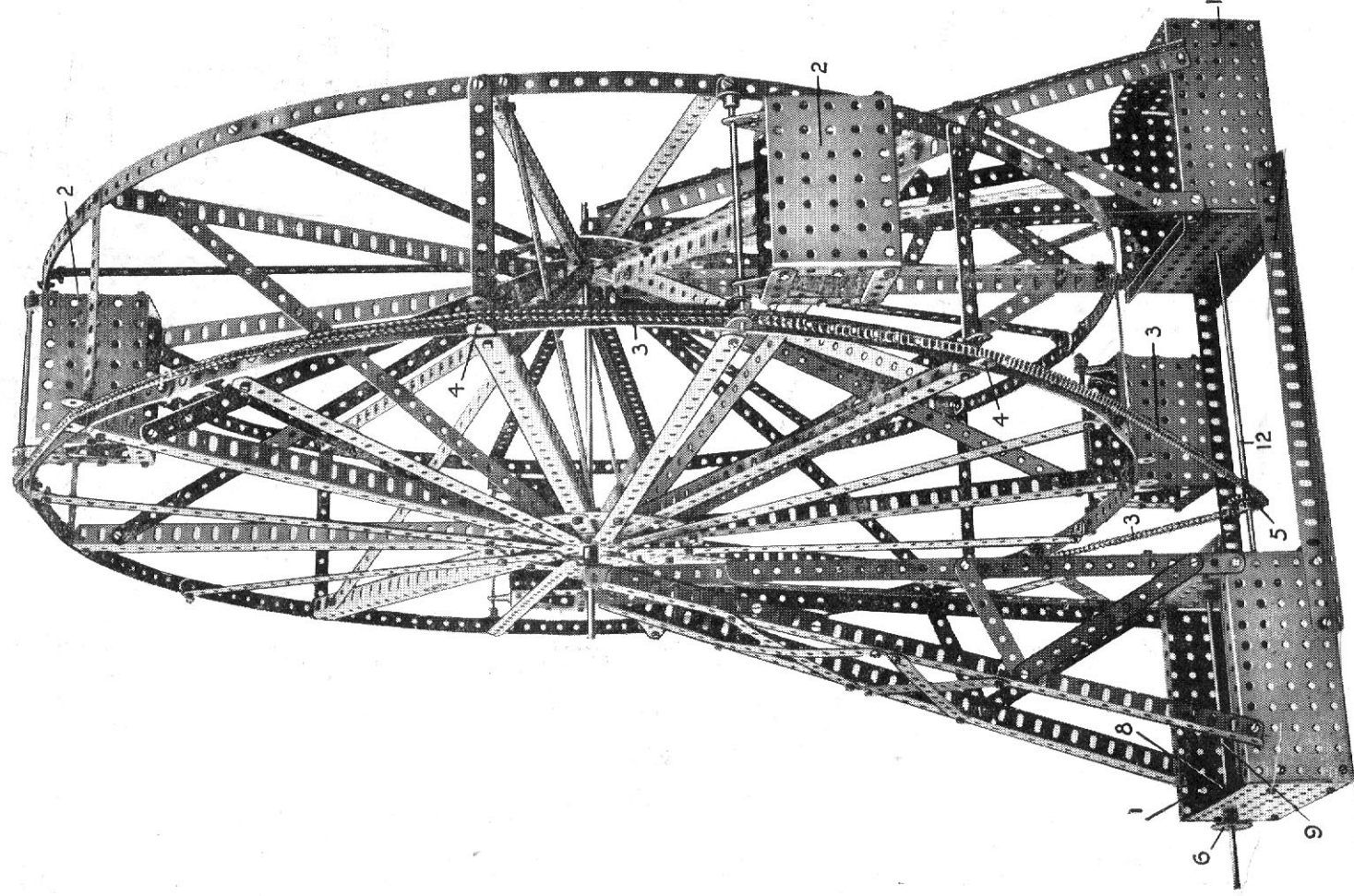
A protractor for the horizontal angular movement of the upper frame 4 consists of a graduated cardboard disc 15, which is bolted by a bolt 16 to a perforated flanged plate $3\frac{1}{2}$ " by $2\frac{3}{8}$ " 17, the head of the bolt 16 being above the cardboard disc, and beneath the 3" pulley wheel 18. The cardboard disc is thus held against movement by the bolt 16, its centre hole engaging round the pivot rod 5. An index mark or pointer 19 is made on the pulley wheel 18. The movement of this pointer round the graduated scale on the disc shows the horizontal angular traverse.

Similarly, the vertical traverse of the sighting arm is indicated by means of a semi-circular protractor 20, bolted to the lower angle girder 1 of the sighting arm, a cord 21 carrying a weight 22, being hung from the rod 14, the position of the thread 21 over the protractor 20 indicating the vertical angular adjustment of the sighting arm. The thread 21 has a loop by which it is hung on the rod 14, so that its direction always points truly radially to the rod 14, and this gives the correct angular reading. In order to bring the double angle strips 23 flush with the outer rim of the pulley wheel 18, three $1\frac{1}{2}$ " packing strips 24 are bolted beneath the double angle strips, as shown in Fig. 605B.

The sighting arm is secured to the rod 14 by a crank bolted to the arm on the opposite side to the protractor and nipped by the set screw to the rod 14.

This Model can be made with MECCANO Outfit No. 6, or No. 5 and No. 5A.

Model No. 606 Big Wheel



Model No. 606 **Big Wheel** *(continued)*

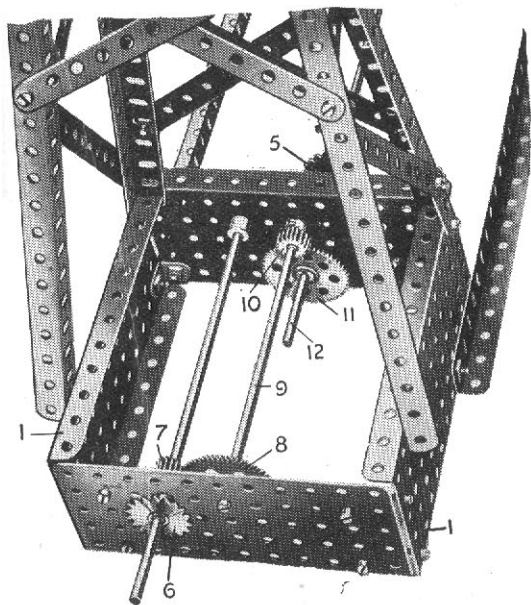


FIG. 606A

Parts required:	
46 of No.	1
24 " "	2
4 " "	3
32 " "	5
26 " "	8
4 " "	9
8 " "	11
44 " "	12
2 " "	13
1 " "	13A
1 " "	14
4 " "	15
2 " "	24
2 " "	26
2 " "	27A
308 " "	37
6 " "	38
4 " "	48D
6 " "	52
8 " "	53
2 " "	54
13 " "	59
2 " "	70
16 " "	90
8 " "	94
2 " "	96
2 " "	109

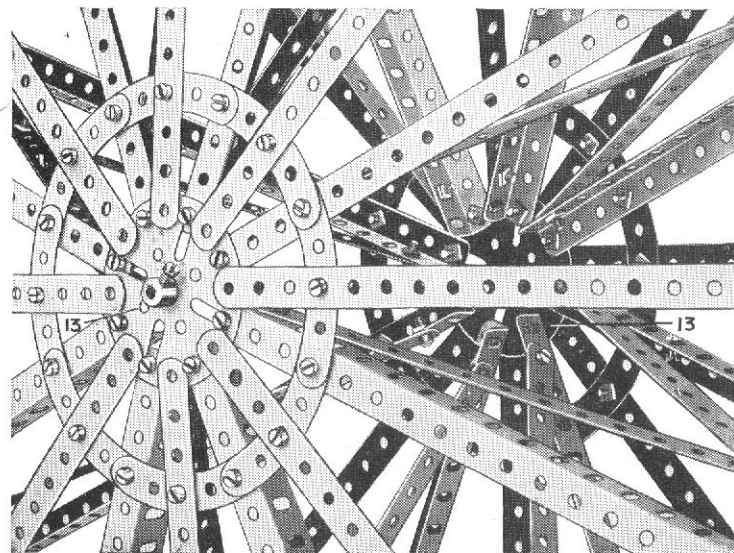
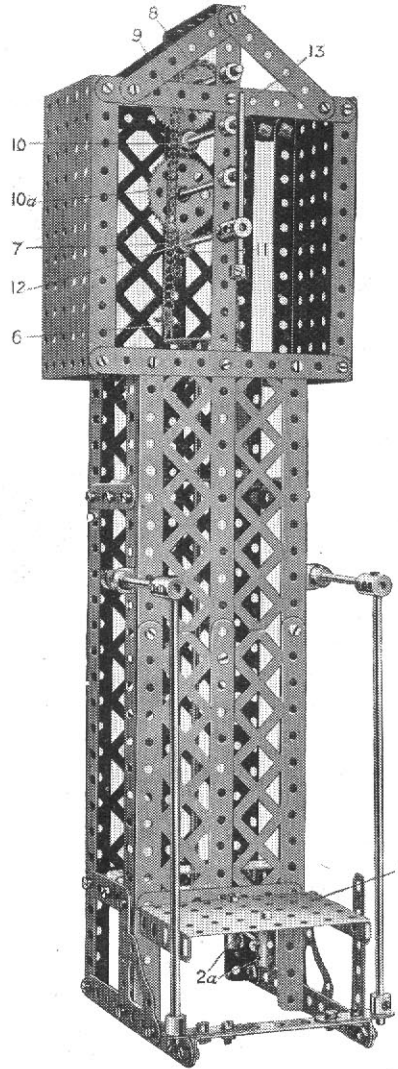


FIG. 606B

In constructing this model, flanged plates 1 are used to form the sides and inner part of the base of the side pedestals, and also to form the suspended cages 2 on the wheel. The driving chain 3 is conveniently kept in position round the periphery of one of the side elements of the wheel by a series of double angle brackets 4, bolted on the ends of the spokes.

Fig. 606A shows how the driving chain 3 is actuated from the sprocket wheel 5. On the axle of the driving sprocket 6 is a $\frac{1}{2}$ " pinion 7 driving a $1\frac{1}{2}$ " gear wheel 8 on an axle 9. On the other end of this axle 9 is a $\frac{1}{2}$ " pinion 10 engaging a $1\frac{1}{2}$ " gear wheel 11 on the rod 12 of the sprocket wheel 5.

Fig. 606B shows how the wheel is built up from the centre face plates 13.



Model No. 607

Automatic Weighing Machine

Parts required:

2 of No.	1	1 of No.	24	12 of No.	59
6 "	"	2 "	"	2 "	"
2 "	"	2 "	"	6 "	"
6 "	"	64 "	"	10 "	"
4 "	"	2 "	"	1 "	"
4 "	"	1 "	"	2 "	"
1 "	"	1 "	"	6 "	"
2 "	"	3 "	"	2 "	"
1 "	"	2 "	"	6 "	"
7 "	"	1 "	"	2 "	"

The platform 1 is connected by cross rod and couplings 2a to a rod 2 (by means of a further coupling) passing through the centre of the machine and guided in the $3\frac{1}{2}$ " double angle strips 3 and 3a connected to side strips 4. At the upper end of this rod 2 is a bush wheel 5, to which is connected a cord 6 and sprocket chain 7. This chain passes round a sprocket wheel 8 on the same spindle as the 57-toothed gear wheel 9 engaging a $\frac{1}{2}$ " pinion 10. The pinion 10 also engages another 57-toothed gear wheel 10a, and this in turn a $\frac{1}{2}$ " pinion 11 on the spindle 12 carrying the pointer 13. The other end of the chain is coupled by a spring 14 to the cross piece 3a, and the pointer is thus always returned to zero immediately the load is removed from the platform.

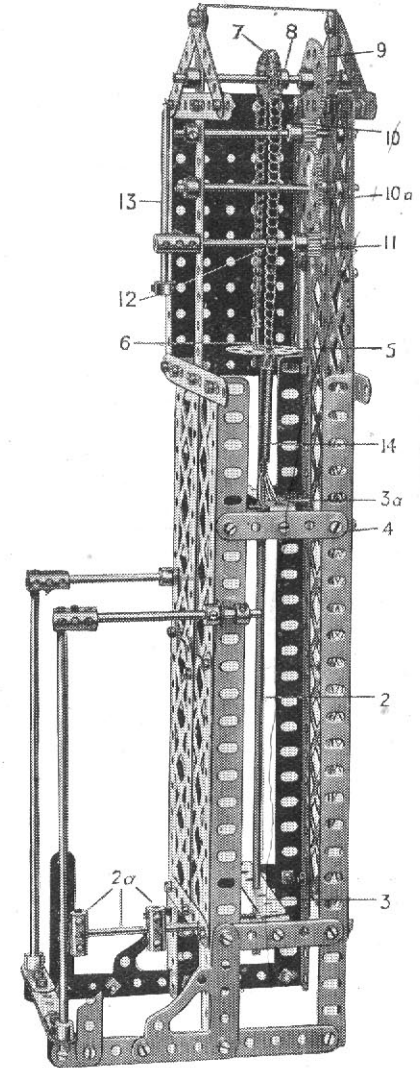


FIG. 607A

Model No. 608 Derricking Grab

The grab 1 is suspended by the cords 2 which pass over the pulleys 3 and round the outer pulleys of a set of four 4 at the head of the standard 5. The cords continue down and under the outer pulleys of a set of smaller pulleys 6 and are wound on a crank handle 7 at the centre of which they are connected by a spring clip. (Care should be taken to see that, when winding up, the double lapping of each cord on the rod occurs simultaneously, as otherwise the grab will cant over).

The grab is opened or closed by the cord 8 which, after passing over one of two inner pulleys at the end of the jib 9, then passes over another of the four pulleys 4 and one of the pulleys 6 to the crank handle 10.

The jib 9 is raised or lowered by the cord 11 which is secured to the standard 5, and having passed around the other of the two inner pulleys at the jib-end is passed back and around one of the four pulleys 4 and one of the pulleys 6 to the crank handle 12. The swinging of the jib is effected from the crank handle 13 on the end of a rod, on which is a $\frac{1}{2}$ " pinion 14 engaging a contrate wheel 15 at the foot of the standard 5.

Gear wheels 16 and 17 are bolted on the crank handles 10 and 7 and are connected by the pinion 18. The crank handle 7 is fixed against longitudinal movement, but the crank handle 10 may be slid clear of the pinion 18, and the handle 7 turning the grab is raised or lowered. If the handle 10 is slid to disengage its gear wheel from the pinion 18 and the handle turned, the grab is opened or closed.

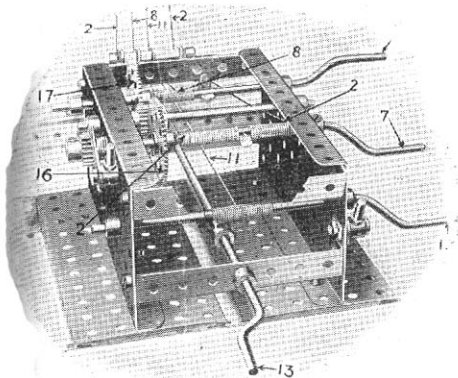
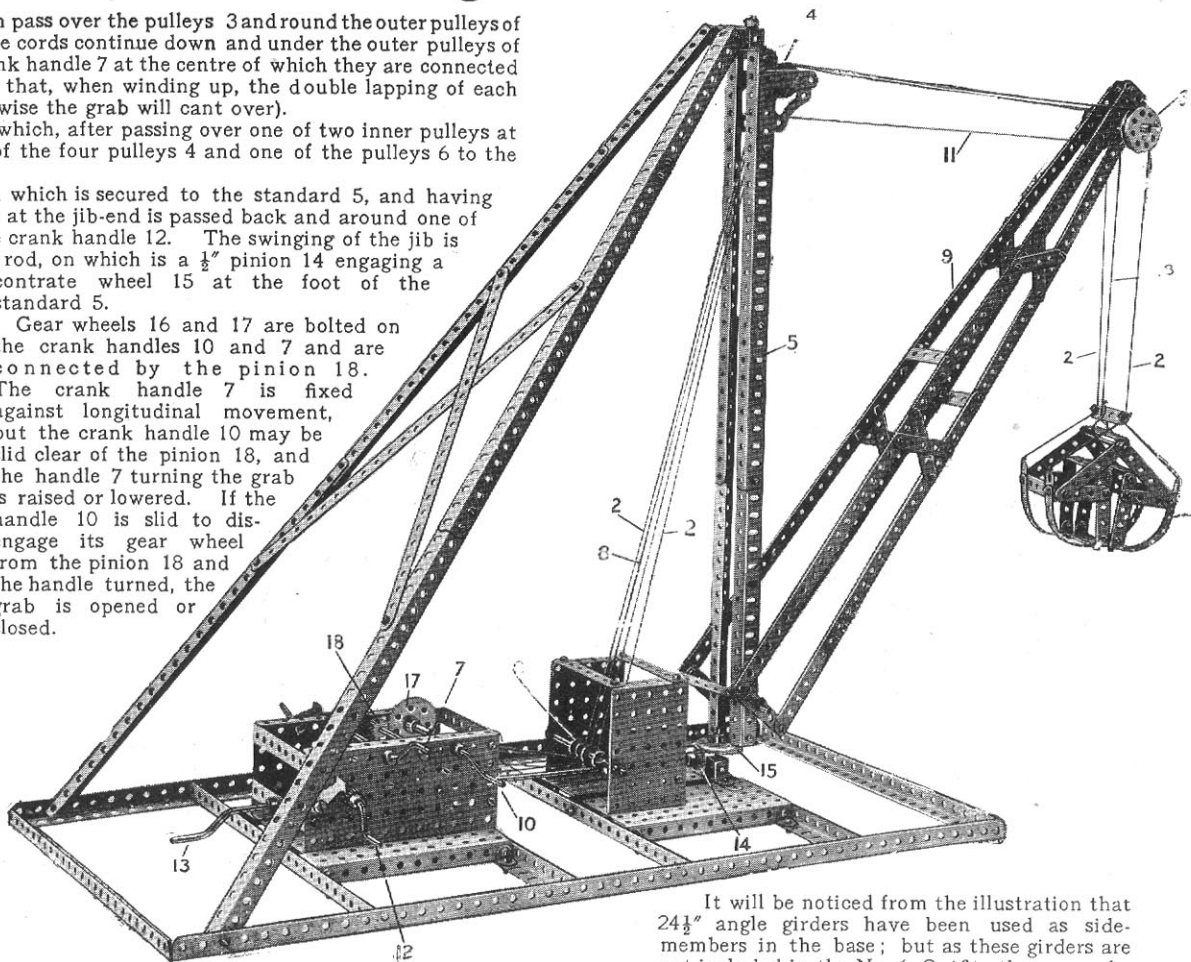


Fig. 608A

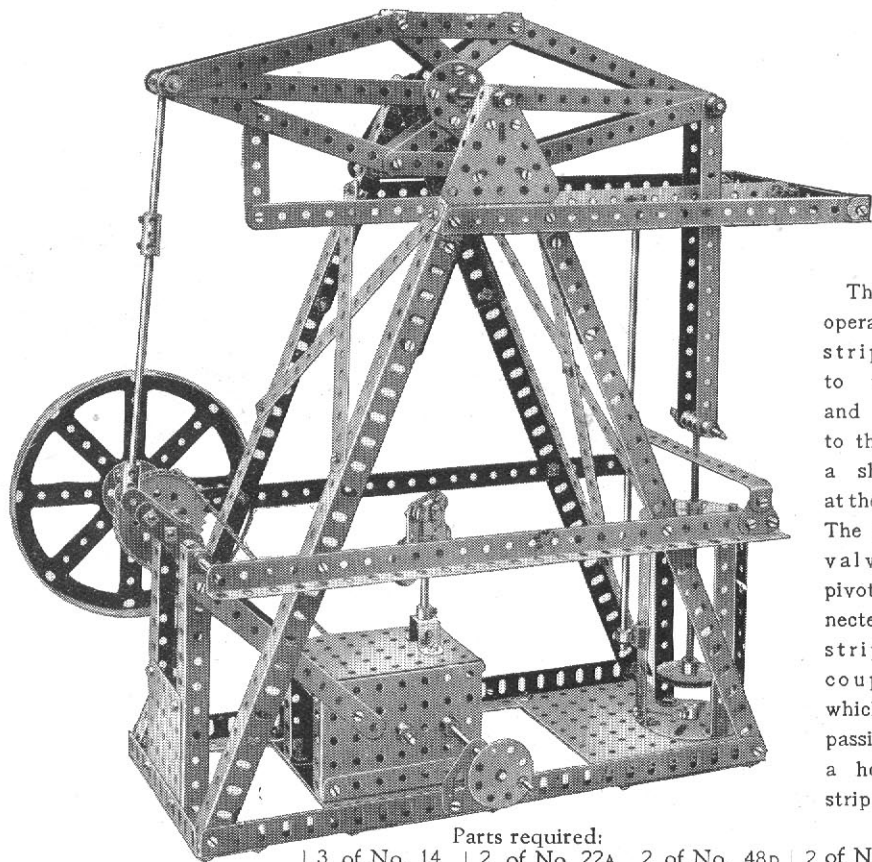
Parts required:

10 of No. 1	1 of No. 18A	9 of No. 48A
6 " " 3	4 " " 19	5 " " 48B
4 " " 4	2 " " 20	6 " " 52
20 " " 5	2 " " 22	2 " " 53
4 " " 6	3 " " 22A	1 " " 57
18 " " 8	4 " " 23	16 " " 59
2 " " 9	2 " " 24	1 " " 63
6 " " 10	2 " " 26	2 " " 108
6 " " 11	2 " " 27A	2 " " 115
10 " " 12	1 " " 28	1 " " 126
1 " " 13	6 " " 35	2 " " 147A
2 " " 15A	16 " " 37	2 " " 147B
3 " " 16	2 " " 44	2 " " 148
2 " " 17	4 " " 48	



It will be noticed from the illustration that $24\frac{1}{2}$ " angle girders have been used as side-members in the base; but as these girders are not included in the No. 6 Outfit, they may be dispensed with, if desired, by substituting two $12\frac{1}{2}$ " girders bolted end to end along each side of the base frame.

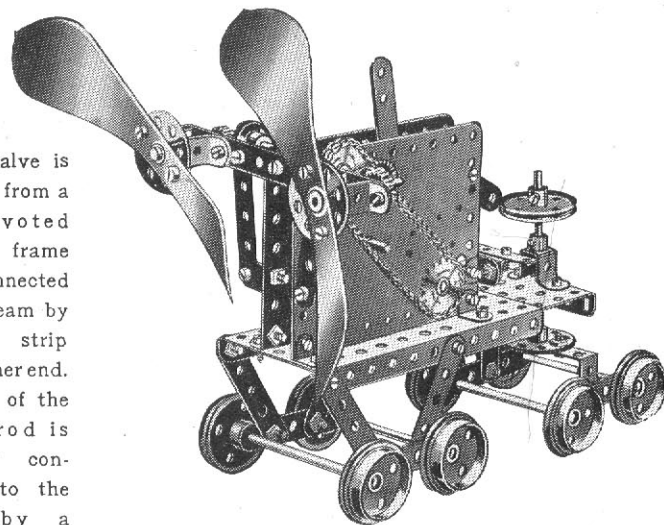
Model No. 609 Beam Engine



Parts required:

5 of No. 1	5 of No. 6A	3 of No. 14	2 of No. 22A	2 of No. 48D	2 of No. 76
4 " " 1B	8 " " 8	3 " " 15	4 " " 24	1 " " 50	2 " " 77
10 " " 2	2 " " 8A	2 " " 15A	2 " " 26	2 " " 52A	1 " " 95
1 " " 2A	7 " " 9	2 " " 16	1 " " 27A	3 " " 53	1 " " 96A
4 " " 4	2 " " 9B	1 " " 16A	1 " " 29	17 " " 59	2 " " 109
1 " " 5	4 " " 11	2 " " 17	120 " " 37	2 " " 62	1 " " 115
8 " " 6	3 " " 12	2 " " 18A	6 " " 38	6 " " 63	1 " " 118
		1 " " 18B	1 " " 45	1 " " 63B	1 " " 126A
		1 " " 21	3 " " 48c	1 " " 72	2 " " 133

Model No. 610 Aerocar



The valve is operated from a strip pivoted to the frame and connected to the beam by a short strip at the other end. The top of the valve rod is pivotally connected to the strip by a coupling into which a bolt passing through a hole in the strip is screwed.

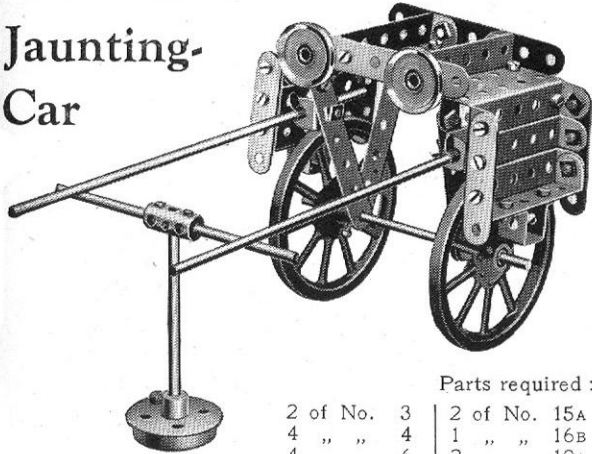
Parts required:

1 of No. 2	2 of No. 29
1 " " 4	47 " " 37
10 " " 5	4 " " 41
10 " " 12	3 " " 45
2 " " 15A	1 " " 46
4 " " 16	1 " " 52
2 " " 17	1 " " 53
8 " " 20	2 " " 59
3 " " 24	2 " " 96
2 " " 26	

Clockwork Motor
(not included in Outfit)

Model No. 611

Jaunting-Car



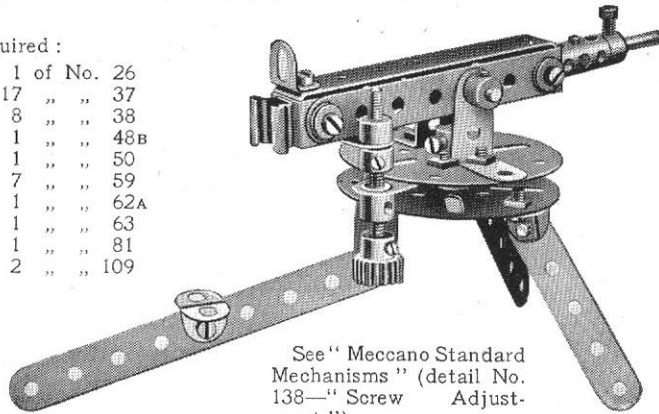
Parts required :

2 of No. 3	2 of No. 15A	39 of No. 37
4 " " 4	1 " " 16B	2 " " 45
4 " " 6	2 " " 19A	10 " " 48A
2 " " 11	1 " " 20	1 " " 53
8 " " 12	2 " " 22	1 " " 63
2 " " 13A	4 " " 35	

Model No. 612 Machine Gun

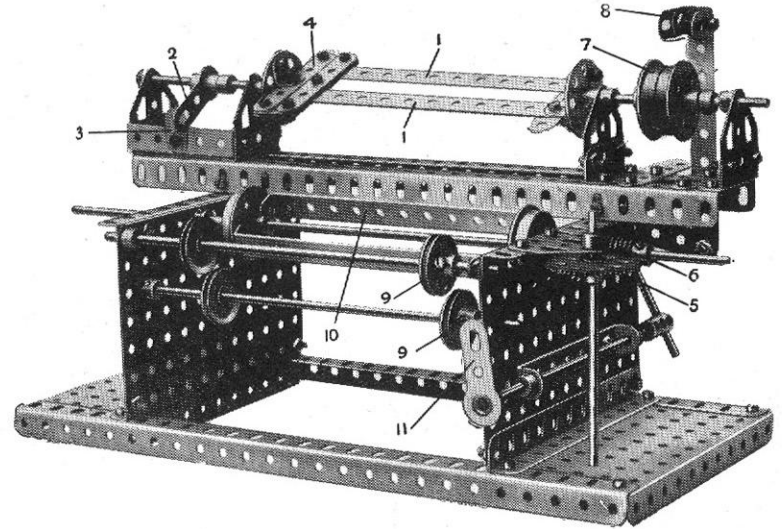
Parts required :

1 of No. 2A	1 of No. 26
2 " " 3	17 " " 37
2 " " 5	8 " " 38
2 " " 11	1 " " 48B
5 " " 12	1 " " 50
2 " " 12A	7 " " 59
2 " " 12B	1 " " 62A
1 " " 17	1 " " 63
1 " " 18A	1 " " 81
1 " " 18B	2 " " 109



See " Meccano Standard Mechanisms " (detail No. 138—" Screw Adjustment.")

Model No. 613 Linen Winder



Parts required :

2 of No. 2	1 of No. 13	1 of No. 27A	2 of No. 48D
1 " " 2A	2 " " 13A	1 " " 32	2 " " 52
8 " " 5	1 " " 14	66 " " 37	2 " " 52A
4 " " 8	1 " " 15A	2 " " 37A	16 " " 59
4 " " 9	2 " " 16	1 " " 37B	2 " " 62
4 " " 9F	1 " " 16A	6 " " 38	2 " " 63
6 " " 10	4 " " 20	1 " " 44	5 " " 126A
1 " " 11	4 " " 22	1 " " 48A	
7 " " 12	2 " " 24	1 " " 48B	

In order to disengage the winding frame bars 1 the Crank 2 is lifted clear of the stop 3 and drawn back, this action disengaging the end cross Strips 4 from the tips of the frame bars 1 and permitting the wound linen to be removed. The Gear Wheel 5 engaging the Worm 6 forms a counter, 7 are the belt Pulleys, and 8 the belt striker operated by Crank 11 ; 9 are the guide Pulleys for the main linen drums 10.

This Model can be built with MECCANO Outfit No. 6 (or No. 5 and 5A)

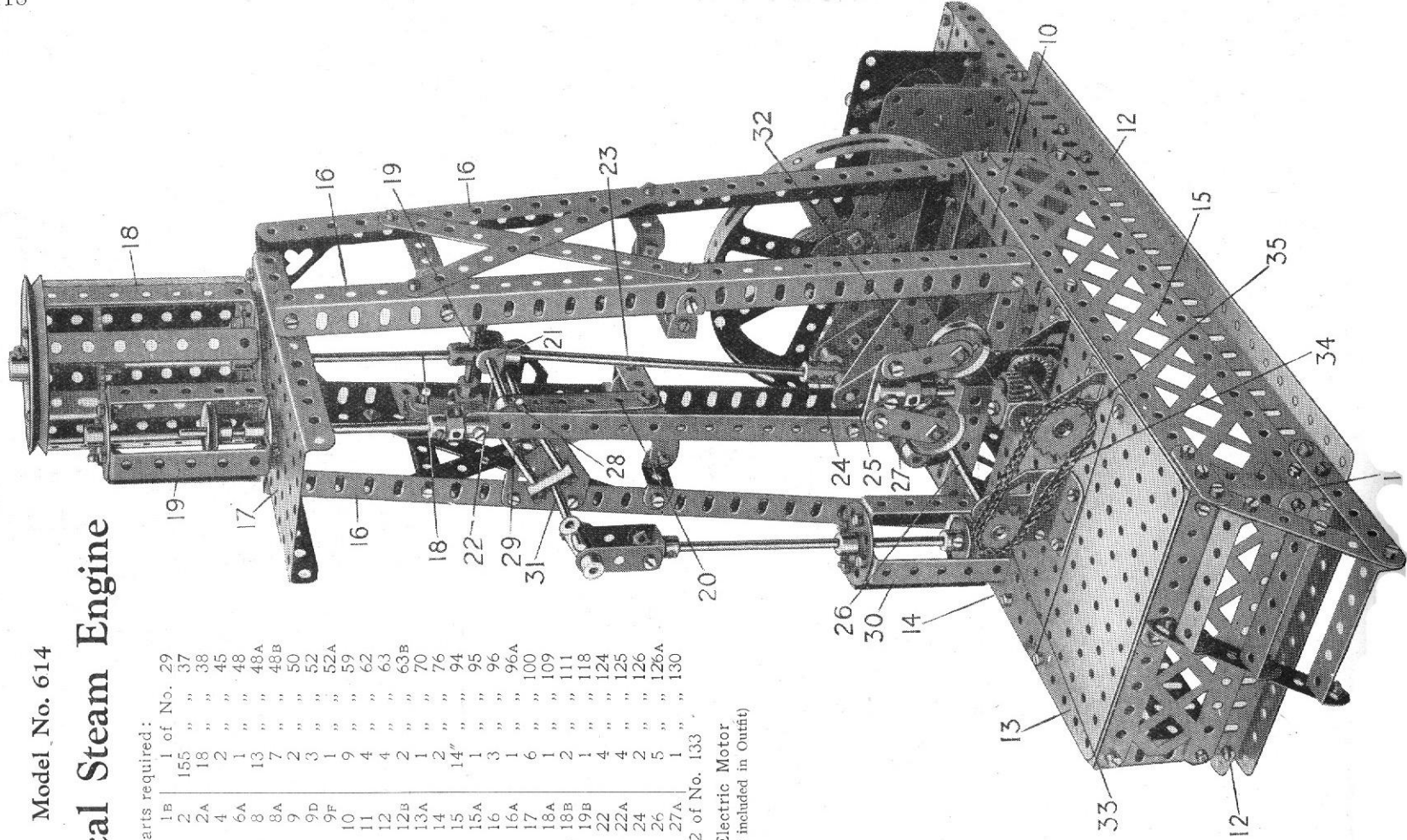
Model No. 614

Vertical Steam Engine

Parts required:

1 of No. 1	1 of No. 29
4 "	37
2 "	38
2 "	18
2 "	2A
3 "	4
3 "	2
6 "	6A
6 "	8
2 "	8A
7 "	7
2 "	9
5 "	9D
1 "	9F
4 "	10
4 "	11
3 "	12
1 "	12B
1 "	13A
1 "	14
1 "	15
2 "	15A
2 "	16
4 "	16A
4 "	17
1 "	18A
1 "	18B
1 "	19B
2 "	22
2 "	22A
5 "	24
4 "	26
3 "	27A
	2 of No. 133

Electric Motor
(not included in Outfit)



Model No. 614

Vertical Steam Engine

(continued)

As shown in Fig. 614A, the motor drives the engine through a reduction gearing arranged as follows:

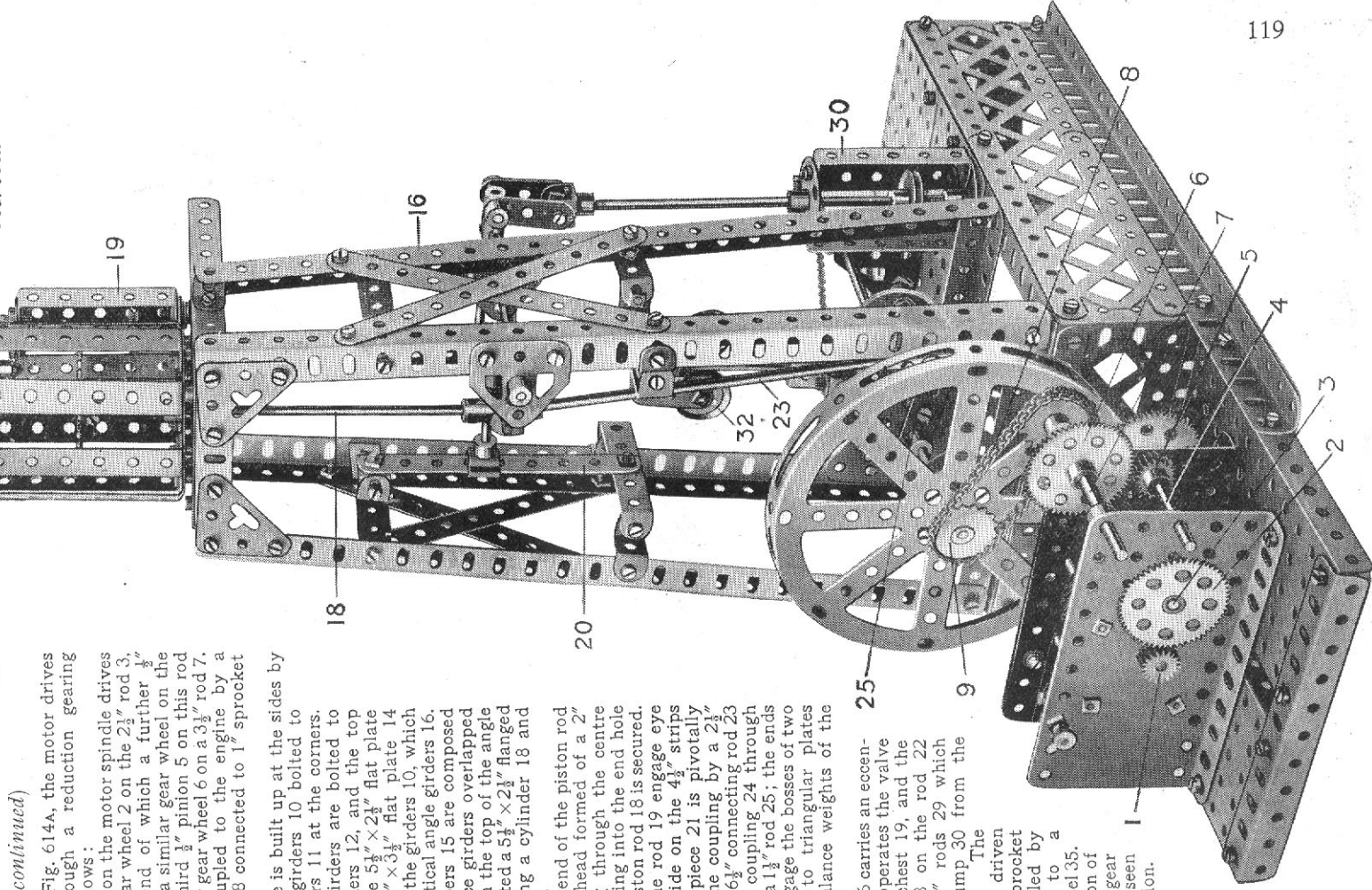
A $\frac{1}{2}$ " pinion 1 on the motor spindle drives a 57-tooth gear wheel 2 on the $2\frac{1}{2}$ " rod 3, on the other end of which a further $\frac{1}{2}$ " pinion engages a similar gear wheel on the $2\frac{1}{2}$ " rod 4; a third $\frac{1}{2}$ " pinion 5 on this rod engages another gear wheel 6 on a $3\frac{1}{2}$ " rod 7. This rod is coupled to the engine by a sprocket chain 8 connected to 1" sprocket wheels 9.

The bed plate is built up at the sides by two $9\frac{1}{2}$ " angle girders 10 bolted to $2\frac{1}{2}$ " angle girders 11 at the corners. These corner girders are bolted to $12\frac{1}{2}$ " angle girders 12, and the top is formed of one $5\frac{1}{2}$ " \times $2\frac{3}{4}$ " flat plate 13 and one $5\frac{1}{2}$ " \times $3\frac{1}{2}$ " flat plate 14 bolted down to the girders 10, which support the vertical angle girders 16. The side members 15 are composed of two $5\frac{1}{2}$ " brace girders overlapped three holes. In the top of the angle girders 16 is bolted a $5\frac{1}{2}$ " \times $2\frac{1}{2}$ " flanged plate 17 carrying a cylinder 18 and valve chest 19.

At the lower end of the piston rod 18 is the crosshead formed of a $2\frac{1}{2}$ " rod 19 passing through the centre hole of a coupling into the end hole of which the piston rod 18 is secured. The ends of the rod 19 engage eye pieces which slide on the $4\frac{1}{2}$ " strips 20. The fork piece 21 is pivotally connected to the coupling by a $2\frac{1}{4}$ " rod 22, and the $6\frac{1}{2}$ " connecting rod 23 is secured to a coupling 24 through which is passed a $1\frac{1}{2}$ " rod 25; the ends of the latter engage the bosses of two cranks bolted to triangular plates forming the balance weights of the crankshaft.

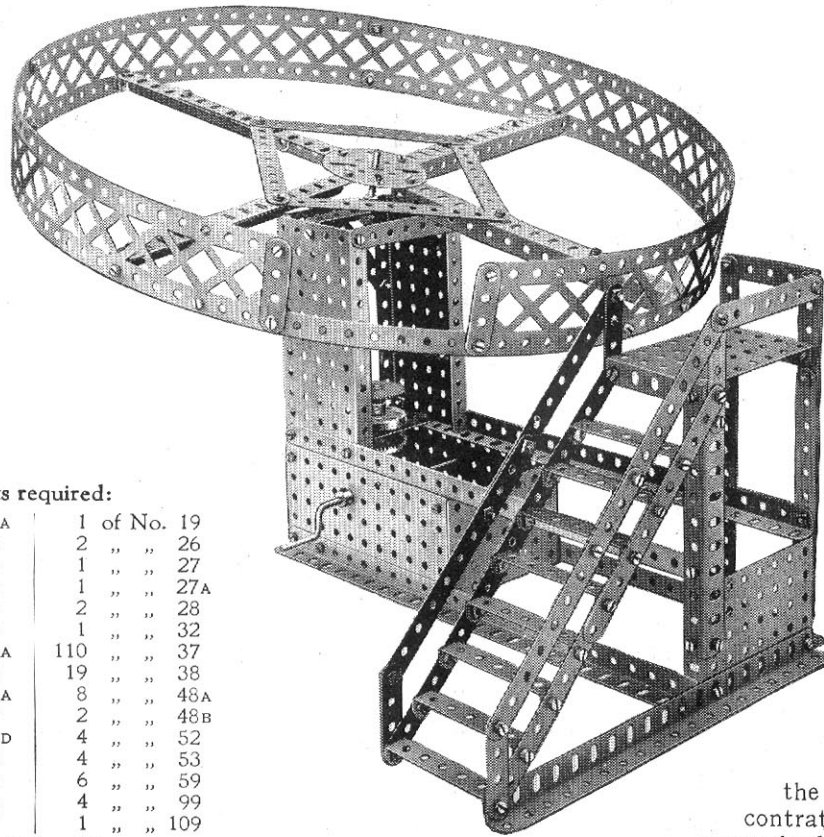
The $4\frac{1}{2}$ " rod 26 carries an eccentric rod 27 which operates the valve in the valve chest 19, and the two collars 28 on the rod 22 engage two 2" rods 29 which actuate the pump 30 from the rocking rod 31. The governor 32 is driven from a $\frac{3}{8}$ " sprocket wheel 33 coupled by a chain 34 to a 1" sprocket wheel 35. The construction of the governor gear can be clearly seen in the illustration.

FIG. 614A



This Model can be made with MECCANO Outfit No. 6, or No. 5 and No. 5A.

Model No. 615 Joy Wheel



Parts required:

1 of No. 1A	1 of No. 19
16 " " 2	2 " " 26
4 " " 3	1 " " 27
2 " " 4	1 " " 27A
2 " " 5	2 " " 28
5 " " 6	1 " " 32
2 " " 6A	110 " " 37
4 " " 8	19 " " 38
1 " " 8A	8 " " 48A
9 " " 9	2 " " 48B
1 " " 9D	4 " " 52
5 " " 12	4 " " 53
1 " " 14	6 " " 59
1 " " 16	4 " " 99
1 " " 17	1 " " 109
1 of No. 126	

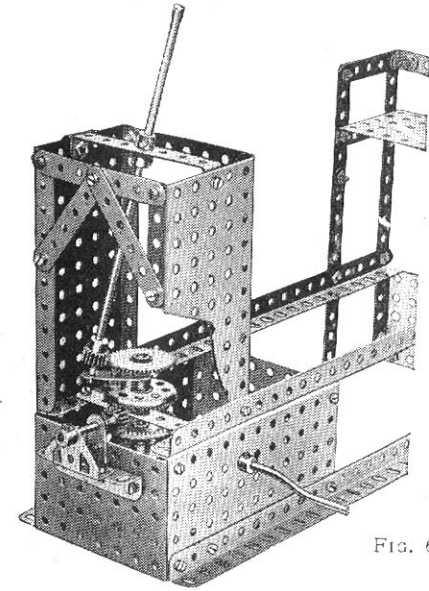


FIG. 615A

This model comprises a new and very interesting Meccano motion.

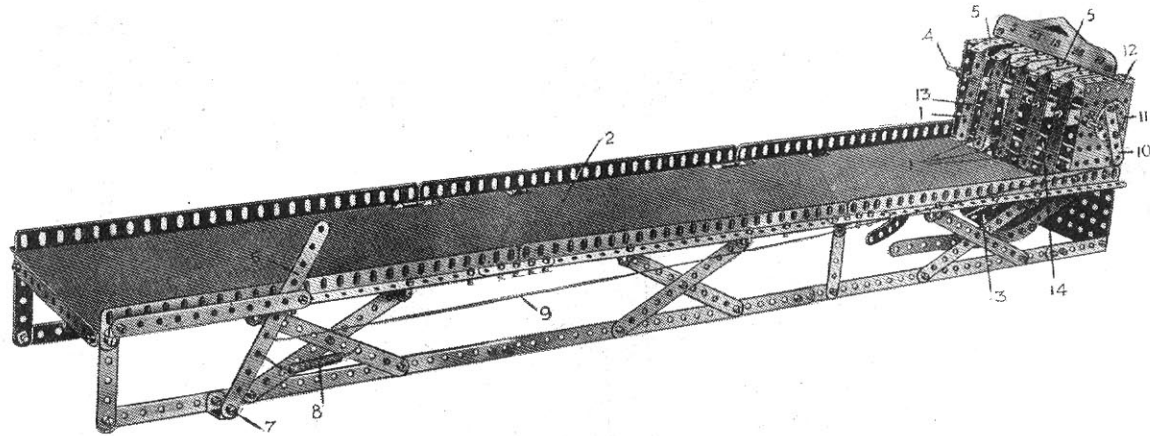
The Crank handle drives by means of a worm wheel and 57-toothed gear wheel a vertical rod carrying two $1\frac{1}{2}$ " contra wheels and a gear wheel, as shown in Figure A. The lower contra wheel is secured to the shaft but the upper one revolves freely upon it. The latter is driven from the fixed contra wheel by means of a $\frac{1}{2}$ " pinion, and its direction of rotation is consequently reversed.

The end of the shaft carrying the revolving part of the model is journaled on a short strip bolted to the upper contra wheel and carries a $\frac{1}{2}$ " pinion which engages with the gear wheel secured on the vertical shaft. Thus, on operation of the crank handle, the model revolves upon its axis, at the same time twisting slowly round with an amusing "wobble." A circular piece of cardboard is cut and placed in position to represent the floor found in real "Joywheels."

Model No. 616 Box Ball Alley

Parts
required:

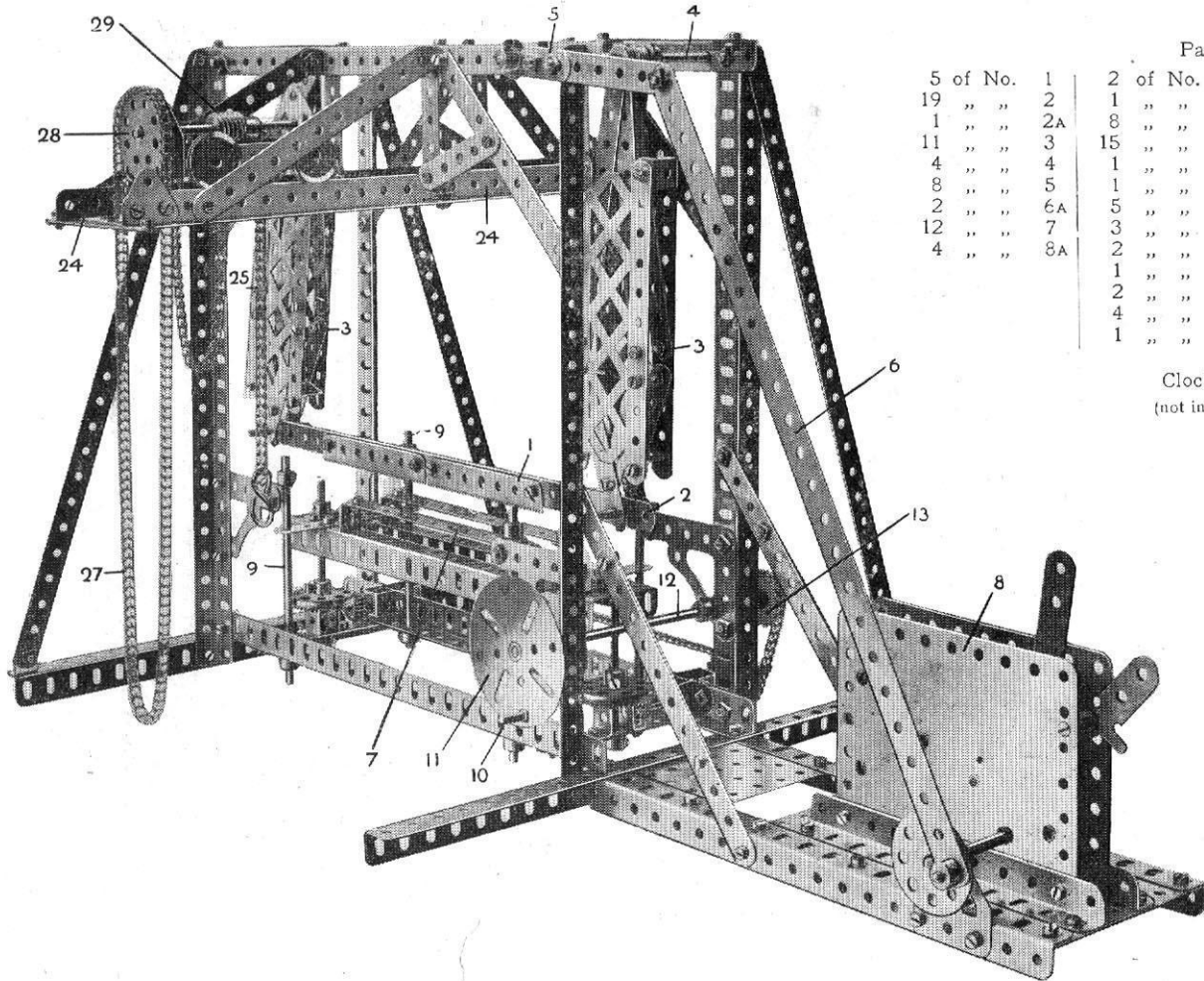
6	of No.	1
19	" "	2
5	" "	3
2	" "	4
15	" "	5
6	" "	8
5	" "	11
27	" "	12
1	" "	14
1	" "	15
2	" "	16
1	" "	24
8	" "	35
132	" "	37
1	" "	43
2	" "	52
2	" "	53
2	" "	54
2	" "	59
2	" "	62
1	" "	63



This model of a Box Ball Alley gives endless amusement, apart from the actual construction.

The object is to hit one of the strips 1, which have various number values, by means of a ball rolled along the platform 2, the ball after striking and tipping one of the strips being returned by the tray 3 to the player. The strips 1 are pivoted by double bent strips on to a rod 4, so that each strip may swing independently. The upper end of each strip is engaged by strips 5, the ends of which are bent slightly down, as shown, so that while the strips 1 are normally held in the position shown, when one of the strips is struck by the ball it is deflected backward and its upper end snaps outward past the bent end of its strip 5, which thus acts as a spring, the deflected strip being then retained in that position until it is reset. To reset any or all of the strips 1 a handle is formed by a strip 6 pivoted at 7 and controlled by a tension spring 8. A cord 9 connects the strip 6 to a short strip 10 forming a crank and bolted to a bush wheel 11 on an axle journalled in the side plates 12. This axle on its interior carries two further bush wheels to which are secured two short strips 13 forming cranks, a long double bent strip 14 being in turn bolted to the strips 13. When therefore the handle 6 is pulled out against the spring 8 the cord 9 rotates the bush wheel 11 and forces out the long double bent strip 14 which pushes out the strips 1 and resets them in their normal positions. During this resetting operation the upper ends of the strips 1 snap back beneath the bent ends of the spring strips 5.

Model No. 617 Stone-Sawing Machine



Parts required :

5 of No. 1	1	2 of No. 9	3 of No. 26	2 of No. 62A
19 " " 2	2	1 " " 10	2 " " 28	2 " " 77
1 " " 2A	2A	8 " " 11	1 " " 32	2 " " 80A
11 " " 3	3	15 " " 12	12 " " 35	40" " " 94
4 " " 4	4	1 " " 13	185 " " 37	1 " " 95A
8 " " 5	5	1 " " 14	32 " " 38	1 " " 96A
2 " " 6A	6A	5 " " 15	6 " " 45	4 " " 100
12 " " 7	7	3 " " 16	1 " " 47	4 " " 108
4 " " 8A	8A	2 " " 16A	5 " " 48A	1 " " 109
		1 " " 17	3 " " 53	2 " " 110
		2 " " 18A	2 " " 57	2 " " 115
		4 " " 22	15 " " 59	4 " " 125
		1 " " 24	2 " " 62	3 " " 126A

Clockwork Motor
(not included in Outfit)

The sawing strip 1 consists of two rack strips bolted to a 12½" strip 2 connected by 1" rods to the ends of the swinging frames 3, one loosely pivoted on one of the rods carried in the frame and the other secured by a crank to the rod 4. The swinging frames 3 are oscillated from the crank 5 and connecting rod 6 driven by the clockwork motor 8.

Model No. 617 Stone-Sawing Machine *(continued)*

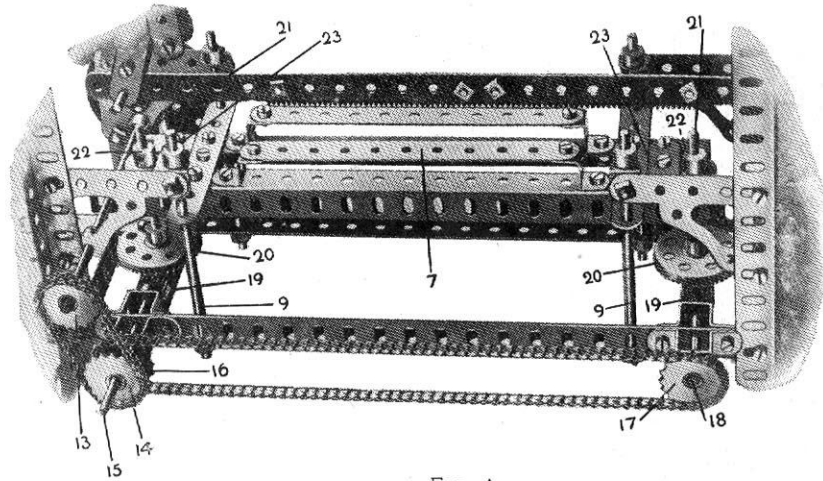


FIG. A

The support frame 7 (Fig. A) for the stone to be sawn is raised and lowered as follows: The frame 7 is guided on the vertical rods 9 and raised and lowered by the operation of the threaded pin 10 forming a handle on the face plate 11. This face plate is mounted on a rod 12 carrying a 1" sprocket wheel 13 connected by a chain to another 1" sprocket wheel 14 on a rod 15. A third 1" sprocket 16 on the same rod is coupled to another 1" sprocket wheel 17 at the other end of the machine.

The rods 15 and 18 carry $\frac{1}{2}$ " pinions 19 driving contrate wheels 20 secured on screwed rods 21 and engaging threaded cranks 22 secured to the frame 7 by $1\frac{1}{2}$ " strips 23.

The trolley (Fig. B) runs on gantry rails 24 and the load chain 25 passes over a $\frac{3}{4}$ " sprocket wheel on the rod 26, to be secured at one end to the trolley frame.

The chain 25 is raised or lowered by the operation of a sprocket chain 27 passing over a $1\frac{1}{2}$ " sprocket wheel 28, the rod of which carries a worm 29. This engages a $\frac{1}{2}$ " pinion on the rod 26 carrying a sprocket wheel 30 over which the load chain 25 passes.

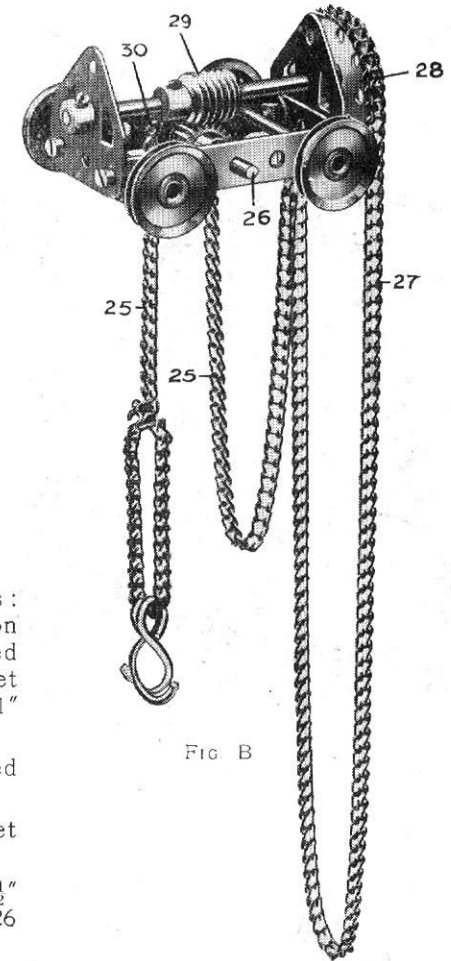


FIG. B

Model No. 618 Bagatelle Table

Parts required:

1 of No. 1	5 of No. 11	3 of No. 17
10 " " 2	9 " " 12	2 " " 18A
2 " " 2A	1 " " 12B	1 " " 18B
1 " " 3	4 " " 13A	1 " " 26
1 " " 4	2 " " 14	2 " " 27A
6 " " 5	1 " " 15	134 " " 37
4 " " 6	2 " " 15A	6 " " 38
6 " " 6A	1 " " 16	
10 " " 8		
11 " " 9		
6 " " 10		

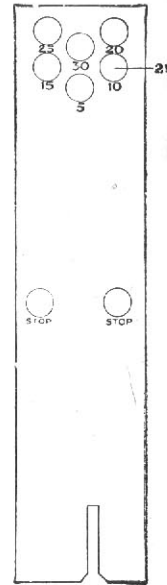
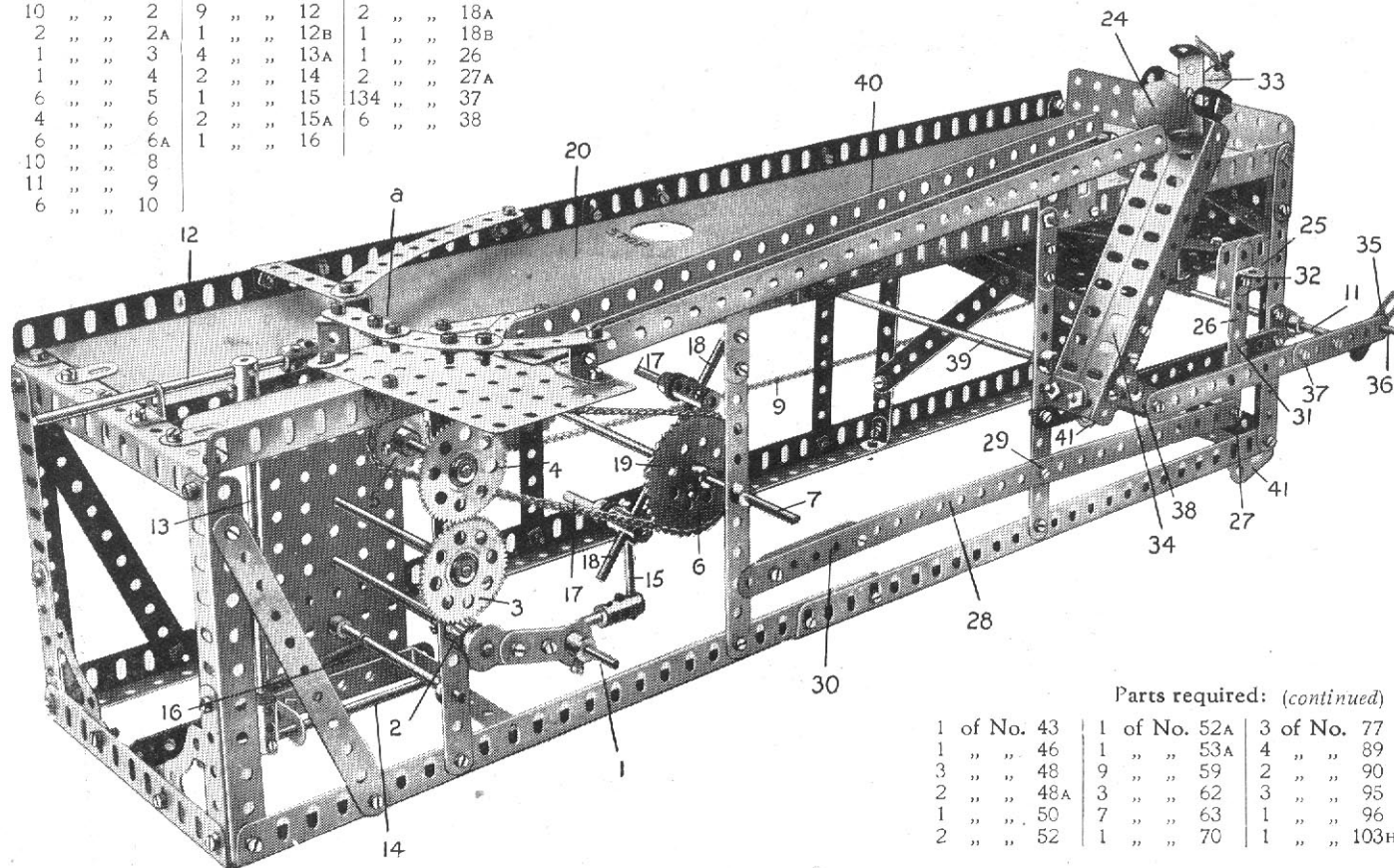


FIG. 618A

Parts required: (continued)

1 of No. 43	1 of No. 52A	3 of No. 77	2 of No. 108
1 " " 46	1 " " 53A	4 " " 89	1 " " 111A
3 " " 48	9 " " 59	2 " " 90	1 " " 115
2 " " 48A	3 " " 62	3 " " 95	1 " " 125
1 " " 50	7 " " 63	1 " " 96	3 " " 126A
2 " " 52	1 " " 70	1 " " 103H	1 " " 128

Model No. 618 Bagatelle Table (continued)

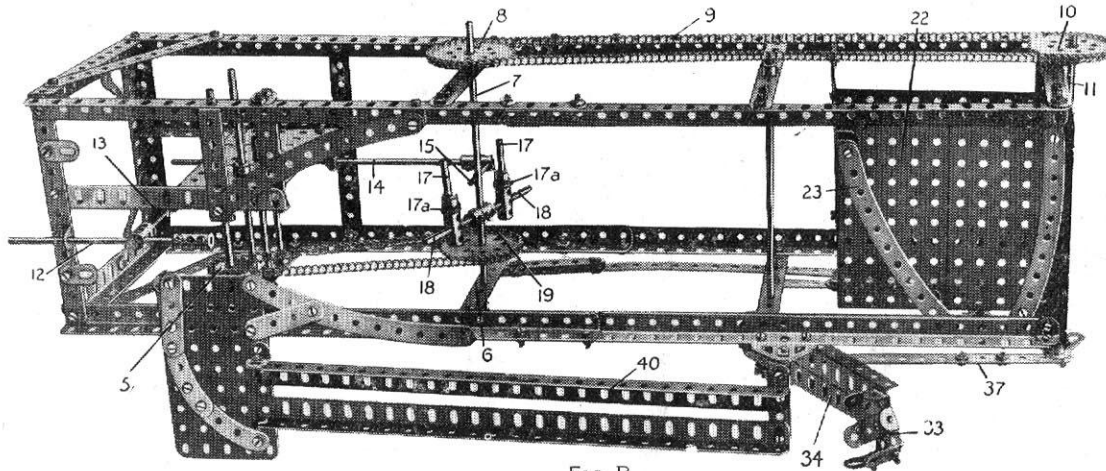


FIG. B

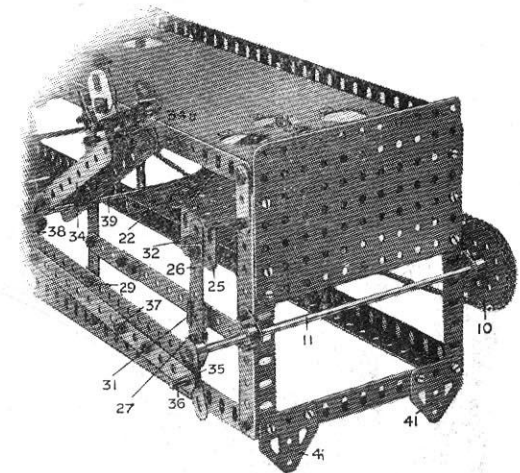


FIG. C

The operating handle 1 drives a $\frac{1}{2}$ " pinion 2 engaging a $1\frac{1}{2}$ " gear wheel 3. This engages another $1\frac{1}{2}$ " gear wheel 4 on the axle rod of which is a 1" sprocket wheel 5 coupled by a chain to a 2" sprocket wheel 6 on the axle rod 7. On the further end of this rod 7 is another 2" gear wheel 8 connected by a chain 9 to a 2" gear wheel 10 on a rear axle rod 11.

The pusher-rod 12 (by means of which the marble is driven from the point a), is carried from a $5\frac{1}{2}$ " vertical rod 13 which is connected to an 8" rod 14. At the front end of the latter is a 2" rod 15 arranged vertically and a spring 16 tends to pull the pusher-rod forward to strike the marble. The pusher-rod is depressed against the spring by the action of two 1" rods 17 upon which are mounted $\frac{1}{2}$ " pulley wheels 17a carried from two couplings secured on two 2" rods 18 which enter the central coupling 19. The axle rod 7 passes completely through the coupling 19.

As the rods 17 rotate, the pulleys 17a bear against the rod 15 and depress the pusher-rod rearwardly until released, when the spring pulls the pusher-rod sharply forward to drive the marble from the point a along the table 20 towards the holes 21 (Fig. A). When the marble falls into any one of the holes 21 it drops on to the Plate 22 (Figs. B and C) formed of two $5\frac{1}{2}$ " flanged plates bolted together. The plate 22 is inclined one hole down, and guides consisting of $5\frac{1}{2}$ " curved strips 23 (Fig. B) connected to the plate by double angle brackets, lead the marble 24 (Fig. 618) to the end of the plate, where it is retained by a $1\frac{1}{2}$ " flat girder 25 (Fig. C) carried on a $3\frac{1}{2}$ " strip 26 pivotally connected at 27 (Fig. 618) by locked nuts to a $12\frac{1}{2}$ " strip pivoted at 29 and weighted at 30 with $2\frac{1}{2}$ " strips.

The strip 26 (Fig. C) is guided in an eye piece 31 and an angle bracket 32 is bolted near the top of the strip. The pocket 33 consists of three $1\frac{1}{2}$ " x $\frac{1}{4}$ " double angle strips at the end of an arm 34 formed by two $5\frac{1}{2}$ " angle girders. The pocket is carried from the arm 34 by a 1" triangular plate 34a the two base holes of which are bolted in the end holes of the angle girders. The pocket is bolted to the apex hole of the triangular plate, with three washers beneath the pocket to set it up.

The arm 34 is rocked from the rod 11 (Fig. 618) by a crank 35, a threaded pin 36 on which engages the end hole of a $5\frac{1}{2}$ " and a 3" strip 37 overlapped three holes. The other end of the strip is connected to a boss bell crank 38 bolted to the arm 34 and secured to the rod 39.

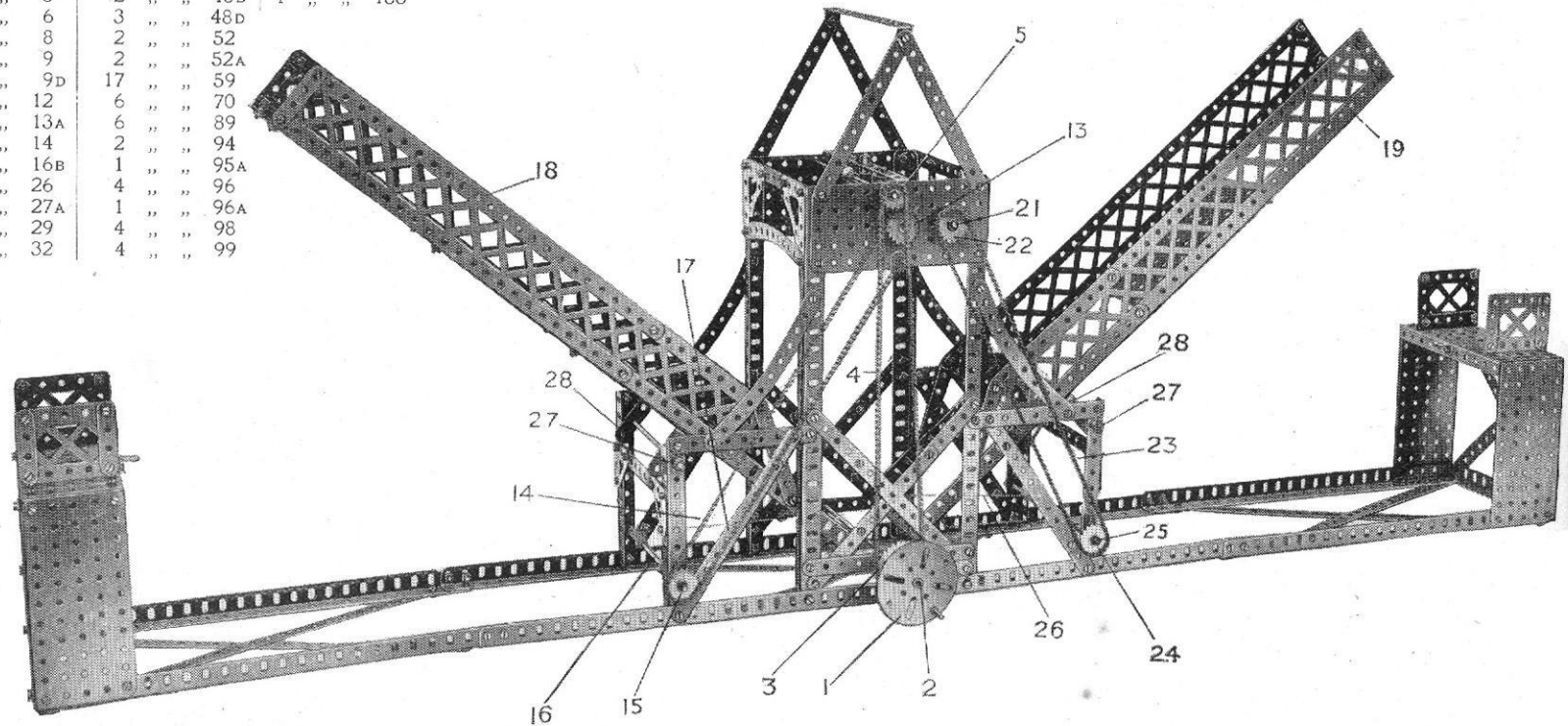
As the axle rod 11 rotates, the arm 34 is permitted to fall, and in so doing makes contact with the angle bracket 32 and depresses the stop plate 25, permitting the marble to drop from the plate 22 into the pocket 33. Further rotary movement of the rod 11 again raises the arm 34 with the marble in the pocket, until the marble is deposited into the chute 40 and is returned to the point a.

Meanwhile, on the rising of the arm 34 the plate 25 is again raised to close the outlet from the inclined plate 22. The bearings for the axle rod 11 are formed by two 1" triangular plates secured to the rear vertical angle girders.

Figure A shows the shape and size of the cardboard table. The holes 21 should be made only slightly larger than the marble used. (The marble is not supplied in Meccano Outfits, but may be purchased separately). The table is given a slight incline towards the pusher-rod end by forming at the other end two feet with two flat trunnions 41 bolted to the lower $5\frac{1}{2}$ " angle girders.

Model No. 619 Jack Knife Bridge

Parts required:		
6 of No. 1	210 of No. 37	4 of No. 100
4 " " 1B	6 " " 38	4 " " 108
26 " " 2	1 " " 40	1 " " 109
4 " " 2A	1 " " 48A	1 " " 115
4 " " 3	2 " " 48B	4 " " 133
16 " " 6	3 " " 48D	
20 " " 8	2 " " 52	
6 " " 9	2 " " 52A	
4 " " 9D	17 " " 59	
6 " " 12	6 " " 70	
1 " " 13A	6 " " 89	
6 " " 14	2 " " 94	
1 " " 16B	1 " " 95A	
2 " " 26	4 " " 96	
2 " " 27A	1 " " 96A	
1 " " 29	4 " " 98	
1 " " 32	4 " " 99	



The arms of the bridge are raised or lowered by rotating the hand-wheel 1. On the 8" Rod 2 of the hand-wheel is mounted a $1\frac{1}{2}$ " Sprocket Wheel 3 which is coupled by a Chain 4 to a $\frac{3}{4}$ " Sprocket Wheel 5 on a $6\frac{1}{2}$ " Rod 6, Fig. 6.19A. On this rod a Worm Wheel 7 drives a $\frac{1}{2}$ " Pinion 8 on a $3\frac{1}{2}$ " Rod 9, on which is a $\frac{3}{4}$ " Contrate Wheel 10. This engages a $\frac{3}{4}$ " Pinion 11 carried on a 3" Rod 12, on the outer end of which is a 1" Sprocket Wheel 13 connected by a Sprocket Chain 14 to a 1" Sprocket Wheel 15 on a $6\frac{1}{2}$ " Rod 16; on this rod a Cord 17 is wound, connected to the end of one arm 18 of the bridge. The other arm 19 is operated from a 57-toothed Gear Wheel 20 on the Rod 12

Model No. 619 Jack Knife Bridge
(continued)

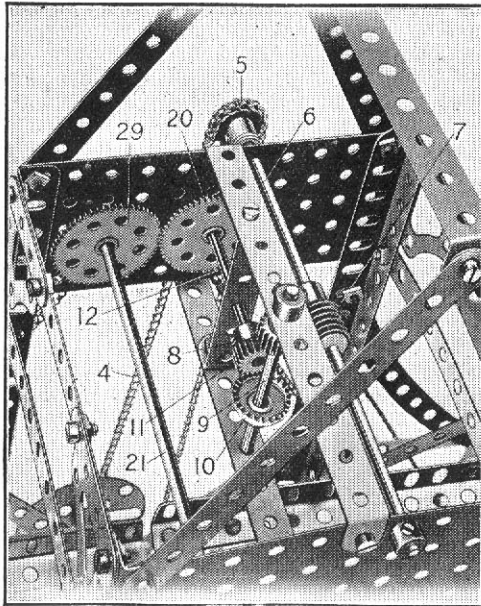
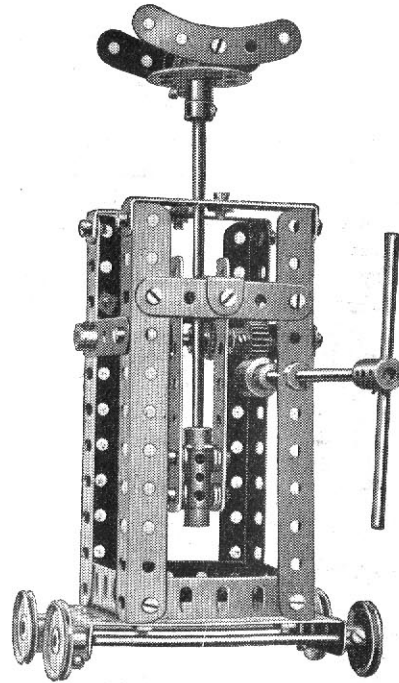


FIG. 619A

engaging a similar wheel 29 on the $6\frac{1}{2}$ " rod 21. On the end of this rod a 1" sprocket wheel 22 is coupled by a chain 23 to another 1" sprocket wheel 24 on the $6\frac{1}{2}$ " winding rod 25, the cord 26 from which is connected to the other arm 19 of the bridge.

The arms 18 and 19 are pivotally carried on $6\frac{1}{2}$ " rods 27 by means of $3\frac{1}{2}$ " x $1\frac{1}{2}$ " double angle strips 28.

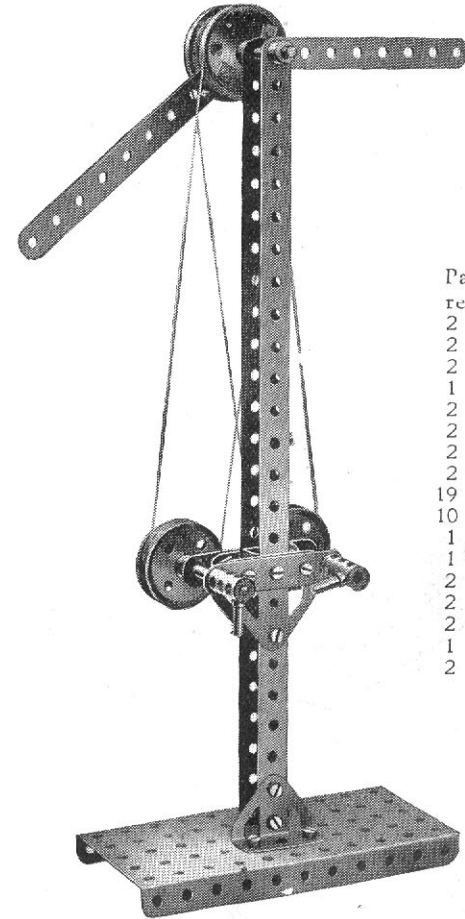
Model No. 620
Jack



Parts required:

5 of No. 5	3 of No. 26
4 " " 9	1 " " 32
4 " " 9D	32 " " 37
2 " " 12	8 " " 38
2 " " 14	3 " " 48A
2 " " 15A	1 " " 53
1 " " 16	7 " " 59
1 " " 16B	2 " " 63
4 " " 22	2 " " 90
1 " " 24	2 " " 110

Model No. 621 Semaphore

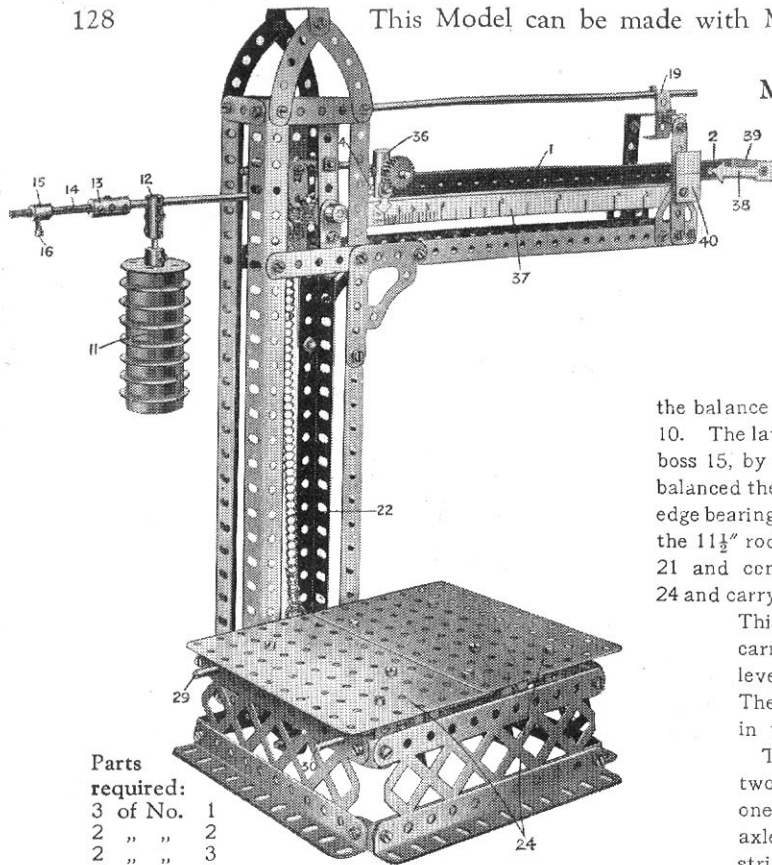


Parts required:

2 of No. 2	
2 " " 5	
2 " " 8	
1 " " 16A	
2 " " 17	
2 " " 20	
2 " " 21	
2 " " 24	
19 " " 37	
10 " " 38	
1 " " 40	
1 " " 52	
2 " " 59	
2 " " 63	
2 " " 115	
1 " " 126	
2 " " 126A	

This Model can be made with MECCANO Outfit No. 6, or No. 5 and No. 5A.

Model No. 622 Platform Scales



Parts required:

3 of No. 1	2 of No. 14	78 of No. 37	1 of No. 64
2 " " 2	1 " " 15	14 " " 38	2 " " 65
2 " " 3	3 " " 16	1 " " 46	1 " " 81
2 " " 4	2 " " 16B	3 " " 48	4 " " 90
3 " " 5	1 " " 17	4 " " 48D	3 " " 100
2 " " 6	2 " " 18A	2 " " 52A	2 " " 102
6 " " 6A	1 " " 18B	6 " " 57	2 " " 108
4 " " 8	2 " " 20	20 " " 59	1 " " 111
2 " " 9	1 " " 25	2 " " 62	1 " " 111A
4 " " 10	2 " " 26	8 " " 63	2 " " 115
1 " " 11	8 " " 35	1 " " 63B	2 " " 126A
2 " " 12			
1 " " 12A			
3 " " 12B			
2 " " 13			

The steelyard 1, consisting of a $12\frac{1}{2}$ " strip, is bolted at its extreme end at 2 to a coupling mounted on an $11\frac{1}{2}$ " rod 3, Fig. C, and at its other end 4 to a second coupling 5, (Fig. C). This coupling is carried on a short rod 6 which passes through two further couplings 7 and 8 and enters another coupling 9 in which a further axle rod 10 is mounted. This rod 10 carries

the balance weights 11 which may be secured by means of the coupling 12 in any position on the rod 10. The latter is also extended at its end by the coupling 13 and threaded rod 14 carrying a threaded boss 15, by which very accurate balance adjustment may be made. When the steelyard is exactly balanced the threaded boss is secured in its position by the bolt 16. The fulcrum 7 rests upon a knife-edge bearing 17 (see "Meccano Standard Mechanisms") and is lifted into weighing position by placing the $11\frac{1}{2}$ " rod 18 under the stop 19. A chain 22 is suspended by means of flat brackets 20 and hook 21 and connects with the levers 23 in the base of the model. These levers are pivoted on hooks 24 and carry a central 3" rod 25 from which hangs a link 26 consisting of a double bracket and $\frac{3}{8}$ " bolt.

This link supports a further rod 27 carried in the ends of another pair of levers 28 pivoted to the hooks 28A. The $6\frac{1}{2}$ " rods 29 and 30 are journaled in the framework of the base.

The platform, Fig. A, is composed of two $5\frac{1}{2}$ " by $3\frac{1}{2}$ " flat plates overlapped one hole and secured together; the axle rod 31 carried in a double angle strip 32 rests upon the levers 23, while the threaded pins 33 bolted in $1"$ by $\frac{1}{2}"$ angle brackets 34 rest upon the levers 28. Two washers are placed on the bolts underneath each end of the double angle strip 32 and four washers are placed beneath each of the brackets 34. Single bent strips 35 form guides for the platform and fit over the rod 30 in the base.

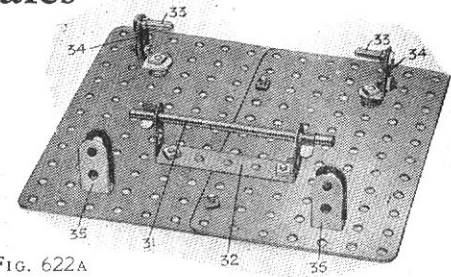


FIG. 622A

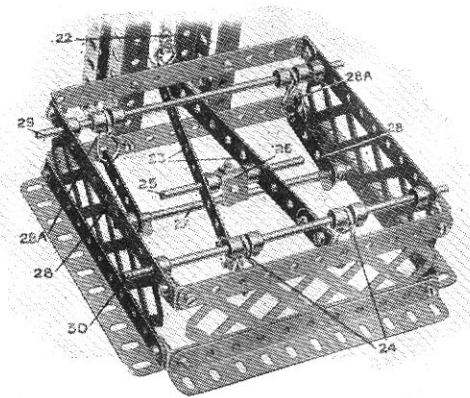


FIG. 622B

Model No. 622 Platform Scales (*continued*)

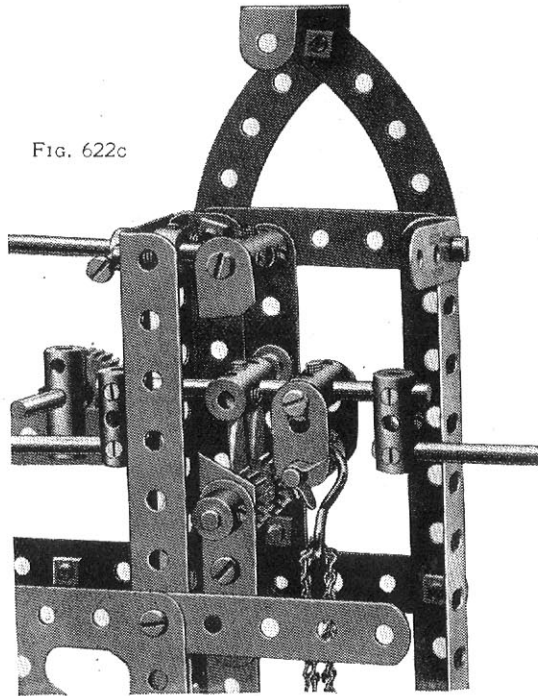


FIG. 622c

A weight 36 consisting of a strip coupling, short rod, and $\frac{3}{4}$ " pinion slides along the steelyard 1 and carries a small arrow, cut from cardboard, which indicates the load being weighed by means of the graduated rule 37. A piece of cardboard 38 also cut in the form of an arrow may be bolted to a 1" reversed angle bracket 39 and arranged to rest against the cardboard indicator 40 when the scales are exactly balanced.

Before commencing to weigh care should be taken in balancing the steelyard so that the arrow 38 points to the line 40 when the sliding weight 36 is at the "O" mark in the rule 37.

Model No. 623 Field Gun

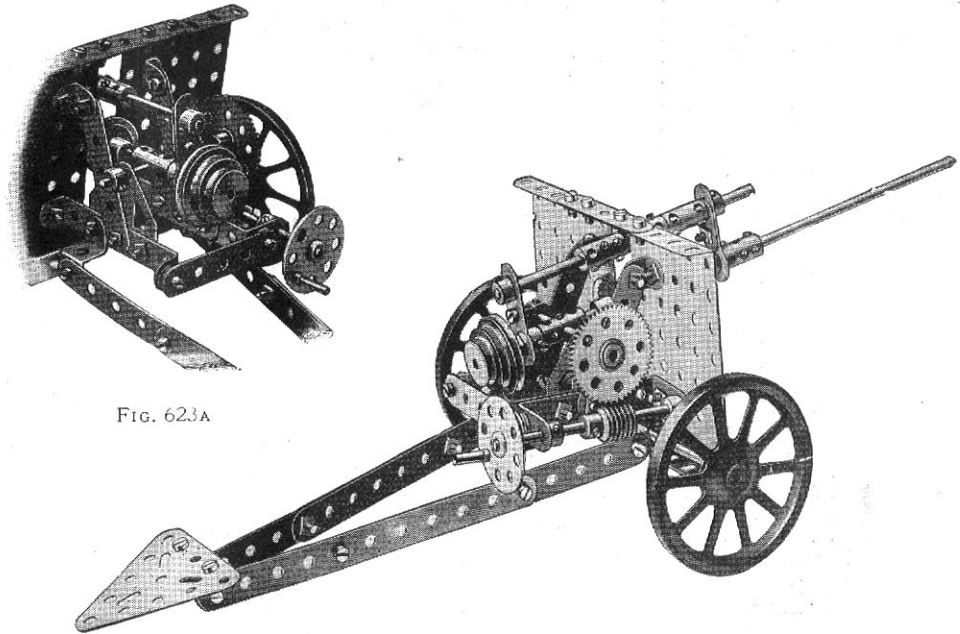


FIG. 623A

Parts required:

4 of No. 2	1 of No. 13A	1 of No. 18B	1 of No. 27A	1 of No. 47	1 of No. 76
5 " " 5	1 " " 14	2 " " 19B	1 " " 32	2 " " 53	1 " " 115
2 " " 10	1 " " 15	3 " " 22	34 " " 37	5 " " 59	1 " " 123
1 " " 11	1 " " 16	1 " " 24	6 " " 38	2 " " 62	2 " " 124
6 " " 12	1 " " 16A	1 " " 26	1 " " 46	4 " " 63	2 " " 126

Model No. 624 Log Saw (continued)

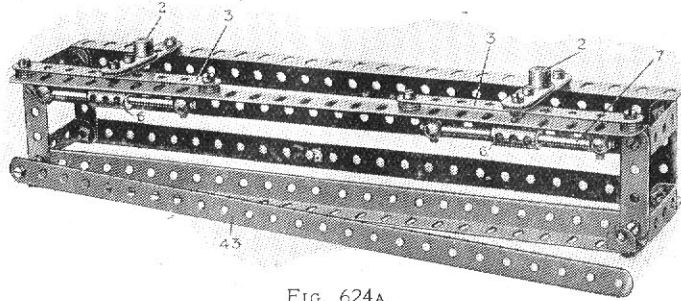


FIG. 624A

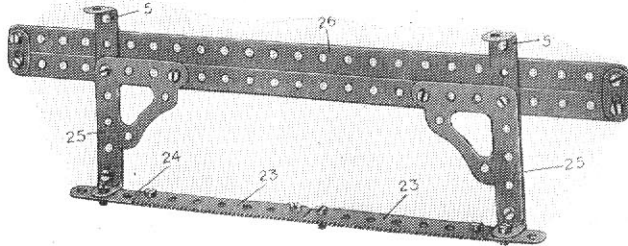


FIG. 624B

The general construction of the main framework of the model is clearly illustrated in Fig. C, while details of the vertically adjustable frame and saw slide are shown in Fig. A and of the saw frame in Fig. B. When completed, the frame (Fig. A) is slipped over the uprights 28. The $9\frac{1}{2}$ " angle girder 27 is then bolted to the $12\frac{1}{2}$ " angle girders 28 as shown and the $12\frac{1}{2}$ " angle girders 29 are joined at 30 to the top of the uprights. The threaded cranks 2 and the strips 3 (Fig. A), are not secured to the saw slide at this stage, but when the slide is in position on the uprights the cranks 2 and strips 3 may be bolted in place. The strips 3 are spaced with washers in order to prevent the bolts, which secure the cranks, from fouling the sliding members 6. The threaded rods 4 are then screwed into the cranks 2 (see book of Meccano Standard Mechanisms, Section IX.)

The saw frame, Fig. B, is bolted and spaced with washers at 5 to the couplings 6 which slide on two $3\frac{1}{2}$ " rods 7 secured to the frame (Fig. A) by rail supports and is reciprocated by means of a $9\frac{1}{2}$ " and $2\frac{1}{2}$ " strip 8 overlapping 3 holes and bolted at 9 to a double bent strip 10 on the frame. The saw frame is further retained on the slide by a $12\frac{1}{2}$ " strip 43. The strip 8 is also bolted to an eccentric 11 on the rod 12, which is driven by a sprocket chain 13 from the motor 14.

The saw slide is adjusted vertically by turning the face plate 15 mounted on a $4\frac{1}{2}$ " rod journalled in a $2\frac{1}{2}$ " x 1" double angle strip (Fig. C.) This rod carries a $1\frac{1}{2}$ " sprocket wheel 17 coupled by a chain 18 to a $\frac{3}{4}$ " sprocket

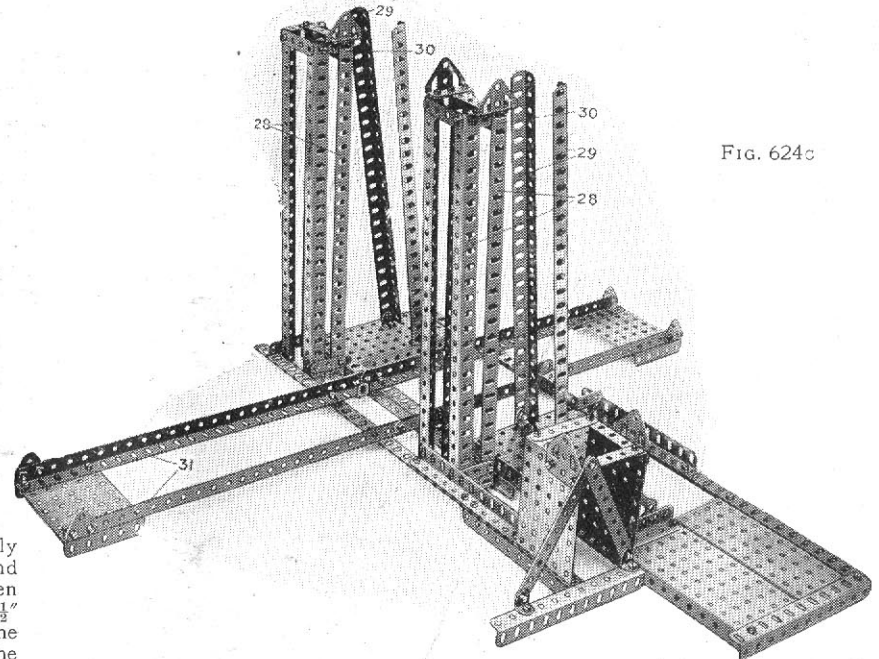


FIG. 624C

wheel 19 on a rod 20 made up of 6" and $3\frac{1}{2}$ " rods coupled together. Two $1\frac{1}{2}$ " pinions 21 engage $1\frac{1}{2}$ " contrate wheels 22 each secured to a $3\frac{1}{2}$ " rod and coupled to the $4\frac{1}{2}$ " screwed rods 4 which engage the cranks 2.

The saw is made up of two rack strips 23 bolted to a $9\frac{1}{2}$ " strip 24 carried by architraves 25 from the saw frame. The latter consists of two $12\frac{1}{2}$ " strips 26 bolted together at the ends.

The feed carriage, which slowly moves the logs against the saw whilst they are being cut, runs on rails 31 formed from $12\frac{1}{2}$ " angle girders butted together, and is advanced by a sprocket chain 32 connected at 33 to the carriage. This chain passes over a $\frac{3}{4}$ " sprocket wheel 34 at either end of the rails, while the lower part of the chain passes under and is driven by a $1\frac{1}{2}$ " sprocket wheel 35 on the 8" rod 36. The latter is connected by a dog clutch to a $3\frac{1}{2}$ " rod carrying a $\frac{3}{4}$ " pinion engaged by a worm wheel 37 on a $2\frac{1}{2}$ " rod. at the other end of which is a 2" sprocket wheel 39. This is driven by a chain 40 from the rod 12. The dog clutch is controlled by the hand lever 41 pivoted at 42. (Meccano Standard Mechanisms, Section V.)

Model No. 625 Crane

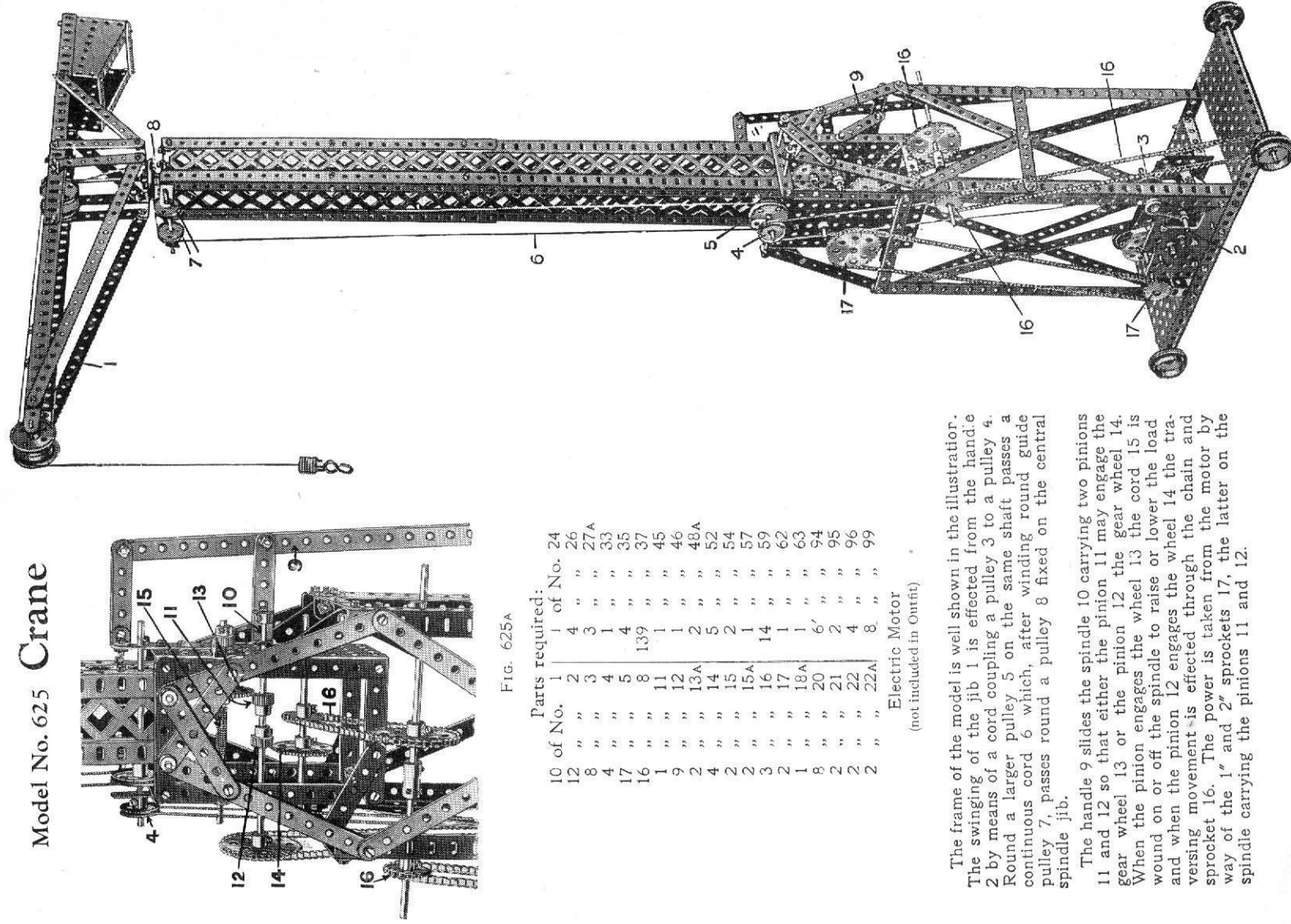


FIG. 625A

Parts required:

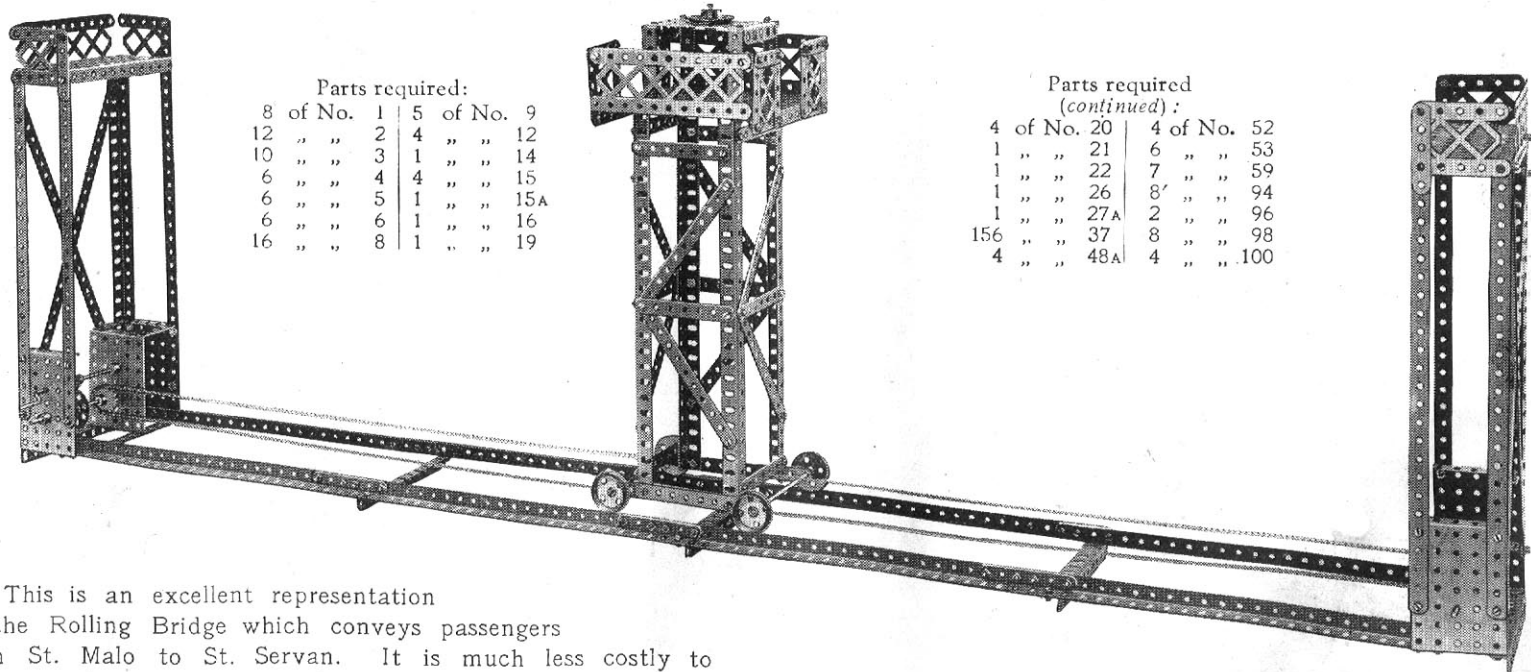
10 of No.	1 of No.	24
12	2	26
8	3	27A
4	1	33
17	4	35
16	8	37
1	11	45
9	12	46
2	13A	48A
4	14	52
2	15	54
2	15A	57
3	16	59
2	17	62
1	18A	63
8	20	94
2	21	95
2	22	96
2	22A	99

Electric Motor
(not included in Outfit)

The frame of the model is well shown in the illustration. The swinging of the jib 1 is effected from the handle 2 by means of a cord coupling a pulley 3 to a pulley 4. Round a larger pulley 5 on the same shaft passes a continuous cord 6 which, after winding round guide pulley 7, passes round a pulley 8 fixed on the central spindle jib.

The handle 9 slides the spindle 10 carrying two pinions 11 and 12 so that either the pinion 11 may engage the gear wheel 13 or the pinion 12 the gear wheel 14. When the pinion engages the wheel 13 the cord 15 is wound on or off the spindle to raise or lower the load and when the pinion 12 engages the wheel 14 the traversing movement is effected through the chain and sprocket 16. The power is taken from the motor by way of the 1" and 2" sprockets 17, the latter on the spindle carrying the pinions 11 and 12.

Model No. 626 St. Malo Transporter Bridge



Parts required:

8 of No. 1	5 of No. 9
12 " " 2	4 " " 12
10 " " 3	1 " " 14
6 " " 4	4 " " 15
6 " " 5	1 " " 15A
6 " " 6	1 " " 16
16 " " 8	1 " " 19

Parts required
(continued):

4 of No. 20	4 of No. 52
1 " " 21	6 " " 53
1 " " 22	7 " " 59
1 " " 26	8 " " 94
1 " " 27A	2 " " 96
156 " " 37	8 " " 98
4 " " 48A	4 " " 100

This is an excellent representation of the Rolling Bridge which conveys passengers from St. Malo to St. Servan. It is much less costly to construct than a transporter bridge of the Newport type, but of course it can only be used over marshy land with shallow water over which a solid track can be laid. The clever Meccano boy will know how to add little decorations to the transporter and the landing platforms in the way of flags, etc., and make a first-class toy of this fine model.

Model No. 627 Automatic Weighing Crane

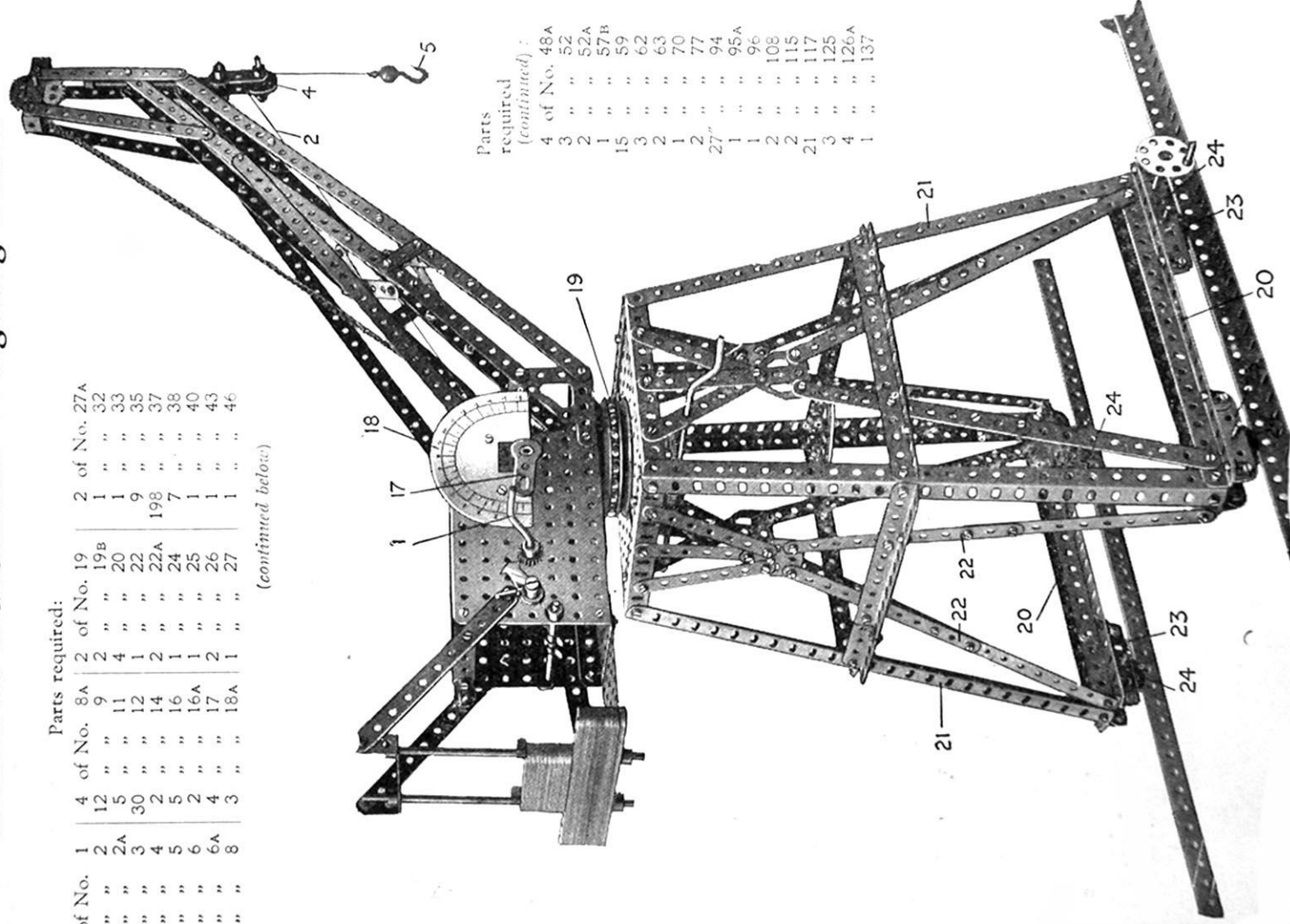
Parts required:

8 of No.	1	4 of No.	8A	2 of No.	19	2 of No.	27A
50 "	2	12 "	9	1 "	"	1 "	32
2 "	2A	5 "	11	4 "	"	1 "	33
10 "	3	30 "	12	1 "	20	9 "	35
12 "	4	2 "	14	2 "	22	198 "	37
36 "	5	5 "	16	1 "	22A	7 "	38
2 "	6	2 "	16A	1 "	25	1 "	40
2 "	6A	4 "	17	2 "	26	1 "	43
8 "	8	3 "	18A	1 "	27	1 "	46

(continued below)

Parts required (continued):

4 of No.	48A
3 "	52
2 "	52A
1 "	57B
15 "	59
3 "	62
2 "	63
1 "	70
2 "	77
27 "	94
1 "	95A
1 "	96
2 "	108
2 "	115
21 "	117
3 "	125
4 "	126A
1 "	137



Model No. 627 Automatic Weighing Crane *(continued)*

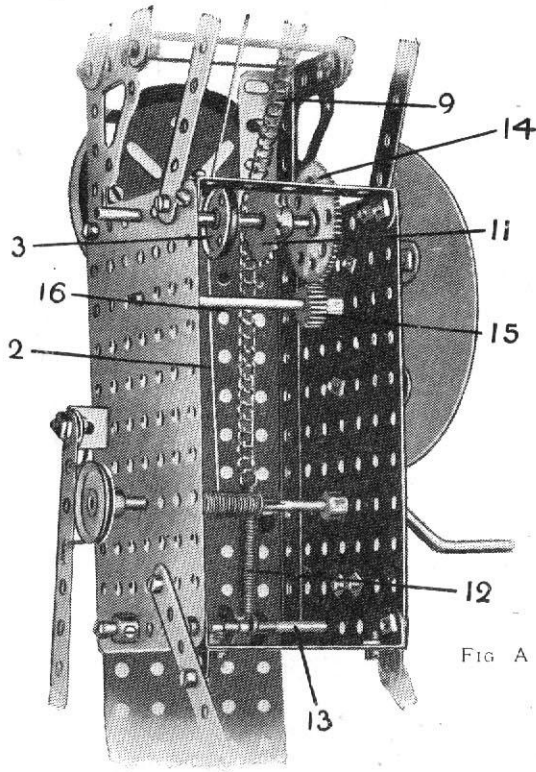


FIG. A

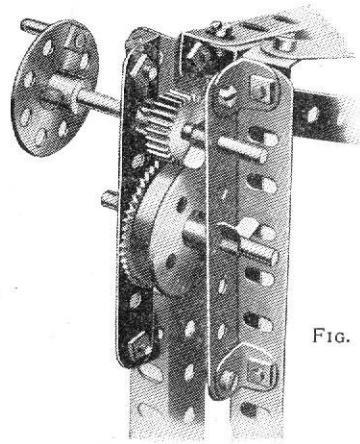


FIG. B

This is a model of a crane that, when raising a load, automatically indicates the weight carried. The load is raised or lowered by the operation of the crank handle 1 upon which is wound a lifting cord 2 passing round a 1" pulley 3 and over another 1" pulley 4 (Fig. C) to the loaded hook 5. The 1" pulley 4, which bears the weight of the load, is carried by two cranks 6 connected to a 3½" rod 7, slidable in two double brackets 8.

To the top of the rod is connected a sprocket chain 9 which passes over a 1½" sprocket wheel 10 and under a 1" sprocket wheel 11 (Fig. A), the other end of the chain being connected to a spring 12, secured to a 3½" rod 13. Thus, when a load is being raised the weight is carried by the rod 7 which pulls down in its bearings, the rod 13 pulling against the spring 12. In this movement, the chain 9 rotates the sprocket wheel 11 and a 1½" gear wheel 14 on the rod of the sprocket 11 engages a ½" pinion 15 on a rod 16. On the outer end of this rod 16 is a crank 17 that sweeps around the graduated

dial 18 to indicate the weight of the load that is being lifted.

The construction of the remainder of the model will be clearly seen from the illustration. The bearings 23 carrying the flanged wheels 24 are formed of 2½" strips connected to the girders 20 by angle brackets.

It will be noted that the crane jib is carried upon ball bearings 19, the balls (Part No. 117) for which are not supplied in the No. 6 Outfit but may be obtained separately. The crane will work well without the ball bearing, but the operation is easier when such a bearing is fitted.

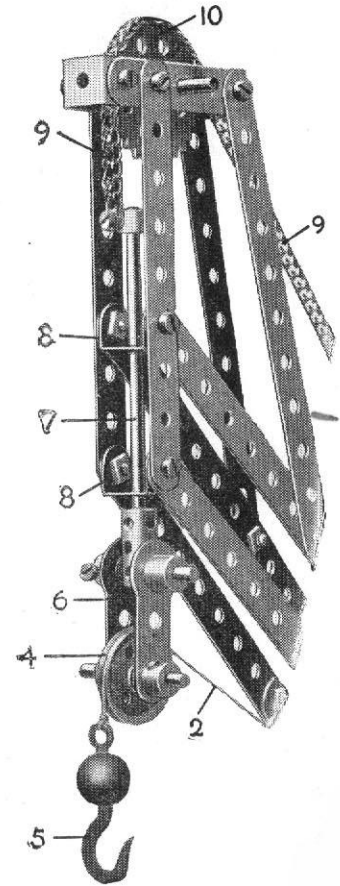
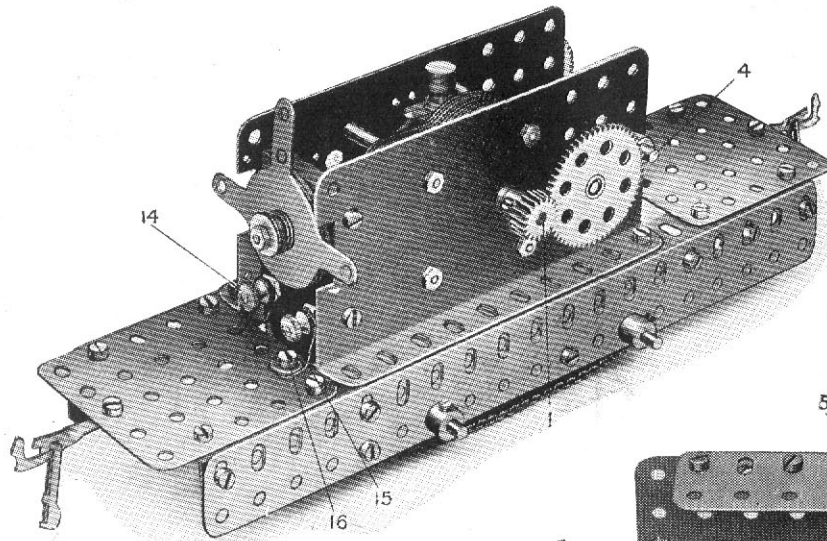


FIG. C

This Model can be made with MECCANO Outfit No. 6, or No. 5 and No. 5A.

Model No. 628 Meccano High-Power Electric Loco Chassis



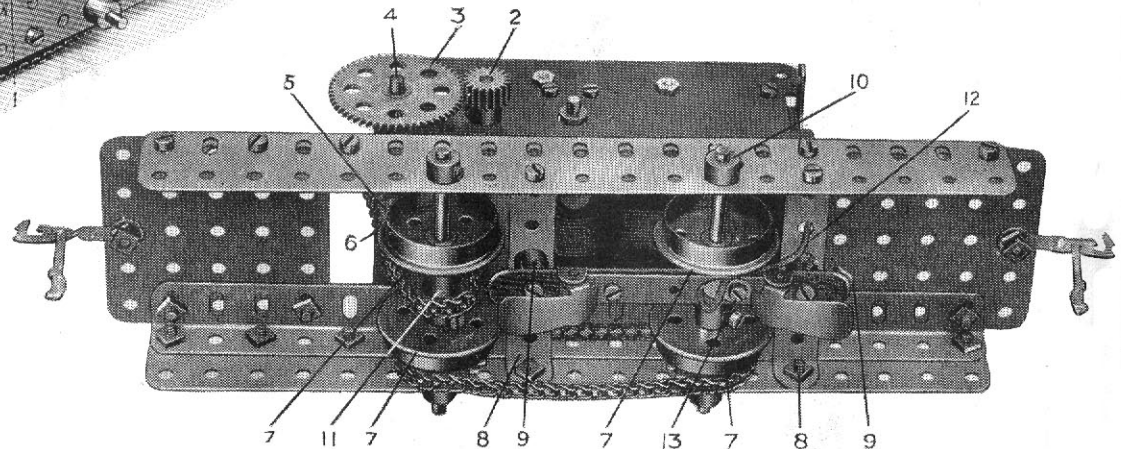
This is a simply constructed and very efficient electric loco, in which either a No. 1 or No. 2 Meccano motor may be used. The construction of the chassis will be clearly seen from the illustrations. The gearing should be built on to the motor before bolting the latter in position. On the motor spindle 1 is secured a $\frac{1}{2}$ " pinion engaging a 57-toothed gear wheel spaced from the motor by three washers.

On the spindle of this gear wheel a second pinion 2 is also secured, but on the opposite side of the motor. The pinion 2 engages a further 57-toothed gear wheel 3 on the spindle 4, and between the side plates, on the latter spindle, is secured a $\frac{3}{4}$ " sprocket wheel 5. Before inserting the spindle 4 a ring of sprocket chain 6, containing 39 links, should be threaded over the sprockets 5 and 11, after which the motor may be bolted on to the chassis. The flanged travelling wheels 7 may now be placed in position as shown. The sprocket wheel 11 is $\frac{3}{4}$ " in diameter and the sprocket wheels connecting the axles are 1". The ring of sprocket chain for these should contain 52 links.

Parts required:

2 of No. 8A	2 of No. 26	4 of No. 59	2 of No. 96
2 " " 16	2 " " 27A	2 " " 64	2 " " 96A
1 " " 17	2 " " 37	2 " " 72	2 " " 103A
4 " " 20	2 " " 48A	1 " " 94	2 " " 121
	1 of No. 149		

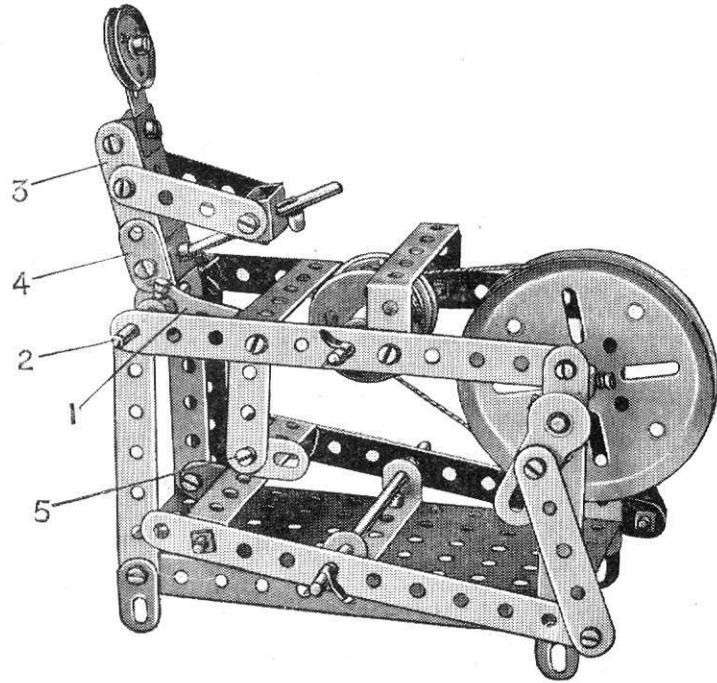
Electric Motor
(not included in outfit)



The new Meccano electric shoe is bolted to the $2\frac{1}{2}$ " double angle strips 8, spaced with a threaded boss 9 at each end to give clearance to the axle rod 10. One end of a piece of insulated wire 12 is connected to the bolt head 13, and the other end to the terminal 14, while another piece of wire is connected with the terminal 15 and the bolt head 16.

The loco is designed to run on "0" gauge electric rails, and may be coupled to Hornby train rolling stock. Any suitable superstructure may be built up on the chassis, to represent an electric loco, to suit the builder's taste.

Model No. 629 Knife Grinder



Parts
required:

4	of No.	2
4	" "	3
2	" "	4
4	" "	5
3	" "	6
4	" "	10
3	" "	11
2	" "	12
1	" "	15
3	" "	16
1	" "	17
1	" "	19A
2	" "	20
1	" "	22
1	" "	22A
2	" "	35
32	" "	37
6	" "	37A
1	" "	46
2	" "	48A
1	" "	48B
1	" "	52
3	" "	62

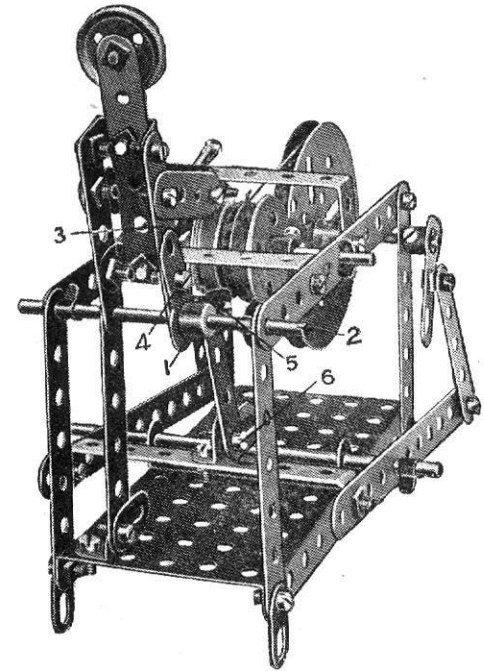
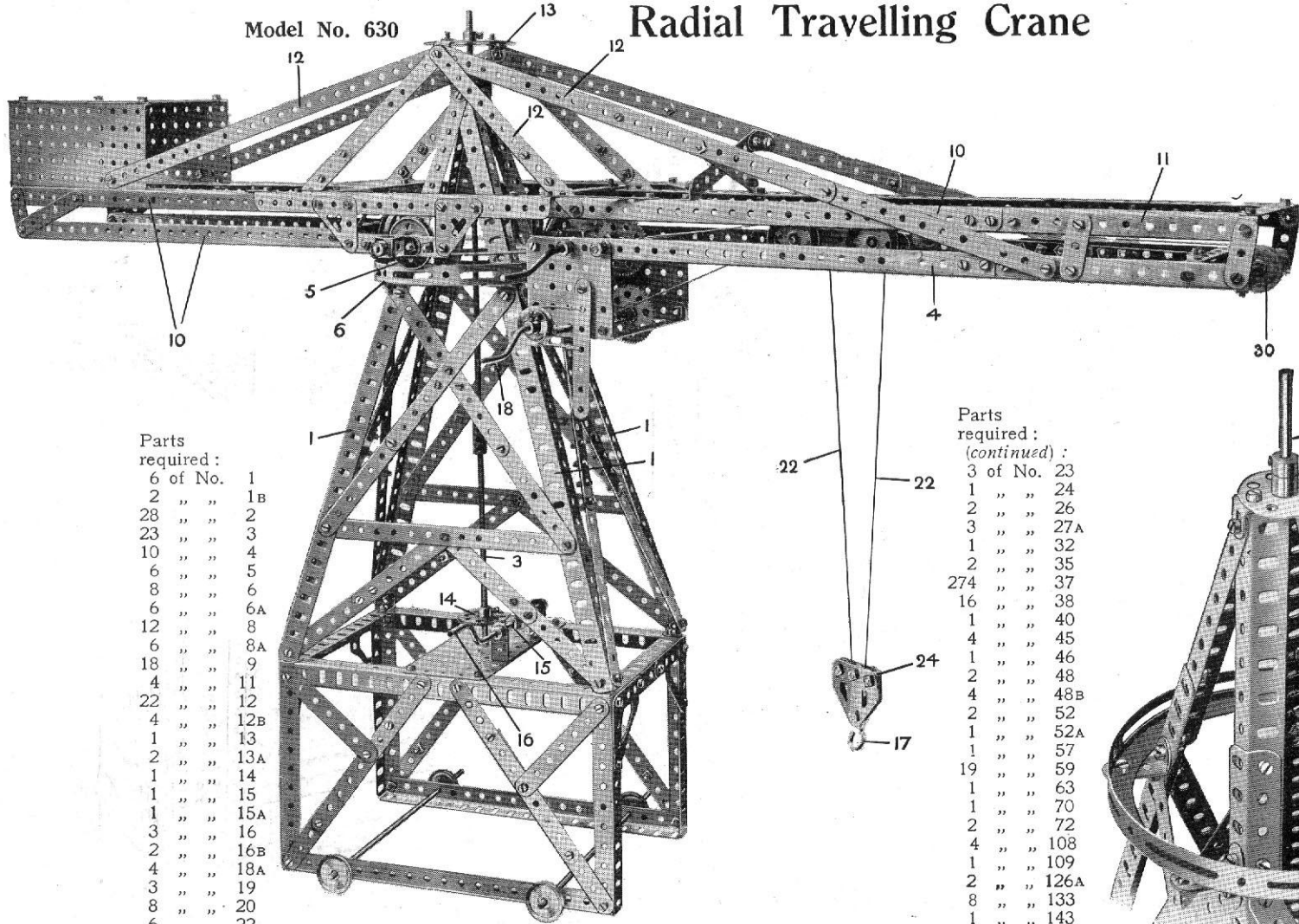


FIG. A

The crank 1 is secured to the rod 2, and the 2½" side-strip 3 is clamped to the crank 1 by the flat bracket 4. The bolt at the end of the crank forming the knee and the bolt 5 are lock-nutted to allow free movement. When the treadle is operated the body works backwards and forwards.

Radial Travelling Crane

Model No. 630



Parts required:

6 of No.	1
2	1B
28	2
23	3
10	4
6	5
8	6
6	6A
12	8
6	8A
18	9
4	11
22	12
4	12B
1	13
2	13A
1	14
1	15
1	15A
3	16
2	16B
4	18A
3	19
8	20
6	22

Parts required:
(continued):

3 of No.	23
1	24
2	26
3	27A
1	32
2	35
274	37
16	38
1	40
4	45
1	46
2	48
4	48B
2	52
1	52A
1	57
19	59
1	63
1	70
2	72
4	108
1	109
2	126A
8	133
1	143

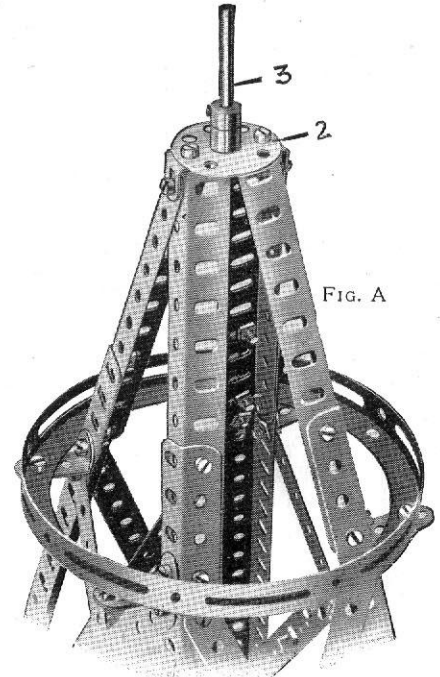


FIG. A

Model No. 630 Radial Travelling Crane (continued)

Begin to build this model by constructing the main tower, the details of which are clearly brought out in the illustrations on the previous page. Notice that the inclined corner angle girders 1 are connected at the top (as shown in Fig. A) by a bush wheel 2 secured by angle brackets. This bush wheel forms a bearing for the vertical rod 3 by which the cantilever arm 4 is turned.

The cantilever arm 4 turns on a wheel-race formed of flanged wheels 5, which run on a circular girder 6 supported by four $1" \times \frac{1}{2}"$ angle brackets bolted to the corner girders 1. The cantilever is built up (as shown in Fig. B) from two $9\frac{1}{2}"$ angle girders 8 braced by two $5\frac{1}{2}"$ angle girders 9 overlapped nine holes. From these, $12\frac{1}{2}"$ angle girders 10 extend on one side, and to similar girders 10 at the other side are connected $5\frac{1}{2}"$ girders 11.

The inclined strips 12 are connected at the top, by means of angle brackets, to a face plate 13 secured to the vertical rod 3. At the foot of the rod 3 is a $1\frac{1}{2}"$ gear wheel 14 engaged by a worm wheel 15 operated by the crank handle 16 and in this way the cantilever arm is swung round, the wheels 5 riding on the circular girder 6.

The load carried from the hook 17 is raised or lowered by the crank handle 18, a $\frac{1}{2}"$ pinion 19 on which engages a $1\frac{1}{2}"$ gear wheel 20 on a rod 21 on which is wound a cord 22. This cord passes over a $\frac{1}{2}"$ pulley 23 to the block 24 and back over another $\frac{1}{2}"$ pulley on the trolley, and is secured to the $3\frac{1}{2}" \times \frac{1}{2}"$ double angle strip 25 at the outer end of the cantilever arm. Consequently, when the trolley is caused to travel along the cantilever arm the load remains suspended at a constant height—an important point and an interesting detail.

The trolley is caused to move to and fro along the cantilever arm by the action of the crank handle 26. On this a $\frac{1}{2}"$ pinion 27 engages a $1\frac{1}{2}"$ gear wheel 28 on a rod on which is wound the cord 29, the opposite ends of which are connected to the opposite ends of the trolley. The cord 29 passes round a pulley 30 at the outer end of the jib. By turning the crank handle 26, therefore, the cord 29 winds on and off its rod, and moves the trolley to and fro, its wheels 31, as shown in Fig. C, running on the angle girders 10.

The wheels 5 are connected to $1\frac{1}{2}"$ rods 5a which are journalled in double bent strips 5b bolted to $3\frac{1}{2}"$ strips 5c carried from the angle girders 8 by corner brackets 5d.

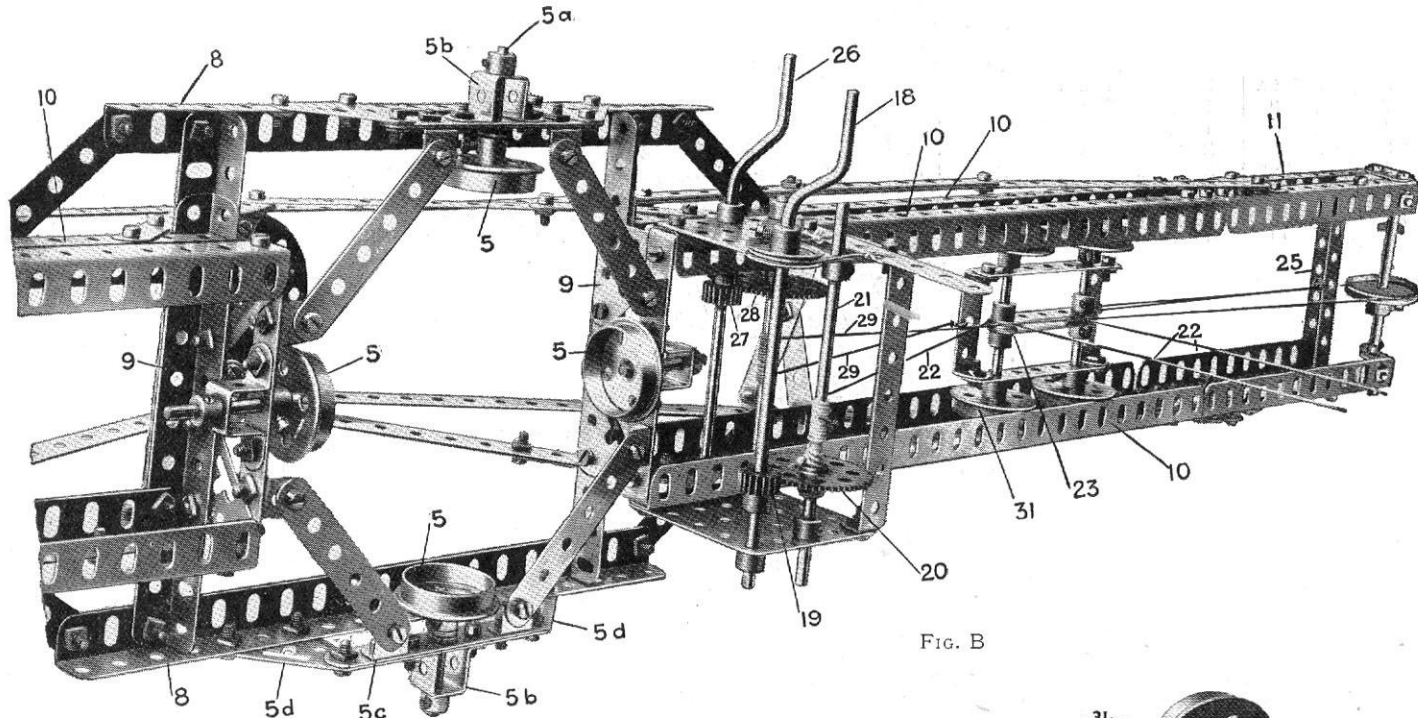


FIG. B

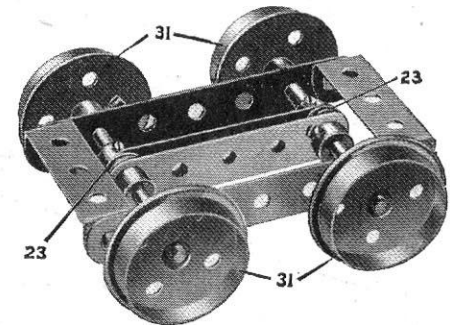


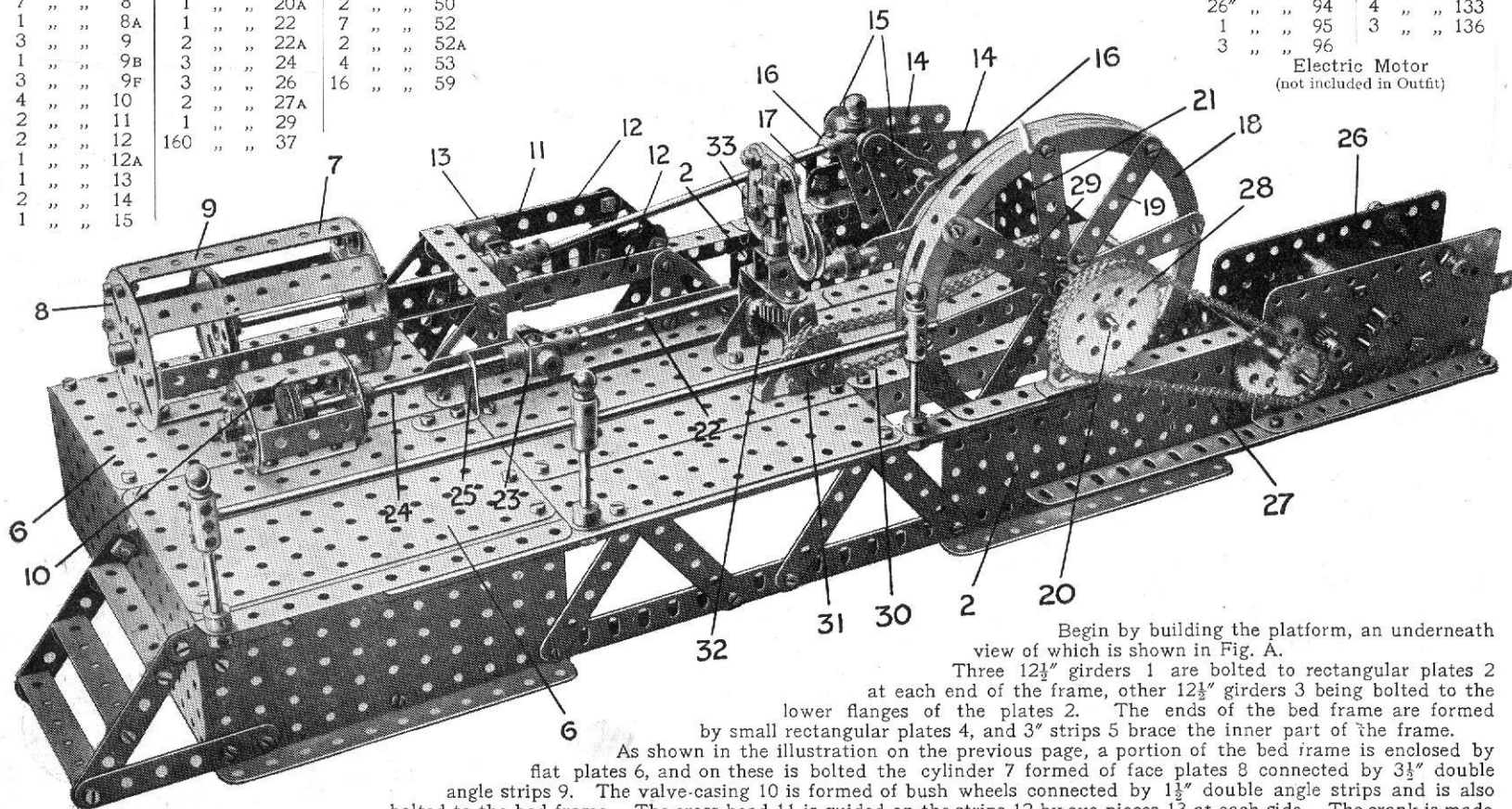
FIG. C

Model No. 631 Horizontal Engine

Parts required :		
2 of No. 3	1 of No. 15A	20 of No. 38
11 " " 4	2 " " 16	1 " " 45
8 " " 5	2 " " 16A	4 " " 48
1 " " 6	5 " " 17	4 " " 48A
5 " " 6A	2 " " 18A	6 " " 48B
7 " " 8	1 " " 20A	2 " " 50
1 " " 8A	1 " " 22	7 " " 52
3 " " 9	2 " " 22A	2 " " 52A
1 " " 9B	3 " " 24	4 " " 53
3 " " 9F	3 " " 26	16 " " 59
4 " " 10	2 " " 27A	
2 " " 11	1 " " 29	
2 " " 12	160 " " 37	
1 " " 12A		
1 " " 13		
2 " " 14		
1 " " 15		

Parts required (continued) :		
4 of No. 62	2 of No. 109	
6 " " 63	2 " " 116	
2 " " 63B	1 " " 118	
3 " " 70	2 " " 126	
2 " " 76	3 " " 126A	
26 " " 94	4 " " 133	
1 " " 95	3 " " 136	
3 " " 96		

Electric Motor
(not included in Outfit)



Begin by building the platform, an underneath view of which is shown in Fig. A. Three 12½" girders 1 are bolted to rectangular plates 2 at each end of the frame, other 12½" girders 3 being bolted to the lower flanges of the plates 2. The ends of the bed frame are formed by small rectangular plates 4, and 3" strips 5 brace the inner part of the frame. As shown in the illustration on the previous page, a portion of the bed frame is enclosed by flat plates 6, and on these is bolted the cylinder 7 formed of face plates 8 connected by 3½" double angle strips 9. The valve-casing 10 is formed of bush wheels connected by 1½" double angle strips and is also bolted to the bed frame. The cross-head 11 is guided on the strips 12 by eye-pieces 13 at each side. The crank is made up of triangular plates 14 representing the balance weights, secured to cranks 15. The main or crank shaft 20 is journaled in flat trunnions 16 secured to 1½" girders 17, which are in turn bolted to the flanges of the rectangular plates 2.

Model No. 631 Horizontal Engine (continued)

The fly-wheel is made of a circular girder 18 connected by strips 19 to a bush wheel secured to the shaft 20. The eccentric 21 is pivotally connected by a rod 22 to the fork piece 23 on the valve rod 24, which slides in the 1" angle bracket 25. The electric motor 26 drives by sprocket chain 27 a 2" gear wheel 28 on the shaft 20. A 1" sprocket wheel 29 drives by sprocket chain 30 another 1" sprocket wheel 31 in the governor.

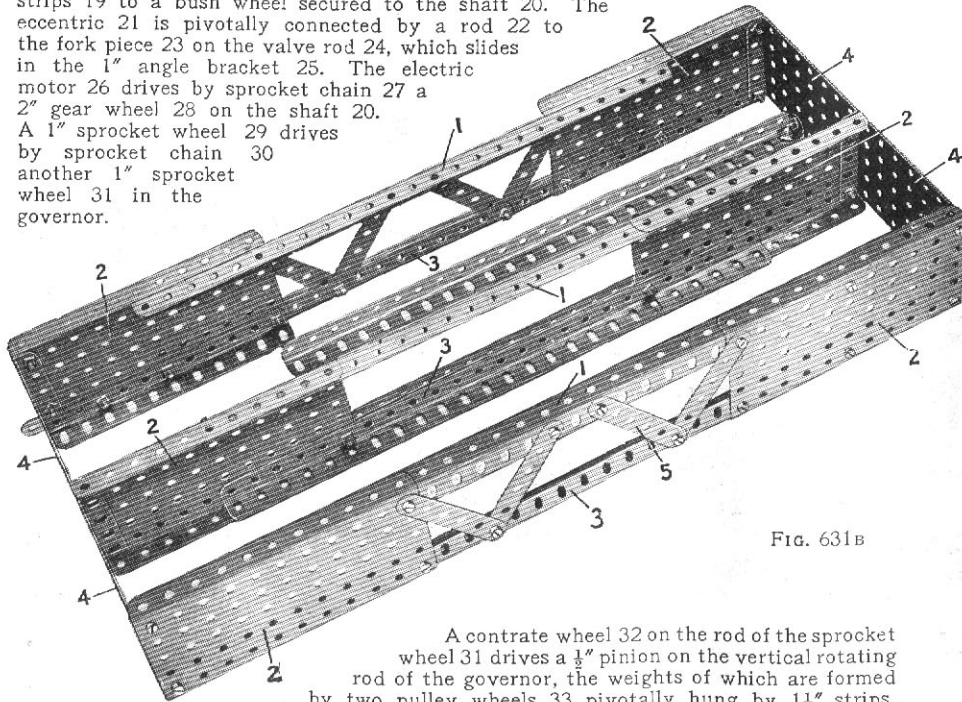


FIG. 631B

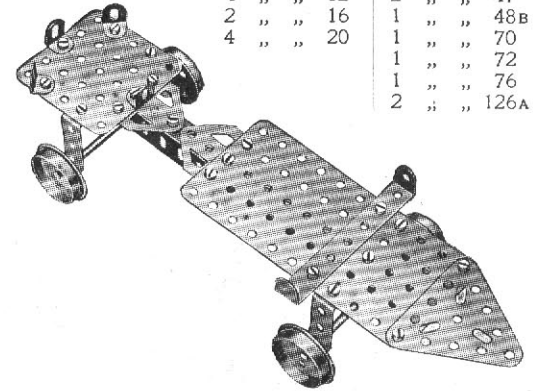
A contra wheel 32 on the rod of the sprocket wheel 31 drives a $\frac{1}{2}$ " pinion on the vertical rotating rod of the governor, the weights of which are formed by two pulley wheels 33 pivotally hung by $1\frac{1}{2}$ " strips, lock-nutted in the outer holes of a horizontal $1\frac{1}{2}$ " strip. This strip is bolted in the slot of an octagonal coupling, secured to the top of the vertical rod of the governor.

In the operation of an engine such as the model represents, the valve 10 controls the admission of steam to each end of the cylinder 7, thus causing the crank shaft 20 to be driven. Should the engine tend to "race," or to exceed a certain speed limit, the weights 33 of the governor fly out and shut off steam, causing the engine to slow down again. The governor thus keeps the engine speed constant.

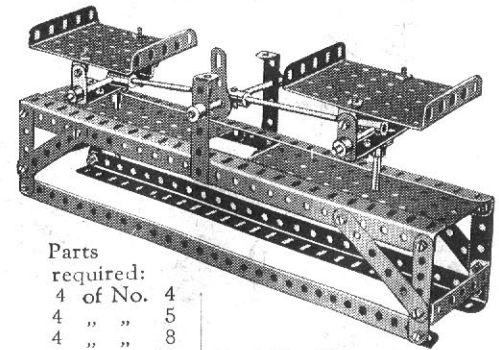
Model No. 632 Roller Skate

Parts required:

2 of No. 8B	19 of No. 37
4 " " 12	2 " " 47
2 " " 16	1 " " 48B
4 " " 20	1 " " 70
	1 " " 72
	1 " " 76
	2 " " 126A



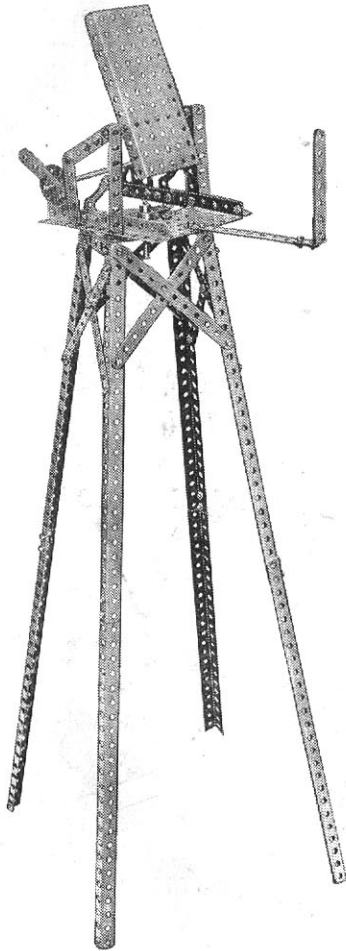
Model No. 633 Scales



Parts required:

4 of No. 4	
4 " " 5	
4 " " 8	
5 " " 16	2 of No. 52
2 " " 17	2 " " 53
30 " " 37	6 " " 59
2 " " 46	3 " " 62
6 " " 48A	3 " " 63

Model No. 634 Heliograph



Parts required:

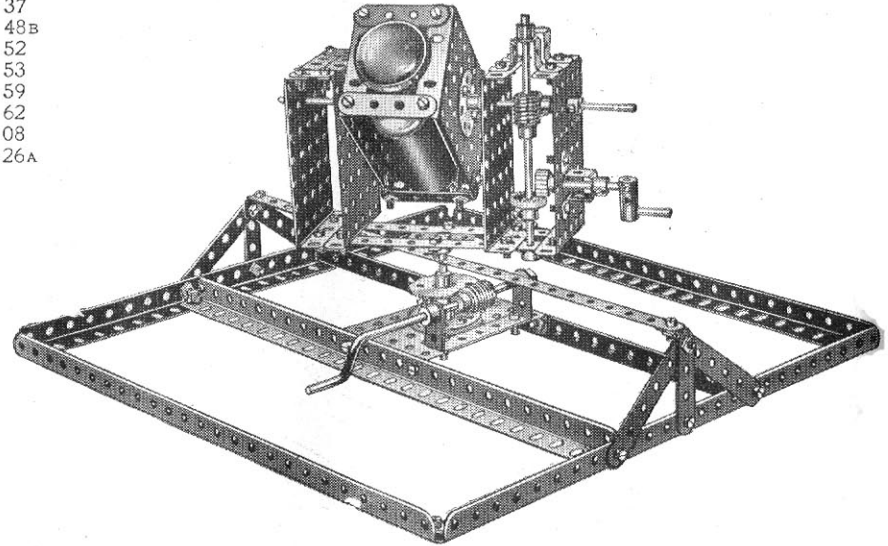
9	of No. 2	1	of No. 17
1	" "	1	" "
1	" "	1	" "
1	" "	6	" "
1	" "	1	" "
6	" "	1	" "
8	" "	2	" "
2	" "	5	" "
2	" "	2	" "
1	" "	2	" "
2	" "	2	" "

A large rectangular plate is secured to an axle, about which it pivots, by means of a crank bolted to one of its flanges, and its position is altered on operation of the lever shown.

The rectangular plate should be fitted with a mirror, and a sighting aperture mounted in front, the operator bringing one of the perforations in the plate in line with the aperture while signalling, so that he can see the opposite instrument in the distance.

The platform is pivotally mounted on the standard so that it may be swung round to any position, a bush wheel being bolted to the top of the standard in which the pivot works. The platform is made of two small rectangular plates butted together and connected on each side by strips.

Model No. 635 Searchlight



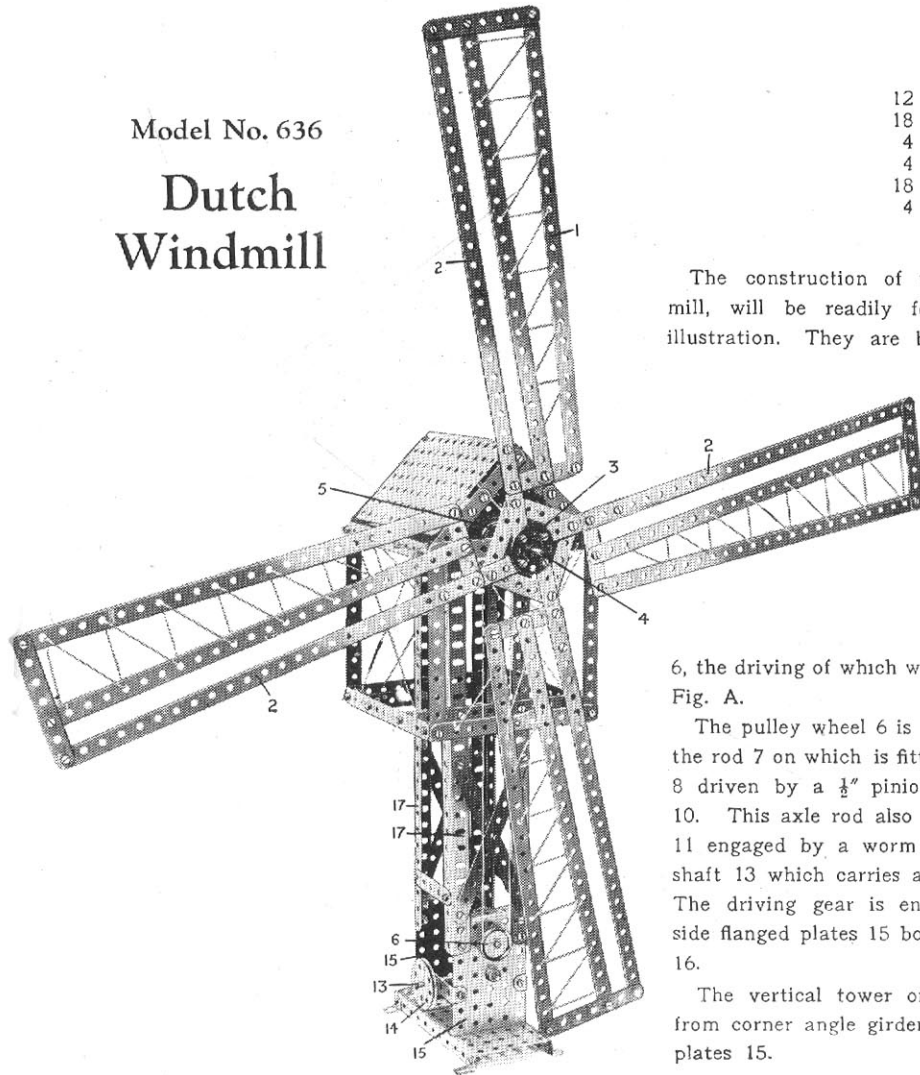
Parts required:

1	of No. 1	6	of No. 12	1	of No. 21	62	of No. 37
2	" "	1	" "	3	" "	3	" "
4	" "	1	" "	2	" "	1	" "
6	" "	2	" "	1	" "	7	" "
6	" "	1	" "	1	" "	8	" "
2	" "	1	" "	2	" "	1	" "

A splendid model with which great fun may be obtained by fitting an electric flash lamp. The light may be quickly manoeuvred in any direction and enemy aircraft "spotted" at once.

Model No. 636

Dutch Windmill



Parts required:

12 of No. 1	24 of No. 12	2 of No. 26	2 of No. 52
18 " " 2	1 " " 14	1 " " 27A	2 " " 52A
4 " " 3	3 " " 16	1 " " 32	2 " " 53
4 " " 4	1 " " 21	124 " " 37	5 " " 59
18 " " 5	2 " " 22	1 " " 40	
4 " " 8	1 " " 24	2 " " 48A	

The construction of the sails 1 of the mill, will be readily followed from the illustration. They are bolted to an inner strip frame 2 and to a bush wheel 3 fixed on a rod 4, on which is also mounted a pulley wheel 5. The driving cord passes round this pulley wheel to a lower pulley wheel

6, the driving of which will be followed from Fig. A.

The pulley wheel 6 is on the outer end of the rod 7 on which is fitted a $1\frac{1}{2}$ " gear wheel 8 driven by a $\frac{1}{2}$ " pinion 9 on the axle rod 10. This axle rod also carries a $\frac{1}{2}$ " pinion 11 engaged by a worm 12 on the driving shaft 13 which carries a driving pulley 14. The driving gear is enclosed in two small side flanged plates 15 bolted to a base plate 16.

The vertical tower of the mill is made from corner angle girders 17 bolted to side plates 15.

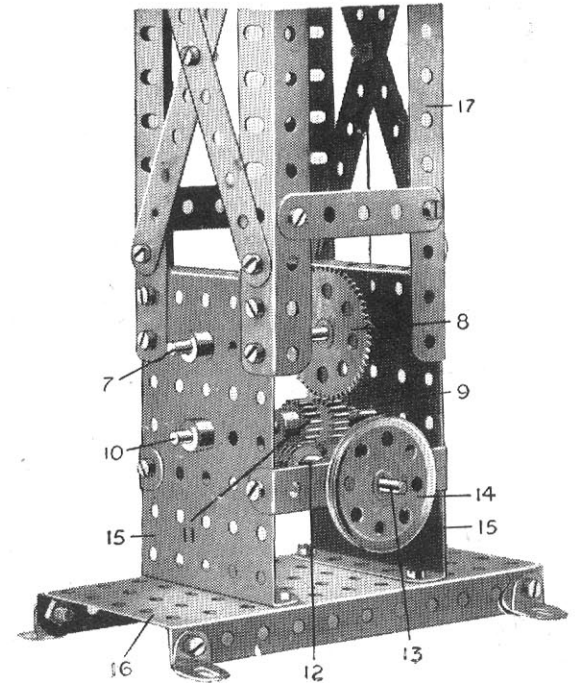
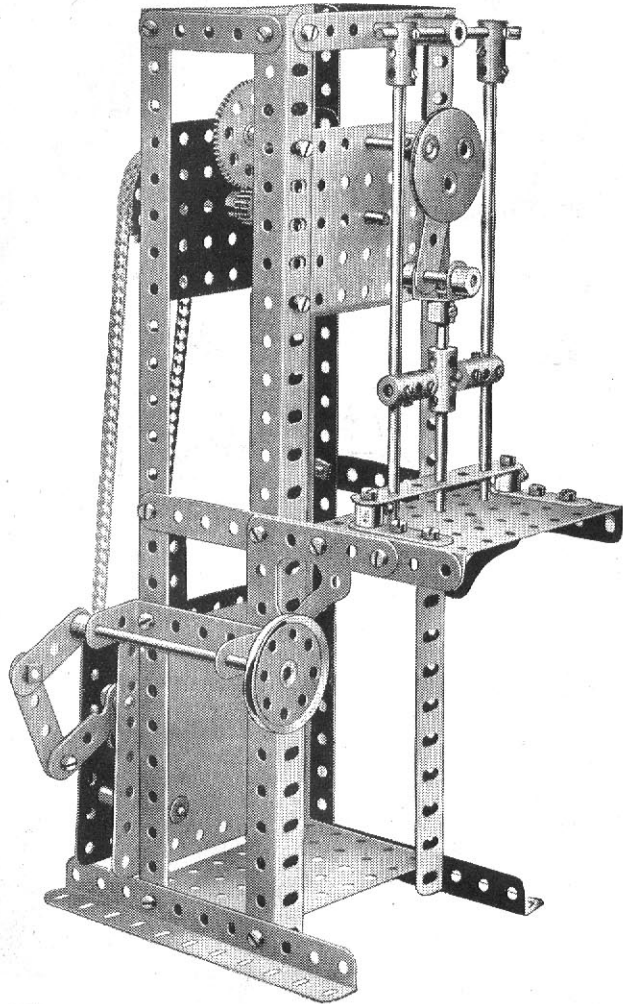


FIG. 636A

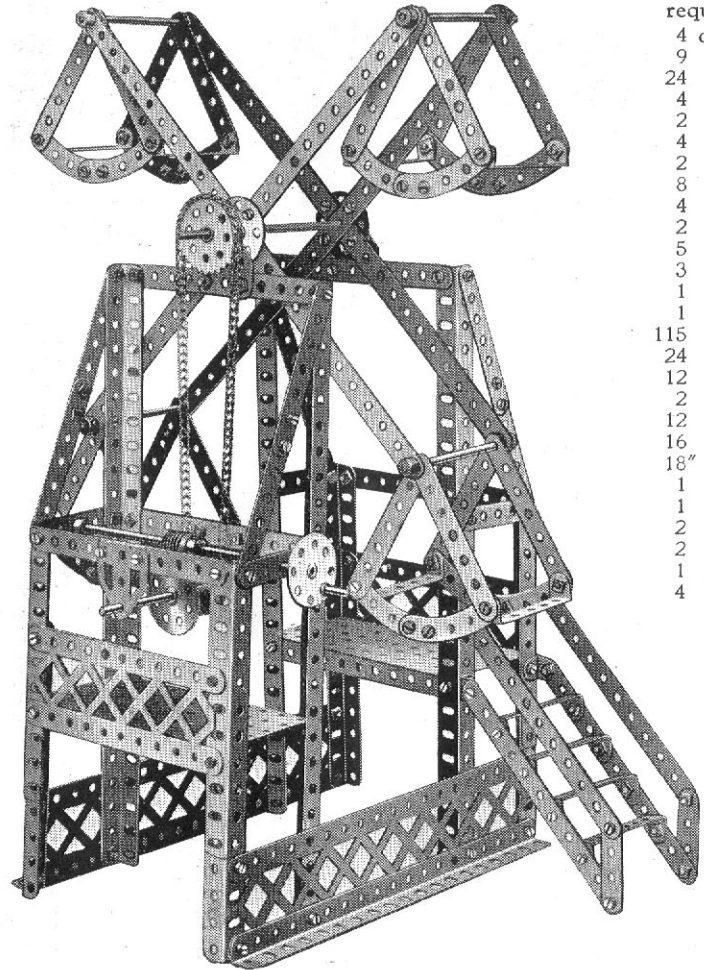
Model No. 637 Punching Machine



- Parts
required:
- | | |
|----------|-----|
| 2 of No. | 2 |
| 3 | 3 |
| 2 | 5 |
| 1 | 6 |
| 4 | 8 |
| 2 | 9 |
| 2 | 14 |
| 2 | 15A |
| 2 | 16 |
| 1 | 16B |
| 1 | 17 |
| 1 | 18A |
| 2 | 18B |
| 1 | 21 |
| 1 | 26 |
| 1 | 27A |
| 42 | 37 |
| 1 | 38 |
| 1 | 46 |
| 4 | 53 |
| 6 | 59 |
| 3 | 62 |
| 6 | 63 |
| 1 | 94 |
| 1 | 95A |
| 1 | 96 |
| 2 | 108 |
| 1 | 116 |
| 1 | 130 |

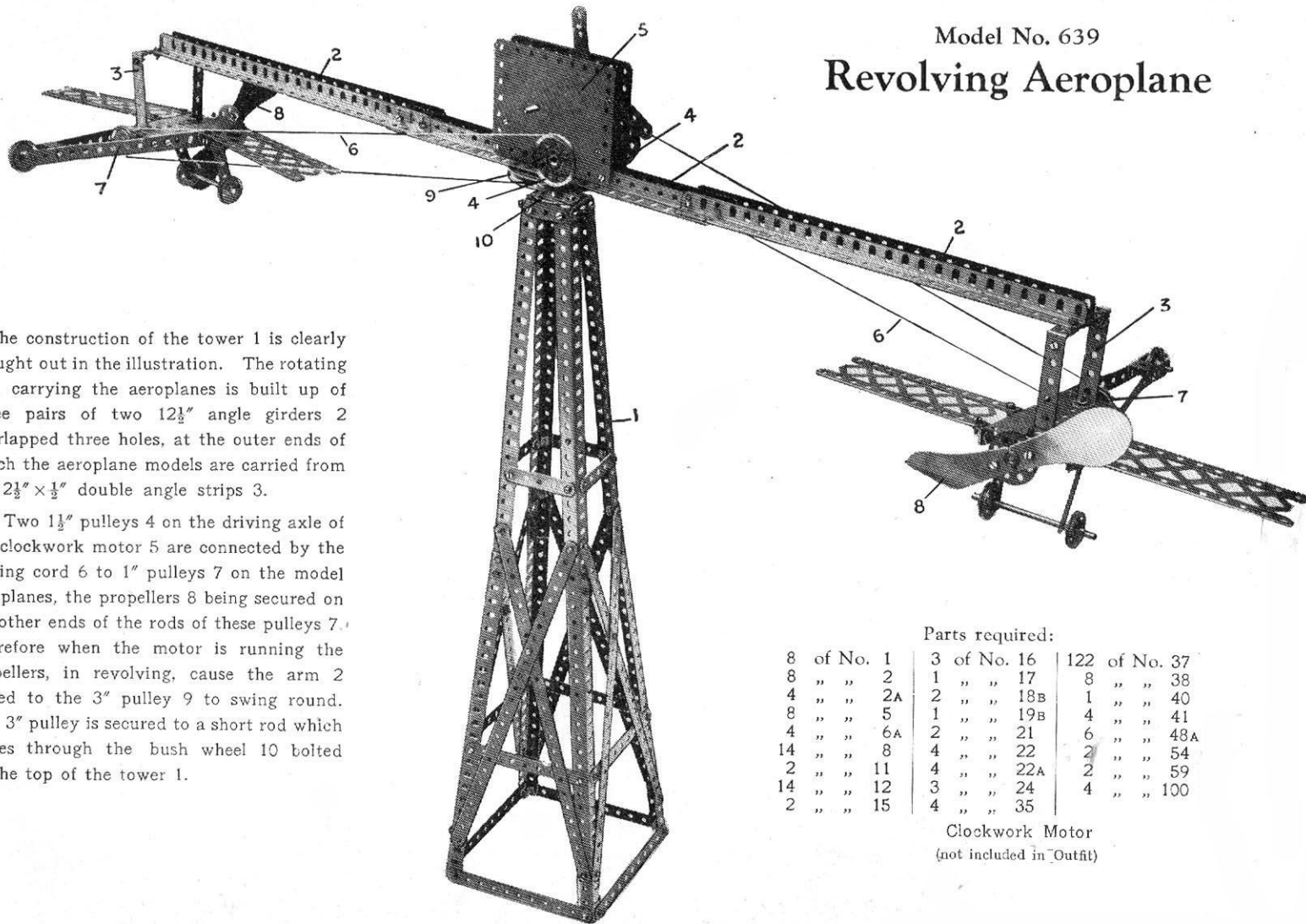
Clockwork
Motor
(not included in
Outfit)

Model No. 638 Fly Boats



- Parts
required:
- | | |
|----------|------|
| 4 of No. | 1 |
| 9 | 2 |
| 24 | 3 |
| 4 | 5 |
| 2 | 6 |
| 4 | 8 |
| 2 | 8A |
| 8 | 9 |
| 4 | 12 |
| 2 | 14 |
| 5 | 16 |
| 3 | 24 |
| 1 | 27A |
| 1 | 32 |
| 115 | 37 |
| 24 | 38 |
| 12 | 48A |
| 2 | 52 |
| 12 | 59 |
| 16 | 90 |
| 18" | 94 |
| 1 | 95A |
| 1 | 96 |
| 2 | 99A |
| 2 | 100 |
| 1 | 115 |
| 4 | 126A |

Model No. 639 Revolving Aeroplane



The construction of the tower 1 is clearly brought out in the illustration. The rotating arm carrying the aeroplanes is built up of three pairs of two $1\frac{1}{2}$ " angle girders 2 overlapped three holes, at the outer ends of which the aeroplane models are carried from the $2\frac{1}{2}$ " \times $\frac{1}{2}$ " double angle strips 3.

Two $1\frac{1}{2}$ " pulleys 4 on the driving axle of the clockwork motor 5 are connected by the driving cord 6 to 1" pulleys 7 on the model aeroplanes, the propellers 8 being secured on the other ends of the rods of these pulleys 7. Therefore when the motor is running the propellers, in revolving, cause the arm 2 bolted to the 3" pulley 9 to swing round. This 3" pulley is secured to a short rod which passes through the bush wheel 10 bolted on the top of the tower 1.

Parts required:

8	of No. 1	3	of No. 16	122	of No. 37
8	" " 2	1	" " 17	8	" " 38
4	" " 2A	2	" " 18B	1	" " 40
8	" " 5	1	" " 19B	4	" " 41
4	" " 6A	2	" " 21	6	" " 48A
14	" " 8	4	" " 22	2	" " 54
2	" " 11	4	" " 22A	2	" " 59
14	" " 12	3	" " 24	4	" " 100
2	" " 15	4	" " 35		

Clockwork Motor
(not included in Outfit)

Model No. 640 Drop Hammer

		Parts required:													
1	of No.	1	10	of No.	8	4	of No.	16	75	of No.	37	5	of No.	59	
2	"	"	1B	2	"	"	9D	6	"	"	20	6	"	"	63
4	"	"	2	1	"	"	11	1	"	"	22A	1	"	"	72
1	"	"	2A	1	"	"	12A	2	"	"	24	4	"	"	95A
4	"	"	3	1	"	"	13	2	"	"	26	2	"	"	97
4	"	"	5	1	"	"	15A	2	"	"	27A	1	"	"	108

The construction details of this model are clearly shown in the illustration. The vertical hammer shaft is guided through $2\frac{1}{2}'' \times \frac{1}{2}''$ double angle strips secured in the upper frame-work. The operating cord is led from a point on the shaft near the hammer-head up to a guide pulley (Standard Mechanism No. 39) situated at the top of the model, and from thence down to the winding drum, consisting of two flange wheels butted together, in the gear box.

The rod carrying the winding drum is rotated through a chain of reduction gearing from the driving shaft carrying a sprocket wheel, which may, of course, be coupled to a Meccano motor or any other driving method. The intermediate shaft is slidable in its bearings and is controlled by the hand lever shewn in Fig. A, while its gears are so arranged that they may be easily slipped out of engagement with the driving shaft, with the result that the hammer, being released, forcibly strikes the table secured in the base of the machine. From this it will be seen that the power of the blow may be altered as desired, since the hammer may be dropped from varying heights.

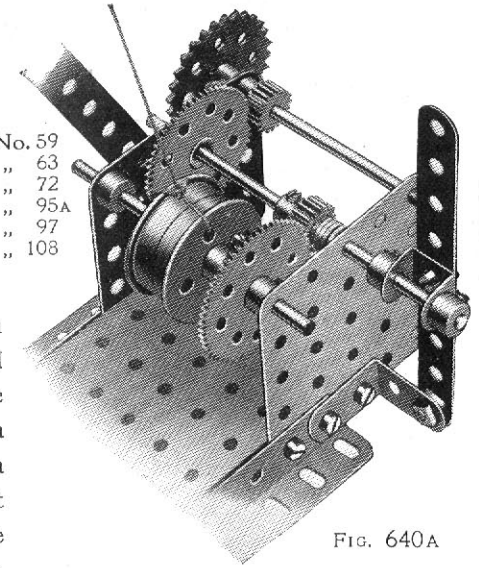
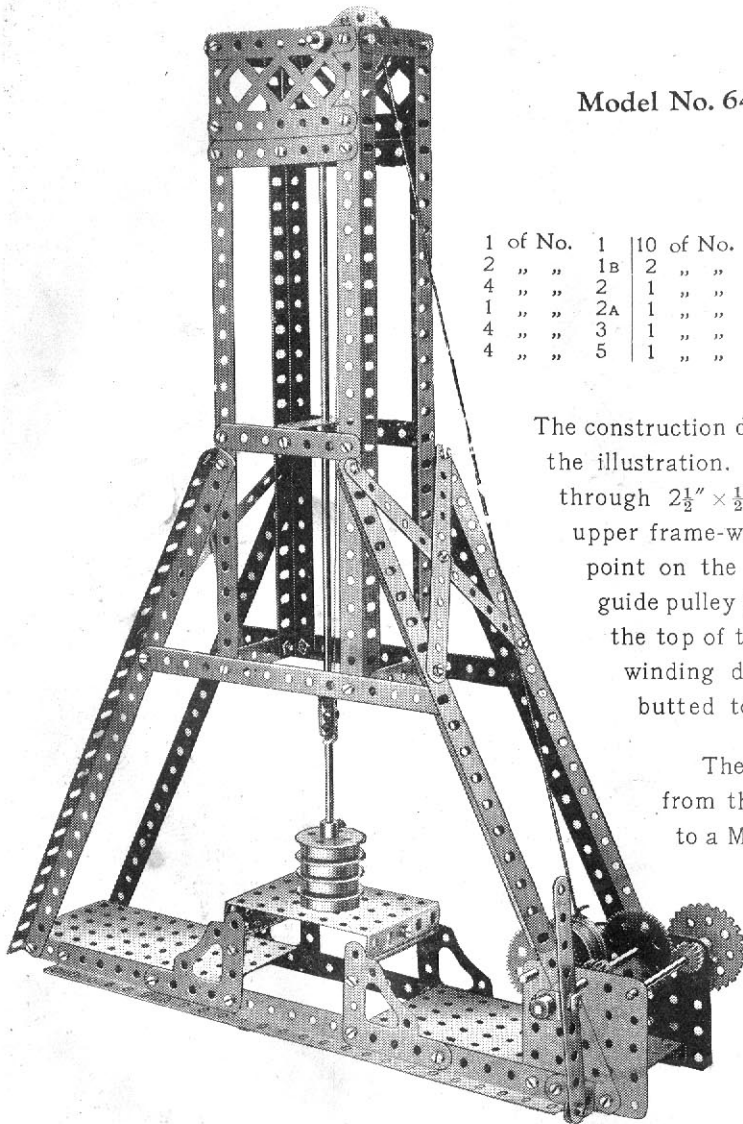
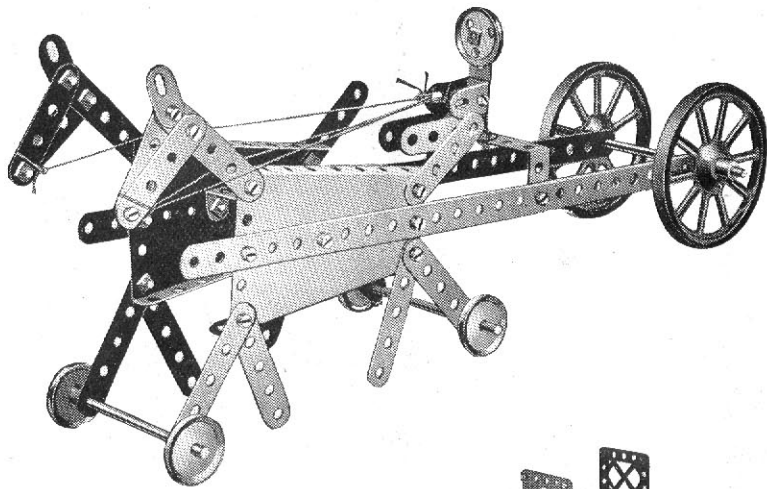


FIG. 640A



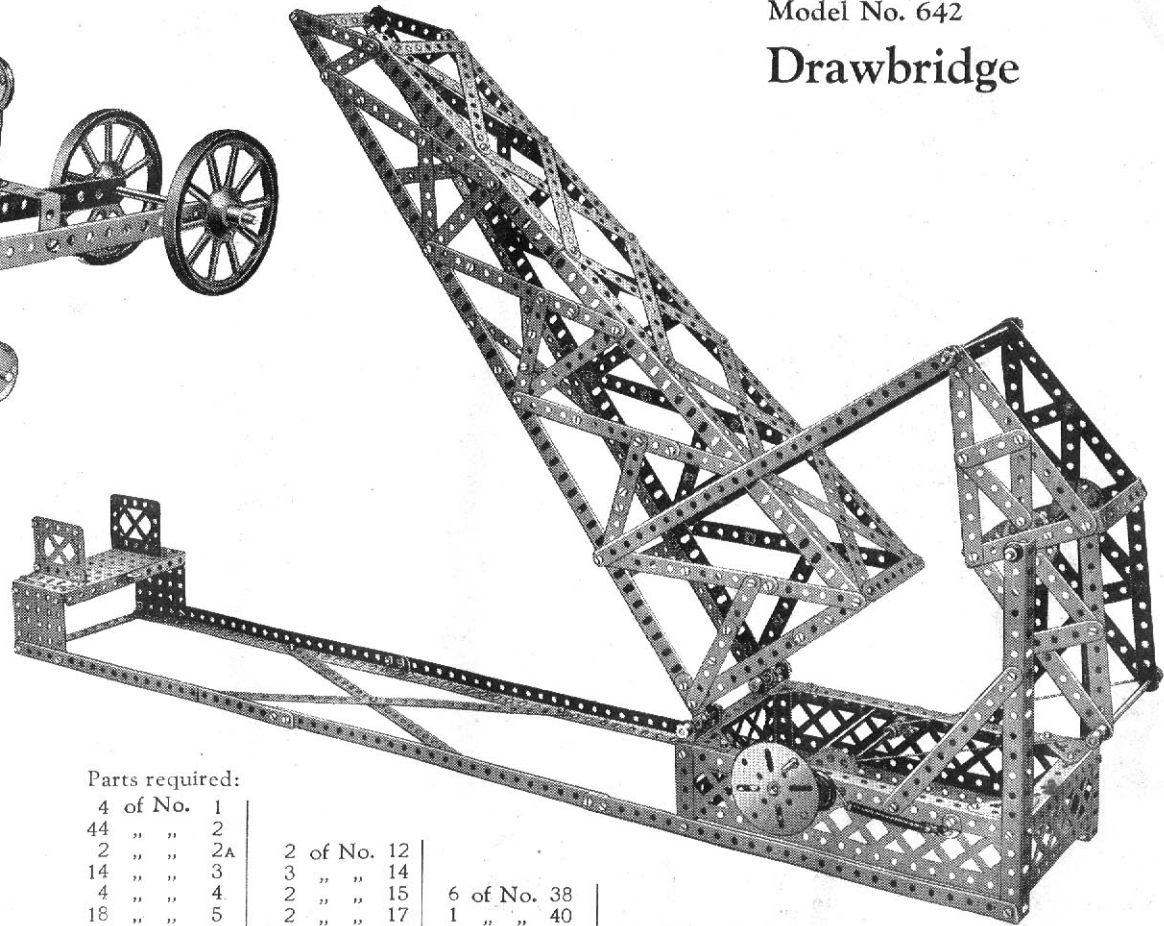


Model No. 641

Sulky and Driver

Parts required:

2 of No. 1	2 of No. 19A
10 " " 5	4 " " 22
9 " " 6	1 " " 22A
4 " " 10	32 " " 37
2 " " 11	1 " " 46
1 " " 12	2 " " 48A
3 " " 15A	2 " " 54



Model No. 642

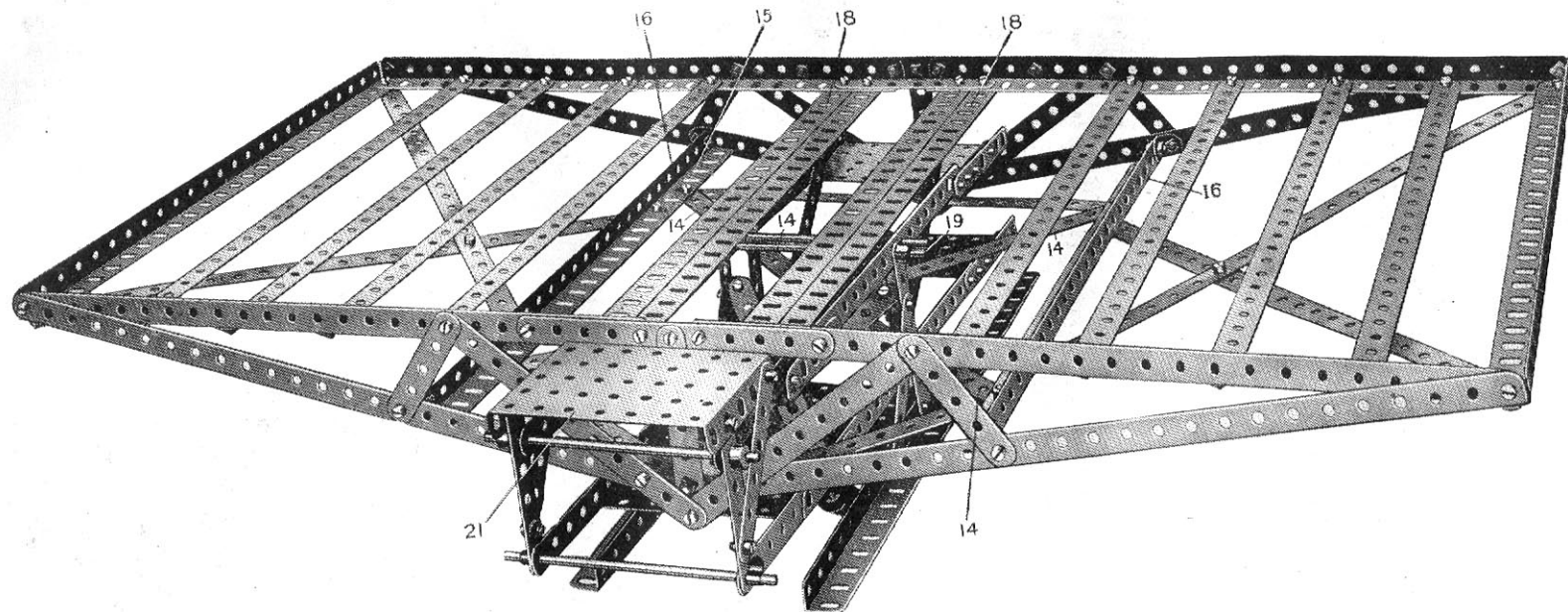
Drawbridge

Parts required:

4 of No. 1	2 of No. 12	6 of No. 38	2 of No. 62	1 of No. 109
44 " " 2	3 " " 14	1 " " 40	2 " " 72	1 " " 115
2 " " 2A	2 " " 15	1 " " 43	2 " " 98	1 " " 133
14 " " 3	2 " " 17	2 " " 48	2 " " 99A	
4 " " 4	2 " " 22	2 " " 48B	2 " " 100	
18 " " 5	1 " " 24	1 " " 52		
8 " " 6	1 " " 26	23 " " 59		
14 " " 8	1 " " 27A			
4 " " 8A	1 " " 37			
2 " " 9				
6 " " 9D				

This Model can be made with MECCANO Outfit No. 6, or No. 5 and No. 5A.

Model No. 643 Weighbridge



Parts required:

22 of No. 1	8 of No. 3	6 of No. 5	10 of No. 12	2 of No. 35	16 of No. 37A
10 " " 2	6 " " 4	14 " " 8	6 " " 15A	107 " " 37	6 " " 53
		6 of No. 59			

Model No. 643 Weighbridge (continued)

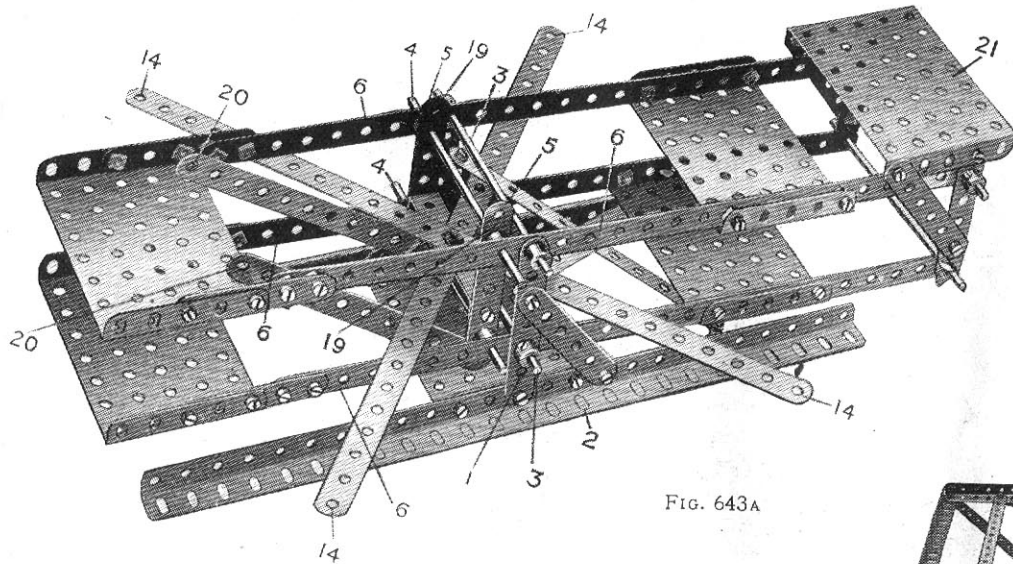


FIG. 643A

Begin the construction of this model by making the weigh beam, Fig A. The side strips 1 are bolted to the base angle girders 2, and in the strips 1 are journaled the rods 3 which form the fixed pivots of the weigh beam. The upper and lower rods 4 are journaled in the strips 5 and form the moving pivots of the beam. All the rods 3 and 4 pass through perforations in the upper and lower strips 6 of the beam. Next construct the platform, Fig. B, leaving the strips at one side unconnected, as shown. The platform is then passed between the upper and lower parts of the weigh beam, and the unconnected strips then bolted, as follows:

The ends 7 are bolted to the lowest hole 8, and the ends 9 to the bolt 10, which also carries an angle bracket. The outer holes 14 of the 12½" crossed strips, Fig. A, are then bolted to the same holes 15 in the angle girders 16 as the strips 17. The other ends of the strips 17 are secured to the angle brackets at 10. The double angle girders 18 are then bolted in position, and the upper holes 19, Fig. A, are bolted to the angle girders 18 in the centre holes and the holes 20, Fig. A, to the angle girders 18 at the fifth hole from the girder ends. The load to be weighed rests on the main platform, and the weights are placed on the small rectangular plate 21 at the end of the weigh beam.

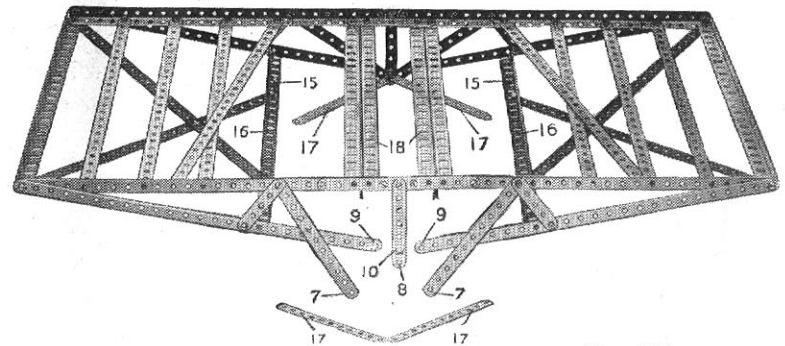
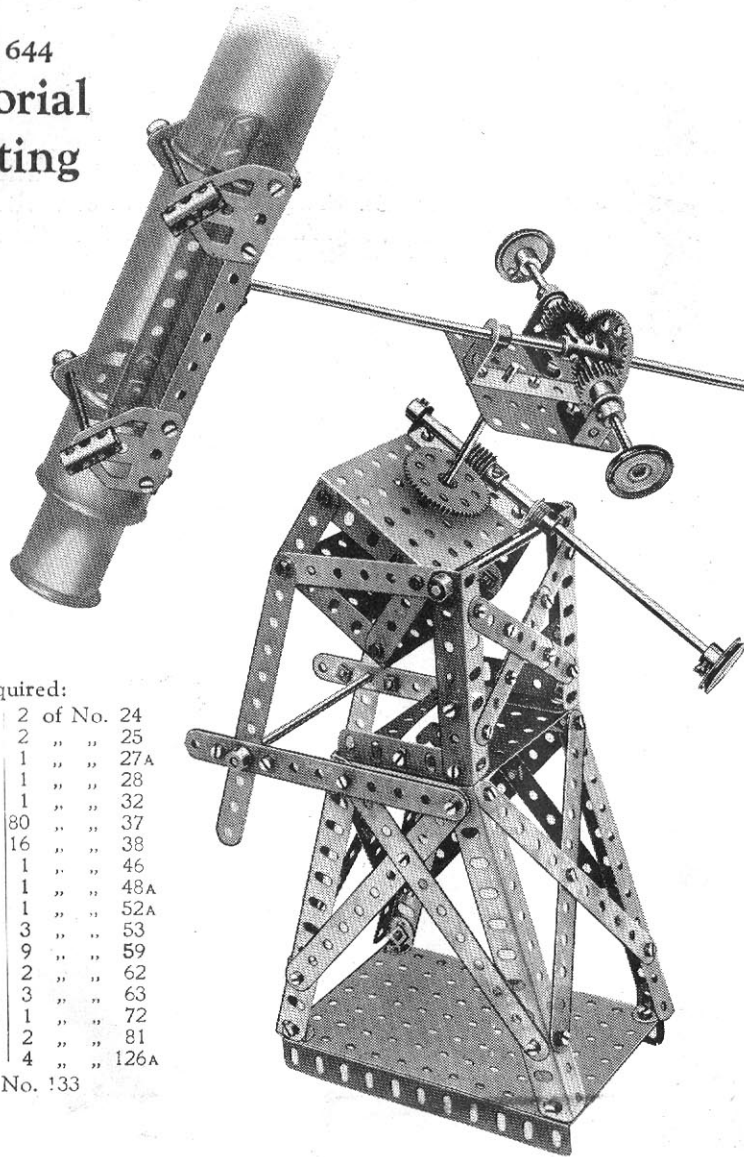


FIG. 643B

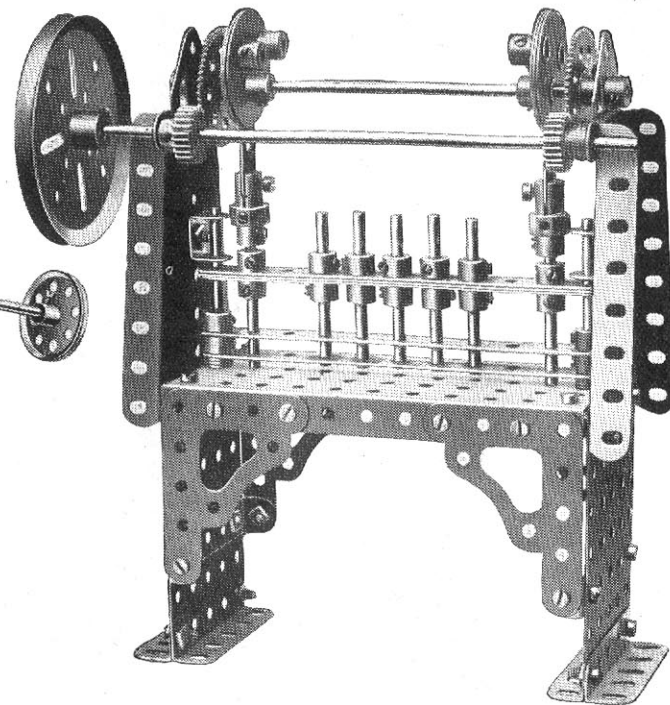
Model No. 644 Equatorial Mounting



Parts required:

4	of No. 2	2	of No. 24
2	" "	2	" "
4	" "	1	" "
4	" "	1	" "
2	" "	1	" "
8	" "	80	" "
2	" "	16	" "
2	" "	1	" "
4	" "	1	" "
2	" "	1	" "
1	" "	3	" "
1	" "	9	" "
1	" "	2	" "
2	" "	3	" "
2	" "	1	" "
1	" "	2	" "
3	" "	4	" "
	2	of No. 133	

Model No. 645 Punching Press



Parts required:

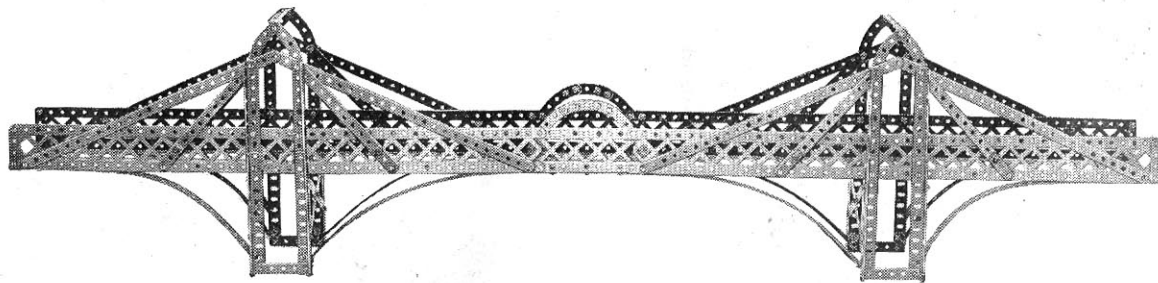
5	of No. 2	1	of No. 19B	2	of No. 53
2	" "	2	" "	2	" "
2	" "	2	" "	21	" "
2	" "	34	" "	2	" "
1	" "	6	" "	4	" "
1	" "	2	" "	2	" "
9	" "	1	" "	2	" "

Model No. 646

Cantilever Bridge

Parts required:

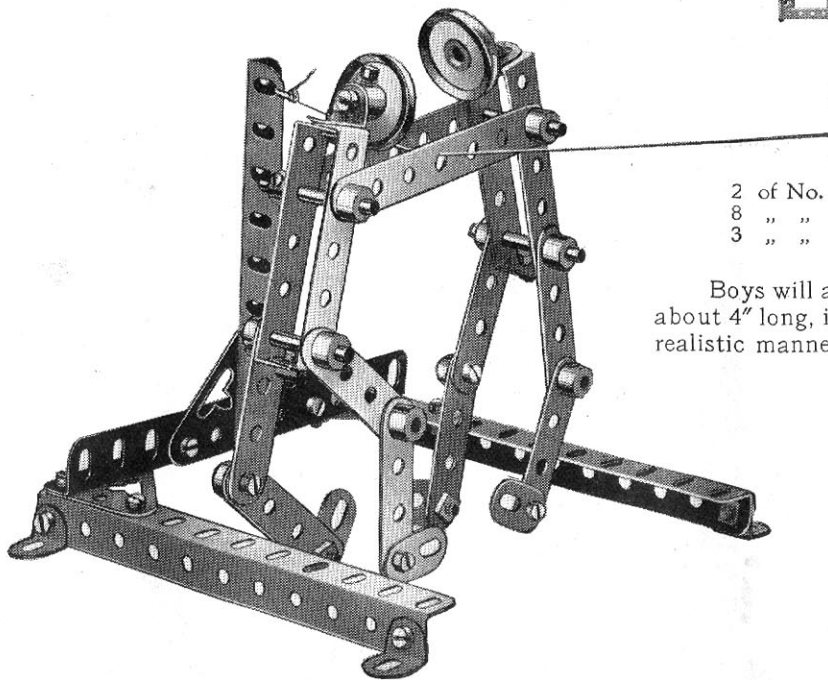
16	of No.	1	8	of No.	6A	2	of No.	48B
16	" "	2	8	" "	8	14	" "	90
3	" "	3	18	" "	9	8	" "	99
4	" "	5	8	" "	12	2	" "	100
4	" "	6	136	" "	37			



Model No. 647 The Wrestlers

Parts required:

2	of No.	3	1	of No.	9A	4	of No.	18A	6	of No.	37B	12	of No.	59
8	" "	6	4	" "	10	2	" "	22	1	" "	38	4	" "	133
3	" "	9	6	" "	12	22	" "	37	4	" "	48A			



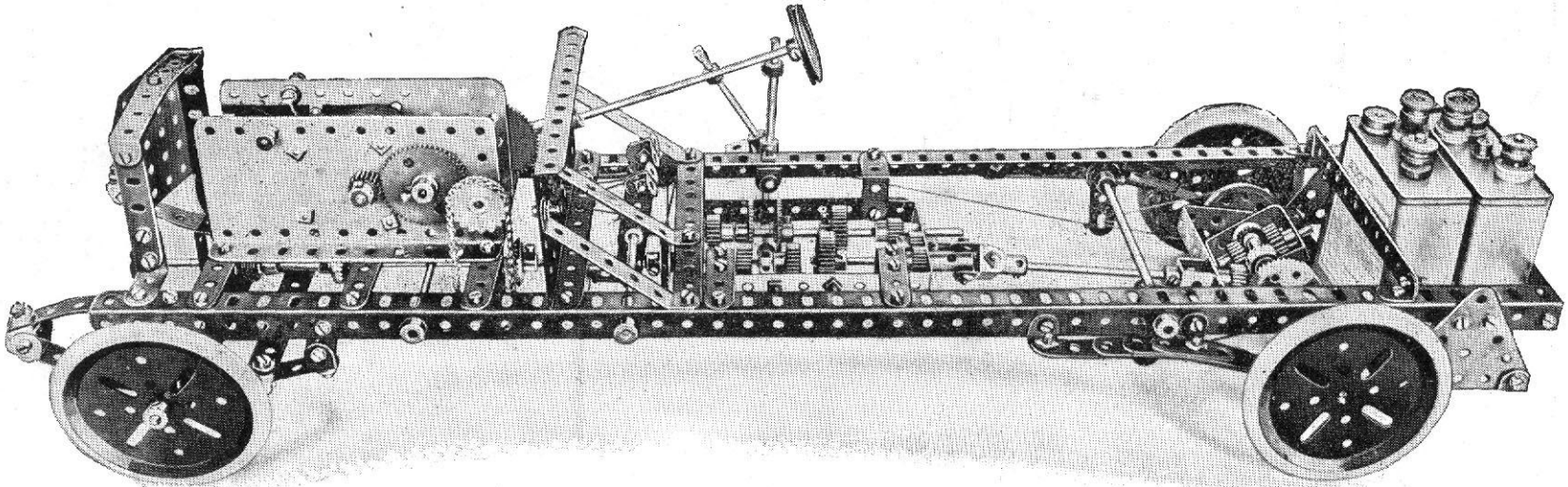
Boys will at once recognise this familiar toy. When the cord, which should be about 4" long, is kept fairly tight and manipulated, the figures will wrestle in a most realistic manner. The model should be mounted on a board, to keep it steady.

HOW TO CONTINUE

This completes the Models which may be made with MECCANO Outfit No. 6. The next Models are a little more advanced, requiring a number of extra parts to construct them. The necessary parts are all contained in a No. 6A Accessory Outfit, the price of which will be found in the List at the end of the Manual.

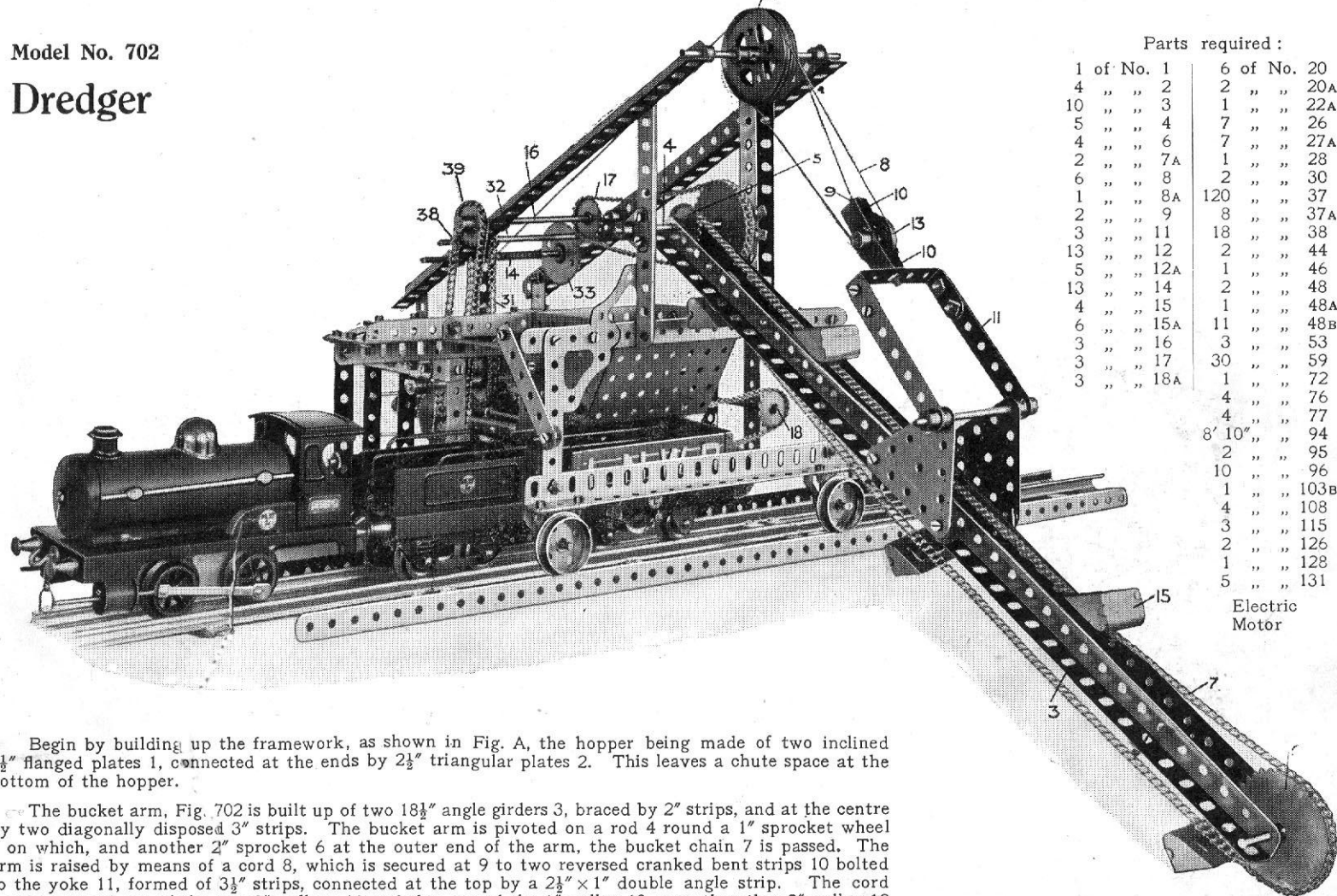
Model No. 701

Meccano Motor Chassis



The Meccano Motor Chassis is a model of exceptional interest as it provides a complete demonstration of a real Motor Chassis. It is equipped with differential, steering gear and gear box, giving two forward speeds and a reverse. It is underslung and is provided with elliptical leaf-springs. In order to make its construction quite clear a number of sectional photographs and drawings are necessary, and it is impossible to find space for these and the necessary instructions which go with them, in this Manual. We have, therefore, compiled a separate sheet, printed on art paper, containing full instructions and clear illustrations. This may be purchased either from your dealer or from Meccano Limited, Liverpool. Price 3d. (post free 4d.).

Model No. 702
Dredger



Parts required :

1	of No. 1	6	of No. 20
4	" " 2	2	" " 20A
10	" " 3	1	" " 22A
5	" " 4	7	" " 26
4	" " 6	7	" " 27A
2	" " 7A	1	" " 28
6	" " 8	2	" " 30
1	" " 8A	120	" " 37
2	" " 9	8	" " 37A
3	" " 11	18	" " 38
13	" " 12	2	" " 44
5	" " 12A	1	" " 46
13	" " 14	2	" " 48
4	" " 15	1	" " 48A
6	" " 15A	11	" " 48B
3	" " 16	3	" " 53
3	" " 17	30	" " 59
3	" " 18A	1	" " 72
		4	" " 76
		4	" " 77
		8' 10"	" " 94
		2	" " 95
		10	" " 96
		1	" " 103B
		4	" " 108
		3	" " 115
		2	" " 126
		1	" " 128
		5	" " 131

Electric Motor

Begin by building up the framework, as shown in Fig. A, the hopper being made of two inclined $3\frac{1}{2}$ " flanged plates 1, connected at the ends by $2\frac{1}{2}$ " triangular plates 2. This leaves a chute space at the bottom of the hopper.

The bucket arm, Fig. 702 is built up of two $18\frac{1}{2}$ " angle girders 3, braced by 2" strips, and at the centre by two diagonally disposed 3" strips. The bucket arm is pivoted on a rod 4 round a 1" sprocket wheel 5 on which, and another 2" sprocket 6 at the outer end of the arm, the bucket chain 7 is passed. The arm is raised by means of a cord 8, which is secured at 9 to two reversed cranked bent strips 10 bolted to the yoke 11, formed of $3\frac{1}{2}$ " strips, connected at the top by a $2\frac{1}{2}$ " x 1" double angle strip. The cord 8 passes round one of the two 2" pulleys 12 and then round the 1" pulley 13, over the other 2" pulley 12 on to the winding rod 14. The buckets 15 are caused to move round the arm by rotation of the rod 4, which is effected from the rod 16 by chain and sprocket gear 17.

Model No. 702 Dredger

(continued)

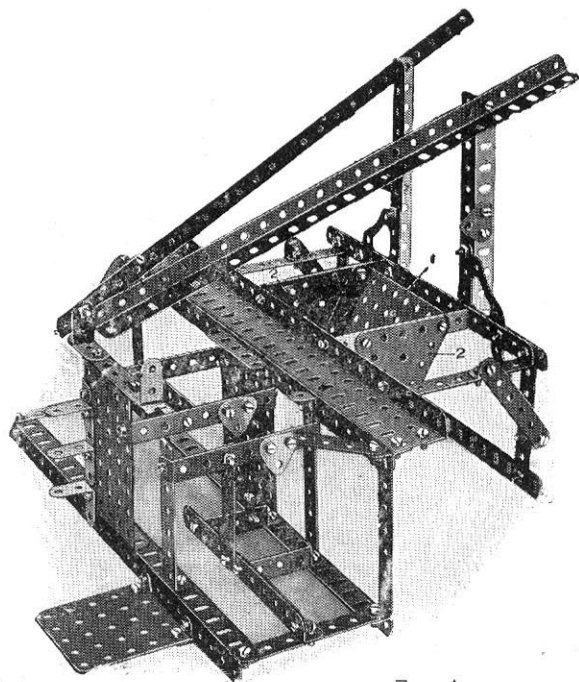


FIG. A

The motor spindle 18, Fig. 702, drives on to the sprocket wheel 19 on a rod 20 on which is a $\frac{1}{2}$ " pinion 21. The upper and lower rods 22, 23, Fig. 702B, are controlled by their clutch handles 24, 25, and carry 57-toothed gear wheels 26, 27, either of which by sliding their rods may be brought into engagement with the driven pinion 21.

The rod 22, Fig. 702B and 702c, carries a $\frac{1}{2}$ " pinion 28 which engages a contrate wheel 29, on the rod carrying which is a sprocket 30 which drives by a chain 31 a sprocket on the rod 32, a $\frac{1}{2}$ " pinion 33A which engages and drives the gear wheel 33 on the winding rod 14 controlling the cord 8, which raises and lowers the arm. Consequently by operating the clutch handle 24 the bucket arm may be raised or lowered.

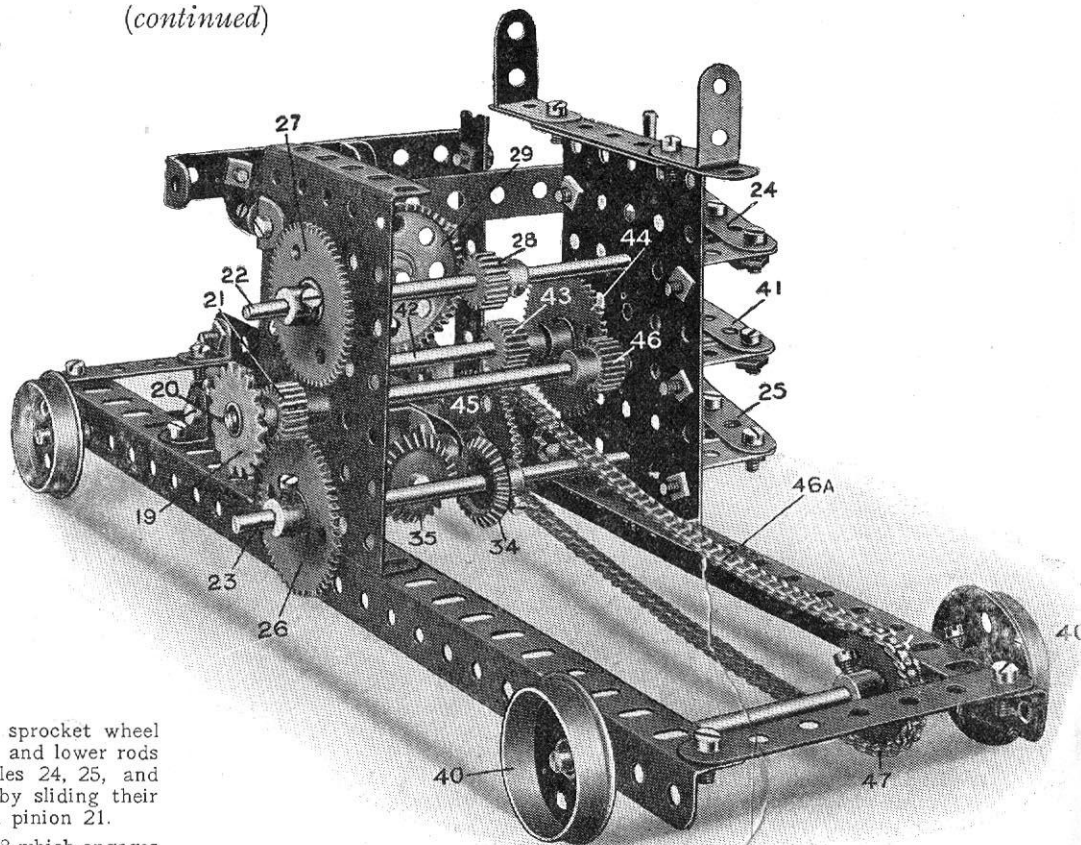


FIG. B

Model No. 702 Dredger *(continued)*

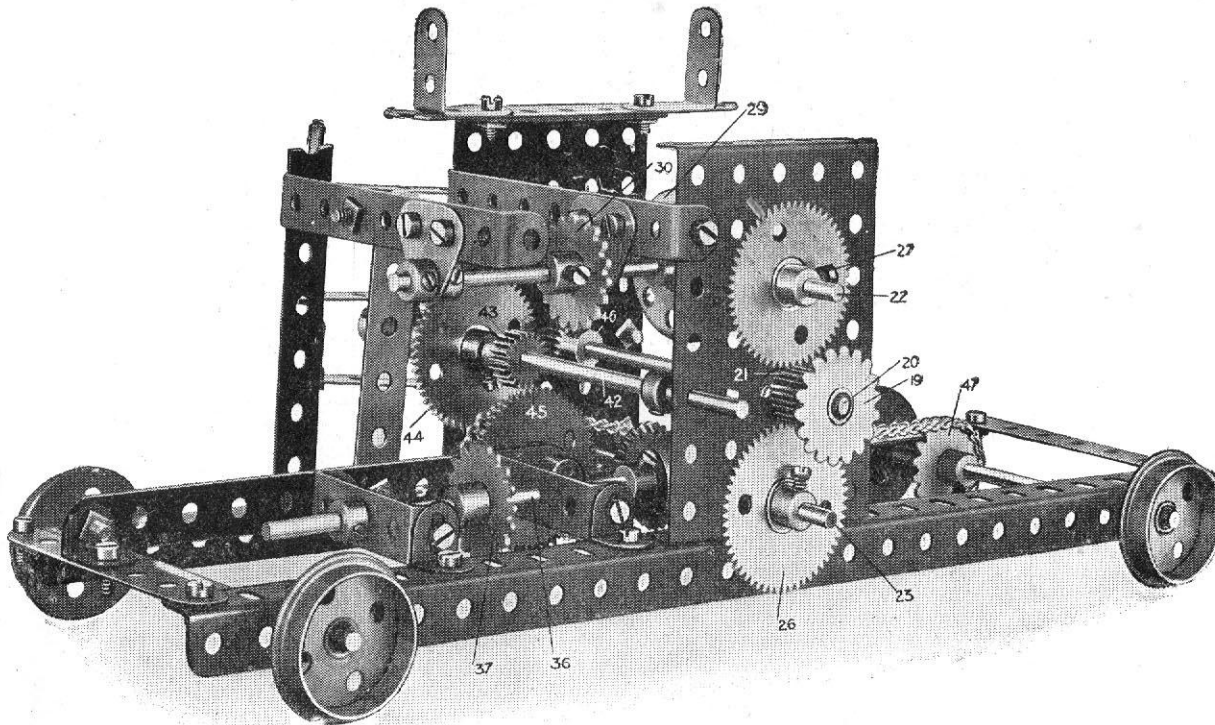


FIG. C

The rod 23, Fig. 702B, similarly may be moved by its clutch arm 25 and the gear wheel 26 brought into engagement with the pinion 21. On the rod 23 is a bevel 34 engaging another bevel wheel 35, on a rod 36, Fig. 702c, on which is a sprocket wheel 37. This sprocket drives by a chain 38, Fig. 702d, a sprocket wheel 39, on the rod 16, which as previously described, operates the movement of the buckets, which are thus under the control of the clutch handle 25.

The travelling of the apparatus on the wheels 40 is controlled by a middle clutch handle 41, which moves the rod 42, Fig. 702c, this rod carrying a $\frac{1}{2}$ " pinion 43 and a 57-toothed gear wheel 44, which are operated by the sliding movement of the rod 42 to engage or disengage respectively with a gear wheel 45 and a $\frac{1}{2}$ " pinion 46, the latter being on the same rod as the pinion 21, whilst the gear wheel 45 is on a short rod, carrying a sprocket 45A, Fig. 702d, which drives through a chain 46A another sprocket 47, Fig. 702B, on the rod of the travelling wheels 40. Consequently, the drive from the motor is taken from the sprocket 19, Fig. 702B, through the pinion 46 and rod 42 to the chain 46A, and so to the sprocket 47 driving the travelling wheels 40. In order to reverse any of the movements, the switch handle of the motor is connected to the bell crank 48 pivoted on the rod 49, Fig. 702d, and provided with a handle strip 50.

Model No. 702

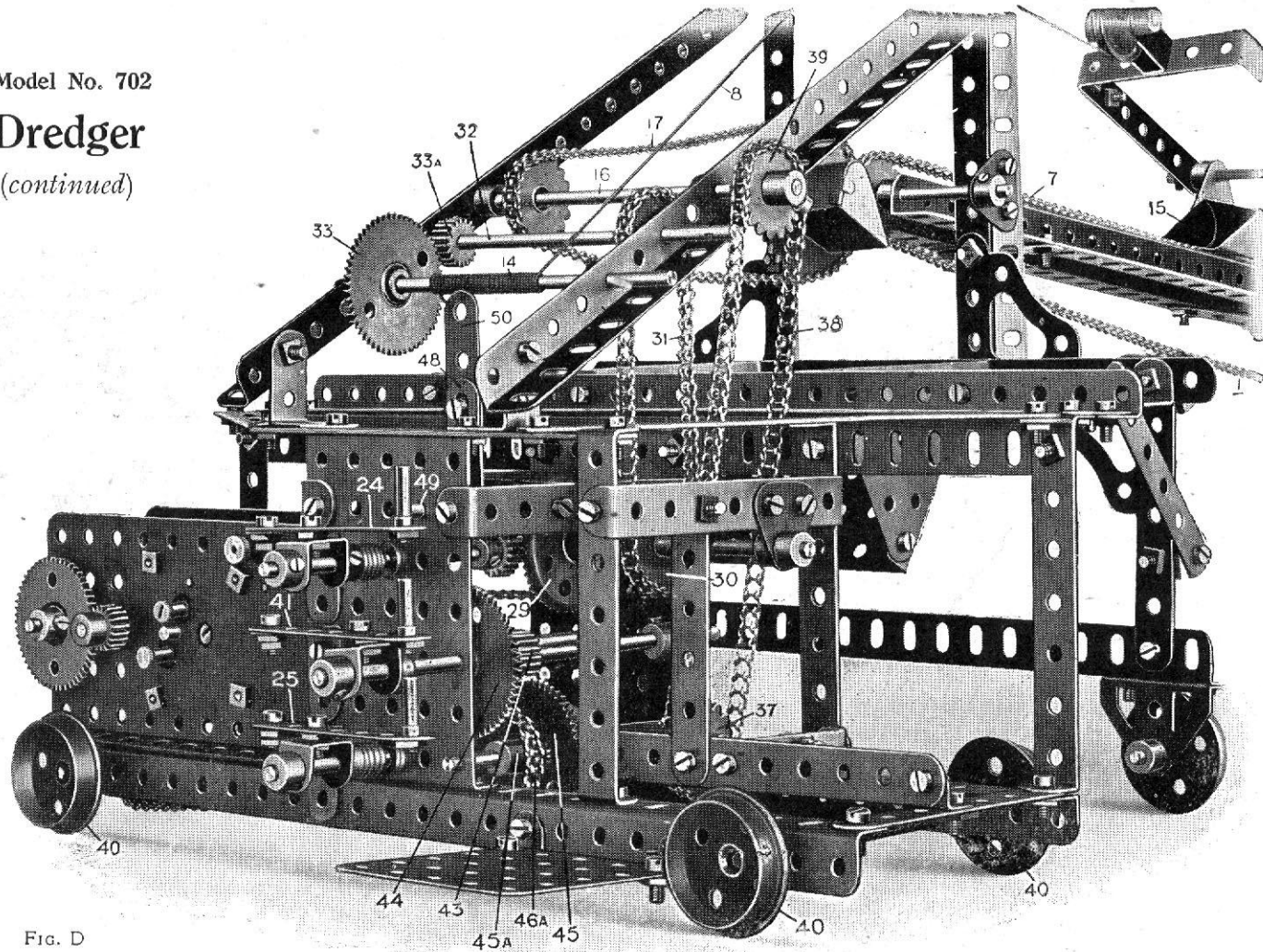
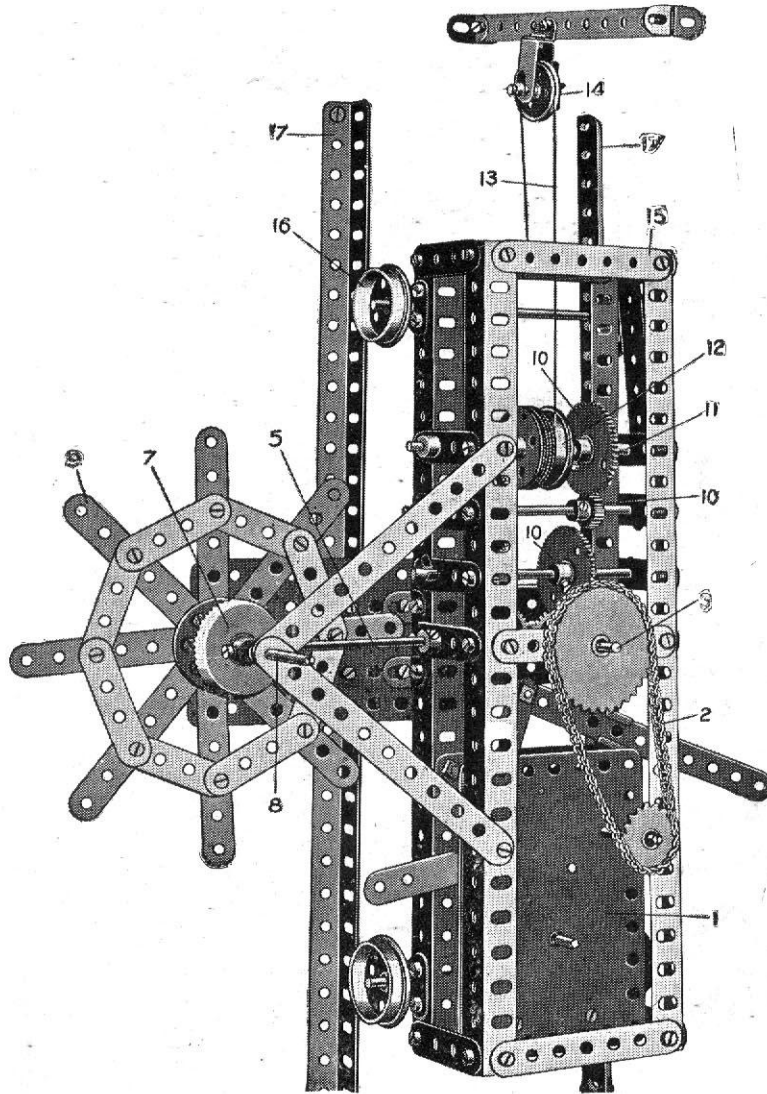
Dredger*(continued)*

FIG. D

Model No. 703 Coal-Cutting Machine



Parts required :

4 of No. 2	4 of No. 26
6 " " 3	3 " " 27A
8 " " 4	1 " " 28
20 " " 6	2 " " 30
2 " " 7	6 " " 35
4 " " 8	75 " " 37
2 " " 9	1 " " 44
9 " " 12	1 " " 50
1 " " 13A	1 " " 52A
5 " " 15	6 " " 59
1 " " 16	1 " " 63
1 " " 17	4 " " 77
1 " " 18A	12 " " 94
6 " " 20	1 " " 95
1 " " 22A	1 " " 96
1 " " 24	

Clockwork Motor

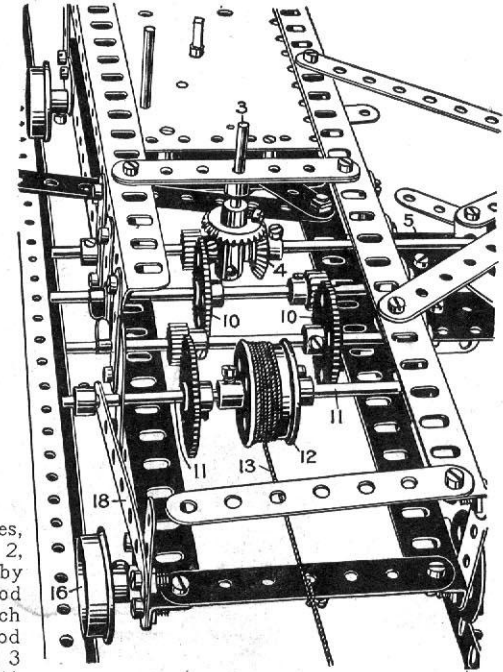


FIG. A

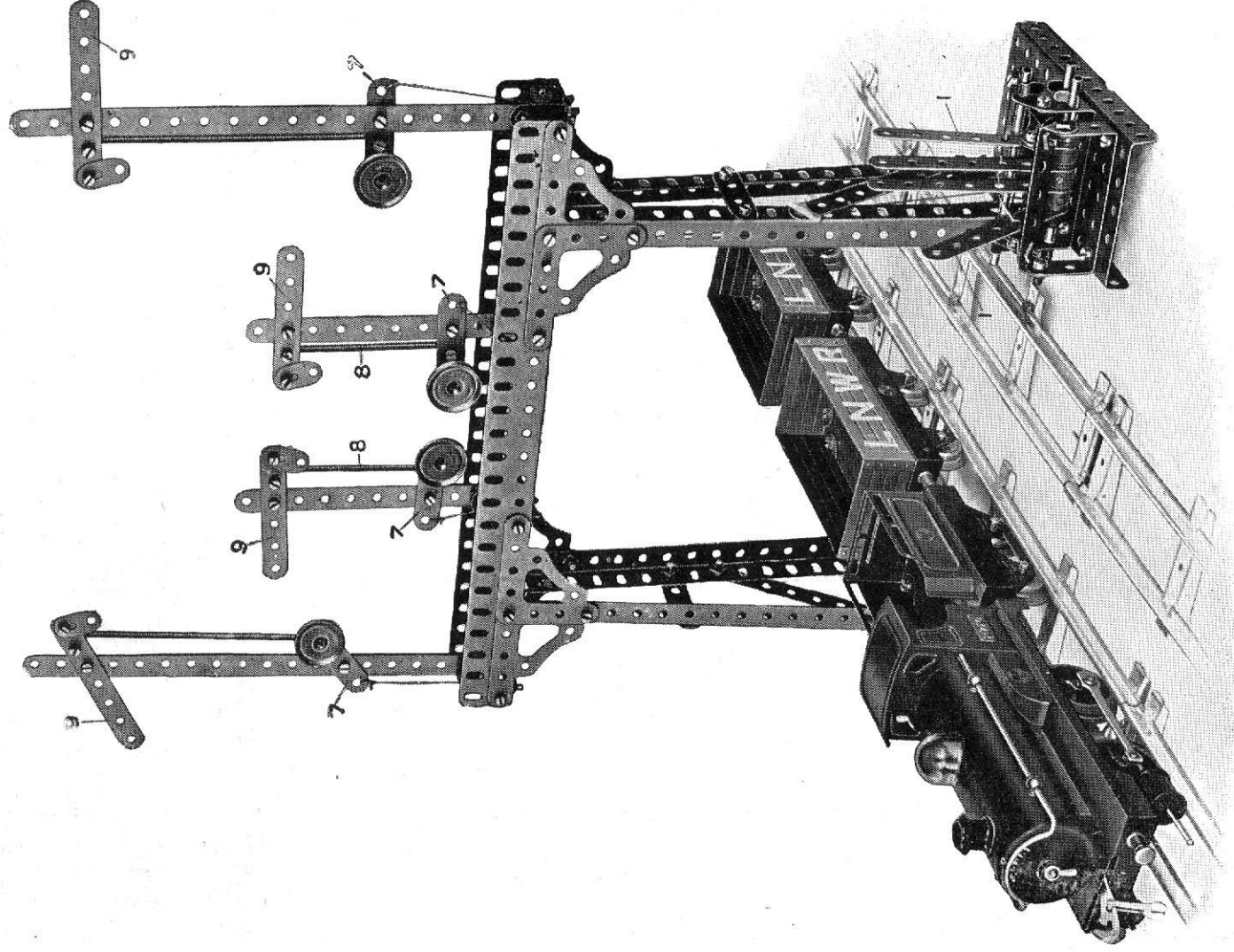
The clockwork motor 1 drives, by the chain and sprocket gear 2, the rod 3, which is connected by bevel wheels 4 to the horizontal rod 5, a $\frac{3}{8}$ " pinion on the end of which drives a contrate wheel 7 on the rod 8 of the cutting wheel 9. The rod 3 also drives through a gear train 10 a rod 11 on which is a drum composed of two flanged wheels 12. A cord 13 winding from the drum round a pulley 14, is connected to the trolley 15. The pulley 14 is fixed to the trolley 15 which runs on flanged wheels 16 on the rails 17. Consequently, as the cutting wheel 9 is rotated from the motor, the cord 13 is also slowly wound on the drum 12, and the whole carriage moving along, the cutting wheel also travels along the coal face.

The mechanism may be thrown out of gear by pressing the rod 11 which slides in its bearings. The strip 18 forms a spring to hold it in gear.

This Model can be made with MECCANO Outfit No. 7, or No. 6 and No. 6A.

Model No. 704

Signal Gantry



Model No. 704

Signal Gantry (continued)

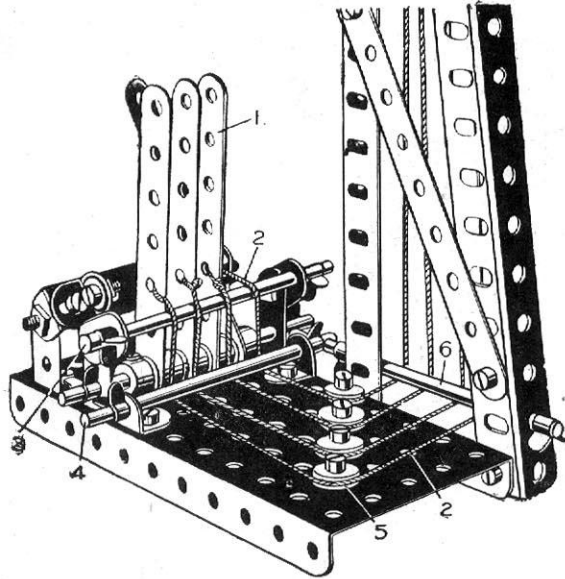


FIG. A

Parts required:

2 of No.	1A
2	2
2	2A
6	3
2	4
1	5
6	6
4	8A
6	10
4	12A
4	16
1	17
4	22
8	23
4	33A
10	35
77	37
4	37B
10	38
2	46
1	48A
1	52
5	59

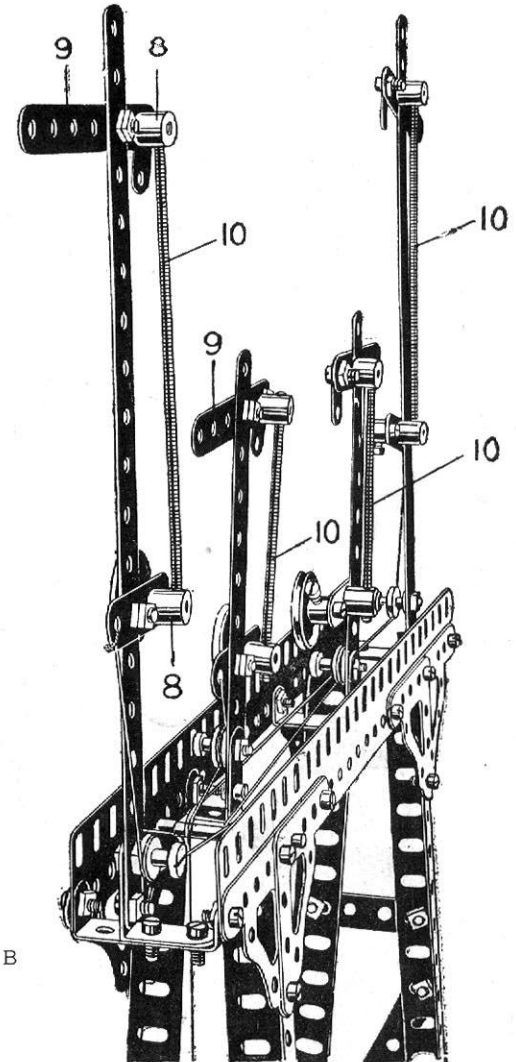
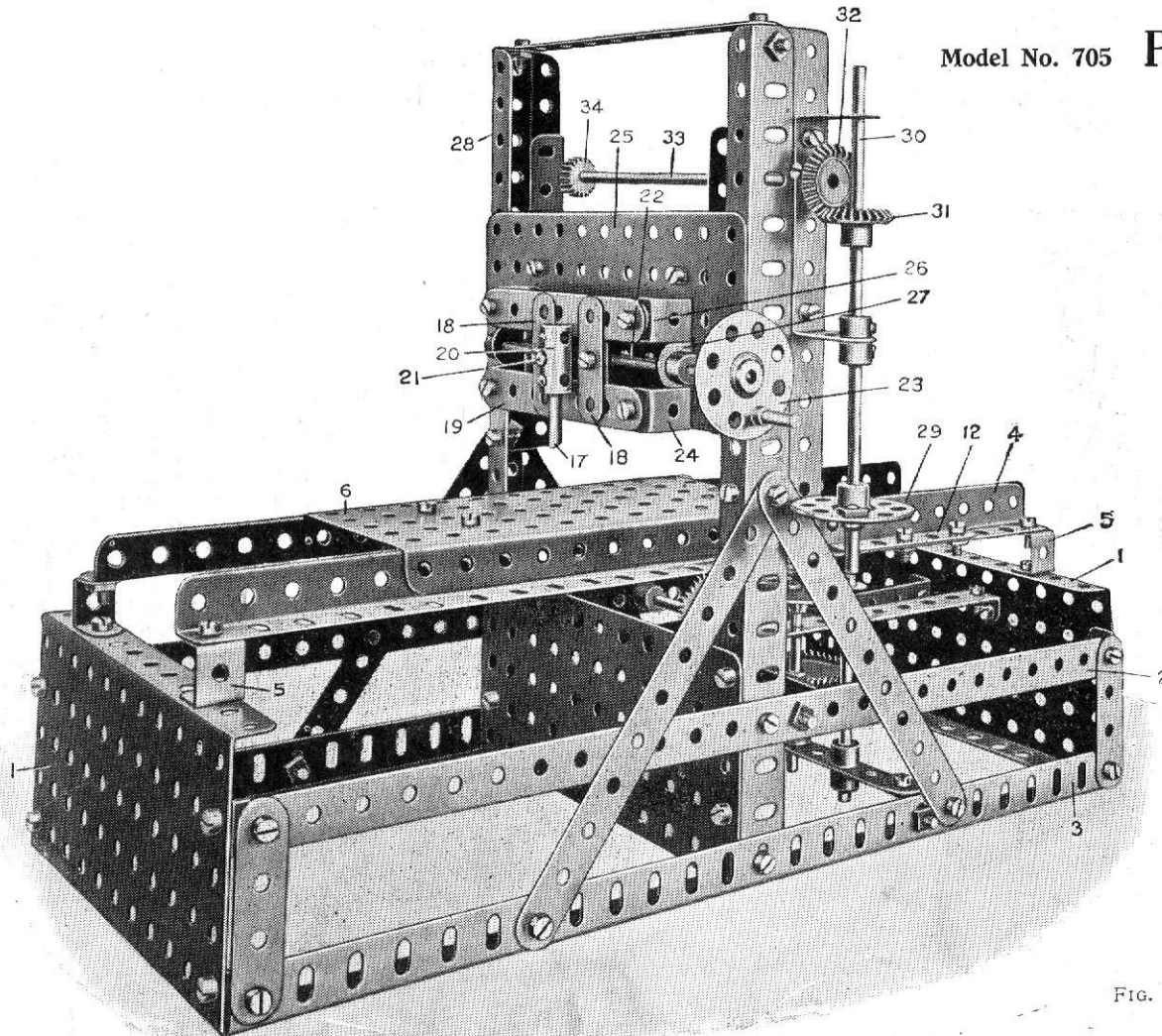


FIG. B

The detail views, Figs. 704A and 704B, bring out the construction of the various parts. In Fig. 704A the levers 1 operate the cords 2 which are passed round the upper and lower rods 3 and 4, and round the $\frac{1}{2}$ " pulleys 5, giving the cords a quarter turn before they pass round the rods 6, thence to the various weighted levers 7, which are connected as shown in Fig. 704B to threaded bosses 8 on the signal arms 9 by threaded rods 10.

This Model can be made with MECCANO Outfit No. 7, or No. 6 and No. 6A.

Model No. 705 Planing Machine



Parts required :

2	of	No. 1	1	of	No. 28
7	"	" 2	2	"	" 30
3	"	" 3	74	"	" 37
1	"	" 5	3	"	" 37A
4	"	" 6	9	"	" 38
3	"	" 6A	2	"	" 46
4	"	" 8	1	"	" 48B
2	"	" 8A	5	"	" 48D
8	"	" 11	1	"	" 50
12	"	" 12	2	"	" 52
1	"	" 14	12	"	" 59
1	"	" 15	1	"	" 63
5	"	" 16	1	"	" 64
1	"	" 18A	2	"	" 70
2	"	" 20	1	"	" 80
3	"	" 24	2	"	" 103
5	"	" 26	2	"	" 110
2	"	" 27A	2	"	" 115

FIG. A

Model No. 705

Planing Machine (continued)

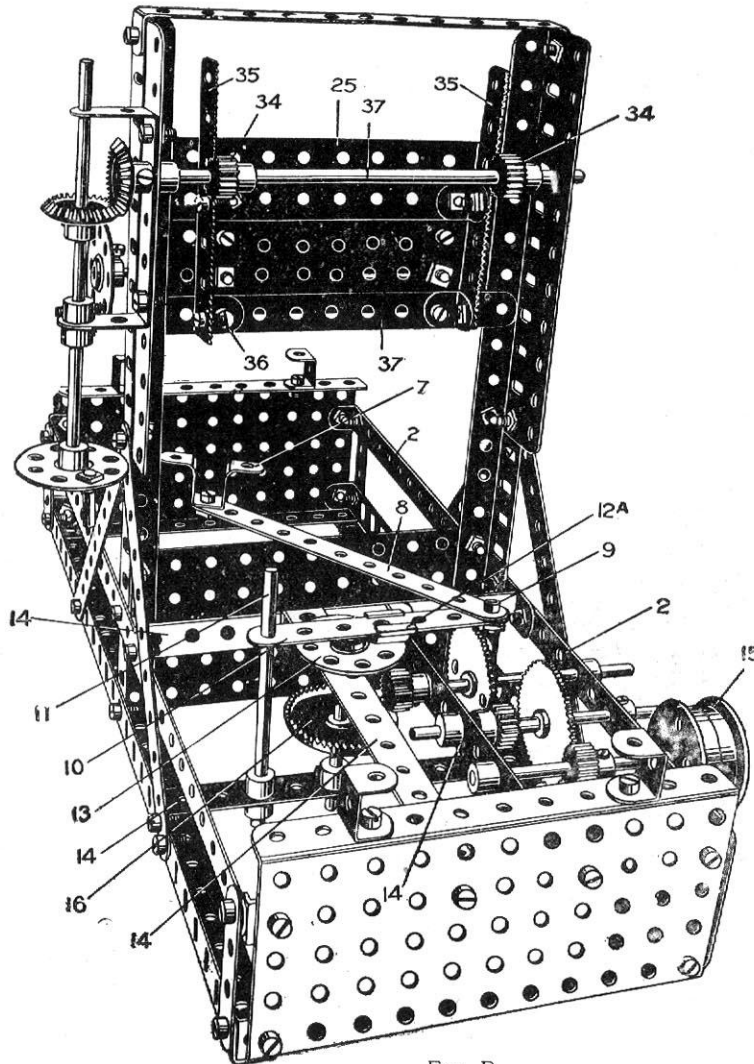


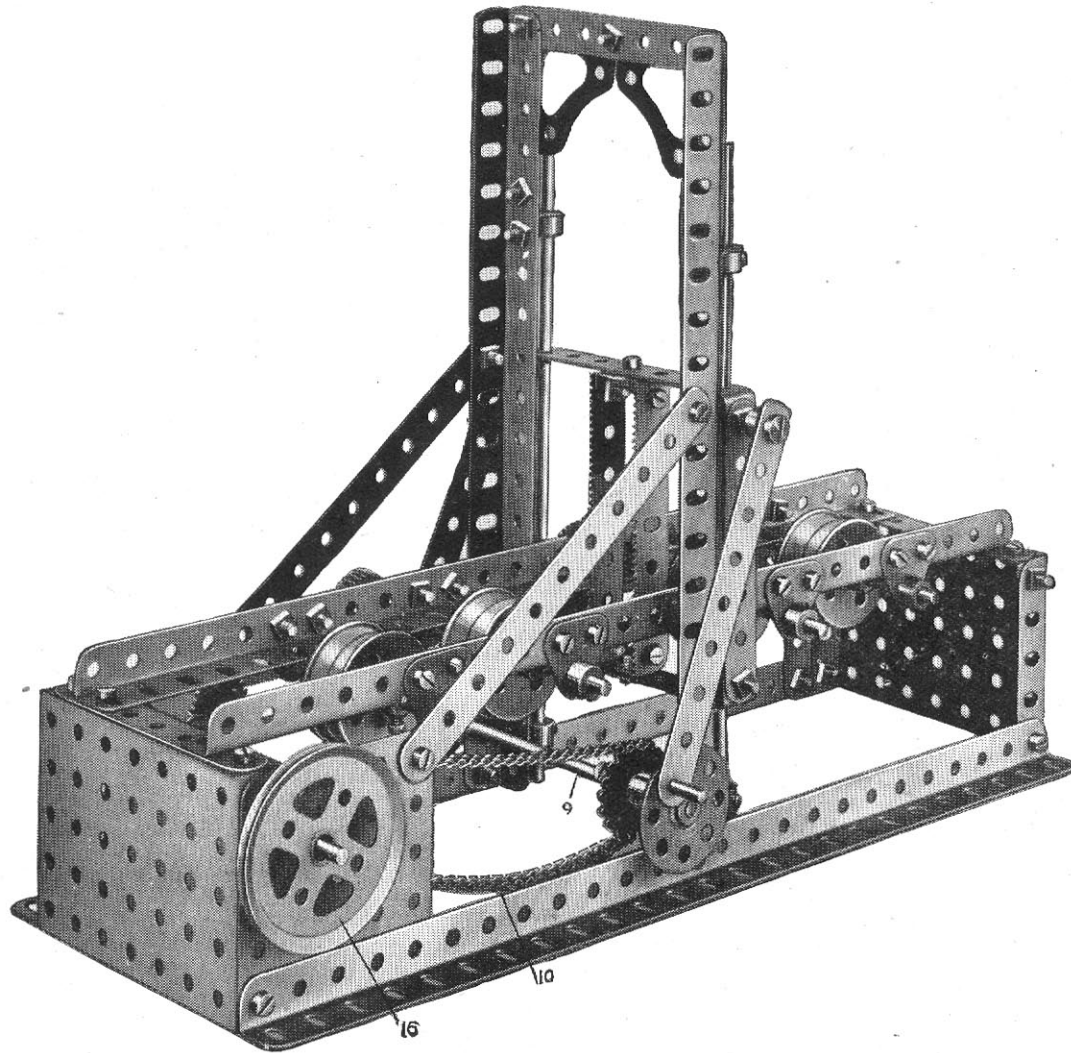
FIG. B

Fig. 705A is a perspective view from the front.

Fig. 705B is a rear view.

The main frame is built up from $5\frac{1}{2}$ " flanged plates 1, connected by angle brackets to $12\frac{1}{2}$ " strips 2 and lower angle girders 3. Angle girders 4 are bolted to the flanged plate 1 by double brackets 5. These angle girders 4 form the rails upon which the table 6 of the planer slides. The table consists of a $5\frac{1}{2}$ " flanged plate. The table is moved to and fro, being bolted by the double bent strip 7, Fig. 705B, to a $5\frac{1}{2}$ " strip 8 the end of which is attached at 9 to a $3\frac{1}{2}$ " strip 10, pivoted on a rod 11. The strips should be lock-nutted to allow free movement. The rod 11 passes through one of the elongated holes in the angle girder 4, and to prevent play of the rod a $2\frac{1}{2}$ " strip 12 is bolted on the flange of the angle girder 4, and in the end hole of this strip the top of the rod 11 is pivoted. The strip 10 engages an eye piece 12A bolted to a bush wheel 13. The eye piece is lock-nutted on the bush wheel, so that while held to the bush wheel it may rotate freely about the bolt as a pivot. Consequently, as the wheel 13 rotates, the table 6 will be moved in one direction, while cutting, more slowly than on the return movement when the work is being brought back. A gear framing by which the bush wheel 13 is driven is made by $5\frac{1}{2}$ " by $\frac{1}{2}$ " double angle strips 14, Fig. 705B. The gear is driven from the belt pulley 15, formed of two flanged wheels reversed. The gear train may be clearly followed from the illustration, terminating in a pinion driving the contrate wheel 16, secured on the bush wheel rod.

The traversing movement of the cutting tool 17 is effected by means of a guide, formed of two $1\frac{1}{2}$ " strips 18, bolted to two corresponding strips at the rear of the horizontal $3\frac{1}{2}$ " strips 19, a middle spacing $1\frac{1}{2}$ " strip being horizontally arranged between the strips 18. The cutting tool 17 is carried in a coupling 20, which is connected by a threaded pin 21, to a threaded boss on a feed screw 22, which is operated from the bush wheel 23, Fig. 705A. The horizontal strips 19 are supported by double angle brackets 24 from the flat plate 25, and washers 26 are placed beneath the nuts on the strips 19, in order to give the necessary distance at the rear for clearance for the threaded boss on the threaded rod 22. The threaded rod 22 is journaled in the ends of a $3\frac{1}{2}$ " by $\frac{1}{2}$ " double angle strip 27, bolted to the plate 25. The vertical movement of the plate 25 on the upright angle girders 28 is effected from the bush wheel 29 mounted on a rod 30, a bevel wheel 31 engaging a corresponding bevel 32 on a rod 33, carrying 2 pinions 34, which engage the racks 35, secured by angle brackets 36 to $5\frac{1}{2}$ " strips 37, bolted to the plate 25, with spacing washers between, so that a clearance is provided between the ends of the strips 37 and the plate 25, to engage in a sliding movement round the flanges of the angle girders 28.



Model No. 706

Vertical Log Saw

Parts
required:

2	of No.	2
2	" "	2A
5	" "	3
1	" "	6
4	" "	8
2	" "	8A
12	" "	12
2	" "	12A
1	" "	13
2	" "	13A
1	" "	15
4	" "	15A
2	" "	16
8	" "	20
1	" "	20A
2	" "	24
2	" "	25
1	" "	26
1	" "	27A
2	" "	30
2	" "	32
59	" "	37
6	" "	37A
2	" "	48B
2	" "	53
17	" "	59
2	" "	72
10	" "	77
12"	" "	94
2	" "	96
2	" "	108
2	" "	110
2	" "	115
2	" "	147B

Model No. 706

Vertical Log Saw

(continued)

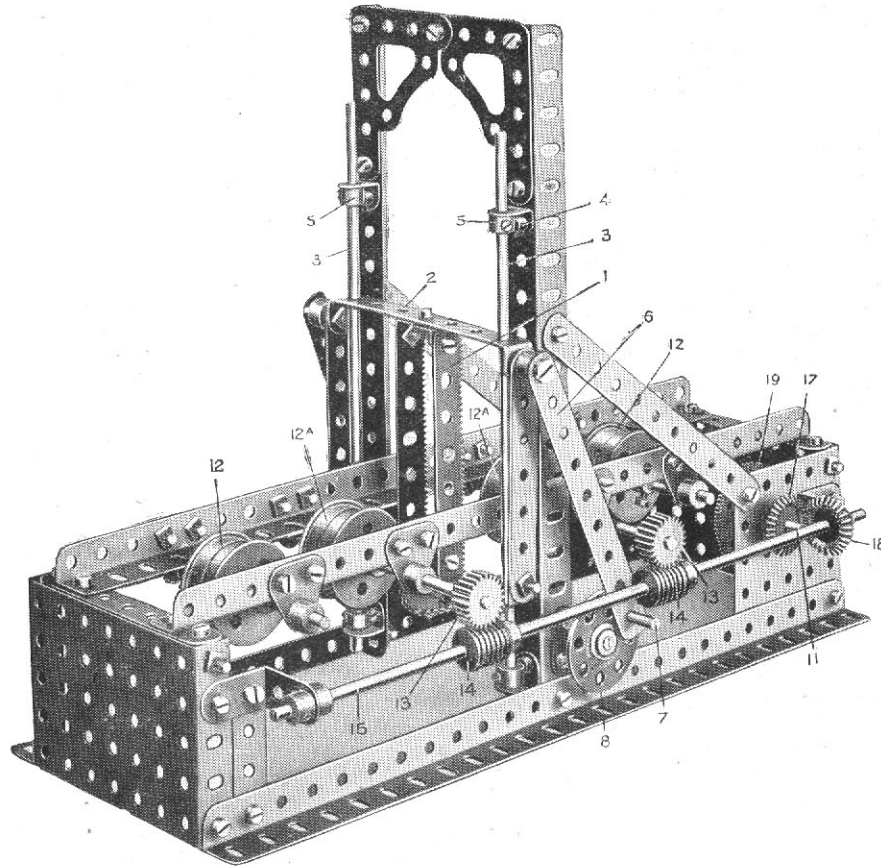


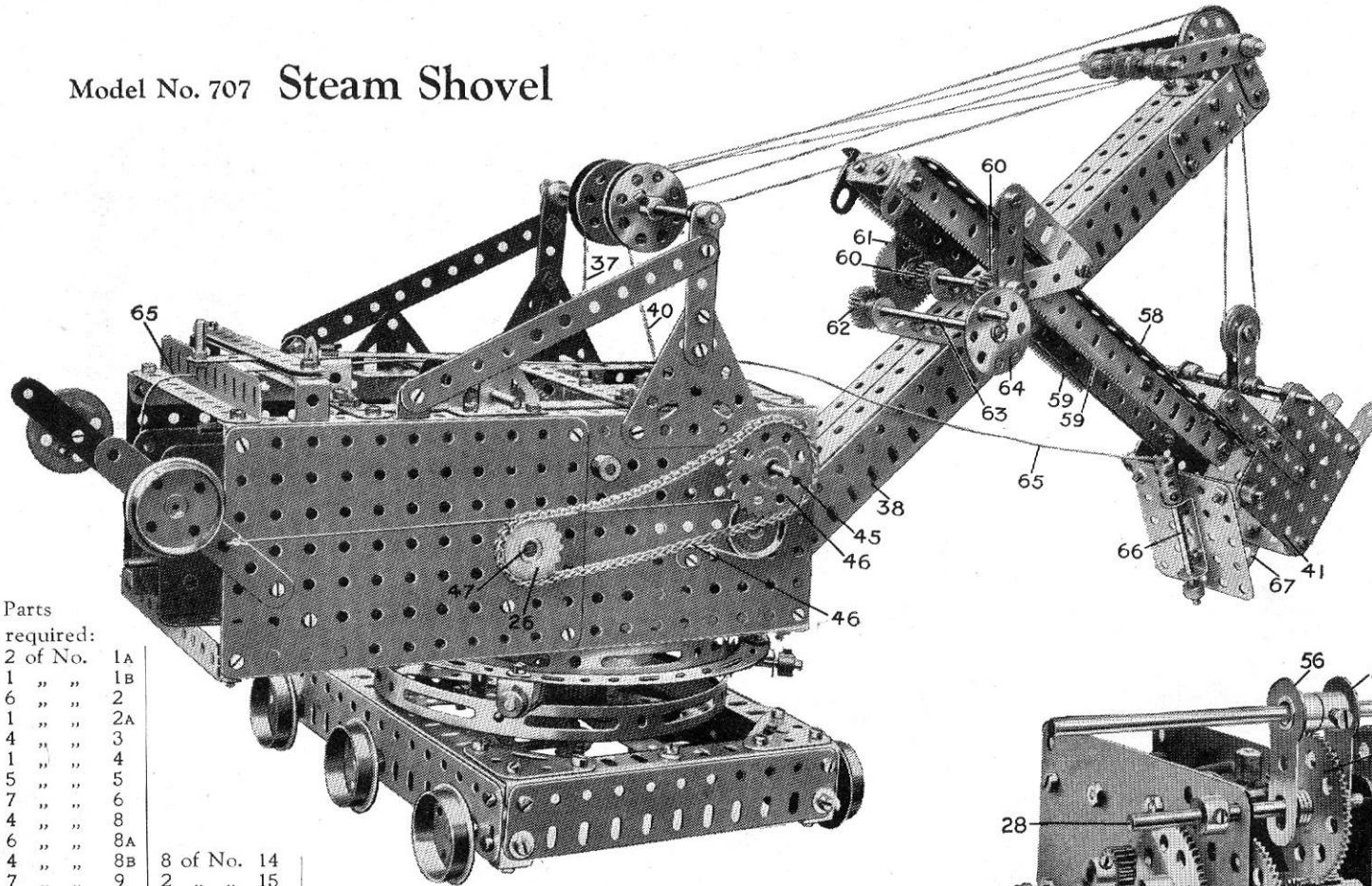
FIG. 706A

This is a model of a machine used for sawing logs into planks.

Fig. 706 is a front perspective view of the log saw, and Fig. 706A a rear perspective view.

The saws represented by the rack strips 1 are carried in a vertical movable frame 2 which slides on the rods 3 as guides. These rods 3 are rigidly held in the angle brackets 4 by the collars 5. The saw frame is reciprocated on the guide rods 3 by the link strips 6, connected to the frame 2 by pivot bolts lock-nutted to the frame and spaced with collars and the lower holes engage the threaded pins 7 on the bush wheels 8, the rod 9 of which is connected by a sprocket chain 10 to a sprocket wheel on the spindle 11. The log is caused to move past the saws by being supported on the pairs of reversed flanged wheels 12 and 12A, the centre pairs of which are positively driven from the $\frac{3}{4}$ " pinions 13, which are engaged by the worm 14 on the rod 15. The movement of the flanged pulleys 12A and of the saws 1 are both effected from the 2" pulley wheel 16, the rod of which carries a $\frac{1}{2}$ " pinion engaging a 56-toothed wheel 19 on the rod 11. At the outer end of this rod 11 is a bevel wheel 17 engaging a corresponding bevel 18 on the rod 15. Consequently, if the pulley wheel 16 be driven, the saw frame is reciprocated vertically, and the centre pairs of the flange wheels rotated, causing the log to be fed towards the saws. The opposite end of the rod carrying the pulley wheel 16 passes through one of the holes of the 1" angle bracket forming the bearing for the rod 15.

Model No. 707 Steam Shovel



Parts required:

2 of No.	1A						
1 " "	1B						
6 " "	2						
1 " "	2A						
4 " "	3						
1 " "	4						
5 " "	5						
7 " "	6						
4 " "	8						
6 " "	8A						
4 " "	8B						
7 " "	9						
2 " "	9B	8 of No.	14				
4 " "	9D	2 " "	15				
4 " "	9F	1 " "	15A				
7 " "	10	7 " "	16				
6 " "	11	4 " "	16A	4 of No.	22A	1 of No.	27
11 " "	12	1 " "	18A	2 " "	23	7 " "	27A
4 " "	12B	5 " "	18B	4 " "	23A	1 " "	27B
2 " "	13A	8 " "	20	1 " "	24	5 " "	28
		1 " "	21	5 " "	25	195 " "	37
		2 " "	22	1 " "	26	24 " "	38
				9 " "	26	5 " "	40
						1 " "	32
						1 " "	33A
						3 " "	48
						1 " "	48A
						1 " "	48D
						5 " "	52A
						36 " "	59

Parts required (continued):

3 of No.	62
2 " "	63
4 " "	72
2 " "	76
2 " "	77
36" " "	94
1 " "	95
1 " "	95A
3 " "	96
1 " "	96A
2 " "	103
2 " "	103B
2 " "	103F
1 " "	103H
2 " "	103K
4 " "	110
4 " "	111
2 " "	115
1 " "	118
4 " "	125
3 " "	126
4 " "	133
1 " "	143
1 " "	145

Electric Motor

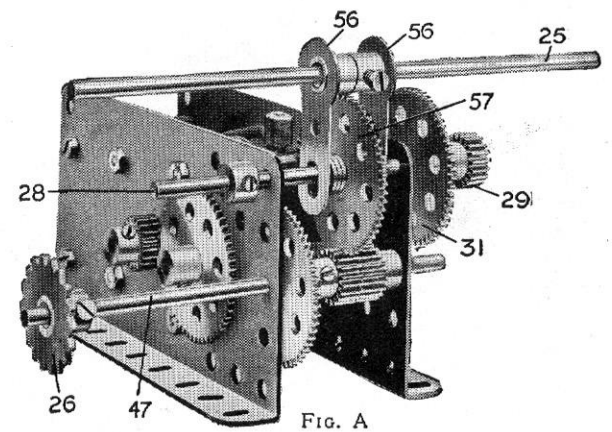


FIG. A

Model No. 707 Steam Shovel

(continued)

Begin by building up the base frame (Fig. D) from $7\frac{1}{2}$ " flat girders 1 at the sides, and $5\frac{1}{2}$ " flat girders 2 at the front. These are joined to $7\frac{1}{2}$ " and $5\frac{1}{2}$ " angle girders 3 and 4, respectively braced with corner brackets 5 at the top and angle brackets at the bottom. A hub disc 6 is bolted to a $7\frac{1}{2}$ " strip 8, which is secured across the angle girders, and also bolted to two side angle girders 3. The vertical $4\frac{1}{2}$ " rod 9 is then passed through the centre hole of the strip 8, and beneath is secured a bevel wheel. This engages another bevel wheel on the axle, which carries the central travelling wheels 10 and is connected by sprocket wheels and chain to the rear axle. The large $3\frac{1}{2}$ " gear wheel 11 is then secured to the hub disc by four $\frac{1}{2}$ " reversed angle brackets by bolts 12.

The body (Fig. C) consists of two $5\frac{1}{2}$ " \times $3\frac{3}{8}$ " flat plates, overlapped three holes to form each side. These are secured to $9\frac{1}{2}$ " angle girders 13 along the upper and lower edges, and these are connected across by $5\frac{1}{2}$ " angle girders 14. Beneath the body is bolted a circular girder 15 by bolts 16, across which,

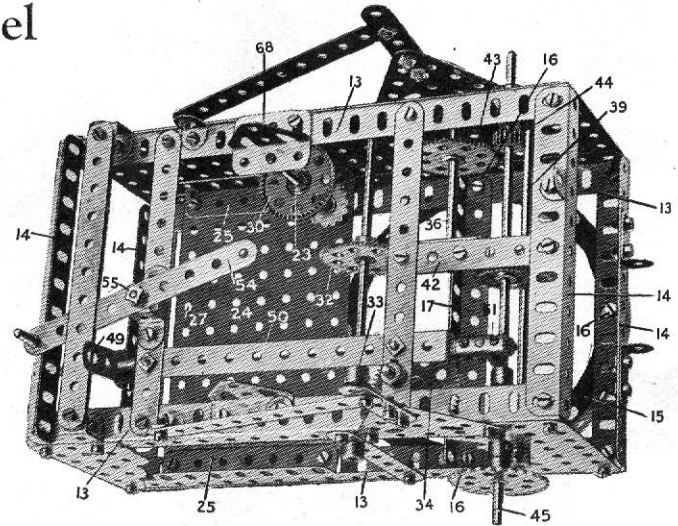


FIG. C.

held by the same bolts, is a $5\frac{1}{2}$ " angle girder 17. Through this angle girder passes the rod 9 carrying a 2" sprocket wheel 18. A collar 19 engages above the angle girder 17. Next build up the roller race (Fig. D) formed of four double brackets 20, bolted to a flat ring 21. $\frac{1}{2}$ " fast pulleys are secured on $1\frac{1}{2}$ " rods 22, which are also secured with collars on the outside. The whole is then placed on the top edge of the hub disc and the body is threaded on to the rod 9 in the centre hole of the angle girder 17. After the collar 19 is secured in position, the sprocket wheel 18 is bolted to the rod 9.

The top bearing for the $3\frac{1}{2}$ " rod 23 is formed by a $1\frac{1}{2}$ " flat girder, over which is secured a trunnion. A $3\frac{1}{2}$ " \times $5\frac{1}{2}$ " flat plate 24 is secured to each side of the body by $3\frac{1}{2}$ " angle girders 25 in the second hole up. This provides a bed to which the electric motor is secured. On the lower part of rod 23 is secured a $\frac{3}{4}$ " sprocket wheel from which a chain drives the sprocket wheel 18 which operates the lower levels to drive the travelling wheels.

Now build up the motor unit, leaving off the rod 25 and sprocket 26. (The gear wheels and rods are clearly seen in Fig. A). The motor is then secured to the plate 24, the correct position being found when the fourth hole from the back of the motor registers with hole 27 in the plate.

When the motor is in position, owing to the rod 28 being slideable the pinion 29 may be engaged with the contrate wheel 30 or the gear wheel 31 with the gear wheel 32. The spindle of the other gear wheel 32 carries a worm 33 (Fig. B) which engages a gear wheel 34. On the spindle of 34 is a pinion 35, which engages and drives the $3\frac{1}{2}$ " gear wheel 11, thus rotating the Shovel.

On the $3\frac{1}{2}$ " rod 36 is wound the cord 37 for raising and lowering the jib 38, and on the 6" rod 39 is wound the cord 40 for raising and lowering the shovel 41. The rod 36 is journaled in a trunnion bolted underneath the strip 42 and carries a $1\frac{1}{2}$ " gear wheel 43, which is engaged by a pinion 44 on an 8" rod, 45. This is driven by a $1\frac{1}{2}$ " sprocket wheel 46 from the 1" sprocket wheel 26 on the motor spindle 47.

The spindle 45 is slideable by the rotation of an 8" rod 48 operated by the crank 49, the rod being journaled in the ends of a $5\frac{1}{2}$ " \times $\frac{1}{2}$ " double angle strip 50, a coupling 51 carrying a 1" rod which engages between two collars on the rod 45. In this way the pinion 44 may be meshed with the gear wheel 43 in order to raise or lower the jib, or a 1" gear wheel 52 on the rod 39 may be engaged with a 1" gear wheel 53 to raise or lower the shovel arm 38.

The rod 28 is slideable by a $4\frac{1}{2}$ " strip 54 pivoted at 55, the outer end of which engages between two cranks 56. These grip on either side of a $1\frac{1}{2}$ " gear wheel 57, several washers being placed between the cranks to take up the slack. The shovel 41 is carried on a sliding frame consisting of angle girders 58 to which are bolted racks 59. These are engaged by $\frac{1}{2}$ " pinions 60 on a $3\frac{1}{2}$ " rod. A 50-toothed gear wheel 61, which is driven by a $\frac{3}{4}$ " pinion 62 on a $3\frac{1}{2}$ " rod 63 operated by the hand wheel 64. The bottom of the shovel is released by a cord 65 connected to a sliding rod 66, the end of which enters the aperture of a flat bracket 67.

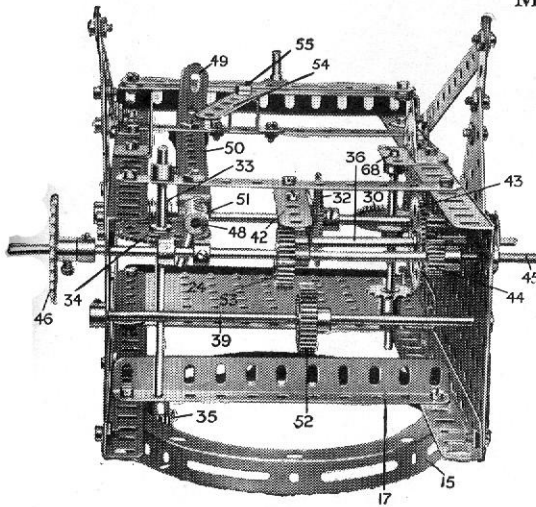


FIG. B.

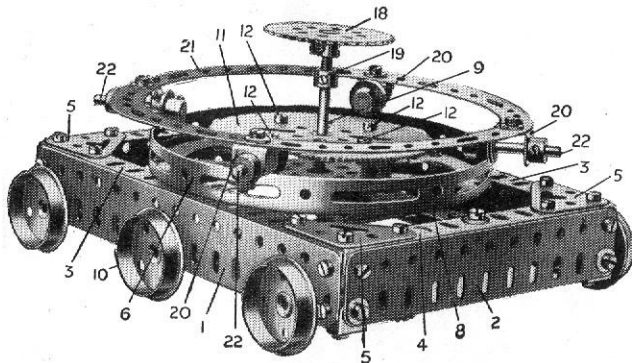
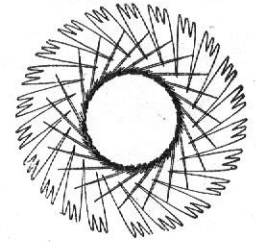


FIG. D.

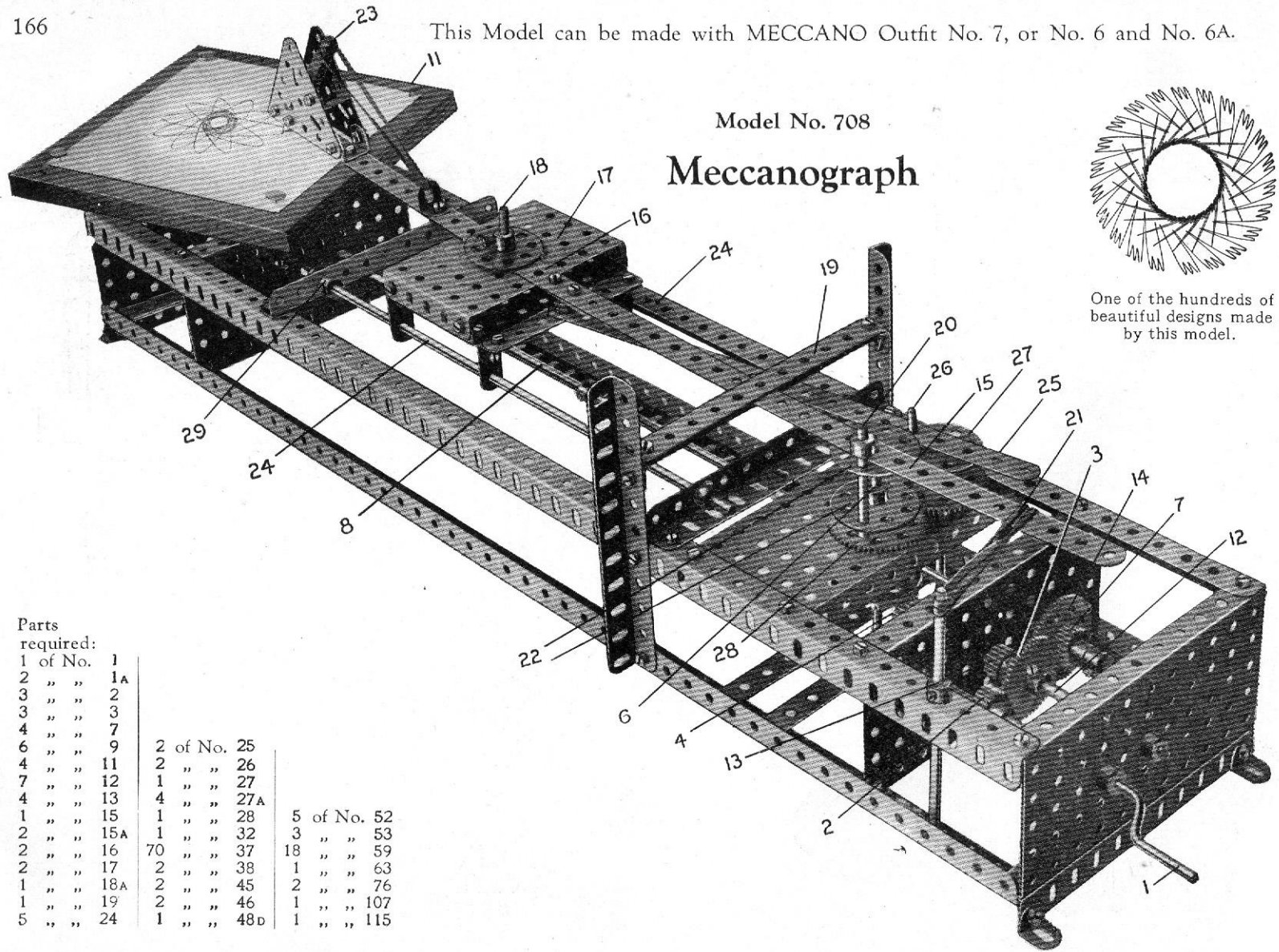
This Model can be made with MECCANO Outfit No. 7, or No. 6 and No. 6A.

Model No. 708

Meccanograph



One of the hundreds of beautiful designs made by this model.



Parts required:

1 of No.	1		
2 " "	1A		
3 " "	2		
3 " "	3		
4 " "	7		
6 " "	9		
4 " "	11		
7 " "	12		
4 " "	13		
1 " "	15		
2 " "	15A		
2 " "	16		
2 " "	17		
1 " "	18A		
1 " "	19		
5 " "	24		
2 of No.	25		
2 " "	26		
1 " "	27		
4 " "	27A		
1 " "	28	5 of No.	52
1 " "	32	3 " "	53
70 " "	37	18 " "	59
2 " "	38	1 " "	63
2 " "	45	2 " "	76
2 " "	46	1 " "	107
1 " "	48D	1 " "	115

Model No. 708

Meccanograph (continued)

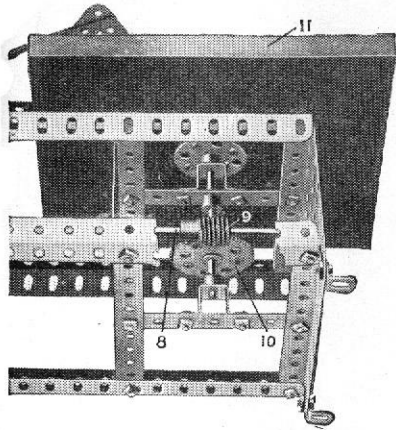


FIG. A

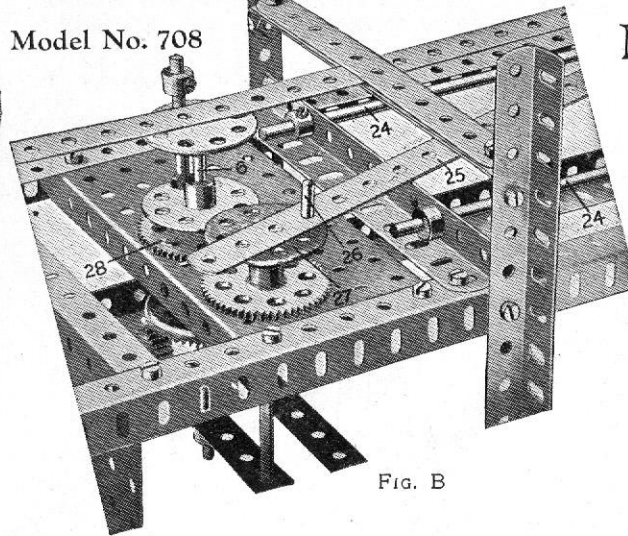


FIG. B

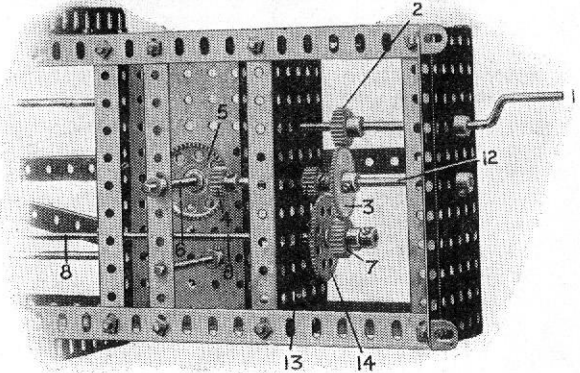


FIG. C

This is a model of extraordinary interest, and we hope that all Meccano boys will build it. With it any boy can make an amazing variety of exquisite designs by fixing a sheet of paper and pen in position and turning the handle. We have reproduced a neat design that has been made with the Meccanograph, and this could be supplemented by thousands of others if we had the space. We must content ourselves by saying that there is no limit whatever to the variety and beauty of the designs to be made by simply varying the adjustments. When tastefully filled-in with different tints of water colours, the effect is most pleasing.

The Meccanograph is driven from the handle 1 on which is a 25-toothed pinion 2 engaging a 50-toothed gear wheel 3 on the axle of which is a 19-toothed pinion 4 engaging a $1\frac{1}{2}$ " conrate wheel 5 on the spindle 6. The gear wheel 3 drives a 25-toothed pinion 7 on an axle rod 8 extending along to the table and by means of a worm 9 (Fig. A) drives a 57-toothed gear wheel 10 on the upright spindle to which the rotating table 11 is secured by a bush wheel. In order to vary the speed of rotation of the table 11 for a constant turning of the handle 1 an alternative drive is arranged. For this purpose there is loosely mounted on the rod 12 a 19-toothed pinion 13 adapted to engage a 57-toothed gear wheel 14. Consequently, the rod 8, when the wheels 13 and 14 are loose, is driven by the toothed wheels 3 and 7, and if the pinion 7 be disconnected from its rod and the pinion 13 and gear wheel 14 be fixed to their respective rods, the table will be driven at a much lower speed.

The arm is built up of a $12\frac{3}{4}$ " strip 15 and a $9\frac{1}{2}$ " strip 16 overlapped three holes and adjustably connected to the carriage 17 by a 1" rod 18. It passes through one of the perforations in the strip 16 so that, in order to vary the design produced, the rod 18 may be inserted in any suitable hole in the strip 16 or in any suitable hole in the carriage 17. The strip 15 is guided between the $5\frac{1}{2}$ " strips 19 spaced by washers at each end. The strip 15 of the arm continually bears against the rod 20 by the pulling action of an elastic band 21, the rod 20 passing through two bush wheels 22 secured on the rod 6. Consequently, as the bush wheels rotate, the rod 20 acts as a crank to oscillate the arm about the pivot rod 18 and moves the pen 23 to and fro across the table 11. The carriage 17 is simultaneously caused to travel to and fro along the guide-rods 24 by means of a strip 25 (Fig. B), one hole of which engages a threaded pin 26 in a bush wheel 27. This is driven by means of a $1\frac{1}{2}$ " gear wheel on its axle rod, being engaged and driven by a similar gear wheel 28 secured on the vertical rod 6.

One series of designs is obtained from the Meccanograph as shown in the illustration, but an entirely different set of designs may be obtained if the strip 25 is disconnected from the threaded pin 26 and the carriage 17 locked on the guide rods 24 by means of collars 29. The pen 23 is held in the holder (Fig. D) formed by two $2\frac{1}{2}$ " triangular plates 30 connected by two double brackets 31 to the arm 16, and connected together also by two further double brackets 32. The pen 23 is retained in this holder by an elastic band 33 connected to an angle bracket 34 on the arm.

Care should be taken to see that all parts of the model work smoothly and that no jolting takes place, otherwise the lines of the design will be uneven.

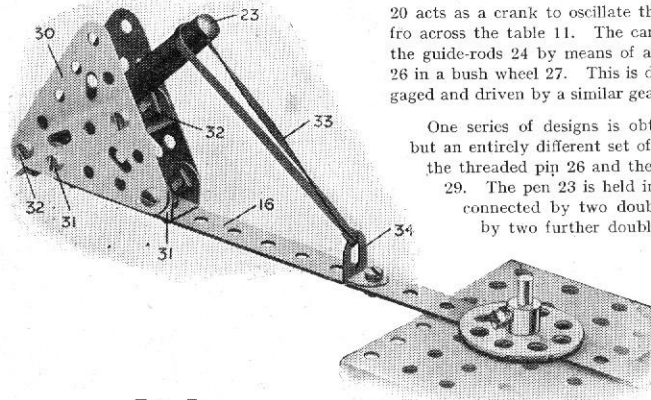


FIG. D

Model No. 709 Stiff-Leg Derrick

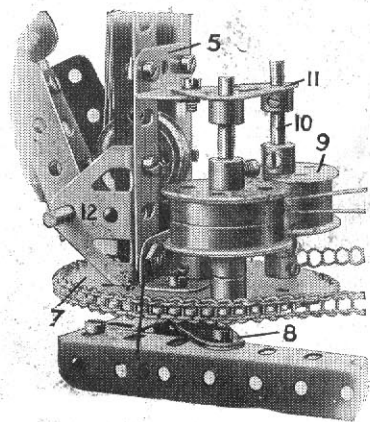
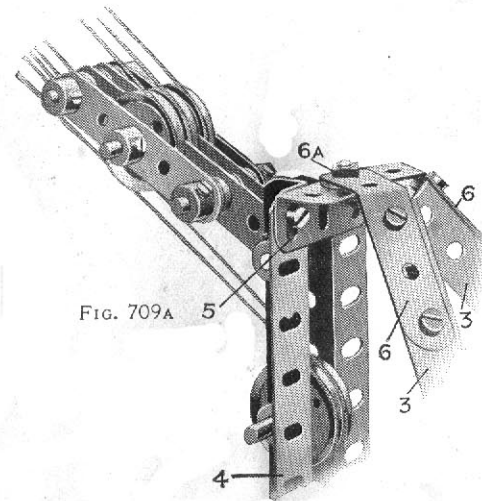
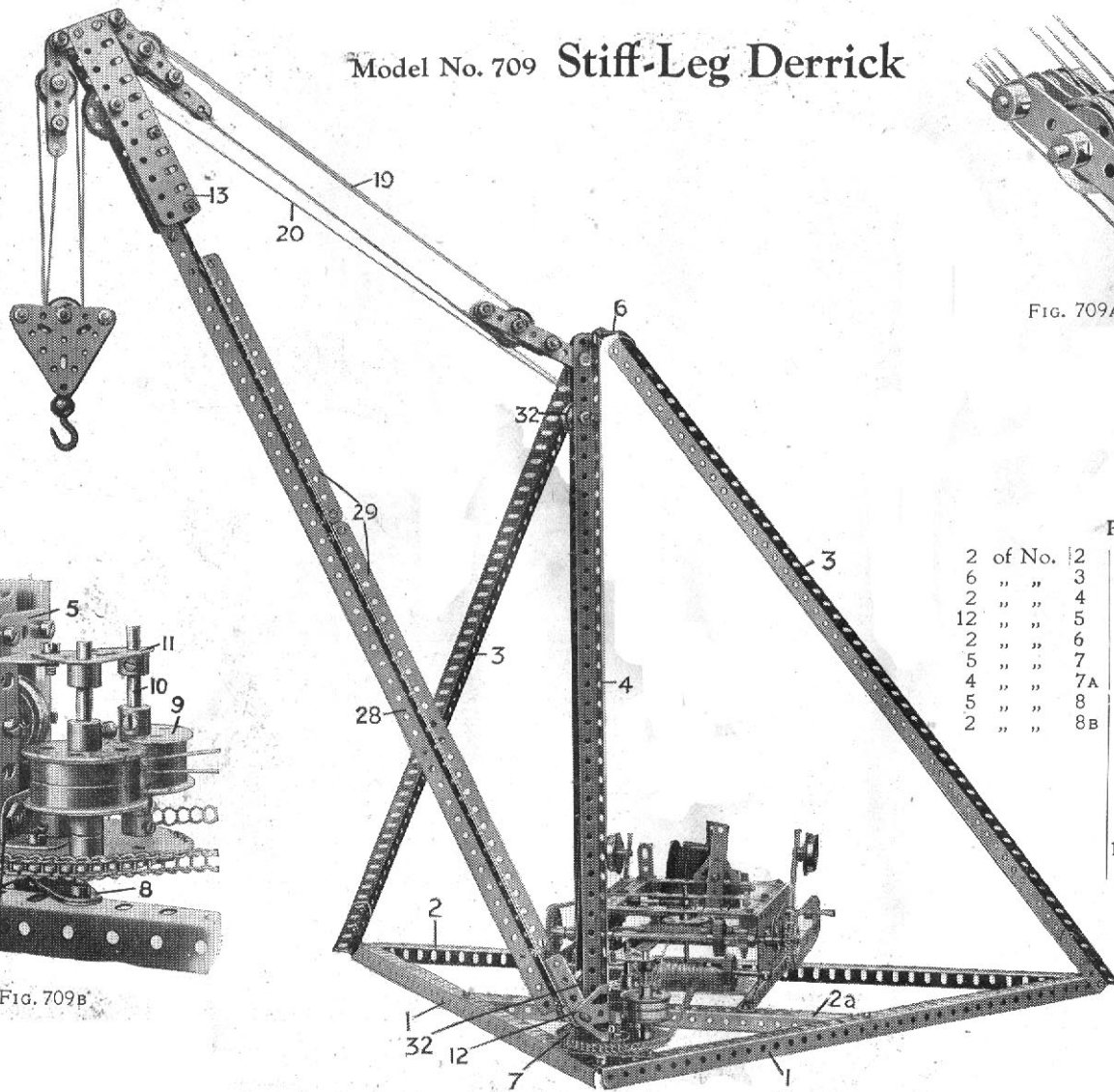


FIG. 709B



Parts required:

2	of No. 2	6	of No. 9B	3	of No. 27A
6	" "	2	" "	2	" "
2	" "	3	" "	1	" "
12	" "	2	" "	3	" "
2	" "	2	" "	79	" "
5	" "	4	" "	88	" "
4	" "	1	" "	2	" "
5	" "	3	" "	1	" "
2	" "	4	" "	2	" "
		5	" "	2	" "
		6	" "	1	" "
		9	" "	50	" "
		2	" "	1	" "
		2	" "	1	" "
		15	" "	2	" "
		2	" "	1	" "
				2	" "
				1	" "
				2	" "
				2	" "
				3	" "
				1	" "
				1	" "
					Electric
					Motor

Model No. 709 Stiff-Leg Derrick (continued)

The base of the model is formed of $18\frac{1}{2}$ " angle girders 1 bolted to a $24\frac{1}{2}$ " girder 2 and held rigid by a $12\frac{1}{2}$ " girder 2a. The side members 3 are constructed from $24\frac{1}{2}$ " angle girders extended at their lower ends by $2\frac{1}{2}$ " girders overlapped three holes. $2\frac{1}{2}$ " strips 6, Fig. A, bolted to the tops of the girders 3 are slightly bent, as shown, and meeting together form a bearing for the bolt 6a, about which the upright member 4 pivots. The latter consists of $18\frac{1}{2}$ " angle girders, bolted together at each extremity by $1\frac{1}{2}$ " girders 5. The lowest of these $1\frac{1}{2}$ " girders is secured to a 3" sprocket wheel 7, which forms the swivelling base of the jib. The pivot is a $1\frac{1}{2}$ " rod passed through the centre hole of the $1\frac{1}{2}$ " girder and through the boss of the sprocket wheel and carried in a bearing 8 built up from two $2\frac{1}{2}$ " strips bolted across the base girders 1. Two collars should be placed on this rod, one above the sprocket 7 and one below the strips 8, Fig. B.

Two flanged wheels butted together form guide pulleys 9 (Standard Mechanism No. 40).

The jib is built up from two $24\frac{1}{2}$ " angle girders 28 bolted together in the form of a T and strengthened by pairs of $12\frac{1}{2}$ " and $7\frac{1}{2}$ " angle girders 29 similarly bolted together and secured along the upper sides of the girders 28. A $2\frac{1}{2}$ " rod, about which the jib pivots, is journalled through trunnions 12, Fig. B, and through the end holes of 2" girders bolted in the first and third holes from the end of the $24\frac{1}{2}$ " girders 28. The head of the jib (Standard Mechanism No. 31) is formed by two $5\frac{1}{2}$ " flat girders 13 secured to $2\frac{1}{2}$ " angle girders, bolted in the first and fourth holes of the girders 28.

The jib is raised or lowered by means of the cord 19 winding on the rod 18, Fig. C. The drive from the motor is led to this rod 18 by way of chain gear 17 and rod 16 which is slideable in its bearings. On operation of the crank 24, the 1" gear wheel 31 is brought into engagement with a similar gear secured to the shaft 18 (Standard Mechanisms). This operates the cord 19, which, after passing round 1" guide pulleys 32 in the vertical member 4, is led round the sheaves of the pulley block pivoted at the rear of the jib-head and those of the pulley-block attached to the head of the upright (Fig. A) in a similar manner to that described in Standard Mechanism No. 37.

The hoisting-block is operated by the cord 20 winding on a rod 21, Fig. C, which also carries a 57-toothed gear wheel. On moving the lever 24 over to the right, a $\frac{1}{2}$ " pinion 23 is brought into mesh with this gear wheel, so connecting the hoisting mechanism with the drive from the motor. The cord 20 is led over the pulleys in the vertical member in a similar manner to the cord 19 before passing over a $1\frac{1}{2}$ " pulley in the jib-head; it next engages alternately the sheaves of the hoisting-block and of the second fixed block in the jib-head, being finally secured to the latter.

The rotation of the jib is effected as follows: a rod 25 driven by sprocket chain from the rod 16 may be moved to and fro in its bearings on operation of a lever 26 (see Standard Mechanisms), and this movement is employed to engage or disengage a $\frac{1}{2}$ " pinion with a 57-toothed gear wheel 22 on a secondary shaft 33. The latter carries a worm wheel gearing with another 57-toothed gear wheel on a vertical rod 27 and a 1" sprocket wheel on this rod rotates by means of a sprocket chain the 3" sprocket wheel 7 forming the base of the jib.

Brakes are provided in the form of weighted levers 34 as described in Section VI., "Meccano Standard Mechanisms." This method prevents falling-back of the jib or hoisting-block when the gears are released.

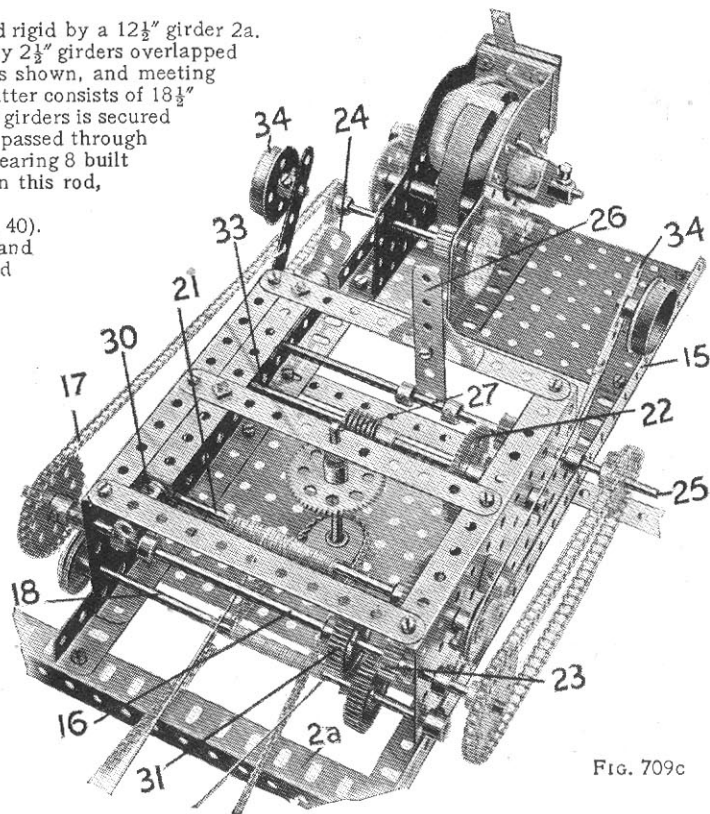


FIG. 709c

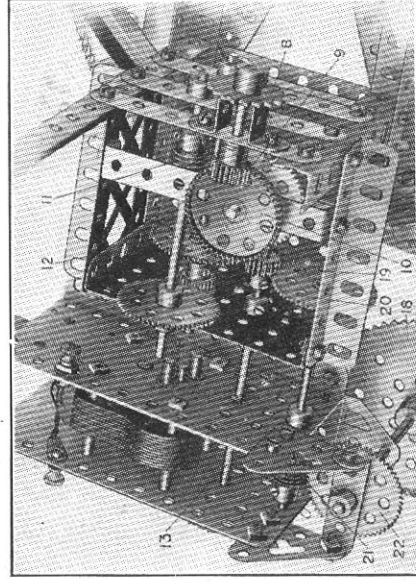


FIG. 710A

Model No. 710 Aeroscope

The rotary roller base of the model is similar to that described in "Meccano Standard Mechanisms." To this rotary frame is bolted at 1 two $3\frac{1}{2}$ " angle girders bolted together, upon which the superstructure 2 is secured. At the top of this superstructure is journaled a $6\frac{1}{2}$ " rod 3 bolted to the swinging arm 4 by means of two bush wheels 5. On the rod 3 is a 3" sprocket wheel 6 driven by a chain 7 from the 1" sprocket wheel 8. This sprocket wheel is driven by a $\frac{1}{2}$ " pinion 9 and a $1\frac{1}{2}$ " contrate wheel 10 which in turn are driven from a worm wheel 11 on a $4\frac{1}{2}$ " rod 12. This rod is driven by a reducing gear train from the 5" rod 13 in the motor, Fig. A.

The gear mechanism just described rotates the arm 4 about the rod 3. The arm is balanced at the foot by thirty-two $12\frac{1}{2}$ " strips 14, and the carriage 15, pivoted at 16, is balanced by a weight on each side consisting of twenty $2\frac{3}{8}$ " strips 17.

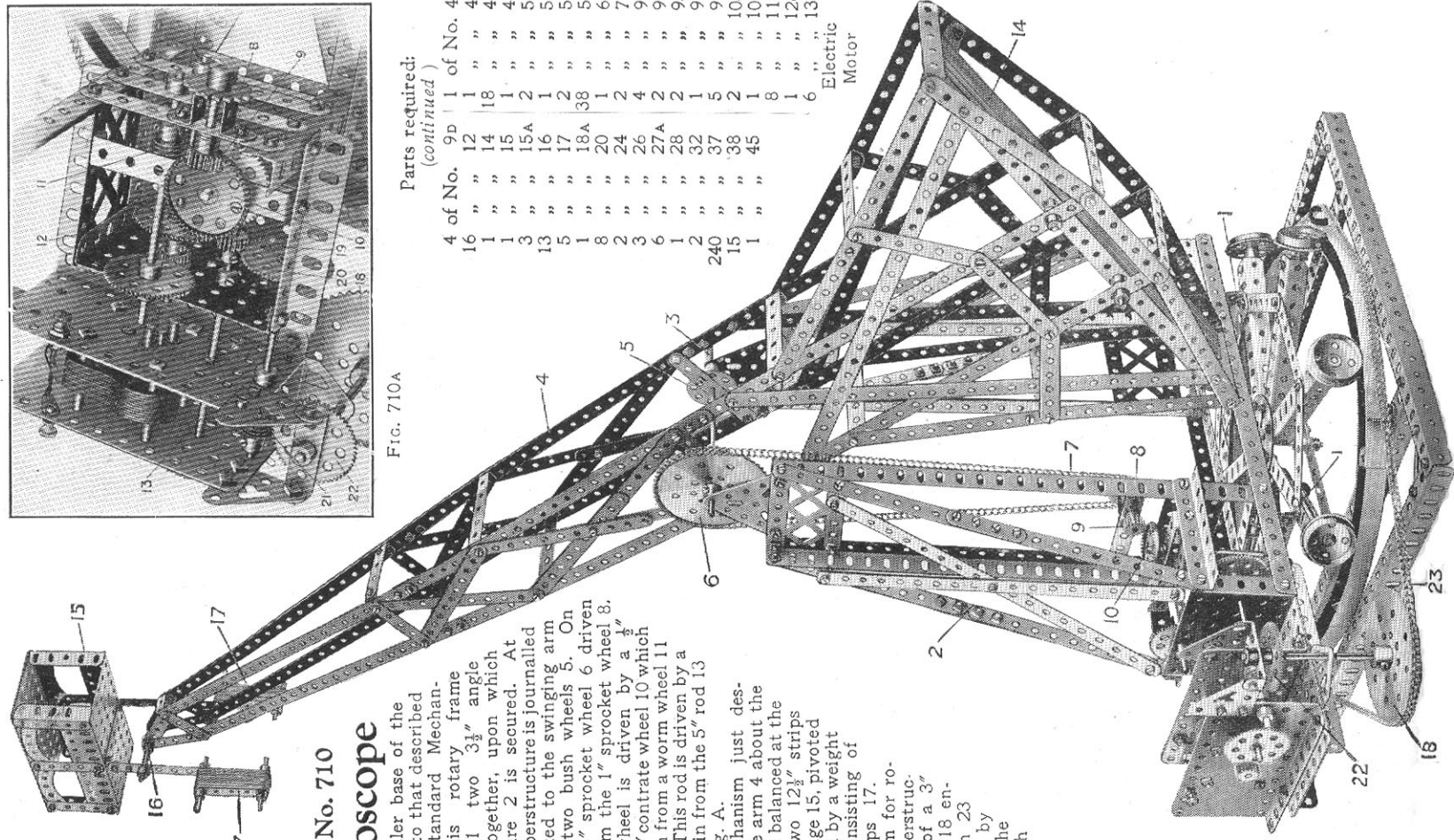
The mechanism for rotating the superstructure 2 consists of a 3" sprocket wheel 18 engaging the chain 23 and is operated by the $\frac{1}{2}$ " pinion 19, the drive from which is led through a 57-toothed gear wheel 20, and worm 21 on to the 57-toothed wheel 22.

Parts required:	
48 of No.	1
4 "	1A
1 "	1B
34 "	2
20 "	3
48 "	5
8 "	6
12 "	8
2 "	9
8 "	9A
7 "	9B

Parts required:
(continued)

4 of No.	9D	1 of No.	46
16 "	12	1 "	48
1 "	14	18 "	48A
1 "	15	1 "	41B
3 "	15A	2 "	52
13 "	16	1 "	52A
5 "	17	2 "	53
1 "	18A	38 "	59
8 "	20	1 "	62
2 "	24	2 "	76
3 "	26	4 "	90
6 "	27A	2 "	94
1 "	28	2 "	95B
2 "	32	1 "	96
240 "	37	5 "	97
15 "	38	2 "	103
1 "	45	8 "	109
		1 "	119
		1 "	126A
		6 "	133

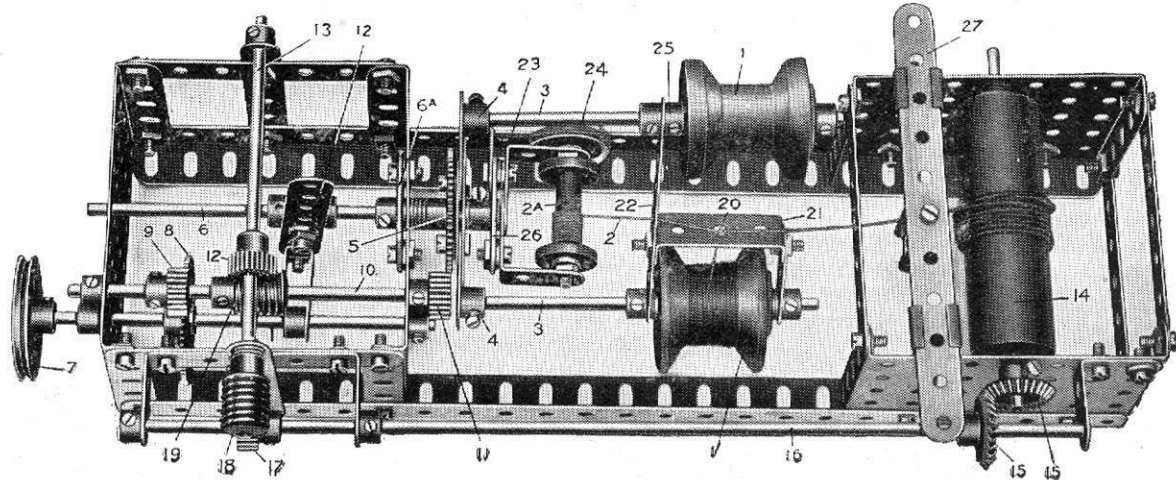
Electric
Motor



Model No. 711 Wire Covering Machine

Parts required:

1 of No. 2	2 of No. 27A
7 " " 3	2 " " 30
2 " " 4	2 " " 32
1 " " 5	41 " " 37
2 " " 6A	17 " " 38
2 " " 8	2 " " 44
1 " " 10	1 " " 46
2 " " 12	1 " " 48
3 " " 12A	2 " " 50
1 " " 13	4 " " 53
3 " " 15	12 " " 59
4 " " 15A	2 " " 62
1 " " 21	1 " " 63
1 " " 22	1 " " 81
2 " " 24	1 " " 106
4 " " 26	1 " " 301



The bobbins 1, carrying the thread by means of which the wire 2 is covered, are carried in a yoke consisting of two rods 3, secured in cranks 4, between a $2\frac{1}{2}$ " and $1\frac{1}{2}$ " strip, and bolted to a 57-toothed gear wheel 5, rotatable loosely on a fixed 5" rod 6. On the rod 6, is a bush wheel 6A, bolted thereto and to the frame. This holds the rod against rotation. The bobbin 2A is carried in the two 1" angle brackets, forming a frame which is bolted to the bush wheel 26, the latter being held by its screw fixedly on the rod 6. The yoke is rotated from the pulley wheel 7, a 57-toothed gear wheel 8, on the spindle of which drives a $\frac{1}{2}$ " pinion 9, on an upper 4" rod 10, another $\frac{1}{2}$ " pinion 11, on the end of which engages and drives the gear wheel 5; this rotates the yoke. The gear 8 is caused to engage or disengage with the pinion 9 by a clutch mechanism operated by the handle 12. As the yoke rotates, the thread from the bobbins is wound closely round the wire 2, and in order to ensure an even wrapping of the thread on the wire, the take-up roller 14, is provided, on to which the wire as it is covered is wound. The take-up roller is driven with a very slow movement by bevel pinions 15, from a side rod 16, a $\frac{1}{2}$ " pinion 17 on which is driven by a worm 18, on the rod 13. Consequently, the same rotary movement of the rod 10, to drive the bobbin yoke, also operates the bobbin yoke, also operates the worm 19, engaging the pinion 12 and worm 18, engaging the pinion 17, which drives the take-up roller 14, bringing the uncovered wire 2 slowly past a perforation 20, in the guide strip 21, formed of $1\frac{1}{2}$ " by $\frac{1}{2}$ " double angle strip and carried from the yoke arm 22.

In order to prevent the wire 2 unwinding too freely from its bobbin 2A, a brake is provided, consisting of a cord 23, passing round a pulley 24, on the spindle of the bobbin 2A, and connected to a flat bracket bolted on the bush wheel 26.

It will be noticed that a collar 25 is placed on one side of the yoke strip 22, which has the effect of setting one of the bobbins slightly to the rear of the other, and the effect of this is to give two windings round the wire, one over the other. The thread on the bobbins may be of different colours, which would give a variegated effect to the covering. In order to cause the covered wire to be wound evenly on the take-up roller 14, a distributor is provided, consisting of a strip 27, beneath which is bolted a double bracket through which the covered wire passes. By moving the strip 27 from one side to the other, the wire winds evenly on the roller 14.

Model No. 712 **Tractor**

Parts required:

3	of No. 2A	2	of No. 137
2	" "	2	" " 147A
4	" "	2	" " 147B
2	" "	2	" " 148
2	" "		Electric Motor
3	" "		
1	" "		
3	" "		
1	" "		
3	" "		
1	" "		
1	" "		
3	" "		
2	" "		
1	" "		
2	" "		
2	" "		
5	" "		
2	" "		
6	" "		
2	" "		
4	" "		
2	" "		
1	" "		
180	" "		
60	" "		
1	" "		
1	" "		
2	" "		
1	" "		
4	" "		
2	" "		
20	" "		
1	" "		
2	" "		
4	" "		
18"	" "		
4	" "		
2	" "		
2	" "		
2	" "		
4	" "		
2	" "		
1	" "		

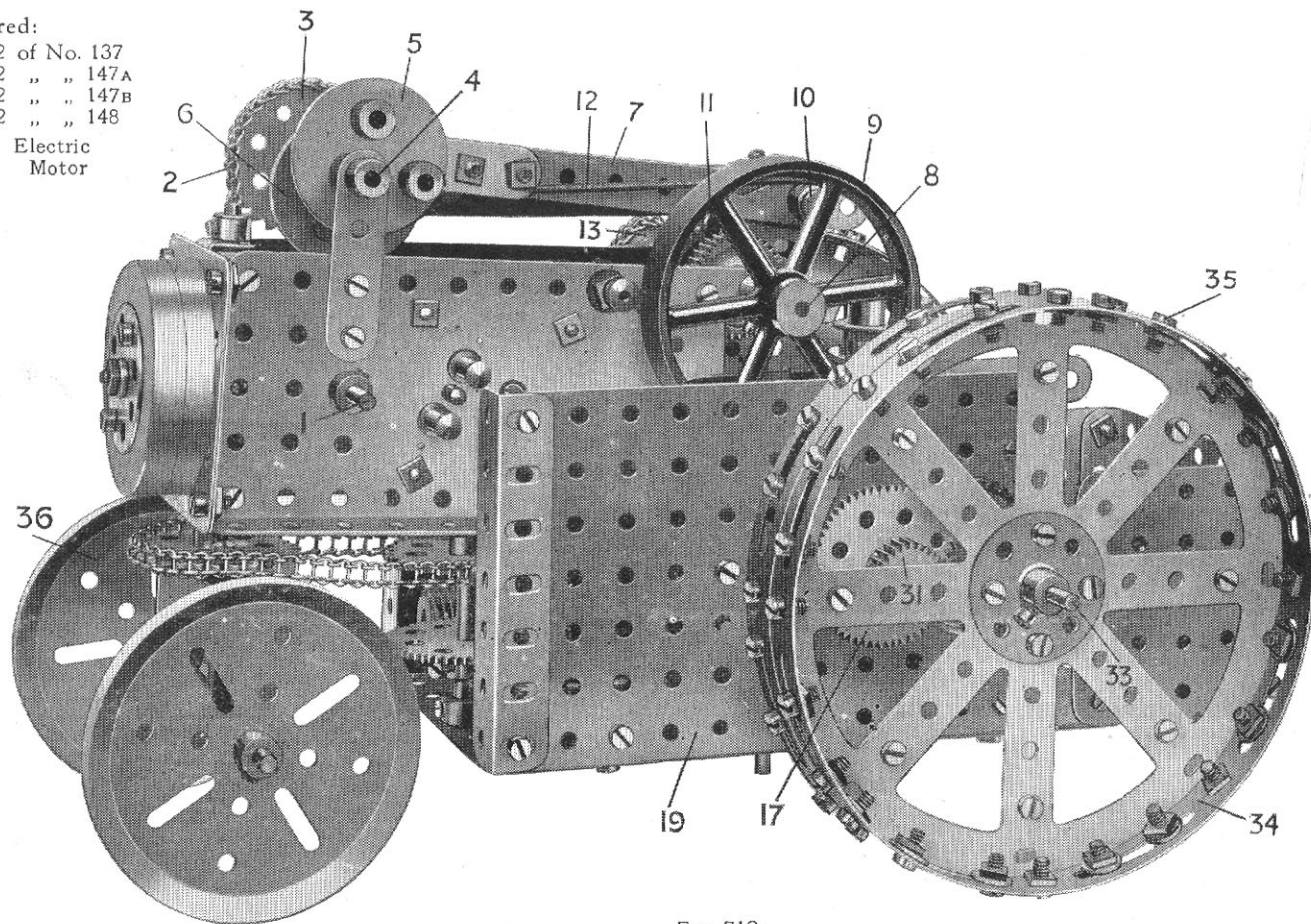


Fig. 712A

Model No. 712 Tractor (continued)

The driven spindle 1, Fig. A, of the electric motor carries a $\frac{3}{8}$ " sprocket wheel, which is coupled by a chain 2 to a $1\frac{1}{2}$ " sprocket wheel 3 on the rod 4.

Secured on this rod are two eccentrics 5 and 6 connected by $4\frac{1}{2}$ " strips 7 to pivot bolts 10, Fig. B. These are secured to $1\frac{1}{2}$ " flat girders $10a$ pivoting about a rod 8 carrying the fly wheel 9. On the pivot bolts 10 are pivoted double pawls, which engage two 1" gear wheels 11 secured on the rod 8. Spring cord 12 connected to the screws 11b keep the pawls in engagement with the gear wheels 11.

Consequently, when the motor is running, the eccentrics 5 and 6 cause the pawls to rock to and fro about the rod 8 and so rotate the gear wheels 11 and the rod 8 to which the wheels are secured. A $\frac{3}{8}$ " sprocket wheel 13 on the end of the rod 8 is coupled by a chain to a $1\frac{1}{2}$ " sprocket wheel 14, Fig. C, on a rod 15. This rod carries at its other end a $\frac{1}{2}$ " pinion 16 engaging a 57-toothed gear wheel 17 on a rod 18, which is mounted to slide in the rectangular plates 19 forming the sides of the tractor.

The rod 18 is caused to slide by turning the crank 20, Fig. C. This movement is fully explained in "Meccano Standard Mechanisms" (see Section V., Drive-changing Gear).

On the rod 18 is a $\frac{1}{2}$ " pinion 53 and when the short rod mounted in the crank 20 is moved to the left to the next hole in the bush wheel 29, this pinion moves into gear with another $\frac{1}{2}$ " pinion 54. This pinion 54 is mounted on a short rod and permanently in engagement with another pinion 55 on the rod 33, upon which are fixed the travelling wheels 34.

The rod 33 also carries two 50-toothed gear wheels 32. Two $\frac{3}{8}$ " pinions 31 on the rod 18 are adapted to be engaged with these 50-toothed gear wheels when the crank 20 is moved one hole to the right in the bush wheel 29 and the pinion 53 is out of engagement with the pinion 54. In this manner the pinions 53, 54 and 55 form a reversing gear, and by moving the crank 20 in either direction a forward or reverse drive of the tractor may be obtained. The central position of the

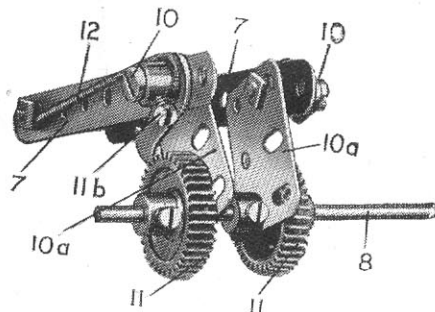


FIG. 712B

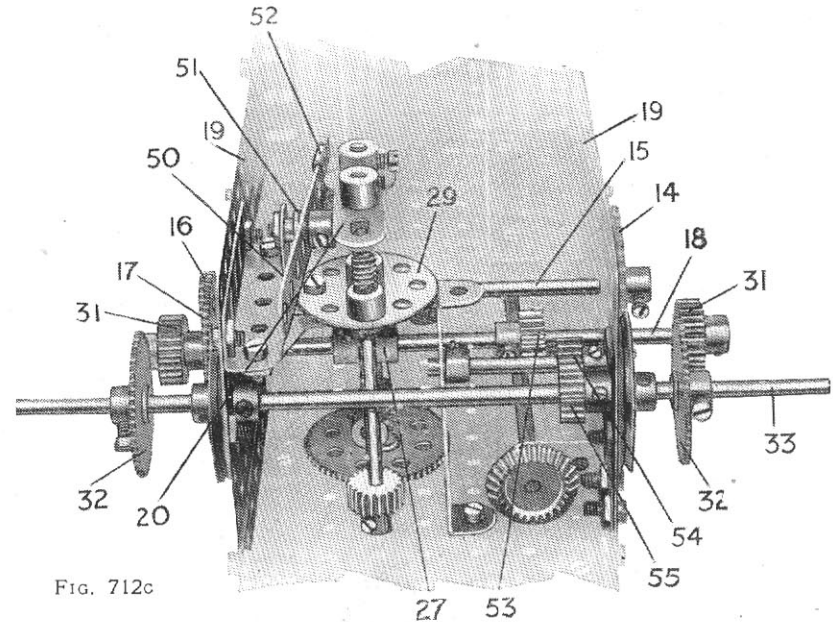


FIG. 712C

crank 20 throws all three pinions on the rod 18 out of gear; the motor is then allowed to run freely.

Each of the road-wheels 34 is made up of two hub discs bolted back to back, a number of bolts 35 being secured round the flanges to enable the wheels to obtain a grip on the ground.

The steering gear is described in "Meccano Standard Mechanisms."

The switching of the motor on or off is controlled by the strip 50, Fig. C, pivoted at 51 and connected to the control lever of the motor by an eye piece 52.

It will therefore be seen that if the motor is switched on and the clutch (formed by the pinions 31) be placed in gear, the drive from the motor to the wheels 34 will be effected through the eccentrics 5 and 6, gear wheels 11 and gear train 16, 17, 31 and 32 to the rod 33 carrying the wheels 34. While the motor is still running the drive may be declutched by operating the crank handle 20.

It should be noted that the eccentrics 5 and 6 are opposed to one another when secured to the Rod 4. In this way they alternately impart the thrust, or driving motion, to the rod 8.

An accumulator may be carried in a box formed from two $2\frac{1}{2}$ " x $2\frac{1}{2}$ " flat plates and one $3\frac{1}{2}$ " x $2\frac{1}{2}$ " flanged plate at the rear of the road wheels, Fig. A.

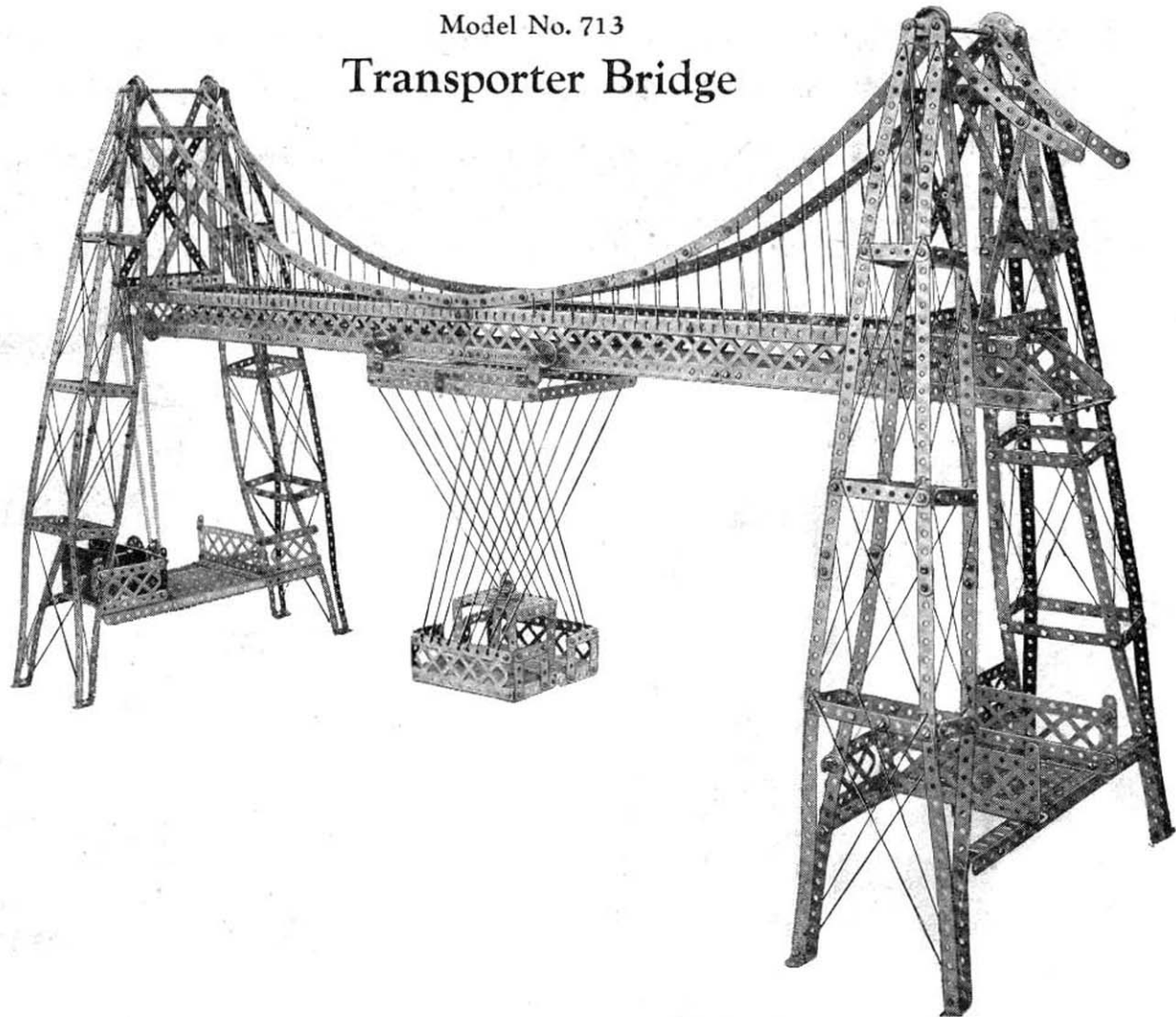
Model No. 713

Transporter Bridge

Parts
required:

32	of No.	1
52	" "	2
8	" "	3
32	" "	4
120	" "	5
32	" "	6
4	" "	7
20	" "	8
8	" "	9
4	" "	10
10	" "	11
89	" "	12
3	" "	14
2	" "	15A
1	" "	17
4	" "	18A
4	" "	20
1	" "	21
5	" "	22
1	" "	26
1	" "	27A
507	" "	37
10	" "	48A
6	" "	52
7	" "	53
15	" "	59
10	" "	94
4	" "	96
3	" "	97
8	" "	99
6	" "	100

Electric Motor



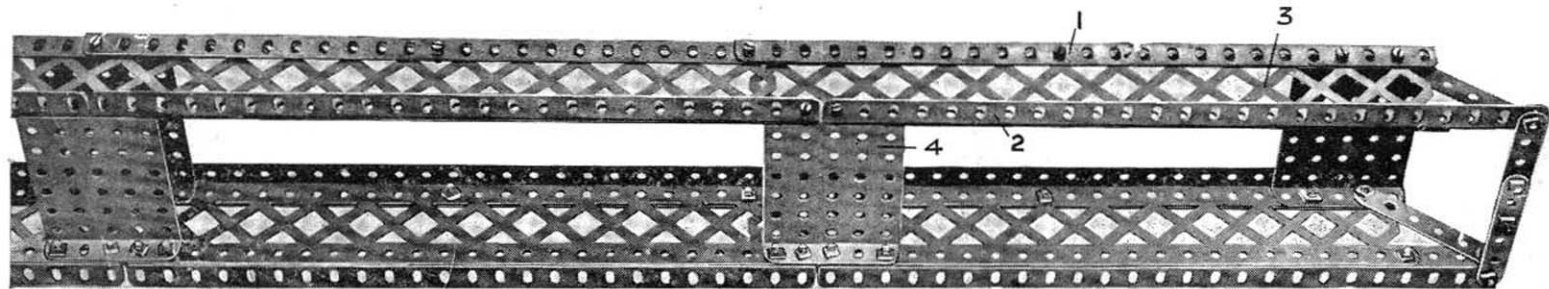
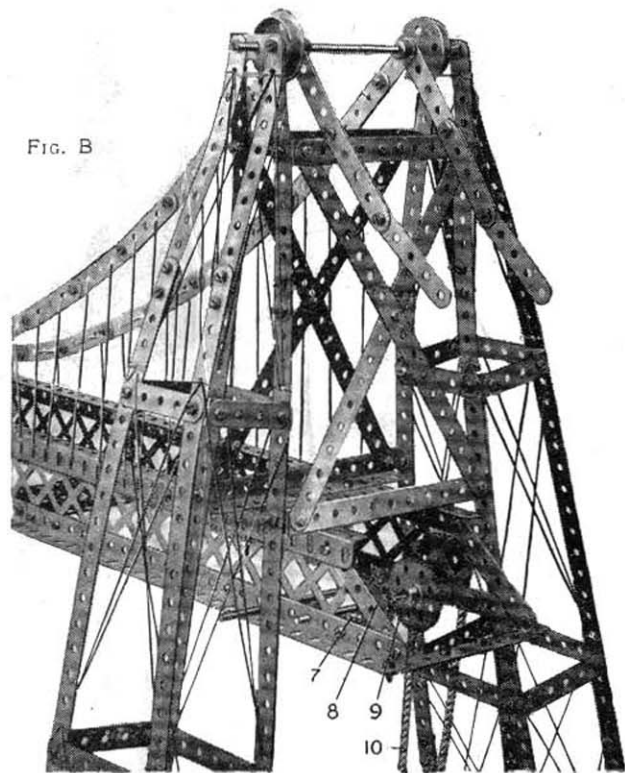


FIG. A

FIG. B



Model No. 713
Transporter
(continued)

The main girder is built up of side pieces, consisting of top and bottom angle girders 1 and 2 (Fig. A) reversed, and connected together by the braced girder 3. The sides are connected across by small rectangular plates 4. The ends of the main girder are supported from the end towers, as shown in Fig. B. The travelling platform 5 (Fig. C), supported from the carriage 6, runs on 1" pulleys, which travel along the outer edges of the lower angle girders 2. The carriage 6 is moved by a sprocket chain 7 passing round wheels 8 supported in the main girder and operated from the pinion and 57-toothed gear wheel 9 by the sprocket chain 10 driven by the motor.

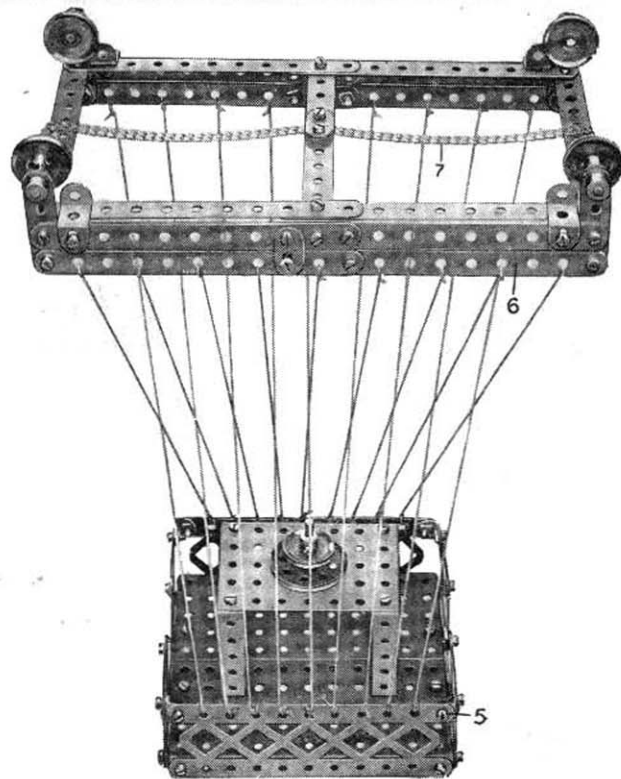
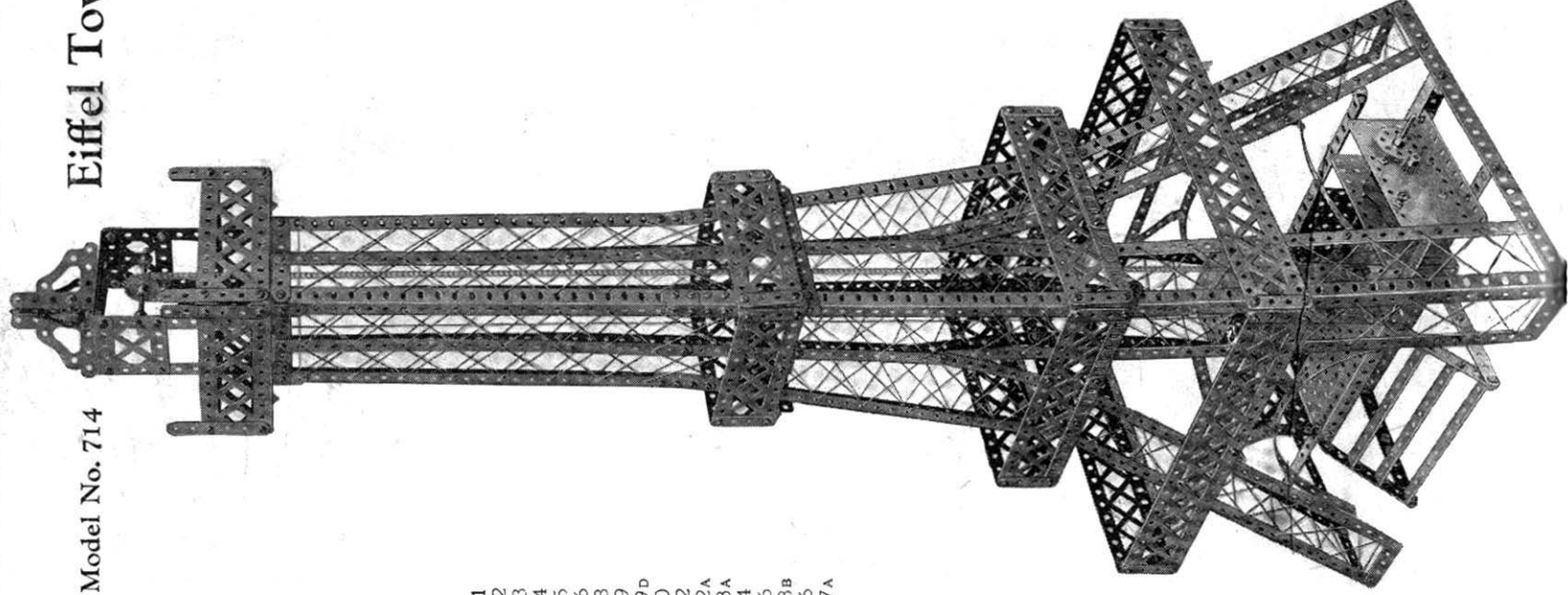


FIG. C

Model No. 714

Eiffel Tower



Parts	
required:	
22	of No. 1
24	" 2
8	" 3
16	" 4
20	" 5
24	" 6
18	" 8
16	" 9
2	" 9D
4	" 10
72	" 12
4	" 12A
4	" 13A
1	" 14
2	" 16
1	" 18B
1	" 26
1	" 27A
2	" "

Parts	
required:	
1	of No. 32
337	" 37
6	" 40
1	" 47
6	" 48A
1	" 48B
3	" 48D
3	" 52
4	" 53
8	" 59
2	" 72
3	" 94
2	" 96
4	" 98
4	" 99
16	" 100
4	" 108

Electric Motor

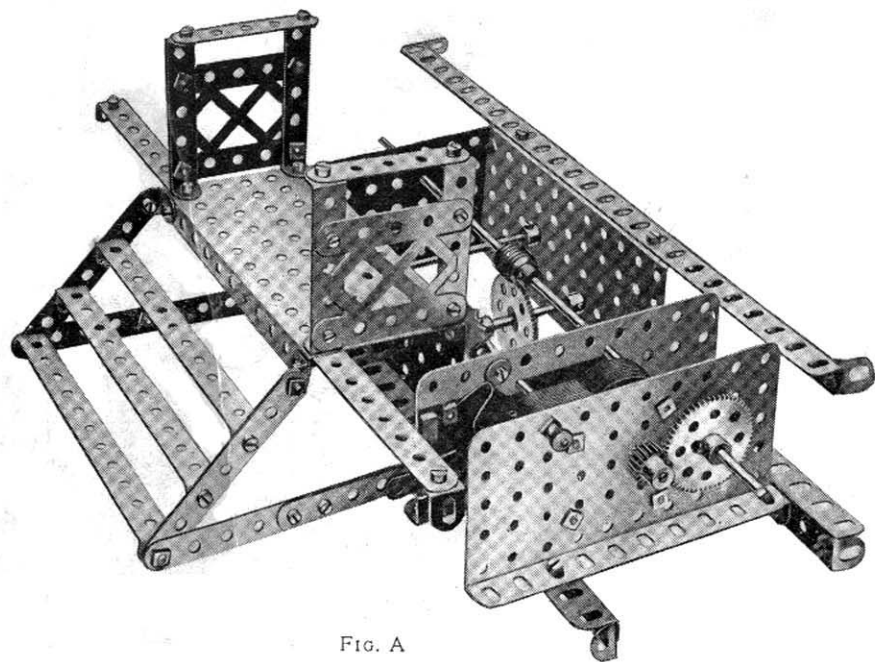
Model No. 714 **Eiffel Tower** *(continued)*

FIG. A

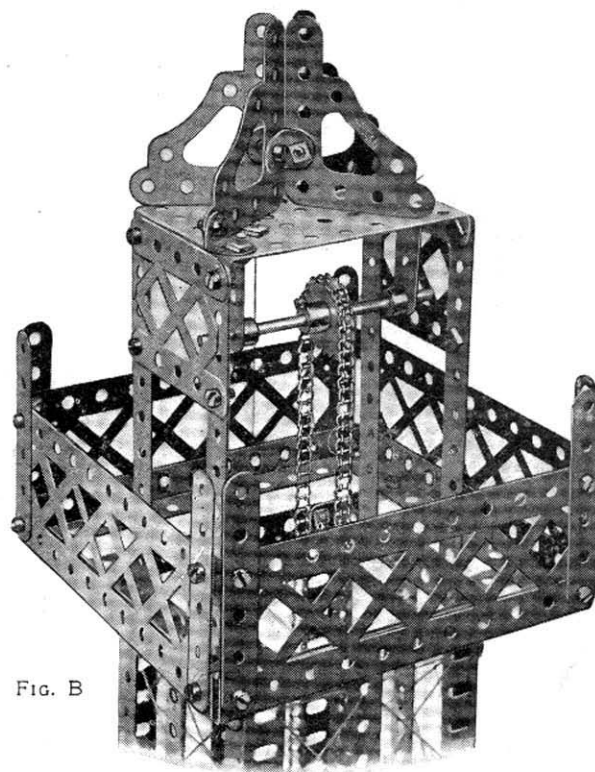


FIG. B

The construction of the tower may be followed from the illustrations. The lift carriage is built up from two $3\frac{1}{2}$ " by $2\frac{1}{2}$ " flange plates and two $2\frac{1}{2}$ " by $2\frac{1}{2}$ " flat plates and runs on a length of cord which acts as a guide line. This cord is secured to the top of the tower and to a transverse rod in the base, and passes through holes in the plates of the lift. The operation of the lift is affected by means of a length of sprocket chain passing round the 1" sprocket wheel situated in the top of the tower, Fig. B, and round a similar wheel in the base, Fig. A. The ends of the chain are secured to the lift. The lower sprocket wheel is operated through worm gearing from the electric motor, Fig. A.

Model No. 715 Locomotive and Tender (4-4-0)

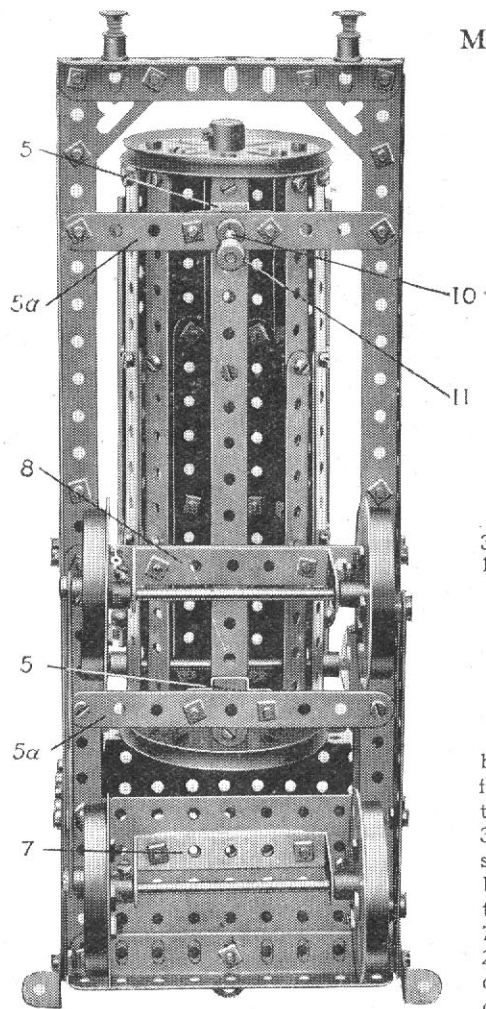
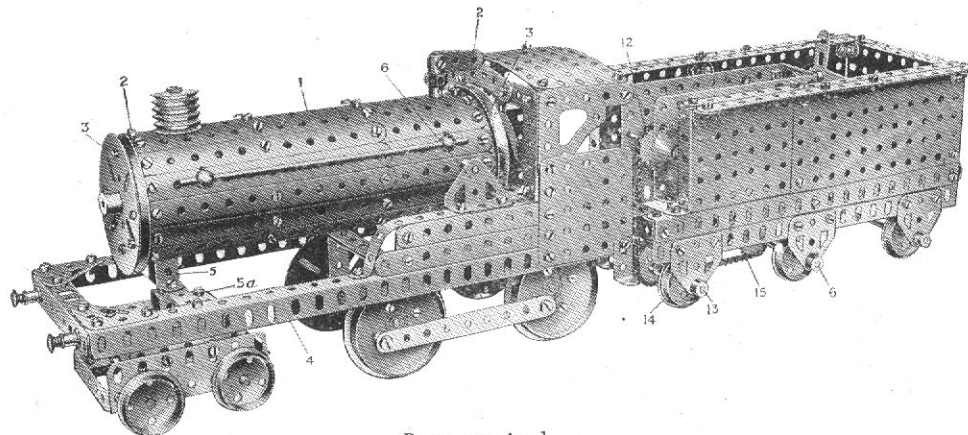


FIG. 715A



Parts required:

37 of No. 2	4 of No. 9D	1 of No. 18A	230 of No. 37	2 of No. 53	4 of No. 96	6 of No. 126A
10 " " 2A	1 " " 10	2 " " 18B	12 " " 38	3 " " 53A	2 " " 103A	1 " " 128
2 " " 3	31 " " 12	2 " " 19B	3 " " 45	16 " " 59	3 " " 103D	2 " " 133
2 " " 5	4 " " 12B	10 " " 20	2 " " 47	1 " " 63B	4 " " 108	4 " " 136
1 " " 6A	2 " " 14	5 " " 22A	1 " " 48	3 " " 72	4 " " 109	4 " " 137
2 " " 8	3 " " 15	1 " " 25	2 " " 48A	1 " " 82	1 " " 115	4 " " 147B
2 " " 8A	4 " " 16	1 " " 27	2 " " 52	1 " " 90	4 " " 120A	
4 " " 9A	2 " " 16A	1 " " 27A	1 " " 52A	1 " " 94	2 " " 126	Electric Motor

The boiler shell is built up of a series of $5\frac{1}{2}$ " strips 1 overlapped six holes and bolted at 2 to two $5\frac{1}{2}$ " strips bent to the curvature of the two 3" pulleys 3 and secured by angle brackets. The boiler is supported from the frame 4 by two double bent strips 5 bolted to $4\frac{1}{2}$ " strips 5a, Fig. A. Two trunnions 6, one on each side of the boiler, are bolted to the frame and a $3\frac{1}{2}$ " rod passed through the boiler and secured at each side by a collar and set screw, the ends resting in the top hole of the trunnions to steady the boiler. The floor of the cab is formed by bolting a $4\frac{1}{2}$ " x $2\frac{1}{2}$ " flat plate to the frame, and to the underside of this is bolted a $2\frac{1}{2}$ " x $1\frac{1}{2}$ " double angle strip 7, which forms the bearings for the axle of the rear driving wheels; two $2\frac{1}{2}$ " strips are spaced between this strip and the footplate to allow proper clearance for the wheels. A similar double angle strip 8 is also bolted to a cross strip and spaced away from the engine frame by a washer on each bolt. The bogie, Fig. B, is connected pivotally to the frame by means of a double bent strip 9, into the hole of which is entered the end of a 1" rod

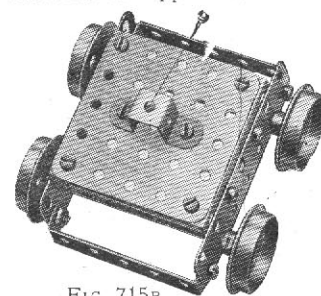


FIG. 715B

Model No. 715 Locomotive and Tender

(continued)

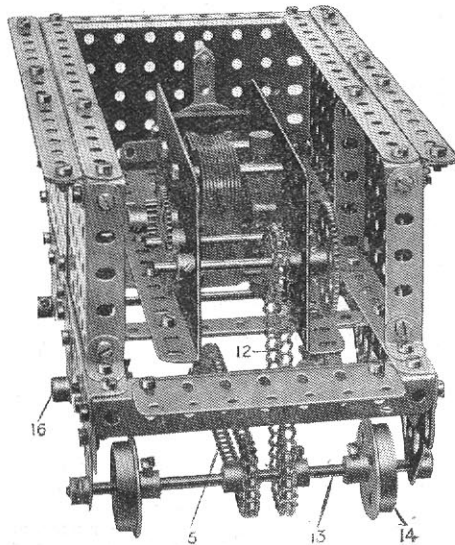
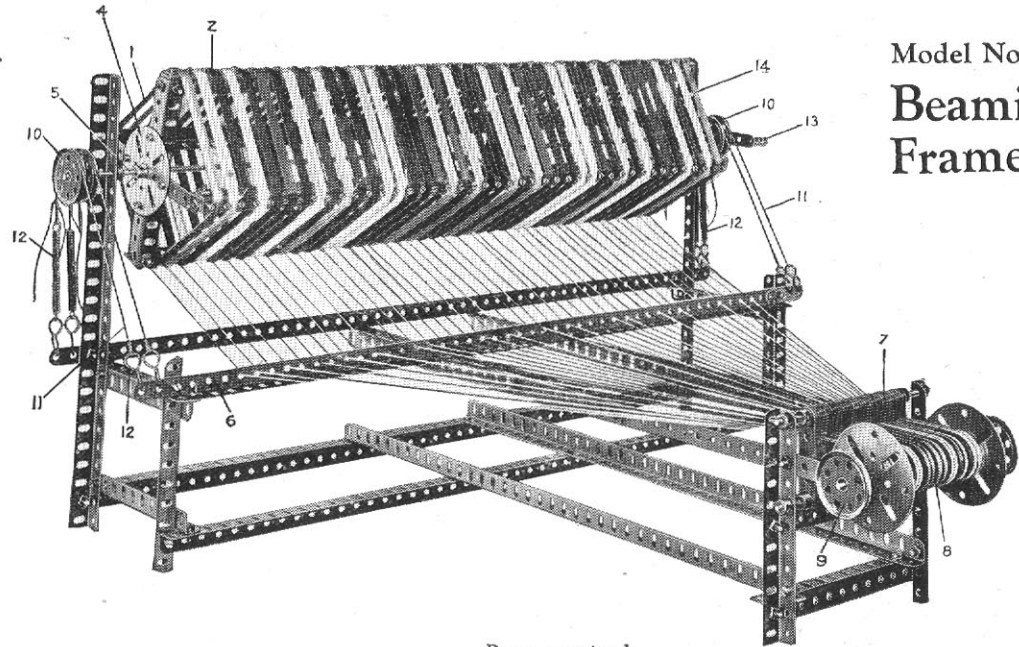


FIG. 715c

10, Fig. A, and retained by two collars 11 on the end of the rod. The loco is propelled from the motor in the tender, Fig. C, the motor driving by the sprocket chain 12 (containing 52 links) the 5" axle rod 13 carrying the flanged wheels 14. The rod 13 is coupled by another chain 15 (containing 59 links) to the middle axle rod 16, thus driving four of the travelling wheels. The four sprocket wheels are 1" in diameter. The accumulator for supplying the current is housed in the tender behind the motor.

Model No. 716
Beaming
Frame



Parts required:

2 of No. 1	4 of No. 7	8 of No. 12	253 of No. 37	10 of No. 59	1 of No. 147A
4 " " 2	2 " " 7A	2 " " 13	89 " " 38	1 " " 63	1 " " 147B
44 " " 5	12 " " 8	3 " " 14	4 " " 43	1 " " 103	1 " " 148
4 " " 6	10 " " 9	6 " " 2!	8 " " 57	4 " " 109	

The frame upon which the warp threads are wound is built up of 12½" angle girders, 2, overlapped seven holes and bolted to a 5½" girder 1 and 5½" strip crossed and connected to face plates 4 on the 11½" rod 5. Inside the frame, two 5½" angle girders are bolted nine holes from each end to form the inner bearings for the rods 5. Another 5½" girder is bolted crosswise to these in the centre to form a stay.

The warp threads are first wound upon the warp-frame, and pass through the holes in a 24½" angle girder 6, and, converging together, pass between the 2½" strips 7 forming the reed, and so on to the beam 8. On the far side of the beam rod is a ½" pinion engaged by a pawl (not shown on the photograph) which prevents backward rotation of the beam as the warp threads are wound thereon by turning the 1½" pulley wheels 9.

A brake mechanism for tensioning the frame 2 is provided by securing two 1" pulley wheels 10 at each end of the frame rod 5, cords 11, secured by hooks passing over the pulleys 10 and being kept taut by the springs 12.

A handle 13 is provided on the rod 5 by means of which the warp threads 14 are originally wound on the frame.

Model No. 717 Boat-Lowering Gear

Parts required:

10 of No. 1A	2 of No. 12	6 of No. 23	2 of No. 48B	3 of No. 109
2 " " 2A	1 " " 12A	4 " " 26	5 " " 52A	1 " " 115
6 " " 3	2 " " 12B	2 " " 27A	6 " " 53	2 " " 126
7 " " 5	1 " " 13	2 " " 31	2 " " 57	2 " " 126A
8 " " 6	2 " " 13A	2 " " 32	13 " " 59	4 " " 129
2 " " 7A	1 " " 15	142 " " 37	2 " " 62	4 " " 147B
2 " " 9	3 " " 16	14 " " 38	2 " " 63	
2 " " 9D	2 " " 16A	1 " " 40	8 " " 90	
3 " " 11	1 " " 18A	5 " " 48A	4 " " 102	

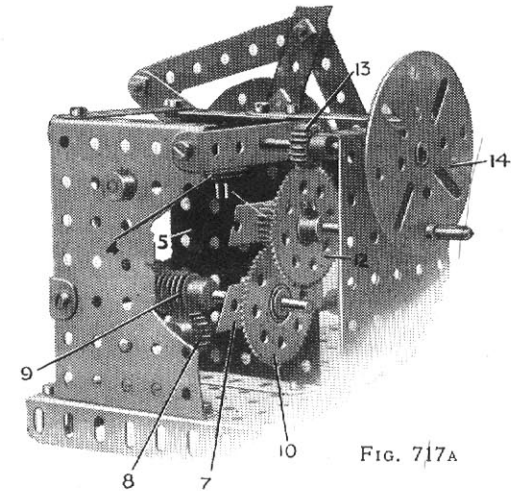
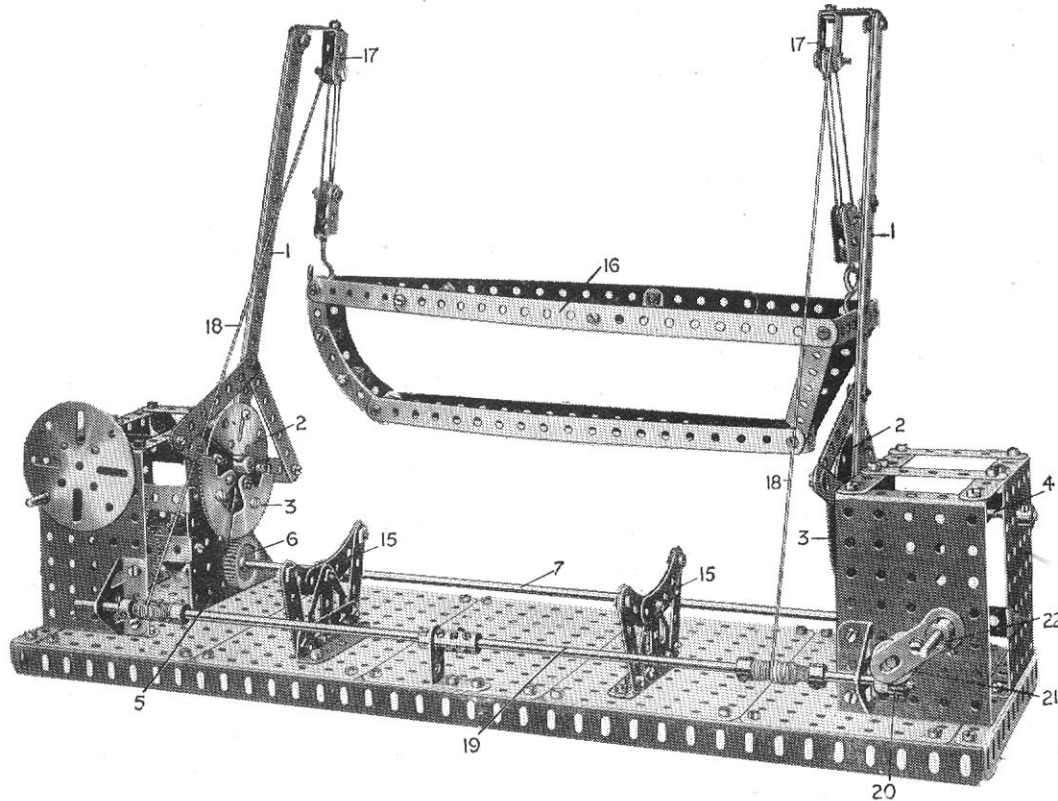


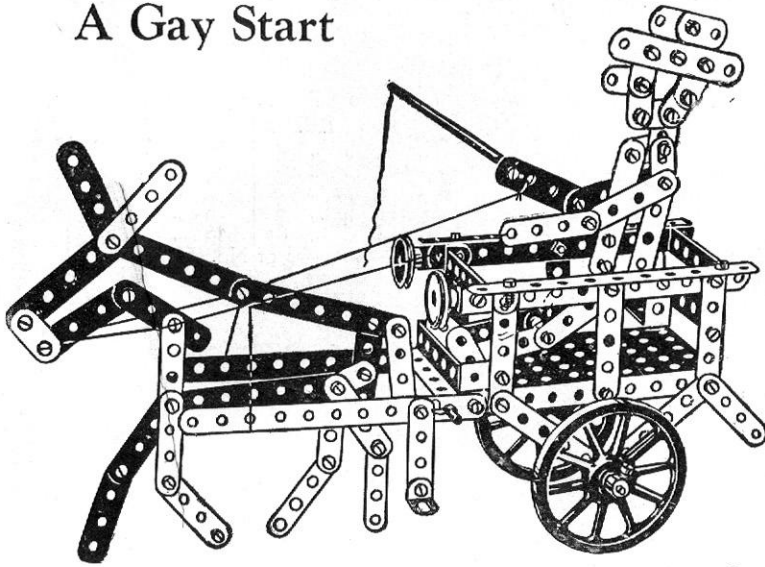
FIG. 717A

The davit arms 1 are connected to face plates 2 to which are bolted two rack segments 3 forming the usual geared quadrants. The davit arms are secured to rods 4 journalled in the face plates 5, the rack segments 3 being engaged and driven by 1" gear wheels 6 on an axle rod 7. This rod 7 carries a pinion 8, Fig. A, driven by a worm 9 and a rod, to which is secured a 1½" gear wheel 10. This is driven by a ½" pinion 11 on a rod to which is also secured a 1½" gear wheel 12 driven by a ¼" pinion 13 rotated by a hand wheel formed by a face plate 14. As the hand wheel is rotated, the davit arms are raised outward when launching the boat 16 or inward when it is desired to deposit the boat on the chocks 15.

The boat 16 is raised or lowered from the blocks 17 by the ropes 18 which wind on to a rod 19. On this rod is secured a ½" pinion 20 engaged by a worm 21 which is rotated by the crank handle 22 formed of two cranks bolted together, and in this way the boat may be lowered over the ship's side.

Model No. 718

A Gay Start



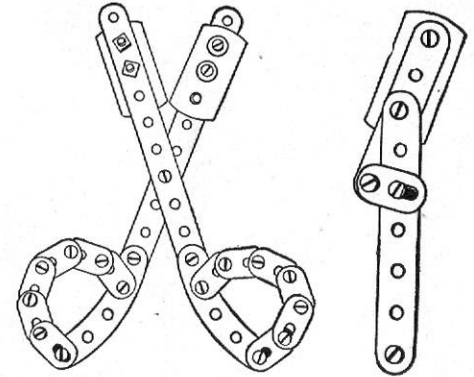
Parts required:

6	of No.	2
2	" "	3
5	" "	4
10	" "	5
24	" "	6
23	" "	10
8	" "	12
1	" "	15
1	" "	15A
1	" "	1b
2	" "	19B
2	" "	22
2	" "	35
71	" "	37
2	" "	46
3	" "	48A
1	" "	52

Model Nos. 720 and 721

Scissors

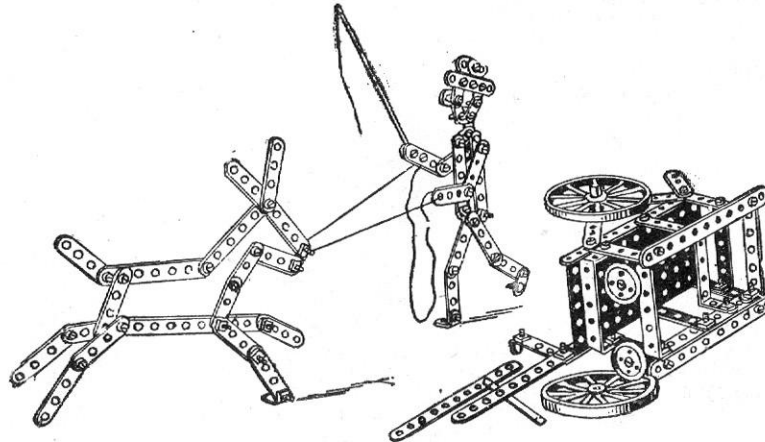
Knife



Suggestions for using old safety razor blades to make a pair of scissors and photographer's trimming knife.

Model No. 719

The End of a Perfect Day

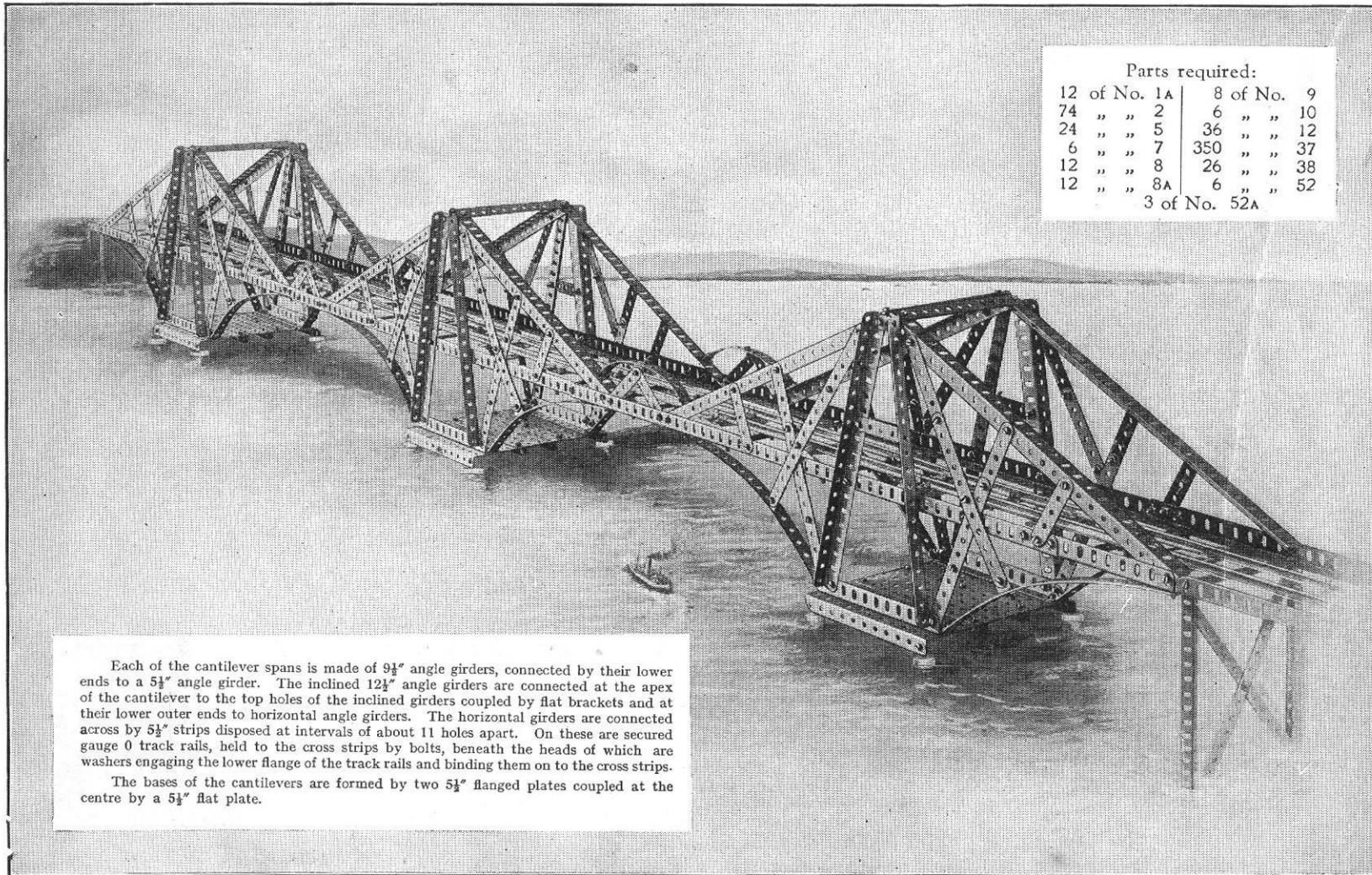


Parts required:

Model No. 720	Model No. 721
2 of No. 2	2 of No. 3
12 " " 10	1 " " 5
21 " " 37	1 " " 10
2 " " 90	5 " " 37
2 razor blades	1 razor blade

This Model can be made with MECCANO Outfit No. 7, or No. 6 and No. 6A.

Model No. 722 Forth Bridge



Parts required:

12	of No. 1A	8	of No. 9
74	" " 2	6	" " 10
24	" " 5	36	" " 12
6	" " 7	350	" " 37
12	" " 8	26	" " 38
12	" " 8A	6	" " 52
	3 of No. 52A		

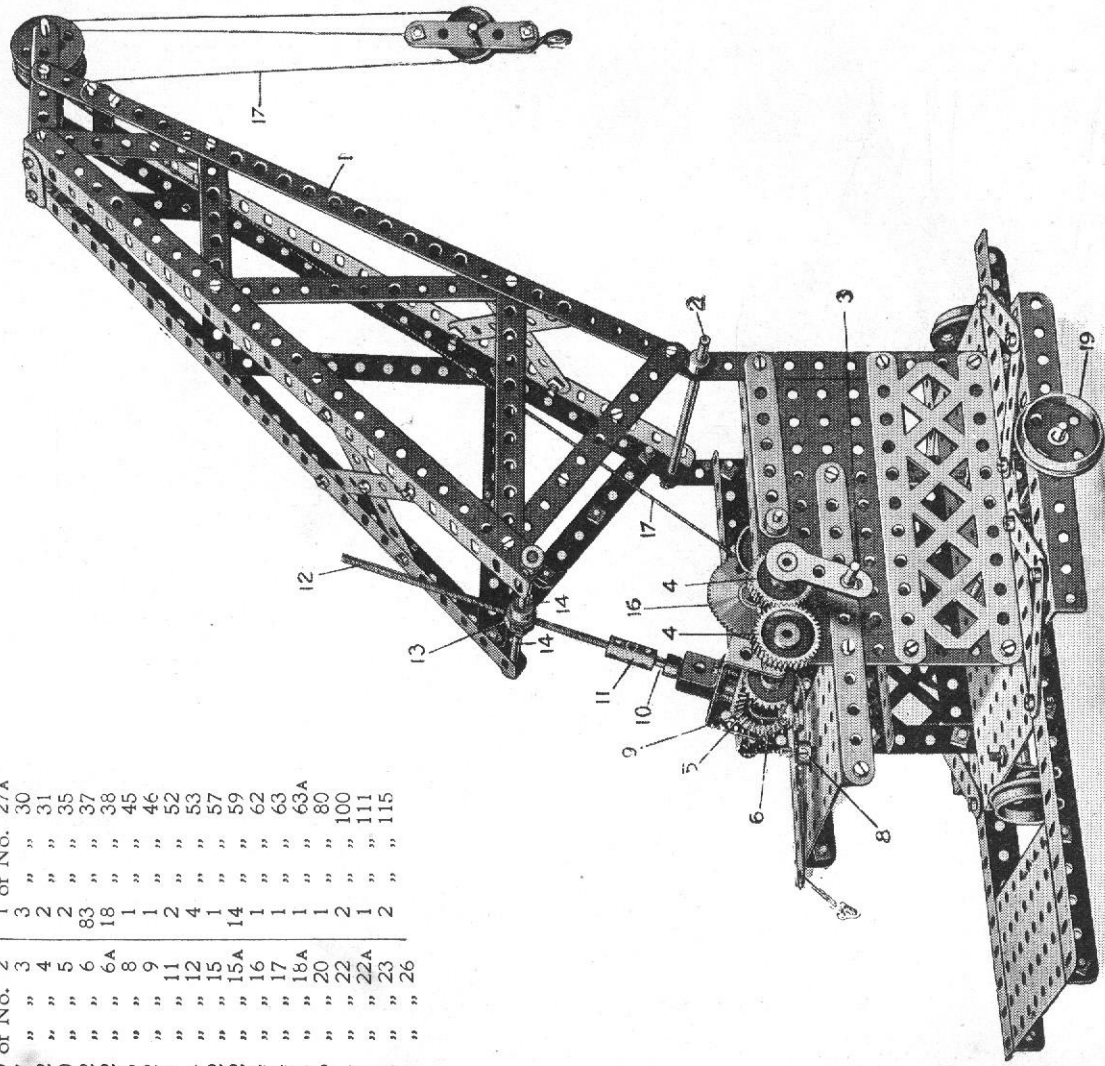
Each of the cantilever spans is made of $9\frac{1}{4}$ " angle girders, connected by their lower ends to a $5\frac{1}{4}$ " angle girder. The inclined $12\frac{1}{2}$ " angle girders are connected at the apex of the cantilever to the top holes of the inclined girders coupled by flat brackets and at their lower outer ends to horizontal angle girders. The horizontal girders are connected across by $5\frac{1}{2}$ " strips disposed at intervals of about 11 holes apart. On these are secured gauge 0 track rails, held to the cross strips by bolts, beneath the heads of which are washers engaging the lower flange of the track rails and binding them on to the cross strips.

The bases of the cantilevers are formed by two $5\frac{1}{4}$ " flanged plates coupled at the centre by a $5\frac{1}{4}$ " flat plate.

This Model can be made with MECCANO Outfit No. 7, or No. 6 and No. 6A.

Model No. 723 Revolving Crane

Parts required:	
9 of No. 2	1 of No. 27A
17 "	3 "
2 "	30 "
3 "	31 "
4 "	35 "
5 "	37 "
6 "	38 "
8 "	45 "
9 "	46 "
11 "	52 "
12 "	53 "
15 "	57 "
15A "	59 "
16 "	62 "
17 "	63 "
18A "	63A "
20 "	80 "
22 "	100 "
22A "	111 "
23 "	115 "
26 "	" "



Model No. 723 Revolving Crane *(continued)*

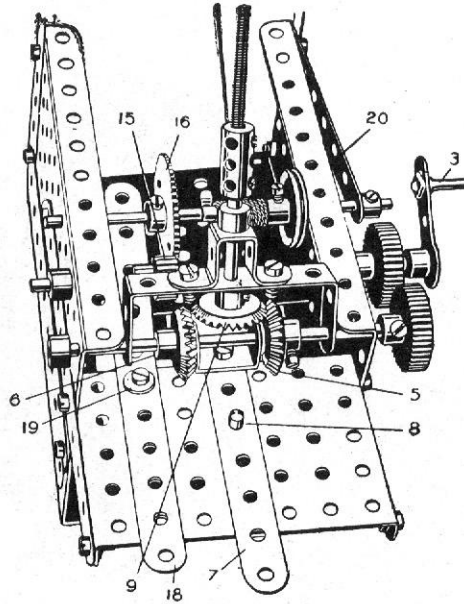


Fig. 723A

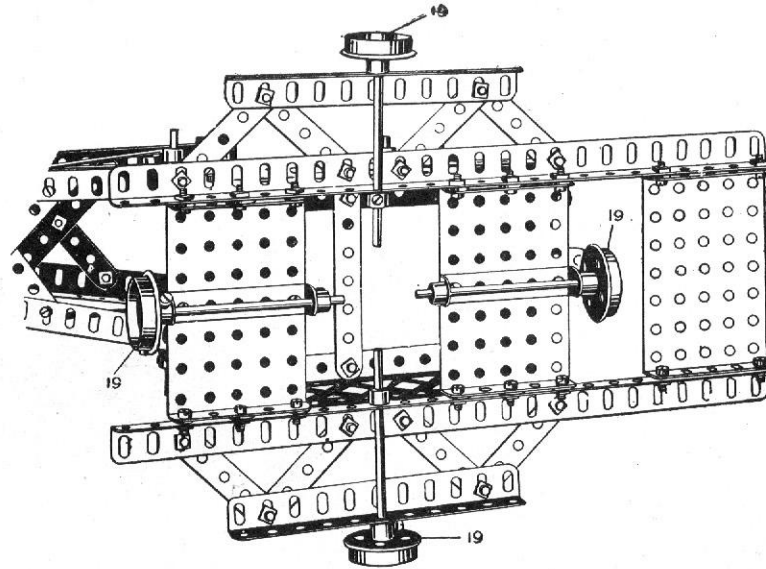


FIG. 723B

The jib 1, the construction of which is clear from the drawing, is pivoted at its lower end on a 5" axle rod 2, the movement of the jib about this pivot being obtained from the handle 3, which drives a rod carrying bevel wheels 5, 6 (from the 1" gear wheels 4). The bevel wheel rod is arranged to slide in its bearings by the strip 7, at the end of which is a double bracket, pivoted at 8, on the frame of the crane, on a threaded pin under which is a collar, and thus bring either the bevel 5, or the bevel 6, into engagement with a third bevel 9, Fig. 723A, on the end of a 2" rod 10, connected by the coupling 11, to a 5" screwed rod 12. This screwed rod engages the transverse threaded hole in an octagonal coupling 13, which is pivotally carried on two 2" rods 14, so as to give a clear way for the screwed rod 12. According to the direction in which the clutch handle 7 is thrown over, and the handle 3 turned, the jib will be raised or lowered. The rod of the handle 3, also carries a $\frac{1}{2}$ " pinion 15, which is adapted to engage and drive a 57-toothed gear wheel 16, round the spindle of which is wound the cord 17, by means of which the load is raised or lowered. The spindle of the wheel 16, is caused to slide in its bearings to engage the pinion 15, by means of the $5\frac{1}{2}$ " strip 18, Fig. 723A, pivoted at 19, by a bolt lock-nutted to the plate, the other end of which is bent up to engage between the boss of the gear wheel 16, and a collar (not shown).

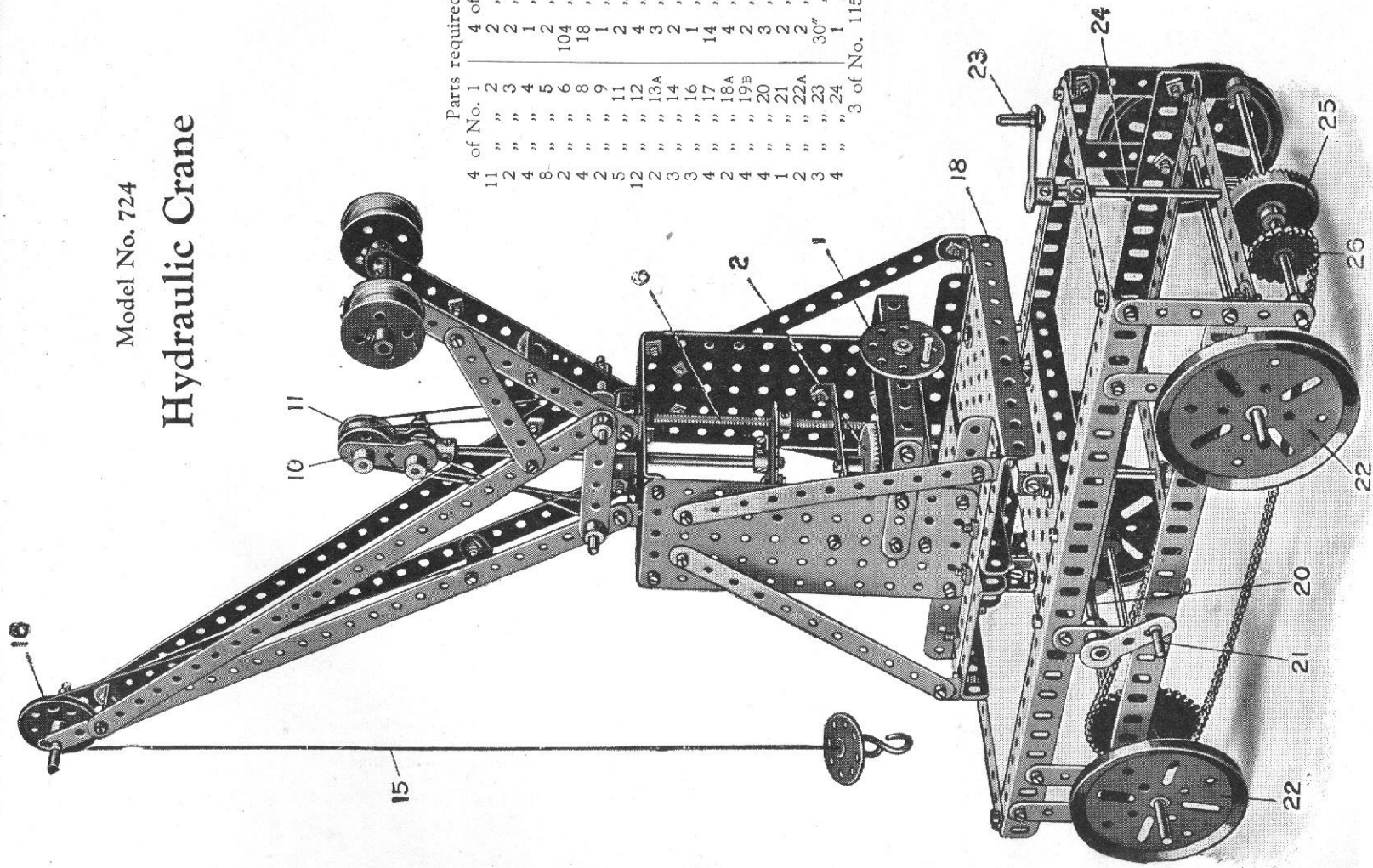
A spring formed by slightly bending a $3\frac{1}{4}$ " strip 20, bolted to the side of the frame, automatically releases the winding spindle from engagement with the pinion 15 when the handle 18 is released.

The crane rotates on the wheels 19, which are carried on rods at right angles, as shown in Fig. 723B.

This Model can be made with MECCANO Out-fit No. 7, or No. 6 and No. 6A.

Model No. 724

Hydraulic Crane



Parts required:

4 of No. 1	4 of No. 26
11 "	2 "
2 "	2 "
4 "	2 "
8 "	1 "
2 "	104 "
4 "	18 "
2 "	8 "
5 "	11 "
12 "	12 "
2 "	13A "
3 "	14 "
3 "	16 "
4 "	17 "
2 "	18A "
4 "	19B "
1 "	20 "
2 "	21 "
3 "	22A "
4 "	23 "
	24 "
	30" "
	1 "
	3 of No. 115 "

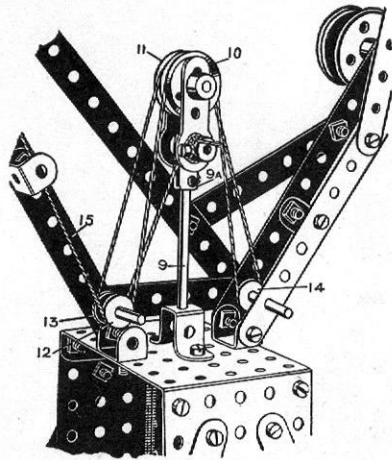


FIG. 724B

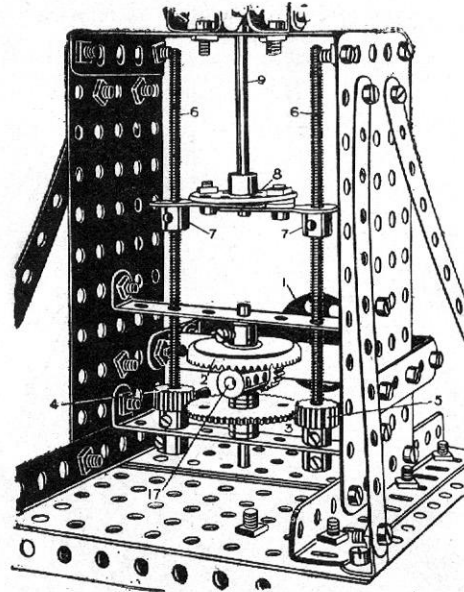


FIG. 724C

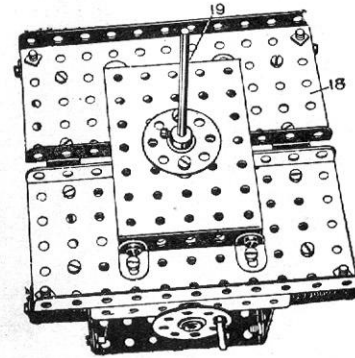


FIG. 724D

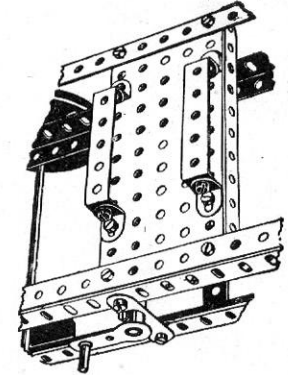


FIG. 724E

Model No. 724

Hydraulic Crane (continued)

This model is designed to illustrate the operating of a Hydraulic Crane, in which great power is utilised to force two or more sets of pulley wheels apart, chains passing round the pulley wheels so that by a small movement of the operating power a great movement of the load is effected. In the model, instead of water-power, screws are used to move the chain or cord pulleys.

The weight is raised or lowered by operating the hand-wheel 1. The rod of this wheel carries a pinion which gears with a $1\frac{1}{2}$ " contrate wheel 2. On the rod of the contrate wheel is a lower 57-toothed gear wheel 3, which engages two $\frac{1}{2}$ " pinions 4 and 5, secured on vertical screwed rods 6, so that these rods are rotated in the same direction on the turning of the handle 1. The rods engage the bosses of threaded cranks 7, secured on a bush wheel 8, in the boss of which is fixed a 6" rod 9. This rod at the top is secured in a coupling 9A, to which are connected on a 1" transverse rod two cranks which support another 1" rod, forming a bearing for two 1" loose pulleys 10 and 11. Two $\frac{1}{2}$ " pulleys 12 and 13 are loosely mounted on a 2" rod at the base of the jib on one side, and a single $\frac{1}{2}$ " pulley 14 on another 2" rod at the other side.

The cord 15 passes over the pulley 16 at the top of the jib, round the pulley 12, up round the pulley 10, round the lower pulley 14, back round the other pulley 11, round the small pulley 13, and is made fast to the coupling 9A.

By turning the handle 1 the contrate wheel 2 is rotated, thus driving the pinions 4 and 5 and rotating the screwed rods, which causes the threaded cranks to be raised or lowered, and the rod 9, carrying the pulleys 10 and 11, also to be raised or lowered. As the pulleys 10 and 11 are forced up, the cord 15 travels round all the pulleys, and, due to the number of loops of the cord, the small movement of the top pulleys 10 and 11 results in a larger movement of the crane hook.

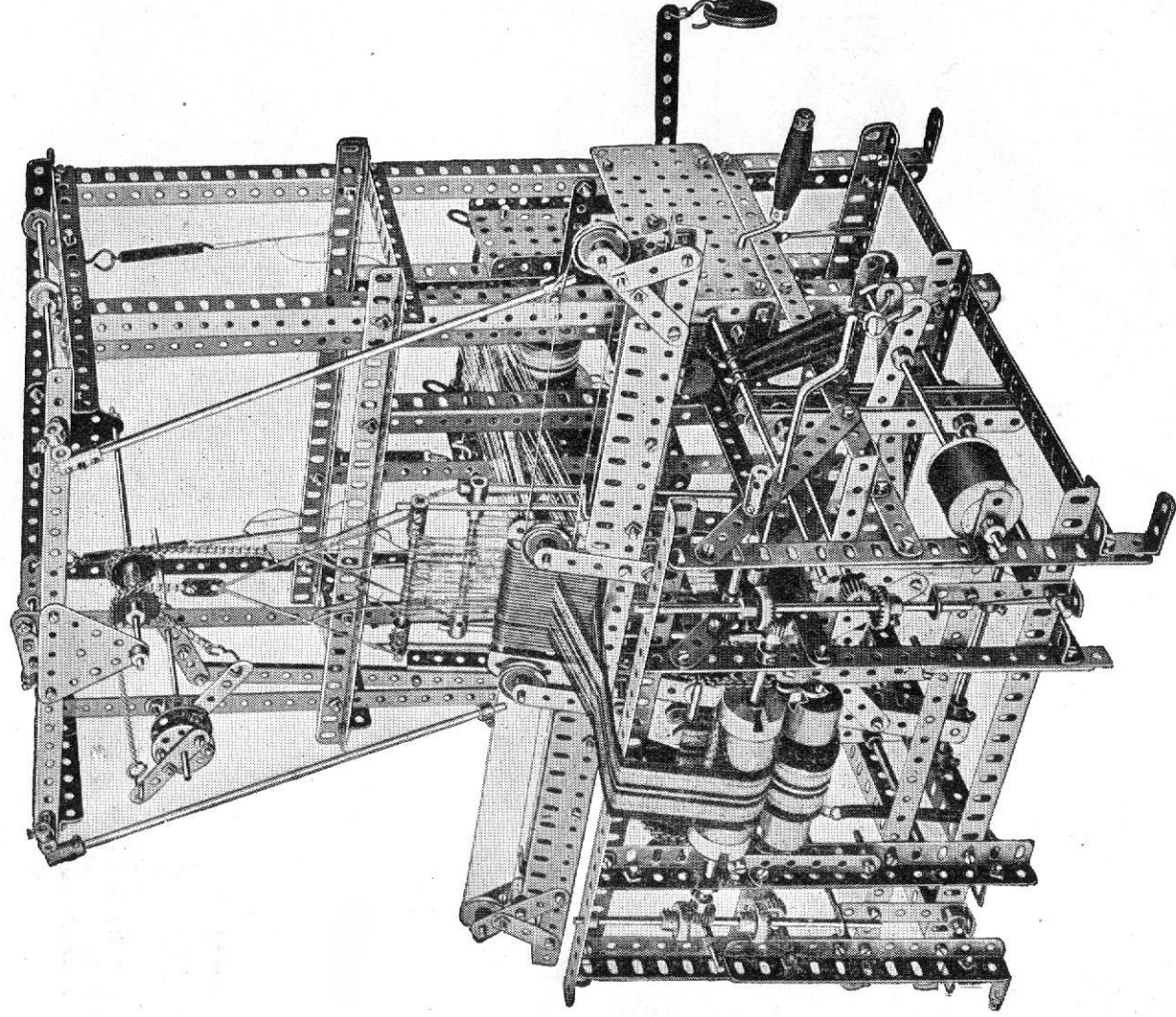
The rod of the bush wheel 1, which carries a $\frac{1}{2}$ " pinion, is journalled in a coupling 17, above and beneath which are placed two washers. The rod is held in position by the wheel 1 on one side of the cross strip, and by a collar on the other side.

The crane is carried on a platform 18, pivoting about a vertical rod 19, on which is a 57-toothed gear wheel engaged and driven by a worm on a rod 20, on the end of which is the operating handle 21.

The crane is caused to travel on the wheels 22 by the handle 23, a $\frac{1}{2}$ " pinion at the foot of its rod 24 driving a $1\frac{1}{2}$ " contrate wheel 25 on the rod 26, coupled by chain and sprocket wheels to the front wheels 22.

This Model can be made with MECCANO Outfit No. 7, or No. 6 and No. 6A.

Model No. 725 Loom



The Meccano Loom is one of the most remarkable and interesting models that can be made with Meccano. It is absolutely automatic and beautiful material may be woven by simply turning the handle. It is a somewhat complicated model, requiring careful construction and accurate adjustment and as it is impossible to do justice to it in this book, we have compiled a special sheet of instructions in which it is illustrated and described in detail. This may be purchased either from your local Meccano dealer or from Meccano Limited, Liverpool. Price 3d. (post free, 4d.).

Model No. 726 Reaping Machine

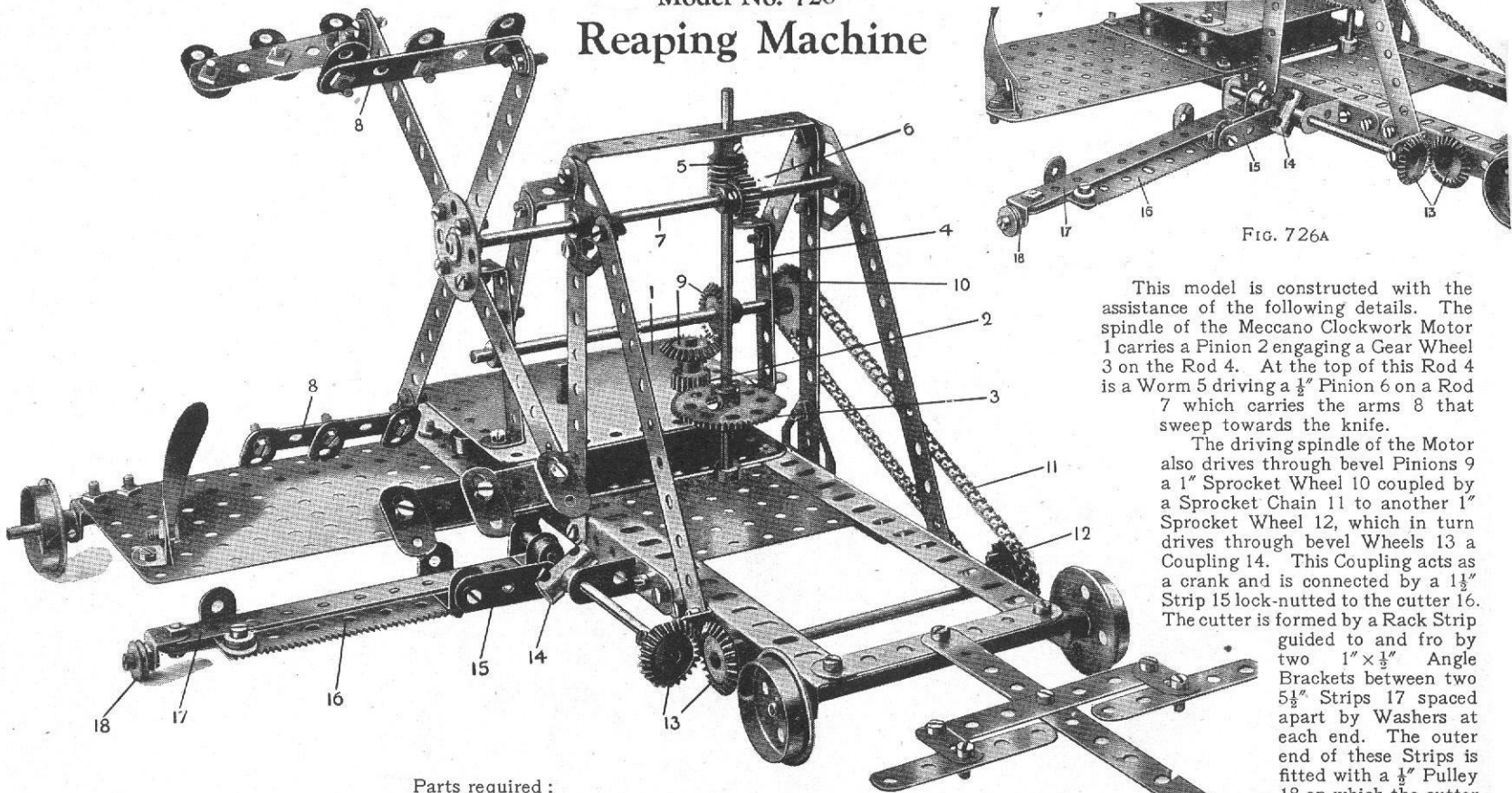


Fig. 726A

This model is constructed with the assistance of the following details. The spindle of the Meccano Clockwork Motor 1 carries a Pinion 2 engaging a Gear Wheel 3 on the Rod 4. At the top of this Rod 4 is a Worm 5 driving a $\frac{1}{2}$ " Pinion 6 on a Rod 7 which carries the arms 8 that sweep towards the knife.

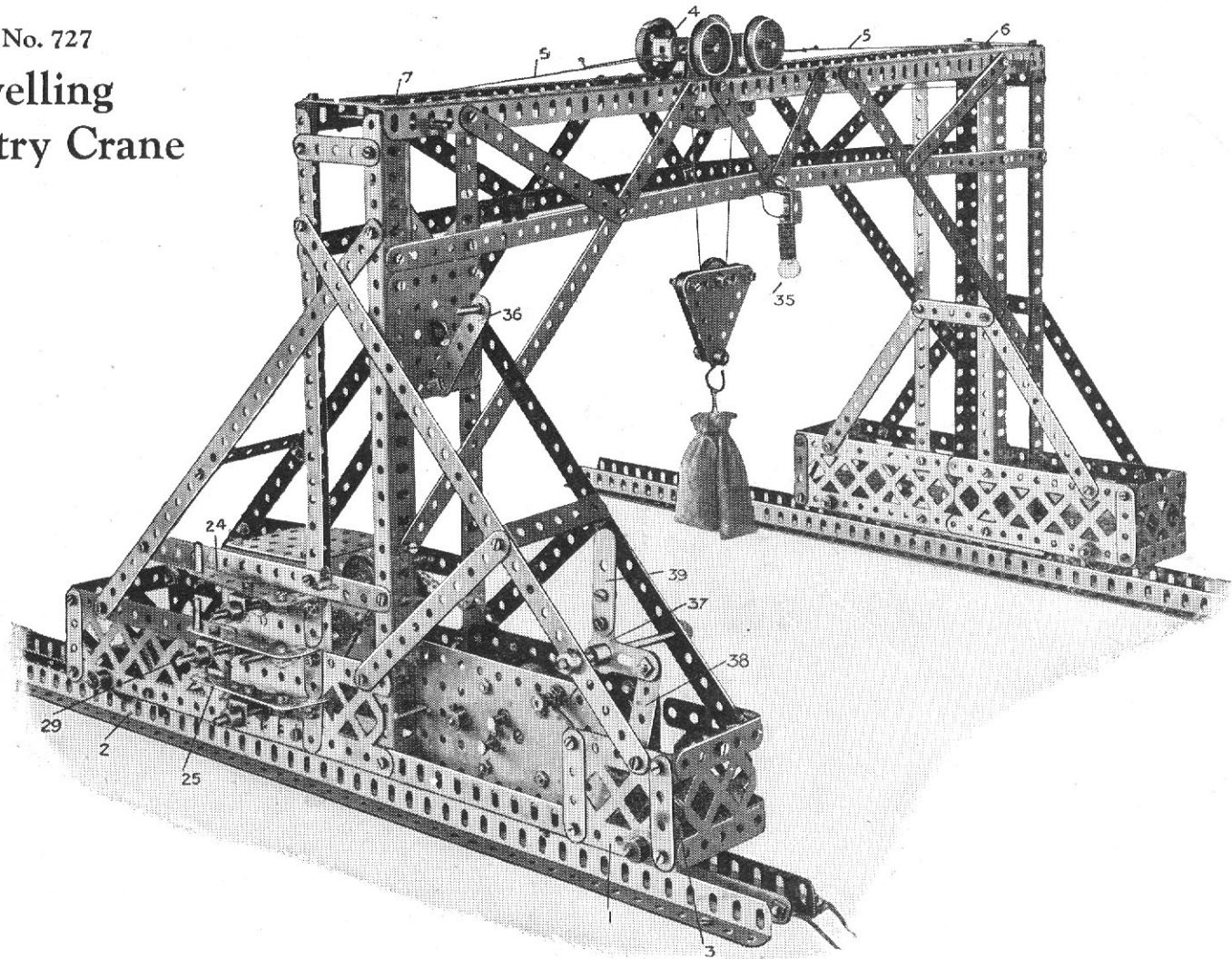
The driving spindle of the Motor also drives through bevel Pinions 9 a 1" Sprocket Wheel 10 coupled by a Sprocket Chain 11 to another 1" Sprocket Wheel 12, which in turn drives through bevel Wheels 13 a Coupling 14. This Coupling acts as a crank and is connected by a $1\frac{1}{2}$ " Strip 15 lock-nutted to the cutter 16. The cutter is formed by a Rack Strip

guided to and fro by two $1" \times \frac{1}{8}"$ Angle Brackets between two $5\frac{1}{2}"$ Strips 17 spaced apart by Washers at each end. The outer end of these Strips is fitted with a $\frac{1}{2}"$ Pulley 18 on which the cutter knife travels. The remainder of the detail of the model will be made quite clear from our illustration. When completed the model works in a very realistic manner.

Parts required :

7 of No. 2	1 of No. 11	2 of No. 15	1 of No. 24	6 of No. 38	1 of No. 53
6 " " 3	7 " " 12	1 " " 15A	2 " " 26	1 " " 41	7 " " 59
8 " " 5	2 " " 12A	2 " " 16B	1 " " 27A	1 " " 48	1 " " 63
1 " " 6A	4 " " 12B	1 " " 17	4 " " 30	2 " " 48A	16" " 94
2 " " 8A	1 " " 13	4 " " 20	1 " " 32	1 " " 48B	1 " " 110
14 " " 10	2 " " 14	1 " " 23	66 " " 37	1 " " 52A	1 " " 125
3 of No. 126A					
Clockwork Motor					

Model No. 727
**Travelling
Gantry Crane**



Model No. 727 Travelling Gantry Crane (continued)

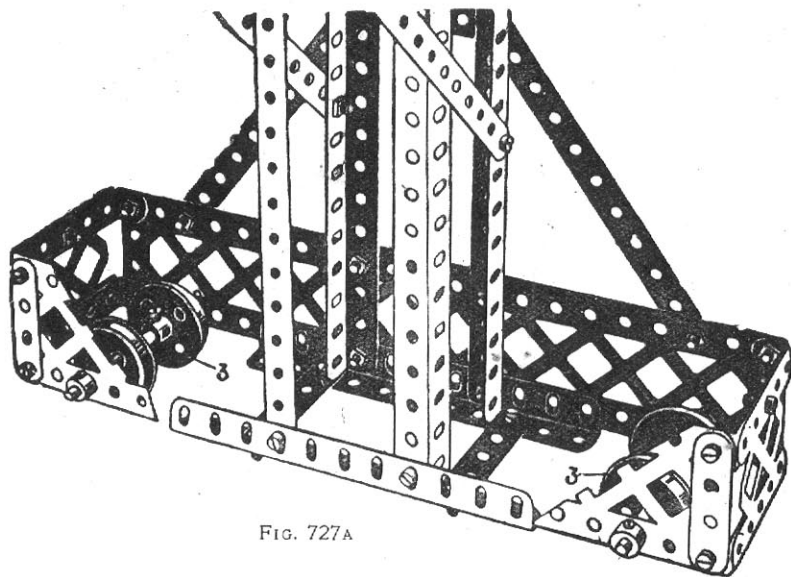


FIG. 727A

Parts required:

12	of No. 1	3	of No. 26
12	" " 2	3	" " 27
6	" " 3	3	" " 27A
3	" " 4	11	" " 35
17	" " 5	149	" " 37
14	" " 6	10	" " 37A
1	" " 6A	38	" " 38
6	" " 7	3	" " 44
10	" " 8	9	" " 48A
2	" " 9	2	" " 53
6	" " 11	1	" " 57
4	" " 12A	30	" " 59
2	" " 15	1	" " 72
2	" " 15A	2	" " 76
11	" " 16	2	" " 90
1	" " 16A	26"	" " 94
2	" " 17	1	" " 95
4	" " 18A	3	" " 96
12	" " 20	8	" " 98
8	" " 22A	6	" " 100
2	" " 23	2	" " 111
2	" " 25	1	" " 128

Electric Motor

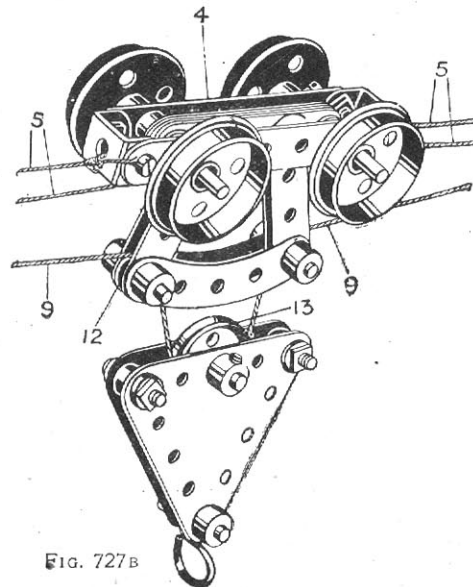


FIG. 727B

The upper part of the framework is well brought out in the illustration. It is to be noted that as regards the feet carrying the motor and the travelling wheels, the centre portion is composed of $12\frac{1}{2}$ " angle girders at the lower edge, extended on one side by $2\frac{1}{2}$ " braced girders 1, overhanging 4 holes, and on the other side by $5\frac{1}{2}$ " braced girders 2 overhanging five holes. The other shorter foot on the gantry is shown in Fig. 727A, and is built up of $5\frac{1}{2}$ " braced girders overlapped and overhanging the lower angle girders five holes on each side. The travelling wheels 3 are carried in the lower holes of the braced girders.

The traversing of the trolley 4, is effected by a cord 5 which passes from the far end of trolley 4, round a pulley 6, and is returned and passed over one of the 1" pulleys 7, down to, and has three turns round the rod 8, then passing up and round another of the pulleys 7, and is connected to the near end of the trolley, Fig. 727B. Consequently, rotation of the rod 8 will wind up one end of the traversing cord 5 and pay out the other end, thus causing the trolley 4 to travel to or fro along the gantry rails.

The load is raised or lowered by another cord 9 which is wound round the upper rod 10, thence round the guide pulley 11, round the third of the pulleys 7, Fig. 727, and over the $\frac{1}{2}$ " pulley 12, Fig. 727B, beneath the 1" pulley 13, on the load block round another $\frac{1}{2}$ " pulley, and is made fast on the far end of the gantry frame. If the rod 10 is not being rotated, therefore, the trolley 4 travels to and fro without the load being raised or lowered. Rotation of the rod 10, however, in one or other direction, will result in the load being raised or lowered.

The travelling of the whole gantry crane upon the wheels 3 is effected from the rod 14, a sprocket wheel 15 on which is connected by a chain 16 to another sprocket wheel 17 on the rod 18 of the travelling wheels, 727c. The rods 8, 10 and 14 are operated as follows: The motor spindle 19, Fig. 727D, drives by the chain 20 a 2" sprocket wheel 21 on a rod 22, on which is a $\frac{1}{2}$ " pinion 23, Fig. 727c. The rods 10 and 8 are slideably controlled by the clutch operating handles 24,

Model No. 727 Travelling Gantry Crane *(continued)*

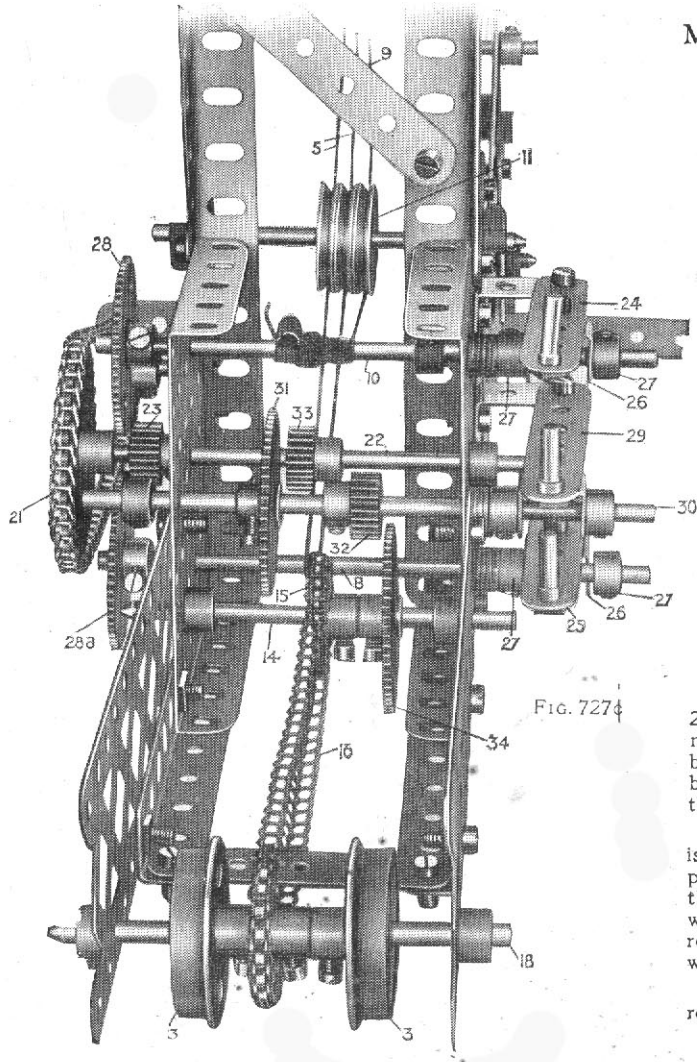


FIG. 727A

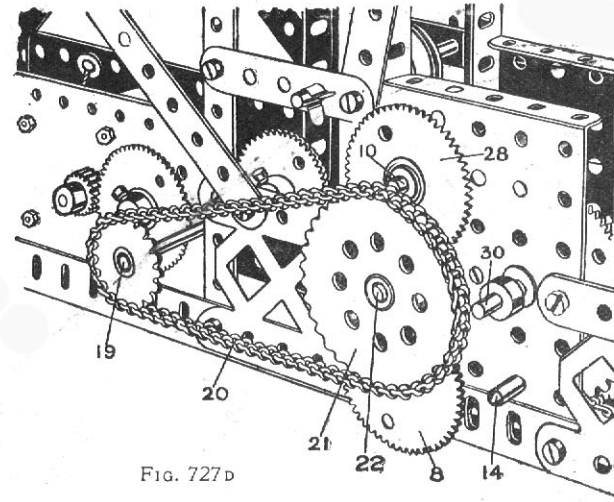


FIG. 727B

25, which are bolted and lock-nutted to double bent strips 26, engaging between collars 27 nipped on the rods. On the outer end of the rod 10 is a 57-toothed wheel 28, a similar wheel being secured on the outer end of the rod 8. By operating the clutch handles 24, 25, either or both of the gear wheels 28 or 28A may be brought into engagement with the $\frac{1}{2}$ " pinion 23 and thus cause the load to be raised or lowered, or the trolley 4 to be traversed.

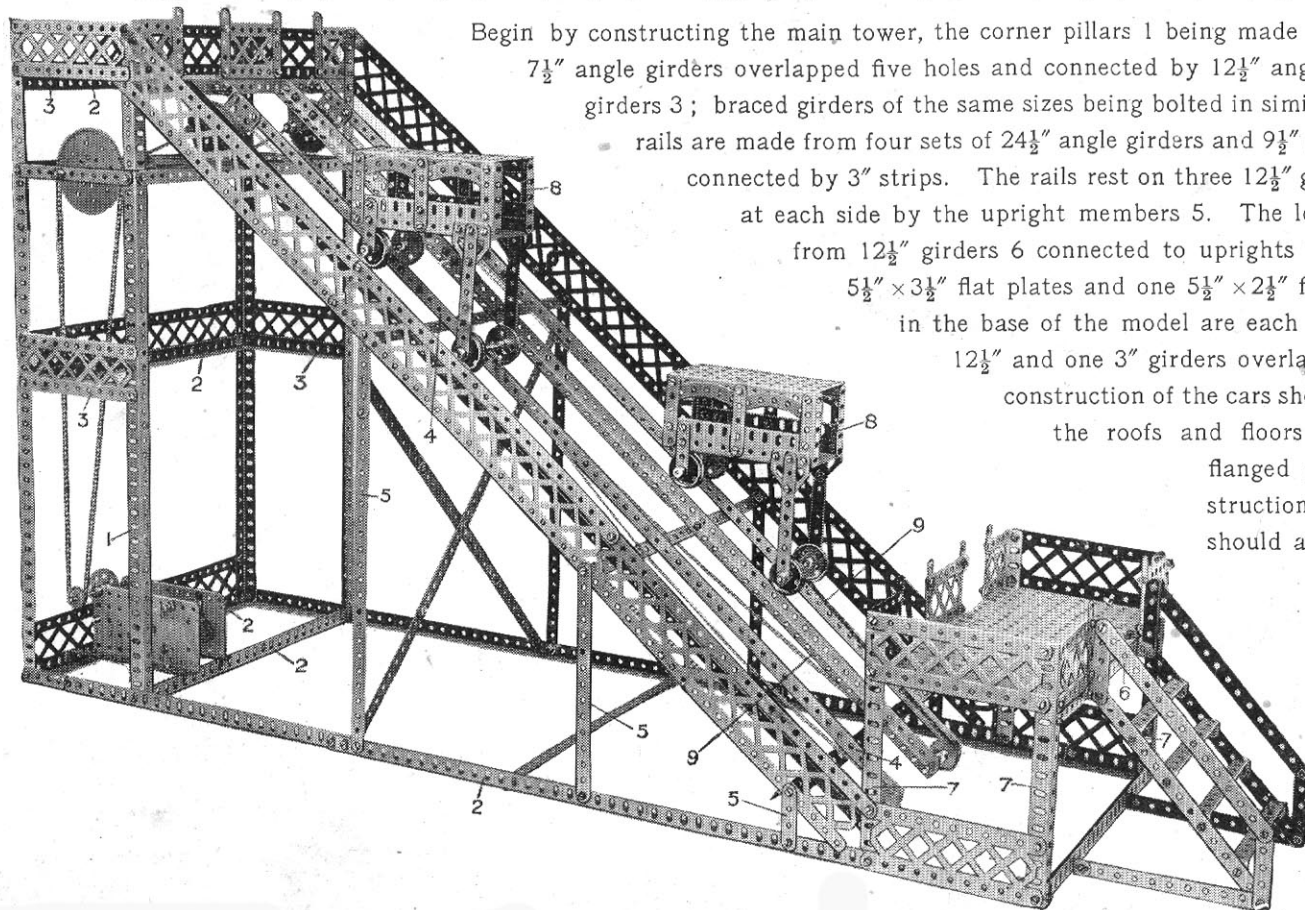
The third clutch handle 29 similarly controls the sliding movement of a rod 30, on which is secured a 57-toothed gear wheel 31 and $\frac{1}{2}$ " pinion 32, and on the rod 22 is secured another $\frac{1}{2}$ " pinion 33, while on the rod 14 is a further 57-toothed gear wheel 34. By moving the handle 29, therefore, the gear wheel 31 and the pinion 32 may be brought into engagement respectively with the pinion 33 and the gear wheel 34, thus providing a reduced gear train from the driven rod 22 to the rod 14, and as the latter is coupled by the chain 16 to the rod 18 of the travelling wheels 3 the whole gantry is caused to move to and fro.

The reversal of the motor is controlled by a bell crank 37, coupled by a $2\frac{1}{2}$ " strip 38 to the reversing lever of the motor, a strip 39 being bolted to the bell crank as an extension handle.

A small electric globe 35 may be mounted on the crane, and controlled by switch 36, Fig. 727.

Model No. 728 Funicular Railway

Parts required:									
9 of No. 1	18 of No. 5	4 of No. 8A	12 of No. 9D	2 of No. 17	7 of No. 48D	8 of No. 90	1 of No. 96A	4 of No. 103	
6 " " 1B	6 " " 6	8 " " 8B	22 " " 12	8 " " 20	4 " " 52	4 " " 74	5 " " 97	8 " " 126A	
4 " " 2	6 " " 7	4 " " 9	2 " " 13A	4 " " 26	6 " " 52A	2 " " 95	4 " " 98		
4 " " 2A	4 " " 7A	2 " " 9B	5 " " 16	3 " " 27A	19 " " 59	1 " " 95B	9 " " 99		Electric Motor
4 " " 4	13 " " 8	2 " " 9C	4 " " 16B	270 " " 37	2 " " 70	6 " " 96	8 " " 100		



Begin by constructing the main tower, the corner pillars 1 being made of $18\frac{1}{2}$ " angle girders and $7\frac{1}{2}$ " angle girders overlapped five holes and connected by $12\frac{1}{2}$ " angle girders 2 and $5\frac{1}{2}$ " angle girders 3; braced girders of the same sizes being bolted in similar positions. The inclined rails are made from four sets of $24\frac{1}{2}$ " angle girders and $9\frac{1}{2}$ " girders butted together and connected by 3" strips. The rails rest on three $12\frac{1}{2}$ " girders 4, and are supported at each side by the upright members 5. The loading platform is built up from $12\frac{1}{2}$ " girders 6 connected to uprights 7 and the floor from three $5\frac{1}{2} \times 3\frac{1}{2}$ " flat plates and one $5\frac{1}{2} \times 2\frac{1}{2}$ " flat plate. The side girders in the base of the model are each formed from one $24\frac{1}{2}$ ", one $12\frac{1}{2}$ " and one 3" girders overlapped two holes each. The construction of the cars should present little difficulty, the roofs and floors being made of $5\frac{1}{2} \times 2\frac{1}{2}$ " flanged plates, and the other constructional details of the framework should also present no trouble.

The cars 8, are connected to the chains 9 which pass over sprocket wheels 10, 2" diameter at the top and 1" at the bottom. The cars move in opposite directions so that the weight of the descending car assists the

Model No. 728 Funicular Railway (*continued*)

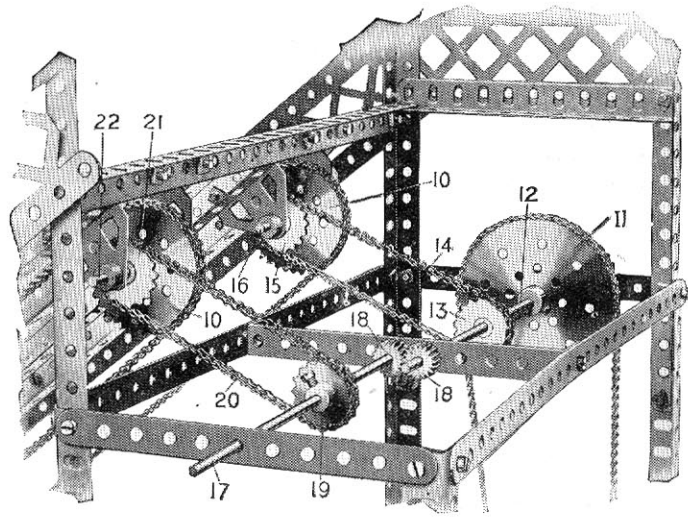
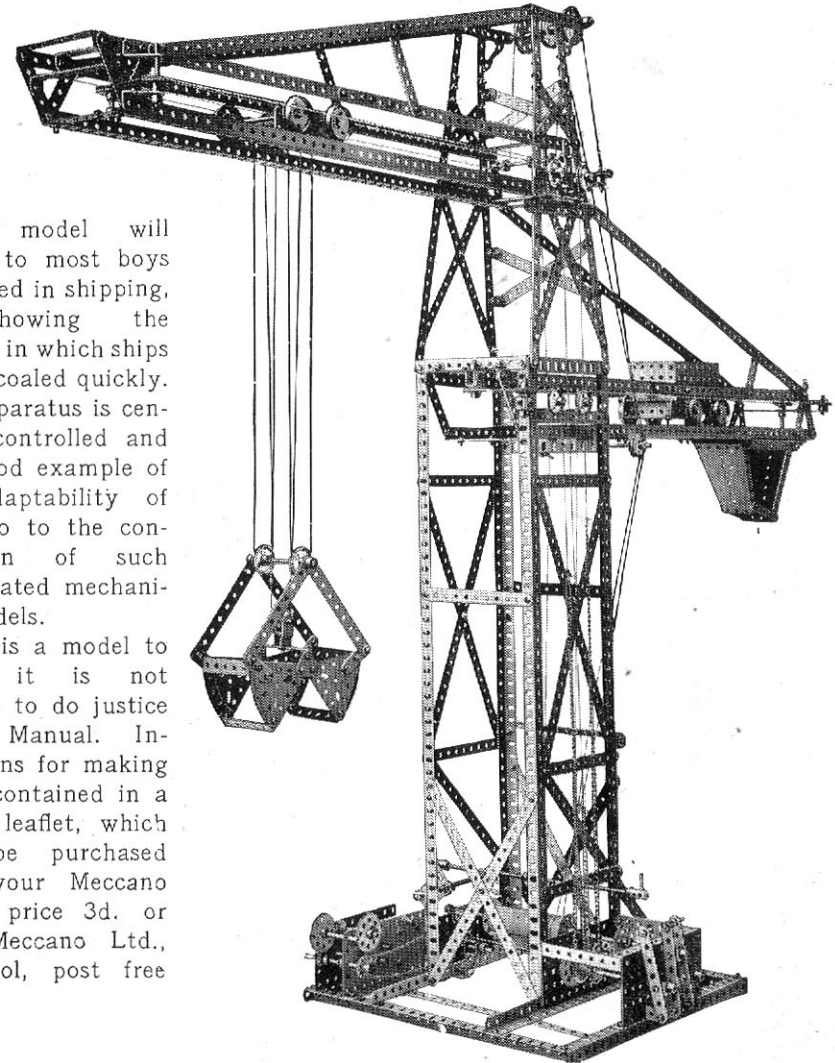


FIG. 728A

other car to ascend. This is effected by driving a 3" sprocket wheel, 11, Fig. A, from the motor, the 8" rod 12 of the sprocket wheel 11 carrying a 1" sprocket wheel 13 which is coupled by the chain 14 to a similar sprocket wheel 15 on the 3" rod 16. The rod 12 is coupled to another 8" rod 17 by a pair of $\frac{1}{2}$ " pinions 18 in order to obtain a reversed rotation, and a 1" sprocket wheel 19 on the rod 17 is coupled by a chain 20 to another 1" sprocket wheel 21 on a 3" rod 22 which drives the chain of the other car. In this way, opposite movement of the two cars is always taking place. The cars, having reached their destinations, are returned by reversing the motor.

Model No. 729 High-Speed Ship Coaler



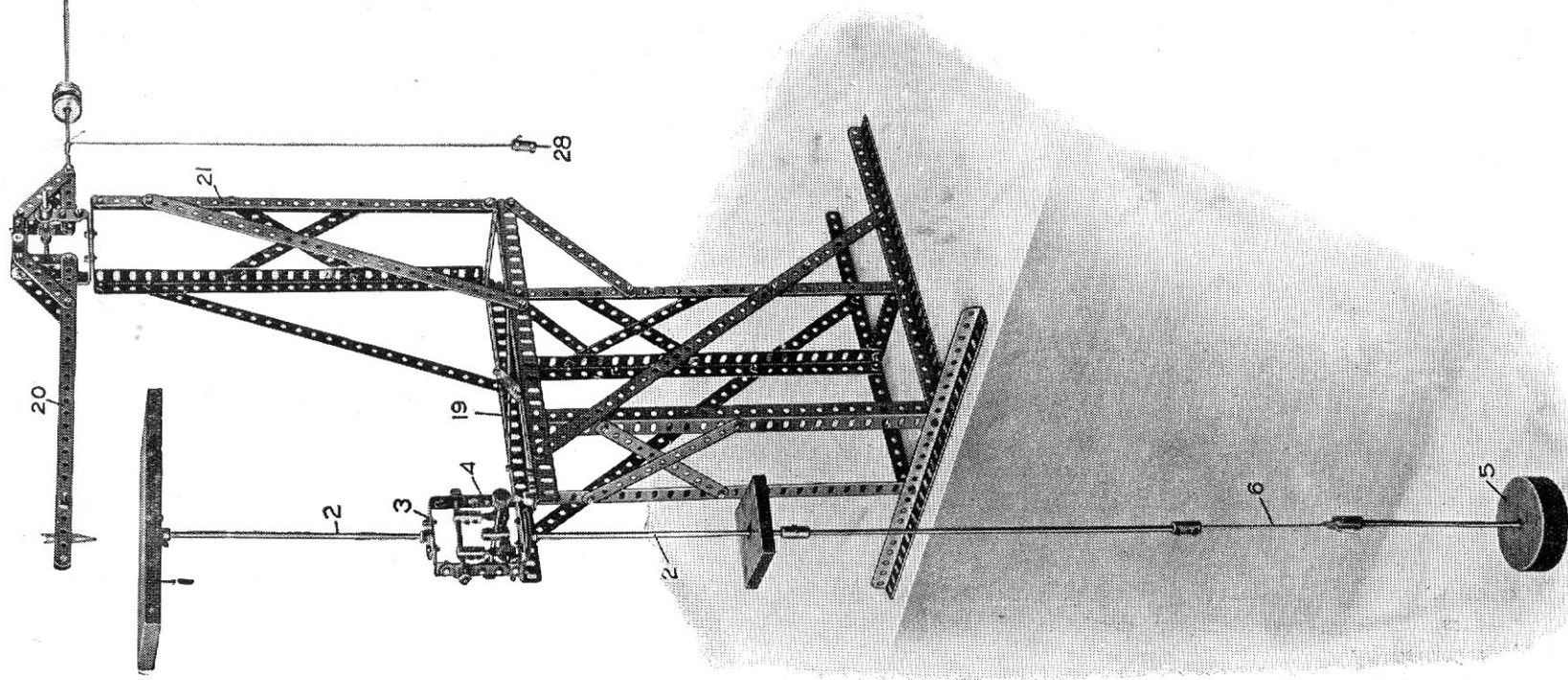
This model will appeal to most boys interested in shipping, as showing the manner in which ships can be coaled quickly. The apparatus is centrally controlled and is a good example of the adaptability of Meccano to the construction of such complicated mechanical models.

This is a model to which it is not possible to do justice in this Manual. Instructions for making it are contained in a special leaflet, which may be purchased from your Meccano dealer, price 3d. or from Meccano Ltd., Liverpool, post free 4d.

This Model can be made with MECCANO Outfit No. 7, or No. 6 and No. 6A.

Model No. 730

Twin- Elliptic Harmonograph



Parts required:

8	of No.	1
10	"	2
3	"	3
4	"	4
6	"	5
4	"	6
11	"	7
5	"	11
2	"	12
2	"	13
2	"	13A
1	"	14
3	"	16
2	"	16A
1	"	17
1	"	21
3	"	22
2	"	22A
2	"	24
6	"	26
86	"	37
2	"	37A
2	"	38
3	"	46
1	"	48B
4	"	59
6	"	62
9	"	63
6	"	65
1	"	107
2	"	111

Model No. 730 Twin-Elliptic Harmonograph *(continued)*

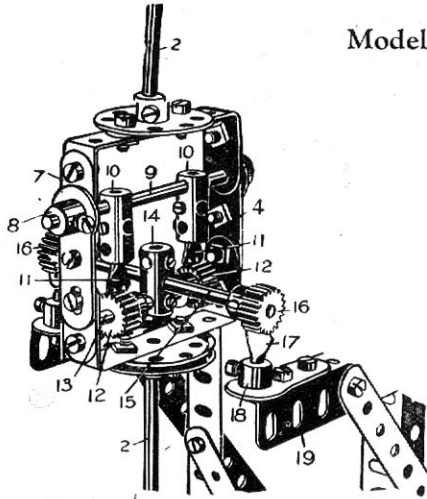


FIG. 730A

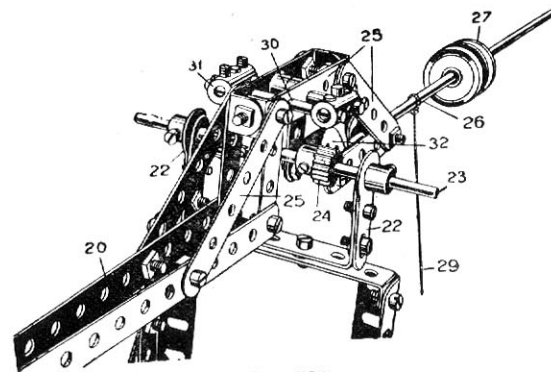


FIG. 730B

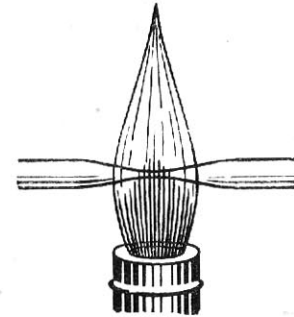


FIG. 730C

The table 1, upon which the paper for the design rests, is carried on a rod 2, the lower end of which is bolted to a bush wheel 3, which in turn is bolted to a frame 4, Fig. 730A, the lower rod 2 being similarly bolted to the frame 4 and carrying a somewhat heavy weight 5.

In order to obtain a flexible movement of the weight 5, the lower parts of the rod are coupled by a short length of string 6.

The frame 4 is built up as shown in Fig. 730A, of double angle strips $2\frac{1}{2}$ " by 1", connected by $2\frac{1}{2}$ " side strips 7, outside which are bolted cranks 8 to provide bearings for a rod 9 secured in the crank bosses. On the rod 9 are secured couplings 10 in the lower ends of which are mounted centre forks 11 forming knife edges engaging between the teeth of two $\frac{1}{2}$ " pinions 12 fixed on a 2" rod 13, which is secured in a centre coupling 14 across which, in the centre hole of each, is bolted a $3\frac{1}{2}$ " rod 15. On the outer ends of this rod 15 are two $\frac{1}{2}$ " pinions 16 which rest upon centre forks 17 forming lower knife edges, secured in the bosses of cranks 18 carried on angle girders 19. Consequently, the frame 4 is balanced so as to swivel in two directions about the knife edges 17 and the knife edges 11. The ink pencil is gripped between the ends of two $12\frac{1}{2}$ " strips 20, forming an arm which is pivotally supported as shown in Fig. 730. At the top of the arm 21, Fig. 730B, are bolted two cranks 22, in the bosses of which is secured a rod 23 carrying two pinions 24. The strips 20 are coupled by 3" and 2" strips 25 to form a yoke, in the rear of which is fixed a rod 26 on which is a balance weight 27, formed by a number of pulleys, and a further weight 28 is suspended from the rod 26 by cord 29. The balance weight is adjusted along the rod so that the pencil will just rest lightly on the paper on the table 1, and the extra weight 28, when hanging free, as in Fig. 730, just lifts the pencil clear of the paper. By lifting the weight 28 and resting it somewhere on the frame, the pencil is brought into light contact with the table 1.

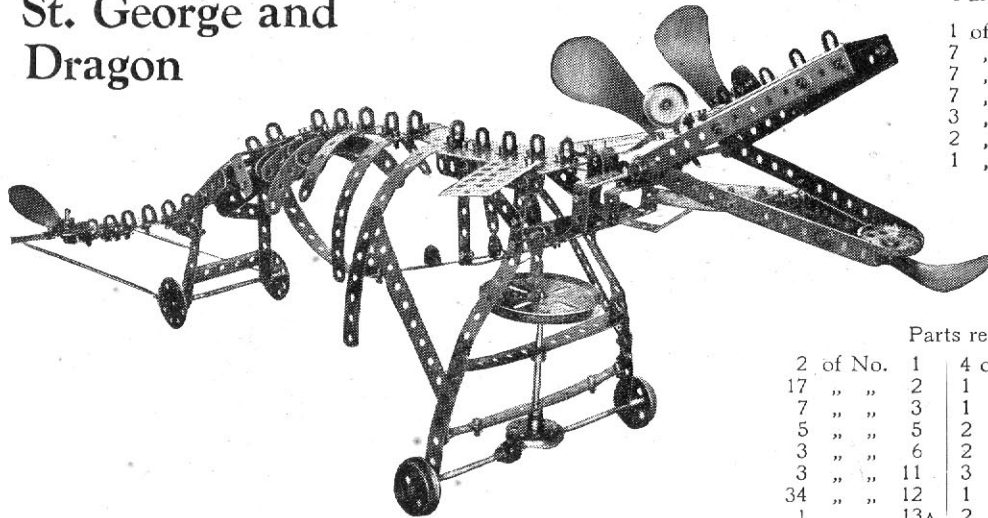
In the yoke 25 are inserted two rods 30, each carrying couplings 31 in the centre holes of which are secured centre forks 32 forming knife-edges, which engage the $\frac{1}{2}$ " pinions 24 about which the pencil arm swivels.

The pencil is made by drawing out a short length of $\frac{1}{8}$ " glass tubing in a bunsen or methylated spirit lamp, about $\frac{1}{8}$ " taper, Fig. 730C, and the end ground smoothly on a clean wet hone laid on the table; the tube is then filled with ink, which flows freely through the fine perforation in the point.

To operate the apparatus, if the weight 5 be given a swinging movement, the table 1 is oscillated, and the stationary pencil describes a diagram on the paper, which is varied according to the direction in which the weight swings.

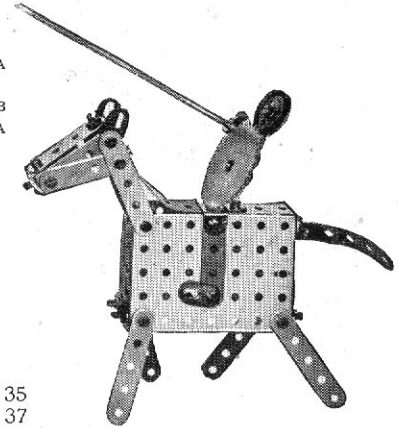
Model No. 731

St. George and Dragon



Parts required, St. George:

1 of No. 3	1 of No. 22A
7 " " 5	31 " " 37
7 " " 6	1 " " 37B
7 " " 10	2 " " 48A
3 " " 11	2 " " 53
2 " " 12	1 " " 62
1 " " 14	1 " " 95

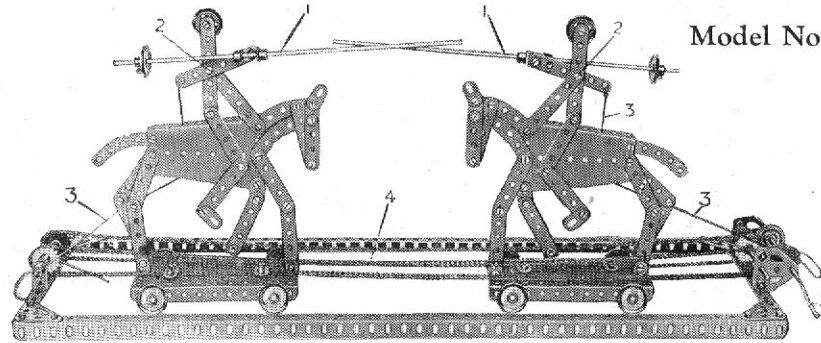


Parts required, Dragon:

2 of No. 1	4 of No. 16	2 of No. 35	
17 " " 2	1 " " 18A	126 " " 37	
7 " " 3	1 " " 19B	7 " " 38	
5 " " 5	2 " " 20	4 " " 41	
3 " " 6	2 " " 22	1 " " 43	6 of No. 59
3 " " 11	3 " " 24	3 " " 46	2 " " 61
34 " " 12	1 " " 26	9 " " 48A	1 " " 69
1 " " 13A	2 " " 28	4 " " 54	2 " " 72
			6 of No. 90
			2 " " 110
			2 " " 114

This model requires little description. The jaws of the dragon work by means of a cord fastened to a 3½" strip which is attached to the 2½" x 2½" flat plate forming the head. The cord is passed through a hole in the 12½" strip, which forms the back-bone. It is attached at its other end to the periphery of a 3" pulley wheel, which is caused to rotate as the dragon moves along the ground. To make the tail wag, cords are fastened to each end of the pivoted 3½" strip which carries the bush wheel and propeller blade forming the tail, and attached at the other ends to angle brackets bolted to the back wheels. As the model moves along the ground the tail wags in quite a realistic way.

Model No. 732 The Tilters



Parts required:

2 of No. 3	2 of No. 31
4 " " 4	73 " " 37
22 " " 5	2 " " 37A
2 " " 7	4 " " 38
2 " " 8B	1 " " 46
10 " " 10	1 " " 47
2 " " 11	2 " " 52
2 " " 12	2 " " 54
2 " " 13	8 " " 59
1 " " 15A	6 " " 90
5 " " 16	2 " " 94
1 " " 19	4 " " 96
10 " " 22	2 " " 126A
2 " " 22A	4 " " 133

The lances 1 pivoted at 2 are raised into position by the cords 3 and the figures caused to advance together by the chains 4 on turning the handle 5. The cords 3, instead of being tied where indicated in the illustration, should, after aim, be made fast to some part of the moving figures.

Model No. 733 Warehouse

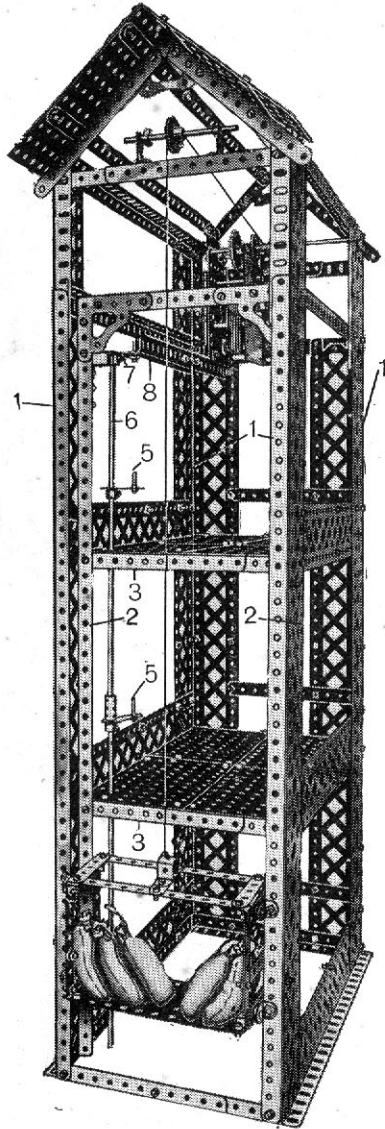


FIG. 733A

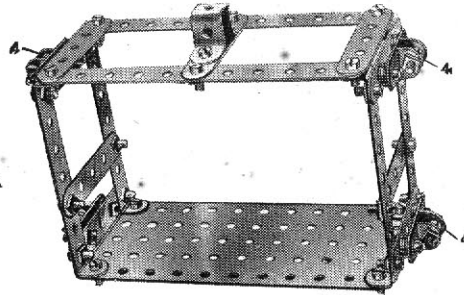


FIG. 733B

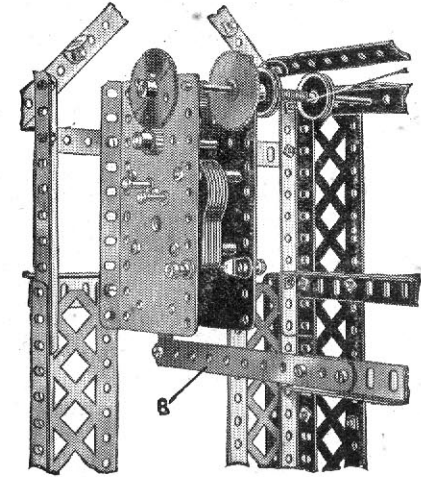
Commence this model by building the framework. $2\frac{1}{2}$ " angle girders are used to form the corner uprights 1 with $5\frac{1}{2}$ " angle girders overlapped eight holes at the top. Two $2\frac{1}{2}$ " angle girders 2 are also used to carry the front portion of the warehouse floors, the latter being bolted to two $5\frac{1}{2}$ " angle girders 3 overlapped eight holes and connected across to the two inner angle girders 2. Two similar $5\frac{1}{2}$ " angle girders are bolted to the back of the framework, to carry the other end of each of the floors. The floor is formed of four $5\frac{1}{2}$ " x $3\frac{1}{2}$ " flat plates butted together and bolted in the centre to a $5\frac{1}{2}$ " flat girder on the underside—the two outer ends being bolted to the angle girders 3. The horizontal side-strips are formed of $1\frac{1}{2}$ " strips to which are bolted the braced girder strips.

Fig. A shows the construction of the cage. This is guided by bolt heads 4, at each side riding along the inwardly turned flanges of the angle girders 2. The bolts are attached to angle brackets, which are secured to a $1\frac{1}{2}$ " strip, this latter being secured to the side-strips of the cage, spaced with three washers to take up the play between the cage and the upright girders 2.

Fig. B shows the position of the motor, and this may be started and stopped from the control crank handles 5, one on each floor of the warehouse. These crank handles are fixed on a vertical rod 6 composed of two $11\frac{1}{2}$ " rods connected by a coupling. A crank 7 is secured to the upper end of this rod and is connected by a $5\frac{1}{2}$ " angle girder and strip 8 to the operating lever of the motor.

1 " brackets secured to the sides of the warehouse by strips form the bearings for the upper and lower ends of the vertical rod.

When the motor is wired up to the accumulator, the elevator is ready to be operated.



Parts required:					
18 of No.	1	2 of No.	13	1 of No.	59
21 "	2	1 "	14	4 "	62
9 "	5	1 "	16	1 "	63
1 "	6	3 "	22	3 "	70
4 "	6A	2 "	35	18 "	99
6 "	7	240 "	37	4 "	100
6 "	8	30 "	38	2 "	103
23 "	9	1 "	45	4 "	108
16 "	12	1 "	46	4 "	115
2 "	12A	8 "	52A		

Electric Motor

Model No. 734 Motor Cycle and Sidecar

Parts required : Motor Cycle

2 of No. 2	1 of No. 15	1 of No. 23A	2 of No. 90	2 of No. 115
2 " " 3	1 " " 15A	2 " " 32	6 1/2 " " 94	1 " " 116
1 " " 4	1 " " 16	28 " " 37	1 " " 96	3 " " 120A
10 " " 5	5 " " 17	10 " " 37A	1 " " 96A	2 " " 126A
1 " " 6A	4 " " 18A	16 " " 38	1 " " 101	2 " " 142
2 " " 10	1 " " 18B	11 " " 59	2 " " 103G	
6 " " 11	2 " " 19B	8 " " 63	3 " " 111	Small elastic band
4 " " 12	1 " " 22	3 " " 77	3 " " 111A	

Parts required :

Sidecar	
2 of No. 2	2
2 " " 2A	2A
5 " " 3	3
5 " " 5	5
2 " " 6A	6A
1 " " 9F	9F
1 " " 10	10
2 " " 11	11
3 " " 12	12
2 " " 16	16
1 " " 16A	16A
1 " " 17	17
1 " " 18A	18A
1 " " 19	19
1 " " 19B	19B
55 " " 37	37
1 " " 37A	37A
3 " " 38	38
2 " " 43	43
7 " " 48A	48A
4 " " 59	59
5 " " 63	63
1 " " 64	64
6 " " 89	89
8 " " 90	90
2 " " 103F	103F
2 " " 103H	103H
1 " " 111A	111A
1 " " 125	125
2 " " 133	133
1 " " 142	142

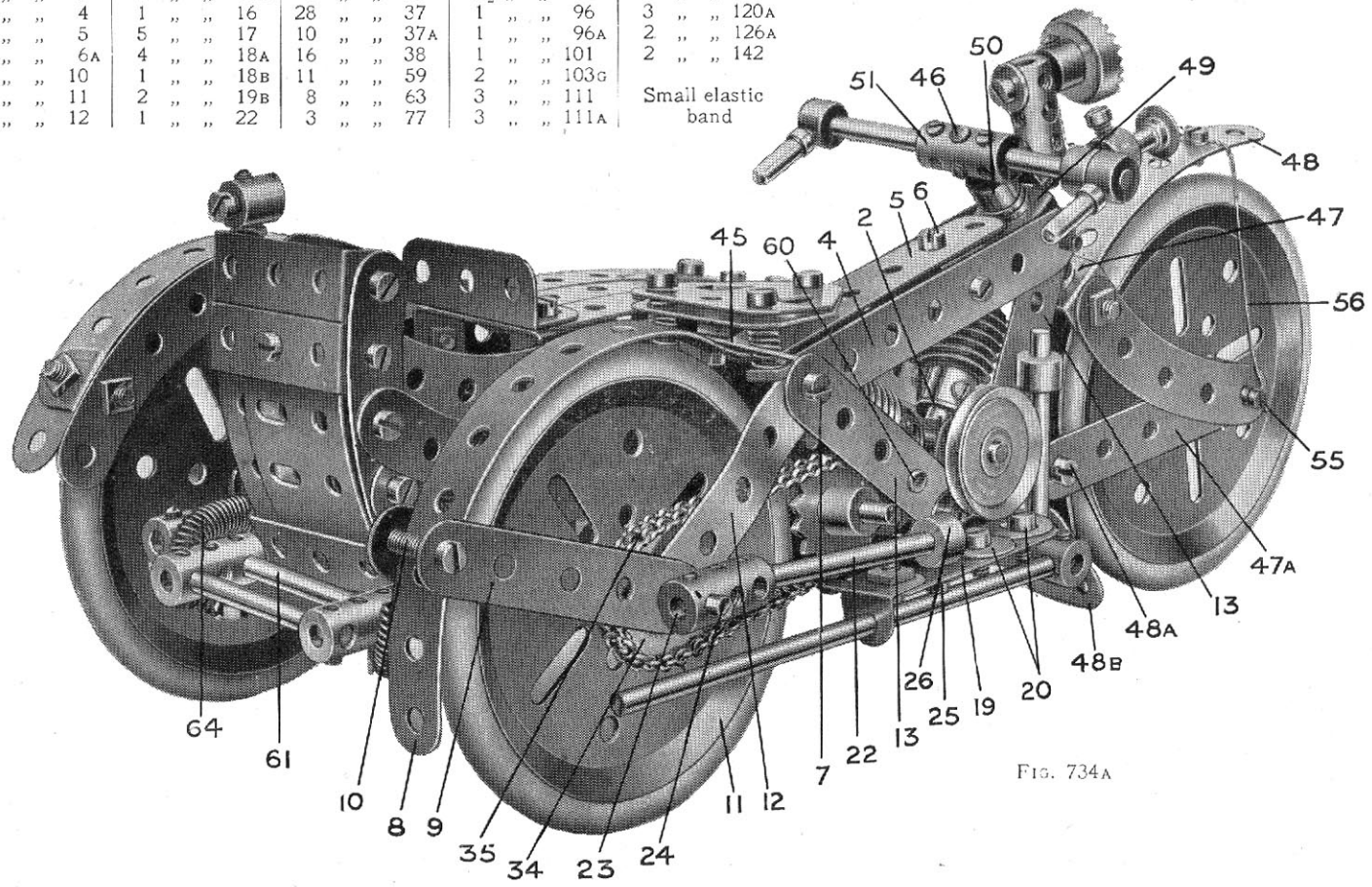


FIG. 734A

Model No. 734 Motor Cycle and Sidecar (continued)

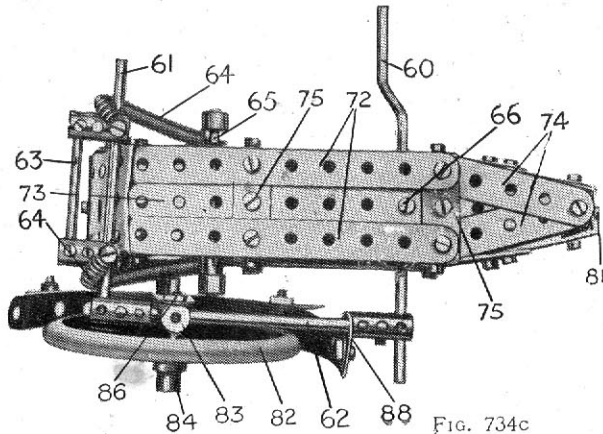
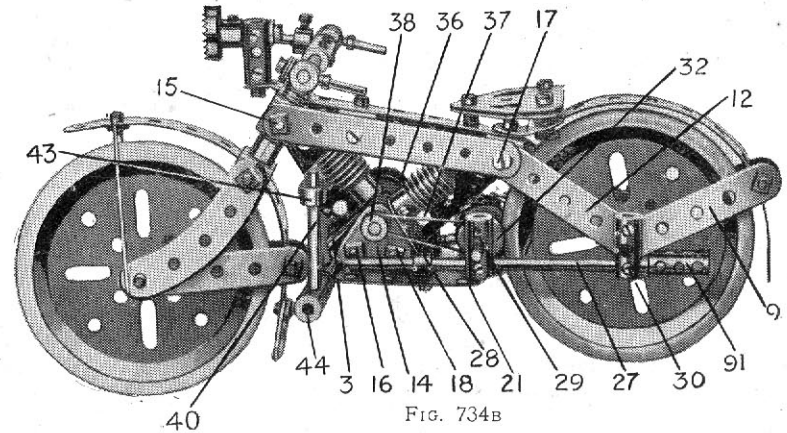
This model is an excellent example of Meccano miniature engineering, and offers a remarkable testimonial to the adaptability of the system. Its construction will prove no light tax on the ingenuity of even long-experienced Meccano boys, and it is undoubtedly a case in which nimble fingers are called for!

The only item included in the model that is not a regular Meccano part consists of a small elastic band; this should be about $1\frac{1}{4}$ " in length when fully extended.

Each engine cylinder consists of a worm wheel, secured by its set-screw to the shank of a bolt passed through a flat bracket 2 carried from a double bracket 3 (Fig. B). The tank consists of two $3\frac{1}{2}$ " strips 4 (Fig. A) and one 3" strip 5 held together by double brackets at 6 and 7. A $5\frac{1}{2}$ " strip 8 is bolted by its end hole to the end of the strip 5, and is bent round as shown to form the rear mudguard. It is clamped in position between two $2\frac{1}{2}$ " strips 9 by means of a $\frac{3}{4}$ " bolt 10. The driving wheel 11 is carried in the ends of $2\frac{1}{2}$ " strips 12, which are bent slightly as shown in Fig. D, as also are the strips 9.

The V-shaped engine frame is built up from $2\frac{1}{2}$ " strips 13 converging upon 1" triangular plates 14 (Figs. B and D). The side $2\frac{1}{2}$ " strips have been removed in Fig. B in order to reveal some of the engine details; normally they are secured by the bolts 15, 16, 17 and 18. A 2" flat girder 19 (Fig. A) is secured to two angle brackets 20 bolted to the base of the outer 1" triangular plate. A similar flat girder 21 (Fig. B) is attached to the first girder 19 by means of bolts passed through the elongated holes of both girders.

A tie-rod provided on the right-hand side of the machine consists of a $2\frac{1}{2}$ " rod 22 (Fig. A) nipped in the end of the coupling 23, in which the back axle



24 is allowed to rotate freely. A set-screw 25, carrying one washer, is passed through a hole in the flat girder 19, and entering the threaded bore of a collar 26, grips the rod 22 fast in position. Another tie-rod fitted to the left-hand side of the machine comprises a $4\frac{1}{2}$ " rod 27 (Fig. B) secured to the flat girder 21 by means of a collar 28, in a similar manner to that just described. Two couplings 29 and 30 are mounted on the rod 27. Coupling 30 forms an additional support for the back axle, and the centre transverse hole of the coupling 29 is employed as a bearing for a 2" rod 31 (Fig. D). This rod 31 carries a $\frac{1}{2}$ " fast pulley 32 (Fig. B) and a $\frac{3}{4}$ " sprocket wheel 33 (Fig. D).

The back axle 24 is gripped by the set-screw of the driving wheel 11, and carries a 1" sprocket wheel 34 (Fig. A) which drives the $\frac{3}{4}$ " sprocket 33 by means of a sprocket chain 35, composed of 39 links. The $\frac{1}{2}$ " pulley 32 (Fig. B) is connected to the shaft of the flywheel 36 by means of a small rubber band 37, which passes round the groove of the pulley and round the flywheel shaft itself, being guided between a washer and collar 38. Hence, as the machine runs along, the flywheel is caused to revolve at considerable speed.

A 5" rod 39 and 2" rod 40 (Fig. D) represent the exhaust pipe. The rod 39 passes through the angle bracket 41, and is secured in the end of the coupling 42, representing the silencer; the rod 40 is secured in the centre transverse hole of the coupling 42, while its upper end is gripped by the set-screw of the collar 43. This screw, carrying a washer, passes through the centre hole of the strip 13 before entering the collar. The short exhaust pipe 40 is duplicated on the other side of the machine (see Fig. B); it should be noted, that the coupling 44 in this illustration is connected to coupling 42 by means of a 1" axle rod.

The saddle is composed of two flat trunnions secured to the framework by means of three $\frac{1}{2}$ " bolts. A $1\frac{1}{2}$ " strip 45 (Fig. A), bolted transversely to the

Model No. 734 Motor Cycle and Sidecar (continued)

second hole of the $5\frac{1}{2}$ " strip 8, forms supports for the rear saddle springs. The small compression springs placed on the $\frac{1}{2}$ " bolts are extracted from spring buffers (Part No. 120a).

The steering column, handle-bars, etc., are constructed as follows: a 2" rod 46 is passed through the fork piece 47 and its end enters the centre hole of the $5\frac{1}{2}$ " strip 48, which is bent round to form the front mudguard. A washer is then placed against the boss of the fork piece and the rod 46 is journaled through two double brackets 49, which are placed one within the other and bolted to the ends of the strips 4 and 13. Three washers, a collar 50, and coupling 51 are then placed in position on the steering column as shown. The handle-bars are built up from threaded pins, collars, and two $1\frac{1}{2}$ " rods, carried from the coupling 51.

The head-lamp is composed of a $\frac{3}{4}$ " conrate wheel 52 (Fig. D) secured to the shank of a $\frac{3}{4}$ " bolt passed completely through the coupling 53. The latter is secured to a bolt passed through an angle bracket, which, in turn, is secured by a set-screw 54 to the collar 50.

The front wheel forks consist of $2\frac{1}{2}$ " strips, 47a (Fig. A) and $2\frac{1}{2}$ " curved strips, all of which are slightly splayed to allow free movement of the road wheel. The mudguard 48 is clamped between the strips 47a by means of a $\frac{3}{4}$ " bolt 48a passed through their end holes, in a similar manner to the bolt 10 on the rear mudguard 8. The set-screw of the front road wheel is removed in order that it may revolve independently on the $1\frac{1}{2}$ " axle rod 55. The wheel is held in a central position on its axle by means of a collar and three washers mounted within the forks on one side of the wheel to equalise the width of the boss on the other. The mudguard 48 is secured by means

of a tie 56. This consists of a Meccano heald (Part No. 101), the end holes of which are slipped over the axle 55 before the $2\frac{1}{2}$ " curved strips are placed in position. The heald is then doubled beneath the curved strip and taken over the strip 48, and thence down to the opposite end of the axle 55. It is secured to the mudguard by means of a bolt passed through its centre hole. A 1" triangular plate 48b bolted to the second hole of the strip 48 forms a "splash-guard."

The horn 57 (Fig. D) is constructed from the "ram" of a spring buffer, the screwed end of which engages the threaded bore of a collar 58 mounted on the handle-bars. A collar 59 with set screw added represents the operating handle.

CONSTRUCTION OF THE SIDECAR

The undercarriage of the sidecar is built up from a crank handle 60 (Fig. C) and $3\frac{1}{2}$ " rod 61 connected by couplings and $3\frac{1}{2}$ " rod 62. Two couplings and a 2" rod 63 serve as a luggage carrier, while bolts inserted in the Couplings carry springs 64, between which the car is suspended. The springs are attached to the car by means of a 2" rod 65. A set-screw 66 passed through the bottom of the car enters the threaded bore of a collar on the crank handle 60, so holding the car in its correct position on its cradle.

Each side of the car is composed of the following parts (see Fig. D): 67; $2\frac{1}{2}$ " and $5\frac{1}{2}$ " curved strips overlapped two holes and bolted together; 68; $2\frac{1}{2}$ " curved strips and $3\frac{1}{2}$ " strips overlapped two holes and bolted together; 69 and 70; $5\frac{1}{2}$ " curved strips. The front ends of all the side members, with the exception of 68, are bolted to a corner bracket 71 in the nose of the car. The floor (Fig. C) is composed of two $4\frac{1}{2}$ " strips 72, a $5\frac{1}{2}$ " strip 73 and two $2\frac{1}{2}$ " strips 74, bolted to $1\frac{1}{2}$ " x $\frac{1}{2}$ " double angle strips 75. The top (Fig. D) consists of three 3" strips 76, two $2\frac{1}{2}$ " strips 77 and one $1\frac{1}{2}$ " strip 78, also secured to $1\frac{1}{2}$ " x $\frac{1}{2}$ " double angle strips. The back is built up from three $1\frac{1}{2}$ " double angle strips, bolted between the corner $2\frac{1}{2}$ " curved strips 80, and two $2\frac{1}{2}$ " flat girders slightly bent as shown and secured by a bolt 79. All four sides taper towards the nose of the car and are secured to two double brackets bolted together by the nut and bolt 81 (Fig. C).

A seat is provided within the sidecar. This is constructed from two $1\frac{1}{2}$ " flat girders secured, by means of a bolt passed through the elongated hole in the end of each, to a $\frac{1}{2}$ " reversed angle bracket. The latter is bolted to the floor of the car by means of the screw 75 (Fig. C).

The third road wheel 82 runs freely upon a $1\frac{1}{2}$ " rod bolted in the top transverse bore of a coupling 83. Two washers are placed on the $1\frac{1}{2}$ " rod between this coupling and the wheel, while the latter is held in place by the collar 84. The coupling 83 is secured to the rod 62, which passes through its centre. A $2\frac{1}{2}$ " strip 85 (Fig. D) is secured to the $\frac{1}{2}$ " bolt 86 (Fig. C) passed through the lower end of coupling 83.

The strip 85 serves to support the mudguard, which is constructed from $5\frac{1}{2}$ " and 2" strips overlapped two holes and bolted together. The mudguard is bent round the wheel as shown in Fig. D and carries two $2\frac{1}{2}$ " curved strips secured by angle brackets 87. A flat bracket 88 (Fig. C) is bolted to the end hole of the 2" strip, and engages the rod 62.

The side-lamp 89 consists of a threaded boss, screwed to the upturned shank of a bolt which serves to secure the angle bracket 90.

The sidecar may be quickly connected or detached from the motor-cycle. The crank handle 60 passes through the strips 13 of the engine-frame (its extreme end is just visible in Figs. A and D), while the rod 61 enters the end hole of a coupling 91 (Fig. B), where it is gripped by the set-screw. It will be seen, therefore, that by loosening this screw, the sidecar may be immediately detached and the motor-cycle used as a solo machine, if so desired.

All three wheels are fitted with Meccano rubber rings (Part No. 142) to represent pneumatic tyres,

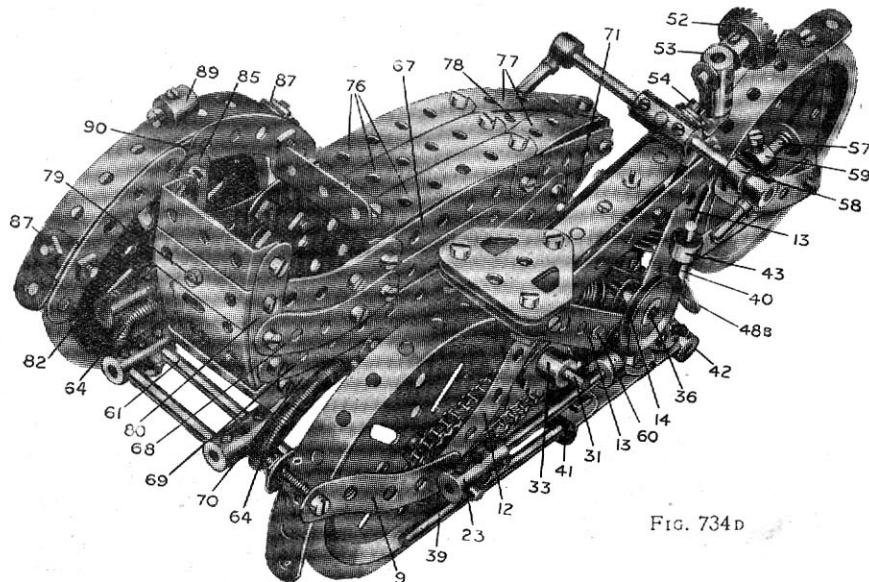
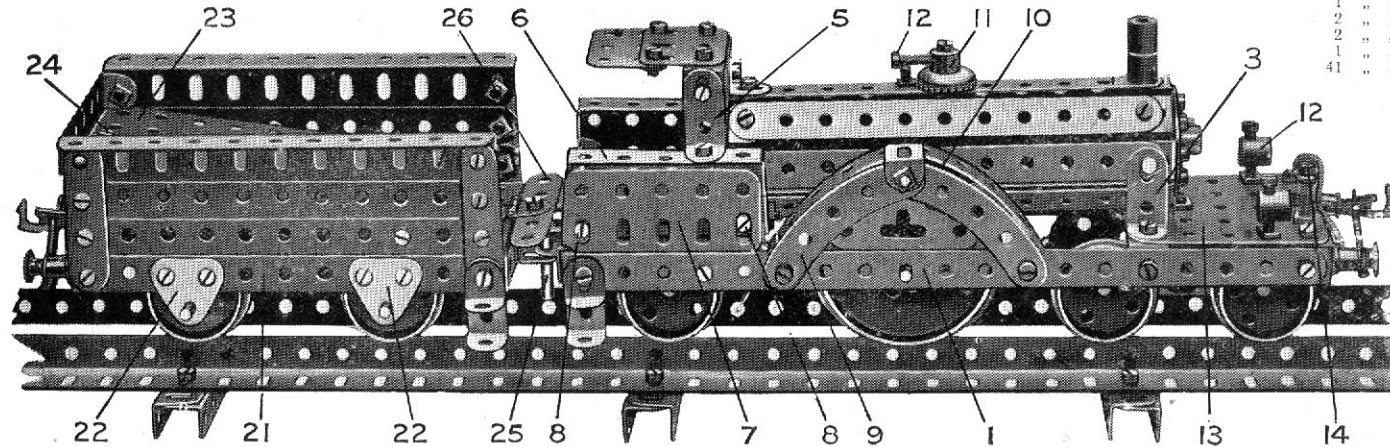


FIG. 734 D

Model No. 735 Locomotive and Tender (Midland, 4-2-2)



Parts required:

2 of No.	1A	8 of No.	12B
13 "	2	3 "	16
1 "	5	3 "	18A
4 "	6	1 "	18B
1 "	6A	10 "	20
2 "	9	2 "	24
2 "	9D	1 "	29
1 "	11	131 "	57
41 "	12	11 "	38
		2 "	46
		1 "	48
		10 "	48A
		1 "	52
		1 "	53A
		6 "	59
		4 "	64
		2 "	72
		4 "	77
		4 "	90
		2 "	105F
		3 "	103H
		2 "	109
		4 "	111
		3 "	111A
		1 "	114
		5 "	120A
		2 "	121
		2 "	126
		2 "	133
		2 "	137
		1 piece of No.	58

This is a well-proportioned model of an old-style Midland "single-wheeler" locomotive. The engine frame is built up from two $9\frac{1}{2}$ " strips 1 joined at the points 2 (Fig. 735A) by $2\frac{1}{2}$ " \times $\frac{1}{2}$ " double angle strips, and further strengthened at each end by $2\frac{1}{2}$ " angle girders. The boiler is composed of seven $5\frac{1}{2}$ " strips bolted at either end to a bush wheel by means of angle brackets. It is supported by $1" \times \frac{1}{2}"$ angle brackets 3, and an angle bracket secured to the lowest hole of the rear bush wheel is bolted at 4 (Fig. 735A) to the floor of the cab.

The cab roof consists of $1\frac{1}{2}"$ flat girders bolted by angle brackets to $1" \times \frac{1}{2}"$ brackets 5. $2\frac{1}{2}" \times 1"$ double angle strips 6 and flat girders 7 bolted together by angle brackets at 8 form the sides, which, in turn, are bolted by angle brackets to the footplate.

The wheel covers for the main drivers are each constructed from two $2\frac{1}{2}"$ curved strips 9 and a $5\frac{1}{2}"$ strip 10 bent to the same curvature. A corner bracket is secured in the centre as shown.

A safety valve in the centre of the boiler consists of a contrate wheel 11, secured by means of a $\frac{3}{8}"$ bolt and carrying a further $\frac{1}{8}"$ bolt 12. The smoke-stack is composed of two threaded bosses mounted on the shank of a $\frac{3}{8}"$ bolt passing through the top strip of the boiler. Two lamps are carried on the front of the engine-frame and consist of threaded bosses 12 mounted on the upturned shanks of $\frac{1}{8}"$ bolts secured in the $2\frac{1}{2}" \times 2\frac{1}{2}"$ flat plate 13, and gripped in position by $7/32"$ bolts inserted in the tops of the bosses. A piece of spring cord, secured to a $\frac{3}{8}"$ bolt 14, represents the front vacuum brake pipe connection.

It will be noticed from Fig. 735A that the front bogie consists of two $2\frac{1}{2}"$ strips 15, bolted to a double bracket 16. It is attached to the locomotive frame by means of a $\frac{1}{2}"$ bolt, secured by two nuts on its end to the flat plate 13. A small compression spring (extracted from Part No. 120A) is placed on the bolt between the double bracket and the base plate. The rear trailing wheels 17 are mounted on a $1\frac{1}{2}"$ rod passed through two trunnions 18 bolted to the under-side of the footplate. The

wheels are retained in their correct position by means of a Collar 19, spaced between two washers.

The driving wheels are built up from face plates and wheel flanges, and are secured to a $3"$ rod 20. They are spaced in the correct position in the centre of the frame by means of three washers placed between the boss of each face plate and the sides 1 of the engine.

A $5\frac{1}{2}" \times 2\frac{1}{2}"$ flanged plate 21 forms the base of the tender and the sides are each built up from two $5\frac{1}{2}"$ strips and one $5\frac{1}{2}"$ angle girder. The back consists of four $2\frac{1}{2}" \times \frac{1}{2}"$ double angle strips. The wheels are carried on axles journalled in $1"$ triangular plates 22 bolted to the base plate 21. A $4\frac{1}{2}" \times 2\frac{1}{2}"$ flat plate 23 is secured inside the tender by means of an angle bracket bolted to the back at 24, and a $2\frac{1}{2}" \times \frac{1}{2}"$ double angle strip at the other end of the plate.

The loco and tender are coupled together by means of a $1"$ rod 25, passed through two angle brackets. An extension of the footplate consists of a $1\frac{1}{2}"$ flat girder and a $2\frac{1}{2}"$ strip 26, bolted by means of a hinge to the tender.

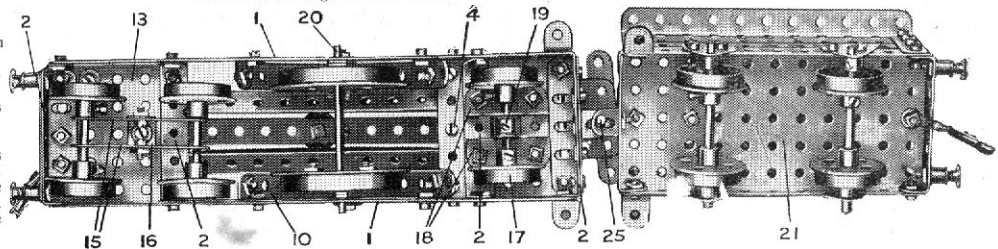


Fig. 735A

Interesting Experiments in Applied Mechanics with Meccano

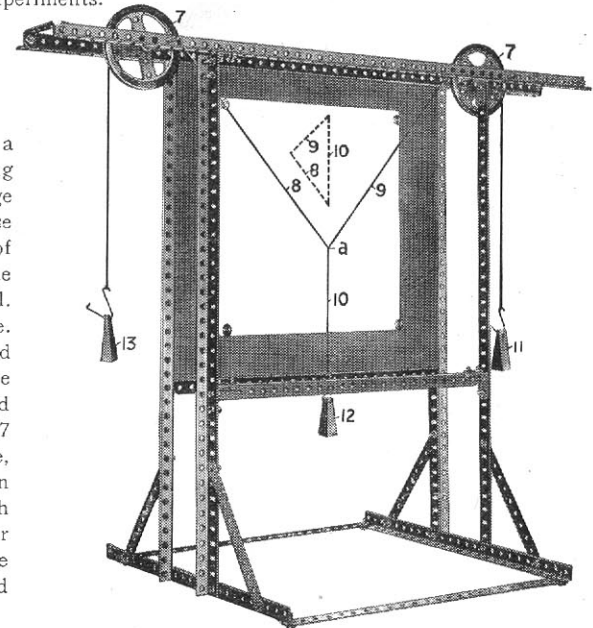
Few boys know what an important part the science of "Applied Mechanics" plays in everything which they see around them. It is this science that enables the engineer to design machines or bridges that will withstand all kinds of strains, for it tells him the extent of the stresses and thrusts with which he has to deal, and exactly where they will be felt. When an engineer builds a crane and guarantees it to lift a load of so many tons, "Applied Mechanics" tells him where the strain will come, exactly what strength of materials he must use, and how his crane ought to be designed.

Of course "Applied Mechanics" is a big subject, and one can only grasp its principles thoroughly after a lot of study; but it is a very fascinating subject, and some of its elementary laws are most interesting and not at all difficult to understand. We reproduce two models that illustrate the possibilities of Meccano in demonstrating mechanical principles, and further examples dealing with levers, pulleys, the inclined plane, etc., will be found in the "Standard Mechanisms" Manual. Any boy can derive much fun and learn a lot of useful points in mechanics by making these experiments.

Model No. 736 Triangle of Forces

This model illustrates the principle of the "Triangle of Forces." Briefly, if three forces meet at a point and balance each other, and we know one of the forces, we may determine the other two by drawing a triangle, making each side parallel to the direction of one of the forces. To demonstrate this, two large pulleys 7 are carried on rods in the upper $24\frac{1}{2}$ " girders of the model, and cords 8, 9, are passed over these pulleys, their ends being joined to another cord 10. Weights 11, 12, and 13 are then hung on the ends of the cords 8, 9, and 10, and when the point of junction (a) of the three cords has come to rest, lines in the direction of the cords are drawn on a sheet of paper pinned to a piece of board incorporated in the model. This board is not included in Meccano Outfits on account of its size, but it may be provided at little expense. The paper is afterwards removed and a triangle drawn, as shown in the illustration, with its sides 8, 9, and 10 parallel to the directions of the three cords. This triangle is shown in dotted lines. If the sides of the triangle are measured it will be found that they are in the same proportion as the weights 11, 12 and 13. For instance, if the weight 12 were 15 units and the weight 13 were 9 units, and the weight 11 were 7 units, the lengths of the sides of the triangle would be 15, 9, and 7 units. By this experiment, therefore, we demonstrate that when three forces meet at a point, and we know their direction and the value in grammes or pounds of one of the forces, if we construct a triangle, making that side of the triangle which corresponds to the known force equal to a number of units of length, each unit representing a gramme or pound of the known force, then by scaling off the other two sides of the triangle we can determine the value of the other two forces in grammes or pounds. Several experiments with different weights should be tried and triangles drawn, and the accuracy of the apparatus for different weights tested.

Little difficulty will be experienced in constructing the Meccano Demonstration Frame from this illustration. It may be well to mention, however, that the rear uprights, which consist of $18\frac{1}{2}$ " angle girders, are secured to the sides of the board shown in the illustration by ordinary wood screws. The $24\frac{1}{2}$ " girder at the top is secured in the same manner, as also is the $12\frac{1}{2}$ " girder at the bottom. The board is used for pinning on sheets of paper, upon which the diagrams are drawn.



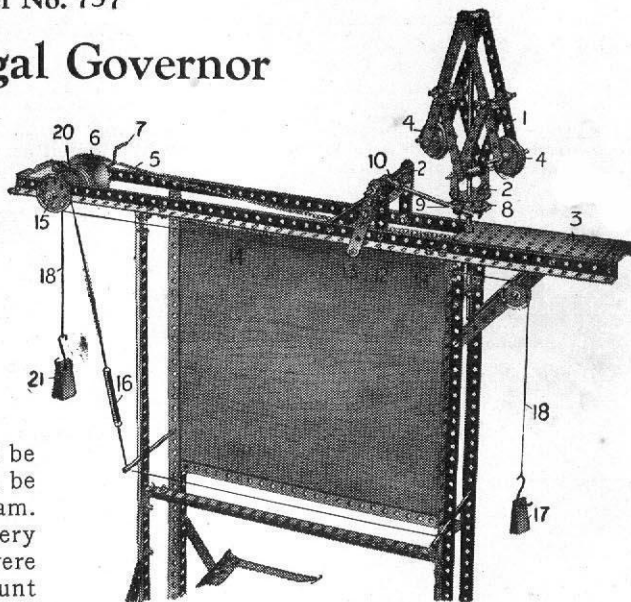
Parts required :

2 of No. 1	4 of No. 12A	3 of No. 57A
4 " " 2	2 " " 16	4 " " 59
2 " " 7	2 " " 19B	3 " " 66
2 " " 7A	36 " " 37	3 " " 67
4 " " 8	4 " " 38	8 " " 68
	2 " " 48A	

Model No. 737

Centrifugal Governor

In this model an apparatus is shown for demonstrating the controlling effect of a governor. A governor is a device which is fitted on an engine in order to make its speed constant. In the case of an engine driving a works, for instance, if all the machinery in the shop were running, the engine would be driving a heavy load and would be using a certain amount of steam. If a great portion of the machinery were stopped and the engine were allowed to take the same amount of steam, owing to the lightness of the load then on the engine it would race at great speed and probably be damaged. To prevent this engineers fit a governor device which, as the load on the engine is lightened, automatically shuts off the steam, or throttles it, and which, as the load comes again on the engine, permits it to take more steam. The governor thus arranges the steam supply to the engine to be suitable for the load which the engine bears and to drive it at a constant speed. Most governors are of the centrifugal ball type, that is to say, they have a pair of ball weights which are spun round by the engine. As the engine's speed increases, the ball weights fly out, and this flying out or centrifugal action is arranged to shut off the steam.



The governor 1, the construction of which is quite clear from the illustration, is mounted on a spindle 2 in a rectangular plate 3 fitted in the top girders. The flanged pulley wheels 4 represent the ball weights of the governor. Below the rectangular plate 3 and on the spindle 2 is a sprocket wheel 22 connected by the sprocket chain 5 to another sprocket wheel 6 on the cranked axle 7.

A bush wheel and a $1\frac{1}{2}$ " pulley wheel 8 are fixed on the spindle of the governor a slight distance apart, and the head of a bolt in the collar 9 engages between the wheels 8. The collar 9 is connected by a coupling 10 to a rod 11 pivoted in the strips 12. The near end of the rod carries a strip 13, clamped between two cranks, to which is connected a cord 14 passed once round the $1\frac{1}{2}$ " pulley 15 and connected to the spring 16. The cord 14 acts as a brake on the pulley 15, another cord 18 connected to the strip 13 carries a weight 17, and another cord 19, which is wound on the flanges of two reversed flanged and grooved wheels, is loaded with different weights 21 in order to conduct the experiments. The weights 21 correspond to the driving force of the engine, and the governor controls this varying driving force by applying the brake which is the cord 14. Different weights 21 should be hung on the cord 19, and the cord then wound up to the top by the crank axle 7. The time taken for different weights 21 to fall should be noted, and if the apparatus has been properly adjusted the different weights 21 should take nearly the same time to fall to the floor. If heavy weights are hung on, the governor ball weights 4 fly out and raise the discs 8 which swing the strip 13 and apply the brake thus retarding the fall of the weights. The student should tabulate his results, using different weights and noting the variation in seconds taken for the weights to fall. The following are examples:—

Weight.	Time in falling.	Weight.	Time in falling.	Weight.	Time in falling.
75 grammes	12 Secs.	100 grammes	11 Secs.	200 grammes	10 Secs.

MECCANO ACCESSORY OUTFITS AND MOTORS



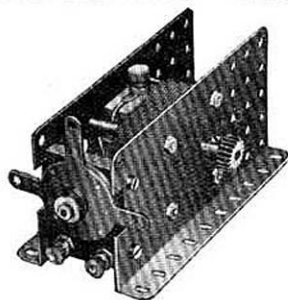
Meccano Accessory Outfits

Our illustration shows one of the Meccano Accessory Outfits. As has already been explained, these Outfits connect the main Outfits from No. 00 to No. 7, making it possible for a boy who commences with one of the earlier Outfits to build up his equipment by easy stages, until he is the possessor of parts that cover the entire system.

Electrical Outfit

All Meccano boys are fascinated by electricity and never become tired of learning more about this wonderful subject. The application of electricity to the Meccano system adds a further and wonderful charm, and the joys of model-building are now increased by the fascinating pastime of carrying out delightful electrical experiments.

The Meccano Electrical Outfit contains a number of specially designed electrical parts which may be used in conjunction with any of the regular Outfits.



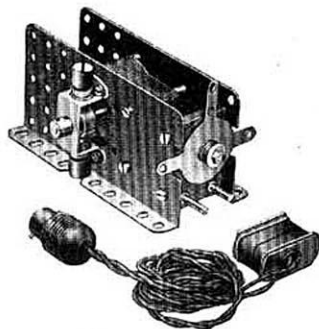
Electric Motor No. 1
(4-Volt)

The 4-volt Motor is specially designed to build into Meccano models. It may be run by a 4-volt Accumulator, or, by employing a suitable transformer, direct from the main. It is fitted with reversing motion, provided with stopping and starting controls, and the gearing is interchangeable.

Electric Motor No. 2
(100-250-Volt AC or DC)

This Electric Motor may be employed for any purpose for which a small motor is suitable, but it is specially adapted for driving Meccano models. The side plates are perforated with standard equidistant holes, thus allowing the motor to be built into any Meccano model. The motor is specially designed for connection with the electric-light main. It is supplied for 100-120-volts or 200-250-volts (alternating or direct), and is fitted with 6 ft. length of flex, an insulated plug for connection with the motor terminals, and an adapter for connection with an ordinary lamp socket.

A suitable resistance is required when the motor is run with a 200-250-volt current, and this is supplied by connecting a 60-watt lamp in series with the motor. A board on which are mounted a suitable lamp-holder (lamp not included) and a switch is provided separately.



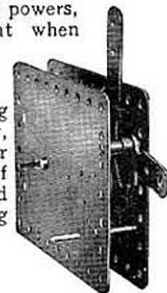
4-Volt Accumulators

These new and excellent types of Accumulators have been adapted to drive the Electric Motor No. 1. They have been subjected to the severest tests and have proved themselves to be the most suitable accumulators for use with any type of electric motor. They are non-spillable, have remarkable recuperative powers, and will continue to supply current when nominally exhausted.



Clockwork Motor

How splendid it is, after spending hours in building a model, to be able to set it in motion with a motor, just as do real engineers! The Meccano Clockwork Motor is specially made for this purpose and is a fine piece of mechanism—simple, powerful, and reliable. It is fitted with starting and stopping levers, and has a reversing movement.



For prices of the above see price list at end of Manual

HORNBY CLOCK WORK TRAINS

205

HORNBY TRAINS are manufactured by Meccano Limited, and they are made from the finest materials obtainable. A most valuable feature of the Locomotives is that all the parts are standardised and any lost or damaged units may be replaced with new ones.

Each Train is a beautiful piece of workmanship with perfect mechanism, ensuring smooth running. A guarantee of efficiency is furnished with each Locomotive.

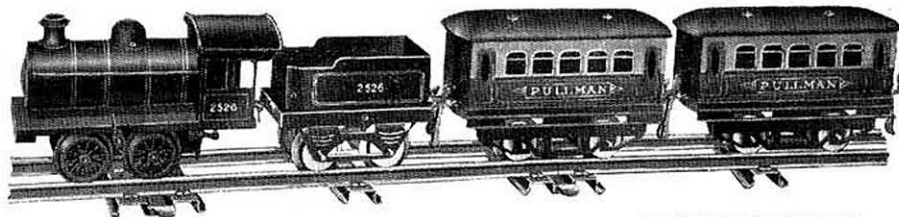
A HORNBY TRAIN LASTS FOR EVER!

Series M, No. 1 Passenger Set

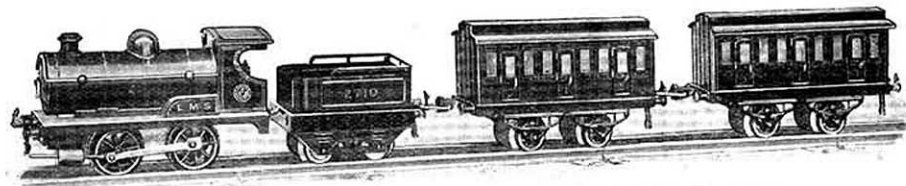
This set contains Locomotive, Tender, two Pullman Coaches and set of Rails. One of the latter is a brake rail by means of which the train may be braked from the track. Richly coloured and well finished; fitted with brake mechanism; non-reversing. Gauge 0.

Series M, No. 2 Passenger Set

Similar in every way to the above excepting that it has three Pullman Coaches instead of two, and additional rails.



M, No. 1 PASSENGER SET



No. 1 PASSENGER SET

No. 2 Pullman Set

This set includes Locomotive and Tender of a larger type, measuring 17 in. in length. The Coaches are beautiful both in colour and finish. Each set includes Locomotive, Tender, and two Pullman Coaches, with set of Rails making a 4 ft. diameter circle. The rails include one brake rail by means of which the train may be both braked and reversed from the track. In colours to represent the principal British Railway Companies' rolling stock. The Locomotive is fitted with reversing gear and brake mechanism. Gauge 0.

No. 2 Goods Set

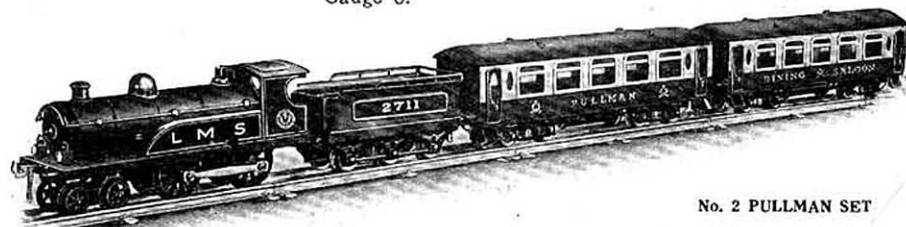
This set contains Locomotive, Tender, and Rails as in No. 2 Pullman Set, and two Wagons. Gauge 0.

No. 1 Passenger Set

Each set contains Locomotive, Tender, and two Coaches, with Rails to form either a circle 2 ft. in diameter or an oval 2 ft. in width by 2 ft. 10 in. in length. One of the curved rails is a brake rail by means of which the train may be braked from the track. The Locomotive is fitted with reversing gear and brake mechanism. In colours to represent the principal British Railway Companies' rolling stock. The doors of the Coaches open. Gauge 0.

No. 1 Goods Set

This set is similar in every way to No. 1 Passenger Set, except that it contains one Wagon in place of Coaches. Gauge 0.

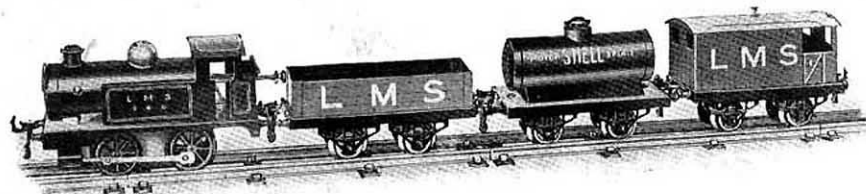


No. 2 PULLMAN SET

For prices of the above see price list at end of Manual.

HORNBY CLOCK WORK TRAINS

The following Hornby Tank Goods and Passenger Sets are very realistic models and are valuable additions to the popular range of Hornby Trains. Each set contains one of the famous Hornby Tank Locos with attractive rolling stock.



No. 1 TANK GOODS SET

No. 1 Tank Goods Set

This set contains a No. 1 Hornby Tank Loco, Hornby Wagon, Petrol Tank Wagon, Brake Van and set of Rails to form either a circle 2 ft. in diameter or an oval 2 ft. in width by 2 ft. 10 in. in length. One of the curved rails is a brake rail by means of which the train may be braked from the track.

Gauge 0, in colours to represent the principal British Railway Companies' rolling stock. The Loco is fitted with reversing gear and brake mechanism.

No. 2 Tank Goods Set

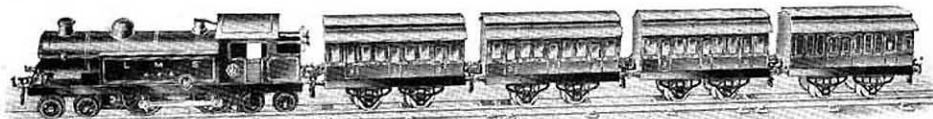
The famous No. 2 Hornby Tank Loco is included in this set. It is 10½ in. in length and is fitted at both ends with a four-wheeled bogie. In addition the set includes a Hornby Wagon, a Petrol Tank Wagon, a No. 1 Cattle Truck and a Brake Van, with a set of Rails to form a circle 4 ft. in diameter. The rails include one brake rail by means of which the train may be both braked and reversed from the track.

Gauge 0, in colours to represent the principal British Railway Companies' rolling stock. The Loco is fitted with reversing gear and brake mechanism.

No. 2 Tank Passenger Set

This set contains a No. 2 Hornby Tank Loco and Rails as in the No. 2 Goods Set, but three Passenger Coaches and one Guard's Van are included in place of the Wagons and Vans.

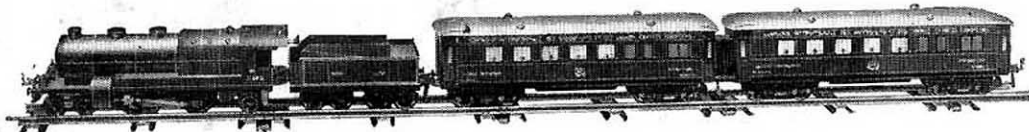
Gauge 0, in colours to represent the principal British Railway Companies' rolling stock.



No. 2 TANK PASSENGER SET

The Riviera "Blue" Train Set

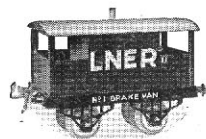
These splendid Train Sets are models of the famous express that runs regularly between Calais and the Mediterranean Coast. The Loco is coloured brown with yellow lining and the Coaches are coloured blue with white roofs. Two types are available, one with Clock-work Loco and the other with Electric Loco.



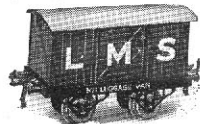
For prices of the above see price list at end of Manual.

ROLLING STOCK AND ACCESSORIES

(HORNBY SERIES)



BRAKE VAN
Finished in grey, with opening doors. Price 6/6



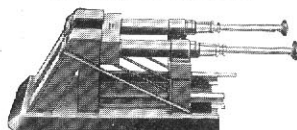
***No. 1 LUGGAGE VAN**
With opening doors. Price 6/6



SECCOTINE WAGON
Beautifully finished in blue, with opening doors. Price 6/6



CRAWFORD'S BISCUIT VAN
Finished in red, with opening doors ... Price 6/6



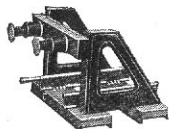
HYDRAULIC BUFFER STOP
Price 10/6



TELEGRAPH POLE
Price 4/6



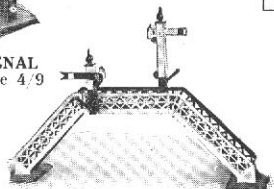
SIGNAL
Price 4/9



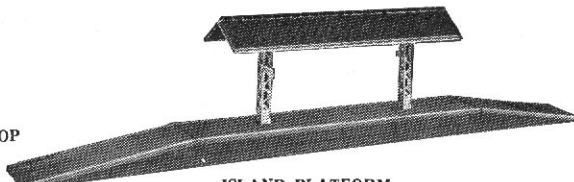
SPRING BUFFER STOP
Price 2/3



DOUBLE LAMP STANDARD
Four-volt bulbs may be fitted into the globes. Price 7/-



FOOTBRIDGE
No. 1. With detachable Signals Price 12/6
No. 2 Without Signals 8/-
Signals only per pair 4/9



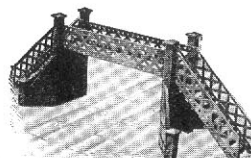
ISLAND PLATFORM
Length 3-1/2-in., height 6-1/2-in., width 3-in. The ramps at either end are detachable, and if desired the platform may be connected to the main station. Attractively coloured in green, blue and white. Price 12/6

THE Hornby system consists of a complete range of Rolling-Stock, Train Accessories, and Rails, Points and Crossings, with which the most elaborate model railway may be constructed. Every component in the Hornby Series is well designed and carefully modelled on its prototype in real life.

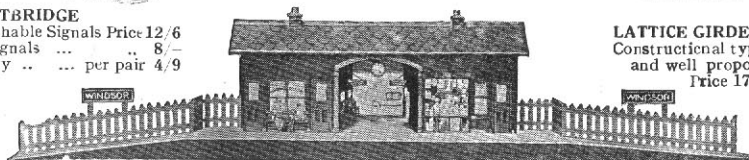
Any boy may gradually build up a complete miniature railway by making use from time to time of the items included in the Hornby Series.



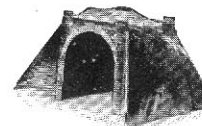
***TROLLEY WAGON**
Finished in grey and red. Suitable for 2-ft. radius rails only ... Price 9/-



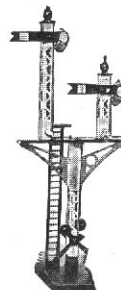
LATTICE GIRDER BRIDGE
Constructional type. Strong and well proportioned. Price 17/6



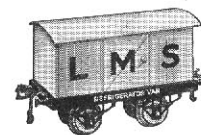
RAILWAY STATION. Excellent model, beautifully designed and finished. Dimensions: Length 2-ft. 9-in., breadth 6-in., height 7-in. Price 22/6



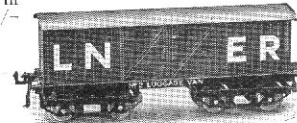
TUNNEL
Realistic and finished in colours ... Price 15/-



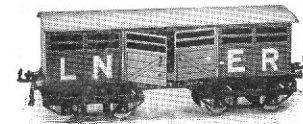
JUNCTION SIGNAL
Signal arms operated by levers at base. Very realistic model standing 14-in. in height. Price 11/6



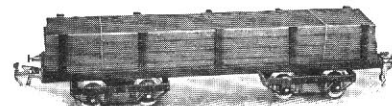
***REFRIGERATOR VAN**
Enamelled in white, with opening doors. Price 6/6



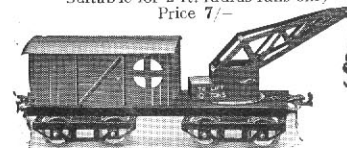
***No. 2 LUGGAGE VAN**
Finished in blue and green. Fitted with double doors. Suitable for 2-ft. radius rails only ... Price 10/6



***No. 2 CATTLE TRUCK**
Splendid model fitted with double doors. Suitable for 2-ft. radius rails only ... Price 10/6



No. 2 TIMBER WAGON
Suitable for 2-ft. radius rails only Price 7/-



***BREAKDOWN VAN AND CRANE**
Beautifully coloured in grey and black, with opening doors. Suitable for 2-ft radius rails only ... Price 11/6

* Lettered L.M.S., L.N.E.R. or G.W.

There are now over 60 items of Rolling Stock and Accessories in the Hornby Series, some of which are illustrated and described above. Send for a complete illustrated price list.

Meccano Price List

MECCANO OUTFITS

No. 00	Meccano Outfit	3/6
" 0	" "	5/-
" 1	" "	8/6
" 2	" "	15/-
" 3	" "	22/6
" 4	" "	40/-
" 5*	" (Carton)	55/-
" 5*	" Presentation Outfit	85/-
" 6*	" Outfit (Carton)	105/-
" 6*	" Presentation Outfit	140/-
" 7	" "	370/-

ACCESSORY OUTFITS

No. 00A	Meccano Outfit	1/6
" 0A	" "	4/-
" 1A	" "	7/6
" 2A	" "	8/6
" 3A	" "	18/6
" 4A	" "	15/-
" 5A*	" (Carton)	50/-
" 5A*	" (Wood)	80/-
" 6A	" "	210/-
	Meccano Clockwork Motor	7/6
	Meccano Electric Motor No. 1 (4-Volt)	15/6
	" " " 2 (100-120 or 200 -250-Volt)	32/6
	Lamp Board (with lamp-holder and switch)	4/6
	Meccano Electrical Outfit X2	42/-
	Meccano Accumulator, 4-Volt 8 amp.	17/6
	" " 4-Volt 20 amp.	25/-

* Outfits Nos. 5, 5A and 6 are supplied in neat and well-made cardboard boxes (cartons) or in superior oak cabinets, with lock and key.

Hornby Train Sets Price List

Series M, No. 1	Passenger Set	7/6
" "	2 Passenger Set	9/-
" "	3 Goods Set	15/-
Hornby No. 0	Goods Set	17/6
" "	0 Passenger Set	24/-
" "	1 Goods Set	21/-
" "	1 Passenger Set	27/6
" "	2 Goods Set	37/6
" "	2 Pullman Set	60/-
* "	2 Pullman Set fitted for Hornby Control	65/-

Hornby No. 1	Tank Goods Set	25/-
" "	2 Tank Goods Set	45/-
" "	2 Tank Passenger Set	45/-
* "	2 Tank Passenger Set fitted for Hornby Control	50/-
	Metropolitan Train Set No. 2 (4-Volt Electric)	95/-
	*Metropolitan Train Set No. 3 (Clockwork)	55/-
	Riviera "Blue" Train Set No. 1 (4-Volt Electric)	85/-
	*Riviera "Blue" Train Set No. 2 (Clockwork)	70/-

*All boys who make a hobby of Hornby Miniature Railway construction will welcome the latest development—the Hornby Control System. This system enables you to manipulate the Signals and Points, and to control the starting and stopping of the train entirely by the levers in the Signal Cabin. A folder is now available entitled "The Hornby Control System" which gives full details and a copy will be sent, post free, on request.

CONTENTS OF OUTFITS

NO.	DESCRIPTION OF PART.	00	000A	0	0A	1	1A	2	2A	3	3A	4	4A	5	5A	6	6A	7
1	Perforated Strips, 12"				4	4	6	10	10	10	2	12	4	16	32	48	2	50
1A	" " 9"																2	10
1B	" " 7"																2	4
2	" " 5 1/2"		4		3	7	7	14	4	18	3	21	5	26	24	50	4	25
2A	" " 4 1/2"																8	75
3	" " 3 1/2"																12	4
3A	" " 3"																24	12
4	" " 2 1/2"																12	24
4A	" " 2"																12	36
5	" " 1 1/2"		9		9	3	12	12	12	6	18	18	18	36	84	20	24	120
5A	" " 1 1/4"																14	14
6	Angle Girders, 24 1/2"																12	12
6A	" " 18 1/2"																6	6
7	" " 12 1/2"																6	26
7A	" " 9 1/2"																6	12
8	" " 7 1/2"																2	6
8A	" " 5 1/2"																2	4
8B	" " 4 1/2"																4	14
9	" " 3 1/2"																2	6
9A	" " 2 1/2"																2	8
9B	" " 2"																2	12
9C	" " 1 1/2"																2	12
9D	" " 1 1/4"																2	12
9E	" " 1 1/8"																2	12
9F	" " 1 1/16"																2	12
10	Flat Brackets		4		5	3	8	8	8	8	8	8	12	4	4	4	4	24
11	Double Brackets																	48
12	Angle Brackets, 3" x 1/4"		6		2	2	2	4	4	4	1	5	3	36	12	48	48	96
12A	" " 1" x 1/8"		2		8	8	2	2	14	8	22	14	36	12	48	48	96	
12B	" " 1" x 1/16"																8	4
13	Axle Rods, 1 1/8"																4	4
13A	" " 8"																2	1
14	" " 6 1/8"																3	13
15	" " 5"																7	13
15A	" " 4 1/2"																9	13
16	" " 3 1/2"																13	13
16A	" " 2 1/2"																13	13
16B	" " 2"																13	13
17	" " 1 1/2"																13	13
17A	" " 1 1/4"																13	13
18	" " 1"																13	13
18A	" " 3/4"																13	13
18B	" " 1/2"																13	13
19	Crank Handles		1		1	1	1	1	1	1	1	2	1	2	2	2	2	2
19A	Wheels, 3"																4	4
19B	Pulley Wheels, 3"																4	4
20	Flanged Wheels																4	4
20A	Pulley Wheels, 2"																4	4
21	" " 1 1/2"																4	4
22	" " 1 1/4"																4	4
23	" " 1 1/8"																4	4
23A	" " 1" (Fast)																4	4
23B	" " 1" (Loose)																4	4
23C	" " 1" (Fast)																4	4
23D	" " 1" (Loose)																4	4
24	Bush Wheels																4	4
24A	Pinion Wheels, 3"																4	4
25	" " 2"																4	4
26	" " 1 1/2"																4	4
27	" " 1 1/4"																4	4
27A	" " 1 1/8"																4	4
27B	" " 1 1/16"																4	4
28	Gear Wheels, 50 Teeth																4	4
29	" " 133 (3 1/2" diam.)																4	4
30	Contrate Wheels, 1 1/2"																4	4
31	Bevel Gears																4	4
32	Gear Wheels, 1", 38 Teeth																4	4
33	Worm Wheels																4	4
34	Spauers																4	4
35	Spring Clips																4	4
36	Screw Drivers																4	4
37	Nuts and Bolts, 7/32"																4	4
37A	" " 1/8"																4	4
37B	" " 3/16"																4	4
38	Washers																4	4
39	Hanks of Cord																4	4
40	Propeller Blades																4	4
41	Spring Scales																4	4
42	Cranked Bolt Strips																4	4
43	Double Bolt Strips																4	4
44	Double Angle Strips, 2 1/2" x 1 1/2"																4	4
45	" " 2" x 1 1/2"																4	4
46	" " 1 1/2" x 1 1/2"																4	4
47	" " 1 1/4" x 1 1/2"																4	4
47A	" " 1 1/8" x 1 1/2"																4	4
48	" " 3/4" x 1 1/2"																4	4
48A	" " 1/2" x 1 1/2"																4	4
48B	" " 3/8" x 1 1/2"																4	4
48C	" " 1/4" x 1 1/2"																4	4
48D	" " 3/16" x 1 1/2"																4	4
50	Flat Plates, Perforated Flanged Plates, 5 1/2" x 2 1/2"																4	4
51	" " 5 1/4" x 3 1/4"																4	4
52	Perforated Flanged Plates, 3 1/2" x 2 1/2"																4	4
53	Flat Plates, 4 1/2" x 2 1/2"																4	4
53A	Perforated Flanged Plates (Sector)																4	4
54	Instruction Manuals																4	4
55	Mechanic Standard Mechanisms Manual																4	4
57	Hooks (Scientific)																4	4
57A	" (Loaded)																4	4
57B	Spring Cord, 40" length																4	4
58	Collars with Set Screws																4	4
59	Windmill Sails																4	4
61	Cranks																4	4
62	Threaded Cranks																4	4
62A	Couplings																4	4
63	Octagonal Couplings																4	4
63A	Strip Couplings																4	4
63B	Threaded Bosses																4	4
64	Centre Forks																4	4

[CONTINUED OVERLEAF

INDEX TO MODELS

Description.	Model No.
A Gay Start	718
Acrobat	247
Aerocar	610
Acroplane	63
Aeroplane, Revolving ...	639
(see also Monoplanes)	
Aeroplage, Seashore ...	239
Aeroscope	710
Anchor	49
Applied Mechanics, Experiments in	736 and 737
Armoured Motor Tricycle	542
Automatic Weighing Machine	607
Automobiles - see under Motors	
Baby Chair	229
Bagatelle Table	618
Bale Lifter	443
Bale Press	430
Barrow, Coster	13 and 523
Battleship	50
Beam Engine	609
Beaming Frame	716
Bed Tables	103 and 420
Belgian Water Wheel ...	502
Bellows	132
Bellows, Forge	134
Big Wheel	606
Boat Lowering Gear	717
Boat, Rowing	131
" Sailing	58
(see also Submarine and Battleship)	
Bogie	5
Boring Machine	324
Box Ball Alley	616
Breast Drill	409
Brewer's Dray	534
Bridges: Cantilever Bridge	646
Drawbridge	642
Forth Bridge	722
High-Level Bridge ...	222
Jack-Knife Bridge ...	619
Railway Footbridge	and Signals
and Signals	253
St. Malo Transporter Bridge	626
Swing Bridge	445
Transporter Bridge ...	713
Buffers	30
Butter Churn	433

Description.	Model No.
Cable Railway	405
Cake Walk	434
Candy Puller	226
Carrier Tricycle	227
Cart	524
" Bullock	525
" Luggage	3
" Manure-Distributing	514
" Station	518
" Tandem	101
Catapult	435
Centrifugal Governor ...	737
Chair, for Wounded Soldier	250
" Baby	229
" Deck	118
" Ducking	537
" Go-	16
" Invalid's	53, 123 and 538
" Rocking	512
Chinese Palanquin	325
Clay-Modelling Machine	418
Clothes-Horse	62
Coal Cutting Machine ...	703
Coaler, High-speed Ship	729
Coaster	311
Coffee Grinder	311
Conductor's Punch	438
Cot on Wheels	212
Crane, Automatic Weighing	627
" Double Action	123
" Elevated Jib	401
" Gantry	425
" Girder	407
" Hydraulic	724
" Jib	33, 121, 128 and 133
" Overhead	118
" Portable	603
" Radial Travelling	630
" Railway Breakdown	316
" Railway Wagon	Swivelling
" Swivelling	308
" Revolving	723
" Rotating	54 and 301
" Shipyard	625
" Swivelling	36, 40 and 104
" " and	
" Luffing Jib	415
" Swivelling Jib	113
" Travelling	17 and 526
" " Gantry	515 and 727
" " Jib	105 and 218

Description.	Model No.
Crane, Travelling Swivel	441
(see also Derricks)	
Croix de Guerre	436
Crossbow	309
Cutlery Rest	47
Cutting Machine	251
Deck Chair	120
Delivery Van	531
Derrick, Dwarf	242
" Stiff Leg	709
Derricking Grab	608
Devil Wall	55
Dinner Wagon	111
Diplodocus	403
Distance Indicators ...	416 and 541
Drafting Machine	329
Dredger	702
Drill, Breast	409
" Rock	16
" Vertical	509
Drilling Machines	28 and 319
Drop Hammer	640
Drop Hammer, Double	214
Drop Stamp	124
Drop the Nigger	314
Easel	244
Eiffel Tower	714
Elevator	219
Elliptic Lathe	428
Embossing Machine	240
End of a Perfect Day, The	109
Endless Rope Railway ...	631
Engine, Horizontal	307
" Steam, Oscillating	614
" " Vertical	644
Equatorial Mounting ...	644
Farm Tractor	506
Field Roller	424
Fire Alarm	130
Fire Escape	336
Fire Watertower	532
Flax Cleaner	332
Fly Boats	638
Flying Machine	422
Frct Saw	510
Funicular Railway	728
Furrow Roller	37

Description.	Model No.
Gangway	22 and 209
" Ferry	246
" Turntable	204
Geometrical Apparatus	410
Giant Foundry Ladle ...	117
Go-Chair	15
Gondola	255
Gong	45
Gong, Automatic	413
" Dinner	241
Grab, Derricking	608
Gun, Anti-aircraft	232 and 453
" Field	623
" Field, and carriage	516
" Machine	612
" Naval Quick-Firing	450
" Quick-Firing	39
Hammer, Drop	640
" " Double	214
" Mechanical	48 and 243
" Treadle	421
" Trip	451
Hand Car	503
" Trolley	338
Harmonograph, Twin Elliptic	730
Hatchet	116
Hay Tedder	228
Hellograph	634
High Speed Ship Coaler	729
Hoisting Block	26
Horizontal Engine	631
Hot-Saw, Swinging	404
Ice Boat	333
Inclined Delivery Chute	447
Invalid Chair	57, 132 and 538
Jack	620
Jaunting Car	611
Joy Wheel	206 and 615
Jumping Jack	248
Kinetograph	310
Knife	721
Knife Grinder	629
Lace Jennie	331
Ladder, Extending, on	Running Carriage
" Running Carriage ...	245
Ladder on Wheels	210
Ladder, Step	507
Ladder, Travelling	106

Important

In future Meccano accessory parts will be supplied in colours unless customers ask specially for nickel-plated parts. The directions at the foot of pages 3 and 4 are not now applicable.

Revised Prices

The prices of most of the Hornby Trains, Rolling Stock and Accessories, featured at the end of this Manual, have been revised as indicated below.

Hornby M 3 Goods Set	23/6
" No. 0 Passenger Set	36/6
" No. 2 Goods Set	52/6
" No. 2 Pullman Set	85/-
" No. 2 Pullman Set	...	fitted for Hornby Control	...	92/6
" No. 1 Tank Goods Set	39/-
" No. 2 Tank Goods Set	62/6
" No. 2 Tank Passenger Set	65/-
" No. 2 Tank Passenger Set	...	fitted for Hornby Control	...	72/6
Brake Van	...	5/6	Crawfords Biscuit Van	6/-
No. 1 Luggage Van	...	6/-	Refrigerator Van	6/-
Breakdown Van and Crane	10/6	Seccotine Van	...	6/-
No. 2 Timber Wagon	...	5/6	Telegraph Poles Per Pair	6/6
No. 2 Cattle Truck	...	9/6	Spring Buffer Stops	1/9
No. 2 Luggage Van	...	9/6	Hydraulic Buffer Stops	8/6
Lattice Girder Bridge	16/6	Footbridge No. 1	...	12/-
Signals for Footbridge per pair	4/6	Junction Signal	...	10/6

MECCANO LIMITED BINNS ROAD LIVERPOOL

MECCANO

Hornby's Original System, First Patented 1901

PATENTS AND DESIGNS

GREAT BRITAIN :

AUSTRALIA :

3,869/14	139,125	671,485	682,934	13,460/19
4,183/14	177,430	671,534	683,011	14,388/14
4,564/15	577,207	671,790	686,112	15,136/14
20,535/13	577,272	680,416	698,054	
21,117/12	648,958	682,208	699,653	
22,962/13	671,484	682,209	699,654	
7,732/25			718,731	
7,733/25			718,404	

Meccano is more than a Toy

IT is important to remember that when a boy is playing with MECCANO he is using engineering parts in miniature, and that these parts act in precisely the same way as do the corresponding engineering elements in actual practice. No other system of model construction can be correct, and other toys which attempt the same object by other methods must avail themselves of constructive elements which are not correct engineering elements. Consequently, though a boy may succeed in building playthings with them, they are merely toys and nothing else, and his mind, as regards proper mechanical construction and methods, is distorted instead of instructed. He thus learns wrong principles, and when his ambition tempts him to invent or construct more elaborate models, he will find that he cannot do so because of the deficiencies of his non-mechanical system.

No Outfit is genuine unless it bears the Trade Mark MECCANO