

MECCANO

(TRADE MARKS 296321, 12633, 10274, 55/13476, 884/25, 2913)

INSTRUCTIONS

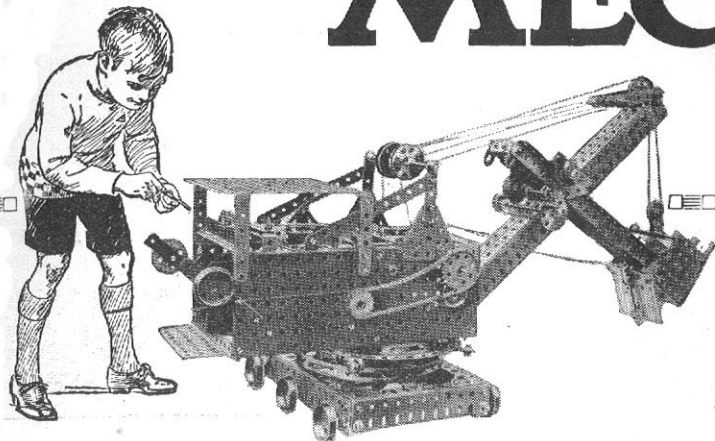
FOR OUTFITS Nos. 4 to 7

2/3

Copyright by MECCANO LIMITED, LIVERPOOL, throughout the world

MECCANO

THE TOY THAT MADE ENGINEERING FAMOUS



The Meccano system consists of accurately made and highly finished engineering parts with which almost every mechanical movement known may be reproduced in model form. More can be accomplished with Meccano than with any other constructional toy, for no other system has such possibilities. The genius is in the parts and the youngest boy can commence to build models as soon as he gets his Outfit home. A screwdriver, provided in the Outfit, is the only tool necessary.

When you have built all the models shown in this book you will want to build others of a more advanced type, and you cannot do better than purchase a copy of the No. 4-7 Manual from your dealer. This Manual contains illustrations of a fine

selection of models, a large number of which you will be able to build by adding a few extra parts to your equipment.

There is practically no limit to the number of models that can be built with Meccano. The most wonderful feature about the system is that it is *real engineering*; it is fascinating and delightful and it gives you a satisfaction beyond anything that you have ever previously experienced.

IF IN DOUBT WRITE TO MECCANO LIMITED

The service of Meccano does not end with selling an Outfit and an Instruction Manual. When you want to know something more about engineering than is now shown in our books, or when you strike a rough problem of any kind, write to us. We receive over 200 letters from boys every day all the year round. Some write to us because they are in difficulty, others because they want advice on their work or pleasures, or about their choice of a career. Others, again, write to us just because they like to do so and we are glad to know that they regard us as their friends.

Although all kinds of queries are put to us on all manner of subjects, the main interest is, of course, engineering. No one has such a wonderful knowledge of engineering matters as that possessed by our staff of experts. This vast store of knowledge, gained only by many years of hard-earned experience, is at your service. *We want the Meccano boy of to-day to be the famous engineer of to-morrow.*

HOW TO BUILD WITH MECCANO

Make the simple models first—there is loads of fun in them—and then try to improve them. Every model can be made in a dozen different ways. It is important to screw up all the nuts and bolts tightly to ensure that your models will be strong and firm when they are completed. When you want to add more parts to your Outfit so that you can build bigger models, you can always get them from your dealer.

Each Outfit may be converted into the one next higher by the purchase of an Accessory Outfit. Thus, a No. 2 may be converted into a No. 3 by adding to it a No. 2A. A No. 3A would then convert it into a No. 4 and so on. In this way, no matter with which Outfit you commence you may by degrees build it up until you have the largest Outfit.

All models shown in this Manual are numbered and for reference purposes each model number is preceded by the number of the Outfit with which it may be built. Thus, for example, model No. 00.60 may be built with No. 00 Outfit, and model No. 2.20 with No. 2 Outfit.



THE "MECCANO MAGAZINE"

The *Meccano Magazine* is the Meccano boy's newspaper. It tells him of the latest Meccano models; what Meccano Clubs are doing how to correspond with other Meccano boys; the Competitions that are running, etc. It contains interesting articles on engineering and electrical subjects, and deals with many other topics of interest to boys, including suggestions from Meccano boys for new Meccano parts and correspondence columns in which the Editor replies to his readers' enquiries. Write to the Editor, *Meccano Magazine*, Binns Road, Liverpool, giving the names and addresses of three of your chums who are not Meccano boys and enclosing 1/- in stamps. He will then forward a specimen copy of the "M.M." post free. It is sent regularly to subscribers at the rate of 7/- for six issues, post free, or it may be ordered from any Meccano dealer, newsagent or bookstall, price 1/- per copy.



MECCANO STANDARD MECHANISMS

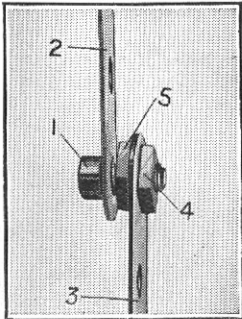
There are a number of Meccano movements that have to a certain extent become standardised, that is to say they may be applied to more than one model, in most cases without any alteration, but in some few instances with only slight alterations to the original movement. These have been collected and classified, and may be obtained in the form of a Manual entitled "Meccano Standard Mechanisms." It will be observed that many of these Standard Mechanisms are referred to in the instructions for building the more intricate models in this book.

You may obtain a copy of the "Standard Mechanisms" Manual from your dealer, price 1/6, or direct from Meccano Ltd., Binns Road, Liverpool, price 1/7½ post free.



IMPROVED MECCANO PARTS

A number of models included in this Manual show the new style 5½" x 2½" Flanged Plate (with flanges at the ends as well as the sides) and improved Sector Plate (with two additional rows of holes), but it should be noted that, although the new parts are more adaptable, the old-style plates may still be used in their place if desired. When it is required to journal an Axle Rod in a slot in the new Flanged Plates, an ordinary Strip should first be bolted to the Plate so that one of its holes forms an additional bearing for the Rod.



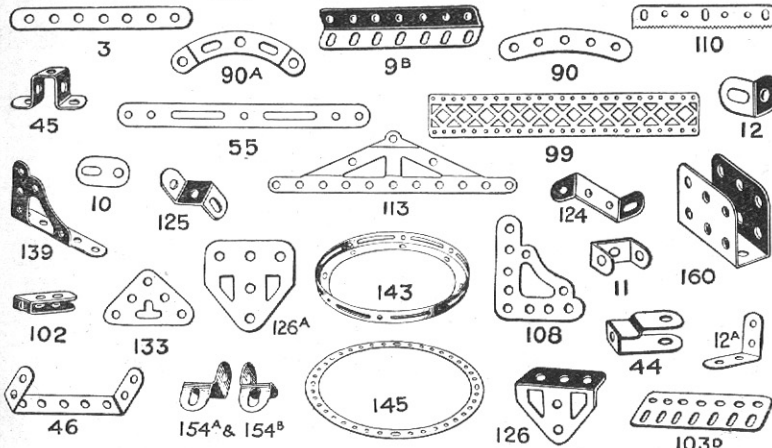
Standard Mechanisms
No. 262

SIMPLE MECCANO PIVOTS

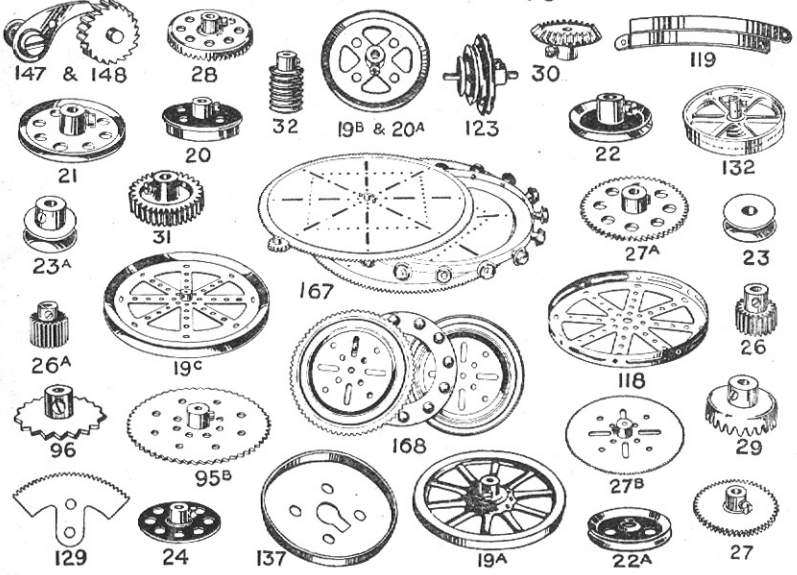
In building Meccano models it is frequently required to attach two parts together so that one or both are quite free to swivel. A very simple way to do this is shown under detail number 262 in the Meccano Standard Mechanisms Manual, and for the benefit of those readers who are unable to consult the special Manual, we have reproduced this detail. As will be seen, it consists of a simple type of pivot or swivel bearing formed by a bolt and two nuts. The bolt is secured rigidly to a Strip or Plate, etc., by means of the nuts, which are secured tightly against opposite sides of the Strip, sufficient space being left beneath the head of the bolt to permit another Strip to turn freely about its shank.

A somewhat similar form of swivel-joint, also widely used, consists of a bolt and lock-nuts (Standard Mechanisms No. 263). The two Strips to be connected pivotally are placed on the bolt and held in position by two nuts locked together on the shank. The Strips must be allowed a certain amount of play so that they can pivot independently about the bolt. These pivoting devices will be found equally valuable in the simplest and the most elaborate models.

STRIPS, GIRDERS AND BRACKETS



WHEELS, GEARS ETC



Particulars and Prices of Meccano Parts

No.	Perforated Strips	s.	d.	No.	s.	d.
1.	12 1/2"	1	6	3.	3 1/2"	0 6
1a.	9 1/2"	1	3	4.	3"	0 5
1b.	7 1/2"	1	0	5.	2 1/2"	0 5
2.	5 1/2"	0	9	6.	2"	0 5
2a.	4 1/2"	0	8	6a.	1 1/2"	0 5
Angle Girders						
7.	24 1/2"	each	1 0	9a.	4 1/2"	1 3
7a.	18 1/2"	0	9	9b.	3 1/2"	1 0
8.	12 1/2"	1/2 doz.	2 9	9c.	3"	1 0
8a.	9 1/2"	2	0	9d.	2 1/2"	1 0
8b.	7 1/2"	1	9	9e.	2"	0 9
9.	5 1/2"	1	6	9f.	1 1/2"	0 9
*10.	Flat Brackets	0 3
*11.	Double Brackets	2 for	0 3
*12.	Angle Brackets, 1 1/2" x 1 1/2"	doz.	0 4
*12a.	" " 1" x 1"	1/2 doz.	0 6
*12b.	" " 1" x 1 1/2"	0 4	
Axle Rods						
13.	11 1/2"	each	0 3	16a.	2 1/2"	0 1
13a.	8"	0	3	16b.	3"	0 1
14.	6 1/2"	0	2	17.	2"	3 for 0 2
15.	5"	0	2	18a.	1 1/2"	0 2
15a.	4 1/2"	0	1	18b.	1"	0 2
16.	3 1/2"	0	1
19.	Crank Handles, Large	0 3
19a.	" " Small	0 3
19b.	Wheels, 3" diam., with set screws	0 9
20.	Flanged Wheels, 1 1/2" diam.	0 8
20b.	" " "	0 6
Pulley Wheels						
19b.	3" dia. with centre boss and set screw	1 0
19c.	6"	3 0
20a.	2"	0 8
21.	1 1/2"	0 6
22.	1"	0 5
23a.	1/2"	0 5
22a.	1" without	0 3
23.	1/2"	0 3
24.	Bush Wheels	0 6
25.	Pinion Wheels, 3/8" diam.	0 9
25a.	" " double width	1 0
26.	" " face	0 6
26a.	" " double width	0 9
Gear Wheels						
27.	50 teeth to gear with 1/2" pinion	0 9
27a.	57 " "	0 9
27b.	133 " "	1 10
28.	Contrate Wheels, 1 1/2" diam.	1 3
29.	" " "	0 9
30.	Bevel Gears, 1/2", 26 teeth	1 2
30a.	" " 1/2", 16 "	0 9
30b.	" " 1 1/2", 48 "	2 3
30c.	Gear Wheels, 1", 38 teeth	1 6
32.	Worm Wheels	0 8
34.	Spanners	0 3
34b.	Box Spanners	0 6
35.	Spring Clips	per box (doz.)	0 5
36.	Screw Drivers	0 5
36a.	Screwdrivers, Extra Long	each	0 9
36b.	Screwdriver, special	1 6
37.	Nuts and Bolts, 7/32"	per box (doz.)	0 9
37a.	Nuts	0 5
37b.	Bolts, 7/32"	0 5
*38.	Washers	0 2
40.	Hanks of Cord	each	0 2
41.	Propeller Blades	per pair	0 6
43.	Springs	each	0 3
*44.	Cranked Bent Strips	0 2
45.	Double	0 2
46.	Double Angle Strips, 2 1/2" x 1"	1/2 doz.	0 9
47.	" " 2 1/2" x 1 1/2"	1 3
47a.	" " 3" x 1 1/2"	1 3
48.	" " 1 1/2" x 1 1/2"	0 6
48a.	" " 1" x 1 1/2"	0 8
48b.	" " 3 1/2" x 2 1/2"	0 9
48c.	" " 4 1/2" x 2 1/2"	1 3
48d.	" " 5 1/2" x 2 1/2"	1 3
50a.	Eye Pieces, with boss	each	0 6
52.	Perforated Flanged Plates, 5 1/2" x 2 1/2"	0 8
52a.	Flat Plates, 5 1/2" x 3 1/2"	0 8
53.	Perforated Flanged Plates, 3 1/2" x 2 1/2"	0 5
53a.	Flat Plates, 4 1/2" x 2 1/2"	0 5
54.	Perforated Flanged Sector Plates	0 5
55.	Perforated Strips, slotted, 5 1/2" long	0 3
55a.	" " 2"	0 2
56.	Instruction Manuals, No. 4-7	2 3
56a.	" " No. 00-3	2 3
56b.	" " No. 0	0 6
56c.	Meccano Standard Mechanisms Manual	1 6
57.	Hooks	0 1
57a.	" Scientific	0 2
57b.	" Loaded	0 5
58.	Spring Cord	per length	1 3
59.	Collars with Set Screws	2 for	0 5
61.	Windmill Sails	4 for	0 9
62.	Cranks	each	0 5
62a.	Threaded Cranks	0 6
62b.	Double Arm Cranks	0 5
63.	Couplings	0 9
63a.	Octagonal Couplings	1 0
63b.	Strip Couplings	1 0
63c.	Threaded Couplings	0 9
64.	Threaded Bosses	0 3
65.	Centre Forks	0 2
66.	Weights, 50 grammes	1 6
67.	" 25	1 6
68.	Woodscrews, 1/2"	doz.	0 5
69.	Set Screws	0 5
69a.	Grub Screws, 5/32"	0 6
69b.	" 7/32"	0 8
70.	Flat Plates, 5 1/2" x 2 1/2"	each	0 6
72.	" 2 1/2" x 2 1/2"	0 3
76.	Triangular Plates, 2 1/2"	0 3
77.	" 1"	0 2
Screwed Rods						
78.	1 1/2"	each	0 9	80a.	3/8"	each 0 5
79.	8"	0	8	80b.	1/4"	0 5
79a.	6"	0	6	81.	2"	0 3
80.	5"	0	5	82.	1"	0 2

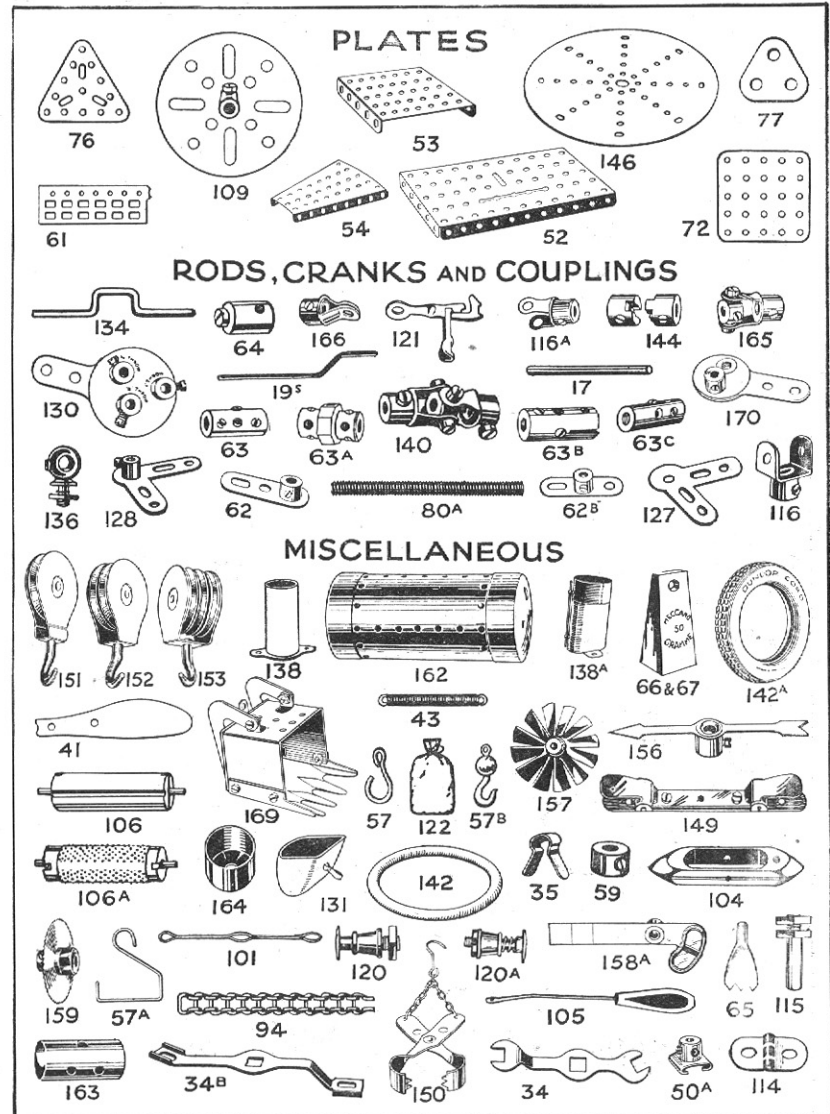
Meccano Accessory Parts will be supplied in colours unless nickelled parts are specially ordered.

*IMPORTANT—These parts are available with nickel finish only.

Particulars and Prices of Meccano Parts (continued)

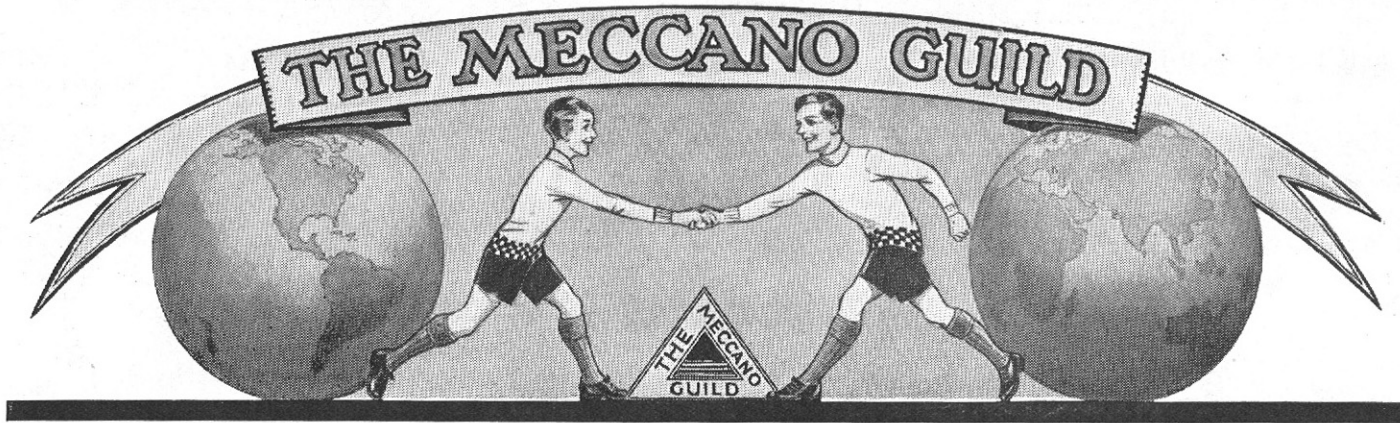
No.	Description	Quantity	s.	d.
89.	5 1/2" Curved Strips, 10" radius	each	0	3
89a.	3" Curved Strips, cranked, 1 1/2" radius, 4 to circle	"	0	3
90.	2 1/2" " " 2 1/2" radius	"	0	2
90a.	2 1/2" " " cranked, 1 1/2" radius, 4 to circle	"	0	2
94.	Sprocket Chain	per 40" length	0	9
*95.	Sprocket Wheels, 2" diam.	each	0	8
*95a.	" " 1 1/2" " "	"	0	6
*95b.	" " 3" " "	"	0	9
*96.	" " 1" " "	"	0	5
*96a.	" " 1/2" " "	"	0	5
97.	Braced Girders, 3 1/2" long	1/2 doz.	1	3
97a.	" " 3" " "	"	1	0
98.	" " 2 1/2" " "	"	1	0
99.	" " 12 1/2" " "	"	3	9
99a.	" " 9 1/2" " "	"	3	0
99b.	" " 7 1/2" " "	"	3	0
100.	" " 5 1/2" " "	"	1	6
100a.	" " 4 1/2" " "	"	1	3
101.	Healds, for looms	doz.	1	3
102.	Single Bent Strips	each	0	2
103.	Flat Girders, 5 1/2" long	1/2 doz.	1	3
103a.	" " 9 1/2" " "	"	1	9
103b.	" " 12 1/2" " "	"	2	0
103c.	" " 14 1/2" " "	"	1	3
103d.	" " 3 1/2" " "	"	1	0
103e.	" " 3" " "	"	0	9
103f.	" " 2 1/2" " "	"	0	8
103g.	" " 2" " "	"	0	6
103h.	" " 1 1/2" " "	"	0	6
103k.	" " 7/8" " "	"	1	6
*104.	Shuttles, for looms	each	1	3
105.	Reed Hooks, for looms	"	0	6
106.	Wood Rollers	"	2	3
106a.	Sand Rollers	"	2	9
107.	Tables for Designing Machines	"	2	3
108.	Architraves	"	0	3
109.	Face Plates, 2 1/2" diam.	"	0	6
110.	Rack Strips, 3 1/2" " "	"	0	3
111.	Bolts, 1/2" " "	"	0	1
111a.	" " " " 3 for 0	"	2	2
111c.	" " " " doz.	"	0	5
*113.	Girder Frames	each	0	5
*114.	Hinges	per pair	0	6
115.	Threaded Pins	each	0	3
*116.	Fork Pieces, Large	"	0	5
116a.	" " Small	"	0	9
117.	Steel Balls, 3/8" diam.	doz.	0	5
118.	Hub Discs, 5/8" " "	each	1	9
119.	Channel Segments (8 to circle, 1 1/2" diam.)	"	0	6
120.	Buffers	"	0	3
120a.	Spring Buffers	per pair	1	0
120b.	Compression Springs	each	0	2
121.	Train Couplings	"	0	3
122.	Minure Loaded Sacks	"	0	3
*123.	Cone Pulleys	"	2	0
*124.	Reversed Angle Brackets, 1" " "	1/2 doz.	0	6
125.	Trunnions	"	0	5
126.	" " " " " "	each	0	3

No.	Description	Quantity	s.	d.
126a.	Flat Trunnions	each	0	2
127.	Simple Bell Cranks	"	0	2
128.	Boss Bell Cranks	"	0	5
*129.	Rack Segments, 3" diam.	"	0	8
*130.	Triple Throw Eccentrics	"	1	6
131.	Dredger Buckets	1/2 doz.	1	6
132.	Flywheels, 2 1/2" diam.	each	3	0
133.	Corner Brackets	"	0	2
*134.	Crank Shafts, 1" stroke	"	0	3
135.	Theodolite Protractors	"	0	3
136.	Handrail Supports	"	0	5
137.	Wheel Flanges	"	0	5
138.	Ship's Funnels	"	0	5
138a.	" Cunard type	"	1	3
139.	Flanged Brackets (right)	"	0	3
139a.	" (left)	"	0	3
140.	Universal Couplings	"	1	3
141.	Wire Lines (for suspending clock weights)	"	1	0
142.	Rubber Rings, 3" rim	"	0	5
142a.	Dunlop Tyre to fit 2" diam. rim	"	0	6
142b.	" " 3" " "	"	0	9
143.	Circular Girders, 5 1/2" diam.	"	1	6
144.	Dog Clutches	"	0	9
145.	Circular Strips, 7" diam. over all	"	1	3
146.	" Plates, 6" " "	"	1	6
*147.	Pawls, with pivot bolt and nuts	"	0	3
*147a.	Pawls do. " "	"	0	3
*147b.	Pivot Bolt with 2 nuts	"	0	3
148.	Ratchet Wheels	"	0	9
149.	Collecting Shoes, for Electric Locos	"	2	3
150.	Crane Grabs	"	1	0
151.	Pulley Blocks, Single Sheave	"	1	0
152.	" " Two	"	1	3
153.	" " Three	"	1	6
*154a.	Corner Angle Brackets, 1/2", right hand	1/2 doz.	0	9
*154b.	Corner Angle Brackets, 1/2", left hand	"	0	9
155.	Rubber Rings, 1/2" " "	each	0	2
*156.	Pointers, 2 1/2" over all, with boss	"	0	6
157.	Fans, 2" diam.	"	0	6
158a.	Signal Arms, Home	"	0	8
158b.	" Distant	"	0	8
*159.	Circular Saws	"	1	6
160.	Channel Bearings, 1 1/2" x 1" x 1/2"	"	0	3
162.	Boiler, complete with ends	"	1	6
162a.	Boiler ends	"	0	5
163.	Sleeve Pieces	pair	0	9
164.	Chimney Adaptors	each	0	3
165.	Swivel Bearings	"	0	9
166.	End	"	0	5
167.	Geared Roller Bearings	"	30	0
167a.	Roller Races, geared, 192 teeth	"	6	9
167b.	Ring Frames for Rollers	"	4	6
167c.	Pinions for Roller Bearings, 16 teeth	"	1	6
168.	Ball Bearings, 4" diam.	"	4	6
168a.	Ball Races, flanged	"	0	9
168b.	" " geared	"	1	3
168c.	Ball Casings, complete with balls	"	2	9
169.	Digger Buckets	"	3	0
*170.	Eccentrics, 1/2" throw	"	1	3



Meccano Accessory Parts will be supplied in colours unless nickelled parts are specially ordered.

*IMPORTANT.—These parts are available with nickel finish only.



WHAT THE GUILD MEANS

THE Meccano Guild is an organisation for boys, started at the request of boys, and conducted as far as possible by boys. In joining the Guild a Meccano boy becomes a member of a great brotherhood of world-wide extent, every member of which has promised to observe its three great objects:—

- (1) *To make every boy's life brighter and happier.*
- (2) *To foster clean-mindedness, truthfulness, ambition, and initiative in boys.*
- (3) *To encourage boys in the pursuit of their studies and hobbies, and especially in the development of their knowledge of mechanical and engineering principles.*

HOW TO BECOME A MEMBER

MEMBERSHIP of the Guild is open to every boy possessing a Meccano Outfit, or Hornby Train Set, who satisfactorily fills in the prescribed application form.

The only conditions are that members promise to observe the objects of the Guild and to wear their badges on all possible occasions.

The price of the Guild membership badge is 7d. post free in the United Kingdom, but members abroad will be required to pay 5d. extra for registered postage. A remittance for the necessary amount should be sent along with the form of application. The Guild badge is beautifully enamelled in blue and white and is made for wearing in the lapel of the coat.

MECCANO CLUBS

MECCANO CLUBS are founded and established under the guidance of the Guild Secretary at Headquarters and at the present time there are active Clubs in over one hundred towns and villages in the United Kingdom and in many countries Overseas. Each Club has its Leader, Secretary, Treasurer, and other officials all of whom, with the exception of the Leader, are boys. Write for information how to form a club, if there is no club near you.

Special awards are given to Club members for good work in connection with their Club and medallions are awarded in connection with the Recruiting Campaign, full particulars of which will be sent on request.



BADGE OF
MEMBERSHIP



GUILD
LEADER'S
BADGE



MECCANO GUILD
MEMBER'S CERTIFICATE

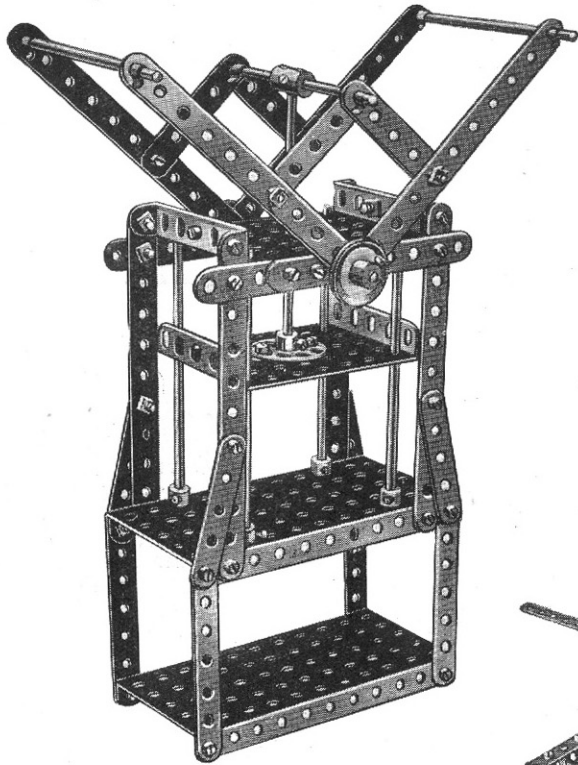


RECRUITING MEDALLION



SPECIAL MERIT MEDALLION

Model No. 4.1 Bale Press



Parts required :

10 of No. 2	1 of No. 24	2 of No. 52
4 " " 3	8 " " 35	2 " " 53
8 " " 5	44 " " 37	4 " " 59
4 " " 15	14 " " 37A	1 " " 63
1 " " 15A	2 " " 38	2 " " 111
2 " " 17	2 " " 48A	

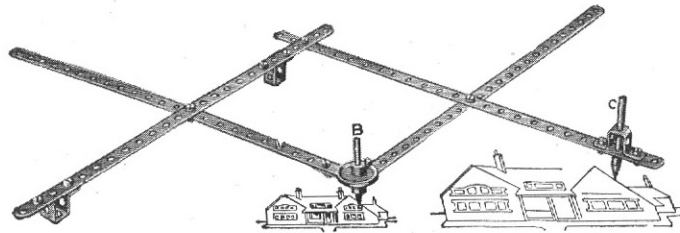
Model No. 4.2 Pantograph

Most boys have heard of the Pantograph but not many have had an opportunity of seeing its principles demonstrated. It is an instrument for copying plans, etc., on the same or on a reduced or enlarged scale.

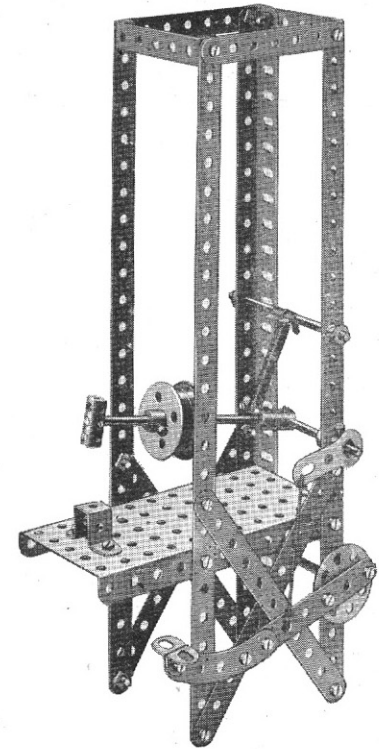
The apparatus is fixed at the point A. If an enlarged sketch is to be made, the point B is traced round the outlines, the writing point C reproducing the sketch on a larger scale. When a reduced drawing is to be made, the point C traces the outline, whilst the point B reproduces the sketch on a smaller scale. The degree of enlargement or reduction varies according to the position in which point C is fixed on the perforated arm.

Parts required :

4 of No. 1	10 of No. 37
2 " " 17	3 " " 45
1 " " 22	2 " " 62



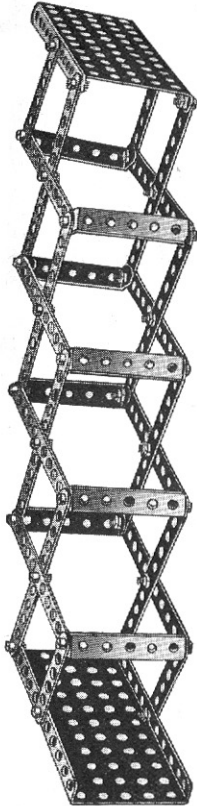
Model No. 4.3 Treadle Hammer



Parts required :

2 of No. 1	3 of No. 16	1 of No. 45
4 " " 2	2 " " 20	1 " " 48A
3 " " 3	1 " " 24	1 " " 52
1 " " 5	2 " " 35	5 " " 59
2 " " 8	23 " " 37	1 " " 62
2 " " 12	2 " " 38	2 " " 63
1 " " 15A	1 " " 43	1 " " 90

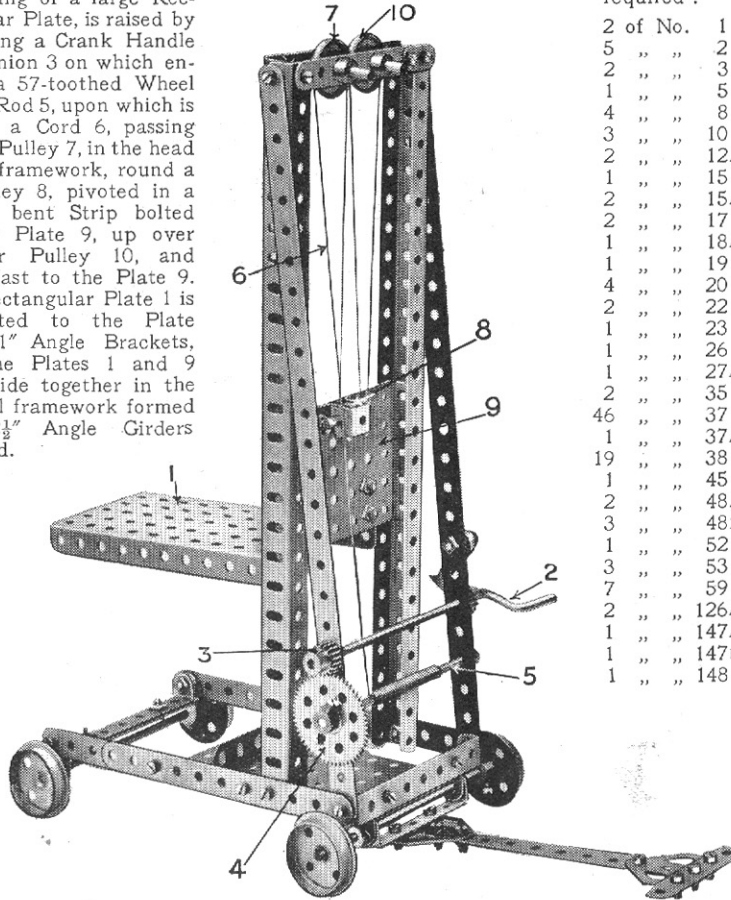
Model No. 4.4 Periscope



Parts required :		Small pieces of
16 of No.	2	looking glass should
4 " "	4	be inserted in the
32 " "	37	top and bottom
8 " "	48A	plates.
2 " "	52	

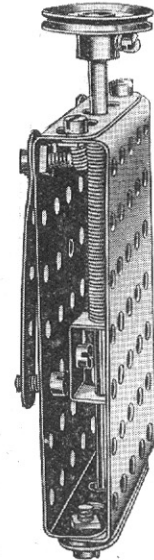
Model No. 4.5 Bale-lifter

The bale platform 1, consisting of a large Rectangular Plate, is raised by operating a Crank Handle 2, a Pinion 3 on which engages a 57-toothed Wheel 4 on a Rod 5, upon which is wound a Cord 6, passing over a Pulley 7, in the head of the framework, round a $\frac{1}{2}$ " Pulley 8, pivoted in a double bent Strip bolted to the Plate 9, up over another Pulley 10, and made fast to the Plate 9. The Rectangular Plate 1 is connected to the Plate 9 by 1" Angle Brackets, and the Plates 1 and 9 thus slide together in the vertical framework formed by 12 $\frac{1}{2}$ " Angle Girders doubled.



Parts required :		
2 of No.	1	
5 " "	2	
2 " "	3	
1 " "	5	
4 " "	8	
3 " "	10	
2 " "	12A	
1 " "	15	
2 " "	15A	
2 " "	17	
1 " "	18A	
1 " "	19	
4 " "	20	
2 " "	22	
1 " "	23	
1 " "	26	
1 " "	27A	
2 " "	35	
46 " "	37	
1 " "	37A	
19 " "	38	
1 " "	45	
2 " "	48A	
3 " "	48B	
1 " "	52	
3 " "	53	
7 " "	59	
2 " "	126A	
1 " "	147A	
1 " "	147B	
1 " "	148	

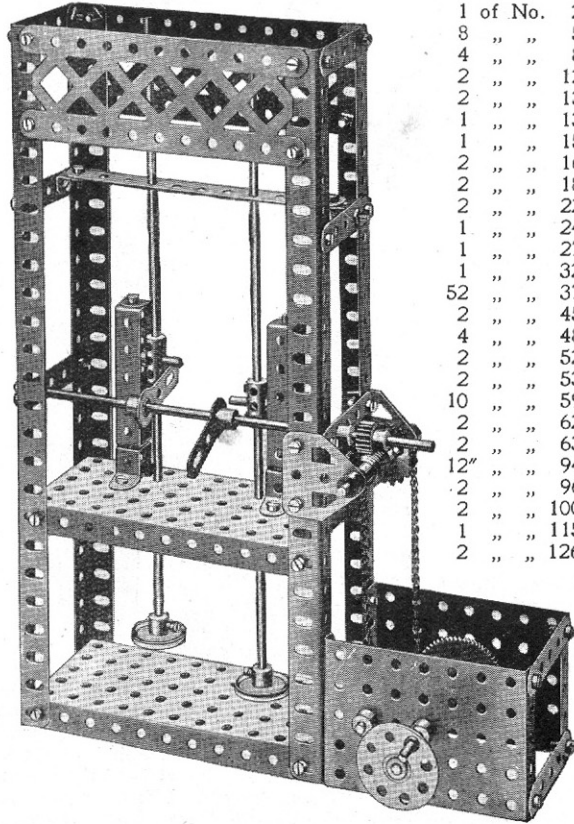
Model No. 4.6 Conductor's Punch



Parts required :		
3 of No.	5	
1 " "	11	
1 " "	15A	
1 " "	22	
9 " "	37	
2 " "	38	
1 " "	43	
2 " "	53	
1 " "	59	

This is just the thing for your younger brother! He only needs a strap with which to hang it over his shoulder to make him into a conductor. The 2 $\frac{1}{2}$ " strip at the bottom is spaced by two Washers away from the body of the punch to allow the ticket to pass in to be punched. The punch Rod is passed completely through the Spring. The lower end of the latter presses against the Double Bracket and the upper end against a Collar secured to the Rod.

Model No. 4.7 Trip Hammer

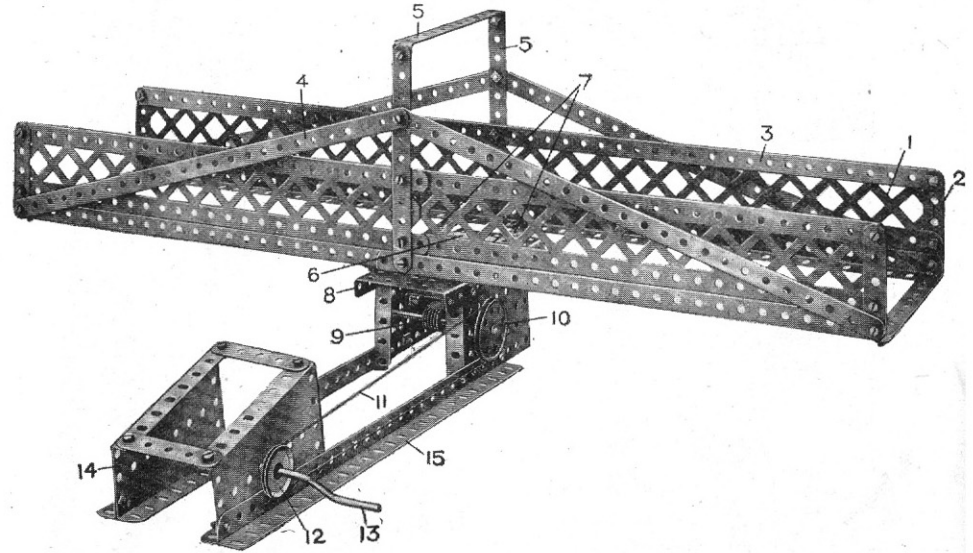


Parts
required :

1 of No.	2
8 "	5
4 "	8
2 "	12
2 "	13
1 "	13A
1 "	15A
2 "	16
2 "	18A
2 "	22
1 "	24
1 "	27A
1 "	32
52 "	37
2 "	45
4 "	48A
2 "	52
2 "	53
10 "	59
2 "	62
2 "	63
12 "	94
2 "	96
2 "	100
1 "	115
2 "	126A

The shafts carrying the hammers are prevented from rotating in their bearings by means of $2\frac{1}{2}'' \times \frac{1}{4}''$ Double Angle Strips bolted in pairs to form guides, in which slide the heads of bolts or short Rods secured to the Couplings in the centre of the hammer shafts. As the Rod carrying the Cranks slowly rotates the hammers rise and fall alternately.

Model No. 4.8 Swing Bridge



Parts required :

8 of No.	1	1 of No.	17	1 of No.	27A	1 of No.	52
6 "	2	1 "	19	1 "	32	2 "	53
6 "	5	1 "	19B	50 "	37	2 "	54
6 "	8	1 "	21	1 "	48A	2 "	59
1 "	16	1 "	22	1 "	48D	4 "	99

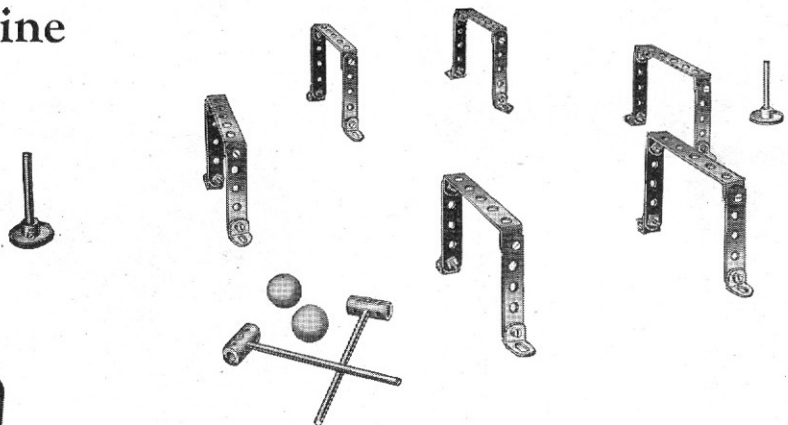
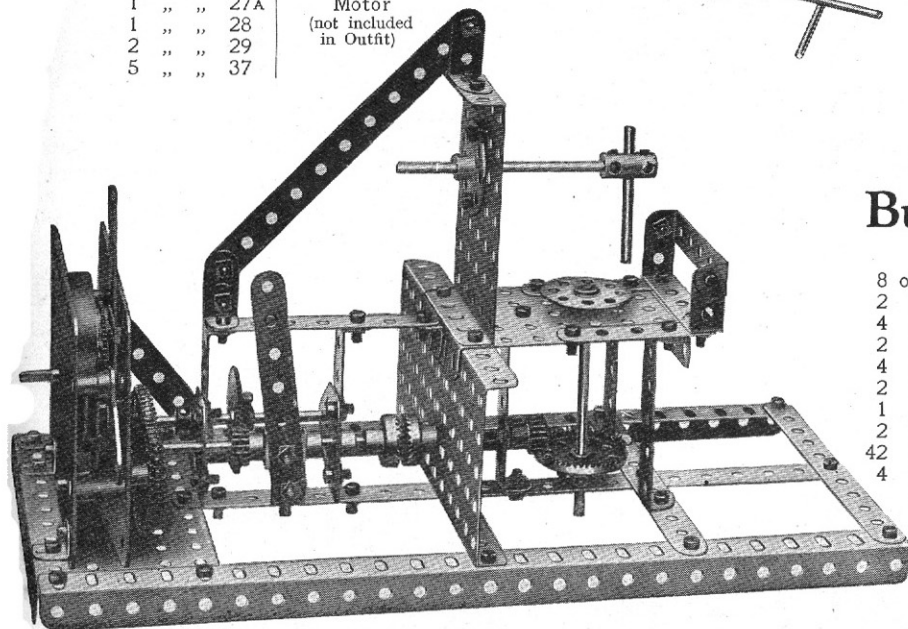
The sides of this model, as shown in the illustration, are made of the Braced Girders 1 secured to the upright Strips 2 and reinforced by the inner Strips 3. Other diagonal Strips 4 brace the side Girders to the top structure 5 forming a stay for the sides 1. The swing base of the bridge is composed of a 3" Pulley Wheel 6 which is bolted to two cross $5\frac{1}{2}''$ Strips 7 which in turn are secured to the main base side Girders. The bridge swings on the Perforated Plate 8 on a short Rod, on the lower end of which is secured a Gear Wheel engaged and driven by a Worm 9 on the spindle of which is the grooved Pulley 10 driven by the Cord 11 which is operated from the smaller grooved Pulley 12 on the Crank Handle 13. The Crank Handle is journalled in two Sector Plates 14 secured to the base Angle Girder 15.

Model No. 4.9

Clay Modelling Machine

Parts required :

5 of No. 2	2 of No. 37A
2 " " 3	2 " " 38
3 " " 5	1 " " 46
2 " " 8	6 " " 48A
1 " " 10	2 " " 52
1 " " 11	2 " " 53
7 " " 12	4 " " 59
1 " " 12A	1 " " 63
4 " " 16	6" " " 94
2 " " 17	2 " " 96
2 " " 24	2 " " 126A
2 " " 26	Clockwork
1 " " 27A	Motor
1 " " 28	(not included
2 " " 29	in Outfit)
5 " " 37	

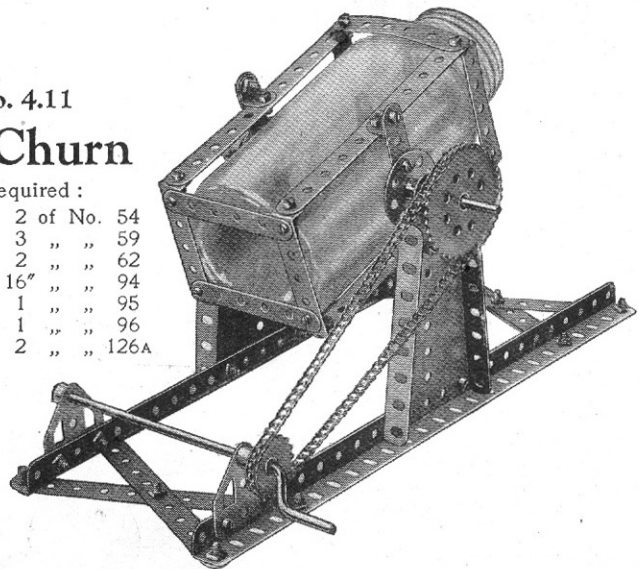


Model No. 4.10 Table Croquet

A most diverting game. Coloured marbles may be used for the balls. Full instructions for playing croquet may be obtained from any sports or games dealer.

Parts required :

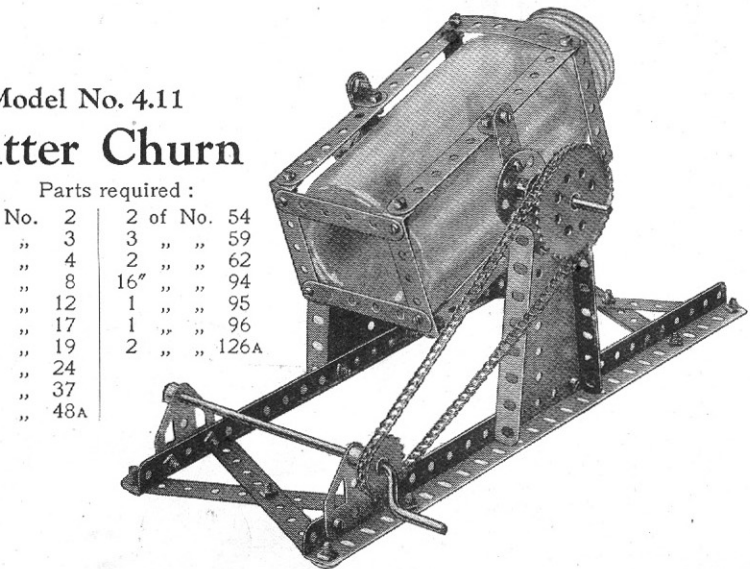
12 of No. 5	2 of No. 22
12 " " 12	24 " " 37
2 " " 16	6 " " 48A
2 " " 17	2 " " 63



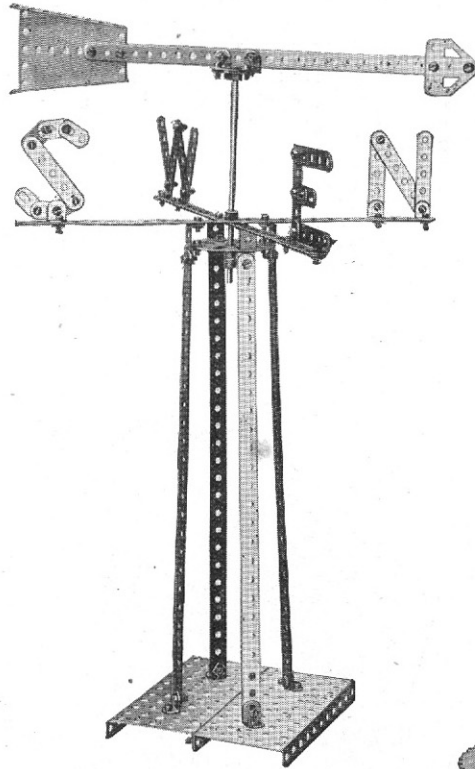
Model No. 4.11 Butter Churn

Parts required :

8 of No. 2	2 of No. 54
2 " " 3	3 " " 59
4 " " 4	2 " " 62
2 " " 8	16" " " 94
4 " " 12	1 " " 95
2 " " 17	1 " " 96
1 " " 19	2 " " 126A
2 " " 24	
42 " " 37	
4 " " 48A	



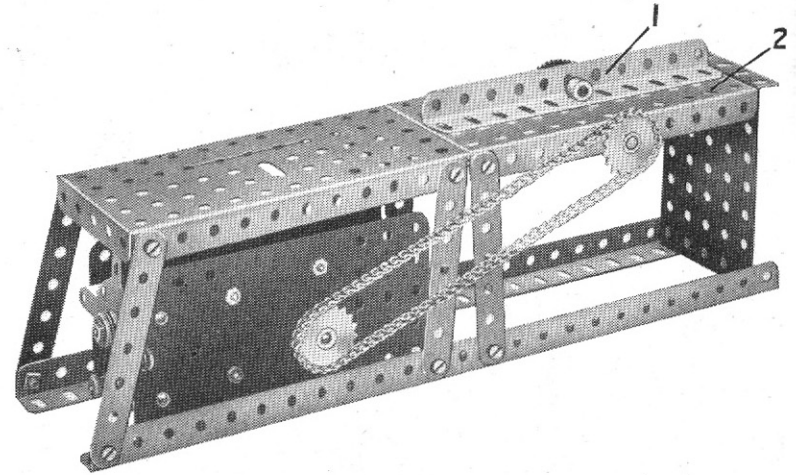
Model No. 4.12 Weather Vane



Parts required :

7 of No. 1	54 of No. 37
11 " " 5	2 " " 38
8 " " 10	2 " " 52
4 " " 11	1 " " 54
17 " " 12	2 " " 59
1 " " 14	1 " " 109
1 " " 24	1 " " 126A

Model No. 4.13 Saw Bench

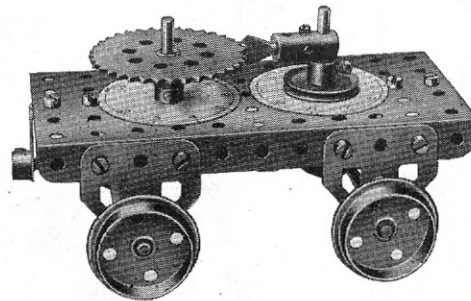


Parts required :

6 of No. 3	
2 " " 8	
1 " " 9	
1 " " 16	
22 " " 37	
2 " " 52	
1 " " 53	
1 " " 59	
15 " " 94	
2 " " 96	
1 " " 111c	
1 " " 159	
1 " " 160	
Electric Motor	
(not included in	
Outfit)	

The guard 1 consists of a 5½" Angle Girder held in place by a Collar, the threaded bore of which engages the shank of a Bolt passed through the elongated hole in the Flanged Plate 2. Hence the guard may be moved nearer or further from the Circular Saw as required to allow for different thicknesses of material.

Model No. 4.14 Distance Indicator



Parts required :

1 of No. 4	1 of No. 37A
4 " " 10	3 " " 38
2 " " 12	1 " " 52
1 " " 15	3 " " 59
2 " " 16	2 " " 62
2 " " 17	1 " " 63
4 " " 20	1 " " 65
2 " " 26	1 " " 95
1 " " 28	1 " " 96
1 " " 32	4 " " 126A
16 " " 37	

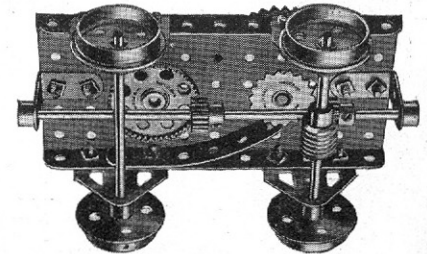
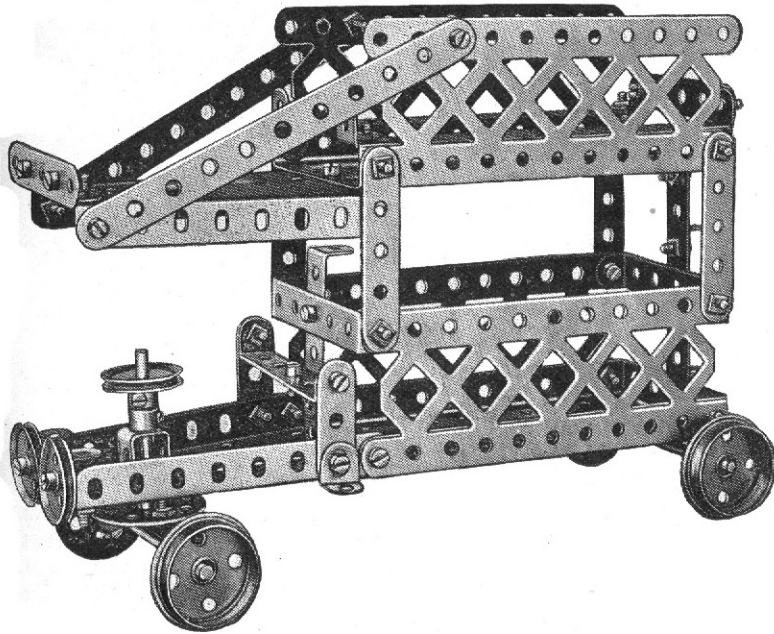


FIG. 4.14A

Model No. 4.15 Motor 'Bus

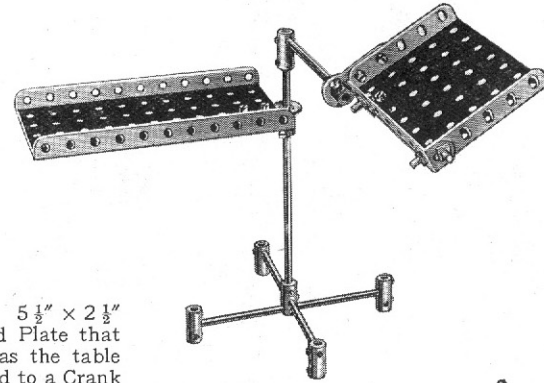
Parts required :

2 of No. 2	12 of No. 12	2 of No. 22A	2 of No. 52
1 " " 3	2 " " 16	1 " " 24	1 " " 54
6 " " 5	1 " " 17	48 " " 37	1 " " 59
2 " " 6A	4 " " 20	1 " " 45	4 " " 100
3 " " 11	1 " " 22	7 " " 48A	



Steering is effected by a 1" Pulley Wheel, the Rod of which is journalled in bearings, consisting of a Double Bent Strip bolted to the Sector Plate, and is secured to a Bush Wheel. The latter is bolted to the $2\frac{1}{2}'' \times \frac{1}{2}''$ Double Angle Strip, the ends of which form bearings for the front axle.

Model No. 4.16 Bed Table



The $5\frac{1}{2}'' \times 2\frac{1}{2}''$ Flanged Plate that serves as the table is bolted to a Crank that is secured to the upright Rod. The book rest consists of a $3\frac{1}{2}'' \times 2\frac{1}{2}''$ Flanged Plate and a $3\frac{1}{2}''$ Strip secured to its lower edge by two Angle Brackets.

Parts required :

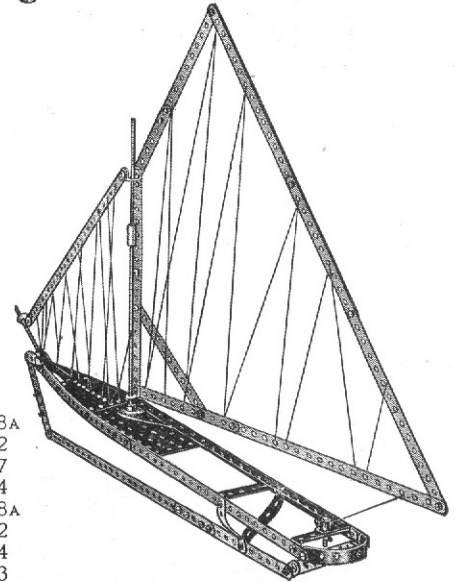
1 of No. 3
1 " " 12
1 " " 14
2 " " 15A
1 " " 16
8 " " 37
1 " " 52
1 " " 53
2 " " 62
6 " " 63

Model No. 4.17

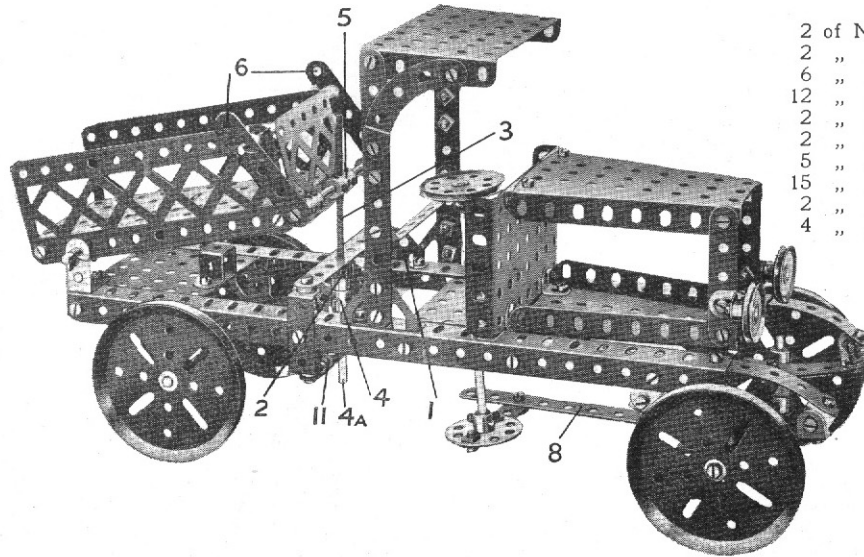
Yacht

Parts required :

9 of No. 1	2 of No. 18A
7 " " 2	1 " " 22
4 " " 3	51 " " 37
2 " " 4	1 " " 44
2 " " 5	2 " " 48A
1 " " 10	1 " " 52
5 " " 12	1 " " 54
1 " " 13A	1 " " 63
2 " " 15	



Model No. 4.18 Tipping Motor Wagon



Parts required :

2 of No. 2	1 of No. 17
2 " " 2A	5 " " 18A
6 " " 3	4 " " 19B
12 " " 5	2 " " 21
2 " " 6A	2 " " 22
2 " " 8	2 " " 24
5 " " 10	1 " " 26
15 " " 12	1 " " 28
2 " " 12A	8 " " 35
4 " " 15A	89 " " 37
	4 " " 37A
	14 " " 38
	2 " " 45
	2 " " 48
	1 " " 48B
	1 " " 52
	2 " " 53
	2 " " 54
	10 " " 59
	2 " " 62
	4 " " 63
	1 " " 80A
	2 " " 90A
	1 " " 98
	2 of No. 100
	4 " " 111c
	1 " " 115
	2 " " 125
	2 " " 126
	2 " " 126A

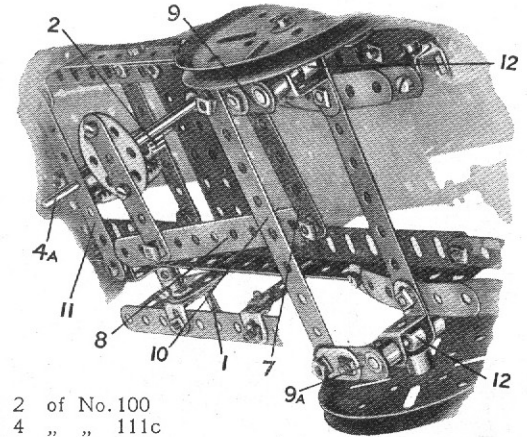
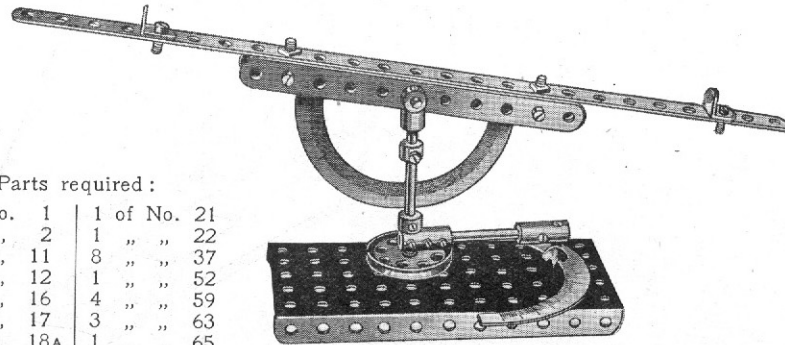


FIG. 4.18A

Model No. 4.19 Sextant and Theodolite



Parts required :

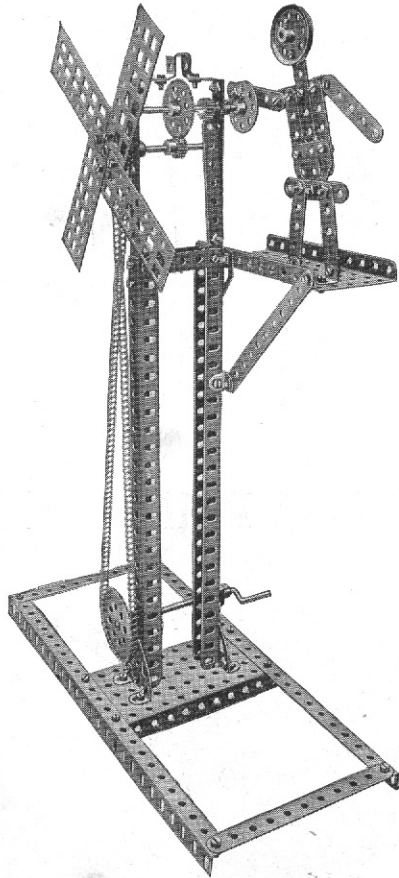
1 of No. 1	1 of No. 21
2 " " 2	1 " " 22
2 " " 11	8 " " 37
2 " " 12	1 " " 52
1 " " 16	4 " " 59
1 " " 17	3 " " 63
2 " " 18A	1 " " 65

Tipping Motor Wagon

The tipping mechanism is operated by the hand wheel 1, the shaft of which carries a $1\frac{1}{2}$ " Contrate Wheel that engages with the $\frac{1}{2}$ " Pinion 2. The $3\frac{1}{2}$ " Threaded Rod 3, to which the Pinion 2 is secured, is journaled in one end of a Coupling 4 and passes through the central threaded bore of a second Coupling 5, which is mounted between the ends of two short Rods that are free to turn on Rods passed through $2\frac{1}{2}$ " Strips 6. These Strips 6 are attached pivotally to the body of the lorry. The short Rod 4a passes through the $3\frac{1}{2}$ " Strip 11 and is secured in the lower end of the Coupling 4, the centre transverse hole of which forms a bearing for the Rod of the hand wheel 1.

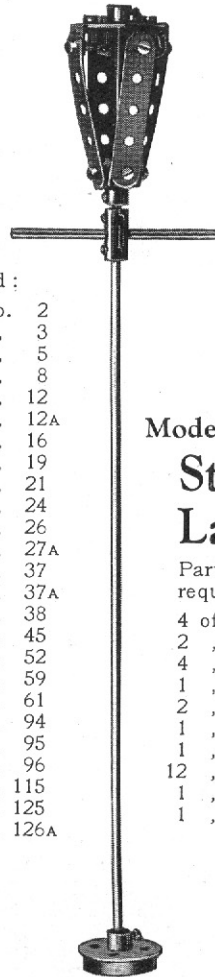
The steering gear is shown in Fig. 4.18A. The $2\frac{1}{2}$ " Strip 7 is pivoted to the Strip 8, but is secured rigidly at right-angles to the Crank 9. The Crank 9A is made to move simultaneously with the Crank 9 by means of the tie-rod 10. The front road wheels are mounted on $\frac{3}{4}$ " Bolts secured in Collars 12.

Model No. 4.23 Windmill Scare



Parts
required :

5	of No.	2
1	" "	3
11	" "	5
6	" "	8
8	" "	12
2	" "	12A
2	" "	16
1	" "	19
1	" "	21
2	" "	24
2	" "	26
1	" "	27A
61	" "	37
2	" "	37A
3	" "	38
1	" "	45
2	" "	52
4	" "	59
4	" "	61
20"	" "	94
1	" "	95
1	" "	96
1	" "	115
2	" "	125
4	" "	126A



Model No. 4.24 Street Lamp

Parts
required :

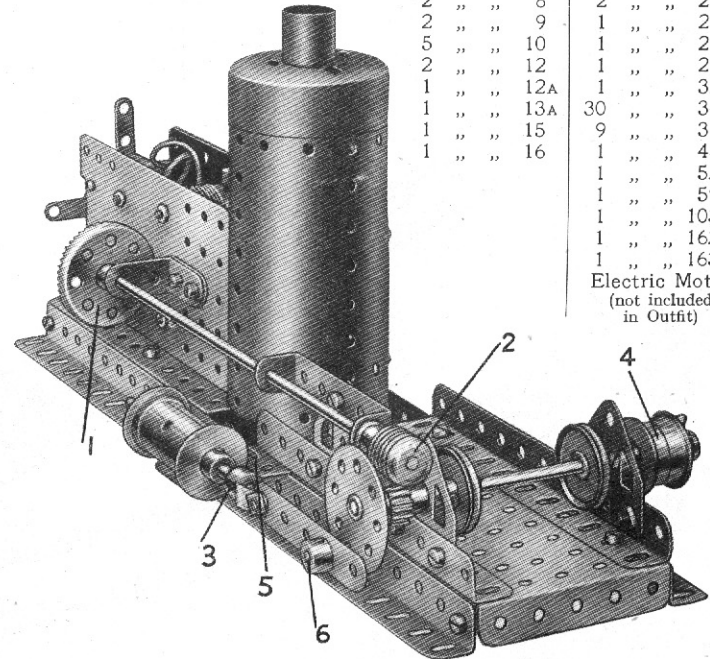
4	of No.	5
2	" "	11
4	" "	12
1	" "	13
2	" "	16
1	" "	20
1	" "	24
12	" "	37
1	" "	59
1	" "	63

Model No. 4.25 Steam Winch

A $\frac{1}{2}$ " Pinion secured to the armature of the Electric Motor turns a $1\frac{1}{2}$ " Contrate Wheel 1 mounted on an 8" Axle Rod, to the opposite end of which is secured a Worm Wheel 2. The drum 4 of the winch consists of two $\frac{3}{4}$ " Flanged Wheels and is secured to the end of a $3\frac{1}{2}$ " Rod, which carries a $\frac{1}{2}$ " Pinion that is driven by the Worm 2. The cylinder is composed of a Sleeve Piece, secured by two nuts and bolts to the end of a $2\frac{1}{2}$ " Flat Girder 5, and two $\frac{3}{4}$ " Flanged Wheels. The piston rod is attached pivotally to the connecting rod by means of an End Bearing 3, and the Crank Pin 6 is formed by a Threaded Pin secured to the Bush Wheel. The Boiler is secured in place by two Angle Brackets bolted to its base and to the $5\frac{1}{2}$ " x $2\frac{1}{2}$ " Flanged Plates forming part of the engine bed. It will be noted that the 1 " x 1 " Angle Bracket supporting one end of the 8" Rod is spaced away from the Motor by a Flat Bracket, in order to obtain proper clearance for the Contrate Wheel 1.

Parts required :

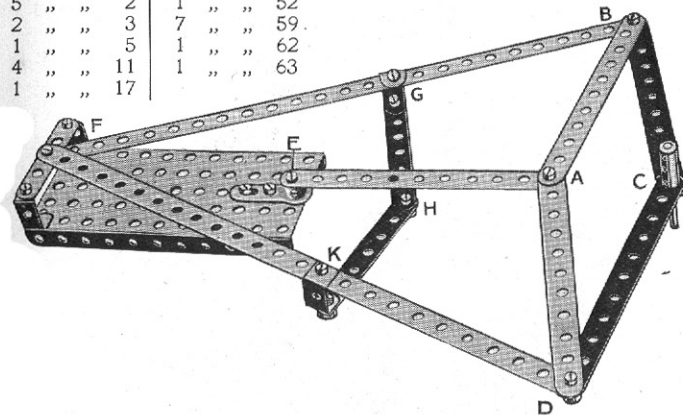
1	of No.	5	4	of No.	20
2	" "	8	2	" "	22
2	" "	9	1	" "	24
5	" "	10	1	" "	26
2	" "	12	1	" "	28
1	" "	12A	1	" "	32
1	" "	13A	30	" "	37
1	" "	15	9	" "	38
1	" "	16	1	" "	48A
			1	" "	52
			1	" "	59
			1	" "	103F
			1	" "	162
			1	" "	163
					Electric Motor (not included in Outfit)



Model No. 4.26 Geometrical Apparatus

Parts required :

2 of No.	1	16 of No.	37
5 "	"	1 "	"
2 "	"	7 "	"
1 "	"	1 "	"
4 "	"	1 "	"
1 "	"	1 "	"



This most ingenious model for transforming a circular movement into a rectilinear movement was designed by M. Pierre-Th. Dufour, who used it in his Thesis (presented to the Faculty of Science in Paris) to obtain his degree of Doctor of the University of Paris. He required an instrument which would transform a circular movement into a movement rigorously rectilinear and he states in his published work that he was able to do this " with the aid of Meccano parts, which permit of making experiments so easily in mechanisms of the most varied types."

The point F is fixed, and is situated at a distance from the fixed point E, equal to AE, the two arms FB and FD being together equal to the four sides of the lozenge ABCD. The trajectory of the point C is then at right angles to EF. It will be found that whilst the point C is moving in a straight line at right angles to EF, the point A is describing a circle round the fixed point E.

Every Meccano Boy should make up this very interesting model and experiment with it.

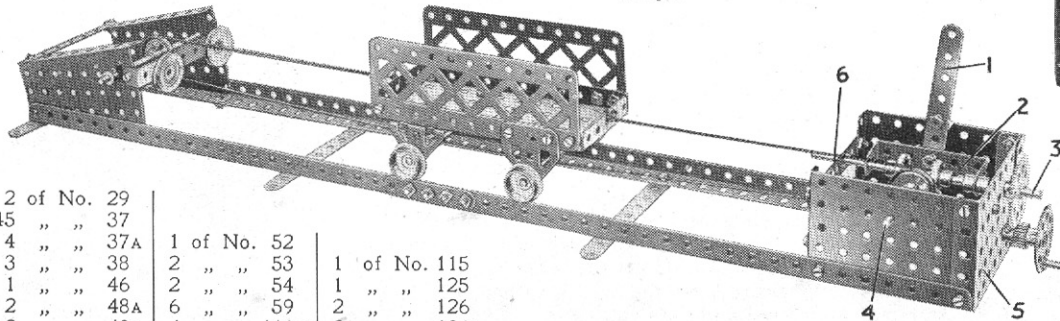
Model No. 4.28 Cable Railway

The reversing lever 1 is pivoted near its centre to a Reversed Angle Bracket and at its lower end to a 2½" Double Angle Strip 2. This Strip is kept in place on the Rod 3 by two Collars. The two ¾" Contrate Wheels are fastened on this Rod in such a position that one or other can be brought into gear with a ½" Pinion secured to the Rod 4 by moving the reversing lever. This Rod 4 is journaled in one of the side plates of the gear box and in a 3½" x ½" Double Angle Strip bolted between Plate 5 and the Strips.

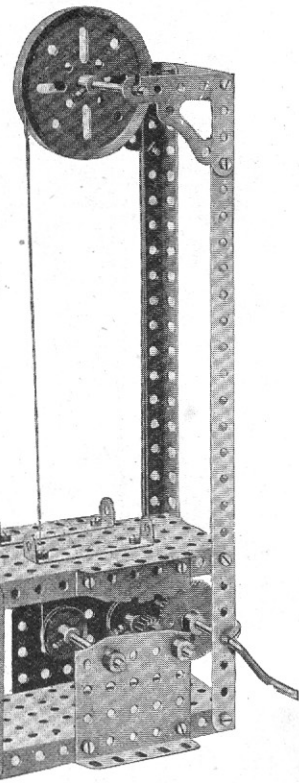
Parts required :

3 of No.	2
4 "	"
2 "	"
4 "	"
1 "	"
2 "	"
2 "	"
1 "	"
4 "	"
4 "	"
1 "	"
2 "	"
1 "	"

2 of No.	29	1 of No.	52	1 of No.	115
45 "	"	4 "	"	2 "	"
4 "	"	3 "	"	1 "	"
1 "	"	2 "	"	2 "	"
4 "	"	6 "	"	2 "	"
2 "	"	4 "	"	2 "	"



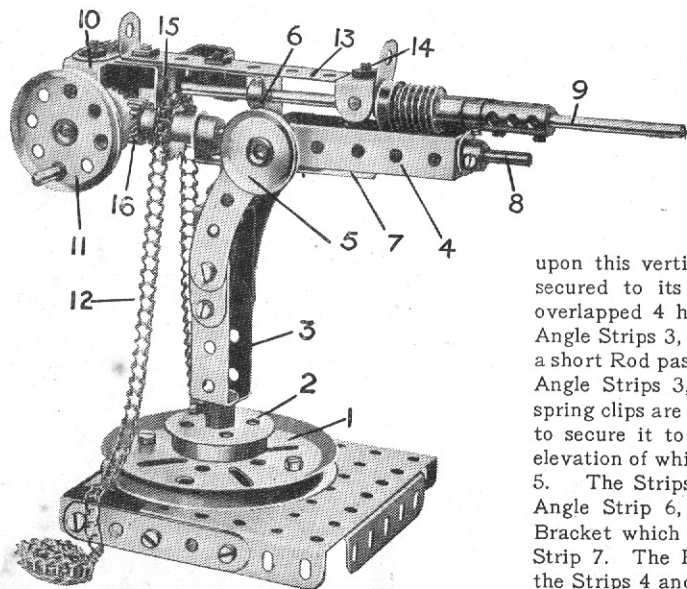
Model No. 4.27 Band Saw



Parts required :

2 of No.	3	1 of No.	27A
1 "	"	4 "	"
2 "	"	26 "	"
3 "	"	2 "	"
1 "	"	2 "	"
1 "	"	2 "	"
2 "	"	4 "	"
1 "	"	2 "	"

Model No. 4.29 Naval Quick-firing Gun



A 3" Pulley Wheel 1 provides a bearing for the vertical 4½" Rod forming the axis about which the gun pivots. The Rod is secured to the base by a Flanged Wheel 2 and a 1" Pulley Wheel attached to it beneath the larger Wheel 1. Two Double Angle Strips 3, spaced apart by a Double Bracket, are mounted

upon this vertical Rod and held in place by a Collar secured to its upper end. Two 2½" Curved Strips overlapped 4 holes are bolted to each of the Double Angle Strips 3, and their upper holes form bearings for a short Rod passing through the ends of further Double Angle Strips 3, and carrying a hand wheel 5. Two spring clips are mounted on this Rod inside the Strips 4 to secure it to the pivoting portion of the gun, the elevation of which may be altered on turning the Wheel 5.

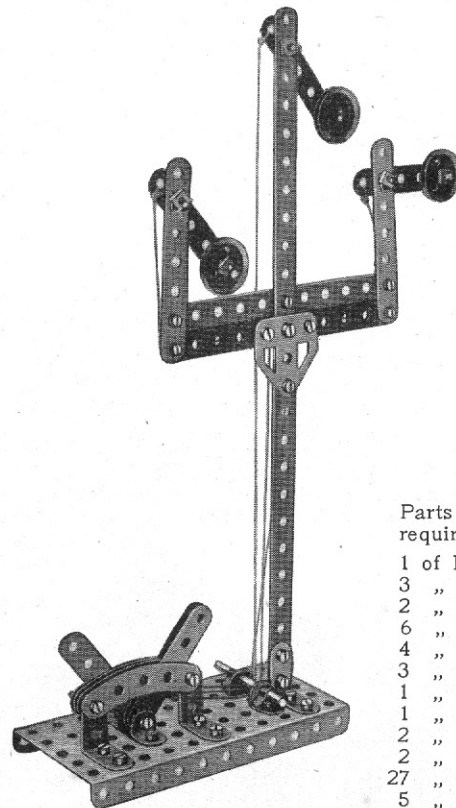
The Strips 4 are bolted to the end of a Double Angle Strip 6, and the same bolt secures an Angle Bracket which in turn is bolted to the Double Angle Strip 7. The Rod 8 passes through the end holes of the Strips 4 and 7 and is held in place by two Collars. On the top of the Strip 6 is bolted a 3½" Double Angle Strip 13, the upturned ends of which form the sighting apertures. The Bolt 14 secures a Double Bracket and an Angle Bracket, the latter together with one of the holes in the Strip 6 forming bearings for the barrel 9. A 1" Angle Bracket 15, bolted beneath the Strip 6, and the end of the Strip 7 provide bearings for the short Rod carrying a ¾" Sprocket Wheel and ½" Pinion 16. Two 1" x 1" Angle Brackets 10 form bearings for a 2" Rod carrying the hand Wheel 11. This Rod is fitted with a ¾" Contrate Wheel which engages with the Pinion 16. On rotation of the Wheel 11, the small Sprocket Wheel actuates the Sprocket Chain 12 which represents the cartridge belt.

Parts required :

2 of No. 5	1 of No. 21	5 of No. 48A
1 " " 10	2 " " 22	2 " " 48B
2 " " 11	1 " " 23A	2 " " 53
1 " " 12	1 " " 26	8 " " 59
3 " " 12A	1 " " 29	1 " " 63
1 " " 14	1 " " 32	4 " " 90
1 " " 15A	2 " " 35	1 " " 94
3 " " 17	24 " " 37	1 " " 96A
1 " " 18B	2 " " 38	2 " " 111A
1 " " 19B	1 " " 45	1 " " 115
1 " " 20	1 " " 46	1 " " 125

Model No. 4.30

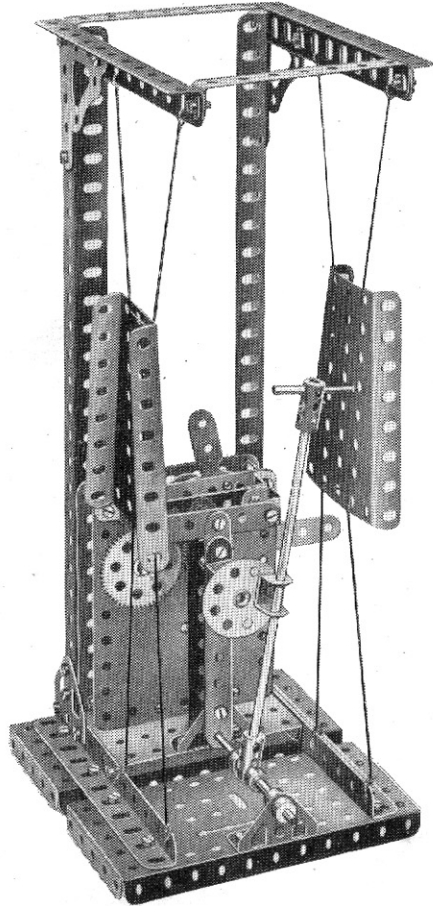
Three-arm Signal



Parts required :

1 of No. 1	
3 " " 2	
2 " " 3	
6 " " 5	
4 " " 12	
3 " " 12A	
1 " " 17	
1 " " 22	
2 " " 22A	
2 " " 35	
27 " " 37	
5 " " 37A	
11 " " 38	
1 " " 52	
4 " " 90	
3 " " 111	
1 " " 126A	

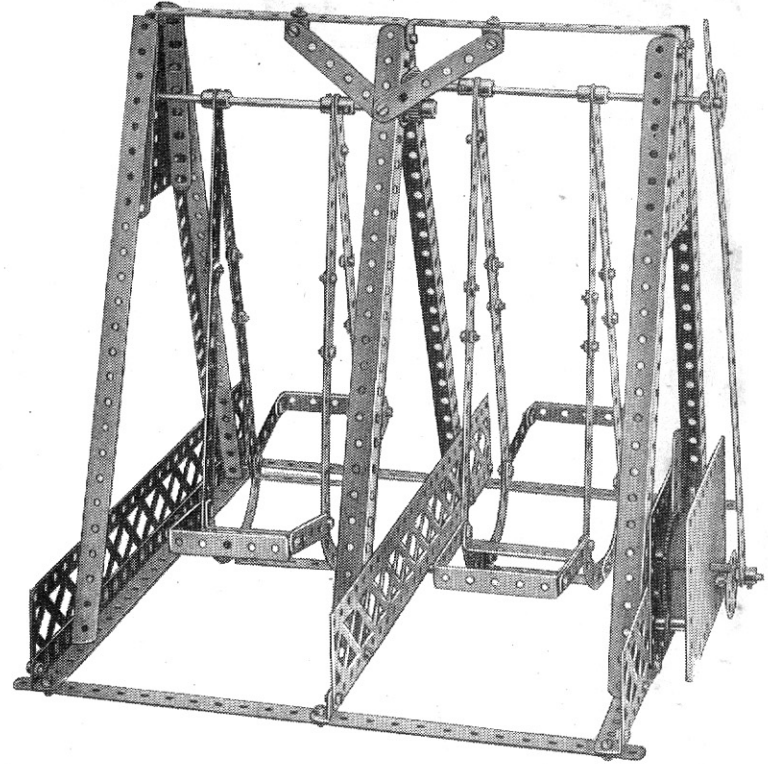
Model No. 4.31 Automatic Gong



- Parts required :
- 2 of No. 2A
 - 2 " " 5
 - 2 " " 8
 - 4 " " 9
 - 3 " " 11
 - 1 " " 12
 - 1 " " 14
 - 1 " " 16
 - 1 " " 17
 - 1 " " 18A
 - 1 " " 24
 - 1 " " 26
 - 1 " " 27A
 - 45 " " 37
 - 2 " " 37A
 - 2 " " 38
 - 1 " " 45
 - 2 " " 48B
 - 2 " " 52
 - 1 " " 53
 - 2 " " 54
 - 4 " " 59
 - 2 " " 63
 - 2 " " 108
 - 1 " " 111C
 - 2 " " 125
 - 2 " " 126
 - 2 " " 126A

Clockwork Motor
(not included in Outfit)

Model No. 4.32 Alternating Swing



Parts required :

3 of No. 1	8 of No. 8	72 of No. 37	9 of No. 59
8 " " 2	4 " " 12	3 " " 37A	2 " " 62
2 " " 4	2 " " 14	10 " " 48A	8 " " 98
9 " " 5	2 " " 24	2 " " 48D	3 " " 99
2 " " 6A	2 " " 26	2 " " 54	1 " " 111c
1 of No. 115			

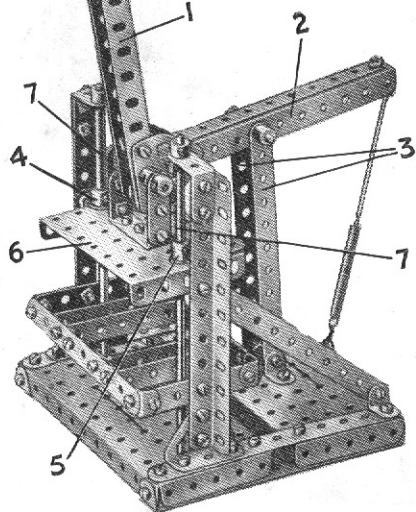
Clockwork Motor
(not included in Outfit)

Model No. 4.33 Potato Chopper

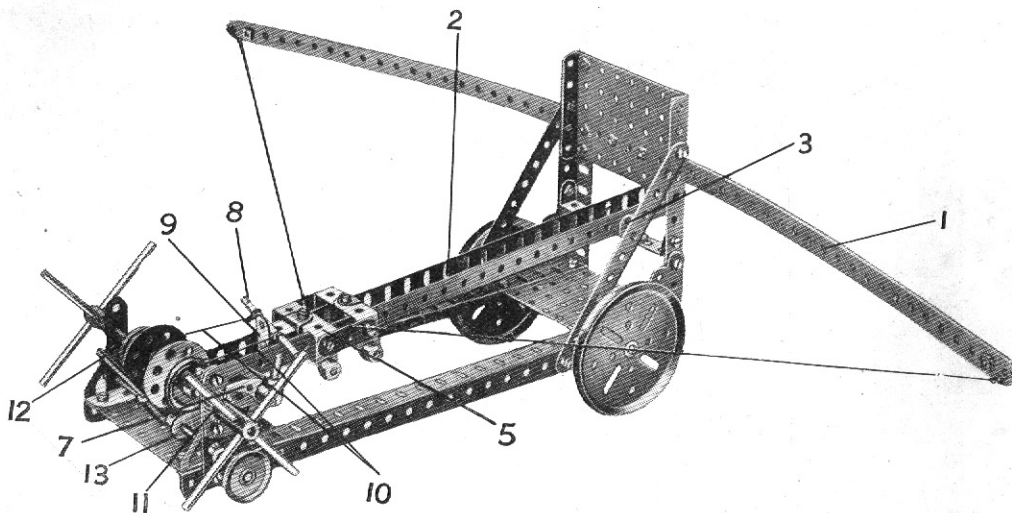
The levers 1 and 2 are secured at right angles to each other by means of two Flat Trunnions. The lever 2 pivots about a short Rod journalled in the tops of the 5½" Strips 3. The Cranks 4 and 5 are bolted to the 3½" × 2½" Flanged Plate 6 and are free to ride up and down the vertical Axle Rods 7 and 8.

Parts required :

8 of No. 2	4 of No. 37A
3 " " 5	4 " " 38
2 " " 6A	1 " " 43
2 " " 8	4 " " 48A
4 " " 9	2 " " 48D
10 " " 12	2 " " 52
4 " " 12A	1 " " 53
2 " " 14	10 " " 59
1 " " 17	2 " " 62
1 " " 18A	2 " " 111c
73 " " 37	2 " " 126
2 of No. 126A	



Model No. 4.34 Mechanical Cross Bow



This model represents a large military weapon of the type used before the invention of gunpowder. It is built on the principal of the crossbow. Each side of the bow 1 is composed of three 12½" Strips bolted together, the centre being strengthened by three 2½" Strips. The trough 2, which is formed from two 12½" Angle Girders, is held loosely between a pair of Angle Brackets 3, and its rear end is secured to a Double Bent Strip bolted to the 3½" × 2½" Flanged Plate. The carriage 5 is composed of four 1" × 1" Angle Brackets joined by a pair of 1½" Strips and guided by two ½" × ½" Angle Brackets. A Double Bracket is bolted to one of the latter, and carries in its turn a Flat Bracket 9. When the handles are turned in an anti-clockwise direction, the Cords 10 draw the carriage back, and are prevented from unwinding by the Pawl 7 engaging a ½" Pinion Wheel 11. When the lever 12 is depressed, the ends of a pair of 2½" Strips bolted to Cranks 13 lift the 2" Rod 8 off the Flat Bracket 9. This releases the carriage, and the projectile (a marble) is shot out of the trough 2 with considerable force.

Parts required :

6 of No. 1	53 of No. 37
7 " " 5	2 " " 37A
2 " " 6A	5 " " 38
4 " " 8	1 " " 45
2 " " 9	1 " " 48
1 " " 10	1 " " 48B
1 " " 11	3 " " 53
4 " " 12	4 " " 59
4 " " 12A	2 " " 62
1 " " 15	3 " " 63
3 " " 15A	2 " " 108
4 " " 16	2 " " 111
4 " " 17	1 " " 115
2 " " 19B	2 " " 126
4 " " 22	1 " " 126A
2 " " 24	1 " " 147A
1 " " 26	1 " " 147B

Model No. 4.35 Speed Indicator

Parts required:

2 of No. 3	1 of No. 45
2 " " 4	3 " " 48A
4 " " 5	1 " " 52
2 " " 8	2 " " 53
4 " " 12	5 " " 59
1 " " 13A	1 " " 63
2 " " 16	
2 " " 17	
2 " " 18A	
5 " " 20	
1 " " 21	
2 " " 24	
1 " " 26	
1 " " 29	
32 " " 37	
2 " " 38	

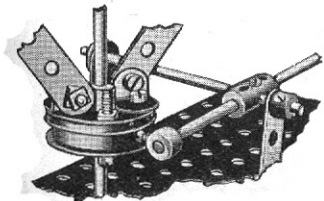
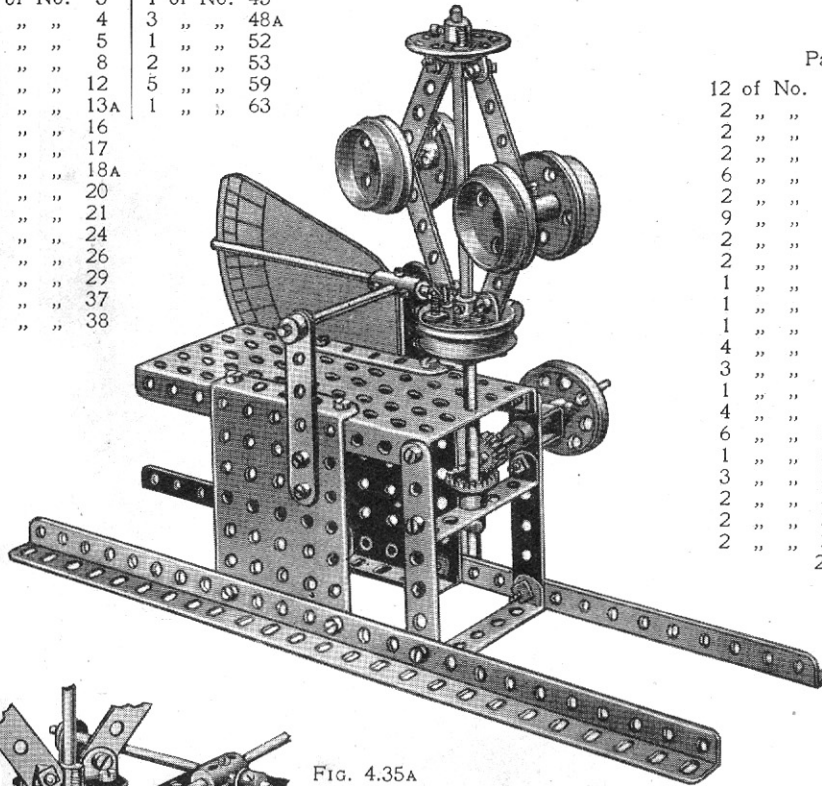
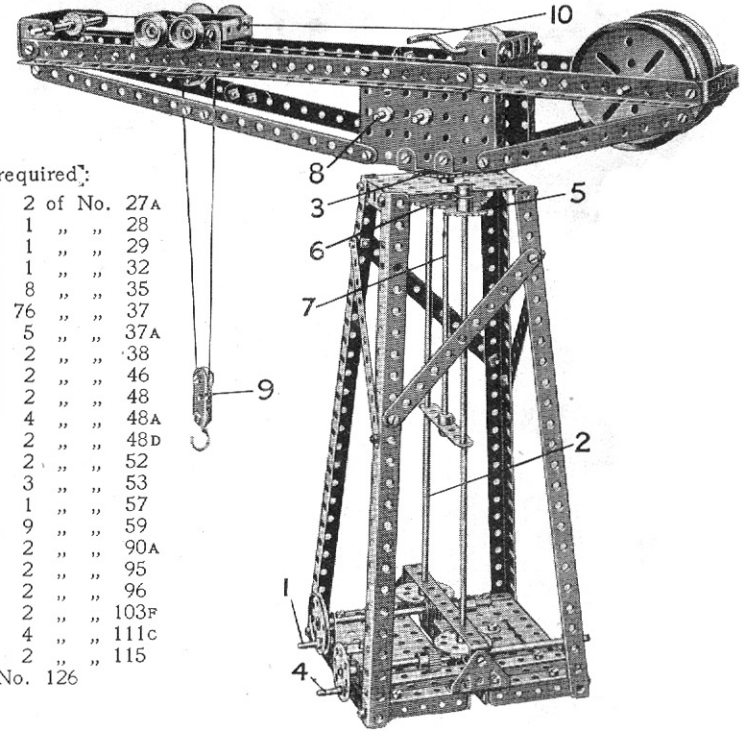


Fig. 4.35A

Model No. 4.36 Girder Crane

Parts required:

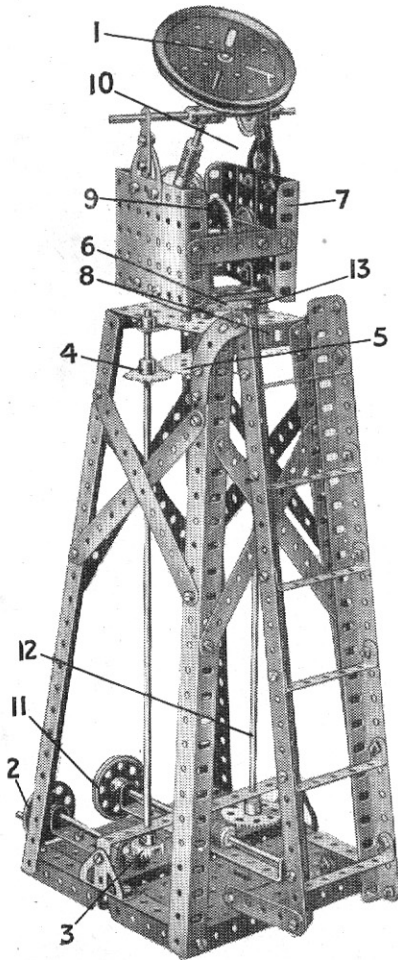
12 of No. 2	2 of No. 27A
2 " " 3	1 " " 28
2 " " 5	1 " " 29
2 " " 6A	1 " " 32
6 " " 8	8 " " 35
2 " " 9	76 " " 37
9 " " 10	5 " " 37A
2 " " 12A	2 " " 38
2 " " 13	2 " " 46
1 " " 13A	2 " " 48
1 " " 14	4 " " 48A
1 " " 15A	2 " " 48D
4 " " 16	2 " " 52
3 " " 17	3 " " 53
1 " " 19	1 " " 57
4 " " 19B	9 " " 59
6 " " 20	2 " " 90A
1 " " 21	2 " " 95
3 " " 22	2 " " 96
2 " " 23	2 " " 103F
2 " " 24	4 " " 111c
2 " " 26	2 " " 115
2 of No. 126	



The boom is rotated by means of the handle 1, on the axle of which is a Worm engaging with a 57-teeth Gear Wheel secured to an $11\frac{1}{2}$ " Rod 2. At the upper end of the Rod 2 is a 1" Sprocket Wheel that meshes with a 2" Sprocket Wheel 3 bolted to the boom of the crane. The handle 4 is connected by means of a $\frac{1}{2}$ " Pinion, $1\frac{1}{2}$ " Contrate Wheel, and a 1" Sprocket Wheel 5 to the 2" Sprocket Wheel 6. The Rod 7, to which the latter is secured, is free to rotate in the boss of the Sprocket Wheel 3, and carries at its upper end a $\frac{3}{4}$ " Contrate Wheel which, by means of a $\frac{1}{2}$ " Pinion and a 57-teeth Gear Wheel, rotates the Rod 8. A Cord wound on the latter Rod raises the pulley block 9. The handle 10 controls the traversing movement of the trolley by an endless rope drive similar to Standard Mechanism No. 169.

Model No. 4.37 Searchlight

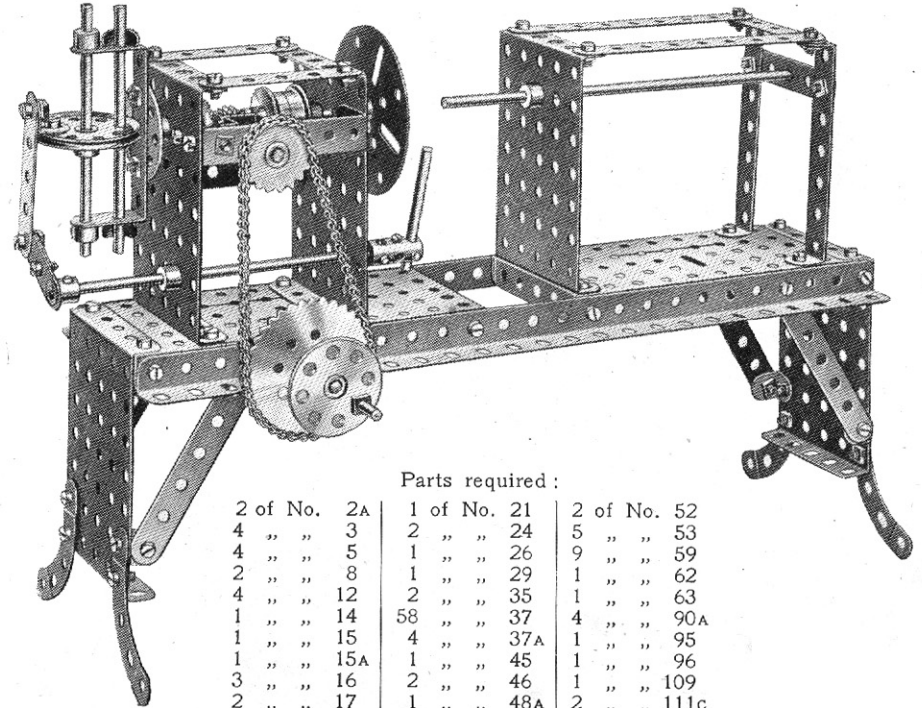
The elevation of the searchlight 1 is controlled by the hand wheel 2, the motion of which is transmitted by means of a $\frac{1}{2}$ " Pinion and $\frac{3}{4}$ " Contrate Wheel 3 and 1" Sprocket Wheel 4 to a 2" Sprocket Wheel 5. The latter is secured to a vertical Rod that is free to revolve in the boss of a second 2" Sprocket Wheel 6 bolted to two $2\frac{1}{2}$ " \times $\frac{1}{2}$ " Double Angle Strips, which, in turn, are secured in the base of the rotating frame 7. This vertical Rod is journaled in a Double Bent Strip that is bolted beneath the Plate 8 to form an additional support, and it carries at its upper end a $\frac{1}{2}$ " Pinion that engages with the $1\frac{1}{2}$ " Contrate Wheel 9. The motion of the Contrate Wheel 9 is transmitted to the pivotal Rod of the searchlight by means of the Pulleys and belt 10. The searchlight is rotated by the second hand wheel 11, the drive from which is transmitted through Worm gearing to the vertical Rod 12, the upper end of which carries a 1" Sprocket Wheel 13, that engages with the 2" Sprocket Wheel 6.



Parts
required :

10	of No.	2
1	" "	3
4	" "	5
2	" "	6A
6	" "	8
2	" "	12
2	" "	13
1	" "	14
3	" "	16
2	" "	17
1	" "	19B
1	" "	21
3	" "	22
2	" "	24
2	" "	26
1	" "	27A
1	" "	28
1	" "	29
1	" "	32
86	" "	37
7	" "	38
1	" "	45
9	" "	48A
1	" "	48B
2	" "	48D
2	" "	52
3	" "	53
4	" "	59
2	" "	63
2	" "	95
2	" "	96
2	" "	115
2	" "	126
2	" "	126A

Model No. 4.38 Elliptical Lathe

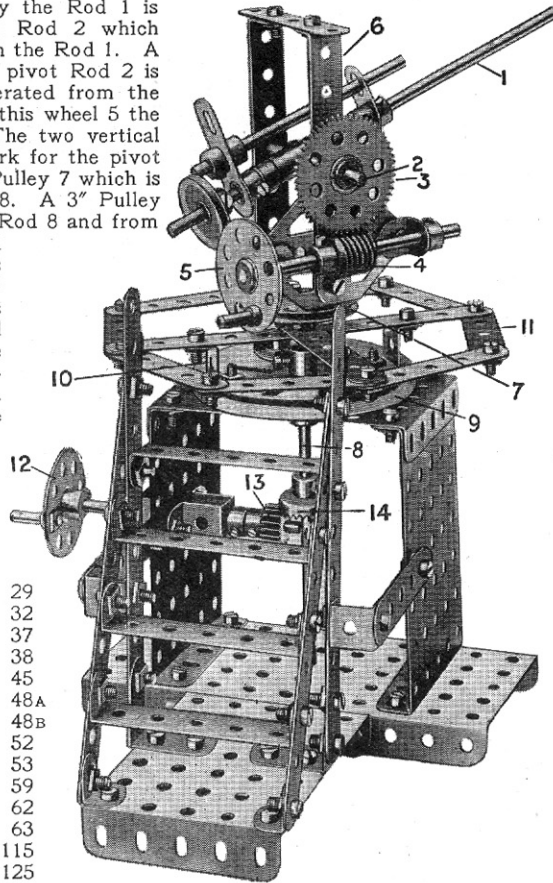


Parts required :

2	of No.	2A	1	of No.	21	2	of No.	52
4	" "	3	2	" "	24	5	" "	53
4	" "	5	1	" "	26	9	" "	59
2	" "	8	1	" "	29	1	" "	62
4	" "	12	2	" "	35	1	" "	63
1	" "	14	58	" "	37	4	" "	90A
1	" "	15	4	" "	37A	1	" "	95
1	" "	15A	1	" "	45	1	" "	96
3	" "	16	2	" "	46	1	" "	109
2	" "	17	1	" "	48A	2	" "	111c
2	" "	20	2	" "	48B	1	" "	115

Model No. 4.39 Anti-Aircraft Gun

The gun represented by the Rod 1 is pivoted upon a transverse Rod 2 which passes through a Coupling on the Rod 1. A 57-toothed Wheel 3 on the pivot Rod 2 is engaged by a Worm 4 operated from the hand wheel 5. By turning this wheel 5 the gun is lifted or lowered. The two vertical Strips forming the framework for the pivot Rod 2 are bolted to a $1\frac{1}{2}$ " Pulley 7 which is secured on a vertical Rod 8. A 3" Pulley Wheel 9 is also bolted to a Rod 8 and from the Pulley Wheel is carried by reversed Angle Brackets 10 a framework 11. The Rod 8 with the framework is rotated from the hand wheel 12, a Pinion 13 on the spindle of which engages a $\frac{3}{4}$ " Contrate Wheel 14 on the Rod 8. By turning the wheel 12 the gun is swivelled round.



Parts required :

6 of No.	2	1 of No.	29
11 " "	5	1 " "	32
1 " "	10	64 " "	37
2 " "	11	12 " "	38
4 " "	12	2 " "	45
2 " "	12A	4 " "	48A
1 " "	15	2 " "	48B
1 " "	15A	1 " "	52
4 " "	16	4 " "	53
1 " "	17	8 " "	59
1 " "	19B	1 " "	62
1 " "	21	2 " "	63
2 " "	22	2 " "	115
2 " "	24	4 " "	125
1 " "	26	2 " "	126A
1 " "	27A		

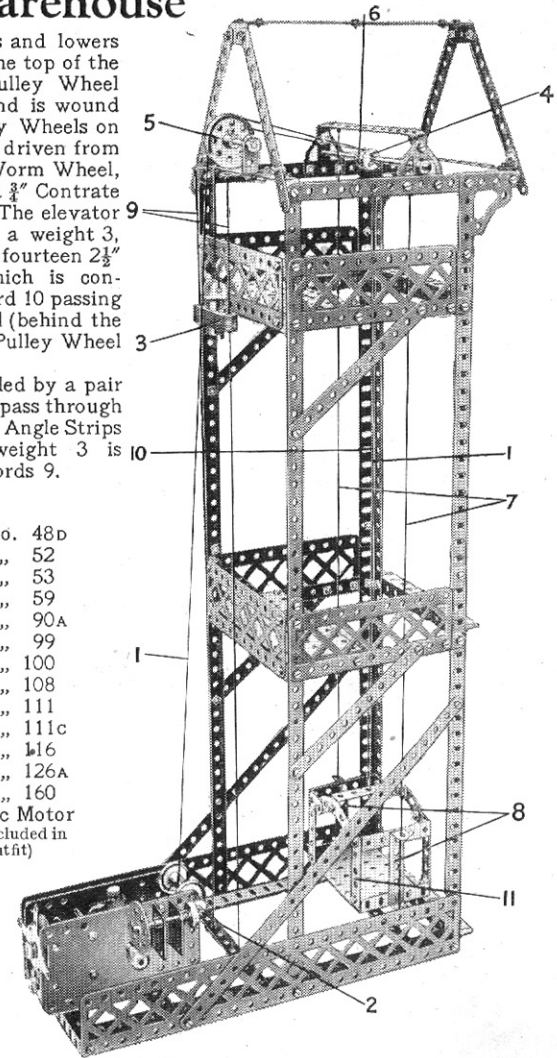
Model No. 4.40 Warehouse

The Cord 1 that raises and lowers the elevator passes from the top of the car 11 over the $\frac{1}{2}$ " loose Pulley Wheel 4 and the $1\frac{1}{2}$ " Pulley 5, and is wound between two 1" fast Pulley Wheels on a 3" Axle Rod 2, which is driven from the Electric Motor via a Worm Wheel, a 57-toothed Gear Wheel, a $\frac{3}{4}$ " Contrate Wheel, and a $\frac{1}{2}$ " Pinion. The elevator car is counterbalanced by a weight 3, consisting of a Fork Piece, fourteen $2\frac{1}{2}$ " Strips, and a Collar, which is connected to the car by a Cord 10 passing over a 1" fast Pulley Wheel (behind the Wheel 5) and the $\frac{1}{2}$ " loose Pulley Wheel 6.

The elevator car is guided by a pair of vertical Cords 7, which pass through holes in the $2\frac{1}{2}$ " x $\frac{1}{2}$ " Double Angle Strips 8 as shown, and the weight 3 is similarly guided by the cords 9.

Parts required :

6 of No.	1	1 of No.	48D
19 " "	2	2 " "	52
18 " "	5	1 " "	53
2 " "	6A	6 " "	59
6 " "	8	2 " "	90A
4 " "	9	2 " "	99
4 " "	10	6 " "	100
16 " "	12	2 " "	108
1 " "	14	2 " "	111
2 " "	16	4 " "	111c
2 " "	17	1 " "	116
1 " "	21	2 " "	126A
3 " "	22	1 " "	160
2 " "	23		Electric Motor
1 " "	26		(not included in
1 " "	27A		Outfit)
1 " "	29		
1 " "	32		
2 " "	35		
126 " "	37		
6 " "	37A		
1 " "	38		
1 " "	46		
5 " "	48A		



Model No. 4.41 Flying Machine

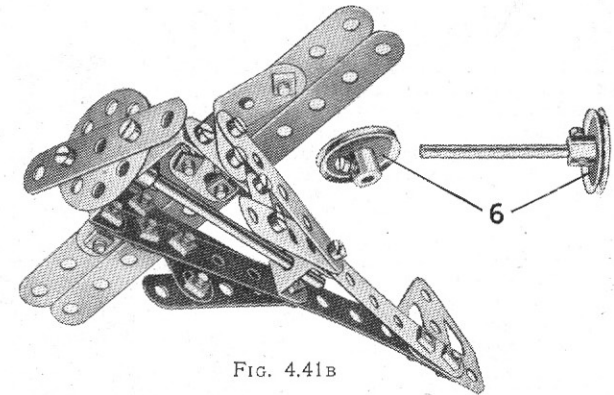
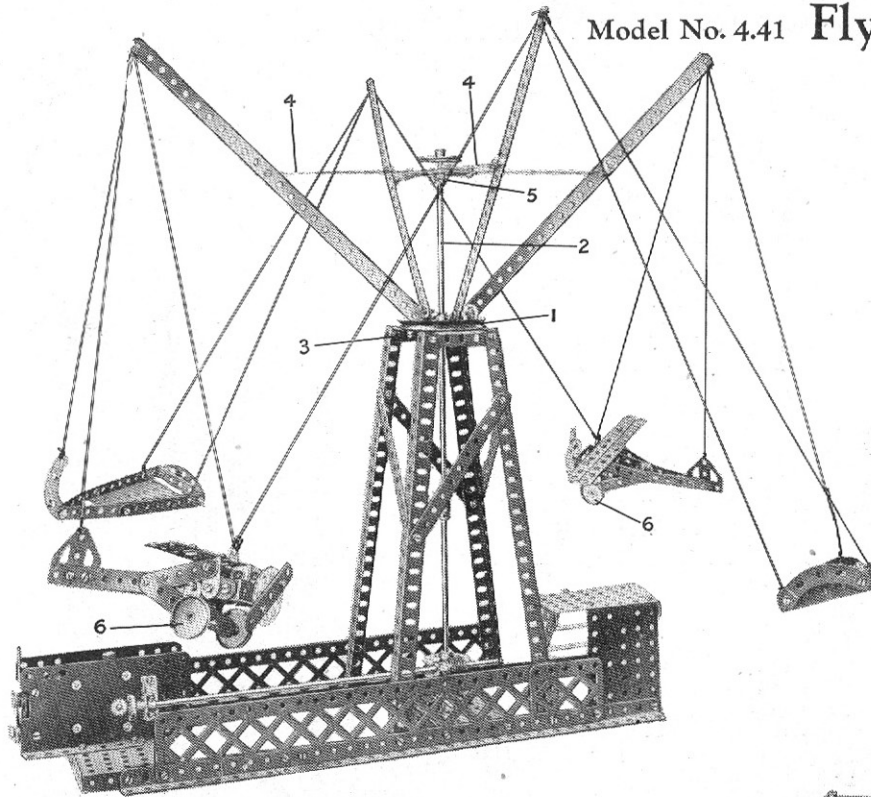


FIG. 4.41B

In Fig. 4.41 the model is shown equipped with a Meccano Electric Motor. Fig. 4.41A, which shows the base of the model only, indicates an alternative arrangement by which the model may be operated by hand if a Motor is not available. The revolving portion of the model consists of four $12\frac{1}{2}$ " Strips bolted to the 3" Pulley Wheel 1 (Fig. 4.41) which is secured to the main vertical shaft 2 and rests directly on the $3\frac{1}{2}$ " \times $2\frac{1}{2}$ " Flanged Plate 3. The $12\frac{1}{2}$ " Strips are supported by two further $12\frac{1}{2}$ " Strips 4, crossed and bolted to a Face Plate 5 secured to the Rod 2. One of the aeroplanes attached to the model is shown in detail in Fig. 4.41B. The Wheels 6 are shown removed from their bearings.

Parts required :

6 of No.	1	4 of No.	12A	1 of No.	27A	2 of No.	54
16 "	2	2 "	13	1 "	29	3 "	59
2 "	2A	1 "	14	1 "	32	1 "	63
11 "	5	2 "	16	122 "	37	4 "	90A
1 "	6A	2 "	17	2 "	37A	2 "	98
6 "	8	1 "	19B	1 "	46	2 "	99
3 "	9	1 "	21	2 "	48	1 "	109
6 "	10	4 "	22	6 "	48A	2 "	111c
3 "	11	2 "	24	2 "	52	2 "	126
2 "	12	1 "	26	3 "	53	2 "	126A

Electric Motor
(not included in Outfit)

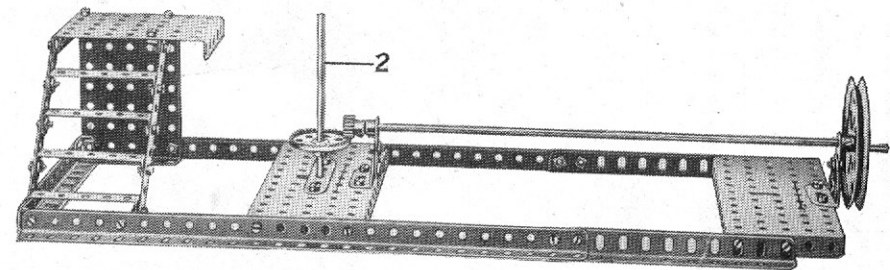


FIG. 4.41A

Model No. 4.42 Elevated Jib Crane

The gear-box 1 is secured to a 3" Pulley Wheel 2 (the boss 3 of which stands up), by means of two 2½" × ½" Double Angle Strips 4. The 11½" Rod 5 passes up through the boss 3, a Collar 6 being positioned on top of the boss within, the Contrate Wheel 7 being secured to the top of the Rod 5. A ½" Pinion 8 engages the Contrate Wheel 7 and also a 57-toothed Wheel 9 on the Rod 14 on which latter the hoisting cord 10 is wound, passing over the 1" Pulley 12 to the Hook 13. The Rod 5 is actuated from the Crank Handle 15 by the Pinion 16 engaging a ¾" Contrate Wheel 17 and through the Gear Wheels 7, 8, and 9, and operates the cord 10 to raise or lower the load. The jib 18 is swivelled from the Crank Handle 19, a continuous cord 20 being wound twice round the Flange Wheel 21, against which is butted a Bush Wheel 22 to make it into a double flange pulley. A Cord 20 passes round 1" guide Pulleys 23 round the 3" Pulley Wheel 2. By turning the Handle 19 the jib is swivelled.

Alternative Construction. In order to make the jib swivel more freely, a ball-race, Fig. 4.42B, may be fitted. This is made by bolting to the top of the frame a 3" Pulley Wheel 24 by Bolts 25 which also secure in the Pulley Wheel 24 a Wheel Flange 26. This provides a circular groove for the reception of the Ball Bearings 27. The Pulley Wheel 2 which is bolted to the gear-box 1 is then placed over the Rod 5 and rests on the Ball Bearings 27 to form a race.

(N.B.—The Wheel Flange and the Balls for the bearing are not provided in this Outfit but can be bought separately. See parts list page).

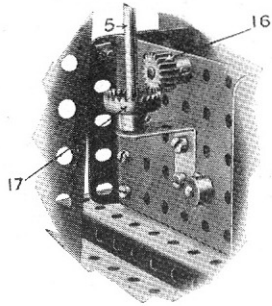


FIG. 4.42A

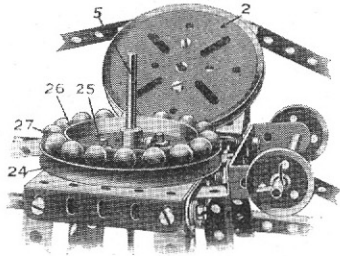


FIG. 4.42B

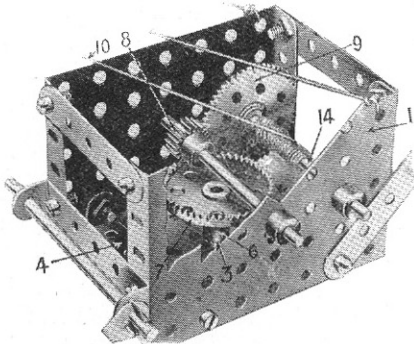
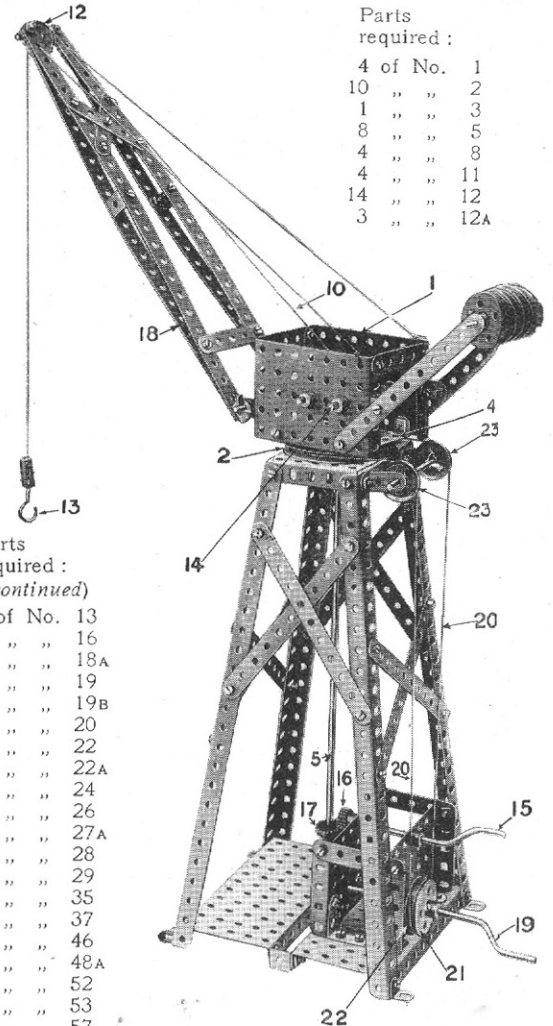


FIG. 4.42c



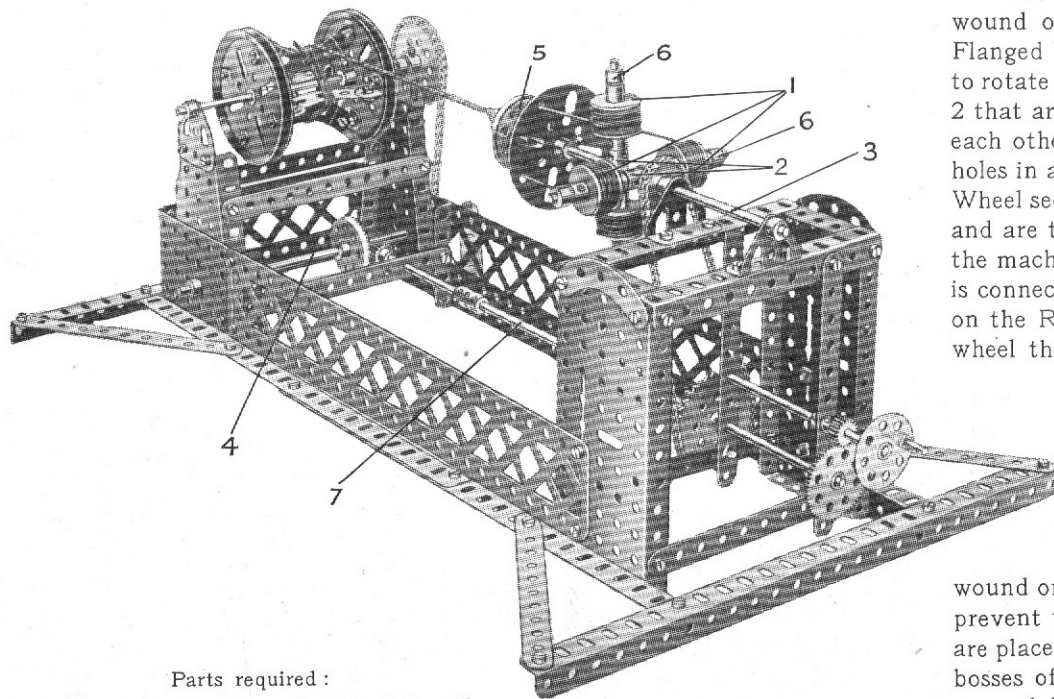
Parts required :

4 of No.	1
10 "	2
1 "	3
8 "	5
4 "	8
4 "	11
14 "	12
3 "	12A

Parts required :
(continued)

1 of No.	13
5 "	16
1 "	18A
2 "	19
1 "	19B
6 "	20
1 "	22
2 "	22A
1 "	24
2 "	26
1 "	27A
1 "	28
1 "	29
4 "	35
85 "	37
1 "	46
3 "	48A
2 "	52
5 "	53
1 "	57
6 "	59
1 "	63

Model No. 4.43 Wire Rope-Making Machine



The wire from which the rope is to be made is wound on four bobbins 1, each consisting of two $\frac{3}{4}$ " Flanged Wheels butted together. The bobbins are free to rotate on 2" Rods secured in the ends of two Couplings 2 that are made fast to the 8" Rod 3 at right angles to each other. The wires from the bobbins pass through holes in a Face Plate, a $1\frac{1}{2}$ " Pulley Wheel 5, and a Bush Wheel secured to the Rod 3 close to the Pulley Wheel 5, and are tied together on a drum at the opposite end of the machine. The drum is mounted on a $6\frac{1}{2}$ " Rod that is connected by Sprocket Chain to a 1" Sprocket Wheel on the Rod 4, which is revolved slowly from the hand wheel through the gearing shown.

The Rod 3, together with the bobbins, Face Plate, Pulley Wheel 5, and the Bush Wheel, are rotated from the main driving shaft 7 by means of 2" and 1" Sprocket Wheels. The wires are thus twisted together between the Pulley Wheel 5 and the drum, and are wound on the latter in the form of a cable. In order to prevent the wire from unwinding too rapidly, Washers are placed on the 2" Rods between the Couplings and the bosses of the Flanged Wheels 1, and the Collars 6 are pressed hard against the wheels before being secured to the 2" Rods.

A considerable amount of tension is essential to the production of good wire rope, and for this reason the $1\frac{1}{2}$ " Pulley Wheel 5 and the Bush Wheel behind it are secured close together on the Rod 3 in such a manner that the friction generated by the wires in passing through the holes in the wheels keeps the cable taut while it is being twisted. String or thin wire may be used in the model.

Parts required :

11 of No. 2	8 of No. 20	4 of No. 90A
6 " " 8	1 " " 21	1 " " 94
2 " " 9	1 " " 24	2 " " 95
8 " " 12	2 " " 26	2 " " 96
1 " " 13	1 " " 27A	2 " " 99
1 " " 13A	1 " " 28	1 " " 100
2 " " 14	84 " " 37	1 " " 109
1 " " 15A	2 " " 52	1 " " 115
1 " " 16	2 " " 54	2 " " 126
4 " " 17	8 " " 59	2 " " 126A
2 " " 19B	3 " " 63	

Model No. 4.44 Submarine

Parts required :

8 of No.	1	2 of No.	35
7 "	"	111 "	"
6 "	"	9 "	"
2 "	"	5 "	"
2 "	"	2 "	"
4 "	"	3 "	"
11 "	"	6 "	"
1 "	"	2 "	"
1 "	"	3 "	"
2 "	"	2 "	"
1 "	"	4 "	"
2 "	"	2 "	"
2 "	"	2 "	"
4 "	"	1 "	"
1 "	"		
3 "	"		
2 "	"		
1 "	"		

This model represents a large submarine of the latest type. It is equipped with wireless mast, periscope, quick-firing gun, and a workable steering gear controlled from the conning-tower.

Figure 4.44A is a sectional view of the conning-tower, and shows the helm. The cord 1, after passing over the 1" fast Pulley 7, is carried round a pair of 1" loose Pulley Wheels on the 5" Rod 2, and is given a complete turn round the 1" fixed Pulley Wheel 3 secured to the rudder head. The rudder consists of two 2½" Flat Girders, which are bolted by means of Angle Brackets to a pair of Cranks mounted on the Rod 4.

The short Rod carrying the Pulley 7 is journalled in a 2½" × ½" Double Angle Strip 8, and is held in place by a Collar and set-screw on its end. Washers should be placed between the Pulley 7 and Strip 8.

The 5½" × 2½" Flanged Plates that form the deck of the submarine are bolted together by means of 5½" Angle Girders, which, in turn, are bolted to 3½" × ½" Double Angle Strips secured transversely in the hull of the vessel. The hull itself is strengthened by vertical 3" Strips 5. The sides of the conning-tower are represented by two 3½" × 2½" Flanged Plates, the forward part being composed of a 2½" small radius Curved Strip and five 2½" × ½" Double Angle Strips. The periscope consists of a Coupling and a 5" Rod, which is supported in a further 2½" × ½" Double Angle Strip 6.

The vertical Rod supporting the quick-firing gun is free to turn in a Bush Wheel bolted to the deck. Two Collars should be placed on the Rod, one on each side of the Bush Wheel, to maintain the gun in position. The model is arranged to travel on two pairs of ¾" Flanged Wheels secured to 3½" Axle Rods.

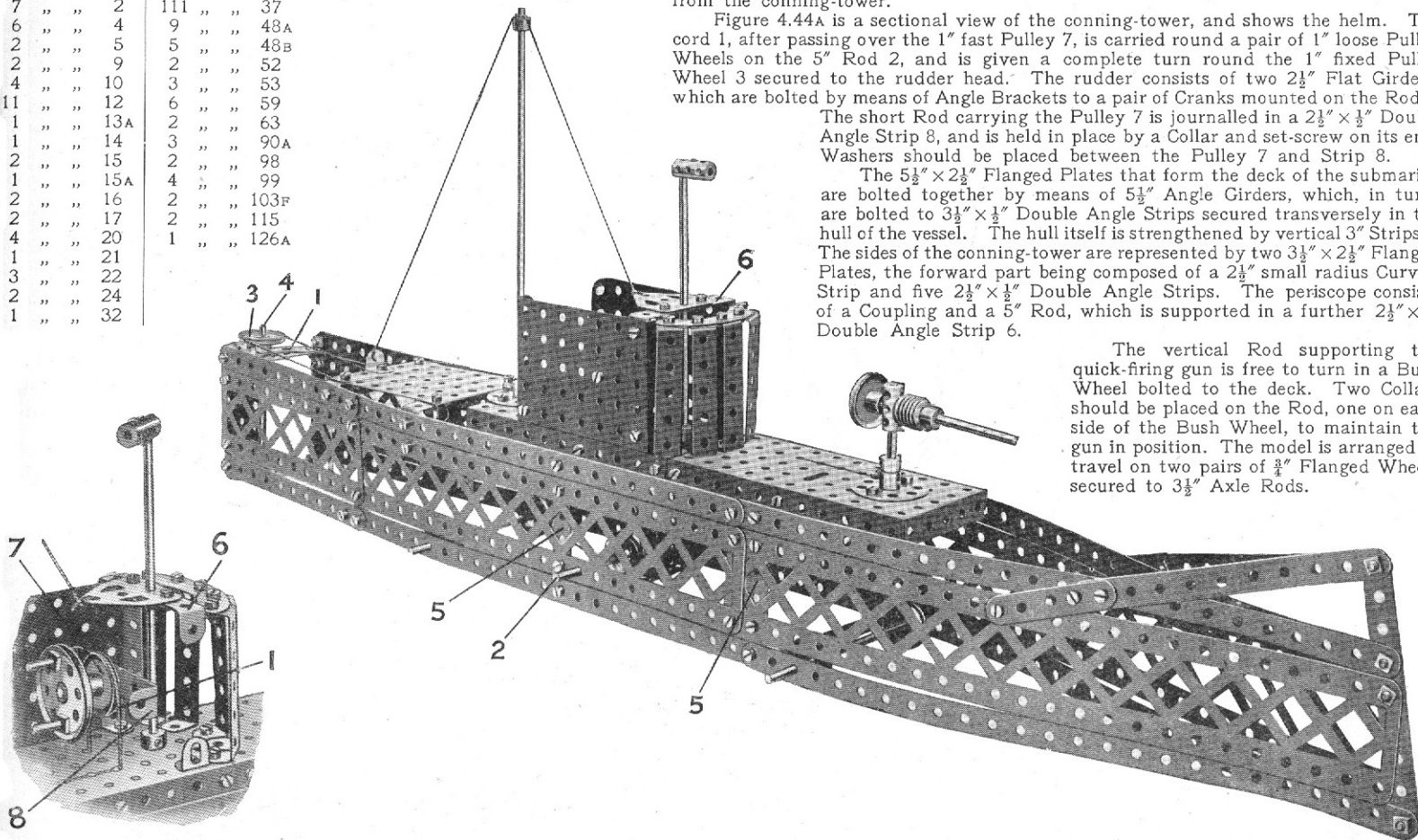


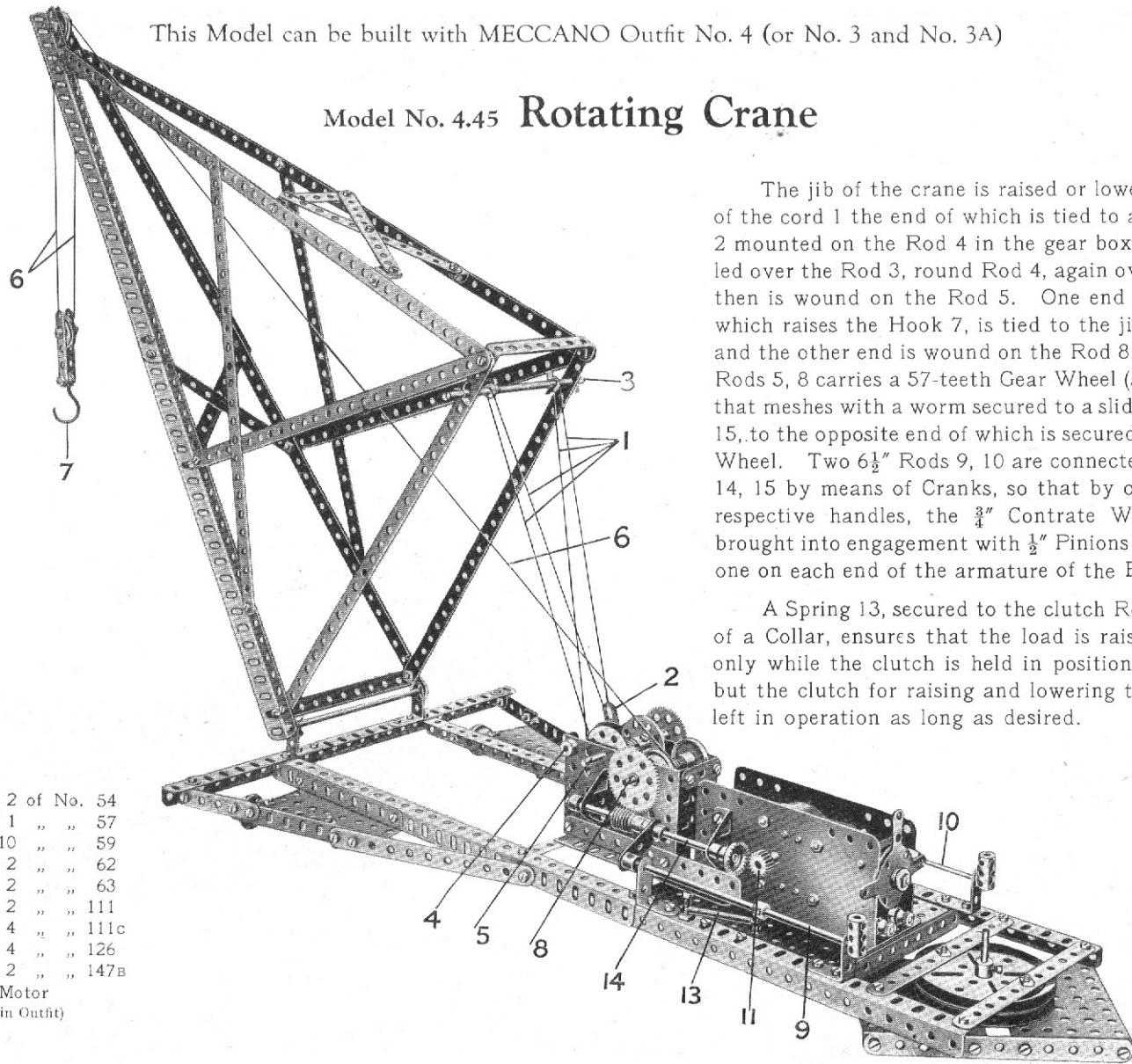
FIG. 4.44A

Model No. 4.45 Rotating Crane

Parts required :

10 of No.	1	
12 "	2	
5 "	5	
1 "	6A	
9 "	8	
2 "	9	
1 "	10	
6 "	12	
6 "	12A	
2 "	14	
4 "	15	
2 "	15A	
2 "	16	
2 "	17	
2 "	19B	
2 "	20	
2 "	22	
2 "	22A	
2 "	24	
2 "	26	
2 "	27A	
2 "	29	
2 "	32	
8 "	35	2 of No. 54
107 "	37	1 " " 57
6 "	37A	10 " " 59
10 "	38	2 " " 62
1 "	43	2 " " 63
2 "	48A	2 " " 111
1 "	48B	4 " " 111c
2 "	52	4 " " 126
4 "	53	2 " " 147B

Electric Motor
(not included in Outfit)



The jib of the crane is raised or lowered by means of the cord 1 the end of which is tied to a Flat Bracket 2 mounted on the Rod 4 in the gear box. The cord is led over the Rod 3, round Rod 4, again over Rod 3, and then is wound on the Rod 5. One end of the cord 6, which raises the Hook 7, is tied to the jib of the crane and the other end is wound on the Rod 8. Each of the Rods 5, 8 carries a 57-teeth Gear Wheel (see Fig. 4.45A) that meshes with a worm secured to a sliding 5" Rod 14, 15, to the opposite end of which is secured a 3/4" Contrate Wheel. Two 6 1/2" Rods 9, 10 are connected to the Rods 14, 15 by means of Cranks, so that by operating their respective handles, the 3/4" Contrate Wheels may be brought into engagement with 1/2" Pinions 11, 12 secured one on each end of the armature of the Electric Motor.

A Spring 13, secured to the clutch Rod 9 by means of a Collar, ensures that the load is raised or lowered only while the clutch is held in position by the hand, but the clutch for raising and lowering the jib may be left in operation as long as desired.

Model No. 4.45 Rotating Crane

(continued)

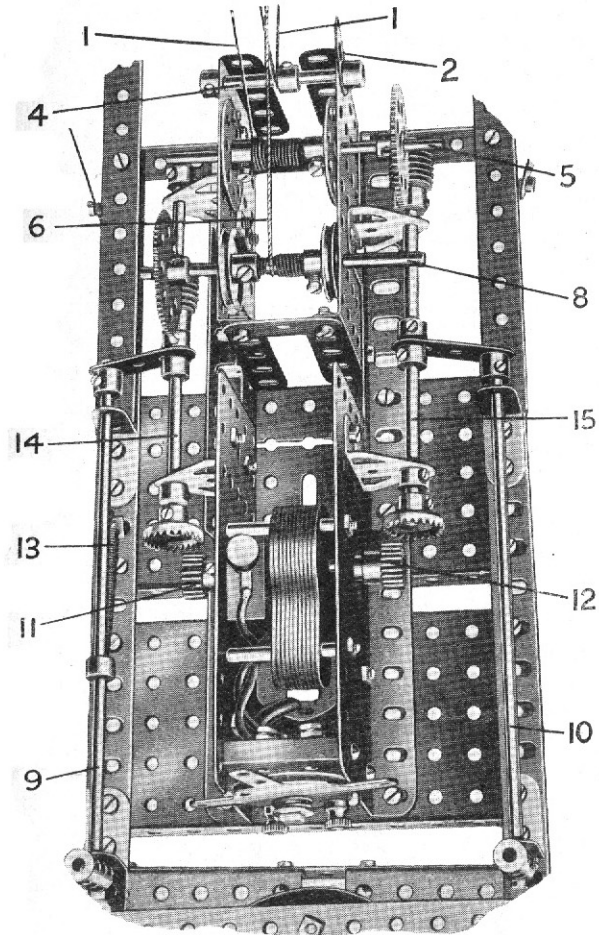


FIG. 4.45A

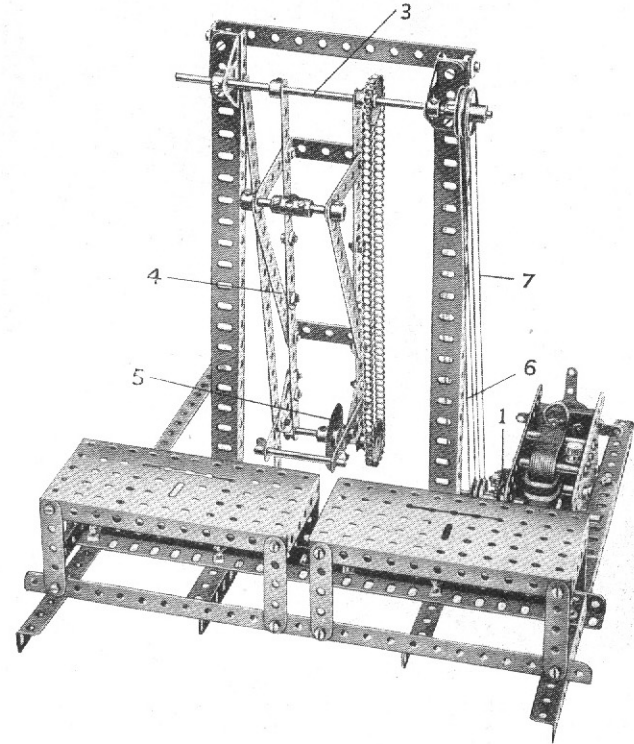
Model No. 4.46 Swing Saw

A $\frac{1}{2}$ " Pinion secured to the armature spindle of the Electric Motor engages with a 57-teeth Gear Wheel 1, the shaft of which carries two 1" Pulleys that transmit the drive by belts to the operating Rod 3. Two driving belts 6 and 7 are used side by side to obtain a more positive grip. The framework 4, carrying the Circular Saw 5, is free to swing about the Rod 3.

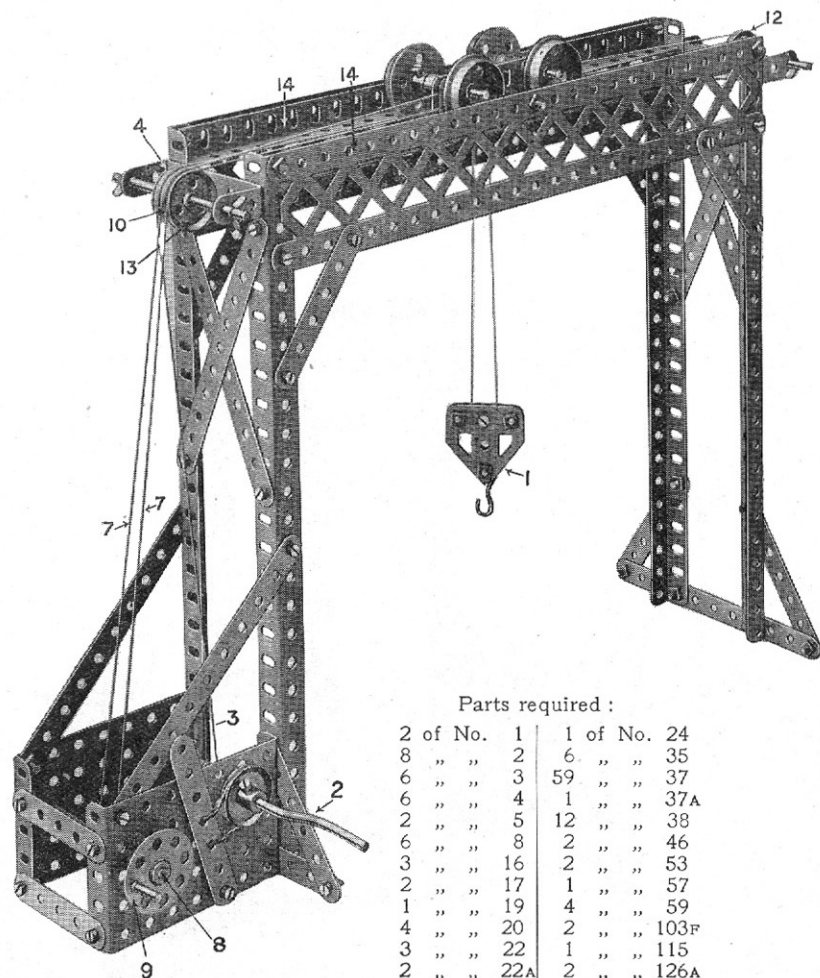
Parts required:

2 of No.	1
6	2
12	5
8	8
2	9
1	14
3	16
1	17
4	22
1	26
1	27A
2	35
57	37
2	48
2	48A
1	48D
2	52
2	53
7	59
1	63
2	96
2	126
2	126A
1	159

Electric Motor
(not included
in Outfit)



Model No. 4.47 Gantry



Parts required :

2 of No. 1	1 of No. 24
8 " " 2	6 " " 35
6 " " 3	59 " " 37
6 " " 4	1 " " 37A
2 " " 5	12 " " 38
6 " " 8	2 " " 46
3 " " 16	2 " " 53
2 " " 17	1 " " 57
1 " " 19	4 " " 59
4 " " 20	2 " " 103F
3 " " 22	1 " " 115
2 " " 22A	2 " " 126A
3 " " 23	

The Pulley 1 is capable of being hoisted to raise the load, or traversed. In order to raise the load the Crank Handle 2 is operated, which winds the Cord 3 passing over the rear Pulley Wheel 4 round the $\frac{1}{2}$ " Pulley 5 and a corresponding Pulley in the block, thence round another $\frac{1}{2}$ " Pulley 6 and is made fast at the end of the gantry. For traversing a continuous Cord 7 is wound several turns on the $3\frac{1}{2}$ " Rod 8 to which is secured a hand wheel 9. The cord passes over the Pulley Wheel 10 and is secured to one of the side Plates 11, and continues round the Pulley 12 returning to and passing over the nearest Pulley Wheel 13 back to the Rod 8. Consequently by turning the hand wheel 8 in one or other direction, the carriage is traversed to and fro along the top Angle Girders 14, which form the travelling rails. The construction of the travelling carriage is shown in Fig. 4.47A, three Washers 15 being placed on each of the outer Bolts, passed through the two Plates 11; and $\frac{1}{2}$ " Pulley Wheels 5, 6, on the inner Bolts. The outer plates being then bolted together, the Rods 16 of the Flanged Wheels are passed through both plates in the end elongated holes, and Collars 17 secured on the exterior. After which the remaining Flanged Wheels 18 are secured on the ends of the Rods 16.

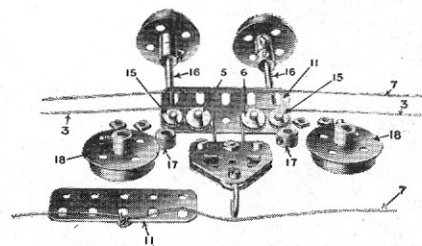


FIG. 4.47A

Fig. 4.47A

Model No. 4.48 Tower Wagon

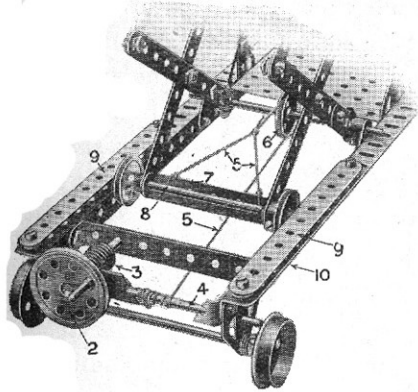
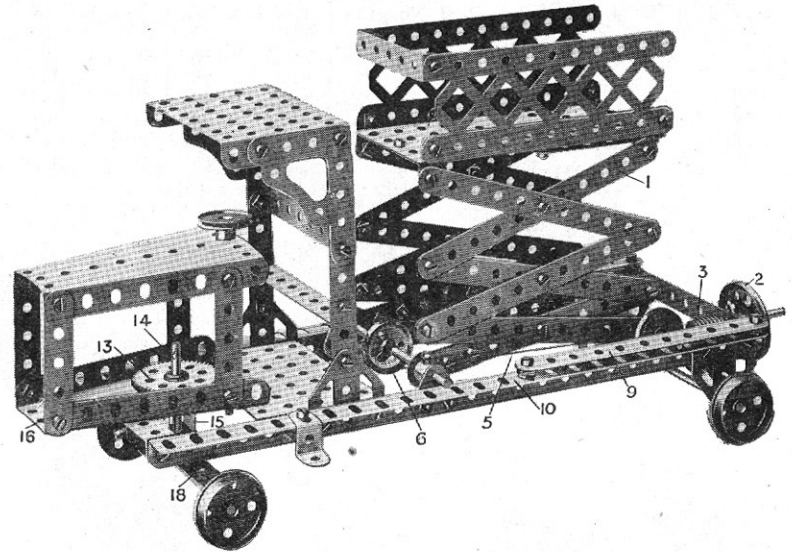


FIG. 4.48A

The Lazy Tongs 1 are extended by turning the Hand Wheel 2, a Worm 3 on which engages a $\frac{1}{2}$ " Pinion not shown, on the Rod 4. On this Rod winds a Cord 5 which passes round a Pulley 6 and is secured to a $2\frac{1}{2}$ " \times $\frac{1}{2}$ " Double Angle Strip 7 on the Rod 8, the ends of which slide in guides on either side formed by the Strips 9 spaced by Washers and the Angle Girders 10 of the carriage. The Lazy Tongs collapse by their own weight. The steering is effected from the Rod 11, a Pinion 12 on which engages a 57-toothed Gear Wheel 13, the 2" Rod 14 of which passes through a Double Bent Strip 15 bolted to the under-side of the Sector Plate 16. The Rod 14 is secured to the Bush Wheel 17 which carries the $3\frac{1}{2}$ " \times $\frac{1}{2}$ " Double Angle Strip 18.



Model No. 4.49 Breast Drill

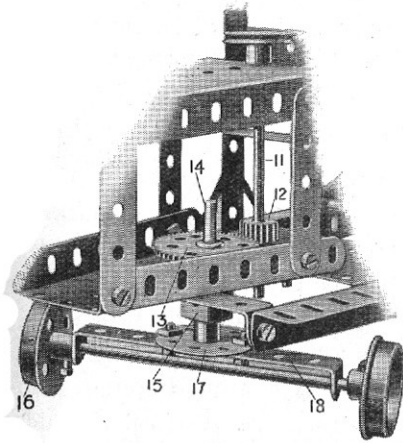
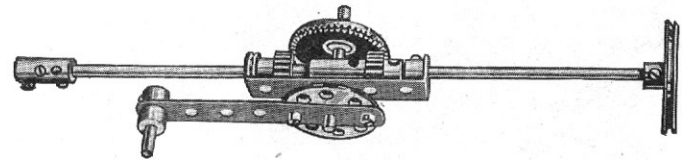


FIG. 4.48B

Parts required :

16 of No. 2	78 of No. 37
2 " " 4	22 " " 37A
4 " " 5	24 " " 38
2 " " 8	1 " " 45
2 " " 15	4 " " 48A
5 " " 15A	6 " " 48B
1 " " 16	1 " " 52
2 " " 17	2 " " 53
4 " " 20	2 " " 54
1 " " 21	3 " " 59
3 " " 22	2 " " 62
1 " " 22A	2 " " 77
1 " " 24	2 " " 100
2 " " 26	2 " " 108
1 " " 27A	1 " " 115
1 " " 32	2 " " 125
2 " " 35	4 " " 126A



Parts required :

1 of No. 3	1 of No. 21	2 of No. 37
2 " " 15	1 " " 23	1 " " 48A
2 " " 17	1 " " 24	3 " " 59
1 " " 18A	2 " " 26	2 " " 63
	1 " " 28	

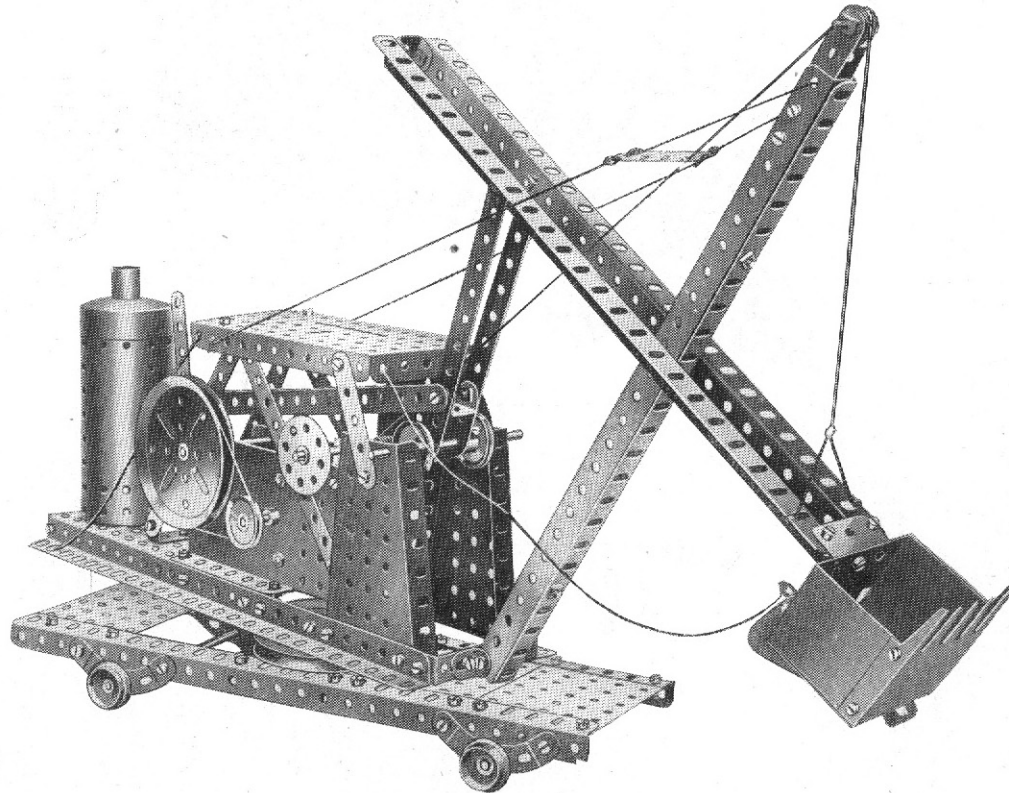
This Model can be built with MECCANO Outfit No. 4 (or No. 3 and No. 3A)

Model No. 4.50 Bucket Excavator

Parts required :

8 of No.	2	2 of No.	15A	9 of No.	37A	2 of No.	54
1 " "	3	3 " "	16	6 " "	38	3 " "	59
5 " "	5	4 " "	19B	1 " "	46	4 " "	90A
8 " "	8	4 " "	20	1 " "	48	1 " "	111
1 " "	10	4 " "	22	3 " "	48A	4 " "	111c
2 " "	11	1 " "	23	2 " "	48B	1 " "	126
7 " "	12	1 " "	24	2 " "	52	1 " "	162
1 " "	15	88 " "	37	3 " "	53	1 " "	169

Electric Motor (not included in Outfit)



The 1" fast Pulley secured to the armature spindle of the Electric Motor drives the 3" Pulley shown, and a second 1" fast Pulley on the axle of the latter is connected to a second 3" Pulley on the hoisting shaft. The cord wound on this shaft passes over a $\frac{1}{2}$ " loose Pulley Wheel at the end of the jib, and is tied to the bucket arm.

The bucket arm is pivoted by means of bolts and lock-nuts (S.M. 263) to a pair of $5\frac{1}{2}$ " Strips, which are connected to a lever fitted near the boiler end of the Motor by means of $5\frac{1}{2}$ " and $3\frac{1}{2}$ " Strips overlapped so that their effective length is $9\frac{1}{2}$ ". When the lever is pushed or pulled, the effective length of the bucket arm is increased or decreased. The Digger Bucket is opened by pulling a cord, thereby releasing the catch that holds the bottom in place. The cord is led back to a position conveniently close to the lever that operates the bucket arm.

Some very realistic effects can be obtained with this model by arranging a supply of suitable material, such as sand or light soil, so that the excavator can actually be set in operation. If the Meccano boy is also the fortunate owner of a Hornby miniature railway he can obtain much fun by loading the excavated material into waiting railway wagons. The excavation would, of course, be planned with a view to laying down an extension or branch line!

Model No. 4.51 Travelling Swivel Crane

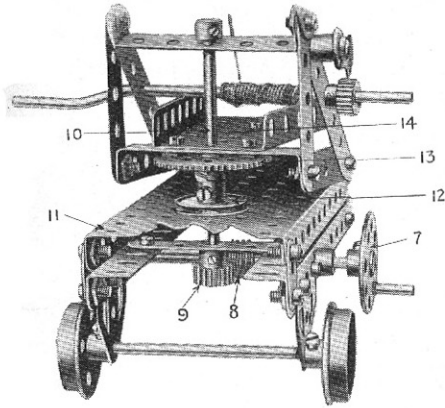
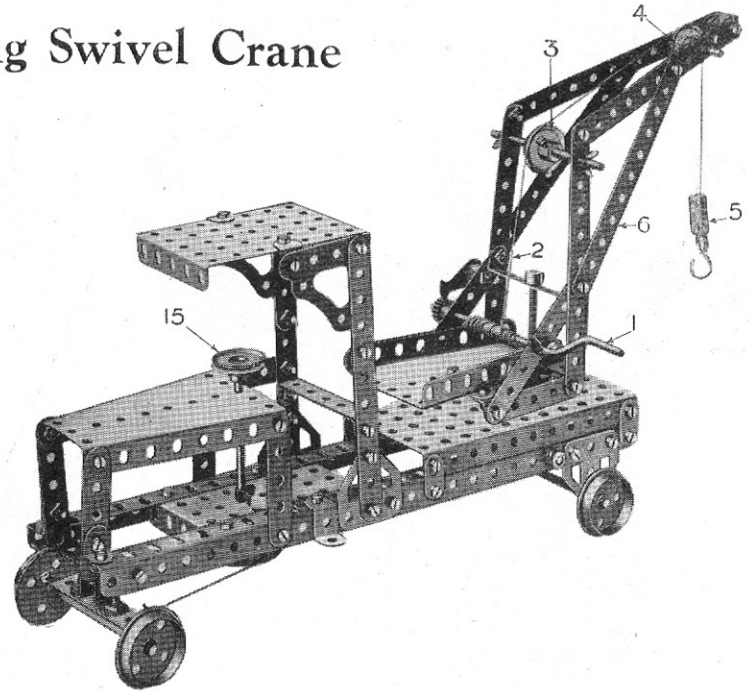


FIG. 4.51A

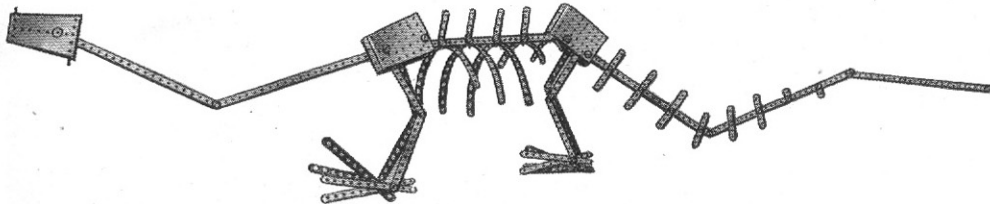
Parts required :			
8 of No.	2	6 of No.	35
2 " "	3	69 " "	37
9 " "	5	3 " "	37A
2 " "	8	1 " "	45
4 " "	10	5 " "	48A
1 " "	11	1 " "	52
8 " "	12	2 " "	53
2 " "	15A	2 " "	54
4 " "	16	1 " "	57
1 " "	17	3 " "	59
1 " "	19	1 " "	63
4 " "	20	2 " "	108
1 " "	21	1 " "	115
4 " "	22	1 " "	125
1 " "	24	4 " "	126A
2 " "	26	1 " "	147A
1 " "	27A	1 " "	147B
1 " "	32	1 " "	148



The load is raised from the Crank Handle 1, a Cord 2 winding on which passes over the 1" Pulleys 3 and 4 to the block 5. The jib 6 is swivelled from the hand wheel 7 on the rod of which is a Worm 8 engaging a Pinion 9 bolted to a vertical Rod 10, to which is secured beneath the platform 11 a 1" Pulley Wheel 12 and a 57-toothed Wheel 13 which carries the swivel platform 14. The steering of the motor vehicle is effected from the 1" Pulley Wheel 15 by a method similar to that described under Standard Mechanism No. 119.

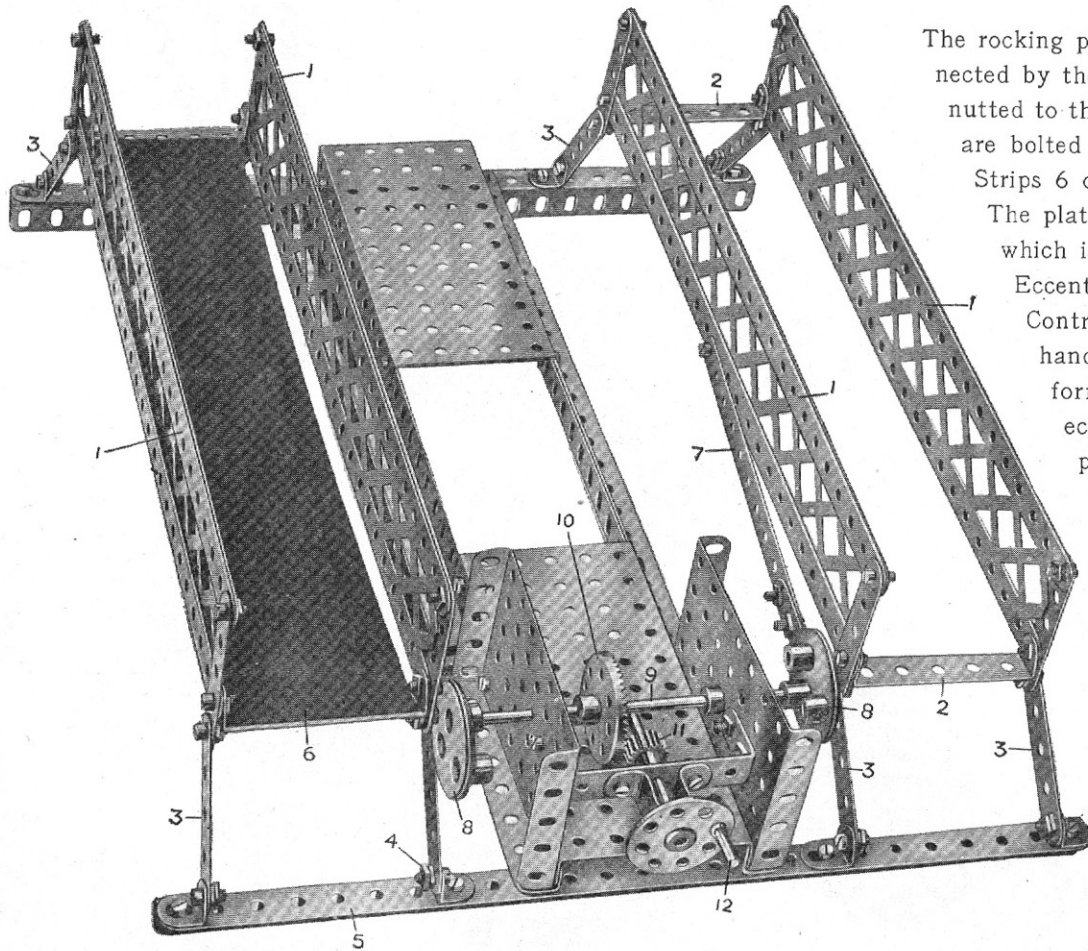
Model No. 4.52 Diplodocus

This representation of a prehistoric animal is a most extraordinary effort sent in by a young French boy to compete in one of the big Meccano Model-building Competitions. We could scarcely class it as an engineering model, but any boy with a brain clever enough and an imagination lively enough to conceive and construct such an animal as this from Meccano parts deserved a good prize, so we awarded him one. Screw the Nuts and Bolts up tightly because the Diplodocus looks most dejected when he droops.



Parts required :					
1 of No.	1	1 of No.	8	40 of No.	37
7 " "	2	4 " "	10	4 " "	53
4 " "	3	1 " "	16	2 " "	54
8 " "	5	4 " "	17	8 " "	59
		2 " "	22		

Model No. 4.53 Cake Walk



The rocking platforms are built up of Braced Girders 1 connected by the end Strips 2 and pivotally bolted and lock-nutted to the Strips 3 forming rocking links. These latter are bolted and lock-nutted at 4 to the Angle Girders 5. Strips 6 of cardboard are secured to the end Strips 2. The platforms are rocked by means of Strips 7, one of which is connected to each rocking platform and to Eccentrics 8 fixed on the Rod 9 on which is secured a Contrate Wheel 10 driven by a Pinion 11 from the handle 12. As the handle 12 is turned the platforms are rocked to and fro on the Strips 3. The eccentrics 8 should be so arranged that the platforms rock in opposite directions.

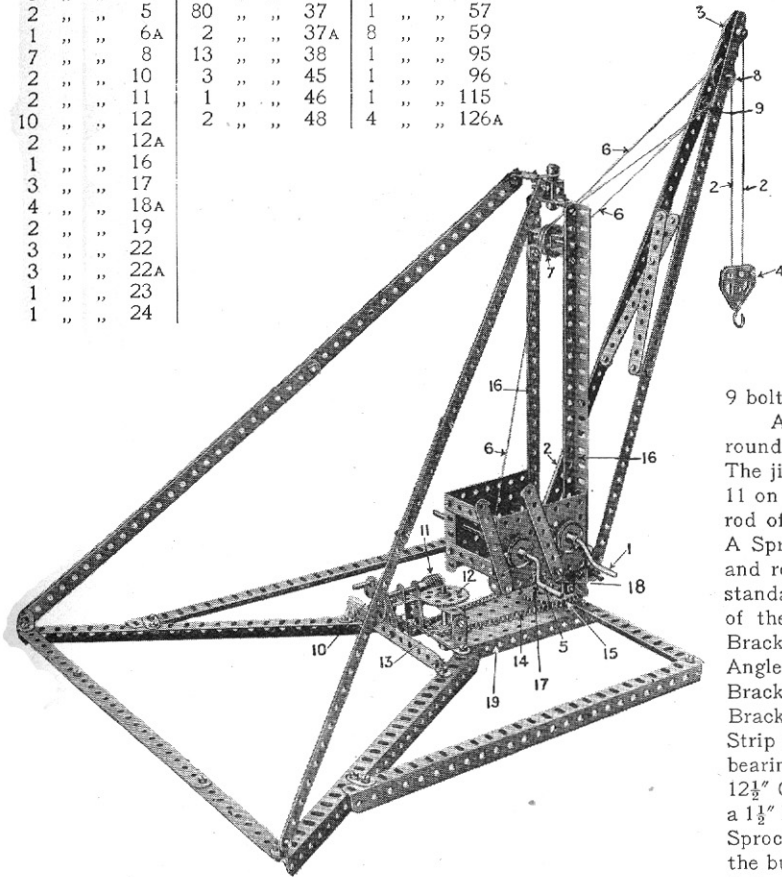
Parts required :

8 of No.	1	66 of No.	37
2 "	"	1 "	38
16 "	"	1 "	45
6 "	"	1 "	46
8 "	"	4 "	48A
1 "	"	2 "	52
1 "	"	2 "	53
1 "	"	2 "	59
1 "	"	4 "	99
1 "	"	1 "	115
		2 of No.	130

Model No. 4.54 Swivelling and Luffing Jib Crane

Parts required:

10 of No. 1	1 of No. 27A	3 of No. 48A
3 " " 2	1 " " 32	1 " " 52
3 " " 3	2 " " 35	2 " " 53
2 " " 5	80 " " 37	1 " " 57
1 " " 6A	2 " " 37A	8 " " 59
7 " " 8	13 " " 38	1 " " 95
2 " " 10	3 " " 45	1 " " 96
2 " " 11	1 " " 46	1 " " 115
10 " " 12	2 " " 48	4 " " 126A
2 " " 12A		
1 " " 16		
3 " " 17		
4 " " 18A		
2 " " 19		
3 " " 22		
3 " " 22A		
1 " " 23		
1 " " 24		



In this model three separate actions are provided, for raising the load, raising the jib, and swivelling the jib. The load is raised by means of a Crank Handle 1 on which the Cord 2 is wound and [passes over the 1" Pulley 3, thence round the ½" Pulley in the block 4 (spacing washers being used to give clearance to the ½" Pulley), the end of the Cord 2 being made fast to the top of the jib. By turning the Handle 1 the load is raised or lowered. The jib itself is raised or lowered by the operation of the Crank Handle 5 on the rod of which a cord is wound, and passes over one of two Pulleys 7 to and round another 1" Pulley 8 in the jib, whence it returns to and passes round the other Pulley 7, being finally made fast to the Double Bracket

9 bolted to the jib.

As the Handle 5 is turned the Cord 6 is wound round the pulleys and the angle of the jib varied. The jib is swivelled by the hand wheel 10, a Worm 11 on which engages a 57-toothed Wheel 12 on the rod of which a 1" Sprocket Wheel 13 is mounted. A Sprocket Chain 14 passes round this Wheel 13 and round a 2" Sprocket Wheel 15 secured to the standard 16 of the crane. The bearing for the Rod of the Worm 11 is made by bolting a 1" Angle Bracket 20 to the rectangular Plate 19, and to the Angle Bracket 20 is secured a 1½" Strip 21 and a 1" Bracket 22. To the Bracket 22 is bolted a Double Bracket 23. A Flat Trunnion 24 is bolted to the 5½" Strip 25 which forms with the Bracket 23 the front bearing for the Rod. The standard is built up of two 12½" Girders 16 which are connected at the base by a 1½" Double Angle Strip 17 which is bolted to the 2" Sprocket Wheel 15. The 1" Rod 18 is secured in the bush of the Sprocket Wheel 15 and fitted with a Collar below the rectangular Plate 19, Fig. 4.54b.

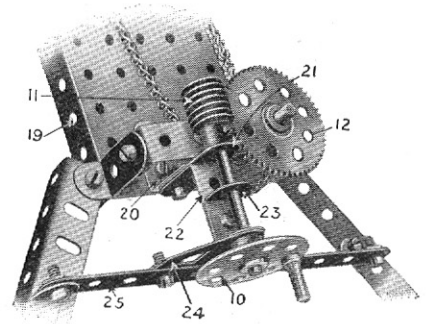


FIG. 4.54A

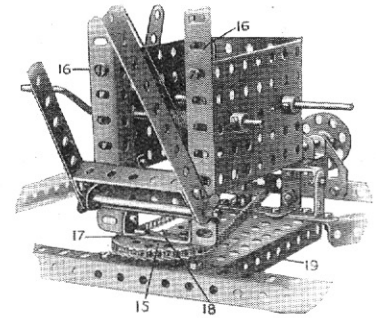
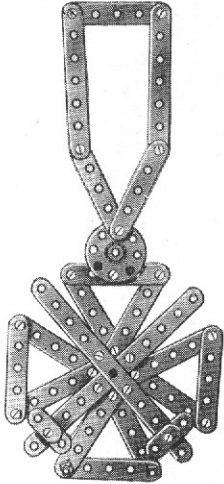


FIG. 4.54B

Model No. 4.55

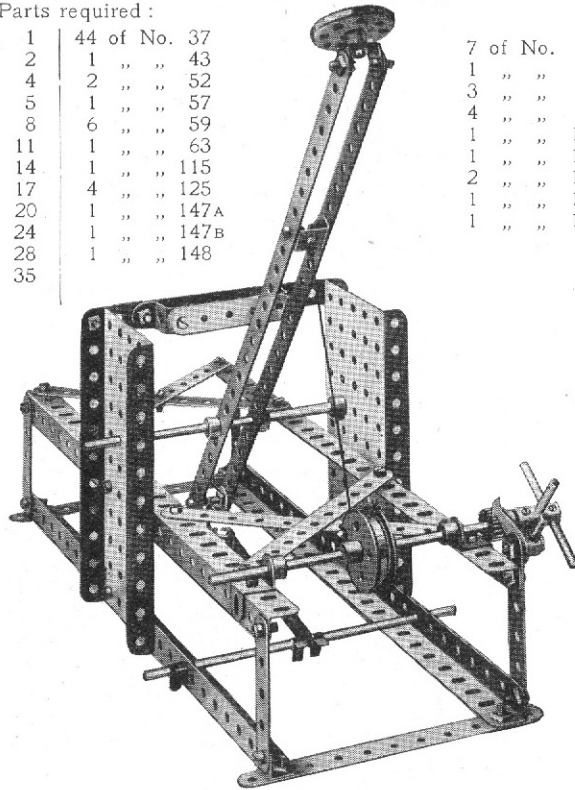
Croix de GuerreParts
required :

2 of No.	2
2 " "	3
15 " "	5
4 " "	10
2 " "	24
24 " "	37

Model No. 4.56 **Catapult**

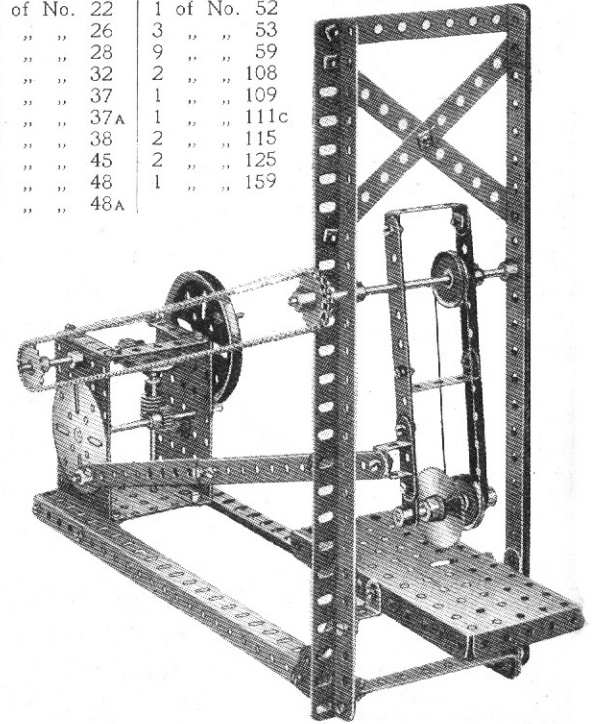
Parts required :

2 of No.	1	44 of No.	37
7 " "	2	1 " "	43
1 " "	4	2 " "	52
6 " "	5	1 " "	57
4 " "	8	6 " "	59
3 " "	11	1 " "	63
3 " "	14	1 " "	115
2 " "	17	4 " "	125
1 " "	20	1 " "	147A
1 " "	24	1 " "	147B
1 " "	28	1 " "	148
4 " "	35		

Model No. 4.57 **Automatic Saw**

Parts required :

7 of No.	2	2 of No.	22	1 of No.	52
1 " "	3	2 " "	26	3 " "	53
3 " "	5	1 " "	28	9 " "	59
4 " "	8	1 " "	32	2 " "	108
1 " "	15	41 " "	37	1 " "	109
1 " "	15A	3 " "	37A	1 " "	111c
2 " "	16	2 " "	38	2 " "	115
1 " "	17	1 " "	45	2 " "	125
1 " "	19B	2 " "	48	1 " "	159
		1 " "	48A		

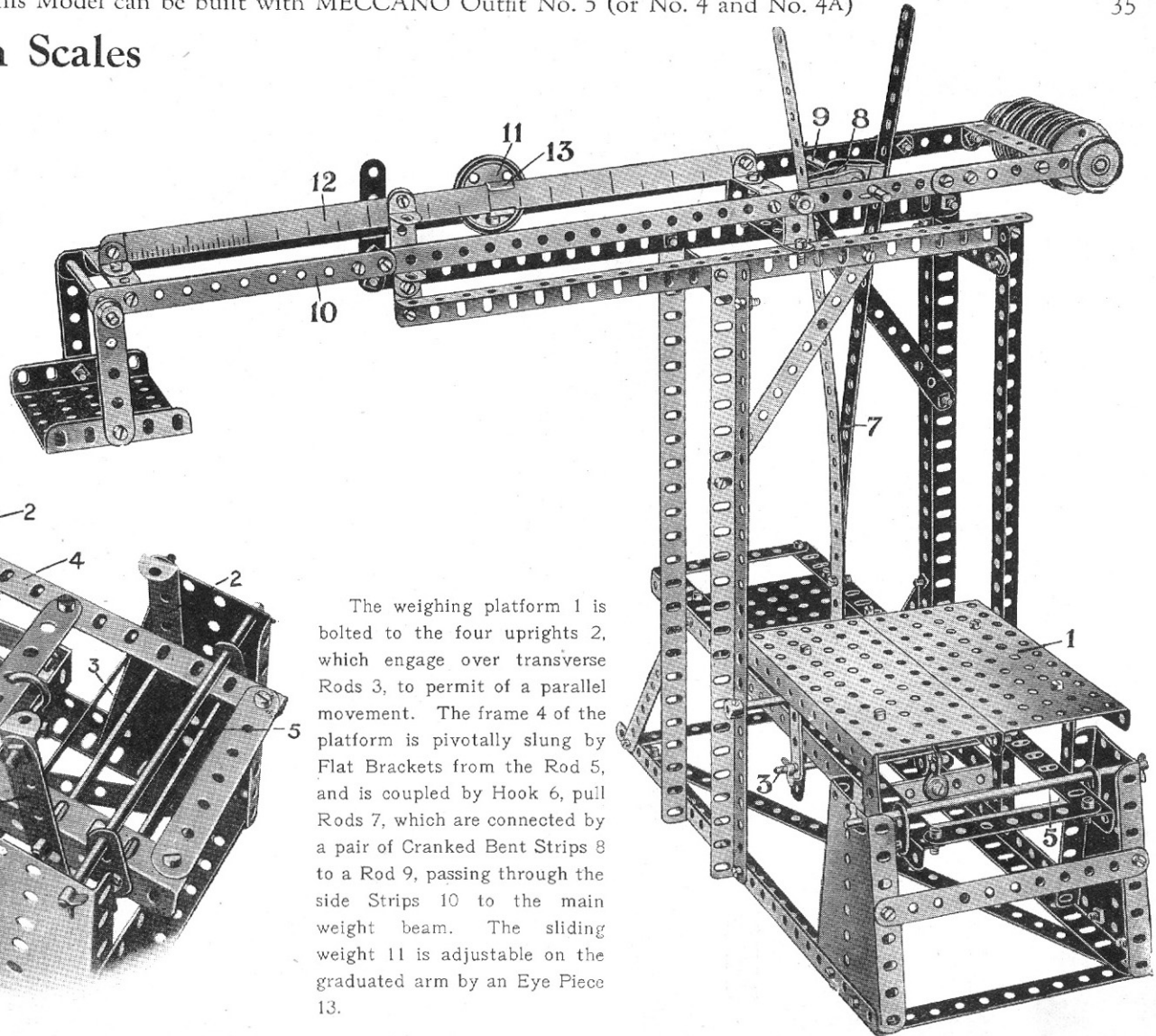
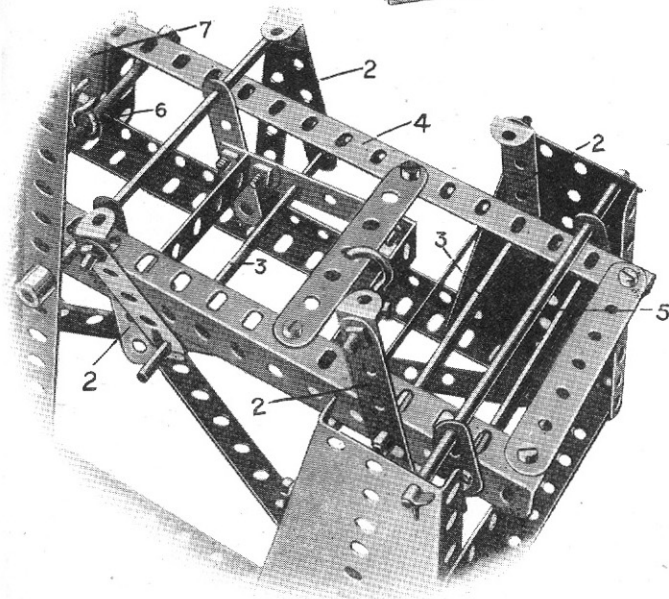
**HOW TO CONTINUE**

This completes our examples of the models that may be made with MECCANO Outfit No. 4. The next models are a little more advanced, requiring a number of extra parts to construct them. The necessary parts are all contained in a No. 4A Accessory Outfit, the price of which will be found in the List at the end of this Manual.

Model No. 5.1 Beam Scales

Parts required :

7 of No.	1	7 of No.	20
10 "	2	2 "	22
8 "	3	88 "	37
2 "	4	2 "	44
10 "	5	1 "	46
10 "	8	5 "	48A
2 "	10	1 "	50
9 "	12	2 "	52
2 "	14	2 "	53
2 "	15	2 "	54
4 "	15A	2 "	57
2 "	16	8 "	59



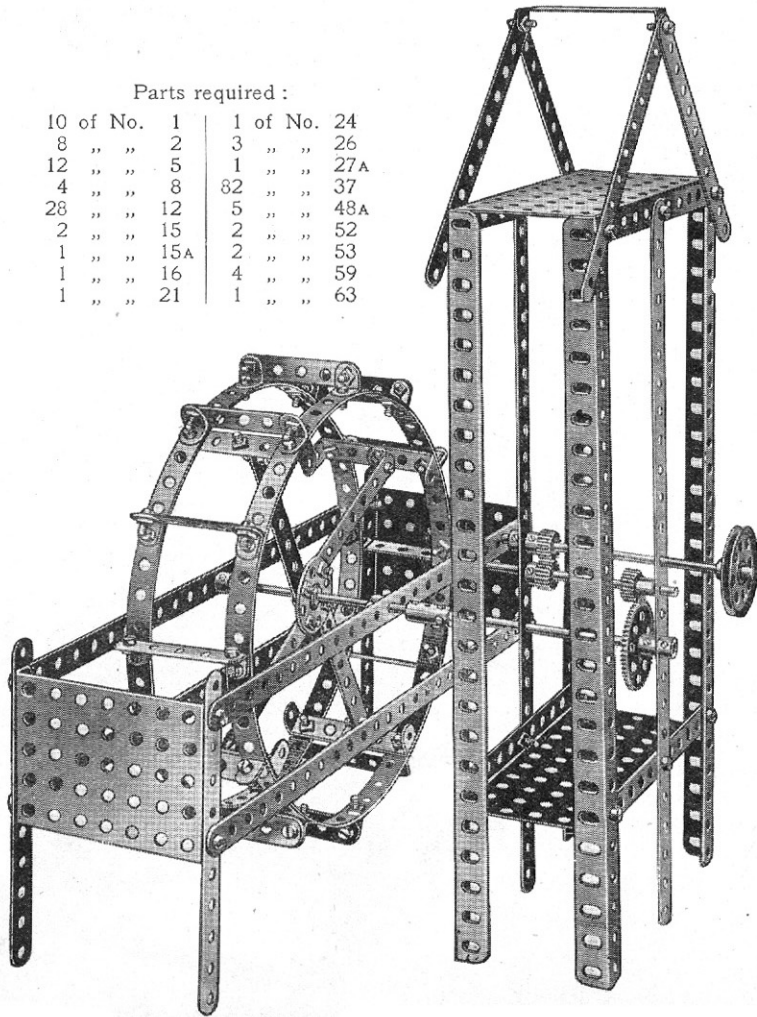
The weighing platform 1 is bolted to the four uprights 2, which engage over transverse Rods 3, to permit of a parallel movement. The frame 4 of the platform is pivotally slung by Flat Brackets from the Rod 5, and is coupled by Hook 6, pull Rods 7, which are connected by a pair of Cranked Bent Strips 8 to a Rod 9, passing through the side Strips 10 to the main weight beam. The sliding weight 11 is adjustable on the graduated arm by an Eye Piece 13.

FIG. 5.1A

Model No. 5.2 Belgian Water Wheel

Parts required :

10 of No.	1	1 of No.	24
8 " "	2	3 " "	26
12 " "	5	1 " "	27A
4 " "	8	82 " "	37
28 " "	12	5 " "	48A
2 " "	15	2 " "	52
1 " "	15A	2 " "	53
1 " "	16	4 " "	59
1 " "	21	1 " "	63



Model No. 5.3 Hand Car

Parts required :

4 of No.	2	1 of No.	26
2 " "	6A	1 " "	27A
2 " "	8	32 " "	37
1 " "	9D	4 " "	37A
4 " "	11	2 " "	45
2 " "	14	1 " "	46
1 " "	15A	7 " "	59
1 " "	16	2 " "	63
1 " "	17	1 " "	70
4 " "	19A	2 " "	126A
2 " "	24		

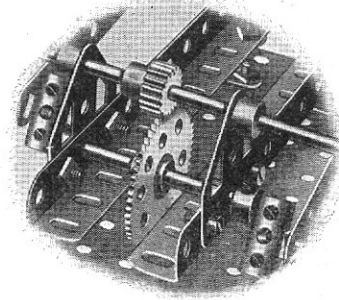
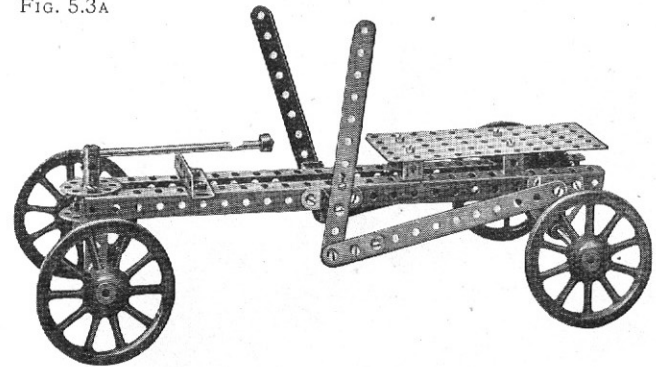


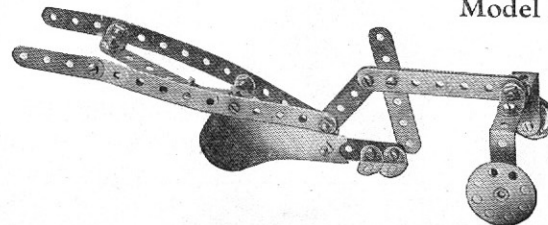
FIG. 5.3A



Model No. 5.4 Plough

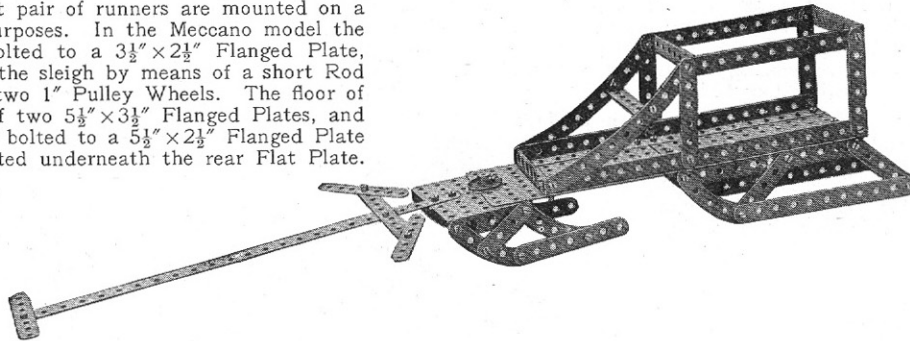
Parts required :

2 of No.	2	1 of No.	22
4 " "	3	1 " "	24
1 " "	4	19 " "	37
3 " "	6	1 " "	41
1 " "	10	1 " "	47
8 " "	12		



Model No. 5.5 Horse Sleigh

The prototype of this model is drawn by two or more horses, and the front pair of runners are mounted on a pivot for steering purposes. In the Meccano model the front runners are bolted to a $3\frac{1}{2}'' \times 2\frac{1}{2}''$ Flanged Plate, which is pivoted to the sleigh by means of a short Rod held in position by two 1" Pulley Wheels. The floor of the sleigh consists of two $5\frac{1}{2}'' \times 3\frac{1}{2}''$ Flanged Plates, and the rear runners are bolted to a $5\frac{1}{2}'' \times 2\frac{1}{2}''$ Flanged Plate that, in turn, is bolted underneath the rear Flat Plate.

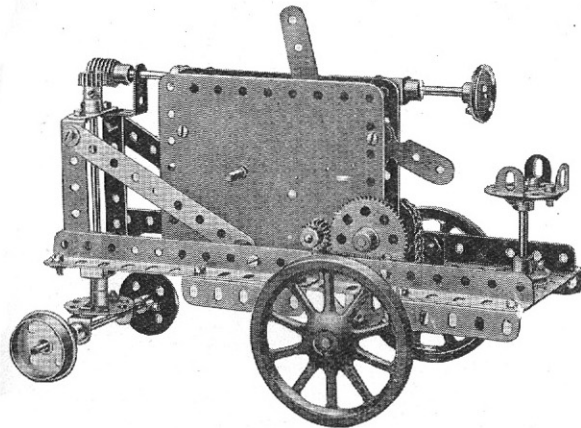


Parts required :

1 of No.	1	2 of No.	22
5 " "	2	50 " "	37
5 " "	3	3 " "	48B
4 " "	4	1 " "	52
4 " "	5	2 " "	52A
2 " "	6	1 " "	53
2 " "	8A	2 " "	89
1 " "	9D	6 " "	90
1 " "	18A		

Model No. 5.6

Farm Tractor



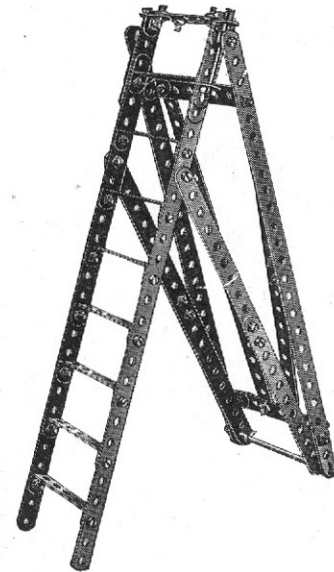
Parts required :

2 of No.	2A	1 of No.	27A
1 " "	3	1 " "	32
1 " "	6A	38 " "	37
4 " "	9	6 " "	38
2 " "	11	1 " "	45
7 " "	12	1 " "	48
1 " "	12A	2 " "	48A
1 " "	13A	2 " "	53
1 " "	15	9 " "	59
1 " "	15A	6" "	94
2 " "	17	2 " "	96
2 " "	19A	2 " "	126A
2 " "	20		
2 " "	22		
2 " "	24		
2 " "	26		

Clockwork
Motor
(not included
in Outfit)

Model No. 5.7

Step Ladder



Parts required :

4 of No.	1
8 " "	2
2 " "	3
3 " "	5
2 " "	10
8 " "	12
1 " "	16
2 " "	17
10 " "	35
44 " "	37
9 " "	48A
2 " "	59

Model No. 5.8 Sighting Apparatus

This model is for determining the heights of buildings, towers, etc. The pointer $11\frac{1}{2}$ " Rod 1 is pivoted on the 2" Rod and controlled by a Spring 3, the pointer 1 being adjusted by the cord 4 which passes round a guide Pulley 5 and on to the Axle 6 upon which it is wound by the Crank Handle 7 which operates the Gear Wheel and Pinion 8. A graduated scale of degrees 9 made of cardboard, or a protractor, is mounted in order to read off the angle of inclination of the pointer.

In finding the height of a building, measure out a number of feet or yards from the foot of the building, and set this out to some scale corresponding to the line ab (Fig. B). Then standing at the point a furthest from the building, and keeping the Angle Girders 10 horizontal, move the pointer 1 until it is directed towards the top of the building. Then read off the angle on the scale 9, and draw a line ac , making the angle bac equal to the angle read off. Then draw a vertical line bc from the point b , and with the same scale used for setting off the distance ab measure the height bc , which will be the height of the building.

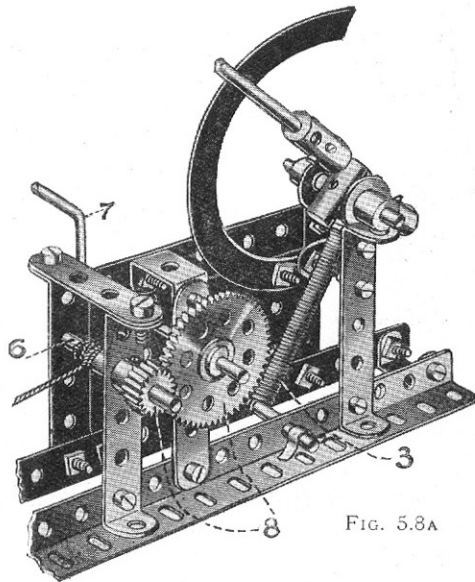
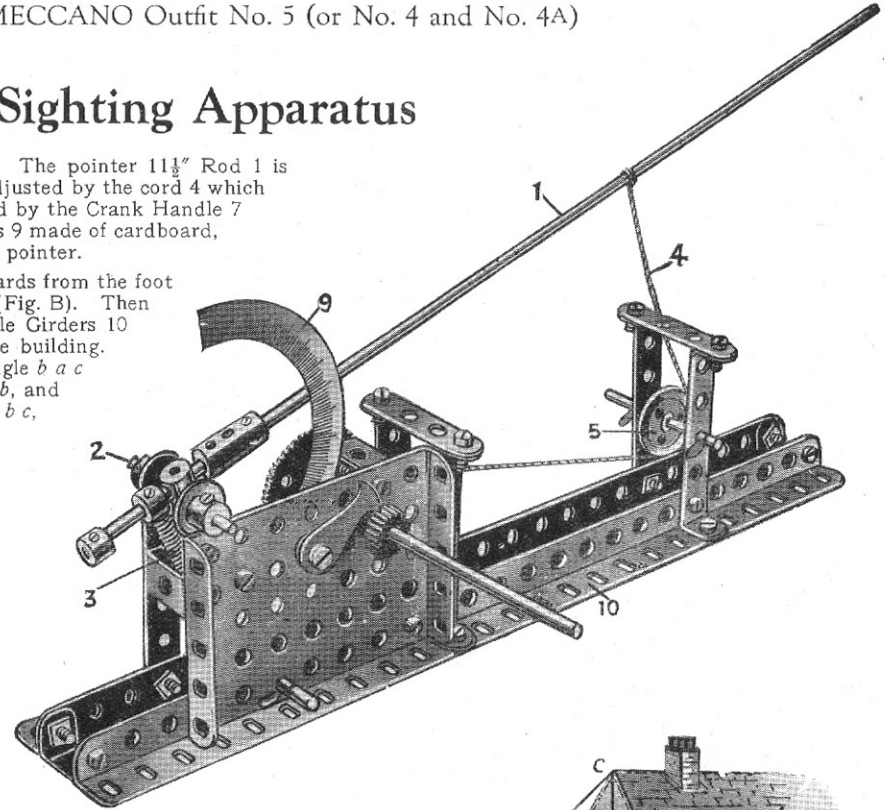


FIG. 5.8A



Parts required :

1 of No. 5	24 of No. 37
2 " " 6	1 " " 43
2 " " 8	5 " " 48A
4 " " 11	1 " " 53
1 " " 13	3 " " 59
4 " " 17	2 " " 62
1 " " 19	2 " " 63
1 " " 22	1 " " 147A
1 " " 26	1 " " 147B
1 " " 27A	1 " " 148
2 " " 35	

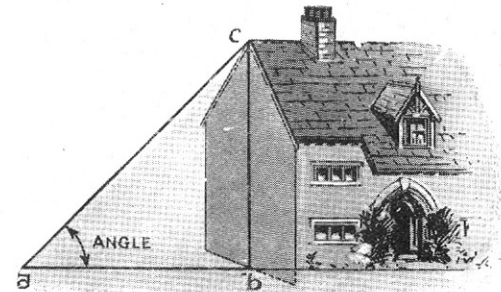
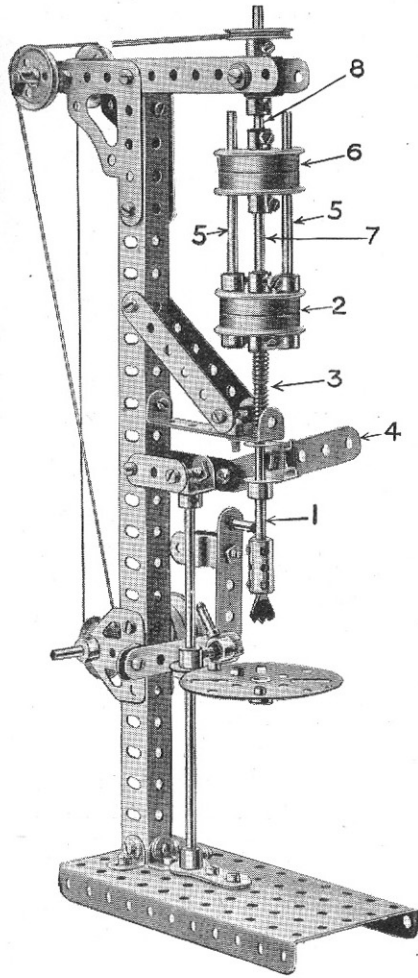


FIG. 5.8B



Model No. 5.9 Vertical Drill

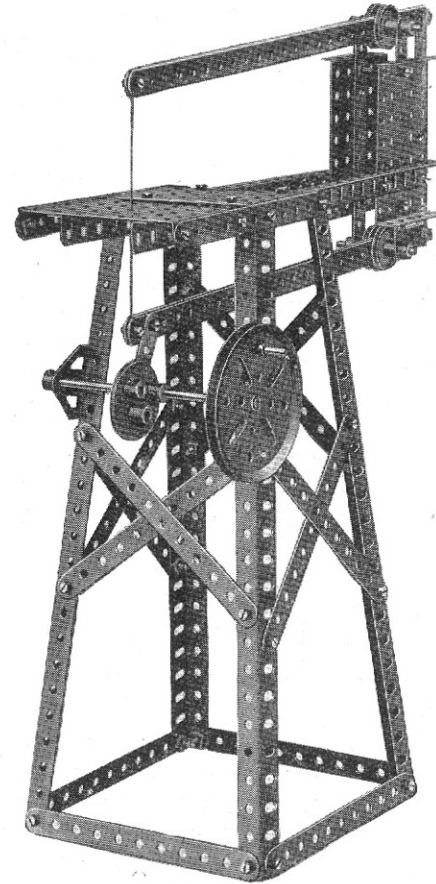
Parts required:

2 of No. 2	4 of No. 16	1 of No. 48A
3 " " 4	1 " " 17	1 " " 50
2 " " 5	6 " " 20	10 " " 59
1 " " 6	2 " " 21	2 " " 62
1 " " 6A	2 " " 22A	1 " " 65
2 " " 8	4 " " 35	2 " " 108
5 " " 11	39 " " 37	1 " " 109
6 " " 12	6 " " 38	1 " " 111
1 " " 14	1 " " 43	2 " " 115
1 " " 15A	1 " " 44	2 " " 126A

The drill Rod 1 is connected to the boss of the lower pair of Flanged Wheels 2 which are reversed, a Spring 3 round the Rod raising the drill after it has been depressed by the handle Strip 4. Bolted in the Wheels 2 are two outer Rods 5 which slide in the upper Flanged Wheels 6. The central Rod 7 is bolted in the upper Wheels and slides in the centre bosses of the lower Wheels 2. The upper Wheels 6 are bolted to the driving spindle 8 and consequently the drill is driven by the Rods 5 when the drill is depressed by the handle 4 against the Spring.

See also " Meccano Standard Mechanisms," under Locking Device (S.M. 137) and Variable Drive (Section XIII).

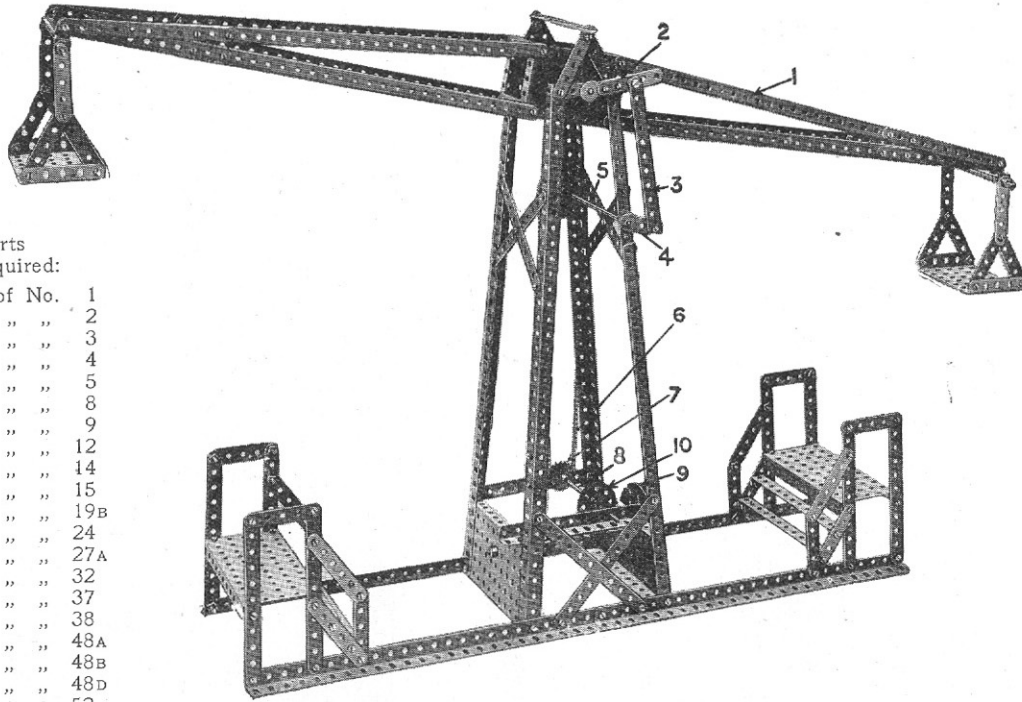
Model No. 5.10 Fret Saw



Parts required:

4 of No. 1
17 " " 2
6 " " 8
1 " " 15
2 " " 17
1 " " 19B
4 " " 22
53 " " 37
4 " " 53
5 " " 59
1 " " 115
2 " " 126A
1 " " 130

Model No. 5.11 Giant Auto Swing

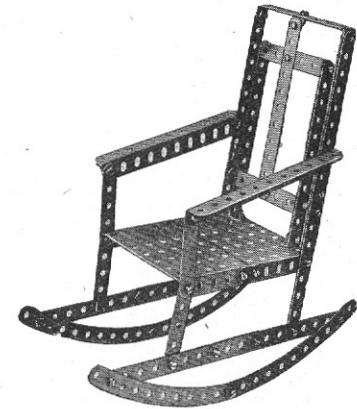


Parts
required:

18	of No.	1
26	" "	2
2	" "	3
8	" "	4
31	" "	5
12	" "	8
1	" "	9
18	" "	12
2	" "	14
4	" "	15
1	" "	19B
1	" "	24
1	" "	27A
1	" "	32
165	" "	37
2	" "	38
2	" "	48A
2	" "	48B
4	" "	48D
4	" "	52
4	" "	53
9	" "	59
2	" "	62
28"	" "	94
1	" "	95
1	" "	96
1	" "	147B

The beam 1 is rocked by means of a Crank 2 secured on the end of a Rod which forms the beam pivot and which is bolted in a Bush Wheel secured to the beam. This Crank 2 is connected by a Strip 3 to another Crank 4 on a Rod 5. On the end of this is a large Sprocket Wheel driven by a Chain 6 from a small Sprocket Wheel 7 on a Rod 8. This Rod is driven by means of a Worm on the Rod of the 3" Pulley 9 which Worm engages and drives the Gear Wheel 10 on the Rod 8. As the Crank 4 continuously rotates the link 3 causes the upper Crank 2 to oscillate and also the beam 1.

Model No. 5.12 Rocking Chair



Parts required:

9	of No.	2	2	of No.	48A
8	" "	5	1	" "	48B
2	" "	10	2	" "	53
3	" "	12	4	" "	89
44	" "	37			

Model No. 5.13

Pit Head Gear

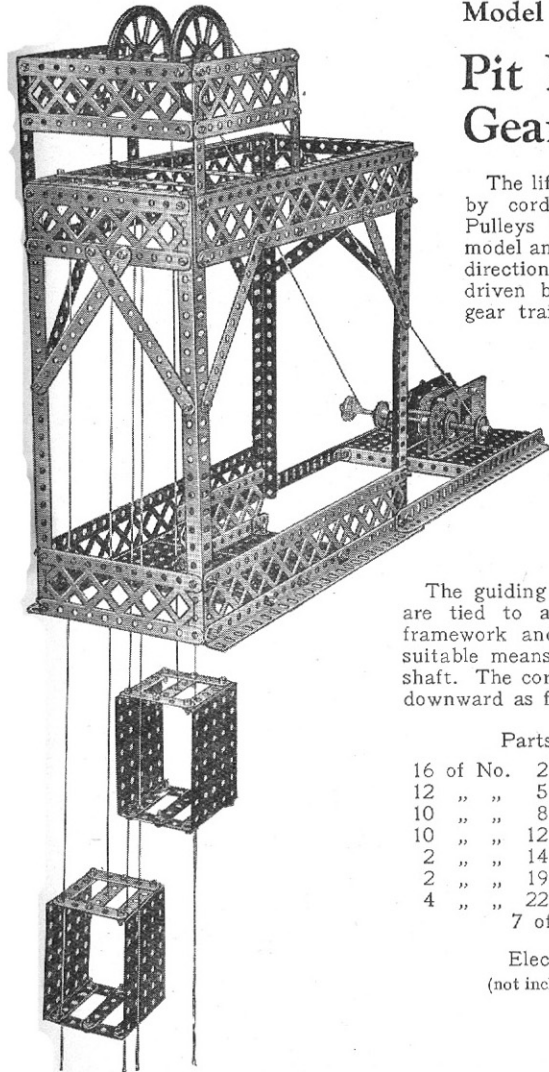
The lift cages are operated by cords passing over 3" Pulleys at the top of the model and wound in opposite directions on to a spindle driven by the Motor. The gear train is as follows: a $\frac{1}{2}$ " Pinion on the driving shaft engages a 57-teeth Gear Wheel, on the Rod of which is fixed another $\frac{1}{2}$ " Pinion that engages with a second 57-teeth Gear Wheel on the hoisting axle.

The guiding cords for the cages are tied to a $5\frac{1}{2}$ " Strip on the framework and are fixed by any suitable means at the base of the shaft. The cords may be extended downward as far as desired.

Parts required :

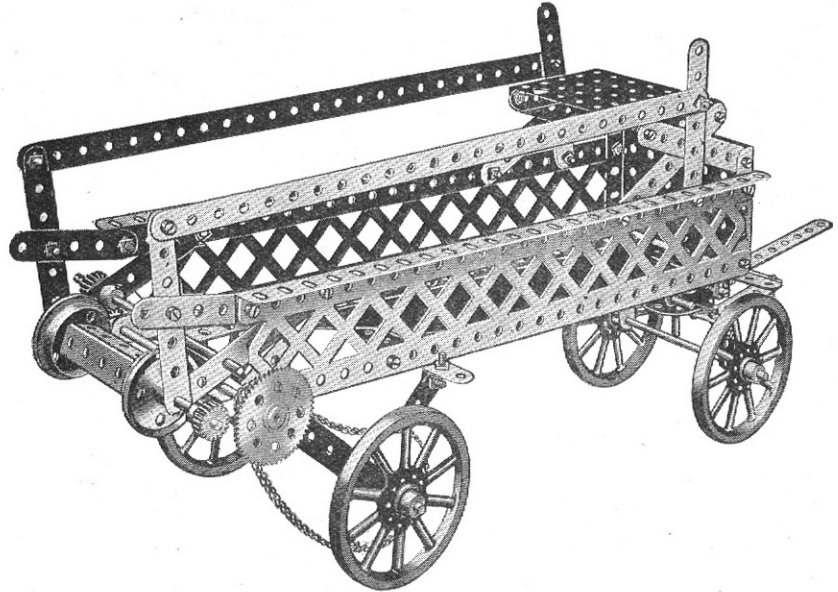
16 of No. 2	1 of No. 26
12 " " 5	1 " " 27A
10 " " 8	110 " " 37
10 " " 12	4 " " 52
2 " " 14	4 " " 53
2 " " 19B	7 " " 59
4 " " 22	4 " " 99
7 of No. 100	

Electric Motor
(not included in Outfit)



Model No. 5.14

Manure Distributing Cart



Parts required :

2 of No. 1	1 of No. 14	1 of No. 24	4 of No. 48A
3 " " 2	3 " " 15	3 " " 26	2 " " 53
10 " " 3	2 " " 15A	1 " " 27A	8 " " 59
9 " " 5	2 " " 17	4 " " 35	1 " " 94
4 " " 8	4 " " 19A	57 " " 37	1 " " 95
6 " " 12	2 " " 20	1 " " 46	1 " " 96
2 of No. 99			

Model No. 5.15 Travelling Gantry Crane

The travelling gantry 1 is traversed along the rails by a hand wheel 2, a Sprocket Chain 3 driving the Rod 4, round the Pulleys 5 on which pass the Cords 6 which are connected to the travelling gantry. The load is raised or lowered by operating the Crank Handle 7 on which a cord 8 is wound, passing round a $\frac{1}{2}$ " Pulley in the block 9 and being secured to a Rod 10. The winch is traversed along the rails of the gantry 1 by means of the Crank Handle 11, a Pinion 12 on which engages a 57-toothed Gear Wheel 13, on the axle of the travelling wheels. The travelling gantry is built up of the rails of the Angle Girders 1 bolted at each end to two $5\frac{1}{2}$ " Angle Girders 14 butted together. The Flanged Wheels 15 are carried upon their Axles 16 passed through the end holes of the Angle Girders 14.

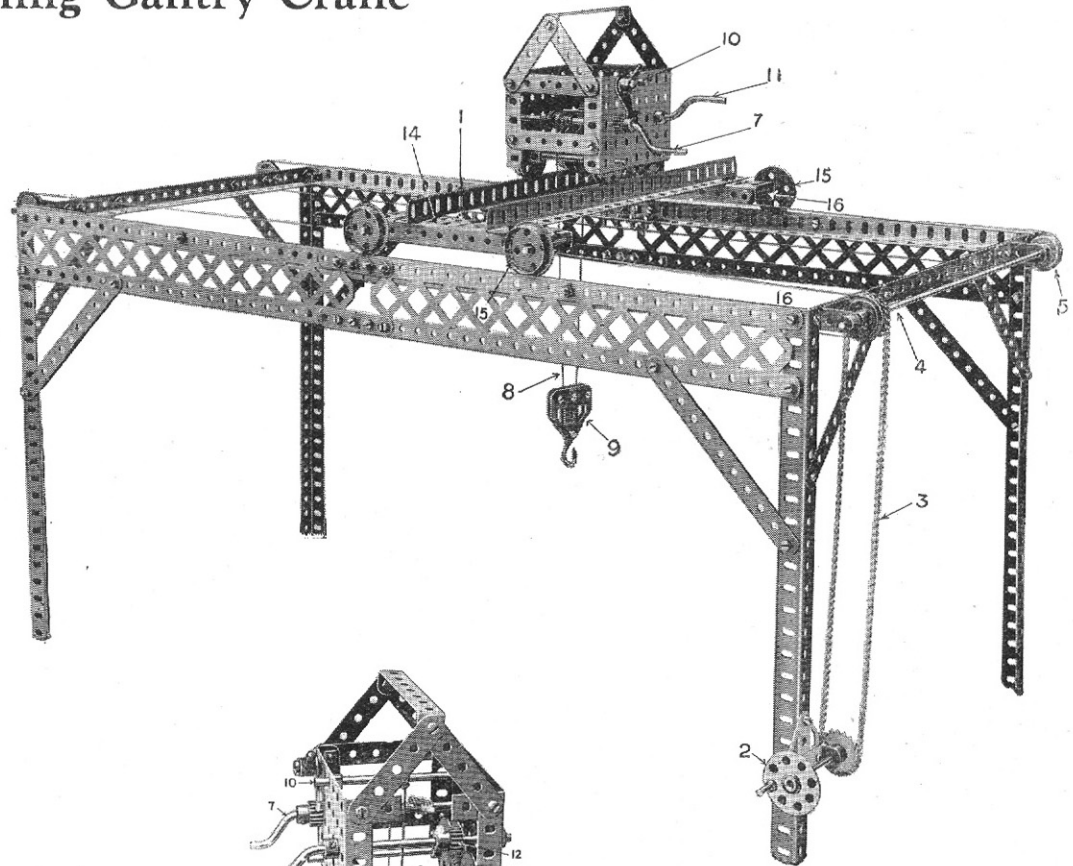
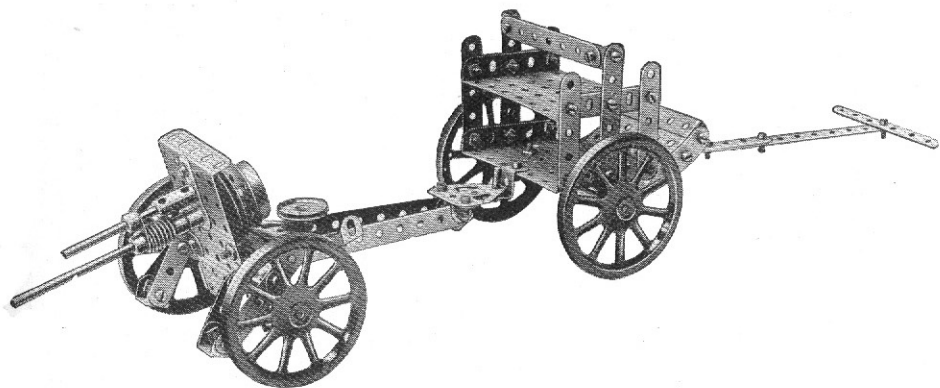


FIG. 5.15A

Parts required :

4 of No. 1	8 of No. 20	1 of No. 57
8 " " 2	4 " " 22	8 " " 59
4 " " 4	1 " " 23	24" " " 94
10 " " 5	1 " " 24	2 " " 96
12 " " 8	1 " " 26	4 " " 99
4 " " 9	1 " " 27A	4 " " 100
2 " " 11	2 " " 35	2 " " 115
4 " " 12A	96 " " 37	3 " " 126A
2 " " 13	6 " " 38	1 " " 147A
3 " " 16	1 " " 48	1 " " 147B
5 " " 17	1 " " 48B	1 " " 148
2 " " 19	2 " " 53	

Model No. 5.16 Field Gun and Carriage



Parts required :

4	cf	No.	2	1	of	No.	22
2	"	"	3	1	"	"	24
2	"	"	4	1	"	"	32
6	"	"	5	62	"	"	37
2	"	"	6A	2	"	"	38
3	"	"	10	3	"	"	48A
3	"	"	11	2	"	"	48B
14	"	"	12	2	"	"	53
2	"	"	15	3	"	"	59
1	"	"	15A	1	"	"	62
1	"	"	16	1	"	"	63
1	"	"	18A	2	"	"	90
4	"	"	19A	1	"	"	115
1	"	"	20	2	"	"	125
1	"	"	21	2	"	"	126A

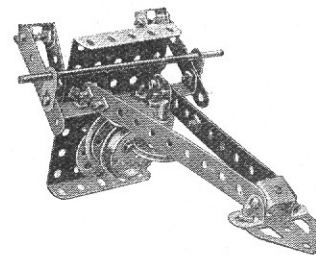
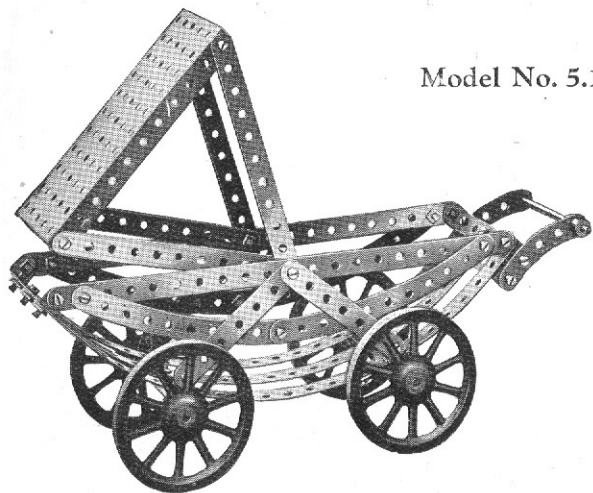


FIG. 5.16A

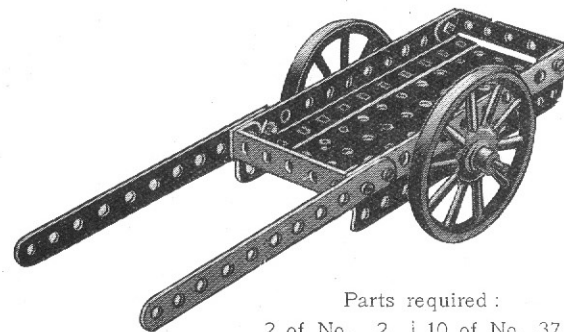
Model No. 5.17 Perambulator



Parts required :

3	cf	No.	1	37	of	No.	37
8	"	"	2	5	"	"	48A
4	"	"	3	1	"	"	52
6	"	"	12	2	"	"	59
3	"	"	16	4	"	"	89
4	"	"	19A	2	"	"	90

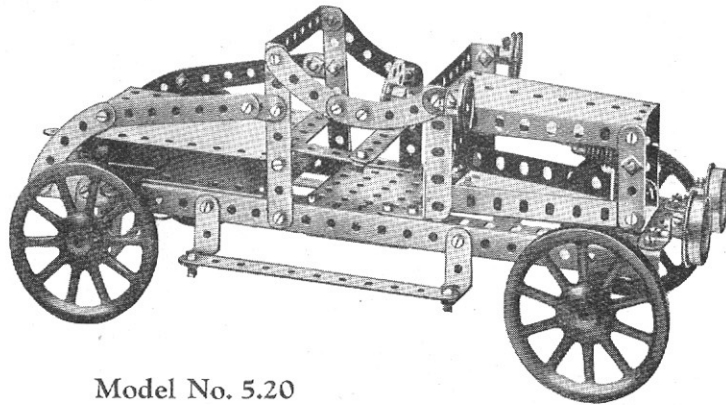
Model No. 5.18 Station Cart



Parts required :

2	of	No.	2	10	of	No.	37
2	"	"	9	2	"	"	48A
1	"	"	15A	1	"	"	52
2	"	"	19A				

Model No. 5.19 Motor Car



Parts
required :

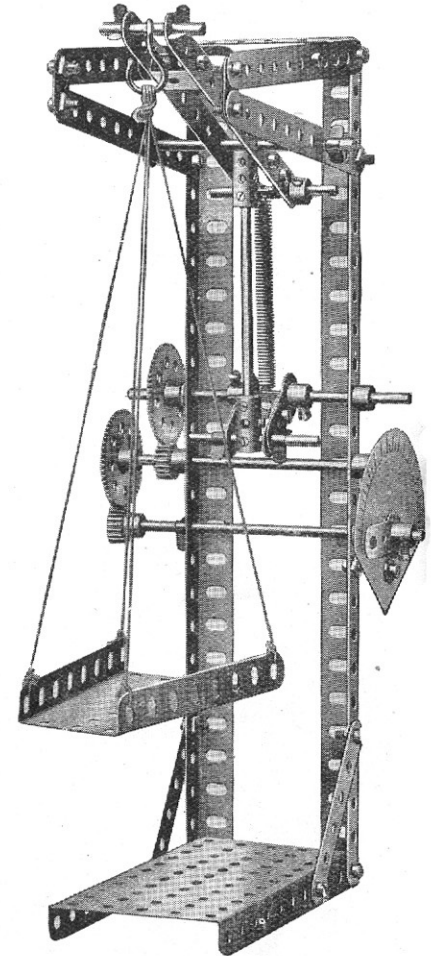
2 of No.	2
8 " "	3
1 " "	5
4 " "	6
2 " "	8
2 " "	10
8 " "	12
6 " "	12A
1 " "	14
2 " "	15
1 " "	16
4 " "	19A
2 " "	20
2 " "	22
2 " "	24
2 " "	26
1 " "	28
1 " "	32
75 " "	37
4 " "	38
3 " "	48B
2 " "	53
2 " "	54
7 " "	59
2 " "	89
2 " "	126A

Clockwork Motor
(not included in Outfit)

Model No. 5.21 Spring Scales

Parts
required :

6 of No.	2
2 " "	4
2 " "	8
2 " "	10
3 " "	11
2 " "	15
1 " "	15A
2 " "	16
2 " "	17
1 " "	18A
2 " "	26
2 " "	27A
23 " "	37
1 " "	43
2 " "	48A
1 " "	52
1 " "	54
1 " "	57
2 " "	59
2 " "	62
2 " "	63
1 " "	111

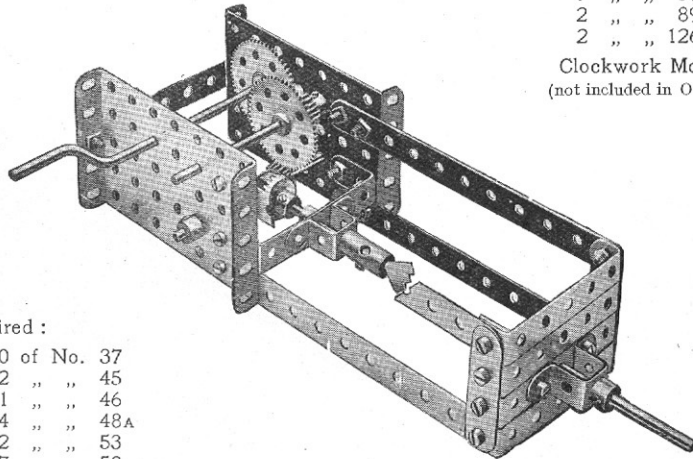


The scale beam consists of two $5\frac{1}{2}$ " Strips distanced by Double Brackets. A vertical Rod is connected pivotally to the beam by means of a $\frac{3}{4}$ " Bolt, and to a short Rod passed through the ends of two Cranks. The latter are secured to an axle which carries a 57-teeth Gear Wheel, the motion of which is led through the gear train shown to a pointer moving over a graduated scale. A Meccano Spring, attached to the Rod carrying the Cranks, is connected to the end of the beam and acts as the spring balance.

Model No. 5.20

Spooling Machine

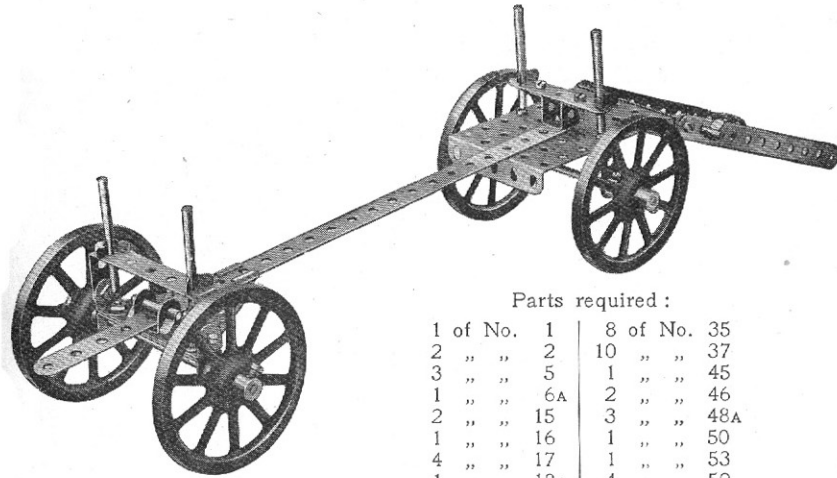
A bobbin is fitted to the stationary Rod and is then held against the Centre Fork by a Collar. The gear train consists of two 57-teeth Gear Wheels and two $\frac{1}{2}$ " Pinions, one of which engages a $\frac{3}{4}$ " Contrate Wheel on the spooling shaft.



Parts required :

4 of No.	2	20 of No.	37
1 " "	3	2 " "	45
3 " "	16	1 " "	46
1 " "	17	4 " "	48A
1 " "	19	2 " "	53
2 " "	26	7 " "	59
2 " "	27A	1 " "	63
1 " "	29	1 " "	65

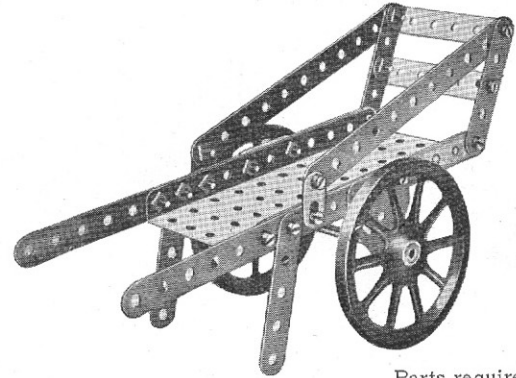
Model No. 5.22 Timber Carriage



Parts required :

1 of No.	1	8 of No.	35
2 " "	2	10 " "	37
3 " "	5	1 " "	45
1 " "	6A	2 " "	46
2 " "	15	3 " "	48A
1 " "	16	1 " "	50
4 " "	17	1 " "	53
1 " "	18A	4 " "	59
4 " "	19A	1 " "	111

Model No. 5.23 Coster's Barrow



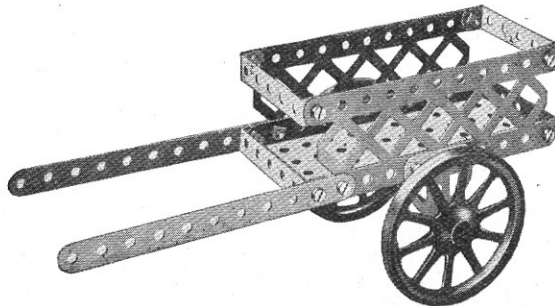
Parts required :

4 of No.	2	18 of No.	37
4 " "	5	2 " "	48A
2 " "	10	1 " "	52
1 " "	16	2 " "	126A
2 " "	19A		

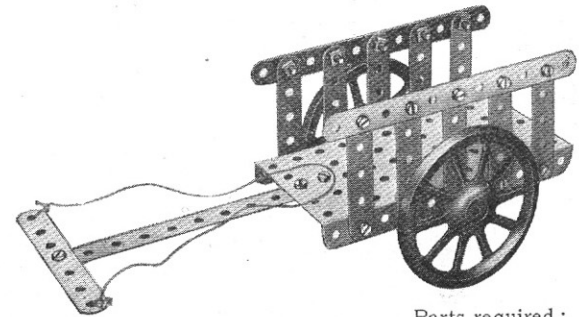
Model No. 5.24 Cart

Parts required :

2 of No.	2
1 " "	16
2 " "	19A
14 " "	37
4 " "	48A
1 " "	52
2 " "	100
2 " "	126A



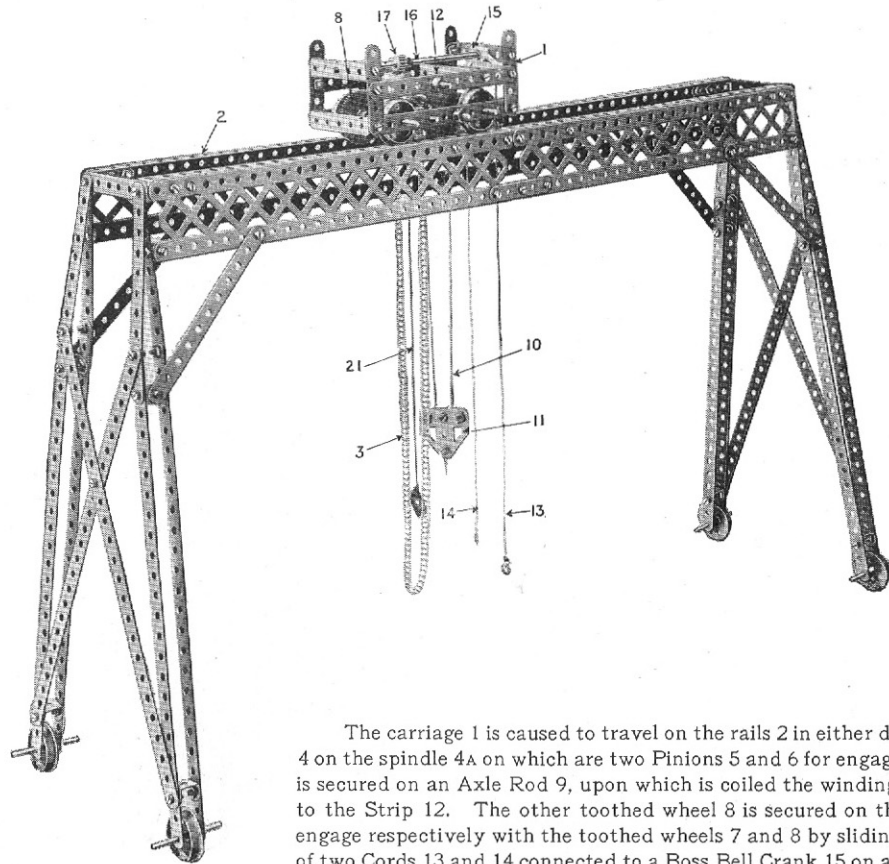
Model No. 5.25 Bullock Cart



Parts required :

3 of No.	2	2 of No.	19A
1 " "	3	21 " "	37
10 " "	5	1 " "	52
1 " "	16		

Model No. 5.26 Travelling Crane



Parts required :

16 of No.	1	2 of No.	27A
16 "	2	1 "	32
6 "	5	86 "	37
4 "	8	8 "	37
2 "	9	2 "	47A
8 "	11	5 "	48A
4 "	12	1 "	57
1 "	14	6 "	59
1 "	15A	1 "	62
4 "	16	1 "	63
4 "	17	30"	94
8 "	20	1 "	96
1 "	22	4 "	99
1 "	23	2 "	126A
3 "	26	1 "	128

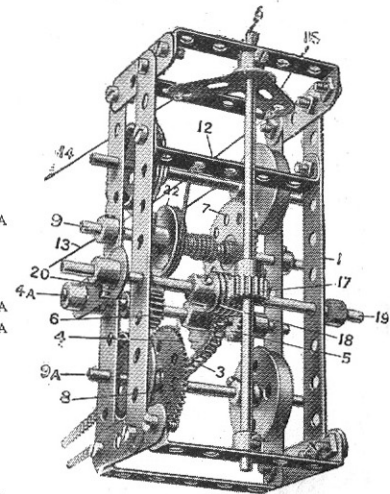
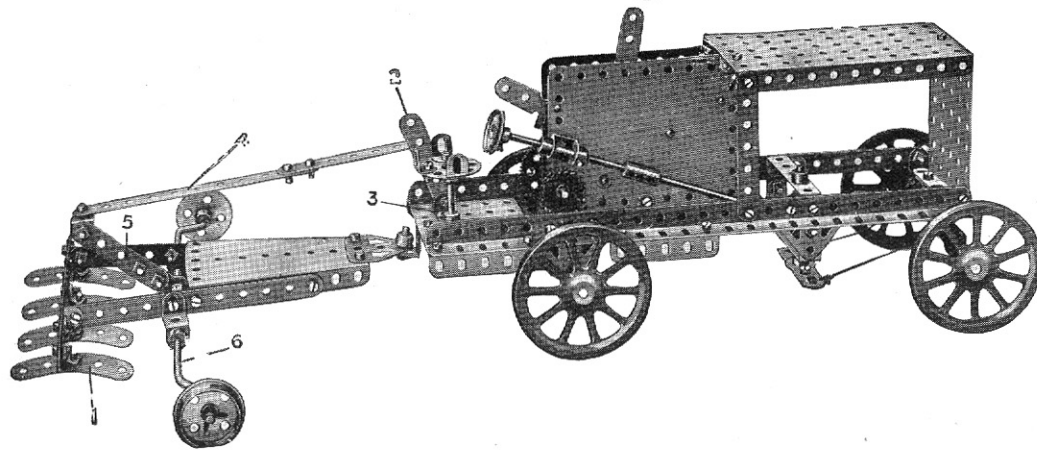


FIG. 5.26A

The carriage 1 is caused to travel on the rails 2 in either direction by the Sprocket Chain 3, which passes over a 1" Sprocket Wheel 4 on the spindle 4A on which are two Pinions 5 and 6 for engagement respectively with toothed Wheels 7 and 8. The toothed Wheel 7 is secured on an Axle Rod 9, upon which is coiled the winding Cord 10 passing round a $\frac{1}{2}$ " Pulley in the block 11, and being made fast to the Strip 12. The other toothed wheel 8 is secured on the Axle of the travelling wheels 9A. The Pinions 5 and 6 are caused to engage respectively with the toothed wheels 7 and 8 by sliding the Pinion Axle 4A in the carriage frame 1. This is effected by means of two Cords 13 and 14 connected to a Boss Bell Crank 15 on a Rod 16, a Pinion 17 which engages a Worm 18 in the manner of a rack. This Worm is secured to a Rod 19, which is connected by means of the Crank 20 to the Rod 4A. The latter revolves freely in the Crank 20, being held in position by a Collar on each side of the Crank. Consequently, by pulling on one or other of the Cords 13, 14, the Bell Crank is racked and the Pinions caused to engage with one or other of the toothed Wheels 7 or 8. When engaging the toothed Wheel 7 the load may be raised or lowered by pulling the Sprocket Chain 3, but when the Pinion 6 engages the toothed wheel 8, the carriage travels on the rails. The Cord 21 passes round a Pulley 22 on the winding Axle and acts as a brake.

Model No. 5.27 Motor Plough



The ploughshares 1 are raised or lowered by the handle 2 pivoted to an Angle Bracket on the far side of the seat pillar, and connected by Strips 4 to a Crank 5 secured on the bent Axle 6 of the wheels formed by Crank Handles. The plough is driven by a Meccano Clockwork Motor.

Parts required :

5 of No. 2	2 of No. 26	1 of No. 54
3 " " 3	1 " " 27A	9 " " 59
3 " " 5	1 " " 29	1 " " 62
2 " " 8	4 " " 35	2 " " 63
2 " " 10	24 " " 37	4 " " 90
1 " " 11	6 " " 38	6 " " 94
19 " " 12	1 " " 45	2 " " 96
3 " " 15A	1 " " 46	1 " " 115
1 " " 16	4 " " 48A	3 " " 125
3 " " 17	1 " " 52	5 " " 126A
2 " " 19	3 " " 53	
4 " " 19A		
2 " " 20		
3 " " 22		
1 " " 24		

Clockwork Motor
(not included in Outfit)

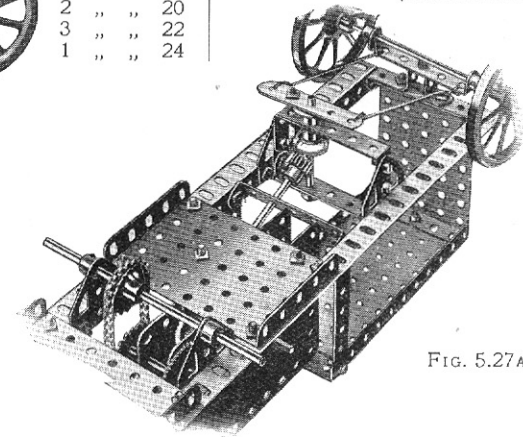
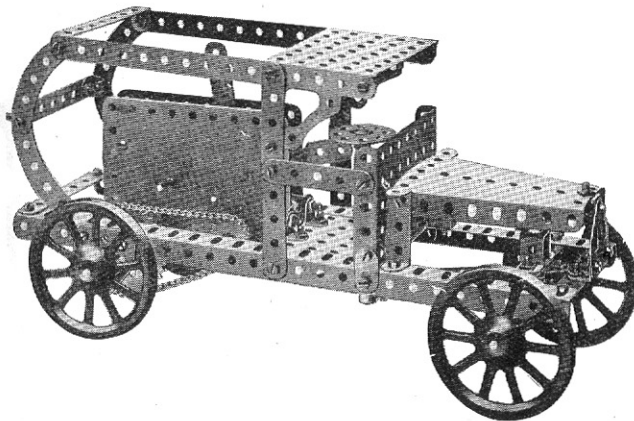


FIG. 5.27A

Model No. 5.28 Motor Car

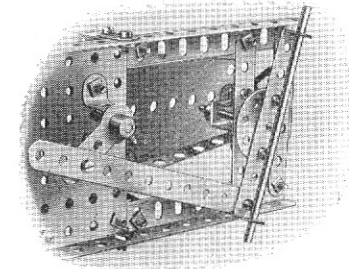


Parts required :

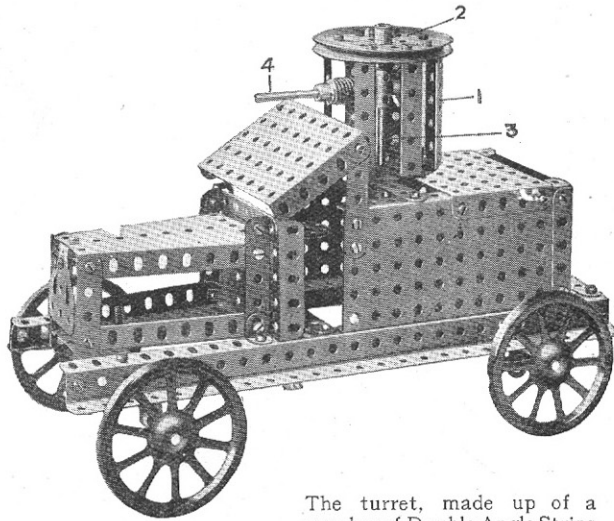
3 of No. 2	2 of No. 45
4 " " 3	2 " " 48
5 " " 5	2 " " 48B
2 " " 8	3 " " 53
2 " " 10	1 " " 54
11 " " 12	3 " " 59
2 " " 15A	1 " " 62
1 " " 16	4 " " 90
1 " " 17	12" " 94
4 " " 19A	1 " " 95
2 " " 24	2 " " 96
63 " " 37	1 " " 108
2 " " 38	1 " " 125
	3 of No. 126A

Clockwork Motor
(not included in Outfit)

FIG. 5.28A



Model No. 5.29 Armoured Motor Car



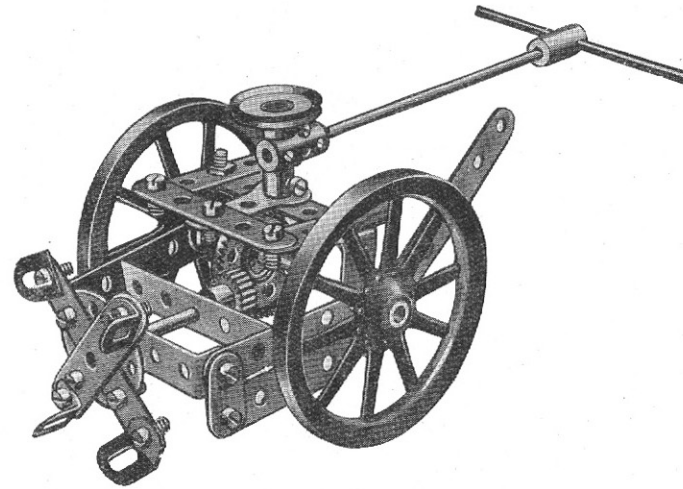
The turret, made up of a number of Double Angle Strips 1 bolted at the top to a 3" Pulley 2 and below to a Face Plate is bolted on a Rod 3 passing up the centre which forms the pivot of the turret so that it may freely turn. The gun 4 is bolted in a Coupling on this pivot Rod.

Parts required:

5 of No.	3
6 " "	5
4 " "	8
5 " "	12
1 " "	12A
2 " "	14
1 " "	15
2 " "	16
2 " "	18A
4 " "	19A
1 " "	19B
2 " "	22
2 " "	24
1 " "	32
77 " "	37
2 " "	38
2 " "	45
7 " "	48A
1 " "	48B
2 " "	52
4 " "	53
2 " "	54
8 " "	59
1 " "	63
1 " "	109
3 " "	126A

Model No. 5.30

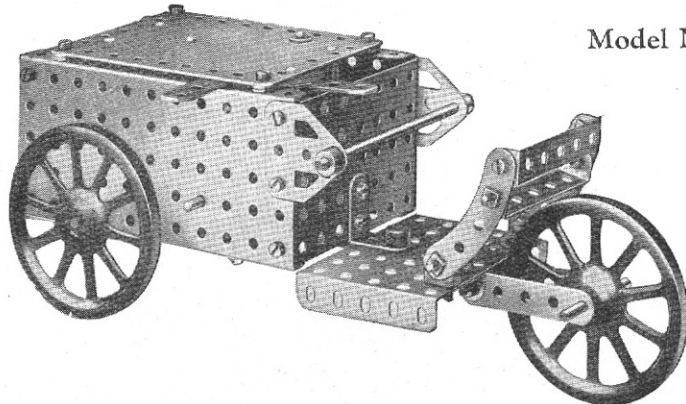
Potato Reaper



Parts required:

1 of No.	3
8 " "	5
2 " "	10
4 " "	12
1 " "	15
2 " "	16
1 " "	17
1 " "	18A
2 " "	19B
1 " "	22
1 " "	24
1 " "	26
1 " "	28
19 " "	37
1 " "	46
2 " "	48A
1 " "	59
1 " "	62
2 " "	63

Model No. 5.31 Delivery Van



Parts required:

1 of No.	3	1 of No.	28
3 " "	5	31 " "	37
4 " "	12	9 " "	38
1 " "	12A	2 " "	48A
1 " "	15	2 " "	52
2 " "	15A	3 " "	53
1 " "	17	7 " "	59
1 " "	18A	2 " "	90
3 " "	19A	9 " "	94
1 " "	26	2 " "	96
2 of No. 126A			

Clockwork Motor
(not included in Outfit)

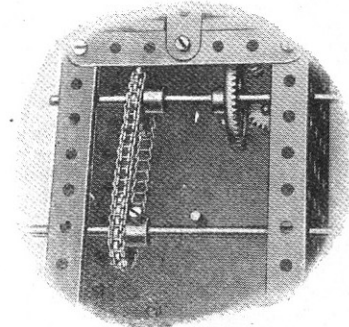
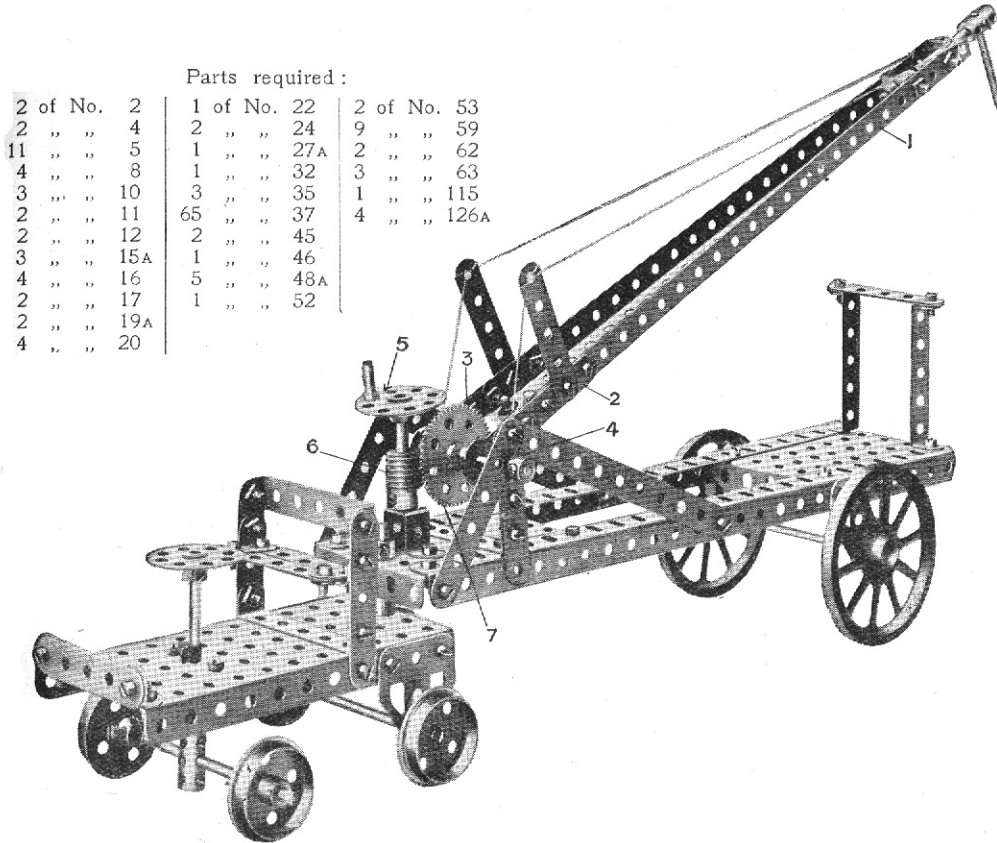


FIG. 5.31A

Model No. 5.32 Fire Watertower

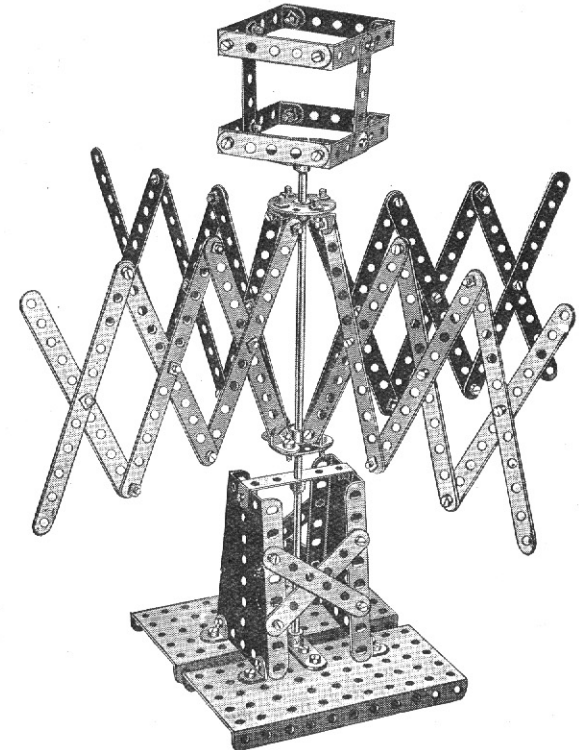


Parts required :

2 of No. 2	1 of No. 22	2 of No. 53
2 " " 4	2 " " 24	9 " " 59
11 " " 5	1 " " 27A	2 " " 62
4 " " 8	1 " " 32	3 " " 63
3 " " 10	3 " " 35	1 " " 115
2 " " 11	65 " " 37	4 " " 126A
2 " " 12	2 " " 45	
3 " " 15A	1 " " 46	
4 " " 16	5 " " 48A	
2 " " 17	1 " " 52	
2 " " 19A		
4 " " 20		

This is an apparatus for raising a water-hose and directing the nozzle towards high buildings. The hose is led along the support 1, formed of two $12\frac{1}{2}$ " Angle Girders, secured by Strips 2 and Cranks 3 to the Rod 4, forming a pivot for the support. The support is raised or lowered about the pivot by turning the hand wheel 5, a Worm 6 on the spindle of which engages a 57-toothed Wheel 7 on the Rod 4.

Model No. 5.33 Skein Winder



Parts required :

24 of No. 2	2 of No. 24
4 " " 4	86 " " 37
7 " " 5	5 " " 48A
8 " " 12	2 " " 52
1 " " 13	2 " " 54
1 " " 21	2 " " 59

Model No. 5.34

Brewer's Dray

Parts
required :

6	of No.	2
3	" "	3
19	" "	5
8	" "	8
2	" "	10
1	" "	11
10	" "	12
1	" "	14
1	" "	15
1	" "	18A
4	" "	19A
1	" "	21
1	" "	24
62	" "	37
1	" "	47
6	" "	39

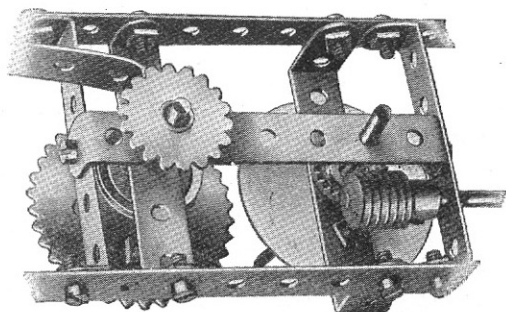
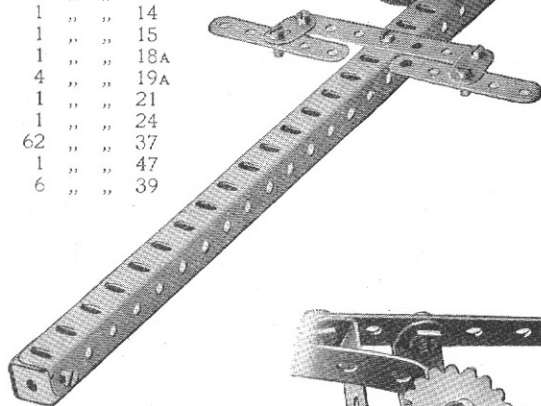
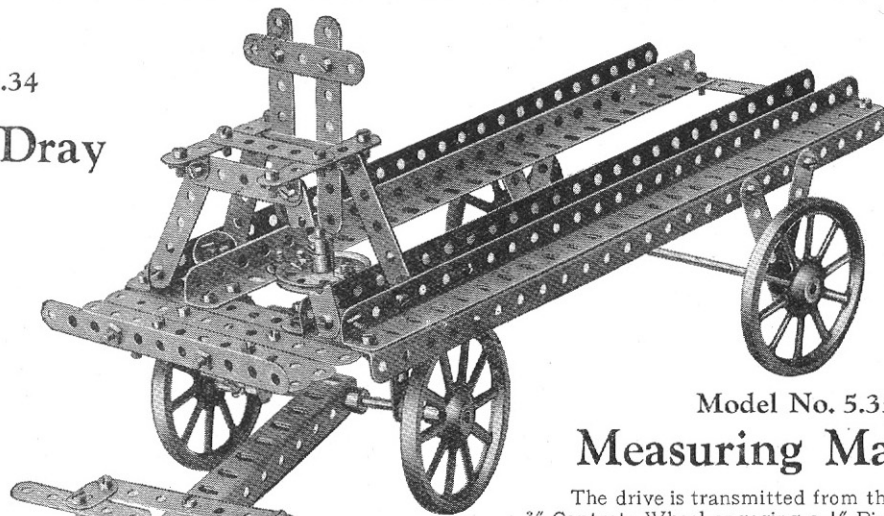


FIG. 5.35A

Model No. 5.35

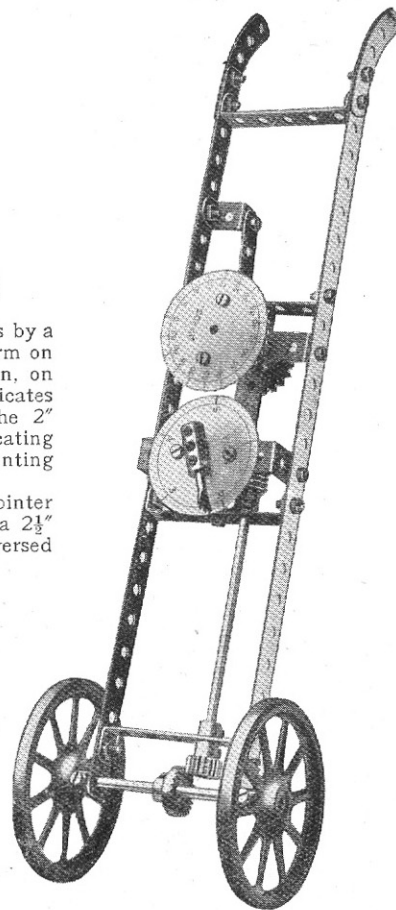
Measuring Machine

The drive is transmitted from the road wheels by a $\frac{3}{4}$ " Contrate Wheel engaging a $\frac{1}{2}$ " Pinion. A Worm on the shaft of the latter engages another $\frac{1}{2}$ " Pinion, on the Rod of which is fixed a pointer which indicates up to 5 yards. When this pointer touches the 2" Sprocket Wheel, on which is fixed a second indicating dial, it turns the wheel round one tooth, representing 5 yards.

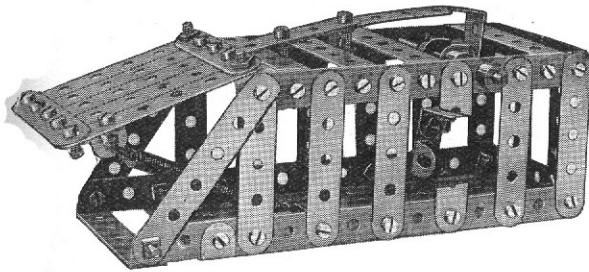
A Ratchet is fixed at the other end of the pointer Rod. It consists of a 1" Sprocket Wheel and a $2\frac{1}{2}$ " Strip that is bolted to the frame by a $\frac{1}{2}$ " Reversed Angle Bracket.

Parts required :

2	of No.	1	22	of No.	37
1	" "	5	1	" "	46
1	" "	15	5	" "	48A
1	" "	16	1	" "	48B
2	" "	17	1	" "	59
2	" "	19A	1	" "	63
1	" "	22	1	" "	65
1	" "	26	2	" "	90
2	" "	29	1	" "	95
1	" "	32	1	" "	96
			1	of No.	125



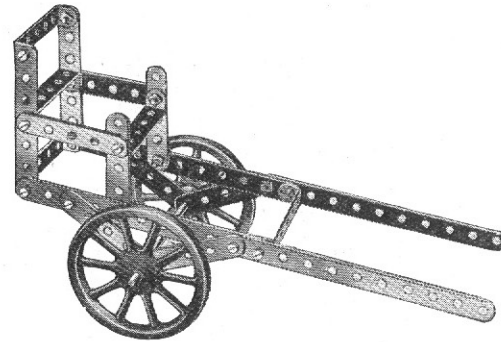
Model No. 5.36 Mouse Trap



Parts required :

3 of No.	2
8 " "	4
18 " "	5
1 " "	10
1 " "	11
4 " "	12
1 " "	16
59 " "	37
5 " "	38
1 " "	43
1 " "	48
9 " "	48A
1 " "	52
4 " "	59

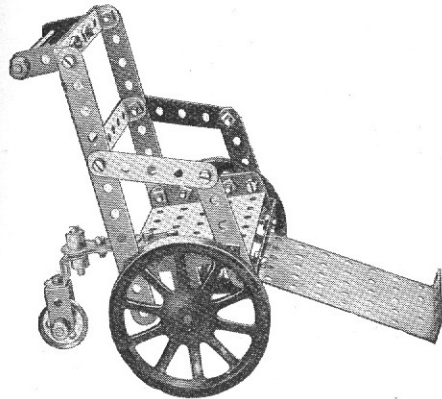
Model No. 5.37 Ducking Chair



Parts required :

4 of No.	2
2 " "	3
8 " "	5
1 " "	15A
2 " "	19A
4 " "	35
16 " "	37
5 " "	48A

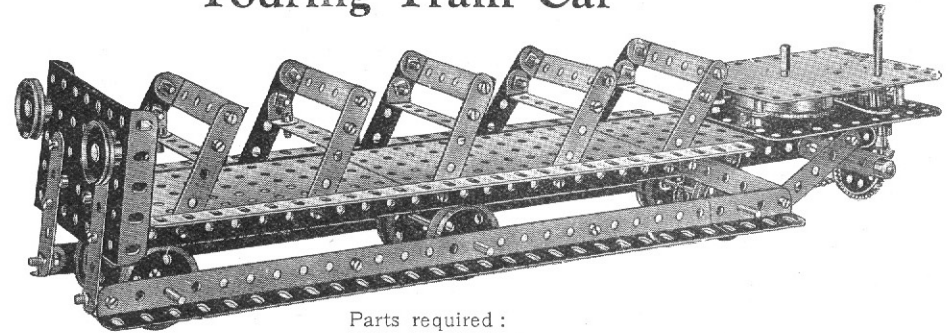
Model No. 5.38 Invalid Chair



Parts required :

2 of No.	2
5 " "	5
1 " "	10
1 " "	15A
1 " "	16
2 " "	18A
2 " "	19A
1 " "	22A
25 " "	37
5 " "	38
1 " "	46
3 " "	48B
2 " "	53
5 " "	59
1 " "	62
1 " "	102
1 " "	125
2 " "	126A

Model No. 5.39 Touring Tram Car

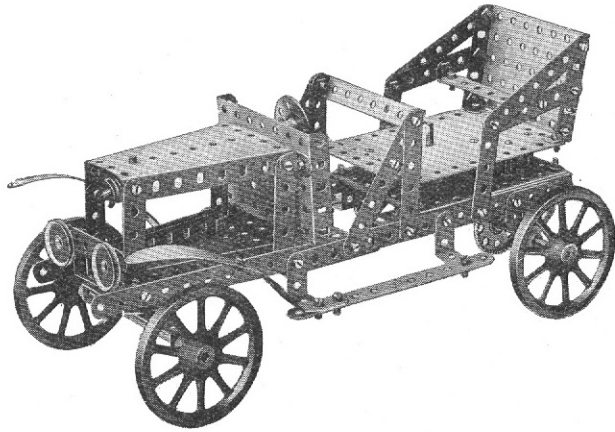


Parts required :

20 of No.	5	6 of No.	20	8 of No.	48A
6 " "	8	2 " "	22	3 " "	52
8 " "	12	1 " "	26	1 " "	53
4 " "	16	1 " "	28	2 " "	59
		64 " "	37		

Clockwork Motor
(not included in Outfit)

Model No. 5.40 Motor Car



Parts required :

2 of No. 1	2 of No. 24
2 " " 2	2 " " 26
7 " " 3	1 " " 28
4 " " 4	1 " " 32
7 " " 5	67 " " 37
2 " " 9	3 " " 38
9 " " 12	2 " " 41
4 " " 12A	1 " " 48A
1 " " 14	3 " " 48B
2 " " 15	3 " " 53
1 " " 16	2 " " 54
4 " " 19A	7 " " 59
2 " " 22	2 " " 126A

Clockwork Motor
(not included in Outfit)

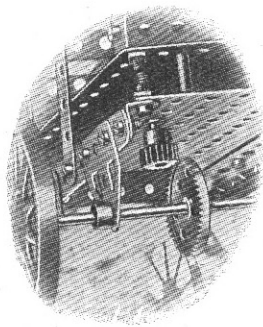
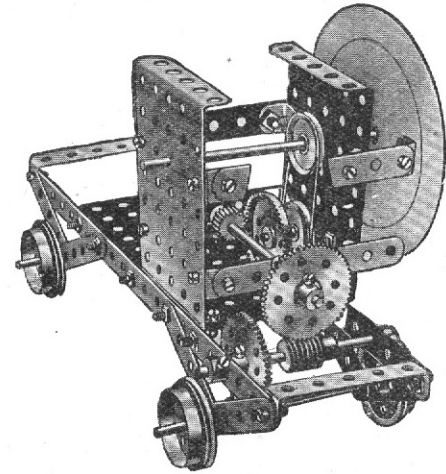


FIG. 5.40A

Model No. 5.41 Distance Indicator



Parts required :

4 of No. 2
4 " " 3
8 " " 5
10 " " 12
2 " " 15
2 " " 15A
1 " " 16
1 " " 17
4 " " 20
1 " " 21
2 " " 22
1 " " 24
2 " " 26
2 " " 27A
1 " " 28
1 " " 32
38 " " 37
2 " " 48A
1 " " 52
2 " " 53
6 " " 59

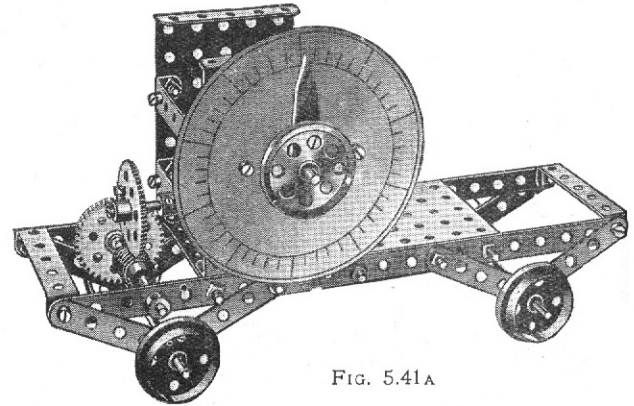


FIG. 5.41A

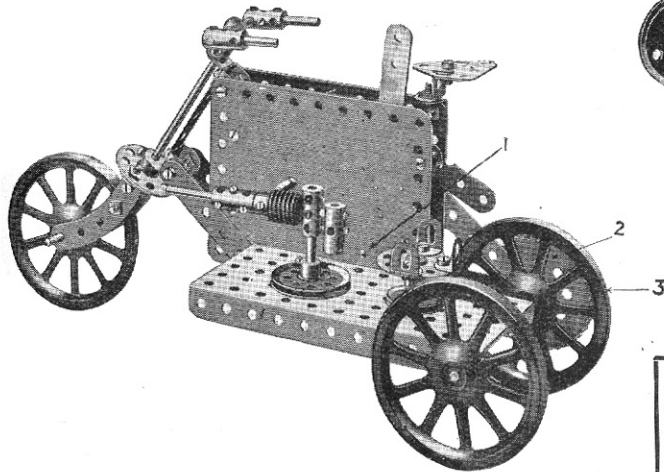
Model No. 5.42

Armoured Motor Tricycle

Parts required :

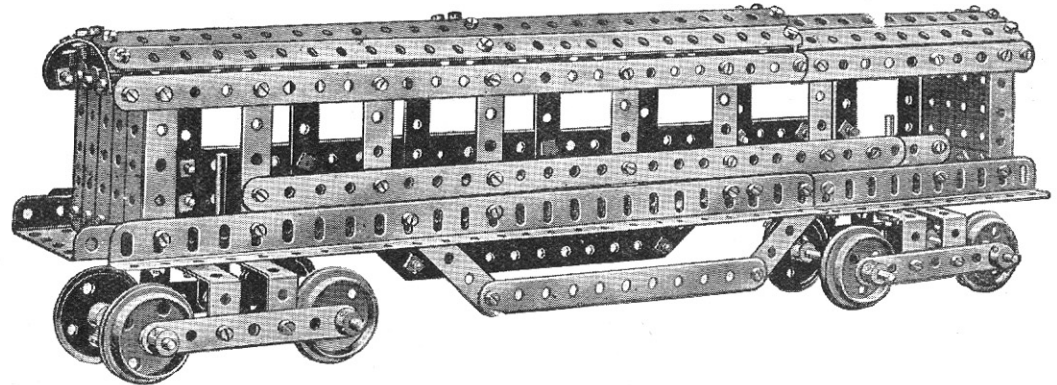
2 of No. 2	4 of No. 18A	1 of No. 52
2 " " 5	3 " " 19A	1 " " 59
1 " " 9D	1 " " 21	6 " " 63
2 " " 11	3 " " 22	2 " " 90
4 " " 12	2 " " 24	1 " " 95
2 " " 12B	1 " " 32	1 " " 96
1 " " 15A	22 " " 37	1 " " 125
2 " " 16	10 " " 38	1 " " 126A
2 " " 17	1 " " 48A	

Clockwork Motor
(not included in Outfit)



This is driven from the Motor Spindle 1, a small Sprocket Wheel at the rear, not shown in the illustration, being geared by a chain to the larger Sprocket Wheel 2 bolted on the Axle Rod of the rear Wheels 3.

Model No. 5.43 Pullman Car



Parts required :

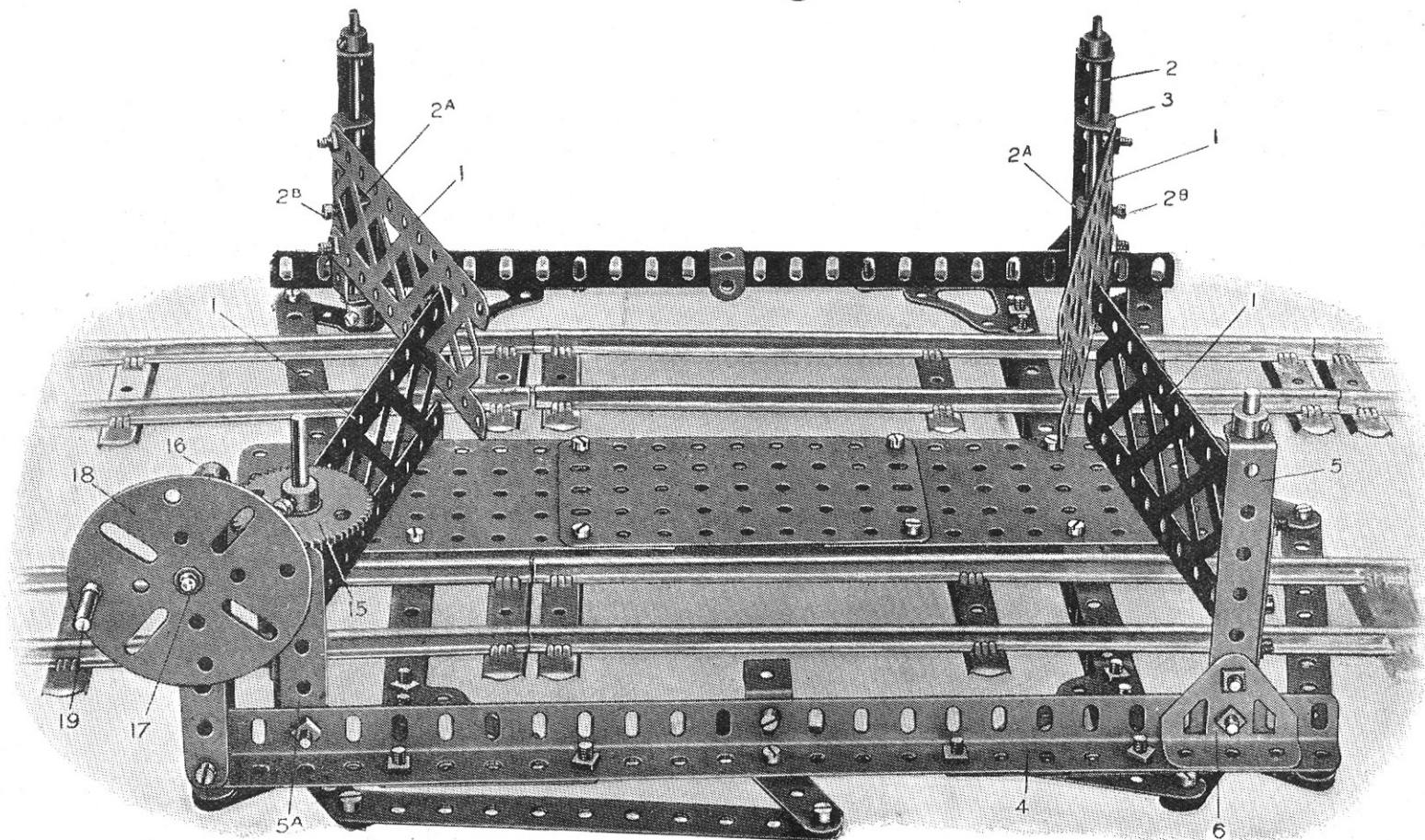
9 of No. 1	4 of No. 8	116 of No. 37
9 " " 2	4 " " 16	4 " " 46
8 " " 3	2 " " 17	3 " " 52
34 " " 5	8 " " 20	10 " " 59
	2 " " 21	

HOW TO CONTINUE

This completes our examples of models that may be made with MECCANO Outfit No. 5. The next models are a little more advanced, requiring a number of extra parts to construct them. The necessary parts are all contained in a No. 5A Accessory Outfit, the price of which will be found in the List at the end of this Manual.

This Model can be built with MECCANO Outfit No. 6 (or No. 5 and No. 5A)

Model No. 6.1
Level Crossing Gates



Model No. 6.1 Level Crossing Gates (continued)

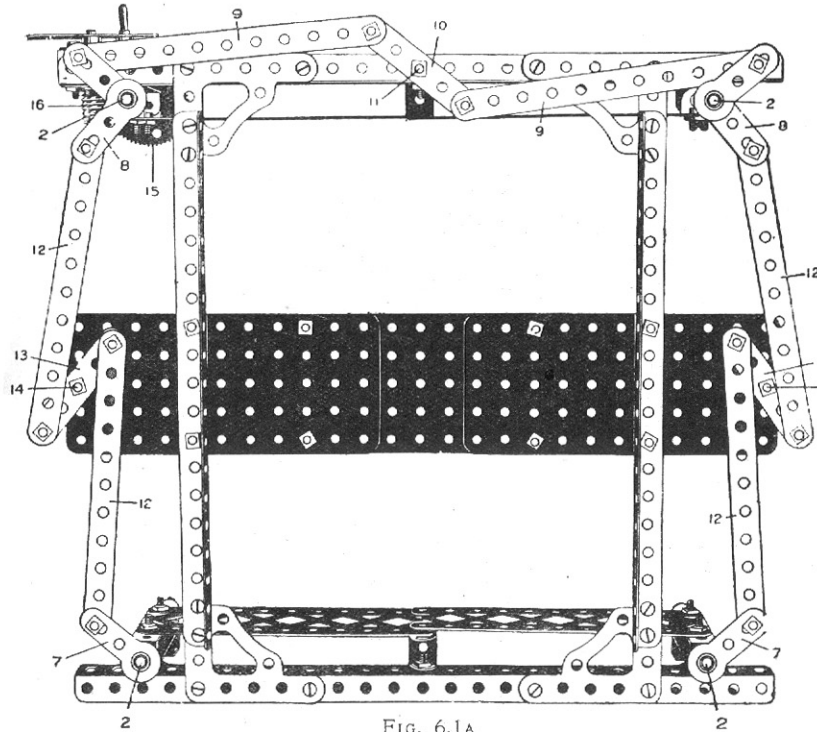


FIG. 6.1A

Parts
required :

6 of No.	2
2 "	4
3 "	5
1 "	6A
2 "	8
2 "	8A
4 "	11
4 "	15A
1 "	17
1 "	27A
1 "	32
53 "	37
16 "	37A
4 "	48A
3 "	48B
1 "	53A
7 "	59
2 "	62
3 "	70
4 "	100
4 "	108
1 "	109
1 "	115
3 "	126
2 "	128

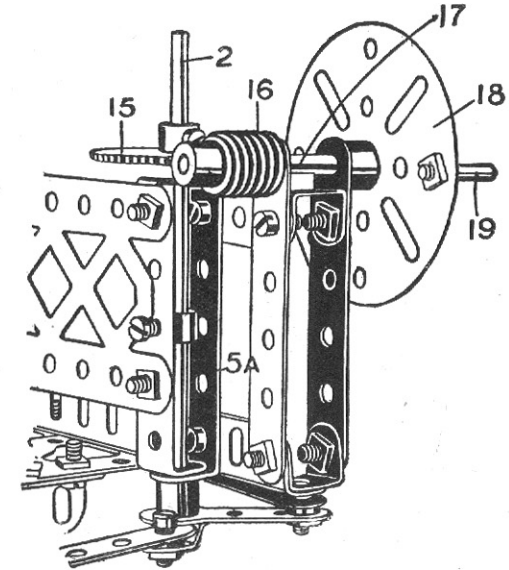


FIG. 6.1B

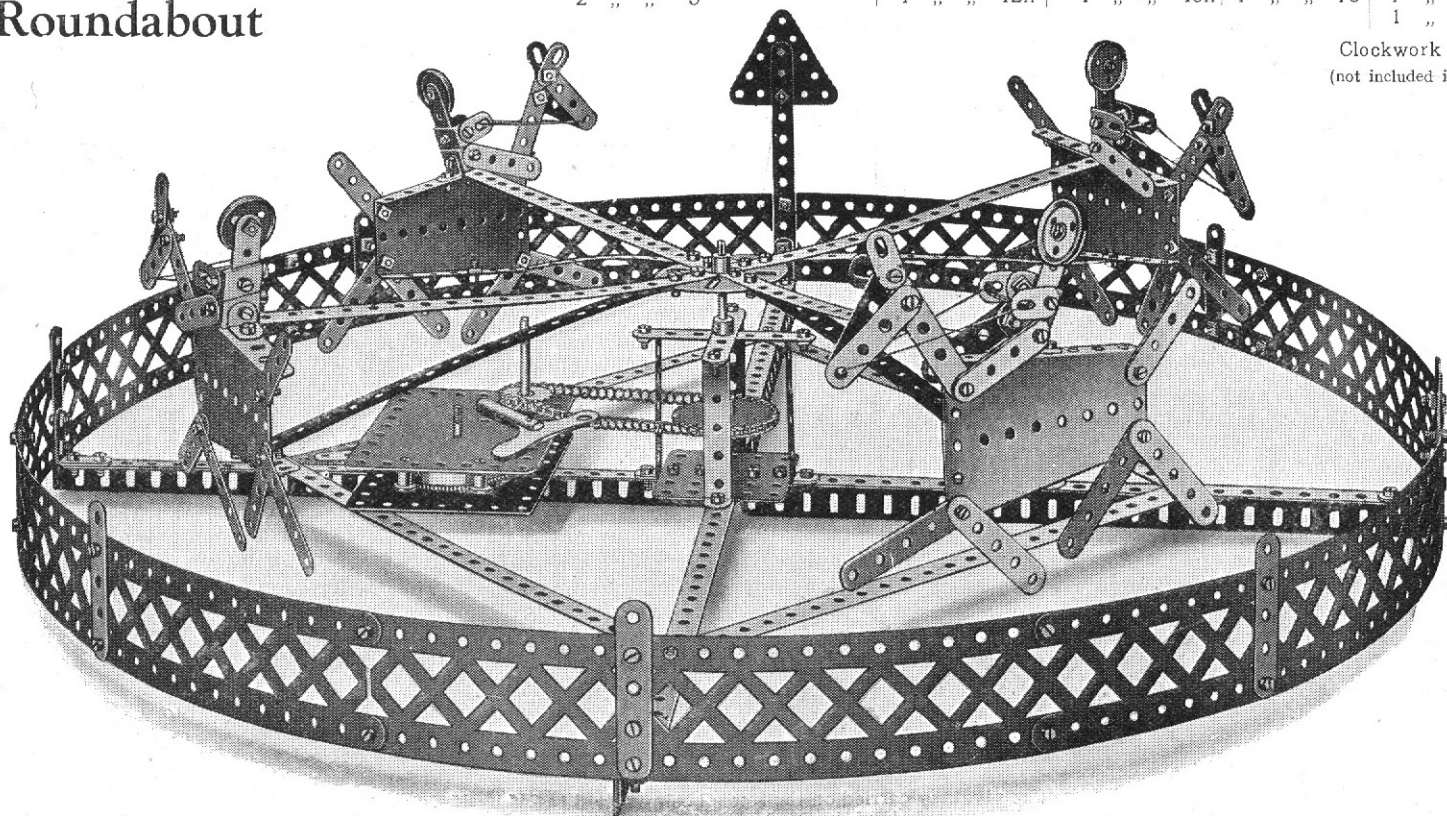
The gates consist of $5\frac{1}{2}$ " Braced Girders 1 and are pivotally carried on the Rods 2 being bolted to $2\frac{1}{2}$ " by $\frac{1}{2}$ " Double Angle Strips 3. On each Rod 2 is threaded a Collar 2A, Fig. 6.1, and a Bolt 2B is passed through the centre hole of the Double Angle Strips 3 and screwed into the thread hole of the Collar 2A, nipping the Collar to the Rod 2, thus ensuring that the Braced Girders 1 shall turn with the Rods 2. Three of the Rods 2 are carried from the lower Angle Girders 4 in $3\frac{1}{2}$ " by $\frac{1}{2}$ " Double Angle Strips 5, and one in a $2\frac{1}{2}$ " by $\frac{1}{2}$ " Double Angle Strip 5A, the feet of the Strips 5 being reinforced to the Angle Girders 4 by the Trunnions 6. The Rods 2 are coupled together by Cranks 7 on the rear Rods, and Bell Cranks 8 on the other Rods, the ends of the two Bell Cranks being connected by Strips 9 to $2\frac{1}{2}$ " Strips 10 pivoted on the Bolt 11, Fig. 6.1A, while the Bell Cranks 8 are connected to the Cranks 7 by other Strips 12, pivotally connected to $2\frac{1}{2}$ " Strips 13, pivoted on the Bolts 14. Consequently, all the Rods 2 are inter-connected. As will be seen from the Figs. 6.1 and 6.1B, a 57-toothed Gear Wheel 15 is secured on one of the Rods 2, and is engaged by a Worm 16 on a Rod 17 to which is secured a Face Plate 18, fitted with a Threaded Pin 19, as an operating handle. By turning the Face Plate 18 the spindles 2 are all rotated, and the gates caused to open or close.

Model No. 6.2 Roundabout

Parts required :

4 of No. 1	27 of No. 5	16 of No. 10	1 of No. 15	4 of No. 54	14" of No. 94
8 " " 1A	24 " " 6	8 " " 11	4 " " 22A	4 " " 59	1 " " 95
1 " " 2	4 " " 8	4 " " 12	135 " " 37	1 " " 72	1 " " 96
2 " " 3		4 " " 12A	4 " " 48A	1 " " 76	7 " " 99
					1 " " 109

Clockwork Motor
(not included in Outfit)



In this model the animals, built up from Sector Plates and short Strips to represent the limbs, are carried from 9½" Strips bolted to a Face Plate, which is rotated from the centre Rod by means of a Chain and a 1" Sprocket Wheel connected to the Spring Motor.

The centre Rod, by means of which the rotating figures are driven, is supported below the Face Plate by a light framing to give rigidity.

The model is surrounded by Braced Girder Strips bolted together, and strengthened by 12½" cross Angle Girders, connected in the centre by a 2½" by 2½" Flat Plate. The centre hole of this Plate carries the lower end of the vertical Rod upon which the animals are mounted.

Model No. 6.3 Portable Crane

Parts required :

12 of No. 2	16 of No. 12	1 of No. 21	2 of No. 44
3 " " 3	1 " " 15	5 " " 22	1 " " 45
6 " " 5	5 " " 16	2 " " 22A	1 " " 48
2 " " 9	4 " " 17	2 " " 23	2 " " 48A
	2 " " 18A	1 " " 24	1 " " 53
	1 " " 19	1 " " 26	1 " " 57
		1 " " 27A	10 " " 59
		74 " " 37	2 " " 62
		4 " " 37A	2 " " 63
		16 " " 38	2 " " 89
		1 " " 40	4 " " 90
			4 " " 111c
			4 " " 126A

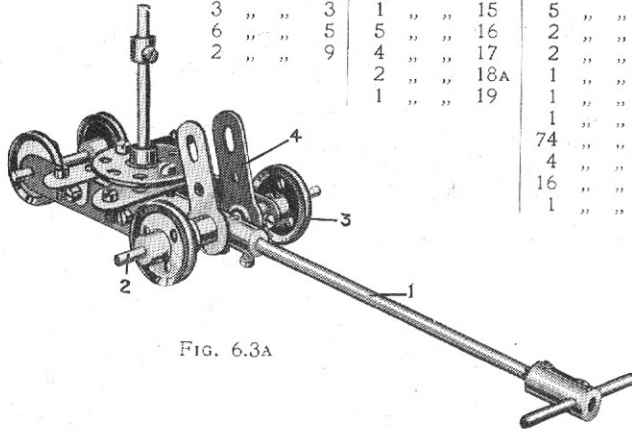
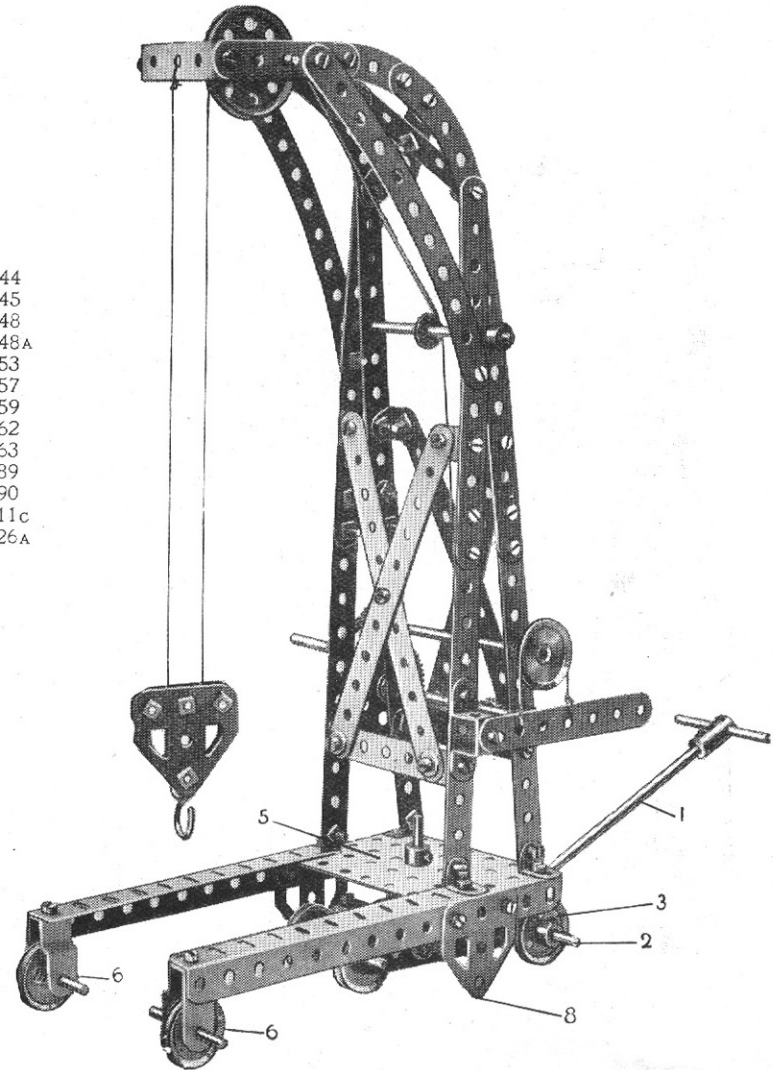


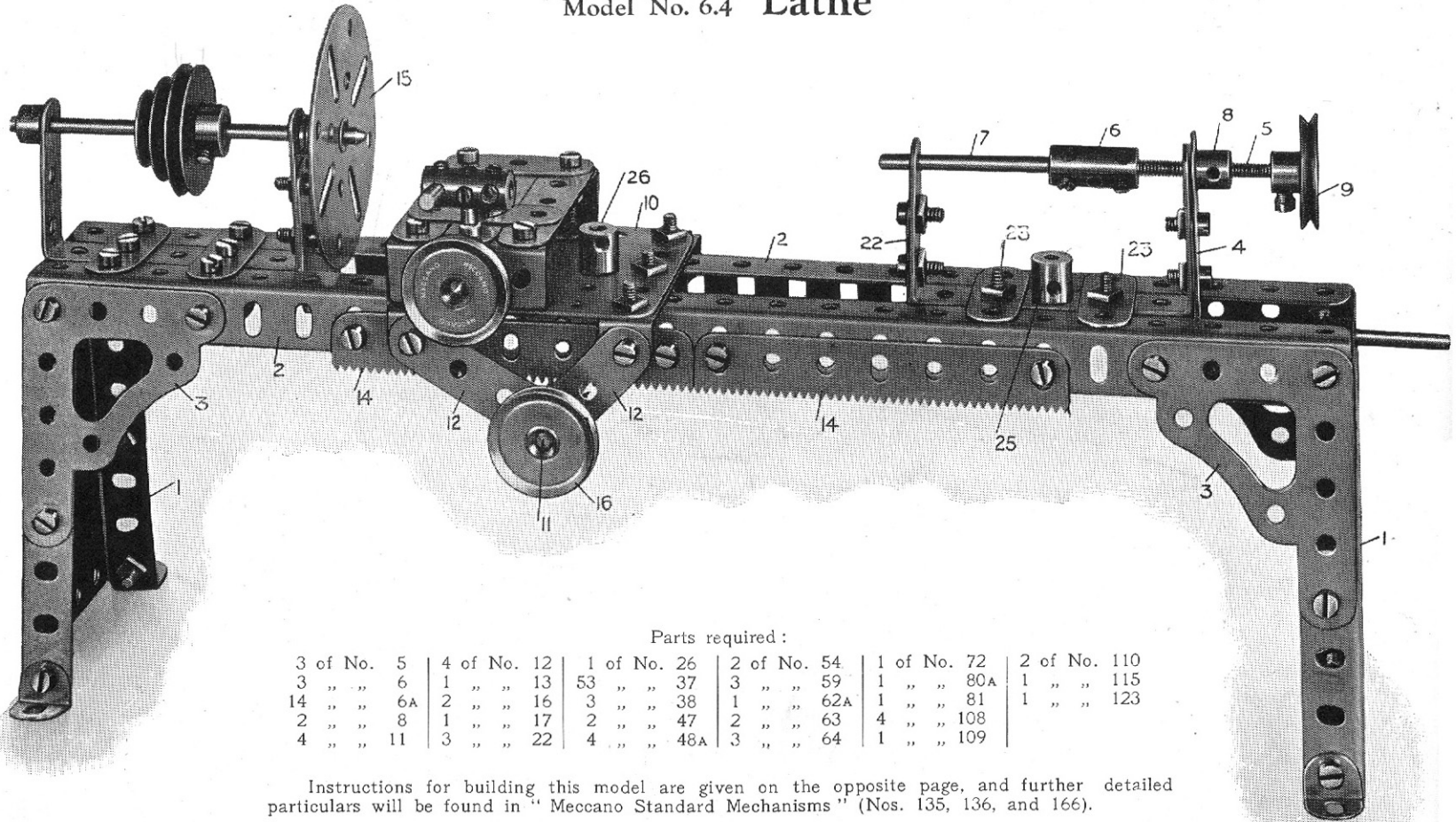
FIG. 6.3A

The construction of the tower is quite clear from the illustration. The crane is moved about by depressing the handle 1 carrying an Axle 2 for the 1" loose Pulley Wheels 3, which are secured in position by Collars and Set Screws. A pair of Cranks 4 are secured to the Axle 2 and are arranged when the handle is depressed to bear against the underface of the small rectangular Plate 5 and lift the crane so that it then runs on the Wheels 3 and 6. When the crane is brought to rest its weight forces down the Cranks 4 which raise the handle 1, and the tips 8 of the Flat Trunnions together with front Wheels 6 then support the crane.

The load is controlled by a strap and lever brake (see "Meccano Standard Mechanisms," detail No. 81).



Model No. 6.4 Lathe



Parts required :

3 of No. 5	4 of No. 12	1 of No. 26	2 of No. 54	1 of No. 72	2 of No. 110
3 " " 6	1 " " 13	53 " " 37	3 " " 59	1 " " 80A	1 " " 115
14 " " 6A	2 " " 16	3 " " 38	1 " " 62A	1 " " 81	1 " " 123
2 " " 8	1 " " 17	2 " " 47	2 " " 63	4 " " 108	
4 " " 11	3 " " 22	4 " " 48A	3 " " 64	1 " " 109	

Instructions for building this model are given on the opposite page, and further detailed particulars will be found in "Meccano Standard Mechanisms" (Nos. 135, 136, and 166).

Model No. 6.4 Lathe (continued)

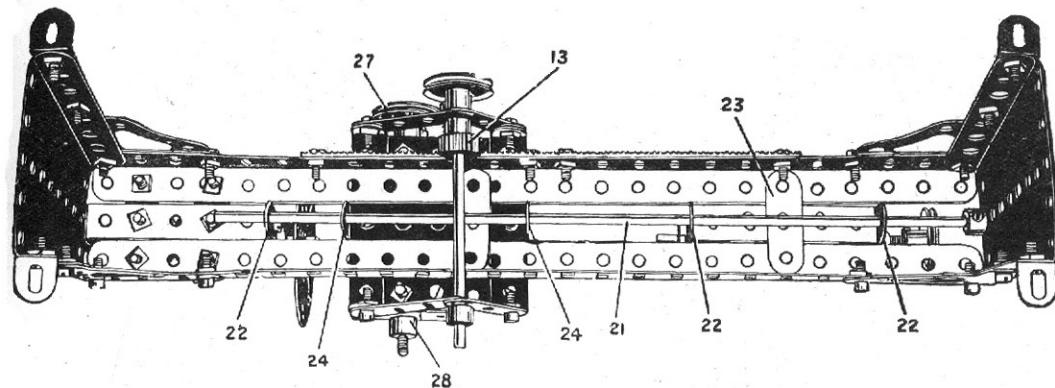


FIG. 6.4A

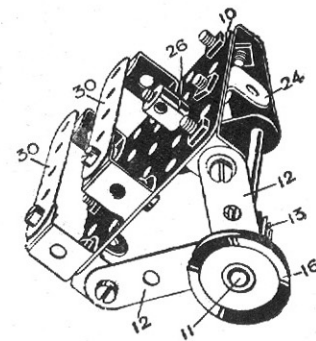


FIG. 6.4B

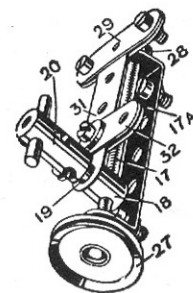


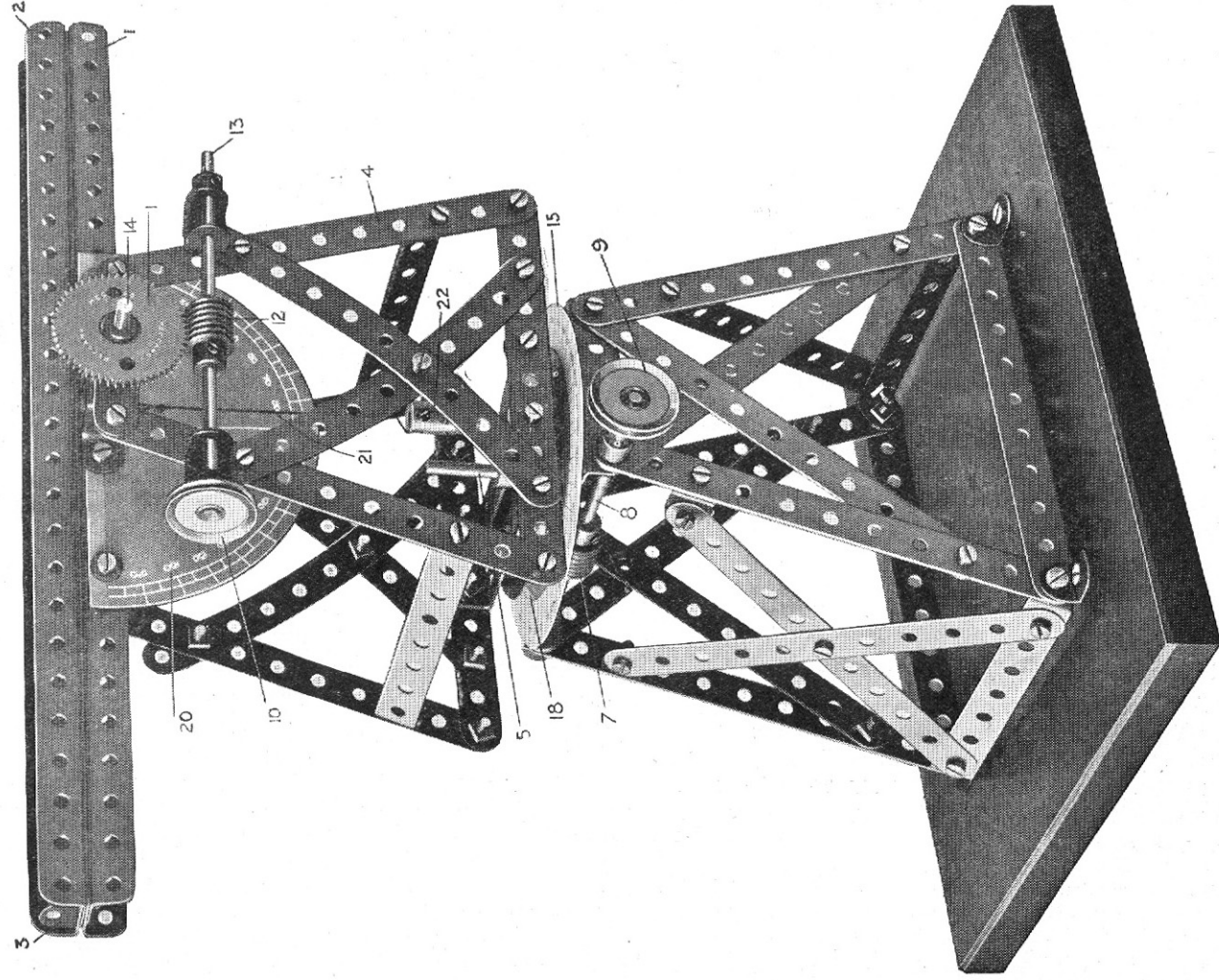
FIG. 6.4C

The lathe frame is built up from Sector Plates 1, at each end bolted to $1\frac{1}{2}$ " Angle Girders 2, forming the bed, by means of Architraves 3. The tail stock 4 slides between the Angle Girders 2, and has a screw adjustment 5, the screw of which is connected by the Coupling 6 to the short Rod 7; the screw 5 is threaded into a Threaded Crank 8, and is operated by the 1" Pulley Wheel 9. The tail stock is locked by turning the Threaded Boss 25, which engages the Bolt holding the underneath cross Strip 23, thus gripping it beneath the lathe bed. The saddle 10, consisting of a $2\frac{1}{2}$ " by $2\frac{1}{2}$ " Flat Plate, carries the Rod 11, journalled in the Strips 12, and carries a Pinion 13, Fig. 6.4B, which engages the racks 14, so that the saddle may be moved to or from the Face Plate 15, by turning the Pulley Wheel 16. The traversing movement is obtained by means of the Screw 17, which engages a Threaded Boss 18, into the end of which is screwed a Threaded Pin 19, carrying the Coupling 20, which forms the tool post. The saddle is locked by the Threaded Boss 26, similar to the tail stock. The Screwed Rod 17 is held against end movement in the $2\frac{1}{2}$ " x $\frac{1}{2}$ " Angle Strip 17A, by the Pulley Wheel 27 at one side and the Collar 28 on the other.

The construction of the saddle is shown in Figs. 6.4B and 6.4C, where the $1\frac{1}{2}$ " Strips 29, of Fig. 6.4C are shown removed from Fig. 6.4B; these Strips 29 are bolted at the end of the guide Strips 30, Fig. 6.4B, and form guides for the $2\frac{1}{2}$ " Strip 31, carrying the tool post. They are spaced apart by the thickness of the Strips 30, and the $1\frac{1}{2}$ " Strips 32, bolted to the Strip 31, slide on the Strips 30. As will be seen from the underneath view, Fig. 6.4A, a guide Rod 21, is fixed beneath the bed plates, and is engaged by the end holes of the $1\frac{1}{2}$ " Strips 22, secured to the sides of the head and tail stocks; $1\frac{1}{2}$ " Strips 23, being bolted above and below to retain the tail stock in position. The saddle engages the Rod 21 by means of a $2\frac{1}{2}$ " by $\frac{1}{2}$ " Double Angle Strip 24.

This Model can be built with MECCANO Outfit No. 6 (or No. 5 and 5A)

Model No. 6.5 Theodolite



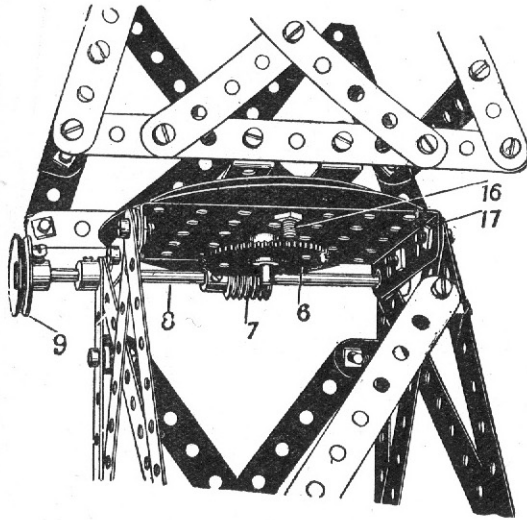
Model No. 6.5 **Theodolite** (continued)

FIG. 6.5A

Parts required :	
20 of No.	
2	5
6	6A
4	8
2	11
10	12
3	15
1	17
1	19B
2	22
2	27A
2	32
60	37
1	45
6	48B
1	53
6	59
1	62
1	63
4	89
1	135

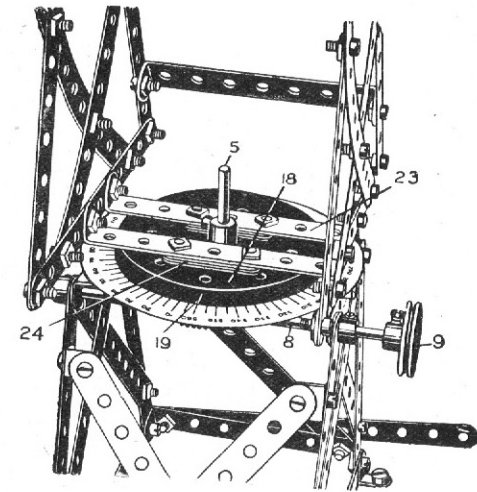


FIG. 6.5B

The Theodolite is represented by two reverse pairs of Angle Girders 1 and 2, which form a "sighting arm," an Angle Bracket 3 being bolted at one end to form an eye piece. A small piece of gummed paper is fastened over the aperture in the Angle Bracket, and a fine pin-hole made in the paper at the centre of the aperture. Two crossed threads are gummed across the aperture of the Angle Bracket bolted at the other end of the sighting arm.

The upper framework 4 swivels horizontally with the vertical spindle 5 as a pivot. On the lower end of this Rod is a Gear Wheel 6, Fig. 6.5A, engaged by a Worm 7 on a Rod 8, operated by the 1" Pulley 9. This gives the horizontal traverse of the upper frame 4, in which the sighting arm is pivotally mounted upon a Rod 14, on which is a Gear Wheel 11 engaged by a Worm 12 on a Rod 13 operated by a 1" Pulley 10. This mechanism gives the vertical traverse or inclination of the sighting arm.

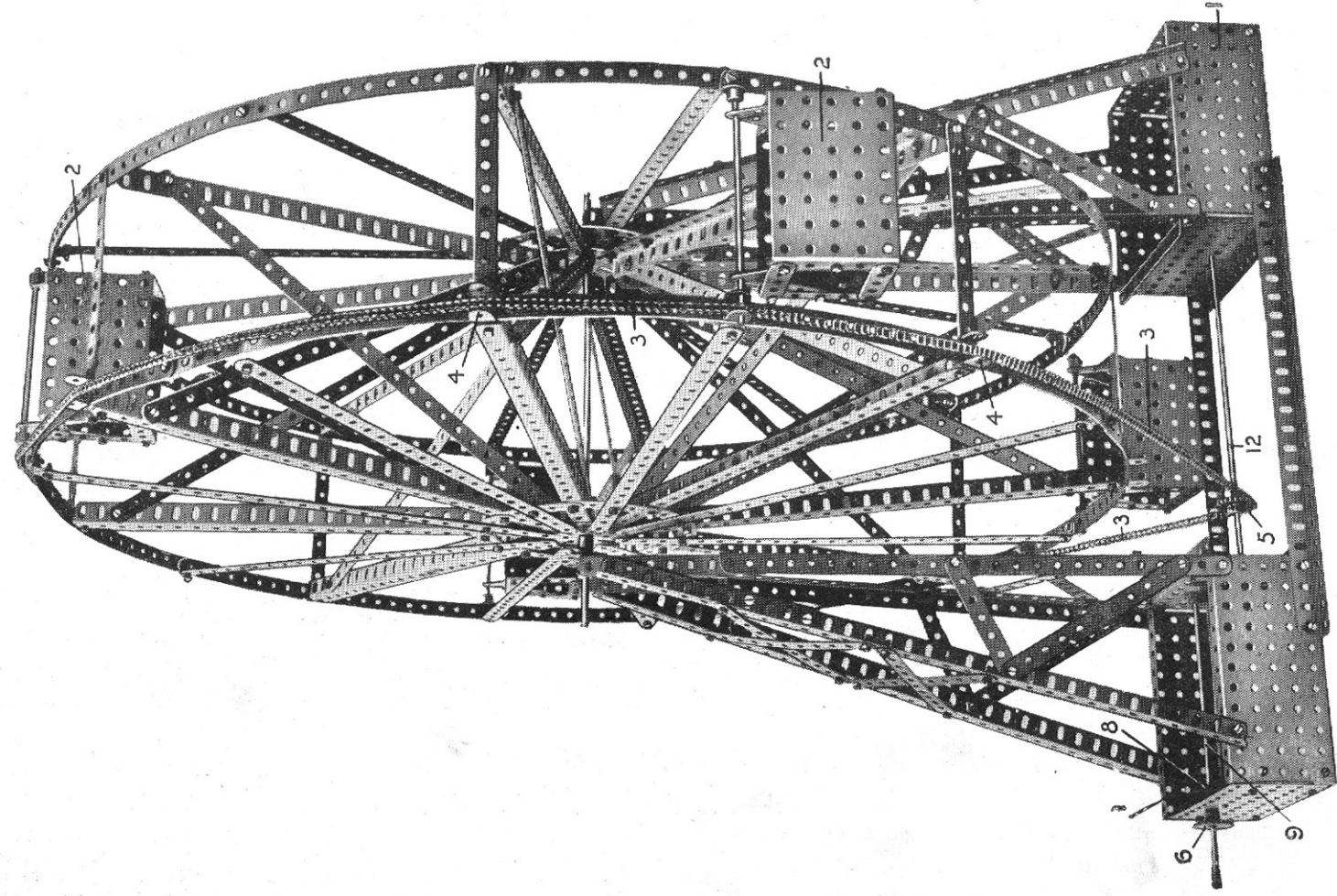
A protractor for the horizontal angular movement of the upper frame 4 consists of a graduated cardboard disc 15, which is bolted by a Bolt 16 to a Perforated Flanged Plate $3\frac{1}{2}$ " by $2\frac{1}{2}$ " 17, the head of the Bolt 16 being above the cardboard disc, and beneath the 3" Pulley Wheel 18. The cardboard disc is thus held against movement by the Bolt 16, its centre hole engaging round the pivot Rod 5. An index mark or pointer 19 is made on the Pulley Wheel 18. The movement of this pointer round the graduated scale on the disc shows the horizontal angular traverse.

Similarly, the vertical traverse of the sighting arm is indicated by means of a semi-circular protractor 20, bolted to the lower Angle Girder 1 of the sighting arm, a Cord 21 carrying a weight 22, being hung from the Rod 14, the position of the thread 21 over the protractor 20 indicating the vertical angular adjustment of the sighting arm. The thread 21 has a loop by which it is hung on the Rod 14, so that its direction always points truly radially to the rod 14, and this gives the correct angular reading. In order to bring the Double Angle Strips 23 flush with the outer rim of the Pulley Wheel 18, three $1\frac{1}{2}$ " packing Strips 24 are bolted beneath the Double Angle Strips, as shown in Fig. 6.5B.

The sighting arm is secured to the Rod 14 by a Crank bolted to the arm on the opposite side to the protractor and nipped by the Set Screw to the Rod 14

This Model can be built with MECCANO Outfit No. 6 (or No. 5 and No. 5A)

Model No. 6.6 Big Wheel



Model No. 6.6 Big Wheel (continued)

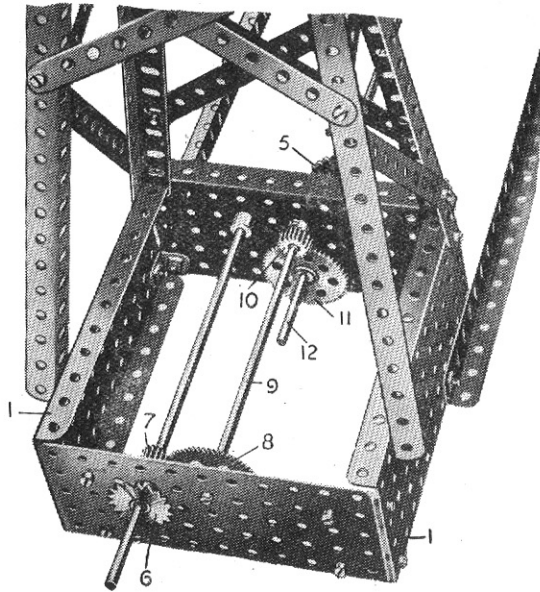


FIG. 6.6A

Parts
required :

46 of No.	1
24 "	2
4 "	3
32 "	5
26 "	8
4 "	9
8 "	11
44 "	12
2 "	13
1 "	13A
1 "	14
4 "	15
2 "	24
2 "	26
2 "	27A
308 "	37
6 "	38
4 "	48D
6 "	52
8 "	53
2 "	54
13 "	59
2 "	70
16 "	90
8 "	94
2 "	96
2 "	109

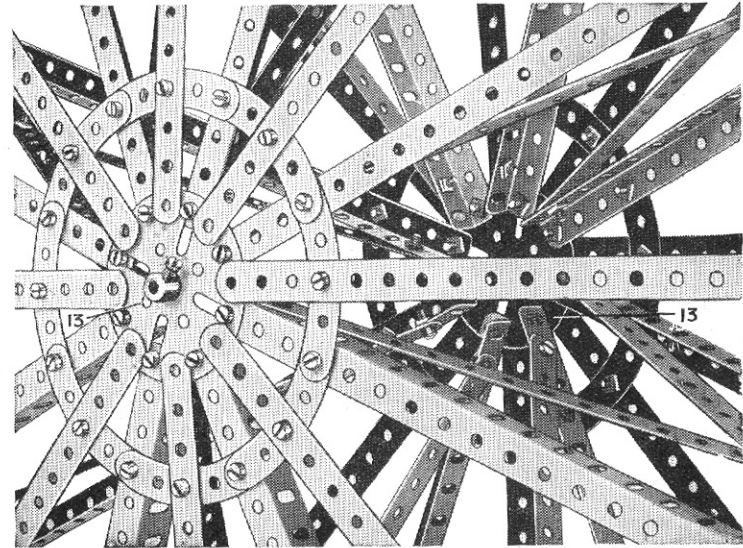


FIG. 6.6B

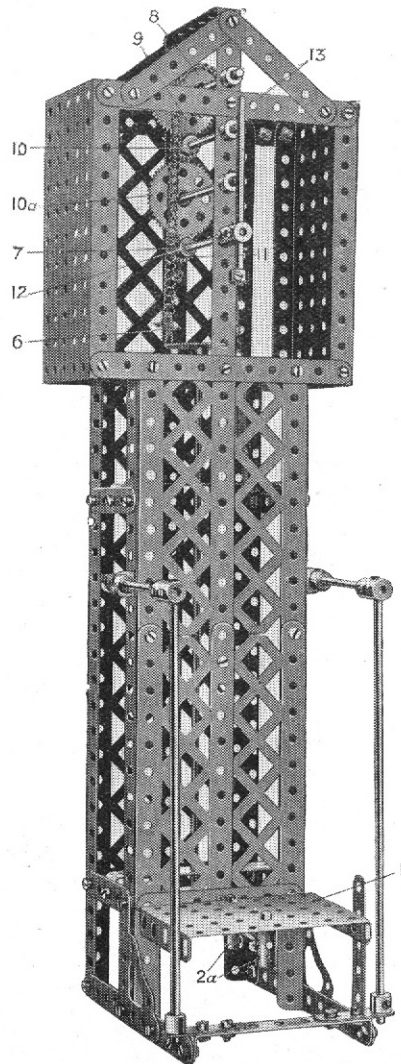
In constructing this model, Flanged Plates 1 are used to form the sides and inner part of the base of the side pedestals, and also to form the suspended cages 2 on the wheel. The driving Chain 3 is conveniently kept in position round the periphery of one of the side elements of the wheel by a series of Double Angle Brackets 4, bolted on the ends of the spokes.

Fig. 6.6A shows how the driving Chain 3 is actuated from the Sprocket Wheel 5. On the axle of the driving Sprocket 6 is a $\frac{1}{2}$ " Pinion 7 driving a $1\frac{1}{2}$ " Gear Wheel 8 on an Axle 9. On the other end of this Axle 9 is a $\frac{1}{2}$ " Pinion 10 engaging a $1\frac{1}{2}$ " Gear Wheel 11 on the Rod 12 of the Sprocket Wheel 5.

Fig. 6.6B shows how the Wheel is built up from the centre Face Plates 13.

Model No. 6.7

Automatic Weighing Machine



Parts required :

2 of No. 1	1 of No. 24	12 of No. 59
6 " " 2	2 " " 26	2 " " 62
2 " " 3	2 " " 27A	6 " " 63
6 " " 4	64 " " 37	10 " " 94
4 " " 5	2 " " 37B	1 " " 96
4 " " 8	1 " " 43	2 " " 99
1 " " 13	1 " " 48A	6 " " 100
2 " " 13A	3 " " 48B	2 " " 108
1 " " 15A	2 " " 52	
7 " " 16	1 " " 53	

The platform 1 is connected by cross Rod and Couplings 2a to a Rod 2 (by means of a further Coupling) passing through the centre of the machine and guided in the $3\frac{1}{2}$ " Double Angle Strips 3 and 3a connected to side Strips 4. At the upper end of this Rod 2 is a Bush Wheel 5, to which is connected a Cord 6 and Sprocket Chain 7. This Chain passes round a Sprocket Wheel 8 on the same spindle as the 57-toothed Gear Wheel 9 engaging a $\frac{1}{2}$ " Pinion 10. The Pinion 10 also engages another 57-toothed Gear Wheel 10a, and this in turn a $\frac{1}{2}$ " Pinion 11 on the spindle 12 carrying the pointer 13. The other end of the Chain is coupled by a Spring 14 to the cross piece 3a, and the pointer is thus always returned to zero immediately the load is removed from the platform.

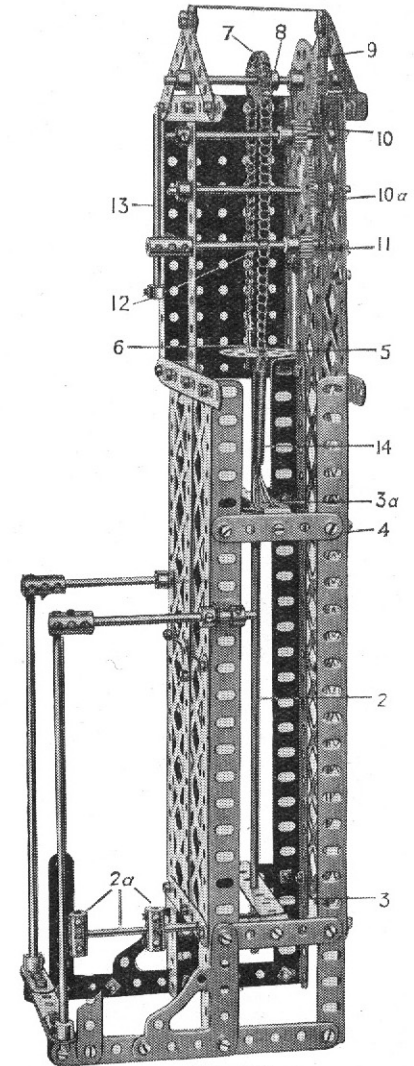


FIG. 6.7A

Model No. 6.8 Derricking Grab

The grab 1 is suspended by Cords 2 which pass over the Pulleys 3 and round the outer Pulleys of a set of four 4 at the head of the standard 5. The cords continue down and under the outer pulleys of a set of smaller Pulleys 6 and are wound on a Crank Handle 7 at the centre of which they are connected by a Spring Clip. (Care should be taken to see that, when winding up, the double lapping of each cord on the rod occurs simultaneously, as otherwise the grab will cant over).

The grab is opened or closed by the Cord 8 which, after passing over one of two inner Pulleys at the end of the jib 9, then passes over another of the four Pulleys 4 and one of the Pulleys 6 to the Crank Handle 10.

The jib 9 is raised or lowered by the Cord 11 which is secured to the standard 5, and having passed around the other of the two inner pulleys at the jib-end is passed back and around one of the four Pulleys 4 and one of the Pulleys 6 to the Crank Handle 12. The swinging of the jib is effected from the Crank Handle 13 on the end of a rod, on which is a $\frac{1}{2}$ " Pinion 14 engaging a Contrate Wheel 15 at the foot of the standard 5.

Gear Wheels 16 and 17 are bolted on the Crank Handles 10 and 7 and are connected by the Pinion 18.

The Crank Handle 7 is fixed against longitudinal movement, but the Crank Handle 10 may be slid clear of the Pinion 18, and the Handle 7 turning the grab is raised or lowered. If the Handle 10 is slid to disengage its gear wheel from the Pinion 18 and the handle turned, the grab is opened or closed.

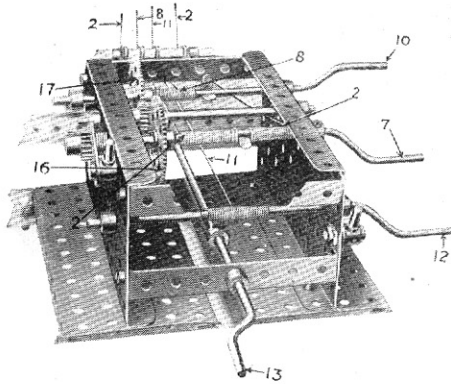
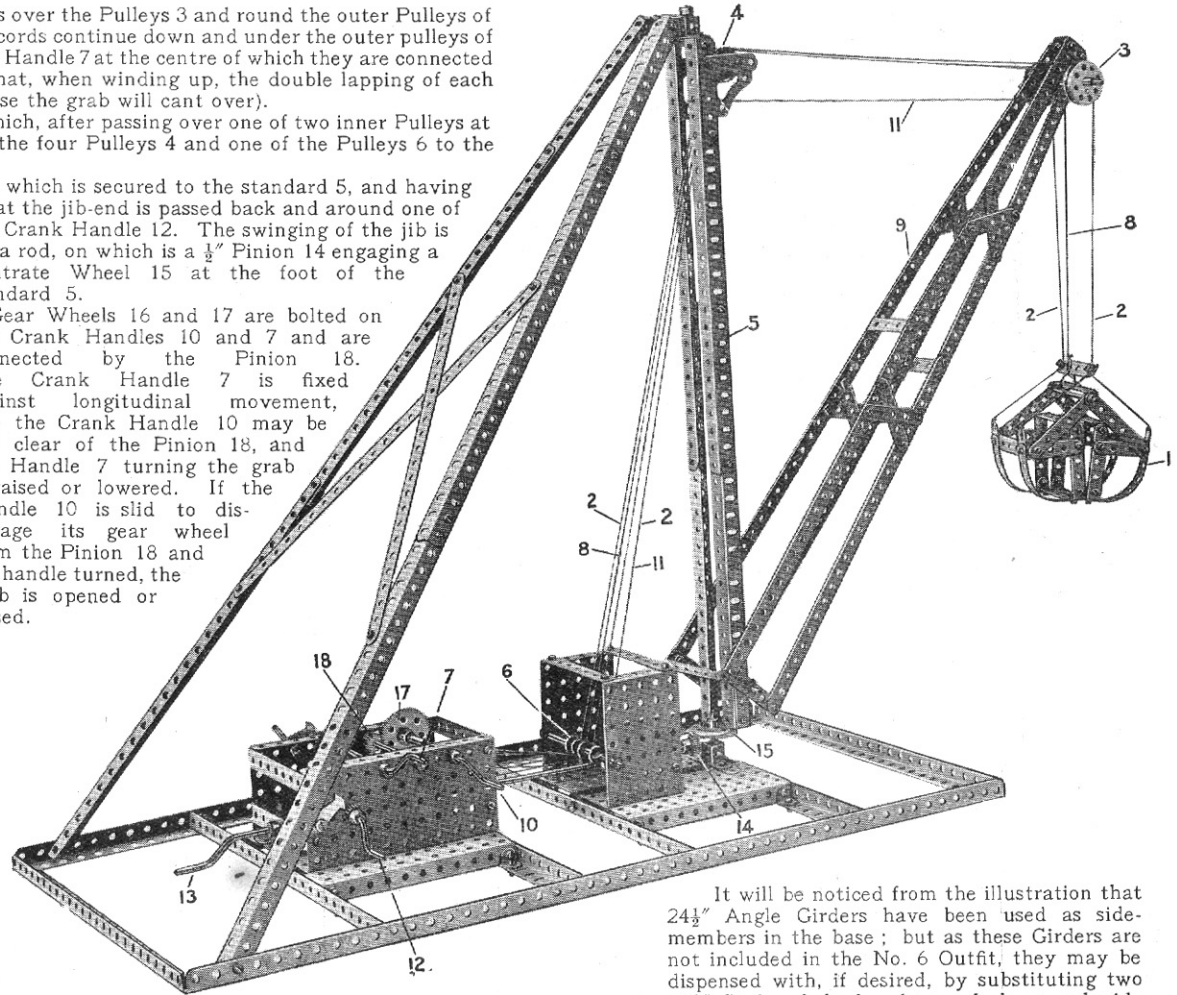


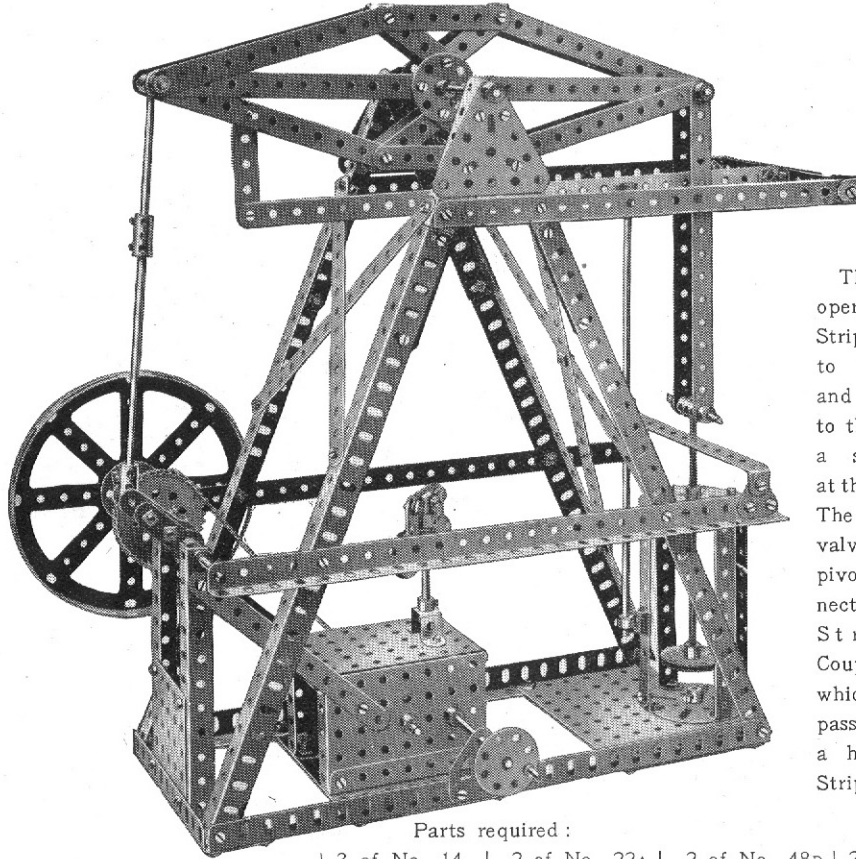
FIG. 6.8A

Parts required					
10 of No.	1	1 of No.	18A	4 of No.	48
6	3	3	19	9	48A
4	4	1	19c	5	48B
20	5	2	20	6	52
4	6	2	22	2	53
18	8	3	22A	1	57
2	9	4	23	16	59
6	10	2	24	1	63
6	11	2	26	2	108
10	12	2	27A	2	115
1	13	1	28	1	126
2	15A	6	35	2	147A
3	16	169	37	2	147B
2	17	2	44	2	148



It will be noticed from the illustration that $2\frac{1}{2}$ " Angle Girders have been used as side-members in the base; but as these Girders are not included in the No. 6 Outfit, they may be dispensed with, if desired, by substituting two $1\frac{1}{2}$ " Girders bolted end to end along each side of the base frame.

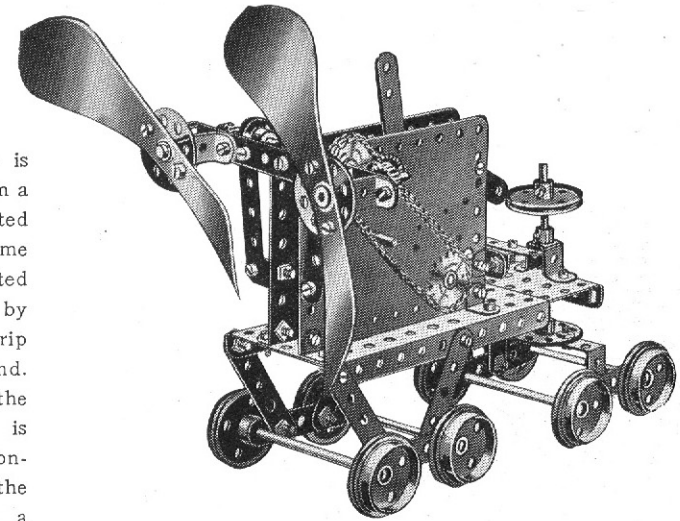
Model No. 6.9 Beam Engine



Parts required :

5 of No.	1	5 of No.	6A	3 of No.	14	2 of No.	22A	2 of No.	48D	2 of No.	76
4 " "	1B	8 " "	8	3 " "	15	4 " "	24	1 " "	50	2 " "	77
10 " "	2	2 " "	8A	2 " "	15A	2 " "	26	2 " "	52A	1 " "	95
4 " "	2A	7 " "	9	2 " "	16	1 " "	27A	3 " "	53	1 " "	96A
4 " "	4	2 " "	9B	1 " "	16A	1 " "	29	17 " "	59	2 " "	109
1 " "	5	2 " "	11	2 " "	17	120 " "	37	2 " "	62	1 " "	115
8 " "	6	2 " "	12	2 " "	18A	6 " "	38	6 " "	63	1 " "	118
		1 " "		1 " "	18B	1 " "	45	1 " "	63B	1 " "	126A
		1 " "		1 " "	21	3 " "	48c	1 " "	72	2 " "	133

Model No. 6.10 Aerocar



The valve is operated from a Strip pivoted to the frame and connected to the beam by a short Strip at the other end. The top of the valve rod is pivotally connected to the Strip by a Coupling into which a bolt passing through a hole in the Strip is screwed.

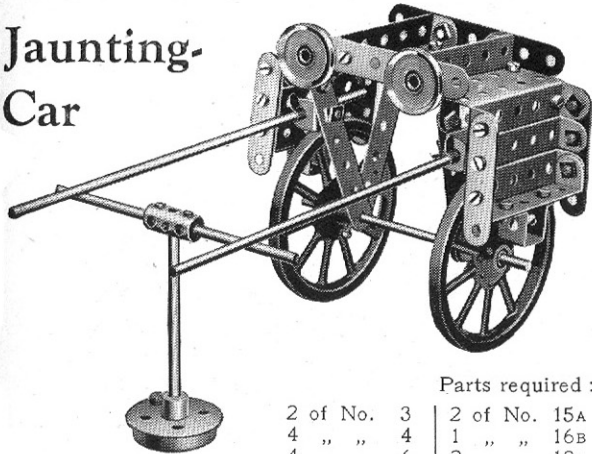
Parts required :

1 of No.	2	2 of No.	29
1 " "	4	47 " "	37
10 " "	5	4 " "	41
10 " "	12	3 " "	45
2 " "	15A	1 " "	46
4 " "	16	1 " "	52
2 " "	17	1 " "	53
8 " "	20	2 " "	59
3 " "	24	2 " "	96
2 " "	26		

Clockwork Motor
(not included in Outfit)

Model No. 6.11

Jaunting-Car



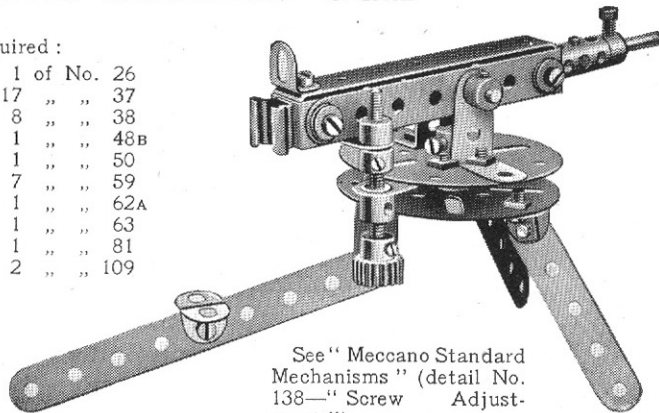
Parts required :

2 of No. 3	2 of No. 15A	39 of No. 37
4 " " 4	1 " " 16B	2 " " 45
4 " " 6	2 " " 19A	10 " " 48A
2 " " 11	1 " " 20	1 " " 53
8 " " 12	2 " " 22	1 " " 63
2 " " 13A	4 " " 35	

Model No. 6.12 Machine Gun

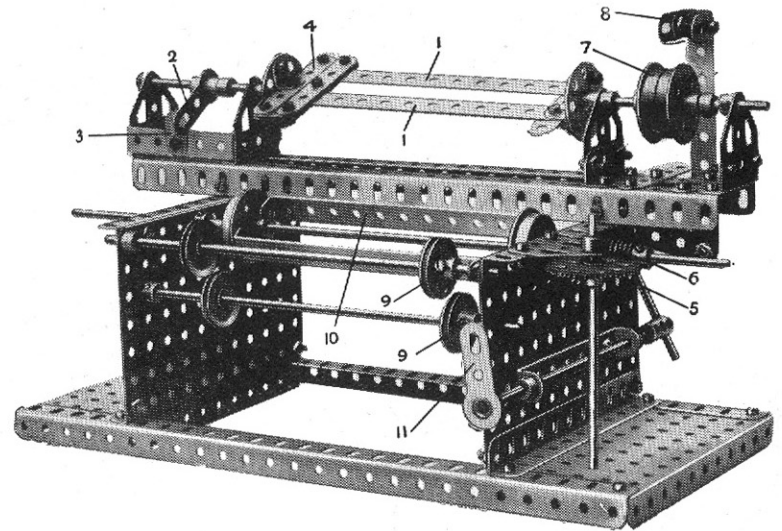
Parts required :

1 of No. 2A	1 of No. 26
2 " " 3	17 " " 37
2 " " 5	8 " " 38
2 " " 11	1 " " 48B
5 " " 12	1 " " 50
2 " " 12A	7 " " 59
2 " " 12B	1 " " 62A
1 " " 17	1 " " 63
1 " " 18A	1 " " 81
1 " " 18B	2 " " 109



See " Meccano Standard Mechanisms " (detail No. 138—" Screw Adjustment.")

Model No. 6.13 Linen Winder



Parts required :

2 of No. 2	1 of No. 13	1 of No. 27A	2 of No. 48D
1 " " 2A	2 " " 13A	1 " " 32	2 " " 52
8 " " 5	1 " " 14	66 " " 37	2 " " 52A
4 " " 8	1 " " 15A	2 " " 37A	16 " " 59
4 " " 9	2 " " 16	1 " " 37B	2 " " 62
4 " " 9F	1 " " 16A	6 " " 38	2 " " 63
6 " " 10	4 " " 20	1 " " 44	5 " " 126A
1 " " 11	4 " " 22	1 " " 48A	
7 " " 12	2 " " 24	1 " " 48B	

In order to disengage the winding frame bars 1 the Crank 2 is lifted clear of the stop 3 and drawn back, this action disengaging the end cross Strips 4 from the tips of the frame bars 1 and permitting the wound linen to be removed. The Gear Wheel 5 engaging the Worm 6 forms a counter, 7 are the belt Pulleys, and 8 the belt striker operated by Crank 11 ; 9 are the guide Pulleys for the main linen drums 10.

This Model can be built with MECCANO Outfit No. 6 (or No. 5 and 5A)

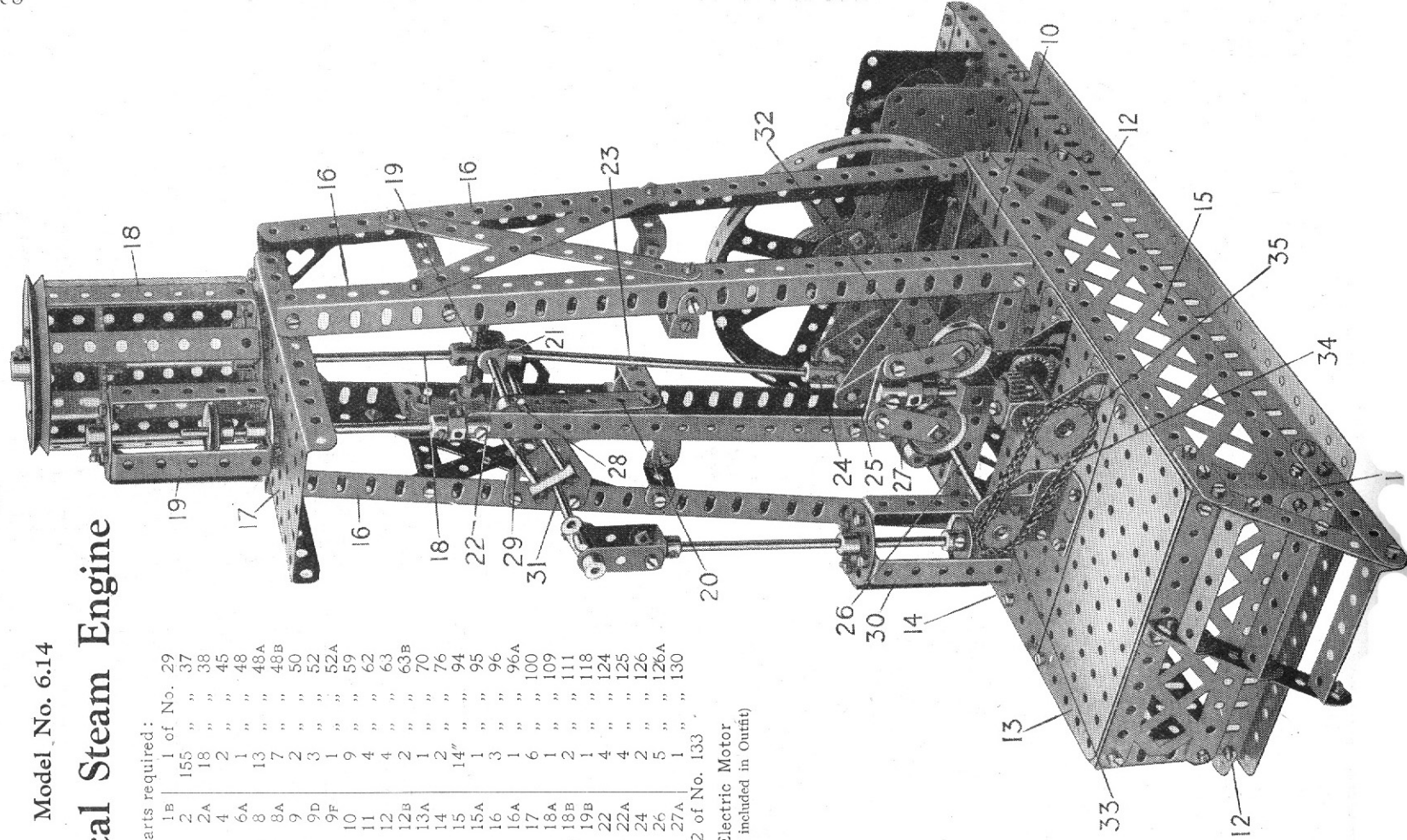
Model No. 6.14

Vertical Steam Engine

Parts required:

1 of No. 1	1 of No. 29
4 "	37
2 "	38
2 "	2A
3 "	4
3 "	2
6 "	6A
6 "	8
2 "	8A
7 "	7
2 "	9
5 "	9D
1 "	9F
4 "	10
3 "	11
3 "	12
1 "	12B
1 "	13A
1 "	14
2 "	15
2 "	15A
2 "	16
4 "	16A
4 "	17
1 "	18A
1 "	18B
1 "	19B
2 "	22
2 "	22A
5 "	24
4 "	26
3 "	27A
	2 of No. 133

Electric Motor
(not included in Outfit)



This Model can be built with MECCANO Outfit No. 6 (or No. 5 and 5A)
Model No. 6.14

Vertical Steam Engine

(continued)

As shown in Fig. 6.14A, the motor drives the engine through a reduction gearing arranged as follows:

A $\frac{3}{8}$ " Pinion 1 on the motor spindle drives a 57-tooth Gear Wheel 2 on the $2\frac{1}{2}$ " Rod 3, on the other end of which a further $\frac{1}{2}$ " Pinion engages a similar Gear Wheel on the $2\frac{1}{4}$ " Rod 4; a third $\frac{3}{8}$ " Pinion 5 on this rod engages another Gear Wheel 6 on a $3\frac{1}{2}$ " Rod 7. This rod is coupled to the engine by a Sprocket Chain 8 connected to 1" Sprocket Wheels 9.

The bed plate is built up at the sides by two $9\frac{1}{2}$ " Angle Girders 10 bolted to $2\frac{1}{2}$ " Angle Girders 11 at the corners. These corner Girders are bolted to $12\frac{1}{2}$ " Angle Girders 12, and the top is formed of one $5\frac{1}{2}$ " \times $2\frac{1}{2}$ " Flat Plate 13 and one $5\frac{3}{8}$ " \times $3\frac{1}{2}$ " Flat Plate 14 bolted down to the Girders 10, which support the Vertical Angle Girders 16. The side members 15 are composed of two $5\frac{1}{2}$ " Braced Girders overlapped three holes. In the top of the Angle Girders 16 is bolted a $5\frac{1}{2}$ " \times $2\frac{3}{8}$ " Flanged Plate 17 carrying a cylinder 18 and valve chest 19.

At the lower end of the Piston Rod 18 is the crosshead formed of a 2" Rod 19 passing through the centre hole of a Coupling into the end hole of which the Piston Rod 18 is secured. The ends of the Rod 19 engage Eye Pieces which slide on the $4\frac{1}{2}$ " Strips 20. The Fork Piece 21 is pivotally connected to the Coupling by a $2\frac{1}{2}$ " Rod 22, and the $6\frac{1}{2}$ " Connecting Rod 23 is secured to a Coupling 24 through which is passed a $1\frac{1}{2}$ " Rod 25; the ends of the latter engage the bosses of two Cranks bolted to Triangular Plates forming the balance weights of the crankshaft.

The $4\frac{1}{2}$ " Rod 26 carries an Eccentric 27 which operates the valve in the valve chest 19, and the two Collars 28 on the Rod 22 engage two 2" Rods 29 which actuate the pump 30 from the rocking Rod 31. The governor 32 is driven from a $\frac{3}{8}$ " Sprocket Wheel 33 coupled by a Chain 34 to a 1" Sprocket Wheel 35. The construction of the governor gear can be clearly seen in the illustration.

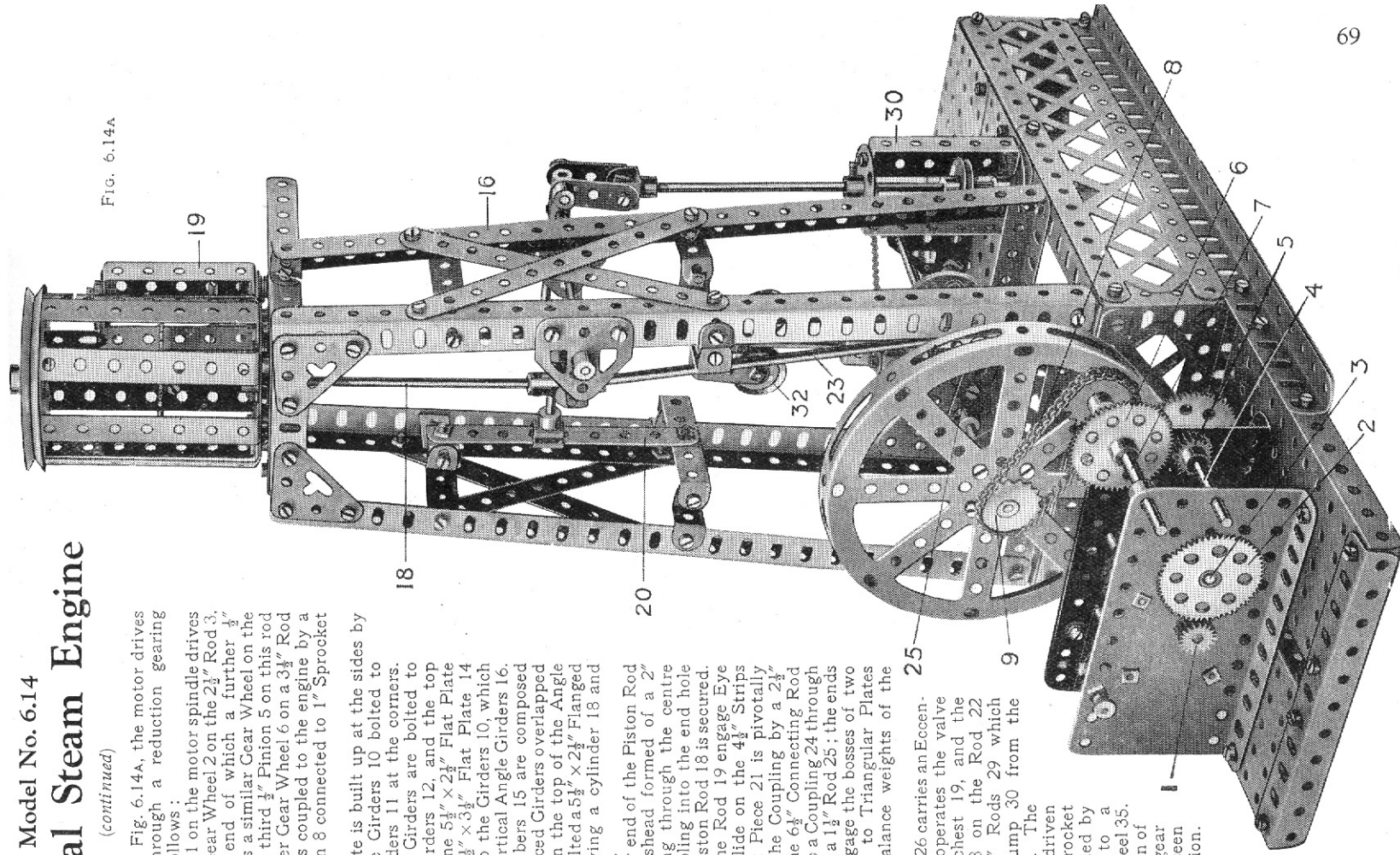
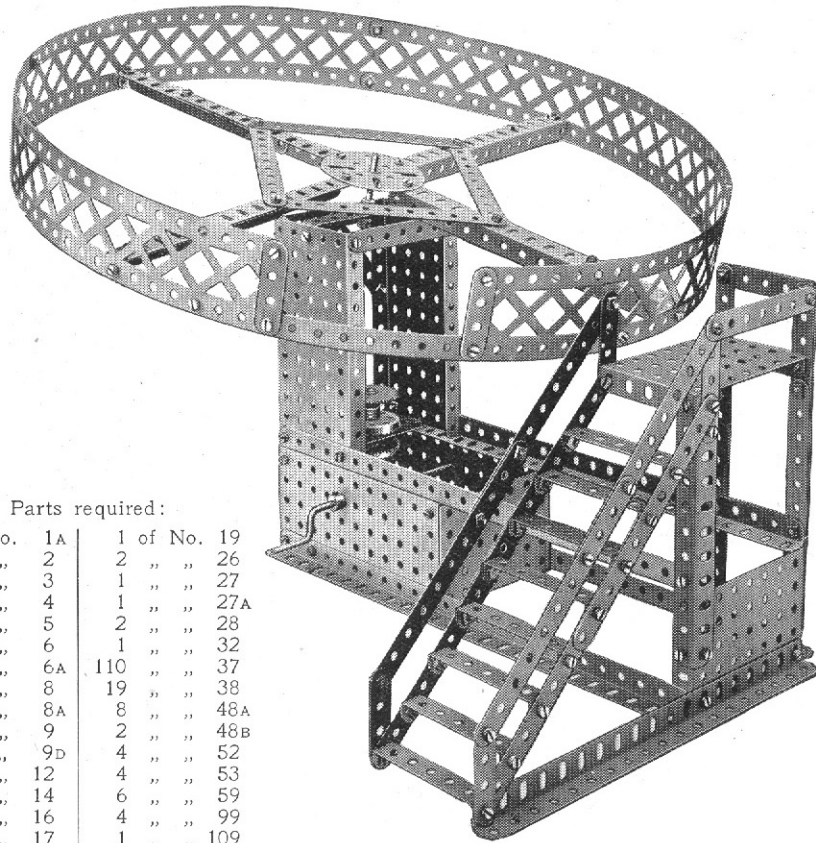


FIG. 6.14A

Model No. 6.15 Joy Wheel



Parts required:

1 of No.	1A	1 of No.	19
16 "	" 2	2 "	" 26
4 "	" 3	1 "	" 27
2 "	" 4	1 "	" 27A
2 "	" 5	2 "	" 28
5 "	" 6	1 "	" 32
2 "	" 6A	110 "	" 37
4 "	" 8	19 "	" 38
1 "	" 8A	8 "	" 48A
9 "	" 9	2 "	" 48B
1 "	" 9D	4 "	" 52
5 "	" 12	4 "	" 53
1 "	" 14	6 "	" 59
1 "	" 16	4 "	" 99
1 "	" 17	1 "	" 109
	1 of No.	126	

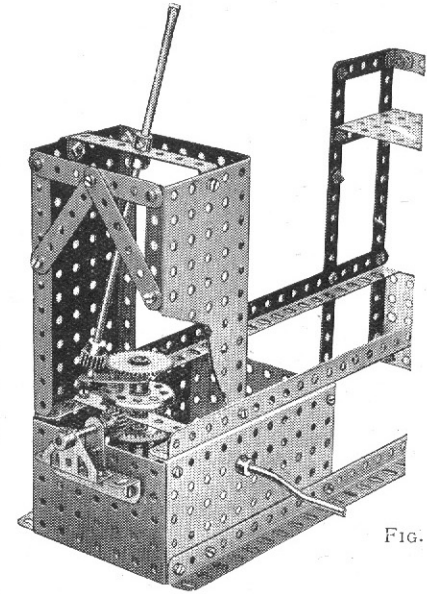


FIG. 6.15A

This model comprises a new and very interesting Meccano motion.

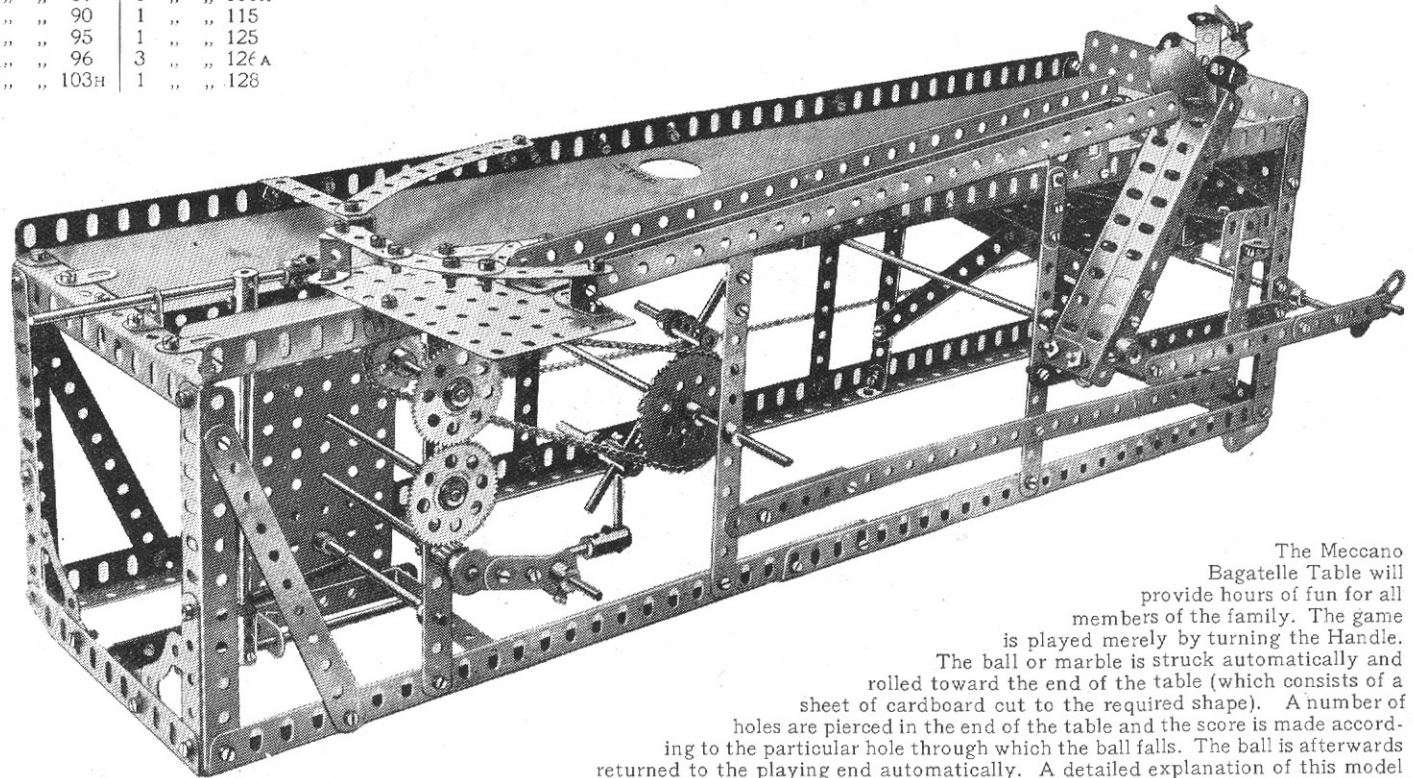
The Crank Handle drives by means of a Worm Wheel and 57-toothed Gear Wheel a vertical Rod carrying two $1\frac{1}{2}$ " Contrate Wheels and a Gear Wheel, as shown in Figure 6.15A. The lower Contrate Wheel is secured to the shaft but the upper one revolves freely upon it. The latter is driven from the fixed Contrate Wheel by means of a $\frac{1}{2}$ " Pinion, and its direction of rotation is consequently reversed.

The end of the shaft carrying the revolving part of the model is journalled on a short Strip bolted to the upper Contrate Wheel and carries a $\frac{1}{2}$ " Pinion which engages with the Gear Wheel secured on the vertical shaft. Thus on operation of the Crank Handle, the model revolves upon its axis, at the same time twisting slowly round with an amusing "wobble." A circular piece of cardboard is cut and placed in position to represent the floor found in real "Joywheels."

Model No. 6.16 Bagatelle Table

Parts required :

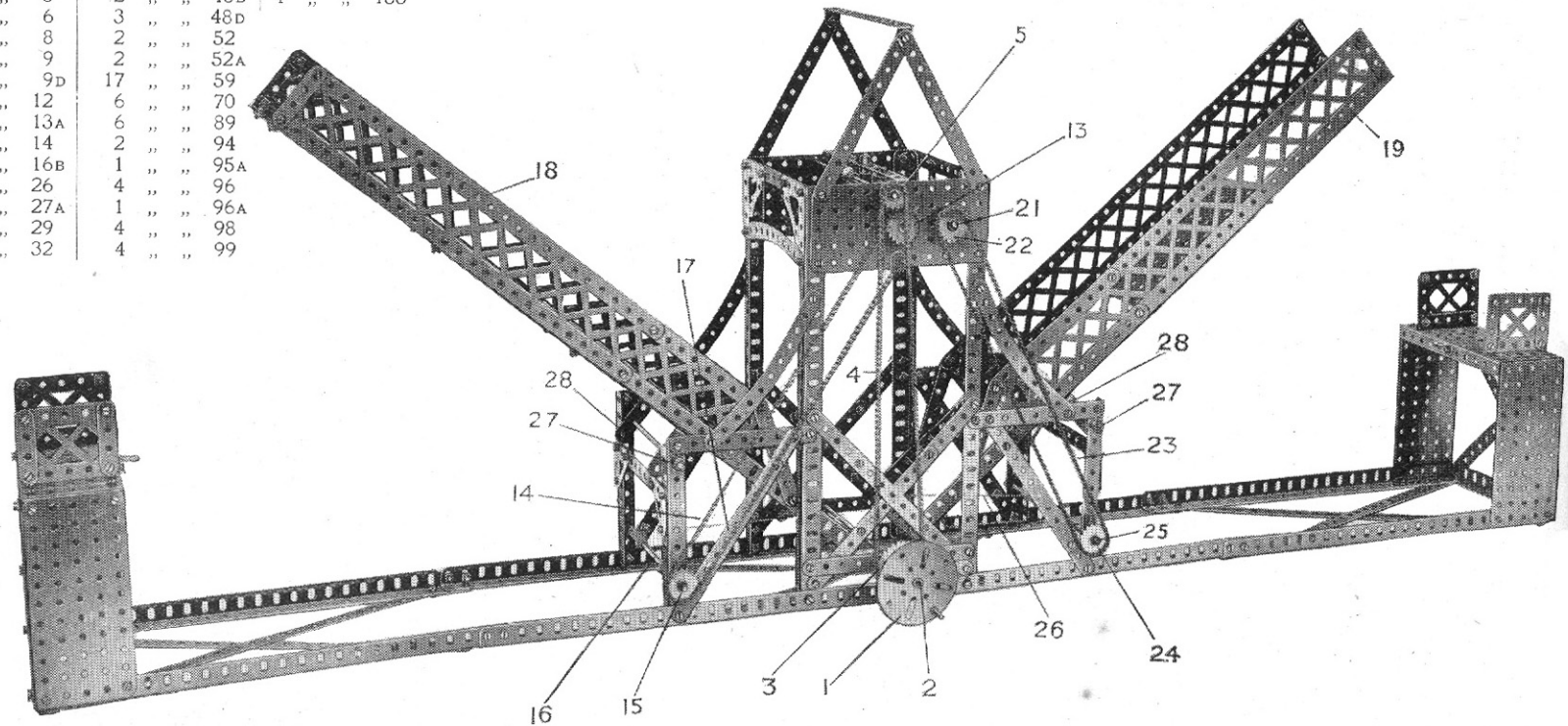
1 of No.	1	3 of No. 77	2 of No. 108
10 " "	2	4 " " 89	1 " " 111A
2 " "	2A	2 " " 90	1 " " 115
1 " "	3	3 " " 95	1 " " 125
1 " "	4	1 " " 96	3 " " 12fA
6 " "	5	1 " " 103H	1 " " 128
4 " "	6		
6 " "	6A		
10 " "	8		
11 " "	9		
6 " "	10		
5 " "	11		
9 " "	12		
1 " "	12B		
4 " "	13A		
2 " "	14		
1 " "	15		
2 " "	15A		
1 " "	16		
3 " "	17		
2 " "	18A		
1 " "	18B		
1 " "	26		
2 " "	27A		
134 " "	37		
6 " "	38		
1 " "	43		
1 " "	46		
3 " "	48		
2 " "	48A		
1 " "	50		
2 " "	52		
1 " "	52A		
1 " "	53A		
9 " "	59		
3 " "	62		
7 " "	63		
1 " "	70		



The Meccano Bagatelle Table will provide hours of fun for all members of the family. The game is played merely by turning the Handle. The ball or marble is struck automatically and rolled toward the end of the table (which consists of a sheet of cardboard cut to the required shape). A number of holes are pierced in the end of the table and the score is made according to the particular hole through which the ball falls. The ball is afterwards returned to the playing end automatically. A detailed explanation of this model would require much space, and full instructions have therefore been prepared in the form of a special leaflet, which is included in the Outfit. The leaflet may also be obtained from your dealer price 2d., or direct from Meccano Ltd., Binns Road, Liverpool, price 2d. post free. It should be noted that the ball and strip of cardboard forming the table are not included in the Meccano Outfit.

Model No. 6.17 Jack Knife Bridge

Parts required:		
6 of No. 1	210 of No. 37	4 of No. 100
4 " " 1B	6 " " 38	4 " " 108
26 " " 2	1 " " 40	1 " " 109
4 " " 2A	1 " " 48A	1 " " 115
4 " " 3	2 " " 48B	4 " " 133
16 " " 6	3 " " 48D	
20 " " 8	2 " " 52	
6 " " 9	2 " " 52A	
4 " " 9D	17 " " 59	
6 " " 12	6 " " 70	
1 " " 13A	6 " " 89	
6 " " 14	2 " " 94	
1 " " 16B	1 " " 95A	
2 " " 26	4 " " 96	
2 " " 27A	1 " " 96A	
1 " " 29	4 " " 98	
1 " " 32	4 " " 99	



The arms of the bridge are raised or lowered by rotating the hand-wheel 1. On the 8" Rod 2 of the hand-wheel is mounted a 1½" Sprocket Wheel 3 which is coupled by a Chain 4 to a ¾" Sprocket Wheel 5 on a 6½" Rod 6, Fig. 6.17A. On this rod a Worm Wheel 7 drives a ½" Pinion 8 on a 3½" Rod 9, on which is a ¾" Contrate Wheel 10. This engages a ¾" Pinion 11 carried on a 3" Rod 12, on the outer end of which is a 1" Sprocket Wheel 13 connected by a Sprocket Chain 14 to a 1" Sprocket Wheel 15 on a 6½" Rod 16; on this rod a Cord 17 is wound, connected to the end of one arm 18 of the bridge. The other arm 19 is operated from a 57-toothed Gear Wheel 20 on the Rod 12

Model No. 6.17 Jack Knife Bridge

(continued)

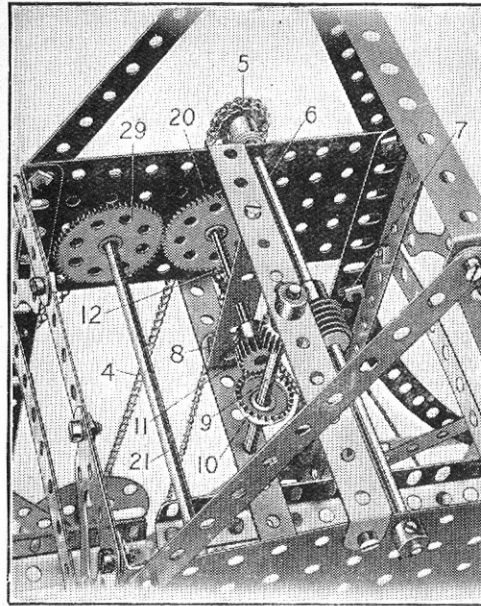


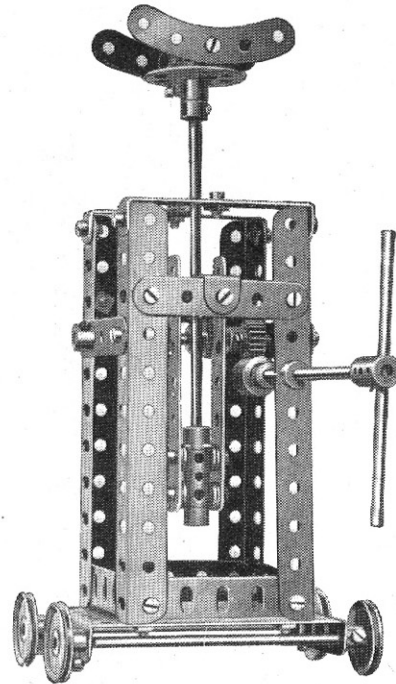
FIG. 6.17A

engaging a similar Wheel 29 on the $6\frac{1}{2}$ " Rod 21. On the end of this rod a 1" Sprocket Wheel 22 is coupled by a Chain 23 to another 1" Sprocket Wheel 24 on the $6\frac{1}{2}$ " winding Rod 25, the Cord 26 from which is connected to the other arm 19 of the bridge.

The arms 18 and 19 are pivotally carried on $6\frac{1}{2}$ " Rods 27 by means of $3\frac{1}{2} \times 1\frac{1}{2}$ " Double Angle Strips 28.

Model No. 6.18

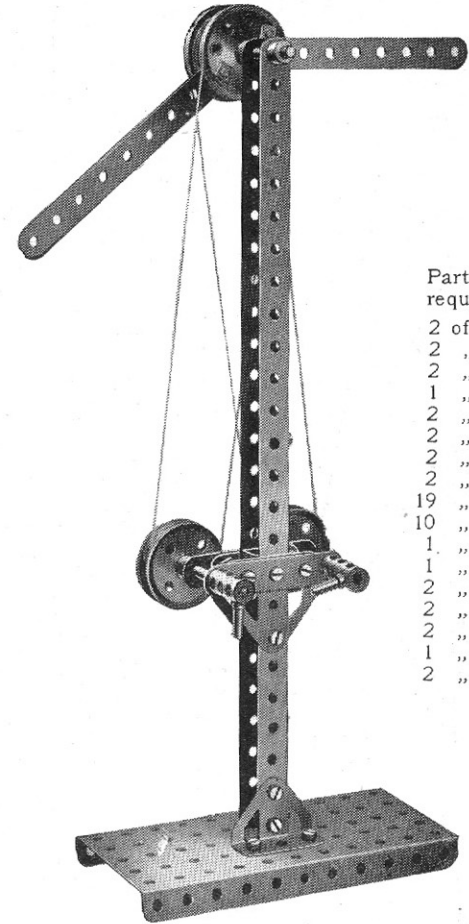
Jack



Parts required :

5 of No. 5	3 of No. 26
4 " " 9	1 " " 32
4 " " 9D	32 " " 37
2 " " 12	8 " " 38
2 " " 14	3 " " 48A
2 " " 15A	1 " " 53
1 " " 16	7 " " 59
1 " " 16B	2 " " 63
4 " " 22	2 " " 90
1 " " 24	2 " " 110

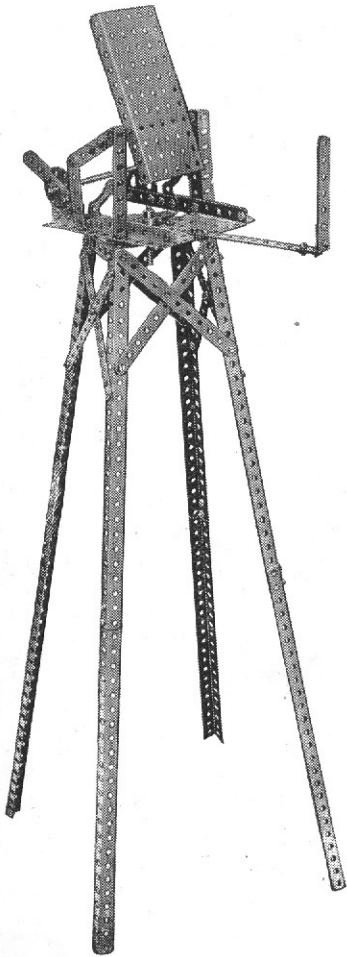
Model No. 6.19 Semaphore



Parts required :

2 of No. 2	
2 " " 5	
2 " " 8	
1 " " 16A	
2 " " 17	
2 " " 20	
2 " " 21	
2 " " 24	
19 " " 37	
10 " " 38	
1 " " 40	
1 " " 52	
2 " " 59	
2 " " 63	
2 " " 115	
1 " " 126	
2 " " 126A	

Model No. 6.20 Heliograph



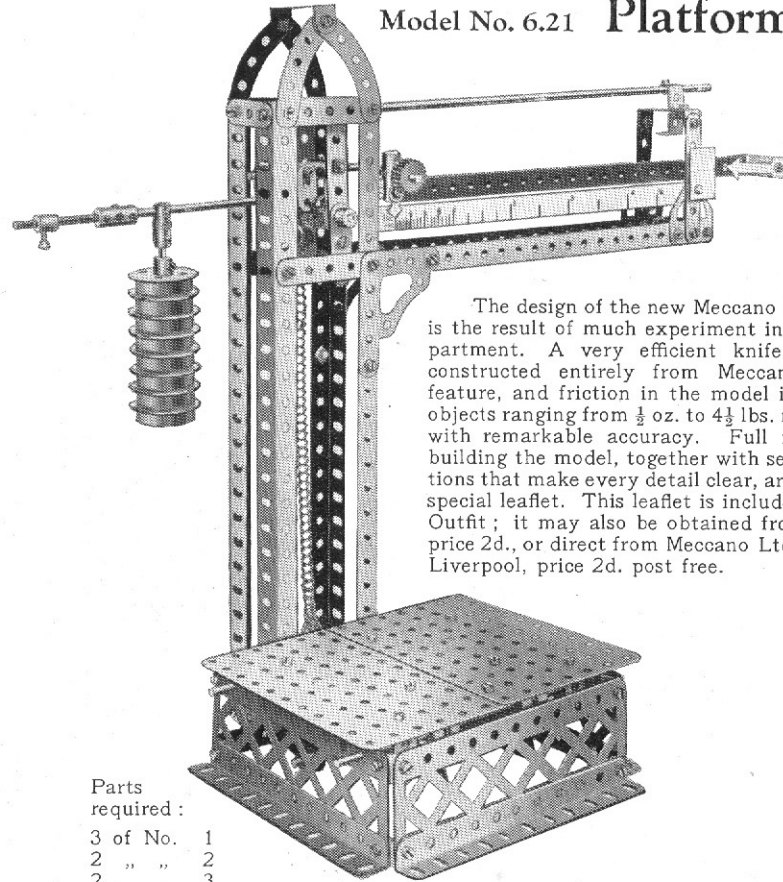
Parts required:	
9 of No. 2	1 of No. 17
1 " " 3	1 " " 19B
1 " " 4	1 " " 24
1 " " 5	61 " " 37
1 " " 6	1 " " 48B
6 " " 6A	1 " " 52
8 " " 8	2 " " 53
2 " " 9	5 " " 59
2 " " 9B	2 " " 62
1 " " 12A	2 " " 108
2 " " 15A	2 " " 126A

A $5\frac{1}{2}'' \times 2\frac{1}{2}''$ Flanged Plate is secured to an Axle, about which it pivots, by means of a Crank bolted to one of its flanges, and its position is altered on operation of the lever shown.

The rectangular Plate should be fitted with a mirror, and a sighting aperture mounted in front, the operator bringing one of the perforations in the Plate in line with the aperture while signalling, so that he can see the opposite instrument in the distance.

The platform is pivotally mounted on the standard so that it may be swung round to any position, a Bush Wheel being bolted to the top of the standard in which the pivot works. The platform is made of two small rectangular Plates butted together and connected on each side by Strips.

Model No. 6.21 Platform Scales



The design of the new Meccano Platform Scales is the result of much experiment in our Model Department. A very efficient knife edge bearing, constructed entirely from Meccano parts, is a feature, and friction in the model is so small that objects ranging from $\frac{1}{2}$ oz. to $4\frac{1}{2}$ lbs. may be weighed with remarkable accuracy. Full instructions for building the model, together with sectional illustrations that make every detail clear, are contained in a special leaflet. This leaflet is included in the No. 6 Outfit; it may also be obtained from your dealer, price 2d., or direct from Meccano Ltd., Binns Road, Liverpool, price 2d. post free.

Parts required:

3 of No. 1	1 of No. 12A	1 of No. 18B	4 of No. 48B	1 of No. 81
2 " " 2	3 " " 12B	8 " " 20	2 " " 52A	4 " " 90
2 " " 3	2 " " 13	1 " " 25	6 " " 57	3 " " 100
2 " " 4	2 " " 14	2 " " 26	20 " " 59	2 " " 102
3 " " 5	1 " " 15	8 " " 35	2 " " 62	2 " " 108
2 " " 6	1 " " 16	78 " " 37	8 " " 63	1 " " 111
6 " " 6A	2 " " 16B	14 " " 38	1 " " 63B	1 " " 111A
4 " " 8	1 " " 17	1 " " 46	1 " " 64	2 " " 115
2 " " 9	2 " " 18A	3 " " 48	2 " " 65	2 " " 126A

Model No. 6.22

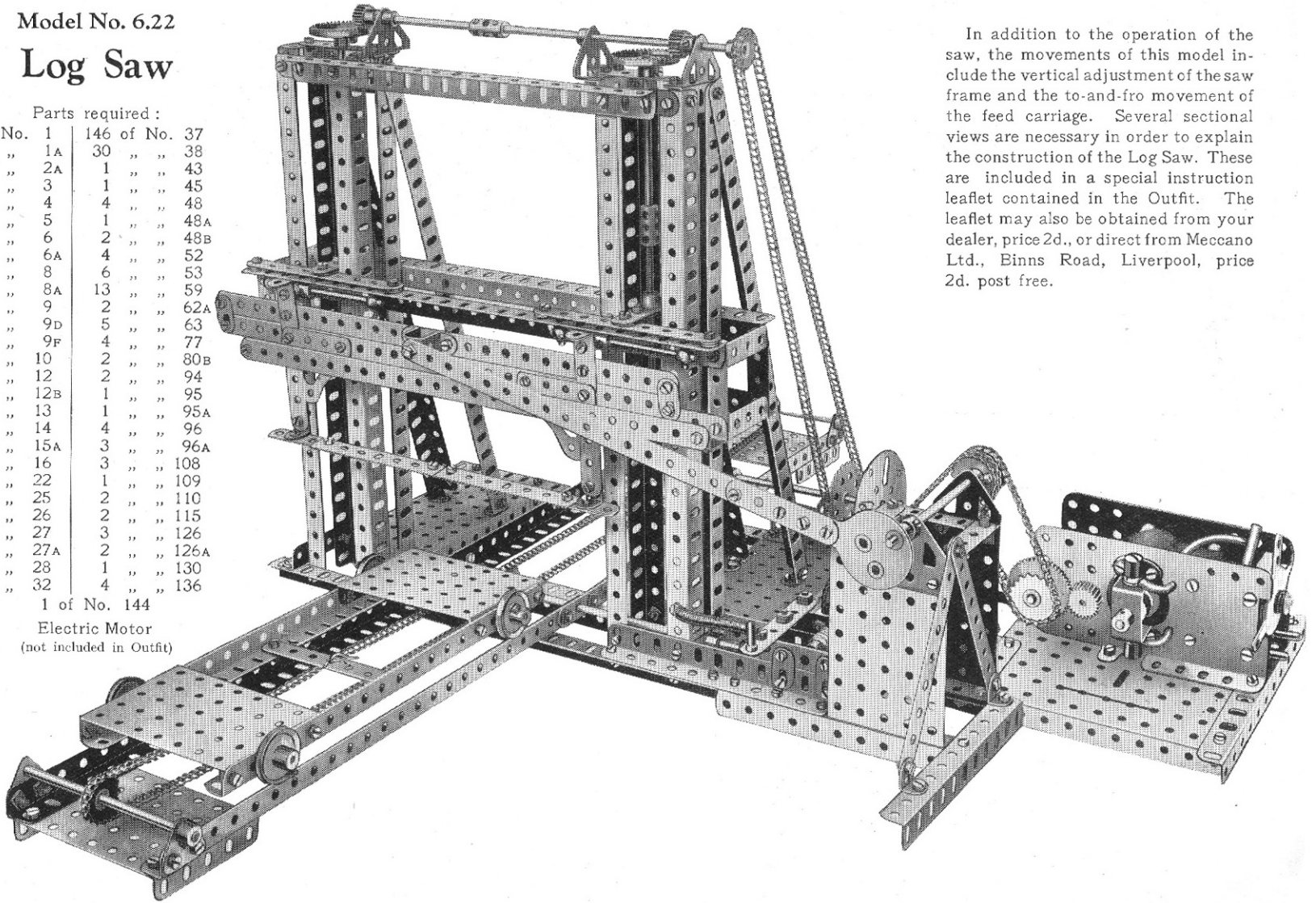
Log Saw

Parts required :

3	of	No. 1	146	of	No. 37
2	"	"	30	"	"
4	"	"	1	"	"
1	"	"	1	"	"
1	"	"	4	"	"
8	"	"	1	"	"
10	"	"	2	"	"
2	"	"	4	"	"
23	"	"	6	"	"
4	"	"	13	"	"
7	"	"	2	"	"
2	"	"	5	"	"
4	"	"	4	"	"
6	"	"	2	"	"
14	"	"	2	"	"
1	"	"	1	"	"
1	"	"	1	"	"
1	"	"	4	"	"
6	"	"	3	"	"
5	"	"	3	"	"
4	"	"	1	"	"
2	"	"	2	"	"
3	"	"	2	"	"
1	"	"	3	"	"
1	"	"	2	"	"
2	"	"	1	"	"
1	"	"	4	"	"

1 of No. 144

Electric Motor
(not included in Outfit)



In addition to the operation of the saw, the movements of this model include the vertical adjustment of the saw frame and the to-and-fro movement of the feed carriage. Several sectional views are necessary in order to explain the construction of the Log Saw. These are included in a special instruction leaflet contained in the Outfit. The leaflet may also be obtained from your dealer, price 2d., or direct from Meccano Ltd., Binns Road, Liverpool, price 2d. post free.

Model No. 6.23 Crane

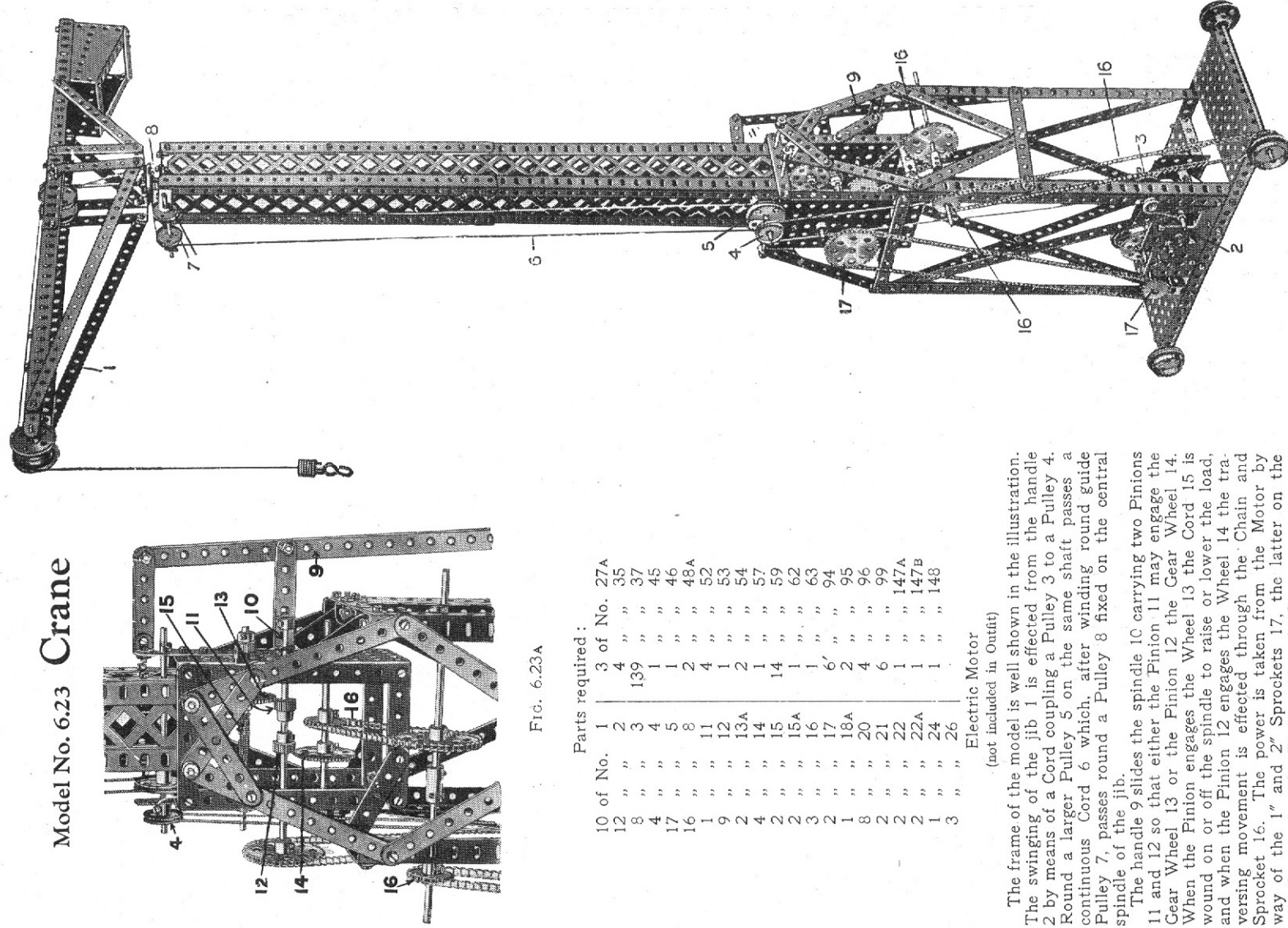


FIG. 6.23A

Parts required :

10 of No.	1	3 of No.	27A
12 "	2	4 "	35
8 "	3	139 "	37
4 "	4	1 "	45
17 "	5	1 "	46
16 "	8	2 "	48A
1 "	11	4 "	52
9 "	12	1 "	53
2 "	13A	2 "	54
4 "	14	1 "	57
2 "	15	14 "	59
2 "	15A	1 "	62
3 "	16	1 "	63
2 "	17	6' "	94
1 "	18A	2 "	95
8 "	20	4 "	96
2 "	21	6 "	99
2 "	22	1 "	147A
2 "	22A	1 "	147B
1 "	24	1 "	148
3 "	26		

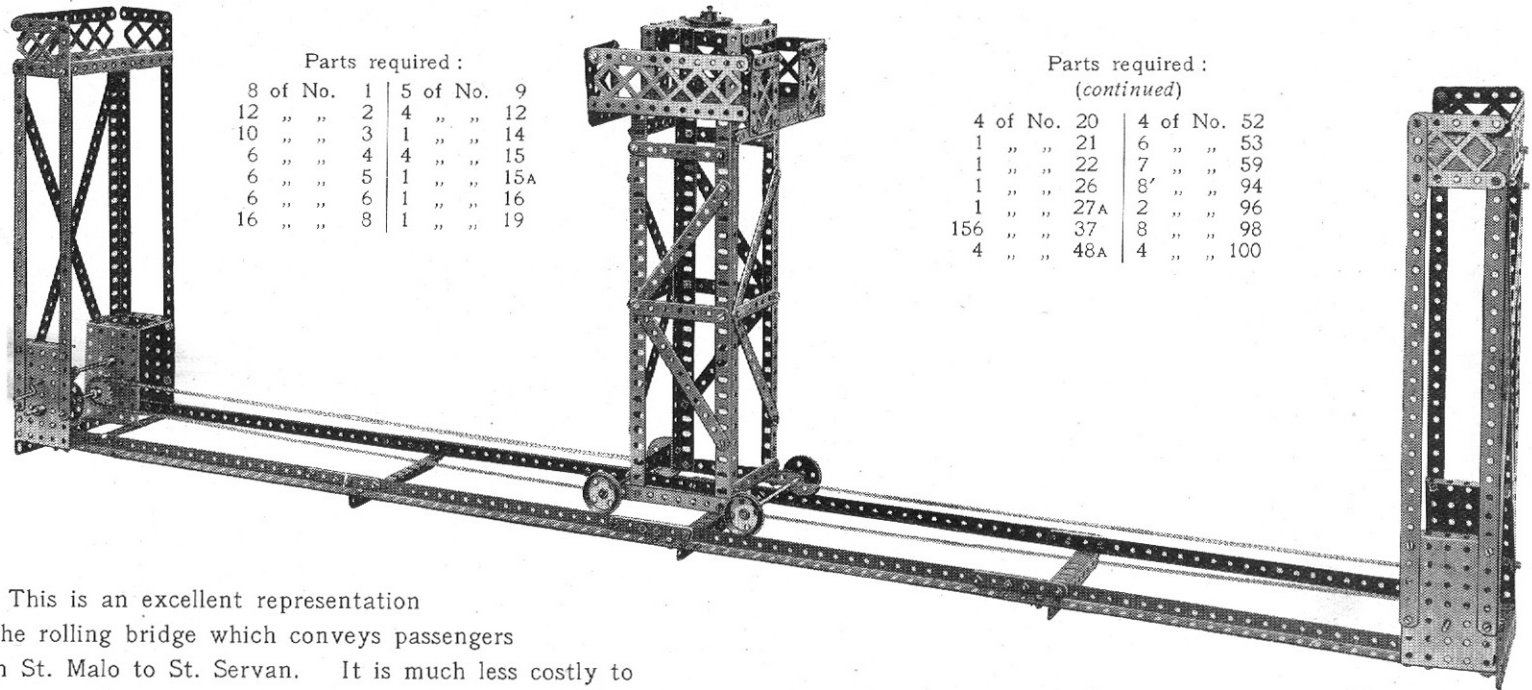
Electric Motor

(not included in Outfit)

The frame of the model is well shown in the illustration. The swinging of the jib 1 is effected from the handle 2 by means of a Cord coupling a Pulley 3 to a Pulley 4. Round a larger Pulley 5 on the same shaft passes a continuous Cord 6 which, after winding round guide Pulley 7, passes round a Pulley 8 fixed on the central spindle of the jib.

The handle 9 slides the spindle 10 carrying two Pinions 11 and 12 so that either the Pinion 11 may engage the Gear Wheel 13 or the Pinion 12 the Gear Wheel 14. When the Pinion engages the Wheel 13 the Cord 15 is wound on or off the spindle to raise or lower the load, and when the Pinion 12 engages the Wheel 14 the reversing movement is effected through the Chain and Sprocket 16. The power is taken from the Motor by way of the 1" and 2" Sprockets 17, the latter on the spindle carrying the Pinions 11 and 12.

Model No. 6.24 St. Malo Transporter Bridge



Parts required :

8 of No.	1	5 of No.	9
12 " "	2	4 " "	12
10 " "	3	1 " "	14
6 " "	4	4 " "	15
6 " "	5	1 " "	15A
6 " "	6	1 " "	16
16 " "	8	1 " "	19

Parts required :

(continued)

4 of No.	20	4 of No.	52
1 " "	21	6 " "	53
1 " "	22	7 " "	59
1 " "	26	8 " "	94
1 " "	27A	2 " "	96
156 " "	37	8 " "	98
4 " "	48A	4 " "	100

This is an excellent representation of the rolling bridge which conveys passengers from St. Malo to St. Servan. It is much less costly to construct than a transporter bridge of the Newport type, but of course it can only be used over marshy land with shallow water over which a solid track can be laid. The clever Meccano boy will know how to add little decorations to the transporter and the landing platforms in the way of flags, etc., and make a first-class toy of this fine model.

Model No. 6.25 Automatic Weighing Crane

Parts required :

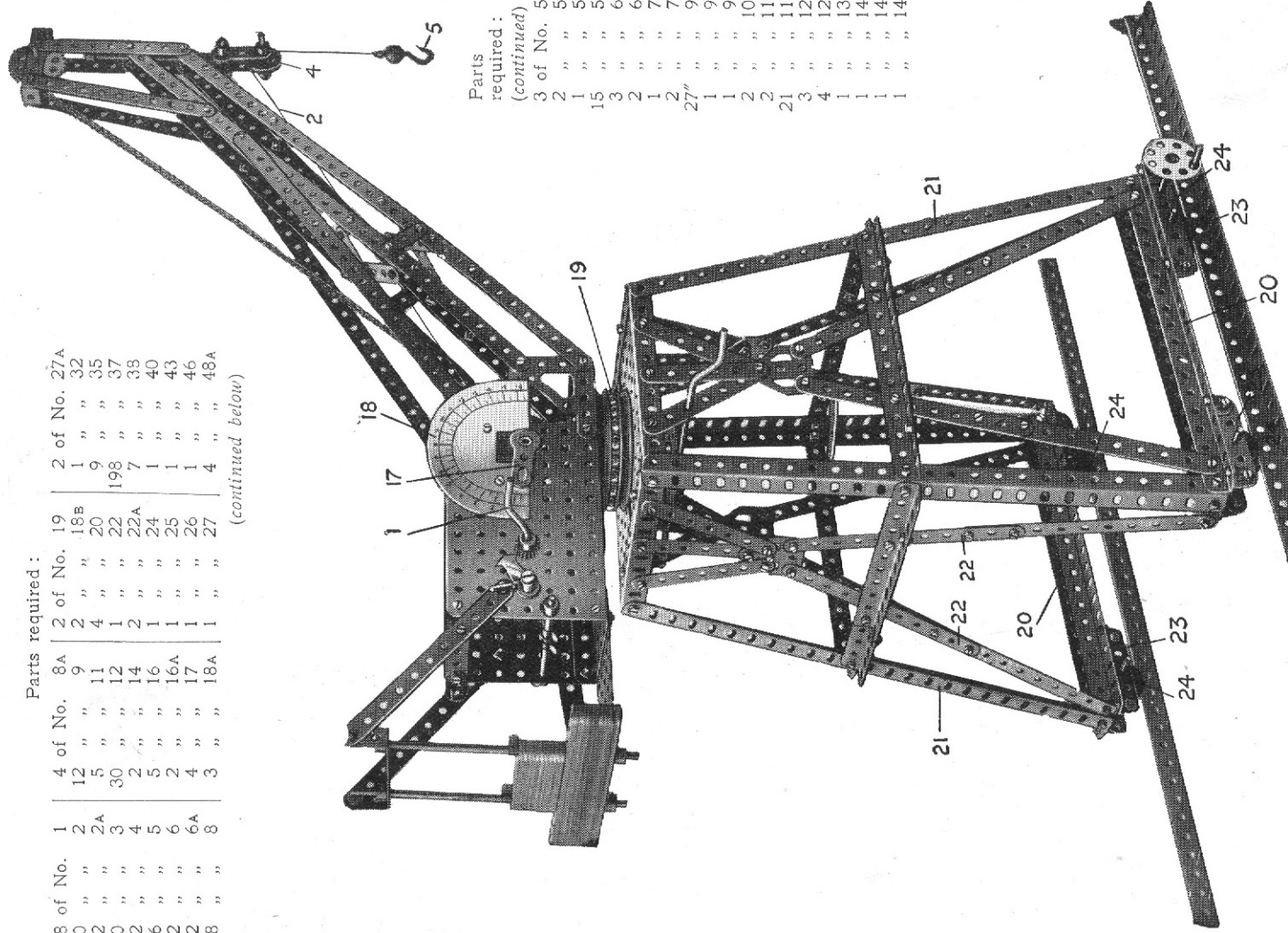
8 of No.	1	4 of No.	8A	2 of No.	19	2 of No.	27A
50	2	12	"	2	"	1	"
"	2A	5	"	4	"	9	"
2	3	30	"	1	"	20	35
10	4	2	"	22	"	198	37
12	"	2	"	2	"	7	38
36	5	5	"	24	"	1	40
"	6	2	"	25	"	1	43
2	"	4	"	1	"	1	46
8	6A	4	"	27	"	4	48A
"	8	3	"	1	"		

(continued below)

Parts required :

(continued)

3 of No.	52
2	52A
1	57B
15	59
3	62
2	63
1	70
2	77
27"	94
1	95A
1	96
2	108
2	115
21	117
3	125
4	126A
1	137
1	147A
1	147B
1	148



Model No. 6.25 Automatic Weighing Crane (continued)

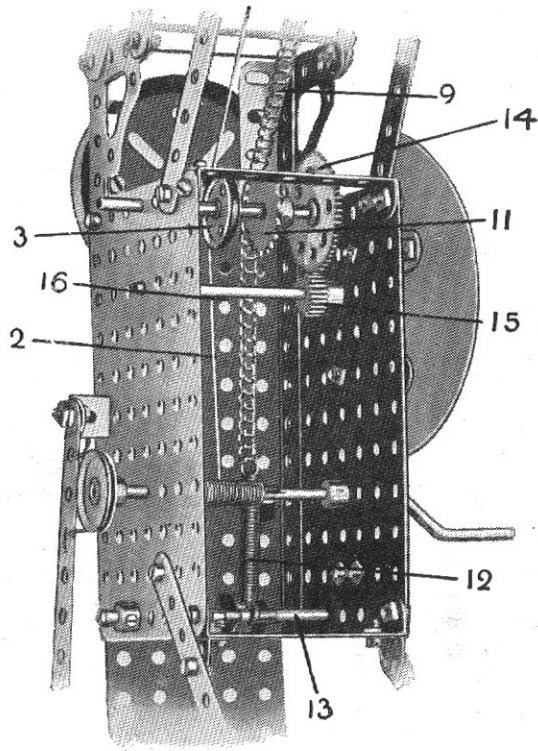


FIG. 6.25A

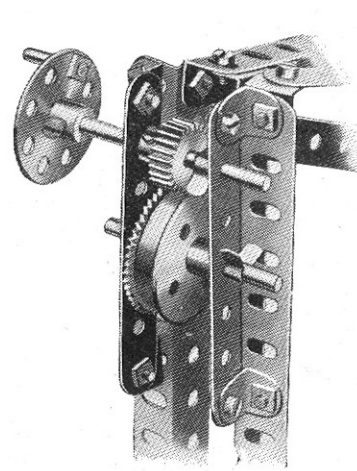


FIG. 6.25B

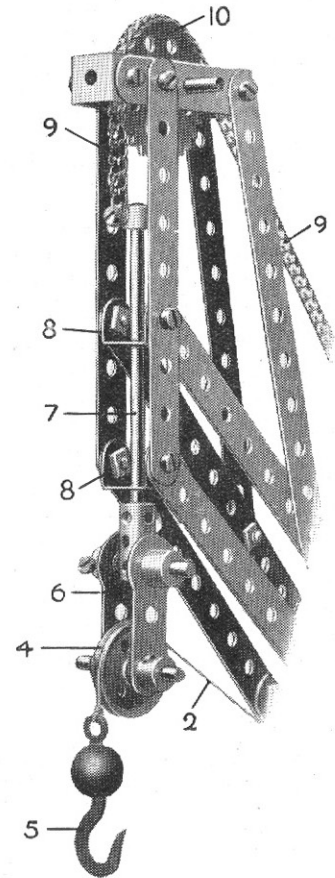


FIG. 6.25C

This is a model of a crane that, when raising a load, automatically indicates the weight carried. The load is raised or lowered by the operation of the Crank Handle 1 upon which is wound a lifting Cord 2 passing round a 1" Pulley 3 and over another 1" Pulley 4 (Fig. 6.25c) to the Loaded Hook 5. The 1" Pulley 4, which bears the weight of the load, is carried by two Cranks 6 connected to a 3½" Rod 7, slidable in two Double Brackets 8.

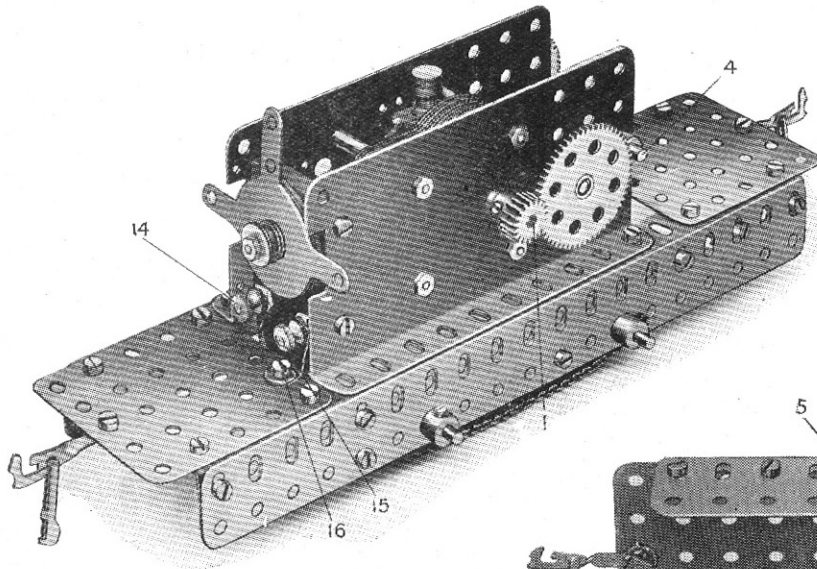
To the top of the rod is connected a Sprocket Chain 9 which passes over a 1½" Sprocket Wheel 10 and under a 1" Sprocket Wheel 11 (Fig. 6.25A), the other end of the Chain being connected to a Spring 12, secured to a 3½" Rod 13. Thus, when a load is being raised the weight is carried by the Rod 7 which pulls down in its bearings and consequently extends the Spring 12. In this movement, the Chain 9 rotates the Sprocket Wheel 11 and a 1½" Gear Wheel 14 on the rod of the Sprocket 11 engages a ½" Pinion 15 on a Rod 16. On the outer end of this Rod 16 is a Crank 17 that sweeps round the

graduated Dial 18 to indicate the weight of the load that is being lifted.

The construction of the remainder of the model will be clearly seen from the illustration. The Bearings 23 carrying the Flanged Wheel 24 are formed of 2½" Strips connected to the Girders 20 by Angle Brackets.

It will be noted that the crane jib is carried upon Ball Bearings 19, the Balls (Part No. 117) for which are not supplied in the No. 6 Outfit but may be obtained separately. The crane will work well without the ball bearing, but the operation is easier when such a bearing is fitted.

Model No. 6.26 Meccano High-Power Electric Loco Chassis



Parts required:

2 of No. 8A	2 of No. 27A	2 of No. 64	2 of No. 103A
2 " " 16	27 " " 37	2 " " 72	2 " " 121
2 " " 16A	4 " " 37B	1 " " 94	1 " " 149
4 " " 20	2 " " 48A	2 " " 96	
1 " " 26	4 " " 59	2 " " 96A	

Electric Motor
(not included in Outfit)

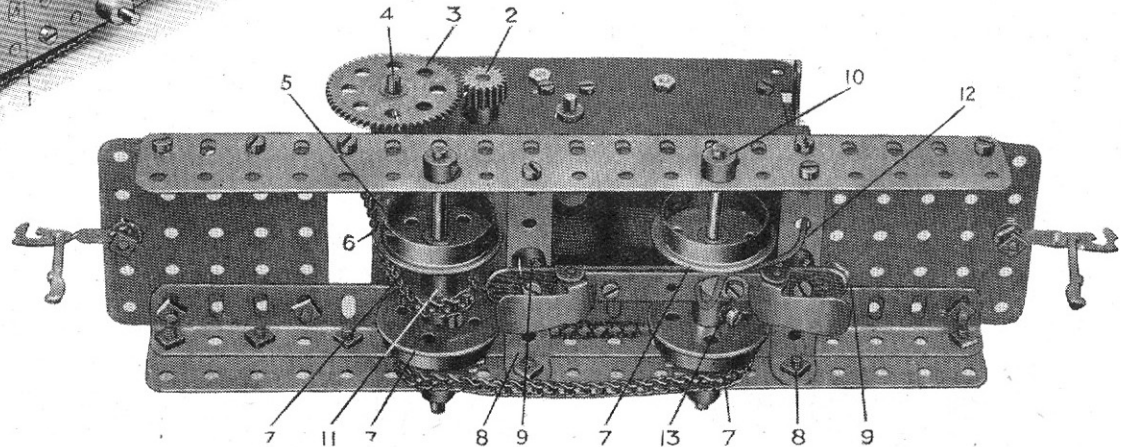


FIG. 6.26A

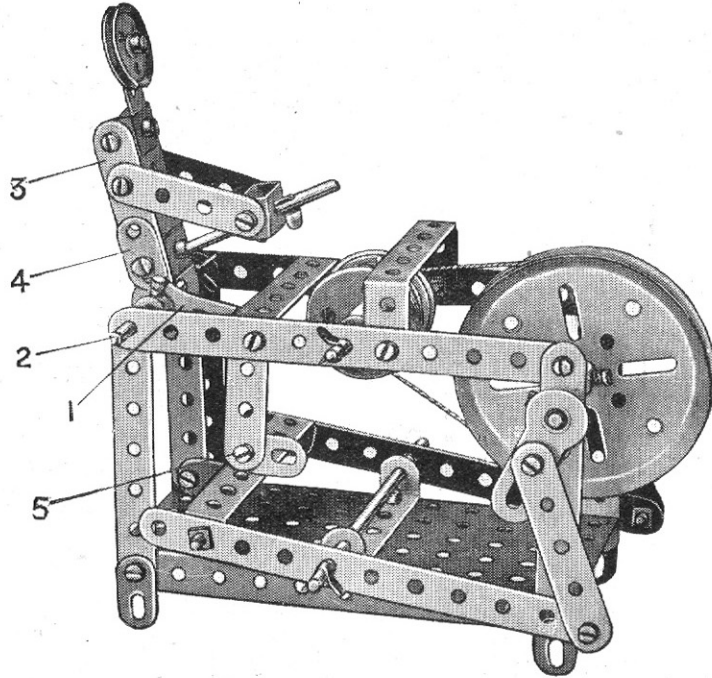
This is a simply constructed and very efficient electric loco, in which either a No. 1 or No. 2 Meccano Motor may be used. The construction of the chassis will be clearly seen from the illustrations. The gearing should be built on to the Motor before bolting the latter in position. On the Motor spindle 1 is secured a $\frac{1}{2}$ " Pinion engaging a 57-toothed Gear Wheel spaced from the Motor by three Washers.

On the spindle of this Gear Wheel a second $\frac{1}{2}$ " Pinion 2 is also secured, but on the opposite side of the Motor. The Pinion 2 engages a further 57-toothed Gear Wheel 3 on the spindle 4, and between the side plates, on the latter spindle, is secured a $\frac{3}{4}$ " Sprocket Wheel 5. Before inserting the spindle 4 a ring of Sprocket Chain 6, containing 39 links, should be threaded over the Sprockets 5 and 11, after which the Motor may be bolted on to the chassis. The flanged travelling Wheels 7 may now be placed in position as shown. The Sprocket Wheel 11 is $\frac{3}{4}$ " in diameter and the Sprocket Wheels connecting the Axles are 1". The ring of Sprocket Chain for these should contain 52 links.

The new Meccano Electric Shoe is bolted to the $2\frac{1}{2}$ " Double Angle Strips 8, spaced with a Threaded Boss 9 at each end to give clearance to the Axle Rod 10. One end of a piece of insulated wire 12 is connected to the bolt head 13, and the other end to the terminal 14, while another piece of wire is connected with the terminal 15 and the bolt head 16.

The loco is designed to run on "0" gauge electric rails, and may be coupled to Hornby train rolling stock. Any suitable superstructure may be built up on the chassis, to represent an electric loco, to suit the builder's taste.

Model No. 6.27 Knife Grinder



Parts
required :

4 of No.	2
4 "	3
2 "	4
4 "	5
3 "	6
4 "	10
3 "	11
2 "	12
1 "	15
3 "	16
1 "	17
1 "	19A
2 "	20
1 "	22
1 "	22A
2 "	35
32 "	37
6 "	37A
1 "	46
2 "	48A
1 "	48B
1 "	52
3 "	62

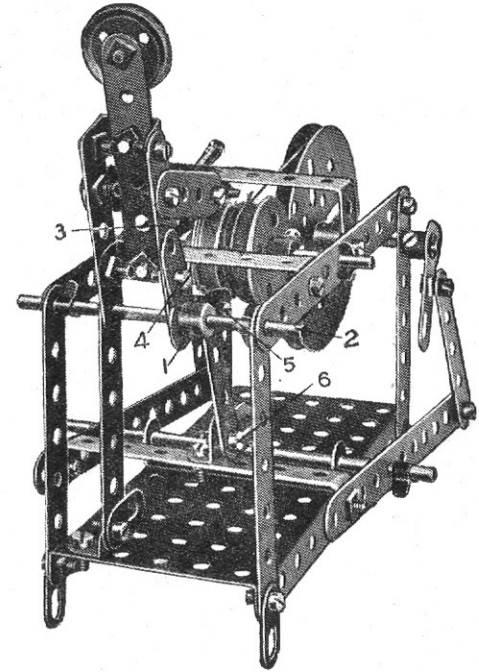
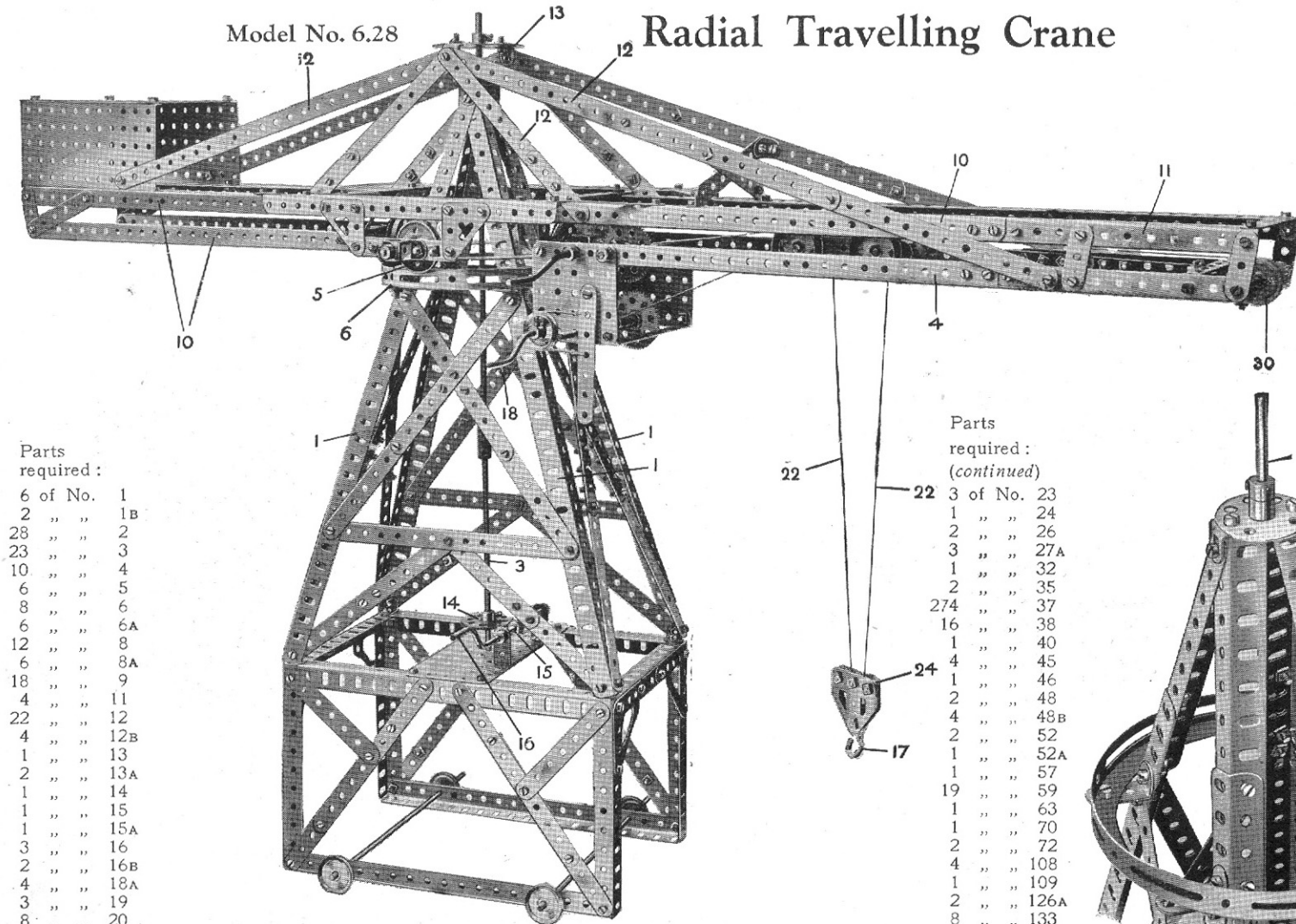


FIG. 6.27A

The Crank 1 is secured to the Rod 2, and the $2\frac{1}{2}$ " side Strip 3 is clamped to the Crank 1 by the Flat Bracket 4. The bolt at the end of the Crank forming the knee and the bolt 5 are lock-nutted to allow free movement. When the treadle is operated the body works backwards and forwards.

Model No. 6.28

Radial Travelling Crane



Parts
required :

6	of No.	1
2	" "	1B
28	" "	2
23	" "	3
10	" "	4
6	" "	5
8	" "	6
6	" "	6A
12	" "	8
6	" "	8A
18	" "	9
4	" "	11
22	" "	12
4	" "	12B
1	" "	13
2	" "	13A
1	" "	14
1	" "	15
1	" "	15A
3	" "	16
2	" "	16B
4	" "	18A
3	" "	19
8	" "	20
6	" "	22

Parts
required :

(continued)

3	of No.	23
1	" "	24
2	" "	26
3	" "	27A
1	" "	32
2	" "	35
274	" "	37
16	" "	38
1	" "	40
4	" "	45
1	" "	46
2	" "	48
4	" "	48B
2	" "	52
1	" "	52A
1	" "	57
19	" "	59
1	" "	63
1	" "	70
2	" "	72
4	" "	108
1	" "	109
2	" "	126A
8	" "	133
1	" "	143

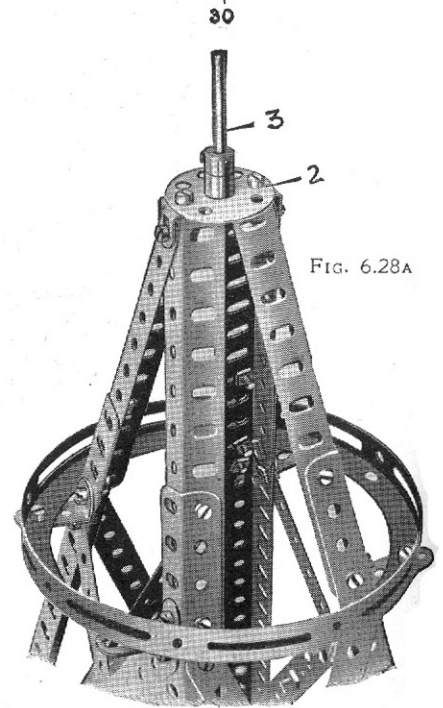


FIG. 6.28A

Model No. 6.28 Radial Travelling Crane (continued)

Begin to build this model by constructing the main tower, the details of which are clearly brought out in the illustrations on the previous page. Notice that the inclined corner Angle Girders 1 are connected at the top (as shown in Fig. A) by a Bush Wheel 2 secured by Angle Brackets. This Bush Wheel forms a bearing for the vertical Rod 3 by which the cantilever arm 4 is turned.

The cantilever arm 4 turns on a wheel-race formed of Flanged Wheels 5, which run on a circular Girder 6 supported by four $1\frac{1}{2}$ " Angle Brackets bolted to the Corner Girders 1. The cantilever is built up (as shown in Fig. B) from two $9\frac{1}{2}$ " Angle Girders 8 braced by two $5\frac{1}{2}$ " Angle Girders 9 overlapped nine holes. From these, $12\frac{1}{2}$ " Angle Girders 10 extend at one side, and to similar Girders 10 at the other side are connected $5\frac{1}{2}$ " Girders 11.

The inclined Strips 12 are connected at the top, by means of Angle Brackets, to a Face Plate 13 secured to the vertical Rod 3. At the foot of the Rod 3 is a $1\frac{1}{2}$ " Gear Wheel 14 engaged by a Worm Wheel 15 operated by the Crank Handle 16 and in this way the cantilever arm is swung round, the Wheels 5 riding on the Circular Girder 6.

The load carried from the Hook 17 is raised or lowered by the Crank Handle 18, a $\frac{1}{2}$ " Pinion 19 on which engages a $1\frac{1}{2}$ " Gear Wheel 20 on a Rod 21 on which is wound a Cord 22. This Cord passes over a $\frac{1}{2}$ " Pulley 23 to the block 24 and back over another $\frac{1}{2}$ " Pulley on the trolley, and is secured to the $3\frac{1}{2}$ " x $\frac{1}{2}$ " Double Angle Strip 25 at the outer end of the cantilever arm. Consequently, when the trolley is caused to travel along the cantilever arm the load remains suspended at a constant height—an important point and an interesting detail.

The trolley is caused to move to and fro along the cantilever arm by the action of the Crank Handle 26. On this a $\frac{1}{2}$ " Pinion 27 engages a $1\frac{1}{2}$ " Gear Wheel 28 on a rod on which is wound the Cord 29, the opposite ends of which are connected to the opposite ends of the trolley. The Cord 29 passes round a Pulley 30 at the outer end of the jib. By turning the Crank Handle 26, therefore, the Cord 29 winds on and off its Rod, and moves the trolley to and fro, its Wheels 31, as shown in Fig. C, running on the Angle Girders 10.

The Wheels 5 are connected to $1\frac{1}{2}$ " Rods 5a which are journalled in Double Bent Strips 5b bolted to $3\frac{1}{2}$ " Strips 5c carried from the Angle Girders 8 by Corner Brackets 5d.

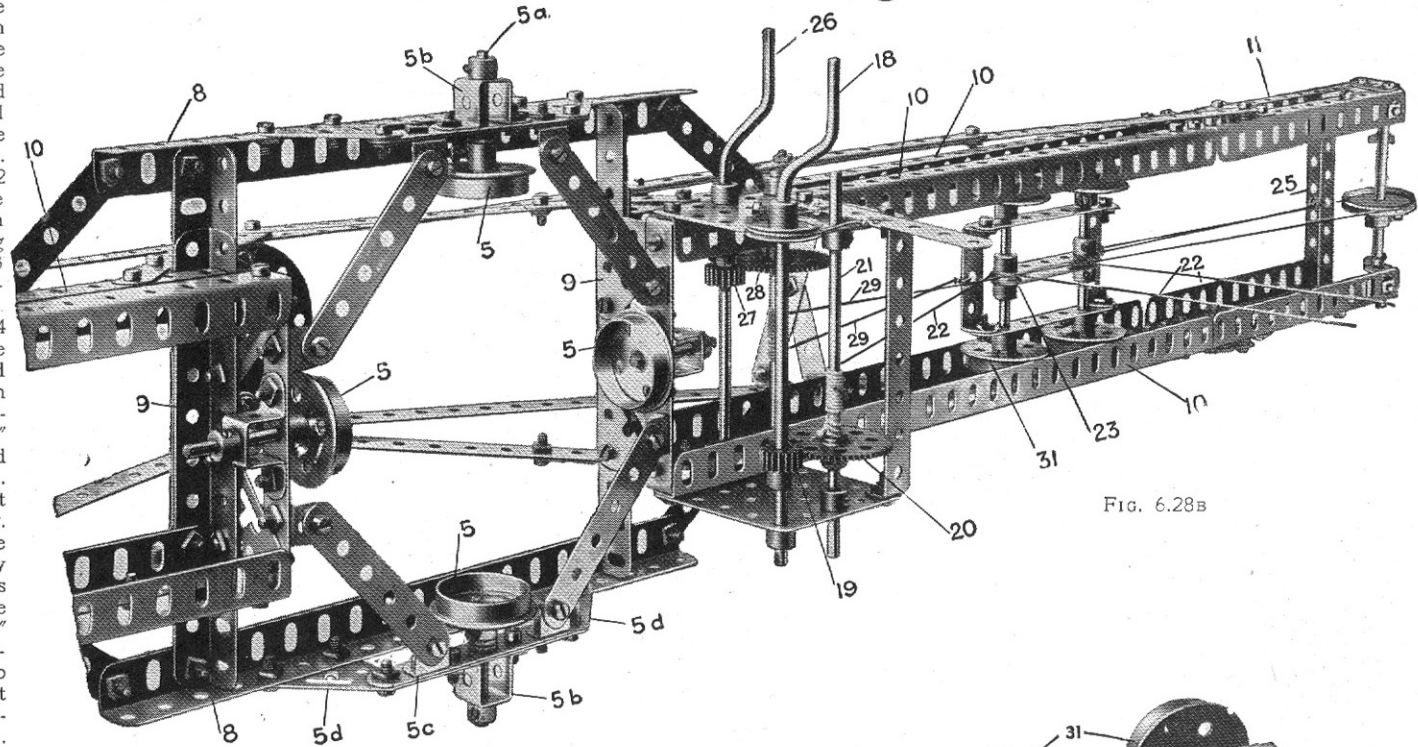


FIG. 6.28B

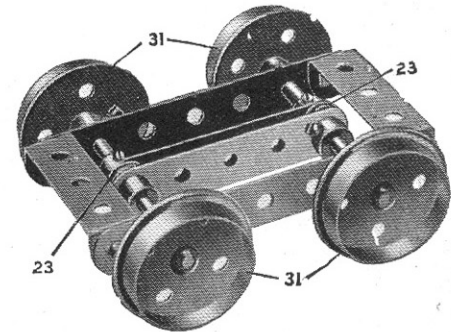


FIG. 6.28C

Parts required :

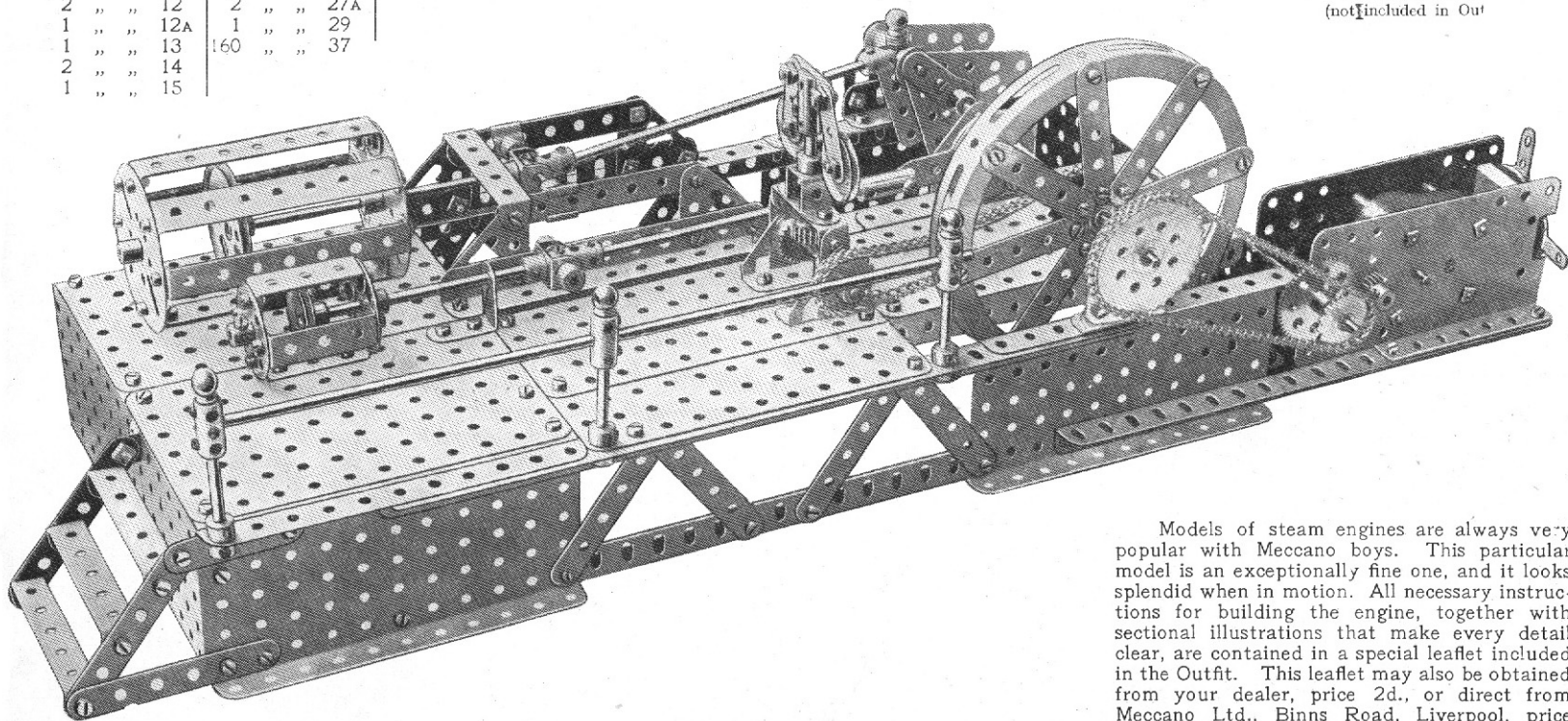
2 of No. 3	1 of No. 15A	20 of No. 38
11 " " 4	2 " " 16	1 " " 45
8 " " 5	2 " " 16A	4 " " 48
1 " " 6	5 " " 17	4 " " 48A
5 " " 6A	2 " " 18A	6 " " 48B
8 " " 8	1 " " 20A	2 " " 50
1 " " 8A	1 " " 22	7 " " 52
3 " " 9	2 " " 22A	2 " " 52A
1 " " 9B	3 " " 24	4 " " 53
3 " " 9F	3 " " 26	16 " " 59
2 " " 12	2 " " 27A	
1 " " 12A	1 " " 29	
1 " " 13	160 " " 37	
2 " " 14		
1 " " 15		

Model No. 6.29 Horizontal Engine

Parts required :

(continued)

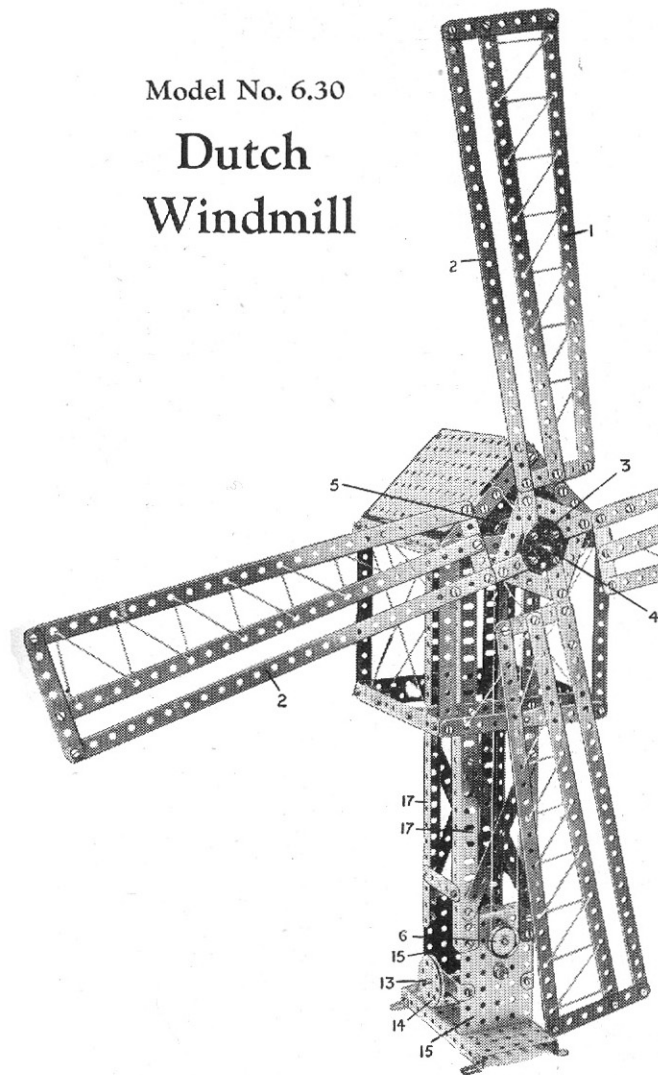
4 of No. 62	2 of No. 109
6 " " 63	2 " " 116
2 " " 63B	1 " " 118
3 " " 70	2 " " 126
2 " " 76	3 " " 126A
26 " " 94	4 " " 133
1 " " 95	4 " " 136
3 " " 96	

Electric Motor
(not included in Out

Models of steam engines are always very popular with Meccano boys. This particular model is an exceptionally fine one, and it looks splendid when in motion. All necessary instructions for building the engine, together with sectional illustrations that make every detail clear, are contained in a special leaflet included in the Outfit. This leaflet may also be obtained from your dealer, price 2d., or direct from Meccano Ltd., Binns Road, Liverpool, price 2d. post free.

Model No. 6.30

Dutch Windmill



Parts required :

12 of No. 1	24 of No. 12	2 of No. 26	2 of No. 52
18 " " 2	1 " " 14	1 " " 27A	2 " " 52A
4 " " 3	3 " " 16	1 " " 32	2 " " 53
4 " " 4	1 " " 21	24 " " 37	5 " " 59
18 " " 5	2 " " 22	2 " " 40	
4 " " 8	1 " " 24	2 " " 48A	

The construction of the sails 1 of the mill, will be readily followed from the illustration. They are bolted to an inner

strip frame 2 and to a Bush Wheel 3 fixed on a Rod 4, on which is also mounted a Pulley Wheel 5. The driving cord passes round this Pulley Wheel to a lower Pulley Wheel

6, the driving of which will be followed from Fig. A.

The Pulley Wheel 6 is on the outer end of the Rod 7 on which is fitted a $1\frac{1}{2}$ " Gear Wheel 8 driven by a $\frac{1}{2}$ " Pinion 9 on the Axle Rod 10. This Axle Rod also carries a $\frac{1}{2}$ " Pinion 11 engaged by a Worm 12 on the driving shaft 13 which carries a driving Pulley 14. The driving gear is enclosed in two small side Flanged Plates 15 bolted to a Base Plate 16.

The vertical tower of the mill is made from Corner Angle Girders 17 bolted to side Plates 15.

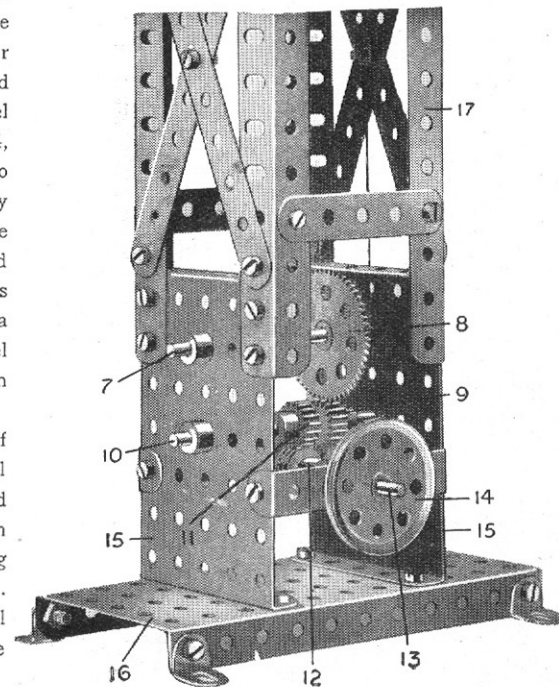
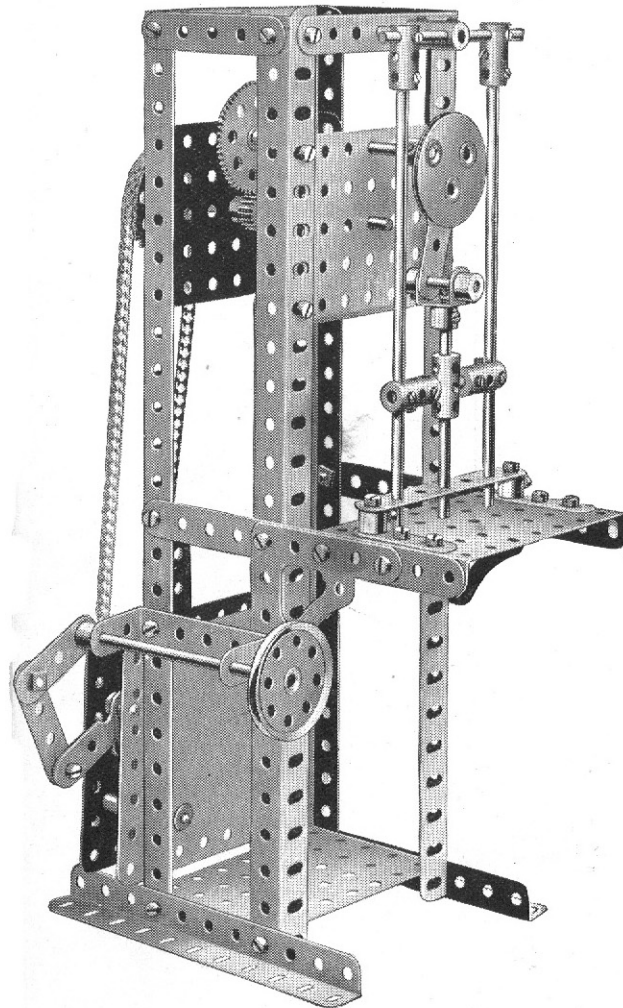


FIG. 6.30A

Model No. 6.31 Punching Machine

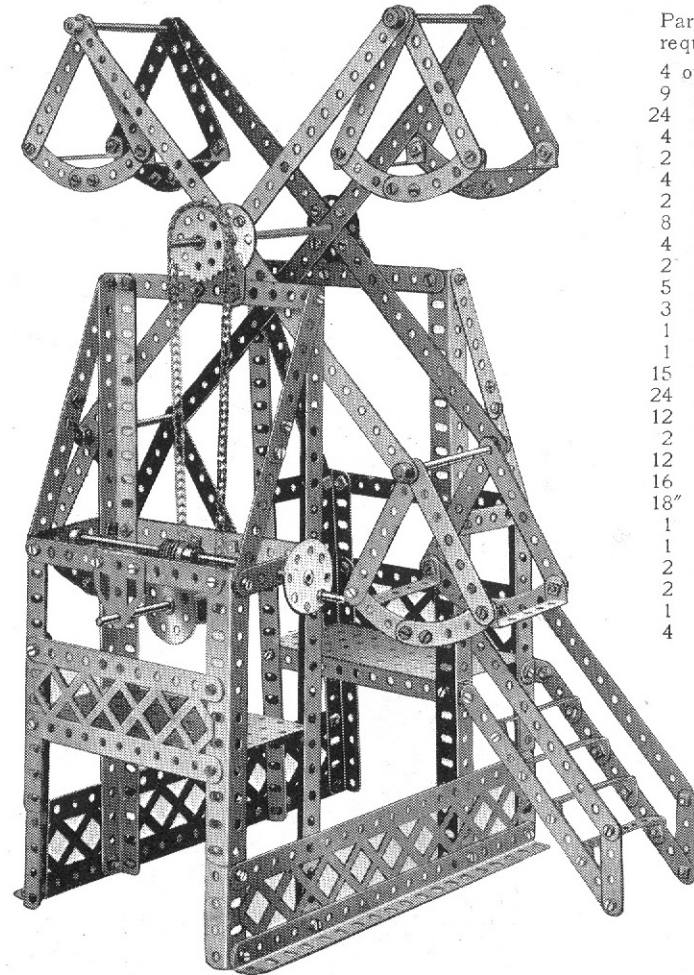


Parts required :

2 of No.	2
3 " "	3
2 " "	5
1 " "	6
4 " "	8
2 " "	9
2 " "	14
2 " "	15A
2 " "	16
1 " "	16B
1 " "	17
1 " "	18A
2 " "	18B
1 " "	21
1 " "	26
1 " "	27A
42 " "	37
1 " "	38
1 " "	46
4 " "	53
6 " "	59
3 " "	62
6 " "	63
1 " "	94
1 " "	95A
1 " "	96
2 " "	108
1 " "	116
1 " "	130

Clockwork
Motor
(not included in
Outfit)

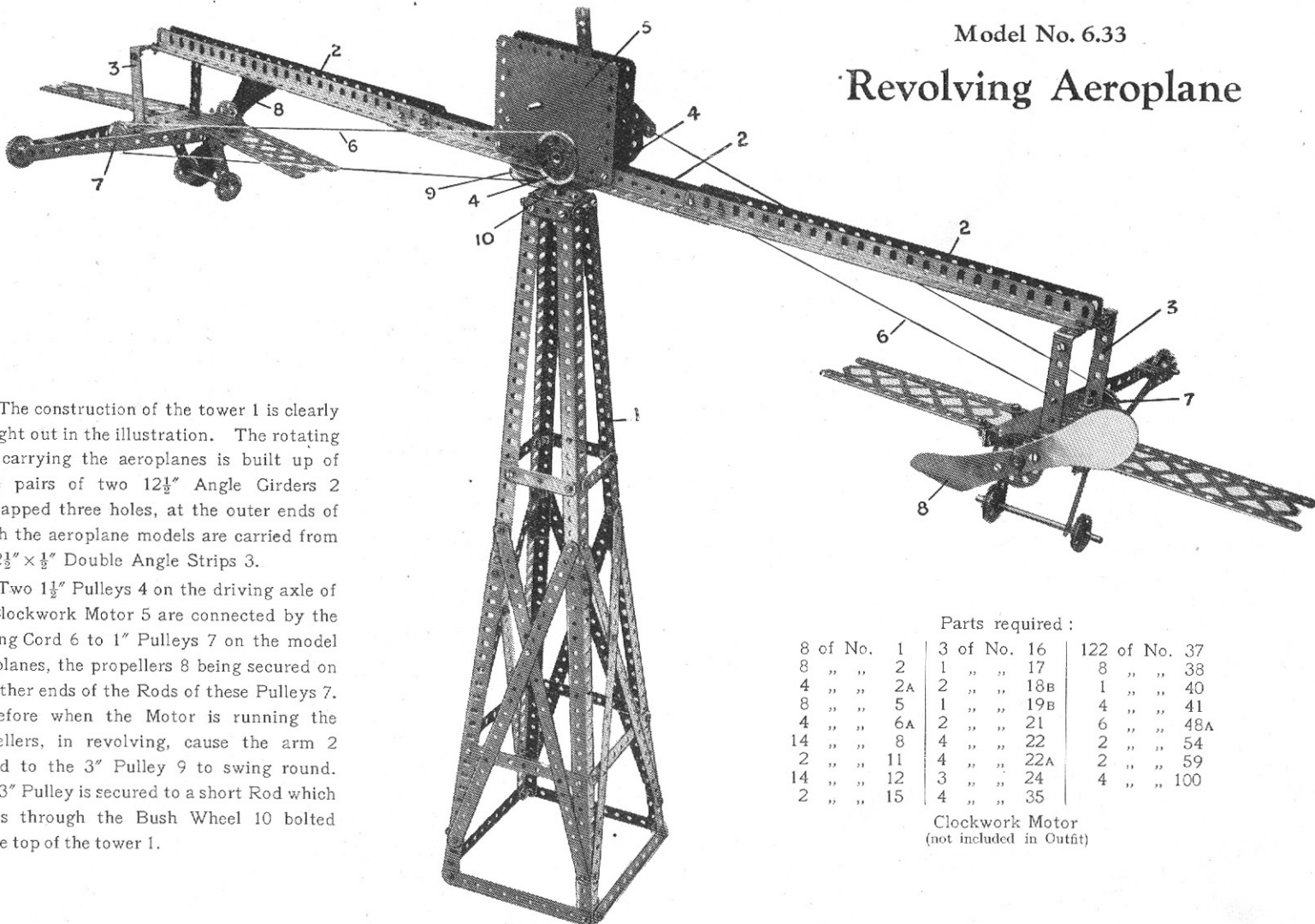
Model No. 6.32 Fly Boats



Parts required :

4 of No.	1
9 " "	2
24 " "	3
4 " "	5
2 " "	6
4 " "	8
2 " "	8A
8 " "	9
4 " "	12
2 " "	14
5 " "	16
3 " "	24
1 " "	27A
1 " "	32
15 " "	37
24 " "	38
12 " "	48A
2 " "	52
12 " "	59
16 " "	90
18 " "	94
1 " "	95A
1 " "	96
2 " "	99A
2 " "	100
1 " "	115
4 " "	126A

Model No. 6.33
Revolving Aeroplane



The construction of the tower 1 is clearly brought out in the illustration. The rotating arm carrying the aeroplanes is built up of three pairs of two 12½" Angle Girders 2 overlapped three holes, at the outer ends of which the aeroplane models are carried from the 2½" x ½" Double Angle Strips 3.

Two 1½" Pulleys 4 on the driving axle of the Clockwork Motor 5 are connected by the driving Cord 6 to 1" Pulleys 7 on the model aeroplanes, the propellers 8 being secured on the other ends of the Rods of these Pulleys 7. Therefore when the Motor is running the propellers, in revolving, cause the arm 2 bolted to the 3" Pulley 9 to swing round. This 3" Pulley is secured to a short Rod which passes through the Bush Wheel 10 bolted on the top of the tower 1.

Parts required :

8 of No. 1	3 of No. 16	122 of No. 37
8 " " 2	1 " " 17	8 " " 38
4 " " 2A	2 " " 18B	1 " " 40
4 " " 5	1 " " 19B	4 " " 41
4 " " 6A	2 " " 21	6 " " 48A
14 " " 8	4 " " 22	2 " " 54
2 " " 11	4 " " 22A	2 " " 59
14 " " 12	3 " " 24	4 " " 100
2 " " 15	4 " " 35	

Clockwork Motor
 (not included in Outfit)

Model No. 6.34 Drop Hammer

		Parts required :									
1 of No.	1	10 of No.	8	4 of No.	16	75 of No.	37	5 of No.	59		
2 "	"	1B	2 "	"	9D	6 "	"	38	1 "	"	63
4 "	"	2	1 "	"	11	1 "	"	22A	1 "	"	40
1 "	"	2A	1 "	"	12A	2 "	"	24	4 "	"	48A
4 "	"	3	1 "	"	13	2 "	"	26	2 "	"	52
4 "	"	5	1 "	"	15A	2 "	"	27A	1 "	"	53
									4 "	"	108

The construction details of this model are clearly shown in the illustration. The vertical hammer shaft is guided through $2\frac{1}{2} \times \frac{1}{2}$ " Double Angle Strips secured in the upper frame-work. The operating Cord is led from a point on the shaft near the hammer-head up to a guide Pulley (Standard Mechanism No. 39) situated at the top of the model, and from thence down to the winding drum, consisting of two Flanged Wheels butted together, in the gear box

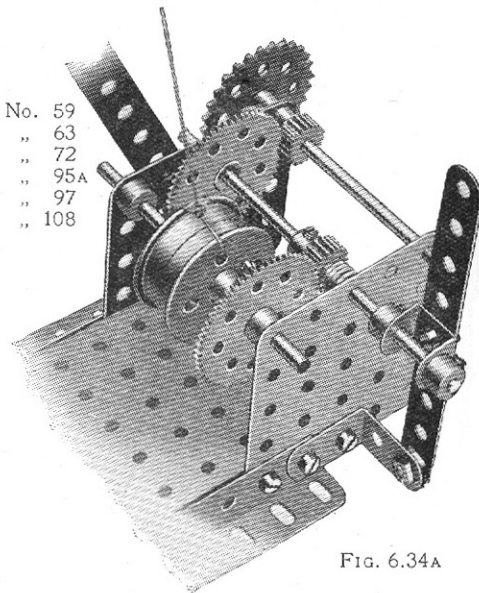
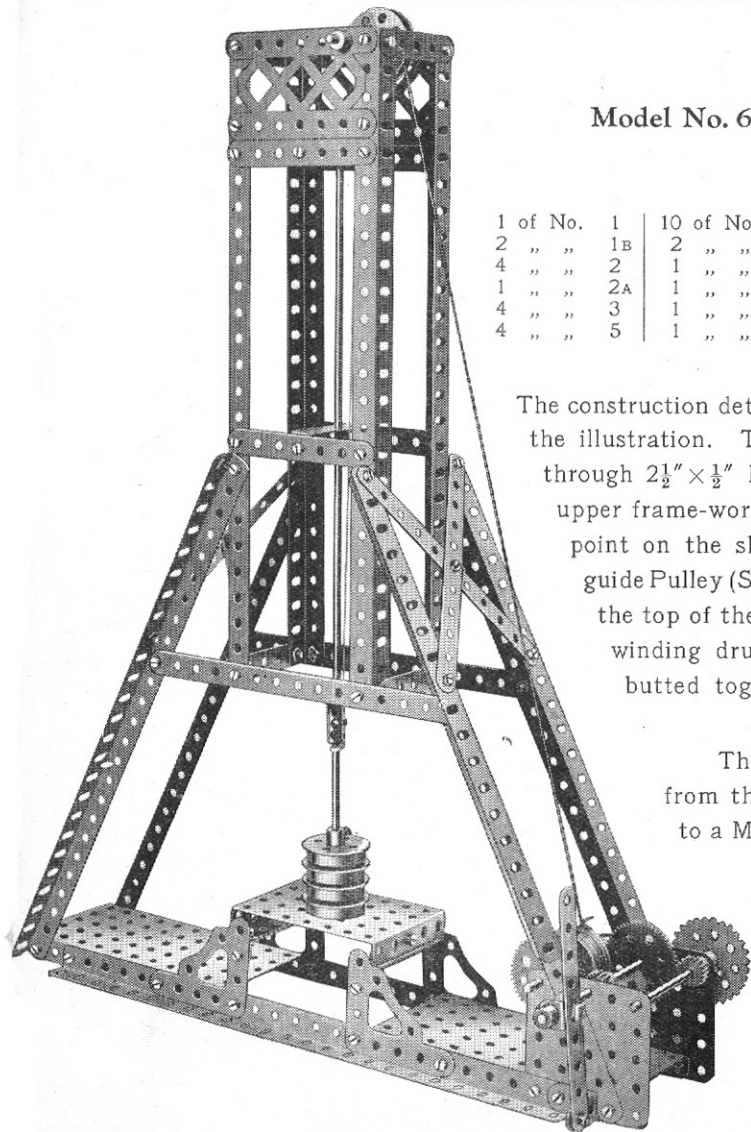


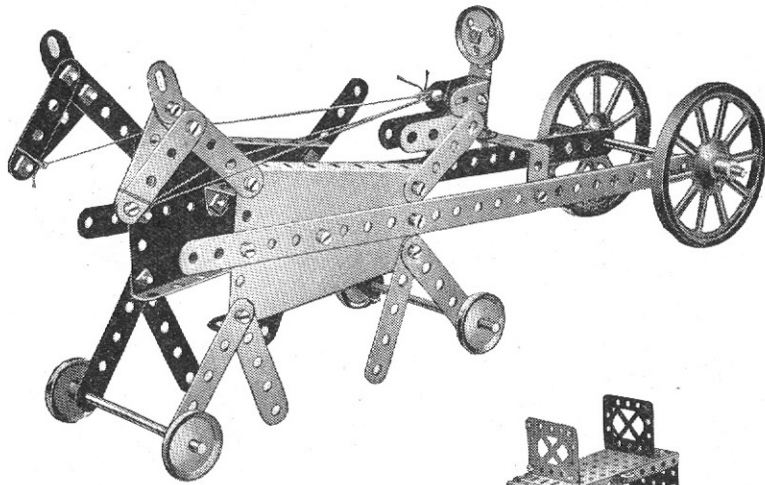
FIG. 6.34A

The Rod carrying the winding drum is rotated through a chain of reduction gearing from the driving shaft carrying a Sprocket Wheel, which may, of course, be coupled to a Meccano Motor or any other driving method. The intermediate shaft is slidable in its bearings and is controlled by the hand lever shown in Fig. 6.34A, while its gears are so arranged that they may be easily slipped out of engagement with the driving shaft, with the result that the hammer, being released, forcibly strikes the table secured in the base of the machine. From this it will be seen that the power of the blow may be altered as desired, since the hammer may be dropped from varying heights.



Model No. 6.35

Sulky and Driver



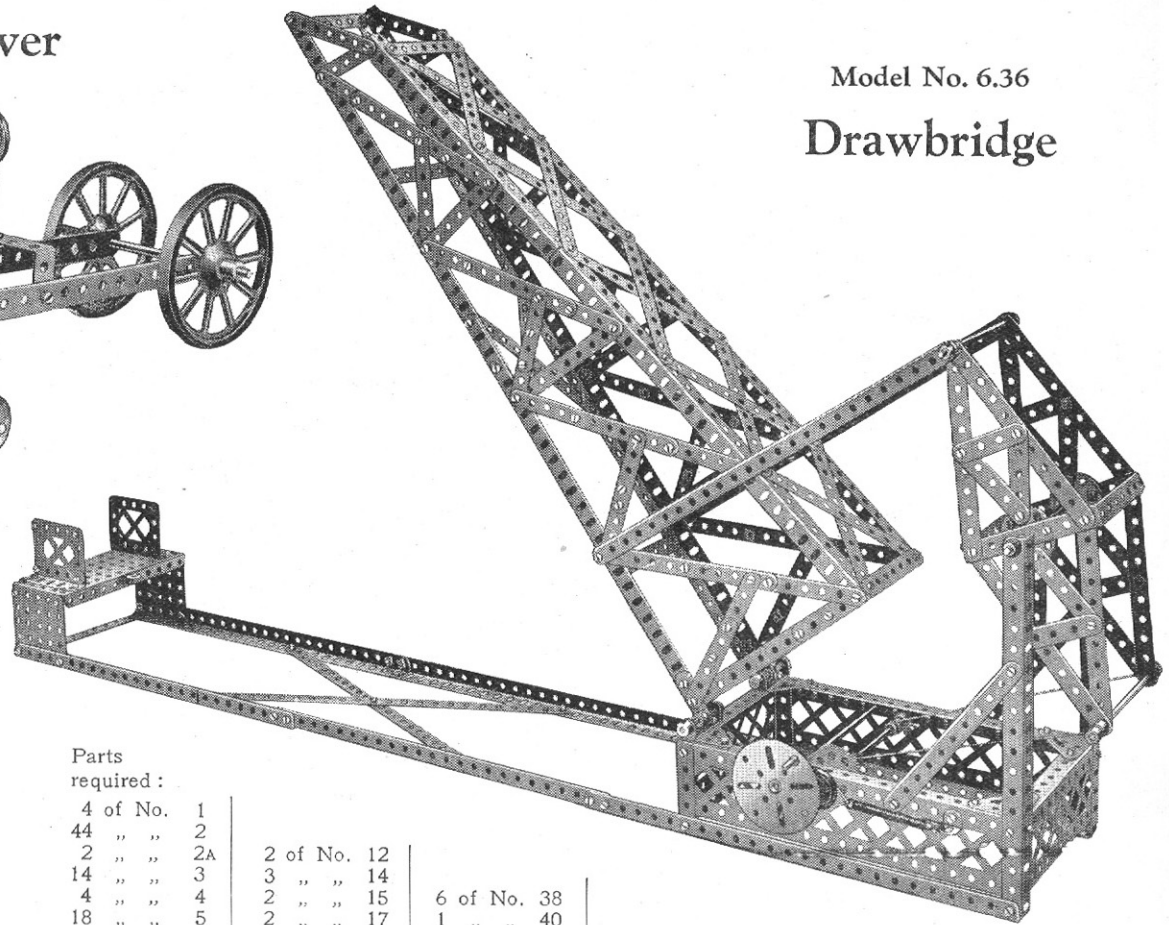
The driver's body is made of a 2" Strip bolted by an Angle Bracket to a 2½" × 1" Double Angle Strip. The horses are joined together by a 2½" × ½" Double Angle Strip, and two 12½" Strips form supports for the wheels and for the driver's seat.

Parts required :

2 of No. 1	2 of No. 19A
10 " " 5	4 " " 22
9 " " 6	1 " " 22A
4 " " 10	32 " " 37
2 " " 11	1 " " 46
1 " " 12	2 " " 48A
3 " " 15A	2 " " 54

Model No. 6.36

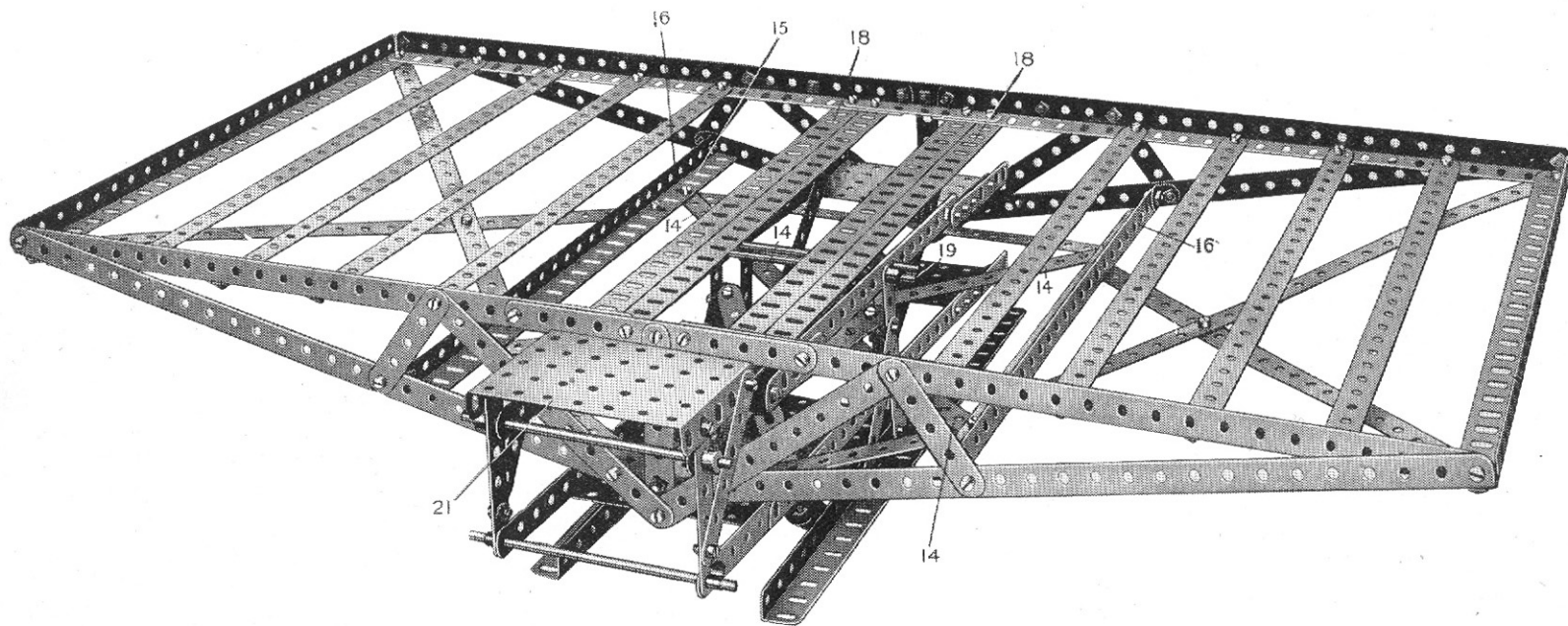
Drawbridge



Parts required :

4 of No. 1	2 of No. 12	6 of No. 38	2 of No. 62	1 of No. 109
44 " " 2	3 " " 14	1 " " 40	2 " " 72	1 " " 115
2 " " 2A	2 " " 15	1 " " 43	2 " " 98	1 " " 99A
14 " " 3	2 " " 17	2 " " 48	2 " " 99A	4 " " 133
4 " " 4	1 " " 22	2 " " 48B	2 " " 100	
18 " " 5	1 " " 24	1 " " 52		
8 " " 6	2 " " 26	1 " " 59		
14 " " 8	1 " " 27A			
4 " " 8A	1 " " 37			
2 " " 9				
6 " " 9D				

Model No. 6.37 Weighbridge



Parts required

22 of No. 1	8 of No. 3	6 of No. 5	10 of No. 12	2 of No. 35	16 of No. 37A
10 " " 2	6 " " 4	14 " " 8	6 " " 15A	107 " " 37	6 " " 53
		6 of No. 59			

Model No. 6.37 Weighbridge *(continued)*

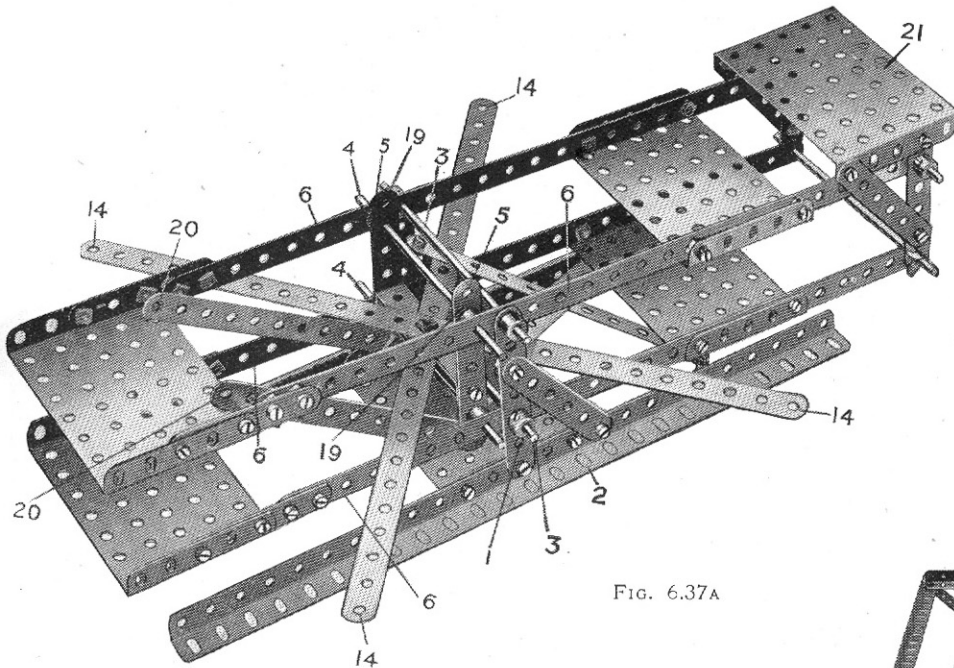


FIG. 6.37A

Begin the construction of this model by making the weigh beam, Fig. 6.37A. The side Strips 1 are bolted to the base Angle Girders 2, and in the Strips 1 are journalled the Rods 3 which form the fixed pivots of the weigh beam. The upper and lower Rods 4 are journalled in the Strips 5 and form the moving pivots of the beam. All the Rods 3 and 4 pass through perforations in the upper and lower Strips 6 of the beam. Next construct the platform, Fig. 6.37B, leaving the Strips at one side unconnected, as shown. The platform is then passed between the upper and lower parts of the weigh beam, and the unconnected Strips then bolted, as follows :

The ends 7 are bolted to the lowest hole 8, and the ends 9 to the Bolt 10, which also carries an Angle Bracket. The outer holes 14 of the 12½" crossed Strips, Fig. 6.37A, are then bolted to the same holes 15 in the Angle Girders 16 as the Strips 17. The other ends of the Strips 17 are secured to the Angle Bracket at 10. The Double Angle Girders 18 are then bolted in position, and the upper holes 19, Fig. 6.37A, are bolted to the Angle Girders 18 in the centre holes and the holes 20, Fig. 6.37A, to the Angle Girders 18 at the fifth hole from the Girder ends. The load to be weighed rests on the main platform, and the weights are placed on the small Rectangular Plate 21 at the end of the weigh beam.

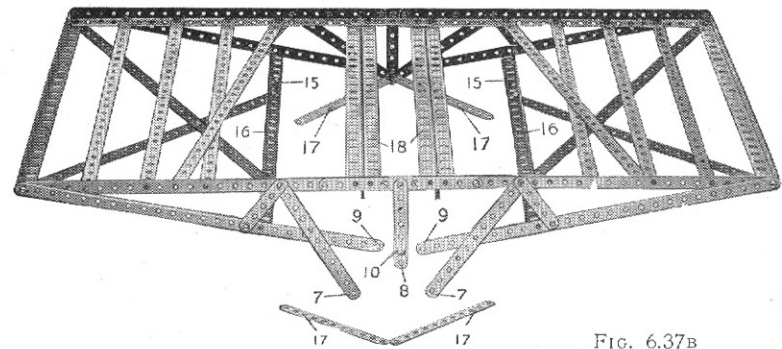
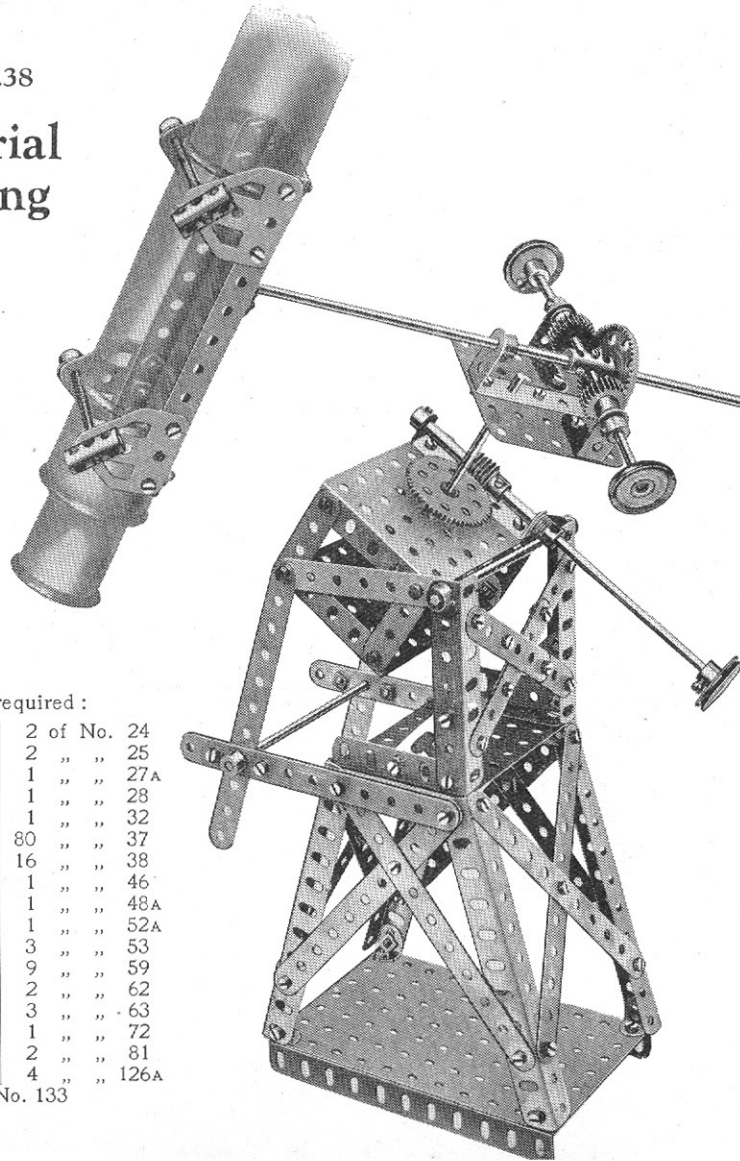


FIG. 6.37B

Model No. 6.38

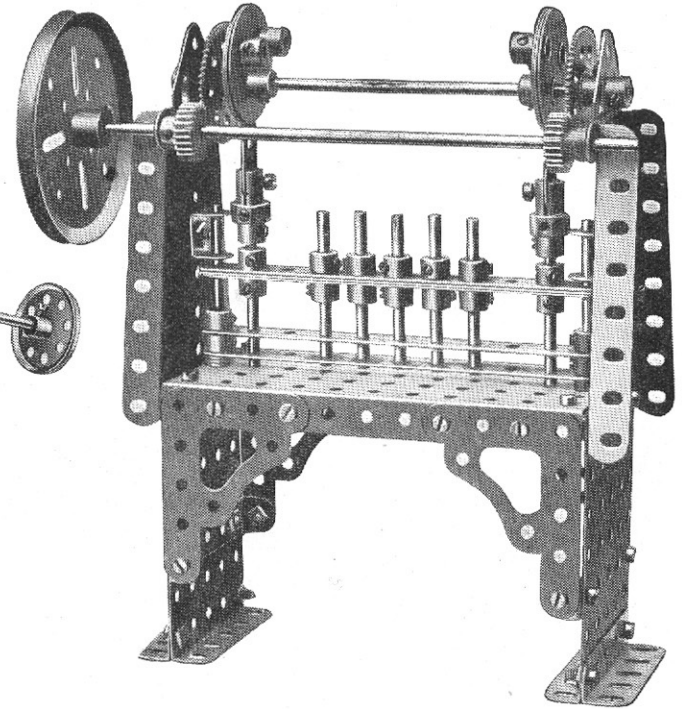
Equatorial Mounting



Parts required :

4 of No.	2	2 of No.	24
2 "	3	2 "	25
4 "	4	1 "	27A
4 "	6	1 "	28
2 "	6A	1 "	32
8 "	9	80 "	37
2 "	9B	16 "	38
2 "	9D	1 "	46
4 "	12	1 "	48A
2 "	12A	1 "	52A
1 "	13	3 "	53
1 "	14	9 "	59
1 "	15	2 "	62
2 "	15A	3 "	63
2 "	16B	1 "	72
1 "	21	2 "	81
3 "	22	4 "	126A
	2 of No.		133

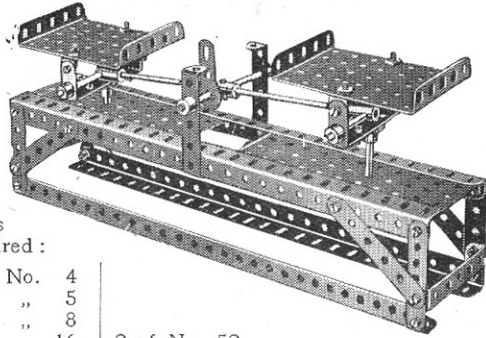
Model No. 6.39 **Punching Press**



Parts required :

5 of No.	2	1 of No.	19B	2 of No.	53
2 "	6	2 "	25	2 "	54
2 "	9D	2 "	27A	21 "	59
2 "	11	34 "	37	2 "	63B
1 "	13A	6 "	38	4 "	108
1 "	14	2 "	48A	2 "	126A
9 "	17	1 "	52	2 "	130

Model No. 6.40 Scales

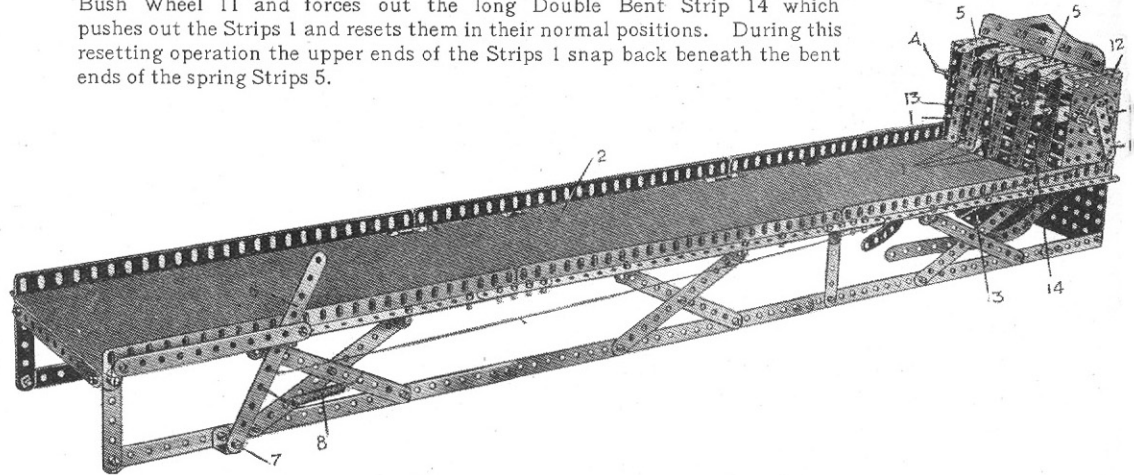


Parts required :

4 of No.	4		
4 "	"	5	
4 "	"	8	
5 "	"	16	2 of No. 52
2 "	"	17	2 " " 53
30 "	"	37	6 " " 59
2 "	"	46	3 " " 62
6 "	"	48A	3 " " 63

Model No. 6.42 Box Ball Alley

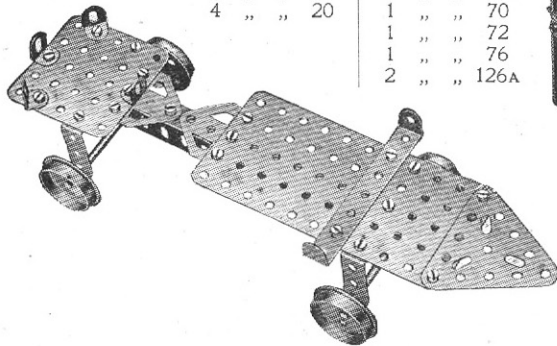
This model of a Box Ball Alley gives endless amusement, apart from the actual construction. The object is to hit one of the Strips 1, which have various number values, by means of a ball rolled along the platform 2, the ball after striking and tipping one of the Strips being returned by the tray 3 to the player. The Strips 1 are pivoted by Double Bent Strips on to a Rod 4, so that each Strip may swing independently. The upper end of each Strip is engaged by Strips 5, the ends of which are bent slightly down, as shown, so that while the Strips 1 are normally held in the position shown, when one of the Strips is struck by the ball it is deflected backward and its upper end snaps outward past the bent end of its Strip 5, which thus acts as a spring, the deflected Strip being then retained in that position until it is reset. To reset any or all of the Strips 1 a handle is formed by a Strip 6 pivoted at 7 and controlled by a tension Spring 8. A Cord 9 connects the Strip 6 to a short Strip 10 forming a Crank and bolted to a Bush Wheel 11 on an axle journalled in the side Plates 12. This axle on its interior carries two further Bush Wheels to which are secured two short Strips 13 forming Cranks, a long Double Bent Strip 14 being in turn bolted to the Strips 13. When therefore the handle 6 is pulled out against the Spring 8 the Cord 9 rotates the Bush Wheel 11 and forces out the long Double Bent Strip 14 which pushes out the Strips 1 and resets them in their normal positions. During this resetting operation the upper ends of the Strips 1 snap back beneath the bent ends of the spring Strips 5.



Model No. 6.41 Roller Skate

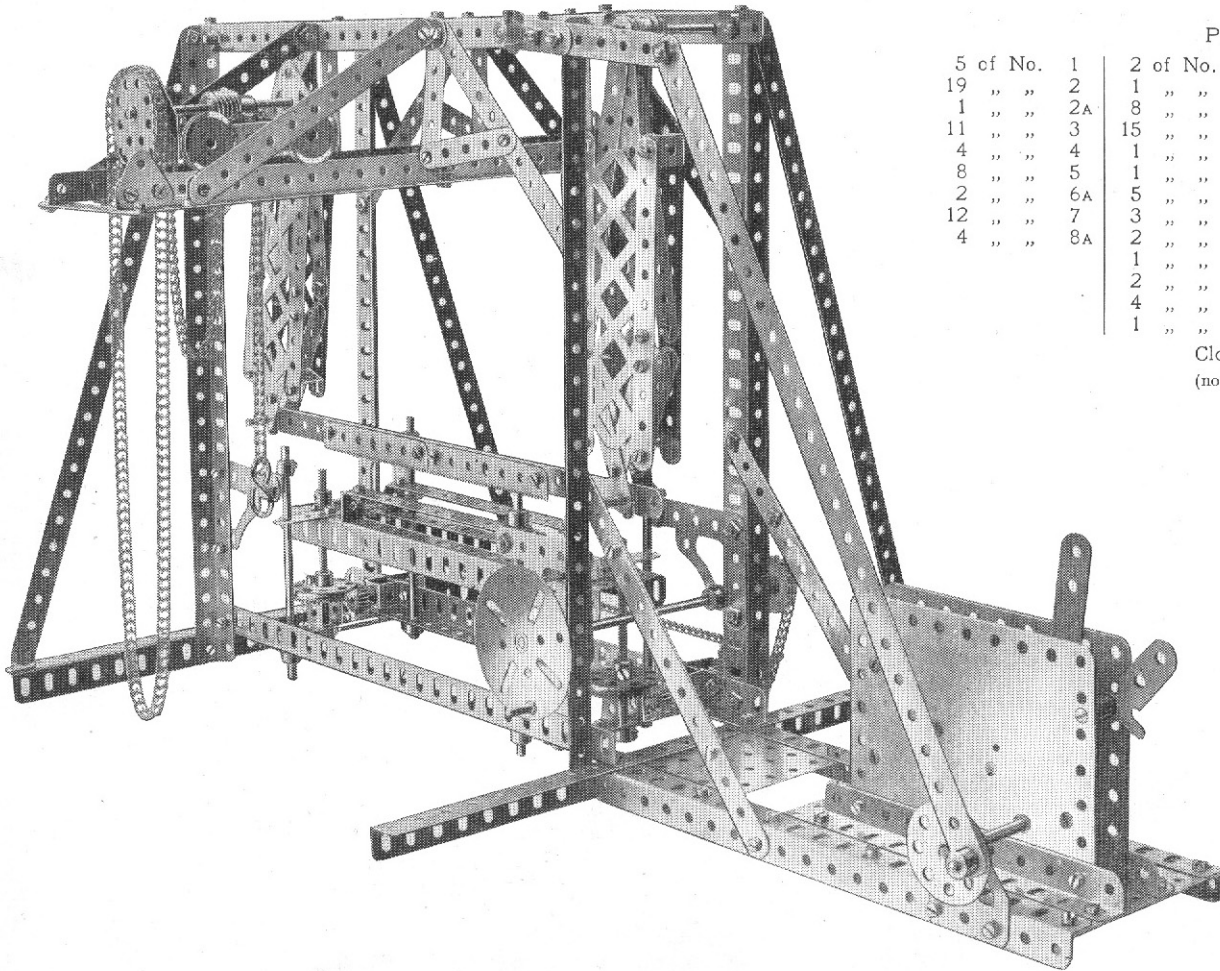
Parts required :

2 of No.	8B	19 of No.	37
4 "	"	2 "	"
2 "	"	1 "	"
4 "	"	1 "	"
		1 "	"
		1 "	"
		2 "	"
			126A



Parts required :	6 of No.	8	132 of No.	37
	5 "	"	11	1 " " 43
	27 "	"	12	2 " " 52
6 of No.	1	"	14	2 " " 53
19 "	2	"	15	2 " " 54
5 "	3	"	16	2 " " 59
2 "	4	"	24	2 " " 62
15 "	5	"	35	1 " " 63

Model No. 6.43 Stone-Sawing Machine



Parts required :

5 of No. 1	2 of No. 9	3 of No. 26	2 of No. 62A
19 " " 2	1 " " 10	2 " " 28	2 " " 77
1 " " 2A	8 " " 11	1 " " 32	2 " " 80A
11 " " 3	15 " " 12	12 " " 35	40" " " 94
4 " " 4	1 " " 14	185 " " 37	1 " " 95A
8 " " 5	1 " " 15	32 " " 38	1 " " 96A
2 " " 6A	5 " " 15A	6 " " 45	4 " " 100
12 " " 7	3 " " 16	1 " " 47	4 " " 108
4 " " 8A	2 " " 16A	5 " " 48A	1 " " 109
	1 " " 17	3 " " 53	2 " " 110
	2 " " 18A	2 " " 57	2 " " 115
	4 " " 22	15 " " 59	4 " " 125
	1 " " 24	2 " " 62	3 " " 126A

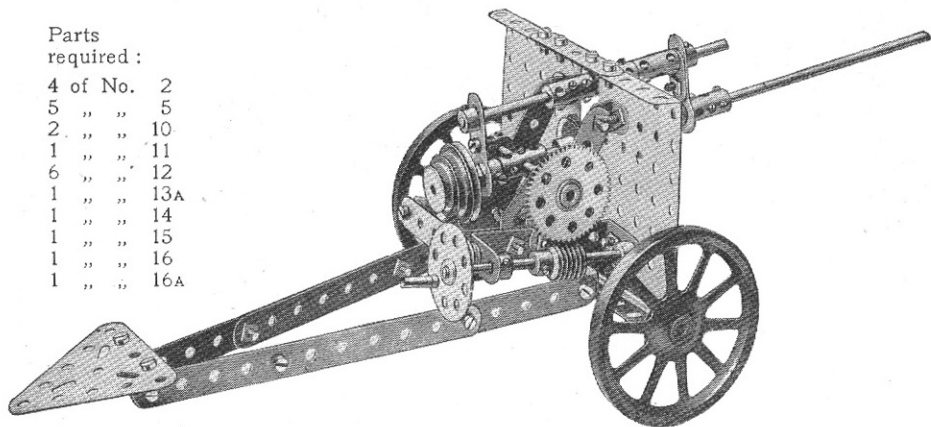
Clockwork Motor
(not included in Outfit)

This is a very interesting model to construct and operate. The saw is represented by two Rack Strips, but if desired these may be substituted by a hack saw blade. The model includes a trolley that runs on overhead rails and carries a self-sustaining chain hoist. The elevation of the sawing table is adjusted by means of a hand wheel. Full instructions for building the model, together with sectional illustrations that make every detail clear, are contained in a special leaflet included in the Outfit. This leaflet may also be obtained from your dealer, price 2d., or direct from Meccano Ltd., Binns Road, Liverpool, price 2d., post free.

Model No. 6.44 Field Gun

Parts
required:

4 of No.	2
5 " "	5
2 " "	10
1 " "	11
6 " "	12
1 " "	13A
1 " "	14
1 " "	15
1 " "	16
1 " "	16A



Parts
required:

1 of No.	18B
2 " "	19B
3 " "	22
1 " "	24
1 " "	26
1 " "	27A
1 " "	32
34 " "	37
6 " "	38
1 " "	46
1 " "	47
2 " "	53
5 " "	59
2 " "	62
4 " "	63
1 " "	76
1 " "	115
1 " "	123
2 " "	124
2 " "	126

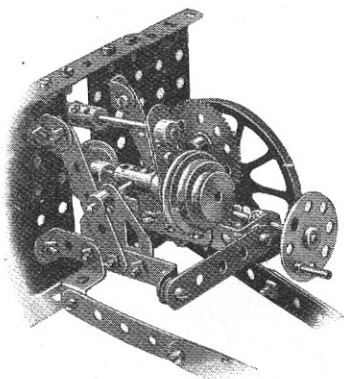


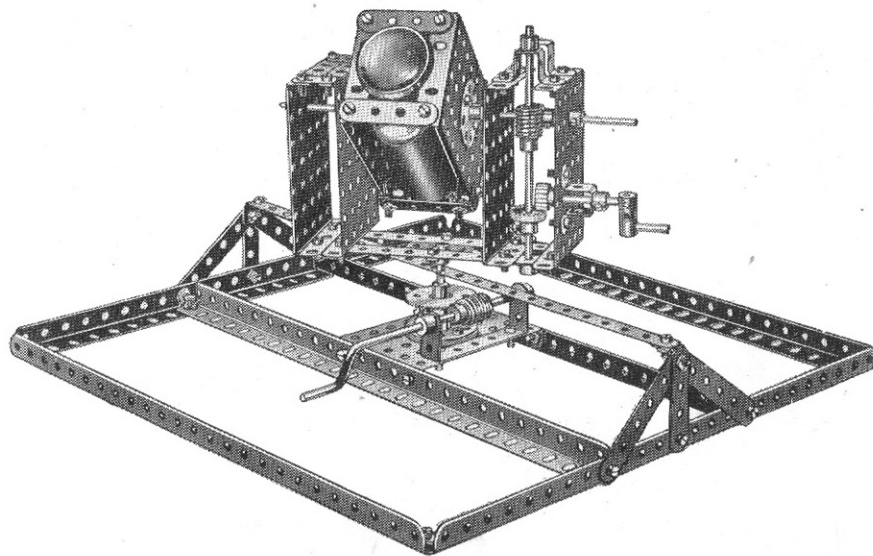
FIG. 6.44A

Model No. 6.45 Searchlight

Parts required:

1 of No.	1	6 of No.	12	1 of No.	21	62 of No.	37
2 " "	2	1 " "	15	3 " "	24	3 " "	45
4 " "	4	1 " "	16	2 " "	26	1 " "	46
6 " "	6	2 " "	17	1 " "	27A	7 " "	53
6 " "	8	1 " "	18A	1 " "	29	8 " "	59
2 " "	10	1 " "	19	2 " "	32	1 " "	63

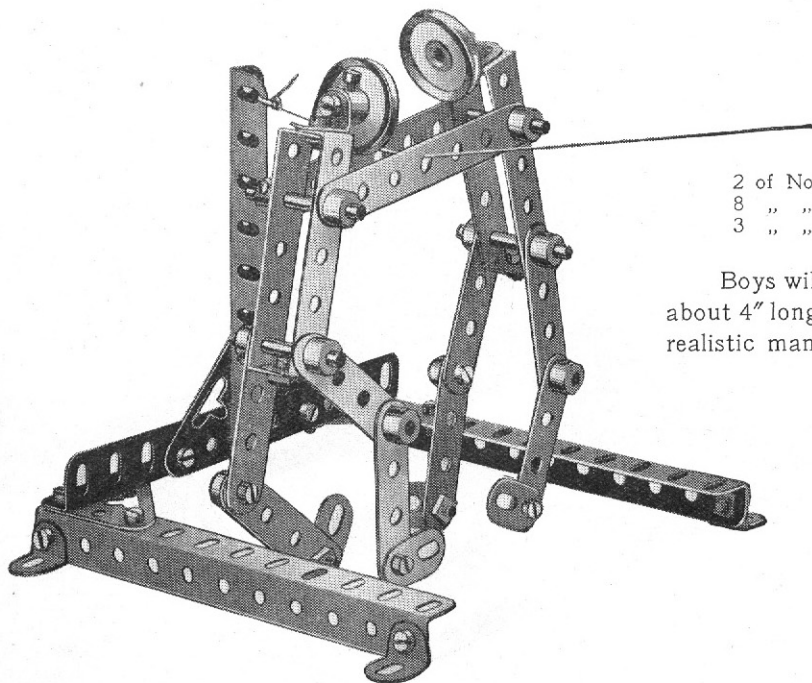
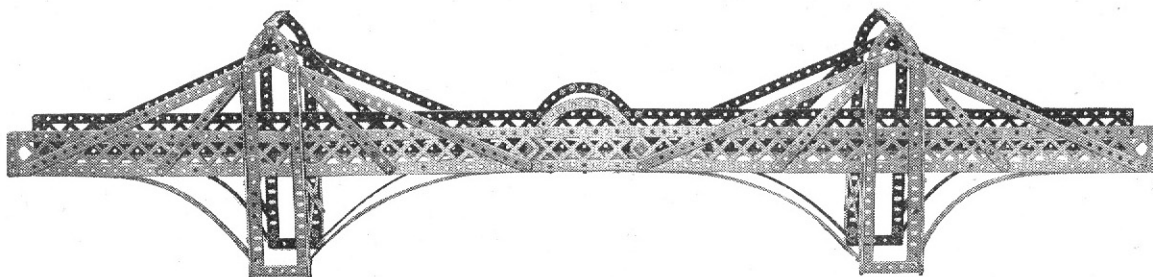
A splendid model with which great fun may be obtained by fitting an electric flash lamp. The light may be quickly manoeuvred in any direction and enemy aircraft "spotted" at once.



Model No. 6.46 Cantilever Bridge

Parts required:

16 of No.	1	8 of No.	6A	2 of No.	48B
16 " "	2	8 " "	8	14 " "	90
3 " "	3	18 " "	9	8 " "	99
4 " "	5	8 " "	12	2 " "	100
4 " "	6	136 " "	37		



Model No. 6.47 The Wrestlers

Parts required:

2 of No.	3	1 of No.	9A	4 of No.	18A	6 of No.	37B	12 of No.	59
8 " "	6	4 " "	10	2 " "	22	1 " "	38	4 " "	133
3 " "	9	6 " "	12	22 " "	37	4 " "	48A		

Boys will at once recognise this familiar toy. When the cord, which should be about 4" long, is kept fairly tight and manipulated, the figures will wrestle in a most realistic manner. The model should be mounted on a board, to keep it steady.

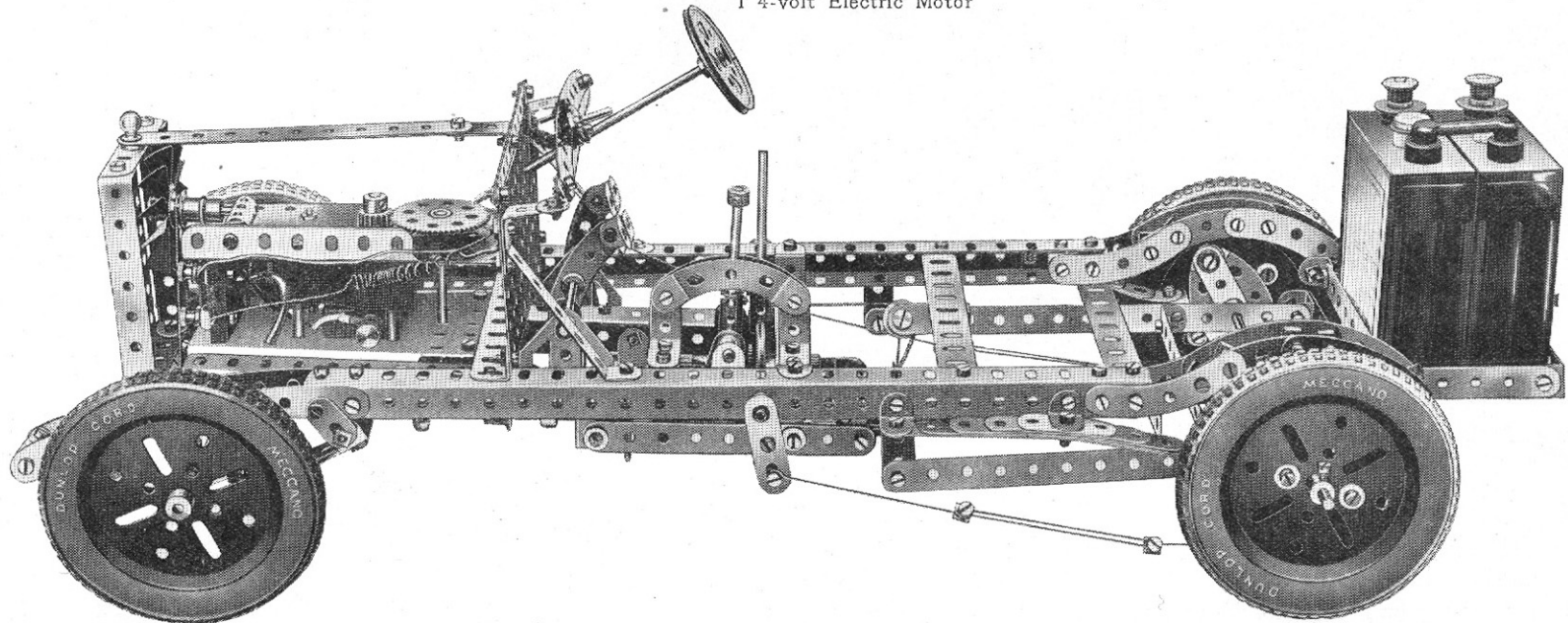
HOW TO CONTINUE

This completes our examples of models that may be made with MECCANO Outfit No. 6. The next models are a little more advanced, requiring a number of extra parts to construct them. The necessary parts are all contained in a No. 6A Accessory Outfit, the price of which will be found in the List at the end of this Manual.

Model No. 7.1 Meccano Motor Chassis

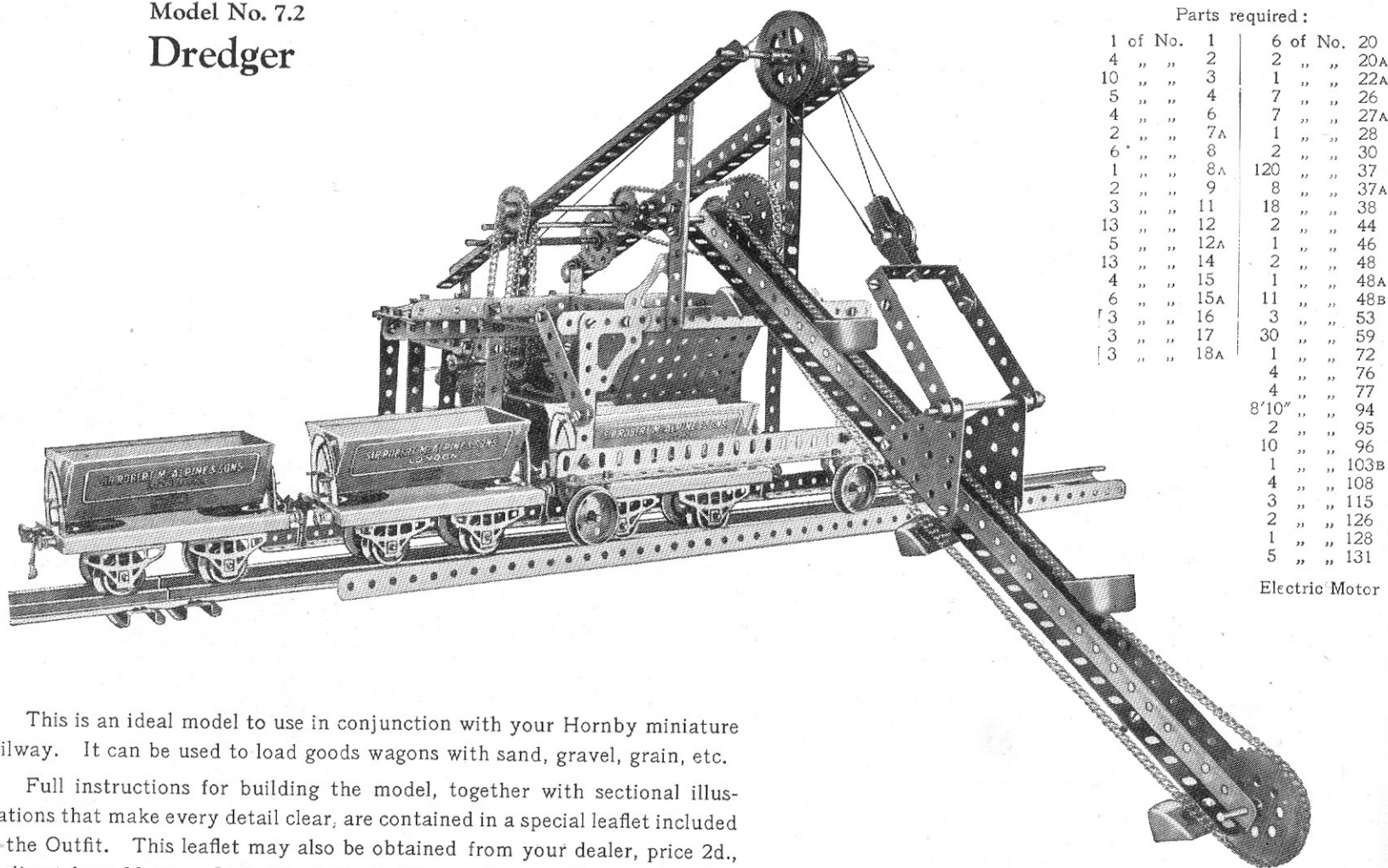
Parts required:									
11 of No. 2	12 of No. 10	5 of No. 16	3 of No. 22	2 of No. 30A	9 of No. 48A	1 of No. 70	9 of No. 111c	4 of No. 142B	
9 " " 2A	8 " " 11	2 " " 16A	2 " " 23	2 " " 30c	2 " " 48B	5 " " 89	1 " " 115	2 " " 147B	
4 " " 3	24 " " 12	1 " " 16B	1 " " 23A	4 " " 31	4 " " 48c	14 " " 90	2 " " 120B	1 " " 155	
6 " " 4	4 " " 12A	5 " " 17	2 " " 25	178 " " 37	1 " " 53	2 " " 90A	4 " " 124	1 " " 157	
6 " " 5	4 " " 12B	5 " " 18A	4 " " 26	38 " " 37A	1 " " 55A	4 " " 101	2 " " 125	2 " " 302	
9 " " 6A	1 " " 13A	3 " " 18B	2 " " 27	40 " " 38	3 " " 58	1 " " 102	2 " " 126	2 " " 303	
4 " " 8	2 " " 14	4 " " 19B	1 " " 27A	1 " " 45	42 " " 59	2 " " 109	1 " " 136	2 " " 304	
2 " " 8A	2 " " 15	1 " " 20	1 " " 28	2 " " 46	5 " " 62	5 " " 111	4 " " 137	2 " " 305	
2 " " 9	1 " " 15A	1 " " 20A	4 " " 30	2 " " 47A	9 " " 63	8 " " 111A	5 " " 140		

1 4-volt Electric Motor



The Meccano Motor Chassis is a model of exceptional interest, for it provides a complete demonstration of the principles of a real motor chassis. It is equipped with differential, Ackermann steering gear, and gear box giving three forward speeds and a reverse with central change lever. It is provided also with a clutch, internal expanding brakes on the rear wheels, and foot brake on the cardan shaft. The frame is suspended at the front on semi-elliptic leaf springs and at the rear on cantilever springs. In order to make the construction of the model quite clear a number of sectional photographs and drawings are necessary and it is impossible to find space for these and the instructions which go with them, in this Manual. We therefore have compiled a separate sheet, printed on art paper, containing full instructions and clear illustrations. A copy of this sheet is included in every No. 7 Outfit. It may also be purchased from any Meccano dealer, price 3d., or direct from Meccano Ltd., Liverpool, price 3d., post free.

Model No. 7.2 Dredger



Parts required:

1 of No.	1	6 of No.	20
4 "	2	2 "	20A
10 "	3	1 "	22A
5 "	4	7 "	26
4 "	6	7 "	27A
2 "	7A	1 "	28
6 "	8	2 "	30
1 "	8A	120 "	37
2 "	9	8 "	37A
3 "	11	18 "	38
13 "	12	2 "	44
5 "	12A	1 "	46
13 "	14	2 "	48
4 "	15	1 "	48A
6 "	15A	11 "	48B
3 "	16	3 "	53
3 "	17	30 "	59
3 "	18A	1 "	72
		4 "	76
		4 "	77
		8'10"	94
		2 "	95
		10 "	96
		1 "	103B
		4 "	108
		3 "	115
		2 "	126
		1 "	128
		5 "	131

Electric Motor

This is an ideal model to use in conjunction with your Hornby miniature railway. It can be used to load goods wagons with sand, gravel, grain, etc.

Full instructions for building the model, together with sectional illustrations that make every detail clear, are contained in a special leaflet included in the Outfit. This leaflet may also be obtained from your dealer, price 2d., or direct from Meccano Ltd., Binns Road, Liverpool, price 2d., post free.

Model No. 7.3 Coal-Cutting Machine

Parts required :

4 of No. 2	4 of No. 26
6 " " 3	3 " " 27A
8 " " 4	1 " " 28
20 " " 6	2 " " 30
2 " " 7	6 " " 35
4 " " 8	75 " " 37
2 " " 9	1 " " 44
9 " " 12	1 " " 50
1 " " 13A	1 " " 52A
5 " " 15	6 " " 59
1 " " 16	1 " " 63
1 " " 17	4 " " 77
1 " " 18A	12" " 94
6 " " 20	1 " " 95
1 " " 22A	1 " " 96
1 " " 24	

Clockwork Motor

This apparatus, by hauling on a rope, pulls itself along in a direction parallel to the coal-face, while its revolving cutters slice into the coal, which may afterwards be removed in large blocks.

The Clockwork Motor 1 drives, by the Chain and Sprocket Gear 2, the Rod 3, which is connected by Bevels Wheels 4 to the horizontal Rod 5, a $\frac{1}{2}$ " Pinion on the end of which drives a Contrate Wheel 7 on the Rod 8 of the cutting wheel 9. The Rod 3 also drives through a gear train 10 a Rod 11 on which is a drum composed of two Flanged Wheels 12. A Cord 13 winding from the drum round a Pulley 14, is connected to the trolley 15. The cord 13 is fixed to the trolley 15 which runs on Flanged Wheels 16 on the rails 17. Consequently, as the cutting wheel 9 is rotated from the Motor, the Cord 13 is also slowly wound on the drum 12, and the whole carriage moving along, the cutting wheel also travels along the coal face. The post carrying the Pulley 14, is secured in a convenient position at the end of the track.

The mechanism may be thrown out of gear by pressing the Rod 11 which slides in its bearings. The Strip 18 forms a spring to hold it in gear.

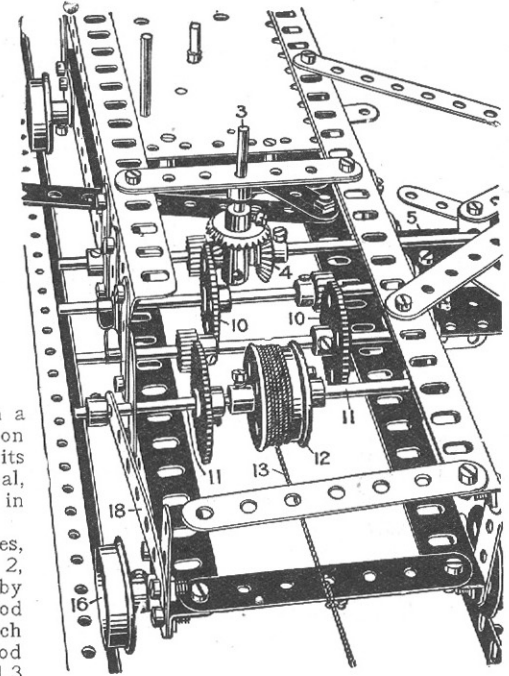
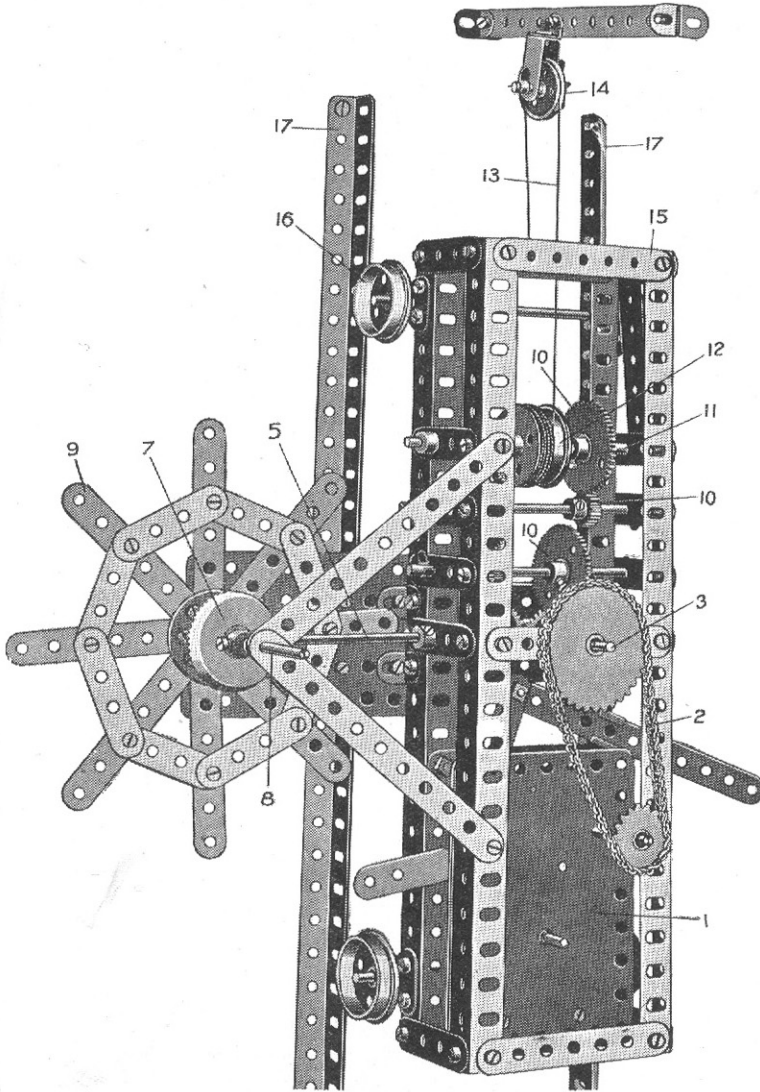
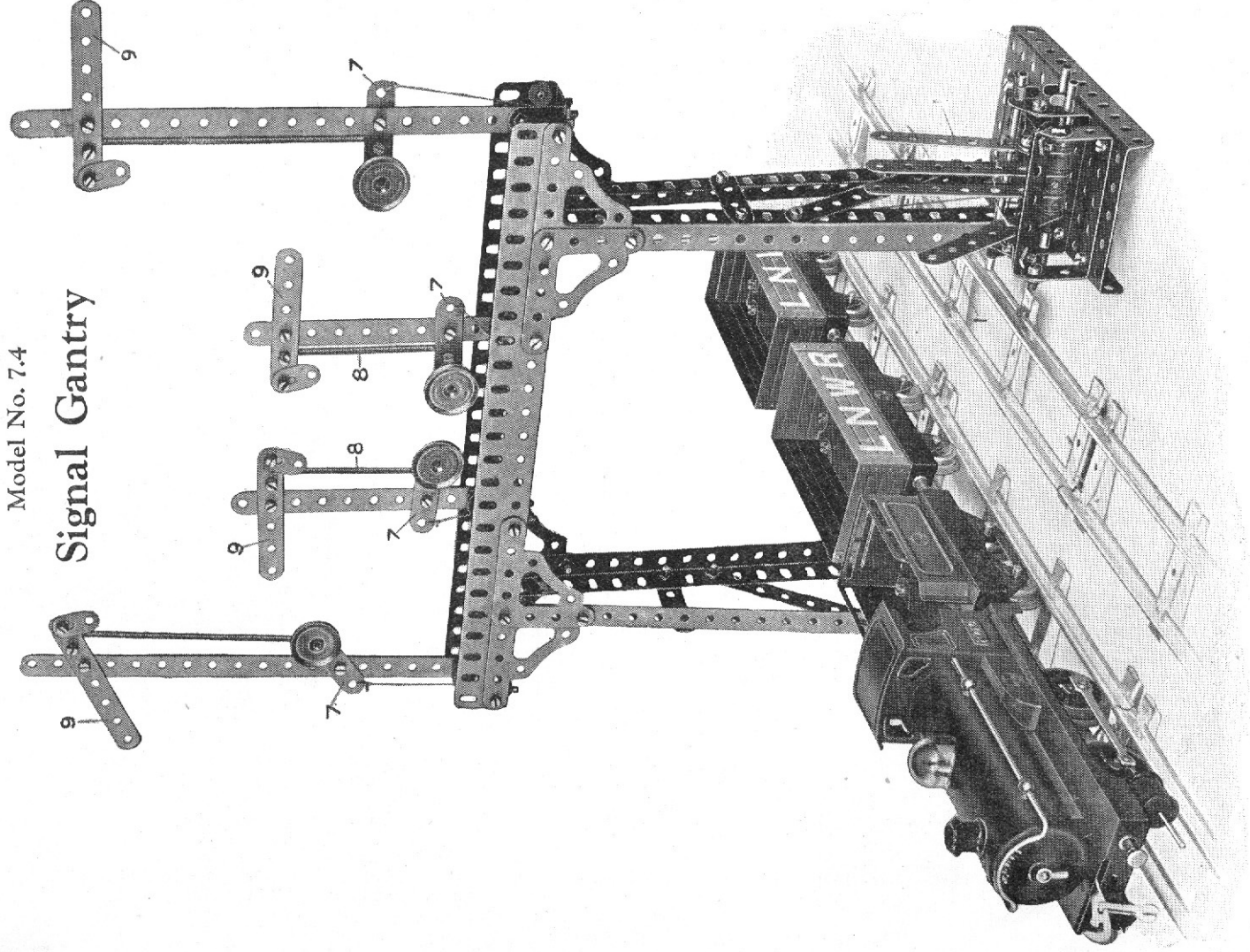


FIG. 7.3A

This Model can be built with MECCANO Outfit No. 7 (or No. 6 and No. 6A)

Model No. 7.4

Signal Gantry



Model No. 7.4

Signal Gantry (continued)

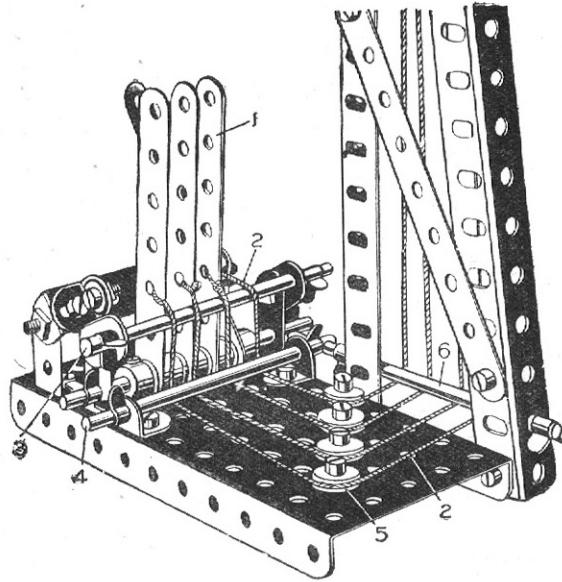


FIG. 7.4A

Parts
required :

2	of No.	1A
2	" "	2
2	" "	2A
6	" "	3
2	" "	4
1	" "	5
6	" "	6
4	" "	8A
6	" "	10
4	" "	12A
4	" "	16
1	" "	17
4	" "	22
8	" "	23
10	" "	35
77	" "	37
4	" "	37B
10	" "	38
2	" "	46
1	" "	48A
1	" "	52
5	" "	59
8	" "	64
2	" "	80
2	" "	80A
2	" "	103B
8	" "	108
4	" "	147B

The detail views, Figs. 7.4A and 7.4B, bring out the construction of the various parts. In Fig. 7.4A the levers 1 operate the Cords 2 which are passed round the upper and lower Rods 3 and 4, and round the $\frac{1}{2}$ " Pulleys 5, giving the Cords a quarter turn before they pass round the Rods 6, thence to the various weighted levers 7, which are connected as shown in Fig. 7.4B to Threaded Bosses 8 on the signal arms 9 by Threaded Rods 10.

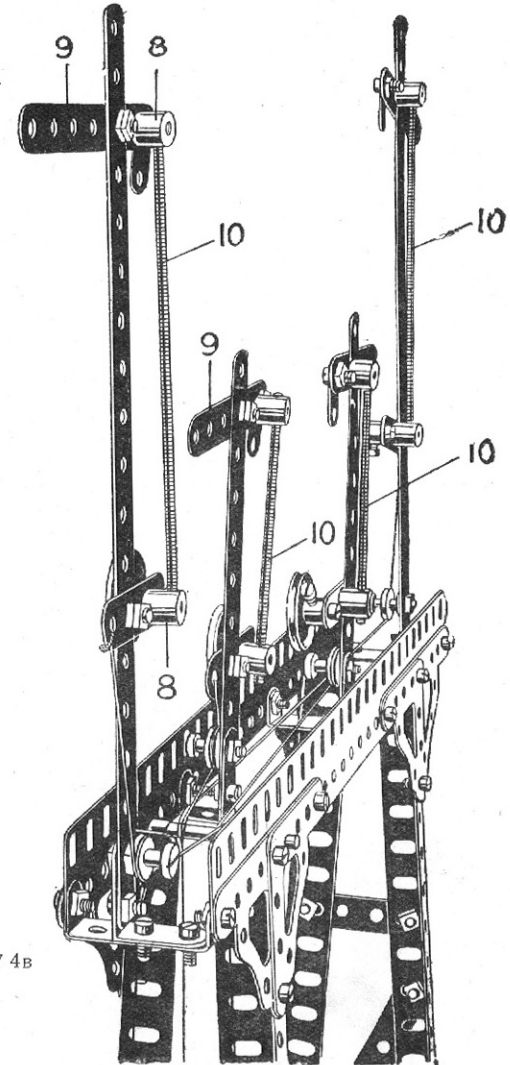
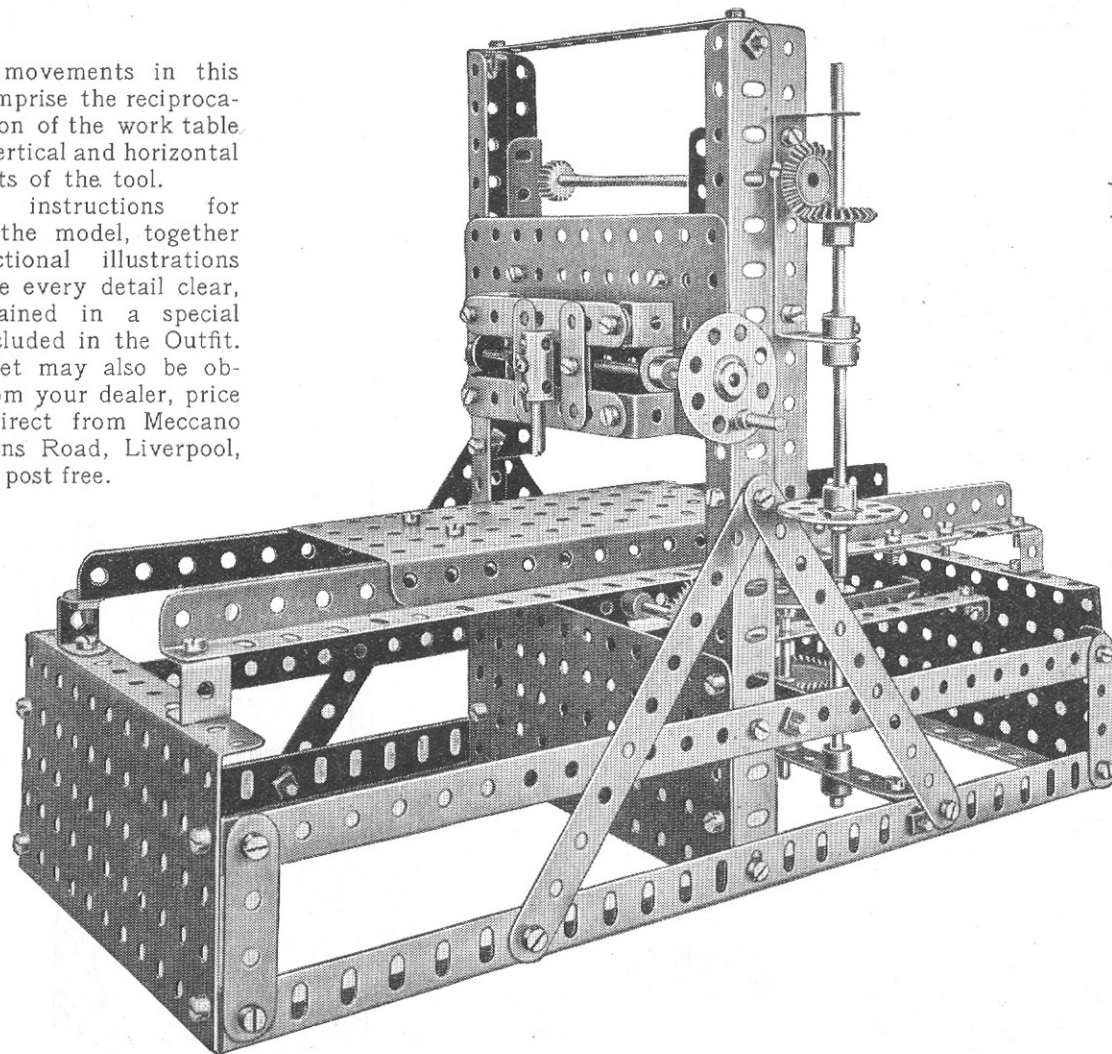


FIG. 7.4B

The movements in this model comprise the reciprocating motion of the work table and the vertical and horizontal movements of the tool.

Full instructions for building the model, together with sectional illustrations that make every detail clear, are contained in a special leaflet included in the Outfit. This leaflet may also be obtained from your dealer, price 2d., or direct from Meccano Ltd., Binns Road, Liverpool, price 2d., post free.



Model No. 7.5

Planing Machine

Parts required :

2 of No.	1	1 of No.	28
7 "	2	2 "	30
3 "	3	74 "	37
1 "	5	3 "	37A
4 "	6	9 "	38
3 "	6A	2 "	46
4 "	8	1 "	48B
2 "	8A	5 "	48D
8 "	11	1 "	50
12 "	12	2 "	52
1 "	14	12 "	59
1 "	15	1 "	63
5 "	16	1 "	64
1 "	18A	2 "	70
2 "	20	1 "	80
3 "	24	2 "	103
5 "	26	2 "	110
2 "	27A	2 "	115

This Model can be built with MECCANO Outfit No. 7 (or No. 6 and No. 6A)

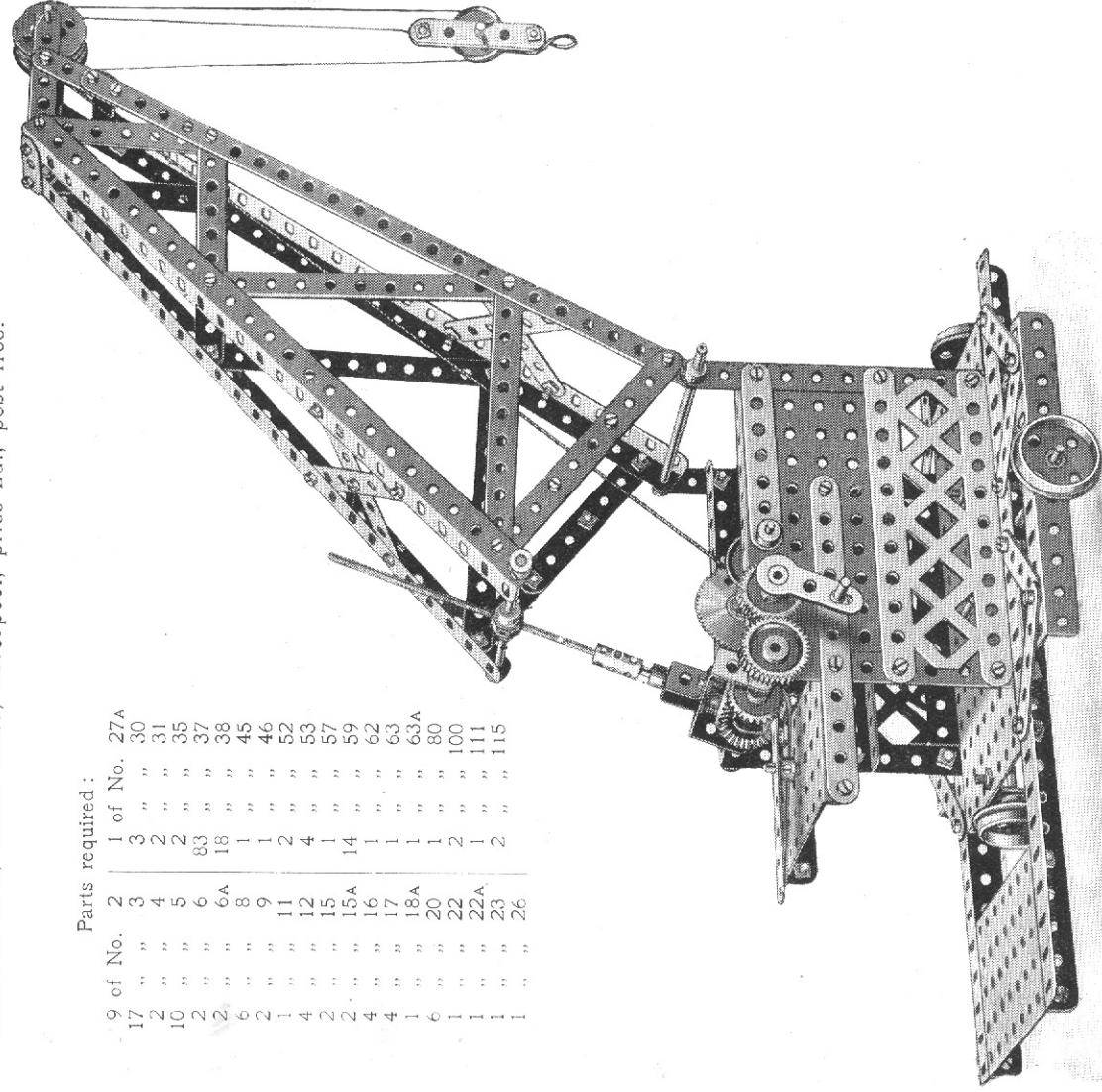
Model No. 7.6 Revolving Crane

An interesting feature of this crane is the luffing mechanism, which makes use of a Threaded Rod engaging the threaded bore of a Coupling attached to the jib. The crane is realistic in appearance and very efficient in operation.

Full particulars for building the Revolving Crane, together with sectional illustrations that make every detail clear, are contained in a special leaflet included in the Outfit. This leaflet may also be obtained from your dealer, price 2d., or direct from Meccano Ltd., Binns Road, Liverpool, price 2d., post free.

Parts required:

9 of No.	2	1 of No.	27A
17	3	3	30
2	4	2	31
10	5	2	35
2	6	83	37
2	6A	18	38
6	8	1	45
2	9	1	46
1	11	2	52
4	12	4	53
2	15	1	57
2	15A	14	59
4	16	1	62
4	17	1	63
1	18	1	63A
6	20	1	80
1	22	2	100
1	22A	1	111
1	23	2	115
1	26		



Model No. 7.7 Steam Shovel

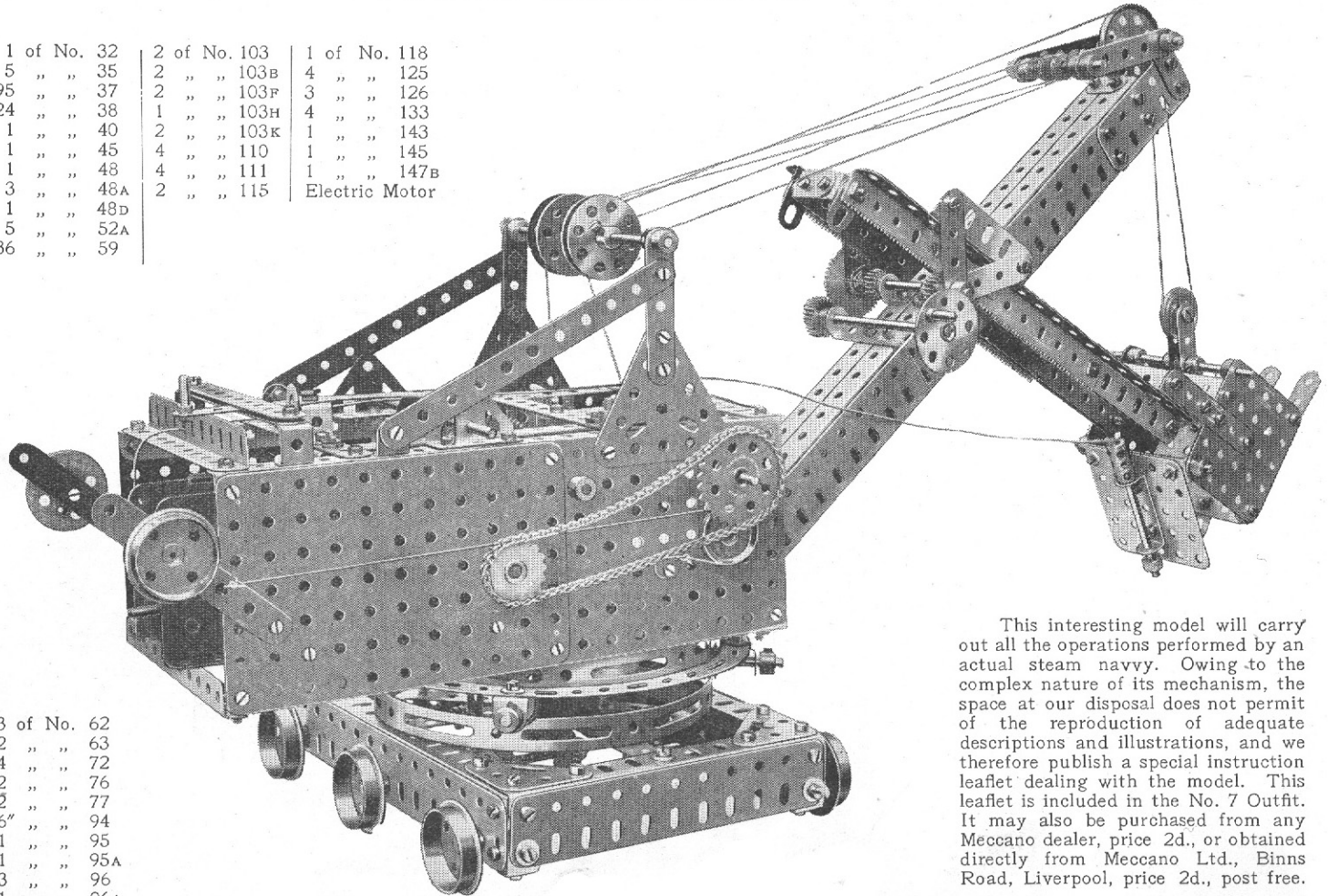
Parts
required :

2 of No.	1A
1	1B
6	2
1	2A
4	3
1	4
5	5
7	6
4	8
6	8A
4	8B
7	9
2	9B
4	9D
4	9F
7	10
6	11
11	12
4	12B
2	13A
8	14
2	15
1	15A
7	16
4	16A
1	18A
5	18B
8	20
1	21
2	22
4	22A
2	23
4	23A
5	24
1	25
9	26
1	27
7	27A
1	27B
1	28
2	30
2	31

1 of No.	32
5	35
195	37
24	38
1	40
1	45
1	48
3	48A
1	48D
5	52A
36	59

2 of No.	103
2	103B
2	103F
1	103H
2	103K
4	110
4	111
2	115

1 of No.	118
4	125
3	126
4	133
1	143
2	145
1	147B
	Electric Motor



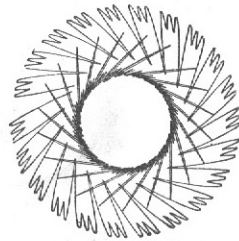
This interesting model will carry out all the operations performed by an actual steam navvy. Owing to the complex nature of its mechanism, the space at our disposal does not permit of the reproduction of adequate descriptions and illustrations, and we therefore publish a special instruction leaflet dealing with the model. This leaflet is included in the No. 7 Outfit. It may also be purchased from any Meccano dealer, price 2d., or obtained directly from Meccano Ltd., Binns Road, Liverpool, price 2d., post free.

Model No. 7.8 Meccanograph

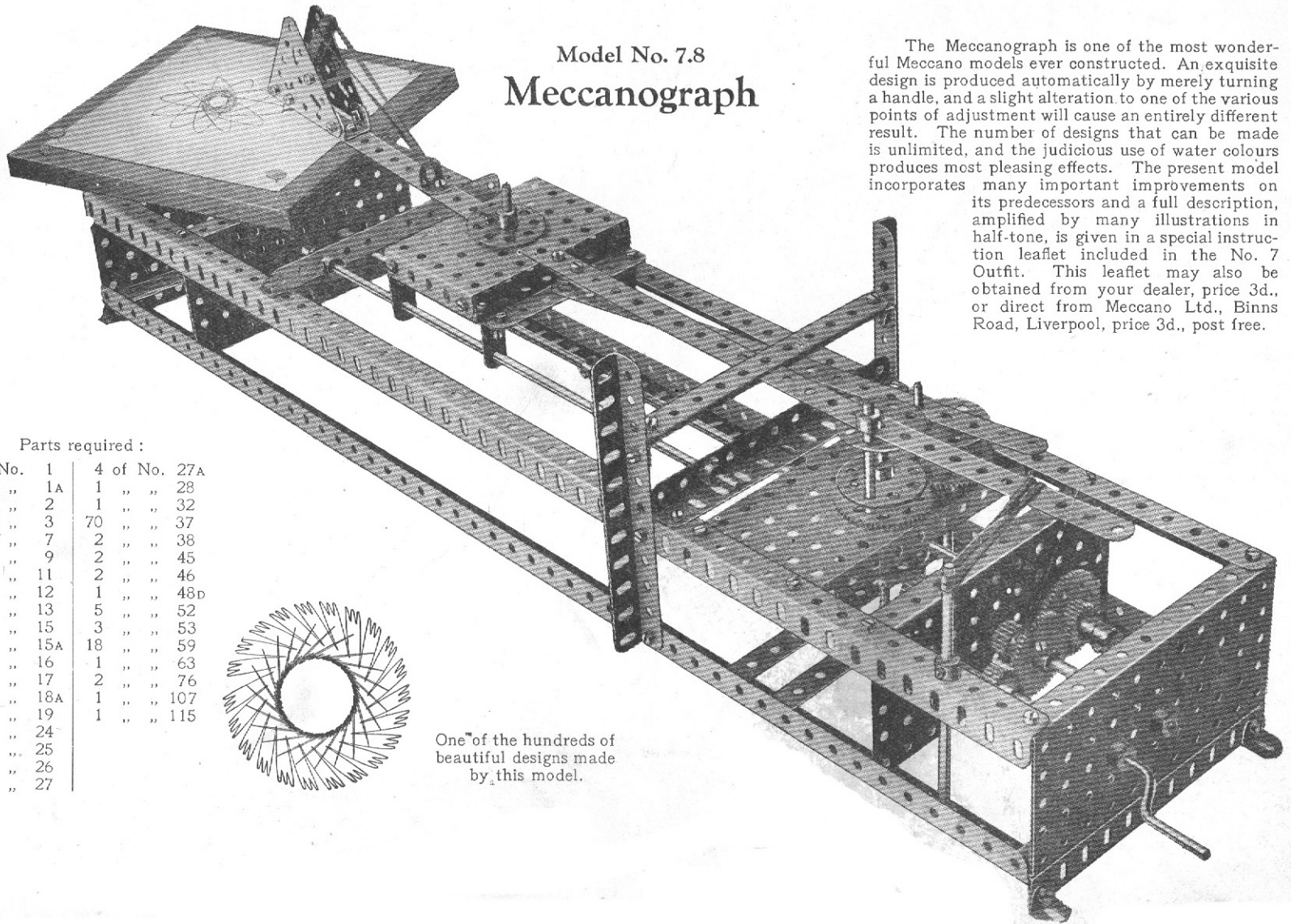
The Meccanograph is one of the most wonderful Meccano models ever constructed. An exquisite design is produced automatically by merely turning a handle, and a slight alteration to one of the various points of adjustment will cause an entirely different result. The number of designs that can be made is unlimited, and the judicious use of water colours produces most pleasing effects. The present model incorporates many important improvements on its predecessors and a full description, amplified by many illustrations in half-tone, is given in a special instruction leaflet included in the No. 7 Outfit. This leaflet may also be obtained from your dealer, price 3d., or direct from Meccano Ltd., Binns Road, Liverpool, price 3d., post free.

Parts required :

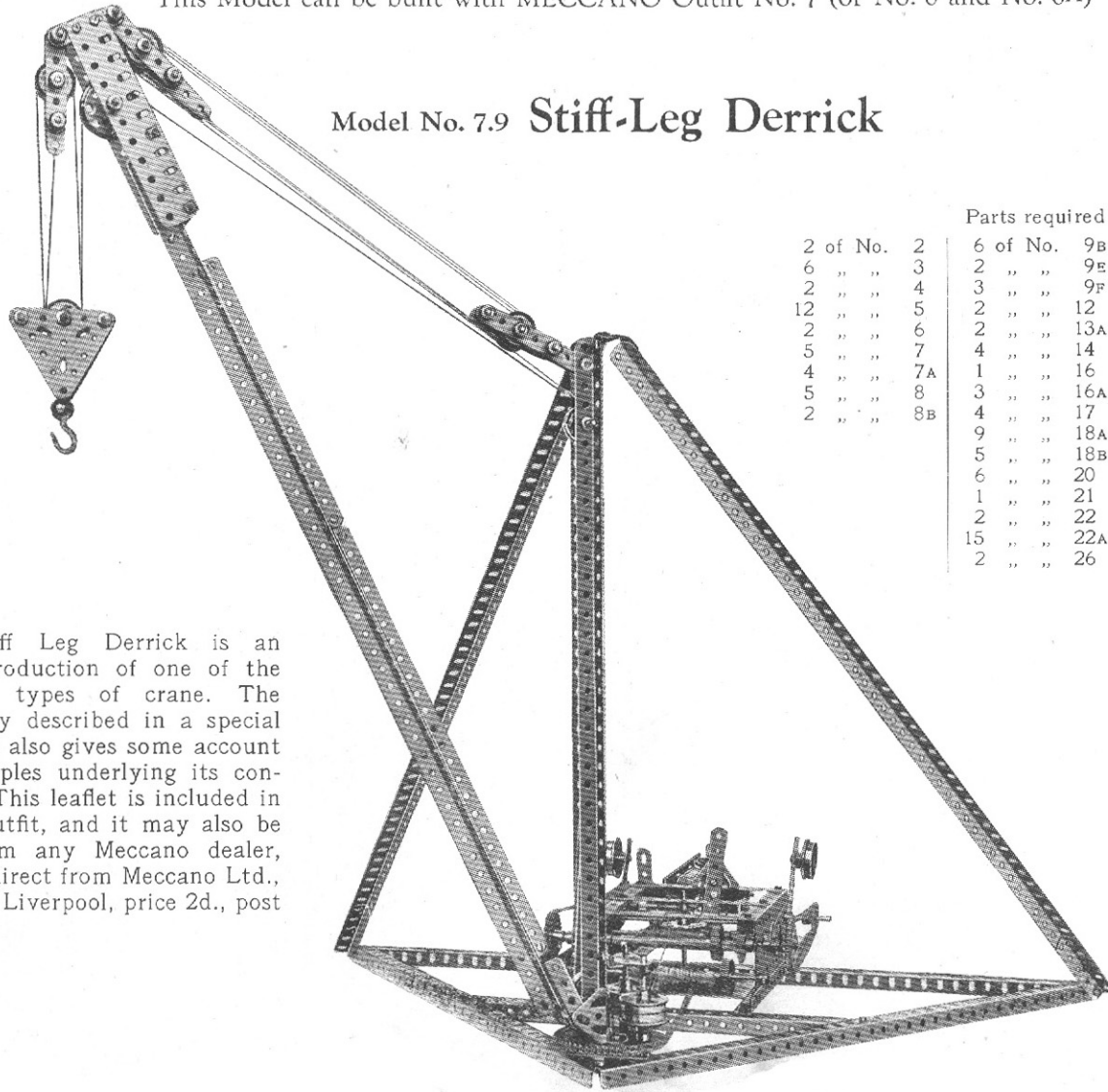
1 of No.	1	4 of No.	27A
2 "	1A	1 "	28
3 "	2	1 "	32
3 "	3	70 "	37
4 "	7	2 "	38
6 "	9	2 "	45
4 "	11	2 "	46
7 "	12	1 "	48D
4 "	13	5 "	52
1 "	15	3 "	53
2 "	15A	18 "	59
2 "	16	1 "	63
2 "	17	2 "	76
1 "	18A	1 "	107
1 "	19	1 "	115
5 "	24		
2 "	25		
2 "	26		
1 "	27		



One of the hundreds of beautiful designs made by this model.



Model No. 7.9 Stiff-Leg Derrick



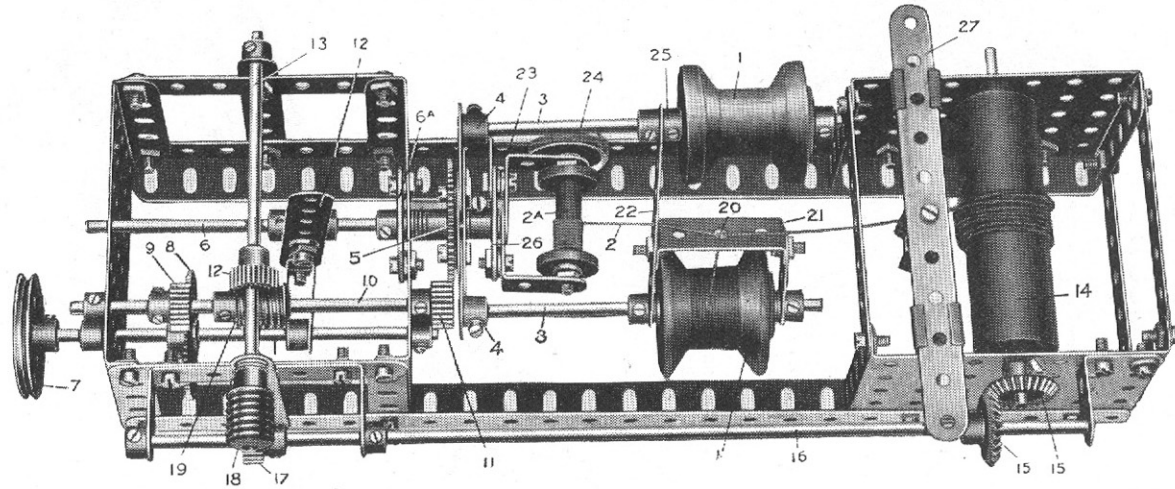
Parts required :

2 of No.	2	6 of No.	9B	3 of No.	27A
6 " "	3	2 " "	9E	2 " "	31
2 " "	4	3 " "	9F	1 " "	32
12 " "	5	2 " "	12	3 " "	35
2 " "	6	2 " "	13A	79 " "	37
5 " "	7	4 " "	14	88 " "	38
4 " "	7A	1 " "	16	2 " "	40
5 " "	8	3 " "	16A	1 " "	48C
2 " "	8B	4 " "	17	2 " "	52
		9 " "	18A	2 " "	52A
		5 " "	18B	1 " "	57B
		6 " "	20	50 " "	59
		1 " "	21	1 " "	62
		2 " "	22	1 " "	63
		15 " "	22A	2 " "	76
		2 " "	26	1 " "	94
				2 " "	95A
				1 " "	95B
				2 " "	96
				2 " "	103
				3 " "	126
				1 " "	133
					Electric Motor

The Stiff Leg Derrick is an accurate reproduction of one of the most useful types of crane. The model is fully described in a special leaflet, which also gives some account of the principles underlying its construction. This leaflet is included in the No. 7 Outfit, and it may also be obtained from any Meccano dealer, price 2d., or direct from Meccano Ltd., Binns Road, Liverpool, price 2d., post free.

Model No. 7.10 Wire Covering Machine

Parts required :			
1 of No.	2	2 of No.	27A
7	3	2	30
2	4	2	32
1	5	41	37
2	6A	17	38
2	8	2	44
1	10	1	46
2	12	1	48
3	12A	2	50
1	13	4	53
3	15	12	59
4	15A	2	62
1	21	1	63
1	22	1	81
2	24	1	106
4	26	1	301

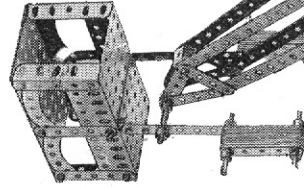


The bobbins 1, carrying the thread by means of which the wire 2 is covered, are carried in a yoke consisting of two Rods 3, secured in Cranks 4, between a $2\frac{1}{2}$ " and $1\frac{1}{2}$ " Strip, and bolted to a 57-toothed Gear Wheel 5, rotatable loosely on a fixed 5" Rod 6. On the Rod 6 is a Bush Wheel 6A, bolted thereto and to the frame. This holds the Rod against rotation. The bobbin 2A is carried in the two 1" Angle Brackets, forming a frame which is bolted to the Bush Wheel 26, the latter being held by its screw fixedly on the Rod 6. The yoke is rotated from the Pulley Wheel 7, a 57-toothed Gear Wheel 8, on the spindle of which drives a $\frac{1}{2}$ " Pinion 9, on an upper 4" Rod 10, another $\frac{1}{2}$ " Pinion 11, on the end of which engages and drives the Gear Wheel 5; this rotates the yoke. The Gear 8 is caused to engage or disengage with the Pinion 9 by a clutch mechanism operated by the handle 12. As the yoke rotates, the thread from the bobbins is wound closely round the wire 2, and in order to ensure an even wrapping of the thread on the wire, the take-up roller 14, is provided, on to which the wire as it is covered is wound. The take-up roller is driven with a very slow movement by Bevel Pinions 15, from a side Rod 16, a $\frac{1}{2}$ " Pinion 17 on which is driven by a Worm 18, on the Rod 13. Consequently, the rotary movement of the Rod 10, drives the bobbin yoke and also operates the Worm 19 and engages the Pinion 12. The Worm 18, engaging the Pinion 17, in turn drives the take-up Roller 14, bringing the uncovered wire 2 slowly past a perforation 20 in the guide Strip 21, formed of $1\frac{1}{2}$ " by $\frac{1}{2}$ " Double Angle Strip and carried from the yoke arm 22.

In order to prevent the wire 2 unwinding too freely from its bobbin 2A, a brake is provided, consisting of a cord 23, passing round a Pulley 24, on the spindle of the bobbin 2A, and connected to a Flat Bracket bolted on the Bush Wheel 26.

It will be noticed that a Collar 25 is placed on one side of the yoke Strip 22, which has the effect of setting one of the bobbins slightly to the rear of the other, and the effect of this is to give two windings round the wire, one over the other. The thread on the bobbins may be of different colours, which would give a variegated effect to the covering. In order to cause the covered wire to be wound evenly on the take-up Roller 14, a distributor is provided, consisting of a Strip 27, beneath which is bolted a Double Bracket through which the covered wire passes. By moving the Strip 27 from one side to the other, the wire winds evenly on the Roller 14.

Model No. 7.11 Aeroscope

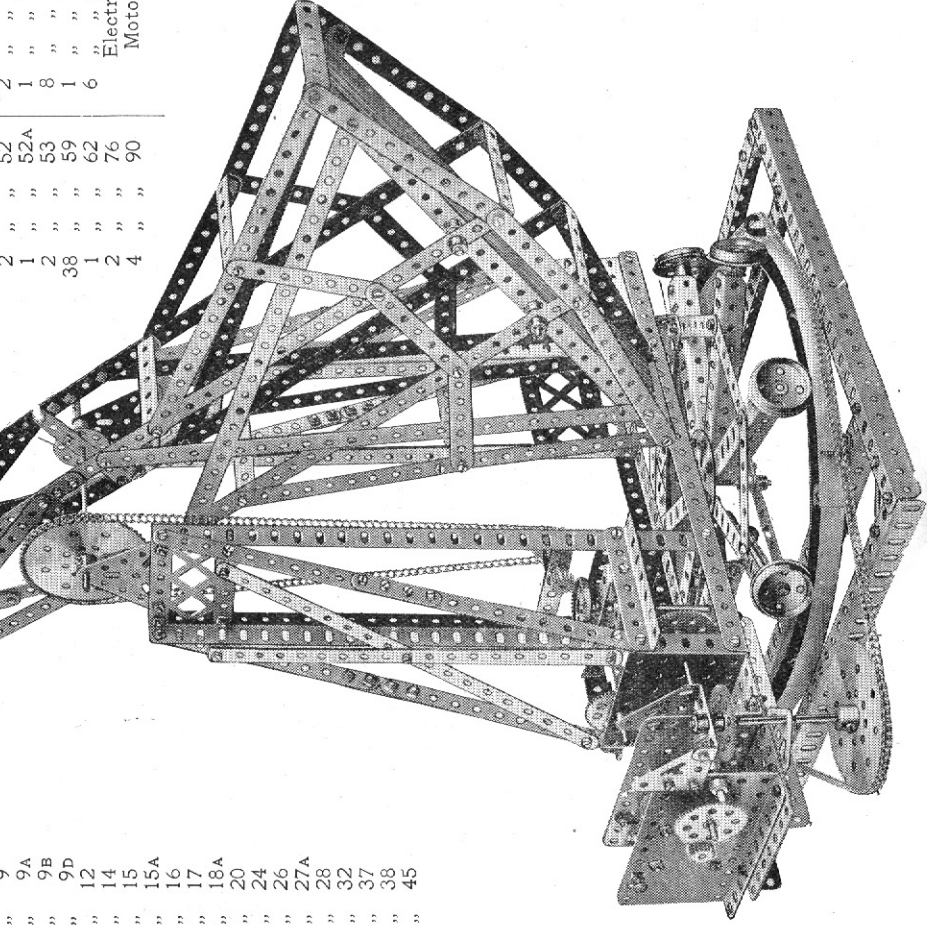


The original aeroscope was a machine used by French armies in wartime for surveying the surrounding country and watching the movements of the enemy. The long arm was lowered to allow a passenger to enter the observation car, which was then swung upward and raised, lowered, or rotated in accordance with the instructions of the observer. With the advent of observation balloons, the aeroscope became obsolete, but enterprising showmen have since made good use of similar structures in fairs, etc. It will readily be imagined that the sensations of being swung up and down, whirled round and rocked about in such a machine rank with the "pleasures" of the giant swing boat and the switchback railway.

Full instructions for building the Meccano model, together with sectional illustrations that make every detail clear are contained in a special leaflet included in the Outfit. This leaflet may also be obtained from any Meccano dealer, price 2d., or direct from Meccano Ltd., Binns Road, Liverpool, price 2d., post free.

Parts required:	
48 of No.	1
4	1A
1	1B
34	2
20	3
48	5
8	6
12	8
2	9
8	9A
7	9B
4	9D
16	12
1	14
1	15
3	15A
13	16
5	17
1	18A
8	20
2	24
3	26
6	27A
1	28
2	32
15	37
1	38
	45

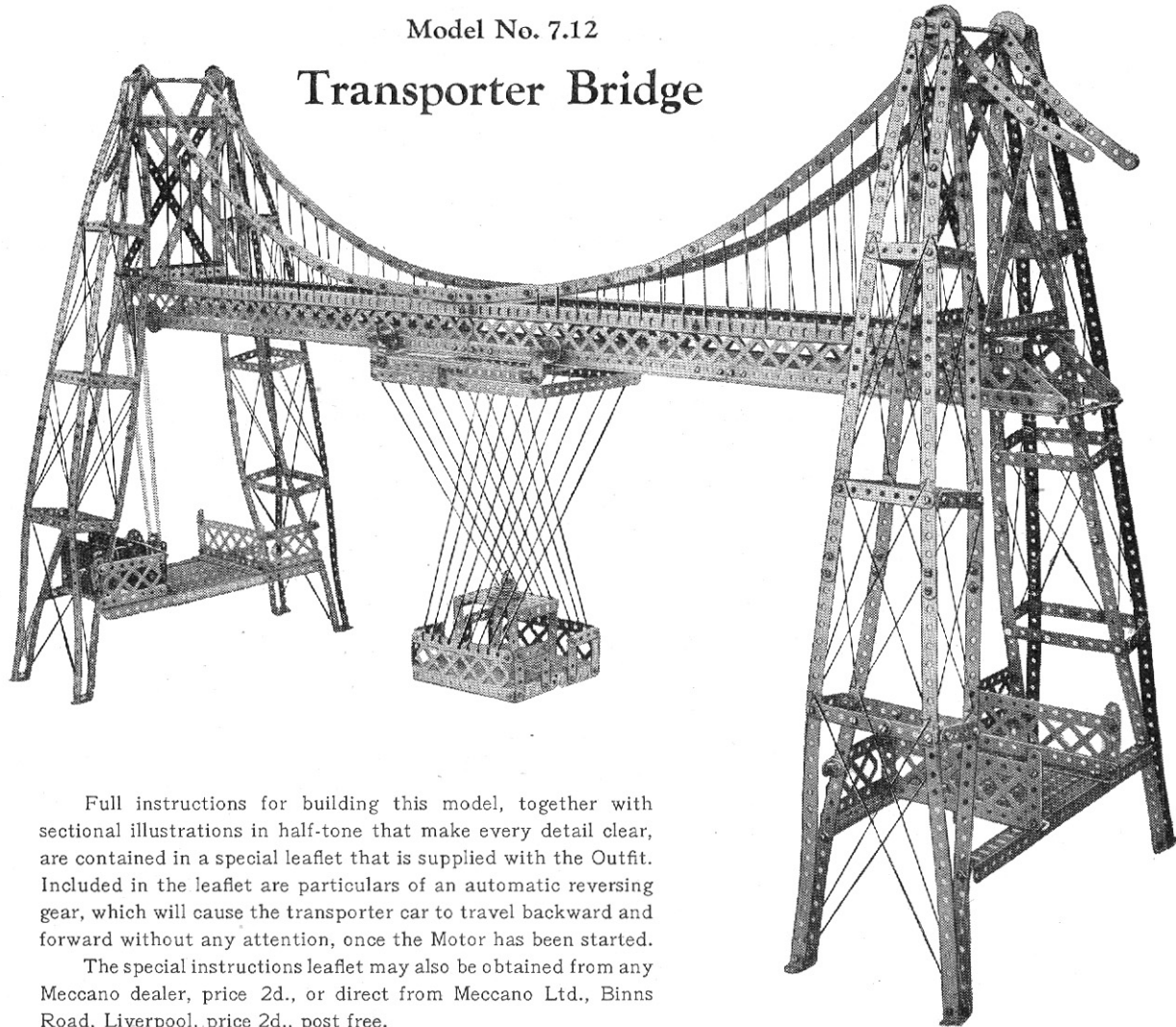
Parts required (continued):	
1 of No.	46
2	48
18	48A
1	48B
2	52
1	52A
2	53
38	59
1	62
2	76
4	90
	2 of No.
	94
	96
	97
	103
	109
	119
	126A
	133
	Electric
	Motor



Model No. 7.12

Transporter Bridge

- Parts
required :
- 32 of No. 1
 - 52 " " 2
 - 8 " " 3
 - 32 " " 4
 - 120 " " 5
 - 32 " " 6
 - 4 " " 7
 - 20 " " 8
 - 8 " " 9
 - 4 " " 10
 - 10 " " 11
 - 89 " " 12
 - 3 " " 14
 - 2 " " 15A
 - 1 " " 17
 - 4 " " 18A
 - 4 " " 20
 - 1 " " 21
 - 5 " " 22
 - 1 " " 26
 - 1 " " 27A
 - 507 " " 37
 - 10 " " 48A
 - 6 " " 52
 - 7 " " 53
 - 15 " " 59
 - 10 " " 94
 - 4 " " 96
 - 3 " " 97
 - 8 " " 99
 - 6 " " 100
- Electric Motor



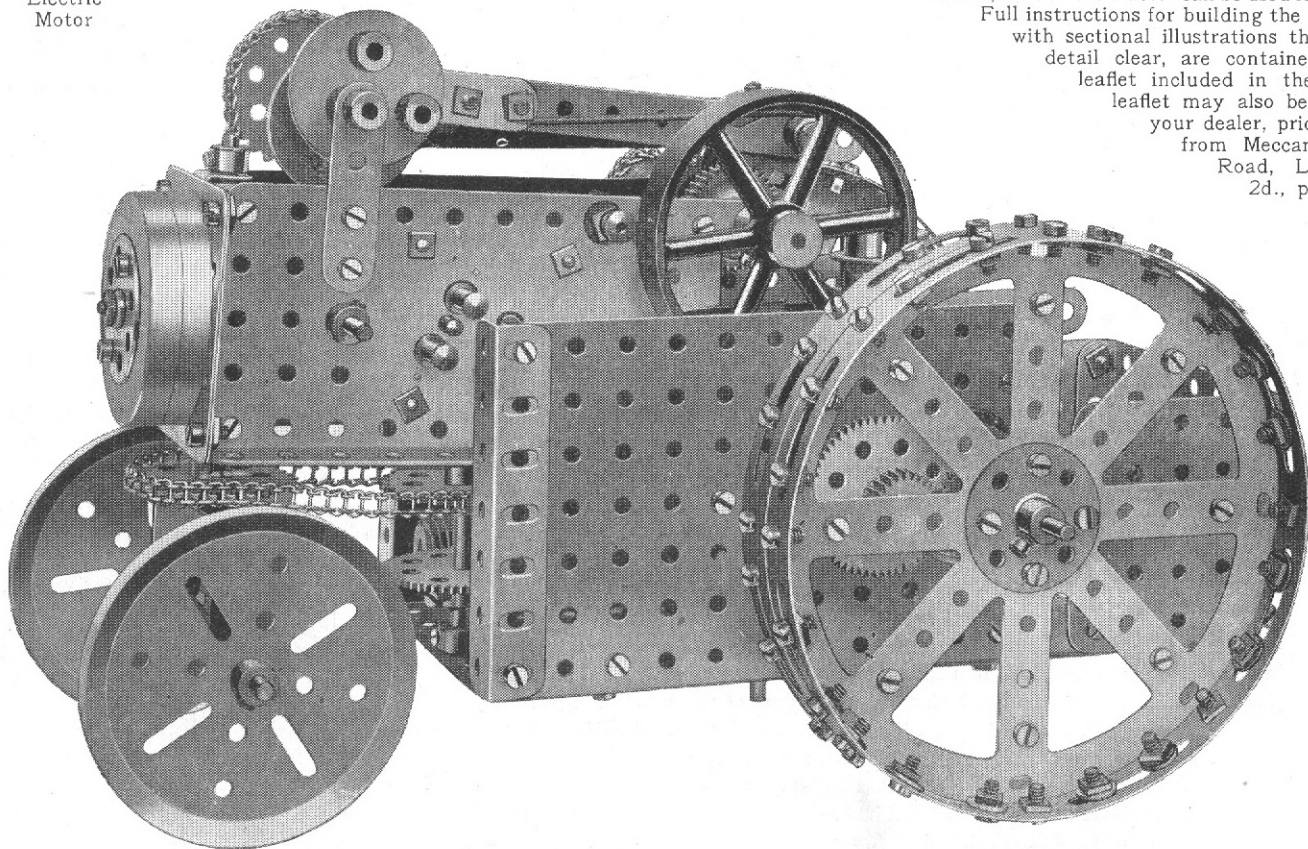
Full instructions for building this model, together with sectional illustrations in half-tone that make every detail clear, are contained in a special leaflet that is supplied with the Outfit. Included in the leaflet are particulars of an automatic reversing gear, which will cause the transporter car to travel backward and forward without any attention, once the Motor has been started.

The special instructions leaflet may also be obtained from any Meccano dealer, price 2d., or direct from Meccano Ltd., Binns Road, Liverpool, price 2d., post free.

Model No. 7.13 Tractor

Parts required :

3 of No. 2A	2 of No. 137
2 " " 6	2 " " 147A
4 " " 6A	2 " " 147B
2 " " 8B	2 " " 148
2 " " 9B	Electric Motor
3 " " 9C	
1 " " 11	
3 " " 12A	
1 " " 13A	
1 " " 14	
3 " " 15	
1 " " 15A	
3 " " 16	
2 " " 16B	
1 " " 17	
2 " " 19B	
2 " " 21	
5 " " 24	
2 " " 25	
6 " " 26	
2 " " 27	
4 " " 27A	
2 " " 30	
1 " " 32	
180 " " 37	
60 " " 38	
1 " " 47	
1 " " 48	
2 " " 48D	
1 " " 50	
4 " " 52A	
2 " " 53	
20 " " 59	
1 " " 62	
2 " " 63	
4 " " 72	
18 " " 94	
4 " " 95A	
2 " " 96A	
2 " " 103H	
2 " " 115	
4 " " 118	
2 " " 130	
1 " " 132	



This interesting model works entirely under its own power, the 4-volt Electric Motor being driven, if desired, from an Accumulator mounted in the rear of the tractor. The drive transmission is designed on novel lines and the model is remarkably powerful. Meccano boys can build trailers, etc., to attach to the model, so that the tractor can be used for hauling loads.

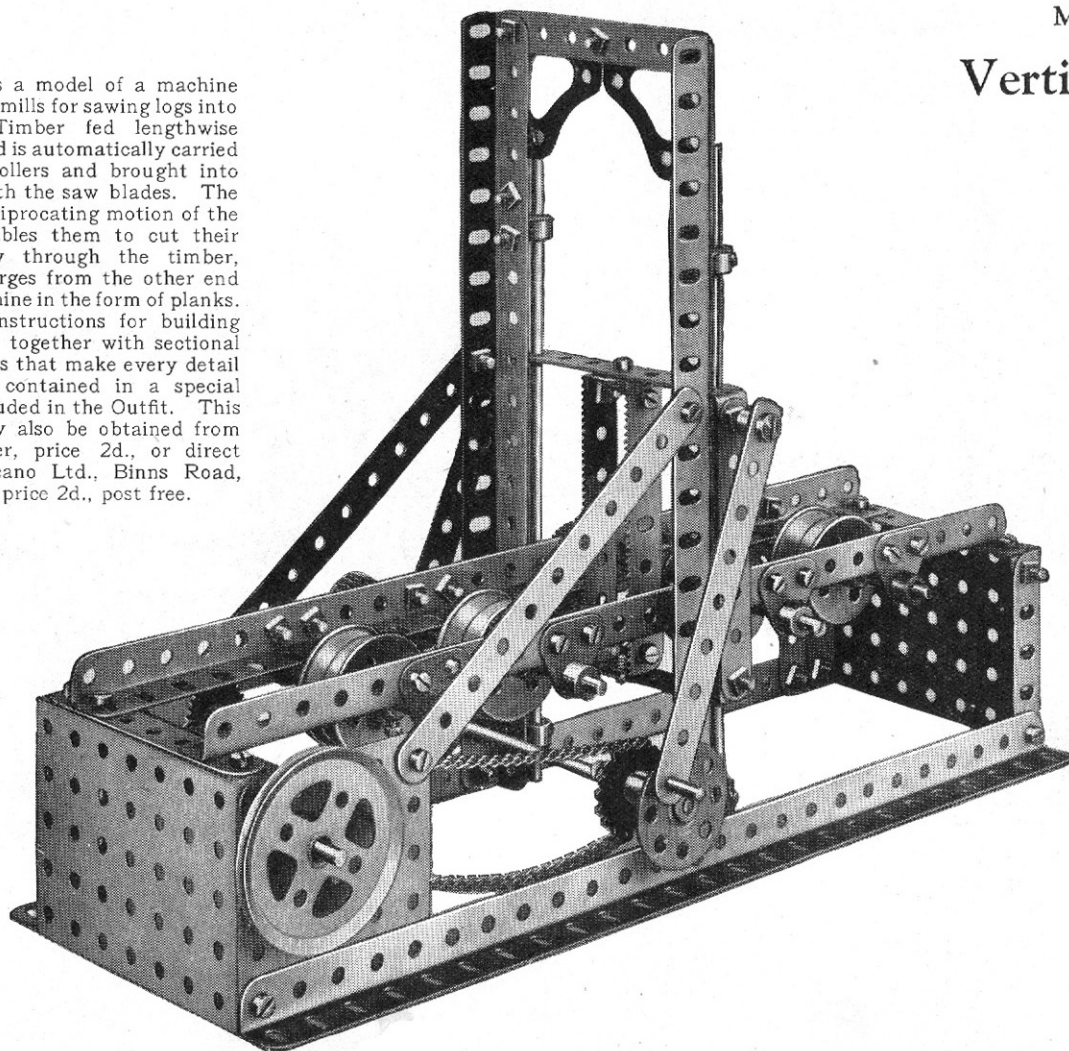
Full instructions for building the model, together with sectional illustrations that make every detail clear, are contained in a special leaflet included in the Outfit. This leaflet may also be obtained from your dealer, price 2d, or direct from Meccano Ltd., Binns Road, Liverpool, price 2d., post free.

Model No. 7.14

Vertical Log Saw

This is a model of a machine used in sawmills for sawing logs into planks. Timber fed lengthwise into one end is automatically carried along on rollers and brought into contact with the saw blades. The vertical reciprocating motion of the blades enables them to cut their way easily through the timber, which emerges from the other end of the machine in the form of planks.

Full instructions for building the model, together with sectional illustrations that make every detail clear, are contained in a special leaflet included in the Outfit. This leaflet may also be obtained from your dealer, price 2d., or direct from Meccano Ltd., Binns Road, Liverpool, price 2d., post free.



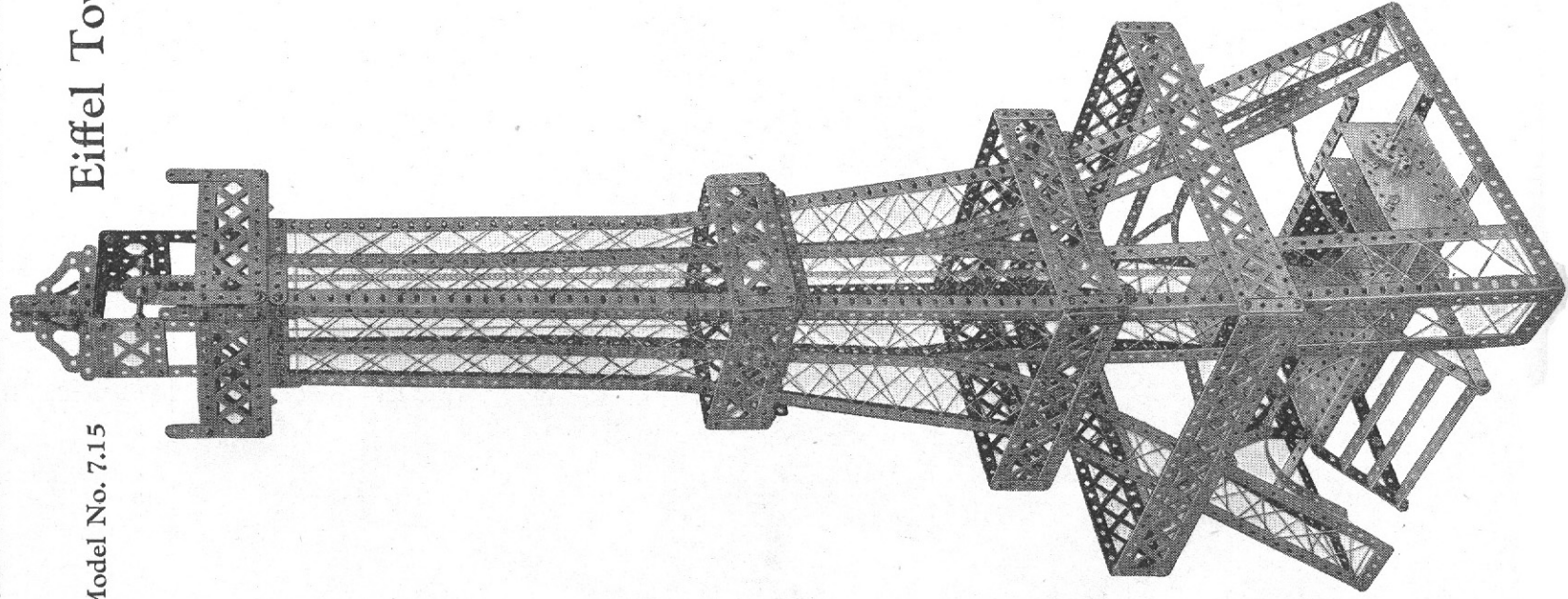
Parts	
required :	
2 of No.	2
2 "	2A
5 "	3
1 "	6
4 "	8
2 "	8A
12 "	12
2 "	12A
1 "	13
2 "	13A
1 "	15
4 "	15A
2 "	16
8 "	20
1 "	20A
2 "	24
2 "	25
1 "	26
1 "	27A
2 "	30
2 "	32
59 "	37
6 "	37A
2 "	48B
2 "	53
17 "	59
2 "	72
10 "	77
12 "	94
2 "	96
2 "	108
2 "	110
2 "	115
2 "	147B

Eiffel Tower

Model No. 7.15

Parts required :	
22 of No.	1
24 " "	2
8 " "	3
16 " "	4
20 " "	5
24 " "	6
18 " "	8
16 " "	9
2 " "	9 ^D
4 " "	10
72 " "	12
4 " "	12A
1 " "	13A
2 " "	14
1 " "	16
1 " "	18 ^B
1 " "	26
2 " "	27A

Parts required :	
1 of No.	32
337 " "	37
6 " "	40
1 " "	47
6 " "	48A
1 " "	48B
3 " "	48D
3 " "	52
4 " "	53
8 " "	59
2 " "	72
3 " "	94
2 " "	96
4 " "	98
4 " "	99
16 " "	100
4 " "	108
Electric Motor	



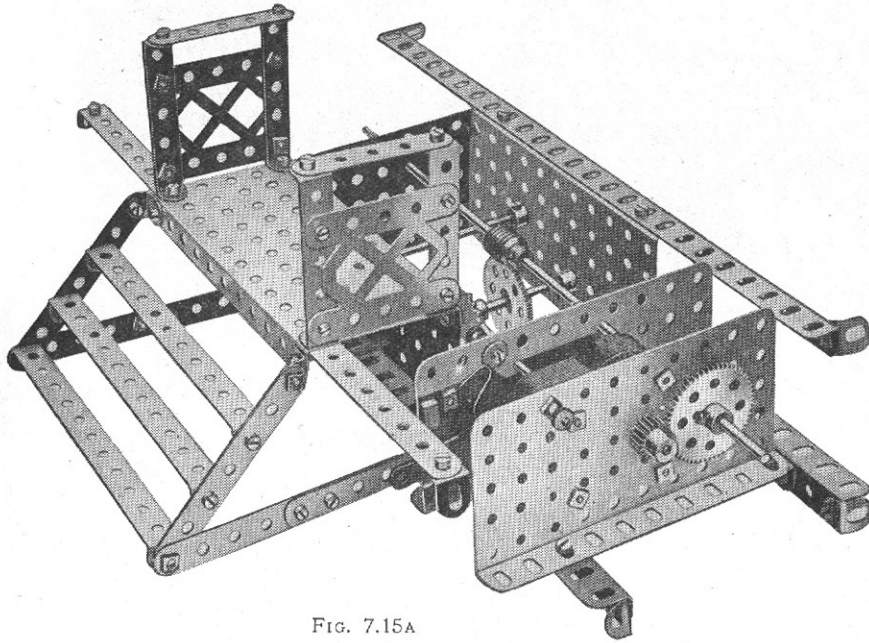
Model No. 7.15 **Eiffel Tower** (*continued*)

FIG. 7.15A

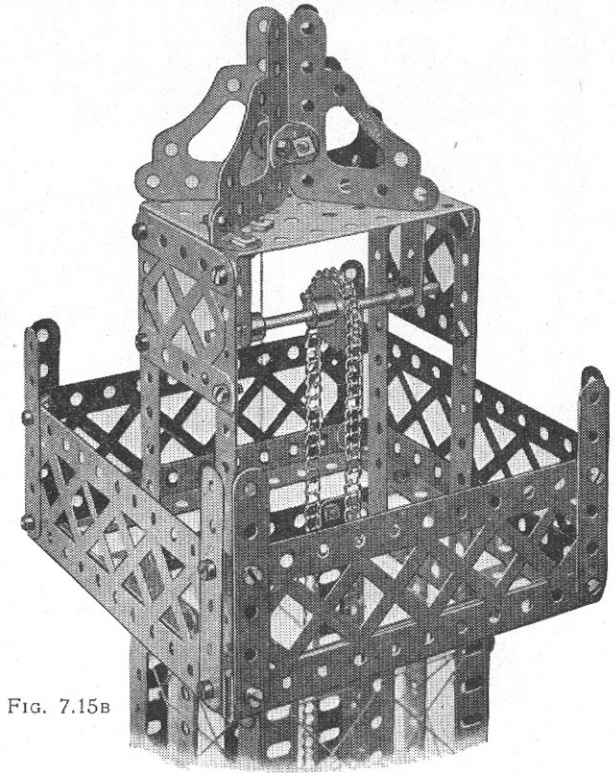


FIG. 7.15B

The construction of the tower may be followed from the illustrations. The lift carriage is built up from two $3\frac{1}{2}$ " by $2\frac{1}{2}$ " Flanged Plates and two $2\frac{1}{2}$ " by $2\frac{1}{2}$ " Flat Plates and runs on a length of cord which acts as a guide line. This cord is secured to the top of the tower and to a transverse Rod in the base, and passes through holes in the Plates of the lift. The operation of the lift is affected by means of a length of Sprocket Chain passing round the 1" Sprocket Wheel situated in the top of the tower, Fig. 7.15B, and round a similar wheel in the base, Fig. 7.15A. The ends of the chain are secured to the lift. The lower Sprocket Wheel is operated through worm gearing from the Electric Motor, Fig. 7.15A

Model No. 7.16 Locomotive and Tender (4-4-0)

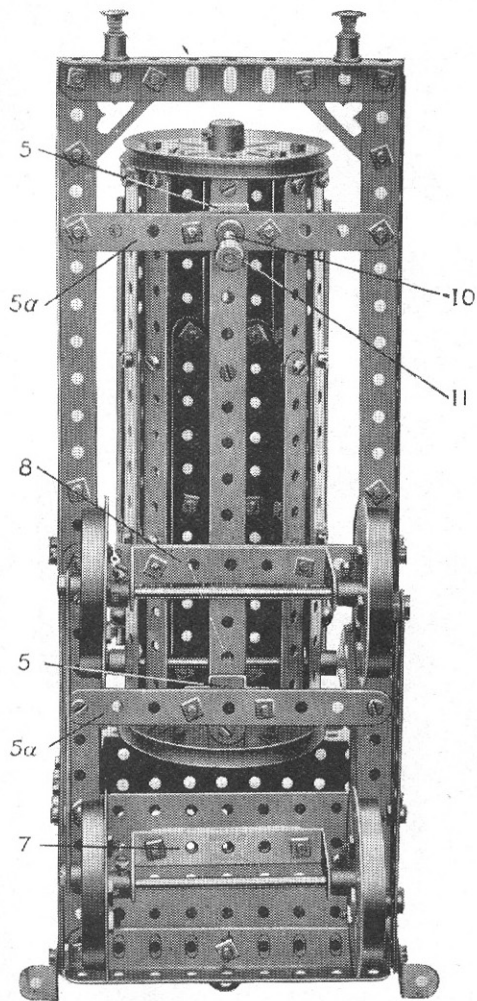
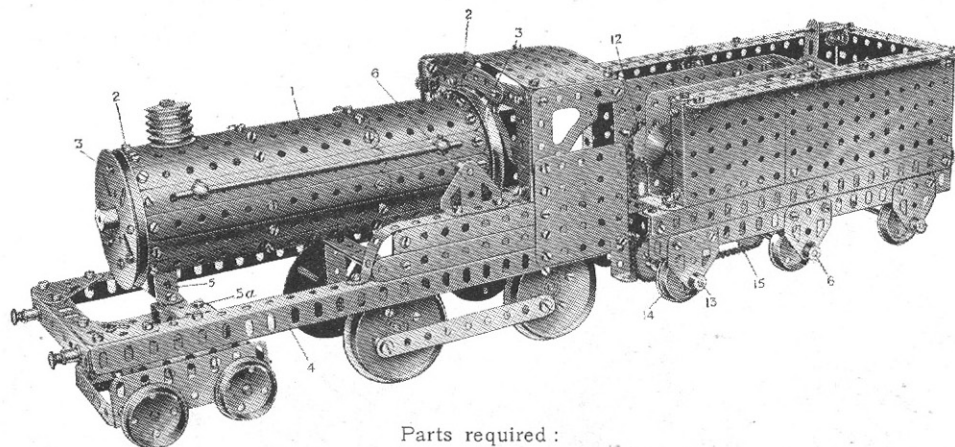


FIG. 7.16A



Parts required :

37 of No. 2	4 of No. 9D	1 of No. 18A	230 of No. 37	2 of No. 53	4 of No. 96	6 of No. 126A
10 " " 2A	1 " " 10	2 " " 18B	12 " " 38	3 " " 53A	2 " " 103A	1 " " 128
2 " " 3	31 " " 12	2 " " 19B	3 " " 45	16 " " 59	3 " " 103D	2 " " 133
2 " " 5	4 " " 12B	10 " " 20	2 " " 47	1 " " 63B	4 " " 108	4 " " 136
1 " " 6A	2 " " 14	5 " " 22A	1 " " 48	3 " " 72	4 " " 109	4 " " 137
2 " " 8	3 " " 15	1 " " 25	2 " " 48A	1 " " 82	1 " " 115	4 " " 147B
2 " " 8A	4 " " 16	1 " " 27	2 " " 52	1 " " 90	4 " " 120A	
4 " " 9A	2 " " 16A	1 " " 27A	1 " " 52A	1 " " 94	2 " " 126	Electric Motor

The boiler shell is built up of a series of $5\frac{1}{2}$ " Strips 1 overlapped six holes and bolted at 2 to two $5\frac{1}{2}$ " Strips bent to the curvature of the two 3" Pulleys 3 and secured by Angle Brackets. The boiler is supported from the frame 4 by two Double Bent Strips 5 bolted to $4\frac{1}{2}$ " Strips 5a, Fig. 7.16A. Two Trunnions 6, one on each side of the boiler, are bolted to the frame and a $3\frac{1}{2}$ " Rod passed through the boiler and secured at each side by a Collar and Set Screw, the ends resting in the top hole of the Trunnions to steady the boiler. The floor of the cab is formed by bolting a $4\frac{1}{2}$ " \times $2\frac{1}{2}$ " Flat Plate to the frame, and to the underside of this is bolted a $2\frac{1}{2}$ " \times $1\frac{1}{2}$ " Double Angle Strip 7, which forms the bearings for the axle of the rear driving wheels; two $2\frac{1}{2}$ " Strips are placed between this Strip and the footplate to allow proper clearance for the wheels. A similar Double Angle Strip 8 is also bolted to a cross Strip and spaced away from the engine frame by a Washer on each Bolt. The bogie, Fig. 7.16B, is connected pivotally to the frame by means of a Double Bent Strip 9, into the hole of which is entered the end of a 1" Rod

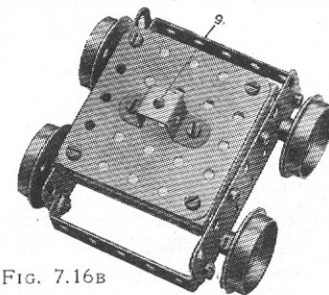


FIG. 7.16B

Model No. 7.16 Locomotive and Tender
(continued)

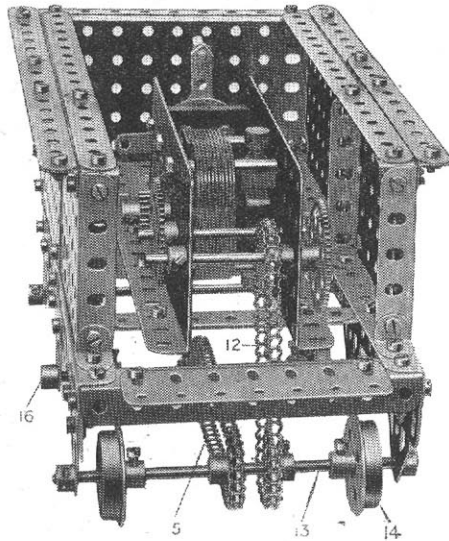
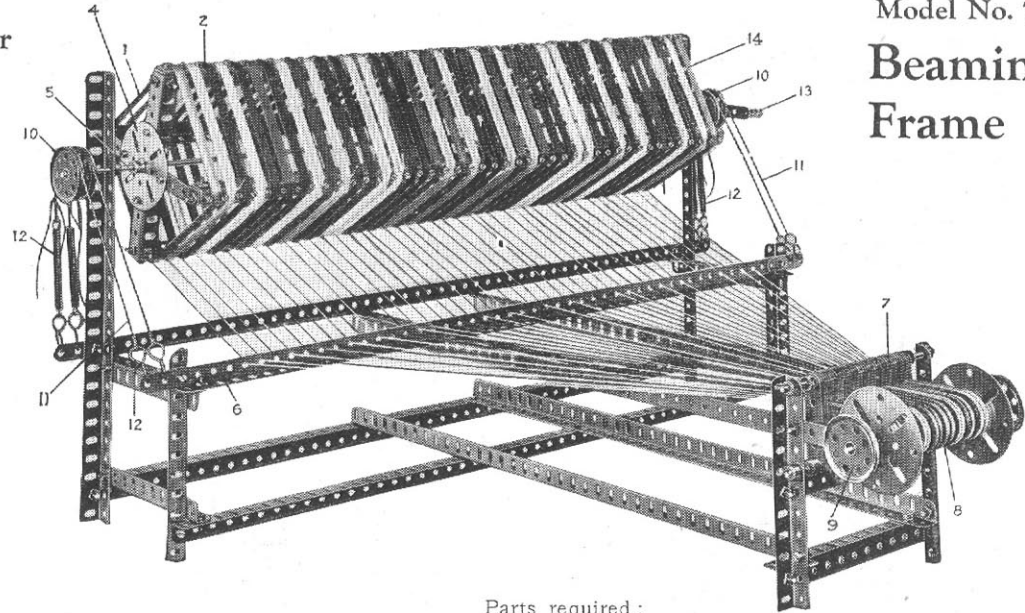


FIG. 7.16c

10, Fig. 7.16A, and retained by two Collars 11 on the end of the Rod. The loco is propelled from the Motor in the tender, Fig. 7.16c, the motor driving by the Sprocket Chain 12 (containing 52 links) the 5" Axle Rod 13 carrying the Flanged Wheels 14. The Rod 13 is coupled by another chain 15 (containing 59 links) to the middle Axle Rod 16, thus driving four of the travelling wheels. The four Sprocket Wheels are 1" in diameter. The accumulator for supplying the current is housed in the tender behind the motor.

Model No. 7.17
Beaming
Frame



Parts required :

2 of No. 1	4 of No. 7	8 of No. 12	253 of No. 37	10 of No. 59	1 of No. 147A
4 " " 2	2 " " 7A	2 " " 13	88 " " 38	1 " " 63	1 " " 147B
44 " " 5	12 " " 8	3 " " 14	4 " " 43	1 " " 103	1 " " 148
4 " " 6	10 " " 9	6 " " 21	8 " " 57	4 " " 109	

The frame upon which the warp threads are wound is built up of 12½" Angle Girders 2, overlapped seven holes and bolted to a 5½" Girder 1 and 5½" Strip crossed and connected to Face Plates 4 on the 11½" Rod 5.

Inside the frame, two 5½" Angle Girders are bolted nine holes from each end to form the inner bearings for the Rods 5. Another 5½" Girder is bolted crosswise to these in the centre to form a stay.

The warp threads are first wound upon the warp-frame, and pass through the holes in a 24½" Angle Girder 6, and, converging together, pass between the 2½" Strips 7 forming the reed, and so on to the beam 8. On the far side of the beam Rod is a ½" Pinion engaged by a Pawl (not shown on the photograph) which prevents backward rotation of the beam as the warp threads are wound thereon by turning the 1½" Pulley wheels 9.

A brake mechanism for tensioning the frame 2 is provided by securing two 1" Pulley Wheels 10 at each end of the frame Rod 5, Cords 11, secured by hooks passing over the Pulleys 10 and being kept taut by the Springs 12.

A handle 13 is provided on the Rod 5 by means of which the warp threads 14 are originally wound on the frame.

Model No. 7.18 Boat-Lowering Gear

Parts required:

10 of No.	1A	2 of No.	12	6 of No.	23	2 of No.	48B	3 of No.	109
2 "	2A	1 "	12A	4 "	26	5 "	52A	1 "	115
6 "	3	2 "	12B	2 "	27A	6 "	53	2 "	126
7 "	5	1 "	13	2 "	31	2 "	57	2 "	126A
8 "	6	2 "	13A	2 "	32	13 "	59	4 "	129
2 "	7A	1 "	15	142 "	37	2 "	62	4 "	147B
2 "	9	3 "	16	14 "	38	2 "	63		
2 "	9D	2 "	16A	1 "	40	8 "	90		
3 "	11	1 "	18A	5 "	48A	4 "	102		

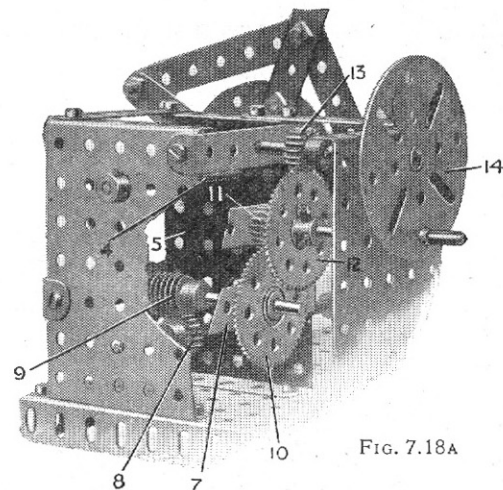
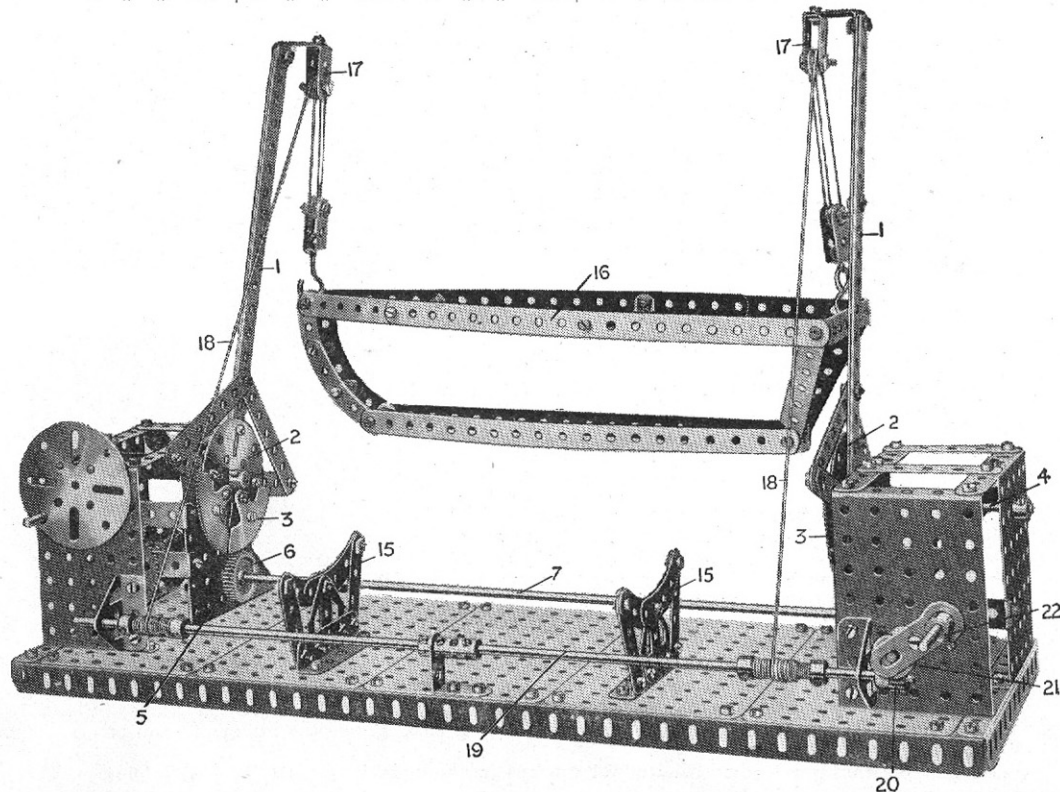


FIG. 7.18A

The davit arms 1 are connected to Face Plates 2 to which are bolted two Rack Segments 3 forming the usual geared quadrants. The davit arms are secured to Rods 4 journalled in the Face Plates 5, the Rack Segments 3 being engaged and driven by 1" Gear Wheels 6 on an Axle Rod 7. This Rod 7 carries a Pinion 8, Fig. 7.18A, driven by a worm 9 and a Rod, to which is secured a 1½" Gear Wheel 10. This is driven by a ½" Pinion 11 on a Rod to which is also secured a 1½" Gear Wheel 12 driven by a ½" Pinion 13 rotated by a hand wheel 14 formed by a face plate 14. As the hand wheel is rotated, the davit arms are raised outward when launching the boat 16 or inward when it is desired to deposit the boat on the chocks 15.

The boat 16 is raised or lowered from the blocks 17 by the ropes 18 which wind on to a Rod 19. On this Rod is roped a ½" Pinion 20 engaged by a Worm 21 which is rotated by the Crank Handle 22 formed of two Cranks bolted together, and in this way the boat may be lowered over the ship's side.

This Model can be built with MECCANO Outfit No. 7 (or No. 6 and No. 6A)

Model No. 7.19

Grandfather Clock

Parts required for Clockwork Movement:

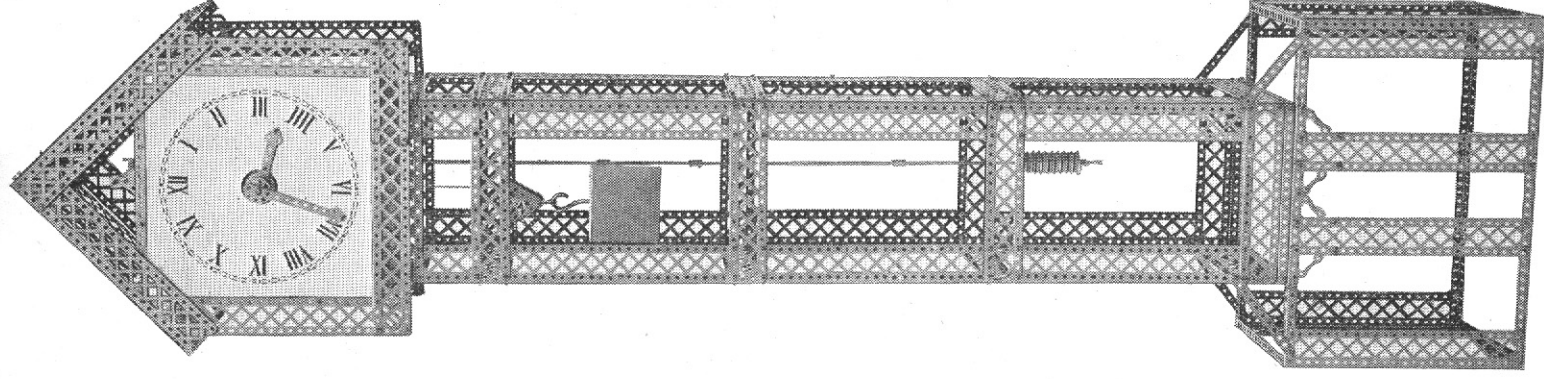
1 of No. 1	2 of No. 18B	2 of No. 72
15 "	10 "	2 "
" "	" 21	" 76
2 "	" 24	" 77
1 "	" 25	" 90
1 "	" 26	" 94
2 "	" 27	" 95A
4 "	" 27A	" 106
" "	" 31	" 109
6 "	" 37	" 111
3 "	" 38	" 125
4 "	" 43	" 126
4 "	" 45	" 126A
1 "	" 48D	" 128
2 "	" 57	" 141
3 "	" 59	" 147
9 "	" 62	1 Clock Face
1 "	" 63	1 18lb. Weight
1 "	" 63B	2" Flat Spring
8 "	" 70	(not included in Outfit)
2 "		

Parts required for Clock Case and Frame:

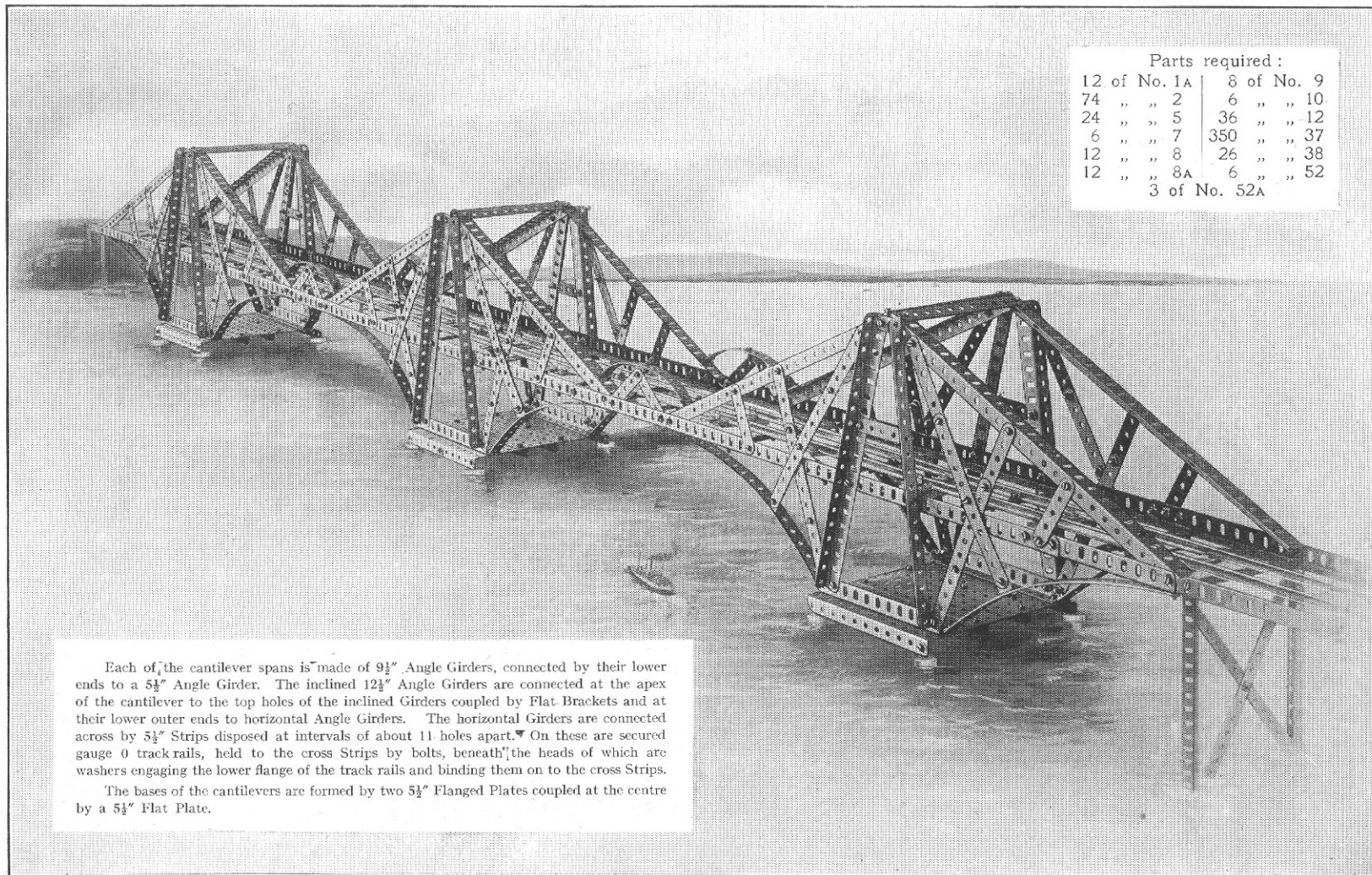
4 of No. 2	12 of No. 8A	4 of No. 97
2 "	4 "	8 "
8 "	" 12	51 "
4 "	7A 337	" 99
14 "	" 8	24 "
" "	" "	" 99A
" "	" "	4 "
" "	" "	" 108

This Meccano model of a Grandfather Clock stands over 6 ft. in height and keeps perfect time. With the exception of an 18 lb. weight, the dial plate and a small piece of flat spring (about 2" in length), the model is made entirely from Meccano parts. It would take up too much space to describe the construction of the Clock in detail in this Manual and we have therefore prepared a special leaflet in which the model is fully described and illustrated. The leaflet is included in the No. 7 Outfit. It may also be purchased either from any Meccano dealer or from Meccano Ltd., Binns Road, Liverpool, price 3d. (post free).

It should be noted that in constructing the Clock frame exactly as shown in the illustration, 33, 12½" and 22 9½" Braced Girders are required in addition to the No. 7 Outfit. These Girders are only ornamental however, and they can be dispensed with if necessary.



Model No. 7.20 Forth Bridge



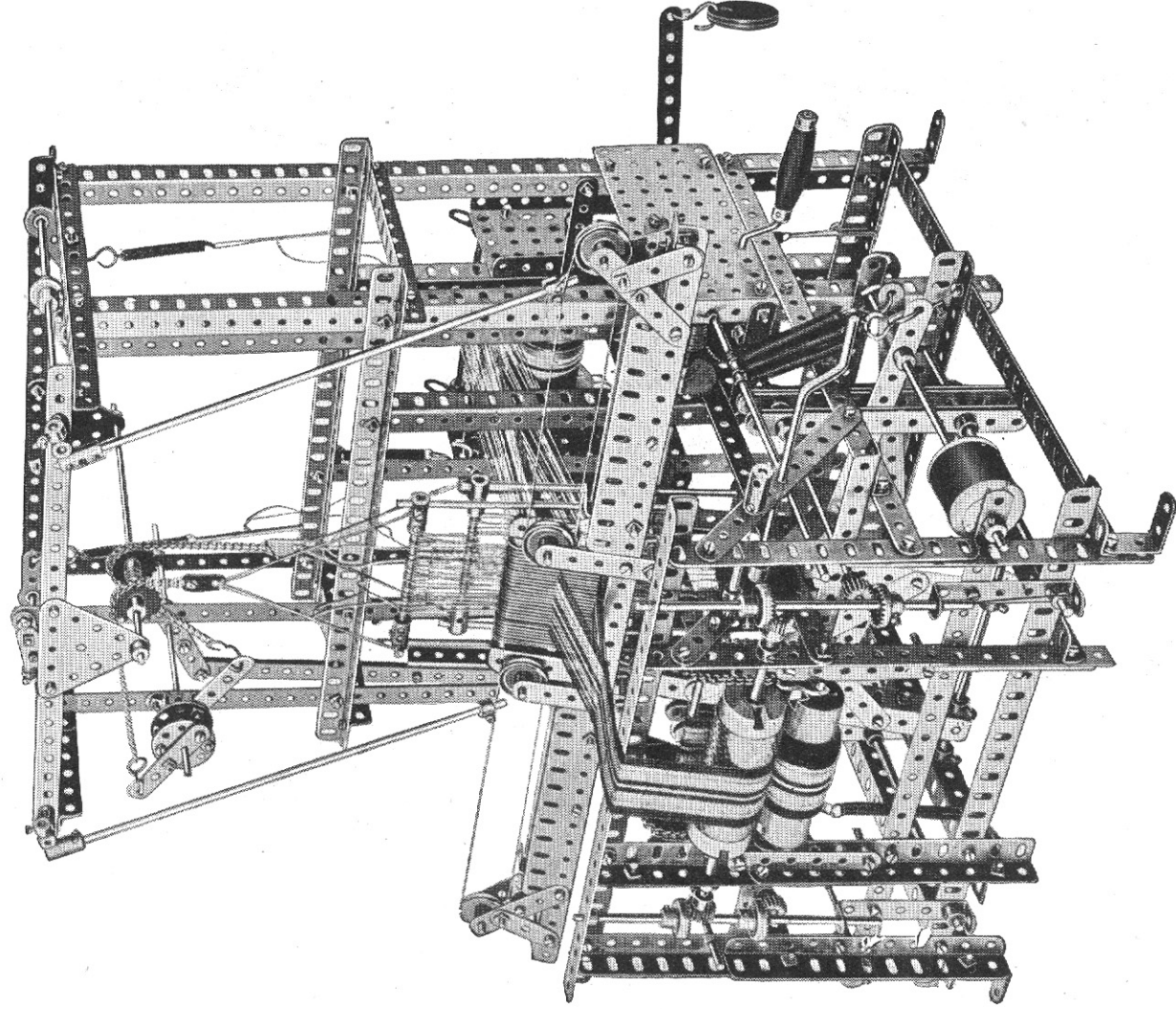
Parts required :			
12 of No. 1A	8 of No. 9		
74 " " 2	6 " " 10		
24 " " 5	36 " " 12		
6 " " 7	350 " " 37		
12 " " 8	26 " " 38		
12 " " 8A	6 " " 52		
	3 of No. 52A		

Each of the cantilever spans is made of $9\frac{1}{2}$ " Angle Girders, connected by their lower ends to a $5\frac{1}{2}$ " Angle Girder. The inclined $12\frac{1}{2}$ " Angle Girders are connected at the apex of the cantilever to the top holes of the inclined Girders coupled by Flat Brackets and at their lower outer ends to horizontal Angle Girders. The horizontal Girders are connected across by $5\frac{1}{2}$ " Strips disposed at intervals of about 11 holes apart. On these are secured gauge 0 track rails, held to the cross Strips by bolts, beneath the heads of which are washers engaging the lower flange of the track rails and binding them on to the cross Strips.

The bases of the cantilevers are formed by two $5\frac{1}{2}$ " Flanged Plates coupled at the centre by a $5\frac{1}{2}$ " Flat Plate.

This Model can be built with MECCANO Outfit No. 7 (or No. 6 and No. 6A)

Model No. 7.21 Loom



The Meccano Loom is one of the most remarkable and interesting models that can be made with Meccano. It is absolutely automatic and beautiful material may be woven by simply turning the handle. It is a somewhat complicated model, requiring careful construction and accurate adjustment and as it is impossible to do justice to it in this book, we have compiled a special sheet of instructions in which it is illustrated and described in detail. This leaflet is included in the Outfit. It may also be purchased from your local Meccano dealer or direct from Meccano Limited, Binns Road, Liverpool. Price 3d. (post free).

Model No. 7.22 Reaping Machine

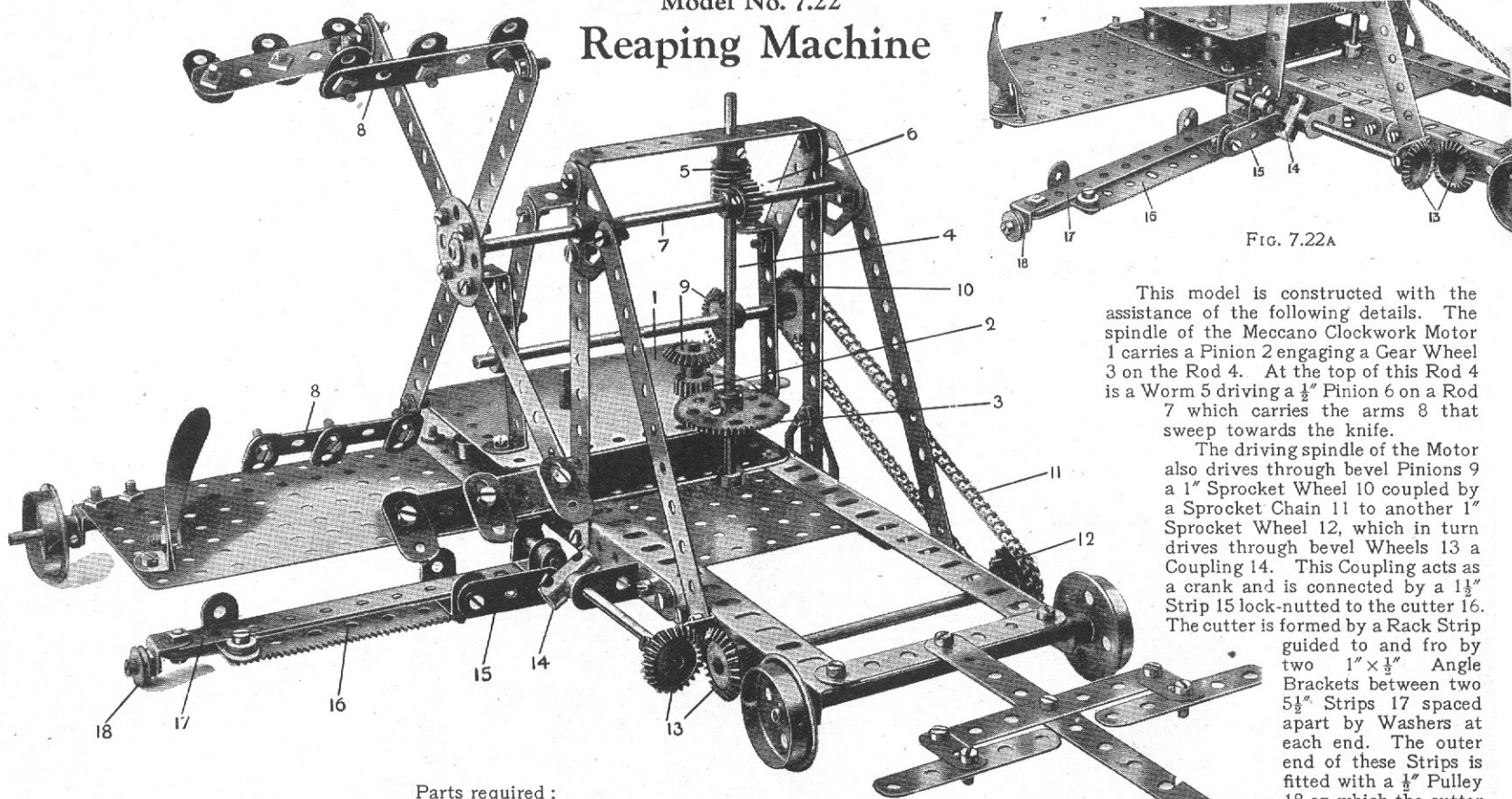


Fig. 7.22A

This model is constructed with the assistance of the following details. The spindle of the Meccano Clockwork Motor 1 carries a Pinion 2 engaging a Gear Wheel 3 on the Rod 4. At the top of this Rod 4 is a Worm 5 driving a $\frac{1}{2}$ " Pinion 6 on a Rod 7 which carries the arms 8 that sweep towards the knife.

The driving spindle of the Motor also drives through bevel Pinions 9 a 1" Sprocket Wheel 10 coupled by a Sprocket Chain 11 to another 1" Sprocket Wheel 12, which in turn drives through bevel Wheels 13 a Coupling 14. This Coupling acts as a crank and is connected by a $1\frac{1}{2}$ " Strip 15 lock-nutted to the cutter 16. The cutter is formed by a Rack Strip guided to and fro by two $1" \times \frac{1}{8}"$ Angle Brackets between two $5\frac{1}{8}"$ Strips 17 spaced apart by Washers at each end. The outer end of these Strips is fitted with a $\frac{1}{2}"$ Pulley 18 on which the cutter knife travels. The remainder of the detail of the model will be made quite clear from our illustration. When completed the model works in a very realistic manner.

Parts required :

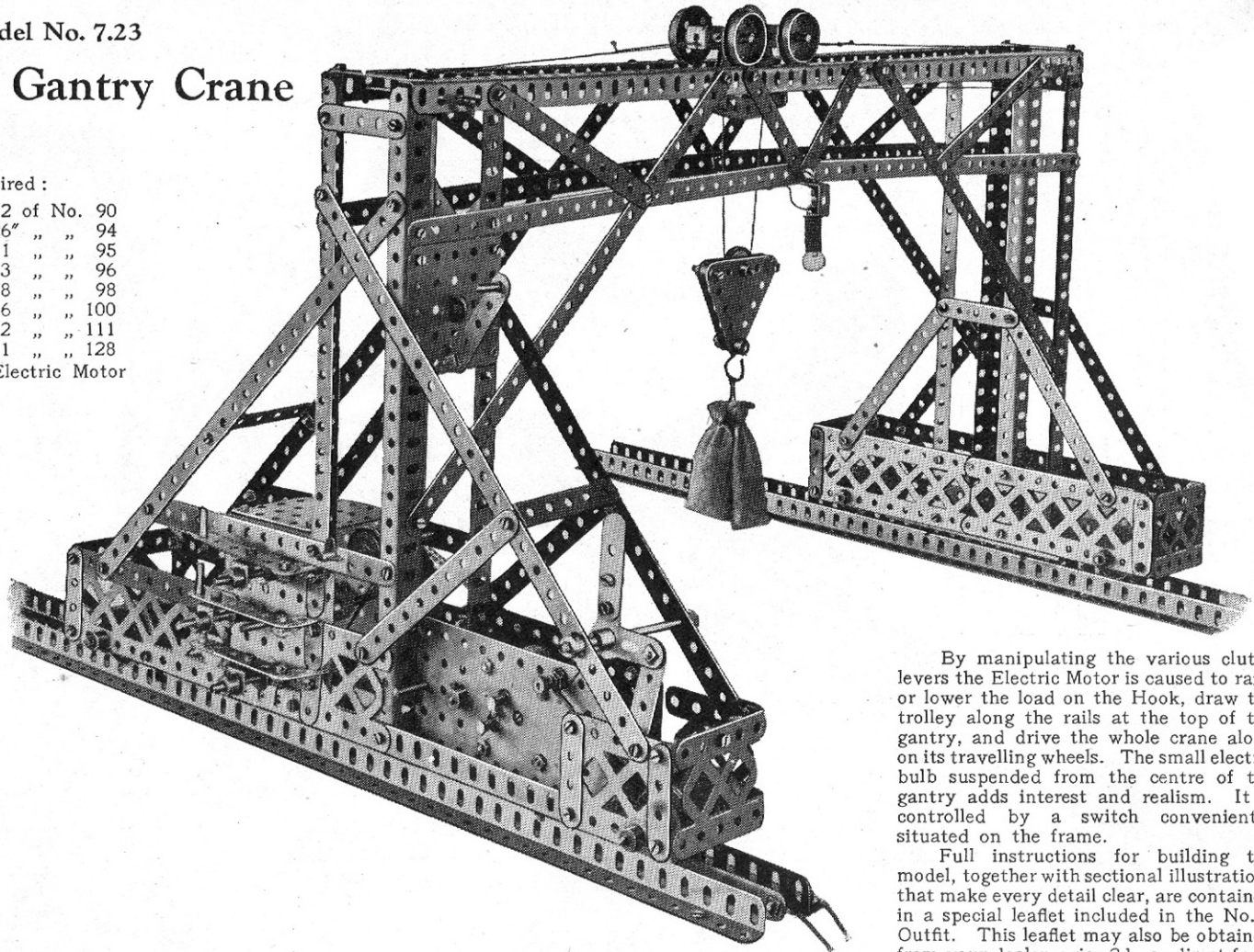
7 of No. 2	1 of No. 11	2 of No. 15	1 of No. 24	6 of No. 38	1 of No. 53
6 " " 3	7 " " 12	1 " " 15A	2 " " 26	1 " " 41	7 " " 59
8 " " 5	2 " " 12A	2 " " 16B	1 " " 27A	1 " " 48	1 " " 63
1 " " 6A	4 " " 12B	1 " " 17	4 " " 30	2 " " 48A	16" " 94
2 " " 8A	1 " " 13	4 " " 20	1 " " 32	1 " " 48B	1 " " 110
14 " " 10	2 " " 14	1 " " 23	66 " " 37	1 " " 52A	1 " " 125
3 of No. 126A Clockwork Motor					

Model No. 7.23

Travelling Gantry Crane

Parts required :

12 of No.	1	2 of No.	90
12 "	2	26"	94
6 "	3	1 "	95
3 "	4	3 "	96
17 "	5	8 "	98
14 "	6	6 "	100
1 "	6A	2 "	111
6 "	7	1 "	128
10 "	8	Electric Motor	
2 "	9		
6 "	11		
4 "	12A		
2 "	15		
2 "	15A		
11 "	16		
1 "	16A		
2 "	17		
4 "	18A		
12 "	20		
8 "	22A		
2 "	23		
2 "	25		
3 "	26		
3 "	27		
3 "	27A		
11 "	35		
149 "	37		
10 "	37A		
38 "	38		
3 "	44		
9 "	48A		
2 "	53		
1 "	57		
30 "	59		
1 "	72		
2 "	76		



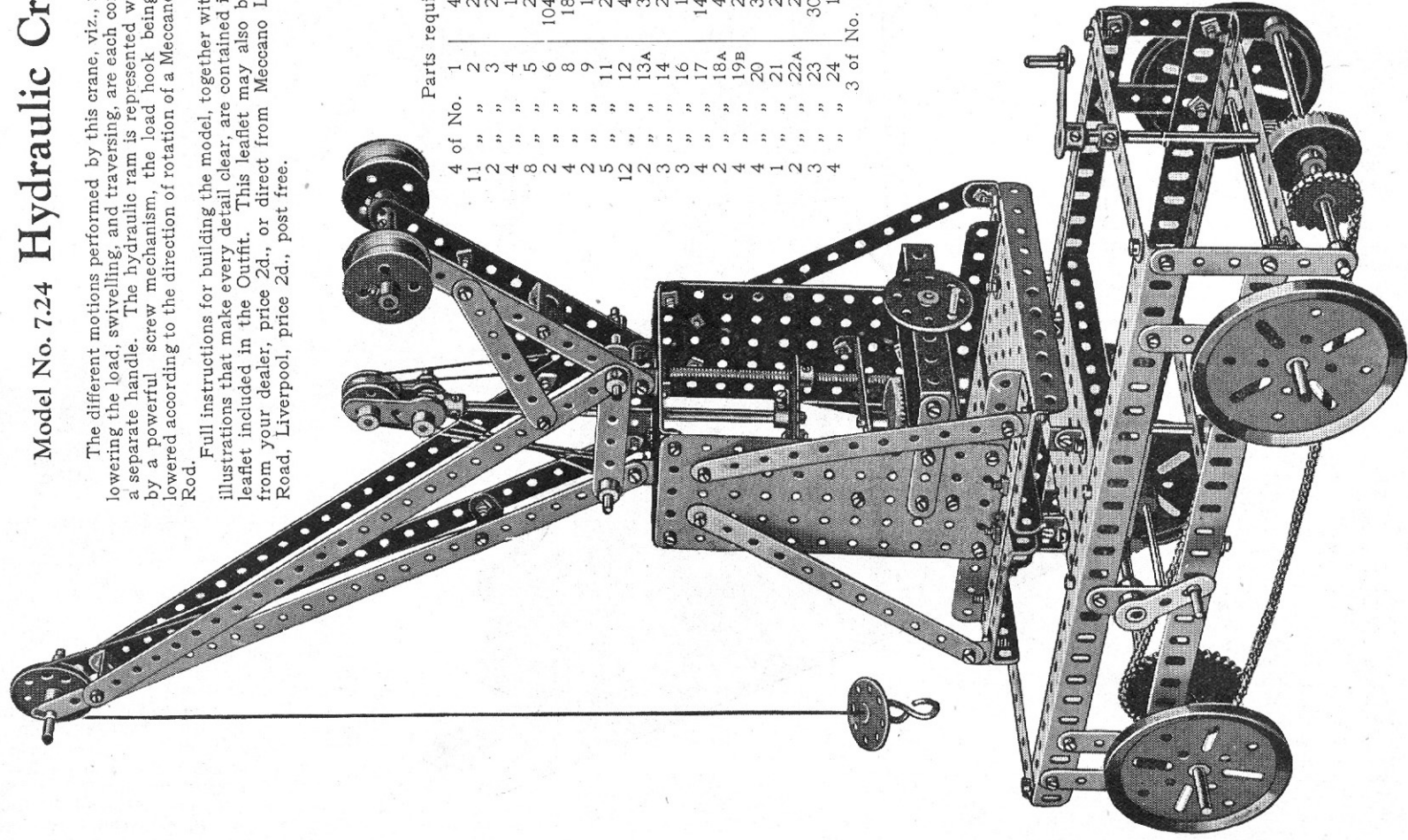
By manipulating the various clutch levers the Electric Motor is caused to raise or lower the load on the Hook, draw the trolley along the rails at the top of the gantry, and drive the whole crane along on its travelling wheels. The small electric bulb suspended from the centre of the gantry adds interest and realism. It is controlled by a switch conveniently situated on the frame.

Full instructions for building the model, together with sectional illustrations that make every detail clear, are contained in a special leaflet included in the No. 7 Outfit. This leaflet may also be obtained from your dealer, price 2d., or direct from Meccano Ltd., Binns Road, Liverpool, price 2d., post free.

Model No. 7.24 Hydraulic Crane

The different motions performed by this crane, viz., raising and lowering the load, swivelling, and traversing, are each controlled by a separate handle. The hydraulic ram is represented with realism by a powerful screw mechanism, the load hook being raised or lowered according to the direction of rotation of a Meccano Threaded Rod.

Full instructions for building the model, together with sectional illustrations that make every detail clear, are contained in a special leaflet included in the Outfit. This leaflet may also be obtained from your dealer, price 2d., or direct from Meccano Ltd., Binns Road, Liverpool, price 2d., post free.

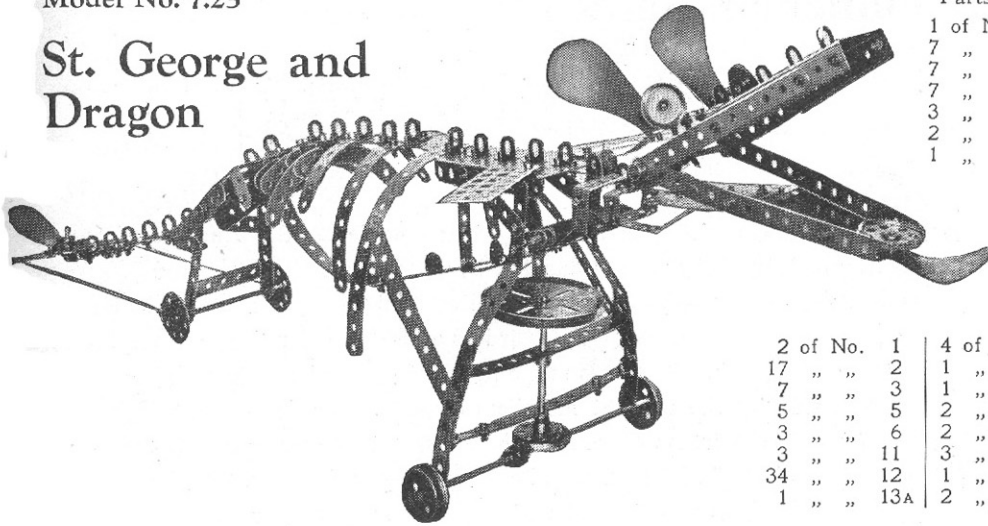


Parts required :

4 of No. 1	4 of No. 26
11 " 2	2 " 27A
2 " 3	2 " 28
4 " 4	1 " 32
8 " 5	2 " 35
2 " 6	104 " 37
4 " 8	18 " 38
2 " 9	1 " 45
5 " 11	2 " 48A
12 " 12	4 " 48B
2 " 13A	3 " 52
3 " 14	2 " 53
3 " 16	1 " 57
4 " 17	14 " 59
2 " 18A	4 " 62
4 " 19B	2 " 62A
4 " 20	3 " 63
1 " 21	2 " 70
2 " 22A	2 " 80
3 " 23	30" " 94
4 " 24	1 " 95
	3 of No. 115

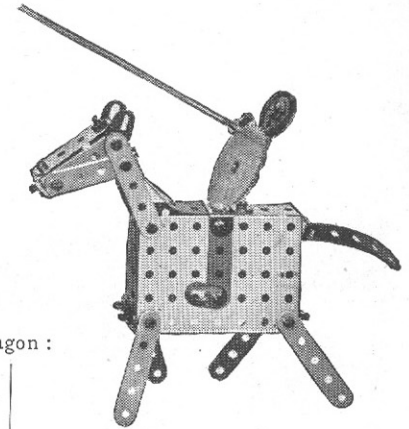
Model No. 7.25

St. George and Dragon



Parts required, St. George :

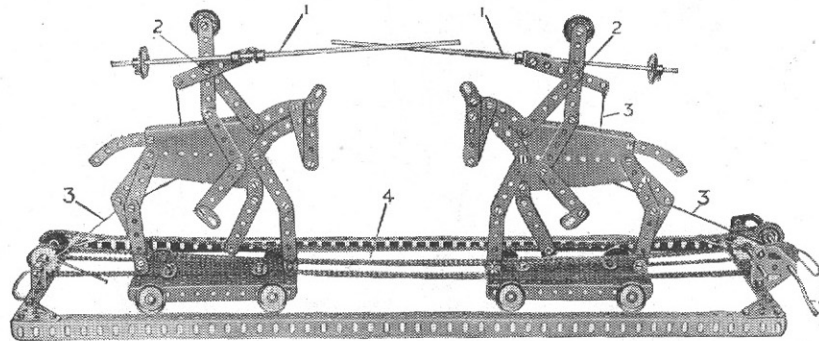
1 of No. 3	1 of No. 22A
7 " " 5	31 " " 37
7 " " 6	1 " " 37B
7 " " 10	2 " " 48A
3 " " 11	2 " " 53
2 " " 12	1 " " 62
1 " " 14	1 " " 95



Parts required, Dragon :

2 of No. 1	4 of No. 16	2 of No. 35	6 of No. 59
17 " " 2	1 " " 18A	126 " " 37	2 " " 61
7 " " 3	1 " " 19B	7 " " 38	6 of No. 90
5 " " 5	2 " " 20	4 " " 41	1 " " 69
3 " " 6	2 " " 22	1 " " 43	2 " " 72
3 " " 11	3 " " 24	3 " " 46	2 " " 110
34 " " 12	1 " " 26	9 " " 48A	2 " " 114
1 " " 13A	2 " " 28	4 " " 54	

This model requires little description. The jaws of the dragon work by means of a Cord fastened to a 3½" Strip which is attached to the 2½" x 2½" Flat Plate forming the head. The Cord is passed through a hole in the 12½" Strip, which forms the back-bone. It is attached at its other end to the periphery of a 3" Pulley Wheel, which is caused to rotate as the dragon moves along the ground. To make the tail wag, Cords are fastened to each end of the pivoted 3½" Strip which carries the Bush Wheel and Propeller Blade forming the tail, and attached at the other ends to Angle Brackets bolted to the back wheels. As the model moves along the ground the tail wags in quite a realistic way.



Model No. 7.26 The Tilters

Parts required :

2 of No. 3	2 of No. 31
4 " " 4	73 " " 37
22 " " 5	2 " " 37A
2 " " 7	4 " " 38
2 " " 8B	1 " " 46
10 " " 10	1 " " 47
2 " " 11	2 " " 52
10 " " 12	2 " " 54
2 " " 13	8 " " 59
1 " " 15A	6 " " 90
5 " " 16	2 " " 94
1 " " 19	4 " " 96
10 " " 22	2 " " 126A
2 " " 22A	4 " " 133

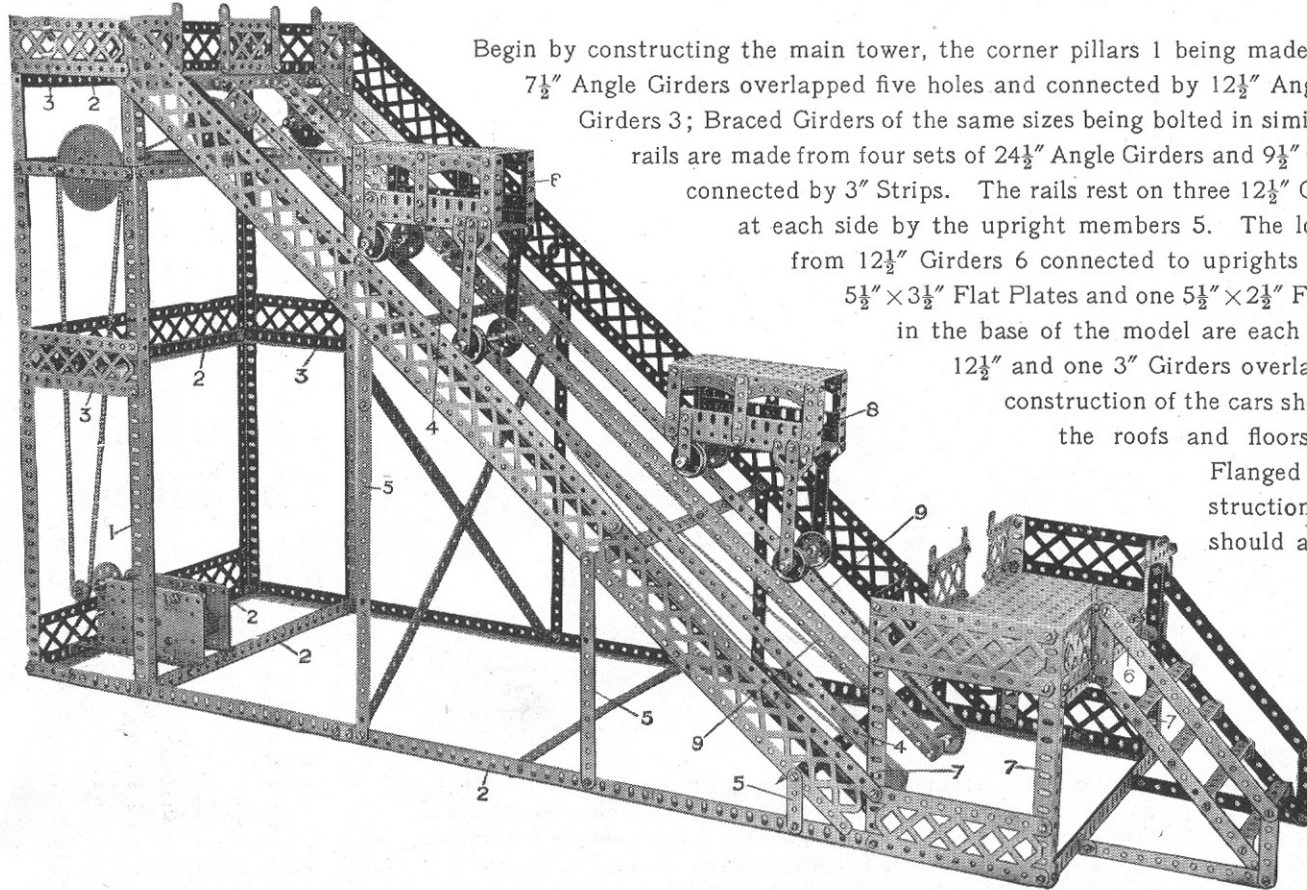
The lances 1 pivoted at 2 are raised into position by the Cords 3 and the figures caused to advance together by the Chains 4 on turning the Handle 5.

The Cords 3, instead of being tied where indicated in the illustration, should, after aim, be made fast to some part of the moving figures.

Model No. 7.27 Funicular Railway

Parts required :

9 of No. 1	18 of No. 5	4 of No. 8A	12 of No. 9D	2 of No. 17	7 of No. 48D	8 of No. 90	1 of No. 96A	4 of No. 103
6 " " 1B	6 " " 6	8 " " 8B	22 " " 12	8 " " 20	4 " " 52	4 " " 94	5 " " 97	8 " " 126A
4 " " 2	6 " " 7	4 " " 9	2 " " 13A	4 " " 26	6 " " 52A	2 " " 95	4 " " 98	
4 " " 2A	4 " " 7A	2 " " 9B	5 " " 16	3 " " 27A	19 " " 59	1 " " 95B	9 " " 99	Electric Motor
4 " " 4	13 " " 8	2 " " 9C	4 " " 16B	270 " " 37	2 " " 70	6 " " 96	8 " " 100	



Begin by constructing the main tower, the corner pillars 1 being made of $18\frac{1}{2}$ " Angle Girders and $7\frac{1}{2}$ " Angle Girders overlapped five holes and connected by $12\frac{1}{2}$ " Angle Girders 2 and $5\frac{1}{2}$ " Angle Girders 3; Braced Girders of the same sizes being bolted in similar positions. The inclined rails are made from four sets of $24\frac{1}{2}$ " Angle Girders and $9\frac{1}{2}$ " Girders butted together and connected by 3" Strips. The rails rest on three $12\frac{1}{2}$ " Girders 4, and are supported at each side by the upright members 5. The loading platform is built up from $12\frac{1}{2}$ " Girders 6 connected to uprights 7 and the floor from three $5\frac{1}{2}$ " \times $3\frac{1}{2}$ " Flat Plates and one $5\frac{1}{2}$ " \times $2\frac{1}{2}$ " Flat Plate. The side Girders in the base of the model are each formed from one $24\frac{1}{2}$ ", one $12\frac{1}{2}$ " and one 3" Girders overlapped two holes each. The construction of the cars should present little difficulty, the roofs and floors being made of $5\frac{1}{2}$ " \times $2\frac{1}{2}$ " Flanged Plates, and the other constructional details of the framework should also present no trouble.

The cars 8, are connected to the Chains 9 which pass over Sprocket Wheels 10, 2" diameter at the top and 1" at the bottom. The cars move in opposite directions so that the weight of the descending car assists the

Model No. 7.27 Funicular Railway (*continued*)

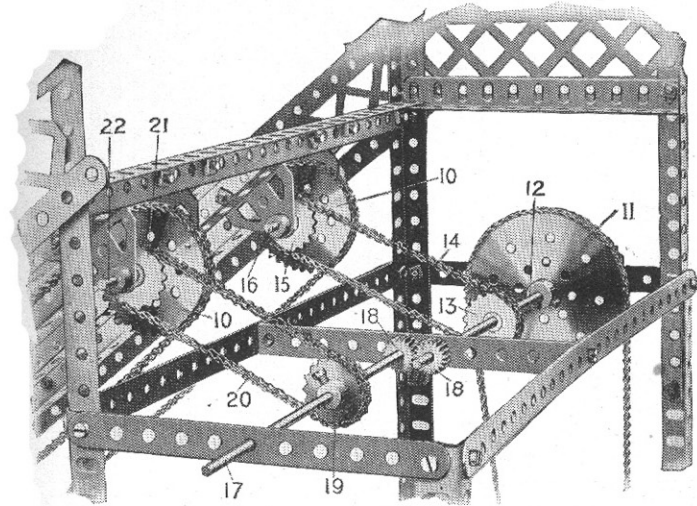
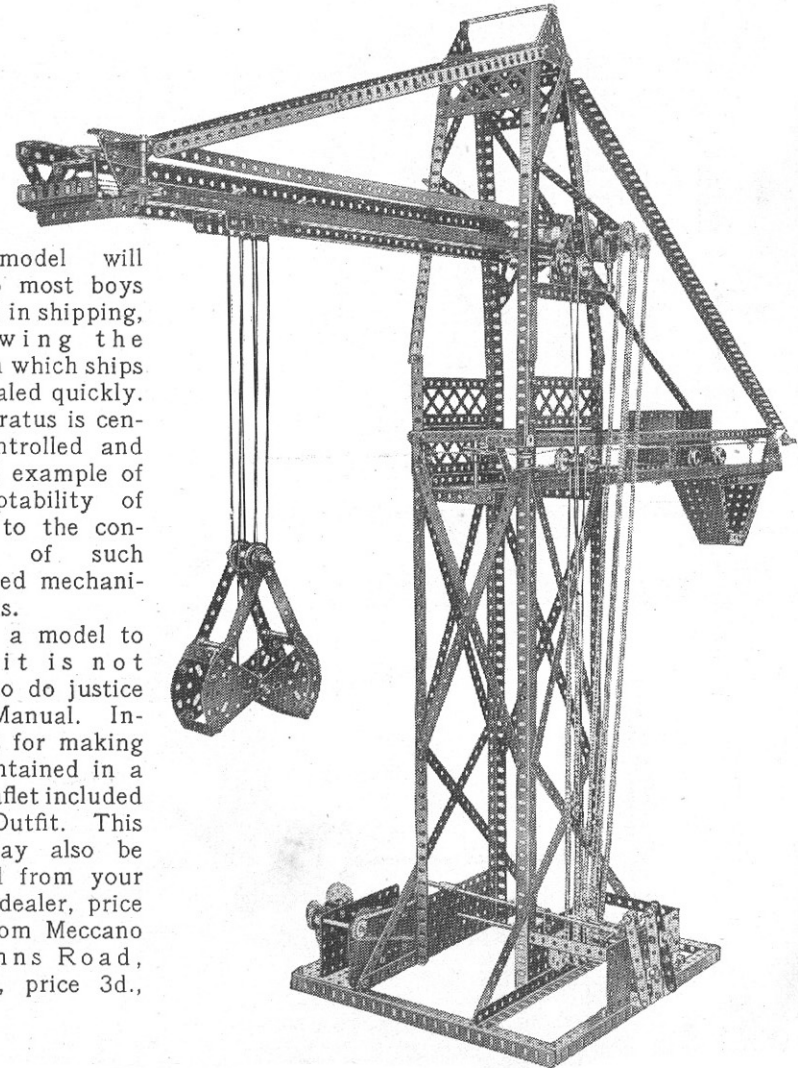


FIG. 7.27A

other car to ascend. This is effected by driving a 3" Sprocket Wheel 11, Fig. 7.27A, from the Motor, the 8" Rod 12 of the Sprocket Wheel 11 carrying a 1" Sprocket Wheel 13 which is coupled by the Chain 14 to a similar Sprocket Wheel 15 on the 3" Rod 16. The Rod 12 is coupled to another 8" Rod 17 by a pair of $\frac{1}{2}$ " Pinions 18 in order to obtain a reversed rotation, and a 1" Sprocket Wheel 19 on the Rod 17 is coupled by a Chain 20 to another 1" Sprocket Wheel 21 on a 3" Rod 22 which drives the Chain of the other car. In this way, opposite movement of the two cars is always taking place. The cars, having reached their destinations, are returned by reversing the Motor.

Model No. 7.28 Ship Coaler



This model will appeal to most boys interested in shipping, as showing the manner in which ships can be coaled quickly. The apparatus is centrally controlled and is a good example of the adaptability of Meccano to the construction of such complicated mechanical models.

This is a model to which it is not possible to do justice in this Manual. Instructions for making it are contained in a special leaflet included in the Outfit. This leaflet may also be purchased from your Meccano dealer, price 3d., or from Meccano Ltd., Binns Road, Liverpool, price 3d., post free.

Model No. 7.30 Warehouse

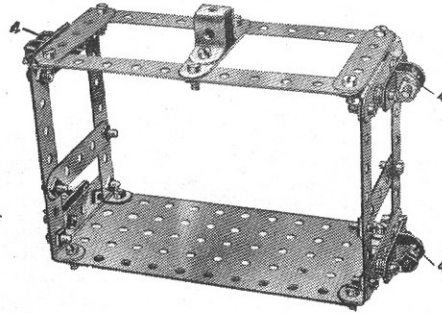
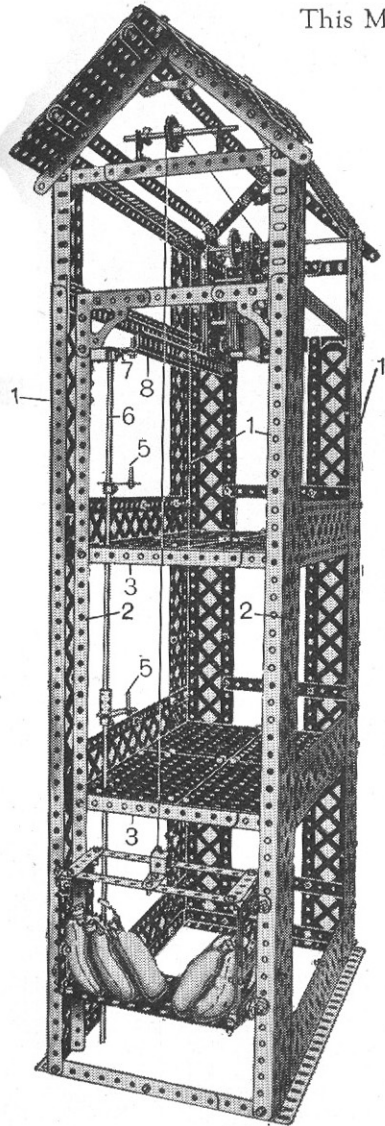


FIG. 7.30A

Commence this model by building the framework. $2\frac{1}{2}$ " Angle Girders are used to form the corner uprights 1 with $5\frac{1}{2}$ " Angle Girders overlapped eight holes at the top. Two $2\frac{1}{2}$ " Angle Girders 2 are also used to carry the front portion of the warehouse floors, the latter being bolted to two $5\frac{1}{2}$ " Angle Girders 3 overlapped eight holes and connected across to the two inner Angle Girders 2. Two similar $5\frac{1}{2}$ " Angle Girders are bolted to the back of the framework, to carry the other end of each of the floors. The floor is formed of four $5\frac{1}{2}$ " \times $3\frac{1}{2}$ " Flat Plates butted together and bolted in the centre to a $5\frac{1}{2}$ " Flat Girder on the underside—the two outer ends being bolted to the Angle Girders 3. The horizontal side-strips are formed of $12\frac{1}{2}$ " Strips to which are bolted the braced Girder Strips.

Fig. 7.30A shows the construction of the cage. This is guided by bolt heads 4, at each side riding along the inwardly turned flanges of the Angle Girders 2. The bolts are attached to Angle Brackets, which are secured to a $1\frac{1}{2}$ " Strip, this latter being secured to the side-strips of the cage, spaced with three Washers to take up the play between the cage and the upright Girders 2.

Fig. 7.30B shows the position of the Motor, and this may be started and stopped from the control Crank Handles 5, one on each floor of the warehouse. These Crank Handles are fixed on a vertical Rod 6 composed of two $11\frac{1}{2}$ " Rods connected by a Coupling. A Crank 7 is secured to the upper end of this Rod and is connected by a $5\frac{1}{2}$ " Angle Girder and Strip 8 to the operating lever of the Motor.

1 " Brackets secured to the sides of the warehouse by Strips form the bearings for the upper and lower ends of the vertical Rod.

When the Motor is wired up to the Accumulator, the elevator is ready to be operated.

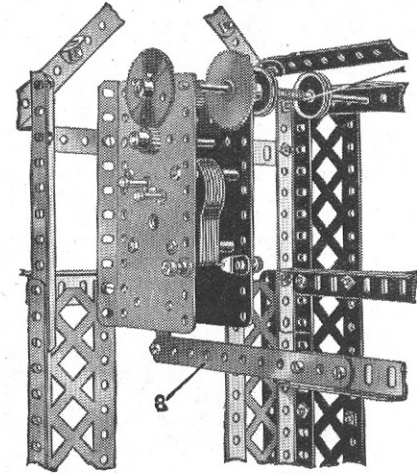


FIG. 7.30B

Parts required :

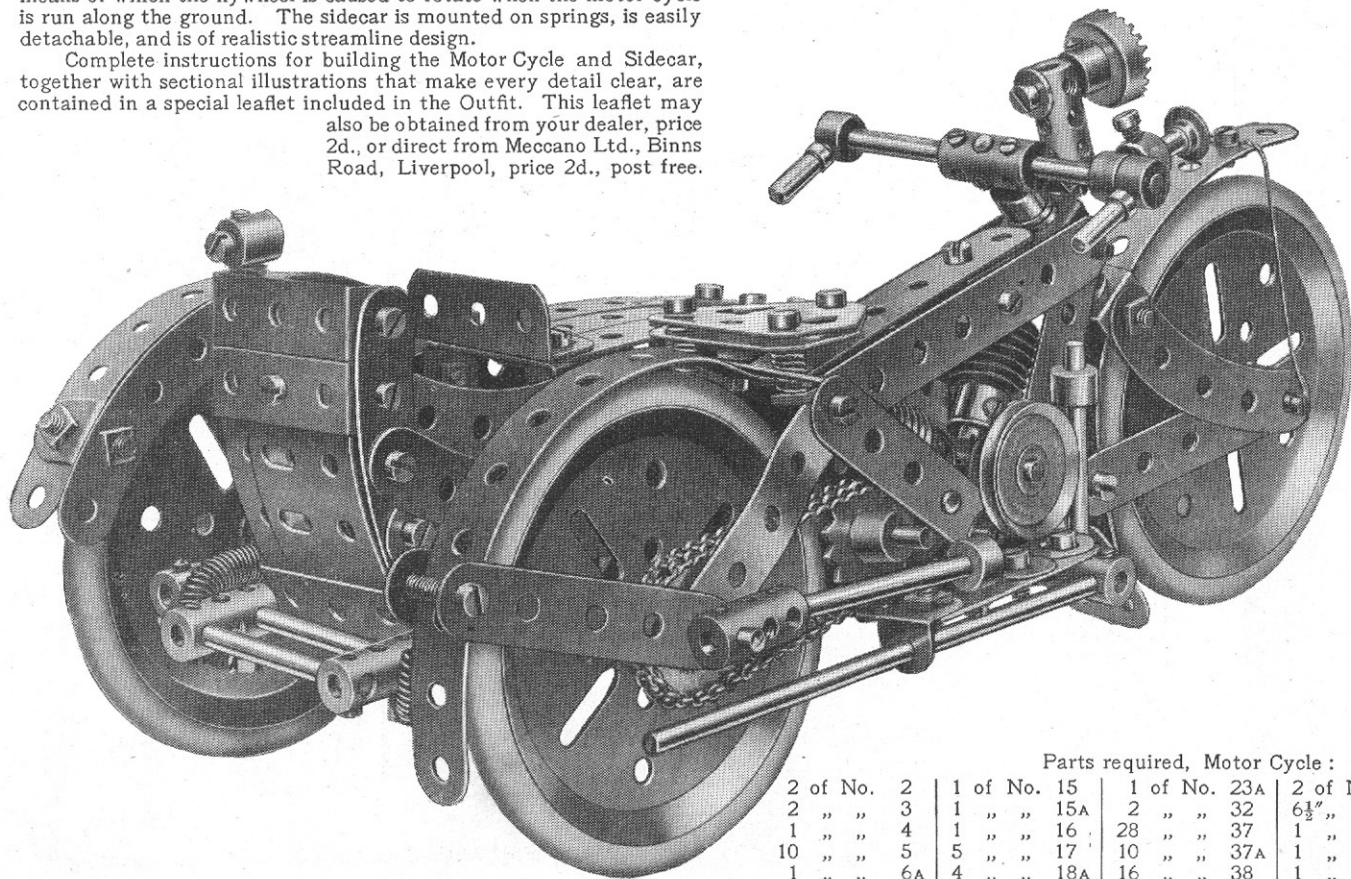
18 of No. 1	2 of No. 13	1 of No. 59
21 " " 2	1 " " 14	4 " " 62
9 " " 5	1 " " 16	1 " " 63
1 " " 6	3 " " 22	3 " " 70
4 " " 6A	2 " " 35	18 " " 99
6 " " 7	240 " " 37	4 " " 100
6 " " 8	30 " " 38	2 " " 103
23 " " 9	1 " " 45	4 " " 108
16 " " 12	1 " " 4y	4 " " 115
2 " " 12A	8 " " 52A	

Electric Motor

Model No. 7.31 Motor Cycle and Sidecar

This model is an excellent example of Meccano miniature engineering, and affords a remarkable testimonial to the adaptability of the system. In spite of its small size, the model includes a device by means of which the flywheel is caused to rotate when the motor cycle is run along the ground. The sidecar is mounted on springs, is easily detachable, and is of realistic streamline design.

Complete instructions for building the Motor Cycle and Sidecar, together with sectional illustrations that make every detail clear, are contained in a special leaflet included in the Outfit. This leaflet may also be obtained from your dealer, price 2d., or direct from Meccano Ltd., Binns Road, Liverpool, price 2d., post free.



Parts
required,
Sidecar :

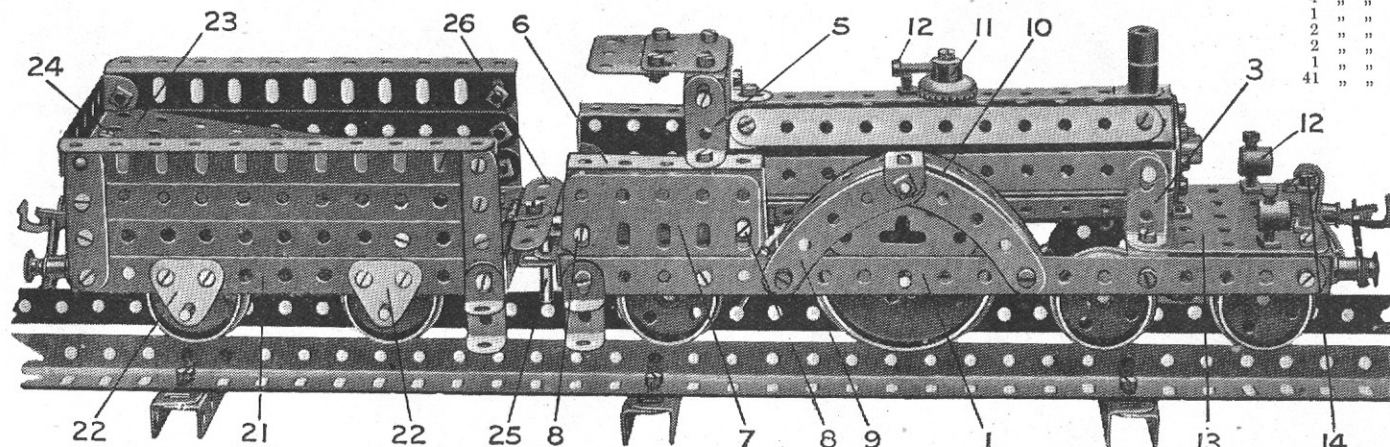
5	of No.	2
2	" "	2A
5	" "	3
5	" "	5
2	" "	6A
1	" "	9F
1	" "	10
2	" "	11
3	" "	12
2	" "	16
1	" "	16A
1	" "	17
1	" "	18A
1	" "	19
1	" "	19B
55	" "	37
1	" "	37A
3	" "	38
2	" "	43
7	" "	48A
4	" "	59
5	" "	63
1	" "	64
6	" "	89
8	" "	90
2	" "	103F
2	" "	103H
1	" "	111A
1	" "	125
2	" "	133
1	" "	142

Parts required, Motor Cycle :

2	of No.	2	1	of No.	15	1	of No.	23A	2	of No.	90	2	of No.	115
2	" "	3	1	" "	15A	2	" "	32	6½"	" "	94	1	" "	116
1	" "	4	1	" "	16	28	" "	37	1	" "	96	3	" "	120A
10	" "	5	5	" "	17	10	" "	37A	1	" "	96A	2	" "	126A
1	" "	6A	4	" "	18A	16	" "	38	1	" "	101	2	" "	142
2	" "	10	1	" "	18B	11	" "	59	2	" "	103G			
6	" "	11	2	" "	19B	8	" "	63	3	" "	111			
4	" "	12	1	" "	22	3	" "	77	3	" "	111A			

Small elastic band

Model No. 7.32 Locomotive and Tender (Midland, 4-2-2)



Parts required:			
2 of No.	1A	8 of No.	12B
13	2	3	16
1	5	3	18A
4	6	1	18B
1	6A	10	20
2	9	2	24
2	9D	1	29
1	11	131	37
41	12	11	38
		2	46
		1	48
		10	48A
		1	52
		1	53A
		6	59
		4	64
		2	72
		4	77
		4	90
		2	103F
		3	1G3H
		2	109
		4	111
		3	111A
		1	114
		5	120A
		2	121
		2	126
		2	133
		2	137
		1 piece of No.	58

This is a well-proportioned model of an old-style Midland "single-wheeler" locomotive. The engine frame is built up from two $9\frac{1}{2}$ " Strips 1 joined at the points 2 (Fig. 7.32A) by $2\frac{1}{2}$ " x $\frac{1}{4}$ " Double Angle Strips, and further strengthened at each end by $2\frac{1}{2}$ " Angle Girders. The boiler is composed of seven $5\frac{1}{2}$ " Strips bolted at either end to a Bush Wheel by means of Angle Brackets. It is supported by 1 " x $\frac{1}{4}$ " Angle Brackets 3, and an Angle Bracket secured to the lowest hole of the rear Bush Wheel is bolted at 4 (Fig. 7.32A) to the floor of the cab.

The cab roof consists of $1\frac{1}{2}$ " Flat Girders bolted by Angle Brackets to 1 " x $\frac{1}{4}$ " Brackets 5. $2\frac{1}{2}$ " x 1 " Double Angle Strips 6 and Flat Girders 7 bolted together by Angle Brackets at 8 form the sides, which, in turn, are bolted by Angle Brackets to the footplate.

The wheel covers for the main drivers are each constructed from two $2\frac{1}{2}$ " Curved Strips 9 and a $5\frac{1}{2}$ " Strip 10 bent to the same curvature. A Corner Bracket is secured in the centre as shown.

A safety valve in the centre of the boiler consists of a Contrade Wheel 11, secured by means of a $\frac{3}{8}$ " Bolt and carrying a further $\frac{1}{8}$ " Bolt 12. The smoke-stack is composed of two threaded bosses mounted on the shank of a $\frac{3}{8}$ " Bolt passing through the top Strip of the boiler. Two lamps are carried on the front of the engine-frame and consist of Threaded Bosses 12 mounted on the upturned shanks of $\frac{3}{8}$ " Bolts secured in the $2\frac{1}{2}$ " x $2\frac{1}{2}$ " Flat Plate 13, and gripped in position by a $\frac{3}{8}$ " Bolt 14, inserted in the tops of the bosses. A piece of Spring Cord, secured to a $\frac{3}{8}$ " Bolt 14, represents the front vacuum brake pipe connection.

It will be noticed from Fig. 7.32A that the front bogie consists of two $2\frac{1}{2}$ " Strips 15, bolted to a Double Bracket 16. It is attached to the locomotive frame by means of a $\frac{3}{8}$ " Bolt, secured by two nuts on its end to the Flat Plate 13. A small Compression Spring (Meccano Part No. 120B) is placed on the Bolt between the Double Bracket and the Base Plate. The rear trailing Wheels 17 are mounted on a $1\frac{1}{2}$ " Rod passed through two Trunnions 18 bolted to the under-side of the footplate. The Wheels are retained in their correct position by means of a Collar 19, spaced between two Washers.

The driving wheels are built up from Face Plates and Wheel Flanges, and are secured to a 3 " Rod 20. They are spaced in the correct position in the centre of the frame by means of three Washers placed between the boss of each Face Plate and the sides 1 of the engine.

A $5\frac{1}{2}$ " x $2\frac{1}{2}$ " Flanged Plate 21 forms the base of the tender and the sides are each built up from two $5\frac{1}{2}$ " Strips and one $5\frac{1}{2}$ " Angle Girder. The back consists of four $2\frac{1}{2}$ " x $\frac{1}{4}$ " Double Angle Strips. The Wheels are carried on axles journalled in 1 " Triangular Plates 22 bolted to the Base Plate 21. A $4\frac{1}{2}$ " x $2\frac{1}{2}$ " Flat Plate 23 is secured inside the tender by means of an Angle Bracket bolted to the back at 24, and a $2\frac{1}{2}$ " x $\frac{1}{4}$ " Double Angle Strip at the other end of the plate.

The loco and tender are coupled together by means of a 1 " Rod 25, passed through two Angle Brackets. An extension of the footplate consists of a $1\frac{1}{2}$ " Flat Girder and a $2\frac{1}{2}$ " Strip 26, bolted by means of a hinge to the tender.

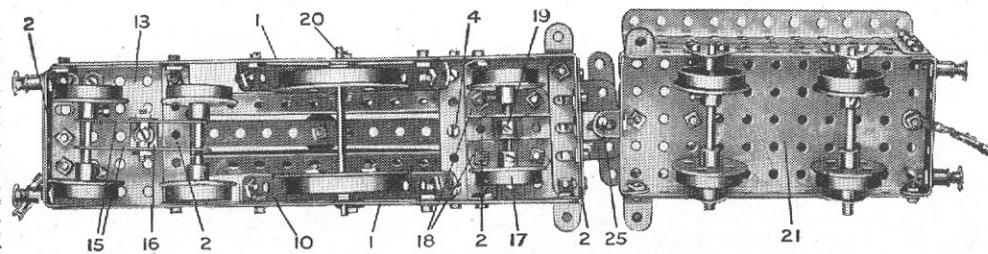


FIG. 7.32A

A Selection of Meccano Standard Mechanisms

Here are a few simple and interesting movements showing how easily real mechanisms can be reproduced with Meccano. They are a selection from the Meccano Standard Mechanisms Manual, which is fully described on page 2 of this Manual.

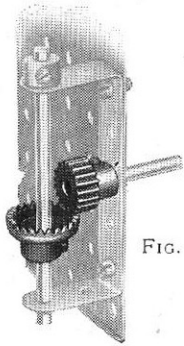


FIG. A

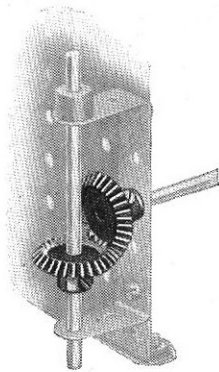


FIG. C

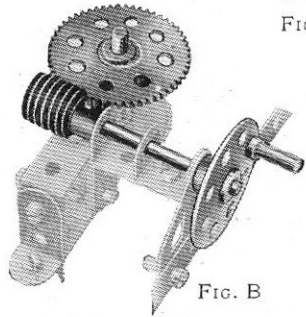


FIG. B

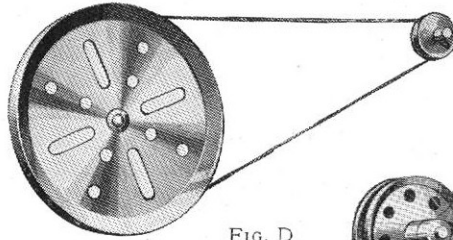


FIG. D

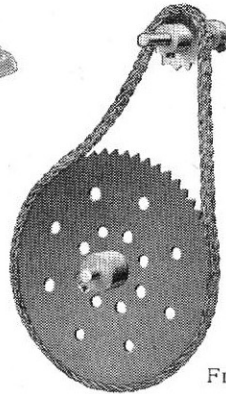


FIG. E

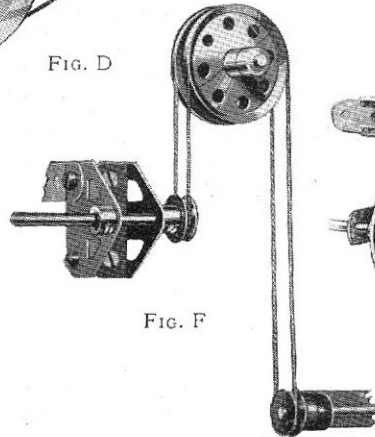


FIG. F

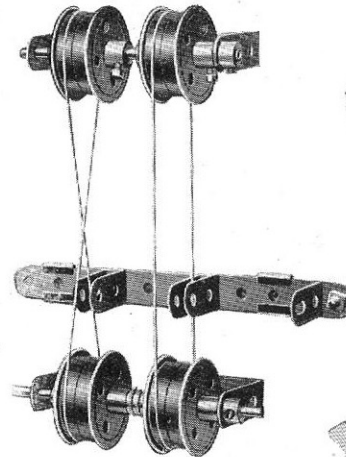


FIG. G

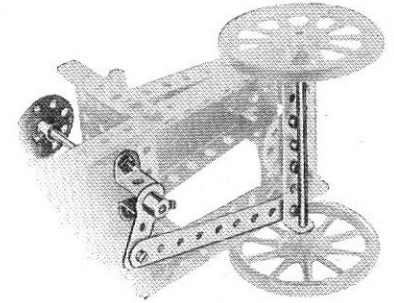


FIG. H

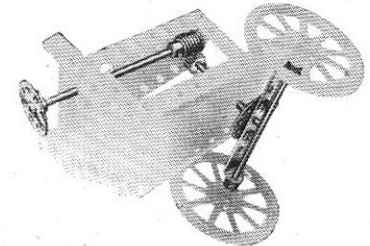


FIG. J

Gears

The Meccano system includes a wide range of Gear Wheels, Bevel Gears, Pinion Wheels, Contrate Wheels and Worm Wheels in various sizes. All manner of interesting movements may be obtained by the use of these gears.

Fig. A shows how a drive may be transmitted from a vertical to a horizontal shaft or vice versa. Fig. B shows a Worm engaged with a Gear Wheel, giving a very great reduction in shaft speed. Fig. C illustrates another right angle drive, obtained by using Meccano Bevel Gears.

Belt and Chain Drives

In Figs. D, E, F and G we show examples of belt and chain drives. The movements illustrated require no explanation excepting, perhaps, Fig. G, which shows a simple method for slipping the belt from the fast to the loose pulleys or vice versa.

Cords usually take the place of belts in Meccano models but miniature belting may be made from strips of canvas, indiarubber, etc., in which case Flanged Wheels should be used instead of grooved Pulleys.

Steering Gears

The various types of steering mechanism commonly in use on vehicles of all descriptions may readily be reproduced with Meccano.

Fig. H. In this case the road wheels are moved about their central pivot by means of a crank, which is secured to the steering shaft, and a connecting strip.

Fig. J. The road wheels in this example are secured to a central rod, which forms a pivot, and is rotated from the hand-wheel by means of a worm gear.

A Selection of Meccano Standard Mechanisms

(continued)

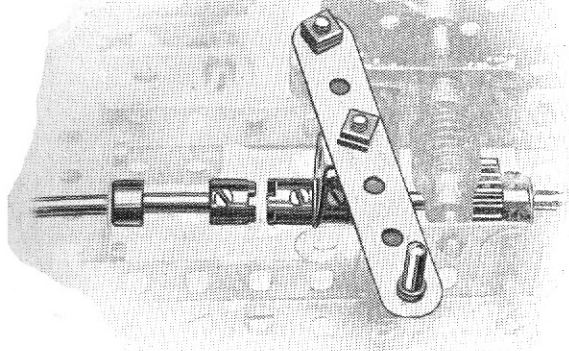


FIG. K

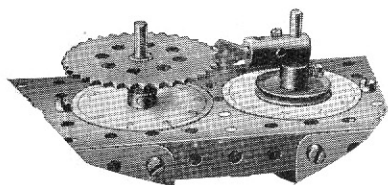


FIG. L

Dog Clutch

The Meccano Dog Clutch (Fig. K) may be used in most models where a simple clutch is required. It is also useful in the construction of drive-changing and reversing mechanisms, etc. Various kinds of clutches, in addition to the Dog Clutch, may be constructed from the standard Meccano parts.

Intermittent Rotary Motion

Fig. L shows one device by means of which intermittent rotary motion may be obtained. Such an arrangement is useful in revolution counters, measuring machines, etc. In addition to mechanisms that give true intermittent motion, different types of cams, converting a regular rotary motion into a constant or intermittent reciprocating motion, are described in the S.M. Manual.

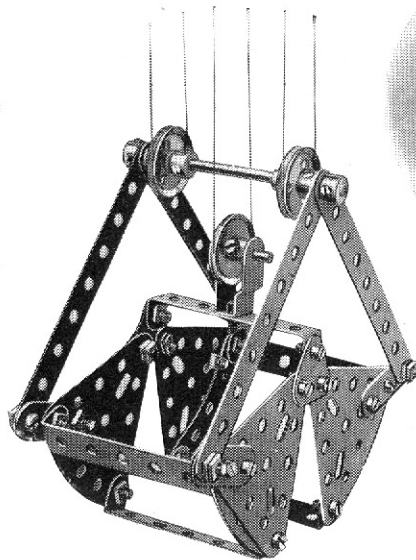


FIG. M

Grab

A typical example of the many kinds of grab that can be constructed from Meccano is shown in Fig. M. If the grab is fitted to a model crane or ship-coaler, all the movements can be controlled from an operating box built into the frame of the model. The outer sides of the jaws may be filled in with cardboard and the grab can then be used to pick up loads of sand, grain, marbles, etc.

Pawl and Ratchet Wheel

Fig. N illustrates the standard Meccano Pawl and Ratchet Wheel gear, which allows the shaft carrying the Ratchet Wheel to rotate in one direction only. The advantages of such an arrangement are obvious, especially when attached to model Cranes, hoisting-tackle, etc., where the Pawl and Ratchet gear prevents falling-back of the load as it is hoisted.

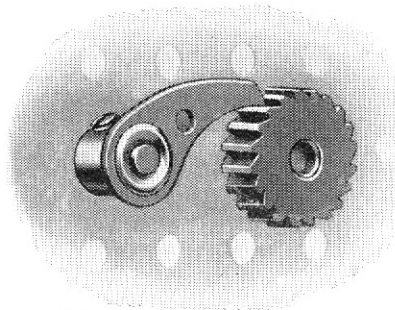


FIG. N

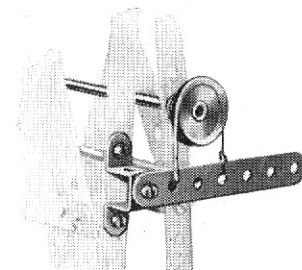


FIG. O

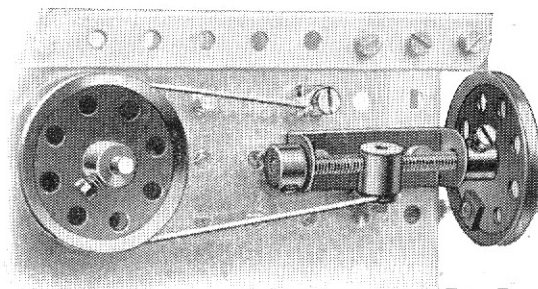


FIG. P

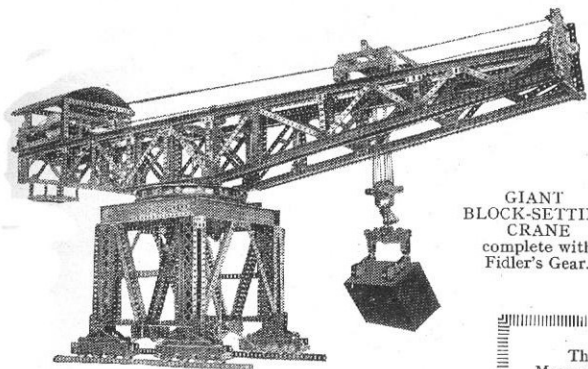
Strap and Lever Brake

This device (Fig. O) will be found very useful as a quick emergency hand-brake. Although it is the most simple of such devices, it is also one of the most valuable.

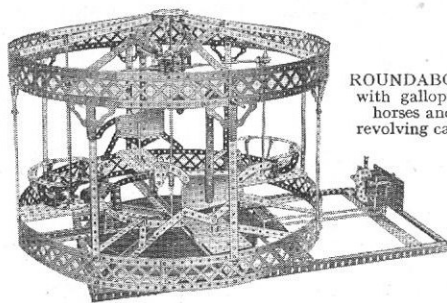
Strap and Screw Brake

The type of brake shown in Fig. P is used to apply a constant retarding effect to a rotating shaft. It can thus be utilized in a crane to prevent the load from falling back when the winding spindle is released. One advantage of the brake is that the speed of the shaft to which it is applied can be infinitely varied, so that in some models it will take the place of a gear-changing mechanism.

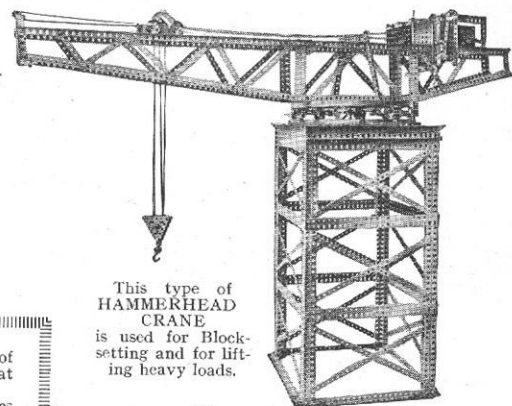
A Selection of Choice Meccano Models



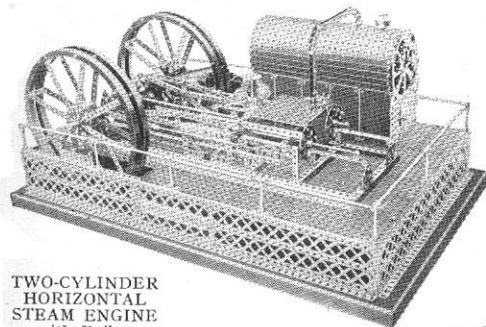
**GIANT
BLOCK-SETTING
CRANE**
complete with
Fidler's Gear.



ROUNDAABOUT
with galloping
horses and
revolving cars.



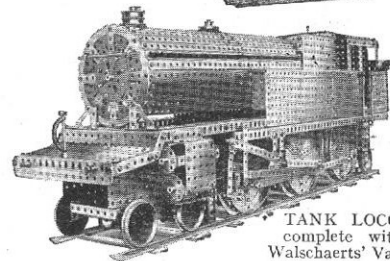
This type of
**HAMMERHEAD
CRANE**
is used for Block-
setting and for lift-
ing heavy loads.



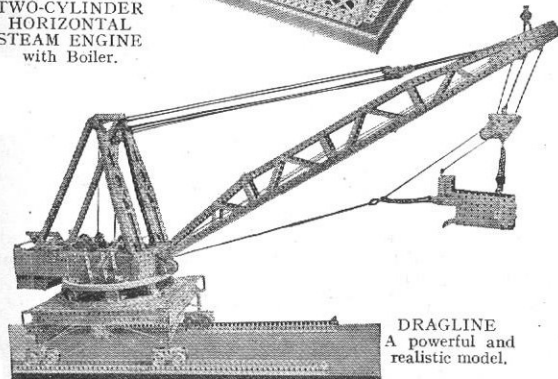
**TWO-CYLINDER
HORIZONTAL
STEAM ENGINE**
with Boiler.

The models illustrated on this page show the wonderful possibilities of Meccano. They comprise a selection from a range of super models that have been specially built for the delight of Meccano boys.

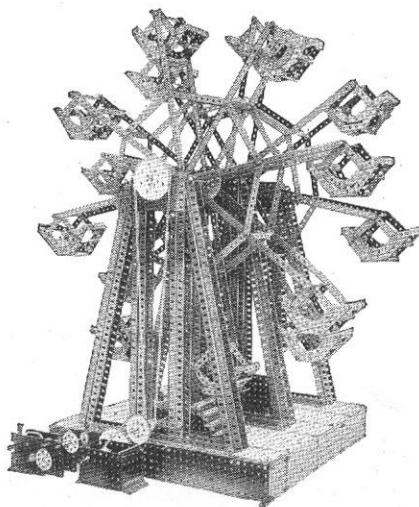
A descriptive leaflet giving full particulars of all the models in the series and the prices of the special Instruction Leaflets that are published in connection with them, may be obtained from your dealer or direct from Meccano Ltd., Binns Road, Liverpool.



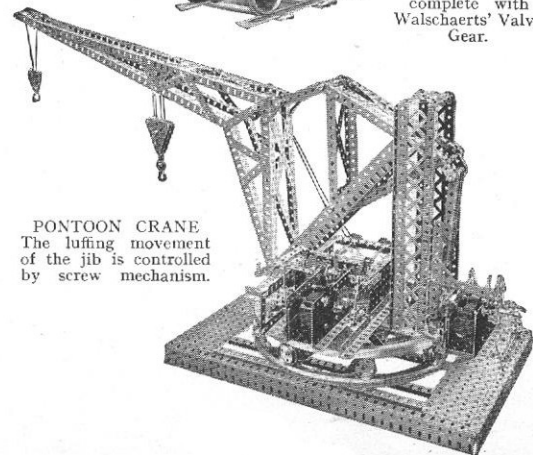
TANK LOCO
complete with
Walschaerts' Valve
Gear.



DRAGLINE
A powerful and
realistic model.



DOUBLE FLYBOATS This is a most
impressive model when in motion.



PONTOON CRANE
The luffing movement
of the jib is controlled
by screw mechanism.

CONTENTS OF OUTFITS

No.	DESCRIPTION OF PART.	00	00A	0	0A	1	1A	2	2A	3	3A	4	4A	5	5A	6	6A	7
1	Perforated Strips, 12 $\frac{1}{2}$ "				4	4	6	10		10	2	12	4	16	32	48	50	
1A	"				4	4	6	10								2	10	12
1B	"				4	4	6	14		18	3	21	5	26	24	2	2	4
2	"	4			4	8	6	14	4	18	2	6	2	26	24	4	25	75
2A	"				4	4	6	14							4	8	12	4
3	"				1	1	2	2	2	6	4	6	2	12	4	4	24	24
3A	"				1	1	2	2	2	6	4	6	2	12	4	4	24	24
4	"	6	3	9	9	9	3	12	2	12	6	18	18	36	84	36	84	120
4A	"				9	9	3	12	2	12	6	18	18	36	24	12	24	36
5	"				9	9	3	12	2	12	6	18	18	36	4	6	14	14
5A	"				9	9	3	12	2	12	6	18	18	36	8	14	14	14
6	Angle Girders, 24 $\frac{1}{2}$ "						2	2		2								
6A	"						2	2		2								
7	"						4	4	4	8	1	9	5	14	12	26	26	26
7A	"						4	4	4	8	1	9	5	14	12	6	12	4
8	"						4	4	4			4	4	4	2	2	2	4
8A	"						4	4	4			4	4	4	2	2	2	4
8B	"						4	4	4			4	4	4	2	2	2	4
9	"																	
9A	"																	
9B	"																	
9C	"																	
9D	"																	
9E	"																	
9F	"																	
10	Flat Brackets...				4	1	5	3	8	8	1	9	3	12	4	4	8	4
11	Double Brackets				4	2	2	4										
12	Angle Brackets, 1" x 1"	8		8	8	4	12	4	2	14	8	22	14	36	12	48	48	96
12A	"				8	4	12	4	2	14	8	22	14	36	12	48	48	96
12B	"						2	2		4		6	4	4	6	6	6	12
12C	"						2	2		4		6	4	4	6	6	6	12
13	Axle Rods, 11 $\frac{1}{2}$ "										2	2	1	2	4	4	4	4
13A	"										2	2	1	2	4	4	4	4
14	"										3	3	3	3	3	6	4	9
14A	"										3	3	3	3	3	6	4	9
15	"										2	2	2	2	2	6	6	6
15A	"										2	2	2	2	2	6	6	6
16	"	2		2	1	3	1	4		4	1	5	5	5	4	4	5	12
16A	"				2	1	3	1	4		4	1	5	5	4	4	5	12
16B	"				2	2	2	2	2	4	3	5	4	4	4	4	5	12
17	"				2	2	2	2	2	4	3	5	4	4	4	4	5	12
17A	"				2	2	2	2	2	4	3	5	4	4	4	4	5	12
18	"																	
18A	"																	
18B	"																	
19	Crank Handles (5" shaft)				1	1	1	1	1	1	1	1	1	1	1	1	1	1
19A	"				1	1	1	1	1	1	1	1	1	1	1	1	1	1
19B	"				1	1	1	1	1	1	1	1	1	1	1	1	1	1
20	Wheels, 3"				4	4	4	4	4	4	4	4	4	4	4	4	4	4
20A	"				4	4	4	4	4	4	4	4	4	4	4	4	4	4
20B	"				4	4	4	4	4	4	4	4	4	4	4	4	4	4
21	Flanged Wheels, 1 $\frac{1}{2}$ "																	
21A	"																	
22	Pulley Wheels, 1 $\frac{1}{2}$ "	4		4	4	4	2	2	1	2	1	2	3	3	1	4	4	4
22A	"				4	4	2	2	1	2	1	2	3	3	1	4	4	4
22B	"				4	4	2	2	1	2	1	2	3	3	1	4	4	4
23	"				1	1	1	1	1	1	1	1	1	1	1	1	1	1
23A	"				1	1	1	1	1	1	1	1	1	1	1	1	1	1
24	"				1	1	1	1	1	1	1	1	1	1	1	1	1	1
25	"				1	1	1	1	1	1	1	1	1	1	1	1	1	1
26	"				1	1	1	1	1	1	1	1	1	1	1	1	1	1
27	"				1	1	1	1	1	1	1	1	1	1	1	1	1	1
27A	"				1	1	1	1	1	1	1	1	1	1	1	1	1	1
27B	"				1	1	1	1	1	1	1	1	1	1	1	1	1	1
28	"				1	1	1	1	1	1	1	1	1	1	1	1	1	1
29	"				1	1	1	1	1	1	1	1	1	1	1	1	1	1
30	"				1	1	1	1	1	1	1	1	1	1	1	1	1	1
30A	"				1	1	1	1	1	1	1	1	1	1	1	1	1	1
30C	"				1	1	1	1	1	1	1	1	1	1	1	1	1	1
31	"				1	1	1	1	1	1	1	1	1	1	1	1	1	1
32	"				1	1	1	1	1	1	1	1	1	1	1	1	1	1
34	"				1	1	1	1	1	1	1	1	1	1	1	1	1	1
35	"				1	1	1	1	1	1	1	1	1	1	1	1	1	1
36	"				1	1	1	1	1	1	1	1	1	1	1	1	1	1
36B	"				1	1	1	1	1	1	1	1	1	1	1	1	1	1
37	"				1	1	1	1	1	1	1	1	1	1	1	1	1	1
37A	"				1	1	1	1	1	1	1	1	1	1	1	1	1	1
38	"				1	1	1	1	1	1	1	1	1	1	1	1	1	1
40	"				1	1	1	1	1	1	1	1	1	1	1	1	1	1
41	"				1	1	1	1	1	1	1	1	1	1	1	1	1	1
43	"				1	1	1	1	1	1	1	1	1	1	1	1	1	1
44	"				1	1	1	1	1	1	1	1	1	1	1	1	1	1
45	"				1	1	1	1	1	1	1	1	1	1	1	1	1	1
46	"				1	1	1	1	1	1	1	1	1	1	1	1	1	1
47	"				1	1	1	1	1	1	1	1	1	1	1	1	1	1
47A	"				1	1	1	1	1	1	1	1	1	1	1	1	1	1
48	"				1	1	1	1	1	1	1	1	1	1	1	1	1	1
48A	"				1	1	1	1	1	1	1	1	1	1	1	1	1	1
48B	"				1	1	1	1	1	1	1	1	1	1	1	1	1	1
48C	"				1	1	1	1	1	1	1	1	1	1	1	1	1	1
48D	"				1	1	1	1	1	1	1	1	1	1	1	1	1	1
50A	"				1	1	1	1	1	1	1	1	1	1	1	1	1	1
52	"				1	1	1	1	1	1	1	1	1	1	1	1	1	1
52A	"				1	1	1	1	1	1	1	1	1	1	1	1	1	1
53	"				1	1	1	1	1	1	1	1	1	1	1	1	1	1
53A	"				1	1	1	1	1	1	1	1	1	1	1	1	1	1
54	"				1	1	1	1	1	1	1	1	1	1	1	1	1	1
55A	"				1	1	1	1	1	1	1	1	1	1	1	1	1	1
56B	"				1	1	1	1	1	1	1	1	1	1	1	1	1	1
56A	"				1	1	1	1	1	1	1	1	1	1	1	1	1	1
56	"				1	1	1	1	1	1	1	1	1	1	1	1	1	1
56C	"				1	1	1	1	1	1	1	1	1	1	1	1	1	1
57	"				1	1	1	1	1	1	1	1	1	1	1	1	1	1
57A	"				1	1	1	1	1	1	1	1	1	1	1	1	1	1
57B	"				1	1	1	1	1	1	1	1	1	1	1	1	1	1
58	"				1	1	1	1	1	1	1	1	1	1	1	1	1	1

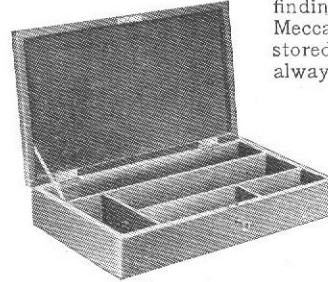
Contents of Outfits—continued

NO.	DESCRIPTION OF PART.	00	00A	0	0A	1	1A	2	2A	3	3A	4	4A	5	5A	6	6A	7
59	Collars with Set Screws
61	Windmill Sails
62	Cranks
62A	Threaded Cranks
63	Couplings
63B	Strip Couplings
64	Threaded Bosses
65	Centre Forks
66	Weights, 50 Gramme
67	Flat Plates, $5\frac{1}{2}'' \times 2\frac{1}{2}''$
70	" " $2\frac{1}{2}'' \times 2\frac{1}{2}''$
72	Triangular Plates, $2\frac{1}{2}''$
76	" " $1\frac{1}{2}''$
78	Screwed Rods, $1\frac{1}{2}''$
80	" " $3\frac{1}{2}''$
80A	" " $4\frac{1}{2}''$
80B	" " $2''$
81	" " $1''$
82	Curved Strips, $5\frac{1}{2}''$
89	" " $2\frac{1}{2}''$, large radius
90	" " $2\frac{1}{2}''$, small
90A	Sprocket Chain
94	Sprocket Wheels, $2''$
95	" " $3''$
95A	" " $1''$
95B	" " $4''$
96	" " $3''$
96A	Braced Girders, $3\frac{1}{2}''$
97	" " $2\frac{1}{2}''$
98	" " $12\frac{1}{2}''$
99	" " $5\frac{1}{2}''$
99A	" " $9\frac{1}{2}''$
100	" " $7\frac{1}{2}''$
101	Headis for Looms
102	Single Bent Strips
103	Flat Girders, $5\frac{1}{2}''$
103A	" " $9\frac{1}{2}''$
103B	" " $12\frac{1}{2}''$
103D	" " $3\frac{1}{2}''$
103E	" " $3''$
103F	" " $2\frac{1}{2}''$
103G	" " $1\frac{1}{2}''$
103H	" " $7\frac{1}{2}''$
104	Shuttles for Looms
105	Reed Hooks
106	Wood Rollers
106A	Sand Rollers
107	Designing Tables
108	Architraves
109	Face Plates, $2\frac{1}{2}''$
110	Rack Strips, $3\frac{1}{2}''$
111	Bolts, $\frac{3}{8}''$
111A	" " $\frac{1}{2}''$
111C	" " $\frac{3}{4}''$
113	Girder Frames
114	Hinges
115	Threaded Pins
116	Fork Pieces
116A	Small Fork Pieces
118	Hub Discs ($5\frac{1}{2}''$ diam.)
119	Channel Segments (8 to circle)
120A	Spring Buffers
120B	Compression Springs
121	Train Couplings
122	Miniature Loaded Sacks
123	Cone Pulleys
124	Reversed Angle Brackets, $1''$
125	" " $1\frac{1}{2}''$
126	Trunnions
126A	Flat Trunnions
128	Boss Bell Cranks
129	Rack Segments ($9''$ diam.)
130	Triple Throw Eccentrics
131	Dredger Buckets
132	Flywheels, $2\frac{1}{2}''$
133	Corner Brackets
134	Crank Shafts, $1''$ stroke
135	Theodolite Protractors
136	Handrail Supports
137	Wheel Flanges
138A	Ship's Funnels, Cuneard Type
140	Universal Couplings
141	Wire Lines
142	Rubber Rings, $3''$ diam.
142b	Dunlop Tyres, $3''$ internal diam.
143	Circular Girders ($5\frac{1}{2}''$ diam.)
144	Dog Clutches
145	Circular Strips ($7''$ diam. overall)
147A	Pawls
147B	Pivot Bolt with two nuts
148	Ratchet Wheels
149	Electric Collecting Shoes
155	Rubber Rings, $\frac{3}{8}''$
157	Fans, $2''$ diam.
159	Circular Saws
160	Channel Bearings
162	Boiler, Complete with Ends

No.	DESCRIPTION OF PART.	00	00A	0	0A	1	1A	2	2A	3	3A	4	4A	5	5A	6	6A	7
163	Sleeve Pieces
164	Chimney Adaptors
165	Swivel Bearings
166	End Bearings
169	Digger Buckets
301	Bobbins
302	Bushes, Insulating
303	Washers
304	6 B.A. Screws
305	6 B.A. Nuts
306	Terminals
307	Contact Screw
308	Pole Pieces
309	Coil Checks
310	Lamp Holders
311	Lamps
312	27 Gauge B.I. Wire, 30" coils
313	26 " S.C.C. Wire, reel 50 yds.
314	23 " S.C.C. Wire, reel 25 yds.
315	Bare Copper Wire, 4 yds. coil
	Electric Manual of Instructions
	Clockwork Motors
	Electric Motor No. 1 (4-volt)
	Accumulators (8 amp.)
	Instruction Leaflets:
	No. 9—Bagatelle Table
	7—Platform Scales
	10—Log Saw
	11—Horizontal Steam Engine
	12—Stone-sawing Machine
	1—Motor Chassis
	5—Dredger
	17—Planing Machine
	18—Revolving Crane
	19—Steam Shovel
	13—Meconograph
	6—Stiff Leg Derrick
	20—Astroscope
	21—Transporter Bridge
	22—Tractor
	23—Vertical Log Saw
	14—Grandfather's Clock
	16—Loom
	24—Travelling Gantry Crane
	25—Hydraulic Crane
	2—High-speed Ship-Cooler
	26—Twin-elliptic Harmonograph
	3—Motor Cycle and Sidecar

STORAGE BOXES FOR MECCANO PARTS

The boxes illustrated and described below are specially designed for the purpose of storing Meccano parts. Almost every Meccano boy purchases additional parts from time to time, but there is sometimes difficulty in finding suitable accommodation for them. The Meccano Storage Boxes enable extra parts to be stored neatly and methodically so that they are always easily accessible.



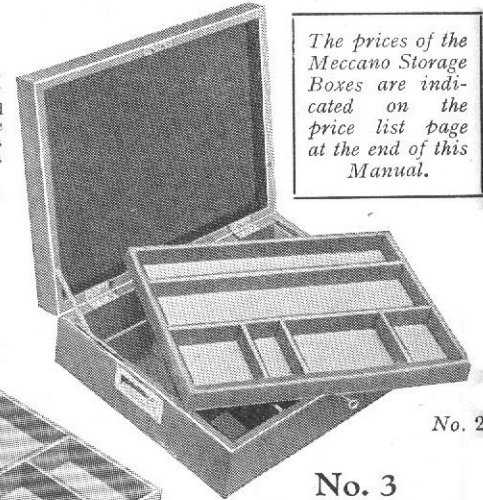
No. 1 Storage Box

Stained and varnished in rich oak finish, and fitted with partitions, as shown in the illustration. The lid is hinged and is secured by means of lock and key.
 Dimensions: Length 15½ ins. Width 8½ ins. Depth 2½ ins.

No. 1

No. 2 Storage Box

Finished as No. 1 Box and provided with lock and key. The tray with which it is fitted enables a much larger quantity of parts to be accommodated.
 Dimensions: Length 14½ ins. Width 11 ins. Depth 3½ ins.



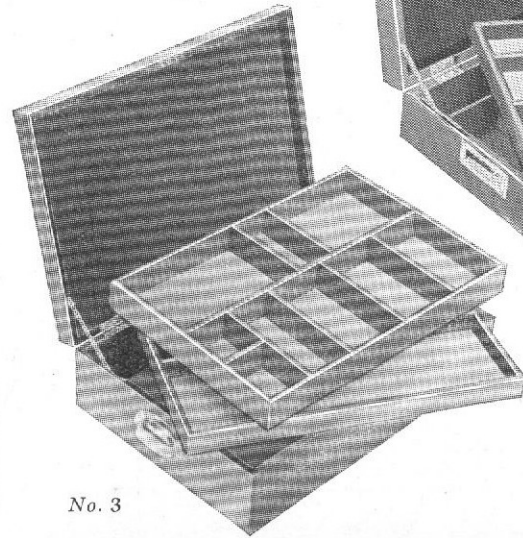
The prices of the Meccano Storage Boxes are indicated on the price list page at the end of this Manual.

No. 2

No. 3 Storage Box

A perfect receptacle for Meccano parts, finished similarly to the No. 1 and No. 2 boxes and provided with lock and key. In addition to accommodation in the bottom section of the box there are two partitioned trays which fit neatly in position one above the other.
 Dimensions: Length 20 ins. Width 14 ins. Depth 5½ ins.

No. 3



HORNBY TRAINS

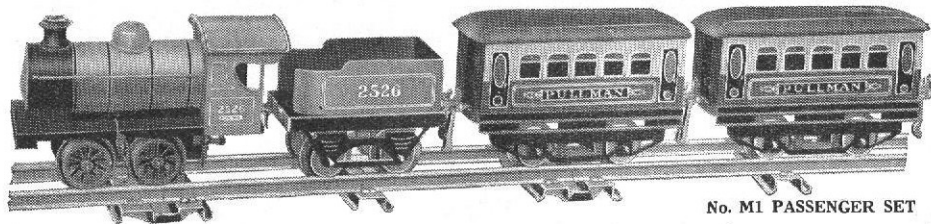
Hornby Trains are manufactured by Meccano Limited and they are made from the finest materials obtainable. Each train is a beautiful piece of workmanship with perfect mechanism. All Hornby Locos are carefully tested before leaving the factory and their efficiency is guaranteed.

No. M 1 Passenger Set

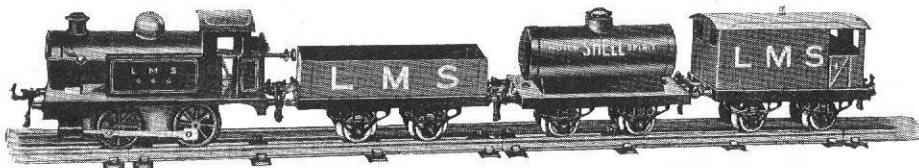
This set contains Loco, Tender, two Pullman Coaches and set of Rails. One of the latter is a brake rail by means of which the train may be braked from the track. Richly coloured and well finished; fitted with brake mechanism; non-reversing. Gauge 0.

No. M 2 Passenger Set

Similar in every way to the above excepting that it has three Pullman Coaches instead of two, and additional rails.



No. M1 PASSENGER SET



No. 1 TANK GOODS SET

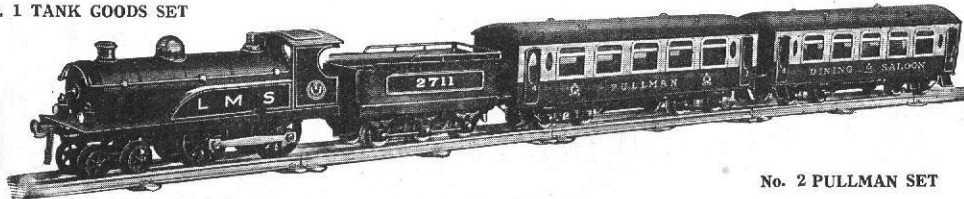
No. 1 Tank Goods Set

This set contains a No. 1 Hornby Tank Loco, Hornby Wagon, Petrol Tank Wagon, Brake Van and set of Rails to form either a circle 2 ft. in diameter or an oval 2 ft. in width by 2 ft. 10 in. in length. One of the rails is a brake rail by means of which the train may be braked from the track.

Gauge 0, in colours to represent the L.M.S.R., L.N.E.R., G.W.R. or S.R. Companies' rolling stock. The Loco is fitted with reversing gear and brake mechanism.

No. 2 Pullman Set

This set includes Loco and Tender of a larger type, measuring 17 in. in length. The Coaches are beautiful both in colour and finish. Each set includes Loco, Tender, and two Pullman Coaches, with set of Rails making a 4 ft. diameter circle. The rails include one brake rail by means of which the train may be both braked and reversed from the track. In colours to represent the L.M.S.R., L.N.E.R., G.W.R. or S.R. Companies' rolling stock. The Loco is fitted with reversing gear and brake mechanism. Gauge 0.



No. 2 PULLMAN SET

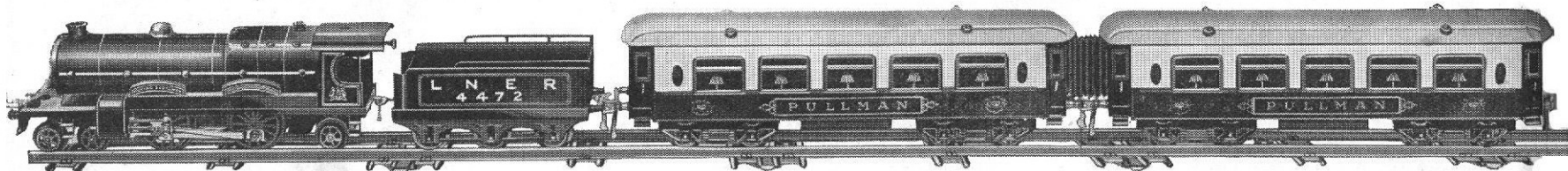
No. 3 Train Sets

These Train Sets are the latest additions to the range of Hornby Trains. They are distinctive in design, beautifully enamelled in correct colours and are guaranteed to give the utmost satisfaction.

Each locomotive carries the name of a famous British locomotive on the front wheel guard at each side. A special feature of the Pullman Coaches is the corridor connection, which gives the

Train a most realistic appearance. All the doors of the coaches open.

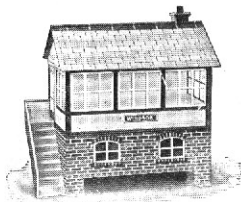
The Trains in this series are "Cornish Riviera" (G.W.R.), "Flying Scotsman" (L.N.E.R.), "Royal Scot" (L.M.S.R.), and "Dover Pullman" (S.R.). In each case the Train Set is available with either Clockwork or 4-Volt Electric Motor. Gauge 0.



No. 3C L.N.E.R. "FLYING SCOTSMAN"

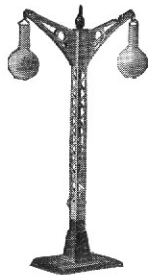
For prices of the above see price list at end of Manual.

ROLLING STOCK AND ACCESSORIES

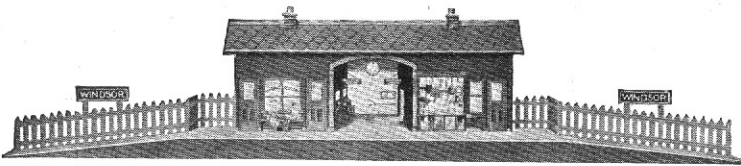


SIGNAL CABIN No. 2

Dimensions: Height 6½-in., Width 3½-in., Length 6½-in. Finished in colours and lettered "Windsor." Roof and back open to allow a signal lever frame to be fitted inside cabin, if desired, and operated ... Price 12/-

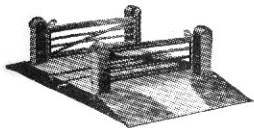


LAMP STANDARD No. 2 (DOUBLE)
Four-volt bulbs may be fitted into the globes.
Price 7/-



RAILWAY STATION No. 2. Excellent model, beautifully designed and finished. Constructed in three sections which are detachable. Dimensions: Length 2-ft. 9-in., breadth 6-in., height 7-in. ... Price 20/-

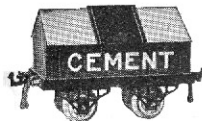
THE Hornby system consists of a complete range of Rolling Stock, Train Accessories, and Rails, Points and Crossings, with which the most elaborate model railway may be constructed. Every component in the Hornby Series is well designed and carefully modelled on its prototype in real life.



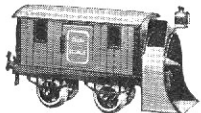
LEVEL CROSSING No. 1
Price 6/-



***CRANE TRUCK**
Finished in grey and black ... Price 5/6



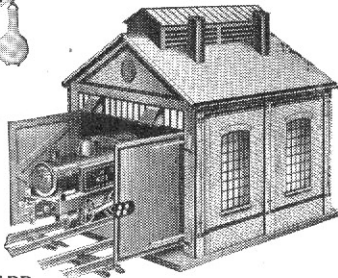
***CEMENT WAGON**
Finished in grey and black ... Price 5/-



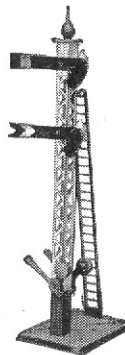
***SNOW PLOUGH**
With revolving plough driven from front axle.
Price 9/-



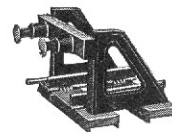
LAMP STANDARD No. 1 (SINGLE)
A 4-volt bulb may be fitted into the globe. Price 5/6



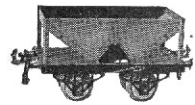
ENGINE SHED No. 1 (illustrated) Price 21/-
ENGINE SHED No. 2
Price 33/6



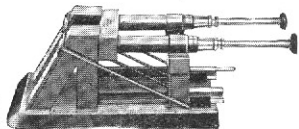
DOUBLE ARM SIGNAL
No. 1 Price 6/6 pair
No. 2 .. 5/6 each



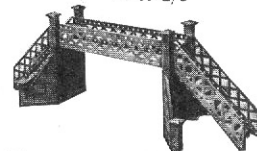
BUFFER STOPS No. 1 (SPRING)
Price 1/9



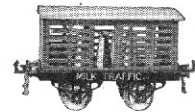
***HOPPER WAGON**
Mechanically unloaded. Finished in grey and black ... Price 6/6



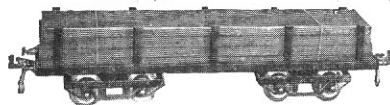
BUFFER STOPS No. 2 (HYDRAULIC)
Price 8/6



LATTICE GIRDER BRIDGE
Constructional type. Strong and well proportioned.
Price 16/6



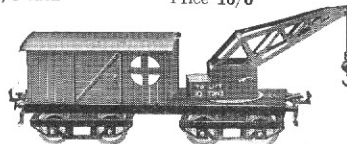
***MILK TRAFFIC VAN**
Fitted with sliding door, complete with milk cans.
Price 5/6



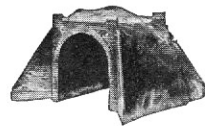
***TIMBER WAGON No. 2**
Beautifully enamelled in green. Suitable for 2-ft. radius rails only ... Price 5/6



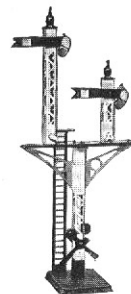
***TROLLEY WAGON**
Finished in grey and red. Suitable for 2-ft. radius rails only ... Price 9/-



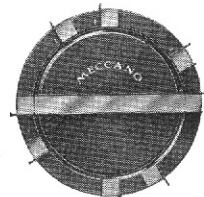
***BREAKDOWN VAN AND CRANE**
Beautifully coloured in grey and black, with opening doors. Suitable for 2-ft. radius rails only ... Price 10/6



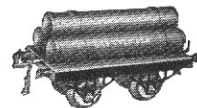
TUNNEL
Realistic and finished in colours ... Price 15/-



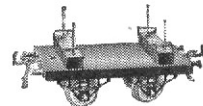
JUNCTION SIGNAL
Signal arms operated by levers at base. Very realistic model standing 14-in. in height.
Price 10/6



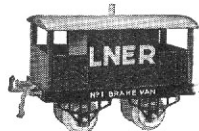
TURN-TABLE No. 1 Price 4/6
TURN-TABLE No. 2 (illustrated) Price 7/6



***GAS CYLINDER WAGON**
Finished in red, lettered gold. Price 4/6



***LUMBER WAGON No. 1**
Fitted with bolsters and stanchions for log transport.
Price 3/6



***BRAKE VAN**
Finished in grey, with opening doors. Price 5/6

*Lettered L.M.S., N.E., G.W. or S.R.

MECCANO MOTORS

Electric Motor No. 1 (4-Volt)

The 4-volt Motor is specially designed to build into Meccano models. It may be run from a 4-volt Accumulator, or, by employing a suitable transformer, direct from the main. It is fitted with reversing motion, provided with stopping and starting controls, and the gearing is interchangeable.

4-Volt Accumulators

These new and excellent types of Accumulators have been adapted to drive the Electric Motor No. 1. They have been subjected to the severest tests and have proved themselves to be the most suitable accumulators for use with any type of electric motor. They are non-spillable, have remarkable recuperative powers, and will continue to supply current when nominally exhausted.

Transformer

By means of this transformer the Meccano Electric Motor No. 1 (4 volt) may be driven direct from the house supply (alternating current only). It is available for all standard supply voltages, from 100 to 250 inclusive, at all standard frequencies. The supply voltage and frequency must be specified when ordering.

Resistance Controller

By employing this variable resistance the speed of the Meccano Electric Motor No. 1 (4 volt) may be regulated as desired. The controller is connected in series with the motor and accumulator, or with the motor and transformer if a transformer is used as the source of power. It will not regulate the speed of a high-voltage motor connected to the main.

Electric Motor No. 2 (100-250 Volt AC or DC)

This reversible Electric Motor may be employed for any purpose for which a small motor is suitable, but it is specially adapted for driving Meccano models. The side plates are perforated with standard equidistant holes, thus allowing the motor to be built into any Meccano model. The motor is specially designed for connection with the electric-light main. It is suitable for 100-120 volts or 200-250 volts (alternating or direct), and is supplied with a 6 ft. length of flex, an insulated plug for connection with the motor terminals, and an adapter for connection with an ordinary lamp socket.

A suitable resistance is required when the motor is run with a 200-250-volt current, and this is supplied by connecting a 60-watt lamp in series with the motor. A board on which are mounted a suitable lamp-holder (lamp not included) and a switch is provided separately.

Clockwork Motor

The Meccano Clockwork Motor is specially made for the purpose of driving Meccano models. It is a fine piece of mechanism—simple, powerful, and reliable. The starting, stopping and reversing levers enable the operator to control the various movements of a model in exactly the same manner as an engineer does in actual practice.

MECCANO ACCESSORY OUTFITS

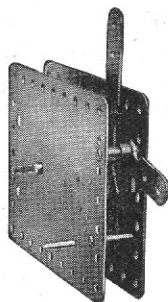
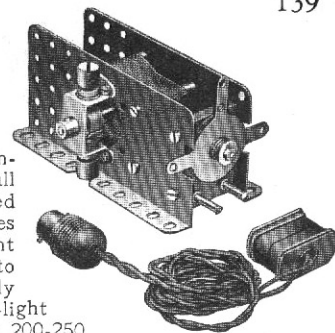
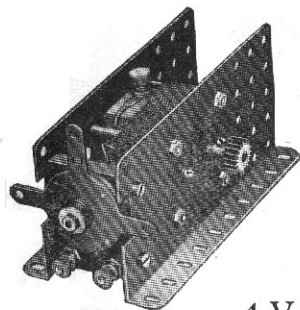
Meccano Accessory Outfits

Our illustration shows one of the Meccano Accessory Outfits. As has already been explained, these Outfits connect the main Outfits from No. 00 to No. 7, making it possible for a boy who commences with one of the earlier Outfits to build up his equipment by easy stages, until he is the possessor of parts that cover the entire system.

Special Inventor's Outfit

This Outfit is intended for boys who already have Meccano, and who wish to satisfy their inventive inclinations by building models from their own designs. The parts contained include four large Pulley Wheels with Dunlop Tyres, Ball Race, Ship's Funnel, Pulley Blocks, Channel Bearing, Crane Grab and many others.

For prices of above see price list at end of Manual.



**Patents and Designs
Great Britain**

20,535/13	253,236
22,962/13	648,958
3,869/14	671,484
4,183/14	671,485
4,564/15	671,534
139,125	671,790
177,430	680,416
250,378	682,208

MECCANO

THE TOY THAT MADE ENGINEERING FAMOUS

Millions of boys in every country throughout the world play with Meccano. These are the Meccano Factories and distributing centres.

**Patents and Designs
Great Britain**

682,209	686,112
682,934	698,054
683,011	718,404
718,731	

Australia

13,460/19	14,388/14
15,136/14	

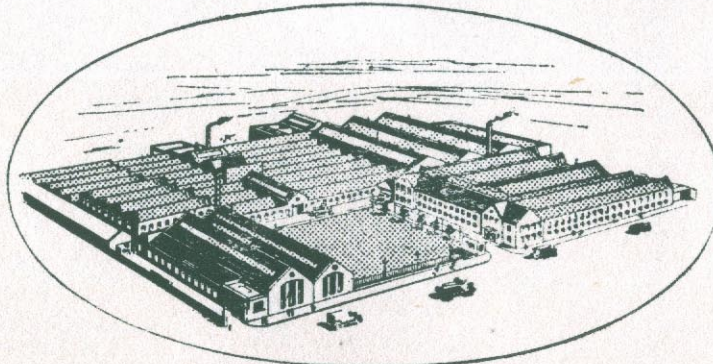


Meccano Ltd.,
5/6, Marshall Street,
London, W.1.

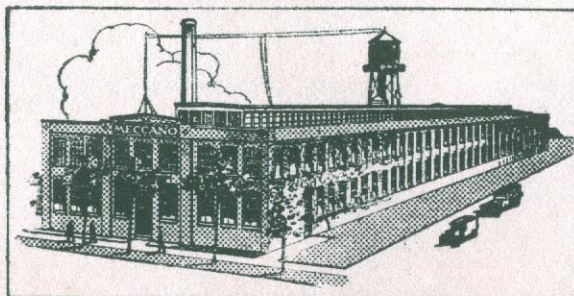
London Office and Warehouse :
Meccano Ltd.,
Walnut Tree Walk,
Kennington Road, London, S.E.11.

Meccano Agencies :

Algiers,	Bogota,
Amsterdam,	Bombay,
Auckland,	Brussels,
Barcelona,	Buenos Aires,
Basle,	Cape Town.



Head Office and Factory :
BINNS ROAD, LIVERPOOL.



Meccano Company Inc.,
Elizabeth, New Jersey, U.S.A.



Meccano (France) Ltd.,
78-80 Rue Rebeval,
Paris XIXeme.

Canadian Office and Warehouse :
Meccano Ltd.,
45, Colborne Street, Toronto.

Meccano Agencies :

Constantinople,	Malta,
Durban,	Monte Video
Genoa,	Oslo,
Iquitos,	Stockholm,
Johannesburg,	Sydney