

MECCANO

(TRADE MARKS 298321, 76, 12633, 10274, 55/13476, 589/13, 884/25, 2613, 80, 124, 336, 18966, 5409, 41812, 4174, 9048, 5549, 2389, 91637, 83171, 157149, 32822, 209639, 209733, 214061, 214062, 12892, 23094, 33318, 1818, 16737, 10200, 72286, 494933-4-5-6-7-8, 139429-1, 383/13, 5848, 30204, 10/12258, 22826, 18982, 20083/925, 2189, 7315, 490686).

HORNBY'S ORIGINAL SYSTEM—FIRST PATENTED IN 1901

INSTRUCTIONS

FOR OUTFITS

Nos. **00 to 3**

Price
1/6

Copyright by MECCANO LIMITED, LIVERPOOL, throughout the world

No. 29 A

ENGLISH EDITION

MECCANO

The Finest Hobby in The World for Boys

The Meccano system is composed of over two hundred and fifty different parts, mostly made of steel or brass, each one of which has a specific mechanical purpose. These parts combine to form a complete miniature engineering system with which practically any mechanical movement may be reproduced in model form. More can be accomplished with Meccano than with any other constructional toy, for no other system has such possibilities. The genius is in the parts and you can commence to build models as soon as you get your Outfit home. A screwdriver, provided in the Outfit, is the only tool necessary.

There is no limit to the number of models that can be built with Meccano—Cranes, Clocks, Motor Cars, Ship Coalers, Machine Tools, Locomotives—in fact everything that interests boys. The most wonderful feature about the system is that it is *real engineering* in miniature; it is fascinating and delightful and it gives you a satisfaction beyond anything that you have ever previously experienced.

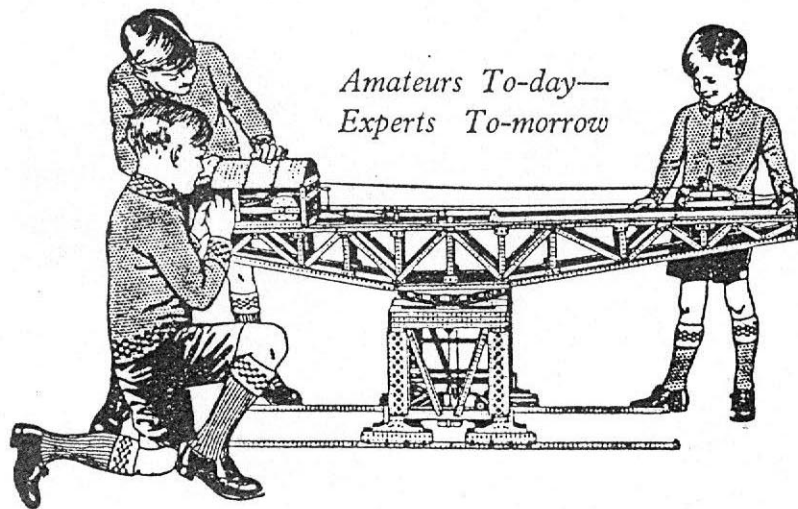

Model-Building with Meccano

Make the simple models first—they will provide hours of fun—and then try to improve them. Every model can be made in a dozen different ways. It is important to screw up all the nuts and bolts tightly to ensure that your models will be strong and firm when they are completed.

Every keen and inventive Meccano model builder should obtain copies of the special Manuals "How to use Meccano Parts" and "Meccano Standard Mechanisms." In the former the principal uses of Meccano parts are outlined, while the latter shows a large number of real engineering mechanisms, built of Meccano parts, that can be incorporated in various models. You can obtain copies of these Manuals from your dealer, or direct from Meccano Ltd., Binns Road, Liverpool 13, England.

How to Build up Your Outfit

Meccano is sold in ten different Outfits, numbered 000 to 7. All Meccano parts are of the same high quality and finish, but the larger Outfits contain a greater quantity and variety of parts, making possible the construction of more elaborate models. Each Outfit from No. 00 upwards may be converted into the one next higher by the purchase of an Accessory Outfit. Thus, a No. 00 may be converted into a No. 0 by adding to it a No. 00A. A No. 0A would then convert into a No. 1, and so on. In this way, no matter with which Outfit you commence you may build it up by degrees until you possess a No. 7 Outfit. It is important to remember that Meccano Parts may be bought separately at any time in any quantity from your Meccano dealer.

Meccano Service

The service of Meccano does not end with selling an Outfit and an Instruction Manual. When you want to know something more about engineering than is now shown in our books, or when you strike a tough problem of any kind, write to us. We receive over 200 letters from boys every day all the year round. Although all kinds of queries are put to us on all manner of subjects, the main interest is, of course, engineering. The wonderful knowledge of engineering matters possessed by our staff of experts is unique. This vast store of knowledge, gained only by many years of hard earned experience, is at your service. *We want the Meccano boy of to-day to be the famous engineer of to-morrow.*

MECCANO

THE TOY THAT MADE ENGINEERING FAMOUS

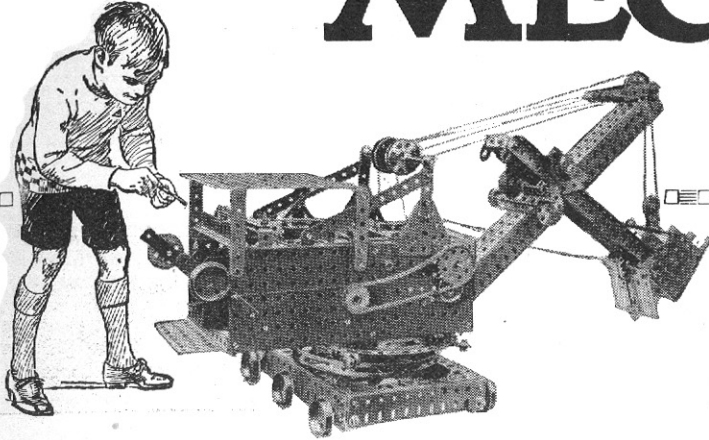

The Meccano system consists of accurately made and highly finished engineering parts with which almost every mechanical movement known may be reproduced in model form. More can be accomplished with Meccano than with any other constructional toy, for no other system has such possibilities. The genius is in the parts and the youngest boy can commence to build models as soon as he gets his Outfit home. A screwdriver, provided in the Outfit, is the only tool necessary.

When you have built all the models shown in this book you will want to build others of a more advanced type, and you cannot do better than purchase a copy of the No. 4-7 Manual from your dealer. This Manual contains illustrations of a fine

selection of models, a large number of which you will be able to build by adding a few extra parts to your equipment.

There is practically no limit to the number of models that can be built with Meccano. The most wonderful feature about the system is that it is *real engineering*; it is fascinating and delightful and it gives you a satisfaction beyond anything that you have ever previously experienced.

IF IN DOUBT WRITE TO MECCANO LIMITED

The service of Meccano does not end with selling an Outfit and an Instruction Manual. When you want to know something more about engineering than is now shown in our books, or when you strike a rough problem of any kind, write to us. We receive over 200 letters from boys every day all the year round. Some write to us because they are in difficulty, others because they want advice on their work or pleasures, or about their choice of a career. Others, again, write to us just because they like to do so and we are glad to know that they regard us as their friends.

Although all kinds of queries are put to us on all manner of subjects, the main interest is, of course, engineering. No one has such a wonderful knowledge of engineering matters as that possessed by our staff of experts. This vast store of knowledge, gained only by many years of hard-earned experience, is at your service. *We want the Meccano boy of to-day to be the famous engineer of to-morrow.*

HOW TO BUILD WITH MECCANO

Make the simple models first—there is loads of fun in them—and then try to improve them. Every model can be made in a dozen different ways. It is important to screw up all the nuts and bolts tightly to ensure that your models will be strong and firm when they are completed. When you want to add more parts to your Outfit so that you can build bigger models, you can always get them from your dealer.

Each Outfit may be converted into the one next higher by the purchase of an Accessory Outfit. Thus, a No. 2 may be converted into a No. 3 by adding to it a No. 2A. A No. 3A would then convert it into a No. 4 and so on. In this way, no matter with which Outfit you commence you may by degrees build it up until you have the largest Outfit.

All models shown in this Manual are numbered and for reference purposes each model number is preceded by the number of the Outfit with which it may be built. Thus, for example, model No. 00.60 may be built with No. 00 Outfit, and model No. 2.20 with No. 2 Outfit.



THE "MECCANO MAGAZINE"

The *Meccano Magazine* is the Meccano boy's newspaper. It tells him of the latest Meccano models; what Meccano Clubs are doing how to correspond with other Meccano boys; the Competitions that are running, etc. It contains interesting articles on engineering and electrical subjects, and deals with many other topics of interest to boys, including suggestions from Meccano boys for new Meccano parts and correspondence columns in which the Editor replies to his readers' enquiries. Write to the Editor, *Meccano Magazine*, Binns Road, Liverpool, giving the names and addresses of three of your chums who are not Meccano boys and enclosing 1/- in stamps. He will then forward a specimen copy of the "M.M." post free. It is sent regularly to subscribers at the rate of 7/- for six issues, post free, or it may be ordered from any Meccano dealer, newsagent or bookstall, price 1/- per copy.



MECCANO STANDARD MECHANISMS

There are a number of Meccano movements that have to a certain extent become standardised, that is to say they may be applied to more than one model, in most cases without any alteration, but in some few instances with only slight alterations to the original movement. These have been collected and classified, and may be obtained in the form of a Manual entitled "Meccano Standard Mechanisms." It will be observed that many of these Standard Mechanisms are referred to in the instructions for building the more intricate models in this book.

You may obtain a copy of the "Standard Mechanisms" Manual from your dealer, price 1/6, or direct from Meccano Ltd., Binns Road, Liverpool, price 1/7½ post free.



IMPROVED MECCANO PARTS

A number of models included in this Manual show the new style 5½" x 2½" Flanged Plate (with flanges at the ends as well as the sides) and improved Sector Plate (with two additional rows of holes), but it should be noted that, although the new parts are more adaptable, the old-style plates may still be used in their place if desired. When it is required to journal an Axle Rod in a slot in the new Flanged Plates, an ordinary Strip should first be bolted to the Plate so that one of its holes forms an additional bearing for the Rod.

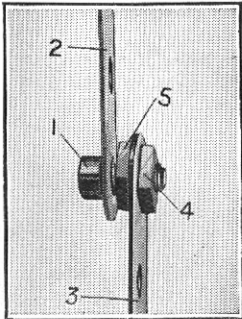

Standard Mechanisms
No. 262

SIMPLE MECCANO PIVOTS

In building Meccano models it is frequently required to attach two parts together so that one or both are quite free to swivel. A very simple way to do this is shown under detail number 262 in the Meccano Standard Mechanisms Manual, and for the benefit of those readers who are unable to consult the special Manual, we have reproduced this detail. As will be seen, it consists of a simple type of pivot or swivel bearing formed by a bolt and two nuts. The bolt is secured rigidly to a Strip or Plate, etc., by means of the nuts, which are secured tightly against opposite sides of the Strip, sufficient space being left beneath the head of the bolt to permit another Strip to turn freely about its shank.

A somewhat similar form of swivel-joint, also widely used, consists of a bolt and lock-nuts (Standard Mechanisms No. 263). The two Strips to be connected pivotally are placed on the bolt and held in position by two nuts locked together on the shank. The Strips must be allowed a certain amount of play so that they can pivot independently about the bolt. These pivoting devices will be found equally valuable in the simplest and the most elaborate models.

Particulars and Prices of Meccano Parts (continued)

No.	Description	Quantity	s. d.
89.	5 1/2" Curved Strips, 10" radius	each 0	3
89a.	3" Curved Strips, cranked, 1 1/2" radius, 4 to circle	" 0	3
90.	2 1/2" " " 2 1/2" radius	" 0	2
90a.	2 1/2" " " cranked, 1 1/2" radius, 4 to circle	" 0	2
94.	Sprocket Chain	per 40" length	0 9
*95.	Sprocket Wheels, 2" diam.	each 0	8
*95a.	" " 1 1/2" " " " " " "	" 0	6
*95b.	" " 3" " " " " " "	" 0	9
*96.	" " 1" " " " " " "	" 0	5
*96a.	" " 1/2" " " " " " "	" 0	5
97.	Braced Girders, 3 1/2" long	1/2 doz. 1	3
97a.	" " 3" " " " " " "	" 1	0
98.	" " 2 1/2" " " " " " "	" 1	0
99.	" " 1 1/2" " " " " " "	" 3	9
99a.	" " 9 1/2" " " " " " "	" 3	0
99b.	" " 7 1/2" " " " " " "	" 3	0
100.	" " 5 1/2" " " " " " "	" 1	6
100a.	" " 4 1/2" " " " " " "	" 1	3
101.	Healds, for looms	doz. 1	3
102.	Single Bent Strips	each 0	2
103.	Flat Girders, 5 1/2" long	1/2 doz. 1	3
103a.	" " 9 1/2" " " " " " "	" 1	9
103b.	" " 12 1/2" " " " " " "	" 2	0
103c.	" " 14 1/2" " " " " " "	" 1	3
103d.	" " 3 1/2" " " " " " "	" 1	0
103e.	" " 3" " " " " " "	" 0	9
103f.	" " 2 1/2" " " " " " "	" 0	8
103g.	" " 2" " " " " " "	" 0	6
103h.	" " 1 1/2" " " " " " "	" 0	6
103k.	" " 7/8" " " " " " "	" 1	6
*104.	Shuttles, for looms	each 1	1 3
105.	Reed Hooks, for looms	" 0	6
106.	Wood Rollers	" 2	3
106a.	Sand Rollers	" 2	9
107.	Tables for Designing Machines	" 2	3
108.	Architraves	" 0	3
109.	Face Plates, 2 1/2" diam.	" 0	6
110.	Rack Strips, 3 1/2" " " " " " "	" 0	3
111.	Bolts, 1/2" " " " " " " "	" 0	1
111a.	" " 3 for 0	" 2	2
111c.	" " doz. 0	" 5	5
*113.	Girder Frames	each 0	5
*114.	Hinges	per pair 0	6
115.	Threaded Pins	each 0	3
*116.	Fork Pieces, Large	" 0	5
116a.	" Small	" 0	9
117.	Steel Balls, 3/8" diam.	doz. 0	5
118.	Hub Discs, 5 1/2" " " " "	each 1	9
119.	Channel Segments (8 to circle, 1 1/2" diam.)	" 0	6
120.	Buffers	" 0	3
120a.	Spring Buffers	per pair 1	0
120b.	Compression Springs	each 0	2
121.	Train Couplings	" 0	3
122.	Minure Loaded Sacks	" 0	3
*123.	Cone Pulleys	" 2	0
*124.	Reversed Angle Brackets, 1" " " " "	1/2 doz. 0	6
125.	Trunnions	" 0	5
126.	" " " " " " " "	each 0	3

No.	Description	Quantity	s. d.
126a.	Flat Trunnions	each 0	2
127.	Simple Bell Cranks	" 0	2
128.	Boss Bell Cranks	" 0	5
*129.	Rack Segments, 3" diam.	" 0	8
*130.	Triple Throw Eccentrics	" 1	6
131.	Dredger Buckets	1/2 doz. 1	6
132.	Flywheels, 2 1/2" diam.	each 3	0
133.	Corner Brackets	" 0	2
*134.	Crank Shafts, 1" stroke	" 0	3
135.	Theodolite Protractors	" 0	3
136.	Handrail Supports	" 0	5
137.	Wheel Flanges	" 0	5
138.	Ship's Funnels	" 0	5
138a.	" Cunard type	" 1	3
139.	Flanged Brackets (right)	" 0	3
139a.	" (left)	" 0	3
140.	Universal Couplings	" 1	3
141.	Wire Lines (for suspending clock weights)	" 1	0
142.	Rubber Rings, 3" rim	" 0	5
142a.	Dunlop Tyre to fit 2" diam. rim	" 0	6
142b.	" 3" " " " " " "	" 0	9
143.	Circular Girders, 5 1/2" diam.	" 1	6
144.	Dog Clutches	" 0	9
145.	Circular Strips, 7" diam. over all	" 1	3
146.	" Plates, 6" " " " " " "	" 1	6
*147.	Pawls, with pivot bolt and nuts	" 0	3
*147a.	" " " " " " " "	" 0	3
*147b.	Pivot Bolt with 2 nuts	" 0	3
148.	Ratchet Wheels	" 0	9
149.	Collecting Shoes, for Electric Locos	" 2	3
150.	Crane Grabs	" 1	0
151.	Pulley Blocks, Single Sheave	" 1	0
152.	" " Two	" 1	3
153.	" " Three	" 1	6
*154a.	Corner Angle Brackets, 1/2", right hand	1/2 doz. 0	9
*154b.	Corner Angle Brackets, 1/2", left hand	" 0	9
155.	Rubber Rings, 1/2" " " " "	each 0	2
*156.	Pointers, 2 1/2" over all, with boss	" 0	6
157.	Fans, 2" diam.	" 0	6
158a.	Signal Arms, Home	" 0	8
158b.	" Distant	" 0	8
*159.	Circular Saws	" 1	6
160.	Channel Bearings, 1 1/2" x 1" x 1/2"	" 0	3
162.	Boiler, complete with ends	" 1	6
162a.	Boiler ends	" 0	5
163.	Sleeve Pieces	pair 0	9
164.	Chimney Adaptors	each 0	3
165.	Swivel Bearings	" 0	9
166.	End	" 0	5
167.	Geared Roller Bearings	" 30	0
167a.	Roller Races, geared, 192 teeth	" 6	9
167b.	Ring Frames for Rollers	" 4	6
167c.	Pinions for Roller Bearings, 16 teeth	" 1	6
168.	Ball Bearings, 4" diam.	" 4	6
168a.	Ball Races, flanged	" 0	9
168b.	" geared	" 1	3
168c.	Ball Casings, complete with balls	" 2	9
169.	Digger Buckets	" 3	0
*170.	Eccentrics, 1/2" throw	" 1	3

Meccano Accessory Parts will be supplied in colours unless nickelled parts are specially ordered.

*IMPORTANT.—These parts in colours are available with nickel finish only.

PLATES

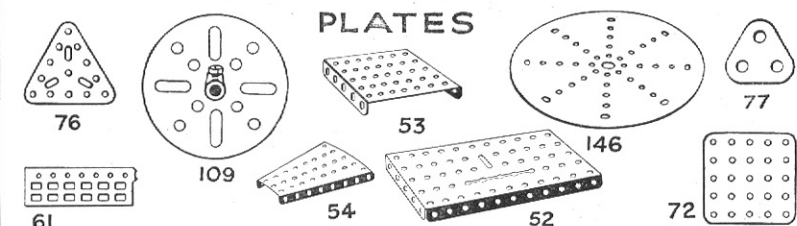

RODS, CRANKS AND COUPLINGS

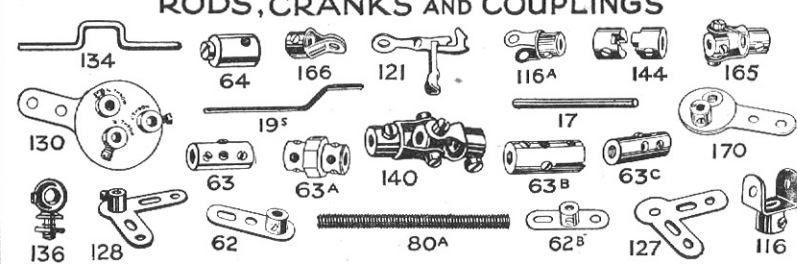

MISCELLANEOUS



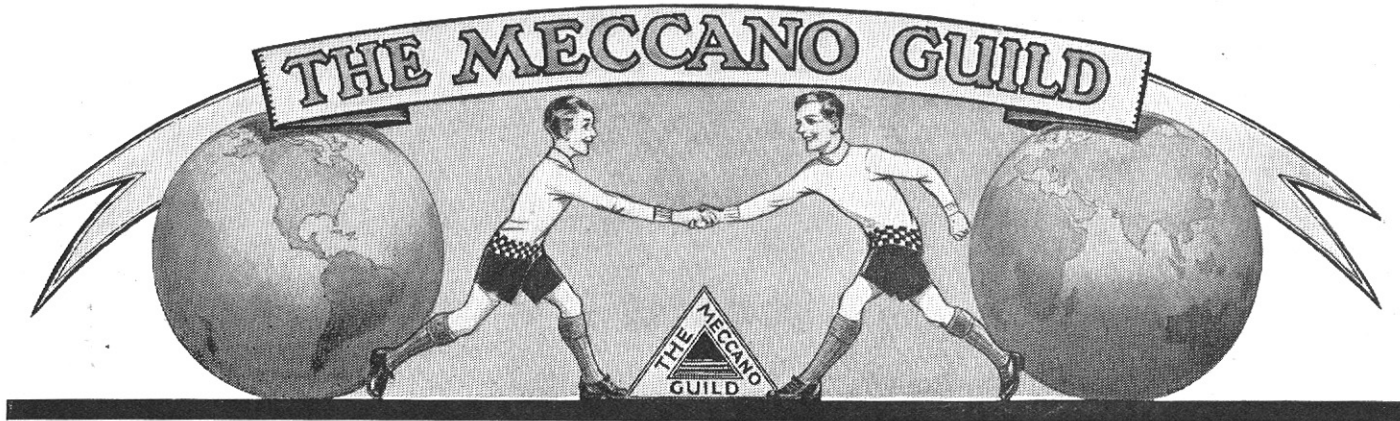

WHAT THE GUILD MEANS

THE Meccano Guild is an organisation for boys, started at the request of boys, and conducted as far as possible by boys. In joining the Guild a Meccano boy becomes a member of a great brotherhood of world-wide extent, every member of which has promised to observe its three great objects:—

- (1) *To make every boy's life brighter and happier.*
- (2) *To foster clean-mindedness, truthfulness, ambition, and initiative in boys.*
- (3) *To encourage boys in the pursuit of their studies and hobbies, and especially in the development of their knowledge of mechanical and engineering principles.*

HOW TO BECOME A MEMBER

MEMBERSHIP of the Guild is open to every boy possessing a Meccano Outfit, or Hornby Train Set, who satisfactorily fills in the prescribed application form. The only conditions are that members promise to observe the objects of the Guild and to wear their badges on all possible occasions.

The price of the Guild membership badge is 7d. post free in the United Kingdom, but members abroad will be required to pay 5d. extra for registered postage. A remittance for the necessary amount should be sent along with the form of application. The Guild badge is beautifully enamelled in blue and white and is made for wearing in the lapel of the coat.

MECCANO CLUBS

MECCANO CLUBS are founded and established under the guidance of the Guild Secretary at Headquarters and at the present time there are active Clubs in over one hundred towns and villages in the United Kingdom and in many countries Overseas. Each Club has its Leader, Secretary, Treasurer, and other officials all of whom, with the exception of the Leader, are boys. Write for information how to form a club, if there is no club near you.

Special awards are given to Club members for good work in connection with their Club and medallions are awarded in connection with the Recruiting Campaign, full particulars of which will be sent on request.



BADGE OF
MEMBERSHIP



GUILD
LEADER'S
BADGE



MECCANO GUILD
MEMBER'S CERTIFICATE



RECRUITING MEDALLION



SPECIAL MERIT MEDALLION

A Selection of Choice Meccano Models

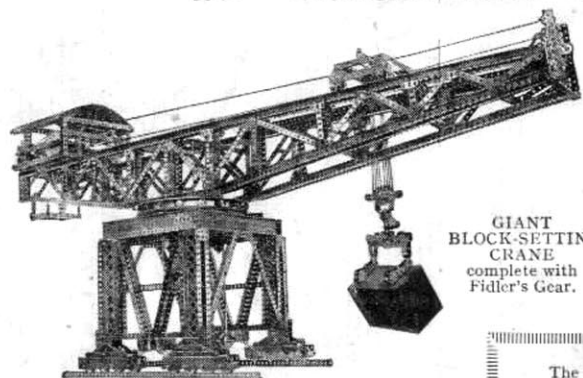

**GIANT
BLOCK-SETTING
CRANE**
complete with
Fidler's Gear.

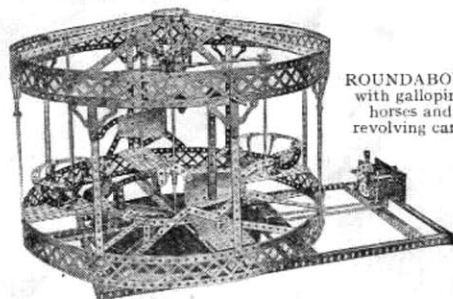

ROUNDABOUT
with galloping
horses and
revolving cars.

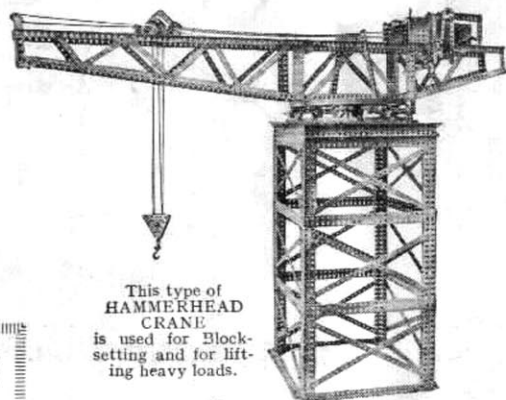

This type of
**HAMMERHEAD
CRANE**
is used for Block-
setting and for lift-
ing heavy loads.

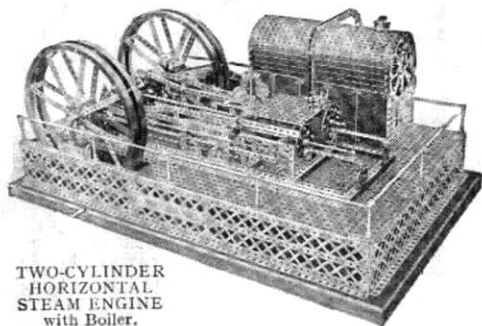

**TWO-CYLINDER
HORIZONTAL
STEAM ENGINE**
with Boiler.

The models illustrated on this page show the wonderful possibilities of Meccano. They comprise a selection from a range of super models that have been specially built for the delight of Meccano boys.

A descriptive leaflet giving full particulars of all the models in the series and the prices of the special Instruction Leaflets that are published in connection with them, may be obtained from your dealer or direct from Meccano Ltd., Binns Road, Old Swan, Liverpool.

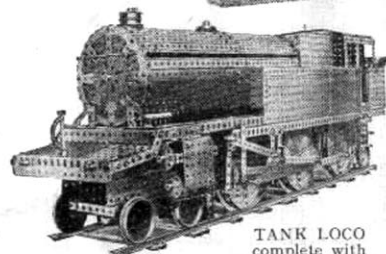

TANK LOCO
complete with
Walschaerts' Valve
Gear.

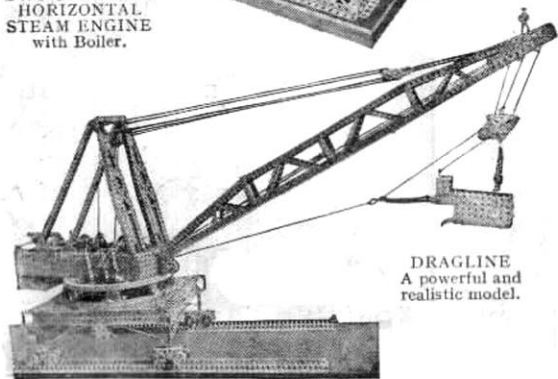

DRAGLINE
A powerful and
realistic model.

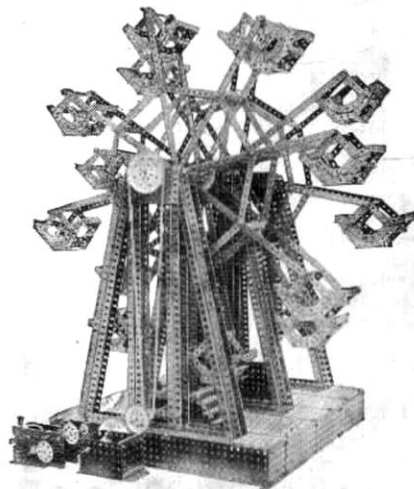

DOUBLE FLYBOATS. This is a most
impressive model when in motion.

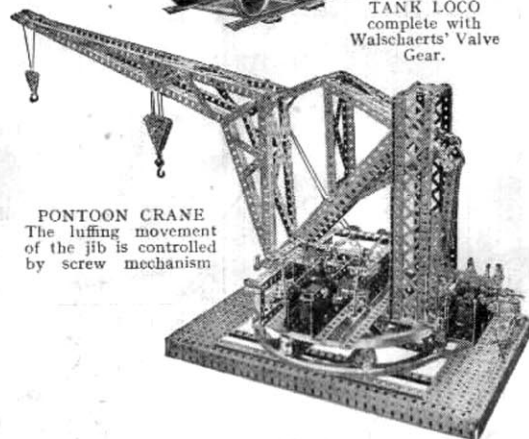

PONTOON CRANE
The luffing movement
of the jib is controlled
by screw mechanism

All these Models can be built with MECCANO Outfit No. 00

Model No. 00.1 Table

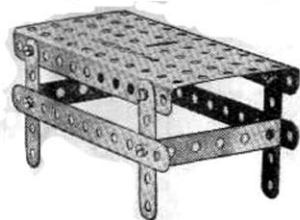

Model No. 00.2 Dividers



Model No. 00.4 Clothes Hanger

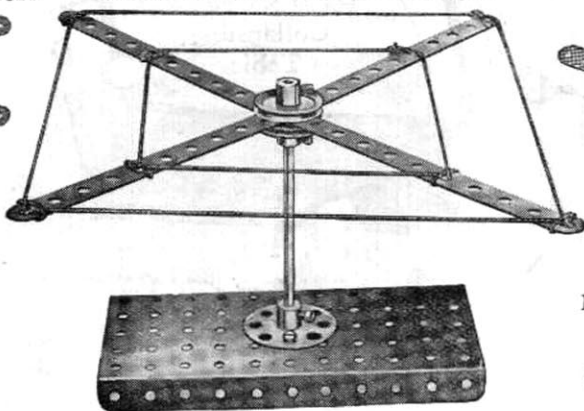

Model No. 00.5
Carpenter's Square



Model No. 00.7
Shipyard Bogie

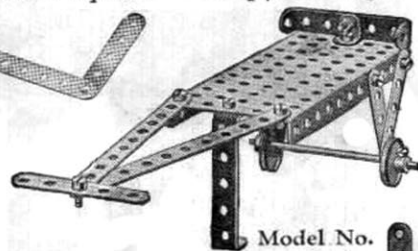

Model No. 00.3
Bench



Model No. 00.8
Meat Saw

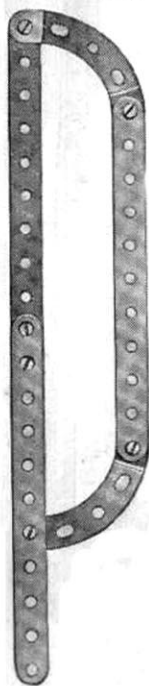

Model No. 00.6 Desk



Model No. 00.15
Rifle with
Bayonet



Model No. 00.14
Farm Sight



Model No. 00.9
Hand Cart

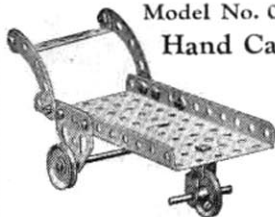

Model No. 00.11
Velocipede

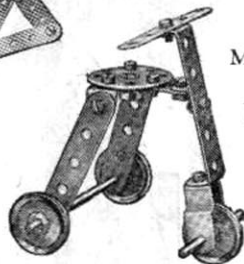

Model No. 00.12
Ladder

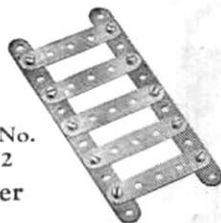

Model No. 00.13
Trowel

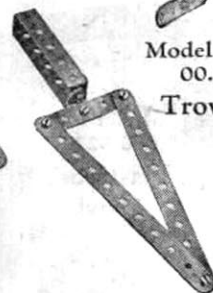

Model No. 00.10
Fire-Axe

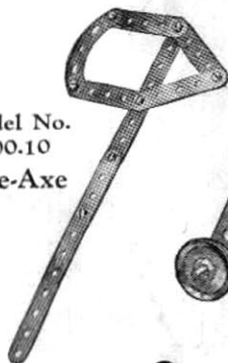

Model No. 00.16
Plough

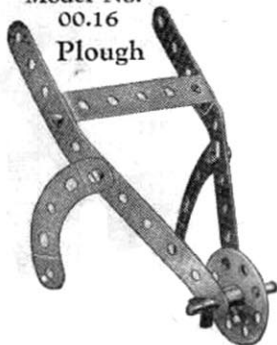

Model No. 00.17 Sled

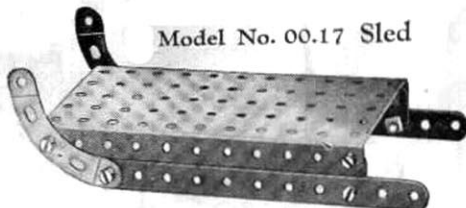

Model No. 00.18
Barrow

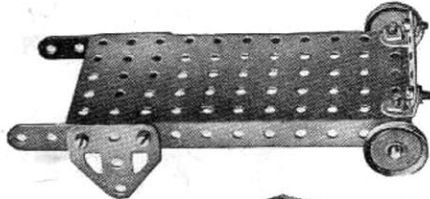
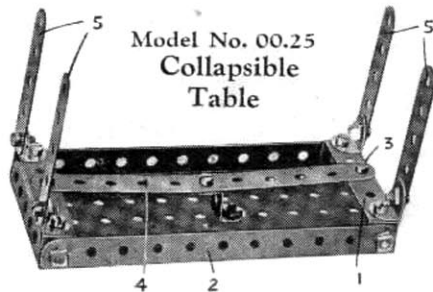

Model No. 00.19 Flat Truck

Model No. 00.25
Collapsible
Table

The $2\frac{1}{2}'' \times \frac{1}{2}''$ Double Angle Strips 1 are attached to the $5\frac{1}{2}'' \times 2\frac{1}{2}''$ Flanged Plate 2 by lock-nutted bolts, as in Standard Mechanism No. 263. The Bolts 3 are secured to the $5\frac{1}{2}''$ Strip 4 and their shanks engage with the centre holes in the $2\frac{1}{2}'' \times \frac{1}{2}''$ Double Angle Strips 1, thus maintaining the legs 5 in an upright position. When it is desired to fold up the legs 5, it is only necessary to raise the ends of the Strip 4, thus freeing the Double Angle Strips 1. The table is shown in the folded position in Fig. 00.25A.

Model No. 00.27 Trolley

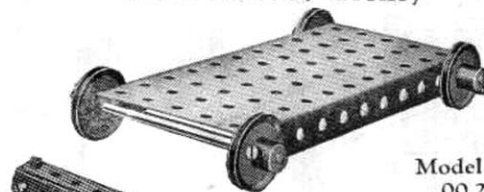
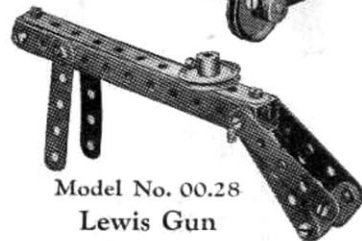
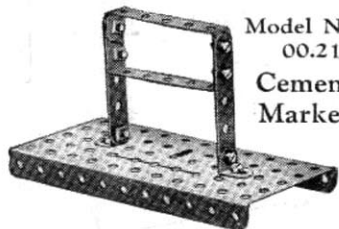
Model No.
00.29
Potato
ChopperModel No.
00.20
SpadeModel No.
00.21
Cement
Marker

Model No. 00.22 Motor Boat

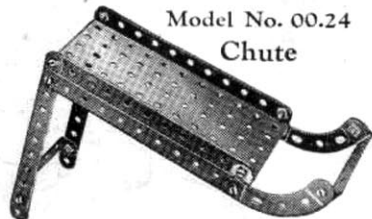
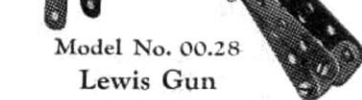
Model No.
00.23Plasterer's
HawkModel No. 00.24
ChuteModel No. 00.28
Lewis Gun

Model No. 00.30 Switch

Model No. 00.31
Mason's TrowelModel No. 00.32
Baggage CartModel No. 00.26
Spinning Top

FIG. 00.25A



All these Models can be built with MECCANO Outfit No. 00

Model No. 00.38 Roulette Wheel

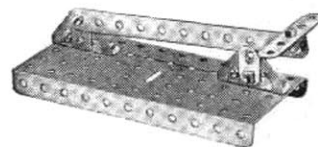
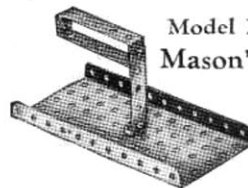
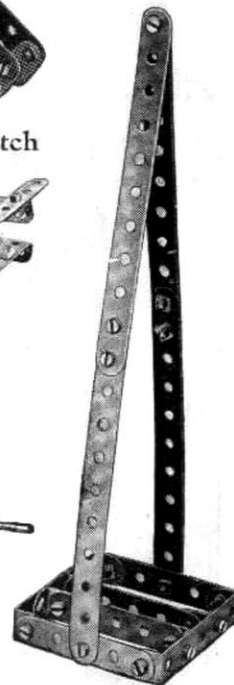
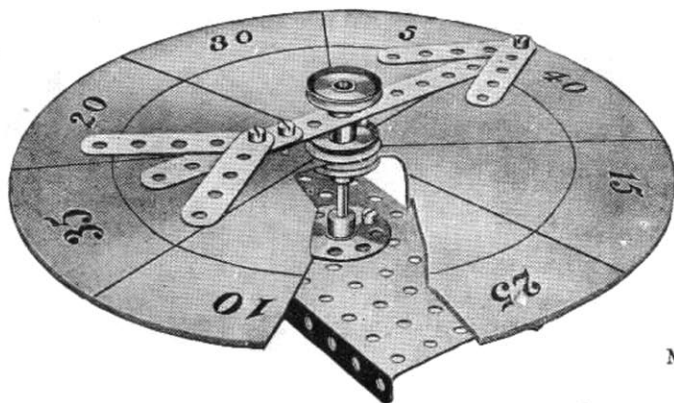

Model No. 00.42 Coat Hanger



Model No. 00.33 Axe

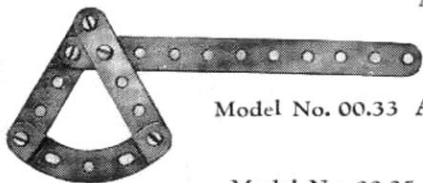

Model No. 00.35 Horse

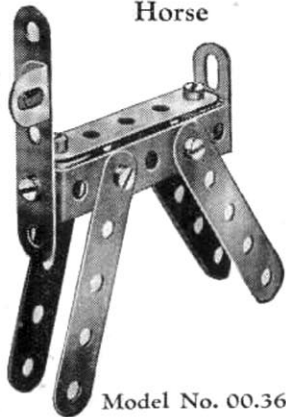

Model No. 00.34 Fork



Model No. 00.43 Roman Balance

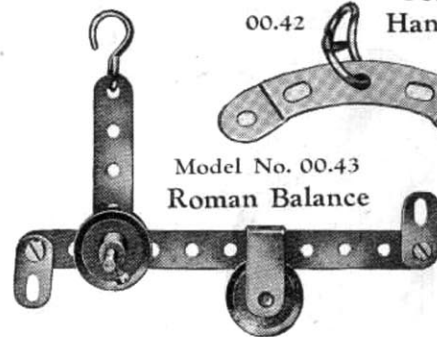

Model No. 00.44 Grill

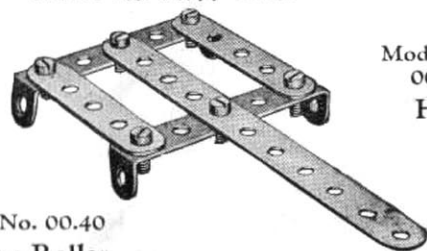

Model No. 00.45 Hoe

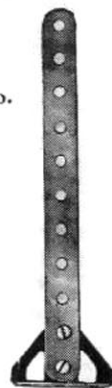

Cut out a circular piece of cardboard, and mark as shown to form scoring board. This is clamped between two 1" Pulley Wheels. The pointer revolves freely on the upright spindle and is held in position by another 1" Pulley Wheel.

Model No. 00.39 Pulley Shafting

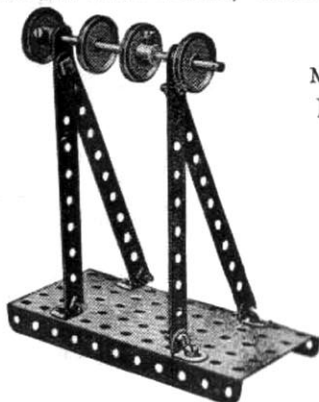

Model No. 00.40 Furrow Roller

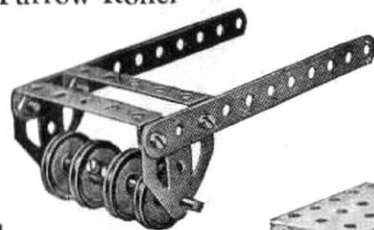

Model No. 00.36 Timber Truck

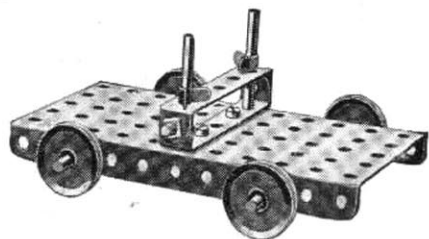

Model No. 00.37 Bogie Truck

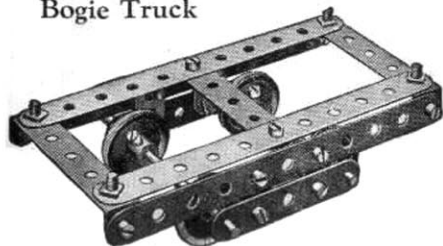

Model No. 00.46 Planing Bench

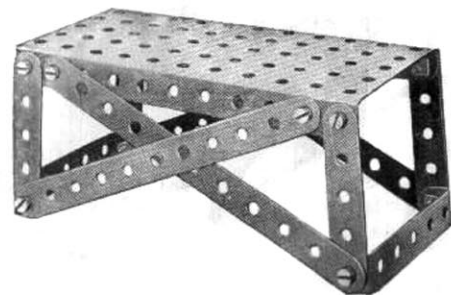

Model No. 00.41 Two-Hand Saw

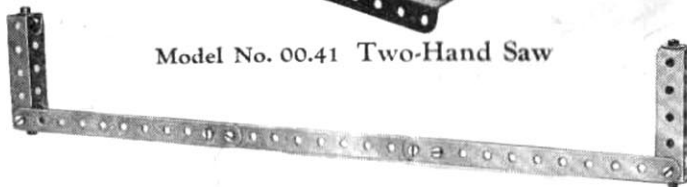

Model No. 00.47
Meccano Man

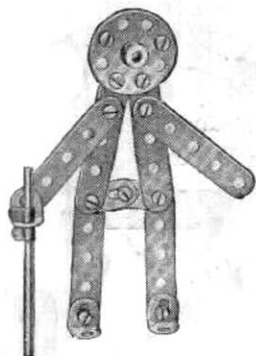

Model No. 00.48
Cannon

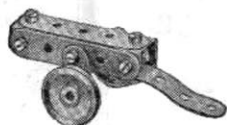

Model No. 00.49
Birdcage
and
Stand



Model No. 00.52 Gate

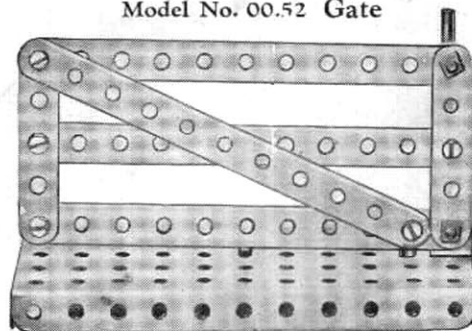

Model No. 00.56
Dog



Model No. 00.58
Clothes Horse

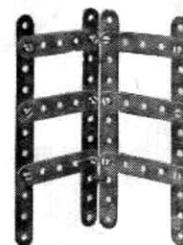

Model No. 00.57
Friction Grip Tong

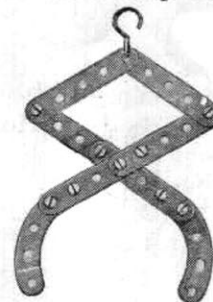

Model No. 00.50
Submarine

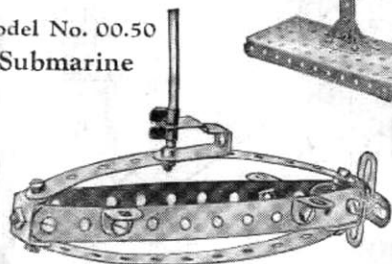

Model No. 00.53
Scrap
Reel

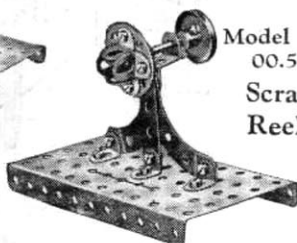

Model No. 00.54
Bed

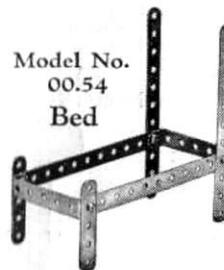

Model No. 00.59
Rake



Model No. 00.51 Pen Rack

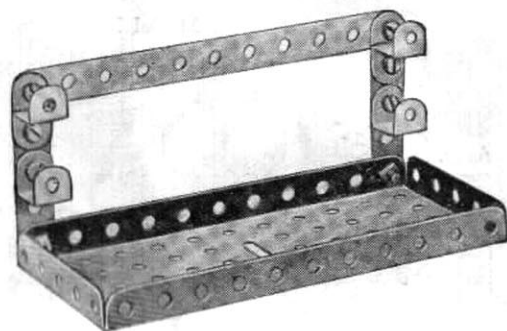

Model No. 00.55
Hanging Scales

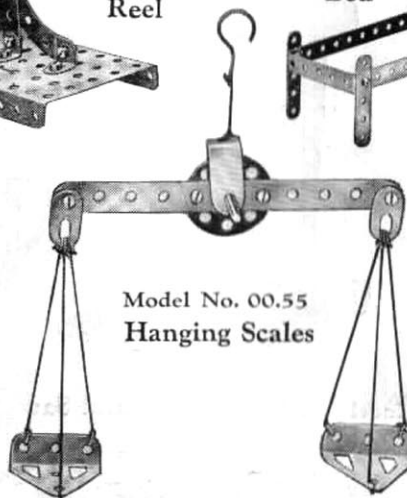

Model No. 00.60
Garden Seat

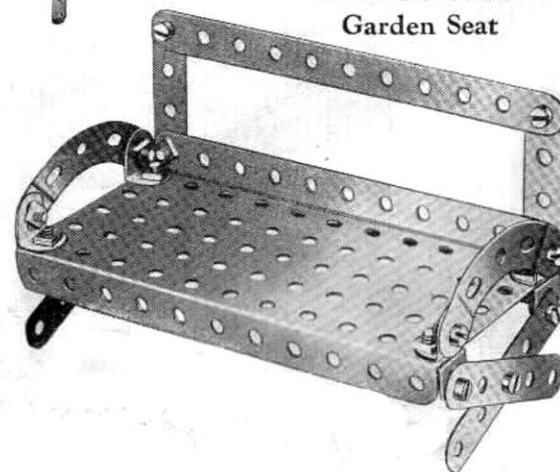

Model No. 00.61 Field Roller

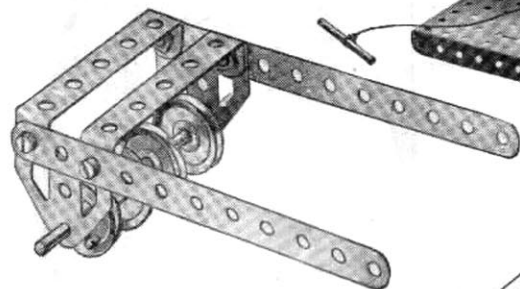

Model No. 00.62 Cheese Cutter

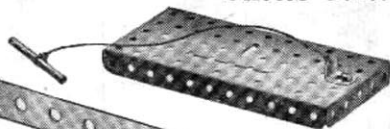

Model No. 00.67 Telegraph Key



Model No. 00.68 Buffers

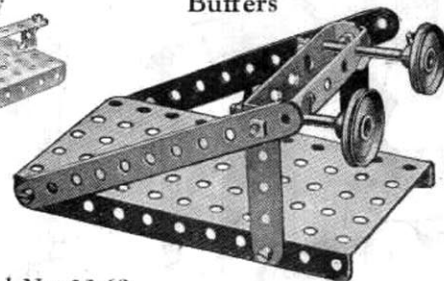

Model No. 00.63 Radial Travelling Crane

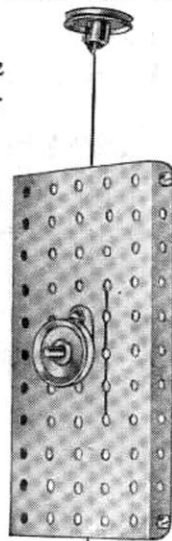
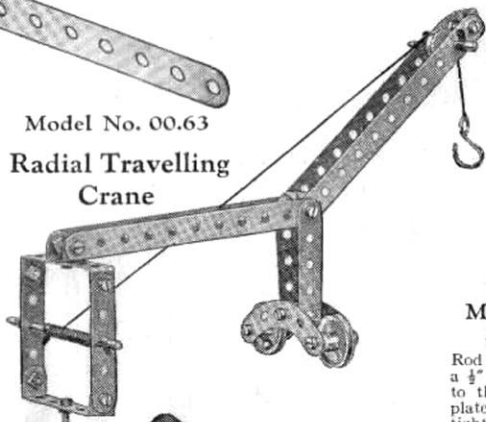

Model No. 00.66 Magic Plate

The cord is wound once round a 2" Axle Rod that is journalled in a Flat Bracket and a 1/2" Reversed Angle Bracket, which are bolted to the Plate. If the cord is held loosely the plate will drop, but as soon as the cord is tightened the plate becomes immovable.

Model No. 00.69 Cutlery Rest

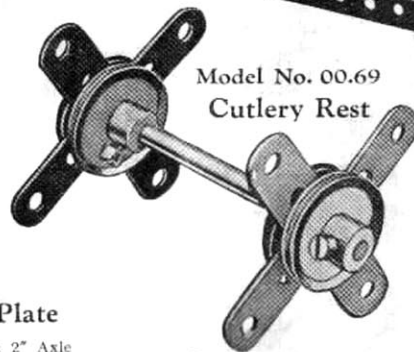

Model No. 00.71 Frame Aerial

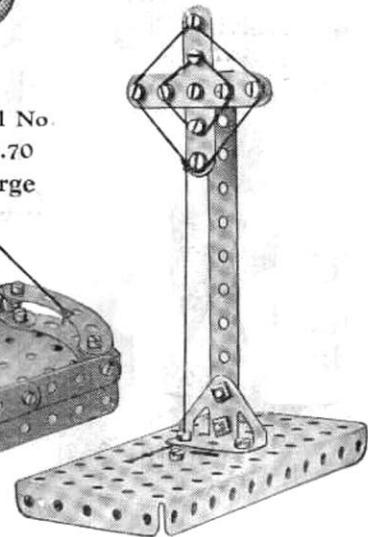

Model No. 00.64 French Railway Signal

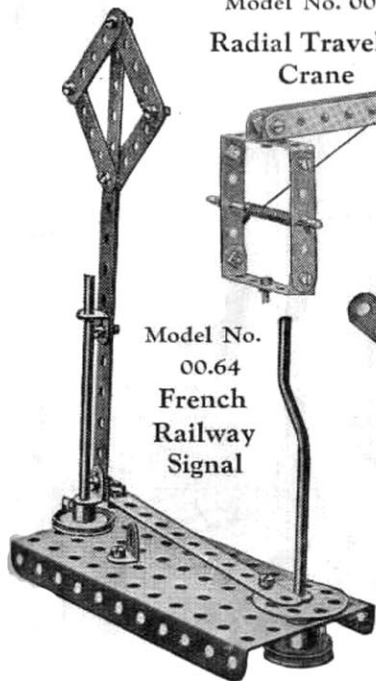

Model No. 00.65 Print Trimmer



Model No. 00.70 Barge

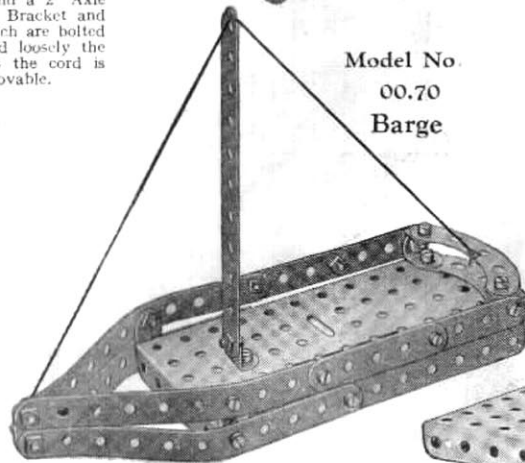

Model No. 00.72
Cage Aerial

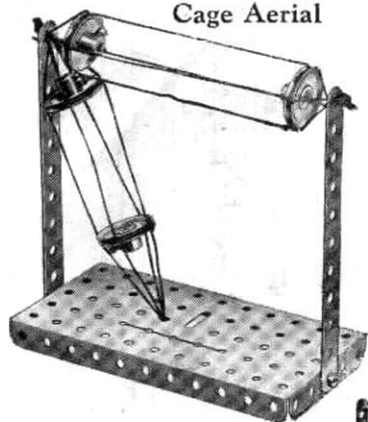

Model No. 00.73 Double Wire
L Aerial

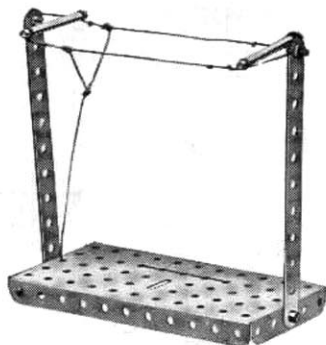

Model No. 00.74
Jumping Jack

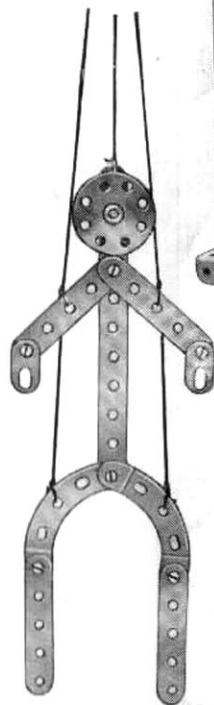

Model No. 00.75
Single Wire
T Aerial

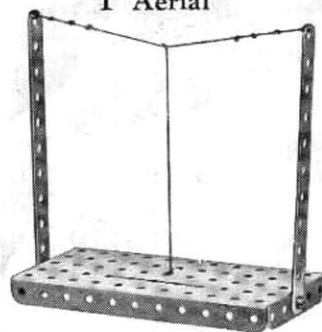

Model No. 00.76
Direction Aerial

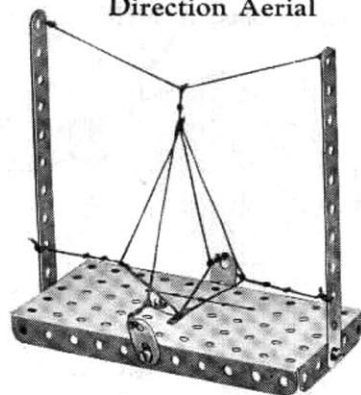

Model No. 00.77
Revolving Crane

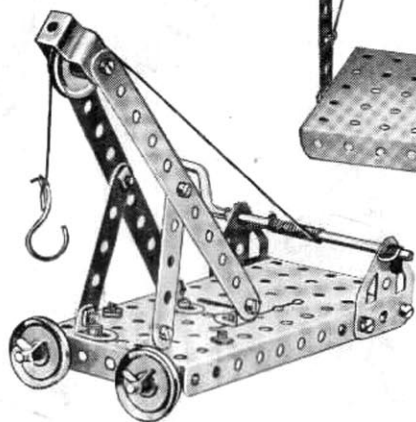

Model No. 00.78
Single Wire
L Aerial

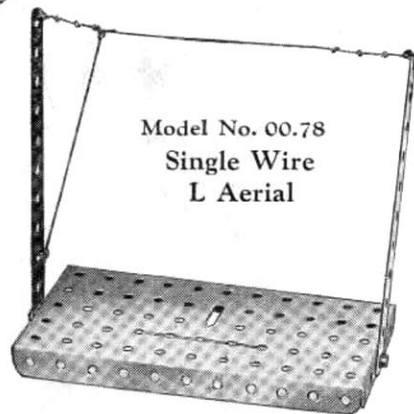

Model No. 00.80
Double Wire
T Aerial



Model No. 00.81
Swing



Model No. 00.79
Timber Wagon

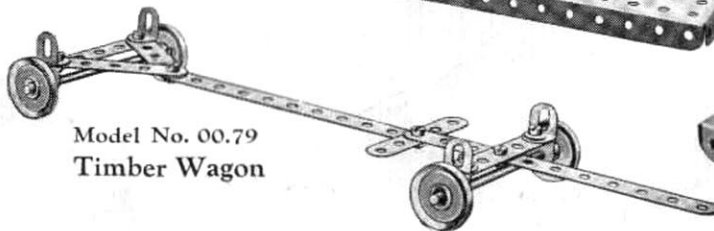

Model No. 00.82
Yacht

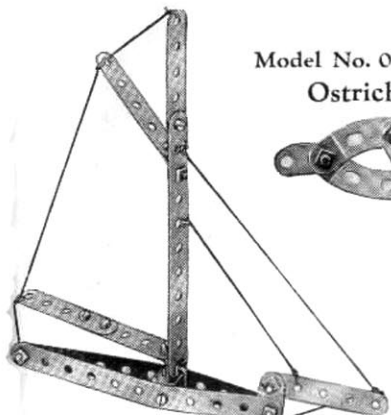

Model No. 00.83
Ostrich

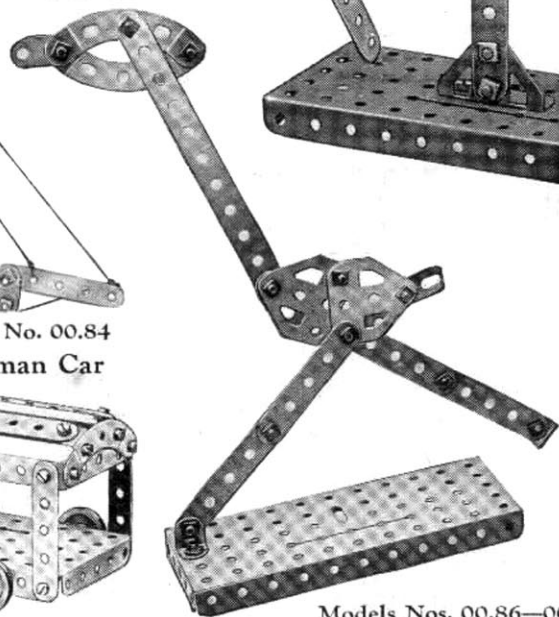

Model No. 00.84
Pullman Car

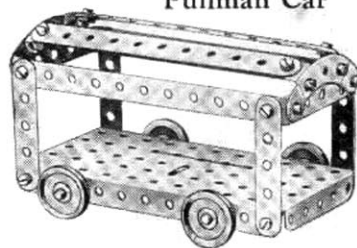

Model No. 00.85 Lever
of the First Order

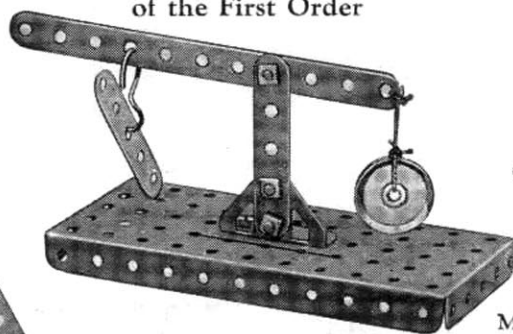

Model No. 00.94
Pen Rack

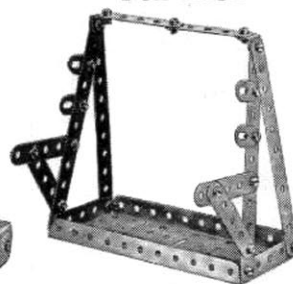

Model No. 00.96
Pulley Shafting



Model No. 00.95
Centrifugal Engine
Governor

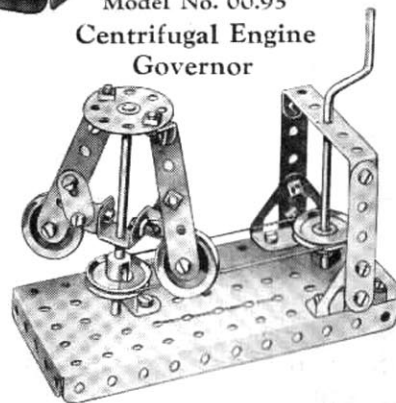

Model No. 00.97
Tricycle

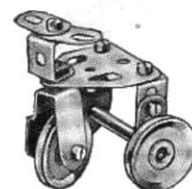

Models Nos. 00.86—00.93 Gradient Indicators

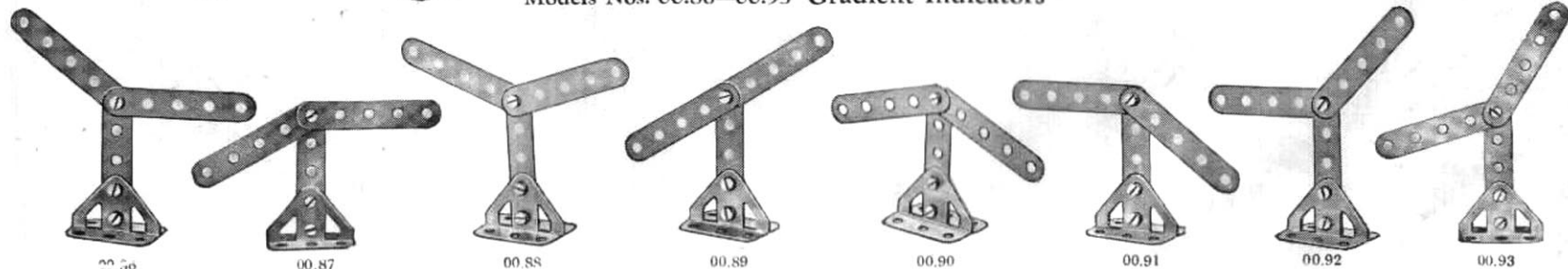

00.86

00.87

00.88

00.89

00.90

00.91

00.92

00.93

All these Models can be built with MECCANO Outfit No. 00

Model No. 00.98
Watch Stand

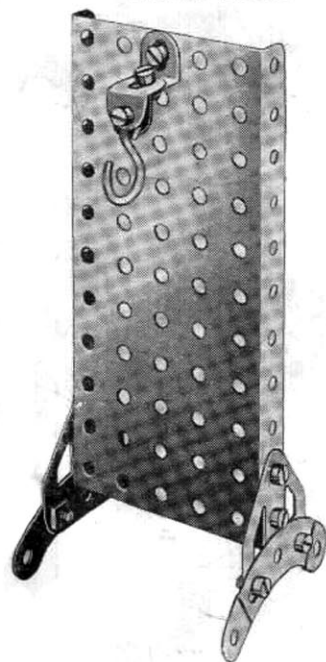

Model No. 00.99
Crib

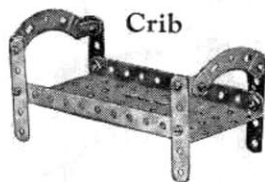

Model No. 00.100
Violin



Model No. 00.105
Mono Rail

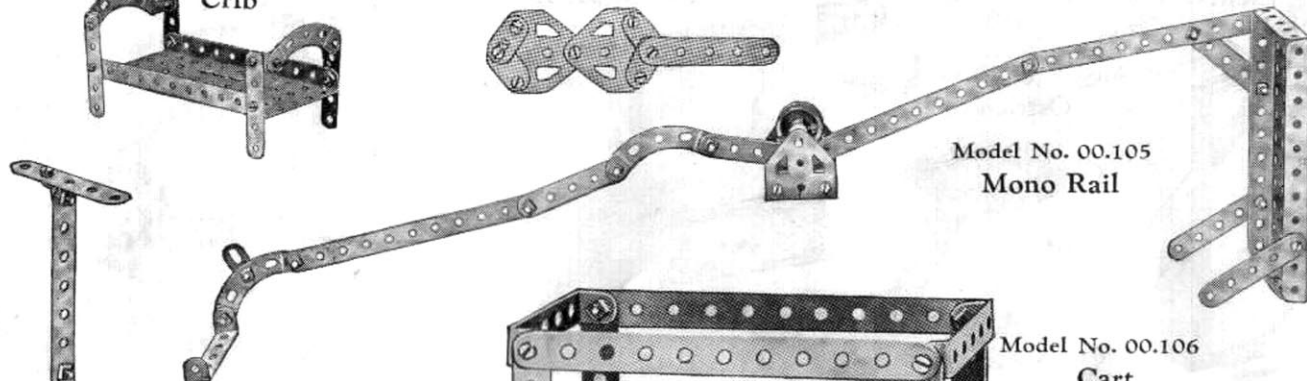

Model No. 00.101 Scooter

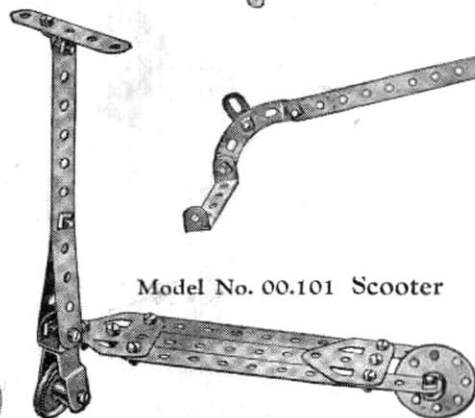

Model No. 00.106
Cart

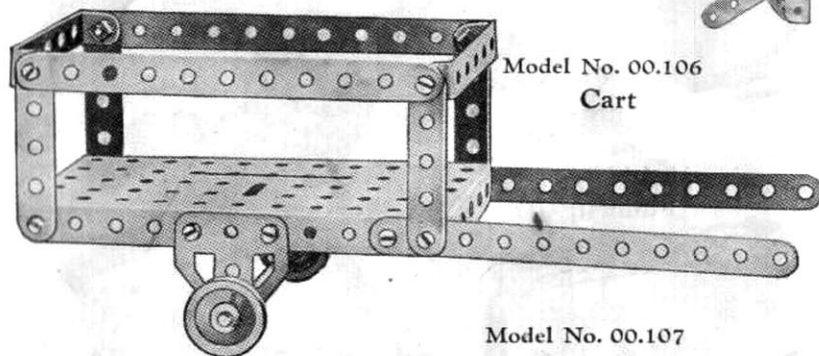

Model No. 00.102
Crocodile

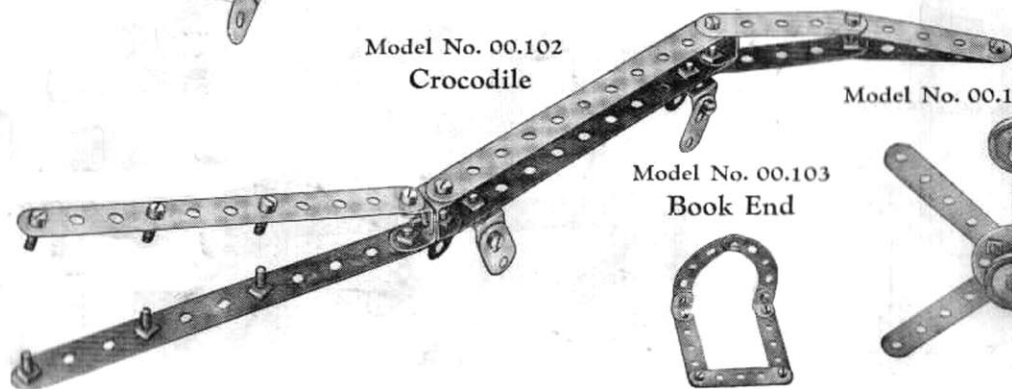

Model No. 00.104 Ceiling Fan

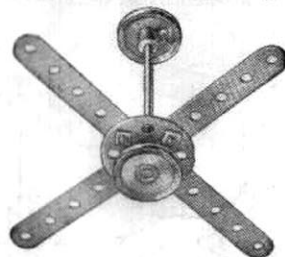

Model No. 00.107
Catapult

The pivoted arm is connected to the base by means of a short piece of elastic, which is not provided in the Outfit.

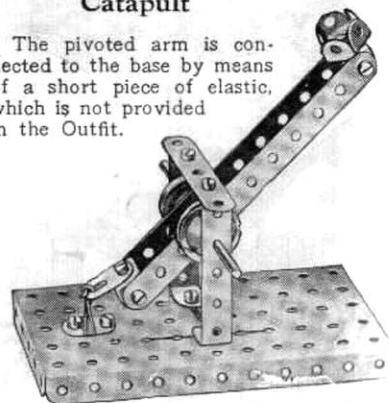

Model No. 00.103
Book End



Model No. 00.108
Track Gauge



Model No. 00.109
2-way Sign Post

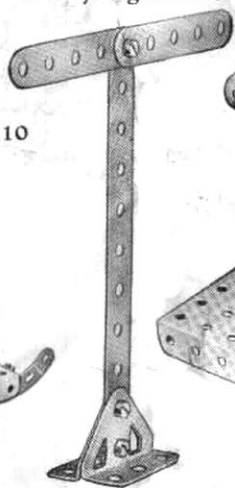

Model No. 00.112 Semaphore

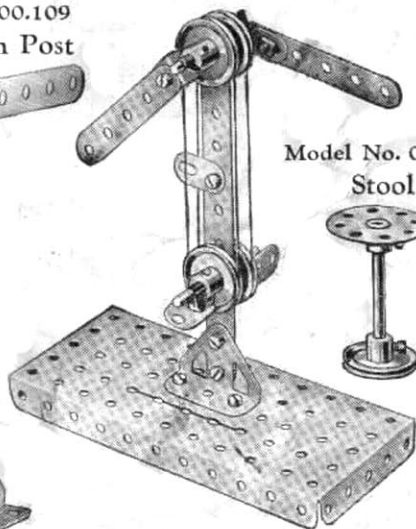

Model No. 00.116
Camera

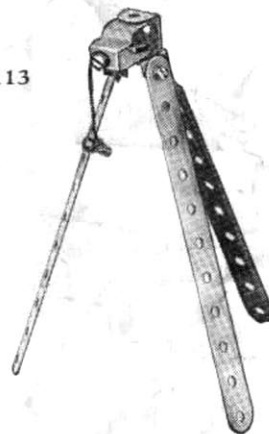

Model No. 00.117
Lumber Truck

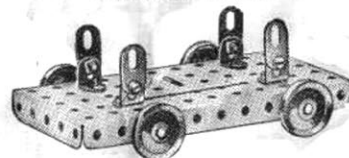

Model No. 00.110
Ice Yacht

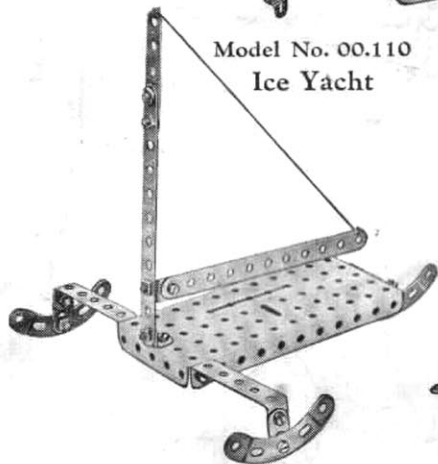

Model No. 00.113
Stool



Model No. 00.118
Circular Saw

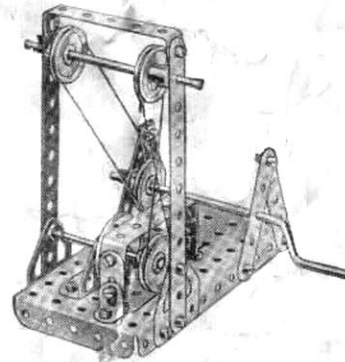

Model No. 00.111
Dinner Wagon

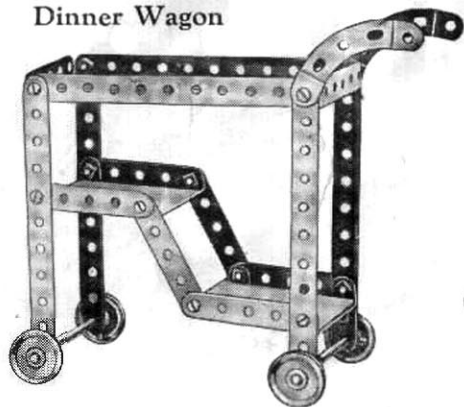

Model No. 00.114
Sword

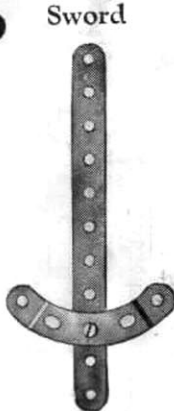

Model No. 00.119
Umbrella Stand



Model No. 00.115
1-way Sign Post

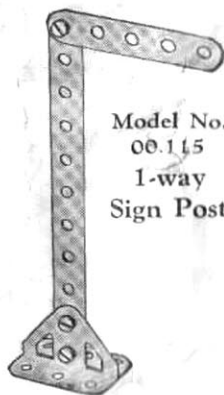

Model No. 00.120 Timber Truck

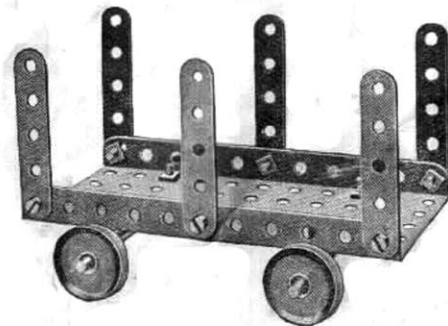

All these Models can be built with MECCANO Outfit No. 00

Model No. 00.121
Road Sign

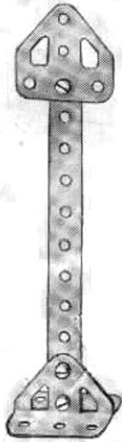

Model No. 00.122 Tweezers



Model No. 00.128
Elevator Car

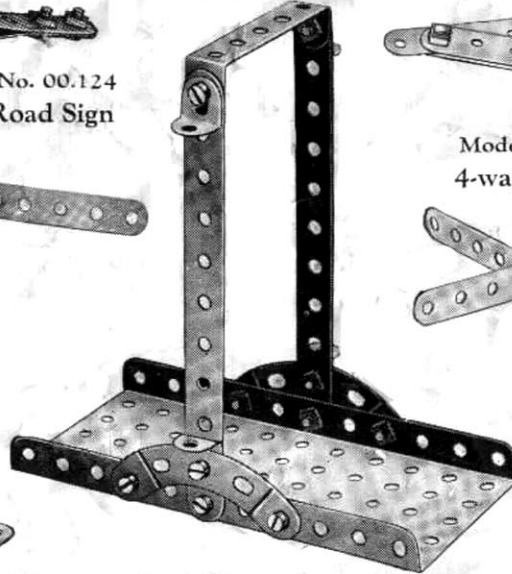

Model No. 00.130
Razor

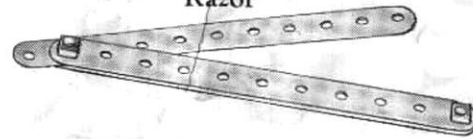

Model No. 00.133
Road Sign



Model No. 00.123
Dividers



Model No. 00.124
3-way Road Sign

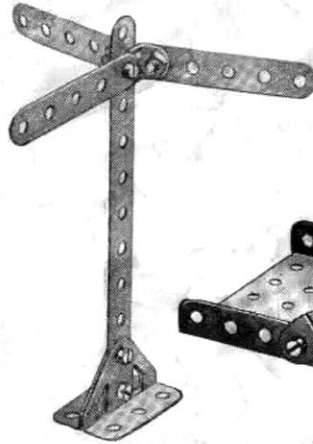

Model No. 00.131
4-way Road Sign

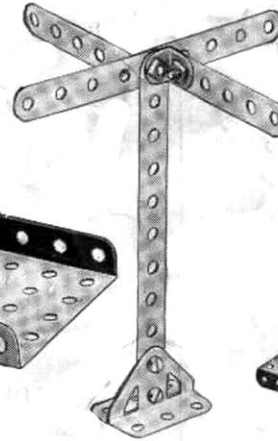

Model No. 00.132
Mail Bag Hanger

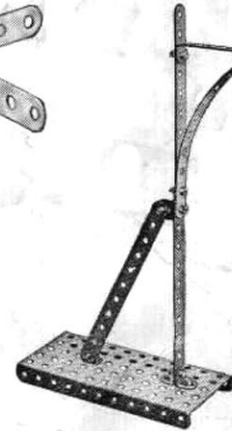

Model No. 00.125
Tin Opener



Model No. 00.126
Porter's Trolley

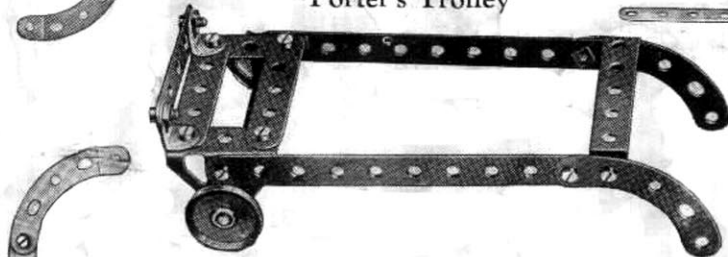

Model No. 00.129
Propeller

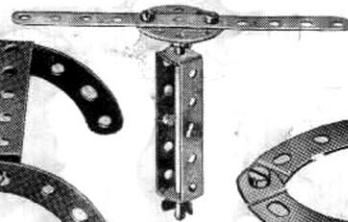

Model No. 00.135
Street
Lamp



Model No. 00.134 Hand Truck

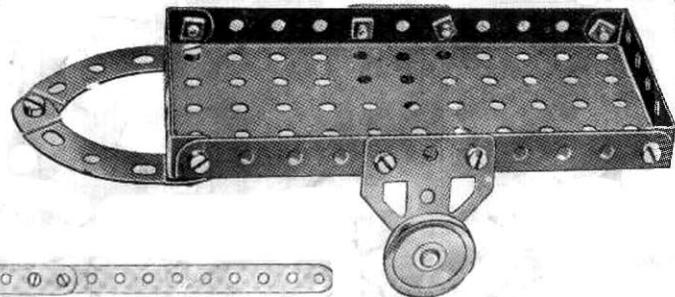

Model No. 00.127 Walking Stick

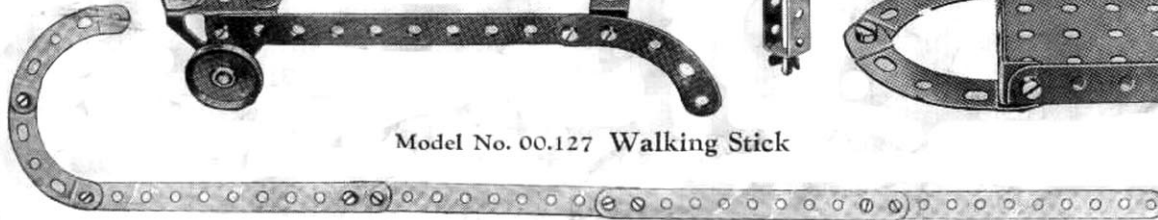

Model No. 00.136
Hand Car

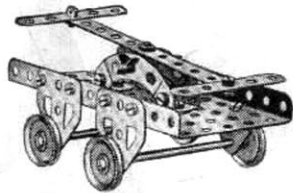

Model No. 00.138
Telescopic Mast

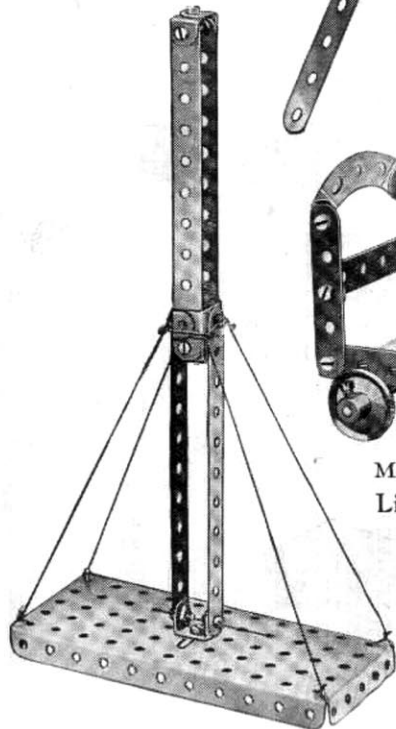

Model No. 00.137
Tripod

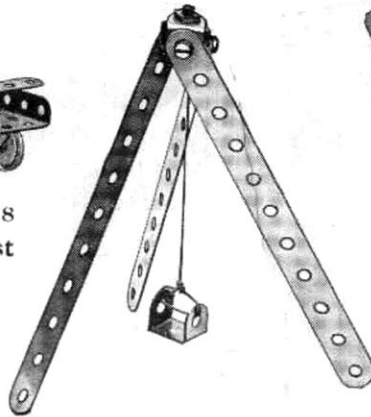

Model No. 00.139
Baggage Truck

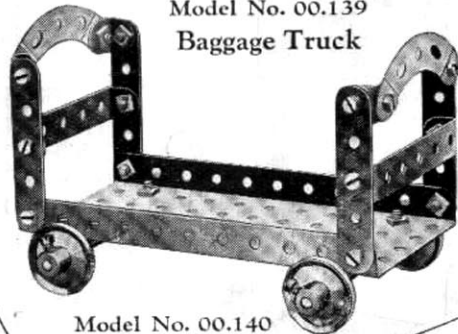

Model No. 00.140
Light Cruiser

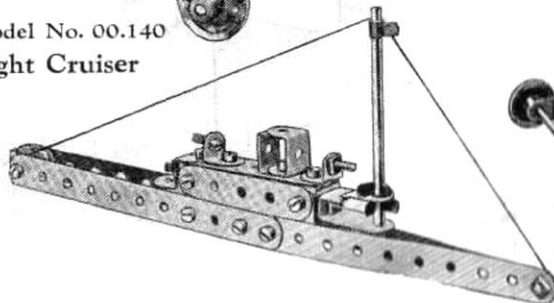

Model No. 00.141

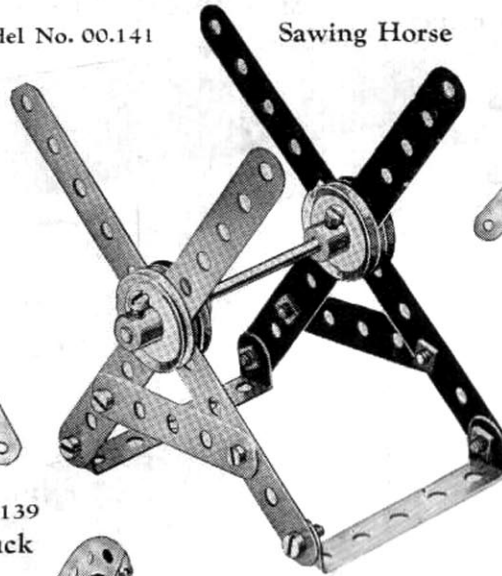

Sawing Horse

Model No. 00.142
Piano Stool



Model No. 00.143
Towel Horse

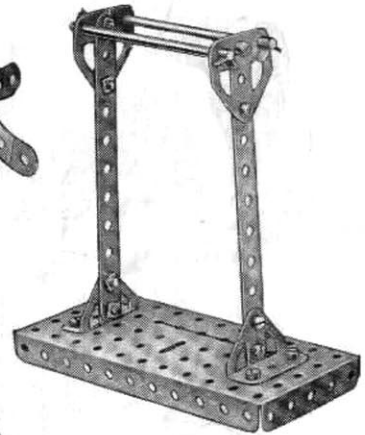

Model No. 00.145
Giraffe

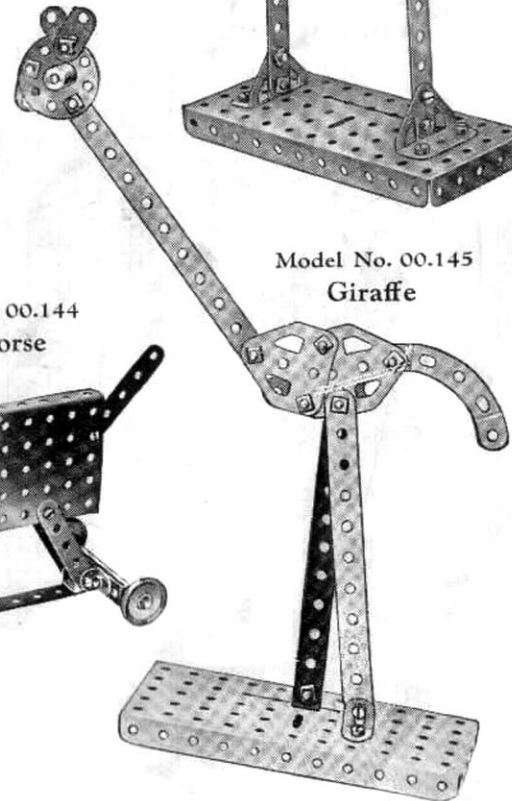

Model No. 00.144
Toy Horse

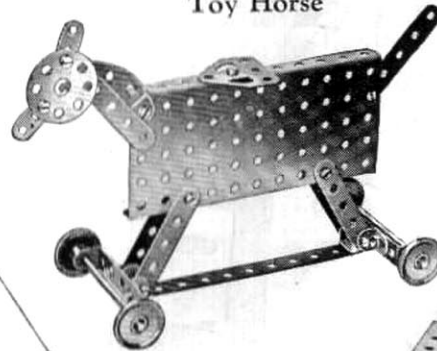

All these Models can be built with MECCANO Outfit No. 00

Model No. 00.146
Step Ladder



Model No. 00.147
Glider

Model No. 00.151 Table

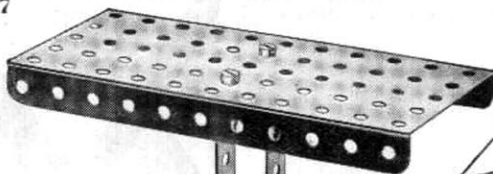

Model No. 00.153
Liner

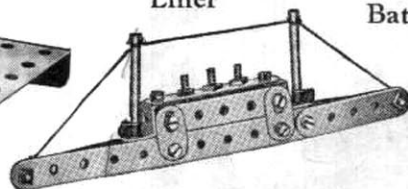

Model No. 00.156
Battle Axe

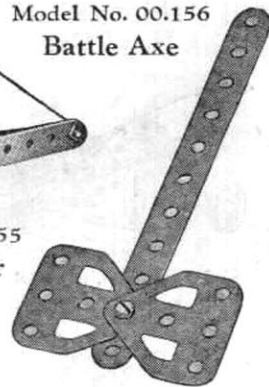

Model No. 00.148
Refreshment Wagon

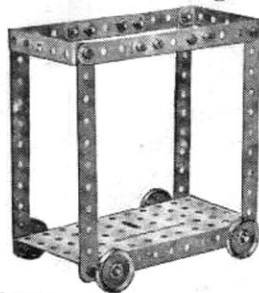

Model No. 00.149
Rake

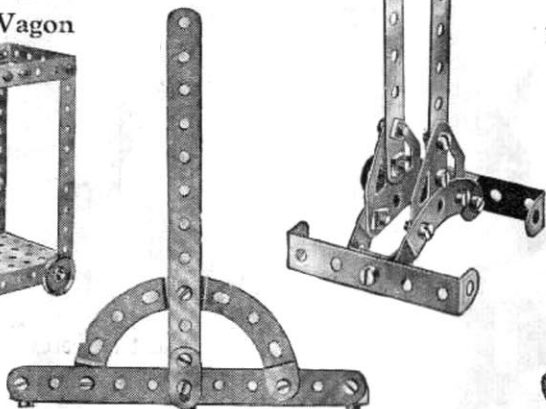

Model No. 00.155
Gravel Sifter

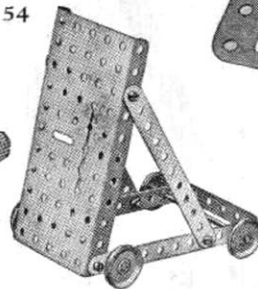

Model No. 00.154
Anchor

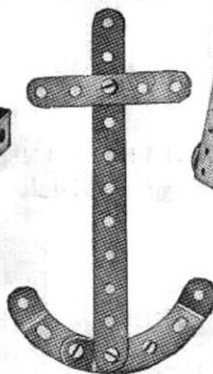

Model No. 00.150
Crane

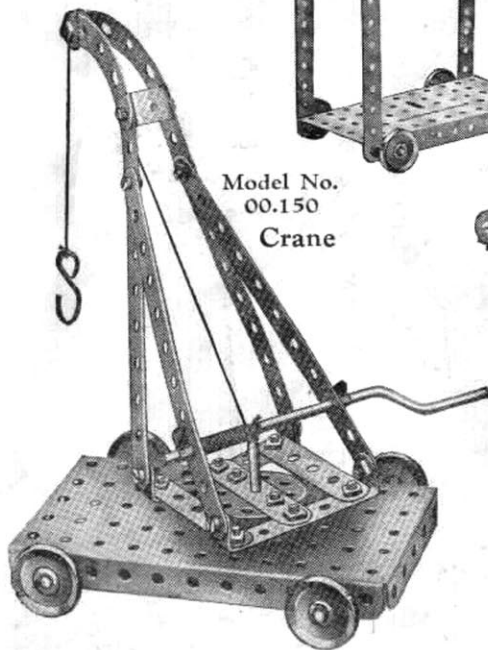

Model No. 00.157
Mail Bag Hanger



Model No. 00.152 Turnstile

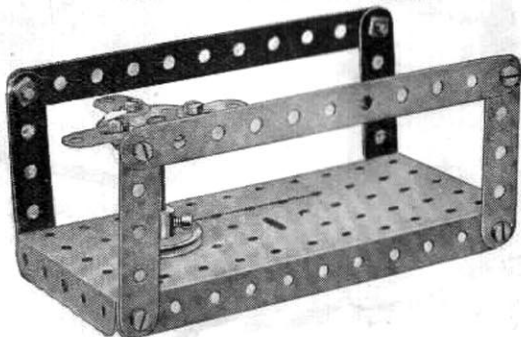

Model No. 00.158
Fire Escape

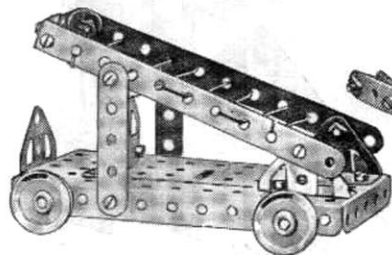

Model No. 00.159
Torpedo Boat

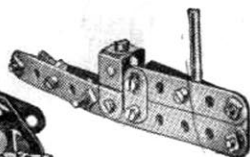

Model No. 00.163 Scales

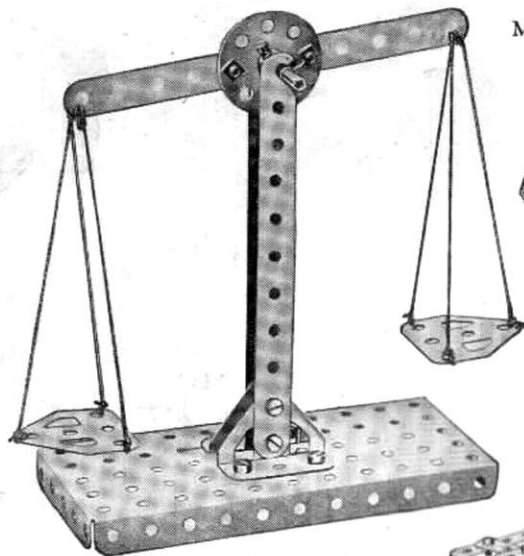

Model No. 00.165 Pistol

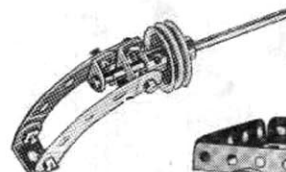

Model No. 00.166
Motor Car

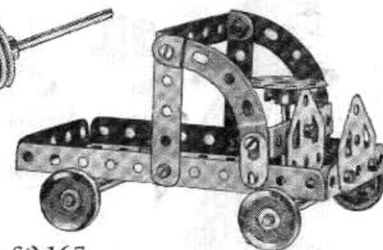

Model No.
00.161
Stamping
Mill

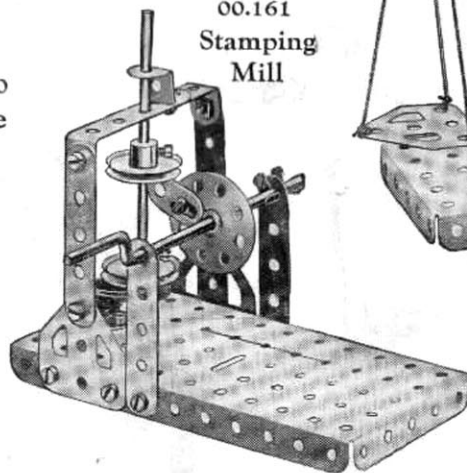

Model No. 00.167
Organ

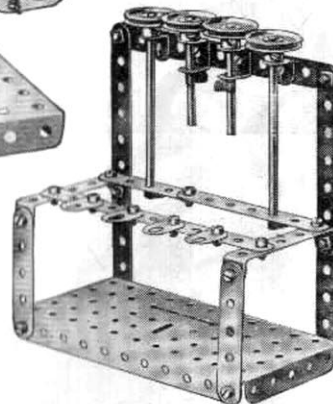

Model No. 00.160
Telegraph Pole



Model No. 00.169
Searchlight

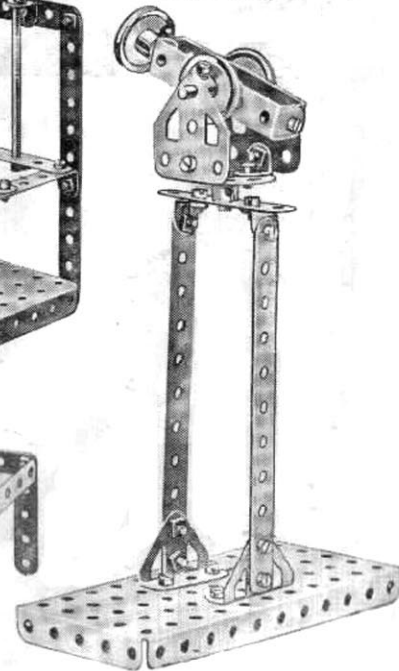

Model No. 00.164
Clothes
Drying Frame

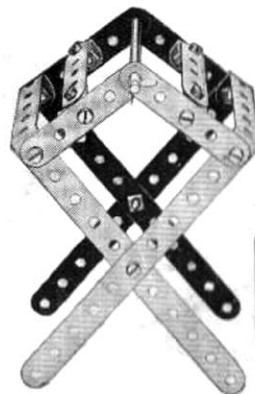

Model No. 00.162
Watch and Chain

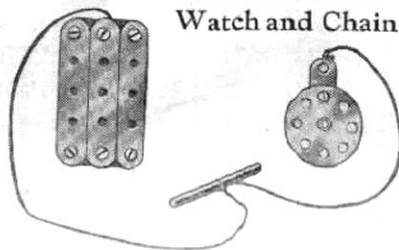

Model No. 00.168
Drinking Trough

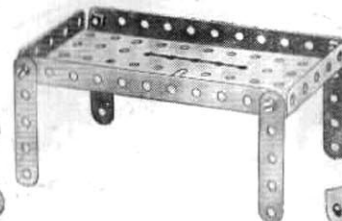

All these Models can be built with MECCANO Outfit No. 00

Model No. 00.170
Roundabout

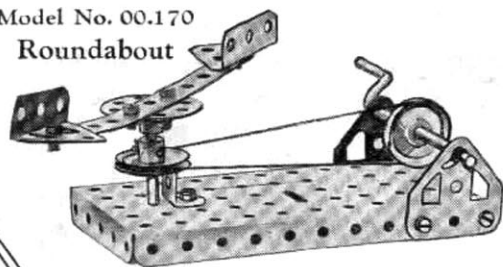

Model No. 00.175
Trolley

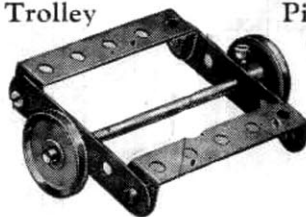

Model No. 00.176
Pit-Head
Gear

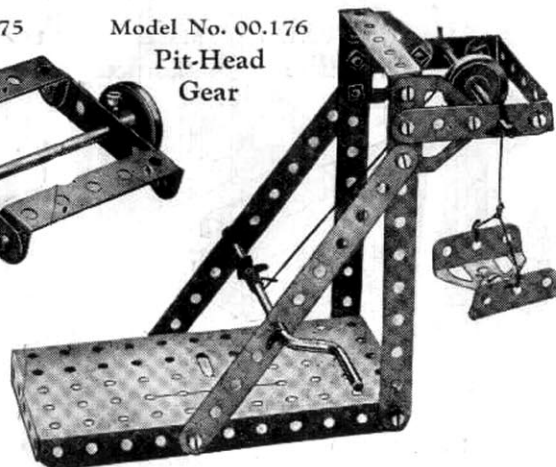

Model No. 00.171
Meccano Boy

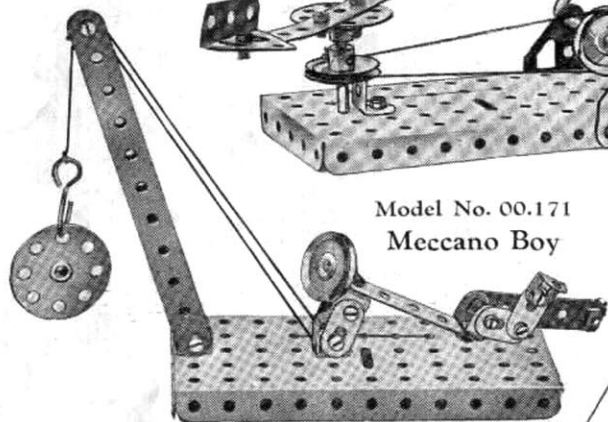

Model
No. 00.173
Sailing
Boat

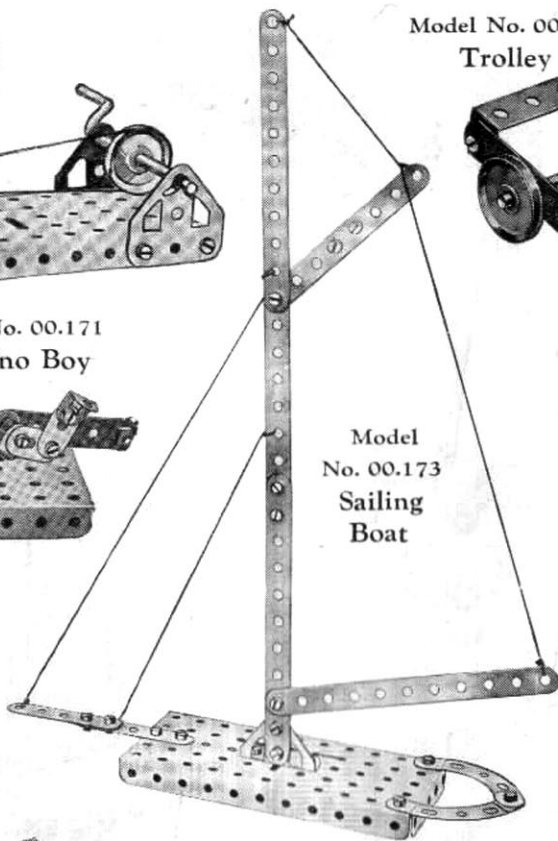

Model No. 00.178
Grandfather's Clock

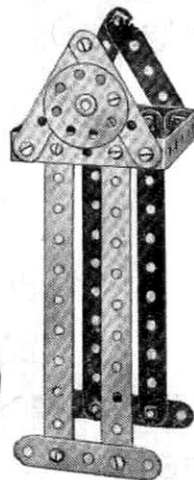

Model No. 00.172
Break-Down
Crane

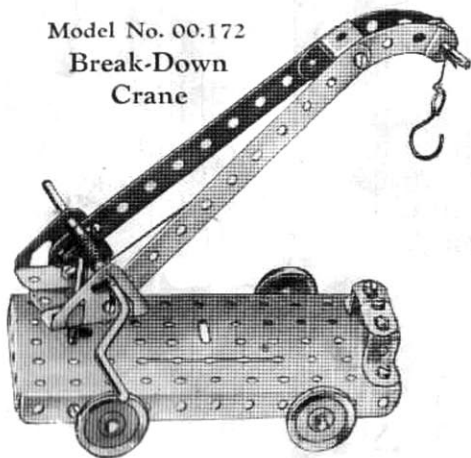

Model No. 00.177
Anti-Aircraft
Gun

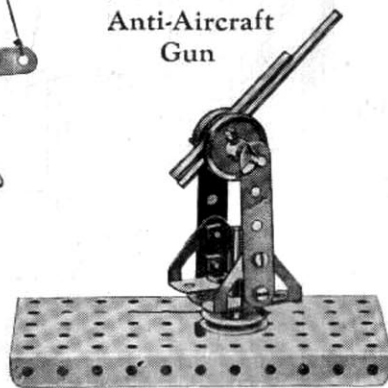

Model No. 00.174
Big Gun

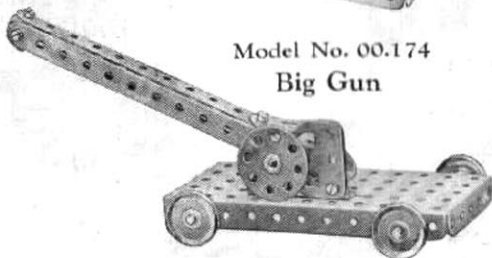

Model No. 00.179 Hand Truck

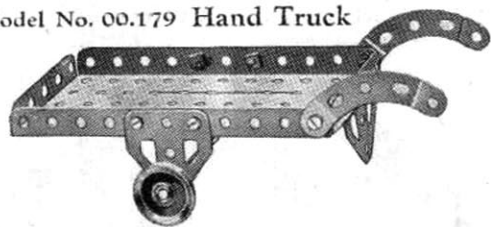

Model No. 00.181 Clock

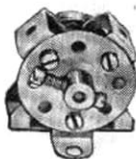

Model No. 00.183 Windmill

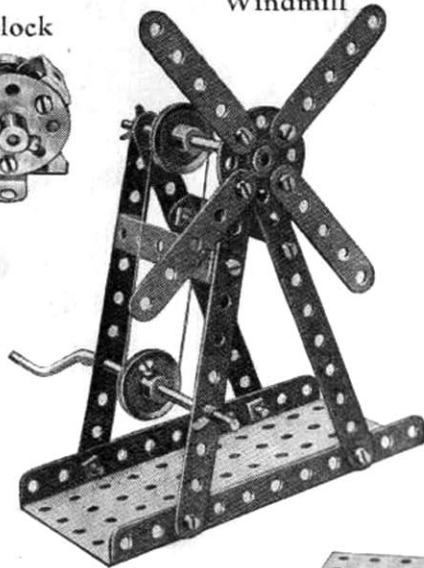

Model No. 00.185 Flower Pot Stand



Model No. 00.186 Airship

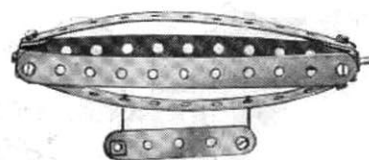

Model No. 00.180 Arc Lamp

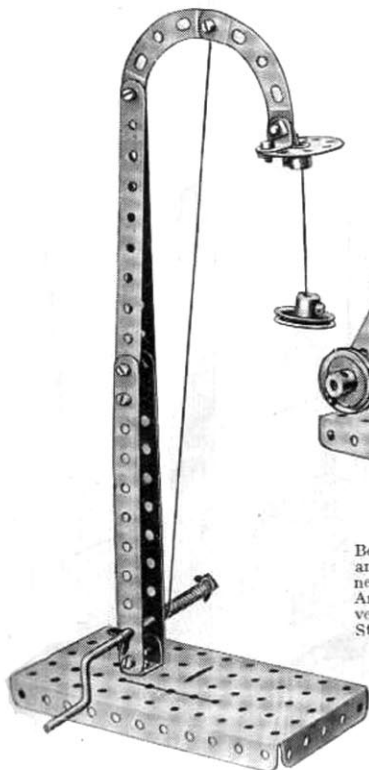

Model No. 00.182 Letter Balance

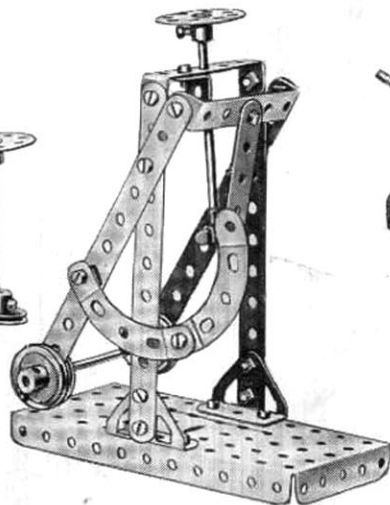

Model No. 00.187 Gallows

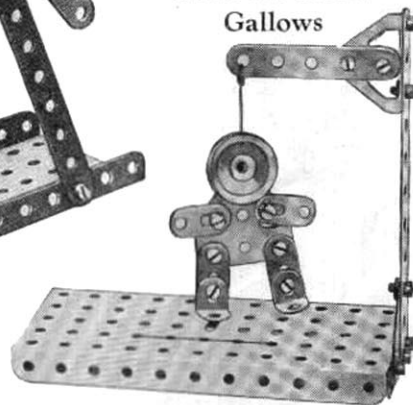

Model No. 00.189 Airship Mooring Mast

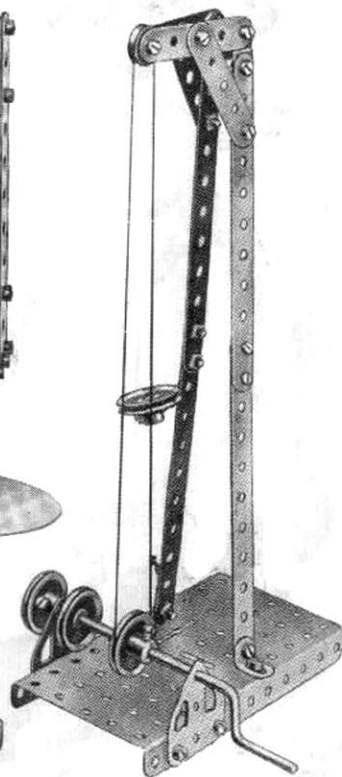

Model No. 00.184 Garden Roller

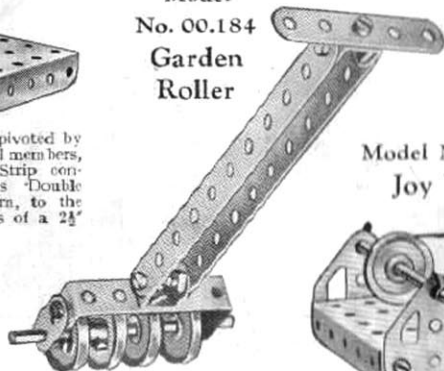

Model No. 00.188 Joy Wheel

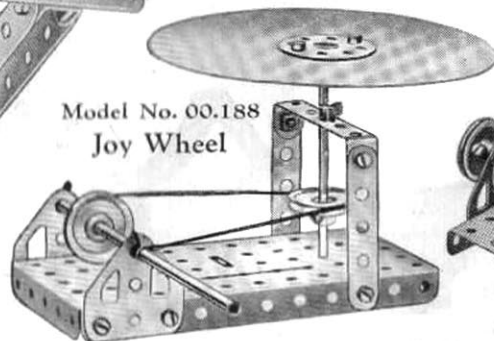

The weighted 5½" Strips are pivoted by Bolts and lock nuts to the vertical members, and a 2½" x ½" Double Angle Strip connects their upper ends. This Double Angle Strip is connected, in turn, to the vertical 3½" Axle Rod by means of a 2½" Strip and an Angle Bracket.

All these Models can be built with MECCANO Outfit No. 00

Model No. 00.190
Buffing Spindle

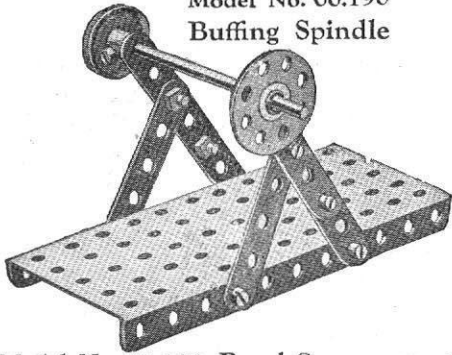

Model No. 00.193
Ski-Runner

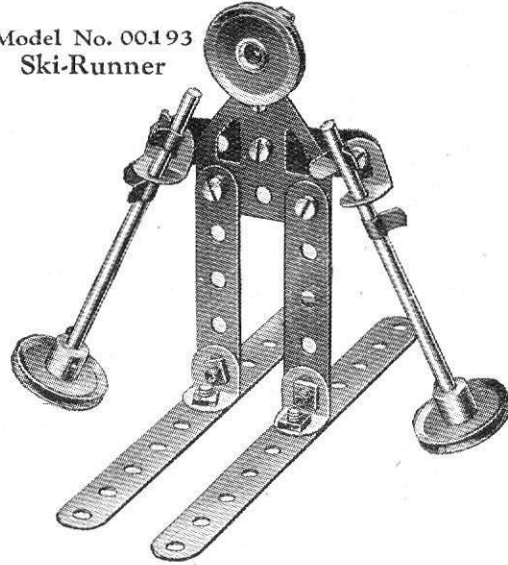

Model No. 00.196 Cutlery Basket

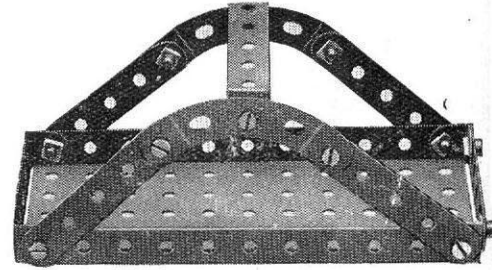

Model No. 00.191 Band Saw

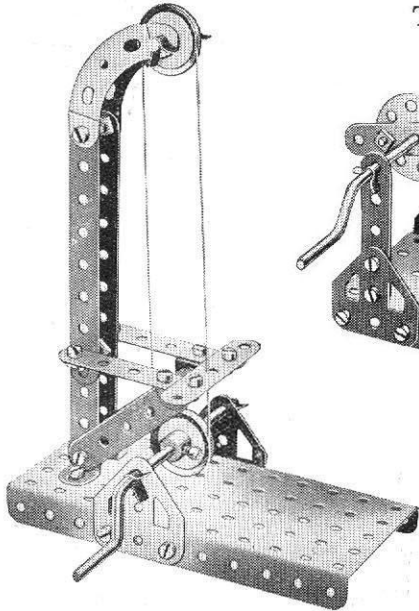

Model No. 00.192
Trip Hammer

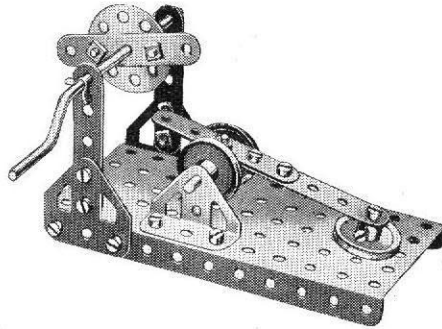

Model No. 00.194 Devil Wall

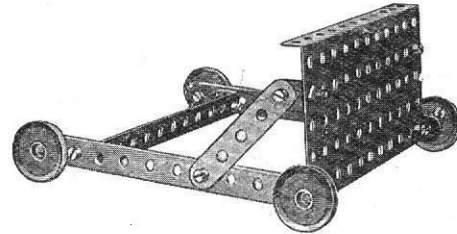

Model No. 00.197
Garden Hose Reel

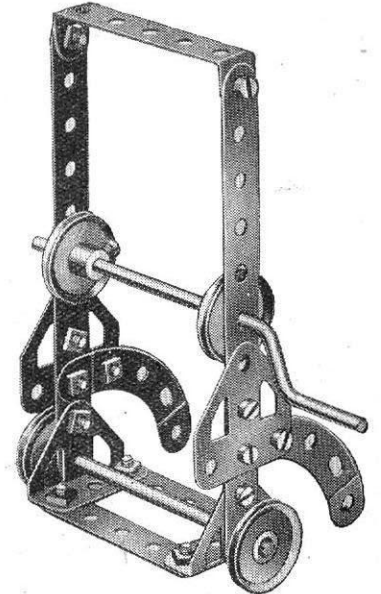

Model No. 00.195 Sled

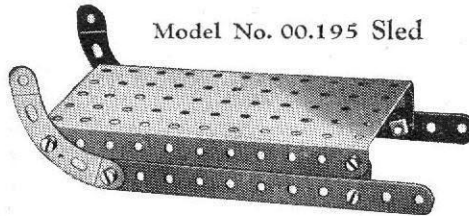

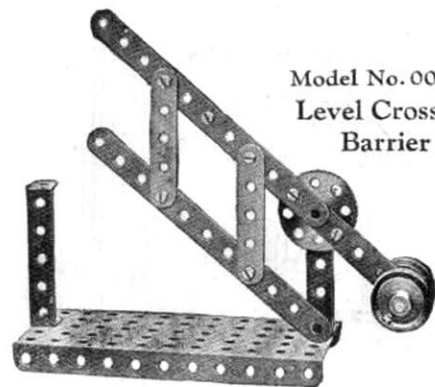

Model No. 00.198
Level Crossing
Barrier

Model No. 00.199
Well Driller

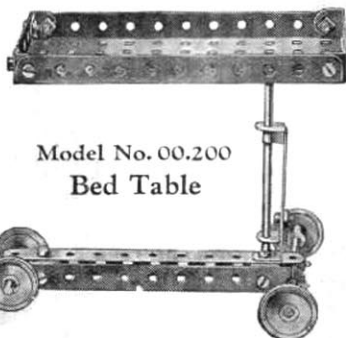
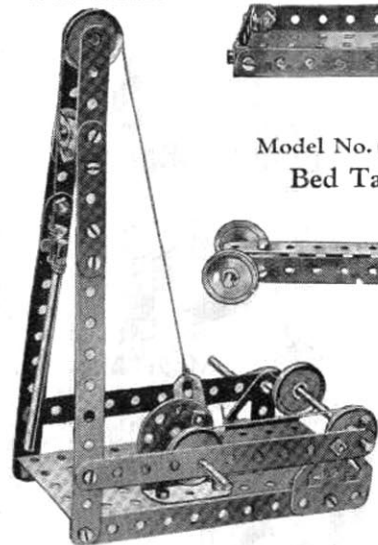

Model No. 00.200
Bed Table

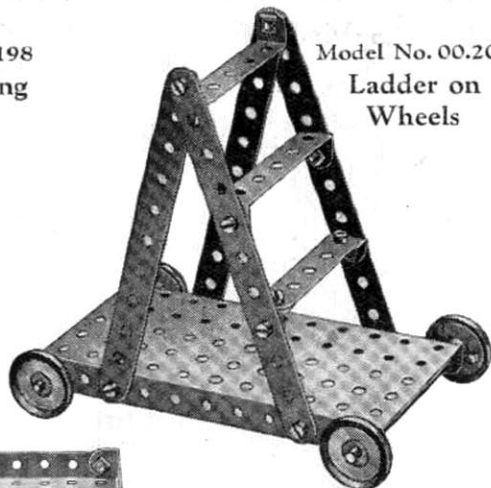

Model No. 00.201
Ladder on
Wheels

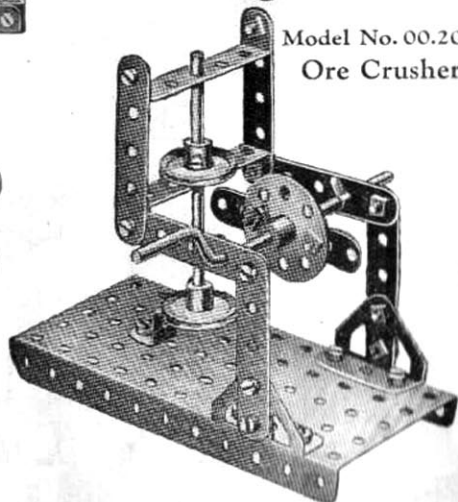

Model No. 00.202
Ore Crusher

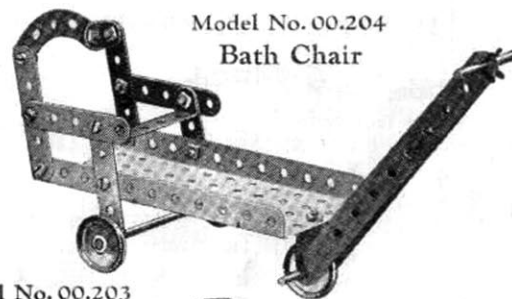

Model No. 00.204
Bath Chair



Model No. 00.203
Tea Wagon

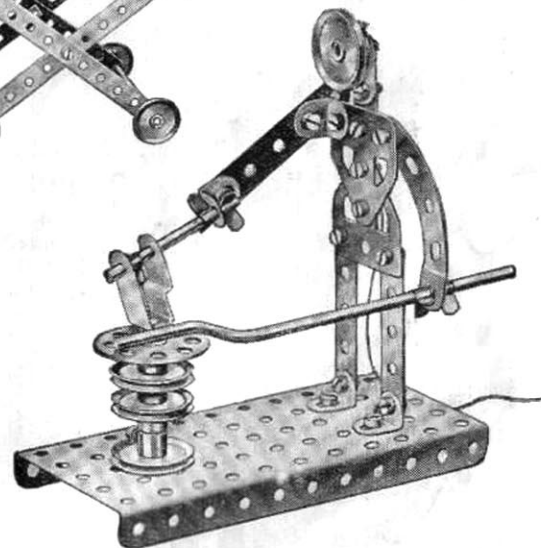

Model No. 00.205
Blacksmith

HOW TO CONTINUE

This completes our examples of models that may be made with MECCANO Outfit No. 00. The next models are a little more advanced, requiring a number of extra parts to construct them. The necessary parts are all contained in a No. 00A Accessory Outfit, the price of which will be found in the list at the end of this Manual.

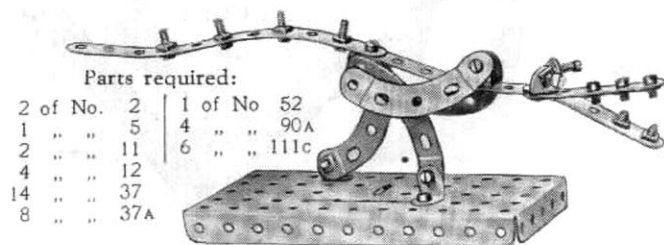
Model No. 0.1 Prehistoric Bird**Model No. 0.5 Medal**

Parts required:

4 of No. 2
8 " " 5
4 " " 10
1 " " 24
13 " " 37
2 " " 90A
1 " " 111c

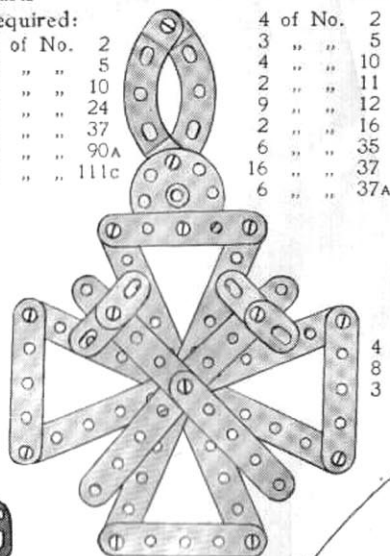
**Model No. 0.6 Battleship**

Parts required:

4 of No. 2	1 of No. 44
3 " " 5	6 " " 111c
4 " " 10	2 " " 125
2 " " 11	
9 " " 12	
2 " " 16	
6 " " 35	
16 " " 37	
6 " " 37A	

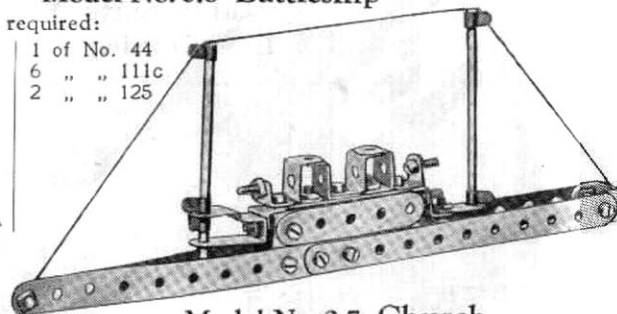
**Model No. 0.2 Cattle Truck**

Parts required:

4 of No. 2	4 of No. 22	2 of No. 48A
8 " " 5	16 " " 37	1 " " 52
2 " " 16	2 " " 37A	2 " " 111c

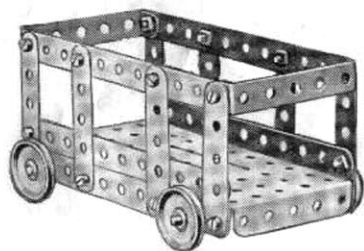
**Model No. 0.3 Hurdler**

Parts required:

3 of No. 5	1 of No. 23	1 of No. 52
1 " " 10	12 " " 37	4 " " 90A
2 " " 11	1 " " 37A	1 " " 111c
2 " " 12	2 " " 48A	

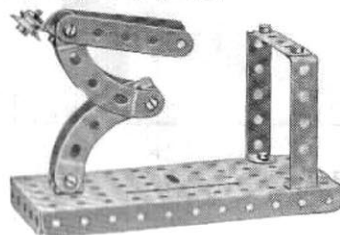
**Model No. 0.4 Tennis Player**

Parts required:

3 of No. 5
2 " " 10
2 " " 11
2 " " 12
1 " " 23
13 " " 37
1 " " 52
2 " " 90A
1 " " 111c
1 " " 126A

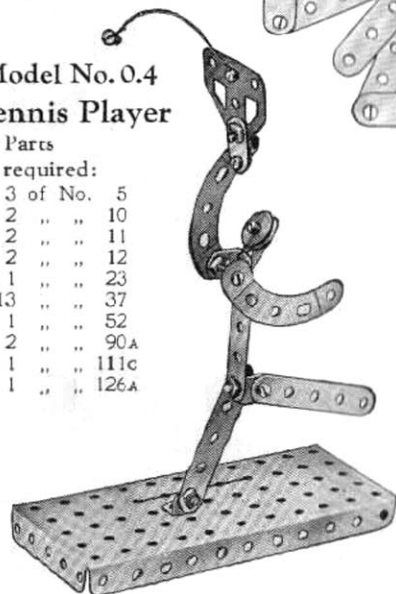
**Model No. 0.8 Angler**

Parts required:

5 of No. 5
2 " " 10
2 " " 11
2 " " 12
1 " " 16
1 " " 23
1 " " 35
11 " " 37
1 " " 37A
1 " " 52
1 " " 111c

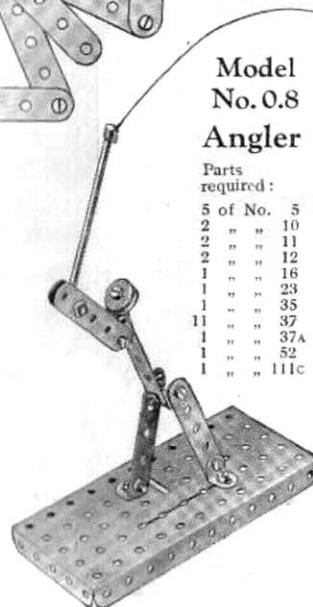
**Model No. 0.7 Church**

Parts required:

4 of No. 2	2 of No. 12	6 of No. 37A	2 of No. 90A
8 " " 5	1 " " 24	2 " " 48A	6 " " 111c
3 " " 10	16 " " 37	1 " " 52	1 " " 126A

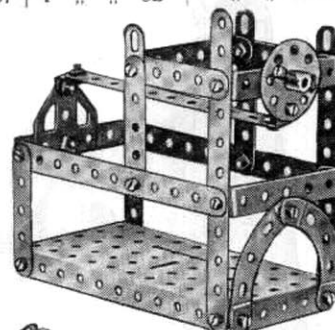
**Model No. 0.9 The Execution**

Parts required:

9 of No. 5	16 of No. 37
3 " " 13	3 " " 37A
2 " " 11	1 " " 48A
5 " " 12	1 " " 52
2 " " 22	1 " " 90A

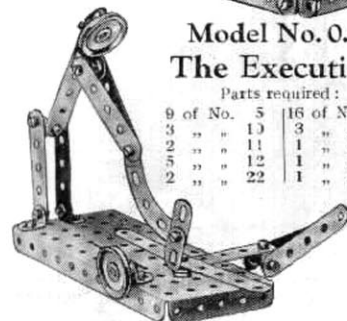

Model No. 0.10 Field Gun and Carriage

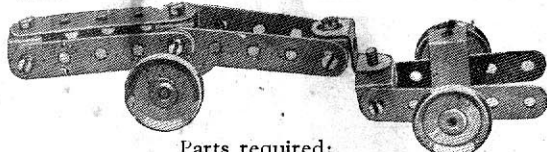

Parts required:

8 of No. 5	2 of No. 17	1 of No. 44
2 " " 10	4 " " 22	1 " " 111
2 " " 11	13 " " 37	1 " " 125
6 " " 12	1 " " 37A	

Model No. 0.11 Trolley

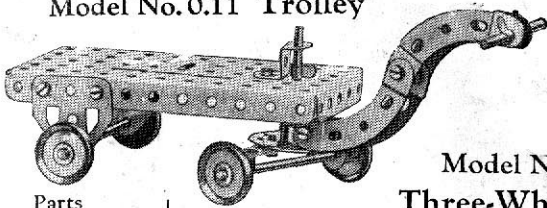

Parts required:

1 of No. 11	12 of No. 37
2 " " 16	1 " " 48A
2 " " 17	1 " " 52
1 " " 24	4 " " 90A
4 " " 35	1 " " 125
	2 " " 126A

Model No. 0.12 Pliers

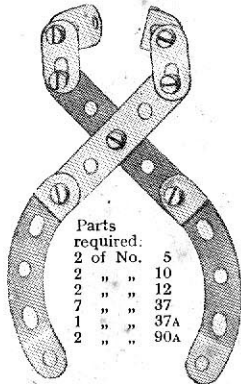

Parts required:

2 of No. 5
2 " " 10
2 " " 12
7 " " 37
1 " " 37A
2 " " 90A

Model No. 0.14 Goose

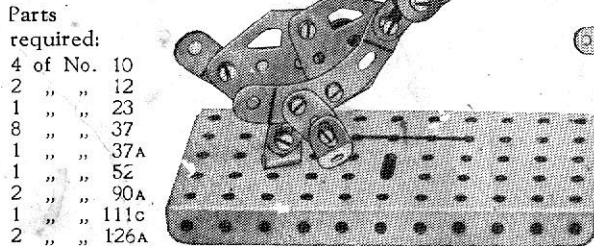

Parts required:

4 of No. 10
2 " " 12
1 " " 23
8 " " 37
1 " " 37A
2 " " 52
1 " " 90A
1 " " 111c
2 " " 126A

Model No. 0.15 Coast Guard

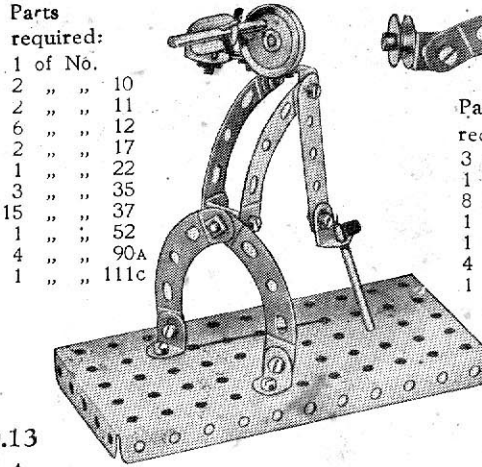

Parts required:

1 of No. 2	10
2 " " 2	11
6 " " 2	12
2 " " 2	17
1 " " 2	22
3 " " 2	35
15 " " 2	37
1 " " 2	52
4 " " 2	90A
1 " " 2	111c

Model No. 0.13 Three-Wheel Auto

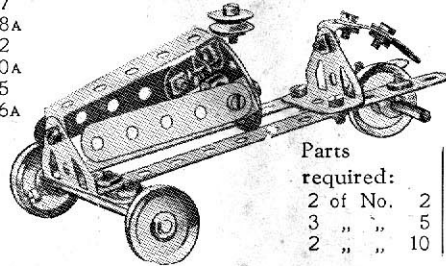

Parts required:

2 of No. 2	6 of No. 12
3 " " 5	1 " " 16
2 " " 10	1 " " 17
	3 " " 22
	1 " " 23
	1 " " 24
	16 " " 37
	2 " " 37A
	1 " " 48A
	2 " " 111c
	2 " " 126

Model No. 0.16 Snake

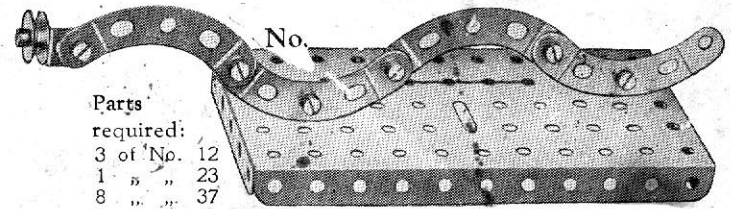

Parts required:

3 of No. 12
1 " " 23
8 " " 37
1 " " 37A
1 " " 52
4 " " 90A
1 " " 111c

Model No. 0.17 Frog

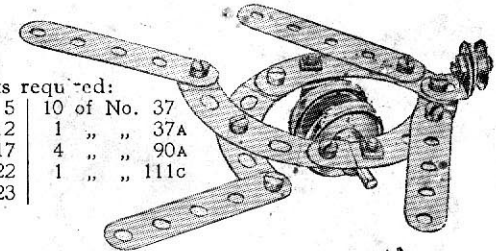

Parts required:

4 of No. 5	10 of No. 37
3 " " 12	1 " " 37A
1 " " 17	4 " " 90A
2 " " 22	1 " " 111c
1 " " 23	

Model No. 0.18 Bucking Broncho

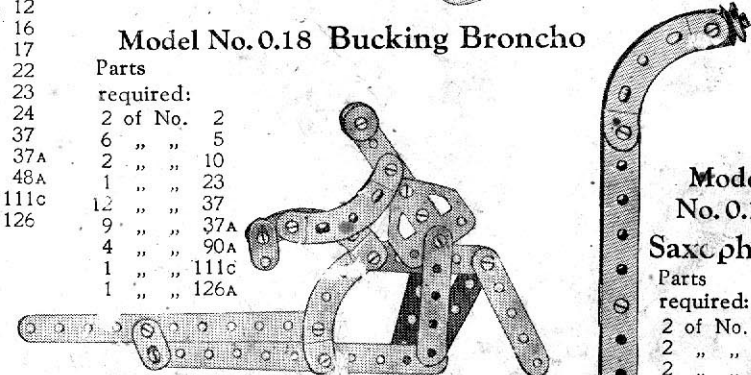

Parts required:

2 of No. 2
6 " " 5
2 " " 10
1 " " 23
12 " " 37
9 " " 37A
4 " " 90A
1 " " 111c
1 " " 126A

The Bolts used for connecting the 5 1/4" Strips, the horse's legs, and the rider's legs and arms, are all lock-nutted (see Standard Mechanism No. 262). The lower 5 1/4" Strip should be held rigidly and the upper one jerked forward; the horse will then throw its rider completely over its head.

Model No. 0.19 Saxophone

Parts required:

2 of No. 2
2 " " 10
2 " " 11
2 " " 12
1 " " 23
1 " " 24
12 " " 37
1 " " 37A
4 " " 90A
2 " " 111c

These Models can be built with MECCANO Outfit No. 0 (or No. 00 and No. 00A)

**Model No. 0.20
Loud Speaker**

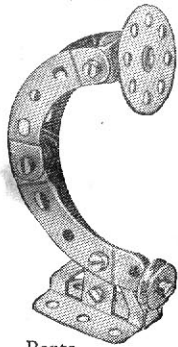

- Parts required:
- 1 of No. 11
 - 1 " " 23
 - 1 " " 24
 - 6 " " 37
 - 1 " " 37A
 - 4 " " 90A
 - 2 " " 111c
 - 2 " " 126

Model No. 0.23 Piano

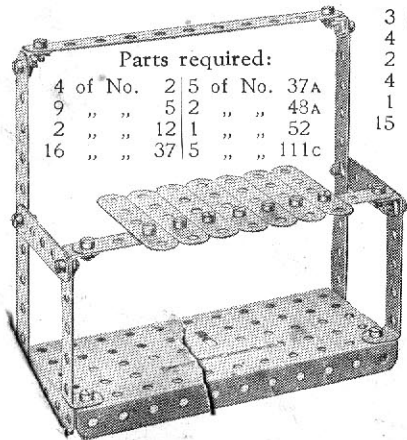

- Parts required:
- | | | | | | | | | | | | |
|------------|------------|-------------|-------------|-------------|-------------|-------------|-------------|--------------|--------------|-------------|---------------|
| 4 of No. 4 | 2 of No. 5 | 2 of No. 10 | 5 of No. 11 | 1 of No. 12 | 1 of No. 15 | 1 of No. 23 | 1 of No. 37 | 1 of No. 37A | 1 of No. 48A | 1 of No. 52 | 1 of No. 111c |
|------------|------------|-------------|-------------|-------------|-------------|-------------|-------------|--------------|--------------|-------------|---------------|

**Model No. 0.21
Strong Man**

- Parts required:
- | | | | | | | | | | | | |
|------------|-------------|--------------|-------------|-------------|-------------|-------------|-------------|--------------|-------------|--------------|---------------|
| 4 of No. 4 | 5 of No. 10 | 13 of No. 11 | 1 of No. 12 | 1 of No. 17 | 4 of No. 22 | 1 of No. 23 | 1 of No. 37 | 1 of No. 37A | 1 of No. 52 | 1 of No. 90A | 1 of No. 111c |
|------------|-------------|--------------|-------------|-------------|-------------|-------------|-------------|--------------|-------------|--------------|---------------|

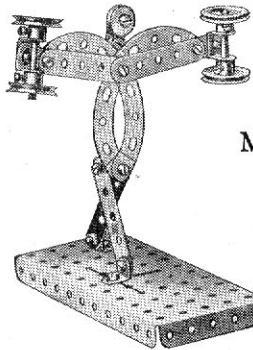

**Model No. 0.22
Boxer**

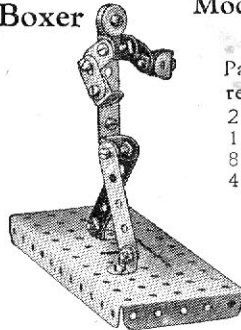

- Parts required:
- | | | | | | | | | |
|------------|-------------|-------------|-------------|-------------|--------------|--------------|-------------|---------------|
| 3 of No. 4 | 5 of No. 10 | 2 of No. 11 | 4 of No. 12 | 1 of No. 23 | 15 of No. 37 | 1 of No. 37A | 1 of No. 52 | 1 of No. 111c |
|------------|-------------|-------------|-------------|-------------|--------------|--------------|-------------|---------------|

**Model No. 0.24
Motor Boat**

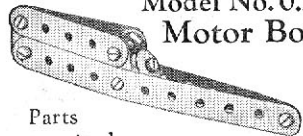

- Parts required:
- | | | | | | | | |
|------------|------------|-------------|-------------|-------------|-------------|--------------|---------------|
| 2 of No. 2 | 2 of No. 5 | 3 of No. 10 | 1 of No. 11 | 1 of No. 23 | 5 of No. 37 | 1 of No. 37A | 1 of No. 111c |
|------------|------------|-------------|-------------|-------------|-------------|--------------|---------------|

**Model No. 0.25
Cot**

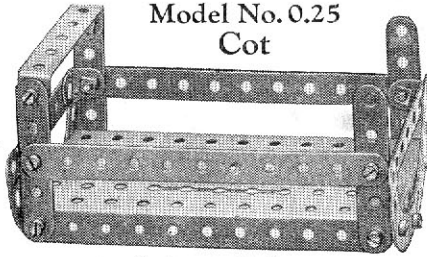

- Parts required:
- | | | | | | | |
|------------|---------|----------|--------------|--------------|-----------|----------|
| 2 of No. 2 | 6 " " 5 | 4 " " 12 | 4 of No. 90A | 16 of No. 37 | 2 " " 48A | 1 " " 52 |
|------------|---------|----------|--------------|--------------|-----------|----------|

**Model No. 0.26
Banjo**

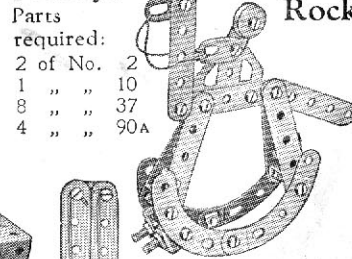

- Parts required:
- | | | | |
|------------|----------|----------|-----------|
| 2 of No. 2 | 1 " " 10 | 8 " " 37 | 4 " " 90A |
|------------|----------|----------|-----------|

Model No. 0.29 Aeroplane

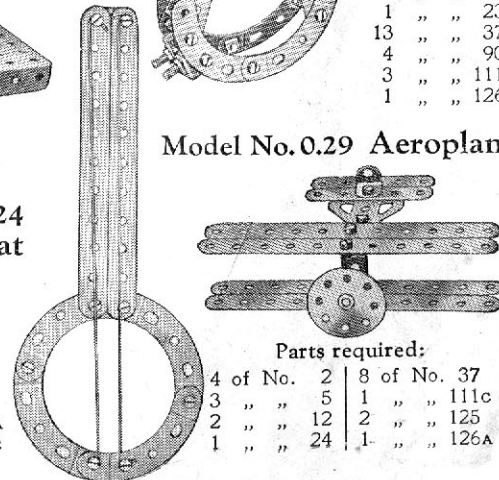

- Parts required:
- | | | | | | | | |
|------------|------------|-------------|-------------|-------------|---------------|--------------|---------------|
| 4 of No. 3 | 2 of No. 5 | 2 of No. 12 | 1 of No. 24 | 8 of No. 37 | 1 of No. 111c | 2 of No. 125 | 1 of No. 126A |
|------------|------------|-------------|-------------|-------------|---------------|--------------|---------------|

Model No. 0.27 Milk Maid

- Parts required:
- | | | | | | | | | | | |
|------------|-------------|-------------|-------------|-------------|-------------|--------------|--------------|-------------|--------------|---------------|
| 5 of No. 3 | 5 of No. 10 | 2 of No. 11 | 4 of No. 12 | 2 of No. 22 | 1 of No. 23 | 14 of No. 37 | 1 of No. 37A | 1 of No. 52 | 1 of No. 90A | 1 of No. 111c |
|------------|-------------|-------------|-------------|-------------|-------------|--------------|--------------|-------------|--------------|---------------|

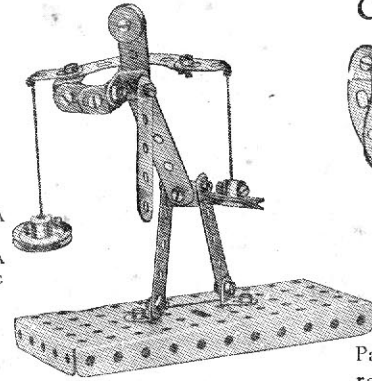

**Model No. 0.30
Catapult**

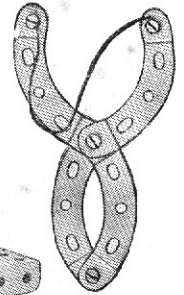

- Parts required:
- | | | |
|------------|-------------|-----------|
| 4 of No. 4 | 1 of No. 37 | 4 " " 90A |
|------------|-------------|-----------|

**Model No. 0.31
Cow and Milkmaid**

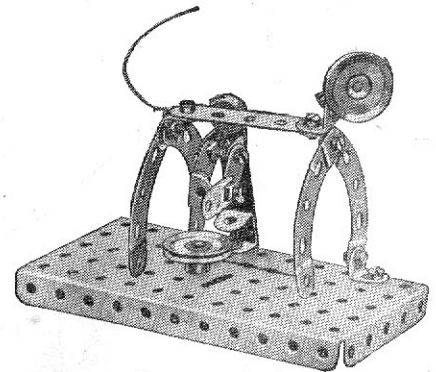

- Parts required:
- | | | | | | | | | | | | | |
|------------|------------|------------|-------------|-------------|-------------|-------------|-------------|--------------|--------------|-------------|--------------|--------------|
| 2 of No. 2 | 4 of No. 4 | 2 of No. 5 | 5 of No. 10 | 2 of No. 11 | 5 of No. 12 | 2 of No. 22 | 1 of No. 23 | 16 of No. 37 | 2 of No. 37A | 1 of No. 52 | 4 of No. 90A | 1 of No. 125 |
|------------|------------|------------|-------------|-------------|-------------|-------------|-------------|--------------|--------------|-------------|--------------|--------------|

Model No. 0.42
Lazy Tong

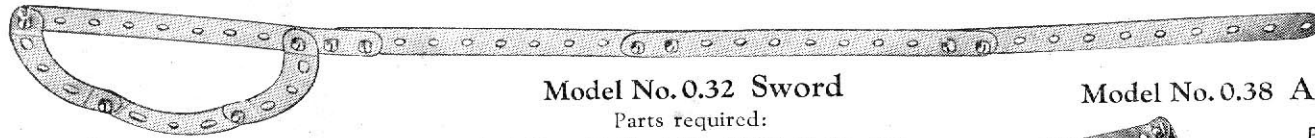

Model No. 0.32 **Sword**

Parts required:

4 of No. 2 | 10 of No. 37 | 3 of No. 90A

Model No. 0.35 **Pecking Hen**

By alternately pushing and pulling the lower of the 5 1/2" Strips, the hen can be made to peck vigorously at the "bowl" (a 1" Pulley). The bolts used for securing the 5 1/2" Strips together should be lock-nutted, care being taken to ensure that no "side play" is permitted.

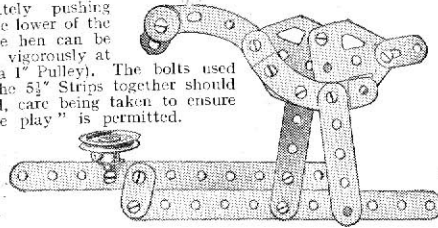

Parts required:

2 of No. 2
2 " " 5
3 " " 10
1 " " 12
1 " " 22
1 " " 23
11 " " 37
5 " " 37A
2 " " 90A
2 " " 111c
2 " " 126A

Model No. 0.38 **Arm Chair**

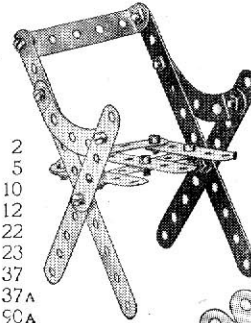

Parts

required:

2 of No. 2
7 " " 5
14 " " 37
2 " " 48A
3 " " 90A

Model No. 0.40
Fan

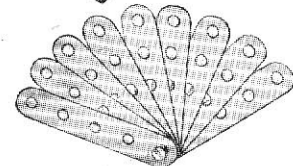

Parts required:

9 of No. 5 | 2 of No. 37A
1 of No. 111c

Model No. 0.33
Bicycle

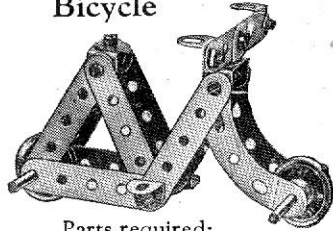

Parts required:

9 of No. 5 | 2 of No. 17
2 " " 11 | 2 " " 22
5 " " 12 | 11 " " 37

Model No. 0.36 **Pen Rack**

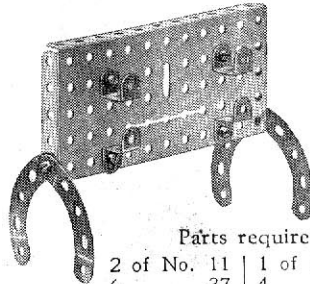

Parts required:

2 of No. 11 | 1 of No. 52
6 " " 37 | 4 " " 90A
2 of No. 125

Model No. 0.39
Prehistoric Armadillo

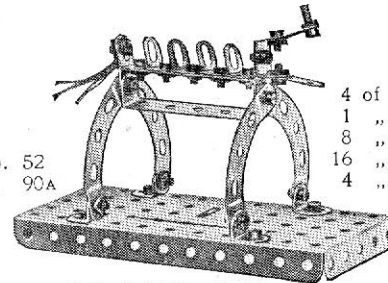

Parts required:

4 of No. 10 | 2 of No. 48A
1 " " 11 | 1 " " 52
8 " " 12 | 4 " " 90A
16 " " 37 | 4 " " 111c
4 " " 37A

Model No. 0.34 **Gramophone**

Parts required:

2 of No. 12
1 " " 22
1 " " 23
1 " " 24
3 " " 37
1 " " 37A
1 " " 52
2 " " 90A
3 " " 111c

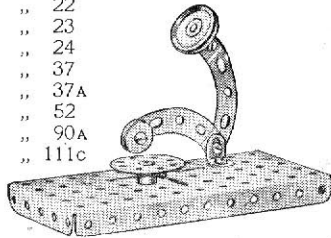

Model No. 0.37 **Gymnast**

Parts required:

2 of No. 2 | 1 of No. 24
4 " " 5 | 12 " " 37
4 " " 10 | 1 " " 37A
1 " " 12 | 1 " " 52
1 " " 16 | 1 " " 90A
2 " " 22 | 1 " " 111c
1 " " 23

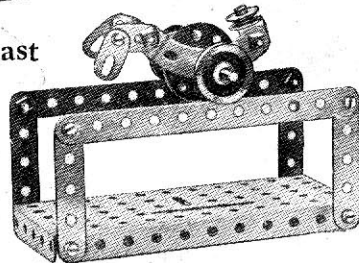

Model No. 0.41
Motor Cycle and Side Car

Parts required:

1 of No. 5 | 3 of No. 22 | 3 of No. 90A
4 " " 10 | 1 " " 23 | 1 " " 111c
2 " " 11 | 10 " " 37 | 1 " " 125
3 " " 12 | 1 " " 37A | 1 " " 126A
1 " " 16 | 1 " " 44

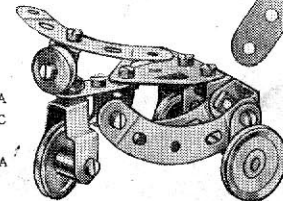

Parts

required:

2 of No. 2
8 " " 5
13 " " 37
9 " " 37A

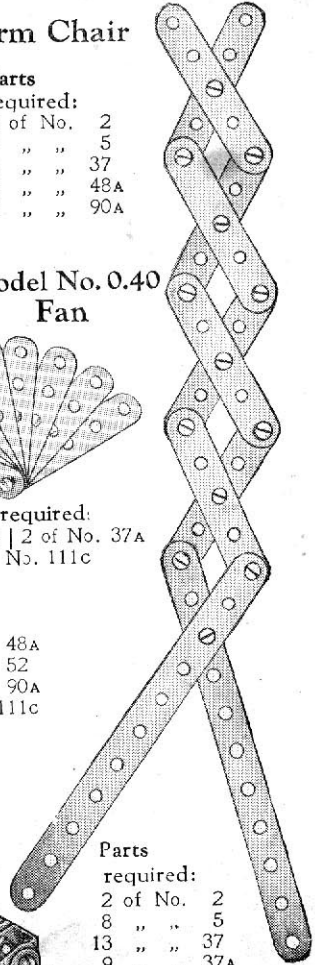

Model No. 0.43 Wrestlers

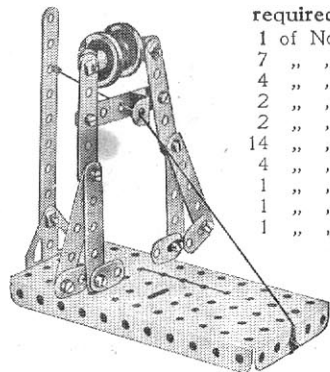

- Parts required:**
- | | |
|----------|------|
| 1 of No. | 2 |
| 7 " " | 5 |
| 4 " " | 10 |
| 2 " " | 12 |
| 2 " " | 22 |
| 14 " " | 37 |
| 4 " " | 37A |
| 1 " " | 52 |
| 1 " " | 125 |
| 1 " " | 126A |

**Model No. 0.44
A Chase**

- Parts required:**
- | | | | |
|----------|----|-----------|------|
| 1 of No. | 5 | 16 of No. | 37 |
| 1 " " | 10 | 1 " " | 37A |
| 2 " " | 11 | 1 " " | 52 |
| 7 " " | 12 | 4 " " | 90A |
| 1 " " | 22 | 2 " " | 111c |
| 1 " " | 23 | 2 " " | 126A |

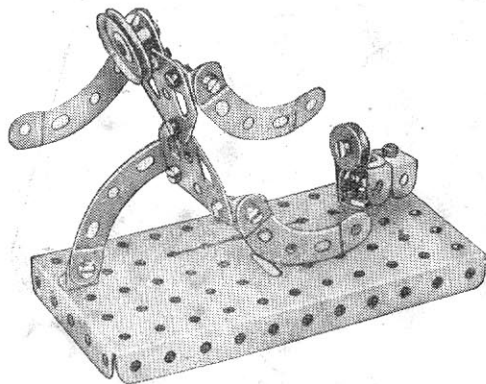

Model No. 0.47 Aerial Flight

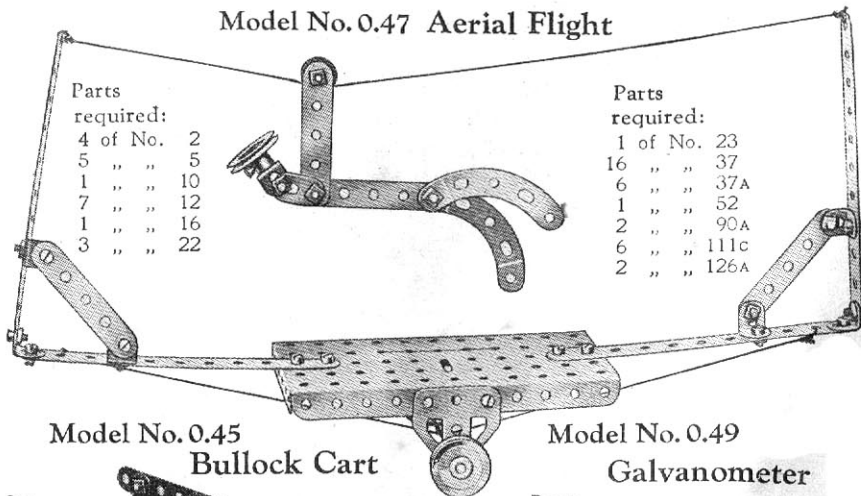

- Parts required:**
- | | |
|----------|----|
| 4 of No. | 2 |
| 5 " " | 5 |
| 1 " " | 10 |
| 7 " " | 12 |
| 1 " " | 16 |
| 3 " " | 22 |

- Parts required:**
- | | |
|----------|------|
| 1 of No. | 23 |
| 16 " " | 37 |
| 6 " " | 37A |
| 1 " " | 52 |
| 2 " " | 90A |
| 6 " " | 111c |
| 2 " " | 126A |

**Model No. 0.45
Bullock Cart**

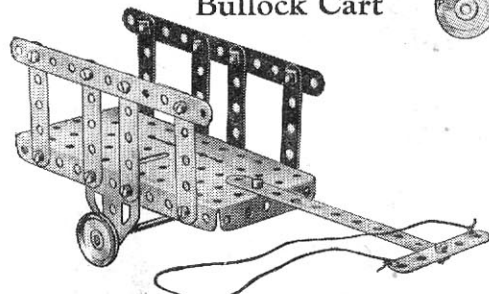

- Parts required:**
- | | | | |
|----------|----|----------|------|
| 3 of No. | 2 | 2 of No. | 37A |
| 9 " " | 5 | 1 " " | 52 |
| 1 " " | 16 | 2 " " | 111c |
| 2 " " | 22 | 2 " " | 126A |
| 16 " " | 37 | | |

**Model No. 0.49
Galvanometer**

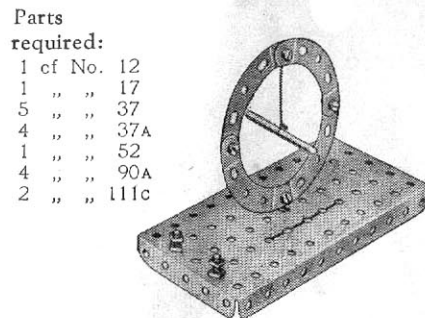

- Parts required:**
- | | |
|----------|------|
| 1 of No. | 12 |
| 1 " " | 17 |
| 5 " " | 37 |
| 4 " " | 37A |
| 1 " " | 52 |
| 4 " " | 90A |
| 2 " " | 111c |

Model No. 0.46 Coster's Barrow

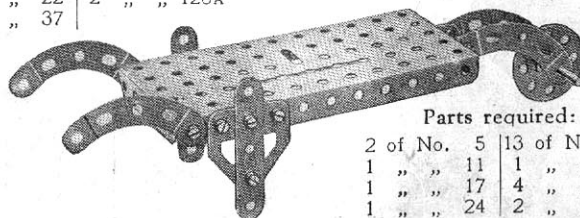

- Parts required:**
- | | | | |
|----------|----|-----------|------|
| 2 of No. | 5 | 13 of No. | 37 |
| 1 " " | 11 | 1 " " | 52 |
| 1 " " | 17 | 4 " " | 90A |
| 1 " " | 24 | 2 " " | 126A |

**Model No. 0.48
The Missing Link**

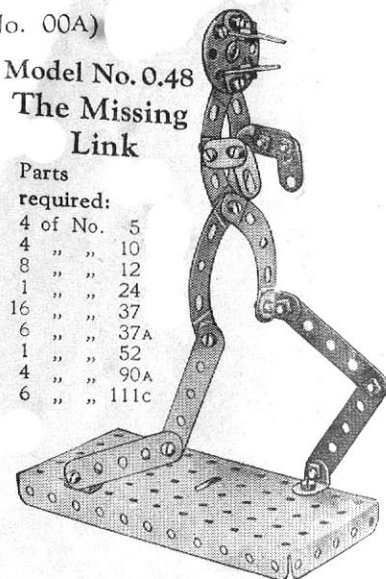

- Parts required:**
- | | |
|----------|------|
| 4 of No. | 5 |
| 4 " " | 10 |
| 8 " " | 12 |
| 1 " " | 24 |
| 16 " " | 37 |
| 6 " " | 37A |
| 1 " " | 52 |
| 4 " " | 90A |
| 6 " " | 111c |

**Model No. 0.50
Steeple-chaser**

- Parts required:**
- | | | | |
|----------|----|----------|------|
| 7 of No. | 5 | 1 of No. | 37A |
| 4 " " | 10 | 1 " " | 48A |
| 1 " " | 12 | 1 " " | 52 |
| 1 " " | 23 | 4 " " | 90A |
| 13 " " | 37 | 1 " " | 111c |
| | | 1 " " | 126A |

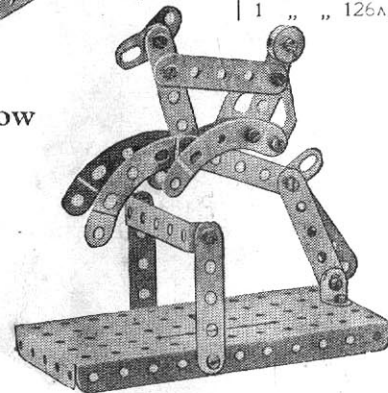

Model No. 0.51 Horseman's Fall

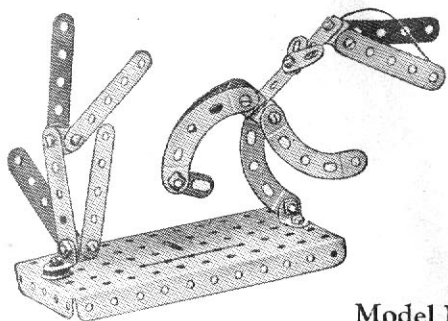

- Parts required:
- 8 of No. 5
 - 3 " " 10
 - 2 " " 11
 - 8 " " 12
 - 1 " " 23
 - 16 " " 37
 - 4 " " 37A
 - 1 " " 52
 - 4 " " 90A
 - 4 " " 111c

Model No. 0.55 Bacon Slicing Machine

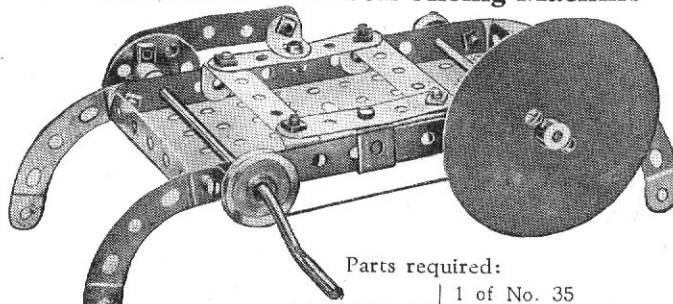

- Parts required:
- | | | |
|------------|-------------|-------------|
| 3 of No. 5 | 1 of No. 16 | 1 of No. 35 |
| 2 " " 11 | 1 " " 19s | 12 " " 37 |
| 1 " " 12 | 2 " " 22 | 2 " " 37A |
| | 1 " " 23 | 2 " " 48A |
| | 1 " " 24 | 1 " " 52 |
| | | 4 " " 90A |

Model No. 0.57 Ape

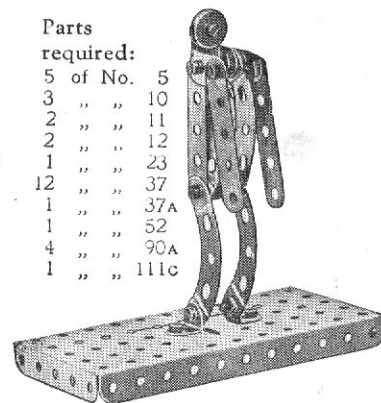

- Parts required:
- 5 of No. 5
 - 3 " " 10
 - 2 " " 11
 - 2 " " 12
 - 1 " " 23
 - 12 " " 37
 - 1 " " 37A
 - 1 " " 52
 - 4 " " 90A
 - 1 " " 111c

Model No. 0.52 Table

- Parts required:
- | | |
|--------------|-------------|
| 2 of No. 2 | 8 of No. 37 |
| 6 " " 12 | 1 " " 52 |
| 4 of No. 90A | |

Model No. 0.53 Windmill

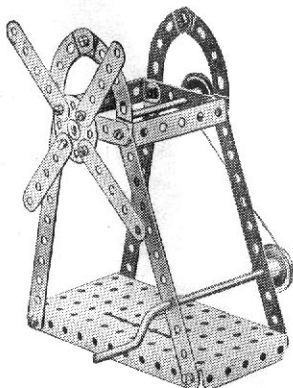

- Parts required:
- 4 of No. 2
 - 6 " " 5
 - 1 " " 16
 - 1 " " 19s
 - 2 " " 22
 - 1 " " 24
 - 14 " " 37
 - 2 " " 48A
 - 1 " " 52
 - 4 " " 90A

Model No. 0.56 Tramway Car

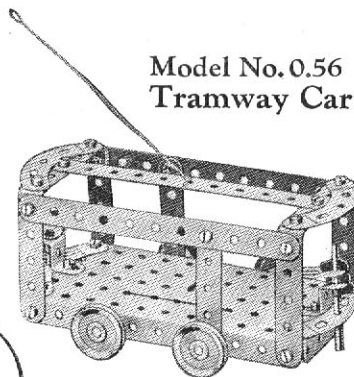

- Parts required:
- | | |
|------------|--------------|
| 3 of No. 2 | 16 of No. 37 |
| 6 " " 5 | 6 " " 37A |
| 2 " " 10 | 2 " " 48A |
| 2 " " 16 | 1 " " 52 |
| 2 " " 17 | 4 " " 90A |
| 4 " " 22 | 6 " " 111c |
| 6 " " 35 | 2 " " 125 |

Model No. 0.58 Gangway

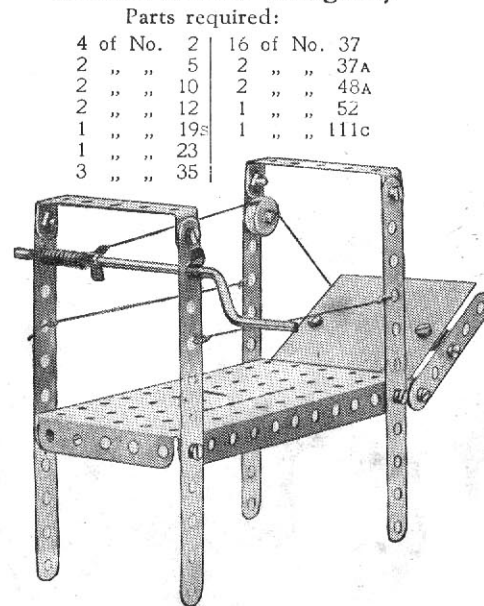

- Parts required:
- | | |
|------------|--------------|
| 4 of No. 2 | 16 of No. 37 |
| 2 " " 5 | 2 " " 37A |
| 2 " " 10 | 2 " " 48A |
| 2 " " 12 | 1 " " 52 |
| 1 " " 19s | 1 " " 111c |
| 1 " " 23 | |
| 3 " " 35 | |

Model No. 0.54 Wiretail

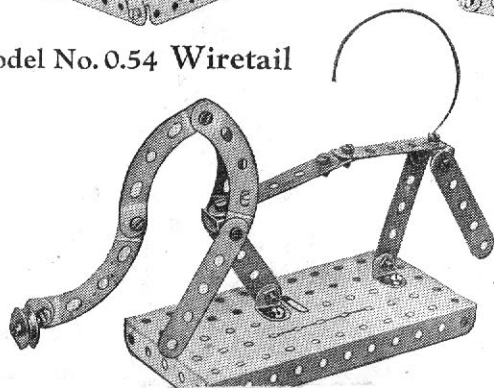

- Parts required:
- 6 of No. 5
 - 1 " " 10
 - 2 " " 11
 - 3 " " 12
 - 1 " " 23
 - 15 " " 37
 - 1 " " 37A
 - 1 " " 52
 - 4 " " 90A
 - 1 " " 111c

**Model No. 0.59
The Fencers**

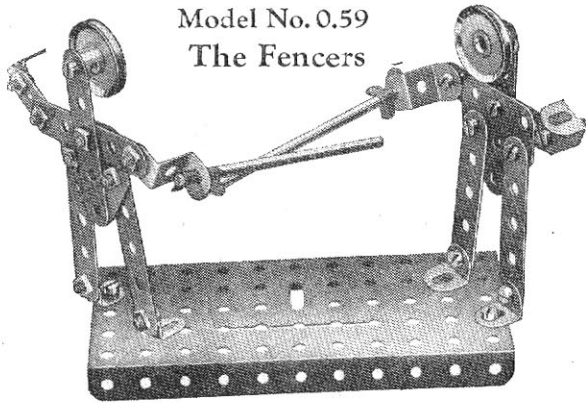

Parts required:

8 of No. 5	4 of No. 35
2 " " 10	20 " " 37
6 " " 12	1 " " 52
2 " " 16	2 " " 125
2 " " 22	2 " " 126A

Model No. 0.61 Rattle

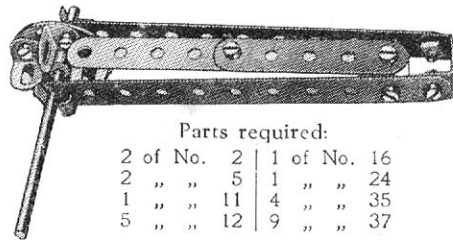

Parts required:

2 of No. 2	1 of No. 16
2 " " 5	1 " " 24
1 " " 11	4 " " 35
5 " " 12	9 " " 37

Model No. 0.65 Aerial Ropeway

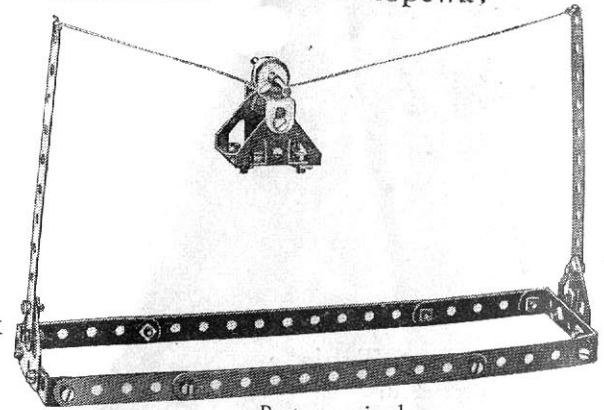

Parts required:

4 of No. 2	1 of No. 23	2 of No. 48A
4 " " 5	2 " " 35	2 " " 125
2 " " 10	22 " " 37	2 " " 126
1 " " 17	1 " " 40	2 " " 126A

**Model No. 0.62
Single Sheave Pulley Block**

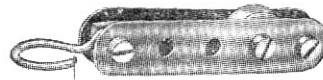

Parts required:

2 of No. 5	7 of No. 37A
1 " " 23	1 " " 57
3 of No. 111c	

Model No. 0.60 Pen Rack

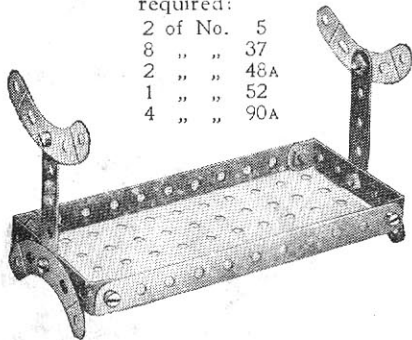

Parts required:

2 of No. 5
8 " " 37
2 " " 48A
1 " " 52
4 " " 90A

**Model No. 0.63
Music Stand**

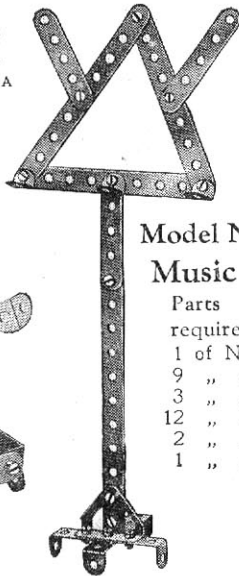

Parts

required:

1 of No. 2
9 " " 5
3 " " 12
12 " " 37
2 " " 48A
1 " " 126

**Model No. 0.64
Arm Chair**

Parts required:

2 of No. 2
4 " " 5
12 " " 37
1 " " 48A
1 " " 52
3 " " 90A

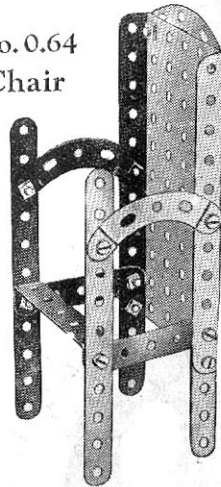

Model No. 0.66 Shearing Machine

Parts required:

4 of No. 2	2 of No. 48A
7 " " 5	1 " " 52
17 " " 37	2 " " 90A

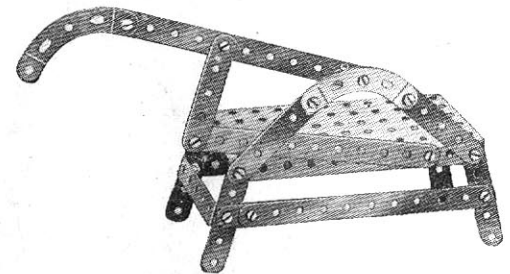

Model No. 0.67 Scooter

Parts required:

4 of No.	2
2 " "	5
2 " "	11
2 " "	12
2 " "	17
2 " "	22
17 " "	37
1 " "	48A
2 " "	90A

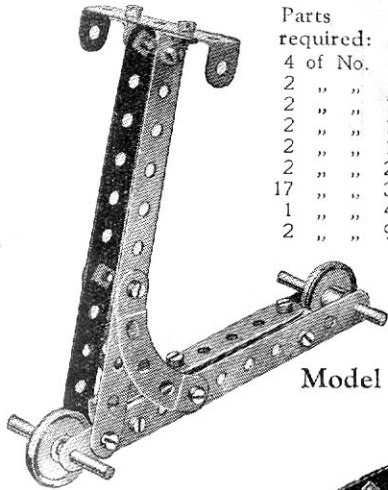

Model No. 0.69 Push Cart

Parts required:

2 of No.	16	1 of No.	52
4 " "	22	4 " "	90A
16 " "	37	2 " "	126
2 " "	48A	2 " "	126A

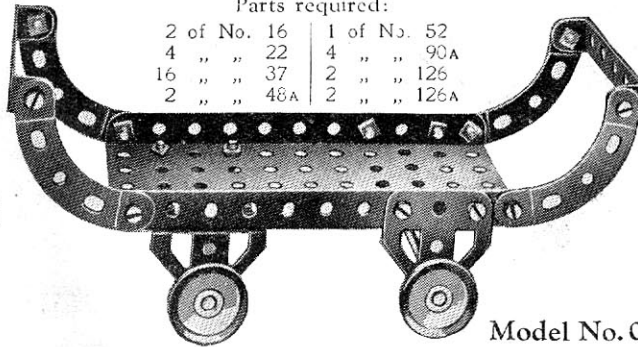

Model No. 0.71 Dog Kennel

Parts required:

3 of No.	2
8 " "	5
6 " "	12
20 " "	37
2 " "	48A
1 " "	52
2 " "	90A

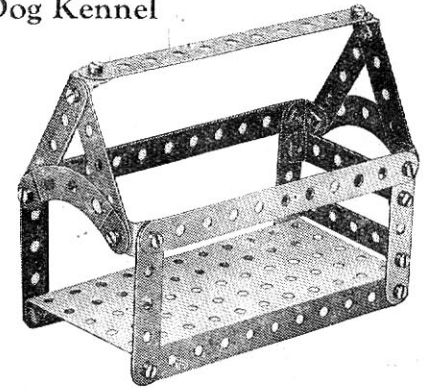

Model No. 0.70 Tipping Cart

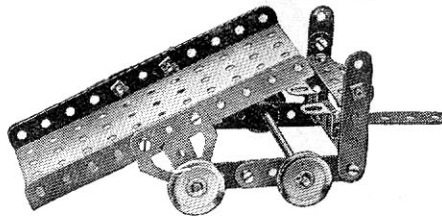

Model No. 0.72 Horse Rake

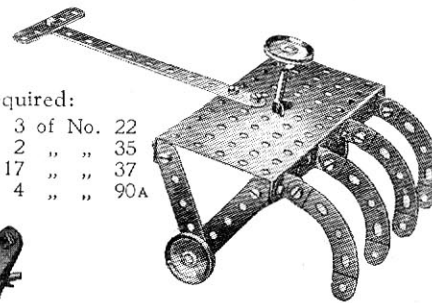

Model No. 0.74 Chaff Cutter

Parts required:

2 of No.	2	2 of No.	22
8 " "	5	1 " "	24
1 " "	11	2 " "	35
2 " "	12	19 " "	37
1 " "	16	1 " "	52
1 " "	19s	2 " "	125

Model No. 0.68 Luggage Truck

Parts required:

2 of No.	2
6 " "	5
2 " "	12
1 " "	16
2 " "	22
12 " "	37
1 " "	52
3 " "	90A

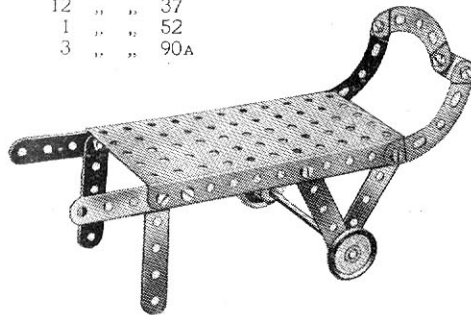

Parts required:

1 of No.	2	3 of No.	22
5 " "	5	2 " "	35
8 " "	12	17 " "	37
1 " "	17	4 " "	90A

Parts required:

7 of No.	5	15 of No.	37	1 of No.	90A
2 " "	16	2 " "	48A	2 " "	125
4 " "	22	1 " "	52	2 " "	126A

Model No. 0.73 Jib Crane

Parts required:

1 of No.	19s
4 " "	22
1 " "	23
1 " "	24
4 " "	35
17 " "	37
4 of No.	2
9 " "	5
2 " "	16
1 " "	17
1 " "	40
1 " "	48A
1 " "	52
1 " "	57

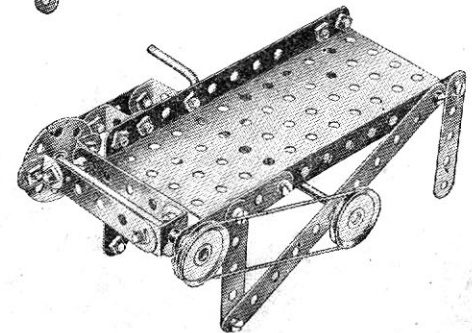
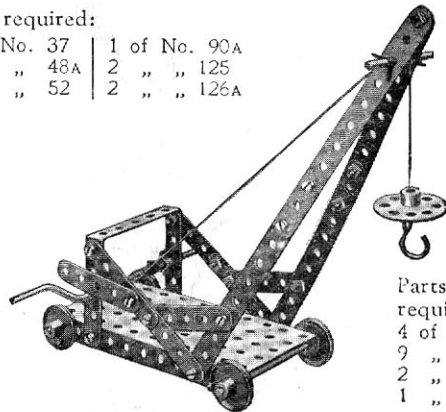

These Models can be built with MECCANO Outfit No. 0 (or No. 00 and No. 00A)

Model No.0.75 Trolley

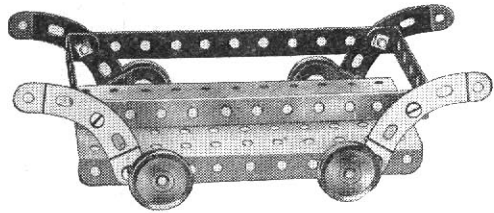

Parts required.
 2 of No. 2 | 8 of No. 37
 2 " " 16 | 2 " " 48A
 4 " " 22 | 1 " " 52
 4 of No. 90A

Model No.0.77 Luggage Truck

Parts required:
 4 of No. 2
 4 " " 5
 2 " " 16
 4 " " 22
 16 " " 37
 1 " " 52
 4 " " 90A

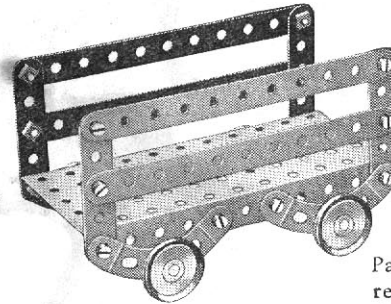

Model No.0.79 Swing

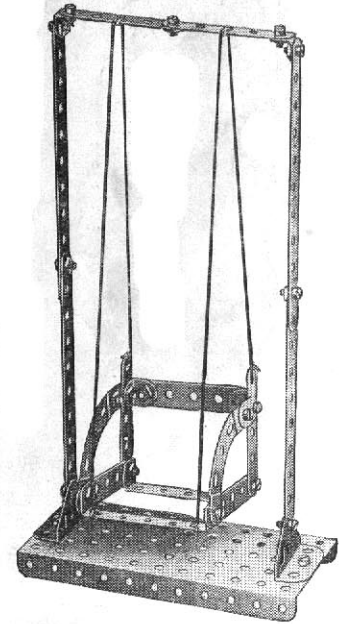

Parts required:
 4 of No. 2
 7 " " 5
 2 " " 10
 4 " " 12
 21 " " 37
 1 " " 40
 2 " " 48A
 1 " " 52
 2 " " 90A
 2 " " 126

Model No.0.78 Lathe

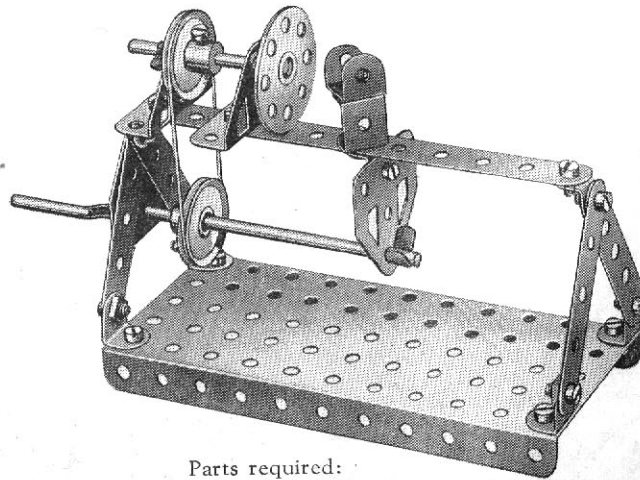

Parts required:
 1 of No. 2 | 2 of No. 22
 4 " " 5 | 1 " " 24
 2 " " 11 | 3 " " 35
 7 " " 12 | 16 " " 37
 1 " " 17 | 1 " " 52
 1 " " 19s | 2 " " 126
 2 of No. 126A

Model No.0.76 Hat Rack

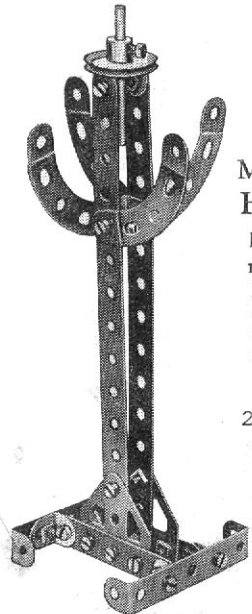

Parts required:
 2 of No. 2
 4 " " 5
 2 " " 11
 5 " " 12
 1 " " 17
 1 " " 22
 20 " " 37
 2 " " 48A
 4 " " 90A
 2 " " 126A

Model No.0.80 Plough

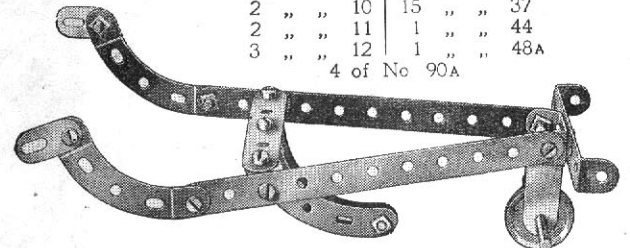

Parts required:
 2 of No. 2 | 1 of No. 17
 1 " " 5 | 1 " " 22
 2 " " 10 | 15 " " 37
 3 " " 11 | 1 " " 44
 3 " " 12 | 1 " " 48A
 4 of No. 90A

Model No. 0.81 Arch

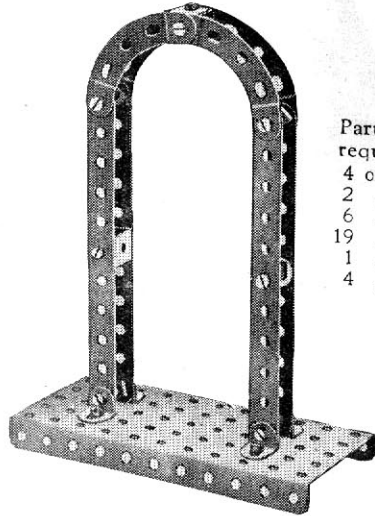

Parts required:
 4 of No. 2
 2 " " 11
 6 " " 12
 19 " " 37
 1 " " 52
 4 " " 90A

Model No. 0.83 Horizontal Engine

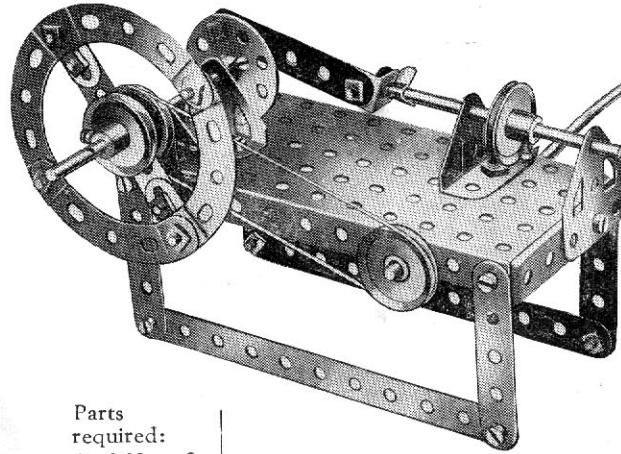

Parts required:
 2 of No. 2
 6 " " 5
 2 " " 10
 1 " " 12
 2 " " 16
 1 " " 19s
 4 of No. 22
 1 " " 24
 3 " " 35
 21 " " 37
 1 " " 48A
 1 of No. 52
 4 " " 90A
 2 " " 126
 2 " " 126A

Model No. 0.85 Notice Board

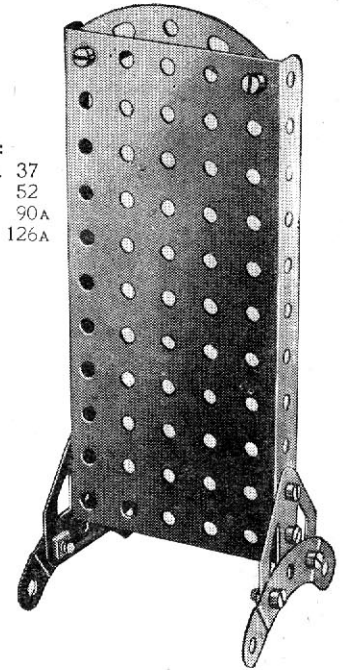

Parts required:
 10 of No. 37
 1 " " 52
 3 " " 90A
 2 " " 126A

Model No. 0.82 Tea Wagon

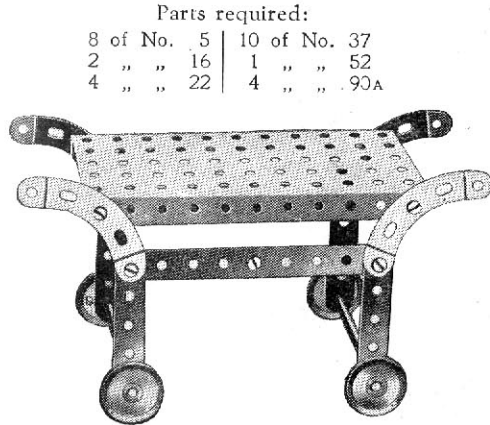

Parts required:
 8 of No. 5 | 10 of No. 37
 2 " " 16 | 1 " " 52
 4 " " 22 | 4 " " 90A

Model No. 0.84 Sulkey

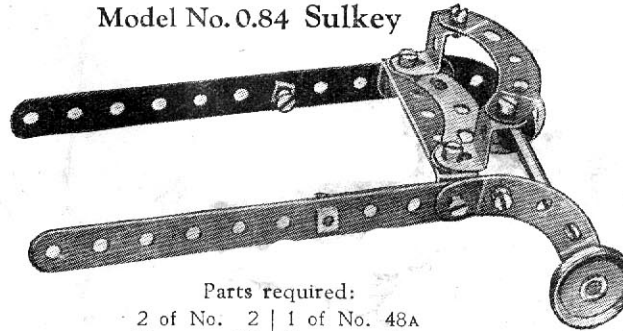

Parts required:
 2 of No. 2 | 1 of No. 48A
 2 " " 22 | 4 " " 90A
 10 " " 37 | 2 " " 125

Model No. 0.86 Drafting Table

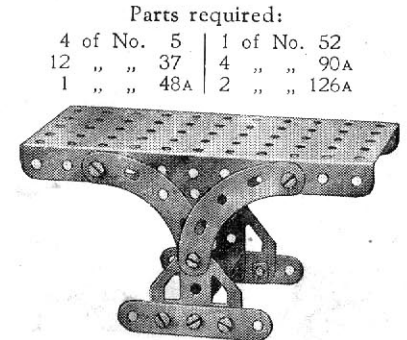

Parts required:
 4 of No. 5 | 1 of No. 52
 12 " " 37 | 4 " " 90A
 1 " " 48A | 2 " " 126A

Model No. 0.87 Well Windlass

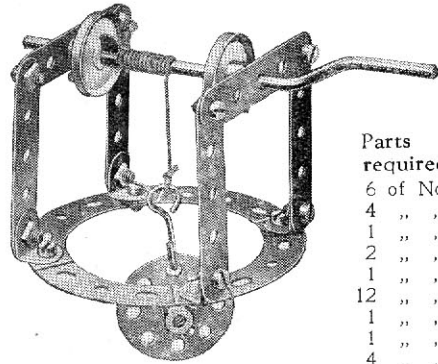

Parts required:

6 of No.	5
4 " "	12
1 " "	19s
2 " "	22
1 " "	24
12 " "	37
1 " "	40
1 " "	57
4 " "	90A

Model No. 0.89 Pulley Block

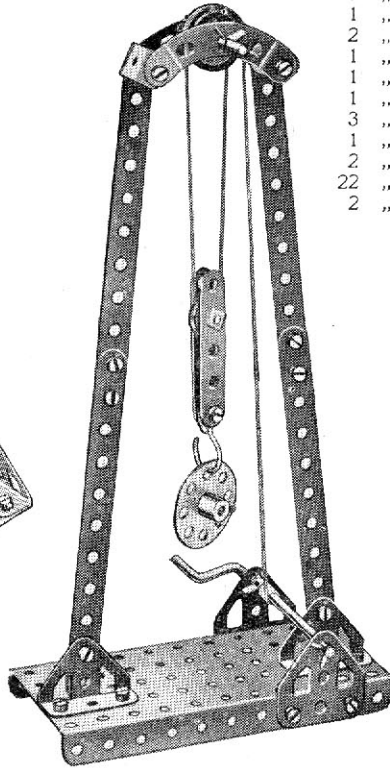

Parts required:

4 of No.	2	1 of No.	22	1 of No.	52
2 " "	5	1 " "	23	1 " "	57
2 " "	11	1 " "	24	2 " "	90A
1 " "	17	5 " "	35	2 " "	126
1 " "	19s	20 " "	37	2 " "	126A

Model No. 0.90 Derricking Crane

Parts required:

4 of No.	2	1 of No.	52
5 " "	5	1 " "	57
1 " "	10	2 " "	125
2 " "	11	2 " "	126
1 " "	16		
1 " "	17		
1 " "	19s		
3 " "	22		
1 " "	23		
2 " "	35		
22 " "	37		
2 " "	48A		

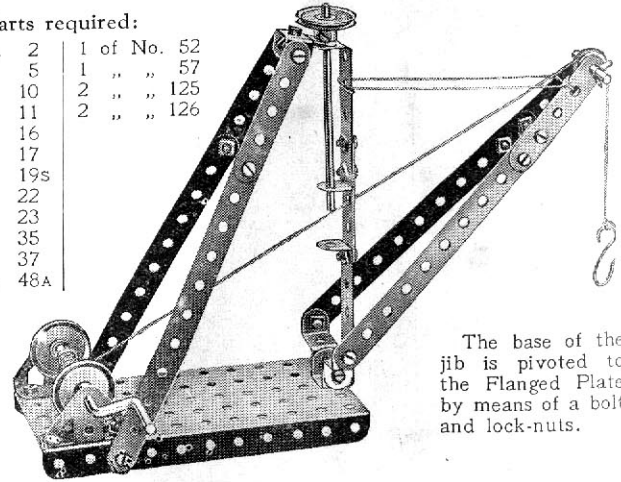

The base of the jib is pivoted to the Flanged Plate by means of a bolt and lock-nuts.

Model No. 0.88 See-Saw

Parts required:

4 of No.	2	1 of No.	52
1 " "	16	4 " "	90A
2 " "	22	2 " "	126
12 " "	37		
1 " "	48A		

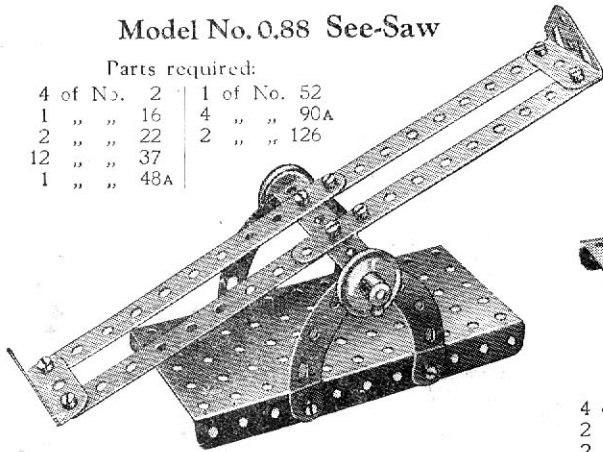

Model No. 0.91 Rock Drill

Parts required:

1 of No.	11	4 of No.	22	2 of No.	48A
2 " "	16	1 " "	24	1 " "	52
1 " "	17	2 " "	35	2 " "	125
1 " "	19s	5 " "	37		

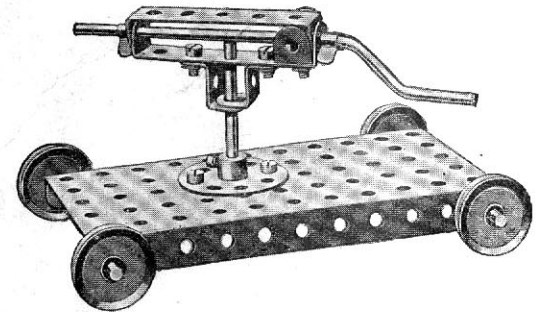

Model No. 0.92 Drilling Machine

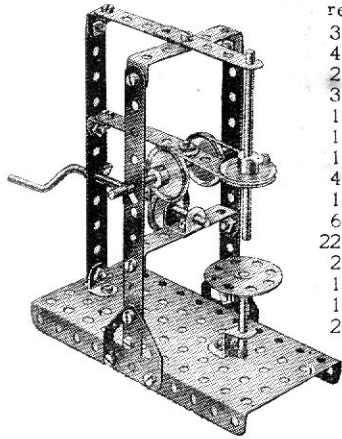

Parts required:

3 of No.	2
4 " "	5
2 " "	11
3 " "	12
1 " "	16
1 " "	17
1 " "	19s
4 " "	22
1 " "	24
6 " "	35
22 " "	37
2 " "	48A
1 " "	52
1 " "	125
2 " "	126A

Model No. 0.94 Scales

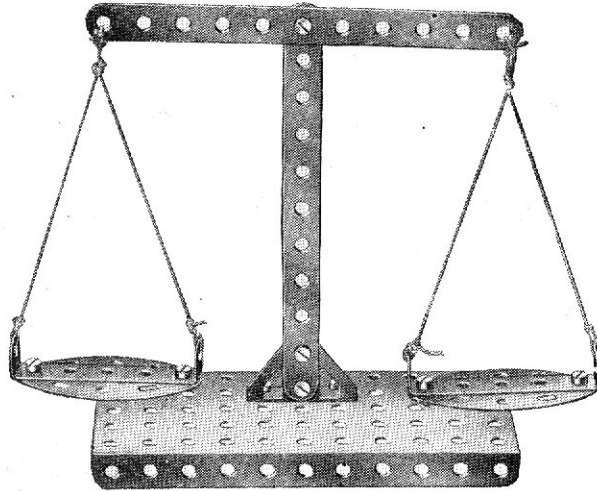

Parts required:

2 of No.	2	2 of No.	48A
9 " "	37	1 " "	52
1 " "	37A	4 " "	90A
1 of No. 166			

Model No. 0.96 Cot

Parts required:

4 of No.	2	4 of No.	22
7 " "	5	18 " "	37
3 " "	12	2 " "	48A
1 of No. 52			

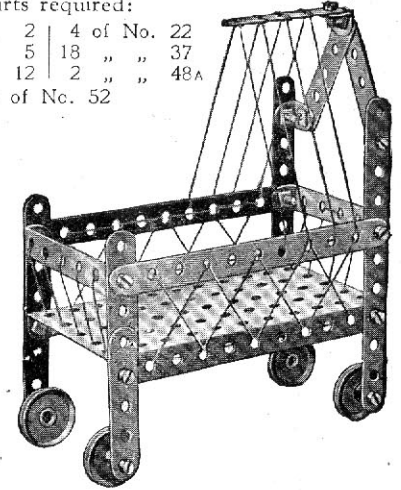

Model No. 0.93 Counter Scales

Parts required:

1 of No.	2	7 of No.	37
2 " "	10	1 " "	44
2 " "	12	1 " "	52
1 " "	17	2 " "	126

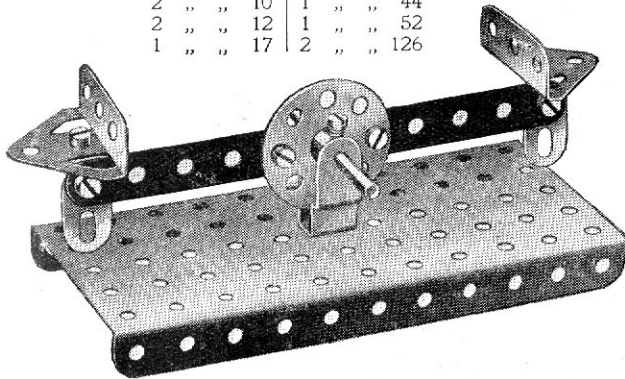

Model No. 0.95 Single Sheave Pulley Block



Parts required:

1 of No.	23
12 " "	37A
1 " "	57
4 " "	111c
2 " "	126A

Model No. 0.97 Couch

Parts required:

1 of No.	2	4 of No.	12	1 of No.	52	
3 " "	5	20 " "	37	4 " "	90A	
2 " "						48A

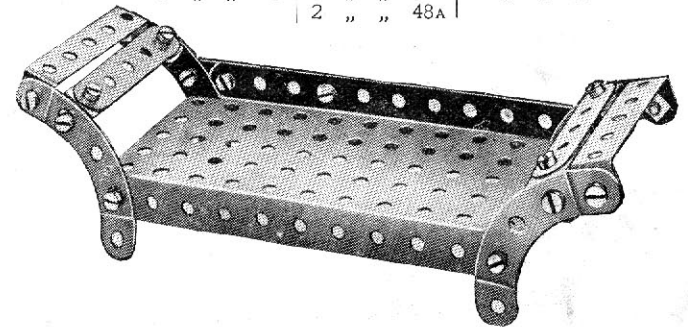

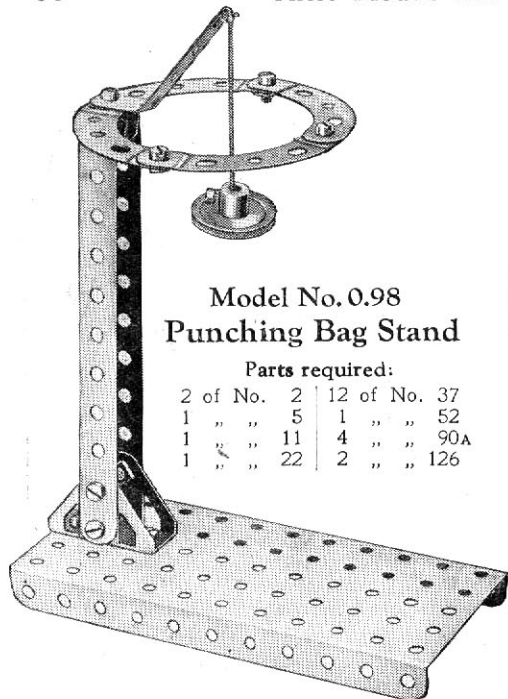

**Model No. 0.98
Punching Bag Stand**

Parts required:

2 of No. 2	12 of No. 37
1 " " 5	1 " " 52
1 " " 11	4 " " 90A
1 " " 22	2 " " 126

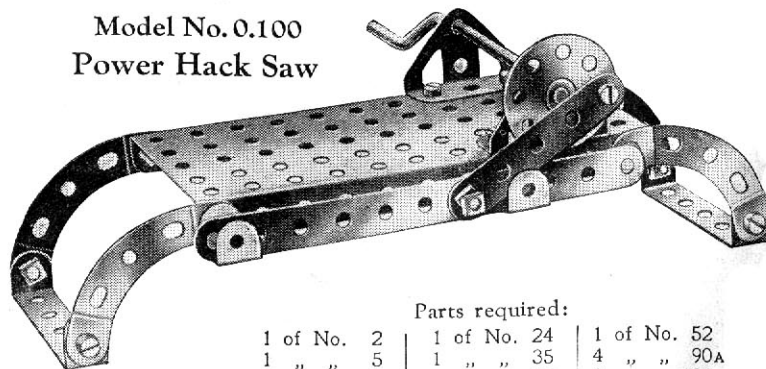

**Model No. 0.100
Power Hack Saw**

Parts required:

1 of No. 2	1 of No. 24	1 of No. 52
1 " " 5	1 " " 35	4 " " 90A
2 " " 11	16 " " 37	2 " " 126
1 " " 19s	2 " " 48A	

**Model No. 0.102
Junction Signal**

**Parts
required:**

3 of No. 2	2
7 " " 5	5
2 " " 10	10
2 " " 11	11
2 " " 12	12
2 " " 17	17
2 " " 22	22
1 " " 23	23
4 " " 35	35
21 " " 37	37
1 " " 40	40
1 " " 52	52
1 " " 126A	126A

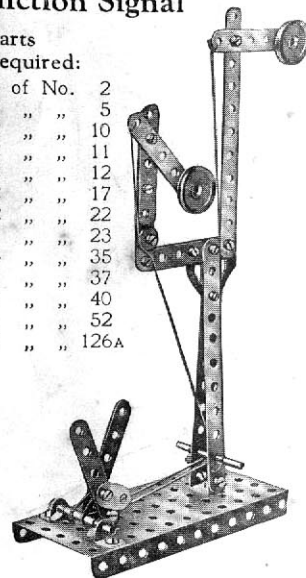

Model No. 0.101 Old Siege Gun

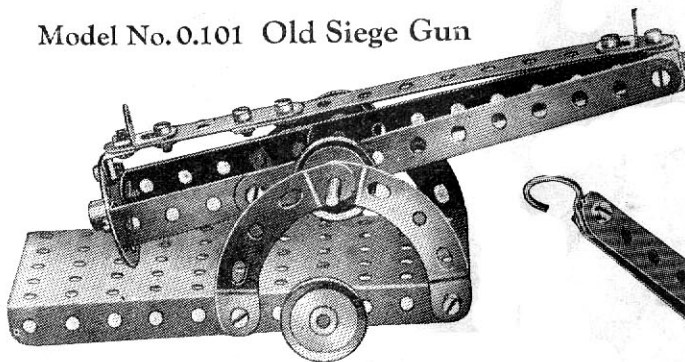

Parts required:

3 of No. 2	1 of No. 24
1 " " 5	18 " " 37
2 " " 11	2 " " 48A
4 " " 12	1 " " 52
2 " " 16	4 " " 90A
4 " " 22	

Model No. 0.103 Anchor

Parts required:

2 of No. 2	1 of No. 11
1 " " 5	10 " " 37
	1 " " 57
	2 " " 90A
	2 " " 126A

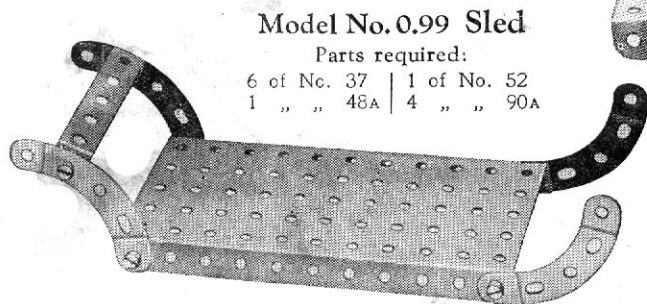
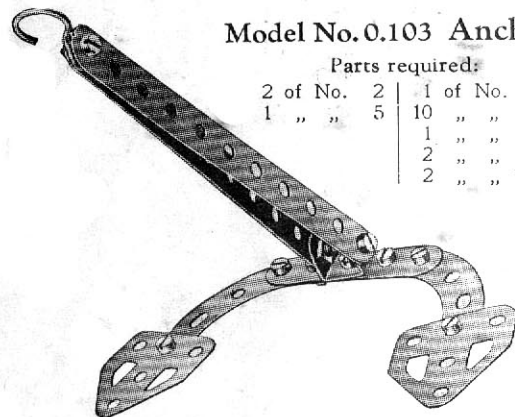

Model No. 0.99 Sled

Parts required:

6 of No. 37	1 of No. 52
1 " " 48A	4 " " 90A

Model No. 0.104 Aeroplane

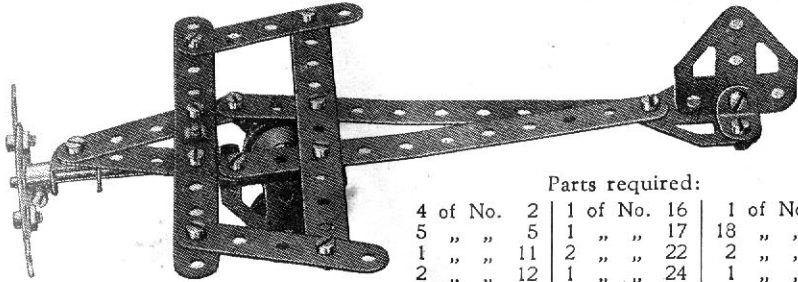

Parts required:

4 of No. 2	1 of No. 16	1 of No. 35
5 " " 5	1 " " 17	18 " " 37
1 " " 11	2 " " 22	2 " " 126
2 " " 12	1 " " 24	1 " " 126A

Model No. 0.107 Bath Chair

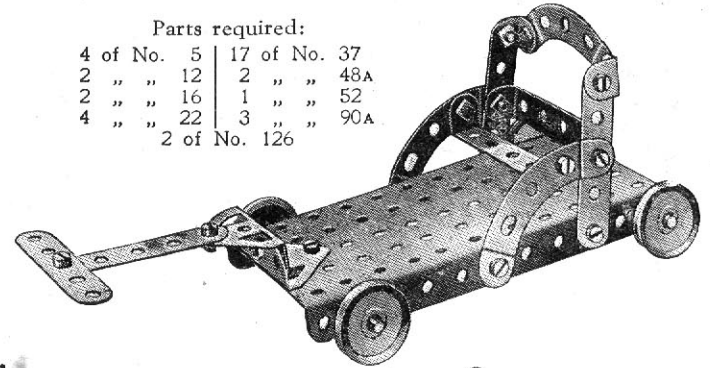

Parts required:

4 of No. 5	17 of No. 37
2 " " 12	2 " " 48A
2 " " 16	1 " " 52
4 " " 22	3 " " 90A
2 of No. 126	

Model No. 0.106 Dump Car

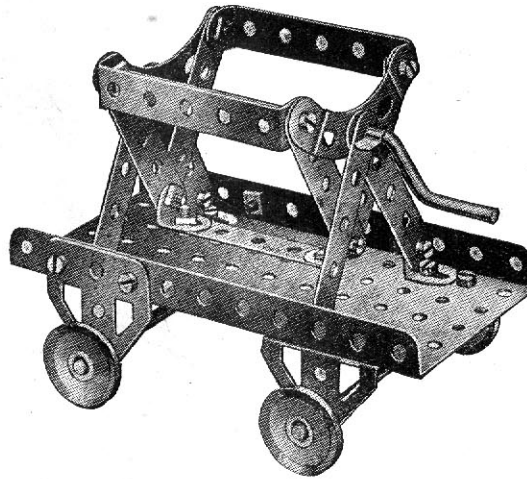

Parts required:

9 of No. 5	2 of No. 35	2 of No. 90A
6 " " 12	22 " " 37	2 " " 126
1 " " 19s	2 " " 48A	2 " " 126A
4 " " 22	1 " " 52	

Model No. 0.105 Bench Lathe

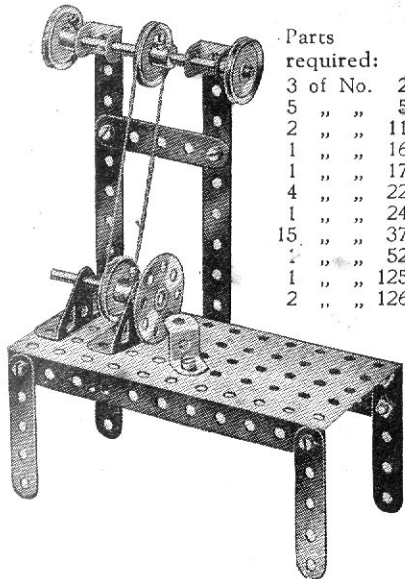

Parts required:

3 of No. 2	2
5 " " 5	5
2 " " 11	11
1 " " 16	16
1 " " 17	17
4 " " 22	22
1 " " 24	24
15 " " 37	37
1 " " 52	52
1 " " 125	125
2 " " 126	126

Model No. 0.108
Punching Machine

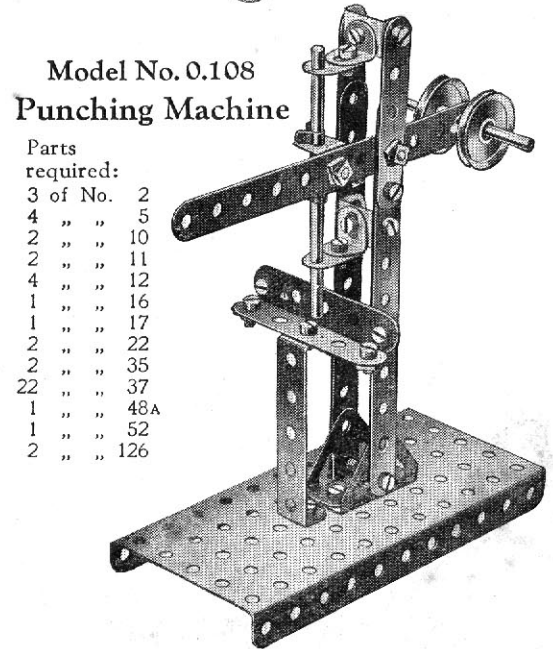

Parts required:

3 of No. 2	2
4 " " 5	5
2 " " 10	10
2 " " 11	11
4 " " 12	12
1 " " 16	16
1 " " 17	17
2 " " 22	22
2 " " 35	35
22 " " 37	37
1 " " 48A	48A
1 " " 52	52
2 " " 126	126

Model No. 0.109
Pneumatic Grain Elevator

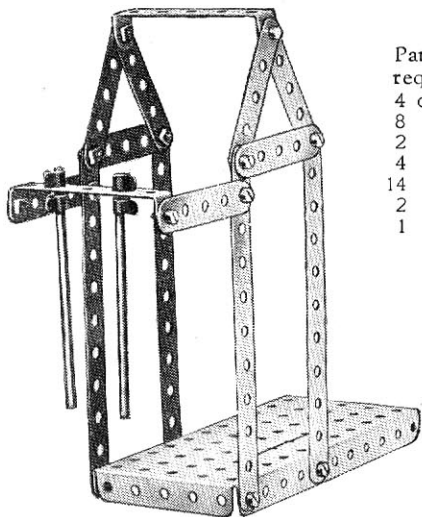

- Parts required:
- | | |
|----------|-----|
| 4 of No. | 2 |
| 8 " " | 5 |
| 2 " " | 16 |
| 4 " " | 35 |
| 14 " " | 37 |
| 2 " " | 48A |
| 1 " " | 52 |

Model No. 0.111 Footbridge

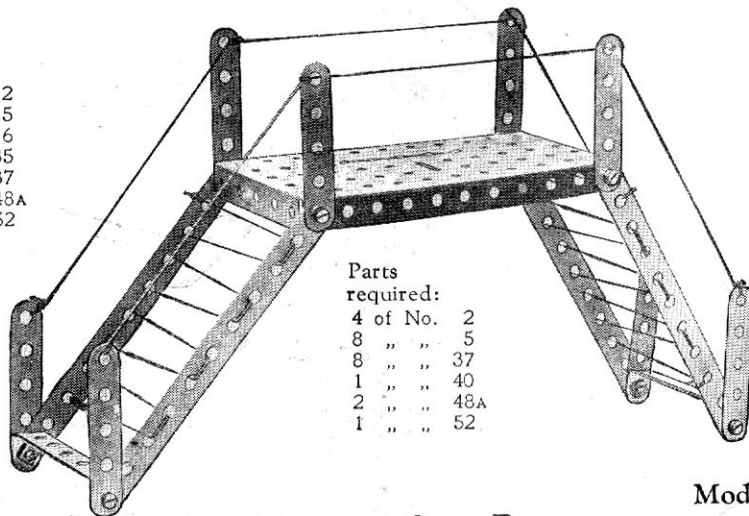

- Parts required:
- | | |
|----------|-----|
| 4 of No. | 2 |
| 8 " " | 5 |
| 8 " " | 37 |
| 1 " " | 40 |
| 2 " " | 48A |
| 1 " " | 52 |

Model No. 0.113 Crane Grab

- Parts required:
- | | |
|----------|-----|
| 6 of No. | 5 |
| 2 " " | 10 |
| 7 " " | 12 |
| 1 " " | 16 |
| 6 " " | 35 |
| 15 " " | 37 |
| 2 " " | 48A |
| 4 " " | 90A |

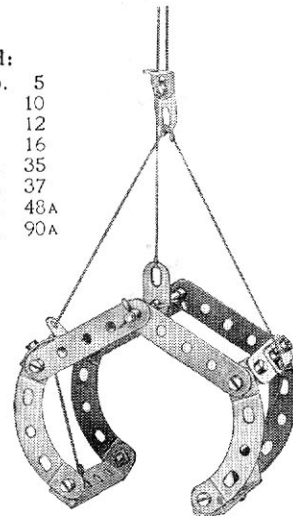

Model No. 0.110
Baboon

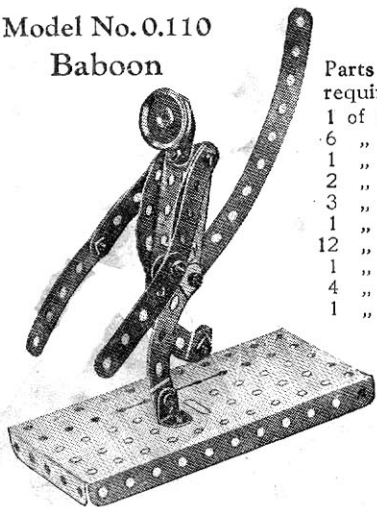

- Parts required:
- | | |
|----------|------|
| 1 of No. | 2 |
| 6 " " | 5 |
| 1 " " | 10 |
| 2 " " | 11 |
| 3 " " | 12 |
| 1 " " | 22 |
| 12 " " | 37 |
| 1 " " | 52 |
| 4 " " | 90A |
| 1 " " | 111c |

Model No. 0.112 Cross-Bow

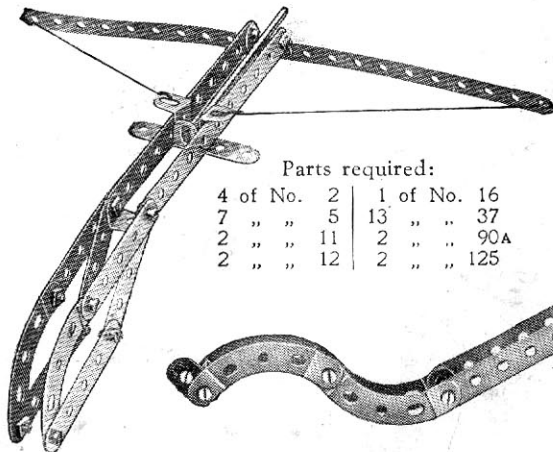

- Parts required:
- | | | | |
|----------|----|----------|-----|
| 4 of No. | 2 | 1 of No. | 16 |
| 7 " " | 5 | 13 " " | 37 |
| 2 " " | 11 | 2 " " | 90A |
| 2 " " | 12 | 2 " " | 125 |

Model No. 0.114 Switchback

- Parts required:
- | | | | |
|----------|----|----------|------|
| 4 of No. | 2 | 2 of No. | 22 |
| 4 " " | 5 | 16 " " | 37 |
| 1 " " | 10 | 3 " " | 37A |
| 2 " " | 11 | 1 " " | 52 |
| 2 " " | 12 | 4 " " | 90A |
| 1 " " | 17 | 3 " " | 111c |

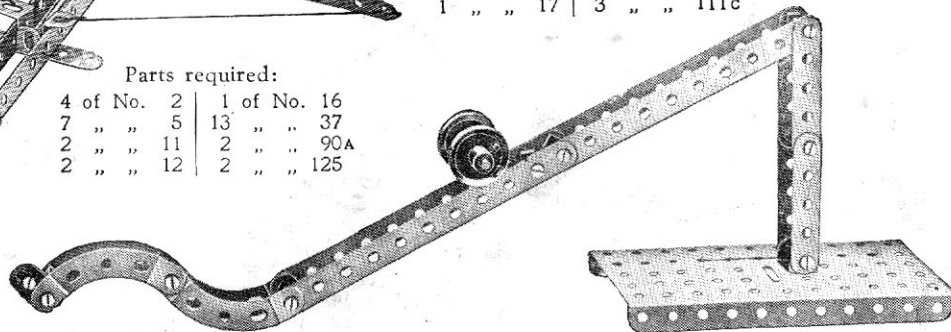

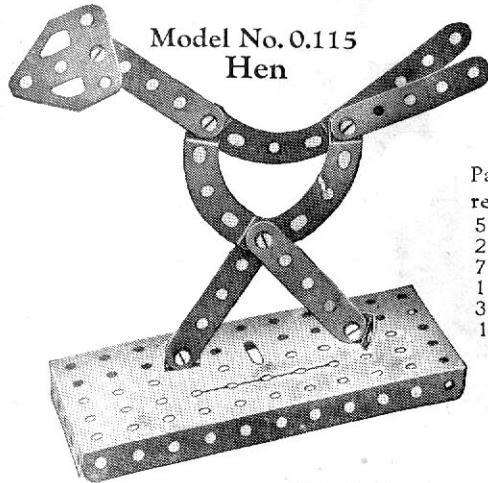

**Model No. 0.115
Hen**

Parts
required:
5 of No. 5
2 " " 12
7 " " 37
1 " " 52
3 " " 90A
1 " " 126A

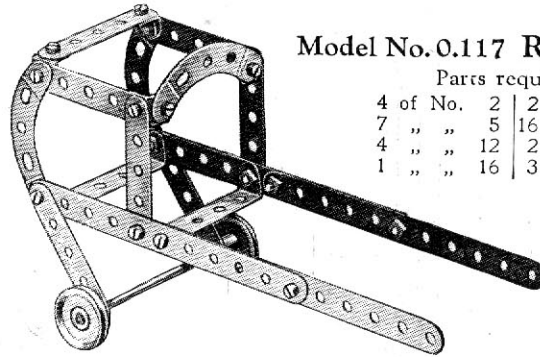

Model No. 0.117 Rickshaw

Parts required:
4 of No. 2 | 2 of No. 22
7 " " 5 | 16 " " 37
4 " " 12 | 2 " " 48A
1 " " 16 | 3 " " 90A

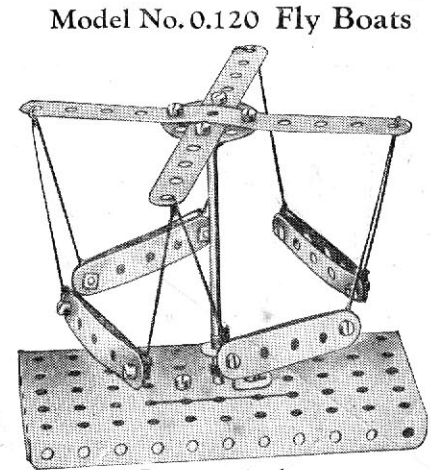

Model No. 0.120 Fly Boats

Parts required:
2 of No. 2 | 13 of No. 37
8 " " 5 | 1 " " 52
1 " " 16 | 1 " " 125
1 " " 24

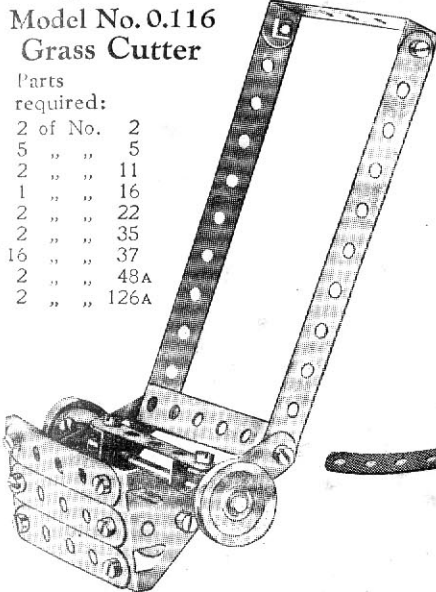

**Model No. 0.116
Grass Cutter**

Parts
required:
2 of No. 2
5 " " 5
2 " " 11
1 " " 16
2 " " 22
2 " " 35
16 " " 37
2 " " 48A
2 " " 126A

Model No. 0.118 Rowing Boat

Parts required:
4 of No. 2 | 4 of No. 111c
6 " " 5 | 2 " " 125
2 " " 10
1 " " 11
16 " " 37
4 " " 37A
1 " " 44
2 " " 48A
4 " " 90A

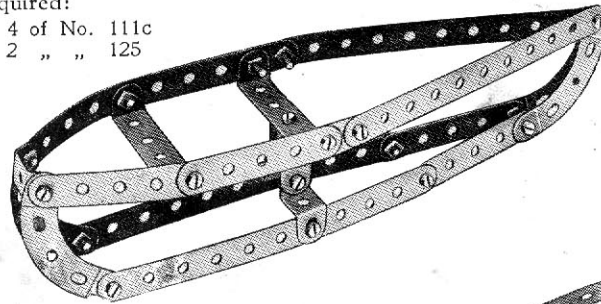

Model No. 0.119 Dinosaur

Parts required:
3 of No. 2 | 5 of No. 12 | 1 of No. 52
1 " " 5 | 1 " " 23 | 2 " " 90A
4 " " 10 | 16 " " 37 | 6 " " 111c
2 " " 11 | 6 " " 37A

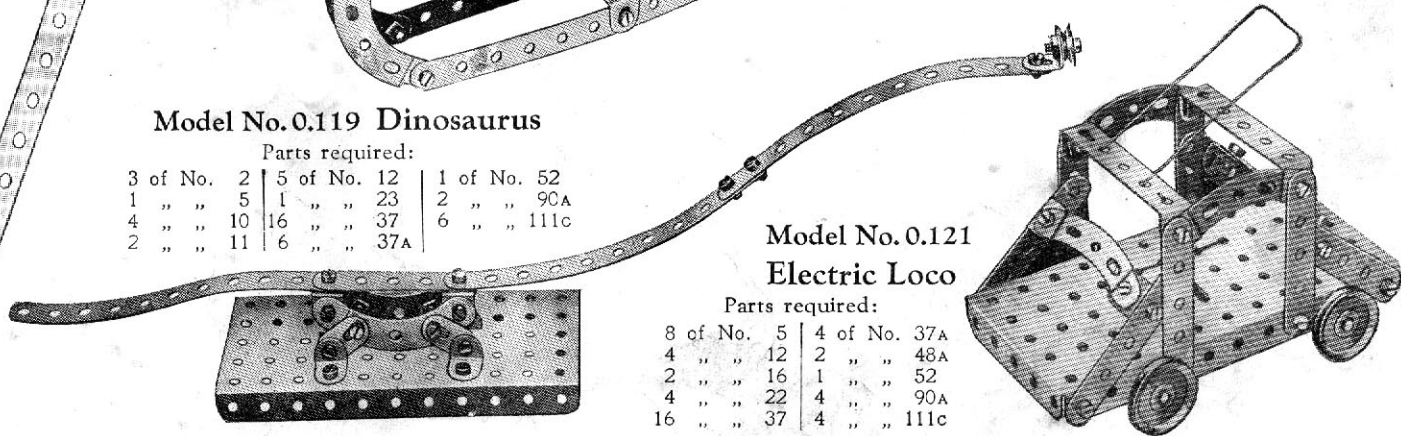

**Model No. 0.121
Electric Loco**

Parts required:
8 of No. 5 | 4 of No. 37A
4 " " 12 | 2 " " 48A
2 " " 16 | 1 " " 52
4 " " 22 | 4 " " 90A
16 " " 37 | 4 " " 111c

**Model No. 0.122
Weather Vane**

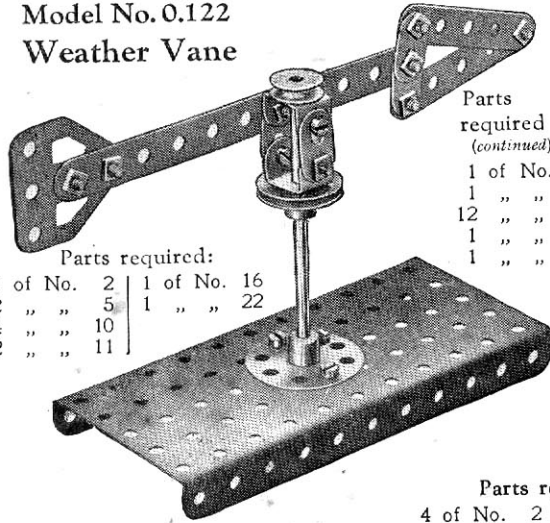

Parts required:
 1 of No. 2 | 1 of No. 16
 2 " " 5 | 1 " " 22
 4 " " 10
 2 " " 11

Parts required
 (continued):
 1 of No. 23
 1 " " 24
 12 " " 37
 1 " " 52
 1 " " 126A

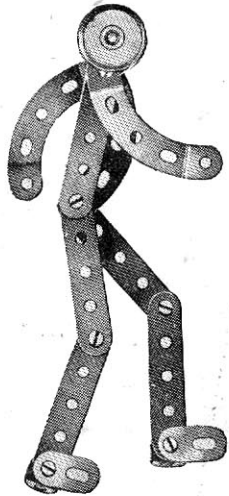

**Model No. 0.123
Walking Man**

Parts required:
 5 of No. 5
 3 " " 10
 2 " " 12
 1 " " 22
 7 " " 37
 3 " " 90A

**Model No. 0.124
Portal**

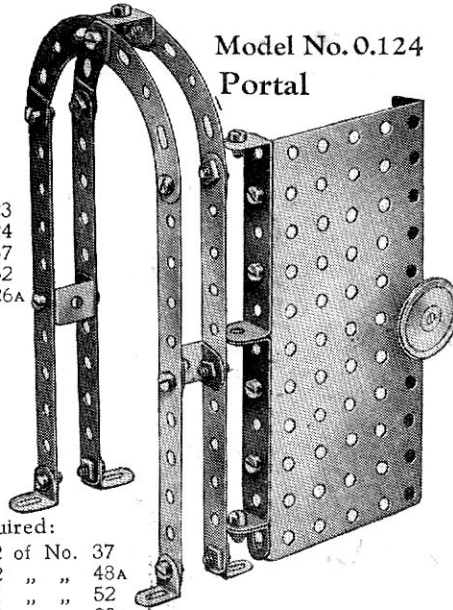

Parts required:
 4 of No. 2 | 22 of No. 37
 2 " " 11 | 2 " " 48A
 8 " " 12 | 1 " " 52
 1 " " 22 | 4 " " 90A

Model No. 0.126 Pump

Parts required:
 1 of No. 2 | 22 of No. 37
 6 " " 5 | 2 " " 48A
 2 " " 11 | 1 " " 52
 3 " " 12 | 2 " " 126
 1 " " 16 | 1 " " 126A
 1 " " 17
 1 " " 19s
 3 " " 22
 1 " " 24
 2 " " 35

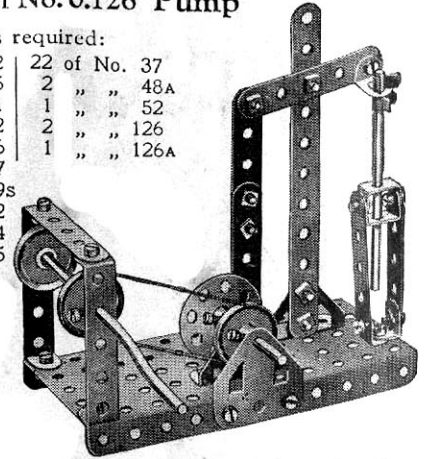

The connecting Strip is pivoted by bolts and nuts at one end to the Bush Wheel and at the other end to the cross beam. The latter is pivoted by the same means to the upright.

Model No. 0.125 Hammock

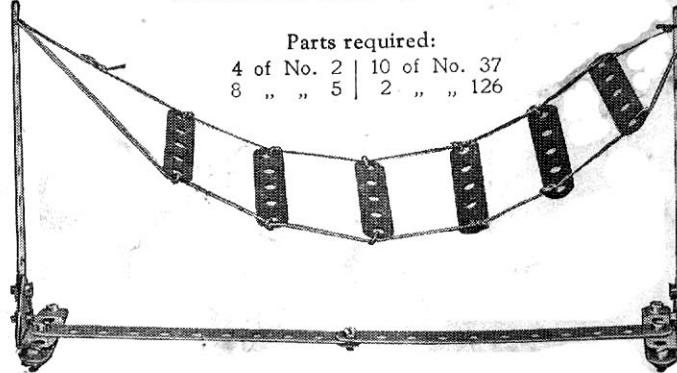

Parts required:
 4 of No. 2 | 10 of No. 37
 8 " " 5 | 2 " " 126

**Model No. 0.127
Go Chair**

Parts required:
 2 of No. 2
 7 " " 5
 2 " " 16
 4 " " 22
 11 " " 37
 2 " " 48A

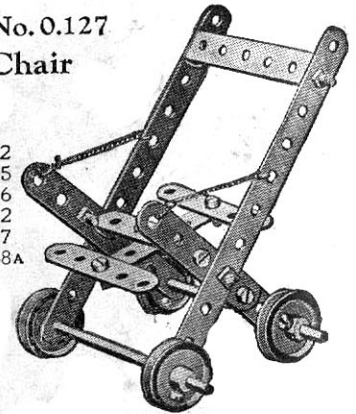

**Model No. 0.128
Machine Gun**

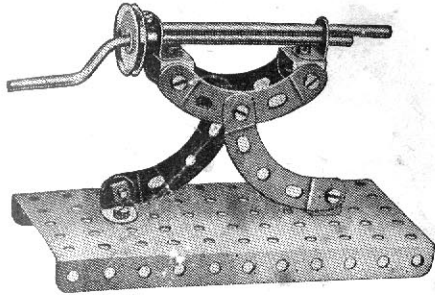

Parts required:

2 of No. 11	1 of No. 22
4 " " 12	12 " " 37
1 " " 16	1 " " 52
1 " " 19s	4 " " 90A

Model No. 0.130 Swivelling Crane

Parts required:

2 of No. 2	1 of No. 24
4 " " 5	4 " " 35
4 " " 12	18 " " 37
2 " " 16	1 " " 40
2 " " 17	1 " " 44
1 " " 19s	2 " " 48A
4 " " 22	1 " " 52
1 " " 23	1 " " 57
	2 of No. 125

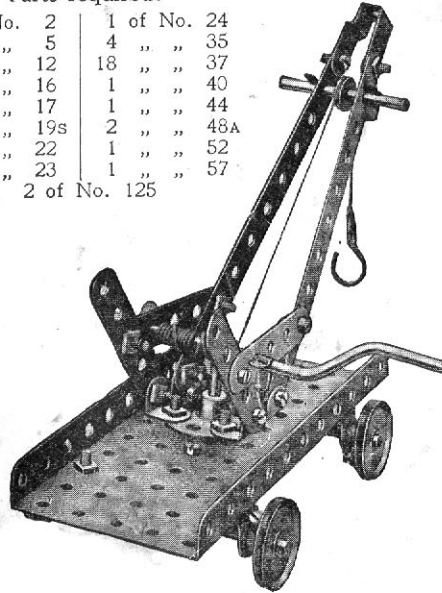

Model No. 0.132 Prancing Horse

Parts required:

6 of No. 5
4 " " 12
1 " " 17
1 " " 19s
4 " " 22
1 " " 24
20 " " 37
1 " " 44
1 " " 52
1 " " 90A
2 " " 125
1 " " 126
1 " " 126A

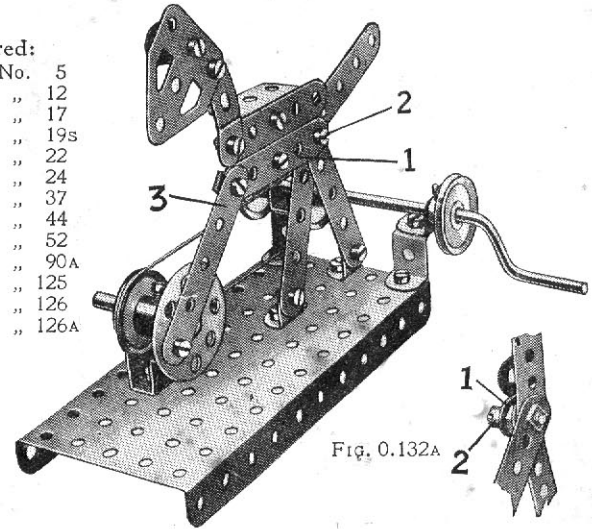
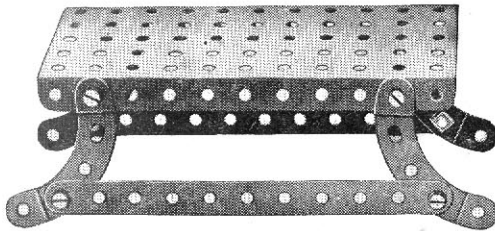

Fig. 0.132A

The Strip 1 forming part of the body is free to move about the Bolt 2, but two nuts on the latter secure the rear legs and tail rigidly together. The arrangement of the various Strips about this Bolt 2 is shown more clearly in Fig. 0.132A. The Strip 3 is free to move at each end about pivots formed from bolts and nuts.

Model No. 0.129 Bench



Parts required:

2 of No. 2
8 " " 37
1 " " 52
4 " " 90A

Model No. 0.131 Battleship

Parts required:

4 of No. 10
1 " " 11
4 of No. 2
1 " " 16
2 " " 5
1 " " 17

3 of No. 22	2 of No. 48A
1 " " 24	1 " " 52
1 " " 35	2 " " 90A
22 " " 37	1 " " 125
2 of No. 126	

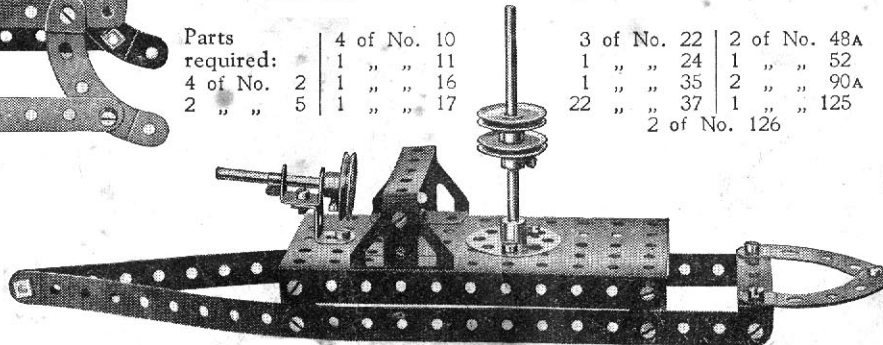

Model No. 0.133 Viaduct

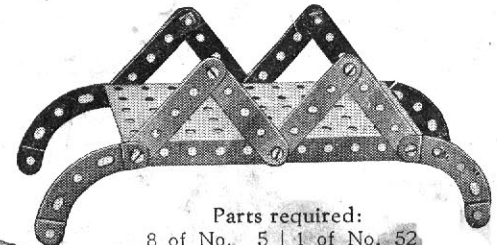

Parts required:

8 of No. 5	1 of No. 52
10 " " 37	4 " " 90A

**Model No.0.134
Parallel Bars**

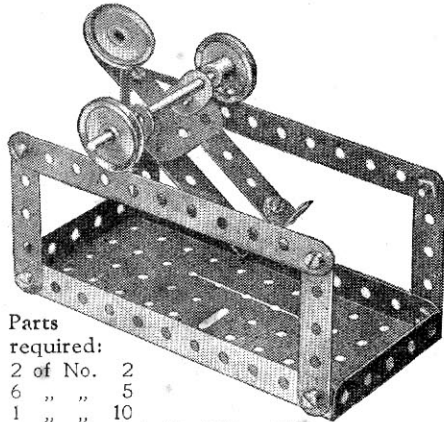

- Parts required:
- | | |
|----------|----|
| 2 of No. | 2 |
| 6 " " | 5 |
| 1 " " | 10 |
| 4 " " | 12 |
| 1 " " | 16 |
| 3 " " | 22 |
| 2 " " | 35 |
- | | |
|-----------|------|
| 13 of No. | 37 |
| 1 " " | 52 |
| 1 " " | 111c |
| 1 " " | 126A |

Model No.0.136 Candle Shade

- Parts required:
- | | |
|----------|-----|
| 4 of No. | 5 |
| 8 " " | 12 |
| 1 " " | 24 |
| 16 " " | 37 |
| 4 " " | 90A |



**Model No.0.137
Prehistoric Animal**



- Parts required:
- | | |
|----------|-----|
| 4 of No. | 2 |
| 2 " " | 5 |
| 5 " " | 10 |
| 2 " " | 11 |
| 4 " " | 12 |
| 14 " " | 37 |
| 4 " " | 90A |

Model No.0.138 Revolving Office Chair

- Parts required:
- | | | | |
|----------|----|-----------|------|
| 3 of No. | 5 | 18 of No. | 37 |
| 1 " " | 12 | 2 " " | 48A |
| 1 " " | 17 | 4 " " | 90A |
| 2 " " | 22 | 2 " " | 126 |
| 1 " " | 24 | 1 " " | 126A |

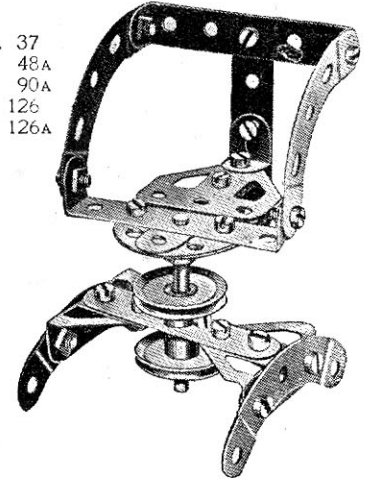

Model No.0.139 Bridge

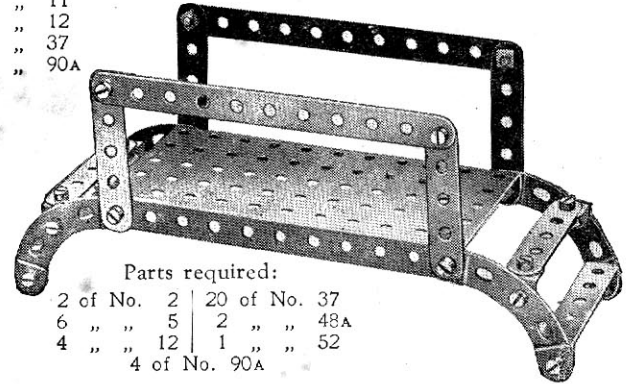

- Parts required:
- | | | | |
|----------|----|-----------|-----|
| 2 of No. | 2 | 20 of No. | 37 |
| 6 " " | 5 | 2 " " | 48A |
| 4 " " | 12 | 1 " " | 52 |
| | | 4 of No. | 90A |

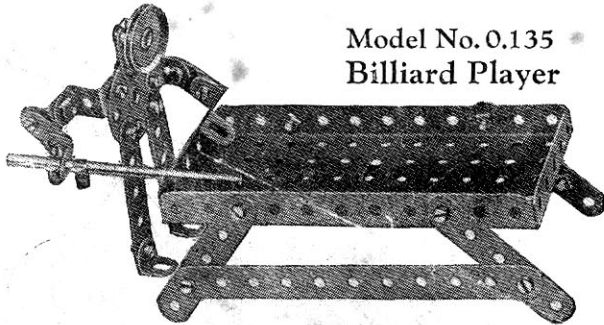

**Model No.0.135
Billiard Player**

- Parts required:
- | | |
|----------|-----|
| 2 of No. | 2 |
| 6 " " | 5 |
| 3 " " | 10 |
| 5 " " | 12 |
| 1 " " | 16 |
| 1 " " | 22 |
| 1 " " | 24 |
| 2 " " | 35 |
| 21 " " | 37 |
| 2 " " | 125 |

HOW TO CONTINUE

This completes our examples of models that may be made with MECCANO Outfit No. 0. The next models are a little more advanced, requiring a number of extra parts to construct them. The necessary parts are all contained in a No. 0A Accessory Outfit, the price of which will be found in the list at the end of this Manual.

Model No. 1.1 Jockey Pulley

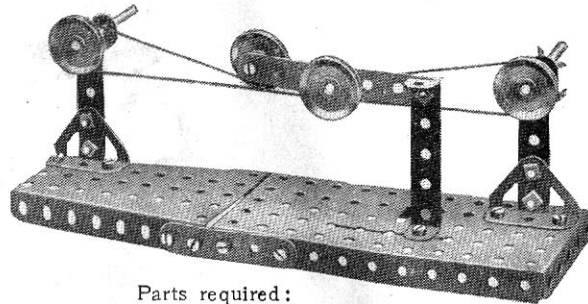

Parts required:

1 of No. 3	2 of No. 35	1 of No. 52
4 " " 5	20 " " 37	1 " " 54
2 " " 17	1 " " 37A	2 " " 111C
4 " " 22	1 " " 48A	2 " " 126

The weight of the pivoted $3\frac{1}{2}$ " Strip, augmented by the 1" fast Pulley Wheel, causes the jockey pulley to press on the belt. Hence the latter is kept always taut.

Model No. 1.2 Triangle of Forces

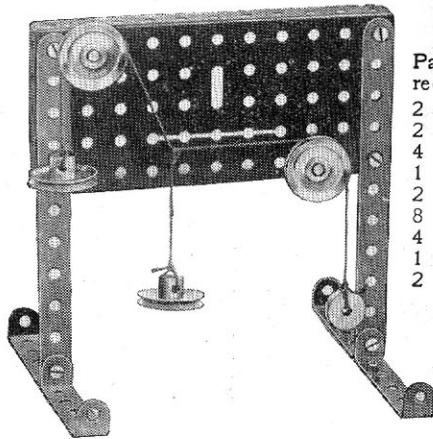

Parts required:

2 of No. 2
2 " " 18A
4 " " 22
1 " " 23
2 " " 35
8 " " 37
4 " " 48A
1 " " 52
2 " " 125

The suspended weights represent three forces acting on a central point. If a triangle is drawn with its sides respectively parallel to the three converging cords, i.e., parallel to the directions of the three forces, the lengths of the sides will be found to be proportional to the respective magnitudes of the forces.

Model No. 1.5 Belt Gear Right-angle Drive Transmission

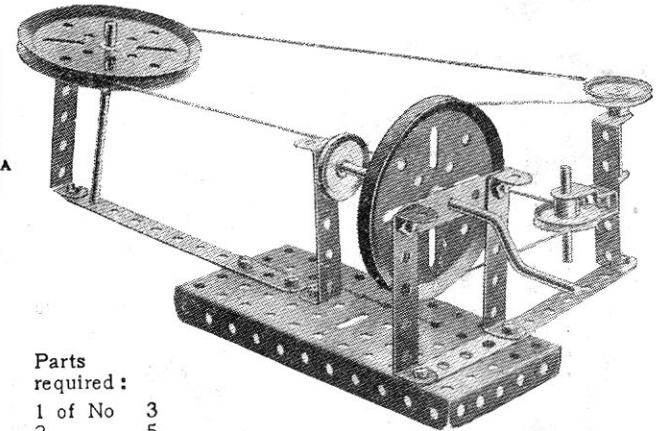

Parts required:

2 of No. 2	3 of No. 22
1 " " 5	1 " " 35
1 " " 16	11 " " 37
1 " " 17	1 " " 44
1 " " 18A	1 " " 48
2 " " 19B	5 " " 48A
1 " " 19s	1 " " 52

Model No. 1.3 Band Brake

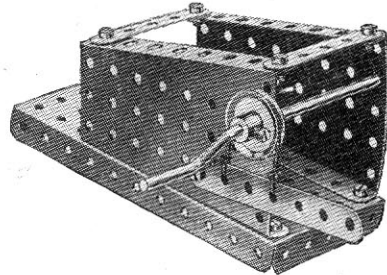

Parts required:

1 of No. 3
2 " " 5
1 " " 19s
1 " " 22
1 " " 35
9 " " 37
1 " " 37A
1 " " 52
2 " " 54

Model No. 1.4 "H" Girder

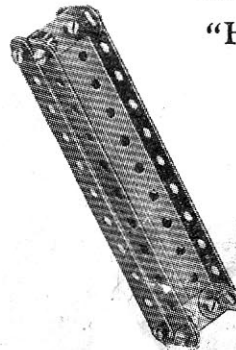

Parts required:

6 of No. 2
2 " " 10
8 " " 12
12 " " 37

Model No. 1.6 Bacon Slicer

Parts required:

6 of No. 5	2 of No. 22
2 " " 10	1 " " 35
1 " " 16	10 " " 37
1 " " 19B	1 " " 52
1 " " 19s	2 " " 125

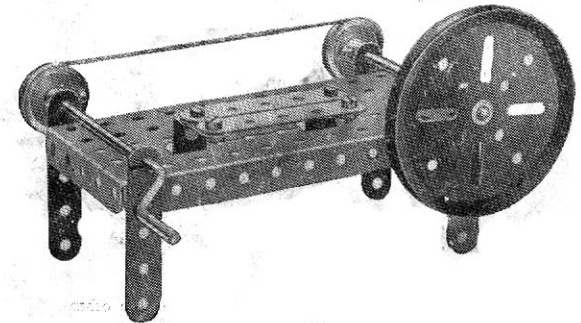

Model No. 1.7

Lever of the Second Order

(Demonstration Model)

Parts required :

- 2 of No. 2
- 4 " " 5
- 1 " " 18A
- 1 " " 22
- 1 " " 35
- 11 " " 37
- 1 " " 52
- 1 " " 57
- 1 " " 125
- 1 " " 126
- 1 " " 126A

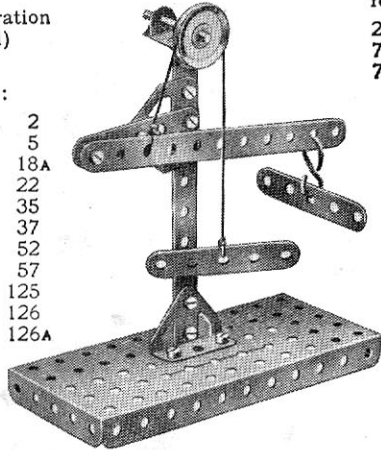

The fulcrum is at one end, the load at the other and the power lies between the two.

Model No. 1.9 Compound Triangulated Truss

Parts required :

- 2 of No. 1
- 7 " " 2
- 7 " " 37

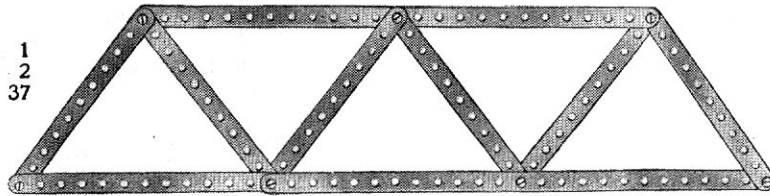

Model No. 1.10 Howe Truss

Parts required :

- 1 of No. 1
- 8 " " 2
- 1 " " 3
- 7 " " 5
- 21 " " 37

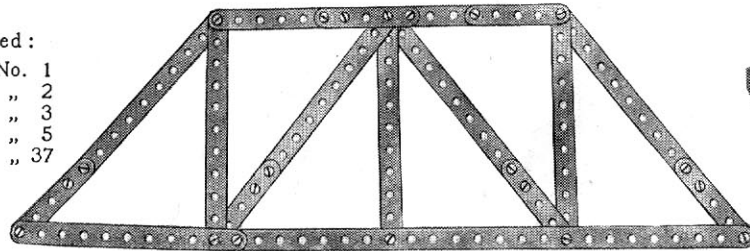

Model No. 1.11 Triangulated Truss

Parts required :

- 1 of No. 1
- 2 " " 2
- 4 " " 5
- 8 " " 37

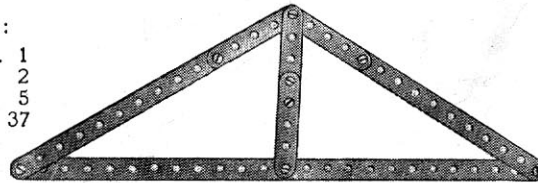

Model No. 1.12 45° Set-Square

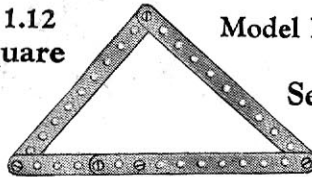

Parts required :

- 3 of No. 2 | 1 of No. 3
- 5 of No. 37

Model No. 1.13 60° Set-Square

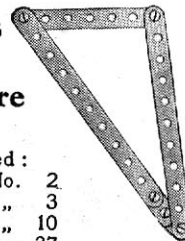

Parts required :

- 2 of No. 2
- 1 " " 3
- 2 " " 10
- 5 " " 37

Model No. 1.14 Belt Gear

For Reversing Motion of Driven Shaft

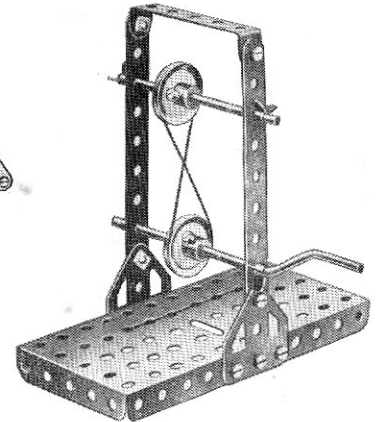

Parts required :

- 2 of No. 2
- 1 " " 16
- 1 " " 19s
- 2 " " 22
- 2 of No. 126A
- 4 of No. 35
- 10 " " 37
- 1 " " 48A
- 1 " " 52

Model No. 1.8

Lever of the Third Order

(Demonstration Model)

Parts required :

- 2 of No. 2
- 4 " " 5
- 1 " " 18A
- 1 " " 22
- 1 " " 35
- 10 " " 37
- 1 " " 52
- 1 " " 57
- 1 " " 125
- 2 " " 126

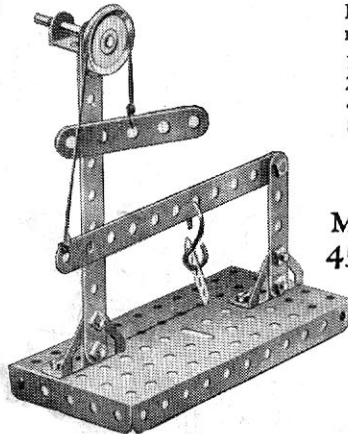

The fulcrum is at one end, the load at the other and the power lies between the two.

Model No. 1.15 Belt Gear

For Driving Shafts at Right Angles

Parts required :

- 2 of No. 2
- 1 " " 16
- 1 " " 19s
- 2 " " 22
- 3 " " 35
- 12 " " 37
- 1 " " 52
- 2 " " 126
- 2 " " 126A

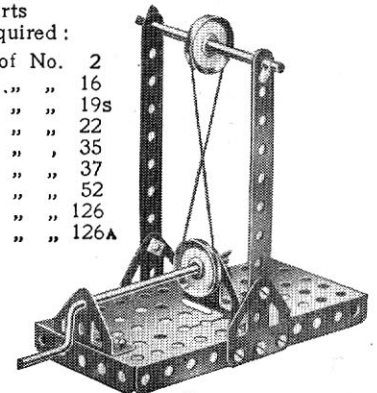

Model No. 1.16 Pulley Block

Demonstration Model :
1 Fixed and 3 Movable Sheaves.
Theoretical Mechanical advantage : 8 to 1

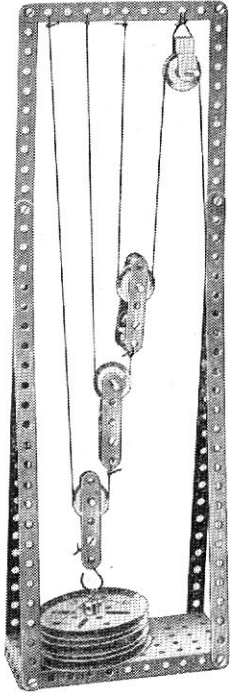

Parts required :

4 of No. 1	2 of No. 18A
3 " " 2	3 " " 19B
6 " " 5	4 " " 22
2 " " 11	15 " " 37
2 " " 12	1 " " 44
2 " " 17	1 " " 52
	1 " " 57

Model No. 1.17 Pulley Block

Demonstration Model :
3 Fixed and 2 Movable Sheaves.
Theoretical Mechanical advantage : 5 to 1

Parts required :

4 of No. 1	4 of No. 19B
7 " " 2	4 " " 22
6 " " 5	6 " " 35
2 " " 10	22 " " 37
2 " " 11	1 " " 44
2 " " 16	1 " " 52
2 " " 17	1 " " 57
2 " " 18A	2 " " 126A

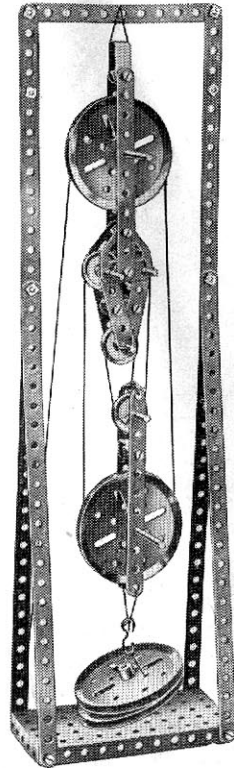

Model No. 1.18 Pulley Block

Demonstration Model :
1 Fixed Sheave and 2 Suspended Blocks.
Theoretical Mechanical advantage : 4 to 1

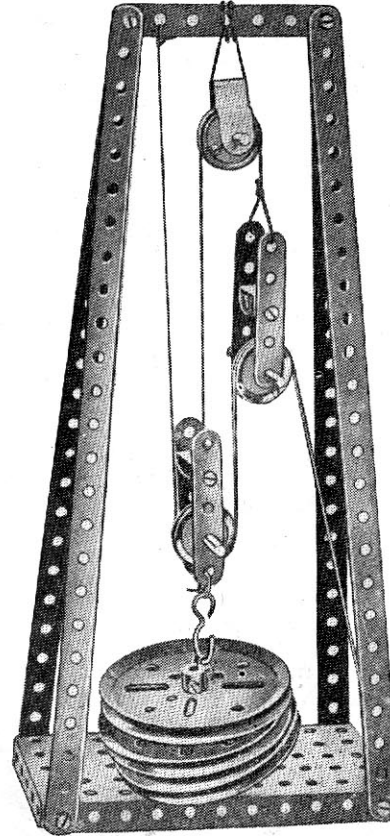

Parts required :

4 of No. 1	4 of No. 19B
1 " " 3	3 " " 22
4 " " 5	10 " " 37
2 " " 11	1 " " 44
1 " " 17	1 " " 52
2 " " 18A	1 " " 57

Model No. 1.19 Belt Gear

Parts required :

2 of No. 2	2
1 " " 5	5
2 " " 16	16
2 " " 19B	19B
1 " " 19s	19s
2 " " 22	22
8 " " 35	35
16 " " 37	37
2 " " 48A	48A
1 " " 52	52
2 " " 126	126
2 " " 126A	126A

Drive Transmission for shafts not in line

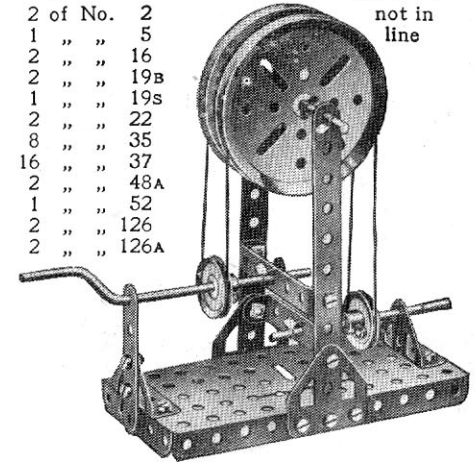

Model No. 1.20 Belt Gear

Parts required :

2 of No. 2	2
1 " " 12	12
2 " " 16	16
2 " " 19B	19B
1 " " 19s	19s
2 " " 22	22
8 " " 35	35
15 " " 37	37
1 " " 48A	48A
1 " " 52	52
1 " " 54	54
1 " " 126	126
2 " " 126A	126A

Obtuse-angle Drive Transmission

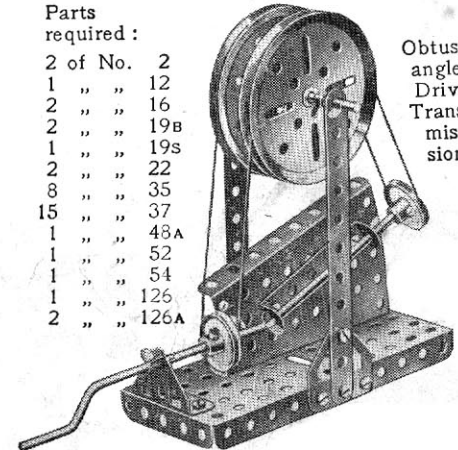

Model No. 1.21 Invalid Chair

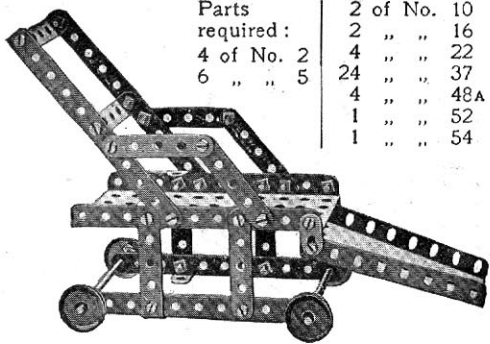

Parts required:	2 of No. 10
2 " " "	2 " " 16
4 of No. 2	4 " " 22
6 " " 5	24 " " 37
	4 " " 48A
	1 " " 52
	1 " " 54

Model No. 1.23 Ticca Gharry

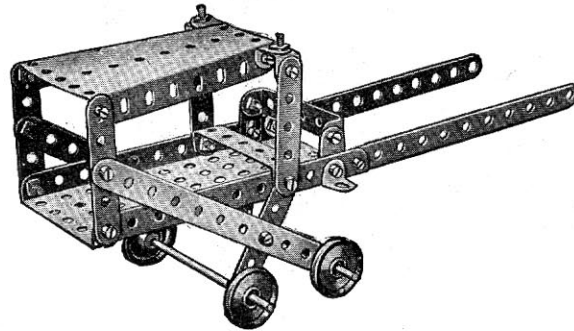

Parts required:	4 of No. 2	6 of No. 12	22 of No. 37
	6 " " 5	2 " " 16	1 " " 52
	2 " " 10	4 " " 22	1 " " 54

Model No. 1.26 Mechanical Saw

Parts required:	1 of No. 2	1 of No. 17	4 of No. 38
	8 " " 5	3 " " 19s	1 " " 44
	1 " " 10	1 " " 22	4 " " 48A
	1 " " 11	1 " " 24	1 " " 52
	4 " " 12	3 " " 35	2 " " 125
	1 " " 16	22 " " 37	1 " " 126A

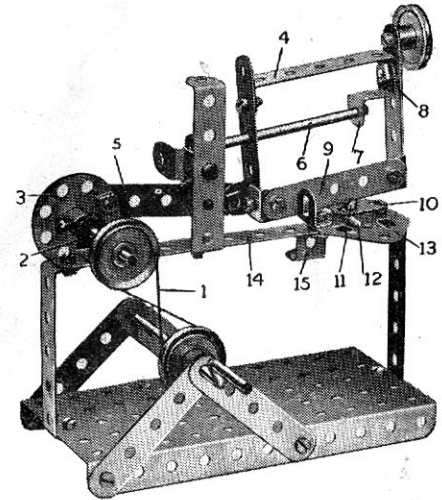

Model No. 1.22 Letter Balance

Parts required:	6 of No. 2	4 of No. 22	2 of No. 48A
	3 " " 5	1 " " 24	1 " " 52
	1 " " 10	26 " " 37	2 " " 111c
	1 " " 12	4 " " 37A	2 " " 126
	2 " " 18A	2 " " 38	2 " " 126A
	1 " " 19B	1 " " 44	

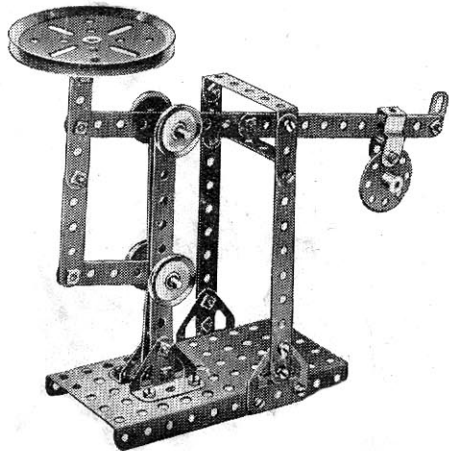

Model No. 1.24 Hatchet

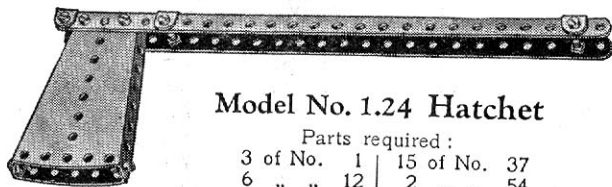

Parts required:	3 of No. 1	15 of No. 37
	6 " " 12	2 " " 54

Model No. 1.25 Truck with Sides

Parts required:	4 of No. 2
	4 " " 5
	2 " " 16
	4 " " 22
	3 " " 37
	4 " " 48A
	1 " " 52

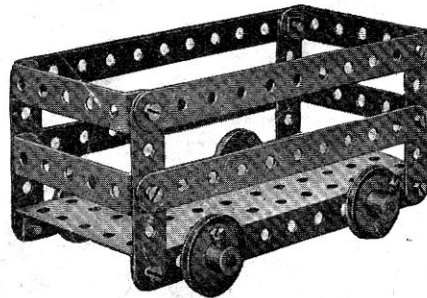

The Strip 9 represents the saw. The Crank Handle drives through a belt 1 a short Rod journalled in a Double Bracket 2 and carrying a Bush Wheel 3. The latter imparts a reciprocating motion to the saw frame 4 through a 2 1/4" Strip 5 loosely mounted on bolts secured to the Bush Wheel and to an Angle Bracket bolted to the saw frame. This frame slides on a 3 1/4" Rod 6, which acts as a guide, passing through the frame and supported in a reversed Angle Bracket 7. A washer is placed on the Bolt 8 behind the Bracket 7. A vice to secure the objects in position for cutting consists of a Flat Bracket 10 mounted on a Bolt 11, a few turns of which causes the Flat Bracket to grip the object 12. The Bolt 11 enters a nut held between the Flat Trunnion 13 and 5 1/4" Strip 14, which are spaced apart for the purpose by washers placed on the two bolts holding the Trunnion in position. The saw frame rests on the stop 15 when not in use. A 1" Pulley secured to the top of the frame acts as a weight and helps to steady the saw.

Model No. 1.27 Dinner Wagon

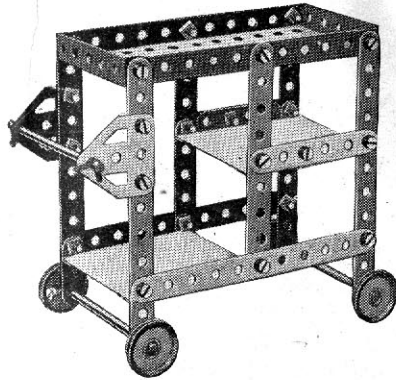

Parts required:

6	of No.	2
8	" "	5
4	" "	12
3	" "	16
4	" "	22
2	" "	35
22	" "	37
4	" "	48A
1	" "	52
2	" "	126A

The two lower platforms are constructed out of pieces of ordinary cardboard, their outer edges resting on 2½" Double Angle Strips and their inner edges on Angle Brackets.

Model No. 1.28 Tip Wagon

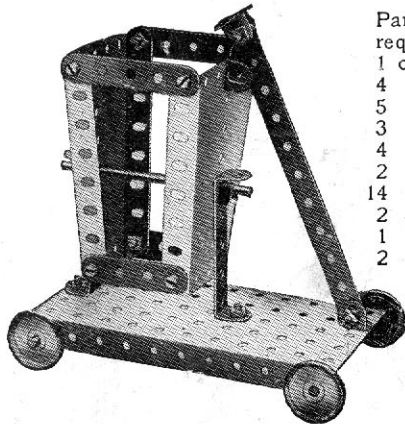

Parts required:

1	of No.	2
4	" "	5
5	" "	12
3	" "	16
4	" "	22
2	" "	35
14	" "	37
2	" "	48A
1	" "	52
2	" "	54

Model No. 1.29 Aeroplane

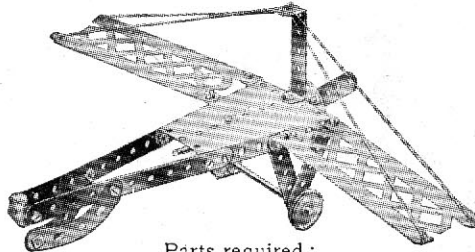

Parts required:

2	of No.	2	2	of No.	16	1	of No.	48A
5	" "	5	2	" "	22	1	" "	54
1	" "	11	1	" "	24	2	" "	90A
6	" "	12	21	" "	37	2	" "	100

Model No. 1.30 Timber Drag

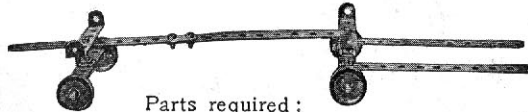

Parts required:

4	of No.	2	2	of No.	16	8	of No.	37
2	" "	11	4	" "	22	4	" "	48A

Model No. 1.31 Lawn Mower

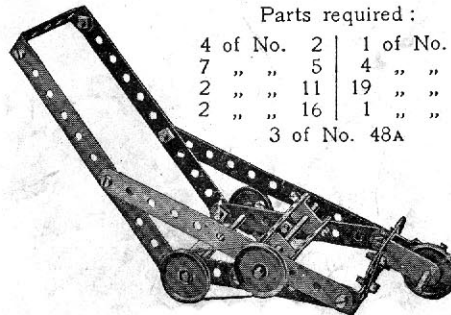

Parts required:

4	of No.	2	1	of No.	17
7	" "	5	4	" "	22
2	" "	11	19	" "	37
2	" "	16	1	" "	44
			3	of No.	48A

Model No. 1.32 Tandem Car

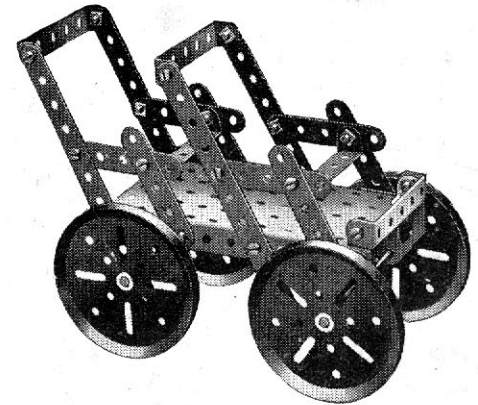

Parts required:

4	of No.	2	26	of No.	37
8	" "	5	5	" "	48A
2	" "	12	1	" "	54
2	" "	16	2	" "	126A
4	" "	19B			

Model No. 1.33 Mechanical Hammer

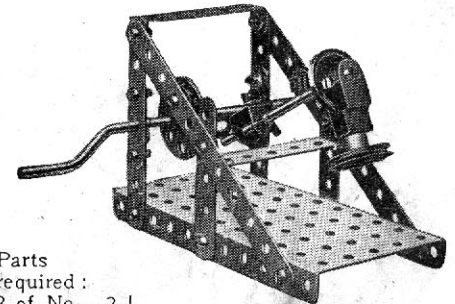

Parts required:

2	of No.	2	1	of No.	19s	18	of No.	37
6	" "	5	2	" "	22	1	" "	44
1	" "	11	1	" "	24	3	" "	48A
1	" "	12	4	" "	35	1	" "	52

Model No. 1.34 Hand Loom

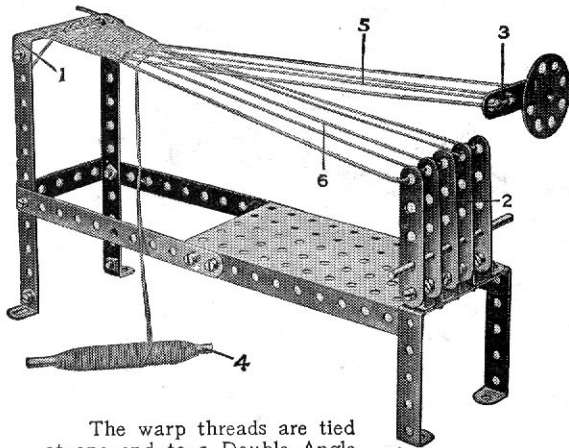

The warp threads are tied at one end to a Double Angle Strip 1, whilst their other ends are secured alternately to the tops of the upright Strips 2, and the 2½" Strip 3. The "shedding" movement of the warp is obtained by moving the Strip 3 up or down each time the shuttle—a 3½" Rod 4—is passed between the two layers of warp 5 and 6. Wool or similar material is particularly suited to this apparatus. The strands 6 should be kept very taut, and the weft threads may be closed up with the woven portion by means of an ordinary comb each time the shuttle passes.

Parts required:

4 of No.	2
6 " "	5
7 " "	12
2 " "	16
1 " "	24
21 " "	37
4 " "	48A
1 " "	52

Model No. 1.35 Gong

Parts required:

4 of No.	2	1 of No.	22
1 " "	5	9 " "	37
3 " "	12	1 " "	52
1 " "	16	1 " "	54

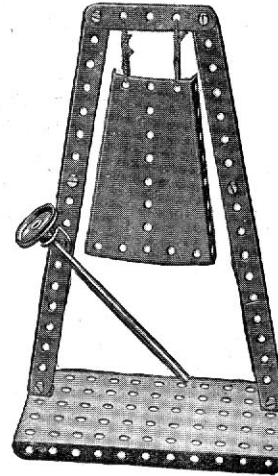

Model No. 1.36 Roundabout

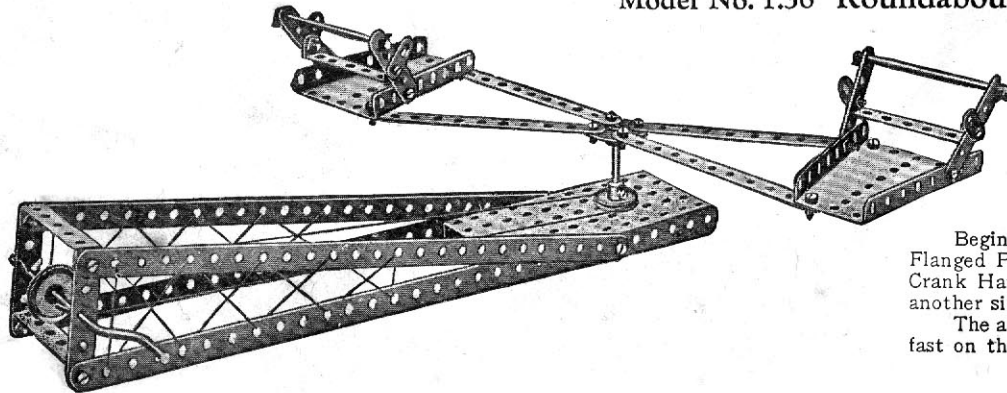

Parts required:

4 of No.	1	1 of No.	17	22 of No.	37
4 " "	2	1 " "	19	4 " "	48A
6 " "	5	3 " "	22	1 " "	52
4 " "	10	1 " "	24	2 " "	54
2 " "	16	6 " "	35		

Begin to build this model by making the platform from a Flanged Plate and 12½" Strips. The drive from the Pulley on the Crank Handle is taken to a 1" Pulley fast on the vertical 2" Rod, another similar Pulley being secured to this Rod beneath the Plate. The arms are formed of four 5½" Strips bolted to a Bush Wheel fast on the 2" Rod.

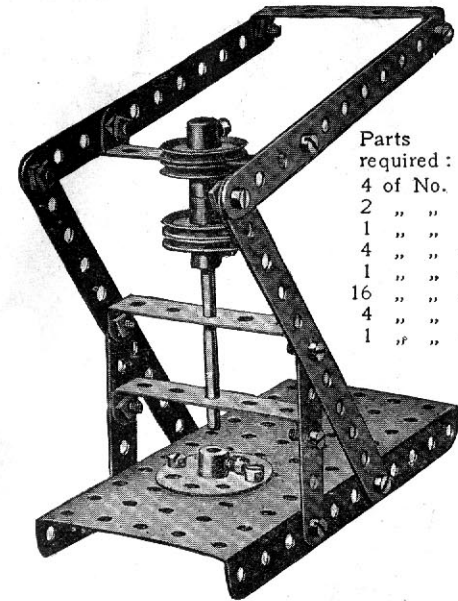
Model No. 1.37
Punching Machine

Parts required:

4 of No.	2
2 " "	5
1 " "	16
4 " "	22
1 " "	24
16 " "	37
4 " "	48A
1 " "	52

Model No. 1.38 Horseman

Parts required:

2	of No.	2
7	" "	5
3	" "	10
2	" "	12
2	" "	16
4	" "	22
1	" "	24
17	" "	37
1	" "	52
1	" "	54
2	" "	90A
1	" "	126A

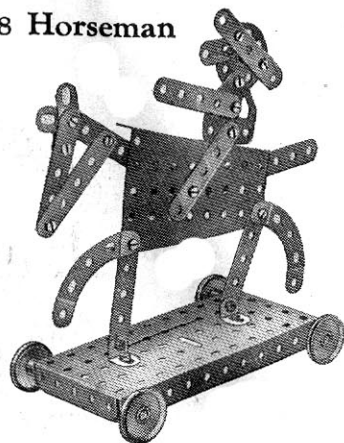

Model No. 1.40 Helve Hammer

Parts required:

4	of No.	1	23	of No.	37
6	" "	5	1	" "	44
2	" "	11	3	" "	48A
2	" "	12	1	" "	52
1	" "	16	2	" "	125
1	" "	17	2	" "	126A
1	" "	19s			
4	" "	22			
1	" "	24			
4	" "	35			

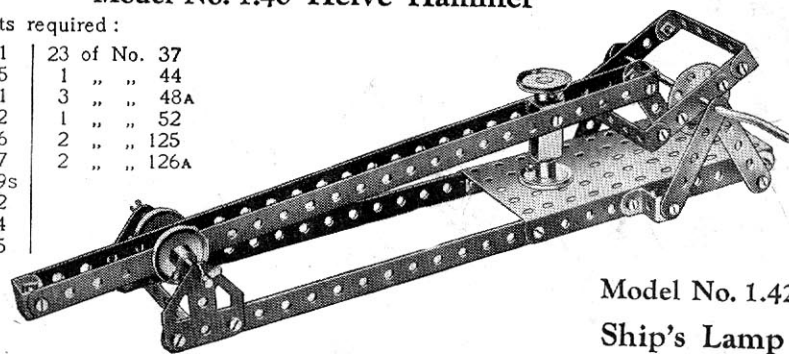

Model No. 1.42 Ship's Lamp

Parts required:

2	of No.	2	4	of No.	37A
4	" "	12	1	" "	48A
1	" "	17	1	" "	52
2	" "	22	1	" "	54
1	" "	24	4	" "	90A
11	" "	37	2	" "	111c

Model No. 1.39 Revolving See-Saw

Parts required:

4	of No.	2	1	of No.	24
3	" "	5	2	" "	35
1	" "	11	25	" "	37
6	" "	12	5	" "	38
1	" "	16	1	" "	44
1	" "	17	4	" "	48A
1	" "	19s	1	" "	52
2	" "	22	1	" "	54
			2	of No.	125

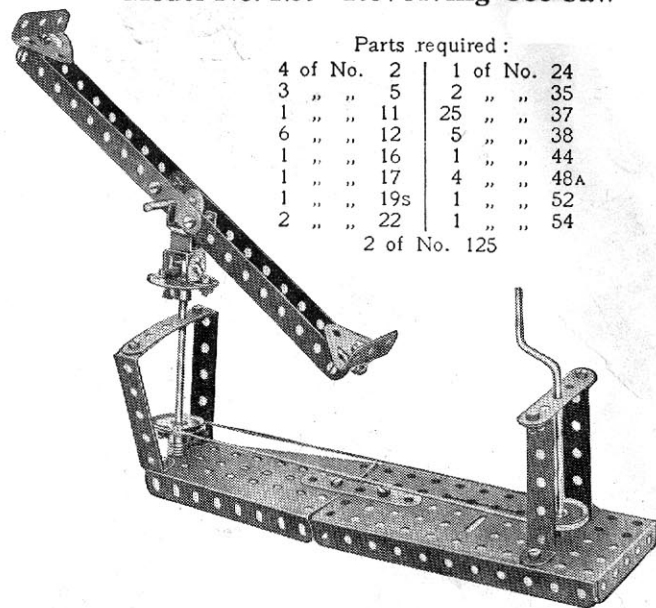

Model No. 1.41 King Meccano

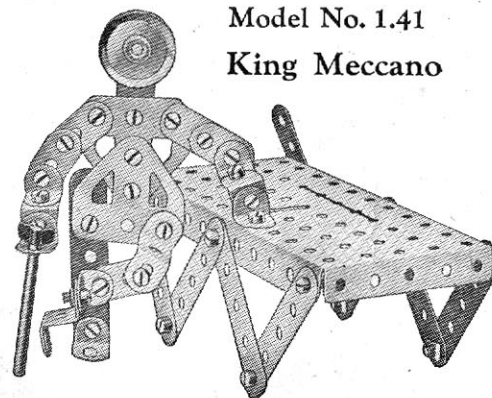

Parts required:

1	of No.	3	1	of No.	35
9	" "	5	30	" "	37
5	" "	10	1	" "	52
8	" "	12	2	" "	111c
1	" "	17	2	" "	125
1	" "	22	2	" "	126A

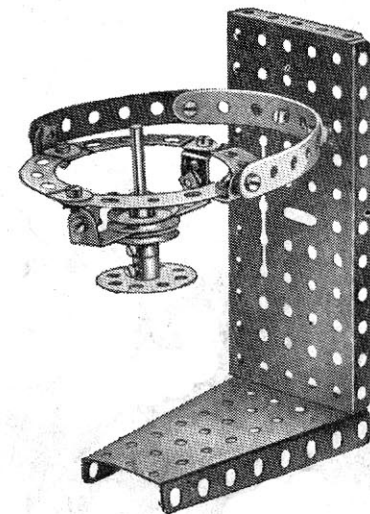

**Model No. 1.43
Automatic
Signal**

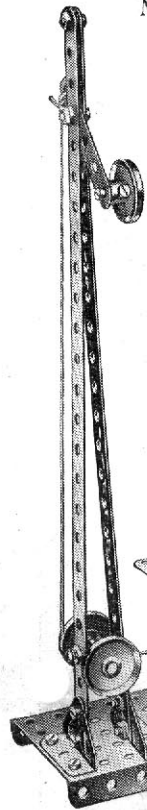

Parts
required :

2 of No.	1
1 " "	2
1 " "	5
1 " "	11
1 " "	12
1 " "	17
1 " "	18A
4 " "	22
1 " "	24
22 " "	37
2 " "	37A
1 " "	38
1 " "	48A
1 " "	52
1 " "	90A
3 " "	111c
2 " "	126
2 " "	126A

The weighted curved Strip normally holds the end of the 5½" Strip against an Angle Bracket, allowing the signal arm to fall to the "all clear" position. Any train passing the signal however, strikes the opposite end of the 5½" Strip, and by means of the cord shown, raises the arm to indicate "danger." The Curved Strip moves to allow the end of the 5½" Strip to pass over it, and is returned to its original position by reason of its weighted end. The signal then remains at "danger" until the mechanism is re-set.

Model No. 1.44 Horse and Cart

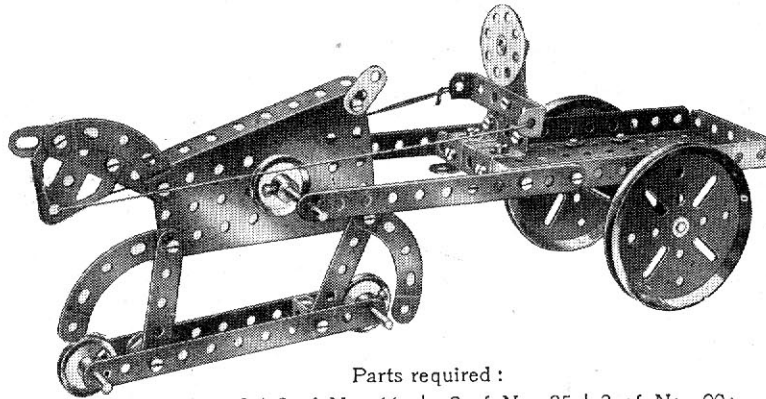

Parts required :

4 of No.	2	2 of No.	16	2 of No.	35	3 of No.	90A
3 " "	5	2 " "	18A	26 " "	37	1 " "	111c
3 " "	10	2 " "	19B	1 " "	48A	2 " "	125
2 " "	11	4 " "	22	1 " "	52	2 " "	126
2 " "	12	1 " "	24	1 " "	54	2 " "	126A

Model No. 1.45 Drill

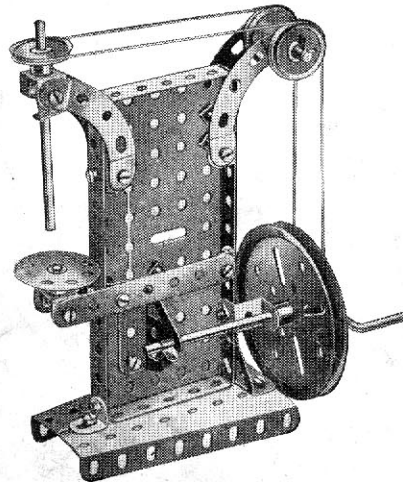

Parts
required :

1 of No.	3
2 " "	11
6 " "	12
1 " "	16
1 " "	18A
1 " "	19B
1 " "	19S
4 " "	22
1 " "	24
2 " "	35
27 " "	37
1 " "	52
1 " "	54
4 " "	90A
1 " "	125
2 " "	126

Model No. 1.46 Patent Luffing Crane

The hoisting cord 1 is operated by the Crank Handle 2. It passes over the 1" Pulley 3, round the 1" Pulley 4 at the jib head, back and round a third 1" Pulley 5, and then over the ½" loose Pulley 6 at the jib head and down to the hook. With this arrangement it will be found that the load remains at a constant height when the jib is luffed. The luffing cords 7 are attached to the jib head, passed over the 2" Rod carrying the Pulleys 3 and 5, and wound on to the luffing winch 8.

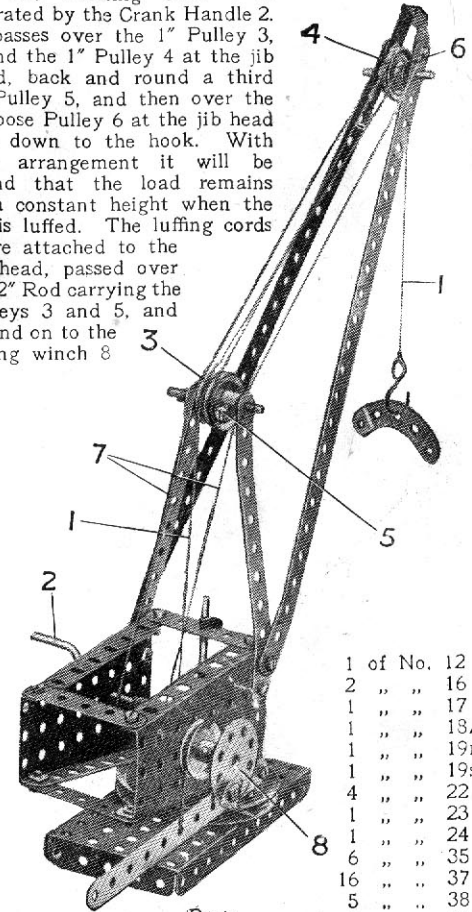

1 of No.	12
2 " "	16
1 " "	17
1 " "	18A
1 " "	19B
1 " "	19S
4 " "	22
1 " "	23
1 " "	24
6 " "	35
16 " "	37
5 " "	38
1 " "	44
1 " "	52
2 of No.	1
3 " "	2
4 " "	5
2 " "	54
1 " "	57
2 " "	111c

Model No. 1.47 Revolving Tricyclist

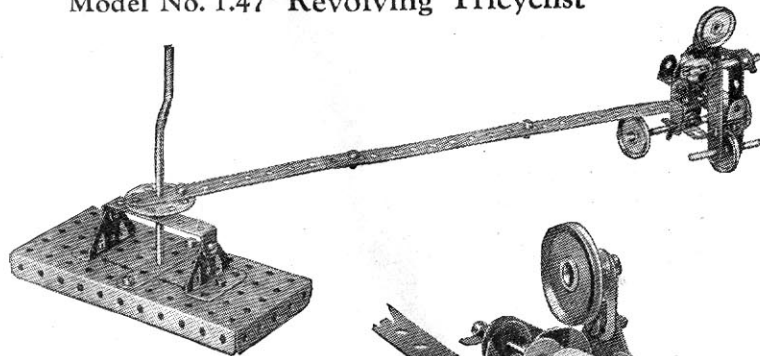

Parts required :

3 of No. 2	1 of No. 24
3 " " 5	5 " " 35
3 " " 10	25 " " 37
1 " " 11	1 " " 44
5 " " 12	2 " " 48A
1 " " 16	1 " " 52
2 " " 17	2 " " 125
1 " " 19s	2 " " 126
4 " " 22	1 " " 126A

Model No. 1.48 Truck

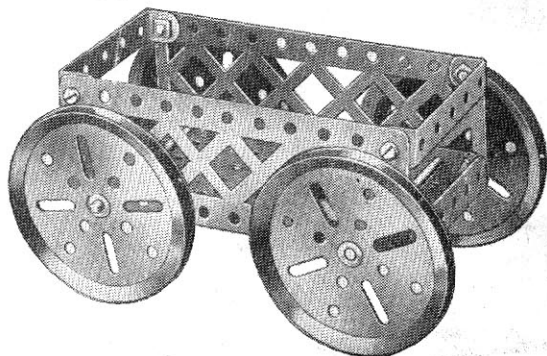

Parts required :

2 of No. 16
4 " " 19B
8 " " 37
2 " " 48A
1 " " 52
2 " " 100

FIG. 1.47A

Model No. 1.49 Steam Shovel

Parts required :

5 of No. 2	1 of No. 52
1 " " 11	1 " " 54
2 " " 12	1 " " 111c
2 " " 16	1 " " 126
2 " " 18A	2 " " 126A
1 " " 19s	
4 " " 22	
1 " " 23	
6 " " 35	
12 " " 37	
2 " " 37A	
2 " " 38	

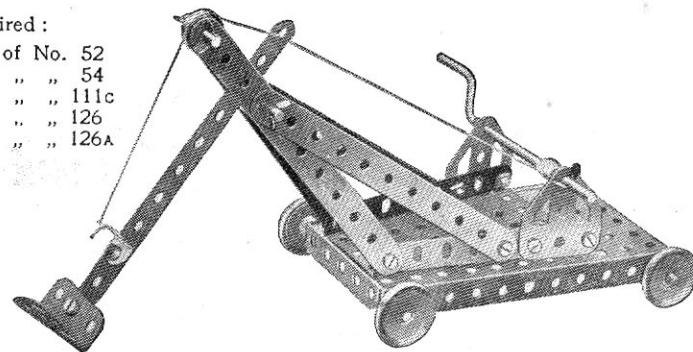

Model No. 1.50 Cot on Wheels

Parts required :

2 of No. 2
5 " " 5
4 " " 12
2 " " 16
4 " " 22
19 " " 37
2 " " 48A
1 " " 52
4 " " 90A
2 " " 100

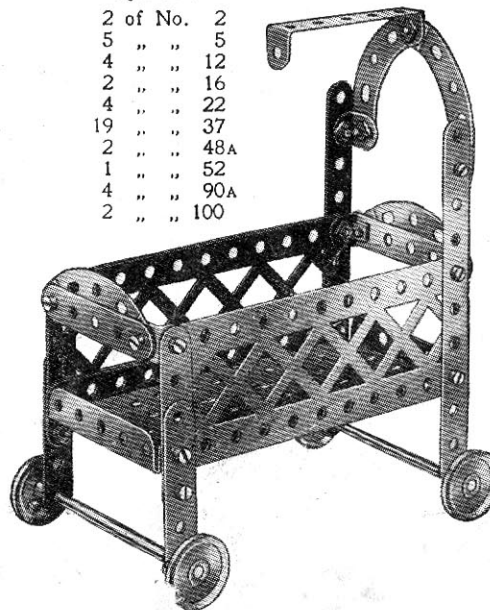

Model No. 1.51 Chair

Parts required :

2 of No. 2
8 " " 5
2 " " 10
22 " " 37
6 " " 48A
1 " " 52
3 " " 90A

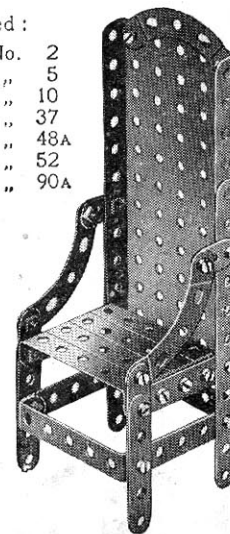

These Models can be built with MECCANO Outfit No. 1 (or No. 0 and No. 0A)

Model No. 1.52 Bow Girder

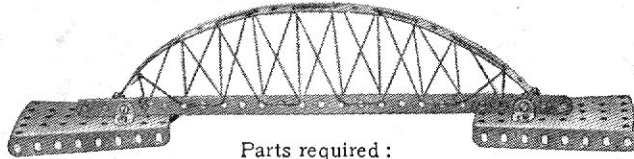

Parts required:
 2 of No. 1 | 6 of No. 37
 4 " " 12 | 2 " " 54

Model No. 1.53 Coaster

The figure 1 is loosely attached by lock-nutted Bolts 2 to the Sector Plate 3 and is connected to the Bush Wheel 4 by the pivotally-attached 2 1/2" Strip 5. The 1 1/2" Rod carrying the Bush Wheel 4 is journaled in the Cranked Bent Strip 6, the 1" fast Pulley 7 being connected to the road wheel by a cord as shown.

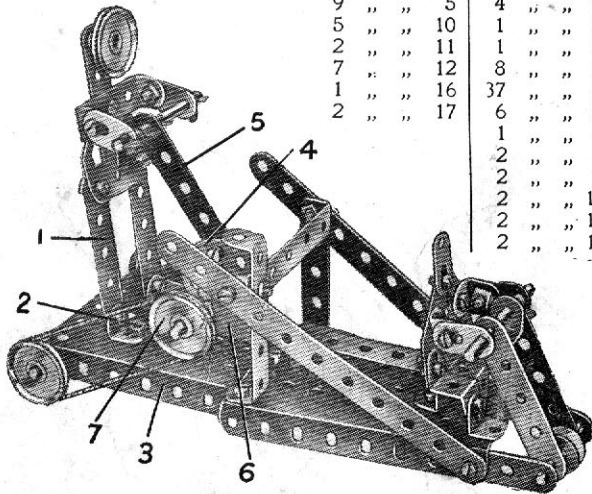

Parts required:

2 of No. 2	2 of No. 18A
9 " " 5	4 " " 22
5 " " 10	1 " " 23
2 " " 11	1 " " 24
7 " " 12	8 " " 35
1 " " 16	37 " " 37
2 " " 17	6 " " 37A
	1 " " 48
	2 " " 48A
	2 " " 54
	2 " " 111c
	2 " " 125
	2 " " 126A

Model No. 1.54 Hooke's Coupling

Parts required:

2 of No. 11	7 of No. 35
2 " " 12	12 " " 37
3 " " 16	1 " " 48
2 " " 19B	2 " " 48A
1 " " 19S	1 " " 52
	2 of No. 54

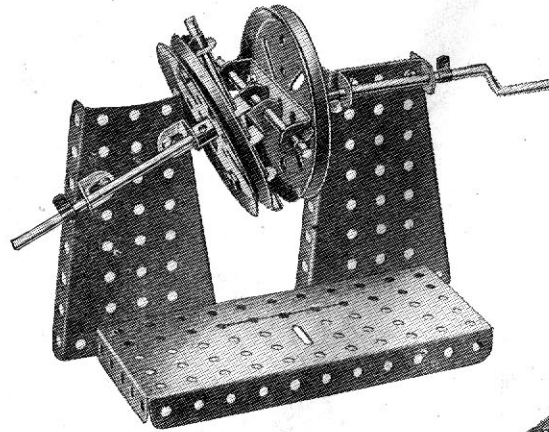

Model No. 1.55 Quick Return Device

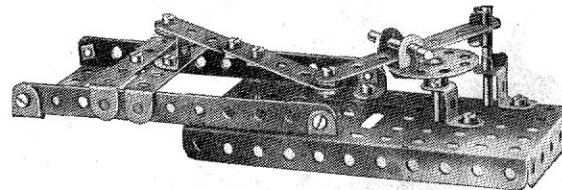

Parts required:

2 of No. 2	1 of No. 24
1 " " 3	6 " " 35
2 " " 5	15 " " 37
2 " " 11	2 " " 37A
2 " " 12	3 " " 48A
1 " " 17	1 " " 52
2 " " 18A	2 " " 125

Model No. 1.56 Arc Lamp

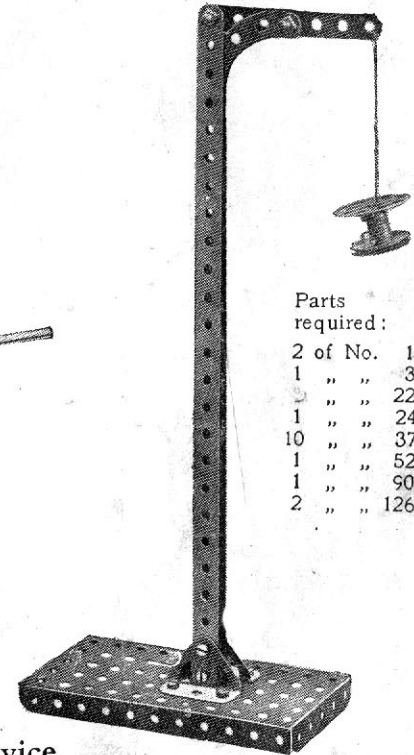

Parts required:

2 of No. 1	
1 " " 3	
	22
1 " " 24	
10 " " 37	
1 " " 52	
1 " " 90A	
2 " " 126	

Model No. 1.57 Bow and Arrow

Parts required:
1 of No. 1 | 1 of No. 16



Model No. 1.58 Friction Grip Tong

The hoisting cord is attached to the Double Bracket 1. The joints 2, 3 are lock-nutted, so that when the grip is raised the $\frac{1}{2}$ " loose Pulley Wheel 4 slides upward between the $2\frac{1}{2}$ " Strips 5, and the grip closes upon the block of wood or other material placed between its jaws.

Parts required:

3 of No. 2	1 of No. 11
8 " " 5	1 " " 23
4 " " 10	2 " " 35
12 of No. 37	

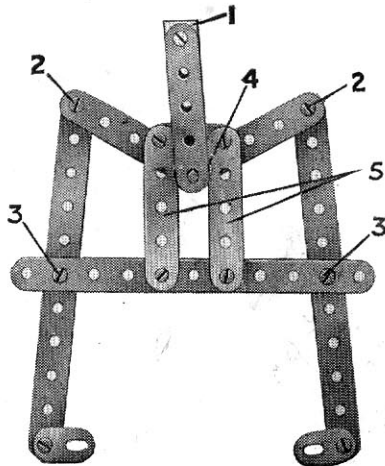

Model No. 1.59 Cum Bak

Parts required:

1 of No. 18A
2 " " 19B
2 " " 22
1 " " 23
1 " " 35
8 " " 37
4 " " 48A

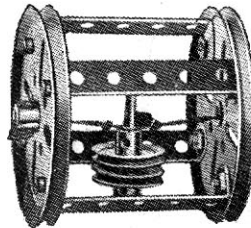

A short length of elastic is doubled and stretched between the centres of the 3" Pulley Wheels. A weight, consisting of two 1" fast Pulley Wheels and a $1\frac{1}{2}$ " Rod, is suspended from it in the middle of the drum. When the Cum Bak is rolled along any smooth level surface, the elastic becomes twisted and stores up sufficient energy to return the drum to its starting point. If the mechanism is concealed by a thin cardboard covering, the model will cause much amusement by its mystifying behaviour.

Model No. 1.60 Aeroplane

Parts required:

4 of No. 2
6 " " 5
4 " " 10
2 " " 11

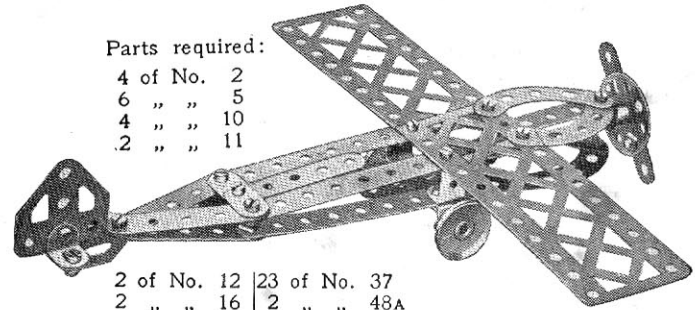

2 of No. 12	23 of No. 37
2 " " 16	2 " " 48A
2 " " 22	4 " " 90A
1 " " 24	2 " " 100
1 " " 35	2 " " 126A

Model No. 1.61 Gangway

Parts required:

4 of No. 2	1 of No. 16	22 of No. 37	2 of No. 100
2 " " 5	1 " " 22	4 " " 48A	1 " " 111c
3 " " 10	1 " " 23	1 " " 52	2 " " 126A
1 " " 12	4 " " 35	1 " " 54	

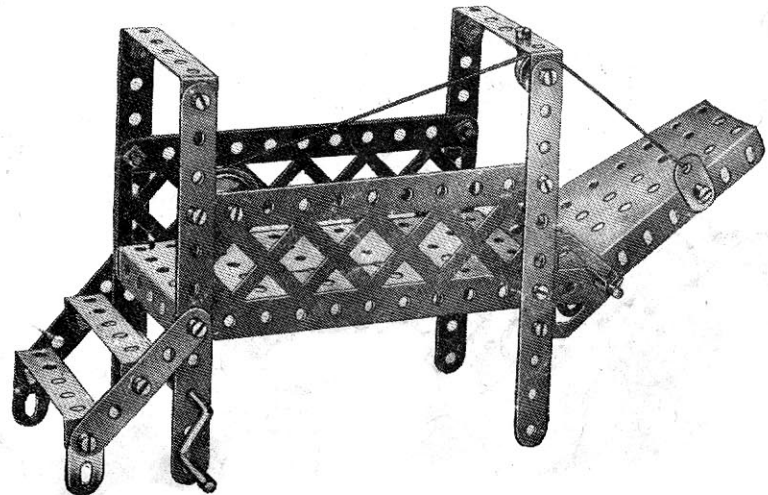

Model No. 1.62 Butter Churn

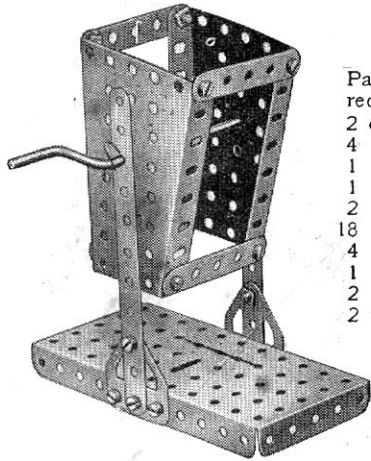

- Parts required:
- 2 of No. 2
 - 4 " " 5
 - 1 " " 19s
 - 1 " " 24
 - 2 " " 35
 - 18 " " 37
 - 4 " " 38
 - 1 " " 52
 - 2 " " 54
 - 2 " " 126A

Model No. 1.64 Cable Railway

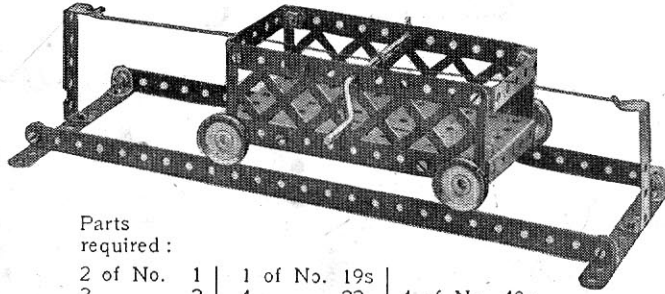

- Parts required:
- | | | |
|------------|--------------|--------------|
| 2 of No. 1 | 1 of No. 19s | |
| 2 " " 2 | 4 " " 22 | 4 of No. 48A |
| 4 " " 12 | 2 " " 35 | 1 " " 52 |
| 2 " " 16 | 18 " " 37 | 2 " " 100 |

Model No. 1.67 Man and Boy



- Parts required:
- 4 of No. 2
 - 1 " " 3
 - 1 " " 5
 - 5 " " 10
 - 1 " " 11
 - 8 " " 12
 - 1 " " 22
 - 1 " " 24
 - 26 " " 37
 - 1 " " 52
 - 2 " " 54
 - 1 " " 90A
 - 2 " " 125
 - 1 " " 126A

Model No. 1.63 Inverted Centrifugal Governor

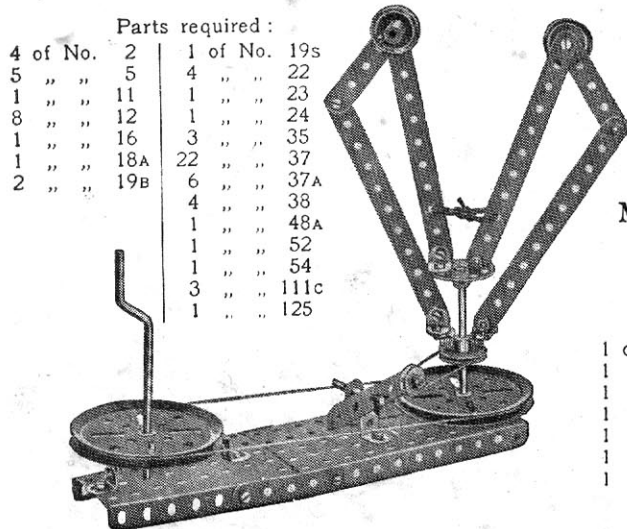

- Parts required:
- | | |
|------------|--------------|
| 4 of No. 2 | 1 of No. 19s |
| 5 " " 5 | 4 " " 22 |
| 1 " " 11 | 1 " " 23 |
| 8 " " 12 | 1 " " 24 |
| 1 " " 16 | 3 " " 35 |
| 1 " " 18A | 22 " " 37 |
| 2 " " 19B | 6 " " 37A |
| | 4 " " 38 |
| | 1 " " 48A |
| | 1 " " 52 |
| | 1 " " 54 |
| | 3 " " 111c |
| | 1 " " 125 |

Model No. 1.65 Candle Stick

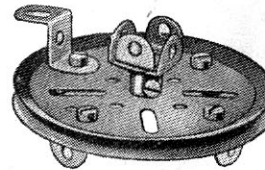

- Parts required:
- 2 of No. 11
 - 4 " " 12
 - 1 " " 19B
 - 4 " " 37
 - 1 " " 111c
 - 1 " " 125

Model No. 1.66 Machine for Tracing a Locus

- Parts required:
- | | |
|------------|-------------|
| 1 of No. 2 | 4 of No. 35 |
| 1 " " 5 | 4 " " 37 |
| 1 " " 11 | 3 " " 37A |
| 1 " " 12 | 4 " " 38 |
| 1 " " 17 | 1 " " 54 |
| 1 " " 18A | 2 " " 111c |
| 1 " " 24 | 1 " " 125 |

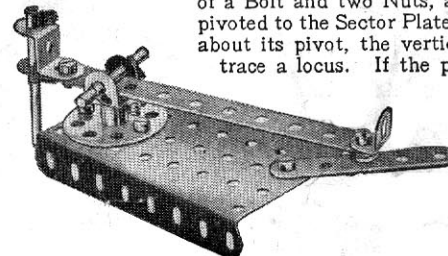

The $5\frac{1}{2}$ " Strip is pivoted to the $2\frac{1}{2}$ " Strip by means of a Bolt and two Nuts, and the $2\frac{1}{2}$ " Strip is similarly pivoted to the Sector Plate. By revolving the $2\frac{1}{2}$ " Strip about its pivot, the vertical $1\frac{1}{2}$ " Rod can be made to trace a locus. If the positions of the $1\frac{1}{2}$ " Rod and the $5\frac{1}{2}$ " Strip are altered, several different loci may be traced. Machines of this type are of advantage in assisting in the design of engine connecting rods.

Model No. 1.68 Gramophone

Parts required:

2 of No. 10	6 of No. 37	1 of No. 52
1 " " 12	1 " " 38	2 " " 111c
1 " " 19B		
1 " " 23		
1 " " 24		

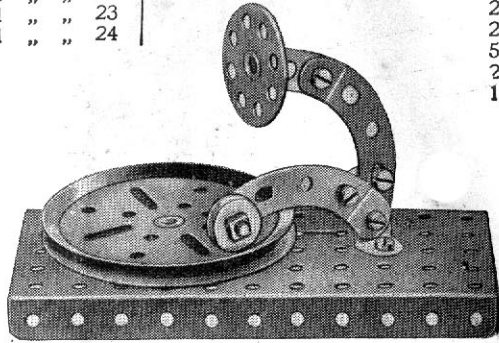

Model No. 1.70 Lancer

Parts required:

1 of No. 2	4 of No. 22
1 " " 5	1 " " 24
9 " " 10	1 " " 35
2 " " 11	27 " " 37
2 " " 12	1 " " 48A
2 " " 16	1 " " 52
1 " " 19s	1 " " 54
1 of No. 126A	4 " " 90A

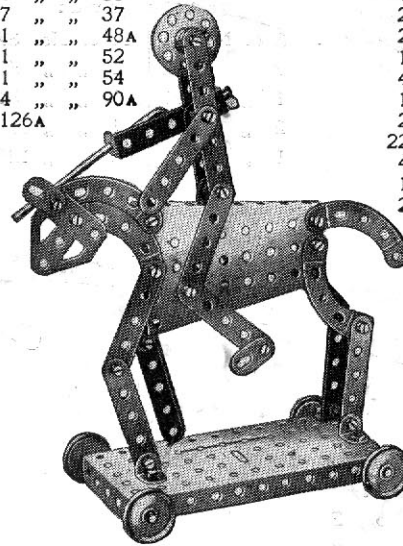

Model No. 1.71 Stamping Machine

Parts required:

4 of No. 2
4 " " 5
2 " " 10
2 " " 16
1 " " 19s
4 " " 22
1 " " 24
2 " " 35
22 " " 37
4 " " 48A
1 " " 52
2 " " 126A

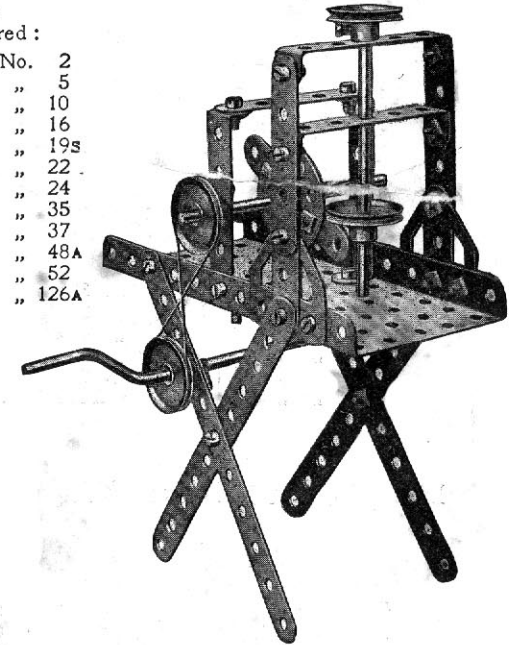

Model No. 1.69 Lorry Crane

Parts required:

4 of No. 2	2 of No. 16
8 " " 5	1 " " 17
2 " " 10	1 " " 18A
2 " " 12	1 " " 19s
	3 " " 22
	1 " " 23
	1 " " 24
	3 " " 35
	29 " " 37
	1 " " 44
	5 " " 48A
	1 " " 52
	1 " " 54
	1 " " 57
	2 " " 125
	4 " " 126

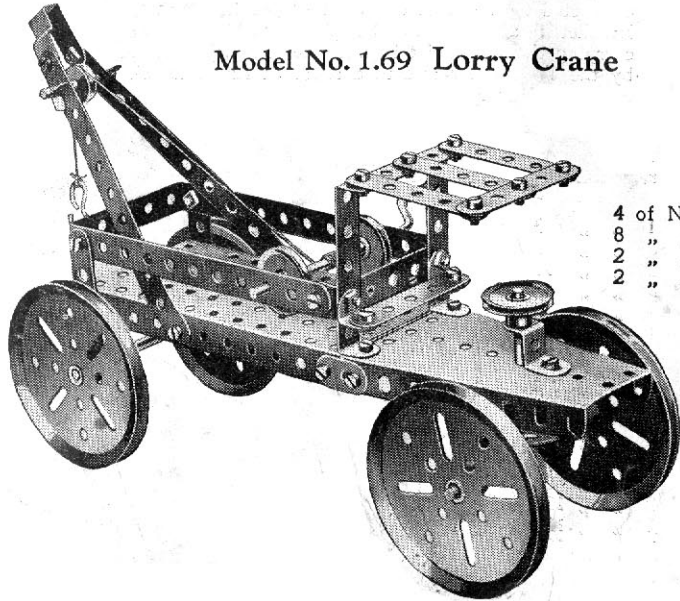

Model No. 1.72 Lazy Tong

Parts required:

2 of No. 1	1 of No. 23	2 of No. 48A
4 " " 2	12 " " 37	2 " " 111c
4 " " 5	10 " " 37A	

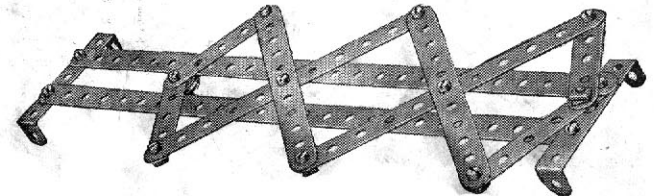

Model No. 1.73 Rowing Boat

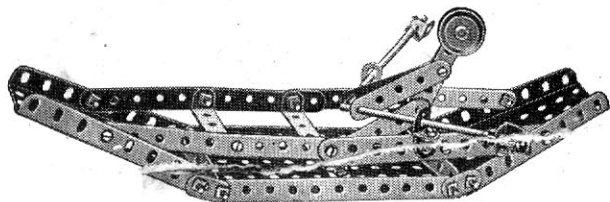

Parts required :

4 of No. 2	4 of No. 35
4 " " 5	24 " " 37
4 " " 10	3 " " 48A
7 " " 12	1 " " 52
2 " " 16	2 " " 54
1 " " 22	1 " " 111c

Model No. 1.74 Tower Wagon

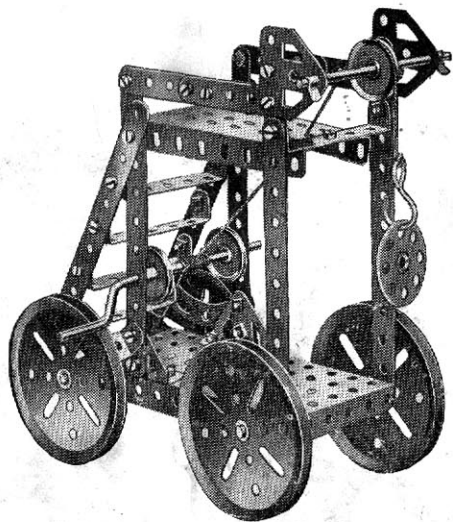

Parts required :

6 of No. 2
6 " " 5
3 " " 16
4 " " 19B
1 " " 19s
3 " " 22
2 " " 35
33 " " 37
5 " " 48A
1 " " 52
1 " " 57
1 " " 125
2 " " 126
2 " " 126A

Model No. 1.75
Weather Vane

Parts required :

3 of No. 1	14 of No. 37
2 " " 2	1 " " 52
1 " " 11	1 " " 54
2 " " 12	1 " " 111c
1 " " 24	2 " " 126

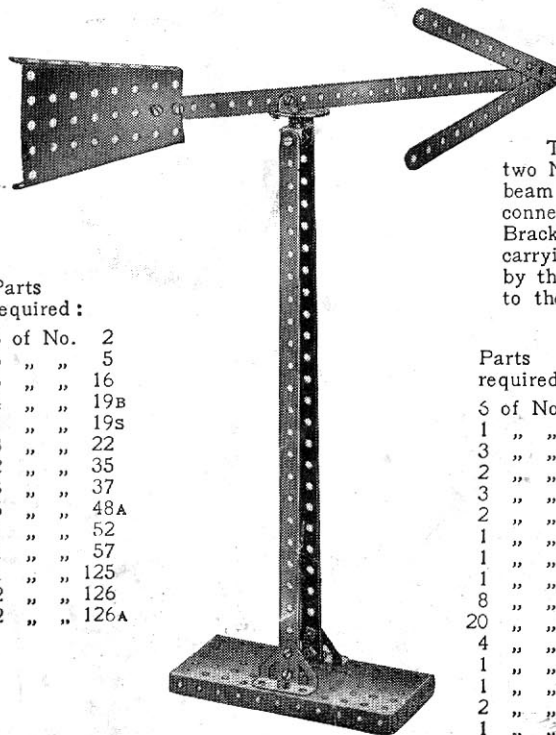

Model No. 1.76 Violin and Bow

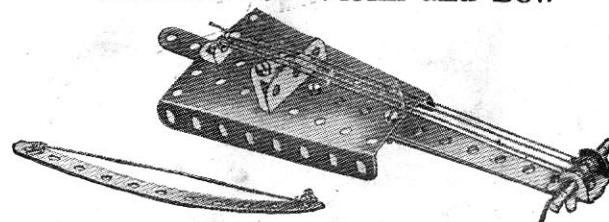

Parts required :

4 of No. 2	1 of No. 12	5 of No. 37
1 " " 5	1 " " 18A	1 " " 54
1 " " 11	2 " " 35	1 " " 126

Model No. 1.77 Beam Engine

The connecting Strip 1 is attached pivotally by a Bolt and two Nuts (Standard Mechanism No. 262) to one end of the beam 2 and to the Bush Wheel 3. The Strip 4 is similarly connected to the other end of the beam 2 and to the Double Bracket 5 attached to the piston rod. The short rod carrying the flywheel 6 is journaled in a 2½" Strip supported by the Trunnion 7 and in a reversed Angle Bracket bolted to the 2½" Strip.

Parts required :

6 of No. 2
1 " " 3
3 " " 5
2 " " 11
3 " " 12
2 " " 16
1 " " 17
1 " " 19B
1 " " 24
8 " " 35
20 " " 37
4 " " 37A
1 " " 48
1 " " 52
2 " " 125
1 " " 126
2 " " 126A

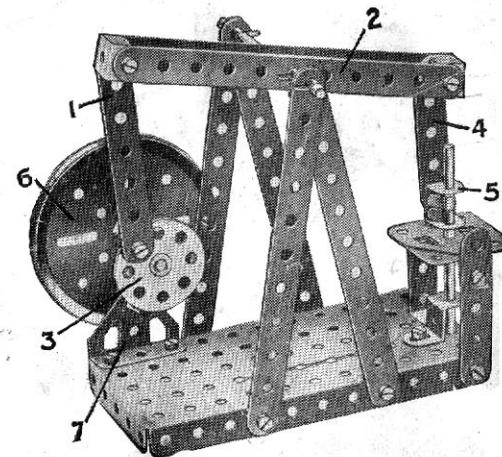

Model No. 1.78 Motor Lorry

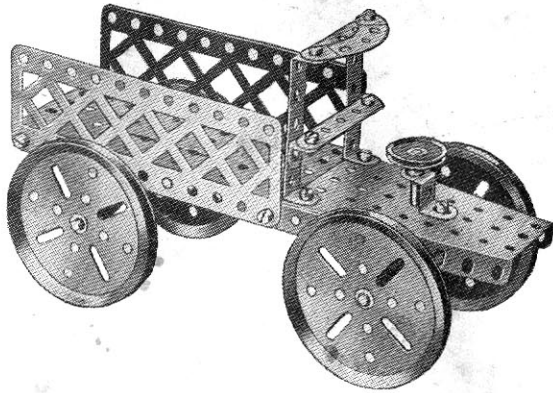

Parts
required.

2 of No.	2
2 " "	5
2 " "	12
2 " "	16
1 " "	18A
4 " "	19B
1 " "	24
25 " "	37
2 " "	38
3 " "	48A
1 " "	52
1 " "	54
1 " "	90A
2 " "	100
2 " "	125
2 " "	126A

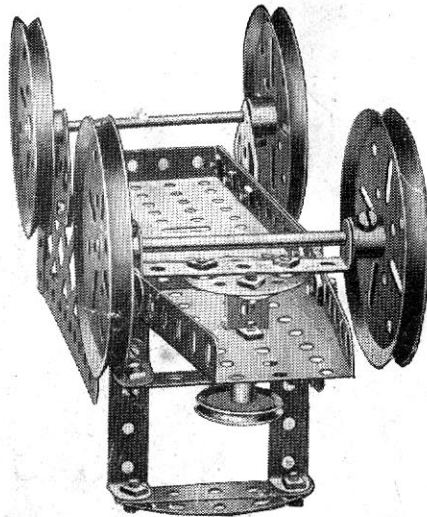
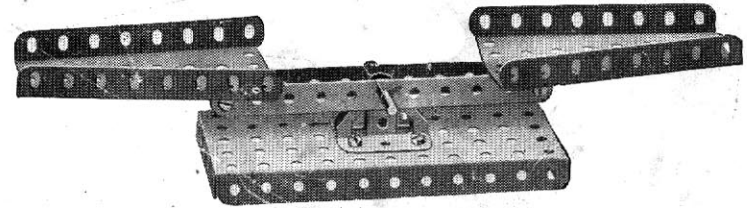

FIG. 1.78A

Parts
required :

2 of No.	2
2 " "	12
1 " "	18A
2 " "	35
8 " "	37
1 " "	52
2 " "	54
2 " "	126

Model No. 1.79 Scales



Model No. 1.80 Spinning Buttons

The Sector Plates 1 and 2 are mounted pivotally on the Rods 3. Two large buttons 4 are placed on lengths of thread or thin elastic stretched between the arms of the Meccanitions 5. Start the model as follows : twist the threads a little with your fingers, pull the Meccanitions outward, then release them sharply. As soon as the buttons are spinning a slight downward touch on the feet of each Meccanition is sufficient to keep them going. The ends of the Sector Plates 1 and 2 are connected to the Flanged Plate 6 by means of pieces of elastic 7.

Parts
required :

2 of No.	1
6 " "	5
4 " "	10
8 " "	12
2 " "	16
2 " "	17
2 " "	22
6 " "	35
28 " "	37
4 " "	48A
2 " "	111c
2 " "	126A

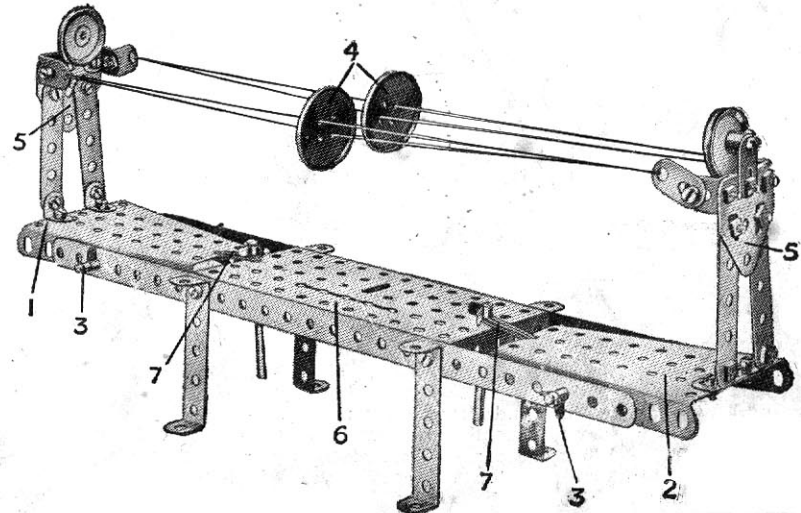

Model No. 1.81 Windlass

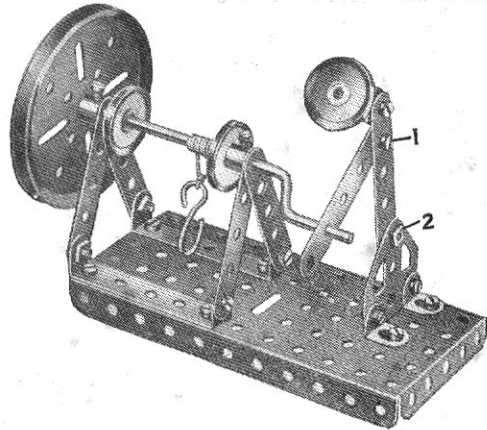

Parts required:

6 of No.	5
3 " "	12
1 " "	19B
1 " "	19S
3 " "	22
15 " "	37
4 " "	37A
2 " "	48A
1 " "	52
1 " "	57
3 " "	111c
1 " "	126A

The figure at the right of the model is arranged to work to and fro when the Crank Handle is rotated. The Bolts 1 and 2 are both secured by two nuts as in Standard Mechanism No. 262.

Model No. 1.82 Top

Parts required:

1 of No. 2	1 of No. 19B
1 " " 16	1 " " 37
1 of No. 125	

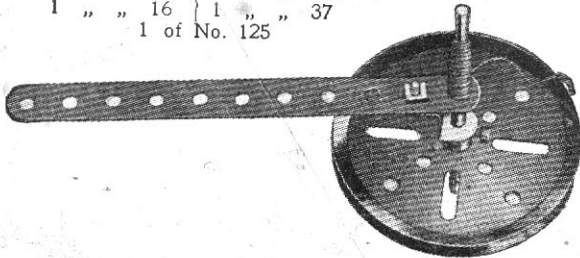

To spin the top wind a length of cord round the rod, as shown, place on a smooth surface and give the cord a sharp pull. When the cord is clear of the rod remove the 5½" Strip and the top will continue to spin for a considerable period.

Parts required:

4 of No.	2
6 " "	5
1 " "	10
4 " "	12
3 " "	16
1 " "	17
4 " "	22
1 " "	23
1 " "	24
4 " "	35
24 " "	37
4 " "	37A
3 " "	38
2 " "	48A
2 " "	54
1 " "	125
1 " "	126A

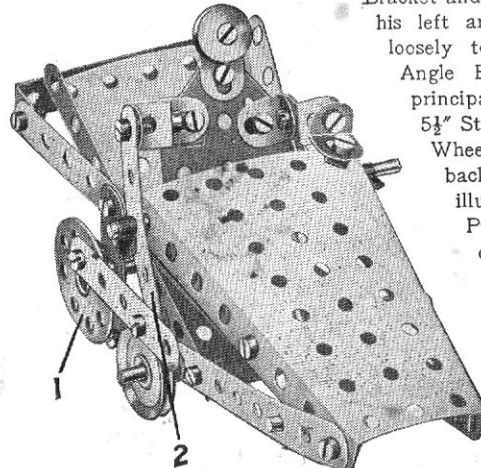

Model No. 1.83 Cart

Parts required:

2 of No. 2	4 of No. 48A
1 " " 16	1 " " 52
2 " " 19B	2 " " 100
14 " " 37	2 " " 126A

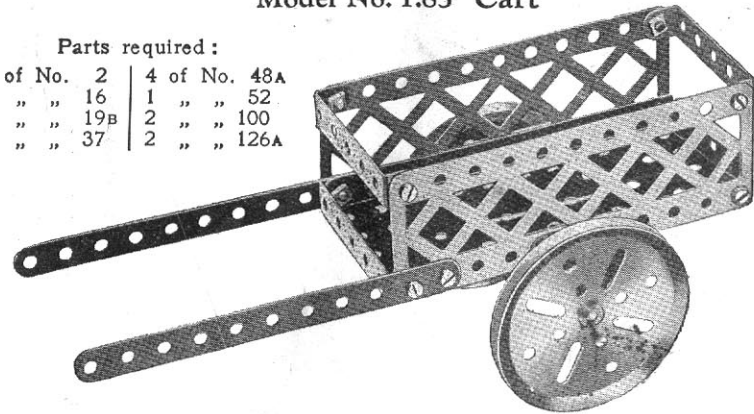

Model No. 1.84 The Invalid

When wheeled along the table the "invalid" appears to push himself energetically along. His neck is a Flat Bracket: his right (or propelling) arm consists of one Angle Bracket and one ½" Reversed Angle Bracket, and his left arm—the hand of which is bolted loosely to the chair—is formed by three Angle Brackets. The chair is composed principally of two Sector Plates and four 5½" Strips, and it runs on three 1" Pulley Wheels—one in front and two at the back. One of these (not visible in the illustration) drives by cord another 1" Pulley Wheel, the shaft of which also carries a Bush Wheel 1. As will be seen, a 2½" Strip is pivoted at one end to this Bush Wheel and at the other end to a second 2½" Strip 2, which, rocking about an axle journaled through its centre hole, is again pivoted to the invalid's hands.

Model No. 1.86 Telpher Span

Parts required:

2 of No	1	1 of No	10	1 of No	23
2 "	2	1 "	11	8 "	35
4 "	5	2 "	12	22 "	37
		3 "	16	1 "	44
		1 "	18A	2 "	48A
		1 "	19s	1 "	52
		4 "	22	2 "	54
				1 "	57
				2 "	126A

Model No. 1.85 Ladder on Wheels

Parts required:

4 of No.	1	16 of No.	37
2 "	16	6 "	48A
4 "	22	1 "	52



This model will provide many hours of enjoyment. The cords may be made to any length to allow the load to be carried from one side of the room to the other, and, if necessary, a better grip may be obtained by winding the operating cord twice round the Pulley on the Crank Handle. The open sides of the bucket may be closed with cardboard so that it may be loaded with marbles, beads, etc. The bed of the Telpher may be screwed on to a solid base with ordinary wood screws to give better support. The Pulley Bracket, and that securing the cord on which the bucket travels should be screwed in a suitable position on the opposite side of the room.

Model No. 1.87 Mountain Transport

Parts required:

2 of No.	1	3 of No.	5	2 of No.	16
2 "	2	2 "	11	4 "	22
		18 of No.	37	1 of No.	52
		3 "	48A	1 "	54

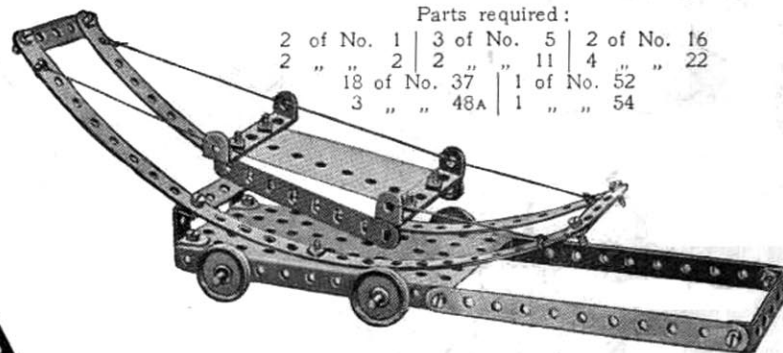

Model No. 1.88 Tower Wagon

Parts required:

4 of No	2
8 "	5
2 "	16
1 "	17
1 "	19s
4 "	22
1 "	23
4 "	35
24 "	37
1 "	52
1 "	54
1 "	57
2 "	126A

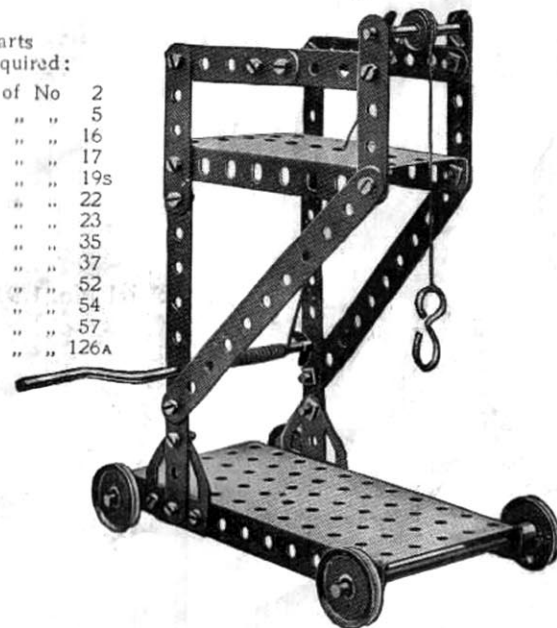

Model No. 1.89 Fire Alarm

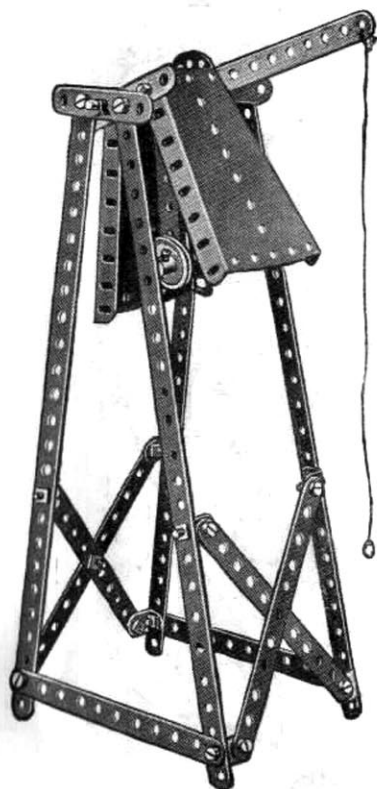

Parts required :			
4 of No.	1	1 of No.	22
7	2	1	24
1	3	4	35
3	5	27	37
8	12	2	54
1	16		

Model No. 1.90 Swivelling Crane

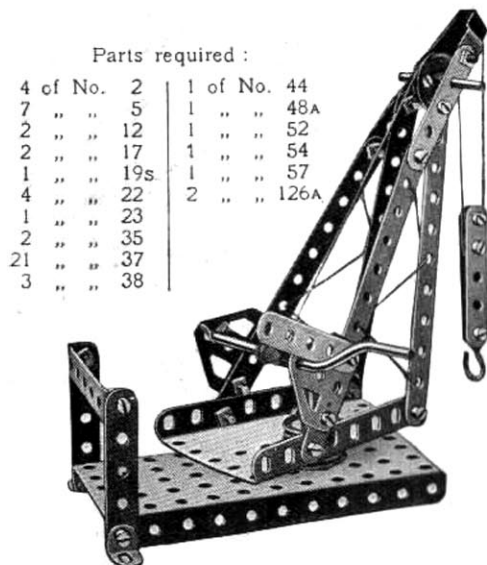

Parts required :			
4 of No.	2	1 of No.	44
7	5	1	48A
2	12	1	52
2	17	1	54
1	19s	1	57
4	22	2	126A
1	23		
2	35		
21	37		
3	38		

The Sector Plate of the Crane in this model is pivoted to the base with a fast Pulley above and below.

Model No. 1.91 Quick-Firing Gun

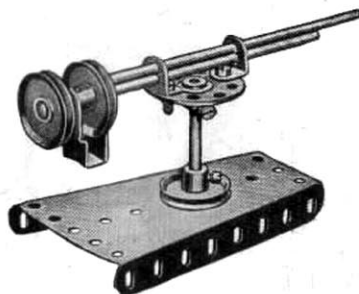

Parts required :	
2 of No.	12
2	16
1	17
4	22
1	24
2	37
1	44
1	54

Model No. 1.92 Toast Rack

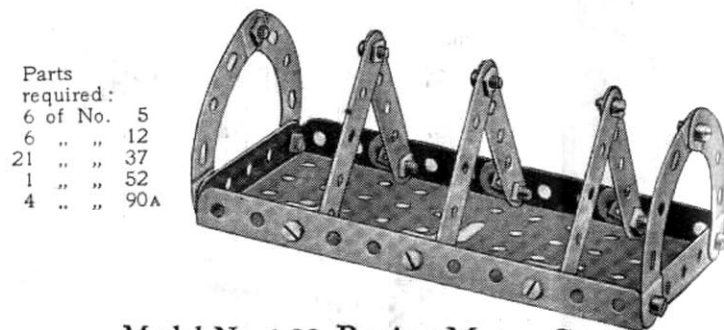

Parts required :	
6 of No.	5
6	12
21	37
1	52
4	90A

Model No. 1.93 Racing Motor Car

The Double Angle Strip 1 carries the front road Wheels and is bolted pivotally to the 5½" Strip 2, whilst the rear axle is journalled in two Angle Brackets rigidly secured to the Strip 2. A Cranked Bent Strip 3 represents a seat. The steering wheel consists of a ½" Pulley 4 bolted to an Angle Bracket.

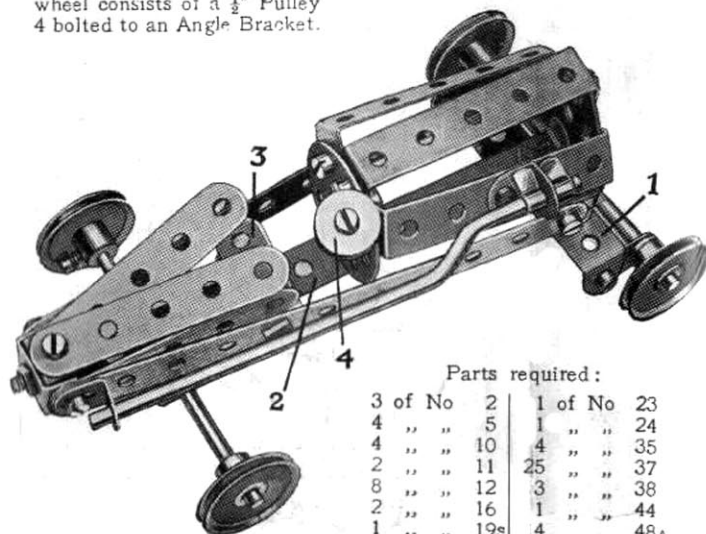

Parts required :			
3 of No.	2	1 of No.	23
4	5	1	24
4	10	4	35
2	11	25	37
8	12	3	38
2	16	1	44
1	19s	4	48A
4	22	1	126A

These Models can be built with MECCANO Outfit No. 1 (or No. 0 and No. 0A)

Model No. 1.94 Swivelling Jib Crane, Electric

Parts required :

4 of No. 1	1 of No. 23	1 of No. 57
6 " " 2	1 " " 24	Electric Motor
1 " " 3	6 " " 35	(not included
1 " " 11	30 " " 37	in Outfit)
6 " " 12	1 " " 40	
2 " " 16	2 " " 48A	
2 " " 17	1 " " 52	
1 " " 18A	1 " " 54	
4 " " 19B		
4 " " 22		

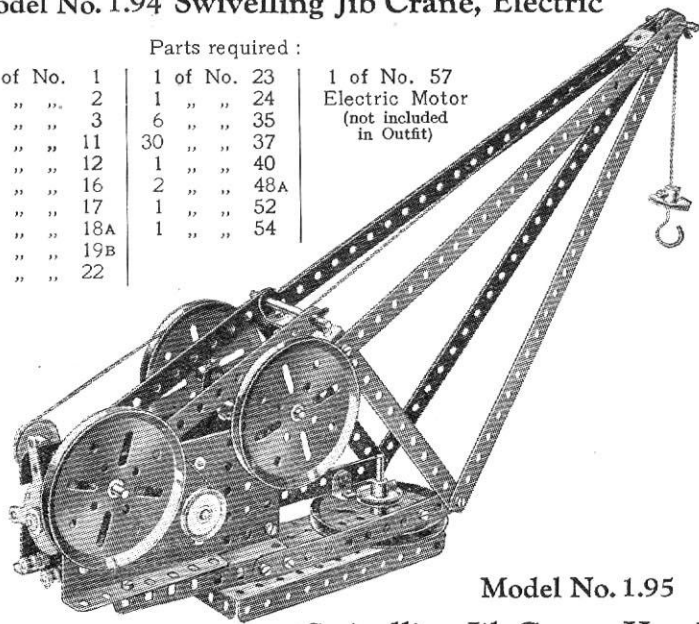

Model No. 1.96 Overhead Crane

Parts required :

4 of No. 2	4 " " 5
2 " " 10	2 " " 12
1 " " 16	1 " " 18A
1 " " 19S	4 " " 22
1 " " 23	1 " " 24
2 " " 35	25 " " 37
1 " " 38	6 " " 48A
1 " " 57	4 " " 90A
2 " " 100	

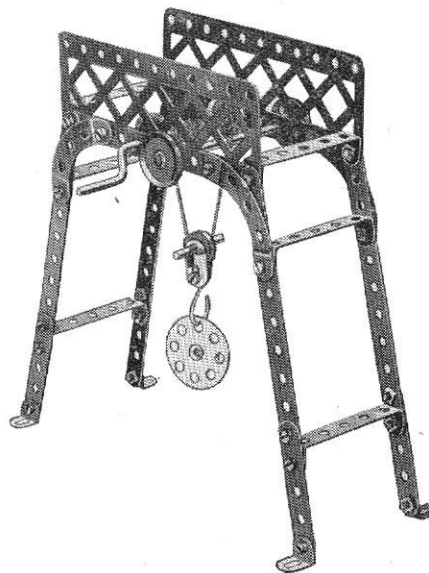

Model No. 1.98 Band Saw

Parts required :

2 of No. 1	2 " " 2
2 " " 5	2 " " 16
1 " " 19B	1 " " 19S
1 " " 19S	2 " " 22
6 " " 35	18 " " 37
3 " " 48A	1 " " 52
2 " " 90A	2 " " 126A

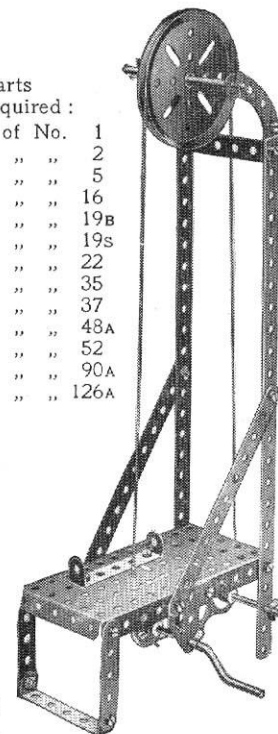

Model No. 1.95

Swivelling Jib Crane, Hand Operated

This illustrates an alternative construction of the base of model No. 1.92, and is intended to show how the model may be operated by hand if an electric motor is not available.

Parts required :

4 of No. 1	4 of No. 12
6 " " 2	2 " " 17
1 " " 5	1 " " 18A
1 " " 11	2 " " 19B
	1 " " 19S
	4 " " 22
	1 " " 23
	1 " " 24
	4 " " 35
	32 " " 37
	4 " " 38
	1 " " 48
	1 " " 48A
	1 " " 52
	2 " " 54
	1 " " 57
	1 " " 126
	1 " " 126A

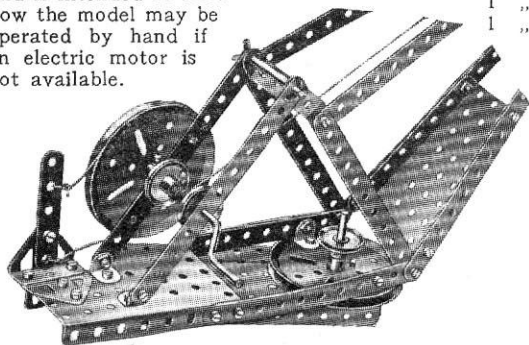

Model No. 1.97 Timber Drag

Parts required :

1 of No. 1	2 of No. 11	4 of No. 48A
1 " " 2	2 " " 16	3 " " 111C
1 " " 3	4 " " 19B	2 " " 125
2 " " 5	19 " " 37	2 " " 126A
2 " " 10	3 " " 37A	

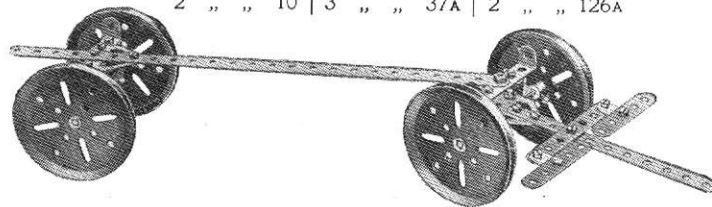

These Models can be built with MECCANO Outfit No. 1 (or No. 0 and No. 0A)

Model No. 1.94 Swivelling Jib Crane, Electric

Parts required :

4 of No. 1	1 of No. 23	1 of No. 57
6 " " 2	1 " " 24	Electric Motor
1 " " 3	6 " " 35	(not included
1 " " 11	30 " " 37	in Outfit)
6 " " 12	1 " " 40	
2 " " 16	2 " " 48A	
2 " " 17	1 " " 52	
1 " " 18A	1 " " 54	
4 " " 19B		
4 " " 22		

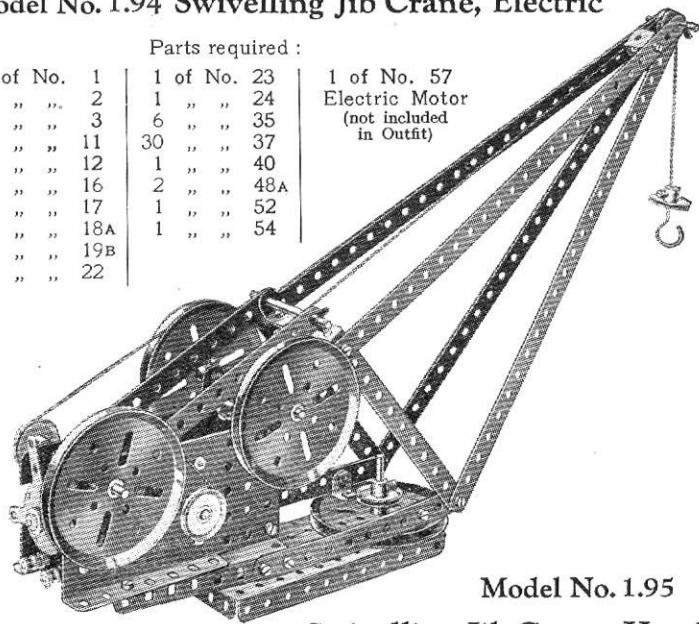

Model No. 1.96 Overhead Crane

Parts required :

4 of No. 2	4 " " 5
2 " " 10	2 " " 12
1 " " 16	1 " " 18A
1 " " 19S	4 " " 22
1 " " 23	1 " " 24
2 " " 35	25 " " 37
1 " " 38	6 " " 48A
1 " " 57	4 " " 90A
2 " " 100	



Model No. 1.98 Band Saw

Parts required :

2 of No. 1	2 " " 2
2 " " 5	2 " " 16
1 " " 19B	1 " " 19S
1 " " 19S	2 " " 22
6 " " 35	18 " " 37
3 " " 48A	1 " " 52
2 " " 90A	2 " " 126A

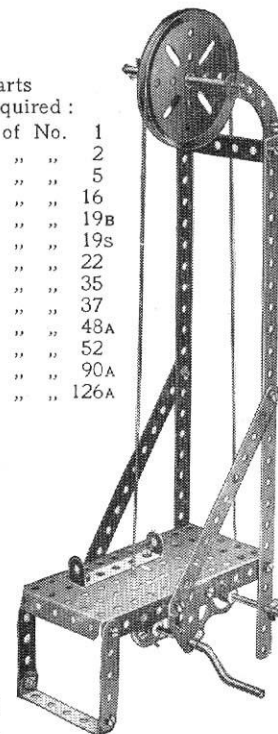

Model No. 1.95

Swivelling Jib Crane, Hand Operated

This illustrates an alternative construction of the base of model No. 1.92, and is intended to show how the model may be operated by hand if an electric motor is not available.

Parts required :

4 of No. 1	4 of No. 12
6 " " 2	2 " " 17
1 " " 5	1 " " 18A
1 " " 11	2 " " 19B
	1 " " 19S
	4 " " 22
	1 " " 23
	1 " " 24
	4 " " 35
	32 " " 37
	4 " " 38
	1 " " 48
	1 " " 48A
	1 " " 52
	2 " " 54
	1 " " 57
	1 " " 126
	1 " " 126A

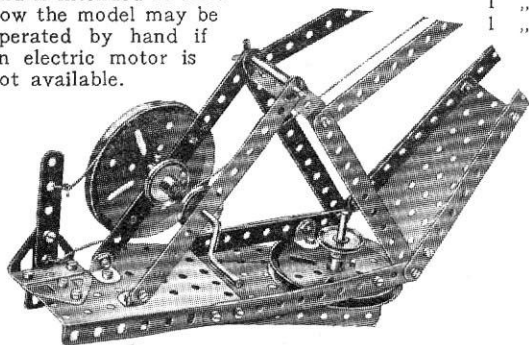

Model No. 1.97 Timber Drag

Parts required :

1 of No. 1	2 of No. 11	4 of No. 48A
1 " " 2	2 " " 16	3 " " 111C
1 " " 3	4 " " 19B	2 " " 125
2 " " 5	19 " " 37	2 " " 126A
2 " " 10	3 " " 37A	

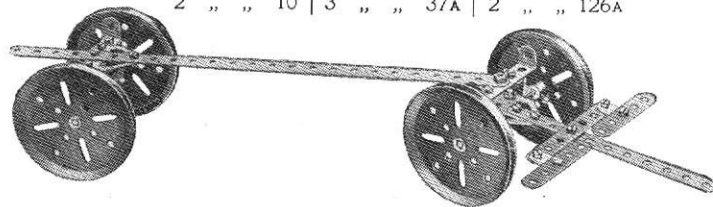

These Models can be built with MECCANO Outfit No. 1 (or No. 0 and No. 0A)

Model No. 1.99 Try-Your-Strength Machine

Parts
required :

4 of No.	1
1 " "	2
6 " "	12
1 " "	17
3 " "	22
1 " "	23
2 " "	35
17 " "	37
1 " "	52
1 " "	111c
2 " "	126
1 " "	126A

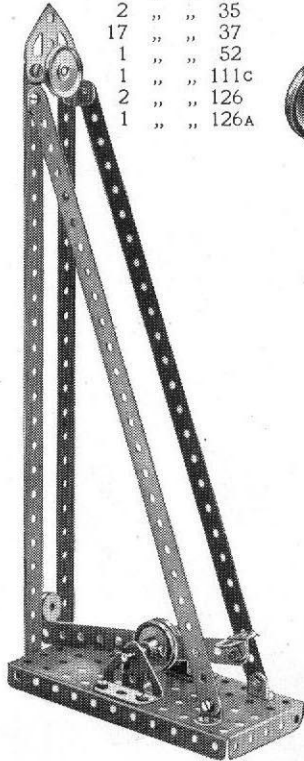

Model No.1.101 Motor Van

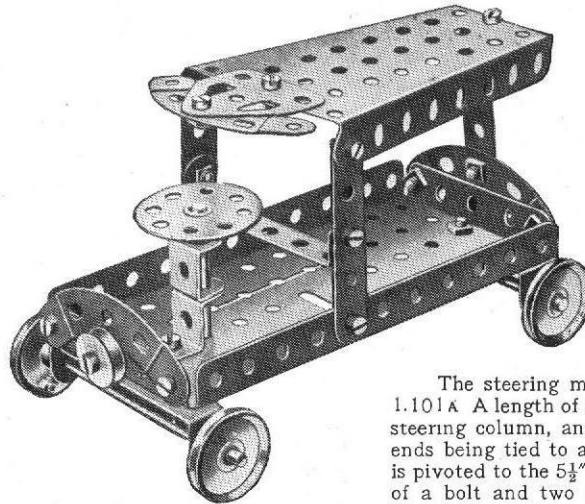

Parts required :

3 of No.	5	1 of No.	35
1 " "	11	17 " "	37
1 " "	12	1 " "	48A
2 " "	16	1 " "	52
1 " "	17	1 " "	54
4 " "	22	3 " "	90A
1 " "	23	1 " "	111c
1 " "	24	1 " "	125
1 of No. 126A			

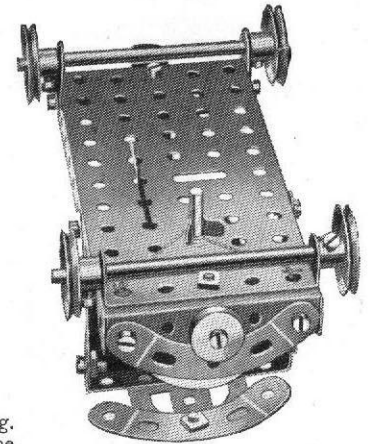

FIG. 1.101A

The steering mechanism is shown more clearly in Fig. 1.101A. A length of cord is given two or three turns round the steering column, and is held in position by a spring clip, its ends being tied to a $2\frac{1}{2}'' \times \frac{1}{2}''$ double angle strip. The latter is pivoted to the $5\frac{1}{2}'' \times 2\frac{1}{2}''$ flanged plate of the lorry by means of a bolt and two nuts (see Standard Mechanisms Manual, Detail No. 262).

Model No. 1.100 Double Cable Key

Parts
required :

2 of No.	2
2 " "	22
4 " "	37
1 " "	52
2 " "	111c

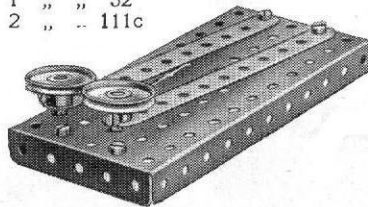

Model No. 1.102 Revolving Hammer-Head Crane

Parts
required :

2 of No.	1
8 " "	2
4 " "	5
2 " "	12
1 " "	16
1 " "	17
1 " "	18A
2 " "	19B
1 " "	19S
2 " "	22

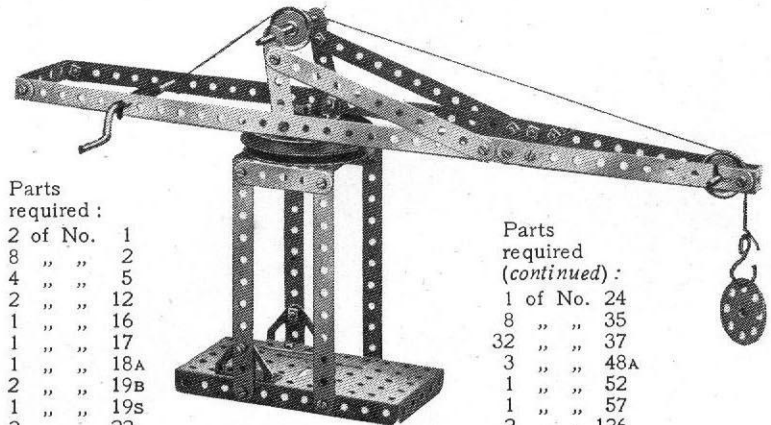

Parts
required
(continued) :

1 of No.	24
8 " "	35
32 " "	37
3 " "	48A
1 " "	52
1 " "	57
2 " "	126

Model No. 1.103 Anti-Aircraft Gun

Parts required :

4 of No. 2	1 of No. 54
4 " " 5	3 " " 111c
8 " " 12	1 " " 125
1 " " 16	2 " " 126
1 " " 17	
2 " " 18A	
2 " " 19B	
3 " " 22	
1 " " 24	
4 " " 35	
18 " " 37	
2 " " 38	
1 " " 48A	

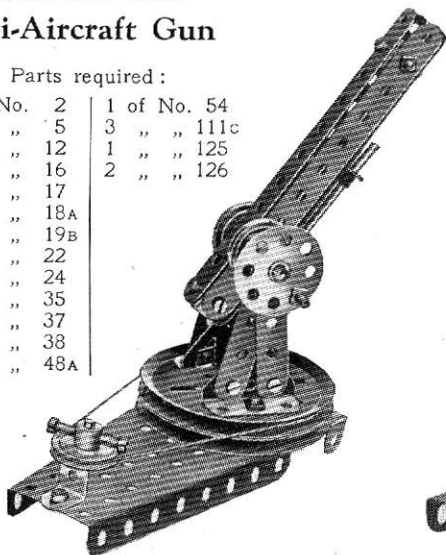

Model No. 1.105 Paddle Steamer

Parts required :

4 of No. 2	1 of No. 52	1 of No. 125
1 " " 3	2 " " 54	2 " " 126
4 " " 5	4 " " 90A	
1 " " 10		
2 " " 12		
2 " " 16		
2 " " 18A		
3 " " 22		
1 " " 24		
3 " " 35		
36 " " 37		
3 " " 48A		

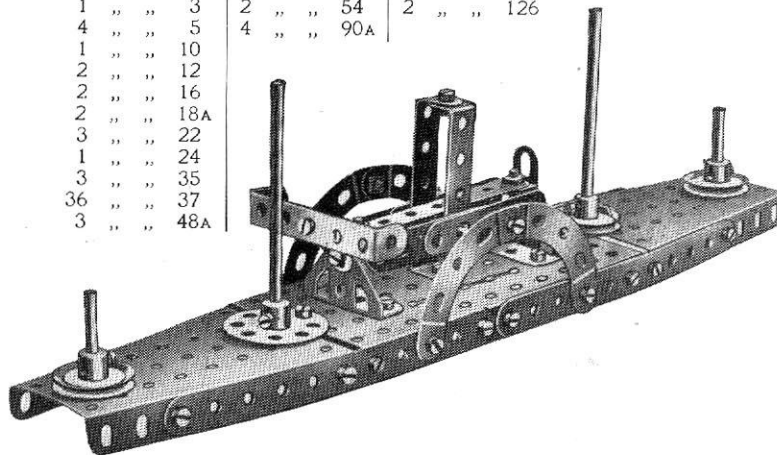

Model No. 1.106 Signal

Parts required :

2 of No. 1
1 " " 3
1 " " 5
2 " " 22
11 " " 37
2 " " 37A
1 " " 52
2 " " 111c

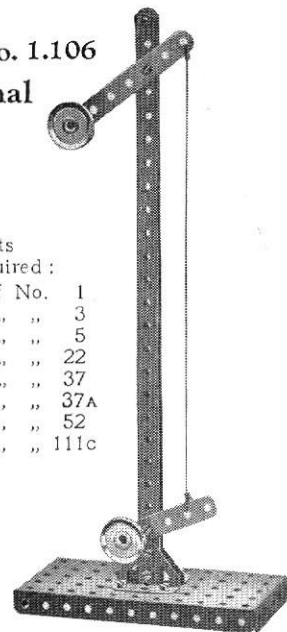

Model No. 1.104 Meccanograph

Parts required :

1 of No. 3
4 " " 5
2 " " 11
6 " " 12
2 " " 16
2 " " 17
1 " " 19B
2 " " 22
1 " " 24
5 " " 35
21 " " 37
2 " " 37A
2 " " 38
2 " " 48A
1 " " 52
2 " " 100
3 " " 111c
2 " " 126

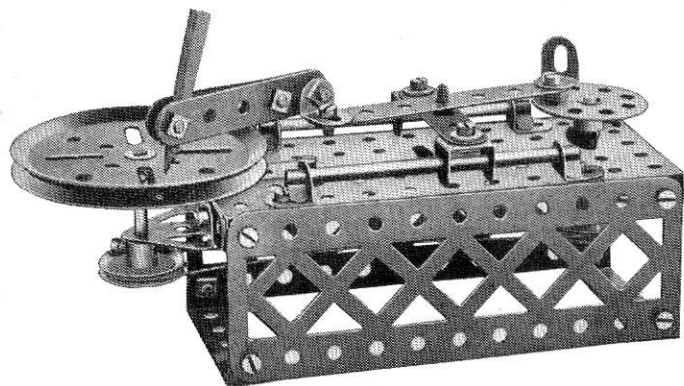

Model No. 1.107 Ladder on Wheels

Parts required :

6 of No. 2
4 " " 5
2 " " 16
4 " " 19B
16 " " 37
8 " " 38
4 " " 48A
1 " " 52

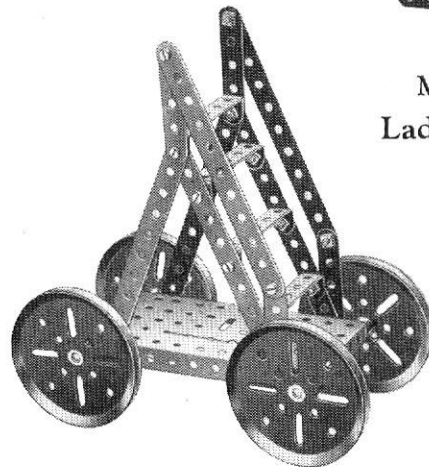

These Models can be built with MECCANO Outfit No. 1 (or No. 0 and No. 0A)

Model No. 1.108 Eccentric Dancers

Parts required :

6 of No. 5	4 of No. 22	2 of No. 111c
4 " " 10	1 " " 23	1 " " 125
6 " " 12	20 " " 37	2 " " 126A
	4 " " 48A	

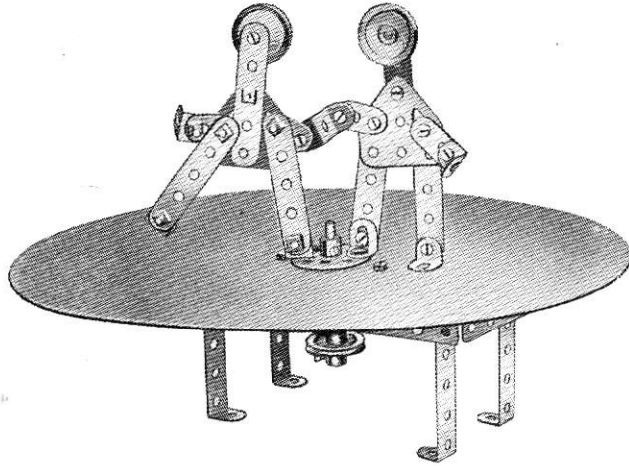

Model No. 1.109 Bellows

Parts required :

4 of No. 2	1 of No. 24
1 " " 3	8 " " 35
3 " " 5	25 " " 37
2 " " 10	6 " " 37A
2 " " 11	1 " " 44
4 " " 12	1 " " 52
1 " " 16	2 " " 54
2 " " 17	1 " " 111c
2 of No. 126	

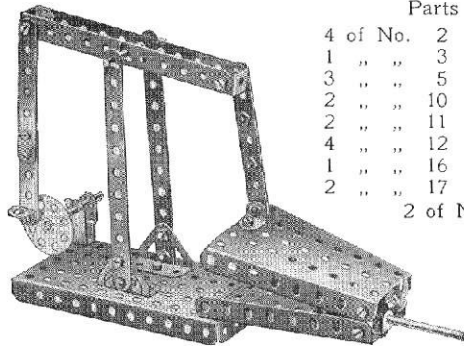

Model No. 1.110 Crosshead Demonstration Model

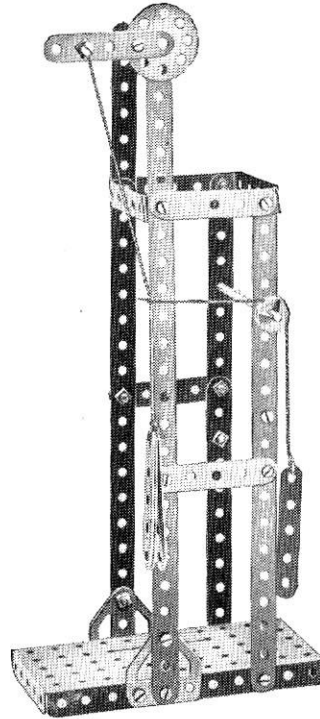

This is an apparatus for determining the forces that act at the crosshead of a reciprocating engine. The upper inclined length of cord represents the connecting rod and the lower, or vertical portion, the piston rod. The pull on the third cord indicates the pressure exerted on the slide bars of the engine due to the angularity of the connecting rod.

Model No. 1.111 Drop Stamp

Parts required :

4 of No. 2
6 " " 5
3 " " 10
2 " " 16
1 " " 19
4 " " 22
1 " " 34
2 " " 35
27 " " 37
3 " " 48A
1 " " 52
1 " " 54
2 " " 126A

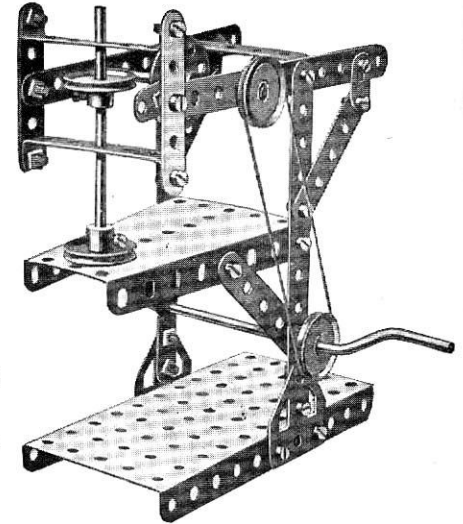

Model No. 1.112 Blacksmith

Parts required :

1 of No. 3	1 of No. 35
8 " " 5	26 " " 37
2 " " 10	4 " " 37A
2 " " 11	1 " " 44
5 " " 12	1 " " 52
1 " " 19s	1 " " 54
1 " " 22	1 " " 111c
1 " " 24	2 " " 125
2 of No. 126A	

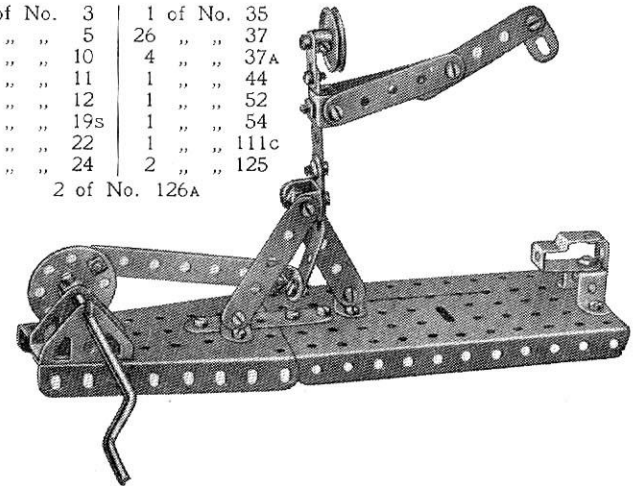

**Model No. 1.113
Telescope**

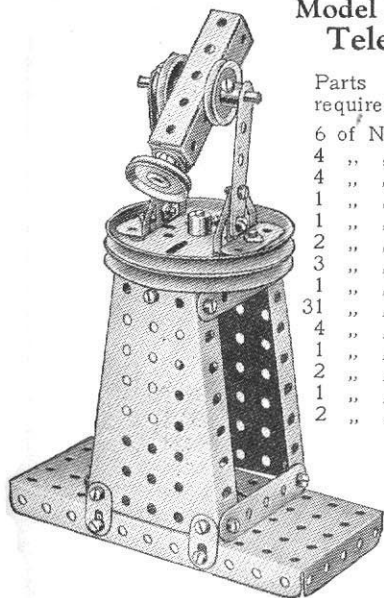

Parts
required :

6 of No.	5
4 " "	10
4 " "	12
1 " "	17
1 " "	18A
2 " "	19B
3 " "	22
1 " "	35
31 " "	37
4 " "	48A
1 " "	52
2 " "	54
1 " "	111c
2 " "	126

Model No. 1.115 Flying Boats

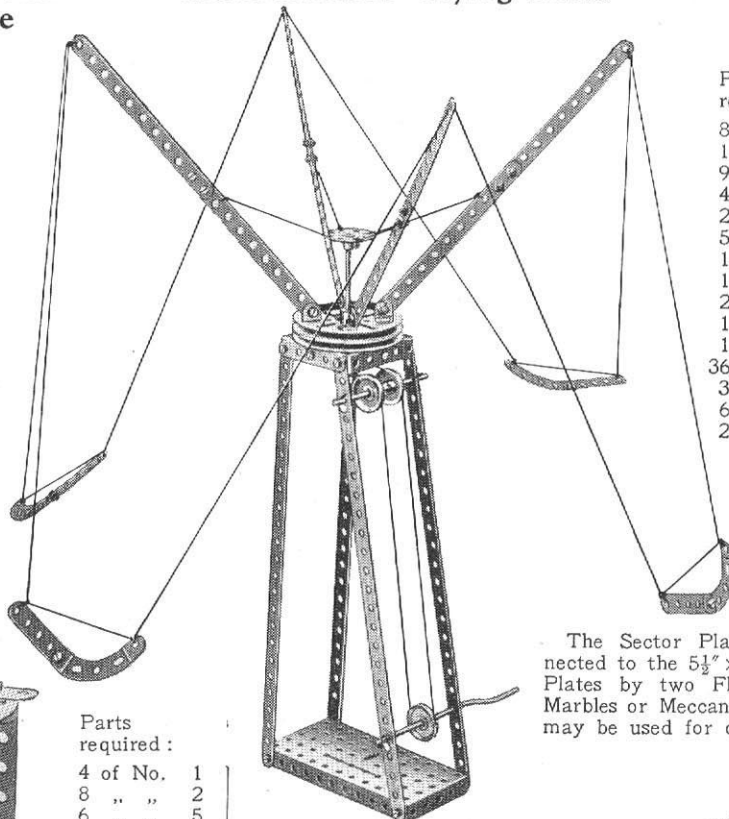

Parts
required :

4 of No.	1	4 of No.	22	3 of No.	48A
8 " "	2	1 " "	24	4 " "	90A
6 " "	5	4 " "	35		
8 " "	12	36 " "	37		
2 " "	16				
2 " "	19B				
1 " "	19S				

Model No. 1.116 Aeroplane

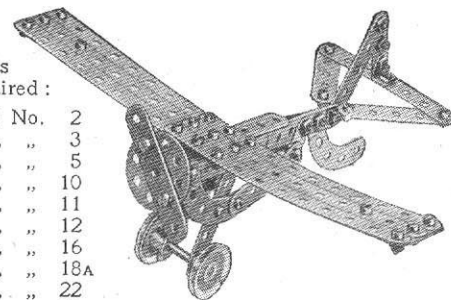

Parts
required :

8 of No.	2
1 " "	3
9 " "	5
4 " "	10
2 " "	11
5 " "	12
1 " "	16
1 " "	18A
2 " "	22
1 " "	24
1 " "	35
36 " "	37
3 " "	90A
6 " "	111c
2 " "	126A

Model No. 1.114 Sedan Chair

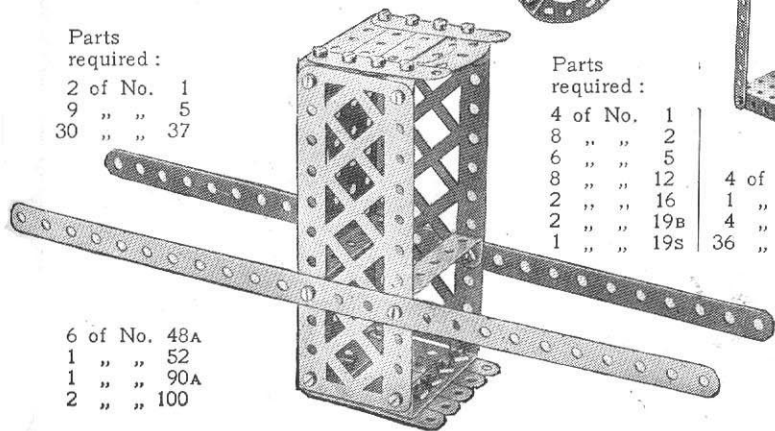

Parts
required :

2 of No.	1
9 " "	5
30 " "	37

6 of No.	48A
1 " "	52
1 " "	90A
2 " "	100

The Sector Plates are connected to the $5\frac{1}{2} \times 2\frac{1}{2}$ " Flanged Plates by two Flat Brackets. Marbles or Meccano Steel Balls may be used for coco-nuts.

**Model No. 1.117
Coco-nut Shy**

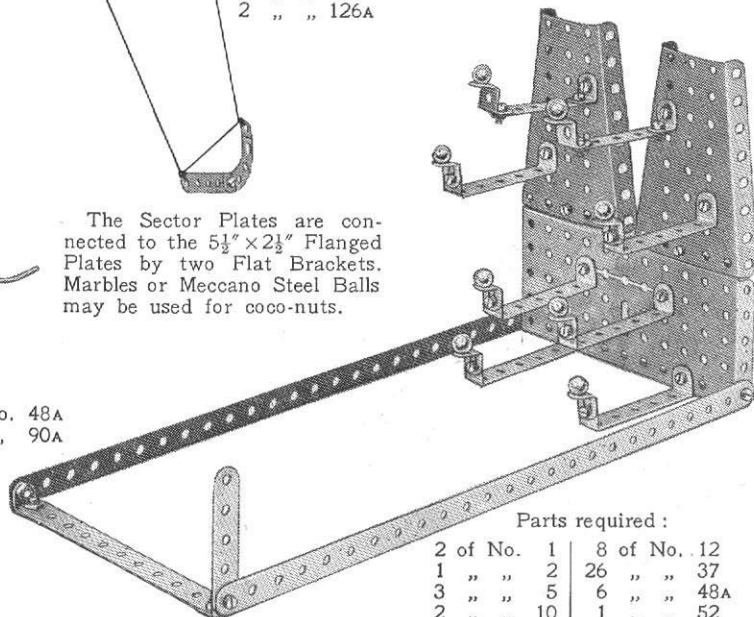

Parts required :

2 of No.	1	8 of No.	12
1 " "	2	26 " "	37
3 " "	5	6 " "	48A
2 " "	10	1 " "	52
2 " "	11	2 " "	54

Model No. 1.118

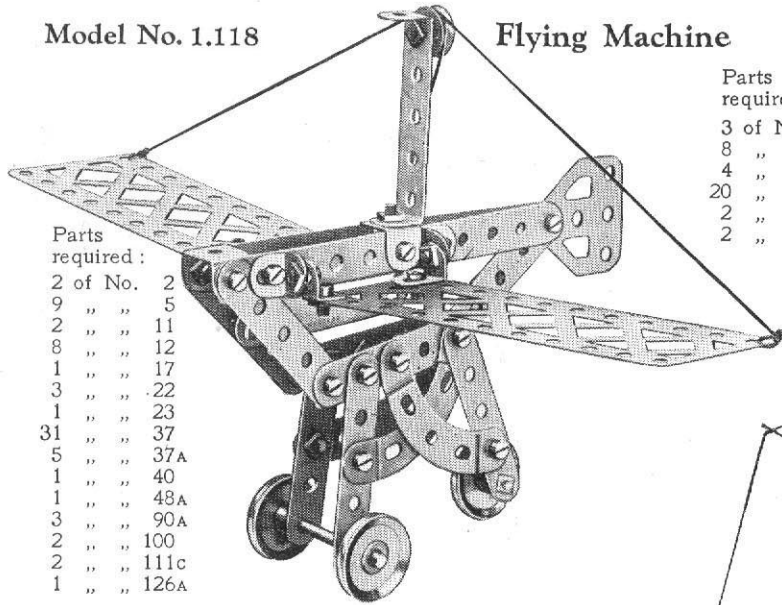

- Parts required:
- 2 of No. 2
 - 9 " " 5
 - 2 " " 11
 - 8 " " 12
 - 1 " " 17
 - 3 " " 22
 - 1 " " 23
 - 31 " " 37
 - 5 " " 37A
 - 1 " " 40
 - 1 " " 48A
 - 3 " " 90A
 - 2 " " 100
 - 2 " " 111c
 - 1 " " 126A

Flying Machine

- Parts required:
- 3 of No. 1
 - 8 " " 2
 - 4 " " 12
 - 20 " " 37
 - 2 " " 54
 - 2 " " 100

Model No. 1.120 Inverted Truss

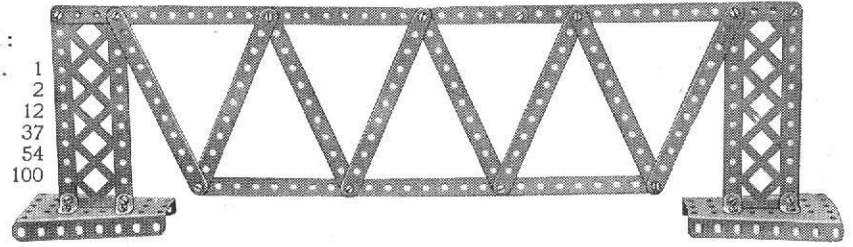

Model No. 1.121 Sand Yacht

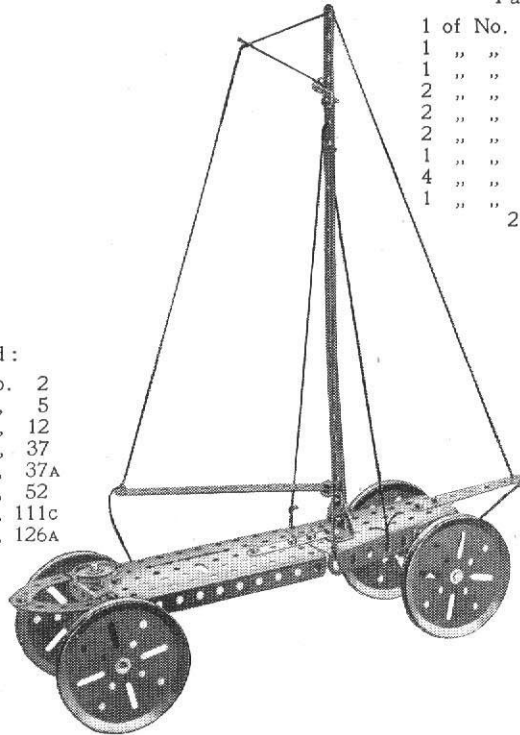

- Parts required:
- | | |
|---------------|-------------|
| 1 of No. 1 | 1 of No. 24 |
| 1 " " 2 | 4 " " 35 |
| 1 " " 3 | 23 " " 37 |
| 2 " " 5 | 1 " " 48A |
| 2 " " 12 | 1 " " 52 |
| 2 " " 16 | 1 " " 54 |
| 1 " " 18A | 2 " " 90A |
| 4 " " 19B | 1 " " 125 |
| 1 " " 22 | 1 " " 126 |
| 2 of No. 126A | |

Model No. 1.122 Box Ball Alley

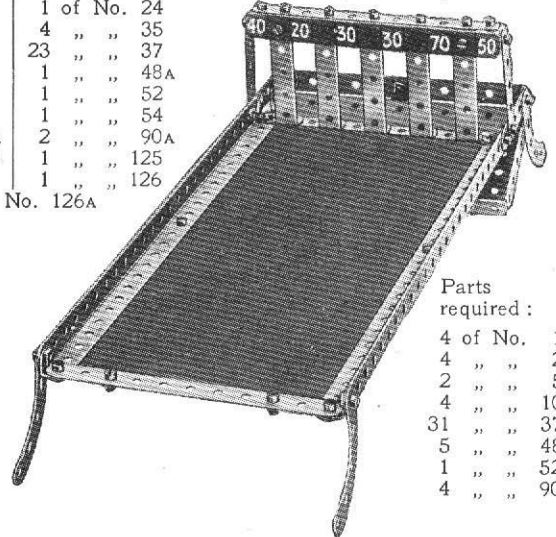

- Parts required:
- 4 of No. 1
 - 4 " " 2
 - 2 " " 5
 - 4 " " 10
 - 31 " " 37
 - 5 " " 48A
 - 1 " " 52
 - 4 " " 90A

Model No. 1.119 Gate

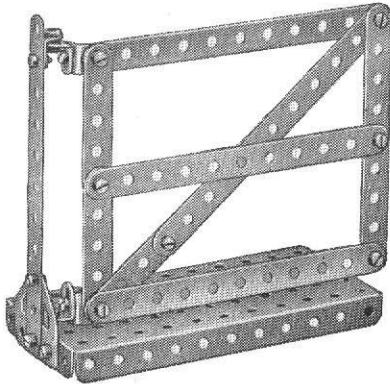

- Parts required:
- 6 of No. 2
 - 4 " " 5
 - 5 " " 12
 - 13 " " 37
 - 4 " " 37A
 - 1 " " 52
 - 2 " " 111c
 - 1 " " 126A

Model No. 1.123 Rake

- Parts required:
- 1 of No. 2
 - 1 " " 3
 - 4 of No. 10
 - 1 " " 1
 - 6 of No. 37

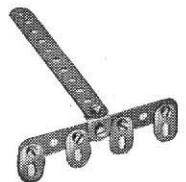

Model No. 1.124 Boat Steering Gear

Model No. 1.126 Gyroscope

Model No. 1.128 Pantograph

Parts required:

4 of No. 2	1 of No. 24
1 " " 3	14 " " 37
2 " " 11	4 " " 37A
1 " " 12	1 " " 40
1 " " 16	1 " " 48A
1 " " 18A	1 " " 52
1 " " 19B	6 " " 111c
3 " " 22	1 " " 126

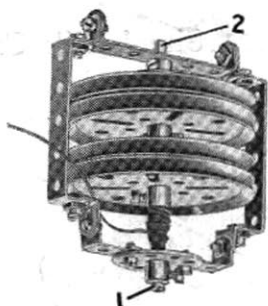
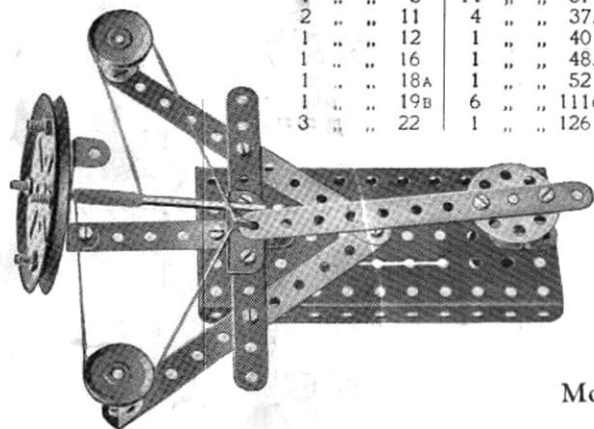

Parts required:

4 of No. 12
1 " " 16
4 " " 19B
1 " " 24
10 " " 37
4 " " 48A

The 7/32" Bolt 1 is gripped by the Set-Screw of the Bush Wheel. The lower end of the Rod 2 of the Gyroscope enters the boss of the Bush Wheel and rests on the shank of the Bolt 1.

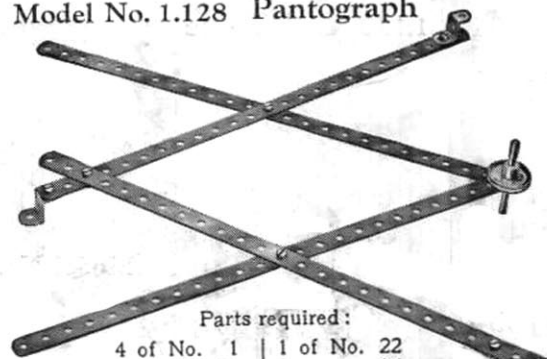

Parts required:

4 of No. 1	1 of No. 22
1 " " 11	1 " " 35
2 " " 12	9 " " 37
1 " " 17	3 " " 37A
2 of No. 125	

The pantograph enables plans, drawings, etc., to be reproduced on a larger or smaller scale than the original. If a pencil, suitably whittled down, is fixed in the Reversed Angle Bracket at the top of the illustration, and the 1 1/2" Rod is made to follow the outlines of the drawing, the pencil will draw an accurately enlarged sketch. If the positions of the Rod and the pencil be reversed, the latter can be made to trace a reduced sketch of the original drawing.

Model No. 1.125 Band Brake

Model No. 1.127 Coat Hanger

Parts required:

1 of No. 2	1 of No. 19s	1 of No. 52
2 " " 5	2 " " 22	2 " " 54
1 " " 12	1 " " 35	1 " " 111c
	10 " " 37	

Parts required:

1 of No. 1	2 of No. 5
2 " " 2	6 " " 37
1 of No. 57	

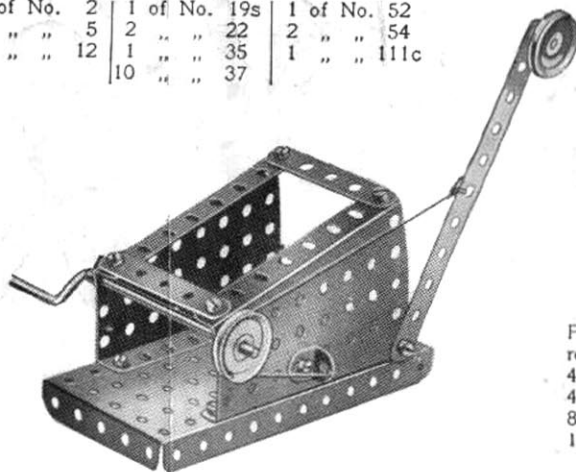

Parts required:

4 of No. 1	4 of No. 12
4 " " 2	3 " " 16
8 " " 5	1 " " 18A
1 " " 10	2 " " 19B
	1 " " 19s

Model No. 1.129 Aerial Flight

Parts required (continued):

3 of No. 22	33 of No. 37	1 of No. 52
1 " " 23	2 " " 38	2 " " 54
6 " " 35	2 " " 48A	2 " " 126
		1 " " 126A

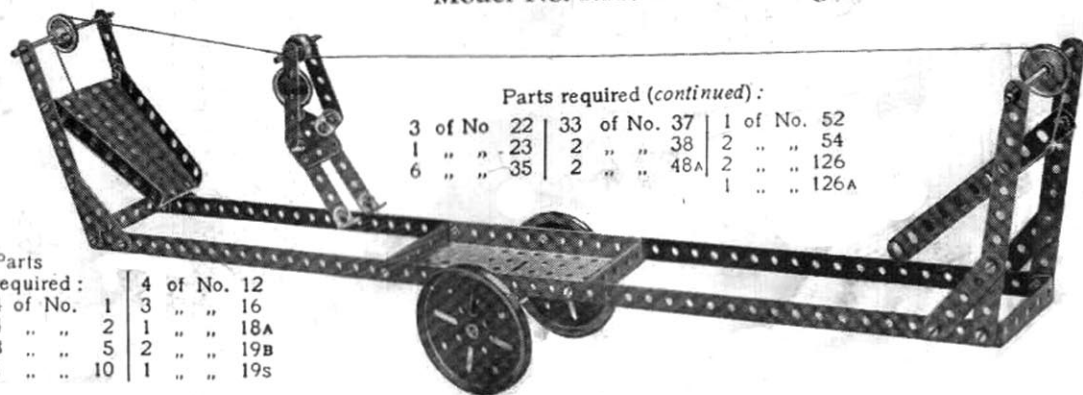

Model No. 1.130 Bed Table

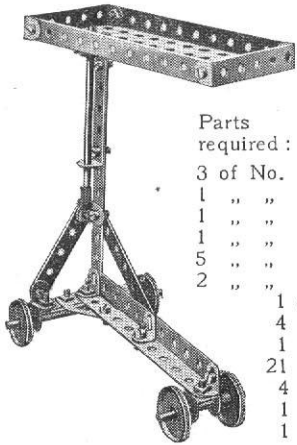

- Parts required :
- | | |
|----------|------|
| 3 of No. | 2 |
| 1 " " | 3 |
| 1 " " | 5 |
| 1 " " | 11 |
| 5 " " | 12 |
| 2 " " | 16 |
| 1 of No. | 17 |
| 4 " " | 22 |
| 1 " " | 24 |
| 21 " " | 37 |
| 4 " " | 48A |
| 1 " " | 52 |
| 1 " " | 126A |

Model No. 1.131 Inclined Plane

- Parts required :
- | | | | |
|----------|----|----------|-----|
| 4 of No. | 1 | 4 of No. | 22 |
| 2 " " | 2 | 1 " " | 23 |
| 6 " " | 5 | 4 " " | 35 |
| 3 " " | 16 | 10 " " | 37 |
| | | 1 " " | 48 |
| | | 3 " " | 48A |
| | | 1 " " | 57 |

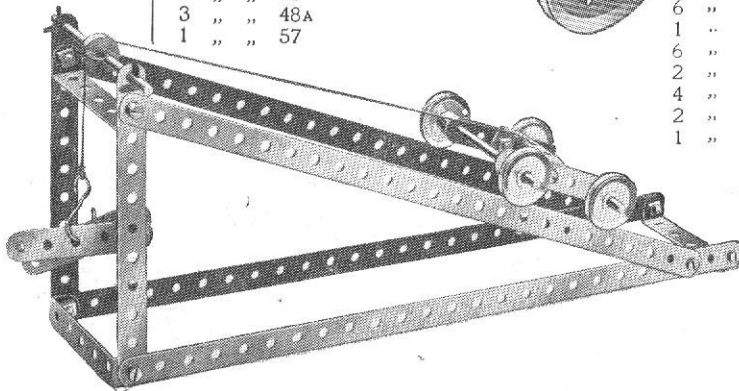

Model No. 1.132 Shepherd's Crook

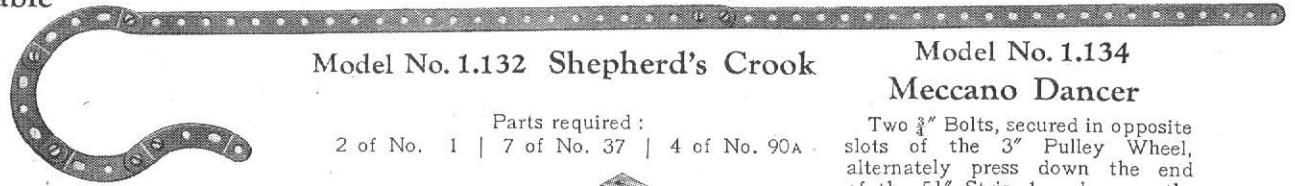

- Parts required :
- 2 of No. 1 | 7 of No. 37 | 4 of No. 90A

Model No. 1.133 Coal Cutter

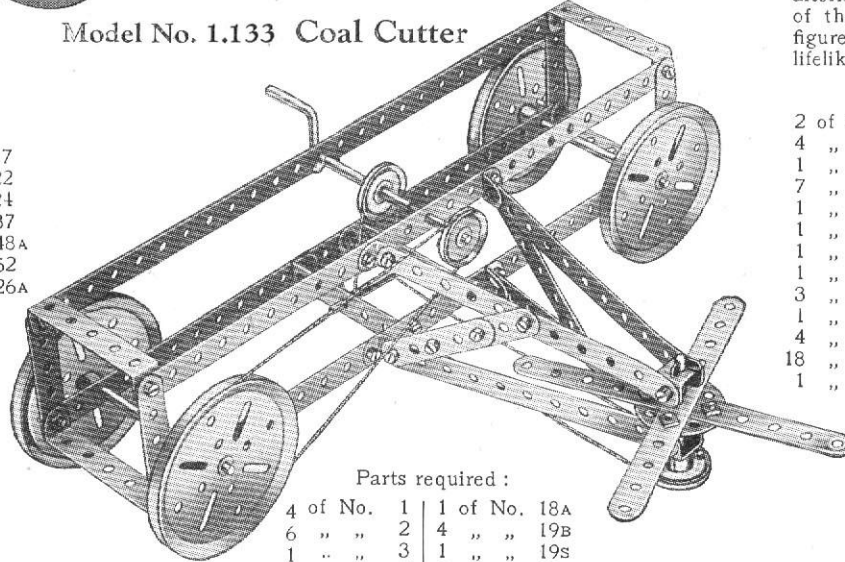

- Parts required :
- | | | | |
|----------|----------|----------|-----|
| 4 of No. | 1 | 1 of No. | 18A |
| 6 " " | 2 | 4 " " | 19B |
| 1 " " | 3 | 1 " " | 19S |
| 6 " " | 5 | 3 " " | 22 |
| 2 " " | 11 | 1 " " | 24 |
| 4 " " | 12 | 5 " " | 35 |
| 2 " " | 16 | 32 " " | 37 |
| 1 " " | 17 | 1 " " | 40 |
| | 6 of No. | | 48A |

Model No. 1.134 Meccano Dancer

Two 3" Bolts, secured in opposite slots of the 3" Pulley Wheel, alternately press down the end of the 5 1/2" Strip 1 and cause the figure to dance in a surprisingly lifelike manner.

- Parts required :
- | | | | |
|----------|-----|----------|------|
| 2 of No. | 1 | 1 of No. | 90A |
| 4 " " | 2 | 3 " " | 111c |
| 1 " " | 3 | 2 " " | 126A |
| 7 " " | 5 | | |
| 1 " " | 16 | | |
| 1 " " | 18A | | |
| 1 " " | 19B | | |
| 1 " " | 19S | | |
| 3 " " | 22 | | |
| 1 " " | 24 | | |
| 4 " " | 35 | | |
| 18 " " | 37 | | |
| 1 " " | 52 | | |

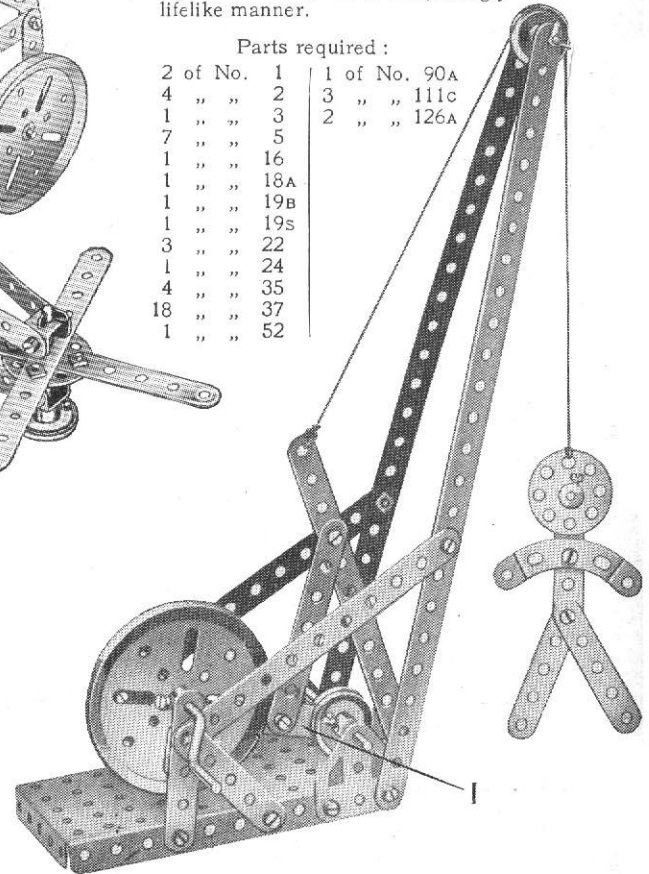

Model No. 1.135

Fly Boats

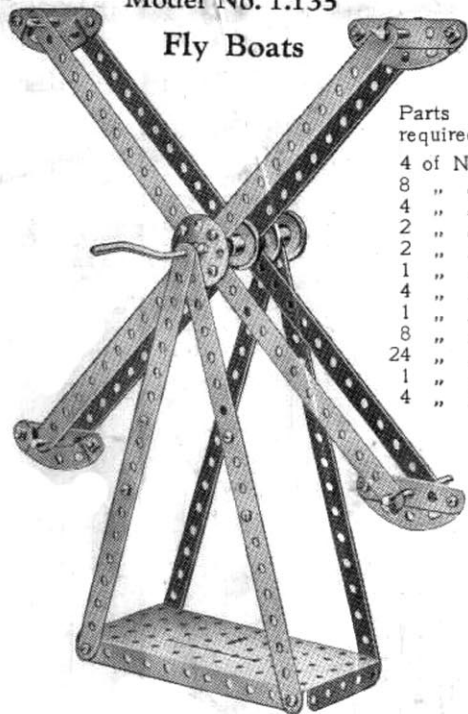

Parts required:

4 of No.	1
8 " "	2
4 " "	5
2 " "	17
2 " "	18A
1 " "	19s
4 " "	22
1 " "	24
8 " "	35
24 " "	37
1 " "	52
4 " "	90A

Model No. 1.137 Double Draw Bridge

Parts required:

4 of No.	1	1 of No.	19s	2 of No.	38
6 " "	2	2 " "	22	6 " "	48A
1 " "	16	8 " "	35	2 " "	126A
		16 " "	37		

Model No. 1.136
Tappet Valve
Demonstration Model

Parts required:

1 of No.	3	1 of No.	24
1 " "	5	5 " "	35
1 " "	10	15 " "	37
1 " "	11	5 " "	37A
3 " "	12	4 " "	38
2 " "	16	1 " "	48A
1 " "	17	1 " "	52
1 " "	18A	1 " "	54
4 " "	22	2 " "	111c
		2 of No.	126A

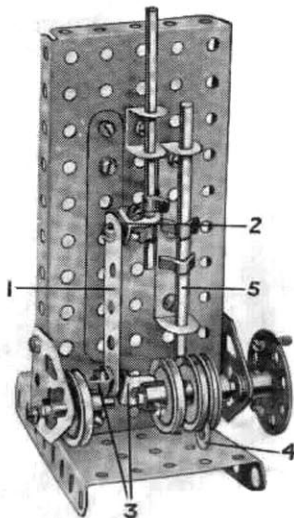

Model No. 1.136

The upper end of the Strip 1 is connected pivotally by a Bolt and two Nuts to the crosshead Bracket 2. The crankshaft is built up as follows: Two Angle Brackets are each secured rigidly to the boss of a Pulley Wheel and are connected to each other by a $\frac{3}{8}$ " Bolt carrying three Nuts. The Nuts are screwed tightly against the Brackets, sufficient space being left between the inner pair to enable the connecting Strip 1 to turn freely. The valve Rod 5 is operated by the Flat Bracket 4 that is clamped between two further 1" Pulleys on the crankshaft in such a way that its protruding end serves as a cam.

Model No. 1.138
Automatic
Drill

Parts required:

1 of No.	3	1 of No.	24
2 " "	5	4 " "	35
1 " "	11	16 " "	37
2 " "	12	1 " "	37A
2 " "	16	1 " "	44
2 " "	18A	1 " "	48
2 " "	19B	2 " "	48A
4 " "	22	1 " "	111c
		2 of No.	126A

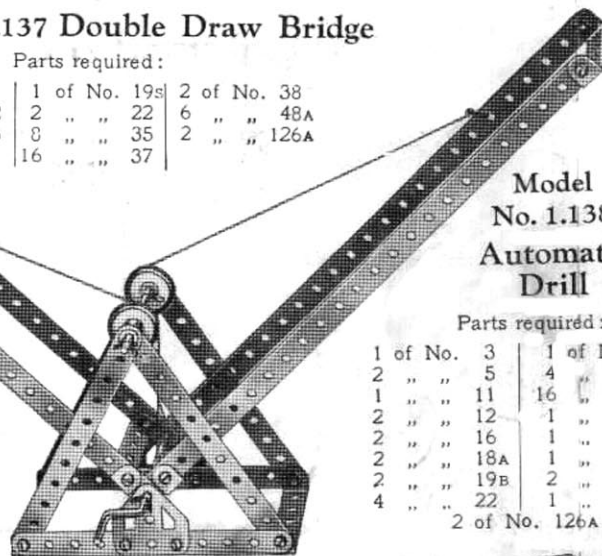

Model No. 1.138

Cord is passed round the Pulley on the drill spindle 4 and thence over the Pulleys 3 and round the shaft of the Pulley 1. The lever 2 (a $3\frac{1}{2}$ " Strip) is pivoted by a Bolt and two Nuts at its inner end to an Angle Bracket, and the latter is bolted to a $1\frac{1}{2}$ " x $\frac{1}{2}$ " Double Angle Strip which, in turn, is bolted between the vertical $2\frac{1}{2}$ " Double Angle Strips. The arm of the lever engages between two Washers on the drill spindle, and on pressing the lever, the drill spindle with its 1" Pulley is forced downwards, thus tightening the Cord, which then transmits the drive to the drill spindle. Immediately pressure on the lever is released, the drill comes to rest.

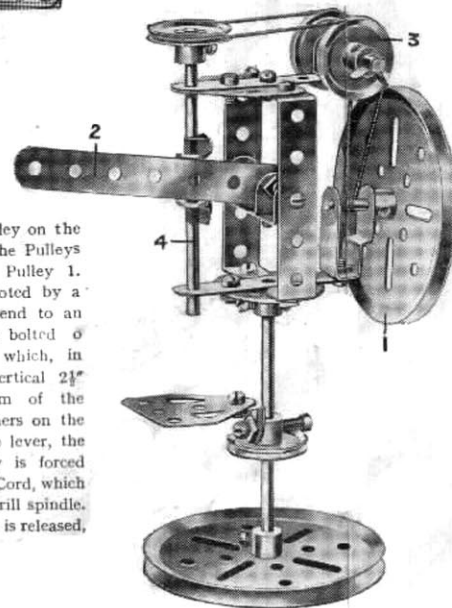

Model No. 1.139. Locomotive

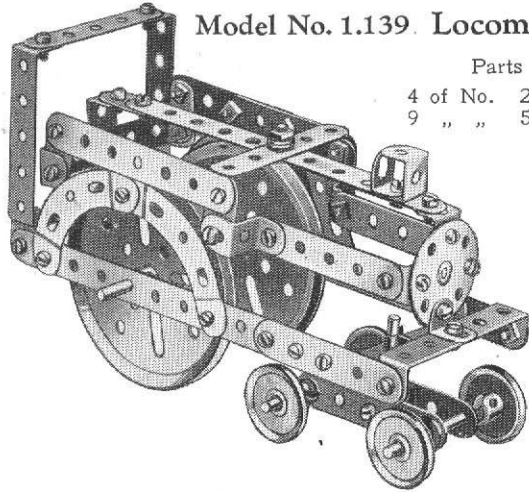

Parts required:

4 of No. 2	5 of No. 10
9 " " 5	2 " " 11
	6 " " 12
	3 " " 16
	1 " " 18A
	2 " " 19B
	4 " " 22
	1 " " 24
	8 " " 35
36 " " 37	6 " " 37A
	6 " " 38
	1 " " 48
	6 " " 48A
	4 " " 90A
	6 " " 111c
	2 " " 125

The bogie is connected pivotally to the locomotive body by means of a 1 1/2" Rod journalled in a Double Bracket, which is secured in the centre of the bogie, and in a 2 1/2" x 1/2" Double Angle Strip that is secured between the main side frames. Two Spring Clips between the Double Angle Strip and Double Bracket space the bogie at the correct distance.

Model No. 1.140

Circular Saw

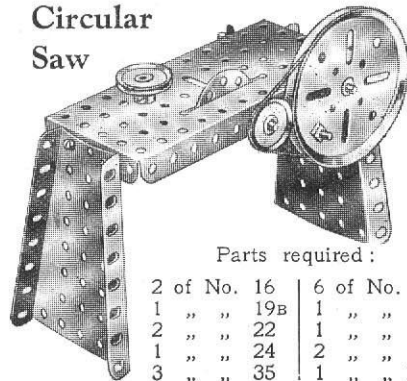

Parts required:

2 of No. 16	6 of No. 37
1 " " 19B	1 " " 37A
2 " " 22	1 " " 52
1 " " 24	2 " " 54
3 " " 35	1 " " 111c
2 of No. 125	

Model No. 1.142
Treadle Grindstone

Parts required:

4 of No. 2	
1 " " 3	
1 " " 5	
1 " " 12	
3 " " 16	
2 " " 19B	
4 " " 22	
1 " " 24	
2 " " 35	
9 " " 37	
2 " " 37A	
1 " " 48A	
1 " " 52	

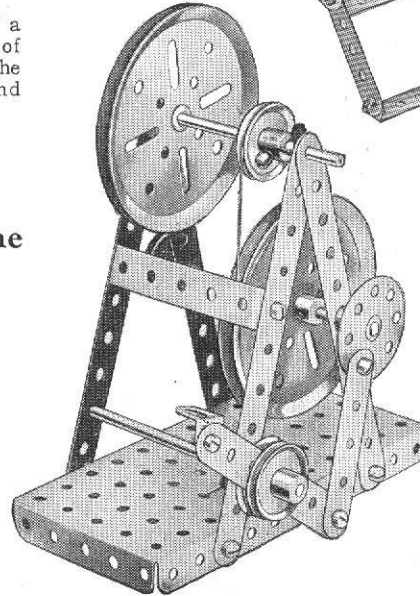

Model No. 1.141
Quick-Delivery Chute

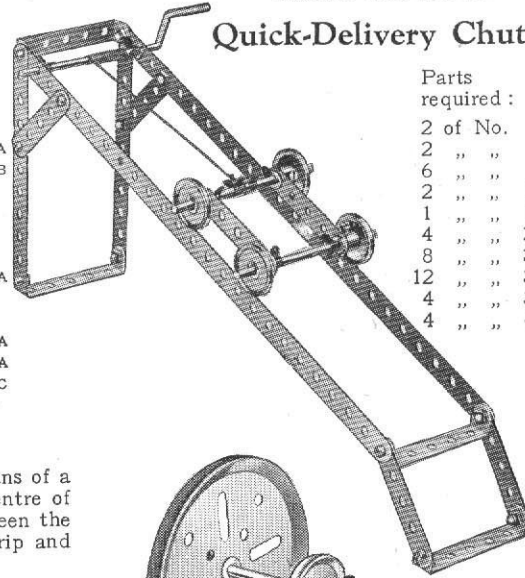

Parts required:

2 of No. 1	
2 " " 2	
6 " " 5	
2 " " 16	
1 " " 19s	
4 " " 22	
8 " " 35	
12 " " 37	
4 " " 38	
4 " " 48A	

Model No. 1.143
Mechanical Gong

A Flat Bracket is connected pivotally to the base at 2 and is clamped rigidly to a 1" Pulley Wheel secured to the Rod 4. The latter passes through the 1 1/2" Double Angle Strip 3 and carries at its upper end another Pulley to which is rigidly secured the striking arm 5. The Double Angle Strip 3 is pivoted to the Bush Wheel 1.

Parts required:

2 of No. 1	
4 " " 2	
1 " " 3	
4 " " 5	
2 " " 10	
1 " " 12	
1 " " 16	
1 " " 19s	
2 " " 22	
1 " " 24	
2 " " 35	
26 " " 37	
1 " " 37A	
2 " " 38	
1 " " 48	
2 " " 48A	
1 " " 52	
2 " " 54	
1 " " 126	
1 " " 126A	

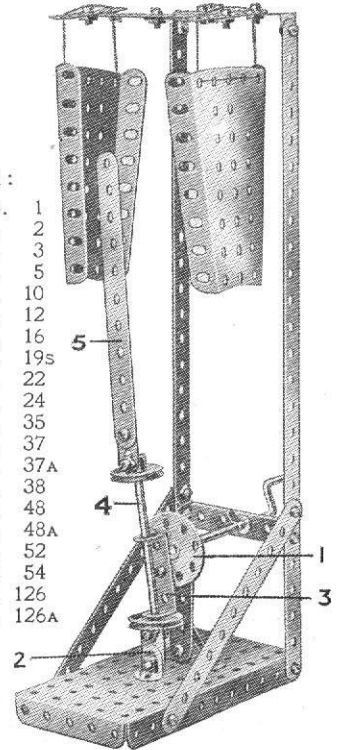

Model No. 1.144 Pile Driver

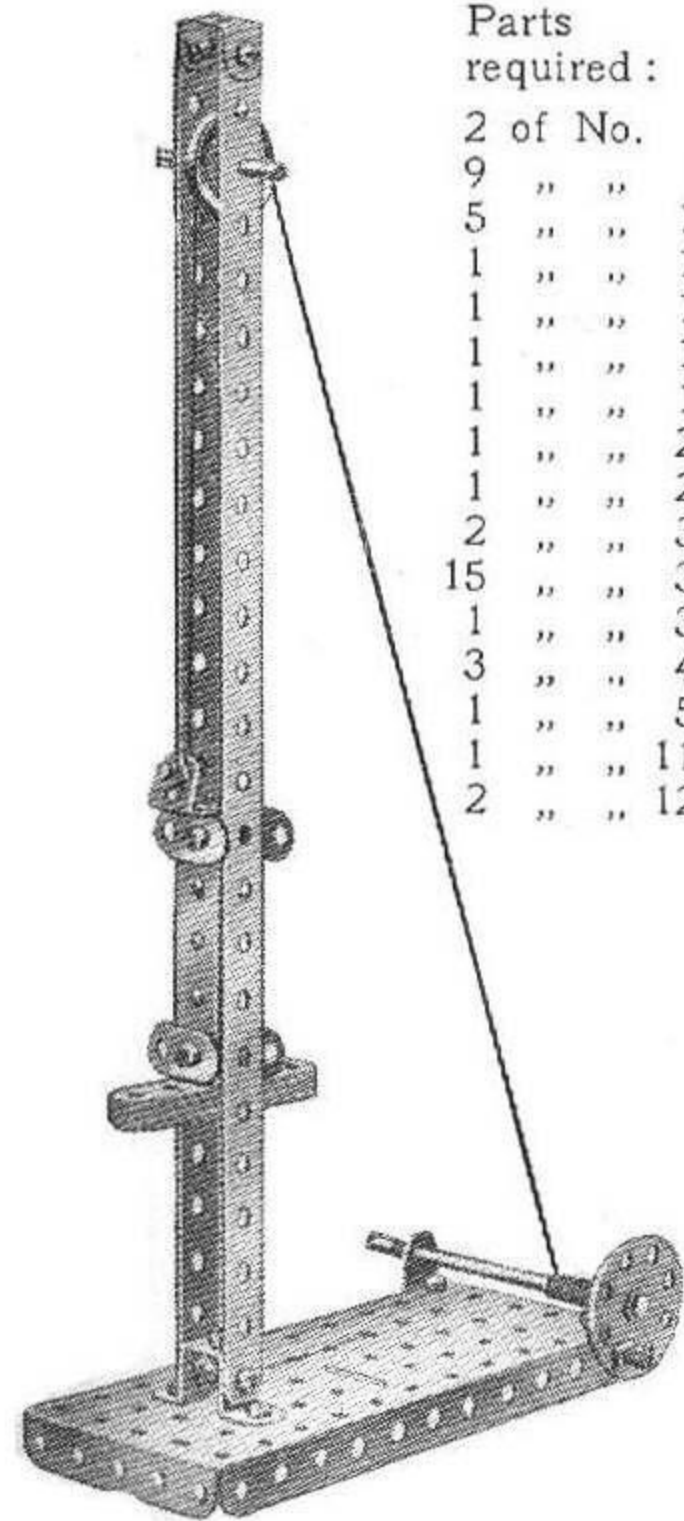

Parts required:

2 of No.	1
9 " "	5
5 " "	10
1 " "	11
1 " "	12
1 " "	16
1 " "	17
1 " "	22
1 " "	24
2 " "	35
15 " "	37
1 " "	37A
3 " "	48A
1 " "	52
1 " "	111c
2 " "	125

The winding cord is passed round the Pulley at the top of the model and is fastened to an Angle Bracket that is hooked under the protruding portion of a Flat Bracket bolted to the top of the driving head. When the Angle Bracket reaches the Pulley at the top it is pushed out a little, thus releasing the driving head.

Model No. 1.145 Foot Hammer

Parts required:

6 of No.	2
1 " "	3
9 " "	5
1 " "	12
2 " "	16
4 " "	22
1 " "	24
2 " "	35
15 " "	37
4 " "	37A
2 " "	38
2 " "	48A
1 " "	52
4 " "	90A

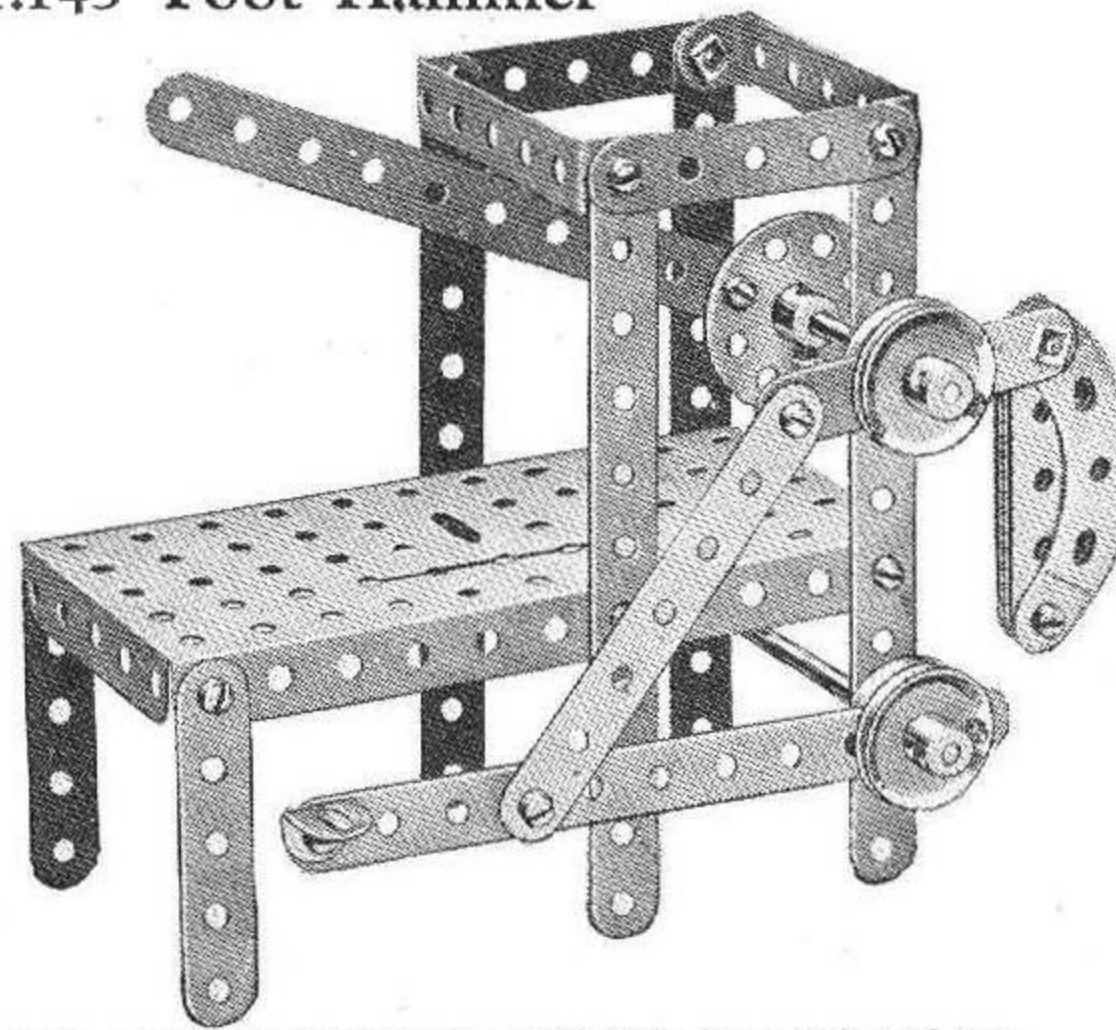

The treadle lever is connected pivotally to a 3½" Strip by a Bolt and two Nuts. The upper end of this Strip 2 is similarly connected to a 2½" Strip that is clamped tightly between two Pulleys on the hammer Rod 4. Pressure on the treadle causes the hammer to descend on the work. When the treadle is released a weight pulls the hammer back to its original position.

Model No. 1.146 Heavy Duty Scales

The five Bolts 1 act as pivots and are secured each by two Nuts (see Standard Mechanism No. 262).

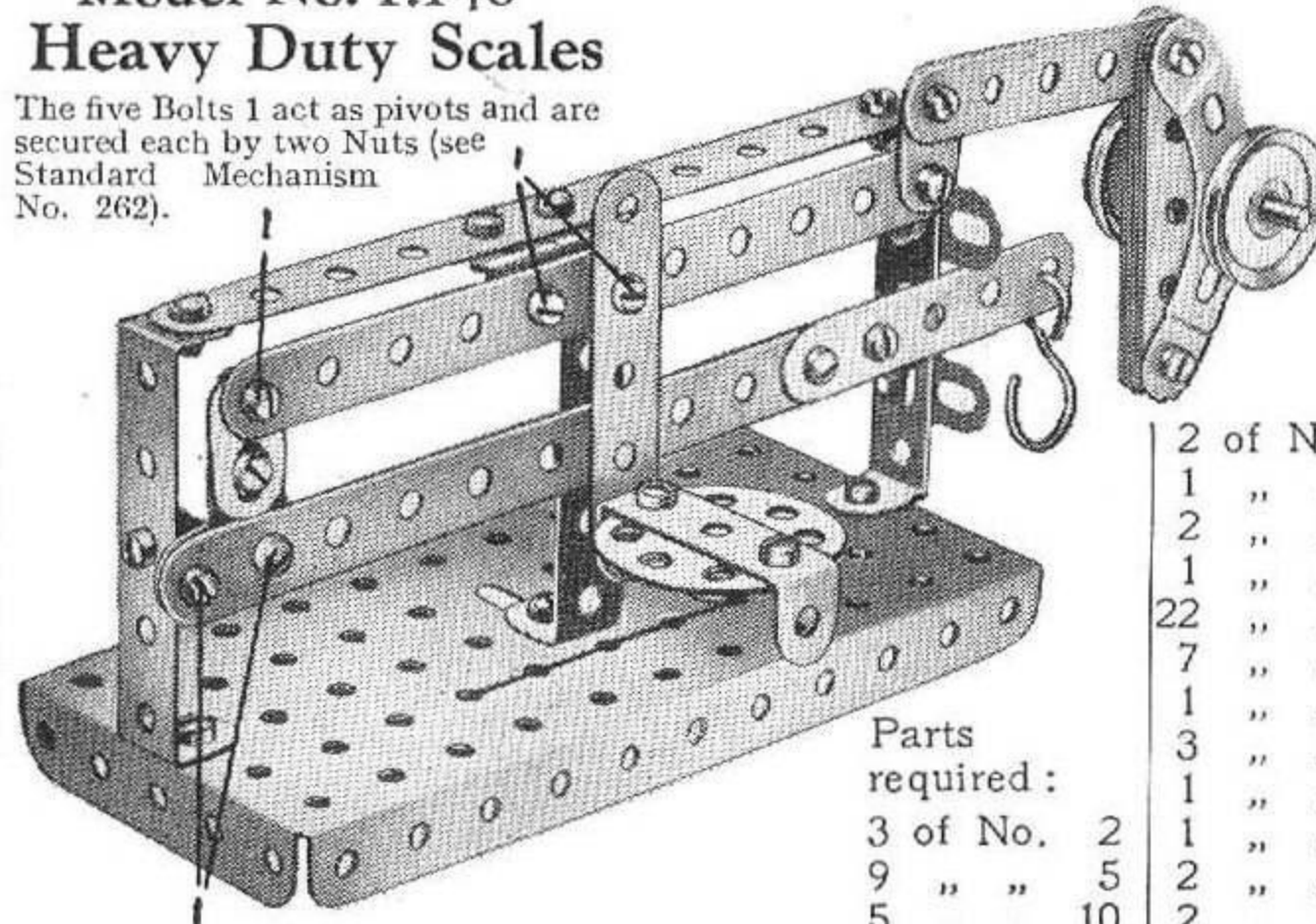

Parts required:

2 of No.	12		
1 " "	18A		
2 " "	22		
1 " "	24		
22 " "	37		
7 " "	37A		
1 " "	48		
3 " "	48A		
1 " "	52		
1 " "	57		
3 of No. 2	1 " "	90A	
9 " "	5	2 " "	90A
5 " "	10	2 " "	111c

Model No. 1.147 Horse Rake

Parts required:

2 of No.	2
2 " "	5

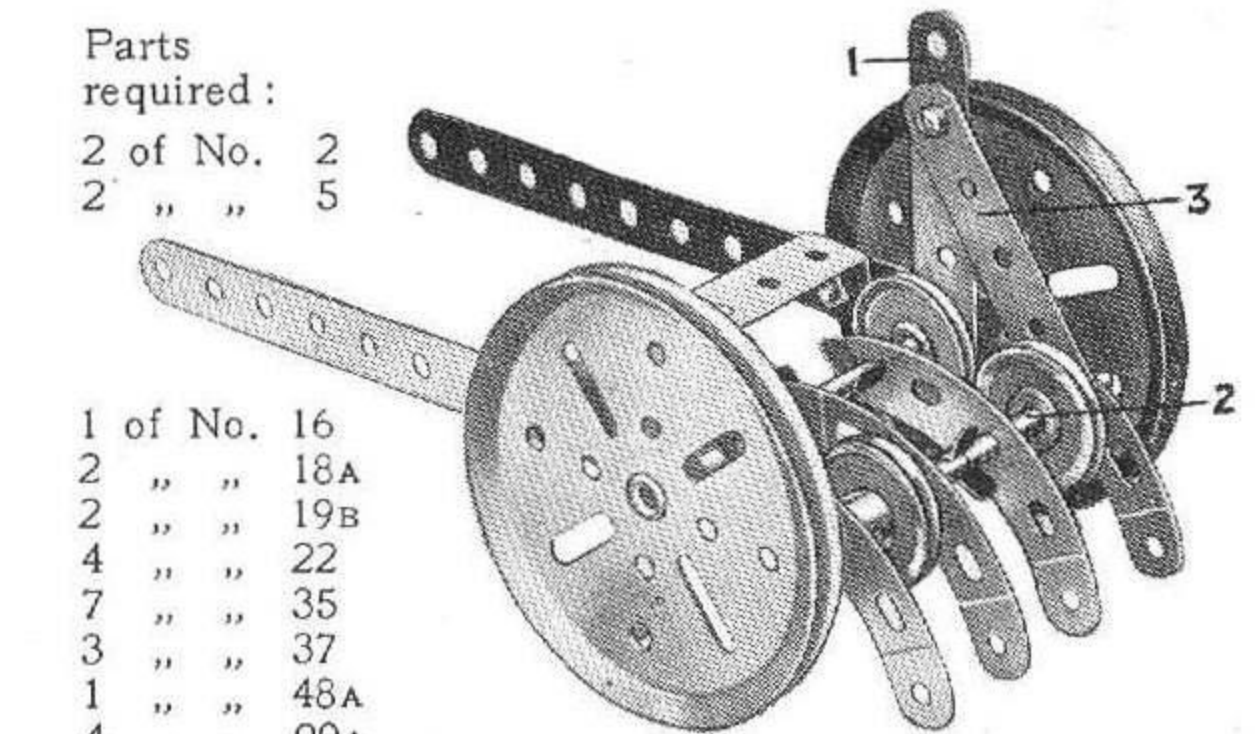

Parts required:

1 of No.	16
2 " "	18A
2 " "	19B
4 " "	22
7 " "	35
3 " "	37
1 " "	48A
4 " "	90A

The 2½" Strip 1 pivots about the wheel axle. A 2½" Strip 3 is connected by a Bolt and two Nuts to the Strip 1 and the Rod 2 passes through its other end. On pulling the lever 1 towards the shafts the rake is lifted from the ground.

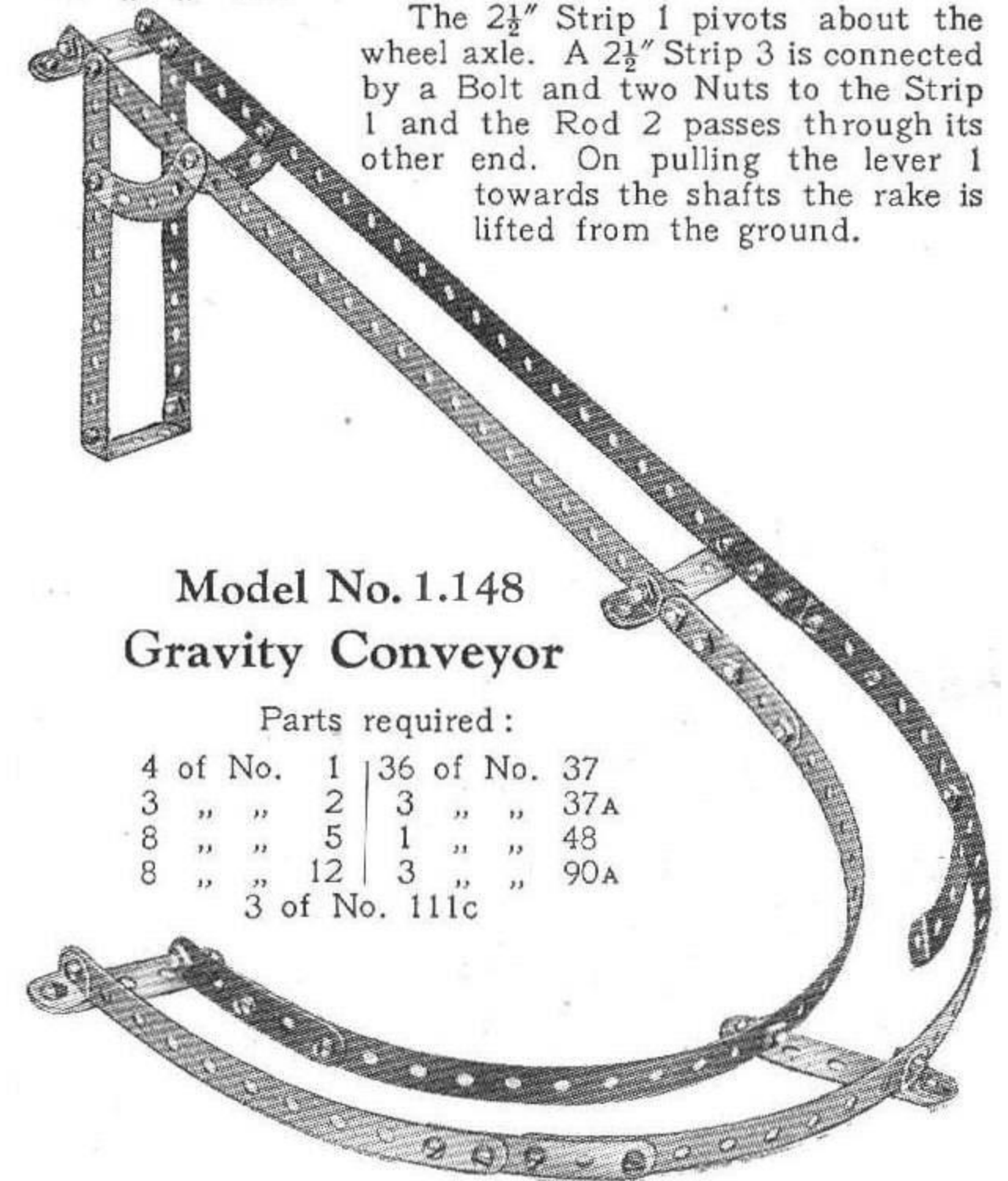

Model No. 1.148 Gravity Conveyor

Parts required:

4 of No.	1	36 of No.	37
3 " "	2	3 " "	37A
8 " "	5	1 " "	48
8 " "	12	3 " "	90A
		3 of No.	111c

These Models can be built with MECCANO Outfit No. 1 (or No. 0 and No. 0A)

Model No. 1.149 Boy on Swing

Parts required:

4 of No.	1	1 of No.	24
6 "	"	2 "	"
2 "	"	5 "	35
5 "	"	10 "	37
8 "	"	1 "	48A
2 "	"	12 "	52
2 "	"	16 "	54
1 "	"	17 "	125
4 "	"	22 "	126A

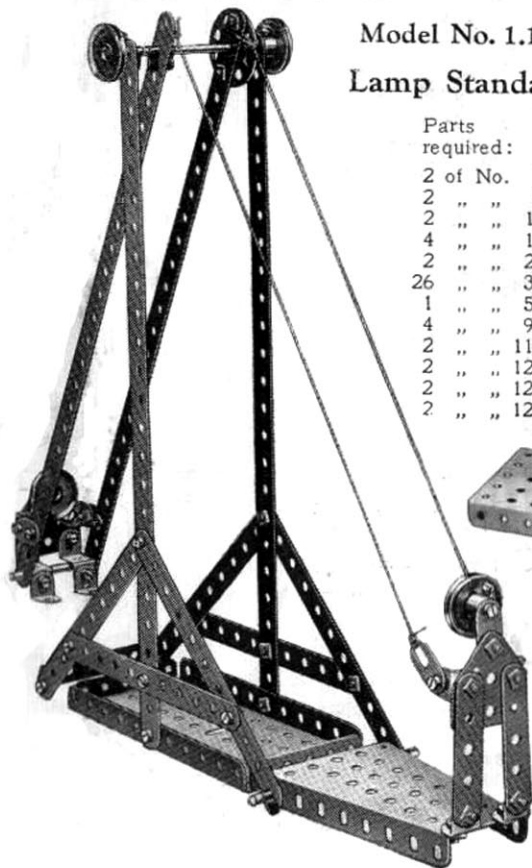

Model No. 1.150 Lamp Standard

Parts required:

2 of No.	1
2 "	2
2 "	11
4 "	12
2 "	22
26 "	37
1 "	52
4 "	90A
2 "	111c
2 "	125
2 "	126
2 "	126A

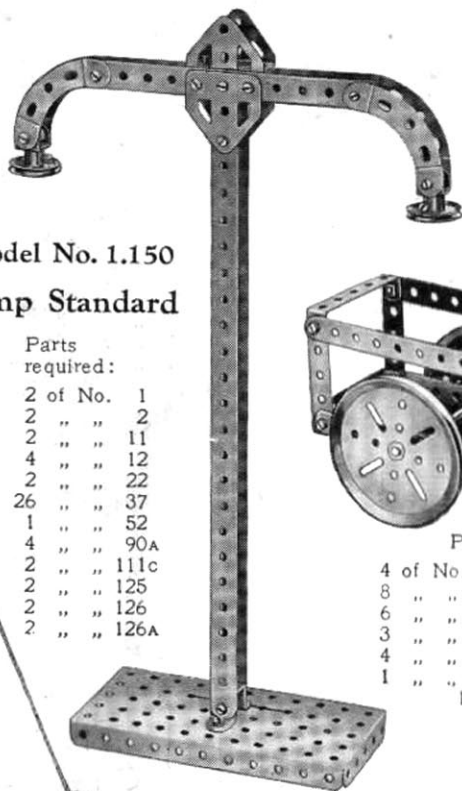

Model No. 1.152 Tower Wagon

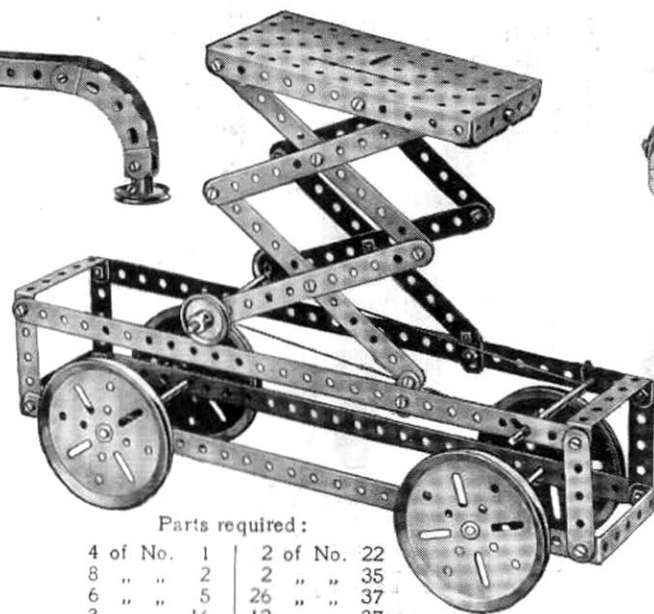

Parts required:

4 of No.	1	2 of No.	22
8 "	"	2 "	35
6 "	"	5 "	37
3 "	"	16 "	37A
4 "	"	19B	40
1 "	"	19s	48A
		1 of No.	52

Model No. 1.151 Bellows

Parts required:

2 of No.	2
1 "	17
9 "	37
4 "	48A
2 "	54

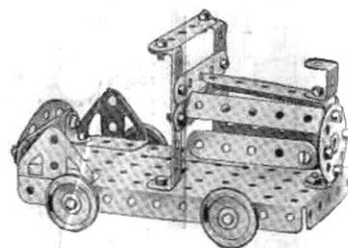
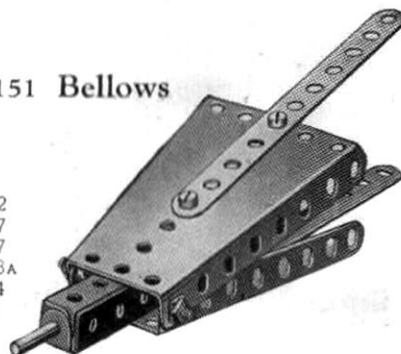

Parts required:

7 of No.	5	1 of No.	24
1 "	11	24 "	37
6 "	12	4 "	48A
2 "	16	1 "	52
4 "	22	1 "	90A
		2 of No.	126A

Model No. 1.154 Chinese Windlass

Parts required:

4 of No.	1
1 "	3
1 "	18A
3 "	19B
1 "	19s
3 "	22
1 "	23
1 "	24
8 "	37
1 "	44
2 "	48A
1 "	52
1 "	57

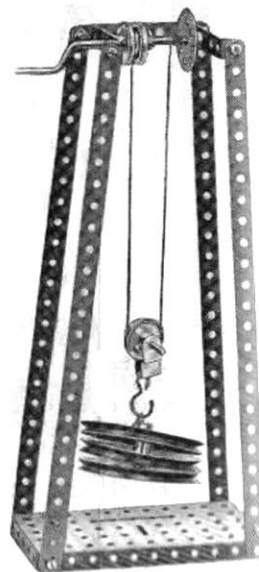

Model No. 1.155 Drilling Machine

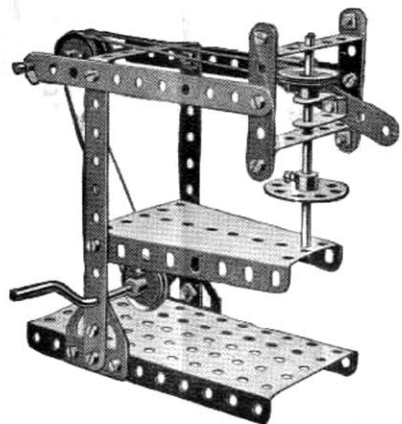

Parts required:

4	of No.	2
3	" "	5
1	" "	11
2	" "	16
1	" "	19 ^s
4	" "	22
1	" "	24
4	" "	35
19	" "	37
1	" "	44
3	" "	48 ^A
1	" "	52
1	" "	54
2	" "	126 ^A

Model No. 1.157 Actuating See-saw

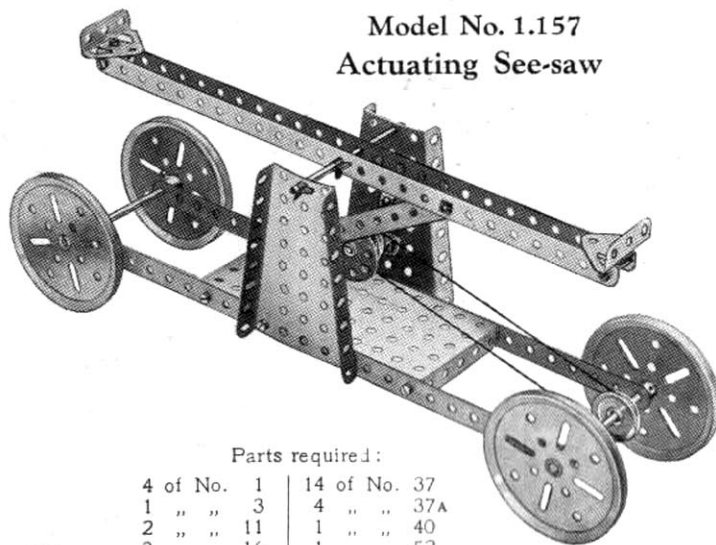

Parts required:

4	of No.	1	14	of No.	37
1	" "	3	4	" "	37 ^A
2	" "	11	1	" "	40
3	" "	16	1	" "	52
1	" "	17	2	" "	54
4	" "	19 ^B	2	" "	111 ^c
2	" "	22	2	" "	125
1	" "	24	2	" "	126
5	" "	35			

Model No. 1.158 Telescopic Mast

Parts required:

4	of No.	1
5	" "	5
2	" "	11
6	" "	12
1	" "	18 ^A
1	" "	22
4	" "	35
16	" "	37
1	" "	52
2	" "	126 ^A

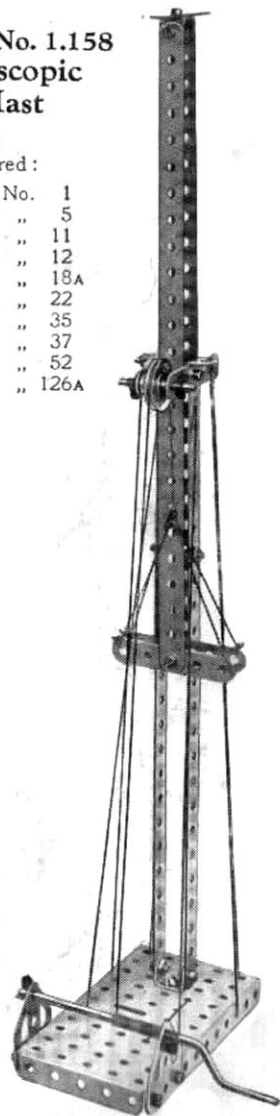

Model No. 1.156 Mechanical Shovel

Parts required:

4	of No.	1	1	of No.	38
6	" "	2	1	" "	48
5	" "	5	6	" "	48 ^A
2	" "	11	1	" "	52
3	" "	16	2	" "	54
1	" "	18 ^A	1	" "	126 ^A
1	" "	19 ^B			
1	" "	19 ^s			
4	" "	22			
1	" "	23			
1	" "	24			
6	" "	35			
35	" "	37			
1	" "	37 ^A			

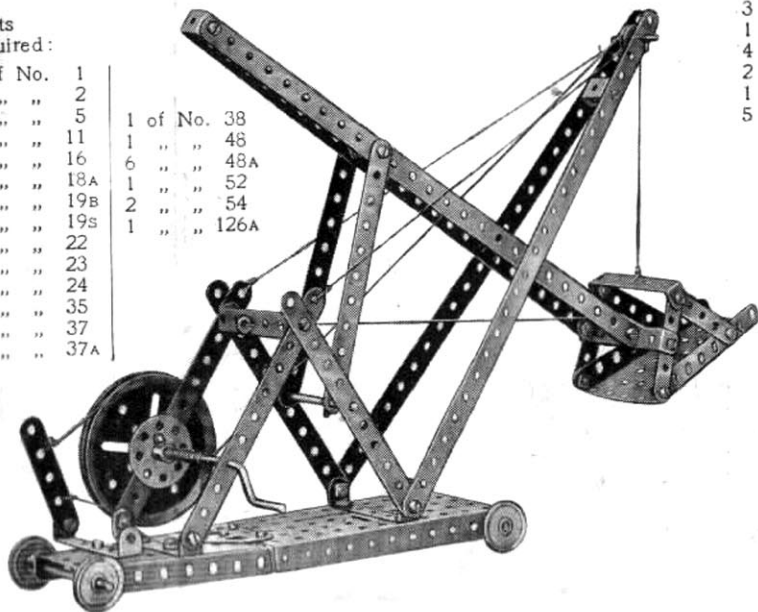

Model No. 1.159 Bagatelle Table

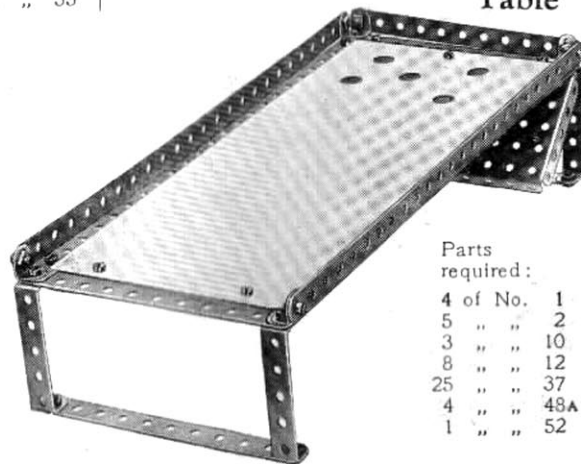

Parts required:

4	of No.	1
5	" "	2
3	" "	10
8	" "	12
25	" "	37
4	" "	48 ^A
1	" "	52

These Models can be built with MECCANO Outfit No. 1 (or No. 0 and No. 0A)

Model No. 1.160 Man Climbing Pole

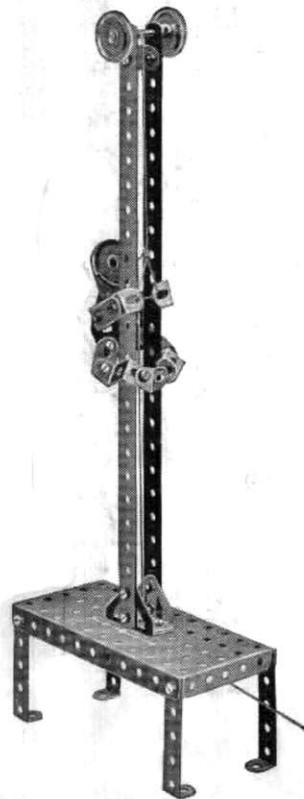

Parts required:	
2 of No. 1	26 of No. 37
5 " " 10	4 " " 48A
1 " " 11	1 " " 52
6 " " 12	2 " " 125
1 " " 18A	2 " " 126
3 " " 22	1 " " 126A

Model No. 1.161 Submarine

Parts required:

3 of No. 1	6 of No. 48A
2 " " 5	1 " " 52
2 " " 11	2 " " 54
2 " " 12	2 " " 125
2 " " 16	2 " " 126A
1 " " 19s	
4 " " 22	
1 " " 24	
3 " " 35	
25 " " 37	

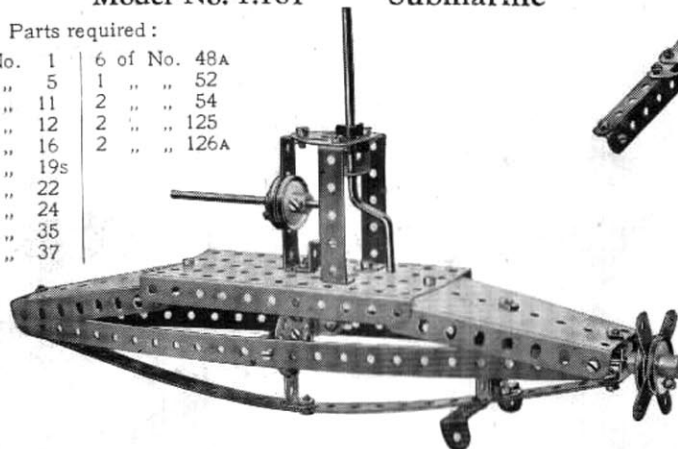

Model No. 1.163 Large Rake

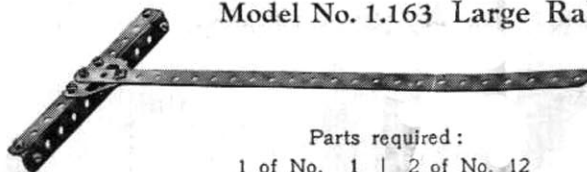

Parts required:

1 of No. 1	2 of No. 12
2 " " 2	8 " " 37
1 of No. 126A	

Model No. 1.164 Jib Crane

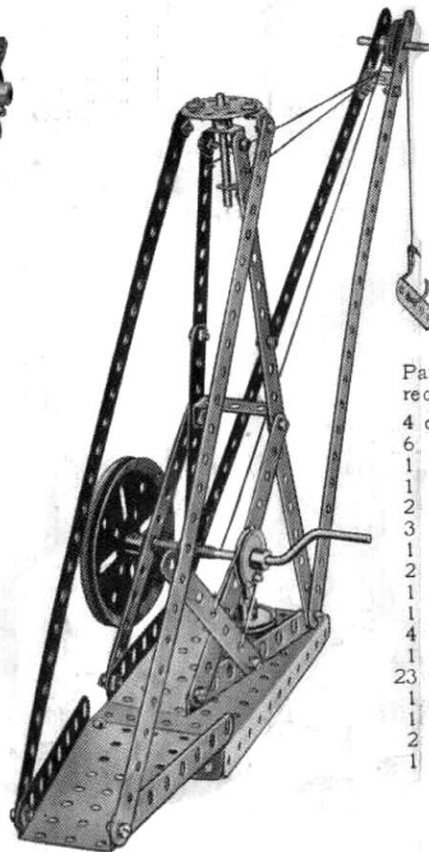

Parts required:

4 of No. 1	1
6 " " 2	2
1 " " 3	3
1 " " 5	5
2 " " 11	11
3 " " 12	12
1 " " 16	16
2 " " 17	17
1 " " 19B	19B
1 " " 19s	19s
4 " " 22	22
1 " " 24	24
23 " " 37	37
1 " " 48	48
1 " " 52	52
2 " " 54	54
1 " " 57	57

Model No. 1.162 Centrifugal Governor

The 3" Pulley Wheel is bolted to the 5½" × 2½" Flanged Plate as shown, and the Rod 6 is free to rotate in its boss. The Bolts 1, 2, 3, are provided with lock-nuts. When the engine to which the governor is attached works at too great a speed, the 1" fast Pulley Wheels 4 fly outward and lift the two Double Brackets 5. In actual practice this movement is utilised to close the engine valves and so reduce speed.

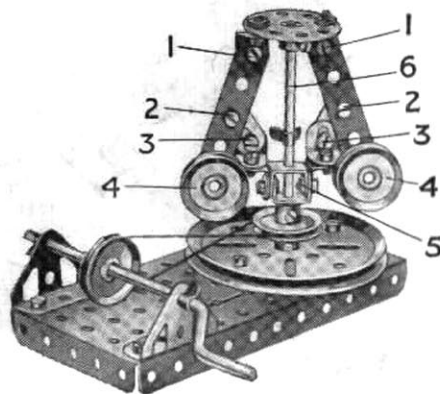

Parts required:

2 of No. 5	5
2 " " 10	10
2 " " 11	11
6 " " 12	12
1 " " 16	16
1 " " 19B	19B
1 " " 19s	19s
4 " " 22	22
1 " " 24	24
3 " " 35	35
18 " " 37	37
6 " " 37A	37A
2 " " 111c	111c
2 " " 126	126

Model No. 1.165 Extended Ash Tip

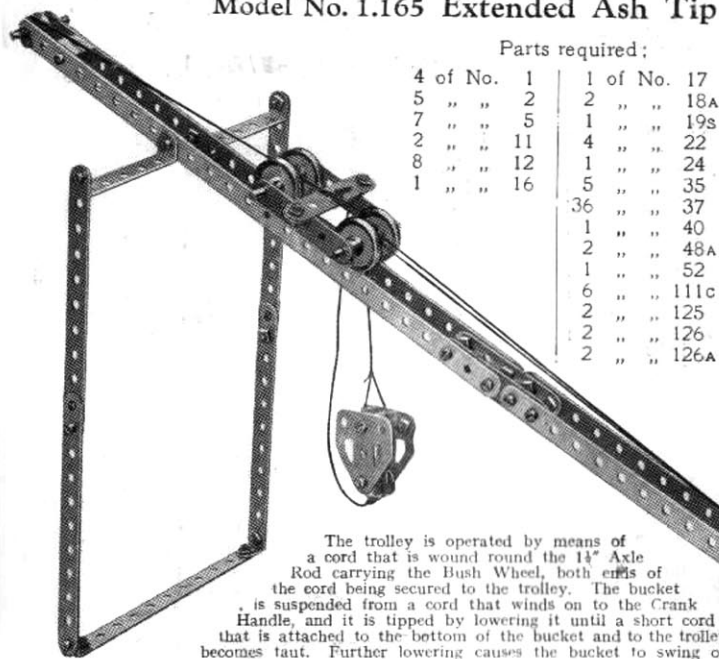

Parts required:

4 of No.	1	1 of No.	17
5 "	2	2 "	18A
7 "	5	1 "	19s
2 "	11	4 "	22
8 "	12	1 "	24
1 "	16	5 "	35
		36	37
		1 "	40
		2 "	48A
		1 "	52
		6 "	111c
		2 "	125
		2 "	126
		2 "	126A

The trolley is operated by means of a cord that is wound round the 14" Axle Rod carrying the Bush Wheel, both ends of the cord being secured to the trolley. The bucket is suspended from a cord that winds on to the Crank Handle, and it is tipped by lowering it until a short cord that is attached to the bottom of the bucket and to the trolley, becomes taut. Further lowering causes the bucket to swing over.

Model No. 1.167 Motor Tractor

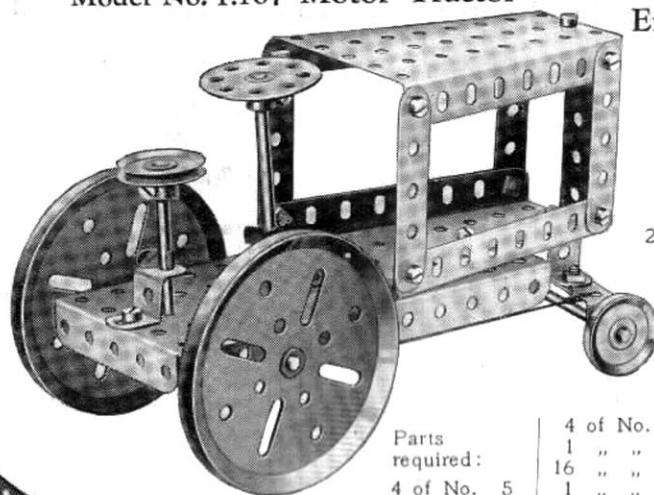

Parts required:

4 of No.	5	4 of No.	22
1 "	11	1 "	24
3 "	16	16 "	37
1 "	17	1 "	37A
2 "	19B	2 "	48A
		1 "	52
		2 "	54
		2 "	125

Model No. 1.168 Eiffel Tower

Parts required:

4 of No.	1
2 "	2
8 "	5
2 "	11
8 "	12
1 "	22
22 "	37
1 "	40
1 "	111c

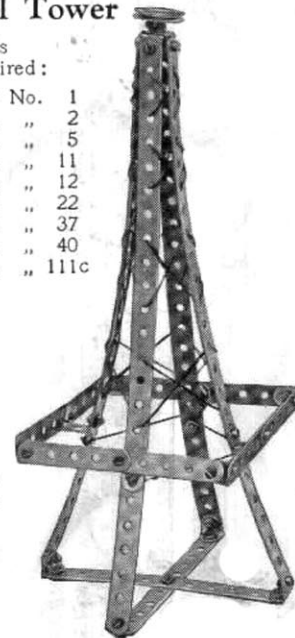

Model No. 1.166 Stone-Sawing Machine

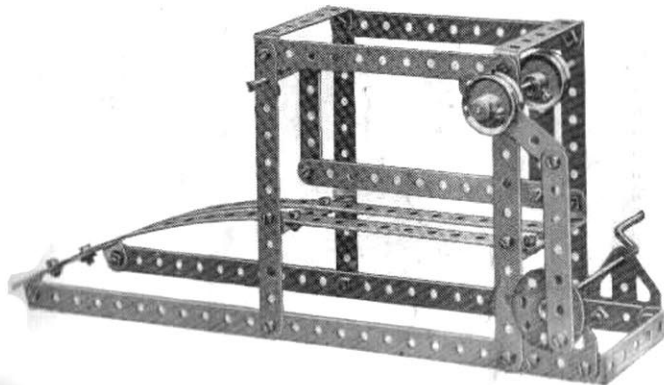

Parts required:

4 of No.	1
7 "	2
1 "	3
3 "	5
2 "	16
1 "	19s
4 "	22
1 "	24
6 "	35
28 "	37
2 "	37A
1 "	48A
2 "	126A

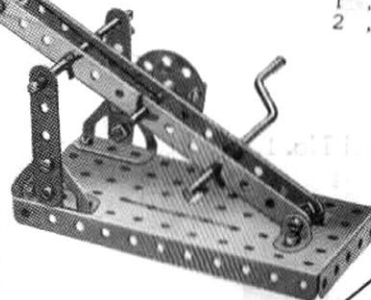

Model No. 1.169 Battleship

Parts required:

2 of No.	1	1 of No.	11
4 "	2	8 "	12
5 "	10	2 "	22
		26 "	37
		1 "	40
		2 "	48A
		6 "	111c
		2 "	125

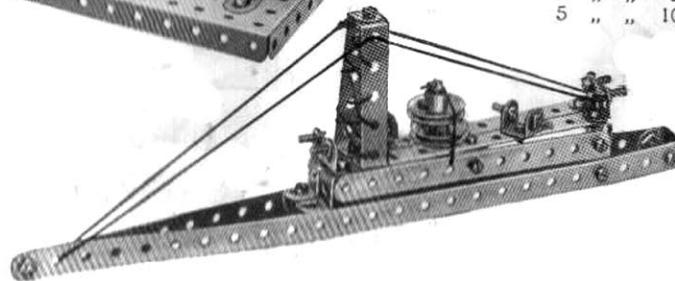

These Models can be built with MECCANO Outfit No. 1 (or No. 0 and No. 0A)

Model No. 1.170 Electric Elevator

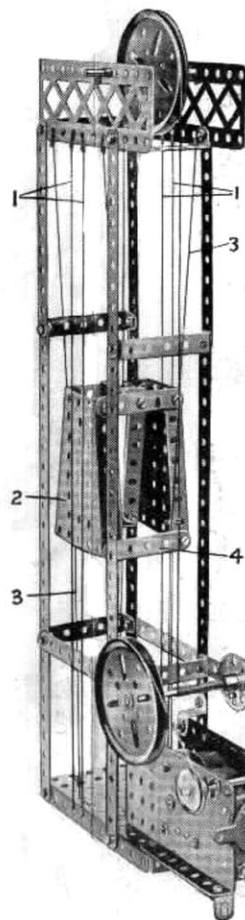

Two pairs of cords 1 are stretched tightly on each side of the lift shaft to guide the cage 2 and two other cords 3 are secured at the top and bottom of the shaft and passed behind $2\frac{1}{2}$ " Strips 4 bolted to the cage. The drive from the motor is transmitted to the 3" Pulley Wheel 5 by means of a cord passed round a $\frac{1}{2}$ " Pulley on the motor armature.

Parts required:

4 of No. 1	3 of No. 35
6 " " 2	34 " " 37
4 " " 5	1 " " 38
2 " " 12	1 " " 48
3 " " 16	6 " " 48A
3 " " 19B	1 " " 52
4 " " 22	2 " " 54
1 " " 24	2 " " 100

2 of No. 125

Electric Motor
(not included in Outfit)

Model No. 1.171 Mounted Cowboy

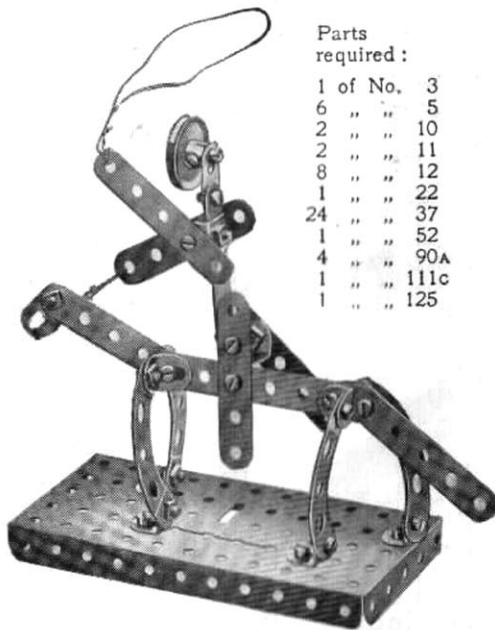

Parts required:

1 of No. 3	
6 " " 5	
2 " " 10	
2 " " 11	
8 " " 12	
1 " " 22	
24 " " 37	
1 " " 52	
4 " " 90A	
1 " " 111c	
1 " " 125	

Parts required:

2 of No. 5	
1 " " 19s	
1 " " 24	
1 " " 35	
8 " " 37	
1 " " 37A	
1 " " 52	
2 " " 54	
1 " " 111c	

Model No. 1.173 Safety Catch for Winding Gear

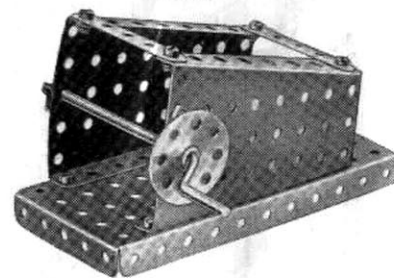

The hoisting cord of a crane, etc. may be wound on the shaft of the Crank Handle. To lock the handle in position, the Bush Wheel should be pushed inward so that one of its holes engages with the shank of a $\frac{3}{8}$ " Bolt projecting from the Sector Plate.

Model No. 1.174 Master and Student

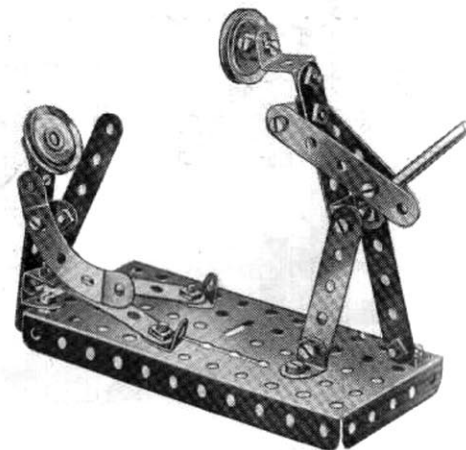

Model No. 1.172 Howitzer

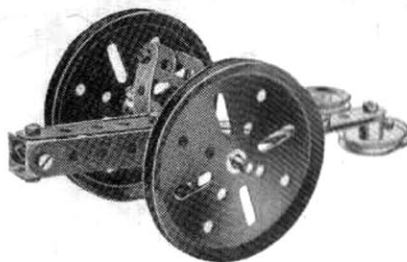

Parts required:

2 of No. 2	
6 " " 5	
4 " " 10	
2 " " 11	
4 " " 12	
1 " " 16	
2 " " 19B	
2 " " 22	
2 " " 35	
14 " " 37	
2 " " 38	
2 " " 111c	
2 " " 125	

Parts required:

9 of No. 5	
1 " " 10	
2 " " 11	
8 " " 12	
2 " " 22	
20 " " 37	
3 " " 37A	
1 " " 52	
1 " " 90A	
4 " " 111c	
1 " " 125	

**Model No. 1.175
Windmill Pump**

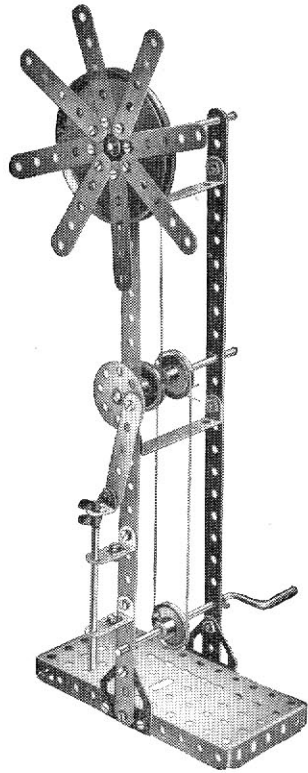

Parts required :

2 of No.	2
2 " "	5
4 " "	10
2 " "	16
1 " "	18A
4 " "	19B
1 " "	22
1 " "	24
22 " "	37
2 " "	37A

Model No. 1.176 Coaster

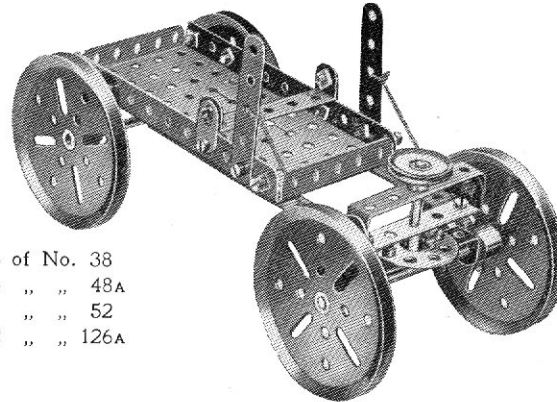

6 of No.	38
4 " "	48A
1 " "	52
2 " "	126A

**Model No. 1.178
Swivelling Crane**

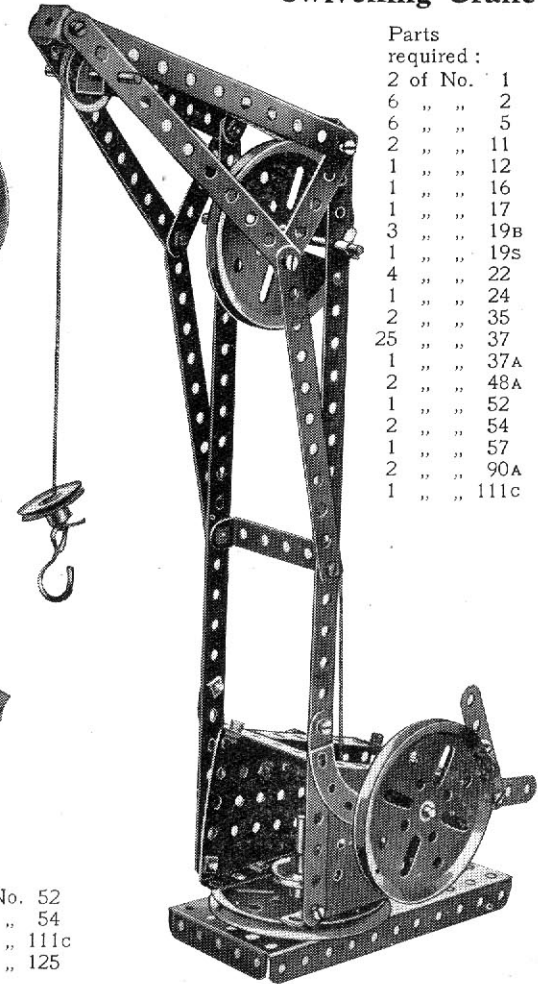

Parts required :

2 of No.	1
6 " "	2
6 " "	5
2 " "	11
1 " "	12
1 " "	16
1 " "	17
3 " "	19B
1 " "	19S
4 " "	22
1 " "	24
2 " "	35
37 " "	37
1 " "	37A
2 " "	48A
1 " "	52
2 " "	54
1 " "	57
2 " "	90A
1 " "	111c

Model No. 1.177 Racing Motor Car

The steering column 1 is journalled in an angle bracket 2 bolted to the $5\frac{1}{2} \times 2\frac{1}{2}$ " flanged plate 3, and in the second hole of the $2\frac{1}{2} \times \frac{1}{2}$ " double angle strip 4. A bush wheel 5, secured to the lower end of the steering column, is connected by two short lengths of cord to a second $2\frac{1}{2} \times \frac{1}{2}$ " double angle strip carrying the front axle. The strip is pivoted to a similar double angle strip 6 by means of a bolt and nuts (Standard Mechanism No. 262).

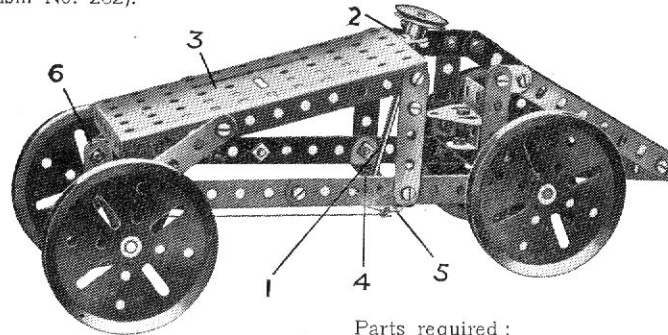

Parts required :

4 of No.	2	3 of No.	16	25 of No.	37	1 of No.	52
7 " "	5	4 " "	19B	2 " "	37A	2 " "	54
1 " "	10	1 " "	22	4 " "	38	1 " "	111c
1 " "	11	1 " "	24	4 " "	48A	1 " "	125
				1 of No.	126		

Parts required :

2 of No.	1	1 of No.	24
9 " "	5	4 " "	35
2 " "	10	24 " "	37
3 " "	12	4 " "	37A
3 " "	16	2 " "	48A
1 " "	19B	1 " "	52
1 " "	19S	2 " "	111c
4 " "	22	2 " "	126A

Model No. 1.179 Elevated Crane

Parts required :

2 of No.	1	1 of No.	52
8 "	"	2 "	"
8 "	"	1 "	"
1 "	"	4 "	"
2 "	"	2 "	"
1 "	"	2 "	"
3 "	"		
1 "	"		
4 "	"		
1 "	"		
1 "	"		
3 "	"		
3 "	"		
3 "	"		
4 "	"		

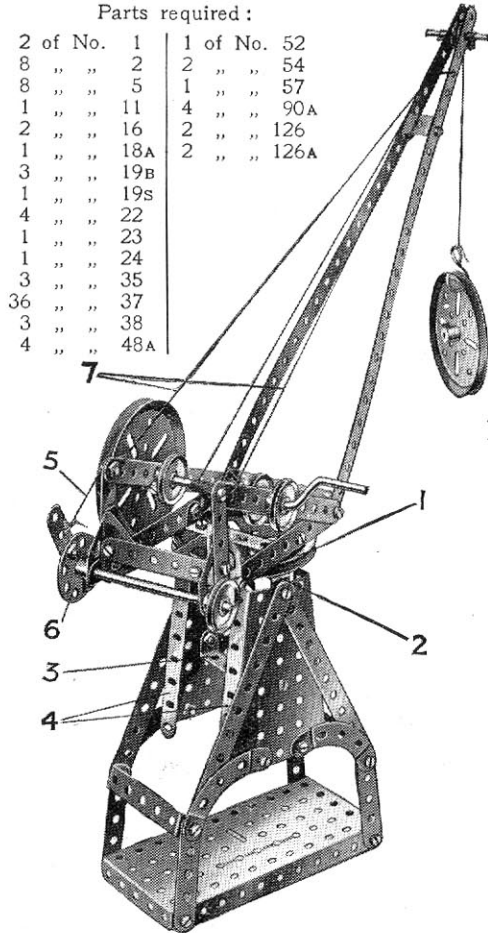

The base of the swivelling portion of the crane consists of a 3" pulley wheel 1, which has a 3" axle rod nipped in its boss. The rod is journalled in two 2 1/2" double angle strips 2 and 3 secured between the sector plates 4. The brake cord 5 passes round the 3" pulley as shown, and is tied to one of the holes in the bush wheel 6. The cords 7 serve merely to support the weight of the jib.

Model No. 1.181 Acrobat on See-Saw

Parts required :

3 of No.	1	3 of No.	22
6 "	"	1 "	"
4 "	"	5 "	"
3 "	"	32 "	"
2 "	"	2 "	"
4 "	"	1 "	"
2 "	"	1 "	"
1 "	"	1 "	"
1 "	"	1 "	"

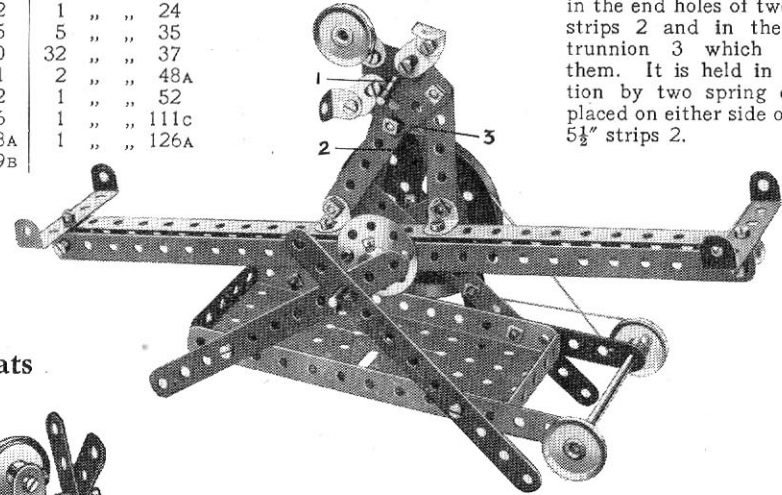

The 1" rod 1 is journalled in the end holes of two 5 1/2" strips 2 and in the flat trunnion 3 which joins them. It is held in position by two spring clips, placed on either side of the 5 1/2" strips 2.

Model No. 1.180 Acrobats

Parts required :

4 of No.	2
6 "	"
4 "	"
4 "	"
1 "	"
1 "	"
4 "	"
1 "	"
3 "	"
24 "	"
5 "	"
6 "	"
1 "	"
2 "	"

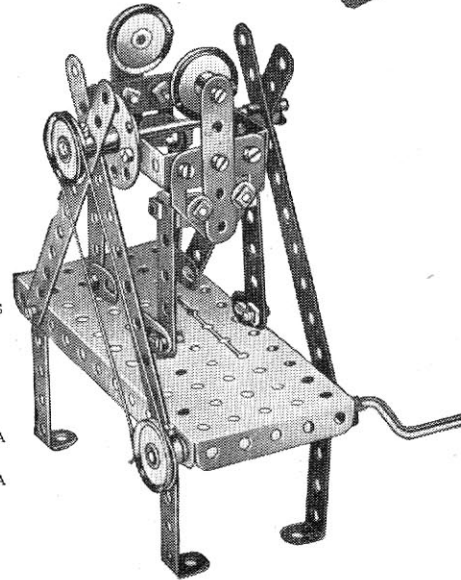
Model No. 1.182
Umpire's Seat

Parts required :

6 of No.	2
7 "	"
2 "	"
4 "	"
24 "	"
3 "	"
2 "	"
2 "	"

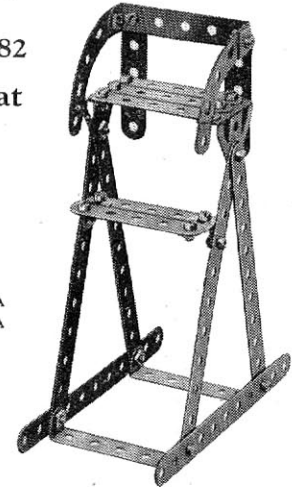

Model No. 1.183 Travelling Crane

Parts required :		
2 of No. 1	1 of No. 24	2 of No. 90A
6 " " 2	4 " " 35	5 " " 111c
1 " " 11	20 " " 37	1 " " 125
3 " " 16	4 " " 37A	2 " " 126
1 " " 18A	1 " " 48	2 " " 126A
2 " " 19B	4 " " 48A	
1 " " 19S	1 " " 52	
4 " " 22	1 " " 57	
1 " " 23		

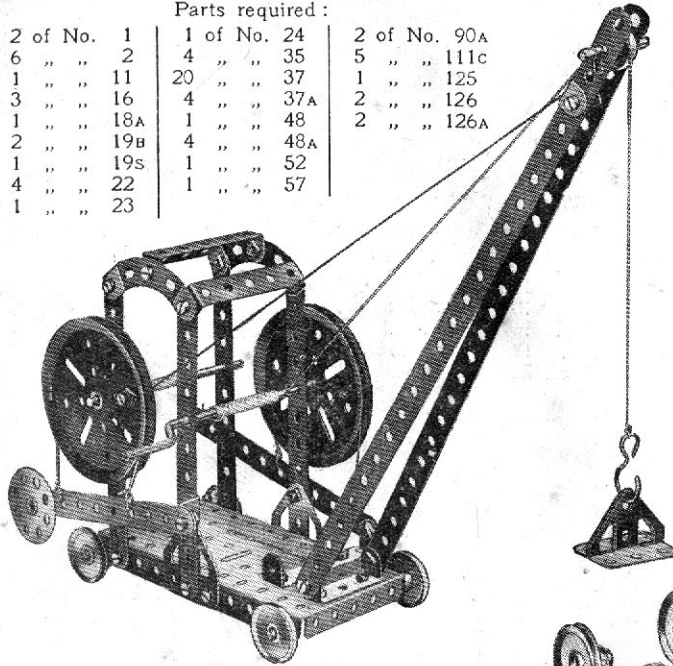

Model No. 1.184 Motor Cyclist and Pillion Rider

Parts required :		
4 of No. 2	4 of No. 22	
9 " " 5	1 " " 24	
4 " " 10	2 " " 35	
2 " " 11	30 " " 37	
8 " " 12	2 " " 48A	
1 " " 16	2 " " 90A	
2 " " 17	2 " " 125	
2 of No. 126A		

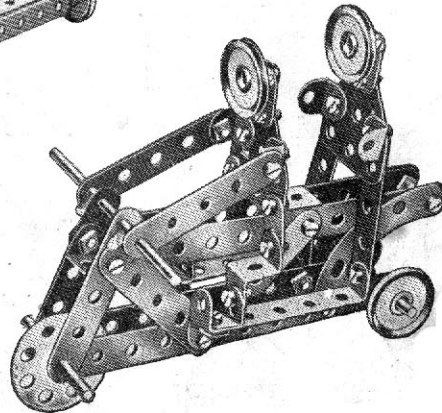

Parts required :	
3 of No. 5	
1 " " 10	
2 " " 12	
2 " " 16	
1 " " 18A	
4 " " 19B	
1 " " 22	
1 " " 24	
15 " " 37	
2 " " 37A	
6 " " 38	
4 " " 48A	
1 " " 52	
1 " " 54	
1 " " 111c	
2 " " 126	
1 " " 126A	

Model No. 1.185 Motor Tractor

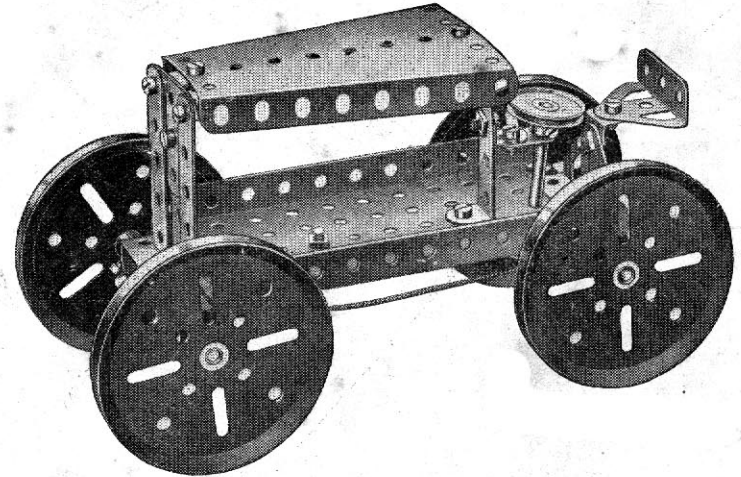

The steering gear is shown in Fig. 1.185A. The front wheels are carried in a $2\frac{1}{2} \times \frac{1}{2}$ " Double Angle Strip 1, which is mounted pivotally by a Bolt and two Nuts (S.M. 262) to a $2\frac{1}{2}$ " Strip 2 secured to the $5\frac{1}{2} \times 2\frac{1}{2}$ " Flanged Plate.

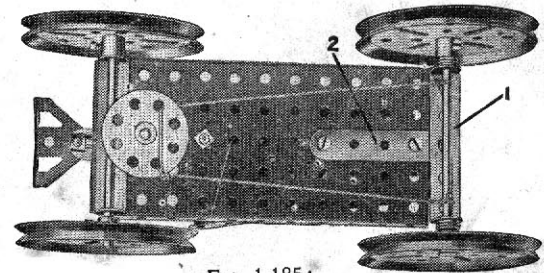
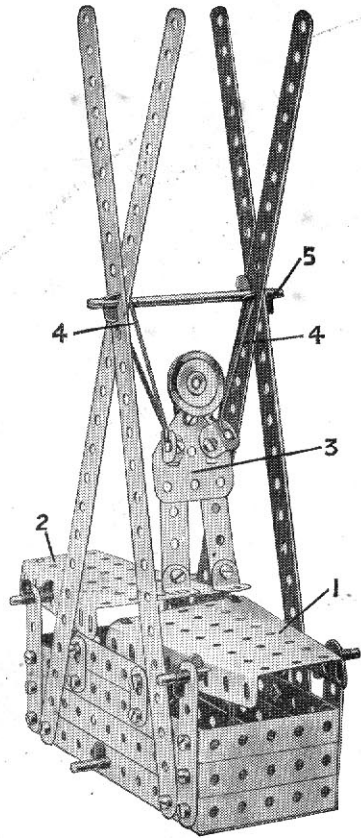

FIG. 1.185A

Model No. 1.186 A Sudden Appearance



The Sector Plate 1, forming the lid, is carried pivotally on an axle rod that passes through its sides three holes from the end, and the rear Sector Plate 2 is pivoted in a similar manner, excepting that the rod in this case passes through the fourth hole from the end. Pieces of thin elastic are tied to the end holes in each side of the front Sector Plate at its widest end, and are connected to the ends of screws at the bottom of the box. The "Meccantian" 3 is placed face downward inside the box with his feet towards the far end of the model. The tension of the elastic holding the lid 1 should be sufficient to keep him in this position. On tilting the Plate 1 slightly, however, he will suddenly shoot out of the box, drawn by the elastic bands 4 connected to the 3 1/2" Axle Rod 5.

Parts required ;

4 of No. 1	14 of No. 35
4 " " 2	29 " " 37
9 " " 5	6 " " 43A
5 " " 10	1 " " 52
4 " " 12	2 " " 54
4 " " 16	1 " " 111c
1 " " 22	1 " " 126A

Model No. 1.187 Bath Chair

Parts required :

4 of No. 2	6 of No. 48A
7 " " 5	1 " " 52
2 " " 16	1 " " 126
1 " " 18A	2 " " 126A
2 " " 19B	
3 " " 22	
24 " " 37	
1 " " 37A	
1 " " 44	

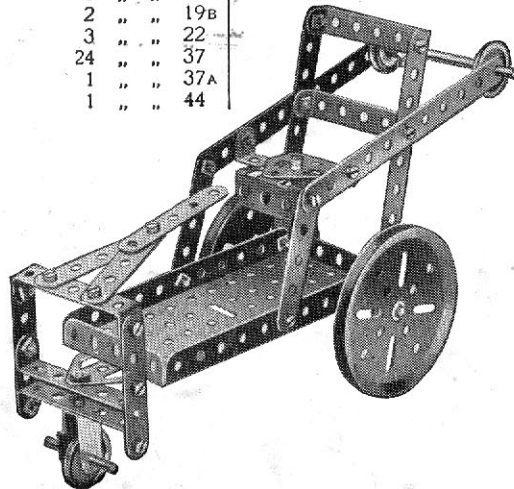

Model No. 1.188 Rat Trap

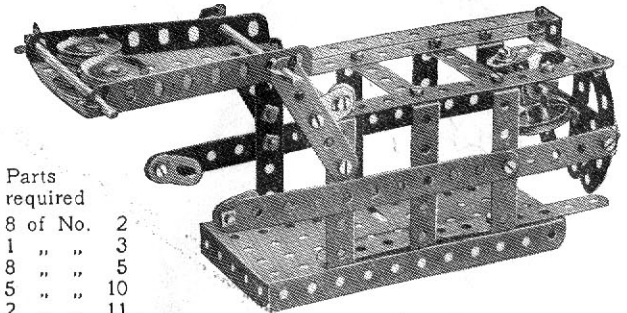

Parts required

8 of No. 2			
1 " " 3			
8 " " 5			
5 " " 10			
2 " " 11			
6 " " 12	1 of No. 23	1 of No. 38	1 of No. 54
2 " " 16	1 " " 24	1 " " 48	1 " " 57
1 " " 17	8 " " 35	6 " " 48A	2 " " 90A
3 " " 22	31 " " 37	1 " " 52	3 " " 111c

The "bait" consists of a 1" fast Pulley and a 1/2" loose Pulley suspended by means of a hook from a Double Bracket. The latter is bolted to a 1 1/2" x 1/2" Double Angle Strip that is free to turn on a 2" Rod journalled in a pair of Angle Brackets. A Flat Bracket bolted to the Double Bracket engages a second Double Bracket on the end of a 5 1/2" Strip that is bolted to the door of the cage. If the "bait" is touched, the heavily-weighted door falls into place, and is prevented from re-opening by catches formed from Flat Brackets secured to 5 1/2" Strips that are bolted to the trap by their extreme ends and act as springs.

Model No. 1.189 Manual Fire Engine

Parts required :

2 of No. 2
2 " " 5
2 " " 11
2 " " 16
2 " " 17
1 " " 18A
4 " " 19B
6 " " 35
12 " " 37
2 " " 38
1 " " 52
2 " " 126

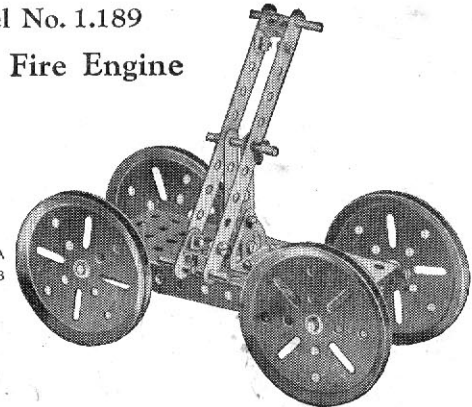

Model No. 1.190 Field Roller

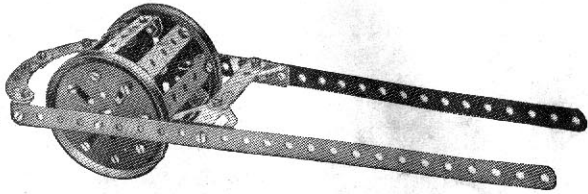

Parts required :

2 of No. 1	1 of No. 16	6 of No. 48A
3 " " 5	2 " " 19B	2 " " 90A
6 " " 12	30 " " 37	2 " " 126

Model No. 1.191

Dignity and Impudence

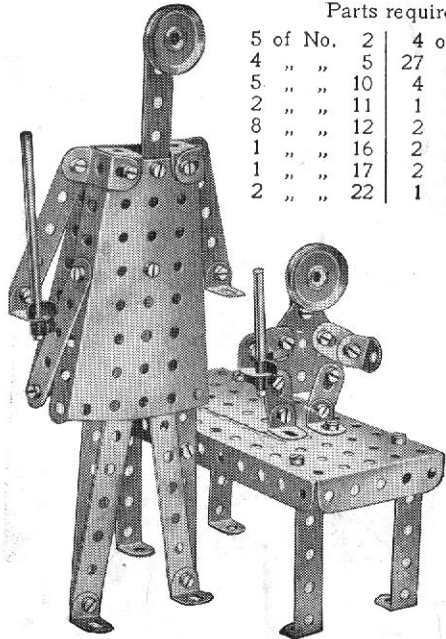

Parts required :

5 of No. 2	4 of No. 35
4 " " 5	27 " " 37
5 " " 10	4 " " 48A
2 " " 11	1 " " 52
8 " " 12	2 " " 54
1 " " 16	2 " " 111c
1 " " 17	2 " " 125
2 " " 22	1 " " 126A

Model No. 1.192
Disappearing Meccanitian

Parts required :

6 of No. 2	23 of No. 37
6 " " 5	1 " " 44
1 " " 10	6 " " 48A
4 " " 12	1 " " 52
2 " " 16	2 " " 54
1 " " 22	1 " " 111c
6 " " 35	1 " " 126A

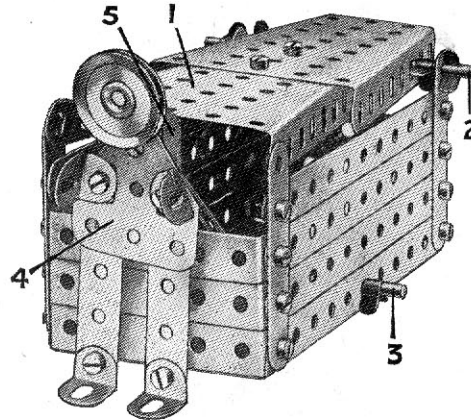

The bottom of the box-like portion of the model consists of a $5\frac{1}{2} \times 2\frac{1}{2}$ " Flanged Plate ; three $5\frac{1}{2}$ " Strips bolted to upright $2\frac{1}{2}$ " Strips form each side and each end consists of three $2\frac{1}{2} \times \frac{1}{2}$ " Double Angle Strips. The lid 1, which is mounted pivotally on an Axle Rod 2, consists of two Sector Plates bolted together. Elastic bands are tied to the sides of these Plates and connected to Rod 3 passed through the bottom of the box. The "Meccanitian" 4 also is connected to this Rod by pieces of elastic. On pressing the end of the rear Sector Plate the lid opens sufficiently to allow the figure to be drawn inside and then snaps back into place. A Cranked Bent Strip 5 is bolted at the back of the figure and rests against the edge of the Sector Plate.

Model No. 1.193 Elevator

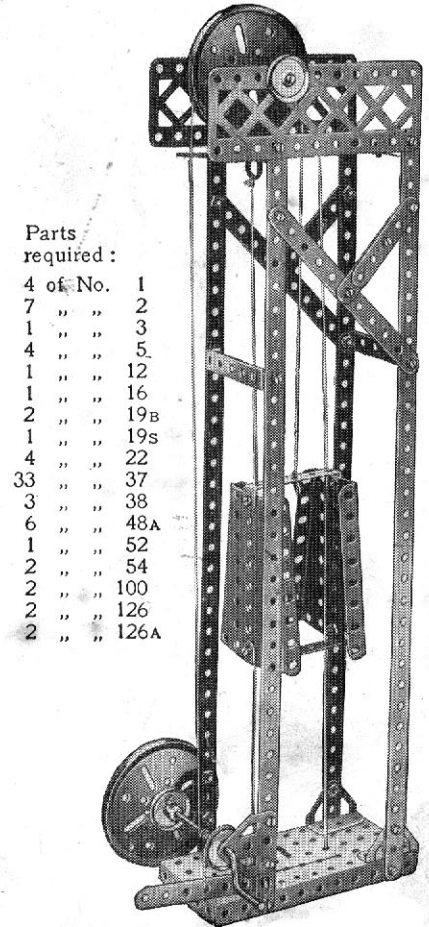

Parts required :

4 of No. 1
7 " " 2
1 " " 3
4 " " 5
1 " " 12
1 " " 16
2 " " 19B
1 " " 19S
4 " " 22
33 " " 37
3 " " 38
6 " " 48A
1 " " 52
2 " " 54
2 " " 100
2 " " 126
2 " " 126A

Model No. 1.194 Sawing Machine

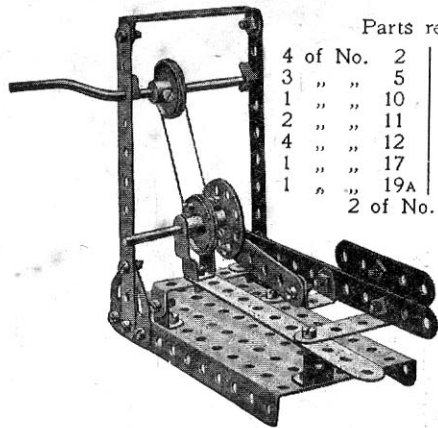

Parts required :

4 of No. 2	2 of No. 22
3 " " 5	1 " " 24
1 " " 10	2 " " 35
2 " " 11	22 " " 37
4 " " 12	1 " " 44
1 " " 17	2 " " 48A
1 " " 19A	1 " " 52
2 of No. 126A	

Parts required.

4 of No. 2
6 " " 5
1 " " 10
6 " " 12
2 " " 16
4 " " 22
1 " " 23
20 " " 37
2 " " 48A
1 " " 52
1 " " 54
1 " " 111c

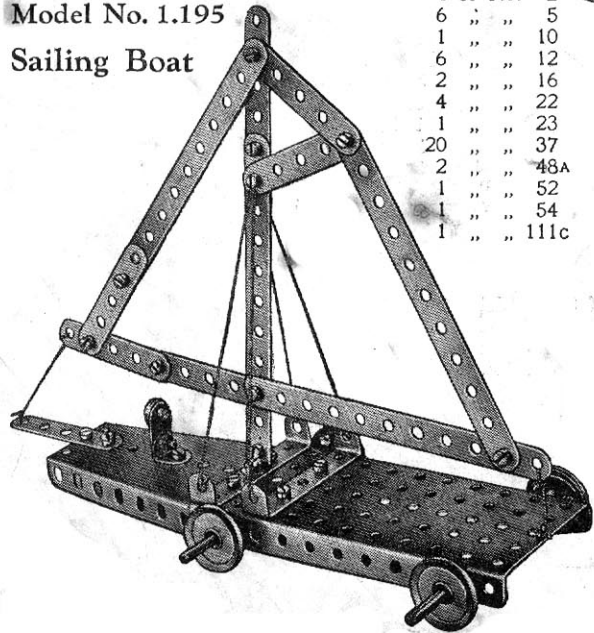
Model No. 1.195
Sailing Boat

Model No. 1.196 Rotating Crane

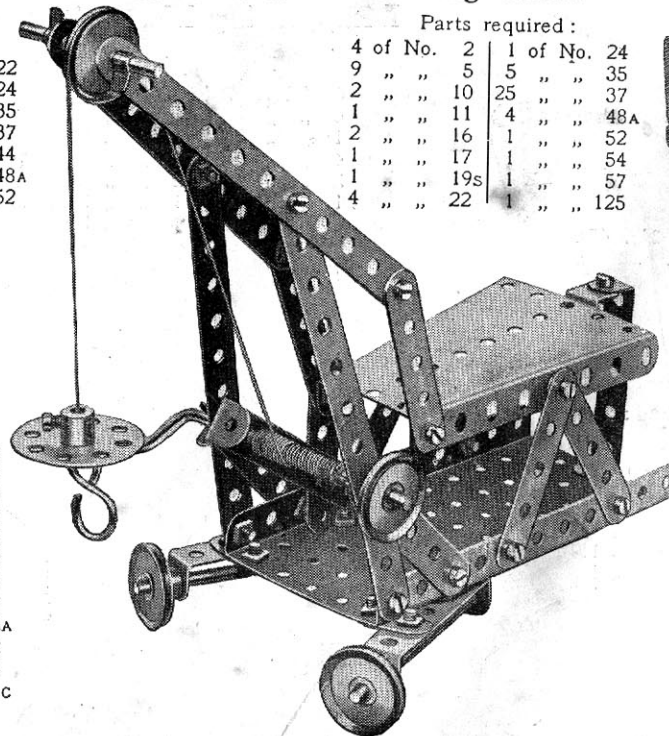

Parts required :

4 of No. 2	1 of No. 24
9 " " 5	5 " " 35
2 " " 10	25 " " 37
1 " " 11	4 " " 48A
2 " " 16	1 " " 52
1 " " 17	1 " " 54
1 " " 19s	1 " " 57
4 " " 22	1 " " 125

Model No. 1.197 Motor Lorry

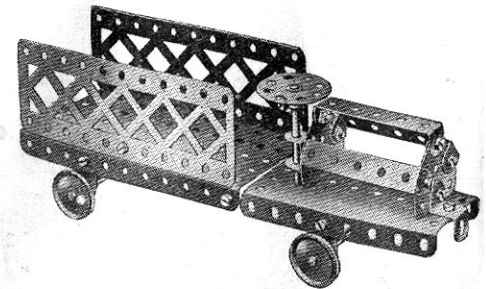

Parts required :

2 of No. 5	1 of No. 17	1 of No. 52
4 " " 10	4 " " 22	1 " " 54
1 " " 11	1 " " 24	2 " " 100
2 " " 12	1 " " 35	1 " " 125
2 " " 16	23 " " 37	2 " " 126A
	4 " " 48A	

Model No. 1.198 Pen Rack

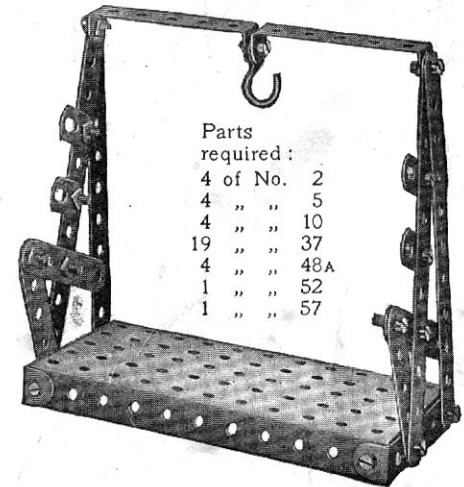

Parts required :

4 of No. 2
4 " " 5
4 " " 10
19 " " 37
4 " " 48A
1 " " 52
1 " " 57

The running wheels of this crane are journaled in Double Angle Strips bolted to the Base Plate and secured at an angle by means of Flat Brackets. The rear of the Base Plate is supported on a Double Bracket. The jib is bolted loosely to the supporting $5\frac{1}{2}$ " Strips and is connected by $2\frac{1}{2}$ " Strips to the Sector Plate which pivots about its supporting bolts. By moving this Sector Plate the elevation of the jib may be altered as desired. The movement is controlled by a Double Angle Strip mounted on the Crank Handle and connected pivotally to the Plate by means of a $2\frac{1}{2}$ " Strip. A Reversed Angle Bracket bolted to an upright Double Angle Strip in the rear of the model serves to restrict the movement of the Sector Plate.

Model No. 1.199 Travelling Crane

The jib 1 is pivoted to the Flat Trunnions 2, which are bolted at 3 to Angle Brackets secured to a Bush Wheel. The latter is nipped to a 2" Rod 4 passing through the Plate 5 and further supported in a Double Angle Strip 6. A Washer and Spring Clip mounted on the Rod 4 below the Strip 6 secure the crane to the carriage. The jib is supported by means of cords 7 tied to 2½" Strips 8, the holes of which engage the shank of a bolt passed through the Sector Plate 9, and its elevation may be altered by inserting this bolt in different holes in the Strips 8. The cord 10 of the brake lever is wound once round the Crank Handle, between two Washers.

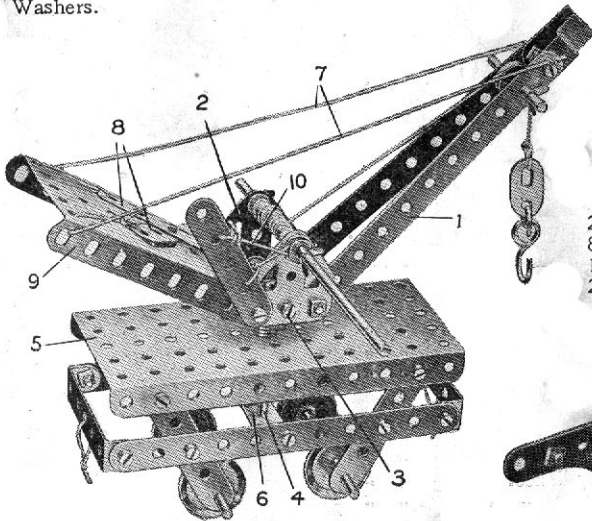

Parts required:		
4 of No. 2	1 of No. 19s	1 of No. 44
7 " " 5	4 " " 22	3 " " 48A
1 " " 10	1 " " 23	1 " " 52
2 " " 12	1 " " 24	1 " " 54
2 " " 16	5 " " 35	1 " " 57
2 " " 17	27 " " 37	1 " " 57
	6 " " 38	2 " " 126A

Model No. 1.200 Bicycle

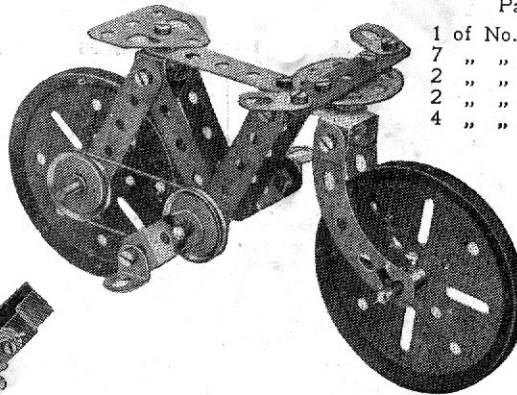

Parts required:	
1 of No. 3	2 of No. 17
7 " " 5	1 " " 18A
2 " " 10	2 " " 19B
2 " " 11	2 " " 22
4 " " 12	1 " " 24
	4 " " 35
	13 " " 37
	4 " " 37A
	3 " " 38
	2 " " 90A
	4 " " 111C
	2 " " 125
	1 " " 126A

Model No. 1.201 Luggage Truck

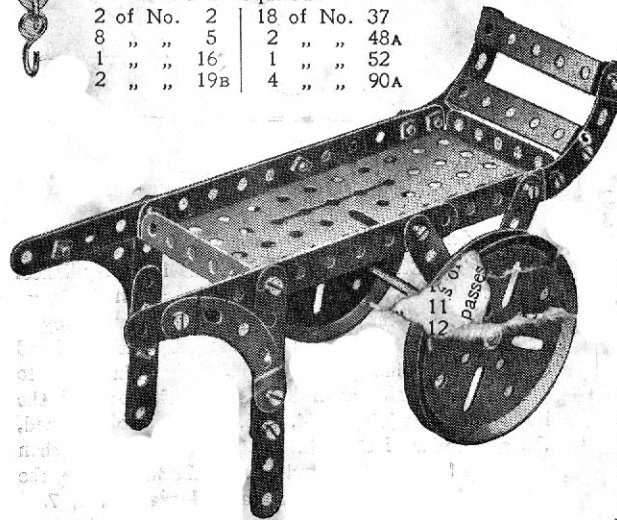

Parts required:	
2 of No. 2	18 of No. 37
8 " " 5	2 " " 48A
1 " " 16	1 " " 52
2 " " 19B	4 " " 90A

Parts required:	
4 of No. 1	3 of No. 35
3 " " 5	25 " " 37
3 " " 10	2 " " 37A
8 " " 12	1 " " 38
1 " " 16	1 " " 52
1 " " 19s	2 " " 54
3 " " 22	1 " " 126A
1 " " 24	

Model No. 1.202 Gymnast

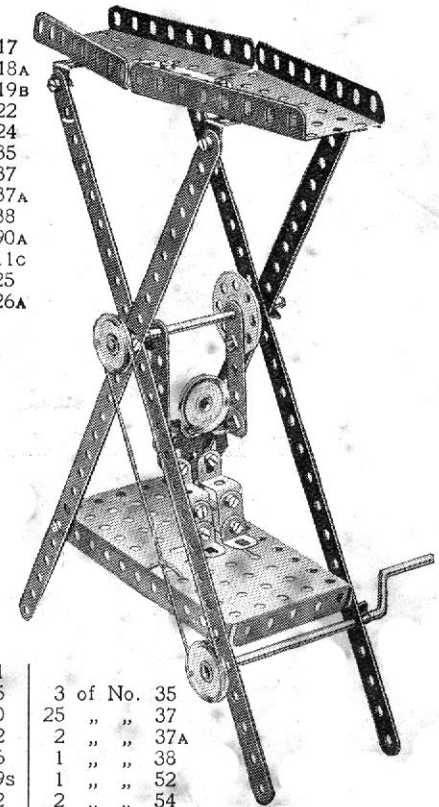

One of the 2½" Strips representing the arms of the gymnast is bolted to a Bush Wheel secured on a 3½" Rod. When the Crank Handle is rotated the gymnast turns complete somersaults in a very amusing manner. The gymnast's "arms" must be pivoted to the Angle Brackets forming his shoulders by means of Bolts and Lock-Nuts.

Model No. 1.203 Giant Foundry Ladle

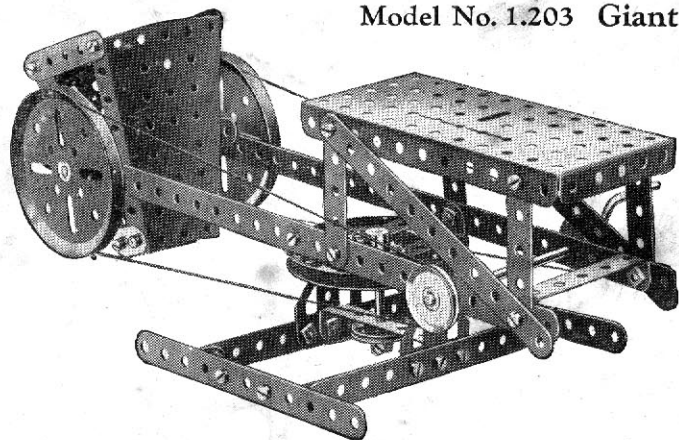

Parts required :

2 of No.	1	1 of No.	23
6 "	2	1 "	24
7 "	5	36 "	37
2 "	10	6 "	37A
1 "	16	7 "	48A
1 "	17	1 "	52
3 "	19B	2 "	54
1 "	19S	6 "	111c
3 "	22	2 "	126A

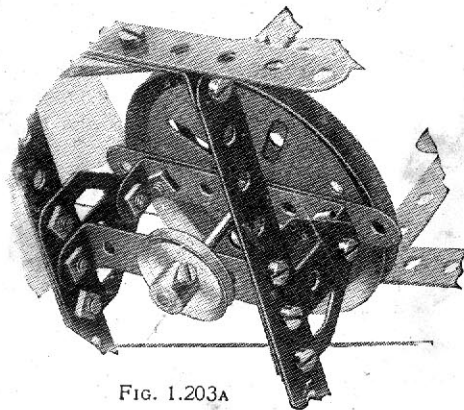
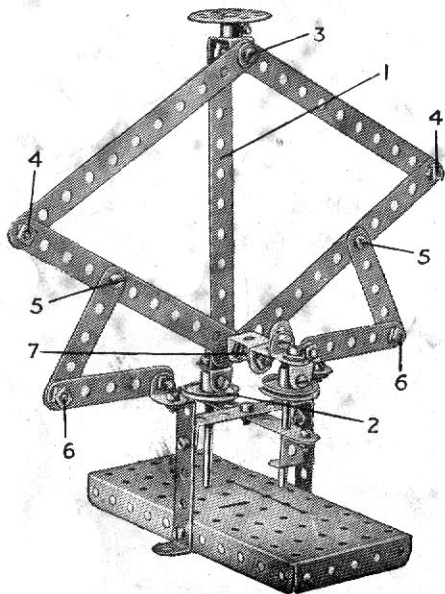

FIG. 1.203A

Model No. 1.204 Double-Action Pump



Parts required :

5 of No.	2
1 "	3
4 "	5
2 "	11
6 "	12
2 "	17
2 "	22
1 "	24
21 "	37
6 "	37A
4 "	38
3 "	48A
1 "	52
6 "	111c
2 "	125

Double-Action Pump

The 5½" Strip 1 is attached to the 1" Pulley Wheel 2 by means of two Angle Brackets, through the lower of which is secured the Set-Screw that secures the Pulley to its 2" Rod. Two Washers are placed beneath the head of the Bolt joining the Angle Brackets in order to prevent its shank from binding on the boss of the Pulley 2. The joints 3, 4, 5, 6, 7, are all lock-nutted, the remainder of the joints being quite rigid. When the Strip 1 descends, together with the first pump, the incidental distortion of the parallelogram 3, 4, 7, 4 causes the second pump to rise. Similarly, when the first pump rises, the second descends.

Model No. 1.205

Elevated Jib Crane

A 1" fast Pulley Wheel secured to the armature spindle of the Electric Motor is connected by an endless cord to the 3" Pulley Wheel 1. A 1" fast Pulley 2 on the same Rod as the latter is similarly connected with a second 3" Pulley Wheel 3. A cord wound on the Rod to which the latter is secured carries the load hook. The jib is supported by two cords 4, and the whole superstructure, which is secured to the 3" Pulley Wheel 6, is capable of revolving with the Rod 5. The latter is journalled in two 2½" x ½" Double Angle Strips secured between the Sector Plates in the base of the model.

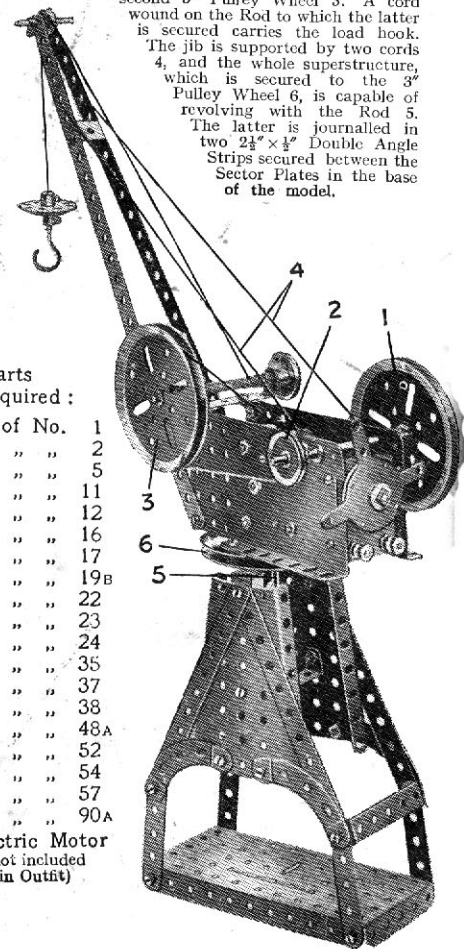

Parts required :

2 of No.	1
4 "	2
4 "	5
1 "	11
2 "	12
3 "	16
1 "	17
3 "	19B
4 "	22
1 "	23
1 "	24
5 "	35
26 "	37
2 "	38
5 "	48A
1 "	52
2 "	54
1 "	57
4 "	90A

Electric Motor
(not included
in Outfit)

Model No. 1.206 Scooter

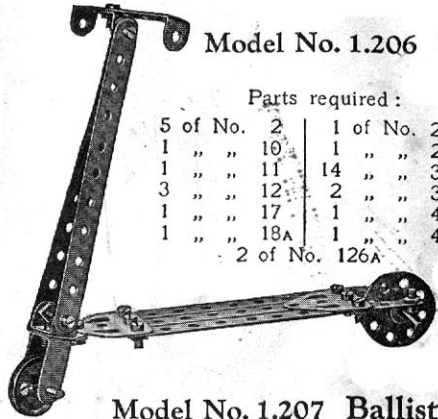

Parts required :

5 of No. 2	1 of No. 22
1 " " 10	1 " " 24
1 " " 11	14 " " 37
3 " " 12	2 " " 38
1 " " 17	1 " " 44
1 " " 18A	1 " " 48A
2 of No. 126A	

Model No. 1.207 Ballista

This is a model of an ancient engine of war, resembling the crossbow. The $3\frac{1}{2}$ " Strip 1 is bolted firmly to the Double Angle Strip 2, which is prevented from turning by the addition of Angle Brackets as shown. A Double Bracket 3 slides on the Strip 1 and is secured to a piece of cord. On rotation of the Crank Handle 4, the Strip 1 is pulled backward until the Double Bracket 3 slips off its end. The Strip then flies forward and strikes the missile, which consists of a 2" Rod placed ready in the Double Bracket 5.

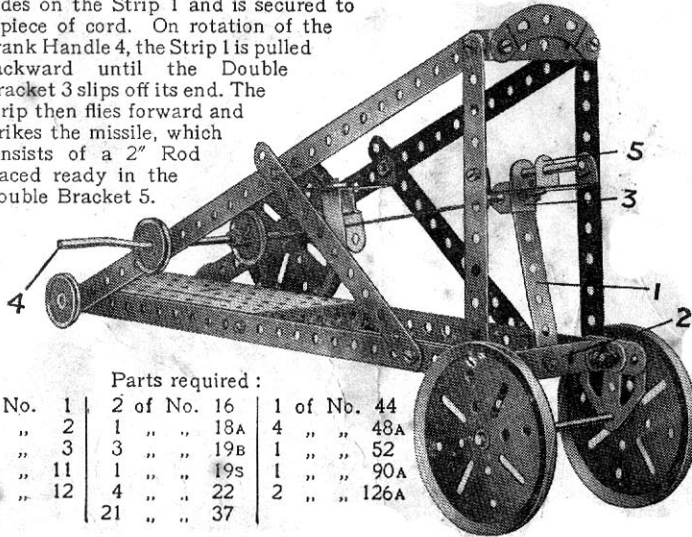

Parts required :

4 of No. 1	2 of No. 16	1 of No. 44
4 " " 2	1 " " 18A	4 " " 48A
1 " " 3	3 " " 19B	1 " " 52
2 " " 11	1 " " 19s	1 " " 90A
2 " " 12	4 " " 22	2 " " 126A
	21 " " 37	

Model No. 1.208 Tight-Rope Walker

The cord on which the "Meccanition" runs is endless and passes over the 1" fast Pulleys at each end of the model. One of the Pulleys is secured to a Crank Handle, by means of which the model may be operated. The Meccanition runs on the upper half of the endless cord, the lower half being attached to one of his feet.

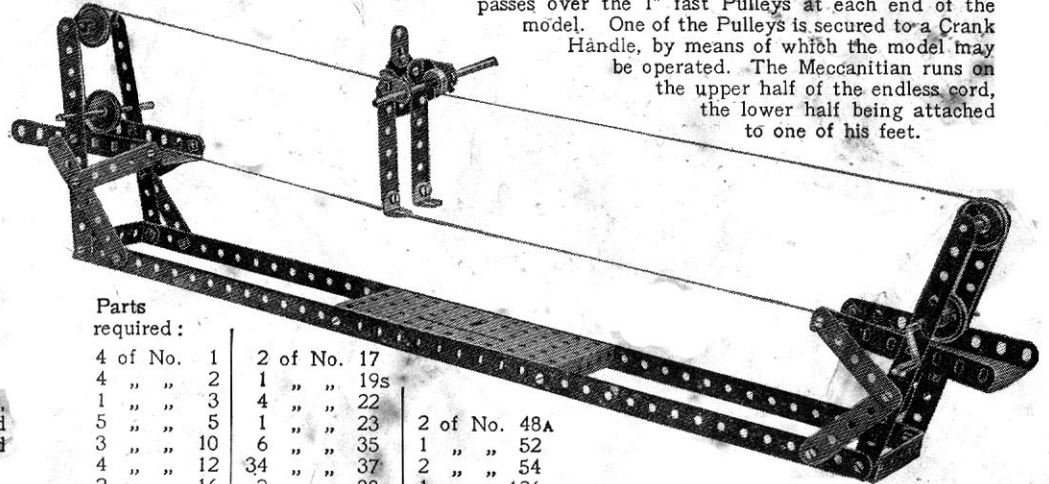

Parts required :

4 of No. 1	2 of No. 17	
4 " " 2	1 " " 19s	
1 " " 3	4 " " 22	
5 " " 5	1 " " 23	2 of No. 48A
3 " " 10	6 " " 35	1 " " 52
4 " " 12	34 " " 37	2 " " 54
2 " " 16	2 " " 38	1 " " 126A

Model No. 1.209 Double-Action Piston Connection

Parts required :

2 of No. 1	1 of No. 23
6 " " 2	1 " " 35
1 " " 3	36 " " 37
5 " " 5	5 " " 37A
4 " " 10	4 " " 48A
2 " " 11	1 " " 52
3 " " 12	1 " " 90A
2 " " 19B	3 " " 111c
1 " " 19s	2 " " 126A

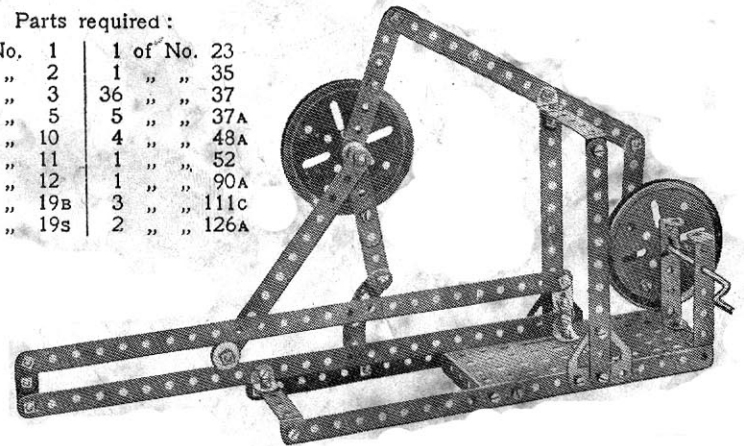

These Models can be built with MECCANO Outfit No. 1 (or No. 0 and No. 0A)

Model No. 1.210 Deck Chair

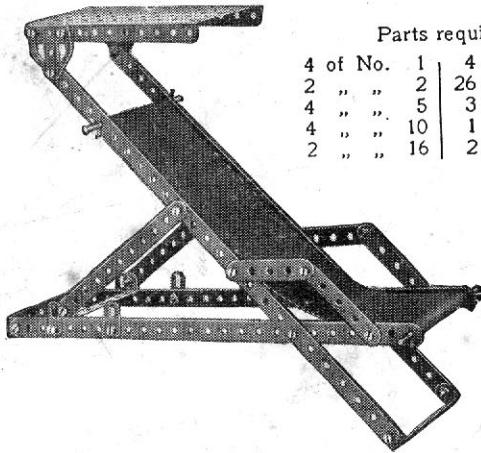

Parts required :

4 of No.	1	4 of No.	35
2 " "	2	26 " "	37
4 " "	5	3 " "	48A
4 " "	10	1 " "	52
2 " "	16	2 " "	126A

Model No. 1.212 Luggage Cart

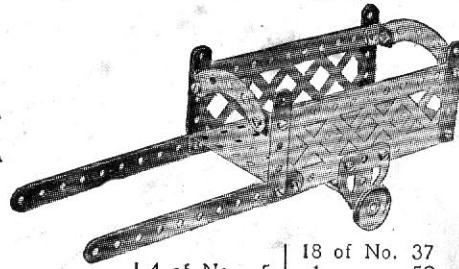

Parts required :	4 of No.	5	18 of No.	37
	4 " "	12	1 " "	52
	1 " "	16	2 " "	90A
	2 of No.	2	2 " "	100
	2 " "	22	2 " "	126A

Model No. 1.214
Mechanical Stamp

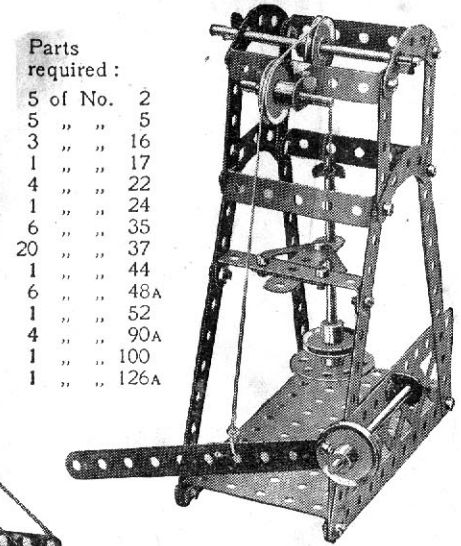

Parts
required :

5 of No.	2
5 " "	5
3 " "	16
1 " "	17
4 " "	22
1 " "	24
6 " "	35
20 " "	37
1 " "	44
6 " "	48A
1 " "	52
4 " "	90A
1 " "	100
1 " "	126A

Model No. 1.211 Potter's Wheel

Parts required :

3 of No.	2	3 of No.	22
4 " "	5	1 " "	24
1 " "	16	1 " "	35
1 " "	18A	12 " "	37
1 " "	19B	3 " "	48A
1 " "	19s	1 " "	52

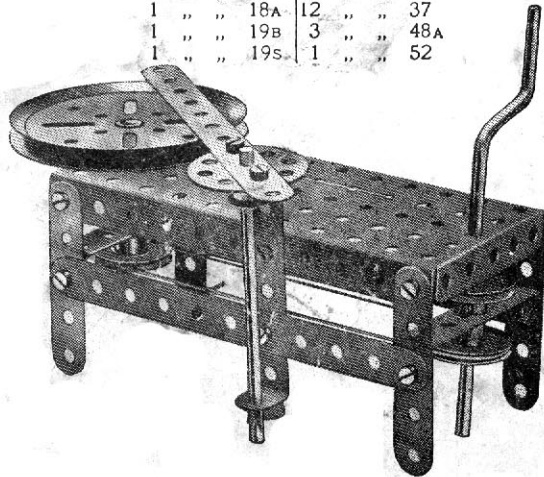

Model No. 1.213 Elevator

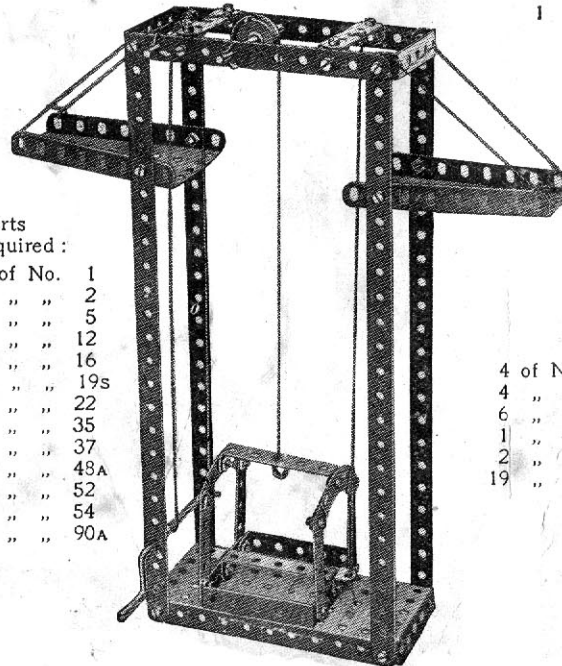

Parts
required :

4 of No.	1
2 " "	2
6 " "	5
6 " "	12
1 " "	16
1 " "	19s
1 " "	22
5 " "	35
32 " "	37
6 " "	48A
1 " "	52
2 " "	54
2 " "	90A

Model No. 1.215 See-Saw

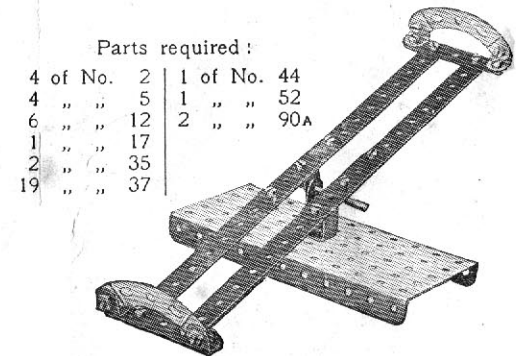

Parts required :

4 of No.	2	1 of No.	44
4 " "	5	1 " "	52
6 " "	12	2 " "	90A
1 " "	17		
2 " "	35		
19 " "	37		

Model No. 1.216 Aeroplane

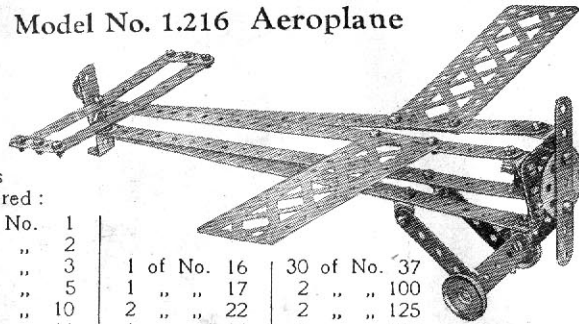

Parts required:

4 of No. 1	1 of No. 16	30 of No. 37
2 " " 2	1 " " 17	2 " " 100
1 " " 3	2 " " 22	2 " " 125
4 " " 5	1 " " 24	1 " " 126
4 " " 10	1 " " 35	2 " " 126A
1 " " 11		
8 " " 12		

**Model No. 1.218
Revolving Gymnasts**

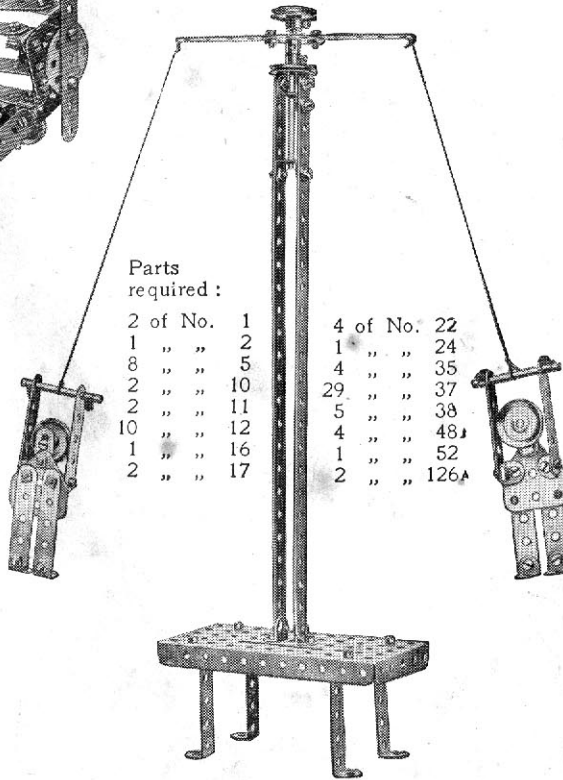

Parts required:

2 of No. 1	4 of No. 22
1 " " 2	1 " " 24
8 " " 5	4 " " 35
2 " " 10	29 " " 37
2 " " 11	5 " " 38
10 " " 12	4 " " 48A
1 " " 16	1 " " 52
2 " " 17	2 " " 126A

**Model No. 1.219
Coster's Barrow**

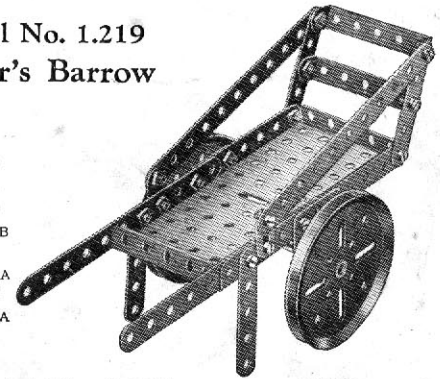

Parts required:

4 of No. 2
4 " " 5
2 " " 10
2 " " 19B
16 " " 37
2 " " 48A
1 " " 52
2 " " 126A

Model No. 1.217 Motor Truck

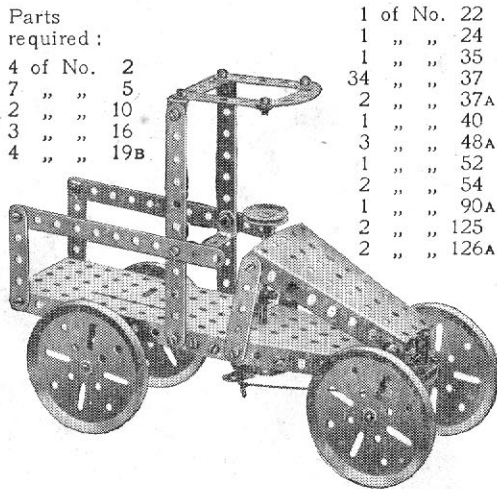

Parts required:

4 of No. 2	1 of No. 22
7 " " 5	1 " " 24
2 " " 10	1 " " 35
3 " " 16	34 " " 37
4 " " 19B	2 " " 37A
	1 " " 40
	3 " " 48A
	1 " " 52
	2 " " 54
	1 " " 90A
	2 " " 125
	2 " " 126A

**Model No. 1.220
Forge Bellows**

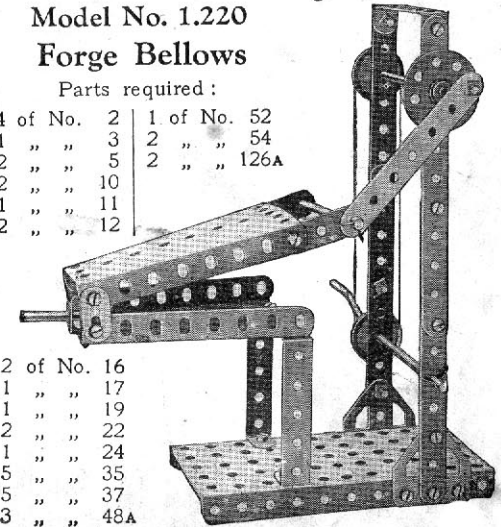

Parts required:

4 of No. 2	1 of No. 52
1 " " 3	2 " " 54
2 " " 5	2 " " 126A
2 " " 10	
1 " " 11	
2 " " 12	
2 of No. 16	
1 " " 17	
1 " " 19	
2 " " 22	
1 " " 24	
5 " " 35	
25 " " 37	
3 " " 48A	

HOW TO CONTINUE

This completes our examples of models that may be made with MECCANO Outfit No. 1. The next models are a little more advanced, requiring a number of extra parts to construct them. The necessary parts are all contained in a No. 1A Accessory Outfit, the price of which will be found in the List at the end of this Manual.

Model No. 2.1 Steam Lorry

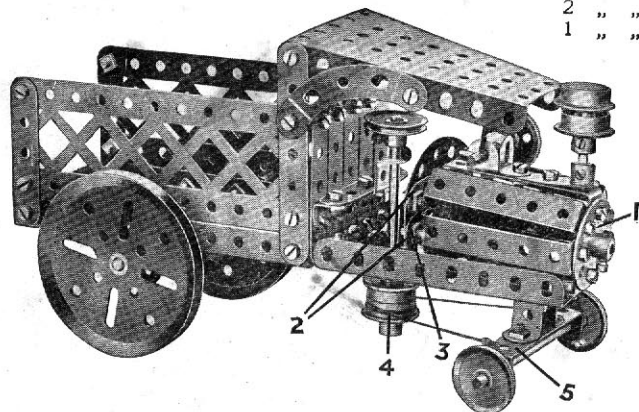

Parts required :

2 of No. 3	3 of No. 12
10 " " 5	3 " " 16
2 " " 10	1 " " 17
1 " " 11	1 " " 18A
	2 " " 19B
	4 " " 20B
	3 " " 22
	1 " " 22A
	1 " " 24
	5 " " 35
	60 " " 37
	5 " " 37A
	1 " " 45
	8 " " 48A
	1 " " 52
	2 " " 54
	1 " " 62
	3 " " 90A
	2 " " 100
	4 " " 111c
	1 " " 125
	2 " " 126A

The boiler of the engine is built up of $2\frac{1}{2} \times \frac{1}{2}$ " Double Angle Strips bolted to the Bush Wheel 1, and to two $2\frac{1}{2}$ " Strips 2, which are joined together by Flat Brackets 3. A $2\frac{1}{2}$ " Curved Strip (small radius) is bolted to the upper Strip 2. A cord is passed completely round two $\frac{3}{4}$ " Flanged Wheels 4 secured to the steering column, and its ends are tied to the $2\frac{1}{2} \times \frac{1}{2}$ " Double Angle Strip 5. The Double Bent Strip bolted to the Strip 5 is pivoted by a bolt and two nuts to the Sector Plate.

Model No. 2.2 Turnstile

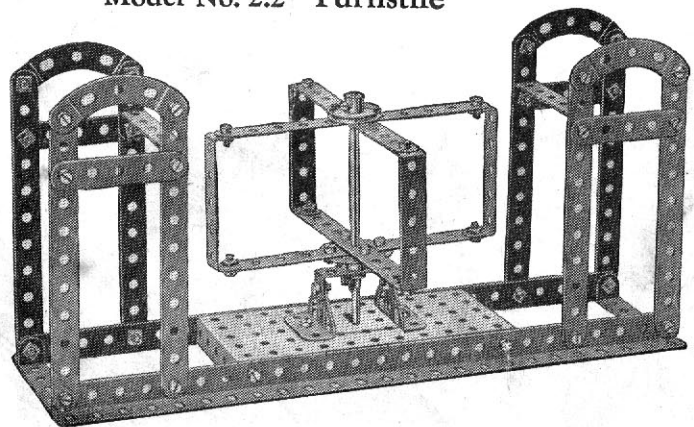

Parts required :

12 of No. 2	2
5 " " 5	5
2 " " 8	8
1 " " 15A	15A
1 " " 22	22
1 " " 24	24
1 " " 35	35
44 " " 37	37
1 " " 38	38
1 " " 48	48
8 " " 48A	48A
1 " " 52	52
4 " " 90A	90A
2 " " 99	99
2 " " 126	126

Model No. 2.3 Mechanical Hammer

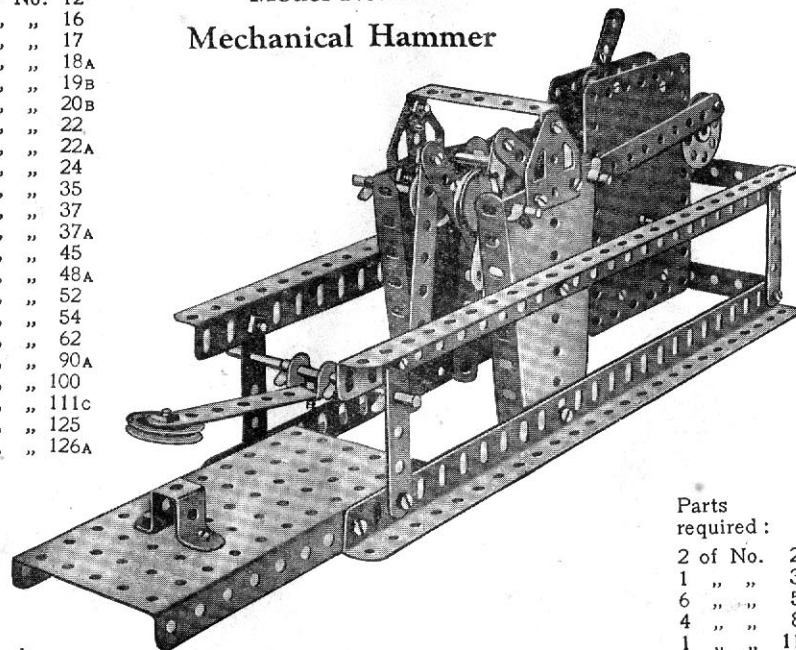

Parts required :

2 of No. 2	2
1 " " 3	3
6 " " 5	5
4 " " 8	8
1 " " 11	11
1 " " 12	12
3 " " 16	16
4 " " 22	22
1 " " 22A	22A
1 " " 24	24
8 " " 35	35
32 " " 37	37
1 " " 45	45
3 " " 48A	48A
1 " " 52	52
2 " " 54	54
2 " " 126A	126A

Clockwork Motor
(not included in Outfit)

Fig. 2.3A

Model No. 2.4 Electric Truck

An underneath view of the truck is shown in Fig. 2.4A. The front axle is journalled in a $1\frac{1}{2}'' \times \frac{1}{2}''$ Double Angle Strip 1 that is free to turn on a Double Bent Strip 2, from which it is spaced by a $\frac{1}{2}''$ loose Pulley. A length of cord is wrapped round the $1''$ Pulley 3, which is secured to the end of the steering column, and then passed through a Cranked Bent Strip 4 and secured to the Double Angle Strip 1 as shown. The brake cord 5 is attached to the Double Bent Strip 2, wrapped several times round the $\frac{3}{4}''$ Flanged Wheels 6, passed through the Angle Bracket 7, and is finally attached to the Crank 8. The operating pedal consists of Double Brackets bolted to another Crank that is secured to the same Rod as the Crank 8.

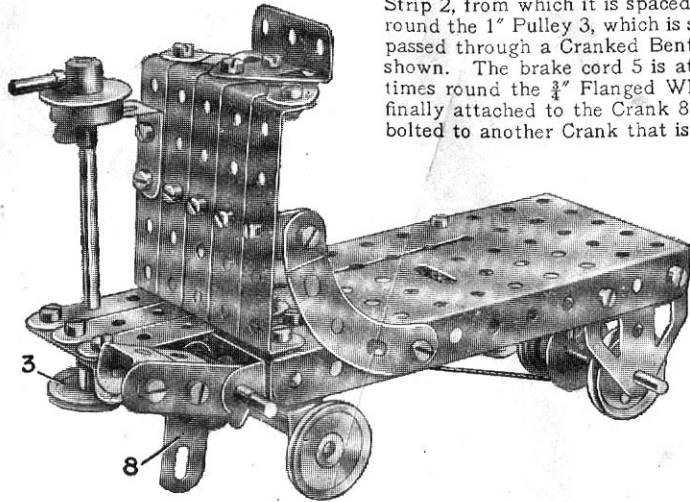

Parts required :

3 of No. 5	1 of No. 22A	7 of No. 48A
1 " " 6A	1 " " 23	1 " " 52
2 " " 11	4 " " 35	2 " " 62
1 " " 12	35 " " 37	3 " " 90A
1 " " 12A	2 " " 37A	1 " " 111c
3 " " 16	5 " " 38	1 " " 115
1 " " 17	1 " " 44	1 " " 126
3 " " 20B	1 " " 45	2 " " 126A
4 " " 22	1 " " 48	

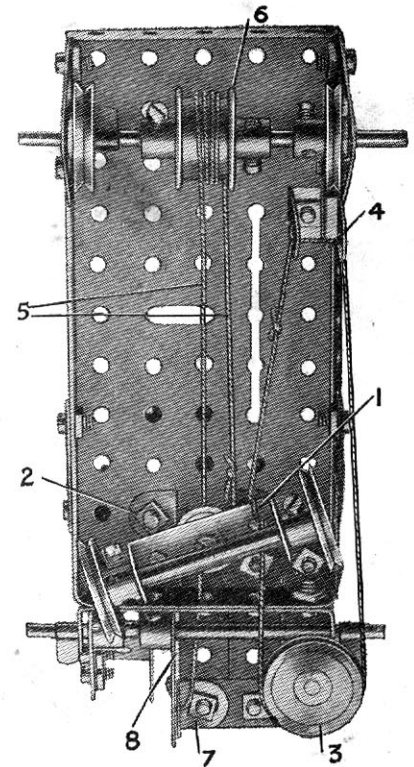
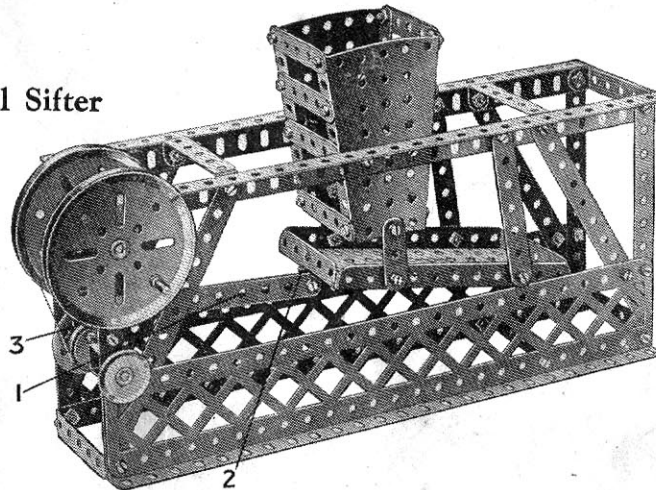

FIG. 2.4A

Model No. 2.5 Coal Sifter

The $5\frac{1}{2}''$ Strip 1 is pivoted to the Angle Bracket 2 by a bolt and two nuts. The Angle Bracket in turn is bolted to the Flanged Plate, which is suspended in such a way that it is free to swing to and fro. The other end of the $5\frac{1}{2}''$ Strip is pivoted to the Bush Wheel 3.



Parts required :

9 of No. 2	2 of No. 35
2 " " 3	54 " " 37
8 " " 5	6 " " 37A
2 " " 6A	8 " " 38
4 " " 8	1 " " 45
1 " " 12	6 " " 48A
1 " " 16	1 " " 52
1 " " 17	2 " " 54
2 " " 19B	2 " " 99
2 " " 22	6 " " 111c
1 " " 24	1 " " 115

Model No. 2.6 Treadle Lathe

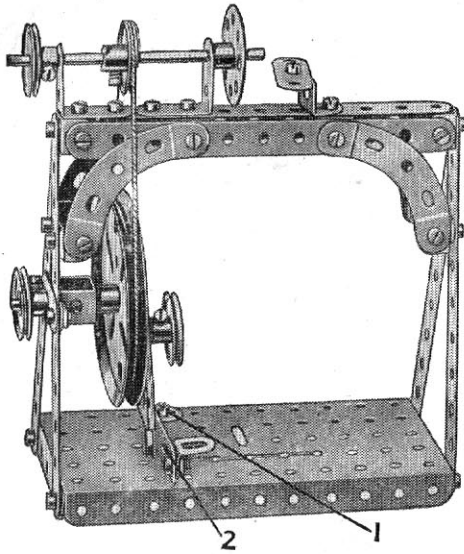

Parts required:

7 of No.	2
1 " "	3
1 " "	5
2 " "	6A
4 " "	11
6 " "	12
2 " "	12A
1 " "	16
1 " "	17
3 " "	19B
4 " "	22
1 " "	24
1 " "	35
34 " "	37
2 " "	37A
4 " "	38
1 " "	45
1 " "	52
4 " "	90A
1 " "	115
1 " "	125

The 2½" Strip 2, forming the treadle, is attached pivotally by means of a bolt and two nuts to the Angle Bracket 1. One end of a further 2½" Strip is connected by the same means to the 2½" Strip 2, and the other end is mounted on a threaded pin secured to the 3" Pulley Wheel.

Model No. 2.9 Mat Frame

Parts required:

10 of No.	1	3 of No.	11	1 of No.	18A
4 " "	8	6 " "	12	54 " "	37
4 " "	10	2 " "	12A	2 " "	37A
				2 " "	38
				1 " "	45
				2 " "	62
				4 " "	90A
				2 " "	111c
				1 " "	115
				4 " "	125
				2 " "	126
				2 " "	126A

Model No. 2.8 Gong

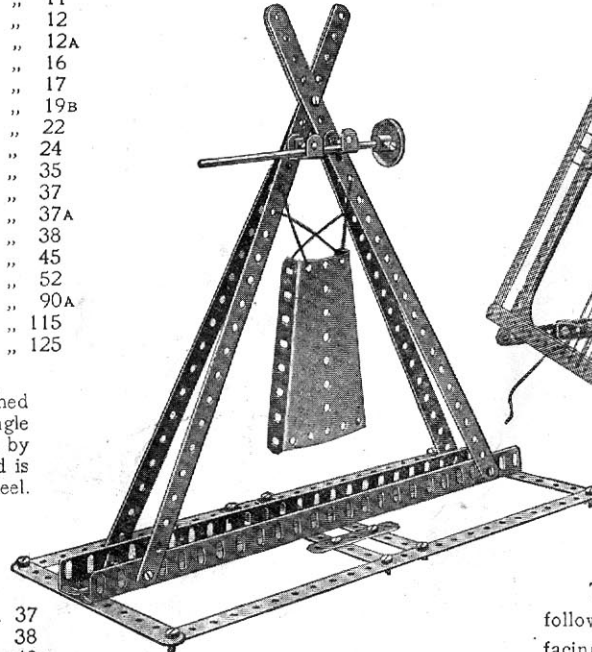

Parts required:

6 of No.	1	2 of No.	11
4 " "	2	1 " "	15
2 " "	5	1 " "	22
2 " "	8	27 " "	37
		1 of No.	54

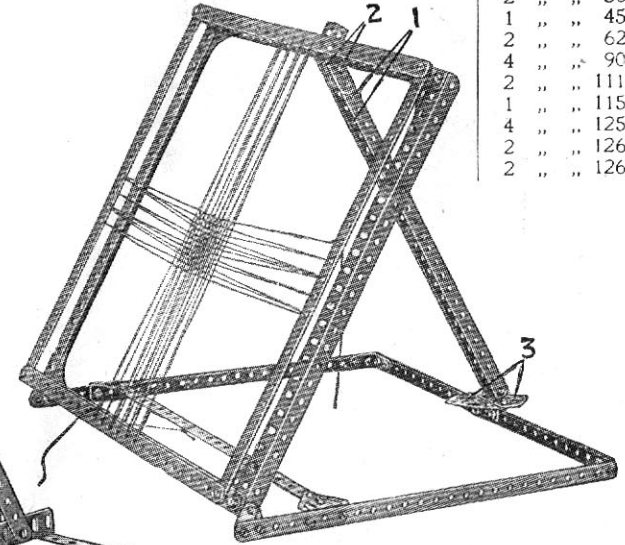

The Strips 1 are hinged to the frame in the following manner. Two Cranks 2 with their bosses facing inward are bolted to the Strips 1 and two Angle Brackets are secured to the frame. A Rod is then pushed through the holes in the Angle Brackets and secured in the bosses of the Cranks. A Double Bracket fastened to the ends of the Strips 1 carries a Threaded Pin, which fits in the holes in the Trunnions 3. By removing this Pin, the frame may be folded flat.

Model No. 2.7 Smoothing Iron

Parts required:

4 of No.	2	20 of No.	37
2 " "	3	2 " "	38
6 " "	10	1 " "	48A
4 " "	11	2 " "	54
2 " "	12	1 " "	126A

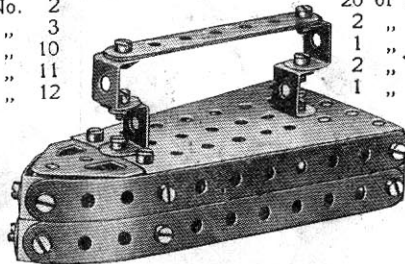

Model No. 2.10 Spinning Top

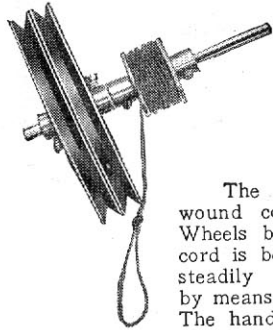

Parts required:

1 of No.	2
1 " "	16
2 " "	19B
2 " "	20
2 " "	37
1 " "	40
1 " "	62

The drum on which the cord is wound consists of two $\frac{3}{4}$ " Flanged Wheels butted together. While the cord is being pulled, the top is held steadily on some smooth surface by means of the handle shown above. The handle is then lifted off, allowing the top to spin freely.

Model No. 2.11 High Level Bridge

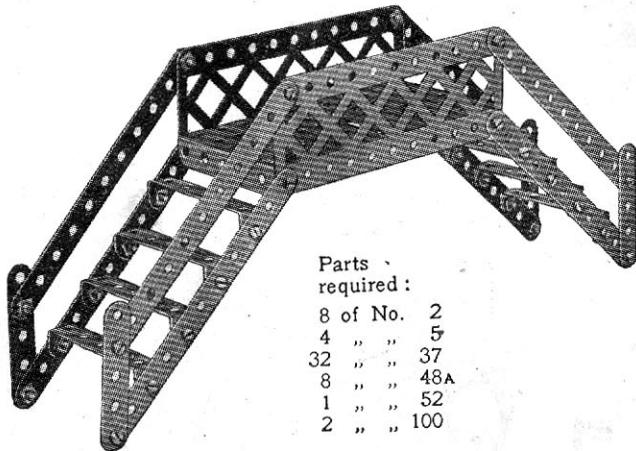

Parts required:

8 of No.	2
4 " "	5
32 " "	37
8 " "	48A
1 " "	52
2 " "	100

Model No. 2.12 Sand Yacht

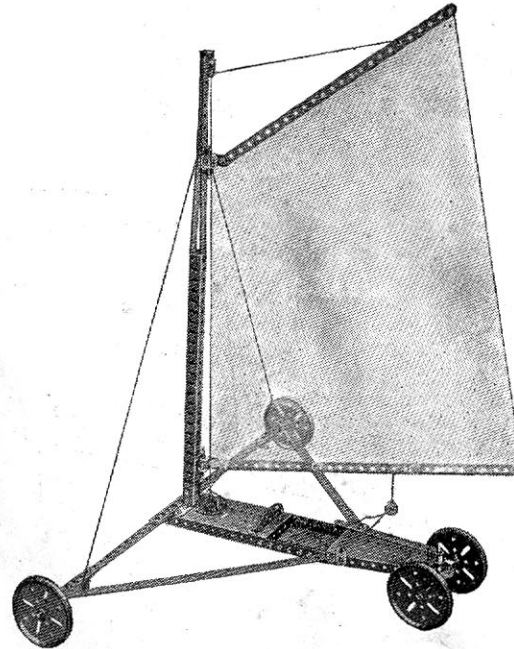

Parts required:

8 of No.	1	1 of No.	24
2 " "	2	12 " "	35
1 " "	5	60 " "	37
4 " "	8	9 " "	38
4 " "	10	8 " "	48A
4 " "	11	1 " "	52
12 " "	12	1 " "	54
2 " "	12A	1 " "	62
3 " "	16	1 " "	90A
1 " "	17	1 " "	115
2 " "	18A	4 " "	125
4 " "	19B	1 " "	126
1 " "	23	2 " "	126A

Model No. 2.13 Polishing Spindle

Parts required:

4 of No.	12	20 of No.	37
1 " "	16	3 " "	48A
2 " "	22	1 " "	52
1 " "	24	2 " "	54
2 " "	35	2 " "	126

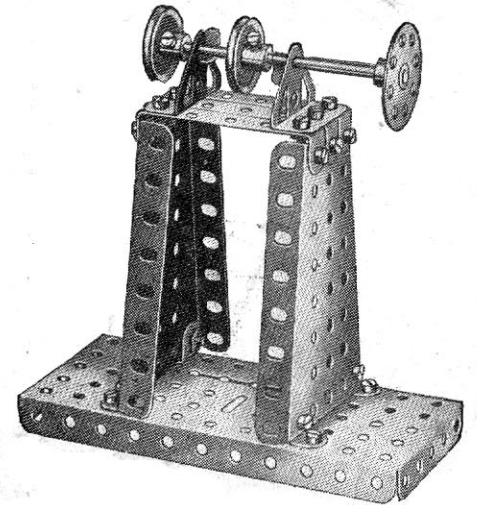

Model No. 2.14 Windmill

The operating cord 1 is given a complete turn round the pair of $\frac{3}{4}$ " Flanged Wheels 2. It is then led round the 1" Loose Pulley 3, over the 3" Pulley 4, then down and round the $\frac{3}{4}$ " Flanged Wheels secured to the Crank Handle 5. The vane 6 is rotated by a cord which passes round a 1" fixed Pulley 7 secured to the shaft of the Flanged Wheels 2.

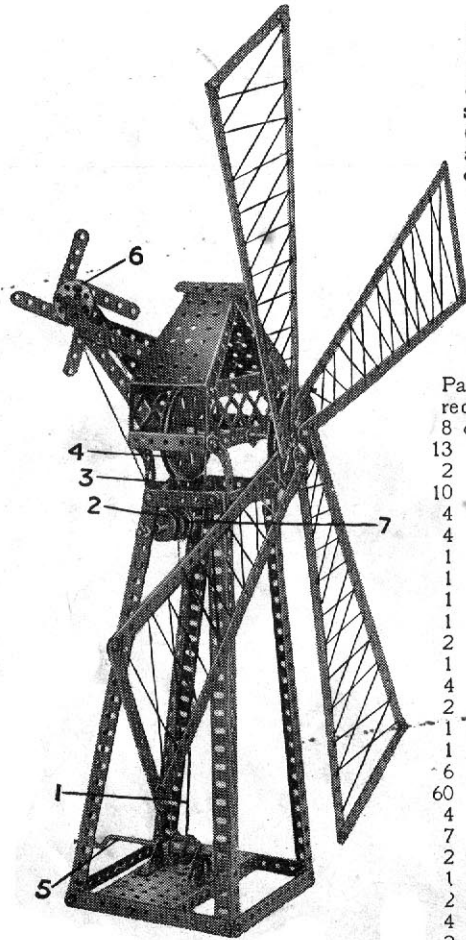

Parts required:	
8 of No.	1
13	2
2	3
10	5
4	8
4	12
1	15
1	15A
1	16
1	18A
2	19B
1	19S
4	20B
2	22
1	22A
1	24
6	35
60	37
4	37A
7	38
2	48A
1	52
2	54
4	90A
2	100
4	111c
2	126

Model No. 2.15 Towel Horse

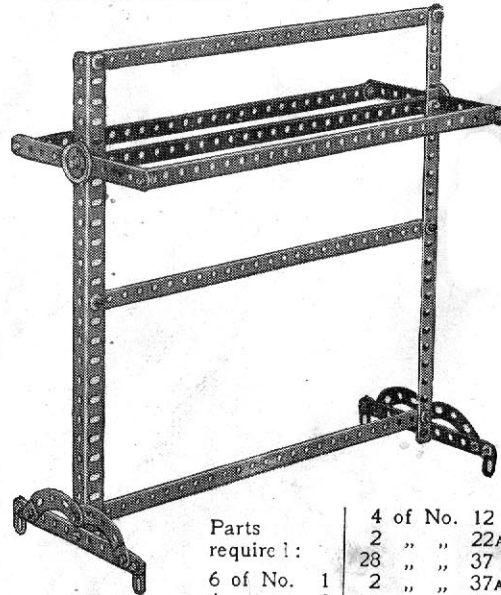

Parts required:	
6 of No.	1
4	2
2	8
4	10
4 of No.	12
2	22A
28	37
2	37A
8	38
4	90A
2	111c

Model No. 2.16 Coaster

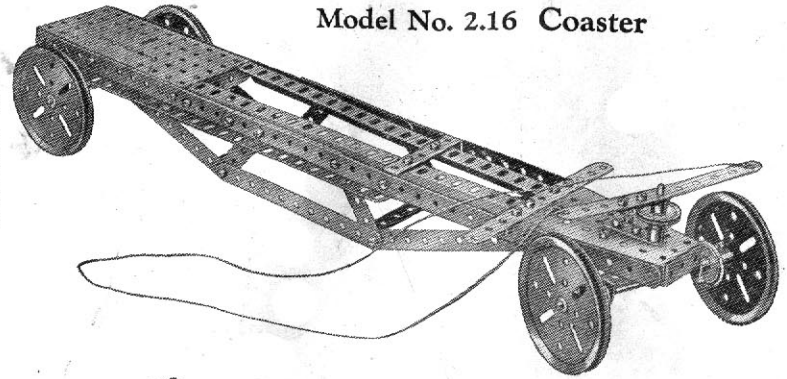

Parts required:

2 of No.	1	1 of No.	23
8	2	1	24
4	5	44	37
4	8	4	38
1	15	1	48
1	15A	4	48A
1	17	1	52
4	19B	1	54
3	22	2	62
		2 of No.	126

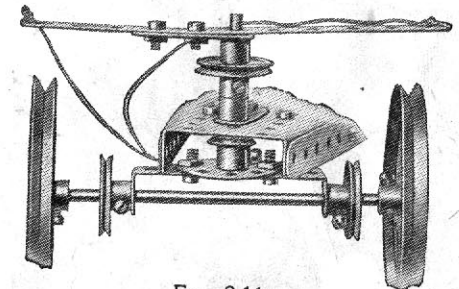
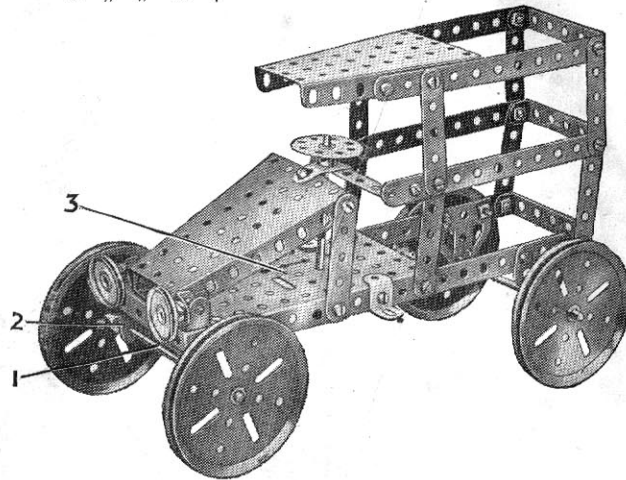

FIG. 2.16A

Model No. 2.17 Motor Van

Parts required:

6 of No. 2	1 of No. 24	6 of No. 48A
10 " " 5	5 " " 35	1 " " 52
1 " " 10	35 " " 37	2 " " 54
2 " " 12	2 " " 37A	3 " " 111c
1 " " 15	1 " " 38	2 " " 125
1 " " 15A	1 " " 45	2 " " 126A
1 " " 16	1 " " 48	
4 " " 19B		
3 " " 22		



The Axle Rod 1 is journalled in a $2\frac{1}{2}'' \times \frac{1}{2}''$ Double Angle Strip 2. The latter is bolted to a Double Bent Strip that is pivoted to the Flanged Plate 3 by a bolt and two nuts. Steering is effected by a cord attached to the ends of the Double Angle Strip 2 and passed round a 1" Pulley Wheel fastened to the lower end of the steering Rod.

Model No. 2.18

Easel

Parts required:

5 of No. 1
3 " " 2
2 " " 3
3 " " 5
4 " " 12
2 " " 12A
1 " " 15A
2 " " 22
19 " " 37
4 " " 38

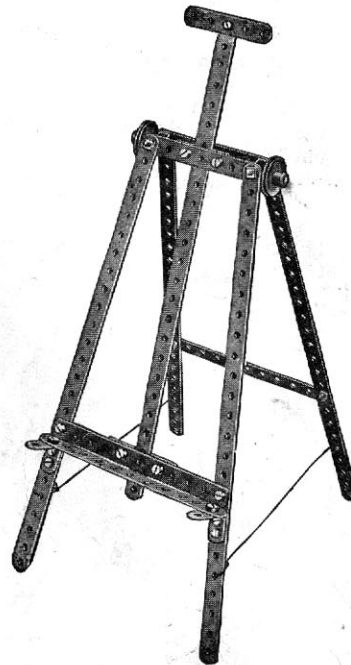

Model No. 2.19 Stamping Mill

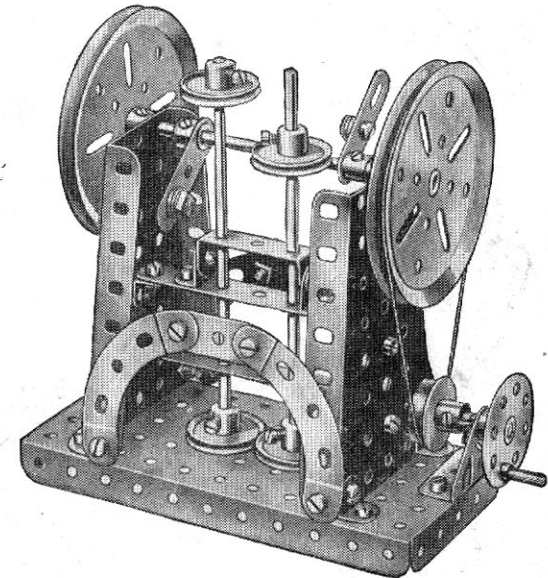

Parts required:

2 of No. 3	30 of No. 37
2 " " 6A	2 " " 37A
10 " " 12	11 " " 38
2 " " 15	1 " " 48
1 " " 15A	1 " " 52
1 " " 17	2 " " 54
2 " " 19B	2 " " 62
1 " " 20B	4 " " 90A
4 " " 22	2 " " 111c
1 " " 24	1 " " 115
1 " " 35	1 " " 126

Model No. 2.20
Candy Puller

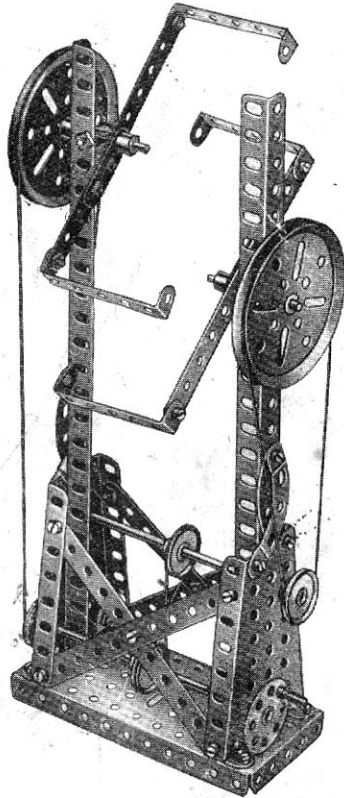

Parts required:

6 of No. 2	3 of No. 35
2 " " 8	36 " " 37
6 " " 12	4 " " 38
2 " " 15	4 " " 48A
2 " " 17	1 " " 52
2 " " 19B	2 " " 54
4 " " 22	2 " " 62
1 " " 24	4 " " 90A
1 of No. 115	

Model No. 2.21 Revolving Truck

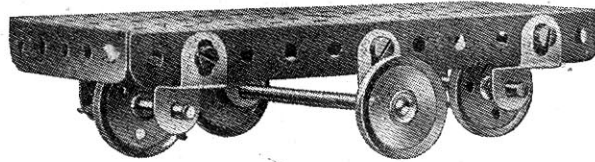

Parts required:

1 of No. 16
2 " " 17
2 " " 22
2 " " 22A
4 " " 35
6 " " 37
1 " " 52
4 " " 125

Model No. 2.22 Sifter

The 5½" Strip 1 is pivoted by a bolt and two nuts (S.M. 262) to the Bush Wheel and also to a Trunnion bolted to the under-surface of the Flanged Plate 2. The Rod carrying the Bush Wheel is journaled in one of the side girders and through a Double Bent Strip.

Parts required:

4 of No. 1	2 of No. 54
5 " " 2	2 " " 99
4 " " 5	2 " " 111c
2 " " 6A	1 " " 115
4 " " 8	1 " " 126
4 " " 10	
2 " " 15	
1 " " 15A	
1 " " 17	
2 " " 19B	
4 " " 20B	
3 " " 22	
1 " " 24	
4 " " 35	
36 " " 37	
4 " " 37A	
1 " " 38	
1 " " 44	
4 " " 48A	
1 " " 52	

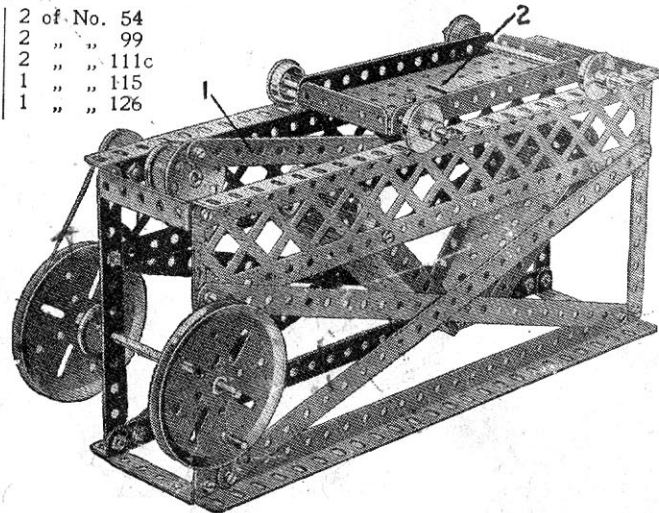

Model No. 2.23
Ladder on Wheels

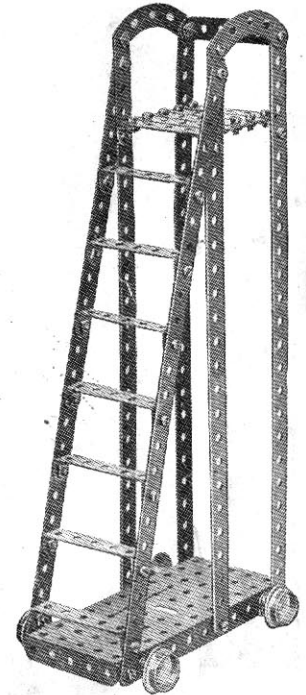

Parts required:

6 of No. 1
7 " " 5
4 " " 12
2 " " 16
4 " " 20B
40 " " 37
4 " " 38
8 " " 48A
1 " " 52
2 " " 90A

Model No. 2.24 Tricycle

Parts required:

4 of No. 2	15 of No. 37
6 " " 5	2 " " 37A
2 " " 10	1 " " 111c
3 " " 11	1 " " 126A
2 " " 12	
1 " " 16	
1 " " 18A	
3 " " 19B	
2 " " 35	

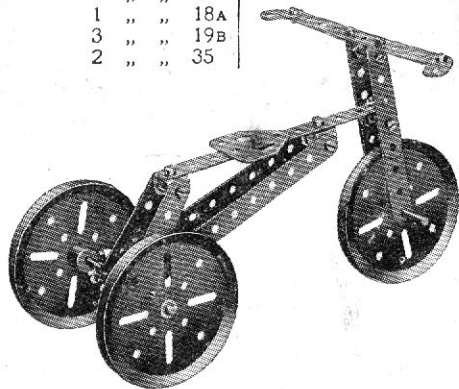

Model No. 2.25 Turntable

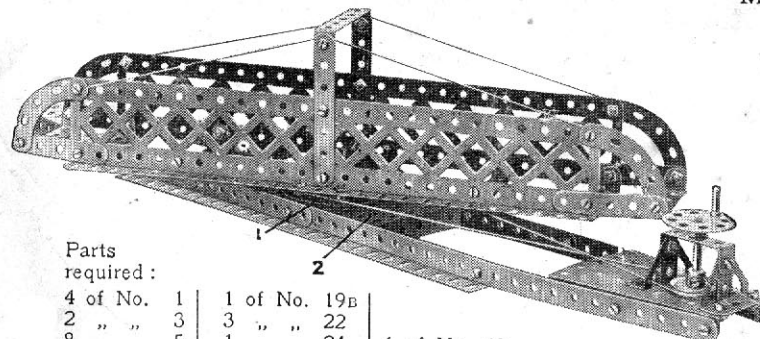

Parts required:

4 of No. 1	1 of No. 19B		
2 " " 3	3 " " 22		
8 " " 5	1 " " 24	1 of No. 48	
4 " " 8	45 " " 37	7 " " 48A	4 of No. 90A
1 " " 17	4 " " 37A	1 " " 52	2 " " 99
1 " " 18A	4 " " 38	2 " " 54	4 " " 111c

The two sides of the revolving portion are joined in the middle by two pairs of 2½" Strips, each pair being overlapped three holes and bolted to the 3" Pulley Wheel 1. An Axle Rod secured in the latter is journaled in the bottom plate 2 and retained in position by a 1" Fast Pulley Wheel beneath the plate.

Model No. 2.26 Motor Truck

Parts required:

2 of No. 2	1 of No. 22	2 of No. 54
2 " " 5	1 " " 24	2 " " 100
2 " " 6A	1 " " 35	1 " " 111c
2 " " 10	23 " " 37	2 " " 126A
1 " " 11	2 " " 37A	
3 " " 16	3 " " 48A	
4 " " 19B	1 " " 52	

A cord passed twice round a 1" fast Pulley Wheel on the lower end of the steering column is tied to the ends of a 2½" x ½" Double Angle Strip, which is pivoted by means of a Bolt and Lock-Nuts to a Double Bracket bolted to the lower Sector Plate. The front axle is journaled in the end holes of the Double Angle Strip.

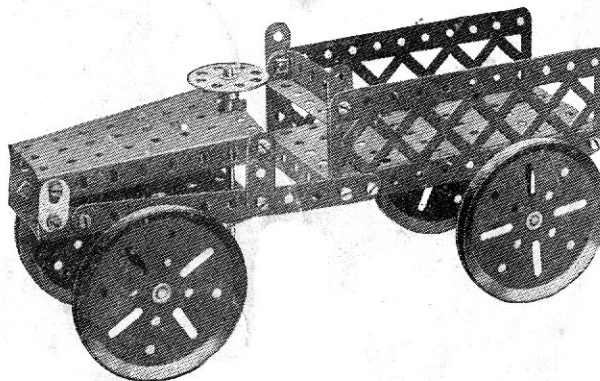

Model No. 2.27 Baby Chair

Parts required:

8 of No. 2	4 of No. 35
2 " " 3	35 " " 37
2 " " 5	2 " " 37A
6 " " 12	4 " " 38
2 " " 16	8 " " 48A
2 " " 17	4 " " 90A
4 " " 22	1 " " 115.

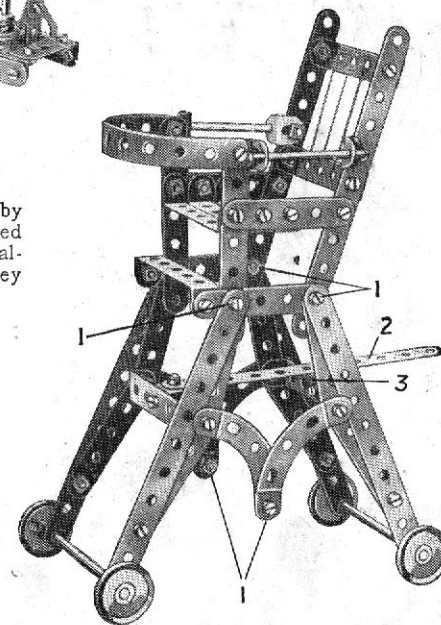

The Bolts 1 are all secured pivotally (see S.M. Nos. 262 and 263), and the height of the chair may be adjusted by fitting any hole in the Strip 2 over the shank of a Bolt that is secured in an Angle Bracket bolted to the Double Angle Strip 3.

Model No. 2.28 Roundabout

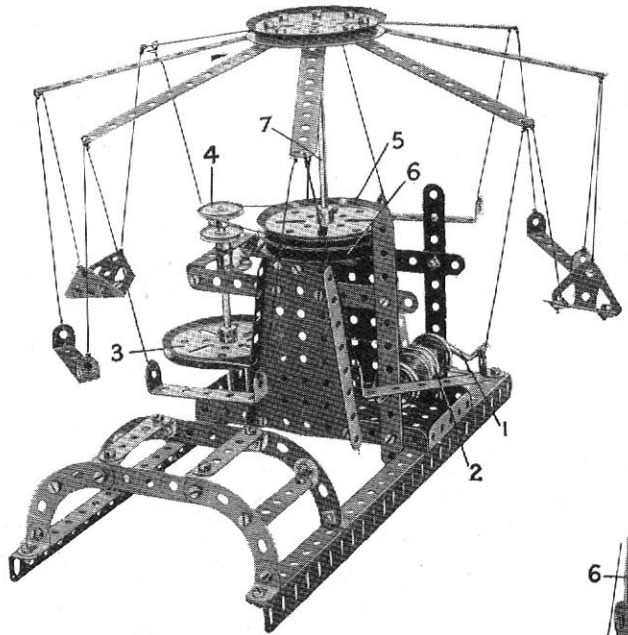

Parts required:

13 of No.	2
6 " "	5
2 " "	8
12 " "	12
2 " "	12A
2 " "	15
1 " "	19
4 " "	19B
2 " "	20
4 " "	22
1 " "	24
48 " "	37
7 " "	48A
1 " "	52
2 " "	54
4 " "	90A
2 " "	126
2 " "	126A

When the crank handle is turned, the drum 2 (formed by butting together two $\frac{3}{4}$ " Flanged Wheels) turns the 3" Pulley Wheel 3 by means of an endless cord. The 1" fast Pulley Wheel 4 similarly turns a second 3" Pulley Wheel 5 resting on another 3" Pulley Wheel 6 (see Fig. 2.28A). The end of the Axle Rod 7 is quite free to revolve in the boss of the lower 3" Pulley Wheel 6.

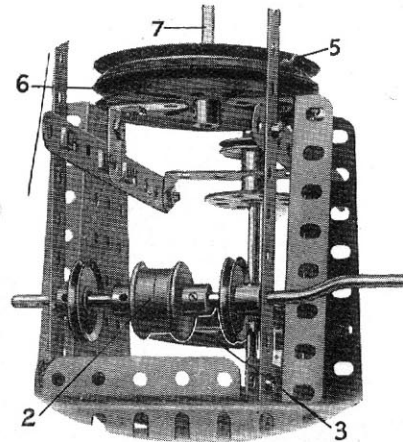
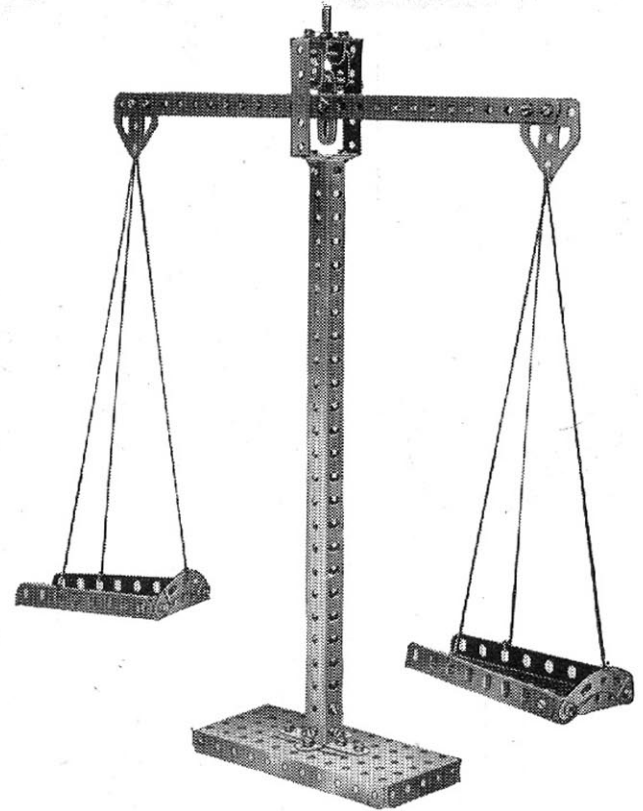

Fig. 2.28A

Model No. 2.29 Scales



Parts required

2 of No.	1	2 of No.	18A	1 of No.	52
1 " "	6A	2 " "	35	2 " "	54
2 " "	8	31 " "	37	2 " "	62
2 " "	10	4 " "	38	2 " "	90A
1 " "	11	1 " "	40	1 " "	115
2 " "	12	1 " "	45	2 " "	126A
2 " "	12A	4 " "	48A		

Model No. 2.30 Pit Head Gear

(Electrically Operated)

Parts
required :

8 of No.	1
8 " "	2
4 " "	5
4 " "	8
2 " "	12
3 " "	16
2 " "	19B
3 " "	22
1 " "	24
2 " "	35
60 " "	37
6 " "	37A
6 " "	38
8 " "	48A
1 " "	52
2 " "	54
2 " "	100
6 " "	111c
2 " "	126

Electric Motor
(not included
in Outfit)

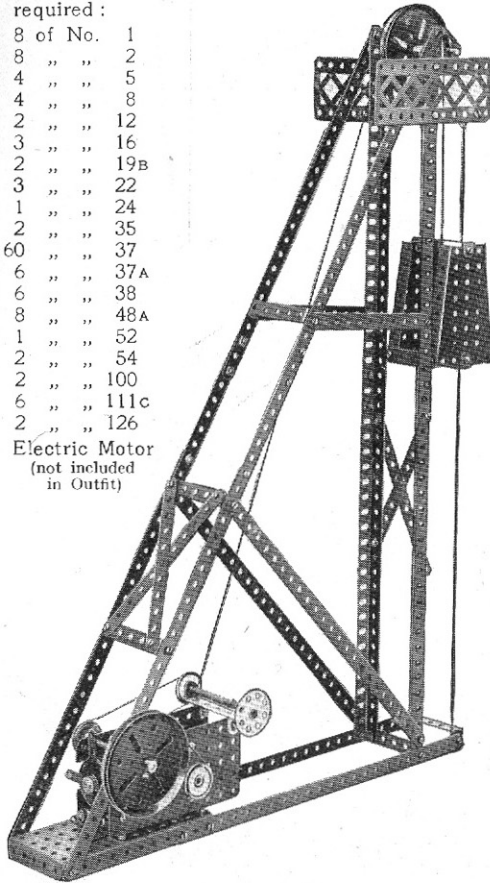

Model No. 2.31 Pit Head Gear

(Hand Operated)

This is an alternative construction of the base of Model No. 2.32, and shows how the electric motor may be dispensed with if necessary. Two 3" pulley wheels 1 are bolted together by four double brackets to form a drum on which the hoisting cord is wound. The cage is raised or lowered on operation of the handle 2, which is connected to the winding drum by an ordinary belt drive. The cage is prevented from overhauling by a band brake that acts on the groove of a third 3" pulley wheel 3. The brake normally is applied by the weight of the $\frac{1}{2}$ " loose pulley wheel 4, which is secured to the end of a 5 $\frac{1}{2}$ " strip that is bolted to the crank 5.

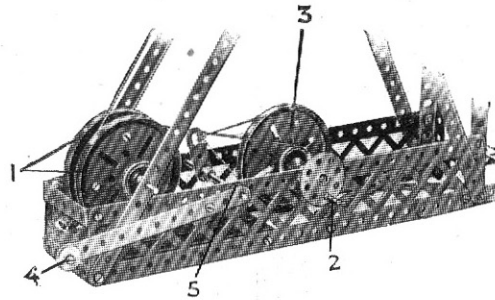

Parts required :

6 of No.	1	4 of No.	22	2 of No.	54
7 " "	2	1 " "	23	2 " "	62
3 " "	5	1 " "	24	2 " "	99
4 " "	8	3 " "	35	2 " "	100
4 " "	11	60 " "	37	6 " "	111c
6 " "	12	6 " "	37A	1 " "	115
4 " "	16	8 " "	48A	2 " "	126A
4 " "	19B	1 " "	52		

Model No. 2.32 Acrobat

Parts required :

4 of No.	1	28 of No.	37
2 " "	3	6 " "	37A
5 " "	5	5 " "	38
2 " "	8	1 " "	45
2 " "	10	1 " "	52
1 " "	15	1 " "	54
2 " "	19B	2 " "	62
2 " "	20B	1 " "	115
3 " "	22	2 " "	126

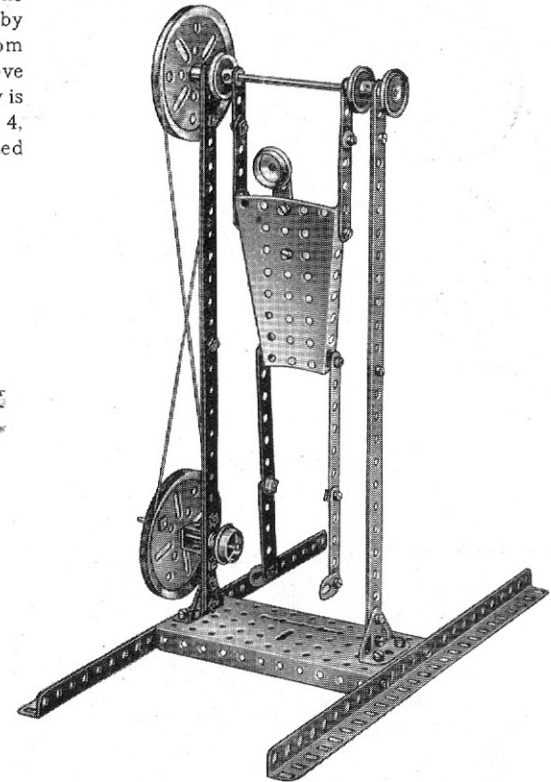

Model No. 2.33 Carrier Tricycle

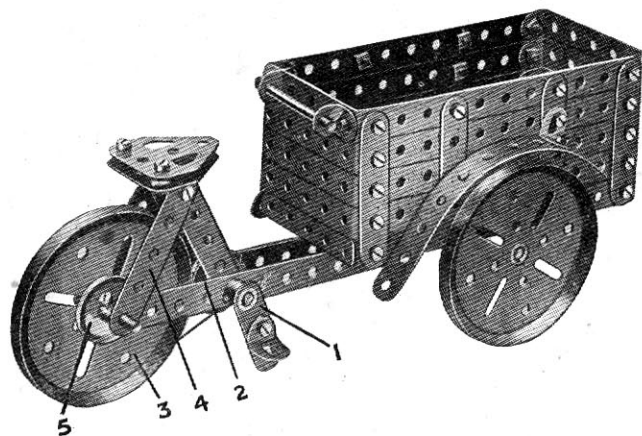

Each pedal of the tricycle consists of an Angle Bracket pivotally attached to a crank 1 by means of a Bolt and two Nuts (see S.M. No. 262). The cranks are secured to a $1\frac{1}{2}$ " Axle Rod carrying a 1" fast Pulley Wheel 2. A cord passes round this Pulley and around the 3" Pulley Wheel 3, which is spaced away from the $2\frac{1}{2}$ " Strips 4 by a 1" fast Pulley Wheel 5. The Double Bracket 6 (Fig. 2.33A) is attached pivotally to the lower framework by a Bolt and Lock-Nuts (S.M. 263).

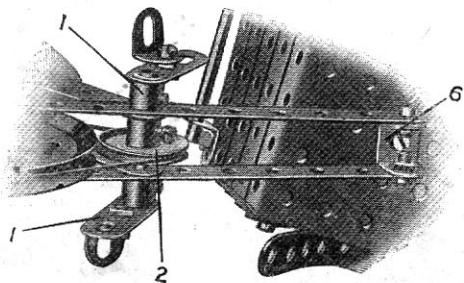
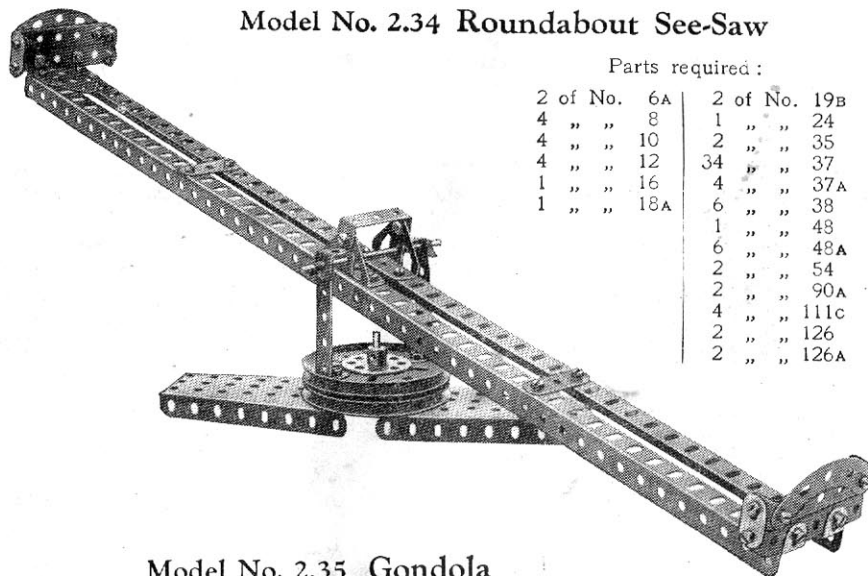

Fig. 2.33A

Parts required :

12 of No.	2
12 "	5
2 "	11
2 "	12
6 "	12
1 "	16
1 "	17
2 "	18A
3 "	19B
2 "	22
45 "	37
5 "	37A
8 "	48A
1 "	52
2 "	62
3 "	111c
2 "	126A

Model No. 2.34 Roundabout See-Saw



Parts required :

2 of No.	6A	2 of No.	19B
4 "	8	1 "	24
4 "	10	2 "	35
4 "	12	34 "	37
1 "	16	4 "	37A
1 "	18A	6 "	38
		1 "	48
		6 "	48A
		2 "	54
		2 "	90A
		4 "	111c
		2 "	126
		2 "	126A

Model No. 2.35 Gondola

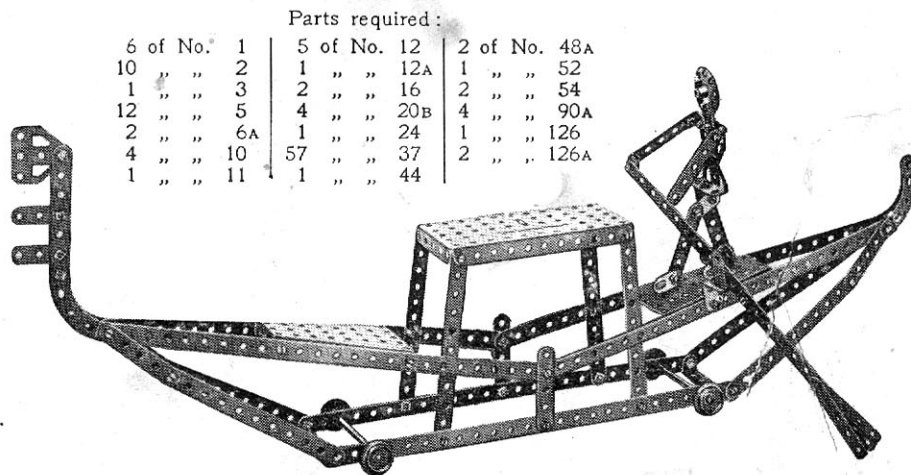

Parts required :

6 of No.	1	5 of No.	12	2 of No.	48A
10 "	2	1 "	12A	1 "	52
1 "	3	2 "	16	2 "	54
12 "	5	4 "	20B	4 "	90A
2 "	6A	1 "	24	1 "	126
4 "	10	57 "	37	2 "	126A
1 "	11	1 "	44		

Model No. 2.36 Double Drop Hammer

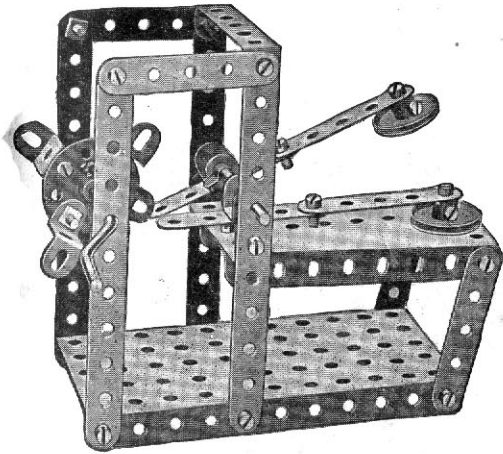

Parts required:

4 of No.	2
8 "	5
2 "	11
1 "	16
1 "	19s
2 "	22
1 "	24
6 "	35
23 "	37
2 "	48A
1 "	52
1 "	54
4 "	125

Model No. 2.37 Hay Tedder

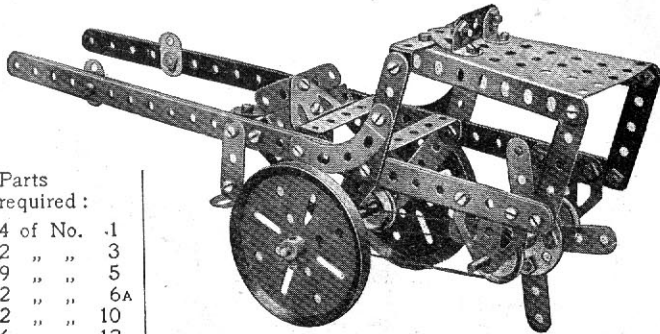

Parts required:

4 of No.	.1		
2 "	3		
9 "	5		
2 "	6A		
2 "	10		
6 "	12		
1 "	15A	2 of No.	22
1 "	16	1 "	24
2 "	19	2 "	35
2 "	20B	34 "	37
		6 of No.	37A
		4 "	38
		4 "	48A
		1 "	54
		3 of No.	90A
		6 "	111c
		2 "	126
		2 "	126A

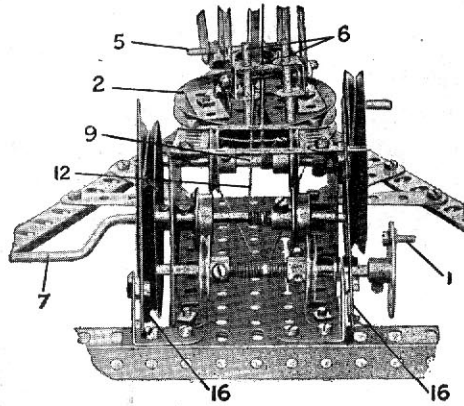

FIG. 2.38A

The 3" Pulley Wheel 2, which supports the jib, is free to turn on a short Axle Rod secured in the boss of the lower 3" Pulley Wheel 2a. The vertical 12½" Strips 13 are bolted at their tops to a Double Bracket, to the centre hole of which is secured a Bolt 14 that is free to turn in the Flat Trunnion 15.

The swivelling movement of the crane is carried out by turning the handle 1, which simultaneously winds and unwinds the ends of a cord passing round the 3" Pulley Wheel 2 (see Fig. 2.38A). The cord 12, which is tied to the Flat Bracket 3 at the head of the jib passes over the 2" Rod 4, under a similar Rod 5, and between two vertical 2" Rods 6, which act as guides, and is finally wound on to the crank handle 7. Hence on operation of the latter the jib is raised or lowered. The cord 8 also passes round the Rods 4, 5 and 6, and is wound on to the Rod 9. Operation of the handle 10 raises and lowers the hook 11. The cords 8 and 12 are prevented from unwinding by band-and-pulley brakes 16.

Model No. 2.38 Derrick

Parts required:

4 of No.	19B	1 of No.	52
4 "	20B	2 "	54
8 of No.	1	1 "	57
4 "	2	1 "	111c
2 "	3	1 "	115
8 "	3	2 "	126
1 "	6A		
3 "	8		
2 "	10		
4 "	11		
6 "	12		
2 "	12A		
3 "	16		
2 "	17		
4 "	18A		
		4 of No.	19B
		4 "	22
		1 "	23
		1 "	24
		11 "	35
		58 "	37
		3 "	37A
		5 "	38

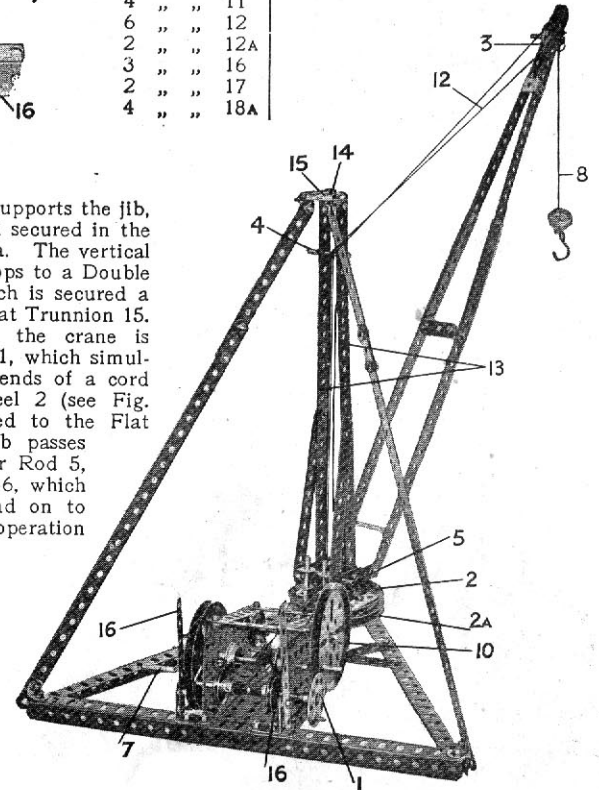

Model No. 2.39 Elevator

The construction of this model is fairly clear in the illustration, but it might be pointed out that one side of the framework consists of four 12½" Angle Girders 1 while the opposite side is composed of four 12½" Strips 2.

Parts required :

4 of No.	1
8 "	2
2 "	3
8 "	5
4 "	8
4 "	10
1 "	11
12 "	12
1 "	16
1 "	18A
2 "	19B
1 "	19S
4 "	22
1 "	35
60 "	37
6 "	37A
2 "	38
7 "	48A
1 "	52
2 "	54
1 "	62
2 "	90A
2 "	99
2 "	100
6 "	111c

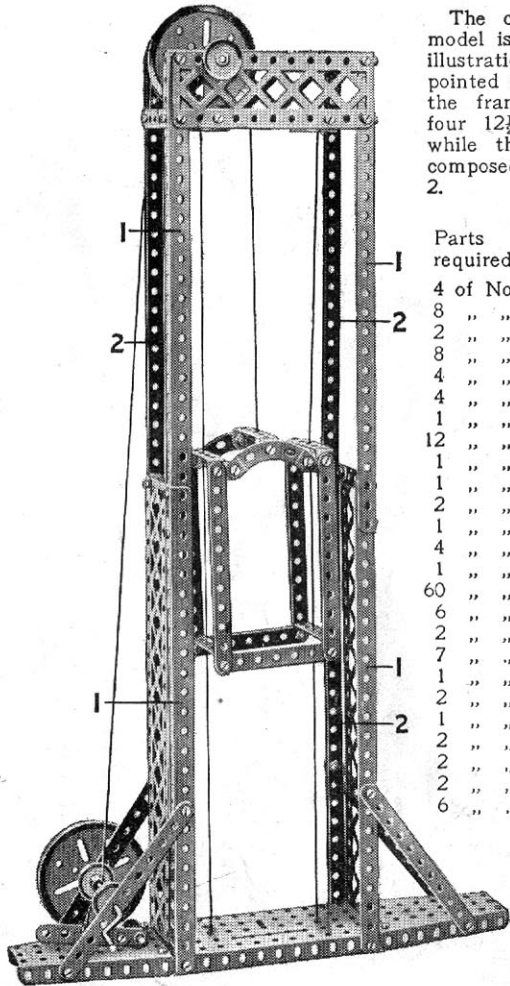

Model No. 2.40 Fire Escape

Parts required :

2 of No.	1
12 "	2
1 "	3
10 "	5
4 "	8
2 "	10
7 "	12
2 "	12A
4 "	16
4 "	19B
1 "	19S
3 "	22
1 "	23
1 "	24
5 "	35
60 "	37
6 "	37A
9 "	38
1 "	44
6 "	111c
1 "	115
2 "	125

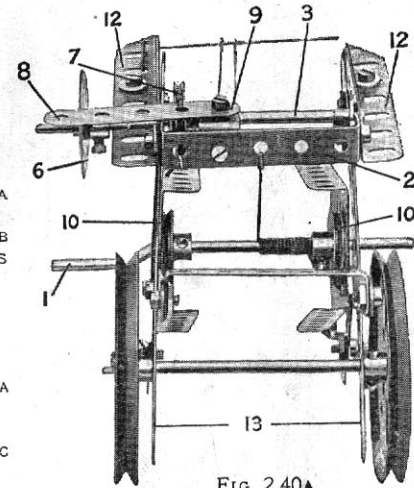
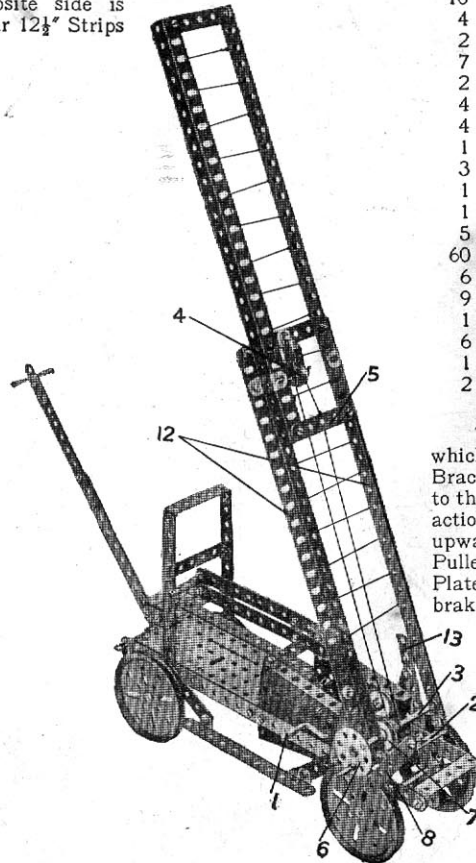

FIG. 2.40A

The ladder is elevated on operation of the crank handle 1, which winds in a cord tied to the Double Angle Strip 2. Angle Brackets bolted to the 12½" Angle Girders 12 are attached pivotally to the 5½" Strips 13 by means of Bolts and Nuts (S.M. 262), and the action of winding in the cord thus causes the ladder to swing upward. It is prevented from falling by the friction of the 1" Pulley Wheels 10 (Fig. 2.40A), which press against the two Sector Plates. When the ladder is fully elevated, its lower ends act as brakes to prevent the road wheels from revolving.

A second cord is wound upon the Rod 3. One end is then carried over the ½" loose Pulley Wheel 4 and tied to the 2½" Strip 5, the opposite end being carried directly to the same Strip and secured to it. When the handle 6 is turned, the two ends of the cord are wound and unwound simultaneously, and the ladder is extended or shortened as required. A permanent brake is provided by a cord passing over the 1" Pulley Wheel 7 and having both its ends secured to the 2½" Strip 8. The Strip 8 is bolted firmly to the Angle Bracket 9 (Fig. 2.40A) and keeps the brake continuously in action.



Model No. 2.41 Aeroplane

Parts required:	
7 of No.	1
2 " "	2
2 " "	3
7 " "	5
2 " "	6A
8 " "	10
2 " "	11
8 " "	12
1 " "	16
2 " "	17
2 " "	20B
4 " "	22
2 " "	22A
8 " "	35
58 " "	37

6 of No.	38
1 " "	48
6 " "	48A
2 " "	54
1 " "	90A
2 " "	99
2 " "	100
2 " "	126A

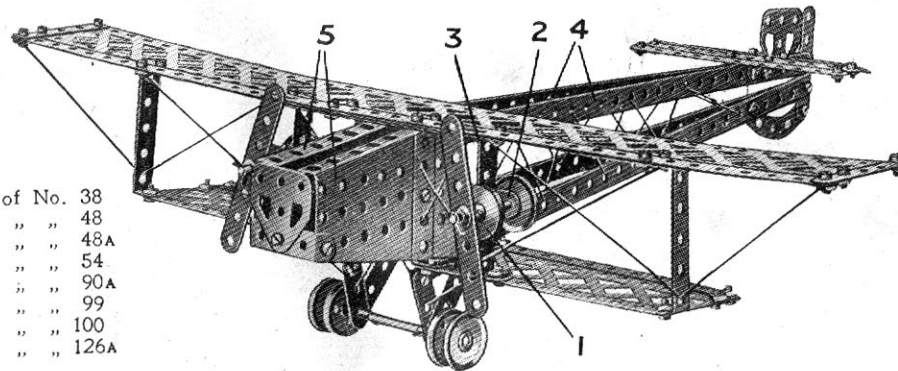

Each engine is represented by a $\frac{3}{4}$ " Flanged Wheel 1 and a 1" fast Pulley Wheel secured to a 2" Rod journalled in a Double Bracket 2, which is bolted to the $2\frac{1}{2}$ " x $\frac{1}{2}$ " vertical Double Angle Strip 3. The $12\frac{1}{2}$ " Strips 4 of the fuselage proper are bolted to the two Sector Plates 5, and also by means of Angle Brackets to the wings. The tail plane consists of two $5\frac{1}{2}$ " Strips to which a similar Strip, representing the movable portion of the plane, is attached by means of Flat Brackets.

Model No. 2.42 Anti-Aircraft Gun

The general construction of the model will be made clear by reference to Figures 2.42A and 2.42B. Rotation of the handle 1 causes the gun to revolve on the 3" Pulley Wheel 2. The barrel of the Gun is so balanced on the Axle Rod 3 that it tends to fall by its own weight, but is prevented from doing so by a cord 4 tied to the gun close to the breech and wound on the $3\frac{1}{2}$ " Rod 5. By turning the Pulley Wheels 6 the muzzle is raised or allowed to fall.

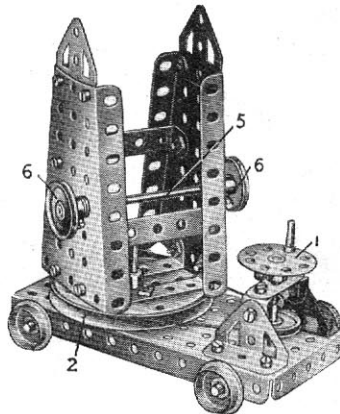

FIG. 2.42A

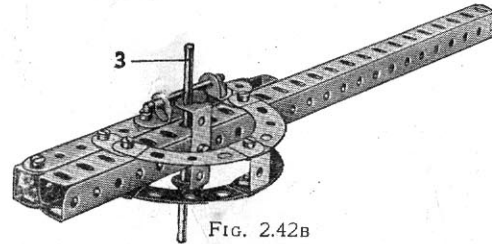
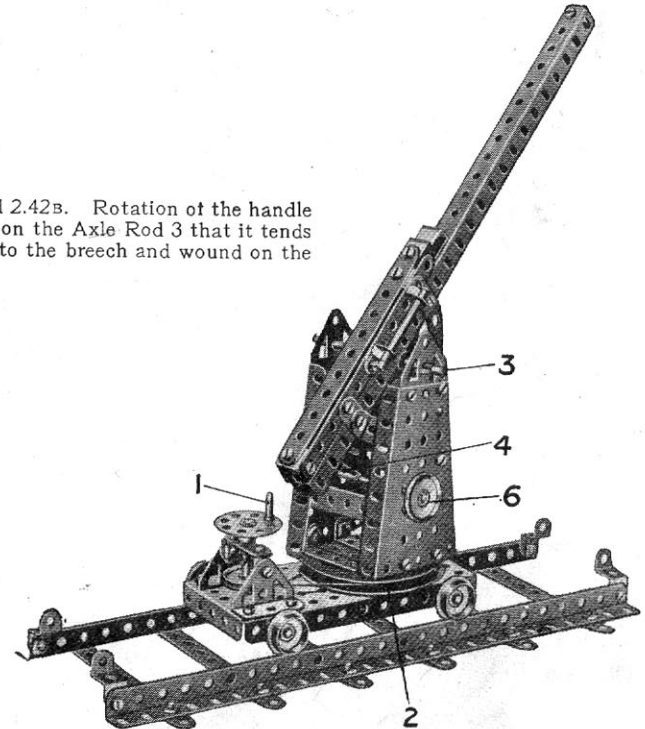

FIG. 2.42B

Parts required:					
9 of No.	2	1 of No.	19B	4 of No.	48A
1 " "	6A	4 " "	20B	1 " "	52
4 " "	8	4 " "	22	2 " "	54
4 " "	10	1 " "	24	4 " "	90A
3 " "	11	8 " "	35	1 " "	115
5 " "	12	57 " "	37	2 " "	126
4 " "	16	6 " "	38	2 " "	126A
2 " "	17	1 " "	44		



Model No. 2.43 Travelling Jib Crane (Electrically Operated)

Parts required:

10 of No. 1	14 of No. 35	4 of No. 90A
9 " " 2	60 " " 37	5 " " 111c
2 " " 3	6 " " 37A	2 " " 126A
2 " " 5	14 " " 38	
2 " " 6A	1 " " 48	Electric Motor
4 " " 8	7 " " 48A	(not included
1 " " 10	1 " " 52	in Outfit)
1 " " 11	1 " " 57	
2 " " 12		
2 " " 15		
1 " " 15A		
2 " " 16		
1 " " 17		
2 " " 18A		
1 " " 19		
4 " " 19B		
4 " " 20B		
4 " " 22		
1 " " 23		
1 " " 24		

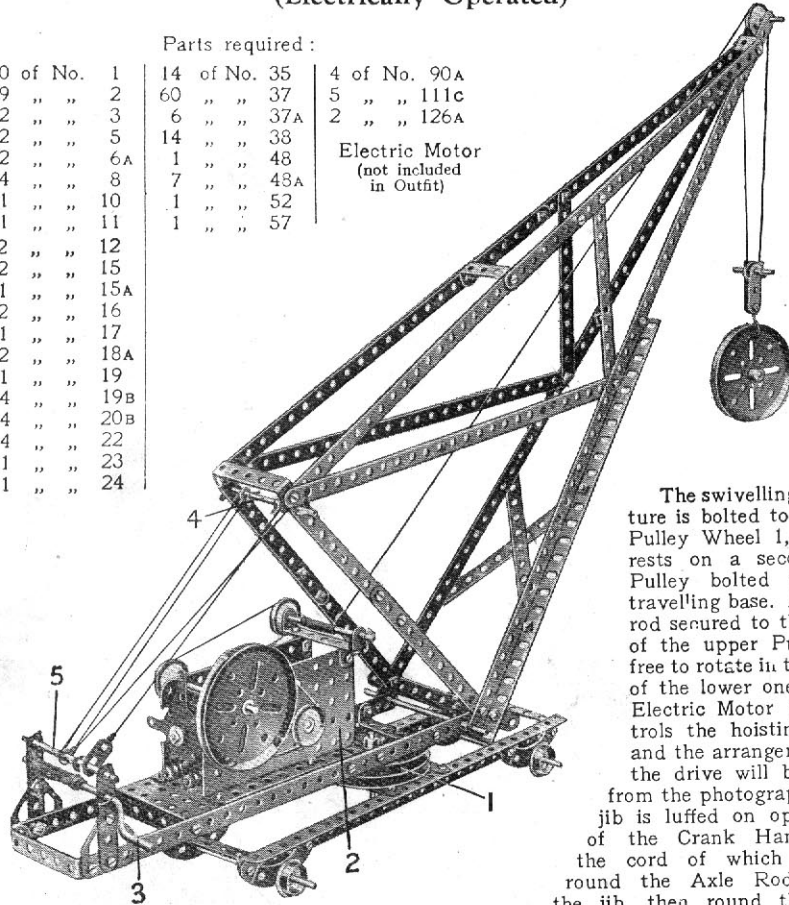

The swivelling structure is bolted to the 3" Pulley Wheel 1, which rests on a second 3" Pulley bolted to the travelling base. A short rod secured to the boss of the upper Pulley is free to rotate in the boss of the lower one. The Electric Motor 2 controls the hoisting gear and the arrangement of the drive will be clear from the photograph. The jib is luffed by operator of the Crank Handle 3, the cord of which passes round the Axle Rod 4 in the jib, then round the Rod 5 in the base, back round the Rod 4 and is finally secured to a Flat Bracket on the Rod 5.

Model No. 2.44 Travelling Jib Crane (Hand Operated)

This shows a section of Model No. 2.43 fitted for hand operation, thus dispensing with the necessity of the Electric Motor. In this case the hoisting cord is operated by the hand wheel 6, the Rod of which is controlled by a band brake 7. The end hole of the lever of the latter is pivotally mounted on the Rod 8. The luffing movement of the jib is effected by the Crank Handle 9. The operating cord passes round the Rod 10 attached to the jib, then round Rod 11 in the base of the model, again round Rod 10, back round Rod 11, and once more round Rod 10. The end of the cord is then tied to a Flat Bracket on the Rod 11.

Parts required:

10 of No. 1	1 of No. 11	4 of No. 20B	7 of No. 48A
11 " " 2	1 " " 15	4 " " 22	1 " " 52
2 " " 3	1 " " 15A	1 " " 23	2 " " 54
6 " " 5	5 " " 16	1 " " 24	1 " " 57
2 " " 6A	2 " " 18A	12 " " 35	1 " " 62
4 " " 3	1 " " 19	57 " " 37	4 " " 90A
3 " " 10	4 " " 19B	1 " " 48	1 " " 111c
	1 of No. 115		

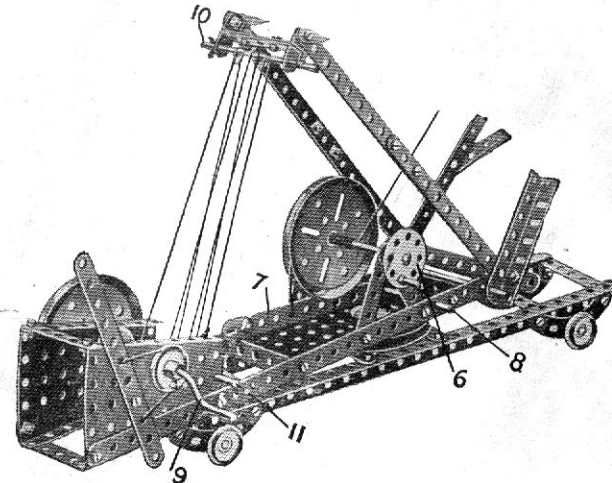

Model No. 2.45 Try-Your-Strength Machine

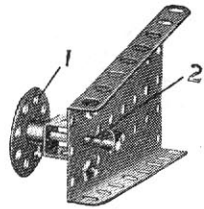

FIG. 2.45A

Parts required :

6 of No. 1	1	60 of No. 37
6 " " 2	2	6 " " 37A
1 " " 3	4	" " 38
2 " " 5	1	" " 45
2 " " 6A	1	" " 48
4 " " 8	1	" " 48A
2 " " 10	1	" " 52
10 " " 12	2	" " 54
2 " " 18A	3	" " 90A
1 " " 23	2	" " 100
1 " " 24	2	" " 126
3 " " 35		

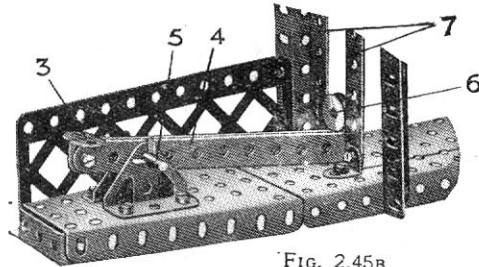
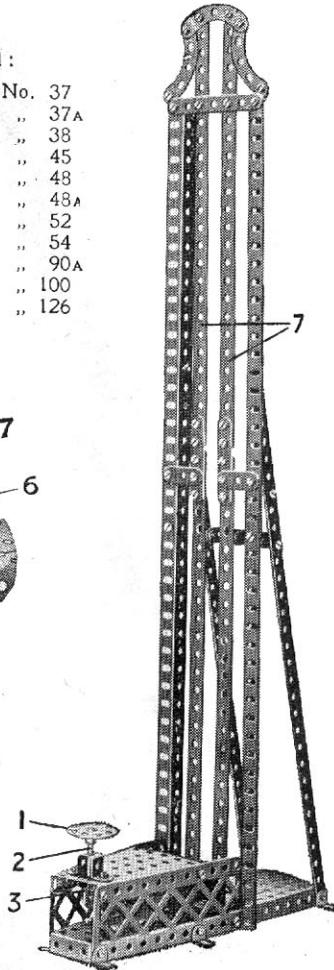

FIG. 2.45B

The Bush Wheel 1 is secured to a short Axle Rod 2, the lower end of which rests on a pair of Angle Brackets 3 bolted to the ends of four $5\frac{1}{2}$ " Strips 4. The Strips 4 are pivoted as shown (Fig. 2.45A) on a $1\frac{1}{2}$ " Rod 5, and on their opposite ends rests a $\frac{1}{2}$ " loose Pulley Wheel 6. When the Bush Wheel 1 is struck, the $5\frac{1}{2}$ " Strips fling the Pulley Wheel 6 upward, but the wheel is guided by the vertical $12\frac{1}{2}$ " Strips 7. The weight of the Strips 4 then causes the Bush Wheel to resume its original position.



Model No. 2.46 Tipping Moto. Wagon

Parts required :

2 of No. 1	1	4 of No. 19B	1 of No. 52
4 " " 2	4	" " 22	2 " " 54
11 " " 5	1	" " 24	4 " " 90A
2 " " 6A	6	" " 35	2 " " 100
6 " " 12	59	" " 37	3 " " 111c
4 " " 16	4	" " 37A	1 " " 115
1 " " 17	1	" " 45	2 " " 126
1 " " 18A	1	" " 48	1 " " 126A
	7	" " 48A	

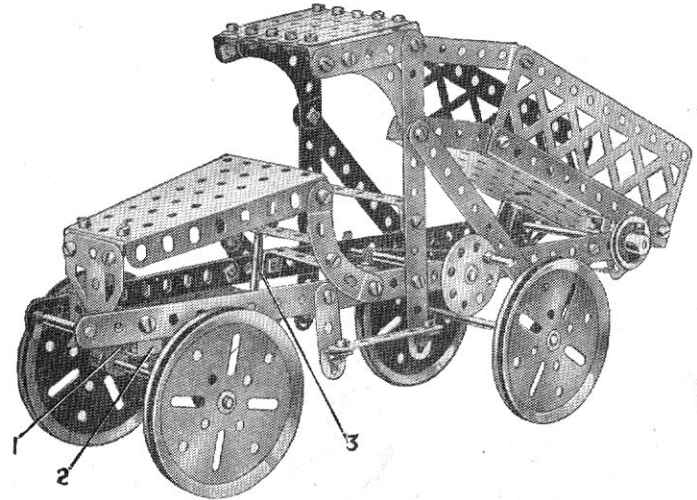

The front Axle Rod is journalled in a $2\frac{1}{2}$ " x $\frac{1}{2}$ " Double Angle Strip 1 which in turn is bolted to a Double Bent Strip 2. The Double Bent Strip is pivoted to the Sector Plate by a bolt and two nuts. Cord passing over a 1 " Pulley Wheel attached to the Rod 3 is fastened to the ends of the Double Angle Strip 1, and by rotating another pulley, which represents the steering wheel, the road wheels are deflected.

Model No. 2.47 Embossing Machine

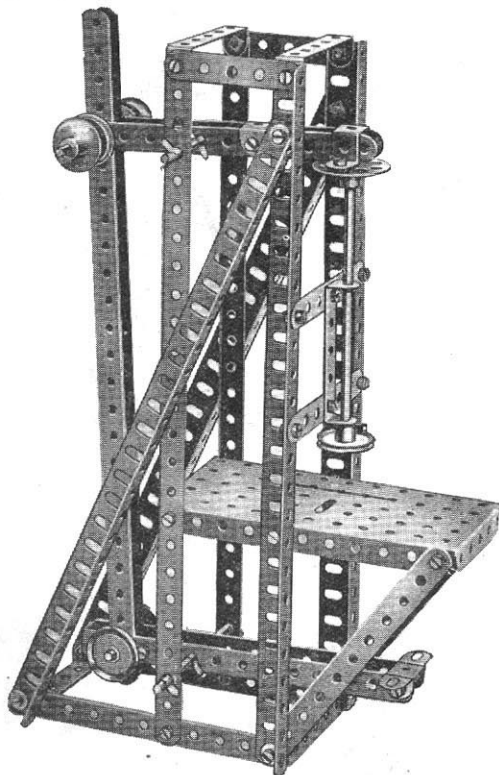
Parts
required :

4	of No.	1
8	" "	2
2	" "	3
2	" "	5
4	" "	8
3	" "	11
2	" "	12
1	" "	15
3	" "	16
1	" "	18A
4	" "	20B
3	" "	22
1	" "	24
10	" "	35
34	" "	37
8	" "	38
1	" "	45
5	" "	48A
1	" "	52

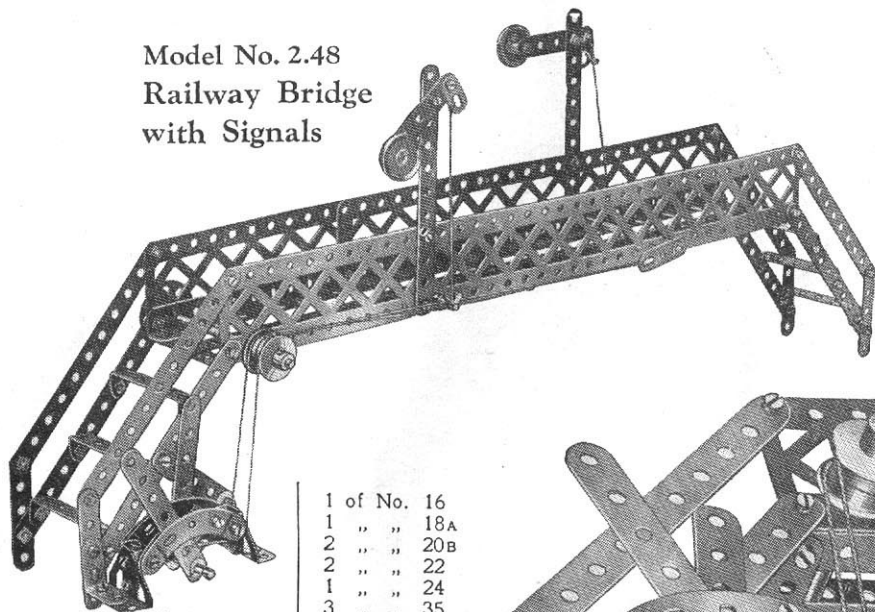
Model No. 2.48
Railway Bridge
with SignalsParts
required :

2	of No.	1
10	" "	2
2	" "	3
8	" "	5
4	" "	8
2	" "	10
3	" "	11
2	" "	12A
1	" "	15A
1	of No.	16
1	" "	18A
2	" "	20B
2	" "	22
1	" "	24
3	" "	35
60	" "	37
3	" "	37A
6	" "	38
7	" "	48A
2	" "	62
4	" "	90A
2	" "	99
2	" "	100
3	" "	11C
1	" "	115
2	" "	126

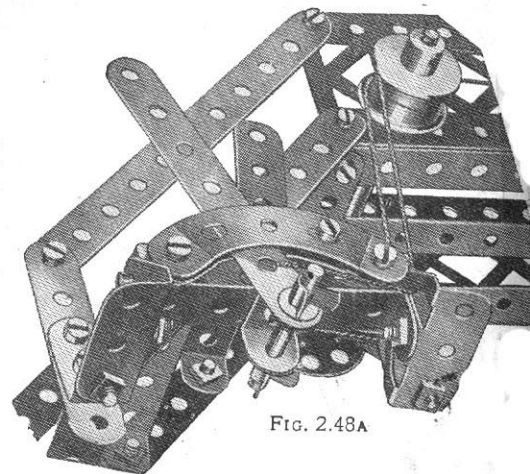
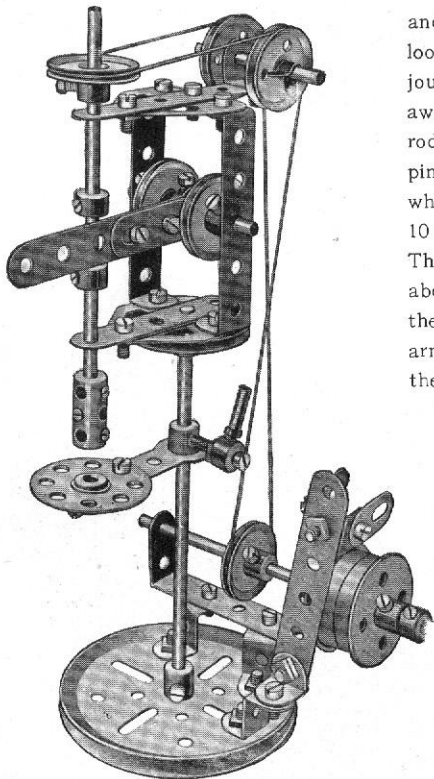

FIG. 2.48A

HOW TO CONTINUE

This completes our examples of models that may be made with MECCANO Outfits No. 2. The next models are a little more advanced, requiring a number of extra parts to construct them. The necessary parts are all contained in a No. 2A Accessory Outfit, the price of which will be found in the List at the end of this Manual.

Model No. 3.1 Drilling Machine



Parts required :

2 of No. 4	1 of No. 19B	2 of No. 48A
2 " " 5	2 " " 20B	5 " " 59
2 " " 10	1 " " 21	2 " " 62
2 " " 11	4 " " 22	1 " " 63
1 " " 12	2 " " 22A	1 " " 111
1 " " 15	1 " " 24	1 " " 115
2 " " 15A	2 " " 35	3 " " 125
2 " " 17	21 " " 37	2 " " 126A
	1 " " 46	

Model No. 3.2 Strip-Bending Machine

This model represents a device for bending bars or rods of metal to circular form, and may be put to practical purpose in shaping strips of tin or similar material. A loose pulley 1 is spaced by a collar and washers in the centre of the short rod 2 journalled in a 1½" strip 3. The latter is secured to the end of a ¾" bolt 4 and spaced away from the 3" pulley 5 by means of a number of washers. The opposite end of the rod is supported by a 5½" strip 6. The handle 7 is secured to a 3½" rod carrying a ½" pinion 8. This engages with a 57-teeth gear wheel 9 mounted on another 3½" rod which is free to revolve in the boss of the wheel 5. The gear wheel 9 carries a 3" strip 10 forming one of the bearings for a short rod carrying a second 1" loose pulley 11. The latter is also spaced by means of a collar and washers so that it lies immediately above the groove of the pulley wheel 5. The material to be shaped is passed between the two loose pulleys at the top of the wheel 5, and on rotation of the handle 7 the arm 10 is caused to move downward, so forcing the object to the same curvature as the circumference of the wheel.

Parts required :

1 of No. 2
2 " " 3
1 " " 4
1 " " 5
1 " " 6A
2 " " 16
1 " " 17
2 " " 18B
1 " " 19B
2 " " 22A
1 " " 26
1 " " 27A

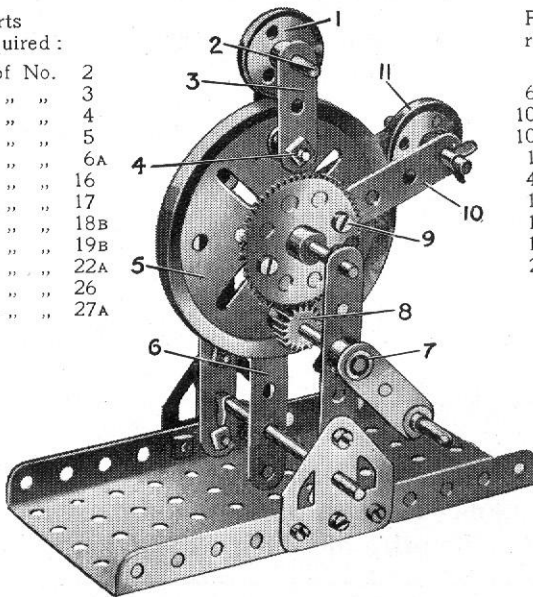

Parts required :

(continued)

6 of No. 35
10 " " 37
10 " " 38
1 " " 52
4 " " 59
1 " " 62
1 " " 111
1 " " 115
2 " " 126A

Model No. 3.3 Boring Machine

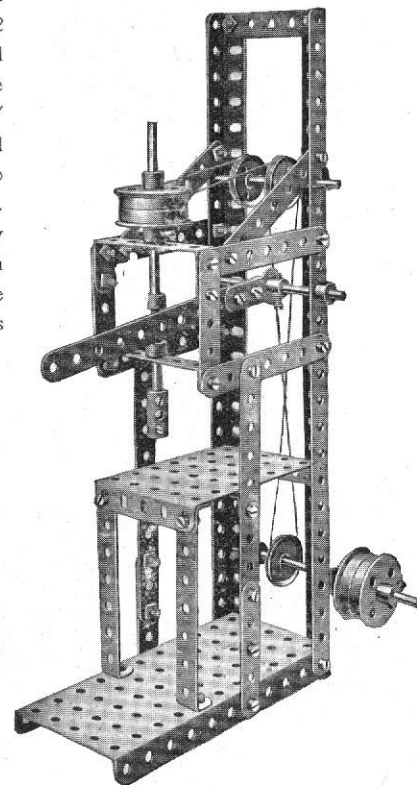

Parts required :

3 of No. 2	4 of No. 20B	2 of No. 48B
6 " " 3	1 " " 22	1 " " 52
5 " " 5	2 " " 22A	1 " " 53
2 " " 8	3 " " 35	4 " " 59
2 " " 11	38 " " 37	1 " " 62
2 " " 15	1 " " 46	1 " " 63
2 " " 16	2 " " 48A	

Model No. 3.4 Roundabout

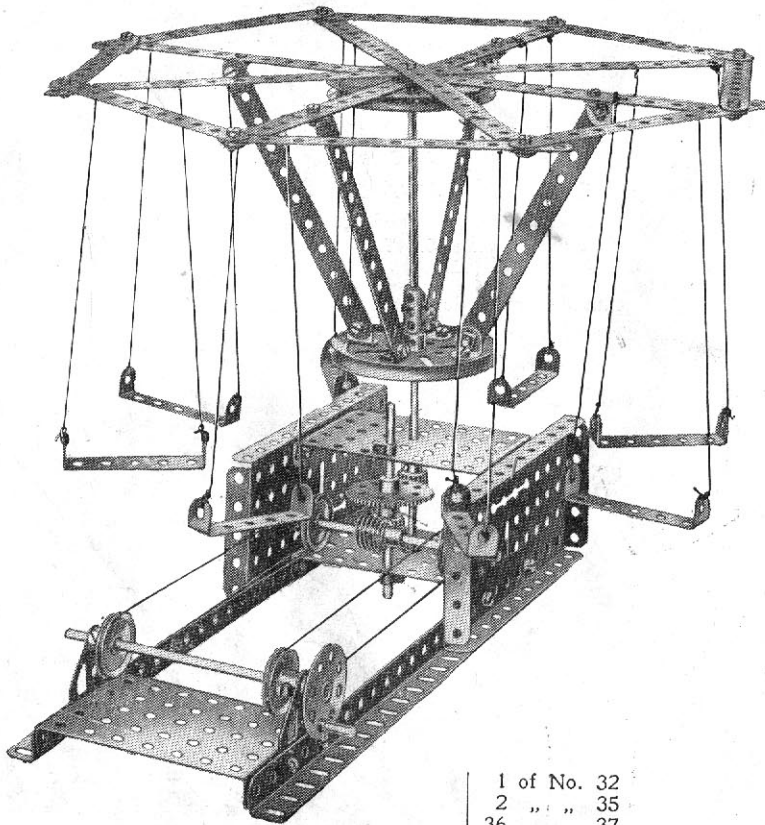

			1 of No. 16	1 of No. 32
			2 " " 19B	2 " " 35
			4 " " 22	36 " " 37
			1 " " 24	8 " " 48A
			2 " " 26	2 " " 52
			1 " " 27A	3 " " 53
				2 " " 59
				1 " " 115
				2 " " 126A
Parts required:	2 of No. 8			
	8 " " 12			
4 of No. 1	1 " " 15			
12 " " 2	3 " " 15A			

Model No. 3.5 Drop the Nigger

The Sector Plate 1 is a target, which, when hit, allows the nigger to be dropped. The Plate 1 is carried on the Strip 2 pivoted at 3, weight of the nigger supported on another Sector Plate 4 pivoted at 5. A cord 6 keeps the lower end of the Strip 2 hard against the short Rod 7 pivoted at 8. When the target is hit and knocked back the Rod 7 is released and falls about its pivot, allowing the Sector Plate 4 with the nigger to drop.

- Parts required:
- 1 of No. 1
 - 6 " " 3
 - 8 " " 8
 - 1 " " 12
 - 3 " " 15A
 - 2 " " 17
 - 1 " " 22
 - 6 " " 35
 - 33 " " 37
 - 1 " " 44
 - 4 " " 48A
 - 2 " " 53
 - 2 " " 54
 - 3 " " 59
 - 1 " " 63

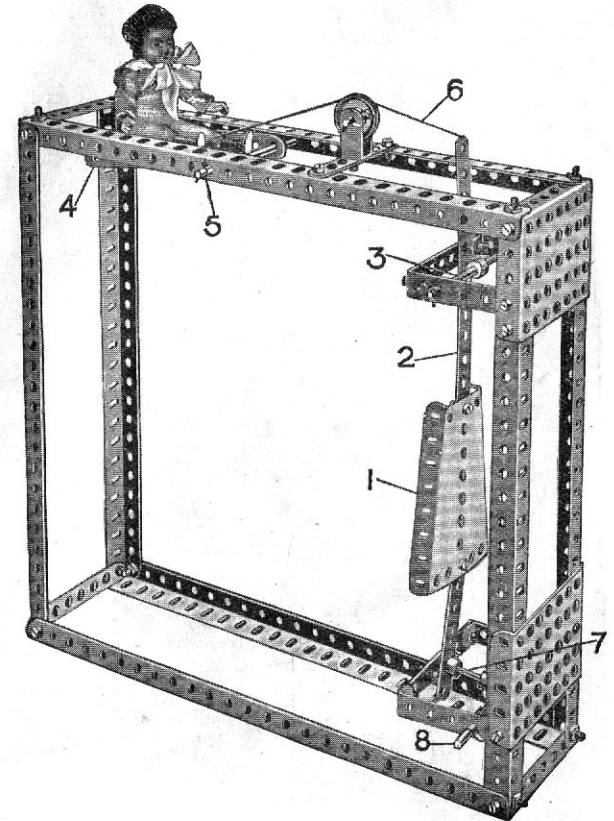

Model No. 3.6 Fire Escape

The main frame 1 is pivotally connected to the running truck 2 about the Rod 3. Ordinarily the frame 1 rests on the running truck 2 when the escape is being transported. In order to raise the main frame about the pivot Rod 3 the handle 4 winds up the cord 5 the outer end of which is connected to the running truck axle. To raise or lower the ladder 6 the handle 7 is turned in one or other direction, the cord 8 passing over the Pulleys 9 and being connected to the sliding ladder.

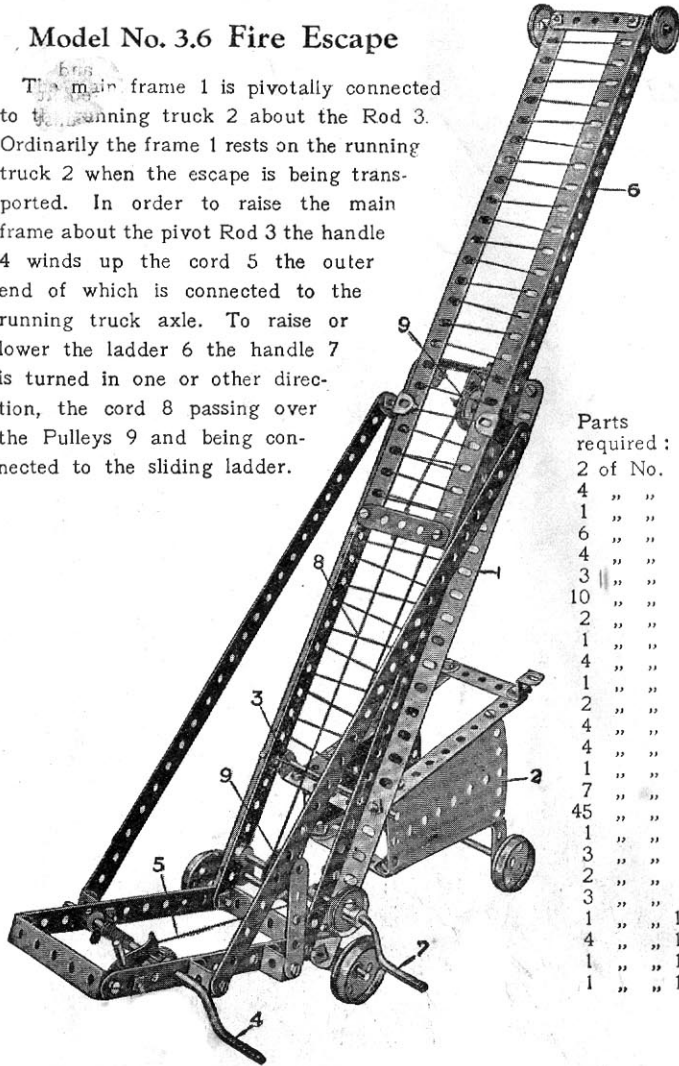

Parts required:

2 of No.	1
4 " "	2
1 " "	3
6 " "	5
4 " "	8
3 " "	11
10 " "	12
2 " "	12A
1 " "	15A
4 " "	16
1 " "	18A
2 " "	19
4 " "	20B
4 " "	22
1 " "	22A
7 " "	35
45 " "	37
1 " "	44
3 " "	48A
2 " "	54
3 " "	59
1 " "	115
4 " "	125
1 " "	147
1 " "	148

Model No. 3.7 Crossbow

Parts required:

5 of No.	1	1 of No.	17
2 " "	2	1 " "	18A
1 " "	3	2 " "	36
4 " "	5	25 " "	37
2 " "	8	1 " "	38
2 " "	11	1 " "	48A
1 " "	12	1 " "	63

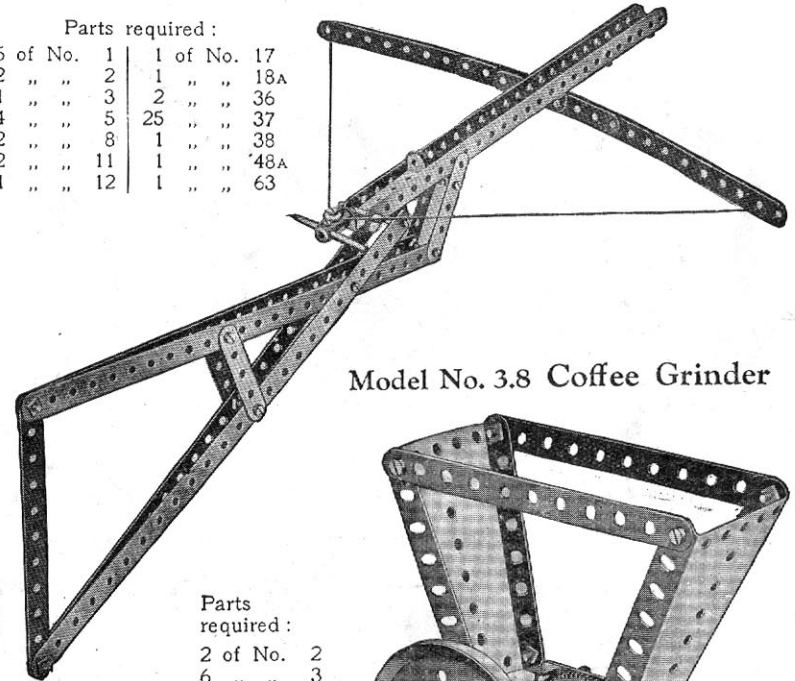

Model No. 3.8 Coffee Grinder

Parts required:

2 of No.	2
6 " "	3
2 " "	4
2 " "	16
1 " "	19B
1 " "	26
1 " "	27A
16 " "	37
2 " "	54
3 " "	59
1 " "	115
4 " "	125

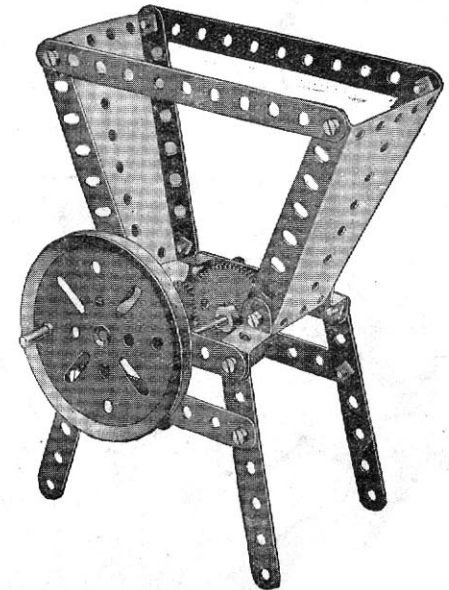

Model No. 3.9 Swing

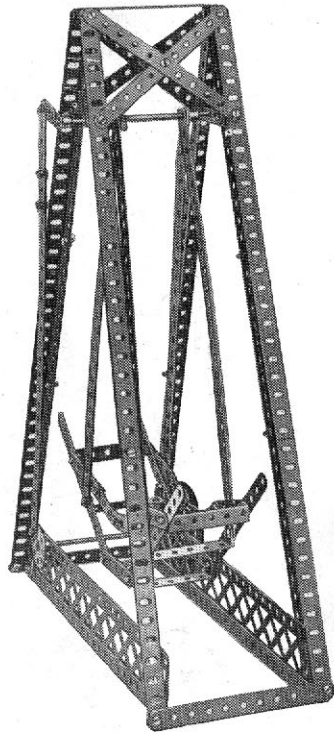

Parts required :

7 of No. 1	56 of No. 37
10 " " 2	4 " " 37A
8 " " 5	6 " " 48A
8 " " 8	1 " " 48B
1 " " 10	2 " " 59
2 " " 15	2 " " 62
1 " " 19B	4 " " 90A
1 " " 24	2 " " 99
2 " " 35	2 " " 111c
1 of No. 115	

Model No. 3.10

Flax Cleaner

Parts required :

4 of No. 2	2 of No. 52
6 " " 3	3 " " 53
6 " " 5	4 " " 59
2 " " 8	1 " " 115
2 " " 12	
3 " " 15A	
1 " " 19B	
4 " " 22	
1 " " 24	
1 " " 26	
1 " " 27A	
1 " " 35	
34 " " 37	
3 " " 38	

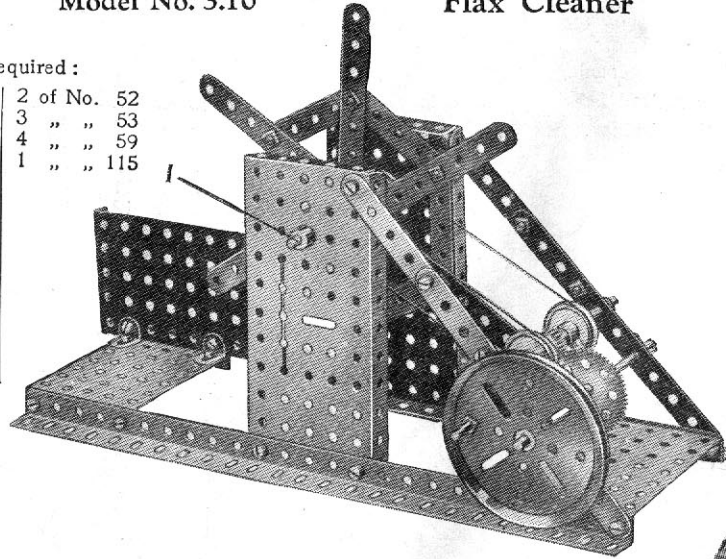

The six 3½" Strips forming the rotating frame are fastened to a Bush Wheel that in turn is attached to the Rod 1. The 3½" Strips are braced by six 2½" Strips. The drive is transmitted from Rod 2 to Rod 1 by means of endless cords. Two separate cords are used in order to secure a more positive drive.

Model No. 3.11 Lawn Mower

The grass box 1 is retained in position by two Flat Brackets bolted to the 2½" x ¼" Double Angle Strip 2 but spaced from it by a Washer on each bolt. The edge of the Double Angle Strip 3 may be slipped in the space between the Double Angle Strip 2 and the Flat Brackets, one of which is shown at 4.

Parts required :

2 of No. 2	2
2 " " 5	5
4 " " 10	10
2 " " 11	11
2 " " 16	16

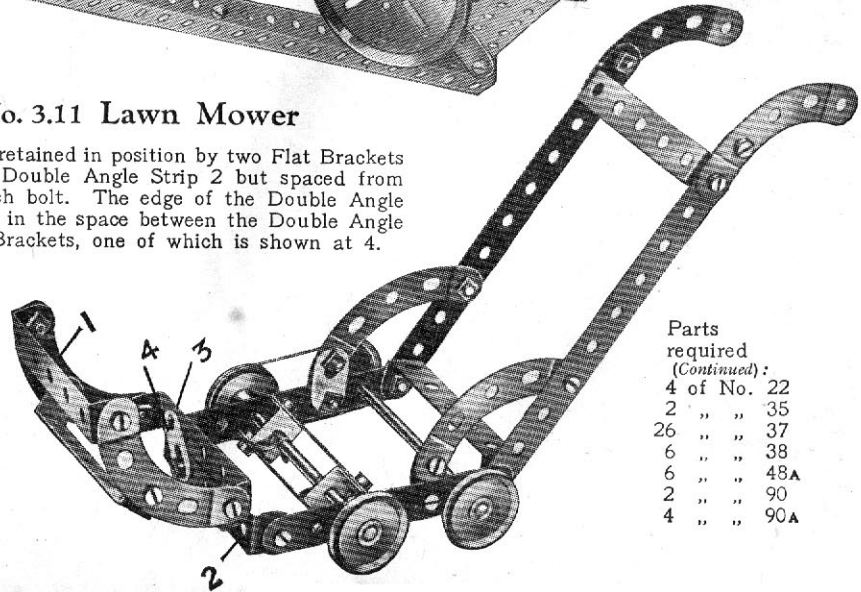

Parts required

(Continued):

4 of No. 22	22
2 " " 35	35
26 " " 37	37
6 " " 38	38
6 " " 48A	48A
2 " " 90	90
4 " " 90A	90A

Model No. 3.12 Horse Sleigh

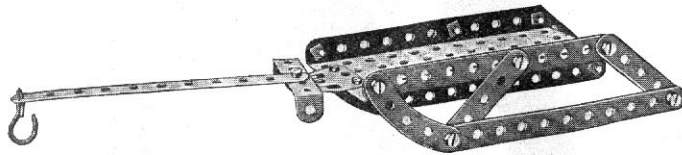

Parts required:

3 of No. 2	13 of No. 37	1 of No. 57
4 " " 5	1 " " 48A	2 " " 90
1 " " 23	1 " " 52	1 " " 126A

Model No. 3.13 Drafting Machine



Parts required:

4 of No. 1	1 of No. 24
3 " " 2	15 " " 37
1 " " 4	1 " " 52
2 " " 5	

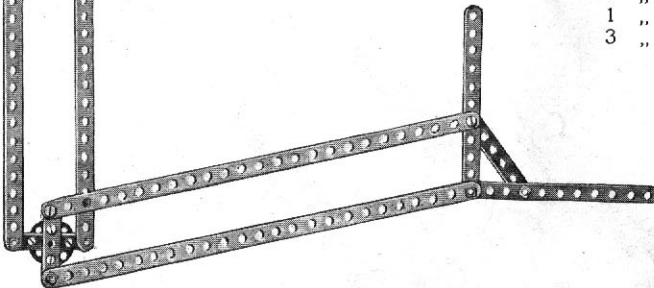

Model No. 3.14 Demonstration Scales

Parts required:

3 of No. 1	1
4 " " 2	2
6 " " 3	3
1 " " 4	4
2 " " 5	5
8 " " 8	8
4 " " 11	11
6 " " 12	12
2 " " 12A	12A
2 " " 17	17
1 " " 18A	18A
1 " " 22	22
2 " " 35	35
58 " " 37	37
1 " " 44	44
2 " " 52	52
2 " " 53	53
2 " " 59	59
2 " " 62	62
4 " " 90	90
1 " " 125	125
3 " " 126A	126A

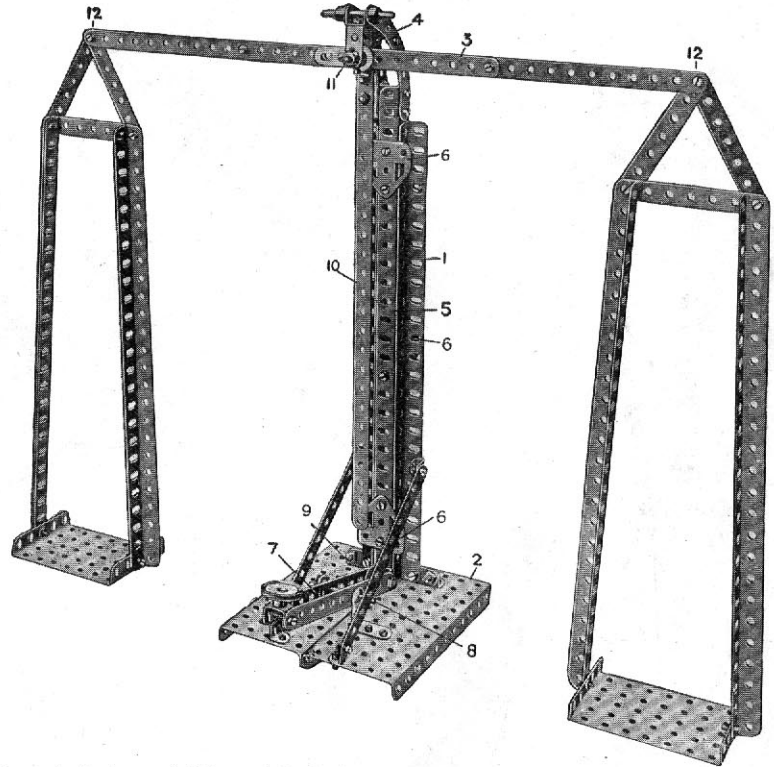

The only feature of this model which needs description is the standard, which is built up of two Angle Girders 1 bolted to the base 2 by Angle Brackets and spaced apart at the top by a 2½" Strip obliquely disposed. The balance lever 3 is pivotally carried in Curved Strips 4 bolted to the top of two Angle Girders 5 sliding between the Girders 1. The Girders 5 are themselves bolted together and in order to guide them as they slide vertically Flat Trunnions 6 are bolted at the front and rear. The balance is raised by depressing the lever 8 pivoted at 9 and pivotally connected at 11 to the vertically sliding Girders 5. The indicator 10 is bolted to a Crank at the rear, the boss of which is fitted on the pivot Rod 11. The connections at 12 are lock-nutted to allow free action.

Model No. 3.15 Pile Driver

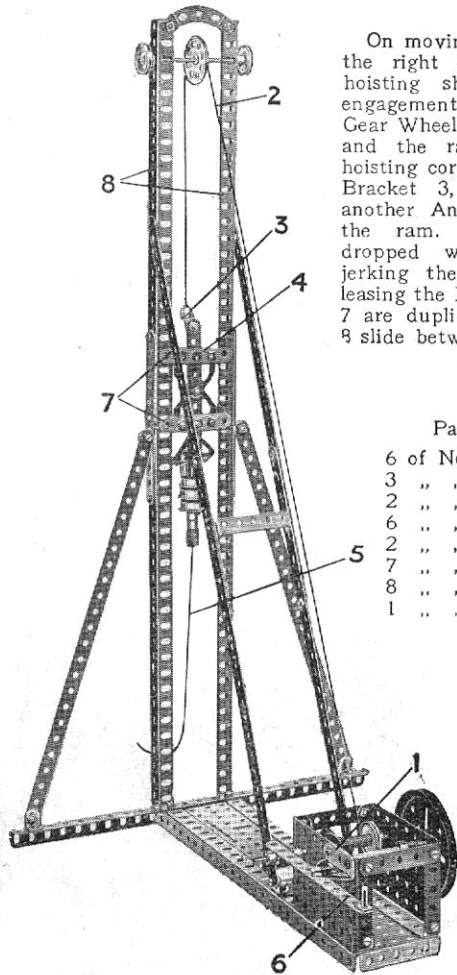

On moving the hand lever 6 to the right a $\frac{1}{2}$ " Pinion on the hoisting shaft is brought into engagement with the 57-teeth Gear Wheel 1 on the driving shaft and the ram 4 is raised. The hoisting cord 2 is tied to an Angle Bracket 3, which lodges under another Angle Bracket bolted to the ram. The latter may be dropped whenever required by jerking the cord 5, thereby releasing the Brackets 3. The Strips 7 are duplicated, and the Girders 8 slide between their ends.

Parts required :

6 of No.	1	3 of No.	16
3 " "	2	1 " "	19B
2 " "	3	3 " "	20B
6 " "	5	1 " "	21
2 " "	6A	2 " "	22
7 " "	8	1 " "	26
8 " "	12	1 " "	27A
1 " "	15A	1 " "	32
		2 " "	35
		60 " "	37
		2 " "	37A
		1 " "	38
		1 " "	45
		1 " "	46
		1 " "	48A
		2 " "	48B
		2 " "	52
		2 " "	53
		4 " "	59
		1 " "	90A
		1 " "	111C
		1 " "	115
		2 " "	126
		2 " "	126A

Model No. 3.16 Hand Trolley

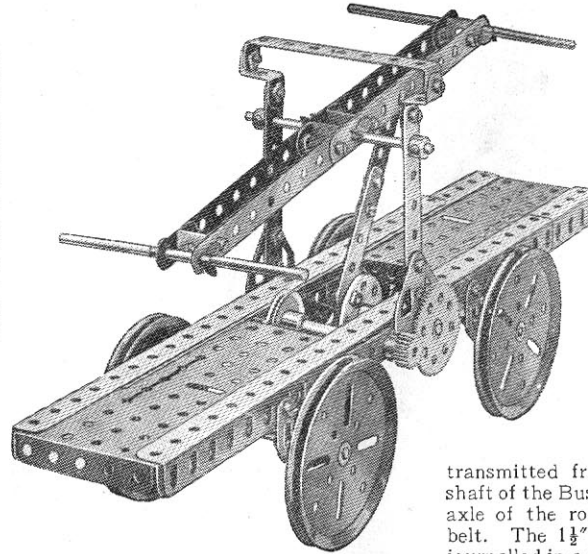

Parts required :

4 of No.	2	1 of No.	24
3 " "	3	1 " "	26
2 " "	5	1 " "	27A
4 " "	8	6 " "	35
8 " "	10	40 " "	37
4 " "	11	1 " "	45
2 " "	15A	1 " "	48B
4 " "	16	2 " "	52
1 " "	18A	3 " "	59
4 " "	19B	4 " "	90A
2 " "	22	2 " "	125
		2 of No.	126A

The connecting arm is pivoted at its lower end to the Bush Wheel and at its upper end to the hand lever a bolt and two nuts being used to pivot the arm in each case. The drive is transmitted from the 1" Pulley Wheel on the shaft of the Bush Wheel to a similar Pulley on the axle of the road wheels by means of a crossed belt. The $1\frac{1}{2}$ " Rod carrying the Bush Wheel is journalled in a $3\frac{1}{2}$ " Strip fastened to the side Angle Girder, and also in a Double Bent Strip secured to the inside of the Girder.

Model No. 3.17 Tank Wagon

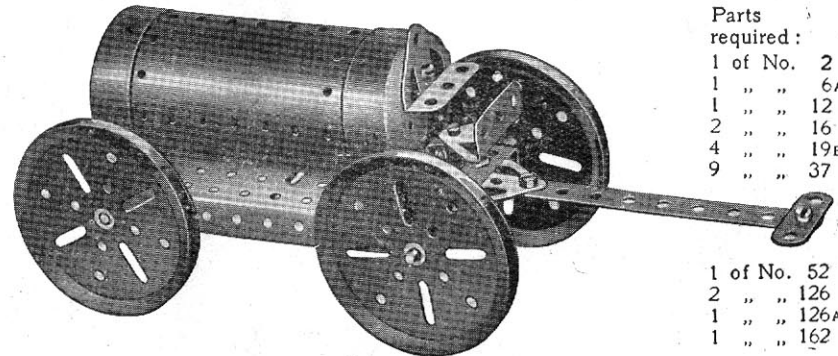

Parts required :

1 of No.	2
1 " "	6A
1 " "	12
2 " "	16
4 " "	19B
9 " "	37
1 of No.	52
2 " "	126
1 " "	126A
1 " "	162

Model No. 3.18 Actuated See-Saw

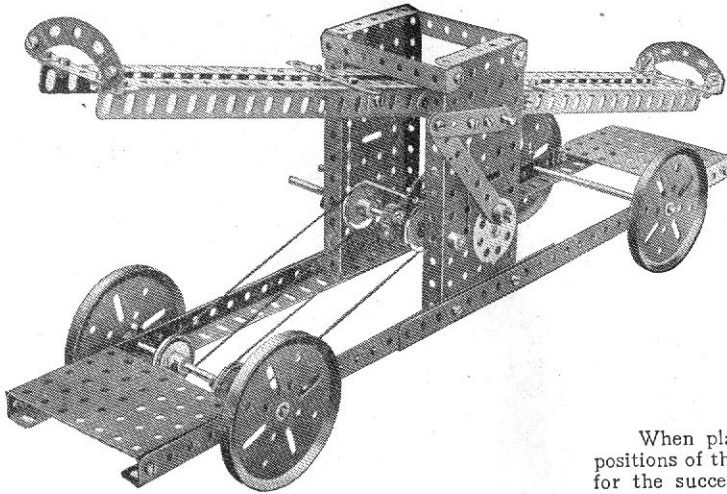

Parts required :

1 of No. 3	4 of No. 22	2 of No. 52
6 " " 5	1 " " 24	2 " " 53
8 " " 8	1 " " 26	3 " " 59
4 " " 12	1 " " 27A	2 " " 62
2 " " 15	2 " " 35	2 " " 90A
3 " " 15A	43 " " 37	1 " " 111c
4 " " 19B	2 " " 37A	1 " " 115
	2 " " 48B	

The model is actuated by the motion of one pair of travelling wheels. The axle to which these wheels are secured carries two 1" fast Pulley Wheels, which are connected by endless cords to similar Pulleys on the same Rod as a $\frac{1}{2}$ " Pinion Wheel. This $\frac{1}{2}$ " Pinion meshes with a 57-teeth Gear Wheel secured to the Rod of a Bush Wheel, and the latter is connected by means of a $5\frac{1}{2}$ " Strip to an extended crank (a $2\frac{1}{2}$ " Strip and a Crank bolted together) secured to the pivotal Rod of the see-saw.

Model No. 3.19 Toboggan

Parts required :

6 of No. 5
22 " " 37
5 " " 48A
1 " " 52
2 " " 90
1 " " 90A

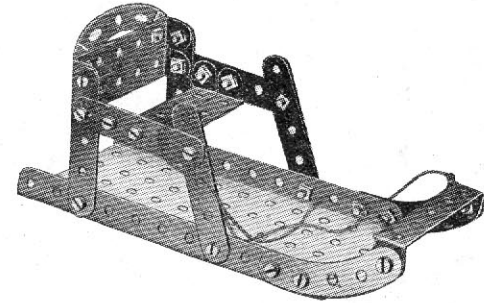

Model No. 3.20 The Meccangaroo

When placed upon an incline the "Meccangaroo" will "walk" with a quaint action. The positions of the various Strips in relation to the body should be reproduced as accurately as possible, for the successful working of the model depends upon them.

The animal rocks about a short Rod secured between the rocker-frame which does duty as "legs." This frame consists of two $3\frac{1}{2}$ " Strips 3 bolted at their upper ends to cranks in which the short Rod is secured, and at their lower ends to two $2\frac{1}{2}$ " large radius Curved Strips 4, which are connected together at their ends by $1\frac{1}{2}$ " Strips 5 and braced to the Strips 3 by $2\frac{1}{2}$ " Strips.

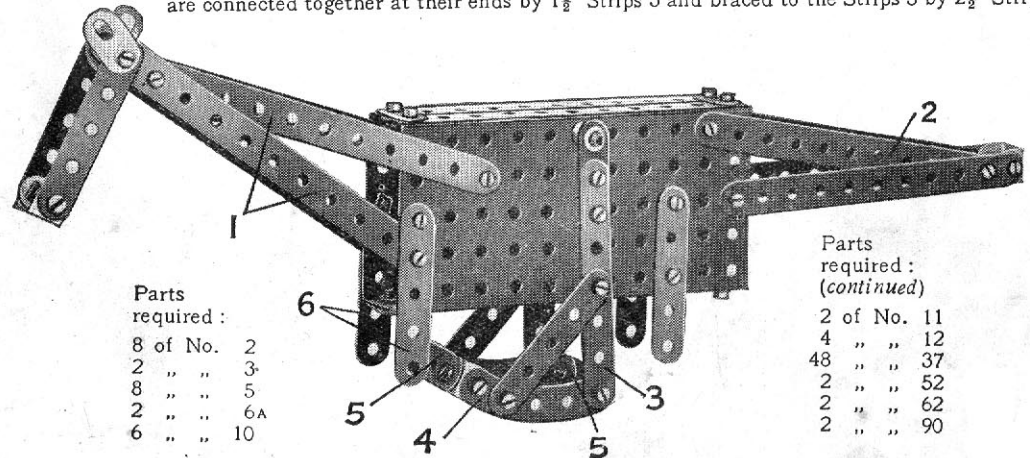

Parts required :

8 of No. 2
2 " " 3
8 " " 5
2 " " 6A
6 " " 10

Parts required :
(continued)

2 of No. 11
4 " " 12
48 " " 37
2 " " 52
2 " " 62
2 " " 90

Model No. 3.21 Ice Boat

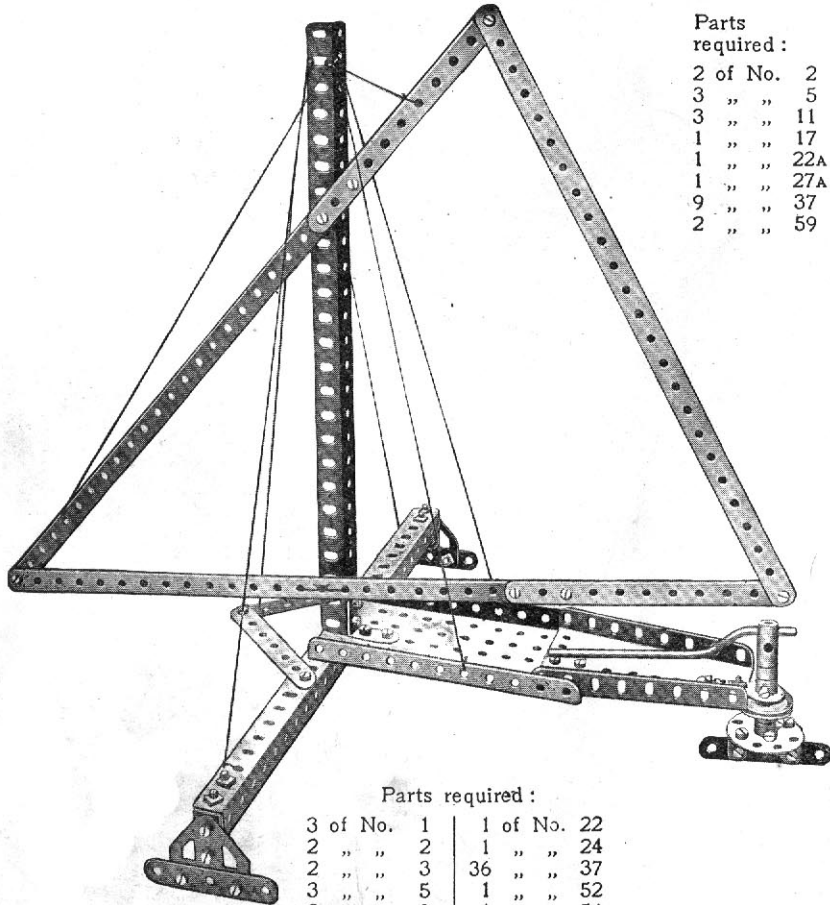

Parts required :

2 of No.	2
3 " "	5
3 " "	11
1 " "	17
1 " "	22A
1 " "	27A
9 " "	37
2 " "	59

Parts required :

3 of No.	1	1 of No.	22
2 " "	2	1 " "	24
2 " "	3	36 " "	37
3 " "	5	1 " "	52
2 " "	8	1 " "	54
2 " "	12	1 " "	59
3 " "	12A	1 " "	62
1 " "	17	1 " "	63
1 " "	19s	2 " "	126A

Model No. 3.22 Pastry Designer

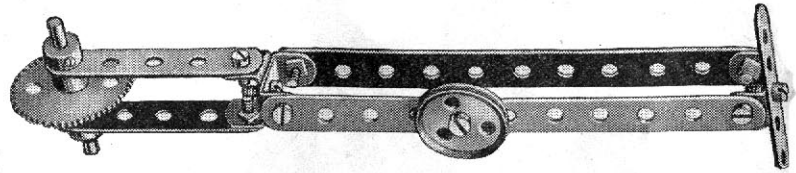

Model No. 3.23 Steam Road Roller

Parts required :

2 of No.	2	3 of No.	22
7 " "	5	1 " "	23
2 " "	11	1 " "	24
1 " "	12	57 " "	37
2 " "	12A	11 " "	38
3 " "	16	1 " "	45
1 " "	17	8 " "	48A
4 " "	19B	1 " "	48B
1 " "	21	3 " "	53

Parts required :
(continued)

4 of No.	59
1 " "	62
4 " "	90A
1 " "	126
1 " "	126A
1 " "	162
1 " "	164

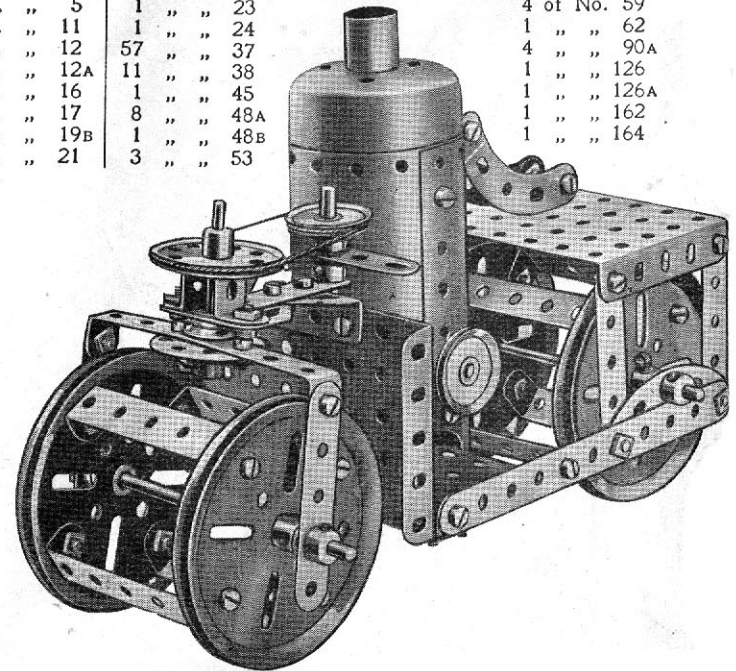

Model No. 3.24 Paddle Boat

Parts required :

6 of No.	1	4 of No.	35	1 of No.	59
4 " "	2	94 " "	37	2 " "	62
6 " "	3	3 " "	37A	1 " "	63
2 " "	4	6 " "	38	2 " "	99
10 " "	5	2 " "	45	2 " "	100
2 " "	6A	1 " "	46	1 " "	111
14 " "	12	2 " "	48	1 " "	116A
2 " "	15	10 " "	48A	1 " "	126A
2 " "	15A	2 " "	52	1 " "	138A
4 " "	16	2 " "	53	1 " "	166
2 " "	18A				
4 " "	19B				
4 " "	20B				
4 " "	22				
1 " "	24				

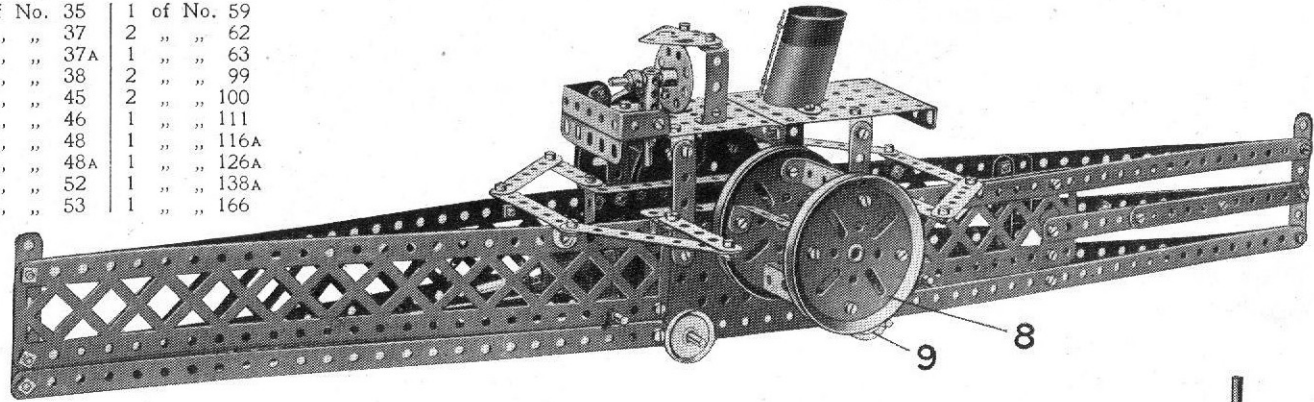

The paddle-wheels are secured to a crankshaft (see Fig. 3.25A) consisting of two $3\frac{1}{2}$ " axle rods 1, two cranks 2, and a $\frac{3}{4}$ " bolt 3 secured to the central holes of the cranks. The two oscillating cylinders 4 are built up from two $\frac{3}{4}$ " flanged wheels and a pair of sleeve pieces, the latter being bolted to the $2\frac{1}{2}$ " \times $\frac{1}{2}$ " double angle strips 5, which are free to turn on rods 6. The ends of the 5" piston rods are secured in the bosses of two small fork pieces 7, which pivot about the $\frac{3}{4}$ " bolt 3 of the crankshaft. As the model runs along the ground, the 3" pulley wheels 8 secured to the rods 1 are rotated by endless cords from the 1" fast pulley wheels 9, while the cylinders 4 oscillate and appear to be actually operating the paddle-wheels.

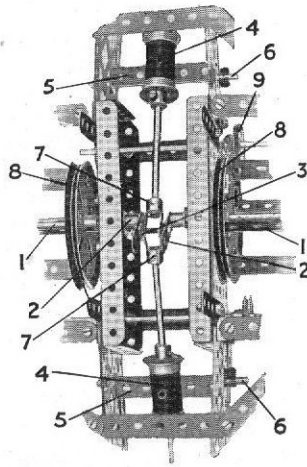
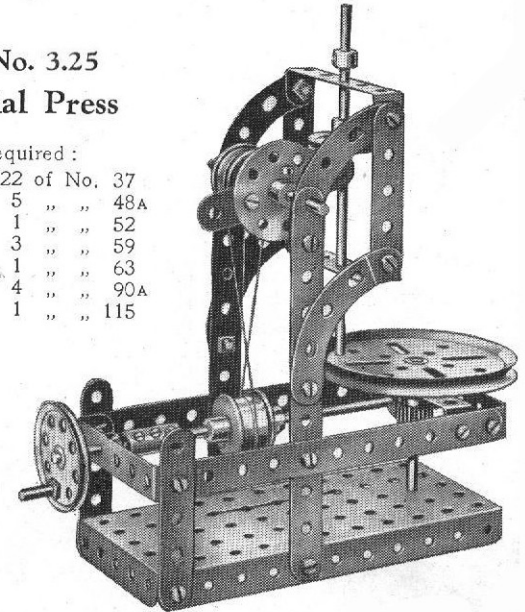

FIG. 3.25A

Model No. 3.25 Auto Dial Press

Parts required :

4 of No.	2	22 of No.	37
5 " "	5	5 " "	48A
2 " "	15	1 " "	52
1 " "	16	3 " "	59
1 " "	17	1 " "	63
1 " "	18A	4 " "	90A
1 " "	19B	1 " "	115
4 " "	20B		
1 " "	21		
1 " "	22		
1 " "	24		
1 " "	26		
1 " "	32		



These Models can be built with MECCANO Outfit No. 3 (or No. 2 and No. 2A)

Model No. 3.26 Scarifier

Parts required:

7 of No. 2	1 of No. 18A
1 " " 3	2 " " 22
4 " " 5	29 " " 37
1 " " 10	2 " " 38
1 " " 11	2 " " 90
11 " " 12	1 " " 126A

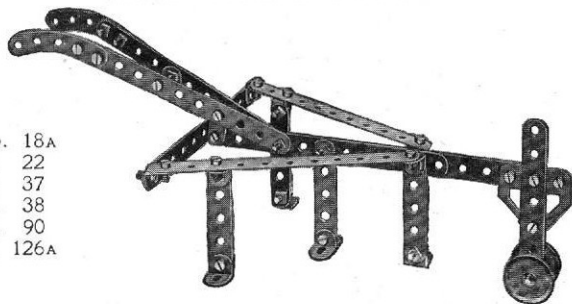

Model No. 3.27 Electric Tramcar

Parts required:

3 of No. 1	1 of No. 18A	2 of No. 53
14 " " 2	4 " " 20	2 " " 54
12 " " 5	3 " " 22	1 " " 59
4 " " 10	1 " " 24	2 " " 62
4 " " 12	1 " " 26	1 " " 63
4 " " 12A	2 " " 35	2 " " 100
1 " " 15	87 " " 37	1 " " 111c
2 " " 16	1 " " 43	1 " " 115
2 " " 17	2 " " 48	4 " " 125
	4 " " 48A	1 " " 116A
	2 " " 52	1 " " 147B

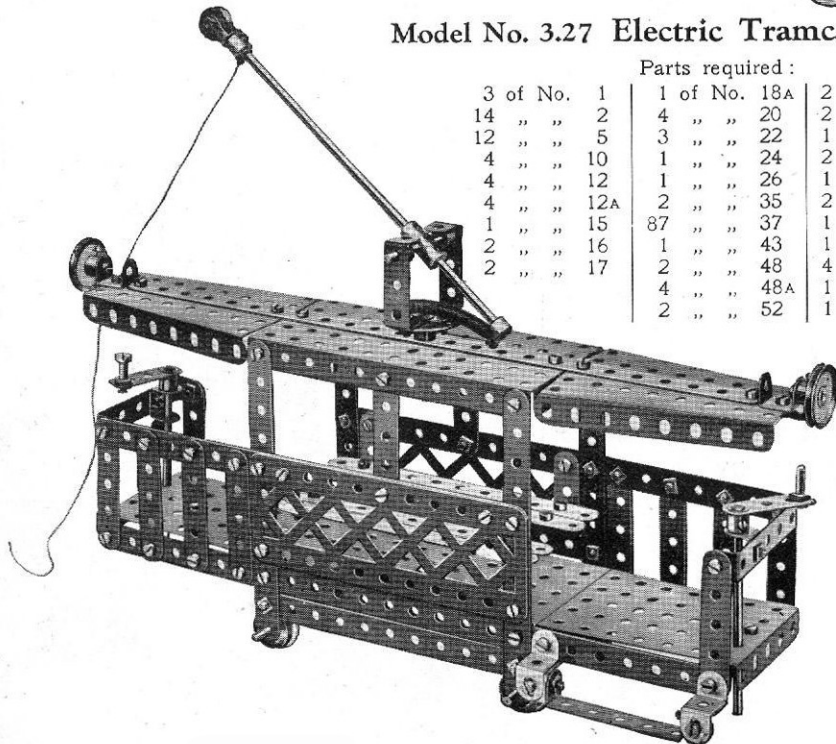

Model No. 3.28 Pit Head Gear

Parts required:

10 of No. 1	6 of No. 35
9 " " 2	74 " " 37
4 " " 3	1 " " 48B
2 " " 4	2 " " 52
8 " " 8	3 " " 53
10 " " 12	2 " " 54
2 " " 15	4 " " 59
3 " " 15A	2 " " 100
1 " " 16	
1 " " 17	
1 " " 19	
1 " " 19B	
1 " " 26	
1 " " 27A	

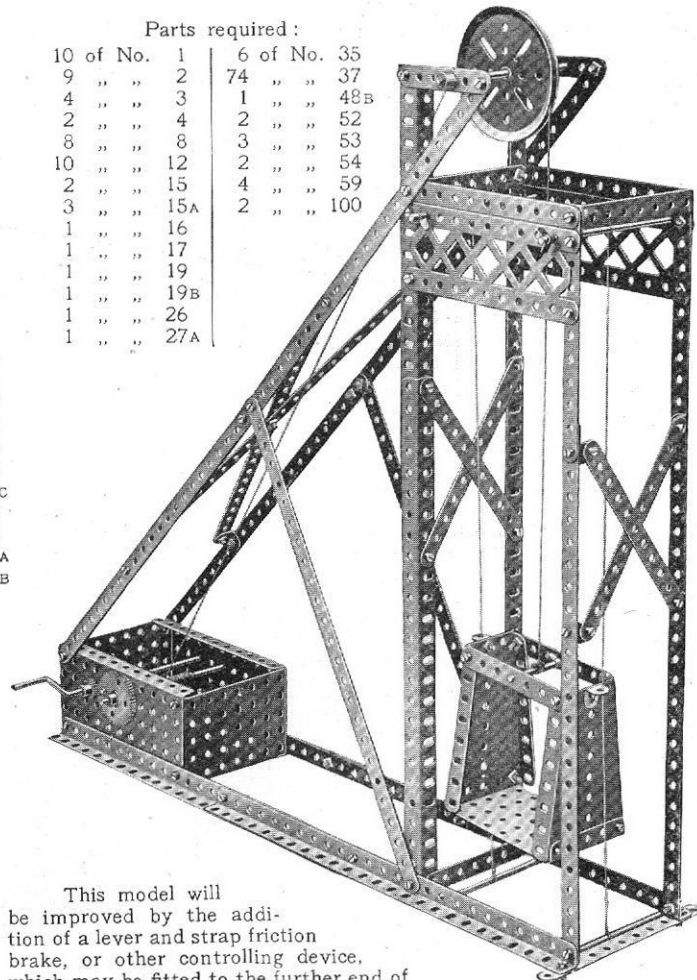

This model will be improved by the addition of a lever and strap friction brake, or other controlling device, which may be fitted to the further end of the driven shaft (see S.M. No. 81).

Model No. 3.29 Tower Wagon

When operated the handle 1 winds in the cord 2, which passes over a 1" fast pulley wheel 3 and is tied to the rod 4. The upper part of the tower is thus raised or lowered as required, being guided by the $\frac{3}{4}$ " flanged wheels 5 and two pairs of reversed angle brackets 6. The steering cords 7 are tied to the 57-teeth gear wheel 8 and to the end of a $2\frac{1}{2} \times \frac{1}{2}$ " double angle strip, which is pivoted to the sector plate 9. The front axle is journaled through the ends of the double angle strip.

Parts required:

4 of No. 1	2 of No. 54
2 " " 4	3 " " 59
6 " " 5	4 " " 90A
2 " " 6A	1 " " 98
8 " " 8	2 " " 100
8 " " 12	1 " " 111c
1 " " 15	1 " " 115
3 " " 15A	4 " " 125
4 " " 16	
1 " " 17	
4 " " 19B	
4 " " 20	
1 " " 21	
2 " " 22	
1 " " 24	
1 " " 26	
1 " " 27A	
1 " " 32	
3 " " 35	
84 " " 37	
2 " " 37A	
1 " " 45	
8 " " 48A	
2 " " 52	
1 " " 53	

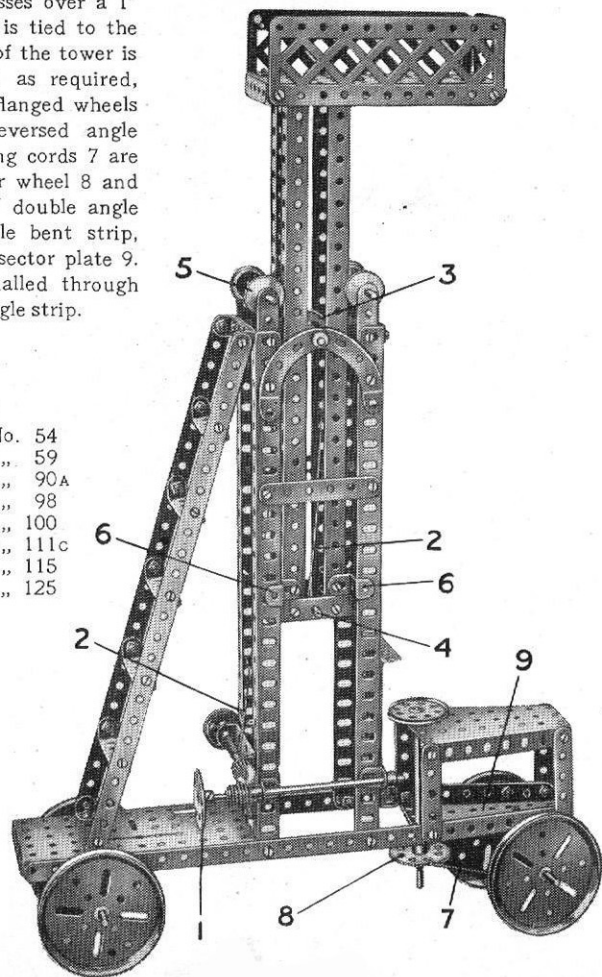

Model No. 3.30

Two-Cylinder Vertical Steam Engine

Parts required:

2 of No. 3
2 " " 8
2 " " 11
3 " " 12
4 " " 16
2 " " 19B
4 " " 20
1 " " 22
1 " " 27A
40 " " 37
7 " " 38
2 " " 48B
2 " " 52
3 " " 53
3 " " 59
2 " " 115
2 " " 125
1 " " 162
2 " " 163
1 " " 164
2 " " 165

Electric Motor
(not included
in Outfit)

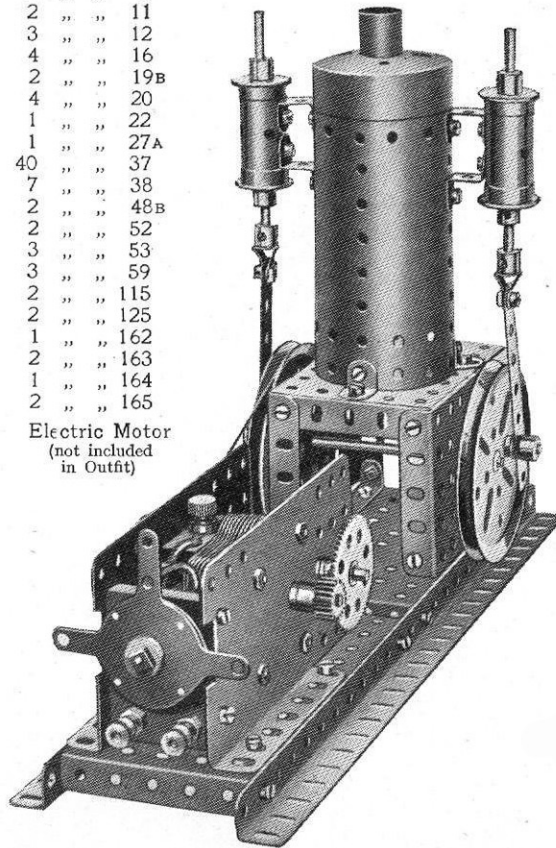

Model No. 3.31 Swinging Cot



Parts required :

2 of No. 1	6 of No. 37A
18 " " 2	8 " " 38
6 " " 3	1 " " 45
2 " " 5	3 " " 48A
8 " " 8	1 " " 52
3 " " 12	4 " " 59
1 " " 15	2 " " 62
1 " " 15A	1 " " 63
3 " " 16	1 " " 98
1 " " 22	2 " " 99c
10 " " 35	2 " " 100
68 " " 37	4 " " 111

Model No. 3.33 Swing Boat

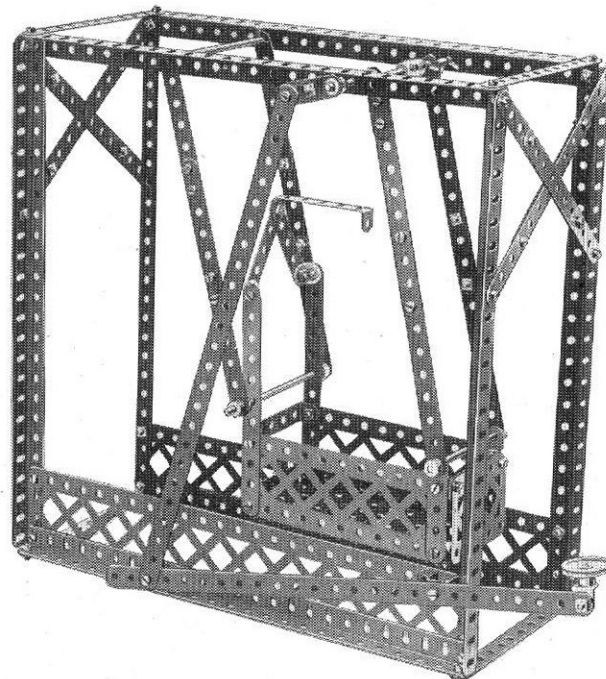

Model No. 3.32 Lace Jennier

Parts required :

6 of No. 2	28 of No. 37
2 " " 8	1 " " 37A
4 " " 11	4 " " 38
2 " " 15	2 " " 48B
1 " " 19B	2 " " 52
1 " " 24	2 " " 53
1 " " 26	2 " " 59
1 " " 27A	1 " " 115

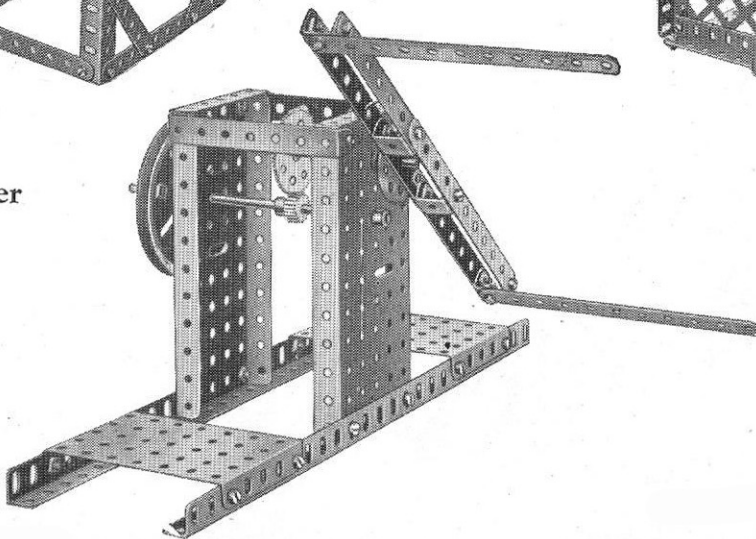

Parts required :

2 of No. 1	2 of No. 22A
17 " " 2	64 " " 37
4 " " 5	2 " " 37A
6 " " 8	2 " " 45
8 " " 12	4 " " 90A
2 " " 17	2 " " 99
2 " " 19E	2 " " 100
2 " " 22	2 " " 111c

Model No. 3.32 Railway Gauge

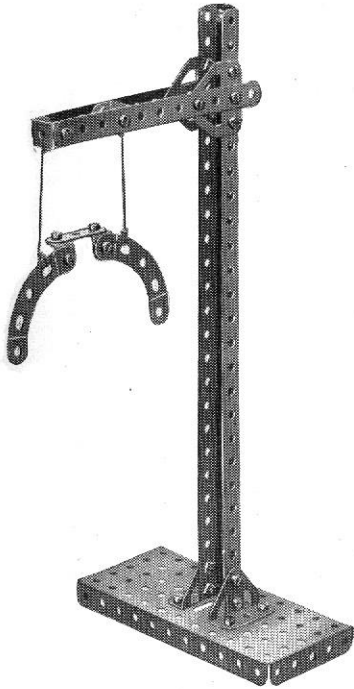

Parts required :

2 of No.	2
1 " "	6A
2 " "	8
2 " "	11
2 " "	12
25 " "	37
1 " "	53
2 " "	90A
2 " "	126
2 " "	126A

Model No. 3.33 Auto Swing Boat

The connecting strip 1 is attached pivotally at one end to a threaded pin secured to the bush wheel 2 on the driving spindle of the motor, and at the other end by means of bolt and lock-nuts to a crank 3 mounted on the shaft 4, which operates the swing boat.

Parts required :

3 of No.	1	1 of No.	10	86 of No.	37	2 of No.	90A
16 " "	2	12 " "	12	2 " "	37A	2 " "	99
6 " "	3	2 " "	15	1 " "	59	2 " "	100
8 " "	5	1 " "	24	2 " "	62	1 " "	111c
8 " "	8	2 " "	35	1 " "	63	1 " "	115
				2 of No.	126A		

Clockwork Motor (not included in Outfit)

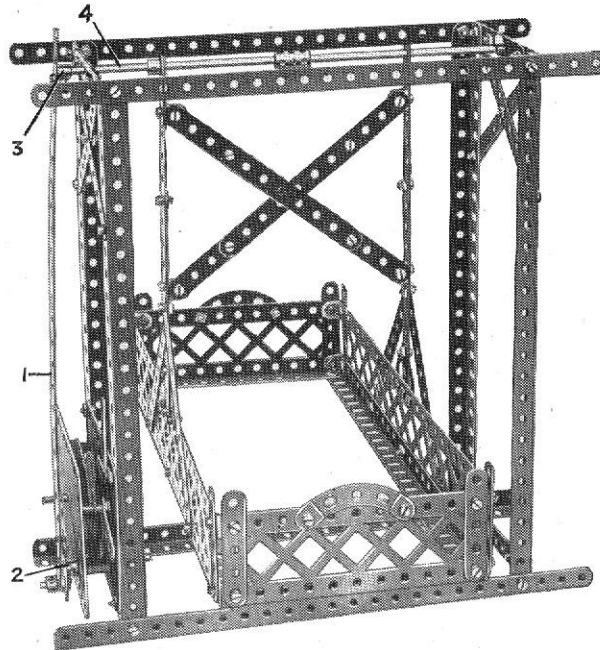

Model No. 3.34 Scales

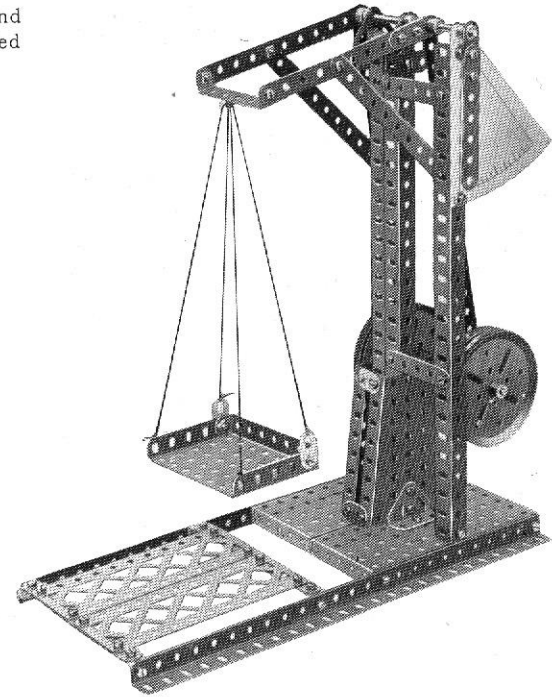

Parts required :

10 of No.	2	2 of No.	48A
1 " "	3	1 " "	48B
2 " "	5	2 " "	52
5 " "	8	1 " "	53
7 " "	10	2 " "	54
5 " "	12	4 " "	59
2 " "	15A	2 " "	62
4 " "	19B	2 " "	100
67 " "	37	2 " "	126
2 " "	38	2 " "	126A

Model No. 3.35 Lathe

The arrangement of the treadle is shown in detail in Fig. 3.35A. The crank 1 is provided with a flat bracket, the round hole of which coincides with the elongated hole of the crank, and receives the short rod 2. The crank 1 is free to turn about a threaded pin 3, secured to the 3" pulley wheel 4, and once the latter is set in motion it can be kept in rotation by working the treadle 5. The strips 6 of the saddle (Fig. 3.35) are duplicated and their ends form slots to receive the flanges of the angle girders 7. The hand wheel 8 is a dummy one, but if desired it may be arranged to operate the saddle by an endless rope device.

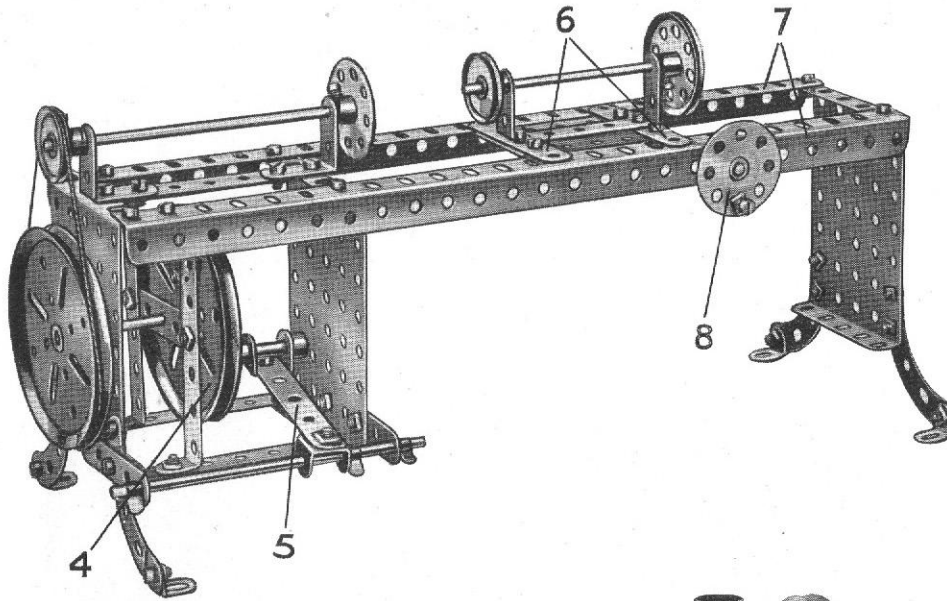

Parts required :

3 of No. 3	2 of No. 16	3 of No. 35	4 of No. 59
10 " " 5	1 " " 17	44 " " 37	1 " " 62
2 " " 8	1 " " 18A	2 " " 37A	4 " " 90A
2 " " 11	2 " " 19B	4 " " 38	1 " " 111c
4 " " 12	1 " " 21	1 " " 46	1 " " 115
2 " " 12A	2 " " 22	2 " " 48B	
2 " " 15A	1 " " 24	3 " " 53	

Model No. 3.36 Vertical Steam Engine

Parts required:

2 of No. 12	1 of No. 45
1 " " 16	1 " " 52
1 " " 17	1 " " 59
1 " " 19B	1 " " 115
2 " " 20B	1 " " 162
3 " " 22	1 " " 163
1 " " 24	1 " " 164
9 " " 37	1 " " 166
2 " " 38	

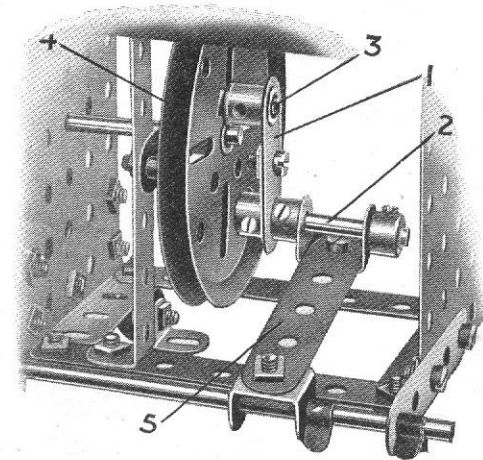
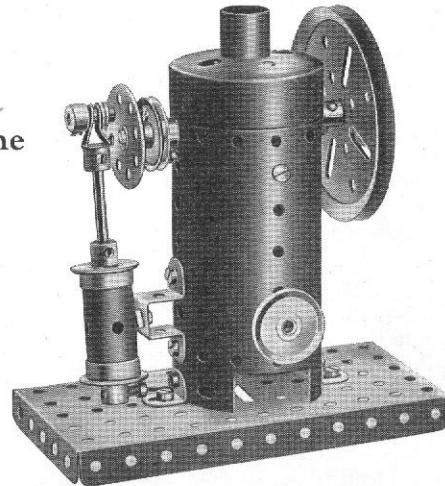
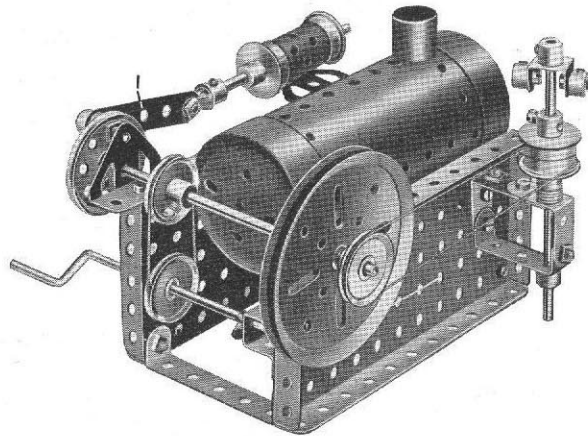

FIG. 3.35A

Model No. 3.39 Horizontal Engine

This model forms an interesting example of the use of the Meccano boiler, sleeve piece and other new parts. The $2\frac{1}{2}$ " strip 1, forming the connecting rod, is attached to the $1\frac{1}{2}$ " pulley wheel by means of a threaded pin. The latter is fastened in one hole of the $1\frac{1}{2}$ " pulley wheel, and two washers are placed upon it between the strip 1 and the wheel. The connecting rod is held in place by a collar locked to the end of the threaded pin. The boiler is attached to the framework by means of two $2\frac{1}{2}$ " x $\frac{1}{2}$ " double angle strips attached by their centre holes to the side of the boiler opposite the chimney. When the boiler is placed in the position shown, the whole is secured by bolting the double angle strips to the side flanged plates.



Parts required :		
1 of No. 5	3 of No. 22	1 of No. 115
2 " " 12A	1 " " 35	1 " " 116
2 " " 15A	25 " " 37	2 " " 126
1 " " 16	7 " " 38	1 " " 126A
1 " " 19B	1 " " 45	1 " " 162
1 " " 19S	1 " " 48	1 " " 163
4 " " 20B	4 " " 48A	1 " " 164
1 " " 21	2 " " 52	1 " " 166
	4 " " 59	

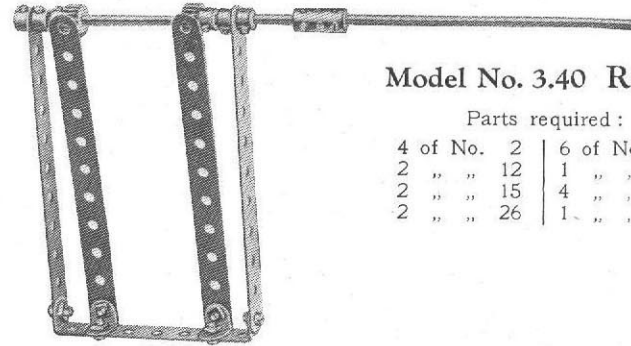

Model No. 3.40 Rattle

Parts required :

4 of No. 2	6 of No. 37
2 " " 12	1 " " 48B
2 " " 15	4 " " 59
2 " " 26	1 " " 63

Model No. 3.41 Oil Cake Chopper

Parts required :

4 of No. 3	1 of No. 52
6 " " 10	2 " " 53
1 " " 15	2 " " 54
1 " " 19B	1 " " 59
4 " " 22	2 " " 90A
24 " " 37	1 " " 115
2 " " 48B	2 " " 125

Fig. 3.41A, shows the hand wheel and shaft removed from the model. It will be seen that the chopping mechanism is represented by flat brackets clamped between two pairs of 1" fixed pulley wheels.

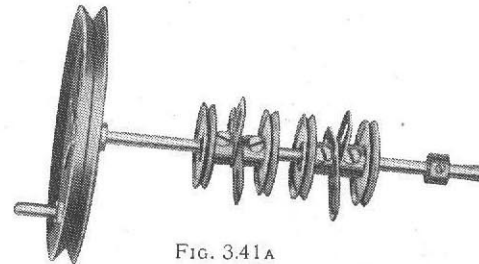
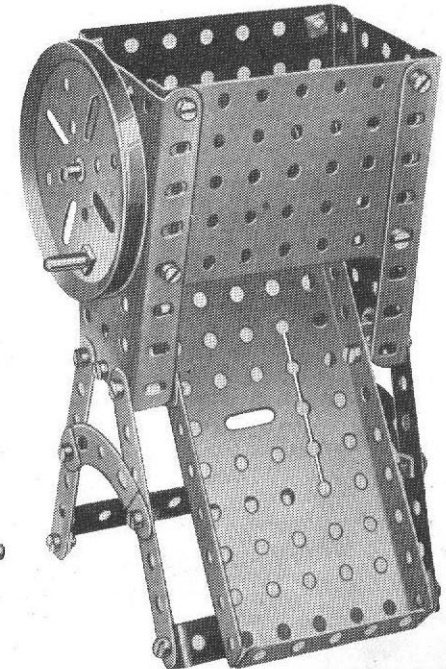

FIG. 3.41A



Model No. 3.42 Railway Wagon Swivel Crane

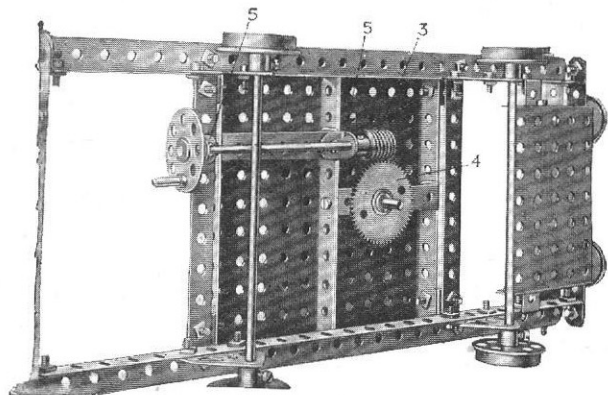
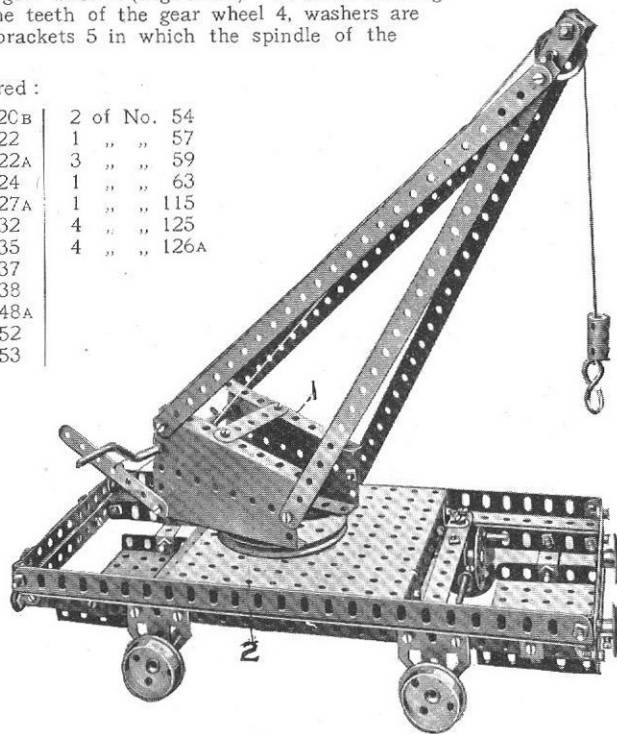

FIG. 3.42A

The flanges of the sector plates 1 are bolted to the 3" pulley wheel upon which the crane swivels, and the spindle of the pulley wheel is rotated by the worm 3 engaging the gear wheel 4 (Fig. 3.42A). In order to bring the worm centrally over the teeth of the gear wheel 4, washers are placed beneath the angle brackets 5 in which the spindle of the worm is journalled.

Parts required :

4 of No.	1	4 of No.	20B	2 of No.	54
6 "	"	4 "	22	1 "	57
1 "	"	1 "	22A	3 "	59
2 "	"	1 "	24	1 "	63
4 "	"	1 "	27A	1 "	115
1 "	"	1 "	32	4 "	125
14 "	"	3 "	35	4 "	126A
2 "	"	70 "	37		
1 "	"	2 "	38		
2 "	"	2 "	48A		
1 "	"	2 "	52		
1 "	"	2 "	53		



Model No. 3.43 Wire Rope Maker

The strands are twisted from both ends by the handles 1 and 2 of the fixed parts. The handle 1 rotates through a large gear wheel 3 two pinions 4 on the rods 5 carrying cranks to which the strands are attached. The other ends of the strands are connected to a double bracket 6 on a bush wheel which is rotated in the opposite direction by a crank handle 2. The carriage 7 runs on rails and the vertical rod 8 is kept just at the formation of the twisted rope and so controls the tightness of the twist.

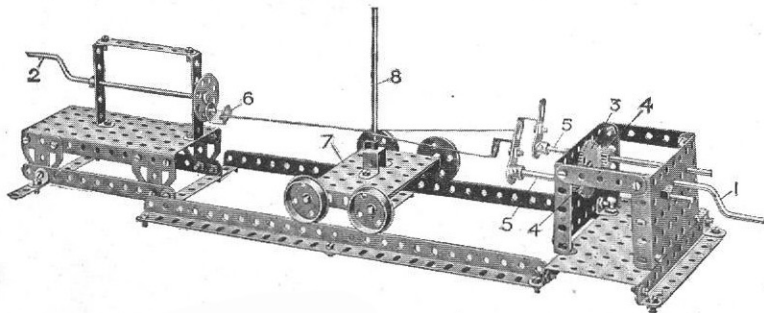

Parts required for Wire Rope Maker :

6 of No.	2	2 of No.	15	1 of No.	27A	2 of No.	52
1 "	"	3 "	15A	3 "	35	3 "	53
2 "	"	2 "	19S	50 "	37	4 "	59
2 "	"	4 "	20B	1 "	45	2 "	62A
3 "	"	1 "	24	2 "	48A	4 "	126
12 "	"	2 "	26				

Model No. 3.44 Letter Balance

Parts required :

4 of No.	2	2 of No.	18A	1 of No.	53
2 " "	3	2 " "	20B	4 " "	59
5 " "	5	2 " "	22A	1 " "	62
2 " "	10	4 " "	35	1 " "	63
1 " "	11	37 " "	37	2 " "	90A
4 " "	12	6 " "	37A	2 " "	111
2 " "	12A	2 " "	48A	4 " "	111c
1 " "	15	1 " "	48B	2 " "	125
2 " "	17	1 " "	52	2 " "	126A

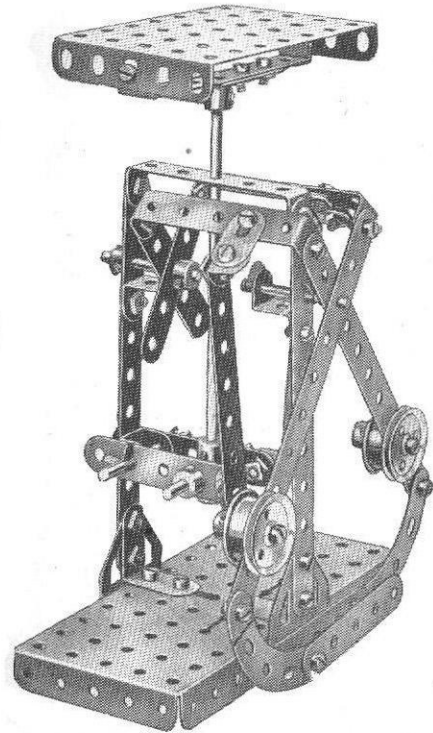

Model No. 3.45 Tank Lorry

Parts

required :

2 of No.	1
8 " "	2
1 " "	3
6 " "	5
1 " "	6A
2 " "	8
2 " "	11
16 " "	12
2 " "	12A
2 " "	15
1 " "	15A
4 " "	19B
2 " "	20B
1 " "	22
1 " "	24
4 " "	35
60 " "	37
1 " "	37A
4 " "	38
1 " "	48
1 " "	48A
2 " "	48B
1 " "	52
2 " "	53
2 " "	54
4 " "	59
3 " "	90A
1 " "	98
2 " "	111c
4 " "	125
2 " "	126
1 " "	162

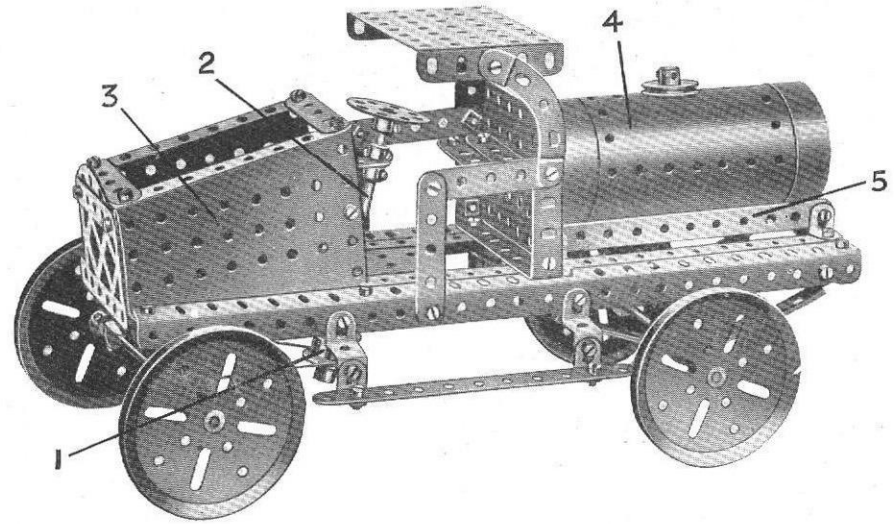

It should be noted that the steering cord is given a complete turn around the two $\frac{3}{4}$ " flanged wheels 1 to prevent slipping. The steering column 2 is journalled in the end of a $1\frac{1}{2}$ " strip, the other end of which is bolted to a $2\frac{1}{2}$ " \times $\frac{1}{2}$ " double angle strip secured between the two sector plates 3. The front road wheels are secured to a 5" rod that is journalled in the end holes of a $3\frac{1}{2}$ " \times $\frac{1}{2}$ " double angle strip. The ends of the steering cord are tied to this strip, which is pivoted by means of a bolt and lock-nuts (S.M. 263) to the central hole of a $1\frac{1}{2}$ " \times $\frac{1}{2}$ " double angle strip. The latter is bolted between a pair of Trunnions attached to the underside of the $5\frac{1}{2}$ " \times $2\frac{1}{2}$ " flanged plate. The tank 4 merely rests on the $5\frac{1}{2}$ " strips 5.

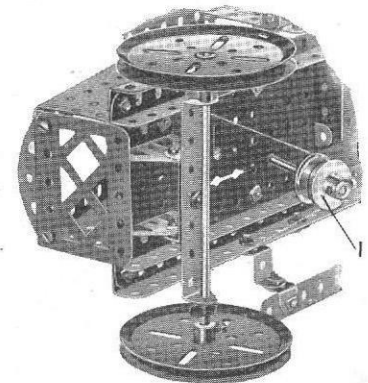
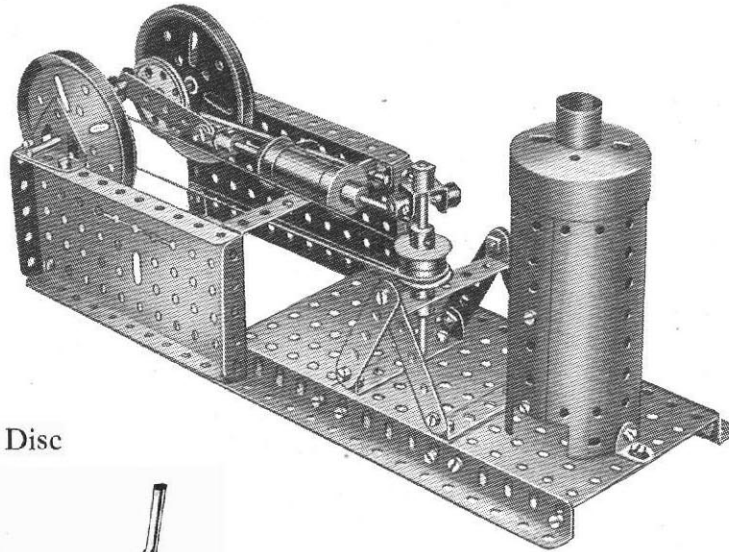

FIG. 3.45A

Model No. 3.46 Horizontal Engine

Parts required :

5 of No. 5	30 of No. 37
2 " " 8	3 " " 48A
2 " " 12	2 " " 48B
3 " " 15A	2 " " 52
1 " " 19S	3 " " 53
2 " " 19B	3 " " 59
4 " " 20B	1 " " 116
1 " " 21	2 " " 126
1 " " 22	1 " " 162
2 " " 35	1 " " 163
1 of No. 165	



Model No. 3.47 Newton's Disc

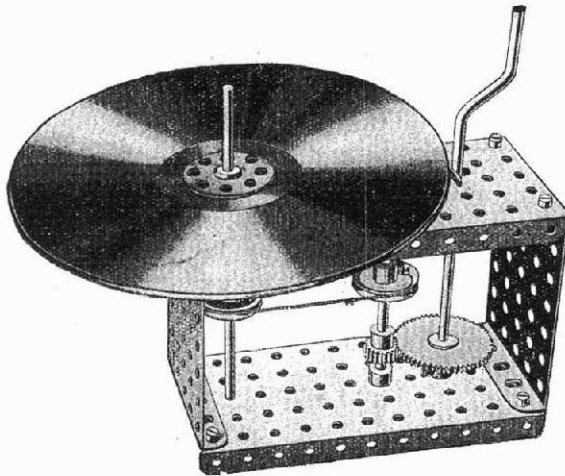

This is a model to show that white light is made up of the three primary colours—red, yellow, blue. Sectors of these three colours are mounted or painted on the disc, which, if then quickly rotated, shows as white.

Parts required :

1 of No. 15	1 of No. 24	8 of No. 37
1 " " 15A	1 " " 26	2 " " 52
1 " " 19	1 " " 27A	2 " " 53
2 " " 22	2 " " 35	4 " " 59

Model No. 3.48 Lawn Marker

The small roller, which consists of two $\frac{3}{4}$ " flanged wheels secured to a short rod, rest on the edges of the two 3" pulley wheels. In actual practice the container is filled with whitewash, in which the inner wheel is partially immersed, and the mixture is transferred via the roller to the outer wheel, which does the actual marking.

Parts required :

2 of No. 1	1
2 " " 4	4
2 " " 5	5
2 " " 12	12
2 " " 12A	12A
2 " " 16	16
2 " " 17	17
2 " " 19B	19B
2 " " 20	20
2 " " 22	22
21 " " 37	37
1 " " 38	38
2 " " 48A	48A
2 " " 53	53
4 " " 59	59
2 " " 90A	90A

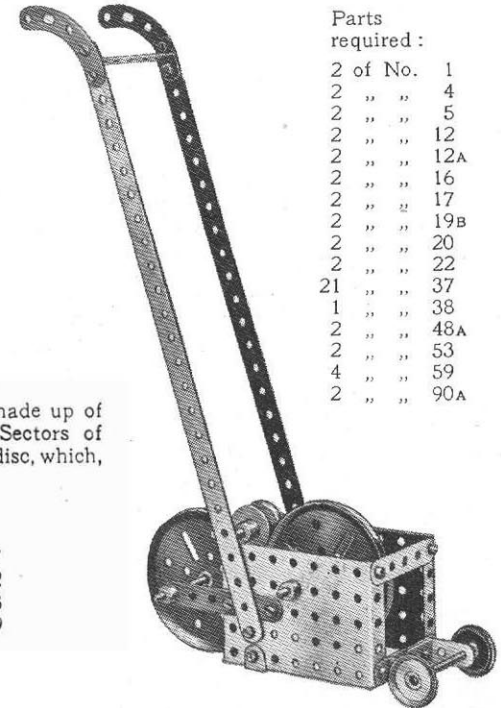

Model No. 3.50 Kinetograph

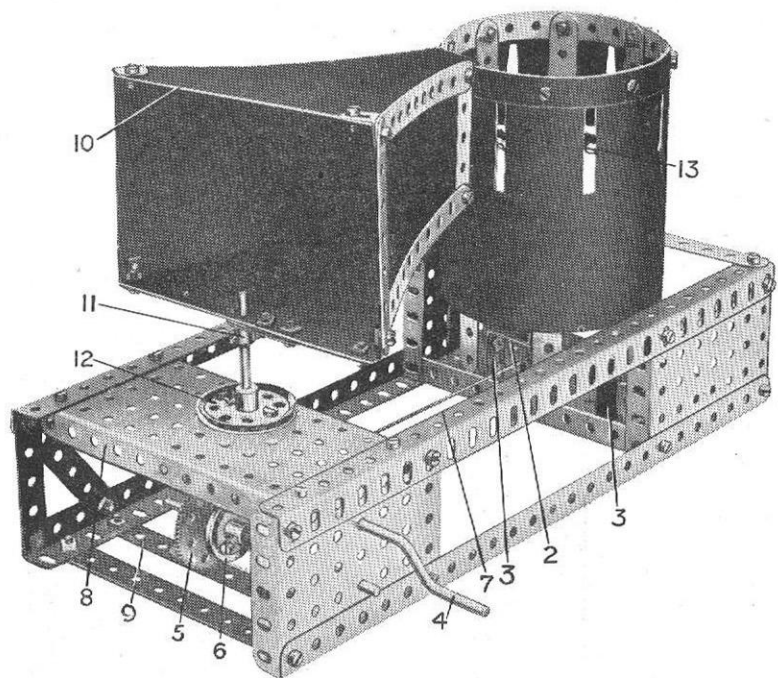

Most Meccano boys probably are aware of the principles of the Kinetograph, but for the benefit of those who have not seen one in action, we may mention that it is a device which imparts an appearance of animation to a series of pictures, each differing slightly from the other and passed in rapid succession before the eyes. In this respect it resembles the remarkable principle upon which the modern cinematograph is based.

In constructing the Meccano model the following details will prove useful:—The drum consists of a $12\frac{1}{2}$ " strip bent to form a circle, with its ends overlapping one hole, and bolted to eight vertical $5\frac{1}{2}$ " strips forming the sides. Two pairs of opposite $5\frac{1}{2}$ " strips are connected by $3\frac{1}{2}$ " strips and angle brackets bolted in the third holes from their lower ends. The $3\frac{1}{2}$ " strips cross at right angles to one another and are bolted in the centre to a bush wheel, in the boss of which is secured a short rod forming the pivot of the revolving drum. This rod is journaled in a double bent strip bolted to a $2\frac{1}{2}$ " \times 1 " double angle strip 2. This, in turn, is secured to the base of the model by two 1 " \times 1 " angle brackets 3. A further bearing for the short rod consists of a crank bolted in the base of the model.

The drum is rotated from the crank handle 4, on which is mounted a $\frac{1}{2}$ " pinion engaging a 57-teeth gear wheel 5 secured to a $3\frac{1}{2}$ " rod carrying a pulley wheel 6. The latter is connected by means of a cord 7 to a similar wheel ripped to the vertical spindle of the drum. Bearings are provided for the inner ends of the crank handle and $3\frac{1}{2}$ " rod by a double angle strip bolted between the plate 8 and $5\frac{1}{2}$ " strip 9. The sighting box 10 is built up from a framework of strips and is secured by means of a crank 11 to a short vertical rod rigidly mounted in the boss of the $1\frac{1}{4}$ " pulley 12. The four sides of the framework 10 are covered with some black material; stiff black paper suitable for this purpose may be obtained from any stationers. The drum is enclosed in the same way, but the covering paper should be cut in a strip measuring $12\frac{1}{2}$ " \times $4\frac{1}{2}$ " and pierced with slots spaced $1\frac{1}{2}$ " apart (from centre to centre) so that they fall exactly between the upright $5\frac{1}{2}$ " strips. The slots should measure $1\frac{1}{2}$ " \times $\frac{1}{4}$ ".

The type of drawing suitable for use in this model is shown in Fig. 3.50A, and the dimensions indicated therein should be followed carefully. No doubt Meccano boys will be able to devise numerous amusing pictures of a similar kind for themselves. The strip of stout white paper carrying the sketches is inserted in the bottom of the drum, as indicated at 13. The model is now ready for operation. Placing the frame 10 over the eyes, the line of vision is directed through the narrow end, where the strips are held apart by means of double brackets, and through the slots in the drum. The latter should be rotated rapidly by operating the handle 4, and as it revolves, the little dog shown in Fig. 3.50A will be seen jumping over the fence with a most realistic and amusing action.

Parts required:			
1 of No. 1	1 of No. 15A	12 of No. 38	
17 " " 2	2 " " 16	1 " " 45	
6 " " 3	1 " " 19s	1 " " 46	
1 " " 4	1 " " 21	1 " " 48A	
3 " " 5	2 " " 22.	2 " " 52	
4 " " 8	1 " " 24	3 " " 53	
2 " " 11	1 " " 26	4 " " 59	
12 " " 12	1 " " 27A	2 " " 62	
2 " " 12A	60 " " 37		

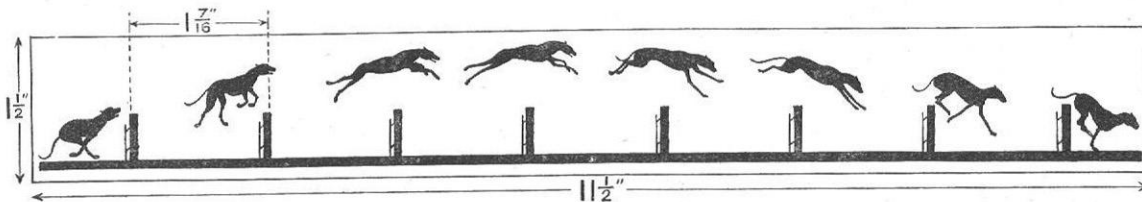
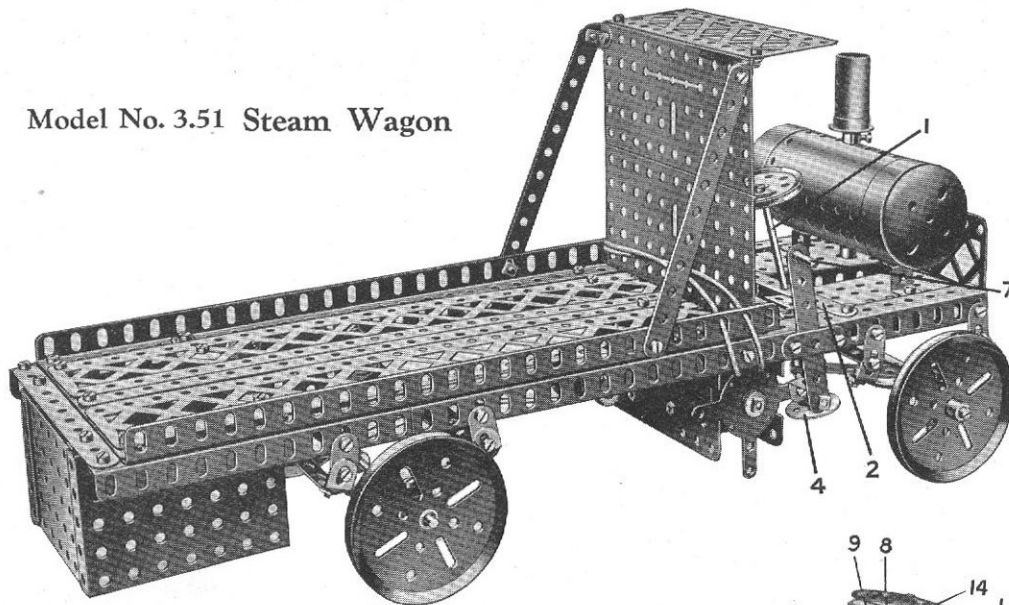

FIG. 3.50A

Model No. 3.51 Steam Wagon



Parts required:		
14 of No. 2	4 of No. 19B	2 of No. 54
6 " " 3	3 " " 20B	4 " " 59
6 " " 5	1 " " 21	2 " " 62
2 " " 6A	4 " " 22	1 " " 63
6 " " 8	1 " " 23	2 " " 99
8 " " 10	1 " " 24	2 " " 100
3 " " 11	1 " " 26	2 " " 111
10 " " 12	79 " " 37	1 " " 115
2 " " 12A	10 " " 38	4 " " 125
1 " " 15	2 " " 48B	1 " " 147B
3 " " 16	2 " " 52	1 " " 162
2 " " 18A	3 " " 53	1 " " 163

Electric Motor
(not included in Outfit)

The steering column 1 is journalled in bearings consisting of a $5\frac{1}{2}$ " strip 2 and two $2\frac{1}{2}$ " strips 3 (Fig. 3.51A), and carries the bush wheel 4, which is secured rigidly to it. A $\frac{3}{4}$ " flanged wheel 5 supports the weight of the steering column 1. The stub axles of the front road wheels consist of $\frac{3}{4}$ " bolts, on which the road wheels are spaced by washers 14. These bolts serve in the place of set-screws to secure two collars to the 1" rods 8. A pair of cranks 9, 9a secured to the rods 8 are joined by two $5\frac{1}{2}$ " strips 15 overlapped eight holes. A $1\frac{1}{2}$ " strip 10, bolted to the face of the bush wheel 4, is connected pivotally by a composite $4\frac{1}{2}$ " strip 11 (a $3\frac{1}{2}$ " strip and a $2\frac{1}{2}$ " strip overlapped three holes) to the end of the crank 9. When the steering wheel is turned, the strip 11 moves the cranks 9, 9a, thereby deflecting the front road wheels.

The electric motor 6 is controlled by raising and depressing the handle 7. Duplicate drive transmission belts 12 and 13 are used in order to secure a more dependable drive to the rear axle.

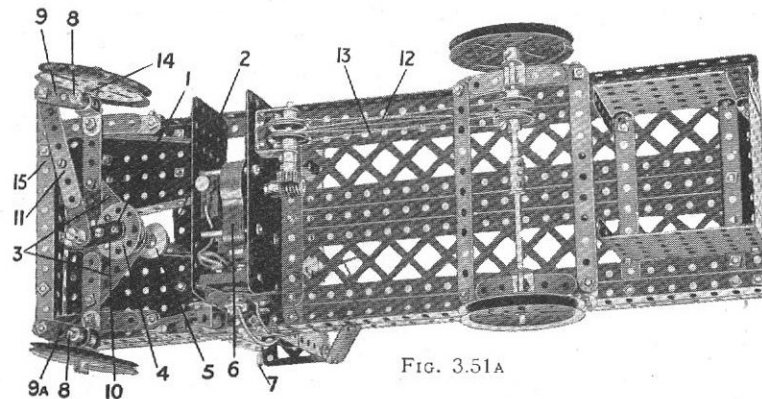

FIG. 3.51A

HOW TO CONTINUE

This completes our examples of models that may be made with MECCANO Outfit No. 3. The next models are a little more advanced, requiring a number of extra parts to construct them. The necessary parts are all contained in a No. 3A Accessory Outfit, the price of which will be found in the List at the end of this Manual.

A Selection of Meccano Standard Mechanisms

Here are a few simple and interesting movements showing how easily real mechanisms can be reproduced with Meccano. They are a selection from the Meccano Standard Mechanisms Manual, which is fully described on page 2 of this Manual.

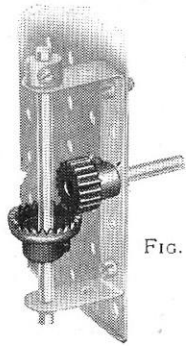

FIG. A

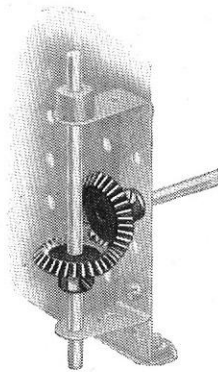

FIG. C

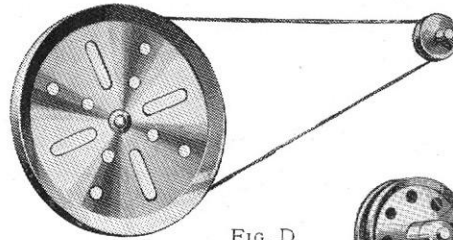

FIG. D

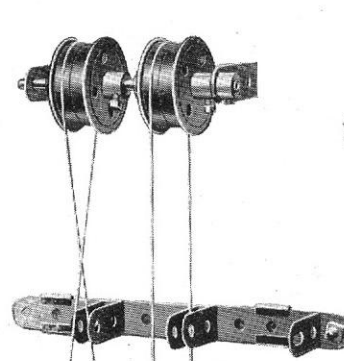

FIG. G

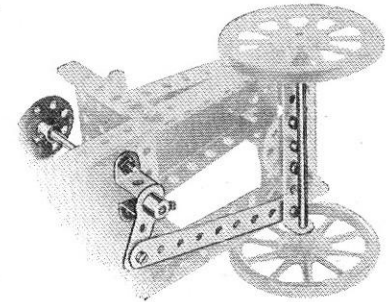

FIG. H

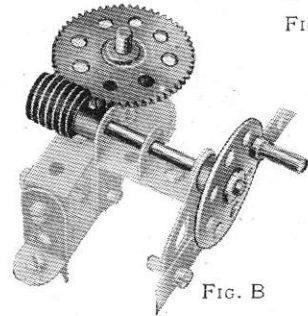

FIG. B

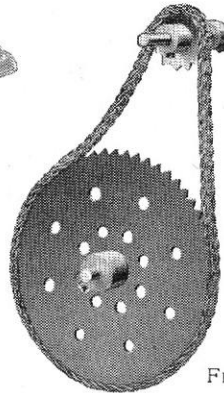

FIG. E

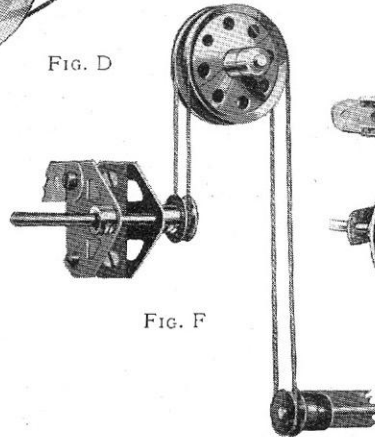

FIG. F

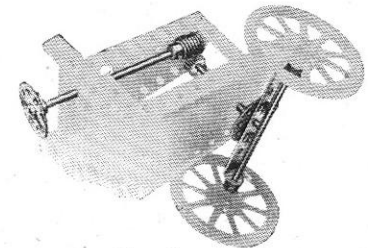

FIG. J

Gears

The Meccano system includes a wide range of Gear Wheels, Bevel Gears, Pinion Wheels, Contrate Wheels and Worm Wheels in various sizes. All manner of interesting movements may be obtained by the use of these gears.

Fig. A shows how a drive may be transmitted from a vertical to a horizontal shaft or vice versa. Fig. B shows a Worm engaged with a Gear Wheel, giving a very great reduction in shaft speed. Fig. C illustrates another right angle drive, obtained by using Meccano Bevel Gears.

Belt and Chain Drives

In Figs. D, E, F and G we show examples of belt and chain drives. The movements illustrated require no explanation excepting, perhaps, Fig. G, which shows a simple method for slipping the belt from the fast to the loose pulleys or vice versa.

Cords usually take the place of belts in Meccano models but miniature belting may be made from strips of canvas, indiarubber, etc., in which case Flanged Wheels should be used instead of grooved Pulleys.

Steering Gears

The various types of steering mechanism commonly in use on vehicles of all descriptions may readily be reproduced with Meccano.

Fig. H. In this case the road wheels are moved about their central pivot by means of a crank, which is secured to the steering shaft, and a connecting strip.

Fig. J. The road wheels in this example are secured to a central rod, which forms a pivot, and is rotated from the hand-wheel by means of a worm gear.

A Selection of Meccano Standard Mechanisms

(continued)

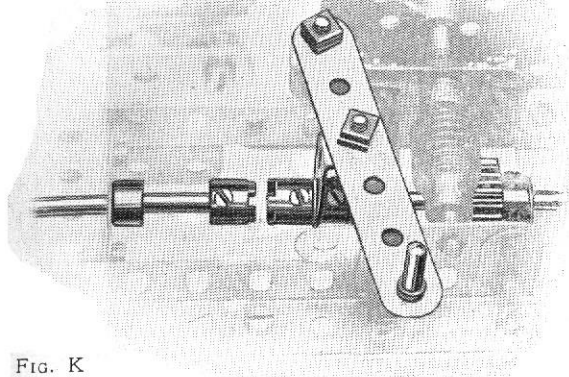

FIG. K

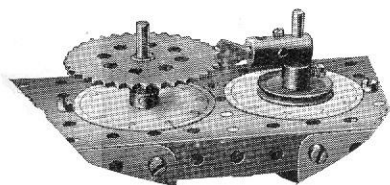

FIG. L

Dog Clutch

The Meccano Dog Clutch (Fig. K) may be used in most models where a simple clutch is required. It is also useful in the construction of drive-changing and reversing mechanisms, etc. Various kinds of clutches, in addition to the Dog Clutch, may be constructed from the standard Meccano parts.

Intermittent Rotary Motion

Fig. L shows one device by means of which intermittent rotary motion may be obtained. Such an arrangement is useful in revolution counters, measuring machines, etc. In addition to mechanisms that give true intermittent motion, different types of cams, converting a regular rotary motion into a constant or intermittent reciprocating motion, are described in the S.M. Manual.

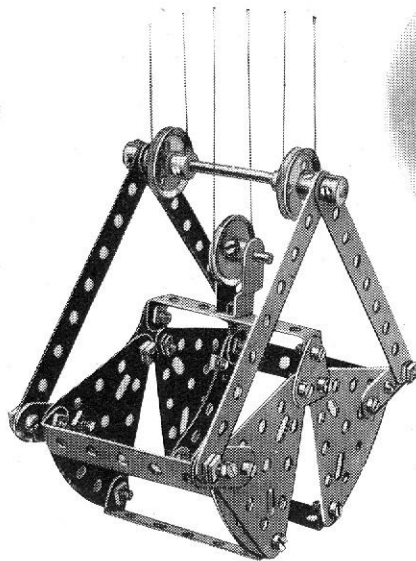

FIG. M

Grabs

A typical example of the many kinds of grab that can be constructed from Meccano is shown in Fig. M. If the grab is fitted to a model crane or ship-coaler, all the movements can be controlled from an operating box built into the frame of the model. The outer sides of the jaws may be filled in with cardboard and the grab can then be used to pick up loads of sand, grain, marbles, etc.

Pawl and Ratchet Wheel

Fig. N illustrates the standard Meccano Pawl and Ratchet Wheel gear, which allows the shaft carrying the Ratchet Wheel to rotate in one direction only. The advantages of such an arrangement are obvious, especially when attached to model Cranes, hoisting-tackle, etc., where the Pawl and Ratchet gear prevents falling-back of the load as it is hoisted.

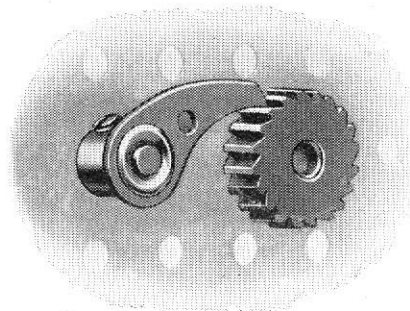

FIG. N

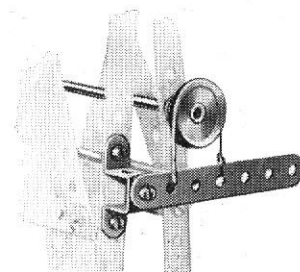

FIG. O

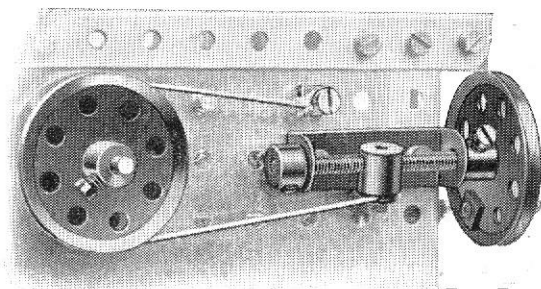

FIG. P

Strap and Lever Brake

This device (Fig. O) will be found very useful as a quick emergency hand-brake. Although it is the most simple of such devices, it is also one of the most valuable.

Strap and Screw Brake

The type of brake shown in Fig. P is used to apply a constant retarding effect to a rotating shaft. It can thus be utilized in a crane to prevent the load from falling back when the winding spindle is released. One advantage of the brake is that the speed of the shaft to which it is applied can be infinitely varied, so that in some models it will take the place of a gear-changing mechanism.

CONTENTS OF OUTFITS

No.	DESCRIPTION OF PART.	00	00A	0	0A	1	1A	2	2A	3	3A	4	4A	5	5A	6	6A	7
1	Perforated Strips, 12"				4	4	6	10		10	2	12	4	16	32	48	2	50
1A	" " " " " "				4	4	6	10		10	2	12	4	16	32	48	2	50
1B	" " " " " "				4	4	6	14		18	3	21	5	26	4	4	10	12
2	" " " " " "				4	4	8	14		18	3	21	5	26	4	4	10	12
2A	" " " " " "				1	1	1	2		4	6	6	2	2	4	8	12	15
3	" " " " " "				1	1	1	2		4	6	6	2	2	4	8	12	15
4	" " " " " "				3	3	9	12		12	6	18	18	36	12	24	36	45
5	" " " " " "				3	3	9	12		12	6	18	18	36	12	24	36	45
6	" " " " " "				2	2	2	2		2	4	4	4	4	4	4	4	4
7	" " " " " "				1	1	1	1		1	1	1	1	1	1	1	1	1
7A	Angle Girders, 24"				4	4	4	4		8	1	9	5	14	26	6	6	6
8	" " " " " "				4	4	4	4		8	1	9	5	14	26	6	6	6
8A	" " " " " "				2	2	2	2		4	4	4	4	4	4	4	4	4
8B	" " " " " "				2	2	2	2		4	4	4	4	4	4	4	4	4
9	" " " " " "				2	2	2	2		4	4	4	4	4	4	4	4	4
9A	" " " " " "				2	2	2	2		4	4	4	4	4	4	4	4	4
9B	" " " " " "				2	2	2	2		4	4	4	4	4	4	4	4	4
9C	" " " " " "				2	2	2	2		4	4	4	4	4	4	4	4	4
9D	" " " " " "				2	2	2	2		4	4	4	4	4	4	4	4	4
9E	" " " " " "				2	2	2	2		4	4	4	4	4	4	4	4	4
9F	" " " " " "				2	2	2	2		4	4	4	4	4	4	4	4	4
10	Flat Brackets				4	1	3	8		8	1	9	3	12	4	16	8	24
11	Double Brackets				4	1	3	8		8	1	9	3	12	4	16	8	24
12	Angle Brackets, 1" x 1"				8	2	4	12		14	8	22	14	36	12	48	48	96
12A	" " " " " "				8	2	4	12		14	8	22	14	36	12	48	48	96
12B	" " " " " "				2	2	2	2		4	2	6	6	6	6	6	6	6
13	Axle Rods, 1 1/2"										2	2	2	2	2	2	2	2
13A	" " " " " "										2	2	2	2	2	2	2	2
14	" " " " " "										2	2	2	2	2	2	2	2
15	" " " " " "										2	2	2	2	2	2	2	2
15A	" " " " " "										2	2	2	2	2	2	2	2
16	" " " " " "										2	2	2	2	2	2	2	2
16A	" " " " " "										2	2	2	2	2	2	2	2
17	" " " " " "										2	2	2	2	2	2	2	2
17A	" " " " " "										2	2	2	2	2	2	2	2
18	" " " " " "										2	2	2	2	2	2	2	2
18A	" " " " " "										2	2	2	2	2	2	2	2
18B	" " " " " "										2	2	2	2	2	2	2	2
19	Crank Handles (5" shaft)				1	1	1	1		1	1	1	1	1	1	1	1	1
19A	" " " " " "				1	1	1	1		1	1	1	1	1	1	1	1	1
19B	" " " " " "				1	1	1	1		1	1	1	1	1	1	1	1	1
20	Pulley Wheels, 3"				4	4	4	4		4	4	4	4	4	4	4	4	4
20A	Flanged Wheels, 1 1/2"				4	4	4	4		4	4	4	4	4	4	4	4	4
20B	Pulley Wheels, 2"				4	4	4	4		4	4	4	4	4	4	4	4	4
21	Flanged Wheels, 1 1/2"				4	4	4	4		4	4	4	4	4	4	4	4	4
21A	" " " " " "				4	4	4	4		4	4	4	4	4	4	4	4	4
22	Pulley Wheels, 1 1/2" (fast)				1	1	1	1		1	1	1	1	1	1	1	1	1
22A	" " " " " "				1	1	1	1		1	1	1	1	1	1	1	1	1
23	" " " " " "				1	1	1	1		1	1	1	1	1	1	1	1	1
23A	" " " " " "				1	1	1	1		1	1	1	1	1	1	1	1	1
24	Both Wheels				2	2	2	2		2	2	2	2	2	2	2	2	2
25	Pinion Wheels				2	2	2	2		2	2	2	2	2	2	2	2	2
25A	" " " " " "				2	2	2	2		2	2	2	2	2	2	2	2	2
26	" " " " " "				2	2	2	2		2	2	2	2	2	2	2	2	2
26A	" " " " " "				2	2	2	2		2	2	2	2	2	2	2	2	2
27	Gear Wheels, 56-teeth				133	133	133	133		133	133	133	133	133	133	133	133	133
27A	" " " " " "				133	133	133	133		133	133	133	133	133	133	133	133	133
27B	" " " " " "				133	133	133	133		133	133	133	133	133	133	133	133	133
28	Contrate Wheels, 1 1/2" (3 1/2" diam.)				1	1	1	1		1	1	1	1	1	1	1	1	1
29	" " " " " "				1	1	1	1		1	1	1	1	1	1	1	1	1
30	Bevel Gears, 1 1/2"				1	1	1	1		1	1	1	1	1	1	1	1	1
30A	" " " " " "				1	1	1	1		1	1	1	1	1	1	1	1	1
30B	" " " " " "				1	1	1	1		1	1	1	1	1	1	1	1	1
31	Gear Wheels, 1 1/2", 38-teeth				1	1	1	1		1	1	1	1	1	1	1	1	1
32	Worm Wheels				1	1	1	1		1	1	1	1	1	1	1	1	1
34	Spawners				1	1	1	1		1	1	1	1	1	1	1	1	1
35	Spring Clips				6	6	6	6		6	6	6	6	6	6	6	6	6
36	Screw Drivers				4	4	4	4		4	4	4	4	4	4	4	4	4
36B	" " " " " "				4	4	4	4		4	4	4	4	4	4	4	4	4
37	Nuts and Bolts, 7/32"				16	16	20	36		34	94	32	126	43	169	314	280	594
37A	" " " " " "				16	16	20	36		34	94	32	126	43	169	314	280	594
38	Washers				8	8	8	8		8	15	10	24	2	24	36	164	200
40	Hanks of Cord				1	1	1	1		1	1	1	1	1	1	1	1	1
41	Propeller Blades				1	1	1	1		1	1	1	1	1	1	1	1	1
43	Springs				1	1	1	1		1	1	1	1	1	1	1	1	1
44	Cranked Bent Strips				1	1	1	1		1	1	1	1	1	1	1	1	1
45	Double Bent Strips				2 1/2" x 1 1/2"	2 1/2" x 1 1/2"	2 1/2" x 1 1/2"	2 1/2" x 1 1/2"		2 1/2" x 1 1/2"	2 1/2" x 1 1/2"	2 1/2" x 1 1/2"	2 1/2" x 1 1/2"	2 1/2" x 1 1/2"	2 1/2" x 1 1/2"	2 1/2" x 1 1/2"	2 1/2" x 1 1/2"	2 1/2" x 1 1/2"
46	Double Angle Strips				2 1/2" x 1 1/2"	2 1/2" x 1 1/2"	2 1/2" x 1 1/2"	2 1/2" x 1 1/2"		2 1/2" x 1 1/2"	2 1/2" x 1 1/2"	2 1/2" x 1 1/2"	2 1/2" x 1 1/2"	2 1/2" x 1 1/2"	2 1/2" x 1 1/2"	2 1/2" x 1 1/2"	2 1/2" x 1 1/2"	2 1/2" x 1 1/2"
47	" " " " " "				3	3	3	3		3	3	3	3	3	3	3	3	3
47A	" " " " " "				3	3	3	3		3	3	3	3	3	3	3	3	3
48	" " " " " "				1	1	1	1		1	1	1	1	1	1	1	1	1
48A	" " " " " "				1	1	1	1		1	1	1	1	1	1	1	1	1
48B	" " " " " "				1	1	1	1		1	1	1	1	1	1	1	1	1
48C	" " " " " "				1	1	1	1		1	1	1	1	1	1	1	1	1
48D	" " " " " "				1	1	1	1		1	1	1	1	1	1	1	1	1
48E	" " " " " "				1	1	1	1		1	1	1	1	1	1	1	1	1
48F	" " " " " "				1	1	1	1		1	1	1	1	1	1	1	1	1
49	Eye Piece, with boss				1	1	1	1		1	1	1	1	1	1	1	1	1
52	Perforated Flanged Plates, 5 1/2" x 2 1/2"				1	1	1	1		1	1	1	1	1	1	1	1	1
52A	Flat Plates, 5 1/2" x 3 1/2"				1	1	1	1		1	1	1	1	1	1	1	1	1
53	Perforated Flanged Plates, 3 1/2" x 2 1/2"				3	3	3	3		3	3	3	3	3	3	3	3	3
53A	Flat Plates, 4 1/2" x 2 1/2"				3	3	3	3		3	3	3	3	3	3	3	3	3
54	Perforated Flanged Sector Plates				2	2	2	2		2	2	2	2	2	2	2	2	2
55	Perforated Strip, slotted, 2"				0	0	0	0		0	0	0	0	0	0	0	0	0
55A	00 Instruction Manuals				1	1	1	1		1	1	1	1	1	1	1	1	1
56	00-3 " " " "				1	1	1	1		1	1	1	1	1	1	1	1	1
56A	00-4 " " " "				1	1	1	1		1	1	1	1	1	1	1	1	1
56B	00-5 " " " "				1	1	1	1		1	1	1	1	1	1	1	1	1
56C	00-6 " " " "				1	1	1	1		1	1	1	1	1	1	1	1	1
57	Meccano Standard Mechanisms Manuals				1	1	1	1		1	1	1	1	1	1	1	1	1
57A	Hooks				1	1												

Contents of Outfits—continued

No.	DESCRIPTION OF PART.	00	00A	0	0A	1	1A	2	2A	3	3A	4	4A	5	5A	6	6A	7
58	Spring Cord, 40" length															1		7
59	Collars with Set Screws															1		
61	Windmill Sails															23	32	4
62	Cranks															4	11	15
62A	Threaded Cranks															2	4	2
63	Couplings															6	3	4
63B	Strip Couplings															3	3	13
64	Threaded Bosses															3	5	8
65	Centre Forks															2	4	6
66	Weights, 50 Gramme															1		5
67	" " " " " " " "															1	5	5
70	Flat Plates, 5 1/2" x 2 1/2"															6	2	6
72	" " " " " " " "															2	6	8
76	Triangular Plates, 2 1/2" x 2 1/2"															2	6	10
77	" " " " " " " "															2	2	2
78	Screwed Rods, 1 1/2"															1		2
80	" " " " " " " "															1		2
80A	" " " " " " " "															1		2
80B	" " " " " " " "															1		2
81	" " " " " " " "															1		2
82	" " " " " " " "															1		2
89	Curved Strips, 5 1/2" large radius															4		4
90	" " " " " " " "															2		6
94	Sprocket Chain															4		20
95	" " " " " " " "															5		6
95A	" " " " " " " "															4		8
95B	" " " " " " " "															2		3
96	" " " " " " " "															1		3
96A	" " " " " " " "															1		3
97	Braaced Girders, 3 1/2"															2		10
98	" " " " " " " "															1		8
99	" " " " " " " "															1		8
99A	" " " " " " " "															1		8
100	Heads for Looms															2		8
101	Single Bent Strips															2		16
102	Flat Girders, 5 1/2"															4		6
103	" " " " " " " "															4		6
103A	" " " " " " " "															4		6
103B	" " " " " " " "															4		6
103C	" " " " " " " "															4		6
103D	" " " " " " " "															4		6
103E	" " " " " " " "															4		6
103F	" " " " " " " "															4		6
103G	" " " " " " " "															4		6
103H	" " " " " " " "															4		6
103K	" " " " " " " "															4		6
104	Shuttles for Looms															2		10
105	Keed Hooks															3		5
106	Wood Rollers															1		5
107	Sand															4		8
108	Designing Tables															1		8
109	Architraves															4		10
110	Face Plates, 2 1/2"															4		18
111	Rack Strips, 3 1/2"															2		2
111A	Bolts, 1/2"															2		2
111B	" " " " " " " "															2		2
111C	" " " " " " " "															2		2
111D	" " " " " " " "															2		2
114	Hinges															1		1
115	Threaded Pins															1		1
116	Forc Pieces															1		1
116A	Small Fork Pieces															1		1
118	Hub Discs (5 1/2" diam.)															1		1
119	Channel Segments (8 to circle)															1		1
120A	Spring Buffers															2		1
120B	Compression Springs															2		1
121	Train Couplings															3		7
122	Miniature Loaded Sacks															1		6
123	Cone Pulleys															6		8
124	Reversed Angle Brackets, 1/2"															2		4
125	" " " " " " " "															2		4
126	Trunnions															2		7
126A	" " " " " " " "															2		7
128	Flat Trunnions															1		1
128A	" " " " " " " "															1		1
128B	" " " " " " " "															1		1
129	Boss Bell Cranks															1		1
130	Rack Segments (6" diam.)															4		4
131	Eccentrics, Tropic Throw															4		4
132	Dredger Hooks															2		2
132A	" " " " " " " "															2		2
132B	" " " " " " " "															2		2
133	Corner Brackets															1		1
134	Crank Shafts, 1" stroke															1		1
135	Theodolite Protractors															1		1
136	Handrail Supports															1		1
137	Whip Flanges															1		1
138A	Ship's Funnels, Cumard Type															8		1
140	Universal Couplings															1		1
141	Wire Links															1		1
142	Rubber Rings, 3" diam.															1		1
142B	Dimple Tyres, 3" internal diam.															1		1
143	Circle Girders (5 1/2" diam.)															1		1
144	Dog Clutches															1		1
145	Circle Girders (7" diam. overall)															1		1
147	Pivot Bolt with two nuts															1		1
147A	" " " " " " " "															1		1
148	Ratchet Wheels															1		1
149	Electric Collecting Shors															1		1
155	Rubber Rings, 1/2"															1		1
157	Fans, 2" diam.															1		1
157A	" " " " " " " "															1		1
160	Channel Bearings, 1 1/2" x 1 1/2" x 1/2"															1		1
162	Boiler, Complete with Ends															1		1

No.	DESCRIPTION OF PART.	00	00A	0	0A	1	1A	2	2A	3	3A	4	4A	5	5A	6	6A	7
163	Sleeve Pieces
164	Chimney Adaptors
165	Swivel Bearings
166	End
169	Digger Buckets
170	Bobbins
302	Bushes, Insulating
303	Washers
304	6 B.A. Screws
305	6 B.A. Nuts
306	Terminals
307	Contact Screw
308	Foil Pieces
309	Coil Checks
310	Lamp Holders
311	27 Gauge B.I. Wire, 30" coils
312	26 " S.C.C. Wire, red 50 yds.
313	Bare Copper Wire, 1/4 yds coil
314	Electric Manual of Instructions
315	Clockwork Motors
	Electric Motor No. 1 (6-volt)
	Instruction Leaflets
	No. 9—Bagatelle Table
	7—Platform Scales
	10—Leg Saw
	11—Horizontal Steam Engine
	12—Stone-sawing Machine
	1—Motor Chassis
	5—Dredger
	17—Planing Machine
	18—Revolving Crane
	19—Steam Shovel
	13—Meccanograph
	6—Stiff Leg Derrick
	20—Electric Mobile Crane
	31—Warehouse
	21—Transporter Bridge
	23—Vertical Log Saw
	14—Grandfather's Clock
	16—Loom
	4—Travelling Gantry Crane
	25—Hydraulic Crane
	2—High-speed Ship-Coaler
	25—Twin-shaft Harmonograph
	3—Motor Cycle and Sidcar

STORAGE BOXES FOR MECCANO PARTS

The boxes illustrated and described below are specially designed for the purpose of storing Meccano parts. Almost every Meccano boy purchases additional parts from time to time, but there is sometimes difficulty in finding suitable accommodation for them. The Meccano Storage Boxes enable extra parts to be stored neatly and methodically so that they are always easily accessible.

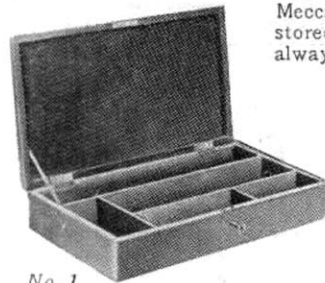

No. 1 Storage Box

Stained and varnished in rich oak finish, and fitted with partitions, as shown in the illustration. The lid is hinged and is secured by means of lock and key.

Dimensions: Length 15½ ins. Width 8½ ins. Depth 2½ ins.

No. 1

No. 2 Storage Box

Finished as No. 1 Box and provided with lock and key. The tray with which it is fitted enables a much larger quantity of parts to be accommodated.

Dimensions: Length 14½ ins. Width 11 ins. Depth 3½ ins.



The prices of the Meccano Storage Boxes are indicated on the price list page at the end of this Manual.

No. 2

No. 3 Storage Box

A perfect receptacle for Meccano parts, finished similarly to the No. 1 and No. 2 boxes and provided with lock and key. In addition to accommodation in the bottom section of the box there are two partitioned trays which fit neatly in position one above the other.

Dimensions: Length 20 ins. Width 14 ins. Depth 5½ ins.

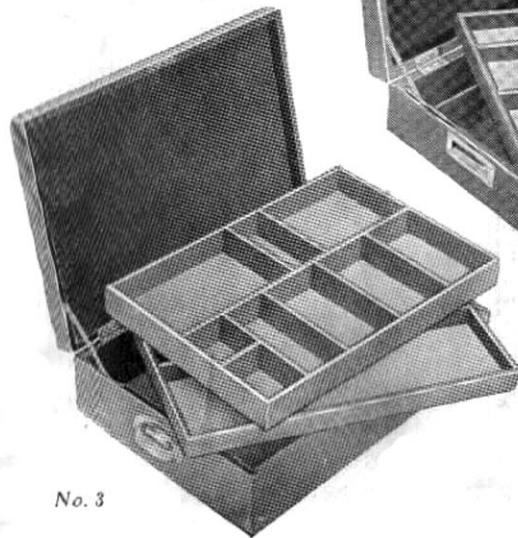

No. 3

MECCANO MOTORS

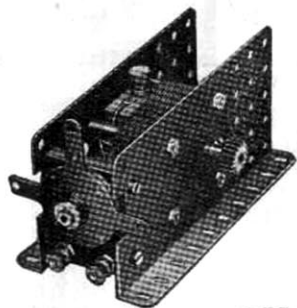

Electric Motor No. 1

(6 Volt)

The 6-volt Motor is specially designed to build into Meccano models. It may be run from a 6-volt Accumulator, or, by employing a suitable transformer, direct from the main. It is fitted with reversing motion, provided with stopping and starting controls, and the gearing is interchangeable.

NOTE.—The Electric Motor No. 1 will not run satisfactorily from dry cells.

6-Volt Accumulator

This new and excellent type of Accumulator has been adapted to drive the Electric Motor No. 1. It has been subjected to the severest tests and has proved itself to be the most suitable accumulator for use with any type of electric motor. It is non-spillable, has remarkable recuperative powers, and will continue to supply current when nominally exhausted.

Transformer

By means of this transformer the Meccano Electric Motor No. 1 (6 volt) may be driven direct from the house supply (alternating current only). It is available for all standard supply voltages, from 100 to 250 inclusive, at all standard frequencies. The supply voltage and frequency must be specified when ordering.

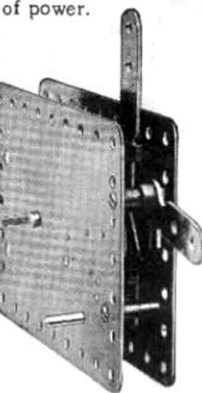

Resistance Controller

By employing this variable resistance the speed of the Meccano Electric Motor No. 1 (6 volt) may be regulated as desired. The controller is connected in series with the motor and accumulator, or with the motor and transformer if a transformer is used as the source of power.

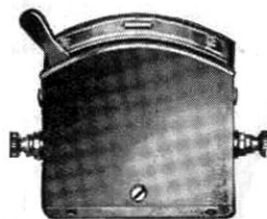

Clockwork Motor

The Meccano Clockwork Motor is specially made for the purpose of driving Meccano models. It is a fine piece of mechanism—simple, powerful, and reliable. The starting, stopping and reversing levers enable the operator to control the various movements of a model in exactly the same manner as an engineer does in actual practice.

MECCANO ACCESSORY OUTFITS



Meccano Accessory Outfits

Our illustration shows one of the Meccano Accessory Outfits. As has already been explained, these Outfits connect the main Outfits from No. 00 to No. 7, making it possible for a boy who commences with one of the earlier Outfits to build up his equipment by easy stages, until he is the possessor of parts that cover the entire system.

Special Inventor's Outfit

This Outfit is intended for boys who already have Meccano, and who wish to satisfy their inventive inclinations by building models from their own designs. The parts contained include four large Pulley Wheels with Dunlop Tyres, Ball Race, Ship's Funnel, Pulley Blocks, Channel Bearing, Crane Grab and many others.



For prices of the above see price list at end of Manual.

HORNBY TRAINS

Hornby Trains are manufactured by Meccano Limited and they are made from the finest materials obtainable. Each train is a beautiful piece of workmanship with perfect mechanism. All Hornby Locos are carefully tested before leaving the factory and their efficiency is guaranteed.

No. M 1 Passenger Set

This set contains Loco, Tender, two Pullman Coaches and set of Rails. One of the latter is a brake rail by means of which the train may be braked from the track. Richly coloured and well finished; fitted with brake mechanism; non-reversing. Gauge 0.

No. M 2 Passenger Set

Similar in every way to the above excepting that it has three Pullman Coaches instead of two, and additional rails.

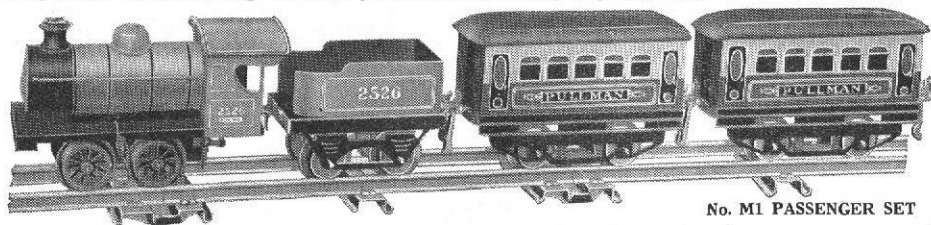

No. M1 PASSENGER SET

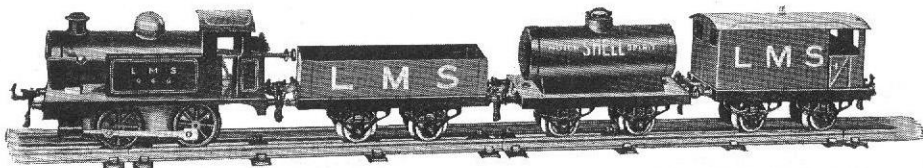

No. 1 TANK GOODS SET

No. 1 Tank Goods Set

This set contains a No. 1 Hornby Tank Loco, Hornby Wagon, Petrol Tank Wagon, Brake Van and set of Rails to form either a circle 2 ft. in diameter or an oval 2 ft. in width by 2 ft. 10 in. in length. One of the rails is a brake rail by means of which the train may be braked from the track.

Gauge 0, in colours to represent the L.M.S.R., L.N.E.R., G.W.R. or S.R. Companies' rolling stock. The Loco is fitted with reversing gear and brake mechanism.

No. 2 Pullman Set

This set includes Loco and Tender of a larger type, measuring 17 in. in length. The Coaches are beautiful both in colour and finish. Each set includes Loco, Tender, and two Pullman Coaches, with set of Rails making a 4 ft. diameter circle. The rails include one brake rail by means of which the train may be both braked and reversed from the track. In colours to represent the L.M.S.R., L.N.E.R., G.W.R. or S.R. Companies' rolling stock. The Loco is fitted with reversing gear and brake mechanism. Gauge 0.

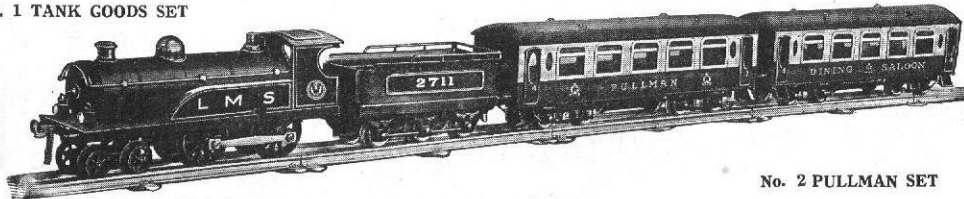

No. 2 PULLMAN SET

No. 3 Train Sets

These Train Sets are the latest additions to the range of Hornby Trains. They are distinctive in design, beautifully enamelled in correct colours and are guaranteed to give the utmost satisfaction.

Each locomotive carries the name of a famous British locomotive on the front wheel guard at each side. A special feature of the Pullman Coaches is the corridor connection, which gives the

Train a most realistic appearance. All the doors of the coaches open.

The Trains in this series are "Cornish Riviera" (G.W.R.), "Flying Scotsman" (L.N.E.R.), "Royal Scot" (L.M.S.R.), and "Dover Pullman" (S.R.). In each case the Train Set is available with either Clockwork or 4-Volt Electric Motor. Gauge 0.

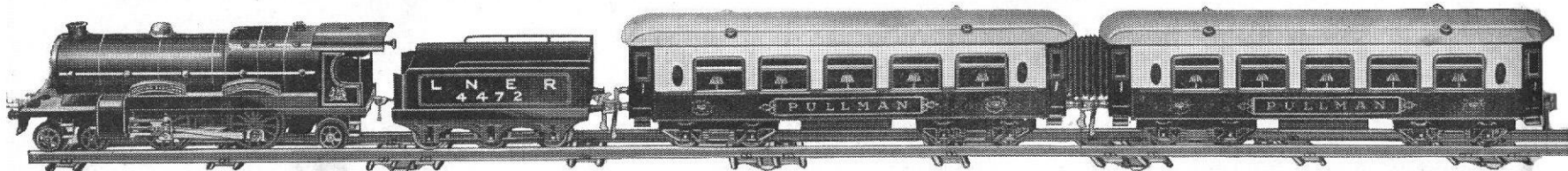

No. 3C L.N.E.R. "FLYING SCOTSMAN"

For prices of the above see price list at end of Manual.

INDEX TO MODELS

Description.	Model No.
Acrobat	2-32
" on See-saw	1-181
Aerial Flight	0-47; 1-129
" Ropeway	0-65
Aerial, Cage	00-72
" Direction	00-76
" Frame	00-71
" Single Wire L	00-78
" Double Wire L	00-73
" Single Wire T	00-75
" Double Wire T	00-80
Aeroplane	0-20; 0-119; 1-29; 1-49; 1-178; 1-225; 2-48
Airship	00-100; 2-43
" Mooring Mast	00-171
Anchor	00-56; 0-105
Angler	0-15
Ape	0-33
Arc Lamp	00-163; 1-105
Arch	0-123
Axe	00-127
" Battle	00-58
" Fire	00-7
Baboon	0-83
Bacon Slicing Machine	0-52; 1-6
Bagatelle Table	1-168
Ballista	1-39
Banjo	0-50
Barge	00-78
Barrier, Level-Crossing	00-1
Barrow	00-15
" Coster's	0-69; 1-228
Battleship	0-23; 0-142; 1-206
Bed	00-40
Bellows	1-78; 1-125
" Forge	1-229
Belt Gear	1-5; 1-14; 1-15; 1-19; 1-20
Bench	00-4; 0-144
Bench, Planing	00-140
Bicycle	0-46; 1-86
Billiard Player	0-150
Birdcage and Stand	00-37
Blacksmith	00-182; 1-128
Boat	1-131
" Ice	3-13
" Motor	00-22; 0-36
" Rowing	0-90; 1-70
" Sailing	00-148; 1-76
" Torpedo	0-38
Boat Steering Gear	1-201
Book End	00-49
Bow and Arrow	1-46
Boxer	0-73
Box Ball Alley	1-154
Boy on Swing	1-166
Brake, Band	1-3; 1-189
Bridge	0-154
" Double Draw	1-109
" High-level	2-10
" Railway with Signals	2-55
Bucking Broncho	0-32
Buffers	00-79
Butter Churn	1-139
Camera	0-54
Candle Shade	0-151
" Stick	1-142
Candy Puller	2-40
Cannon	00-36
Car, Hand	00-159; 3-29

Description.	Model No.
Car, Tandem	1-32
Car Lifting Apparatus	3-49
Carpenter's Square	00-12
Cart	00-143; 1-36
" Baggage	00-31
" Bullock	0-67
" Hand	00-5
" Push	0-4
" Tipping	0-3
Catamaran	1-90
Catapult	00-181; 0-53
Cement Marker	00-21
Chaff Cutter	0-8
Chair	1-59
" Arm	0-37; 0-102
" Baby	2-30
" Bath	00-164; 0-148; 1-183
" Deck	1-219
" Go	0-136
" Invalid	1-21
" Revolving Office	0-153
Chase, A	0-65
Cheese Cutter	00-73
Church	0-16
Chute	00-24
Clock	0-79
" Grandfather	00-149
Clothes Drying Frame	00-121
" Hanger	00-8
" Horse	00-43
Coal Sifter	2-19
" Cutter	1-122
Coaster	1-83; 1-110; 2-36
Coast Guard	0-76
Coat Hanger	00-135; 1-102
Coco-nut Shy	1-179
Cot	0-26; 0-129
" Swing	3-35
Cot on Wheels	1-58
Couch	0-130
Cow and Milkmaid	0-47
Crane	0-58
" Breakdown	0-77
" Derricking	0-115
" Elevated	1-69
" Jib	1-203
" Grab	0-86
" Jib	0-6; 1-66
" Lorry	1-196
" Mobile	1-79
" Overhead	1-158
" Patent Luffing	1-54
" Radial Travelling	00-71
" Railway Breakdown	3-55
" Wagon Swivel	3-45
" Revolving	00-61
" Hammerhead	1-133
" Rotating	1-187
" Swivelling	0-135; 1-60; 1-165
" Jib	1-156; 1-157
" Travelling	1-85; 1-213
" Jib	2-16; 2-17
Crib... ..	00-50
Crocodile	0-28
Crossbow	0-85; 3-16
Crosshead Demonstration Model	1-126
Cum-bak	1-48
Cutlery Basket	00-189
" Rest	00-77
Dancer, The Meccano	1-123

Description.	Model No.
Dancers, Eccentric	1-124
Derrick	2-45
Desk	00-13
Devil Wall	00-187
Dignity and Impudence	1-96
Dinosaur	0-91
Disappearing Meccanitian	1-95
Dividers	00-3; 00-84
Dog	00-122
" Kennel	0-7
Drafting Machine	3-8
Drill	1-53
" Automatic	1-103
" Rock	0-131
Driller, Well	00-174
Drilling Machine	0-125; 1-134; 3-1
Drinking Trough	00-124
Drop the Nigger	3-51
Dump Car	0-116
Easel	2-37
Eiffel Tower	1-104
Electric Loco	0-94
Elevator	1-98; 1-222; 2-11
" Car	00-88
" Electric	1-80
Embossing Machine	2-54
Emery Wheel	1-210
Engine, Beam	1-74
" Horizontal	0-146; 3-17; 3-23
" Two-cylinder Vertical	3-30
" Vertical Steam	3-47
Execution, The	0-56
Extended Ash Tip	1-164
Fan	0-75
" Ceiling	00-142
Farm Sight	00-18
Fencers, The	0-107
Fire Alarm... ..	1-217
" Engine, Manual	1-107
" Escape	00-115; 2-12; 3-25
Flax Cleaner	3-44
Flex Making Machine	3-54
Flip-Flap	1-77
Flower Pot Stand	00-175
Fly Boats	0-93; 1-182
Flying Boats	1-177
" Machine	1-150
Footbridge	0-84
Foot Hammer	1-115
Fork	00-128
Friction Grip Tongs	00-44; 1-47
Frog	0-81
Gallows	00-168
Galvanometer	0-68
Gangway	0-34; 1-50
Garden Roller	00-170
" Hose Reel	00-190
Gate	00-38; 1-151
Gauge, Railway	3-15
" Track	00-34
Girder, Bow	1-214
Glider	00-117
Gondola	2-2
Gong	1-209; 2-8
Goose	0-18
Governor, Centrifugal Engine	0-63; 1-67
" Inverted Centrifugal	1-140
Gramophone	0-40; 1-195

Description.	Model No.
Grass Cutter	0-89
Gradient Indicators	00-107 to 00-114
Gravel Sifter	00-57
Gravity Conveyor... ..	1-118
Grill	00-137
Grinder, Coffee	3-39
" Knife	3-33
Guillotine	1-99
Gun, Anti-Aircraft	00-158; 1-145; 2-47
" Big	00-180
" Field, and Carriage	0-31
" Lewis... ..	00-28
" Machine	0-108
" Old Siege	0-140
" Quick Firing	1-161
Gymnast	0-24; 1-88
" Revolving	1-227
Gyroscope	1-202
Hack Saw, Power	0-139
Hammer, Double Drop	2-1
" Helve	1-91
" Mechanical	1-33; 2-22
" Trip	00-166
Hammock	0-134
Hand Punch	3-43
Hatchet	1-24
Hat Rack	0-120
Hay Tedder	2-9
Hen... ..	0-88
" H" Girder	1-4
High-level Bridge	2-10
Hoe... ..	00-139
Hoisting Block	1-89
Hooke's Coupling	1-188
Horse	00-130
" and Cart	1-52
" Prancing	0-133
" Toy	00-104
Horseman	1-75
Horseman's Fall	0-74
Howitzer	1-82
Hurdler	0-60
Inclined Plane	1-120
Invalid, The	1-37
Inverted Truss	1-152
Jockey Pulley	1-1
Joy Wheel	00-178
Jumping Jack	00-64
Key, Double Cable	1-130
Kinetograph	3-57
King Meccano	1-212
Lace Jennier	3-9
Ladder	00-10
" on Wheels	00-185; 1-42; 1-148; 2-39
" Step	00-47; 3-7
Ladle, Giant Foundry	1-200
Lamp Standard	1-193
Lancer	1-197
Lathe	0-111; 3-48
" Bench	0-143
" Treadle	2-6
Lawn Marker	3-28
" Mower	1-31; 3-34
Lazy Tongs	0-22; 1-199
Letter Balance	00-177; 1-22; 3-3
Level Crossing Barrier	00-173

Description.	Model No.
Level of the First Order	00:85
" " Second "	1-7
" " Third "	1-8
Light Cruiser	0-9
Liner	00-55
Locomotive	1-170; 1-207
Loom, Hand	1-92
Lorry, Motor	1-94; 1-204; 1-224
" Steam	2-20
" Tank	3-38
Loud Speaker	0-45
Luggage Cart	1-221
Machine for tracing a locus	1-143
Magic Plate	00-74
Mail Bag Hanger	00-59; 00-92
Man and Boy	1-144
" Climbing Pole	1-64
Master and Student	1-84
Mat Frame	2-28
Meccanaroo	3-24
Meccano Boy	0-48
" Man	00-33
Meccanograph	1-146
Mechanical Gong	1-174
Medal	0-13
Milk Maid	0-41
Missing Link, The	0-70
Monoplane	2-25
Mono Rail	00-147
Motor Car	00-125; 1-137
" Racing	1-135
" Cycle and Sidecar	0-44
" Cyclist and Pillion Rider	1-112
Mountain Transport	1-44
Mounted Cowboy	1-81
Music Stand	0-122
Newton's Disc	3-46
Notice Board	0-121
Oil Cake Chopper	3-12
Ore Crusher	00-176
Organ	00-123
Ostrich	00-48
Pantograph	1-192
Parallel Bars	0-149
Pastry Designer	3-50
Pecking Hen	0-59
Pen Rack 00-152; 0-11; 0-72; 0-96; 1-106	
Performing Meccanitian	2-29
Piano	0-39
Pile Driver	1-114; 3-19
Pistol	0-57
Piston Connection, Double Action	1-41
Pithead Gear 00-145; 2-13; 2-14; 3-37	
Planing Bench	00-140
Plasterer's Hawk	00-23
Pliers	0-62
Plough	00-6; 0-118
Pneumatic Grain Elevator	0-82
Polishing Spindle	2-53
Portal	0-106
Potato Chopper	00-32
Potter's Wheel	1-220
Prehistoric Animal	0-152
" Armadillo	0-43
" Bird	0-14; 00-162

Description.	Model No.
Press, Automatic Dial	3-10
Print Trimmer	00-75
Propeller	00-89
Pulley Block 0-114; 1-16; 1-17; 1-18	
" Single Sheave 0-109; 0-128	
" Sha'fing	00-133; 00-156
Pullman Car	00-179
Pump	0-98
" Double Action	1-215
" Windmill	1-138
Punching Bag Stand	0-137
Machine	0-147; 1-162
Quick Delivery Chute	1-173
Return Device	1-169
Railway Cable	1-141
" Signal, French	00-72
" Wagon Swivel Crane	3-45
Rake	00-52; 00-45; 1-155
" Horse	0-5; 1-117
" Large	1-63
Rat Trap	1-190
Rattle	0-103; 3-31
Razor	00-90
Refreshment Wagon	00-51
Rickshaw	0-92
Rifle with Bayonet	00-17
Road Sign	00-94; 00-99
Rocking Horse	0-25
Roller, Field	00-70; 1-97
" Furrow	00-138
" Steam Road	3-32
Roman Balance	00-136
Roulette Wheel	00-132
Roundabout 00-153 1-211 2-51; 3-52	
Safety Catch for Winding Gear	1-62
Sand Yacht	1-153; 2-34
Saw, Band	00-184; 1-160
" Circular	00-118; 1-140
" Meat	00-2
" Mechanical	1-26
" Two-hand	00-134
Sawing Horse	00-155
Machine	1-185
Saxophone	0-29
Scales 00-41; 00-120; 0-126; 0-127; 1-116; 1-163; 2-32; 3-6; 3-27	
Scarifier	3-4
Schooner, Square Topsail	2-31
Scooter	0-1; 0-55; 1-38
Scrap Reel	00-39
Seaplane, Schneider Trophy	2-50
Searchlight	00-126
Seat, Garden	00-46
" Umpire's	1-180
Sedan Chair	1-176
See-Saw	0-124; 1-224
" Actuating	1-100; 3-20
" Revolving	1-186
" Roundabout	2-3
Seismograph	1-65
Semaphore	00-101
Set-Square, 45°	1-12
" 60°	1-13
Sewing Machine	2-46
Shade, Candle	0-151
Shearing Machine	0-104

Description.	Model No.
Shepherd's Crook	1-121
Ship's Lamp	1-208
Shipyard Bogie	00-16
Shovel, Mechanical	1-205
" Steam	1-57
Sifter	2-38
Signal	1-149
" Automatic	1-51
" French Railway	00-72
" Junction	0-141
Sign Post, one-way	00-97
" two-way	00-81
" three-way	00-85
" four-way	00-91
Single Sheave Pulley Block	0-109; 0-128
Ski-Runner	00-186
Sled	00-11; 00-188; 0-138
Sleigh, Horse	3-36
Smoothering Iron	2-4
Snake	0-78
Spade	00-20
Spindle, Buffing	00-183
Spinning Buttons	1-61
Stamp, Drop	1-127
" Mechanical	1-223
Stamping Machine	1-198
" Mill	00-118; 2-49
Steam Engine, Vertical	3-47
" Road Roller	3-32
Steamer, Paddle	1-147; 3-56
Steeple Chaser	0-71
Stone Sawing Machine	1-68
Stool	00-146
" Piano	00-103
Street Lamp	00-95
Strip Bending Machine	3-2
Strong Man	0-19
Submarine	0-17; 1-181
Sudden Appearance, A	1-108
Sulkey	0-145
Swing	00-69; 0-117; 3-11
" Boat	3-53
" Automatic	3-26
Switch	00-29
Switchback	0-87
Sword	00-105; 0-42
Table	00-1; 00-53; 0-27
" Bed	00-169; 1-119
" Collapsible	00-25
" Drafting	0-101
Tappet Valve Demonstration	
Model	1-111
Telegraph Key	00-76
" Pole	00-116
Telescope	1-175
Telescopic Mast	0-49; 1-93
Telpher Span	1-43
Tennis Player	0-12
Three Wheel Auto	0-10
Ticca Gharry	1-23
Tight Rope Walker	1-40
Timber Drag	1-30; 1-159
Tin Opener	00-82
Tipping Motor Wagon	2-52
Toast Rack	1-191
Toboggan	3-14
Top	1-35
" Spinning	00-26; 2-27
Towel Horse	00-161; 2-35
Tractor, Farm	3-42

Description.	Model No.
Tractor, Motor	1-136; 1-167
Tramway Car	0-35
Tramcar, Electric	3-5
Treadle Grindstone	1-172
Triangle of Forces	1-2
Tricycle	0-61; 2-23
" Carrier	2-41
Tricyclist, Revolving	1-55
Trip Hammer	00-166
Tripod	00-102
Trolley	00-27; 00-157; 0-30; 0-95
" Hand	3-22
" Porter's	00-86
Trowel	00-14
" Mason's	00-30
Truck	1-56
" Baggage	00-96
" Bogie	00-129
" Cattle	0-21
" Electric	2-18
" Fire	3-41
" Flat	00-19
" Hand	00-93; 00-172
" Lumber	00-131; 00-144
" Luggage	0-2; 0-100; 1-87
" Motor	1-226; 2-33
" Revolving	2-7
" Timber	00-54
" with Sides	1-25
Truss, Compound Triangulated	1-9
" Howe	1-10
" Triangulated	1-11
Try-your-strength Machine	1-129; 2-50
Turnstile	00-35; 2-21
Turntable	2-26
Tweezers	00-83
Umbrella Stand	00-106
Van, Motor	1-132; 2-44
Velocipede	00-9
Viaduct	0-113
Violin	00-42
" and Bow	1-73
Wagon, Dinner	00-141; 1-27
" Steam	3-58
" Tank	3-21
" Tea	00-165; 0-110
" Timber	0-65
" Tip	1-28
" Tower	1-45; 1-194; 1-216; 3-18
Walking Man	0-97
" Stick	00-87
Watch and Chain	00-119
" Stand	00-150
Weather Vane	0-112; 1-72
Well Driller	00-174
" Windlass	0-132
Windlass	1-34
" Chinese	1-113
" Well	0-132
Windmill	00-167; 0-80; 2-42
Wire Rope Maker	1-101
Wiretail	0-51
Wrestlers	0-64; 1-71
Yacht	00-98
" Ice	00-160
" Land	3-40

Patents and Designs
Great Britain

20,535/13	253,236
22,962/13	648,958
3,869/14	671,484
4,183/14	671,485
4,564/15	671,534
139,125	671,790
177,430	680,416
250,378	682,208

MECCANO

THE TOY THAT MADE ENGINEERING FAMOUS

Millions of boys in every country throughout the world play with Meccano. These are the Meccano Factories and distributing centres.

Patents and Designs
Great Britain

682,209	686,112
682,934	698,054
683,011	718,404
718,731	

Australia

13,460/19	14,388/14
15,136/14	



Meccano Ltd.,
5/6, Marshall Street,
London, W.1.

London Office and Warehouse :
Meccano Ltd.,
Walnut Tree Walk,
Kennington Road, London, S.E.11.

Meccano Agencies :

Algiers,	Bogota,
Amsterdam,	Bombay,
Auckland,	Brussels,
Barcelona,	Buenos Aires,
Basle,	Cape Town.

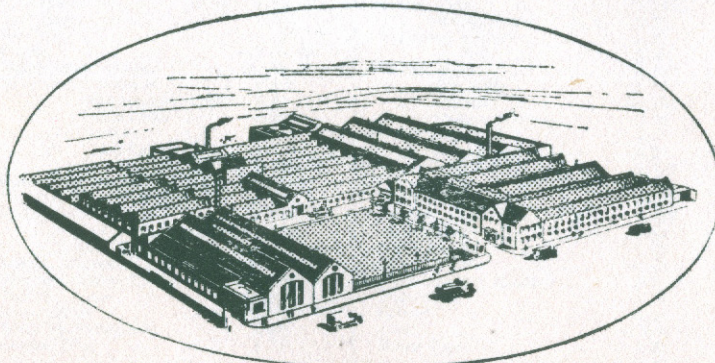

Head Office and Factory :
BINNS ROAD, LIVERPOOL.

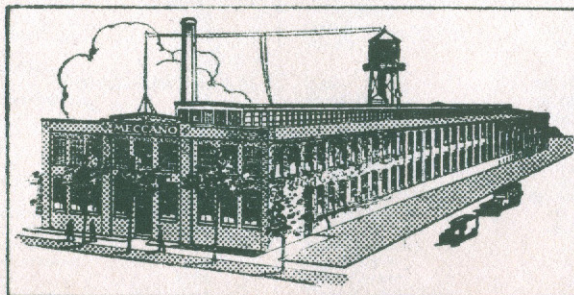

Meccano Company Inc.,
Elizabeth, New Jersey, U.S.A.

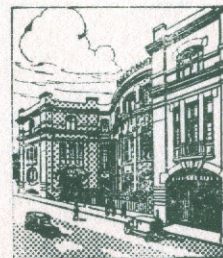

Meccano (France) Ltd.,
78-80 Rue Rebeval,
Paris XIXeme.

Canadian Office and Warehouse :
Meccano Ltd.,
45, Colborne Street, Toronto.

Meccano Agencies :

Constantinople,	Malta,
Durban,	Monte Video,
Genoa,	Oslo,
Iquitos,	Stockholm,
Johannesburg,	Sydney.