

MECCANO

(TRADE MARKS 296321, 501113, 76, 12633, 10274, 55/13476, 569/13, 884/25, 2913, 80, 124, 336, 18066, 5403, 41812, 4174, 9048, 5549, 2389, 91637, 83171, 157149, 32822, 200639, 209733, 214061, 214062, 12892, 29094, 33316, 1818, 16737, 16900, 72286, 494933-4-5-6, 139420, 383/13, 5848, 50204, 10/12258, 22826, 18982, 20063/925, 2189, 7315, 29041, 26877, 6595, 404718, 410379)

HORNBY'S ORIGINAL SYSTEM—FIRST PATENTED IN 1901

INSTRUCTIONS

FOR OUTFITS

Nos. 00 to 3

Price
1/6

Copyright by MECCANO LIMITED, LIVERPOOL, throughout the world

No. 30A

ENGLISH EDITION

MECCANO

REAL ENGINEERING IN MINIATURE

The Meccano system is composed of over two hundred and fifty different parts, mostly made of steel or brass, each one of which has a specific mechanical purpose. These parts combine to form a complete miniature engineering system with which practically any mechanical movement may be reproduced in model form. More can be accomplished with Meccano than with any other constructional toy, for no other system has such possibilities. The genius is in the parts and you can commence to build models as soon as you get your Outfit home. A screw-driver, provided in the Outfit, is the only tool necessary.

There is no limit to the number of models that can be built with Meccano—Cranes, Clocks, Motor Cars, Ship-Coalers, Machine Tools, Locomotives—in fact everything that interests boys. The most wonderful feature about the system is that it is *real engineering*; it is fascinating and delightful and it gives you a satisfaction beyond anything that you have ever previously experienced.

*The Finest Hobby
in the World
for Boys*

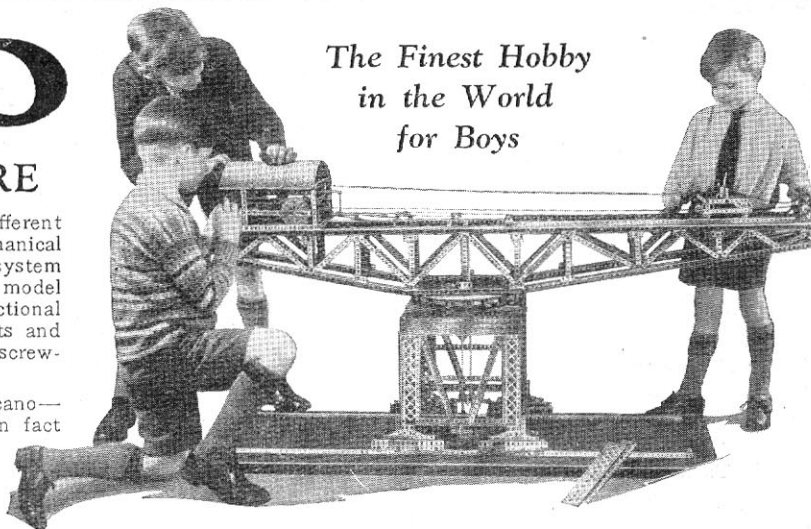

HOW TO BUILD WITH MECCANO

Make the simple models first—there is loads of fun in them—and then try to improve them. Every model can be made in a dozen different ways. It is important to screw up all the nuts and bolts tightly to ensure that your models will be strong and firm when they are completed. When you have built all the models shown in this book you will want to build others of a more advanced type, and you cannot do better than purchase a copy of the No. 4-7 Manual from your dealer. This Manual contains illustrations of a fine selection of models, a large number of which you will be able to build by adding a few extra parts to your equipment.

Meccano is sold in ten different Outfits, numbered 000 to 7. All Meccano parts are of the same high quality and finish, but the larger Outfits contain a greater quantity and variety of parts, making possible the construction of more elaborate models. Each Outfit, except the No. 000, may be converted into the one next higher by the purchase of an Accessory Outfit (see page 125). Thus a No. 00 may be converted into a No. 0 by adding to it a No. 00A. A No. 0A then converts it into a No. 1 and so on up to No. 7. No matter with which Outfit you commence, you may build it up by degrees until you possess a No. 7. It is important to remember that Meccano parts may be bought separately at any time in any quantity.

All models shown in this Manual are numbered and for reference purposes each model number is preceded by the number of the Outfit with which it may be built. Thus, for example, model No. 00.60 may be built with No. 00 Outfit, and model No. 2.20 with No. 2 Outfit.

MECCANO SERVICE

The service of Meccano does not end with selling an Outfit and an Instruction Manual. When you want to know something more about engineering than is now shown in our books, or when you strike a tough problem of any kind, write to us. We receive over 200 letters from boys every day all the year round. Some write to us because they are in difficulty, others because they want advice on their work or pleasures, or about the choice of a career. Others, again, write to us just because they like to do so and we are glad to know that they regard us as their friends.

Although all kinds of queries are put to us on all manner of subjects, the main interest is, of course, engineering. No one has such a wonderful knowledge of engineering matters as that possessed by our staff of experts. This vast store of knowledge, gained only by many years of hard-earned experience, is at your service. *We want the Meccano boy of to-day to be the famous engineer of to-morrow.*



THE "MECCANO MAGAZINE"

The *Meccano Magazine* is the Meccano boy's own newspaper. It tells him of the latest Meccano models; what Meccano Clubs are doing; how to correspond with other Meccano boys; the Competitions that are running, etc. It contains splendid articles on such subjects as Railways, Famous Engineers and Inventors, Electricity, Bridges, Cranes, Wonderful Machinery, Aeronautics, Latest Patents, Radio, Stamps, Photography, Books and other topics of interest to boys, including suggestions from Meccano boys for new Meccano parts and correspondence columns in which the Editor replies to his readers' enquiries. The Magazine is published on the first of each month. Write to the Editor, *Meccano Magazine*, Old Swan, Liverpool, enclosing 6d. in stamps, and giving the names and addresses of three of your chums who are not Meccano boys. He will then forward a specimen copy of the "*M.M.*" post free. If you wish to become a regular subscriber the rates are 4/- for six issues or 8/- for twelve issues, post free. If you prefer to do so, you may order the Magazine from your Meccano dealer or from any newsagent or bookstall, price 6d.

MECCANO STANDARD MECHANISMS

There are many Meccano movements that have to a certain extent become standardised; that is to say they may be applied to more than one model, in most cases without any alteration, but in some few instances with only slight alterations to the original movement. These have been collected and classified, and may be obtained in the form of a Manual entitled "Meccano Standard Mechanisms." This Manual describes in detail various belt and rope mechanisms, roller and ball bearings, screw mechanisms, gear boxes and gear ratios, etc. Every Meccano experimenter has need of this useful book.



You may obtain a copy of the "Standard Mechanisms" Manual from your dealer, price 1/-, or direct from Meccano Ltd., Old Swan, Liverpool, price 1/1½ post free.

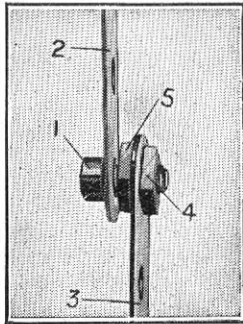

S.M. 262

SIMPLE MECCANO PIVOTS

In building Meccano models it is frequently required to attach two parts together so that one or both are quite free to swivel. A very simple way to do this is shown under detail number 262 in the "Meccano Standard Mechanisms" Manual, and for the benefit of those readers who are unable to consult the special Manual, we have reproduced this detail. As will be seen, it consists of a simple type of pivot or swivel bearing formed by a bolt and two nuts. The bolt is secured rigidly to a Strip or Plate, etc., by means of the nuts, which are secured tightly against opposite sides of the Strip, sufficient space being left beneath the head of the bolt to permit another Strip to turn freely about its shank.

A somewhat similar form of swivel-joint, also widely used, consists of a bolt and lock-nuts (Standard Mechanism No. 263). The two Strips to be connected pivotally are placed on the bolt and held in position by two nuts locked together on the shank. The Strips must be allowed a certain amount of play so that they can pivot independently about the bolt. These pivoting devices will be found equally valuable in the simplest and the most elaborate models.

Particulars of Meccano Parts

STRIPS, GIRDERS AND BRACKETS

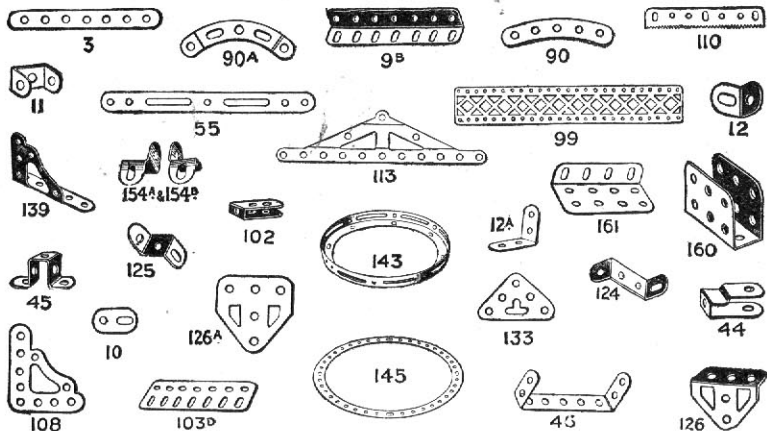

WHEELS, GEARS, ETC.

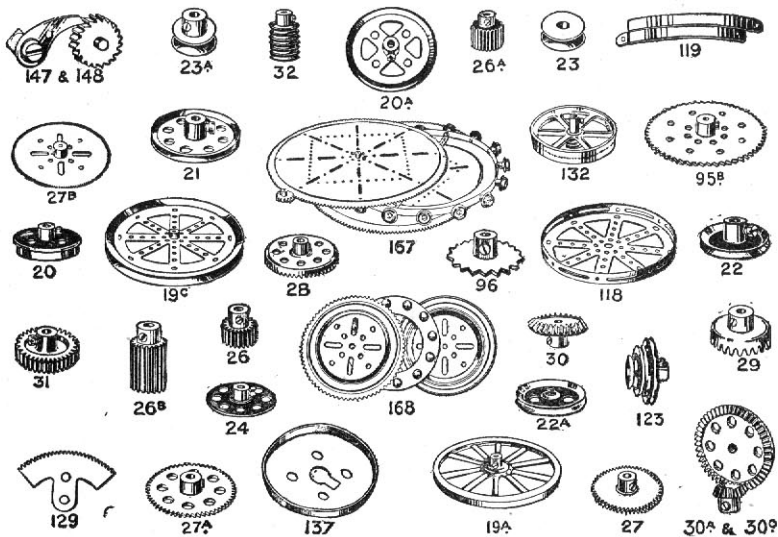

Perforated Strips	
No.	1/2 No.
1.	12 1/2"
1a.	9 3/4"
1b.	7 1/2"
2.	5 3/4"
2a.	4 1/2"
Angle Girders	
7.	24 1/2"
7a.	18 1/2"
8.	12 1/2"
8a.	9 1/2"
8b.	7 1/2"
9.	5 1/2"
Flat Brackets...	
10.	
Double Brackets	
11.	
Angle Brackets	
12.	
12a.	" "
12b.	" "
Axle Rods	
13.	11 1/2"
13a.	8"
14.	6 1/2"
15.	5"
15a.	4 1/2"
16.	3 1/2"
Crank Handles, Large ...	
19.	"
Small ...	
19s.	"
Wheels, 3" diam., with set screws	
19a.	"
Flanged Wheels, 1 1/2" diam. ...	
20.	"
Pulley Wheels	
19b.	3" dia. with centre boss and set screw
19c.	6" " " " " "
20a.	2" " " " " "
21.	1 1/2" " " " " "
22.	1" " " " " "
23a.	1/2" " " " " "
22a.	1" " without " " "
23.	1/2" " " " " "
Bush Wheels ...	
24.	"
Pinion Wheels, 1/2" diam., 1" wide	
25a.	"
25b.	"
26.	"
26a.	"
26b.	"
Gear Wheels	
27.	50 teeth to gear with 1/2" pinion ...
27a.	57 " " " " " "
27b.	133 " " " " (3 1/2" diam.)
Contrate Wheels, 1 1/2" diam. ...	
28.	"
29.	"
Bevel Gears, 7/26 teeth ...	
30.	"
30a.	" " 1 1/2, 16 " Can only be used together
30c.	" " 1 1/2, 48 " " " "
Gear Wheels, 1", 38 teeth ...	
31.	"
Worms ...	
32.	"
Spanners ...	
34.	"
Box Spanners ...	
34b.	"
Spring Clips ...	
35.	"
Screw Drivers ...	
36.	" Extra Long ...
36a.	" Special ...
36b.	" " " "
Nuts and Bolts, 7/32" ...	
37.	"
Nuts...	
37a.	"
Bolts, 7/32" ...	
37b.	"

No.		37f. Nuts and Bolts, 7/32" ...	
37g.			
38.			
40.			
41.			
43.			
44.			
Cranked Bent Strips			
Double			
45.			
" Angle Strips, 2 1/2" x 1 1/2"			
46.			
47.			
47a.			
48.			
48a.			
48b.			
48c.			
48d.			
Eye Pieces, with boss ...			
50a.			
52.			
52a.			
53.			
53a.			
54.			
Perforated Flanged Sector Plates			
55.			
55a.			
Instruction Manual, No. 4-7 ...			
56.			
56a.			
56b.			
56c.			
Meccano Standard Mechanisms Manual			
56d.			
Book of New Models ...			
56f.			
Bound Manual			
57.			
Hooks ...			
57a.			
57b.			
58.			
Spring Cord ...			
58a.			
59.			
Collars with Set Screws ...			
61.			
Windmill Sails ...			
62.			
Crankes ...			
62a.			
62b.			
Double Arm Cranks ...			
63.			
Couplings ...			
63a.			
63b.			
63c.			
Threaded Couplings ...			
64.			
Bosses ...			
65.			
Centre Forks ...			
66.			
Weights, 50 grammes ...			
67.			
Woodscrews, 1/2" ...			
68.			
Set Screws ...			
69.			
Grub Screws, 5/32" ...			
69b.			
70.			
72.			
76.			
77.			
Screwed Rods			
78.			
79.			
79a.			
80.			
80a.			
80b.			
81.			
82.			
Curved Strips, 10" radius ...			
89.			
89a.			
89b.			
90.			

Ask your dealer for a free illustrated list giving details and prices of all Meccano parts.

Particulars of Meccano Parts (continued)

No.	
90a.	2 1/2" Curved Strips, cranked, 1 1/2" radius, 4 to circle
94.	Sprocket Chain
95.	" Wheels, 36 teeth, 2" diam.
95a.	" " 28 " 1 1/2"
95b.	" " 56 " 3"
96.	" " 18 " 1"
96a.	" " 14 " 3/4"
97.	Braced Girders, 3 1/2" long
97a.	" " 3" "
98.	" " 2 1/2" "
99.	" " 1 1/2" "
99a.	" " 9 1/2" "
99b.	" " 7 1/2" "
100.	" " 5 1/2" "
100a.	" " 4 1/2" "
101.	Healds, for looms
102.	Single Bent Strips
103.	Flat Girders, 3 1/2" long
103a.	" " 9 1/2" "
103b.	" " 12 1/2" "
103c.	" " 4 1/2" "
103d.	" " 3 1/2" "
103e.	" " 3" "
103f.	" " 2 1/2" "
103g.	" " 2" "
103h.	" " 1 1/2" "
103k.	" " 7 1/2" "
104.	Shuttles, for looms
105.	Reed Hooks, for looms
106.	Wood Rollers
106a.	Sand Rollers
107.	Tables for Designing Machines
108.	Architraves
109.	Face Plates, 2 1/2" diam.
110.	Rack Strips, 3 1/2"
110a.	" " 6 1/2"
111.	Bolts, 3/4"
111a.	" " 1/2"
111c.	" " 3/8"
113.	Girder Frames
114.	Hinges
115.	Threaded Pins
116.	Fork Pieces, Large
116a.	" Small
117.	Steel Balls, 3/8" diam.
118.	Hub Discs, 5 1/2"
119.	Channel Segments (8 to circle, 1 1/4" diam.)
120.	Buffers
120a.	Spring Buffers
120b.	Compression Springs
121.	Train Couplings
122.	Miniature Loaded Sacks
123.	Cone Pulleys
124.	Reversed Angle Brackets, 1 1/2"
125.	" " 1"
126.	Trunnions
126a.	Flat Trunnions
127.	Simple Bell Cranks
128.	Boss Bell Cranks
129.	Rack Segments, 3" diam.
130.	Triple Throw Eccentrics

No.	
131.	Dredger Buckets
132.	Flywheels, 2 1/2" diam.
133.	Corner Brackets
134.	Crank Shafts, 1" stroke
135.	Theodolite Protractors
136.	Handrail Supports
137.	Wheel Flanges
138.	Ships' Funnels
138az.	" Raked
139.	Flanged Brackets (right)
139a.	" (left)
140.	Universal Couplings
141.	Wire Line (for suspending clock weights)
142.	Rubber Rings, 3" rim
142a.	Dunlop Tyre to fit 2" diam. rim
142b.	" " " 3" " "
142c.	" " " 1" " "
142d.	" " " 1 1/2" " "
143.	Circular Girders, 5 1/2" diam.
144.	Dog Clutches
145.	Circular Strips, 7 1/2" diam. over-all
146.	" Plates, 6"
147.	Pawls, with pivot bolt and nuts
147a.	Pawls
147b.	Pivot Bolt with 2 nuts
148.	Ratchet Wheels
149.	Collecting Shoes, for Electric Locomotives
150.	Crane Grabs
151.	Pulley Blocks, Single Sheave
152.	" Two
153.	" Three
154a.	Corner Angle Brackets, 1/2", right hand
154b.	" " " " left hand
155.	Rubber Rings, 5/8"
156.	Pointers, 2 1/2" over all, with boss
157.	Fans, 2" diam.
158a.	Signal Arms, Home
158b.	" Distant
159.	Circular Saws
160.	Channel Bearings, 1 1/2" x 1" x 1/2"
161.	Girder Brackets, 2" x 1" x 1/2"
162.	Boiler, complete with ends
162a.	" " ends
162b.	" " without ends
163.	Sleeve Pieces
164.	Chimney A-pieces
165.	Swivel Bearings
166.	End
167.	Geared Roller Bearings
167a.	Roller Races, gear 1, 192 teeth
167b.	Ring Frames for Rollers
167c.	Pinions for Roller Bearings, 16 teeth
168.	Ball Bearings, 4" diam.
168a.	" Races, flanged disc
168b.	" " toothed
168c.	" Casings, complete with balls
169.	Digger Buckets
170.	Eccentrics, 1/2" throw
171.	Socket Couplings
172.	Fend-off Connection
173.	Rail Adaptor

* The series includes 26 funnels in the correct design and colours of leading shipping companies.

PLATES

76, 109, 53, 146, 77, 61, 54, 52, 72

RODS, CRANKS AND COUPLINGS

134, 64, 166, 121, 116A, 144, 165, 130, 19c, 171, 17, 170, 63, 63A, 140, 63B, 63C, 136, 128, 62, 80A, 62B, 127, 116

MISCELLANEOUS

151, 152, 153, 138, 162, 138A, 66&67, 142A, 41, 106, 169, 57, 122, 57B, 157, 156, 106A, 164, 151, 142, 35, 59, 149, 101, 120, 120A, 158A, 104, 159, 57A, 94, 150, 105, 65, 115, 163, 34B, 34, 50A, 114

Ask your dealer for a free illustrated list giving details and prices of all Meccano parts

Meccano Super Models

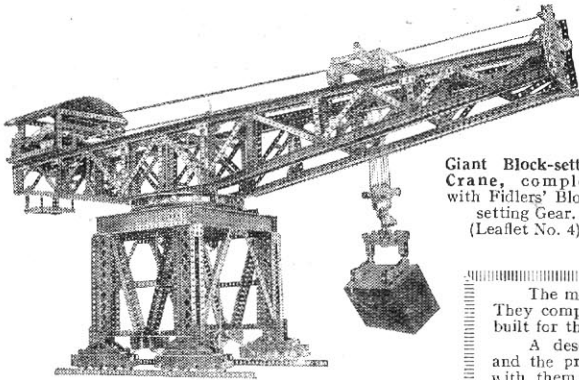

Giant Block-setting Crane, complete with Fidler's Block-setting Gear. (Leaflet No. 4)

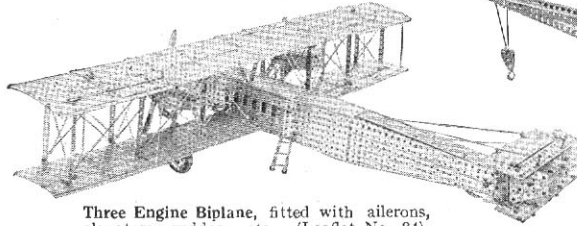

Three Engine Biplane, fitted with ailerons, elevators, rudders, etc. (Leaflet No. 34)

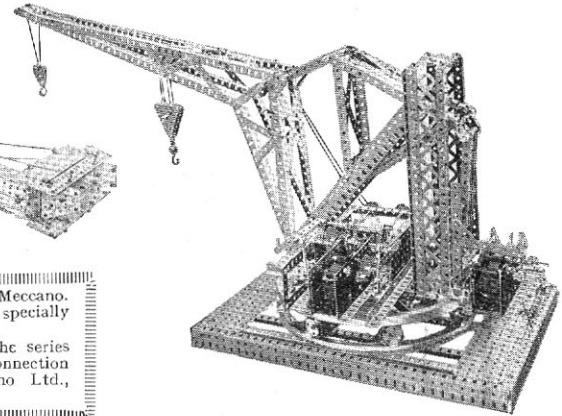

Pontoon Crane. Movements include hoisting, luffing and slewing. (Leaflet No. 28)

The models illustrated on this page show the wonderful possibilities of Meccano. They comprise a selection from a range of super models that has been specially built for the delight of Meccano boys.

A descriptive leaflet giving full particulars of all the models in the series and the prices of the special Instruction Leaflets that are published in connection with them, may be obtained from your dealer or direct from Meccano Ltd., Old Swan, Liverpool.

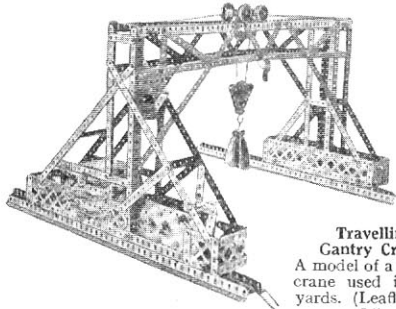

Travelling Gantry Crane. A model of a type of crane used in ship-yards. (Leaflet No. 24)

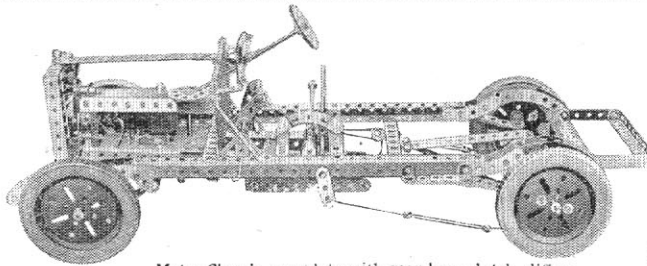

Motor Chassis, complete with gear box, clutch, differential, internal expanding brakes, etc. (Leaflet No. 1)

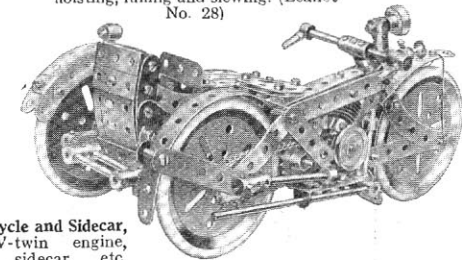

Motor Cycle and Sidecar, with V-twin engine, sprung sidecar, etc. (Leaflet No. 3)

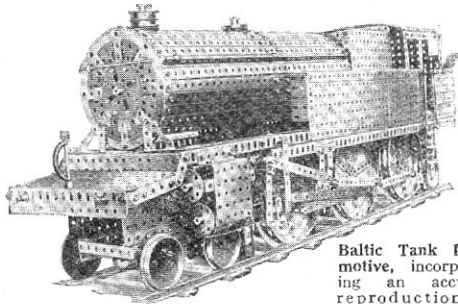

Baltic Tank Locomotive, incorporating an accurate reproduction of Walschaerts' valve gear. (Leaflet No. 15)

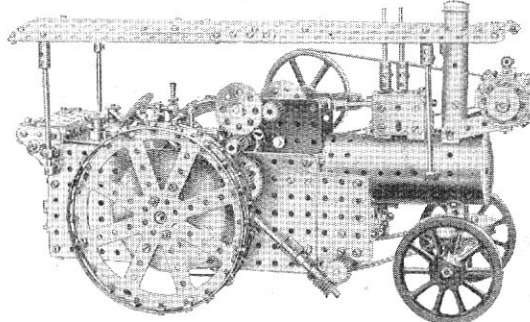

The Traction Engine is driven by a 6-volt Motor and will haul 140 lbs. (Leaflet No. 22)

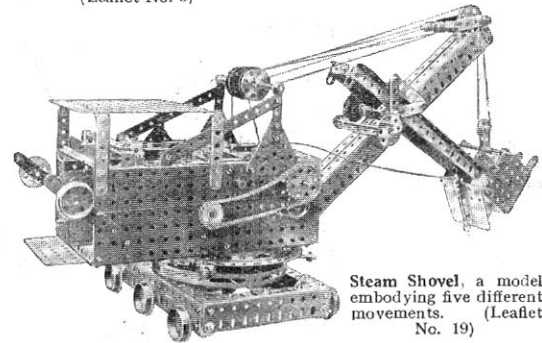

Steam Shovel, a model embodying five different movements. (Leaflet No. 19)

All these Models can be built with MECCANO Outfit No. 00

Model No. 00.1 Table

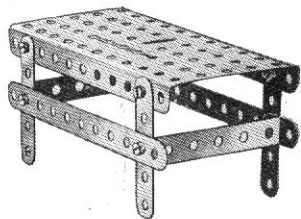

Model No. 00.3 Dividers

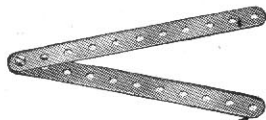

Model No. 00.8 Clothes Hanger

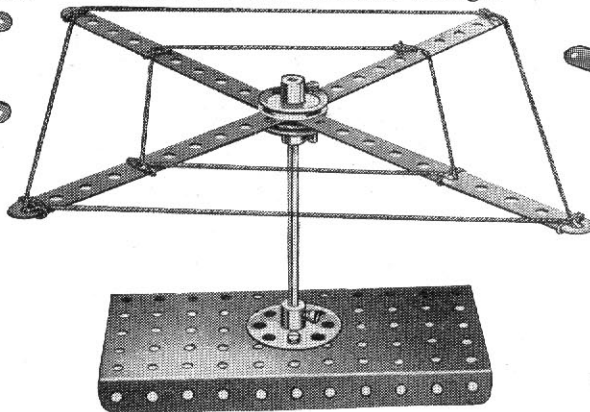

Model No. 00.12 Carpenter's Square

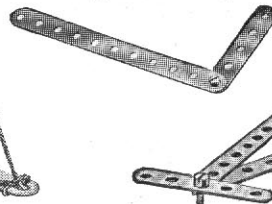

Model No. 00.16 Shipyard Bogie

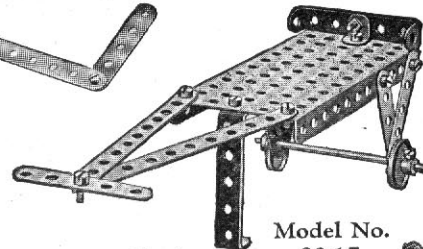

Model No. 00.4 Bench



Model No. 00.2 Meat Saw

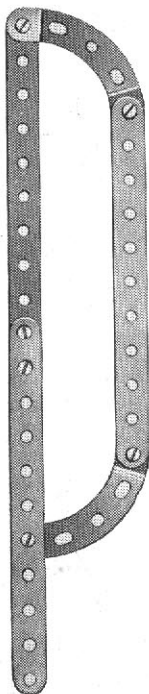

Model No. 00.13 Desk

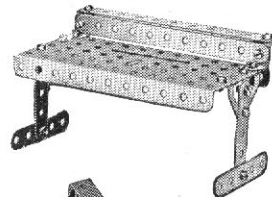

Model No. 00.17 Rifle with Bayonet

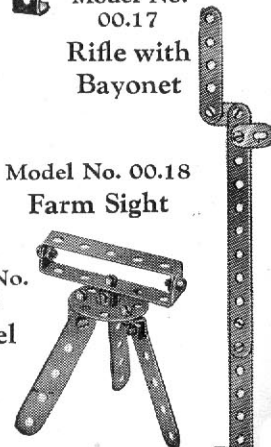

Model No. 00.5 Hand Cart

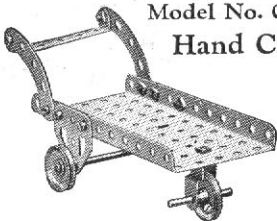

Model No. 00.9 Velocipede

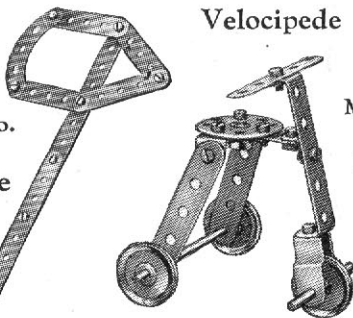

Model No. 00.18 Farm Sight

Model No. 00.14 Trowel

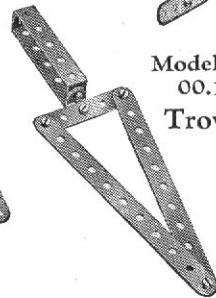

Model No. 00.7 Fire-Axe

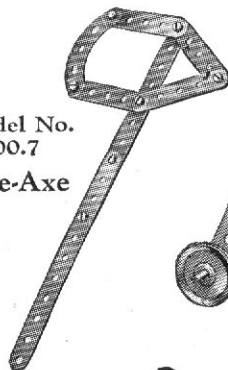

Model No. 00.10 Ladder

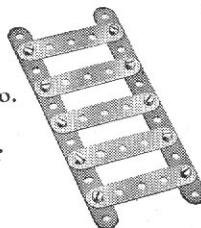

Model No. 00.6 Plough

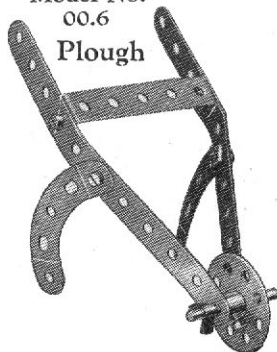

Model No. 00.11 Sled

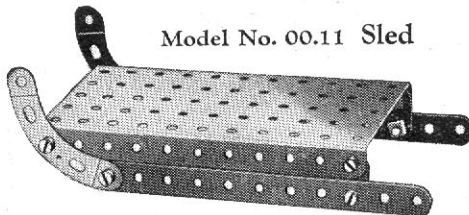

Model No. 00.15 Barrow

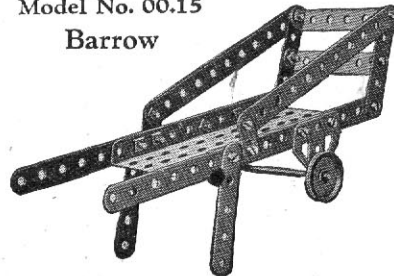

Model No. 00.19 Flat Truck

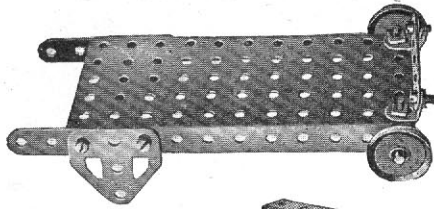

Model No. 00.25 Collapsible Table

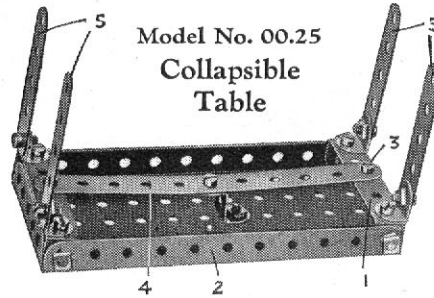

Model No. 00.27 Trolley

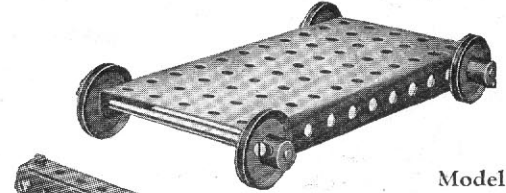

Model No. 00.20 Spade



Model No. 00.21 Cement Marker

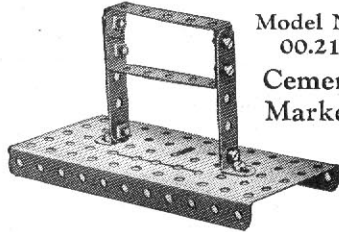

The $2\frac{1}{2}'' \times \frac{1}{2}''$ Double Angle Strips 1 are attached to the $5\frac{1}{2}'' \times 2\frac{1}{2}''$ Flanged Plate 2 by lock-nutted bolts, as in Standard Mechanism No. 263. The Bolts 3 are secured to the $5\frac{1}{2}''$ Strip 4 and their shanks engage with the centre holes in the $2\frac{1}{2}'' \times \frac{1}{2}''$ Double Angle Strips 1, thus maintaining the legs 5 in an upright position. When it is desired to fold up the legs 5, it is only necessary to raise the ends of the Strip 4, thus freeing the Double Angle Strips 1. The table is shown in the folded position in Fig. 00.25A.

Model No. 00.32 Potato Chopper

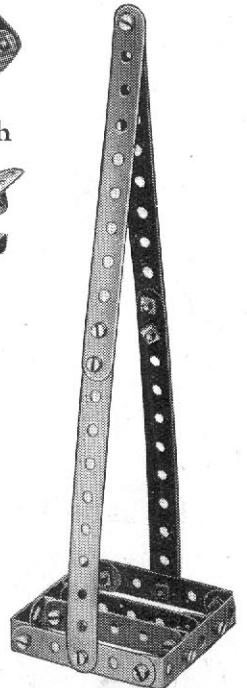

Model No. 00.28 Lewis Gun

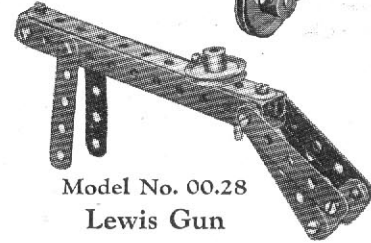

Model No. 00.22 Motor Boat

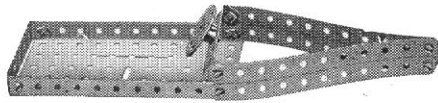

Model No. 00.29 Switch

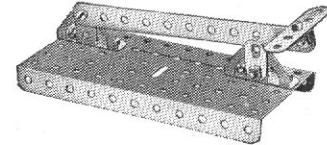

Model No. 00.23 Plasterer's Hawk

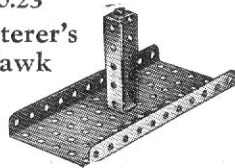
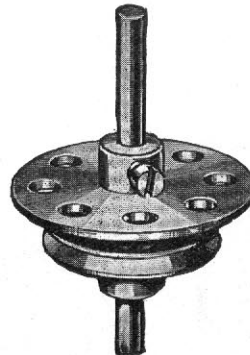
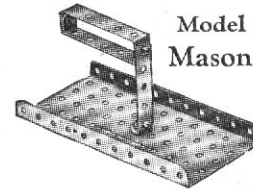

FIG. 00.25A

Model No. 00.26 Spinning Top



Model No. 00.30 Mason's Trowel



Model No. 00.24 Chute

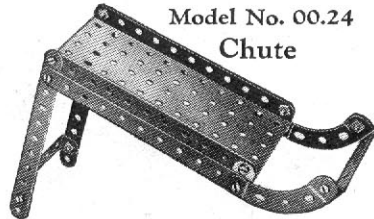

Model No. 00.31 Baggage Cart

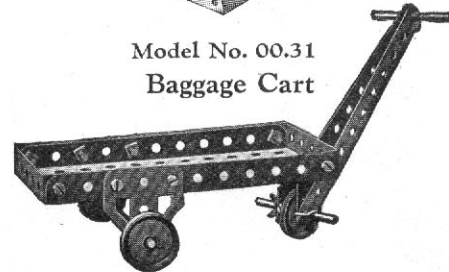

Model No. 00.33
Meccano Man

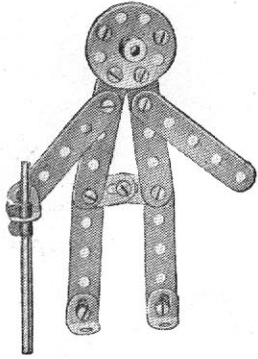

Model No. 00.36
Cannon

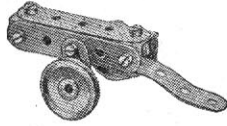

Model No. 00.38 Gate

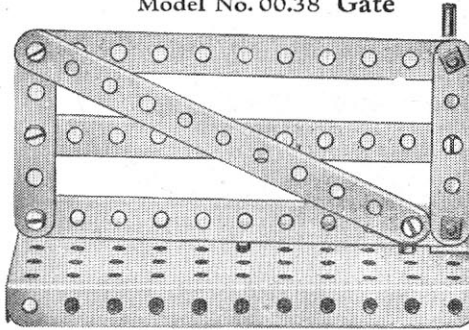

Model No. 00.42
Violin

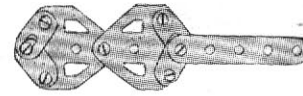

Model No. 00.44
Friction Grip Tong

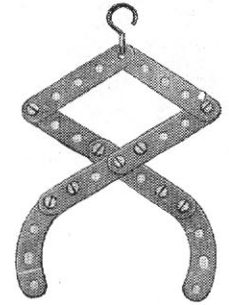

Model No. 00.37
Birdcage Stand

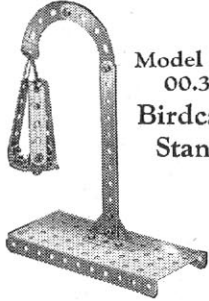

Model No. 00.43
Clothes Horse

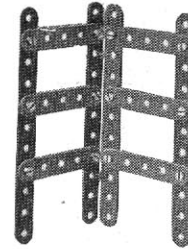

Model No. 00.34
Track Gauge

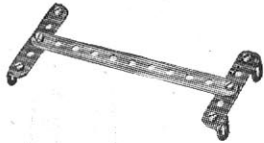

Model No. 00.39
Scrap Reel

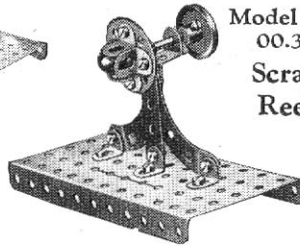

Model No. 00.40
Bed

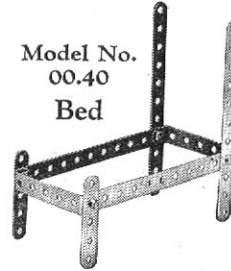

Model No. 00.45
Rake



Model No. 00.35 Turnstile

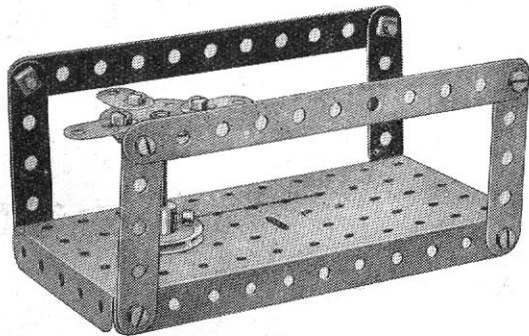

Model No. 00.41
Hanging Scales

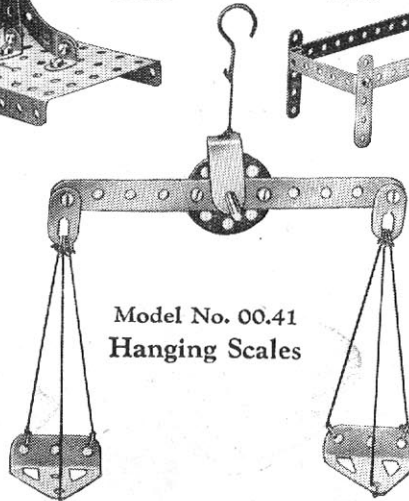

Model No. 00.46
Garden Seat

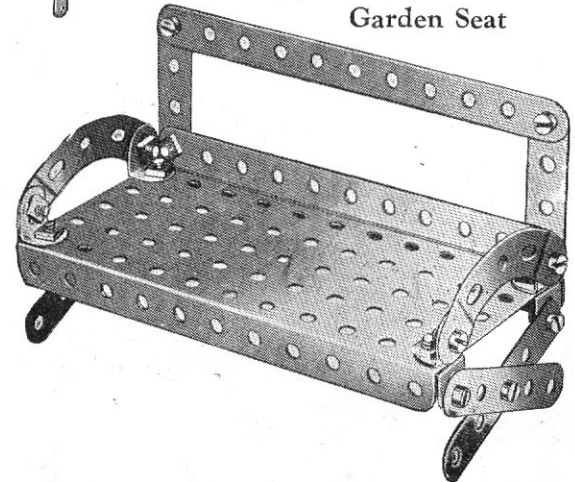

All these Models can be built with MECCANO Outfit No. 00

Model No. 00.47
Step Ladder

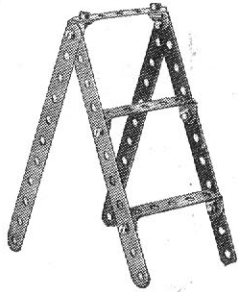

Model No. 00.50
Crib

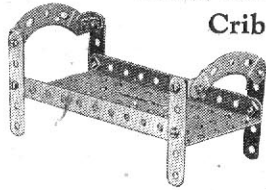

Model No. 00.53 Table

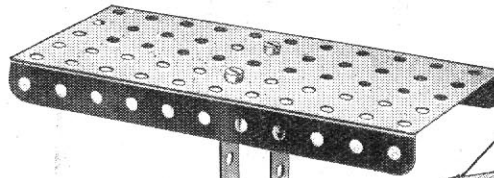

Model No. 00.55
Liner

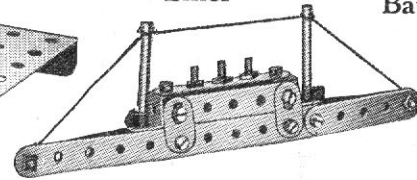

Model No. 00.58
Battle Axe

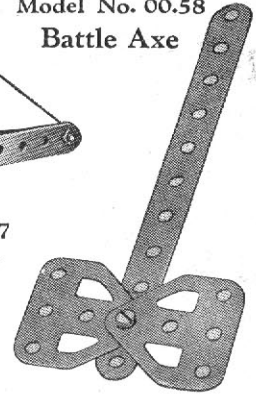

Model No. 00.51
Refreshment Wagon

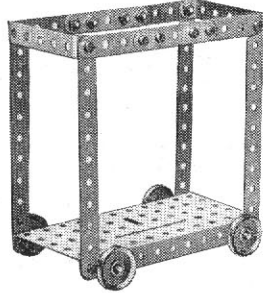

Model No. 00.52
Rake

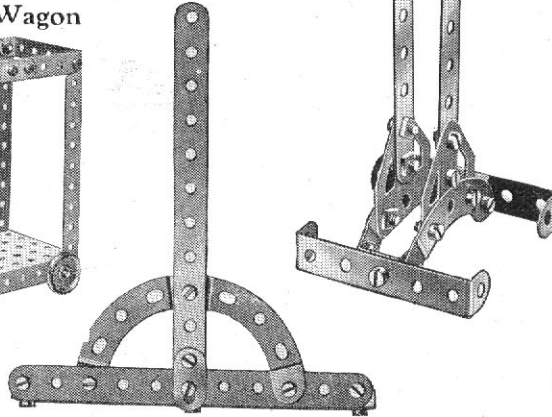

Model No. 00.57
Gravel Sifter

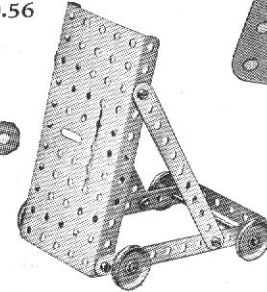

Model No. 00.56
Anchor

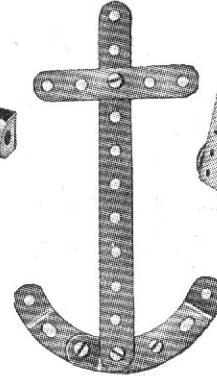

Model No. 00.48
Ostrich

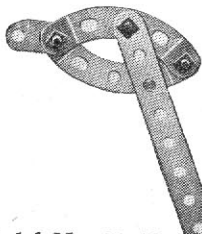

Model No. 00.49
Book End

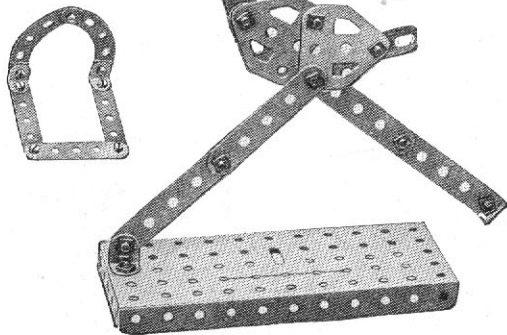

Model No. 00.54 Timber Truck

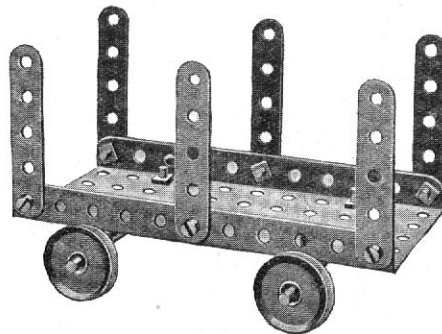

Model No. 00.59
Mail Bag Hanger

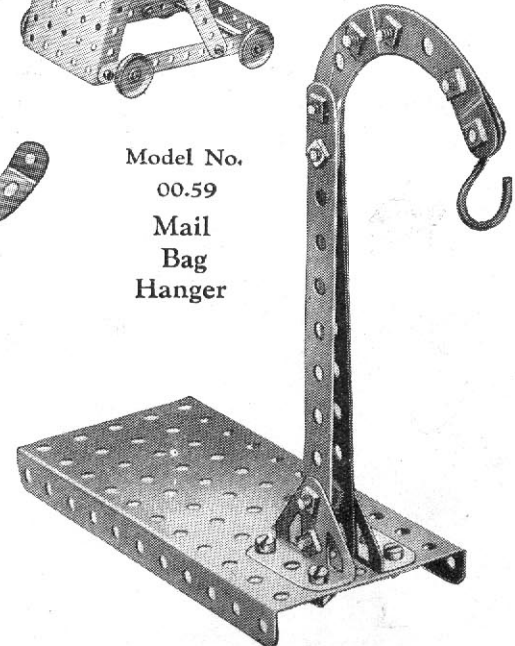

All these Models can be built with MECCANO Outfit No. 00

Model No. 00.60
Cage Aerial

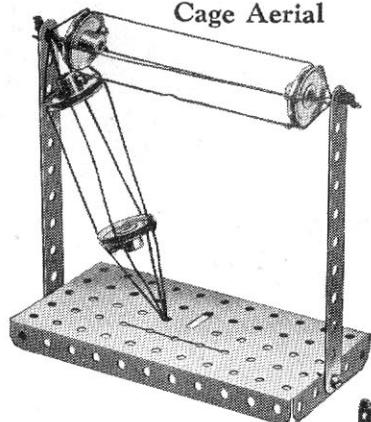

Model No. 00.62 Double Wire
L Aerial

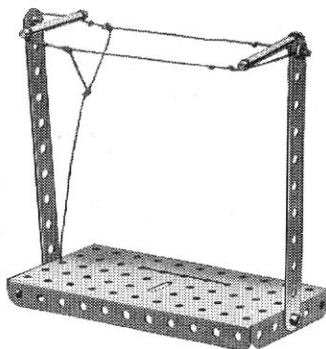

Model No. 00.64
Jumping Jack

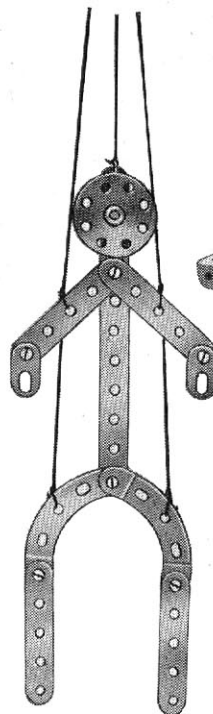

Model No. 00.66
Single Wire
T Aerial

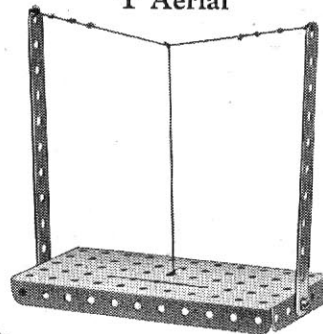

Model No. 00.68
Direction Aerial

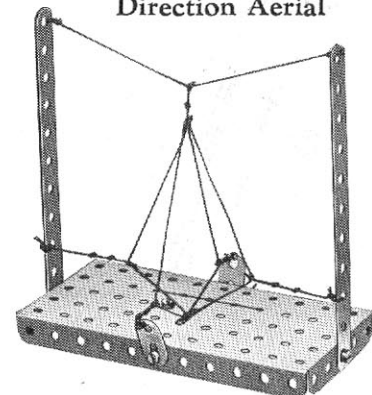

Model No. 00.61
Revolving Crane

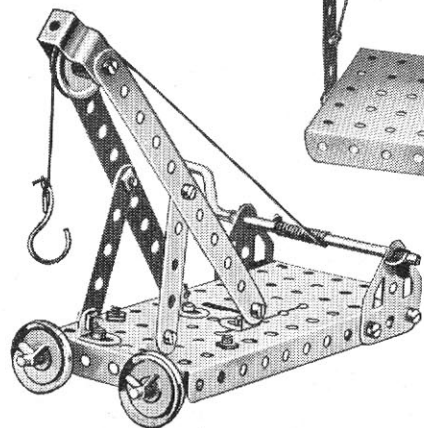

Model No. 00.63
Single Wire
L Aerial

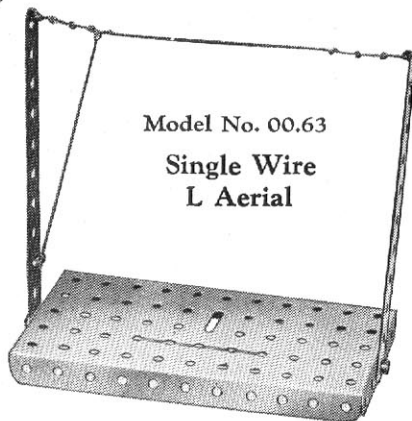

Model No. 00.67
Double Wire
T Aerial

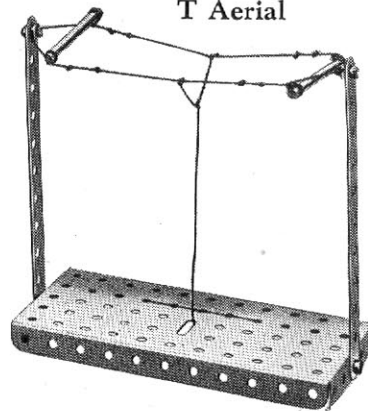

Model No. 00.69
Swing

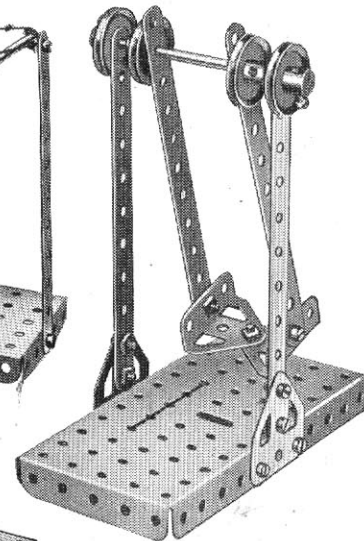

Model No. 00.65
Timber Wagon

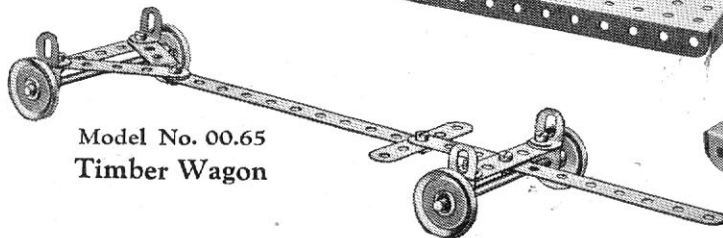

Model No. 00.70 Field Roller

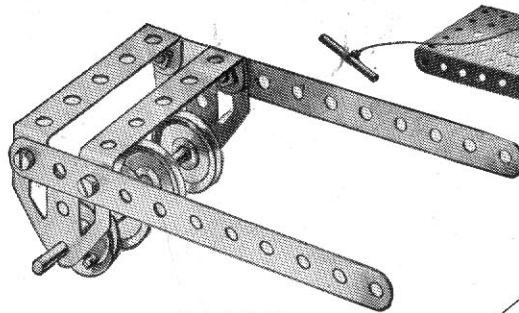

Model No. 00.73 Cheese Cutter

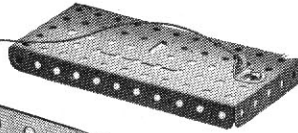

Model No. 00.76 Telegraph Key

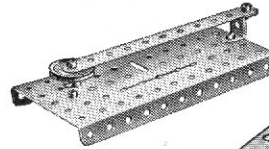

Model No. 00.79 Buffers

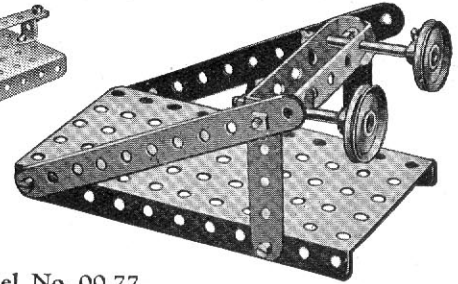

Model No. 00.71 Radial Travelling Crane

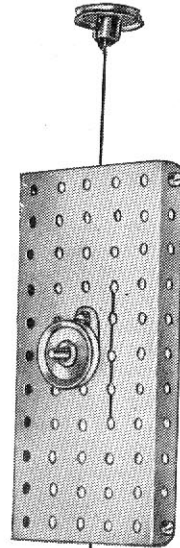
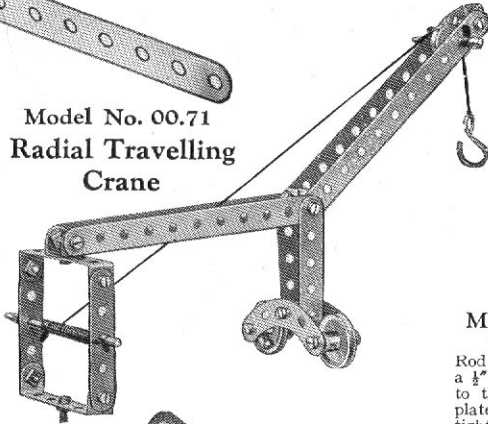

Model No. 00.74 Magic Plate

The cord is wound once round a 2" Axle Rod that is journaled in a Flat Bracket and a 1/2" Reversed Angle Bracket, which are bolted to the Plate. If the cord is held loosely the plate will drop, but as soon as the cord is tightened the plate becomes immovable.

Model No. 00.77 Cutlery Rest

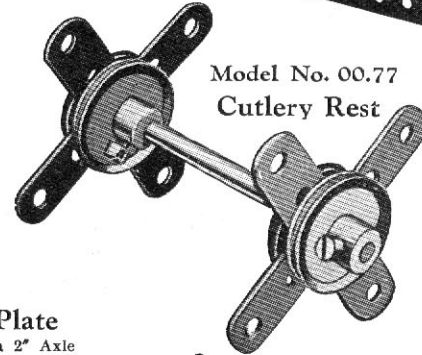

Model No. 00.80 Frame Aerial

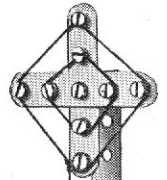

Model No. 00.72 French Railway Signal

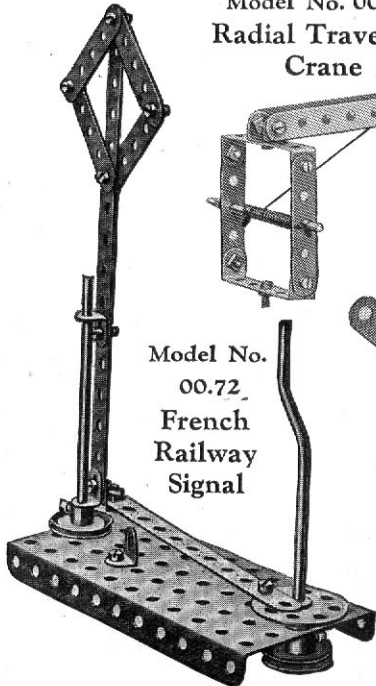

Model No. 00.75 Print Trimmer

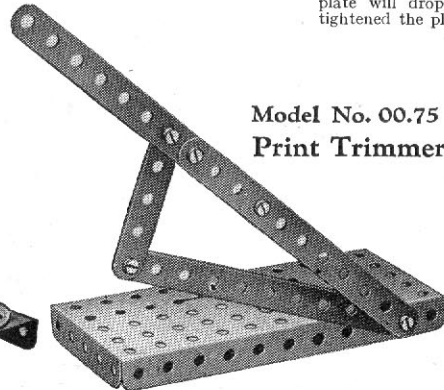

Model No. 00.78 Barge

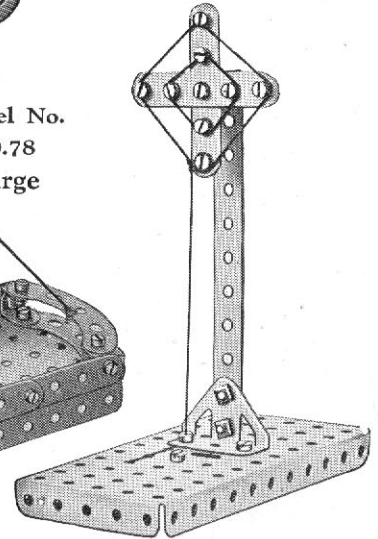
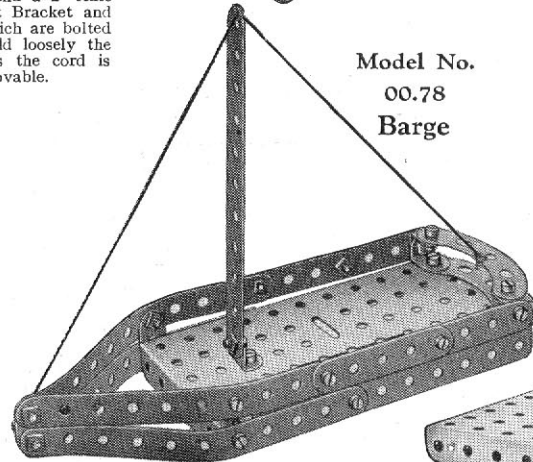

All these Models can be built with MECCANO Outfit No. 00

Model No. 00.81
2-way Sign Post

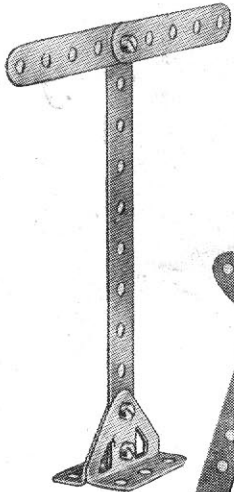

Model No. 00.83 Tweezers



Model No. 00.88
Elevator Car

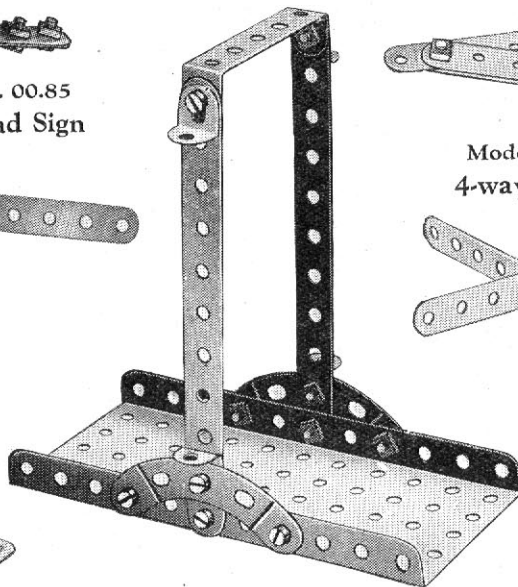

Model No. 00.90
Razor

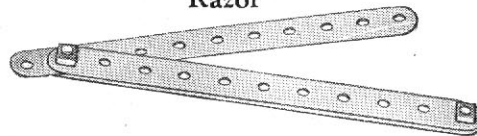

Model No. 00.94
Road Sign

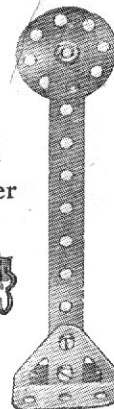

Model No. 00.84
Dividers

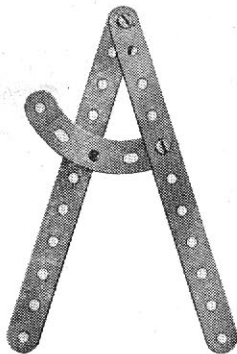

Model No. 00.85
3-way Road Sign

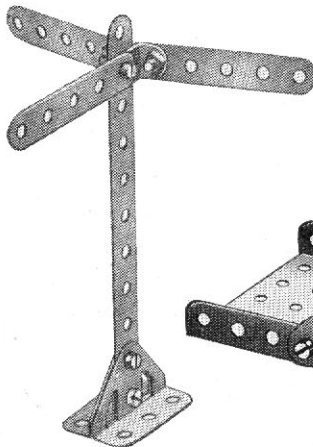

Model No. 00.91
4-way Road Sign

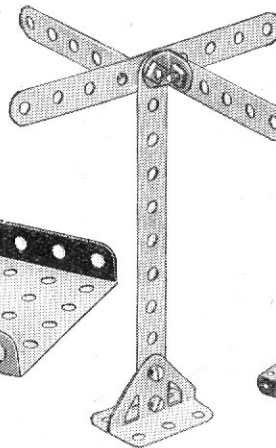

Model No. 00.92
Mail Bag Hanger

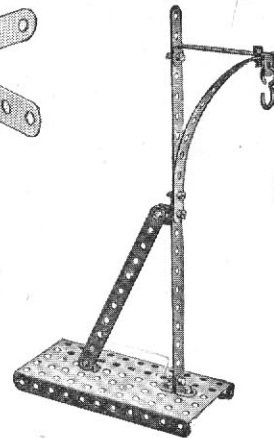

Model No. 00.82
Tin Opener



Model No. 00.89
Propeller

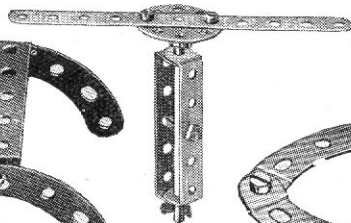

Model No. 00.95
Street Lamp



Model No. 00.86
Porter's Trolley

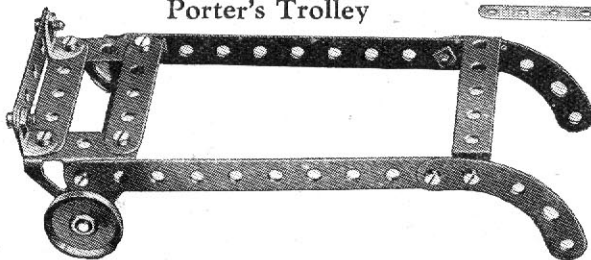

Model No. 00.93 Hand Truck

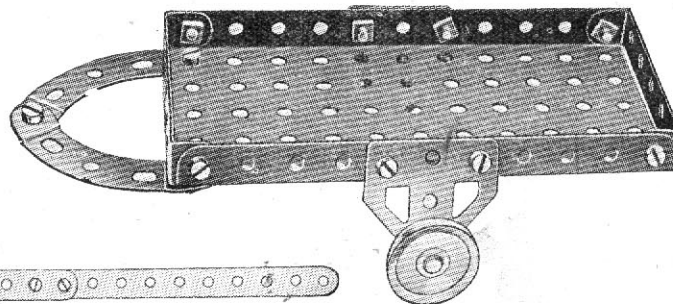

Model No. 00.87 Walking Stick

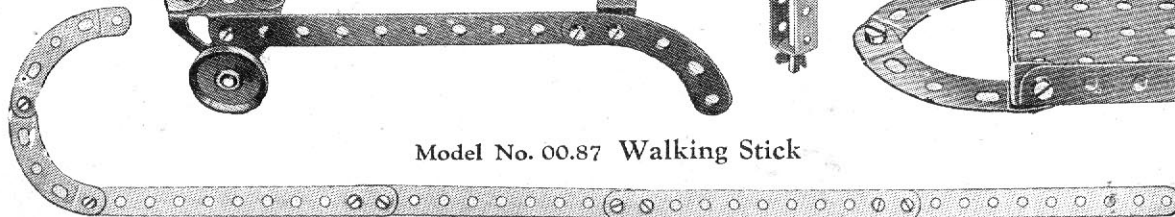

All these Models can be built with MECCANO Outfit No. 00

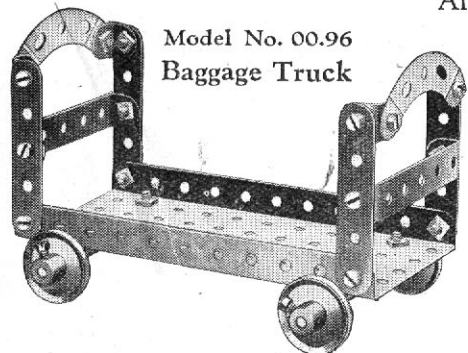

Model No. 00.96
Baggage Truck

Model No. 00.99
Road Sign

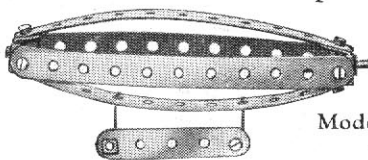
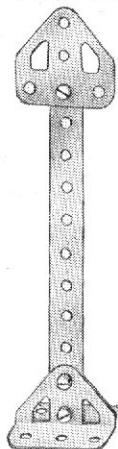

Model No. 00.100 Airship

Model No. 00.102
Tripod

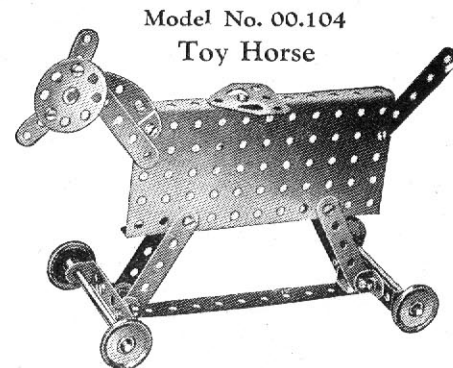
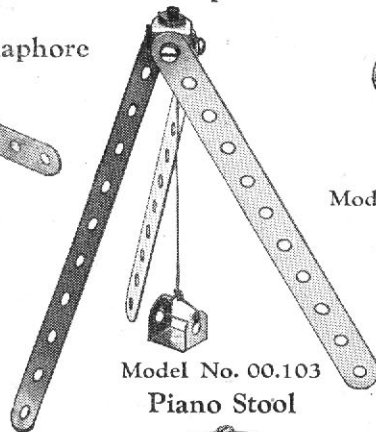

Model No. 00.104
Toy Horse

Model No. 00.101 Semaphore

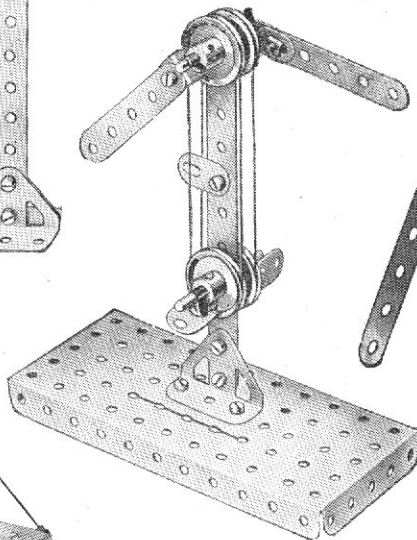

Model No. 00.98
Yacht

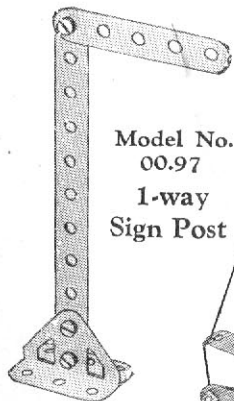
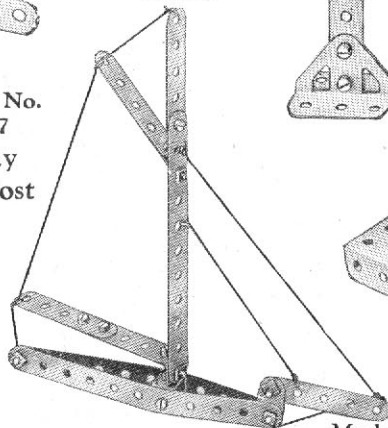

Model No. 00.97
1-way
Sign Post

Model No. 00.105
Sword

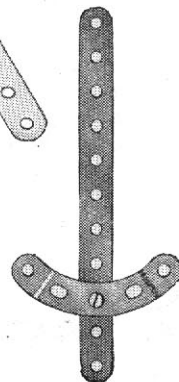

Model No. 00.106
Umbrella Stand

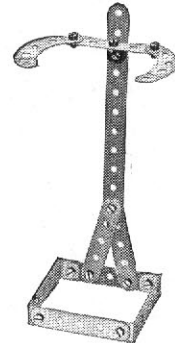

Model No. 00.103
Piano Stool



Models Nos. 00.107-00.114 Gradient Indicators

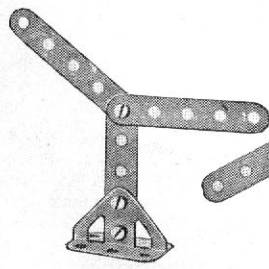

00.107

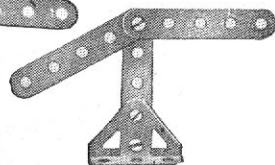

00.108

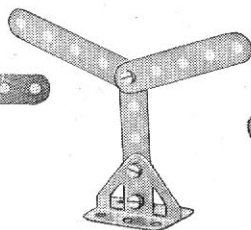

00.109

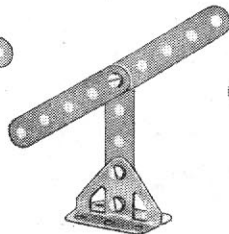

00.110

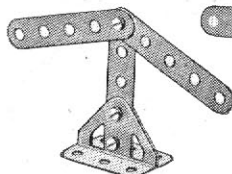

00.111

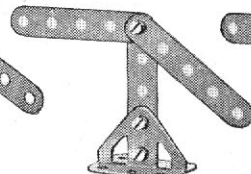

00.112

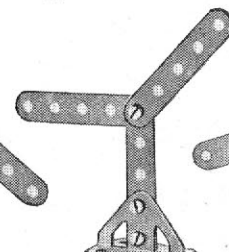

00.113

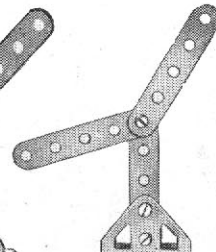

00.114

Model No. 00.115
Fire Escape

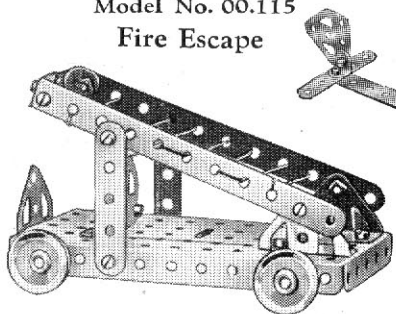

Model No. 00.117
Glider

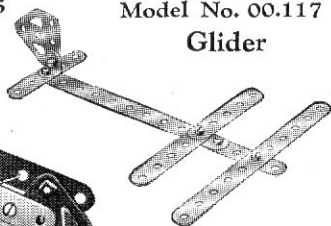

Model No. 00.120 Scales

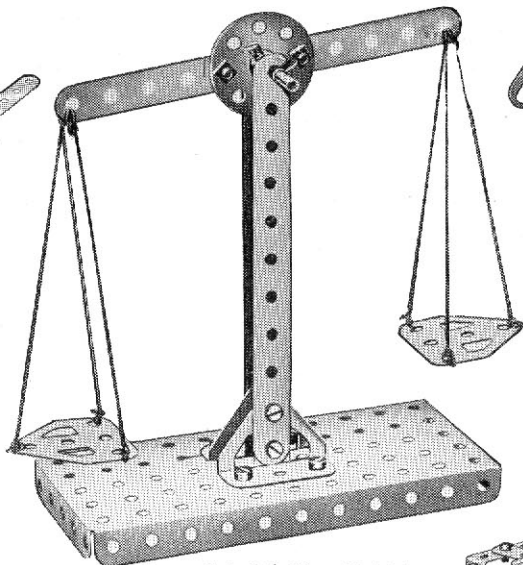

Model No. 00.122
Dog



Model No. 00.125
Motor Car

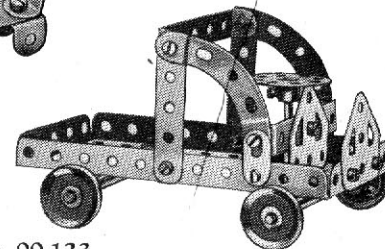

Model No.
00.118
Stamping
Mill

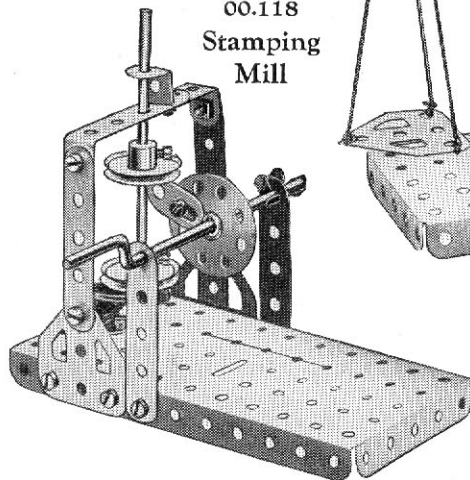

Model No. 00.123
Organ

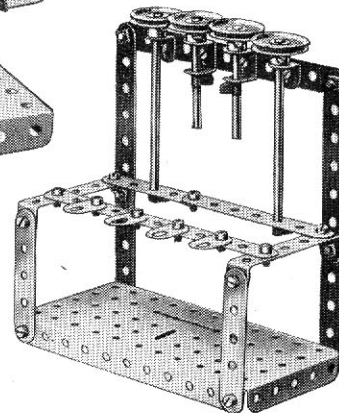

Model No. 00.126
Searchlight

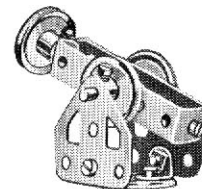

Model No. 00.116
Telegraph Pole

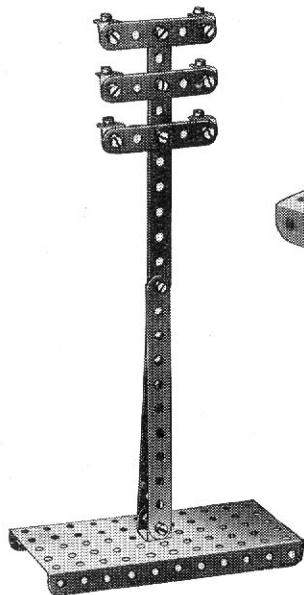

Model No. 00.121
Clothes
Drying Frame

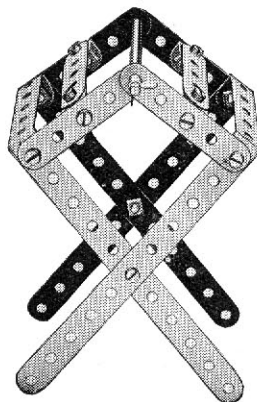

Model No. 00.119
Watch and Chain

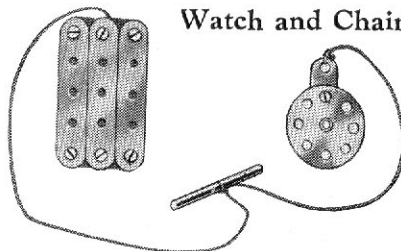

Model No. 00.124
Drinking Trough

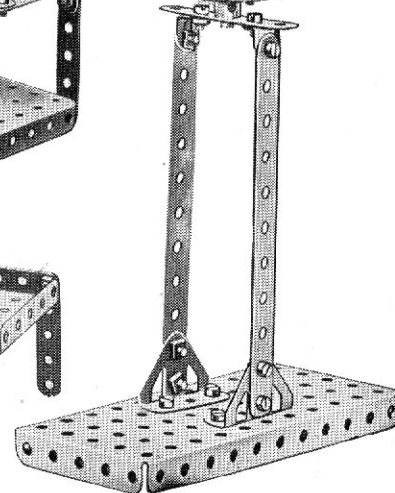
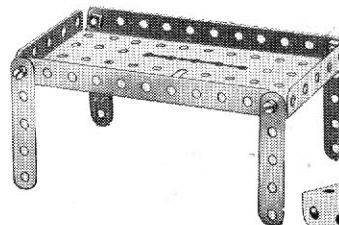

All these Models can be built with MECCANO Outfit No. 00

Model No. 00.132 Roulette Wheel

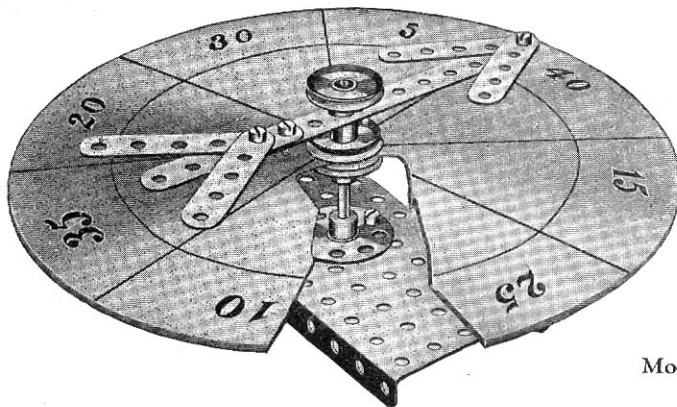

Cut out a circular piece of cardboard and mark as shown to form scoring board. This is clamped between two 1" Pulley Wheels. The pointer revolves freely on the upright spindle and is held in position by another 1" Pulley Wheel.

Model No. 00.133 Pulley Shafting

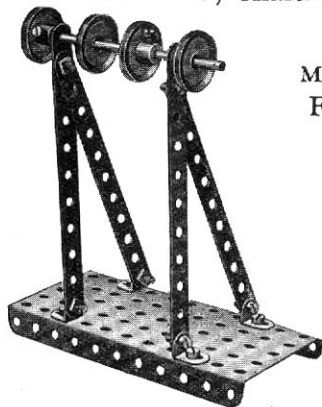

Model No. 00.134 Two-Hand Saw

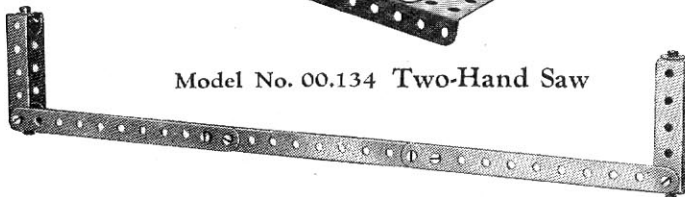

Model No. 00.135 Coat Hanger



Model No. 00.136 Roman Balance

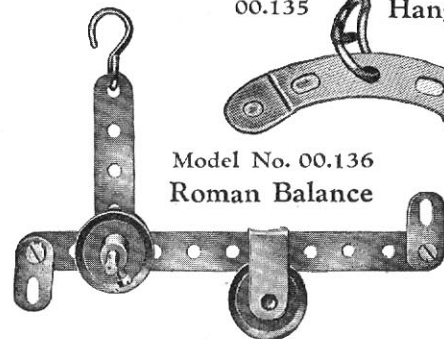

Model No. 00.137 Grill

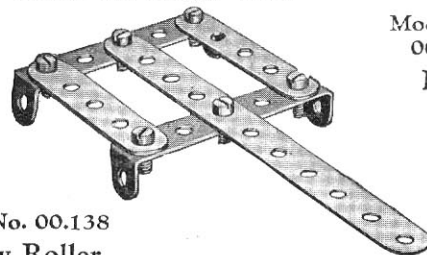

Model No. 00.139 Hoe

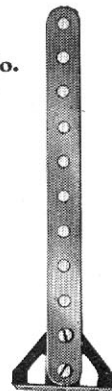

Model No. 00.138 Furrow Roller

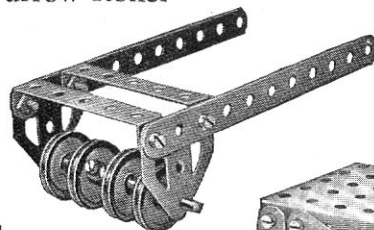

Model No. 00.140 Planing Bench

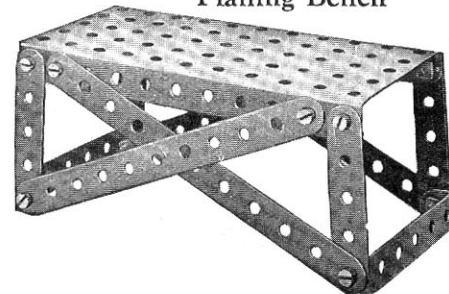

Model No. 00.127 Axe

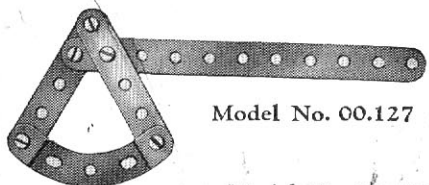

Model No. 00.130 Horse

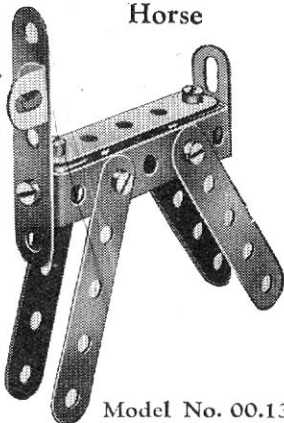

Model No. 00.128 Fork

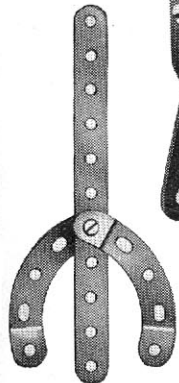

Model No. 00.131 Lumber Truck

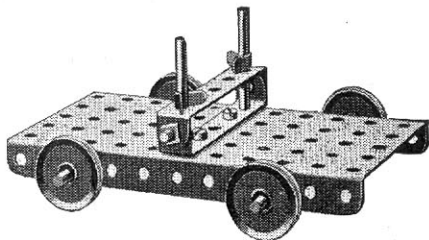

Model No. 00.129 Bogie Truck

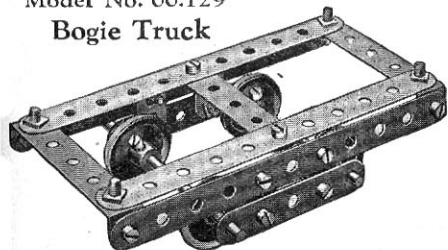

All these Models can be built with MECCANO Outfit No. 00

Model No. 00.141
Dinner Wagon

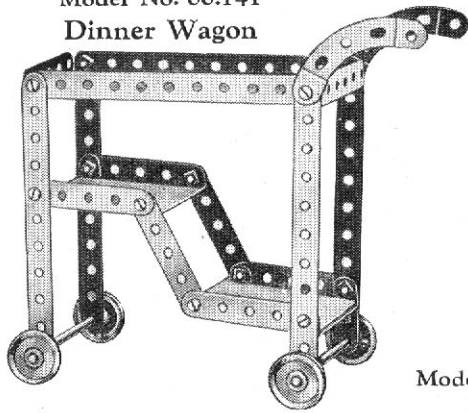

Model No. 00.144 Lumber Truck

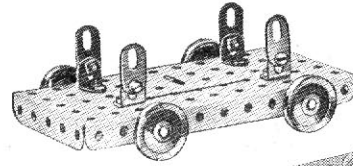

Model No. 00.147 Mono Rail

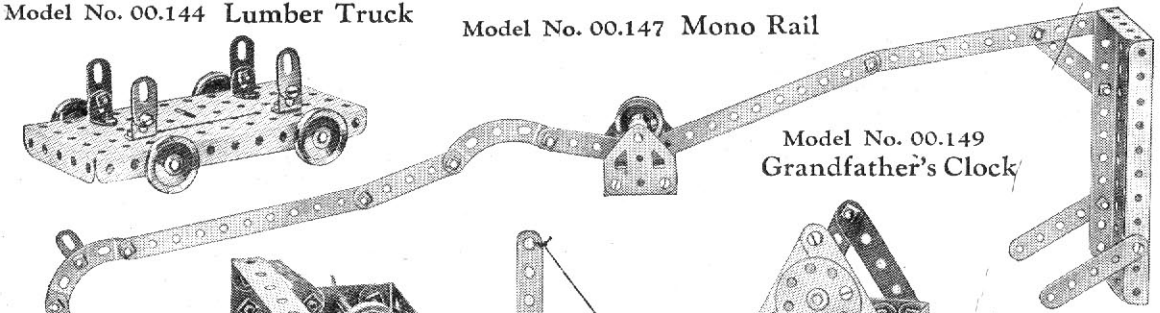

Model No. 00.149
Grandfather's Clock

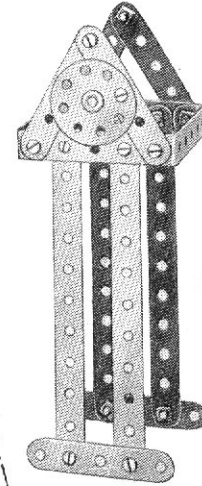

Model No. 00.150
Watch Stand



Model No. 00.142 Ceiling Fan

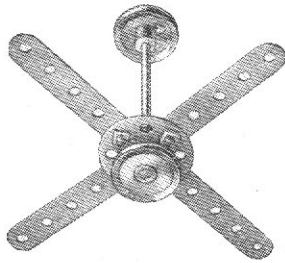

Model No. 00.145
Pit-Head
Gear

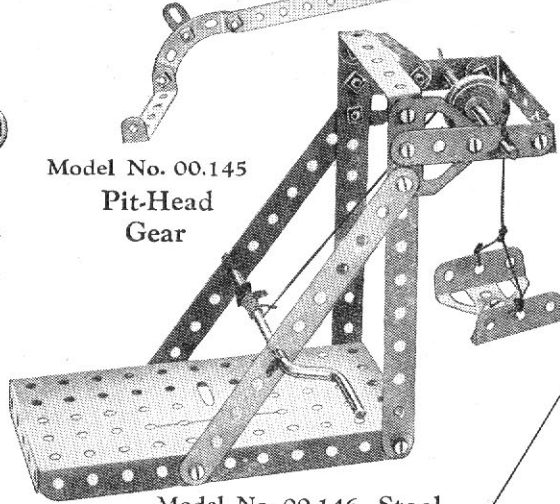

Model No. 00.146 Stool

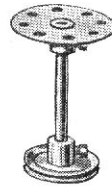

Model
No. 00.148
Sailing
Boat

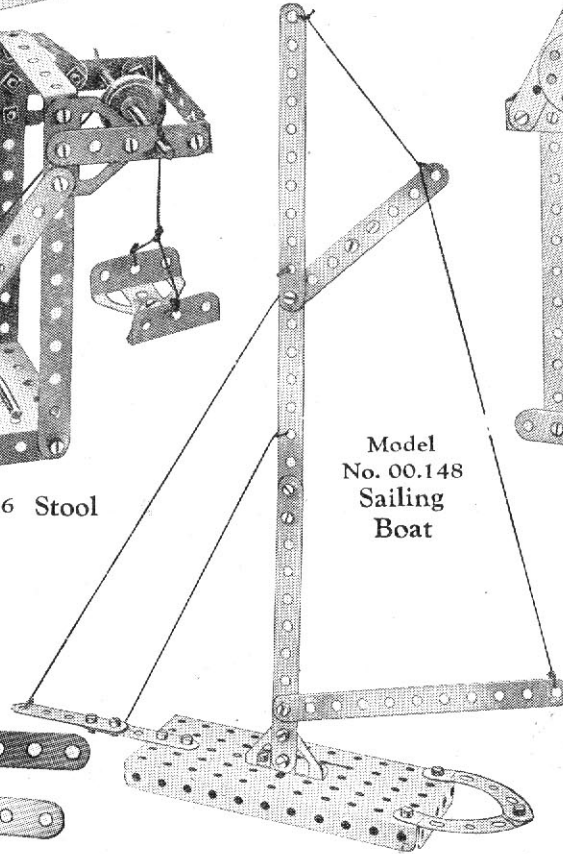

Model No. 00.143 Cart

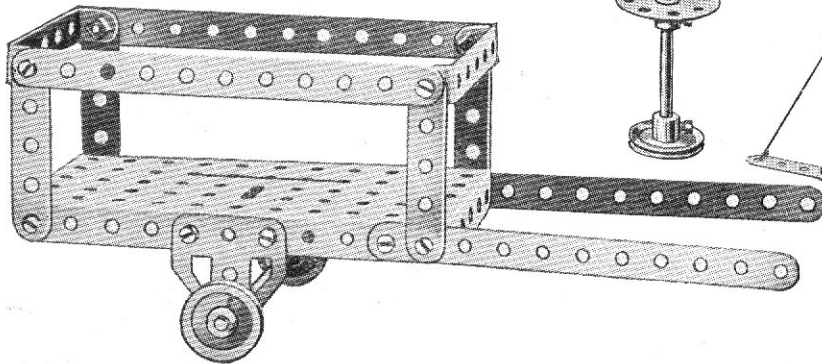

Model No. 00.151
Circular Saw

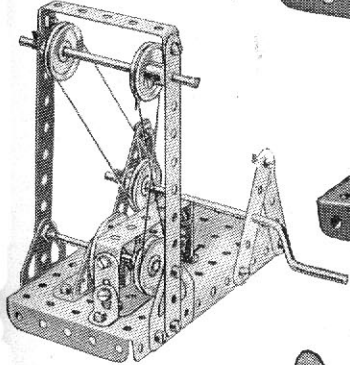

Model No. 00.154 Lever
of the First Order

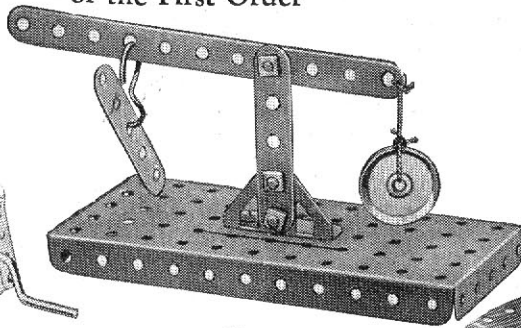

Model No. 00.156 Pulley Shafting

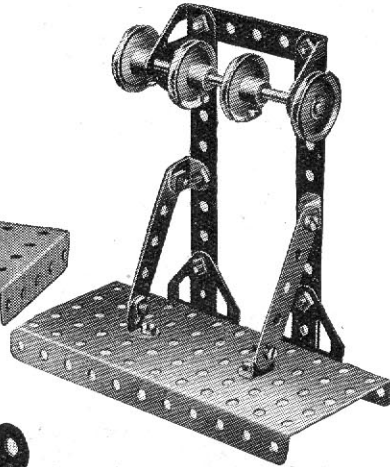

Model No. 00.159
Hand Car

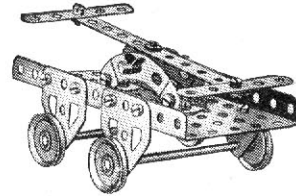

Model No. 00.161
Towel Horse

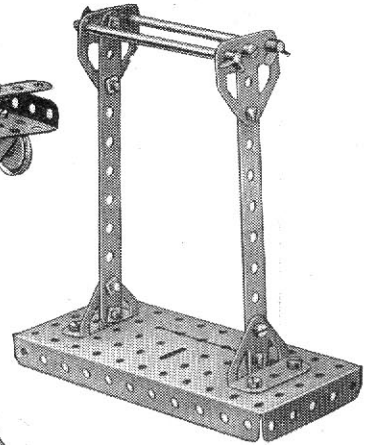

Model No.
00.155
Sawing
Horse

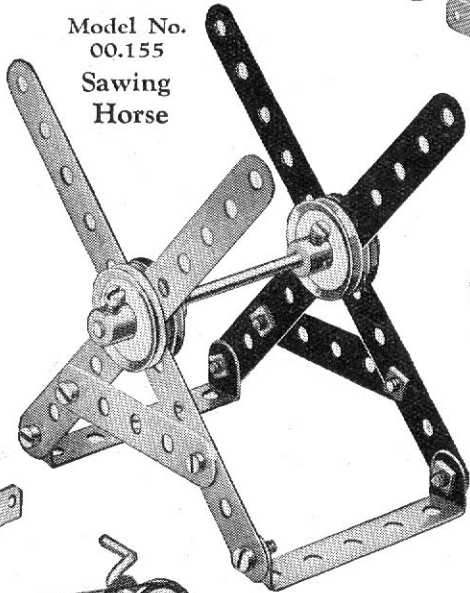

Model No. 00.152
Pen Rack

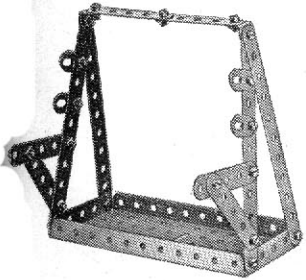

Model No. 00.157
Trolley

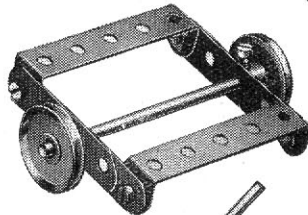

Model No. 00.160
Ice Yacht

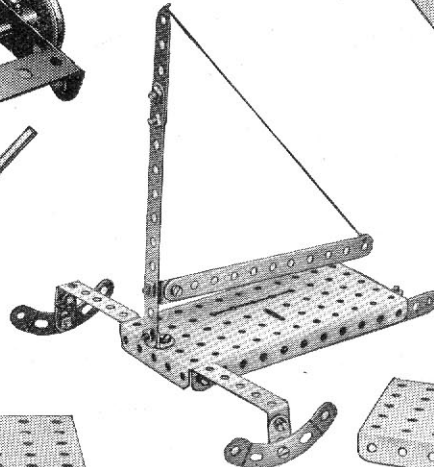

Model No. 00.162
Prehistoric Bird

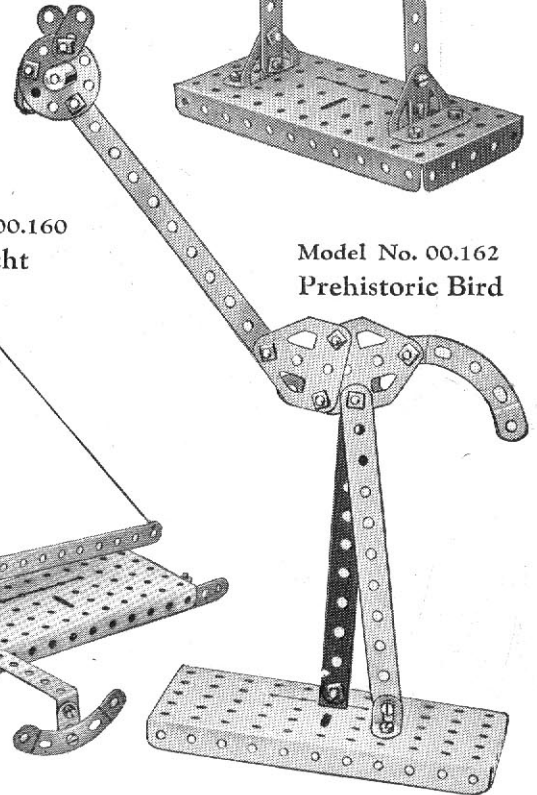

Model No. 00.153
Roundabout

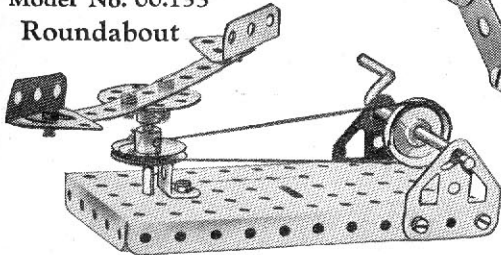

Model No. 00.158
Anti-Aircraft Gun

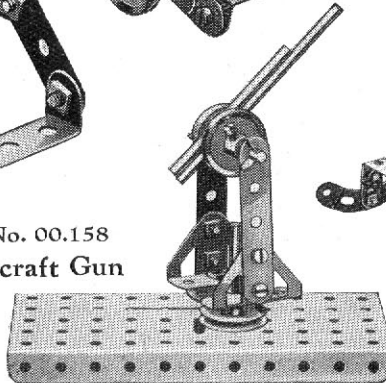

Model No. 00.163
Arc Lamp

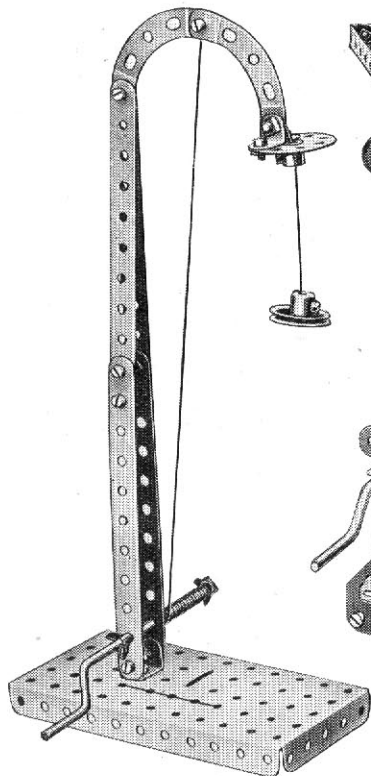

Model No. 00.165
Tea Wagon

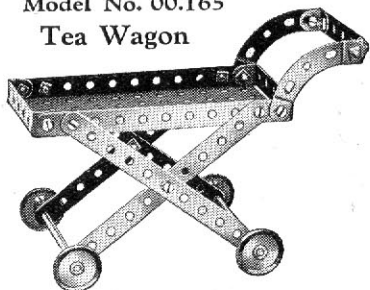

Model No. 00.167
Windmill

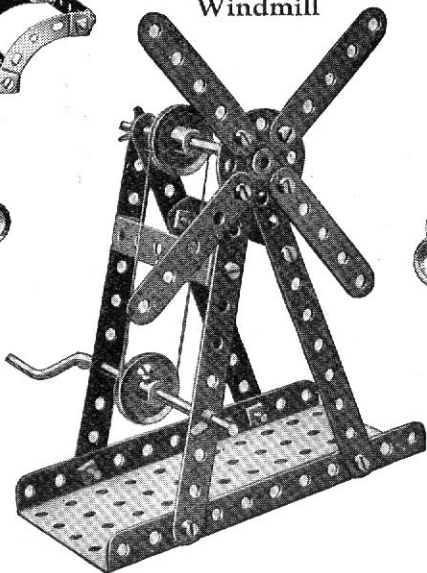

Model No. 00.171
Airship Mooring Mast

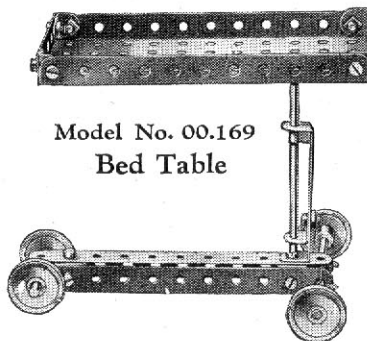

Model No. 00.169
Bed Table

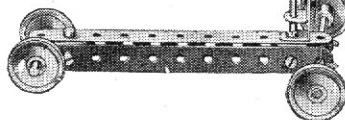

Model No. 00.166
Trip Hammer

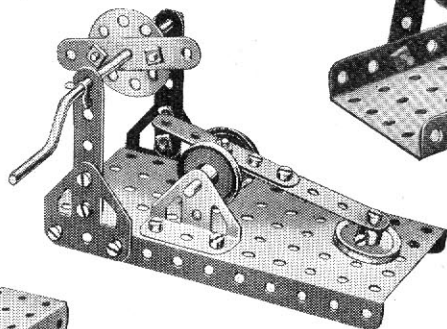

Model
No. 00.170
Garden
Roller

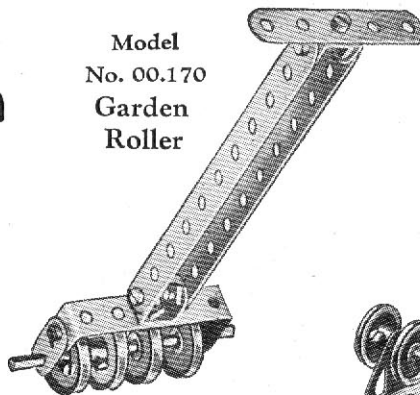

Model No. 00.168
Gallows

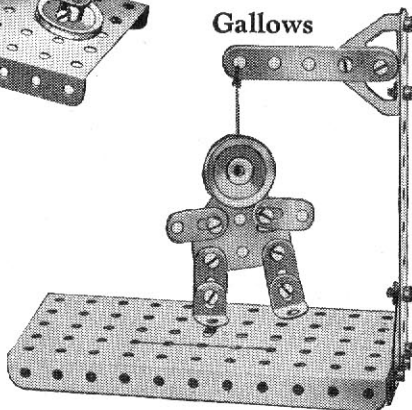

Model No. 00.164
Bath Chair

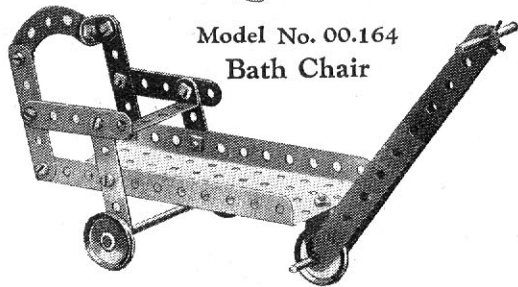

Model No. 00.172 Hand Truck

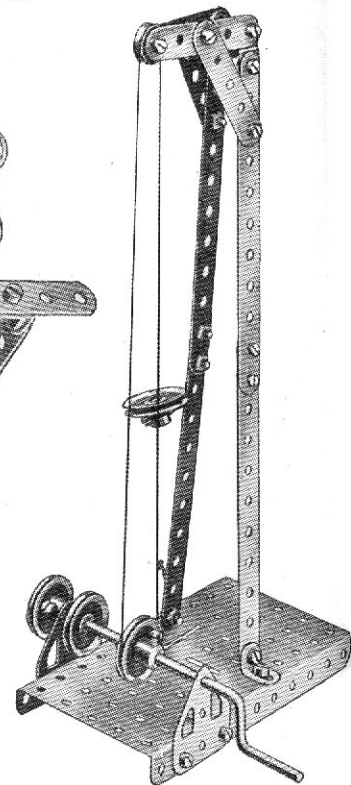
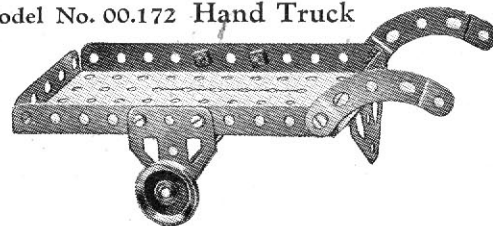

All these Models can be built with MECCANO Outfit No. 00

Model No. 00.173
Level Crossing
Barrier

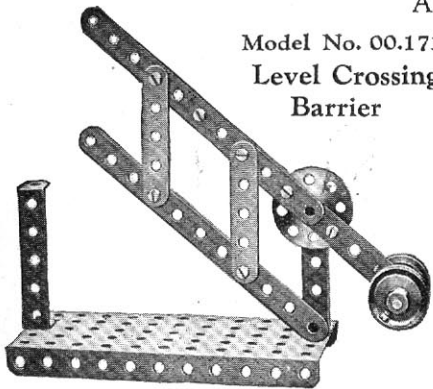

Model No. 00.175
Flower Pot
Stand



Model No. 00.177
Letter Balance

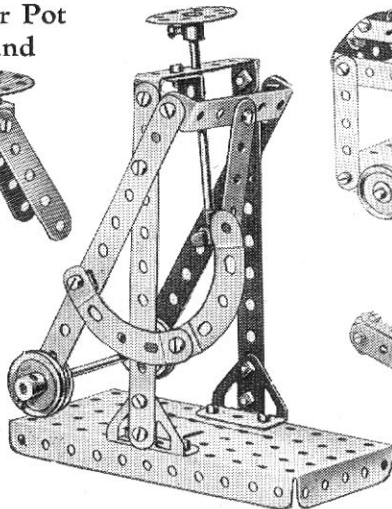

Model No. 00.179
Pullman Car

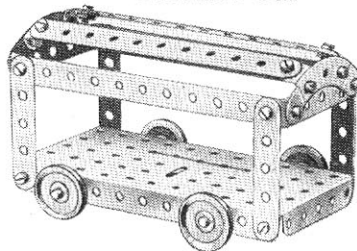

Model No. 00.181
Catapult

The pivoted arm is connected to the base by means of a short piece of elastic, which is not provided in the Outfit.

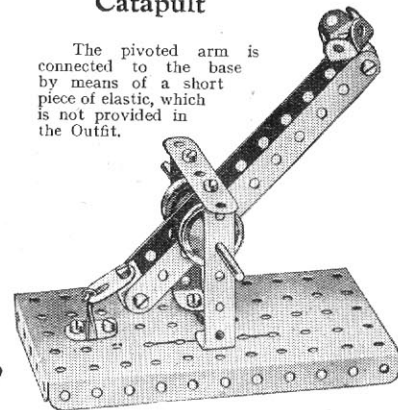

Model No. 00.176
Ore Crusher

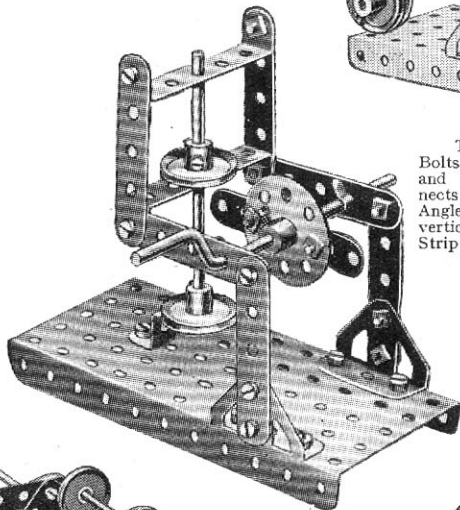

Model No. 00.174
Well Driller

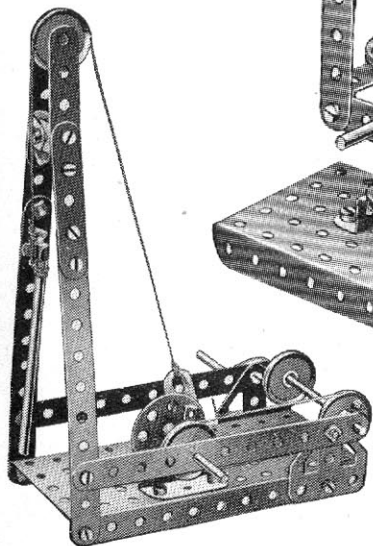

Model No. 00.180
Big Gun

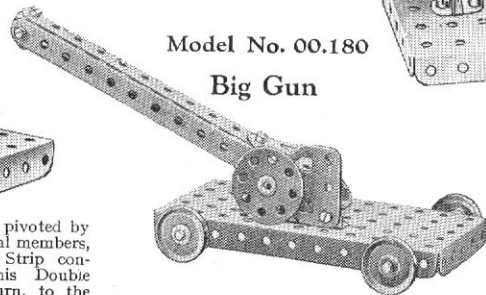

Model No. 00.182
Blacksmith

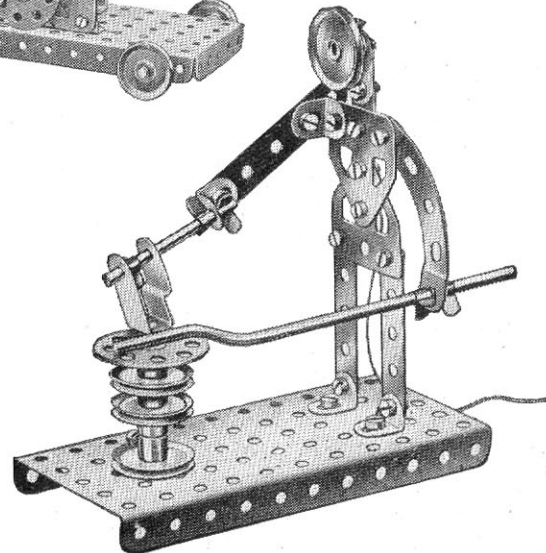

The weighted 5 1/2" Strips are pivoted by Bolts and lock-nuts to the vertical members, and a 2 1/2" x 1/2" Double Angle Strip connects their upper ends. This Double Angle Strip is connected, in turn, to the vertical 3 1/2" Axle Rod by means of a 2 1/2" Strip and an Angle Bracket.

Model No. 00.178 Joy Wheel

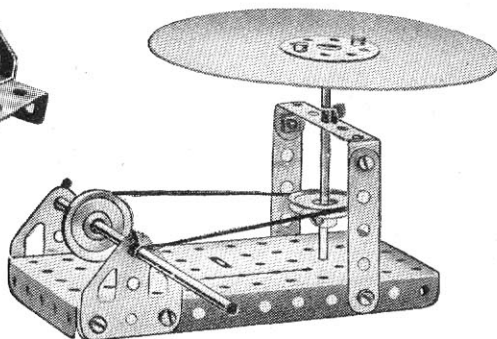

All these Models can be built with MECCANO Outfit No. 00

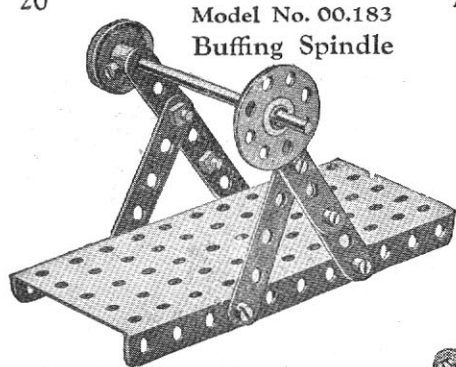

Model No. 00.183
Buffing Spindle

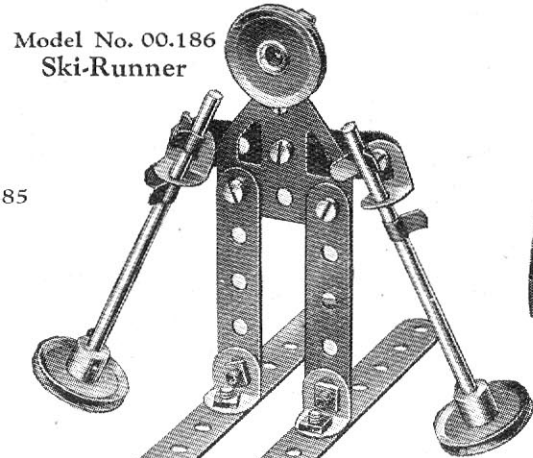

Model No. 00.186
Ski-Runner

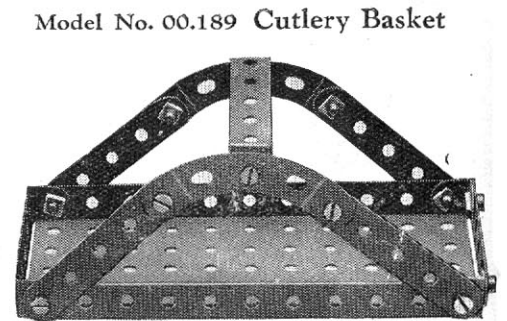

Model No. 00.189 Cutlery Basket

Model No. 00.185
Ladder on
Wheels

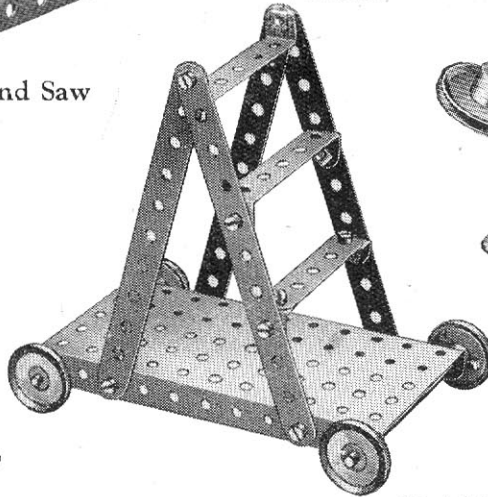

Model No. 00.184 Band Saw

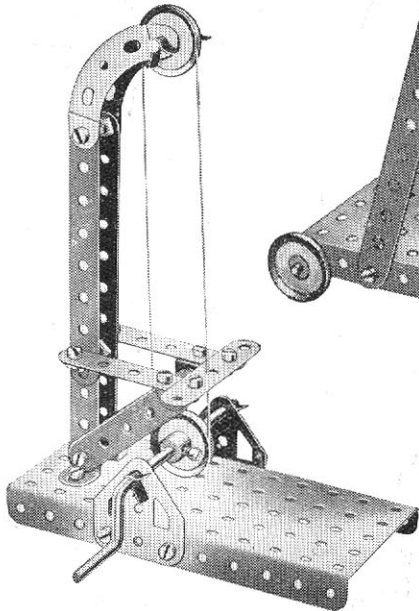

Model No. 00.187 Devil Wall

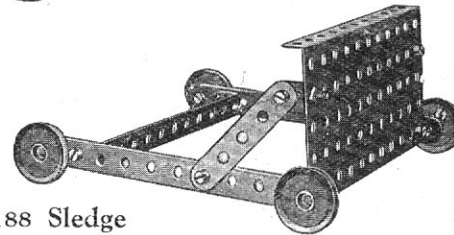

Model No. 00.188 Sledge

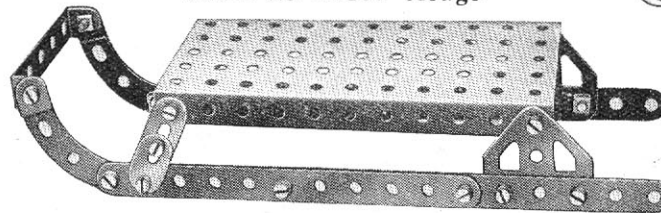

Model No. 00.190
Garden Hose Reel

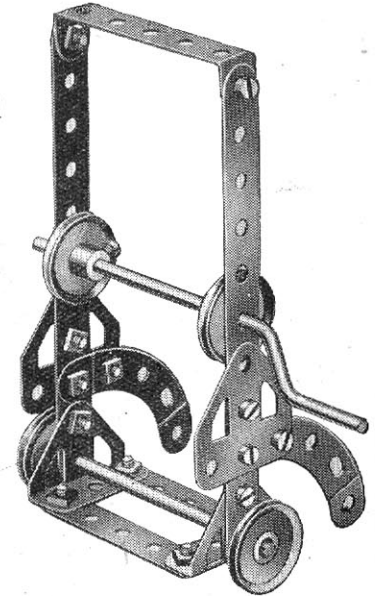

HOW TO CONTINUE

This completes our examples of models that may be made with MECCANO Outfit No. 00. The next models are a little more advanced, requiring a number of extra parts to construct them. The necessary parts are all contained in a No. 00A Accessory Outfit, the price of which may be obtained from any Meccano dealer.

Model No. 0.1 Scooter

Parts required:

4 of No.	2
2 " "	5
2 " "	11
2 " "	12
2 " "	17
2 " "	22
16 " "	37
1 " "	37A
1 " "	48A
2 " "	90A
1 " "	111c

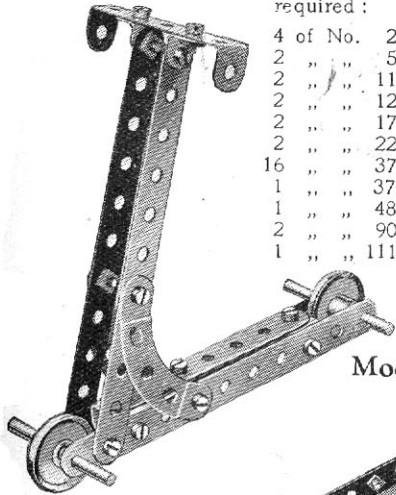

Model No. 0.4 Push Cart

Parts required:

2 of No.	16	1 of No.	52
4 " "	22	4 " "	90A
16 " "	37	2 " "	126
2 " "	48A	2 " "	126A

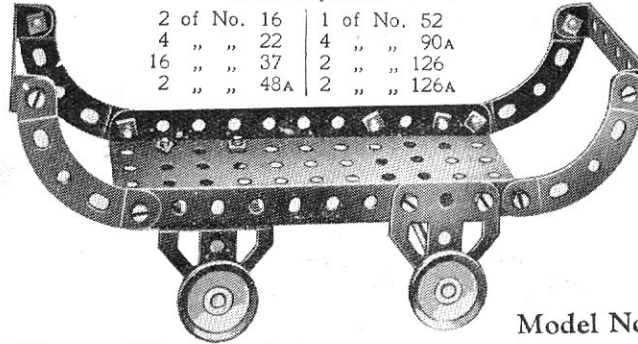

Model No. 0.7 Dog Kennel

Parts required:

3 of No.	2
8 " "	5
6 " "	12
16 " "	37
4 " "	37A
2 " "	48A
1 " "	52
2 " "	90A
4 " "	111c

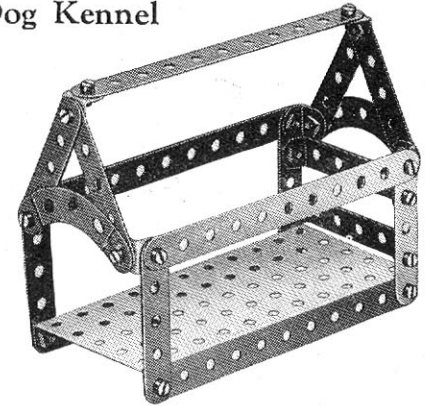

Model No. 0.3 Tipping Cart

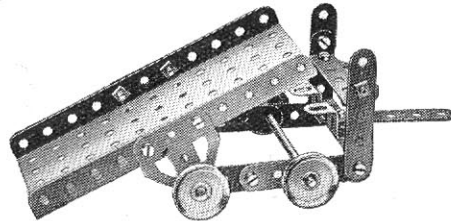

Model No. 0.5 Horse Rake

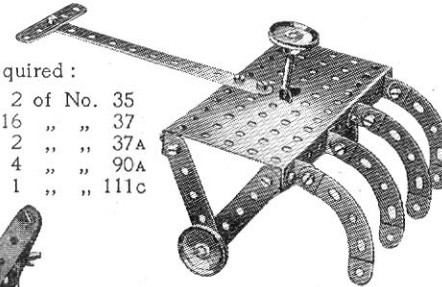

Parts required:

1 of No.	2	2 of No.	35
5 " "	5	16 " "	37
8 " "	12	2 " "	37A
1 " "	17	4 " "	90A
3 " "	22	1 " "	111c

Model No. 0.8 Chaff Cutter

Parts required:

2 of No.	2	1 of No.	24
8 " "	5	2 " "	35
1 " "	11	16 " "	37
2 " "	12	5 " "	37A
1 " "	16	1 " "	52
1 " "	19s	5 " "	111c
2 " "	22	2 " "	125

Model No. 0.2 Luggage Truck

Parts required:

2 of No.	2
6 " "	5
2 " "	12
1 " "	16
2 " "	22
12 " "	37
1 " "	52
3 " "	90A

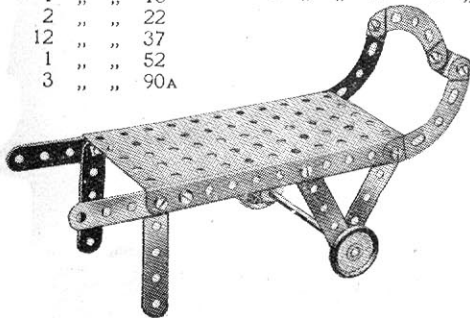

Parts required:

7 of No.	5	15 of No.	37	1 of No.	90A
2 " "	16	2 " "	48A	2 " "	125
4 " "	22	1 " "	52	2 " "	126A

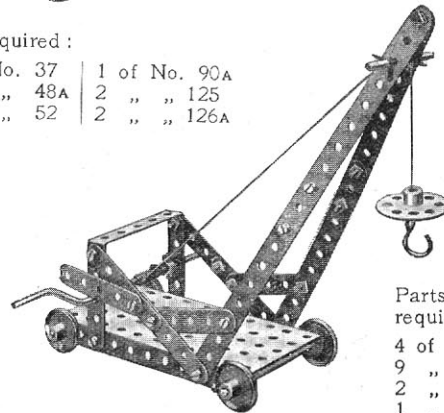

Model No. 0.6 Jib Crane

Parts required:

1 of No.	19s
4 " "	22
1 " "	23
1 " "	24
4 " "	35
16 " "	37
1 " "	37A
1 " "	40
1 " "	48A
1 " "	52
9 " "	5
2 " "	16
1 " "	17

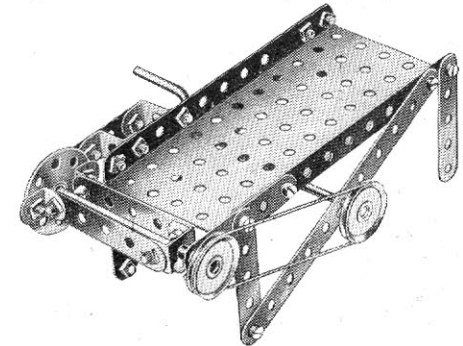

Model No. 0.9

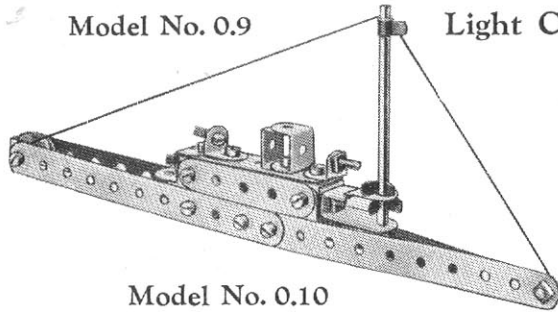

Light Cruiser

Parts required:

4 of No.	2
3 " "	5
4 " "	10
2 " "	11
7 " "	12
1 " "	16
3 " "	35
16 " "	37
6 " "	37A
1 " "	44
6 " "	111c
1 " "	125

Model No. 0.13 Medal

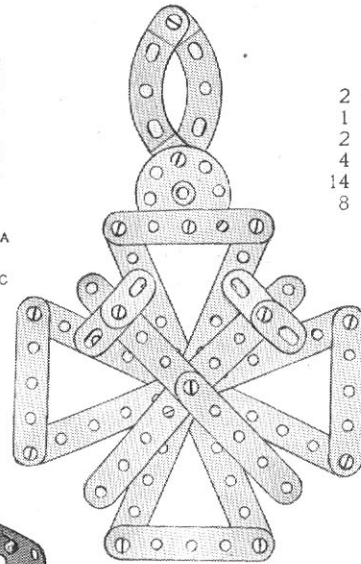

Parts required:

4 of No.	2
8 " "	5
4 " "	10
1 " "	24
13 " "	37
2 " "	90A
1 " "	111c

Model No. 0.14 Prehistoric Bird

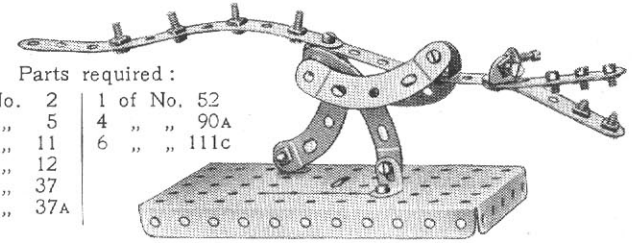

Parts required:

2 of No.	2	1 of No.	52
1 " "	5	4 " "	90A
2 " "	11	6 " "	111c
4 " "	12		
14 " "	37		
8 " "	37A		

Model No. 0.10
Three-Wheel Auto

Parts required:

2 of No.	2	1 of No.	17	2 of No.	37A
3 " "	5	3 " "	22	1 " "	48A
2 " "	10	1 " "	23	2 " "	111c
8 " "	12	1 " "	24	2 " "	126
1 " "	16	16 " "	37		

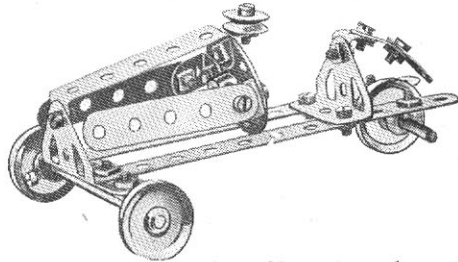

Model No. 0.11 Pen Rack

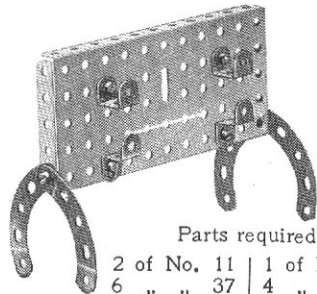

Parts required:

2 of No.	11	1 of No.	52
6 " "	37	4 " "	90A
		2 of No.	125

Model No. 0.12
Tennis Player

Parts required:

3 of No.	5
2 " "	10
2 " "	11
2 " "	12
1 " "	23
13 " "	37
1 " "	52
2 " "	90A
1 " "	111c
1 " "	126A

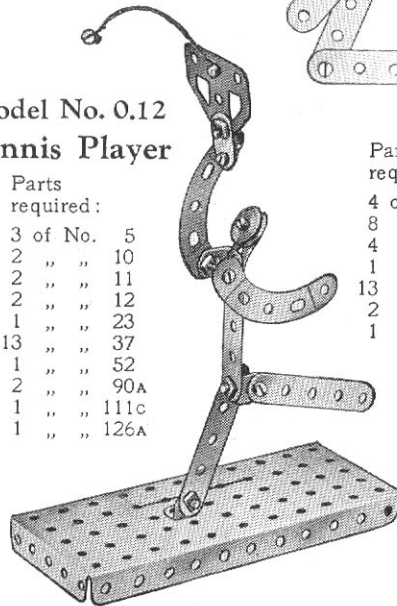

Model
No. 0.15
Angler

Parts required:

5 of No.	5		
2 " "	10		
2 " "	11		
2 " "	12		
1 " "	16		
1 " "	23	1 of No.	37A
1 " "	35	1 " "	52
11 " "	37	1 " "	111c

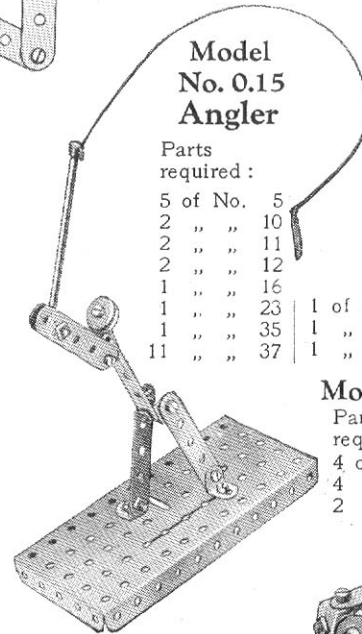

Model No. 0.16 Church

Parts required:

4 of No.	2	2 of No.	12	6 of No.	37A	2 of No.	90A
8 " "	5	1 " "	24	4 " "	48A	6 " "	111c
3 " "	10	16 " "	37	1 " "	52	1 " "	126A

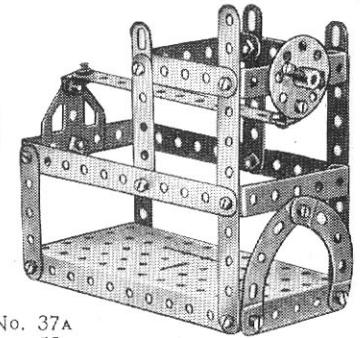

Model No. 0.17 Submarine

Parts required:

8 of No.	12
1 " "	17
2 " "	35
4 of No.	2
15 " "	10
2 " "	11
1 " "	37
	44

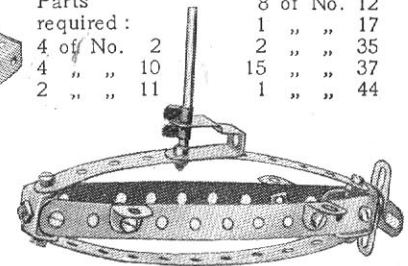

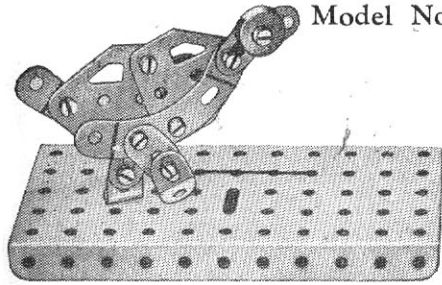

Model No. 0.18 Goose

Parts required :

4 of No.	10
2 "	12
1 "	23
8 "	37
1 "	37A
1 "	52
2 "	90A
1 "	111c
2 "	126A

Model No. 0.22
Lazy Tong

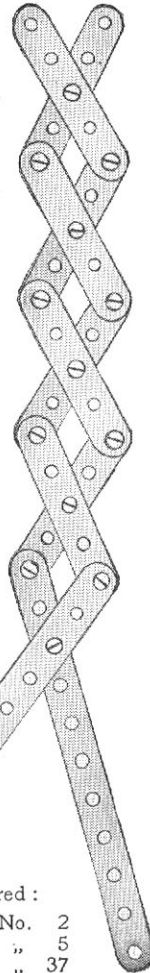

Parts required :

2 of No.	2
8 "	5
13 "	37
9 "	37A

Parts required :

4 of No.	2	1 of No.	44
3 "	5	6 "	111c
4 "	10	2 "	125
2 "	11		
9 "	12		
2 "	16		
6 "	35		
16 "	37		
6 "	37A		

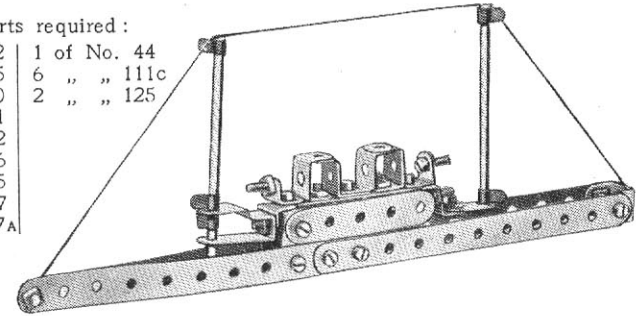

Model No. 0.23 Battleship

Model No. 0.19 Strong Man

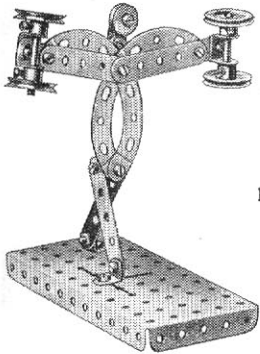

Parts required :

4 of No.	5
4 "	10
2 "	11
4 "	12
2 "	17
4 "	22
1 "	23
13 "	37
1 "	37A
1 "	52
4 "	90A
1 "	111c

Model No. 0.20
Aeroplane

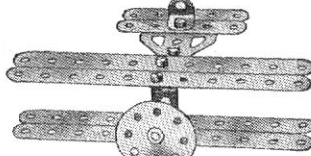

Parts required :

4 of No.	2	8 of No.	37
3 "	5	1 "	111c
2 "	12	2 "	125
1 "	24	1 "	126A

Model No. 0.24 Gymnast

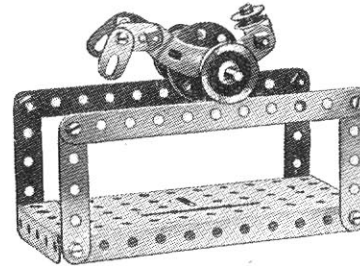

Parts required :

2 of No.	2	1 of No.	24
4 "	5	12 "	37
4 "	10	1 "	37A
1 "	12	1 "	52
1 "	16	1 "	90A
2 "	22	1 "	111c
1 "	23		

Model No. 0.25
Rocking Horse

Parts required :

7 of No.	5
4 "	10
2 "	11
2 "	12
1 "	23
13 "	37
4 "	90A
3 "	111c
1 "	126A

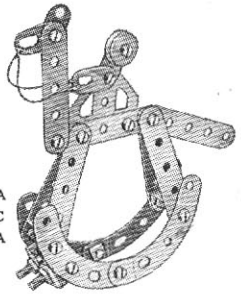

Model No. 0.21 Cattle Truck

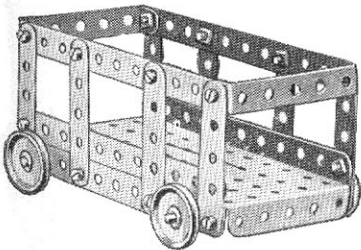

Parts required :

4 of No.	2
8 "	5
2 "	16
4 "	22
16 "	37
2 "	37A
2 "	48A
1 "	52
2 "	111c

Model No. 0.26
Cot

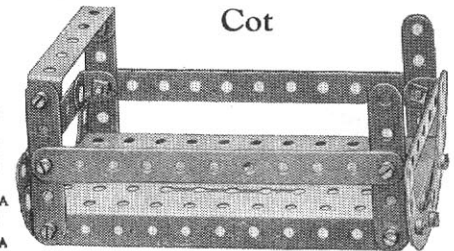

Parts required :

2 of No.	2
6 "	5
2 "	12
16 "	37
2 "	48A
1 "	52
4 "	90A

Model No. 0.27 Table

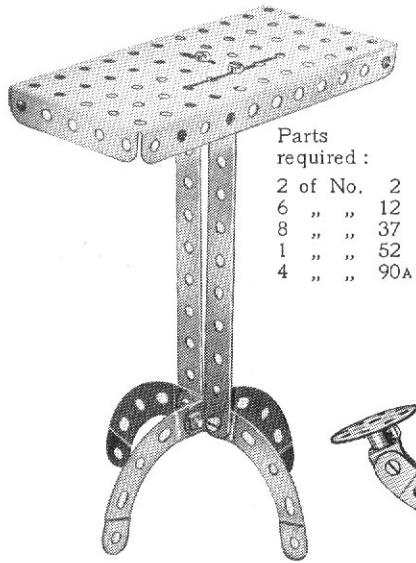

Parts required:
 2 of No. 2
 6 " " 12
 8 " " 37
 1 " " 52
 4 " " 90A

Model No. 0.28 Crocodile

Parts required:
 4 of No. 2 | 6 of No. 12
 4 " " 5 | 16 " " 37
 4 " " 10 | 6 " " 37A
 2 " " 11 | 6 " " 111c

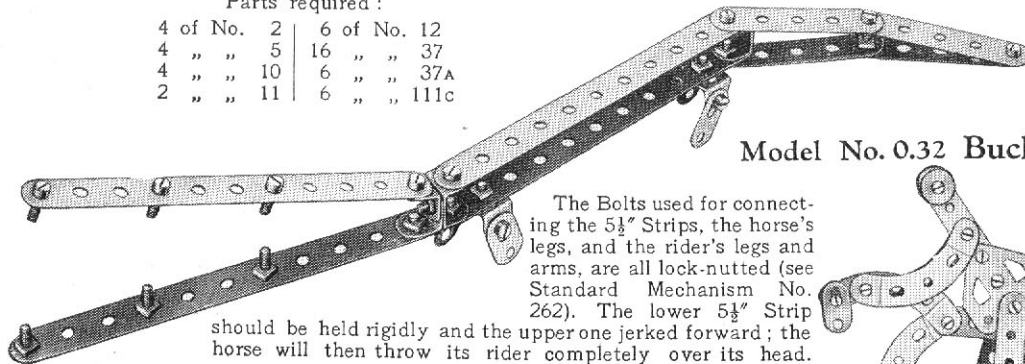

The Bolts used for connecting the 5 1/2" Strips, the horse's legs, and the rider's legs and arms, are all lock-nutted (see Standard Mechanism No. 262). The lower 5 1/2" Strip should be held rigidly and the upper one jerked forward; the horse will then throw its rider completely over its head.

Model No. 0.30 Trolley

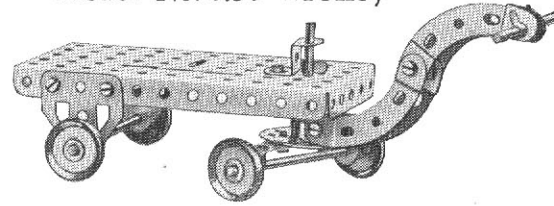

Parts required:
 1 of No. 11 | 4 of No. 35 | 4 of No. 90A
 2 " " 16 | 12 " " 37 | 1 " " 125
 2 " " 17 | 1 " " 48A | 2 " " 126A
 1 " " 24 | 1 " " 52

Model No. 0.31 Field Gun and Carriage

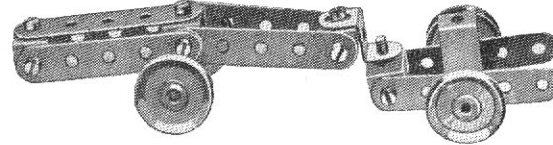

Parts required:
 8 of No. 5 | 2 of No. 17 | 1 of No. 44
 2 " " 10 | 4 " " 22 | 1 " " 111c
 2 " " 11 | 13 " " 37 | 1 " " 125
 6 " " 12 | 1 " " 37A

Model No. 0.32 Bucking Broncho

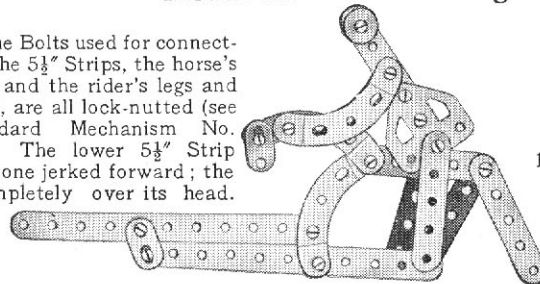

Parts required:
 2 of No. 2
 6 " " 5
 2 " " 10
 1 " " 23
 12 " " 37
 9 " " 37A
 4 " " 90A
 1 " " 111c
 1 " " 126A

Model No. 0.33 Ape

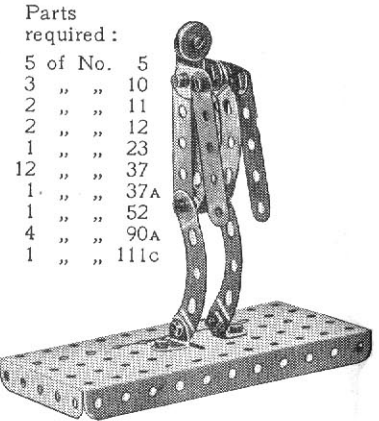

Parts required:
 5 of No. 5
 3 " " 10
 2 " " 11
 2 " " 12
 1 " " 23
 12 " " 37
 1 " " 37A
 1 " " 52
 4 " " 90A
 1 " " 111c

Model No. 0.34 Gangway

Parts required:
 4 of No. 2 | 16 of No. 37
 2 " " 5 | 2 " " 37A
 2 " " 10 | 2 " " 48A
 2 " " 12 | 1 " " 52
 1 " " 19s | 1 " " 111c
 1 " " 23
 3 " " 35

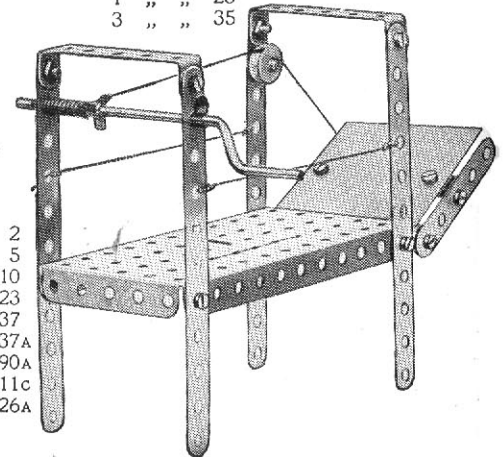

**Model No. 0.35
Tramway Car**

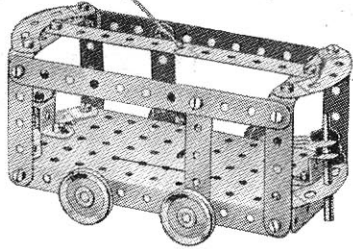

Parts required:

3 of No. 2	16 of No. 37
6 " " 5	6 " " 37A
2 " " 10	2 " " 48A
2 " " 16	1 " " 52
2 " " 17	4 " " 90A
4 " " 22	6 " " 111c
6 " " 35	2 " " 125

**Model No. 0.38
Torpedo Boat**

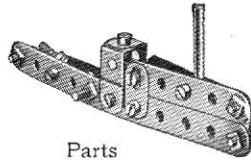

Parts required:

2 of No. 2
2 " " 5
3 " " 10
2 " " 11
2 " " 12
1 " " 17
1 " " 37
4 " " 37A
5 " " 111c

**Model No. 0.40
Gramophone**

Parts required:

2 of No. 12
1 " " 22
1 " " 23
1 " " 24
3 " " 37
1 " " 37A
1 " " 52
2 " " 90A
3 " " 111c

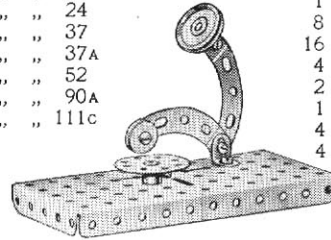

Parts required:

4 of No. 10
1 " " 11
8 " " 12
16 " " 37
4 " " 37A
2 " " 48A
1 " " 52
4 " " 90A
4 " " 111c

**Model No. 0.43
Prehistoric Armadillo**

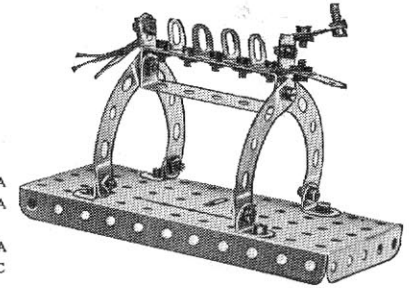

**Model No. 0.44
Motor Cycle and
Side Car**

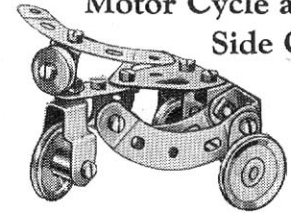

Parts required:

1 of No. 5	10 of No. 37
4 " " 10	1 " " 37A
2 " " 11	1 " " 44
3 " " 12	3 " " 90A
1 " " 16	1 " " 111c
3 " " 22	1 " " 125
1 " " 23	1 " " 126A

**Model No. 0.36
Motor Boat**

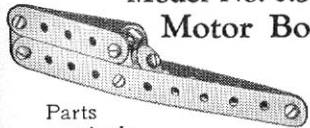

Parts required:

2 of No. 2	1 of No. 23
2 " " 5	7 " " 37
3 " " 10	1 " " 37A
1 " " 11	1 " " 111c

Model No. 0.37 Arm Chair

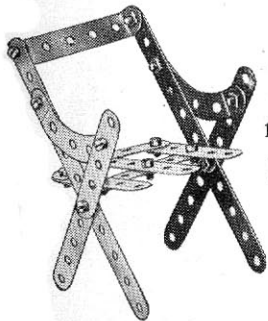

Parts required:

2 of No. 2
7 " " 5
14 " " 37
2 " " 48A
3 " " 90A

Model No. 0.39 Piano

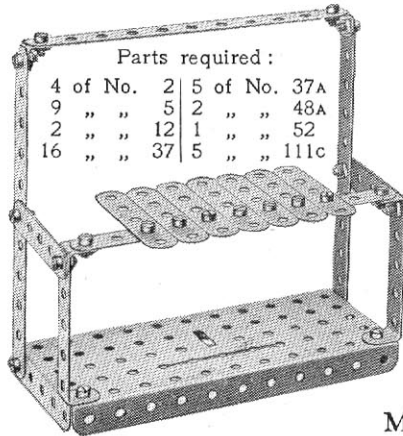

Parts required:

4 of No. 2	5 of No. 37A
9 " " 5	2 " " 48A
2 " " 12	1 " " 52
16 " " 37	5 " " 111c

Model No. 0.41 Milk Maid

Parts required:

5 of No. 5
3 " " 10
2 " " 11
4 " " 12
2 " " 22
1 " " 23
14 " " 37
1 " " 37A
1 " " 52
1 " " 90A
1 " " 111c

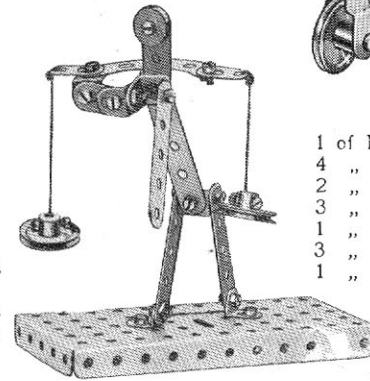

Model No. 0.42 Sword

Parts required:

4 of No. 2	10 of No. 37	3 of No. 90A
------------	--------------	--------------

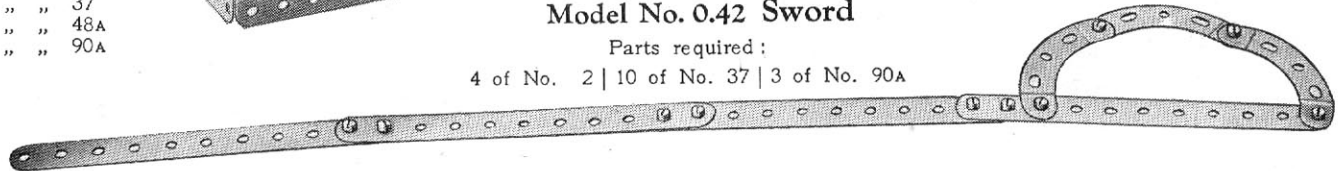

**Model No. 0.45
Loud Speaker**

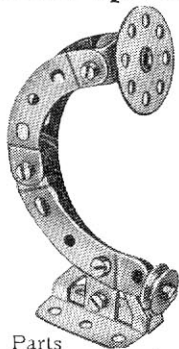

Parts
required:

- 1 of No. 11
- 1 " " 23
- 1 " " 24
- 6 " " 37
- 1 " " 37A
- 4 " " 90A
- 2 " " 111c
- 2 " " 126

Model No. 0.46 Bicycle

- Parts
required:
- 9 of No. 5
 - 2 " " 11
 - 5 " " 12
 - 2 " " 17
 - 2 " " 22
 - 11 " " 37

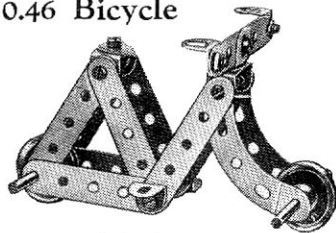

**Model No. 0.47
Cow and Milkmaid**

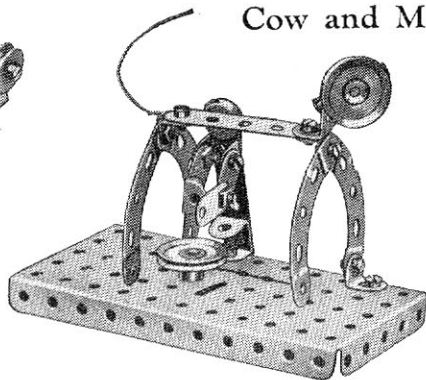

Parts
required:

- 2 of No. 5
- 4 " " 10
- 2 " " 11
- 2 " " 12
- 5 " " 12
- 2 " " 22
- 1 " " 23
- 16 " " 37
- 2 " " 37A
- 1 " " 52
- 4 " " 90A
- 4 " " 111c
- 1 " " 125

**Model No. 0.49
Telescopic
Mast**

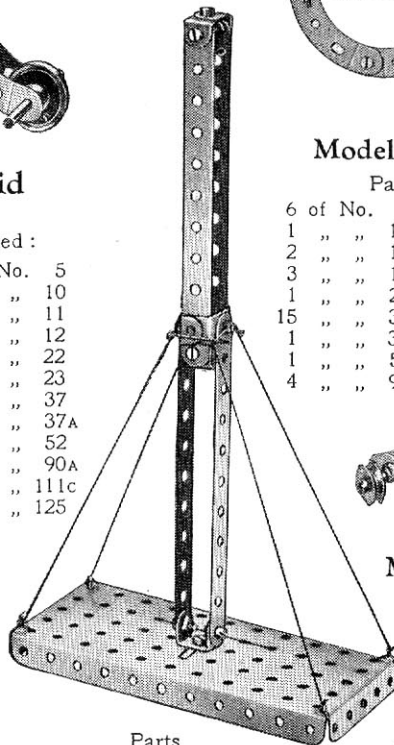

Parts
required:

- 4 of No. 2
- 2 " " 11
- 6 " " 12
- 11 " " 37
- 1 " " 40
- 1 " " 52

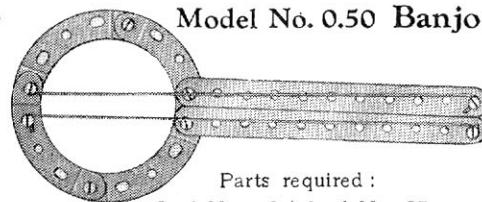

Model No. 0.50 Banjo **Model No. 0.53
Catapult**

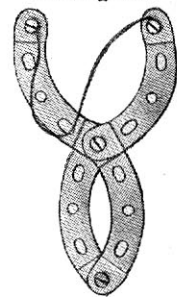

Parts required:

- 2 of No. 2
- 1 " " 10
- 8 of No. 37
- 4 " " 90A

Model No. 0.51 Wiretail

Parts required:

- 6 of No. 5
- 1 " " 10
- 2 " " 11
- 3 " " 12
- 1 " " 23
- 15 " " 37
- 1 " " 37A
- 1 " " 52
- 4 " " 90A
- 1 of No. 111c

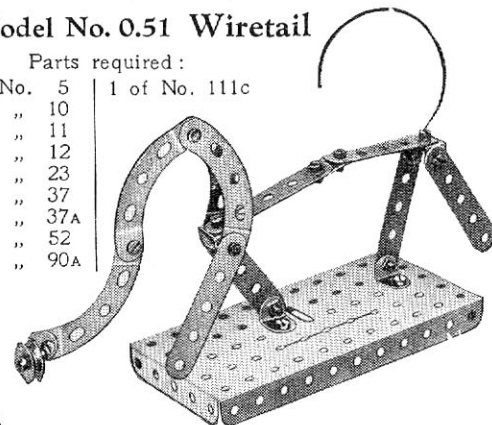

Parts
required:

- 4 of No. 37
- 4 " " 90A

Model No. 0.48 Meccano Boy

Parts required:

- 2 of No. 2
- 2 " " 5
- 4 " " 10
- 2 " " 11
- 2 " " 12
- 6 " " 12
- 1 of No. 111c
- 1 of No. 22
- 1 " " 24
- 16 " " 37
- 1 " " 52
- 1 " " 57

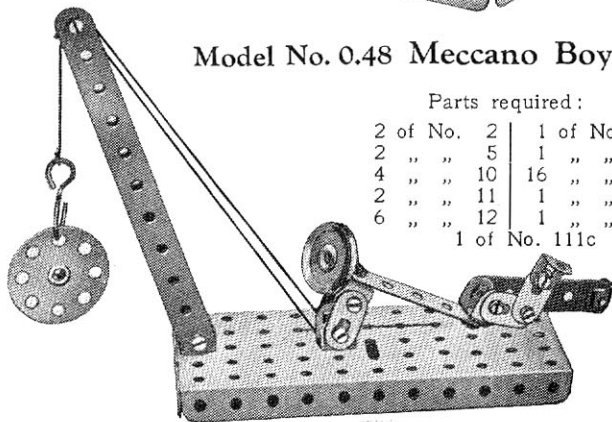

Model No. 0.52 Bacon Slicing Machine

Parts
required:

- 3 of No. 5
- 2 " " 11
- 1 of No. 12
- 1 " " 16
- 1 " " 19s
- 2 " " 22
- 1 " " 23
- 1 " " 24
- 1 of No. 35
- 12 " " 37
- 2 " " 37A
- 2 " " 48A
- 1 " " 52
- 4 " " 90A

Parts
required:

- 4 of No. 2
- 2 " " 11
- 6 " " 12
- 11 " " 37
- 1 " " 40
- 1 " " 52

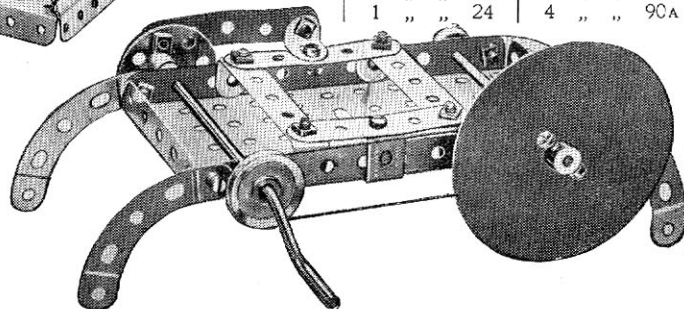

Model No. 0.54
Camera

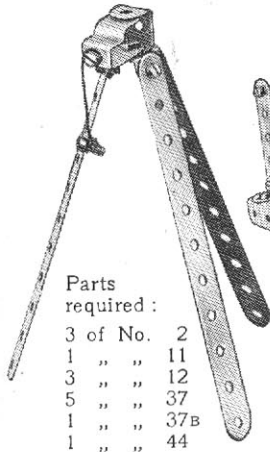

Model No. 0.56
The Execution

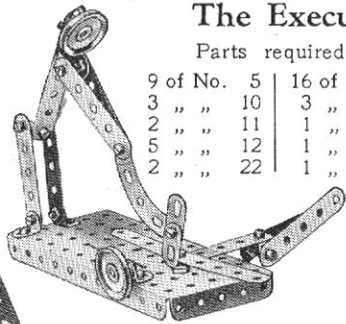

Model No. 0.58
Crane

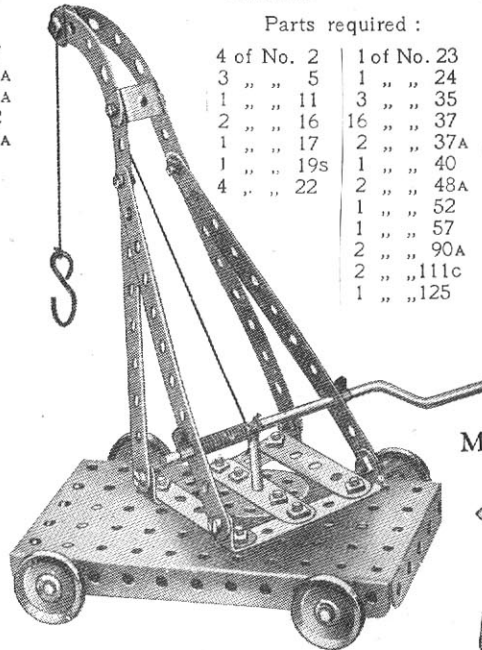

Model No. 0.60 Hurdler

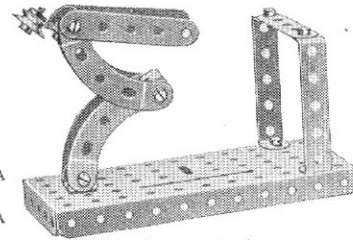

Model No. 0.62
Pliers

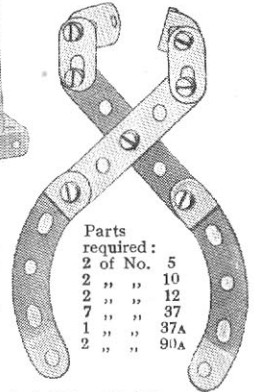

Model No. 0.57 Pistol

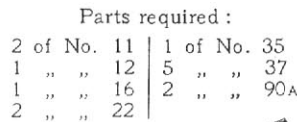

Model No. 0.55
Scooter

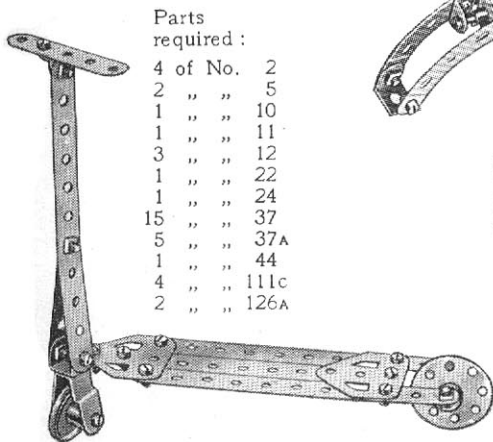

Model No. 0.61
Tricycle

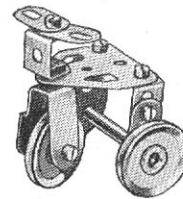

Model No. 0.63
Centrifugal Engine Governor

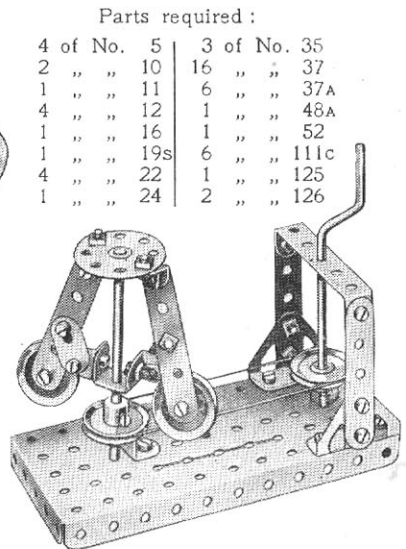

Model No. 0.59 Pecking Hen

By alternately pushing and pulling the lower of the 5½" Strips, the hen can be made to peck vigorously at the "bowl" (a 1" Pulley). The bolts used for securing the 5½" Strips together should be lock-nutted, care being taken to ensure that no "side play" is permitted.

Parts required:

2 of No. 2	11 of No. 37
2 " " 5	5 " " 37A
3 " " 10	2 " " 90A
1 " " 12	2 " " 111c
1 " " 22	2 " " 126A
1 " " 23	

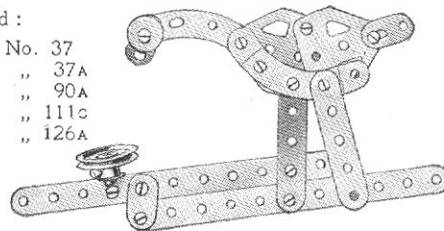

Model No. 0.64 Wrestlers

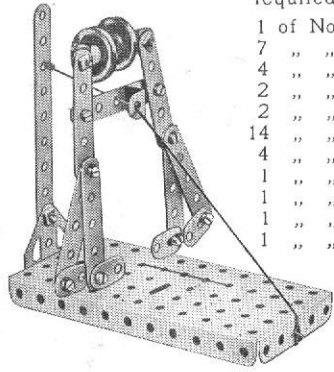

- Parts required:
- | | |
|----------|------|
| 1 of No. | 2 |
| 7 " " | 5 |
| 4 " " | 10 |
| 2 " " | 12 |
| 2 " " | 22 |
| 14 " " | 37 |
| 4 " " | 37A |
| 1 " " | 40 |
| 1 " " | 52 |
| 1 " " | 125 |
| 1 " " | 126A |

Model No. 0.66 Aerial Flight

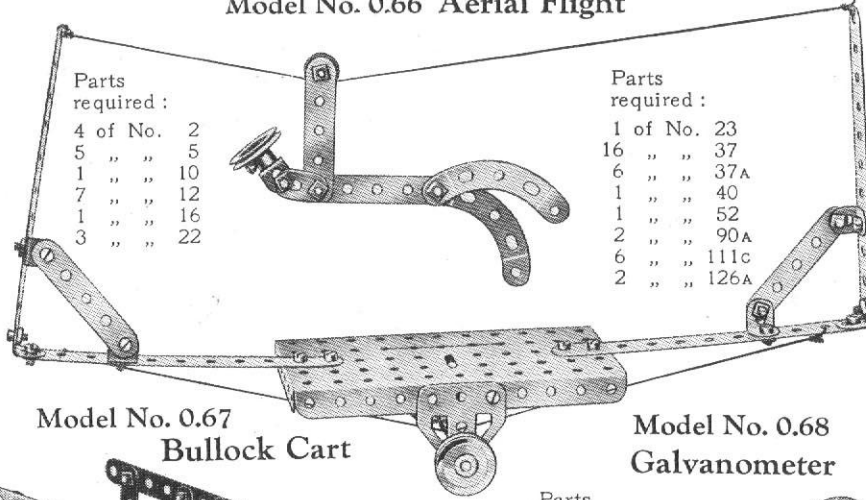

- Parts required:
- | | |
|----------|----|
| 4 of No. | 2 |
| 5 " " | 5 |
| 1 " " | 10 |
| 7 " " | 12 |
| 1 " " | 16 |
| 3 " " | 22 |

- Parts required:
- | | |
|----------|------|
| 1 of No. | 23 |
| 16 " " | 37 |
| 6 " " | 37A |
| 1 " " | 40 |
| 1 " " | 52 |
| 2 " " | 90A |
| 6 " " | 111c |
| 2 " " | 126A |

Model No. 0.70 The Missing Link

- Parts required:
- | | |
|----------|------|
| 4 of No. | 5 |
| 4 " " | 10 |
| 8 " " | 12 |
| 1 " " | 24 |
| 16 " " | 37 |
| 6 " " | 37A |
| 1 " " | 52 |
| 4 " " | 90A |
| 6 " " | 111c |

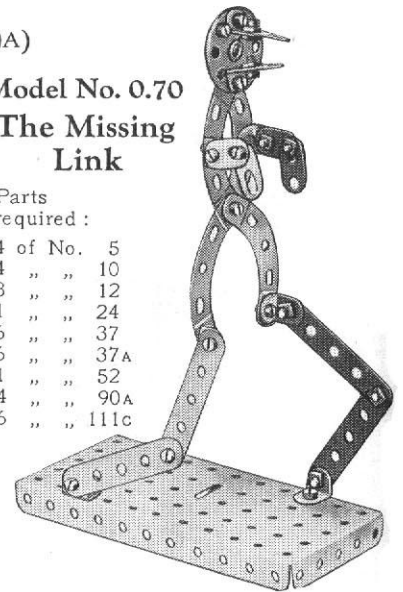

Model No. 0.65 A Chase

- Parts required:
- | | | | |
|----------|----|-----------|------|
| 1 of No. | 5 | 16 of No. | 37 |
| 1 " " | 10 | 1 " " | 37A |
| 2 " " | 11 | 1 " " | 52 |
| 7 " " | 12 | 4 " " | 90A |
| 1 " " | 22 | 2 " " | 111c |
| 1 " " | 23 | 2 " " | 126A |

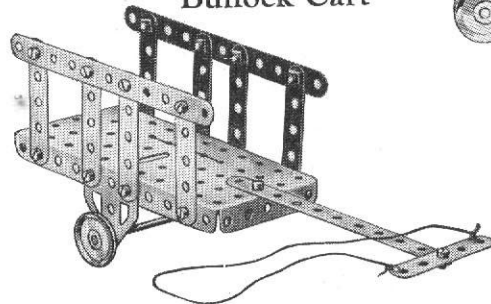

Model No. 0.67 Bullock Cart

Model No. 0.68 Galvanometer

- Parts required:
- | | |
|----------|------|
| 1 of No. | 12 |
| 1 " " | 17 |
| 5 " " | 37 |
| 4 " " | 37A |
| 1 " " | 40 |
| 1 " " | 52 |
| 4 " " | 90A |
| 2 " " | 111c |

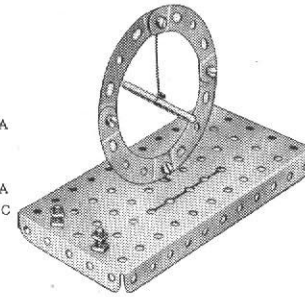

Model No. 0.71 Steeple-chaser

- Parts required:
- | | | | |
|----------|----|----------|------|
| 7 of No. | 5 | 1 of No. | 37A |
| 4 " " | 10 | 1 " " | 48A |
| 1 " " | 12 | 1 " " | 52 |
| 1 " " | 23 | 4 " " | 90A |
| 13 " " | 37 | 1 " " | 111c |
| | | 1 " " | 126A |

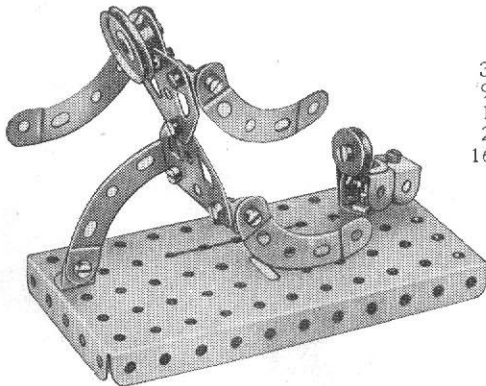
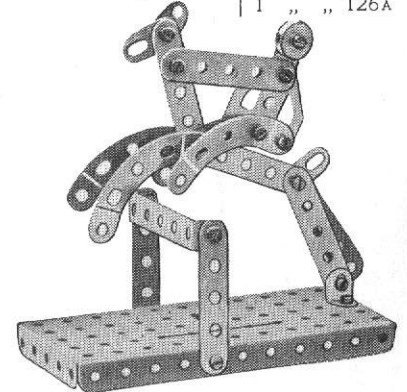

- Parts required:
- | | | | |
|----------|----|----------|------|
| 3 of No. | 2 | 2 of No. | 37A |
| 9 " " | 5 | 1 " " | 40 |
| 1 " " | 16 | 1 " " | 52 |
| 2 " " | 22 | 2 " " | 111c |
| 16 " " | 37 | 2 " " | 126A |

Model No. 0.69 Coster's Barrow

- Parts required:
- | | | | |
|----------|----|-----------|------|
| 2 of No. | 5 | 13 of No. | 37 |
| 1 " " | 11 | 1 " " | 52 |
| 1 " " | 17 | 4 " " | 90A |
| 1 " " | 24 | 2 " " | 126A |

Model No. 0.72 Pen Rack

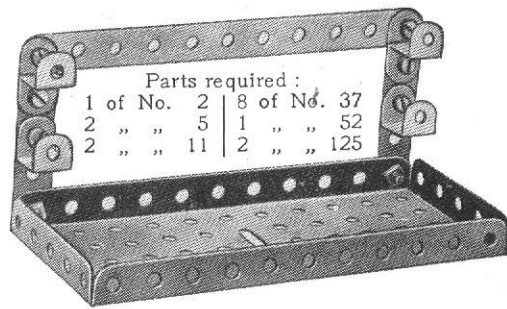

Parts required:
 1 of No. 2 | 8 of No. 37
 2 " " 5 | 1 " " 52
 2 " " 11 | 2 " " 125

Model No. 0.76 Coast Guard

Parts required:
 1 of No. 5
 2 " " 10
 2 " " 11
 6 " " 12
 2 " " 17
 1 " " 22
 3 " " 35
 15 " " 37
 1 " " 52
 4 " " 90A
 1 " " 111c

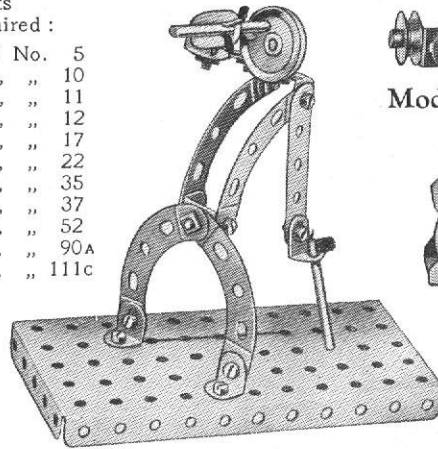

Model No. 0.79 Clock

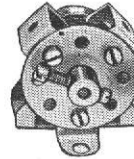

Parts required:
 2 of No. 11
 2 " " 12
 1 " " 17
 1 " " 22
 1 " " 24
 5 " " 37
 1 " " 111c
 2 " " 126

Model No. 0.78 Snake

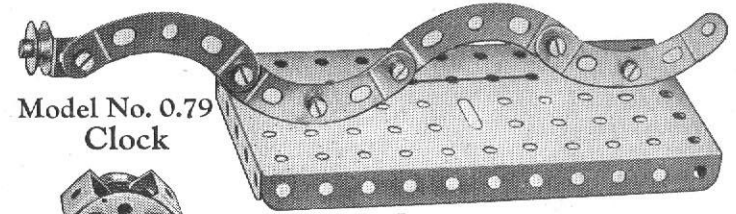

Parts required:
 3 of No. 12 | 1 of No. 37A
 1 " " 23 | 1 " " 52
 8 " " 37 | 4 " " 90A
 1 of No. 111c

Model No. 0.73 Boxer

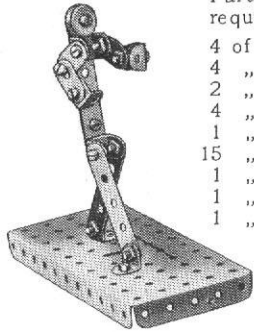

Parts required:
 4 of No. 5
 4 " " 10
 2 " " 11
 4 " " 12
 1 " " 23
 15 " " 37
 1 " " 37A
 1 " " 52
 1 " " 111c

Model No. 0.75 Fan

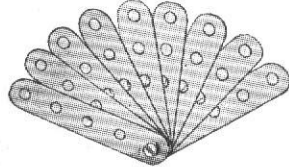

Parts required:
 9 of No. 5 | 2 of No. 37A
 1 of No. 111c

Model No. 0.77 Break-Down Crane

Parts required:
 2 of No. 2 | 13 of No. 37 | 1 of No. 57c
 2 " " 10 | 1 " " 40 | 2 " " 90A
 1 " " 11 | 1 " " 48A | 2 " " 125
 2 " " 16 | 1 " " 52 | 2 " " 126
 2 " " 17
 1 " " 19s
 4 " " 22
 1 " " 23
 1 " " 24
 6 " " 35

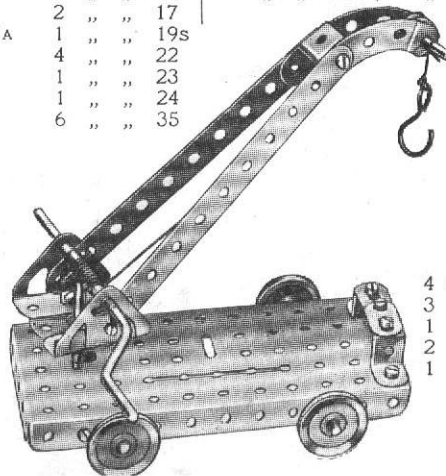

Model No. 0.74 Horseman's Fall

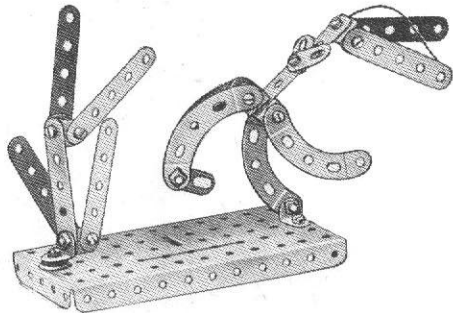

Parts required:
 8 of No. 5
 3 " " 10
 2 " " 11
 8 " " 12
 1 " " 23
 16 " " 37
 4 " " 37A
 1 " " 40
 1 " " 52
 4 " " 90A
 4 " " 111c

Model No. 0.80 Windmill

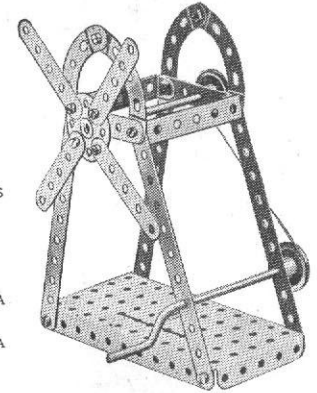

Parts required:
 4 of No. 2
 6 " " 5
 1 " " 16
 1 " " 19s
 2 " " 22
 1 " " 24
 14 " " 37
 1 " " 40
 2 " " 48A
 1 " " 52
 4 " " 90A

Model No. 0.81 Frog

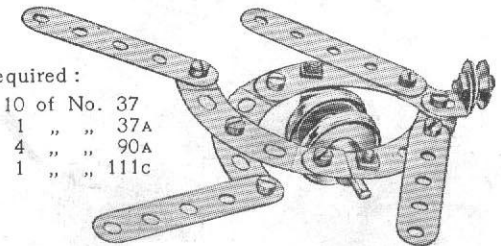

Parts required:
 4 of No. 5 | 10 of No. 37
 3 " " 12 | 1 " " 37A
 1 " " 17 | 4 " " 90A
 2 " " 22 | 1 " " 111c
 1 " " 23

**Model No. 0.82
Pneumatic Grain Elevator**

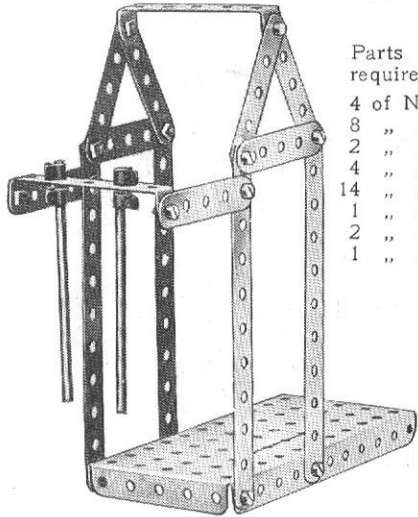

- Parts required :
- | | |
|----------|-----|
| 4 of No. | 2 |
| 8 " " | 5 |
| 2 " " | 16 |
| 4 " " | 35 |
| 14 " " | 37 |
| 1 " " | 40 |
| 2 " " | 48A |
| 1 " " | 52 |

Model No. 0.84 Footbridge

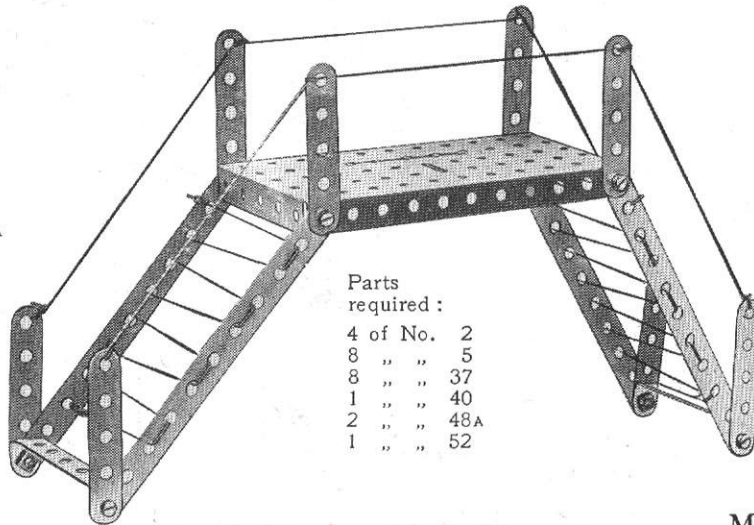

- Parts required :
- | | |
|----------|-----|
| 4 of No. | 2 |
| 8 " " | 5 |
| 8 " " | 37 |
| 1 " " | 40 |
| 2 " " | 48A |
| 1 " " | 52 |

Model No. 0.86 Crane Grab

- Parts required :
- | | |
|----------|-----|
| 6 of No. | 5 |
| 2 " " | 10 |
| 7 " " | 12 |
| 1 " " | 16 |
| 6 " " | 35 |
| 15 " " | 37 |
| 1 " " | 40 |
| 2 " " | 48A |
| 4 " " | 90A |

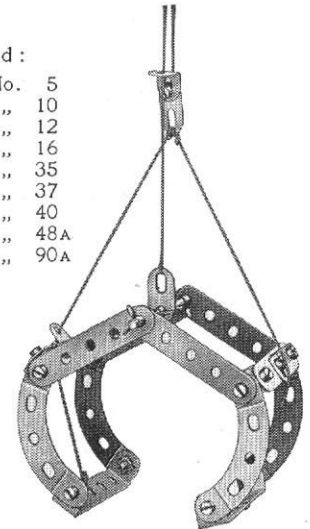

**Model No. 0.83
Baboon**

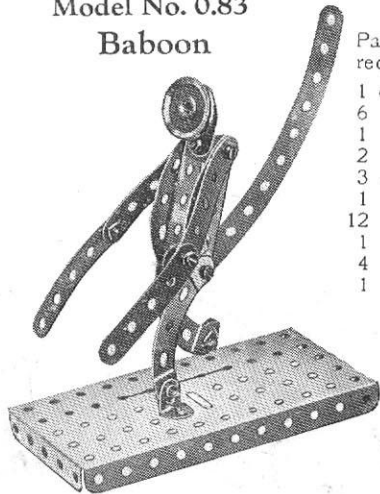

- Parts required :
- | | |
|----------|------|
| 1 of No. | 2 |
| 6 " " | 5 |
| 1 " " | 10 |
| 2 " " | 11 |
| 3 " " | 12 |
| 1 " " | 22 |
| 12 " " | 37 |
| 1 " " | 52 |
| 4 " " | 90A |
| 1 " " | 111c |

Model No. 0.85 Cross-Bow

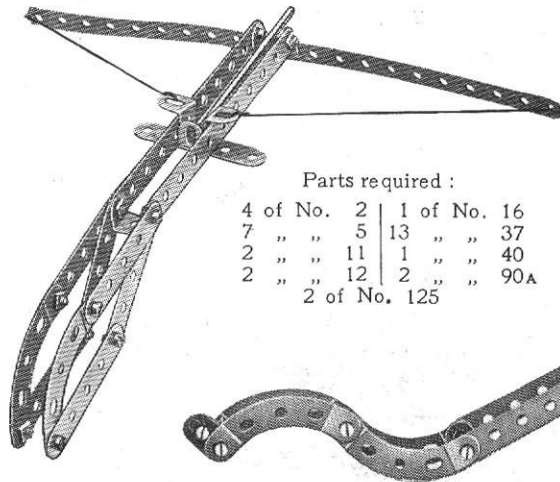

- Parts required :
- | | | | |
|----------|----|----------|-----|
| 4 of No. | 2 | 1 of No. | 16 |
| 7 " " | 5 | 13 " " | 37 |
| 2 " " | 11 | 1 " " | 40 |
| 2 " " | 12 | 2 " " | 90A |
| | | 2 of No. | 125 |

Model No. 0.87 Switchback

Parts required :

- | | | | |
|----------|----|----------|------|
| 4 of No. | 2 | 2 of No. | 22 |
| 4 " " | 5 | 16 " " | 37 |
| 1 " " | 10 | 3 " " | 37A |
| 2 " " | 11 | 1 " " | 52 |
| 2 " " | 12 | 4 " " | 90A |
| 1 " " | 17 | 3 " " | 111c |

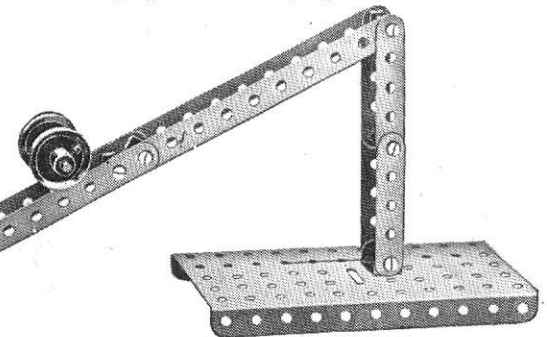

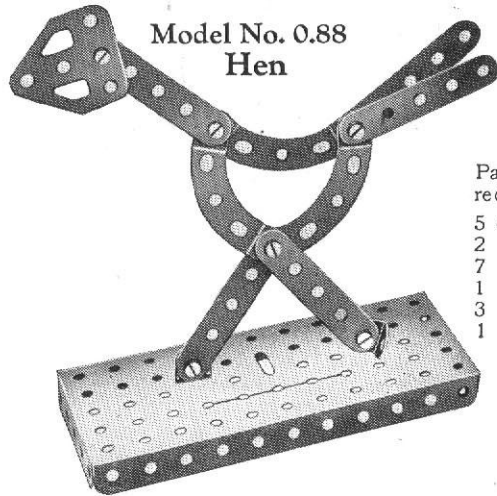

**Model No. 0.88
Hen**

Parts
required :

5 of No.	5
2 " "	12
7 " "	37
1 " "	52
3 " "	90A
1 " "	126A

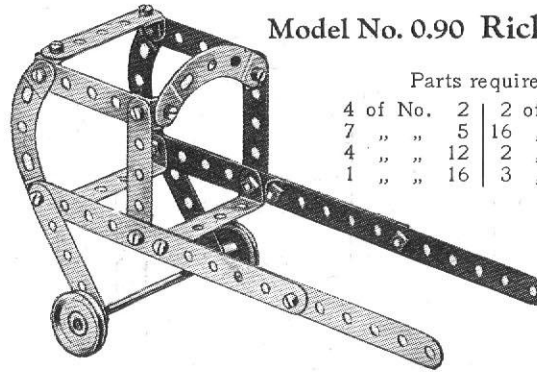

Model No. 0.90 Rickshaw

Parts required :

4 of No.	2	2 of No.	22
7 " "	5	16 " "	37
4 " "	12	2 " "	48A
1 " "	16	3 " "	90A

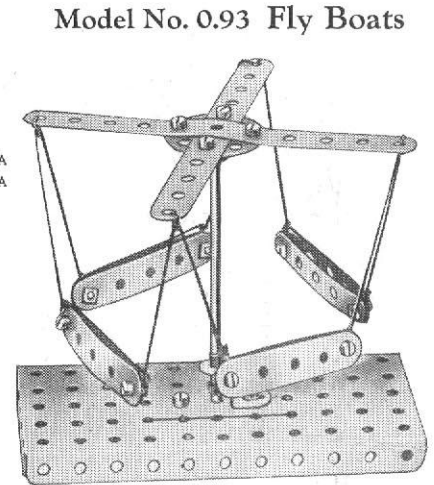

Model No. 0.93 Fly Boats

Parts required :

2 of No.	2	13 of No.	37
8 " "	5	1 " "	40
1 " "	16	1 " "	52
1 " "	24	1 " "	125

**Model No. 0.89
Grass Cutter**

Parts
required :

2 of No.	2
7 " "	5
2 " "	11
1 " "	16
2 " "	22
2 " "	35
16 " "	37
2 " "	48A
2 " "	126

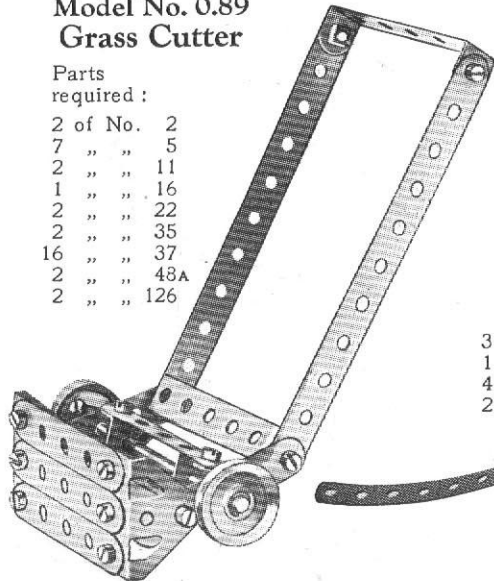

Model No. 0.91 Rowing Boat

Parts required :

4 of No.	2	4 of No.	111c
6 " "	5	2 " "	125
2 " "	10		
1 " "	11		
16 " "	37		
4 " "	37A		
1 " "	44		
2 " "	48A		
4 " "	90A		

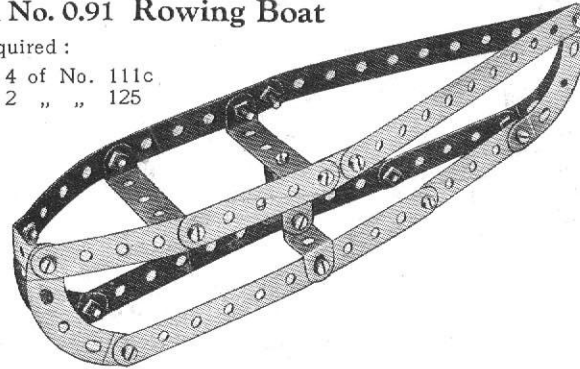

Model No. 0.92 Dinosaur

Parts required :

3 of No.	2	5 of No.	12	1 of No.	52
1 " "	5	1 " "	23	2 " "	90A
4 " "	10	16 " "	37	6 " "	111c
2 " "	11	6 " "	37A		

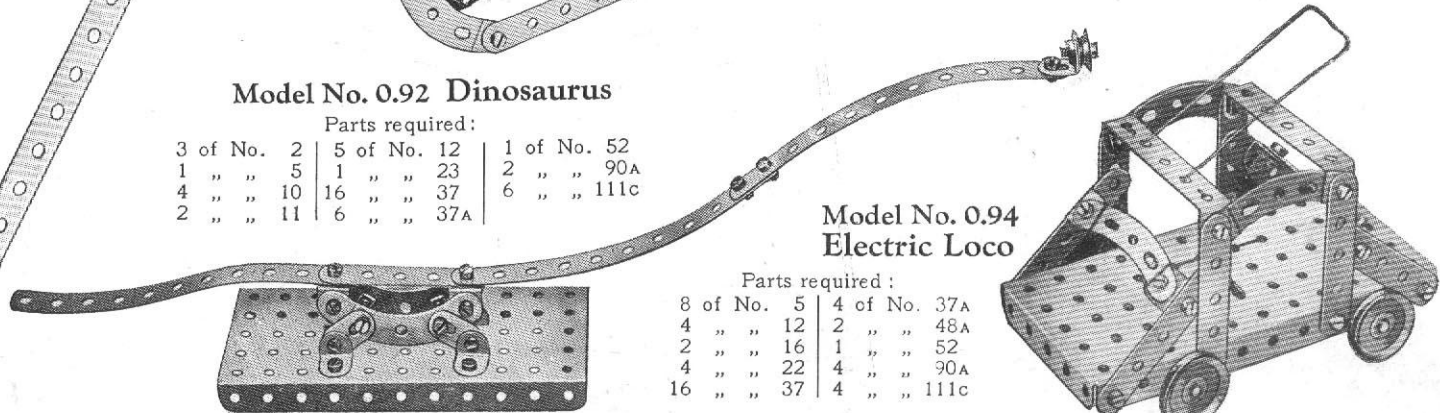

**Model No. 0.94
Electric Loco**

Parts required :

8 of No.	5	4 of No.	37A
4 " "	12	2 " "	48A
2 " "	16	1 " "	52
4 " "	22	4 " "	90A
16 " "	37	4 " "	111c

Model No. 0.95 Trolley

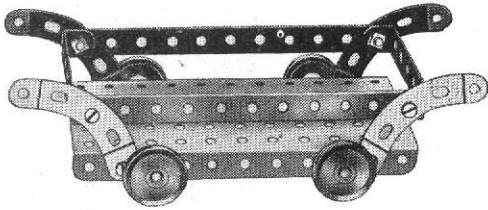

Parts required :

2 of No. 2	8 of No. 37
2 " " 16	2 " " 48A
4 " " 22	1 " " 52
4 of No. 90A	

Model No. 0.98 Pump

Parts required :

1 of No. 2	16 of No. 37
6 " " 5	6 " " 37A
2 " " 11	1 " " 40
3 " " 12	1 " " 52
1 " " 16	6 " " 111c
1 " " 17	2 " " 126
1 " " 19s	1 " " 126A
3 " " 22	
1 " " 24	
2 " " 35	

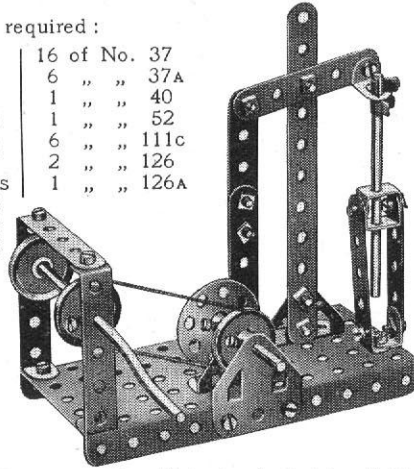

The connecting Strip is pivoted by Bolts and Nuts at one end to the Bush Wheel and at the other end to the cross beam. The latter is pivoted by the same means to the upright.

Model No. 0.100 Luggage Truck

Parts required :

4 of No. 2
4 " " 5
2 " " 16
4 " " 22
16 " " 37
1 " " 52
4 " " 90A

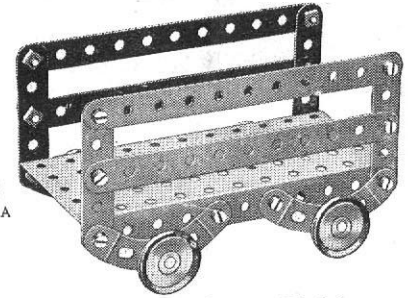

Model No. 0.96 Pen Rack

Parts required :

2 of No. 5
4 " " 37
1 " " 52
4 " " 90A

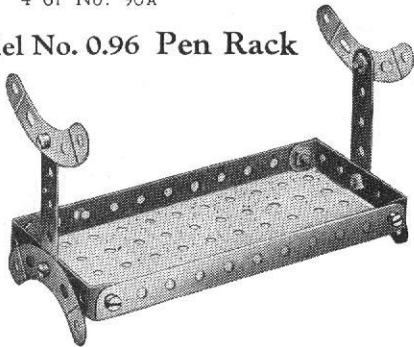

Model No. 0.101 Drafting Table

Parts required :

4 of No. 5
12 " " 37
1 " " 48A
1 " " 52
4 " " 90A
2 " " 126A

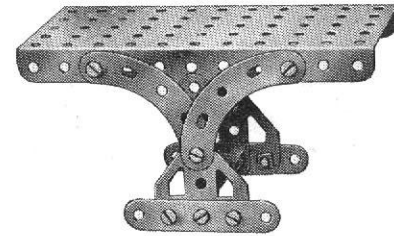

Model No. 0.99 Aerial Ropeway

Parts

4 of No. 2	1 of No. 23	2 of No. 48A
4 " " 5	2 " " 35	6 " " 111c
2 " " 10	16 " " 37	2 " " 125
1 " " 17	6 " " 37A	2 " " 126
	1 " " 40	2 " " 126A

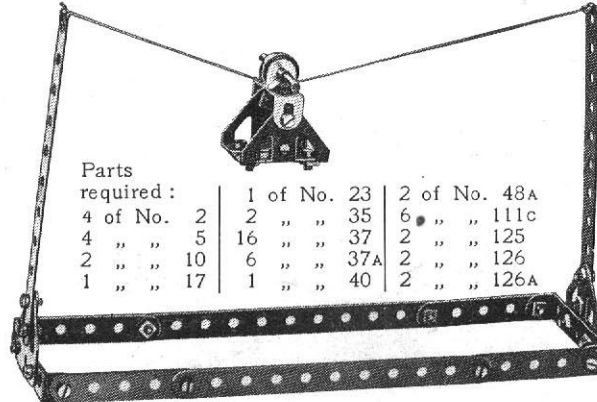

Model No. 0.102 Arm Chair

Parts required :

2 of No. 2
4 " " 5
12 " " 37
1 " " 48A
1 " " 52
3 " " 90A

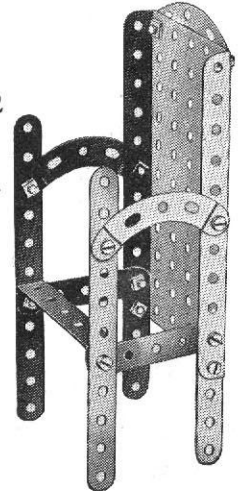

Model No. 0.97 Walking Man

Parts required :

5 of No. 5
3 " " 10
2 " " 12
1 " " 22
7 " " 37
3 " " 90A

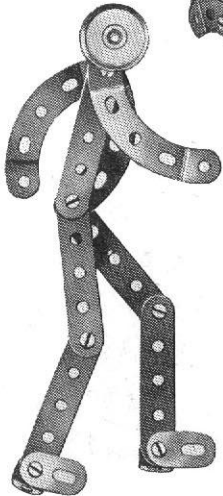

Model No. 0.103 Rattle

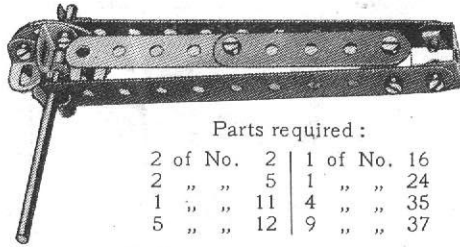

Parts required :

2 of No. 2	1 of No. 16
2 " " 5	1 " " 24
1 " " 11	4 " " 35
5 " " 12	9 " " 37

Model No. 0.104 Shearing Machine

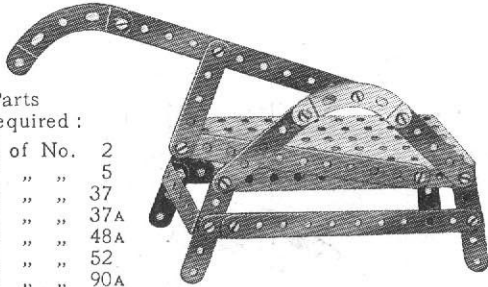

Parts required :

4 of No. 2
7 " " 5
16 " " 37
1 " " 37A
2 " " 48A
1 " " 52
2 " " 90A
1 " " 111c

Model No. 0.105 Anchor

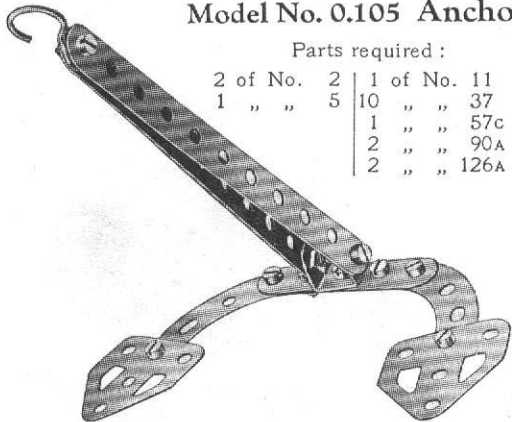

Parts required :

2 of No. 2	1 of No. 11
1 " " 5	10 " " 37
	1 " " 57c
	2 " " 90A
	2 " " 126A

Model No. 0.106 Portal

Parts required :

4 of No. 2
2 " " 11
8 " " 12
1 " " 22
16 " " 37
2 " " 37A
2 " " 48A
4 " " 52
4 " " 90A
6 " " 111c



Model No. 0.107 The Fencers

Parts required :

8 of No. 5	16 of No. 37
2 " " 10	4 " " 37A
6 " " 12	1 " " 52
2 " " 16	4 " " 111c
2 " " 22	2 " " 125
4 " " 35	2 " " 126A

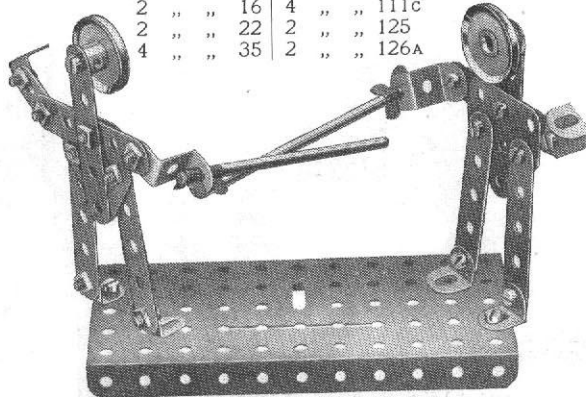

Model No. 0.108 Machine Gun

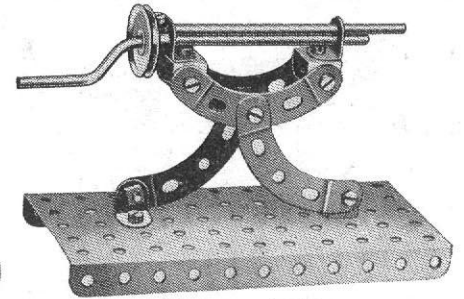

Parts required :

2 of No. 11	1 of No. 22
4 " " 12	12 " " 37
1 " " 16	1 " " 52
1 " " 19s	4 " " 90A

Model No. 0.109 Single Sheave Pulley Block

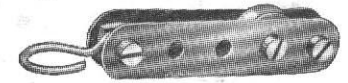

Parts required :

2 of No. 5	7 of No. 37A
1 " " 23	1 " " 57c
3 of No. 111c	

Model No. 0.110 Tea Wagon

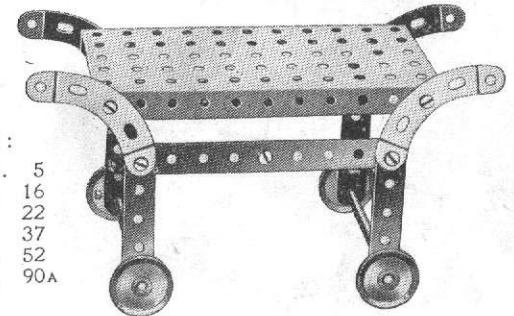

Parts required :

8 of No. 5
2 " " 16
4 " " 22
10 " " 37
1 " " 52
4 " " 90A

These Models can be built with MECCANO Outfit No. 0 (or No. 00 and No. 00A)

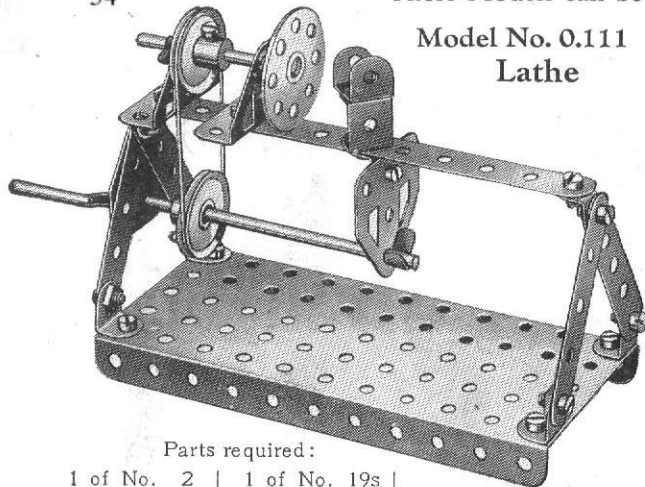

Model No. 0.111
Lathe

Parts required:

1 of No. 2	1 of No. 19s	1 of No. 40
4 " " 5	2 " " 22	1 " " 52
2 " " 11	1 " " 24	2 " " 126
7 " " 12	3 " " 35	2 " " 126A
1 " " 17	16 " " 37	

Model No. 0.112
Weather Vane

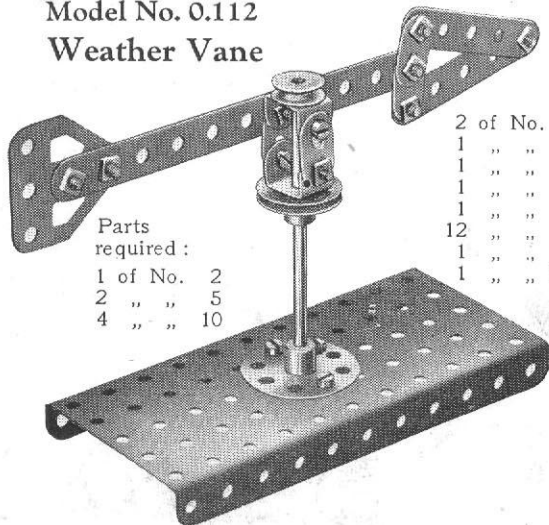

Parts
required:

1 of No. 2
2 " " 5
4 " " 10

2 of No. 11
1 " " 16
1 " " 22
1 " " 23
1 " " 24
12 " " 37
1 " " 52
1 " " 126A

Model No. 0.113 Viaduct

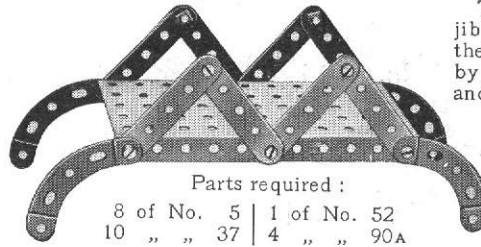

Parts required:

8 of No. 5	1 of No. 52
10 " " 37	4 " " 90A

Model No. 0.114 Pulley Block

Parts
required:

4 of No. 2
2 " " 5
2 " " 11
1 " " 17
1 " " 19s
1 " " 22
1 " " 23
1 " " 24
5 " " 35
16 " " 37
4 " " 37A
1 " " 40
1 " " 52
1 " " 57c
2 " " 90A
4 " " 111c
4 " " 126
2 " " 126A

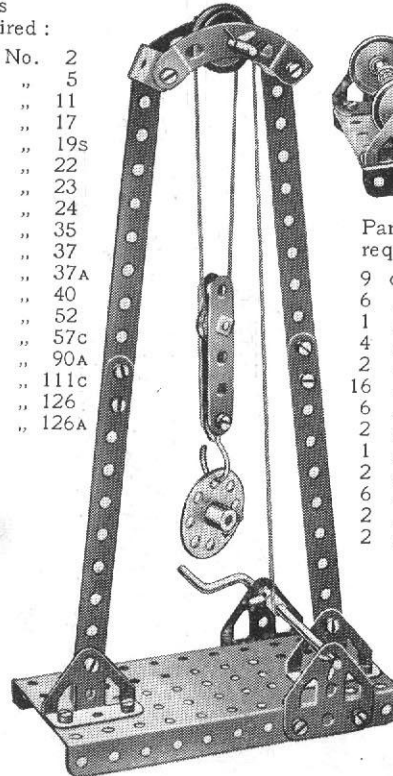

Model No. 0.115 Derricking Crane

The base of the
jib is pivoted to
the Flanged Plate
by means of a bolt
and lock-nuts.

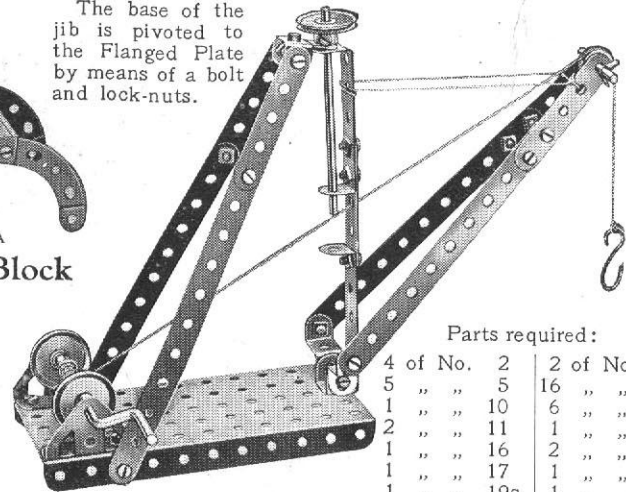

Parts required:

4 of No. 2	2 of No. 35
5 " " 5	16 " " 37
1 " " 10	6 " " 37A
2 " " 11	1 " " 40
1 " " 16	2 " " 48A
1 " " 17	1 " " 52
1 " " 19s	1 " " 57c
3 " " 22	6 " " 111c
1 " " 23	2 " " 125
	2 of No. 126

Parts
required:

9 of No. 5
6 " " 12
1 " " 19s
4 " " 22
2 " " 35
16 " " 37
6 " " 37A
2 " " 48A
1 " " 52
2 " " 90A
6 " " 111c
2 " " 126
2 " " 126A

Model No. 0.116 Dump Car

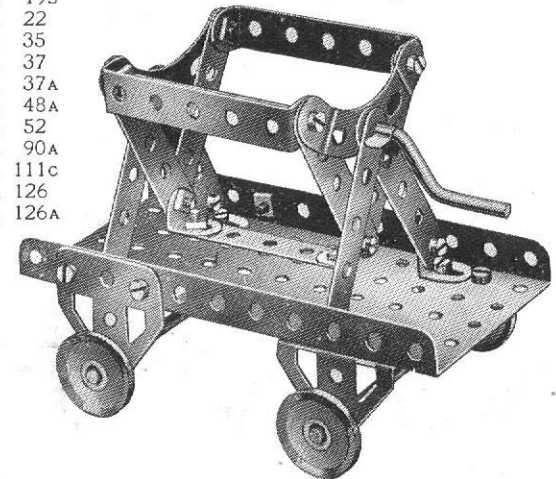

Model No. 0.117 Swing

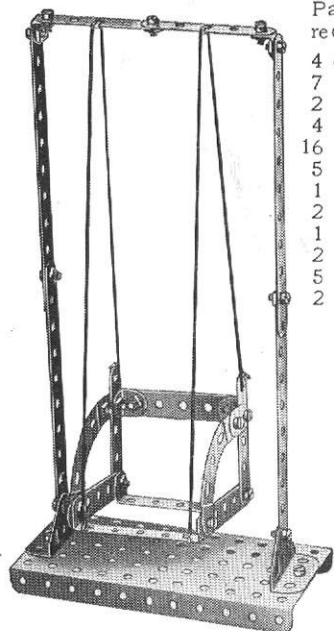

Parts required :

4 of No.	2
7 " "	5
2 " "	10
4 " "	12
16 " "	37
5 " "	37A
1 " "	40
2 " "	48A
2 " "	52
2 " "	90A
5 " "	111c
2 " "	126

Model No. 0.119 Aeroplane

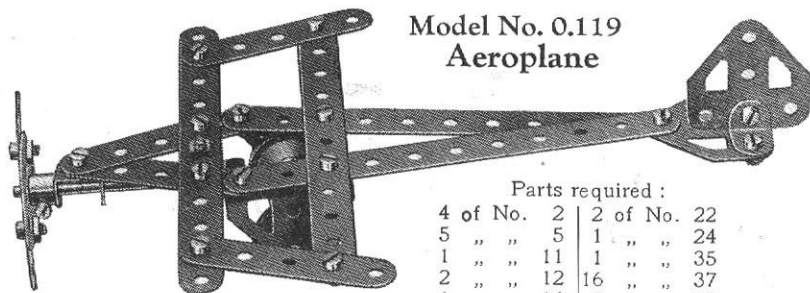

Parts required :

4 of No.	2	2 of No.	22
5 " "	5	1 " "	24
1 " "	11	1 " "	35
2 " "	12	16 " "	37
1 " "	16	2 " "	37A
1 " "	17	2 " "	111c
		2 " "	126
		1 " "	126A

Model No. 0.123 Arch

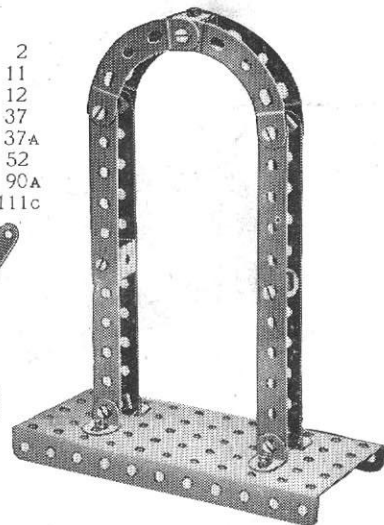

Parts required :

4 of No.	2
2 " "	11
6 " "	12
16 " "	37
3 " "	37A
1 " "	52
4 " "	90A
3 " "	111c

Model No. 0.120 Hat Rack

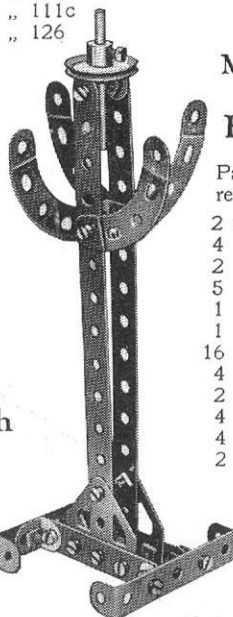

Parts required :

2 of No.	2
4 " "	5
2 " "	11
5 " "	12
1 " "	17
1 " "	22
16 " "	37
4 " "	37A
2 " "	48A
4 " "	90A
4 " "	111c
2 " "	126A

Model No. 0.121 Notice Board

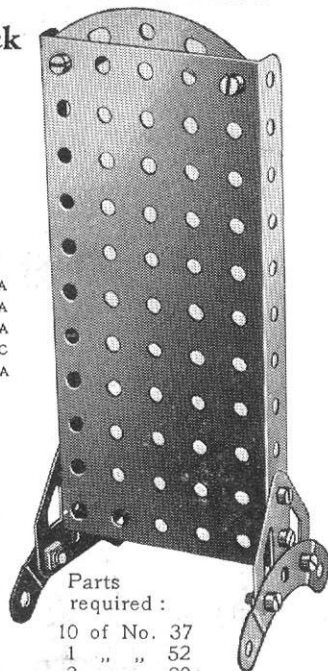

Parts required :

10 of No.	37
1 " "	52
3 " "	90A
2 " "	126A

Model No. 0.122 Music Stand

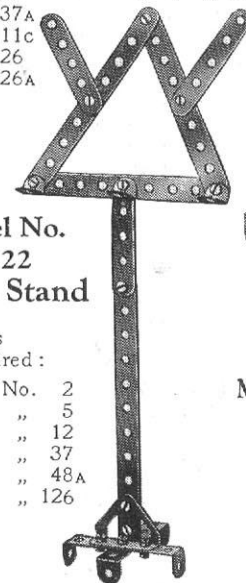

Parts required :

1 of No.	2
9 " "	5
3 " "	12
12 " "	37
2 " "	48A
1 " "	126

Model No. 0.124 See-Saw

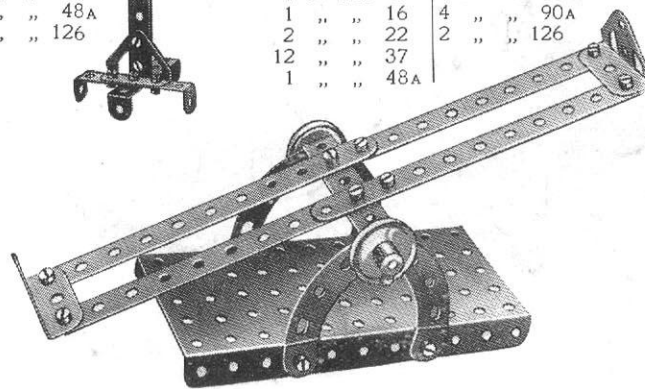

Parts required :

4 of No.	2	1 of No.	52
1 " "	16	4 " "	90A
2 " "	22	2 " "	126
12 " "	37		
1 " "	48A		

Model No. 0.118 Plough

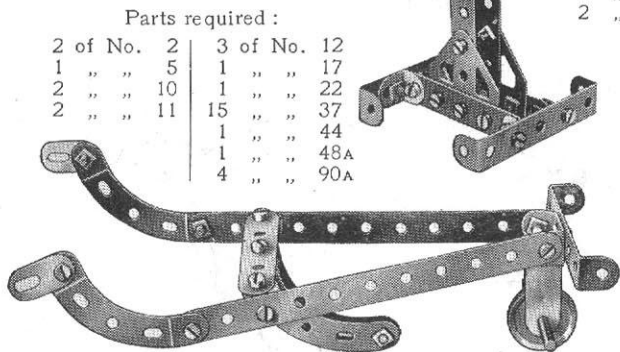

Parts required :

2 of No.	2	3 of No.	12
1 " "	5	1 " "	17
2 " "	10	1 " "	22
2 " "	11	15 " "	37
		1 " "	44
		1 " "	48A
		4 " "	90A

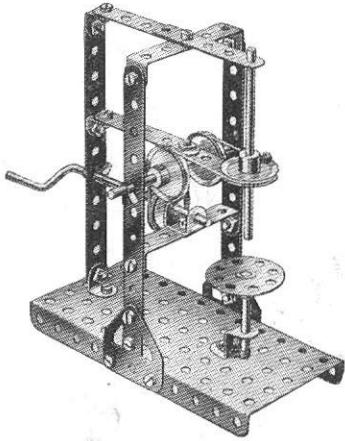
Model No. 0.125 Drilling Machine

Parts required :

3 of No.	2
4 " "	5
2 " "	11
3 " "	12
1 " "	16
1 " "	17
1 " "	19s
4 " "	22
1 " "	24
6 " "	35
16 " "	37
6 " "	37A
1 " "	40
2 " "	48A
1 " "	52
6 " "	111c
1 " "	125
2 " "	126A

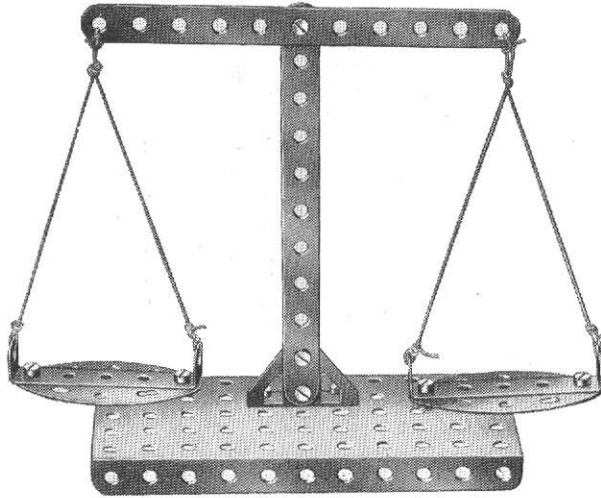
Model No. 0.127 Scales**Model No. 0.129 Cot**

Parts required :

4 of No.	2	14 of No.	37
7 " "	5	1 " "	40
3 " "	12	2 " "	48A
4 " "	22	1 " "	52
	4 of No.	111c	

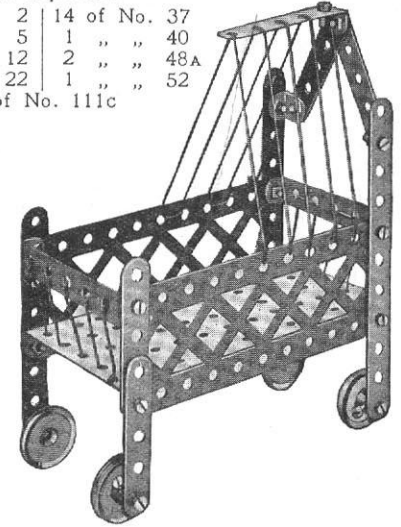
**Model No. 0.126 Counter Scales**

Parts required :

1 of No.	2	7 of No.	37
2 " "	10	1 " "	44
2 " "	12	1 " "	52
1 " "	17	2 " "	126

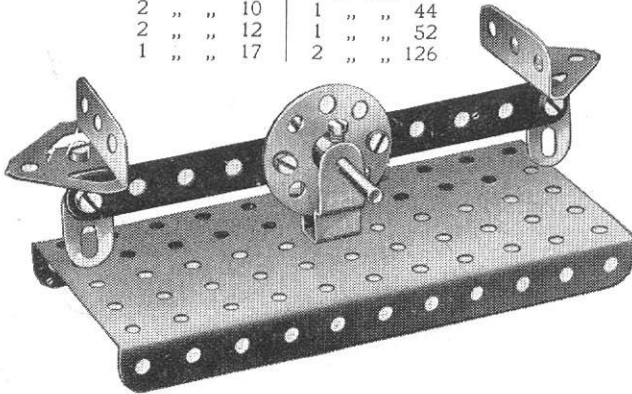
**Parts required :**

2 of No.	2	2 of No.	48A
9 " "	37	1 " "	52
1 " "	37A	4 " "	90A
1 " "	40	1 " "	126

**Model No. 0.128
Single Sheave
Pulley Block****Parts required :**

1 of No.	23
12 " "	37A
1 " "	57c
4 " "	111c
2 " "	126A

Model No. 0.130 Couch

Parts required :

1 of No.	2	16 of No.	37	1 of No.	52
3 " "	5	4 " "	37A	4 " "	90A
4 " "	12	2 " "	48A	4 " "	111c

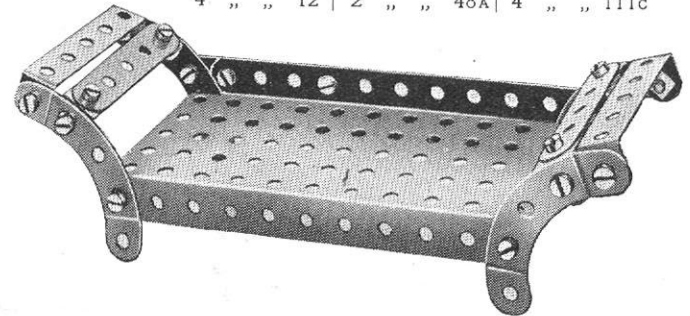

Model No. 0.131 Rock Drill

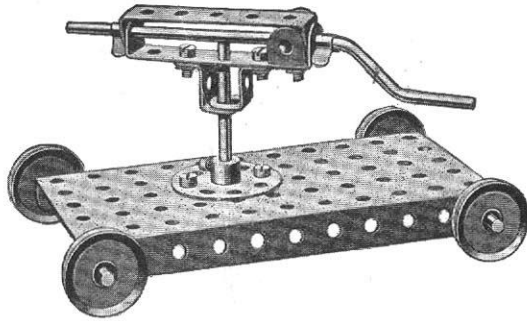

Parts required :

1 of No. 11	4 of No. 22	2 of No. 48A
2 " " 16	1 " " 24	1 " " 52
1 " " 17	2 " " 35	2 " " 125
1 " " 19s	5 " " 37	

Model No. 0.133 Prancing Horse

Parts required :

6 of No. 5
4 " " 12
1 " " 17
1 " " 19s
4 " " 22
1 " " 24
16 " " 37
4 " " 37A
1 " " 40
1 " " 44
1 " " 52
1 " " 90A
4 " " 111c
2 " " 125
1 " " 126
1 " " 126A

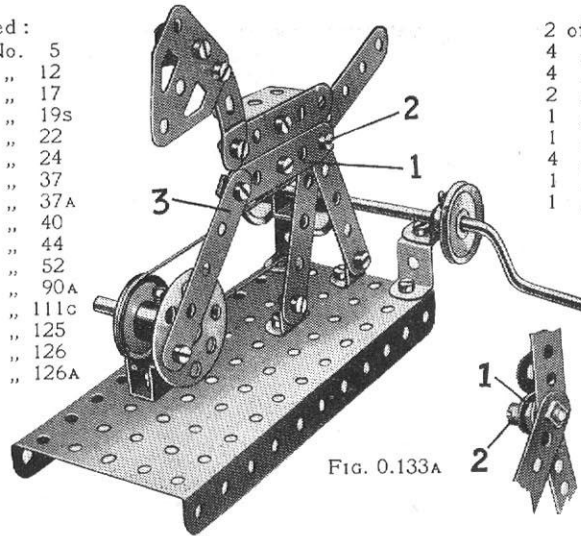
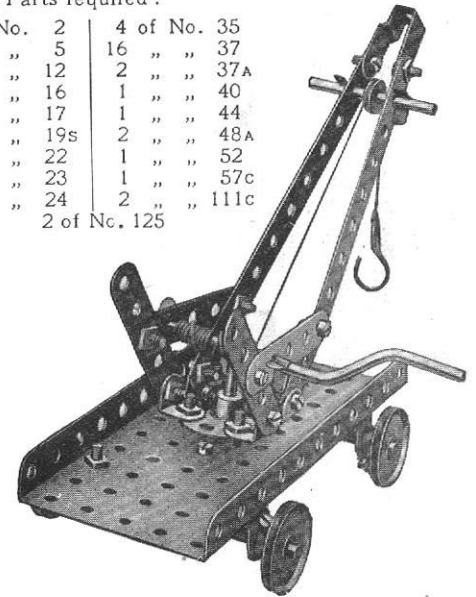

FIG. 0.133A

Model No. 0.135 Swivelling Crane

Parts required :

2 of No. 2	4 of No. 35
4 " " 5	16 " " 37
4 " " 12	2 " " 37A
2 " " 16	1 " " 40
1 " " 17	1 " " 44
1 " " 19s	2 " " 48A
4 " " 22	1 " " 52
1 " " 23	1 " " 57c
1 " " 24	2 " " 111c
	2 of No. 125



Model No. 0.132 Well Windlass

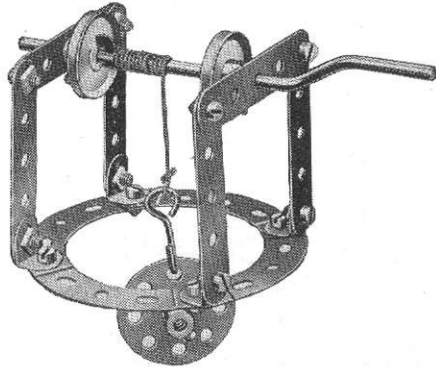

Parts required :

6 of No. 5	2 of No. 22	1 of No. 40
4 " " 12	1 " " 24	1 " " 57c
1 " " 19s	12 " " 37	4 " " 90A

The Strip 1 forming part of the body is free to move about the Bolt 2, but two Nuts on the latter secure the rear legs and tail rigidly together. The arrangement of the various Strips about this Bolt 2 is shown more clearly in Fig. 0.133A. The Strip 3 is free to move at each end about pivots formed from Bolts and Nuts.

Model No. 0.134 Hammock

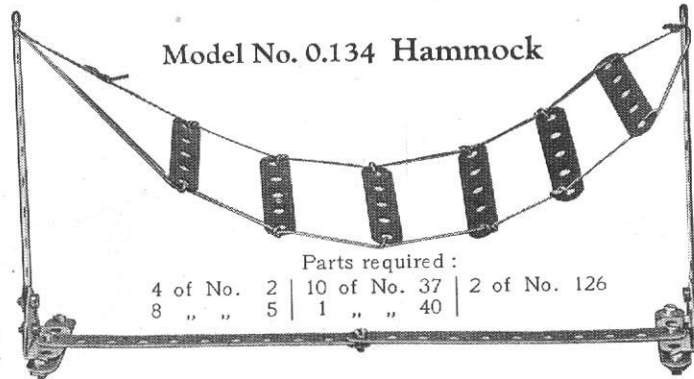

Parts required :

4 of No. 2	10 of No. 37	2 of No. 126
8 " " 5	1 " " 40	

Model No. 0.136 Go Chair

Parts required :

2 of No. 2
7 " " 5
2 " " 16
4 " " 22
11 " " 37
1 " " 40
2 " " 48A

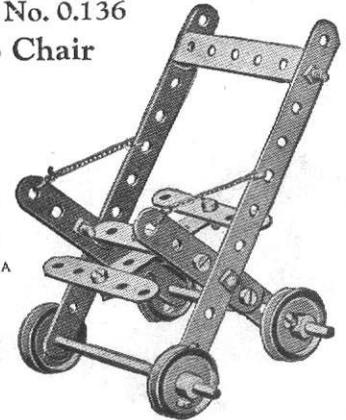

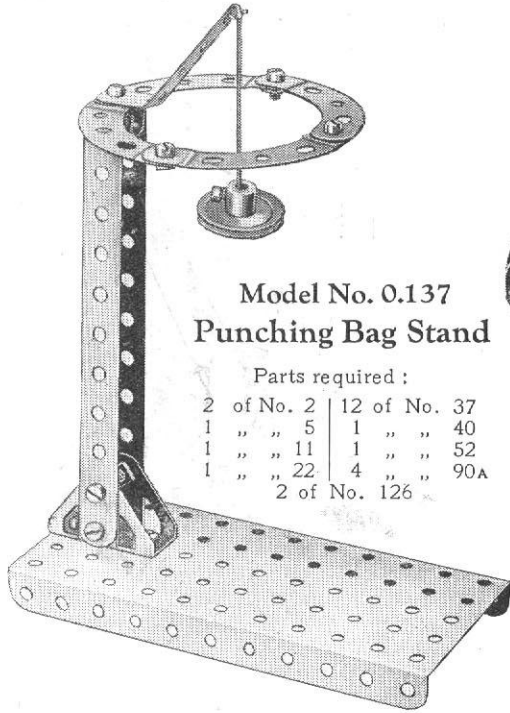

**Model No. 0.137
Punching Bag Stand**

Parts required :

2 of No. 2	12 of No. 37
1 " " 5	1 " " 40
1 " " 11	1 " " 52
1 " " 22	4 " " 90A
	2 of No. 126

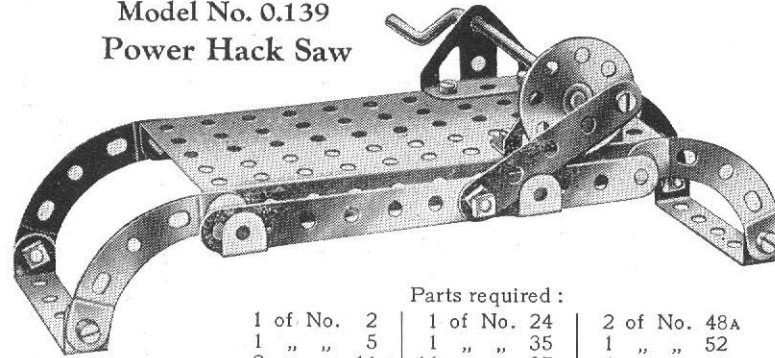

**Model No. 0.139
Power Hack Saw**

Parts required :

1 of No. 2	1 of No. 24	2 of No. 48A
1 " " 5	1 " " 35	1 " " 52
2 " " 11	16 " " 37	4 " " 90A
1 " " 19s	2 " " 37A	2 " " 126

**Model No. 0.141
Junction Signal**

Parts required :

3 of No. 2	2
7 " " 5	5
2 " " 10	10
2 " " 11	11
2 " " 12	12
2 " " 17	17
2 " " 22	22
1 " " 23	23
4 " " 35	35
16 " " 37	37
5 " " 37A	37A
1 " " 40	40
1 " " 52	52
5 " " 111c	111c
1 " " 126A	126A

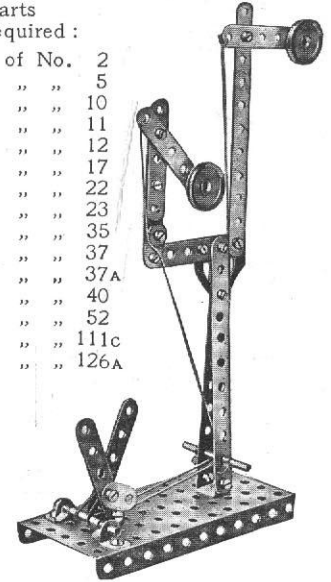

Model No. 0.140 Old Siege Gun

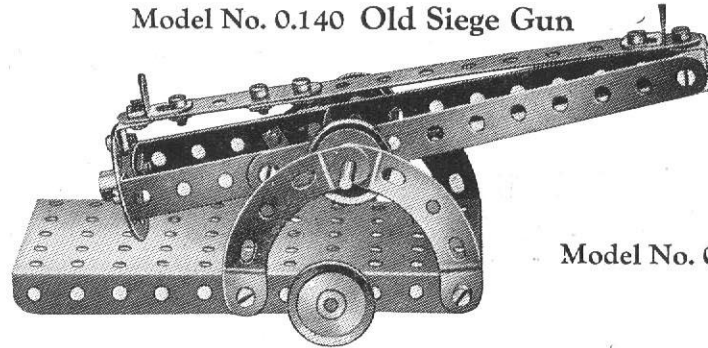

Parts required :

3 of No. 2	1 of No. 24
1 " " 11	16 " " 37
4 " " 12	2 " " 37A
1 " " 15	2 " " 48A
2 " " 16	1 " " 52
4 " " 22	4 " " 90A
	2 of No. 111c

Model No. 0.142 Battleship

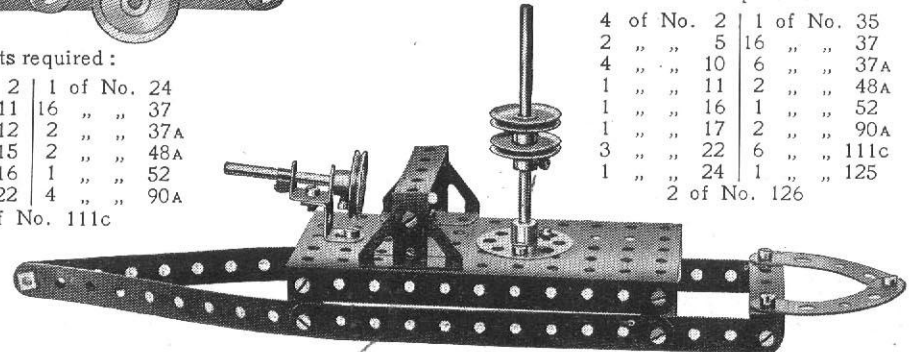

Parts required :

4 of No. 2	1 of No. 35
2 " " 5	16 " " 37
4 " " 10	6 " " 37A
1 " " 11	2 " " 48A
1 " " 16	1 " " 52
1 " " 17	2 " " 90A
3 " " 22	6 " " 111c
1 " " 24	1 " " 125
	2 of No. 126

Model No. 0.138 Sled

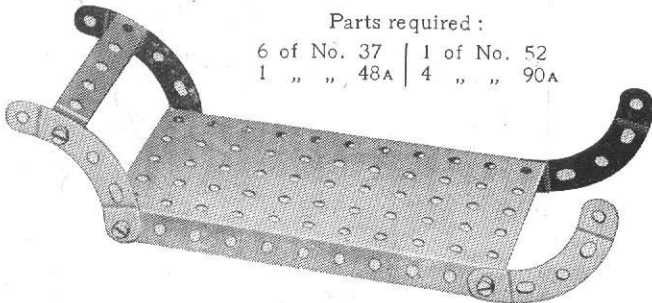

Parts required :

6 of No. 37	1 of No. 52
1 " " 48A	4 " " 90A

Model No. 0.143 Bench Lathe

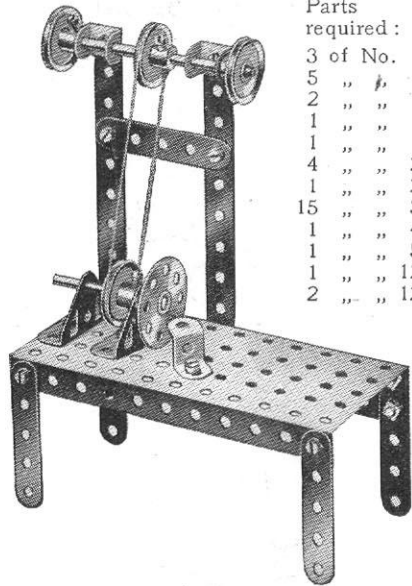

Parts required:
 3 of No. 2
 5 " " 5
 2 " " 11
 1 " " 16
 1 " " 17
 4 " " 22
 1 " " 24
 15 " " 37
 1 " " 40
 1 " " 52
 1 " " 125
 2 " " 126

Model No. 0.145 Sulkey

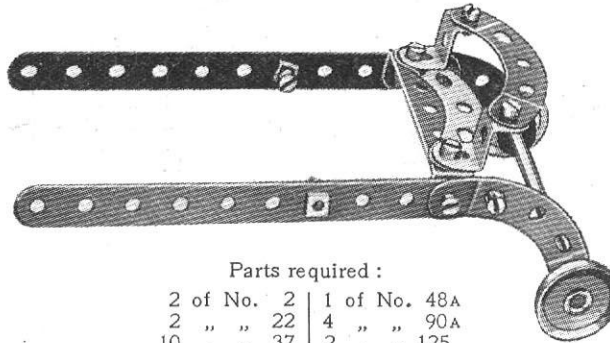

Parts required:
 2 of No. 2 | 1 of No. 48A
 2 " " 22 | 4 " " 90A
 10 " " 37 | 2 " " 125

Model No. 0.147 Punching Machine

Parts required:
 3 of No. 2
 4 " " 5
 2 " " 10
 2 " " 11
 6 " " 12
 1 " " 16
 1 " " 17
 2 " " 22
 2 " " 35
 16 " " 37
 6 " " 37A
 1 " " 48A
 1 " " 52
 6 " " 111c
 2 " " 126

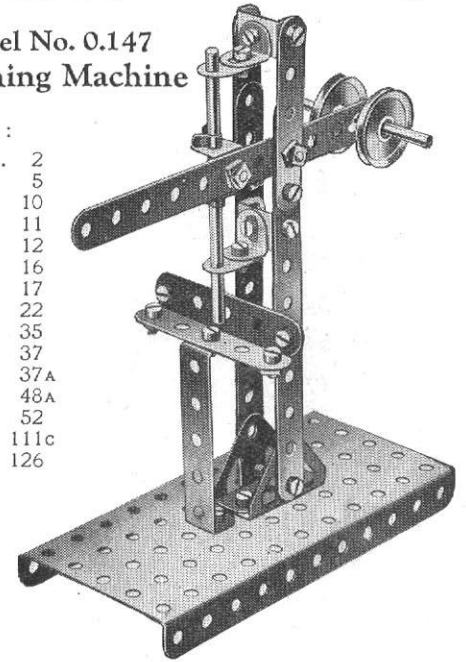

Model No. 0.146 Horizontal Engine

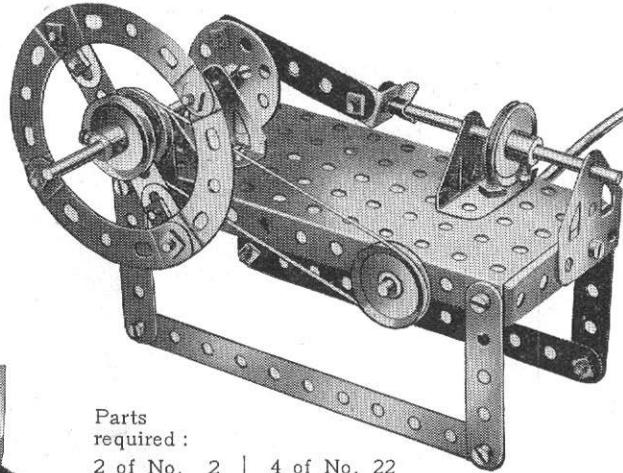

Parts required:
 2 of No. 2 | 4 of No. 22 | 1 of No. 52
 6 " " 5 | 1 " " 24 | 4 " " 90A
 2 " " 10 | 3 " " 35 | 5 " " 111c
 1 " " 12 | 16 " " 37 | 2 " " 126
 2 " " 16 | 5 " " 37A | 2 " " 126A
 1 " " 19s | 1 " " 40 | 2 " " 126A

Model No. 0.144 Bench

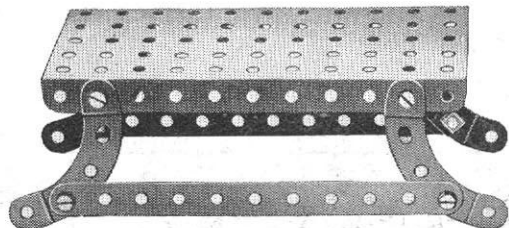

Parts required:
 2 of No. 2 | 1 of No. 52
 8 " " 37 | 4 " " 90A

Model No. 0.148 Bath Chair

Parts required:
 4 of No. 5 | 16 of No. 37
 2 " " 12 | 2 " " 48A
 2 " " 16 | 1 " " 52
 4 " " 22 | 3 " " 90A
 2 of No. 126

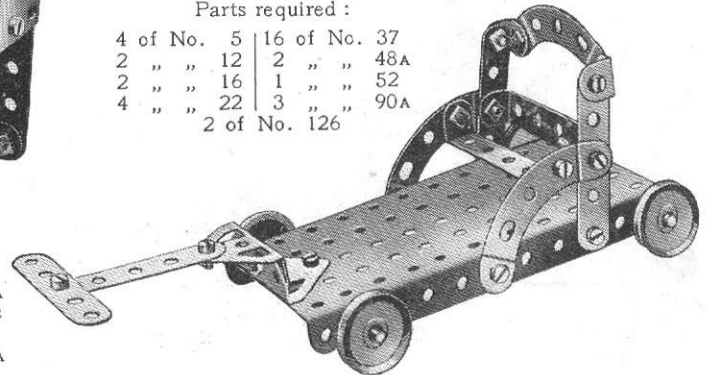

Model No. 0.149
Parallel Bars

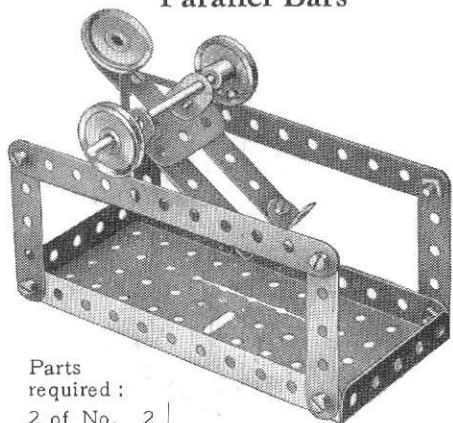

Parts
required :

2 of No. 2		2 of No. 35
6 " " 5		13 " " 37
1 " " 10		1 " " 52
4 " " 12		1 " " 111c
1 " " 16		1 " " 126A
3 " " 22		

Model No. 0.150
Billiard Player

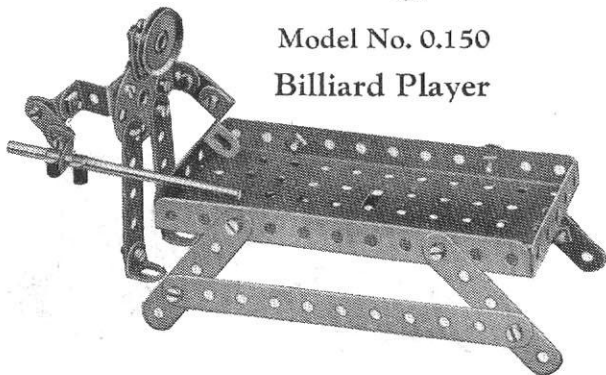

Parts
required :

2 of No. 2	
6 " " 5	
3 " " 10	
5 " " 12	
1 " " 16	
1 " " 22	
1 " " 24	
2 " " 35	
16 " " 37	
5 " " 37A	
5 " " 111c	
2 " " 125	

Model No. 0.151 Candle Shade

Parts
required :

4 of No. 5	
8 " " 12	
1 " " 24	
16 " " 37	
4 " " 90A	



Model No. 0.152
Prehistoric Animal

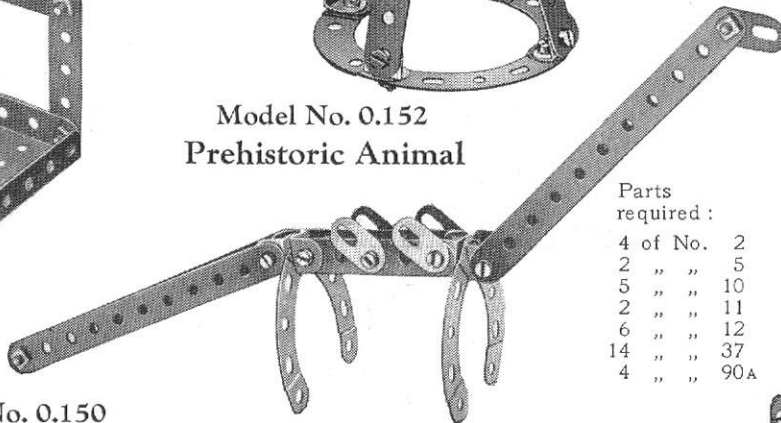

Parts
required :

4 of No. 2	
2 " " 5	
5 " " 10	
2 " " 11	
6 " " 12	
14 " " 37	
4 " " 90A	

Model No. 0.153 Revolving Office Chair

Parts required :

3 of No. 5	2 of No. 37A
1 " " 12	2 " " 48A
1 " " 17	4 " " 90A
2 " " 22	2 " " 111c
1 " " 24	2 " " 126
16 " " 37	1 " " 126A

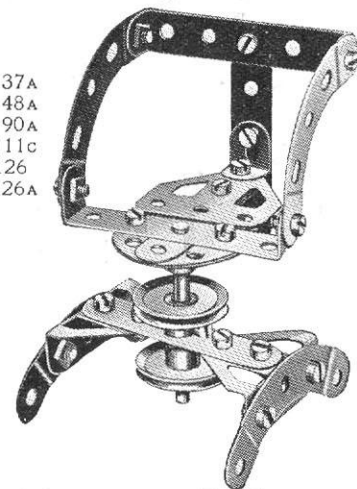

Model No. 0.154 Bridge

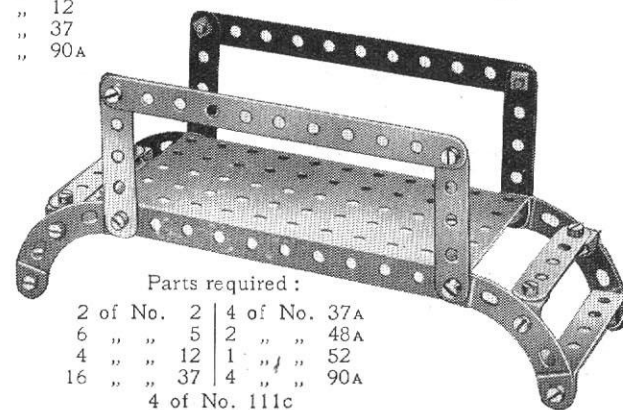

Parts required :

2 of No. 2	4 of No. 37A
6 " " 5	2 " " 48A
4 " " 12	1 " " 52
16 " " 37	4 " " 90A
	4 of No. 111c

HOW TO CONTINUE

This completes our examples of models that may be made with MECCANO Outfit No. 0 (or No. 00 and No. 00A). The next models are a little more advanced, requiring extra parts to construct them. The necessary parts are all contained in a No. 0A Accessory Outfit, the price of which may be obtained from any Meccano dealer.

Model No. 1.1 Jockey Pulley

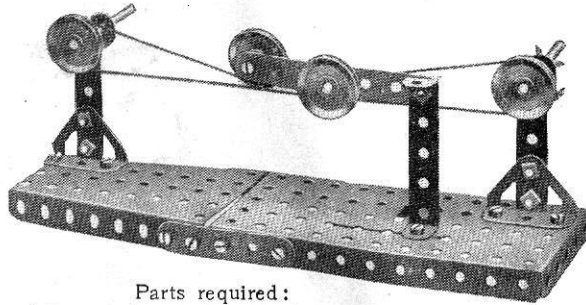

Parts required:

1 of No. 3	2 of No. 35	1 of No. 52
4 " " 5	20 " " 37	1 " " 54
2 " " 17	1 " " 37A	2 " " 111C
4 " " 22	1 " " 48A	2 " " 126

The weight of the pivoted $3\frac{1}{2}$ " Strip, augmented by the 1" fast Pulley Wheel, causes the jockey pulley to press on the belt. Hence the latter is kept always taut.

Model No. 1.5 Belt Gear Right-angle Drive Transmission

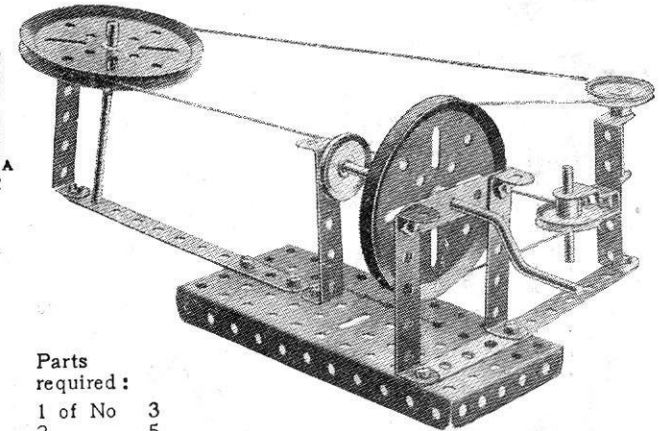

Parts required:

2 of No. 2	3 of No. 22
1 " " 5	1 " " 35
1 " " 16	11 " " 37
1 " " 17	1 " " 44
1 " " 18A	1 " " 48
2 " " 19B	5 " " 48A
1 " " 19s	1 " " 52

Model No. 1.3 Band Brake

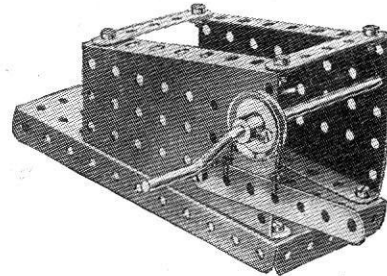

Parts required:

1 of No. 3
2 " " 5
1 " " 19s
1 " " 22
1 " " 35
9 " " 37
1 " " 37A
1 " " 52
2 " " 54

Model No. 1.2 Triangle of Forces

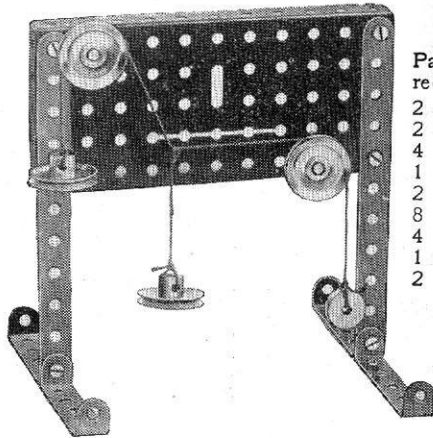

Parts required:

2 of No. 2
2 " " 18A
4 " " 22
1 " " 23
2 " " 35
8 " " 37
4 " " 48A
1 " " 52
2 " " 125

The suspended weights represent three forces acting on a central point. If a triangle is drawn with its sides respectively parallel to the three converging cords, i.e., parallel to the directions of the three forces, the lengths of the sides will be found to be proportional to the respective magnitudes of the forces.

Model No. 1.6 Bacon Slicer

Parts required:

6 of No. 5	2 of No. 22
2 " " 10	1 " " 35
1 " " 16	10 " " 37
1 " " 19B	1 " " 52
1 " " 19s	2 " " 125

Model No. 1.4 "H" Girder

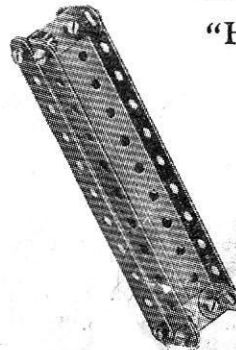

Parts required:

6 of No. 2
2 " " 10
8 " " 12
12 " " 37

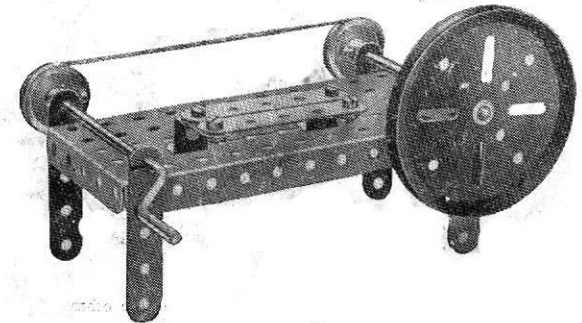

Model No. 1.7

Lever of the Second Order

(Demonstration Model)

- Parts required :
- 2 of No. 2
 - 4 " " 5
 - 1 " " 18A
 - 1 " " 22
 - 1 " " 35
 - 11 " " 37
 - 1 " " 52
 - 1 " " 57
 - 1 " " 125
 - 1 " " 126
 - 1 " " 126A

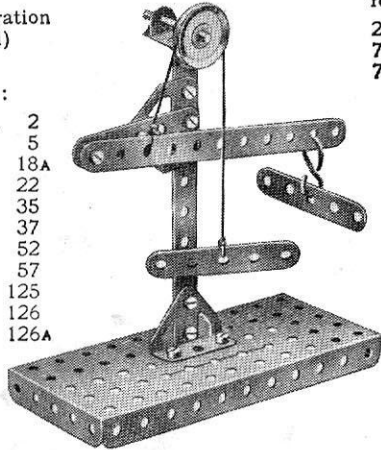

The fulcrum is at one end, the load at the other and the power lies between the two.

Model No. 1.9 Compound Triangulated Truss

- Parts required :
- 2 of No. 1
 - 7 " " 2
 - 7 " " 37

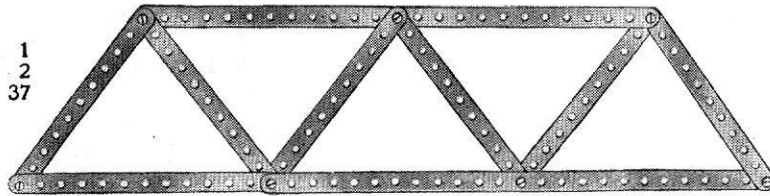

Model No. 1.10 Howe Truss

- Parts required :
- 1 of No. 1
 - 8 " " 2
 - 1 " " 3
 - 7 " " 5
 - 21 " " 37

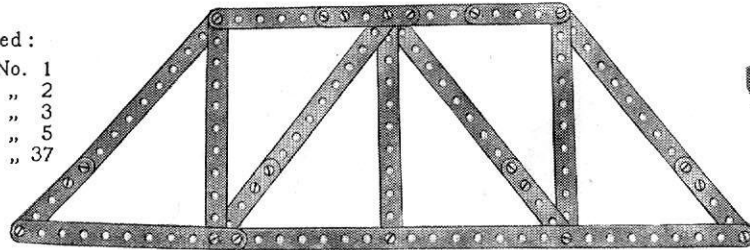

Model No. 1.11 Triangulated Truss

- Parts required :
- 1 of No. 1
 - 2 " " 2
 - 4 " " 5
 - 8 " " 37

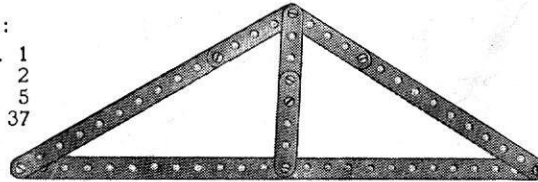

Model No. 1.12 45° Set-Square

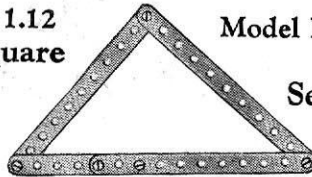

- Parts required :
- 3 of No. 2
 - 1 of No. 3
 - 5 of No. 37

Model No. 1.13 60° Set-Square

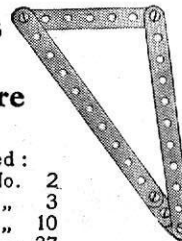

- Parts required :
- 2 of No. 2
 - 1 " " 3
 - 2 " " 10
 - 5 " " 37

Model No. 1.14 Belt Gear

For Reversing Motion of Driven Shaft

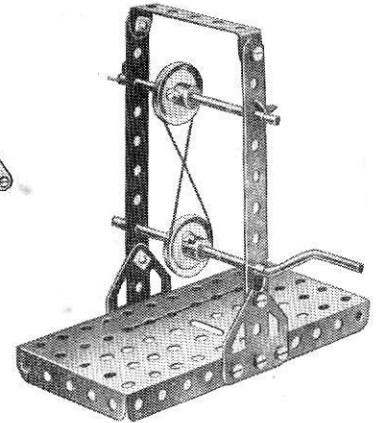

- Parts required :
- | | |
|---------------|-------------|
| 2 of No. 2 | 4 of No. 35 |
| 1 " " 16 | 10 " " 37 |
| 1 " " 19s | 1 " " 48A |
| 2 " " 22 | 1 " " 52 |
| 2 of No. 126A | |

Model No. 1.8

Lever of the Third Order

(Demonstration Model)

- Parts required :
- 2 of No. 2
 - 4 " " 5
 - 1 " " 18A
 - 1 " " 22
 - 1 " " 35
 - 10 " " 37
 - 1 " " 52
 - 1 " " 57
 - 1 " " 125
 - 2 " " 126

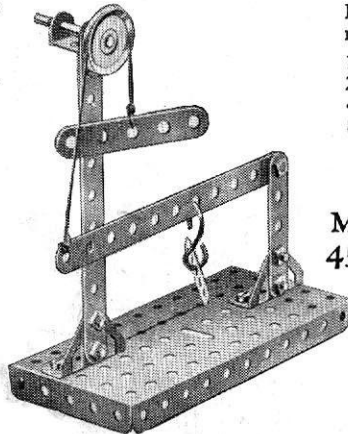

The fulcrum is at one end, the load at the other and the power lies between the two.

Model No. 1.15 Belt Gear

For Driving Shafts at Right Angles

- Parts required :
- 2 of No. 2
 - 1 " " 16
 - 1 " " 19s
 - 2 " " 22
 - 3 " " 35
 - 12 " " 37
 - 1 " " 52
 - 2 " " 126
 - 2 " " 126A

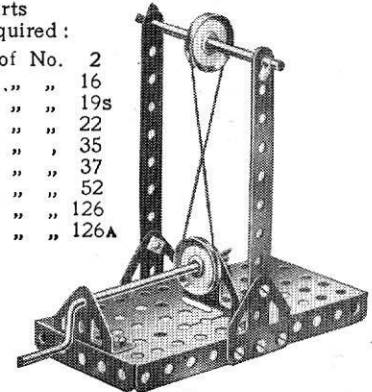

Model No. 1.16 Pulley Block

Demonstration Model:
1 Fixed and 3 Movable Sheaves.
Theoretical Mechanical advantage: 8 to 1

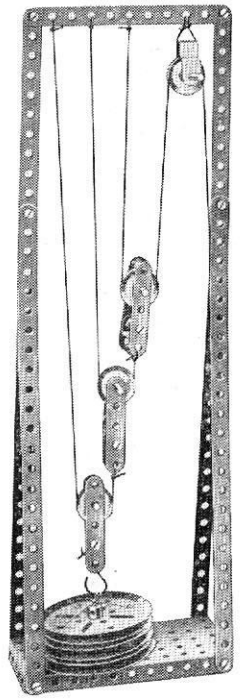

Parts required:

4 of No.	1	2 of No.	18A
3	2	3	19B
6	5	4	22
2	11	15	37
2	12	1	44
2	17	1	52
2	18A	1	57

Model No. 1.17 Pulley Block

Demonstration Model:
3 Fixed and 2 Movable Sheaves.
Theoretical Mechanical advantage: 5 to 1

Parts required:

4 of No.	1	4 of No.	19B
7	2	4	22
6	5	6	35
2	10	22	37
2	11	1	44
2	16	1	52
2	17	1	57
2	18A	2	126A

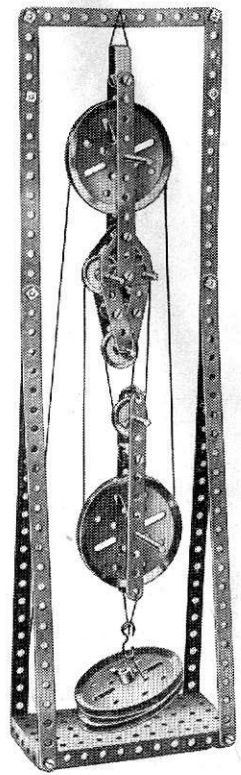

Model No. 1.18 Pulley Block

Demonstration Model:
1 Fixed Sheave and 2 Suspended Blocks.
Theoretical Mechanical advantage: 4 to 1

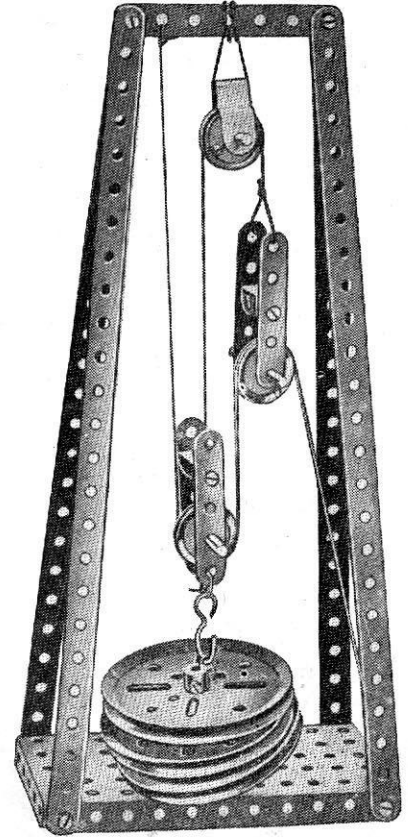

Parts required:

4 of No.	1	4 of No.	19B
1	3	3	22
4	5	10	37
2	11	1	44
1	17	1	52
2	18A	1	57

Model No. 1.19 Belt Gear

Parts required:

2 of No.	2
1	5
2	16
2	19B
1	19s
2	22
8	35
16	37
2	48A
1	52
2	126
2	126A

Drive Transmission
for shafts
not in
line

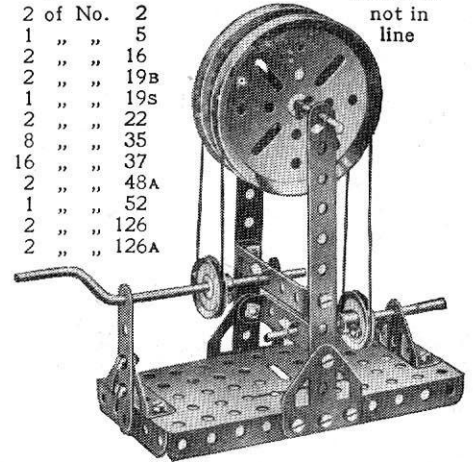

Model No. 1.20 Belt Gear

Parts required:

2 of No.	2
1	12
2	16
2	19B
1	19s
2	22
8	35
15	37
1	48A
1	52
1	54
1	126
2	126A

Obtuse-angle
Drive
Transmission

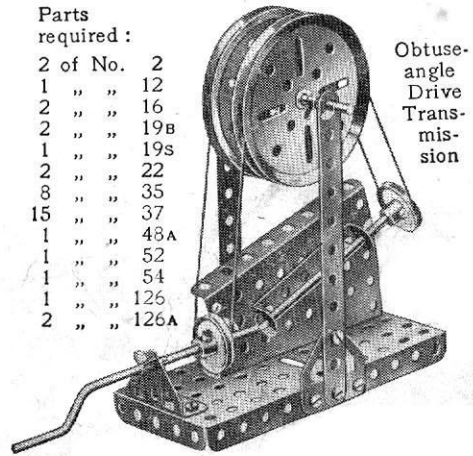

Model No. 1.21 Invalid Chair

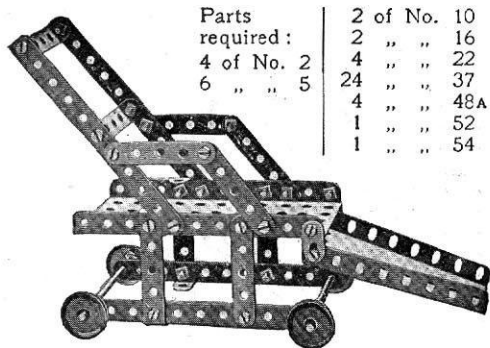

Parts required:	2 of No. 10
2 " " 2	2 " " 16
4 of No. 2	4 " " 22
6 " " 5	24 " " 37
	4 " " 48A
	1 " " 52
	1 " " 54

Model No. 1.22 Letter Balance

6 of No. 2	4 of No. 22	2 of No. 48A
3 " " 5	1 " " 24	1 " " 52
1 " " 10	26 " " 37	2 " " 111c
1 " " 12	4 " " 37A	2 " " 126
2 " " 18A	2 " " 38	2 " " 126A
1 " " 19B	1 " " 44	

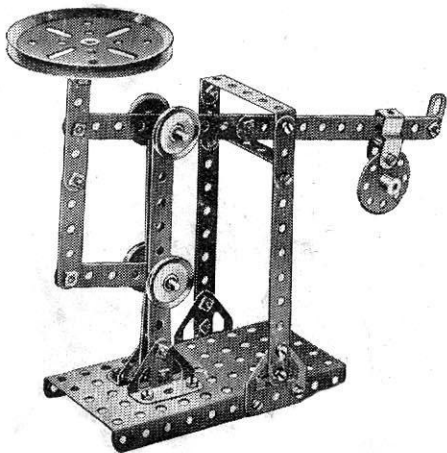

Model No. 1.23 Ticca Gharry

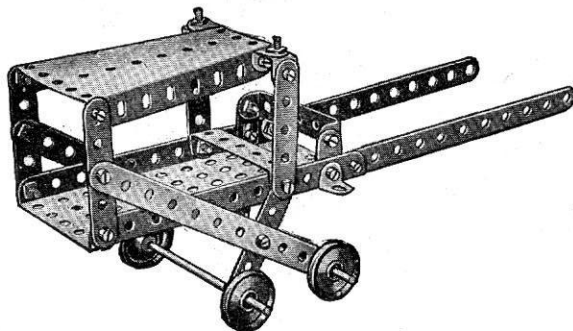

4 of No. 2	6 of No. 12	22 of No. 37
6 " " 5	2 " " 16	1 " " 52
2 " " 10	4 " " 22	1 " " 54

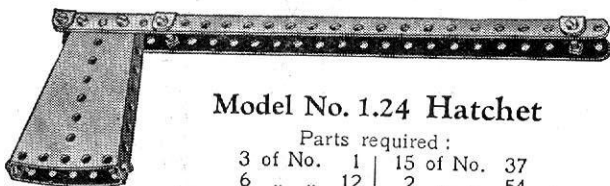

Model No. 1.24 Hatchet

3 of No. 1	15 of No. 37
6 " " 12	2 " " 54

Model No. 1.25 Truck with Sides

Parts required:	4 of No. 2
	4 " " 5
	2 " " 16
	4 " " 22
	2 " " 37
	4 " " 48A
	1 " " 52

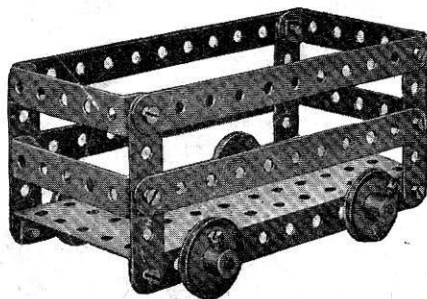

Model No. 1.26 Mechanical Saw

Parts required:		
1 of No. 2	1 of No. 17	4 of No. 38
8 " " 5	3 " " 19s	1 " " 44
1 " " 10	1 " " 22	4 " " 48A
1 " " 11	1 " " 24	1 " " 52
4 " " 12	3 " " 35	2 " " 125
1 " " 16	22 " " 37	1 " " 126A

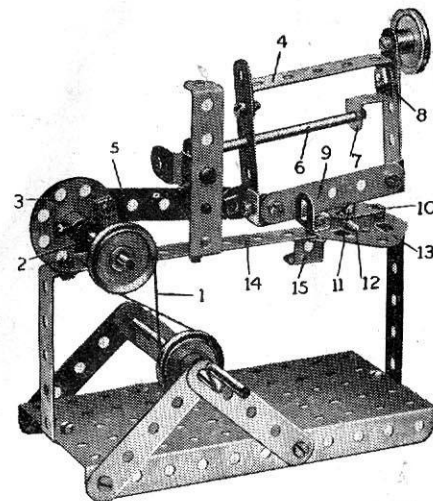

The Strip 9 represents the saw. The Crank Handle drives through a belt 1 a short Rod journalled in a Double Bracket 2 and carrying a Bush Wheel 3. The latter imparts a reciprocating motion to the saw frame 4 through a 2 1/4" Strip 5 loosely mounted on bolts secured to the Bush Wheel and to an Angle Bracket bolted to the saw frame. This frame slides on a 3 1/4" Rod 6, which acts as a guide, passing through the frame and supported in a reversed Angle Bracket 7. A washer is placed on the Bolt 8 behind the Angle Bracket 7. A vice to secure the objects in position for cutting consists of a Flat Bracket 10 mounted on a Bolt 11, a few turns of which causes the Flat Bracket to grip the object 12. The Bolt 11 enters a nut held between the Flat Trunnion 13 and 5 1/4" Strip 14, which are spaced apart for the purpose by washers placed on the two bolts holding the Trunnion in position. The saw frame rests on the stop 15 when not in use. A 1" Pulley secured to the top of the frame acts as a weight and helps to steady the saw.

Model No. 1.27 Dinner Wagon

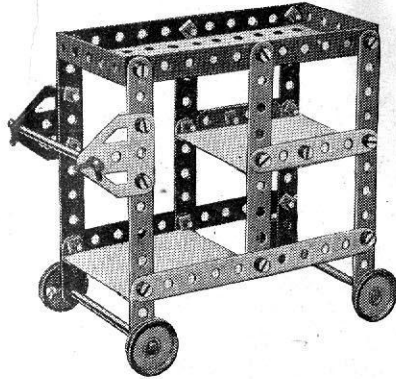

Parts required:

6	of No.	2
8	" "	5
4	" "	12
3	" "	16
4	" "	22
2	" "	35
22	" "	37
4	" "	48A
1	" "	52
2	" "	126A

The two lower platforms are constructed out of pieces of ordinary cardboard, their outer edges resting on 2½" Double Angle Strips and their inner edges on Angle Brackets.

Model No. 1.28 Tip Wagon

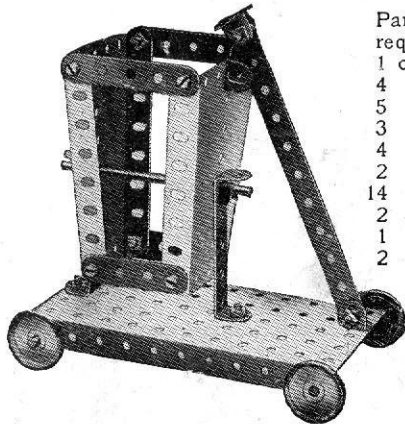

Parts required:

1	of No.	2
4	" "	5
5	" "	12
3	" "	16
4	" "	22
2	" "	35
14	" "	37
2	" "	48A
1	" "	52
2	" "	54

Model No. 1.29 Aeroplane

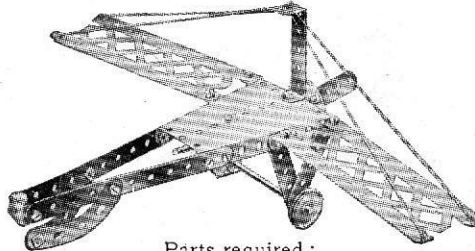

Parts required:

2	of No.	2	2	of No.	16	1	of No.	48A
5	" "	5	2	" "	22	1	" "	54
1	" "	11	1	" "	24	2	" "	90A
6	" "	12	21	" "	37	2	" "	100

Model No. 1.30 Timber Drag

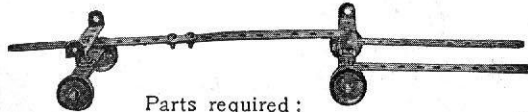

Parts required:

4	of No.	2	2	of No.	16	8	of No.	37
2	" "	11	4	" "	22	4	" "	48A

Model No. 1.31 Lawn Mower

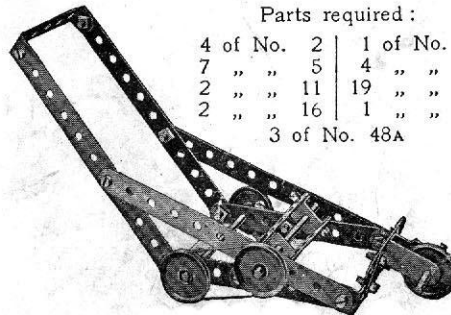

Parts required:

4	of No.	2	1	of No.	17
7	" "	5	4	" "	22
2	" "	11	19	" "	37
2	" "	16	1	" "	44
			3	of No.	48A

Model No. 1.32 Tandem Car

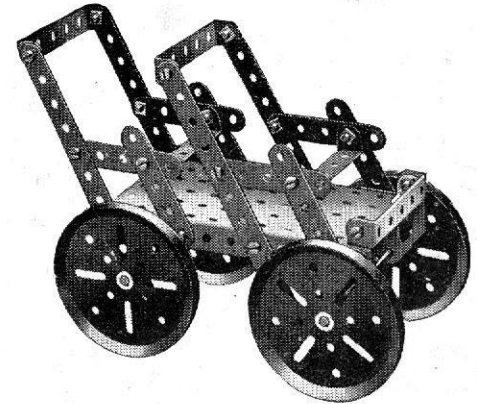

Parts required:

4	of No.	2	26	of No.	37
8	" "	5	5	" "	48A
2	" "	12	1	" "	54
2	" "	16	2	" "	126A
4	" "	19B			

Model No. 1.33 Mechanical Hammer

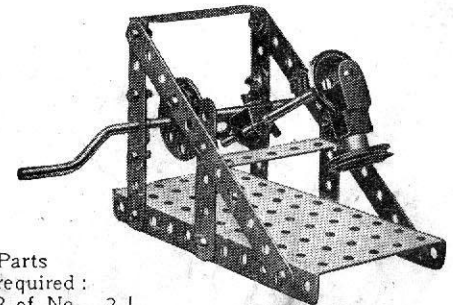

Parts required:

2	of No.	2	1	of No.	19s	18	of No.	37
6	" "	5	2	" "	22	1	" "	44
1	" "	11	1	" "	24	3	" "	48A
1	" "	12	4	" "	35	1	" "	52

Model No. 1.34 Windlass

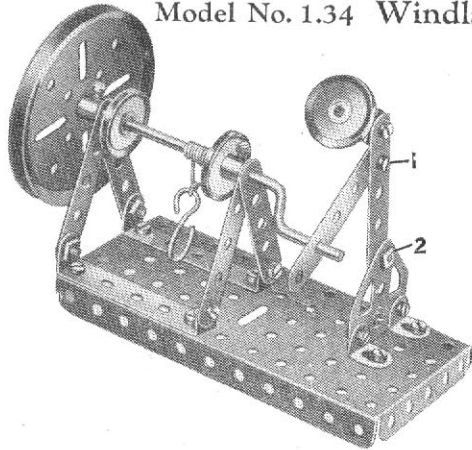

Parts required:

6 of No.	5
3 "	12
1 "	19B
1 "	19S
3 "	22
15 "	37
4 "	37A
2 "	48A
1 "	52
1 "	57
3 "	111c
1 "	126A

The figure at the right of the model is arranged to work to and fro when the Crank Handle is rotated. The Bolts 1 and 2 are both secured by two nuts as in Standard Mechanism No. 262.

Model No. 1.35 Top

Parts required

1 of No. 2	1 of No. 19B
1 " " 16	1 " " 37
1 of No. 125	

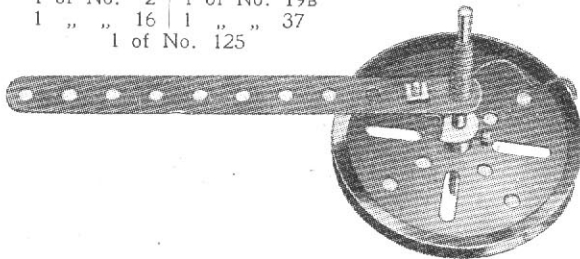

To spin the top wind a length of cord round the rod, as shown, place on a smooth surface and give the cord a sharp pull. When the cord is clear of the rod remove the $5\frac{1}{2}$ " Strip and the top will continue to spin for a considerable period.

Parts required:

4 of No.	2
6 "	5
1 "	10
4 "	12
3 "	16
1 "	17
4 "	22
1 "	23
1 "	24
4 "	35
24 "	37
4 "	37A
3 "	38
2 "	48A
2 "	54
1 "	125
1 "	126A

Model No. 1.36 Cart

Parts required:

2 of No. 2	2 of No. 48A
1 " " 16	1 " " 52
2 " " 19B	2 " " 100
14 " " 37	2 " " 126A

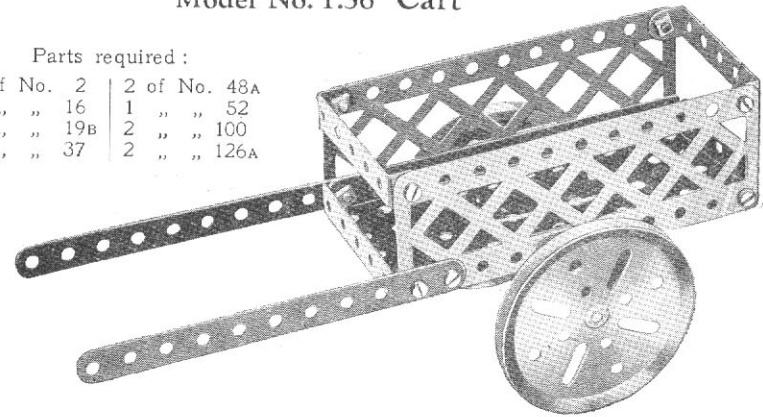

Model No. 1.37 The Invalid

When wheeled along the table the "invalid" appears to push himself energetically along. His neck is a Flat Bracket: his right (or propelling) arm consists of one Angle Bracket and one $\frac{1}{2}$ " Reversed Angle Bracket, and his left arm—the hand of which is bolted loosely to the chair—is formed by three Angle Brackets. The chair is composed principally of two Sector Plates and four $5\frac{1}{2}$ " Strips, and it runs on three 1" Pulley Wheels—one in front and two at the back. One of these (not visible in the illustration) drives by cord another 1" Pulley Wheel, the shaft of which also carries a Bush Wheel 1. As will be seen, a $2\frac{1}{2}$ " Strip is pivoted at one end to this Bush Wheel and at the other end to a second $2\frac{1}{2}$ " Strip 2, which, rocking about an axle journalled through its centre hole, is again pivoted to the invalid's hands.

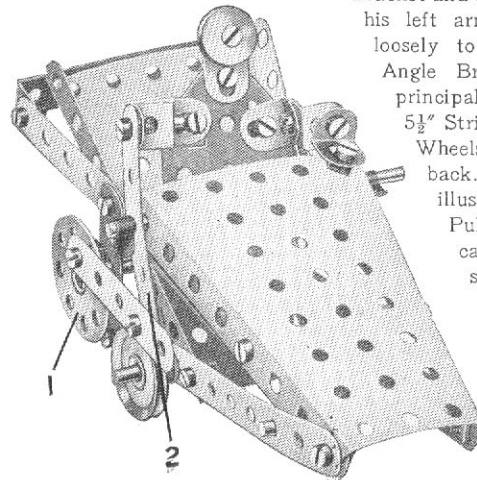

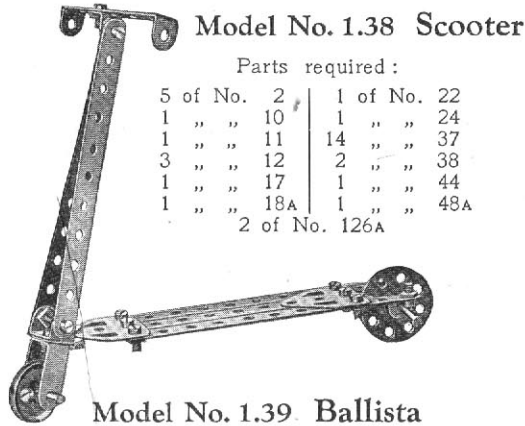

Model No. 1.38 Scooter

Parts required :

5 of No. 2	1 of No. 22
1 " " 10	1 " " 24
1 " " 11	14 " " 37
3 " " 12	2 " " 38
1 " " 17	1 " " 44
1 " " 18A	1 " " 48A
2 of No. 126A	

Model No. 1.40 Tight-Rope Walker

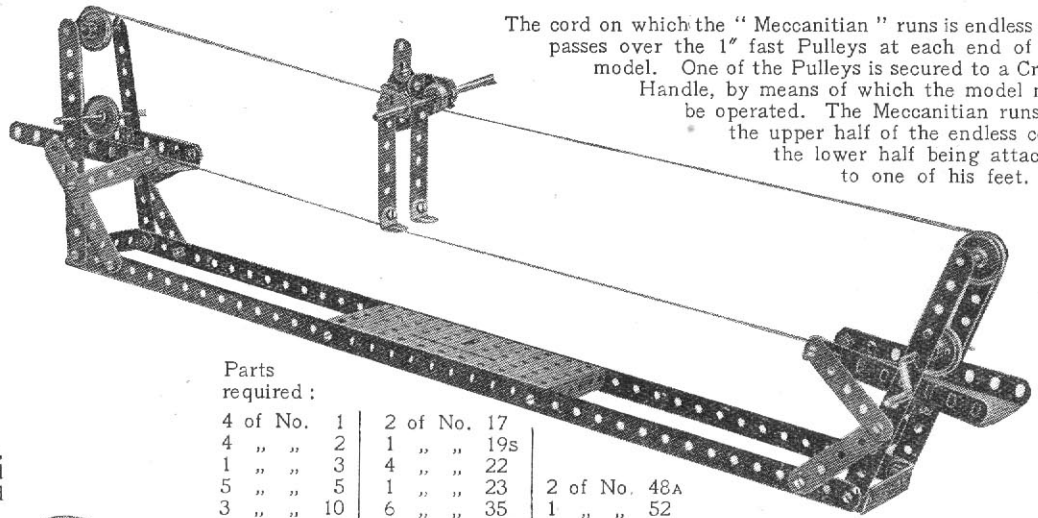

The cord on which the "Meccanitian" runs is endless and passes over the 1" fast Pulleys at each end of the model. One of the Pulleys is secured to a Crank Handle, by means of which the model may be operated. The Meccanitian runs on the upper half of the endless cord, the lower half being attached to one of his feet.

Parts required :

4 of No. 1	2 of No. 17	
4 " " 2	1 " " 19s	
1 " " 3	4 " " 22	
5 " " 5	1 " " 23	2 of No. 48A
3 " " 10	6 " " 35	1 " " 52
4 " " 12	34 " " 37	2 " " 54
2 " " 16	2 " " 38	1 " " 126A

Model No. 1.39 Ballista

This is a model of an ancient engine of war, resembling the crossbow. The 3 1/2" Strip 1 is bolted firmly to the Double Angle Strip 2, which is prevented from turning by the addition of Angle Brackets as shown. A Double Bracket 3 slides on the Strip 1 and is secured to a piece of cord. On rotation of the Crank Handle 4, the Strip 1 is pulled backward until the Double Bracket 3 slips off its end. The Strip then flies forward and strikes the missile, which consists of a 2" Rod placed ready in the Double Bracket 5.

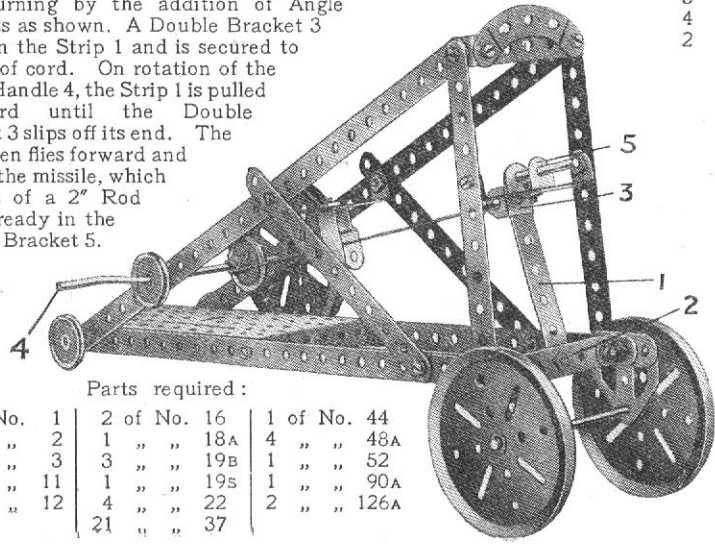

Parts required :

4 of No. 1	2 of No. 16	1 of No. 44
4 " " 2	1 " " 18A	4 " " 48A
1 " " 3	3 " " 19B	1 " " 52
2 " " 11	1 " " 19s	1 " " 90A
2 " " 12	4 " " 22	2 " " 126A
	21 " " 37	

Model No. 1.41 Double-Action Piston Connection

Parts required :

2 of No. 1	1 of No. 23
6 " " 2	1 " " 35
1 " " 3	36 " " 37
5 " " 5	5 " " 37A
4 " " 10	4 " " 48A
2 " " 11	1 " " 52
3 " " 12	1 " " 90A
2 " " 19B	3 " " 111c
1 " " 19s	2 " " 126A

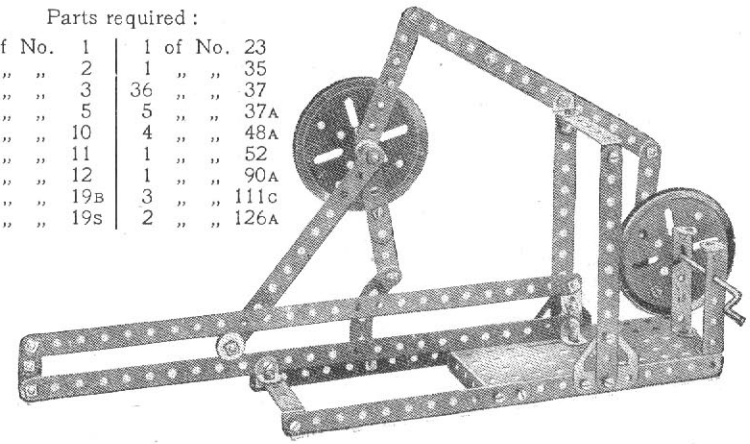

These Models can be built with MECCANO Outfit No. 1 (or No. 0 and No. 0A)

Model No. 1.43 Telfer Span

Parts required :

2 of No. 1	1 of No. 10	1 of No. 23
2 " " 2	1 " " 11	8 " " 35
4 " " 5	2 " " 12	22 " " 37
	3 " " 16	1 " " 44
	1 " " 18A	2 " " 48A
	1 " " 19s	1 " " 52
	4 " " 22	2 " " 54
		1 " " 57
		2 " " 126A

Model No. 1.44 Mountain Transport

Parts required :

2 of No. 1	3 of No. 5	2 of No. 16
2 " " 2	2 " " 11	4 " " 22
	18 of No. 37	1 of No. 52
3 " " 48A	1 " " 54	

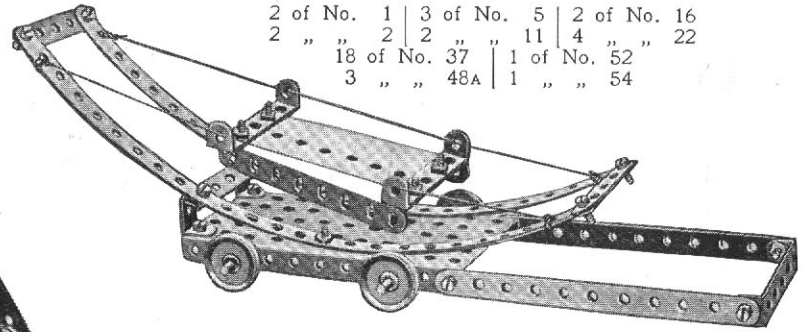

Model No. 1.42 Ladder on Wheels

Parts required :

4 of No. 1	16 of No. 37
2 " " 16	6 " " 48A
4 " " 22	1 " " 52

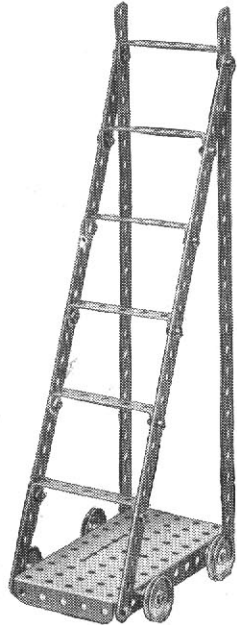

This model will provide many hours of enjoyment. The cords may be made to any length to allow the load to be carried from one side of the room to the other, and, if necessary, a better grip may be obtained by winding the operating cord twice round the Pulley on the Crank Handle. The open sides of the bucket may be closed with cardboard so that it may be loaded with marbles, beads, etc. The bed of the Telfer may be screwed on to a solid base with ordinary wood screws to give better support. The Pulley Bracket, and that securing the cord on which the bucket travels should be screwed in a suitable position on the opposite side of the room.

Model No. 1.45 Tower Wagon

Parts required :

4 of No. 2
8 " " 5
2 " " 16
1 " " 17
1 " " 19s
4 " " 22
1 " " 23
4 " " 35
24 " " 37
1 " " 52
1 " " 54
1 " " 57
2 " " 126A

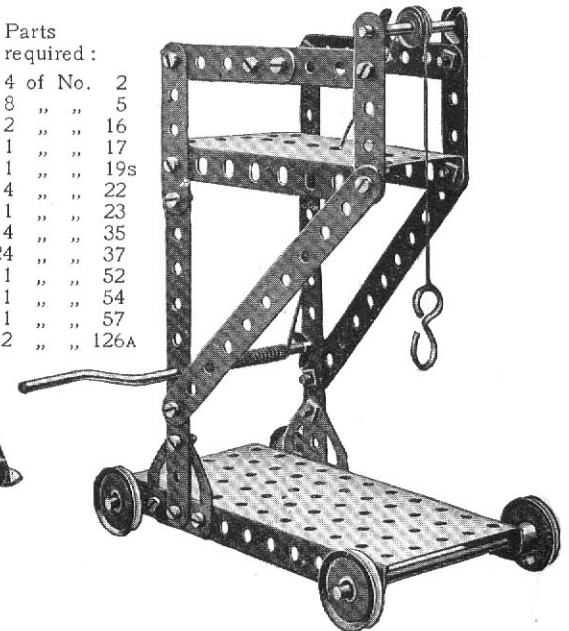

Model No. 1.46 Bow and Arrow

Parts required:
1 of No. 1 | 1 of No. 16



Model No. 1.47 Friction Grip Tong

The hoisting cord is attached to the Double Bracket 1. The joints 2, 3 are lock-nutted, so that when the grip is raised the $\frac{1}{2}$ " loose Pulley Wheel 4 slides upward between the $2\frac{1}{2}$ " Strips 5, and the grip closes upon the block of wood or other material placed between its jaws.

Parts required:

3 of No. 2		1 of No. 11
8 " " 5		1 " " 23
4 " " 10		2 " " 35
12 of No. 37		

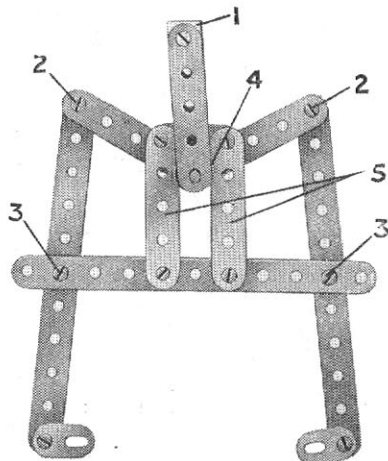

Model No. 1.48 Cum Bak

Parts required:
1 of No. 18A
2 " " 19B
2 " " 22
1 " " 23
1 " " 35
8 " " 37
4 " " 48A

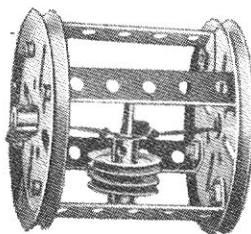

A short length of elastic is doubled and stretched between the centres of the 3" Pulley Wheels. A weight, consisting of two 1" fast Pulley Wheels and a $1\frac{1}{2}$ " Rod, is suspended from it in the middle of the drum. When the Cum Bak is rolled along any smooth level surface, the elastic becomes twisted and stores up sufficient energy to return the drum to its starting point. If the mechanism is concealed by a thin cardboard covering, the model will cause much amusement by its mystifying behaviour.

Model No. 1.49 Aeroplane

Parts required:
4 of No. 2
6 " " 5
4 " " 10
2 " " 11

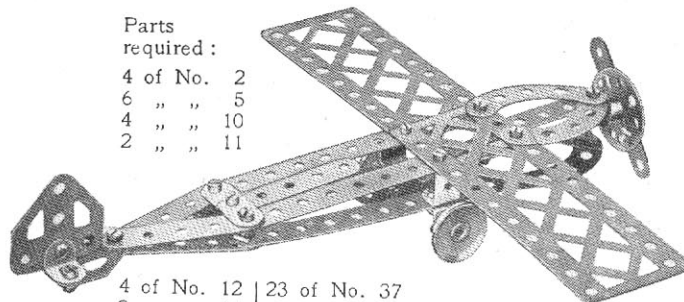

4 of No. 12		23 of No. 37
2 " " 16		1 " " 48A
1 " " 22		4 " " 90A
1 " " 24		2 " " 100
1 " " 35		2 " " 126A

Model No. 1.50 Gangway

Parts required:

4 of No. 2		1 of No. 16		22 of No. 37		2 of No. 100
2 " " 5		1 " " 22		4 " " 48A		1 " " 111c
3 " " 10		1 " " 23		1 " " 52		2 " " 126A
1 " " 12		4 " " 35		1 " " 54		

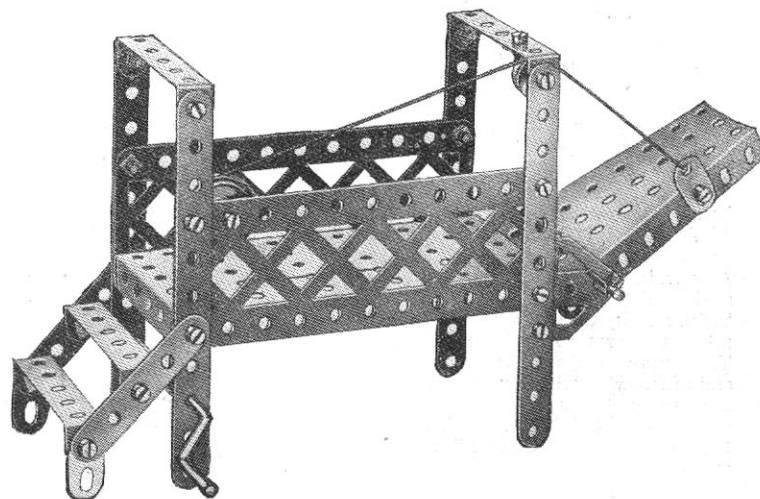

Model No. 1.51

Automatic Signal

Parts required:

2	of No.	1
1	" "	2
1	" "	5
1	" "	11
1	" "	12
1	" "	17
1	" "	18A
4	" "	22
1	" "	24
22	" "	37
2	" "	37A
1	" "	38
1	" "	48A
1	" "	52
1	" "	90A
3	" "	111c
2	" "	126
2	" "	126A

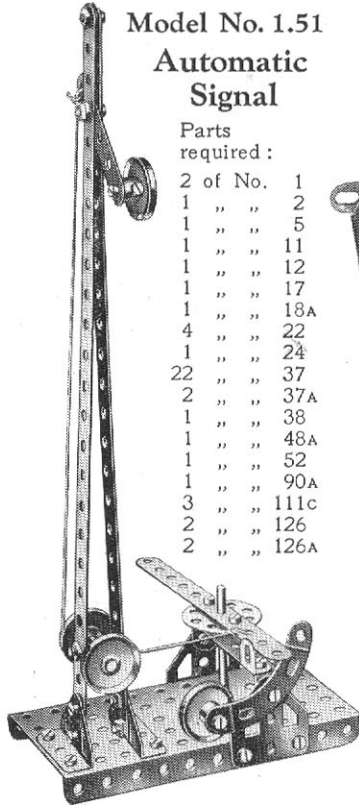

The weighted curved Strip normally holds the end of the 5½" Strip against an Angle Bracket, allowing the signal arm to fall to the "all clear" position. Any train passing the signal however, strikes the opposite end of the 5½" Strip, and by means of the cord shown, raises the arm to indicate "danger." The Curved Strip moves to allow the end of the 5½" Strip to pass over it, and is returned to its original position by reason of its weighted end. The signal then remains at "danger" until the mechanism is re-set.

Model No. 1.52 Horse and Cart

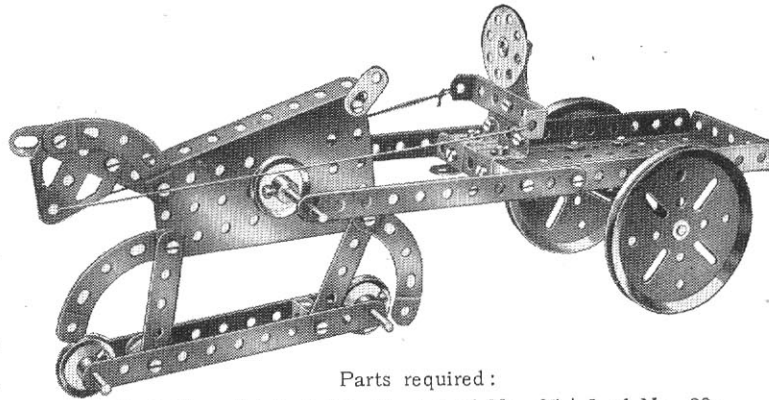

Parts required:

4	of No.	2	2	of No.	16	2	of No.	35	3	of No.	90A
3	" "	5	2	" "	18A	26	" "	37	1	" "	111c
3	" "	10	2	" "	19B	1	" "	48A	2	" "	125
2	" "	11	4	" "	22	1	" "	52	2	" "	126
2	" "	12	1	" "	24	1	" "	54	2	" "	126A

Model No. 1.53 Drill

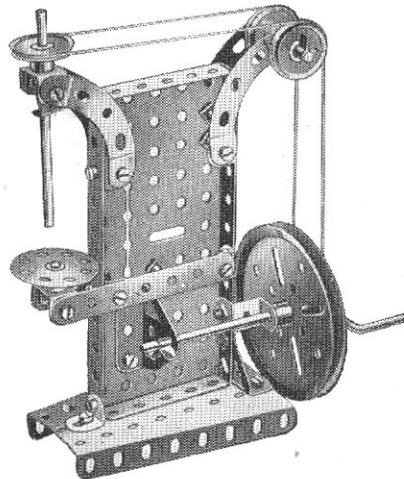

Parts required:

1	of No.	3
2	" "	11
6	" "	12
1	" "	16
1	" "	18A
1	" "	19B
1	" "	19S
4	" "	22
1	" "	24
2	" "	35
27	" "	37
1	" "	52
1	" "	54
4	" "	90A
1	" "	125
2	" "	126

Model No. 1.54 Patent Luffing Crane

The hoisting cord 1 is operated by the Crank Handle 2. It passes over the 1" Pulley 3, round the 1" Pulley 4 at the jib head, back and round a third 1" Pulley 5, and then over the ½" loose Pulley 6 at the jib head and down to the hook. With this arrangement it will be found that the load remains at a constant height when the jib is luffed. The luffing cords 7 are attached to the jib head, passed over the 2" Rod carrying the Pulleys 3 and 5, and wound on to the luffing winch 8.

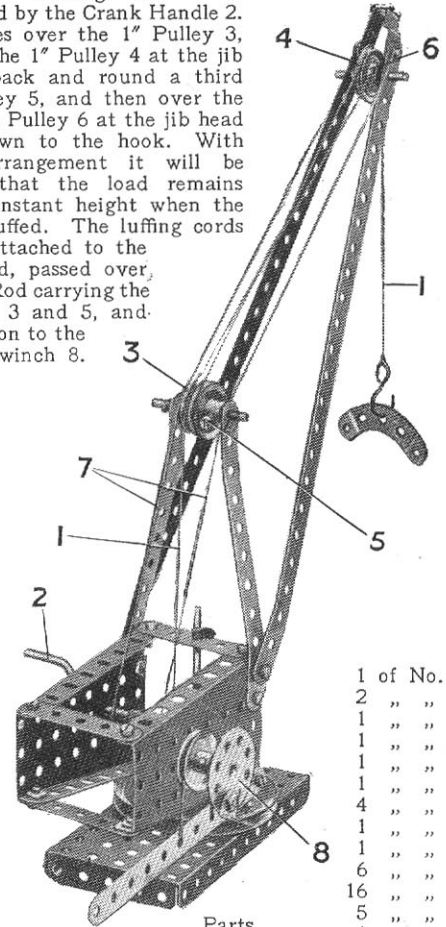

1	of No.	12
2	" "	16
1	" "	17
1	" "	18A
1	" "	19B
1	" "	19S
4	" "	22
1	" "	23
1	" "	24
6	" "	35
16	" "	37
5	" "	38
1	" "	44
1	" "	52
2	" "	54
3	" "	57
4	" "	111c

Parts required:

2	of No.	1
3	" "	2
4	" "	5

Model No. 1.55 Revolving Tricyclist

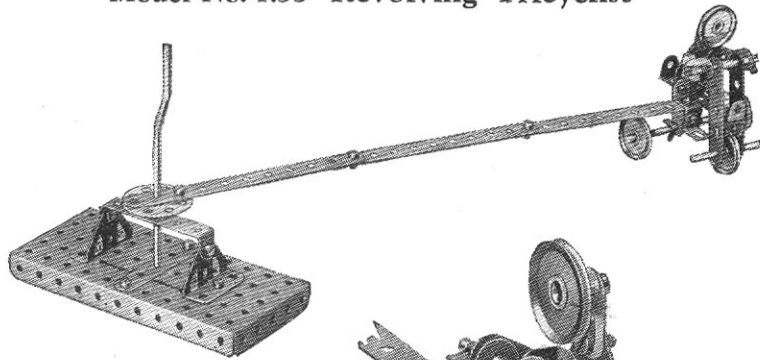

Parts required :

3 of No. 2	1 of No. 24
3 " " 5	5 " " 35
3 " " 10	25 " " 37
1 " " 11	1 " " 44
5 " " 12	2 " " 48A
1 " " 16	1 " " 52
2 " " 17	2 " " 125
1 " " 19s	2 " " 126
4 " " 22	1 " " 126A

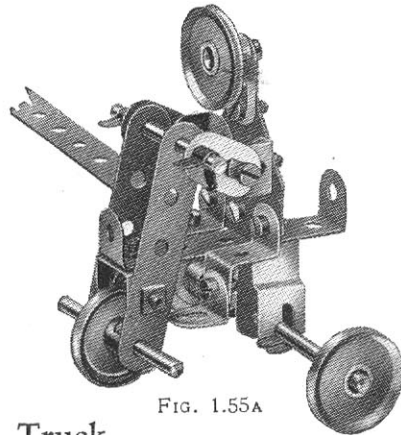
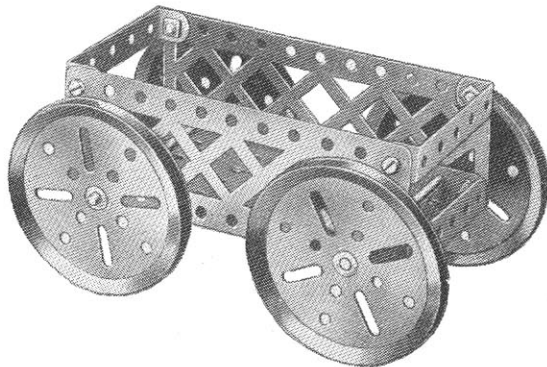

FIG. 1.55A

Model No. 1.56 Truck



Parts required :

2 of No. 16
4 " " 19B
8 " " 37
2 " " 48A
1 " " 52
2 " " 100

Model No. 1.57 Steam Shovel

Parts required :

5 of No. 2	1 of No. 52
1 " " 11	1 " " 54
1 " " 12	1 " " 111c
2 " " 16	1 " " 126
2 " " 18A	2 " " 126A
1 " " 19s	
4 " " 22	
1 " " 23	
6 " " 35	
12 " " 37	
2 " " 37A	
2 " " 38	

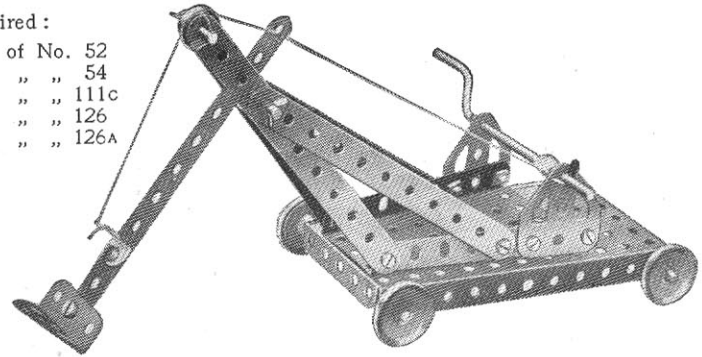

Model No. 1.58 Cot on Wheels

Parts required :

2 of No. 2
5 " " 5
4 " " 12
2 " " 16
4 " " 22
19 " " 37
2 " " 48A
1 " " 52
4 " " 90A
2 " " 100

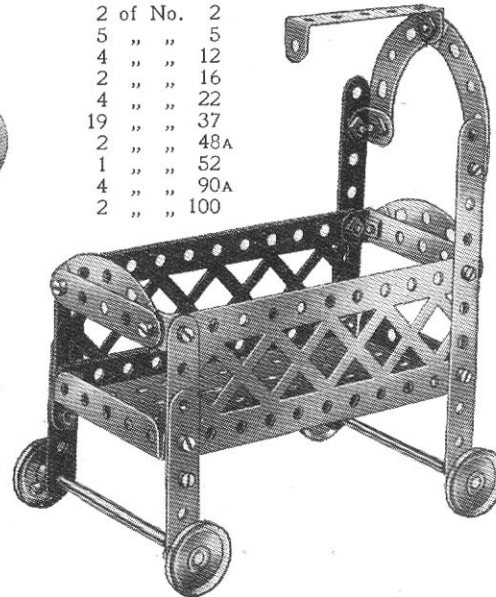

Model No. 1.59 Chair

Parts required :

2 of No. 2
8 " " 5
2 " " 10
22 " " 37
6 " " 48A
1 " " 52
3 " " 90A

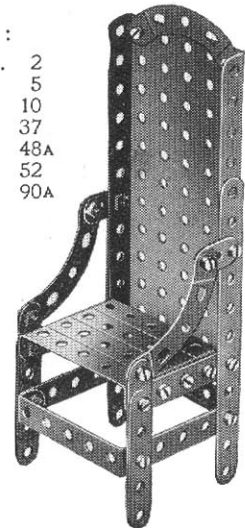

These Models can be built with MECCANO Outfit No. 1 (or No. 0 and No. 0A)

Model No. 1.60

Swivelling
Crane

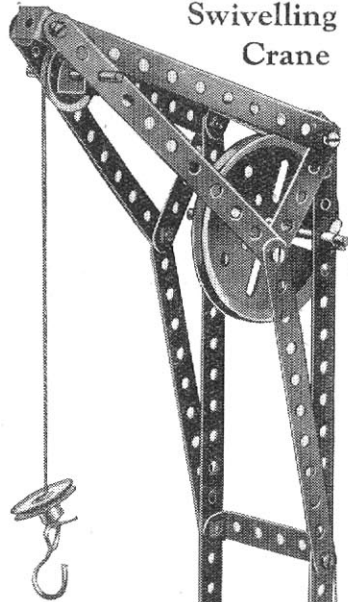

Parts
required :

2 of No.	1
6 " "	5
4 " "	10
8 " "	12
2 " "	16
2 " "	17
2 " "	22
6 " "	35
28 " "	37
4 " "	48A
2 " "	111c
2 " "	126A

Parts
required :

2 of No.	1
6 " "	2
6 " "	5
2 " "	11
1 " "	12
1 " "	16
1 " "	17
3 " "	19B
1 " "	19s
4 " "	22
1 " "	24
2 " "	35
25 " "	37
1 " "	37A
	2 of No. 48A
	1 " " 52
	2 " " 54
	1 of No. 57
	2 " " 90A
	1 " " 111c

Model No. 1.61 Spinning Buttons

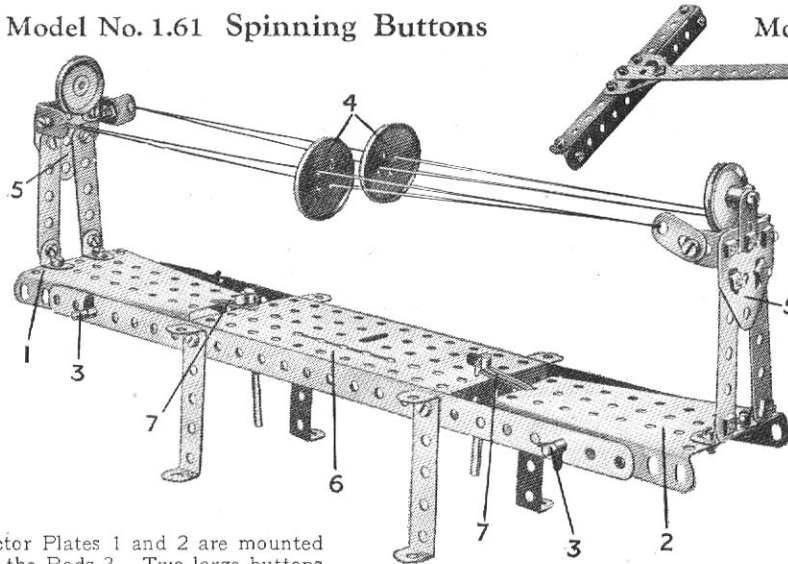

The Sector Plates 1 and 2 are mounted pivotally on the Rods 3. Two large buttons 4 are placed on lengths of thread or thin elastic stretched between the arms of the Meccanitions 5. Start the model as follows: twist the threads a little with your fingers, pull the Meccanitions outward, then release them sharply. As soon as the buttons are spinning a slight downward touch on the feet of each Meccanition is sufficient to keep them going. The ends of the Sector Plates 1 and 2 are connected to the Flanged Plate 6 by means of pieces of elastic 7.

Model No. 1.62 Safety Catch for Winding Gear

Parts
required :

2 of No.	5
1 " "	19s
1 " "	24
1 " "	35
8 " "	37
1 " "	37A
1 " "	52
2 " "	54
1 " "	111c

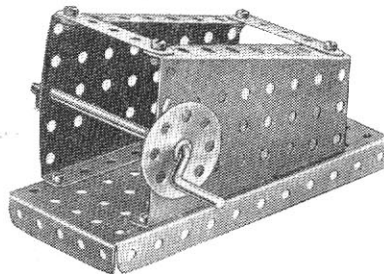

The hoisting cord of a crane, etc., may be wound on the shaft of the Crank Handle. To lock the handle in position, the Bush Wheel should be pushed inward so that one of its holes engages with the shank of a $\frac{3}{8}$ " Bolt projecting from the Sector Plate.

Model No. 1.63 Large Rake

Parts required :

1 of No.	1	2 of No.	12
2 " "	2	8 " "	37
		1 of No.	126A

Model No. 1.64
Man Climbing Pole

Parts
required :

2 of No.	1
5 " "	10
1 " "	11
6 " "	12
1 " "	18A
3 " "	22
26 " "	37
4 " "	48A
1 " "	52
2 " "	125
2 " "	126
1 " "	126A

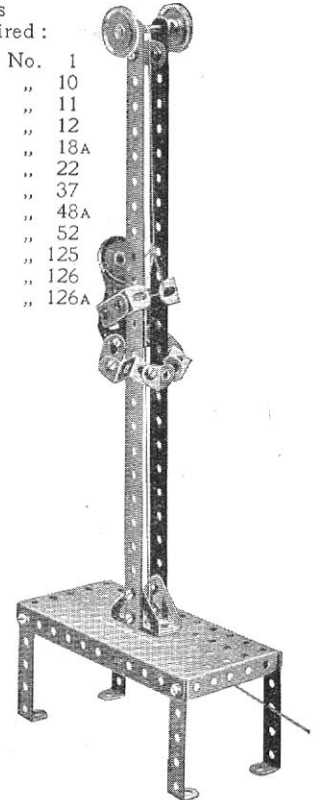

Model No. 1.65 Seismograph

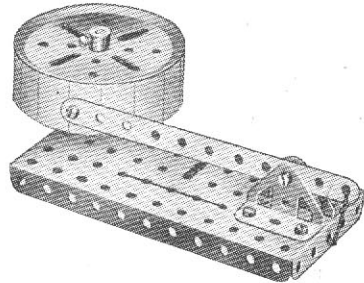

- Parts required:
- | | |
|----------|------|
| 1 of No. | 2 |
| 1 " " | 11 |
| 1 " " | 17 |
| 2 " " | 19B |
| 6 " " | 37 |
| 1 " " | 37A |
| 1 " " | 52 |
| 1 " " | 111c |
| 2 " " | 126 |
- and a short length of elastic

Model No. 1.66 Jib Crane

Parts required:

- | | |
|----------|-----|
| 4 of No. | 1 |
| 6 " " | 2 |
| 1 " " | 3 |
| 1 " " | 5 |
| 2 " " | 11 |
| 3 " " | 12 |
| 1 " " | 16 |
| 2 " " | 17 |
| 1 " " | 19B |
| 1 " " | 19s |
| 4 " " | 22 |
| 1 " " | 24 |
| 23 " " | 37 |
| 1 " " | 48 |
| 1 " " | 52 |
| 2 " " | 54 |
| 1 " " | 57 |

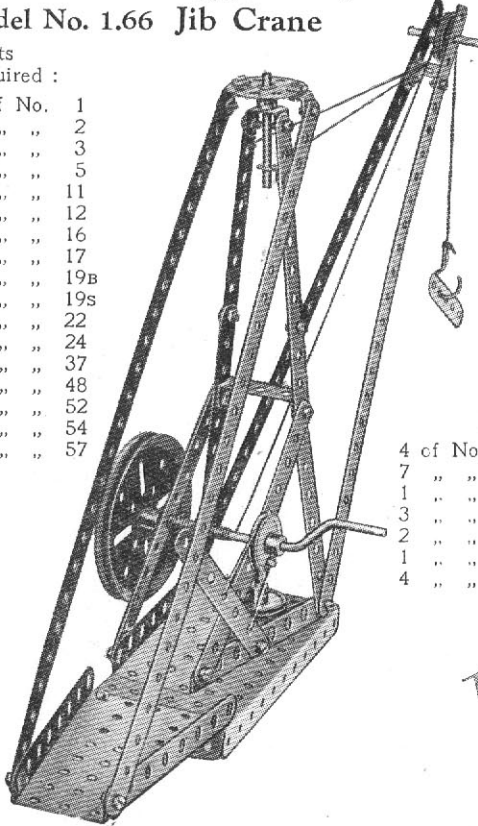

Model No. 1.67 Centrifugal Governor

Parts required

- | | |
|----------|------|
| 2 of No. | 5 |
| 2 " " | 10 |
| 2 " " | 11 |
| 2 " " | 12 |
| 6 " " | 16 |
| 1 " " | 19B |
| 1 " " | 19s |
| 4 " " | 22 |
| 1 " " | 24 |
| 3 " " | 35 |
| 18 " " | 37 |
| 6 " " | 37A |
| 4 " " | 38 |
| 2 " " | 111c |
| 2 " " | 126 |

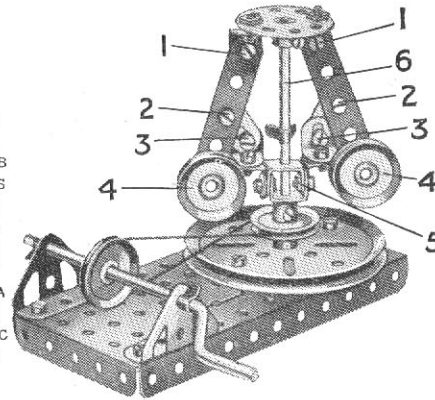

The 3" Pulley Wheel is bolted to the 5½" x 2½" Flanged Plate as shown, and the Rod 6 is free to rotate in its boss. The Bolts 1, 2, 3, are provided with lock-nuts. When the engine to which the governor is attached works at too great a speed, the 1" fast Pulley Wheels 4 fly outward and lift the two Double Brackets 5. In actual practice this movement is utilised to close the engine valves and so reduce speed.

Model No. 1.68 Stone-Sawing Machine

Parts required:

- | | | | |
|----------|-----|----------|------|
| 4 of No. | 1 | 1 of No. | 24 |
| 7 " " | 2 | 6 " " | 35 |
| 1 " " | 3 | 28 " " | 37 |
| 3 " " | 5 | 4 " " | 37A |
| 2 " " | 16 | 6 " " | 48A |
| 1 " " | 19s | 2 " " | 126A |
| 4 " " | 22 | | |

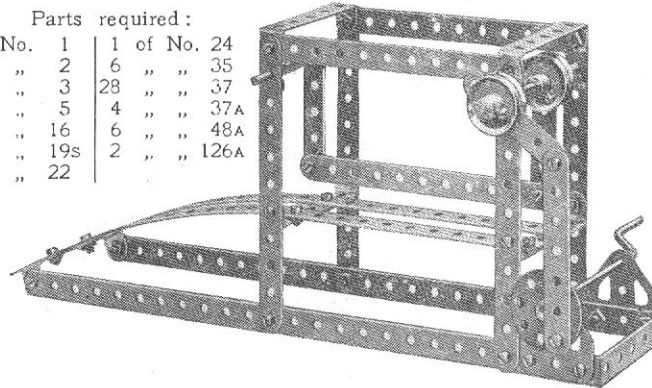

Model No. 1.69 Elevated Crane

Parts required:

- | | | | |
|----------|-----|----------|------|
| 2 of No. | 1 | 1 of No. | 52 |
| 8 " " | 2 | 2 " " | 54 |
| 8 " " | 5 | 1 " " | 57 |
| 1 " " | 11 | 4 " " | 90A |
| 2 " " | 16 | 2 " " | 126 |
| 1 " " | 18A | 2 " " | 126A |
| 3 " " | 19B | | |
| 1 " " | 19s | | |
| 4 " " | 22 | | |
| 1 " " | 23 | | |
| 1 " " | 24 | | |
| 3 " " | 35 | | |
| 3 " " | 37 | | |
| 3 " " | 38 | | |
| 6 " " | 48A | | |

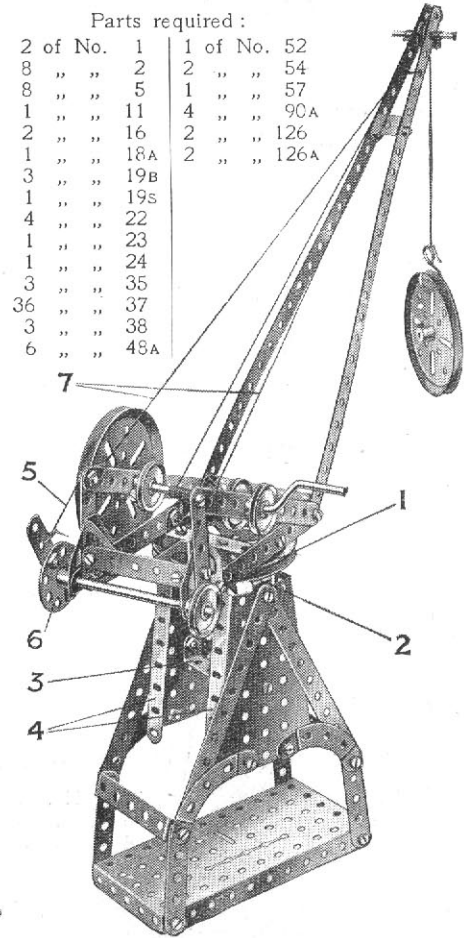

The base of the swivelling portion of the crane consists of a 3" Pulley Wheel 1, which has a 3½" Axle Rod nipped in its boss. The Rod is journaled in two 2½" Double Angle Strips 2 and 3 secured between the Sector Plates 4. The brake cord 5 passes round the 3" Pulley as shown, and is tied to one of the holes in the Bush Wheel 6. The cords 7 serve merely to support the weight of the jib.

Model No. 1.70 Rowing Boat

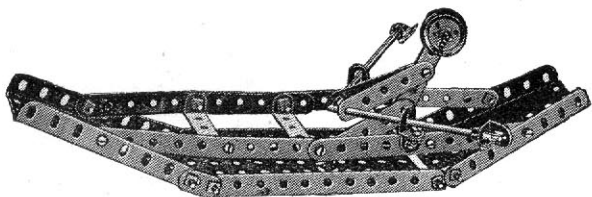

Parts required:

4 of No. 2	4 of No. 35
4 " " 5	24 " " 37
4 " " 10	3 " " 48A
7 " " 12	1 " " 52
2 " " 16	2 " " 54
1 " " 22	1 " " 111c

Model No. 1.71 The Wrestlers

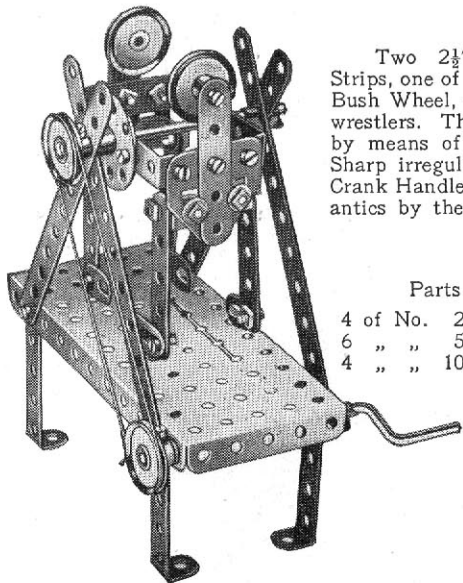

Two $2\frac{1}{2}'' \times \frac{1}{2}''$ Double Angle Strips, one of which is bolted to the Bush Wheel, form the arms of the wrestlers. The legs are all pivoted by means of bolts and lock-nuts. Sharp irregular movements of the Crank Handle will result in amusing antics by the wrestlers.

Parts required:

4 of No. 2	4 of No. 12
6 " " 5	1 " " 16
4 " " 10	1 " " 19S
	4 " " 22
	1 " " 24
	3 " " 35
	24 " " 37
	5 " " 38
	6 " " 48A
	1 " " 52
	2 " " 111c
	2 " " 126A

Model No. 1.72
Weather Vane

Parts required:

3 of No. 1	14 of No. 37
2 " " 2	1 " " 52
1 " " 11	1 " " 54
2 " " 12	1 " " 111c
1 " " 24	2 " " 126

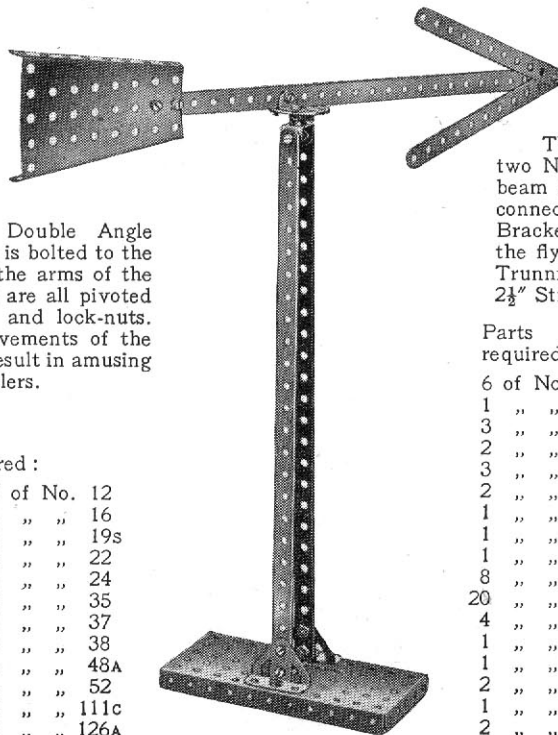

Model No. 1.73 Violin and Bow

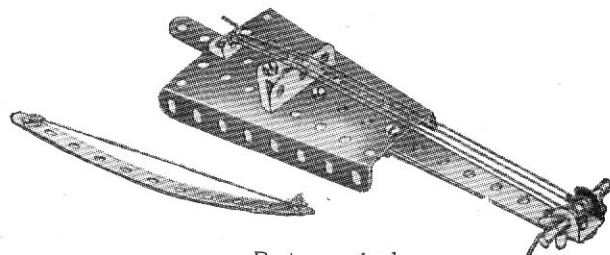

Parts required:

4 of No. 2	1 of No. 12	5 of No. 37
1 " " 5	1 " " 18A	1 " " 54
1 " " 11	2 " " 35	1 " " 126

Model No. 1.74 Beam Engine

The connecting Strip 1 is attached pivotally by a Bolt and two Nuts (Standard Mechanism No. 262) to one end of the beam 2 and to the Bush Wheel 3. The Strip 4 is similarly connected to the other end of the beam 2 and to the Double Bracket 5 attached to the piston rod. The short rod carrying the flywheel 6 is journaled in a $2\frac{1}{2}''$ Strip supported by the Trunnion 7 and in a reversed Angle Bracket bolted to the $2\frac{1}{2}''$ Strip.

Parts required:

6 of No. 2	2
1 " " 3	3
3 " " 5	5
2 " " 11	11
3 " " 12	12
2 " " 16	16
1 " " 17	17
1 " " 19B	19B
1 " " 24	24
8 " " 35	35
20 " " 37	37
4 " " 37A	37A
1 " " 48	48
1 " " 52	52
2 " " 125	125
1 " " 126	126
2 " " 126A	126A

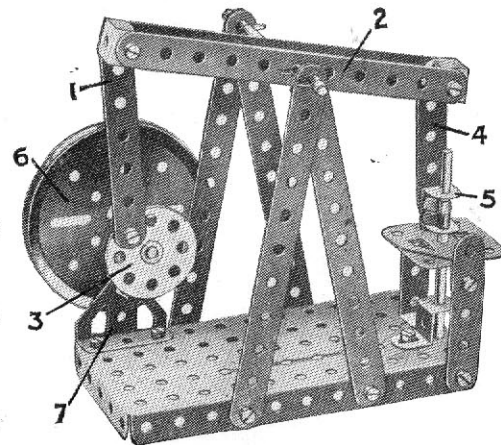

Model No. 1.75 Horseman

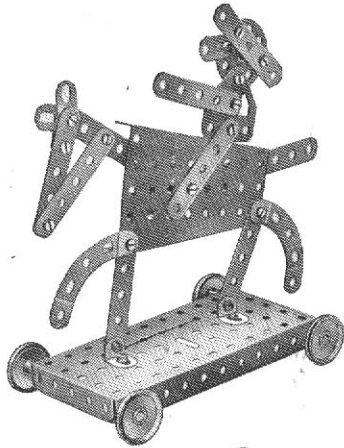

Parts required :

2 of No.	2
7 " "	5
3 " "	10
2 " "	12
2 " "	16
4 " "	22
1 " "	24
17 " "	37
1 " "	52
1 " "	54
2 " "	90A
1 " "	126A

Model No. 1.77
Flip Flap

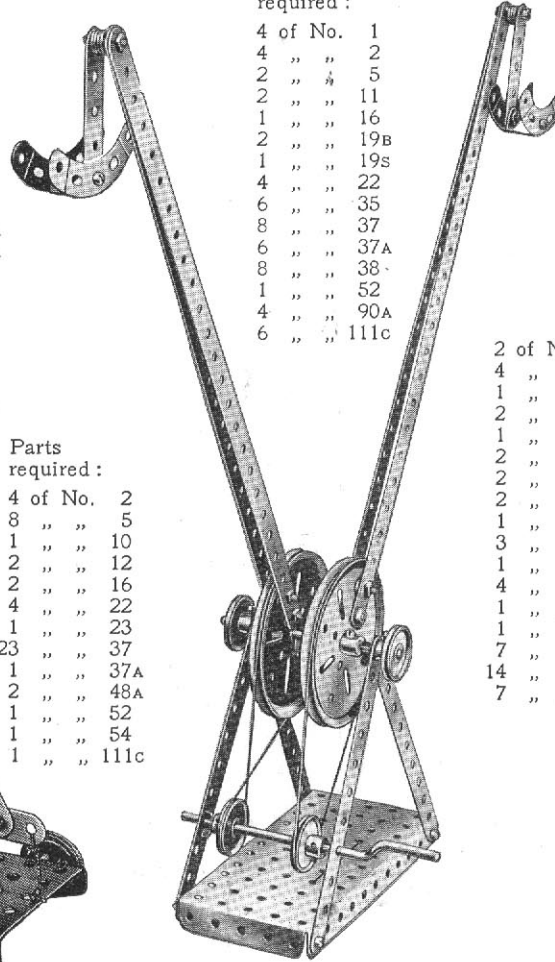

Parts required :

4 of No.	1
4 " "	2
2 " "	5
2 " "	11
1 " "	16
2 " "	19B
1 " "	19s
4 " "	22
6 " "	35
8 " "	37
6 " "	37A
8 " "	38
1 " "	52
4 " "	90A
6 " "	111c

Model No. 1.78 Bellows

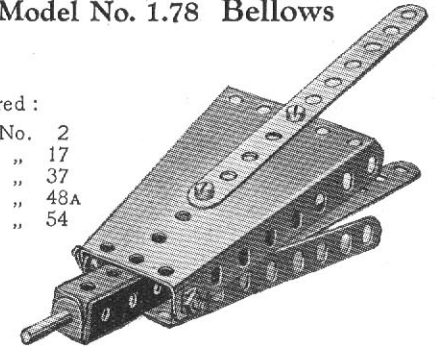

Parts required :

2 of No.	2
1 " "	17
9 " "	37
4 " "	48A
2 " "	54

Model No. 1.76

Sailing Boat

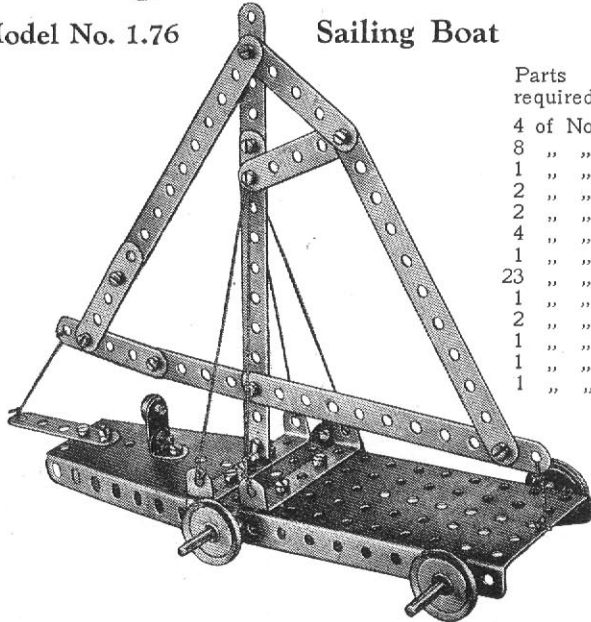

Parts required :

4 of No.	2
8 " "	5
1 " "	10
2 " "	12
2 " "	16
4 " "	22
1 " "	23
23 " "	37
1 " "	37A
2 " "	48A
1 " "	52
1 " "	54
1 " "	111c

Model No. 1.79 Mobile Crane

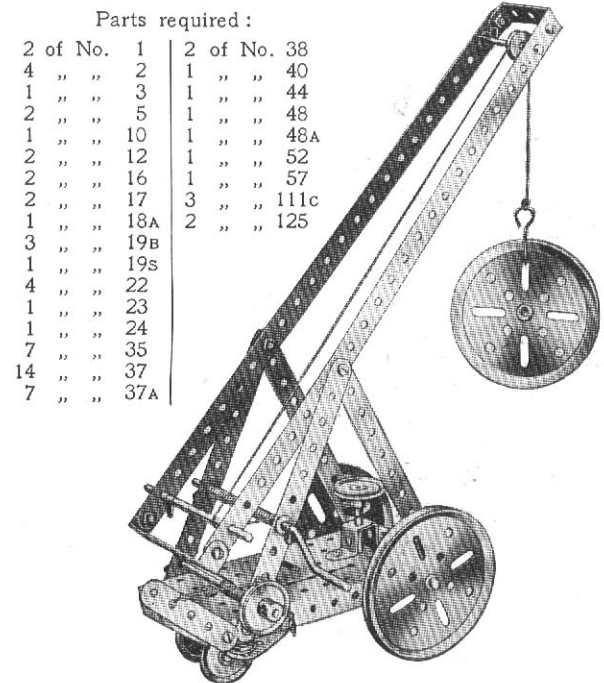

Parts required :

2 of No.	1	2 of No.	38
4 " "	2	1 " "	40
1 " "	3	1 " "	44
2 " "	5	1 " "	48
1 " "	10	1 " "	48A
2 " "	12	1 " "	52
2 " "	16	1 " "	57
2 " "	17	3 " "	111c
1 " "	18A	2 " "	125
3 " "	19B		
1 " "	19s		
4 " "	22		
1 " "	23		
1 " "	24		
7 " "	35		
14 " "	37		
7 " "	37A		

Model No. 1.80 Electric Elevator

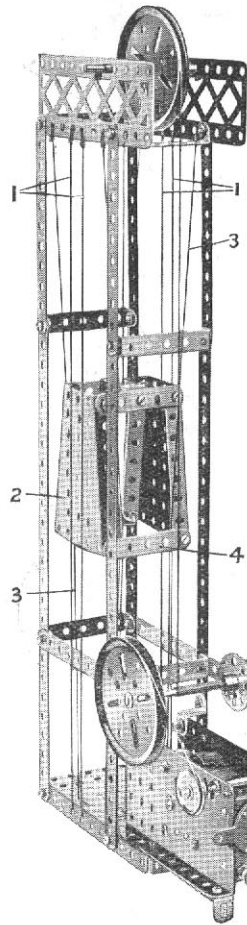

Two pairs of cords 1 are stretched tightly on each side of the lift shaft to guide the cage 2 and two other cords 3 are secured at the top and bottom of the shaft and passed behind $2\frac{1}{2}$ " Strips 4 bolted to the cage. The drive from the motor is transmitted to the 3" Pulley Wheel 5 by means of a cord passed round a 1" Pulley on the motor armature.

Parts required:

4 of No. 1	3 of No. 35
6 " " 2	34 " " 37
4 " " 5	1 " " 38
2 " " 12	1 " " 48
3 " " 16	6 " " 48A
3 " " 19B	1 " " 52
4 " " 22	2 " " 54
1 " " 24	2 " " 100
2 of No. 125	

Electric Motor
(not included in Outfit)

Model No. 1.81 Mounted Cowboy

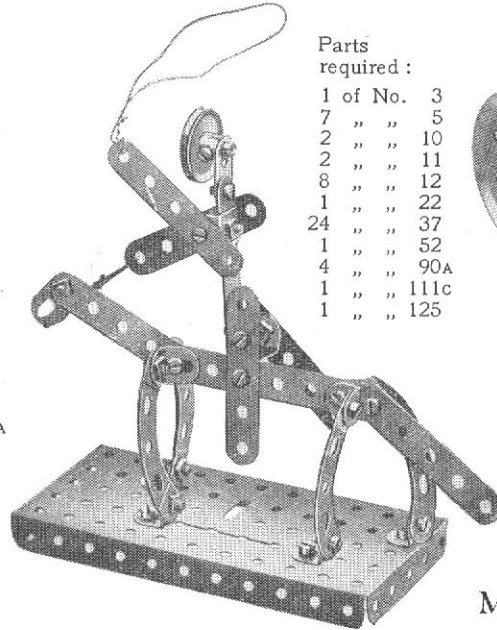

Parts required:

1 of No. 3	7 " " 5	2 " " 10	2 " " 11	8 " " 12	1 " " 22	24 " " 37	1 " " 52	4 " " 90A	1 " " 111c	1 " " 125
------------	---------	----------	----------	----------	----------	-----------	----------	-----------	------------	-----------

Model No. 1.83 Coaster

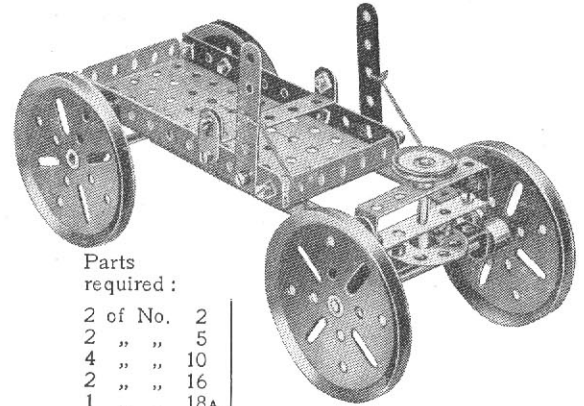

Parts required:

2 of No. 2	5	22 of No. 37	4 of No. 48A
2 " " 5	2	2 " " 37A	1 " " 52
4 " " 10	10	6 " " 38	2 " " 126A
2 " " 16	16		
1 " " 18A	18A		
4 " " 19B	19B		
1 " " 22	22		
1 " " 24	24		

Model No. 1.84
Master and Student

Model No. 1.82 Howitzer

Parts required:

2 of No. 2	2
6 " " 5	5
4 " " 10	10
2 " " 11	11
4 " " 12	12
1 " " 16	16
2 " " 19B	19B
2 " " 22	22
2 " " 35	35
14 " " 37	37
2 " " 38	38
2 " " 111c	111c
2 " " 125	125

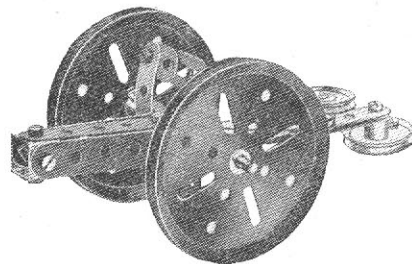

Parts required:

9 of No. 5	5
1 " " 10	10
2 " " 11	11
8 " " 12	12
2 " " 22	22
20 " " 37	37
3 " " 37A	37A
1 " " 52	52
1 " " 90A	90A
4 " " 111c	111c
1 " " 125	125

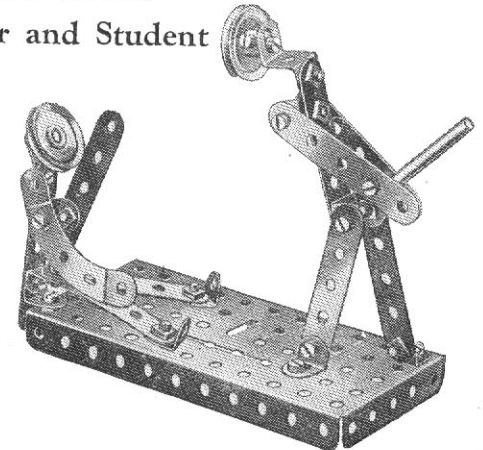

Model No. 1.85 Travelling Crane

The jib 1 is pivoted to the Flat Trunnions 2, which are bolted at 3 to Angle Brackets secured to a Bush Wheel. The latter is piped to a 2" Rod 4 passing through the Plate 5 and further supported in a Double Angle Strip 6. A Washer and Spring Clip mounted on the Rod 4 below the Strip 6 secure the crane to the carriage. The jib is supported by means of cords 7 tied to 2½" Strips 8, the holes of which engage the shank of a bolt passed through the Sector Plate 9, and its elevation may be altered by inserting this bolt in different holes in the Strips 8. The cord 10 of the brake lever is wound once round the Crank Handle, between two Washers.

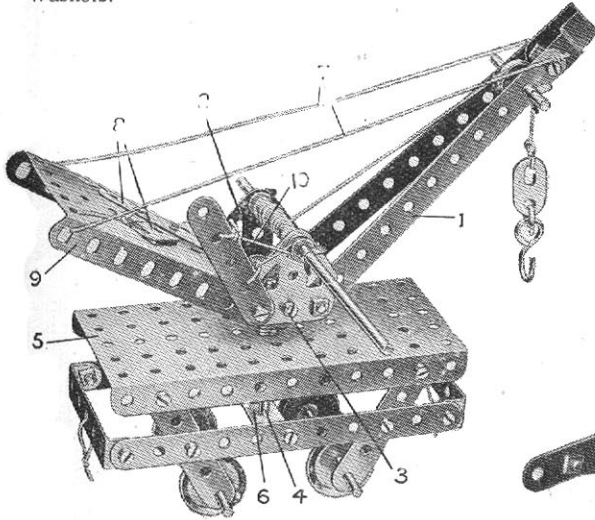

Parts required:		
4 of No. 2	1 of No. 19s	1 of No. 44
7 " " 5	4 " " 22	3 " " 48A
1 " " 10	1 " " 23	1 " " 52
2 " " 12	5 " " 24	1 " " 54
2 " " 16	27 " " 35	1 " " 57
2 " " 17	6 " " 37	2 " " 126A
	6 " " 38	

Model No. 1.86 Bicycle

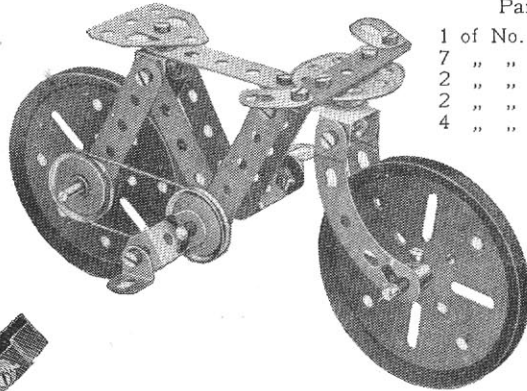

Parts required:		
1 of No. 3	2 of No. 17	
7 " " 5	1 " " 18A	
2 " " 10	2 " " 19B	
2 " " 11	2 " " 22	
4 " " 12	1 " " 24	
	4 " " 35	
	13 " " 37	
	4 " " 37A	
	3 " " 38	
	2 " " 90A	
	4 " " 111C	
	2 " " 125	
	1 " " 126A	

Model No. 1.87 Luggage Truck

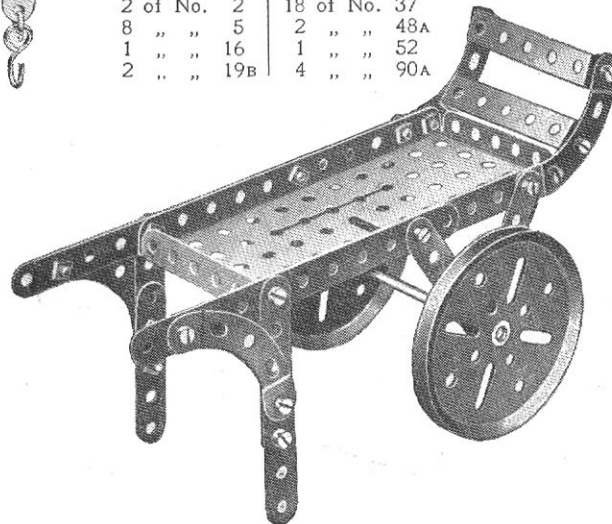

Parts required:		
2 of No. 2	18 of No. 37	
8 " " 5	2 " " 48A	
1 " " 16	1 " " 52	
2 " " 19B	4 " " 90A	

Parts required:		
4 of No. 1	3 of No. 35	
3 " " 5	25 " " 37	
3 " " 10	2 " " 37A	
4 " " 12	1 " " 38	
1 " " 16	2 " " 48A	
1 " " 19s	1 " " 52	
3 " " 22	2 " " 54	
1 " " 24	1 " " 126A	

Model No. 1.88 Gymnast

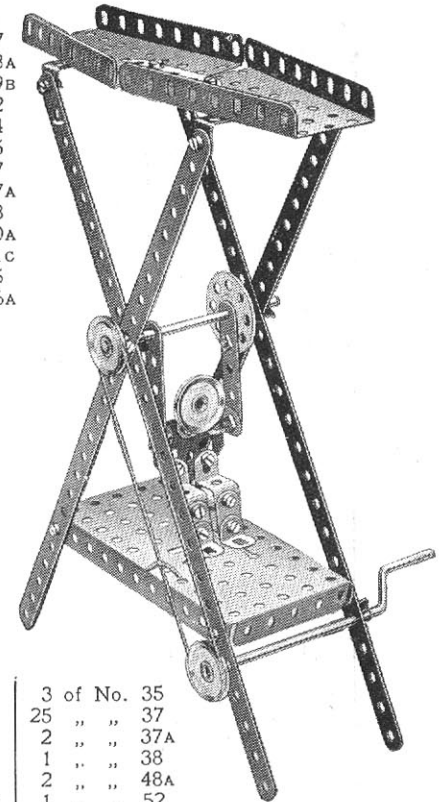

One of the 2½" Strips representing the arms of the gymnast is bolted to a Bush Wheel secured on a 3½" Rod. When the Crank Handle is rotated the gymnast turns complete somersaults in a very amusing manner. The gymnast's "arms" must be pivoted to the Angle Brackets forming his shoulders by means of Bolts and Lock-Nuts.

These Models can be built with MECCANO Outfit No. 1 (or No. 0 and No. 0A)

Model No. 1.89 Hoisting Block

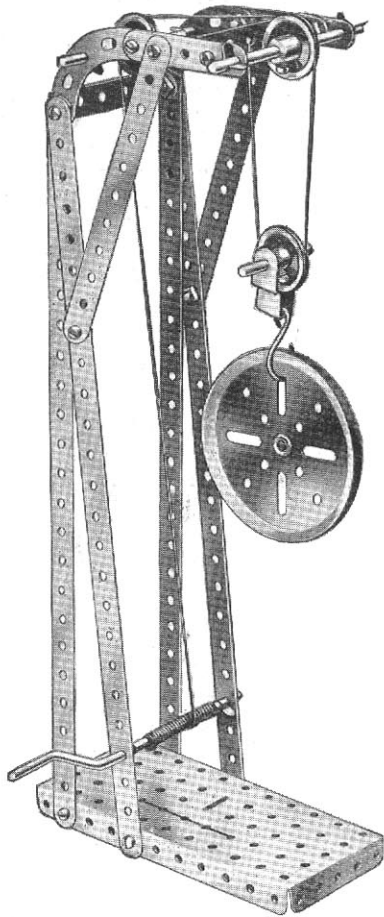

Parts required :

4 of No.	1	23 of No.	37
6 "	" 5	1 "	" 44
2 "	" 11	3 "	" 48A
2 "	" 12	1 "	" 52
1 "	" 16	2 "	" 125
1 "	" 17	2 "	" 126A
1 "	" 19s		
4 "	" 22		
1 "	" 24		
4 "	" 35		

Model No. 1.91 Helve Hammer

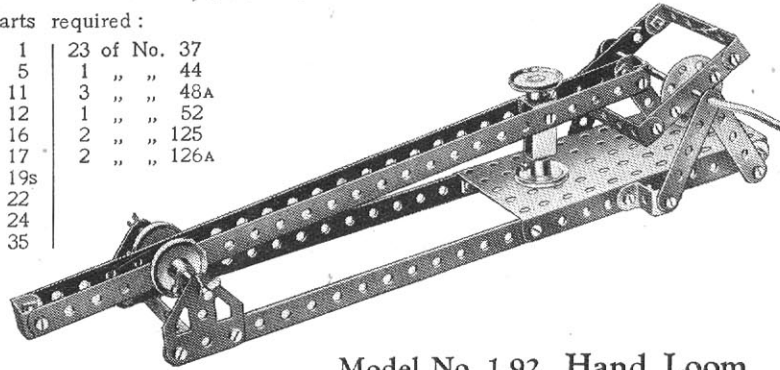

Model No. 1.93 Telescopic Mast

Telescopic Mast

Parts required :

4 of No.	1
5 "	" 5
2 "	" 11
6 "	" 12
1 "	" 18A
1 "	" 22
4 "	" 35
16 "	" 37
1 "	" 52
2 "	" 126A

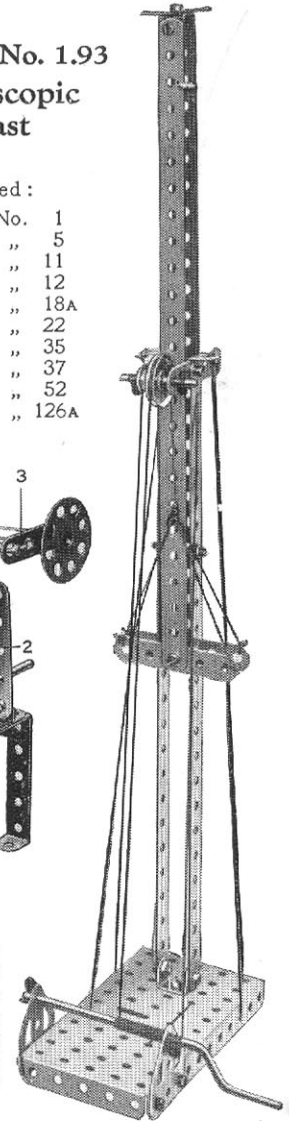

Model No. 1.92 Hand Loom

Parts required :

4 of No.	2
6 "	" 5
7 "	" 12
2 "	" 16
1 "	" 24
21 "	" 37
4 "	" 48A
1 "	" 52

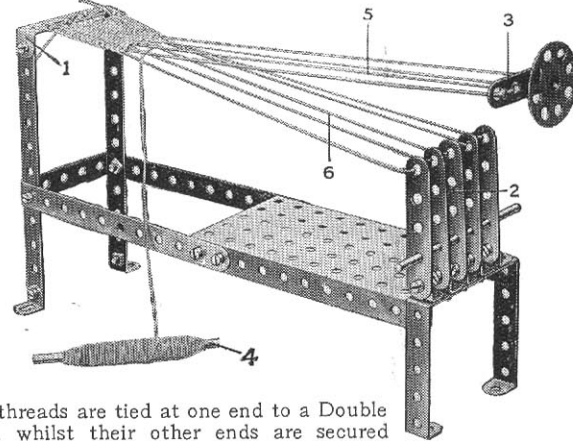

The warp threads are tied at one end to a Double Angle Strip 1, whilst their other ends are secured alternately to the tops of the upright Strips 2, and the 2½" Strip 3. The "shedding" movement of the warp is obtained by moving the Strip 3 up or down each time the shuttle—a 3½" Rod 4—is passed between the two layers of warp 5 and 6. Wool or similar material is particularly suited to this apparatus. The strands 6 should be kept very taut, and the weft threads may be closed up with the woven portion by means of an ordinary comb each time the shuttle passes.

Model No. 1.90 Catamaran

Parts required :

4 of No.	1
6 "	" 2
2 "	" 10
1 "	" 11
17 "	" 37
2 "	" 48A
Short piece of cord	

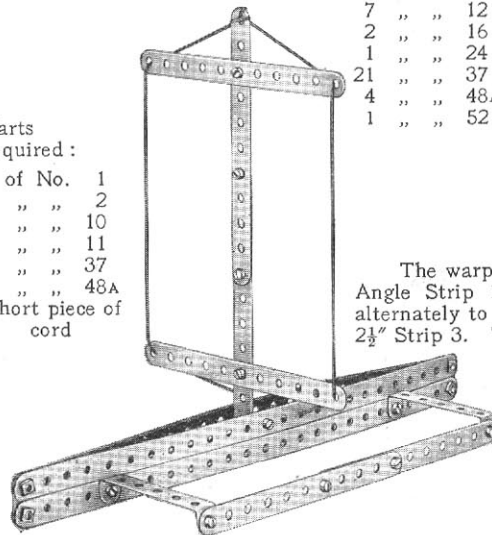

Parts required :	1 of No.	18A	1 of No.	40
4 of No.	1	" 19B	1 "	" 44
2 "	" 2	" 19s	2 "	" 48A
2 "	" 3	" 22	1 "	" 52
2 "	" 5	" 35	1 "	" 57
2 "	" 16	" 37	2 "	" 90A

Model No. 1.94 Motor Lorry

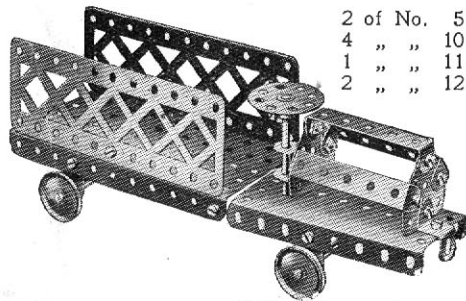

Parts required:

2 of No. 5	2 of No. 16
4 " " 10	1 " " 17
1 " " 11	4 " " 22
2 " " 12	4 " " 24
	1 " " 35
	23 " " 37
	4 " " 48A
	1 " " 52
	1 " " 54
	2 " " 100
	1 " " 125
	2 " " 126A

Model No. 1.95 Disappearing Meccanitian

The bottom of the box-like portion of the model consists of a $5\frac{1}{2}'' \times 2\frac{1}{2}''$ Flanged Plate; three $5\frac{1}{2}''$ Strips bolted to upright $2\frac{1}{2}''$ Strips form each side and each end consists of three $2\frac{1}{2}'' \times \frac{1}{2}''$ Double Angle Strips. The lid 1, which is mounted pivotally on an Axle Rod 2, consists of two Sector Plates bolted together. Elastic bands are tied to the sides of these Plates and connected to Rod 3 passed through the bottom of the box. The "Meccanitian" 4 also is connected to this Rod by pieces of elastic. On pressing the end of the rear Sector Plate the lid opens sufficiently to allow the figure to be drawn inside and then snaps back into place. A Cranked Bent Strip 5 is bolted at the back of the figure and rests against the edge of the Sector Plate.

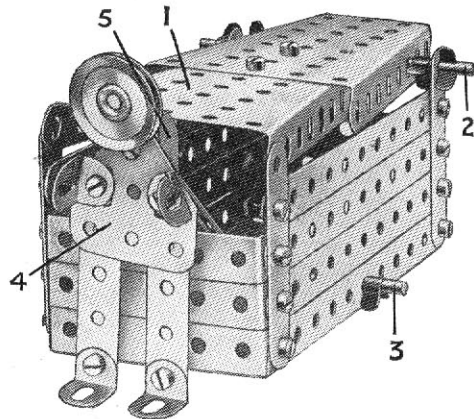

Parts required:

6 of No. 2
1 " " 5
4 " " 10
2 " " 12
2 " " 16
1 " " 22
6 " " 35
23 " " 37
1 " " 44
4 " " 48A
1 " " 52
2 " " 54
1 " " 111c
1 " " 126A

Model No. 1.96 Dignity and Impudence

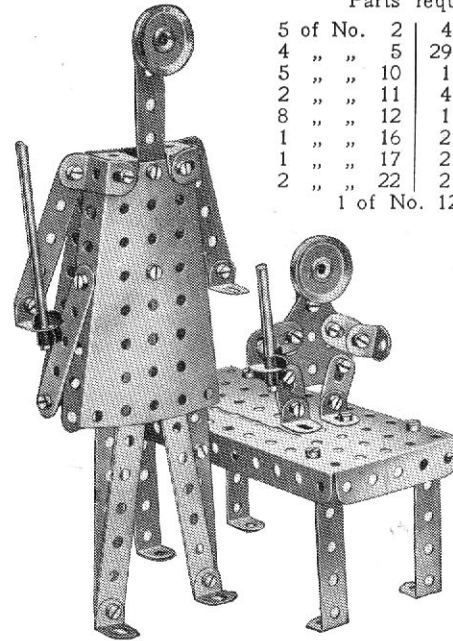

Parts required:

5 of No. 2	4 of No. 35
4 " " 5	29 " " 37
5 " " 10	1 " " 48
2 " " 11	4 " " 48A
8 " " 12	1 " " 52
1 " " 16	2 " " 54
1 " " 17	2 " " 111c
2 " " 22	2 " " 125
1 of No. 126A	

Model No. 1.97 Field Roller

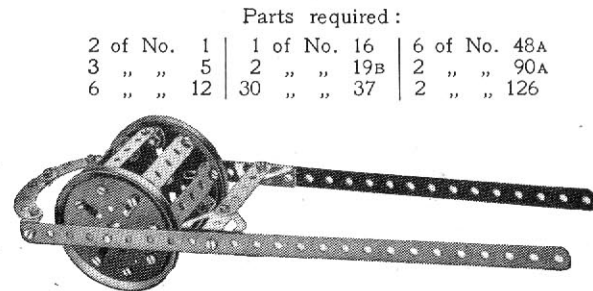

Parts required:

2 of No. 1	1 of No. 16	6 of No. 48A
3 " " 5	2 " " 19B	2 " " 90A
6 " " 12	30 " " 37	2 " " 126

Model No. 1.98 Elevator

Parts required:

4 of No. 1
7 " " 2
1 " " 3
4 " " 5
1 " " 12
1 " " 16
2 " " 19B
1 " " 19S
4 " " 22
33 " " 37
3 " " 38
6 " " 48A
1 " " 52
2 " " 54
2 " " 100
2 " " 126
2 " " 126A

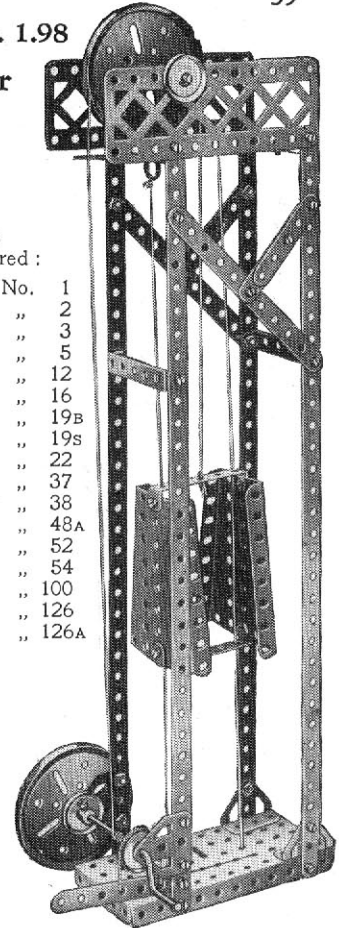

Two cords stretched between the base plate of the model and the upper structure are passed through holes in the Double Angle Strips of the cage to form guides. A further cord is tied to the upper Double Angle Strip, and after being led over the 3" Pulley at the head of the model is tied to the shaft of a Crank Handle.

Model No. 1.99 Guillotine

Parts required :

2 of No. 1	1 of No. 16
1 " " 3	1 " " 22
9 " " 5	2 " " 35
2 " " 10	24 " " 37
2 " " 11	3 " " 48A
1 of No. 52	

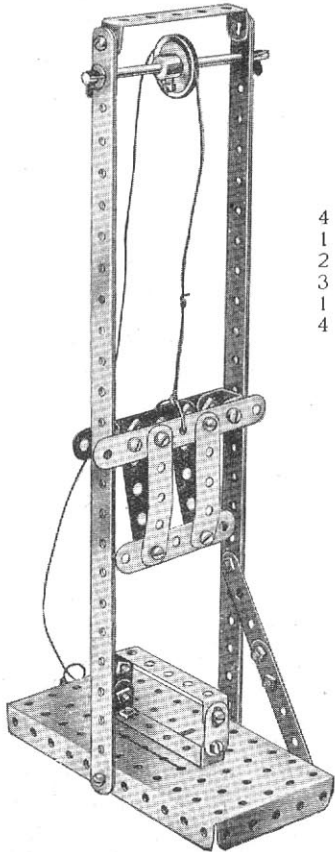

Model No. 1.100 Actuating See-saw

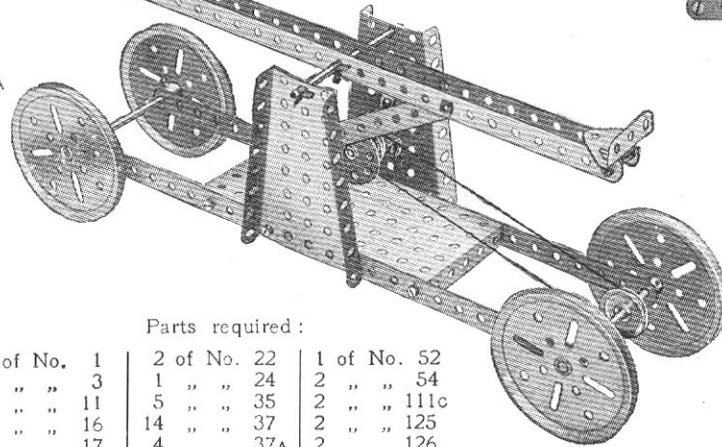

Parts required :

4 of No. 1	2 of No. 22	1 of No. 52
1 " " 3	1 " " 24	2 " " 54
2 " " 11	5 " " 35	2 " " 111c
3 " " 16	14 " " 37	2 " " 125
1 " " 17	4 " " 37A	2 " " 126
4 " " 19B	1 " " 40	

Parts required :

3 of No. 2
1 " " 3
3 " " 5
1 " " 10
2 " " 11
2 " " 16
2 " " 18A
1 " " 19B
3 " " 22
1 " " 24
6 " " 35
16 " " 37
2 " " 37A
1 " " 52
1 " " 111c
2 " " 125
1 " " 126
1 " " 126A

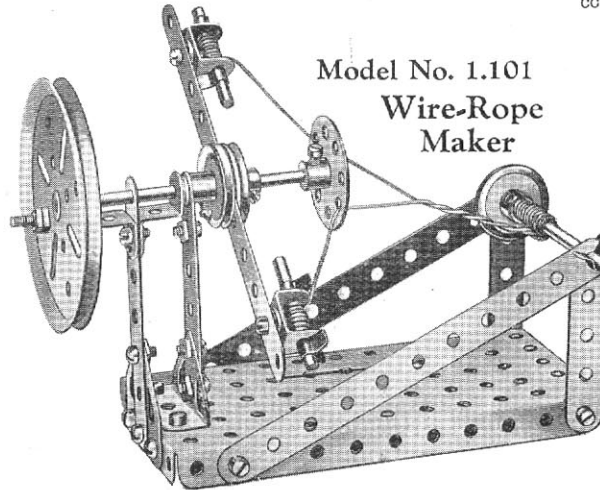

Model No. 1.101 Wire-Rope Maker

Model No. 1.102

Coat Hanger



Parts required :

1 of No. 1	2 of No. 5	1 of No. 87
2 " " 2	6 " " 37	

Model No. 1.103 Automatic Drill

Cord is passed round the Pulley on the drill spindle 4 and thence over the Pulleys 3 and round the shaft of the Pulley 1. The lever 2 (a 3 1/2" Strip) is pivoted by a Bolt and two Nuts at its inner end to an Angle Bracket, and the latter is bolted to a 1 1/2" x 1/2" Double Angle Strip which, in turn, is bolted between the vertical 2 1/2" Double Angle Strips. The arm of the lever engages between two Washers on the drill spindle, and on pressing the lever, the drill spindle with its 1" Pulley is forced downwards, thus tightening the Cord, which then transmits the drive to the drill spindle. Immediately pressure on the lever is released, the drill comes to rest.

Parts required :

1 of No. 3
2 " " 5
1 " " 11
2 " " 12
2 " " 16
2 " " 18A
2 " " 19B
4 " " 22
1 " " 24
4 " " 35
16 " " 37
1 " " 37A
1 " " 44
1 " " 48
2 " " 48A
1 " " 111c
2 " " 126A

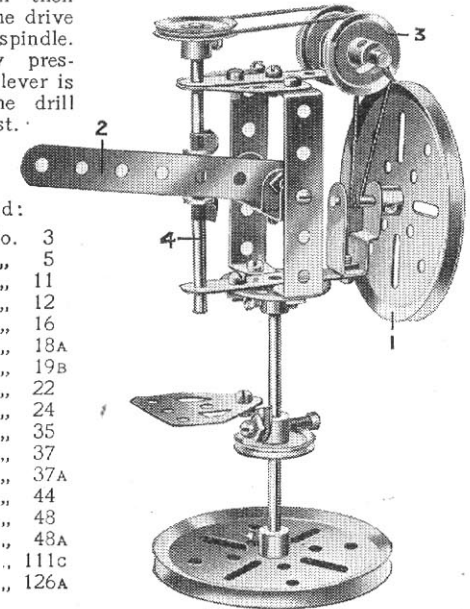

Model No. 1.104
Eiffel Tower

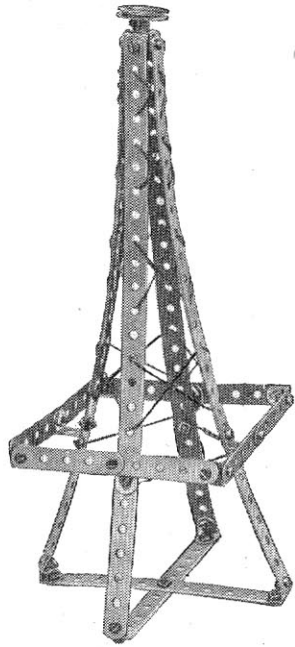

- Parts required :
- | | |
|------------|---------------|
| 4 of No. 1 | 8 of No. 12 |
| 2 " " 2 | 1 " " 22 |
| 8 " " 5 | 22 " " 37 |
| 2 " " 14 | 1 " " 40 |
| | 1 of No. 111c |

Model No. 1.105
Arc Lamp

- Parts required :
- | | |
|------------|--------------|
| 2 of No. 1 | 10 of No. 37 |
| 1 " " 3 | 1 " " 52 |
| 1 " " 22 | 1 " " 90A |
| 1 " " 24 | 2 " " 126 |

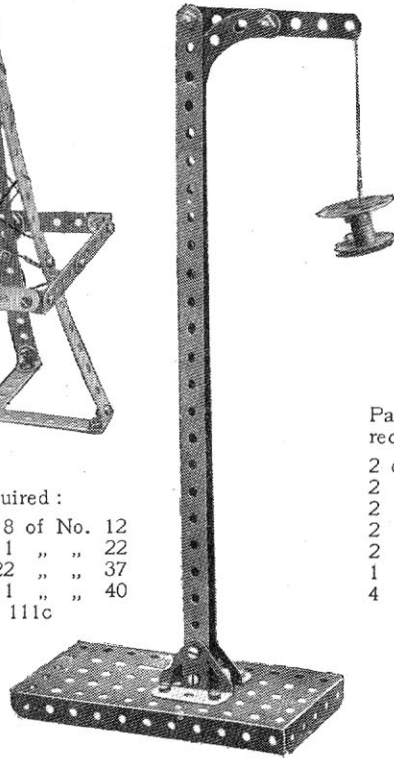

Model No. 1.106 Pen Rack **Model No. 1.108 A Sudden Appearance**

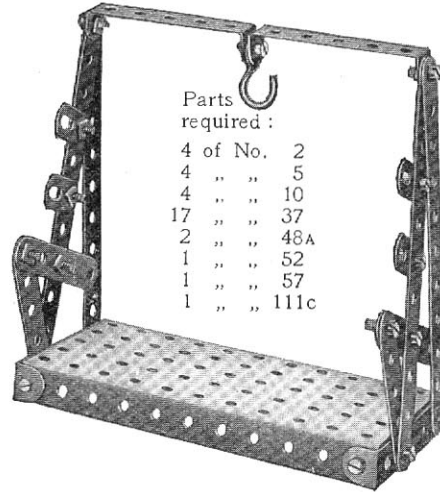

- Parts required :
- | | |
|------------|------|
| 4 of No. 2 | 2 |
| 4 " " 5 | 5 |
| 4 " " 10 | 10 |
| 17 " " 37 | 37 |
| 2 " " 48A | 48A |
| 1 " " 52 | 52 |
| 1 " " 57 | 57 |
| 1 " " 111c | 111c |

Model No. 1.107
Manual Fire Engine

- Parts required :
- | | |
|------------|-------------|
| 2 of No. 2 | 6 of No. 35 |
| 2 " " 5 | 12 " " 37 |
| 2 " " 11 | 2 " " 38 |
| 2 " " 16 | 1 " " 52 |
| 2 " " 17 | 2 " " 126 |
| 1 " " 18A | |
| 4 " " 19B | |

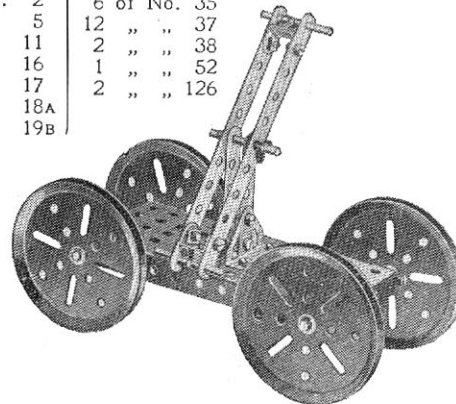

The Sector Plate 1, forming the lid, is carried pivotally on an axle rod that passes through its sides three holes from the end, and the rear Sector Plate 2 is pivoted in a similar manner, excepting that the rod in this case passes through the fourth hole from the end. Pieces of thin elastic are tied to the end holes in each side of the front Sector Plate at its widest end, and are connected to a Rod journalled in the sides of the box. The "Mechanician" 3 is placed face downward inside the box with his feet towards the far end of the model. The tension of the elastic holding the lid 1 should be sufficient to keep him in this position. On tilting the Plate 1 slightly, however, he will suddenly shoot out of the box, drawn by the elastic bands 4 connected to the 3 1/2" Axle Rod 5.

- Parts required :
- | | |
|------------|------|
| 4 of No. 1 | 1 |
| 4 " " 2 | 2 |
| 8 " " 5 | 5 |
| 5 " " 10 | 10 |
| 4 " " 12 | 12 |
| 4 " " 16 | 16 |
| 1 " " 22 | 22 |
| 8 " " 35 | 35 |
| 29 " " 37 | 37 |
| 4 " " 48A | 48A |
| 1 " " 52 | 52 |
| 2 " " 54 | 54 |
| 1 " " 111c | 111c |
| 1 " " 126A | 126A |

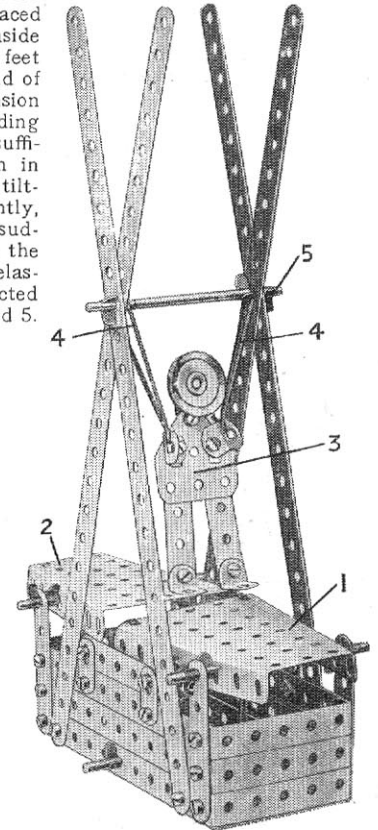

These Models can be built with MECCANO Outfit No. 1 (or No. 0 and No. 0A)

Model No. 1.109 Double Draw Bridge

Parts required:

4 of No. 1	1 of No. 19s	2 of No. 38
6 " " 2	2 " " 22	6 " " 48A
1 " " 16	8 " " 35	2 " " 126A
	16 " " 37	

Model No. 1.110 Coaster

The figure 1 is loosely attached by lock-nutted Bolts 2 to the Sector Plate 3 and is connected to the Bush Wheel 4 by the pivotally-attached $2\frac{1}{2}$ " Strip 5. The $1\frac{1}{2}$ " Rod carrying the Bush Wheel 4 is journaled in the Cranked Bent Strip 6, the 1" fast Pulley 7 being connected to the road wheel by a cord as shown.

Parts required:

2 of No. 2	2 of No. 11	1 of No. 24
9 " " 5	7 " " 12	8 " " 35
5 " " 10	1 " " 16	37 " " 37
	2 " " 17	6 " " 37A
	2 " " 18A	1 " " 48
	4 " " 22	2 " " 48A
	1 " " 23	2 " " 54
		2 " " 111c
		2 " " 125
		2 " " 126A

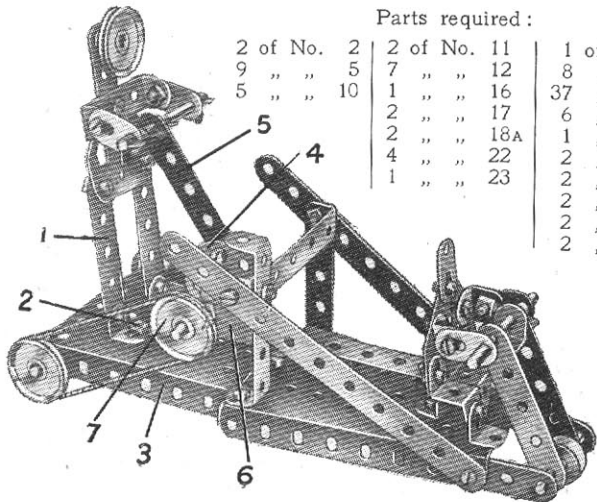

Model No. 1.112 Motor Cyclist and Pillion Rider

Parts required:

4 of No. 2	2 of No. 17	2 of No. 48A
9 " " 5	4 " " 22	2 " " 90A
4 " " 10	1 " " 24	2 " " 125
2 " " 11	2 " " 35	2 " " 126A
8 " " 12	30 " " 37	
1 " " 16		

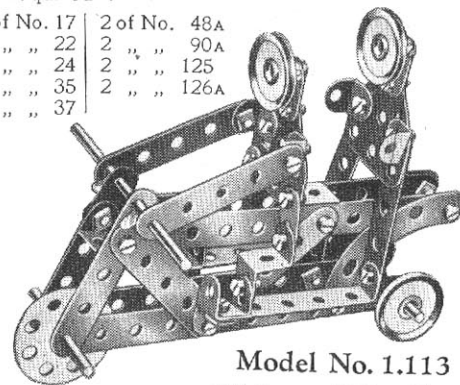

Model No. 1.111 Tappet Valve Demonstration Model

Parts required:

1 of No. 3	1 of No. 3
1 " " 5	1 " " 5
1 " " 10	1 " " 10
1 " " 11	1 " " 11
3 " " 12	3 " " 12
2 " " 16	2 " " 16
1 " " 17	1 " " 17
1 " " 18A	1 " " 18A
4 " " 22	4 " " 22
1 " " 24	1 " " 24
5 " " 35	5 " " 35
15 " " 37	15 " " 37
5 " " 37A	5 " " 37A
4 " " 38	4 " " 38
1 " " 48A	1 " " 48A
1 " " 52	1 " " 52
1 " " 54	1 " " 54
2 " " 111c	2 " " 111c
2 " " 126A	2 " " 126A

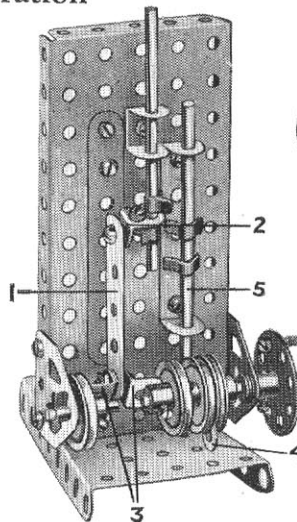

The upper end of the Strip 1 is connected pivotally by a Bolt and two Nuts to the crosshead Bracket 2. The crankshaft is built up as follows: Two Angle Brackets are each secured rigidly to the boss of a Pulley Wheel and are connected to each other by a $\frac{3}{8}$ " Bolt carrying three Nuts. The Nuts are screwed tightly against the Brackets, sufficient space being left between the inner pair to enable the connecting Strip 1 to turn freely. The valve Rod 5 is operated by the Flat Bracket 4 that is clamped between two further 1" Pulleys on the crankshaft in such a way that its protruding end serves as a cam.

Model No. 1.113 Chinese Windlass

Parts required:

4 of No. 1	4 of No. 1
1 " " 3	1 " " 3
1 " " 18A	1 " " 18A
3 " " 19B	3 " " 19B
1 " " 19s	1 " " 19s
3 " " 22	3 " " 22
1 " " 23	1 " " 23
1 " " 24	1 " " 24
8 " " 37	8 " " 37
1 " " 44	1 " " 44
2 " " 48A	2 " " 48A
1 " " 52	1 " " 52
1 " " 57	1 " " 57

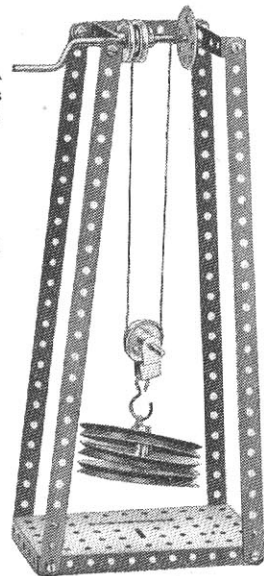

Model No. 1.114 Pile Driver

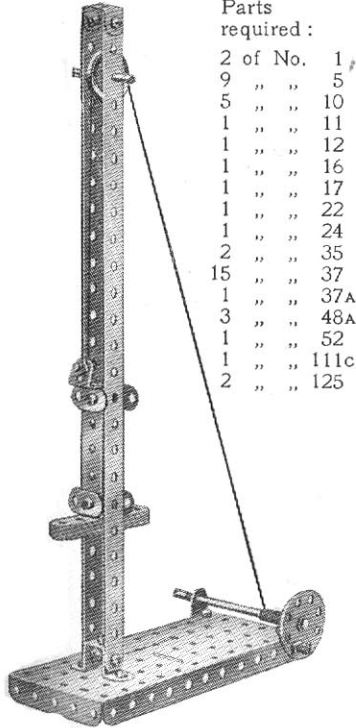

Parts required:	
2 of No.	1
9 " "	5
5 " "	10
1 " "	11
1 " "	12
1 " "	16
1 " "	17
1 " "	22
1 " "	24
2 " "	35
15 " "	37
1 " "	37A
3 " "	48A
1 " "	52
1 " "	111c
2 " "	125

The winding cord is passed round the Pulley at the top of the model and is fastened to an Angle Bracket that is hooked under the protruding portion of a Flat Bracket bolted to the top of the driving head. When the Angle Bracket reaches the Pulley at the top it is pushed out a little, thus releasing the driving head.

Model No. 1.115 Foot Hammer

Parts required:	
6 of No.	2
1 " "	3
9 " "	5
1 " "	12
2 " "	16
4 " "	22
1 " "	24
2 " "	35
15 " "	37
4 " "	37A
2 " "	38
2 " "	48A
1 " "	52
4 " "	90A

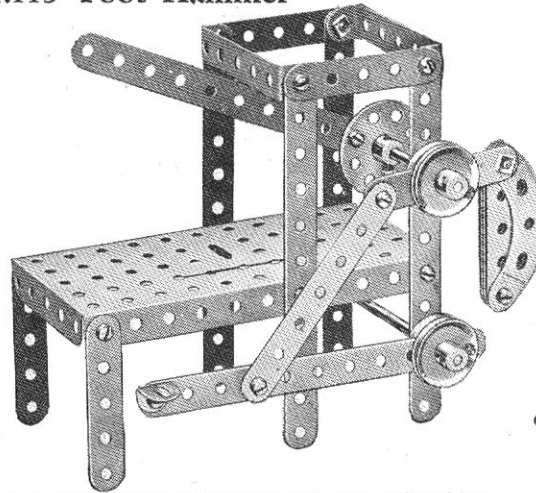

The treadle lever is connected pivotally to a 3½" Strip by a Bolt and two Nuts. The upper end of this Strip 2 is similarly connected to a 2½" Strip that is clamped tightly between two Pulleys on the hammer Rod 4. Pressure on the treadle causes the hammer to descend on the work. When the treadle is released a weight pulls the hammer back to its original position.

Model No. 1.116 Heavy Duty Scales

The five Bolts 1 act as pivots and are secured each by two Nuts (see Standard Mechanism No. 262).

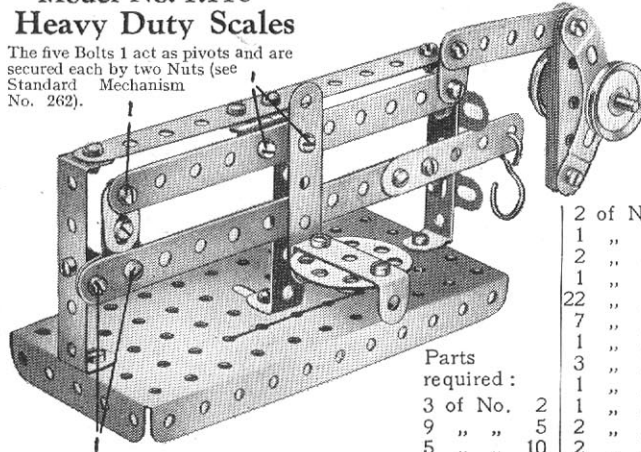

2 of No.	12
1 " "	18A
2 " "	22
1 " "	24
22 " "	37
7 " "	37A
1 " "	48
3 " "	48A
1 " "	52
3 of No.	2
9 " "	5
5 " "	10

Model No. 1.117 Horse Rake

Parts required:	
2 of No.	2
2 " "	5
1 of No.	16
2 " "	18A
2 " "	19B
4 " "	22
7 " "	35
3 " "	37
1 " "	48A
4 " "	90A

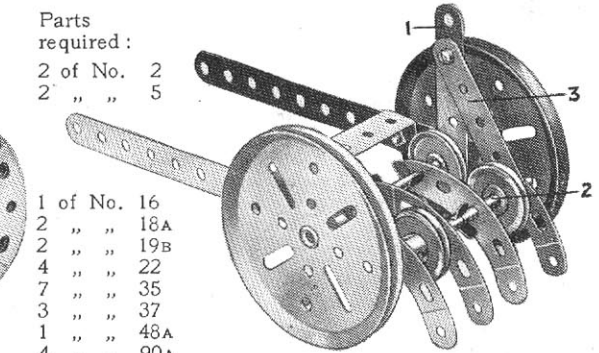

The 2½" Strip 1 pivots about the wheel axle. A 2½" Strip 3 is connected by a Bolt and two Nuts to the Strip 1 and the Rod 2 passes through its other end. On pulling the lever 1 towards the shafts the rake is lifted from the ground.

Model No. 1.118 Gravity Conveyor

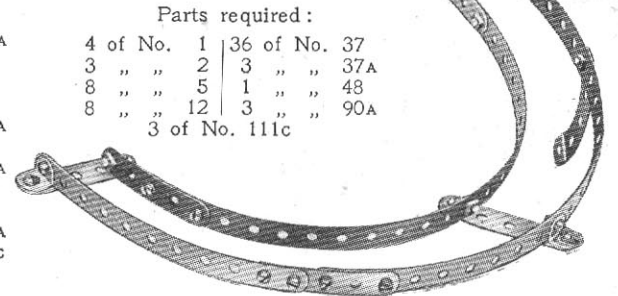

Parts required:			
4 of No.	1	36 of No.	37
3 " "	2	3 " "	37A
8 " "	5	1 " "	48
8 " "	12	3 " "	90A
		3 of No.	111c

Model No. 1.119 Bed Table

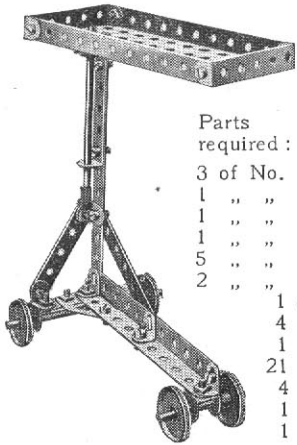

Parts required :

3 of No.	2
1 " "	3
1 " "	5
1 " "	11
5 " "	12
2 " "	16
1 of No.	17
4 " "	22
1 " "	24
21 " "	37
4 " "	48A
1 " "	52
1 " "	126A

Model No. 1.120 Inclined Plane

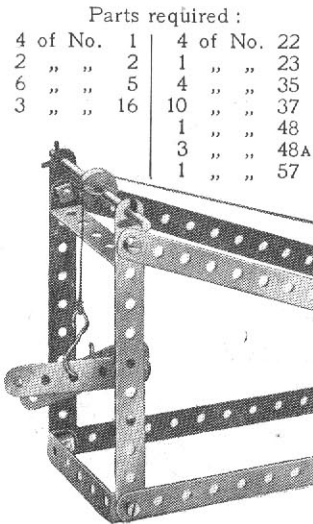

Parts required :

4 of No.	1	4 of No.	22
2 " "	2	1 " "	23
6 " "	5	4 " "	35
3 " "	16	10 " "	37
		1 " "	48
		3 " "	48A
		1 " "	57

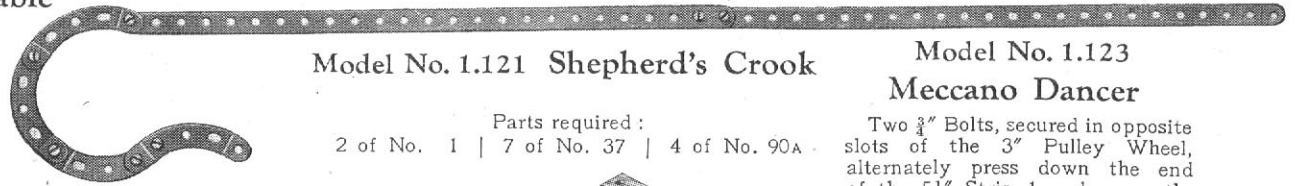

Model No. 1.121 Shepherd's Crook

Parts required :

2 of No.	1	7 of No.	37	4 of No.	90A
----------	---	----------	----	----------	-----

Model No. 1.122 Coal Cutter

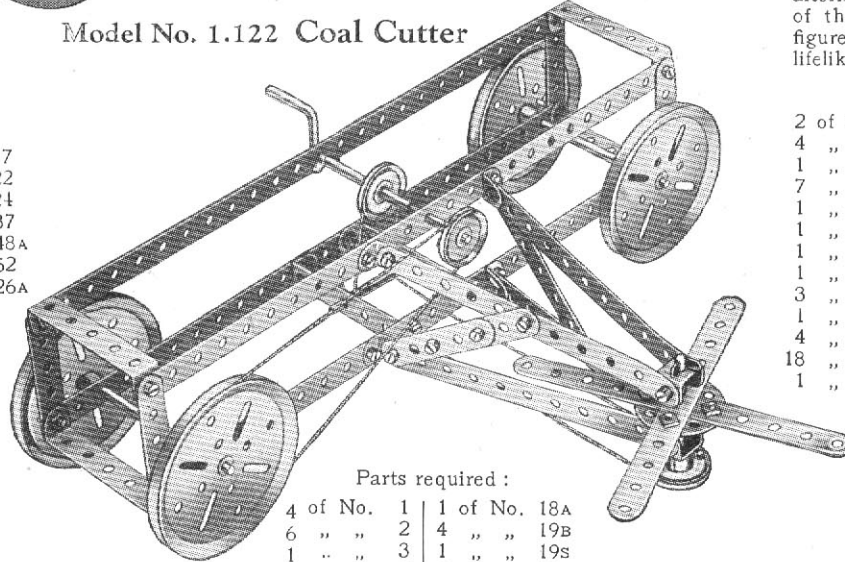

Parts required :

4 of No.	1	1 of No.	18A
6 " "	2	4 " "	19B
1 " "	3	1 " "	19S
6 " "	5	3 " "	22
2 " "	11	1 " "	24
4 " "	12	5 " "	35
2 " "	16	32 " "	37
1 " "	17	1 " "	40
	6 of No.		48A

Model No. 1.123 Meccano Dancer

Two 3" Bolts, secured in opposite slots of the 3" Pulley Wheel, alternately press down the end of the 5 1/2" Strip 1 and cause the figure to dance in a surprisingly lifelike manner.

Parts required :

2 of No.	1	1 of No.	90A
4 " "	2	3 " "	111c
1 " "	3	2 " "	126A
7 " "	5		
1 " "	16		
1 " "	18A		
1 " "	19B		
1 " "	19S		
3 " "	22		
1 " "	24		
4 " "	35		
18 " "	37		
1 " "	52		

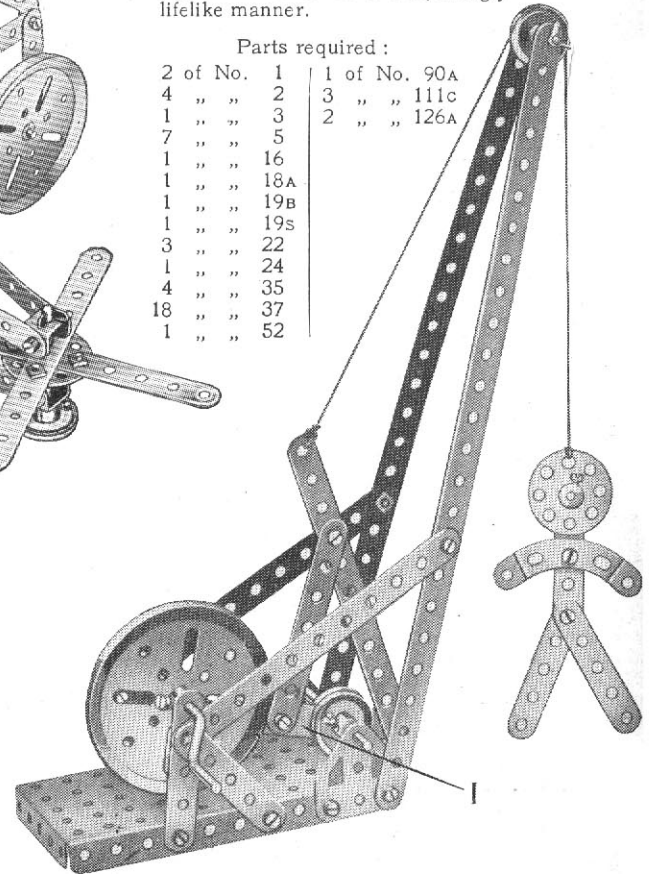

Model No. 1.124 Eccentric Dancers

Parts required :

- 6 of No. 5
- 4 " " 10
- 6 " " 12
- 1 " " 17
- 4 " " 22
- 1 " " 23
- 1 " " 24

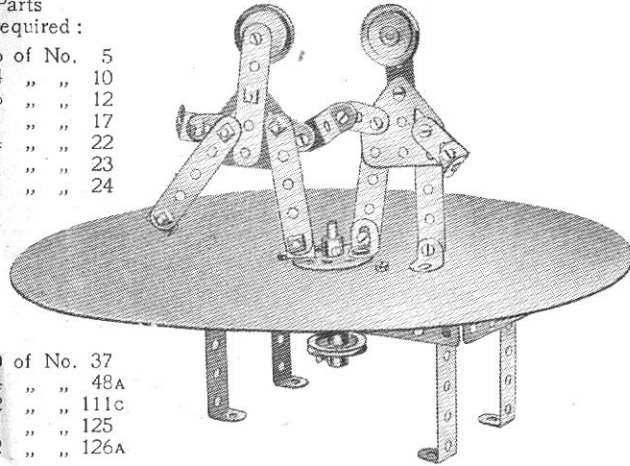

- 20 of No. 37
- 4 " " 48A
- 2 " " 111c
- 1 " " 125
- 2 " " 126A

Model No. 1.125 Bellows

Parts required :

- | | |
|--------------|-------------|
| 4 of No. 2 | 1 of No. 24 |
| 1 " " 3 | 8 " " 35 |
| 3 " " 5 | 25 " " 37 |
| 2 " " 10 | 6 " " 37A |
| 2 " " 11 | 1 " " 44 |
| 4 " " 12 | 1 " " 52 |
| 1 " " 16 | 2 " " 54 |
| 2 " " 17 | 1 " " 111c |
| 2 of No. 126 | |

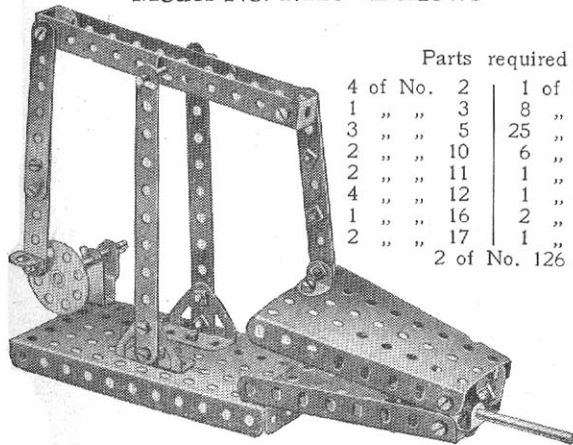

Model No. 1.126 Crosshead Demonstration Model

Parts required :

- | | |
|---------------|-------------|
| 2 of No. 1 | 1 of No. 24 |
| 4 " " 2 | 3 " " 35 |
| 9 " " 5 | 20 " " 37 |
| 2 " " 16 | 2 " " 48A |
| 1 " " 23 | 1 " " 52 |
| 2 of No. 126A | |

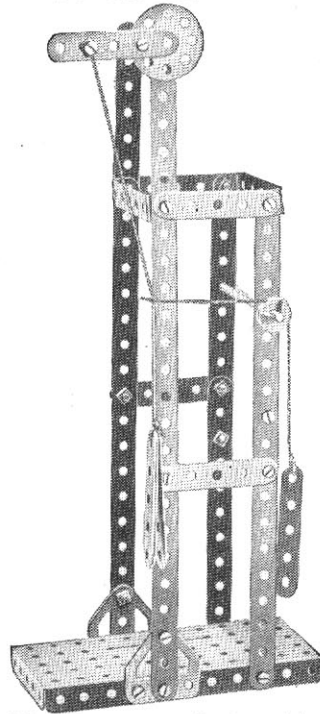

This is an apparatus for determining the forces that act at the crosshead of a reciprocating engine. The upper inclined length of cord represents the connecting rod and the lower, or vertical portion, the piston rod. The pull on the third cord indicates the pressure exerted on the slide bars of the engine due to the angularity of the connecting rod.

Model No. 1.127 Drop Stamp

Parts required :

- 4 of No. 2
- 6 " " 5
- 3 " " 10
- 2 " " 16
- 1 " " 19s
- 4 " " 22
- 1 " " 24
- 2 " " 35
- 27 " " 37
- 3 " " 48A
- 1 " " 52
- 1 " " 54
- 2 " " 126A

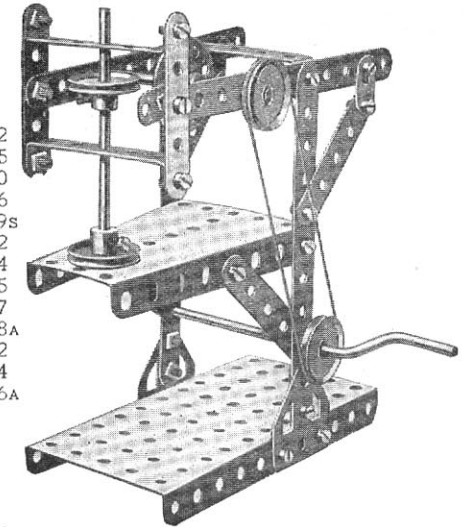

Model No. 1.128 Blacksmith

Parts required :

- | | |
|--------------|-------------|
| 1 of No. 3 | 1 of No. 35 |
| 8 " " 5 | 26 " " 37 |
| 2 " " 10 | 4 " " 37A |
| 2 " " 11 | 1 " " 44 |
| 5 " " 12 | 1 " " 52 |
| 1 " " 19s | 1 " " 54 |
| 1 " " 22 | 1 " " 111c |
| 1 " " 24 | 2 " " 125 |
| 2 of No. 126 | |

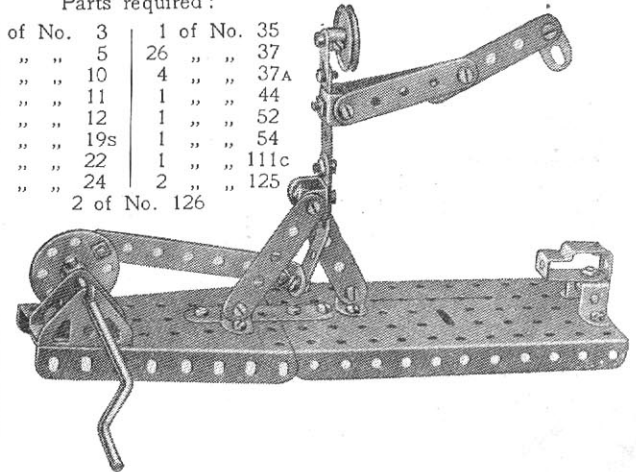

**Model No. 1.129
Try-Your-Strength
Machine**

Parts required :

4 of No.	1
1 " "	2
6 " "	12
1 " "	17
3 " "	22
1 " "	23
2 " "	35
17 " "	37
1 " "	52
1 " "	111c
2 " "	126
1 " "	126A

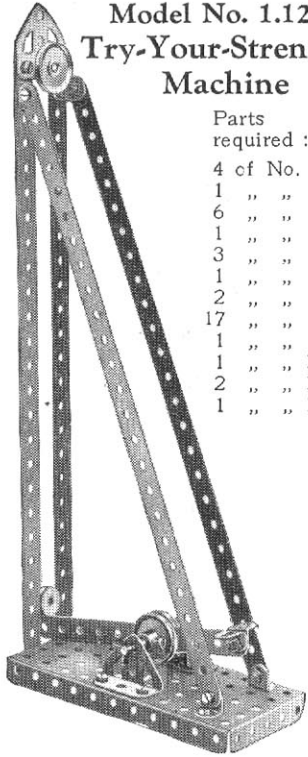

**Model No. 1.130
Double Cable Key**

Parts required :

2 of No.	2	1 of No.	52
2 " "	22	2 " "	111c
4 " "	37		

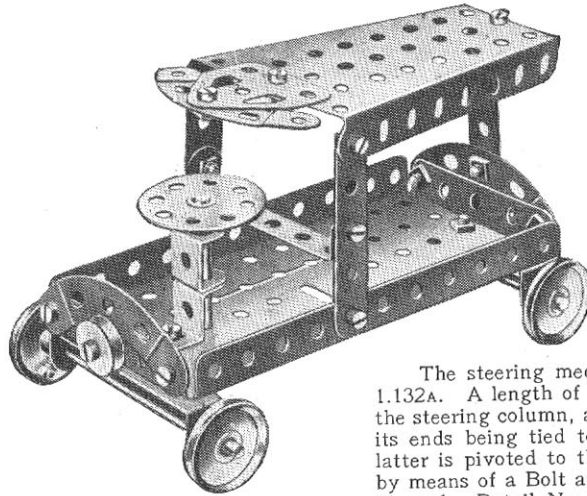
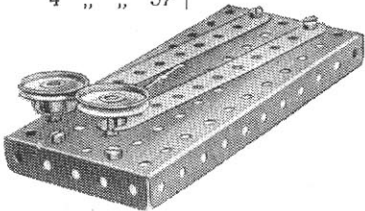

Model No. 1.132 Motor Van

Parts required :

3 of No.	5	1 of No.	35
1 " "	11	17 " "	37
1 " "	12	3 " "	48A
2 " "	16	1 " "	52
1 " "	17	1 " "	54
4 " "	22	3 " "	90A
1 " "	23	1 " "	111c
1 " "	24	1 " "	125
		1 of No.	126A

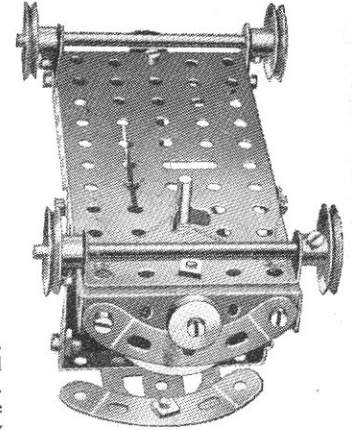

FIG. 1.132A

The steering mechanism is shown more clearly in Fig. 1.132A. A length of cord is given two or three turns round the steering column, and is held in position by a Spring Clip, its ends being tied to a $2\frac{1}{2}'' \times \frac{1}{2}''$ Double Angle Strip. The latter is pivoted to the $5\frac{1}{2}'' \times 2\frac{1}{2}''$ Flanged Plate of the lorry by means of a Bolt and two Nuts (see Standard Mechanisms Manual. Detail No. 262).

Model No. 1.131 Boat

Parts required :

4 of No.	1
2 " "	2
1 " "	5
2 " "	11
21 " "	37
1 " "	48A
1 " "	52
2 " "	90A
2 " "	125

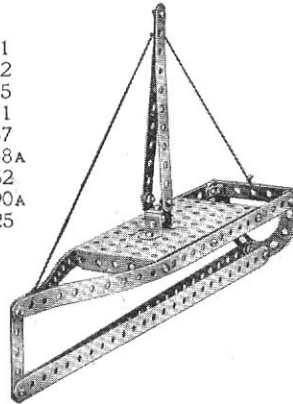

Model No. 1.133 Revolving Hammerhead Crane

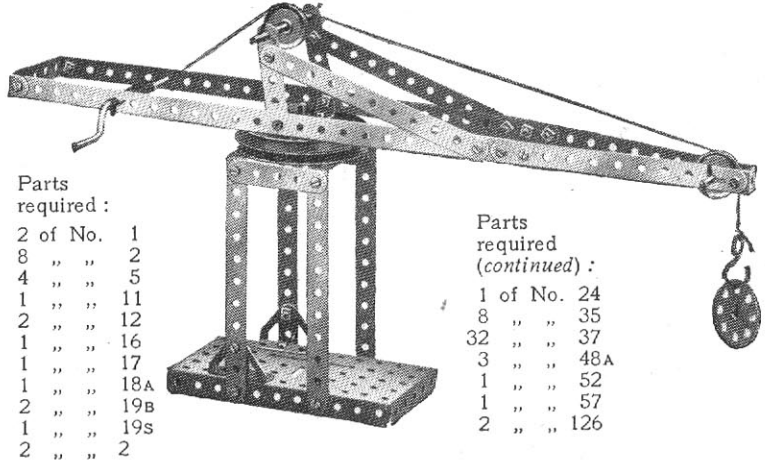

Parts required :

2 of No.	1
8 " "	2
4 " "	5
1 " "	11
2 " "	12
1 " "	16
1 " "	17
1 " "	18A
2 " "	19B
1 " "	19S
2 " "	2

Parts required (continued) :

1 of No.	24
8 " "	35
32 " "	37
3 " "	48A
1 " "	52
1 " "	57
2 " "	126

Model No. 1.134 Drilling Machine

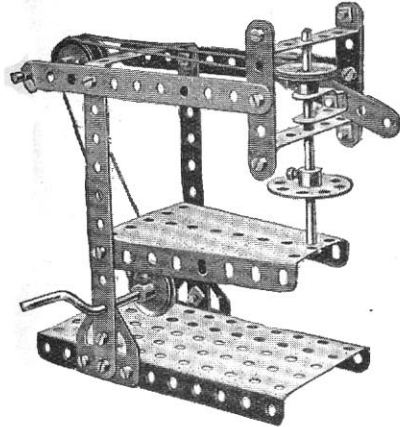

Parts required:

4 of No.	2
3 " "	5
1 " "	11
2 " "	16
1 " "	19s
4 " "	22
1 " "	24
4 " "	35
19 " "	37
1 " "	44
3 " "	48A
1 " "	52
1 " "	54
2 " "	126A

Model No. 1.136 Motor Tractor

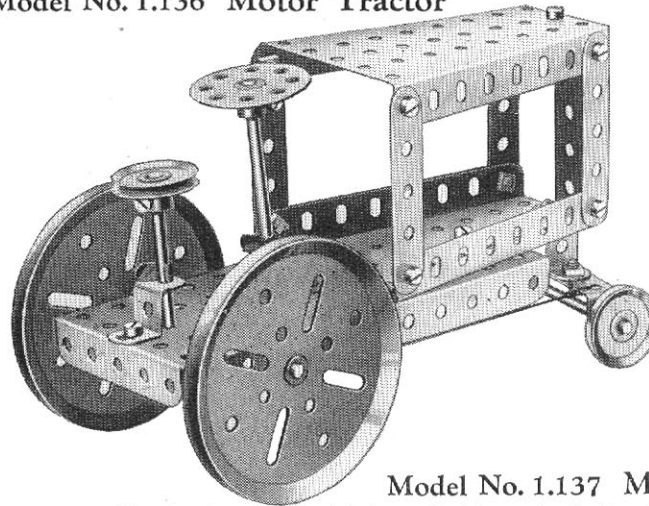

Parts required:

4 of No.	5
1 " "	11
3 " "	16
1 " "	17
2 " "	19B
4 " "	22
1 " "	24
3 " "	35
16 " "	37
1 " "	37A
2 " "	48A
1 " "	52
2 " "	54
2 " "	125

Model No. 1.138 Windmill Pump

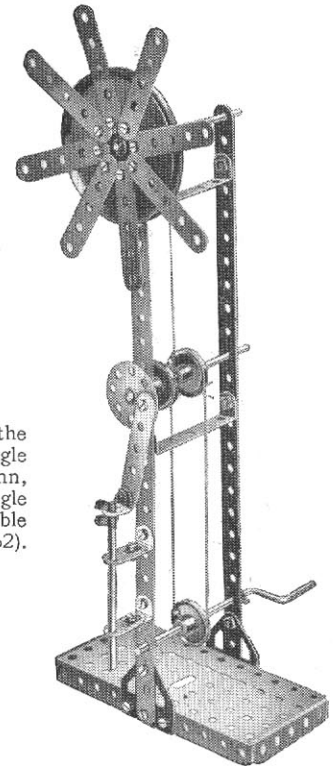

Model No. 1.135 Racing Motor Car

Parts required:

3 of No.	2	25 of No.	37
4 " "	5	3 " "	38
4 " "	10	1 " "	44
2 " "	11	4 " "	48A
8 " "	12	1 " "	126A
2 " "	16		
1 " "	19s		
4 " "	22		
1 " "	23		
1 " "	24		
4 " "	35		

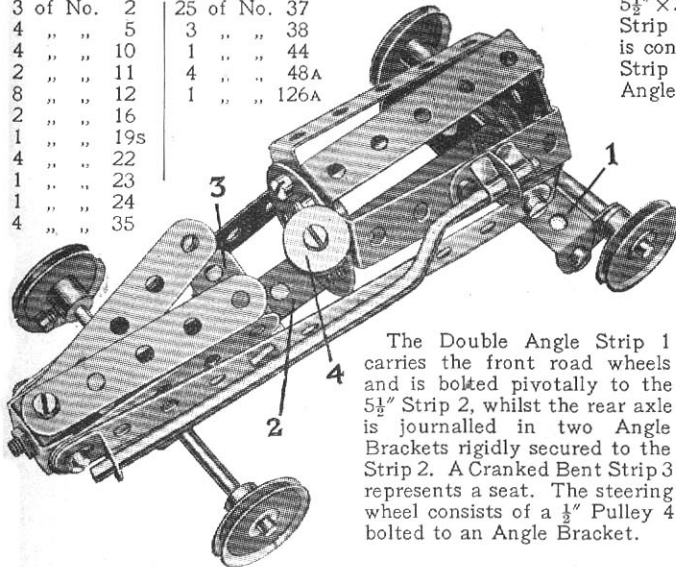

The Double Angle Strip 1 carries the front road wheels and is bolted pivotally to the $5\frac{1}{2}$ " Strip 2, whilst the rear axle is journalled in two Angle Brackets rigidly secured to the Strip 2. A Cranked Bent Strip 3 represents a seat. The steering wheel consists of a $\frac{1}{2}$ " Pulley 4 bolted to an Angle Bracket.

Model No. 1.137 Motor Car

The steering column 1 is journalled in an Angle Bracket 2 bolted to the $5\frac{1}{2}$ " x $2\frac{1}{2}$ " Flanged Plate 3, and in the second hole of the $2\frac{1}{2}$ " x $\frac{1}{2}$ " Double Angle Strip 4. A Bush Wheel 5, secured to the lower end of the steering column, is connected by two short lengths of cord to a second $2\frac{1}{2}$ " x $\frac{1}{2}$ " Double Angle Strip carrying the front axle. The Strip is pivoted to a similar Double Angle Strip 6 by means of a Bolt and Nuts (Standard Mechanism No. 262).

Parts required:

4 of No.	2	3 of No.	16	25 of No.	37	1 of No.	52
7 " "	5	4 " "	19B	2 " "	37A	2 " "	54
1 " "	10	1 " "	22	4 " "	38	1 " "	111c
1 " "	11	1 " "	24	4 " "	48A	1 " "	125
						1 " "	126

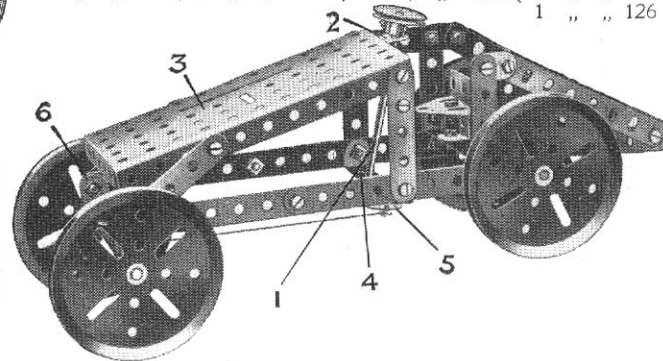

Parts required:

2 of No.	1	1 of No.	24
9 " "	5	4 " "	35
2 " "	10	24 " "	37
3 " "	12	4 " "	37A
3 " "	16	3 " "	38
1 " "	19B	2 " "	48A
1 " "	19s	1 " "	52
4 " "	22	2 " "	111c
		2 of No.	126A

Model No. 1.139 Butter Churn

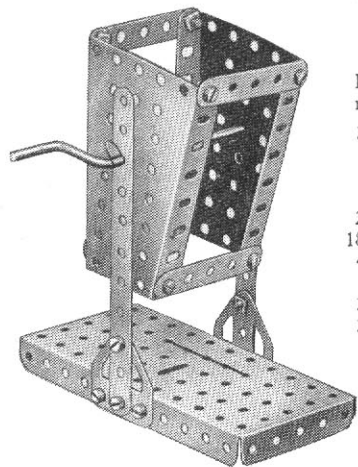

Parts required :

2 of No.	2
4 " "	5
1 " "	19s
1 " "	24
2 " "	35
18 " "	37
4 " "	38
1 " "	52
2 " "	54
2 " "	126A

Model No. 1.141 Cable Railway

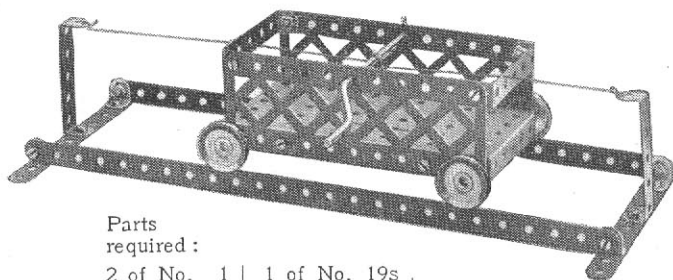

Parts required :

2 of No.	1	1 of No.	19s	4 of No.	48A
2 " "	2	4 " "	22	1 " "	52
4 " "	12	2 " "	35	2 " "	100
2 " "	16	18 " "	37		

Model No. 1.144 Man and Boy

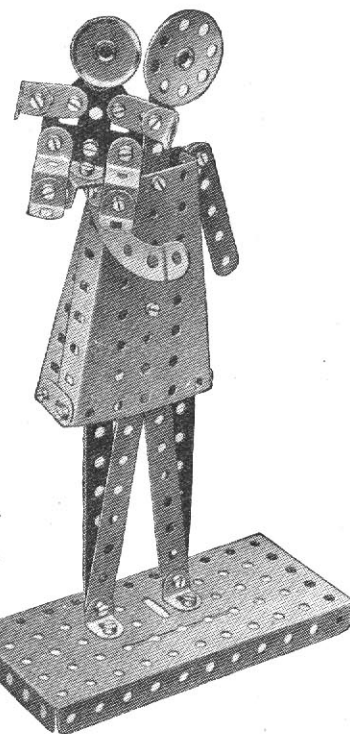

Parts required :

4 of No.	2
1 " "	3
1 " "	5
5 " "	10
1 " "	11
8 " "	12
1 " "	22
1 " "	24
26 " "	37
1 " "	52
2 " "	54
1 " "	90A
2 " "	125
1 " "	126A

Model No. 1.140 Inverted Centrifugal Governor

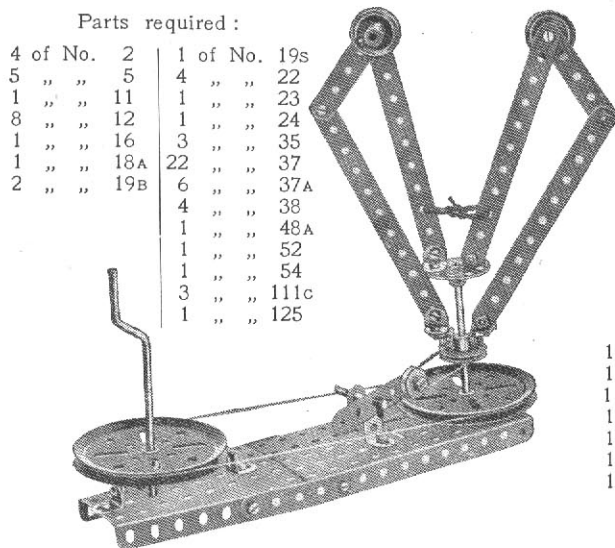

Parts required :

4 of No.	2	1 of No.	19s
5 " "	5	4 " "	22
1 " "	11	1 " "	23
8 " "	12	1 " "	24
1 " "	16	3 " "	35
1 " "	18A	22 " "	37
2 " "	19B	6 " "	37A
		4 " "	38
		1 " "	48A
		1 " "	52
		1 " "	54
		3 " "	111c
		1 " "	125

Model No. 1.142 Candle Stick

Parts required :

2 of No.	11
4 " "	12
1 " "	19B
4 " "	37
1 " "	111c
1 " "	125

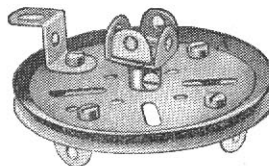

Model No. 1.143 Machine for Tracing a Locus

Parts required :

1 of No.	2	4 of No.	35
1 " "	5	4 " "	37
1 " "	11	3 " "	37A
1 " "	12	4 " "	38
1 " "	17	1 " "	54
1 " "	18A	2 " "	111c
1 " "	24	1 " "	125

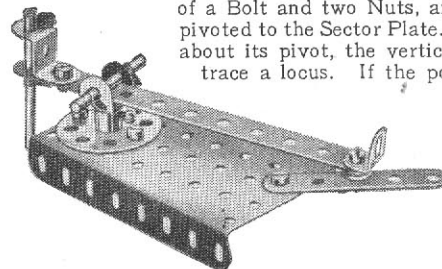

The $5\frac{1}{2}$ " Strip is pivoted to the $2\frac{1}{2}$ " Strip by means of a Bolt and two Nuts, and the $2\frac{1}{2}$ " Strip is similarly pivoted to the Sector Plate. By revolving the $2\frac{1}{2}$ " Strip about its pivot, the vertical $1\frac{1}{2}$ " Rod can be made to trace a locus. If the positions of the $1\frac{1}{2}$ " Rod and the $5\frac{1}{2}$ " Strip are altered, several different loci may be traced. Machines of this type are of advantage in assisting in the design of engine connecting rods.

Model No. 1.145
Anti-Aircraft Gun

Parts required :

4 of No. 2	1 of No. 54
4 " " 5	3 " " 111c
8 " " 12	1 " " 125
1 " " 16	2 " " 126
1 " " 17	
2 " " 18A	
2 " " 19B	
3 " " 22	
1 " " 24	
4 " " 35	
18 " " 37	
2 " " 38	
1 " " 48A	

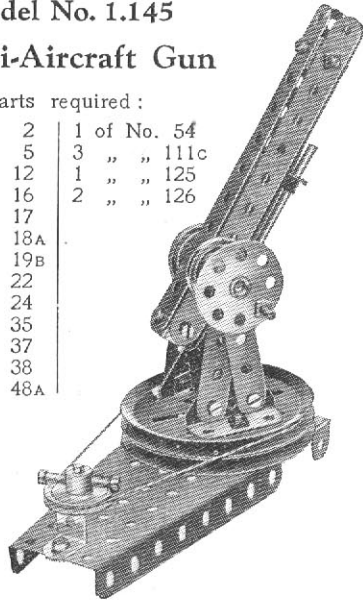

Model No. 1.147 Paddle Steamer

Parts required :

4 of No. 2	1 of No. 52	1 of No. 125
1 " " 3	2 " " 54	2 " " 126
4 " " 5	4 " " 90A	
1 " " 10		
2 " " 12		
2 " " 16		
2 " " 18A		
3 " " 22		
1 " " 24		
3 " " 35		
36 " " 37		
3 " " 48A		

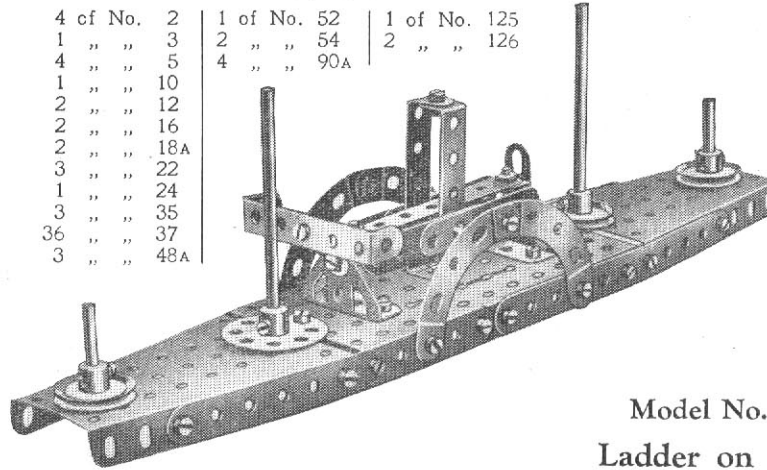

Model No. 1.149
Signal

Parts required :

2 of No. 1
1 " " 3
1 " " 5
2 " " 22
11 " " 37
2 " " 37A
1 " " 52
2 " " 111c

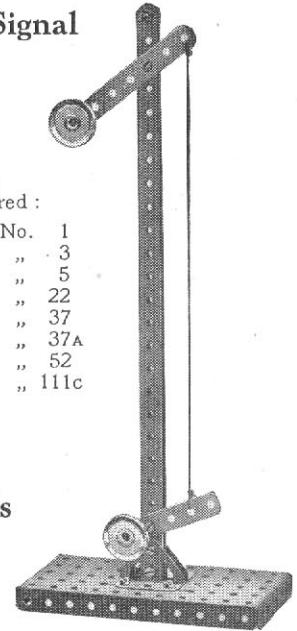

Model No. 1.148
Ladder on Wheels

Parts required :

1 of No. 3
4 " " 5
2 " " 11
6 " " 12
2 " " 16
2 " " 17
1 " " 19B
1 " " 22
1 " " 24
5 " " 35
21 " " 37
2 " " 37A
2 " " 38
2 " " 48A
1 " " 52
3 " " 100
3 " " 111c
2 " " 126

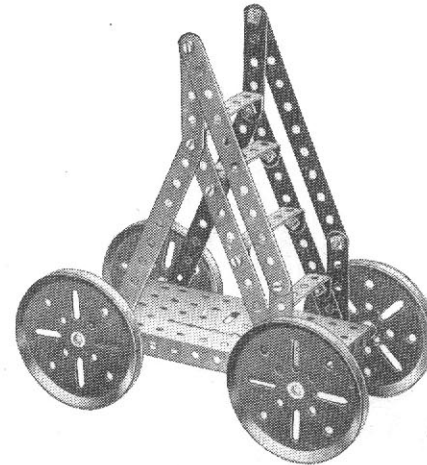

Parts required :

6 of No. 2
4 " " 5
2 " " 16
4 " " 19B
16 " " 37
8 " " 38
4 " " 48A
1 " " 52

Model No. 1.146 Meccanograph

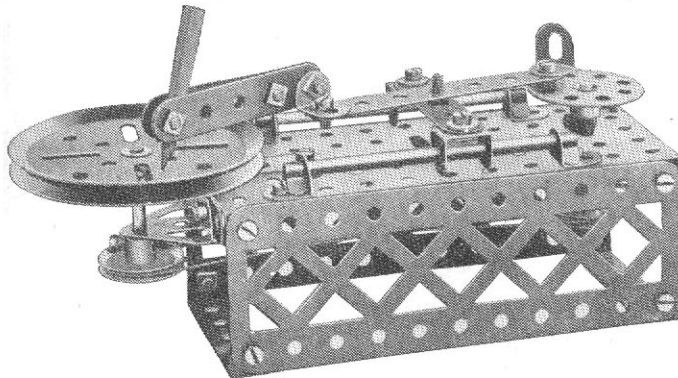

Model No. 1.150

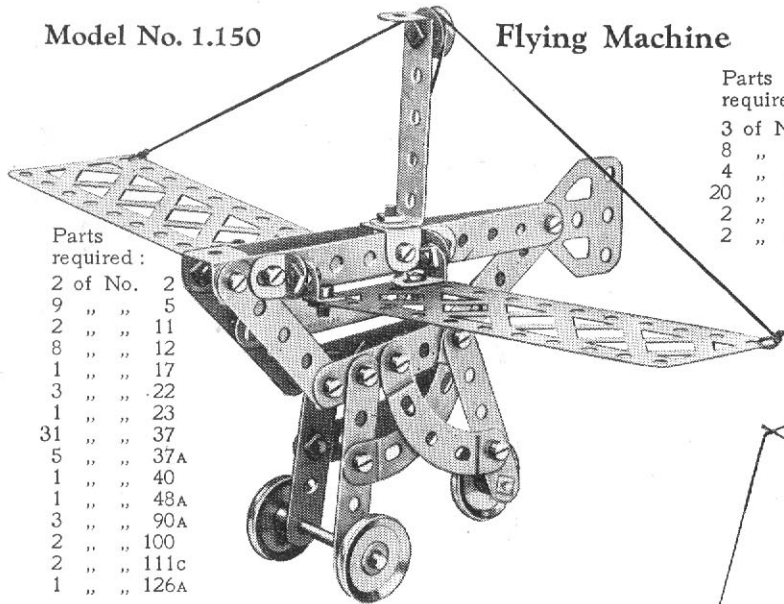

- Parts required:
- 2 of No. 2
 - 9 " " 5
 - 2 " " 11
 - 8 " " 12
 - 1 " " 17
 - 3 " " 22
 - 1 " " 23
 - 31 " " 37
 - 5 " " 37A
 - 1 " " 40
 - 1 " " 48A
 - 3 " " 90A
 - 2 " " 100
 - 2 " " 111c
 - 1 " " 126A

Flying Machine

- Parts required:
- 3 of No. 1
 - 8 " " 2
 - 4 " " 12
 - 20 " " 37
 - 2 " " 54
 - 2 " " 100

Model No. 1.152 Inverted Truss

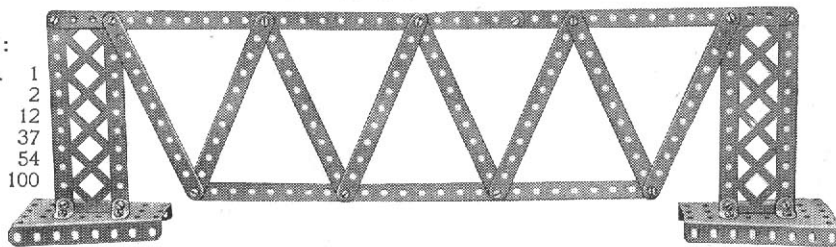

Model No. 1.153 Sand Yacht

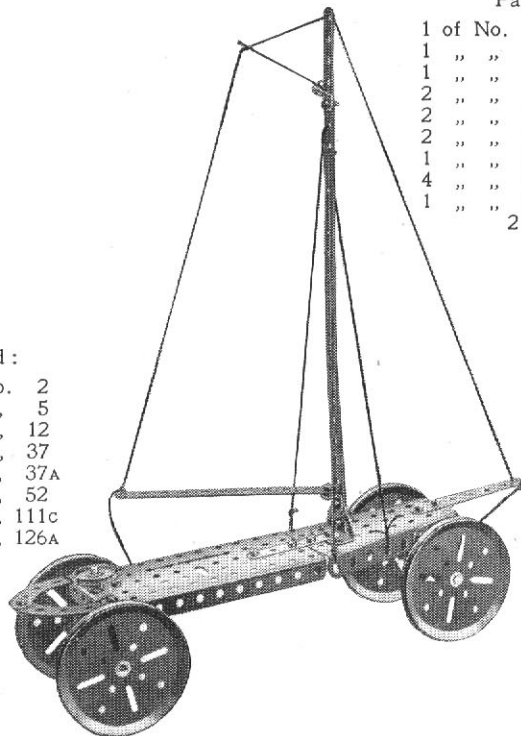

- Parts required:
- | | |
|---------------|-------------|
| 1 of No. 1 | 1 of No. 24 |
| 1 " " 2 | 4 " " 35 |
| 1 " " 3 | 23 " " 37 |
| 2 " " 5 | 1 " " 48A |
| 2 " " 12 | 1 " " 52 |
| 2 " " 16 | 1 " " 54 |
| 1 " " 18A | 2 " " 90A |
| 4 " " 19B | 1 " " 125 |
| 1 " " 22 | 1 " " 126 |
| 2 of No. 126A | |

Model No. 1.154 Box Ball Alley

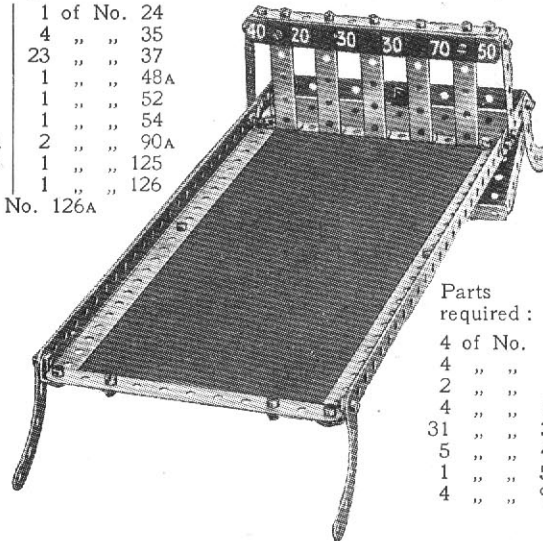

- Parts required:
- 4 of No. 1
 - 4 " " 2
 - 2 " " 5
 - 4 " " 10
 - 31 " " 37
 - 5 " " 48A
 - 1 " " 52
 - 4 " " 90A

Model No. 1.151 Gate

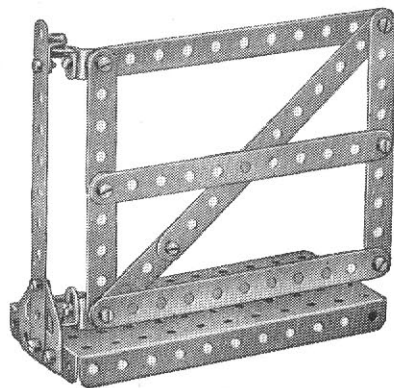

- Parts required:
- 6 of No. 2
 - 4 " " 5
 - 5 " " 12
 - 13 " " 37
 - 4 " " 37A
 - 1 " " 52
 - 2 " " 111c
 - 1 " " 126A

Model No. 1.155 Rake

- Parts required:
- 1 of No. 2
 - 1 " " 3
 - 4 of No. 10
 - 1 " " 12
 - 6 of No. 37

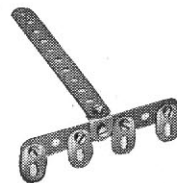

Model No. 1.156 Swivelling Jib Crane, Electric

Parts required :		
4 of No. 1	1 of No. 23	1 of No. 57
6 " " 2	1 " " 24	Electric Motor
1 " " 3	6 " " 35	(not included in
1 " " 11	30 " " 37	Outfi)
6 " " 12	1 " " 40	
2 " " 16	2 " " 48A	
2 " " 17	1 " " 52	
1 " " 18A	1 " " 54	
4 " " 19B		
4 " " 22		

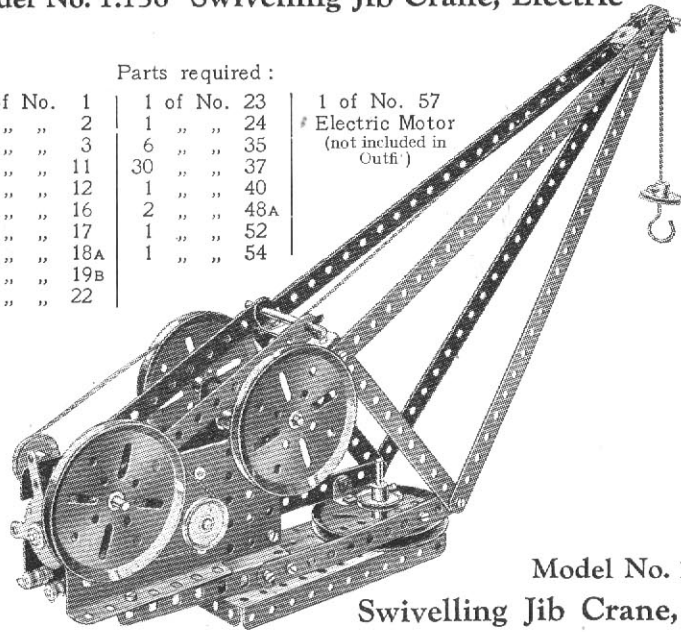

Model No. 1.158 Overhead Crane

Parts required :	
4 of No. 2	2
4 " " 5	5
2 " " 10	10
4 " " 12	12
1 " " 16	16
1 " " 18A	18A
1 " " 19s	19s
4 " " 22	22
1 " " 23	23
1 " " 24	24
2 " " 35	35
25 " " 37	37
1 " " 38	38
6 " " 48A	48A
1 " " 57	57
4 " " 90A	90A
2 " " 100	100



Model No. 1.160 Band Saw

Parts required :	
2 of No. 1	1
2 " " 2	2
2 " " 5	5
2 " " 16	16
1 " " 19B	19B
1 " " 19s	19s
2 " " 22	22
6 " " 35	35
18 " " 37	37
3 " " 48A	48A
1 " " 52	52
2 " " 90A	90A
2 " " 126A	126A

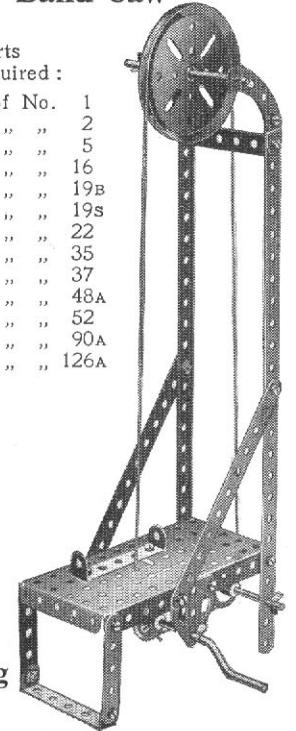

Model No. 1.157 Swivelling Jib Crane, Hand Operated

This illustrates an alternative construction of the base of Model No. 1.156, and is intended to show how the model may be operated by hand if an electric motor is not available.

Parts required :	
4 of No. 1	4 of No. 12
6 " " 2	2 " " 17
1 " " 5	1 " " 18A
1 " " 11	2 " " 19B
	1 " " 19s
	4 " " 22
	1 " " 23
	1 " " 24
	4 " " 35
	32 " " 37
	4 " " 38
	1 " " 48
	1 " " 48A
	1 " " 52
	2 " " 54
	1 " " 57
	1 " " 126
	1 " " 126A

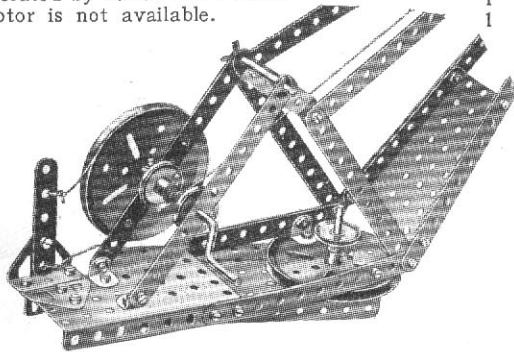

Model No. 1.159 Timber Drag

Parts required :		
1 of No. 1	2 of No. 11	4 of No. 48A
1 " " 2	2 " " 16	3 " " 111c
1 " " 3	4 " " 19B	2 " " 125
2 " " 5	19 " " 37	2 " " 126A
2 " " 10	3 " " 37A	

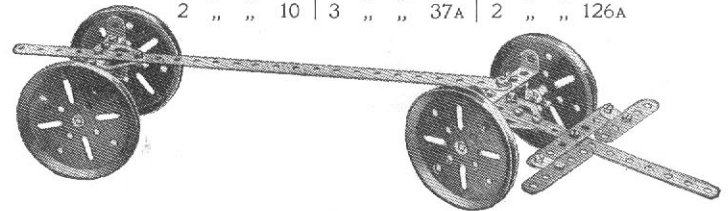

Model No. 1.161 Quick-Firing Gun

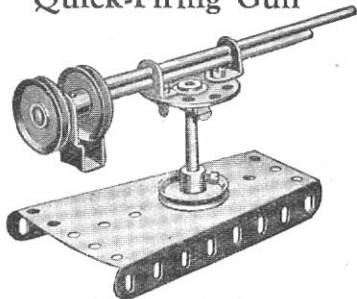

Parts required:

2 of No. 12	1 of No. 24
2 " " 16	2 " " 37
1 " " 17	1 " " 44
4 " " 22	1 " " 54

Parts
required:

2 of No. 2	2
2 " " 11	11
1 " " 18A	18A
2 " " 35	35
8 " " 37	37
1 " " 52	52
2 " " 54	54
2 " " 126	126

Model No. 1.163 Scales

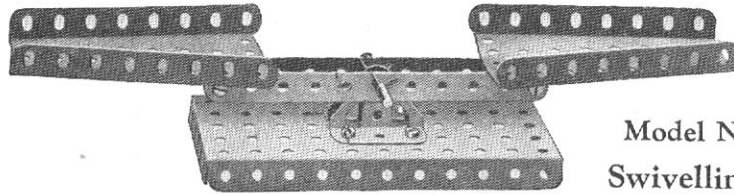

Model No. 1.165 Swivelling Crane

Parts required:

4 of No. 2	1 of No. 44
7 " " 5	1 " " 48A
2 " " 12	1 " " 52
2 " " 17	1 " " 54
1 " " 19s	1 " " 57
4 " " 22	2 " " 126A
1 " " 23	
2 " " 35	
21 " " 37	
3 " " 38	

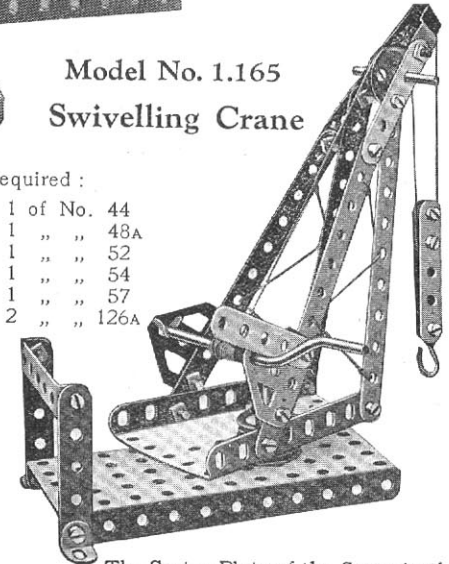

The Sector Plate of the Crane in the above model is pivoted to the base with a fast Pulley above and below.

Model No. 1.162 Punching Machine

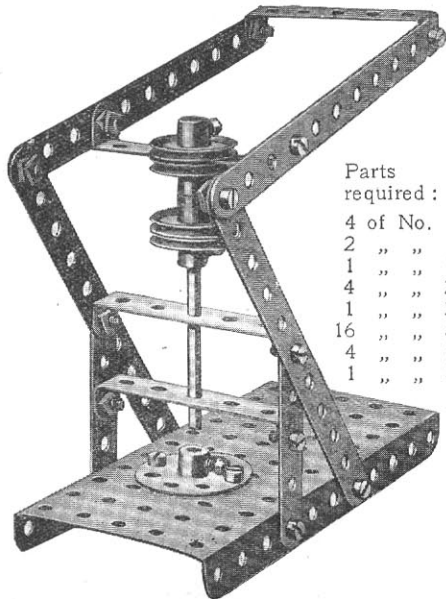

Parts
required:

4 of No. 2	2
2 " " 5	5
1 " " 16	16
4 " " 22	22
1 " " 24	24
16 " " 37	37
4 " " 48A	48A
1 " " 52	52

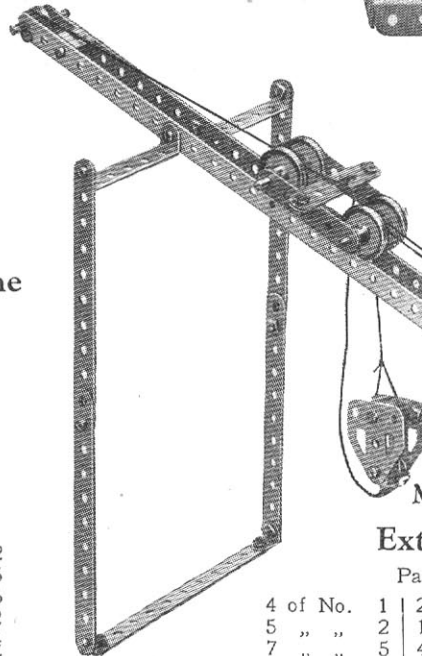

Model No. 1.164

Extended Ash Tip

Parts required:

4 of No. 1	2 of No. 18A	2 of No. 48A
5 " " 2	1 " " 19s	1 " " 52
7 " " 5	4 " " 22	6 " " 111c
2 " " 11	1 " " 24	2 " " 125
8 " " 12	5 " " 35	2 " " 126
1 " " 16	36 " " 37	2 " " 126A
2 " " 17	1 " " 40	

The trolley is operated by means of a cord that is wound round the $1\frac{1}{2}$ " Axle Rod carrying the Bush Wheel, both ends of the cord being secured to the trolley. The bucket is suspended from a cord that winds on to the Crank Handle, and it is tipped by lowering it until a short cord that is attached to the bottom of the bucket and to the trolley, becomes taut. Further lowering causes the bucket to swing over.

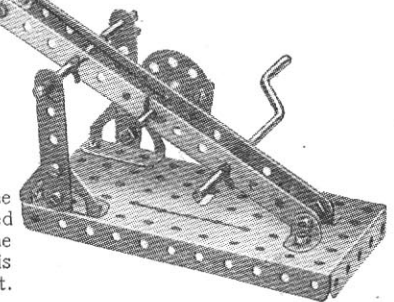

Model No. 1.166 Boy on Swing

Parts required :

4 of No.	1	1 of No.	24
6 "	2	7 "	35
2 "	5	35 "	37
5 "	10	1 "	48A
8 "	12	1 "	52
2 "	16	1 "	54
1 "	17	2 "	125
4 "	22	2 "	126A

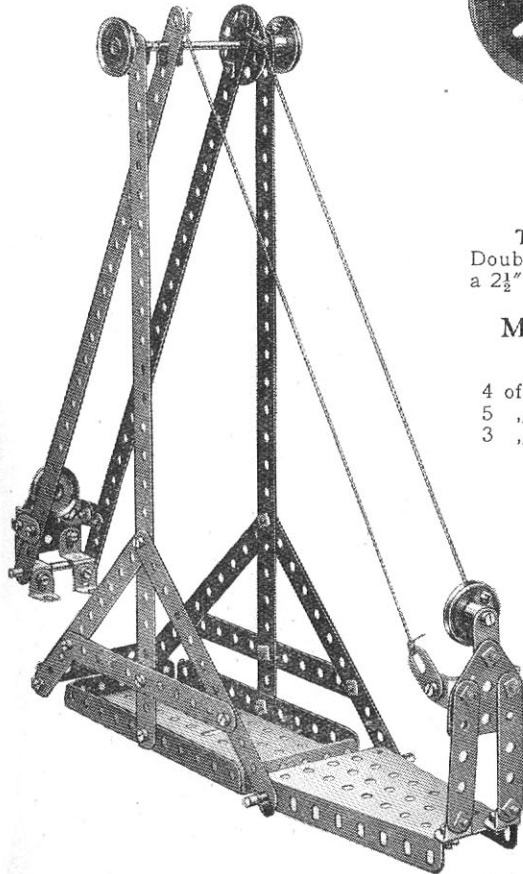

Model No. 1.167 Motor Tractor

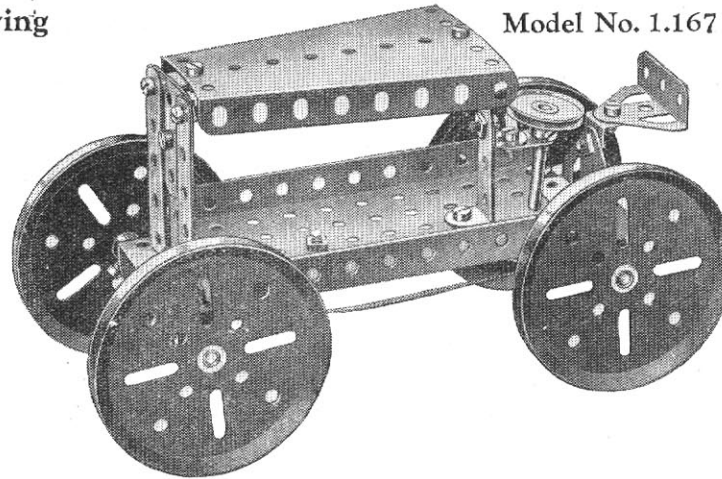

Parts required :

3 of No.	5
1 "	10
2 "	12
2 "	16
1 "	18A
4 "	19B
1 "	22
1 "	24
15 "	37
2 "	37A
6 "	38
4 "	48A
1 "	52
1 "	54
1 "	111c
2 "	126
1 "	126A

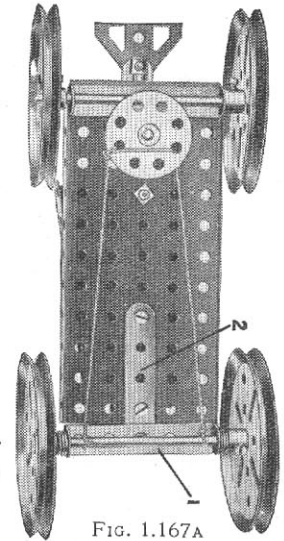

FIG. 1.167A

The steering gear is shown in Fig. 1.167A. The front wheels are carried in a $2\frac{3}{8} \times \frac{1}{2}$ " Double Angle Strip 1, which is mounted pivotally by a Bolt and two Nuts (S.M. 262) to a $2\frac{1}{2}$ " Strip 2 secured to the $5\frac{1}{2} \times 2\frac{1}{2}$ " Flanged Plate.

Model No. 1.168 Bagatelle Table

Parts required :

4 of No.	1	8 of No.	12
5 "	2	25 "	37
3 "	10	4 "	48A
		1 of No.	52

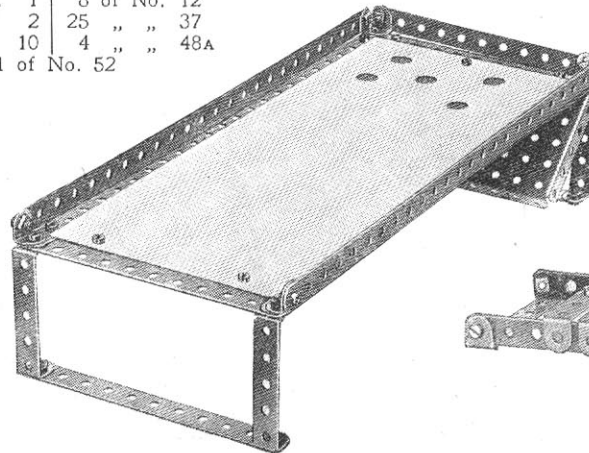

Model No. 1.169 Quick Return Device

Parts required :

2 of No.	2	1 of No.	24
1 "	3	6 "	35
2 "	5	15 "	37
2 "	11	2 "	37A
2 "	12	3 "	48A
1 "	17	1 "	52
2 "	18A	2 "	125

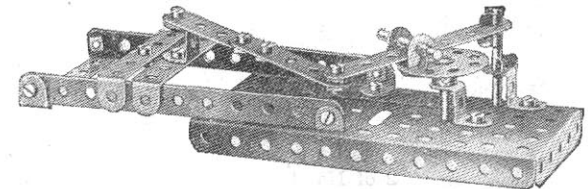

Model No. 1.170. Locomotive

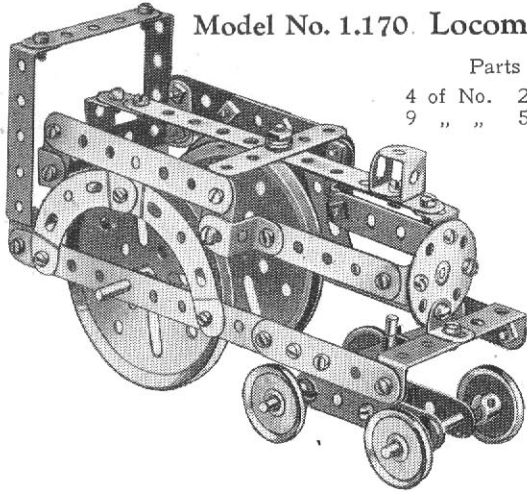

Parts required:

4 of No.	2	5 of No.	10
9 " "	5	2 " "	11
		6 " "	12
		3 " "	16
		1 " "	18A
		2 " "	19B
		4 " "	22
		1 " "	24
		8 " "	35
		36 " "	37
		6 " "	37A
		6 " "	38
		1 " "	48
		6 " "	48A
		4 " "	90A
		6 " "	111c
		2 " "	125

The bogie is connected pivotally to the locomotive body by means of a 1 1/2" Rod journalled in a Double Bracket, which is secured in the centre of the bogie, and in a 2 1/2" x 1/2" Double Angle Strip that is secured between the main side frames. Two Spring Clips between the Double Angle Strip and Double Bracket space the bogie at the correct distance.

**Model No. 1.171
Circular
Saw**

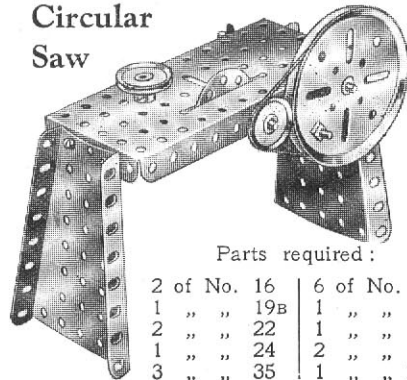

Parts required:

2 of No.	16	6 of No.	37
1 " "	19B	1 " "	37A
2 " "	22	1 " "	52
1 " "	24	2 " "	54
3 " "	35	1 " "	111c
	2 of No.		125

**Model No. 1.172
Treadle Grindstone**

Parts required:

4 of No.	2
1 " "	3
1 " "	5
1 " "	12
3 " "	16
2 " "	19B
4 " "	22
1 " "	24
2 " "	35
9 " "	37
2 " "	37A
1 " "	48A
1 " "	52

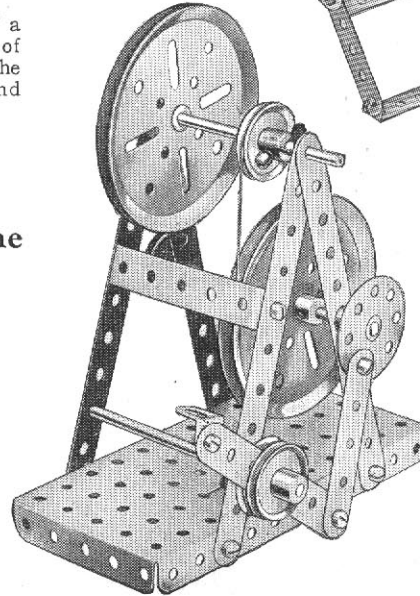

**Model No. 1.173
Quick-Delivery Chute**

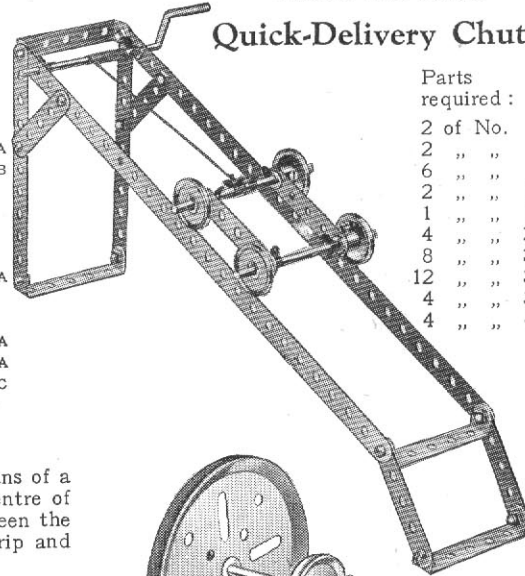

Parts required:

2 of No.	1
2 " "	2
6 " "	5
2 " "	16
1 " "	19s
4 " "	22
8 " "	35
12 " "	37
4 " "	38
4 " "	48A

**Model No. 1.174
Mechanical Gong**

A Flat Bracket is connected pivotally to the base at 2 and is clamped rigidly to a 1" Pulley Wheel secured to the Rod 4. The latter passes through the 1 1/2" Double Angle Strip 3 and carries at its upper end another Pulley to which is rigidly secured the striking arm 5. The Double Angle Strip 3 is pivoted to the Bush Wheel 1.

Parts required:

2 of No.	1
4 " "	2
1 " "	3
4 " "	5
2 " "	10
1 " "	12
1 " "	16
1 " "	19s
2 " "	22
1 " "	24
2 " "	35
26 " "	37
1 " "	37A
2 " "	38
1 " "	48
2 " "	48A
1 " "	52
2 " "	54
1 " "	126
1 " "	126A

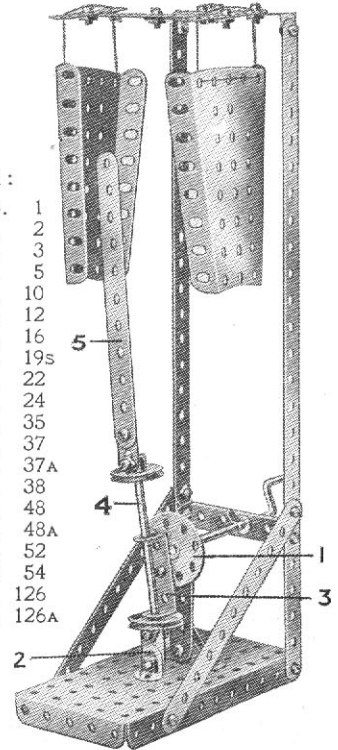

**Model No. 1.175
Telescope**

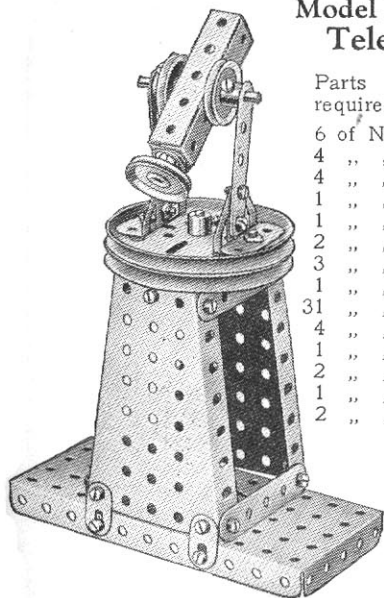

Parts
required :

6 of No.	5
4 " "	10
4 " "	12
1 " "	17
1 " "	18A
2 " "	19B
3 " "	22
1 " "	35
31 " "	37
4 " "	48A
1 " "	52
2 " "	54
1 " "	111c
2 " "	126

Model No. 1.177 Flying Boats

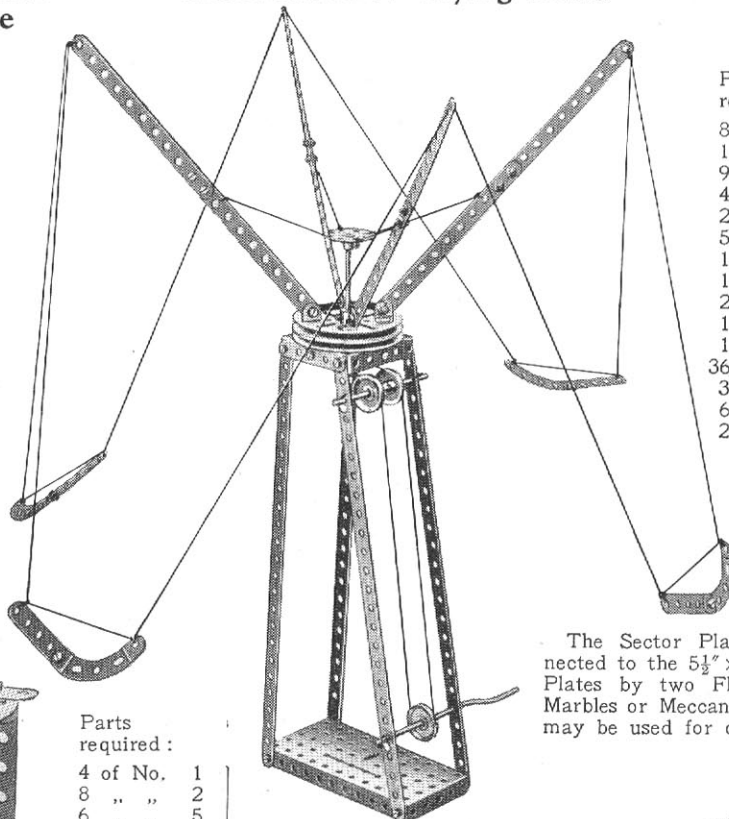

Parts
required :

4 of No.	1
8 " "	2
6 " "	5
8 " "	12
2 " "	16
2 " "	19B
1 " "	19S
4 of No.	22
1 " "	24
4 " "	35
36 " "	37
3 of No.	48A
4 " "	90A

Model No. 1.178 Aeroplane

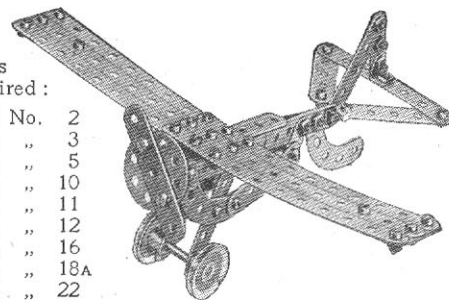

Parts
required :

8 of No.	2
1 " "	3
9 " "	5
4 " "	10
2 " "	11
5 " "	12
1 " "	16
1 " "	18A
2 " "	22
1 " "	24
1 " "	35
36 " "	37
3 " "	90A
6 " "	111c
2 " "	126A

Model No. 1.176 Sedan Chair

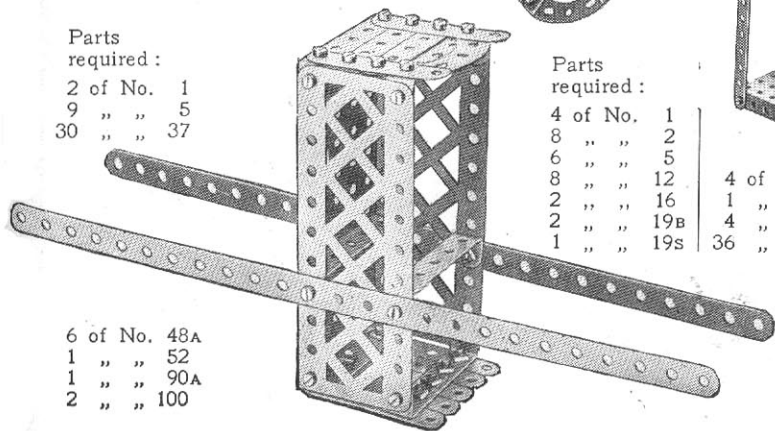

Parts
required :

2 of No.	1
9 " "	5
30 " "	37

6 of No.	48A
1 " "	52
1 " "	90A
2 " "	100

The Sector Plates are connected to the 5 1/2" x 2 1/4" Flanged Plates by two Flat Brackets. Marbles or Meccano Steel Balls may be used for coco-nuts.

**Model No. 1.179
Coco-nut Shy**

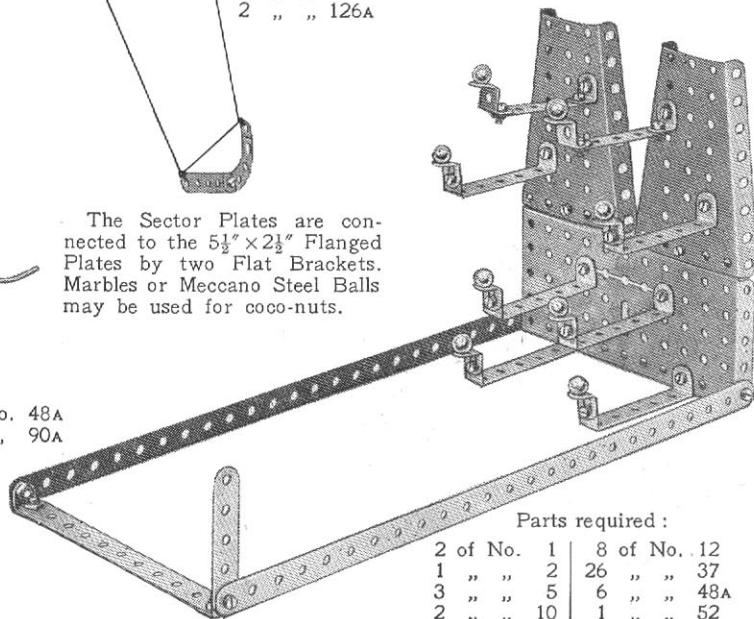

Parts required :

2 of No.	1	8 of No.	12
1 " "	2	26 " "	37
3 " "	5	6 " "	48A
2 " "	10	1 " "	52
2 " "	11	2 " "	54

These Models can be built with MECCANO Outfit No. 1 (or No. 0 and No. 0A)



Model No. 1.180
Umpire's
Seat

Parts
required :

6 of No.	2
7 " "	5
2 " "	10
4 " "	12
24 " "	37
3 " "	48A
2 " "	90A
2 " "	126

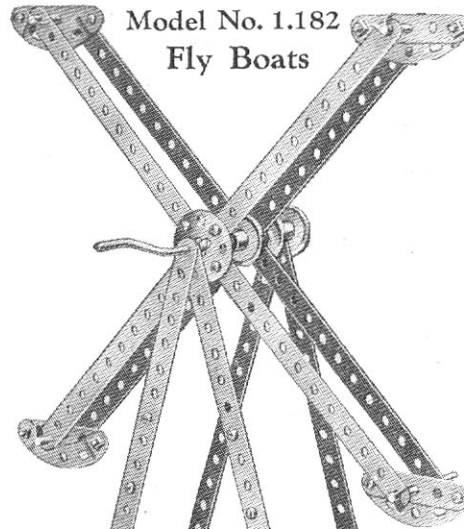

Model No. 1.182
Fly Boats

Parts required :

4 of No.	1	2 of No.	18A
8 " "	2	1 " "	19s
4 " "	5	4 " "	22
2 " "	17	1 " "	24
		8 " "	35
		24 " "	37
		1 " "	52
		4 " "	90A

Model No. 1.183 Bath Chair

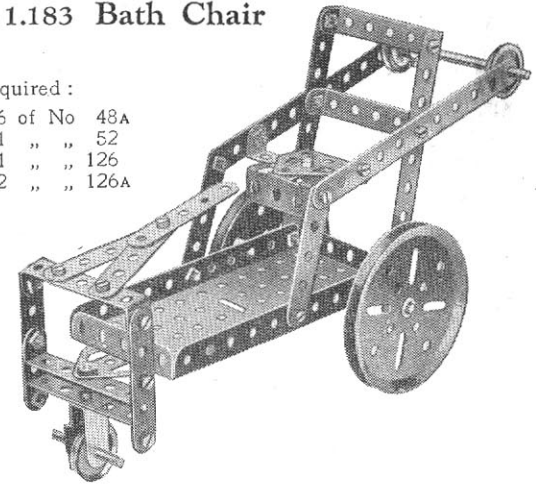

Parts required :

4 of No.	2	6 of No.	48A
7 " "	5	1 " "	52
2 " "	16	1 " "	126
1 " "	18A	2 " "	126A
2 " "	19B		
3 " "	22		
24 " "	37		
1 " "	37A		
1 " "	44		

Model No. 1.181 Submarine

Parts required :

4 of No.	1	2 of No.	35
5 " "	10	28 " "	37
2 " "	11	3 " "	37A
8 " "	12	2 " "	38
2 " "	17	1 " "	48
3 " "	22	1 " "	48A
1 " "	24	2 " "	125
		2 " "	126

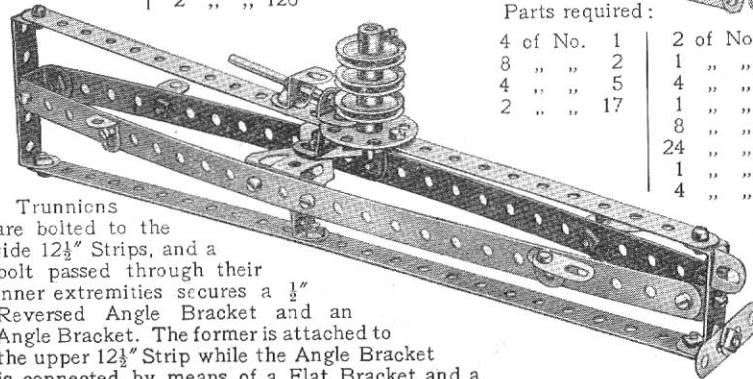

Trunnions are bolted to the side $12\frac{1}{2}$ " Strips, and a bolt passed through their inner extremities secures a $\frac{1}{2}$ " Reversed Angle Bracket and an Angle Bracket. The former is attached to the upper $12\frac{1}{2}$ " Strip while the Angle Bracket is connected by means of a Flat Bracket and a further Angle Bracket to the lower Strip.

Model No. 1.184 Acrobat on See-Saw

Parts
required :

3 of No.	1
6 " "	2
4 " "	5
3 " "	10
2 " "	11
4 " "	12
2 " "	16
1 " "	18A
1 " "	19B

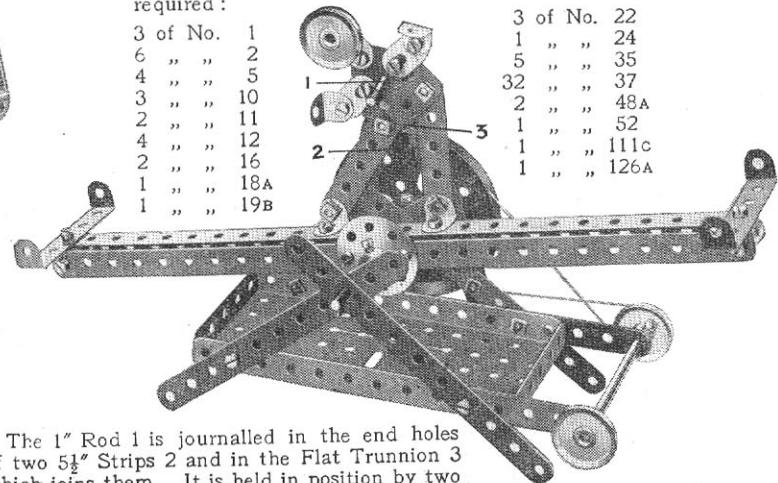

3 of No.	22
1 " "	24
5 " "	35
32 " "	37
2 " "	48A
1 " "	52
1 " "	111c
1 " "	126A

The 1" Rod 1 is journaled in the end holes of two $5\frac{1}{2}$ " Strips 2 and in the Flat Trunnion 3 which joins them. It is held in position by two Spring Clips, placed on either side of the $5\frac{1}{2}$ " Strips 2.

Model No. 1.185 Sawing Machine.

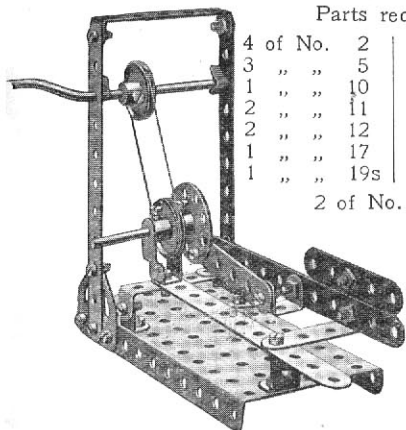

Parts required :

4 of No. 2	2 of No. 22
3 " " 5	1 " " 24
1 " " 10	2 " " 35
2 " " 11	22 " " 37
2 " " 12	1 " " 44
1 " " 17	2 " " 48A
1 " " 19s	1 " " 52
2 of No. 126A	

Model No. 1.187 Rotating Crane

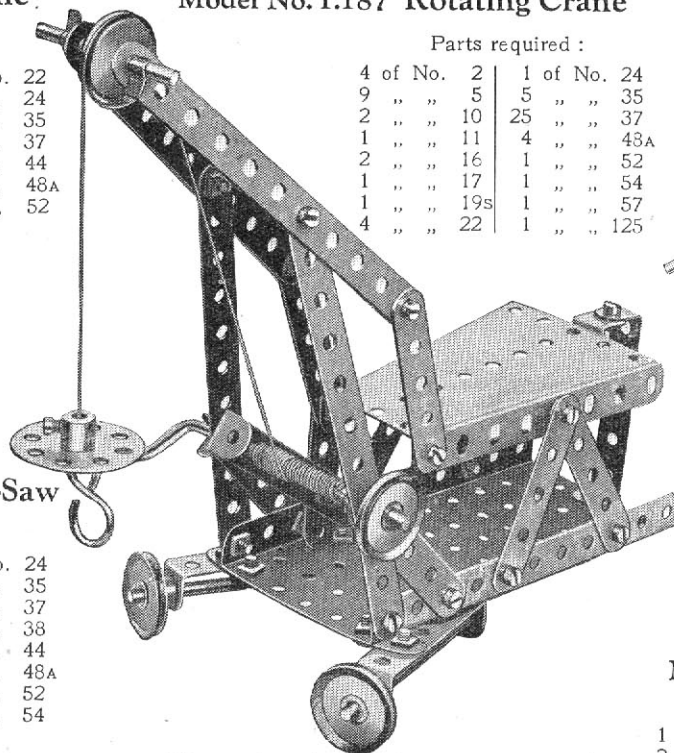

Parts required :

4 of No. 2	1 of No. 24
9 " " 5	5 " " 35
2 " " 10	25 " " 37
1 " " 11	4 " " 48A
2 " " 16	1 " " 52
1 " " 17	1 " " 54
1 " " 19s	1 " " 57
4 " " 22	1 " " 125

Model No. 1.188 Hooke's Coupling

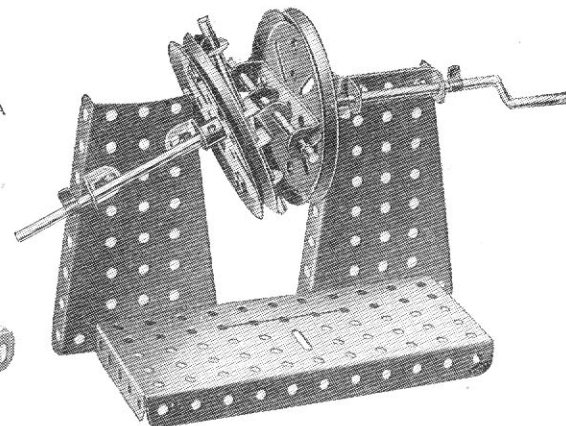

Parts required :

2 of No. 11	7 of No. 35
2 " " 12	12 " " 37
3 " " 16	1 " " 48
2 " " 19B	2 " " 48A
1 " " 19s	1 " " 52
2 of No. 54	

Model No. 1.186 Revolving See-Saw

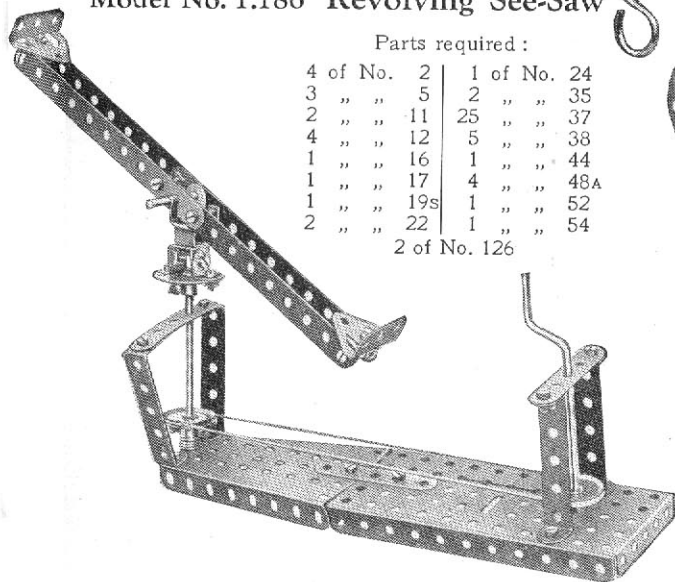

Parts required :

4 of No. 2	1 of No. 24
3 " " 5	2 " " 35
2 " " 11	25 " " 37
4 " " 12	5 " " 38
1 " " 16	1 " " 44
1 " " 17	4 " " 48A
1 " " 19s	1 " " 52
2 " " 22	1 " " 54
2 of No. 126	

Model No. 1.189 Band Brake

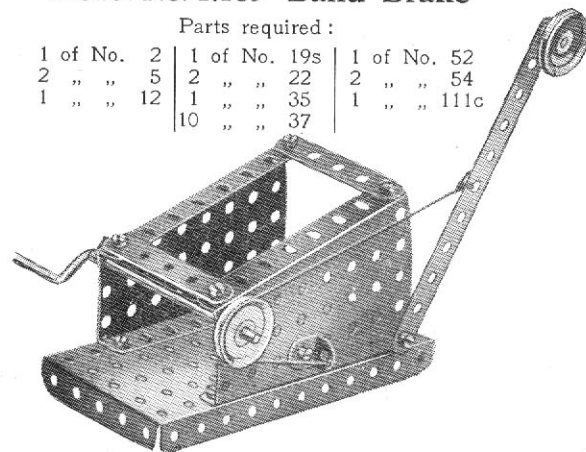

Parts required :

1 of No. 2	1 of No. 19s	1 of No. 52
2 " " 5	2 " " 22	2 " " 54
1 " " 12	1 " " 35	1 " " 111c
	10 " " 37	

The running wheels of this crane are journaled in Double Angle Strips bolted to the Base Plate and secured at an angle by means of Flat Brackets. The rear of the Base Plate is supported on a Double Bracket. The jib is bolted loosely to the supporting 5½" Strips and is connected by 2½" Strips to the Sector Plate which pivots about its supporting bolts. By moving this Sector Plate the elevation of the jib may be altered as desired. The movement is controlled by a Double Angle Strip mounted on the Crank Handle and connected pivotally to the Plate by means of a 2½" Strip. A Reversed Angle Bracket bolted to an upright Double Angle Strip in the rear of the model serves to restrict the movement of the Sector Plate.

Model No. 1.190 Rat Trap

Parts required :

8 of No. 2	8 of No. 35	1 of No. 48	1 of No. 54
1 " " 3	31 " " 37	6 " " 48A	2 " " 90A
8 " " 5	1 " " 38	1 " " 52	3 " " 111c
5 " " 10			
2 " " 11			
6 " " 12			
2 " " 16			
1 " " 17			
3 " " 22			
1 " " 23			
1 " " 24			

The "bait" consists of a 1" fast Pulley and a 1/2" loose Pulley suspended by means of a cord from a Double Bracket. The latter is bolted to a 1 1/2" x 1/2" Double Angle Strip that is free to turn on a 2" Rod journalled in a pair of Angle Brackets. A Flat Bracket bolted to the Double Bracket engages a second Double Bracket on the end of a 5 1/2" Strip that is bolted to the door of the cage. If the "bait" is touched, the heavily-weighted door falls into place, and is prevented from re-opening by catches formed from Flat Brackets secured to 5 1/2" Strips that are bolted to the trap by their extreme ends and act as springs.

Model No. 1.191 Toast Rack

Parts required :

6 of No. 5	21 of No. 37
6 " " 12	1 " " 52
4 of No. 90A	

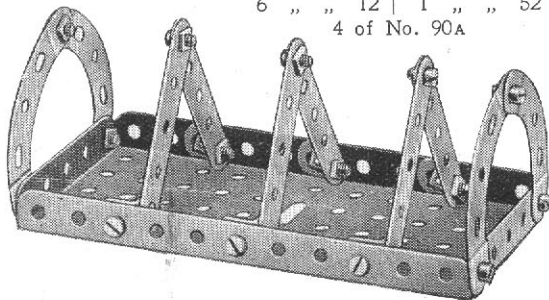

Model No. 1.192 Pantograph

Parts required :

4 of No. 1	11
2 " " 2	18A
1 " " 1	22
1 " " 1	35
7 " " 7	37
3 " " 3	37A
2 " " 2	125

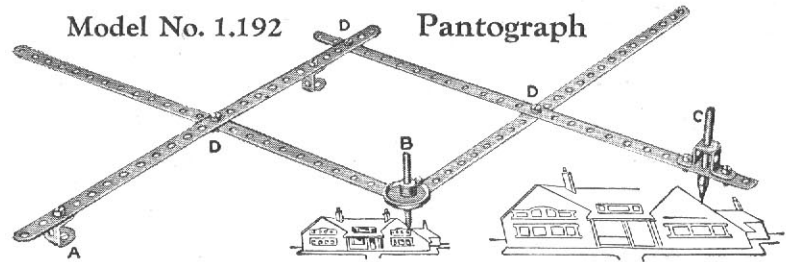

Most boys have heard of the Pantograph but not many have had an opportunity of seeing its principles demonstrated. It is an instrument for copying plans, etc., on the same or on a reduced or enlarged scale.

The apparatus is fixed at the point A. If an enlarged sketch is to be made, the point B is traced round the outlines, the writing point C reproducing the sketch on a larger scale. When a reduced drawing is to be made, the point C traces the outline, whilst the point B reproduces the sketch on a smaller scale. The degree of enlargement or reduction varies according to the position in which point C is fixed on the perforated arm.

The bolts at D are fitted with lock-nuts to allow free movement of the 12 1/2" Strips.

Model No. 1.193

Lamp Standard

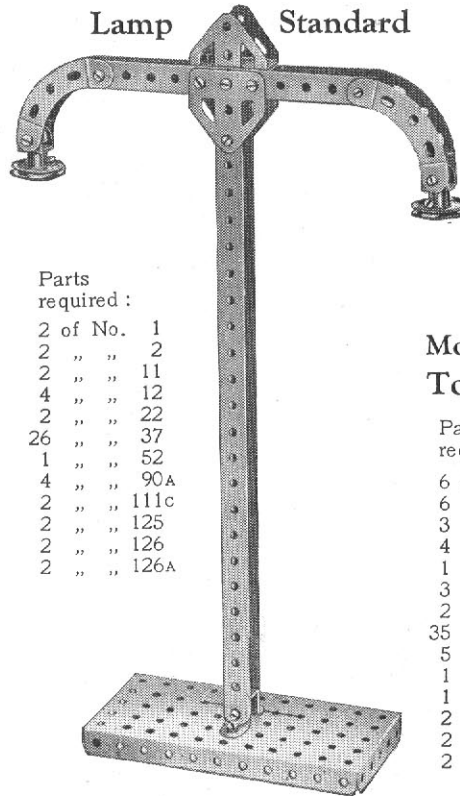

Parts required :

2 of No. 1	2
2 " " 2	11
4 " " 4	12
2 " " 2	22
26 " " 26	37
1 " " 1	52
4 " " 4	90A
2 " " 2	111c
2 " " 2	125
2 " " 2	126
2 " " 2	126A

Model No. 1.194 Tower Wagon

Parts required :

6 of No. 2	5
6 " " 6	16
3 " " 3	19B
4 " " 4	19S
1 " " 1	22
3 " " 3	35
2 " " 2	37
35 " " 35	48A
5 " " 5	52
1 " " 1	57
1 " " 1	90A
2 " " 2	126
2 " " 2	126A

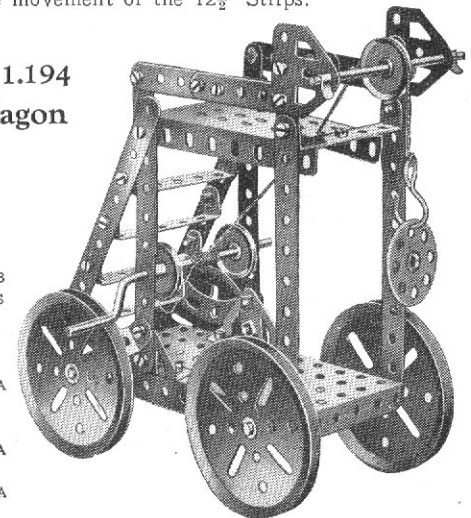

Model No. 1.195 Gramophone

Parts required :

2 of No. 10	6 of No. 37	1 of No. 52
1 " " 12	1 " " 38	2 " " 90A
1 " " 19B		2 " " 111c
1 " " 23		
1 " " 24		

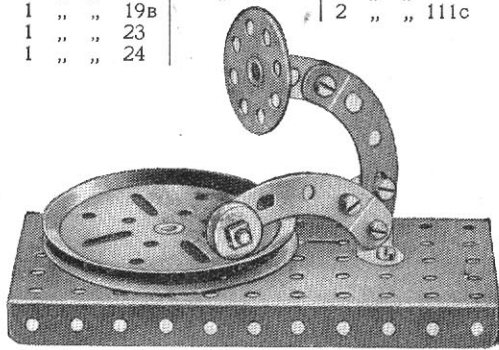

Model No. 1.197 Lancer

Parts required :

1 of No. 2
1 " " 3
9 " " 5
2 " " 10
2 " " 11
5 " " 12
2 " " 16
1 " " 19s
4 " " 22
1 " " 24
1 " " 35
27 " " 37
1 " " 48A
1 " " 52
1 " " 54
4 " " 90A
1 " " 126A

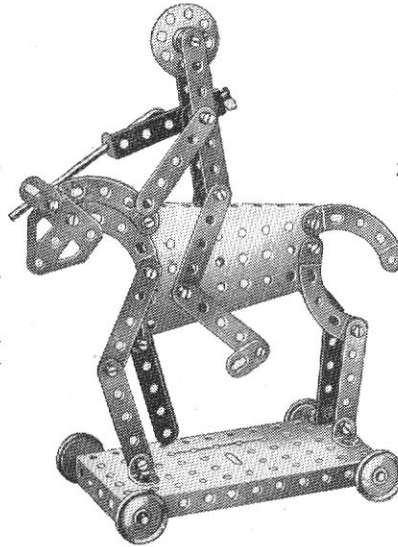

Model No. 1.198 Stamping Machine

Parts required :

4 of No. 2
5 " " 5
2 " " 10
2 " " 16
1 " " 19s
4 " " 22
1 " " 24
2 " " 35
22 " " 37
4 " " 48A
1 " " 52
2 " " 126A

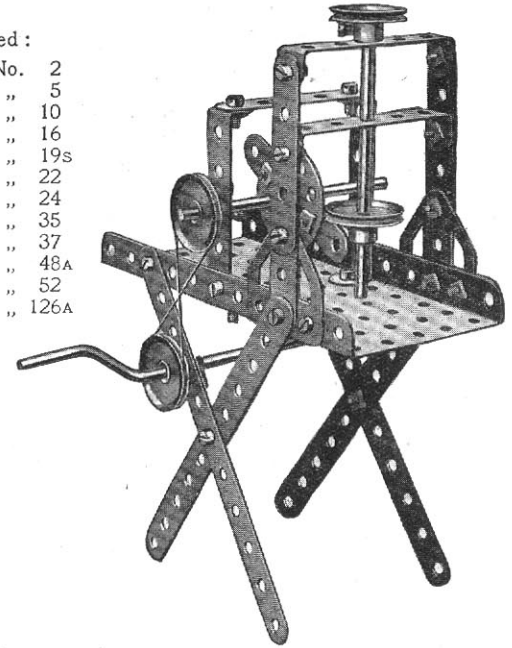

Model No. 1.196 Lorry Crane

Parts required :

4 of No. 2	2 of No. 16
8 " " 5	1 " " 17
2 " " 10	1 " " 18A
2 " " 12	4 " " 19B
	1 " " 19s
	3 " " 22
	1 " " 23
	1 " " 24
	3 " " 35
	29 " " 37
	1 " " 44
	5 " " 48A
	1 " " 52
	1 " " 54
	1 " " 57
	2 " " 125

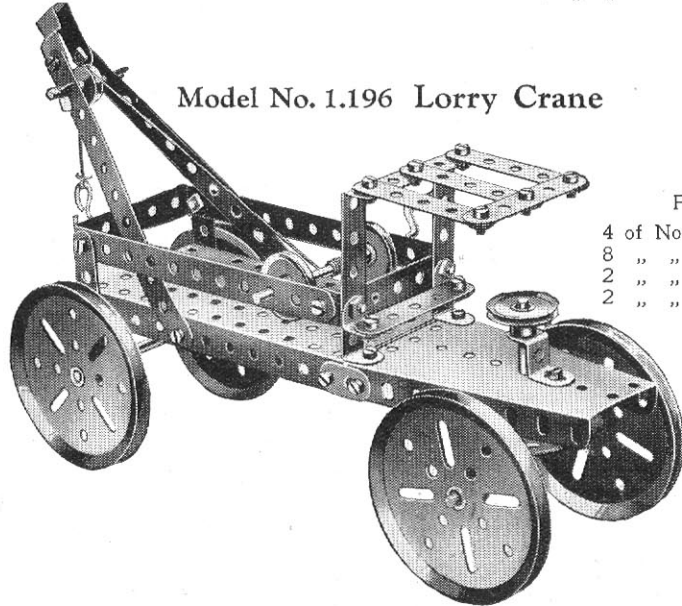

Model No. 1.199 Lazy Tong

Parts required :

2 of No. 1	1 of No. 23	2 of No. 48A
4 " " 2	12 " " 37	2 " " 111c
4 " " 5	10 " " 37A	

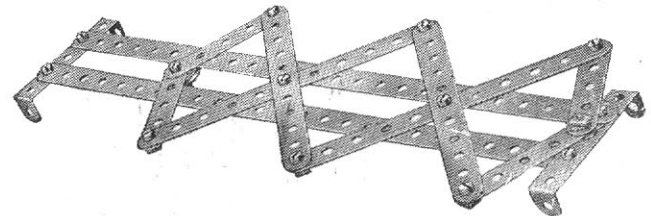

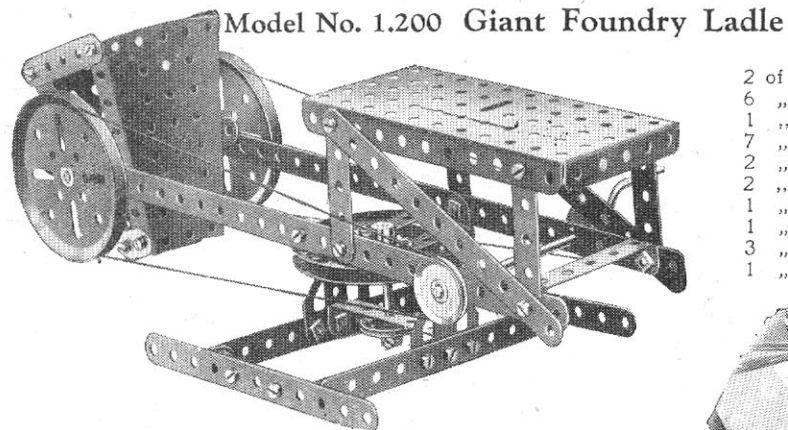

Parts required:

2 of No. 1	3 of No. 22
6 " " 2	1 " " 24
1 " " 3	36 " " 37
7 " " 5	6 " " 37A
2 " " 10	6 " " 48A
2 " " 12	1 " " 52
1 " " 16	2 " " 54
1 " " 17	6 " " 111c
3 " " 19B	2 " " 126A
1 " " 19s	

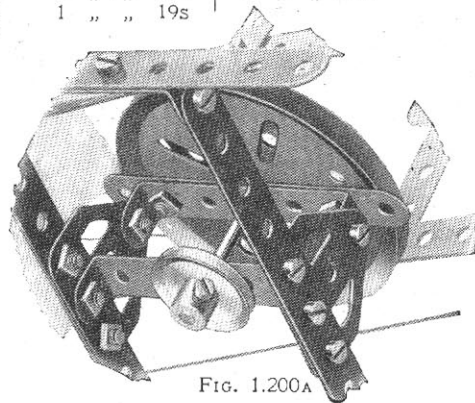

The ladle pivots about a $3\frac{1}{2}$ " Axle Rod carrying a 3" Pulley at each end in addition to a Bush Wheel and a $2\frac{1}{2}$ " Strip. The two latter parts are bolted to the side flanges of the Sector Plates and the Bush Wheel is nipped in position on the Rod. The pivot about which the superstructure turns is shown in Fig. 1.200A.

Model No. 1.201 Boat Steering Gear

Parts required:

4 of No. 2	1 of No. 24
1 " " 3	14 " " 37
2 " " 11	4 " " 37A
1 " " 12	1 " " 40
1 " " 16	1 " " 48A
1 " " 18A	1 " " 52
1 " " 19B	6 " " 111c
3 " " 22	1 " " 125
	1 of No. 126

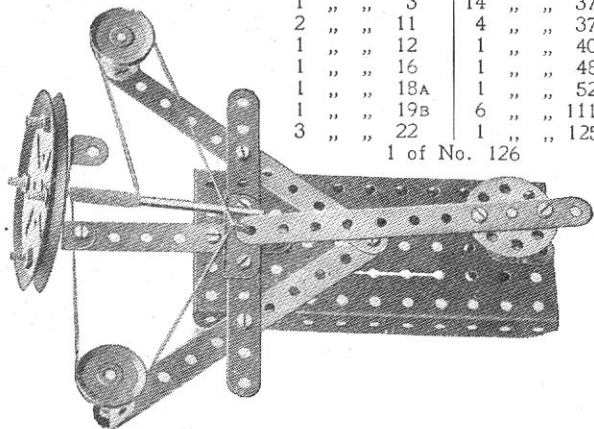

Model No. 1.202 Gyroscope

The $7/32$ " Bolt 1 is gripped by the Set-Screw of the Bush Wheel. The lower end of the Rod 2 of the Gyroscope enters the boss of the Bush Wheel and rests on the shank of the Bolt 1.

Parts required:

4 of No. 12
1 " " 16
4 " " 19B
1 " " 24
10 " " 37
4 " " 48A

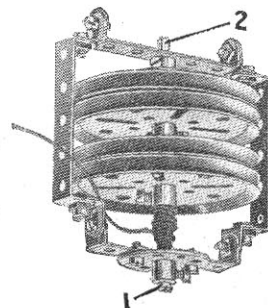

Model No. 1.203 Elevated Jib Crane

A 1" fast Pulley Wheel secured to the armature spindle of the Electric Motor is connected by an endless cord to the 3" Pulley Wheel 1. A 1" fast Pulley 2 on the same Rod as the latter is similarly connected with a second 3" Pulley Wheel 3. A cord wound on the Rod to which the latter is secured carries the load hook. The jib is supported by two cords 4, and the whole superstructure, which is secured to the 3" Pulley Wheel 6, is capable of revolving with the Rod 5. The latter is journaled in two $2\frac{1}{2} \times \frac{1}{4}$ " Double Angle Strips secured between the Sector Plates in the base of the model.

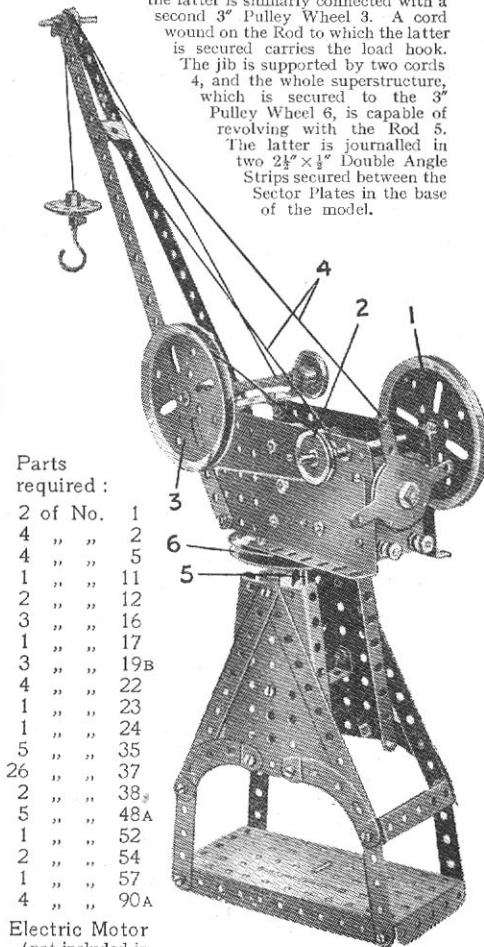

Parts required:

2 of No. 1
4 " " 2
4 " " 5
1 " " 11
2 " " 12
3 " " 16
1 " " 17
3 " " 19B
4 " " 22
1 " " 23
1 " " 24
5 " " 35
26 " " 37
2 " " 38s
5 " " 48A
1 " " 52
2 " " 54
1 " " 57
4 " " 90A

Electric Motor
(not included in
Outfit)

Model No. 1.204 Motor Lorry

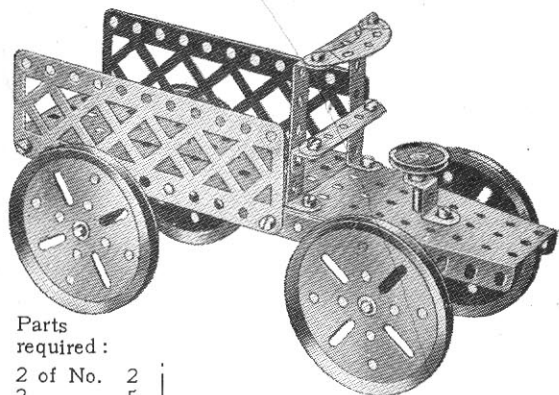

Parts required:

2 of No. 2			
2 " " 5			
2 " " 12	25 of No. 37	1 of No. 90A	
2 " " 16	2 " " 38	2 " " 100	
1 " " 18A	3 " " 48A	2 " " 125	
4 " " 19B	1 " " 52	1 " " 126A	
1 " " 24	1 " " 54		

Model No. 1.205 Mechanical Shovel

Parts required:

4 of No. 1	1 of No. 38
6 " " 2	1 " " 48
5 " " 5	6 " " 48A
2 " " 11	1 " " 52
3 " " 16	2 " " 54
1 " " 18A	1 " " 126A
1 " " 19B	
1 " " 19S	
4 " " 22	
1 " " 23	
1 " " 24	
6 " " 35	
35 " " 37	
1 " " 37A	

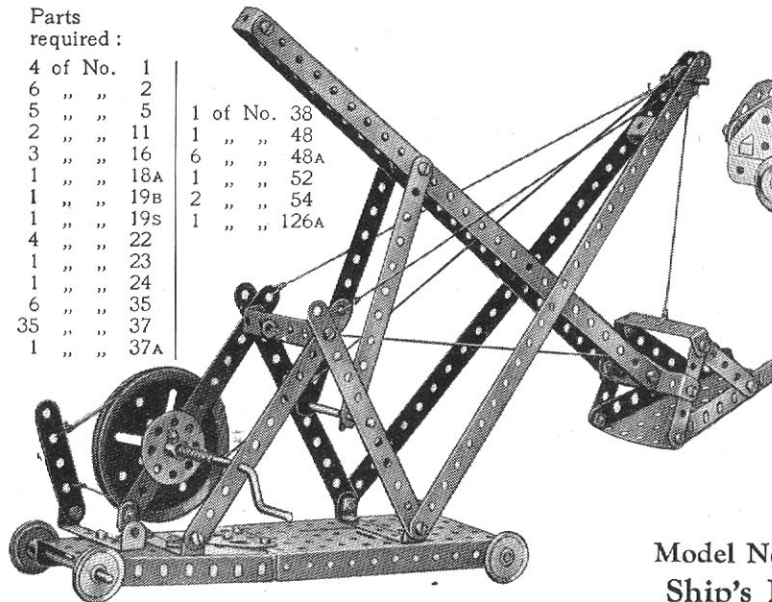

Model No. 1.207 Locomotive

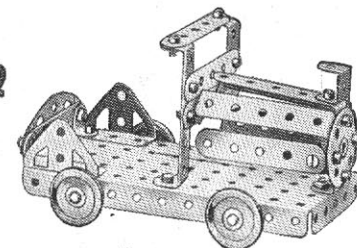

Parts required:

7 of No. 5
1 " " 11
6 " " 12
2 " " 16
4 " " 22
1 " " 24
24 " " 37
4 " " 48A
1 " " 52
1 " " 90A
2 " " 126

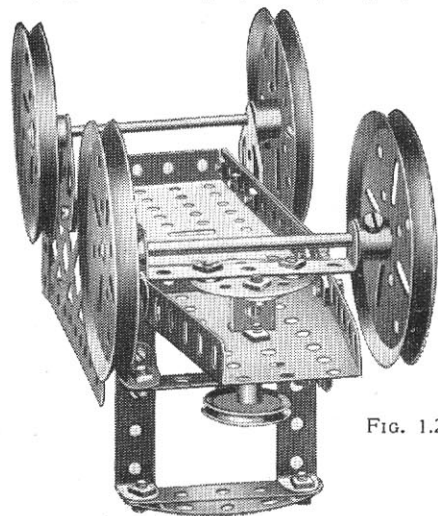
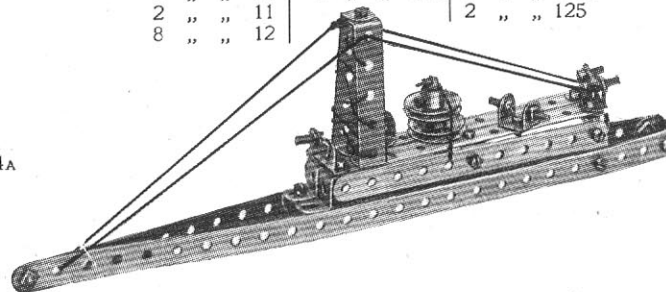

FIG. 1.204A

Model No. 1.206 Battleship

Parts required:

2 of No. 1	2 of No. 22	1 of No. 40
4 " " 2	26 " " 37	2 " " 48A
5 " " 10	6 " " 37A	6 " " 111c
2 " " 11		2 " " 125
8 " " 12		



Model No. 1.208 Ship's Lamp

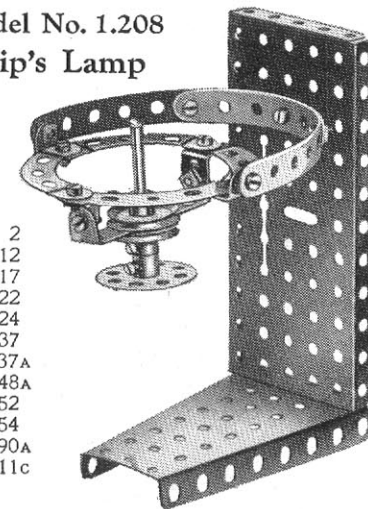

Parts required:

2 of No. 2
4 " " 12
1 " " 17
2 " " 22
1 " " 24
11 " " 37
4 " " 37A
1 " " 48A
1 " " 52
1 " " 54
4 " " 90A
2 " " 111c

Model No. 1.209 Gong

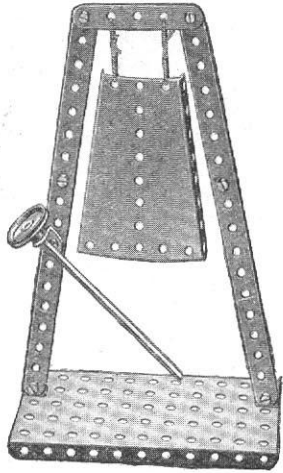

Parts required :

4 of No. 2	1 of No. 22
1 " " 5	9 " " 37
3 " " 12	1 " " 52
1 " " 16	1 " " 54

Model No. 1.210 Emery Wheel

Parts required :

1 of No. 17	1 of No. 22	10 of No. 37
1 " " 18A	1 " " 24	1 " " 48A
2 " " 19B	2 " " 35	1 " " 52
		1 " " 111c
		2 " " 125
		2 " " 126A
		Disc of emery paper 3" diameter

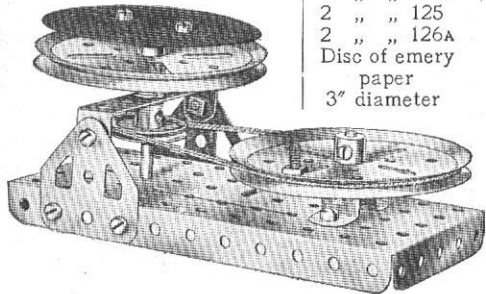

Model No. 1.211

Roundabout

Begin to build this model by making the platform from a Flanged Plate and 12 1/2" Strips. The drive from the Pulley on the Crank Handle is taken to a 1" Pulley fast on the vertical 2" Rod, another similar Pulley being secured to this Rod beneath the Plate.

The arms are formed of four 5 1/2" Strips bolted to a Bush Wheel fast on the 2" Rod.

Parts required :

4 of No. 1	3 of No. 22
4 " " 2	1 " " 24
6 " " 5	6 " " 35
4 " " 10	22 " " 37
2 " " 16	4 " " 48A
1 " " 17	1 " " 52
1 " " 19s	2 " " 54

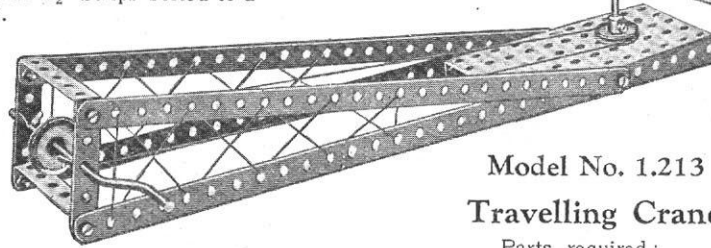

Model No. 1.213

Travelling Crane

Parts required :

2 of No. 1	1 of No. 24	2 of No. 90A
6 " " 2	4 " " 35	2 " " 111c
1 " " 11	25 " " 37	1 " " 125
3 " " 16	6 " " 37A	2 " " 126
1 " " 18A	1 " " 48	2 " " 126A
2 " " 19B	4 " " 48A	
1 " " 19s	1 " " 52	
4 " " 22	1 " " 57	
1 " " 23		

Model No. 1.212

King Meccano

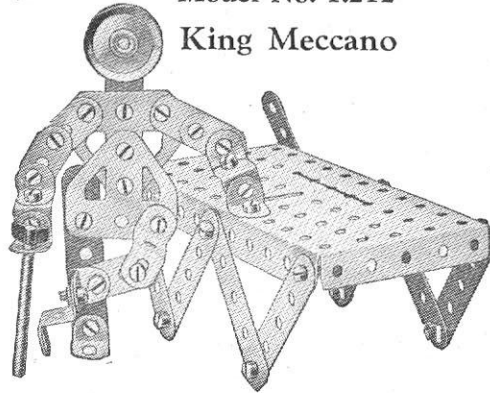

Parts required :

1 of No. 3	1 of No. 35
9 " " 5	30 " " 37
5 " " 10	1 " " 52
8 " " 12	1 " " 111c
1 " " 17	2 " " 125
1 " " 22	2 " " 126A

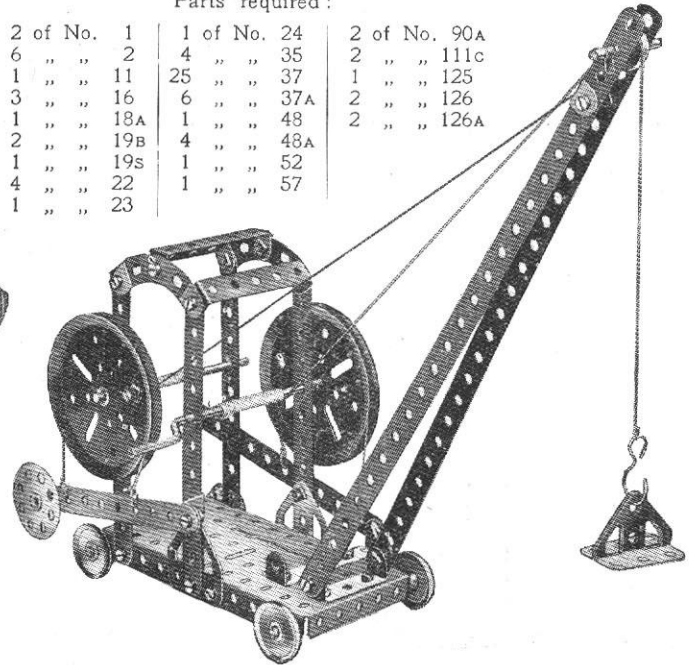

These Models can be built with MECCANO Outfit No. 1 (or No. 0 and No. 0A) Model No. 1.217

Model No. 1.214 Bow Girder

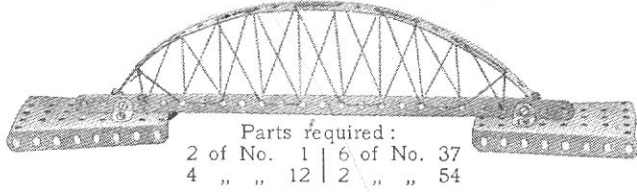

Model No. 1.215 Double-Action Pump

The 5½" Strip 1 is attached to the 1" Pulley Wheel 2 by means of two Angle Brackets, through the lower of which passes the Set-Screw that secures the Pulley to its 2" Rod. Two Washers are placed beneath the head of the Bolt joining the Angle Brackets in order to prevent its shank from binding on the boss of the Pulley 2. The joints 3, 4, 5, 6, 7, are all lock-nutted, the remainder of the joints being quite rigid. When the Strip 1 descends, together with the first pump, the incidental distortion of the parallelogram 3, 4, 7, 4 causes the second pump to rise. Similarly, when the first pump rises, the second descends.

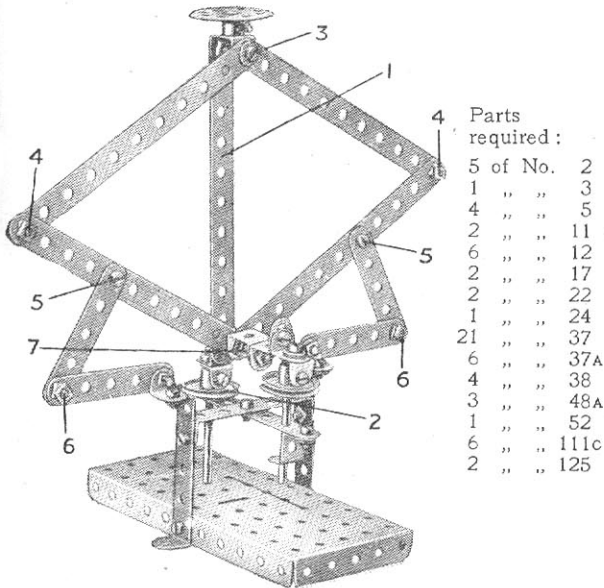

Model No. 1.216 Tower Wagon

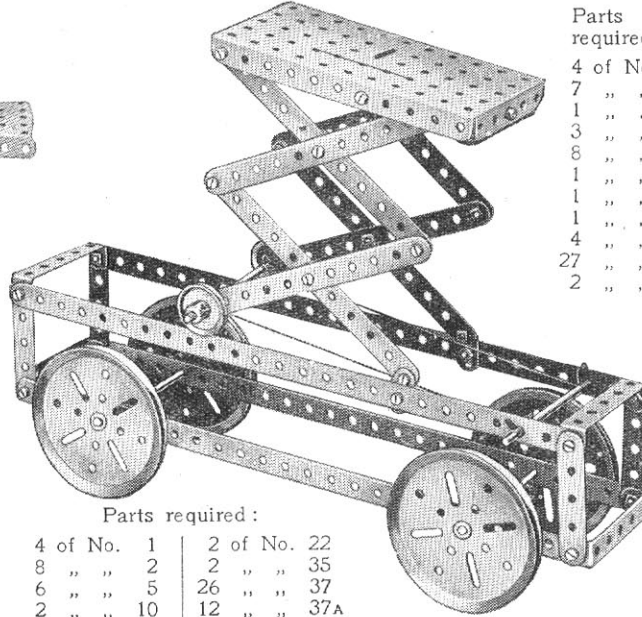

Fire Alarm

- Parts required:
 4 of No. 1
 7 " " 2
 1 " " 3
 3 " " 5
 8 " " 12
 1 " " 16
 1 " " 22
 1 " " 24
 4 " " 35
 27 " " 37
 2 " " 54

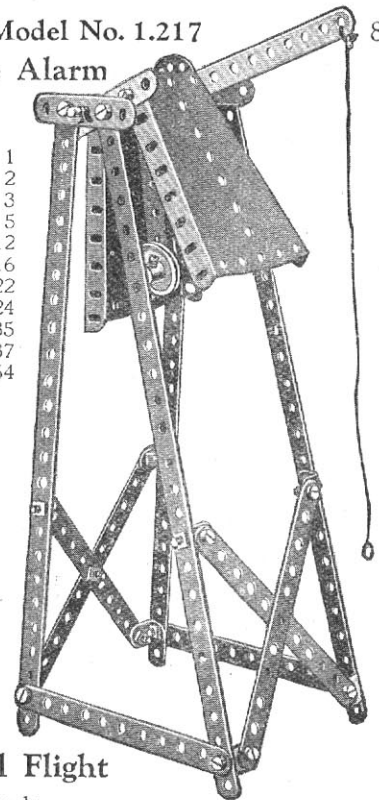

Model No. 1.218 Aerial Flight

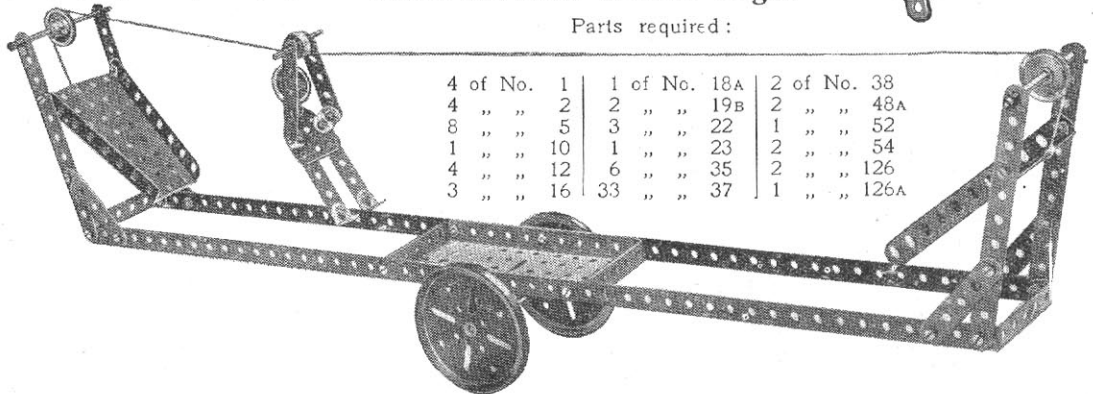

These Models can be built with MECCANO Outfit No. 1 (or No. 0 and No. 0A)

Model No. 1.219 Deck Chair

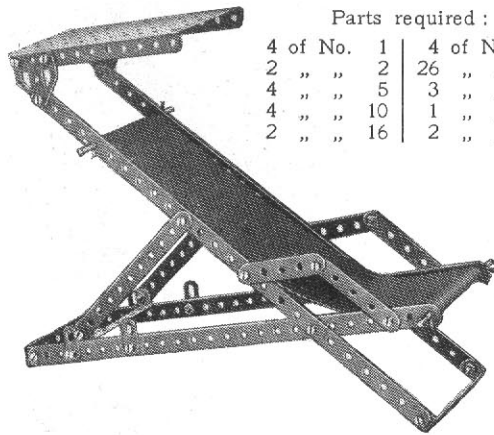

Parts required :

4 of No. 1	4 of No. 35
2 " " 2	26 " " 37
4 " " 5	3 " " 48A
4 " " 10	1 " " 52
2 " " 16	2 " " 126A

Model No. 1.220 Potter's Wheel

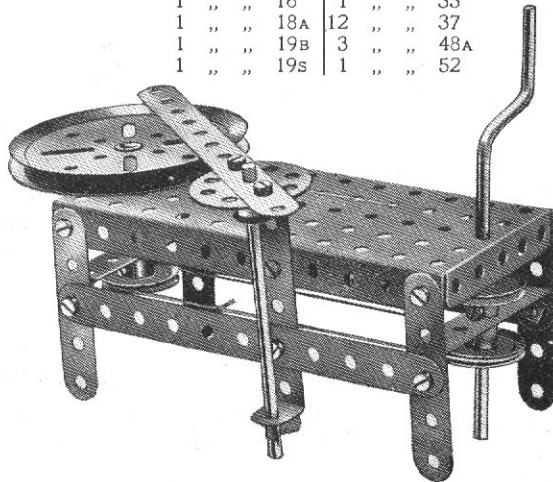

Parts required :

3 of No. 2	3 of No. 22
4 " " 5	1 " " 24
1 " " 16	1 " " 35
1 " " 18A	12 " " 37
1 " " 19B	3 " " 48A
1 " " 19S	1 " " 52

Model No. 1.221 Luggage Cart

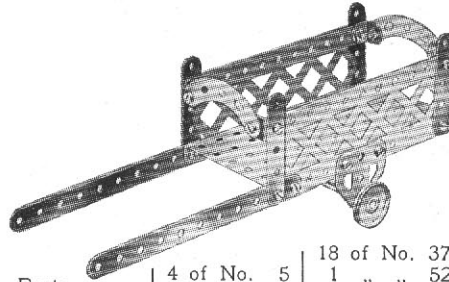

Parts required :	4 of No. 5	18 of No. 37
	4 " " 12	1 " " 52
	1 " " 16	2 " " 90A
2 of No. 2	2 " " 22	2 " " 100
		2 " " 126A

Model No. 1.222 Elevator

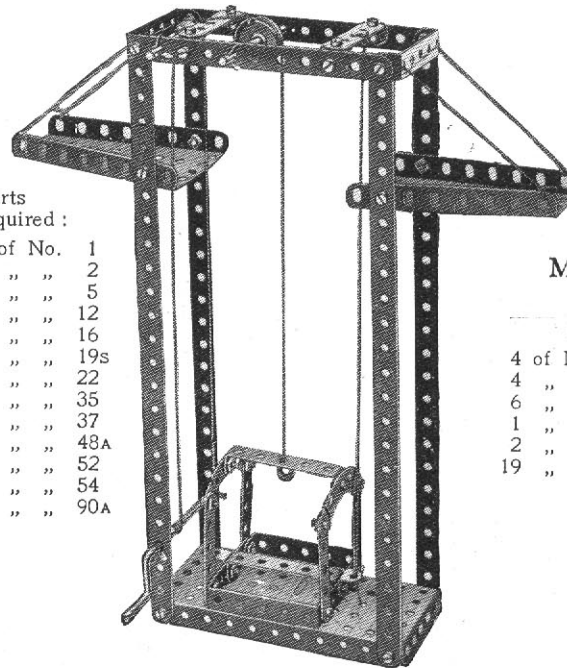

Parts required :

4 of No. 1
2 " " 2
6 " " 5
6 " " 12
1 " " 16
1 " " 19S
1 " " 22
5 " " 35
32 " " 37
6 " " 48A
1 " " 52
2 " " 54
2 " " 90A

Model No. 1.223 Mechanical Stamp

Parts required :

5 of No. 2
5 " " 5
3 " " 16
1 " " 17
4 " " 22
1 " " 24
6 " " 35
20 " " 37
1 " " 44
6 " " 48A
1 " " 52
4 " " 90A
1 " " 100
1 " " 126A

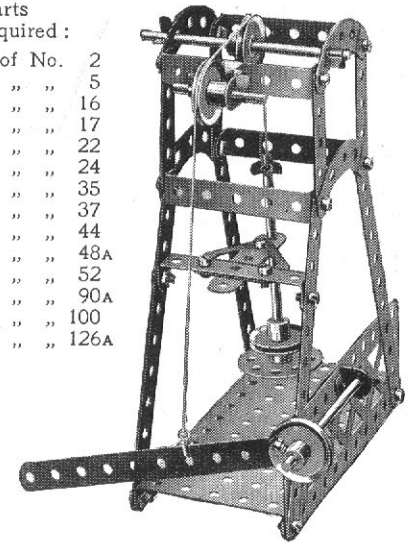

Model No. 1.224 See-Saw

Parts required :

4 of No. 2	1 of No. 44
4 " " 5	1 " " 52
6 " " 12	2 " " 90A
1 " " 17	
2 " " 35	
19 " " 37	

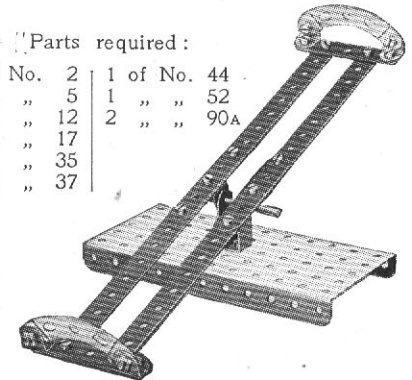

These Models can be built with MECCANO Outfit No. 1 (or No. 0 and No. 0A)

Model No. 1.225 Aeroplane

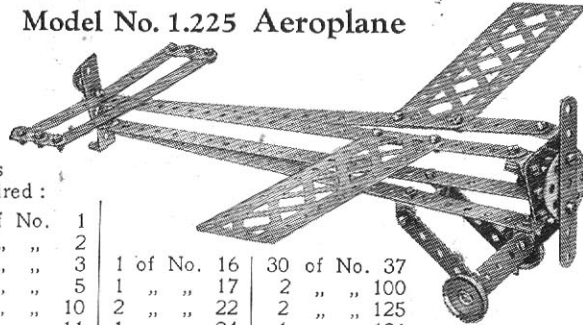

Parts required:

4 of No.	1		
2 "	2		
1 "	3	1 of No.	16
4 "	5	1 "	17
4 "	10	2 "	22
1 "	11	1 "	24
8 "	12	1 "	35
		30 of No.	37
		2 "	100
		2 "	125
		1 "	126
		2 "	126A

Model No. 1.226 Motor Truck

Parts required:

4 of No.	2		
9 "	5		
2 "	10		
3 "	16		
4 "	19B		
		1 of No.	22
		1 "	24
		1 "	35
		34 "	37
		2 "	37A
		1 "	40
		3 "	48A
		1 "	52
		2 "	54
		1 "	90A
		2 "	125
		2 "	126A

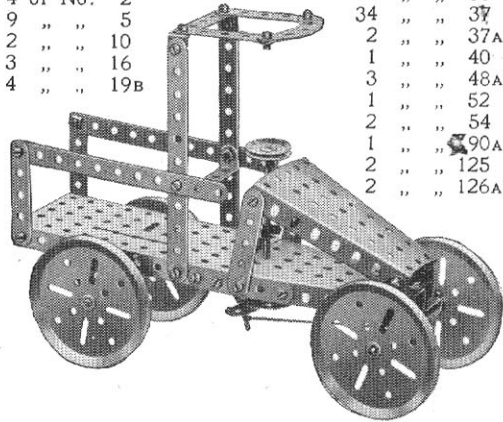

Model No. 1.227
Revolving Gymnasts

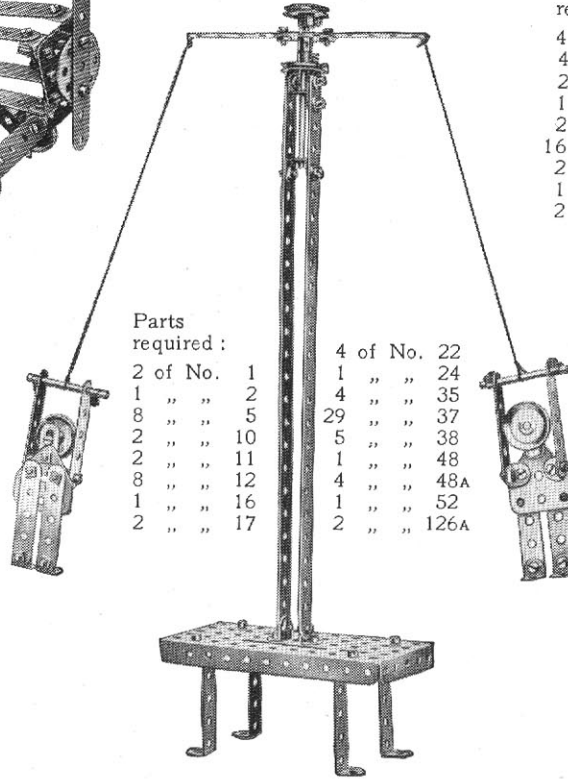

Parts required:

2 of No.	1		
1 "	2	4 of No.	22
1 "	2	1 "	24
8 "	5	4 "	35
2 "	10	29 "	37
2 "	11	5 "	38
8 "	12	1 "	48
1 "	16	4 "	48A
2 "	17	1 "	52
		2 "	126A

Model No. 1.228
Coster's Barrow

Parts required:

4 of No.	2
4 "	5
2 "	10
1 "	16
2 "	19B
16 "	37
2 "	48A
1 "	52
2 "	126A

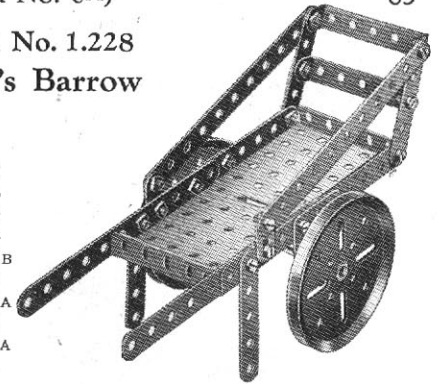

Model No. 1.229
Forge Bellows

Parts required:

4 of No.	2	1 of No.	52
1 "	3	2 "	54
2 "	5	2 "	126A
2 "	10		
1 "	11		

2 of No.	16
1 "	17
1 "	19s
2 "	22
1 "	24
5 "	35
25 "	37
3 "	48A

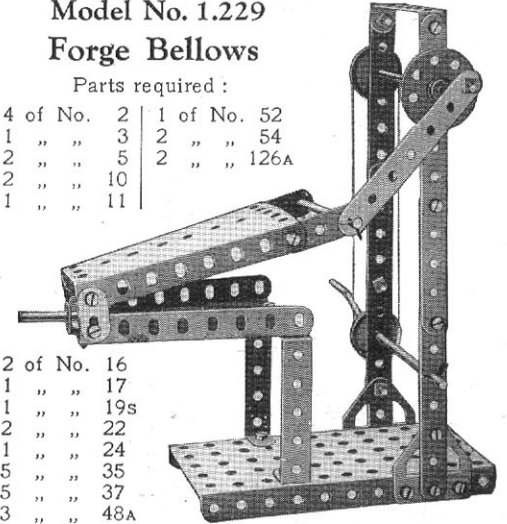

HOW TO CONTINUE

This completes our examples of models that may be made with MECCANO Outfit No. 1. The next models are a little more advanced, requiring a number of extra parts to construct them. The necessary parts are all contained in a No. 1A Accessory Outfit, the price of which may be obtained from any Meccano dealer.

Model No. 2.1 Double Drop Hammer

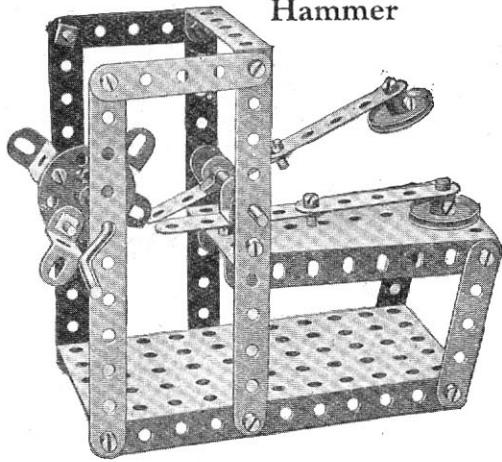

Parts required:

4	of No.	2
8	" "	5
2	" "	11
1	" "	16
1	" "	19s
2	" "	22
1	" "	24
6	" "	35
23	" "	37
2	" "	48A
1	" "	52
1	" "	54
4	" "	125

Model No. 2.2 Gondola

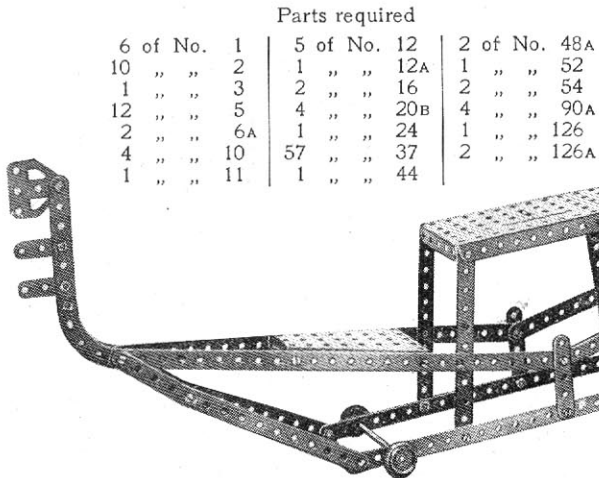

Parts required

6 of No.	1	5 of No.	12	2 of No.	48A
10	" "	1	" "	1	" "
1	" "	2	" "	2	" "
12	" "	4	" "	4	" "
2	" "	1	" "	1	" "
4	" "	57	" "	2	" "
1	" "	1	" "		

Model No. 2.3 Roundabout See-Saw

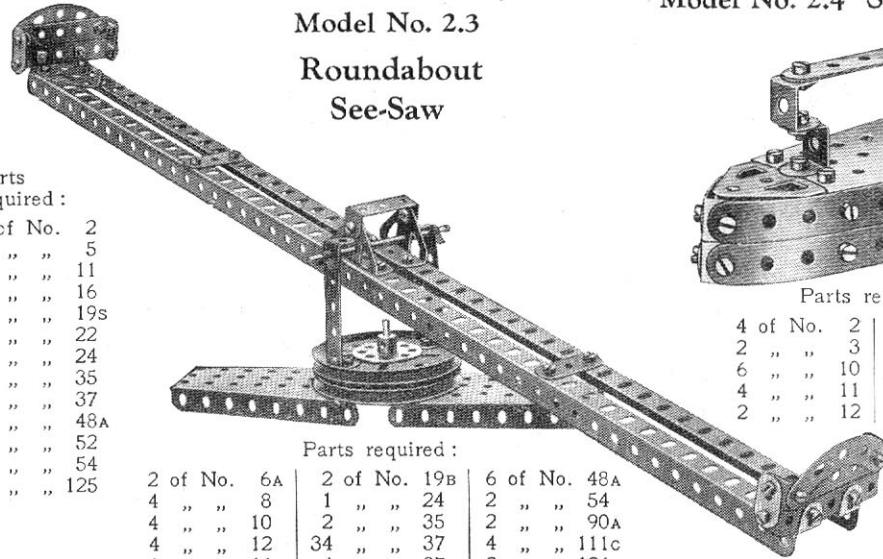

Parts required:

2 of No.	6A	2 of No.	19B	6 of No.	48A
4	" "	1	" "	2	" "
4	" "	2	" "	2	" "
4	" "	34	" "	4	" "
1	" "	4	" "	2	" "
1	" "	6	" "	2	" "
		1	" "		

Model No. 2.4 Smoothing Iron

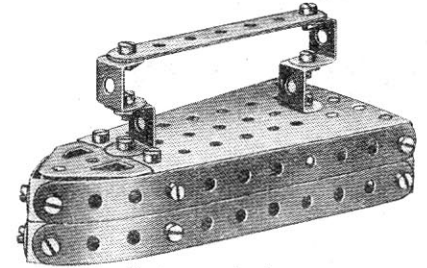

Parts required:

4 of No.	2	20 of No.	37
2	" "	2	" "
6	" "	1	" "
4	" "	2	" "
2	" "	1	" "

Model No. 2.5 Schneider Trophy Seaplane

Parts required:

6	of No.	2
12	" "	5
2	" "	6A
2	" "	11
12	" "	12
34	" "	37
3	" "	37A
6	" "	38
2	" "	111c
2	" "	126
1	" "	126A

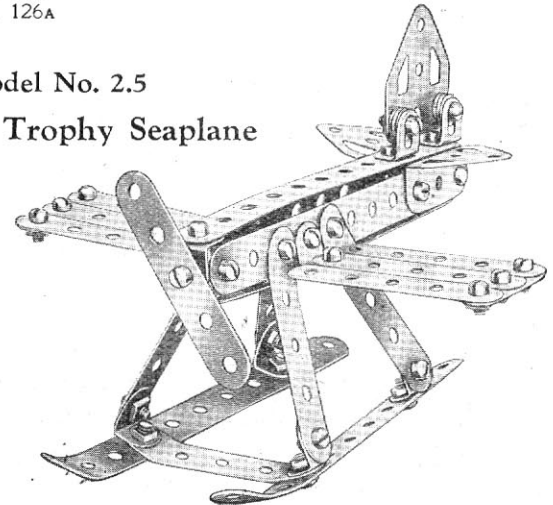

Model No. 2.6 Treadle Lathe

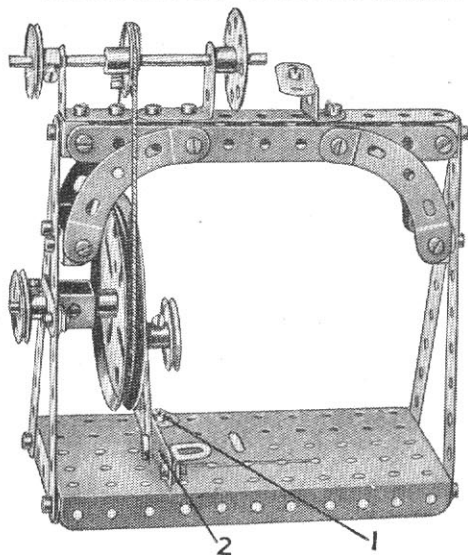

Parts required:

7 of No.	2
1 " "	3
1 " "	5
2 " "	6A
4 " "	11
6 " "	12
2 " "	12A
1 " "	16
1 " "	17
3 " "	19B
4 " "	22
1 " "	24
1 " "	35
34 " "	37
2 " "	37A
4 " "	38
4 " "	45
1 " "	52
4 " "	90A
1 " "	115
1 " "	125

The 2½" Strip 2, forming the treadle, is attached pivotally by means of a bolt and two nuts to the Angle Bracket 1. One end of a further 2½" Strip is connected by the same means to the 2½" Strip 2, and the other end is mounted on a threaded pin secured to the 3" Pulley Wheel.

Model No. 2.8

Gong

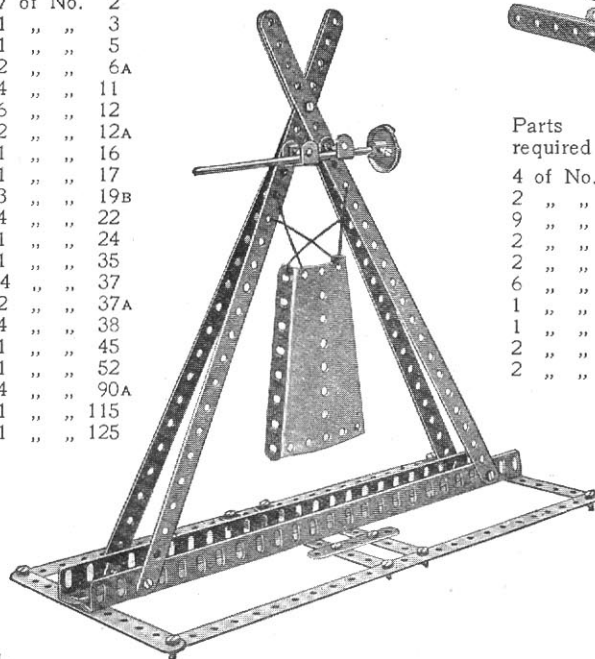

Parts required:

6 of No.	1	2 of No.	11
4 " "	2	1 " "	15
2 " "	5	1 " "	22
2 " "	8	27 " "	37
1 of No. 54			

Model No. 2.9 Hay Tedder

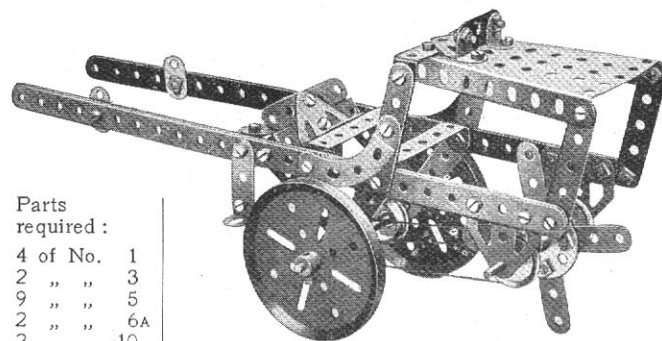

Parts required:

4 of No.	1
2 " "	3
9 " "	5
2 " "	6A
2 " "	10
6 " "	12
1 " "	15A
1 " "	16
2 " "	19
2 " "	20B
2 of No.	22
1 " "	24
2 " "	35
34 " "	37
6 of No.	37A
4 " "	38
4 " "	48A
1 " "	54
3 of No.	90A
6 " "	111c
2 " "	126
2 " "	126A

Model No. 2.10 High Level Bridge

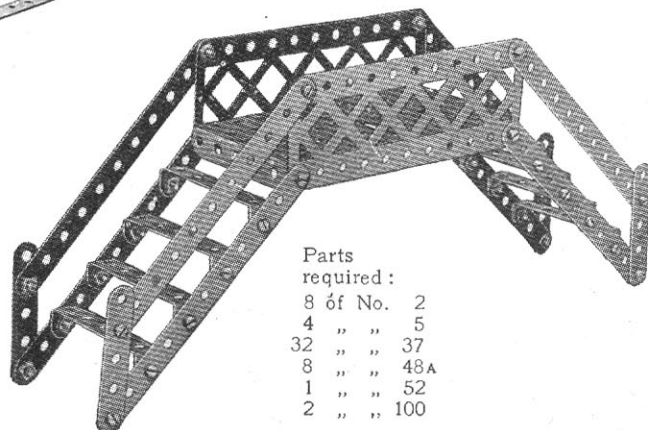

Parts required:

8 of No.	2
4 " "	5
32 " "	37
8 " "	48A
1 " "	52
2 " "	100

Model No. 2.7 Revolving Truck

Parts required:

1 of No.	16	2 of No.	22A	1 of No.	52
2 " "	17	4 " "	35	4 " "	125
2 " "	22	6 " "	37		

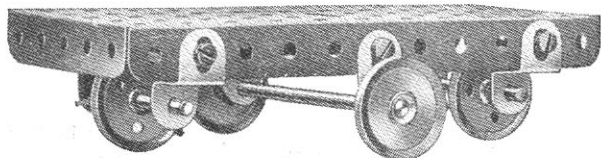

Model No. 2.11 Elevator

The construction of this model is fairly clear in the illustration, but it might be pointed out that one side of the framework consists of four 12½" Angle Girders 1 while the opposite side is composed of four 12½" Strips 2.

Parts required :

4 of No.	1
8 "	2
2 "	3
8 "	5
4 "	8
4 "	10
1 "	11
12 "	12
1 "	16
1 "	18A
2 "	19B
1 "	19S
4 "	22
1 "	35
60 "	37
6 "	37A
2 "	38
7 "	48A
1 "	52
2 "	54
1 "	62
2 "	90A
2 "	99
2 "	100
6 "	111c

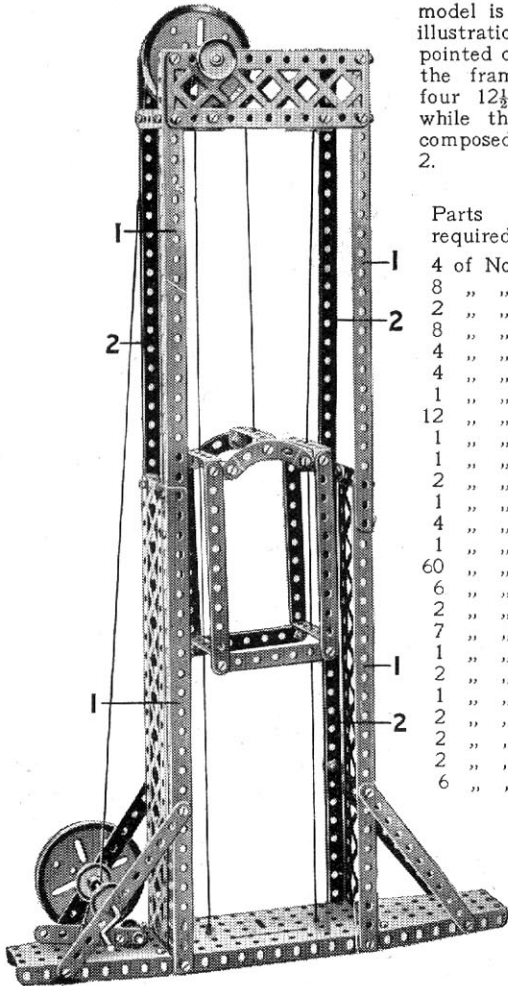

Model No. 2.12 Fire Escape

Parts required :

2 of No.	1
12 "	2
1 "	3
10 "	5
4 "	8
2 "	10
7 "	12
2 "	12A
4 "	16
4 "	19B
1 "	19S
3 "	22
1 "	23
1 "	24
5 "	35
60 "	37
6 "	37A
9 "	38
1 "	44
6 "	111c
1 "	115
2 "	125

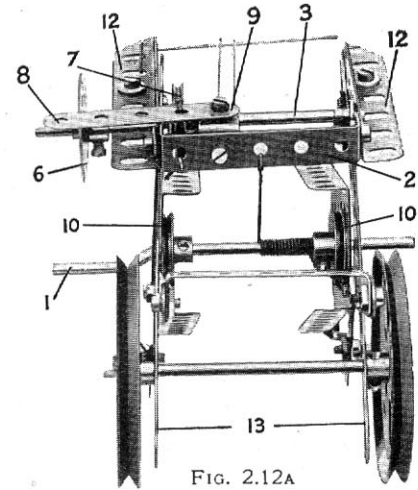
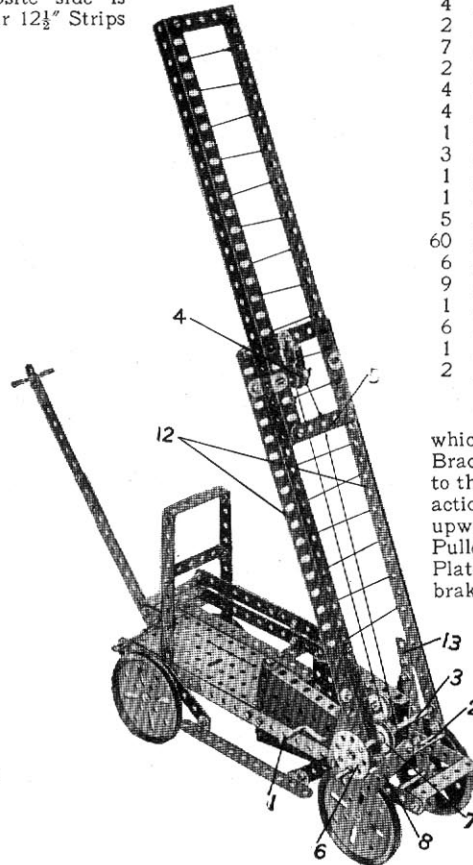

FIG. 2.12A

The ladder is elevated on operation of the crank handle 1, which winds in a cord tied to the Double Angle Strip 2. Angle Brackets bolted to the 12½" Angle Girders 12 are attached pivotally to the 5½" Strips 13 by means of Bolts and Nuts (S.M. 262), and the action of winding in the cord thus causes the ladder to swing upward. It is prevented from falling by the friction of the 1" Pulley Wheels 10 (Fig. 2.12A), which press against the two Sector Plates. When the ladder is fully elevated, its lower ends act as brakes to prevent the road wheels from revolving.

A second cord is wound upon the Rod 3. One end is then carried over the ½" loose Pulley Wheel 4 and tied to the 2½" Strip 5, the opposite end being carried directly to the same Strip and secured to it. When the handle 6 is turned, the two ends of the cord are wound and unwound simultaneously, and the ladder is extended or shortened as required. A permanent brake is provided by a cord passing over the 1" Pulley Wheel 7 and having both its ends secured to the 2½" Strip 8. The Strip 8 is bolted firmly to the Angle Bracket 9 (Fig. 2.12A) and keeps the brake continuously in action.



Model No. 2.13 Pit Head Gear

(Electrically Operated)

Parts required :

8	of No.	1
8	" "	2
4	" "	5
4	" "	8
2	" "	12
3	" "	16
2	" "	19B
3	" "	22
1	" "	24
2	" "	35
60	" "	37
6	" "	37A
6	" "	38
8	" "	48A
1	" "	52
2	" "	54
2	" "	100
6	" "	111c
2	" "	126

Electric Motor
(not included in
Outfit)

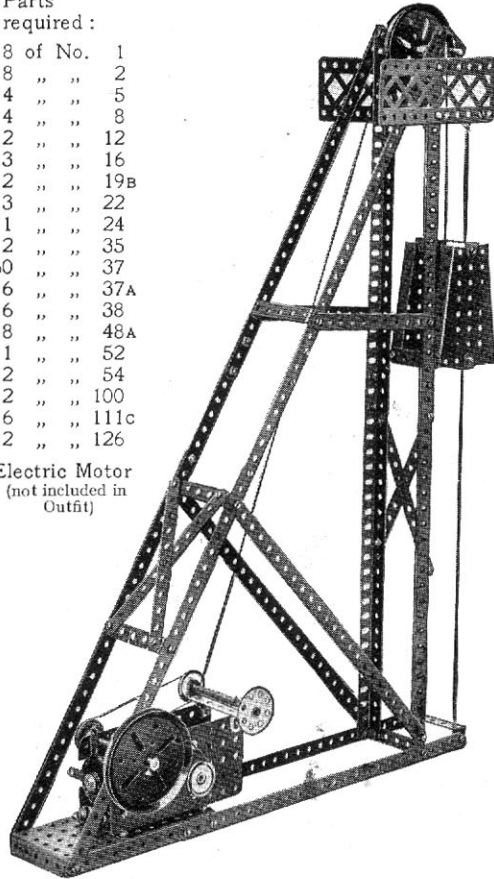

Model No. 2.14 Pit Head Gear

(Hand Operated)

This is an alternative construction of the base of Model No. 2.13, and shows how the Electric Motor may be dispensed with if necessary. Two 3" Pulley Wheels 1 are bolted together by four Double Brackets to form a drum on which the hoisting cord is wound. The cage is raised or lowered on operation of the handle 2, which is connected to the winding drum by an ordinary belt drive. The cage is prevented from overhauling by a hand brake that acts on the groove of a third 3" Pulley Wheel 3. The brake normally is applied by the weight of the $\frac{1}{2}$ " loose Pulley Wheel 4, which is secured to the end of a $5\frac{1}{2}$ " Strip that is bolted to the crank 5.

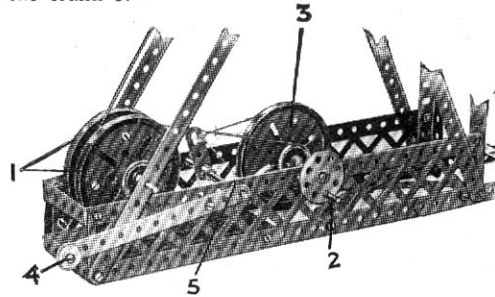

Parts required :

6	of No.	1	4	of No.	22	2	of No.	54
7	" "	2	1	" "	23	2	" "	62
3	" "	5	1	" "	24	2	" "	99
4	" "	8	3	" "	35	2	" "	100
4	" "	11	60	" "	37	6	" "	111c
6	" "	12	6	" "	37A	1	" "	115
4	" "	16	8	" "	48A	2	" "	126A
4	" "	19B	1	" "	52			

Model No. 2.15 Acrobat

Parts required :

4	of No.	1	28	of No.	37
2	" "	3	6	" "	37A
5	" "	5	5	" "	38
2	" "	8	1	" "	45
2	" "	10	1	" "	52
1	" "	15	1	" "	54
2	" "	19B	2	" "	62
2	" "	20B	1	" "	115
3	" "	22	2	" "	126

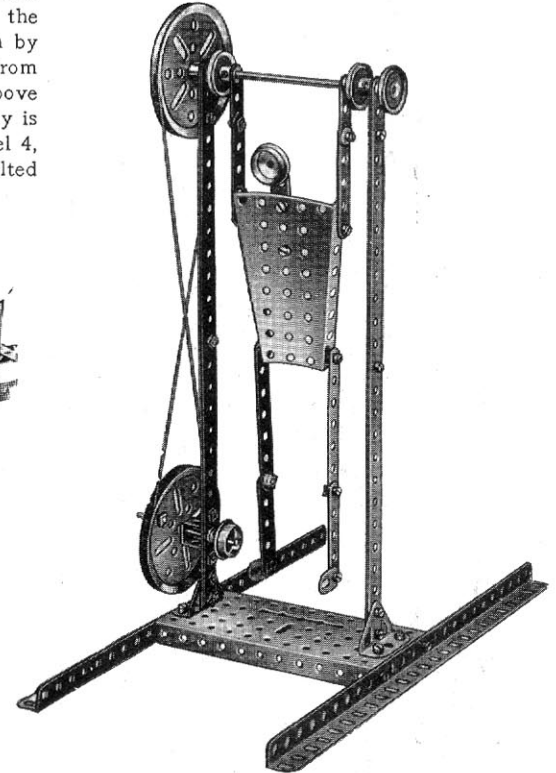

Model No. 2.16 Travelling Jib Crane (Electrically Operated)

Parts required :

10 of No. 1	14 of No. 35	4 of No. 90A
9 " " 2	60 " " 37	5 " " 111c
2 " " 3	6 " " 37A	2 " " 126A
2 " " 5	14 " " 38	Electric Motor
2 " " 6A	1 " " 48	(not included in
4 " " 8	7 " " 48A	Outfit)
1 " " 10	1 " " 52	
1 " " 11	1 " " 57	
2 " " 12		
2 " " 15		
1 " " 15A		
2 " " 16		
1 " " 17		
2 " " 18A		
1 " " 19		
4 " " 19B		
4 " " 20B		
4 " " 22		
1 " " 23		
1 " " 24		

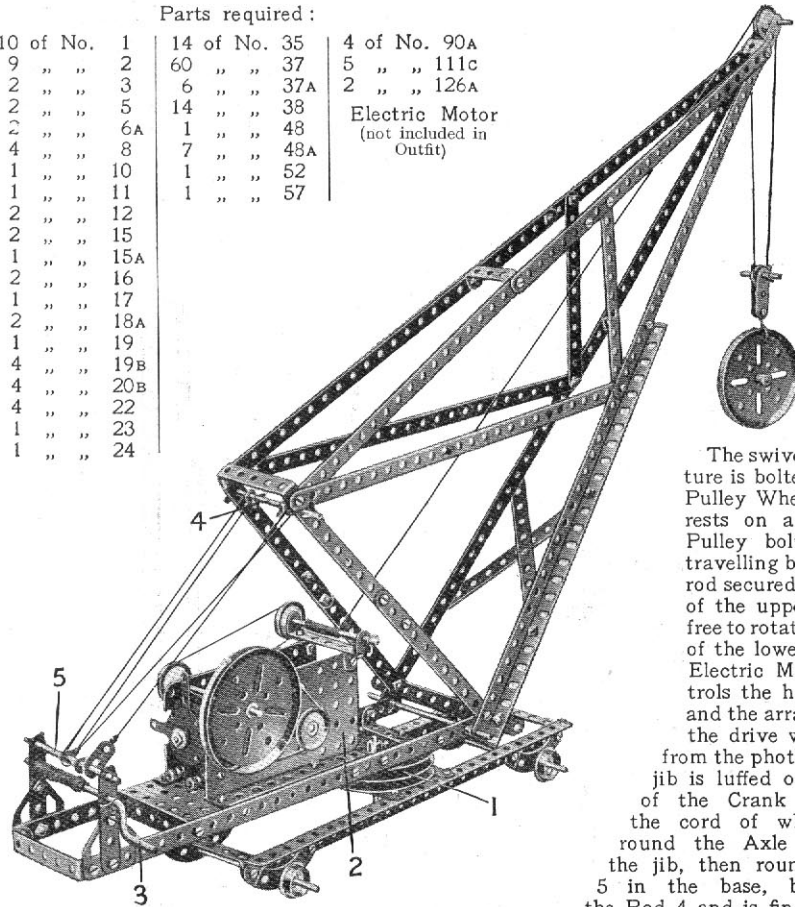

The swivelling structure is bolted to the 3" Pulley Wheel 1, which rests on a second 3" Pulley bolted to the travelling base. A short rod secured to the boss of the upper Pulley is free to rotate in the boss of the lower one. The Electric Motor 2 controls the hoisting gear and the arrangement of the drive will be clear from the photograph. The jib is luffed on operation of the Crank Handle 3, the cord of which passes round the Axle Rod 4 in the jib, then round the Rod 5 in the base, back round the Rod 4 and is finally secured to a Flat Bracket on the Rod 5.

Model No. 2.17 Travelling Jib Crane (Hand Operated)

This shows a section of Model No. 2.16 fitted for hand operation, thus dispensing with the necessity of the Electric Motor. In this case the hoisting cord is operated by the hand wheel 6, the Rod of which is controlled by a hand brake 7. The end hole of the lever of the latter is pivotally mounted on the Rod 8. The luffing movement of the jib is effected by the Crank Handle 9. The operating cord passes round the Rod 10 attached to the jib, then round Rod 11 in the base of the model, again round Rod 10, back round Rod 11, and once more round Rod 10. The end of the cord is then tied to a Flat Bracket on the Rod 11.

Parts required :

10 of No. 1	1 of No. 11	4 of No. 20B	7 of No. 48A
11 " " 2	1 " " 15	4 " " 22	1 " " 52
2 " " 3	1 " " 15A	1 " " 23	2 " " 54
6 " " 5	5 " " 16	1 " " 24	1 " " 57
2 " " 6A	2 " " 18A	12 " " 35	1 " " 62
4 " " 8	1 " " 19	57 " " 37	4 " " 90A
3 " " 10	4 " " 19B	1 " " 48	1 " " 111c
1 of No. 115			

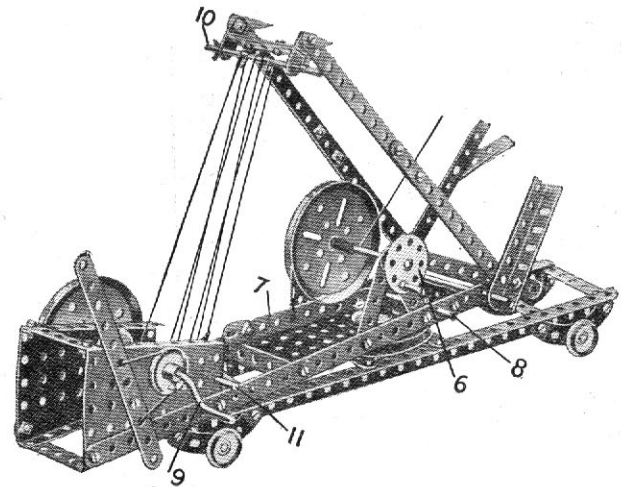

Model No. 2.18 Electric Truck

An underneath view of the truck is shown in Fig. 2.18A. The front axle is journalled in a $1\frac{1}{2} \times \frac{1}{2}$ " Double Angle Strip 1 that is free to turn on a Double Bent Strip 2, from which it is spaced by a $\frac{1}{2}$ " loose Pulley. A length of cord is wrapped round the 1" Pulley 3, which is secured to the end of the steering column, and then passed through a Cranked Bent Strip 4 and secured to the Double Angle Strip 1 as shown. The brake cord 5 is attached to the Double Bent Strip 2, wrapped several times round the $\frac{3}{4}$ " Flanged Wheels 6, passed through the Angle Bracket 7, and is finally attached to the Crank 8. The operating pedal consists of Double Brackets bolted to another Crank that is secured to the same Rod as the Crank 8.

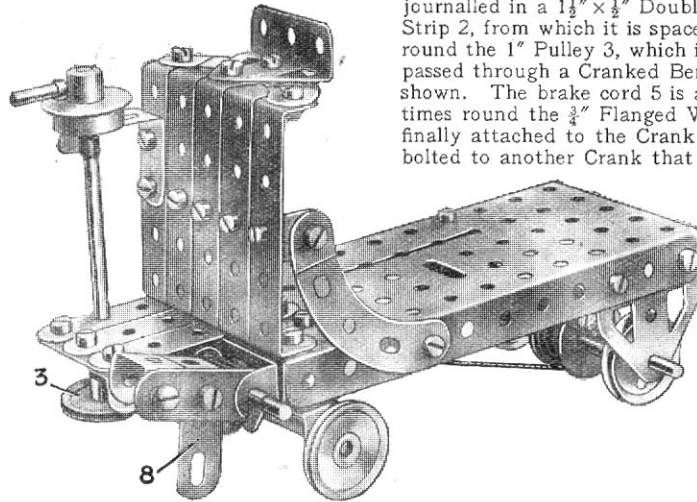

Parts required :

3 of No. 5	1 of No. 22A	7 of No. 48A
1 " " 6A	1 " " 23	1 " " 52
2 " " 11	4 " " 35	2 " " 62
1 " " 12	35 " " 37	3 " " 90A
1 " " 12A	2 " " 37A	1 " " 111c
3 " " 16	5 " " 38	1 " " 115
1 " " 17	1 " " 44	1 " " 126
3 " " 20B	1 " " 45	2 " " 126A
4 " " 22	1 " " 48	

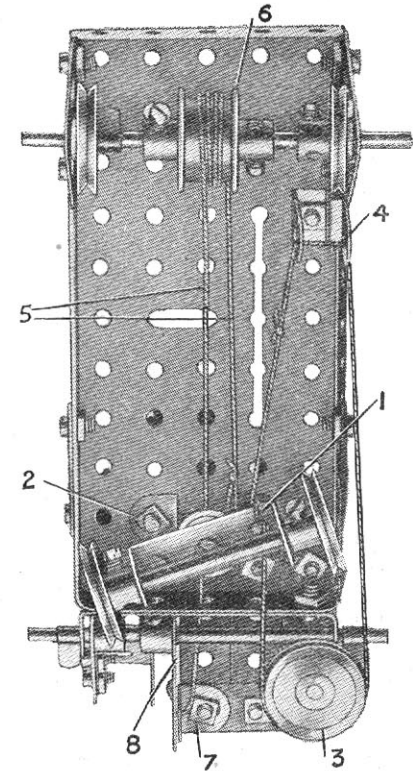

FIG. 2.18A

Parts required :

9 of No. 2	2 of No. 35
2 " " 3	54 " " 37
8 " " 5	6 " " 37A
2 " " 6A	8 " " 38
4 " " 8	1 " " 45
1 " " 12	6 " " 48A
1 " " 16	1 " " 52
1 " " 17	2 " " 54
2 " " 19B	2 " " 99
2 " " 22	6 " " 111c
1 " " 24	1 " " 115

Model No. 2.19 Coal Sifter

The $5\frac{1}{2}$ " Strip 1 is pivoted to the Angle Bracket 2 by a bolt and two nuts. The Angle Bracket in turn is bolted to the Flanged Plate, which is suspended in such a way that it is free to swing to and fro. The other end of the $5\frac{1}{2}$ " Strip is pivoted to the Bush Wheel 3.

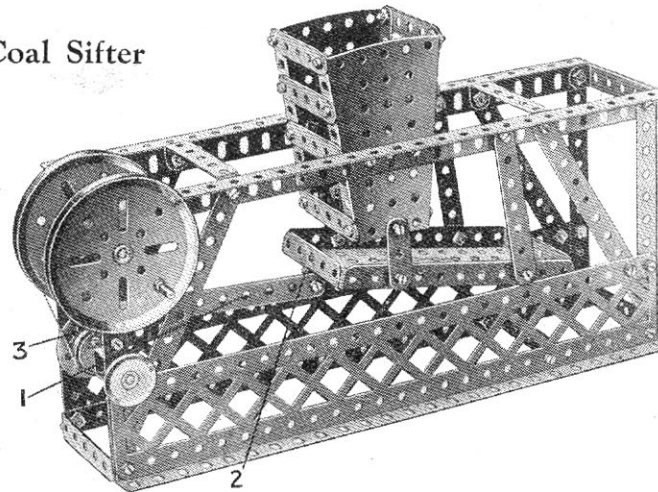

Model No. 2.20 Steam Lorry

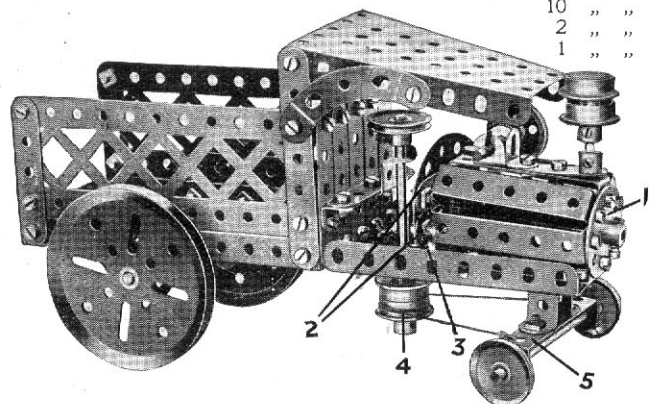

Parts required

2 of No.	3	3 of No.	12
10 " "	5	3 " "	16
2 " "	10	1 " "	17
1 " "	11	1 " "	18A
		2 " "	19B
		4 " "	20B
		3 " "	22
		1 " "	22A
		1 " "	24
		5 " "	35
		60 " "	37
		5 " "	37A
		1 " "	45
		8 " "	48A
		1 " "	52
		2 " "	54
		1 " "	62
		3 " "	90A
		2 " "	100
		4 " "	111c
		1 " "	125
		2 " "	126A

The boiler of the engine is built up of $2\frac{1}{2}'' \times \frac{1}{2}''$ Double Angle Strips bolted to the Bush Wheel 1, and to two $2\frac{1}{2}''$ Strips 2, which are joined together by Flat Brackets 3. A $2\frac{1}{2}''$ Curved Strip (small radius) is bolted to the upper Strip 2. A cord is passed completely round two $\frac{3}{4}''$ Flanged Wheels 4 secured to the steering column, and its ends are tied to the $2\frac{1}{2}'' \times \frac{1}{2}''$ Double Angle Strip 5. The Double Bent Strip bolted to the Strip 5 is pivoted by a bolt and two nuts to the Sector Plate.

Model No. 2.21 Turnstile

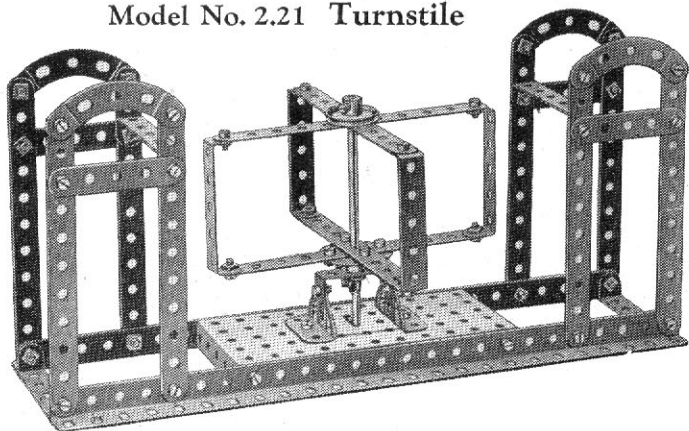

Parts required:

12 of No.	2
5 " "	5
2 " "	8
1 " "	15A
1 " "	22
1 " "	24
1 " "	35
44 " "	37
1 " "	38
1 " "	48
8 " "	48A
1 " "	52
4 " "	90A
2 " "	99
2 " "	126

Model No. 2.22 Mechanical Hammer

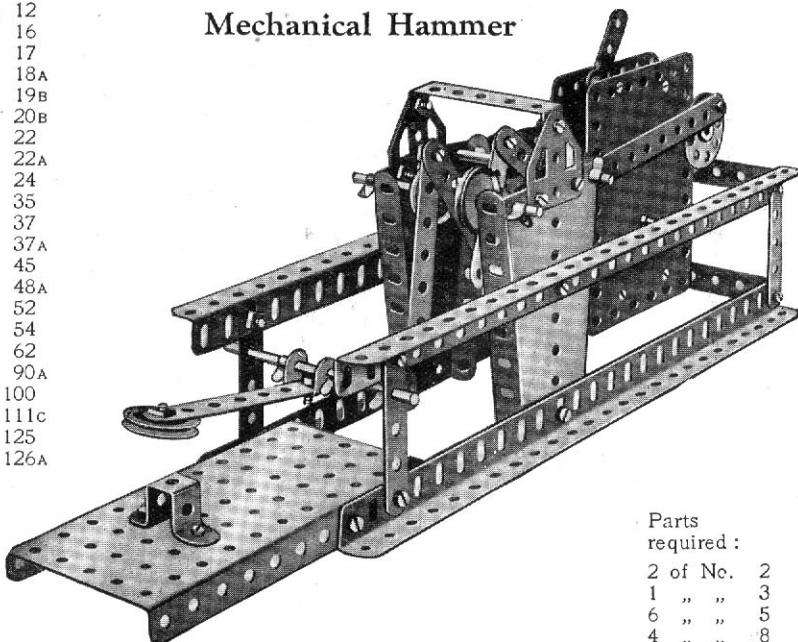

Parts required:

2 of No.	2
1 " "	3
6 " "	5
4 " "	8
1 " "	11
1 " "	12
3 " "	16
4 " "	22
1 " "	22A
1 " "	24
8 " "	35
32 " "	37
1 " "	45
3 " "	48A
1 " "	52
2 " "	54
2 " "	126A

Clockwork Motor (not included in Outfit)

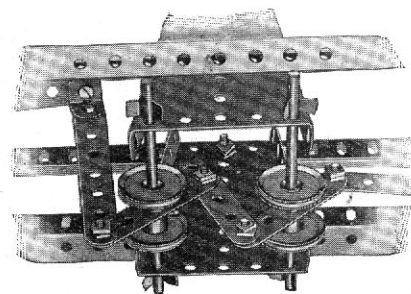
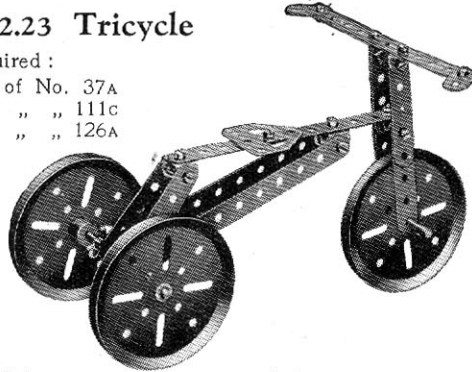

FIG. 2.22A

Model No. 2.23 Tricycle

Parts required:

4 of No. 2	2 of No. 37A
6 " " 5	1 " " 111c
2 " " 10	1 " " 126A
3 " " 11	
2 " " 12	
1 " " 16	
1 " " 18A	
3 " " 19B	
2 " " 35	
15 " " 37	



Model No. 2.25 Monoplane

The nose of the fuselage, which is formed by the two Sector Plates, is secured to the fuselage proper by means of two $2\frac{1}{2}$ " Strips bolted to the top rear corners of the

Parts required:

6 of No. 1	1
9 " " 2	2
1 " " 3	3
12 " " 5	5
2 " " 6A	6A
4 " " 8	8
5 " " 12	12
1 " " 15A	15A
1 " " 17	17
2 " " 20B	20B
2 " " 22	22
1 " " 24	24
60 " " 37	37
4 " " 37A	37A

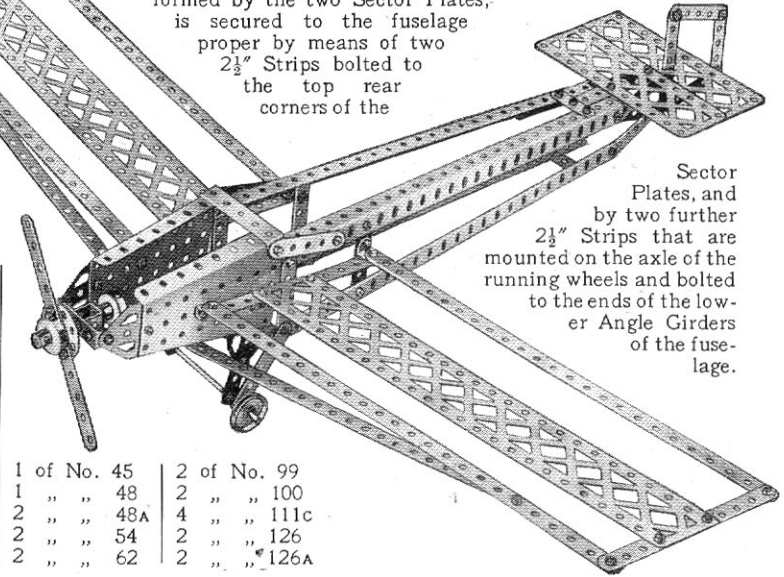

Sector Plates, and by two further $2\frac{1}{2}$ " Strips that are mounted on the axle of the running wheels and bolted to the ends of the lower Angle Girders of the fuselage.

1 of No. 45	2 of No. 99
1 " " 48	2 " " 100
2 " " 48A	4 " " 111c
2 " " 54	2 " " 126
2 " " 62	2 " " 126A

Model No. 2.24

Parts required:

Motor Lorry

8 of No. 2	1 of No. 15A	1 of No. 24	4 of No. 48A
1 " " 3	2 " " 16	12 " " 35	1 " " 52
10 " " 5	1 " " 18A	49 " " 37	1 " " 54
6 " " 10	4 " " 19B	3 " " 38	2 " " 62
1 " " 15	2 " " 22	1 " " 45	2 " " 111c

Clockwork Motor (not included in Outfit)

The driving spindle of the Clockwork Motor is removed and in its place is inserted a $3\frac{1}{2}$ " Rod forming the rear axle, the special Pinion inside the Motor being secured to this Rod, of course, instead of to the driving spindle. The steering is operated by a Bush Wheel on a vertical $3\frac{1}{2}$ " Rod journaled in a Double Bent Strip. Cord is wound round the lower part of this Rod and its ends are secured one to each end of a Double Angle Strip carrying the front axle. A Crank is bolted to this Double Angle Strip and carries a short Rod that is journaled in the boss of a further Crank bolted to the Flanged Plate.

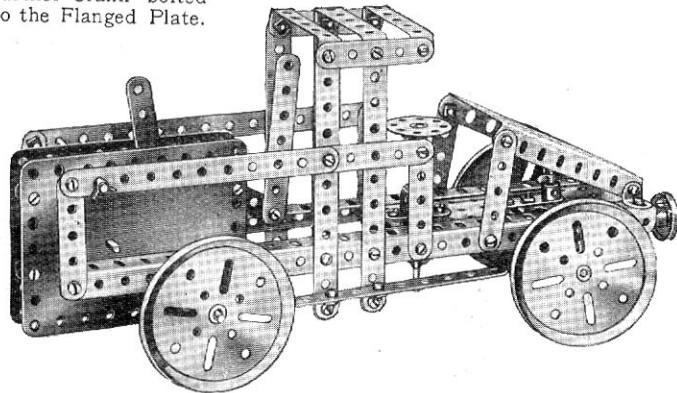

Parts required:

4 of No. 1	3
2 " " 3	3
8 " " 5	5
4 " " 8	8
1 " " 17	17
1 " " 18A	18A
1 " " 19B	19B
3 " " 22	22
1 " " 24	24
45 " " 37	37
4 " " 37A	37A
4 " " 38	38
1 " " 48	48
7 " " 48A	48A
1 " " 52	52
2 " " 54	54
4 " " 90A	90A
2 " " 99	99
4 " " 111c	111c

Model No. 2.26 Turntable

The two sides of the revolving portion are joined in the middle by two pairs of $2\frac{1}{2}$ " Strips, each pair being overlapped three holes and bolted to the $3\frac{1}{2}$ " Pulley Wheel 1. An Axle Rod secured in the latter is journaled in the bottom plate 2 and retained in position by a 1" Fast Pulley Wheel beneath the plate.

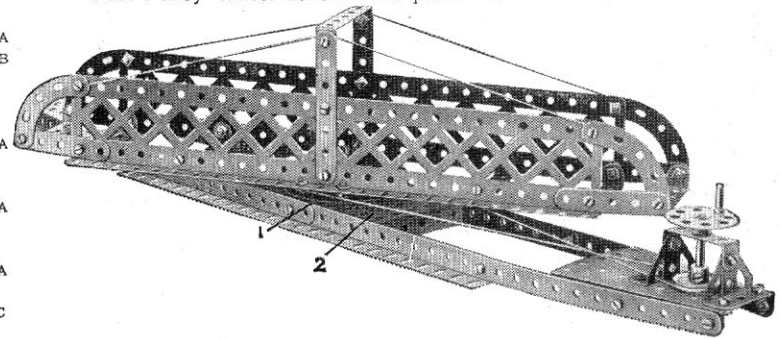

Model No. 2.27 Spinning Top

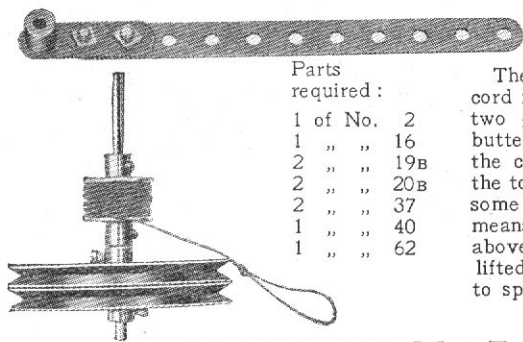

Parts required:

1 of No.	2
1 " "	16
2 " "	19B
2 " "	20B
2 " "	37
1 " "	40
1 " "	62

The drum on which the cord is wound consists of two 3/4" Flanged Wheels butted together. While the cord is being pulled, the top is held steadily on some smooth surface by means of the handle shown above. The handle is then lifted off, allowing the top to spin freely.

Model No. 2.28 Mat Frame

The Strips 1 are hinged to the frame in the following manner. Two Cranks 2 with their bosses facing inward are bolted to the Strips 1 and two Angle Brackets are secured to the frame. A Rod is then pushed through the holes in the Angle Brackets and secured in the bosses of the Cranks. A Double Bracket fastened to the ends of the Strips 1 carries a Threaded Pin, which fits in the holes in the Flat Trunnions 3. By removing this Pin, the frame may be folded flat.

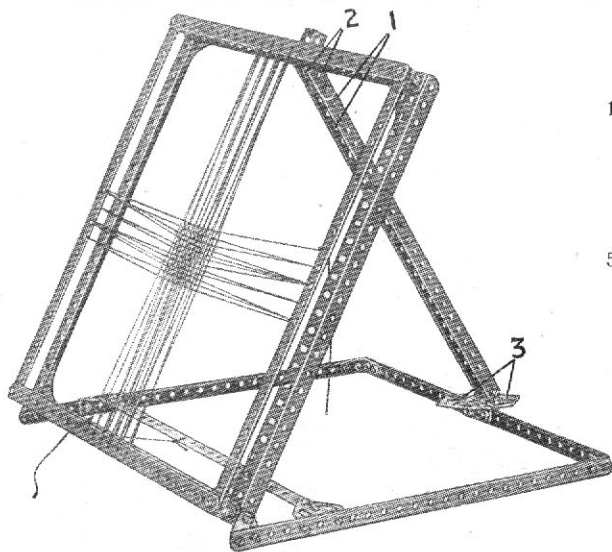

Parts required:

10 of No.	1
4 " "	8
4 " "	10
3 " "	11
6 " "	12
2 " "	12A
1 " "	18A
54 " "	37
2 " "	37A
2 " "	38
1 " "	45
2 " "	62
4 " "	90A
2 " "	111c
1 " "	115
4 " "	125
2 " "	126
2 " "	126A

Model No. 2.29 Performing Meccanitian

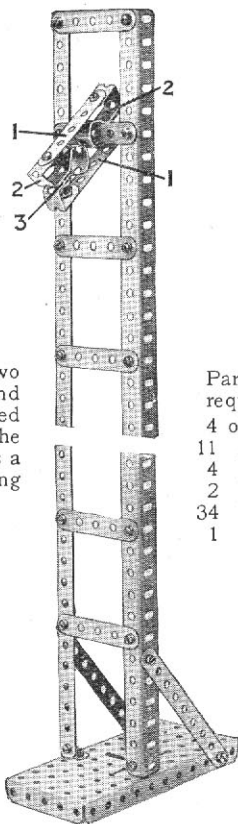

Parts required:

4 of No.	2
11 " "	5
4 " "	8
2 " "	12
34 " "	37
1 " "	52

The Meccanitian consists of two 2 1/2" Strips 1 to the ends of which two 5 1/2" Strips 2, bent as shown, are bolted. The slot 3 should be passed over the top strip of the ladder, when the device will fall "head over heels" to the bottom.

Model No. 2.30 Baby Chair

Parts required:

8 of No.	2	4 of No.	35
2 " "	3	35 " "	37
12 " "	5	2 " "	37A
6 " "	12	4 " "	38
2 " "	16	8 " "	48A
2 " "	17	4 " "	90A
4 " "	22	1 " "	111c

The Bolts 1 are all secured pivotally (see S.M. Nos. 262 and 263), and the height of the chair may be adjusted by fitting any hole in the Strip 2 over the shank of a Bolt that is secured in an Angle Bracket bolted to the Double Angle Strip 3.

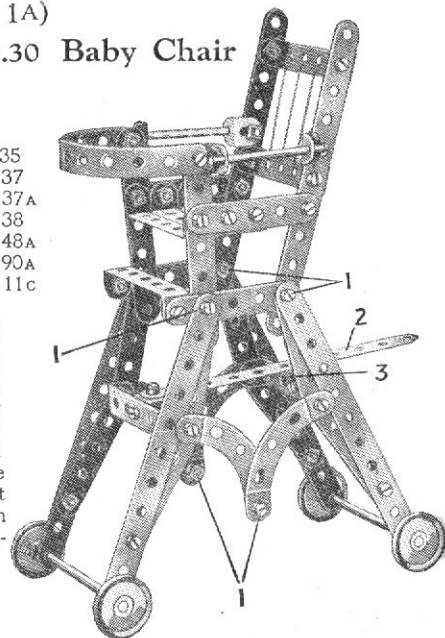

Model No. 2.31 Square-topsail Schooner

Parts required:

4 of No.	1
6 " "	2
1 " "	3
10 " "	5
4 " "	10
1 " "	11
5 " "	12

41 of No.	37
1 " "	40
4 " "	48A
2 " "	90A

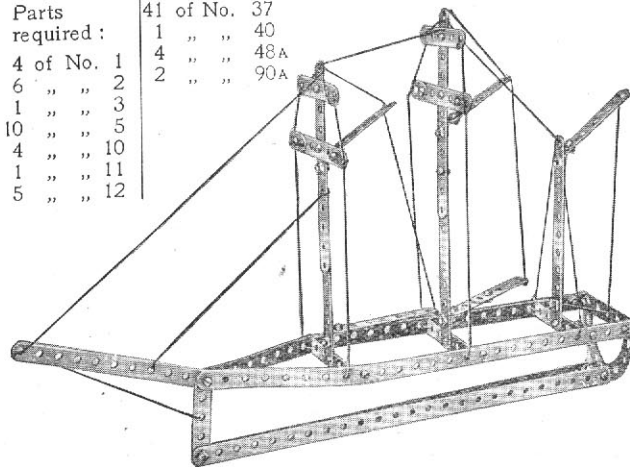

Model No.

2.32 Scales

Model No. 2.33 Motor Truck

Parts required :

2 of No. 2	4 of No. 19B	3 of No. 48A
2 " " 5	1 " " 22	1 " " 52
2 " " 6A	1 " " 24	2 " " 54
2 " " 10	1 " " 35	2 " " 100
1 " " 11	23 " " 37	1 " " 111c
3 " " 16	2 " " 37A	2 " " 126A

A cord passed twice round a 1" fast Pulley Wheel on the lower end of the steering column is tied to the ends of a 2½" x ½" Double Angle Strip, which is pivoted by means of a Bolt and Lock-Nuts to a Double Bracket bolted to the lower Sector Plate. The front axle is journalled in the end holes of the Double Angle Strip.

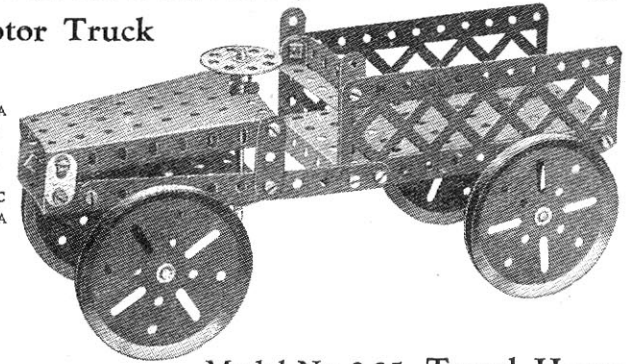

Model No. 2.35 Towel Horse

Parts required :	4 of No. 12
2 " " 22A	2 " " 28
6 of No. 1	28 " " 37
4 " " 2	2 " " 37A
2 " " 8	8 " " 38
4 " " 10	4 " " 90A
2 of No. 111c	

Model No. 2.34 Sand Yacht

Parts required :

8 of No. 1
2 " " 2
1 " " 5
4 " " 8
4 " " 10
4 " " 11
12 " " 12
2 " " 12A
3 " " 16
1 " " 17
2 " " 18A
4 " " 19B
1 " " 23
1 " " 24
12 " " 35
60 " " 37
9 " " 38
8 " " 48A
1 " " 52
1 " " 54
1 " " 62
1 " " 90A
1 " " 115
4 " " 125
1 " " 126
2 " " 126A

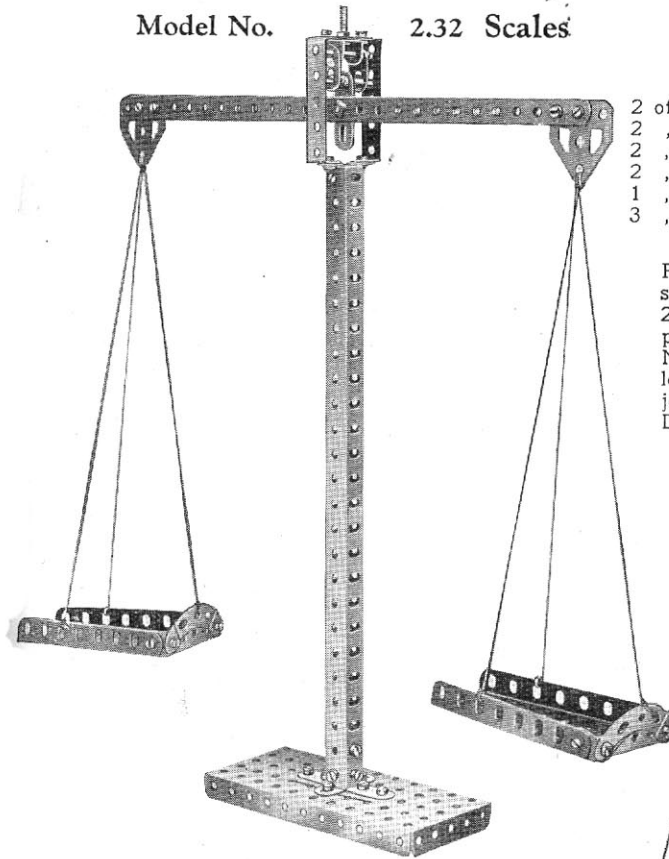

Parts required :		
2 of No. 1	2 of No. 18A	1 of No. 52
1 " " 6A	2 " " 35	2 " " 54
2 " " 8	31 " " 37	2 " " 62
2 " " 10	4 " " 38	2 " " 90A
1 " " 11	1 " " 40	1 " " 115
2 " " 12	1 " " 45	2 " " 126A
2 " " 12A	4 " " 48A	

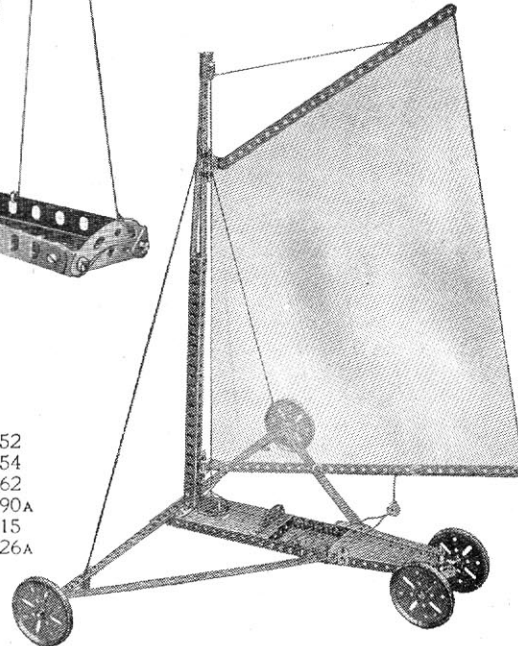

These Models can be built with MECCANO Outfit No. 2 (or No. 1 and No. 1A)

Model No. 2.36 Coaster

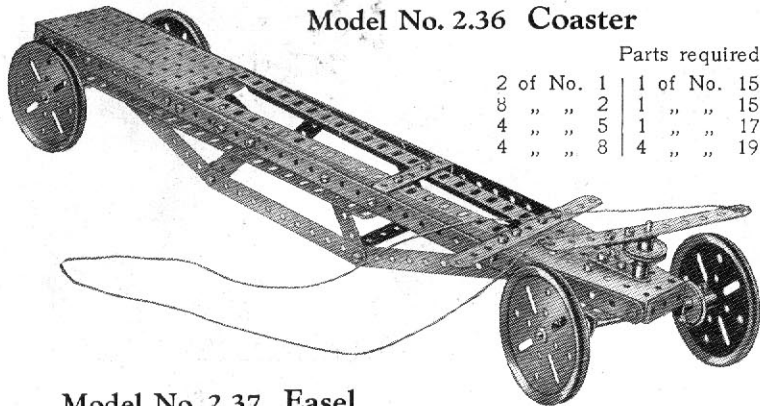

Parts required :

2 of No. 1	1 of No. 15	3 of No. 22
8 " " 2	1 " " 15A	1 " " 23
4 " " 5	1 " " 17	1 " " 24
4 " " 8	4 " " 19B	44 " " 37
		4 " " 38
		1 " " 48
		4 " " 48A
		1 " " 52
		1 " " 54
		2 " " 62
		2 " " 126

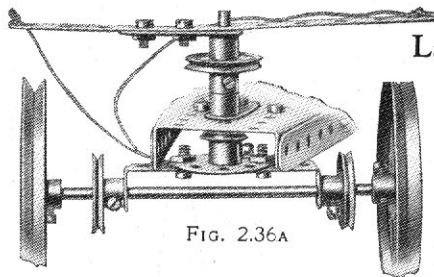

FIG. 2.36A

Model No. 2.39 Ladder on Wheels

Parts required :

6 of No. 1
7 " " 5
4 " " 12
2 " " 16
4 " " 20B
40 " " 37
4 " " 38
8 " " 48A
1 " " 52
2 " " 90A

Model No. 2.37 Easel

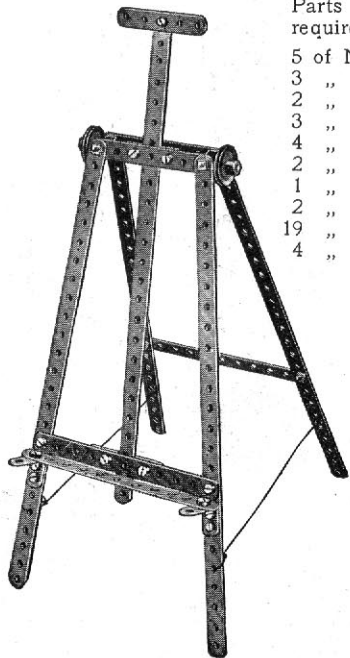

Parts required :

5 of No. 1
3 " " 2
2 " " 3
3 " " 5
4 " " 12
2 " " 12A
1 " " 15A
2 " " 22
19 " " 37
4 " " 38

Model No. 2.38 Sifter

The 5½" Strip 1 is pivoted by a bolt and two nuts (S.M. 262) to the Bush Wheel and also to a Trunnion bolted to the under-surface of the Flanged Plate 2. The Rod carrying the Bush Wheel is journaled in one of the side girders and through a Double Bent Strip.

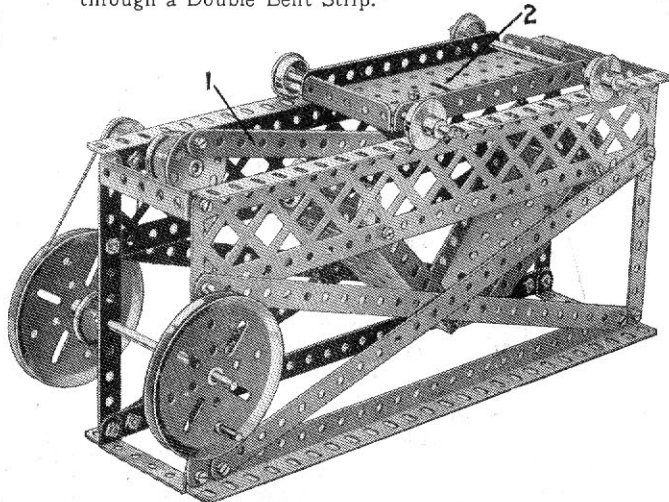

Parts required :

4 of No. 1
5 " " 2
4 " " 5
2 " " 6A
4 " " 8
4 " " 10
2 " " 15
1 " " 15A
1 " " 17
2 " " 19B
4 " " 20B
3 " " 22
1 " " 24
4 " " 35
36 " " 37
4 " " 37A
1 " " 38
1 " " 44
4 " " 48A
1 " " 52
2 " " 54
2 " " 99
2 " " 111c
1 " " 115
1 " " 126

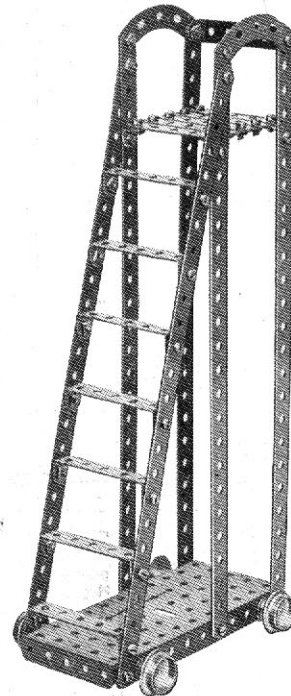

Model No. 2.40 Candy Puller

Parts required :

6 of No. 2	3 of No. 35
2 " " 8	36 " " 37
6 " " 12	4 " " 38
2 " " 15	4 " " 48A
2 " " 17	1 " " 52
2 " " 19B	2 " " 54
4 " " 22	2 " " 62
1 " " 24	4 " " 90A
1 of No. 115	

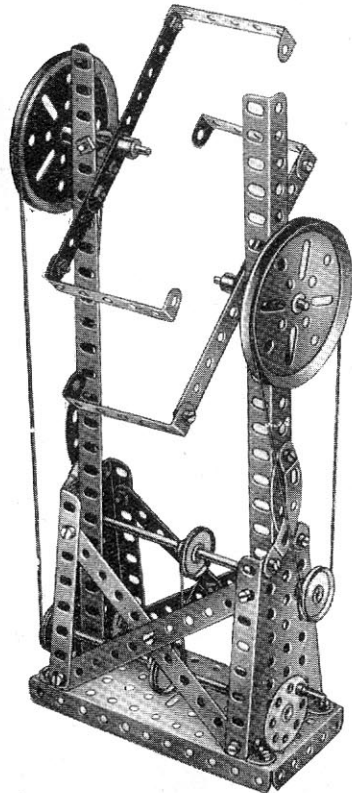

Model No. 2.41 Carrier Tricycle

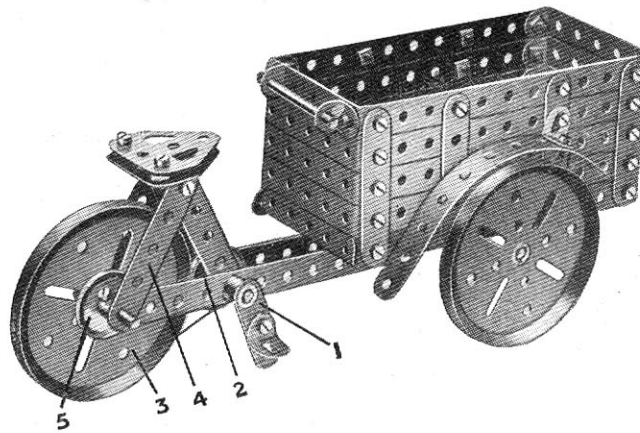

Each pedal of the tricycle consists of an Angle Bracket pivotally attached to a crank 1 by means of a Bolt and two Nuts (see S.M. No. 262). The cranks are secured to a 1½" Axle Rod carrying a 1" fast Pulley Wheel 2. A cord passes round this Pulley and around the 3" Pulley Wheel 3, which is spaced away from the 2½" Strips 4 by a 1" fast Pulley Wheel 5. The Double Bracket 6 (Fig. 2.41A) is attached pivotally to the lower framework by a Bolt and Lock-Nuts (S.M. 263).

Parts required :

12 of No. 2	2
12 " " 5	5
2 " " 11	11
6 " " 12	12
1 " " 16	16
1 " " 17	17
2 " " 18A	18A
3 " " 19B	19B
2 " " 22	22
45 " " 37	37
5 " " 37A	37A
8 " " 48A	48A
1 " " 52	52
2 " " 62	62
3 " " 111C	111C
2 " " 126A	126A

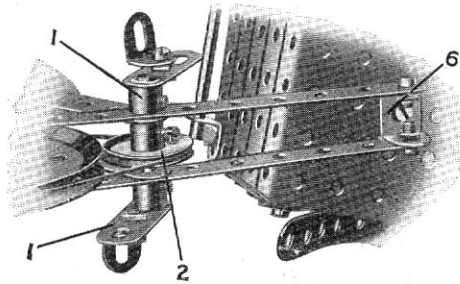

FIG. 2.41A

Model No. 2.42 Windmill

Parts required :

8 of No. 1	1
13 " " 2	2
2 " " 3	3
10 " " 5	5
4 " " 8	8

4 of No. 12	12
1 " " 15	15
1 " " 15A	15A
1 " " 16	16
1 " " 18A	18A
2 " " 19B	19B
1 " " 19S	19S
4 " " 20B	20B
2 " " 22	22
1 " " 22A	22A
1 " " 24	24
6 " " 35	35
60 " " 37	37
4 " " 37A	37A
7 " " 38	38
2 " " 48A	48A
1 " " 52	52
2 " " 54	54
4 " " 90A	90A
2 " " 100	100
4 " " 111C	111C
2 " " 126	126

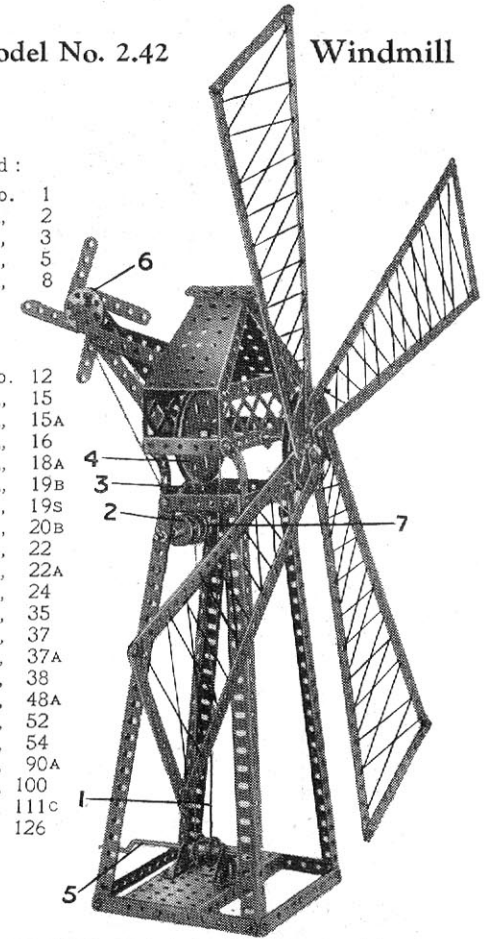

The operating cord 1 is given a complete turn round the pair of ¾" Flanged Wheels 2. It is then led round the 1" Loose Pulley 3, over the 3" Pulley 4, then down and round the ¾" Flanged Wheels secured to the Crank Handle 5. The vane 6 is rotated by a cord which passes round a 1" fixed Pulley 7 secured to the shaft of the Flanged Wheels 2.

Model No. 2.43 Airship

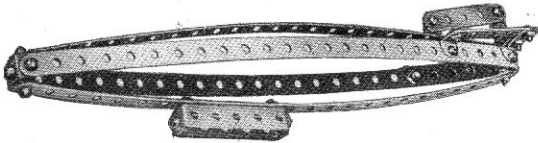

Parts required:

4 of No. 1	2 of No. 11
3 " " 5	10 " " 12
3 " " 10	25 " " 37
3 of No. 48A	

Model No. 2.44 Motor Van

The Axle Rod 1 is journaled in a $2\frac{1}{2} \times \frac{1}{2}$ " Double Angle Strip 2. The latter is bolted to a Double Bent Strip that is pivoted to the Flanged Plate 3 by a bolt and two nuts. Steering is effected by a cord attached to the ends of the Double Angle Strip 2 and passed round a 1" Pulley Wheel fastened to the lower end of the steering Rod.

Parts required:

6 of No. 2	1 of No. 38	3 of No. 111c
10 " " 5	1 " " 45	2 " " 125
1 " " 10	1 " " 48	2 " " 126A
2 " " 12	6 " " 48A	
1 " " 15	1 " " 52	
1 " " 15A	2 " " 54	
1 " " 16		
4 " " 19B		
3 " " 22		
1 " " 24		
5 " " 35		
35 " " 37		
2 " " 37A		

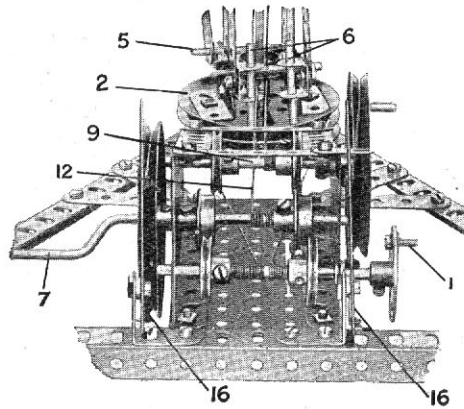
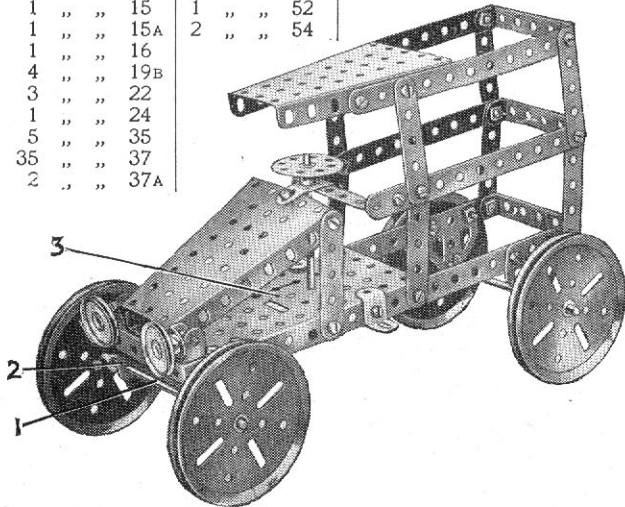

FIG. 2.45A

Model No. 2.45 Derrick

Parts required:	4 of No. 19B	1 of No. 52
4 " " 20B	4 " " 22	2 " " 54
8 of No. 1	1 " " 23	1 " " 57
4 " " 2	1 " " 24	1 " " 111c
2 " " 3	58 " " 35	1 " " 115
8 " " 5	3 " " 37	2 " " 126
1 " " 6A	3 " " 37A	
3 " " 8	5 " " 38	
2 " " 10		
4 " " 11		
6 " " 12		
2 " " 12A		
3 " " 16		
2 " " 17		
4 " " 18A		

The 3" Pulley Wheel 2, which supports the jib, is free to turn on a short Axle Rod secured in the boss of the lower 3" Pulley Wheel 2a. The vertical $12\frac{1}{2}$ " Strips 13 are bolted at their tops to a Double Bracket, to the centre hole of which is secured a Bolt 14 that is free to turn in the Flat Trunnion 15.

The swivelling movement of the crane is carried out by turning the handle 1, which simultaneously winds and unwinds the ends of a cord passing round the 3" Pulley Wheel 2 (see Fig. 2.45A). The cord 12, which is tied to the Flat Bracket 3 at the head of the jib passes over the 2" Rod 4, under a similar Rod 5, and between two vertical 2" Rods 6, which act as guides, and is finally wound on to the Crank Handle 7. Hence on operation of the latter the jib is raised or lowered. The cord 8 also passes round the Rods 4, 5 and 6, and is wound on to the Rod 9. Operation of the handle 10 raises and lowers the hook. The cords 8 and 12 are prevented from unwinding by band-and-pulley brakes 16.

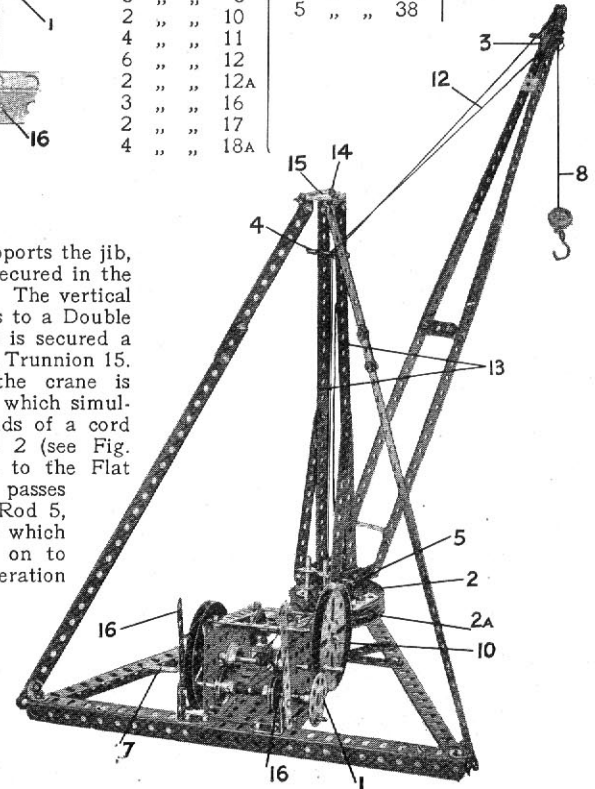

Model No. 2.46

Sewing Machine

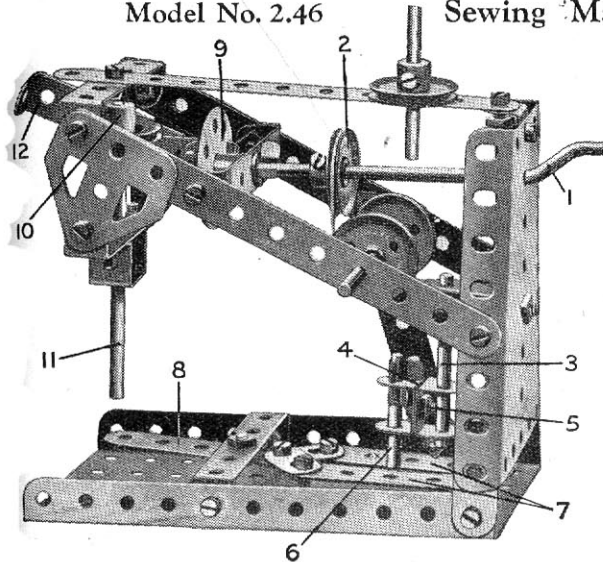

Parts required :

3 of No.	2
6 " "	5
3 " "	10
2 " "	11
3 " "	12
2 " "	16
2 " "	17
1 " "	18A
1 " "	19s
4 " "	22
2 " "	22A
1 " "	24
5 " "	35
24 " "	37
3 " "	38
1 " "	44
5 " "	48A
1 " "	52
1 " "	54
2 " "	125
2 " "	126A

Model No. 2.47 Anti-Aircraft Gun

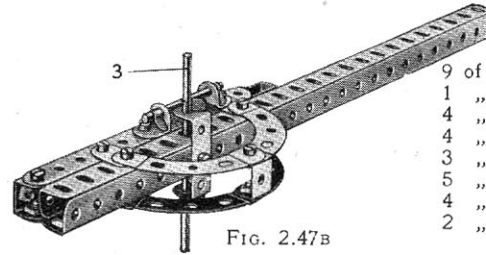

FIG. 2.47B

Parts required :

9 of No.	2	1 of No.	19B	4 of No.	48A
1 " "	6A	4 " "	20B	1 " "	52
4 " "	8	4 " "	22	2 " "	54
4 " "	10	1 " "	24	4 " "	90A
3 " "	11	8 " "	35	1 " "	115
5 " "	12	57 " "	37	2 " "	126
4 " "	16	6 " "	38	2 " "	126A
2 " "	17	1 " "	44		

The general construction of the model will be made clear by reference to Figures 2.47A and 2.47B. Rotation of the handle 1 causes the gun to revolve on the 3" Pulley Wheel 2. The barrel of the Gun is so balanced on the Axle Rod 3 that it tends to fall by its own weight, but is prevented from doing so by a cord 4 tied to the gun close to the breech and wound on the 3 1/2" Rod 5. By turning the Pulley Wheels 6 the muzzle is raised or allowed to fall.

The handle 1 carries a 1" Pulley 2, which drives by means of a cord a similar Pulley on a 2" Rod 3 journalled in a Cranked Bent Strip bolted to the Sector Plate. Two Double Brackets 4 are secured together by a Bolt 5, the shank of which presses very tightly on the Rod 3. This locks the double Brackets in position, and they revolve with the Rod 3. The outer Double Bracket carries a 1 1/2" Rod 6, the end of which lies between two Strips 7, arranged at a short distance apart from each other and bolted to two Flat Brackets. These are secured to a further Strip 8 bolted pivotally to a transverse Double Angle Strip. As the shaft 3 rotates, the Rod 6 slides between the Strips 7 and so rocks the Strip 8 to represent the shuttle.

The Bush Wheel 9 carries two Angle Brackets placed together in the form of a Double Bracket, with their elongated holes overlapping, and in such a position that an imaginary line drawn through their opposite round holes, would cross the centre of the Bush Wheel. A Flat Bracket is bolted to the inner Angle Bracket in a line with the crank handle and forms a lever which engages 1" Pulley 10 mounted on a vertical sliding Rod 11. This Rod is journalled in a Double Angle Strip bolted between the lower holes of the two flat Trunnions and is further supported by two 1/2" Reversed Angle Brackets secured to the Angle Strip. As the Bush Wheel rotates, the Flat Bracket imparts to the Rod 11 a movement corresponding to the action of the needle.

The outer Angle Bracket on the Bush Wheel strikes once in every revolution the end of a Double Angle Strip 12. This is pivotally mounted by a Bolt passed through its second hole from the Bush Wheel end to the centre hole of the Flat Trunnion on that side of the model. The resulting movement of the Strip 12 represents the apparatus that pays out the cotton from the reel.

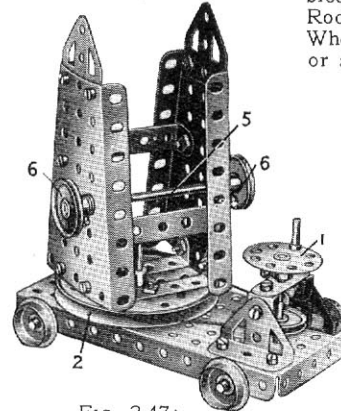
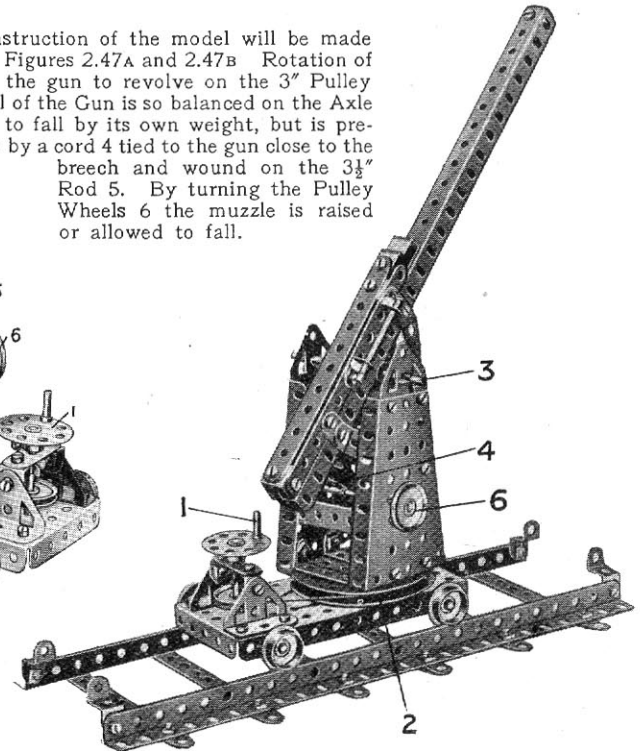
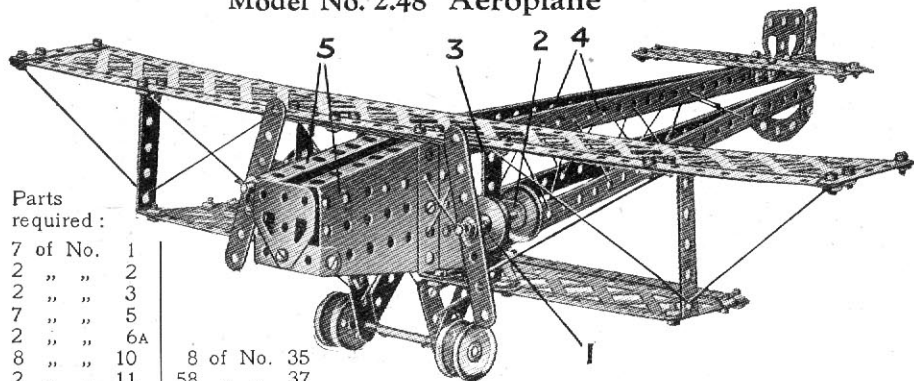

FIG. 2.47A



Model No. 2.48 Aeroplane



Parts required:

7 of No.	1	8 of No.	35
2 " "	2	58 " "	37
2 " "	3	6 " "	38
7 " "	5	1 " "	48
2 " "	6A	6 " "	48A
8 " "	10	2 " "	54
2 " "	11	2 " "	90A
8 " "	12	2 " "	99
1 " "	16	2 " "	100
2 " "	17	2 " "	126A
2 " "	20B		
4 " "	22		
2 " "	22A		
4 " "	22A		

Each engine is represented by a $\frac{3}{4}$ " Flanged Wheel 1 and a 1" fast Pulley Wheel secured to a 2" Rod journalled in a Double Bracket 2, which is bolted to the $2\frac{1}{2}$ " x $\frac{1}{2}$ " vertical Double Angle Strip 3. The $12\frac{1}{2}$ " Strips 4 of the fuselage proper are bolted to the two Sector Plates 5, and also by means of Angle Brackets to the wings. The tail plane consists of two $5\frac{1}{2}$ " Strips to which a similar Strip, representing the movable portion of the plane, is attached by means of Flat Brackets.

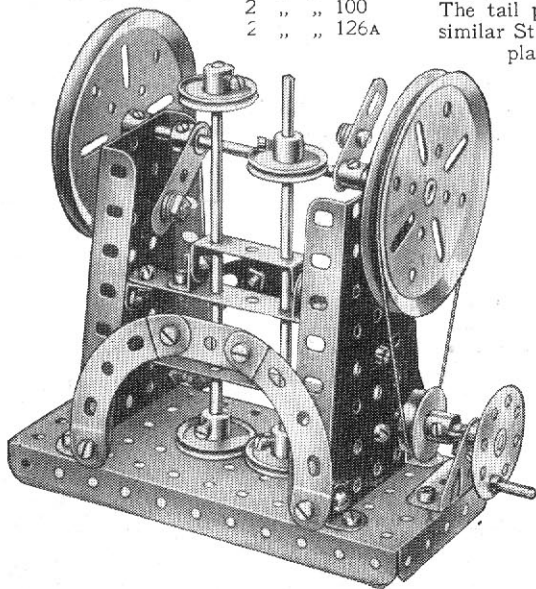

Model No. 2.49 Stamping Mill

Parts required:

2 of No.	3	30 of No.	37
2 " "	6A	2 " "	37A
10 " "	12	11 " "	38
2 " "	15	1 " "	48
1 " "	15A	1 " "	52
1 " "	17	2 " "	54
2 " "	19B	2 " "	62
1 " "	20B	4 " "	90A
4 " "	22	2 " "	111c
1 " "	24	1 " "	115
1 " "	35	1 " "	126

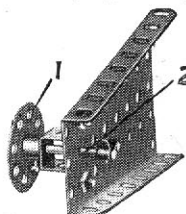

FIG. 2.50B

Model No. 2.50 Try-Your-Strength Machine

The Bush Wheel 1 is secured to a short Axle Rod 2, the lower end of which rests on a pair of Angle Brackets 3 bolted to the ends of four $5\frac{1}{2}$ " Strips 4. The Strips 4 are pivoted as shown (Fig. 2.50A) on a $1\frac{1}{2}$ " Rod 5, and on their opposite ends rests a $\frac{1}{2}$ " loose Pulley Wheel 6. When the Bush Wheel 1 is struck, the $5\frac{1}{2}$ " Strips fling the Pulley Wheel 6 upward, but the wheel is guided by the vertical $12\frac{1}{2}$ " Strips 7. The weight of the Strips 4 then causes the Bush Wheel to resume its original position.

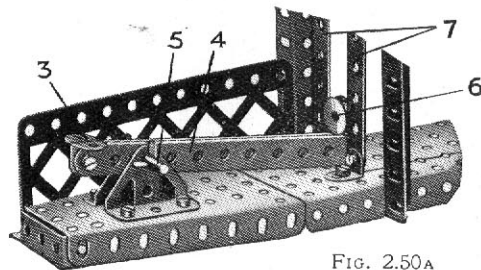
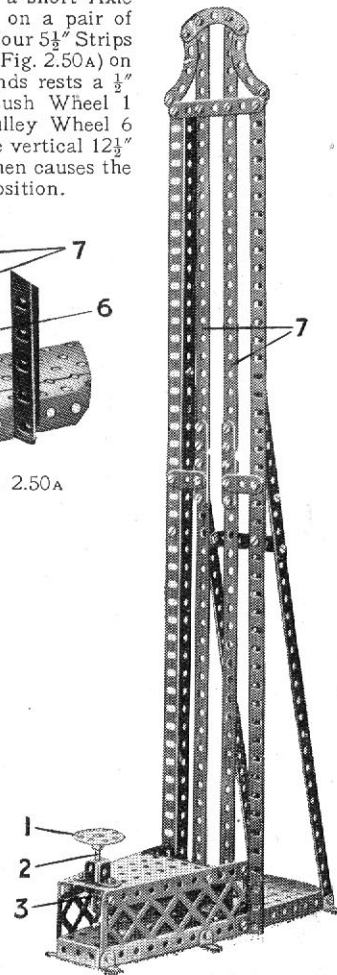

FIG. 2.50A

Parts required:

6 of No.	1	2 of No.	10
6 " "	2	10 " "	12
1 " "	3	2 " "	18A
2 " "	5	1 " "	23
2 " "	6A	1 " "	24
4 " "	8	3 " "	35
		60 " "	37
		6 " "	37A
		4 " "	38
		1 " "	45
		1 " "	48
		1 " "	48A
		2 " "	52
		2 " "	54
		3 " "	90A
		2 " "	100
		2 " "	126



Model No. 2.51 Roundabout

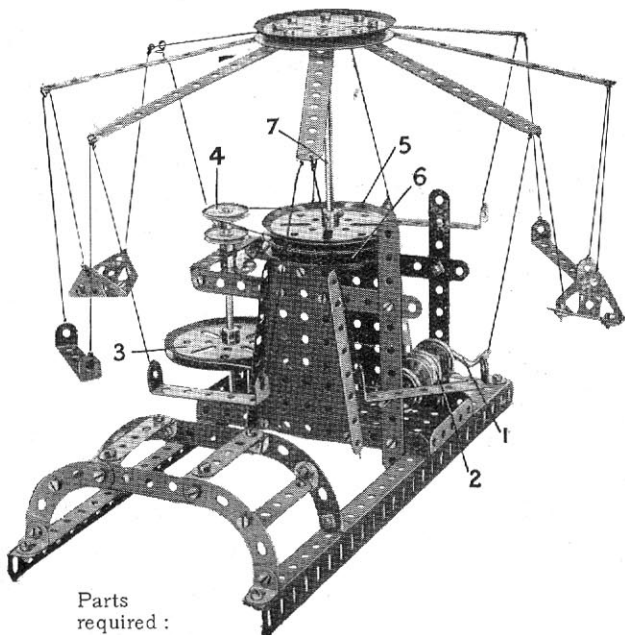

Parts required :

13 of No. 2	1 of No. 19	7 of No. 48A
6 " " 5	4 " " 19B	1 " " 52
2 " " 8	2 " " 20B	2 " " 54
12 " " 12	4 " " 22	4 " " 90A
2 " " 12A	1 " " 24	2 " " 126
2 " " 15	48 " " 37	2 " " 126A

When the crank handle is turned, the drum 2 (formed by butting together two $\frac{3}{4}$ " Flanged Wheels) turns the 3" Pulley Wheel 3 by means of an endless cord. The 1" fast Pulley Wheel 4 similarly turns a second 3" Pulley Wheel 5 resting on another 3" Pulley Wheel 6 (see Fig. 2.51A). The end of the Axle Rod 7 is quite free to revolve in the boss of the lower 3" Pulley Wheel 6.

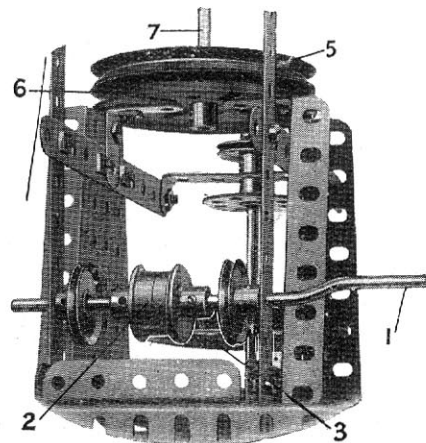

Fig. 2.51A

Model No. 2.52 Tipping Motor Wagon

Parts required :

2 of No. 1	4 of No. 19B	1 of No. 52
4 " " 2	4 " " 22	2 " " 54
11 " " 5	1 " " 24	4 " " 90A
2 " " 6A	6 " " 35	2 " " 100
6 " " 12	59 " " 37	3 " " 111c
4 " " 16	4 " " 37A	1 " " 115
1 " " 17	1 " " 45	2 " " 126
1 " " 18A	1 " " 48	1 " " 126A
	7 " " 48A	

The front Axle Rod is journalled in a $2\frac{1}{2} \times \frac{1}{2}$ " Double Angle Strip 1 which in turn is bolted to a Double Bent Strip 2. The Double Bent Strip is pivoted to the Sector Plate by a bolt and two nuts. Cord passing over a 1" Pulley Wheel attached to the Rod 3 is fastened to the ends of the Double Angle Strip 1, and by rotating another pulley, which represents the steering wheel, the road wheels are deflected.

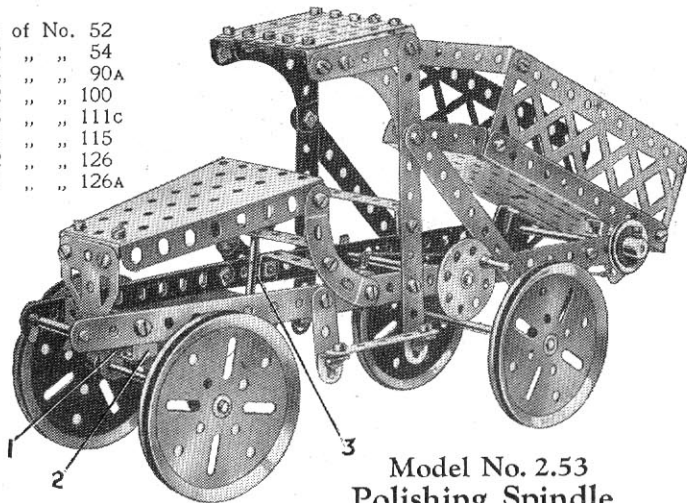

Model No. 2.53 Polishing Spindle

Parts required :

4 of No. 12
1 " " 16
2 " " 22
1 " " 24
2 " " 35
20 " " 37
3 " " 48A
1 " " 52
2 " " 54
2 " " 126

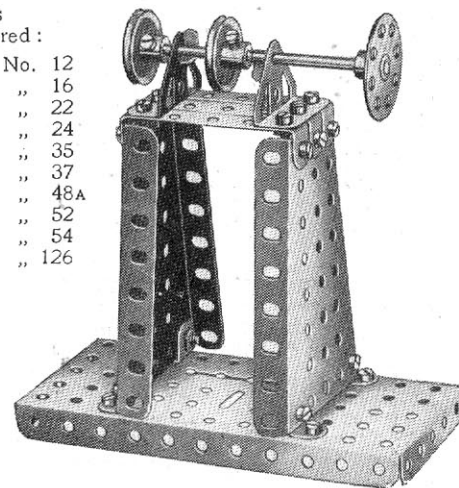

Model No. 2.54 Embossing Machine

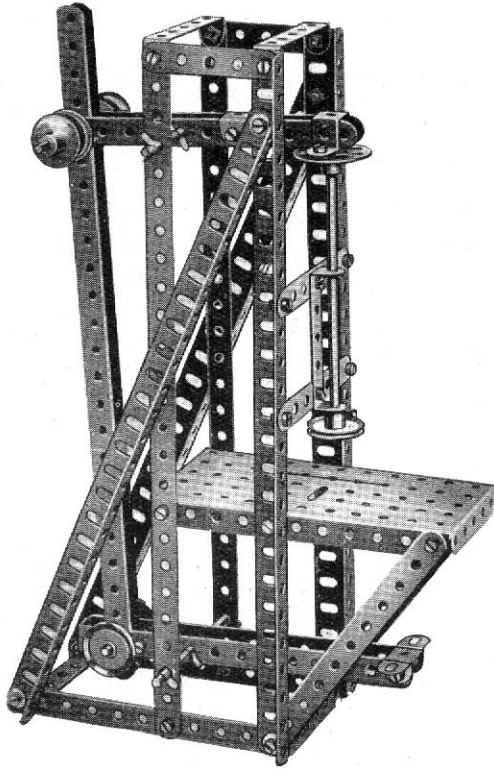
Parts
required :

4	of No.	1
8	" "	2
2	" "	3
2	" "	5
4	" "	8
3	" "	11
2	" "	12
1	" "	15
3	" "	16
1	" "	18A
4	" "	20B
3	" "	22
1	" "	24
10	" "	35
34	" "	37
8	" "	38
1	" "	45
5	" "	48A
1	" "	52

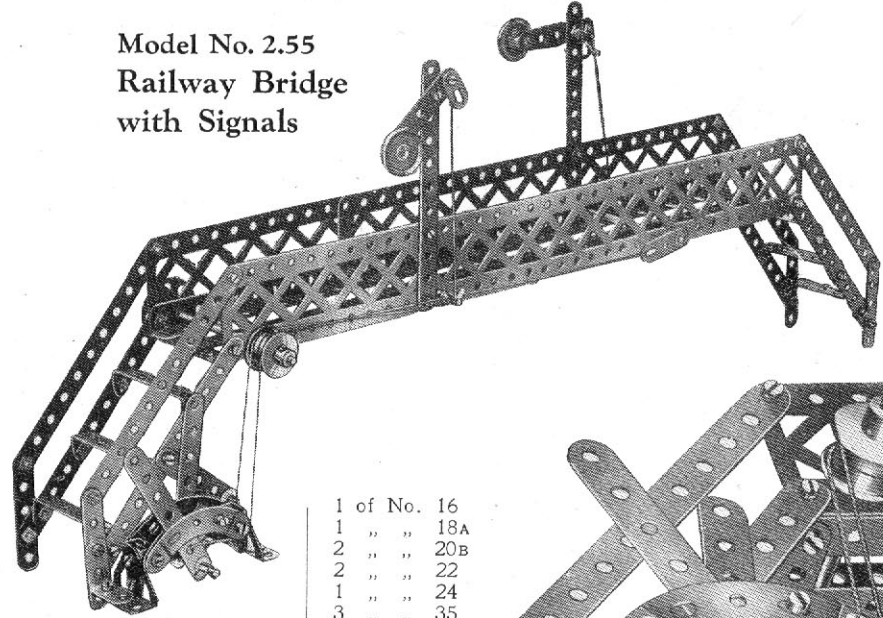
Model No. 2.55
Railway Bridge
with SignalsParts
required :

2	of No.	1
10	" "	2
2	" "	3
2	" "	5
10	" "	8
4	" "	10
2	" "	11
3	" "	12A
2	" "	15A
1	" "	16

1	" "	18A
2	" "	20B
2	" "	22
1	" "	24
3	" "	35
60	" "	37
3	" "	37A
6	" "	38
7	" "	48A
2	" "	62
4	" "	90A
2	" "	99
2	" "	100
3	" "	111c
1	" "	115
2	" "	126

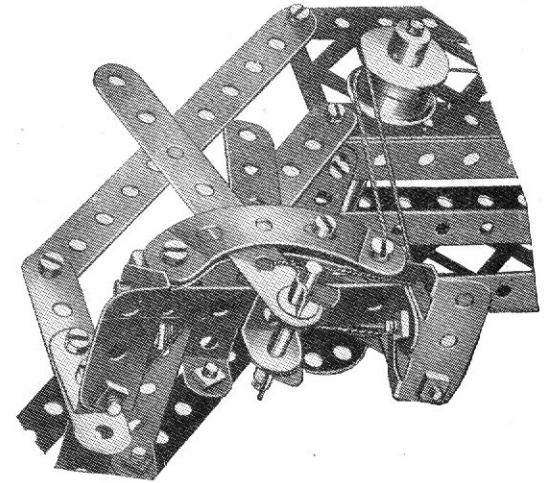

HOW TO CONTINUE

This completes our examples of models that may be made with MECCANO Outfit No. 2. The next models are a little more advanced, requiring a number of extra parts to construct them. The necessary parts are all contained in a No. 2A Accessory Outfit, the price of which may be obtained from any Meccano dealer.

**Model No. 3.1
Drilling Machine**

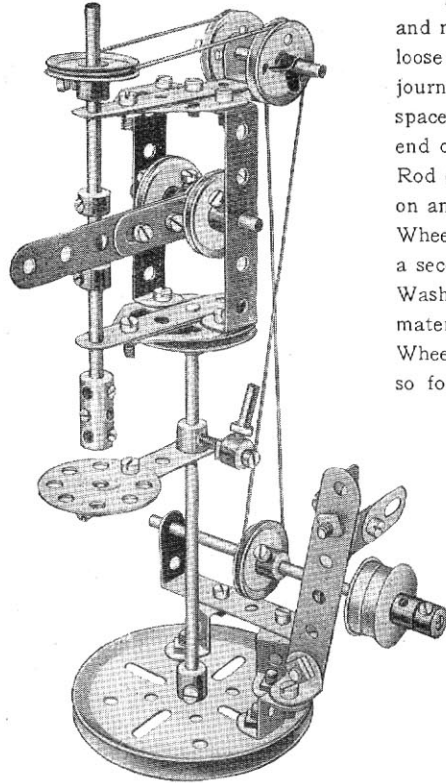

Parts required :		
2 of No. 4	1 of No. 19B	2 of No. 48A
2 " " 5	2 " " 20B	4 " " 59
2 " " 10	1 " " 21	2 " " 62
2 " " 11	4 " " 22	1 " " 63
1 " " 12	2 " " 22A	1 " " 111
1 " " 15	1 " " 24	1 " " 115
2 " " 15A	3 " " 35	3 " " 125
2 " " 17	21 " " 37	2 " " 126A
	1 " " 46	

Model No. 3.2 Strip-Bending Machine

This model represents a device for bending bars or rods of metal to circular form, and may be put to practical purpose in shaping strips of tin or similar material. A loose Pulley 1 is spaced by a Collar and Washers in the centre of the short Rod 2 journalled in a 1½" Strip 3. The latter is secured to the end of a ¾" Bolt 4 and spaced away from the 3" Pulley 5 by means of a number of Washers. The opposite end of the Rod is supported by a 5½" Strip 6. The Handle 7 is secured to a 3½" Rod carrying a ½" Pinion 8. This engages with a 57-teeth Gear Wheel 9 mounted on another 3½" Rod which is free to revolve in the boss of the Wheel 5. The Gear Wheel 9 carries a 3" Strip 10 forming one of the bearings for a short Rod carrying a second 1" loose Pulley 11. The latter is also spaced by means of a Collar and Washers so that it lies immediately above the groove of the Pulley Wheel 5. The material to be shaped is passed between the two loose Pulleys at the top of the Wheel 5, and on rotation of the handle 7 the arm 10 is caused to move downward so forcing the object to the same curvature as the circumference of the wheel.

Parts required :	
1 of No. 2	2
2 " " 3	3
1 " " 4	4
1 " " 5	5
1 " " 6A	6A
2 " " 16	16
1 " " 17	17
2 " " 18B	18B
1 " " 19B	19B
2 " " 22A	22A
1 " " 26	26
1 " " 27A	27A

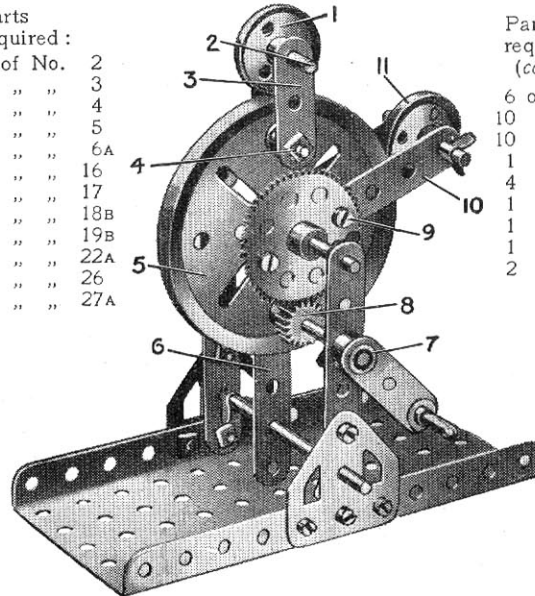

Parts required (continued):	
6 of No. 35	35
10 " " 37	37
10 " " 38	38
1 " " 52	52
4 " " 59	59
1 " " 62	62
1 " " 111	111
1 " " 115	115
2 " " 126A	126A

Model No. 3.3 Letter Balance

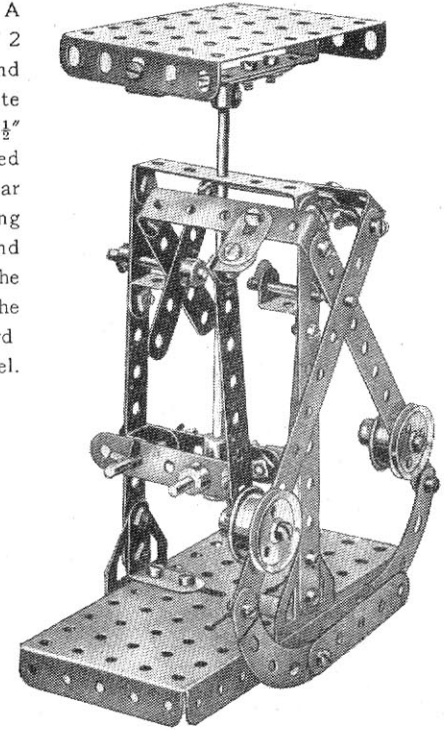

Parts required :		
4 of No. 2	2 of No. 18A	1 of No. 53
2 " " 3	2 " " 20B	4 " " 59
2 " " 10	2 " " 22A	1 " " 62
5 " " 5	4 " " 35	1 " " 63
2 " " 11	37 " " 37	2 " " 90A
4 " " 12	6 " " 37A	2 " " 111
2 " " 12A	2 " " 48A	4 " " 111c
1 " " 15	1 " " 48B	2 " " 125
2 " " 17	1 " " 52	2 " " 126A

Model No. 3.4 Scarifier

Parts required :

7 of No.	2
1 " "	3
4 " "	5
1 " "	10
1 " "	11
11 " "	12

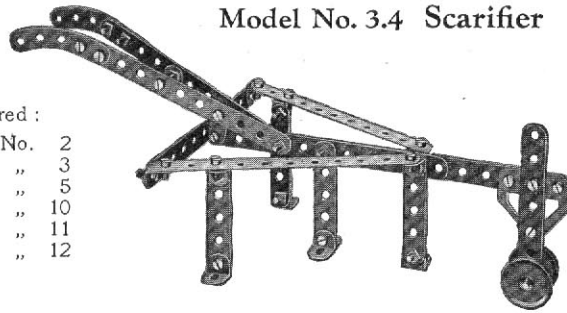

Parts required
(continued):

1 of No.	18A
2 " "	22
29 " "	37
2 " "	38
2 " "	90
1 " "	126A

Model No. 3.5 Electric Tramcar

Parts required :

14 of No.	2	4 of No.	20B	2 of No.	53
12 " "	5	2 " "	22	2 " "	54
4 " "	11	1 " "	23	3 " "	59
4 " "	12	1 " "	24	2 " "	62
4 " "	12A	2 " "	35	1 " "	63
1 " "	15	87 " "	37	2 " "	100
4 " "	16	1 " "	43	2 " "	111c
2 " "	17	2 " "	48	1 " "	115
		4 " "	48A	1 " "	116A
		2 " "	52	4 " "	125
				1 " "	147B

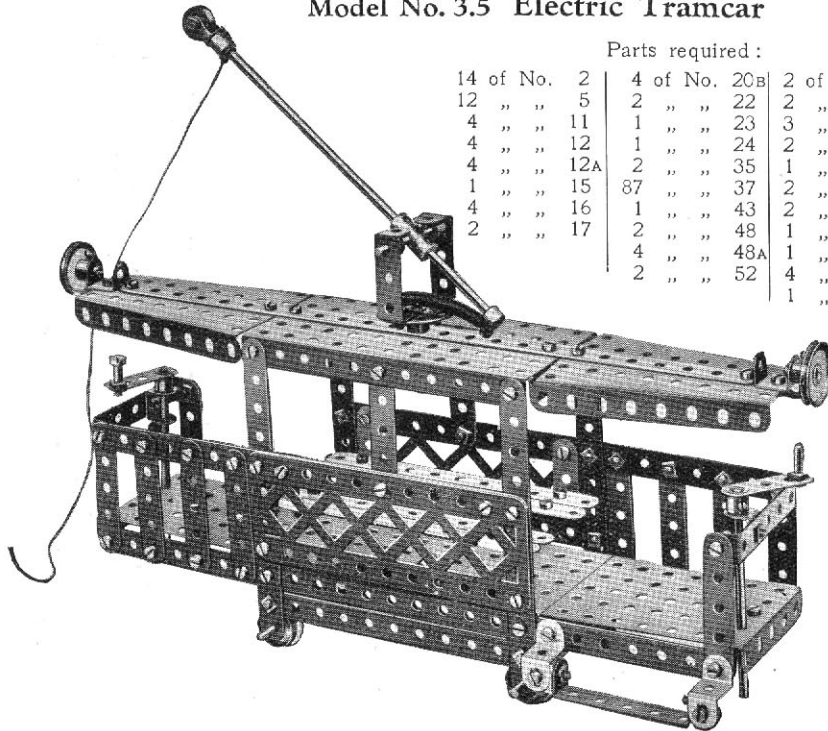

Model No. 3.6 Demonstration Scales

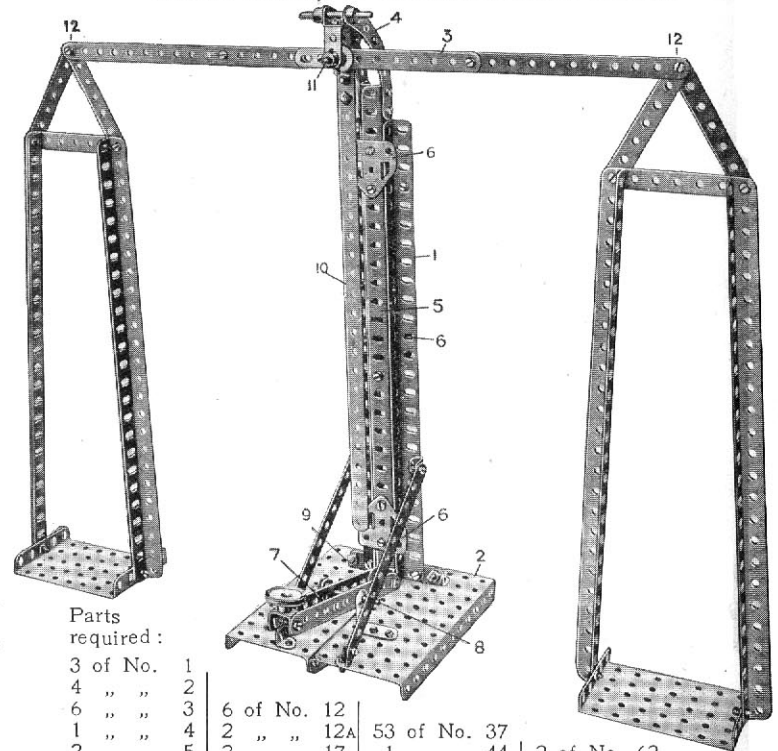

Parts required :

3 of No.	1	6 of No.	12	53 of No.	37	2 of No.	62
4 " "	2	2 " "	12A	1 " "	44	4 " "	90
6 " "	3	2 " "	17	2 " "	52	1 " "	125
1 " "	4	1 " "	18A	2 " "	53	2 " "	126A
2 " "	5	1 " "	22	2 " "	59		
1 " "	6A	2 " "	35				
8 " "	8						
4 " "	11						

The only feature of this model which needs description is the standard, which is built up of two Angle Girders 1 bolted to the base 2 by Angle Brackets and spaced apart at the top by a 2½" Strip obliquely disposed. The balance lever 3 is pivotally carried in Curved Strips 4 bolted to the top of two Angle Girders 5 sliding between the Girders 1. The Girders 5 are themselves bolted together and in order to guide them as they slide vertically two Flat Trunnions 6 and two 1½" Strips are bolted at the front and rear. The balance is raised by depressing the lever 7 pivoted at 8 and pivotally connected at 11 to the vertically sliding Girders 5. The indicator 10 is bolted to a Crank at the rear, the boss of which is fitted on the pivot Rod 11. The connections at 12 are lock-nutted to allow free action.

**Model No. 3.7
Step Ladder**

Parts
required :

4 of No.	1
8 " "	2
2 " "	3
3 " "	5
2 " "	10
10 " "	12
1 " "	16
2 " "	17
10 " "	35
38 " "	37
8 " "	48A
2 " "	59

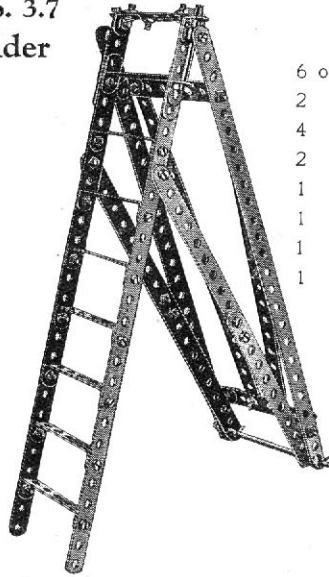

Model No. 3.9

Parts required :

6 of No.	2	28 of No.	37
2 " "	8	1 " "	37A
4 " "	11	4 " "	38
2 " "	15	2 " "	48B
1 " "	19B	2 " "	52
1 " "	24	2 " "	53
1 " "	26	2 " "	59
1 " "	27A	1 " "	115

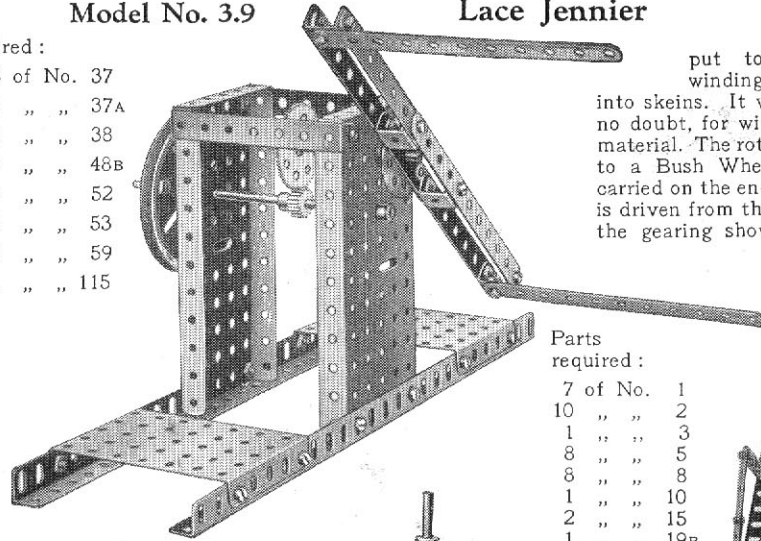

This model can be put to practical use in winding lengths of lace into skeins. It will also prove useful, no doubt, for winding wool and other material. The rotating frame is secured to a Bush Wheel, and the latter is carried on the end of an Axle Rod that is driven from the hand wheel through the gearing shown.

**Model No. 3.11
Swing**

Parts
required :

7 of No.	1
10 " "	2
1 " "	3
8 " "	5
8 " "	8
1 " "	10
2 " "	15
1 " "	19B
1 " "	24
2 " "	35
56 " "	37
4 " "	37A
6 " "	48A
1 " "	48B
2 " "	59
2 " "	62
4 " "	90A
2 " "	99
2 " "	111c
1 " "	115

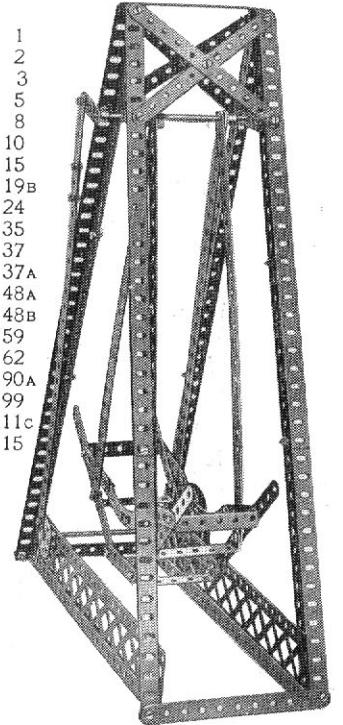

**Model No. 3.10
Auto Dial Press**

Parts required :

4 of No.	2	22 of No.	37
5 " "	5	5 " "	48A
2 " "	15	1 " "	52
1 " "	16	3 " "	59
1 " "	17	1 " "	63
1 " "	18A	4 " "	90A
1 " "	19B	1 " "	115
4 " "	20B		
1 " "	21		
1 " "	22		
1 " "	24		
1 " "	26		
1 " "	32		

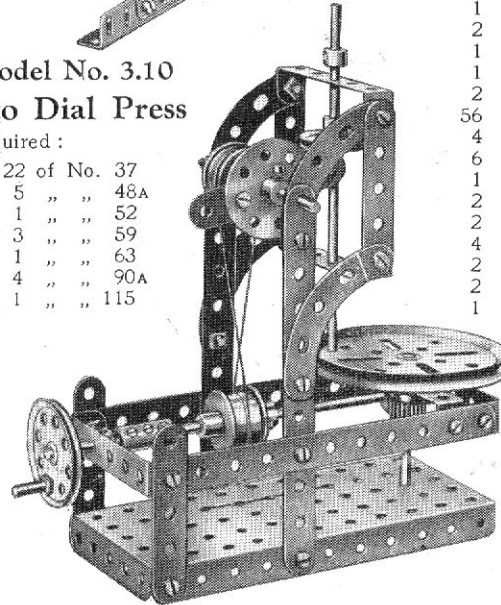

**Model No. 3.8
Drafting Machine**

Parts required :

4 of No.	1	2 of No.	5
3 " "	2	1 " "	24
1 " "	4	15 " "	37
		1 of No.	52

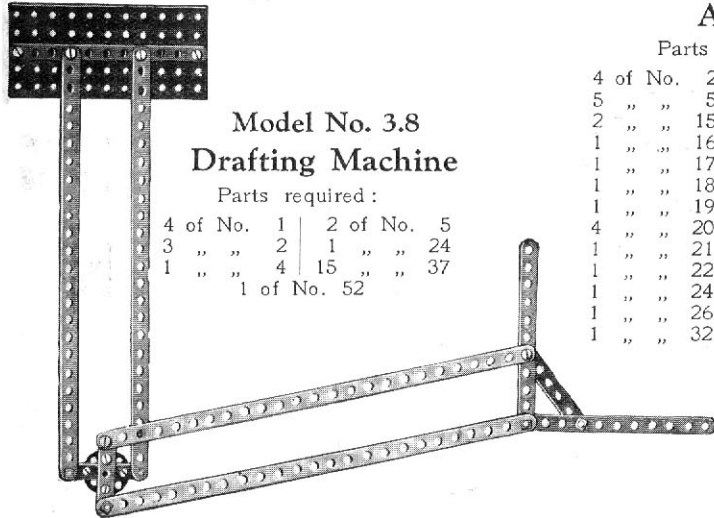

Model No. 3.12 Oil Cake Chopper

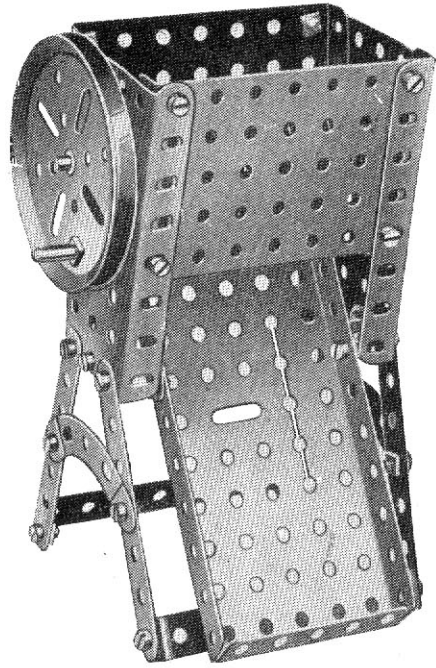

Parts required :

4 of No.	3
6 " "	10
1 " "	15
1 " "	19 ^B
4 " "	22
24 " "	37
2 " "	48 ^B
1 " "	52
2 " "	53
2 " "	54
1 " "	59
2 " "	90 ^A
1 " "	115
2 " "	125

Model No. 3.13 Ice Boat

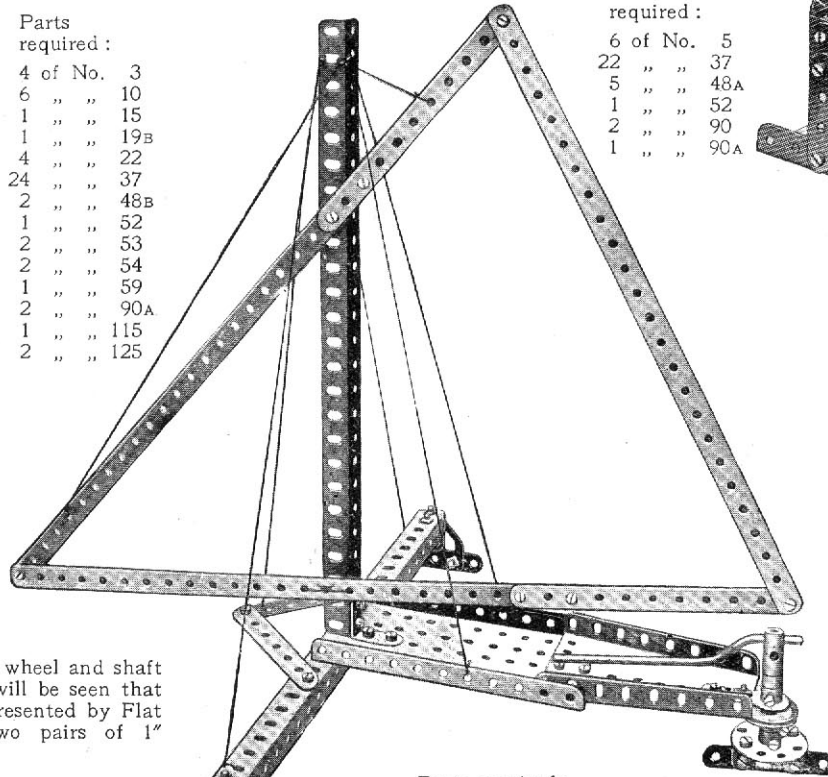

Parts required :

6 of No.	5
22 " "	37
5 " "	48 ^A
1 " "	52
2 " "	90
1 " "	90 ^A

Model No. 3.14 Toboggan

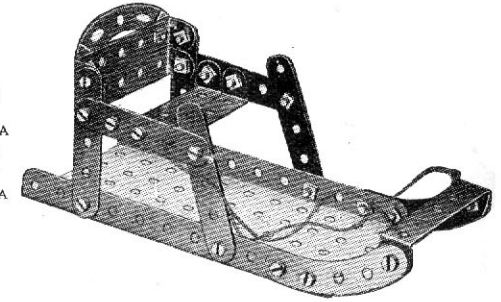

Model No. 3.15 Railway Gauge

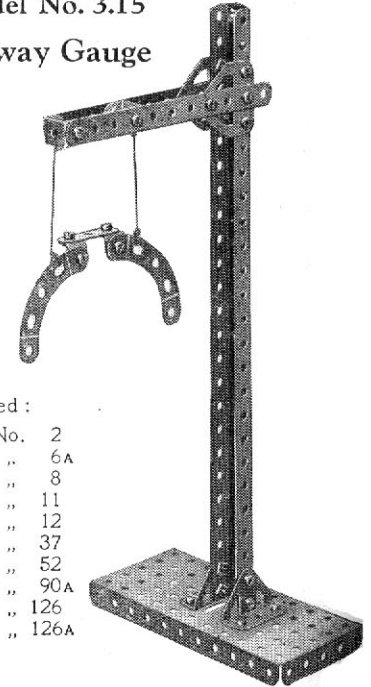

Parts required :

2 of No.	2
1 " "	6 ^A
2 " "	8
2 " "	11
2 " "	12
25 " "	37
1 " "	52
2 " "	90 ^A
2 " "	126
2 " "	126 ^A

Fig. 3.12A shows the hand wheel and shaft removed from the model. It will be seen that the chopping mechanism is represented by Flat Brackets clamped between two pairs of 1" fixed Pulley Wheels.

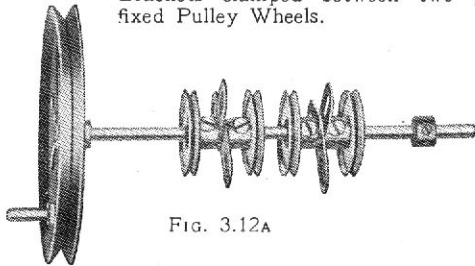

FIG. 3.12A

Parts required :

3 of No.	1	1 of No.	22
2 " "	2	1 " "	24
2 " "	3	36 " "	37
3 " "	5	1 " "	52
2 " "	8	1 " "	54
2 " "	12	1 " "	59
3 " "	12 ^A	1 " "	62
1 " "	17	1 " "	63
1 " "	19 ^S	2 " "	126 ^A

Model No. 3.16 Crossbow

Parts required :

5 of No.	1	1 of No.	18A
2 " "	2	2 " "	35
1 " "	3	25 " "	37
4 " "	5	1 " "	38
2 " "	8	1 " "	48A
2 " "	11	1 " "	63
1 " "	12		
1 " "	17		

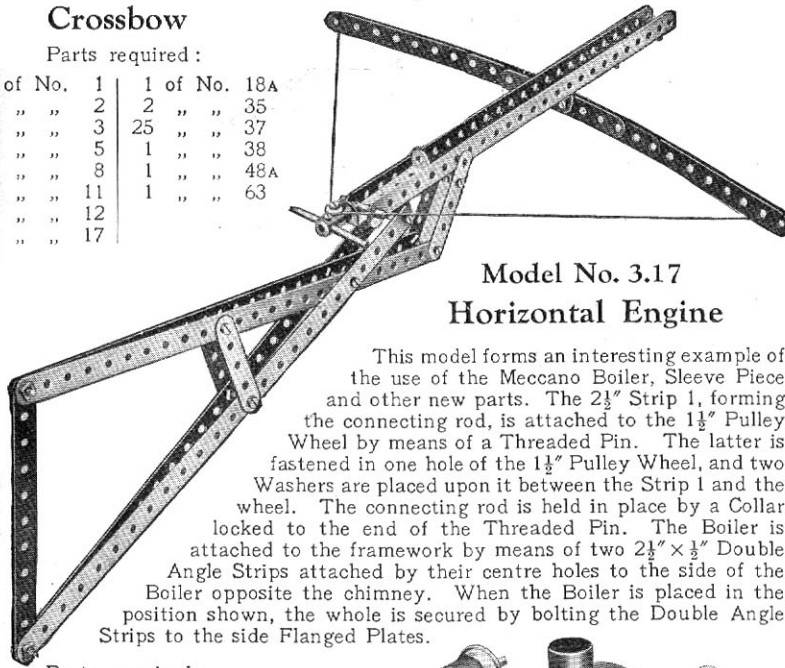

Model No. 3.17 Horizontal Engine

This model forms an interesting example of the use of the Meccano Boiler, Sleeve Piece and other new parts. The $2\frac{1}{2}$ " Strip 1, forming the connecting rod, is attached to the $1\frac{1}{2}$ " Pulley Wheel by means of a Threaded Pin. The latter is fastened in one hole of the $1\frac{1}{2}$ " Pulley Wheel, and two Washers are placed upon it between the Strip 1 and the wheel. The connecting rod is held in place by a Collar locked to the end of the Threaded Pin. The Boiler is attached to the framework by means of two $2\frac{1}{2}$ " x $\frac{1}{2}$ " Double Angle Strips attached by their centre holes to the side of the Boiler opposite the chimney. When the Boiler is placed in the position shown, the whole is secured by bolting the Double Angle Strips to the side Flanged Plates.

Parts required :

1 of No.	5	1 of No.	115
2 " "	12A	1 " "	116
2 " "	15A		
1 " "	16		
1 " "	19B		
1 " "	19s		
4 " "	20B		
1 " "	21		
3 " "	22		
1 " "	35		
25 " "	37		
7 " "	38	2 of No.	126
1 " "	45	1 " "	126A
1 " "	48	1 " "	162
4 " "	48A	1 " "	163
2 " "	52	1 " "	164
4 " "	59	1 " "	166

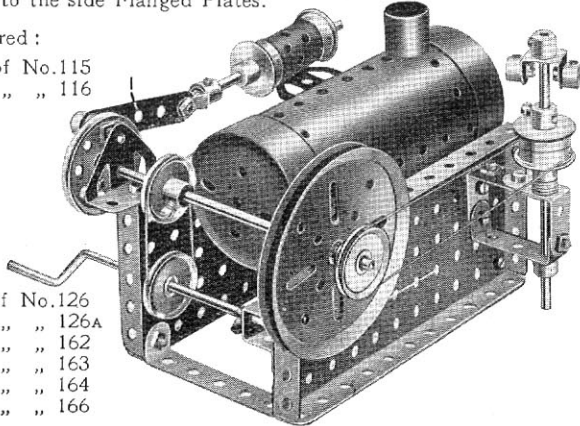

Model No. 3.18 Tower Wagon

When operated the handle 1 winds in the cord 2, which passes over a 1" fast Pulley Wheel 3 and is tied to the Rod 4. The upper part of the tower is thus raised or lowered as required, being guided by the $\frac{3}{4}$ " Flanged Wheels 5 and two pairs of Reversed Angle Brackets 6. The steering cords 7 are tied to the 57-teeth Gear Wheel 8 and to the end of a $2\frac{1}{2}$ " x $\frac{1}{2}$ " Double Angle Strip bolted to a Double Bent Strip, which is pivoted to the Sector Plate 9. The front axle is journalled through the ends of the Double Angle Strip.

Parts required :

4 of No.	1	2 of No.	54
2 " "	4	3 " "	59
6 " "	5	4 " "	90A
2 " "	6A	1 " "	98
8 " "	8	2 " "	100
8 " "	12	1 " "	111c
1 " "	15	1 " "	115
3 " "	15A	4 " "	125
4 " "	16		
1 " "	17		
4 " "	19B		
4 " "	20B		
1 " "	21		
2 " "	22		
1 " "	24		
1 " "	26		
1 " "	27A		
1 " "	32		
3 " "	35		
8 " "	37		
2 " "	37A		
1 " "	45		
8 " "	48A		
2 " "	52		
1 " "	53		

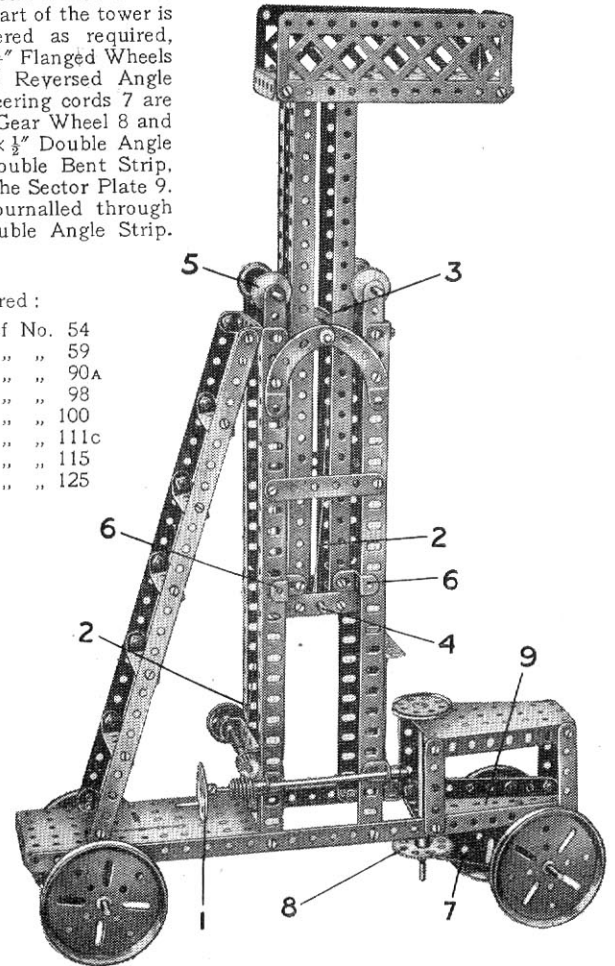

Model No. 3.19 Pile Driver

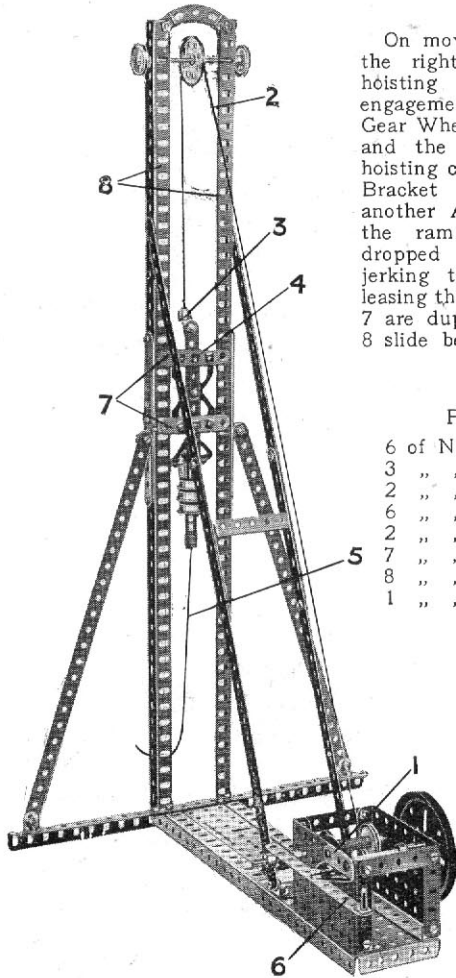

On moving the hand lever 6 to the right a $\frac{1}{2}$ " Pinion on the hoisting shaft is brought into engagement with the 57-teeth Gear Wheel 1 on the driving shaft and the ram 4 is raised. The hoisting cord 2 is tied to an Angle Bracket 3, which lodges under another Angle Bracket bolted to the ram. The latter may be dropped whenever required by jerking the cord 5, thereby releasing the Brackets 3. The Strips 7 are duplicated, and the Girders 8 slide between their ends.

Parts required:

6 of No. 1	3 of No. 16
3 " " 2	1 " " 19B
2 " " 3	3 " " 20B
6 " " 5	1 " " 21
2 " " 6A	2 " " 22
7 " " 8	1 " " 26
8 " " 12	1 " " 27A
1 " " 15A	1 " " 32
	2 " " 35
	60 " " 37
	2 " " 37A
	1 " " 38
	1 " " 45
	1 " " 46
	1 " " 48A
	2 " " 48B
	2 " " 52
	2 " " 53
	4 " " 59
	1 " " 90A
	1 " " 111c
	1 " " 115
	2 " " 126
	2 " " 126A

Model No. 3.20 Actuated See-Saw

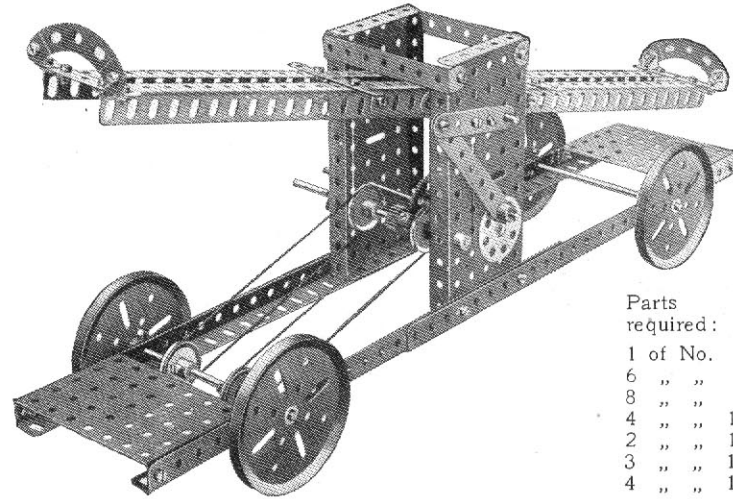

	4 of No. 22
	1 " " 24
	1 " " 26
	1 " " 27A
	2 " " 35
	43 " " 37
Parts required:	2 " " 37A
	2 " " 48B
1 of No. 3	2 " " 52
6 " " 5	2 " " 53
8 " " 8	3 " " 59
4 " " 12	2 " " 62
2 " " 15	2 " " 90A
3 " " 15A	1 " " 111c
4 " " 19B	1 " " 115

The model is actuated by the motion of one pair of travelling wheels. The axle to which these wheels are secured carries two 1" fast Pulley Wheels, which are connected by endless cords to similar Pulleys on the same Rod as a $\frac{1}{2}$ " Pinion Wheel. This $\frac{1}{2}$ " Pinion meshes with a 57-teeth Gear Wheel secured to the Rod of a Bush Wheel, and the latter is connected by means of a $5\frac{1}{2}$ " Strip to an extended crank (a $2\frac{1}{2}$ " Strip and a Crank bolted together) secured to the pivotal Rod of the see-saw.

Model No. 3.21 Tank Wagon

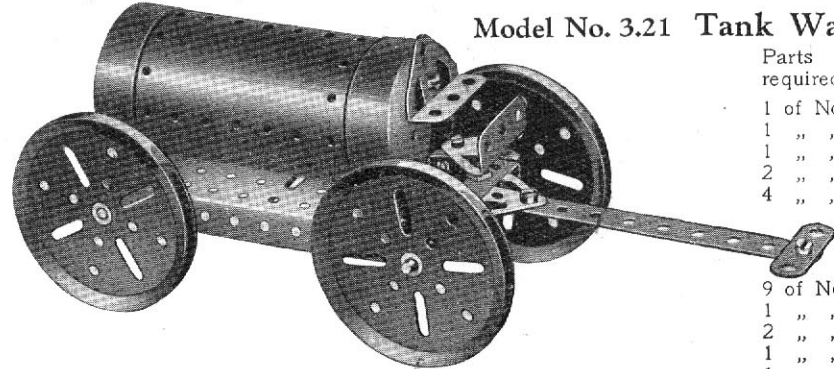

Parts required:
1 of No. 2
1 " " 6A
1 " " 12
2 " " 16
4 " " 19B
9 of No. 37
1 " " 52
2 " " 126
1 " " 126A
1 " " 162

Model No. 3.22 Hand Trolley

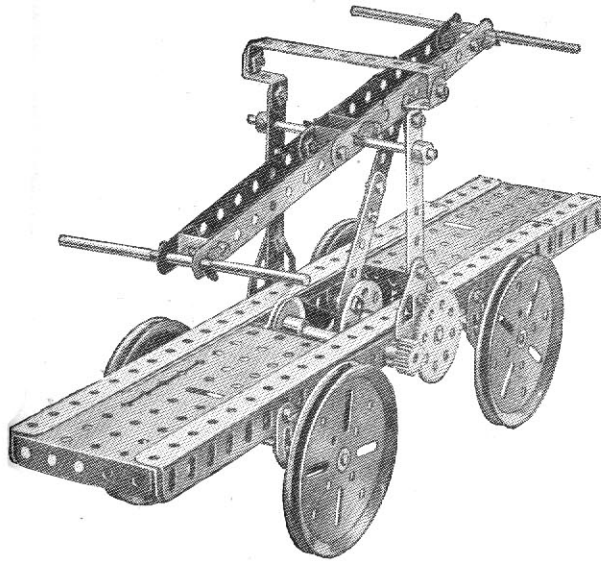

Parts required :

4 of No. 2	1 of No. 18A	1 of No. 45
3 " " 3	4 " " 19B	1 " " 48B
2 " " 5	2 " " 22	2 " " 52
4 " " 8	1 " " 24	3 " " 59
8 " " 10	1 " " 26	4 " " 90A
4 " " 11	1 " " 27A	2 " " 125
2 " " 15A	6 " " 35	2 " " 126A
4 " " 16	40 " " 37	

The connecting arm is pivoted at its lower end to the Bush Wheel and at its upper end to the hand lever, a bolt and two nuts being used to pivot the arm in each case. The drive is transmitted to a 1" Pulley Wheel on the axle of the road wheels by means of a crossed belt passing round another 1" Pulley that is secured to a Rod connected via a 3:1 gear ratio to the 1½" Rod carrying the Bush Wheel. This Rod is journalled in a 3½" Strip fastened to the side Angle Girder, and also in a Double Bent Strip secured to the inside of the Girder.

Model No. 3.23

Horizontal Engine

Parts required :

5 of No. 5	3 of No. 48A
2 " " 8	2 " " 48B
2 " " 12	2 " " 52
3 " " 15A	3 " " 53
2 " " 19B	3 " " 59
1 " " 19s	1 " " 63
4 " " 20B	1 " " 116
1 " " 21	1 " " 125
1 " " 22	2 " " 126
2 " " 35	1 " " 162
32 " " 37	1 " " 163
1 " " 48	1 " " 164
1 of No. 166	

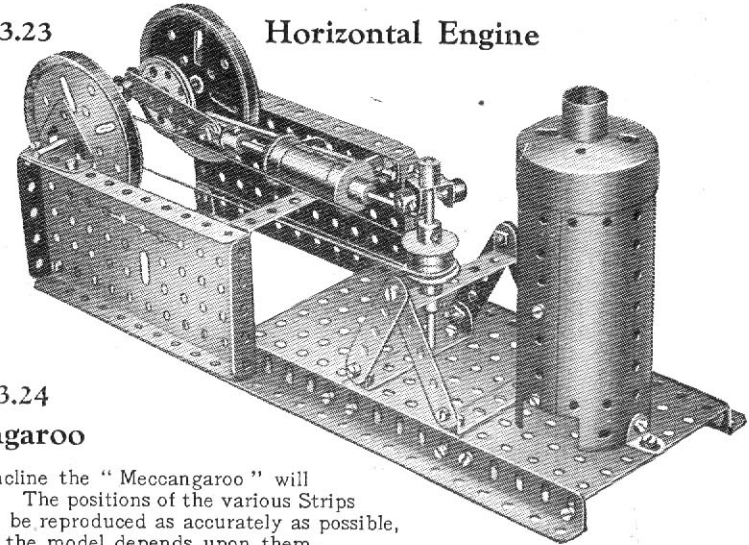

Model No. 3.24

The Meccangaroo

When placed upon an incline the "Meccangaroo" will "walk" with a quaint action. The positions of the various Strips in relation to the body should be reproduced as accurately as possible, for the successful working of the model depends upon them.

The animal rocks about a short Rod secured between the rocker-frame which does duty as "legs." This frame consists of two 3½" Strips 3 bolted at their upper ends to cranks in which the short Rod is secured, and at their lower ends to two 2½" large radius Curved Strips 4, which are connected together at their ends by 1½" Strips 5 and braced to the Strips 3 by 2½" Strips.

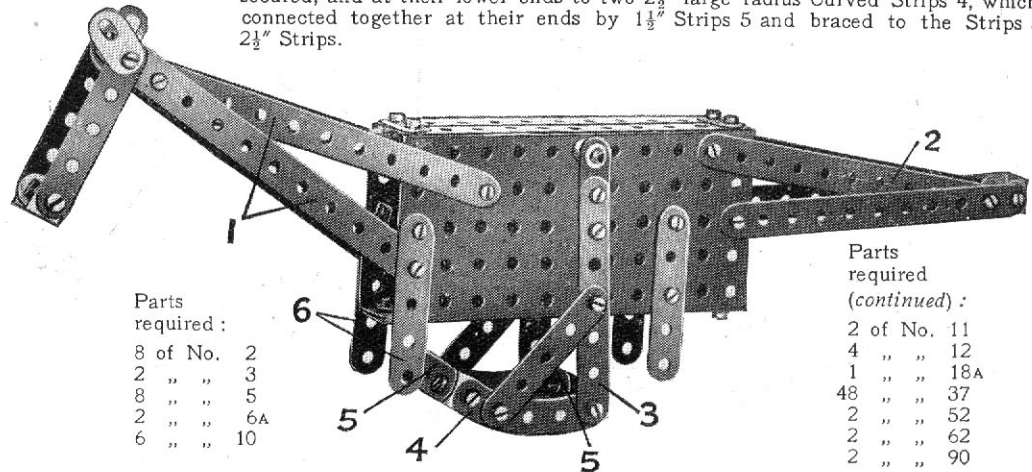

Parts required :

8 of No. 2
2 " " 3
8 " " 5
2 " " 6A
6 " " 10

Parts required
(continued) :

2 of No. 11
4 " " 12
1 " " 18A
48 " " 37
2 " " 52
2 " " 62
2 " " 90

Model No. 3.25 Fire Escape

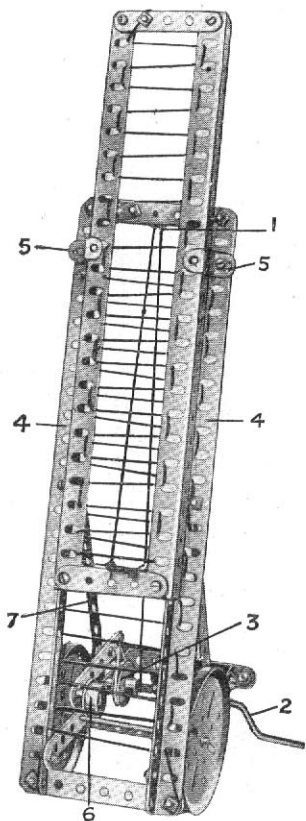

- Parts required:
- 4 of No. 2
 - 3 " " 3
 - 1 " " 4
 - 2 " " 5
 - 4 " " 8
 - 3 " " 12
 - 1 " " 16
 - 1 " " 19s
 - 2 " " 19B
 - 1 " " 20B
 - 1 " " 22
 - 1 " " 23
 - 26 " " 37
 - 6 " " 37A
 - 5 " " 38
 - 2 " " 40
 - 2 " " 48A
 - 3 " " 59
 - 5 " " 111c
 - 2 " " 125
 - 1 " " 126A

The moving portion of the escape slides on the 12½" Angle Girders 4 of the fixed ladder and is guided by two ½" Reversed Angle Brackets 5. The cord for extending the ladder passes over the ½" loose Pulley 1 and is wound on the

Crank Handle 2. The Pulley 1 revolves freely on a ¾" Bolt that is secured by two nuts to an Angle Bracket bolted to the 3½" Strip.

A 3" Strip, weighted with a ¼" Flanged Wheel 6 to form a brake lever, is pivoted by a ⅜" Bolt to the 5½" Strip 7, and a piece of cord is passed round the 1" Pulley 3 on the hoisting shaft, and tied to the Strip. The pressure of the weighted lever is sufficient to keep the ladder raised in any position.

Model No. 3.26 Auto Swing Boat

The connecting Strip 1 is attached pivotally at one end to a Threaded Pin secured to the Bush Wheel 2 on the driving spindle of the motor, and at the other end by means of Bolt and Lock-Nuts to a Crank 3 mounted on the shaft 4, which operates the swing boat.

Parts required:

3 of No. 1	1 of No. 10	86 of No. 37	2 of No. 90A
16 " " 2	12 " " 12	2 " " 37A	2 " " 99
6 " " 3	2 " " 15	1 " " 59	2 " " 100
8 " " 5	1 " " 24	2 " " 62	1 " " 111c
8 " " 8	2 " " 35	1 " " 63	1 " " 115
	2 of No. 126A		

Clockwork Motor (not included in Outfit)

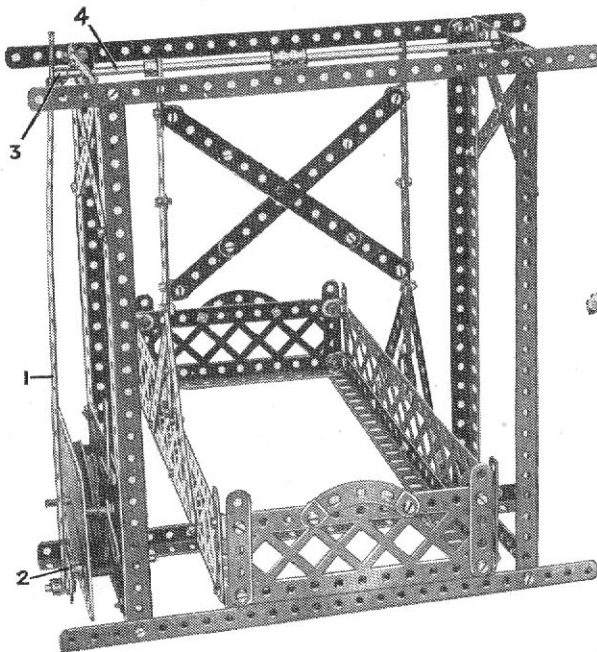

Model No. 3.27 Scales

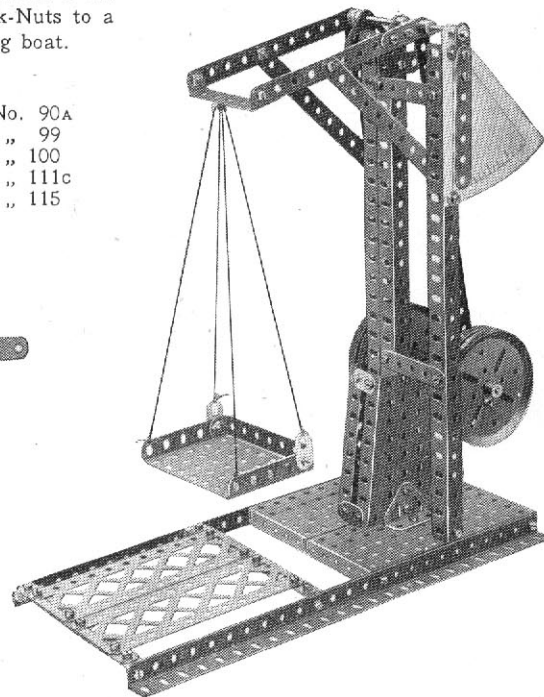

Parts required:

10 of No. 2	2 of No. 48A
1 " " 3	1 " " 48B
2 " " 5	2 " " 52
5 " " 8	1 " " 53
7 " " 10	2 " " 54
5 " " 12	4 " " 59
2 " " 15A	2 " " 62
4 " " 19B	2 " " 100
67 " " 37	2 " " 126
2 " " 38	2 " " 126A

Model No. 3.28 Lawn Marker

The small roller, which consists of two $\frac{3}{4}$ " Flanged Wheels secured to a short Rod, rests on the edges of the two 3" Pulley Wheels. In actual practice the container is filled with whitewash, in which the inner wheel is partially immersed, and the mixture is transferred via the roller to the outer wheel, which does the actual marking.

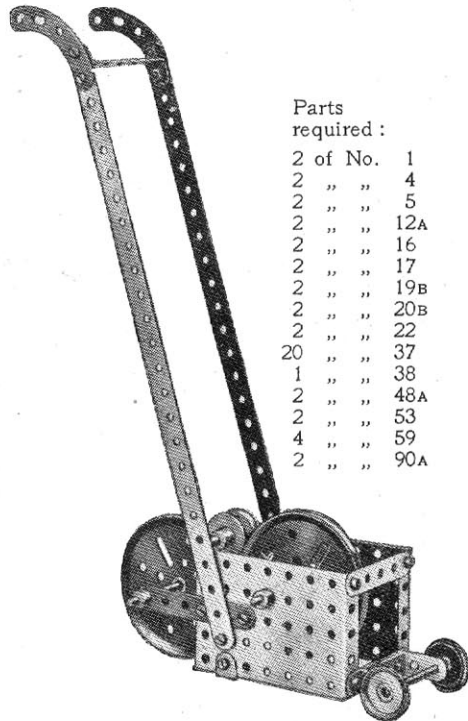

Parts required :	
2 of No.	1
2 " "	4
2 " "	5
2 " "	12A
2 " "	16
2 " "	17
2 " "	19B
2 " "	20B
2 " "	22
2 " "	37
1 " "	38
2 " "	48A
2 " "	53
4 " "	59
2 " "	90A

Model No. 3.29 Hand Car

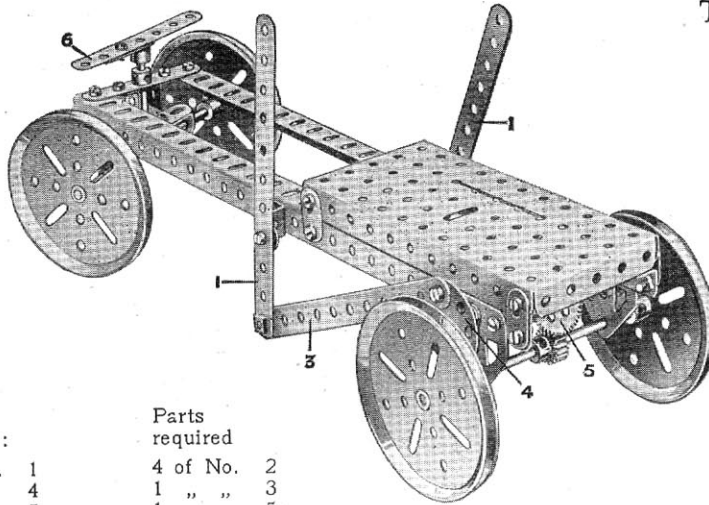

Parts required			
4 of No.	2	1 of No.	27A
1 " "	3	4 " "	35
1 " "	5	26 " "	37
2 " "	8	5 " "	37A
4 " "	10	4 " "	38
2 " "	15	1 " "	45
1 " "	16	1 " "	48A
1 " "	17	1 of No.	52
4 " "	19B	1 " "	59
1 " "	24	2 " "	62
1 " "	26	1 " "	63
		1 " "	111c
		2 " "	125
		2 " "	126A

The hand levers 1 are each pivotally attached to the car by a bolt and two nuts (see Standard Mechanism No. 262) and are connected in a similar manner to two further levers, one of which, seen at 3, is pivoted to a Bush Wheel 4 whilst the other, on the further side of the model, is pivoted to a Coupling, which serves as a crank in the same way as the Bush Wheel 4. Both Bush Wheel and Coupling are secured to the Rod carrying the Gear Wheel 5, and motion is thus transmitted to the rear wheels. The steering foot lever 6 is secured by a Crank to a short vertical Rod which, in turn, is secured by another Crank to the Double Angle Strip carrying the front axle.

Model No. 3.30 Two-Cylinder Vertical Steam Engine

Parts required :	2 of No.	125	1 of No.	166
2 of No.	3	1 " "	162	Electric Motor
2 " "	8	2 " "	163	(not included in
2 " "	11	1 " "	164	Outfit)
3 " "	12			
4 " "	16			
2 " "	19B			
4 " "	20B			
1 " "	22			
1 " "	27A			
40 " "	37			
7 " "	38			
2 " "	48B			
2 " "	52			
3 " "	53			
3 " "	59			
2 " "	115			
1 " "	116A			

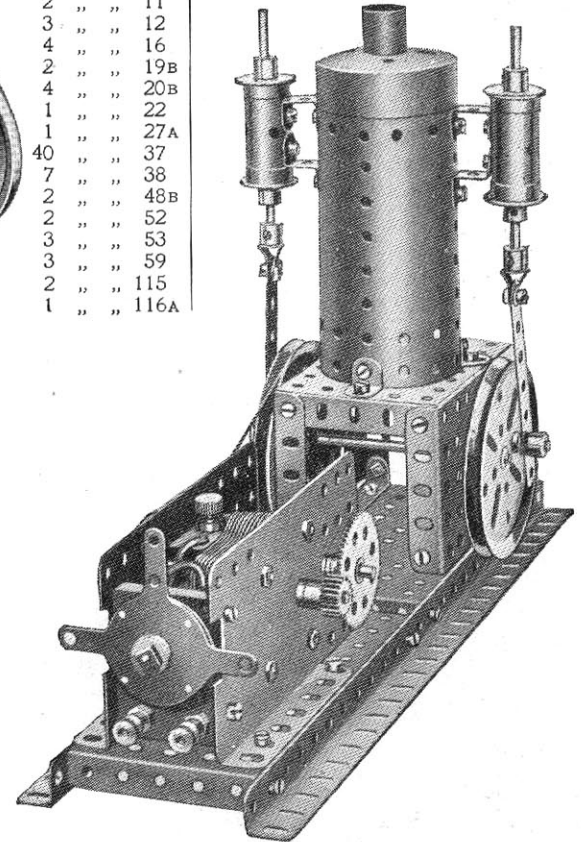

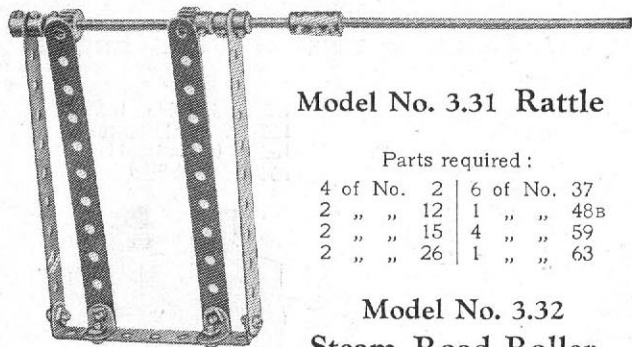

Model No. 3.31 Rattle

Parts required :

4 of No. 2	6 of No. 37
2 " " 12	1 " " 48B
2 " " 15	4 " " 59
2 " " 26	1 " " 63

**Model No. 3.32
Steam Road Roller**

Parts required :

2 of No. 2
7 " " 5
2 " " 11
1 " " 12
2 " " 12A
3 " " 16
1 " " 17
1 " " 18A
4 " " 19B
1 " " 21
3 " " 22
1 " " 23
1 " " 24

57 of No. 37
11 " " 38
1 " " 45
8 " " 48A
2 " " 48B
3 " " 53
4 " " 59
1 " " 62
4 " " 90A

1 of No. 126
1 " " 126A
1 " " 162
1 " " 164

Parts required :

4 of No. 2
4 " " 3
4 " " 5
4 " " 10
1 " " 11
1 " " 12
1 " " 15A
3 " " 16
1 " " 19B
2 " " 20B
1 " " 23
3 " " 35
27 " " 37
9 " " 37A
1 " " 38
1 " " 46
1 " " 48
2 " " 48A
1 " " 48B
1 " " 52
4 " " 59

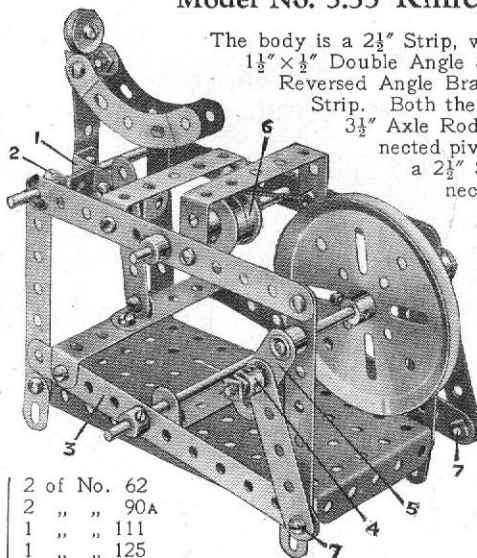

Model No. 3.33 Knife Grinder

The body is a 2½" Strip, which is bolted at its lower end to a 1½" × ½" Double Angle Strip 1 and is held upright by a ½" Reversed Angle Bracket 2 secured to the Double Angle Strip. Both the latter parts are free to turn about a 3½" Axle Rod and the Double Angle Strip is connected pivotally with the treadle 3 by means of a 2½" Strip. The treadle, in turn, is connected pivotally with the crankshaft by two further 2½" Strips, each of the bolts 7 being secured by two nuts as in Standard Mechanism No. 262. The Collar 4 is mounted loosely on a ¾" Bolt secured rigidly to the Crank 5, and forms a handle by means of which the model may be set in motion. The Grinding Wheel 6 is driven from the 3" Pulley Wheel by an endless belt.

2 of No. 62
2 " " 90A
1 " " 111
1 " " 125

Model No. 3.34 Lawn Mower

The grass box 1 is retained in position by two Flat Brackets bolted to the 2½" × ½" Double Angle Strip 2 but spaced from it by a Washer on each bolt. The edge of the Double Angle Strip 3 may be slipped in the space between the Double Angle Strip 2 and the Flat Brackets, one of which is shown at 4.

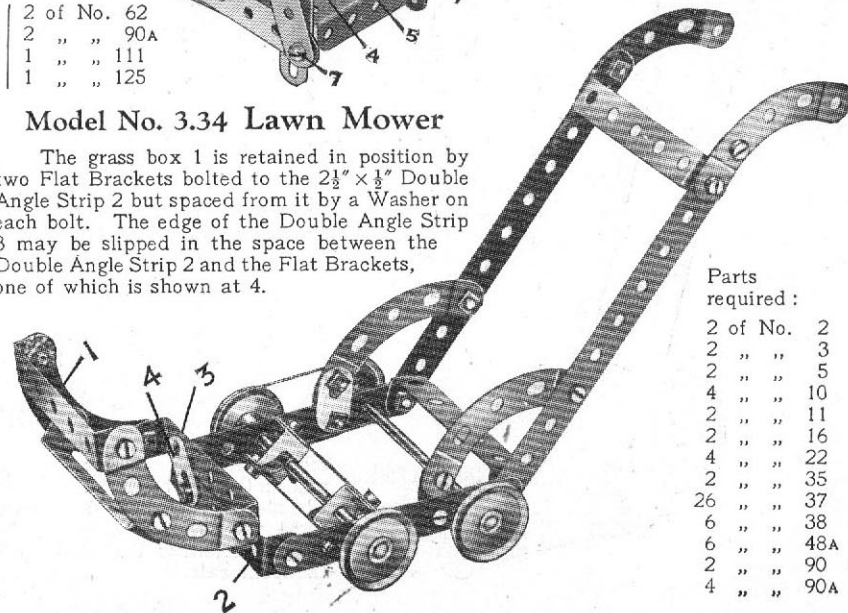

Parts required :

2 of No. 2
2 " " 3
2 " " 5
4 " " 10
2 " " 11
2 " " 16
4 " " 22
2 " " 35
26 " " 37
6 " " 38
6 " " 48A
2 " " 90
4 " " 90A

**Model No. 3.35
Swinging Cot**

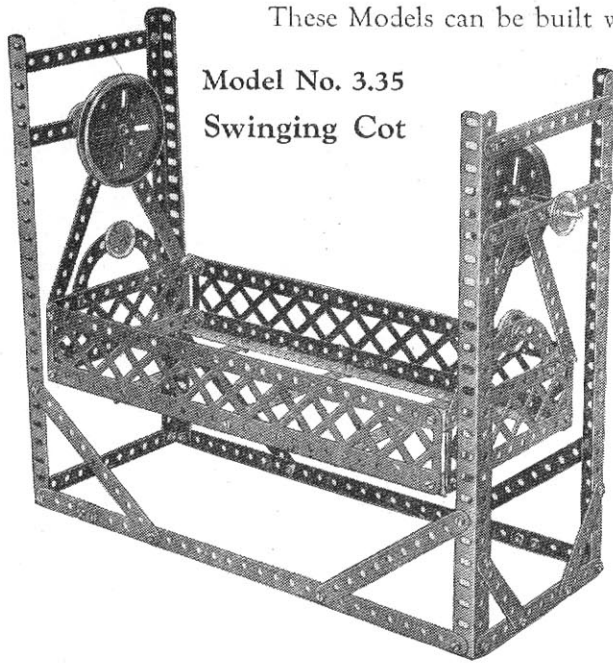

Parts required :

2 of No. 1	6 of No. 8	2 of No. 22	2 of No. 45
17 " " 2	8 " " 12	2 " " 22A	4 " " 90A
2 " " 4	2 " " 17	64 " " 37	2 " " 99
2 " " 5	2 " " 19B	2 " " 37A	2 " " 100
			2 " " 111c

Model No. 3.36 Horse Sleigh

Parts required :

3 of No. 2	13 of No. 37	1 of No. 57
4 " " 5	1 " " 48A	2 " " 90
1 " " 23	1 " " 52	1 " " 126A

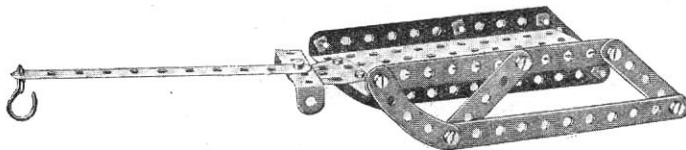

Model No. 3.37 Pit Head Gear

The cage is raised and lowered by the cord 1 which is wound between two 3" Pulleys on the 4½" Axle Rod 2. The Rod also carries a further 3" Pulley which is provided with a Threaded Pin to form the operating handle, while a 5½" Strip 3 secured by an Angle Bracket to the 5½" x 2½" Flanged Plate bears against the periphery of the Pulley and so serves as a brake. The Strip must be depressed slightly with the fingers whilst winding.

A Bush Wheel 4 on the Rod 2 carries a Threaded Pin that serves as the crank pin of a dummy engine, which is formed by a Sleeve Piece 5 fitted at each end with a ¾" Flanged Wheel. The Sleeve Piece is mounted on a pivot Bolt that is passed through its centre hole and lock-nutted to the Plate, being spaced from the latter by a Collar. A 2" Rod passes through the boss of one of the Flanged Wheels and carries at one end a Swivel bearing, the "spider" of which is mounted loosely on the Threaded Pin. The bolts securing the Fork Piece to the "spider" should be provided with nuts to prevent their shanks gripping the Pin. A Crank Handle representing the exhaust steam pipe is secured by bolts passed through the Boiler, and inserted in the tapped holes of a Coupling and a Collar.

Parts required :

10 of No. 1	1
8 " " 2	2
4 " " 3	3
2 " " 4	4
8 " " 8	8
1 " " 11	11
14 " " 12	12
1 " " 12A	12A
1 " " 15	15
3 " " 15A	15A
2 " " 17	17
4 " " 19B	19B
1 " " 19S	19S
4 " " 20B	20B
1 " " 22	22
1 " " 24	24
4 " " 35	35
88 " " 37	37
3 " " 38	38
1 " " 40	40
2 of No. 48B	48B
2 " " 52	52
3 " " 53	53
2 " " 54	54
4 " " 59	59
1 " " 63	63
2 " " 100	100
2 " " 115	115
1 " " 147B	147B
1 of No. 162A	162A
1 " " 162B	162B
2 " " 163	163
1 " " 164	164
1 " " 165	165

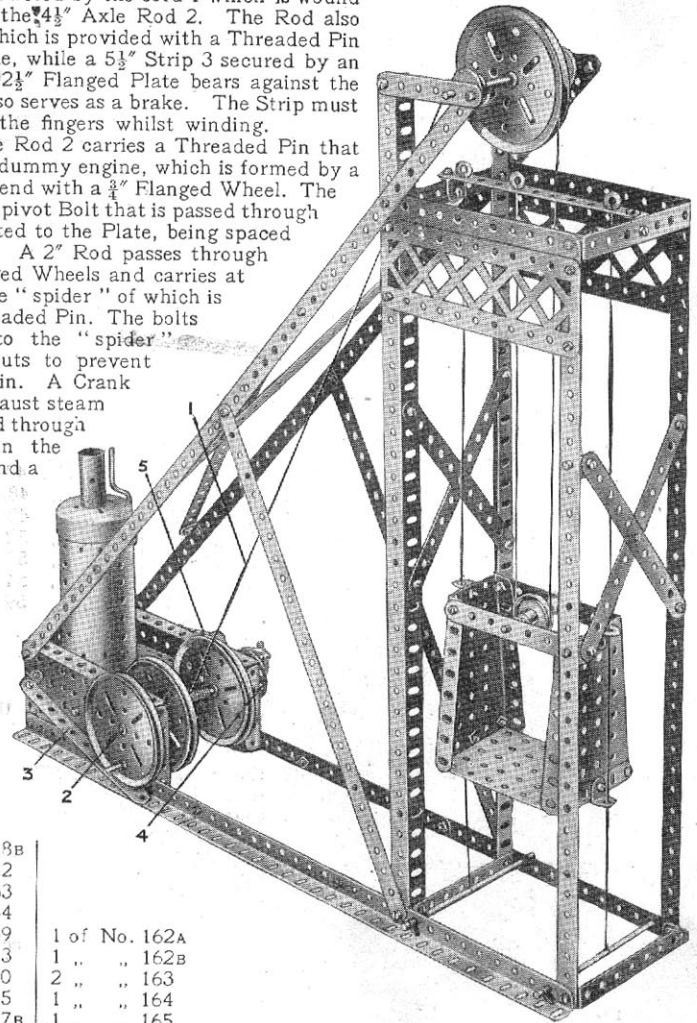

**Model No. 3.38
Tank Lorry**

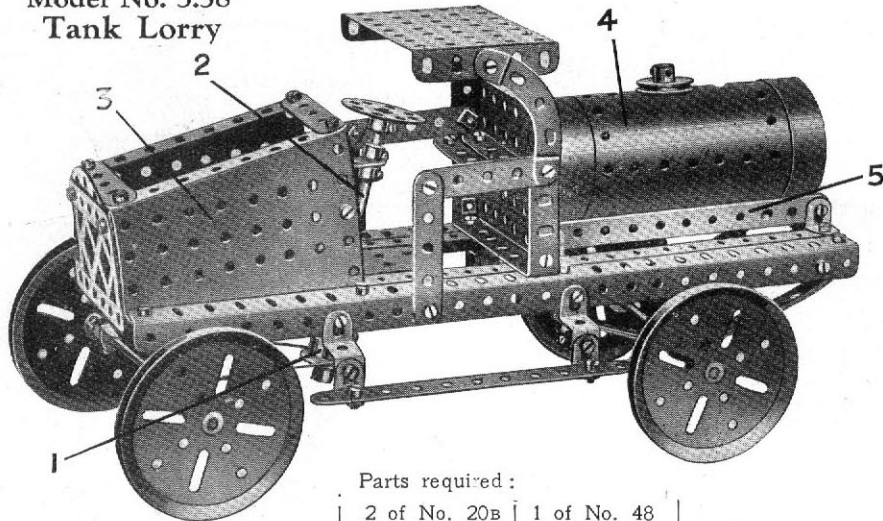

Parts required :

2 of No. 1	2 of No. 11	2 of No. 20B	1 of No. 48		
8 " " 2	14 " " 12	1 " " 22	1 " " 48A	3 of No. 90A	
3 " " 3	2 " " 12A	1 " " 24	2 " " 48B	1 " " 98	
6 " " 5	2 " " 15	4 " " 35	1 " " 52	2 " " 111c	
1 " " 6A	1 " " 15A	60 " " 37	2 " " 53	4 " " 125	
2 " " 8	4 " " 19B	1 " " 37A	2 " " 54	2 " " 126	
		4 " " 38	4 " " 59	1 " " 162	

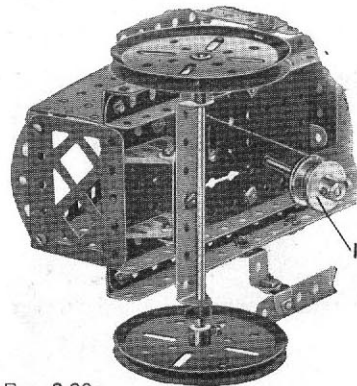

FIG. 3.38A

It should be noted that the steering cord is given a complete turn around the two $\frac{3}{4}$ " Flanged Wheels 1 to prevent slipping. The steering column 2 is journalled in the end of a $1\frac{1}{2}$ " Strip, the other end of which is bolted to a $2\frac{1}{2}$ " x $\frac{1}{2}$ " Double Angle Strip secured between the two Sector Plates 3. The front road wheels are secured to a 5" Rod that is journalled in the end holes of a $3\frac{1}{2}$ " x $\frac{1}{2}$ " Double Angle Strip. The ends of the steering cord are tied to this Strip, which is pivoted by means of a Bolt and Lock-nuts (S.M. 263) to the central hole of a $1\frac{1}{2}$ " x $\frac{1}{2}$ " Double Angle Strip. The latter is bolted between a pair of Trunnions attached to the underside of the $5\frac{1}{2}$ " x $2\frac{1}{2}$ " Flanged Plate. The tank 4 merely rests on the $5\frac{1}{2}$ " Strips 5.

Model No. 3.39 Coffee Grinder

Parts required :

2 of No. 2	1 of No. 27A
6 " " 3	16 " " 37
2 " " 4	2 " " 54
2 " " 16	3 " " 59
1 " " 19B	1 " " 115
1 " " 26	4 " " 125

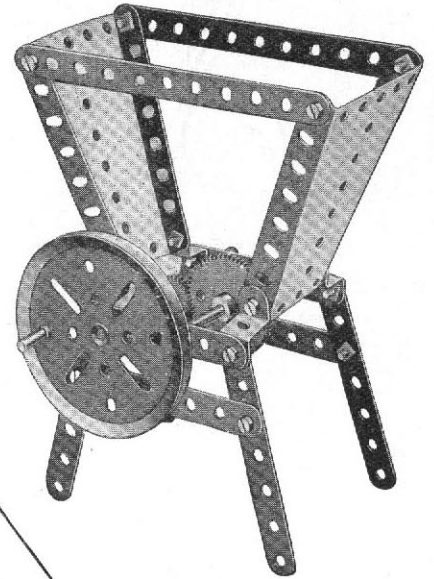

**Model No. 3.40
Land Yacht**

Parts required :

1 of No. 1	1 of No. 40
1 " " 3	1 " " 45
4 " " 8	2 " " 48A
1 " " 10	1 " " 48B
1 " " 13	1 " " 54
1 of No. 15	6 " " 59
3 " " 16	19 " " 62
1 " " 18A	4 " " 63
4 " " 19B	2 of No. 111
1 " " 24	
6 " " 35	
19 " " 37	
4 " " 37A	

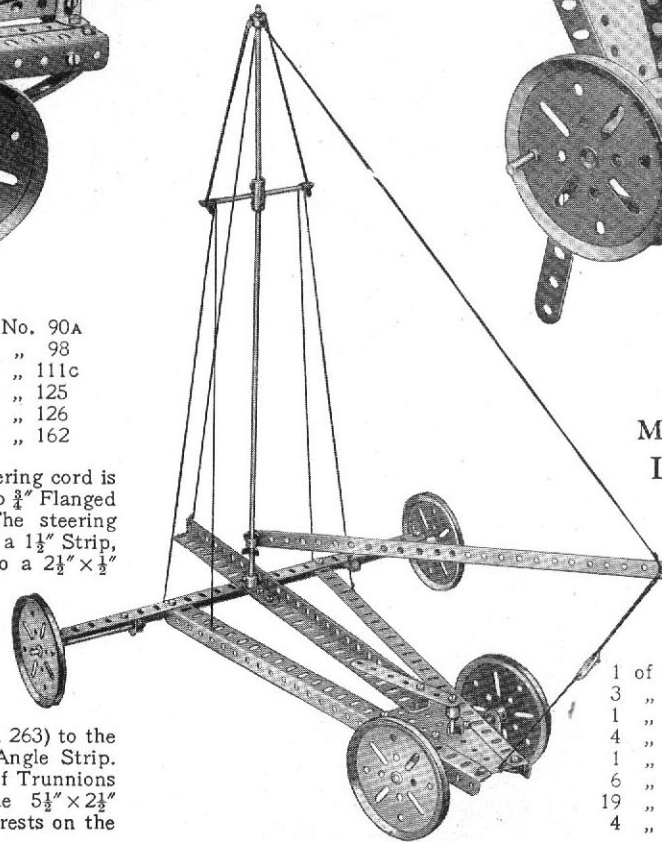

Model No. 3.41 Fire Truck

The front axle is journalled in a $2\frac{1}{2}$ " Double Angle Strip that is pivoted through its centre hole to a Double Bent Strip secured to the Flanged Plate 15. Steering is effected from the Pulley 13 secured on a $3\frac{1}{2}$ " Rod that is passed through the $3\frac{1}{2}$ " x $2\frac{1}{2}$ " Flanged Plate 16, and held in position by Collars. On the lower end of the Rod is a Bush Wheel 14, which is connected to the pivoted Double Angle Strip by cords tied to opposite holes in the Bush Wheel and to the ends of the Double Angle Strip.

The lower part of the escape is mounted pivotally on Bolts 10 passed through the upturned ends of a $2\frac{1}{2}$ " x $1\frac{1}{2}$ " Double Angle Strip that is bolted to a $3\frac{1}{2}$ " x $\frac{1}{2}$ " Double Angle Strip which, in turn, is supported on two vertical $2\frac{1}{2}$ " x $\frac{1}{2}$ " Double Angle Strips. The upper or moving portion of the escape slides between the $12\frac{1}{2}$ " Angle Girders 9 and is held freely in position by the Nuts of the Bolts 11.

The ladder is extended from the Crank Handle 2 (Fig. 3.41A) that is journalled in a $2\frac{1}{2}$ " x $\frac{1}{2}$ " Double Angle Strip bolted to a $5\frac{1}{2}$ " Strip that, in turn, is bolted across the flanges of the Sector Plates. A Cord 7 is wound on to the Crank Handle and one of its ends is tied to a $2\frac{1}{2}$ " Strip that spans the inner end of the $12\frac{1}{2}$ " Strips forming the sides of the extending ladder. Its other end 7A is then led towards the outer end of the fixed ladder, round a $1\frac{1}{2}$ " loose Pulley held on a bolt in the centre hole of a $2\frac{1}{2}$ " Double Angle Strip that spans the outer ends of the $12\frac{1}{2}$ " Girders 9, and finally is tied to the same $2\frac{1}{2}$ " Strip to which the end 7 is already attached. Thus by turning the Handle 2 the escape is pulled inward or outward.

The Crank Handle 1 carries a $\frac{1}{2}$ " Pinion 3 that engages a 57-teeth Gear 4 secured to a Rod 12. A Cord 8 is wound a few turns round the Rod 12 and is then led to the $2\frac{1}{2}$ " Strip 5 where it is secured. By turning the Crank Handle the Cord is wound in, thus raising the pivoted escape.

On turning the Handle in the opposite direction, the escape is lowered by its own weight.

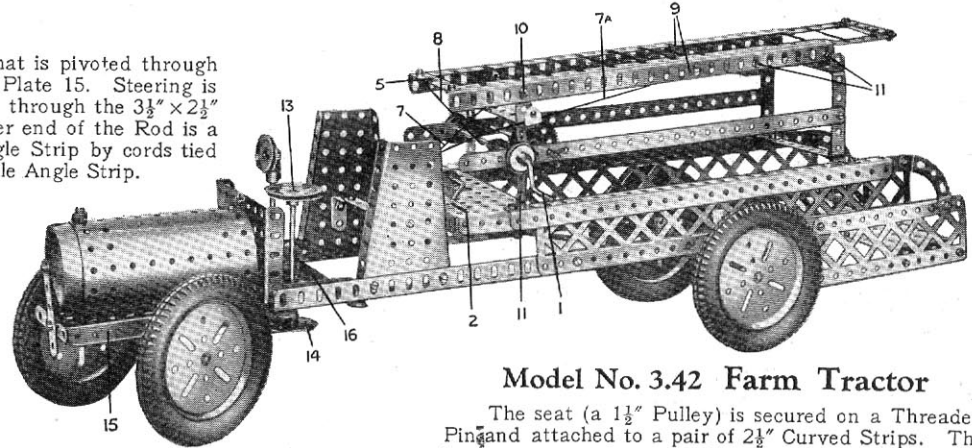

Model No. 3.42 Farm Tractor

The seat (a $1\frac{1}{2}$ " Pulley) is secured on a Threaded Pin and attached to a pair of $2\frac{1}{2}$ " Curved Strips. The latter are secured to two $5\frac{1}{2}$ " Strips fixed in the bottom row of holes of the Motor Plates. A $2\frac{1}{2}$ " Strip is pivoted to the Motor reversing lever by means of a Reversed Angle Bracket, and is supported by a $1\frac{1}{2}$ " Strip which is attached pivotally to the Motor.

Parts required :

2 of No. 2	4 of No. 11	1 of No. 17	1 of No. 27A
5 " " 5	5 " " 12	2 " " 19B	1 " " 32
1 " " 6A	1 " " 15	2 " " 20A	28 " " 37
2 " " 10	2 " " 16	1 " " 21	7 " " 37A
		1 " " 22	5 " " 38
		1 " " 24	1 " " 48A
		2 " " 26	2 " " 59
			1 " " 63
			4 " " 90A
			2 " " 111
			1 " " 111c
			1 " " 115
			1 " " 125
			Clockwork
			Motor
			(not included in
			Outfit)

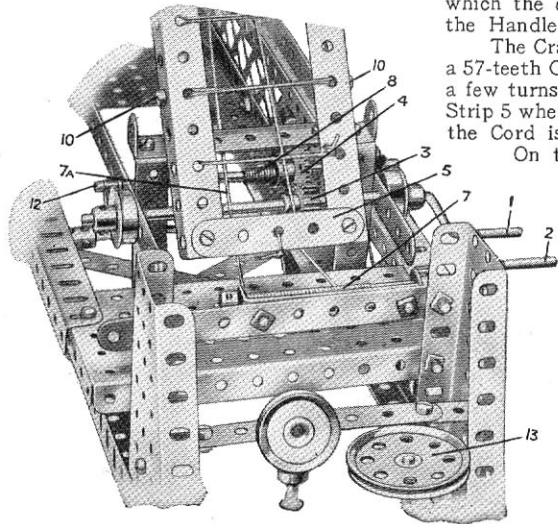
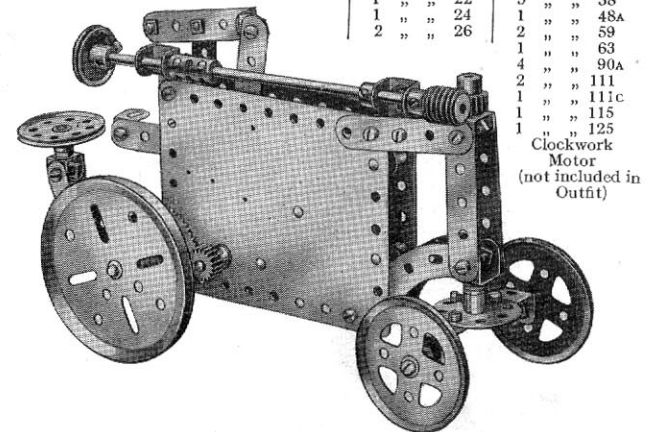

FIG. 3.41A

Parts required :

4 of No. 1	3 of No. 20B	2 of No. 48B
6 " " 2	1 " " 21	2 " " 52
3 " " 3	2 " " 22	2 " " 53
4 " " 5	1 " " 23	2 " " 54
8 " " 8	1 " " 24	4 " " 59
4 " " 11	1 " " 26	1 " " 63
1 " " 12	1 " " 27A	2 " " 90A
2 " " 12A	4 " " 35	2 " " 99
2 " " 15	87 " " 37	2 " " 100
2 " " 15A	8 " " 37A	4 " " 111c
2 " " 16	10 " " 38	2 " " 126A
1 " " 18A	2 " " 40	1 " " 162A
1 " " 19	1 " " 45	1 " " 162B
1 " " 19S	1 " " 46	1 " " 165
4 " " 19B	8 " " 48A	

4 3" Dunlop Tyres (not included in Outfit)



Model No. 3.43 Hand Punch

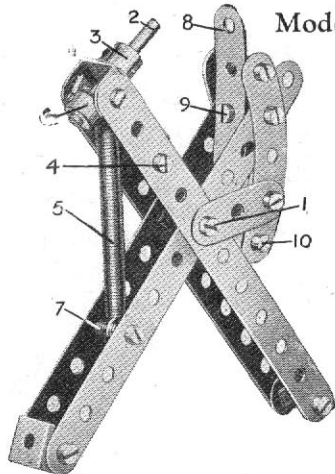

Two pairs of $5\frac{1}{2}$ " Strips are connected loosely towards their centres by means of nuts and bolts 1. The punch 2 consists of a $1\frac{1}{2}$ " Rod secured in the boss of a Crank 3, which is bolted to a Double Bracket secured at 4. A Spring 5 serves to open the handles after the punch has been used; it is placed on the Rod 2 and held in position by means of a Collar 6, while its other end is attached to a $\frac{3}{8}$ " Bolt 7 passed through one pair of $5\frac{1}{2}$ " Strips. After passing through the paper the punch enters the

end hole of a 3" Strip 8. The latter is bolted at 9 to a Double Bracket, while its other end passes beneath a similar bracket at 10.

Parts required :

4 of No. 2	4 of No. 12	1 of No. 59
1 " " 5	1 " " 18A	1 " " 62
2 " " 6A	21 " " 37	2 " " 90
4 " " 11	3 " " 37A	1 " " 111c
	1 " " 43	

Model No. 3.44 Flax Cleaner

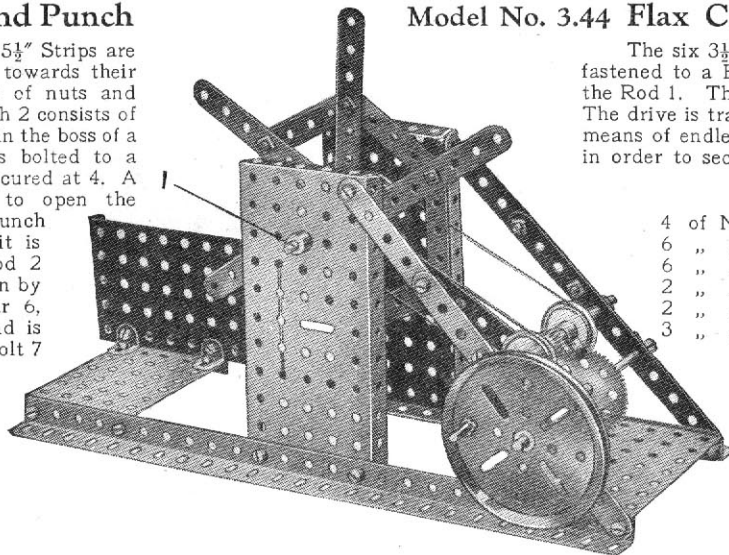

The six $3\frac{1}{2}$ " Strips forming the rotating frame are fastened to a Bush Wheel that in turn is attached to the Rod 1. The $3\frac{1}{2}$ " Strips are braced by six $2\frac{1}{2}$ " Strips. The drive is transmitted from the operating shaft by means of endless cords. Two separate cords are used in order to secure a more positive drive.

Parts required :

4 of No. 2	1 of No. 19B	34 of No. 37
6 " " 3	4 " " 22	3 " " 38
6 " " 5	1 " " 24	2 " " 52
2 " " 8	1 " " 26	3 " " 53
2 " " 12	1 " " 27A	4 " " 59
3 " " 15A	1 " " 35	1 " " 115

Model No. 3.45 Railway Wagon Swivel Crane

The flanges of the Sector Plates 1 are bolted to the 3" Pulley Wheel 2 upon which the crane swivels, and the spindle of the Pulley Wheel is rotated by the Worm 3 engaging the Gear Wheel 4 (Fig. 3.45A). In order to bring the Worm centrally over the teeth of the Gear Wheel 4, Washers are placed beneath the Angle Brackets 5 in which the spindle of the Worm is journaled.

Parts required :

4 of No. 1	1 of No. 27A
6 " " 2	1 " " 32
1 " " 3	3 " " 35
2 " " 5	70 " " 37
4 " " 8	2 " " 38
3 " " 11	2 " " 48A
14 " " 12	2 " " 52
2 " " 15	2 " " 53
1 " " 15A	2 " " 54
2 " " 17	1 " " 57
1 " " 19	3 " " 59
1 " " 19B	1 " " 63
4 " " 20B	1 " " 115
4 " " 22	4 " " 125
1 " " 22A	2 " " 126
1 " " 24	2 " " 126A

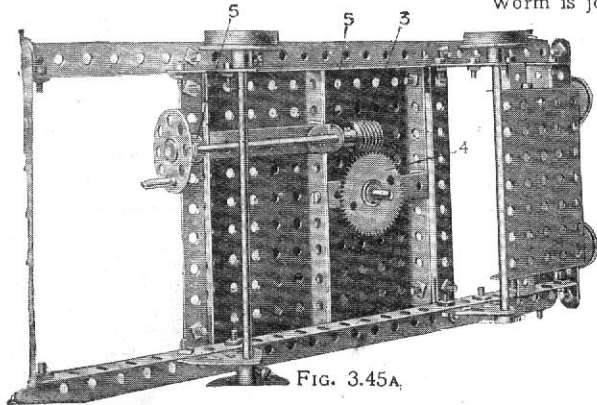
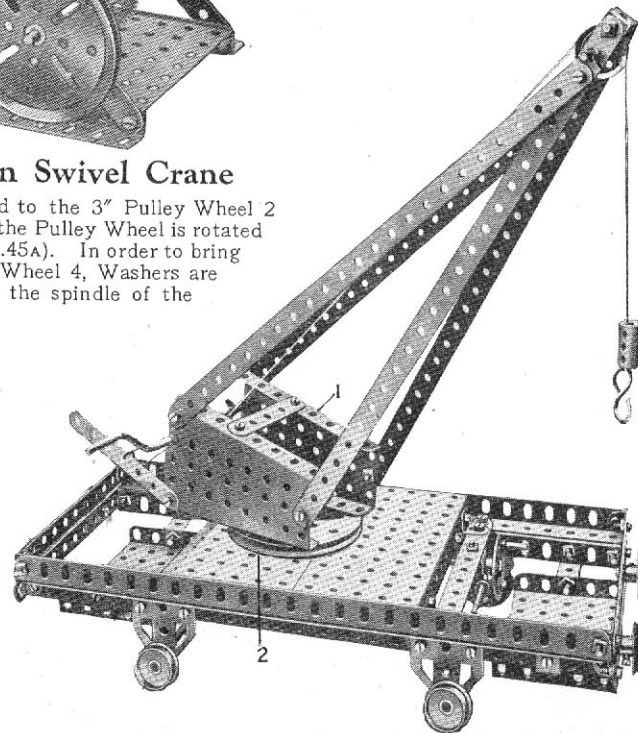
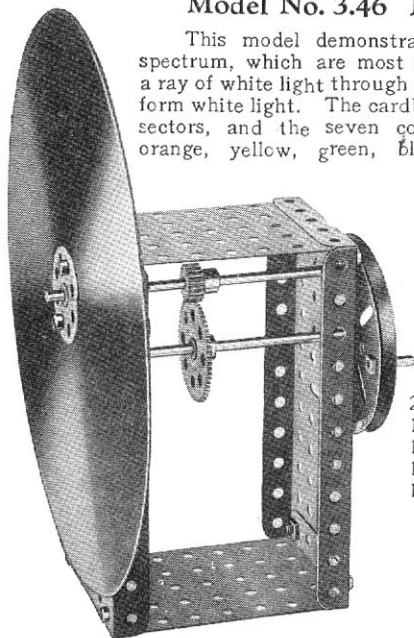

FIG. 3.45A



Model No. 3.46 Newton's Disc

This model demonstrates that the colours of the spectrum, which are most simply produced by directing a ray of white light through a prism, can be re-combined to form white light. The cardboard disc is divided into equal sectors, and the seven colours of the spectrum—red, orange, yellow, green, blue, indigo, and violet—are painted on separate sectors. If the disc is rotated at a high speed by means of the hand wheel and the gears shown, the disc appears to be of a greyish-white colour.



Parts required :

2 of No. 15	10 of No. 37
1 " " 19B	1 " " 38
1 " " 24	2 " " 52
1 " " 26	2 " " 53
1 " " 27A	2 " " 59
	1 of No. 115

Model No. 3.47 Vertical Steam Engine

Parts required :

2 of No. 12	2 of No. 38
1 " " 16	1 " " 45
1 " " 17	1 " " 52
1 " " 19B	1 " " 59
2 " " 20B	1 " " 115
3 " " 22	1 " " 162
1 " " 24	1 " " 163
9 " " 37	1 " " 164
	1 of No. 166

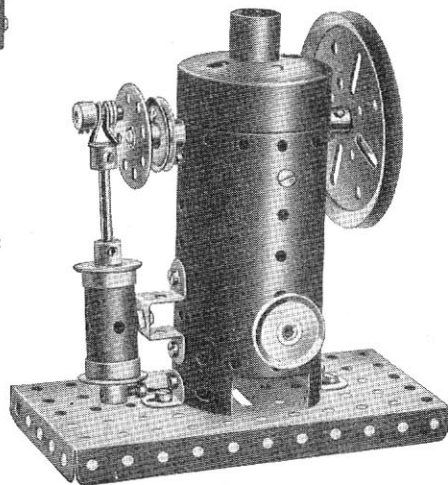

Model No. 3.48 Lathe

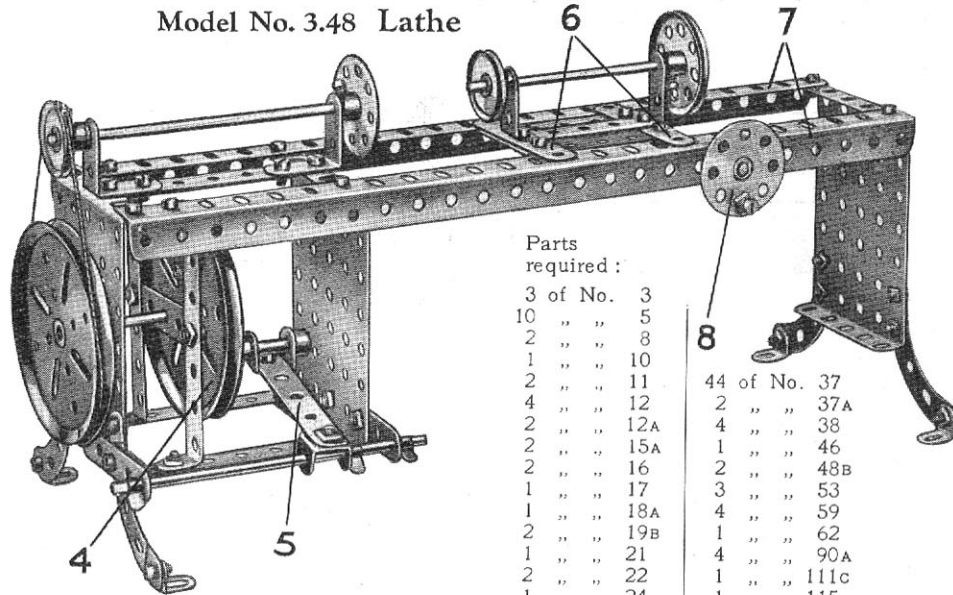

Parts required :

3 of No. 3	5	
10 " " 10	8	
2 " " 2	10	
1 " " 1	11	44 of No. 37
2 " " 4	12	2 " " 37A
2 " " 2	12A	4 " " 38
2 " " 2	15A	1 " " 46
2 " " 2	16	2 " " 48B
1 " " 1	17	3 " " 53
1 " " 1	18A	4 " " 59
2 " " 2	19B	1 " " 62
1 " " 1	21	4 " " 90A
2 " " 2	22	1 " " 111c
1 " " 1	24	1 " " 115
3 " " 3	35	

The arrangement of the treadle is shown in detail in Fig. 3.48A. The Crank 1 is provided with a Flat Bracket, the round hole of which coincides with the elongated hole of the Crank, and receives the short Rod 2. The Crank 1 is free to turn about a Threaded Pin 3, secured to the 3" Pulley Wheel 4, and once the latter is set in motion it can be kept in rotation by working the treadle 5. The Strips 6 of the saddle (Fig. 3.48) are duplicated and their ends form slots to receive the flanges of the Angle Girders 7. The hand wheel 8 is a dummy one, but if desired it may be arranged to operate the saddle by an endless rope device.

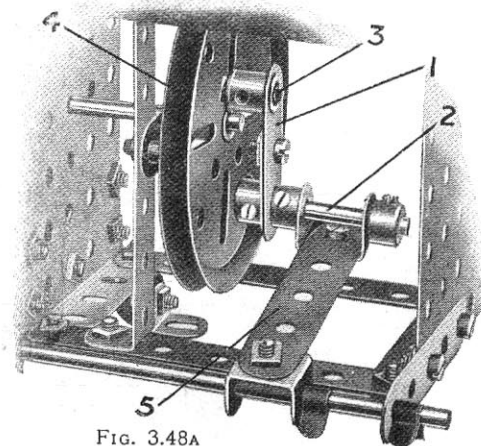
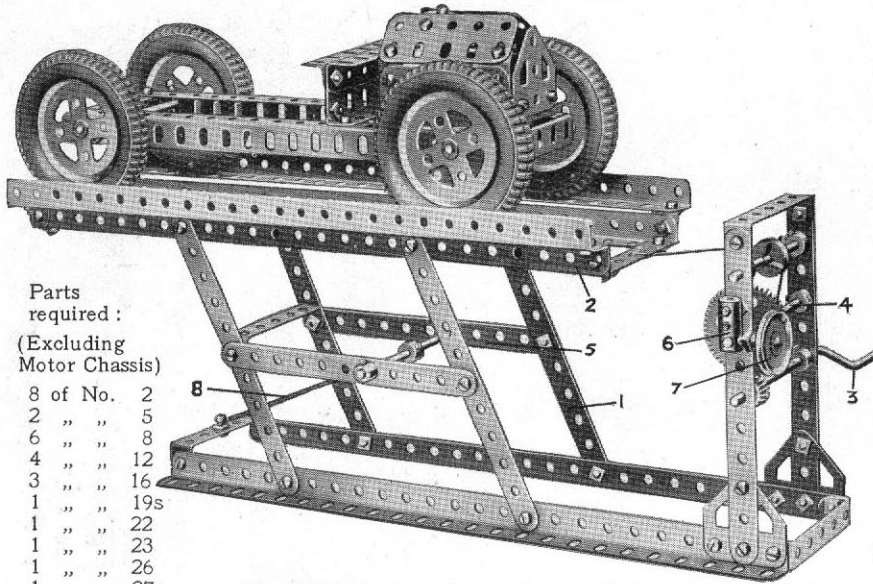

FIG. 3.48A

Model No. 3.49 Car Lifting Apparatus



Parts required:
(Excluding Motor Chassis)

8 of No.	2
2 "	5
6 "	8
4 "	12
3 "	16
1 "	19s
1 "	22
1 "	23
1 "	26
1 "	27A
5 "	35
36 "	37
12 "	37A
4 "	48A
4 "	59
1 "	63
2 "	115
2 "	126A

Four $5\frac{1}{2}$ " Strips 1 are attached pivotally by lock-nutted bolts to the $12\frac{1}{2}$ " Angle Girders, which form the base of the model, and to the carrier 2, which receives the car. The Crank Handle 3 carries a $\frac{1}{2}$ " Pinion meshing with a 57-teeth Gear on the Rod 4, which forms a drum for a length of cord attached to the carrier. The Rod runs freely in the transverse hole of a Coupling 6 that is secured to the upright Strip by a $\frac{3}{8}$ " Bolt. A Threaded Pin carries the 1" Pulley 7 and its shank is inserted in the tapped hole of the Coupling, so that when the Pulley is rotated clockwise the Pin nips the Rod. The carrier 2 is returned to its original position by a length of elastic or Spring Cord 8.

Model No. 3.50 Pastry Designer

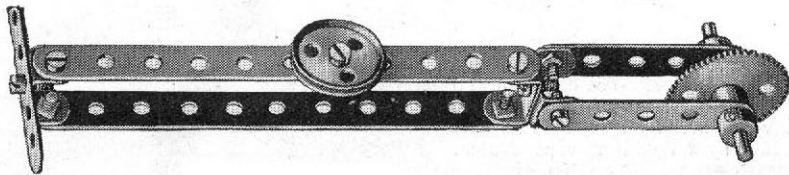

Model No. 3.51 Drop the Nigger

The Sector Plate 1 is a target, which, when hit, allows the nigger to be dropped. The Plate 1 is carried on the Strip 2 pivoted at 3, and the weight of the nigger supported on another Sector Plate 4 pivoted at 5 by means of the cord 6 keeps the lower end of the Strip 2 hard against a short Rod 7 pivoted at 8. When the target is hit and knocked back the Rod 7 is released and falls about its pivot, allowing the Sector Plate 4 with the nigger to drop.

Parts required:

1 of No.	1
6 "	3
8 "	8
1 "	12
3 "	15A
2 "	17
1 "	22
6 "	35
33 "	37
1 "	44
4 "	48A
2 "	53
2 "	54
3 "	59
1 "	63

Parts required:

2 of No.	2
3 "	5
3 "	11
1 "	17
1 "	22A
1 "	27A
9 "	37
2 "	59

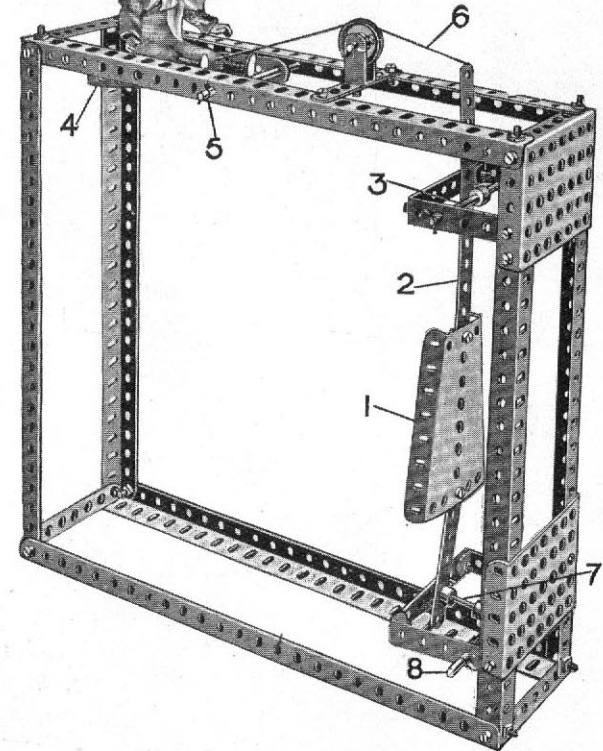

Model No. 3.52 Roundabout

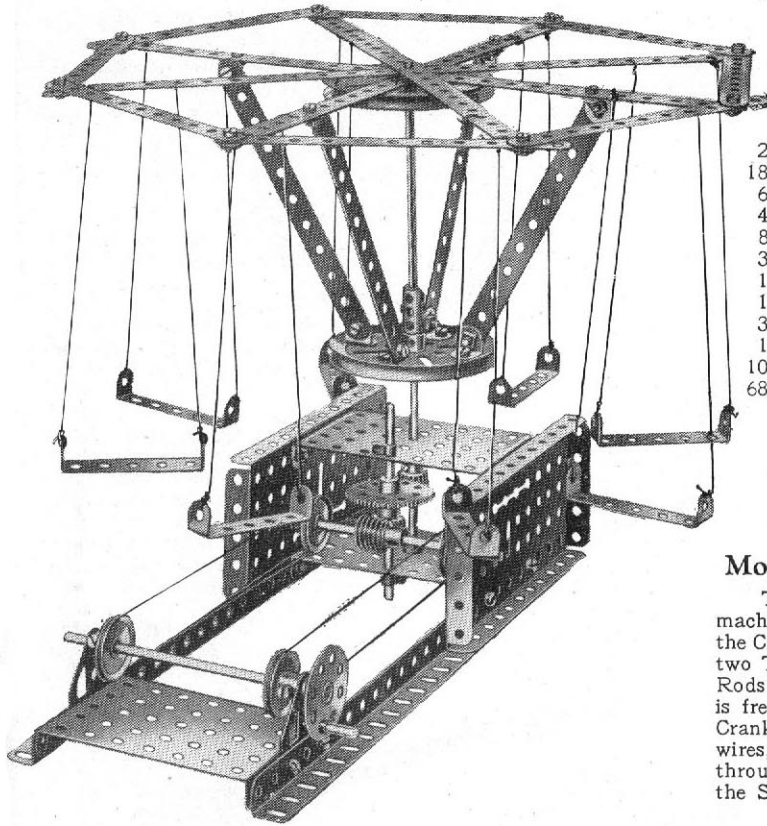

Model No. 3.53
Swing Boat

Parts required :

2 of No.	1	6 of No.	37A
18 "	2	8 "	38
6 "	3	1 "	45
4 "	5	3 "	48A
8 "	8	1 "	52
3 "	12	4 "	59
1 "	15	2 "	62
1 "	15A	1 "	63
3 "	16	1 "	98
1 "	22	2 "	99
10 "	35	2 "	100
68 "	37	4 "	111c

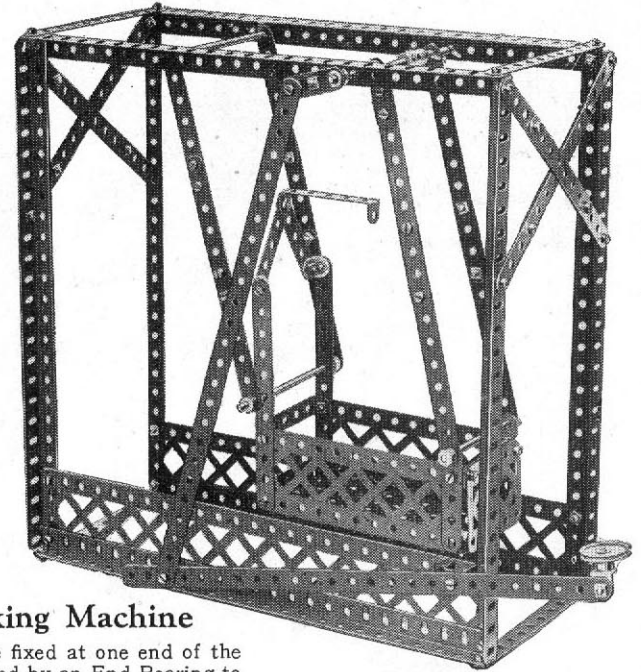

Model No. 3.54 Flex Making Machine

The two wires to be twisted are fixed at one end of the machine to a Hook 1 which is attached by an End Bearing to the Crank Handle. At the other end the wires are looped over two Threaded Pins fixed by Collars to the spring controlled Rods 2. The $3\frac{1}{2} \times 2\frac{1}{2}$ " Flanged Plate 3 carrying a $3\frac{1}{2}$ " Rod is free to slide in the built-up channel girders, and as the Crank Handle is turned it is pushed ahead of the twisting wires, so keeping the finished flex even. As the wires shorten through twisting, the Rods 2 slide longitudinally, extending the Spring.

Parts required :

3 of No.	5	1 of No.	19s
1 "	6A	2 "	35
4 "	8	32 "	37
4 "	12	2 "	38
2 "	15A	1 "	43
1 "	16	1 "	45
		2 "	48A
		2 "	52
		3 "	53
		1 "	57
		3 "	59
		2 "	115
		1 "	166

Parts required :

4 of No.	1	2 of No.	19B	36 of No.	37
12 "	2	4 "	22	8 "	48A
2 "	8	1 "	24	2 "	52
8 "	12	2 "	26	3 "	53
1 "	15	1 "	27A	2 "	59
3 "	15A	1 "	32	1 "	63
1 "	16	2 "	35	1 "	115
				2 "	126A

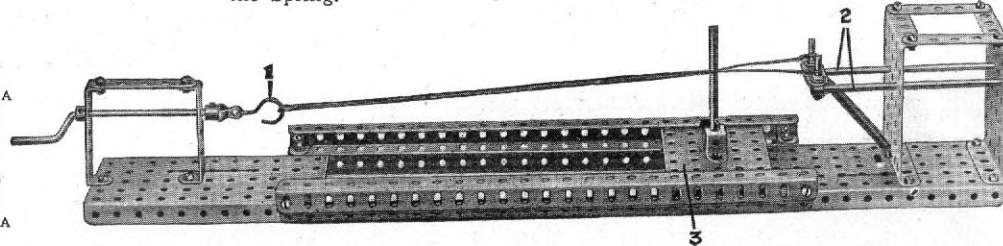

This Model can be built with MECCANO Outfit No. 3 (or No. 2 and No. 2A)

Model No. 3.55 Railway Breakdown Crane

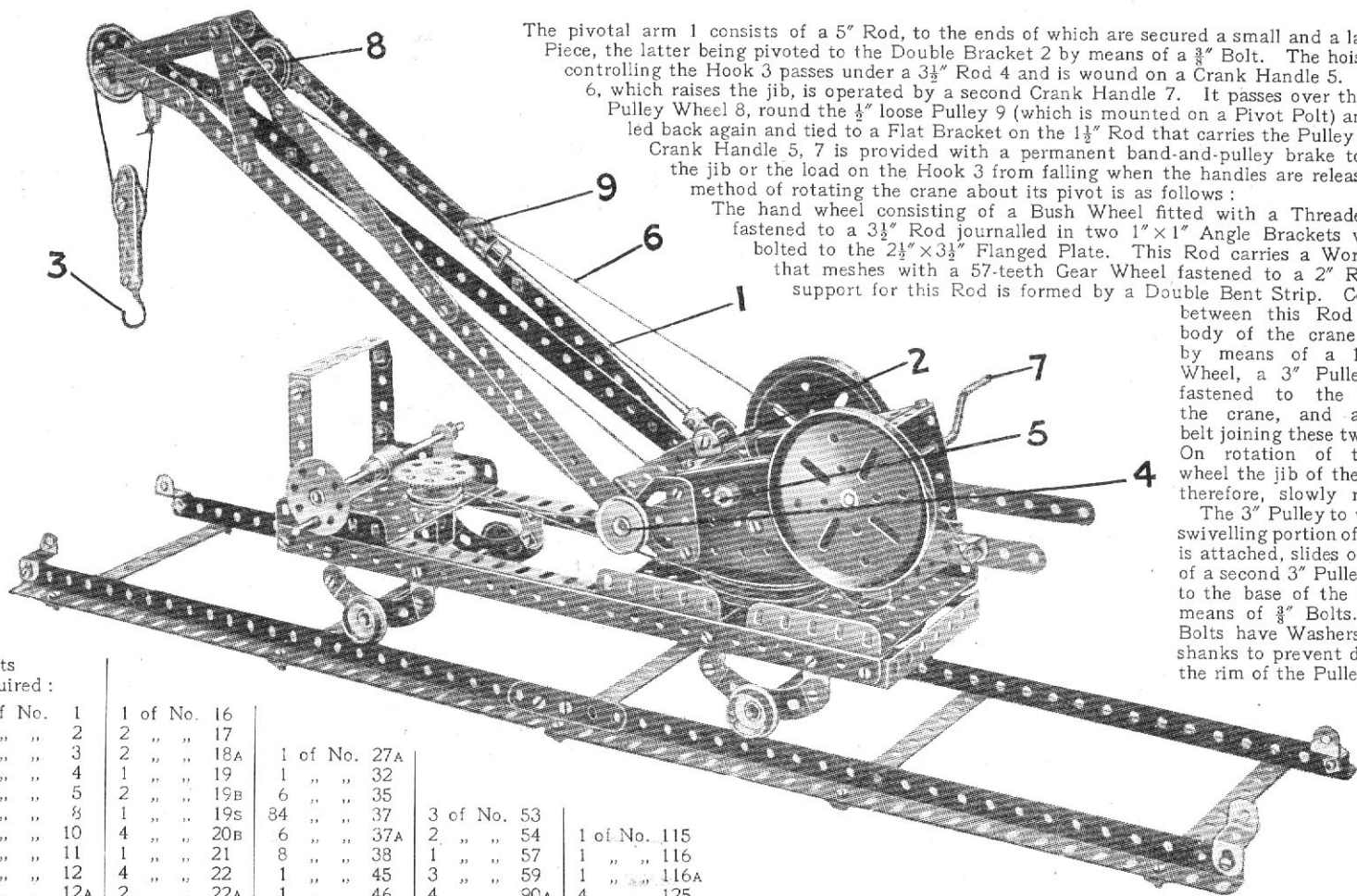

The pivotal arm 1 consists of a 5" Rod, to the ends of which are secured a small and a large Fork Piece, the latter being pivoted to the Double Bracket 2 by means of a $\frac{3}{8}$ " Bolt. The hoisting cord controlling the Hook 3 passes under a $3\frac{1}{2}$ " Rod 4 and is wound on a Crank Handle 5. The cord 6, which raises the jib, is operated by a second Crank Handle 7. It passes over the 1" loose Pulley Wheel 8, round the $\frac{1}{2}$ " loose Pulley 9 (which is mounted on a Pivot Bolt) and is then led back again and tied to a Flat Bracket on the $1\frac{1}{2}$ " Rod that carries the Pulley 8. Each Crank Handle 5, 7 is provided with a permanent band-and-pulley brake to prevent the jib or the load on the Hook 3 from falling when the handles are released. The method of rotating the crane about its pivot is as follows:

The hand wheel consisting of a Bush Wheel fitted with a Threaded Pin is fastened to a $3\frac{1}{2}$ " Rod journalled in two 1" x 1" Angle Brackets which are bolted to the $2\frac{1}{2}$ " x $3\frac{1}{2}$ " Flanged Plate. This Rod carries a Worm Wheel that meshes with a 57-teeth Gear Wheel fastened to a 2" Rod. The support for this Rod is formed by a Double Bent Strip. Connection

between this Rod and the body of the crane is made by means of a 1" Pulley Wheel, a 3" Pulley Wheel fastened to the base of the crane, and a crossed belt joining these two wheels. On rotation of the hand wheel the jib of the crane is, therefore, slowly rotated.

The 3" Pulley to which the swivelling portion of the crane is attached, slides on the rim of a second 3" Pulley secured to the base of the model by means of $\frac{3}{8}$ " Bolts. These Bolts have Washers on their shanks to prevent damage to the rim of the Pulley.

Parts required:

2 of No.	1	1 of No.	16				
11 "	2	2 "	17				
2 "	3	2 "	18A	1 of No.	27A		
2 "	4	1 "	19	1 "	32		
12 "	5	2 "	19B	6 "	35		
6 "	8	1 "	19S	84 "	37	3 of No.	53
10 "	10	4 "	20B	6 "	37A	2 "	54
2 "	11	1 "	21	8 "	38	1 "	57
3 "	12	4 "	22	1 "	45	3 "	59
2 "	12A	2 "	22A	1 "	46	4 "	90A
1 "	15	1 "	23	3 "	48A	1 "	111
3 "	15A	1 "	24	2 "	48B	6 "	111c
						1 of No.	115
						1 "	116
						1 "	116A
						4 "	125
						2 "	126A
						1 "	147B

Model No. 3.56 Paddle Steamer

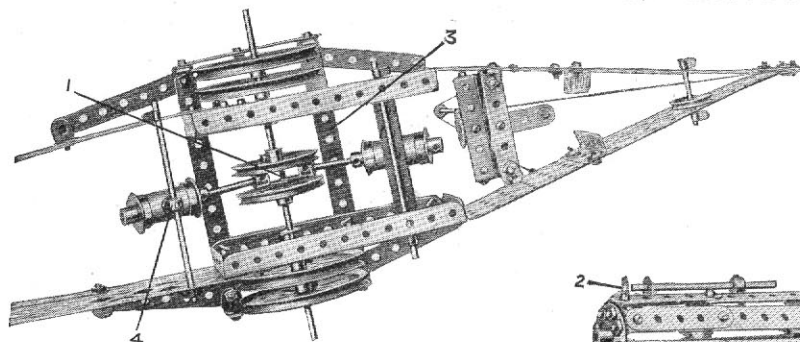

FIG. 3.56A

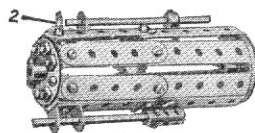

FIG. 3.56B

Parts required :			
6 of No. 2	4 of No. 19B	1 of No. 45	4 of No. 90A
6 " " 3	2 " " 20A	1 " " 46	2 " " 99
2 " " 4	4 " " 20B	10 " " 48A	2 " " 100
10 " " 5	1 " " 21	1 " " 48B	2 " " 111
5 " " 10	1 " " 22	2 " " 52	1 " " 115
4 " " 11	1 " " 22A	2 " " 53	1 " " 116A
14 " " 12	1 " " 24	1 " " 54	2 " " 125
1 " " 13	6 " " 35	4 " " 59	2 " " 163
2 " " 15A	93 " " 37	1 " " 62	1 " " 165
4 " " 16	4 " " 37A	1 " " 63	
2 " " 17	14 " " 38		
1 " " 18A	1 " " 40		

The 3" Pulley Wheels forming the paddles are attached to 3½" Rods, to the inner ends of which 2" Pulleys are fixed (Fig. 3.56A), and the 2" Pulleys are connected together rigidly by a ¾" Bolt 1 that is locked in position by nuts. The Bolt 1 forms also a pivot for two small Fork Pieces (one of which is taken from a Swivel Bearing) to which the piston rods of the oscillating cylinders are fixed. The cylinders pivot about 4½" Rods, one cylinder being mounted on a 3½" x ½" Double Angle Strip while the other is attached rigidly to a Collar 4 by a bolt on which are placed two Washers. The Collar is secured, of course, to the Rod.

The funnel is built up of eight 2½" Strips and eight 2½" x ½" Double Angle Strips, which are attached at the top to a 1½" Pulley and at the bottom to a Bush Wheel. It is attached to the hull by the lower hole of the Double Bracket 2, Fig. 3.56B. The top hole of this Double Bracket forms a support for the lower end of the escape pipe.

The bridge consists of a 2½" x 1" Double Angle Strip and two 2½" x ½" Double Angle Strips, and the complete assembly is bolted to a Double Bent Strip. The latter is attached to a transverse 2½" Strip. The bolt holding the bridge to the 2½" Strip serves also to retain a Crank in which the foot of the mast is secured.

The steering wheel 5 consists of a 1" fast Pulley mounted by its set-screw hole on the end of a ¾" Bolt that is secured to the floor of the bridge. The binnacle is merely a Threaded Pin on which is fixed a Collar.

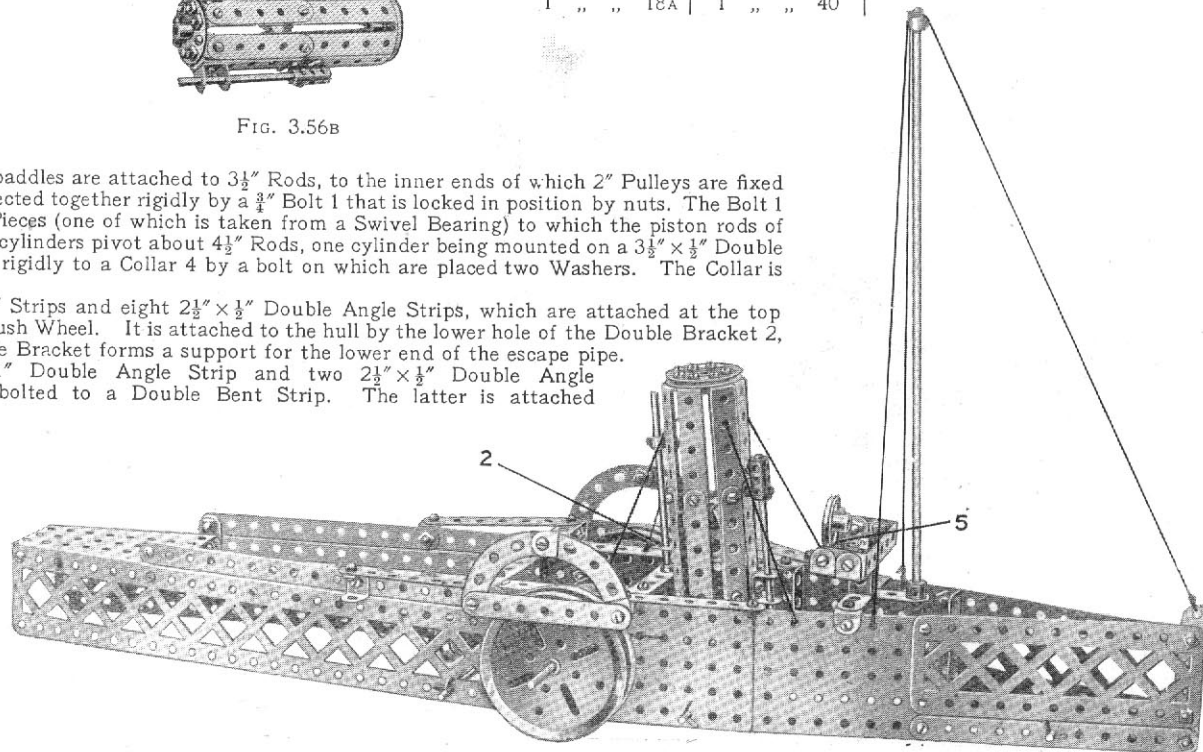

Model No. 3.57 Kinetograph

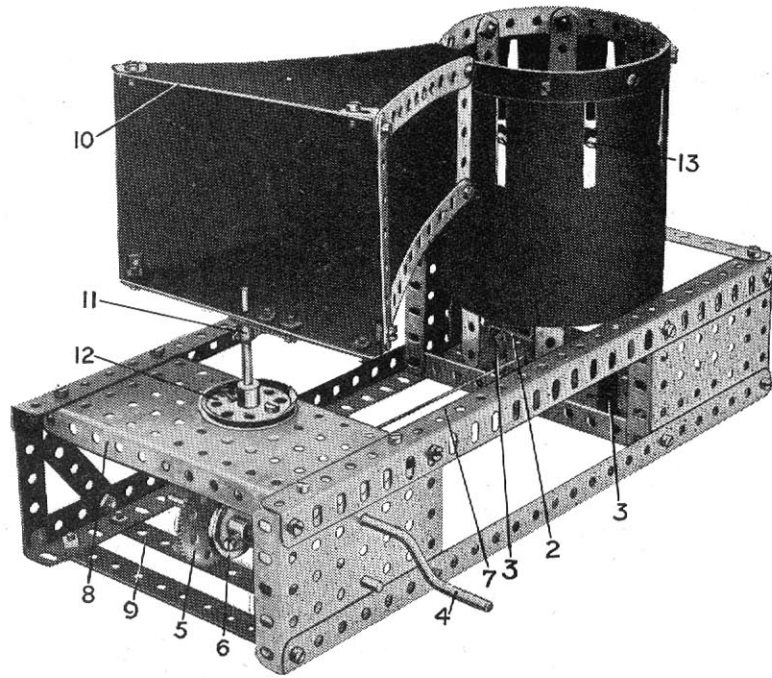

Most Meccano boys probably are aware of the principles of the Kinetograph, but for the benefit of those who have not seen one in action, we may mention that it is a device which imparts an appearance of animation to a series of pictures, each differing slightly from the other and passed in rapid succession before the eyes. In this respect it resembles the remarkable principle upon which the modern cinematograph is based.

In constructing the Meccano model the following details will prove useful:—The drum consists of a 12½" Strip bent to form a circle, with its ends overlapping one hole, and bolted to eight vertical 5½" Strips forming the sides. Two pairs of opposite 5½" Strips are connected by 3½" Strips and Angle Brackets bolted in the third holes from their lower ends. The 3½" Strips cross at right angles to one another and are bolted in the centre to a Bush Wheel, in the boss of which is secured a short Rod forming the pivot of the revolving drum. This Rod is journalled in a Double Bent Strip bolted to a 2½"×1" Double Angle Strip 2. This, in turn, is secured to the base of the model by two 1"×1" Angle Brackets 3. A further bearing for the short Rod consists of a Crank Handle to the base of the model.

The drum is rotated from the Crank Handle 4, on which is mounted a ¼" Pinion engaging a 57-teeth Gear Wheel 5 secured to a 3½" Rod carrying a Pulley Wheel 6. The latter is connected by means of a cord 7 to a similar wheel nipped to the vertical spindle of the drum. Bearings are provided for the inner ends of the Crank Handle and 3½" Rod by a Double Angle Strip bolted between the Plate 8 and 5½" Strip 9. The sighting box 10 is built up from a framework of Strips and is secured by means of a Crank 11 to a short vertical Rod rigidly mounted in the boss of the 1½" Pulley 12. The four sides of the framework 10 are covered with some black material; stiff black paper suitable for this purpose may be obtained from any stationers. The drum is enclosed in the same way, but the covering paper should be cut in a strip measuring 12¼"×4½" and pierced with slots spaced 1½" apart (from centre to centre) so that they fall exactly between the upright 5½" Strips. The slots should measure 1½"×¼".

The type of drawing suitable for use in this model is shown in Fig. 3.57A, and the dimensions indicated therein should be followed carefully. No doubt Meccano boys will be able to devise numerous amusing pictures of a similar kind for themselves. The strip of stout white paper carrying the sketches is inserted in the bottom of the drum, as indicated at 13. The model is now ready for operation. Placing the frame 10 over the eyes, the line of vision is directed through the narrow end, where the Strips are held apart by means of Double Brackets, and through the slots in the drum. The latter should be rotated rapidly by operating the handle 4, and as it revolves, the little dog shown in Fig. 3.57A will be seen jumping over the fence, with a most realistic and amusing action.

Parts required :

1 of No. 1	1 of No. 15A	12 of No. 38
17 " " 2	2 " " 16	1 " " 45
6 " " 3	1 " " 19s	1 " " 46
1 " " 4	1 " " 21	1 " " 48A
3 " " 5	2 " " 22	2 " " 52
4 " " 8	1 " " 24	3 " " 53
2 " " 11	1 " " 26	4 " " 59
12 " " 12	1 " " 27A	2 " " 62
2 " " 12A	60 " " 37	

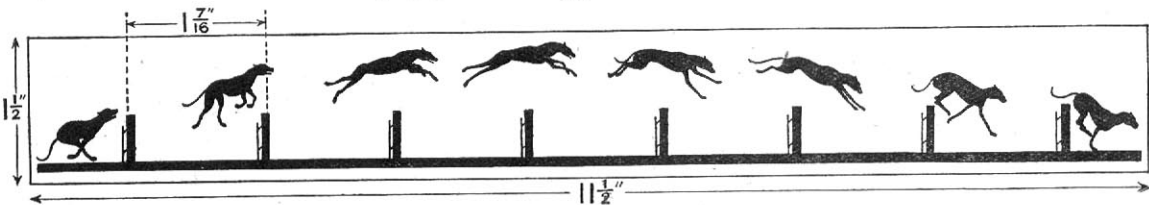
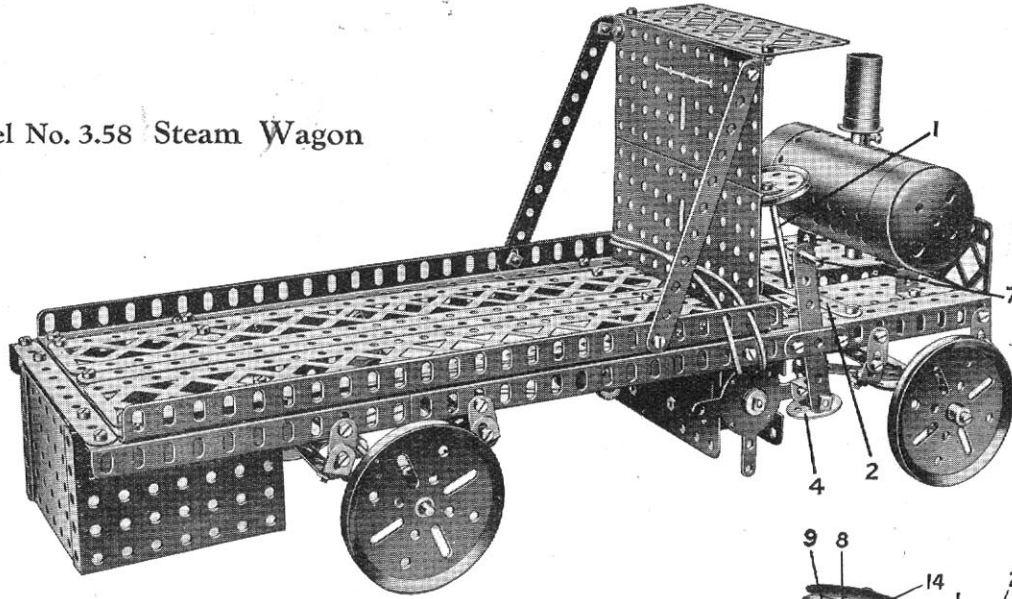

FIG. 3.57A

Model No. 3.58 Steam Wagon



Parts required :		
14 of No. 2	4 of No. 19B	2 of No. 54
6 " " 3	3 " " 20B	4 " " 59
6 " " 5	1 " " 21	2 " " 62
2 " " 6A	4 " " 22	1 " " 63
6 " " 8	1 " " 23	2 " " 99
8 " " 10	1 " " 24	2 " " 100
3 " " 11	1 " " 26	2 " " 111
10 " " 12	79 " " 37	1 " " 115
2 " " 12A	10 " " 38	4 " " 125
1 " " 15	2 " " 48B	1 " " 147
3 " " 16	2 " " 52	1 " " 162
2 " " 18A	3 " " 53	1 " " 163

Electric Motor
(not included in) rfit

The steering column 1 is journalled in bearings consisting of a 5½" Strip 2 and two 2½" Strips 3 (Fig. 3.58A), and carries the Bush Wheel 4, which is secured rigidly to it. A ¾" Flanged Wheel 5 supports the weight of the steering column 1. The stub axles of the front road wheels consist of ¾" Bolts, on which the road wheels are spaced by Washers 14. These Bolts serve in the place of set screws to secure two collars to the 1" Rods 8. A pair of Cranks 9, 9a secured to the Rods 8 are joined by two 5½" Strips 15 overlapped eight holes. A 1½" Strip 10, bolted to the face of the Bush Wheel 4, is connected pivotally by a composite 4½" Strip 11 (a 3½" Strip and a 2½" Strip overlapped three holes) to the end of the Crank 9. When the steering wheel is turned, the Strip 11 moves the Cranks 9 9a, thereby deflecting the front road wheels.

The electric motor 6 is controlled by raising and depressing the handle 7. Duplicate drive transmission belts 12 and 13 are used in order to secure a more dependable drive to the rear axle.

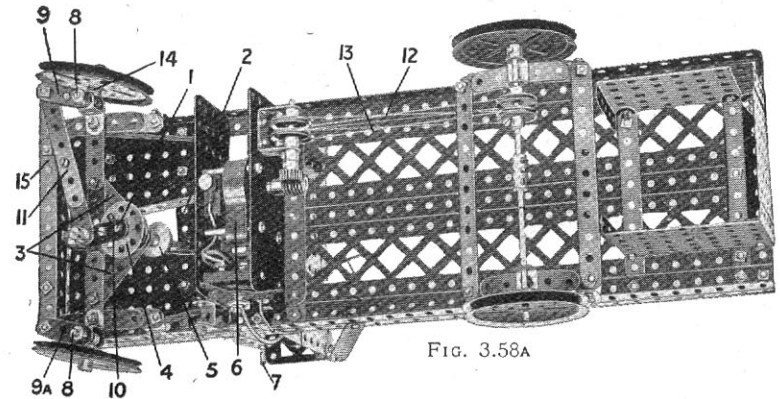

FIG. 3.58A

HOW TO CONTINUE

This completes our examples of models that may be made with MECCANO Outfit No. 3. The next models are a little more advanced, requiring a number of extra parts to construct them. The necessary parts are all contained in a No. 3A Accessory Outfit, the price of which may be obtained from any Meccano dealer.

CONTENTS OF OUTFITS

No.	DESCRIPTION OF PART.		CONTENTS OF PART.														
	00	00A	0	0A	1	1A	2	2A	3	3A	4	4A	5	5A	6	6A	7
1																	
1A				4	4	6	10			10		10	6	16	14	30	8
1B														6	6	10	16
2			4	4	8	6	14	4	18	3	21	2	2	8	10	3	13
2A										2	2	2	2	4	4	8	12
3				1	1	1	2	4	6	2	4	6	2	6	12	24	24
3					9	3	12	2	2	2	4	6	2	8	4	12	24
4			6	3	9					12	6	18	18	36	36	84	120
5													4	4	20	24	6
6						2	2			2	2	4	6	8	14	14	14
6A																	
7																	
7A						4	4	4	8	1	9	5	14	12	26	26	26
8													4	4	8	9	17
8A													2	2	6	8	8
8B																	
9										4	4		4	14	18	6	24
9A														2	2	13	15
9B															2	2	5
9C															2	2	5
9D															2	2	5
9E															2	2	5
9F													1	1	5	6	1
10			4	4	1	5	3	8	8	1	9	3	12	4	16	14	30
11					2	2	4	2	4	1	5	3	8	4	12	4	12
12			8	8	8	4	12	2	14	8	22	14	36	12	48	28	76
12A										2	2	2	2	6	6	6	12
12B															4	4	12
13										1	1	2	2	1	3	5	8
13A													1	1	3	4	7
14															3	3	7
15															3	3	7
15A															3	3	7
16			2	2	1	3	1	4	4	1	5	5	2	7	5	12	7
16A															3	3	4
16B															2	2	3
17															2	2	3
18															2	2	3
18A															2	2	3
18B															2	2	3
19															2	2	3
19A															2	2	3
19B															2	2	3
20															2	2	3
20A															2	2	3
20B															2	2	3
21															2	2	3
22															2	2	3
22A															2	2	3
23															2	2	3
23A															2	2	3
24															2	2	3
25															2	2	3
25A															2	2	3
26															2	2	3
26A															2	2	3
27															2	2	3
27A															2	2	3
27B															2	2	3
28															2	2	3
29															2	2	3
30															2	2	3
30A															2	2	3
30C															2	2	3
31															2	2	3
32															2	2	3
33															2	2	3
34															2	2	3
35															2	2	3
36															2	2	3
36B															2	2	3
37															2	2	3
37A															2	2	3
38															2	2	3
40															2	2	3
41															2	2	3

INDEX TO MODELS

Description.	Model No.	Description.	Model No.	Description.	Model No.	Description.	Model No.
Acrobat ...	2-15	Car, Tandem ...	1-32	Dancers, Eccentric ...	1-124	Grass Cutter ...	0-89
on See-saw ...	1-184	Car Lifting Apparatus ...	3-49	Derrick ...	2-45	Gradient Indicators ...	00-107 to 00-114
Aerial Flight ...	0-68; 1-218	Carpenter's Square ...	00-12	Desk ...	00-13	Gravel Sifter ...	00-57
Ropeway ...	0-99	Cart ...	00-143; 1-36	Devil Wall ...	00-187	Gravity Conveyor ...	1-118
Aerial, Cage ...	00-60	" Baggage ...	00-31	Dignity and Impudence ...	1-96	Grill ...	00-137
" Direction ...	00-68	" Bullock ...	0-67	Dinosaur ...	0-91	Grinder, Coffee ...	3-39
" Frame ...	00-80	" Hand ...	00-5	Disappearing Meccanitan	1-95	" Knife ...	3-33
" Single Wire L ...	00-63	" Push ...	0-4	Dividers ...	00-3; 00-84	Guillotine ...	1-99
" Double Wire L ...	00-62	" Tipping ...	0-3	Dog ...	00-122	Gun, Anti-Aircraft ...	00-158; 1-145; 2-47
" Single Wire T ...	00-66	Catamaran ...	1-90	" Kennel ...	0-7	" Big ...	00-180
" Double Wire T ...	00-67	Catapult ...	00-181; 0-53	Drafting Machine ...	3-8	" Field, and Carriage ...	0-31
Aeroplane ...	0-20; 0-119; 1-29;	Cement Marker ...	00-21	Drill ...	1-53	" Lewis ...	00-28
" 1-49; 1-178; 1-225; 2-48		Chaff Cutter ...	0-8	" Automatic ...	1-103	" Machine ...	0-108
Airship ...	00-100; 2-43	Chair ...	1-59	" Rock ...	0-131	" Old Siege ...	0-140
" Mooring Mast ...	00-171	" Arm ...	0-37; 0-102	Driller, Well ...	00-174	" Quick Firing ...	1-161
Anchor ...	00-56; 0-105	" Baby ...	2-30	Drilling Machine ...	0-125; 1-134; 3-1	Gymnast ...	0-24; 1-88
Angler ...	0-15	" Bath ...	00-164; 0-148; 1-183	Drinking Trough ...	00-124	" Revolving ...	1-227
Ape ...	0-33	" Deck ...	1-219	Drop the Nigger ...	3-51	Gyroscope ...	1-202
Arc Lamp ...	00-163; 1-105	" Go ...	0-136	Dump Car ...	0-116		
Arch ...	0-123	" Invalid ...	1-21				
Axe ...	00-127	" Revolving Office ...	0-153	Easel ...	2-37	Hack Saw, Power ...	0-139
" Battle ...	00-58	Chase, A ...	0-65	Eiffel Tower ...	1-104	Hammer, Double Drop ...	2-1
" Fire ...	00-7	Cheese Cutter ...	00-73	Electric Loco ...	0-94	" Helve ...	1-91
		Church ...	0-16	Elevator ...	1-98; 1-222; 2-11	" Mechanical ...	1-33; 2-22
Baboon ...	0-83	Chute ...	00-24	" Car ...	00-88	" Trip ...	00-166
Bacon Slicing Machine ...	0-52; 1-6	Clock ...	0-79	" Electric ...	1-80	Hammock ...	0-134
Bagatelle Table ...	1-168	" Grandfather ...	00-149	Embossing Machine ...	2-54	Hand Punch ...	3-43
Ballista ...	1-39	Clothes Drying Frame ...	00-121	Emery Wheel ...	1-210	Hatchet ...	1-24
Banjo ...	0-50	" Hanger ...	00-8	Engine, Beam ...	1-74	Hat Rack ...	0-120
Barge ...	00-78	" Horse ...	00-43	" Horizontal ...	0-146; 3-17; 3-23	Hay Tedder ...	2-9
Barrier, Level-Crossing ...	00-173	Coal Sifter ...	2-19	" Two-cylinder Vertical ...	3-30	Hen... ..	0-88
Barrow ...	00-15	" Cutter ...	1-122	" Vertical Steam ...	3-47	" H " Girder ...	1-4
" Coster's ...	0-69; 1-228	Coaster ...	1-83; 1-110; 2-36	Execution, The ...	0-56	High-level Bridge ...	2-10
Battleship ...	0-23; 0-142; 1-206	Coast Guard ...	0-76	Extended Ash Tip ...	1-164	Hoe... ..	00-139
Bed ...	00-40	Coat Hanger ...	00-135; 1-102			Hoisting Block ...	1-89
Bellows ...	1-78; 1-125	Coco-nut Shy ...	1-179	Fan ...	0-75	Hooke's Coupling ...	1-188
" Forge ...	1-229	Cot ...	0-26; 0-129	" Ceiling ...	00-142	Horse ...	00-130
Belt Gear ...	1-5; 1-14; 1-15; 1-19; 1-20	" Swinging ...	3-35	Farm Sight ...	00-18	" and Cart ...	1-52
Bench ...	00-4; 0-144	Cot on Wheels ...	1-58	Fencers, The ...	0-107	" Prancing ...	0-133
Bench, Planing ...	00-140	Couch ...	0-130	Fire Alarm... ..	1-217	" Toy ...	00-104
Bicycle ...	0-46; 1-86	Cow and Milkmaid ...	0-47	" Engine, Manual ...	1-107	Horseman ...	1-75
Billiard Player ...	0-150	Crane ...	0-58	" Escape ...	00-115; 2-12; 3-25	Horseman's Fall ...	0-74
Birdcage and Stand ...	00-37	" Breakdown ...	0-77	Flax Cleaner ...	3-44	Howitzer ...	1-82
Blacksmith ...	00-182; 1-128	" Derricking ...	0-115	Flex Making Machine ...	3-54	Hurdler ...	0-60
Boat ...	1-131	" Elevated ...	1-69	Flip-Flap ...	1-77		
" Ice ...	3-13	" Jib ...	1-203	Flower Pot Stand ...	00-175	Inclined Plane ...	1-120
" Motor ...	00-22; 0-36	" Grab ...	0-86	Fly Boats ...	0-93; 1-182	Invalid, The ...	1-37
" Rowing ...	0-90; 1-70	" Jib ...	0-6; 1-66	Flying Boats ...	1-177	Inverted Truss ...	1-152
" Sailing ...	00-148; 1-76	" Lorry ...	1-196	" Machine ...	1-150		
" Torpedo ...	0-38	" Mobile ...	1-79	Footbridge ...	0-84	Jockey Pulley ...	1-1
Boat Steering Gear ...	1-201	" Overhead ...	1-158	Foot Hammer ...	1-115	Joy Wheel ...	00-178
Book End ...	00-49	" Patent Luffing ...	1-54	Fork ...	00-128	Jumping Jack ...	00-64
Bow and Arrow ...	1-46	" Radial Travelling ...	00-71	Friction Grip Tongs ...	00-44; 1-47		
Boxer ...	0-73	" Railway Breakdown ...	3-55	Frog ...	0-81	Key, Double Cable ...	1-130
Box Ball Alley ...	1-154	" Wagon Swivel ...	3-45			Kinetograph ...	3-57
Boy on Swing ...	1-166	" Revolving ...	00-61	Gallows ...	00-168	King Meccano ...	1-212
Brake, Band ...	1-3; 1-189	" Hammerhead ...	1-133	Galvanometer ...	0-68		
Bridge ...	0-154	" Rotating ...	1-187	Gangway ...	0-34; 1-50	Lace Jennier ...	3-9
" Double Draw ...	1-109	" Swivelling ...	0-135; 1-60; 1-165	Garden Roller ...	00-170	Ladder ...	00-10
" High-level ...	2-10	" Jib ...	1-156; 1-157	" Hose Reel ...	00-190	" on Wheels ...	00-185; 1-42; 1-148; 2-39
" Railway with Signals ...	2-55	" Travelling ...	1-85; 1-213	Gate ...	00-38; 1-151	" Step ...	00-47; 3-7
Bucking Broncho ...	0-32	" Jib ...	2-16; 2-17	Gauge, Railway ...	3-15	Ladle, Giant Foundry ...	1-200
Buffers ...	00-79	Crib... ..	00-50	" Track ...	00-34	Lamp Standard ...	1-193
Butter Churn ...	1-139	Crocodile ...	0-28	Girder, Bow ...	1-214	Lancer ...	1-197
		Crossbow ...	0-85; 3-16	Glider ...	00-117	Lathe ...	0-111; 3-48
Camera ...	0-54	Crosshead Demonstration Model	1-126	Gondola ...	2-2	" Bench ...	0-143
Candle Shade ...	0-151	Cum-bak ...	1-48	Gong ...	1-209; 2-8	" Treadle ...	2-6
" Stick ...	1-142	Cutlery Basket ...	00-189	Goose ...	0-18	Lawn Marker ...	3-28
Candy Puller ...	2-40	" Rest ...	00-77	Governor, Centrifugal Engine	0-63; 1-67	" Mower ...	1-31; 3-34
Cannon ...	00-36			" Inverted Centrifugal	1-140	Lazy Tongs ...	0-22; 1-199
Car, Hand ...	00-159; 1-229	Dancer, The Meccano ...	1-123	Gramophone ...	0-40; 1-195	Letter Balance ...	00-177; 1-22; 3-3

Patents and Designs
Great Britain

250,378	671,485
253,236	671,534
290,121	671,790
648,958	680,416
671,484	682,208

MECCANO

THE TOY THAT MADE ENGINEERING FAMOUS

Millions of boys in every country throughout the world play with Meccano.
These are the Meccano Factories and distributing centres.

Patents and Designs
Great Britain

682,209	718,404
682,934	718,731
683,011	733,541
686,112	733,542
698,054	740,413
	740,723

London Office and Warehouse :
Meccano Ltd.,
Walnut Tree Walk,
Kennington Road, London, S.E.11.



London Service and Repair Depot :
Meccano Ltd.,
5/6, Marshall Street,
London, W.1.

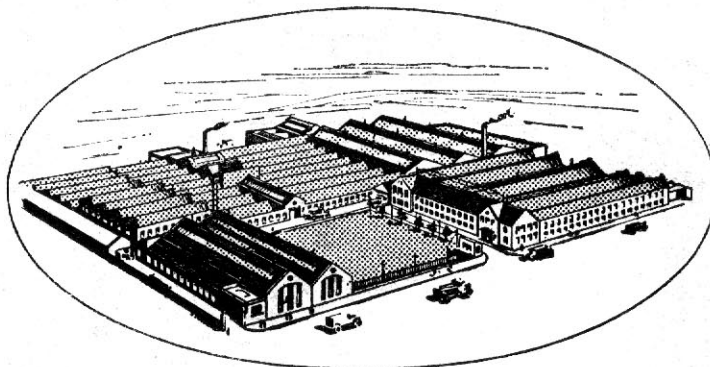

Head Office and Factory :
OLD SWAN, LIVERPOOL.

Meccano Agencies :

Alexandria,
Algiers,
Amsterdam,
Auckland,
Barcelona,
Basle,
Bogota,
Bombay,

Brussels,
Buenos Aires,
Cairo,
Calcutta,
Cape Town,
Caracas,
Constantinople,
Durban,

Genoa,
Hong Kong,
Iquitos,
Johannesburg,
Karachi,
Mexico City,
Monte Video,
Oslo,

Para,
Rio de Janeiro,
Santiago,
Sao Paulo,
Stockholm,
Sydney,
Tampico,
Tanga.

Hornby-Meccano G.m.b.H.,
Alte Jakobstrasse 20-22 (Bergmannshof),
Berlin SW.68.

Canadian Office and Warehouse :
Meccano Ltd.,
34, St. Patrick Street, Toronto.



Meccano (France) Ltd.,
78-80, Rue Rébeval,
Paris XIXeme.