

# MECCANO BOOK OF NEW MODELS



PRIZE-  
WINNING  
MODELS,  
MOVEMENTS  
AND  
IDEAS  
OF THE  
YEAR

9d.



GIANT  
TURNING, BORING  
AND  
BOSSING LATHE



ELECTRIC TRAIN



SUBMARINE



HIGH PRESSURE  
TURBINE



# The Progress of Meccano

THE FIRST PASSENGER LOCOMOTIVE

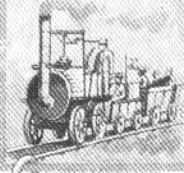

THE FLYING SCOTSMAN

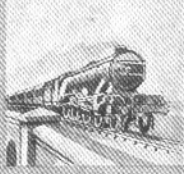

CUGNOT'S ROAD VEHICLE

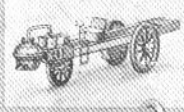

MODERN RACING CAR



ENGINE OF EARLY STEAMBOAT



THE great development of the Meccano system during the past few years has made possible the construction of a very large number of entirely new models, all perfect reproductions of their originals in real life. There is also another development of enormous importance—the introduction of steam power to the Meccano system. By means of the new Meccano Steam Engine models can be operated with real steam power just in the same manner as their prototypes. Steam has added 100 per cent. more fun to Meccano!

## Engineering for Boys

Before the invention of Meccano a boy who wanted to learn something of the wonders of engineering had to gain his knowledge from books. Very often these books did not contain the kind of information he required, and in any case the knowledge gained was not practical. Meccano has changed all this. To-day a boy who acquires engineering knowledge from books can put it into practice straight away by means of a Meccano Outfit. More wonderful than this, however, a boy can commence to build models immediately *without any study or preparatory work*, and all the models he builds will be constructed on sound engineering principles, because Meccano is real engineering in miniature.

## Unlimited Possibilities

The possibilities of a Meccano Outfit are unlimited. Each day new ideas can be put into practice and tried out, and there is always the chance that a valuable invention may result from a casual experiment made with some combination of Meccano parts.

When a boy builds a model in Meccano he uses component parts that are exact miniatures of those used in real engineering

practice. He experiences all the enthusiasm and excitement of the real engineer who sees an intricate mechanism gradually taking shape, piece by piece, under his hands. Girders, Gear Wheels, Pinions, Pulleys and Couplings are all at his disposal, ready for incorporation in any machine or mechanism that he may devise; and all the time he is building like an engineer because he is using real engineering parts.

## The 1930 Book of New Models

This book contains a collection of the latest Meccano models in which most of the recent Meccano parts are included. In the "Mechanisms" section will be found a number of interesting Gear Boxes, Clutches, various methods of Brake Gear, etc., all of which form valuable additions to the range of existing mechanisms.

Meccano boys who already possess Outfits, and particularly those who have just taken up the hobby, are reminded that the model-building possibilities of their Outfits will be greatly increased by the addition of the latest Meccano parts.

## Meccano Service

The service of Meccano does not end with selling an Outfit and an Instruction Manual. When a boy wants to know something more about engineering than is now shown in our books, or when he strikes a tough problem or requires advice on his work or pleasures, he writes to us. Although all kinds of queries are received, the main interest is, of course, engineering. No one has such a wonderful knowledge of engineering matters as that possessed by our staff of experts. This vast store of knowledge, gained only by many years of hard-earned experience, is at your service.

## A Book All Meccano Boys Should Have

The Standard Mechanisms Manual contains a large number of Meccano movements that may be adapted to numerous models. It describes in



detail various belt and rope mechanisms, brakes, roller and ball bearings, screw mechanisms, gear boxes, and gear ratios, etc. Every Meccano experimenter has need of this useful book. It may be obtained through any Meccano dealer.

WRIGHT'S GLIDER



SUPERMARINE NAPIER SEAPLANE



AN EARLY 'AEROSTAT'

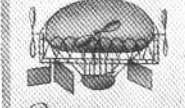

DIRIGIBLE AIRSHIP



EARLY STEAMBOAT



GIANT MARINE ENGINE



EARLY TRIP HAMMER

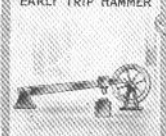

1200-TON PRESS



HAND LOOM OF 1825



MODERN LOOM



H.M.S. NELSON.



**Model No. 1. Jib Crane**

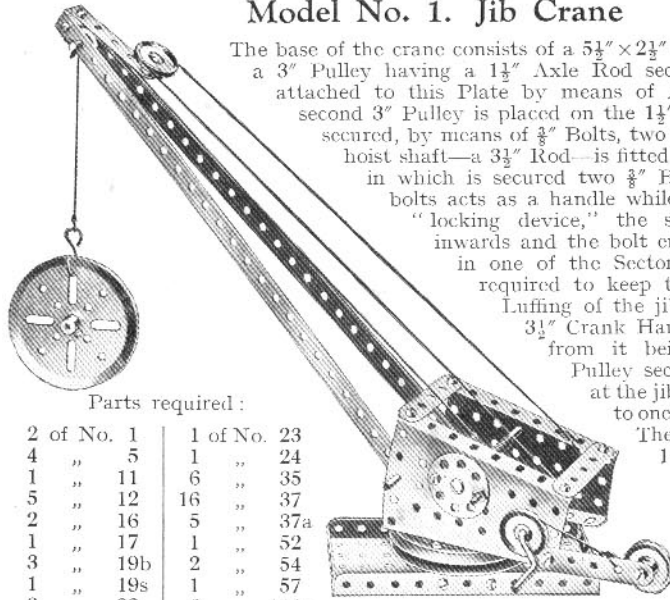

The base of the crane consists of a  $5\frac{1}{2}'' \times 2\frac{1}{2}''$  Flanged Plate, and a 3" Pulley having a  $1\frac{1}{2}''$  Axle Rod secured in its boss is attached to this Plate by means of Angle Brackets. A second 3" Pulley is placed on the  $1\frac{1}{2}''$  Axle and to it are secured, by means of  $\frac{3}{8}''$  Bolts, two Sector Plates. The hoist shaft—a  $3\frac{1}{2}''$  Rod—is fitted with a Bush Wheel in which is secured two  $\frac{3}{8}''$  Bolts. One of these Bolts acts as a handle while the other forms a "locking device," the shaft being pushed inwards and the bolt engaging with a hole in one of the Sector Plates when it is required to keep the Rod stationary. Luffing of the jib is effected by the  $3\frac{1}{2}''$  Crank Handle, a cord passing from it being led over a 1" Pulley secured to a  $2\frac{1}{2}''$  Strip at the jib head, and then tied to one of the Sector Plates.

Parts required:

2 of No. 1	1 of No. 23
4 " 5	1 " 24
1 " 11	6 " 35
5 " 12	16 " 37
2 " 16	5 " 37a
1 " 17	1 " 52
3 " 19b	2 " 54
1 " 19s	1 " 57
3 " 22	6 " 111c

The jib comprises two  $12\frac{1}{2}''$  Strips connected at their outer ends by a Double Bracket and pivotally mounted on a Rod journaled as shown.

**Model No. 3. Hand Car**

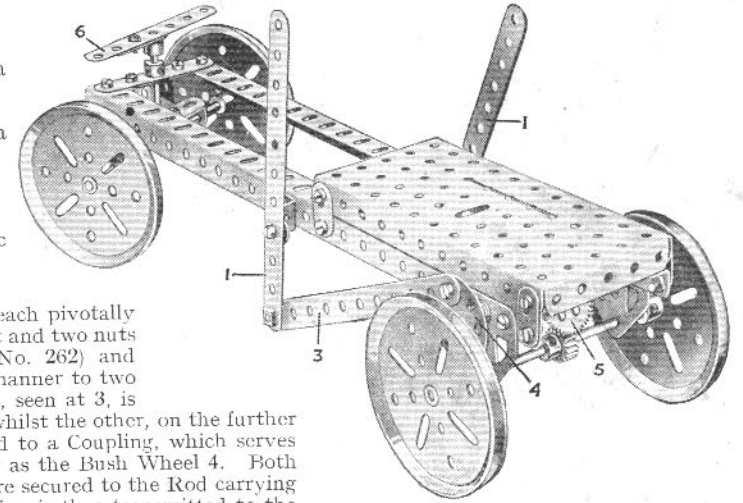

Parts required:

4 of No. 2	4 of No. 35
1 " 3	26 " 37
1 " 5	5 " 37a
2 " 8	4 " 38
4 " 10	1 " 45
2 " 15	1 " 48a
1 " 16	1 " 52
1 " 17	1 " 59
4 " 19b	2 " 62
1 " 24	1 " 63
1 " 26	1 " 111c
1 " 27a	2 " 125
2 of No. 126a	

The hand levers 1 are each pivotally attached to the car by a bolt and two nuts (see Standard Mechanism No. 262) and are connected in a similar manner to two further levers, one of which, seen at 3, is pivoted to a Bush Wheel 4 whilst the other, on the further side of the model, is pivoted to a Coupling, which serves as a crank in the same way as the Bush Wheel 4. Both Bush Wheel and Coupling are secured to the Rod carrying the Gear Wheel 5, and motion is thus transmitted to the rear wheels. The steering foot lever 6 is secured by a Crank to a short vertical Rod which, in turn, is secured by another Crank to the Double Angle Strip carrying the front axle.

**Model No. 2. Knife Grinder**

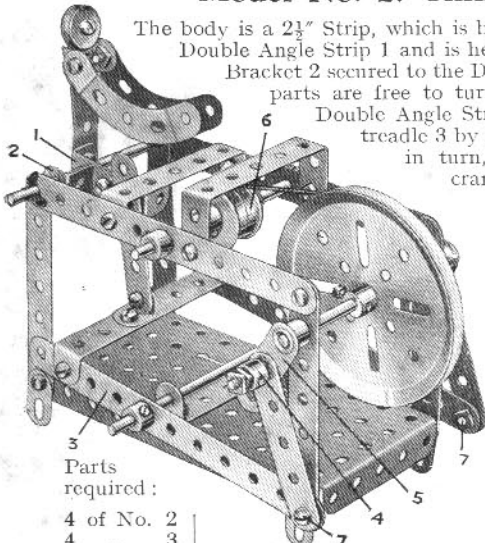

The body is a  $2\frac{1}{2}''$  Strip, which is bolted at its lower end to a  $1\frac{1}{2}'' \times \frac{1}{2}''$  Double Angle Strip 1 and is held upright by a  $\frac{1}{2}''$  Reversed Angle Bracket 2 secured to the Double Angle Strip. Both the latter parts are free to turn about a  $3\frac{1}{2}''$  Axle Rod and the Double Angle Strip is connected pivotally with the treadle 3 by means of a  $2\frac{1}{2}''$  Strip. The treadle, in turn, is connected pivotally with the crankshaft by two further  $2\frac{1}{2}''$  Strips, each of the Bolts 7 being secured by two nuts as in Standard Mechanism No. 262.

The Collar 4 is mounted loosely on a  $\frac{3}{4}''$  Bolt secured rigidly to the Crank 5, and forms a handle by means of which the model may be set in motion. The grinding wheel 6 is driven from the 3" Pulley Wheel by an endless belt.

Parts required:

4 of No. 2	1 of No. 12	1 of No. 19b
4 " 3	1 " 15a	1 " 19b
4 " 5	3 " 16	2 " 20b
4 " 10		
1 " 11		

1 of No. 23	2 of No. 48a
27 " 35	1 " 48b
8 " 37	5 " 52
1 " 37a	2 " 59
1 " 38	2 " 62
1 " 46	1 " 90a
1 " 48	1 " 111
	1 " 125

**Model No. 4. Stephenson's "Rocket" Locomotive**

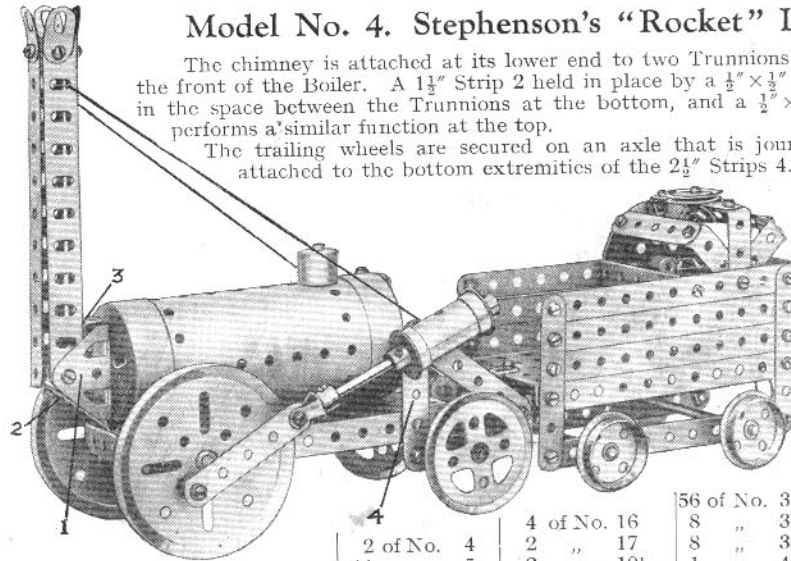

The chimney is attached at its lower end to two Trunnions 1 that are bolted to the front of the Boiler. A  $1\frac{1}{2}''$  Strip 2 held in place by a  $\frac{1}{2}'' \times \frac{1}{2}''$  Angle Bracket closes in the space between the Trunnions at the bottom, and a  $\frac{1}{2}'' \times \frac{1}{2}''$  Angle Bracket 3 performs a similar function at the top.

The trailing wheels are secured on an axle that is journaled in  $2\frac{1}{2}''$  Strips attached to the bottom extremities of the  $2\frac{1}{2}''$  Strips 4. The rearmost ends of the horizontal Strips are secured by Flat Brackets. The upper ends of the Strips 4 serve as mountings for the cylinders, which are secured rigidly thereon by  $\frac{3}{8}''$  Bolts.

Parts required:

8 of No. 2	4 of No. 16	56 of No. 37	1 of No. 109
4 " 3	2 " 17	8 " 37a	1 " 111
	2 " 19b	8 " 38	5 " 111c
	4 " 20	1 " 40	1 " 116a
	2 " 20a	9 " 48a	2 " 126
	2 " 20b	2 " 52	1 " 162
	4 " 20b	1 " 57	2 " 163
	1 " 22a	2 " 59	1 " 164
			1 " 166

## Model No. 5. Paddle Steamer

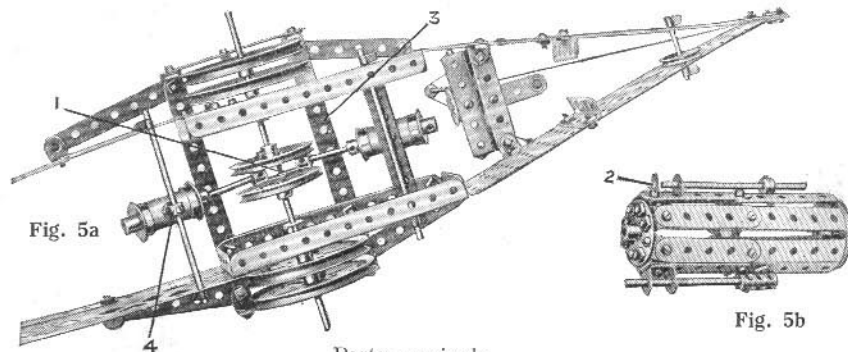

Parts required :

6 of No. 2	4 of No. 16	1 of No. 24	1 of No. 48b	2 of No. 100
6 " 3	2 " 17	6 " 35	2 " 52	2 " 111
2 " 4	1 " 18a	93 " 37	2 " 53	1 " 115
10 " 5	4 " 19b	4 " 37a	1 " 54	1 " 116a
5 " 10	2 " 20a	14 " 38	4 " 59	2 " 125
4 " 11	4 " 20b	1 " 40	1 " 62	2 " 163
14 " 12	1 " 21	1 " 45	1 " 63	1 " 165
1 " 13	1 " 22	1 " 46	4 " 90a	
2 " 15a	1 " 22a	10 " 48a	2 " 99	

The 3" Pulley Wheels forming the paddles are attached to 3½" Rods, to the inner ends of which are fixed 2" Pulleys (Fig. 5a), connected together rigidly by a ¾" Bolt 1. The Bolt 1 forms also a pivot for two small Fork Pieces to which the piston rods of the oscillating cylinders are fixed. The cylinders pivot about 4½" Rods, one cylinder being mounted on a 4½" x ½" Double Angle Strip while the other is attached rigidly to a Collar 4 by a bolt on which are placed two Washers. The Collar is secured, of course, to the Rod.

The funnel comprises eight 2½" Strips and eight 2½" x ½" Double Angle Strips, which are attached at the top to a 1½" Pulley and at the bottom to a Bush Wheel. The top hole of this Double Bracket forms a support for the lower end of the escape pipe.

The bridge consists of a 2½" x 1" Double Angle Strip and two 2½" x ½" Double Angle Strips, and the complete assembly is bolted to a Double Bent Strip. The latter is attached to a transverse 2½" Strip. The bolt holding the bridge to the 2½" Strip serves also to retain a Crank in which the foot of the mast is secured.

The steering wheel 5 (a 1" fast Pulley) is mounted by its set-screw hole on the end of a ¾" Bolt that is secured to the floor of the bridge. The binnacle is merely a Threaded Pin on which is fixed a Collar.

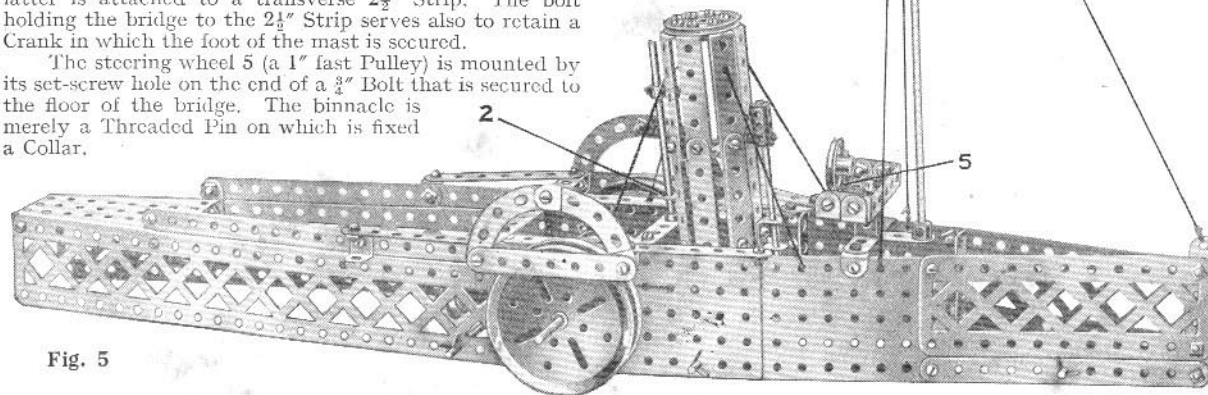

Fig. 5

## Model No. 6. Speed Indicator

Parts required :

2 of No. 2	1 of No. 28
4 " 3	39 " 37
2 " 4	8 " 37a
6 " 5	8 " 38
2 " 8	1 " 43
4 " 12	2 " 45
1 " 13a	2 " 52
1 " 16	3 " 59
2 " 17	1 " 62
4 " 18a	3 " 63
4 " 20b	2 " 90
1 " 21	1 " 111
2 " 24	2 " 111c
2 " 26	1 " 115
1 " 27a	2 " 125
	2 of No. 126

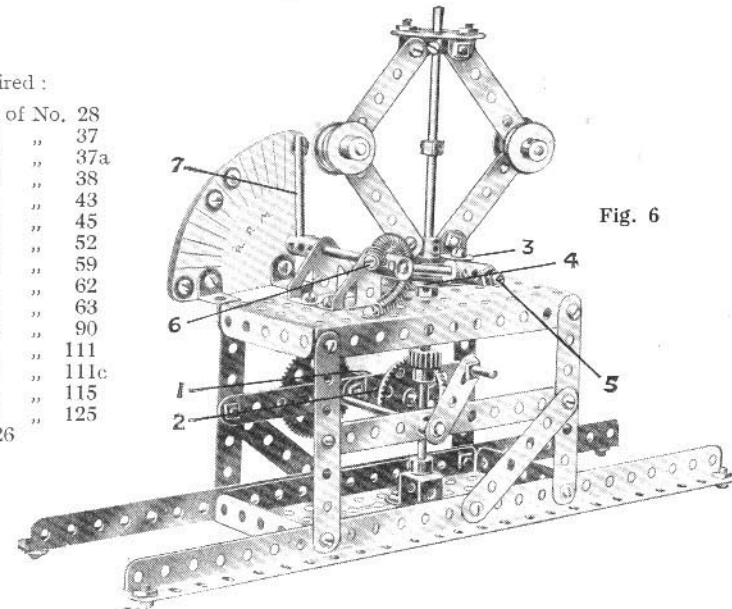

Fig. 6

A Crank fitted with a Threaded Pin to form a handle is secured on a 3½" Rod carrying a 57-teeth Gear that meshes with a ½" Pinion 1 on a 1½" Rod. The latter Rod carries a Contrate Wheel and is journalled in one of the holes of a 5½" Strip and a Double Bent Strip 2. A Pinion on the vertical 8" Rod which carries the governor is in engagement with the Contrate.

The 2½" Strips forming the governor arms are lock-nutted to Angle Brackets which in turn are secured rigidly to Bush Wheels. The upper Bush Wheel is secured to the Rod, while the lower wheel 3, which is free on the Rod, is connected to a 1½" Pulley 4 by ¾" Bolts, but spaced therefrom by nuts on the shanks of the bolts. The ¾" Bolt 5 is passed through the end tapped hole of the Coupling and locked in position by a nut so that its shank protrudes into the space between the Bush Wheel and Pulley. As the weights of the governor fly outward under centrifugal force the Bush Wheel and Pulley unit 3 rises, carrying with it the Bolt 5 and its Coupling and so actuating the pointer (a 2" Rod 7). The extent of the movement of the latter over the graduated scale indicates the speed at which the vertical shaft rotates. A Spring secured to the 5½" x 2½" Flanged Plate is fixed by the Bolt 6 to the Coupling on the Rod of the pointer 7 in such a manner that the pointer tends to return to its original position as the motion decreases.



**Model No. 7. Flywheel-Propelled Truck**

The model truck shown in Fig. 7 consists of a Rod 1 that carries at its extremities two Flywheels 2 and presses lightly against the peripheries of the Dunlop Tyres fitted to the 2" Pulleys that form the road wheels. By setting the Rod carrying the Flywheels in rapid motion, a remarkably powerful drive may be applied to the road wheels. The model will proceed along the ground at a fair pace and will climb steep gradients or surmount obstacles, such as thin books, etc., placed in its path.

The Rod 1 is journalled in two Flat Brackets bolted to the Flanged Plate by their slotted holes. Its position should be adjusted by moving the bolts in the slotted holes, until it makes contact with all four wheels equally.

To operate the model, one end of a piece of string about 36" in length should be wrapped round the Bolt 4. This bolt is secured in a Collar that is attached rigidly to the Rod 1. The cord should be wound evenly on the Rod and then given a smart pull, thus setting the Flywheels in rapid motion, when the model will immediately commence to travel forward.

The proper working of the model depends upon the Rod 1 making efficient contact with the rubber tyres.

**Parts required :**

2 of No. 10	2 of No. 37
1 " 15	3 " 59
2 " 16	2 " 132
4 " 20a	4 " 142a

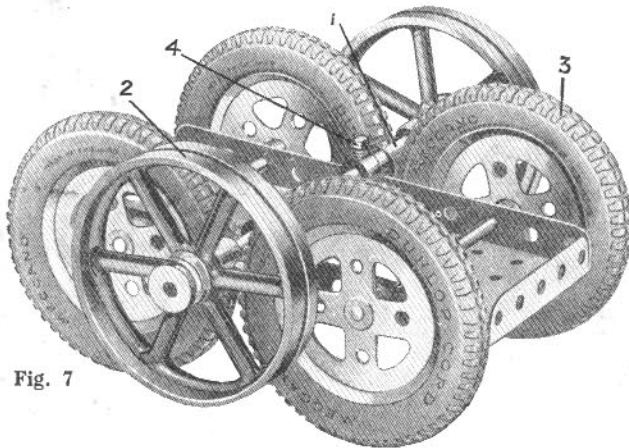

Fig. 7

**Model No. 8. Hand Operated Gantry Crane**

The gantry consists of two 12½" Angle Girders extended at each end by means of 5½" Girders. Braced Girders 13 support further 12½" Angle Girders that form the track along which travels the crane trolley.

The construction of the trolley or traveller is shown clearly in Fig. 8a. Two pairs of 3½" x ½" Double Angle Strips are spaced apart by means of 2" Strips and 1½" Strips are bolted between each pair. Two 2½" Rods journalled in the Double Angle Strips carry the ¾" Flanged Wheels 1 and 1a. The Rod of the Wheels 1a also carries a 57-teeth Gear that meshes with the ½" Pinion 10.

By hauling on the Chain 9, which is passed over the Sprocket Wheel 12, the ½" Pinion 10 and the 57-teeth Gear Wheel 12 is made to rotate, thus driving the Flanged Wheels 1a and causing the trolley to travel along the gantry.

The hoisting mechanism is operated by the chain 2 that passes over a 1" Sprocket on the Rod of which is a Worm 4 that engages the teeth of a ½" Pinion on the Rod 5 that also carries a 1½" Sprocket Wheel 6. A length of Sprocket Chain 7 is placed over this Wheel, one end of it being secured between two Flat Trunnions 15 (Fig. 8); the other end is secured to the frame at 8.

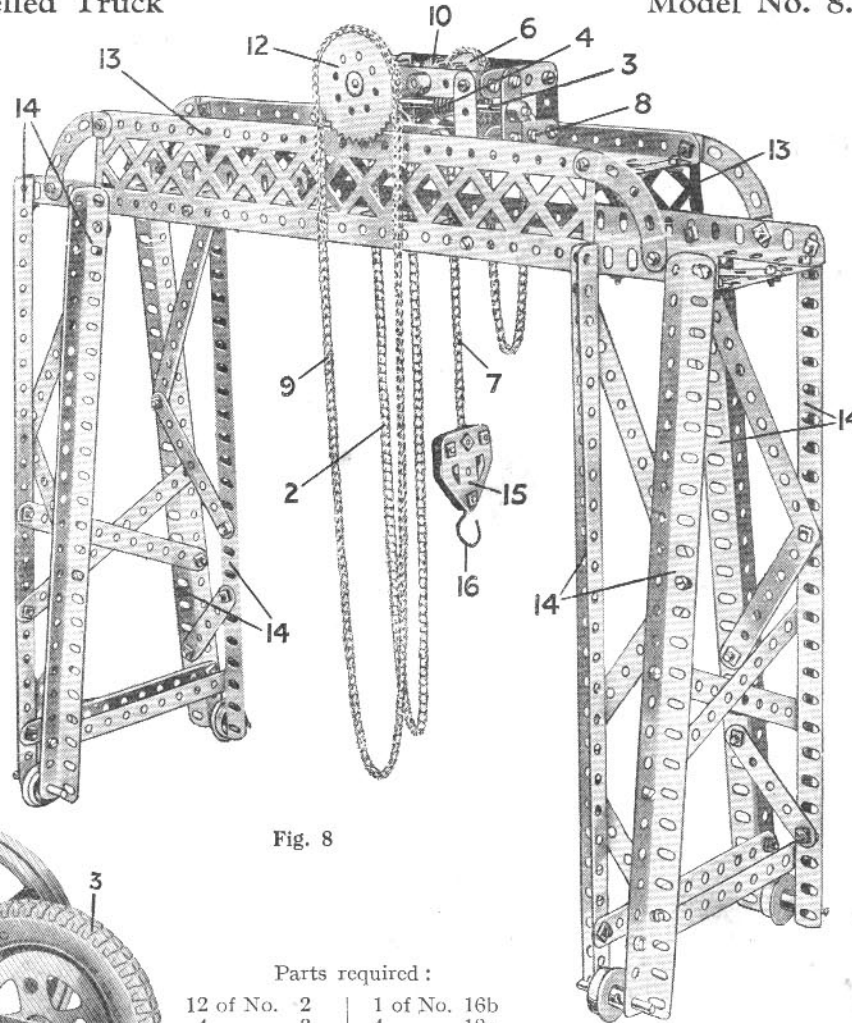

Fig. 8

**Parts required :**

12 of No. 2	1 of No. 16b	1 of No. 57	2 of No. 96
4 " 3	4 " 18a	6 " 59	2 " 99
6 " 4	8 " 20b	4 " 90a	4 " 111c
4 " 5	2 " 26	60" " 94	2 " 126a
4 " 6	1 " 27a	1 " 95	
6 " 6a	1 " 32		
12 " 8	87 " 37		
4 " 9	8 " 37a		
1 " 15a	2 " 38		
3 " 16a	4 " 48b		

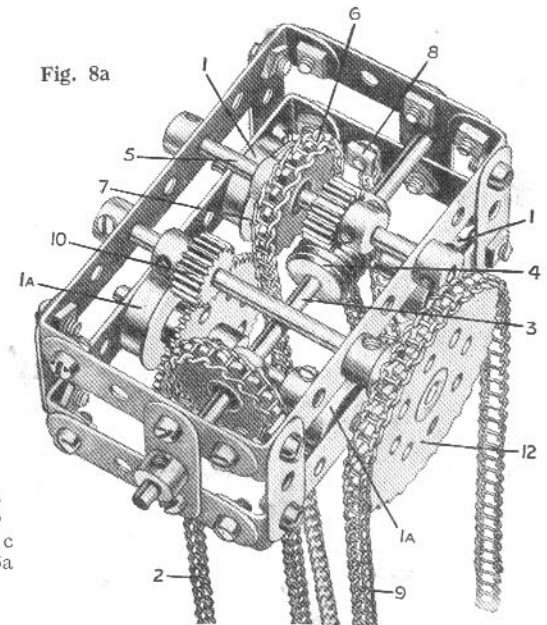

Fig. 8a

### Model No. 9. An Ancient Motor Car

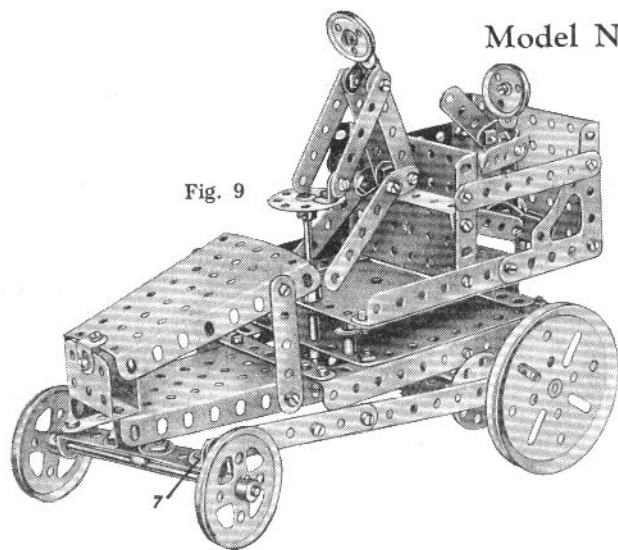

Fig. 9

When the model shown in Fig. 9 is set in motion it wobbles in a most amusing manner along the floor, the driver meanwhile frantically endeavouring to keep it in a straight line.

A  $\frac{1}{2}$ " Pinion on the Motor shaft engages with the  $1\frac{1}{3}$ " Contrate Wheel 1 (Fig. 9a) attached to the back axle 2. The latter is journaled in two  $2\frac{1}{2}$ " Flat Girders bolted to two  $5\frac{1}{2}$ " Angle Girders to which the Clockwork Motor is attached. Two Couplings 3 are fixed to each end of the Rod 2, and the road wheels are attached to their centre threaded holes by Threaded Pins. The Couplings are set at an angle of 180 degrees to one another, and so cause the car to wobble when it is running.

A 57-teeth Gear 4 is fixed to a  $4\frac{1}{2}$ " Rod 5 that carries at one end a Bush Wheel. This is connected to the front wheels by a link built up of  $3\frac{1}{2}$ " and  $4\frac{1}{2}$ " Strips and attached by an Angle Bracket 7 to the  $2\frac{1}{2}$ " Double Angle Strip 8. This results in the front road wheels being turned alternately from side to side. The  $1\frac{1}{2}$ " Rod forming the pivot for the steering should

be kept fairly loose to allow for the rolling of the chassis as the car wobbles along.

A  $4\frac{1}{2}$ " Strip 6 is lock-nutted to the Double Angle Strip 8 at one end and at the other to a Crank 9 which is fixed to a  $3\frac{1}{2}$ " Rod. This is journaled in the holes of the Clockwork Motor and at its top a Bush Wheel is secured. The driver is attached pivotally to the Bush Wheel by an Angle Bracket and  $2\frac{1}{2}$ " Strip. The passenger at the back is attached to the frame by a Spring held between two  $1\frac{1}{2}$ " Strips.

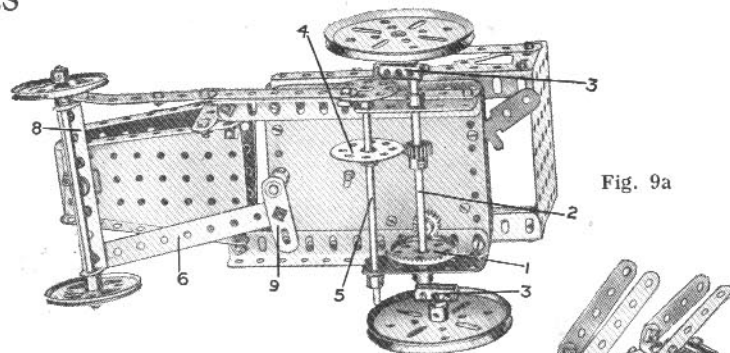
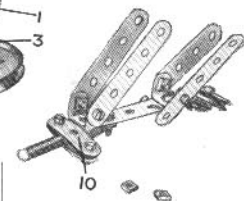

Fig. 9a

#### Parts required :

2 of No. 13	2a	1 of No. 17	1 of No. 19b	1 of No. 43	
3 "	3	2 "	20a	1 "	45
13 "	5	2 "	22a	2 "	48b
2 "	6a	2 "	24	2 "	53
4 "	9	2 "	26	2 "	54
4 "	10	2 "	27a	10 "	59
4 "	11	1 "	28	1 "	62
3 "	12	1 "	37	2 "	63
1 "	15	57 "	37a	2 "	103f
2 "	15a	14 "	38	2 "	108
1 "	16	8 "			
				5 of No. 111c	
				2 "	115
				1 "	160
				1	Clockwork Motor



### Model No. 10. Battle Cruiser

Parts required :			
13 of No. 1	3 of No. 35		
8 "	2	146 "	37
2 "	3	4 "	38
35 "	5	1 "	45
4 "	6	2 "	48
5 "	6a	6 "	48a
2 "	8	1 "	52
11 "	10	1 "	53
1 "	11	2 "	54
27 "	12	9 "	59
3 "	14	1 "	63
5 "	16	2 "	111c
1 "	18a	1 "	139
1 "	20		
1 "	21		
3 "	22		
2 "	24		

The hull comprises rows of  $12\frac{1}{2}$ " and  $5\frac{1}{2}$ " Strips held together by diagonal  $2\frac{1}{2}$ " Strips. The completed sides are bolted to a  $1\frac{1}{2}$ " Strip at stem and stern. The deck is built up from  $5\frac{1}{2}$ " x  $2\frac{1}{2}$ " Flanged Plates and Sector Plates, the space between the two former Plates being filled in by  $5\frac{1}{2}$ " Strips on either side of the Girders forming the superstructure.

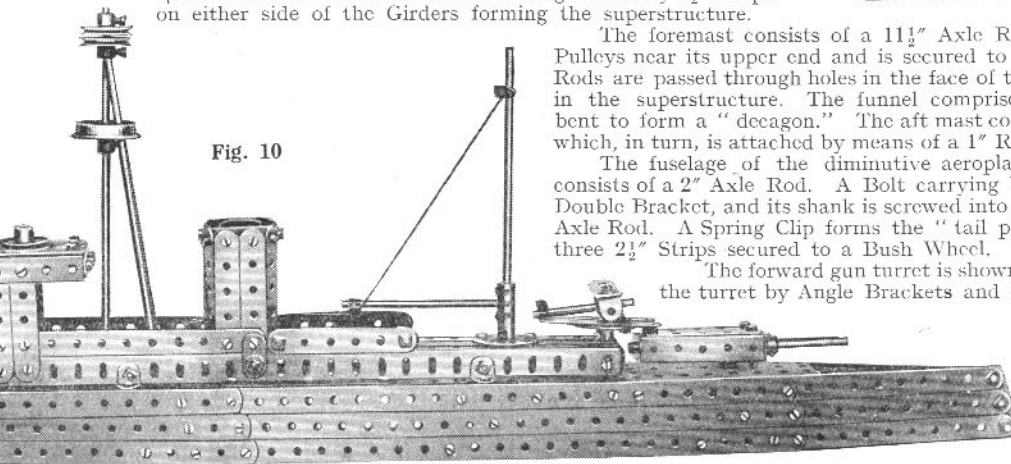

Fig. 10

The foremast consists of a  $11\frac{1}{2}$ " Axle Rod that carries a Flanged Wheel and two  $1\frac{1}{2}$ " Pulleys near its upper end and is secured to the deck by a  $1\frac{1}{2}$ " Pulley Wheel. Two  $11\frac{1}{2}$ " Rods are passed through holes in the face of the Flanged Wheel and their lower ends secured in the superstructure. The funnel comprises ten  $2\frac{1}{2}$ " Strips bolted to  $5\frac{1}{2}$ " Strips that are bent to form a "decagon." The aft mast consists of a  $7\frac{1}{2}$ " Axle Rod secured in a Coupling which, in turn, is attached by means of a  $1\frac{1}{2}$ " Rod to a Bush Wheel bolted to the deck.

The fuselage of the diminutive aeroplane that can be seen resting on the platform, consists of a  $2\frac{1}{2}$ " Axle Rod. A Bolt carrying Washers is passed through a  $1\frac{1}{2}$ " Strip and a Double Bracket, and its shank is screwed into the threaded bore of a Collar placed on the  $2\frac{1}{2}$ " Axle Rod. A Spring Clip forms the "tail plane." The landing platform is formed from three  $2\frac{1}{2}$ " Strips secured to a Bush Wheel.

The forward gun turret is shown in Fig. 10a. A  $1\frac{1}{2}$ " Triangular Plate is bolted to the turret by Angle Brackets and carries a  $\frac{3}{8}$ " Bolt which forms the pivot about which the unit swivels. Two  $3\frac{1}{2}$ " Axle Rods represent the guns.

The aft gun turret comprises two  $2\frac{1}{2}$ " x  $1\frac{1}{2}$ " Double Angle Strips and two  $2\frac{1}{2}$ " Strips, that are secured to a Flat Bracket at the rear of the turret. The remainder of its construction is similar to that of the forward turret.

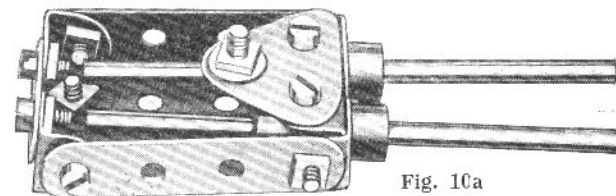

Fig. 10a



Model No. 11. 4-6-2 Tank Locomotive

The construction of the frame is shown clearly in Fig. 11b. It will be seen that each side member comprises a 12½" Angle Girder extended by a 3½" Girder. The rectangular frame is completed by bolting 3½" Girders to the ends, additional Girders 7 being attached at the front of the frame to form the front buffer beam. The buffer beam at the rear of the engine comprises a 3½" Flat Girder secured to the 3½" Angle Girder forming the end of the frame.

A 7½" Angle Girder 14 is bolted to the right-hand side of the main frame and to each of its ends a 1½" Strip is secured in a vertical position. Two 7½" Strips, bolted to these complete the right-hand side tank. The left-hand tank 5 is constructed similarly, with the exception that 4½" and 2½" Girders are used in place of the 7½" Girder, so that an aperture is formed through which the winding key of the Clockwork Motor may be passed.

It will be seen that the rear portion of the tanks form part of the cab sides. To complete the cab, Angle Girders 16 (Fig. 11b) are bolted to the Girders 14 and 15, and 2½" Strips are secured two holes further back, while 1½" Strips hold the Strips and Girders at the correct distance apart.

The roof is composed of four 3½" x ½" Double Angle Strips and one 3½" Strip bolted to two 2½" large radius Curved Strips, one of which is bolted between the tops of the Girders 16 whilst the other is bolted across two 3" Angle Girders 17. The 3½" Strip in the centre of the roof is supported by Angle Brackets; this Strip is so arranged to obtain a slot through which may protrude the reversing lever 8 (Fig. 11) of the Clockwork Motor. Four 2" Strips form each side of the coal bunker and two Girder Brackets bolted to their ends form the rear, the space between these Girders being filled in by a 2" Strip.

The firebox top consists of two 3" Angle Girders 2 (Fig. 11) spaced apart by 2" Strips. Two 3" Strips are secured between the Girders and to these is secured the Ross pop safety valve which consists of two outer "sleeves" removed from Meccano Spring Buffers. Each side of the firebox consists of two horizontal 3" Strips secured at their ends to vertical 1½" Strips which, in turn, are bolted to the sides of the Girders 2. The completed firebox is held in position by means of an Angle Bracket bolted to the cab, and Flat Brackets secured to the Boiler 1.

The Boiler is secured in position by bolts passed through the side tanks, and by two 2" Angle Girders bolted to Flat Girders that, in turn, are secured to the front of side frames of the locomotive. Two Chimney Adapters are mounted on the Boiler as shown, and smoke-box 4 is formed from two Boiler Ends held together by a ¾" Bolt passed through their centres.

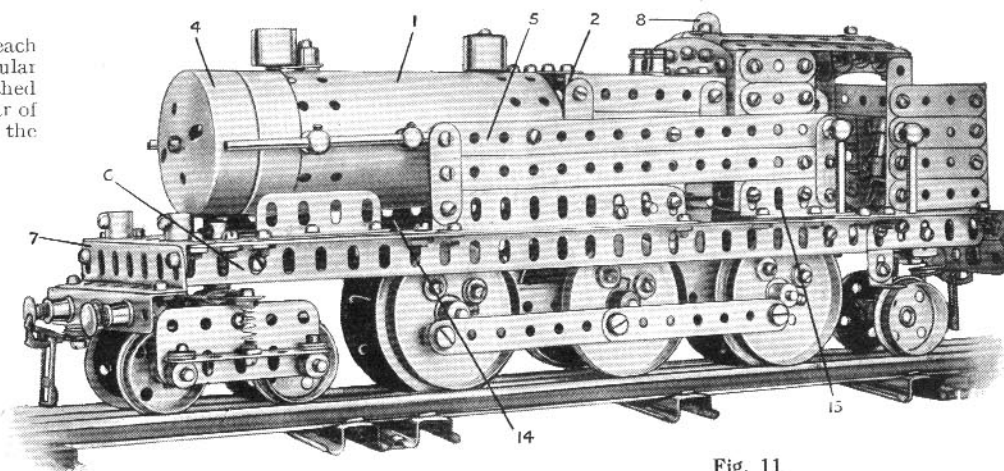

Fig. 11

Fig. 11a shows the power unit. This consists of the Clockwork Motor, the drive being taken from the pinion on the driving shaft by a ¾" Pinion 12 on the Axle of the rear pair of driving wheels.

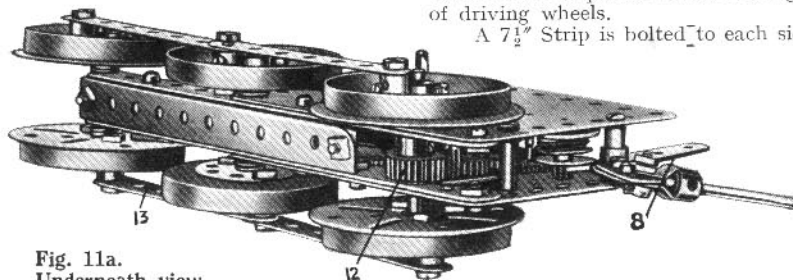

Fig. 11a. Underneath view of the Power Unit, showing connecting rods, etc.

A 7½" Strip is bolted to each side plate of the Motor to form a journal for the axle carrying the rear pair of driving wheels, and two 5½" Angle Girders are also secured in position to give extra strength. The centre pair of wheels are not provided with flanges, Bush Wheels being substituted for the Face Plates, thus allowing the loco to negotiate sharper curves than would otherwise be possible. The Motor is held in position by Axle Rods passed through the Double Arm Cranks 10 (Fig. 11b) so that the reversing lever 8 (Fig. 11) passes through the cab top. A 1½" Strip is bolted to the brake lever and an End Bearing is connected pivotally to its extremity. This carries an Axle Rod which, after

passing through a 1" x 1" Angle Bracket secured to the coal bunker, is fitted with a Collar. The rear pony truck consists of two 1½" Flanged Wheels mounted on a 1½" Rod that is passed through a Collar. A Threaded Pin gripped in the tapped hole of this Collar is secured in the boss of an Eye Piece 18 (Fig. 11b) and is spaced from same by a Collar. The Eye Piece slides on the 2½" Curved Strip 11.

The bogie employed in the model is the standard equalising pattern, which forms the subject of S.M. 219 in the new edition of the "Standard Mechanisms" Manual.

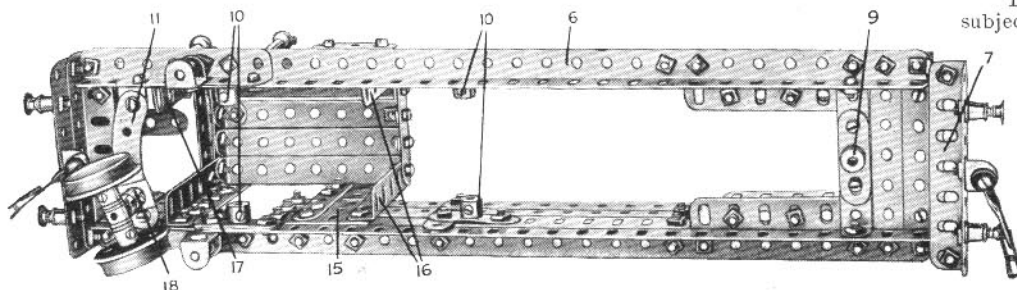

Fig. 11b. Underneath view of Main Frames, with rear pony truck and cab in position.

Parts required to build the Model 4-6-2 Tank Loco :

6 of No.	1b	2 of No.	9d	2 of No.	24	1 of No.	103d	8 of No.	136
5	3	3	9e	1	25	2	103e	6	137
7	4	2	10	156	37	2	103f	8	147b
5	5	8	12	8	37a	6	109	2	161
11	6	1	12a	25	38	3	111	1	162a
9	6a	2	12b	5	48b	1	111a	2	164
2	8	4	16	2	50a	1	111c	1	166
1	8b	2	16a	25	59	1	115	1	Clockwork Motor
3	9	4	17	4	62b	6	120a		
6	9b	5	18a	2	64	2	120b		
4	9c	6	20	3	90	2	121		

Model No. 12. Power Press

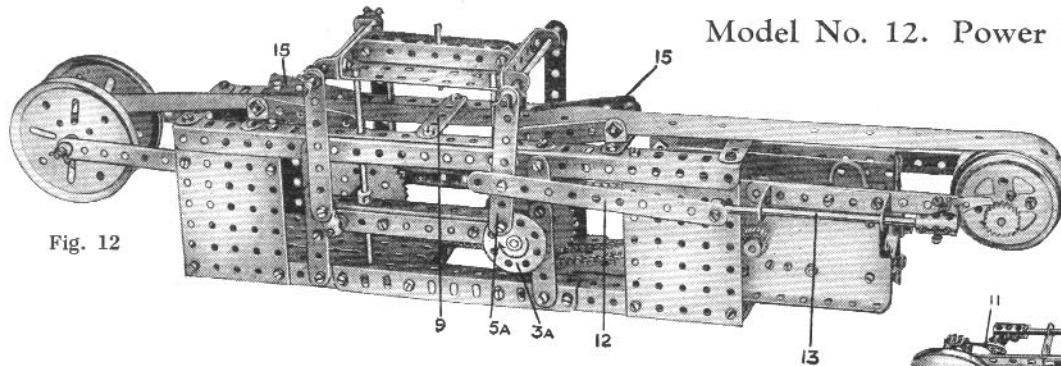

Fig. 12

The model shown in the illustration represents a type of automatic press used in factories for stamping out small metal parts. Although the model does not stamp out steel parts, it will cut neat round holes at equal distances in a strip of paper with great rapidity and precision.

The drive from the Electric Motor is transmitted via the  $\frac{1}{2}$ " Pinion on the armature shaft to a 57-teeth Gear on the Rod 1a (Fig. 12a) and from another  $\frac{1}{2}$ " Pinion on this Rod to a second 57-teeth Gear on the Rod 1. Two 1" Sprocket Wheels on the latter Rod are connected by Sprocket Chain to 2" Sprocket Wheels on the "crankshafts" 2. One crankshaft is formed from a  $3\frac{1}{2}$ " Rod and two Bush Wheels 3, 3a, and the other from a  $3\frac{1}{2}$ " Rod carrying two Couplings 4 placed at exactly similar angles. Four Strips 5 (Fig. 12b) which form connecting links between the Plate 6 and the crankshafts, are locked-nutted to the Bush Wheels and attached pivotally to the Couplings by  $\frac{3}{8}$ " Bolts. They are pivoted to the Plate 8 by means of two  $4\frac{1}{2}$ " Rods and retained in place by Spring Clips.

The  $3\frac{1}{2}$ " x  $2\frac{1}{2}$ " Flanged Plate 6 is strengthened with two  $3\frac{1}{2}$ " Strips 7 bolted to the Plate by Double Brackets.

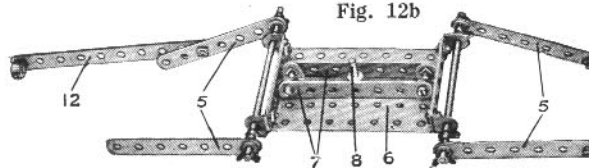

Fig. 12b

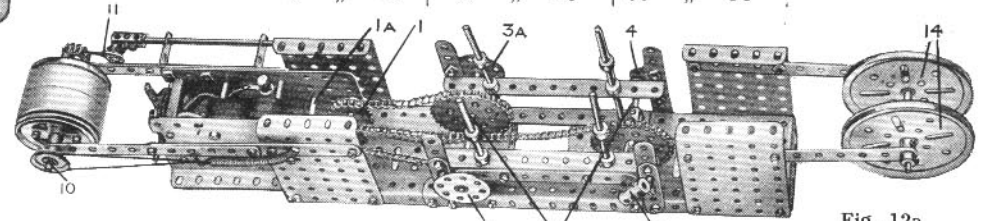

Fig. 12a

The die 8, a  $1\frac{1}{2}$ " Rod, is secured rigidly to the Plate 6 by means of a Crank. The paper Strip passes through two  $2\frac{1}{2}$ " Strips 9 (Fig. 12) bolted to the frame of the model and spaced apart by Washers. Guides 15 are provided to keep the material in correct alignment.

The feed drum is composed of two Boiler Ends attached to the Rod 10 by means of two 2" Pulleys. At one end of this Rod is affixed a 1" Pulley on which works a spring-controlled brake, and on the other end is attached a Ratchet Wheel that engages with a Pawl 11, which is retained in constant engagement by means of Spring Cord. The Pawl is attached to a  $4\frac{1}{2}$ " Rod 13 that is pivotally connected to the Strip 5a. The arrow on the Bush Wheel 3a shows the direction of travel; the drum must only turn when the die platten is at the top of its stroke.

Parts required :

8 of No. 2	2 of No. 17	1 of No. 43	2 of No. 95
2 " 2a	1 " 18a	1 " 46	2 " 96
6 " 3	2 " 19b	2 " 48	2 " 111c
18 " 5	2 " 20a	2 " 48a	1 " 147a
2 " 8	2 " 24	2 " 52	1 " 147b
4 " 9	1 " 26	5 " 53	1 " 148
2 " 11	2 " 27a	10 " 59	2 " 162a
1 " 15	13 " 35	1 " 62	1 Electric Motor
5 " 15a	102 " 37	3 " 63	
5 " 16	19 " 38	30" " 94	

Model No. 13. Fishing Reel

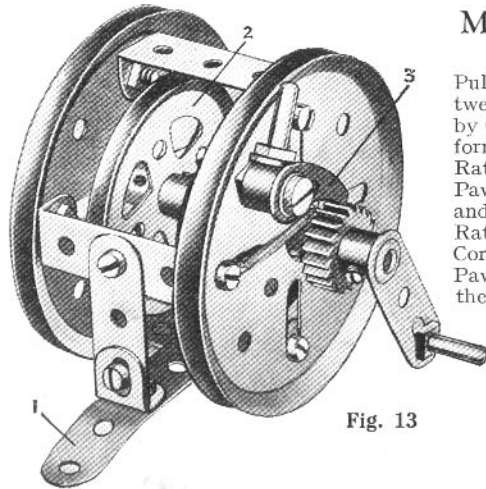

Fig. 13

The winding drum consists of two 2" Pulleys 2 secured to a  $2\frac{1}{2}$ " Rod, the space between the bosses of the Pulleys being taken up by Collars and Washers. A winding handle is formed from a Crank and a Threaded Pin. A Ratchet Wheel on the  $2\frac{1}{2}$ " Rod engages with a Pawl 3 that is mounted loosely on a Pivot Bolt, and normally is held in engagement with the Ratchet by means of a short length of Spring Cord. When it is desired to make a cast, the Pawl is thrown out of engagement by moving the Threaded Pin that is secured in its boss.

Parts required :

1 of No. 3	12 of No. 37
1 " 6a	3 " 48
1 " 12	1" " 58
1 " 16a	1 " 62
2 " 19b	1 " 115
2 " 20a	1 " 147
1 of No. 148	

Model No. 14. Opisometer

This is a simple device for measuring contours and map routes, etc. It consists of a Face Plate 1 mounted on a Screwed Rod 3 and attached by a bolt to a Coupling 2, the lower tapped hole of which engages with the thread of Rod 3. The Rod itself is secured in two Cranks that are bolted to a  $2\frac{1}{2}$ " x 1" Double Angle Strip.

The Face Plate is run along the line that is to be measured. As the Face Plate revolves it moves along the Threaded Rod and its movement may be measured by means of a scale 4. The latter may be graduated by running the instrument along a line of given length and marking the position of the Face Plate against the scale for each inch or so.

Parts required :

7 of No. 37	2 of No. 48b	1 of No. 80a
1 " 46	2 " 62	1 " 109
	1 " 63	

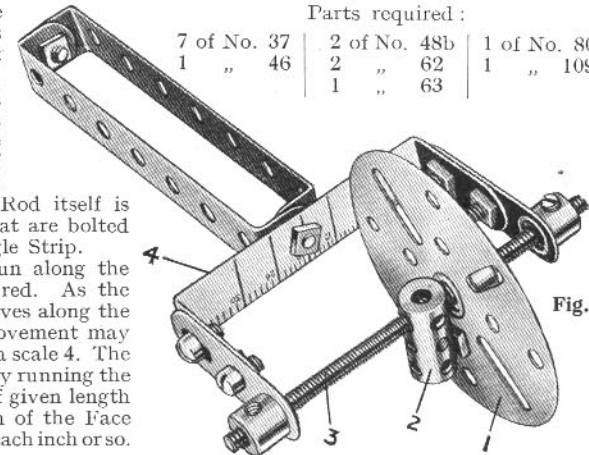

Fig. 14



Model No. 15. Useful Aerial-Earth Switch

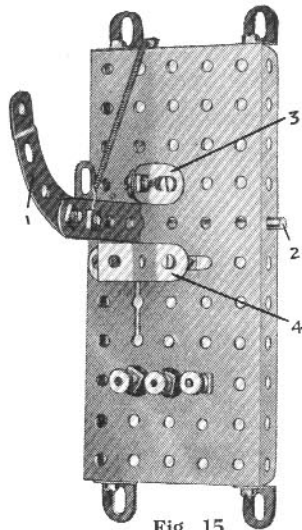

Fig. 15

Parts required :

1 of No. 5	2" of No. 58
1 " 9f	4 " 59
5 " 12	1 " 90a
1 " 16b	6 " 302
7 " 37	6 " 303
1 " 45	6 " 304
1 " 52	6 " 305
	6 of No. 306

The novel switch shown in Fig. 15 makes an excellent aerial-earthing switch for wireless sets. When the 'phones are placed on the hooked end of the switch arm, the aerial is automatically connected direct to the earth and static charges in the aerial can be passed to earth without causing damage to the set.

The switch consists of a pivoted arm 1 composed of a 2½" Strip and a 2½" small radius Curved Strip, mounted pivotally on a 3" Rod 2. This Rod is mounted in the flanges of the 5½" x 2½" Flanged Plate forming the base, the switch arm being passed through the slot in the Plate. One of the contacts consists of a Double Bent Strip 4 which is carefully insulated from the Plate by means of Insulating Bushes and Washers on the 6 B.A. retaining Bolts 6, and is connected by a short length of insulated wire to one of the three terminals, the shank of which must be insulated from the Plate. This terminal should be connected to the earth lead (near the earth end) by a suitable length of wire. The various connections of the switch are clearly shown in Fig. 15a, which is a rear view of the device.

The second contact 3 consists of a ½" x ½" Angle Bracket carrying a bolt that is arranged to make contact with the switch arm 1 when the latter is pulled upward by the tension of a length of Spring Cord. This contact is secured to the Plate by an insulated 6 B.A. Bolt 5 (Fig. 15a) which is connected to one of the terminals. This terminal is insulated and is connected to the aerial terminal of the set, whilst the third terminal, which is not insulated, is attached to the aerial lead-in.

As soon as the 'phones are lifted off the hook, the switch arm is pulled upward by the Spring Cord into contact with the bolt on the Bracket 3, thus connecting the set with the aerial system.

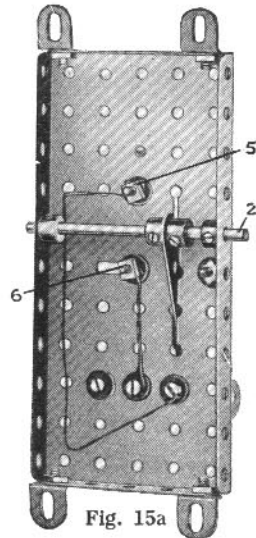
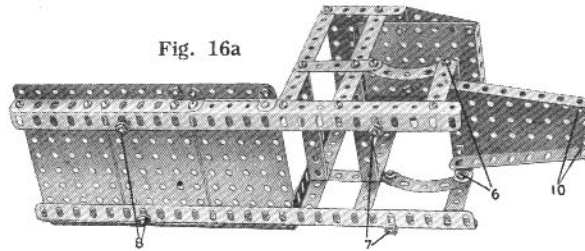

Fig. 15a

Fig. 16a



Parts required :	4 of No. 9	4 of No. 18a
6 of No. 2	4 " 10	4 " 20a
2 " 2a	4 " 11	2 " 22
5 " 3	8 " 12	1 " 24
2 " 4	1 " 13a	2 " 26
11 " 5	1 " 15	1 " 28
1 " 6a	1 " 15a	1 " 29
6 " 8	1 " 16	95 " 37
	3 " 17	14 " 37a

The constructional details of the chassis are shown clearly in Fig. 16, and it will be noticed that the front wheels are mounted on ¾" Bolts, which form the stub axles and are secured in Couplings 1. Each of the latter carries in its centre transverse hole a 1½" Rod 2, which is passed through the end holes of two 4½" Strips that are laid one upon the other, and loosely clamped in place by Collars. The end transverse holes of the Couplings hold the Rods 3 and 4 which are connected pivotally together at their ends by Swivel Bearings and two short Rods joined by a Coupling. A 2" Rod 5 is held in another Coupling on the Rod 4 and is connected by means of a Swivel Bearing and 3½" Rod to a Crank on the lower end of the steering column. A Pivot Bolt is passed through the end transverse hole of the Coupling on the 3½" Rod and is secured to the Crank by two nuts.

The engine bonnet is attached pivotally to the body (Fig. 16a) by Bolts 6 and lock-nuts so that it may be raised to allow the winding key of the Motor to be inserted. The shanks of the Bolts 10 enter the top holes of the 2½" Double Angle Strips in the front of the chassis, but they are not secured to the Strips.

The construction of the body will be apparent from a glance at Fig. 16a. The Bolts 7 are inserted in the hole 9 (Fig. 16b) and the opposite hole in the other side Girder; Bolts 8 are passed through the end holes but one of the two side Girders.

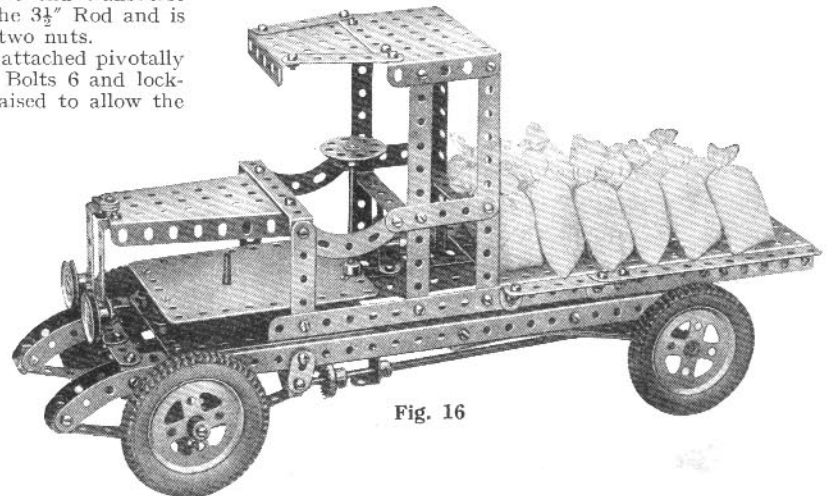

Fig. 16

Model No. 16. Motor Lorry

15 of No. 38
1 " 48
2 " 48a
3 " 48b
5 " 53
1 " 54
10 " 59
1 " 62
6 " 63
4 " 90
2 " 90a
2 " 111
6 " 111c
1 " 115
1 " 116a
1 " 125
4 " 142a
1 " 147b
2 " 165
1 Clockwork Motor

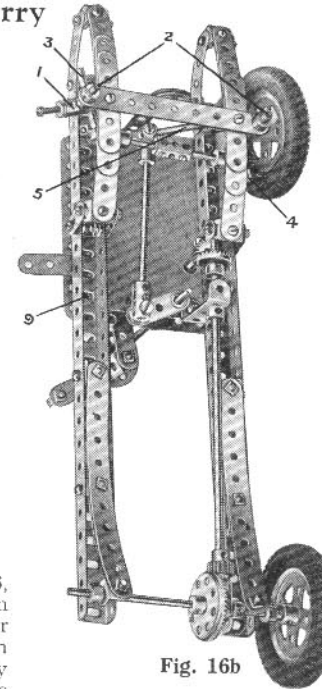

Fig. 16b

Model No. 17. Novel Electric Game

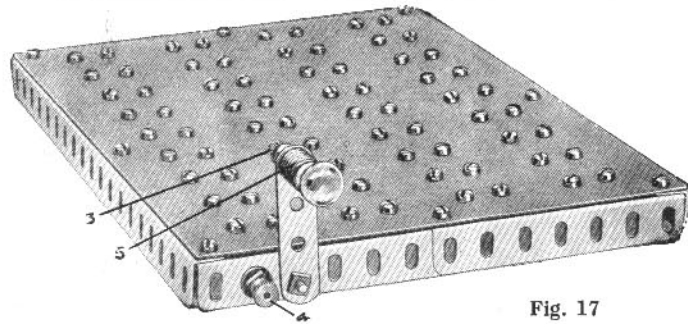

Fig. 17

This model is designed on the lines of a sideshow attraction that may be seen at many fairs. The object in this game is to throw a coin on to a table covered with electrical contacts. If the thrower is lucky (the odds are, of course, against him!) the coin comes to rest across certain contacts, a bell rings and a lamp bearing a number is illuminated. He then receives a prize, the value of which varies according to the number shown.

Fig. 17 shows the finished model whilst Fig. 17a is a diagram of the electrical connections. The panel on which the contact studs—ordinary Meccano bolts—are mounted is composed of a piece of cardboard.

The studs are connected together by lengths of copper wire in such a manner that they form two distinct electrical circuits 1, 2 (Fig. 17a). One end of the circuit 1 is brought to the bolt that secures the 2" Strip carrying the Lamp Holder 5, and one end of the circuit 2 is taken to the insulated terminal 4. The Lamp Holder is attached to the 2" Strip by a 6 B.A. Bolt, the shank of which is insulated from the Strip by an Insulating Bush. The base of the Lamp Holder must be in electrical contact with the 2" Strip and hence the Bush must be on the reverse side of the Strip. The projecting end of the 6 B.A. Bolt is provided with a terminal 3 by means of which connection may be effected with the Meccano 6-volt Accumulator; the other terminal of the latter is connected to terminal 4. A Meccano 6-volt bulb should now be screwed into the Lamp Holder 5. As an alternative an ordinary electric bell may be used instead of the lamp, simply by connecting the terminals of the bell to the wires shown attached to the Lamp Holder in Fig. 17a.

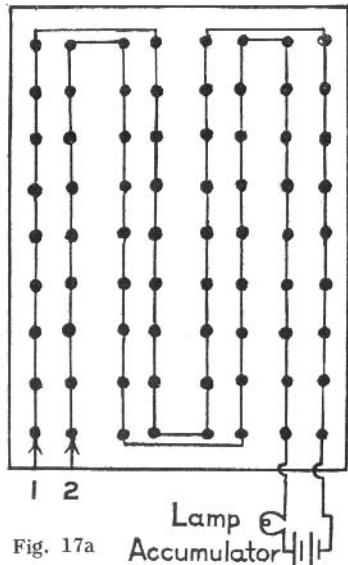

Fig. 17a

Parts required :

1 of No. 6	2 of No. 303
2 " 8a	3 " 304
4 " 9b	3 " 305
76 " 37	2 " 306
3 " 302	1 " 310
	1 of No. 311

Model No. 18. Automatic Traffic Control Signal

Three 1" x 1/2" Angle Brackets, secured to the 4 1/2" Angle Girders of the lamp casing, have Flat Brackets bolted in their end holes and at right angles to them, and the Lamp Holders (part No. 310) are secured to them by an insulated 6 B.A. Bolt. The sides of the lamp casing are filled in with cardboard, in which three holes are cut out and pieces of red, orange, and green transparent paper stuck over the holes. When in place the two top "glasses" on opposite sides should show red whilst the two remaining sides show green. Each of the middle glasses should be orange, and the bottom ones should be green on the sides where the top glasses are red, and red where the upper ones are green. Cardboard masks 4 also are fitted round the base of the Lamp Holders.

A wire from the Lamp 14 is connected to the terminal 5 on the base plate and a wire from the Lamp 15 connected to the terminal 6, the Lamp 16 being connected to the remaining terminal 7. These three terminals are insulated from the base plate; the terminal E, however, is in direct metallic contact with the Plate.

The Rod of the rotary switches 9, 10, 11, 12, is driven by the Electric Motor through the gearing shown. Each of the rotary switches consists of a Face Plate carrying six 1/2" x 1/2" Angle Brackets, which are bolted to the Face Plate and insulated therefrom by Insulating Bushes and Washers. The brushes consist of 3 1/2" Strips to which Double Brackets are attached by insulated Bolts. Each one is kept in proper contact by means of a short length of Spring Cord, one end of which is secured to the brush and the other end to an insulated 6 B.A. Bolt attached to the frame.

The brushes pressing on the switches 9 and 11 are connected together by a length of insulated wire 13, and a wire is taken from the latter brush to the terminal 6. The terminal 5 is connected to the brush of the switch 10 and the remaining brush to the terminal 7. One of the Motor terminals is connected to the frame whilst the other terminal of the Motor is connected to the terminal E on the Lamp standard, and also to the Accumulator. The return lead from the latter is taken to the terminal 8, which is in direct metallic contact with the Motor side plate.

The mechanism should be so arranged that when the upper Lamp is extinguished, by the brush controlling that light passing on

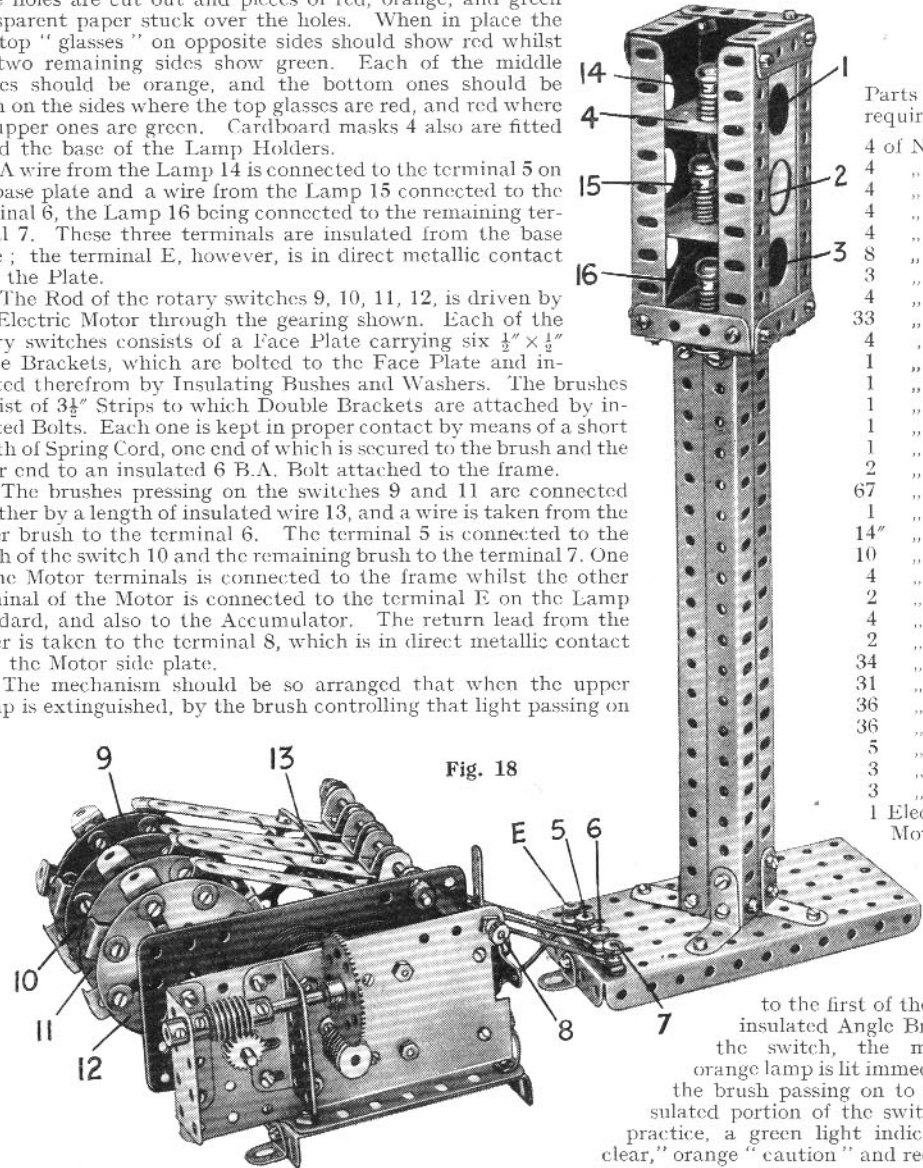

Fig. 18

Parts required :

4 of No. 3	
4 " 8a	
4 " 8b	
4 " 9a	
4 " 9b	
8 " 9f	
3 " 10	
4 " 11	
33 " 12	
4 " 12a	
1 " 13a	
1 " 15	
1 " 16a	
1 " 26	
1 " 27a	
2 " 32	
67 " 37	
1 " 52	
14 " 58	
10 " 59	
4 " 103a	
2 " 108	
4 " 109	
2 " 161	
34 " 302	
31 " 303	
36 " 304	
36 " 305	
5 " 306	
3 " 310	
3 " 311	
1 Electric Motor	

to the first of the series of insulated Angle Brackets of the switch, the middle or orange lamp is lit immediately by the brush passing on to the un-insulated portion of the switch 9. In practice, a green light indicates "all clear," orange "caution" and red "stop."



Model No. 19. Toplis Level-luffing Crane

Parts required:

15 of No. 2	6 of No. 3	2 of No. 9b	1 of No. 22	3 of No. 52
8 " 2a	5 " 4	4 " 10	3 " 22a	1 " 57b
	15 " 5	1 " 14	3 " 24	22 " 59
	4 " 6a	2 " 15	1 " 26	3 " 62
	4 " 7	1 " 16	2 " 27a	1 " 63
	2 " 8	1 " 16a	1 " 28	2 " 70
	17 " 9	2 " 16b	2 " 32	2 " 77
		1 " 17	138 " 37	1 " 111
		1 " 18a	4 " 37a	4 " 111c
		1 " 19	12 " 38	2 " 115
		3 " 19b	1 " 40	21 " 117
		2 " 21	1 " 46	6 " 133
			1 " 48a	1 " 137

ally to the jib by means of  $4\frac{1}{2}$ " Strips  
5. A 57-teeth Gear on the Rod 4 meshes with a Worm attached to a Crank Handle, which is journalled in a  $2\frac{1}{2}$ " x 1" Double Angle Strip, indicated by the two Bolts A, and a  $2\frac{1}{2}$ " Strip situated at the rear end of the gear box.

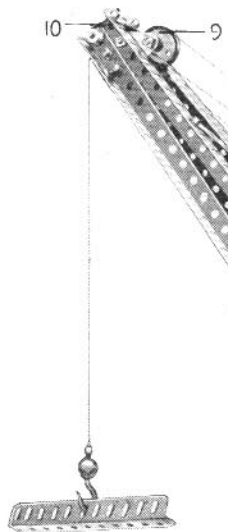
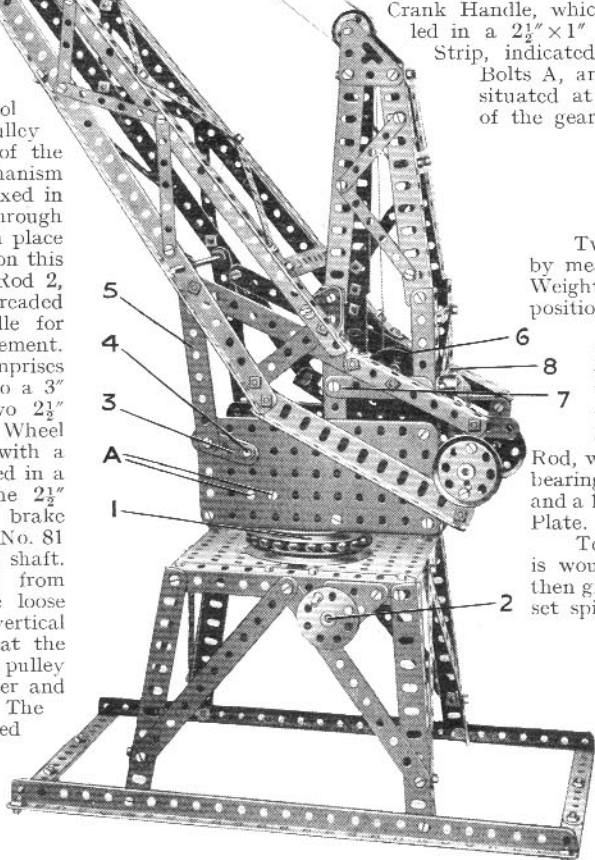

Fig. 19

A  $5\frac{1}{2}$ " x  $2\frac{1}{2}$ " Flanged Plate serves as the base of the control cabin, and is bolted to a 3" Pulley 1 that forms the upper half of the ball race (see Standard Mechanism No. 105). A 2" Rod that is fixed in the boss of the Pulley 1 passes through the lower Pulley and is held in place by a Collar. A 57-teeth Gear on this Rod engages a Worm on the Rod 2, on which a Bush Wheel with a Threaded Pin is fixed to form a handle for operating the swivelling movement.

The hoisting drum comprises two Bush Wheels 6 attached to a 3" Rod that is journalled in two  $2\frac{1}{2}$ " Strips 7, and a  $\frac{3}{4}$ " Contrate Wheel attached to this Rod meshes with a  $\frac{1}{2}$ " Pinion on a 2" Rod journalled in a Double Bent Strip and in the  $2\frac{1}{2}$ " Strip 8. A strap and lever brake similar to Standard Mechanism No. 81 is fitted to act on the hoisting shaft. The hoisting cord is taken from the drum 6 over one of the loose Pulleys at the top of the vertical member, round the Pulley 9 at the jib head, back to the remaining pulley at the top of the vertical member and finally over the Pulley 10. The crane Hook may now be attached to the cord.

The luffing movement is actuated by Cranks 3 rigidly attached to Rod 4 and connected pivot-



Model No. 20. Farm Tractor

Parts required:

2 of No. 2	5 of No. 38	2 of No. 111
5 " 5	1 " 48a	1 " 111c
1 " 6a	2 " 59	1 " 125
2 " 10	37 " 63	1 Clockwork Motor
4 " 11	4 " 90a	
5 " 12		
1 " 15		
2 " 16		
1 " 17		
2 " 19b		
2 " 20a		
1 " 21		
1 " 22		
1 " 24		
2 " 26		
1 " 27a		
1 " 32		
1 " 37		
7 " 37a		

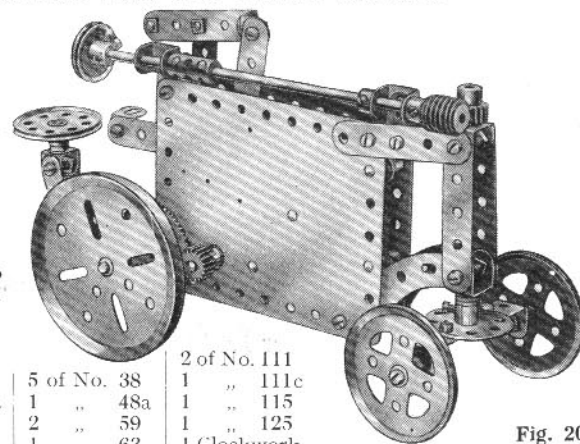

Fig. 20

The seat (a  $1\frac{1}{2}$ " Pulley) is secured on a Threaded Pin, which is attached to two Angle Brackets. The latter are bolted to a pair of  $2\frac{1}{2}$ " large radius Curved Strips, which are secured rigidly to two  $5\frac{1}{2}$ " Strips fixed in the bottom row of holes of the Motor Plates. A  $2\frac{1}{2}$ " Strip pivoted to the Motor reversing lever by a Reversed Angle Bracket, is supported by a  $1\frac{1}{2}$ " pivoted Strip.

Model No. 21. Gyroscope

Two Hub Discs 1 are secured to an Axle Rod by means of two Bush Wheels. Four 50-gramme Weights 2 are bolted to each Hub Disc in the positions shown.

A Circular Strip 3 is attached by  $\frac{1}{2}$ " x  $\frac{1}{2}$ " Angle Brackets and lock-nuts to a Strip that is bent in the form of a U, and has a Double Arm Crank bolted to its lower extremity to form a means of connection with a  $1\frac{1}{2}$ " Rod. This Rod, which forms a pivot, is free to turn in a bearing consisting of a Double Bent Strip and a  $1\frac{1}{2}$ " Strip bolted to the  $5\frac{1}{2}$ " x  $2\frac{1}{2}$ " Flanged Plate.

To start the gyroscope, a length of string is wound on to the spindle and its end is then given a smart pull so that the wheel is set spinning.

Parts required:

1 of No. 1	2 of No. 37a
1 " 6a	1 " 45
4 " 12	3 " 59
1 " 14	1 " 62b
1 " 18	8 " 66
2 " 24	2 " 118
22 " 37	1 " 145

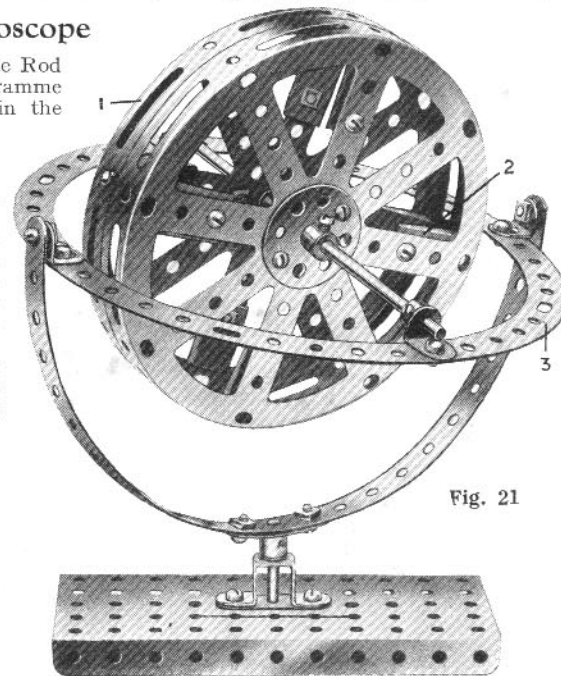

Fig. 21

## Model No. 22. Flying Boat

Parts required :

3 of No. 1	1 of No. 29
20 " 2	154 " 37
2 " 2a	5 " 37a
5 " 3	12 " 38
4 " 4	1 " 45
6 " 5	2 " 46
2 " 6	1 " 48
5 " 6a	4 " 52a
5 " 8	2 " 53a
4 " 8a	5 " 59
4 " 9	2 " 62b
1 " 9d	4 " 90
2 " 10	2 " 90a
8 " 11	4 " 103f
8 " 12	
2 " 15a	
2 " 16a	
1 " 21	
2 " 22	
1 " 26	
1 " 27a	

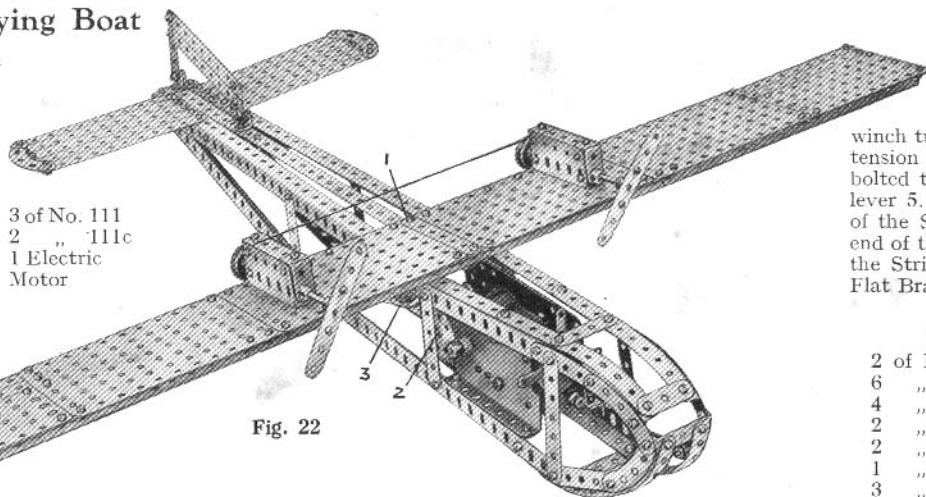

Fig. 22

The Flat Plates of the main plane are secured to a girder consisting of one 12½" Angle Girder extended at each end by 9½" Girders and bolted along the leading edge of the plane with the projecting flange toward the tail of the model. A 2½" Angle Girder is bolted to the centre of the girder so formed and is secured, in turn, across the fuselage. The wings are held rigid by the ¾" Bolt 1, which is passed through the 12½" Strip in the centre of the fuselage but is spaced therefrom by a Collar.

The Electric Motor is fixed to the lower pair of Angle Girders. The armature spindle carries a ½" Pinion meshing with a 57-teeth gear on the 2½" Rod 2, which carries a ¾" Contrace Wheel that engages a Pinion on the Rod of the 1½" Pulley 3. Bearings for the Rod are formed by a 1½" Strip and Double Bent Strip which are bolted by Angle Brackets to the side plates of the Motor. Cord is passed round the Pulley 3 to each of the 1" Pulleys on the propeller shafts of the miniature engines.

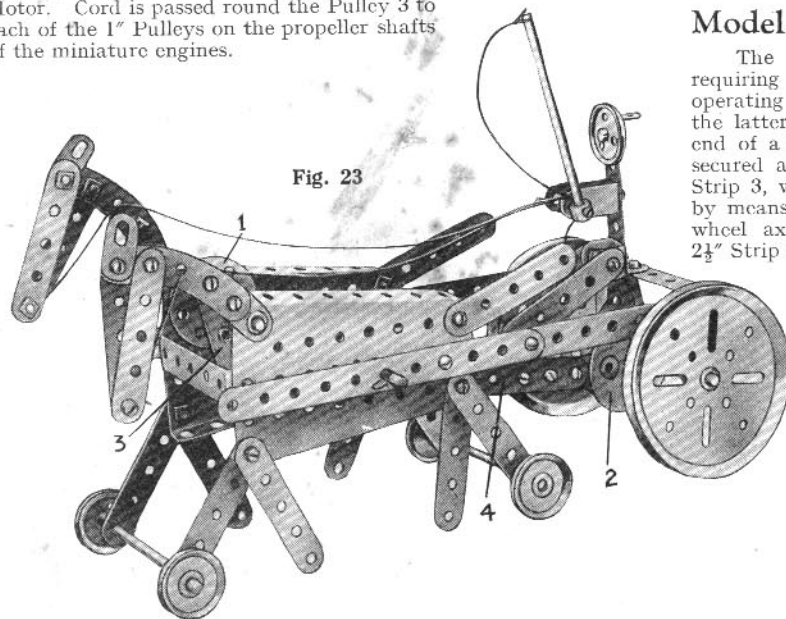

Fig. 23

## Model No. 23. Trotting Car

The only portion of this model requiring description is the mechanism operating the horses' heads. Each of the latter is secured by a Crank to one end of a 3½" Rod. To this Rod is also secured a Bush Wheel 1 carrying a 2½" Strip 3, which is given a rocking motion by means of an Eccentric 2 on the road wheel axle. The Eccentric 2 and the 2½" Strip 3 are connected by the link 4.

Parts required :

6 of No. 2	1 of No. 37a
17 " 5	2 " 38
2 " 10	1 " 44
1 " 11	3 " 48a
2 " 15a	1 " 48b
4 " 16	2 " 54
2 " 19b	1 " 59
4 " 22	2 " 62
1 " 22a	2 " 90
1 " 24	2 " 126a
4 " 35	1 " 130
42 " 37	

## Model No. 24. Catapult

Two equal lengths of cord are attached to each end of the 1½" Rod 1 and to the winch 2, which is operated by the hand levers at each end. The Rod 1 is placed over the end of a Flat Bracket 3 and the winch turned so as to pull down the arm of the catapult, against the tension of the Spring. The release gear consists of 2½" Strips 4 bolted to two Cranks that are secured to a Rod operated by the lever 5. When the model is ready for firing, the Rod 1 is in front of the Strips 4, so that when the end of the lever 5 is pressed down, the Strips 4 push the Rod off its Flat Bracket and release the arm.

Parts required :

2 of No. 1	1 of No. 57
6 " 2	3 " 59
4 " 3	2 " 62
2 " 5	3 " 63
2 " 8	1 " 147a
1 " 10	1 " 147b
3 " 11	1 " 148
3 " 15	1 " 162a
4 " 15a	
4 " 16	
2 " 17	
2 " 19b	
4 " 22	
2 " 24	
1 " 32	
6 " 35	
36 " 37	
2 " 37a	
4 " 38	
1 " 43	
1 " 48	
2 " 52	
4 " 53	

Fig. 24

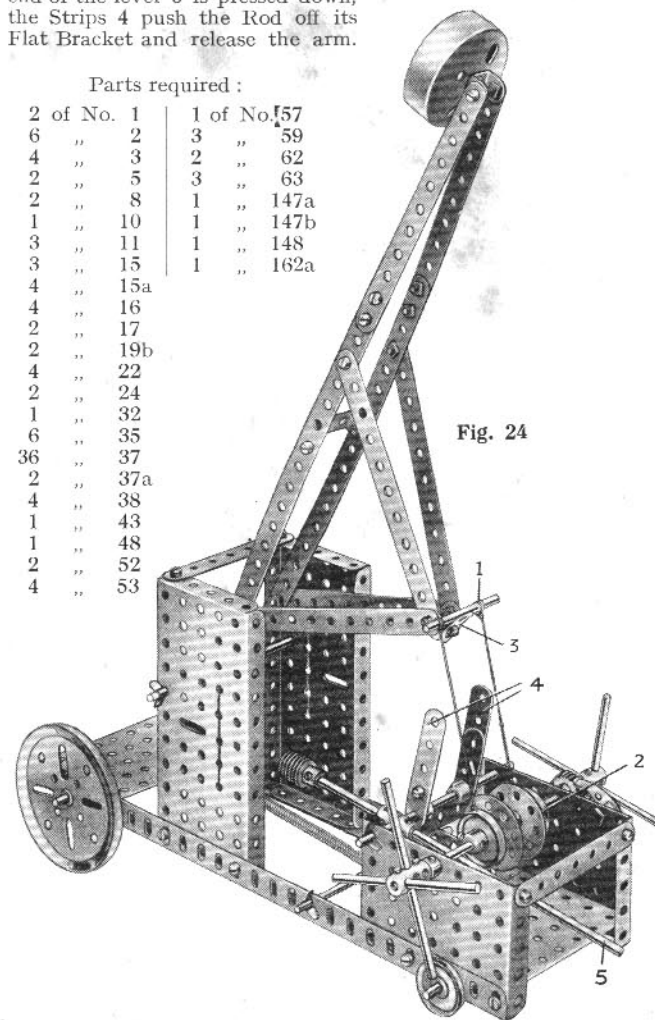



Model No. 25. Fire Truck

The realistic fire truck shown in Fig. 25 is quite simple to build and when completed forms an excellent working model. The construction of the chassis is shown clearly in the illustrations and does not require any detailed description.

The front wheel axle is journalled in a  $2\frac{1}{2}$ " Double Angle Strip that is pivoted loosely through its centre hole to a Double Bent Strip that, in turn, is secured to the under surface of the Flanged Plate 15 (Fig. 25). Steering is effected from the  $1\frac{1}{2}$ " Pulley 13 secured on a  $3\frac{1}{2}$ " Rod that is passed through the

$3\frac{1}{2}$ " x  $2\frac{1}{2}$ " Flanged Plate 16, and held in position by Collars. To the lower end of the Rod a Bush Wheel 14 is secured, and this is connected to the Double Angle Strip carrying the front axle by means of cord that is tied to diametrically opposite holes in the Bush Wheel and also to the ends of the Double Angle Strip.

The lower or stationary part of the escape is mounted pivotally on Bolts 10 (Fig. 25a) passed through the upturned ends of a  $2\frac{1}{2}$ " x  $1\frac{1}{2}$ " Double Angle Strip that is bolted to a  $3\frac{1}{2}$ " x  $\frac{1}{2}$ " Double Angle Strip which, in turn, is supported on two vertical  $2\frac{1}{2}$ " x  $\frac{1}{2}$ " Double Angle Strips that are bolted in the positions indicated. The upper or moving portion of the escape slides between the  $12\frac{1}{2}$ " Angle Girders 9 and is held freely in position by the nuts of the Bolts 11.

Fig. 25a is a larger view of the mechanism that controls the elevation of the ladder. The ladder is extended from the Crank Handle 2 that is journalled in a  $2\frac{1}{2}$ " x  $\frac{1}{2}$ " Double Angle Strip bolted to a  $5\frac{1}{2}$ " Strip that, in turn, is bolted across the flanges of the Sector Plates. A length of Cord 7 is wound on to the Crank Handle and one of its ends is tied to a  $2\frac{1}{2}$ " Strip that spans the inner end of the  $12\frac{1}{2}$ " Strips forming the sides of the extending ladder. Its other end 7a is then led towards the outer end of the fixed ladder, round a  $\frac{1}{2}$ " loose Pulley held in a bolt in the centre hole of a  $2\frac{1}{2}$ " Double Angle Strip that spans the outer end of the  $12\frac{1}{2}$ " Girders 9, and finally is tied to the same  $2\frac{1}{2}$ " Strip to which the end 7 is already attached. Thus by turning the Handle 2 the escape is pulled inward or outward.

The Crank Handle 1 (Fig. 25a) controls the elevation of the movable ladder. It carries a  $\frac{1}{2}$ " Pinion 3 that engages a 57-teeth Gear 4 secured to a Rod 12. A cord 8 is wound a few turns round the Rod 12 and is then led to the  $2\frac{1}{2}$ " Strip 5 where it is made secure. By turning the Crank Handle the Cord is wound in, thus raising the pivoted escape. On turning the Handle in the opposite direction, the escape is lowered by its own weight.

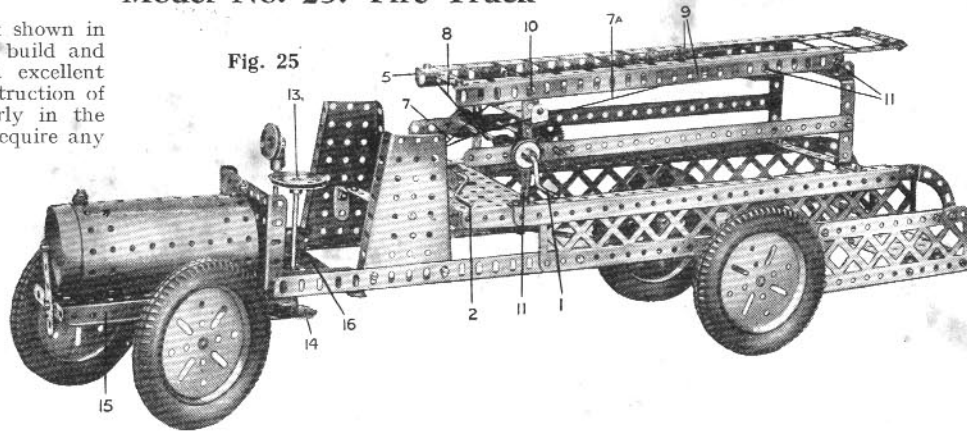

Fig. 25

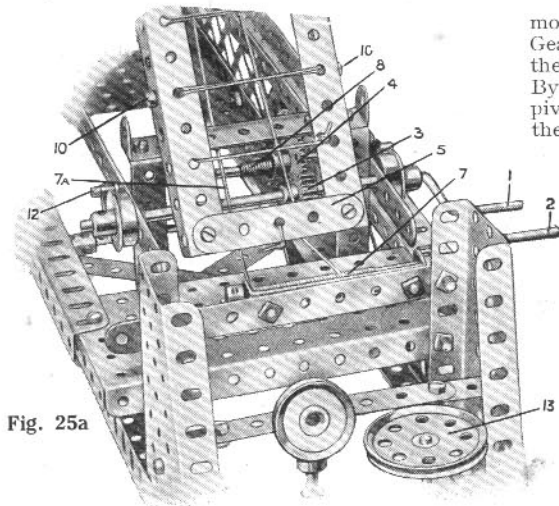

Fig. 25a

Parts required :

4 of No. 1	3 of No. 20b	2 of No. 48b
6 " 2	1 " 21	2 " 52
3 " 3	2 " 22	2 " 53
4 " 5	1 " 23	2 " 54
8 " 8	1 " 24	4 " 59
4 " 11	1 " 26	1 " 63
1 " 12	1 " 27a	2 " 90a
2 " 12a	4 " 35	2 " 99
2 " 15	87 " 37	2 " 100
2 " 15a	8 " 37a	4 " 111c
2 " 16	10 " 38	2 " 126a
1 " 18a	2 " 40	1 " 162a
1 " 19	1 " 45	1 " 162b
1 " 19s	1 " 46	1 " 165
4 " 19b	8 " 48a	

Model No. 26. Undertype Steam Engine

The crankshaft is built up of four Couplings joined together by  $\frac{3}{4}$ " Bolts. A  $\frac{3}{4}$ " Bolt 1 is passed through the centre threaded hole of the Coupling 2 and screwed up as tightly as possible. The connecting Rod 3 is now slipped on and spaced by two Washers, one on each side of the Strip, after which the Coupling 4 is screwed on to the Bolt 1 so that the connecting rod revolves easily in the intervening space. A  $\frac{3}{8}$ " Bolt 5 is next screwed into the Coupling 4 until it strikes the end of Bolt 1. The second crank is assembled in the same way—that is, a  $\frac{3}{4}$ " Bolt is passed through the centre threaded holes of two Couplings—but two Washers are placed at 6, and a  $\frac{3}{8}$ " Bolt 8 is inserted in the Coupling 9 in the same way as the Bolt 5 in Coupling 4. A  $\frac{3}{4}$ " Bolt is now passed through the inner transverse hole of Coupling 9 and through the corresponding hole in Coupling 4, and is gripped securely by the set-screws of both Couplings. The whole crankshaft is held rigid by the  $\frac{3}{8}$ " Bolts, for the head of Bolt 5 engages with the hole in the end of Coupling 9 whilst the head of Bolt 8 engages the end of Coupling 4.

Two 2" Rods are used for the ends of the crankshaft, one carrying a 3" Pulley to represent a flywheel and the other a 1" Pulley round which a length of cord is passed which takes the drive to the centrifugal governor. The latter is built up from a Large Fork Piece with Collars attached. It is secured to a  $1\frac{1}{2}$ " Rod journalled loosely in the Coupling 9, which is secured to the base as shown.

Parts required :

2 of No. 5	40 of No. 37	2 of No. 111
4 " 9	4 " 37a	4 " 111c
3 " 12	6 " 38	2 " 115
2 " 17	1 " 46	1 " 116
3 " 18a	4 " 48a	1 " 116a
1 " 19b	1 " 52	2 " 126a
3 " 20b	4 " 53	1 " 162
2 " 22	4 " 59	2 " 163
	5 " 63	1 " 166

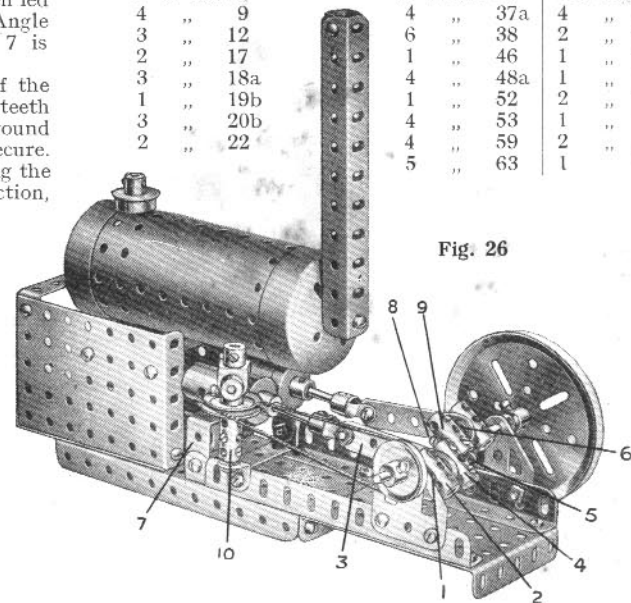

Fig. 26

Model No. 27. Steam Shovel

The base of this model consists essentially of two 5½" x 21" Flanged Plates connected together by 12½" Angle Girders, and the vertical member 1 is secured firmly to a 2" Sprocket Wheel 2 that is free to turn about a Pivot Bolt attached to one of the base plates. It should be noted that the 2½" x 1" Double Angle Strip 3 is spaced from the Sprocket 2 by the thickness of two Washers.

The gear box provides four movements—hoisting and lowering, racking, slewing, and travelling, all of which are driven by the Electric Motor. On the armature spindle of the Motor is a Worm meshing with a ½" Pinion on a horizontal Rod on which is secured also a ¾" Contrate. The latter is in constant mesh with a ½" Pinion 4 on a short Rod that is journalled in the Motor side plates and carries a Worm 5.

The slewing and travelling motions are actuated through a novel form of clutch, shown in Figs. 27 and 27a. A 57-teeth Gear 6 meshes with the Worm 5. It is loose on its Rod 10 and may be raised or lowered by means of two Cranks 9, which are secured to a Rod and have in their end holes bolts, the shanks of which engage with the underside of the Gear.

When the Gear is moved downwards, one of two ¾" Bolts 6a secured to it, engages with one of the holes in a 2" Sprocket 7 which is loose on the Rod 10 and is connected to the Sprocket 2 by a length of Sprocket Chain. By this means the model is slewed. By raising the Gear 6 the second ¾" Bolt engages with a Bush Wheel 8, which is fastened to the Rod 10. A 1" fast Pulley 11 on the lower end of this shaft is connected by a short belt of cord to a similar Pulley on the front axle.

It should be borne in mind that the Gear 6 must be always in mesh with the Worm 5, unless it is required to throw it out of gear entirely, when it is only necessary to slide it up the Rod to its fullest extent. To prevent the Gear coming out of mesh with the Worm when in the slewing position, a Collar is fixed on the lower ¾" Bolt, and in order to maintain the operating lever in position after movement, a Spring Clip 9a is mounted on the end of the Rod carrying the Cranks 9, and prevented from rotation by its ends engaging with a ½" x ½" Angle Bracket bolted to the Flat Trunnion. Hence the required stiffness in the movement of the lever is obtained.

The drive for the racking movement is taken off a ½" fast Pulley 12 secured to the top end of a Rod that carries a ½" Pinion 13, which may be brought into mesh with the Worm 5 by sliding the Rod downward with the aid of the

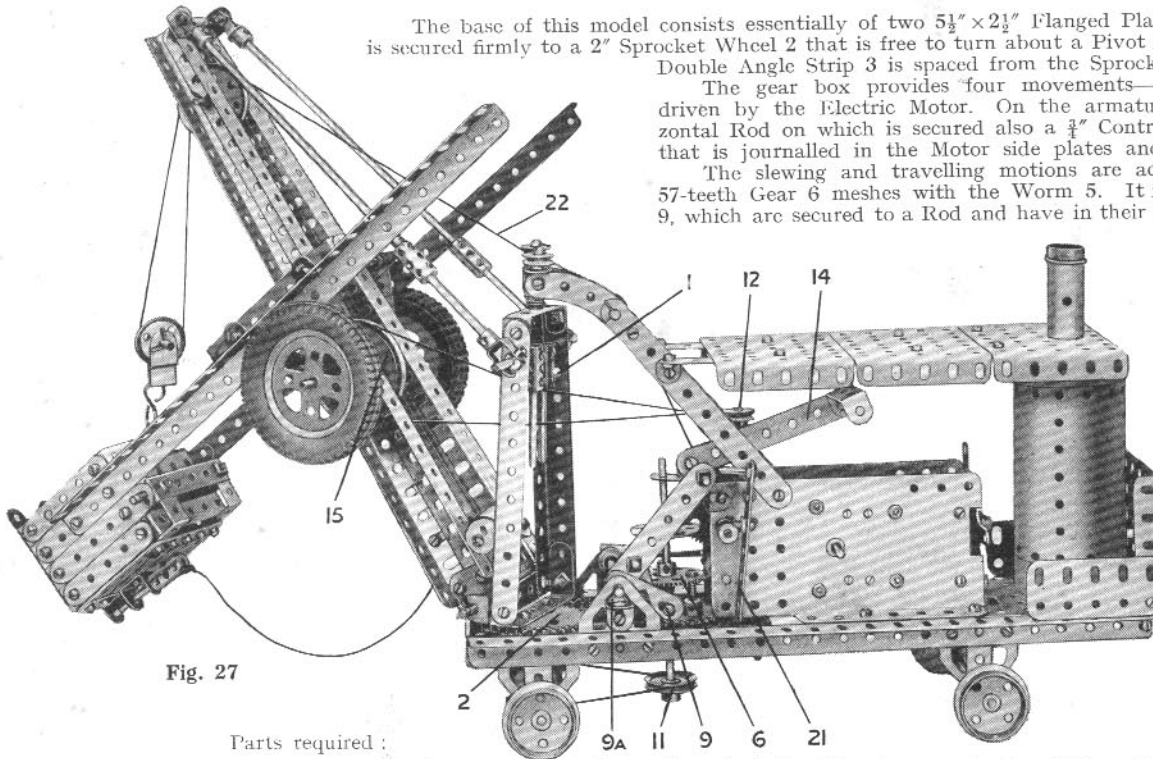

Fig. 27

Parts required:

6 of No. 2	1 of No. 22a	6 of No. 63
2 " 2a	3 " 23	2 " 77
6 " 3	1 " 23a	3 " 90
4 " 4	2 " 24	11" " 94
18 " 5	2 " 26	2 " 95
2 " 6a	2 " 27a	2 " 103f
8 " 8	1 " 29	2 " 111
2 " 9	2 " 32	3 " 111c
3 " 10	10 " 35	2 " 115
1 " 11	125 " 37	1 " 116a
12 " 12	7 " 37a	3 " 126
4 " 12a	21 " 38	4 " 126a
3 " 14	1 " 40	2 " 142a
1 " 15	1 " 44	1 " 147b
5 " 15a	1 " 45	1 " 162
5 " 16	1 " 46	1 " 163
5 " 17	2 " 48	1 " 164
4 " 18a	10 " 48a	2 " 165
4 " 20	2 " 52	1 " 166
3 " 20a	4 " 53	1 Electric
1 " 20b	1 " 57	Motor
1 " 21	10 " 59	
2 " 22	2 " 62	

lever 14. A belt of cord connects the Pulley 12 with a 2" Pulley 15 secured on a Rod that is journalled in the sides of the jib and which carries two other 2" Pulleys shod with Dunlop Tyres. The frame 16 (Fig. 27c) also is mounted on this Rod in the holes 17, and the Girders of the bucket arm engage between the ½" x ½" Angle Brackets 18 and the tyre-shod Pulleys. The Brackets 18 should press the bucket arm only lightly into contact with the tyres, and the driving belt should be taken several times round the Pulleys 12 and 15.

The construction of the bucket itself should be fairly obvious from Fig. 27c, with the exception of the catch for releasing the hinged bottom. The catch consists of a 1½" Rod free to slide in a Double Bracket that is bolted rigidly to the underneath of the bucket. One end of the Rod is fitted with a Coupling, to which the release cord is attached, and the other end fits into the lower hole of a 3" Strip 19.

The hoisting winch consists of a 3½" Rod 20 that is free to slide in the Motor side plates and is controlled by the lever 21, so that the 57-teeth Gear on its extremity may be thrown into or out of engagement with the ½" Pinion 4. When out of gear the projecting shank of a bolt on the Motor side plate engages with one of the holes of the 57-teeth Gear and thus prevents the unwinding of the winch. The grub-screw in the boss of the Pinion 4 should

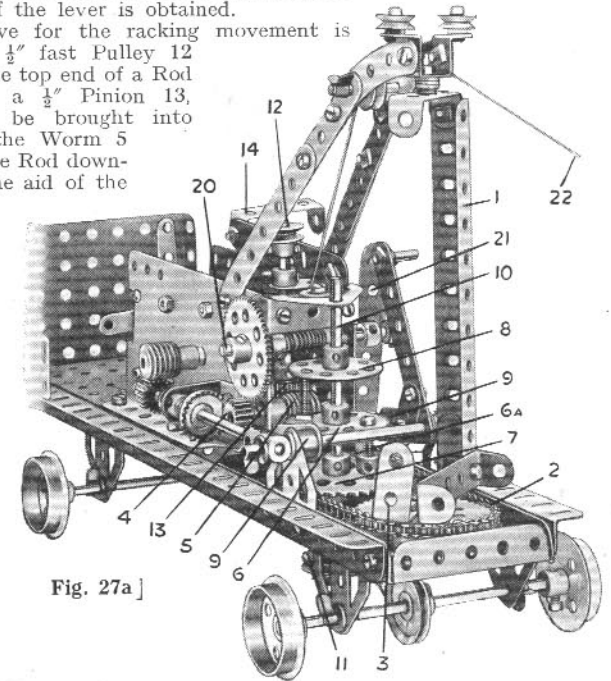

Fig. 27a ]



Model No. 27. Steam Shovel

(continued)

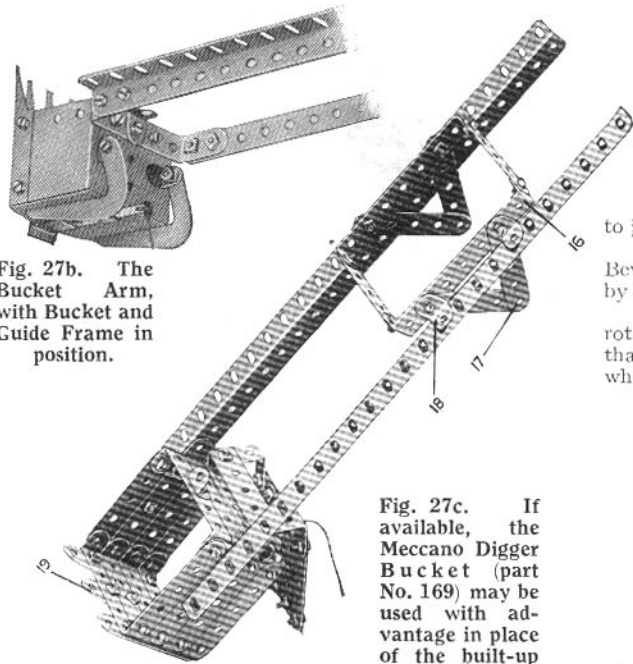

Fig. 27b. The Bucket Arm, with Bucket and Guide Frame in position.

Fig. 27c. If available, the Meccano Digger Bucket (part No. 169) may be used with advantage in place of the built-up Bucket, as shown.

be filed, if necessary, so that it does not foul the teeth of the 57-teeth Gear.

The pair of  $\frac{1}{2}$ " Loose Pulleys mounted at the top of the vertical member form guides round which the hoisting cord 22 passes when the jib is slewed round. The Boiler is retained in position by a  $6\frac{1}{2}$ " Rod, which passes completely through it, and through the base plate, and is secured by a Bush Wheel on its lower end, and at its upper extremity by a  $\frac{3}{4}$ " Flanged Wheel that forms the chimney cap.

Parts required for Model No. 29:

1 of No. 5	4 of No. 38	3 of No. 302
1 " 6	1 " 45	2 " 303
1 " 6a	3 " 53	5 " 304
5 " 12	4 " 59	5 " 305
2 " 16	1 " 62	3 " 306
1 " 20	2 " 72	1 " 310
1 " 24	1 " 90a	1 " 311
23 " 37	1 " 111a	

Model No. 28. Screw Jack

The short Rod of the Bush Wheel 4 is journalled in a Double Bent Strip and a  $1\frac{1}{2}$ " Strip bolted between two 1" Triangular Plates that are attached to the upright Angle Girders; a  $7\frac{1}{2}$ " Strip 1 mounted pivotally on this Rod forms the operating lever. It carries two Pawls 3 that are mounted loosely on a  $1\frac{1}{2}$ " Rod and held in place by Collars. Each Pawl engages with a Ratchet Wheel secured to the Rod of the Bush Wheel 4 and is normally held in engagement with the teeth of the Ratchet Wheel by means of a length of Spring Cord.

On operation of the lever one Pawl rotates the wheel 4 in one direction while the other rotates it in the reverse direction, and each Pawl may be withdrawn from its respective Ratchet by means of the levers 2. These consist of Cranks mounted loosely on a short Rod and prolonged by 2" Strips. The Cranks are connected to the Pawls by lengths of wire attached to  $\frac{3}{8}$ " Bolts that are inserted in the tapped holes of both the Cranks and the Pawls as shown.

The Threaded Rod 5 is rotated by means of a  $\frac{3}{8}$ " Bevel that meshes with a similar Bevel on the Rod of the Bush Wheel 4. A Threaded Boss on the Rod 5 is connected by the two  $1\frac{1}{2}$ " Strips 6, to two new-style Collars secured on the parallel vertical Rods.

When it is desired to throw one of the Pawls out of engagement so that the lever 1 rotates the Bush Wheel shaft in one direction only, the Pin 7 is passed through a Strip 2 that controls the Pawl and through a hole in the lever. The jack may be manipulated when no load is applied by disengaging the Pawls and turning the Bush Wheel.

Parts required:

1 of No. 1b	2 of No. 30	1 of No. 72
4 " 2a	36 " 37	2 " 77
6 " 5	1 " 45	1 " 80b
4 " 6	1 " 52	2 " 90a
3 " 6a	7 " 59	1 " 115
1 " 18b	2 " 62b	2 " 147a
1 " 24	1 " 64	2 " 148

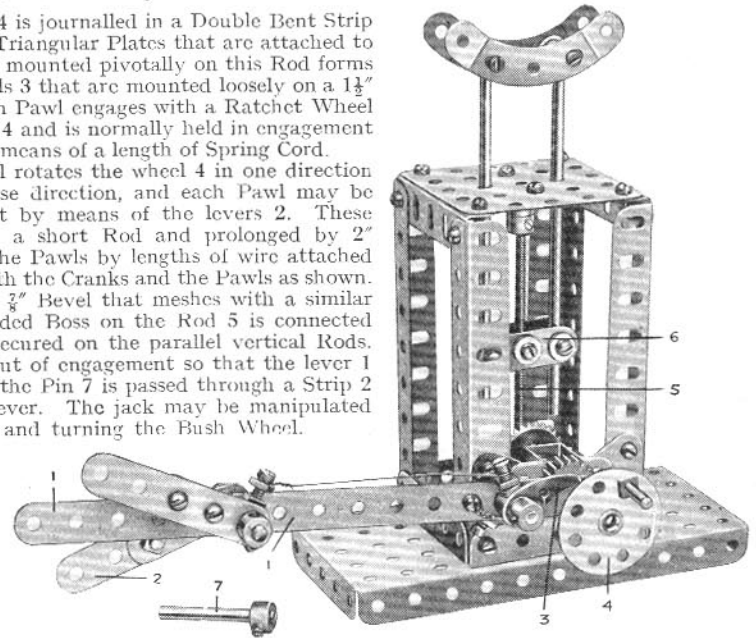

Model No. 29. An Electric Target

Those Meccano boys who possess air guns will welcome the idea illustrated in Fig. 29. The apparatus replaces the usual paper target, the advantage obtained being that the marksman is always certain whether he has hit the bull's-eye or not, for when he does so an electric bulb automatically lights up.

The bull's-eye consists of a circle of cardboard fastened to a Crank 3 by two Angle Brackets. A  $2\frac{1}{2}$ " large radius Curved Strip 4 is attached pivotally by a bolt and lock-nuts to the end of the Crank 3 and has a 1" Rod placed in the hole at its other end. Two Couplings (only one of which can be seen in the illustration) are fastened to the ends of this Rod, one on each side of the Curved Strip. A Bush Wheel 5 is bolted to, but insulated from, the base plate by a 6 B.A. Bolt and an Insulating Bush and Washer. The Bush Wheel 5 is joined by wire to the terminal 6, which is also insulated from the framework.

The Flanged Wheel 7 is held firmly against the nickelled Strip 1 by means of a Collar on the other end of the Rod 8. The Lamp Holder 9 is secured to a Double Bent Strip by a 6 B.A. Bolt, an Insulating Washer being placed between the 6 B.A. Nut and the under surface of the Double Bent Strip. One end of a length of wire is connected to the Bolt and its other end is attached to the terminal 2.

Terminal 10 is secured direct to the Plate. If enamelled parts are used a length of wire should join this terminal with the screwed part of the lamp holder. A 6-volt Accumulator should be connected to the terminals 6 and 10. When the bull's-eye is struck the Couplings on the Curved Strip 4 make contact with the Bush Wheel 5, thereby completing the electrical circuit through the lamp and Accumulator.

To set the target, Wheel 7 should be turned so as to lift the Strip 4 and its Couplings from the wheel 5 so that they rest on the  $3\frac{1}{2}$ " Axle Rod, which can just be seen in the illustration. The Couplings are prevented from falling forward by two vertical 2" Strips placed one on each side of the Crank 3.

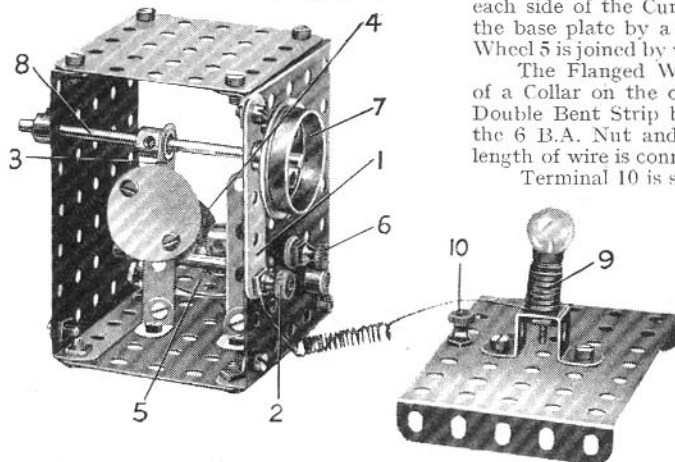

Model No. 30  
Motor Breakdown Crane

Parts required:

8	of No. 2								
2	"	2a							
2	"	3							
4	"	5							
2	"	6a							
2	"	8							
4	"	9							
7	"	10							
10	"	12							
1	"	15							
3	"	16							
3	"	17							
4	"	18a							
1	"	19s							
4	"	20a							
2	"	20b							
1	"	21							
1	"	22	2 of No. 48						
2	"	22a	1 " 48a						
2	"	24	3 " 48b						
1	"	26	1 " 52						
1	"	28	4 " 53						
1	"	32	2 " 54	3 of No. 63	4 of No. 111c				
8	"	35	1 " 57	2 " 77	1 " 115				
94	"	37	10 " 59	2 " 90	1 " 116a	1 of No. 147a	1 of No. 148		
7	"	38	1 " 62	2 " 90a	2 " 126a	1 " 147b	2 " 165		
					4 " 142a				

Fig. 30

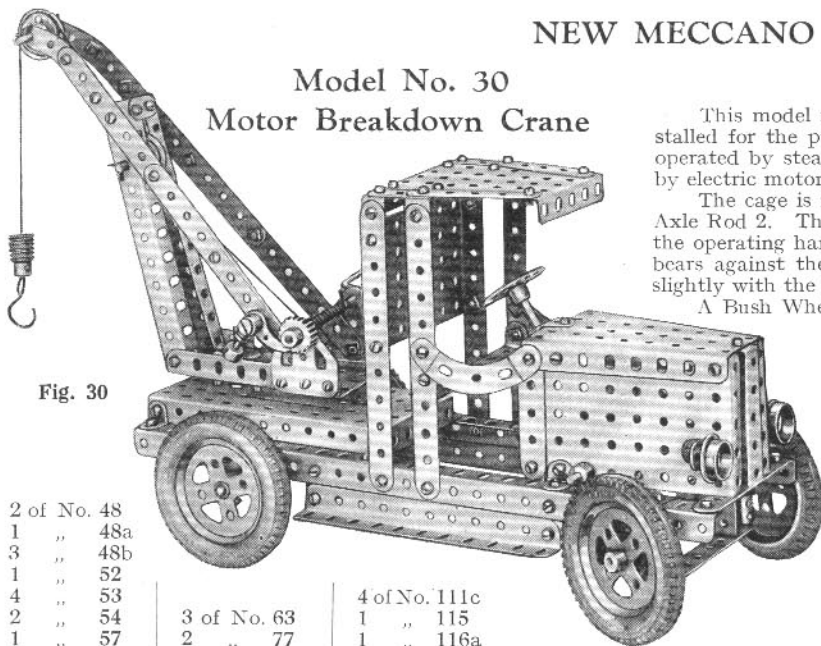

Bearings for the steering column 1 (Fig. 30a) are formed by a Flat Bracket and Coupling 2. A 2 1/2" Rod passes through the centre transverse hole of the latter and carries a 1 1/2" Contrate Wheel which is spaced by means of three Washers from the Coupling. The teeth of the Contrate are engaged by a 1/2" Pinion on the Rod 1. The Crank 3 carries a Flat Bracket bolted so that its round hole is over the elongated perforation of the Crank, and a bolt passed through both is screwed into the tapped bore of a Collar on a 2" Rod. This Rod is attached pivotally to the inner end of a stub axle by means of a swivel bearing formed from a Collar and small Fork Piece.

The front road wheels rotate freely on the 1 1/2" Rods, and are held in position by Collars. The Couplings 4 are pivoted by means of 3/8" Bolts to the extremities of two 4 1/2" Strips that are bolted together face to face to form the front axle. Two 1 1/2" x 1/2" Double Angle Strips 5 secure the 4 1/2" Strips to the side Girders of the model.

The constructional details of the crane proper will be made clear from a glance at Fig. 30. The load is raised or lowered by turning a Crank Handle that is journaled in Flat Trunnions that, in turn, are bolted to the flanges of the Flanged Plate that forms the base of the crane. The load is prevented from falling when the handle is released by means of a Pawl engaging a Ratchet Wheel mounted on the end of the Crank Handle.

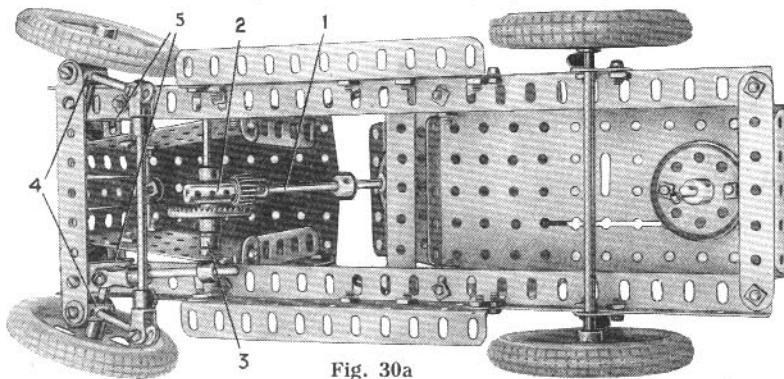

Fig. 30a

Model No. 31. Pit Head Gear

This model represents a type of headgear frequently to be seen at large collieries where it is installed for the purpose of hoisting or lowering the pit cages. In actual practice the gear is usually operated by steam driven winding engines, although in some of the modern mines the gear is driven by electric motors.

The cage is raised and lowered by the cord 1 which is wound between two 3" Pulleys on the 4 1/2" Axle Rod 2. The Rod also carries a further 3" Pulley which is provided with a Threaded Pin to form the operating handle, while a 5 1/2" Strip 3 secured by an Angle Bracket to the 5 1/2" x 2 1/2" Flanged Plate bears against the periphery of the Pulley and so serves as a brake. The Strip must be depressed slightly with the fingers whilst winding.

A Bush Wheel 4 on the Rod 2 carries a Threaded Pin that serves as the crank pin of a dummy engine, which is formed by a Sleeve Piece 5, fitted at each end with a 3" Flanged Wheel. The Sleeve Piece is mounted on a Pivot Bolt that is passed through its centre hole and lock-nutted to the Plate, being spaced from the latter by a Collar. A 2" Rod passes through the boss of one of the Flanged Wheels and carries at one end a Swivel Bearing, the "spider" of which is mounted loosely on the Threaded Pin. The bolts securing the Fork Piece to the "spider" should be provided with nuts to prevent their shanks gripping the Pin. A Crank Handle representing the exhaust steam pipe is secured by bolts passed through the Boiler and inserted in the tapped holes of a Coupling and a Collar.

Parts required:

10	of No. 1								
10	"	2							
4	"	3							
2	"	4							
8	"	8							
11	"	12							
1	"	12a							
1	"	15							
3	"	15a							
2	"	17							
1	"	19s							
4	"	19b							
4	"	20b							
1	"	22							
4	"	24							
88	"	35							
3	"	37							
1	"	38							
2	"	40							
2	"	48b							
3	"	52							
2	"	53							
4	"	54							
1	"	59							
2	"	63							
2	"	100							
1	"	115	2 of No. 162b						
1	"	147b	1 " 163						
1	"	162a	1 " 165						

Fig. 31

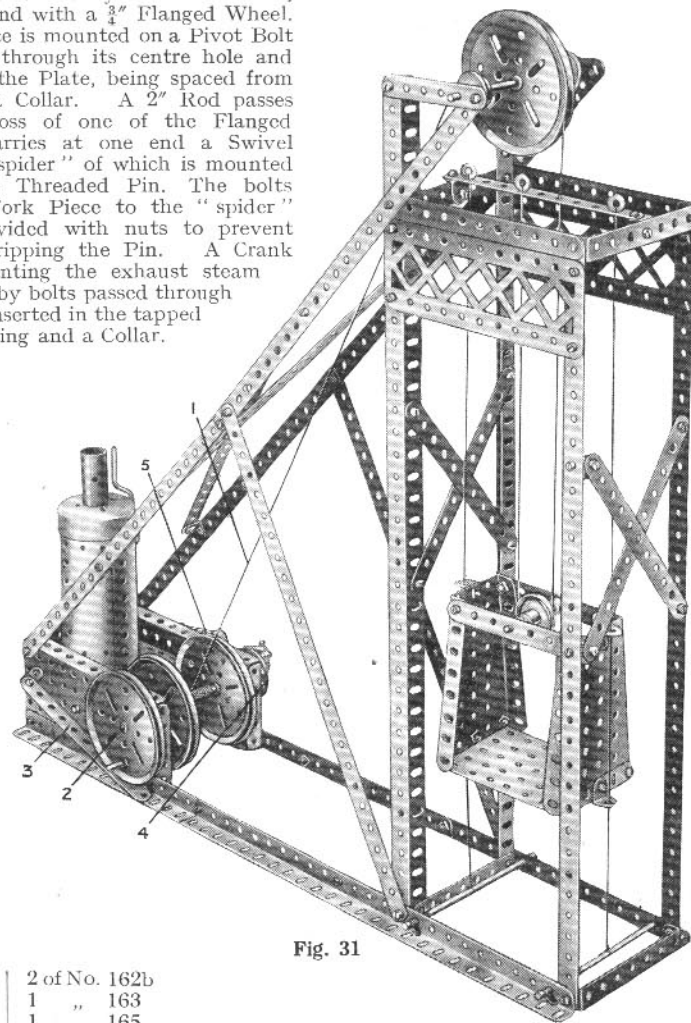



The Meccano movements shown on this and the following five pages have been selected from the "Suggestions Section" of various issues of the "Meccano Magazine." They are shown here because each movement is adaptable to a large number of models, and each should suggest to the keen Meccano boy quite a number of new models. The gear box illustrated below, for example, could be adapted to a Meccano motor car chassis and similar models incorporating variable speed gear boxes.

No. 1. Sliding Dog Constant Mesh Gear Box

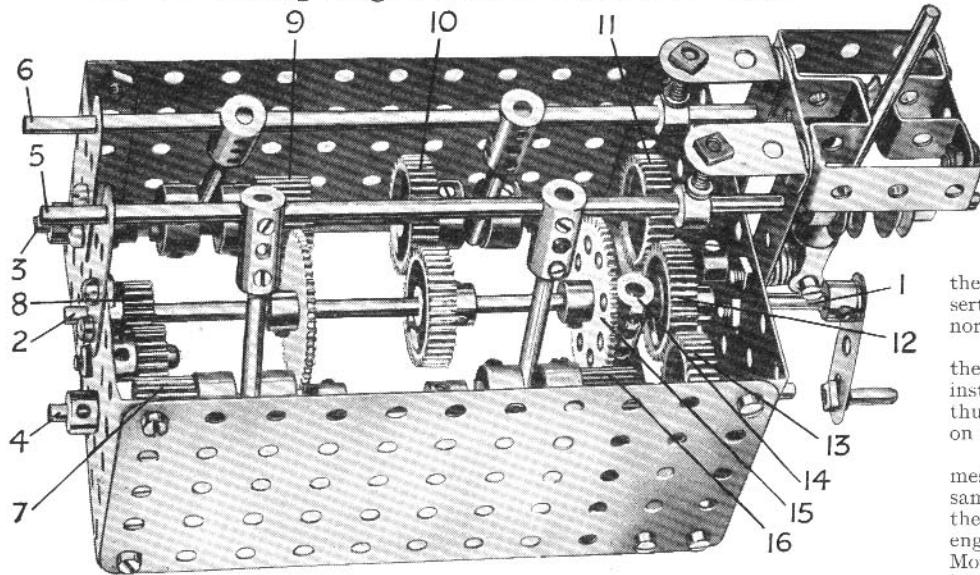

In this gear box the fact that the gears are in constant mesh reduces wear and facilitates gear-changing, while the employment of a "gate" change ensures that a particular gear cannot be engaged unless all the others are in neutral.

The shaft 1 is journaled in one of the end Plates and also half-way through the top transverse bore of the Coupling 14, which is secured to a Threaded Pin that, in turn, is secured to a 3 1/2" x 1/2" Double Angle Strip bolted to the side Plates of the gear box. The Rod 1 carries a 1" Gear 12 that meshes with the Gears 11 and 13 on the Rods 3 and 4.

The Rod 3 carries two sliding clutch units 9 and 10, the former of which comprises a portion of a Dog Clutch and a 1/2" diam. 1/2" face Pinion connected together by means of a Socket Coupling. The other member of the Dog Clutch is secured on the Rod. The unit 10 is similar but a 1" Gear is used instead of the Pinion. The two clutch units on the Rod 4 are identical, each consisting of a 1/2" diam. 1/2" face Pinion and one portion of a Dog Clutch held together by a Socket Coupling. Either of these engage at will with the appropriate fixed portions of the Dog Clutches on the Rod.

The "gate" in which the gear change lever moves, prevents a false change being made, and is composed of two 1 1/2" Strips, two Double Angle Strips and two Double Bent Strips, the entire assembly being attached to the end plate of the gear box. The gear lever is held in the boss of a Swivel Bearing and when moved sideways through the gate, engages between the pair of 1/2" fast Pulleys on either of the gear selector Rods 5 and 6; the latter may then be moved backwards or forwards to change gear. The selector Rods have short Rods secured to them by Couplings and engaging with opposite sides of the grooves of the Socket Couplings.

The device for locking each selector Rod after movement of the lever consists of a 1/2" Bolt mounted on a 1" x 1/2" Angle Bracket. The head of the bolt rests in the hole of a Collar secured to the rod to lock the gears in the neutral position. Matters must be so arranged that when both selector rods are in the neutral position, they are retained therein by the heads of the bolts of the locking devices falling into the holes of the Collars. It should then be impossible to move the gear lever across the gate, without first restoring it to the neutral position, thus preventing "jamming" and undue wear of the gear teeth.

No. 2. Demonstration Model of Bendix Drive

Not the least interesting part of a modern motor car is the Bendix pinion, which is designed to disconnect automatically the starting motor from the crankshaft of the engine immediately the latter starts. It will be readily understood that if no such provision were made, the starting motor would be driven at a very high rate of speed when the engine started, with disastrous results to the former. The action of this highly interesting device is completely demonstrated in the Meccano model shown below.

The Electric Motor is bolted to a frame, the construction of which will be apparent from the illustration. The Rod 1 is driven from the Motor through a gear train of 9:1 reduction ratio, and carries a Coupling that has a 2" Threaded Rod secured rigidly in its other end. The Bendix pinion unit 3 consists of a 1/2" Pinion to the boss of which a Threaded Boss is soldered. A Collar 4 is secured in the position indicated by a bolt passed completely through its set-screw holes and inserted in the Threaded Boss. The object of this is to add weight to the unit so that normally it may be screwed along the Rod without turning round, as in the actual gear.

When the Motor is set in motion in the correct direction, the unit will travel along the Rod toward the 57-teeth Gear 5 and eventually come into mesh with it. At this instant the Pinion butts up against the face of the Coupling and turns with the shaft, thus imparting motion to the 57-teeth Gear. The latter is fastened securely to its Rod on which is secured also a Flywheel.

The hand wheel 7 is connected by Sprocket Chain drive to a 57-teeth Gear 6 that meshes with a 1/2" Pinion on the flywheel shaft. If the Wheel 7 is turned by hand in the same direction as it is already being turned by the starting Motor, but at a faster rate, the Bendix pinion is caused to travel backwards along the Screwed Rod, and thus disengage itself from the 57-teeth Gear Wheel 5. This, of course, disconnects the starting Motor. The rotation of the hand wheel corresponds to the starting up of the engine in the actual device.

The model will be made more realistic and still easier to manipulate, if a simple push button switch is incorporated. A suitable switch for this purpose is included in the Electric Indicating Device (see Fig. 8).

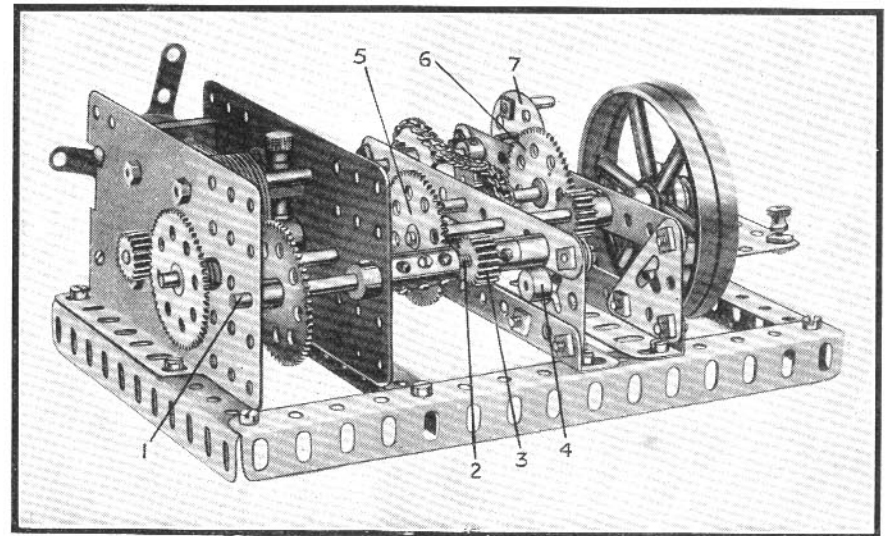

### No. 3. A Mechanical Screwdriver

The apparatus illustrated in Fig. 3 is designed to help in the erection or demolition of large Meccano models. The driving unit is a Meccano 6-volt Motor, the power of which is transmitted to the screwdriver unit through a flexible drive connection. A reduction ratio of 27 : 1 is employed between the armature spindle of the Motor and the screwdriver, the necessary reduction being obtained by the use of three  $\frac{1}{2}$ " Pinions and a similar number of 57-teeth Gear Wheels. One of the Pinions is mounted on the armature spindle and meshes with a 57-teeth Gear on a short Rod that carries also a second  $\frac{1}{2}$ " Pinion that, in turn, engages with a 57-teeth Gear. The latter is secured to another short Rod carrying a further  $\frac{1}{2}$ " Pinion that meshes with the 57-teeth Gear on the final driven shaft.

The screwdriver consists of a handle built up from Double Angle Strips bolted to two Bush Wheels, the blade 1 being journaled in one Bush Wheel and the driving Rod 3 in the other. The screwdriver blade used in the device is obtained from the Special Screwdriver (part No. 36b).

The blade carries at its inner end a  $\frac{3}{4}$ " Contrate Wheel that is secured in place by a  $\frac{1}{2}$ " Bolt 2 inserted in one of its set-screw holes. On the inner end of the Rod 3 a  $\frac{3}{4}$ " diam.  $\frac{1}{4}$ " face Pinion is secured, which together with the Contrate, forms a clutch. A Compression Spring 5 pressing against the face of the Bush Wheel keeps the Contrate Wheel normally out of engagement with the  $\frac{3}{4}$ " Pinion.

The flexible driving connection consists of a piece of Bowden wire cable 6 about 18" in length. (Bowden wire, which is used to operate the brakes of bicycles, etc., may be obtained from most cycle dealers for a few pence. The outer sheath is cut about 2" shorter than the inner wire in order that the latter may project an equal amount at each end. The projecting ends are now divided into two equal portions, which are formed into loops so that Bolts 7 may be passed through them and inserted in new style Collars, one of which is fitted to the driving Rod of the Motor and the other to the Rod 3 of the screwdriver. The sheath is clamped at each end by the jaws of End Bearings.

As the Bowden cable will not transmit a large torque, a means must be provided to "start" the bolts when undoing them and also to give the final "tighten up." The  $\frac{1}{2}$ " Bolt 2 secured in the boss of the  $\frac{3}{4}$ " Contrate Wheel is arranged to butt up against one of the Bolts 4 when the clutch is disengaged and when a slight twist is given to the handle. The movable portion of the screwdriver is now locked solid with the handle, thus enabling quite stubborn bolts to be loosened. When the handle is pushed down harder toward the blade the clutch is engaged, the blade is rotated rapidly, and the bolt quickly extracted.

Meccano boys should remember that they are following correct modern engineering practice in employing mechanical labour-saving tools whenever possible for their model-building.

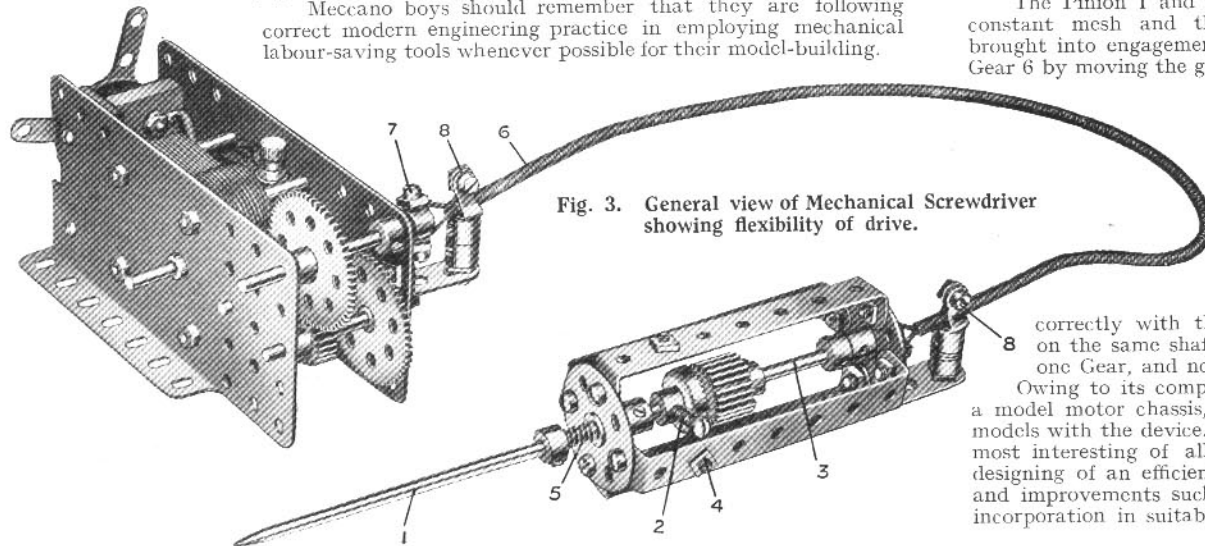

Fig. 3. General view of Mechanical Screwdriver showing flexibility of drive.

### No. 4. Grisen Gear Box

The model gear box illustrated in Fig. 4 possesses several features of interest, chief amongst which may be mentioned the very novel method of changing from one gear ratio to another.

A  $4\frac{1}{2}$ " Rod journaled in the  $3\frac{1}{2}$ "  $\times 2\frac{1}{2}$ " l-flanged Plates forming the sides of the gear box, is free to slide longitudinally. It has a  $\frac{3}{4}$ " Pinion 1 secured to it and also a Coupling in which is held a Rod representing the gear lever. The latter has two Couplings secured to it, one carrying a 1" Gear Wheel 2 by means of a Pivot Bolt that is inserted in one of its tapped holes, and the other, which forms the top of the gear change lever, has a 1" Rod 3 sliding freely in the end transverse bore. A  $\frac{3}{4}$ " Pinion 5, a 1" Gear Wheel (not shown in the photograph) and a 50-teeth Gear Wheel 6 are mounted at short distances apart on the Rod 4.

The Pinion 1 and the Gear 2 are in constant mesh and the latter may be brought into engagement with the 50-teeth Gear 6 by moving the gear lever with a combined vertical and lateral movement until the plunger Rod 3 of the gear change lever is enabled to fall into the end hole of the  $1\frac{1}{2}$ " Strip 7. This gives a reduction ratio between the driving and driven shafts. By placing the plunger rod in the end holes of the 2" Strip, as shown in the illustration, the 1" Gear 2 may be made to mesh with the other similar Gear on the driven shaft; this gives a ratio of unity. Lastly, when the plunger rod is made to drop into the hole of the Flat Bracket 8, the 1" Gear 2 and the  $\frac{3}{4}$ " Pinion 5 are engaged. A step-up ratio is now obtained.

The distance between the 2" and  $1\frac{1}{2}$ " Strips and the Flat Bracket should be carefully adjusted so that the Gear 2 meshes correctly with those on the shaft 4. The distance between the respective gears on the same shaft is also important; it should be carefully adjusted so that only one Gear, and not two at a time, are engaged.

Owing to its compact nature, the gear box is particularly suitable for inclusion in a model motor chassis, and model-builders should have little difficulty in fitting their models with the device. Gear box mechanisms in their many forms are probably the most interesting of all mechanical movements. In actual engineering practice, the designing of an efficient gear box is an exceedingly difficult problem and new inventions and improvements such as are suggested in the Grisen gear box are well worthy of incorporation in suitable Meccano models.

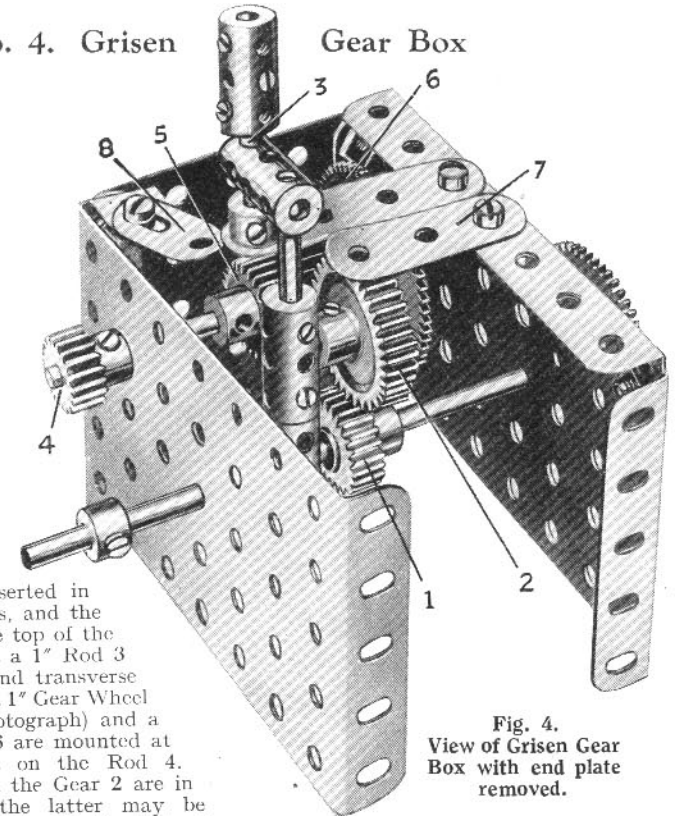

Fig. 4. View of Grisen Gear Box with end plate removed.



No. 5. Feathering Paddle-Wheel

In the early days of steam navigation the paddle steamer reigned supreme, but to-day all is changed. The screw steamship has ousted the paddle-wheel ship, except for a few that are engaged in coastal pleasure cruises and those which trade on shallow rivers such as the Mississippi.

There are two methods of fixing the "floats" in a ship's paddle-wheel. In the first the floats are clamped immovably to the spokes, and in the second they are actuated by a mechanism in such a manner that they remain practically perpendicular throughout their period of immersion in the water, and thus drive the vessel in the most efficient manner. Such a wheel is known as a feathering paddle-wheel, and represents a great advance on the fixed or radial float type of wheel.

The device shown in Fig. 5 is a demonstration model of a feathering paddle-wheel. Each rim of the wheel is composed of eight Channel Segments, connected together by  $3\frac{1}{2} \times \frac{1}{2}$ " Double Angle Strips, the retaining bolts of which serve to secure also the  $5\frac{1}{2}$ " Strips forming the spokes. Each series of spokes is bolted to a Face Plate that is secured to an  $11\frac{1}{2}$ " Rod 1 journalled in the back Girders of the demonstration frame. (Note that the Rod is not journalled in the front Angle Girder). In order to make the Rod more rigid a number of Couplings are mounted on it and secured thereon by their grub-screws.

The floats 2 each consist of two  $4\frac{1}{2}$ " Flat Girders, with a  $1 \times 1$ " Angle Bracket 3 at one end and a

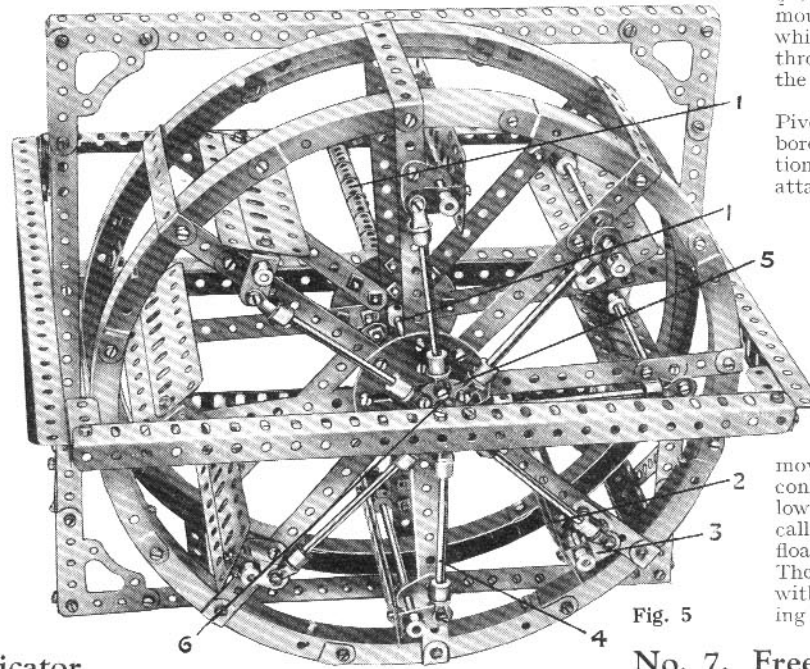

Fig. 5

$\frac{1}{2} \times \frac{1}{2}$ " Angle Bracket at the other. They are mounted pivotally in the wheel by means of Rods, which pass through both Angle Brackets and through  $1$ " Triangular Plates that are secured to the spokes.

A Bush Wheel 5 should next be mounted on a Pivot Bolt, that is inserted in the end transverse bore of a Threaded Coupling and secured in position by a lock-nut. The Threaded Coupling is attached to a  $1$ " Triangular Plate 6 by a Bolt passing into its tapped longitudinal bore.

The floats are all linked to the Bush Wheel 5 by Rods 4 fitted with End Bearings, which are attached freely (with one exception) to the Bush Wheel and to the  $1 \times 1$ " Angle Brackets 3. One of the Rods 4, which forms the exception, is secured as rigidly as possible to the Bush Wheel in order that the latter may rotate solidly with the paddle-wheel.

The axes of the Bush Wheel and paddle-wheel do not coincide, hence an eccentric movement is imparted to the system of links connected to the floats, thus giving to the three lowest floats in any position of the wheel a practically perpendicular position. In practice these floats would, of course, be immersed in the water. The mechanism also ensures that the floats meet with minimum resistance at the moment of entering the water.

No. 6. Gradient Indicator

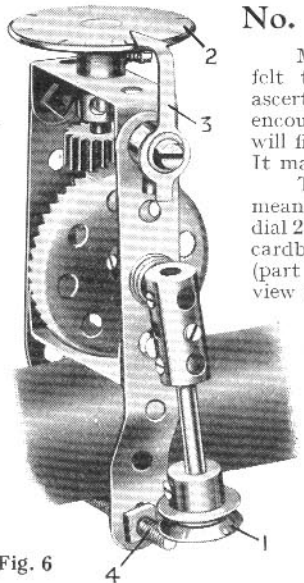

Fig. 6

Many Meccano boys who are cyclists must often have felt the want of some simple means whereby they might ascertain accurately the various changes in the gradients encountered whilst cycling or motoring, etc., and these boys will find the device shown in Fig. 6 very useful for the purpose. It may also be used in various other models.

The pendulum 1 consists of a short Rod that is secured by means of a Coupling to a Rod carrying a  $1\frac{1}{2}$ " Contrate Wheel. The dial 2 consists of a Bush Wheel, on which is stuck a circular disc of cardboard, suitably graduated. In the illustration the Pointer 3 (part No. 156) is shown partly cut away in order to expose to view the top end of the pendulum.

The spindle of the dial is journalled at its top end in a  $1\frac{1}{2}$ " Double Angle Strip and at its bottom end in the longitudinal bore of a Coupling that is mounted on the Rod carrying the  $1\frac{1}{2}$ " Contrate. A  $\frac{1}{2}$ " Pinion is secured on the dial spindle and meshes with the Contrate.

When complete, the device may be clamped to the top bar of the cycle by the  $2$ " Screwed Rod 4. Matters should be so arranged that the zero mark on the scale is opposite the Pointer 3 with the machine standing on a perfectly level surface.

The pendulum may be made longer than shown in the illustration in order to render it more sensitive to slight changes in the gradient.

No. 7. Free Wheel Clutch

The free wheel clutch illustrated comprises two  $3$ " Pulleys joined together by means of two  $2$ " Screwed Rods. Four nuts on each of the Rods serve to hold the Pulleys such a distance apart that two  $1\frac{1}{8}$ " Flanged Wheels 1 may be accommodated in the space between. The Flanged Wheels are bolted together face to face and secured on a  $3\frac{1}{2}$ " Rod that is free to turn in the bosses of the  $3$ " Pulleys.

A short length of Meccano Cord 2 is doubled and wrapped round the Wheels and the free ends are then passed through the loop and secured to one of the Screwed Rods as shown in the illustration. It will be found that when the  $3\frac{1}{2}$ " Rod is prevented from rotating it is possible to turn the  $3$ " Pulleys easily in one direction, but in the reverse direction considerably greater effort is needed.

This apparatus could be included in the drive of a model Big Wheel or roundabout so that when the Motor was stopped, instead of the model coming to an abrupt standstill and straining the gearing, it would come to rest gradually. Many other instances of the use of this device will occur to Meccano boys.

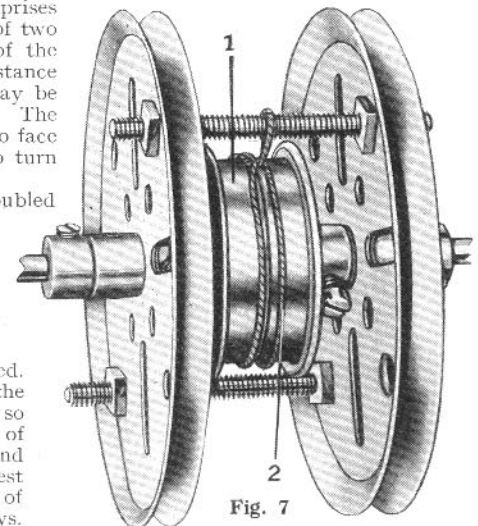

Fig. 7

## No. 8. Electric Indicating Device

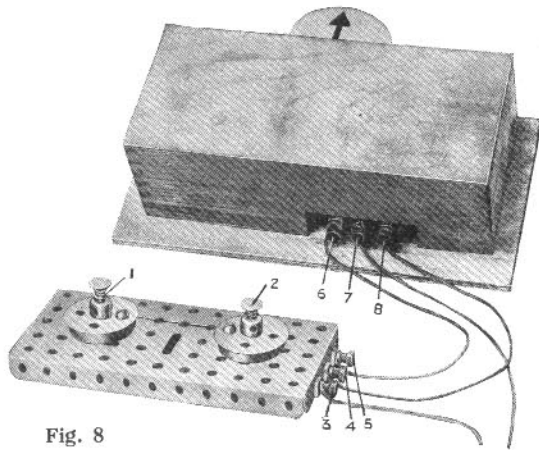

Fig. 8

The model illustrated in Fig. 8 is an electro-magnetic indicating device constructed entirely from Meccano parts, and we have little doubt that many uses for this model will suggest themselves to Meccano boys. One of the chief advantages of the device lies in the fact that it only uses current whilst the push switches are operated. Once the indicator has taken up a new position no current is used until it is required to change its position. Fig. 8 is a view of the complete device, and Fig. 8a shows the apparatus dismantled, revealing the solenoids and indicator mechanism.

Each of the operating solenoids consists of a Meccano Bobbin, 9, 10, wound to capacity with No. 26 S.C.C. wire. The completed Bobbins are covered with a layer of paper to protect their windings and they are then clamped between  $1\frac{1}{2}'' \times \frac{1}{2}''$  Angle Brackets in the position shown. A  $4\frac{1}{2}''$  Rod 11 is passed through the centre of both Bobbins, and a Worm is secured midway along its length. Care should be taken to ensure that the Rod works quite freely in the bores of the Bobbins. A short Rod, journalled in the top and bottom Plates of the device (the top Plate is shown removed in Fig. 8a) carries a Pinion in engagement with the Worm on the Rod 11, and on its upper extremity the pointer itself is secured. The latter consists of a piece of stiff card cut to the shape shown in the detail view and secured to a Bush Wheel. A small balance weight 12 is added to maintain the pointer in a state of equilibrium.

One end of the winding of the solenoid 9 is taken to the terminal 6 (Fig. 8a) and one end of the solenoid 10 to the terminal 7, whilst the remaining ends of the two solenoids are joined together and connected to the terminal 5. All three terminals must be insulated carefully by Insulating Bushes and Washers from the bare metal of the Plate.

The two push-button switches 1 and 2 are mounted together on a  $5\frac{1}{2}'' \times 2\frac{1}{2}''$  Flanged Plate. Each switch consists of a Flanged Wheel with the shank portion of a Spring Buffer working in its boss. The Flanged Wheel is secured by a  $\frac{1}{2}''$  Bolt to the Plate, immediately over an insulated 6 B.A. Bolt, so that when the Buffer is depressed, its end makes contact with the head of the 6 B.A. Bolt. Compression Springs, cut in half, normally keep the ends of the Buffers out of contact with the 6 B.A. Bolts. Each of the latter is connected by a short length of insulated wire to one of the terminals 3, 4, both of which are insulated. The terminal 5, however, is uninsulated.

One lead from the battery is taken to the terminal 3 and the other is attached to the terminal 7 whilst the terminals 4, 8, and 5, 6, are connected together by similar wire. The length of these wires may, of course, be varied as necessary. When completed the entire mechanism may be enclosed in a wooden case as shown in Fig. 8 and secured in such a position that the pointer protrudes through a slot cut in one side of the box when in the engaged position. In the disengaged position the pointer disappears inside the box.

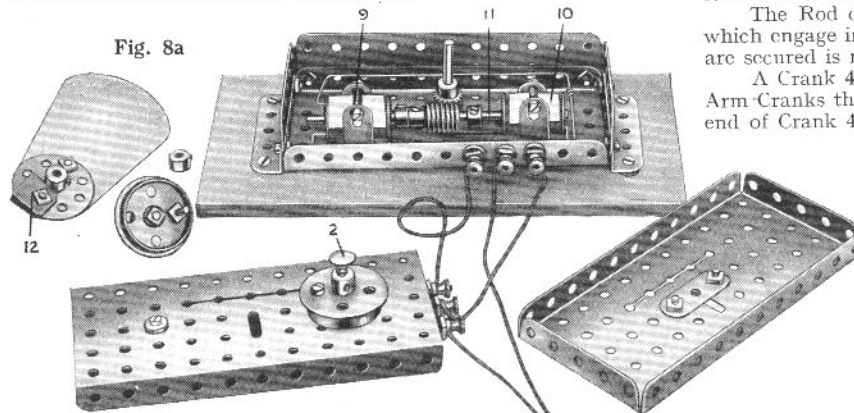

Fig. 8a

## No. 9. Automatic Gear Change

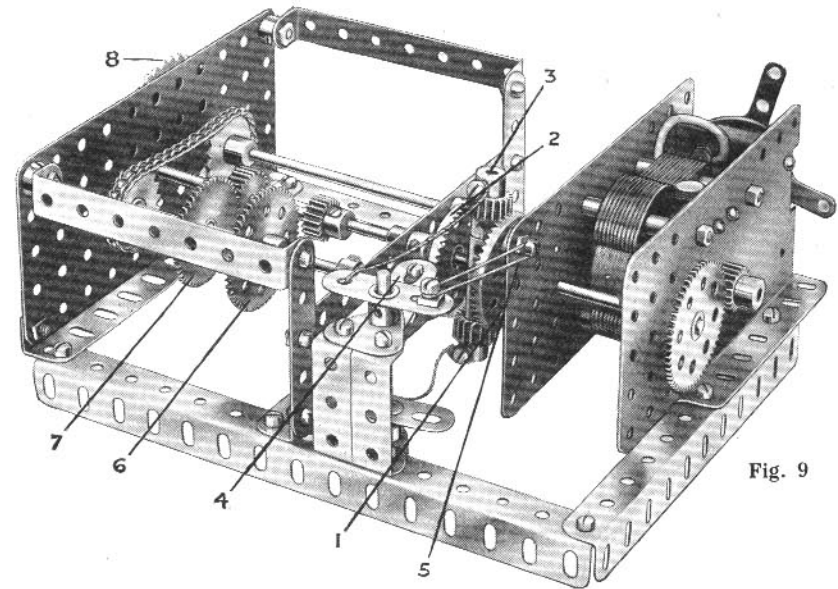

Fig. 9

One of the greatest difficulties that the beginner in motoring has to master is the art of changing gear, and realising this motor engineers have given much attention to the type of gear box that will facilitate gear changing. The device illustrated in Fig. 9 is a Meccano demonstration model of an automatic change gear box.

The Rod of the  $1\frac{1}{2}''$  Contrate Wheel 1 is driven from the armature spindle of the Electric Motor through a 3:1 reduction ratio. A similar contrate 2 is secured on a Rod that is journalled in the gear box in such a manner that its end is in line with the Rod carrying the Contrate 1. A Coupling with a  $1''$  Rod held in each end, is then placed loosely on the Rod, and a  $\frac{1}{2}''$  Pinion is mounted loosely on each Rod, being held in place by a Collar 3.

The Rod carrying the Contrate 2 has secured to it a  $\frac{3}{4}''$  and a  $\frac{1}{2}''$  Pinion, which engage in turn with the Gears 6 and 7 when the Rod on which the latter are secured is moved laterally in its bearings.

A Crank 4 is secured to a short vertical Rod that carries also two Double Arm-Cranks that are connected by short lengths of cord to the Collars 3. The end of Crank 4 is fitted with a bolt, the shank of which engages between two Collars on the sliding shaft.

A short piece of elastic 5, attached to the end of the upper Double Arm Crank and to the Motor, normally keeps the  $\frac{3}{4}''$  Pinion and 50-teeth Gear 7 in mesh but when an extra load is thrown on the device, the Pinions tend to climb round the Contrate 3, thus pulling over the Crank 4 and causing the lower gear to come into action.

The drive from the gear box is taken off the 2" Sprocket Wheel 8, which is secured to a Rod that is connected to the sliding Rod by a Sprocket drive.

An adaptation of this device would be very suitable for a Meccano model motor chassis. In this case the unit could be made much more compact than that shown in Fig. 9.



**No. 10  
Mine Cage  
Depth  
Indicator**

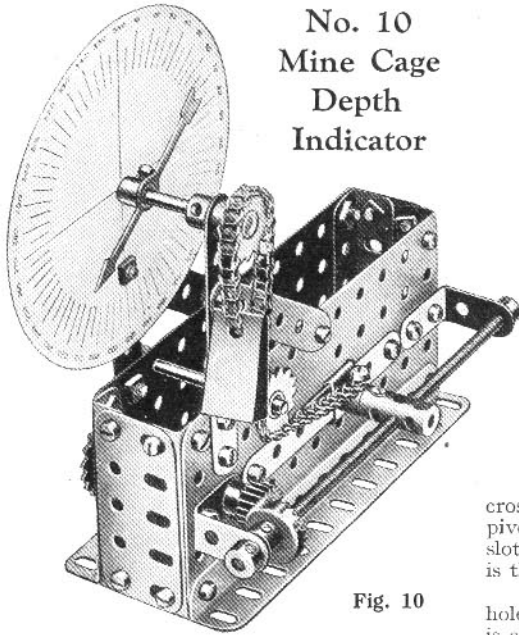

Fig. 10

This cage depth indicator will add interest to any Meccano model pithead gear. It consists of two Flat Plates, connected together by Angle Girders bolted to Flat Girders. The dial is part of a Theodolite Protractor (part No. 135) and should be marked off to represent feet or inches.

Two 1" x 1" Angle Brackets and a 3" Strip are secured to one of the side Plates, a Washer on each retaining bolt serving to space the parts from the Plate. Before fixing the Strip in place, however, an Eye Piece should be placed on it as shown.

A 1" Rod is secured in the boss of the Eye Piece, a Coupling being fixed on the projecting end of the Rod and a 4 1/2" Screwed Rod passed through the centre tapped bore. The Screwed Rod is journalled in the 1" x 1" Angle Brackets, and carries a 3/4" Contrate Wheel. A 1/2" Pinion on a Rod journalled in the Flat Plates, meshes with the 1" Contrate, and a 1" Sprocket Wheel connects it by Sprocket Chain to the model. A length of Chain is secured to the Eye Piece, led over a guide Sprocket and over the Sprocket on the Pointer Shaft, and then is finally attached to a 25 grammes Meccano Weight (Part No. 67).

**No. 11. Automatic Release Gear**

This is an ingenious device that may be fitted into any form of Meccano drop-hammer.

The drive is transmitted to the hoisting drum through a reduction gear of 2 : 1 comprising a 3/4" Pinion engaging with a 50-teeth Gear Wheel secured to the drum shaft. The drum consists of two 1 1/8" Flanged Wheels butted together, flanges inward.

The Worm 1 is fixed to the driving shaft and meshes with a 1/2" Pinion that is secured to a Rod journalled in two Trunnions. A Handrail Support 2 is fixed to this Rod, and when rotated, its shank engages periodically with a 1/2" loose Pulley 3, which is held loosely on the Rod 4 between two Collars.

This has the effect of pushing the Rod 4 to the left, thus throwing the 50-teeth Gear Wheel out of mesh with the 3/4" Pinion, and disengaging the drum from the driving shaft. Immediately the loose Pulley is released from the Handrail Support the spring on the Rod 4 returns the Rod to its original position, so re-engaging the 50-teeth Gear with the 3/4" Pinion, when the process is repeated.

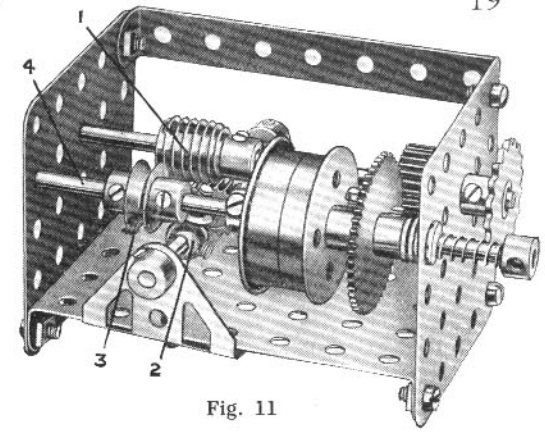

Fig. 11

**No. 12. Demonstration Model of "Servo" Motor Car Brake**

The device illustrated in Fig. 12 demonstrates the principle of the Dewandre power braking system, used on Daimler motor cars.

The 1" fast Pulley 1 is secured to a Rod driven from the armature spindle of the Motor through a gear train of 9 : 1 reduction ratio. A crossed belt of cord 3 is placed round the Pulleys 1 and 2. The latter Pulley is mounted at the bottom end of a 2" Strip 4, which is mounted pivotally on a 3/4" Bolt and spaced from the Plate by a Washer. To the upper end of the Strip is attached pivotally a 2" Strip and a 2" slotted Strip 6 bolted together. A 3/8" Bolt is inserted in the slot of the Slotted Strip and two Washers are placed on its shank; the bolt is then secured by double nuts and spaced so that the Strip can slide freely on its shank.

Pivoted to the link 6 is a 2 1/2" Strip 8 to which, in turn, is pivoted the 3" Strip 5, and also a 1 1/2" Strip 7 by a 1/2" Bolt in the bottom hole of the former Strip, a Collar and Washer on the shank of the bolt being used for spacing purposes. The upper end of the 1 1/2" Strip is connected pivotally to the two 1" x 1" Angle Brackets. A 2" Rod is suitably journalled and two Couplings are secured to its ends to form cranks. To one of these Couplings a 1 1/2" Strip 10 is attached pivotally and the centre hole of the latter is connected to the 3 1/2" Strip as shown. The brake cords are secured one to the Strip 10 and the other to the Coupling on the opposite end of the 3" Rod, and are then passed round the 1 1/2" Pulleys representing the brake drums. The arrangement is shown clearly in Fig. 12.

The bottom of the lever 8 is connected to a point in the belt 3 by a length of cord. When the pedal 9 is depressed the link 6 is moved to the left, thus swinging the 1/2" Pulley to the right. As a result of this movement the belt 2 is tightened round the Pulley 1 and the cord attached to the lever 8 commences to travel towards the left and drags with it the lever 8, thus adding considerably to the pressure on the 3 1/2" Strip representing the brake pull rod. The Motor should be running in the correct direction to ensure this result, of course.

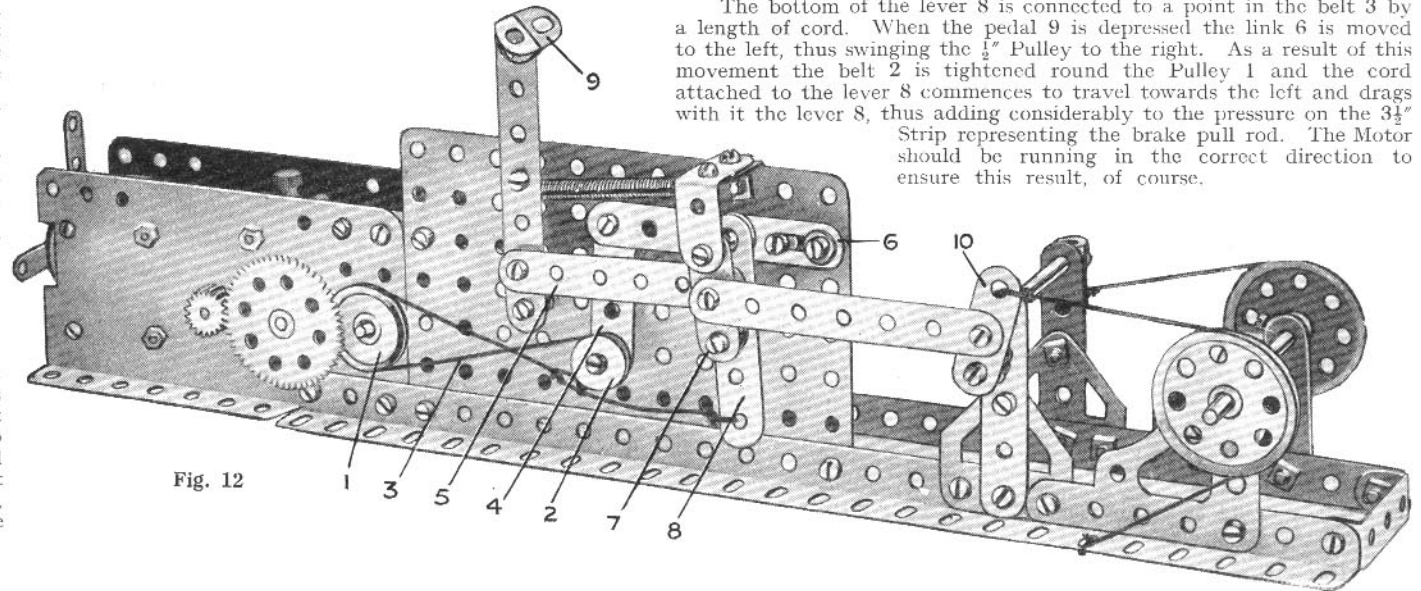

Fig. 12

## No. 13. Automatic Speed Change for Winding Gear

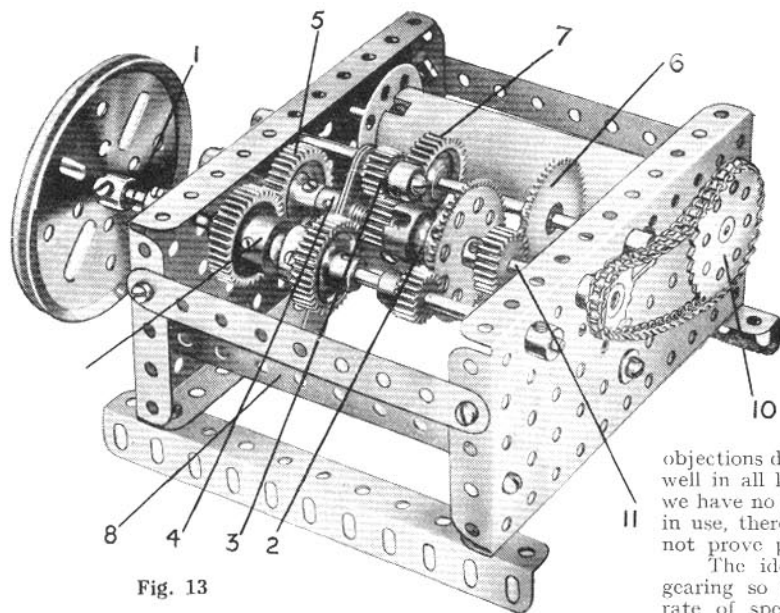

Fig. 13

One method of lowering the load attached to a crane hook is by throwing the hoisting barrel out of gear with the motor and allowing the load to descend under control of a brake. If this method is not practicable for reasons of safety or because of the dimensions of the load, it is necessary to lower the load by reversing the hoisting motor. This, however, causes unnecessary waste of power; also in many cases the load could safely be lowered at a greater speed than is possible when the motor is in gear with the winding mechanism.

The gear box shown in Fig. 13 provides an entirely new and very interesting method of handling the load in such a way that these objections do not apply. It should work extremely well in all kinds of Meccano cranes, and although we have no knowledge of a similar gearing actually in use, there seems to be no reason why it should not prove practicable.

The idea in brief consists in arranging the gearing so that the load is hoisted at a slower rate of speed than that at which the lowering operation is accomplished. The alteration in the

speed is obtained entirely automatically on reversing the direction of rotation of the Motor.

The Rod 1 may be termed the mainshaft of the gear box, for it is the one from which the various gears derive their motion. It carries a unit 9 which consists of two 1" Gears held together by a Socket Coupling. The unit is free to revolve on the Rod, and it is prevented from moving sideways by Collars. A  $\frac{1}{2}$ " Pinion is secured to the mainshaft in the position indicated in the illustration.

A 1" Gear Wheel 5 is fixed to a Rod 11 and next to it is a Double Arm Crank 4, freely pivoting on the Rod 11. This Crank carries a 3" Strip so that one of its arms is prolonged 2", and a  $\frac{1}{2}$ " Pinion 3 is free to turn about a  $\frac{1}{2}$ " Bolt on its shorter arm. Also on the Rod 11 is the unit 2, which consists of a  $\frac{1}{2}$ " Pinion and a 57-teeth Gear Wheel connected together by means of a Socket Coupling. The Pinion is in constant mesh with the Pinion 3 on the Double Arm Crank, and a Compression Spring is placed on the Rod between the Crank and the unit 2. The latter is of course free on the Rod 11. Finally a  $\frac{3}{4}$ " Pinion is secured to the Rod.

A third Rod journalled in the gear box carries a 50-teeth Gear 6 and 1" Gear 7, the latter being arranged to mesh with the  $\frac{1}{2}$ " Pinion 3 and the former with the  $\frac{3}{4}$ " Pinion on the Rod 11.

With the mechanism in the position shown in the illustration, the motion of the shaft 1 is transmitted via the  $\frac{1}{2}$ " Pinion and the 57-teeth Gear and  $\frac{1}{2}$ " Pinion of the unit 2, to the Pinion 3, which is in mesh with the 1" Gear Wheel 7. The 50-teeth Gear 6 and the  $\frac{3}{4}$ " Pinion with which it is in mesh brings the drive back to the Rod 11, and the motion of the latter is conveyed by means of Sprocket Chain to the Sprocket Wheel 10 on the winding shaft. The unit 9 revolves idly. The hoisting drum now rotates slowly and the cord should be wound round it in such a manner that the crane hook is raised.

When the direction of rotation of the shaft 1 is reversed the Crank 4 will swing over and come into engagement with the Gear Wheel of the unit 9, and the drive will then be transmitted via the unit 2, which is constantly driven from the  $\frac{1}{2}$ " Pinion on the Rod 1, and the unit 9, to the 1" Gear Wheel 5, which is secured to the Rod 11. The hoisting drum now rotates at a greater speed, lowering the load. The Compression Spring on the Rod 11 presses the boss of the Double Arm Crank lightly against that of the Gear Wheel 5 and thus aids the Crank to swing over when the direction of rotation is changed. The movement of the Crank is checked at each end of its swing by the end of the 3" Strip coming into contact with a  $4\frac{1}{2}" \times \frac{1}{2}"$  Double Angle Strip; one of the two Double Angle Strips required may be seen at 8. This prevents the  $\frac{1}{2}$ " Pinion 3 jamming itself between the 1" Gears that it drives. The device may be incorporated in practically any type of Meccano crane.

## No. 14. Electric Solenoid-operated Brake

The solenoid-operated brake shown in Fig. 14 is in electrical connection with the Motor and functions immediately the current supply is cut off. Such a brake would prove useful as a safety measure in model lifts, cranes, etc.

A 1" fast Pulley 1 shod with a Rubber Ring (part No. 155) is secured to a Rod driven off the armature spindle through suitable gearing. Two 1" fast Pulleys 2 are fastened rigidly to  $1\frac{1}{2}"$  Strips which are attached pivotally by lock-nuts at their upper extremities to 2" Strips 3, and at their lower ends are mounted loosely on lock-nutted bolts attached to the side plates of the Motor. The other ends of the links 3 are attached pivotally to the 2" Slotted Strip 4, the slot in which engages with the shank of the  $\frac{3}{8}"$  Bolt 4a. The Strip 4 also is attached to a  $4\frac{1}{2}"$  Strip that is connected to the plunger of the solenoid 5. This Strip pivots about a lock-nutted bolt secured to a Trunnion on the Motor side plate in the manner indicated.

The solenoid 5 consists of a Meccano Bobbin wound with four layers of 23 S.C.C. Wire. One end of the finished coil is taken to the insulated terminal 6 and the other is connected to the frame of the model. One of the Motor terminals also is connected to the frame, the other being connected to one Accumulator terminal; terminal 6 is connected to the other terminal of the Accumulator.

When the Motor is running the current is flowing through the solenoid, and the plunger is held in the raised position. Immediately the current is switched off the solenoid loses its holding power, and the plunger and lever drop down. This causes the short end of the lever to rise, bringing the Pulleys 2 to bear against the Rubber Ring, so applying the brake and bringing the rotating shaft to a standstill.

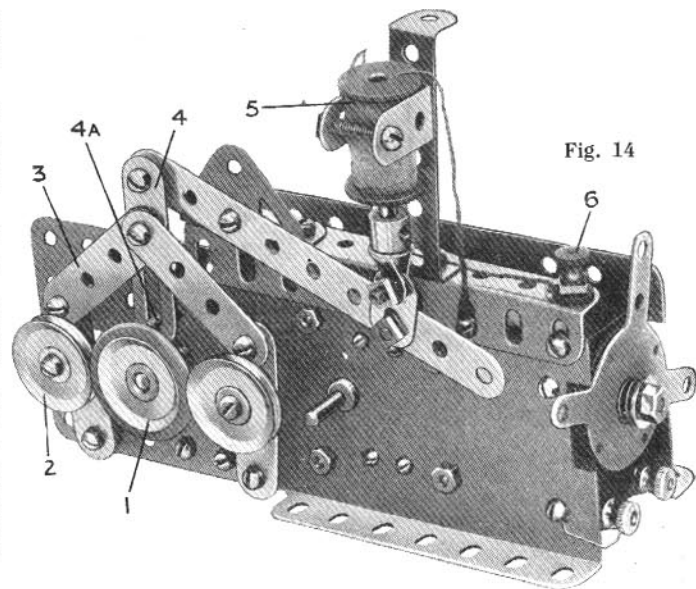

Fig. 14



### Hundreds of Prizes for Meccano Boys

Every Meccano boy who likes to build up models from his own ideas should enter the special Model-building Competitions that are announced each month in the Meccano Magazine. These contests afford the Meccano boy the valuable opportunity of measuring his model-building ability with that of his fellow Meccanoites. In addition, there is the chance of winning a valuable cash prize or a very useful quantity of Meccano or Hornby Train Accessories.

Full details of new competitions are announced each month in the Meccano Magazine. There is nothing whatever to pay and no special entrance forms are necessary. The type of models to be submitted in each competition is fully described in the competition announcement in the Magazine.

It will interest intending competitors to know that it is not necessary to send an actual model, a good photograph is all that is required, or a drawing will do provided care is taken in drawing the details. If the model is very intricate, then a written description of the mechanism may be advisable. That is all there is to do in order to compete for the splendid prizes offered.

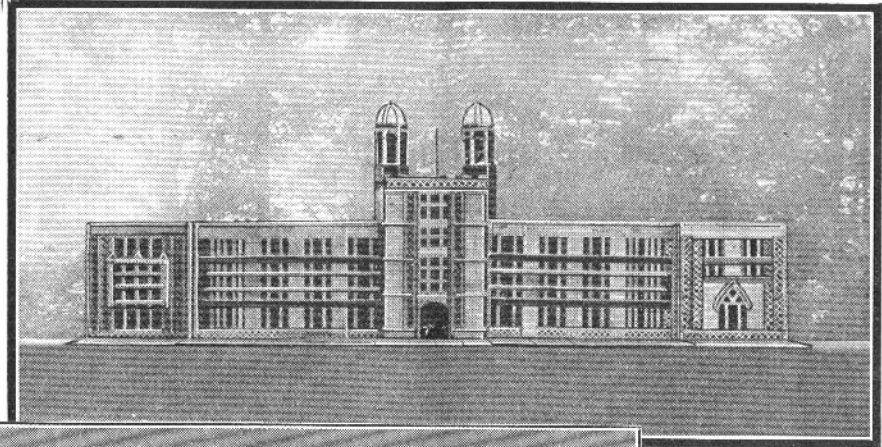

Right: A fine prize-winning model of a Triple Expansion Marine Engine, built by L. W. Grey (East Ham, London). Below: Meccano Tram Steamer, by E. Roberts (Southampton),

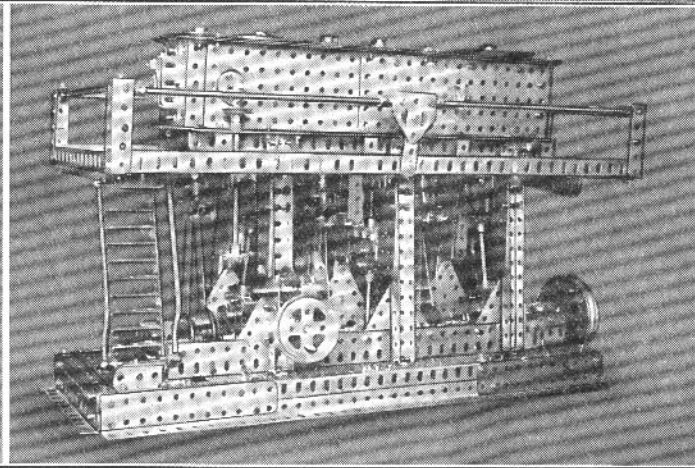
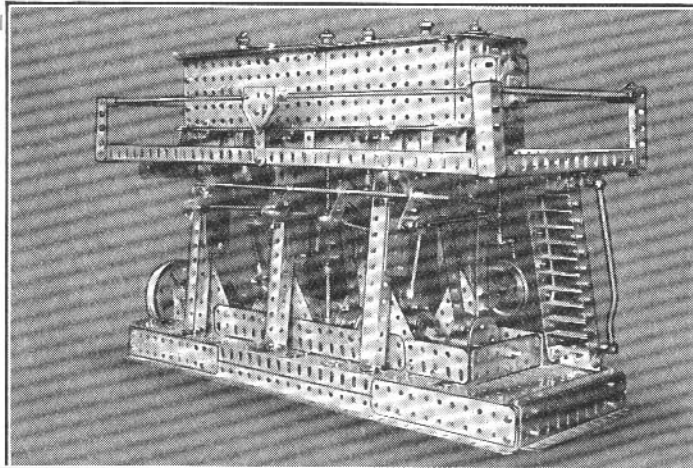

This Meccano model of Stonyhurst College was built by the boys of Hodder Place, the Preparatory School for Stonyhurst College, near Blackburn.

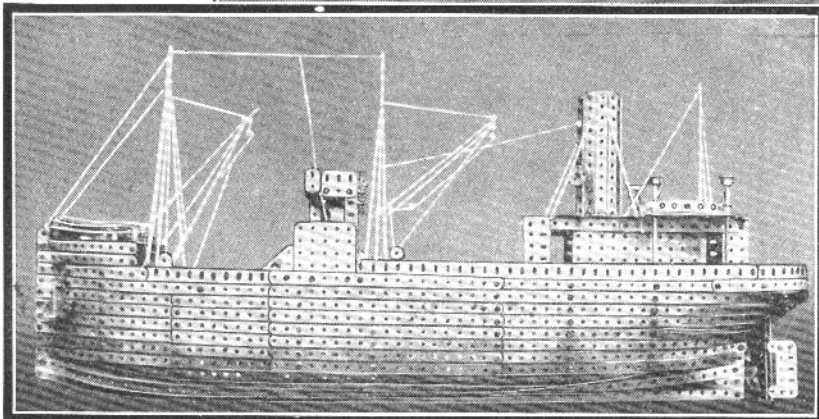

### It is Easy to Build Meccano Models

Many boys seem to be under the impression that in order to win a prize in a Meccano model-building contest one must be something of an inventive genius! This is a mistaken idea, however, for any boy of average intelligence can enter the competitions with the knowledge that he has a good chance of winning a prize.

All models submitted, of course, must be new. That is, a competitor must not copy models from the Meccano Instruction Manuals, or any other Meccano publication.

Prize-winning models, if suitable, are included in various Meccano publications, and are also described in the Meccano Magazine, so that a competitor's model may be rebuilt again and again by Meccano boys all over the world! This in itself will be regarded by most Meccano boys as a sufficient reward for the labour involved.

On this and the following three pages we illustrate a few of the prize-winning models entered in recent competitions.



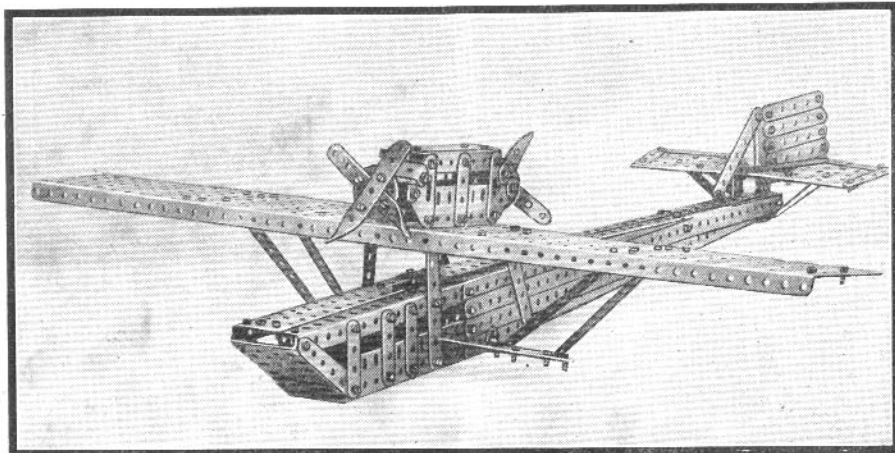

Above: A particularly well-built model of a Dornier Super Whale Flying Boat, constructed by Philip Lyth of Newcastle, Staffs. Below: An original model of a Canadian Logging Tractor. It is the work of J. A. Rodriguez (London), and secured one of the biggest prizes in the £100 Model-building Competition, 1929. The model employs caterpillar track and the drive is so arranged that when the front sled is turned to either right or left the corresponding caterpillar is disengaged from the main drive, thus facilitating steering.

The realistic appearance of the Electric Shovel shown on the right will at once be noted. It was built by J. L. Aguilar (Barcelona), and secured a prize in a recent "M.M." contest.

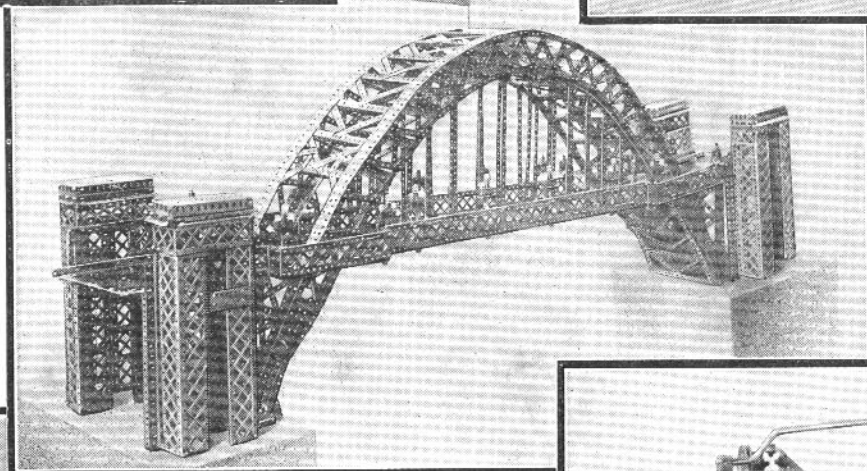
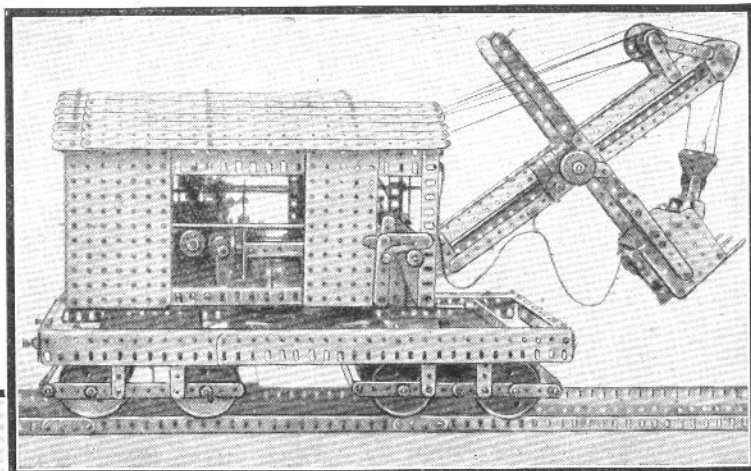

The remarkably fine model shown in the centre of the page represents the new Tynce Bridge at Newcastle. It was built under the direction of Mr. G. W. Horn of the Halford Cycle Co. Ltd. Proof of its excellence is shown by the fact that it has received high commendation from Dorman, Long and Co. Ltd., the builders of the actual bridge.

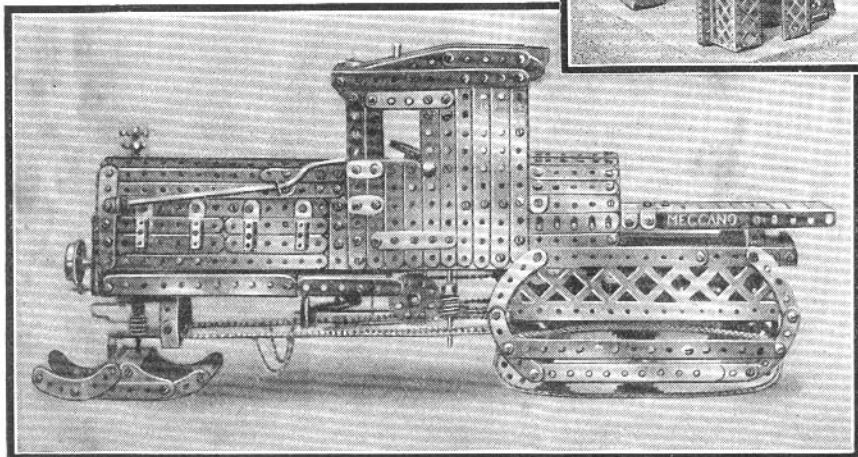

A link with the past! An interesting prize-winning model of an 1894 P. and L. car. It was built by N. B. Scott (Winnipeg, Canada), and secured a prize in a recent model-building competition.

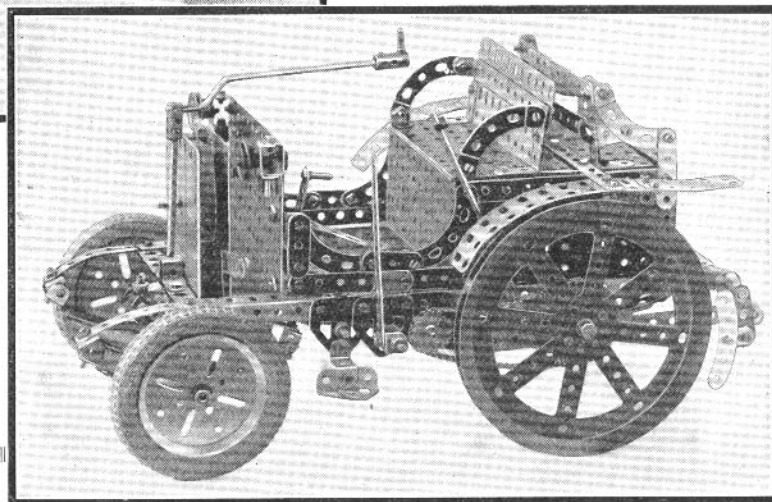

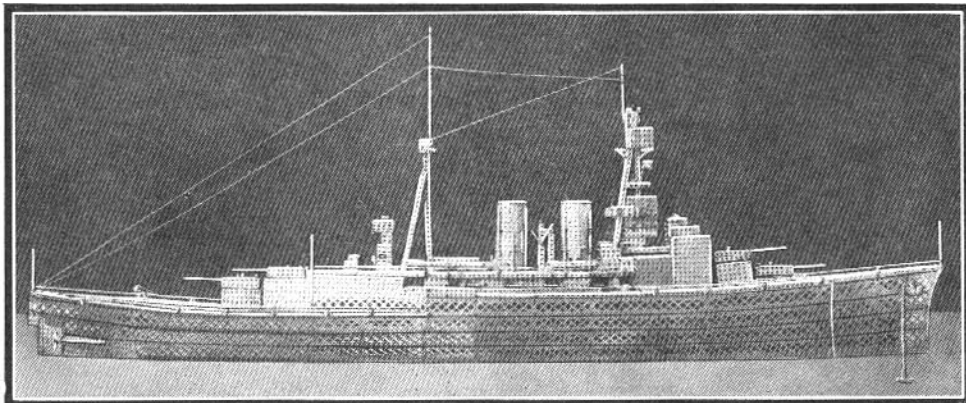

THE prototype of the remarkable model warship illustrated above is the famous battleship H.M.S. "Hood," the largest warship in the world. Some idea of the splendid proportions of this model will be obtained by noting the number of Braced Girders that comprise one side of its hull, but when it is mentioned that the builder in completing the model used no less than 1,300 nuts and bolts, the immensity of the task will be better understood. Owing to the large size of the model, the builder was able to incorporate a considerable amount of detail in the deck fittings, gun-turrets, etc. It will be noted that these portions have been constructed with great care and accuracy and are devoid of all "scrapiness." The model was built by Clarence Robinson, of Milton, Otago, New Zealand.

**"The Flying Scotsman"**

The composite illustration in the centre of this page shows a remarkable model of the famous L.N.E.R. passenger express locomotive, the "Flying Scotsman." It is the work of R. S. Miller (Newark), a Meccano enthusiast who has constructed many distinguished models. The dimensions of the various units of the engine and tender have been accurately scaled and the constructional details have been so well carried out that quite a good idea of the power, grace, and speed suggested by the appearance of the actual locomotive is reflected in the model. The tender as will be seen from the front and

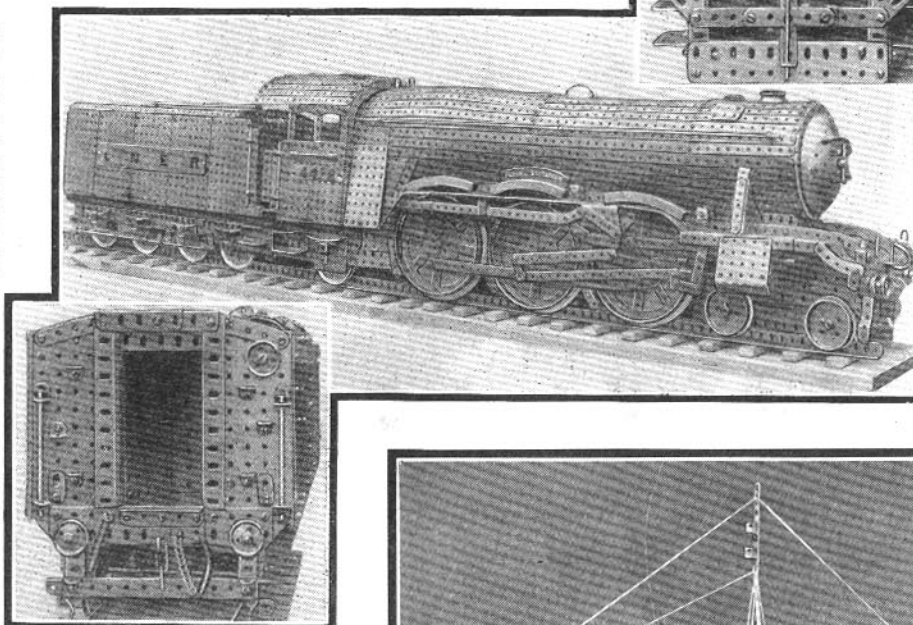

back views included in the illustration, is modelled on the latest corridor type which has been introduced to make possible a change-over of the engine crew during the long daily run which this famous express performs.

**Steam Trawler**

Illustrated at the foot of this page is a particularly faithful reproduction of a steam trawler constructed by T. M. Baskcomb (Grimsby) who won a prize in the £100 Model-building Contest, 1929. The lower portion of the hull has been omitted so that the model when placed upon a table, has the appearance of being "well down in the water." Special notice should be paid to the many deck fittings, the construction of which has been carried out with considerable dexterity.

A small windlass "weighing," or "casting" the anchor will be seen near the prow of the boat, while the large trawl winch for hauling and paying out the trawl net is placed amidships. The model is mounted on four Flanged Wheels, the rear pair acting as "steering" wheels. The helm, represented by a Bush Wheel, is connected by Bevels to a vertical shaft, on the lower end of which a Double Arm Crank is secured, and lengths of Sprocket Chain are connected to the arms of this Crank and also to the rear wheel axle.

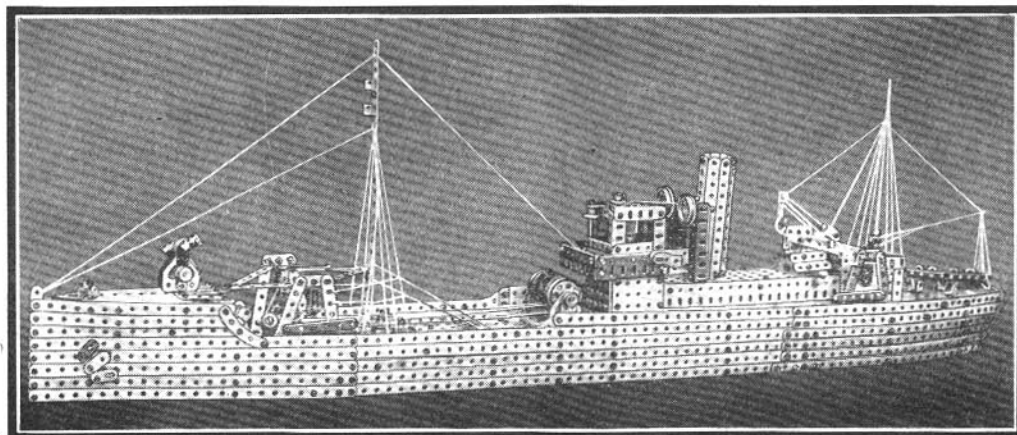



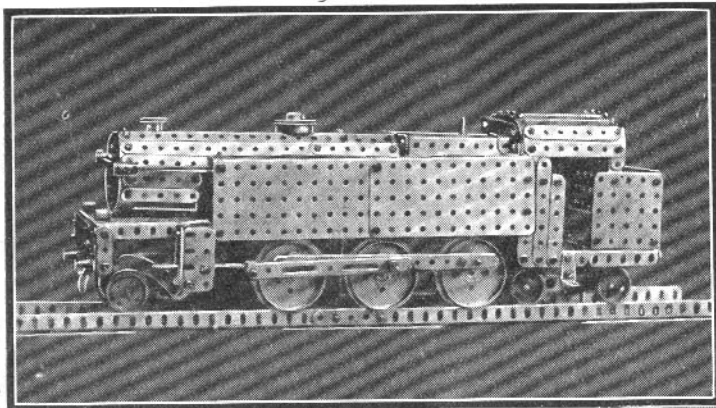

Left: A Meccano model 2-6-4 "River" class Southern Railway Tank Engine. It was built by Donald Martin, Shifnal, Salop. If fitted with a Motor, a model of this type will provide many hours of fun.

Right: A full-rigged model sailing ship constructed by Leslie Hope of Weston-super-Mare. The framework and masts of this excellent vessel are constructed entirely from Meccano parts, while the sails, which consist of white cardboard, give a lifelike touch to the finished ship. Below: A Steam-electric power plant built by E. H. Bradshaw, Sheffield. The engine is driven by a Meccano Electric Motor hidden inside the Boiler.

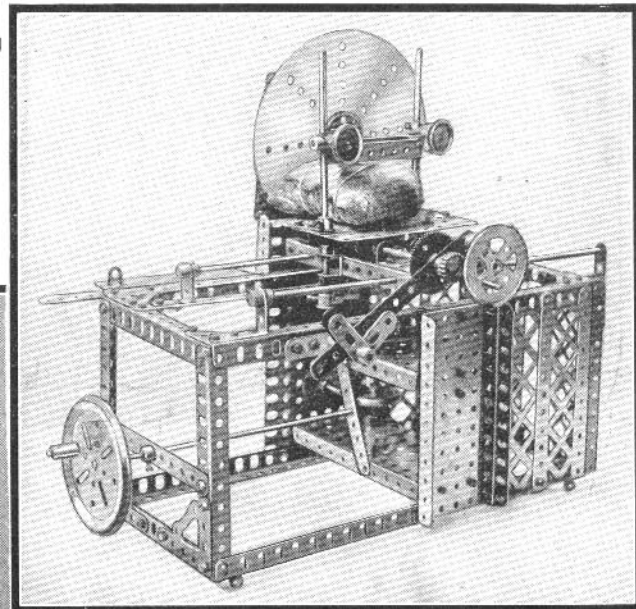
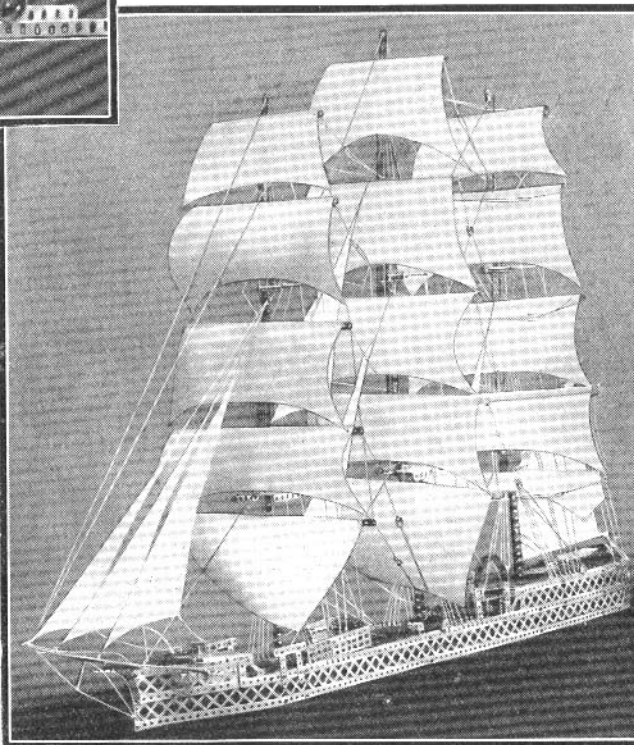

The bacon slicing machine shown above is the work of S. G. Couch, Napier, N.Z. The mechanism whereby the carriage is given an oscillating motion consists of a Face Plate rotated by means of the hand wheel, and having a Strip bolted to it, the other end of the Strip being attached pivotally to a second Strip bolted to the bacon carriage.

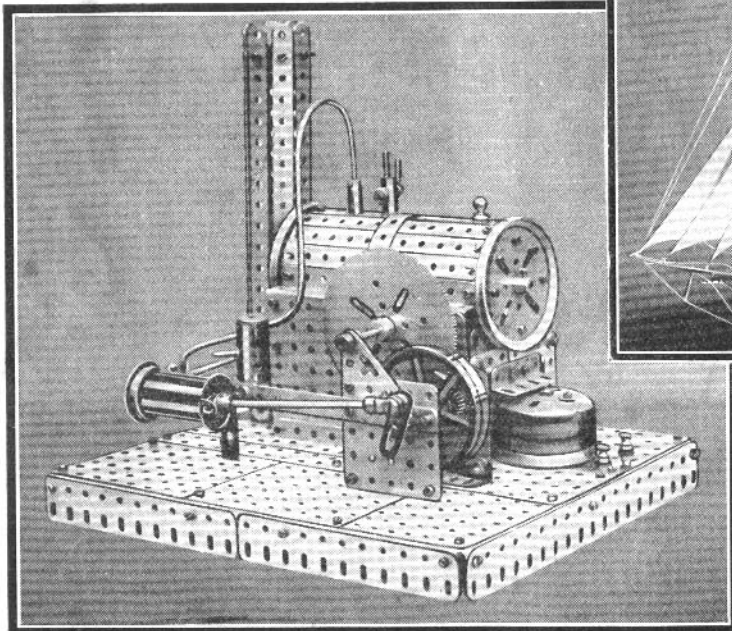

Nowadays a fire fighter is able to make use of a handy motor cycle outfit for conveying him and his equipment to the scene of an outbreak. The photograph reproduced on the right shows a cleverly constructed model of one of these machines. This splendid example was built by R. W. Baker, of Twickenham.

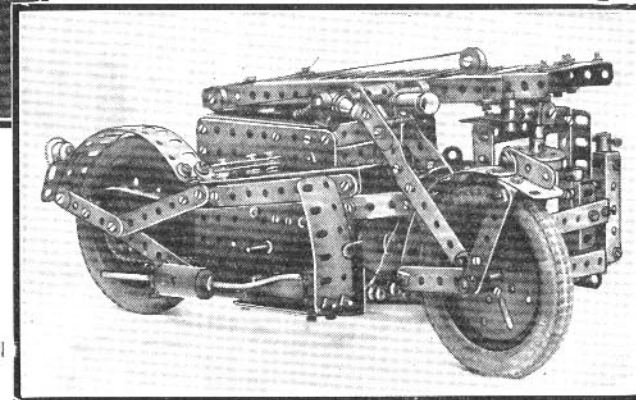



# USES FOR MECCANO PARTS

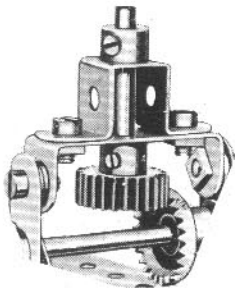
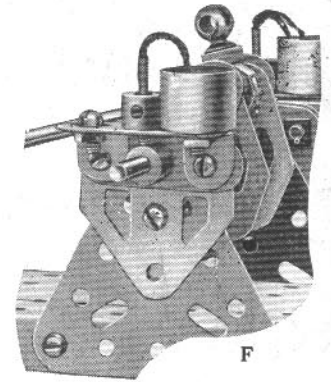
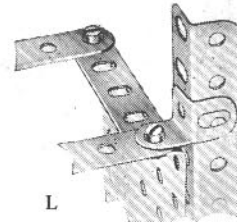
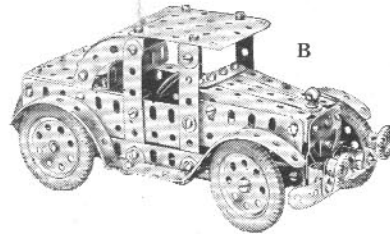
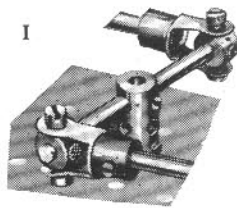
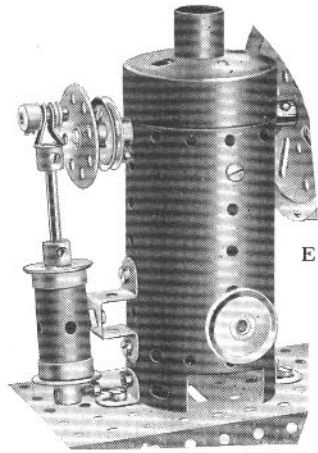

- Here are a few suggested uses for some of the newer Meccano parts. Each example will probably suggest innumerable other instances in which the particular part may be employed.
- (A) A typical Meccano free-wheel movement employing two Paws and a Ratchet Wheel.
- (B) Meccano Dunlop Tyres are now available in four sizes, viz. 1", 1½", 2" and 3½" internal diameter. The illustration shows a miniature car equipped with 1½" diam. tyres.
- (C) ½" and 1½" Bevel Gears, used as part of the steering mechanism of a motor chassis.
- (D) No. 118, Hub Disc. This part is admirably suited to form a flywheel or large travelling wheel. It is here shown in use as a rear travelling wheel of the Meccano Traction Engine.
- (E) No. 162, Boiler, can be used in Meccano locomotives, stationary engines and numerous other models of a similar type. With one Boiler End removed it may be incorporated in a model as a vertical boiler or with both ends closed it will serve equally well as a horizontal boiler. The illustration shows it in the former capacity.
- (F) No. 164, Chimney Adaptor, can be used for innumerable purposes. Here it is shown as the oil receptacle in a Meccano syphon lubricator.
- (G) A realistic cylinder formed from two ¾" Flanged Wheels and a Sleeve Piece (part No. 163).
- (H) The Geared Roller Bearing (part No. 167) makes easy the construction of large models of the swivelling type, such as a Hammerhead Crane, Dragline, etc.
- (I) Two Swivel Bearings used to convert a "thrust" on a sliding lever to a "pull" on another lever.
- (J) A ½" Pinion engaging a 1½" Contrace Wheel forms a handy means of transmitting motion from one shaft to another at right-angles to the driven shaft.
- (K) No. 45, Double Bent Strip. Is invaluable for use as a reinforced bearing for Axle Rods.
- (L) Corner Angle Bracket, used as a guide shoe for a lift cage. The Bracket is secured by one of its flanges to the top of the lift cage, thus leaving the other two flanges free to slide against the Girder which forms one of the guides for the lift.

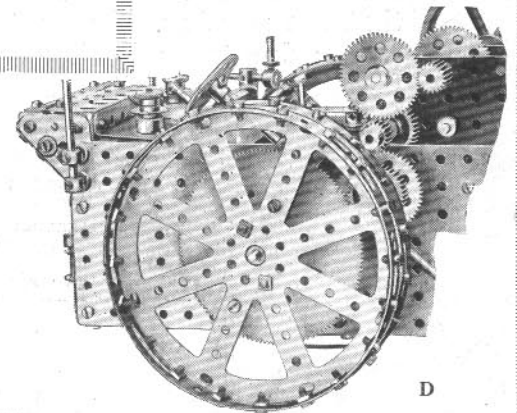
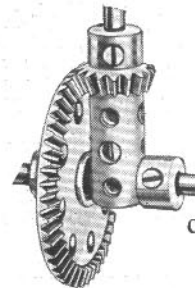
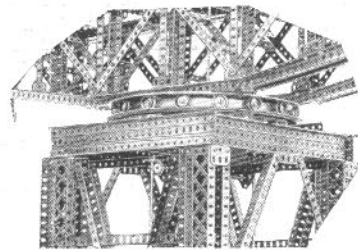
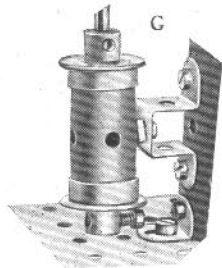
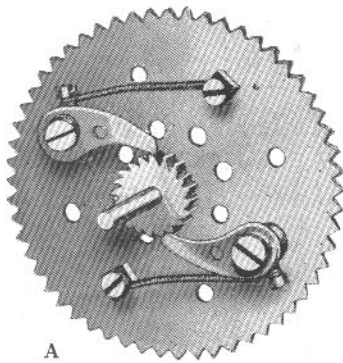
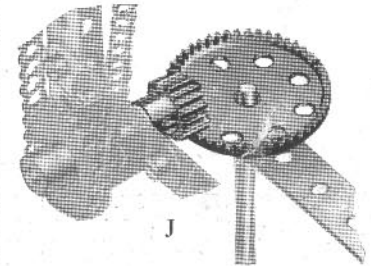



# MECCANO

# MAGAZINE



Price 1/2

Price 1/2

## A Fine Engineering Monthly for Boys

The "Meccano Magazine" is the Meccano boy's newspaper. He reads it regularly and corresponds with his friend the Editor when he feels inclined.

The Magazine tells him of the latest Meccano models; what Meccano Clubs are doing; how to correspond with other Meccano boys; the Competitions that are running. It contains splendid articles on such subjects as Railways, Famous Engineers and Inventors, Electricity, Bridges, Cranes, Wonderful Machinery, Aeroplanes, Latest Patents, Radio, Stamps, Photography, Books and other topics of interest to boys, including suggestions for new Meccano parts

and correspondence columns in which the Editor replies to his readers' enquiries. The publishing date is the 1st of each month.

Write to the Editor, "Meccano Magazine," Old Swan, Liverpool, England, enclosing 1/2 in stamps. He will then forward a specimen copy of the "M.M.", post free. If you wish to become a regular subscriber the rates are 8/- for six issues or 16/- for twelve issues, post free.

If you prefer to do so, you may order the Magazine from your Meccano dealer or from any newsagent or bookstall, price 1/2. *Place a standing order to-day.*

*Meccano and Hornby Train Agents in Australia:*

**E. G. PAGE & CO., 52, Clarence Street, SYDNEY (P.O. BOX 1832K)**

*Published by*

**MECCANO LIMITED, LIVERPOOL, ENGLAND**