

MECCANO

STANDARD MECHANISMS

STANDARD
MECHANICAL MOVEMENTS
CONSTRUCTED AND
DEMONSTRATED WITH
MECCANO

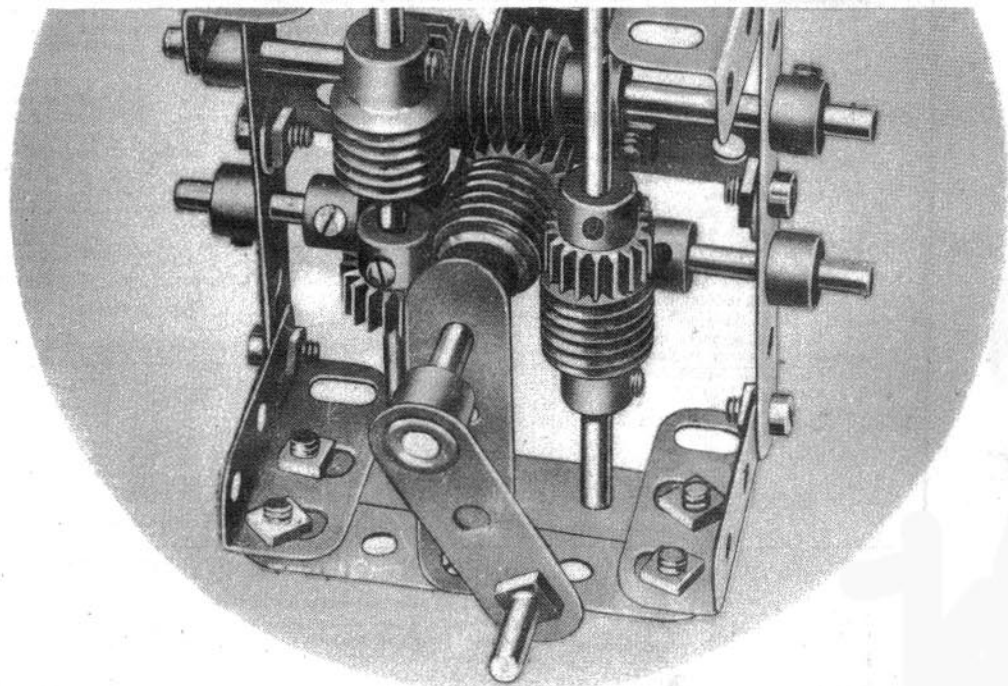

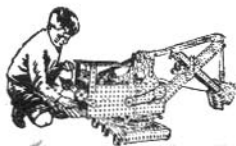

MODEL BUILDING WITH MECCANO

Real Engineering in Miniature



THE JOY OF INVENTING

This book has been published with the object of showing the endless possibilities of Meccano for producing practically every mechanical device and movement that is used in actual engineering practice.

The wide range of models illustrated in the Instructions Books included with every Meccano Outfit was specially selected to make clear the Meccano methods of construction, and to provide suggestions for models coming within the scope of each Outfit. Very few Meccano boys are content to build only the models shown in our Books however. When they have constructed these they begin to experiment and to build models based on their own ideas, and in doing so they become in the true sense of the word—inventors. There is nothing to be compared to the joy of creating something new, and inventing new models and movements in Meccano is a most fascinating pastime.

With this in mind, and to assist Meccano boys to base their models on correct engineering practice, we have collected and classified a number of Meccano mechanisms, which have to a certain extent become standardised. That is to say these mechanisms may be applied to more than one kind of model—in many cases without any alteration to the standard movements, but in a few instances with some slight modifications.

Boys who wish to launch out and build models to their own design will find these movements, which we now publish as "Standard Mechanisms," of great assistance in helping them to work out their ideas. The various devices described are arranged so that immediate reference may be made to any particular mechanism that it is desired to incorporate in a model.

THE VALUE OF MECCANO

When you build models with Meccano you use real engineering parts in miniature, for they act in a manner precisely similar to the corresponding elements in actual engineering practice. This means that with Meccano it is possible to build more realistically and to construct a far wider range of models than with any other system of model construction.

Meccano model-building is not only a most enjoyable and fascinating hobby—it is also an educational pastime of very real value. Many large engineering firms, bridge builders and draughtsmen regularly use Meccano for trying out experimental schemes and for perfecting their ideas before work is commenced on the designing of the actual structures. Many inventors also use Meccano for working out new movements, while in many schools and colleges it is used to demonstrate the principles of mechanics.

Meccano Experts Always at Your Service

If you require advice in the construction of a particular model, hints on the countless uses of Meccano parts, or information on any aspect of Meccano model-building, our experts are always ready to assist you. Write to "Information Service, Meccano Ltd.,

Binns Road, Liverpool 13," Your letters will be answered personally and promptly by one of our staff of experts, who will be delighted to give you all possible help.

IMPORTANT

Since the mechanisms pages of this Book were printed the names and catalogue numbers of some Meccano parts mentioned in the text have been changed. The parts concerned are as follows:—

Old Name	Old Part No.	New Name	New Part No.
Flat Bracket	10	Fishplate	10
Cranked Bent Strip	44	Bent Strip, Stepped	44
Eye Piece, with boss	50a	Slide Piece	50
Ball Bearing	168	Ball Thrust Bearing	168
Ball Casing	168c	Ball Cage	168c
Rack Segment	129	Toothed Segment	129

The Meccano Plates are shown with white cross lines. These parts are now plain.

CONTENTS OF THIS BOOK

For easy reference purposes, the various mechanisms have been grouped under the following SECTIONS:—

- | | | |
|----------------------------------|------------------------------------|----------------------------------|
| I. Levers | VII. Cranks, Cams and Eccentrics | XIII. Quick Return Mechanisms |
| II. Pulley Systems | VIII. Clutches and Friction Drives | XIV. Steering Mechanisms |
| III. Belt and Chain Drives | IX. Brakes | XV. Traversing Mechanisms |
| IV. Gear Trains and Gear Boxes | X. Bearing and Shafting Supports | XVI. Springs and Shock Absorbers |
| V. Planetary and Epicyclic Gears | XI. Roller and Slide Bearings | XVII. Special Movements |
| VI. Intermittent Rotary Motions | XII. Applied Screw Mechanisms | |

Section I. LEVERS

AND SOME OF THEIR APPLICATIONS

The most elementary form of mechanical appliance is the lever, which is simply a rod or bar of wood, metal or other suitable material, used to increase the effect of a force or to change its direction. The simplest example of the use of a lever is given when a crowbar is employed to move a "load" consisting of a heavy object, such as a large stone. One end of the crowbar is pushed under the load, and a small piece of stone is placed under the crowbar and as near as possible to the object to be moved. A downward force or "power" applied to the free end of the crowbar then raises the load, so that it can be turned over. The small stone acts as a pivot, and is known as the fulcrum.

In Meccano models, a lever usually consists of a Perforated Strip or an Axle Rod, and its fulcrum can be formed from either a Rod or a Bolt.

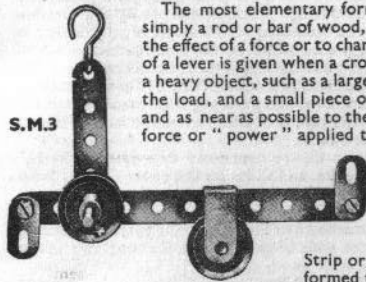

S.M.3

Bolt 1 carries a Strip loosely on its shank, a Nut 5 then being passed on to the Bolt without being tightened up against the Strip. A second Strip 3 is now placed on the Bolt 1, and this is secured rigidly against the Nut 5 by means of a second Nut 4. In this way the Strip 2 is allowed to swing without affecting the position of the Strip 3.

S.M.1a. A second form of lock-nut can be used, which, unlike S.M.1, allows both Strips to swing free of the Bolt. In this pivot both Strips are placed on the Bolt 1 without any intervening Nut. They are then held in position by locking the Nuts 4 and 5 together on the outer extremity of the Bolt. A supporting Strip in this attachment may be accommodated between the two Nuts, thus attaching the Bolt rigidly to the framework of a model. Also, as in S.M.73, for example, more than two Strips may be mounted pivotally on the Bolt.

There are three types or "orders" of levers, and these differ only in the position of the fulcrum relative to the power and the loads.

LEVERS OF THE FIRST ORDER

A lever is said to belong to the First Order if the fulcrum is between the load and the power, and the illustration we have given is therefore an example of the use of a lever of this order.

S.M.2. This model illustrates the principle of the First Order of Levers. The moving weight and the fixed weight are interchangeable for experimental purposes.

S.M.3. The steelyard or Roman Balance is an example of a Lever of the First Order. It consists of a straight bar suspended at a point near one end. A heavy weight hung on the end of the short arm of the bar is measured by moving a smaller weight along the long arm, which is graduated, until a balance is attained. This simple contrivance has been employed throughout the ages, and at the present time forms the basis of the most elaborate and sensitive weighing machines.

In the model, **S.M.3**, of the steelyard, the lever, a $5\frac{1}{2}$ " Strip, is mounted by a $1\frac{1}{2}$ " Rod on a vertical $2\frac{1}{2}$ " Strip, side play being prevented by two 1 " fast Pulleys.

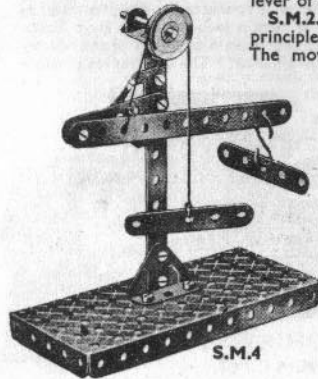

S.M.4

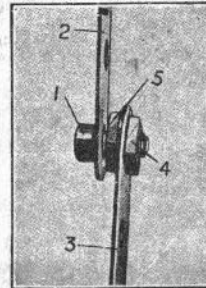

S.M.1

For new Meccano Mechanisms and Models read the "Meccano Magazine," published monthly, price 15c, subscription rate \$2.00 a year. Write to H. Hudson Dobson, 200 Fifth Avenue, New York 10, New York, for full details and a specimen copy.

A Hook is fitted, to secure the balance in an elevated position. Two Flat Brackets are provided, that on the short arm forming a point of attachment for the weighing pan. The second Flat Bracket prevents the weight from slipping off, this weight being represented by a Cranked Bent Strip fitted with a 1 " fast Pulley, the necessary connection being made by a $\frac{3}{8}$ " Bolt.

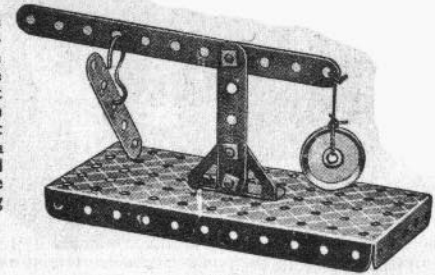

S.M.2

LEVERS OF THE SECOND ORDER

In the Second Order of Levers, the fulcrum is at one end of the lever and the power is applied at the other, the load being between the two. A wheelbarrow is a good example, and a pair of nutcrackers forms a double lever of this order.

S.M.4. For the model illustrating this order, a $5\frac{1}{2}$ " Strip is required as a supporting member, for the load hangs below the lever. The support is secured to the $5\frac{1}{2}$ " x $2\frac{1}{2}$ " Flanged Plate forming the base, a $2\frac{1}{2}$ " Strip being attached to the support by a Flat Trunnion. At the extreme upper end the support is fitted with a Reversed Angle Bracket, the upper lug of which forms one of the bearings for a horizontally disposed 2 " Rod carrying a 1 " fast Pulley.

The lever is pivotally attached at one end to the extremity of the $2\frac{1}{2}$ " Strip already mentioned, and is prevented from falling by a length of cord, secured to it as shown, passing over the 1 " fast Pulley. The free end of this cord carries a $2\frac{1}{2}$ " Strip forming the balance weight, all other weight attached to the apparatus at this point being simply to counteract the different forces set up in varying the position of the movable weight along the lever.

LEVERS OF THE THIRD ORDER

In the Third Order of Levers the load is placed at one end of the lever and the fulcrum at the other. The power is applied between the two, and is always greater than the load. The treadle of a lathe or a grindstone is a lever of this order, and a pair of sugar tongs is a double example.

S.M.5. The model illustrating the Third Order of Levers carries a vertical standard similar to that employed in S.M.4., with the exception that the horizontal $2\frac{1}{2}$ " Strip is dispensed with. Its place is taken by a $2\frac{1}{2}$ " Strip secured vertically to the base by means of a Trunnion, and the upper end of this Strip carries the pivot for the lever. The load consists of a $2\frac{1}{2}$ " Strip suspended from a length of cord that passes over a 1 " fast Pulley at the top of the taller support. It is then attached to the unsupported end of the lever. The power can be represented by any suitable weight suspended from an intermediate point on the lever.

An excellent example of the practical application of a lever of the third order is to be found in a platform type weighing scales.

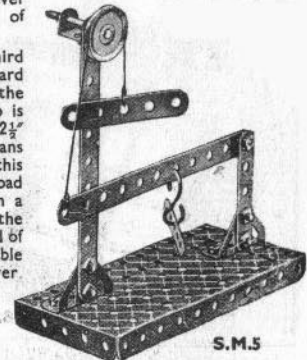

S.M.5

Section I. Levers—(continued)

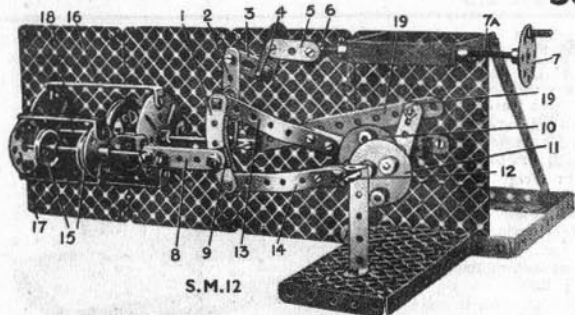

S.M.12

pressure applied to the outside of the platform to a common point, and two supporting the centre and front edge. The Sprocket Chain A forms the point of concentration of all forces, being connected by a Hook to two $5\frac{1}{2}$ " Strips D and C forming the centre levers. These Strips are extended at their front ends by $1\frac{1}{2}$ " Strips fitted with Hooks by means of which the ends of the levers are hung. A Rod is used to secure the Hooks to the framework housing the levers.

The $5\frac{1}{2}$ " Strips carry, seven holes from their rear ends, a $2\frac{1}{4}$ " Rod. This Rod supports a Double Bracket G that is prevented from slipping off the Rod by a nut and bolt, as shown. The lower lug of the Double Bracket also carries a nut and bolt, forming a stop for a $4\frac{1}{2}$ " Rod. The ends of this Rod support two $2\frac{1}{2}$ " Strips H, which are prevented from moving laterally by Spring Clips and Collars F. The free ends of these Strips are linked up to a transverse Rod by means of Hooks at the points E.

The platform, that fits over the levers, carries three brackets, one of which is built up from a $2\frac{1}{2}$ " x $\frac{1}{4}$ " Double Angle Strip fitted in the end holes of the lugs with a 3 " Rod. This Rod rests across the fore portion of the levers C and D at a point $1\frac{1}{2}$ " from their ends. The two remaining brackets each consists of a 1 " x $\frac{1}{2}$ " Angle Bracket fitted with a horizontally disposed Threaded Pin. These Threaded Pins rest on their respective levers at the points H.

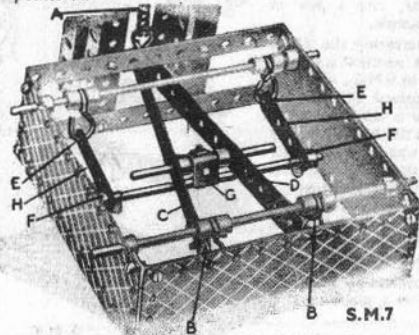

S.M.7

STEPHENSON'S LINK MOTION

S.M.12. The expansion link I is built up from two $2\frac{1}{2}$ " large radius Curved Strips secured and spaced apart at the top and bottom by nuts placed on the shanks of $\frac{3}{8}$ " Bolts. On the centre of these Bolts, loosely mounted between the two inner spacing nuts, are the eccentric rods 13 and 14. These are bolted at their other ends to the Eccentrics 10 and 11, which are secured to the main driving axle 12 by the bosses nearest their centres, giving a throw to each Eccentric of $\frac{1}{4}$ ".

The Eccentrics work in opposite positions in order to rock the expansion link about its centre.

LEVERS IN PLATFORM SCALES

S.M.7. Platform scales are an excellent example of the use, in actual practice, of the Third Order of Levers. In the illustration it will be seen that four of these levers are used, two

transmitting the

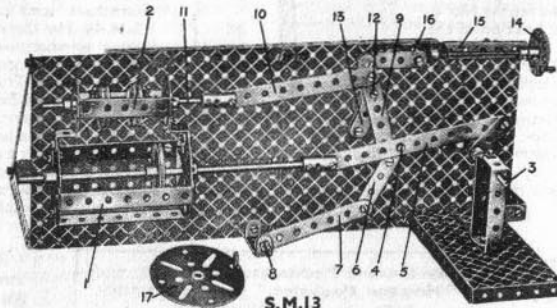

S.M.13

S.M.13. The crankshaft or driving axle of the engine is built up from two Cranks mounted on the end of the short Rod 3 and rigidly secured together at their outer ends by a $\frac{3}{8}$ " Bolt, on the shank of which the connecting rod 5 is pivoted. A $1\frac{1}{2}$ " Pulley takes the place of the piston, and the 8 " Rod to which it is secured forms the piston rod. The crosshead consists of a Strip Coupling.

JOY'S VALVE GEAR

The motion is derived from a point 4 in the connecting rod 5, at which point the connecting link 6 is attached pivotally by a bolt and two nuts. The lower end of the connecting link 6 is pivoted by the same means to an anchor link 7, which in turn pivots about a fixed point 8. It may be noted that the point 8 is the only fixed point in the gear. The valve lever 9 is pivoted to a point in the link 6 just below the bolt 4, and at its upper end is bolted pivotally to the valve rod 10, one end of which is connected to the valve spindle 11 by means of a Strip Coupling.

The motion is derived from a point 4 in the connecting rod 5, at which point the connecting link 6 is attached pivotally by a bolt and two nuts. The lower end of the connecting link 6 is pivoted by the same means to an anchor link 7, which in turn pivots about a fixed point 8. It may be noted that the point 8 is the only fixed point in the gear. The valve lever 9 is pivoted to a point in the link 6 just below the bolt 4, and at its upper end is bolted pivotally to the valve rod 10, one end of which is connected to the valve spindle 11 by means of a Strip Coupling.

WALSCHAERTS' VALVE GEAR

S.M.14. The movement of the piston valves 1 is derived from two sources, namely, the combining lever 2, and a Crank 7 attached to the end of the crank pin in the rear driving wheel. The combining lever is connected to the crosshead by a $1\frac{1}{2}$ " Strip 4, bolted rigidly to an Angle Bracket that in turn is secured to the Strip Coupling forming the crosshead, its other end being pivoted to the valve 5 by means of an ordinary Meccano bolt passed through the lever and inserted in a Collar. The bolt serves in place of the grub-screw to secure this Collar to the spindle 5. The expansion link 8 consists of two $2\frac{1}{2}$ " large radius Curved Strips joined at their ends by $\frac{3}{8}$ " Bolts. Two nuts are placed on each bolt between the Strips so that the latter are spaced about $\frac{3}{8}$ " apart. The inner Curved Strip is pivoted at its centre hole by a bolt and two nuts to an Angle Bracket bolted to a Trunnion.

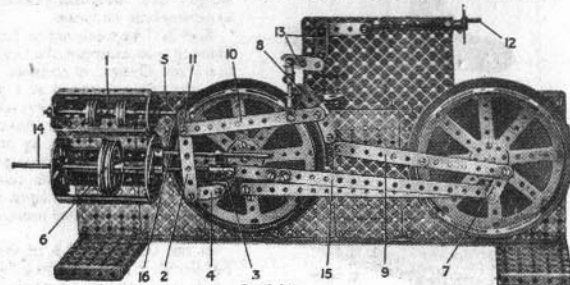

S.M.14

Section II. PULLEY SYSTEMS

One of the most outstanding machines in engineering is the crane. Its adaptability is universal, and it is found in different forms in shipyards, docks, engine sheds, factories and engineering works of all kinds.

The lifting of great weights by cranes is made possible largely by the use of pulleys that are incorporated between the jib head and the load. These pulley systems may be composed of two pulley blocks having any number of pulleys, but there are seldom more than six, and more usually three or four.

With the aid of Meccano any pulley system in existence may be reproduced, and the following models represent some of the more simple types. Any one of them may be modified to suit individual requirements.

SIMPLE HOIST

S.M.15. The most elementary pulley arrangement consists essentially of a single pulley suitably mounted, with a cord passing over it. The load is hung at one end and power is applied at the other, the load in this manner being raised without any mechanical gain.

A Single Bent Strip forms a support for a 1" Rod, held in place by two Collars, that carries a freely rotating 1" loose Pulley. The cord passes over this Pulley, one end of which is secured temporarily to the framework of the model. The other end carries a large hook on which can be placed a suitable weight.

This pulley can be used for a number of purposes, among which is the determination of friction in bearings and the relative values of different oils when used on rotating parts.

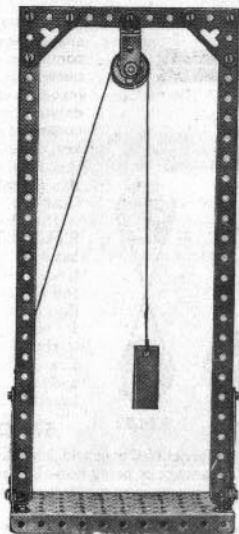

S.M.15

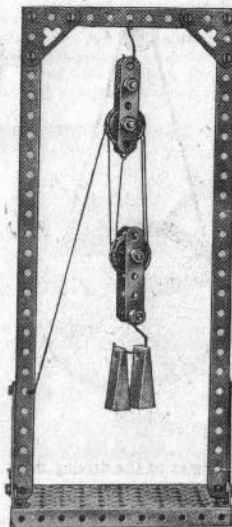

S.M.16

TWO-FOLD PULLEY SYSTEM

S.M.16. This pulley system conforms closely to those found in actual practice on cranes, and it gives a theoretical mechanical advantage of 4 : 1. The base and structure of the model are similar in every respect to that used for S.M.15, and therefore, need no description.

A Hook carried in the centre of the upper horizontal 5 1/2" Strip supports the uppermost pulley block. This consists of two 2 1/2" Strips coupled to-

gether by means of two 1 1/2" Rods, arranged as illustrated and prevented by Collars from moving laterally. The lower Rod carries two 1" loose Pulleys spaced apart from each other and from the frame of the block, by Washers. The moveable pulley block is constructed in a similar manner, except that the bottom 1 1/2" Rod is placed lower and forms a support for a suitable hook.

The hoisting cord is first secured to the lower extremity of the upper pulley block and is then led round upper and lower pulleys alternately. The free end is finally secured to a suitable point on the frame of the model. It will now be found that a weight of 100 grammes, for example, will only need 25 grammes to balance it at the hoisting end of the cord, but in order to move the heavier weight through a given distance it will be necessary for the smaller weight to move through a distance four times as great.

EXPERIMENTAL PULLEY SYSTEM

S.M.17. This piece of apparatus is used exten-

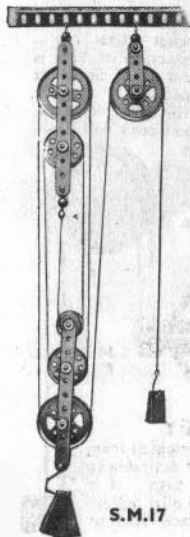

S.M.17

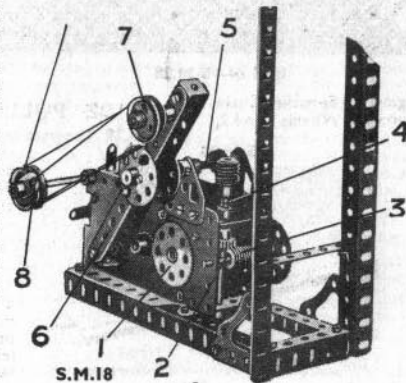

S.M.18

The Electric Motor is secured on a suitable base, and the armature shaft carries a 1/2" Pinion engaging with a 57-teeth Gear 1, connected by a second stage of 3 : 1 reduction gearing to a Worm 3 that is in mesh with a 1/2" Pinion 2. This Pinion is mounted on a vertical Rod 4, together with a second Worm engaging with still another 1/2" Pinion.

The Rod 5 on which this last-mentioned Pinion is mounted carries two Bush Wheels on its outer section, and these are attached to two 5 1/2" Strips 6 as shown. One pair of pulleys 7 is attached to the arm 6, and the other pair to a horizontal Rod carried in the Motor side plates. One end of the cord is secured to a Flat Bracket 8, and after passing round the various pulleys is taken over a pulley at the top of the lift shaft and fixed to the lift cage. As the arm 6 rotates, the pulleys 7 mounted on it alternately approach and recede from the fixed pulleys.

DIFFERENTIAL PULLEY BLOCK

S.M.19. The Sprocket Chain is fitted in one continuous length, and this complete pulley system is operated by pulling on one side of the free loop.



S.M.19

sively in laboratories for many purposes, the formation although, seldom used in actual practice, having found favour in experimental work because of the ease with which unwanted pulleys can be removed, and also because of the open arrangement of the cords.

The girder supporting the system may be of any length and fitted into any suitable position. The side members of the upper pulley block consist of 5 1/2" Strips held together at each end by 1 1/2" Rods and Collars. A 2" Pulley and a 1 1/2" Pulley are fitted between the two Strips, as shown, and are carried on 1" Rods. The Rod at the lower extremity of the block is fitted with a Small Loaded Hook.

The second pulley block is built up in a similar manner, but instead of a Hook at its inner end it carries a 1" fast Pulley. A suitable Hook is attached at its lower extremity however. A single 2" Pulley, which converts the upward direction of the cord into a downward direction but in no way increases the ratio of the apparatus, is fitted, as shown, to one side of the upper block. The arrangement of the cord can be followed easily by reference to the photograph. The theoretical advantage gained by this block is 6 : 1.

AUTOMATIC REVERSING HOIST

S.M.18. By making the distance between the two blocks of a pulley system automatically variable, it is possible to cause the free end of the cord to be alternately extended and returned. This movement is utilised to operate an automatic lift cage and crane hook, or any other similar movement. In the example on this page it is shown in its simplest form, but can be elaborated at will.

Section III. BELT AND CHAIN DRIVES

CORD TRANSMISSION

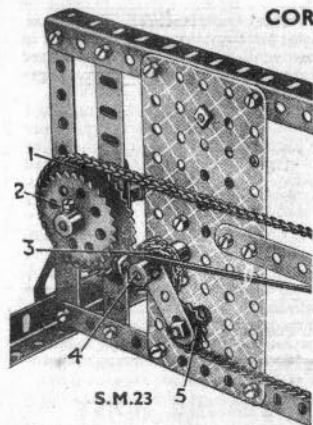

S.M.23

For small models, and for drives transmitting small power, Pulleys and Cord are often used. Several reduction and step-up ratios are possible by this means, and although they are of little use for accurate transmission, their simplicity makes them extremely useful in a great many ways.

S.M.20. shows how an approximate 6:1 stage can be built up from a 3" and a 1/2" Pulley, a 12:1 stage being possible by the aid of a 1/2" and a 6" Pulley. In order to increase the grip in the groove of the small

Pulley the cord may be passed twice round this part.

S.M.21. illustrates a method of driving a shaft that is set at right-angles to the driving shaft, and S.M.22 shows how a reverse drive can be obtained between two shafts.

In S.M.31 is shown the method whereby the drive between two shafts out of line, both horizontally and vertically, can be transmitted. The driving shaft carries a 1/2" fast Pulley, and an idler shaft 2, carrying two freely rotating 1 1/2" Pulleys 1, is fitted in place above it. The cord from the driving shaft passes over these Pulleys, and from there round a second 1/2" fast Pulley on the driven shaft.

DERAILLEUR TWO-SPEED GEAR

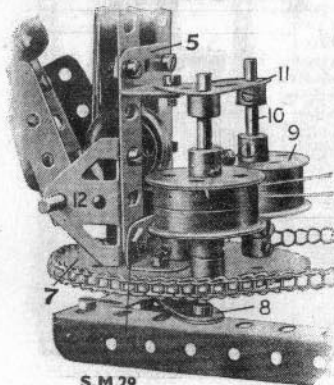

S.M.29

S.M.23.

With this arrangement which is largely used on bicycles, two-speed ratios can be obtained by changing the Sprocket Chain from one to the other of the Sprocket Wheels 1 and 2, which are mounted face to face, but spaced apart approximately 1/2". The 3/4" Sprocket Wheel 3 is free to rotate on the Rod 4 carrying a Crank, which forms the tensioning arm. A Pivot Bolt is held by two nuts in the end hole of the Crank, and carries a 3/8" Sprocket Wheel 5. The Sprocket Wheel 5 keeps the chain at the correct tension by means of a length of Spring Cord attached to a 3/8" Bolt held in the

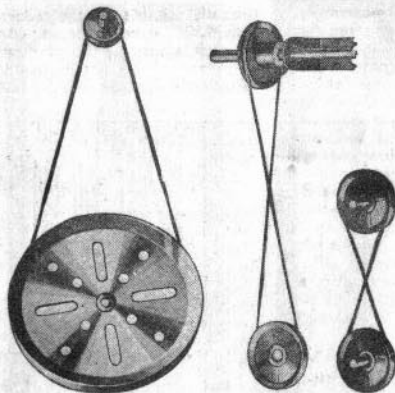

S.M.20

S.M.21

S.M.22

boss of the Crank. Operation of the gear-change lever causes the tensioning arm, complete with both Sprockets, to move outward, so that the Sprocket 3 is brought into line with the Sprocket 2; and as the driving Sprocket rotates, the Chain is conveyed on to the smaller driven Sprocket. The Wheel 3 is held in position on the Rod 4 by the Crank and a Collar, a washer being placed behind the Crank for spacing purposes.

The changing mechanism is shown in S.M.23a. The Rod 4 is held in a reinforced bearing formed from a Double Arm Crank, and carries a Compression Spring and Collar. A Bell Crank is fitted on a 1 1/2" Rod passing through two 1 1/2" Strips that are held by 1" x 1 1/2" Angle Brackets secured to the 5 1/2" x 2 1/2" Flat Plate. One arm of the Crank presses against the end of Rod 4, and the other arm is connected by a length of wire to the gear-change lever.

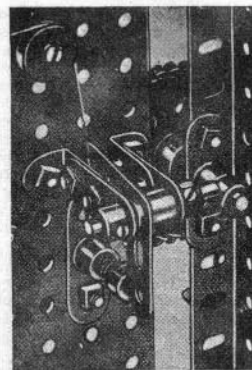

S.M.23a

SPROCKET CHAIN TRANSMISSION

Sprocket Chain and Sprocket Wheels can be used in similar conditions to cord, and have the advantage of being non-slipping. This arrangement is somewhat noisy at high speeds, however, and can be used satisfactorily only when the Sprockets are carried on horizontal shafts.

S.M.24. A 3:1 gear composed of a 3" Sprocket Wheel and a 1" Sprocket Wheel.

S.M.25. A 2:1 gear consisting of a 1" and 2" Sprocket Wheel.

S.M.26. A method of obtaining a fractional reduction of 2:1 by means of a 3/4" and 1" Sprocket Wheel.

S.M.27. Another fractional reduction of 1 1/2:1 is shown in this illustration, a 1" and a 1 1/2" Sprocket Wheel forming the necessary components.

S.M.28. The larger sprocket in this example is the Toothed Disc, Part No. 168b, taken from a Ball Bearing, Part No. 168. It is mounted on a Bush Wheel, and when used with a 1" Sprocket Wheel will give a 4:1 reduction. When used as shown with a 3/4" Sprocket Wheel the reduction is a little over 5:1

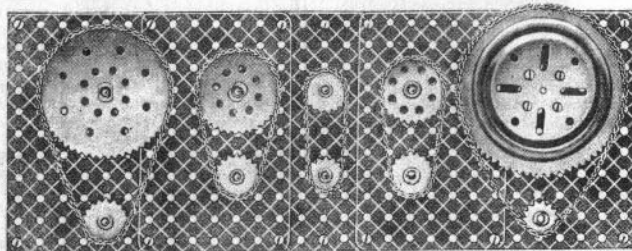

S.M.24—S.M.28

GUIDE PULLEY FOR CRANES

S.M.29. The vertical members of the derrick are bolted at their base to a 3" Sprocket Wheel or Gear, a Sprocket Wheel 7 being shown in this example. The built-up bracket 5 supports two Rods 10, on each of which is secured two 1 1/2" Flanged Wheels 9 as shown.

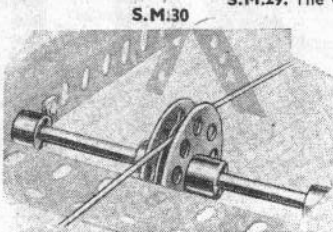

S.M.30

DEEP GROOVE GUIDE PULLEY

S.M.30. Where considerable side movement is anticipated from a cord passing over a Meccano Pulley, it will be found desirable to make use of the deep groove pulley illustrated on this page. It is built up from a 1" loose Pulley and two Bush Wheels. Similar pulleys for larger models can be fitted at their sides, with Face Plates or Wheel Flanges.

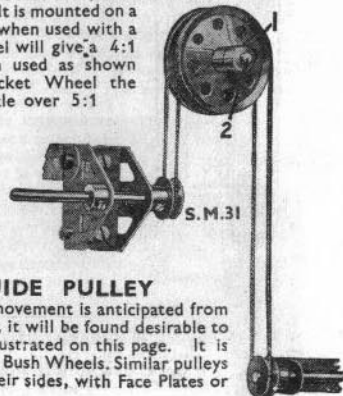

S.M.31

Section IV. GEAR TRAINS AND GEAR-BOXES

In order to make the best of the wide range of gears in the Meccano system it is necessary to know the various ratios that result from using them in any given combination.

The ratio or relative speeds of any two shafts carrying meshing spur, bevel or contrate gears is found by dividing the number of teeth in the smaller gear into the number of teeth in the larger gear. For example, a simple reduction gear using a $\frac{3}{4}$ " Pinion, which has 25 teeth, and a 50-tooth Gear, gives a ratio of 2:1.

When a Meccano Worm is meshed with a Pinion, Contrate or other gear, the ratio is determined by the number of teeth in the meshing gear, the Worm being rated as 1. For example, a Worm meshed with a $\frac{3}{4}$ " Pinion, which has 19 teeth, gives a ratio of 19:1.

The Meccano Worm is of the non-reversing type and therefore must always be used as the driver when meshed with other gears.

specially suitable for the reduction sometimes necessary with Clockwork Motors.

S.M.37. A more recent addition to the Meccano range is the $2\frac{1}{2}$ " Gear Wheel, by means of which it is possible to arrive at any gear ratio having a common multiple of five, such as 25 : 1, 50 : 1 and 100 : 1. It is shown in this example meshing with a $\frac{3}{4}$ " Pinion, this arrangement resulting in a gear ratio of 5 : 1. A $1\frac{1}{2}$ " Gear used in place of the Pinion will result in a ratio of $2\frac{1}{2}$: 1.

S.M.38. For right-angle drives where the two shafts are not in the same plane, or where a very low reduction gear is required, a Worm is used. Although non-reversing, these gears have a very wide range of application, and can be meshed with all the spur gears and pinions in the Meccano range. The ratio between a Meccano Worm and Gear or Pinion is arrived at by counting the number of teeth of the spur wheel. This, when expressed in the usual way, for example 57 : 1, gives the gear reduction. As already mentioned, these Worms cannot be rotated from a spur wheel when a step-up gear is required.

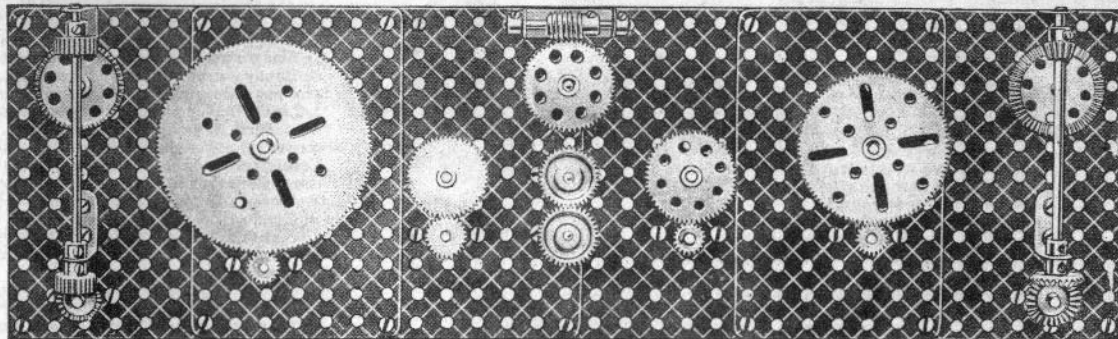

S.M.32 and 32a

S.M. 33

S.M.34

S.M.35

S.M.36

S.M.37

S.M.39 and 39a

EXAMPLES OF MECCANO GEARING

S.M.32 and 32a. Contrate Gears are available in two separate sizes, $1\frac{1}{2}$ " and $\frac{3}{4}$ ", the first size having 50 teeth and the second 25 teeth. By meshing these with $\frac{3}{4}$ " Pinions it is possible to produce ratios of 2 : 1 and 1 : 1, the driving shaft in both instances being set at 90 deg. to the driven shaft.

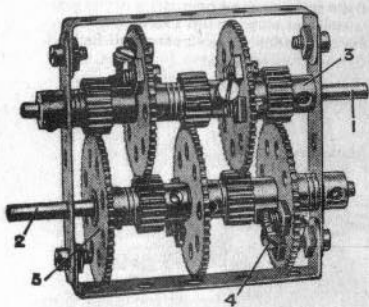

S.M.40

two $1\frac{1}{2}$ " Gears having 38 teeth each, but $\frac{3}{4}$ " Pinions and 57-teeth Gears give similar results, only with different distances between the axles.

S.M.36. Perhaps the most used gear trains in the Meccano system are those using the 57-teeth Gears and $\frac{3}{4}$ " Pinions, resulting in a 3 : 1 reduction or step-up. This formation of gears is

S.M.39 and 39a. In place of Contrate Gears, Bevel Gears can be used, and these are available in three sizes, giving two different reductions. Two $\frac{3}{4}$ " Bevels used together will produce a 1 : 1 gear, and a $1\frac{1}{2}$ " and a $\frac{3}{4}$ " Bevel used together will result in a 3 : 1 gear ratio. These Bevels are not interchangeable like Contrate Gears, however.

S.M.33. This illustrates the greatest reduction possible in a single stage of Meccano spur gearing. The $3\frac{1}{2}$ " Gear, of 133 teeth, meshing with a $\frac{3}{4}$ " Pinion of 19 teeth, results in a speed variation of 7 : 1. This particular example is used chiefly in conjunction with the turntables of swivelling cranes as described in this book.

S.M.34. A 2 : 1 gear ratio showing the 50-teeth Gear and $\frac{3}{4}$ " Pinion used together.

S.M.35. A number of different 1 : 1 gear trains can be constructed with Meccano, and S.M.35 shows one method. This makes use of

tioned, these Worms cannot be rotated from a spur wheel when a step-up gear is required.

COMPACT GEAR REDUCTION

S.M.40. A very compact gear-box is shown in S.M.41, and this will be found useful in many instances where a fairly large reduction ratio is required. A ratio of 243 : 1 is provided between the driving shaft 1 and the driven shaft 2, yet spur gearing is used throughout and only two shafts are necessary.

The Rod 1 carries a fixed Pinion 3 that engages a 57-teeth Gear loose on the Rod 2. The Gear is provided with two Bolts, the shanks of which are arranged on each side of the $\frac{3}{4}$ " Bolt 4. This Bolt is inserted in the boss of a $\frac{3}{4}$ " Pinion, but a nut prevents it from gripping the Rod. In this way, Gear and Pinion rotate freely on the Rod as one unit. The Pinion engages a second 57-teeth Gear coupled in a similar manner to another $\frac{3}{4}$ " Pinion. The final Gear 5 is fixed on its Rod, and a glance at the illustration will show that the drive can be taken from either end of the Rod 2. Similarly the Rod 1 can be driven from whichever end is more convenient in the model.

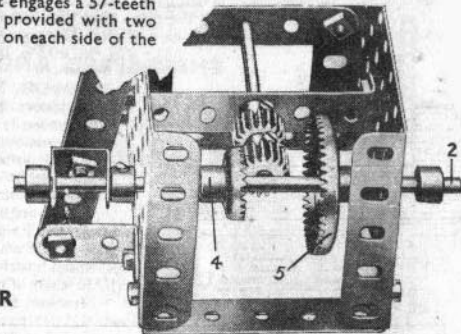

S.M.41

TWO-SPEED REVERSE GEAR

S.M.41. This mechanism is designed to give a slow forward speed and a rapid reverse, or vice versa, and either of the Rods can be used as the driving shaft.

The Rod 2 is capable of sliding in its bearings, and is controlled by a suitable hand lever as shown. The Rod carries two Contrate Wheels 4 and 5, which are $\frac{3}{4}$ " and $1\frac{1}{2}$ " in diameter respectively, and on operation of the lever one of these Contrate Wheels is brought into

Section IV. Gear Trains and Gear-Boxes—(continued)

engagement with one of the two $\frac{1}{2}$ " Pinions on the driving Rod. If desired, a $\frac{1}{2}$ " diameter $\frac{1}{2}$ " face Pinion can be used in place of the two separate Pinions. Hence if the Rod 2 is used as the driven shaft and the large Contrate Wheel 5 is thrown into gear with its respective Pinion, the Rod 1 is driven nearly three times as fast as the Rod 2, the actual ratio being 2 and 12/19 : 1.

Alternatively, if the small Contrate Wheel 4 is thrown into engagement, the other Rod turns only a little faster than the driving Rod, the ratio in this case being 16/19 : 1.

COMPACT THREE-SPEED GEAR-BOX

S.M.42. This three-speed and reverse gear-box is of particular interest on account of its extreme compactness. It is in fact probably the smallest gear-box that can be built with Meccano to give three forward speeds and reverse.

The end of the Rod 1 is inserted in the bore of the $\frac{1}{2}$ " Pinion 4 that is carried on a separate Rod 2 from which the final drive is taken. The latter Rod carries also a $\frac{3}{8}$ " Pinion and Collar. The sliding layshaft is a $\frac{1}{2}$ " Rod on which are a $\frac{1}{2}$ " Pinion 5, a $\frac{3}{8}$ " Pinion 6, and a $\frac{1}{2}$ " Pinion 7. A $\frac{1}{2}$ " Pinion 8 is carried on a $\frac{3}{8}$ " Bolt screwed into the transverse bore of a Threaded Boss and locked by means of a grub-screw screwed into the opposite end of the bore. The Threaded Boss is rigidly attached to the gear-box frame by a $\frac{1}{2}$ " Bolt 9, but is spaced by a Collar and two Washers.

The movement of the sliding shaft is controlled by a $\frac{3}{8}$ " Bolt 10, the head of which fits between the bosses of the Pinions 6 and 7. The Bolt is fixed in a Collar on the end of a 3" Rod forming the gear change lever, and pivoted to a 1" Triangular Plate by a further Collar secured in place on the Rod by its grub-screw, and carrying also a bolt whose shank passes through one of the holes in the Triangular Plate. The Bolt is locked in position by a nut to allow the Rod to pivot freely.

As shown in the illustration, first forward speed is in engagement, the drive passing through the $\frac{1}{2}$ " Pinion on the driving shaft 1 to the $\frac{3}{8}$ " Pinion 6 on the layshaft. The $\frac{1}{2}$ " Pinion 7 engages the $\frac{3}{8}$ " Pinion on the driven shaft, so that there are two stages of reduction gearing between driving and driven Rods. By sliding the layshaft to the right the Pinion 7 disengages, but Pinion 6 remains in engagement with its $\frac{1}{2}$ " Pinion and at the same time meshes with Pinion 4. This gives a straight through drive. Further movement of the sliding Rod brings into engagement Pinions 3 and 5, and 6 and 4, in this case providing two step-up stages for top gear.

Reverse gear is obtained when the rod is slid over to the extreme left, and the drive then goes through Pinions 3 and 8—which are in constant mesh—to Pinion 6, Pinion 7 engaging the $\frac{3}{8}$ " Pinion.

THREE-SPEED AND REVERSE GEAR

S.M.43. This is a compact gear-box built specially for incorporation in a front-wheel drive chassis, but it can easily be adapted for use with a chassis of the conventional type with driven back wheels.

The sides of the gear-box consist of $3\frac{1}{2}$ " Flat Girders bolted by means of $\frac{1}{2}$ " x $\frac{1}{2}$ " Angle Brackets to the underside of an Electric Motor. These are joined together at each end by a $2\frac{1}{2}$ " x $\frac{1}{2}$ " Double Angle Strip fitted with Flat Trunnions, the end holes of which form bearings for the lay-shaft. The third hole from the left-hand side of the illustration, in each of the Flat Girders, carries a $\frac{1}{2}$ " x $\frac{1}{2}$ " Angle Bracket, and these two parts form supports for two $2\frac{1}{2}$ " Strips spaced apart, as shown, by Washers.

A Rod 8 carrying a $\frac{3}{8}$ " Pinion and 1" Gear, and held in place by Collars, one of which is shown at 8a, is now fitted. The inner end of this Rod is journaled in one of the $2\frac{1}{2}$ " Strips already mentioned. The other $2\frac{1}{2}$ " Strip supports the inner end of a second Rod that carries a 50-teeth and a 1" Gear, a $\frac{1}{2}$ "

Pinion 18 also being fitted outside the gear-box as illustrated. Immediately above this Pinion is mounted, on the Flat Trunnion, a second similar Pinion carried on a $\frac{3}{8}$ " Bolt. This Pinion forms the connection between the two Pinions 18 and 19, when reverse gear is engaged.

The lay-shaft supports two 1" Gears 20 and 22, a $\frac{3}{8}$ " Pinion 21, and a 50-teeth Gear 23. The Rod from the gear lever is coupled up to the layshaft between the last-mentioned Gear and a Collar.

THREE-MOVEMENT GEAR-BOX

S.M.44. The outstanding feature of this gear-box is that it can be used to provide three movements each of which can be independently stopped, started or reversed. The drive is taken to the gear-box through Sprocket Chain that passes round the Sprockets 1, 2 and 3 in such a manner that the centre Sprocket 2 is driven in the reverse direction to the other two. The Sprockets are each carried on a 2" Axle Rod fitted with a Collar and $\frac{3}{8}$ " Pinion. The Collars retain the Rods in place, and the Pinions on the upper and lower Rods are placed close to the outer side plate, whereas the Pinion 4 is arranged nearer the centre of its shaft. Three secondary shafts are arranged as shown, and each carries a 50-teeth Gear Wheel. These shafts are provided with a Collar on one end, and at the other end carry two Collars with a space between them to admit the head as a bolt. Three control levers are mounted in Small Fork Pieces pivoted on an Axle Rod secured to the base Plates by Handrail Supports.

The method of operation is as follows. The Gear 5 is shown in engagement with the Pinion on the rod of the Sprocket 1. By moving the appropriate gear lever over to the left, this Gear is thrown out of mesh with its Pinion, so that no drive is transmitted; and by further movement of the gear lever the Gear is brought into engagement with the Pinion 4 that causes it to rotate in the opposite direction. The other two shafts each operate with a similar movement, and it will be seen that each one can be controlled independently to rotate in either direction or to remain stationary.

THREE-SPEED AND REVERSE GEAR

S.M.45. The Rod 64 forms the primary driving shaft, and is provided with a $\frac{3}{8}$ " Pinion 68 and a 1" Gear Wheel 69. The countershaft consists of a 6 $\frac{1}{2}$ " Rod 71 that is slidable in the end Double Angle Strips of the gear-box. This Rod carries the following parts—two Collars, acting as stops to limit its sliding movement; a 50-teeth Gear 72; a 1" Gear 73; two more Collars, one of which, 74, is free on the Rod; a $\frac{3}{8}$ " Pinion 75; a 1" Gear 76, and a $\frac{1}{2}$ " Pinion 77. The driven 3" Rod 78 carries a 50-teeth Gear 79, a 1" Gear 80, and a $\frac{1}{2}$ " Pinion 81.

A Washer should be placed between the $\frac{1}{2}$ " Pinion 81 and the Double Angle Strip. This Pinion is in constant engagement with another $\frac{1}{2}$ " Pinion 83, which is free to turn upon a $\frac{3}{8}$ " Bolt secured to the end Double Angle Strip by two nuts.

The different speeds are obtained in the following manner. Assume that the sliding Rod 71 is at the farthest limit of its travel to the left. Then the drive from the engine is led through the following gears—

S.M. 45

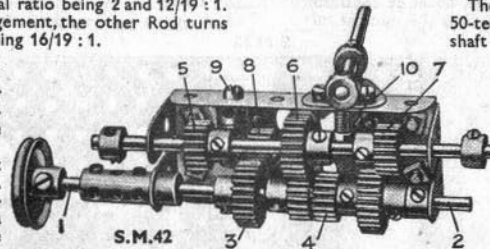

S.M.42

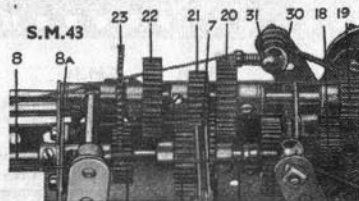

S.M.43

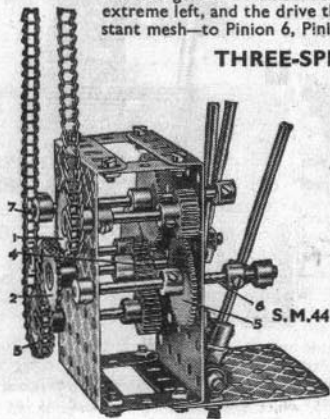

S.M.44

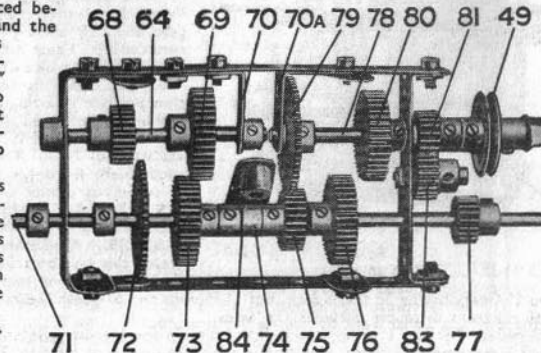

S.M. 45

Section IV. Gear Trains and Gear-Boxes—(continued)

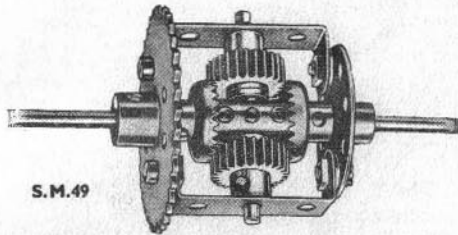

S.M.49

81. This constitutes reverse gear and the speed ratio between the driven shaft 78 and the driving rod 64 is 2:1. A slight movement of the gear change lever disengages the Pinion 77 from Pinion 83 and "neutral" gear results, the secondary shaft revolving idly. The pivot for the lever should be made rather hard to move, so that when it is set in any position the selected gears cannot slide out of mesh. Further movement of the lever slides the Rod 71 farther to the right and causes the following gears to be engaged—68, 72, 75 and 79. This gives first speed forward, the ratio between shafts 78 and 64 being 4:1. Continuing the movement of the lever, the second forward speed is obtained, the drive now being directed via 69, 73, 75, and 79, and the ratio being 2:1. When the lever is hard over and the Rod 71 at the limit of its travel to the right, the gears in engagement are 69, 73, 76 and 80. This represents top forward speed, with a ratio of 1:1.

DIFFERENTIAL FOR SPROCKET DRIVE

S.M.49. This differential is intended for use in a Meccano lorry, motor, etc. where the usual shaft drive has been dispensed with and Sprocket Chain substituted.

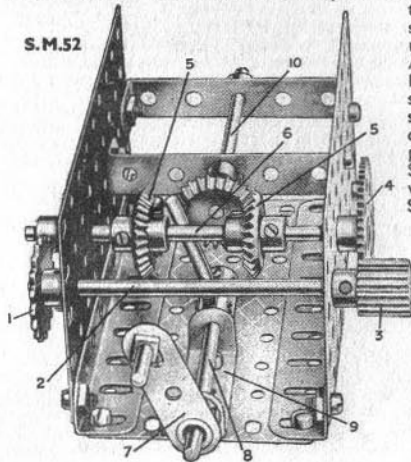

S.M.52

A 2" Sprocket Wheel is secured to a Bush Wheel by means of two $1\frac{1}{2} \times \frac{1}{4}$ " Double Angle Strips, each of the four Bolts carrying a Washer for spacing purposes. A Rod of sufficient length to reach one of the road wheels is now passed through the boss of the Sprocket Wheel and fitted with a $\frac{3}{8}$ " Contrate Wheel. Sufficient Rod is left projecting in order to allow it to pass into the longitudinal bore of a Coupling. A second Rod passing through the Bush Wheel is fitted with a Contrate Wheel and treated in the same way as the first.

The transverse bore of the Coupling is fitted with a 2" Rod secured in place by a grub-screw. This Rod forms a bearing for two $\frac{3}{8}$ " Pinions that are each spaced away from the Coupling by means of two Washers, so that the Pinions fit snugly against the Double Angle Strip forming the frame of the mechanism.

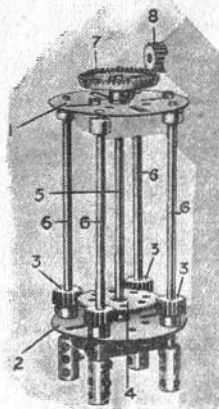

S.M.51

REVERSING GEAR

S.M.50. With this gear in both forward and reverse positions the ratio between the driving and driven shafts is 1:1, so that these always rotate at equal speeds.

The driving shaft 1 and the driven shaft 2 are journaled in a Channel Bearing secured to the base plate, and each carries a $\frac{3}{8}$ " Sprocket and a $\frac{3}{8}$ " Contrate. A Washer is placed between each Contrate and the Channel Bearing for spacing purposes. Two 1×1 " Angle Brackets form journals for a 3" Rod carrying the $\frac{1}{2}$ " Pinion 3 and $\frac{1}{2}$ " diameter $\frac{3}{8}$ " face Pinion 4. This Rod is slidable, but its movement is limited by the Pinion 3 and a Collar on the opposite end of the Rod. The $2\frac{1}{2}$ " Strip 5 is pivotally connected to an Angle Bracket attached to the base, and carries in its second hole a Bolt the shank of which fits into the space between the boss of the Pinion 3 and a Collar on the same Rod.

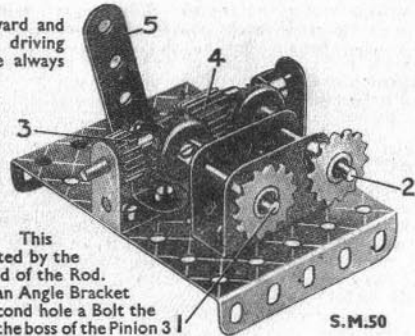

S.M.50

MULTIPLE-DRIVE MECHANISM

S.M.51. This mechanism is frequently employed in multiple drilling machines and similar apparatus where several shafts are required to rotate at a uniform speed and in the same direction. A vertical Rod 5 carries a $1\frac{1}{2}$ " Contrate Wheel 7, which is driven by the $\frac{3}{4}$ " Pinion 8 secured to the belt pulley shaft. The Rod 5 is journaled through the bosses of two Face Plates 1 and 2, bolted to the upright column of the machine, and carries a 57-tooth Gear Wheel 4. This Gear Wheel drives $\frac{1}{2}$ " Pinions 3 secured to the four countershafts 6, which carry the tools mounted in Couplings.

BEVEL REVERSING GEAR

S.M.52. A $\frac{3}{8}$ " diameter $\frac{3}{8}$ " face Pinion 3 meshes with a 57-tooth Gear 4 secured on a sliding Rod. The lateral movement of this Rod is controlled by a Collar on the opposite side of the framework to the Gear 4. Between the side plates of the gearbox are fitted two $\frac{1}{4}$ " Bevels 5 and two Collars, the latter being stationed on the Rod close to the inner faces of the Bevels.

The movement of the Rod is controlled by a 1" Rod attached at right angles to the 2" Rod 8, which is journaled in the two end holes of a $1\frac{1}{2}$ " $\times \frac{1}{2}$ " Double Angle Strip 9. A Crank 7, fitted with a Threaded Pin, forms the controlling handle.

DIFFERENTIAL GEAR.

S.M.53. Differential gear is incorporated in the drive of practically every motor car, its object being to allow for the difference between the speeds of the inner and outer road wheels when the vehicle is turning a corner.

The back axle shaft consists of two separate Rods 1 and 2, the inner ends of which are journaled in opposite ends of a Coupling 3. In the centre transverse hole of this Coupling is secured a 2" Rod 4 that serves to carry the $\frac{3}{8}$ " Bevel Gears 5. The grub-screws of the Bevels are removed so that they are free to turn about the 2" Rod. They engage with two similar Bevels 6 and 7 secured to the shafts 1 and 2 respectively.

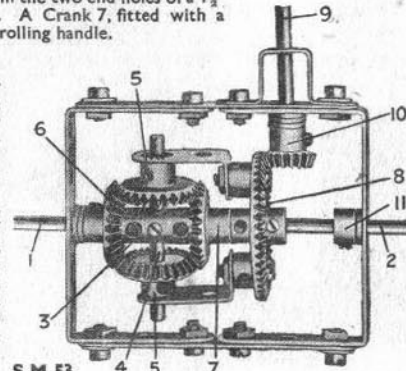

S.M.53

Section V. PLANETARY AND EPICYCLIC GEARS

EPICYCLIC GEAR CLUTCH

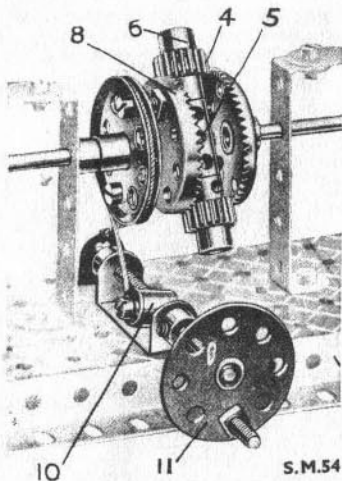

S.M.54. The left-hand rod is the driving shaft, and the opposite rod is the driven shaft. The former carries a $1\frac{1}{2}$ " Contrate Wheel which engages with $\frac{3}{4}$ " Pinions 4 mounted on 1" Rods secured in the ends of a Coupling 5. The Pinions are free to revolve, but are held in place by Collars. The latter rod carries at its end a Pulley and the second $1\frac{1}{2}$ " Contrate Wheel 8, and its inner end is secured in the centre of the Coupling 5. The Pulley and Contrate Wheel 8 are free to turn independently of the Rod 2, but they are secured together by two $\frac{3}{4}$ " Bolts, each of which is fitted with three nuts, one immediately behind the Pulley and one on each side of the Contrate 8.

The Pulley 7 is controlled by a friction brake consisting of a length of cord, one end of which is tied to an Angle Bracket 9, and the other end to a Threaded Boss 10 mounted on a Threaded Rod that carries a hand wheel 11.

If the brake is in the "off" position, that is with cord slack, the unit 8 is free to revolve about its Rod. Hence, if power is applied to the Contrate driving, the Pinions 4 commence to turn on their axes, driving the Contrate Wheel 8 in an opposite direction, and no movement is imparted to the driven Rod. If the hand wheel 11 is rotated, thus gradually applying the brake, the Contrate Wheel 8 becomes increasingly difficult to turn, and the Pinions 4 commence to climb round its teeth, thereby rotating the Coupling 5 and its Rod.

SUN AND PLANET WINDLASS

S.M.55. This example shows how it is possible to obtain a gear reduction of 2:1 between an operating handle 10 and a driven shaft 1, while the latter forms the centre, about which the handle revolves.

The shaft 1 is free to turn in a 1" Gear 2, which is secured to the framework by a bolt passed through an Angle Bracket 3 and inserted in the threaded bore in the wheel boss. The bolt is fixed by a nut beneath the Angle Bracket and must be spaced by Washers to clear the shaft 1. A second 1" Gear 4 engages with Gear 2, and is secured to a $1\frac{1}{2}$ " Rod 5 journaled in 2" Strips 6, which are free to turn about the shaft 1. Washers are placed between the inner 2" Strip and the Gears 2 and 4 for spacing purposes. The Rod 5 carries a $\frac{3}{4}$ " Pinion 7 engaging with a 50-teeth Gear 8 secured to the shaft 1. The 2" Screwed Rod 9 serves to hold the Strips 6 in position, and 2 is fitted with a Coupling 10 to form the handle.

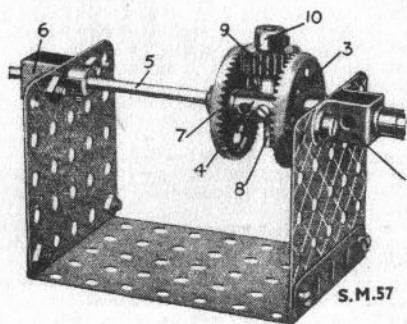

S.M.55

EPICYCLOIDAL GEAR

S.M.56. In epicycloidal gear one toothed wheel is caused to rotate about the circumference of another. The Pinion 1 in this detail engages with the Gear Wheel 2, and is carried on a shaft journaled in a $1\frac{1}{2}$ " Strip 3

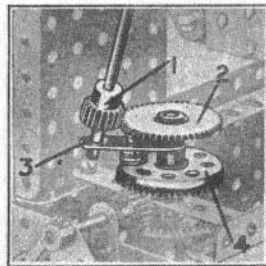

S.M.56

bolted to a Contrate Wheel 4, which rotates freely on the vertical Rod. This Rod may be secured in position, so preventing the Gear Wheel 2 from turning; or it may be rotated at a different speed, or in an opposite direction to the Contrate Wheel 4. The number of revolutions described by the Pinion 1 always exceeds that of the Contrate 4, but the speed ratio varies according to the sizes of the Pinion and Gear Wheel 2, and to the movement, if any, of the latter.

EPICYCLIC TRANSMISSION GEAR

S.M.57. The device is designed to provide a gear ratio of two to one between two shafts. Its chief merits lie in the compactness of its construction and in the fact that the driving and driven shafts can be mounted in direct line with one another.

The handle is secured to a 2" Axle Rod journaled in bearings 2. This Rod is free to rotate in the boss of a $1\frac{1}{2}$ " Contrate Wheel 3, but is secured in one end of the Coupling 4. A further Rod 5, which runs freely in the other end of the Coupling 4, and is journaled in further reinforced bearings 6, carries the $1\frac{1}{2}$ " Contrate Wheel 7 fixed in the position shown. A $1\frac{1}{2}$ " Rod 8 gripped in the central transverse hole of the Coupling 4, carries a $\frac{3}{4}$ " Pinion 9, which is free to rotate about the Rod, but is retained in position by a Collar 10. The Pinion is engaged by the teeth of both Contrate Wheels 3 and 7. The Double Bent Strip forming the bearing 2 for the driving Rod is bolted to the plate by two $\frac{1}{2}$ " Bolts, the shanks of which enter holes in the Contrate Wheel 3 and so prevent it from rotating.

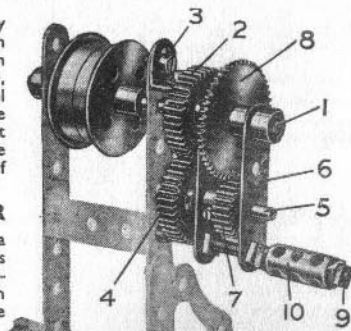

S.M.55

TWO-SPEED EPICYCLIC GEAR-BOX

S.M.58. This type of epicyclic gear-box has certain advantages over the more orthodox gear-box, chief of which are the smoothness with which the drive can be taken up and the fact that all gears are in constant mesh.

The gear-box illustrated is shown mounted between the side girders of a Meccano motor chassis. The driving shaft 1 carries two Face Plates, which are spaced apart about $\frac{3}{4}$ " and carry two 2" Axle Rods 3. Each Rod carries a $\frac{3}{4}$ " and a $\frac{1}{2}$ " Pinion, and a $2\frac{1}{2}$ " Strip 4 is fitted between the two Pinions, a Washer being placed between the Strip and $\frac{1}{2}$ " Pinion. Rods 3 are held in place by Collars, and it is important they rotate freely.

The driven shaft 2 is passed through the centre hole of the Strip 4 and is inserted in the boss of the Face Plate on the Rod 1 for a short distance to keep it correctly centred. A 57-teeth Gear 5, fixed on the Rod, is spaced from the Face Plate by a Washer, and from the Strip 4 by three Washers. The 50-teeth Gear 6 is held in a Socket Coupling in which also a $1\frac{1}{2}$ " Pulley is secured. The Socket Coupling unit is free on the Rod 2, and a Collar is placed between the Gear 6 and the $2\frac{1}{2}$ " Strip. A length of Cord is tied to an Angle Bracket fixed to the frame, passed round the $1\frac{1}{2}$ " Pulley, and then led round a $\frac{3}{8}$ " Bolt fixed by two nuts to the Angle Bracket and two Washers to keep the Cord in place. The Cord is finally tied to the foot pedal 8, consisting of a pivoted $1\frac{1}{2}$ " Strip to which an Angle Bracket is bolted. A Bush Wheel 7 is fixed on the driven Rod, in such a way

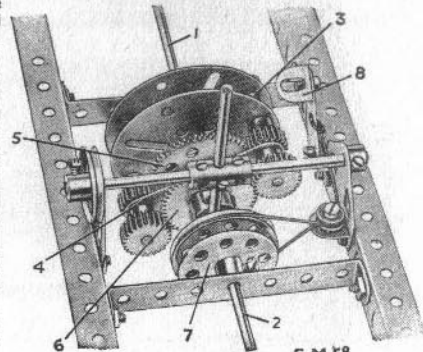

S.M.58

Section V. Planetary and Epicyclic Gears—(continued)

that the shanks of Bolts fitted to the $1\frac{1}{2}$ " Pulley can be made to engage the holes in the Bush Wheel to form a dog-clutch.

The Socket Coupling unit is free to slide on its Rod, and its movement is controlled by a hand lever consisting of a $2\frac{1}{2}$ " Axle Rod. The lever is held in a Coupling carrying two 2 " Rods journalled in Flat Trunnions bolted to the side girders. To engage low gear the hand lever is pulled back, thus disengaging the dog-clutch, and the foot pedal is depressed to apply the brake to the $1\frac{1}{2}$ " Pulley, which is held stationary. Top gear is engaged by releasing the foot pedal and moving the hand lever forward. This engages the dog-clutch and gives a "straight through" drive, as the two Gears 5 and 6 become solid on the driven Rod 2.

HOBBS' INERTIA GEAR

S.M.59. The type of gear-box in which sliding gears are brought into mesh by the movements of a gear lever has never been regarded as ideal for use in motor cars in spite of the great improvements effected in its design since its introduction for this purpose. In recent years new types of gear-boxes therefore have occupied the attention of inventors, and this ingenious mechanism, developed by Mr. H. F. Hobbs, an Australian engineer, automatically provides gear ratios suitable for the load imposed on the engine of the car to which it is fitted. Its use makes the inclusion of a clutch unnecessary.

S.M.60a

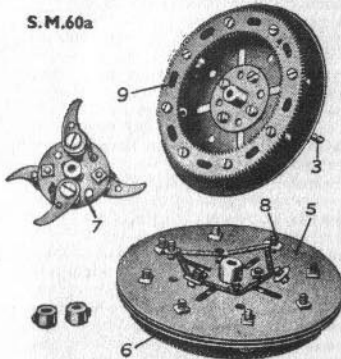

The driving shaft 1 and the driven shaft 3 are arranged in line with a short intermediate shaft 2. The driving shaft corresponds to the engine crankshaft in actual practice, and is fitted with two Face Plates, bearings for the Rod being formed by the end Plate of the frame and a $3\frac{1}{2}$ " x $\frac{1}{2}$ " Double Angle Strip bolted between the side Plates, but spaced from them by Washers. The 2 " Rod 2 is inserted for a short distance in the

boss of the end Face Plate on the Rod 1, but is free to rotate, and is supported also in a Double Angle Strip fitted between the side Plates. A 50-teeth Gear, a Collar and a Face Plate are fixed to the Rod. The driven Rod 3, which is journalled in a Double Angle Strip and the $3\frac{1}{2}$ " x $2\frac{1}{2}$ " Plate of the casing, carries a Ratchet Wheel, and a Pulley fitted with a band brake.

The two Face Plates on the Rod 1 carry two $1\frac{1}{2}$ " Rods 4 that are free to rotate and are provided with $\frac{3}{8}$ " Pinions and Couplings. The Rods are inserted in the end transverse bores of the Couplings, and the latter each bear two Collars firmly fixed by means of $\frac{3}{8}$ " Bolts. The Couplings are spaced from the Face Plates by a Washer on each side. The Pinions mesh with the Gear Wheel 6, and when they are correctly placed the weights 5 should be arranged in exactly opposite positions before the grub-screws are tightened up. The correct placing of the weights in relation to each other is very important if smooth running is to be obtained, as any inaccuracy will cause excessive vibration at high speeds.

The Face Plate on the Rod 2 carries two Pawls 8, mounted on Pivot Bolts and held in constant engagement with the Ratchet Wheel 7 by means of Spring Cord. This arrangement serves as a freewheel and smooths out the drive. If the shaft 1 is rotated and the Gear 6 held stationary, the planet Pinions will rotate round the Gear, causing the weights 5 also to rotate. Centrifugal force acting on these weights imparts a series of impulses to the Gear 6, tending to turn it first in one

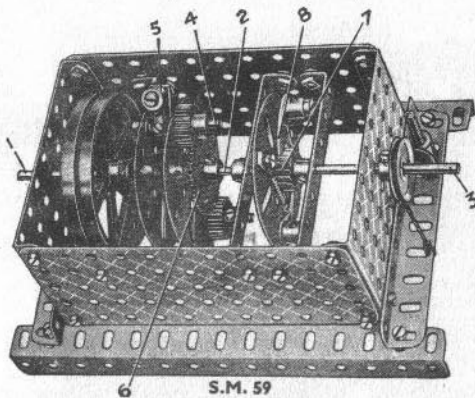

S.M.59

fitted with a weight made up of a number of Flat Brackets. The actual number used will depend upon the maximum speed of the driven shaft, and they are pivotally connected by means of $1\frac{1}{2}$ " Strips to the Screwed Rods 4 on the driving Plate. The flywheel or "pendulum wheel" 5 is built up by placing the bosses of Bush Wheels through the centre holes of two 4 " Circular Plates, the two Plates then being mounted with the Bush Wheels inward on each side of a third Plate, and secured by eight $\frac{3}{8}$ " Bolts on the shanks of each of which are two Washers, one between each Plate. The same Bolts hold the Gear Ring 6, which is spaced from the Plate by a Collar and Washer on each Bolt. To the rear of the flywheel so formed lengths of Spring Cord are fitted, being attached by Bolts 8 to the $4\frac{1}{2}$ " x $2\frac{1}{2}$ " Flat Plate fixed to the frame.

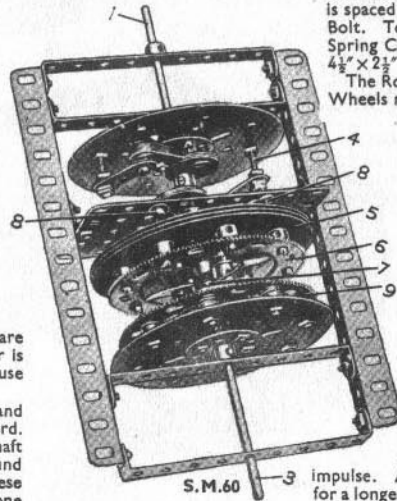

S.M.60

direction and then in the other; and as the speed of the driving shaft increases a greater force is exerted on the weights 5, and the resistance offered by the Gear 6 is overcome.

SPONTAN TRANSMISSION GEAR

S.M.60. The operation of this mechanism will best be understood by reference to the three photographs of the Meccano model reproduced on this page. S.M.60 shows the complete gear, and S.M.60a and S.M.60b show the components before assembly.

The working parts are housed in a frame consisting of two $7\frac{1}{2}$ " Angle Girders, between which are bolted four $4\frac{1}{2}$ " x $\frac{1}{2}$ " Double Angle Strips and a $4\frac{1}{2}$ " x $2\frac{1}{2}$ " Flat Plate. These form bearings for the driving shaft 1, the intermediate shaft 2, S.M.60b, and the driven shaft 3. The Rod 1 carries a 4 " Circular Plate that is bolted to a Bush Wheel and fitted with two 1 " Screwed Rods 4, each held firmly in place by two nuts screwed tightly against the Plate. The $3\frac{1}{2}$ " Rod 2 is journalled in the Flat Plate, and also in the boss of the inner Bush Wheel bolted to the Circular Plate on the Rod 3. This Bush Wheel can be seen in S.M.60a.

The end of the Rod 2 carries two Single Throw Eccentrics mounted with the bosses facing outward and in directly opposite positions. The strap of each Eccentric is fitted with a weight made up of a number of Flat Brackets. The actual number used will depend upon the maximum speed of the driven shaft, and they are pivotally connected by means of $1\frac{1}{2}$ " Strips to the Screwed Rods 4 on the driving Plate. The flywheel or "pendulum wheel" 5 is built up by placing the bosses of Bush Wheels through the centre holes of two 4 " Circular Plates, the two Plates then being mounted with the Bush Wheels inward on each side of a third Plate, and secured by eight $\frac{3}{8}$ " Bolts on the shanks of each of which are two Washers, one between each Plate. The same Bolts hold the Gear Ring 6, which is spaced from the Plate by a Collar and Washer on each Bolt. To the rear of the flywheel so formed lengths of Spring Cord are fitted, being attached by Bolts 8 to the $4\frac{1}{2}$ " x $2\frac{1}{2}$ " Flat Plate fixed to the frame.

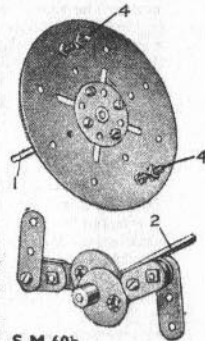

S.M.60b

The Rod 2 is free to rotate in the bosses of the two Bush Wheels mounted between the Plates, and carries the Bush Wheel 7, which is fitted with four Pivot Bolts carrying Pawls. The Bush Wheel is spaced from the flywheel 5 by means of Washers, and a Collar is placed between the wheel 5 and the Flat Plate. The Pawls on one side of the Bush Wheel engage the inside teeth of the Gear Ring 6, and the second pair of Pawls engages the teeth inside the Gear Ring 9, which is bolted to a circular Plate by eight $\frac{1}{2}$ " Bolts each carrying a Collar and two Washers for spacing purposes.

When the Rod 1 is rotated slowly, the connecting links attached to the Rods 4 cause the bobweights on the Eccentric straps to rotate round the Eccentrics. These unbalanced weights tend to turn the Eccentrics first in one direction and then in the other, the impulses increasing in intensity as the engine speed increases. This alternate to-and-fro motion is transmitted through the Rod 2 to the Bush Wheel 7, and backward rotation is damped out by the action of the Pawls on the flywheel 5, which is prevented from rotating by the Spring Cord. The spring-mounted wheel tends to smooth out the drive and the reaction of the springs by which it is held assists the forward motion.

The second set of Pawls on the Bush Wheel 7 rotate the Gear Ring 9, thus causing the car to travel forward, the tendency being for the car to free-wheel on the backward stroke until it receives another forward impulse. As the car picks up speed the forward impulses act on the Eccentrics for a longer period and the reverse impulses are proportionately reduced. Eventually a stage is reached when the Rod 2 rotates uniformly with the driving shaft.

Section V. Planetary and Epicyclic Gears—(continued)

FOUR-SPEED and REVERSE PLANETARY GEAR-BOX

S.M.61. By means of planetary gearing it is possible to obtain a wide range of gear ratios that are not easily obtained by direct gearing. The construction of a planetary gear-box offers much scope for ingenuity, and a cleverly-designed box of this type is illustrated in S.M.61. The $6\frac{1}{2}$ " Axle Rod 1 takes up the drive from the power unit, and is journalled in the centre holes of a $5\frac{1}{2}$ " Angle Girder and a $5\frac{1}{2}$ " \times $\frac{1}{2}$ " Double Angle Strip forming part of the framework for the gear-box. The driven 5" Rod 2 is journalled in a similar manner at the other end of the frame. A cage for the planet gears is built up from two Face Plates, between which two 2" Axle Rods are secured by means of Threaded Couplings rigidly bolted to the Plates, which are arranged with their bosses outermost. The Face Plates should be lined up carefully so that the holes through the bosses are in perfect alignment, and the complete cage is free to slide on the Rods 1 and 2. The Rod 2 carries at its inner extremity a 1" Gear Wheel 4, in the centre hole of which the end of the Rod 1 is inserted to prevent wobble. The Rod 1 carries a fixed $\frac{3}{4}$ " Pinion 3.

The sun wheels 6 and 7, consisting of a 57 and a 50-teeth Gear Wheel, are held together by a Socket Coupling placed over their bosses, and the Rod 1 is free to rotate in their centres. The Gears are prevented from rotating by a $3\frac{1}{2}$ " \times $\frac{1}{2}$ " Double Angle Strip attached to the 57-teeth Gear by $\frac{1}{2}$ " Bolts, on the shank of each of which is a Collar for spacing purposes.

Two 3" Axle Rods are placed as shown and passed through the Double Angle Strip to prevent it from rotating, at the same time allowing it to slide to and fro. The 5" Axle Rods 8 and 9, journalled in the cage, carry the planet Pinions that rotate about the Gears 6 and 7. Rod 8 carries a $\frac{1}{2}$ " Pinion engaging the Gear 6, and the Rod 9 a $\frac{3}{4}$ " Pinion that meshes with the Gear 7.

Each Rod carries a Coupling, and these Couplings are connected together by $2\frac{1}{2}$ " Rods held in their end transverse bores. The two Rods engage the groove of the Socket Coupling, so that as the sun wheels are slid to and fro by means of the $3\frac{1}{2}$ " \times $\frac{1}{2}$ " Double Angle Strip, they also cause the cage to slide with a corresponding movement, but at the same time allow it to rotate independently.

The Rod 8 carries, in addition to the planetary Pinion, two 50-teeth Gears 10 and 11, and a 1" Gear 13. The Rod 9 carries a 50-teeth Gear 14 and a 1" Gear 12, placed inside the cage, and another 50-teeth Gear placed outside the cage at the opposite end to the sun and planet wheels.

The $9\frac{1}{2}$ " Angle Girders forming the top and bottom members of the main frame are fitted with two Flanged Brackets spaced from the Girders by three Washers on each securing Bolt. A 5" Axle Rod is journalled in the outer holes of these Brackets, and carries two Couplings, in the upper one of which a $3\frac{1}{2}$ " Axle is fitted, and in the lower one a $4\frac{1}{2}$ " Axle. These Rods carry Couplings that are connected by a $4\frac{1}{2}$ " Rod. A third Coupling on the lower Rod carries a Threaded Pin and a 1" Axle Rod, the Pin forming a handle for the gear-change mechanism, while the 1" Rod fits into the holes of a 4" Curved Strip, fixed as shown. To allow correct placing of

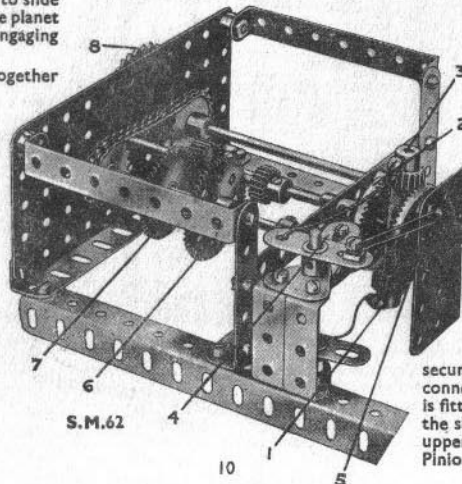
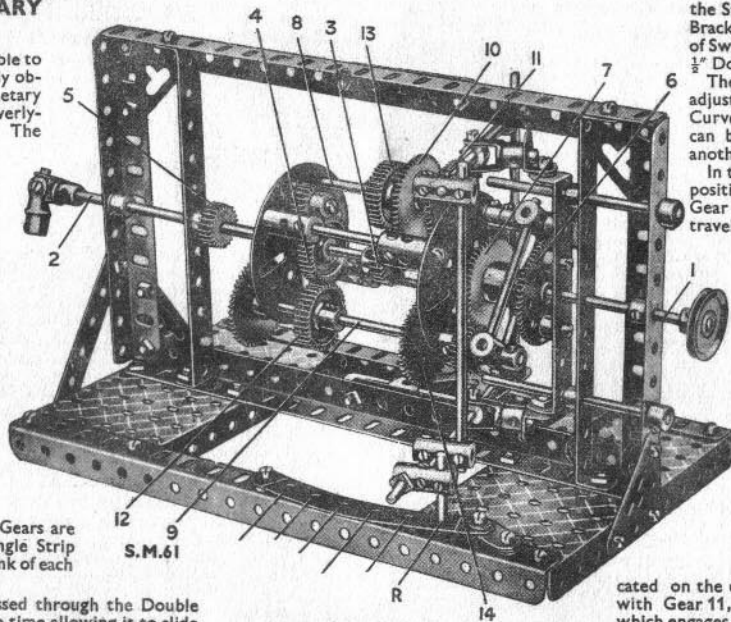

the Strip, one end is attached to the slotted hole of a Flat Bracket. The two horizontal Rods are connected by means of Swivel Bearings and pivoted Angle Brackets to the $3\frac{1}{2}$ " \times $\frac{1}{2}$ " Double Angle Strip attached to the sun wheels.

The 1" Rod at the end of the gear-change lever should be adjusted so that normally it fits into one of the holes in the Curved Strip, but by a slight upward movement of the lever can be disengaged to allow the lever to be moved in another position.

In the illustration reverse gear is in engagement. In this position the Pinion 3 on the driving shaft engages with the Gear 10, thus causing the $\frac{1}{2}$ " planet Pinion on the Rod 8 to travel round the sun wheel 6. This movement causes the cage to revolve, and for reverse gear the cage is locked "solid" with the driven shaft by means of a fixed $\frac{1}{2}$ " Pinion that engages the 1" Gear 4. The Pinion is mounted on a $\frac{3}{4}$ " Bolt and spaced by two Washers from the Face Plate, the Bolt being inserted in one of the elongated holes so that the Pinion can be correctly placed for the teeth to engage the 1" Gear.

By moving the gear lever one position to the left, the fixed Pinion is thrown out of engagement with the Gear 4, which is brought into mesh with the 1" Gear 12 on the Rod 9. The driving Pinion 3 still remains in mesh with the Gear 10, thus causing the cage to rotate, and the $\frac{3}{4}$ " Pinion on the Rod 9 to run round the Gear 7. Thus the Gear 12 drives the Gear 4. By moving the gear lever into the next position, Pinion 3 is disengaged from the Gear 10, so that no drive is transmitted to the cage.

For second gear, the position of which is indicated on the quadrant, the Pinion 3 is brought into engagement with Gear 11, and the Gear 12 slides out of mesh with the Gear 4, which engages the Gear 13. In this case the Rod 9 rotates idly. The Gears 4 and 13 remain in mesh for third gear, but the driving Pinion is disengaged from the Gear 11 and brought into mesh with the 50-teeth Gear 14.

Further sliding movement of the cage disengages the two 1" Gears and causes the 50-teeth Gear mounted outside the cage to engage with the Pinion 5.

AUTOMATIC GEAR CHANGE

S.M.62. The device illustrated is a Meccano demonstration model of an automatic change gear-box. The Rod on which the $1\frac{1}{2}$ " Contrate Wheel 1 is journalled is driven from the armature spindle of the Electric Motor through 3:1 reduction gear. A similar Contrate 2 is secured on a Rod journalled in the gear-box in such a manner that its end is in line with the Rod carrying the Contrate 1. A Coupling with a 1" Rod held in each end is then placed loosely on the Rod, and a $\frac{1}{2}$ " Pinion is mounted loosely on each Rod, being held in place by a Collar 3.

The Rod carrying the Contrate 2 has secured to it a $\frac{3}{4}$ " and a $\frac{1}{2}$ " Pinion, which engage in turn with the Gears 6 and 7 when the Rod on which the Gears are secured is moved laterally. A Crank 4 is secured to a short vertical Rod that carries also two Double Arm Cranks connected by short lengths of cord to the Collars 3. The end of Crank 4 is fitted with a Bolt, the shank of which engages between two Collars on the sliding shaft. A short piece of elastic 5, attached to the end of the upper Double Arm Crank and to the Motor, normally keeps the $\frac{3}{4}$ " Pinion and 50-teeth Gear 7 in mesh.

Section VI. INTERMITTENT ROTARY MOTIONS

AUTOMATIC REVERSING GEAR

S.M.63. In constructing models of lifts, cranes, cable railways, etc., it is often desirable to incorporate a mechanism that will give a periodical reversal of the movement of the model for demonstration purposes. A mechanism for this purpose is shown in S.M.63. The framework in this example consists of $7\frac{1}{2}$ " Angle Girders built up in the form of a square with two channel section girders crossing it. The latter girders support a short channel section girder composed of two $2\frac{1}{2}$ " Angle Girders bolted in place in the position shown. At each side of this compound girder a Flat Trunnion is bolted in place, the intermediate $7\frac{1}{2}$ " compound girders forming supports for these. The upper holes of the Trunnions each carry one end of a $2\frac{1}{2}$ " x $\frac{1}{2}$ " Double Angle Strip.

A 2" Rod is journalled at its lower end in the short compound girder already mentioned, the Double Angle Strip forming the upper support to the Rod. A $\frac{1}{2}$ " Pinion is secured on the Rod between its two bearings, and above the Double Angle Strip a $\frac{1}{2}$ " throw Eccentric is carried. The purpose of this will be described later.

The bottom edge of the $2\frac{1}{2}$ " Girder supports the lower edge of a Flat Trunnion, the upper hole of which forms a bearing for one end of a Rod



S.M.64

mounted in reinforced bearings. The other end of the Rod is journalled in the upper holes of a Trunnion bolted to the outer edge of the frame of the mechanism. (It should be noted that at all points where a Rod is journalled in a hole, a Crank or Double Arm Crank is fitted to form a reinforced bearing). This above-mentioned Rod carries a Worm that is in constant engagement with the $\frac{1}{2}$ " Pinion of the vertical shaft. A second $\frac{1}{2}$ " Pinion engages with a $1\frac{1}{2}$ " Contrate Wheel journalled in suitable bearings and driven from the source of power, an Electric Motor or similar unit.

At right angles to this latter Rod a second Rod is fitted so that it is free to slide in bearings built up from Flat Trunnions and Cranks. This second Rod supports two $\frac{1}{2}$ " Pinions that are brought alternately into engagement with the $1\frac{1}{2}$ " Contrate Wheel by means of the Eccentric that is coupled to the Rod by a 3" Strip and Swivel Bearing. The Strip is connected rigidly to the Swivel Bearing by a Pivot Bolt and Collar, the "spider" of the Swivel Bearing being allowed to rotate freely about the Rod. It is, however prevented from moving laterally, independent of the Rod, by means of two Collars. The action of the model will now be seen. As the Contrate is rotated it drives the Eccentric which in turn causes the two Pinions to engage alternately with the Contrate, thus giving a reverse to the Rod.

SILENT INTERMITTENT ROTARY MOTION

S.M.64. This mechanism is used in actual practice to drive an oil pump, but may be applied to a great many Meccano models. It is positive in its action and practically silent. The flywheel is secured on a Rod representing the pump spindle, at the outer end of which is placed a Collar holding a $5\frac{1}{2}$ " Strip in position. This Strip is pivoted $2\frac{1}{2}$ " from its lower end, and carries at its upper end a cam built from one $2\frac{1}{2}$ " Strip and one $1\frac{1}{2}$ " Strip and a $2\frac{1}{2}$ " small radius Curved Strip. The complete cam is pivotally secured to the Strip by a $\frac{3}{8}$ " Bolt, in such a position as to allow the outer edge of the Curved Strip to engage with the groove cut in the rim of the flywheel. A short length of Spring Cord is utilised to hold the cam in position.

The lower end of the $5\frac{1}{2}$ " Strip is secured by a lock-nutted Bolt to a 2" Strip bolted to the strap extension of a Triple Throw Eccentric. This part is mounted on one end of a Rod of suitable length that is connected up to the source of power.

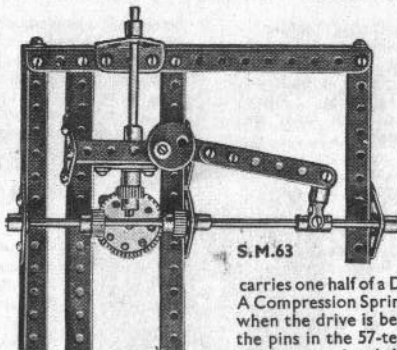

S.M.63

carries one half of a Dog Clutch, the other portion being secured to the inner end of a sliding Rod. A Compression Spring on this Rod preserves contact between the two sections of the Dog Clutch when the drive is being transmitted. As the Rod, driven by the Bevel Gears, rotates, however, the pins in the 57-teeth Gear come into engagement with a tappet rod. The movement from this is transmitted through a sliding Rod and Crank to the Rod carrying the Compression Spring, and in this way the members of the Dog Clutch are drawn apart.

CENTRIFUGAL INTERMITTENT MOTION

S.M.66. This device is really a speed regulator, but because of its unique action it falls under the heading of intermittent rotary motion.

The demonstration framework is strongly constructed from Angle Girders, but it may, of course, be altered to suit individual requirements.

The $3\frac{1}{2}$ " Gear Wheel 1 is secured to a $3\frac{1}{2}$ " Rod journalled in a $2\frac{1}{2}$ " x $\frac{1}{2}$ " Double Angle Strip attached to the top Angle Girders of the frame. One end of a length of cord is wound round this Rod, and the other end is attached to a weight of approximately 4lb., which provides the necessary driving power.

The $3\frac{1}{2}$ " Gear meshes with a $\frac{1}{2}$ " Pinion on a short Rod, which also carries a $\frac{1}{2}$ " Bevel that is in engagement with a $1\frac{1}{2}$ " Bevel on the vertical Rod 2. A Coupling is placed loosely on the Rod 2, beneath the $1\frac{1}{2}$ " Bevel, to form a bearing for one end of the Rod carrying the $\frac{1}{2}$ " Bevel and Pinion. The Coupling is spaced the necessary distance from the $1\frac{1}{2}$ " Bevel by Washers to ensure the correct engagement of the two Bevels and to prevent binding.

To the top end of the Rod 2 is secured a Coupling that carries an $11\frac{1}{2}$ " Rod 5. This Rod 5 carries a Coupling at each end, and to one of these Couplings a small weight is attached by a short length of cord. The other Coupling has a 25-gramme Weight attached rigidly to it to balance the effect of the suspended weight.

A $4\frac{1}{2}$ " Rod 4 is now secured in the boss of a Double Arm Crank, and the latter is bolted to the top of the framework in the position shown.

SMALL MALTESE CROSS MECHANISM

S.M.67. This type of mechanism is very largely used in cinematograph machines for pulling the film through the projector in a series of intermittent movements, so that each tiny picture is made to pause for a moment behind the lens. If the film were pulled through in a continuous movement the screen would have the appearance of a confused series of pictures instead of the familiar clear and steady picture.

The driving member consists of a Bush Wheel mounted on a suitable shaft and fitted in seven of its holes with Threaded Bosses, six of which are held in place by their Bolts. The remaining Threaded Boss is held in place by a 1" Threaded Rod 1 and a Nut. The driving member, that rotates the drum carrying the film in an actual machine, is represented in the model by two built-up fittings carried on

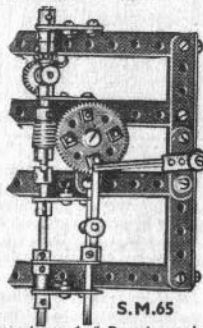

S.M.65

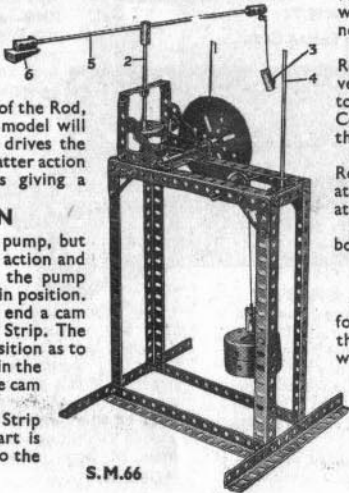

S.M.66

Section VI. Intermittent Rotary Motions—(continued)

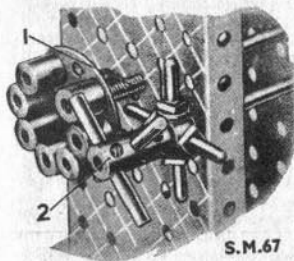

S.M.67

and at the same time the gap in the circle of Threaded Bosses allows one of the $1\frac{1}{2}$ " Rods to pass. Except when the Threaded Rod rotates it, the driven member is locked in position by the Rods in the Coupling 2.

the least danger of slip. In the model the base consists of a $5\frac{1}{2}$ " x $2\frac{1}{2}$ " Flat Plate fitted on the reverse side with two bearings formed from Double Bent Strips. The lower bearing carries a short Rod coupled to a driving shaft and fitted with a 1" Gear Wheel 5. This Gear engages with a half section of a 3" gear built up from a Bush Wheel 4 and two Rack Segments 2. The Bush Wheel is locked on a Rod 1 that transmits the intermittent drive to the desired point of a model. A third Rack Segment 3, bolted to a $1\frac{1}{2}$ " Strip, is free to swing about the Rod 1, a Collar being used to hold it in position.

A short length of Spring Cord is now fitted, one end of this being secured to the Bolt that connects the Rack Segment 3 to its $1\frac{1}{2}$ " Strip. The other end of this Spring Cord is passed once round the boss of the Bush Wheel 4 and held in place by the Set-screw. In order to enable the mechanism to work correctly, a load sufficient to overcome the resistance of the Spring Cord must be placed on the Rod carrying the 1" Gear Wheel 5. As the Rod 1 rotates, the 1" Gear turns until the end of the two fixed Rack Segments is reached. Immediately the Gear passes on to the Segment 3, that Segment stops under the influence of the Spring Cord. It continues its movement, however, when the end of the two Segments 2 come into contact with 1" on the reverse side. As soon as it passes the Gear 5, it is returned to its normal position, ready for another cycle, by the Spring Cord.

VARIABLE RATCHET MOVEMENT

S.M.73. The necessity sometimes arises to adjust the feed of a ratchet without stopping the driving mechanism, and an ingenious arrangement for carrying this out is shown in S.M.73. The Bush Wheel 1 forms the driving crank that imparts reciprocating motion to the $5\frac{1}{2}$ " Strip forming the connecting rod. The end of this Strip is connected to two pivoted links, one of which is attached by a bolt and lock-nuts to a 1" Triangular Plate at the end of the 2" Strip swinging about the Rod that carries the 57-teeth Gear. The Strip is spaced from the Gear by two Washers, and at its other end is a Pivot Bolt carrying a Pawl 4 that is held in constant engagement with the Gear Wheel by a length of Spring Cord. A second Pawl prevents backward movement of the Gear.

The 2" Strip 2 is pivoted on a Bolt that is screwed into the end hole of a Threaded Boss and locked by a nut. The Threaded Boss is carried on a 2" Screwed Rod, the upper end of which is

one Rod. The inner fitting consists of a "spider" taken from a Swivel Bearing, carrying four Threaded Pins. These Threaded Pins lock the "spider" securely to the Rod. The second fitting is built up from a Coupling 2 carrying two $1\frac{1}{2}$ " Rods. These parts are fitted at right-angles to each other by securing them in the two outer holes of the Coupling.

The operation of the movement is as follows. As the driving member rotates, the Threaded Rod 1 strikes one of the Threaded Pins on the driven member,

CONSTANT ENGAGEMENT INTERMITTENT MOTION

S.M.72. In most movements that transform a continuous rotary motion into an intermittent rotary motion, some part of the mechanism is periodically out of engagement. Unless a suitable locking mechanism is incorporated this means that the disengaged section of the movement is practically out of control for a short period, and therefore is liable to error. The mechanism shown in S.M.72 avoids this difficulty, and transmits timed impulses to a shaft accurately and without

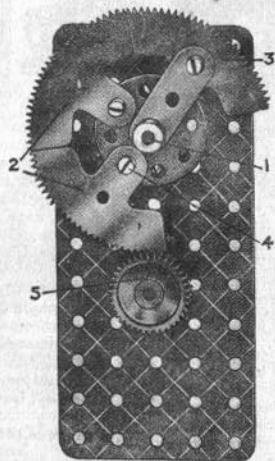

S.M.72

In the model the base consists of a $5\frac{1}{2}$ " x $2\frac{1}{2}$ " Flat Plate fitted on the reverse side with two bearings formed from Double Bent Strips. The lower bearing carries a short Rod coupled to a driving shaft and fitted with a 1" Gear Wheel 5. This Gear engages with a half section of a 3" gear built up from a Bush Wheel 4 and two Rack Segments 2. The Bush Wheel is locked on a Rod 1 that transmits the intermittent drive to the desired point of a model. A third Rack Segment 3, bolted to a $1\frac{1}{2}$ " Strip, is free to swing about the Rod 1, a Collar being used to hold it in position.

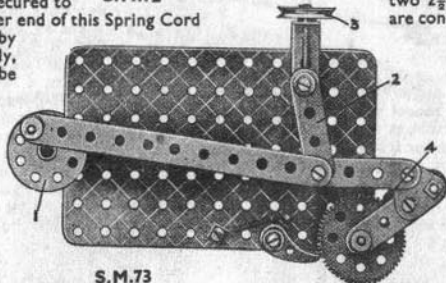

S.M.73

fitted with a handwheel 3. By operating this wheel the position of the link 2 can be varied, and when the Threaded Boss is at the lower end of its Screwed Rod the maximum movement is imparted to the swinging Strip carrying a Pawl 4, which causes the 57-teeth Gear to move through a corresponding distance. As the link 2 is raised the movement of the connecting rod is partially absorbed by the two 2" Strips, and the movement of the Pawl is decreased until it reaches its minimum when the Threaded Boss carrying the link 2 reaches the end of its travel.

If very fine adjustments of feed are required, a larger gear should be substituted for the 57-teeth gear. The smallest variation possible with this Gear is $1/57$ th of a revolution, that is the movement through one tooth of the gear; but by using a $2\frac{1}{2}$ " or $3\frac{1}{2}$ " Gear, adjustments as fine as $1/95$ th or $1/133$ rd of a revolution can be made.

CLOCK ESCAPEMENT

S.M.74. The ordinary clock, fitted with a pendulum, incorporates one of the most ingenious, yet simple, controlling mechanisms ever used in engineering. By means of this movement it is possible to make an actual clock run for an amazing length of time, many on one winding being capable of operating without a stop for over a year. Such accurate time-pieces as the master clock at Greenwich Observatory and others at similar institutions throughout the world have been in operation without a pause for a great number of years, and owing to the careful workmanship exercised in their construction, have never varied more than a fraction of a minute during periods extending over years. This amazing accuracy is chiefly the result of the use of the escapement mechanism, a reproduction of which is shown in S.M.74. This example is shown incorporated in the Meccano Grandfather Clock; many models of which have been in use for many years and have given complete satisfaction.

The escapement wheel consists of a Face Plate 76 fitted with eight $\frac{1}{2}$ " Reversed Angle Brackets 77. Each of these is held in place by one nut and bolt 78 and care must be taken to see that the distance between the Reversed Angle Brackets is the same in each case.

The pallet is suspended above the escapement wheel and is constructed in the following manner. A Crank 73 is carried on the same Rod as the crutch operating the pendulum. A $1\frac{1}{2}$ " Strip is bolted to this Crank together with two $2\frac{1}{2}$ " large radius Curved Strips, the points at which each of these parts are connected together being the positions for two $\frac{1}{2}$ " x $\frac{1}{2}$ " Angle Brackets 75. As

the pendulum swings, the escapement wheel is allowed to rotate one tooth at a time by the Angle Brackets, and at the same time sufficient energy is transmitted to the pallet to keep the pendulum in motion.

The adjustment of this movement is very fine, and considerable patience must be exercised before an accurate beat is obtained. The $\frac{1}{2}$ " x $\frac{1}{2}$ " Angle Brackets call for particular attention in this direction, but before these are adjusted the $\frac{1}{2}$ " Reversed Angle Brackets 77 must be trued-up. This can be easily accomplished by making use of a circle, drawn on a sheet of paper, and divided in eight equal segments.

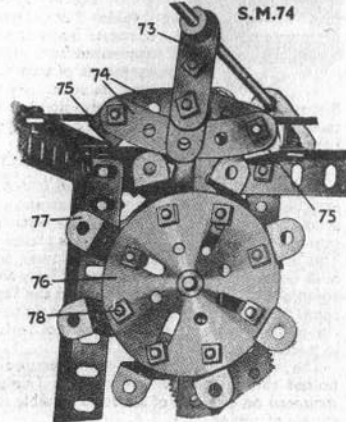

S.M.74

Section VII. CRANKS, CAMS AND ECCENTRICS

SIMPLE CRANKSHAFT

S.M.75. In an engine where an ordinary type of balance crank is required an arrangement similar to that shown in S.M.75 will be found very suitable. Its construction is comparatively simple, and because of this it may be incorporated in almost any model. If a smaller crank is required it can be built up from two Double Arm Cranks fitted at their unoccupied arms with 1" Corner Brackets representing balance weight.

In this example each crank web is built up from a Triangular Plate fitted with two Cranks, one of which has its boss in the centre of one side of the Plate, the other having its boss at the apex of the Plate on the inside. When the two webs are completed they are joined together by a 1" Rod forming the crank pin on which is carried a Coupling. The crank pin passes through the end transverse bore of this Coupling. The end vertical tapped hole is fitted with a Handrail Support representing a grease box, the shank of which is fitted with three Washers to prevent it from

gripping the Rod. On one side of the crank is a short Rod forming part of the crankshaft, the part on the other side

S.M.75

consisting of a considerably longer Rod carrying a Triple Throw Eccentric and a 1" Sprocket Wheel. The Sprocket forms a connection between the crankshaft and governor. The Eccentric, which is set at 180 deg. to the crank, is connected either direct to the valve or, in more complicated models, to the valve gear. The connecting rod, coupling up the crank with the piston rod, consists of a Rod of any suitable length. If desired the Coupling may be dispensed with and a Strip used as the connecting rod.

TRIPLICATED CRANKSHAFT

S.M.76. This model is a reproduction of a special formation of cranks designed primarily for use in connection with Duxford type diesel engines. In these engines the cylinders each contain two pistons working in opposite directions to each other, although both are actuated at the same time. One piston moves downward as the other moves upward, the movement being reversed for every cycle of operation. This twin movement is coupled up to the crankshaft by means of three connecting rods, the two outside connecting rods working in unison as they are attached to the upper piston.

The main section of each threefold crank consists of two separate webs, each of which is constructed from two 2 1/2" Strips and two Cranks, these Cranks being bolted to opposite sides of the Strips at each end. At the point 10 the two webs are joined rigidly together by a 1" Rod, a 3 1/2" Strip being carried on the Rod between the two Cranks. This Strip is coupled to the bottom end of the lower piston rod by means of an End Bearing.

Each of the small webs 9 and 11 is built up from two Cranks and two 1 1/2" Strips, the entire assembly being secured together by a single nut and bolt. These webs are attached to the unoccupied ends of the larger cranks by means of 1" Rods carrying 3 1/2" Strips 12 in a similar manner to that already described, and pivotally attached to the lower ends of 1 1/2" Rods by Bolts carried in the threaded transverse holes of Collars. The upper ends of the 1 1/2" Rods are joined by short Strips, the centres of which are connected by a Coupling to the upper piston rod.

Similarly, a three or four-fold crankshaft may be built up on a small scale suitable for a car engine or other similar movement.

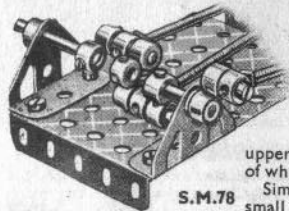

S.M.76

SLIDE CRANK MOVEMENT

S.M.77 One of the disadvantages of a steam engine of normal design is the great comparative distance between the crank and cylinder cover, this waste of space being largely due to the length of the connecting rod necessary for economical working. Many ways of reducing this distance have been invented from time to time, and among these is the slide-crank. This arrangement overcomes the difficulty of the connecting rod entirely, and although the frictional losses in the moving parts are slightly higher than those in the more usual mechanism, the exceptional neatness of the arrangement makes it preferable in many cases.

The base of the Meccano reproduction of the movement consists of a 3 1/2" x 2 1/2" Flanged Plate fitted at one end with a Flat Trunnion and three holes from the same end with a Trunnion. One of these parts supports a 3 1/2" Strip while the other carries a 5 1/2" Strip, both of which are connected together at the point shown, by means of a 1 1/2" x 1/2" Double Angle Strip. The 5 1/2" Strip carries at its upper end a Double Bracket and a second similar part at a point 2 1/2" from the base. The two outer flanges of these Brackets support a 3" Strip on which two Eye Pieces slide, these having been fitted before the Strip was finally bolted in position. It should be noted that Washers are placed under the 3" Strip on its securing Bolts for spacing purposes.

The two Eye Pieces are both arranged about 1/2" apart on a 5" Rod, and are secured in position by Grubscrews. The upper end of this Rod may be extended as desired in order to enable it to pass into the cylinder. The lower end of the Rod carries two Collars each of which is fitted with a 1 1/2" Strip 2 and 3. Bolts fitted with two Washers each form the necessary connections. The inner edges of the two Strips must be so arranged that the shank of a 3/8" Bolt 1 fits snugly between them without jamming. This Bolt is attached to a Bush Wheel by two nuts, the shaft on which the Bush Wheel is fitted forming the crankshaft.

A NEAT CRANKSHAFT

S.M.78. This example illustrates a novel method of building up small crankshafts of one or more throws; that shown is a triple-throw two bearing crankshaft. The crank webs are constructed by screwing the head of a grubscrew into one of the holes of a Collar so that one half of its shank is left projecting beyond the surface of the Collar. A second Collar is then screwed on to the shank of the grubscrew and tightened up so that both Collars are secured firmly. The centre web portion consists of two Collars secured by grubscrews to a "spider," removed from a Swivel Bearing, so that they are at right angles to one another. Grubscrews inserted in the remaining tapped holes of the various Collars serve to secure in place the crankpins and journals of the crankshaft. The connecting rods

consist of Screwed Rods that are partially inserted in the grubscrew holes of Collars that turn freely on the crankpins.

SUN AND PLANET MECHANISM

S.M.79. "Sun and planet" gear is used to convert the reciprocating motion of a piston into rotary motion. The Strip 1 represents the connecting rod. This Strip is bolted to a 37-teeth Gear Wheel 2, which is free to move about a Pivot Bolt 3 secured to a 2" Strip 4. The Strip 1 should be spaced away from the Gear Wheel 2 by means of a Washer placed on each of the two Bolts shown, in order that the Strip may clear the second Gear Wheel 5 when in motion, whilst another Washer should be placed on the Pivot Bolt 3 behind the Wheel 2.

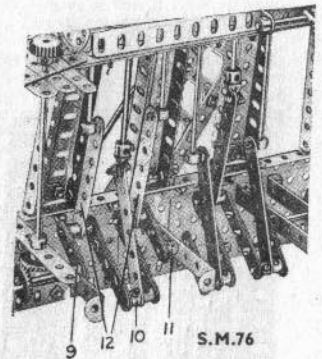

S.M.77

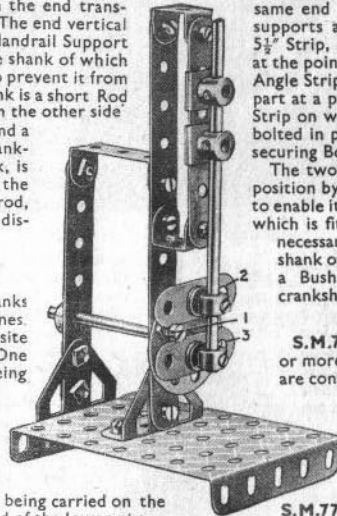

S.M.78

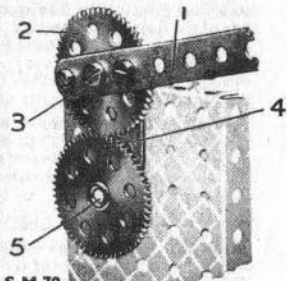

S.M.79

Section VII. Cranks, Cams and Eccentrics—(continued)

A SILENT OVERHEAD CAMSHAFT DRIVE

S.M.87. Overhead valves have become common on motor car engines because they are more efficient than side valves. The valves of such engines can be operated either by rocker arms and push rods from a camshaft placed in the position usual with side-valve engines, or the camshaft itself may be placed above the head and parallel with the crankshaft, so that the cams act directly on the ends of the rockers. The latter method is the better of the two for many reasons, but the drive from the crankshaft to the overhead camshaft must possess hard-wearing qualities be comparatively noiseless, and must not require constant checking for adjustment. S.M.87 illustrates a Meccano demonstration model of a novel form of patented overhead camshaft drive.

The model consists of two Rods mounted in suitable bearings one above the other. The lower Rod is driven in actual practice by a 2:1 reduction gear off the front end of the crankshaft and the upper Rod represents the overhead camshaft. Each Rod has three Eccentrics secured to it, the point of maximum throw of each being 120 degrees from that of its fellow on the same Rod. Each set of Eccentrics on the lower Rod is connected to those on the camshaft by Strips bolted to the eccentric "straps." Careful adjustment of the Eccentrics on their

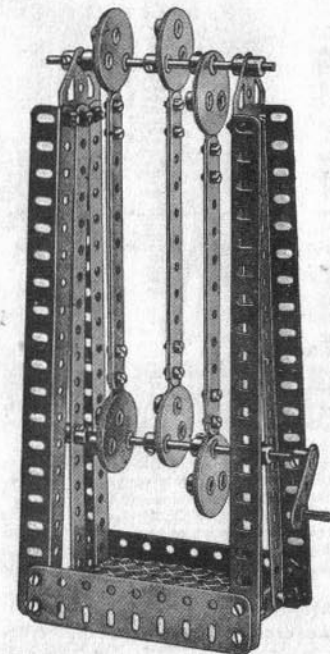

S.M.87

respective Rods in relation to one another is necessary in order to obtain a smooth and easy drive.

SMOOTH MOVEMENT CAM

S.M.88. The cam disc consists of a $1\frac{1}{2}$ " Pulley attached by one nut and bolt to a Face Plate. The Rod carrying this Face Plate is journaled in the model in one of the holes of the vertical plate, and also in the boss of a Double Arm Crank. The end of the Rod passes for a distance of about $\frac{3}{8}$ " through the boss of the Face Plate. This shaft extension also passes through the inner hole of the $1\frac{1}{2}$ " Pulley, and in this way prevents the part from twisting on its one retaining bolt.

The tappet arm is represented by a $4\frac{1}{2}$ " Strip carrying at its fixed end a Crank. A Pivot Bolt passes through this Crank and is locked to the vertical plate by means of two nuts. As will be seen, the edge of the tappet arm rests in the groove of the $1\frac{1}{2}$ " Pulley, the movement being transmitted to the desired point by a Strip pivotally attached to the tappet as shown.

BIG END FOR MECCANO CRANKSHAFT

S.M.89. The Meccano Crankshaft is designed to give a stroke of 1", but because it is made entirely from one length of rod it is often difficult to design a suitable big end for use with it. If Strips are to be used to represent the connecting rod, their ends can easily be passed round the

angles of the crankshaft, but where a Rod is to be used to represent the connecting rod, the attachment will prove somewhat more complicated. S.M.89 illustrates one method of accomplishing this.

A Spring Clip 5 is first clipped on to the centre of the cranked portion of the Crankshaft, and on each side of this is carried a Washer. On the outside of each of the Washers is placed a $1\frac{1}{2}$ " Strip, and these are connected together by means of a Coupling 1. A $\frac{3}{8}$ " Bolt 3 passes completely through the two $1\frac{1}{2}$ " Strips at their centre holes and also through the inner transverse tapped hole of the Coupling 1. The outer tapped holes are fitted with set-screws 4 under the heads of which a Washer is placed. These Washers allow the connecting rod 2 to pass into the longitudinal bore of the Coupling easily, a grub-screw holding it securely in place.

QUICK ACTION CAM MOVEMENT

S.M.90 In contrast to S.M.88, this mechanism has been designed to give a sharp drop once every revolution. It is shown in the illustration fitted into a Meccano cloth-weaving loom, but it can be incorporated in a great many other models. It can also be used as a quick-return motion if the tappet rod is loaded sufficiently with Springs.

On account of the strain under which it works, the Rod carrying the cam should be carried in reinforced bearings built up from Double Arm Cranks as described in S.M.131. The cam is built up from two Bush Wheels, three holes in each of which carry $\frac{3}{8}$ " Bolts. Each of these Bolts carries a Collar on its shank, and the three Collars in this way form a suitable cam surface. If necessary these Collars may be made to rotate by locking the Bolts to the Bush Wheels by nuts.

The tappet arm is built up from two $5\frac{1}{2}$ " Strips bolted together at the moving end by two nuts and bolts. One of these bolts also holds a 2" Flat Girder in place, and the other, although passing through both the Flat Girder and Strips, is a pivoted joint only, by means of which an End Bearing is

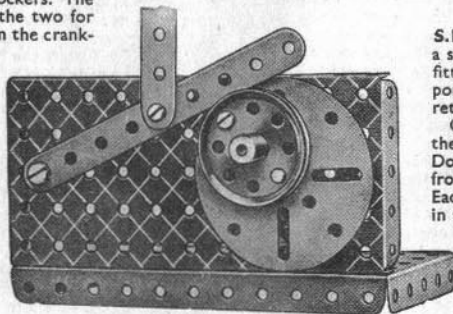

S.M.88

secured to the tappet arm. This End Bearing is secured to the bottom of a long Rod, which, in the Loom, couples up the cam mechanism with the picking mechanism.

The stationary end of the tappet arm is fitted one hole from the end with a $\frac{3}{8}$ " Bolt. The shank of this Bolt carries a Collar for spacing purposes, and the entire unit is attached to a $5\frac{1}{2}$ " x $2\frac{1}{2}$ " Flat Plate by two nuts. These nuts are placed one on each side of the Plate and hold the Bolt rigid.

Side play in the tappet arm is prevented in the following manner. Two vertical $3\frac{1}{2}$ " Strips are secured together at each end by $\frac{3}{8}$ " Bolts, Washers being placed between the Strips for spacing purposes. The $\frac{3}{8}$ " Bolts each hold a $\frac{1}{2}$ " x $\frac{1}{2}$ " Angle Bracket in place, by means of which the $3\frac{1}{2}$ " Strips are attached to two transverse Strips of any suitable length.

The centre section of the tappet arm passes between the two Strips the inner faces of which take up any lateral strain applied to the movement. If necessary the mechanism may be spring loaded by connecting one end of a Spring to the $5\frac{1}{2}$ " Strips four holes from their lower ends. The free end of the Spring may then be attached by a $\frac{3}{8}$ " Bolt to the bottom row of holes in the $5\frac{1}{2}$ " x $2\frac{1}{2}$ " Flat Plate already mentioned.

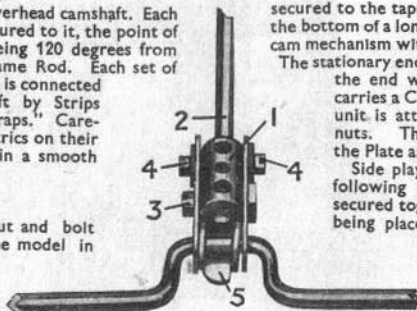

S.M.89

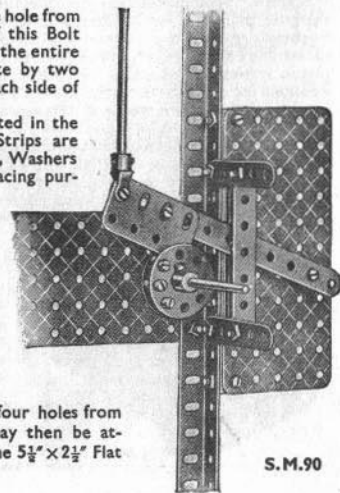

S.M.90

Section VIII. CLUTCHES AND FRICTION DRIVES

PAWL AND RATCHET FREE WHEEL

S.M.91. A "free-wheel" movement of this type can be used in all models where it is required to transmit the drive in one direction only, as in model bicycles, clock-winding mechanisms, models operated by treadles, pedal motors, etc. It is invaluable also for converting reciprocating motion into intermittent rotary motion.

The free-wheel mechanism is shown attached to a 3" Sprocket Wheel, but this may be replaced by a 3½" Gear Wheel, large Pulley, or Face Plate, etc. The Sprocket revolves freely on its axle, but is kept in position by the Ratchet Wheel secured to the axle on one side and a Collar on the other side.

Two Pawls are mounted pivotally on the face of the Sprocket by means of Pivot Bolts and lock-nuts, and are held in engagement with the Ratchet by pieces of Spring Cord attached to set-screws in the Pawls and also to the face of the Sprocket. It will be evident that the axle and Sprocket Wheel can each move independently in one direction only. The driving power may be imparted primarily to either the axle or the Sprocket, to suit requirements.

FRICTION FREE WHEEL

S.M.92. The usual type of free wheel makes use of pawls and ratchets as illustrated in S.M.91, but in this example an interesting substitute has been found for this noisy and often cumbersome ratchet type of mechanism.

A Coupling 3 is secured to a Rod, which also has a Flanged Wheel 1 mounted freely on it. The Flanged Wheel is spaced away from the Coupling by four Washers, and is attached to a 1" Gear by a Socket Coupling. The 1" Gear meshes with a second similar Gear secured on a Rod that carries also a 2" Sprocket Wheel.

In each of the end transverse bores of the Coupling is secured a Threaded Pin in such a manner that the square shanks are on opposite sides, and the flats of the shanks are turned at an angle to the longitudinal axis of the Coupling. Two Collars are free to "float" inside the Flanged Wheel. When the Coupling

is turned in a certain direction the Collars will be found to jam between the flange of the wheel and the inclined edges of the Threaded Pin shanks, so locking the Flanged Wheel to the rotating Rod. When, on the other hand, the Coupling is turned in the reverse direction, the Collars ride idly and the Rod is free to rotate independently of the Flanged Wheel.

In practice a device of this kind has important advantages over the ordinary ratchet and pawl mechanism, in that it is quicker and smoother in action and there is less wear and tear.

These advantages render it particularly suitable for use in, say, the Meccano model of the Constantinesco Torque Converter. In the existing model a pawl and ratchet device is employed, and in certain conditions of working the pawl may fail to make proper engagement with the next tooth of the ratchet. With this apparatus, however, the slightest reverse movement of the Flanged Wheel locks the two parts of the free wheel together.

CORD OPERATED FREE WHEEL

S.M.93. Although this movement is considerably simpler than S.M.92 and almost as efficient, it is unsuitable for heavy transmission owing to excessive wear of the cord. It will be found an excellent substitute for more complicated mechanisms of a similar nature, however.

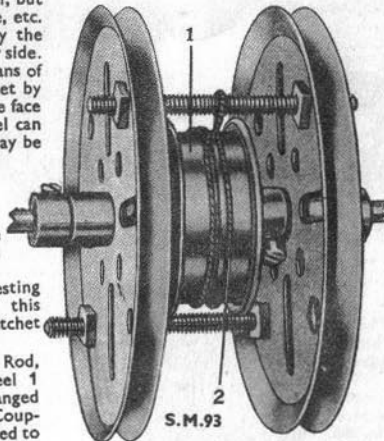

S.M.93

This free wheel comprises two 3" Pulleys joined together by means of two 2" Screwed Rods. Four nuts on each of the Rods serve to hold the Pulleys such a distance apart that two 1½" Flanged Wheels 1 can be accommodated in the space between.

The Flanged Wheels are butted together face to face and secured on a 3½" Rod that is free to turn in the bosses of the 3" Pulleys. A short length of Meccano Cord 2 is doubled and wrapped round the Wheels, and the free ends are then passed through the loop formed in the cord and secured to one of the Screwed Rods as shown in the illustration. It will be found that when the 3½" Rod is prevented from rotating it is possible to turn the 3" Pulleys easily in one direction, but in the reverse direction considerably greater effort is needed.

This apparatus could be included in the drive of a model Big Wheel or roundabout so that, when the Motor is stopped, instead of the model coming to an abrupt standstill and straining the gearing, it comes to rest gradually.

S.M.93a. If space is very limited and the load somewhat bigger than is thought desirable to drive through S.M.93, an Anchoring Spring for Cord will be found to act perfectly. The spring is mounted on the Rod carrying the Gear, preferably a 57-teeth Gear, that is to free-wheel. A ½" x ½" Angle Bracket attached to the Gear at one of its outside holes is secured in place in such a way that its horizontally arranged hole fits over the loop of the Spring.

When rotating one way the Gears tend to unwind the coil of the Spring, and it is thus prevented from gripping the Rod. When the Gear rotates in the opposite direction, however, the coiled spring tends to grip the Rod, and in this way a positive drive is imparted to the driven shaft.

The excessive friction of this mechanism when free-wheeling will prohibit it from many models, but no doubt many occasions will occur when it will be found useful.

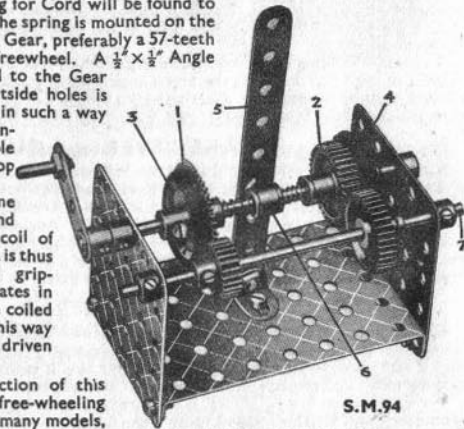

S.M.94

CLUTCH CONTROLLED GEAR-BOX

S.M.94. This example shows an extremely simple and efficient gear-box of the constant mesh type. The great advantage of this type is that the shafts do not have to be moved in order to change gear, hence the driving connections are simplified and wear and tear on gears is minimised.

The driving shaft has two 1" fast Pulleys 3 and 4 secured to it. Placed against these Pulleys, but loose on the shaft, are a 50-teeth Gear Wheel 1 and 1" Gear Wheel 2. Also on the shaft are two Compression Springs mounted between Washers and placed one on each side of a Collar 6, which is also free on the shaft.

The Collar is connected to a lever 5 that is attached pivotally to the base plate by a bolt and two lock-nuts. With the lever normal, or in the central position, no power is transmitted to the secondary Rod 7, but on moving the lever to one side or the other, one of the Springs is caused to press its respective Gear Wheel firmly against a rubber-shod Pulley, and consequently the Gear Wheel commences to revolve "solid" with the driving shaft, while the other Gear Wheel continues to ride idly upon it. Hence slight movements of the lever 5 will throw the Rod 7 out of engagement, cause it to be driven at the same speed as the driving shaft, or to rotate twice as fast as the driving shaft.

It should be a simple matter to construct on the lines suggested above an efficient gear-box.

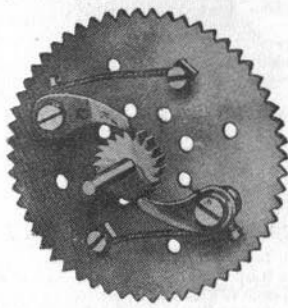

S.M.92

Section IX. BRAKES

Brakes form the subject of many interesting and ingenious Meccano mechanisms, which reproduce faithfully practically all the types of friction brakes now in use.

SIMPLE BAND BRAKE

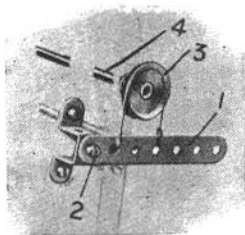

S.M.111

round which a short length of cord is passed. The two ends of this cord are secured to the brake lever at the points shown in the illustration.

If increased braking effect is desired a larger Pulley may be used in place of the 1" fast Pulley 3, the brake lever 1 being attached in a lower position if necessary. Alternatively a weight can be hung from the end of the brake lever.

BRAKE LEVER and QUADRANT

S.M.112. This mechanism is a somewhat more advanced form of band brake than that already described, as the lever can be held in any position by means of the quadrant. In this way varying pressures can be applied to the Pulley forming the brake drum.

One end of the brake cord is attached to a $\frac{1}{2}'' \times \frac{1}{4}''$ Angle Bracket bolted in a suitable position on the model. After passing round the 1" fast Pulley forming the brake drum the cord is secured at the next to bottom hole of a 3" Strip 1. This Strip forms the brake lever, and it is secured to the frame of the model by a lock-nutted Bolt.

SCREW and STRAP

S.M.113. When a very powerful constant braking effort is required S.M.112 is unsuitable, as the lever is liable to slip in its quadrant. In such circumstances, therefore, a strap and screw brake is employed, for this is capable of exerting a powerful braking effort and remains in any predetermined position.

The brake drum 5, a 1 $\frac{1}{2}''$ Pulley, is mounted on the driven shaft 6, preferably by two set-screws, as it is liable to twist loose when under full braking strain. A cord 4, held in place at one end by a $\frac{3}{8}''$ Bolt and two nuts, passes round the Pulley and the free end is secured by means of a Bolt to a Threaded Boss 2.

This Threaded Boss is free to move in a horizontal direction when the 2" Threaded Rod 3 on which it is carried is turned. The Threaded Rod is held in place at one end by a Collar and at the other by a 1 $\frac{1}{2}''$ Pulley 1 that is fitted with a Threaded Pin to form the handle.

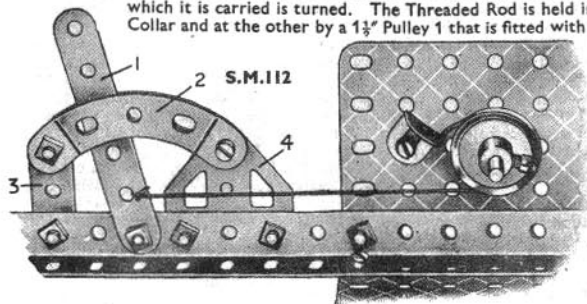

S.M.112

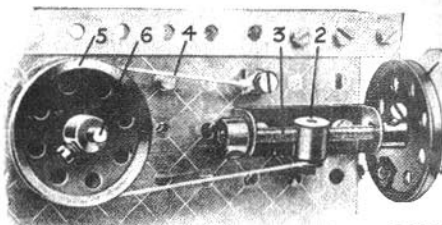

S.M.113

normal type of either band or shoe brake is unsuitable as it is liable to slip. A brake of the jamming type that is necessary in these circumstances is not required to give a gradually increasing pressure, and therefore can be very robust and also very simple in its construction.

S.M.115. shows the method of constructing a simple brake of this type. The hoisting shaft 4, which is operated through a 3:1 reduction gear train from the Crank Handle 3, is journaled at one end in the lower transverse hole of a Coupling 6, in addition to its normal bearing. The upper transverse hole of this Coupling is fitted with the shank of a $\frac{3}{8}''$ Bolt secured to the frame of the model by a nut. This Bolt takes up the braking strain when the brake is applied.

The mechanism, as shown, is applied to a car lifting apparatus, the hoisting cord of which is attached to the winding drum by an Anchoring Spring and then passed over a $\frac{1}{2}''$ loose Pulley mounted on a suitable Rod situated at the top of the mechanism frame. The scheme can be applied to other hoisting mechanisms, and also to the slewing movements of cranes.

SIMPLE INTERNAL EXPANDING BRAKE

S.M.116. This example is one of the simplest forms of internal expanding brake that can be built with Meccano parts. The brake disc, or cover plate, consist of a Face Plate 1 rigidly secured to the spring by means of two Angle Brackets. A $\frac{3}{8}''$ Bolt is now inserted in two opposite elongated holes, and the shanks of these each carry a 1 $\frac{1}{2}''$ Strip 2 and Collar 3. The two Collars are fitted with set-screws each carrying one end of a length of Spring Cord. This Spring Cord returns the brake to the "off" position after it has been applied.

The 1 $\frac{1}{2}''$ Strips 2 are connected by lock-nuts, as shown, to a 2 $\frac{1}{2}''$ Strip 5 that is pivoted, one hole from its inner end, on the rear axle. The lower end of the 2 $\frac{1}{2}''$ Strip is fitted with the rear end of the brake rod.

This is built up from two Healds and is attached at its free end to the bottom of the Crank 8. The brake rod may be made any length by introducing extra Healds.

The brake drum may consist of either a Wheel Flange bolted to a 3" Pulley or a Boiler End secured to a similar part. The 3" Pulley, when fitted with a 3" Motor Tyre forms the road wheel. If a Boiler End is used for the brake drum a 2" Tyre may be pressed directly on to it, the complete wheel and brake drum being fixed on the back axle by a Bush Wheel.

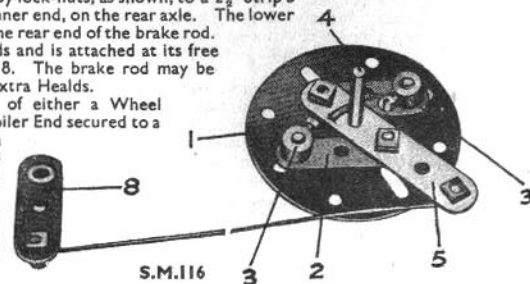

S.M.116

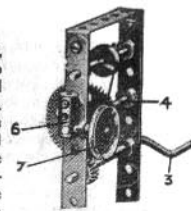

S.M.115

LIGHT DUTY BRAKE

S.M.114. It is sometimes necessary, in the construction of model cranes, etc., to apply a slight constant pressure to a gear-change lever. In order to prevent it from slipping. This can be accomplished in a number of ways and one very neat method is shown in S.M.114.

The shaft carrying the gear-change lever, a Crank fitted with a 2 $\frac{1}{2}''$ Strip, carries at one end a Spring Clip. The shaft is journaled in the top hole of a Flat Trunnion, the hole immediately below being occupied by a $\frac{1}{2}'' \times \frac{1}{2}''$ Angle Bracket. This Bracket is secured in place by a nut and bolt, the elongated hole of the part being used for this purpose in order to enable adjustment to be carried out. The two lugs of the Clip are in contact with the Angle Bracket, and in this way the Spring Clip is prevented from turning.

SIMPLE SCREW BRAKE

S.M.114



Section IX. Brakes—(continued)

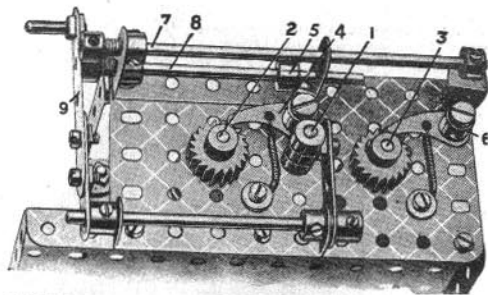

S.M.121

SELF-ACTING BRAKE FOR CRANES

S.M.121. Safety devices now play a very important part in our everyday life, and in every branch of engineering ingenious mechanisms are employed to minimise the possibility of accidents. This device is an interesting example. It automatically applies the brake to the hoisting drums of a model crane immediately they are thrown out of gear with the driving shaft. The shaft 1 is slidable in its bearings, and carries a $\frac{1}{2}$ " Pinion that can be brought into mesh with a 57-teeth Gear on the Rod 2 or with a similar Gear on the Rod 3. The Rod 1 bears two fixed Collars, between which a third Collar is free to rotate on the Rod; and a bolt is inserted through the elongated hole of a Crank and fitted with a nut before being screwed into the tapped bore of the centre Collar.

The nut locks the bolt in position and prevents it from touching the Rod 1, but should allow free movement of the Crank. The Crank is fixed on a $3\frac{1}{2}$ " Axle Rod journalled in a $2\frac{1}{2}$ " x $\frac{1}{2}$ " Double Angle Strip, and a second Crank is fixed on the other end of the Rod. To this is bolted a $2\frac{1}{2}$ " Strip 9 bearing a Threaded Pin and serving as the gear-change lever. By moving the lever to the left the Pinion on the Rod 1 is brought into engagement with the 57-teeth Gear on the Rod 2, and with the lever 9 in its opposite position the Pinion is thrown out of gear and engaged with the Gear Wheel on the Rod 3.

Both driven Rods carry Ratchet Wheels fitted with Pawls 4 and 6 as shown in the photograph. The Pawls are held in engagement by short lengths of Spring Cord and the Pawl 4 has a bolt in its tapped hole. The Collar 5, mounted on a sliding $3\frac{1}{2}$ " Rod 8, bears against the head of the Bolt, the Rod being free to slide in the end hole of a $2\frac{1}{2}$ " x $1\frac{1}{2}$ " Double Angle Strip. At its outer end this Rod carries a Compression Spring and a Collar.

SCREW OPERATED SHOE BRAKE

S.M.122. The most powerful type of brake used in engineering is the screw operated shoe brake, the shoes being of the external contracting type. Mine cage-winding engines and very large cranes often employ this form of retarding apparatus. It has the great disadvantage, however, of being somewhat slow in operation.

The comparatively simple form of this type of brake shown in the illustration on this page is constructed in the following manner. The brake drum 4 is built up from two $1\frac{1}{4}$ " Flanged Wheels

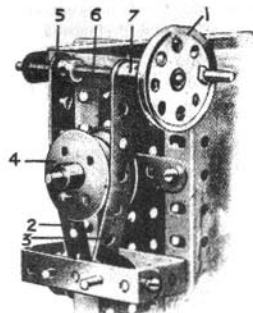

S.M.122

For new Meccano Mechanisms and Models read the "Meccano Magazine," published monthly, price 15c, subscription rate \$2.00 a year. Write to H. Hudson Dobson, 200 Fifth Avenue, New York 10, New York, for full details and a specimen copy.

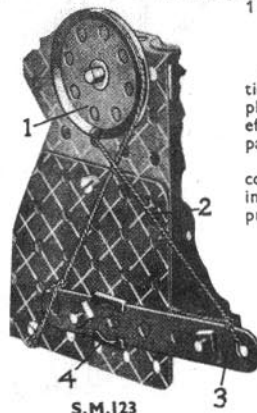

S.M.123

which may be replaced by Wheel Flanges if great pressure is required. Each brake shoe consists of a $3\frac{1}{2}$ " Strip 2 and 3 pivotally attached at its base by a Double Bracket and $1\frac{1}{2}$ " Rod to the framework.

The inner end of the Rod is carried in one hole of a $2\frac{1}{2}$ " x $1\frac{1}{2}$ " Double Angle Strip, while the outer end rests in a similarly positioned hole of a $2\frac{1}{2}$ " x $\frac{1}{2}$ " Double Angle Strip. The Strip is fitted with a Threaded Crank 5 that moves laterally on a $3\frac{1}{2}$ " Threaded Rod 6. The end hole of the Strip 3 passes over the Threaded Rod and that end of the Strip bears against a Threaded Boss 7.

One end of the Threaded Rod is journalled in the end hole of a short Strip, the other end of this Rod being fitted with a $1\frac{1}{2}$ " Pulley 1 and Threaded Pin forming a handle.

REVERSIBLE BAND BRAKE

S.M.123. This brake is arranged to apply to a shaft a braking effort in one direction only, but the direction in which the effort is applied is predetermined, by a simple movement of a lever. Thus the device forms a kind of ratchet, the controlling effect of which is more gradual and smooth than that obtainable in the more usual pawl and ratchet method.

The $1\frac{1}{2}$ " Pulley 1 is secured to the shaft that is to be controlled and is engaged by a cord 2, the ends of which are tied to the extremities of a $3\frac{1}{2}$ " Strip 3. The latter slides in an Eye Piece 4 secured to the frame. Two bolts are inserted in the Strip 3 to prevent it from sliding beyond certain limits.

INTERNAL EXPANDING FRONT WHEEL BRAKE

S.M.124. In the design of front wheel brake mechanisms it is important to keep the distance between the road wheels and the stub axle support as small as possible. This point has been considered fully in the brake shown in S.M.124. The stub axle pivot 1, which is journalled freely in the two portions of the front axle, has mounted on it a Coupling that carries the stub axle. This has secured rigidly to it a Face Plate, in the opposite slots of which

of each Bolt, before inserting them in the slots. Collars are secured on the ends of their shanks. The Collars form the brake shoes, and a short length of Spring Cord is attached to their set-screws to keep them in contact with the cam.

The $\frac{1}{2}$ " Bolts are actuated by a cam 3, which consists of two $2\frac{1}{2}$ " small radius Curved Strips bolted to a $2\frac{1}{2}$ " Strip.

SAFETY CATCH FOR WINDING GEAR

S.M.125. The Compression Spring 3 is mounted on the Crank Handle 1 between the Collar 4 and a Washer, and normally holds the Collar 2 against the inner side of the plate. The Collar 2 is fitted with a $\frac{3}{8}$ " Bolt, and if the Crank Handle commences to rotate, the head of this bolt strikes against the stop 5 and prevents further movement.

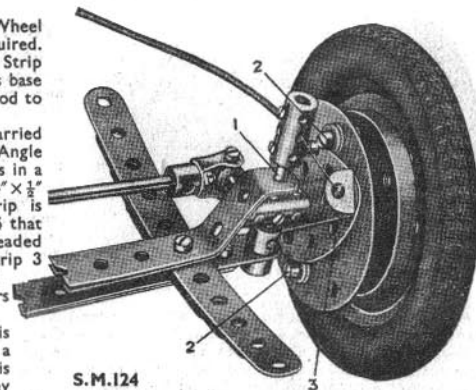

S.M.124

S.M.125

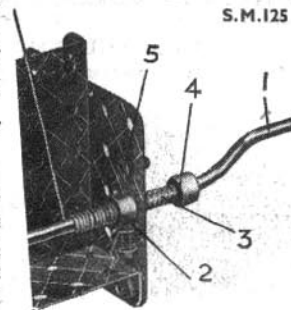

Section X. BEARINGS AND SHAFTING SUPPORTS

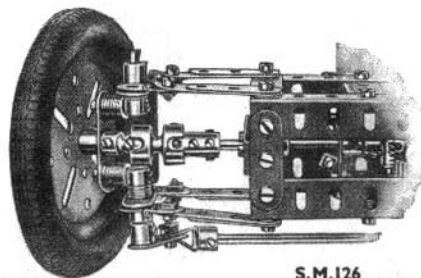

S.M.126

Although the Handrail Coupling is free to move universally, it is prevented from rotating free of the Socket Coupling by means of a $\frac{3}{16}$ " grub-screw. This grub-screw is locked in place by means of a $\frac{1}{8}$ " grub-screw passed into the opposite hole of the Handrail Support and the portion of the long grub-screw that projects engages with the slot in the Socket Coupling.

The opposite end of the Socket Coupling carries a Coupling by means of which the drive from the differential is transmitted through a Rod of suitable length to this part of the movement. The Rod is journaled in a bearing consisting of $1\frac{1}{2}$ " x $\frac{1}{2}$ " Double Angle Strips bolted to the box girder type of front axle.

REINFORCED BEARINGS

S.M.127. Where a shaft is subjected to unusual pressure it is advisable to extend, or reinforce, the ordinary bearing afforded by a Meccano Strip or Plate. S.M.127 shows the method adopted to reinforce the bearings of the back axle of a large Meccano Tractor. The axle is held at each end in a $1\frac{1}{2}$ " Pulley 1, with set-screw removed, securely bolted to the side plate 2. The recess cut in the boss of the Pulley to receive the set-screw forms a useful receptacle for oil when lubricating the axle.

ANTI-FRICTION BEARING

S.M.128. In actual engineering practice, and also in Meccano engineering, there are various types of both ball and roller bearings. The type shown in S.M.128 is unusual, and is specially suitable for delicate mechanisms.

The axle carrying the flywheel, a Circular Plate, runs on the circumferences of four Face Plates, which are journaled loosely on Pivot Bolts. The pair of Face Plates on each side are arranged so that their inner edges overlap one another by mounting the Pivot Bolts 2in. apart. It should be noted that this device can be used only when the load on the axle is exerting pressure in a downward direction, for a load acting sideways or upwards would cause the spindle to leave its bearings.

WORM AND PINION BEARING

S.M.129. The compact rear axle drive unit illustrated in S.M.129 is intended chiefly for use in small models of motor cars. Two Corner Angle Brackets are secured by bolts passing through their elongated holes to a $1\frac{1}{2}$ " Strip to which a Double Bent Strip also is secured. The Rod carrying the Worm is passed through the centre hole of the Strips and held in position by a Collar, a Washer being placed between the Worm and $1\frac{1}{2}$ "

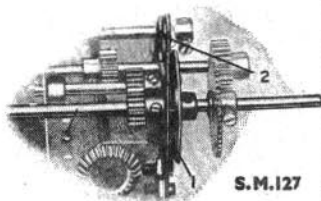

S.M.129

FRONT WHEEL DRIVE

S.M.126. A front wheel drive arrangement similar to that fitted to many sports cars, is shown in S.M.126 and can be fitted to almost any Meccano chassis of suitable size. The front wheel is carried on a 1" Rod journaled in the boss of a Double Arm Crank. The inner end of this Rod supports a Handrail Coupling, the rounded portion of which fits into one end of a Socket Coupling.

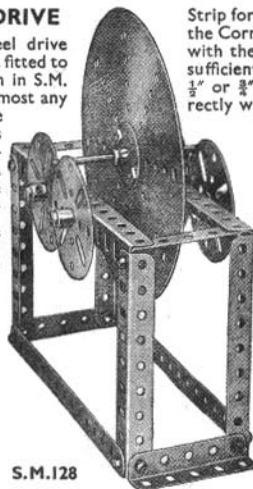

S.M.128

Strip for spacing purposes. The driven Rod is journaled in the Corner Angle Brackets and carries a Pinion that engages with the Worm. The slotted holes of the Brackets allow sufficient adjustment to be made so that either a $\frac{1}{2}$ " or $\frac{3}{4}$ " Pinion can be arranged to mesh correctly with the Worm.

A feature of this bearing that should not be overlooked is that the useful gear ratio of 25:1 is provided by employing a $\frac{3}{4}$ " Pinion.

KNIFE-EDGE BEARING

S.M.130. The knife-edge is employed almost universally in weighing machines, balances, etc., where it is necessary to reduce friction at the fulcrum of a lever to a minimum. In this mechanism the steel or agate prisms, known as knife-edges, that are used in actual practice are represented by two Centre Forks 1 secured in a Coupling 2 with their points resting between the teeth of two $\frac{1}{2}$ " Pinions 3 bolted to a short Rod rigidly held at each end in a Crank 4. The beam 5 is secured in the centre hole of the Coupling 2 and it will be noticed that the lever arms 6 and 7 are bolted in Couplings 8 at a lower level than the Coupling 2. The beam is shaped in this way in order to lower the centre of gravity at the fulcrum 1.

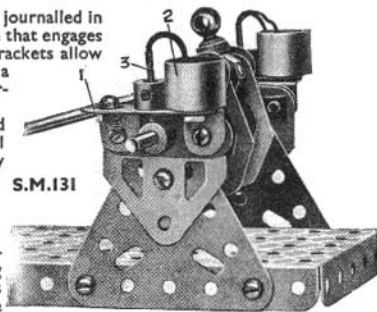

S.M.130

SIPHON WICK LUBRICATOR

S.M.131. This illustration shows lubricators of the siphon type applied to a two-bearing crankshaft. The photograph indicates the general layout of the system and should enable any reader to install a complete lubrication system in almost any model.

A Chimney Adaptor 2 forms an oil cup and a length of worsted is threaded through a length of Spring Cord 3 and its upper end dipped into the cup. The lower end is inserted in the set-screw hole of the Double Arm Crank that forms the bearing at that section of the crankshaft.

The Spring Cord gives a neat appearance to the whole system in addition to forming a convenient means of leading the worsted wherever it is needed. In the example illustrated it is held in position by the grub-screw of the Crank 1.

It should be noted that the device will only work satisfactorily when the oil cup is above the level of the part requiring lubrication.

BALL-AND-SOCKET JOINT

S.M.132. Although it is not possible to reproduce an actual ball-and-socket joint with standard

Meccano parts, a close approximation to one can be obtained, as shown in the illustration. In this the "socket" is represented by a Swivel Bearing 1 while the "ball" is a Collar 2 secured to the shaft 3. The Swivel Bearing is mounted on a short Rod that is free to turn in bearings 4. Hence the Rod 3, while rotating in the Collar of the bearing 1, can be moved through any angle to the vertical.

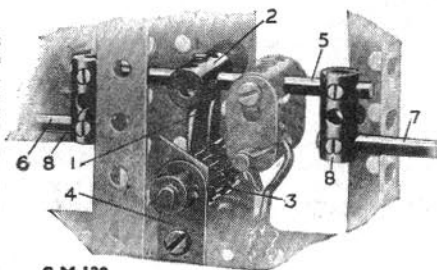

S.M.132

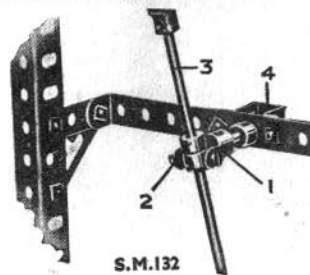

S.M.132

Section XI. Roller and Slide Bearings

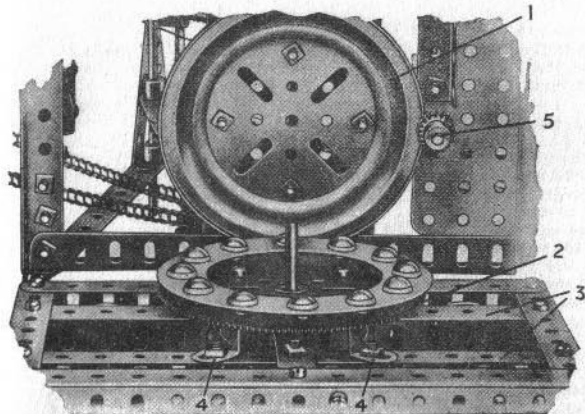

S.M.138

Bolts, a Collar being used for spacing purposes on each Bolt between the Flanged Race and the platform. The Geared Race is bolted directly to the base 1 of the model. The short Rod on which the crane slews is secured in the boss of a Bush Wheel that is bolted to the upper face of the lower section of the Ball Bearing.

When the Ball Casing is in position this short Rod is passed through the centre hole of the upper section of the Ball Bearing and also through one of the holes in the base of the crane. A Collar is then locked on the Rod to hold the two halves of the turntable in contact with the steel balls.

Slewing is carried out by passing Sprocket Chain round the Geared Race and round a $\frac{3}{8}$ " or 1" Sprocket Wheel 19 driven from the gear-box.

MODIFIED BALL BEARING

S.M.138. It is sometimes desirable to substitute spur gearing for the sprocket driven ball race already described. A suitable way of obtaining this is shown in S.M.138. The usual method of construction is employed, as in S.M.137, with the exception that the place of the Geared Ball Race is taken by a $3\frac{1}{2}$ " Gear Wheel 2. The Gear is screwed to the base of the model by means of four $\frac{1}{2}$ " Reversed Angle Brackets 4 that rest on the longitudinal Girder 3.

Slewing of the crane is accomplished by securing a $\frac{1}{2}$ " Pinion 5 to the end of the Rod that may be driven, at will, from the gear-box. This Pinion is in constant mesh with the $3\frac{1}{2}$ " Gear 2.

BUILT-UP ROLLER RACE

S.M.139. For models of medium size the Ball Bearing unit often is too small to give sufficient stability. In these cases it is therefore necessary to devise a built-up bearing of intermediate size.

One method of constructing such a bearing is shown in S.M.139. The bottom fixed race consists of a Hub Disc held in place by four nuts and bolts. A Bush Wheel without its grub-screw is bolted in the centre of this Hub Disc to form one bearing for the centre Rod.

MECCANO BALL BEARING

S.M.137. The Meccano Ball Bearing is a correctly designed unit made to give a very free turning movement even when working under a heavy load. It consists of three sections, the Flanged Ball Race, Part No. 168a, the Geared Ball Race, Part No. 168b and the Ball Casing, Part ; No. 168c. In S.M.137 this part is shown built into a Meccano model Scotch type derrick. The Flanged Ball Race is secured to the underside of the revolving platform of the model by means of four $\frac{3}{8}$ "

A Gear Ring, shown in the illustration, is now secured in place by means of four $\frac{3}{8}$ " Bolts, each of which carries eleven Washers on its shank for spacing purposes.

The ring frame consists essentially of a $7\frac{1}{2}$ " Circular Strip, that is fitted at four equidistant points round its edge with rollers, consisting of $\frac{1}{2}$ " fast Pulleys on $1\frac{1}{2}$ " Rods.

The upper race of the roller bearing consists of a Circular Girder that is bolted directly to the base of the revolving superstructure.

Slewing is carried out from a $\frac{1}{2}$ " Pinion secured on the lower end of a Rod, a gear on the upper end of which can be engaged or disengaged at will with gears in the gear-box. The Pinion must be so adjusted for height that it meshes with the Gear Ring attached to the travelling base.

BALL BEARING ROD SUPPORT

S.M.139a. When experimental work is being carried out with the aid of Meccano Parts it is sometimes necessary to support a horizontal revolving shaft carrying considerable weight, in bearings offering as little friction as possible. One efficient method of obtaining this is described in S.M.138, but this takes up too much room for many purposes. A smaller bearing therefore has been devised, and although this is not quite so free running as the larger movement, it has many advantages because of its compactness.

A Socket Coupling is secured to a suitable base by means of a Double Arm Crank and carries in its upper end a Steel Ball, free to rotate. Each tapped hole at this end of the Socket Coupling carries the inner end of the shank of a $\frac{1}{2}$ " Bolt. This Bolt holds a $\frac{1}{2}$ " Reversed Angle Bracket in place, the elongated hole of the Bracket being used for this purpose. Two Washers are placed between the Bracket and the Bolt head and six Washers between it and the Socket Coupling.

The space between the two vertical lugs of these Reversed Angle Brackets must form a vertical slot about $3/16$ " in width immediately over the Steel Ball and these lugs are held together at this point by a $\frac{3}{8}$ " Bolt. Three Washers are placed between the two lugs for spacing purposes.

Two of these bearings of course are required to support a Rod employed as a horizontal shaft. This Rod can be of any desired length and is passed across the tops of the Steel Ball and underneath the slots formed by the two Reversed Angle Brackets. By careful adjustment of these Brackets the Rod can be exactly centred over the Steel Balls.

BUILT-UP BALL BEARING

S.M.140. This built-up Meccano ball bearing is constructed from two 3" Pulley Wheels, one Wheel Flange and 21 Steel Balls, and is applicable chiefly to models where a bearing similar to the Meccano Ball Bearing is required. The fixed ballrace is built up from the Wheel Flange and one 3" Pulley 2 bolted together and secured to any suitable base. The balls are placed in the groove formed between the outer edges of this Pulley and the Wheel Flange, and the second Pulley 2, which is bolted to the swivelling portion of the model, rests upon them. The upper Pulley is secured by its set-screw to the central Rod

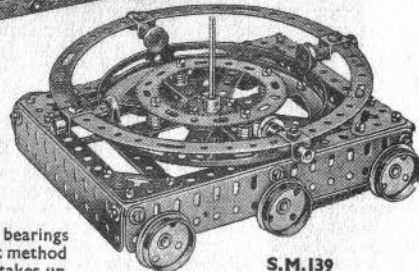
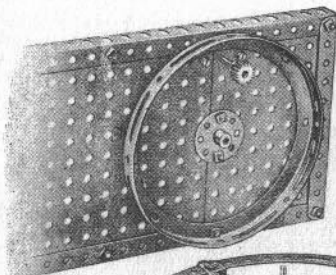

S.M.139

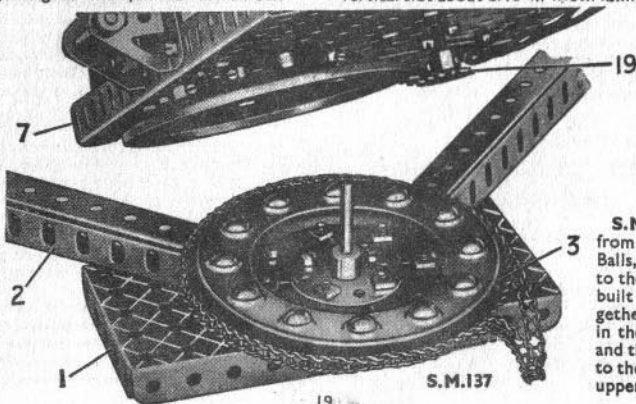

S.M.137

Section XI. Roller and Slide Bearings—(continued)

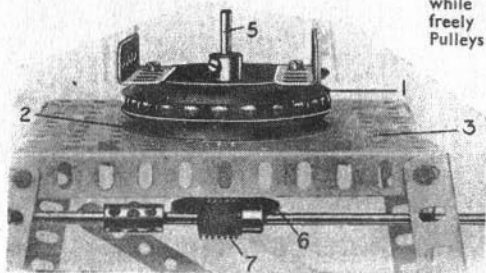

S.M.140

model is secured to the base by a Collar bolted on the Rod 5 just beneath the platform. The worm gear ensures that the slewing is carried out only when required.

SIDE THRUST BEARING

S.M.141. This type of bearing is intended primarily for taking up side stresses so that the Rod passing through its centre is protected from any bending stresses. It is not fitted with rollers or ball bearings and is, therefore, not suitable for supporting swivelling superstructures, but it can be adapted for this purpose if so desired. This example illustrates its use in the drill head of a drilling machine.

A Wheel Flange 10 is bolted securely in place by means of $\frac{3}{8}$ " Bolts to a $2\frac{1}{2}$ " x 1" Double Angle Strip, four $1\frac{1}{2}$ " Strips being used for spacing purposes between the Wheel Flange and Double Angle Strip. A Boiler End, fitting easily in the open end of the Wheel Flange, is now added as shown, and this is fitted with a 57-teeth Gear and a $2\frac{1}{2}$ " x 1" Double Angle Strip 9. These are held in place by $\frac{3}{8}$ " Bolts, Collars being used for spacing purposes between the Gear and Boiler End, and also between the Gear and Double Angle Strip. The Double Angle Strip carries the sliding drill head, the drive to which is transmitted by means of a $1\frac{1}{4}$ " Contrate and $\frac{1}{2}$ " Pinion from the horizontal shaft passing through the bearing already described.

The entire drill head stock may be rotated about the drill spindle by means of a Worm meshing with the 57-teeth Gear already described. This Worm is carried on a shaft running transversally across the bearing, and mounted in the end holes of two $1\frac{1}{2}$ " Strips. These Strips, as will be seen, are secured to the Flat Girders forming the sides of the mechanism. The turning movement will be considerably facilitated by the application of a little heavy oil at fairly frequent intervals.

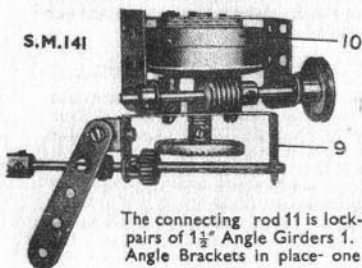

S.M.141

CROSSHEAD FOR STATIONARY ENGINE

S.M.142. This type of crosshead is used largely in big, slow-moving, single-cylinder engines, in which this part of the engine is required to withstand great thrusting pressures. In this example it is shown fitted to a large single, cylinder engine fitted with Corliss Valve Gear.

The connecting rod 11 is lock-nutted on each side of Coupling 4 that carries two pairs of $1\frac{1}{2}$ " Angle Girders 1. The Bolts securing these Girders also hold $\frac{1}{2}$ " x $\frac{1}{2}$ " Angle Brackets in place—one of which is shown at 2. A second Coupling 3,

while the other is allowed to turn freely on the Rod 5. When the Pulleys are placed together, it is impossible for the balls to move out of position.

The illustration shows the jib of a small crane running on this built-up ball bearing. The Rod 5, about which the upper section of the crane pivots, is secured in the upper Pulley 1, which is bolted to the jib. The latter is rotated from a Crank Handle by means of a Worm engaging with a 57-teeth Gear Wheel carried on the Rod 5. The swivelling portion of the

carrying the piston rod, is secured to the $1\frac{1}{2}$ " Angle Girders and, as with Coupling 4, two Angle Brackets 2 are fitted. Two $1\frac{1}{2}$ " x $\frac{1}{2}$ " Double Angle Strips 5 are bolted between the two sets of $\frac{1}{2}$ " x $\frac{1}{2}$ " Angle Brackets 2 and these form the sliding faces of the crosshead.

Each slide bar 6 rests on its respective Double Angle Strip and lies between the protruding edges of the $1\frac{1}{2}$ " Angle Girders 1 thus preventing side play in the crosshead. The inner ends of the slide bars are bolted to a $1\frac{1}{2}$ " x $\frac{1}{2}$ " Double Angle Strip that is secured to a Wheel Flange, forming the cylinder head. The $\frac{3}{8}$ " Bolts holding the Double Angle Strip in place also secure the cylinder head to the cylinder block.

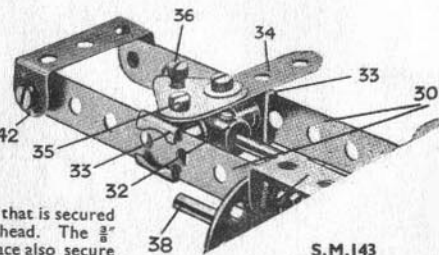

S.M.143

LOCOMOTIVE CROSSHEAD

S.M.143. This type of crosshead is designed for use in Meccano model locomotives, but it is suitable for use in small models in place of the larger crosshead already described. The connecting rod is not shown in the illustration, but the crosshead link 34 is shown in position for the fitting of Walschaerts Valve Motion.

The slide bars 30 consist of $4\frac{1}{2}$ " Strips attached to the cylinder end by means of $\frac{1}{2}$ " x $\frac{1}{2}$ " Angle Brackets. These Strips are secured to the insides of the Angle Bracket lugs in order to place them the correct distance apart.

The construction of the crosshead is carried out in the following manner. A Strip Coupling 32 is mounted on the end of the piston rod, and this carries a 1" Threaded Rod in its centre transverse tapped bore. Each end of this Rod is fitted with an Eye Piece 33, one Washer being used for spacing purposes between each Eye Piece and the Strip Coupling. The Eye Pieces fit over the slide bars 30, which are carefully adjusted so that the crosshead slides freely. The 2" Strip 34 and the 1" Triangular Plate 35 are now fitted, and secured together by two Set Screws. The Set Screw 35 has two Washers on its shank and it passes into the tapped bore of the upper Eye Piece. The other Set Screw has a Washer under its head for spacing purposes, and is locked in place by a nut. The $\frac{3}{8}$ " Bolt 36 passes through the end tapped hole of the Strip Coupling, and when fitted into a model, carries the forward end of the connecting rod on its shank. Finally, the $1\frac{1}{2}$ " x $\frac{1}{2}$ " Double Angle Strip 42 is fitted. This connects the outer ends of the slide bars, and its upper retaining bolt carries two Washers for spacing purposes.

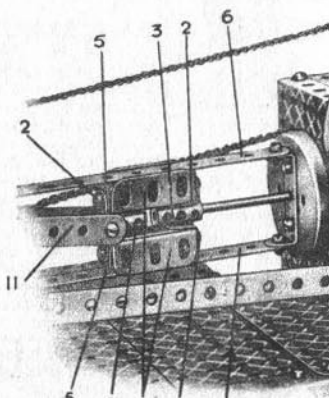

S.M.142

SIMPLE CIRCULAR SLIDE BEARING

S.M.144. In simple models incorporating crane superstructures or swivelling bogies, it is often quite adequate to use two plain rubbing surfaces instead of a roller or ball-bearing turntable. A bogie fitted with such a turntable is shown in S.M.144. The 2" Pulley 4 is secured by means of $\frac{3}{8}$ " Bolts to the underside of a model 6. A second 2" Pulley 5 is attached in a similar manner to the bogie, and the bolts securing this in position must be arranged at right angles to the Bolts carrying the first mentioned 2" Pulley 4.

These Bolt heads overlap each other slightly when the assembly is complete, thus limiting the slewing movement to a little less than 180°. In cranes and other similar models this limited slewing movement is found to be a disadvantage, the 2" Pulleys can be replaced by 3" Pulleys, which are more deeply recessed.

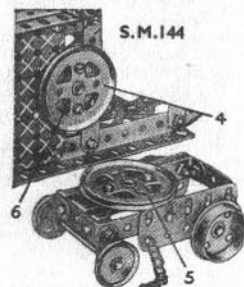

S.M.144

Section XII. APPLIED SCREW MECHANISMS

SCREW OPERATED SHOE BRAKE

S.M.145. The screw operated shoe brake, the most powerful of all brakes, can be reproduced in Meccano in many different forms. One type is shown in S.M.145, and this is shown incorporated in the field gun, typical of many Meccano models of this type.

The 3" Wheel forming one of the road wheels is mounted in very strong bearings to prevent the axle from being bent by the strain due to braking. The brake shoe 14 consists of a $\frac{1}{2} \times \frac{1}{2}$ " Angle Bracket bolted to a second similar Angle Bracket that is locked securely to one end of a $1\frac{1}{2}$ " Strip, the inner end of which is pivotally attached to the frame of the model by means of a $\frac{3}{8}$ " Bolt and two lock-nuts.

The centre hole of the $1\frac{1}{2}$ " Strip carries a Threaded Boss, the necessary connection being made by a bolt and lock-nut. The transverse tapped hole of the Threaded Boss must be uppermost when the brake unit is in place, and through this passes a $3\frac{1}{2}$ " Threaded Rod which is fitted with a 1" fast Pulley forming the operating handle. The forward end of this Rod is carried in a bearing consisting of a Handrail Support connected to the frame of the model by means of a Double Bracket. If necessary a second brake shoe may be fitted and operated in a similar manner to that described in S.M.122.

SCREW LIFTING APPARATUS

S.M.146. This mechanism demonstrates how the combination of a screw and cranks can be utilised to raise heavy loads. This type of lifting apparatus is incorporated in many small trucks and motor wagons in order to facilitate unloading.

The base of the truck is represented by a $5\frac{1}{2}$ " $\times 2\frac{1}{2}$ " Flanged Plate fitted at each side with a $5\frac{1}{2}$ " Flat Girder. The two centre holes in the side flanges are fitted with Bolts carrying, on each of their shanks, two $1\frac{1}{2}$ " Strips for spacing purposes. The outer extremity of each Bolt is fitted with a Collar and each of these two parts carries a vertically placed 2" Rod 4.

In the finished mechanism these Rods prevent any longitudinal movement of the platform. Two transverse Rods are now fitted under the base, one of which is carried in the second set of holes from one end of the Flanged Plate forming the base.

The other Rod is stationed at a point 2" from the opposite end of the base. Each Rod is fitted with a Coupling 1, and these two parts are joined together by means of a $3\frac{1}{2}$ " Strip. The connection between the Strip and Couplings is formed by $\frac{3}{8}$ " Bolts. One of the Couplings also has attached to it a $1\frac{1}{2}$ " Strip, as shown in the photograph, and this is connected to a third Coupling by means of a $\frac{3}{8}$ " Bolt. The lower transverse tapped hole of this Coupling is supported on a 2" Threaded Rod that is mounted in suitable bearings consisting of a $\frac{1}{2} \times \frac{1}{2}$ " Angle Bracket and the end flange of the base Plate. The end of the Threaded Rod is fitted with a handle 3 formed from a Bush Wheel and Threaded Pin.

The two transverse Rods are fitted at their outer ends with Cranks and care must be taken to see that the ends of these make contact with the underside of the platform at exactly the same time when they are rotated. If this is not attended to, the platform will lift unevenly and the distribution of the load will suffer accordingly.

SCREW JACK

S.M.147. This neat movement is a reproduction of a typical motor car screw jack. The base of the Meccano model consists of a Flat Trunnion on which a Threaded Coupling is secured rigidly, with its tapped hole uppermost. A Cranked Bent Strip also is secured to the Flat Trunnion, as indicated in the illustration,

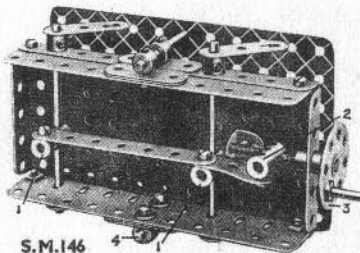

S.M.146

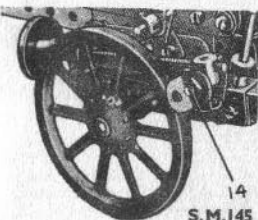

S.M.145

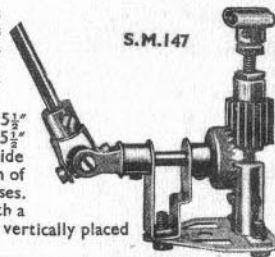

S.M.147

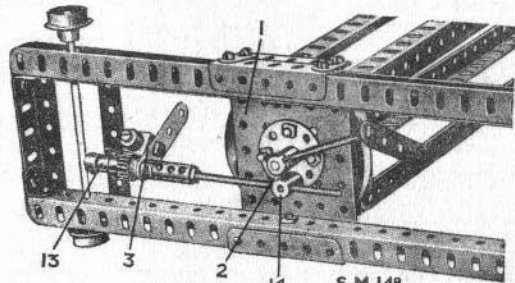

S.M.148

tion, and this serves as a bearing for a short Rod carrying a Universal Coupling at one end and a $\frac{3}{4}$ " Contrate Wheel at the other.

An Axle Rod is secured in the remaining portion of the Universal Coupling and its upper extremity is fitted with a handle consisting of a Collar having two Threaded Pins screwed into its tapped holes. The $\frac{3}{4}$ " Contrate Wheel meshes with a $\frac{1}{2}$ " diam. $\frac{1}{2}$ " face Pinion secured on a Screwed Rod, 2" in length. The Screwed Rod works in the threaded bore of the Coupling and the jack is raised or lowered by rotating the Contrate.

SCREW RATCHET FEED

S.M.148. Heavy machines such as lathes and drilling machines provide excellent examples of applied screw movements. In this illustration a screw travelling mechanism is shown fitted to a drilling machine for moving the vertical pillar along the base. The pillar is built up from $12\frac{1}{2}$ " Angle Strips and a 3" Pulley Wheel.

The Double Angle Strips are bolted to the Pulley, which is secured to the Flanged Plate by a 1" Rod that is free to turn in the boss of a Bush Wheel as shown and is held in place by a Collar. When necessary the Rod can be locked in position by means of a 2" Threaded Rod fitted with a lever consisting of a 2" Strip held in place by two lock-nuts.

The traversing mechanism is constructed as follows. The Bush Wheel already mentioned is fitted at one side with a Threaded Boss 14 through the transversal tapped hole of which a $3\frac{1}{2}$ " Threaded Rod 2 passes. One end of this Rod passes into the threaded portion of a Threaded Coupling and is locked in place by a nut. The other end of the Coupling is fitted with a 2" Rod journalled in a Collar 13 that is attached to a transverse Strip by means of a bolt carrying two Washers on its shank for spacing purposes. Between the Coupling and Collar 13 is a $\frac{1}{2}$ " Pinion, together with a 2" Strip spaced away from the Pinion by means of four Washers. The Pinion is locked on the Rod but the Strip

is free to move between the Washers and a Collar. A $\frac{1}{2} \times \frac{1}{2}$ " Angle Bracket 3 is pivotally attached to the 2" Strip and this forms a pawl. It is kept in engagement with the $\frac{1}{2}$ " Pinion by means of a weight consisting of a Collar secured to the Angle Bracket by a $\frac{3}{8}$ " Bolt. When a reverse action has to be transmitted from the lever to the Threaded Rod the pawl is passed over to the opposite side of the Pinion.

ADJUSTABLE TOOL HOLDER

S.M.149. This movement is in effect a miniature reproduction of S.M.148. It represents a type of cutting tool holder for a lathe, by means of which the depth of cut can be varied by the operation of a handle.

The Threaded Rod 1, journalled in a Double Angle Strip 2 and held in place by a Collar 3, is rotated by a hand-wheel 4. The tool post 5 is secured to a Threaded Pin 6, which is screwed into a Threaded Boss 7 engaging the Rod 1. Consequently rotation of the hand-wheel causes the tool post to travel to and fro. Two $2\frac{1}{2}$ " Strips on the lathe saddle are bolted between the $1\frac{1}{2}$ " Strips 8 and form guides on which further $1\frac{1}{2}$ " Strips 9 are allowed to slide.

The $2\frac{1}{2}$ " Strip 10, secured to the tool post, slides between the $1\frac{1}{2}$ " Strips 8.

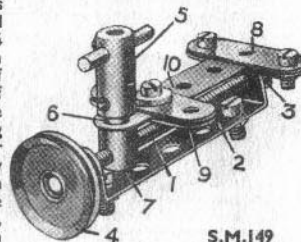

S.M.149

Section XIII. QUICK RETURN MECHANISMS

Quick return mechanisms are used extensively in planing machines for speeding up operations by increasing the speed of the return or idle stroke. They can be employed also for intermittent feed movements in which a moving Pawl is used for rotating a Ratchet Wheel. In this case the arm carrying the Pawl would be speeded up on the return stroke so that the pause between each movement of the Ratchet would be decreased.

Many different types of quick return motions can be reproduced in Meccano, and interesting examples appear on this page.

SIMPLE LEVER QUICK RETURN MOTION

S.M.150. This movement is particularly useful on account of the few working parts, and it is very efficient because the only sliding part is the reciprocating Eye Piece representing the bed plate.

The driving Crank 1 is pivotally attached to a $3\frac{1}{2}$ " Strip that is secured at 2 to a further $3\frac{1}{2}$ " Strip and a 3" Strip, the last being bolted to a Crank that is free to swing about a fixed pivot 4, consisting of a Pivot Bolt attached to the frame by two Nuts. The second $3\frac{1}{2}$ " Strip is connected to the part of the model requiring a quick return motion, and in the photograph is shown pivoted at 3 to a sliding Eye Piece, and in a planing machine model this part of the mechanism would be replaced by the work table.

In the position shown, the Crank 1, rotating anti-clockwise, is on the power stroke and thus the Eye Piece slides slowly over to the left. When the web of the Crank swings over towards the pivot 4, the Eye Piece returns more rapidly. The closer the Crank 1 is to the pivot 4, the more rapid will be the return movement of the Eye Piece.

The device is very smooth in operation and gives satisfactory results at fairly high speeds.

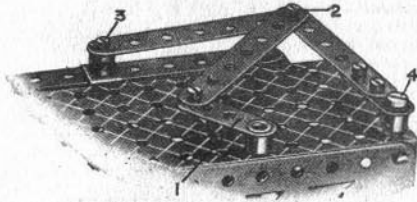

S.M.150

HEAVY DUTY QUICK RETURN MOTION

S.M.151. This mechanism is particularly suited for incorporating in large model planing machines and for use in similar cases where a very robust and positive quick idle stroke movement is required.

The table of the machine is represented in the illustration by a $2\frac{1}{2}$ " \times $\frac{1}{2}$ " Double Angle Strip in order to show the mechanism as clearly as possible. A vertical driving shaft 5 carries a Bush Wheel 6 and a $\frac{3}{8}$ " Bolt passing through one of the holes in the Bush Wheel is secured in the boss of an Eye Piece 7. A $3\frac{1}{2}$ " Strip 3 passed through the Eye Piece pivots about an upright fixed Rod 4, and is attached at its outer end 2 by a pivot bolt and nuts to a connecting lever 1. The latter, in turn, is pivotally connected to the underside of the table, which slides on the Girders 8.

The Bush Wheel 6 rotates in an anti-clockwise direction, rocking the lever 3 to and fro, and the swivel-guide 7 slides on the lever as it follows the movement of the Bush Wheel. Consequently, the guide 7 is at a greater distance from the fulcrum of the lever during the forward stroke than it is on the return, with the result that the point 2 moves slowly on the forward stroke and more rapidly on the return.

The one great disadvantage of this mechanism is that considerable resistance is introduced by friction between the sliding Eye Piece and the Strip 3, but this can be reduced by careful adjustment and constant oiling.

GEARED QUICK RETURN MOTION

S.M.152. The two movements already described transmit their power through cranks and levers only. This mechanism incorporates a gear move-

S.M.151

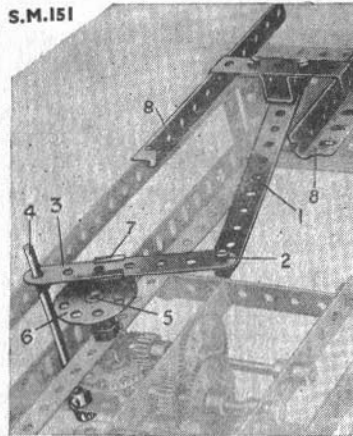

S.M.152

ment, however, and because of this a much smoother and stronger movement is the result. Its construction is comparatively simple and is carried out in the following manner.

A Face Plate is secured to a Rod that is journalled in vertical $5\frac{1}{2}$ " \times $2\frac{1}{2}$ " Flanged Plates, and an Eye Piece is attached to the Face Plate by passing a $\frac{3}{8}$ " Bolt through one of the holes in the latter and securing the Bolt in the boss of the Eye Piece by the grub-screws. Two Washers are placed on the shank of the Bolt for spacing purposes.

A $5\frac{1}{2}$ " Strip is mounted pivotally on a $\frac{3}{8}$ " Bolt that is lock-nutted to a Double Bent Strip, and the Eye Piece slides on the longer arm of the lever so formed, whilst the short arm carries a Rack Segment that engages with a 1" Gear. The latter is secured on a Rod journalled in the Flanged Plates and connected by any suitable means to the model that it is intended to operate.

When the device is set in motion, the Rack Segment on the end of the $5\frac{1}{2}$ " Strip moves from side to side at a speed that varies according to the distance of the Eye Piece from the fulcrum of the Strip, and this causes the 1" Gear to rotate slowly in one direction and rapidly on reversing.

OFFSET QUICK RETURN MOTION

S.M.153.

This movement is of special interest, as it is an entirely new departure from the usual lever or gear-operated movement. Its action is controlled by a spring, and therefore is quick and positive. Its construction is carried out in the following manner.

The driving shaft 2 is journalled in two $2\frac{1}{2}$ " Triangular Plates secured in the slotted holes of $2\frac{1}{2}$ " Angle Girders, which are spaced from the base plate by two Washers on each securing bolt. The bearings for the driven Rod 1 are formed by 2" Strips held in Trunnions. The two sets of bearings should be so arranged that the centres of the Rods are exactly $\frac{1}{2}$ " apart, and it is essential that the Rods should be parallel to each other.

Two Face Plates 3 are secured on the Rod 1 and spaced apart about $\frac{3}{4}$ " with the slots in each Plate directly opposite. The Face Plates 4 are mounted in a similar manner on the Rod 2, and a $1\frac{1}{2}$ " Rod 5 is passed through slots in each pair of wheels. The Rod carries five $\frac{1}{2}$ " loose Pulleys arranged as shown, and a Collar on each end holds it in position. The Face Plates should be spaced so that the Pulleys slide freely. A Spring, controlling the movement of the gear, is fitted to one end of the Rod, the other end being secured by a $\frac{3}{8}$ " Bolt to the left-hand side Face Plate 3.

The drive from the Rod 1 passes through the Face Plates to the Rod 2 by means of the Rod 5. This Rod slides up and down in the slots so that in its lowest position it is at the lower ends of the slots in the Face Plates 3, and at the upper ends of the slots in the Face Plates 4. Thus the Rod 2 rotates faster than the Rod 1, but as the Plates move round the difference in speed is gradually reduced, and in the opposite position is reversed.

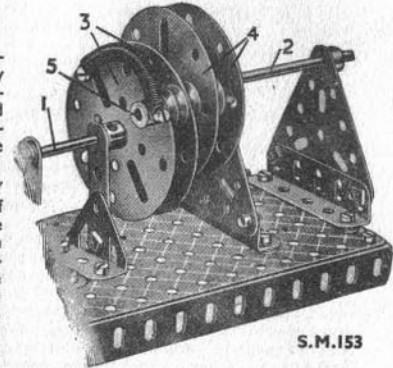

S.M.153

Section XIV. STEERING MECHANISMS

BOAT STEERING GEAR

S.M.154. The device shown in S.M.154 can be used in many Meccano models of ships. The $1\frac{1}{2}$ " Strip that represents the tiller is bolted to a Bush Wheel that in turn is secured to the top of a Rod forming the rudder post. A length of cord is taken round the steering rod several times, and each end is then passed over the 1" fast Pulleys and tied to the tiller. The Pulleys are secured to $\frac{3}{8}$ " Bolts journalled in Double Brackets.

As the steering wheel is rotated, one end of the cord is paid out while the other end is wound on to the Rod. The tiller is pulled to one side or the other according to the direction in which the steering wheel is turned. The steering wheel can be placed conveniently on the bridge of a model ship and the cords taken to the tiller through suitable guides fixed to the deck or inside the hull.

DUAL AEROPLANE CONTROL

S. M.155. Many aeroplanes are fitted with dual control to enable them to be controlled independently from two points. Machines so fitted are invaluable in teaching beginners how to fly and this mechanism demonstrates the principle on which dual control gear works.

The joysticks 1 are held in the bosses of Fork Pieces, which are bolted to pairs of $2\frac{1}{2}$ " Strips 2. Each pair of the latter is free to pivot on two Bolts 3 inserted in opposite sides of a Collar secured on the Rod 5, which is journalled in upright $3\frac{1}{2}$ " Strips secured to the frame of the model. The lower ends of the two joysticks are connected

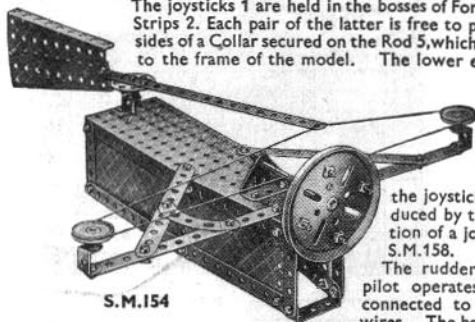

S.M.154

$2\frac{1}{2}$ " Strips mounted pivotally by means of bolts and nuts on Double Bent Strips. They are connected by wires so that each must follow the movement of the other.

CASTOR STEERING

S.M.156. This form of steering is used when it is necessary to steer the driving wheels of a lorry and at the same time give great manoeuvring ability. The steering wheel actuates a Worm 32, which in turn rotates the 57-teeth Gear 30. The frame supporting the road wheels is carried on this Gear, and the Rod forming the pivot transmits the drive to the wheels from the motor in the lorry.

AUTOMATIC YACHT'S STEERING GEAR

S.M.157. This is an interesting and ingenious movement and is used on model racing yachts.

An $11\frac{1}{2}$ " Rod, representing the boom of the boat, is fitted with a Collar 3 and to this are tied the ends

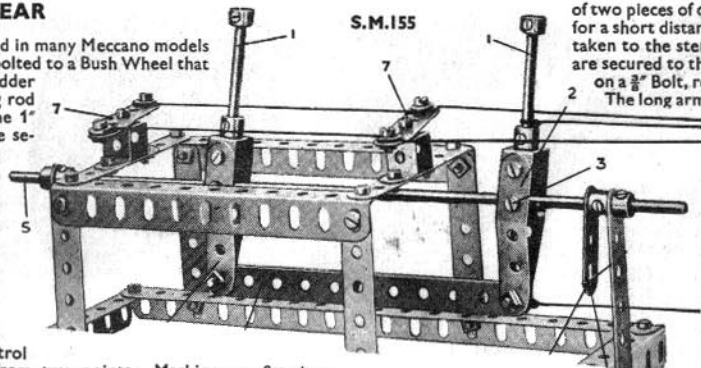

S.M.155

of two pieces of cord. These cords are carried forward towards the mast for a short distance, where they pass round $\frac{1}{2}$ " loose Pulleys and are then taken to the stern, crossing each other in doing so. At the stern they are secured to the short arms 1 of a "T" shaped crank carried as shown on a $\frac{3}{8}$ " Bolt, representing the rudder post.

The long arm of the "T" crank passes under a $2\frac{1}{2}$ " Strip and is held in a fore and aft position by means of a length of Spring Cord 2.

Thus when the boom is blown over to one side of the ship by the force of the wind the rudder is moved in the opposite direction, and in this way the vessel is prevented from veering from her true course.

AEROPLANE CONTROL GEAR

S.M.158. This illustration is of a typical control gear that may be embodied in the majority of Meccano aeroplanes.

The joystick 59 is a $1\frac{1}{2}$ " Rod held in the boss of a Swivel Bearing. The spider of the latter is secured to a $3\frac{1}{2}$ " Rod horizontally and carries a $\frac{1}{2}$ " loose Pulley 61. A $\frac{1}{2}$ " loose Pulley 61 is journalled on a $\frac{3}{8}$ " Bolt tion by means of a Collar. The centre to the Flat Plate.

secured to the Plate by two nuts, and is retained in position by a wire 57.

The rudder bar 65 consists of a $2\frac{1}{2}$ " Strip pivoted at its one end to a short lever secured at right angles to the under surface of the elevator; it is then attached to the joystick 59, led round the Pulley 61 and back to another short lever secured to the upper side of the elevator. When the stick is pushed forward the resulting movement of the elevator sends the nose of the aeroplane downward. When the stick is pulled back the elevator is raised.

The wire 70 is secured at its centre to the Coupling 62 and its ends, after being led round guide pulleys, are fastened to short levers projecting at right angles from the

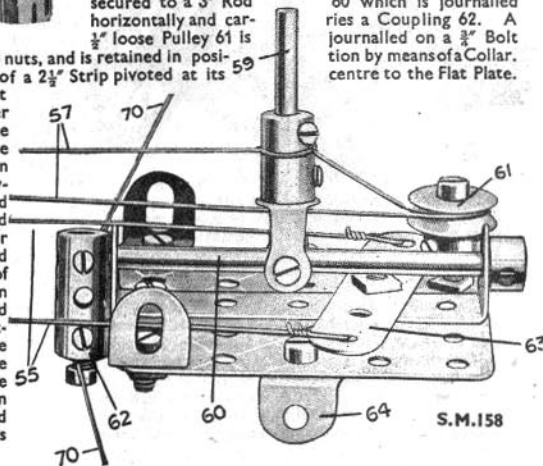

S.M.158

The wire 70 is secured at its centre to the Coupling 62 and its ends, after being led round guide pulleys, are fastened to short levers projecting at right angles from the

S.M.157

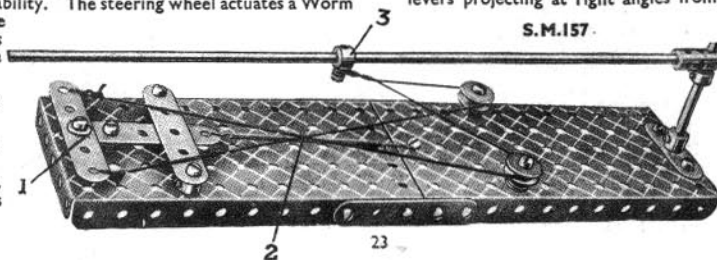

2

23

ailerons. The latter are connected together by another wire attached to further levers projecting from their opposite sides. Consequently, when the stick is moved to the left the aileron on the right side is pulled down, causing the wing on that side to rise. At the same time the aileron on the left side is pulled up, assisting the downward motion of the left wing, and the machine banks. When the lever is pushed to the right, the reverse takes place.

The ends of the rudder bar 63 are connected by wires 55 to levers projecting on opposite sides of the rudder, which can be moved right or left by pushing the lever with either the right or left foot.

Section XIV. Steering Mechanisms—(continued)

WORM AND CHAIN STEERING GEAR

S.M.159. This example shows a form of steering gear that will be found very suitable for large model traction engines, and similar models. The steering wheel is secured to a Rod of any convenient length that is journalled in Double Brackets bolted to the side frame plate of the tractor. It carries at its lower end a Worm 3 engaging a $\frac{3}{4}$ " Pinion 4 on a horizontal rod that carries several Couplings and Collars. The heads of the grub-screws of these serve to grip a continuous length of Sprocket Chain 5 that is given five or six turns round the Couplings and thence passed round the 2" Sprocket Wheel 6 attached to the front axle. The ends of the chain of course are joined together.

STEERING GEAR FOR CATERPILLAR TRACKS

S.M.160. Tanks, tractors, and other forms of transport in

which creeper track is employed are often steered by employing separate power units to drive the tracks and varying the speeds of these units. This is not always practicable, however, and this mechanism is a Meccano model of another device.

The power is transmitted from the motor by a single length of Sprocket Chain that drives a 1" Sprocket Wheel 42 secured on a lay shaft, as shown in the

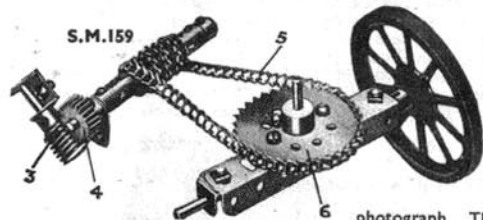

photograph. This shaft is journalled in a suitable frame-work and is moved from side to side by means of a Crank 46. A Bolt in the end of this Crank is accommodated between two Collars 44 on the lay shaft, and the boss of the Crank is secured on a long Rod running the entire length of the tank or vehicle in which this mechanism is fitted. This Rod is fitted with a handle at the point from which the model is controlled.

A $\frac{1}{2}$ " Pinion 45 is secured on each end of the lay shaft, and these Pinions may be engaged or disengaged at will with two $1\frac{1}{2}$ " Gears that drive the track through 2" Sprockets 49.

If both sets of gears are in mesh, the vehicle proceeds on a straight course, because the creeper tracks are in line with the frame of the vehicle. The tracks can be rotated independently at will by sliding the $\frac{1}{2}$ " Pinions in and out of mesh with their respective Gears in order to give the necessary steering effect.

ACKERMANN STEERING GEAR

S.M.161. With this type of steering gear, when a car is rounding a curve the inner front wheel is inclined at a greater angle than the corresponding outer wheel, which turns in a larger circle. A $1\frac{1}{2}$ " Axle Rod 16, secured in each Crank 15, serves as a vertical swivel pin upon which a Coupling 17 carrying the stub axle, a 1" Axle Rod, is free to turn. The Coupling 17 carries a 1" Rod to which is secured a Swivel Bearing. The fork of the latter is fixed to the track rod 12, the other end of which is connected to the other stub axle by another Swivel Bearing secured to the $1\frac{1}{2}$ " Rod 11.

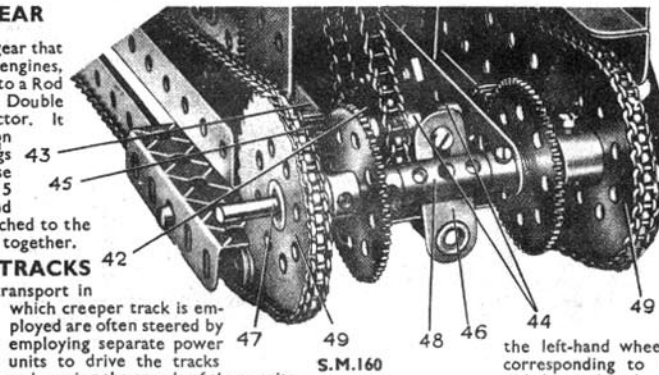

the left-hand wheel is corresponding to and the track rod.

The fixed front axle 14 is secured to the front chassis springs by means of $\frac{3}{8}$ " Bolts. The Cranks 15 are bent so that the fixed swivel pins 16 are slightly out of the vertical, with their upper ends pointed outward. This brings the points of contact between the front wheels and the ground as nearly as possible beneath the centres of the swivel pins. In practice the object of canting the swivel pins in this way is to avoid heavy drag on the steering.

SIMPLE STEERING GEAR

S.M.162. For very simple models, a form of steering gear that does not necessarily operate on Ackermann's

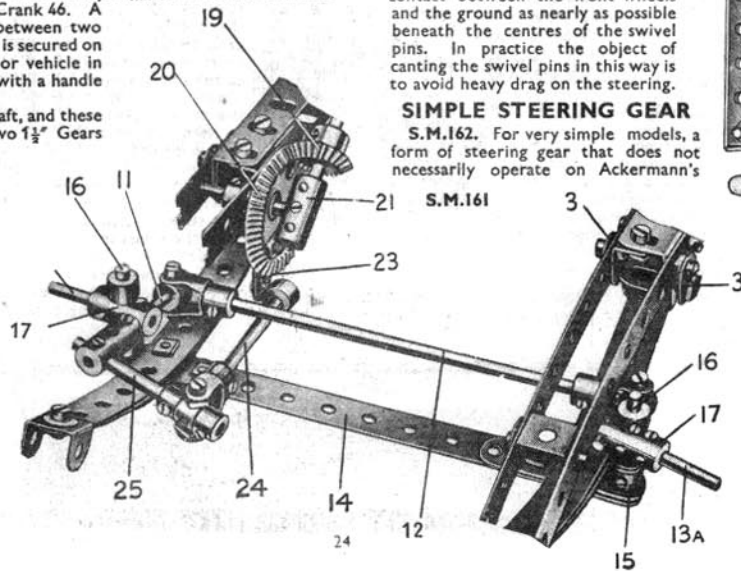

The steering rod carries a $\frac{1}{2}$ " Bevel 19 that gears with a $1\frac{1}{2}$ " Bevel Wheel 20 that is free to turn on a $1\frac{1}{2}$ " Rod journalled in the side frame member and secured in the centre of a Coupling 21. One end of this Coupling forms a journal bearing for the end of the steering column, which consists of an 8" Rod carrying a 2" Pulley Wheel to represent the steering wheel.

A Flat Bracket 23 bolted to the $1\frac{1}{2}$ " Bevel Wheel 20 forms the steering lever, and a set-screw passed through its elongated hole is used to secure a Collar to the $2\frac{1}{2}$ " Rod 24. The other end of this Rod 24 carries a Swivel Bearing, the collar of which is free to turn between two Collars which are locked on the 2" Rod 25. Nuts are placed on the bolts against the spider of the Swivel Bearing in order to hold them rigidly, but not gripping the Rod 25, which is fixed in a Coupling secured to the $1\frac{1}{2}$ " Rod 11. It will now be seen that the movement of the steering wheel is transmitted to the right-hand road wheel via the Bevel Wheel 20 and linkage 24 and 25, and caused to move simultaneously but at a different angle, the point of turning of the car, by means of the Rod 11,

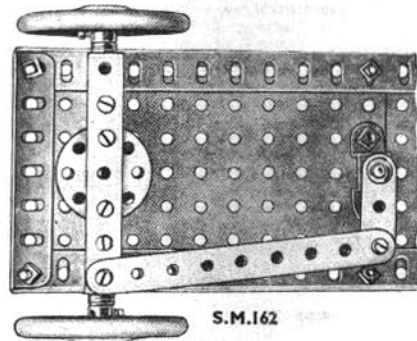

principle, is often suitable, and this mechanism fulfils these requirements.

In this example the two front wheels are mounted on separate stub axles that are secured to each end of a rigid front axle. The base of the chassis consists of two long Angle Girders connected together at the front end by a $3\frac{1}{2}$ " Angle Girder and filled in along their length by means of $5\frac{1}{2}$ " x $3\frac{1}{2}$ " Flat Plates.

The front axle, a $3\frac{1}{2}$ " x $\frac{1}{2}$ " Double Angle Strip, is pivotally mounted at its centre on a Bush Wheel and short Rod. It is fitted, $\frac{1}{2}$ " from each end, with a $\frac{1}{2}$ " x $\frac{1}{2}$ " Angle Bracket, thus forming the inner bearing for its respective stub axle. The outer bearing for the axle consists of the upturned lug of the Double Angle Strip. One end of this latter part is fitted with a pivotally attached $4\frac{1}{2}$ " Strip, by means of which the front axle is linked up to a Crank. This is attached to the steering column.

Section XV. TRAVERSING MECHANISMS

RACK AND PINION TRAVERSING MECHANISM

S.M.163. The photograph shows a rack and pinion mechanism adapted to actuate the saddle of a lathe. The saddle 1 rests upon the Girders 2, and is bolted to a $2\frac{1}{2} \times \frac{1}{2}$ Double Angle Strip sliding upon a Rod set longitudinally between the Girders. The shaft 3 carrying the hand-wheel 4 is journaled in Strips 5 bolted to the saddle and carries a $\frac{1}{2}$ " Pinion which engages with the Rack Strips 6. As the hand-wheel rotates, the Pinion travels along the Rack, carrying the saddle with it.

DRIVE TO HEAVY DUTY TRAVELLING WHEELS

S.M.164. In very heavy cranes where the weight has to be distributed over a large number of wheels, compensating bogies driven through a system of universal joints are generally used. Sometimes, especially in large draglines, lengths of sprocket chain are employed to transmit power to the travelling wheels, but this is only done in exceptional circumstances. Compensating of course is necessary so that all the wheels may carry their share of the weight when the machine is travelling over an uneven surface.

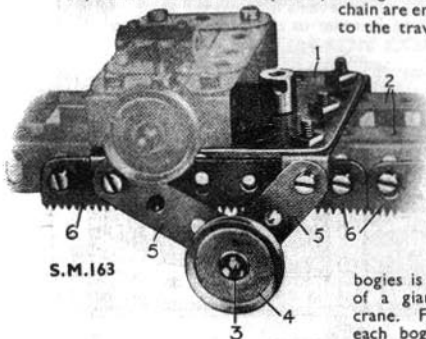

S.M.163

S.M.164 shows how the drive to a pair of compensating bogies is accomplished in the case of a giant Meccano blocksetting crane. Four wheels are fitted to each bogie. Each wheel consists of a Bush Wheel and

$1\frac{1}{8}$ " Flanged Wheel, butted together and held in position on a Rod. Two of the Rods are 2" in length, while the remaining two are $2\frac{1}{2}$ " in length and have their ends protruding from the bogie for a distance of about $\frac{1}{2}$ " to accommodate $\frac{3}{8}$ " Bevel Gears, as shown. These Gears mesh with similar parts that are locked on a horizontal $3\frac{1}{2}$ " Rod journaled in the end holes of two 1×1 " Angle Brackets.

The drive to the $3\frac{1}{2}$ " Rod is transmitted, via two Universal Couplings and a short Rod, from a lay shaft 2 on which is mounted a $1\frac{1}{2}$ " Bevel 1. This Bevel and a similar part, driving the other bogie, are driven from a $\frac{1}{2}$ " Bevel that derives its motion from a long vertical Rod rotated from the gear-box.

MOMENTUM TRAVERSING

S.M.165. When it is not practicable to drive a model by clockwork, electricity or steam, it is occasionally possible to utilise the energy stored up in a heavy flywheel. This power is of course only available for comparatively short periods, but in the case of tractors and other vehicles, it can

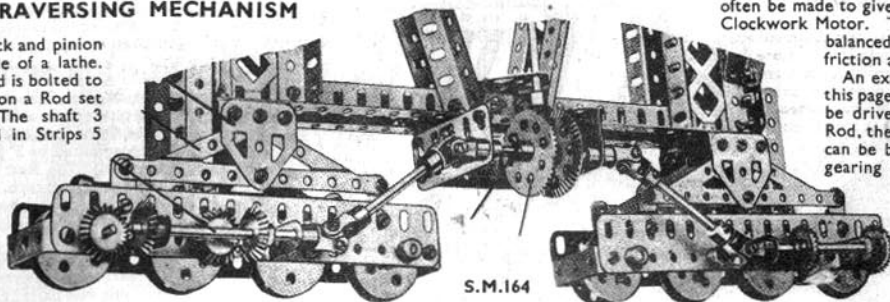

S.M.164

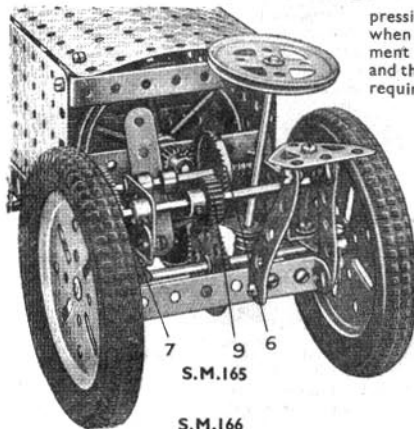

S.M.165

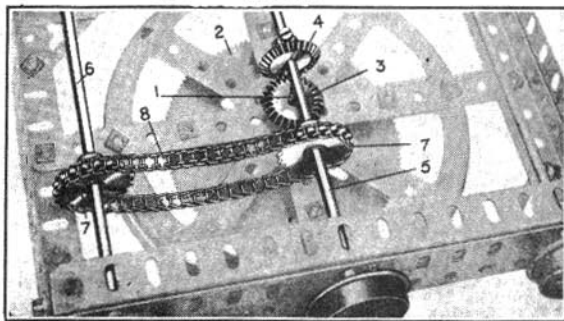

S.M.166

often be made to give out power for periods almost as long as a Clockwork Motor. The flywheel must be very heavy and well balanced, and its bearings must be as free from friction as it is possible to make them.

An example of momentum traction is shown on this page, in this case a tractor forming the model to be driven. The flywheel is mounted on a short Rod, the front end of which carries a $\frac{1}{2}$ " Pinion that can be brought into mesh through a high step-up gearing with the starting handle. When this handle is pushed inwards the gear train is brought into operation automatically and the flywheel can then be set in motion.

At the opposite end of the flywheel Rod is fitted a second $\frac{1}{2}$ " Pinion. This can be brought into engagement with a $1\frac{1}{2}$ " Contrate 6, that is secured on a sliding Rod controlled by a short lever. A Compression Spring normally keeps the Contrate in gear with the Flywheel, but when the latter is set in motion the lever is moved over to one side. No movement is then imparted to the road wheels while the Flywheel is being started and they are brought into gear when required by the return movement of the lever.

TRANSMISSION TO SIX WHEELS

S.M.166. This illustration shows an underneath view of the wheel base of a Meccano steam shovel. In this model the Motor is carried in the swivelling superstructure and the drive is led to the road wheels by way of the vertical shaft 1. This shaft is journaled in the boss of the $3\frac{1}{2}$ " Gear Wheel 2, about which the superstructure

pivots, and carries a $\frac{3}{4}$ " Bevel Gear 3 meshing with a similar wheel 4 on the transverse Rod 5. The latter forms an axle for the centre pair of the six road wheels, and the drive is carried to the remaining pair of wheels by means of 1" Sprocket Wheels 7 and Sprocket Chain 8.

OVERHEAD TRAVELLER

S.M.167. The traversing movement of the trolley is obtained from the cord 8, the ends of which are shown connected to the cross Strips 2.

The pulley block 7 is built up from two Flat Trunnions bolted together, Washers being placed between the Trunnions on the shanks of the Bolts 12.

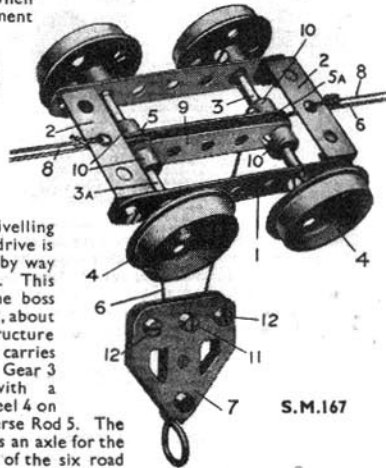

S.M.167

Section XVI. SPRINGS AND SHOCK ABSORBERS

RUBBER SHOCK ABSORBERS

S.M.168. In vehicles intended for carrying abnormal loads rubber shock absorbers are often fitted in place of the more usual springs. They are less liable to sudden collapse, but are only suitable for very slow moving vehicles as, except in very special circumstances, they are incapable of absorbing sudden shocks.

An excellent example of the use of rubber shock absorbers is shown in model form in S.M.168 on this page.

The set of rear wheels for one side of the lorry is carried on a Rod of suitable length that is journalled in a strong compensating beam, the forward end of which is pivotally attached to the underside of the main frame of the lorry so that it is capable of universal movement. The other end of the beam is fitted with a large Fork Piece as shown and a Rod in the boss of this moves vertically in a set of $\frac{1}{2}$ " fast and loose Pulleys 37. The lower and upper Pulleys of this set are secured to the main frame by a $\frac{3}{8}$ " Bolt, and by the shank of a Handrail Support 35. The purpose of the Handrail Support will be shown later. The complete fitting represents the primary shock absorber of the actual lorry.

A 1" Rod, part of which is shown at 33, passes through the end hole of the bottom Girder of the lorry frame. The inner end of this Rod carries a Collar that is in contact with one end of a

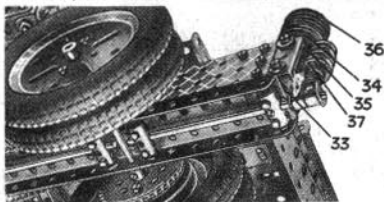

S.M.168

Rubber Rings that are held in place by a second 1" fast Pulley 36 locked on the Threaded Rod by two Grub Screws. As the beam carrying the road wheels rises, the Single Bent Strip presses against the underside of the Pulley 34. This action tends to compress the Rubber Rings, as they are prevented from moving vertically by the pulley 36 and its 1" Threaded Rod. A similar action would take place in the primary shock absorber if the $\frac{1}{2}$ " loose Pulleys were replaced by rubber rings, but scale dimensions could not be retained in the model if this were done.

SEMI-ELLIPTIC SPRING

S.M.169. Springing is a very important construction of any motor vehicle. The springs that they will stand up to the strains imposed by loads or violent shocks, and yet be so sensitive that vibrations. Those shown in the illustration are a the type used in the majority of motor cars. The

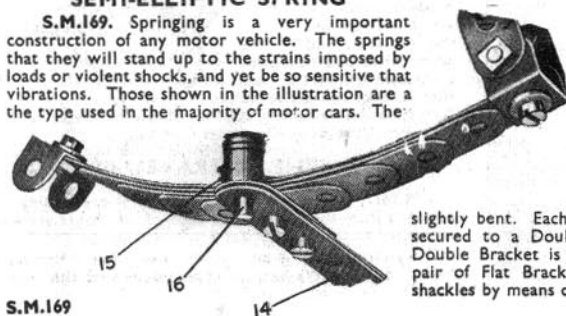

S.M.169

consideration in the must be so designed comparatively heavy they will absorb lesser faithful reproduction of are of the semi-elliptic type, and each consists of one $5\frac{1}{2}$ ", one $4\frac{1}{2}$ ", one $3\frac{1}{2}$ ", one $2\frac{1}{2}$ " and one $1\frac{1}{2}$ " Strip placed upon each other, in order, and slightly bent. Each end of the $5\frac{1}{2}$ " Strip is secured to a Double Bracket. The rear Double Bracket is bolted pivotally to the pair of Flat Brackets 3, which form the shackles by means of which the rear ends of

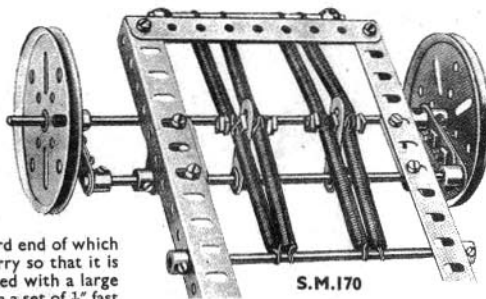

S.M.170

the springs are attached pivotally to the frame.

The front Double Bracket is mounted on a $\frac{3}{8}$ " Bolt passing through the side frame members.

TENSION SPRINGING FOR ROAD WHEELS

S.M.170. This device is an interesting departure from the usual type of rear axle suspension that with little or no alteration can be fitted into any Meccano motor chassis. The road wheels are represented by 3" Pulleys that are secured to the ends of an 8" Axle Rod. The Rod is journalled freely in the bosses of two Cranks which in turn, are bolted to two further Cranks secured to the ends of another Rod carried in Trunnions bolted to the underside of side girders of the chassis. This Rod has two more Cranks secured to it. Four Springs are attached to these Cranks by 1" Screwed Rods, two pairs of the springs being attached to a Rod mounted between the side Girders of the frame, and the remaining two pairs being anchored to the rear end of the chassis.

LOCOMOTIVE SPRINGING

S.M.171. A model of a typical spring fitted to locomotives and rolling stock is shown in the illustration on this page. The axle carrying the travelling wheels is supported at its end in a Collar, the Grub Screw of which has been removed in order to allow freedom for the axle.

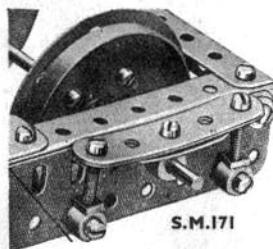

S.M.171

The upper tapped hole of the Collar carries the end of the shank of a Bolt that supports the spring in its centre. This spring is built up from two $2\frac{1}{2}$ " Strips and a $1\frac{1}{2}$ " Strip, but other sizes may be used if desired.

Each end hole of the spring accommodates a $\frac{3}{8}$ " Bolt, the bottom end of which passes into the tapped hole of a Collar. A nut

locks the bolt in place. The Collar is pivotally mounted on a $\frac{1}{2}$ " Bolt that is locked to the frame of the model by two nuts.

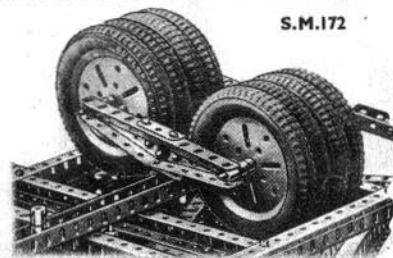

S.M.172

COMPENSATING LEVERS FOR ROAD WHEELS

S.M.172. Although this mechanism is not a spring in the true sense of the word, the arrangement is designed to reduce road shocks and may therefore be considered here. The construction of the compensating lever illustrated is shown in the photograph. It is mounted pivotally on a Rod at its centres and carries in its end holes the axles supporting the road Wheels. As the foremost wheel touches a bump on the road, the compensating lever lifts about its pivots and thus reduces the amount of vertical movement that otherwise would be transmitted to the chassis.

CANTILEVER SPRINGS

S.M.173. This type of spring is intended primarily for supporting the back axles of cars but is sometimes used for front axles. The spring is built up from 2", $2\frac{1}{2}$ ", $3\frac{1}{2}$ ", $4\frac{1}{2}$ " and $5\frac{1}{2}$ " Strips connected together as shown and fitted with two $\frac{1}{2}$ " x $\frac{1}{2}$ " Angle Brackets at their upper ends.

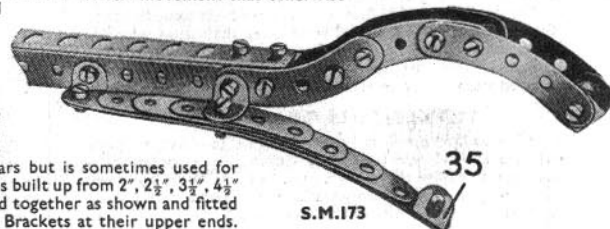

S.M.173

Section XVII. SPECIAL MOVEMENTS

OUT OF LINE DRIVE

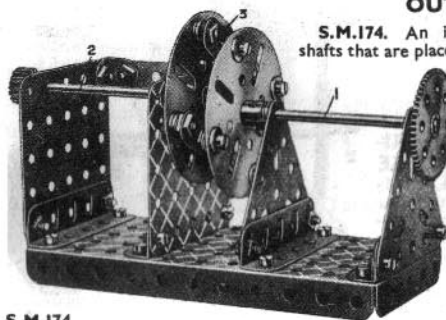

S.M.174

As the Rod 1 rotates, the movement of one Face Plate is imparted to the other by means of the Flat Brackets.

BALANCED AILERON CONTROL

S.M.175. As the speed of an aeroplane increases, the handling of the controls becomes increasingly difficult, especially on large machines, on account of the greater wind pressure, which of course tends to force the ailerons back into their normal position. In order to assist the pilot in operating the controls, the balanced aileron has been evolved.

A small auxiliary flap is incorporated in the trailing edge of the aileron, and pivoted to it. This flap operates with a similar movement to the aileron itself, but its movement is in opposition to that of the aileron. It is connected to the wing by a pivoted link so that its motion is entirely automatic when the aileron is moved.

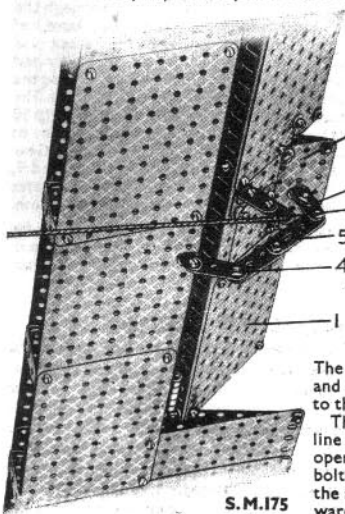

S.M.175

A model of a balanced aileron is illustrated in S.M.175. The flap 2 is made from two $3' \times 1\frac{1}{2}'$ Plates secured together at their outer edges, the inner edges being spaced apart by Collars, and secured by bolts inserted in the opposite tapped bores of the Collars.

A Rod passed through both Collars is pivoted in a second set of Collars secured to the aileron. A Flat Bracket 3 is rigidly bolted to an Angle Bracket secured on the underside of the flap. The connecting link 5 consists of two 2" Slotted Strips, and a $1\frac{1}{2}'$ Strip 4 is bolted to an Angle Bracket attached to the wing.

The link 5 is arranged so that when the aileron 1 is in line with the wing, the auxiliary flap also is in line. For operating the aileron, cords are attached to $1\frac{1}{2}'$ Strips 6, bolted at right angles to the upper and lower surfaces of the aileron by means of $1'' \times 1''$ Angle Brackets. Downward movement of the aileron causes the auxiliary flap to move upward and similarly, when the aileron is raised,

the flap has a slight downward angle. The flap thus tends to keep the aileron in position when banking and reduces the effort required on the part of the pilot when handling the joystick.

INTERLOCKING LEVERS

S.M.176. The levers consist of $5\frac{1}{2}'$ Strips mounted on a Rod and retained in position by Collars. The sides of the lever frame are built up from Sector Plates joined together at their upper ends by two $5\frac{1}{2}'$ Angle Girders. Four $2\frac{1}{2}'$ Flat Girders are bolted transversely across the $5\frac{1}{2}'$ Angle Girders to form quadrants for the levers.

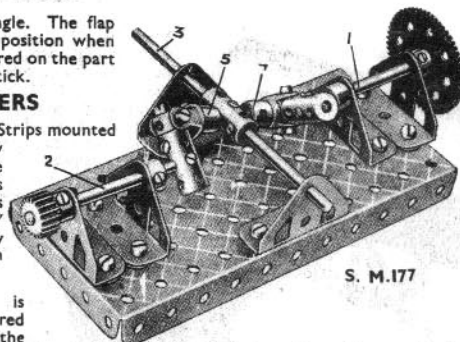

S. M.177

end of each of the 3" Rods 1, 2, 3, and in each case a Flat Bracket forms a connection between the End Bearing and the bottom end of each lever. The movements of the Rods are limited by Collars secured on their outer ends.

Each tappet 7, 8, 9, 10, consists of one Collar and two Washers mounted on a $\frac{1}{2}'$ Bolt that is inserted in the set-screw hole of a Coupling. All four Couplings slide freely on the central $6\frac{1}{2}'$ Rod 5, but the Couplings carrying the tappets 7 and 8 are secured rigidly to the Rod 4, while the remaining two are secured to the Rod 6. This arrangement ensures that the respective groups of tappets move as one. Careful attention should be paid to the position of the tappets on their supporting Couplings.

Each pair of tappets has a limited sideways movement that is controlled by the Collars on the Rods 1, 2, 3. For example, in moving the central lever to the position shown in the illustration the tappet 8 has been moved to the left, by riding up the Collars on the Rod 2 as the latter moves towards the front of the photograph, and the tappet 7 is forced into the "step" formed by the end of the Collar and the Rod 1.

REVERSE DRIVE

S.M.177. This is an ingenious device for driving two shafts, arranged in line, so that they revolve in opposite directions. The details of the mechanism are shown in the photograph, and it will be noted that the reverse drive is obtained without the use of gears.

The driven Rod 1 bears a Collar and a Coupling mounted on the end of the Rod by its centre transverse hole. The driven Rod 2 is provided with a Coupling similarly mounted, and both Rods are journaled in Trunnions spaced from the base plate by two Washers on each fixing bolt. The Washers raise the mechanism slightly and prevent it from fouling the base plate.

Two further Trunnions provide bearings for the transverse unit 3 formed by fixing two 2" Rods in a Coupling through the centre of which is passed a $1\frac{1}{2}'$ Rod. At the ends of this short Rod the forks of Swivel Bearings 4 and 5 are free to slide, and their "spiders" are pivotally attached by means of $\frac{3}{4}'$ Bolts to the Couplings on the driving and driven shafts. The final drive is taken from a $\frac{1}{2}'$ Pinion on the Rod 2.

DEVICE TO INCREASE CRANK STROKE

S.M.178. This ingenious mechanism gives a stroke almost double the length of the actual crank stroke. A suitable frame is built up

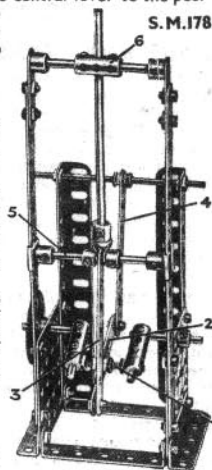

S.M.178

Section XVII. Special Movements—(continued)

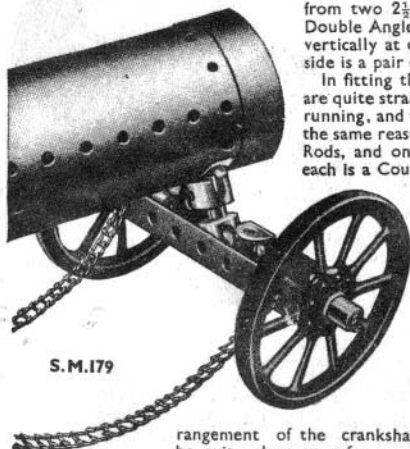

S.M.179

arrangement of the crankshaft assembly will be quite clear on reference to the illustration. The $2\frac{1}{2}$ " Strip 2 is pivoted at its centre hole on the Rod 1, and is held in place by lock-nuts on each side. One end of the Strip is pivoted to a $3\frac{1}{2}$ " Strip 4, the upper extremity of which is held loosely on the Screwed Rod connecting the vertical $5\frac{1}{2}$ " Angle Girders. For the connecting rod, a $3\frac{1}{2}$ " Strip 3 is used, and a $2\frac{1}{2}$ " Rod 5 is passed through its end hole. The Strip is placed in the forked end of an End Bearing and is centred on the Rod by two Collars. Eye Pieces fixed at the ends of the Rod slide up and down on the $7\frac{1}{2}$ " Strips which are spaced apart at the top by two 1" Rods held in Cranks and a Coupling 6. This Coupling forms a guide for the piston Rod that is fixed in the End Bearing at the end of the connecting rod 3.

FRONT AXLE TRACTOR MOUNTING

S.M.179. This front axle is built up from two $3\frac{1}{2}$ " Angle Girders bolted together to form a channel section, the Rods that carry the road wheels being journalled in Double Brackets. The central pivot is in two parts, a Handrail Support secured to the front axle and a Socket Coupling that is attached to the boss of a Double Arm Crank bolted to the underside of the boiler. The Handrail Support rests in the recess in the lower end of the Socket Coupling and is retained in place by two $\frac{1}{2}$ " \times $\frac{1}{2}$ " Angle Brackets that are secured to the front axle as shown.

S.M.180—REVOLUTION INDICATOR

A Centre Fork, carried in a Coupling secured to a revolving shaft, engages for a brief period in each revolution with the teeth of a 2" Sprocket Wheel secured to a second shaft, so imparting to the latter an intermittent rotary movement. This device is useful in revolution indicators, measuring instruments, etc.

Intermittent rotary motion may also be obtained by pawl and ratchet gear. For example, if one of

from two $2\frac{1}{2}$ " \times $2\frac{1}{2}$ " Flat Plates spaced apart by $2\frac{1}{2}$ " \times $\frac{1}{2}$ " Double Angle Strips. Two $5\frac{1}{2}$ " Angle Girders are placed vertically at one side of the Flat Plates and at the other side is a pair of $7\frac{1}{2}$ " Strips.

In fitting these, care should be taken to see that they are quite straight, as even a slight bend will impair smooth running, and they should also be placed exactly parallel for the same reason. The crankshaft is built up from two $1\frac{1}{2}$ " Rods, and on the inner end of each is a Coupling placed transversely and carrying a 1" Rod. These two Rods are provided with Collars that are connected by a 1" Screwed Rod 1. It is necessary to fit the Collars on the Screwed Rod before placing them in position. The details and arrangement of the crankshaft assembly will

be quite clear on reference to the illustration. The $2\frac{1}{2}$ " Strip 2 is pivoted at its centre hole on the Rod 1, and is held in place by lock-nuts on each side. One end of the Strip is pivoted to a $3\frac{1}{2}$ " Strip 4, the upper extremity of which is held loosely on the Screwed Rod connecting the vertical $5\frac{1}{2}$ " Angle Girders. For the connecting rod, a $3\frac{1}{2}$ " Strip 3 is used, and a $2\frac{1}{2}$ " Rod 5 is passed through its end hole. The Strip is placed in the forked end of an End Bearing and is centred on the Rod by two Collars. Eye Pieces fixed at the ends of the Rod slide up and down on the $7\frac{1}{2}$ " Strips which are spaced apart at the top by two 1" Rods held in Cranks and a Coupling 6. This Coupling forms a guide for the piston Rod that is fixed in the End Bearing at the end of the connecting rod 3.

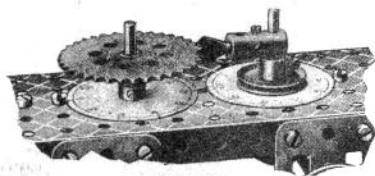

S.M.180

of the Pawls in S.M.91 is removed and the Sprocket Wheel given a to-and-fro motion by crank and connecting-rod gear, the Ratchet Wheel will have a motion similar to that in S.M.180.

REVERSING GEAR WITH VARIABLE PAUSE

S.M.181. By means of this gear it is possible to reverse a movement and to arrange a pause of variable length at the end of each operation.

The drive is supplied to the 8" Axle Rod 1 that carries a Worm and a $\frac{1}{2}$ " \times $\frac{3}{4}$ " Pinion. The Worm engages a $\frac{1}{2}$ " Pinion on a vertical Rod 2 that is journalled in 2" Strips secured in place by means of Angle Brackets. The Rod 2 carries a Worm that meshes with a $\frac{1}{2}$ " Pinion on the Rod carrying the Pinion 3, and another Rod is journalled below this and carries a 57-teeth Gear Wheel 4.

The Rod 5 is slidable in its bearings and carries two $\frac{1}{2}$ " \times $\frac{1}{2}$ " Pinions, one of which is in constant mesh with a $\frac{1}{2}$ " Pinion on the Rod 1. A loose Collar 6 on the Rod is retained in place between two fixed Collars. Two Compression Springs are fitted on the Rod on each side of the Flat Plate on the right-hand side of the frame.

The sliding movement of the Rod is controlled by a lever consisting of a 2" Strip pivoted at the base of the model and extended by means of a 2" Slotted Strip. A bolt is passed through the slot in the Strip and fitted with a nut before being screwed into the bore of the Collar 6. The nut is tightened against the Collar to prevent the shank of the bolt gripping the Axle Rod 5. At the lower end of the lever a bolt is inserted in a similar manner into the bore of the Collar 9 that is fixed to a sliding 5" Rod. The Collar 7 is loose on the Rod, and the 2" Slotted Strip 10 is pivotally attached to it. This Strip is firmly secured to a $3\frac{1}{2}$ " Strip that is pivoted to the Gear 4. As the Gear rotates the Collar 7 slides between the Collars 8 and 9, and as soon as it strikes either of these Collars it causes the lever to slide the Rod 5 in the corresponding direction.

Owing to the arrangement of the lever the Rod 5 slider more quickly than the Collars 8 or 9 and throws one of the $\frac{1}{2}$ " Pinions into engagement with the $\frac{3}{4}$ " Contrary Wheel on the Rod 11.

SWASHPLATE MOVEMENT

S.M.182. The driving shaft 1 is journalled in two $1\frac{1}{2}$ " \times $\frac{1}{2}$ " Double Angle Strips connected together by a Flat Bracket, and spaced from the Plate by one Washer beneath each. The Rod carries a Coupling which is mounted by means of its centre traverse hole, and the driven shaft 2 is provided with another Coupling mounted in a similar manner. Bearings for the Rod 2 are formed from a $3\frac{1}{2}$ " \times $2\frac{1}{2}$ " Flanged Plate and a $3\frac{1}{2}$ " \times $\frac{1}{2}$ " Double Angle Strip, the latter being spaced from the base plate by a Washer.

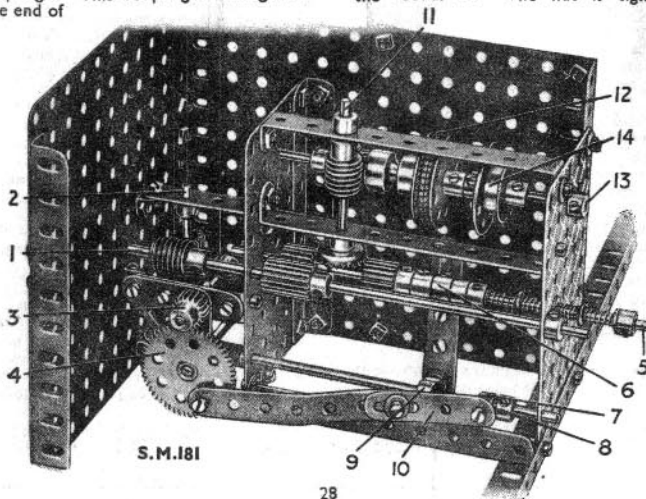

S.M.181

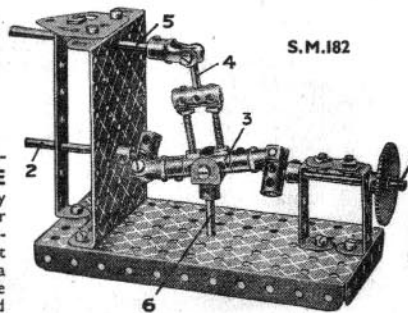

S.M.182

LIST OF MOVEMENTS ILLUSTRATED IN THIS BOOK

	<i>Model No.</i>		<i>Model No.</i>		<i>Model No.</i>
Ackermann Steering Gear	161	Four-Speed and Reverse Planetary Gear-Box	61	Safety Catch for Winding Gear	125
Adjustable Tool Holder	149	Friction Free Wheel	92	Screw and Strap Brake	113
Aeroplane Control Gear	158	Front Axle Tractor Mounting	179	Screw-Operated Shoe Brake	122, 145
Anti-Friction Bearing	128	Front Wheel Drive	126	Screw Jack	147
Automatic Gear Change	62	Geared Quick Return Motion	152	Screw Lifting Apparatus	146
Automatic Reversing Gear	63	Guide Pulley for Cranes	29	Screw Ratchet Feed	148
Automatic Reversing Hoist	18	Guide Pulley, deep groove	30	Self-Acting Brake for Cranes	121
Automatic Steering Gear for Yacht	157	Heavy Duty Quick Return Movement	151	Semi-Elliptic Spring	169
Balanced Aileron Control	175	Hobbs' Inertia Gear	59	Side Thrust Bearing	141
Ball-and-Socket Joint	132	Interlocking Levers	176	Silent Intermittent Rotary Motion	64
Ball Bearing Rod Support	139a	Intermittent Rotary Motion	65	Silent Overhead Camshaft Drive	87
Bevel Reversing Gear	52	Internal Expanding Front Wheel Brake	124	Simple Band Brake	111
Big End for Meccano Crankshaft	89	Joy's Valve Gear	13	Simple Circular Slide Bearing	144
Boat Steering Gear	154	Knife-Edge Bearing	130	Simple Crankshaft	75
Brake Lever and Quadrant	112	Lever in Platform Scales	7	Simple Hoist	15
Built-up Ball Bearing	140	Levers of the First Order	2, 3	Simple Internal Expanding Brake	116
Built-up Roller Race	139	Levers of the Second Order	4	Simple Lever Quick Return Motion	150
Cantilever Springs	173	Levers of the Third Order	5	Simple Screw Brake	115
Castor Steering	156	Light Duty Brake	114	Simple Steering Gear	162
Centrifugal Intermittent Motion	66	Locomotive Crosshead	143	Siphon Wick Lubricator	131
Clock Escapement	74	Locomotive Springing	171	Slide Crank Movement	77
Clutch-controlled Gear-Box	94	Lock-nutting	1, 1a	Small Crankshaft	78
Compact Gear Reduction	40	Meccano Ball Thrust Bearing	137	Small Maltese Cross Mechanism	67
Compact Three-Speed Gear-Box	42	Modified Ball Bearing	138	Smooth Movement Cam	88
Compact Free Wheel	93a	Momentum Traversing	165	Spontan Transmission Gear	60
Compensating Levers for Road Wheels	172	Multiple-Drive Mechanism	51	Sprocket Chain Transmission	24-28
Constant Engagement Intermittent Motion	72	Offset Quick Return Motion	153	Stephenson's Link Motion	12
Cord-Operated Free Wheel	93	Overhead Traveller	167	Steering Gear for Caterpillar Tracks	160
Cord Transmission	20, 21, 22, 31	Out of Line Drive	174	Sun and Planet Mechanism	79
Crosshead for Stationary Engine	142	Pawl and Ratchet Free Wheel	91	Sun and Planet Windlass	95
Derailleur Two-Speed Gear	23	Quick Action Cam Movement	90	Swashplate Movement	182
Device to Increase Crank Stroke	178	Rack and Pinion Traversing Mechanism	163	Tension Springing for Road Wheels	170
Differential for Sprocket Drive	49	Reinforced Bearings	127	Three-Movement Gear-Box	44
Differential Gear	53	Reverse Drive	177	Three-Speed and Reverse Gear	43, 45
Differential Pulley Block	19	Reversible Band Brake	123	Transmission to Six Wheels	166
Drive for Heavy Duty Travelling Wheels	164	Reversing Gear	50	Triplicated Crankshaft	76
Dual Aeroplane Control	155	Reversing Gear with Variable Pause	181	Two-Fold Pulley System	16
Epicyclic Gear Clutch	54	Revolution Indicator	180	Two-Speed Epicyclic Gear-Box	58
Epicyclic Transmission Gear	57	Rubber Shock Absorbers	168	Two-Speed Reverse Gear	41
Epicycloidal Gear	56			Variable Ratchet Movement	73
Examples of Meccano Gearing	32-39a			Walschaerts' Valve Gear	14
Experimental Pulley System	17			Worm and Chain Steering Gear	159
				Worm and Pinion Bearing	129

COPYRIGHT BY MECCANO LTD.

Printed in England