

# MECCANO

TRADE MARKS 296321, 501113, 76, 12633, 10274, 55/13476, 569/13, 884/25, 2913, 80, 124, 336, 4174, 91637, 83171, 157149, 32822, 200639, 209733, 214061, 214062, 12892, 29094, 33316, 1818, 16737, 383/13, 5848, 50204, 10/12258, 22826, 18982, 20063/925, 9048, 5549, 2189, 16900, 72286, 2389, 41812, 5403, 7315, 18066, 139420, 494933-4-5-6, 29041, 26877, 6595, 404718, 410379, 55096, 12240

HORNBY'S ORIGINAL SYSTEM—FIRST PATENTED 1901



## INSTRUCTIONS



FOR BUILDING No. 5 OUTFIT MODELS

Copyright by MECCANO LIMITED, LIVERPOOL, throughout the world

No. 31.4A

ENGLISH EDITION

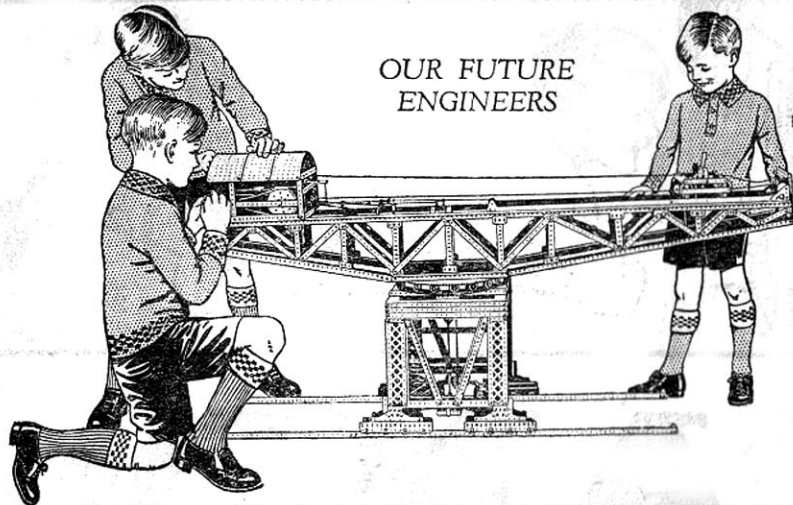

OUR FUTURE  
ENGINEERS

# MECCANO

## Real Engineering in Miniature

The Meccano No. 4A Accessory Outfit converts your No. 4 Outfit into a No. 5, and enables you to build the splendid models illustrated in this Manual. As a Meccano enthusiast, you will realise that our examples do not exhaust the possibilities of your Outfit. It is no exaggeration to say that the possibilities of Meccano are limitless—there is always something new that you can invent and build, and most models can be constructed in many alternative ways. In addition to the fascination and satisfaction obtained by building new models, you can enter them in the model-building competitions that are a regular feature of the "Meccano Magazine." These competitions are open to all Meccano boys, and valuable prizes are offered.

## The "Meccano Magazine"

The "Meccano Magazine" is essential to the full enjoyment of the Meccano hobby. A section of it is devoted to the Editor's replies to his readers' enquiries; the progress of Meccano clubs throughout the world is reported; and full details are given of the latest model-building achievements. In addition, a wealth of informative articles on all subjects of interest to boys is included in every issue. The publishing date is the first of each month. If you are not already a reader of the "Meccano Magazine" write to the Editor for full particulars, or order a copy from your Meccano dealer or from any newsagent.

## How to Progress

When you desire to build the bigger and better models that the No. 6 Outfit makes, it is only necessary for you to purchase a No. 5A Accessory Outfit. In turn, a No. 6A Accessory Outfit will convert your equipment into a No. 7—which is the ambition of every Meccano enthusiast—and enable you to build every model in all the Meccano Instruction Manuals.

As a keen and inventive Meccano model-builder you should possess copies of the special Manuals "How to use Meccano Parts" and "Meccano Standard Mechanisms." In the former the principal uses of Meccano parts are outlined, while the latter shows a large number of real engineering mechanisms, built of Meccano parts, that can be incorporated in various models. You can obtain copies of these Manuals from your dealer, or direct from Meccano Ltd., Old Swan, Liverpool.

A complete list showing the contents of each Meccano Outfit and Accessory Outfit will be supplied, free of charge, on application to Meccano Limited, Liverpool.

## Meccano Service

The service of Meccano does not end with selling an Outfit and an Instruction Manual. When you want to know something more about engineering than is now shown in our books, or when you strike a tough problem of any kind, write to us. We receive over 200 letters from boys every day all the year round. Some write to us because they are in difficulty, others because they want advice on their work or pleasures, or about the choice of a career. Others, again, write to us just because they like to do so and we are glad to know that they regard us as their friends.

Although all kinds of queries are put to us on all manner of subjects, the main interest is, of course, engineering. The wonderful knowledge of engineering matters possessed by our staff of experts is unique. This vast store of knowledge, gained only by many years of hard-earned experience, is at your service. *We want the Meccano boy of to-day to be the famous engineer of to-morrow.*

**IMPORTANT** :—Meccano Parts may be bought separately at any time in any quantity from your Meccano dealer.

### Model No. 5.1 Spooling Machine

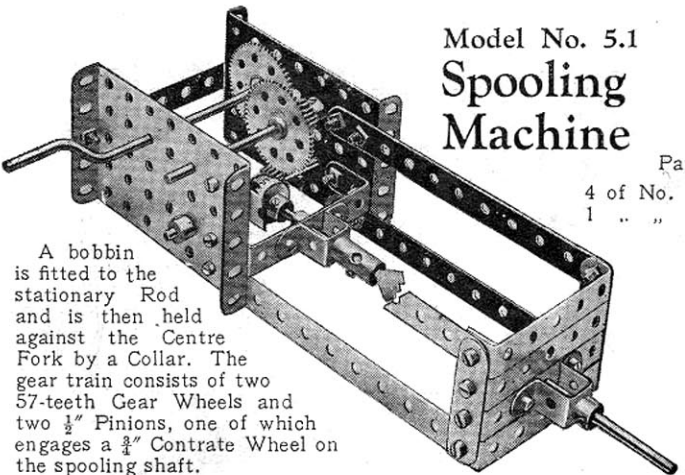

A bobbin is fitted to the stationary Rod and is then held against the Centre Fork by a Collar. The gear train consists of two 57-teeth Gear Wheels and two  $\frac{1}{2}$ " Pinions, one of which engages a  $\frac{3}{4}$ " Contrate Wheel on the spooling shaft.

Parts required:

4 of No. 2	3 of No. 16
1 " " 3	1 " " 17
	1 " " 19
	2 " " 26
	2 " " 27A
	1 " " 29
	20 " " 37
	2 " " 45
	1 " " 46
	4 " " 48A
	2 " " 53
	7 " " 59
	1 " " 63
	1 " " 65

### Model No. 5.2 Motor Car

Parts required:

2 of No. 2	2 of No. 10	1 of No. 16	2 of No. 26	3 of No. 48B
8 " " 3	8 " " 12	4 " " 19A	1 " " 28	2 " " 53
1 " " 5	6 " " 12A	2 " " 20	1 " " 32	2 " " 54
4 " " 6	1 " " 14	2 " " 22	75 " " 37	7 " " 59
2 " " 8	2 " " 15	2 " " 24	4 " " 38	2 " " 89
				2 " " 126A

Clockwork Motor  
(not included in Outfit)

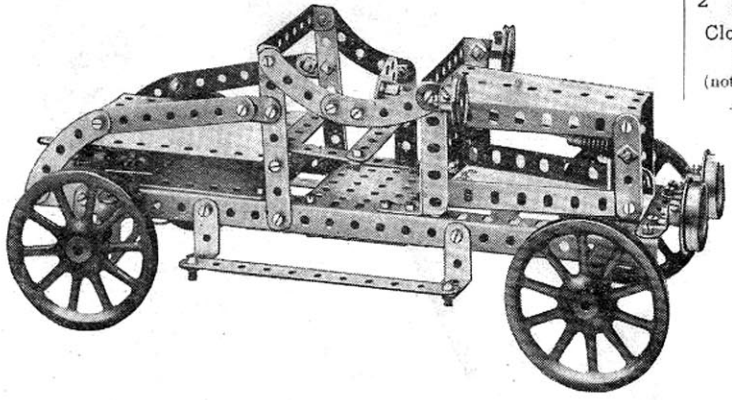

### Model No. 5.3 Cabin Monoplane

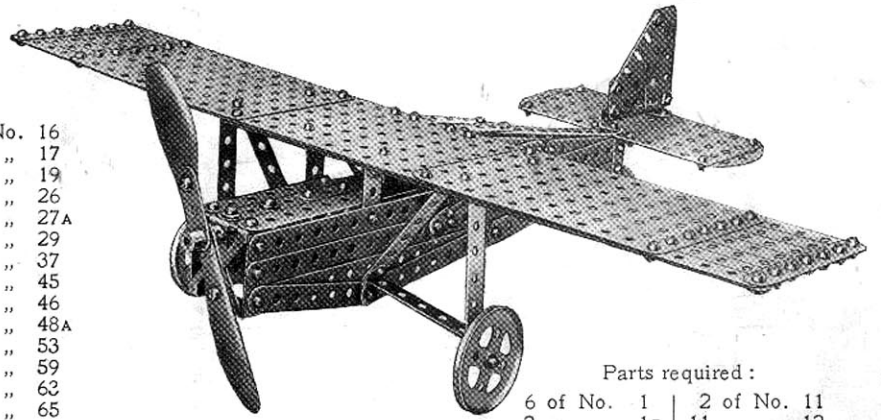

Parts required:

6 of No. 1	2 of No. 11
2 " " 1B	11 " " 12
6 " " 2	2 " " 12A
4 " " 2A	1 " " 16A
12 " " 3	2 " " 20A
6 " " 4	106 " " 37
17 " " 5	6 " " 37A
2 " " 6	8 " " 38
5 " " 6A	2 " " 41
6 " " 10	1 " " 48
	2 " " 48A
	3 " " 52A
	1 " " 59
	2 " " 62
	1 " " 70
	2 " " 90A
	3 " " 103F
	2 " " 111
	2 " " 111c
	2 " " 126

Fig. 5.3A is an underneath view of the model with one side removed, to show the construction of the fuselage and method of securing the wings to the undercarriage.

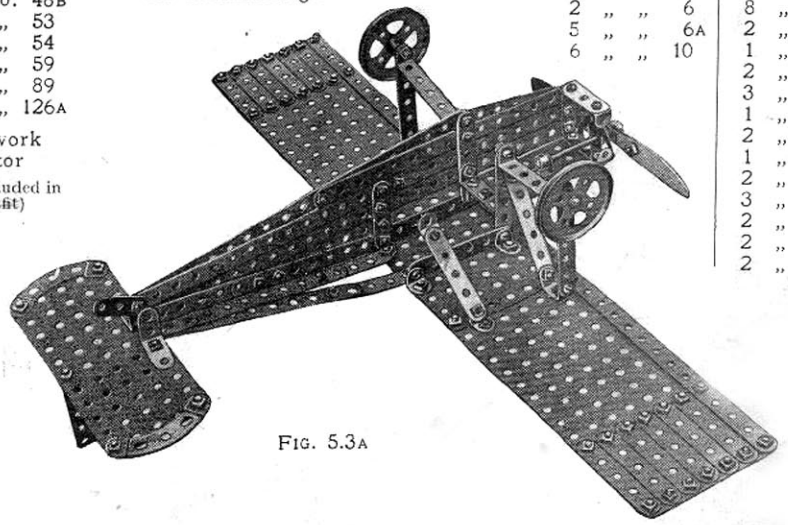
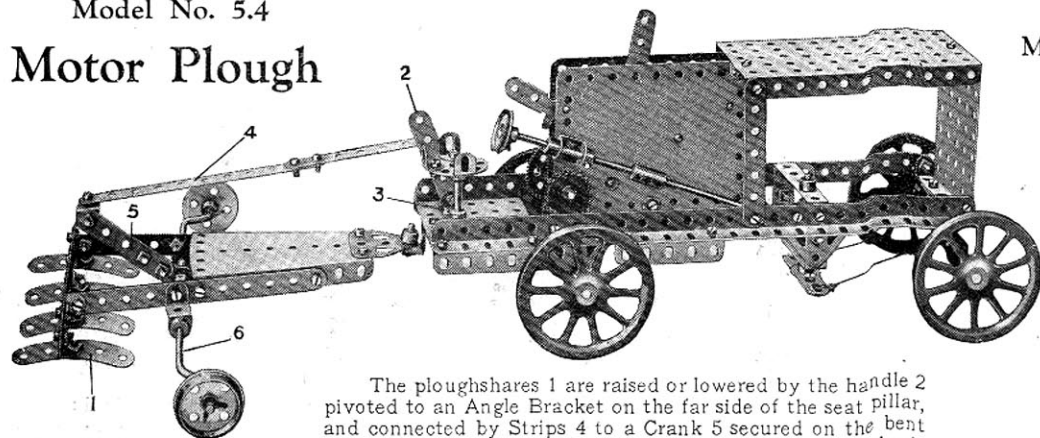

Fig. 5.3A

## Model No. 5.4 Motor Plough



The ploughshares 1 are raised or lowered by the handle 2 pivoted to an Angle Bracket on the far side of the seat pillar, and connected by Strips 4 to a Crank 5 secured on the axle 6 of the wheels formed by Crank Handles. The plough is driven by a Meccano Clockwork Motor.

Parts required :

5 of No. 2	19 of No. 12	1 of No. 19s
3 " " 3	1 " " 15A	2 " " 20
3 " " 5	1 " " 16	3 " " 22
2 " " 8	3 " " 17	1 " " 24
2 " " 10	1 " " 19	2 " " 26
1 " " 11	4 " " 19A	1 " " 27A

1 of No. 29
4 " " 35
24 " " 37
6 " " 38
1 " " 45
1 " " 46
4 " " 48A
1 " " 52
3 " " 53
1 " " 54
9 " " 59
1 " " 62
2 " " 63
4 " " 90
6 " " 94
2 " " 96
1 " " 115
3 " " 125
5 " " 126A

Clockwork Motor  
(not included in Outfit)

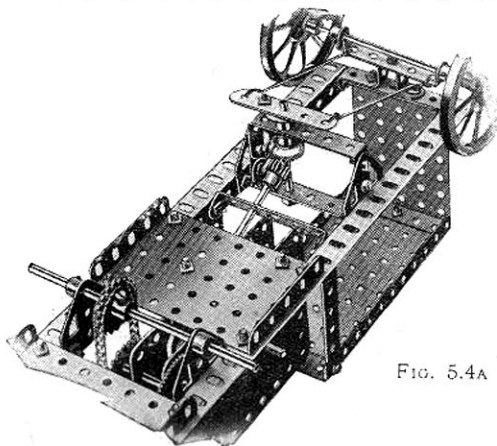
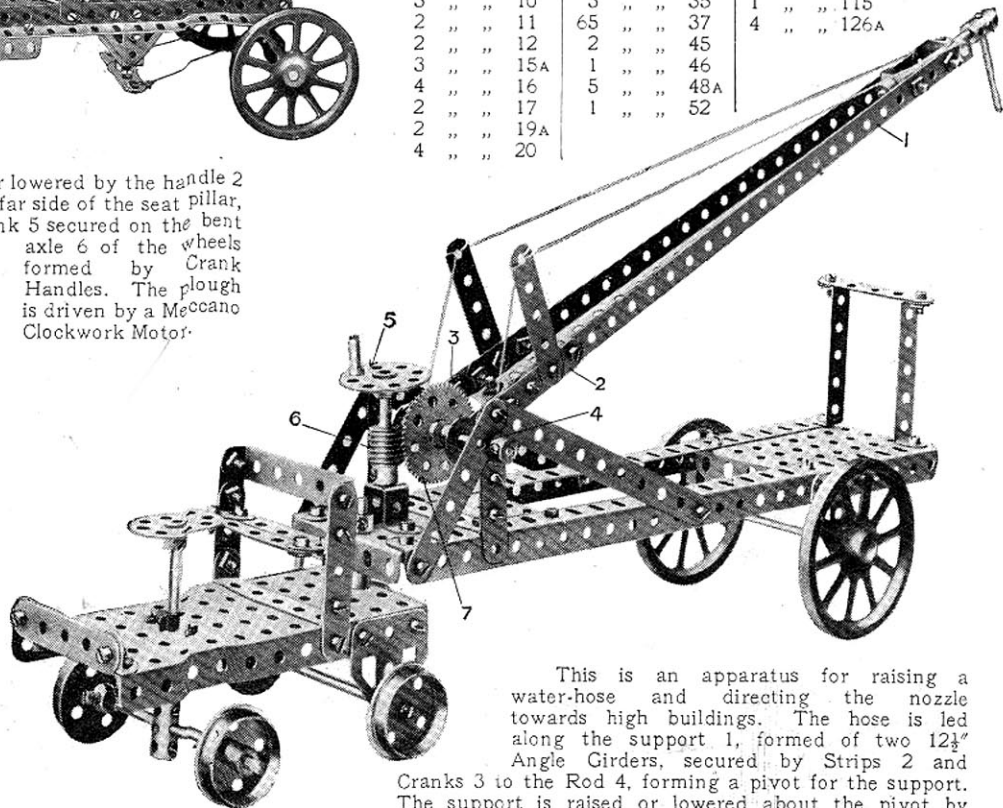

FIG. 5.4A

## Model No. 5.5 Fire Watertower

Parts required :

2 of No. 2	1 of No. 22	2 of No. 53
2 " " 4	1 " " 24	9 " " 59
11 " " 5	1 " " 27A	2 " " 62
4 " " 8	1 " " 32	3 " " 63
3 " " 10	3 " " 35	1 " " 115
2 " " 11	65 " " 37	4 " " 126A
2 " " 12	2 " " 45	
3 " " 15A	1 " " 46	
4 " " 16	5 " " 48A	
2 " " 17	1 " " 52	
2 " " 19A		
4 " " 20		



This is an apparatus for raising a water-hose and directing the nozzle towards high buildings. The hose is led along the support 1, formed of two 12½" Angle Girders, secured by Strips 2 and Cranks 3 to the Rod 4, forming a pivot for the support. The support is raised or lowered about the pivot by turning the hand wheel 5, a Worm 6 on the spindle of which engages a 57-toothed Wheel 7 on the Rod 4.

### Model No. 5.6 Spring Pistol

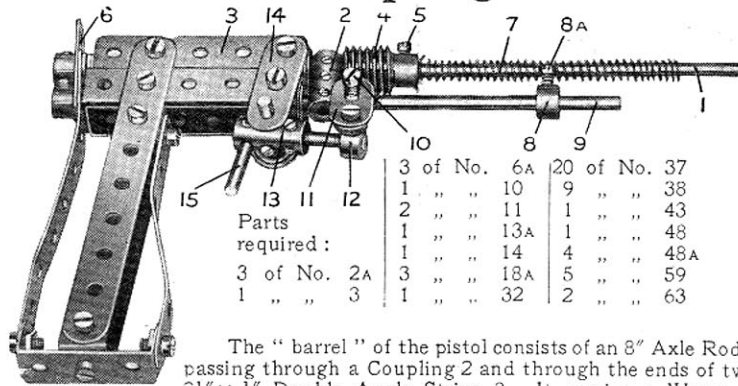

3 of No.	6A	20 of No.	37
1 "	10	9 "	38
2 "	11	1 "	43
1 "	13A	1 "	48
1 "	14	4 "	48A
3 of No.	2A	3 "	59
1 "	3	1 "	63

The "barrel" of the pistol consists of an 8" Axle Rod 1 passing through a Coupling 2 and through the ends of two 2 1/2" x 1/2" Double Angle Strips 3. It carries a Worm 4, which is secured by a Bolt 5 in place of its grub-screw. This Bolt serves as the foresight, the backsight being formed by the upper hole of a 1 1/2" Strip 6. A Meccano Spring secured by one of its end loops to the Bolt 5, is mounted on the barrel and opened out to form a compression spring. The loop at the other end should be cut away.

Collars, with set-screws extracted, may be used as bullets, or small pieces of wood of similar shape may be employed. The gun is loaded by placing the bullet upon the barrel and pushing the Spring 7 back until the bullet passes the Collar 8. The latter is rigidly secured by means of a 5/32" Bolt 8A to a 6 1/2" Rod 9, which is free to turn slightly in its bearings. The Bolt 8A is pushed in front of the bullet, so preventing the Spring 7 from expelling it from the barrel. Another Collar and Bolt 10 is secured to the Rod 9 and coupled by means of a Flat Bracket 11 to a Bolt mounted in a Collar 12. This in turn, is secured to a 1 1/2" Rod inserted in a Coupling 13 pivotally mounted and spaced on either side by two Washers between 1 1/2" Strips 14. A further Rod 15 forms a trigger, and a slight touch on this pulls the Bolt 8A clear of the bullet, so firing the pistol.

The pistol should possess a range of ten yards or more.

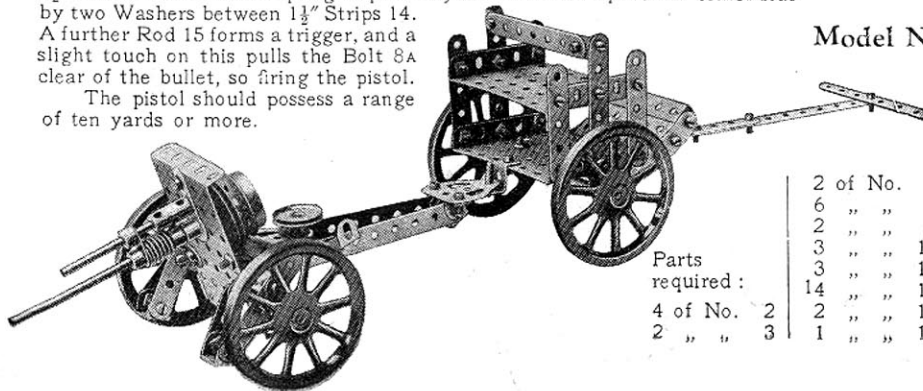

4 of No.	2
2 "	3

2 of No.	4	1 of No.	16
6 "	5	1 "	18A
2 "	6A	4 "	19A
3 "	10	1 "	20
3 "	11	1 "	21
14 "	12	1 "	22
2 "	15	1 "	24
2 "	15A	1 "	32
1 "	15A	62 "	37

### Model No. 5.7

### Fertiliser Distributing Cart

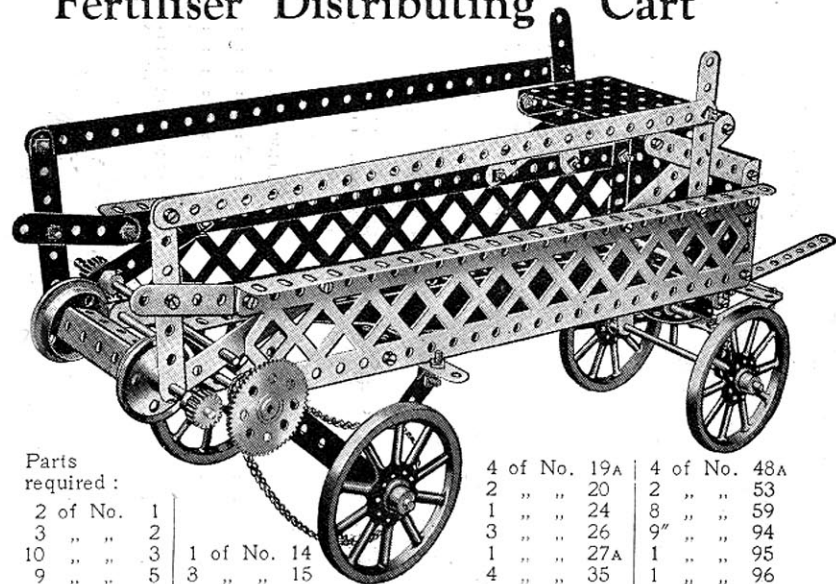

Parts required :

2 of No.	1	1 of No.	14
3 "	2	3 "	15
10 "	3	2 "	15A
9 "	5	2 "	17
4 "	8		
6 "	12		

4 of No.	19A	4 of No.	48A
2 "	20	2 "	53
1 "	24	8 "	59
3 "	26	9 "	94
1 "	27A	1 "	95
4 "	35	1 "	96
57 "	37	2 "	99
1 "	46		

### Model No. 5.8 Field Gun and Carriage

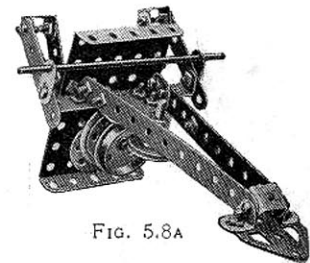
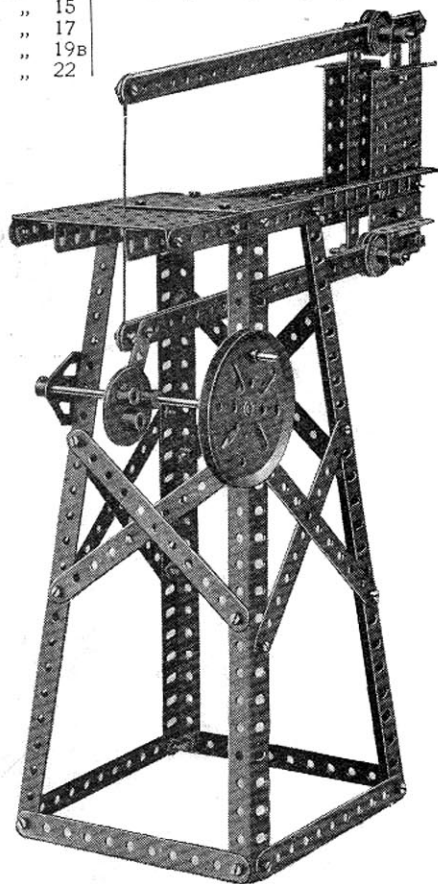

FIG. 5.8A

2 of No.	38
3 "	48A
2 "	48B
2 "	53
3 "	59
1 "	62
1 "	63
2 "	90
1 "	115
2 "	125
2 "	126A

## Model No. 5.9 Fret Saw

Parts required:			
4 of No.	1	53 of No.	37
17 " "	2	4 " "	53
6 " "	8	5 " "	59
1 " "	15	1 of No.	115
2 " "	17	2 " "	126A
1 " "	19B	1 " "	130
4 " "	22		



Parts required:	
1 of No.	1
1 " "	1B
4 " "	2
2 " "	2A
12 " "	3
1 " "	5
5 " "	6A
2 " "	8
2 " "	8A
4 " "	9
12 " "	10
21 " "	12
2 " "	12A
1 " "	15
1 " "	15A
1 " "	16
1 " "	16A
1 " "	17
4 " "	20A
1 " "	21
4 " "	22
1 " "	23
1 " "	26
1 " "	27A
2 " "	29
112 " "	37
11 " "	37A
4 " "	38
1 " "	40
1 " "	48A
6 " "	48B
2 " "	52A
2 " "	53
1 " "	54
9 " "	59
2 " "	77
4 " "	90A
7" "	94
1 " "	96
1 " "	96A
3 " "	111
3 " "	111c
4 " "	142A
1 " "	160

Clockwork Motor  
(not included  
in Outfit)

## Model No. 5.10 Char-à-Banc

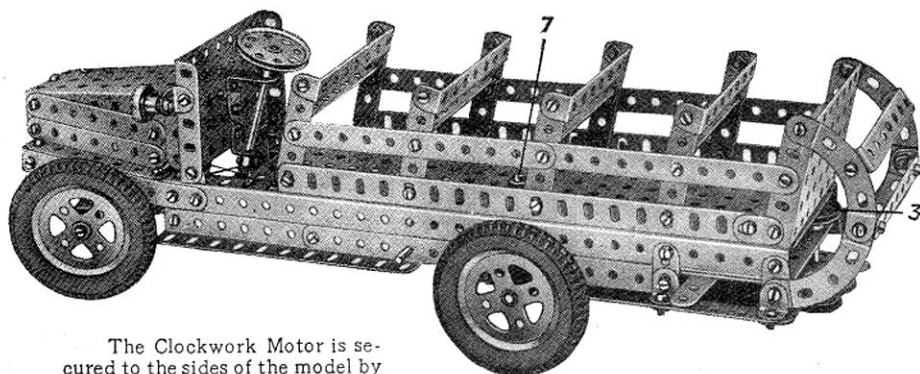

The Clockwork Motor is secured to the sides of the model by means of two  $5\frac{1}{2}$ " Angle Girders 8

(Fig. 5.10A) and the  $\frac{1}{2}$ " Pinion on the Motor driving shaft engages with a 57-teeth Gear on the Rod 1. Two 1" Pulleys 2 and 3 are secured to each extremity of this Rod and are connected by cord to the Pulleys on the Rod 4. The jockey pulley 5, over which one side of the cord passes, is mounted on the Motor side plate by a Flat Bracket and an Angle Bracket. The Rod 6, which guides the cord to and from the Pulley 3, is journalled at one end in the side of the model and at the other in a Collar secured to the floor by a Bolt 7.

Steering is accomplished by means of a cord passed about four times round the lower end of the steering column and connected to each end of the  $3\frac{1}{2}$ "  $\times$   $\frac{1}{2}$ " Double Angle Strip 9. This latter is pivoted at its centre hole to a  $1\frac{1}{2}$ " Strip secured to the fore part of the bonnet by a 1"  $\times$  1" Angle Bracket.

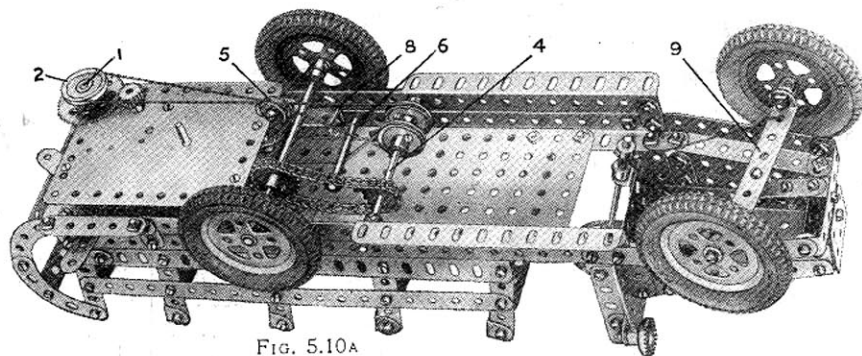
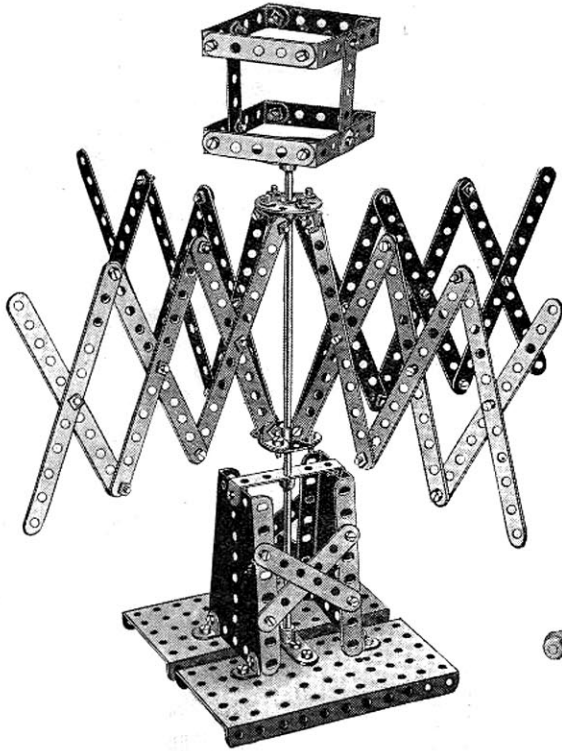

Fig. 5.10A

### Model No. 5.11 Skein Winder



Parts required :

2	of	No.	1
1	"	"	5
1	"	"	15
1	"	"	16
2	"	"	17
2	"	"	19A
1	"	"	22
1	"	"	26
2	"	"	29
1	"	"	32
22	"	"	37
1	"	"	46
5	"	"	48A
1	"	"	48B
1	"	"	59
1	"	"	63
1	"	"	65
2	"	"	90
1	"	"	95
1	"	"	96
1	"	"	125

Parts required :

24	of	No.	2	2	of	No.	24
4	"	"	4	86	"	"	37
7	"	"	5	5	"	"	48A
8	"	"	12	2	"	"	52
1	"	"	13	2	"	"	54
1	"	"	21	2	"	"	59

### Model No. 5.12 Measuring Machine

The drive is transmitted from the road wheels by a  $\frac{3}{4}$ " Contrate Wheel engaging a  $\frac{1}{2}$ " Pinion. A Worm on the shaft of the latter engages another  $\frac{1}{2}$ " Pinion, on the Rod of which is fixed a pointer which indicates up to five yards. When this pointer touches the 2" Sprocket Wheel, on which is fixed a second indicating dial, it turns the wheel round one tooth, representing five yards.

A Ratchet is fixed at the other end of the pointer Rod. It consists of a 1" Sprocket Wheel and a  $2\frac{1}{2}$ " Strip that is bolted to the frame by a  $\frac{1}{2}$ " Reversed Angle Bracket.

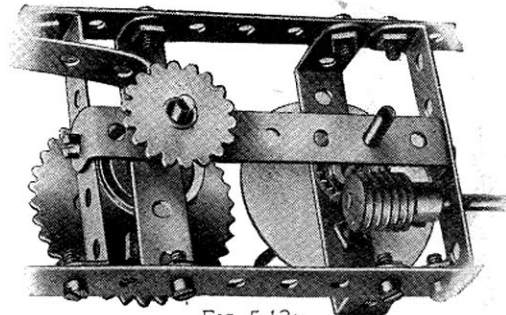
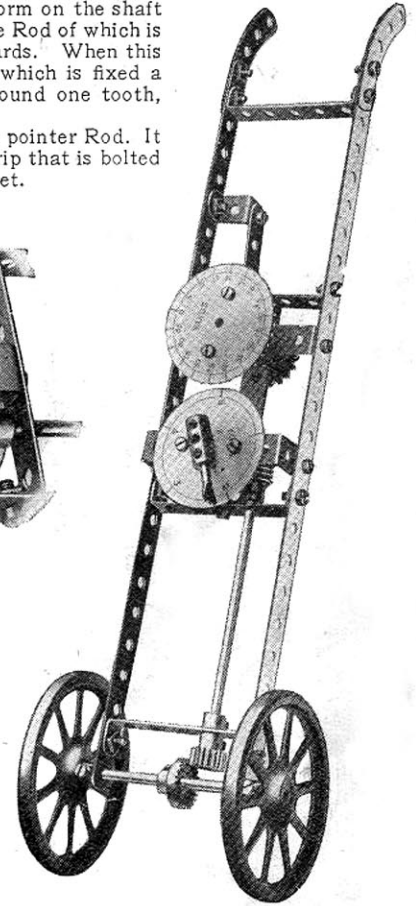
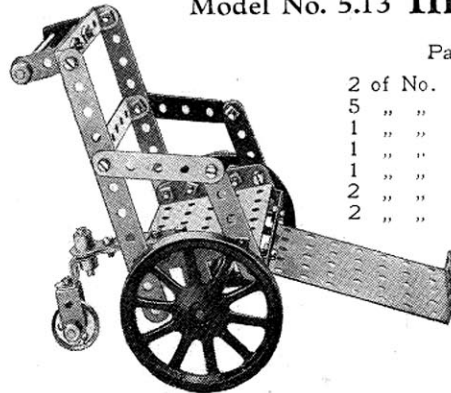

FIG. 5.12A



### Model No. 5.13 Invalid Chair



Parts required :

2	of	No.	2	1	of	No.	22A
5	"	"	5	25	"	"	37
1	"	"	10	5	"	"	38
1	"	"	15A	1	"	"	46
1	"	"	16	3	"	"	48B
2	"	"	18A	2	"	"	53
2	"	"	19A	5	"	"	59
				1	"	"	62
				1	"	"	102
				1	"	"	125
				2	"	"	126A

These Models can be built with MECCANO Outfit No. 5 (or No. 4 and No. 4A)

## Model No. 5.14 Pit Head Gear

The Rod 1 is driven from the Motor by means of the gearing shown (the short Rod carrying the two  $\frac{1}{2}$ " Pinions being journaled in a Channel Bearing bolted to the side of the Motor) and has a Worm secured to it between the Motor side plates. This Worm engages with the  $\frac{1}{2}$ " Pinion 2, which rotates the depth indicating disc when the model is working, the depth being marked by the fixed pointer 3. A  $\frac{3}{4}$ " Sprocket secured to the end of Rod 1 is connected by the Sprocket Chain 14 to a 2" Sprocket Wheel on the wind shaft, which consists of two  $\frac{1}{4}$ " Rods joined together by a Coupling. The winding drum, a Boiler, is carried between two 3" Pulleys 4 secured to this shaft, and to prevent the drum from slipping, a  $\frac{3}{4}$ " Rod 5 is passed through both sides of the Boiler and secured in the centre transverse hole of the Coupling joining the two halves of the winding shaft.

A brake consisting of a  $\frac{3}{4}$ " Screwed Rod working in the threaded hole of a fixed Angle Bracket 7 and in the end hole of the  $1\frac{1}{2} \times 1\frac{1}{2}$ " Angle Bracket 7 carries a Small Fork Piece, to which one end of the brake band is secured, the other end being attached to the base of the model. The Fork Piece is allowed to revolve freely between a Collar and locknuts.

When one of the cages reaches the top it engages with the  $\frac{1}{4}$ " Strip 8 and thus raises the gate. As the latter nears the top of the slide it raises a Coupling 9, which is connected to the reversing lever of the Motor by a length of cord. In this way a very effective safety switch is provided. The cord from each Coupling 9 passes round a  $1\frac{1}{2}$ " loose Pulley 12 and a  $1\frac{1}{2}$ " fast Pulley 10 and finally round a  $\frac{1}{4}$ " Rod 11 journaled in a Double Bracket.

The cages can, of course, be made to descend to any desired depth, but they must be arranged so that as one reaches ground level and stops the Motor by pushing the gate against one of the Couplings 9, the other is exactly at the bottom of the shaft. To economise in space, the lower cage is shown raised in the illustration to a point just below the cage which has reached ground level.

The guide cords 13 are secured at the top to  $\frac{1}{4}$ " Strips secured across the framework and at the bottom to  $\frac{1}{4}$ " Angle Girders not shown in the illustration. The latter girders should be screwed to the floor or held down firmly by heavy weights.

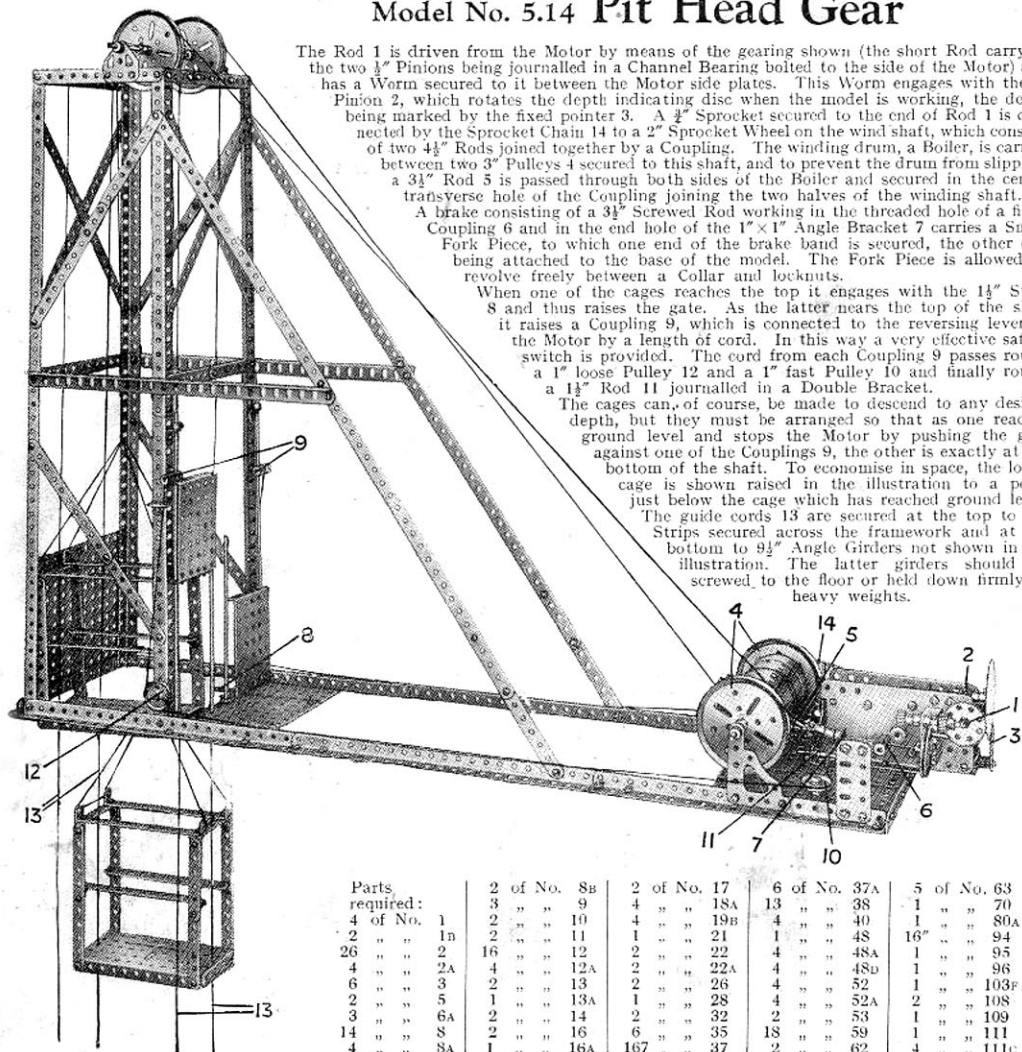

Parts required:	2 of No. 8B	2 of No. 17	6 of No. 37A	5 of No. 70	2 of No. 115
4 of No. 1	3 " " 9	4 " " 18A	13 " " 38	1 " " 70	1 " " 116A
2 " " 1a	2 " " 10	4 " " 19B	4 " " 40	1 " " 80A	2 " " 126A
26 " " 2	2 " " 11	1 " " 21	1 " " 48	16 " " 94	1 " " 147B
4 " " 2A	16 " " 12	2 " " 22	4 " " 48A	1 " " 95	1 " " 160
6 " " 3	4 " " 12A	2 " " 22A	4 " " 48D	1 " " 96	1 " " 162
2 " " 3	2 " " 13	2 " " 26	4 " " 52	1 " " 103P	
2 " " 5	1 " " 13A	1 " " 28	4 " " 52	2 " " 108	Electric Motor
3 " " 6A	2 " " 14	2 " " 32	2 " " 53	1 " " 109	(not included in Outfit)
14 " " 8	2 " " 16	6 " " 35	18 " " 59	1 " " 111	
4 " " 8A	1 " " 16A	167 " " 37	2 " " 62	4 " " 111C	(not included in Outfit)

## Model No. 5.15 Motor Car

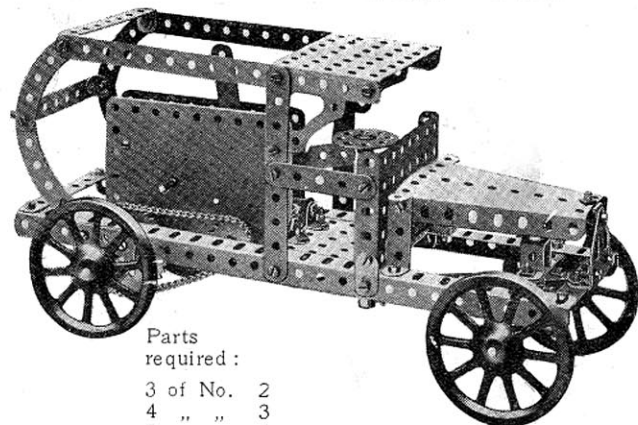

Parts required:

3 of No. 2
4 " " 3
5 " " 5
2 " " 8
2 " " 10
11 " " 12
2 " " 15A
1 " " 16
1 " " 17
4 " " 19A
2 " " 24
63 " " 37
2 " " 38
2 " " 45
2 " " 48
2 " " 48B
3 " " 53
1 " " 54
3 " " 59
1 " " 62
4 " " 90
12" " " 94
1 " " 95
2 " " 96
1 " " 116A
1 " " 108
1 " " 125
3 " " 126A

The steering wheel is mounted on a short Rod that is journaled in a  $3\frac{1}{2} \times 2\frac{1}{2}$ " Flanged Strip and in a Double Bent Strip secured to the Plate (see Fig. 5.15A). The lower end of the Rod carries a Crank that is connected to the swivelling front axle by a  $\frac{1}{4}$ " Strip, which is pivoted at both ends by bolts and nuts (S.M. 262).

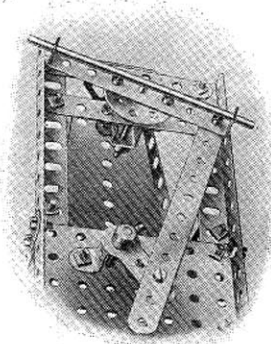
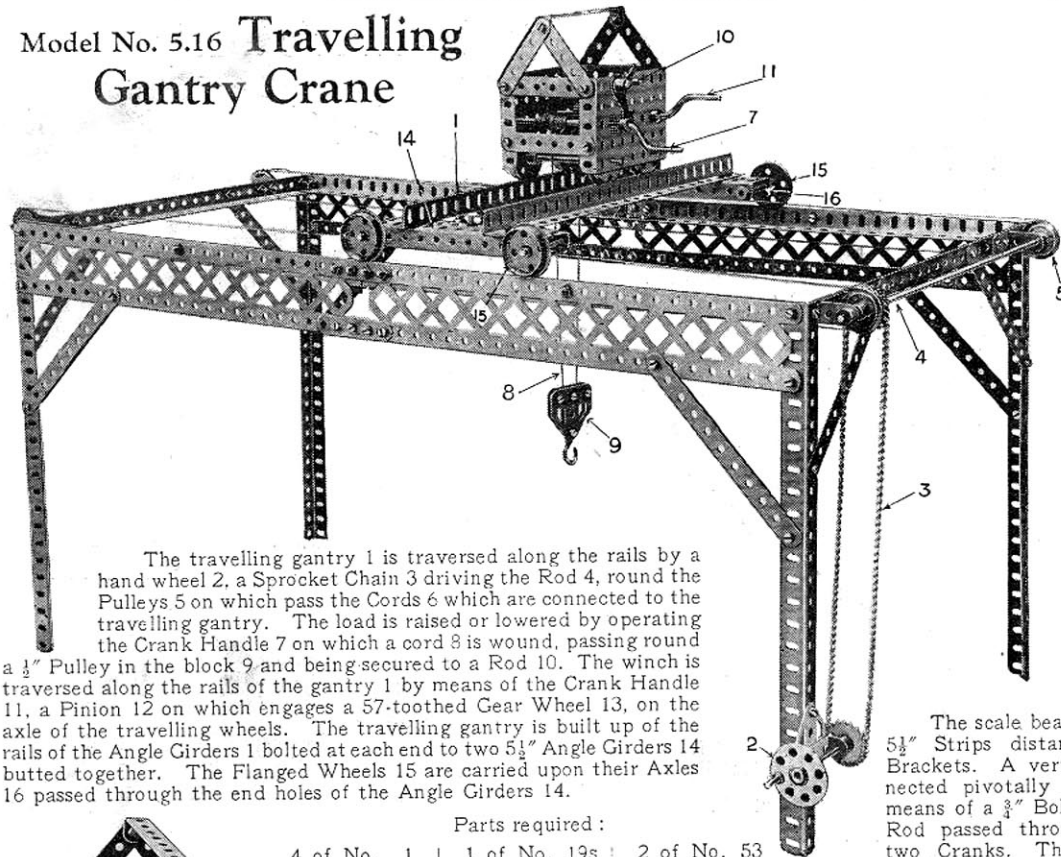

Fig. 5.15A



# Model No. 5.16 Travelling Gantry Crane



The travelling gantry 1 is traversed along the rails by a hand wheel 2, a Sprocket Chain 3 driving the Rod 4, round the Pulleys 5 on which pass the Cords 6 which are connected to the travelling gantry. The load is raised or lowered by operating the Crank Handle 7 on which a cord 8 is wound, passing round a  $\frac{1}{2}$ " Pulley in the block 9 and being secured to a Rod 10. The winch is traversed along the rails of the gantry 1 by means of the Crank Handle 11, a Pinion 12 on which engages a 57-toothed Gear Wheel 13, on the axle of the travelling wheels. The travelling gantry is built up of the rails of the Angle Girders 1 bolted at each end to two  $5\frac{1}{2}$ " Angle Girders 14 bolted together. The Flanged Wheels 15 are carried upon their Axles 16 passed through the end holes of the Angle Girders 14.

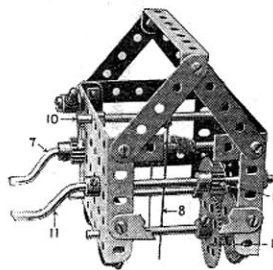

FIG. 5.16A

Parts required :

4 of No. 1	1 of No. 19s	2 of No. 53
8 " " 2	8 " " 20	1 " " 57
4 " " 4	4 " " 22	8 " " 59
10 " " 5	1 " " 23	24 " " 94
12 " " 8	1 " " 24	2 " " 96
4 " " 9	1 " " 26	4 " " 99
2 " " 11	1 " " 27A	4 " " 100
4 " " 12A	2 " " 35	2 " " 115
2 " " 13	96 " " 37	3 " " 126A
3 " " 16	6 " " 38	1 " " 147A
5 " " 17	1 " " 48	1 " " 147B
1 " " 19	1 " " 48B	1 " " 148

# Model No. 5.17 Spring Scales

Parts required :

6 of No. 2	2
2 " " 4	4
2 " " 8	8
2 " " 10	10
3 " " 11	11
2 " " 15	15
1 " " 15A	15A
2 " " 16	16
2 " " 17	17
1 " " 18A	18A
2 " " 26	26
2 " " 27A	27A
23 " " 37	37
1 " " 43	43
2 " " 48A	48A
1 " " 52	52
1 " " 54	54
1 " " 57	57
2 " " 59	59
2 " " 62	62
2 " " 63	63
1 " " 111	111

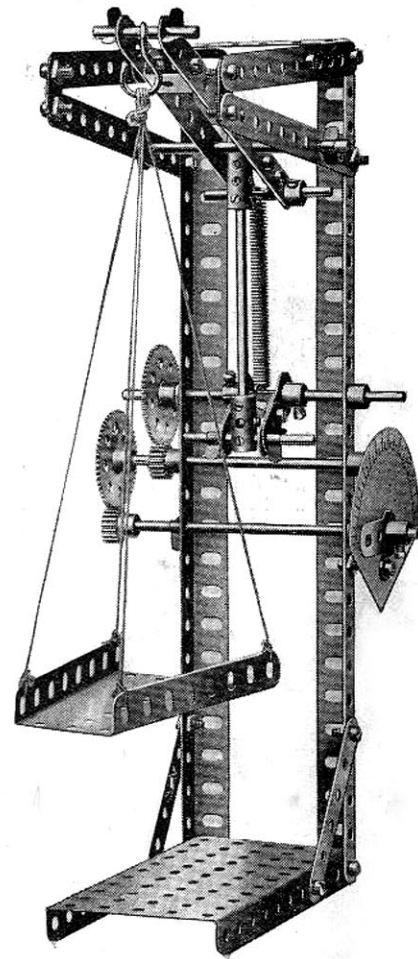

The scale beam consists of two  $5\frac{1}{2}$ " Strips distanced by Double Brackets. A vertical Rod is connected pivotally to the beam by means of a  $\frac{3}{8}$ " Bolt, and to a short Rod passed through the ends of two Cranks. The latter are secured to an axle which carries a 57-teeth Gear Wheel, the motion of which is led through the gear train shown to a pointer moving over a graduated scale. A Meccano Spring, attached to the Rod carrying the Cranks, is connected to the end of the beam and acts as the spring balance.

### Model No. 5.18 Distance Indicator

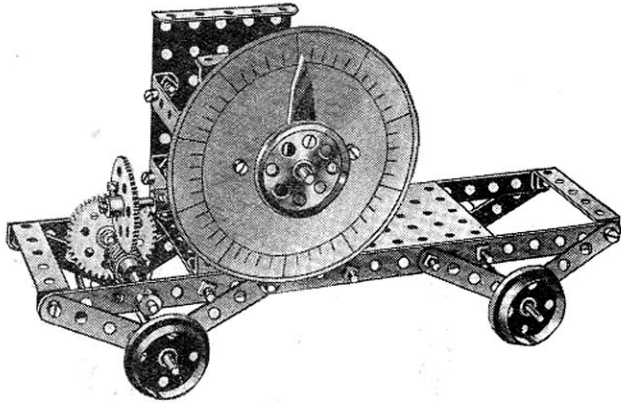

Parts required :

4 of No. 2	2 of No. 15A	2 of No. 22	1 of No. 32
4 " " 3	1 " " 16	1 " " 24	38 " " 37
8 " " 5	1 " " 17	2 " " 26	2 " " 48A
10 " " 12	4 " " 20	2 " " 27A	1 " " 52
2 " " 15	1 " " 21	1 " " 28	2 " " 53
			6 " " 59

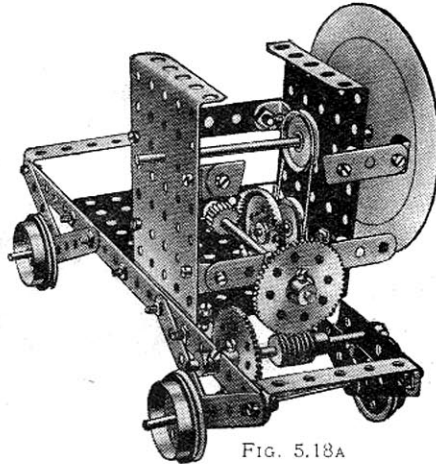
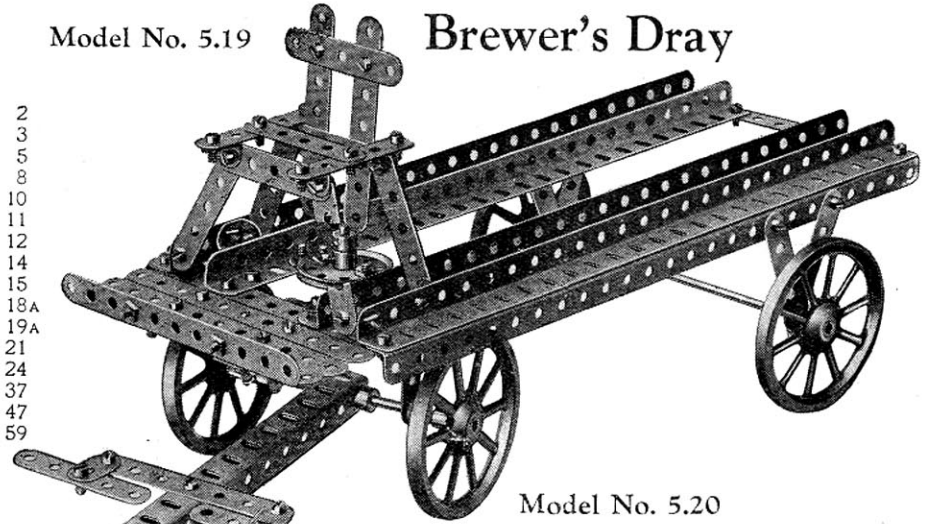

FIG. 5.18A

### Model No. 5.19 Brewer's Dray

Parts required :

6 of No. 2
3 " " 3
19 " " 5
8 " " 8
2 " " 10
1 " " 11
10 " " 12
1 " " 14
1 " " 15
1 " " 18A
4 " " 19A
1 " " 21
1 " " 24
62 " " 37
1 " " 47
6 " " 59



Model No. 5.20

### Armoured Motor Car

The turret, made up of a number of Double Angle Strips 1 bolted at the top to a 3" Pulley 2 and below to a Face Plate, is bolted on a Rod 3 passing up the centre which forms the pivot of the turret so that it may freely turn. The gun 4 is bolted in a Coupling on this pivot Rod.

Parts required :

5 of No. 3	1 of No. 32
6 " " 5	77 " " 37
4 " " 8	2 " " 38
5 " " 12	2 " " 45
1 " " 12A	7 " " 48A
2 " " 14	1 " " 48B
1 " " 15	2 " " 52
2 " " 16	4 " " 53
2 " " 18A	2 " " 54
4 " " 19A	8 " " 59
1 " " 19B	1 " " 63
2 " " 22	1 " " 109
2 " " 24	3 " " 126A

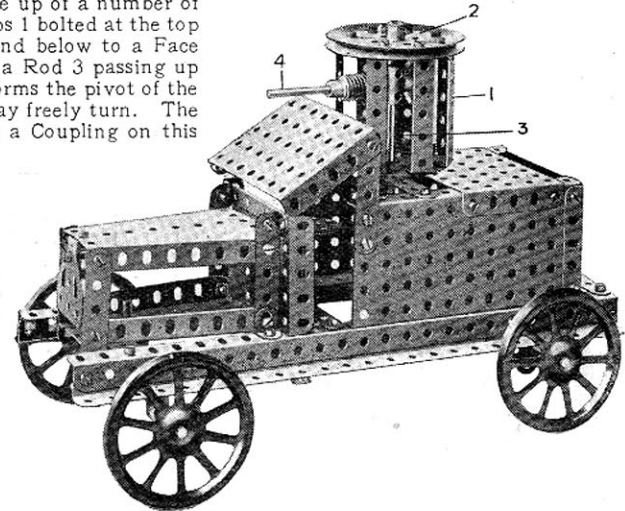

## Model No. 5.21 Sighting Apparatus

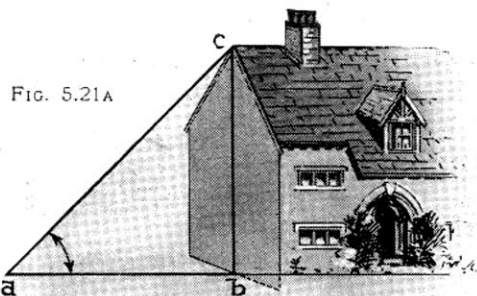

FIG. 5.21A

This model is for determining the heights of buildings, towers, etc. The pointer  $11\frac{1}{2}$ " Rod 1 is pivoted on the 2" Rod 2 and controlled by a Spring 3, the pointer 1 being adjusted by the cord 4 which passes round a guide Pulley 5 and on to the Axle 6 upon which it is wound by the Crank Handle 7 which operates the Gear Wheel and Pinion 8. A graduated scale of degrees 9 made of cardboard, or a protractor, is mounted in order to read off the angle of inclination of the pointer.

In finding the height of a building, measure out a number of feet or yards from the foot of the building, and set this out to some scale corresponding to the line *a b* (Fig. 5.21A). Then standing at the point *a* furthest from the building,

keeping the Angle Girders 10 horizontal, move the pointer 1 until it is directed towards the top of the building. Then read off the angle on the scale 9, and draw a line *a c*, making the angle *b a c* equal to the angle read off. Then draw a vertical line *b c* from the point *b*, and with the same scale used for setting off the distance *a b* measure the height *b c*, which will be the height of the building.

Parts required :

1 of No. 5	24 of No. 37	2 of No. 63
2 " " 6	1 " " 43	1 " " 147A
2 " " 8	5 " " 48A	1 " " 147B
4 " " 11	1 " " 53	1 " " 148
1 " " 13	3 " " 59	
4 " " 17	2 " " 62	
1 " " 19		
1 " " 22		
1 " " 26		
1 " " 27A		
2 " " 35		

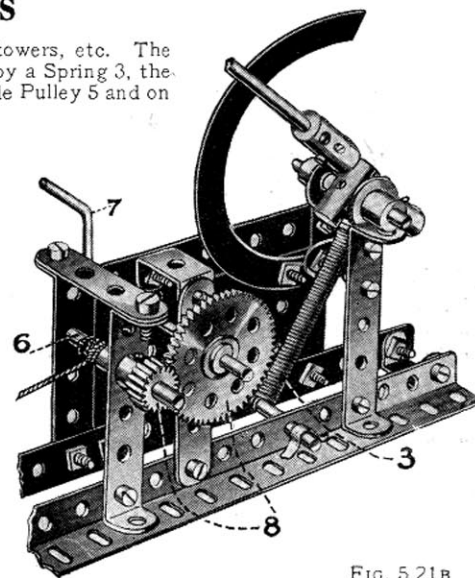
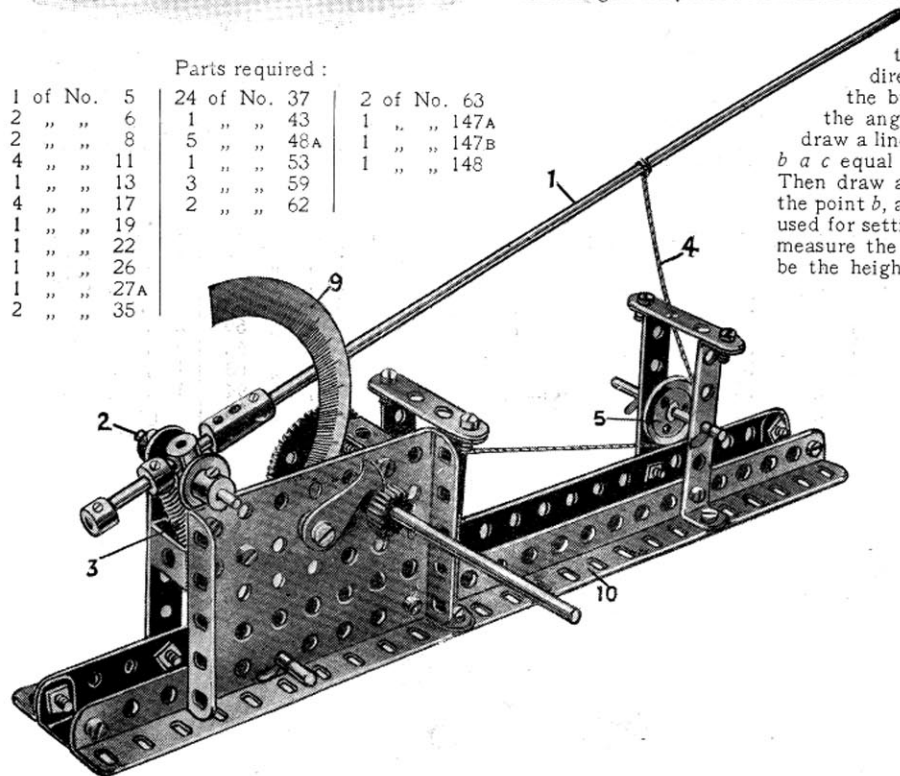
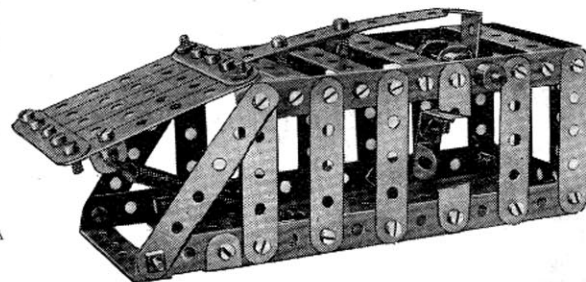

FIG. 5.21B

Parts required :

3 of No. 2
8 " " 4
18 " " 5
1 " " 10
1 " " 11
4 " " 12
1 " " 16
59 " " 37
5 " " 38
1 " " 43
1 " " 48
9 " " 48A
1 " " 52
4 " " 59

## Model No. 5.22 Mouse Trap



# Model No. 5.23 Helicopter Toy

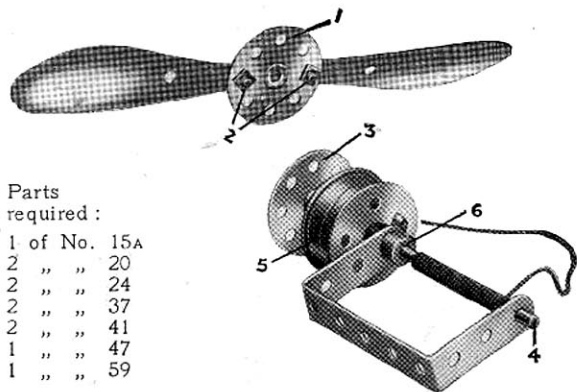

- Parts required:
- 1 of No. 15A
  - 2 " " 20
  - 2 " " 24
  - 2 " " 37
  - 2 " " 41
  - 1 " " 47
  - 1 " " 59

The Bush Wheel 3 and the two Flanged Wheels 5, which act as a flywheel, are all secured to the 4 1/2" Rod 4, and the latter is journalled in a 2 1/2" x 1 1/2" Double Angle Strip, in which it is retained by a Collar 6. The Double Angle Strip forms a convenient handle with which to hold the toy.

A piece of cord about 24" long is wound on the Rod 4. The propeller 1 should be placed so that the shanks of the Bolts 2 lodge freely in the holes of the Bush Wheel 3. It now the free end of the cord wound on the Rod 4 is given a smart pull, the propeller will immediately leap off into the air.

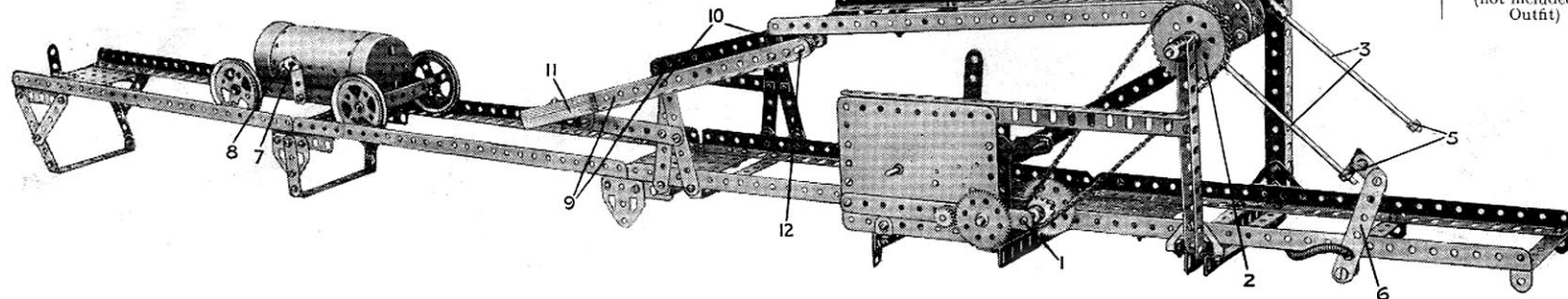

# Model No. 5.24 Automatic Racer

The car is lifted, by means of rotating arms driven by the Clockwork Motor, from the lower track on to an elevated chute, which tilts and allows the car to descend rapidly so that its momentum carries it to the upper end of the inclined track, where a 1" x 1" Angle Bracket forms a stop to prevent it running off the end. Gravity then causes the car to descend and pass under the raised chute—which has been automatically lifted by means of balance weights—to the lower extremity of the track, where it releases a catch, thus allowing the cycle of operations to be carried out until the spring of the Motor is run down.

For the construction of the main track 12 1/2" Girders are secured by means of bolts passed through their elongated holes and through 3 1/2" x 2 1/2" Flanged Plates. The bolt heads should be spaced from the upturned flanges of the girders to allow sufficient room for the 2" Pulleys of the car to pass unimpeded. Two 5 1/2" Girders are bolted vertically to Trunnions which, in turn, are secured to 5 1/2" Transverse Girders near the lower end of the track. The vertical Girders are braced by 9 1/2" Girders.

A 1/2" Pinion on the Motor driving spindle meshes with a 57-teeth Gear, the Rod of which carries a 1/2" Pinion meshing with a further Gear on a 1 1/2" Rod 1. This Rod carries a 3" Sprocket Wheel transmitting the drive through Chain to the Sprocket on a 6 1/2" Rod journalled in the vertical Angle Girders. The 6 1/2" Rod also carries two Couplings carrying the Rods 3, two Double Brackets to which the Girders of the elevated chute are secured, and two Bush Wheels clamped on either side of the balance weight 4. The Rods 3 carry near their outer ends Collars, in the tapped holes of which Bolts 5 are screwed and arranged to face inward.

A 3" Strip 6 is held loosely to a Pivot Bolt and carries a Flat Bracket to which two Angle Brackets are fixed so that they catch the bolt 5 and prevent the Rods 3 revolving. The mechanism should be very carefully adjusted so that the Angle Brackets 7 and 8 of the car release the catch and then come into position directly above the Bolts 5, which, being freed, are raised by means of the Motor. The lower edges of the Brackets 7 should be slightly higher than those of the Brackets 8. The Bolts 5 carry the car up and deposit it on the upper girders, which are normally held in a horizontal position by the Girders 9. The latter are pivoted by lock-nutted bolts at 10 and are provided with balance weights 11 consisting of 2 1/2" Strips. A Rod 12 held in Cranks at the ends of the Girders carries Collars which are so arranged to keep the side members of the chute in alignment with the lower track.

Before setting the model in operation all parts on rotating shafts should be fixed securely. The Sprocket 2, the Couplings carrying the Rods 3 and the Bush Wheels which hold the weight 4, should all be provided with two grub screws, since they must be absolutely immovable on the horizontal 6 1/2" Rod.

### Parts required:

26 of No. 2	4 of No. 9	2 of No. 17	2 of No. 27A	2 of No. 48D	1 of No. 96A
7 " " 3	3 " " 10	2 " " 18A	120 " " 37	1 " " 52	2 " " 111
3 " " 4	2 " " 11	4 " " 20A	8 " " 37A	1 " " 52A	4 " " 111C
32 " " 5	13 " " 12	2 " " 22	24 " " 38	3 " " 53	1 " " 115
2 " " 6	1 " " 12A	2 " " 24	1 " " 43	14 " " 59	2 " " 126
2 " " 6A	1 " " 13A	2 " " 26	4 " " 48B	2 " " 62	4 " " 126A
10 " " 8	1 " " 14			4 " " 63	1 " " 147B
4 " " 8A	2 " " 15			16 " " 94	1 " " 162
2 " " 8B	2 " " 16			1 " " 95	

Clockwork Motor  
(not included in Outfit)

## Model No. 5.25 Travelling Crane

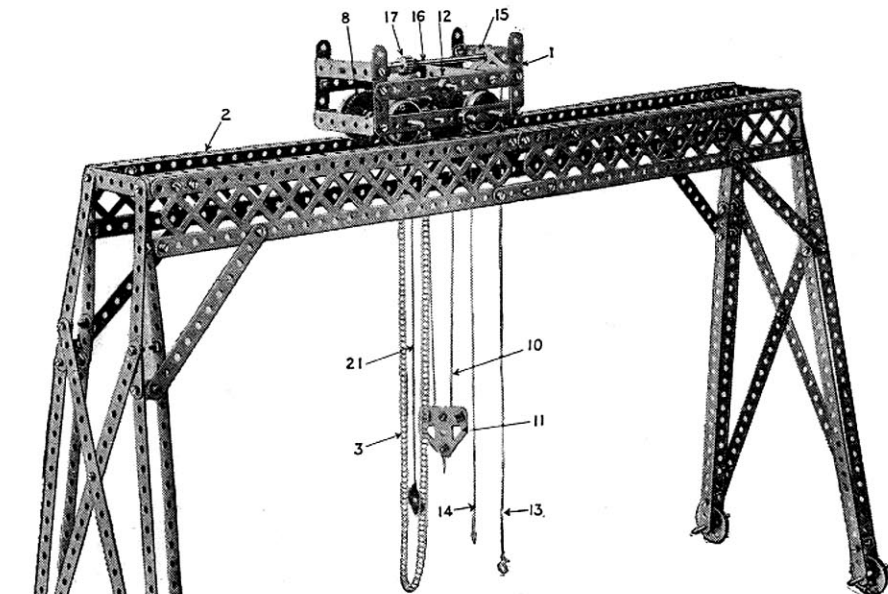

The carriage 1 is caused to travel on the rails 2 in either direction by the Sprocket Chain 3, which passes over a 1" Sprocket Wheel 4 on the spindle 4A on which are two Pinions 5 and 6 for engagement respectively with 57-teeth Gears 7 and 8. The Gear Wheel 7 is secured on an Axle Rod 9, upon which is coiled the winding Cord 10 passing round a  $\frac{1}{2}$ " Pulley in the block 11, and being made fast to the Strip 12. The other Gear Wheel 8 is secured on the axle of the travelling wheels 9A. The Pinions 5 and 6 are caused to engage respectively with the Gear Wheels 7 and 8 by sliding the Pinion Axle 4A in the carriage frame 1. This is effected by means of two Cords 13 and 14 connected to a Boss Bell Crank 15 on a Rod 16, a Pinion 17 which engages a Worm 18 in the manner of a rack. This Worm is secured to a Rod 19, which is connected by means of the Crank 20 to the Rod 4A. The latter revolves freely in the Crank 20, being held in position by a Collar on each side of the Crank. Consequently, by pulling on one or other of the Cords 13, 14, the Bell Crank is racked and the Pinions caused to engage with one or other of the toothed Wheels 7 or 8. When engaging the toothed Wheel 7 the load may be raised or lowered by pulling the Sprocket Chain 3, but when the Pinion 6 engages the toothed wheel 8, the carriage travels on the rails. The Cord 21 passes round a Pulley 22 on the winding Axle and acts as a brake.

### Parts required :

16 of No. 1	1 of No. 32
16 " " 2	86 " " 37
6 " " 5	9 " " 37A
4 " " 8	2 " " 38
2 " " 9	2 " " 47A
8 " " 11	5 " " 48A
4 " " 12	1 " " 57
1 " " 14	6 " " 59
1 " " 15A	1 " " 62
4 " " 16	1 " " 63
4 " " 17	30" " " 94
8 " " 20	1 " " 96
1 " " 22	4 " " 99
1 " " 23	4 " " 111c
3 " " 26	2 " " 126A
2 " " 27A	1 " " 128

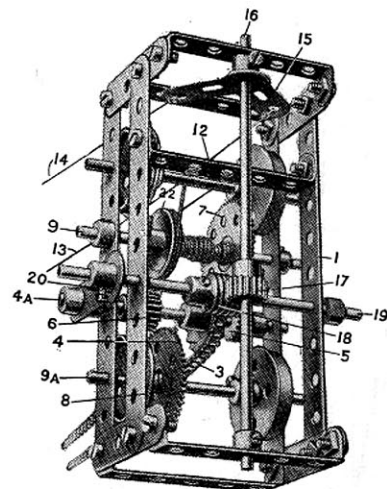
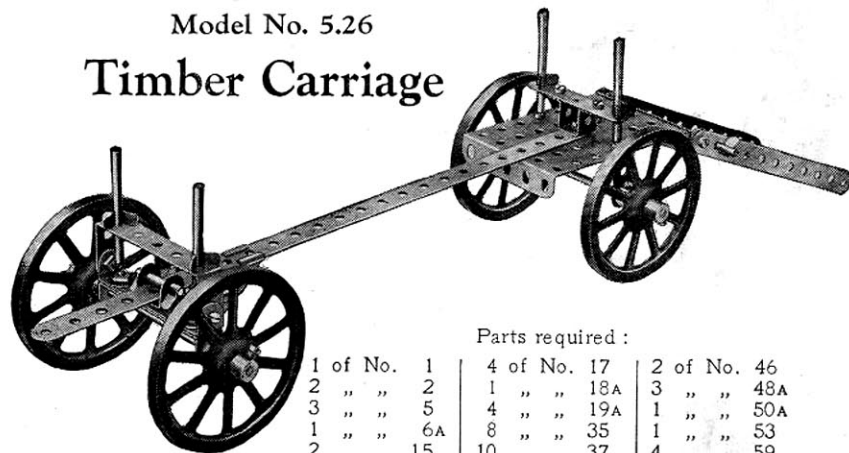

FIG. 5.25A

## Model No. 5.26 Timber Carriage



### Parts required :

1 of No. 1	4 of No. 17	2 of No. 46
2 " " 2	1 " " 18A	3 " " 48A
3 " " 5	4 " " 19A	1 " " 50A
1 " " 6A	8 " " 35	1 " " 53
2 " " 15	10 " " 37	4 " " 59
1 " " 16	1 " " 45	1 " " 111

## Model No. 5.27 Vertical Drill

Parts required:

2 of No. 2	1 of No. 6A	6 of No. 12
3 " " 4	2 " " 8	1 " " 14
2 " " 5	5 " " 11	1 " " 15A
1 " " 6		1 " " 16
		4 " " 17
		1 " " 20
		6 " " 21
		2 " " 22A
		4 " " 35
		39 " " 37
		6 " " 38
		1 " " 43
		1 " " 44
		1 " " 48A
		1 " " 50A
		10 " " 59
		2 " " 62
		1 " " 65
		2 " " 108
		1 " " 109
		1 " " 111
		2 " " 115
		2 " " 126A

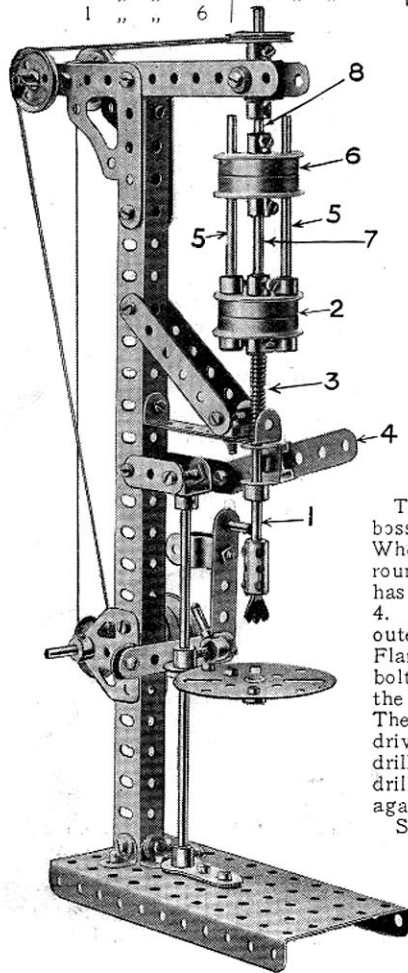

The drill Rod 1 is connected to the boss of the lower pair of Flanged Wheels 2 which are reversed, a Spring 3 round the Rod raising the drill after it has been depressed by the handle Strip 4. Bolted in the Wheels 2 are two outer Rods 5 which slide in the upper Flanged Wheels 6. The central Rod 7 is bolted in the upper Wheels and slides in the centre bosses of the lower Wheels 2. The upper Wheels 6 are bolted to the driving spindle 8 and consequently the drill is driven by the Rods 5 when the drill is depressed by the handle 4 against the Spring.

See also "Meccano Standard Mechanisms," under Locking Device (S.M. 137) and Variable Drive (Section XIII).

## Model No. 5.28 Giant Auto Swing

Parts required:

8 of No. 1	1 of No. 24	4 of No. 53
26 " " 2	1 " " 27A	9 " " 59
2 " " 3	1 " " 32	2 " " 62
8 " " 4	165 " " 37	28" " " 94
31 " " 5	2 " " 38	1 " " 95
12 " " 8	2 " " 48A	1 " " 96
1 " " 9	2 " " 48B	1 " " 147B
18 " " 12	4 " " 48D	
2 " " 14	4 " " 52	
4 " " 15		
1 " " 19B		

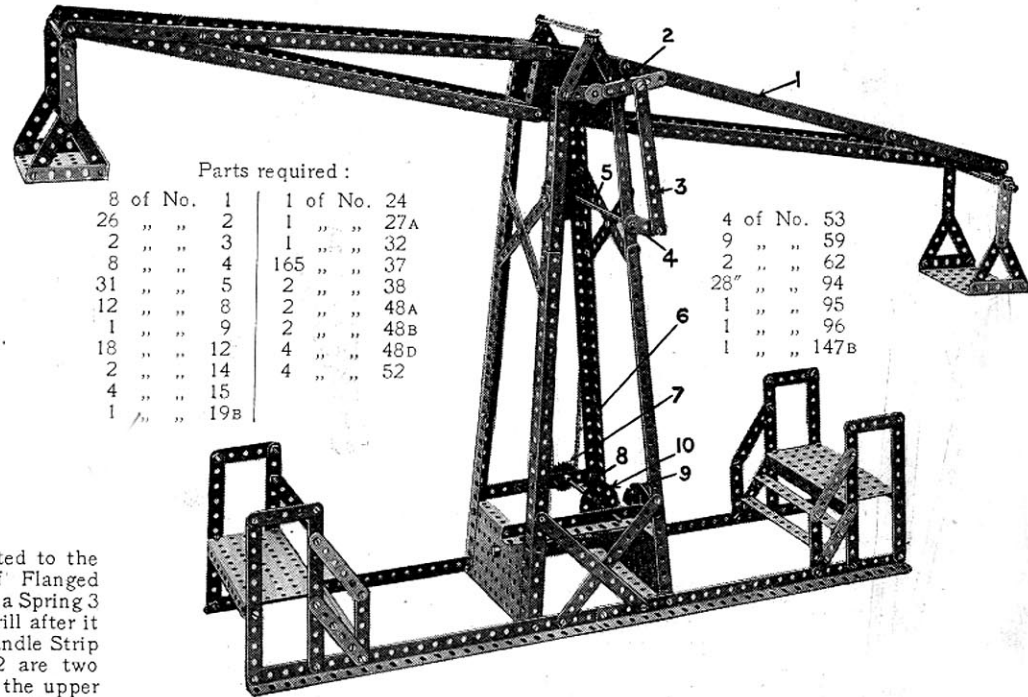

The beam 1 is rocked by means of a Crank 2 secured on the end of a Rod which forms the beam pivot and which is bolted in a Bush Wheel secured to the beam. This Crank 2 is connected by a Strip 3 to another Crank 4 on a Rod 5. On the end of this is a large Sprocket Wheel driven by a Chain 6 from a small Sprocket Wheel 7 on a Rod 8. This Rod is driven by means of a Worm on the Rod of the 3" Pulley 9 which Worm engages and drives the Gear Wheel 10 on the Rod 8. As the Crank 4 continuously rotates the link 3 causes the upper Crank 2 to oscillate and also the beam 1.

## Model No. 5.29 Beam Scales

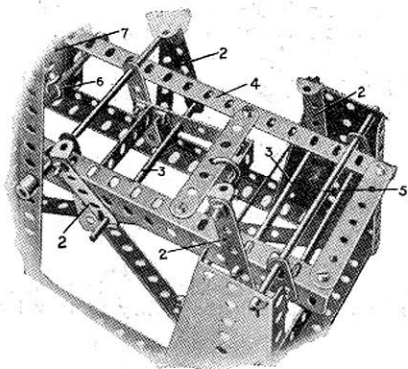
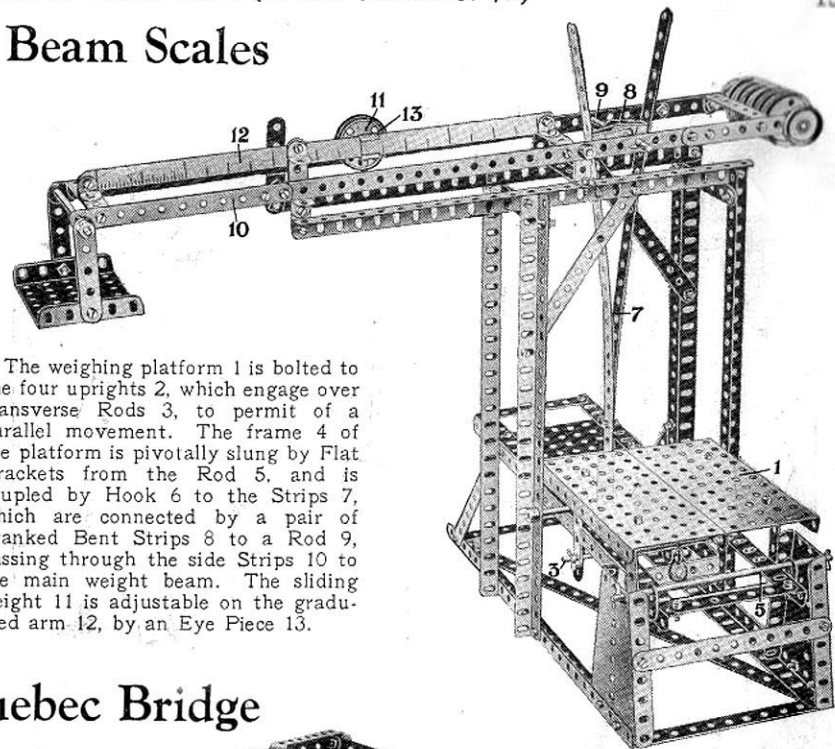

FIG. 5.29A

Parts required :

7 of No.	1
10 " "	2
8 " "	3
2 " "	4
10 " "	5
10 " "	8
2 " "	10
9 " "	12
2 " "	14
2 " "	15
4 " "	15A
2 " "	16
4 " "	20
2 " "	22
88 " "	37
2 " "	44
1 " "	46
5 " "	48A
1 " "	50A
2 " "	52
2 " "	53
2 " "	54
2 " "	57
8 " "	59
1 " "	102



The weighing platform 1 is bolted to the four uprights 2, which engage over transverse Rods 3, to permit of a parallel movement. The frame 4 of the platform is pivotally slung by Flat Brackets from the Rod 5, and is coupled by Hook 6 to the Strips 7, which are connected by a pair of Cranked Bent Strips 8 to a Rod 9, passing through the side Strips 10 to the main weight beam. The sliding weight 11 is adjustable on the graduated arm 12, by an Eye Piece 13.

## Model No. 5.30 Quebec Bridge

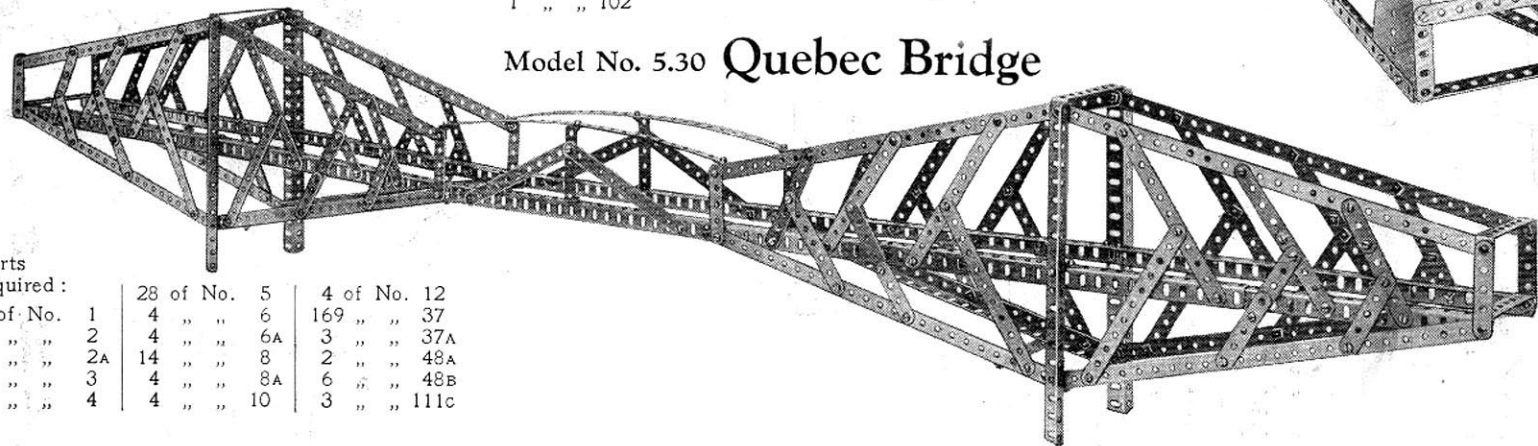

Parts required :

14 of No.	1	28 of No.	5	4 of No.	12
20 " "	2	4 " "	6	169 " "	37
4 " "	2A	4 " "	6A	3 " "	37A
10 " "	3	14 " "	8	2 " "	48A
5 " "	4	4 " "	8A	6 " "	48B
		4 " "	10	3 " "	111c

## Model No. 5.31 Hand Operated Gantry Crane

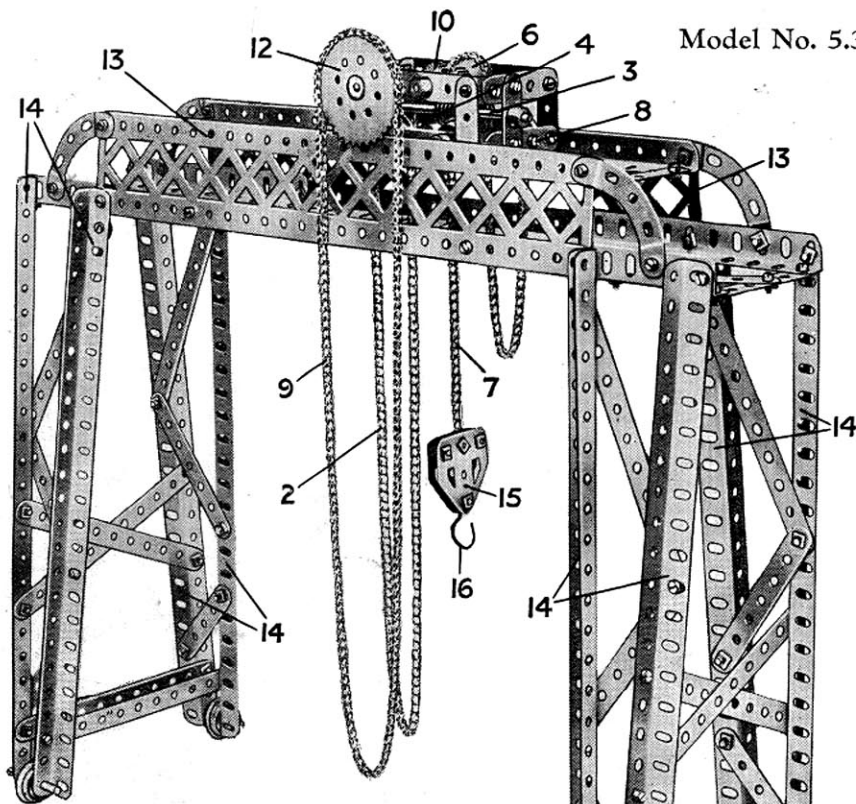

### Parts required :

12 of No. 2	3 of No. 16A	4 of No. 48B
4 " " 3	4 " " 18A	1 " " 57
6 " " 4	4 " " 20	6 " " 59
4 " " 5	4 " " 20B	4 " " 90A
4 " " 6	2 " " 26	60" " " 94
6 " " 6A	1 " " 27A	1 " " 95
12 " " 8	1 " " 32	2 " " 96
4 " " 9	87 " " 37	2 " " 99
1 " " 15A	8 " " 37A	4 " " 111c
1 " " 16	2 " " 38	2 " " 126A

The gantry consists of two  $12\frac{1}{2}$ " Angle Girders extended at each end by means of  $5\frac{1}{2}$ " Girders. Braced Girders 13 support further  $12\frac{1}{2}$ " Angle Girders that form the track along which travels the crane trolley.

The end towers comprise  $12\frac{1}{2}$ " Angle Girders 14 braced by Strips.  $1\frac{1}{2}$ " Axle Rods are journalled in the lower ends of the Girders, and carry  $\frac{3}{4}$ " Flanged Wheels that form the travelling wheels.

The construction of the trolley or traveller is shown clearly in Fig. 5.31A. Two pairs of  $3\frac{1}{2}$ " x  $\frac{1}{2}$ " Double Angle Strips are spaced apart by means of 2" Strips and  $1\frac{1}{2}$ " Strips are bolted between each pair. Two  $2\frac{1}{2}$ " Rods journalled in the Double Angle Strips carry the  $\frac{3}{4}$ " Flanged Wheels 1 and 1A. The Rod of the Wheels 1A also carries a 57-teeth Gear that meshes with the  $\frac{1}{2}$ " Pinion 10.

By hauling on the Chain 9, which is passed over the Sprocket Wheel 12, the  $\frac{1}{2}$ " Pinion 10 and the 57-teeth Gear Wheel is made to rotate, thus driving the Flanged Wheels 1A and causing the trolley to travel along the gantry.

The hoisting mechanism is operated by the chain 2 that passes over a 1" Sprocket on the Rod of which is a Worm 4 that engages the teeth of a  $\frac{1}{2}$ " Pinion on the Rod 5 that also carries a 1" Sprocket Wheel 6. A length of Sprocket Chain 7 is placed over this Wheel, one end of it being secured between two Flat Trunnions 15 (Fig. 5.31); the other end is secured to the frame at 8. By operating the Chain 2 the load hook 16 is raised or lowered.

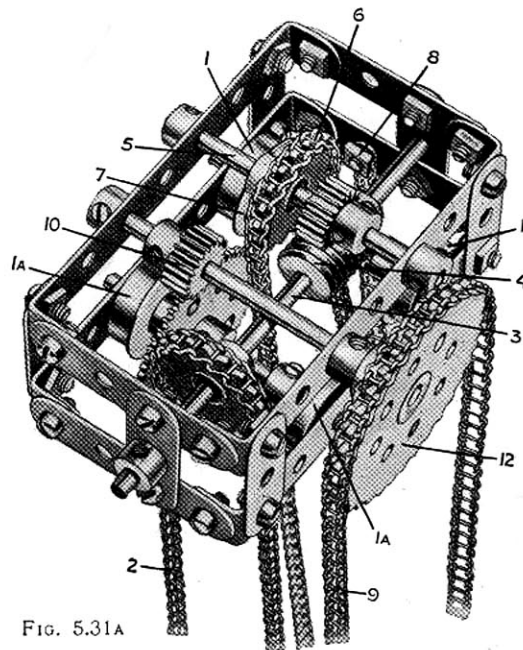
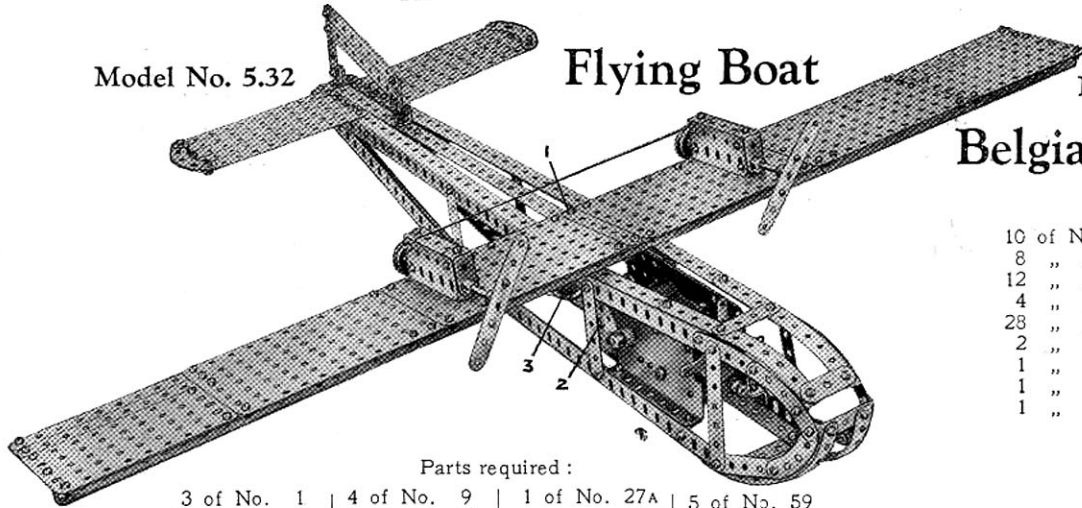

FIG. 5.31A



Model No. 5.32

# Flying Boat



Parts required :

3 of No. 1	4 of No. 9	1 of No. 27A	5 of No. 59
20 " " 2	1 " " 9D	1 " " 29	2 " " 62B
2 " " 2A	2 " " 10	154 " " 37	4 " " 90
5 " " 3	8 " " 11	5 " " 37A	2 " " 90A
4 " " 4	8 " " 12	12 " " 38	4 " " 103F
6 " " 5	2 " " 15A	1 " " 45	3 " " 111
2 " " 6	2 " " 16A	2 " " 46	2 " " 111c
5 " " 6A	1 " " 21	1 " " 48	Electric Motor
5 " " 8	2 " " 22	4 " " 52A	(not included in
4 " " 8A	1 " " 26	2 " " 53A	Outfit)

The Flat Plates of the main plane are secured to a girder consisting of one  $12\frac{1}{2}$ " Angle Girder extended at each end by  $9\frac{1}{2}$ " Girders and bolted along the leading edge of the plane with the projecting flange toward the tail of the model. A  $2\frac{1}{2}$ " Angle Girder is bolted to the centre of the girder so formed and is secured, in turn, across the fuselage. The wings are held rigid by the  $\frac{3}{4}$ " Bolt 1, which is passed through the  $12\frac{1}{2}$ " Strip in the centre of the fuselage but is spaced therefrom by a Collar.

The Electric Motor is fixed to the lower pair of Angle Girders by means of two Angle Brackets at the front, and two  $\frac{3}{4}$ " Bolts at the rear passed through the Motor Flanges and secured by nuts below the lower faces of the Girders. The armature spindle carries a  $\frac{1}{2}$ " Pinion meshing with a 57-teeth gear on the  $2\frac{1}{2}$ " Rod 2, which carries a  $\frac{3}{4}$ " Contrate Wheel. The latter engages a Pinion on a further  $2\frac{1}{2}$ " Rod to which the  $1\frac{1}{2}$ " Pulley 3 is secured. Bearings for the Rod are formed by a  $1\frac{1}{2}$ " Strip and Double Bent Strip which are bolted by Angle Brackets to the side plates of the Motor. Cord is passed round the Pulley 3 to each of the 1" Pulleys on the propeller shafts of the miniature engines.

Each of the engines consists of two  $2\frac{1}{2}$ " Flat Girders and a  $2\frac{1}{2}$ " x 1" Double Angle Strip held together by means of Double Brackets and fixed to the wings by similar means.

Model No. 5.33

# Belgian Water Wheel

Parts required :

10 of No. 1	1 of No. 24
8 " " 2	3 " " 26
12 " " 5	1 " " 27A
4 " " 8	82 " " 37
28 " " 12	5 " " 48A
2 " " 15	2 " " 52
1 " " 15A	2 " " 53
1 " " 16	4 " " 59
1 " " 21	1 " " 63

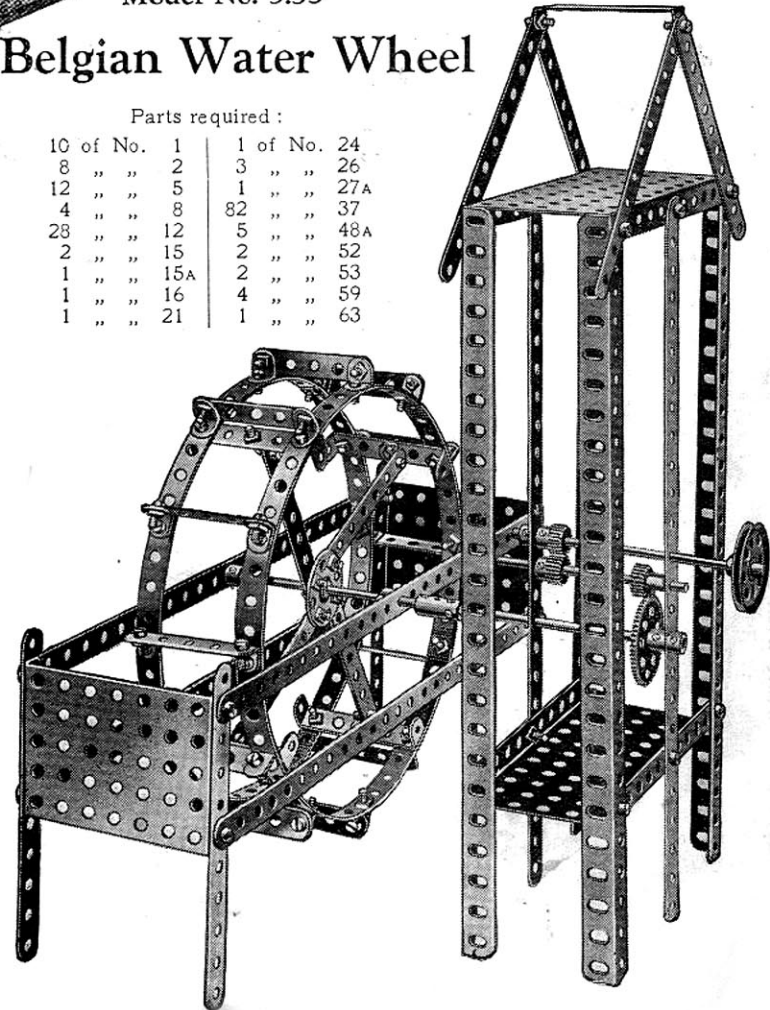

Model No. 5.34

# Oil Well-Drilling Apparatus

The drive is transmitted from the Motor armature shaft to the Rod 1 by means of two sets of 57-teeth Gears and  $1\frac{1}{2}$ " Pinions. This Rod carries a  $\frac{3}{8}$ " Sprocket Wheel and 1" fast Pulley that is connected when desired to a 3" Pulley on the Rod 2, which forms the hoisting drum for the sand pump 3. The latter is represented by an  $11\frac{1}{2}$ " Rod secured by a Small Fork Piece to the hoisting cord, which passes over one of the 1" loose Pulleys at the derrick head.

The  $\frac{3}{4}$ " Sprocket on the Rod 1 is connected by Sprocket Chain to a 2" Sprocket on the Rod 4. A 1" Sprocket 5 and  $1\frac{1}{2}$ " fast Pulley are nipped on the other end of this Rod, the  $1\frac{1}{2}$ " Pulley being connected by cord to a 1" fast Pulley on the crankshaft of the steam engine. The 1" Sprocket 5 may be connected, by two different lengths of Sprocket Chain, to either of the Sprockets 6 and 7. The 1" Sprocket 6 is secured to the tool hoisting drum, which is supplied with a Pawl and Ratchet 8. The cord is wound on to this shaft, carried over the remaining 1" loose Pulley at the derrick head, and attached to an End Bearing on the tool, the construction of which is clearly shown in the illustration.

The 2" Sprocket 7 is secured to the crankshaft 9, which is built up from two short Rods and two Cranks, the latter being rigidly secured together at their ends by a  $\frac{3}{8}$ " Bolt having three nuts. The

crankshaft is connected to the beam 10 by a  $3\frac{1}{2}$ " Strip 11. The beam is pivoted at its centre on a  $3\frac{1}{2}$ " Rod journalled in the  $7\frac{1}{2}$ " Angle Girders 12, and a Double Bracket is attached pivotally to its inner end by means of a  $1\frac{1}{2}$ " Rod and Collars. A  $3\frac{1}{2}$ " Screwed Rod, turning freely between two Collars in the centre hole of this Double Bracket, passes through the end threaded hole of a Coupling 13. This Coupling carries a  $\frac{3}{8}$ " Bolt and Washer 14, behind which is clamped the tool cord when it is desired to carry out the actual digging operation.

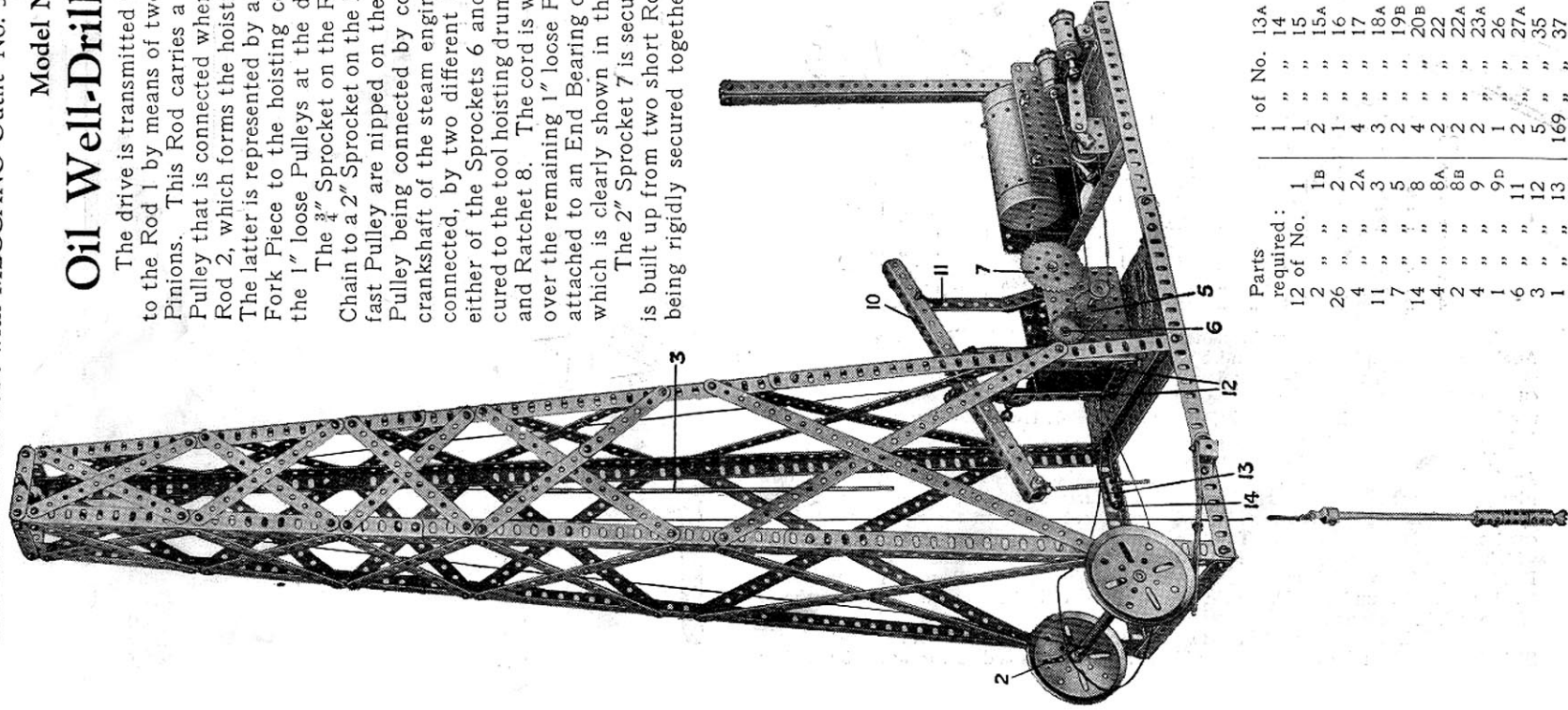

Parts required:	1 of No.	13A	6 of No.	37A	2 of No.	96
12 of No.	1	14	20	" 38	1	" 96A
26	1B	15	2	" 40	6	" 111c
2	2	15A	1	" 45	1	" 115
4	2A	16	2	" 48A	1	" 116A
11	3	17	1	" 52	2	" 126
7	5	18A	1	" 52A	1	" 147
14	8	19B	5	" 53	1	" 148
4	8A	20B	1	" 53A	1	" 160
2	8B	22	19	" 59	1	" 162
4	9	22A	2	" 62	2	" 163
1	9B	23A	6	" 63	1	" 165
6	11	26	1	" 65		Electric
3	12	27A	1	" 80A		Motor
1	13	35	29"	" 94		(not included in
		37	2	" 95		Outfit)

Model No. 5.34

Oil Well-Drilling Apparatus (continued)

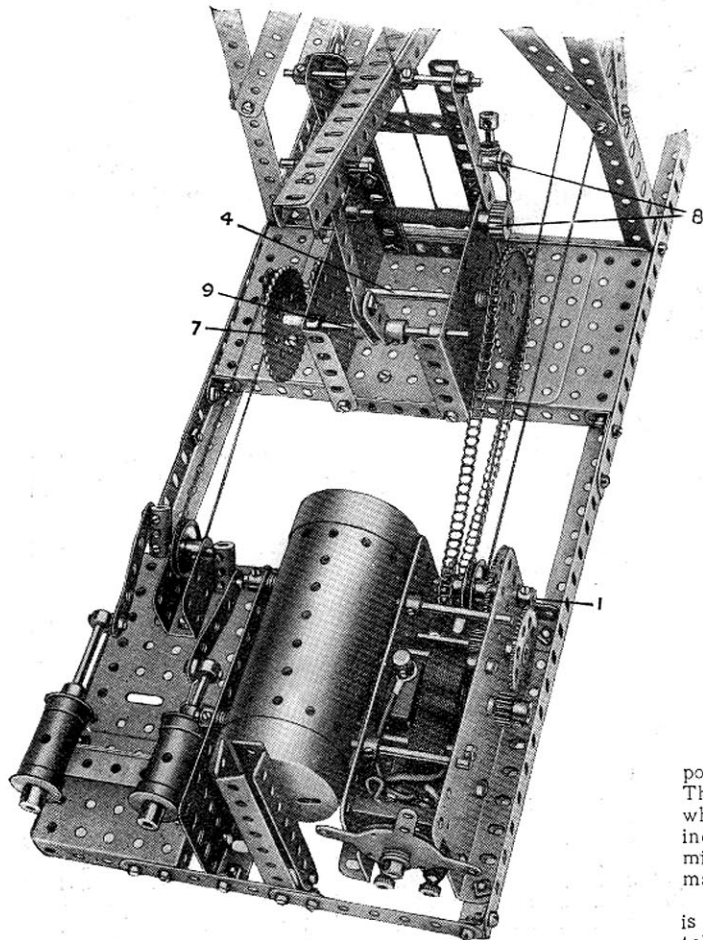
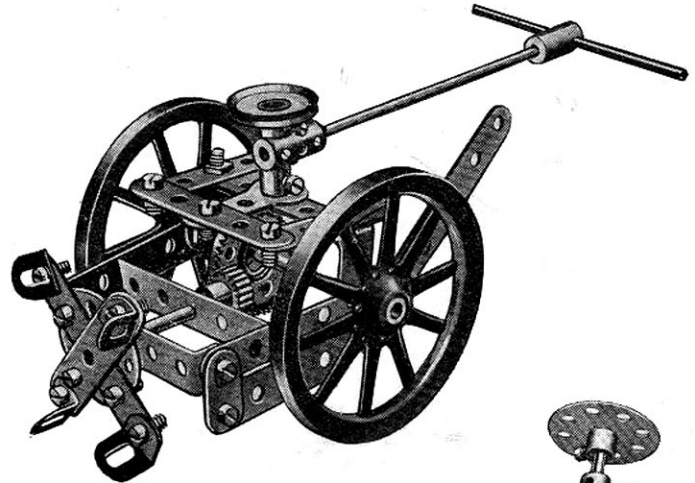

FIG. 5.34A

Model No. 5.35 Potato Reaper

Parts required :

1	of No.	3
8	" "	5
2	" "	10
4	" "	12
1	" "	15
2	" "	16
1	" "	17
1	" "	18A
2	" "	19B
1	" "	22
1	" "	24
1	" "	26
1	" "	28
19	" "	37
1	" "	46
2	" "	48A
1	" "	59
1	" "	62
2	" "	63



Model No. 5.36

Map Measuring Instrument

Parts required :

2 of No. 2	2 of No. 24	5 of No. 37	1 of No. 62B
3 " " 17	2 " " 26	1 " " 48	1 " " 109
1 " " 18A	2 " " 27A	4 " " 59	1 " " 125

By rolling this model along any desired route in a map, it is possible to obtain a very close approximation of the actual distance. The dial consists of a Face Plate on which is stuck a circular disc of white cardboard, and is divided into forty equal parts representing inches, which, when compared with the scale of the map, will give the mileage. Thus, if the dial gives a reading of 10, and the scale of the map is  $\frac{1}{2}$ " to the mile, the actual distance will be 20 miles.

The Bush Wheel 1 forms the "travelling wheel," and its motion is transmitted through a gear train to the dial shaft 3. Readings are taken through the hole in the Reversed Angle Bracket 4.

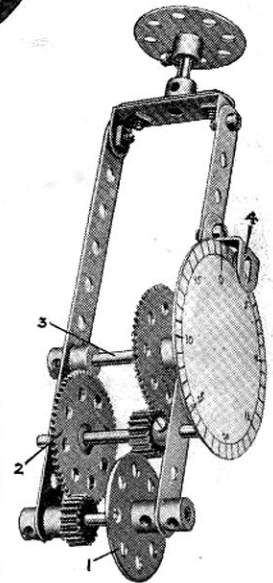

## Model No. 5.37

## Cable Ploughing Engine

Two 12½" Angle Girders 1, forming the main frames, are extended at the front by the 5½" Girders 2, the complete frames being joined together at the front by the 5½" × 3½" Flat Plates 3, 3A and at the rear by a 3½" × 2½" Flanged Plate 4. Each side of the gear box and controlling platform is built up from a 3½" × 2½" Flanged Plate and a 4½" × 2½" Flat Plate. These are held rigid by the 3½" Strip 5 (shank portion cut away in Fig. 5.37A) and the 3½" × ½" Double Angle Strip 6.

The front axle pivot 7 (a Pivot Bolt) has a Bush Wheel secured to it which carries two 1" × 1" Angle Brackets 8 and two ½" × ½" Angle Brackets 9. The tool tray, which is built up of four 2½" × ½" Double Angle Strips and one 2½" Flat Girder, is secured to one of the Angle Brackets 8 by means of a ½" × ½" Angle Bracket. The front axle proper, a 3½" × ½" Double Angle Strip, carries four ½" × ½" Angle Brackets 10 and 11, the latter forming bearings for the front wheel stub axles. A 2½" Rod 12 passed through the Angle Brackets 9 and 10 forms a suitable connection for the three-point suspension system. The worm and pinion steering is similar to Standard Mechanism No. 166.

A ½" Pinion on the Motor armature shaft engages with a 57-teeth Gear on the Rod 13, which carries a ¾" Contrate engaging with a ½" Pinion on the Rod 14. This Rod, journalled in a 1½" × ½" Double Angle Strip 15 and in the 3½" × ½" Double Angle Strip 6, carries a Worm that meshes with a ½" Pinion on the layshaft 16. The latter is slidable in its bearings and is controlled by the lever 17 (a 3½" Strip that is pivoted at its second hole from the handle end to a ½" × ½" Angle Bracket, which, in turn, is secured to the Double Angle Strip 6, in the second hole from one end). A bolt is secured to the lever 17 so that its shank lies between two Collars secured to the layshaft. Operation of the lever causes the ½" Pinion on the layshaft to engage with either of the two gears 18 and 19 at the same time remaining in mesh with the Worm on the Rod 14.

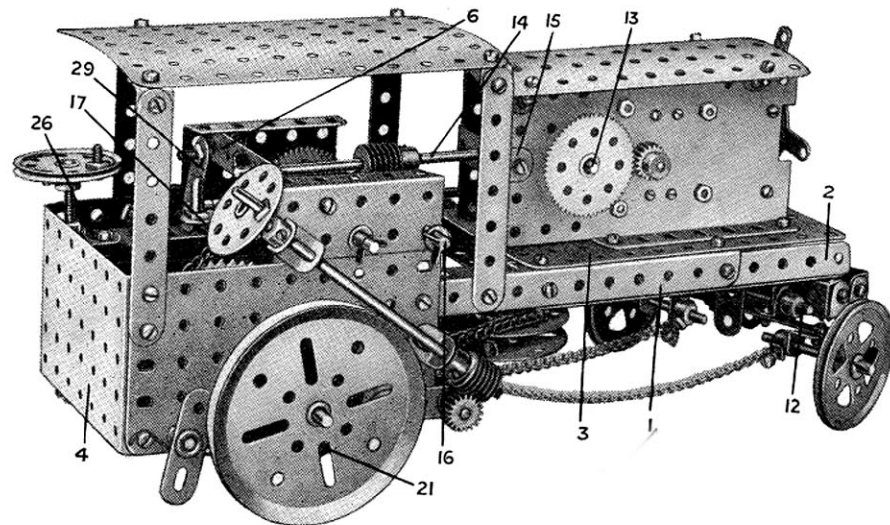

The 57-teeth Gear 18 is secured to a 4½" Rod 20 on which is fixed a ¾" Sprocket Wheel connected by Sprocket Chain to a 2" Sprocket Wheel on the rear axle. The 1½" Contrate 19 is secured to a 2½" Rod that is journalled in the 3½" Strips 5 and 5A and has attached to it a 1" Sprocket Wheel that is connected by Sprocket Chain to a 2" Sprocket Wheel on the cable drum shaft 28.

Brake drums (2" Pulleys 21) are fitted to the rear axle and round these are passed cords that are attached at one end to the side plates of the model and at the other to Double Arm Cranks 22. The latter are secured to each end of a 4½" Rod 23 that carries a Bush Wheel 24 connected pivotally by a 1½" Strip to the Coupling 25, which has a 3½" Screwed Rod passing through its end transverse threaded bore. The Screwed Rod is journalled in the Girder 1 and Flat Bracket 26 and in the Angle Bracket 27, which is spaced by four Washers to keep the Rod in correct alignment. A suitable handle is attached consisting of a 1½" Pulley fitted with a ¾" Bolt.

The Crank 29, secured to the shaft 30, manipulates the reversing handle of the Electric Motor through the Coupling and 1½" Strip 31. The latter is lock-nutted to the reversing handle and attached loosely to the Coupling by a ¾" Bolt. The shaft 30 consists of one 6½" and one 1" Rod joined by a Coupling and is journalled in two Angle Brackets secured to the main frame.

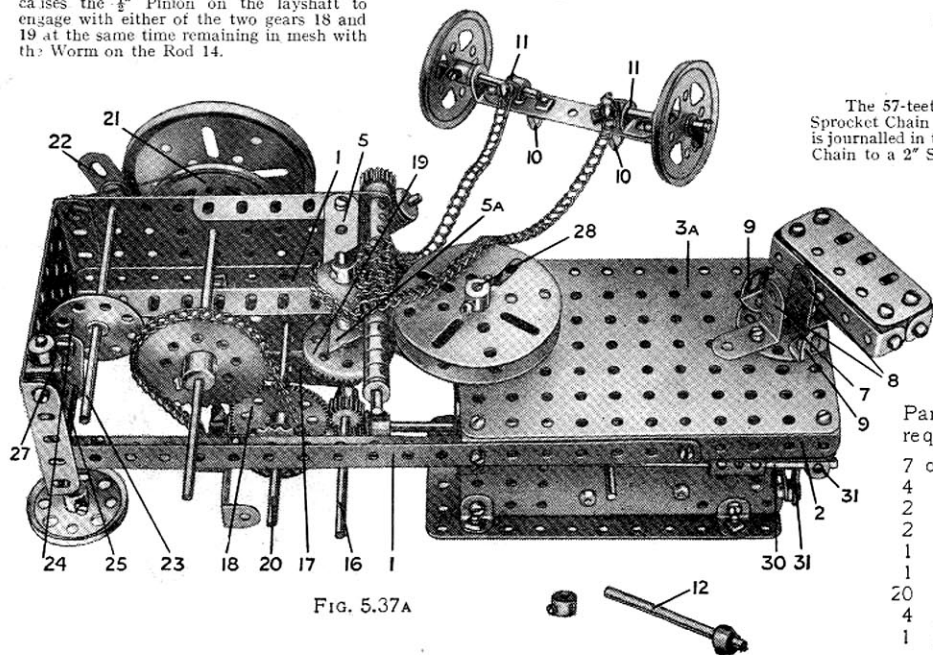

FIG. 5.37A

Parts required:	1 of No.	14	2 of No.	27A	3 of No.	52A	2 of No.	96			
7 of No.	3	2	" "	15	1	" "	28	3	" "	103F	
4	" "	4	" "	15A	1	" "	29	2	" "	109	
4	" "	6A	2	" "	16A	2	" "	32	16	" "	59
2	" "	8A	2	" "	17	7	" "	35	1	" "	62
2	" "	9	2	" "	18A	35	" "	37	2	" "	62B
1	" "	10	4	" "	19B	4	" "	37A	6	" "	63
1	" "	11	2	" "	20A	21	" "	38	1	" "	70
20	" "	12	1	" "	21	1	" "	48	1	" "	80A
4	" "	12A	2	" "	24	4	" "	48A	34"	" "	94
1	" "	13A	3	" "	26	2	" "	48B	2	" "	95

Electric Motor  
(not included in Outfit)

## Model No. 5.38 Vertical Marine Engine

The crosshead 1 consists of two Flat Trunnions secured together by two Double Brackets, which are free to slide between  $4\frac{1}{2}$ " Strips 2 forming the crosshead guide. The latter is attached at its upper extremity to a  $1\frac{1}{2}$ " x  $\frac{1}{2}$ " Angle Bracket on the bottom cylinder cover, and at its lower extremity to a  $1\frac{1}{2}$ " x  $\frac{1}{2}$ " Angle Bracket that is mounted on a Trunnion. The Strips of the guide are spaced apart by a Washer on each of the retaining bolts. A Coupling is secured rigidly to the apex of the crosshead by bolts, which are inserted in its upper transverse tapped bore. This Coupling is secured to the piston rod and is attached pivotally to the connecting rod by a Fork Piece that rides on two bolts inserted in its lower transverse tapped bore.

The crankshaft is built up from two Rods on the inner ends of which Cranks are secured very rigidly. The crank pin is a  $\frac{3}{4}$ " Bolt, which is fixed rigidly by nuts in the end holes of the Cranks and in Flat Trunnions that form the balance weights. The "big end" (a Coupling 3) is free to turn on the crank pin between the Cranks, and is attached to the lower end of the connecting rod.

The model is fitted with Stephenson's valve gear. This comprises two Eccentrics, which are mounted upon the crankshaft in such a manner that their throws are opposite, and each Eccentric is connected by a  $4\frac{1}{2}$ " Strip, to one end of an "expansion link" 4. The latter consists of two  $2\frac{1}{2}$ " large Radius Curved Strips, bolted together at each end by a  $\frac{3}{4}$ " Bolt and three nuts. On one of these Strips slides a "die block" 5 and the other is connected pivotally to a crank arm 6 by a  $2\frac{1}{2}$ " Strip. The die block is an Eye Piece, which is attached to the lower end of the valve spindle by a  $\frac{1}{2}$ " Reversed Angle Bracket and an End Bearing. The crank 6 is mounted on the "weigh shaft" 6a, to one end of which is secured a  $1\frac{1}{2}$ " Pulley carrying a "spider" (taken from a Swivel Bearing) in which works a Screwed Rod. The latter is rotated by turning the Wheel 7, so actuating the crank 6 and moving the expansion link in the die block.

The "thrust block" 8 consists of two Trunnions and one Flat Trunnion. The two former are bolted down to four Double Brackets 9, Washers spacing each Trunnion from the Double Brackets, whilst  $1\frac{1}{2}$ " Strips keep the Trunnions apart. The lower portions of the Double Brackets are clamped between pairs of  $2\frac{1}{2}$ " Strips bolted to the bed plate to keep the thrust block in position whilst the Flat Trunnion is secured in place by a  $1\frac{1}{2}$ " x  $\frac{1}{2}$ " Angle Bracket. Collars fixed to the crankshaft represent the thrust collars of the actual device.

The circulating pump is represented by a Sleeve Piece 10 fitted with a  $\frac{1}{2}$ " Flanged Wheel, through which the pump plunger passes. The pump is retained in position by being pushed on to a Chimney Adaptor that is bolted to the base plate, and it is worked off the crosshead through a lever and links. The Boiler secured next to the pump represents the condenser.

FIG. 5.38A

The Marine Engine from the condenser side, with two supporting Girders and one side of cylinder removed.

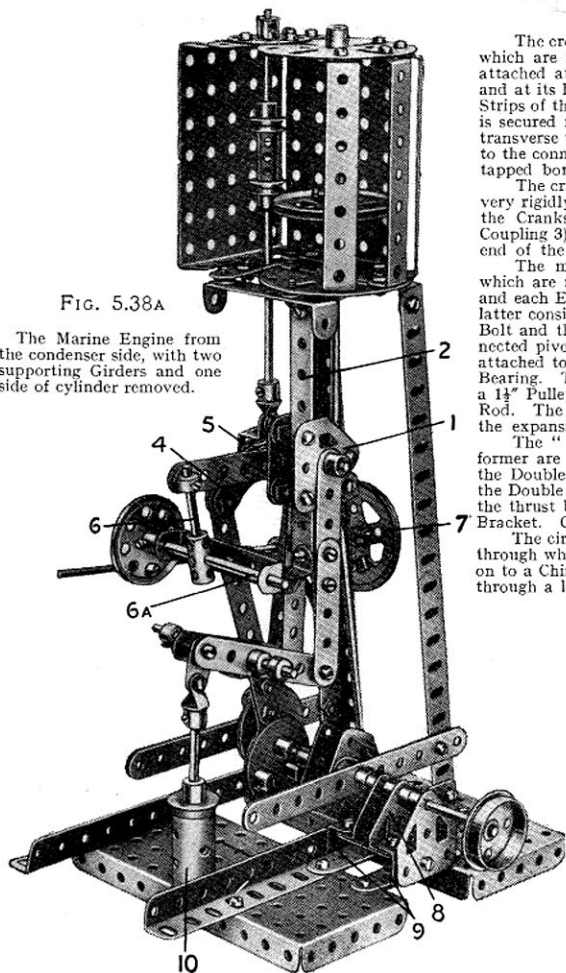

### Parts required :

4 of No. 2	1 of No. 20	2 of No. 62
4 " " 2A	2 " " 20A	4 " " 63
1 " " 3	1 " " 20B	1 " " 80A
2 " " 4	1 " " 21	2 " " 90
10 " " 5	1 " " 23	2 " " 109
4 " " 6A	1 " " 23A	2 " " 111
4 " " 8A	2 " " 24	6 " " 111C
2 " " 8B	86 " " 37	1 " " 115
1 " " 10	18 " " 37A	1 " " 116
7 " " 11	24 " " 38	1 " " 125
5 " " 12	1 " " 48	4 " " 126
1 " " 14	3 " " 48A	5 " " 126A
2 " " 15	3 " " 48B	1 " " 162
4 " " 16	1 " " 50A	1 " " 163
1 " " 16A	2 " " 52	1 " " 164
1 " " 17	3 " " 53	1 " " 165
2 " " 18A	15 " " 59	1 " " 166

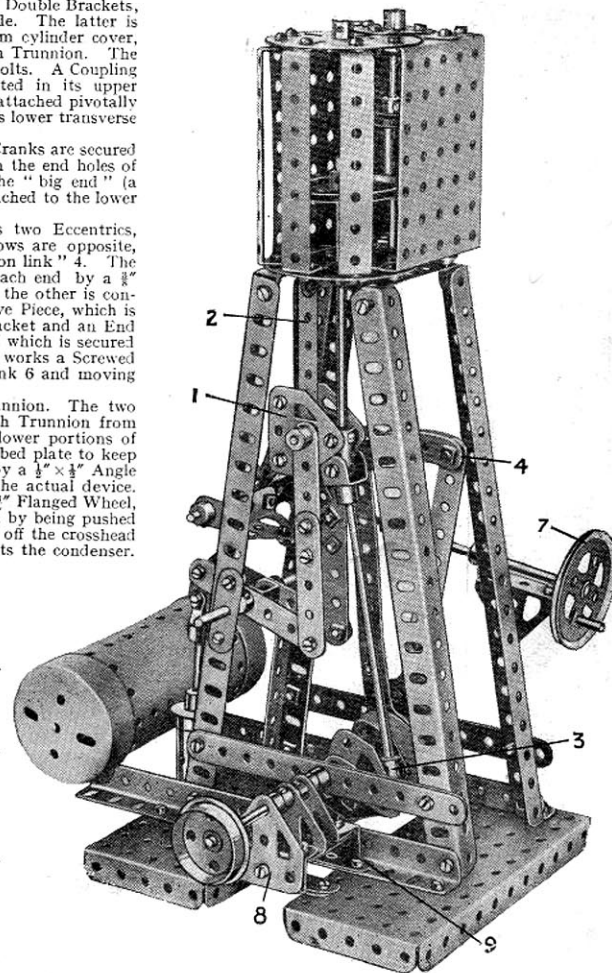

## Electric Telfer Crane

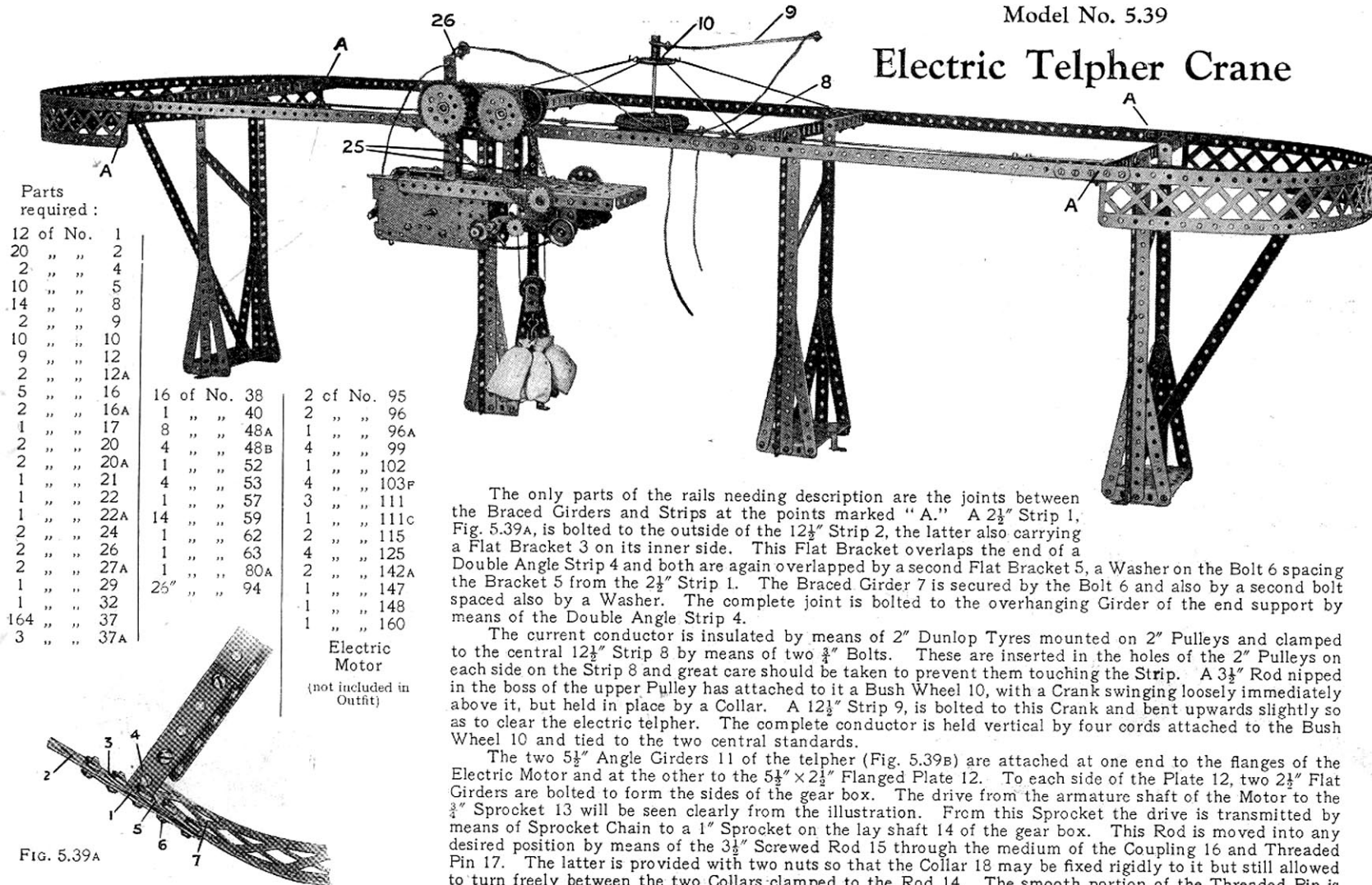
Parts  
required :

12	of No.	1
20	" "	2
2	" "	4
10	" "	5
14	" "	8
2	" "	9
10	" "	10
9	" "	12
2	" "	12A
5	" "	16
2	" "	16A
1	" "	17
2	" "	20
2	" "	20A
1	" "	21
1	" "	22
1	" "	22A
2	" "	24
2	" "	26
2	" "	27A
1	" "	29
1	" "	32
164	" "	37
3	" "	37A

16	of No.	38
1	" "	40
8	" "	48A
4	" "	48B
1	" "	52
4	" "	53
1	" "	57
14	" "	59
1	" "	62
1	" "	63
1	" "	80A
25"	" "	94

2	of No.	95
2	" "	96
1	" "	96A
4	" "	99
1	" "	102
4	" "	103F
3	" "	111
1	" "	111C
2	" "	115
4	" "	125
2	" "	142A
1	" "	147
1	" "	148
1	" "	160

Electric  
Motor(not included in  
Outfit)

Fig. 5.39A

The only parts of the rails needing description are the joints between the Braced Girders and Strips at the points marked "A." A  $2\frac{1}{2}$ " Strip 1, Fig. 5.39A, is bolted to the outside of the  $12\frac{1}{2}$ " Strip 2, the latter also carrying a Flat Bracket 3 on its inner side. This Flat Bracket overlaps the end of a Double Angle Strip 4 and both are again overlapped by a second Flat Bracket 5, a Washer on the Bolt 6 spacing the Bracket 5 from the  $2\frac{1}{2}$ " Strip 1. The Braced Girder 7 is secured by the Bolt 6 and also by a second bolt spaced also by a Washer. The complete joint is bolted to the overhanging Girder of the end support by means of the Double Angle Strip 4.

The current conductor is insulated by means of 2" Dunlop Tyres mounted on 2" Pulleys and clamped to the central  $12\frac{1}{2}$ " Strip 8 by means of two  $\frac{3}{4}$ " Bolts. These are inserted in the holes of the 2" Pulleys on each side on the Strip 8 and great care should be taken to prevent them touching the Strip. A  $3\frac{1}{2}$ " Rod nipped in the boss of the upper Pulley has attached to it a Bush Wheel 10, with a Crank swinging loosely immediately above it, but held in place by a Collar. A  $12\frac{1}{2}$ " Strip 9, is bolted to this Crank and bent upwards slightly so as to clear the electric telfer. The complete conductor is held vertical by four cords attached to the Bush Wheel 10 and tied to the two central standards.

The two  $5\frac{1}{2}$ " Angle Girders 11 of the telfer (Fig. 5.39B) are attached at one end to the flanges of the Electric Motor and at the other to the  $5\frac{1}{2}$ " x  $2\frac{1}{2}$ " Flanged Plate 12. To each side of the Plate 12, two  $2\frac{1}{2}$ " Flat Girders are bolted to form the sides of the gear box. The drive from the armature shaft of the Motor to the  $\frac{3}{4}$ " Sprocket 13 will be seen clearly from the illustration. From this Sprocket the drive is transmitted by means of Sprocket Chain to a 1" Sprocket on the lay shaft 14 of the gear box. This Rod is moved into any desired position by means of the  $3\frac{1}{2}$ " Screwed Rod 15 through the medium of the Coupling 16 and Threaded Pin 17. The latter is provided with two nuts so that the Collar 18 may be fixed rigidly to it but still allowed to turn freely between the two Collars clamped to the Rod 14. The smooth portion of the Threaded Pin is inserted in the Coupling, but not gripped therein.

Model No. 5.39

Electric Telfer Crane (continued)

The  $\frac{1}{2}$ " Pinion 19 on the end of the layshaft engages with either of the 57-teeth Gears 20 and 20A. Gear 20A is fixed to the hoisting shaft, which is provided with a Pawl and Ratchet 21, the Pawl being locknuttred to a  $2\frac{1}{2}$ " Strip 22. Gear 20 is nipped on one end of the Rod 23, the other end of which carries a 1" Sprocket Wheel that is connected by Sprocket Chain to the two 2" Sprockets 24 on the driving axles. The latter are supported in  $3\frac{1}{2}$ " x  $\frac{1}{2}$ " Double Angle Strips 25, which are joined together at the top by a  $3\frac{1}{2}$ " Strip. Two 1" Angle Brackets and one  $\frac{1}{2}$ " Angle Bracket 26 surmount one of the axle bearings. This is to keep the conductor wire clear of the Sprockets. The travelling wheels are built up from  $1\frac{1}{4}$ " Flanged Wheels and Bush Wheels butted together, the wide groove thus obtained being required to enable the telfer to negotiate small curves.

To wire the model the following notes will be useful. One wire is taken from a terminal of the Accumulator to the set-screw in the boss of the top Pulley of the insulator. The current runs from here to the end of the conductor arm and a wire attached to this passes through the bracket 26 and is fixed to a terminal of the Motor. The remaining terminals on the Motor and Accumulator are earthed to the frame of the model.

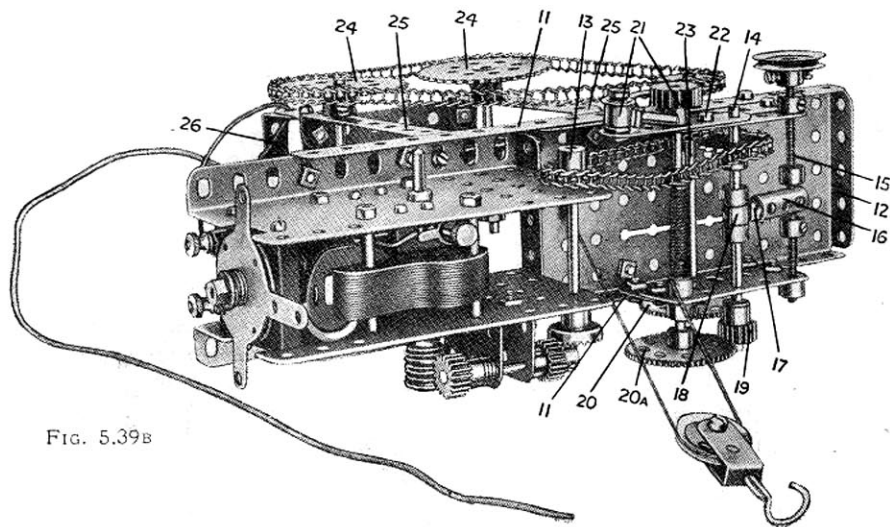
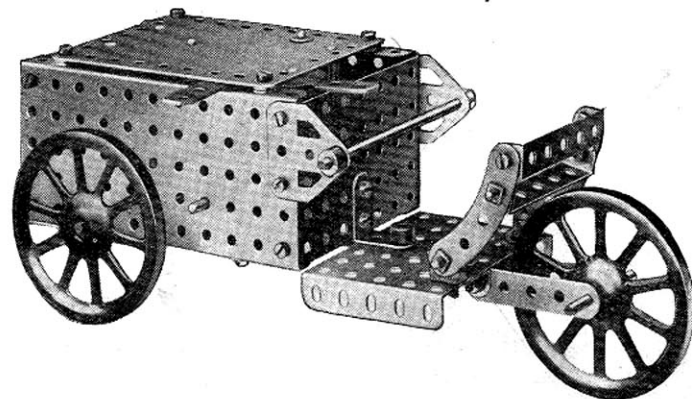

FIG. 5.39B

Model No. 5.40 Delivery Van



Parts required:

- 1 of No. 3
- 3 " " 5
- 4 " " 12
- 1 " " 12A
- 1 " " 15
- 2 " " 15A
- 1 " " 17
- 1 " " 18A
- 3 " " 19A
- 1 " " 26
- 1 " " 28
- 31 " " 37
- 9 " " 38
- 2 " " 48A
- 2 " " 52
- 3 " " 53
- 7 " " 59
- 2 " " 90
- 9" " " 94
- 2 " " " 96
- 2 " " " 126A

Clockwork Motor  
(not included in Outfit)

A  $\frac{1}{2}$ " Pinion on the Motor driving shaft (see Fig. 5.40A) engages with a  $1\frac{1}{2}$ " Contrate Wheel that is secured to a  $3\frac{1}{2}$ " Rod journalled in the side plates of the model. This Rod carries a 1" Sprocket Wheel that is connected by Sprocket Chain to a further 1" Sprocket on the axle of the front road wheels.

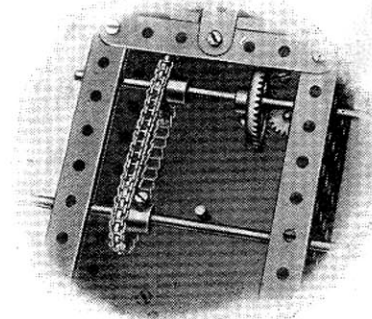
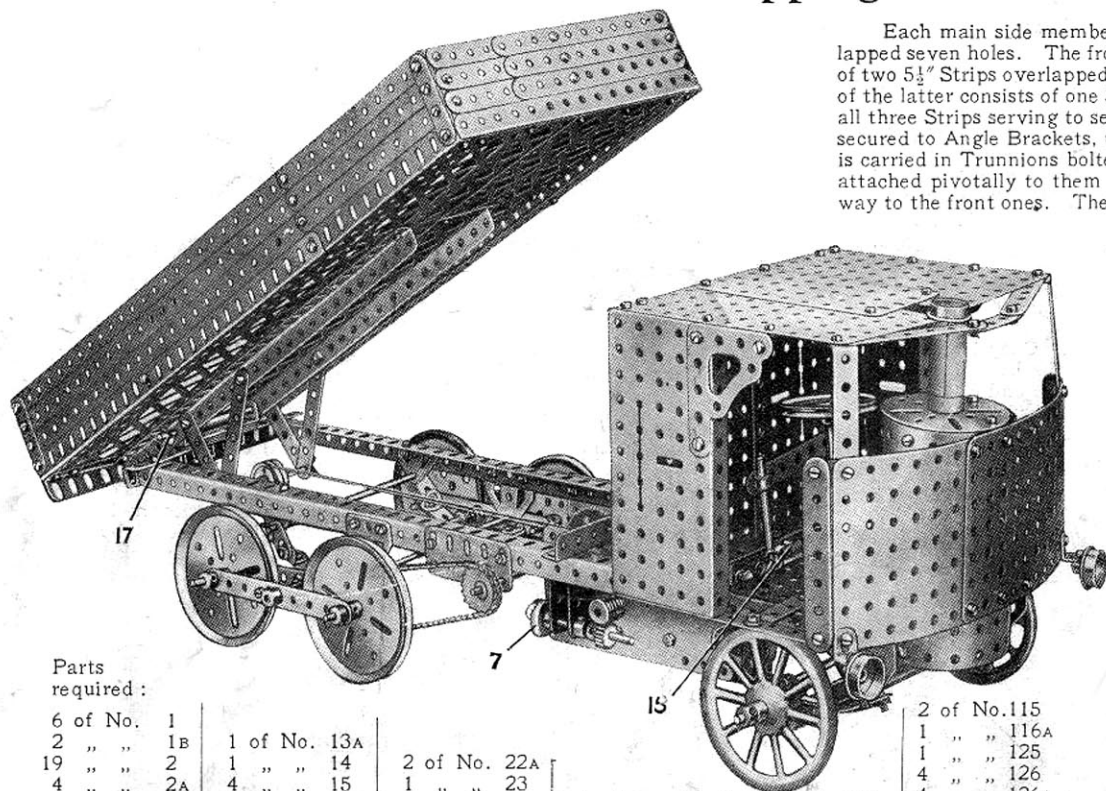

FIG. 5.40A

## Model No. 5.41 Tipping Steam Wagon



Parts  
required :

6 of No. 1	1 of No. 13A	2 of No. 22A	1 of No. 48A	1 of No. 190	2 of No. 115
2 " " 1B	1 " " 14	1 " " 23	1 " " 48B	24" " " 94	1 " " 116A
19 " " 2	4 " " 15	1 " " 26	2 " " 48D	2 " " " 95	1 " " 125
4 " " 2A	3 " " 15A	2 " " 27A	4 " " 52	2 " " " 96	4 " " 126
12 " " 3	5 " " 16	1 " " 29	4 " " 52A	4 " " " 99	4 " " 126A
1 " " 4	3 " " 16A	1 " " 32	2 " " 53A	4 " " " 100	1 " " 160
8 " " 5	5 " " 17	1 " " 35	1 " " 57	2 " " " 103F	1 " " 162
4 " " 6	4 " " 18A	14 " " 37	4 " " 59	2 " " " 108	1 " " 163
4 " " 6A	1 " " 19S	10 " " 37A	19 " " 59	2 " " " 109	1 " " 164
10 " " 8	2 " " 19A	10 " " 38	38 " " 62B	1 " " " 109	2 " " 165
2 " " 8B	4 " " 19B	1 " " 40	5 " " 63	2 " " " 111	1 " " 166
4 " " 9	20A	1 " " 43	1 " " 70	4 " " " 111c	
7 " " 10	3 " " 20B				
21 " " 12	3 " " 22				
4 " " 12A					

Each main side member of the chassis consists of two  $1\frac{1}{2}$ " Angle Girders overlapped seven holes. The front axle is duplicated for strength, each portion consisting of two  $5\frac{1}{2}$ " Strips overlapped nine holes and bolted to one side of the leaf springs. Each of the latter consists of one  $3\frac{1}{2}$ ", one  $2\frac{1}{2}$ ", and one  $1\frac{1}{2}$ " Strip, a  $\frac{1}{8}$ " Bolt passing through all three Strips serving to secure the spring to the axle. The ends of the Springs are secured to Angle Brackets, the front Angle Brackets being mounted on a Rod 1 that is carried in Trunnions bolted to the chassis, whilst the rear ones have Flat Brackets attached pivotally to them by lock-nutted bolts and mounted on a Rod in a similar way to the front ones. The Springs for the rear wheels are constructed and mounted in an exactly similar manner to the front ones.

The equalising beams of each bogie are two  $4\frac{1}{2}$ " Strips that are connected at their centres by  $1" \times 1"$  Angle Brackets 2. Each pair of equalising beams pivots freely about an 8" Rod 3, that is passed through Collars attached by  $\frac{3}{8}$ " Bolts to the Springs.

The steering gear is based on the correct Ackermann principle and is built up in the following way: The stub axles are secured in Couplings 4, which are free to turn about  $\frac{3}{4}$ " Bolts inserted in their centre holes and attached by double nuts to the extremities of the front axle. The track rod (which connects the Wheels so that they turn together) is attached pivotally by means of Swivel Bearings 5, to the ends of short Rods that are held in the end bores of the Couplings. The free end of one of these Rods carries a third Swivel Bearing 6 which is connected by a Rod to a Double Arm Crank on the lower extremity of the steering column. The latter is journalled in a reinforced bearing consisting of a  $\frac{1}{2}$ " Reversed Angle Bracket that is bolted to the floor of the cab.

The Motor armature spindle carries a Worm meshing with a  $\frac{1}{2}$ " Pinion on a Rod that has also a  $\frac{3}{4}$ " Contrate Wheel 7 secured to it. The latter is in constant mesh with a  $\frac{1}{2}$ " Pinion on a sliding Rod 8. This Rod has two further  $\frac{1}{2}$ " Pinions, one between and the other outside the Motor side plates, and by sliding it in its bearings, the Pinions may be brought into mesh with either of the 57-teeth Gears 9 and 10. The Gear 10 is secured to a short Rod journalled in the Motor side plates and carrying also a 1" loose Pulley 11, which is retained in place on the Rod, together with a Flat Bracket, by Collars. One end of a length of cord is tied to the Flat Bracket and is passed over one of the 1" loose Pulleys 12 that are free on a Rod, which is carried by Strips attached rigidly to the underside of the tipping body. The cord then passes

Electric Motor  
(not included in  
Outfit)



### Model No. 5.41 Tipping Steam Wagon

(continued)

to the Pulley 11 back over the second Pulley 12, and is attached finally to the Rod on which the Gear 10 is secured.

The Gear 9 is mounted on a  $6\frac{1}{2}$ " Rod that passes completely through both Motor side plates and is also supported in additional bearings consisting of  $2\frac{1}{2}$ " Flat Girders bolted to the chassis members. 1" Sprocket Wheels are secured on each end of the Rod and are connected by Sprocket Chain to the 2" Sprockets on the road wheel axles. It will be seen, therefore, that by sliding the Rod 8, either the travelling or tipping movement may be effected. The sliding of the Rod is accomplished by a 2" Rod that engages between a  $\frac{1}{2}$ " loose and a  $\frac{1}{2}$ " fast Pulley, and is secured in a Coupling on a Rod 13. The latter is journalled in a  $3\frac{1}{2}$ " Double Angle Strip bolted to the chassis and carries on its other end another Coupling in which is held a Rod to serve as a lever. In order to manipulate the latter conveniently a Strip 14 that projects through the slot of the  $5\frac{1}{2}$ " x  $2\frac{1}{2}$ " Flanged Plate forming the side of the cab is attached pivotally to it by a bolt inserted in a Collar on the upper extremity of the lever. A Spring 15 keeps the lever normally in the travelling position, so that to engage the tipping movement it is necessary to pull out the Strip against the tension of the Spring. A similar scheme is followed in the case of the Motor control switch; a  $5\frac{1}{2}$ " Strip 16 is attached pivotally to the top end of a Crank Handle, which is secured rigidly by means of a Coupling to the motor switch arm.

The tipping body pivots about a  $3\frac{1}{2}$ " Rod 17 that is passed through holes in two  $12\frac{1}{2}$ " Angle Girders bolted to the underside of the body, and also through the ends of a  $2\frac{1}{2}$ " x  $\frac{1}{2}$ " Double Angle Strip. This Double Angle Strip is secured by  $\frac{3}{8}$ " Bolts to a  $5\frac{1}{2}$ " Angle Girder spanning the end of the chassis, and is spaced therefrom by three  $2\frac{1}{2}$ " Strips.

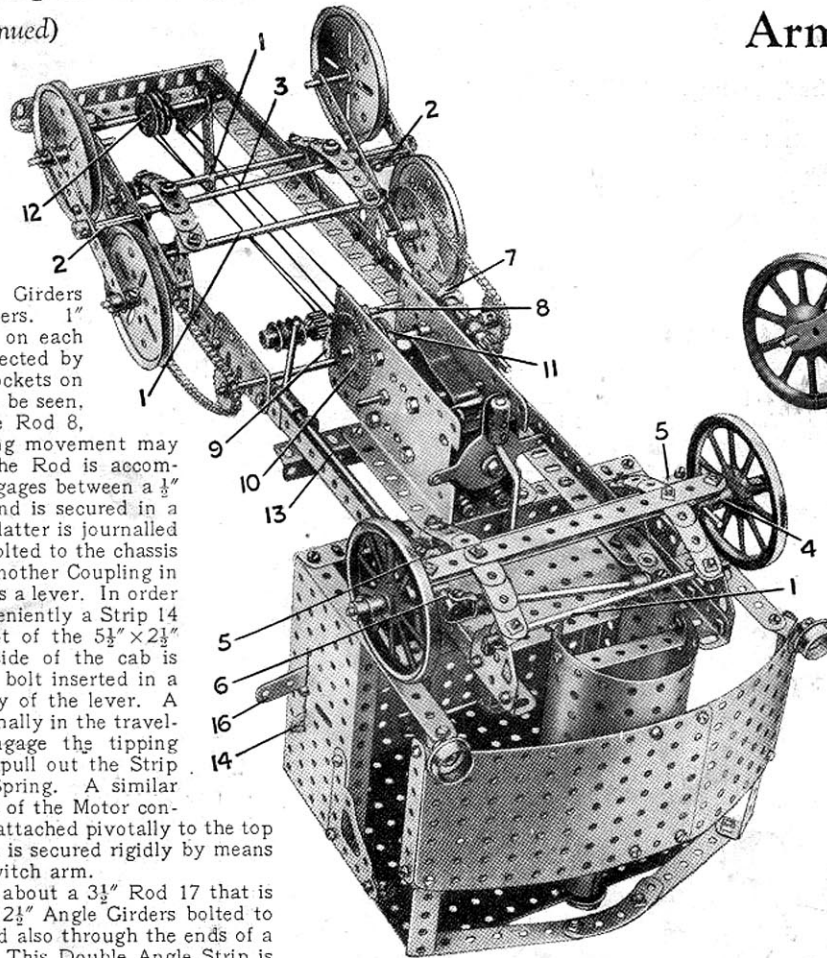
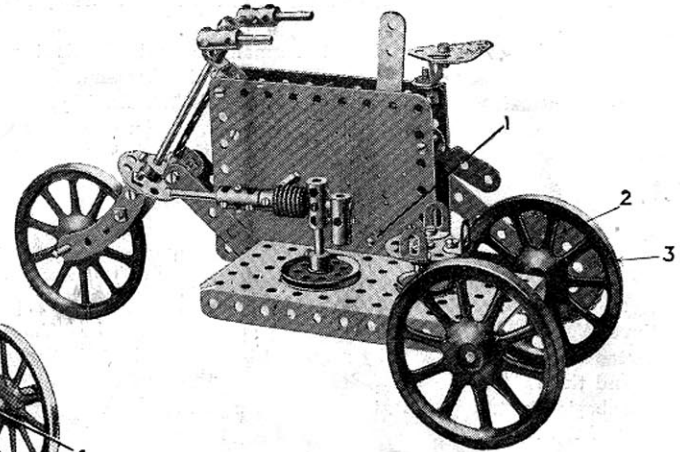

FIG. 5.41A

### Model No. 5.42 Armoured Motor Tricycle



Parts required :		
2 of No. 2	4 of No. 18A	1 of No. 52
2 " " 5	3 " " 19A	1 " " 59
1 " " 9D	1 " " 21	6 " " 63
2 " " 11	3 " " 22	2 " " 90
4 " " 12	2 " " 24	1 " " 95
2 " " 12A	1 " " 32	1 " " 96
1 " " 15A	22 " " 37	1 " " 125
2 " " 16	10 " " 38	1 " " 126A
2 " " 17	1 " " 48A	

Clockwork Motor  
(not included in Outfit)

This is driven from the Motor Spindle 1, a small Sprocket Wheel at the rear, not shown in the illustration, being geared by a chain to the larger Sprocket Wheel 2 bolted on the Axle Rod of the rear Wheels 3.

## Model No. 5.43 Electric Tram Car

The external construction of the model is shown clearly in Figs. 5.43 and 5.43A.

The bells are composed of two small Flanged Wheels 1 attached to the roof of the lower deck by means of Angle Brackets, and Collars attached to a cord running through the bosses of both Wheels, form the strikes.

The seats on the upper deck are constructed as follows: backs are two sets of  $5\frac{1}{2}$ " Strips 2 connected together at the ends by means of 2" Strips, which are secured to the floor of the upper deck by means of two  $9\frac{1}{2}$ " Angle Girders 3. The seats proper are  $5\frac{1}{2}$ " Strips similar to 2 but are joined together by Flat Brackets and secured to the backs by Angle Brackets.

The construction of the bogies will be seen clearly in Fig. 5.43A the mounting of the 2" Pulleys 4 and 5 being the only part needing description. Each Pulley 5 is secured to the  $1\frac{1}{2}$ " x  $\frac{1}{2}$ " Double Angle Strip and the Trunnion on the bogie by means of  $\frac{3}{8}$ " Bolts, three Washers on each being used for spacing purposes. The second Pulley 4 is connected to two  $1\frac{1}{2}$ " Strips 6 by means of  $\frac{3}{8}$ " Bolts spaced similarly to those on the Pulley 5, and the  $1\frac{1}{2}$ " Strips 6 are bolted to the  $3\frac{1}{2}$ " Strip 7 and the  $5\frac{1}{2}$ " x  $3\frac{1}{2}$ " Flanged Plate 8. The bogie pivot, a  $\frac{3}{4}$ " Bolt, is passed through the boss of the Pulley 4 and secured in the boss of the Pulley 5.

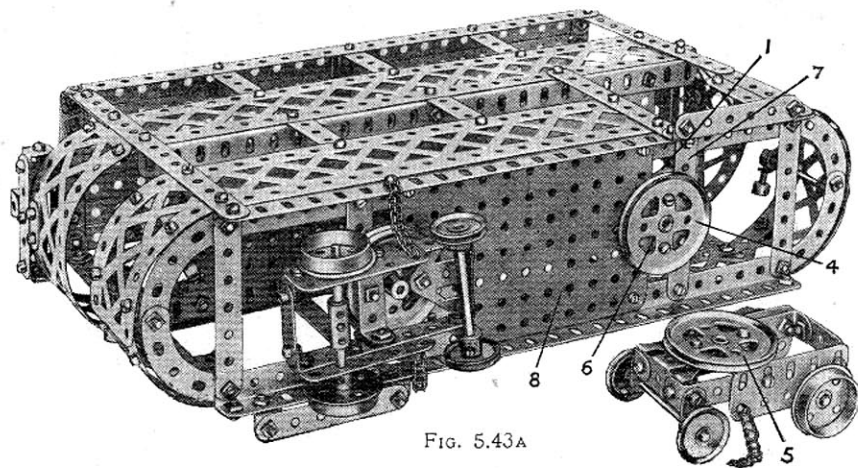
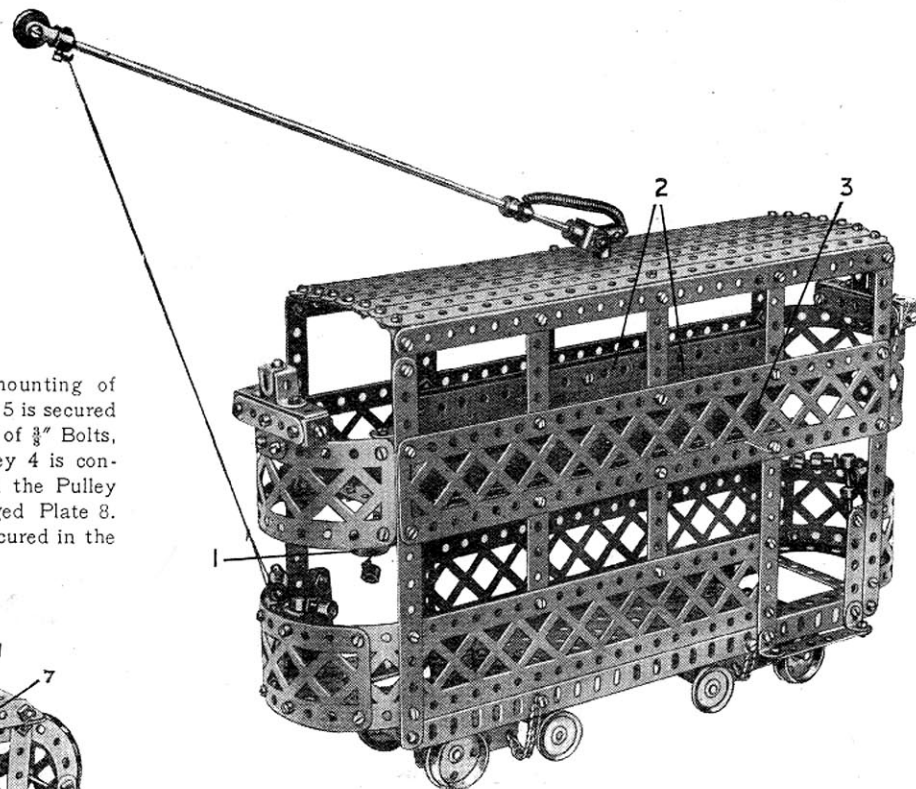

FIG. 5.43A



### Parts required :

9 of No. 1	4 of No. 11	6 of No. 37A	4 of No. 90A
2 " " 1B	20 " " 12	24 " " 38	8 " " 94
12 " " 2	1 " " 13	1 " " 40	4 " " 99
2 " " 2A	3 " " 16A	1 " " 43	4 " " 100
7 " " 3	4 " " 17	2 " " 45	4 " " 103F
2 " " 4	2 " " 18A	2 " " 48	3 " " 111
18 " " 5	4 " " 20	2 " " 48A	6 " " 111C
4 " " 6	4 " " 20A	4 " " 48B	2 " " 115
6 " " 6A	2 " " 20B	3 " " 52A	1 " " 116
4 " " 8	4 " " 22	13 " " 59	1 " " 116A
4 " " 8A	1 " " 23	4 " " 63	2 " " 126
12 " " 10	169 " " 37	2 " " 77	1 " " 147B

## Model No. 5.44 Truck Weighing Machine

Two 5½" Strips 2 (Fig. 5.44B) are supported pivotally at one end by Flat Brackets held loosely between Collars on the Rod 1, and are spaced apart at the other end by two ½" Reversed Angle Brackets 7, the out-turned portions of which carry a Flat Bracket 7A. Meccano Sprocket Chain 8 connects the Bracket 7A with the Screwed Rod 9, which is held in the centre transverse hole of a Coupling 11. This Rod 9 is connected by another Coupling 11 to a 4½" Rod on which a weight 12 (a Worm Wheel) is free to slide. Another weight 10 (two Flanged Wheels) is secured to a Coupling that may be fixed at any suitable point on the other end of the balance arm, and the entire arm is suspended from the Coupling 13 by means of a piece of strong silk 14.

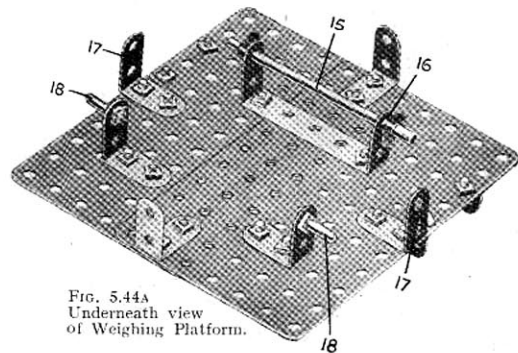
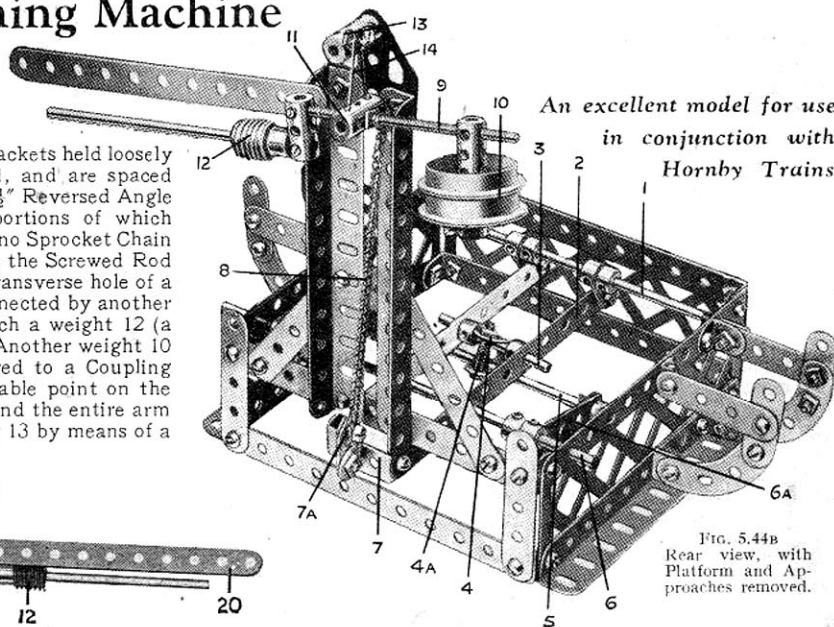

FIG. 5.44A  
Underneath view  
of Weighing Platform.

Parts required :

7 of No. 2	1 of No. 16	2 of No. 52A
2 " " 4	1 " " 17	13 " " 59
4 " " 5	1 " " 18A	4 " " 63
4 " " 6	2 " " 20	1 " " 80A
6 " " 6A	1 " " 32	4 " " 90A
4 " " 8	8 " " 35	6" " " 94
4 " " 9	76 " " 37	3 " " 100
9 " " 10	5 " " 37A	1 " " 111
1 " " 11	10 " " 38	1 " " 111c
8 " " 12	1 " " 46	2 " " 115
6 " " 12A	2 " " 48	2 " " 125
2 " " 14	4 " " 48B	1 " " 126A
2 " " 15A		



An excellent model for use  
in conjunction with  
Hornby Trains

FIG. 5.44B  
Rear view, with  
Platform and Approaches  
removed.

Two 2½" Strips 6A are connected pivotally by Flat Brackets to the Rod 6, and their other ends hold a Rod 5 that passes under the Strips 2. A Double Bracket 4 is passed over the Rods 3 and 5 and held in place by a ¾" Bolt 4A. The platform merely rests on the levers in the base, the Rod 15 and Threaded Pins 18 (Fig. 5.44A) making contact with the Strips 2 and 6A respectively. The Angle Brackets 17 are merely guides and rest against the innersides of the Braced Girders in the base.

The position of the weight 10 should be adjusted so that the balance arm is horizontal when no load is applied to the platform. A truck placed on the rails 19 causes the arm 9 to be pulled downwards by the Chain 8,

and the extent of the load may be calculated by noting the distance through which it is necessary to move weight 12 in order to return the arm to the horizontal.

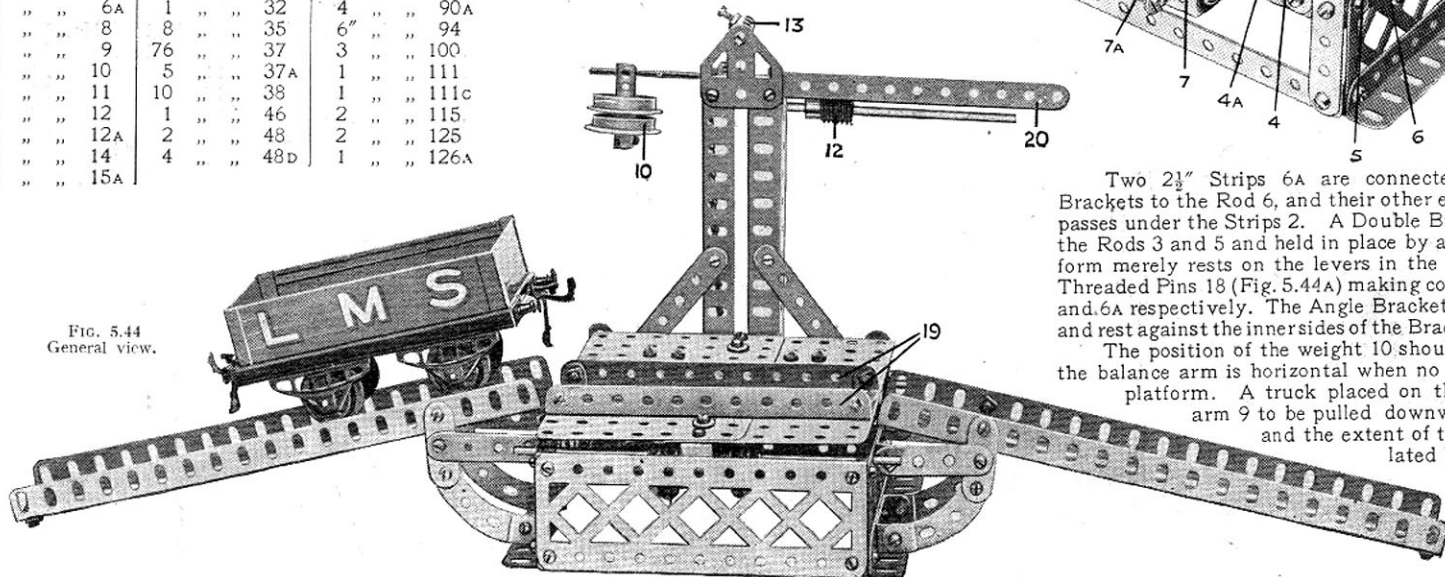

FIG. 5.44  
General view.

## Model No. 5.45 Battle Cruiser

The hull consists of three rows of  $12\frac{1}{2}$ " and  $5\frac{1}{2}$ " Strips, the upper row being bolted to the flanges of the Sector Plates and  $5\frac{1}{2}$ "  $\times$   $2\frac{1}{2}$ " Flanged Plates which form the deck. The superstructure is built up on two  $12\frac{1}{2}$ " Angle Girders, which are spaced apart by  $1\frac{1}{2}$ " Strips and a longitudinal  $12\frac{1}{2}$ " Strip and secured by Angle Brackets to the Flanged Plates.  $2\frac{1}{2}$ " Strips are bolted vertically to support  $2\frac{1}{2}$ "  $\times$   $\frac{1}{2}$ " Double Angle Strips, to which further Strips are secured to form the navigating bridge.

The tripod mast is placed directly behind the bridge. The mast proper, which consists of one  $6\frac{1}{2}$ " Axle Rod, is secured to the deck by a  $1\frac{1}{2}$ " Pulley Wheel and carries a Flanged Wheel and two 1" Pulleys. Two further  $6\frac{1}{2}$ " Rods are passed through holes in the Flanged Wheel and their lower ends are inserted in holes in the upper deck and secured by Spring Clips. The funnel consists of ten  $2\frac{1}{2}$ " Strips bolted in a vertical position and held together by Flat Brackets slightly bent. It is secured to the ship by Angle Brackets.

The aeroplane launching platform consists of  $2\frac{1}{2}$ " Strips bolted to a Bush Wheel, while the miniature aeroplane is built up from a 2" Rod carrying a Collar, in the tapped hole of which a bolt is securely fixed. A Double Bracket and a  $1\frac{1}{2}$ " Strip are held on the shank of the bolt. The tail plane is represented by a Spring Clip.

Figs. 5.45A and 5.45B show the gun turrets. The guns, which are formed from Rods, are held in position by Collars. The completed turrets pivot about  $\frac{3}{8}$ " Bolts secured to the 1" Triangular Plates and loosely attached to the Sector Plates by lock-nuts.

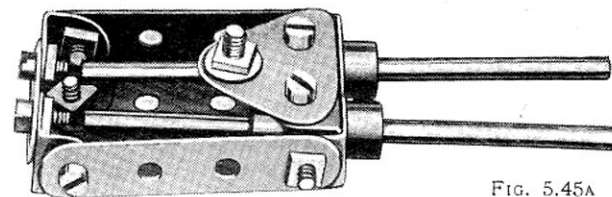
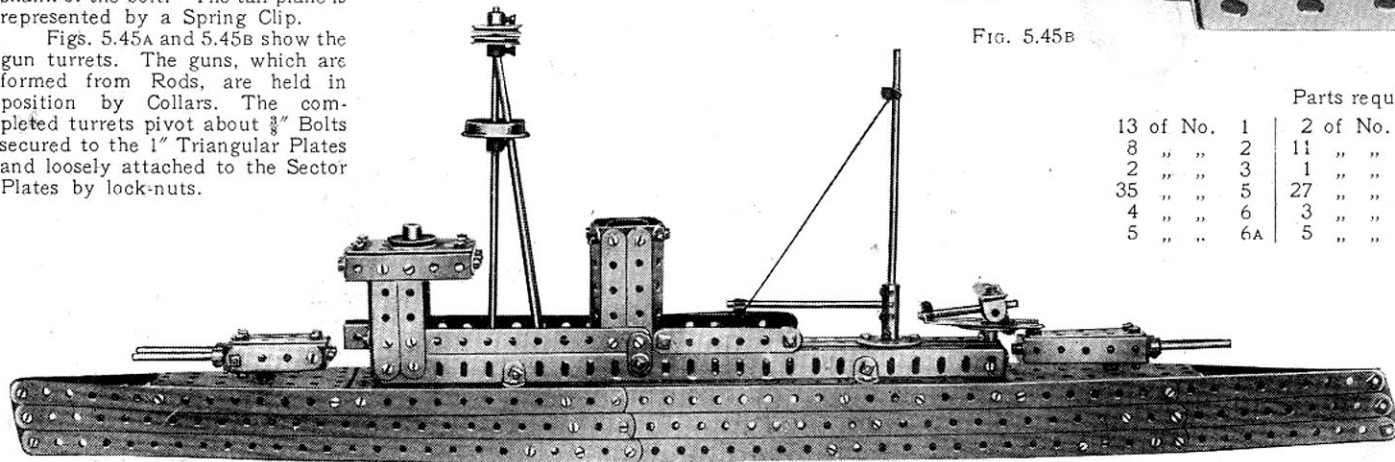

FIG. 5.45A

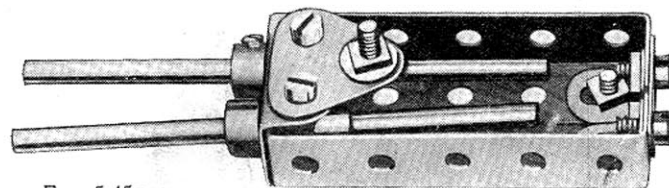
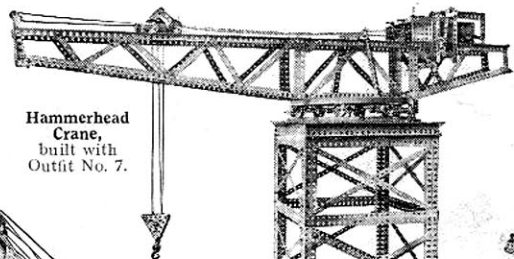

FIG. 5.45B

Parts required :		
13 of No. 1	2 of No. 8	1 of No. 18A
8 " " 2	11 " " 10	1 " " 20
2 " " 3	1 " " 11	1 " " 21
35 " " 5	27 " " 12	3 " " 22
4 " " 6	3 " " 14	2 " " 24
5 " " 6A	5 " " 16	3 " " 35
		146 " " 37
		4 " " 38
		1 " " 45
		2 " " 48
		6 " " 48A
		1 " " 52
		1 " " 53
		2 " " 54
		9 " " 59
		1 " " 63
		2 " " 111c

### HOW TO CONTINUE

This completes our examples of models that may be made with MECCANO Outfit No. 5 (or No. 4 and No. 4A). The next models are a little more advanced, requiring extra parts to construct them. The necessary parts are all contained in a No. 5A Accessory Outfit, the price of which may be obtained from any Meccano dealer.



**Hammerhead  
Crane,**  
built with  
Outfit No. 7.

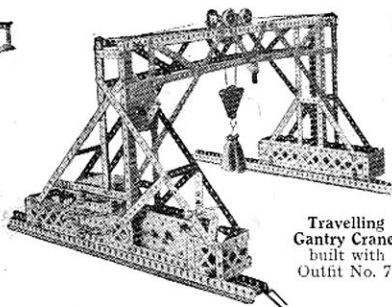

**Travelling  
Gantry Crane,**  
built with  
Outfit No. 7.

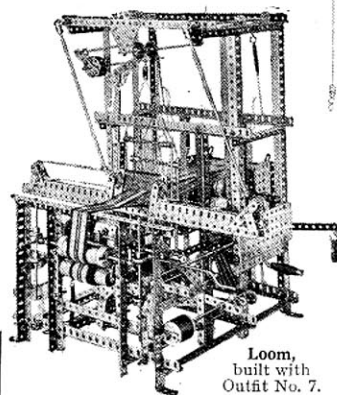

**Loom,**  
built with  
Outfit No. 7.

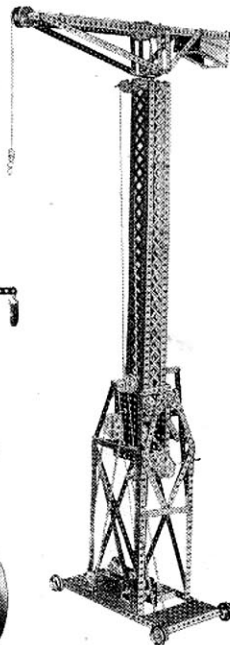

**Crane,** built with  
Outfit No. 6.

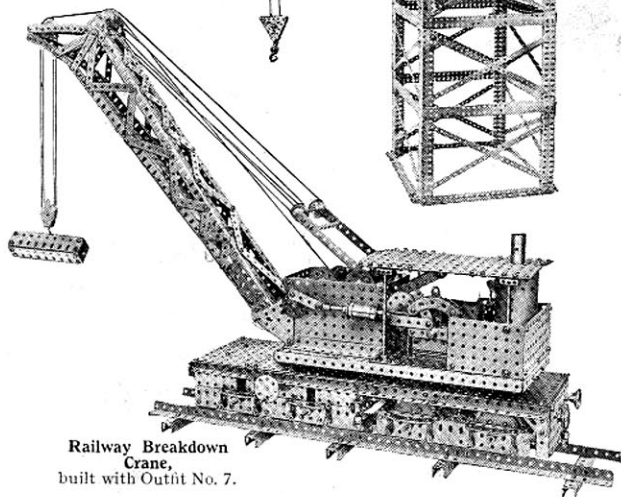

**Railway Breakdown  
Crane,**  
built with Outfit No. 7.

## Keep Adding to your Outfit

The more Meccano parts you have, the bigger and better the models you are able to build. Keen and enthusiastic model-builders keep adding to their Outfits, until they are able to build all the wonderful models shown in the Meccano Manuals.

The model-building possibilities of the Meccano System are limitless. All the fine models illustrated on this page are examples of the types you will be able to build as your Outfit develops.

You can purchase separate Meccano parts as you require them, or, if you prefer, you can purchase Accessory Outfits that connect all the main Outfits.

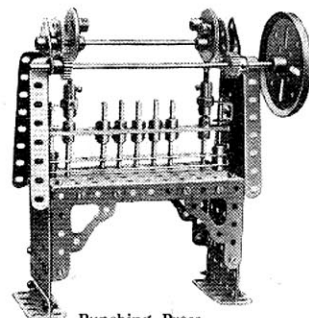

**Punching Press,**  
built with  
Outfit No. 6.

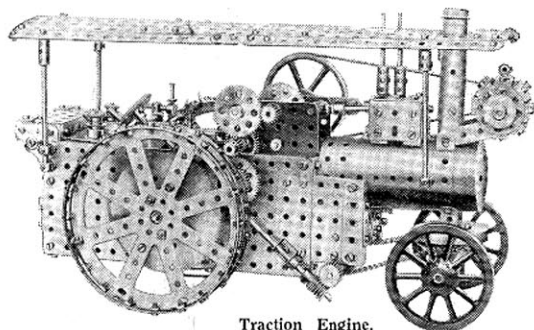

**Traction Engine,**  
built with Outfit No. 7.

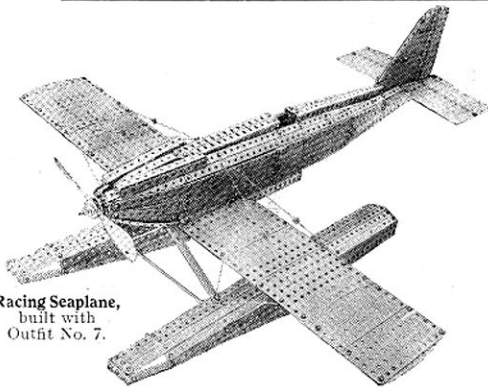

**Racing Seaplane,**  
built with  
Outfit No. 7.

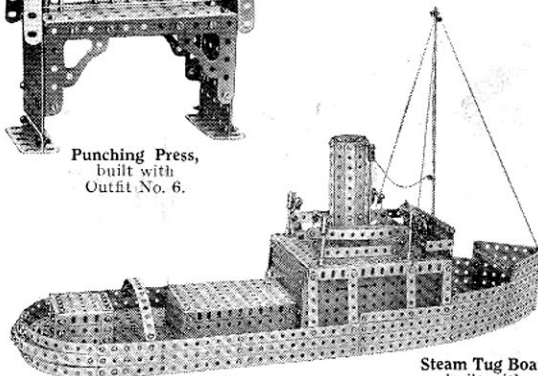

**Steam Tug Boat,**  
built with  
Outfit No. 6.

# The Possibilities of Meccano are Unlimited

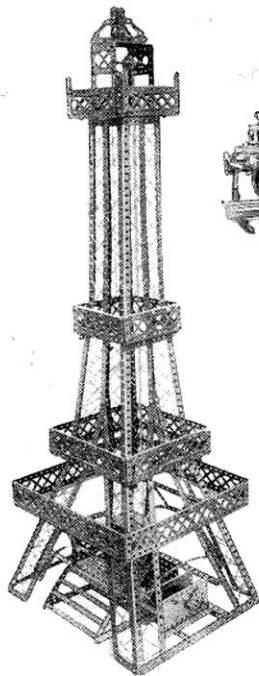

Eiffel Tower, built with Outfit No. 7.

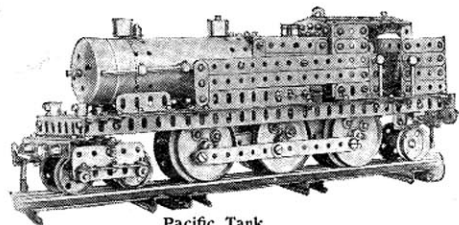

Pacific Tank Locomotive, built with Outfit No. 7.

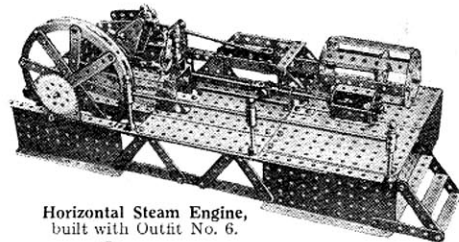

Horizontal Steam Engine, built with Outfit No. 6.

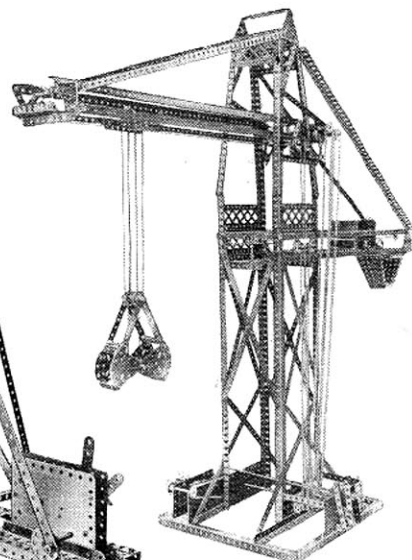

Ship Cooler, built with Outfit No. 7.

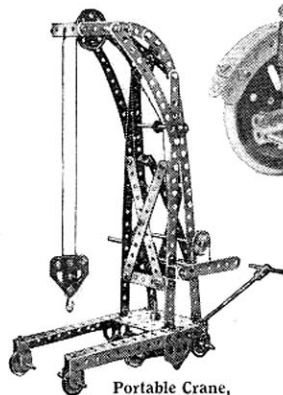

Portable Crane, built with Outfit No. 6.

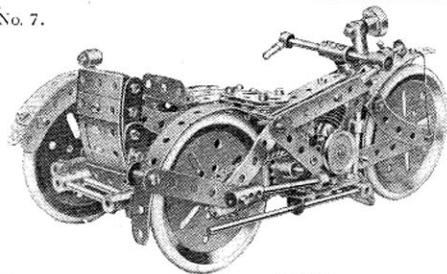

Motor Cycle and Sidecar, built with Outfit No. 7.

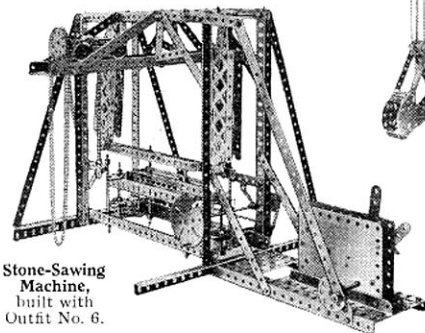

Stone-Sawing Machine, built with Outfit No. 6.

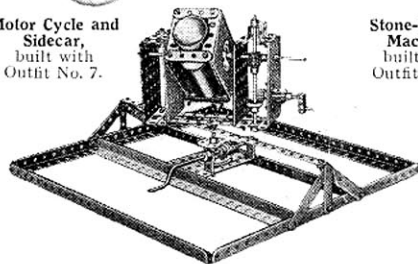

Searchlight, built with Outfit No. 6.

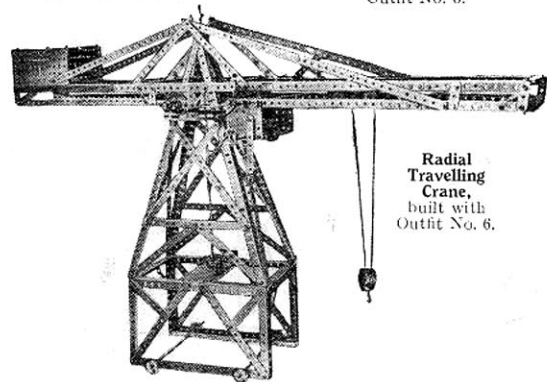

Radial Travelling Crane, built with Outfit No. 6.

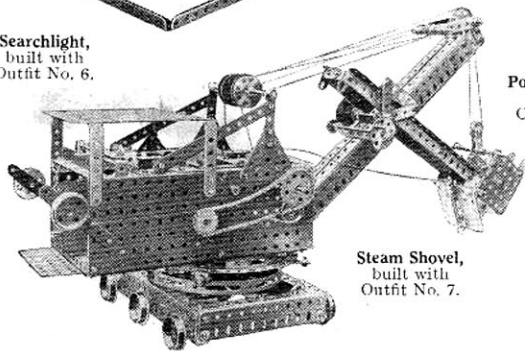

Steam Shovel, built with Outfit No. 7.

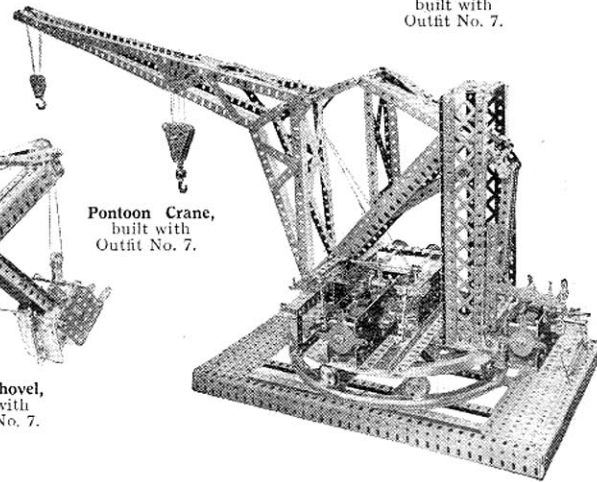

Pontoon Crane, built with Outfit No. 7.

# MECCANO

## MOTORS AND ACCESSORIES

In order to obtain the fullest possible enjoyment from the Meccano hobby the models should be operated with a Meccano power unit. The side plates and bases are pierced with the standard Meccano equidistant holes, which enable the motors or the steam engine to be built into any Meccano model in the position that is most suitable.

### MECCANO ELECTRIC MOTOR

#### No. E. 1 (6-volt)

This is a highly efficient electric motor (non-reversing) that will give excellent service. A 6-volt Accumulator will operate it, but it may also be driven from the main (alternating current only) through the Transformer described on this page.

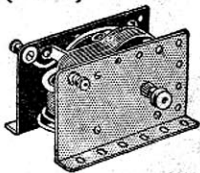

### MECCANO ELECTRIC MOTOR

#### No. E. 6 (6-volt)

This powerful and reliable 6-volt Motor may be run from a 6-volt accumulator or, by employing the Transformer described on this page, from the main. It is fitted with a control mechanism that enables the motor to be started, stopped or reversed as desired.

*NOTE.—The above Electric Motors will not run satisfactorily from dry cells.*

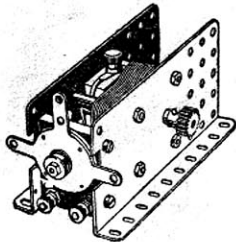

### MECCANO ACCUMULATOR

#### (6-volt, 20 amps.)

The Meccano Accumulator is of substantial construction and is specially recommended for running the Meccano 6-volt Electric Motors.

### MECCANO RESISTANCE CONTROLLER

By employing this variable resistance the speed of the Meccano 6-volt Electric Motors may be regulated as desired. The controller is connected in series with the motor and accumulator, or with the motor and transformer if a transformer is used as the source of power. It will not regulate the speed of a high-voltage motor connected to the main.



### TRANSFORMER

By means of this transformer the Meccano 6-volt Electric Motors may be driven from the main supply (alternating current only). It is available for all standard supply voltages, from 100 to 250 inclusive, at all standard frequencies. The supply voltage and frequency must be specified when ordering.

### MECCANO CLOCKWORK

#### MOTOR No. 1

#### (Non-Reversing)

A long-running and highly efficient clockwork motor (non-reversing), fitted with a brake lever by means of which it may be stopped and started, as desired.

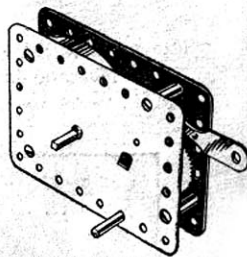

### MECCANO STEAM ENGINE

#### Strong - Powerful Safe - Reliable

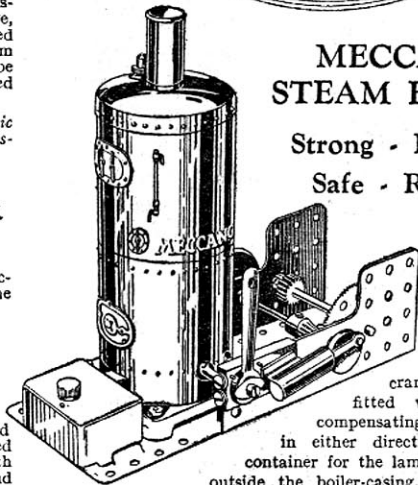

On actual test this powerful steam unit has lifted over 56 lbs. Operation of the reversing lever enables the crankshaft, which is fitted with a special compensating flywheel, to run in either direction. The spirit container for the lamp is placed well outside the boiler-casing, eliminating all risk of the spirit becoming heated. There is no danger whatever of the boiler exploding. A special Manual of Instructions is supplied with each engine.

### MECCANO

### CLOCKWORK

#### MOTOR No. 2

#### (Reversing)

This strongly-built clockwork motor is a compact self-contained power unit. An efficient governor controls the powerful spring that is fitted on the motor, and ensures a long steady run at each winding. Brake and reverse levers enable the motor to be stopped, started and reversed, as required.

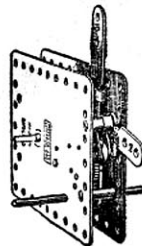

Ask your dealer for a Meccano price list, and keep it by you for reference.

Patents and Designs

Great Britain

250,378	671,485
253,236	671,534
290,121	671,790
323,234	680,416
671,484	682,208

# MECCANO

THE TOY THAT MADE ENGINEERING FAMOUS  
Millions of boys in every country throughout the world play with Meccano.  
These are the Meccano Factories and distributing centres.

Patents and Designs

Great Britain

682,209	718,404
682,934	718,731
683,011	733,541
686,112	733,542
698,054	740,413
740,723	

Canadian Office and Warehouse :  
Meccano Ltd.,  
34, St. Patrick Street, Toronto.



London Office and Warehouse :  
Meccano Ltd.,  
Walnut Tree Walk,  
Kennington Road, London, S.E.11.

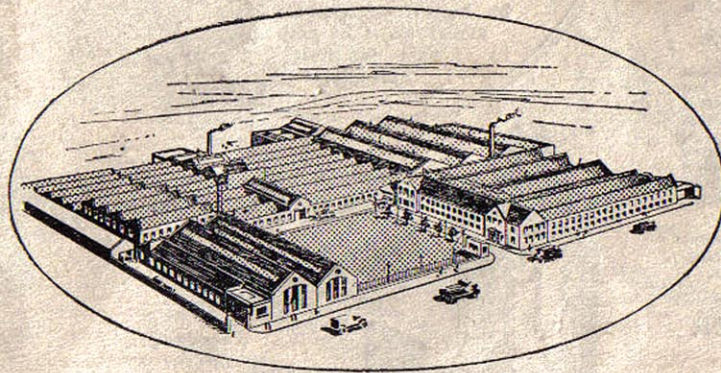

Head Office and Factory :  
OLD SWAN, LIVERPOOL.

Meccano Agencies :

Amsterdam,  
Asuncion,  
Auckland,  
Barcelona,  
Basle,  
Batavia,  
Bogota,  
Bombay,  
Brussels,

Buenos Aires,  
Calcutta,  
Cape Town,  
Caracas,  
Colombo,  
Constantinople,  
Durban,  
Genoa,  
Guayaquil,

Helsingfors,  
Hong Kong,  
Iquitos,  
Jerusalem,  
Johannesburg,  
Karachi,  
Mexico,  
Monte Video,  
Oslo,

Rio de Janeiro,  
Santiago,  
Sao Paulo,  
Shanghai,  
Stockholm,  
Sydney,  
Trinidad,  
Vienna.

Meccano G.m.b.H.,  
Berlin SW.68, Alte Jakobstrasse 20-22.



Meccano (France) Ltd.,  
78-80, Rue Rébeval,  
Paris XIXeme.