

# MECCANO

(TRADE MARKS 286321, 501113, 76, 12633, 10274, 55/13476, 569/13, 884/25, 2913, 80, 124, 336, 18066, 5403, 41812, 4174, 9048, 5549, 2389, 91637, 83171, 157149, 32822, 200639, 209733, 214061, 214062, 12692, 29094, 33316, 1818, 16737, 16900, 72286, 494933-4-5-6, 139420, 333/13, 5848, 50204, 10/12256, 22826, 18982, 20063/925, 2189, 7315, 29041, 26877, 6595, 404718, 410379)

HORNBY'S ORIGINAL SYSTEM - FIRST PATENTED 1901

## INSTRUCTIONS

FOR OUTFITS

# 4 to 7

Copyright by **MECCANO LIMITED, LIVERPOOL, ENGLAND**

No. 35.4-7

# MECCANO

## The Finest Hobby in The World for Boys

The Meccano system is composed of over two hundred and fifty different parts, mostly made of steel or brass, each one of which has a specific mechanical purpose. These parts combine to form a complete miniature engineering system with which practically any mechanical movement may be reproduced in model form. More can be accomplished with Meccano than with any other constructional toy, for no other system has such possibilities. The genius is in the parts and you can commence to build models as soon as you get your Outfit home. A screwdriver, provided in the Outfit, is the only tool necessary.

There is no limit to the number of models that can be built with Meccano—Cranes, Clocks, Motor Cars, Ship Coalers, Machine Tools, Locomotives—in fact everything that interests boys. The most wonderful feature about the system is that it is *real engineering* in miniature; it is fascinating and delightful and it gives you a satisfaction beyond anything that you have ever previously experienced.

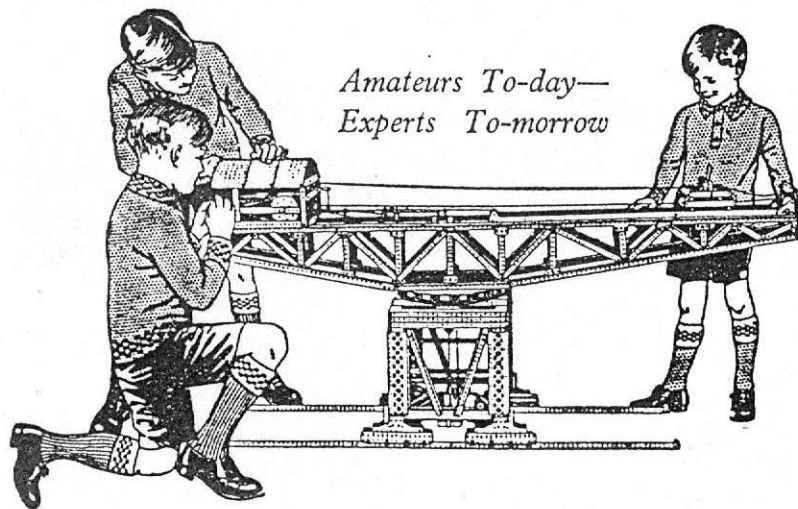

## Model-Building with Meccano

Make the simple models first—they will provide hours of fun—and then try to improve them. Every model can be made in a dozen different ways. It is important to screw up all the nuts and bolts tightly to ensure that your models will be strong and firm when they are completed.

Every keen and inventive Meccano model builder should obtain copies of the special Manuals "How to use Meccano Parts" and "Meccano Standard Mechanisms." In the former the principal uses of Meccano parts are outlined, while the latter shows a large number of real engineering mechanisms, built of Meccano parts, that can be incorporated in various models. You can obtain copies of these Manuals from your dealer, or direct from Meccano Ltd., Binns Road, Liverpool 13, England.

## How to Build up Your Outfit

Meccano is sold in ten different Outfits, numbered 000 to 7. All Meccano parts are of the same high quality and finish, but the larger Outfits contain a greater quantity and variety of parts, making possible the construction of more elaborate models. Each Outfit from No. 00 upwards may be converted into the one next higher by the purchase of an Accessory Outfit. Thus, a No. 00 may be converted into a No. 0 by adding to it a No. 00A. A No. 0A would then convert into a No. 1, and so on. In this way, no matter with which Outfit you commence you may build it up by degrees until you possess a No. 7 Outfit. It is important to remember that Meccano Parts may be bought separately at any time in any quantity from your Meccano dealer.

## Meccano Service

The service of Meccano does not end with selling an Outfit and an Instruction Manual. When you want to know something more about engineering than is now shown in our books, or when you strike a tough problem of any kind, write to us. We receive over 200 letters from boys every day all the year round. Although all kinds of queries are put to us on all manner of subjects, the main interest is, of course, engineering. The wonderful knowledge of engineering matters possessed by our staff of experts is unique. This vast store of knowledge, gained only by many years of hard earned experience, is at your service. *We want the Meccano boy of to-day to be the famous engineer of to-morrow.*

### Model No. 4.1 Periscope

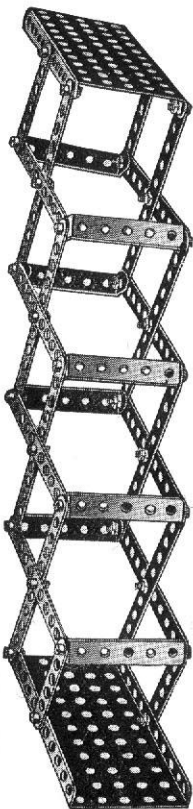

- Parts required:
- |             |                      |
|-------------|----------------------|
| 16 of No. 2 | Small pieces of      |
| 4 " " 4     | looking glass should |
| 32 " " 37   | be inserted in the   |
| 8 " " 48A   | top and bottom       |
| 2 " " 52    | plates.              |

### Model No. 4.2 Steam Winch

A  $\frac{1}{2}$ " Pinion secured to the armature of the Electric Motor turns a  $1\frac{1}{2}$ " Contrate Wheel 1 mounted on an 8" Axle Rod, to the opposite end of which is secured a Worm Wheel 2. The drum 4 of the winch consists of two  $\frac{3}{4}$ " Flanged Wheels and is secured to the end of a  $3\frac{1}{2}$ " Rod, which carries a  $\frac{1}{2}$ " Pinion that is driven by the Worm 2. The cylinder is composed of a Sleeve Piece, secured by two Nuts and Bolts to the end of a  $2\frac{1}{2}$ " Flat Girder 5, and two  $\frac{3}{4}$ " Flanged Wheels. The piston rod is attached pivotally to the connecting rod by means of an End Bearing 3, and the crank pin 6 is formed by a Threaded Pin secured to the Bush Wheel. The Boiler is secured in place by two Angle Brackets bolted to its base and to the  $5\frac{1}{2}$ " x  $2\frac{1}{2}$ " Flanged Plates forming part of the engine bed. It will be noted that the 1" x 1" Angle Bracket supporting one end of the 8" Rod is spaced away from the Motor by a Flat Bracket, in order to obtain proper clearance for the Contrate Wheel 1.

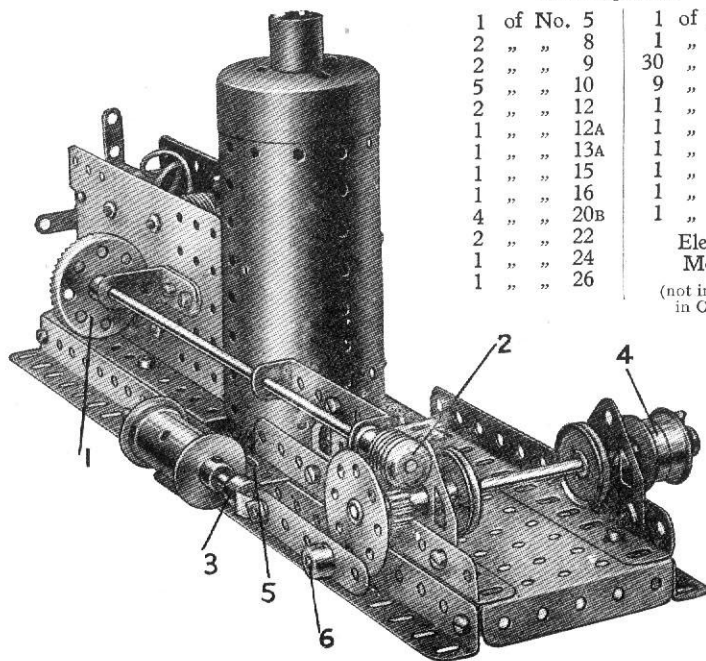

Parts required:

- |            |               |
|------------|---------------|
| 1 of No. 5 | 1 of No. 28   |
| 2 " " 8    | 1 " " 32      |
| 2 " " 9    | 30 " " 37     |
| 5 " " 10   | 9 " " 38      |
| 2 " " 12   | 1 " " 48A     |
| 1 " " 12A  | 1 " " 52      |
| 1 " " 13A  | 1 " " 59      |
| 1 " " 15   | 1 " " 103F    |
| 1 " " 16   | 1 " " 162     |
| 4 " " 20B  | 1 " " 163     |
| 2 " " 22   | Electric      |
| 1 " " 24   | Motor         |
| 1 " " 26   | (not included |
|            | in Outfit)    |

### Model No. 4.3 Band Saw

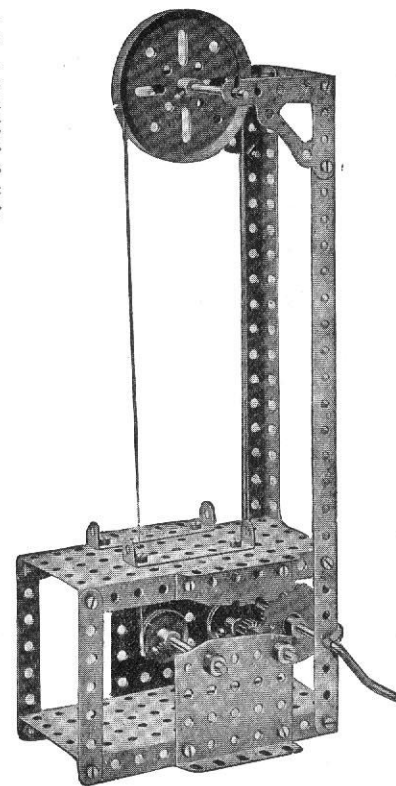

Parts required:

- |            |              |
|------------|--------------|
| 2 of No. 3 | 1 of No. 27A |
| 1 " " 5    | 4 " " 35     |
| 2 " " 8    | 26 " " 37    |
| 3 " " 16   | 1 " " 40     |
| 1 " " 19   | 2 " " 48A    |
| 1 " " 19B  | 2 " " 52     |
| 2 " " 22   | 2 " " 53     |
| 1 " " 26   | 4 " " 59     |
|            | 2 of No. 108 |

These Models can be built with MECCANO Outfit No. 4 (or No. 3 and No. 3A)

## Model No. 4.4 Elliptical Lathe

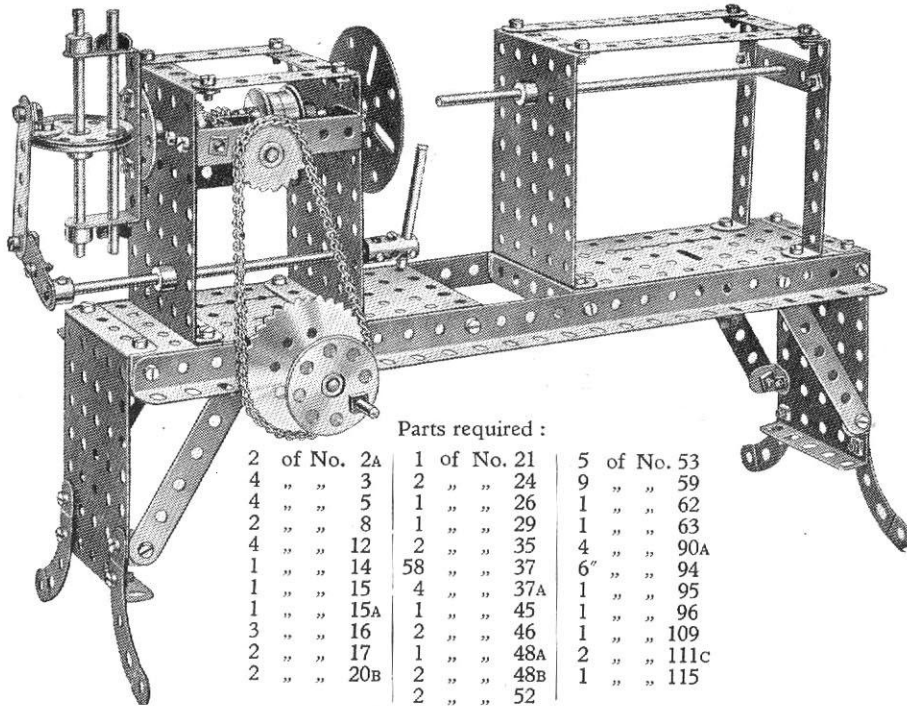

Parts required :

2 of No. 2A	1 of No. 21	5 of No. 53
4 " " 3	2 " " 24	9 " " 59
4 " " 5	1 " " 26	1 " " 62
2 " " 8	1 " " 29	1 " " 63
4 " " 12	2 " " 35	4 " " 90A
1 " " 14	58 " " 37	6" " 94
1 " " 15	4 " " 37A	1 " " 95
1 " " 15A	1 " " 45	1 " " 96
3 " " 16	2 " " 46	1 " " 109
2 " " 17	1 " " 48A	2 " " 111c
2 " " 20B	2 " " 48B	1 " " 115
	2 " " 52	

## Model No. 4.6 Swing Saw

Parts required :

2 of No. 1	1
6 " " 2	2
12 " " 5	5
8 " " 8	8
2 " " 9	9
1 " " 14	14
1 " " 16	16
3 " " 17	17
4 " " 22	22
1 " " 26	26
1 " " 27A	27A
2 " " 35	35
57 " " 37	37
1 " " 40	40
2 " " 48	48
2 " " 48A	48A
1 " " 48D	48D
2 " " 52	52
2 " " 53	53
7 " " 59	59
1 " " 63	63
12" " 94	94
2 " " 96	96
2 " " 126	126
2 " " 126A	126A
1 " " 159	159

Electric Motor  
(not included  
in Outfit)

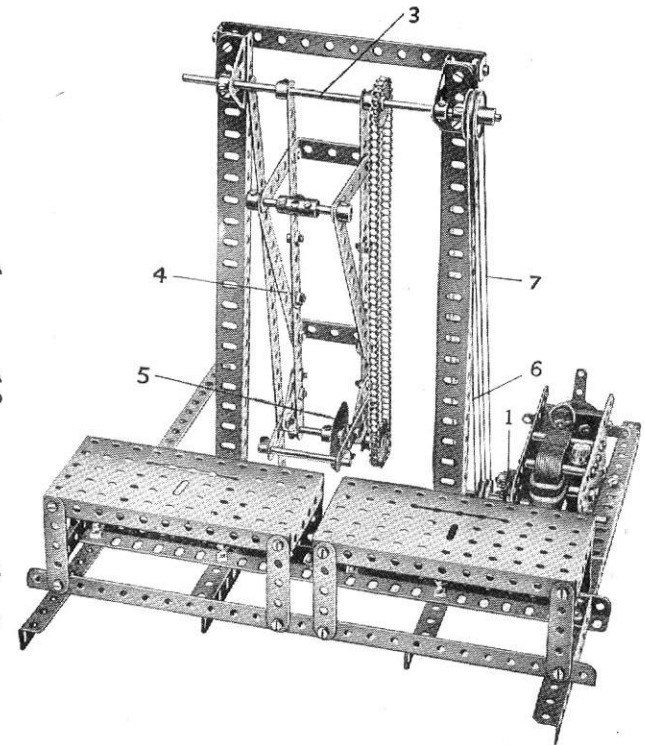

## Model No. 4.5 Distance Indicator

Parts required :

1 of No. 4	16 of No. 37
4 " " 10	1 " " 37A
2 " " 12	3 " " 38
1 " " 15	1 " " 52
2 " " 16	3 " " 59
2 " " 17	2 " " 62
4 " " 20B	1 " " 63
2 " " 26	1 " " 65
1 " " 28	1 " " 95
1 " " 32	1 " " 96
	4 of No. 126A

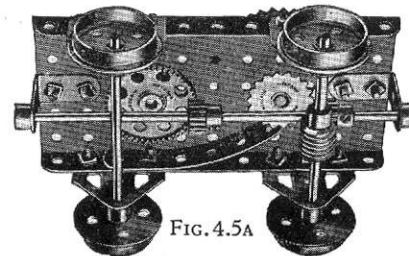
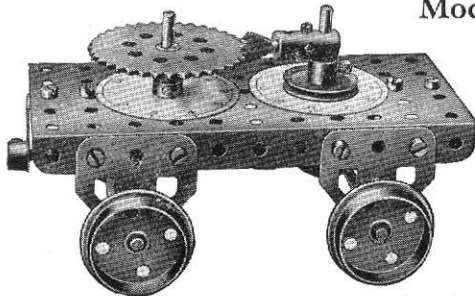

FIG. 4.5A

(Model No. 4.6).

A  $\frac{1}{2}$ " Pinion secured to the armature spindle of the Electric Motor engages with a 57-teeth Gear Wheel 1, the shaft of which carries two 1" Pulleys that transmit the drive by belts to the operating Rod 3. Two driving belts 6 and 7 are used side by side to obtain a more positive grip. The framework 4, carrying the Circular Saw 5, is free to swing about the Rod 3.

## Model No. 4.7 Windmill

Parts required :

8	of No.	1
16	" "	2
2	" "	2A
6	" "	3
4	" "	4
16	" "	5
2	" "	6A
8	" "	8
5	" "	10

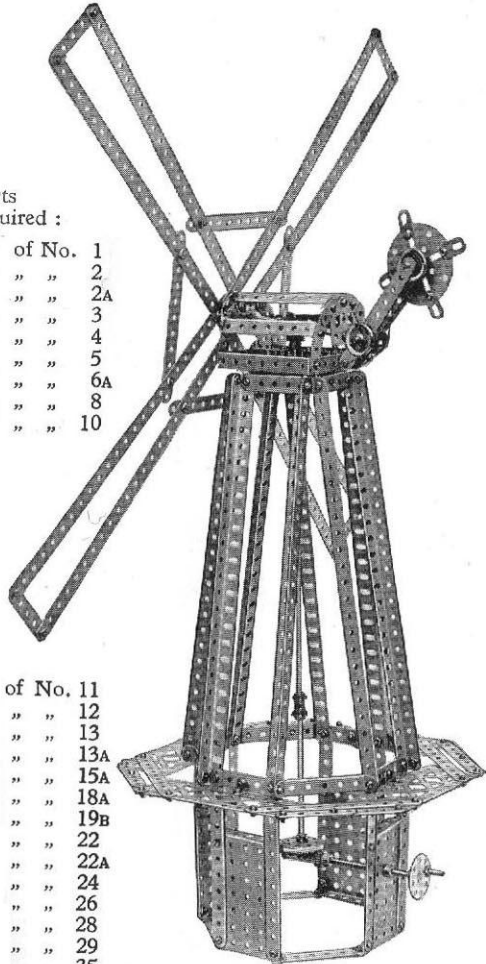

1	of No.	11
12	" "	12
1	" "	13
1	" "	13A
2	" "	15A
2	" "	18A
2	" "	19B
1	" "	22
2	" "	22A
2	" "	24
2	" "	26
1	" "	28
1	" "	29
2	" "	35
126	" "	37
6	" "	37A
10	" "	38
4	" "	48A
6	" "	48B

4	of No.	53
9	" "	59
2	" "	63
4	" "	90
2	" "	90A

4	of No.	100
1	" "	109
6	" "	111c
1	" "	115
1	" "	126A

## Model No. 4.8

Parts required:

8	of No.	1
6	" "	2
6	" "	5
6	" "	8
1	" "	16
1	" "	17
1	" "	19B
1	" "	19s
1	" "	21
1	" "	22
1	" "	27A
1	" "	32
50	" "	37
1	" "	40
1	" "	48A
1	" "	48D
1	" "	52
2	" "	53
2	" "	54
2	" "	59
4	" "	99

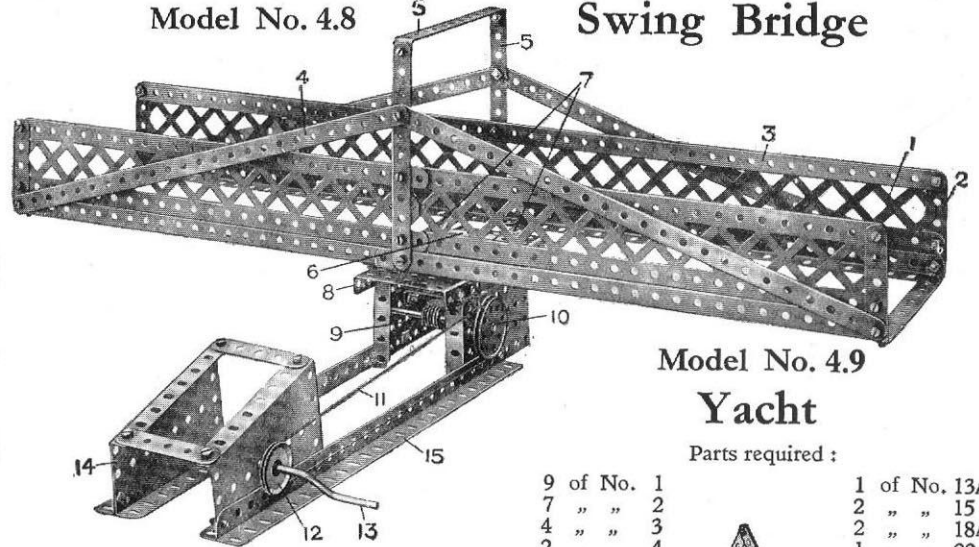

## Swing Bridge

## Model No. 4.9 Yacht

Parts required :

9	of No.	1
7	" "	2
4	" "	3
2	" "	4
2	" "	5
1	" "	10
5	" "	12

1	of No.	13A
2	" "	15
2	" "	18A
1	" "	22
51	" "	37
1	" "	40
1	" "	44
2	" "	48A
1	" "	52
1	" "	54
1	" "	63

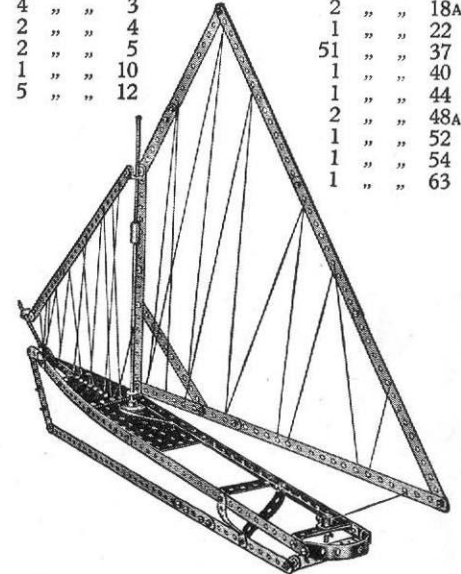

The sides of this model, as shown in the illustration, are made of the Braced Girders 1 secured to the upright Strips 2 and reinforced by the inner Strips 3. Other diagonal Strips 4 brace the side Girders to the top structure 5 forming a stay for the sides 1. The swing base of the bridge is composed of a 3" Pulley Wheel 6 which is bolted to two cross 5½" Strips 7 which in turn are secured to the main base side Girders. The bridge swings on the 5½" x 2½" Flanged Plate 8 on a short Rod, on the lower end of which is secured a Gear Wheel 9, on the spindle of which is the 1½" Pulley 10 driven by the Cord 11 which is operated from the 1" fast Pulley 12 on the Crank Handle 13. The Crank Handle is journaled in two Sector Plates 14 secured to the base Angle Girder 15.

### Model No. 4.10

## Inclined Delivery Chute

The cage 1 is raised from the hand wheel 2 by means of an endless Cord 3 which passes over the upper  $1\frac{1}{2}$ " Pulley 4. A Cord 5 winding on Rod 6 between two 1" fast Pulleys raises or lowers the cage. The truck 7 is raised or lowered along the inclined rails 8 by a Crank Handle 9, a Cord 10 being wound on the Rod 11, passing over a Pulley 12, and connected to the truck 7. When the truck reaches the end of the inclined rails 8 it rests upon two  $5\frac{1}{2}$ " Strips 13 pivoted at 14, the weight of the truck depressing these pivoted Strips and tipping the load.

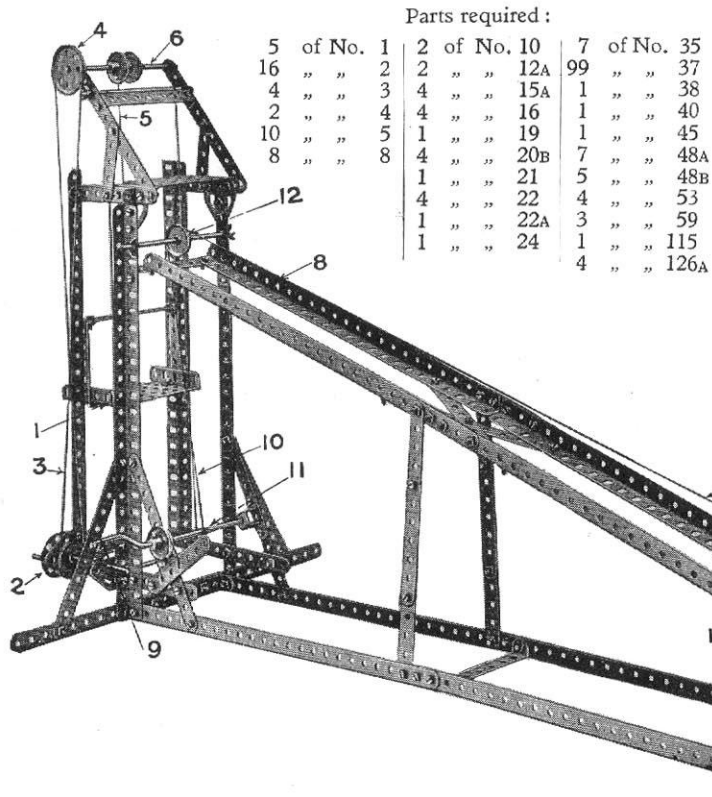

### Model No. 4.11 Puzzle

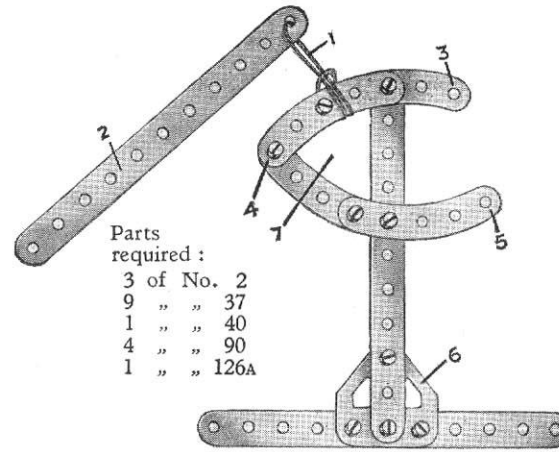

The problem, which is to remove the Strip 2 from the frame, is by no means an easy one to solve. Cutting the String or undoing the knot is not allowed!

The loop of string 1, attached to the end of the  $5\frac{1}{2}$ " Strip 2, should reach halfway along the Strip 2 (when removed from the frame). To assemble the puzzle first pass the loop over the points 3, 4 and 5 and then slip it down to the Trunnion 6. Next pass the  $5\frac{1}{2}$ " Strip 2 through the space 7 and again take the loop over 3, 4 and 5. The loop 1 and Strip 2 are now attached to the frame as shown in the illustration.

### Model No. 4.12 Three-arm Signal

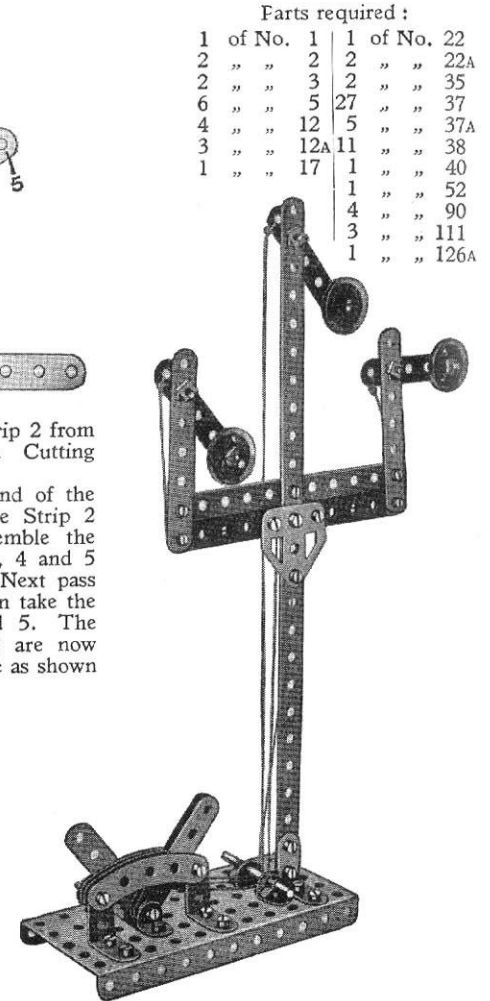

## Model No. 4.13 Breast Drill

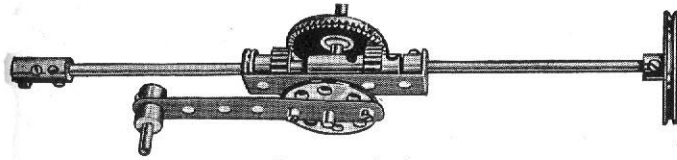

Parts required :

1 of No. 3	1 of No. 21	2 of No. 26	1 of No. 48A
2 " " 15	1 " " 23	1 " " 28	3 " " 59
2 " " 17	1 " " 24	2 " " 37	2 " " 63
1 " " 18A			

## Model No. 4.14 Trotting Car

The only portion of this model requiring description is the mechanism operating the horses' heads. Each of the latter is secured by a Crank to one end of a  $3\frac{1}{2}$ " Rod. To this Rod is also secured a Bush Wheel 1 carrying a  $2\frac{1}{2}$ " Strip 3, which is given a rocking motion by means of an Eccentric 2 on the road wheel axle. The Eccentric 2 and the  $2\frac{1}{2}$ " Strip 3 are connected together by the link 4.

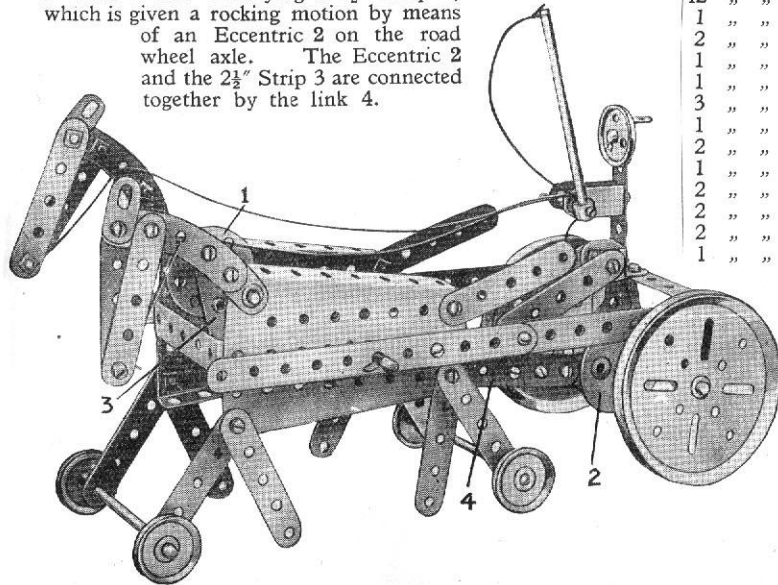

Parts required :

6 of No. 2	4 of No. 16
17 " " 5	2 " " 19B
2 " " 10	4 " " 22
1 " " 11	1 " " 22A
2 " " 15A	1 " " 24
	4 " " 35
	42 " " 37
	1 " " 37A
	2 " " 38
	1 " " 40
	1 " " 44
	3 " " 48A
	1 " " 48B
	2 " " 54
	1 " " 59
	2 " " 62
	2 " " 90
	2 " " 126A
	1 " " 130

## Model No. 4.15 Warehouse

The Cord 1 that raises and lowers the elevator passes from the top of the car 11 over the  $\frac{1}{2}$ " loose Pulley Wheel 4 and the  $1\frac{1}{2}$ " Pulley 5, and is wound between two 1" fast Pulley Wheels on a 3" Axle Rod 2, which is driven from the Electric Motor via a Worm Wheel, a 57-toothed Gear Wheel, a  $\frac{3}{4}$ " Contrate Wheel, and a  $\frac{1}{2}$ " Pinion. The elevator car is counterbalanced by a weight 3, consisting of a Fork Piece, fourteen  $2\frac{1}{2}$ " Strips, and a Collar, which is connected to the car by a Cord 10 passing over a 1" fast Pulley Wheel (behind the Wheel 5) and the  $\frac{1}{2}$ " loose Pulley Wheel 6.

The elevator car is guided by a pair of vertical Cords 7, which pass through holes in the  $2\frac{1}{2}$ " x  $\frac{1}{2}$ " Double Angle Strips 8 as shown, and the weight 3 is similarly guided by the cords 9.

Parts required :

6 of No. 1	1 of No. 40
19 " " 2	1 " " 46
18 " " 5	5 " " 48A
2 " " 6A	1 " " 48D
2 " " 8	2 " " 52
4 " " 9	1 " " 53
6 " " 10	6 " " 59
16 " " 12	2 " " 90A
1 " " 14	2 " " 99
2 " " 16	6 " " 100
2 " " 17	2 " " 108
1 " " 21	2 " " 111
3 " " 22	4 " " 111c
2 " " 23	1 " " 116
1 " " 26	2 " " 126A
1 " " 27A	1 " " 160
1 " " 29	Electric Motor
1 " " 32	(not included in
2 " " 35	Outfit)
126 " " 37	
6 " " 37A	
1 " " 38	

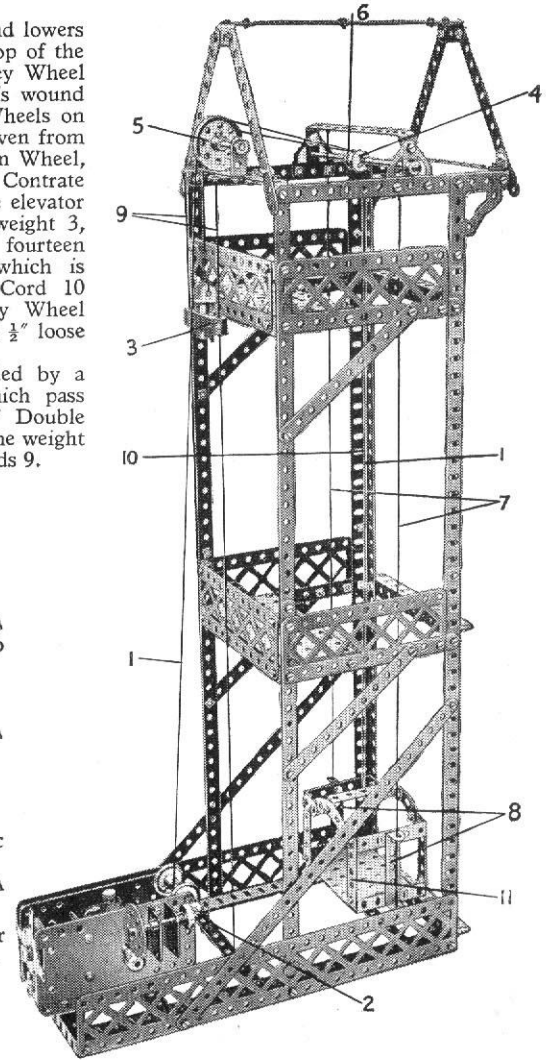

These Models can be built with MECCANO Outfit No. 4 (or No. 3 and No. 3A)

## Model No. 4.16 Sheerlegs

The fixed pulley block at the top of the sheerlegs consists of a Cranked Bent Strip carrying two 1" loose Pulleys. The Cranked Bent Strip has a Small Fork Piece secured to it by a  $\frac{3}{4}$ " Bolt, which passes through the hole in the bottom of the Cranked Bent Strip, and is held in place by a  $1\frac{1}{2}$ " Rod 1. The Sleeve Piece forming the cylinder is free to turn about the Rod 2, on which it is held in place by two Collars secured one on the inside and the other on the outside of the Sleeve Piece.

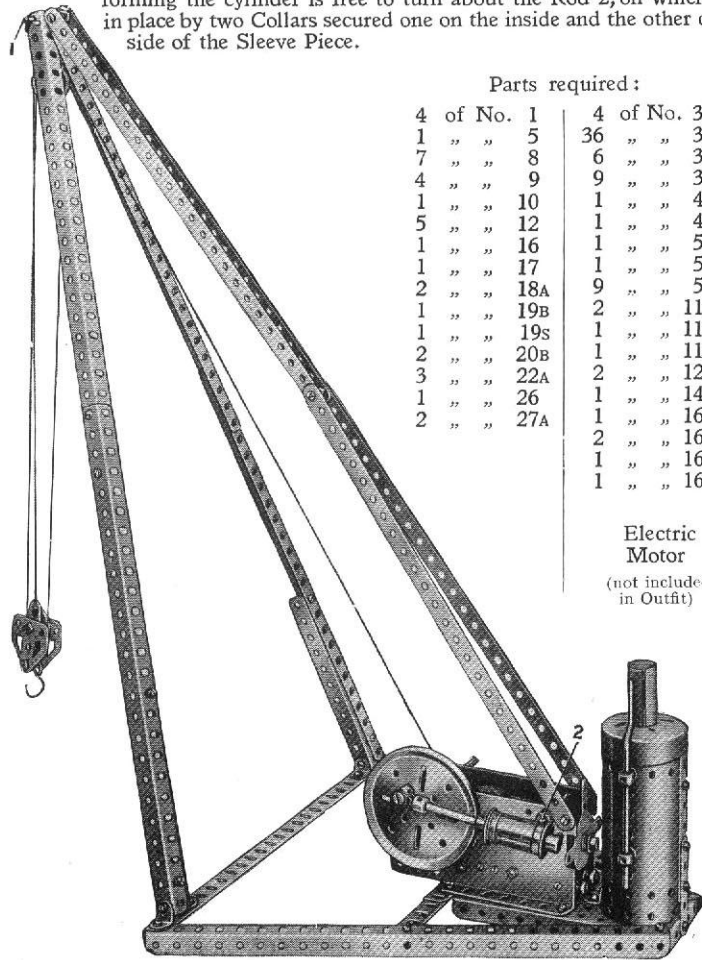

Parts required :

4 of No. 1	4 of No. 35
1 " " 5	36 " " 37
7 " " 8	6 " " 37A
4 " " 9	9 " " 38
1 " " 10	1 " " 40
5 " " 12	1 " " 44
1 " " 16	1 " " 52
1 " " 17	1 " " 57C
2 " " 18A	9 " " 59
1 " " 19B	2 " " 111
1 " " 19S	1 " " 111C
2 " " 20B	1 " " 116A
3 " " 22A	2 " " 126A
1 " " 26	1 " " 147B
2 " " 27A	1 " " 162
	2 " " 163
	1 " " 164
	1 " " 166

Electric  
Motor

(not included  
in Outfit)

## Model No. 4.17 Butter Churn

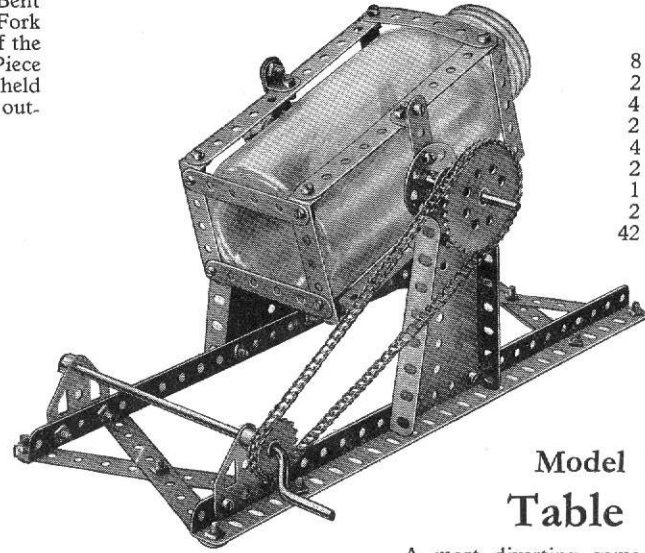

Parts required:

8 of No. 2	4 of No. 48A
2 " " 3	2 " " 54
4 " " 4	3 " " 59
2 " " 8	2 " " 62
4 " " 12	16" " " 94
2 " " 17	1 " " " 95
1 " " 19	1 " " " 96
2 " " 24	2 " " " 126A
42 " " 37	

## Model No. 4.18 Table Croquet

A most diverting game. Coloured marbles may be used for the balls. Full instructions for playing croquet may be obtained from any sports or games dealer.

Parts  
required :

12 of No. 5
12 " " 12
2 " " 16
2 " " 17
2 " " 22
24 " " 37
6 " " 48A
2 " " 63

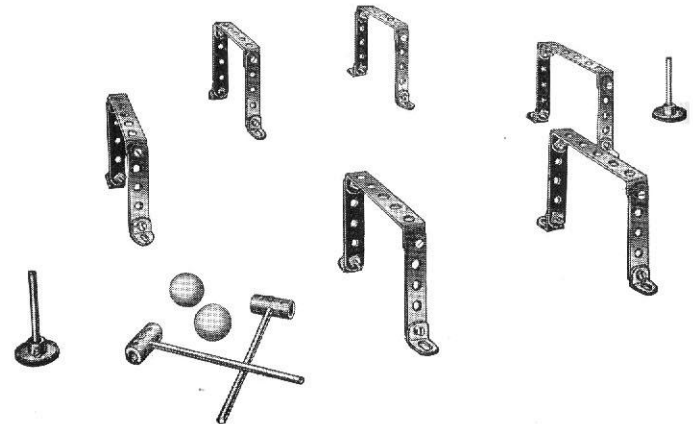



## Model No. 4.19 Speed Indicator

A Crank fitted with a Threaded Pin to form a handle is secured on a  $3\frac{1}{2}$ " Rod carrying a 57-teeth Gear that meshes with a  $\frac{1}{2}$ " Pinion 1 on a  $1\frac{1}{2}$ " Rod. The latter Rod carries a Contrate Wheel and is journaled in one of the holes of a  $5\frac{1}{2}$ " Strip and a Double Bent Strip 2. A Pinion on the vertical 8" Rod which carries the governor is in engagement with the Contrate.

The  $2\frac{1}{2}$ " Strips forming the governor arms are lock-nutted to Angle Brackets which in turn are secured rigidly to Bush Wheels. The upper Bush Wheel is secured to the Rod, while the lower wheel 3, which is free on the Rod, is connected to a  $1\frac{1}{2}$ " Pulley 4 by  $\frac{3}{4}$ " Bolts, but spaced therefrom by Nuts on the shanks of the Bolts. The  $\frac{3}{4}$ " Bolt 5 is passed through the end tapped hole of the Coupling and locked in position by a Nut so that its shank protrudes into the space between the Bush Wheel and Pulley. As the weights of the governor fly outward under centrifugal force the Bush Wheel and Pulley unit 3 rises, carrying with it the Bolt 5 and its Coupling and so actuating the pointer (a 2" Rod 7). The extent of the movement of the latter over the graduated scale indicates the speed at which the vertical shaft rotates. A Spring secured to the  $5\frac{1}{2}$ " x  $2\frac{1}{2}$ " Flanged Plate is fixed by the Bolt 6 in such a manner that the pointer tends to return to its original position as the motion decreases.

Parts required :

2	of No.	2
4	" "	3
2	" "	4
6	" "	5
2	" "	8
4	" "	12
1	" "	13A
1	" "	16
2	" "	17
4	" "	18A
4	" "	20B
1	" "	21
2	" "	24
2	" "	26
1	" "	27A
1	" "	28
39	" "	37
8	" "	37A

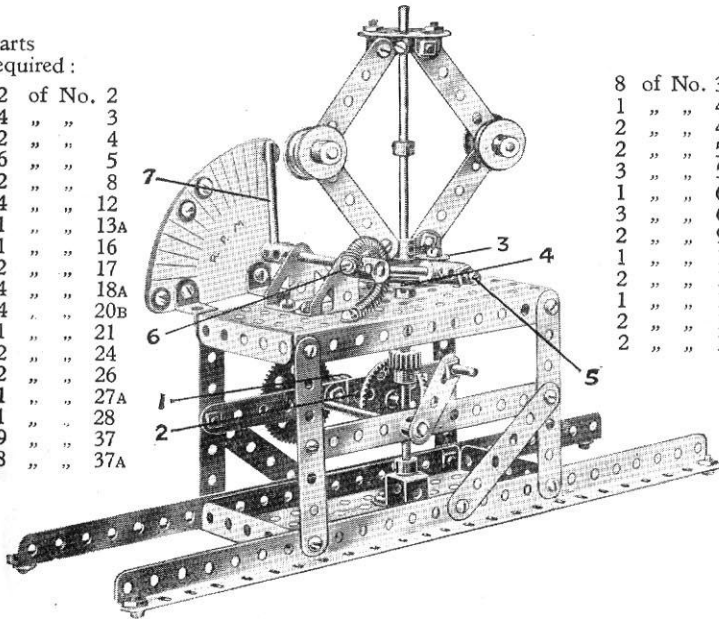

8	of No.	38
1	" "	43
2	" "	45
2	" "	52
3	" "	59
1	" "	62
3	" "	63
2	" "	90
1	" "	111
2	" "	111c
1	" "	115
2	" "	125
2	" "	126

## Model No. 4.20 Conductor's Punch

This is just the thing for your younger brother! He only needs a strap with which to hang it over his shoulder to make him into a conductor. The

Parts required :

3	of No.	5
1	" "	11
1	" "	15A
1	" "	22
9	" "	37
2	" "	38
1	" "	43
2	" "	53
1	" "	59

$2\frac{1}{2}$ " Strip at the bottom is spaced by two Washers away from the body of the punch to allow the ticket to pass in to be punched. The punch Rod is passed completely through the Spring. The lower end of the latter presses against the Double Bracket and the upper end against a Collar secured to the Rod.

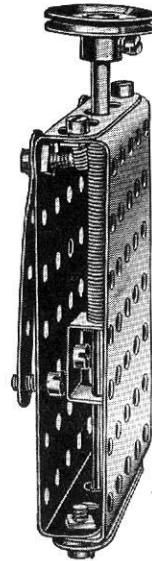

## Model No. 4.21 Automatic Saw

Parts required :

7	of No.	2
1	" "	3
3	" "	5
4	" "	8
1	" "	15
1	" "	15A
2	" "	16
1	" "	17
1	" "	19B
2	" "	22
2	" "	26
1	" "	28
1	" "	32
41	" "	37
3	" "	37A
2	" "	38
1	" "	45
2	" "	48
1	" "	48A
1	" "	52
3	" "	53
9	" "	59
24	" "	94
2	" "	108

1	of No.	109
1	" "	111c
2	" "	115
2	of No.	125
1	" "	159

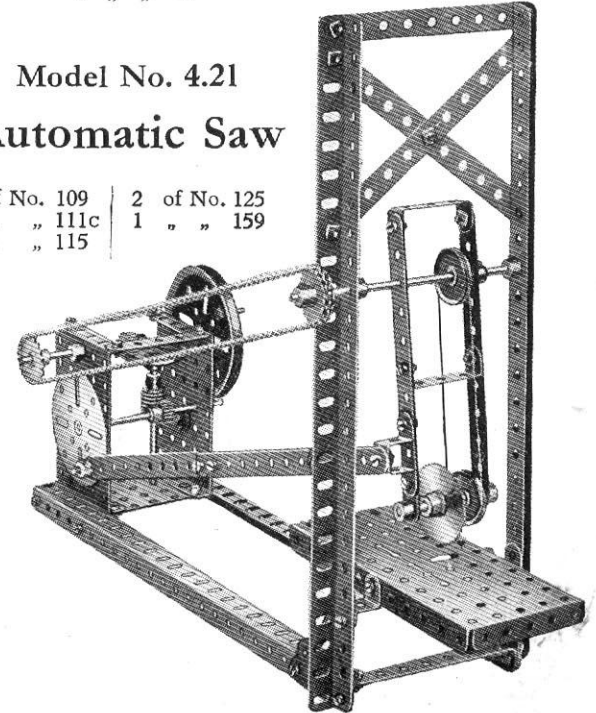

## Model No. 4.22 Diplodocus

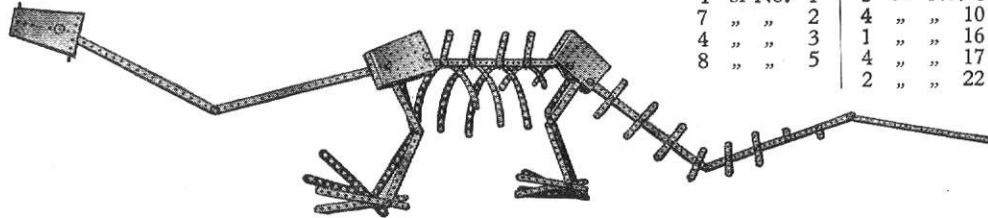

Parts required :

1 of No. 1	1 of No. 8	40 of No. 37
7 " " 2	4 " " 10	4 " " 53
4 " " 3	1 " " 16	2 " " 54
8 " " 5	4 " " 17	8 " " 59
	2 " " 22	

This representation of a prehistoric animal is a most extraordinary effort sent in by a young French boy to compete in one of the big Meccano Model-building Competitions. We could scarcely class it as an engineering model, but any boy with a brain clever enough and an imagination lively enough to conceive and construct such an animal as this from Meccano parts deserved a good prize, so we awarded him one. Screw the Nuts and Bolts up tightly because the Diplodocus looks most dejected when he droops.

## Model No. 4.23

## Clay Modelling Machine

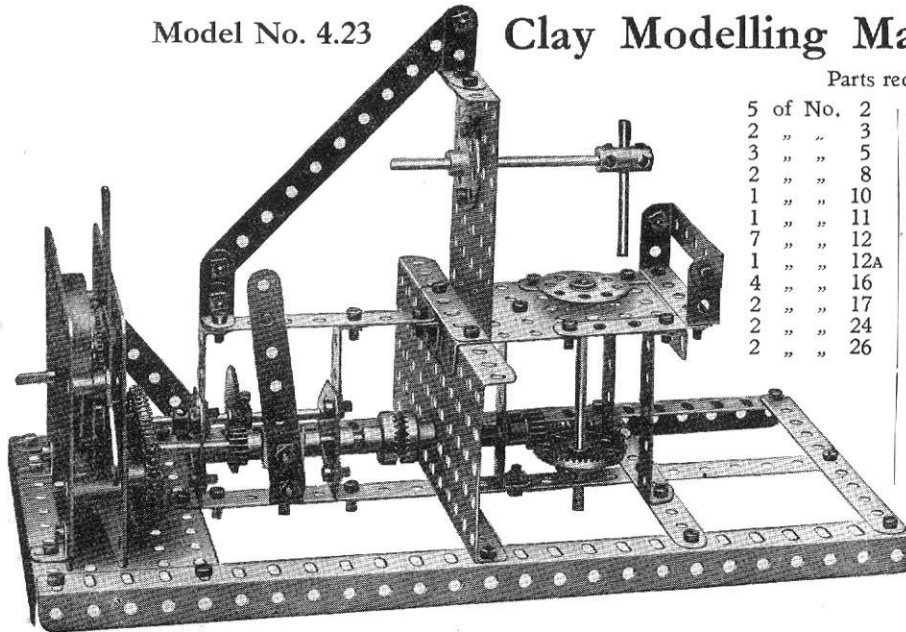

Parts required :

5 of No. 2	1 of No. 27A
2 " " 3	1 " " 28
3 " " 5	2 " " 29
2 " " 8	50 " " 37
1 " " 10	2 " " 37A
1 " " 11	2 " " 38
7 " " 12	1 " " 46
1 " " 12A	6 " " 48A
4 " " 16	2 " " 52
2 " " 17	2 " " 53
2 " " 24	4 " " 59
2 " " 26	1 " " 63
	6 " " 94
	2 " " 96
	2 " " 126A

Clockwork  
Motor  
(not included  
in Outfit)

## Model No. 4.24 Bale Press

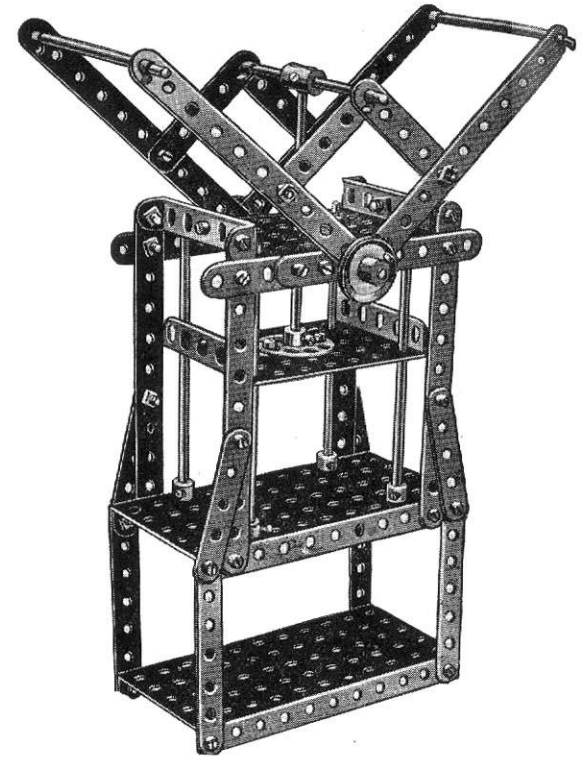

Parts required :

10 of No. 2	1 of No. 24	2 of No. 52
4 " " 3	8 " " 35	2 " " 53
8 " " 5	44 " " 37	4 " " 59
4 " " 15	14 " " 37A	1 " " 63
1 " " 15A	2 " " 38	2 " " 111
2 " " 17	2 " " 48A	

## Model No. 4.25 Weather Vane

Parts required :

7 of No. 1	54 of No. 37
11 " " 5	2 " " 38
8 " " 10	2 " " 52
4 " " 11	1 " " 54
17 " " 12	2 " " 59
1 " " 14	1 " " 109
1 " " 24	1 " " 126A

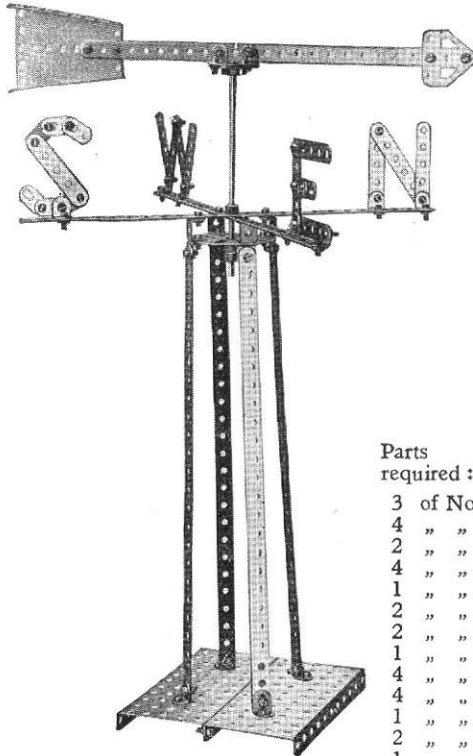

Parts required :

3 of No. 2	2 of No. 29	1 of No. 52	1 of No. 115
4 " " 3	45 " " 37	2 " " 53	1 " " 125
2 " " 5	4 " " 37A	2 " " 54	1 " " 126
4 " " 8	3 " " 38	6 " " 59	2 " " 126A
1 " " 15	1 " " 40	4 " " 111c	
1 " " 15A	1 " " 46		
2 " " 16	2 " " 48A		
1 " " 17	2 " " 48B		
4 " " 20B			
4 " " 22			
1 " " 24			
2 " " 26			
1 " " 27A			

## Model No. 4.26 Geometrical Apparatus

This most ingenious model for transforming a circular movement into a rectilinear movement was designed by M. Pierre-Th. Dufour, who used it in his Thesis (presented to the Faculty of Science in Paris) to obtain his degree of Doctor of the University of Paris. He required an instrument which would transform a circular movement into a movement rigorously rectilinear and he states in his published work that he was able to do this "with the aid of Meccano parts, which permit of making experiments so easily in mechanisms of the most varied types."

The point F is fixed, and is situated at a distance from the fixed point E, equal to AE, the two arms FB and FD being together equal to the four sides of the lozenge ABCD. The trajectory of the point C is then at right angles to EF. It will be found that whilst the point C is moving in a straight line at right angles to EF, the point A is describing a circle round the fixed point E.

Every Meccano Boy should make up this very interesting model and experiment with it.

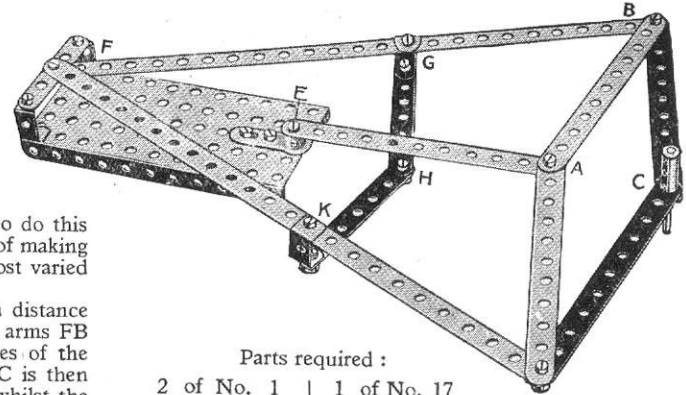

Parts required :

2 of No. 1	1 of No. 17
5 " " 2	16 " " 37
2 " " 3	1 " " 52
1 " " 5	7 " " 59
4 " " 11	1 " " 62
	1 of No. 63

## Model No. 4.27 Cable Railway

The reversing lever 1 is pivoted near its centre to a Reversed Angle Bracket and at its lower end to a  $2\frac{1}{2} \times 1$ " Double Angle Strip 2. This Strip is kept in place on the Rod 3 by two Collars. The two  $\frac{3}{4}$ " Contrate Wheels are fastened on this Rod in such a position that one or other can be brought into gear with a  $\frac{1}{2}$ " Pinion secured to the Rod 4 by moving the reversing lever. This Rod 4 is journaled in one of the side plates of the gear box and in a  $3\frac{1}{2} \times \frac{1}{2}$ " Double Angle Strip bolted between Plate 5 and the Strips.

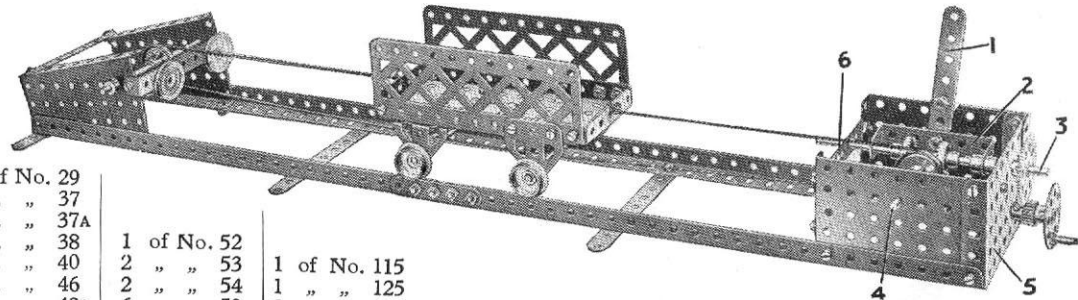

### Model No. 4.28 Motor Bus

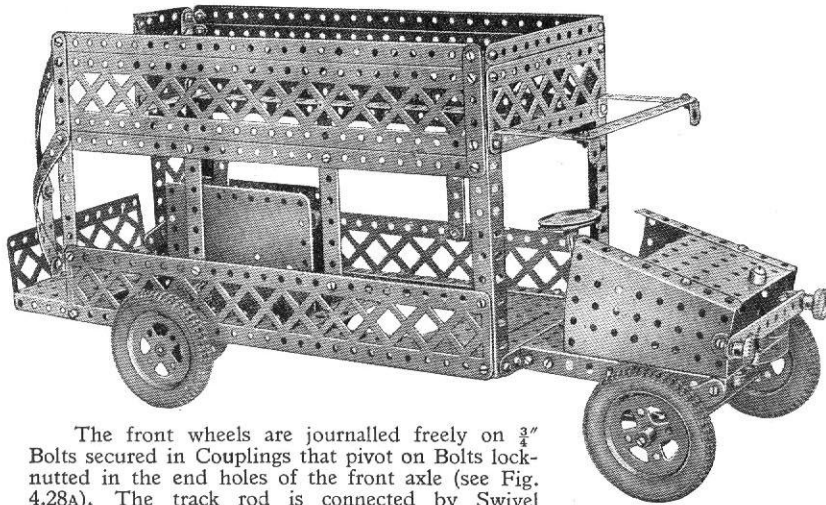

The front wheels are journalled freely on  $\frac{3}{4}$ " Bolts secured in Couplings that pivot on Bolts lock-nutted in the end holes of the front axle (see Fig. 4.28A). The track rod is connected by Swivel Bearings to the ends of Rods 1 and 2, which are secured in the inner transverse holes of the Couplings. Connection is made, in the manner shown, with a Crank 3 on the bottom end of the steering column and the Rod 2.

The front springs are represented by a pair of  $2\frac{1}{2}$ " small radius Curved Strips, to which the axle is attached by means of  $\frac{1}{2}$ " x  $\frac{1}{2}$ " Angle Brackets, the axle being spaced therefrom by a Collar on each Bolt.

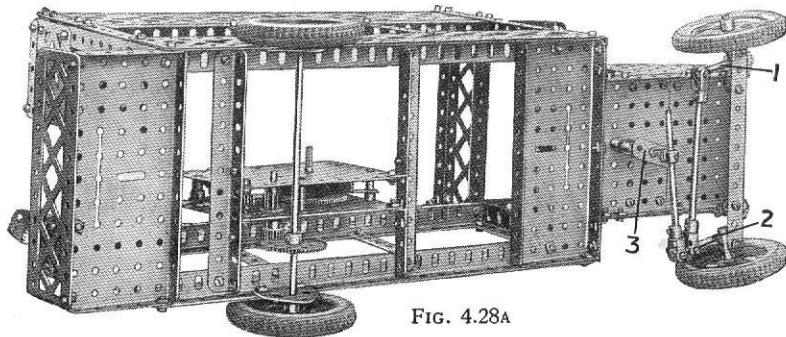

FIG. 4.28A

### Model No. 4.29 Automatic Gong

Parts required :

2	of No.	1
9	" "	2
1	" "	2A
4	" "	3
4	" "	4
2	" "	5
4	" "	8
4	" "	9
3	" "	10
14	" "	12
2	" "	12A
1	" "	14
1	" "	15A
2	" "	16
1	" "	17
1	" "	18A
4	" "	20A
1	" "	21
1	" "	26
1	" "	27A
2	" "	29
98	" "	37
4	" "	37A
3	" "	38
3	" "	48A
2	" "	52
3	" "	53
2	" "	54
5	" "	59
1	" "	62
2	" "	63
2	" "	90A
1	" "	98
4	" "	99
3	" "	100
3	" "	111
3	" "	111c
1	" "	116A
1	" "	125
2	" "	126A
4	" "	142A
1	" "	147B
2	" "	165

Clockwork Motor  
(not included in Outfit)

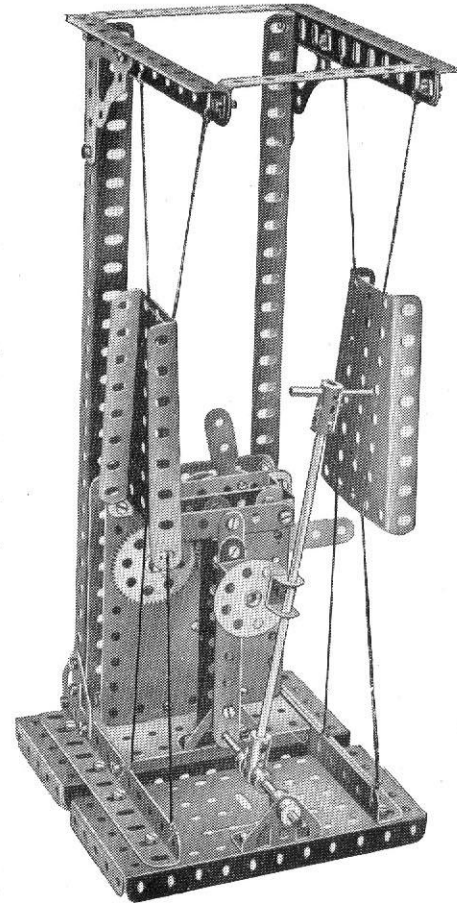

Parts required :

2	of No.	2A
2	" "	5
2	" "	8
4	" "	9
3	" "	11
1	" "	12
1	" "	14
1	" "	16
1	" "	17
1	" "	18A
1	" "	24
1	" "	26
1	" "	27A
45	" "	37
2	" "	37A
2	" "	38
1	" "	40
1	" "	45
2	" "	48B
2	" "	52
1	" "	53
2	" "	54
4	" "	59
2	" "	63
2	" "	108
1	" "	111c
2	" "	125
2	" "	126
2	" "	126A

Clockwork Motor  
(not included in Outfit)

## Model No. 4.30 Searchlight

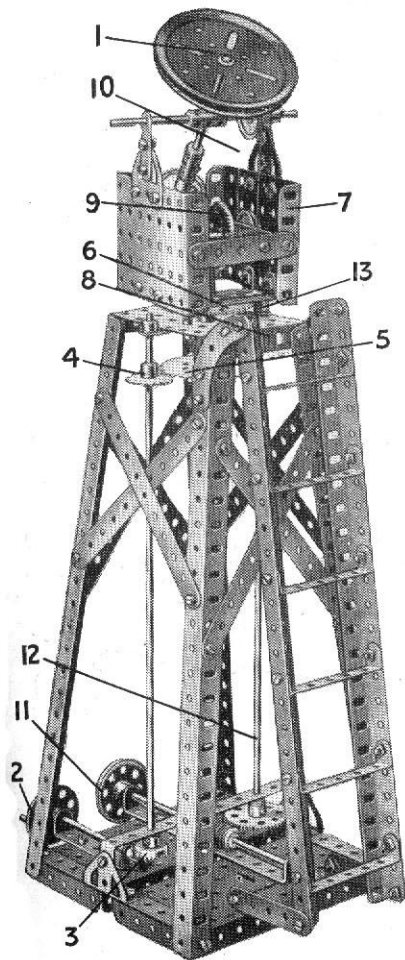

Parts required :

10 of No. 2	1 of No. 21	1 of No. 48B
1 " " 3	3 " " 22	2 " " 48D
4 " " 5	2 " " 24	2 " " 52
2 " " 6A	2 " " 26	3 " " 53
6 " " 8	1 " " 27A	4 " " 59
2 " " 12	1 " " 28	2 " " 63
2 " " 13	1 " " 29	2 " " 95
1 " " 14	1 " " 32	2 " " 96
3 " " 16	86 " " 37	2 " " 115
2 " " 17	7 " " 38	2 " " 126
1 " " 19B	1 " " 45	2 " " 126A
	9 " " 48A	

The elevation of the searchlight 1 is controlled by the hand wheel 2, the motion of which is transmitted by means of a  $\frac{1}{2}$ " Pinion and  $\frac{3}{4}$ " Contrate Wheel 3 and 1" Sprocket Wheel 4 to a 2" Sprocket Wheel 5. The latter is secured to a vertical Rod that is free to revolve in the boss of a second 2" Sprocket Wheel 6 bolted to two  $2\frac{1}{2}$ " x  $\frac{1}{2}$ " Double Angle Strips, which in turn, are secured in the base of the rotating frame 7. This vertical Rod is journaled in a Double Bent Strip that is bolted beneath the Plate 8 to form an additional support, and it carries at its upper end a  $\frac{1}{2}$ " Pinion that engages with the  $\frac{1}{2}$ " Contrate Wheel 9. The motion of the Contrate 9 is transmitted to the pivotal Rod of the searchlight by means of the Pulleys and cord 10. The searchlight is rotated by the second hand wheel 11, the drive from which is transmitted through Worm gearing to the vertical Rod 12, the upper end of which carries a 1" Sprocket Wheel 13, that engages with the 2" Sprocket Wheel 6.

## Model No. 4.31 Alternating Swing



Parts required :

3 of No. 1	4 of No. 12	10 of No. 48A	4 of No. 90A
8 " " 2	2 " " 14	2 " " 48D	3 " " 99
2 " " 4	2 " " 24	2 " " 54	1 " " 111c
9 " " 5	2 " " 26	9 " " 59	1 " " 115
2 " " 6A	72 " " 37	2 " " 62	
8 " " 8	3 " " 37A	4 " " 90	

Clockwork Motor  
(not included in Outfit)



## Model No. 4.33 Tipping Motor Wagon

Parts required :

2	of No. 2	2	of No. 17	2	of No. 100
2	" " 2A	4	" " 18A	4	" " 111c
6	" " 3	4	" " 19B	1	" " 115
12	" " 5	1	" " 21	2	" " 125
2	" " 6A	2	" " 22	2	" " 126
2	" " 8	2	" " 24	2	" " 126A
5	" " 10	1	" " 26		
15	" " 12	1	" " 28		
2	" " 12A	8	" " 35		
4	" " 15A	89	" " 37		
		4	" " 37A		
		14	" " 38		
		2	" " 45		
		2	" " 48		
		1	" " 48B		
		1	" " 52		
		2	" " 53		
		2	" " 54		
		10	" " 59		
		2	" " 62		
		4	" " 63		
		1	" " 80A		
		2	" " 90A		
		1	" " 98		

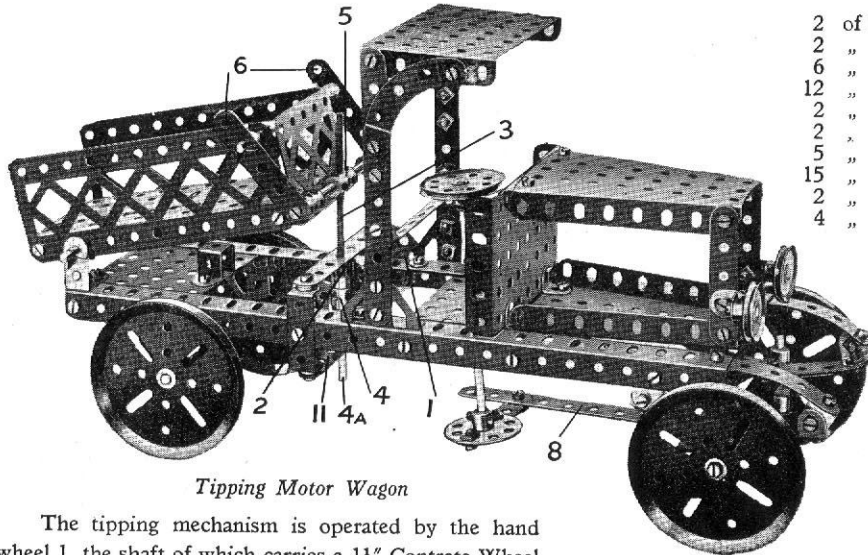

*Tipping Motor Wagon*

The tipping mechanism is operated by the hand wheel 1, the shaft of which carries a  $1\frac{1}{2}$ " Contrate Wheel that engages with the  $\frac{1}{2}$ " Pinion 2. The  $3\frac{1}{2}$ " Threaded Rod 3, to which the Pinion 2 is secured, is journaled in one end of a Coupling 4 and passes through the central threaded bore of a second Coupling 5, which is mounted between the ends of two short Rods that are free to turn on Bolts passed through  $2\frac{1}{2}$ " Strips 6. These Strips 6 are attached pivotally to the body of the lorry. The short Rod 4A passes through the  $3\frac{1}{2}$ " Strip 11 and is secured in the lower end of the Coupling 4, the centre transverse hole of which forms a bearing for the Rod of the hand wheel 1.

The steering gear is shown in Fig. 4.33A. The  $2\frac{1}{2}$ " Strip 7 is pivoted to the Strip 8, but is secured rigidly at right-angles to the Crank 9. The Crank 9A is made to move simultaneously with the Crank 9 by means of the tie-rod 10. The front road wheels are mounted on  $\frac{3}{4}$ " Bolts secured in Collars 12.

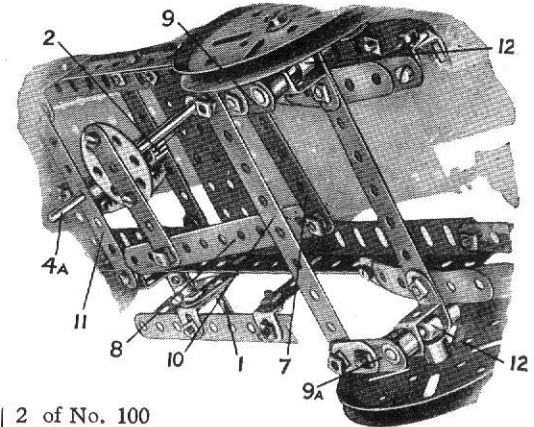

FIG. 4.33A

## Model No. 4.34 Sextant and Theodolite

Parts required :

1	of No. 1	1	of No. 21
2	" " 2	1	" " 22
2	" " 11	8	" " 37
2	" " 12	1	" " 52
1	" " 16	4	" " 59
1	" " 17	3	" " 63
2	" " 18A	1	" " 65

Cardboard for Quadrants  
(not included in Outfit)

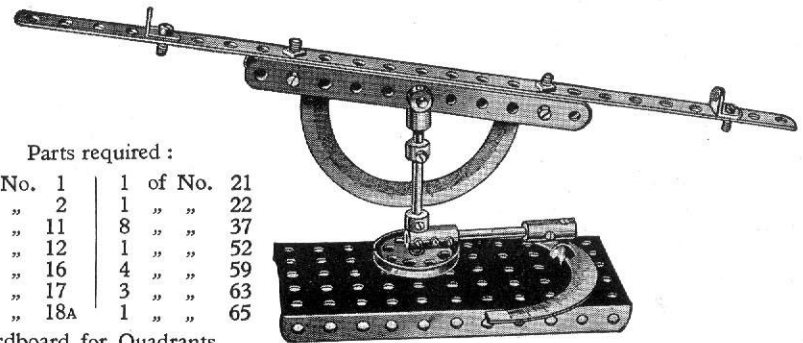

## Model No. 4.35 Potato Chopper

The levers 1 and 2 are secured at right angles to each other by means of two Flat Trunnions. The lever 2 pivots about a short rod journalled in the tops of the  $5\frac{1}{2}$ " Strips 3. The Cranks 4 and 5 are bolted to the  $3\frac{1}{2} \times 2\frac{1}{2}$ " Flanged Plate 6 and are free to ride up and down the vertical Axle Rods 7 and 8.

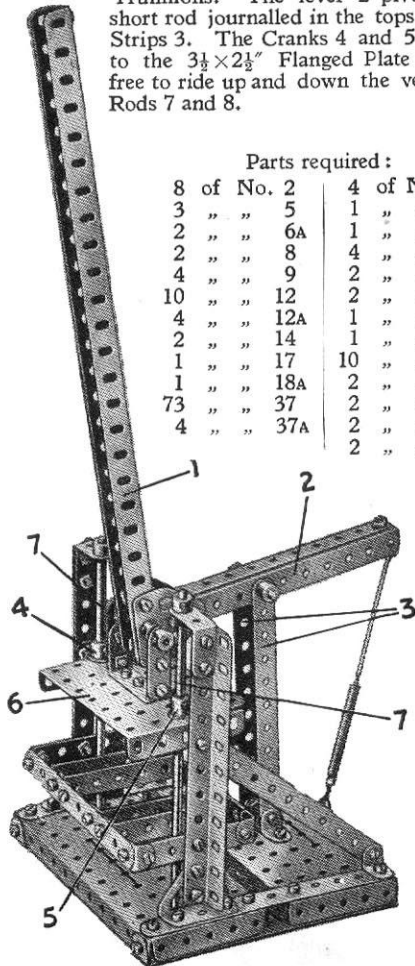

### Parts required :

8 of No. 2	4 of No. 38
3 " " 5	1 " " 40
2 " " 6A	1 " " 43
2 " " 8	4 " " 48A
4 " " 9	2 " " 48D
10 " " 12	2 " " 52
4 " " 12A	1 " " 53
2 " " 14	1 " " 57C
1 " " 17	10 " " 59
1 " " 18A	2 " " 62
73 " " 37	2 " " 111C
4 " " 37A	2 " " 126
	2 " " 126A

## Model No. 4.36 Mechanical Cross Bow

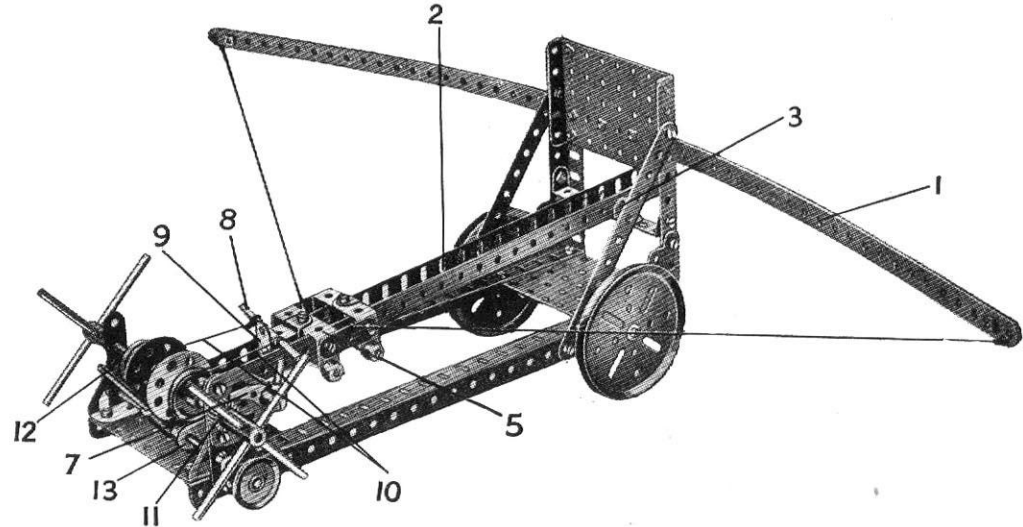

This model represents a large military weapon of the type used before the invention of gunpowder. It is built on the principle of the crossbow. Each side of the bow 1 is composed of three  $12\frac{1}{2}$ " Strips bolted together, the centre being strengthened by three  $2\frac{1}{2}$ " Strips. The trough 2, which is formed from two  $12\frac{1}{2}$ " Angle Girders, is held loosely between a pair of Angle Brackets 3, and its rear end is secured to a Double Bent Strip bolted to the  $3\frac{1}{2} \times 2\frac{1}{2}$ " Flanged Plate. The carriage 5 is composed of four  $1" \times 1"$  Angle Brackets joined by a pair of  $1\frac{1}{2}$ " Strips and guided by two  $\frac{1}{2} \times \frac{1}{2}$ " Angle Brackets. A Double Bracket is bolted to one of the latter, and carries in its turn a Flat Bracket 9. When the handles are turned in an anti-clockwise direction, the Cord 10 draws the carriage back, and are prevented from unwinding by the Pawl 7 engaging a  $\frac{1}{2}$ " Pinion Wheel 11. When the lever 12 is depressed, the ends of a pair of  $2\frac{1}{2}$ " Strips bolted to Cranks 13 lift the 2" Rod 8 off the Flat Bracket 9. This releases the carriage, and the projectile (a marble) is shot out of the trough 2 with considerable force.

### Parts required :

6 of No. 1	53 of No. 37
7 " " 5	2 " " 37A
2 " " 6A	5 " " 38
4 " " 8	1 " " 40
2 " " 9	1 " " 45
1 " " 10	1 " " 48
1 " " 11	1 " " 48B
4 " " 12	3 " " 53
4 " " 12A	4 " " 59
1 " " 15	2 " " 62
3 " " 15A	3 " " 63
4 " " 16	2 " " 108
4 " " 17	2 " " 111
2 " " 19B	1 " " 115
4 " " 22	2 " " 126
2 " " 24	1 " " 126A
1 " " 26	1 " " 147A
1 of No. 147B	



## Model No. 4.37 Stephenson's "Rocket" Locomotive

The chimney is attached at its lower end to two Trunnions 1 that are bolted to the front of the boiler. A  $1\frac{1}{2}$ " Strip 2 held in place by a  $\frac{1}{2}$ "  $\times$   $\frac{1}{2}$ " Angle Bracket closes in the space between the Trunnions at the bottom, and a  $\frac{1}{2}$ "  $\times$   $\frac{1}{2}$ " Angle Bracket 3 performs a similar function at the top.

The trailing wheels are secured on an axle that is journalled in  $2\frac{1}{2}$ " Strips attached to the bottom extremities of the  $2\frac{1}{2}$ " Strips 4. The rearmost ends of the horizontal Strips are secured by Flat Brackets. The upper ends of the Strips 4 serve as mountings for the cylinders, which are secured rigidly thereon by  $\frac{3}{8}$ " Bolts, on each of which are four Washers between the cylinder and the Strip.

### Parts required

8 of No. 2	10 of No. 12	56 of No. 37	1 of No. 111
4 " " 3	4 " " 16	8 " " 37A	5 " " 111c
2 " " 4	2 " " 17	8 " " 38	1 " " 116A
11 " " 5	2 " " 19B	1 " " 40	2 " " 126
1 " " 6A	4 " " 20	9 " " 48A	1 " " 162
2 " " 9	2 " " 20A	2 " " 52	2 " " 163
6 " " 10	4 " " 20B	1 " " 57c	1 " " 164
	1 " " 22A	2 " " 59	1 " " 166
		1 " " 109	

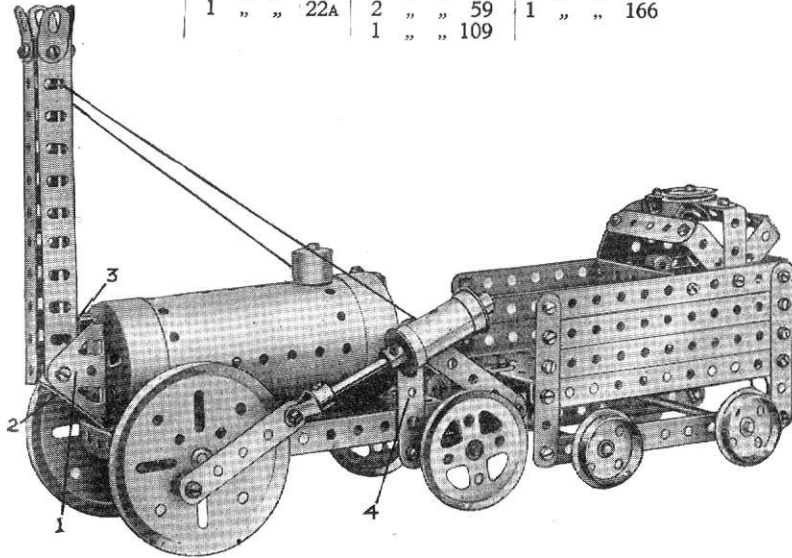

## Model No. 4.38 Girder Crane

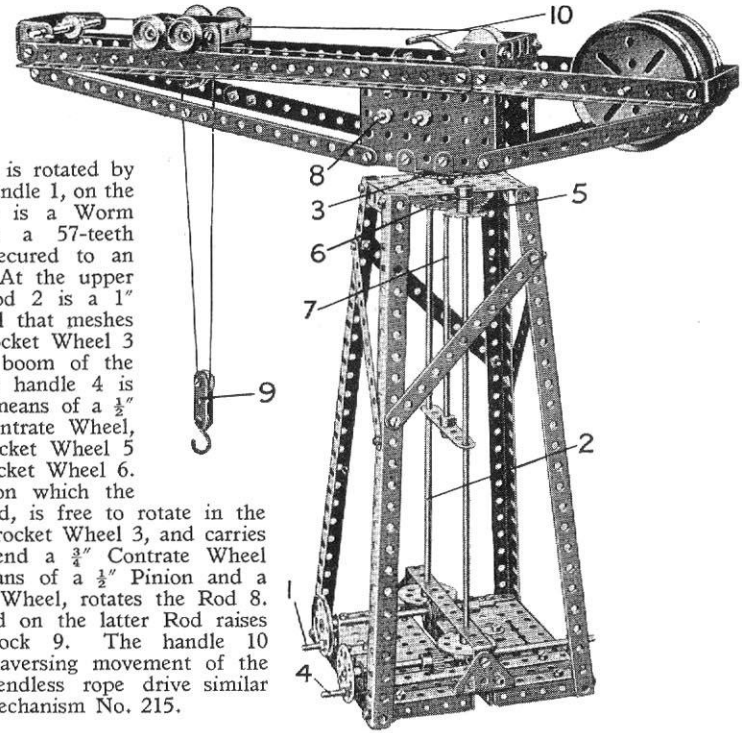

The boom is rotated by means of the handle 1, on the axle of which is a Worm engaging with a 57-teeth Gear Wheel secured to an  $11\frac{1}{2}$ " Rod 2. At the upper end of the Rod 2 is a 1" Sprocket Wheel that meshes with a 2" Sprocket Wheel 3 bolted to the boom of the crane. The handle 4 is connected by means of a  $\frac{1}{2}$ " Pinion,  $1\frac{1}{2}$ " Contrate Wheel, and a 1" Sprocket Wheel 5 to the 2" Sprocket Wheel 6. The Rod 7, on which the latter is secured, is free to rotate in the boss of the Sprocket Wheel 3, and carries at its upper end a  $\frac{3}{4}$ " Contrate Wheel which, by means of a  $\frac{1}{2}$ " Pinion and a 57-teeth Gear Wheel, rotates the Rod 8. A Cord wound on the latter Rod raises the pulley block 9. The handle 10 controls the traversing movement of the trolley by an endless rope drive similar to Standard Mechanism No. 215.

### Parts required :

12 of No. 2	1 of No. 15A	2 of No. 27A	2 of No. 48b
2 " " 3	4 " " 16	1 " " 28	2 " " 52
2 " " 5	3 " " 17	1 " " 29	3 " " 53
2 " " 6A	4 " " 19B	1 " " 32	1 " " 57c
6 " " 8	1 " " 19s	8 " " 35	9 " " 59
2 " " 9	4 " " 20B	76 " " 37	2 " " 90A
9 " " 10	1 " " 21	5 " " 37A	2 " " 95
2 " " 12A	2 " " 22	2 " " 38	2 " " 96
2 " " 13	2 " " 22A	1 " " 40	2 " " 103F
1 " " 13A	2 " " 23	2 " " 46	4 " " 111c
1 " " 14	2 " " 24	2 " " 48	2 " " 115
	2 " " 26	4 " " 48A	2 " " 126

## Model No. 4.39 Motor Lorry

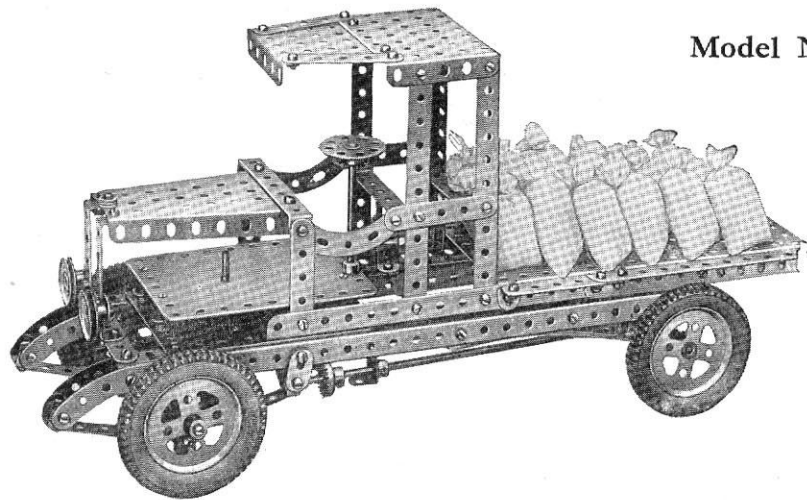

Parts required :			
6 of No. 2	1 of No. 13A	1 of No. 29	6 of No. 63
2 " " 2A	1 " " 15	95 " " 37	4 " " 90
5 " " 3	1 " " 15A	14 " " 37A	2 " " 90A
2 " " 4	1 " " 16	15 " " 38	2 " " 111
1 " " 5	3 " " 17	1 " " 48	6 " " 111C
11 " " 6A	4 " " 18A	2 " " 48A	1 " " 115
6 " " 8	4 " " 20A	3 " " 48B	1 " " 116A
4 " " 9	2 " " 22	5 " " 53	1 " " 125
4 " " 10	1 " " 24	1 " " 54	4 " " 142A
4 " " 11	2 " " 26	10 " " 59	1 " " 147B
8 " " 12	1 " " 28	1 " " 62	2 " " 165

Clockwork Motor and  
Meccano Loaded Sacks  
(not included in outfit)

The front wheels are mounted on  $\frac{3}{4}$ " Bolts, which form the stub axles and are secured in Couplings 1 (Fig. 4.39A). Each of the latter carries in its centre transverse hole a  $1\frac{1}{2}$ " Rod 2, which is passed through the end holes of two  $4\frac{1}{2}$ " Strips laid one upon the other, and loosely clamped in place by Collars. The end transverse holes of the Couplings hold the Rods 3 and 4 which are connected pivotally together at their ends by Swivel Bearings and two short Rods joined by a Coupling. A 2" Rod 5 is held in another Coupling on the Rod 4 and is connected by means of a Swivel Bearing and  $3\frac{1}{2}$ " Rod to a Crank on the lower end of the steering column. A Pivot Bolt is passed through the end transverse hole of the Coupling on the  $3\frac{1}{2}$ " Rod and is secured to the Crank by two Nuts.

The bonnet is attached pivotally to the body by Bolts 6 and lock-nuts so that it may be raised to allow the winding key of the Motor to be inserted. The shanks of the Bolts 10 enter the top holes of the  $2\frac{1}{2}$ " Double Angle Strips in the front of the chassis, but they are not secured to the Strips.

FIG. 4.39B

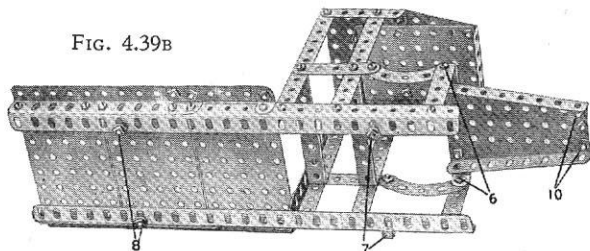

The complete body shown in Fig. 4.39B can be detached from the chassis (Fig. 4.39A) by undoing the  $\frac{3}{8}$ " Bolts 7 and 8, which are passed through holes in the Angle Girders of the chassis and spaced therefrom by Washers. The Bolts 7 are inserted in the hole marked 9 (Fig. 4.39A) and the corresponding hole in the other side Girder, whilst Bolts 8 are passed through the end holes but one of the two side Girders.

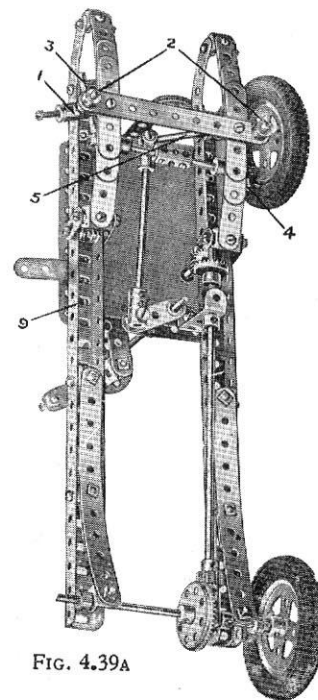
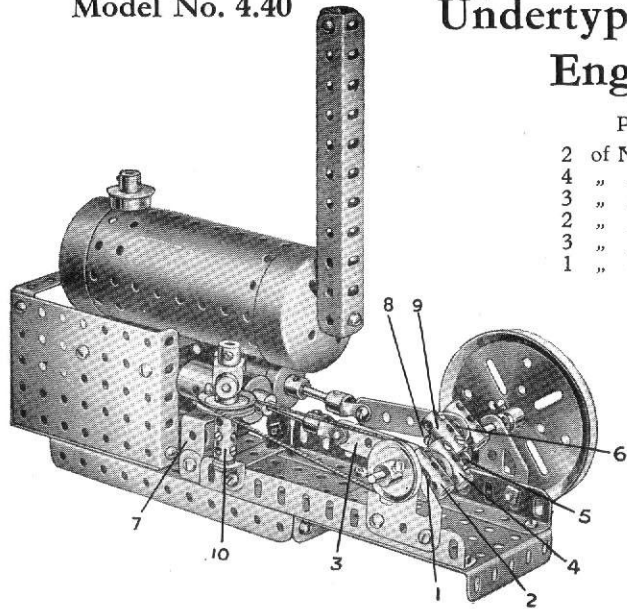

FIG. 4.39A

Model No. 4.40

# Undertype Steam Engine



Parts required :

2 of No. 5	3 of No. 20B
4 " " 9	2 " " 22
3 " " 12	40 " " 37
2 " " 17	4 " " 37A
3 " " 18A	6 " " 38
1 " " 19B	1 " " 40
	1 " " 46
	4 " " 48A
	1 " " 52
	4 " " 53
	4 " " 59
	5 " " 63
	2 " " 111
	4 " " 111c
	2 " " 115
	1 " " 116
	1 " " 116A
	2 " " 126A
	1 " " 162
	2 " " 163
	1 " " 166

The crankshaft is built up of four Couplings joined together by  $\frac{3}{4}$ " Bolts. A  $\frac{3}{4}$ " Bolt 1 is passed through the centre threaded hole of the Coupling 2 and screwed up as tightly as possible. The connecting Rod 3 is now slipped on and spaced by two Washers, one on each side of the Strip, after which the Coupling 4 is screwed on to the Bolt 1 so that the connecting Rod revolves easily in the intervening space. A  $\frac{3}{4}$ " Bolt 5 is next screwed into the Coupling 4 until it strikes the end of Bolt 1. The second crank is assembled in the same way—that is, a  $\frac{3}{4}$ " Bolt is passed through the centre threaded holes of two Couplings—but two Washers are placed at 6 and a  $\frac{3}{8}$ " Bolt 8 is inserted in the Coupling 9 in the same way as the Bolt 5 in Coupling 4. A  $\frac{3}{4}$ " Bolt is now passed through the inner transverse hole of Coupling 9 and through the corresponding hole in Coupling 4, and is gripped securely by the set-screws of both Couplings. The whole crankshaft is held rigid by the  $\frac{3}{8}$ " Bolts, for the head of Bolt 5 engages with the hole in the end of Coupling 9 whilst the head of Bolt 8 engages the end of Coupling 4.

Two 2" Rods are used for the ends of the crankshaft, one carrying a 3" Pulley to represent a flywheel and the other a 1" Pulley round which a length of cord is passed which takes the drive to a 1" Pulley on the centrifugal governor. The latter is built up from a Large Fork Piece with Collars attached by means of  $\frac{3}{8}$ " Bolts, to represent the governor weights. The Fork Piece and 1" Pulley are attached to a  $1\frac{1}{2}$ " Rod that turns in the top of the Coupling 9, which is secured on a Threaded Pin and attached to the base by an Angle Bracket.

The cylinders are composed of two Sleeve Pieces, each fitted with one  $\frac{3}{4}$ " Flanged Wheel, and are bolted to a  $2\frac{1}{2}$ " x 1" Double Angle Strip 7.

Model No. 4.41

# Bale Lifter

The bale platform 1, consisting of a  $2\frac{1}{2}$ " x  $5\frac{1}{2}$ " Flanged Plate, is raised by a Crank Handle 2, operating a Pinion 3 which engages with a 57-teeth Wheel 4 on a Rod 5. This Rod carries the Cord 6, passing over a Pulley 7, in the head of the frame-work, round a  $\frac{3}{4}$ " Bolt 8, pivoted in a Double Bent Strip bolted to the Plate 9, up over another Pulley 10, and made fast to the Plate 9. The  $2\frac{1}{2}$ " x  $5\frac{1}{2}$ " Flanged Plate 1 is connected to the Plate 9 by 1" Angle Brackets, and the Plates 1 and 9 thus slide together in the vertical framework formed by 12 $\frac{1}{2}$ " Angle Girders doubled.

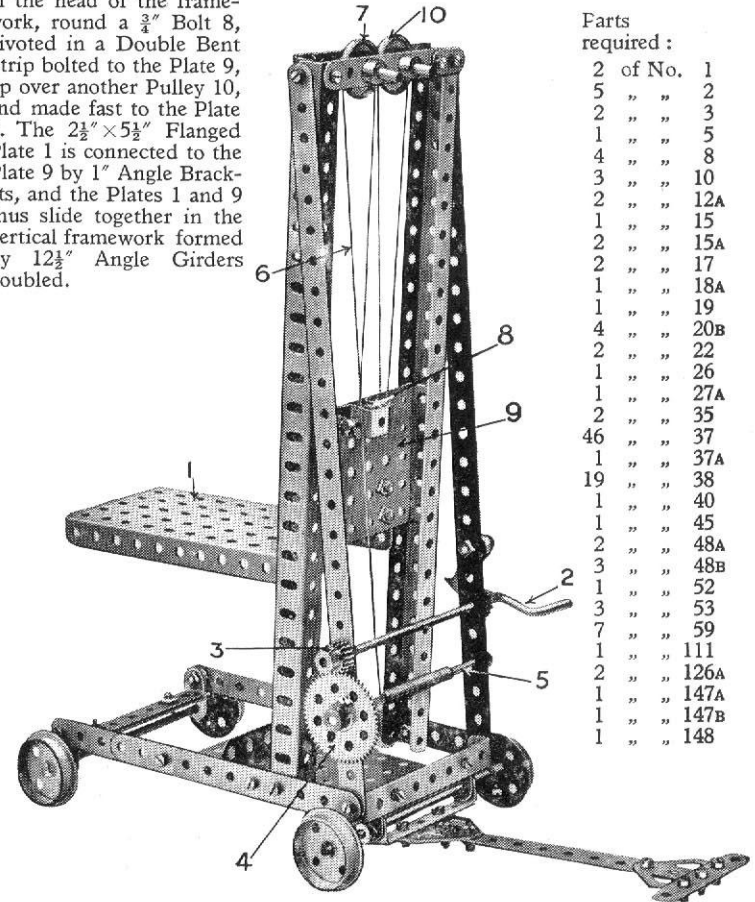

Parts required :

2 of No. 1	1
5 " " 2	2
2 " " 3	3
1 " " 5	5
4 " " 8	8
3 " " 10	10
2 " " 12A	12A
1 " " 15	15
2 " " 17	17
1 " " 18A	18A
2 " " 19	19
1 " " 20B	20B
4 " " 22	22
2 " " 26	26
1 " " 27A	27A
2 " " 35	35
46 " " 37	37
1 " " 37A	37A
19 " " 38	38
1 " " 40	40
1 " " 45	45
2 " " 48A	48A
3 " " 48B	48B
1 " " 52	52
3 " " 53	53
7 " " 59	59
1 " " 111	111
2 " " 126A	126A
1 " " 147A	147A
1 " " 147B	147B
1 " " 148	148

## Model No. 4.42 Power Press

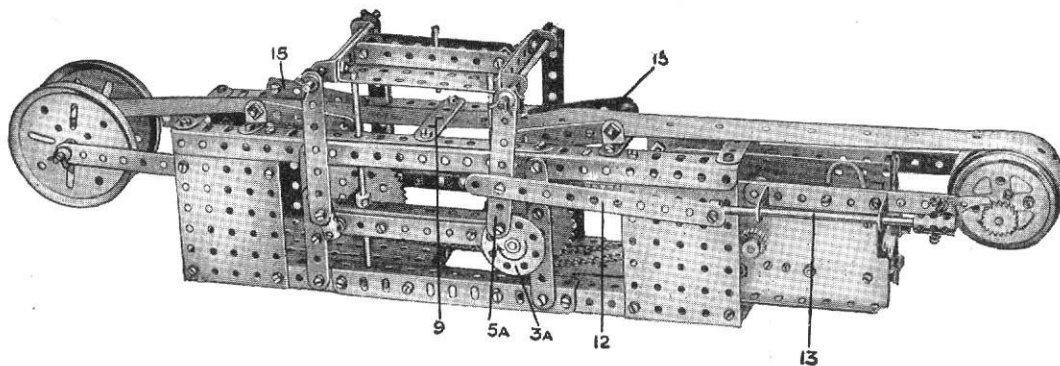

The model shown in the illustration represents a type of automatic press used in factories for stamping out small metal parts. Although the model does not stamp out steel parts, it will cut neat round holes at equal distances in a strip of paper with great rapidity.

The drive from the Electric Motor is transmitted via the  $\frac{1}{2}$ " Pinion on the armature shaft to a 57-teeth Gear on the Rod 1A, and from another  $\frac{1}{2}$ " Pinion on this Rod to a second 57-teeth Gear on the Rod 1. Two 1" Sprocket Wheels on the latter Rod are connected by Sprocket Chain to 2" Sprocket Wheels on the "crankshafts" 2. One crankshaft is formed from a  $3\frac{1}{2}$ " Rod and two Bush Wheels 3, 3A, and the other from a  $3\frac{1}{2}$ " Rod carrying two Couplings 4 placed at exactly similar angles. Four Strips 5, which form connecting links between the "die platten" 6 and the crankshafts, are lock-nutted to the Bush Wheels and attached pivotally to the Couplings by  $\frac{3}{8}$ " Bolts. They are pivoted to the die platten by means of two  $4\frac{1}{2}$ " Rods and retained in place by Spring Clips.

The  $3\frac{1}{2} \times 2\frac{1}{2}$ " Flanged Plate forming the die platten is strengthened with two  $3\frac{1}{2}$ " Strips 7 bolted to the Plate by Double Brackets. The die 8, a  $1\frac{1}{2}$ " Rod, is secured rigidly to the platten by means of a Crank. Two  $2\frac{1}{2}$ " Strips 9 bolted to the frame of the model and spaced apart by Washers form the "sink" through which passes the paper strip. Guides 15 are provided to keep the material in correct alignment.

The feed drum is composed of two Boiler Ends attached to the Rod 10 by means of

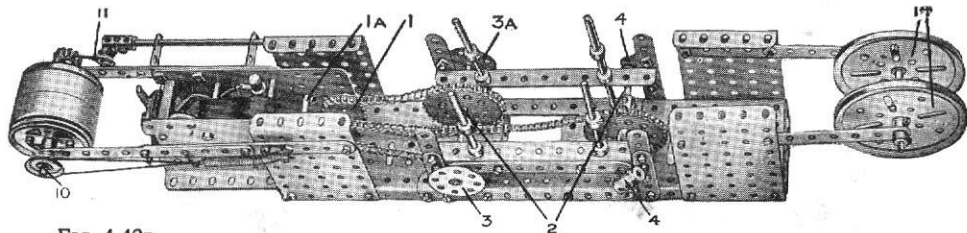

FIG. 4.42B

### Parts required :

8 of No. 2	1 of No. 46
2 " " 2A	2 " " 48
6 " " 3	2 " " 48A
18 " " 5	2 " " 52
2 " " 8	5 " " 53
4 " " 9	10 " " 59
2 " " 11	1 " " 62
1 " " 15	3 " " 63
5 " " 15A	30" " " 94
5 " " 16	2 " " 95
2 " " 17	2 " " 96
1 " " 18A	2 " " 111c
2 " " 19B	1 " " 147A
2 " " 20A	1 " " 147B
2 " " 24	1 " " 148
1 " " 26	2 " " 162A
2 " " 27A	
13 " " 35	Electric Motor
102 " " 37	(Not included
19 " " 38	in outfit)
1 " " 43	

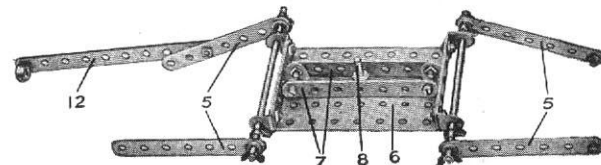
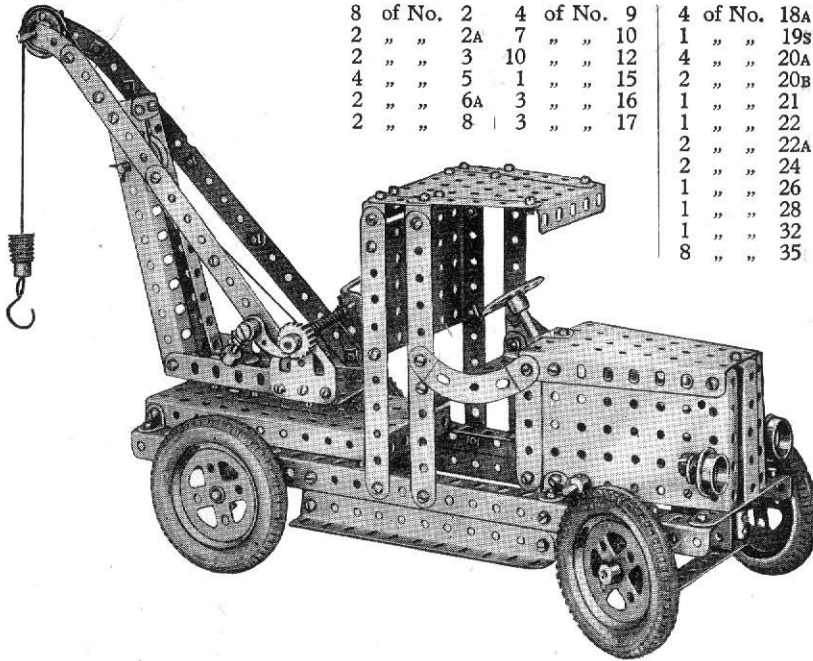

FIG. 4.42A

two 2" Pulleys. At one end of this Rod is affixed a 1" Pulley on which works a spring-controlled brake, and on the other end is attached a Ratchet Wheel that engages with a Pawl 11, which is retained in constant engagement by means of a piece of Spring Cord or elastic. The Pawl is attached to a  $4\frac{1}{2}$ " Rod 13 by means of a Coupling and the Rod is pivotally connected by a  $5\frac{1}{2}$ " Strip 12 to the Strip 5A.

The arrow on the Bush Wheel 3A shows the direction of travel, this being very important as the feed drum must only turn when the die platten is at the top of its stroke. The paper to be stamped is first wound on to the drum 14, then passed through the guides 15 and through the guide 9 and its end is stuck to the feed drum at the other end of the model.

## Model No. 4.43 Motor Breakdown Crane



Parts required:

8	of No.	2	4	of No.	9	4	of No.	18A	94	of No.	37
2	"	"	2A	7	"	"	1	"	7	"	38
2	"	"	3	10	"	"	4	"	1	"	40
4	"	"	5	1	"	"	2	"	2	"	48
2	"	"	6A	3	"	"	1	"	1	"	48A
2	"	"	8	3	"	"	1	"	3	"	48B
							2	"	1	"	52
							2	"	4	"	53
							1	"	2	"	54
							1	"	1	"	57C
							1	"	10	"	59
							8	"	1	"	62
									3	"	63
									2	"	77
									2	"	90
									2	"	90A
									4	"	111C
									1	"	115
									1	"	116A
									2	"	126A
									4	"	142A
									1	"	147A
									1	"	147B
									1	"	148
									2	"	165

Bearings for the steering column 1 (Fig. 4.43A) are formed by a Flat Bracket and Coupling 2. A  $3\frac{1}{2}$ " Rod passes through the centre transverse hole of the latter and carries a  $1\frac{1}{2}$ " Contrate Wheel which is spaced by means of three Washers from the Coupling. The teeth of the Contrate are engaged by a  $\frac{1}{2}$ " Pinion on the Rod 1. The Crank 3 carries a Flat Bracket bolted so that its round hole is over the elongated perforation of the Crank, and a Bolt passed through both is screwed into the tapped bore of a Collar on a 2" Rod. This Rod is attached pivotally to the inner end of a stub axle by means of a swivel bearing formed from a Collar and Small Fork Piece.

The front road wheels rotate freely on the  $1\frac{1}{2}$ " Rods, and are held in position by Collars. The Couplings 4 are pivoted by means of  $\frac{3}{4}$ " Bolts to the extremities of two  $4\frac{1}{2}$ " Strips that are bolted together face to face to form the front axle. Two  $1\frac{1}{2} \times \frac{1}{2}$ " Double Angle Strips 5 secure the  $4\frac{1}{2}$ " Strips to the side Girders of the model.

## Model No. 4.44 Opisometer

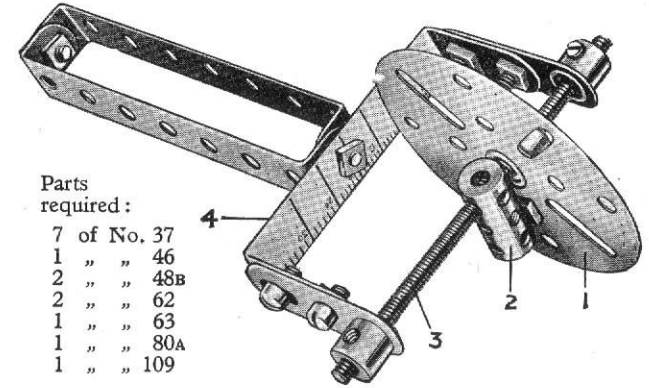

Parts required:

7	of No.	37
1	"	46
2	"	48B
2	"	62
1	"	63
1	"	80A
1	"	109

This instrument can be put to practical use for measuring curved lines, the perimeter of bodies, map routes, etc. The Face Plate 1 is free on the Screwed Rod 3, but is attached by a Bolt to a Coupling 2, the end transverse tapped hole of which engages with the thread of the Rod. The scale 4 may be graduated by running the Face Plate along a line of given length and marking its position in relation to the scale for every inch. The Screwed Rod is of course immovable, being gripped by the set-screws of the two Cranks.

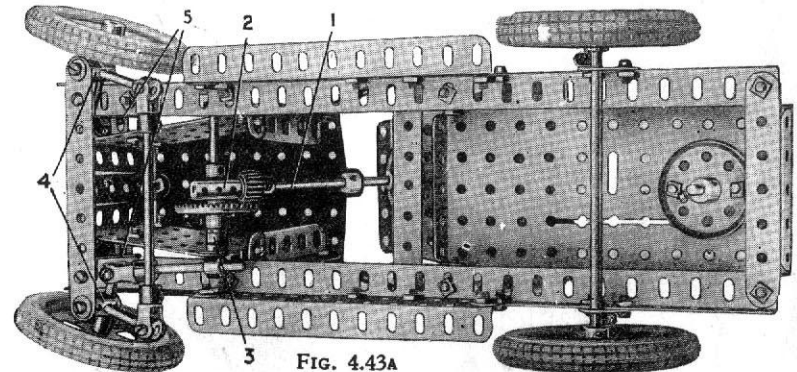

FIG. 4.43A

This Model can be built with MECCANO Outfit No. 4 (or No. 3 and No. 3A)

## Model No. 4.45 Level Luffing Jib Crane

The side plates of the gear box,  $5\frac{1}{2}'' \times 2\frac{1}{2}''$  Flanged Plates, are connected together at each end by  $2\frac{1}{2}''$  Strips, the front also being fitted with a  $2\frac{1}{2}'' \times \frac{1}{2}''$  Double Angle Strip 1, which forms a bearing for the jib pivot. A 3" Pulley 2 bolted to the bottom of the gear box slides on the rim of a second 3" Pulley 3, which is fixed to the travelling base, and a 2" Rod is secured in the boss of Pulley 3 and passed through the boss of Pulley 2. A  $1\frac{1}{2}''$  Contrate 4 (Fig. 4.45A) is next secured to the Rod, together with a Coupling 5, the latter being spaced from the Contrate by Washers and held in place by a Collar. A  $3\frac{1}{2}''$  Rod, on which is fixed a  $\frac{1}{2}''$  Pinion engaging with the Contrate, is journaled in the Coupling 5 and in the  $2\frac{1}{2}''$  Strip 6. A handle consisting of a Bush Wheel and a Threaded Pin attached to this Rod manipulates the slewing movement.

The Crank Handle 7 carrying a  $\frac{1}{2}''$  Pinion slides in the side plates of the gear box, so that the Pinion may be engaged with either of the two 57-teeth Gears 8 and 9. The Gear 8 is attached to a  $3\frac{1}{2}''$  Rod on which are fixed two drums consisting of four small Flanged Wheels. These form the luffing barrel. Two lengths of cord are attached to the jib head, passes over the 1" Pulleys 10, and are then wound four times round the luffing barrel. From here they are carried over the two  $1\frac{1}{2}''$  Rods 11 and the  $4\frac{1}{2}''$  Rod 12, and finally are secured to the moving carriage 13. When the model is working the Boiler End on the carriage should be weighed until it exactly counterbalances the jib.

The 57-teeth Gear 9 is fixed to the  $3\frac{1}{2}''$  Rod forming the hoisting barrel. A length of cord attached to this is passed over one of the remaining 1" loose Pulleys on the Rod 14, round one of the  $\frac{1}{2}''$  loose Pulleys at the jib head, back to the remaining 1" loose Pulley at 14, and finally over the other  $\frac{1}{2}''$  loose Pulley at the jib head and down to the hook. When a load is put on the hook the cords between the jib head and the top of the superstructure tend to contract, thus taking all the load off the luffing cords.

The rails of the carriage 13 should be kept well oiled, so that the carriage slides easily.

### Parts required :

10	of No.	1	
20	" "	2	
5	" "	3	
5	" "	5	
2	" "	6A	2 of No. 27A
6	" "	8	9 " " 35
1	" "	11	105 " " 37
2	" "	12	8 " " 37A
2	" "	14	24 " " 38
1	" "	15A	2 " " 40
5	" "	16	2 " " 46
2	" "	17	2 " " 48
2	" "	18A	3 " " 48A
1	" "	19S	1 " " 48B
2	" "	19B	2 " " 52
4	" "	20	1 " " 57C
4	" "	20B	7 " " 59
2	" "	22	3 " " 63
2	" "	22A	1 " " 111
2	" "	23	6 " " 111c
2	" "	24	1 " " 115
1	" "	26	1 " " 147B
			1 " " 162A

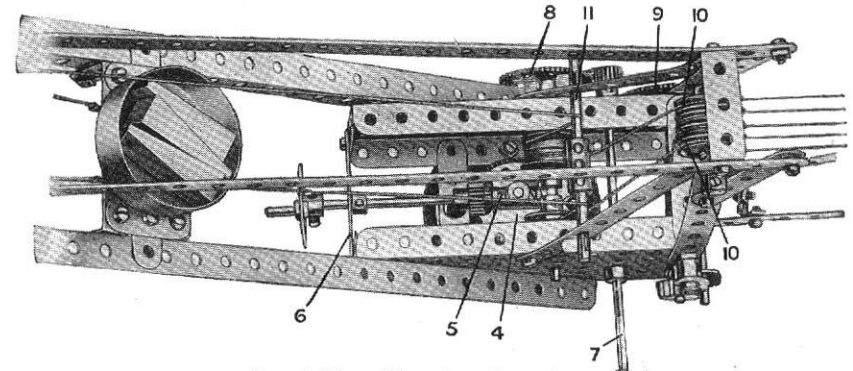
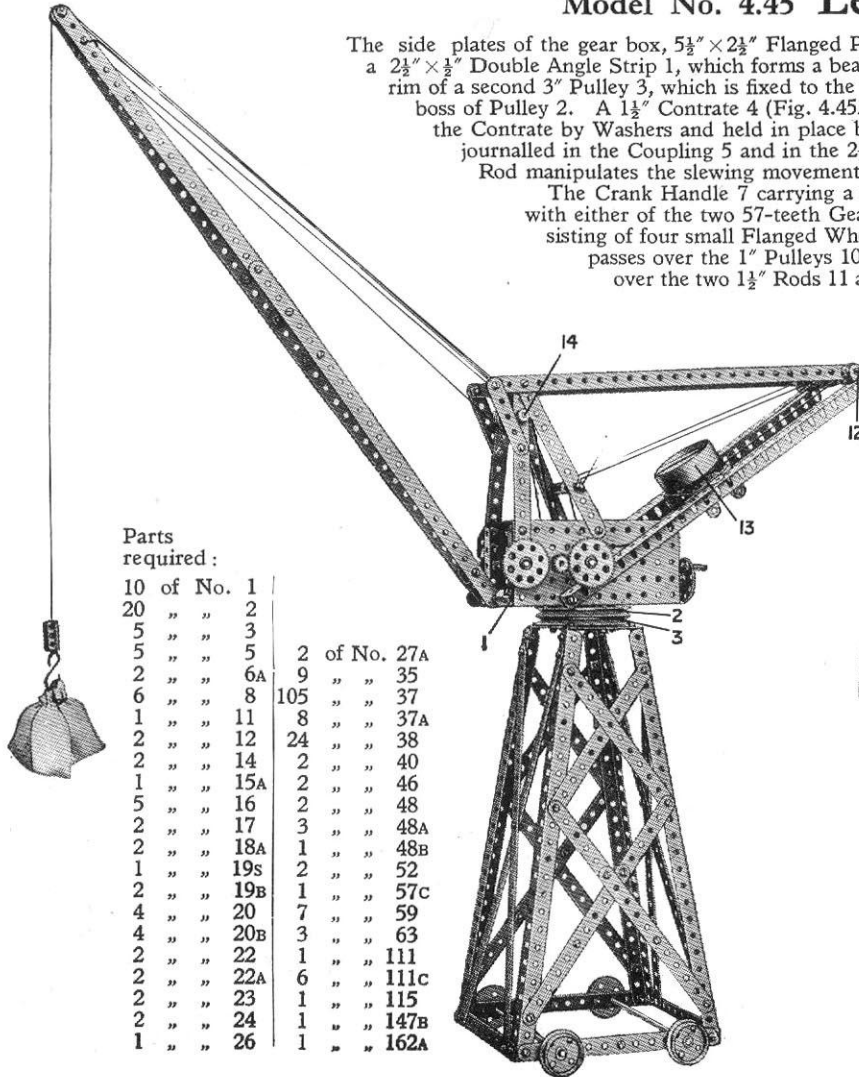
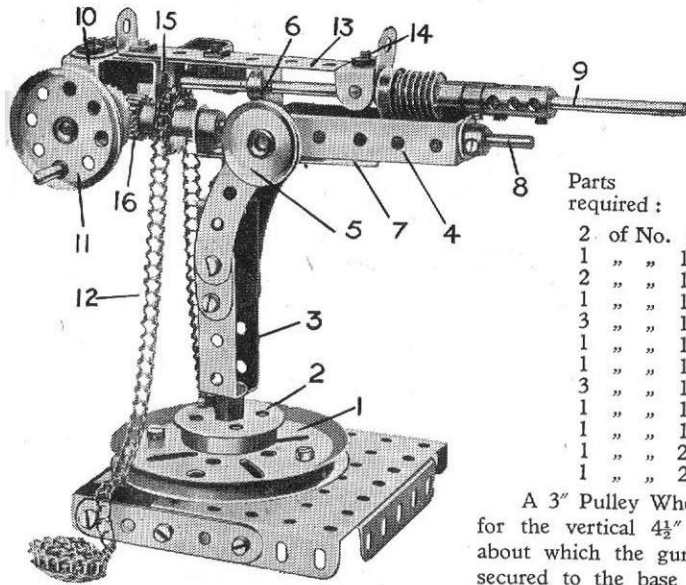

FIG. 4.45A. Plan view of gear box.

## Model No. 4.46 Naval Quick-firing Gun



Parts  
required :

2 of No. 5	24 of No. 22
1 " " 10	1 " " 23
2 " " 11	1 " " 26
1 " " 12	1 " " 29
3 " " 12A	1 " " 32
1 " " 14	2 " " 35
1 " " 15A	2 " " 37
3 " " 17	2 " " 38
1 " " 18A	1 " " 45
1 " " 19B	1 " " 46
1 " " 20B	5 " " 48A
1 " " 21	2 " " 48B
	2 " " 53
	8 " " 59
	1 " " 63
	4 " " 90
	40" " 94
	1 " " 96A
	2 " " 111C
	1 " " 115
	1 " " 125

A 3" Pulley Wheel 1 provides a bearing for the vertical 4½" Rod forming the axis about which the gun pivots. The Rod is secured to the base by a Flanged Wheel 2 and a 1" Pulley Wheel attached to it beneath the larger Wheel 1. Two Double Angle

Strips 3, spaced apart by a Double Bracket, are mounted upon this vertical Rod and held in place by a Collar secured to its upper end. Two 2½" Curved Strips, overlapped 4 holes, are bolted to each of the Double Angle Strips 3, and their upper holes form bearings for a short Rod passing through the ends of further Double Angle Strips 4, and carrying a hand wheel 5. Two Spring Clips are mounted on this Rod inside the Strips 4 to secure it to the pivoting portion of the gun, the elevation of which may be altered on turning the Wheel 5. The Strips 4 are bolted to the end of a Double Angle Strip 6, and the same Bolt secures an Angle Bracket which in turn is bolted to the Double Angle Strip 7. The Rod 8 passes through the end holes of the Strips 4 and 7 and is held in place by two Collars. On the top of the Strip 6 is bolted a 3½" Double Angle Strip 13, the upturned ends of which form the sighting apertures. The Bolt 14 secures a Double Bracket and an Angle Bracket, the latter together with one of the holes in the Strip 6 forming bearings for the barrel 9. A 1" x 1" Angle Bracket 15, bolted beneath the Strip 6, and the end of the Strip 7 provide bearings for the short Rod carrying a ¾" Sprocket Wheel and ½" x 1" Pinion 16. Two 1" x 1" Angle Brackets 10 form bearings for a 2" Rod carrying the hand Wheel 11. This Rod is fitted with a ¾" Contrate Wheel which engages with the Pinion 16. On rotation of the Wheel 11, the small Sprocket Wheel actuates the Sprocket Chain 12 which represents the cartridge belt.

## Model No. 4.47 Catapult

Two equal lengths of cord are attached to each end of the 1½" Rod 1 and to the winch 2, which is operated by the hand levers at each end. The Rod 1 is placed over the end of a Flat Bracket 3 and the winch turned so as to pull down the arm of the catapult against the tension of the Spring. The release gear consists of 2½" Strips 4 bolted to two Cranks that are secured to a Rod operated by the lever 5. When the model is ready for firing, the Rod 1 is in front of the Strips 4, so that when the end of the lever 5 is pressed down, the Strips 4 push the Rod off its Flat Bracket and release the arm.

Parts  
required :

2 of No. 1	2 of No. 1
6 " " 2	6 " " 2
4 " " 3	4 " " 3
2 " " 5	2 " " 5
2 " " 8	2 " " 8
1 " " 10	1 " " 10
3 " " 11	3 " " 11
3 " " 15	3 " " 15
4 " " 15A	4 " " 15A
4 " " 16	4 " " 16
2 " " 17	2 " " 17
2 " " 19B	2 " " 19B
4 " " 22	4 " " 22
2 " " 24	2 " " 24
1 " " 32	1 " " 32
6 " " 35	6 " " 35
36 " " 37	36 " " 37
2 " " 37A	2 " " 37A
4 " " 38	4 " " 38
1 " " 40	1 " " 40
1 " " 43	1 " " 43
1 " " 48	1 " " 48
2 " " 52	2 " " 52
4 " " 53	4 " " 53
1 " " 57C	1 " " 57C
3 " " 59	3 " " 59
2 " " 62	2 " " 62
3 " " 63	3 " " 63
1 " " 147A	1 " " 147A
1 " " 147B	1 " " 147B
1 " " 148	1 " " 148
1 " " 162A	1 " " 162A

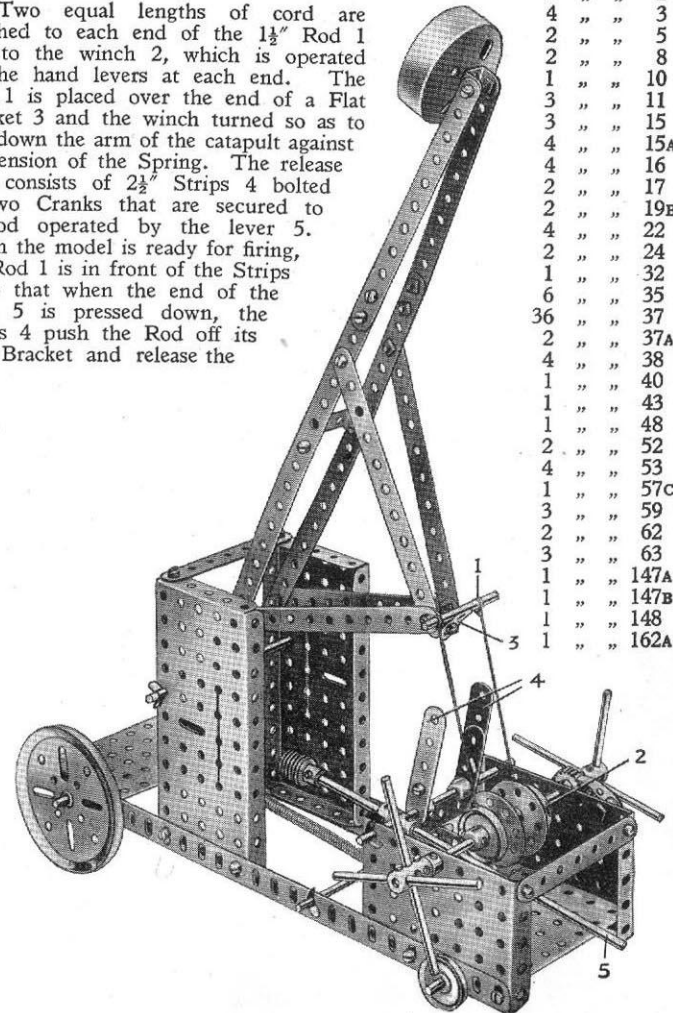

This Model can be built with MECCANO Outfit No. 4 (or No. 3 and No. 3A)

## Model No. 4.48 Flying Machine

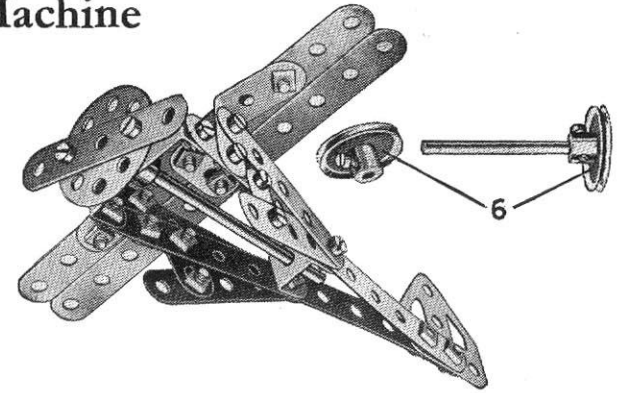
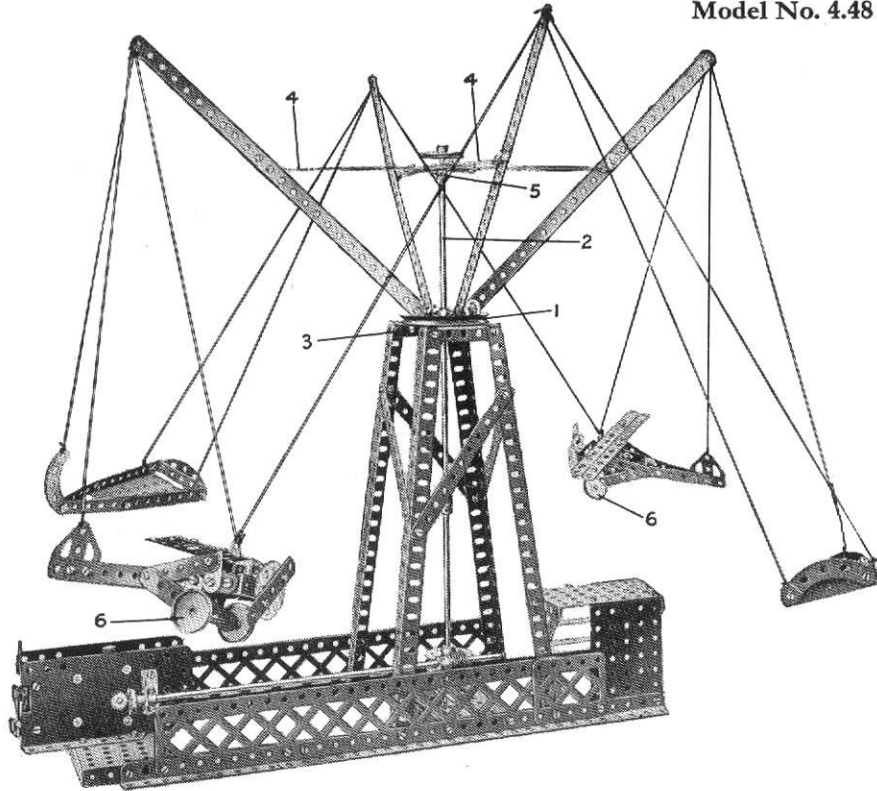

FIG. 4.48B

In Fig. 4.48 the model is shown equipped with a Meccano Electric Motor. Fig. 4.48A, which shows the base of the model only, indicates an alternative arrangement by which the model may be operated by hand if a Motor is not available. The revolving portion of the model consists of four  $12\frac{1}{2}$ " Strips bolted to the 3" Pulley Wheel 1 (Fig. 4.48) which is secured to the main vertical shaft 2 and rests directly on the  $3\frac{1}{2}$ "  $\times$   $2\frac{1}{2}$ " Flanged Plate 3. The  $12\frac{1}{2}$ " Strips are supported by two further  $12\frac{1}{2}$ " Strips 4, crossed and bolted to a Face Plate 5 secured to the Rod 2. One of the aeroplanes attached to the model is shown in detail in Fig. 4.48B. The Wheels 6 are shown removed from their bearings.

### Parts required:

6	of No.	1	4	of No.	12A	1	of No.	27A	3	of No.	53			
16	"	"	2	"	"	13	1	"	"	29	2	"	"	54
2	"	"	2A	1	"	14	1	"	"	32	3	"	"	59
11	"	"	5	2	"	16	122	"	"	37	1	"	"	63
1	"	"	6A	2	"	17	2	"	"	37A	4	"	"	90A
6	"	"	8	1	"	19B	2	"	"	40	1	"	"	98
3	"	"	9	1	"	21	1	"	"	46	2	"	"	99
6	"	"	10	4	"	22	2	"	"	48	1	"	"	109
3	"	"	11	2	"	24	6	"	"	48A	2	"	"	111C
2	"	"	12	1	"	26	2	"	"	52	2	"	"	126
											2	"	"	126A

Electric Motor  
(not included in Outfit)

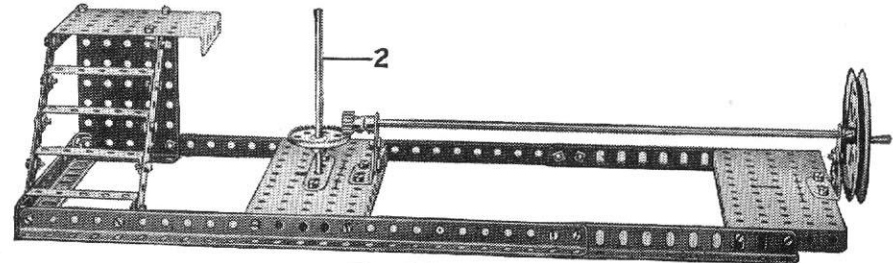
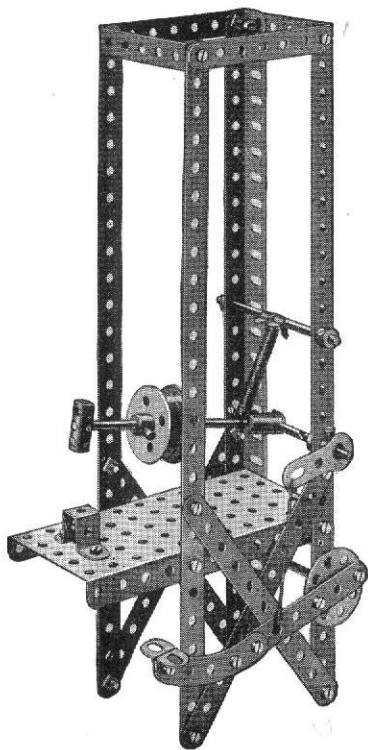

FIG. 4.48A



## Model No. 4.49 Treadle Hammer



Parts required :

2 of No. 1	3 of No. 16	1 of No. 45
4 " " 2	2 " " 20B	1 " " 48A
3 " " 3	1 " " 24	1 " " 52
1 " " 5	2 " " 35	5 " " 59
2 " " 8	23 " " 37	1 " " 62
2 " " 12	2 " " 38	2 " " 63
1 " " 15A	1 " " 43	1 " " 90

## Model No. 4.50 Ancient Motor Car

This model performs very amusing antics, all its movements being derived from a Clockwork Motor in the chassis. When the Motor is set in motion the model wobbles violently along the floor, while the driver seems to be endeavouring to keep it in a straight line and the passenger (who seems to have fallen on to the floor!) appears in constant danger of being thrown completely out of the car!

A  $\frac{1}{2}$ " Pinion on the Motor shaft engages with the  $1\frac{1}{2}$ " Contrate Wheel 1 attached to the back axle 2. The latter is journalled in two  $2\frac{1}{2}$ " Flat Girders bolted to two  $5\frac{1}{2}$ " Angle Girders to which the Clockwork Motor is attached. Two Couplings 3 are fixed to each extremity of the Rod 2, and the road wheels are attached to their centre threaded holes by Threaded Pins. The Couplings are set at an angle of 180 degrees to one another and so cause the car to wobble in a most peculiar manner when it is running.

A 57-teeth Gear 4 is fixed to a  $4\frac{1}{2}$ " Rod 5 that carries at one end a Bush Wheel. This is connected to the front wheels by a link built up of  $3\frac{1}{2}$ " and  $4\frac{1}{2}$ " Strips and attached by an Angle Bracket 7 to the  $2\frac{1}{2}$ " Double Angle Strip 8 that forms a bearing for the front axle. This results in the front road wheels being turned alternately from side to side. The  $1\frac{1}{2}$ " Rod forming the pivot for the steering should be kept fairly loose to allow for the rolling of the chassis.

A  $4\frac{1}{2}$ " Strip 6 is lock-nutted to the Double Angle Strip 8 at one end and at the other to a Crank 9 which is fixed to a  $3\frac{1}{2}$ " Rod. This is journalled in the holes of the Clockwork Motor and at its top a Bush Wheel is secured. The driver is attached pivotally to the Bush Wheel by an Angle Bracket and  $2\frac{1}{2}$ " Strip, so that when the Motor is in motion he steers quite realistically. The passenger at the back is attached to the frame by a Spring clamped between two  $1\frac{1}{2}$ " Strips.

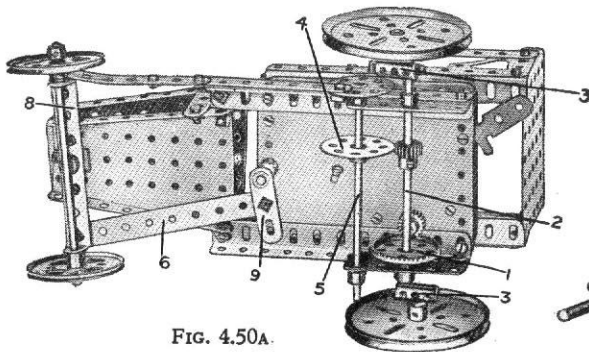
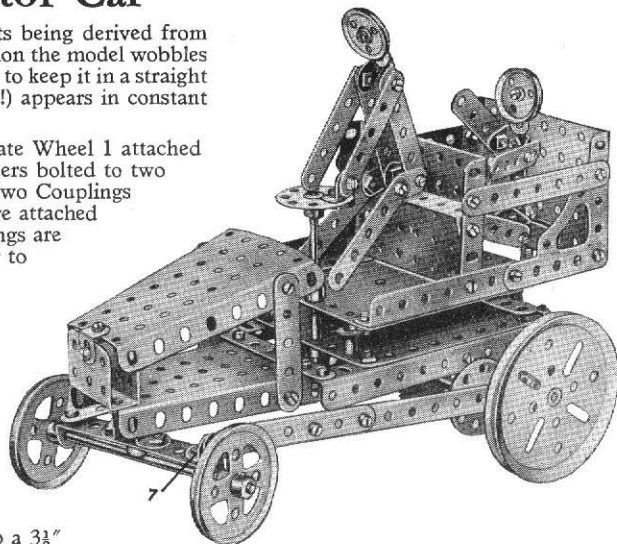

FIG. 4.50A.

2 of No. 2A
13 " " 3
3 " " 5
2 " " 6A
4 " " 9
4 " " 10
4 " " 11

Parts required :

3 of No. 12	8 of No. 38
1 " " 15	1 " " 43
2 " " 15A	1 " " 45
1 " " 16	2 " " 48B
1 " " 17	2 " " 53
2 " " 19B	2 " " 54
2 " " 20A	10 " " 59
2 " " 22A	1 " " 62
2 " " 24	2 " " 63
2 " " 26	2 " " 103F
1 " " 27A	2 " " 108
1 " " 28	5 " " 111C
57 " " 37	2 " " 115
14 " " 37A	1 " " 160

Clockwork Motor  
(not included in Outfit)

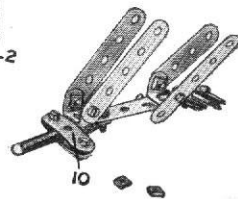

## Model No. 4.51 Telpher Span

A Worm Wheel on the armature spindle of the Electric Motor engages with a  $\frac{1}{2}$ " Pinion that is secured, together with a second  $\frac{1}{2}$ " Pinion, on a vertical 2" Rod. This Rod is journalled in a Channel Bearing secured to the Motor side plates. The second  $\frac{1}{2}$ " Pinion engages with a  $1\frac{1}{2}$ " Contrate Wheel carried on the hoisting drum, the latter being formed by a  $2\frac{1}{2}$ " Rod journalled in the end holes of the Motor side plates. The lift and telpher hoisting rope, which is continuous is wound round the hoisting drum three turns, and is then connected to the lift and telpher in the following manner.

One side of the cord is passed over 1" and  $\frac{1}{2}$ " loose Pulleys at the top of the tower, then over a 1" fast Pulley attached to the cage, and is finally attached to a Flat Bracket that is carried on the same Rod as the  $\frac{1}{2}$ " Pulley. The other side of the cord is passed over a second 1" loose Pulley at the top of the tower, and down to a  $2\frac{1}{2}$ " x  $\frac{1}{2}$ " Double Angle Strip on the telpher.

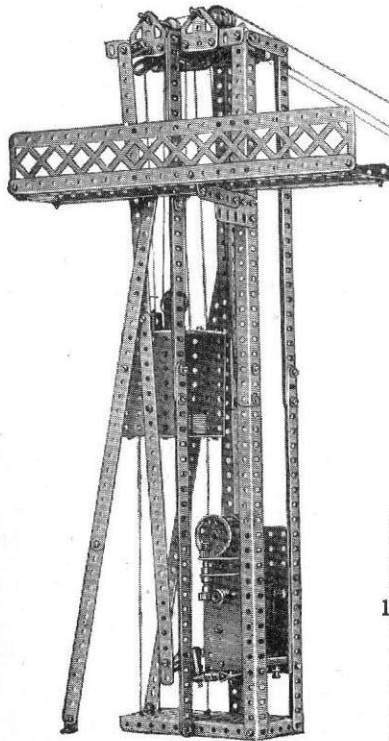

Parts required :

8 of No. 1	3 of No. 22A	5 of No. 48A	4 of No. 126A
2 " " 2	1 " " 23	2 " " 52	1 " " 160
3 " " 3	2 " " 26	2 " " 53	1 " " 162A
2 " " 4	1 " " 28	10 " " 59	1 " " 165
18 " " 5	1 " " 32	2 " " 62	1 " " 166
9 " " 8	4 " " 35	3 " " 63	Electric Motor
4 " " 9	126 " " 37	1 " " 98	(not included in Outfit)
1 " " 11	6 " " 37A	1 " " 99	
7 " " 12	24 " " 38	2 " " 103F	
1 " " 15A	1 " " 40	4 " " 111c	
5 " " 16	1 " " 44	1 " " 115	
2 " " 18A	1 " " 45		
2 " " 20			
4 " " 22			

## Model No. 4.52 Saw Bench

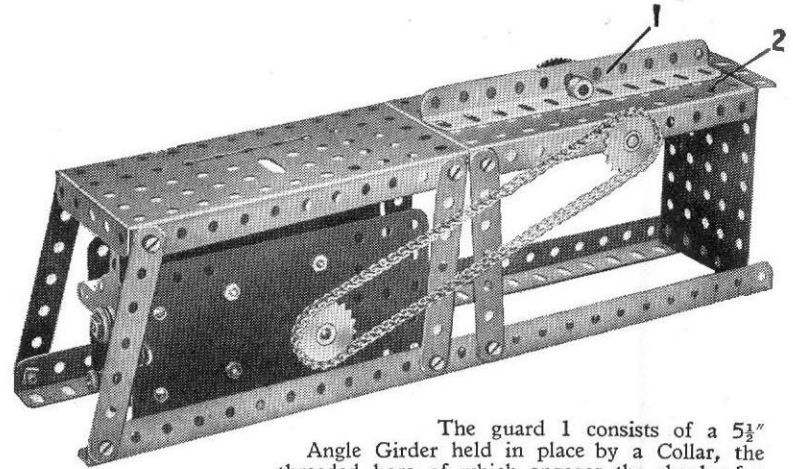

The guard 1 consists of a  $5\frac{1}{2}$ " Angle Girder held in place by a Collar, the threaded bore of which engages the shank of a Bolt passed through one of the holes in the Flanged Plate 2. Hence by altering the position of the Bolt in the Flanged Plate, the guard may be moved nearer or further from the Circular Saw as required to allow for different thicknesses of material.

Parts required :

6 of No. 3	1 of No. 8
2 " " 8	1 " " 9
1 " " 9	1 " " 16
1 " " 16	22 " " 37
2 " " 37	2 " " 52
1 " " 52	1 " " 53
1 " " 53	1 " " 59
1 " " 59	15" " " 94
15" " " 94	2 " " " 96
2 " " " 96	1 " " " 111c
1 " " " 111c	1 " " " 159
1 " " " 159	1 " " " 160
1 " " " 160	Electric Motor
	(not included in Outfit)

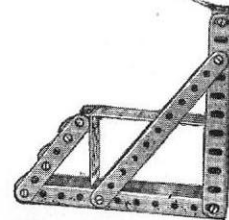

## Model No. 4.53 Swivelling and Luffing Jib Crane

Parts required :

10	of No.	1	1	of No.	27A	3	of No.	48A
3	"	2	1	"	32	1	"	52
3	"	3	2	"	35	2	"	53
2	"	5	80	"	37	1	"	57C
1	"	6A	2	"	37A	8	"	59
7	"	8	13	"	38	12"	"	94
2	"	10	1	"	40	1	"	95
2	"	11	3	"	45	1	"	96
10	"	12	1	"	46	1	"	115
2	"	12A	2	"	48	4	"	126A
1	"	16						
3	"	17						
4	"	18A						
2	"	19						
3	"	22						
3	"	22A						
1	"	23						
1	"	24						

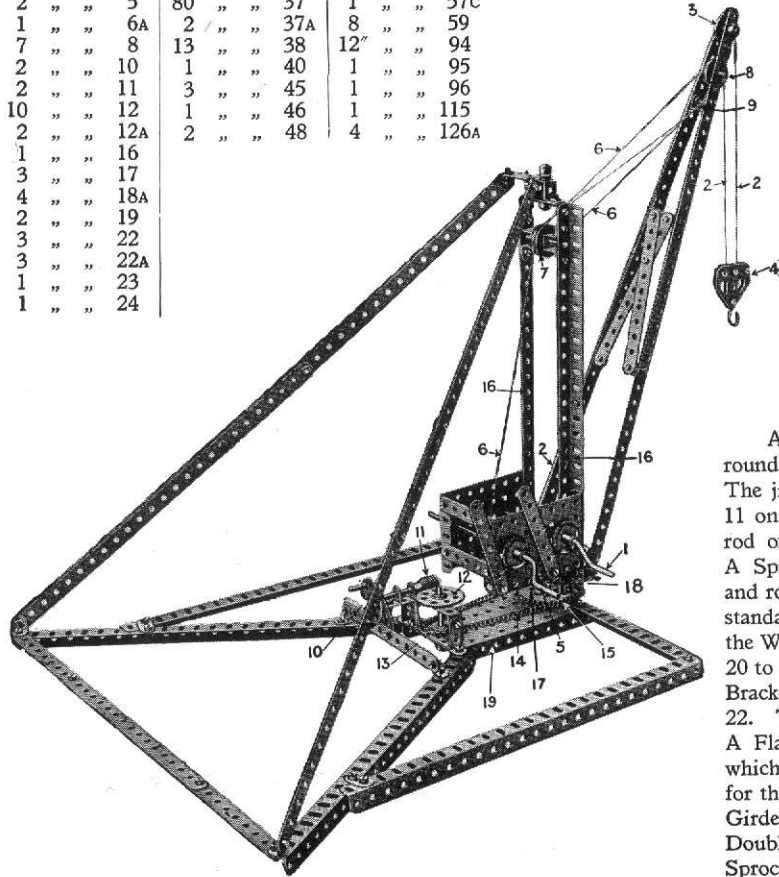

In this model three separate actions are provided, for raising the load, raising the jib, and swivelling the jib. The load is raised by means of a Crank Handle 1 on which the Cord 2 is wound and passes over the 1" Pulley 3, thence round the 1/2" Pulley in the block 4 (spacing Washers being used to give clearance to the 1/2" Pulley), the end of the Cord 2 being made fast to the top of the jib. By turning the Handle 1 the load is raised or lowered. The jib itself is raised or lowered by the operation of the Crank Handle 5 on the rod of which a cord is wound, and passes over one of two Pulleys 7 to and round another 1" Pulley 8 in the jib, whence it returns to and passes round the other Pulley 7, being finally made fast to the Double Bracket 9 bolted to the jib.

As the Handle 5 is turned the Cord 6 is wound round the pulleys and the angle of the jib varied. The jib is swivelled by the hand wheel 10, a Worm 11 on which engages a 57-toothed Wheel 12 on the rod of which a 1" Sprocket Wheel 13 is mounted. A Sprocket Chain 14 passes round this Wheel 13 and round a 2" Sprocket Wheel 15 that is secured to the standard 16 of the crane. The bearing for the Rod of the Worm 11 is made by bolting a 1" x 1" Angle Bracket 20 to the 5 1/2" x 2 1/2" Flanged Plate 19, and to the Angle Bracket 20 is secured a 1 1/2" Strip 21 and a 1" Bracket 22. To the Bracket 22 is bolted a Double Bracket 23. A Flat Trunnion 24 is bolted to the 5 1/2" Strip 25 which forms with the Bracket 23 the front bearing for the Rod. The standard is built up of two 12 1/2" Girders 16 which are connected at the base by a 1 1/2" Double Angle Strip 17 which is bolted to the 2" Sprocket Wheel 15. The 1" Rod 18 is secured in the bush of the Sprocket Wheel 15 and fitted with a Collar below the 5 1/2" x 2 1/2" Flanged Plate 19, Fig. 4.53B.

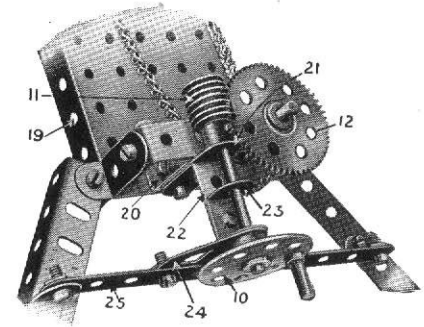

FIG. 4.53A

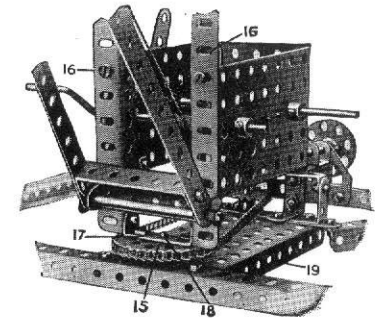
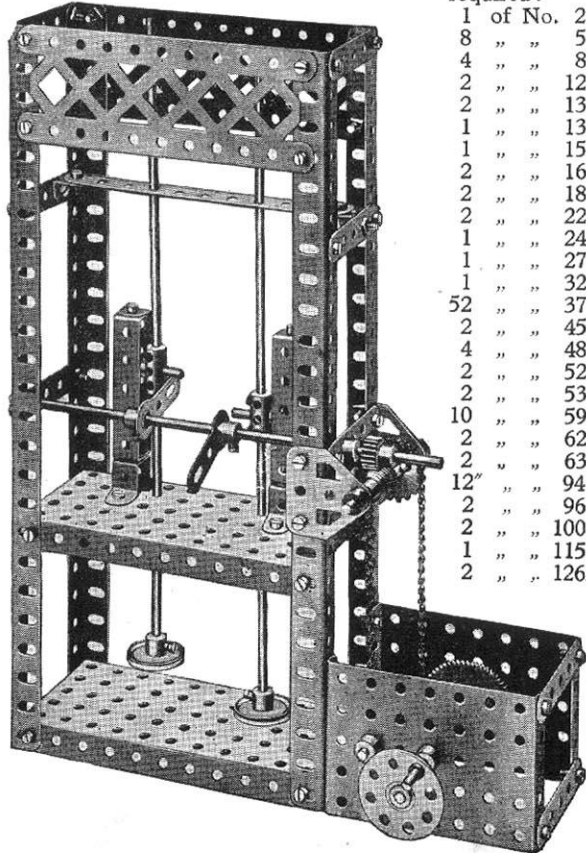

FIG. 4.53B

## Model No. 4.54 Trip Hammer

The shafts carrying the hammers are prevented from rotating in their bearings by means of  $2\frac{1}{2}'' \times \frac{1}{2}''$  Double Angle Strips bolted in pairs to form guides, in which slide the heads of Bolts or short Rods secured to the Couplings in the centre of the hammer shafts. As the Rod carrying the Cranks slowly rotates the hammers rise and fall alternately.



Parts required:	
1	of No. 2
8	" " 5
4	" " 8
2	" " 12
2	" " 13
1	" " 13A
1	" " 15A
2	" " 16
2	" " 18A
2	" " 22
1	" " 24
1	" " 27A
1	" " 32
52	" " 37
2	" " 45
4	" " 48A
2	" " 52
2	" " 53
10	" " 59
2	" " 62
2	" " 63
12"	" " 94
2	" " 96
2	" " 100
1	" " 115
2	" " 126A

## Model No. 4.55 Coal Tipper

Each of the main vertical columns consists of a  $12\frac{1}{2}''$  and a  $5\frac{1}{2}''$  Angle Girder overlapped three holes. The platform carrying the truck is constructed from  $5\frac{1}{2}''$  Strips, and it slides freely between the upright members. Four cords of equal length, attached to each corner of the platform, are taken over Pulleys at the top of the structure, each pair of cords being wound on to a Rod 4. These Rods each carry a 57-teeth Gear that engages with a  $\frac{1}{2}''$  Pinion on a Rod 5. This, as will be seen, is driven by means of Sprocket Chain and a Crank Handle.

The truck rests on a pair of rails consisting of  $5\frac{1}{2}''$  Strips 1, which are pivoted at their front ends on  $\frac{1}{2}'' \times \frac{1}{2}''$  Angle Brackets. A  $2\frac{1}{2}''$  Strip 2 is secured to a transverse Strip fixed across the rails, and a length of cord is tied to its end so that when the platform reaches a certain height of the platform the truck is tipped. A Spring 3 secured to a length of cord is attached to the rear end of the platform, in order to keep the platform in a horizontal plane when the truck tips.

To keep the truck in place on the rails, a pivoted Strip 6, with a  $\frac{1}{2}'' \times \frac{1}{2}''$  Angle Bracket on its end, can be swung round so that the Angle Bracket engages with the back of the truck; while further  $\frac{1}{2}'' \times \frac{1}{2}''$  Angle Brackets on the top of the vertical Strips are arranged to engage with the top edges of the truck.

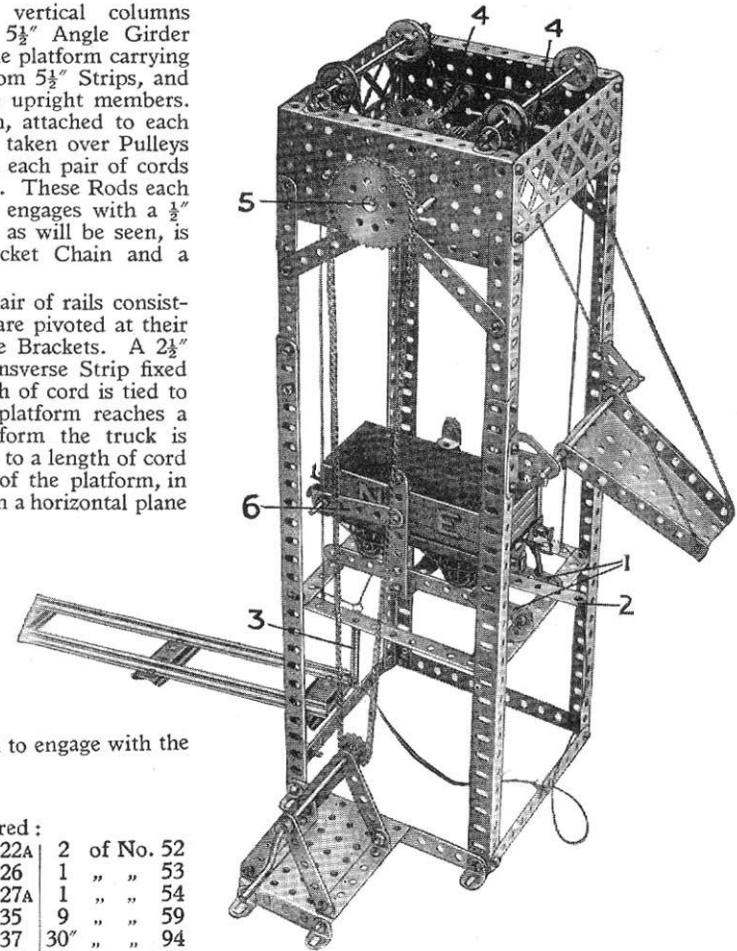

Parts required:					
10	of No. 2	3	of No. 22A	2	of No. 52
2	" " 3	1	" " 26	1	" " 53
6	" " 4	2	" " 27A	1	" " 54
9	" " 5	12	" " 35	9	" " 59
4	" " 8	85	" " 37	30"	" " 94
4	" " 9	9	" " 37A	1	" " 95
21	" " 12	6	" " 38	1	" " 96A
3	" " 14	1	" " 40	2	" " 100
3	" " 15	1	" " 43	2	" " 111
1	" " 19s	1	" " 46	1	" " 115
1	" " 22	3	" " 48A	2	" " 126

## Model No. 4.56 Cake Walk

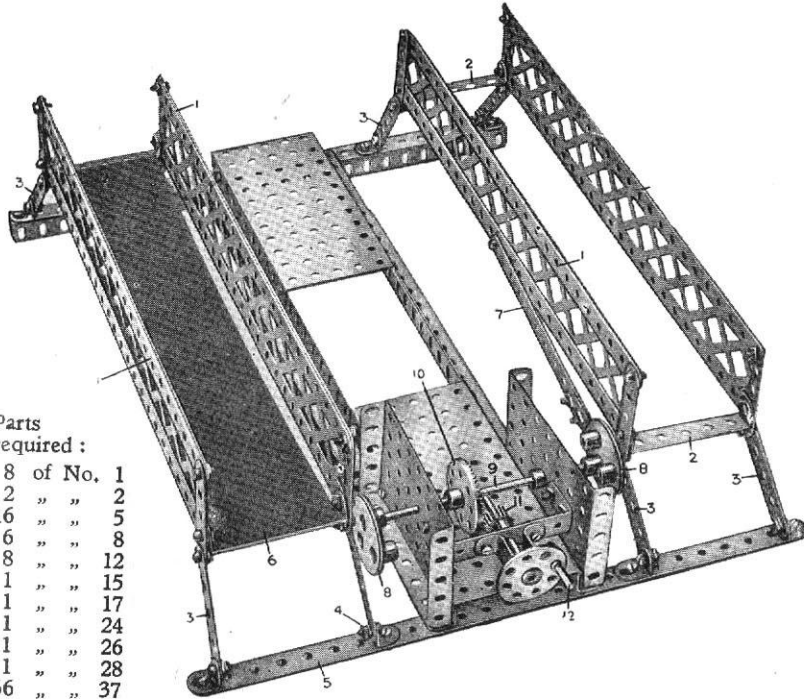

Parts required :

8	of No.	1
2	" "	2
16	" "	5
6	" "	8
8	" "	12
1	" "	15
1	" "	17
1	" "	24
1	" "	26
1	" "	28
66	" "	37
1	" "	38
1	" "	45
1	" "	46
4	" "	48A
2	" "	52
2	" "	53
2	" "	59
4	" "	99
1	" "	115
2	" "	130

The rocking platforms are built up of Braced Girders 1 connected by the end Strips 2 and pivotally bolted and lock-nutted to the Strips 3 forming rocking links. These latter are bolted and lock-nutted at 4 to the Angle Girders 5. Strips 6 of cardboard are secured to the end Strips 2. The platforms are rocked by means of Strips 7, one of which is connected to each rocking platform and to Eccentrics 8 fixed on the Rod 9 on which is secured a Contrate Wheel 10 driven by a Pinion 11 from the handle 12. As the handle 12 is turned the platforms are rocked to and fro on the Strips 3. The eccentrics 8 should be so arranged that the platforms rock in opposite directions.

## Model No. 4.57 Anti-Aircraft Gun

The gun, represented by the Rod 1, is pivoted upon a transverse Rod 2 which passes through a Coupling on the Rod 1. A 57-toothed Wheel 3 on the pivot Rod 2 is engaged by a Worm 4 operated from the hand wheel 5. By turning this wheel 5 the gun is lifted or lowered. The two vertical Strips forming the framework for the pivot Rod 2 are bolted to a 1½" Pulley 7 which is secured on a vertical Rod 8. A 3" Pulley Wheel 9 is also bolted to a Rod 8 and from the Pulley Wheel is carried by reversed Angle Brackets 10 to a framework 11. The Rod 8 with the framework is rotated from the hand wheel 12, a Pinion 13 on the spindle of which engages a ¾" Contrate Wheel 14 on the Rod 8. By turning the wheel 12 the gun is swivelled.

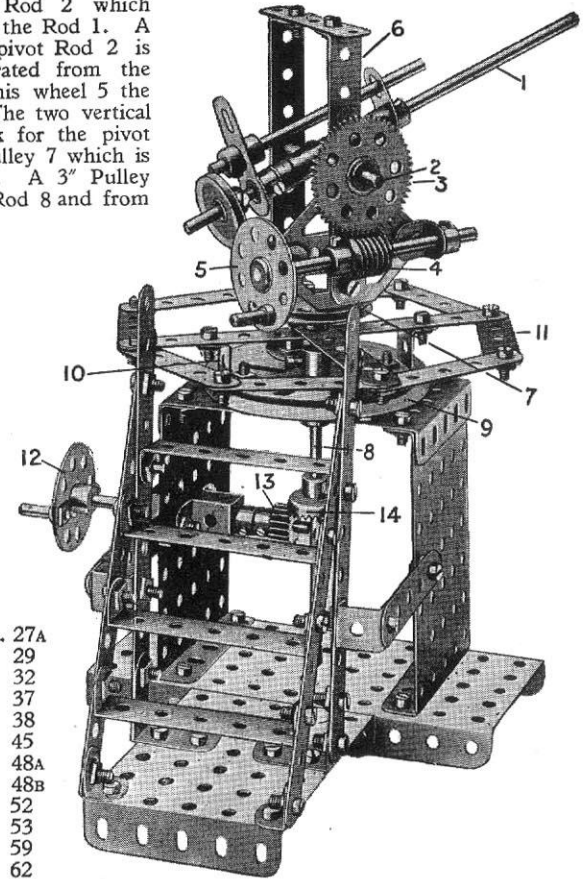

Parts required :

6	of No.	2	1	of No.	27A
11	" "	5	1	" "	29
1	" "	10	1	" "	32
2	" "	11	64	" "	37
4	" "	12	12	" "	38
2	" "	12A	2	" "	45
1	" "	15	4	" "	48A
1	" "	15A	2	" "	48B
4	" "	16	1	" "	52
1	" "	17	4	" "	53
1	" "	19B	8	" "	59
1	" "	21	1	" "	62
2	" "	22	2	" "	63
2	" "	24	2	" "	115
1	" "	26	4	" "	125

## Model No. 4.58 Spring Balance

The architraves 1 are pivoted on the Rod 3 and secured at their upper ends to a Spring 2. Two  $2\frac{1}{2}$ " Strips 4 are attached pivotally to their lower ends by Bolts and lock-Nuts and connected together in a similar manner. The Hook 6 suspended from a Flat Bracket receives the article to be weighed, which causes the upper ends of the Architraves to move outward, and the weight may be ascertained from the scale that is bolted in position at 7.

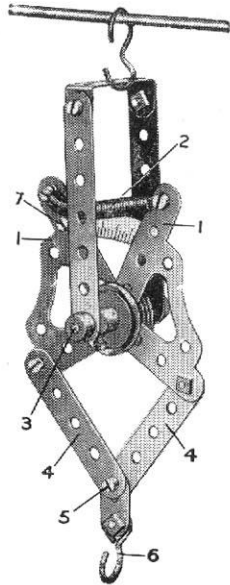

Parts  
required :

2	of No.	3
2	" "	5
1	" "	10
1	" "	17
2	" "	22
8	" "	37
3	" "	37A
1	" "	43
1	" "	48
1	" "	57C
2	" "	59
2	" "	108

## Model No. 4.59 Wire Rope-Making Machine

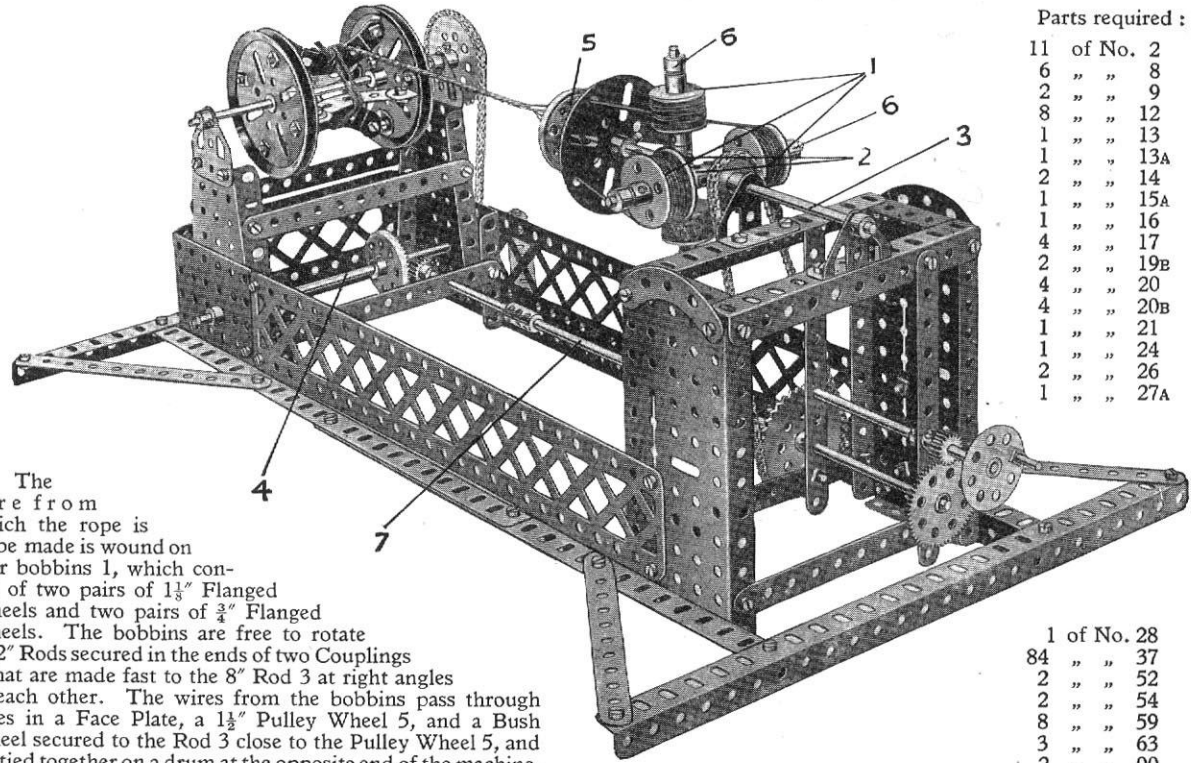

The wire from which the rope is to be made is wound on four bobbins 1, which consist of two pairs of  $1\frac{1}{8}$ " Flanged Wheels and two pairs of  $\frac{3}{4}$ " Flanged Wheels. The bobbins are free to rotate on 2" Rods secured in the ends of two Couplings 2 that are made fast to the 8" Rod 3 at right angles to each other. The wires from the bobbins pass through holes in a Face Plate, a  $1\frac{1}{2}$ " Pulley Wheel 5, and a Bush Wheel secured to the Rod 3 close to the Pulley Wheel 5, and are tied together on a drum at the opposite end of the machine. The drum is mounted on a  $6\frac{1}{2}$ " Rod that is connected by Sprocket Chain to a 1" Sprocket Wheel on the Rod 4, which is revolved slowly from the hand wheel through the gearing shown.

The Rod 3, together with the bobbins, Face Plate, Pulley Wheel 5, and the Bush Wheel, are rotated from the main driving shaft 7 by means of 2" and 1" Sprocket Wheels. The wires are thus twisted together between the Pulley Wheel 5 and the drum, and are wound on the latter in the form of a cable. In order to prevent the wire from unwinding too rapidly, Washers are placed on the 2" Rods between the Couplings and the bosses of the Flanged Wheels 1, and the Collars 6 are pressed hard against the wheels before being secured to the 2" Rods.

A considerable amount of tension is essential to the production of good wire rope, and for this reason the  $1\frac{1}{2}$ " Pulley Wheel 5 and the Bush Wheel behind it are secured close together on the Rod 3 in such a manner that the friction generated by the wires in passing through the holes in the wheels keeps the cable taut while it is being twisted. String or thin wire may be used in the model.

Parts required :

11	of No.	2
6	" "	8
2	" "	9
8	" "	12
1	" "	13
1	" "	13A
2	" "	14
1	" "	15A
1	" "	16
4	" "	17
2	" "	19B
4	" "	20
4	" "	20B
1	" "	21
1	" "	24
2	" "	26
1	" "	27A

1	of No.	28
84	" "	37
2	" "	52
2	" "	54
8	" "	59
3	" "	63
2	" "	90
4	" "	90A
15"	" "	94
2	" "	95
2	" "	96
2	" "	99
1	" "	100
1	" "	109
1	" "	115
2	" "	126
2	" "	126A

## Model No. 4.60 Elevated Jib Crane

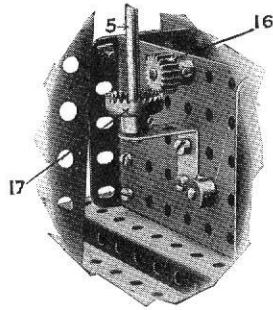

FIG. 4.60A

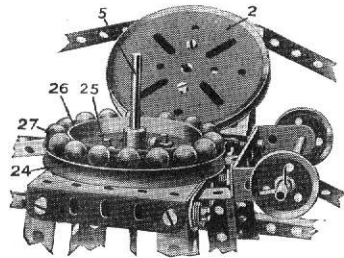

FIG. 4.60B

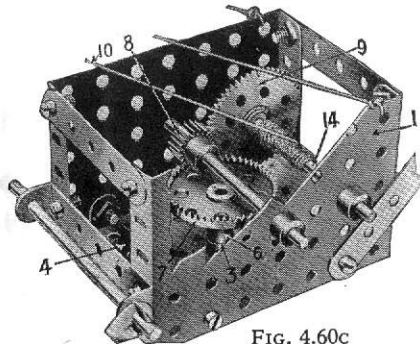
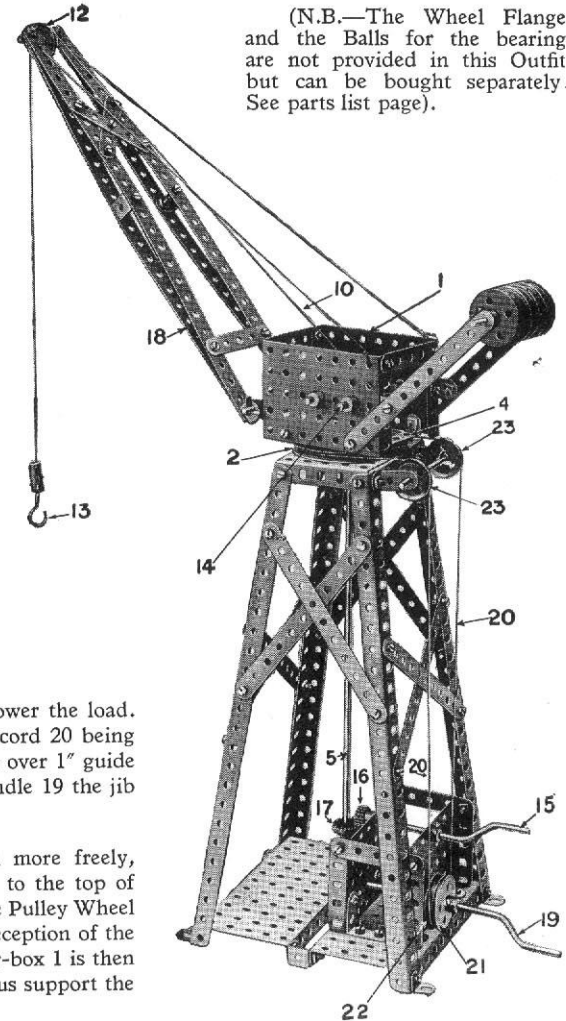

FIG. 4.60c

Parts required :		
4 of No. 1	1 of No. 19	1 of No. 29
10 " " 2	1 " " 19B	4 " " 35
1 " " 3	1 " " 19s	85 " " 37
8 " " 5	4 " " 20	1 " " 40
4 " " 8	2 " " 20B	1 " " 46
4 " " 11	1 " " 21	3 " " 48A
14 " " 12	1 " " 22	2 " " 52
3 " " 12A	2 " " 22A	5 " " 53
1 " " 13	2 " " 26	1 " " 57C
5 " " 16	1 " " 27A	6 " " 59
1 " " 18A	1 " " 28	1 " " 63

The gear-box 1 is secured to a 3" Pulley Wheel 2 (the boss 3 of which is upward) by means of two 2½" × ½" Double Angle Strips 4. The 11½" Rod 5 passes up through the boss 3, a Collar 6 being placed on top of the boss. The Contrate Wheel 7 is then secured to the top of the Rod 5. A ½" Pinion 8 engages the Contrate Wheel 7 and also a 57-toothed Wheel 9 on the Rod 14 on which latter the hoisting cord 10 is wound, passing over the 1" Pulley 12 to the Hook 13. The Rod 5 is actuated from the Crank Handle 15 by the Pinion 16 engaging a ¾" Contrate Wheel 17 and through the Gear Wheels 7, 8, and 9, and operates the cord 10 to raise or lower the load. The jib 18 is swivelled from the Crank Handle 19, a continuous cord 20 being wound twice round the ¾" Flange Wheels 21. The cord 20 passes over 1" guide Pulleys 23 and round the 3" Pulley Wheel 2. By turning the handle 19 the jib is swivelled.

*Alternative Construction.* In order to make the jib swivel more freely, a ball-race, Fig. 4.60B, may be fitted. This is made by bolting to the top of the frame a 3" Pulley Wheel 24 by Bolts 25 which also secure in the Pulley Wheel 24 a Wheel Flange 26. This provides a circular groove for the reception of the Ball Bearings 27. The Pulley Wheel 2 which is bolted to the gear-box 1 is then placed over the Rod 5 and rests on the Ball Bearings 27, which thus support the weight of the superstructure.



(N.B.—The Wheel Flange and the Balls for the bearing are not provided in this Outfit but can be bought separately. See parts list page).

## Model No. 4.61 Steam Shovel

The base of this model consists essentially of two  $5\frac{1}{2}'' \times 2\frac{1}{2}''$  Flanged Plates connected together by 12  $\frac{1}{2}''$  Angle Girders, and the vertical member 1 is secured firmly to a 2" Sprocket Wheel 2 that is free to turn about a Pivot Bolt attached to one of the base plates. It should be noted that the  $2\frac{1}{2}'' \times 1''$  Double Angle Strip 3 is spaced from the Sprocket 2 by the thickness of two Washers.

The gear box provides four movements—hoisting and lowering, racking, slewing, and travelling, all of which are driven by the Electric Motor. On the armature spindle of the Motor is a Worm meshing with a  $\frac{1}{2}''$  Pinion on a horizontal Rod on which is secured also a  $\frac{3}{4}''$  Contrate. The latter is in constant mesh with a  $\frac{1}{2}''$  Pinion 4 on a short Rod that is journalled in the Motor side plates and carries a Worm 5.

The slewing and travelling motions are actuated through a novel form of clutch, shown in Figs. 4.61 and 4.61c. A 57-teeth Gear 6 meshes with the Worm 5. It is loose on its Rod 10 and may be raised or lowered by means of two Cranks 9, which are secured to a Rod and have in their end holes, Bolts, the shanks of which engage with the underside of the Gear. When the Gear is moved downwards, one of two  $\frac{3}{4}''$  Bolts 6A secured to it, engages with one of the holes in a 2" Sprocket 7, which is loose on the Rod 10 and is connected to the Sprocket 2 by a length of Sprocket Chain. By this means the model is slewed. By raising the Gear 6 the second  $\frac{3}{4}''$  Bolt engages with a Bush Wheel 8, which is fastened to the Rod 10. A 1" fast Pulley 11 on the lower end of this shaft is connected by a short belt of cord to a similar Pulley on the front axle.

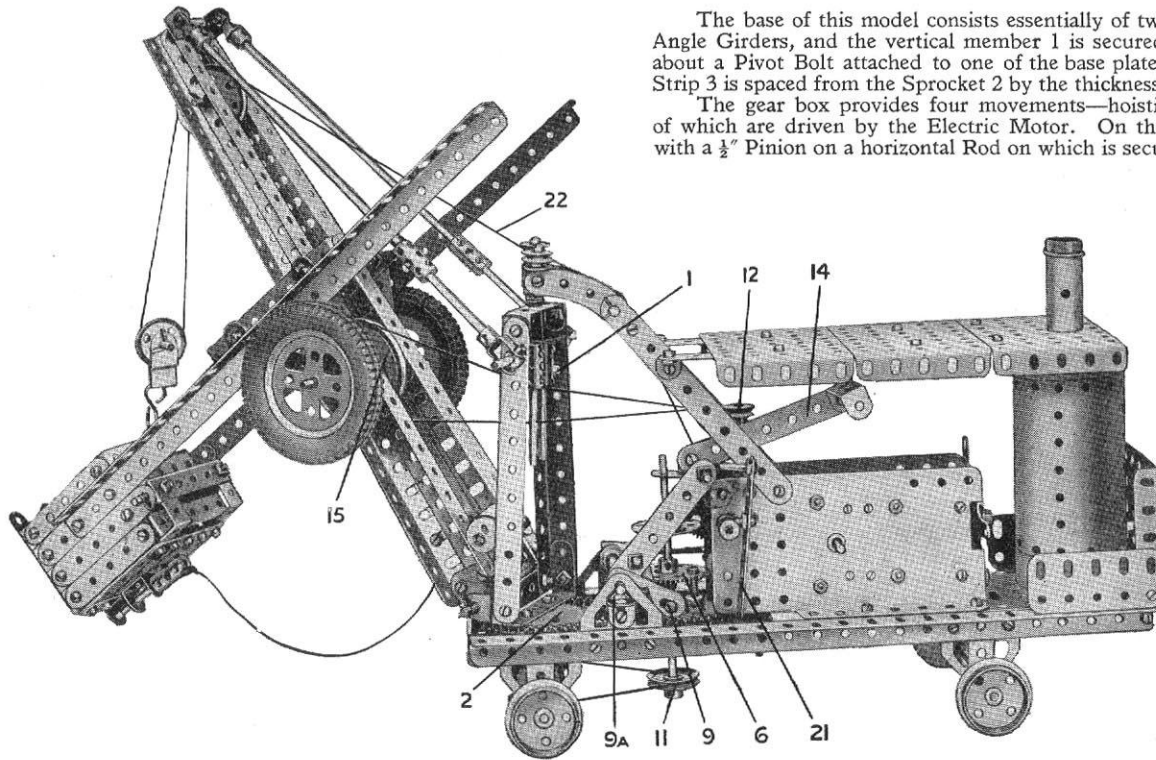

### Parts required:

6 of No. 2	3 of No. 14	3 of No. 23	1 of No. 44	3 of No. 90	1 of No. 162
2 " " 2A	1 " " 15	1 " " 23A	1 " " 45	11" " " 94	1 " " 163
6 " " 3	5 " " 15A	2 " " 24	1 " " 46	2 " " 95	1 " " 164
4 " " 4	5 " " 16	2 " " 26	2 " " 48	2 " " 103F	2 " " 165
18 " " 5	5 " " 17	2 " " 27A	10 " " 48A	2 " " 111	1 " " 166
2 " " 6A	4 " " 18A	1 " " 29	2 " " 52	3 " " 111c	
8 " " 8	4 " " 20	2 " " 32	4 " " 53	2 " " 115	
2 " " 9	3 " " 20A	10 " " 35	1 " " 57c	1 " " 116A	
3 " " 10	1 " " 20B	125 " " 37	10 " " 59	3 " " 126	
1 " " 11	1 " " 21	7 " " 37A	2 " " 62	4 " " 126A	
12 " " 12	2 " " 22	21 " " 38	6 " " 63	2 " " 142A	
4 " " 12A	1 " " 22A	1 " " 40	2 " " 77	1 " " 147B	

Electric  
Motor  
(not included  
in Outfit)

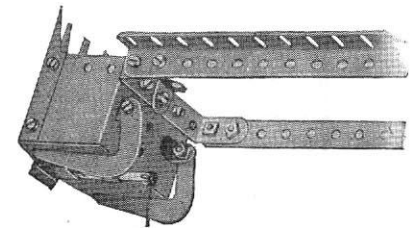

FIG. 4.61A. If available, the Meccano Digger Bucket (part No. 169) may be used with advantage in place of the built-up Bucket, as shown.



## Model No. 4.61 Steam Shovel (continued)

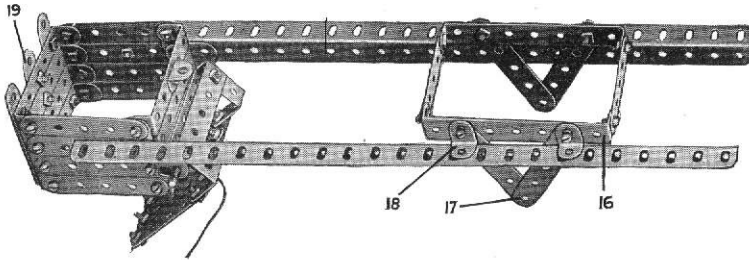

FIG. 4.61B. The Bucket Arm, with Bucket and Guide Frame in position.

secured to the top end of a Rod that carries a  $\frac{1}{2}$ " Pinion 13, which may be brought into mesh with the Worm 5 by sliding the Rod downward with the aid of the lever 14. A belt of cord connects the Pulley 12 with a 2" Pulley 15 secured on a Rod that is journalled in the sides of the jib and which carries two other 2" Pulleys shod with Dunlop Tyres. The frame 16 (Fig. 4.61B) also is mounted on this Rod in the holes 17, and the Girders of the bucket arm engage between the  $\frac{1}{2}$ "  $\times$   $\frac{1}{2}$ " Angle Brackets 18 and the tyre-shod Pulleys. The Brackets 18 should press the bucket arm only lightly into contact with the Tyres, and the driving belt should be taken several times round the Pulleys 12 and 15.

The construction of the bucket itself should be fairly obvious from Fig. 4.61B, with the exception of the catch for releasing the hinged bottom. The catch consists of a  $1\frac{1}{2}$ " Rod free to slide in a Double Bracket that is bolted rigidly to the underneath of the bucket. One end of the Rod is fitted with a Coupling, to which the release cord is attached, and the other end fits into the lower hole of a 3" Strip 19.

The hoisting barrel consists of a  $3\frac{1}{2}$ " Rod 20 that is free to slide in the Motor side plates and is controlled by the lever 21, so that the 57-teeth Gear on its extremity may be thrown into or out of engagement with the  $\frac{1}{2}$ " Pinion 4. When out of gear the projecting shank of a Bolt on the Motor side plate engages with one of the holes of the 57-teeth Gear and thus prevents the unwinding of the barrel. The grub-screw in the boss of the Pinion 4 should be filed, if necessary, so that it does not foul the teeth of the 57-teeth Gear.

The pair of  $\frac{1}{2}$ " loose Pulleys mounted at the top of the vertical member form guides round which the hoisting cord 22 passes when the jib is slewed round. The Boiler is retained in position by a  $6\frac{1}{2}$ " Rod, which passes completely through it, and through the base plate, and is secured by a Bush Wheel on its lower end, and at its upper extremity by a  $\frac{3}{4}$ " Flanged Wheel that forms the chimney cap.

It is an advantage to fill the Boiler with heavy objects so as to prevent the machine from tipping forward. Also, when working cross-track it is advisable to provide "out riggers." These should take the form of arms pivoted to the truck so that they may be swung out at right angles, and by having their ends packed up, used to relieve the wheels and axles from strain.

Much fun may be had with this model, not only during its construction but afterwards when it is set to work. Also, it may easily be converted into a crane by detaching the bucket arm and unhooking the bucket from the Pulley Block.

It should be borne in mind that the Gear 6 must be always in mesh with the Worm 5, unless it is required to throw it out of gear entirely, when it is only necessary to slide it up the Rod to its fullest extent. To prevent the Gear coming out of mesh with the Worm when in the slewed position, a Collar is fixed on the lower  $\frac{3}{4}$ " Belt, and in order to maintain the operating lever in position after movement, a Spring Clip 9A is mounted on the end of the Rod carrying the Cranks 9, and prevented from rotation by its ends engaging with a  $\frac{1}{2}$ "  $\times$   $\frac{1}{2}$ " Angle Bracket bolted to the Flat Trunnion. Hence the required stiffness in the movement of the lever is obtained.

The drive for the racking movement is taken off a  $\frac{1}{2}$ " fast Pulley 12

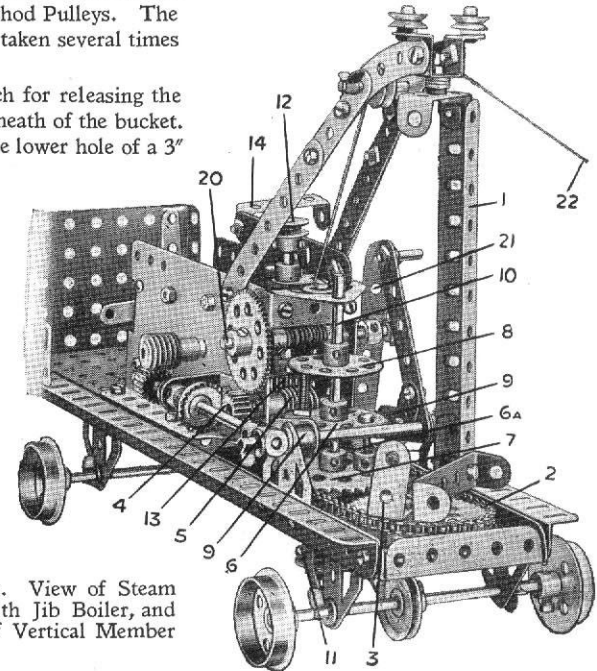

FIG. 4.61C. View of Steam Shovel with Jib Boiler, and portion of Vertical Member removed.

## Model No. 4.62 Steam Wagon

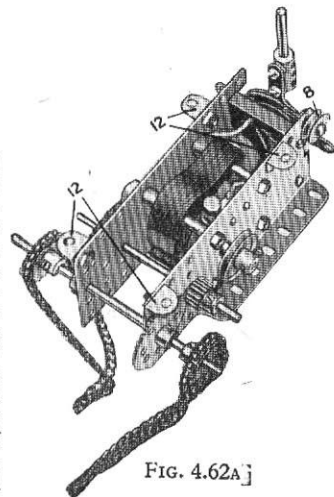
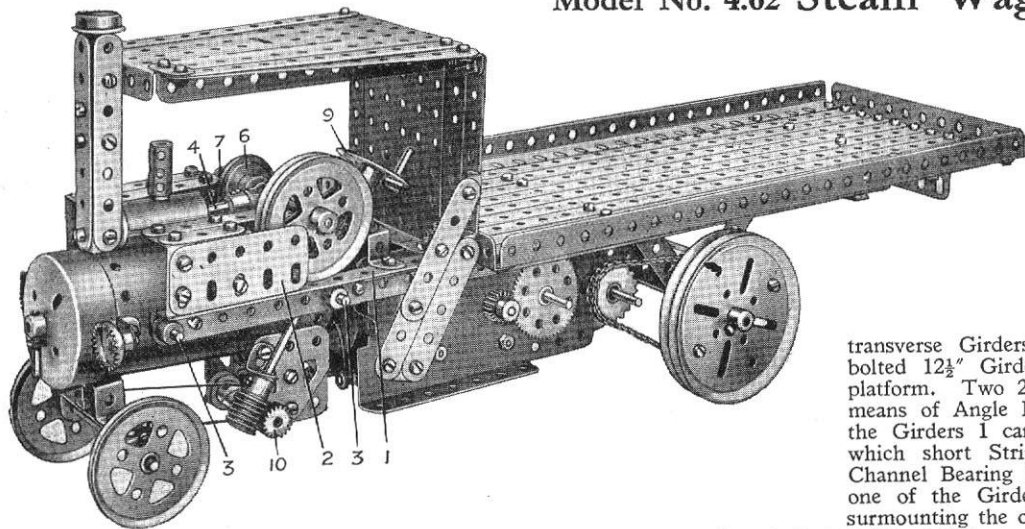

FIG. 4.62A]

The main frame and the bodywork (Fig. 4.62B) should first be constructed. The frame consists essentially of two Girders 1 each formed from two  $12\frac{1}{2}$ " Angle Girders overlapped and bolted together. The Girders 1 are spaced apart by  $5\frac{1}{2}$ " transverse Girders, to the ends of which are bolted  $12\frac{1}{2}$ " Girders forming the sides of the platform. Two  $2\frac{1}{2}$ " Flat Girders 2 secured by means of Angle Brackets to the front ends of the Girders 1 carry  $1" \times 1"$  Angle Brackets, to which short Strips are bolted as shown. A Channel Bearing is also secured in position to one of the Girders. The  $\frac{3}{4}"$  Flanged Wheel surmounting the chimney is mounted on a short

Rod carrying a Collar that is secured by the Bolt 14 (Fig. 4.62B).

The boiler unit (Fig. 4.62C) is held in position by two  $3\frac{1}{2}"$  Rods 3 that are passed through holes in the Girders 1,  $5\frac{1}{2}"$  Strips being bolted to the Girders to cover the elongated holes. A Sleeve Piece represents the cylinder, on the inside of which an Angle Bracket is secured to hold a short Rod 4 representing the piston connecting Rod. A small Fork Piece is carried on the Rod so that its fork engages with the  $3"$  Rod 5, journals for which are provided by a Double Bracket secured to the Boiler and by a Flat Bracket 7 that is bolted to the Channel Bearing on the frame. Two  $2"$  Pulleys serve as a flywheel while a  $1"$  Pulley 6 on the Rod takes up the drive from the armature spindle of the Electric Motor.

### Parts required :

9	of No.	1	5	of No.	16	1	of No.	35	2	of No.	96
6	"	2	3	"	17	127	"	37	2	"	103F
6	"	3	2	"	18A	5	"	37A	2	"	111
10	"	5	4	"	19B	24	"	38	6	"	111C
1	"	6A	4	"	20A	1	"	45	2	"	115
6	"	8	1	"	20B	2	"	48	1	"	116A
3	"	9	2	"	22	3	"	48A	1	"	125
4	"	10	3	"	23	1	"	52	4	"	126A
5	"	11	1	"	24	1	"	53	1	"	160
19	"	12	2	"	26	10	"	59	1	"	162A
4	"	12A	2	"	27A	2	"	63	1	"	162B
1	"	15	2	"	29	19"	"	94	1	"	163
2	"	15A	1	"	32	2	"	95	1	"	164

Electric Motor

(not included in Outfit)

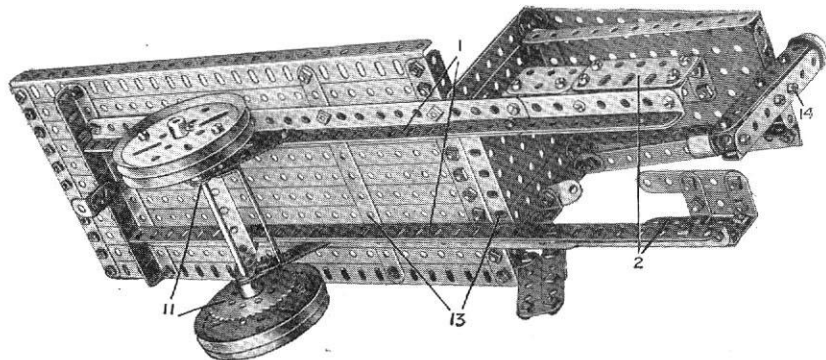

FIG. 4.62B

### Model No. 4.62 Steam Wagon (continued)

The "firebox" is formed by two pairs of Flat Trunnions held together by  $1\frac{1}{2} \times \frac{1}{2}$ " Double Angle Strips, one of which is secured to the Boiler. The frame so formed holds the steering mechanism, which is operated by the hand wheel 9, the Rod of which carries a Worm engaging the  $\frac{1}{2}$ " Pinion 10. This Pinion is secured on the end of a 2" Rod carrying a Coupling between two  $\frac{1}{2}$ " Pulleys, and a length of cord wound round the Coupling has its ends secured to the Double Angle Strip carrying the front axle. The Double Angle Strip is bolted to a Double Bent Strip, which is pivoted by a Bolt and two Nuts to the underside of the Boiler.

Fig 4.62A shows the arrangement of the gearing for the drive to the rear axle. A  $\frac{1}{2}$ " Pinion on the Motor armature spindle engages a 57-teeth Gear on a Rod that carries a further Pinion engaging a second Gear. The Rod of the latter carries two  $\frac{1}{2}$ " Sprockets from which the drive is led by means of

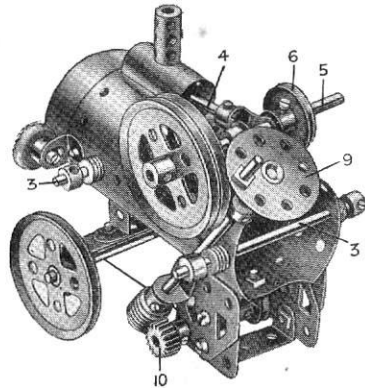

FIG. 4.62c

The switch arm of the Motor is extended by means of a short Rod held in a Coupling, to facilitate control from the cab. The Coupling is secured by two bolts passed through holes in the switch arm and screwed into the tapped holes of the Coupling. Each of the Bolts carries a Nut for spacing purposes.

When the three units, Figs. 4.62A, 4.62B, and 4.62c have been assembled and fitted together to form the complete model, all moving parts should be examined to see if they work freely. Rotating shafts should be oiled, and for this purpose Meccano Lubricating Oil is excellent.

Rubber covered wire is used for connecting the Accumulator and Motor.

Gear. The Rod of the latter carries two  $\frac{1}{2}$ " Sprockets from which the drive is led by means of the Sprockets 11 (Fig. 4.62B). The armature shaft of the Motor also carries a 1" Pulley which transmits the drive via a belt to the Rod carrying the flywheel. The belt after passing round the Pulley 6 is crossed, passed on either side of the Pulley 8 (Fig. 4.62A), and again crossed before being led round the Pulley on the Motor spindle. The Motor is held in position by the Angle Brackets 12, the Bolts of which pass through the holes 13 (Fig. 4.62B) and corresponding holes on the opposite side of the wagon.

### Model No. 4.63 Trailer (for Lorry or Traction Engine)

Parts required :

9	of No.	1
4	" "	2
4	" "	3
8	" "	5
2	" "	8
4	" "	9
2	" "	10
1	" "	11

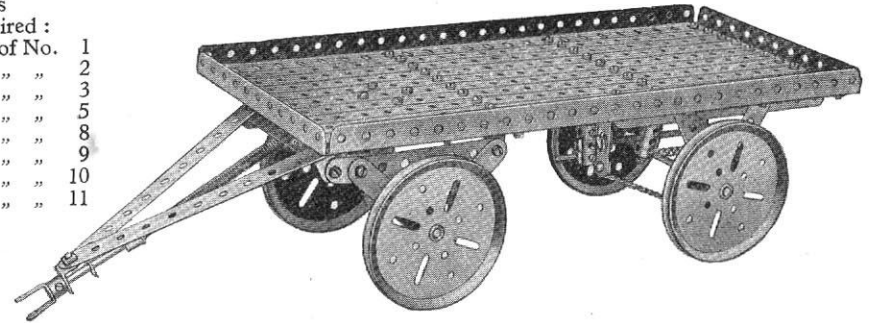

2	of No.	15A
1	" "	17
1	" "	18A
4	" "	19B
1	" "	20
1	" "	24
68	" "	37
7	" "	37A
6	" "	38
1	" "	43
1	" "	46
3	" "	48B
3	" "	59
2	" "	63
1	" "	80A
7"	" "	94
1	" "	109
2	" "	111
1	" "	111c
1	" "	115
1	" "	116
1	" "	162A
1	" "	166

A Face Plate 1 (Fig. 4.63A) is bolted to the Strips of the platform and a  $1\frac{1}{2}$ " Rod 2 secured in its boss passes through the centre hole of a Boiler End, which is held in position on the Rod by a Collar. Two  $3\frac{1}{2} \times \frac{1}{2}$ " Strips are bolted to the Boiler End and to these  $3\frac{1}{2} \times \frac{1}{2}$ " Double Angle Strips are secured but spaced by means of Collars and Washers. A further Double Angle Strip, to which the drawbar is connected, is attached loosely by lock-nutted Bolts 3.

A brake is provided by the Sprocket Chain 4, which passes over a drum formed from a Flanged Wheel and Bush Wheel on the back axle. The tension on the Chain is varied by operating the hand Wheel 5 on a Threaded Rod, along which travels a Coupling carrying one end of the Chain.

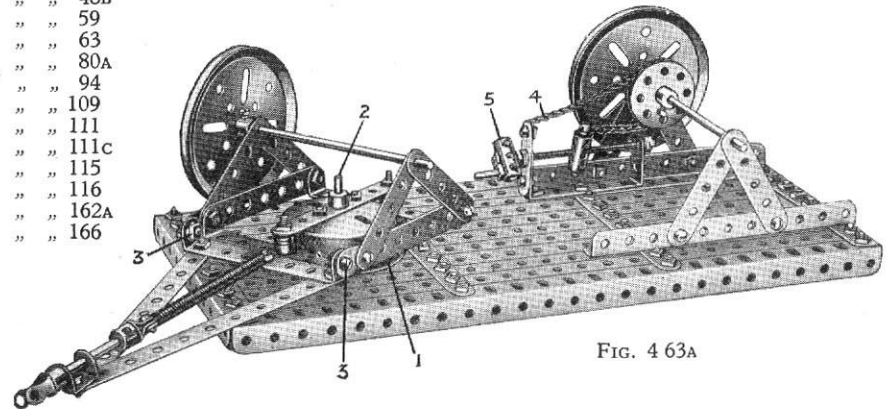

FIG. 4.63A

## Model No. 4.64 Rotating Crane

The jib of the crane is raised or lowered by means of the cord 1 the end of which is tied to a Flat Bracket 2 mounted on the Rod 4 in the gear box. The cord is led over the Rod 3, round Rod 4, again over Rod 3, and then is wound on the Rod 5. One end of the cord 6, which raises the Hook 7, is tied to the jib of the crane and the other end is wound on the Rod 8. Each of the Rods 5, 8 carries a 57-teeth Gear Wheel (see Fig. 4.64A) that meshes with a Worm secured to a sliding 5" Rod 14, 15, to the opposite end of which is secured a  $\frac{3}{4}$ " Contrate Wheel. Two 6 $\frac{1}{2}$ " Rods 9, 10 are connected to the Rods 14, 15 by means of Cranks, so that by operating their respective handles the  $\frac{3}{4}$ " Contrate Wheels may be brought into engagement with  $\frac{1}{2}$ " Pinions 11, 12 secured one on each end of the armature of the Electric Motor.

A Spring 13, secured to the clutch Rod 9 by means of a Collar, ensures that the load is raised or lowered only while the clutch is held in position by the hand, but the clutch for raising and lowering the jib may be left in operation as long as desired.

### Parts required:

10	of No. 1		
12	" "	2	
5	" "	5	
1	" "	6A	
9	" "	8	
2	" "	9	
1	" "	10	
6	" "	12	
6	" "	12A	
2	" "	14	
4	" "	15	
2	" "	15A	
2	" "	16	
2	" "	17	
2	" "	19B	
2	" "	20B	2 of No. 32
2	" "	22	8 " " 35
2	" "	22A	107 " " 37
2	" "	24	6 " " 37A
2	" "	26	10 " " 38
2	" "	27A	1 " " 40
2	" "	29	1 " " 43
			2 of No. 48A
			1 " " 48B
			2 " " 52
			4 " " 53

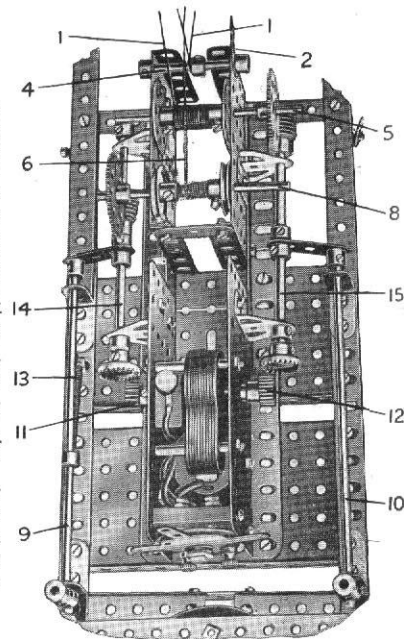

FIG. 4.64A

### Parts required (continued):

2	of No. 54
1	" " 57c
10	" " 59
2	" " 62
2	" " 63
2	" " 111
5	" " 111c
4	" " 126
1	" " 147B

Electric Motor  
(not included  
in Outfit)

## Model No. 4.65 Submarine

Parts required :

8	of	No. 1	2	of	No. 35
7	"	"	111	"	"
6	"	"	1	"	"
2	"	"	9	"	48A
2	"	"	5	"	48B
4	"	"	2	"	52
11	"	"	3	"	53
1	"	"	6	"	59
1	"	"	2	"	63
2	"	"	3	"	90A
1	"	"	4	"	99
2	"	"	2	"	100
2	"	"	2	"	103F
4	"	"	2	"	115
1	"	"	1	"	126A
3	"	"			
2	"	"			
1	"	"			

This model represents a large submarine of the latest type. It is equipped with wireless mast, periscope, quick-firing gun, and a workable steering gear controlled from the conning-tower.

Figure 4.65A is a sectional view of the conning-tower, and shows the helm. The cord 1, after passing over the 1" fast Pulley 7, is carried round a pair of 1" loose Pulley Wheels on the 5" Rod 2, and is given a complete turn round the 1" fixed Pulley Wheel 3 secured to the rudder head. The rudder consists of two 2½" Flat Girders, which are bolted by means of Angle Brackets to a pair of Cranks mounted on the Rod 4. The short Rod carrying the Pulley 7 is journalled in a 2½" × ½" Double Angle Strip 8, and is held in place by a Collar and set-screw on its end. Washers should be placed between the Pulley 7 and Strip 8.

The 5½" × 2½" Flanged Plates that form the deck of the submarine are bolted together by means of 5½" Angle Girders, which in turn, are bolted to 3½" × ½" Double Angle Strips secured transversely in the hull of the vessel. The hull itself is strengthened by vertical 3" Strips 5. The sides of the conning-tower are represented by two 3½" × 2½" Flanged Plates, the forward part being composed of a 2½" small radius Curved Strip and five 2½" × ½" Double Angle Strips. The periscope consists of a Coupling and a 5" Rod, which is supported in a further 2½" × ½" Double Angle Strip 6.

The vertical Rod supporting the quick-firing gun is free to turn in a Bush Wheel bolted to the deck. Two Collars should be placed on the Rod, one on each side of the Bush Wheel, to maintain the gun in position. The model is arranged to travel on two pairs of ¾" Flanged Wheels secured to 3½" Axle Rods.

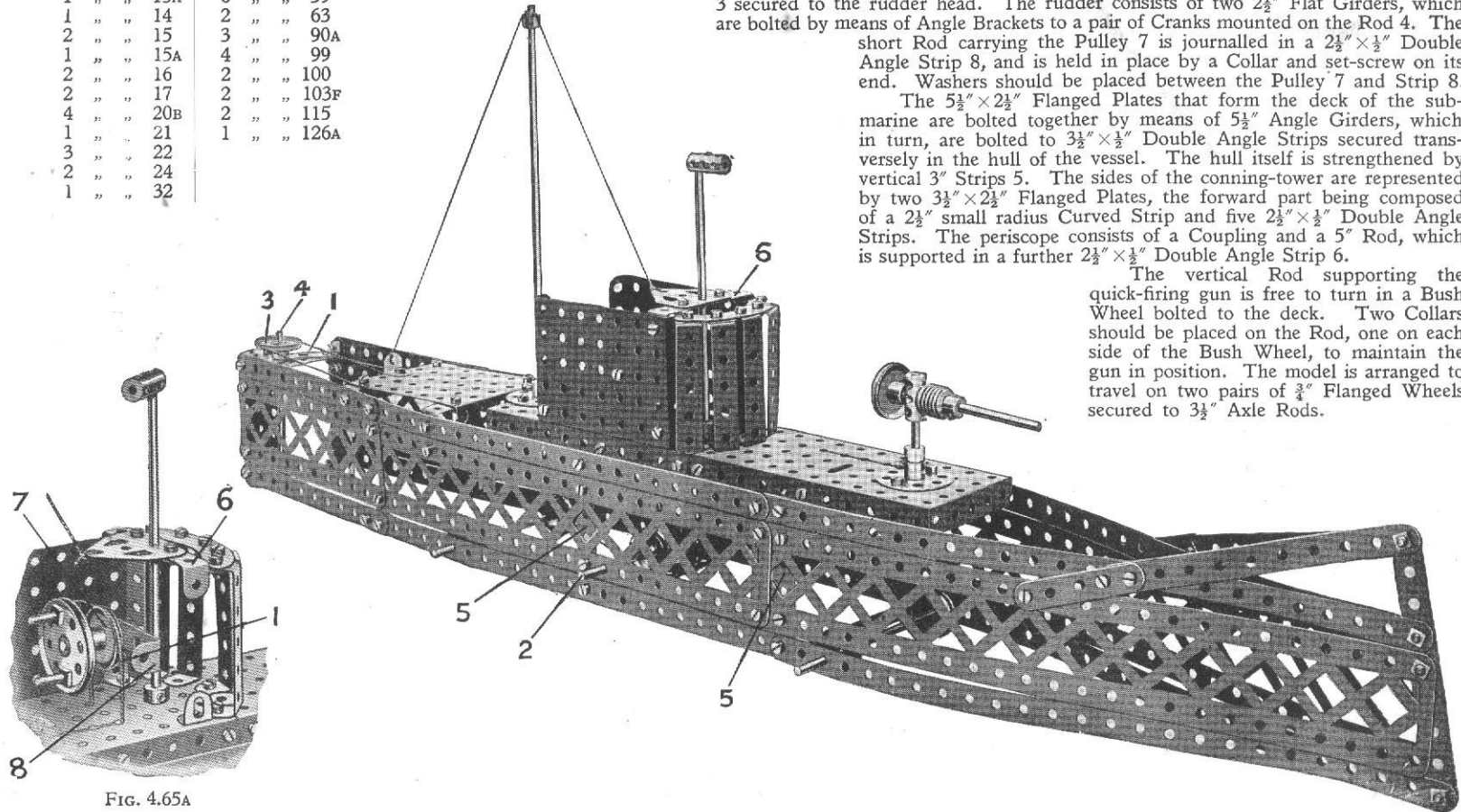
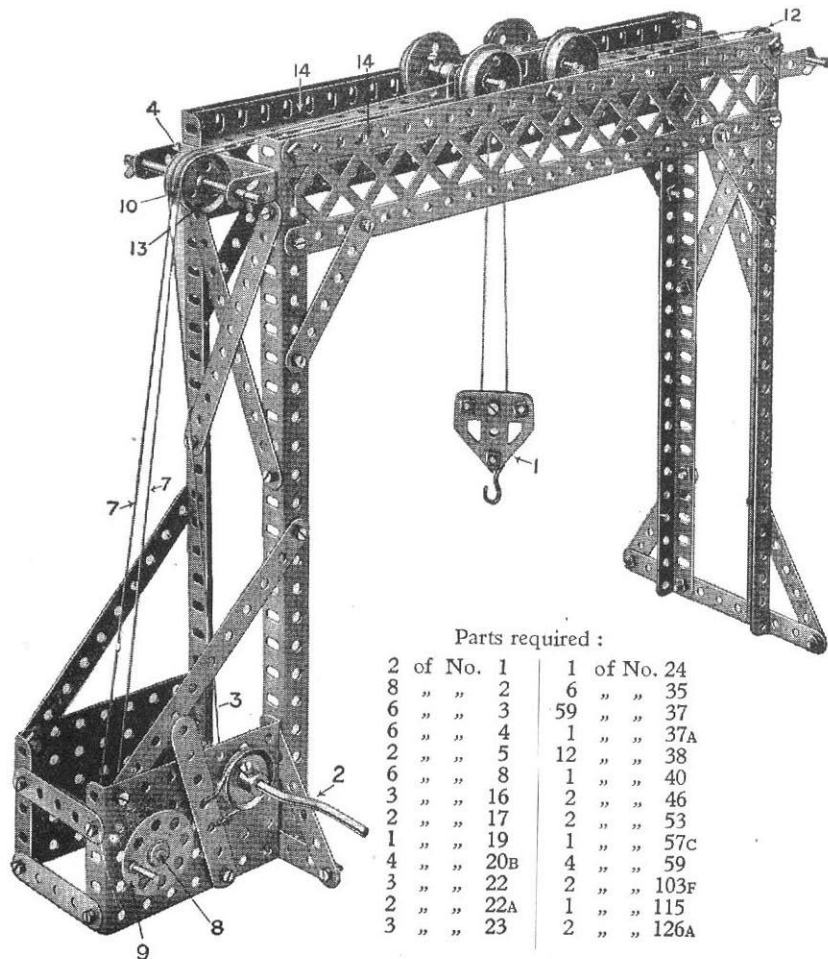

FIG. 4.65A



## Parts required :

2	of No. 1	1	of No. 24
8	" " 2	6	" " 35
6	" " 3	59	" " 37
6	" " 4	1	" " 37A
2	" " 5	12	" " 38
6	" " 8	1	" " 40
3	" " 16	2	" " 46
2	" " 17	2	" " 53
1	" " 19	1	" " 57C
4	" " 20B	4	" " 59
3	" " 22	2	" " 103F
2	" " 22A	1	" " 115
3	" " 23	2	" " 126A

## Model No. 4.66 Gantry Crane

The Pulley 1 is capable of being hoisted to raise the load, or traversed. In order to raise the load the Crank Handle 2 is operated, which winds the Cord 3 passing over the rear Pulley Wheel 4 round the  $\frac{1}{2}$ " Pulley 5 and a corresponding Pulley in the block, thence round another  $\frac{1}{2}$ " Pulley 6 and is made fast at the end of the gantry. For traversing, a continuous Cord 7 is wound several turns on the  $3\frac{1}{2}$ " Rod 8 to which is secured a hand wheel 9. The cord passes over the Pulley Wheel 10 and is secured to one of the side Plates 11, and continues round the Pulley 12 returning to and passing over the nearest Pulley Wheel 13 back to the Rod 8. Consequently by turning the hand wheel 8 in one or other direction, the carriage is traversed to and fro along the top Angle Girders 14, which form the travelling rails. The construction of the travelling carriage is shown in Fig. 4.66A, three Washers 15 being placed on each of the outer Bolts, passing through the two Plates 11; and  $\frac{1}{2}$ " Pulley Wheels 5, 6, on the inner Bolts.

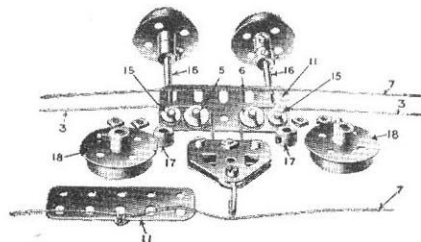

FIG. 4.66A.

then bolted together, the Rods 16 of the Flanged Wheels are passed through both plates in the end elongated holes, and Collars 17 secured on the exterior, after which the remaining Flanged Wheels 18 are secured on the ends of the Rods 16.

## HOW TO CONTINUE

This completes our examples of models that may be made with MECCANO Outfit No. 4 (or No. 3 and No. 3A). The next models are a little more advanced, requiring extra parts to construct them. The necessary parts are all contained in a No. 4A Accessory Outfit, the price of which may be obtained from any Meccano dealer.

### Model No. 5.1 Spooling Machine

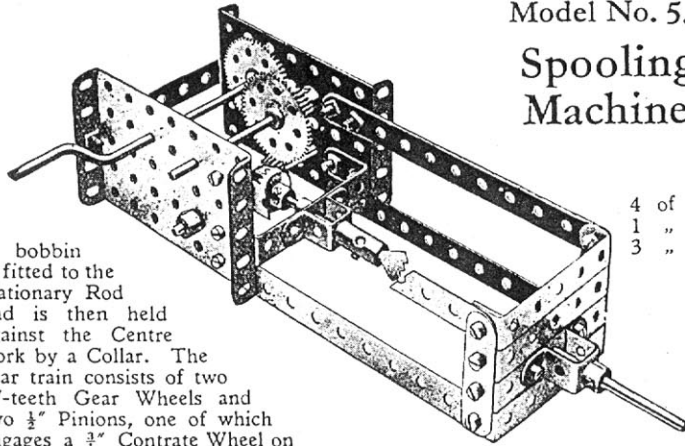

A bobbin is fitted to the stationary Rod and is then held against the Centre Fork by a Collar. The gear train consists of two 57-teeth Gear Wheels and two  $\frac{1}{2}$ " Pinions, one of which engages a  $\frac{1}{4}$ " Contrate Wheel on the spooling shaft.

Parts required :

4 of No. 2	1 of No. 17
1 " " 3	1 " " 19
3 " " 16	2 " " 26
	2 " " 27A
	1 " " 29
	20 " " 37
	2 " " 45
	1 " " 46
	4 " " 48A
	2 " " 53
	7 " " 59
	1 " " 63
	1 " " 65

### Model No. 5.2 Motor Car

Parts required :

2 of No. 2	2 of No. 10	1 of No. 16	2 of No. 26	3 of No. 48B
8 " " 3	8 " " 12	4 " " 19A	1 " " 28	2 " " 53
1 " " 5	6 " " 12A	2 " " 20	1 " " 32	2 " " 54
4 " " 6	1 " " 14	2 " " 22	75 " " 37	7 " " 59
2 " " 8	2 " " 15	2 " " 24	4 " " 38	2 " " 89
				2 " " 126A

Clockwork Motor  
(not included in outfit)

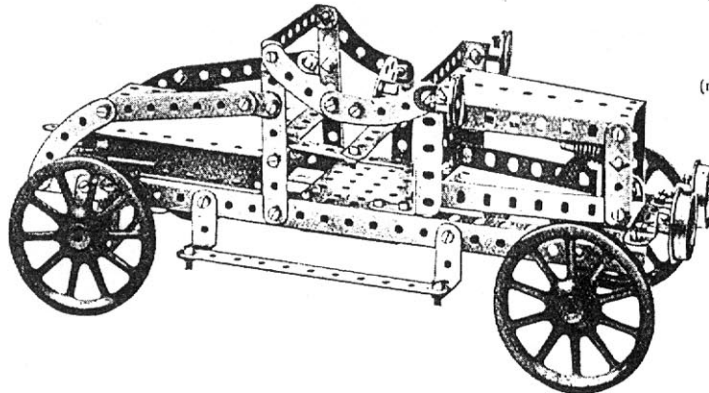

### Model No. 5.3 Cabin Monoplane

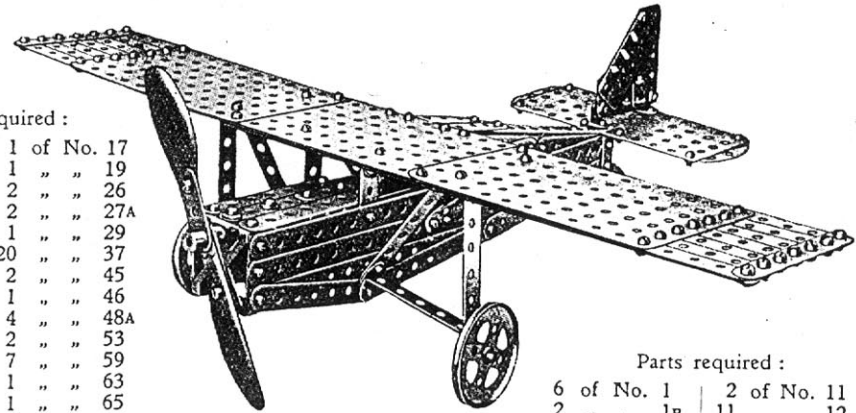

Parts required :

6 of No. 1	2 of No. 11
2 " " 1B	11 " " 12
6 " " 2	2 " " 12A
4 " " 2A	1 " " 16A
12 " " 3	2 " " 20A
6 " " 4	106 " " 37
17 " " 5	6 " " 37A
2 " " 6	8 " " 38
5 " " 6A	2 " " 41
6 " " 10	1 " " 48
	2 " " 48A
	3 " " 52A
	1 " " 59
	2 " " 62
	1 " " 70
	2 " " 90A
	3 " " 103F
	2 " " 111
	2 " " 111c
	2 " " 126

Fig. 5.3A is an underneath view of the model with one side removed, to show the construction of the fuselage and method of securing the wings to the undercarriage.

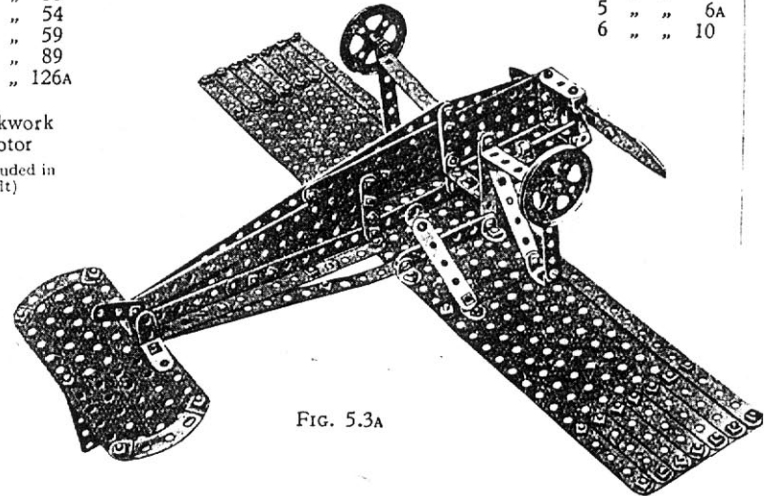
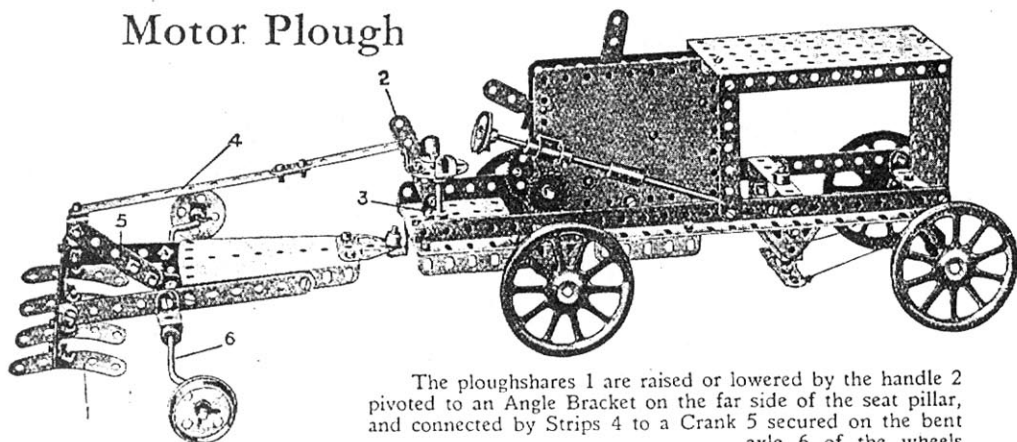

FIG. 5.3A

## Model No. 5.4 Motor Plough



The ploughshares 1 are raised or lowered by the handle 2 pivoted to an Angle Bracket on the far side of the seat pillar, and connected by Strips 4 to a Crank 5 secured on the bent axle 6 of the wheels formed by Crank Handles. The plough is driven by a Meccano Clockwork Motor.

### Parts required :

5 of No. 2	19 of No. 12	1 of No. 19s	1 of No. 29
3 " " 3	3 " " 15A	2 " " 20	4 " " 35
3 " " 5	1 " " 16	3 " " 22	24 " " 37
2 " " 8	3 " " 17	1 " " 24	6 " " 38
2 " " 10	1 " " 19	2 " " 26	1 " " 45
1 " " 11	4 " " 19A	1 " " 27A	1 " " 46
			4 " " 48A
			1 " " 52
			3 " " 53
			1 " " 54
			9 " " 59
			1 " " 62
			2 " " 63
			4 " " 90
			6 " " 94
			2 " " 96
			1 " " 115
			3 " " 125
			5 " " 125A

Clockwork  
Motor  
(not included in  
Outfit)

FIG. 5.4A

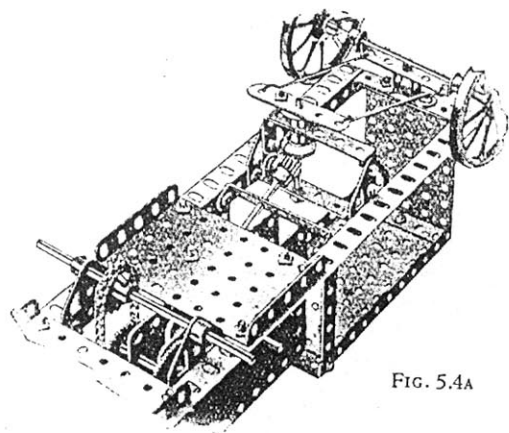

## Model No. 5.5 Fire Watertower

### Parts required :

2 of No. 2	1 of No. 22	2 of No. 53
2 " " 4	2 " " 24	9 " " 59
11 " " 5	1 " " 27A	2 " " 62
4 " " 8	1 " " 32	3 " " 63
3 " " 10	3 " " 35	1 " " 115
2 " " 11	65 " " 37	4 " " 126A
2 " " 12	2 " " 45	
3 " " 15A	1 " " 46	
4 " " 16	5 " " 48A	
2 " " 17	1 " " 52	
2 " " 19A		
4 " " 20		

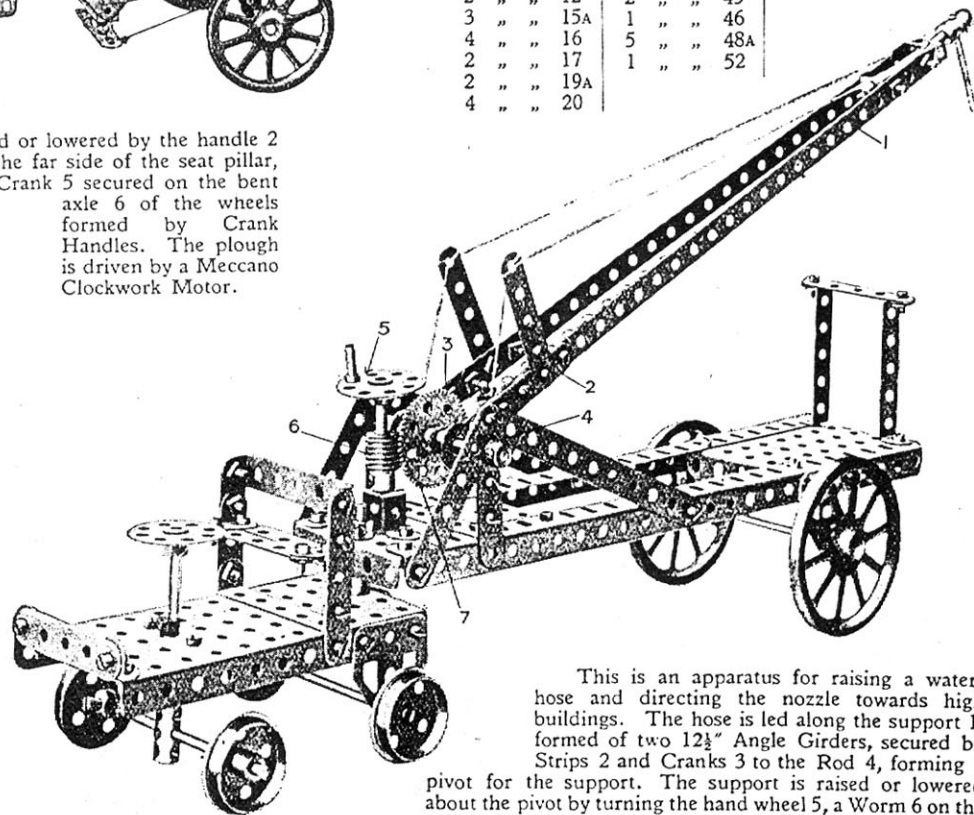

This is an apparatus for raising a water-hose and directing the nozzle towards high buildings. The hose is led along the support 1, formed of two 12½" Angle Girders, secured by Strips 2 and Cranks 3 to the Rod 4, forming a pivot for the support. The support is raised or lowered about the pivot by turning the hand wheel 5, a Worm 6 on the spindle of which engages a 57-toothed Wheel 7 on the Rod 4.



### Model No. 5.6 Spring Pistol

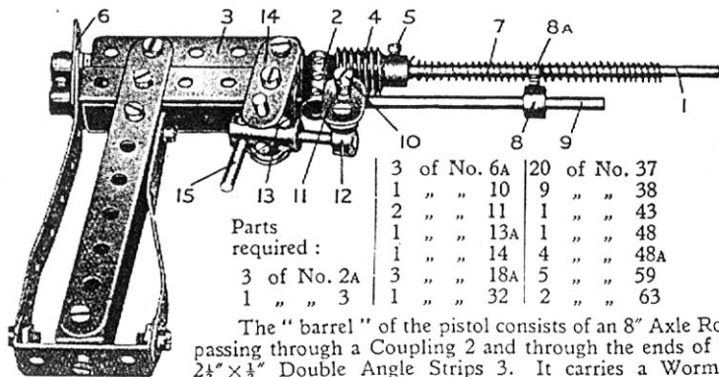

	3 of No. 6A	20 of No. 37
	1 " " 10	9 " " 38
	2 " " 11	1 " " 43
Parts required :	1 " " 13A	1 " " 48
	1 " " 14	4 " " 48A
	3 of No. 2A	3 " " 18A
	1 " " 3	5 " " 59
		2 " " 63

The "barrel" of the pistol consists of an 8" Axle Rod 1 passing through a Coupling 2 and through the ends of two 2½" x ½" Double Angle Strips 3. It carries a Worm 4 which is secured by a Bolt 5 in place of its grub-screw. This Bolt serves as the foresight, the backsight being formed by the upper hole of a 1½" Strip 6. A Meccano Spring secured by one of its end loops to the Bolt 5, is mounted on the barrel and opened out to form a compression spring. The loop at the other end should be cut away.

Collars, with set-screws extracted, may be used as bullets, or small pieces of wood of similar shape may be employed. The gun is loaded by placing the bullet upon the barrel and pushing the Spring 7 back until the bullet passes the Collar 8. The latter is rigidly secured by means of a Bolt 8A to a 6½" Rod 9, which is free to turn slightly in its bearings. The Bolt 8A is pushed in front of the bullet, so preventing the Spring 7 from expelling it from the barrel. Another Collar and Bolt 10 is secured to the Rod 9 and coupled by means of a Flat Bracket 11 to a Bolt mounted in a Collar 12. This in turn, is secured to a 1½" Rod inserted in a Coupling 13 pivotally mounted and spaced on either side by two Washers between 1½" Strips 14. A further Rod 15 forms a trigger, and a slight touch on this pulls the Bolt 8A clear of the bullet, so firing the pistol.

The pistol should possess a range of ten yards or more.

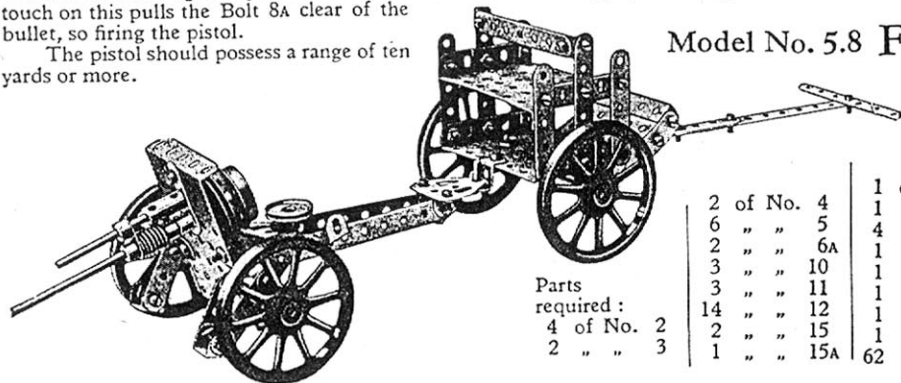

	2 of No. 4	1 of No. 16
	6 " " 5	1 " " 18A
	2 " " 6A	4 " " 19A
Parts required :	3 " " 10	1 " " 20
	3 " " 11	1 " " 21
	14 " " 12	1 " " 22
	2 " " 15	1 " " 24
	2 " " 3	1 " " 32
	1 " " 15A	62 " " 37
		2 of No. 38
		3 " " 48A
		2 " " 48B
		2 " " 53
		3 " " 59
		1 " " 62
		1 " " 63
		2 " " 90
		1 " " 115
		2 " " 125
		2 " " 126A

### Model No. 5.7 Fertiliser Distributing Cart

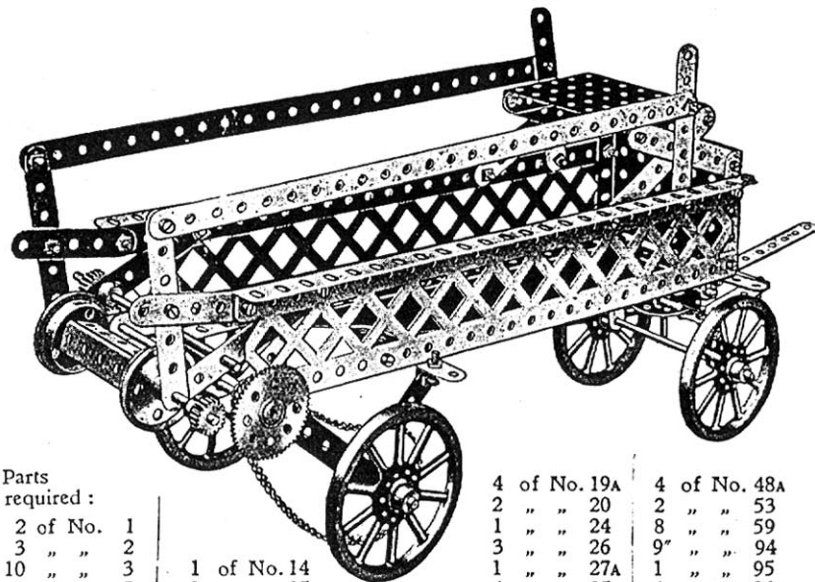

Parts required :	4 of No. 19A	4 of No. 48A
	2 " " 20	2 " " 53
	1 " " 24	8 " " 59
	3 " " 26	9 " " 94
	1 " " 27A	1 " " 95
	4 " " 35	1 " " 96
	57 " " 37	2 " " 99
	1 " " 46	

### Model No. 5.8 Field Gun and Carriage

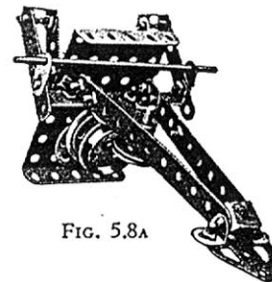
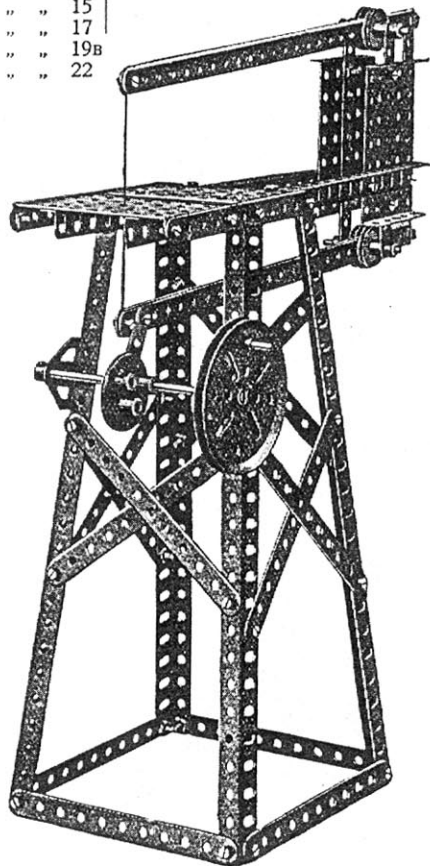

FIG. 5.8A

### Model No. 5.9 Fret Saw

Parts required :

4 of No. 1	53 of No. 37	1 of No. 115
17 " " 2	4 " " 53	2 " " 126A
6 " " 8	5 " " 59	1 " " 130
1 " " 15		
2 " " 17		
1 " " 19B		
4 " " 22		



Parts required :

1 of No. 1
1 " " 1B
4 " " 2
2 " " 2A
12 " " 3
1 " " 5
5 " " 6A
2 " " 8
2 " " 8A
4 " " 9
12 " " 10
21 " " 12
2 " " 12A
1 " " 15
1 " " 15A
1 " " 16
1 " " 16A
1 " " 17
4 " " 20A
1 " " 21
4 " " 22
1 " " 23
1 " " 26
1 " " 27A
2 " " 29
112 " " 37
11 " " 37A
4 " " 38
1 " " 40
1 " " 48A
6 " " 48B
2 " " 52A
2 " " 53
1 " " 54
9 " " 59
2 " " 77
4 " " 90A
7 " " 94
1 " " 96
1 " " 96A
3 " " 111
3 " " 111C
4 " " 142A
1 " " 160

Clockwork Motor  
Motor  
(not included in Outfit)

### Model No. 5.10 Char-à-Banc

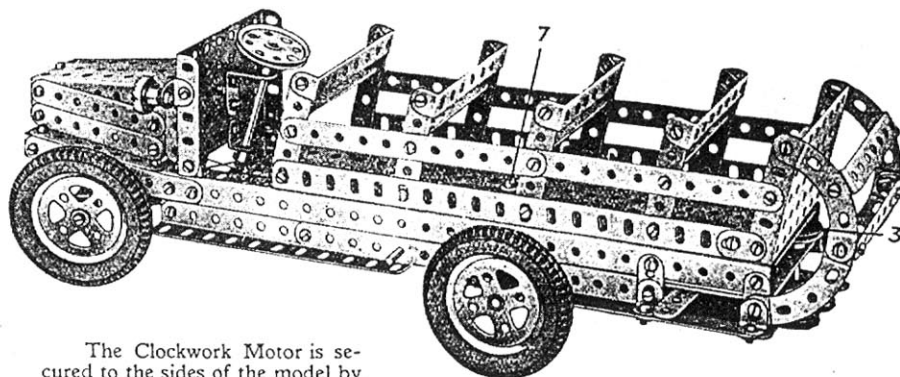

The Clockwork Motor is secured to the sides of the model by means of two 5½" Angle Girders 8 (Fig. 5.10A) and the ½" Pinion on the Motor driving shaft engages with a 57-teeth Gear on the Rod 1. Two 1" Pulleys 2 and 3 are secured to each extremity of this Rod and are connected by cord to the Pulleys on the Rod 4. The jockey pulley 5, over which one side of the cord passes, is mounted on the Motor side plate by a Flat Bracket and an Angle Bracket. The Rod 6, which guides the cord to and from the Pulley 3, is journalled at one end in the side of the model and at the other in a Collar secured to the floor by a Bolt 7.

Steering is accomplished by means of a cord passed about four times round the lower end of the steering column and connected to each end of the 3½" x ½" Double Angle Strip 9. This latter is pivoted at its centre hole to a 1½" Strip secured to the fore part of the bonnet by a 1" x 1" Angle Bracket.

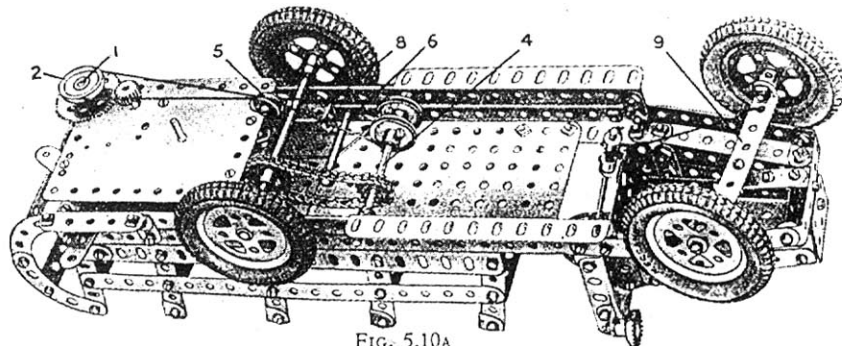
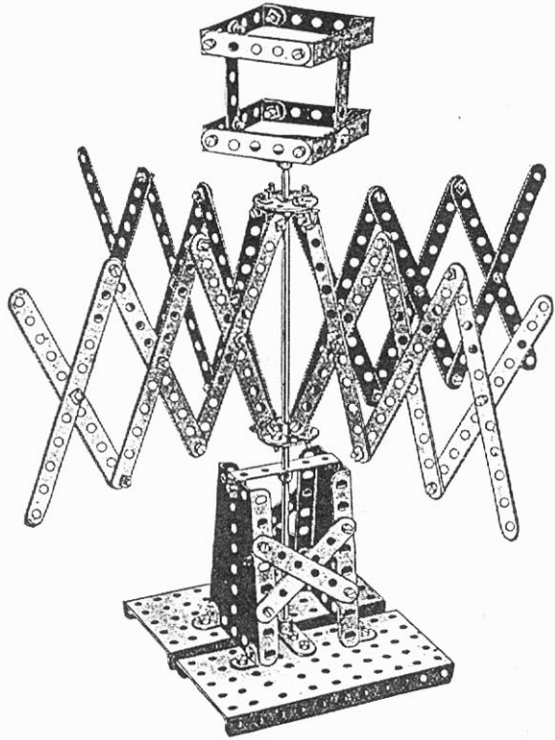

FIG. 5.10A

## Model No. 5.11 Skein Winder



Parts required :

24 of No.	2	2 of No.	24
4 " "	4	86 " "	37
7 " "	5	5 " "	48A
8 " "	12	2 " "	52
1 " "	13	2 " "	54
1 " "	21	2 " "	59

Parts required :

2 of No.	1
1 " "	5
1 " "	15
1 " "	16
2 " "	17
2 " "	19A
1 " "	22
1 " "	26
2 " "	29
1 " "	32
22 " "	37
1 " "	46
5 " "	48A
1 " "	48B
1 " "	59
1 " "	63
1 " "	65
2 " "	90
1 " "	95
1 " "	96
1 " "	125

## Model No. 5.12 Measuring Machine

The drive is transmitted from the road wheels by a  $\frac{3}{4}$ " Contrate Wheel engaging a  $\frac{1}{2}$ " Pinion. A Worm on the shaft of the latter engages another  $\frac{1}{2}$ " Pinion, on the Rod of which is fixed a pointer which indicates up to five yards. When this pointer touches the 2" Sprocket Wheel, on which is fixed a second indicating dial, it turns the wheel round one tooth, representing five yards.

A Ratchet is fixed at the other end of the pointer Rod. It consists of a 1" Sprocket Wheel and a  $2\frac{1}{2}$ " Strip that is bolted to the frame by a  $\frac{1}{2}$ " Reversed Angle Bracket.

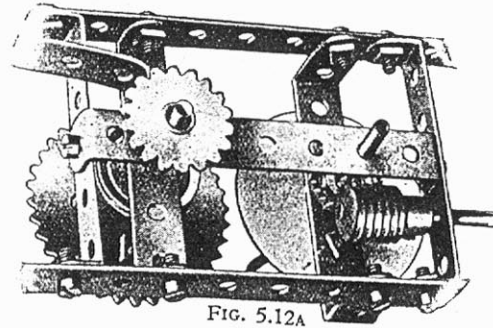
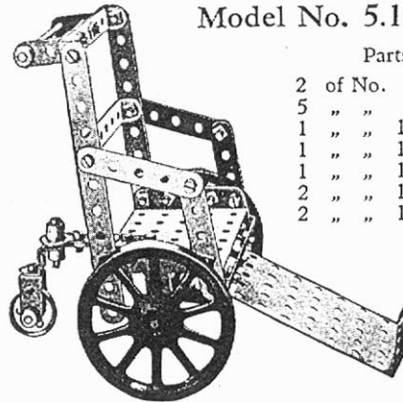

FIG. 5.12A

## Model No. 5.13 Invalid Chair



Parts required :

2 of No.	2	1 of No.	22A
5 " "	5	25 " "	37
1 " "	10	5 " "	38
1 " "	15A	1 " "	46
1 " "	16	3 " "	48B
2 " "	18A	2 " "	53
2 " "	19A	5 " "	59
		1 " "	62
		1 " "	102
		1 " "	125
		2 " "	126A

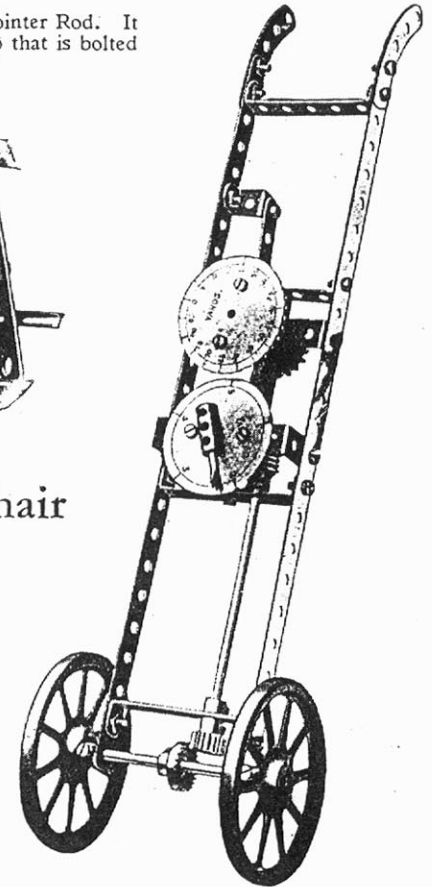

### Model No. 5.14 Pit Head Gear

The Rod 1 is driven from the Motor by means of the gearing shown (the short Rod carrying the two  $\frac{1}{2}$ " Pinions being journalled in a Channel Bearing bolted to the side of the Motor) and has a Worm secured to it between the Motor side plates. This Worm engages with the  $\frac{1}{4}$ " Pinion 2, which rotates the depth indicating disc when the model is working, the depth being marked by the fixed pointer 3. A  $\frac{1}{2}$ " Sprocket secured to the end of Rod 1 is connected by the Sprocket Chain 14 to a 2" Sprocket Wheel on the wind shaft, which consists of two  $\frac{1}{2}$ " Rods joined together by a Coupling. The winding drum, a Boiler, is carried between two 3" Pulleys 4 secured to this shaft, and to prevent the drum from slipping, a  $1\frac{1}{2}$ " Rod 5 is passed through both sides of the Boiler and secured in the centre transverse hole of the Coupling joining the two halves of the winding shaft.

A brake consisting of a  $3\frac{1}{2}$ " Screwed Rod working in the threaded hole of a fixed Coupling 6 and in the end hole of the  $1\frac{1}{2} \times 1\frac{1}{2}$ " Angle Bracket 7 carries a Small Fork Piece, to which one end of the brake band is secured, the other end being attached to the base of the model. The Fork Piece is allowed to revolve freely between a Collar and locknuts.

When one of the cages reaches the top it engages with the  $1\frac{1}{2}$ " Strip 8 and thus raises the gate. As the latter nears the top of the slide it raises a Coupling 9, which is connected to the reversing lever of the Motor by a length of cord. In this way a very effective safety switch is provided. The cord from each Coupling 9 passes round a  $1\frac{1}{2}$ " loose Pulley 12 and a  $1\frac{1}{2}$ " fast Pulley 10 and finally round a  $1\frac{1}{2}$ " Rod 11 journalled in a Double Bracket.

The cages can, of course, be made to descend to any desired depth, but they must be arranged so that as one reaches ground level and stops the Motor by pushing the gate against one of the Couplings 9, the other is exactly at the bottom of the shaft. To economise in space, the lower cage is shown raised in the illustration to a point just below the cage which has reached ground level.

The guide cords 13 are secured at the top to  $5\frac{1}{2}$ " Strips secured across the framework and at the bottom to  $9\frac{1}{2}$ " Angle Girders not shown in the illustration. The latter girders should be screwed to the floor or held down firmly by heavy weights.

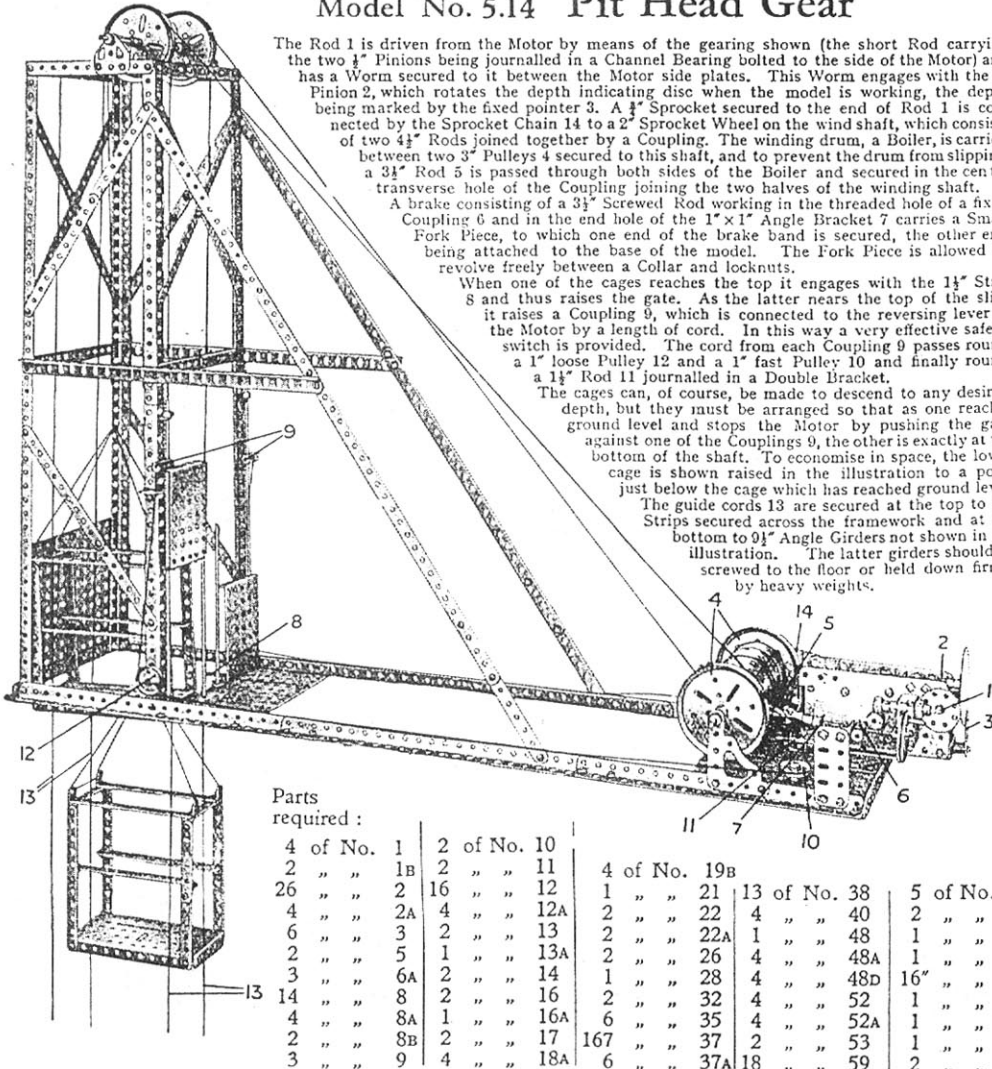

Parts required :

4 of No. 1	2 of No. 10
2 " " 1B	2 " " 11
26 " " 2	16 " " 12
4 " " 2A	4 " " 12A
6 " " 3	2 " " 13
2 " " 5	1 " " 13A
3 " " 6A	2 " " 14
14 " " 8	2 " " 16
4 " " 8A	1 " " 16A
2 " " 8B	2 " " 17
3 " " 9	4 " " 18A

4 of No. 19B

1 " " 21	13 of No. 38
2 " " 22	4 " " 40
2 " " 22A	1 " " 48
2 " " 26	4 " " 48A
1 " " 28	4 " " 48D
2 " " 32	4 " " 52
6 " " 35	4 " " 52A
167 " " 37	2 " " 53
6 " " 37A	18 " " 59

5 of No. 26
2 " " 63
1 " " 70
1 " " 80A
16" " 94
1 " " 95
1 " " 96
1 " " 103F
2 " " 108

1 of No. 109
1 " " 111
4 " " 111c
2 " " 115
1 " " 116A
2 " " 126A
1 " " 147B
1 " " 160
1 " " 162
Electric Motor (not included in Outfit)

Parts required :	2
3 of No. 2	3
4 " " 3	5
5 " " 5	8
2 " " 8	10
2 " " 10	12
11 " " 12	15A
2 " " 15A	16
1 " " 16	17
1 " " 17	24
4 " " 24	37
2 " " 37	38
63 " " 38	45
2 " " 45	48
2 " " 48	48B
2 " " 48B	53
3 " " 53	54
1 " " 54	59
3 " " 59	62
1 " " 62	90
4 " " 90	94
12" " 94	95
1 " " 95	96
2 " " 96	108
1 " " 108	125
1 " " 125	126A
3 " " 126A	
Clockwork Motor (not included in Outfit)	

### Model No. 5.15 Motor Car

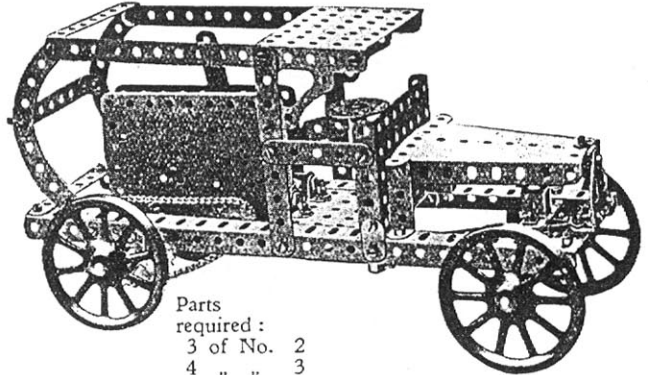

The steering wheel is mounted on a short Rod that is journalled in a  $3\frac{1}{2} \times 2\frac{1}{2}$ " Flanged Plate and in a Double Bent Strip secured to the Plate (see Fig. 5.15A). The lower end of the Rod carries a Crank that is connected to the swivelling front axle by a  $5\frac{1}{2}$ " Strip, which is pivoted at both ends by Bolts and Nuts (S.M. 262).

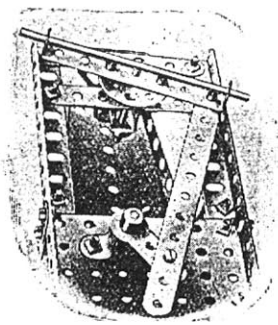
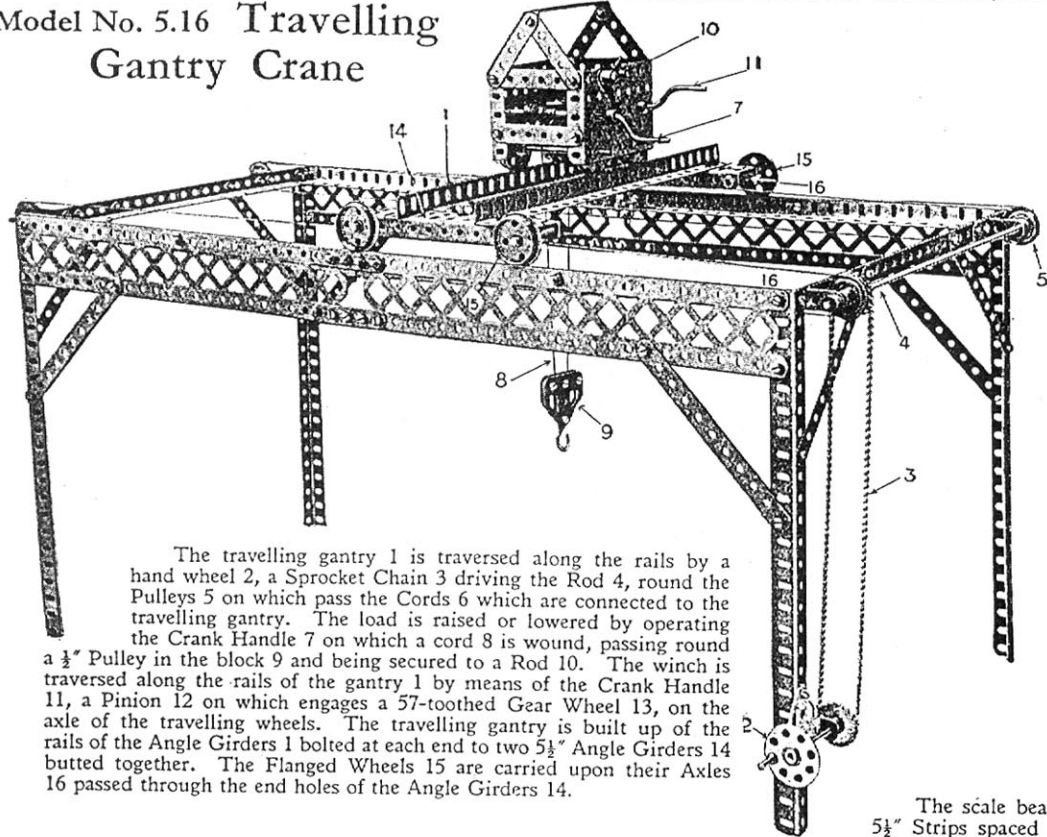

FIG. 5.15A

# Model No. 5.16 Travelling Gantry Crane

# Model No. 5.17 Spring Scales



The travelling gantry 1 is traversed along the rails by a hand wheel 2, a Sprocket Chain 3 driving the Rod 4, round the Pulleys 5 on which pass the Cords 6 which are connected to the travelling gantry. The load is raised or lowered by operating the Crank Handle 7 on which a cord 8 is wound, passing round a  $\frac{1}{2}$ " Pulley in the block 9 and being secured to a Rod 10. The winch is traversed along the rails of the gantry 1 by means of the Crank Handle 11, a Pinion 12 on which engages a 57-toothed Gear Wheel 13, on the axle of the travelling wheels. The travelling gantry is built up of the rails of the Angle Girders 1 bolted at each end to two  $5\frac{1}{2}$ " Angle Girders 14 bolted together. The Flanged Wheels 15 are carried upon their Axles 16 passed through the end holes of the Angle Girders 14.

Parts required :

- 6 of No. 2
- 2 " " 4
- 2 " " 8
- 2 " " 10
- 3 " " 11
- 2 " " 15
- 1 " " 15A
- 2 " " 16
- 2 " " 17
- 1 " " 18A
- 2 " " 26
- 2 " " 27A
- 23 " " 37
- 1 " " 40
- 1 " " 43
- 2 " " 48A
- 1 " " 52
- 1 " " 54
- 1 " " 57C
- 2 " " 59
- 2 " " 62
- 2 " " 63
- 1 " " 111

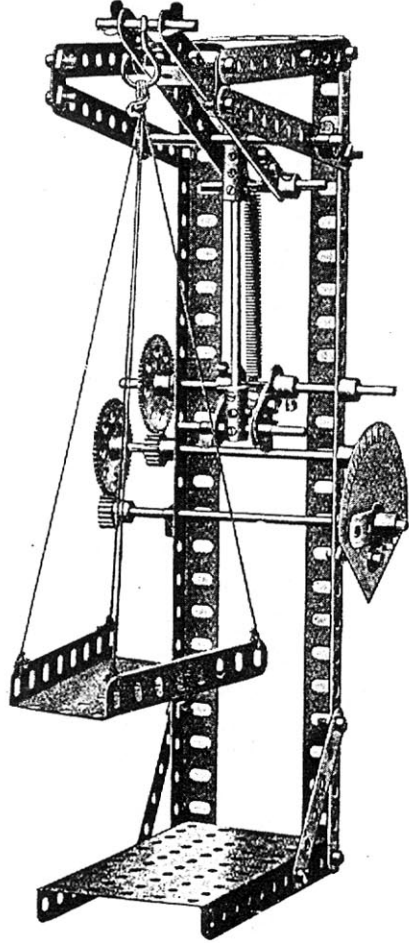

The scale beam consists of two  $5\frac{1}{2}$ " Strips spaced apart by Double Brackets. A vertical Rod is connected pivotally to the beam by means of a  $\frac{3}{8}$ " Bolt, and to a short Rod passed through the ends of two Cranks. The latter are secured to an axle which carries a 57-teeth Gear Wheel, the motion of which is led through the gear train shown to a pointer moving over a graduated scale. A Meccano Spring, attached to the Rod carrying the Cranks, is connected to the end of the beam and acts as the spring balance.

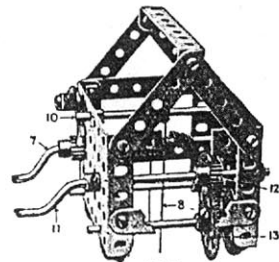
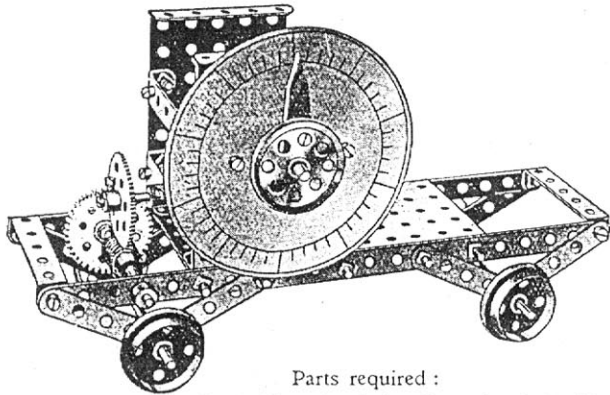

FIG. 5.16A.

Parts required :

- |            |             |             |               |
|------------|-------------|-------------|---------------|
| 4 of No. 1 | 5 of No. 17 | 2 of No. 35 | 24" of No. 94 |
| 8 " " 2    | 1 " " 19    | 96 " " 37   | 2 " " 96      |
| 4 " " 4    | 1 " " 19s   | 6 " " 38    | 4 " " 99      |
| 10 " " 5   | 8 " " 20    | 1 " " 40    | 4 " " 100     |
| 12 " " 8   | 4 " " 22    | 1 " " 48    | 2 " " 115     |
| 4 " " 9    | 1 " " 23    | 1 " " 48B   | 3 " " 126A    |
| 2 " " 11   | 1 " " 24    | 2 " " 53    | 1 " " 147A    |
| 4 " " 12A  | 1 " " 26    | 1 " " 57C   | 1 " " 147B    |
| 2 " " 13   | 1 " " 27A   | 8 " " 59    | 1 " " 148     |
| 3 " " 16   |             |             |               |

### Model No. 5.18 Distance Indicator



Parts required :

4 of No. 2	2 of No. 15A	2 of No. 22	1 of No. 32
4 " " 3	1 " " 16	1 " " 24	38 " " 37
8 " " 5	1 " " 17	2 " " 26	2 " " 48A
10 " " 12	4 " " 20	2 " " 27A	1 " " 52
2 " " 15	1 " " 21	1 " " 28	2 " " 53
			6 " " 59

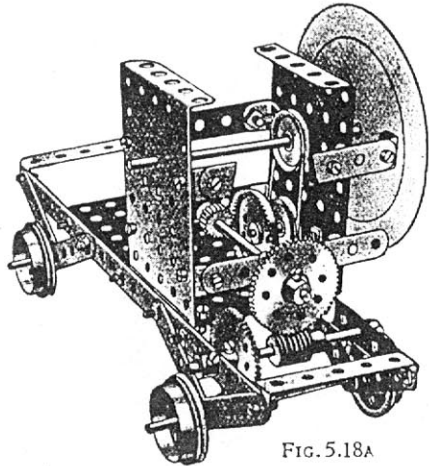

FIG. 5.18A

### Model No. 5.19

Parts required :

6 of No. 2	2
3 " " 3	3
19 " " 5	5
8 " " 8	8
2 " " 10	10
1 " " 11	11
10 " " 12	12
1 " " 14	14
1 " " 15	15
1 " " 18A	18A
4 " " 19A	19A
1 " " 21	21
1 " " 24	24
62 " " 37	37
1 " " 47	47
6 " " 59	59

### Brewer's Dray

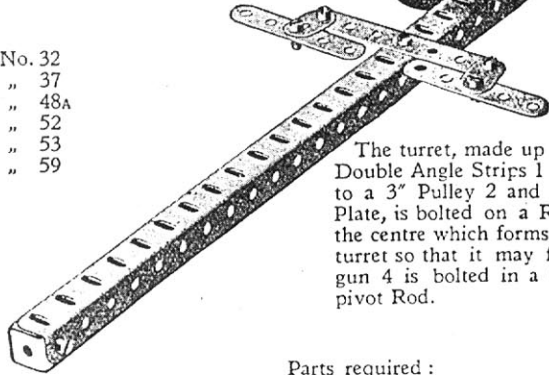
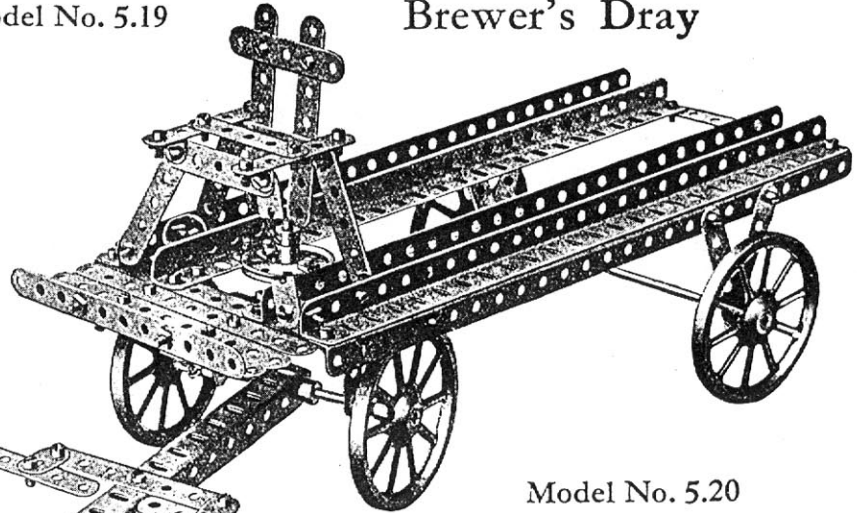

The turret, made up of a number of Double Angle Strips 1 bolted at the top to a 3" Pulley 2 and below to a Face Plate, is bolted on a Rod 3 passing up the centre which forms the pivot of the turret so that it may freely turn. The gun 4 is bolted in a Coupling on this pivot Rod.

Parts required :

5 of No. 3	1 of No. 32
6 " " 5	77 " " 37
4 " " 8	2 " " 38
5 " " 12	2 " " 45
1 " " 12A	7 " " 48A
2 " " 14	1 " " 48B
1 " " 15	2 " " 52
2 " " 16	4 " " 53
2 " " 18A	2 " " 54
4 " " 19A	8 " " 59
1 " " 19B	1 " " 63
2 " " 22	1 " " 109
2 " " 24	3 " " 126A

### Model No. 5.20 Armoured Car Motor

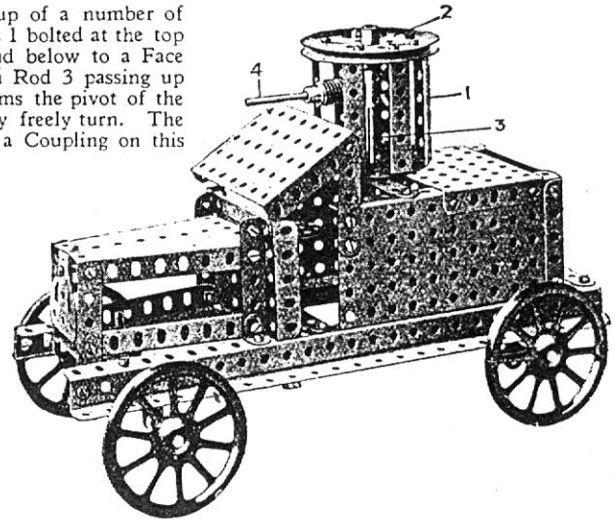

### Model No. 5.21 Sighting Apparatus

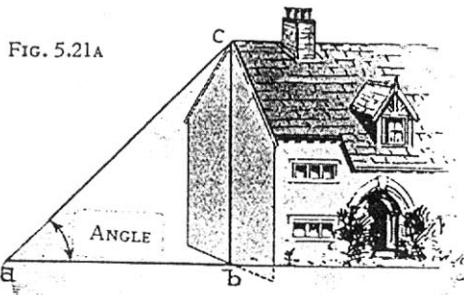

Parts required :

1 of No. 5	24 of No. 37	2 of No. 62
2 " " 6	1 " " 40	1 " " 63
2 " " 8	1 " " 43	1 " " 147A
4 " " 11	5 " " 48A	1 " " 147B
1 " " 13	1 " " 53	1 " " 148
4 " " 17	3 " " 59	
1 " " 19		
1 " " 22		
1 " " 26		
1 " " 27A		
2 " " 35		

This model is for determining the heights of buildings, towers, etc. The pointer 11½" Rod 1 is pivoted on the 2" Rod 2 and controlled by a Spring 3, the pointer 1 being adjusted by the cord 4 which passes round a guide Pulley 5 and on to the Axle 6 upon which it is wound by the Crank Handle 7 which operates the Gear Wheel and Pinion 8. A graduated scale of degrees 9 made of cardboard, or a protractor, is mounted in order to read off the angle of inclination of the pointer.

In finding the height of a building, measure out a number of feet or yards from the foot of the building, and set this out to some scale corresponding to the line *a b* (Fig. 5.21A). Then standing at the point *a* furthest from the building, and keeping the Angle Girders 10 horizontal, move the pointer 1 until it is directed towards the top of the building. Then read off the angle on the scale 9, and draw a line *a c*, making the angle *b a c* equal to the angle read off. Then draw a vertical line *b c* from the point *b*, and with the same scale used for setting off the distance *a b* measure the height *b c*, which will be the height of the building.

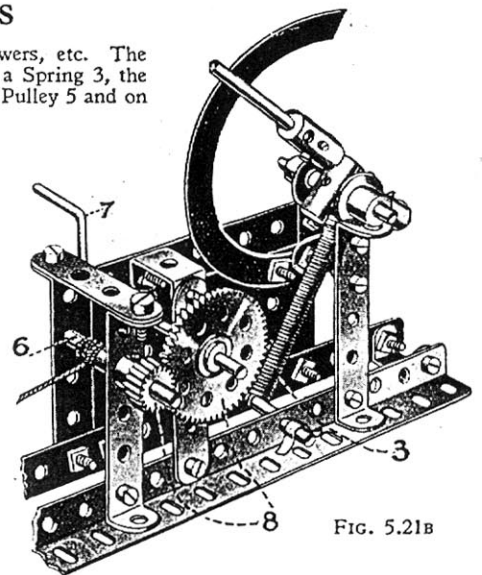
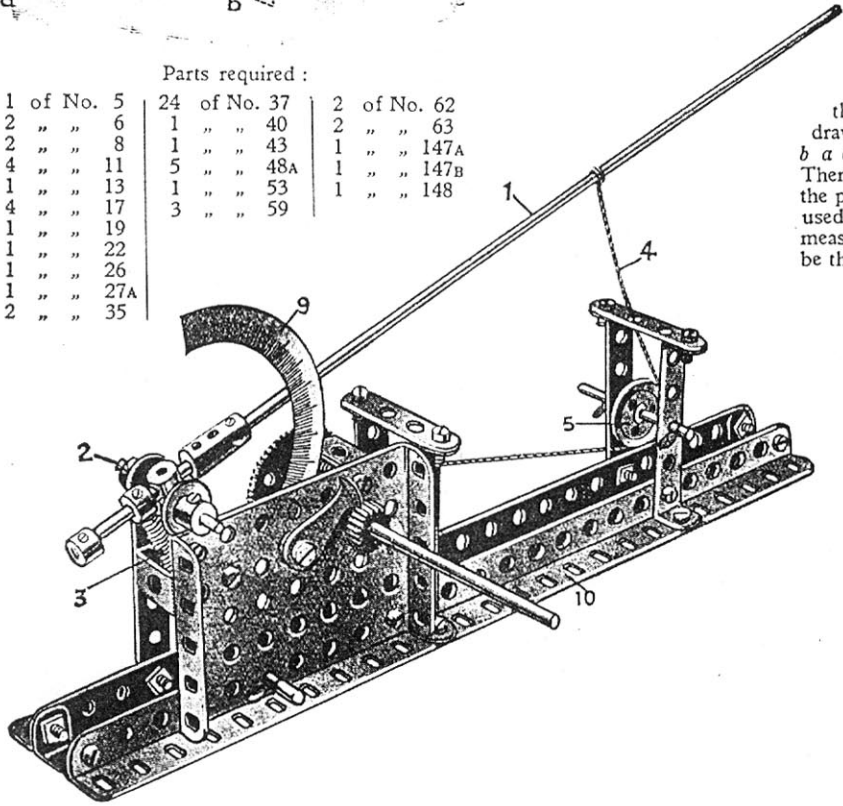

### Model No. 5.22 Mouse Trap

Parts required :

3 of No. 2
8 " " 4
18 " " 5
1 " " 10
1 " " 11
4 " " 12
1 " " 16
59 " " 37
5 " " 38
1 " " 43
1 " " 48
9 " " 48A
1 " " 52
4 " " 59

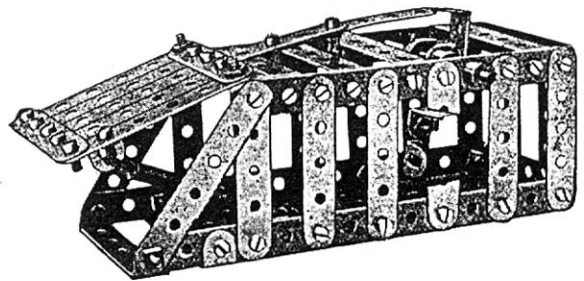

## Model No. 5.23 Helicopter Toy

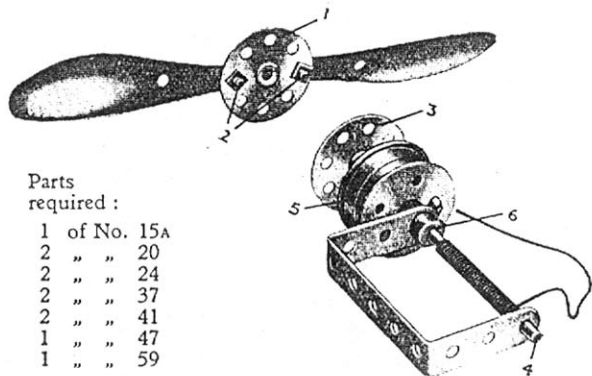

Parts  
required :

1	of No. 15A
2	" " 20
2	" " 24
2	" " 37
2	" " 41
1	" " 47
1	" " 59

The Bush Wheel 3 and the two Flanged Wheels 5, which act as a flywheel, are all secured to the  $4\frac{1}{2}$ " Rod 4, and the latter is journaled in a  $2\frac{1}{2}$ " x  $1\frac{1}{2}$ " Double Angle Strip, in which it is retained by a Collar 6. The Double Angle Strip forms a convenient handle with which to hold the toy.

A piece of cord about 24" long is wound on the Rod 4. The propeller 1 should be placed so that the shanks of the Bolts 2 lodge freely in the holes of the Bush Wheel 3. If now the free end of the cord wound on the Rod 4 is given a smart pull, the propeller will immediately leap off into the air.

## Model No. 5.24 Automatic Racer

The car is lifted, by means of rotating arms driven by the Clockwork Motor, from the lower track on to an elevated chute which tilts and allows the car to descend rapidly so that its momentum carries it to the upper end of the inclined track, where a  $1" \times 1"$  Angle Bracket forms a stop to prevent it running off the end. Gravity then causes the car to descend and pass under the raised chute—which has been automatically lifted by means of balance weights—to the lower extremity of the track, where it releases a catch, thus allowing the cycle of operations to be carried out until the spring of the Motor is run down.

For the construction of the main track  $12\frac{1}{2}$ " Girders are secured by means of Bolts passed through their elongated holes and through  $3\frac{1}{2}$ " x  $2\frac{1}{2}$ " Flanged Plates. The Bolt heads should be spaced from the upturned flanges of the girders to allow sufficient room for the 2" Pulleys of the car to pass unimpeded. Two  $5\frac{1}{2}$ " Girders are bolted vertically to Trunnions which, in turn, are secured to  $5\frac{1}{2}$ " transverse Girders near the lower end of the track. The vertical Girders are braced by  $9\frac{1}{2}$ " Girders.

A  $\frac{1}{2}$ " Pinion on the Motor driving spindle meshes with a 57-teeth Gear, the Rod of which carries a  $\frac{1}{2}$ " Pinion meshing with a further Gear on a  $1\frac{1}{2}$ " Rod 1. This Rod carries a  $\frac{1}{2}$ " Sprocket Wheel transmitting the drive through Chain to the Sprocket on a  $6\frac{1}{2}$ " Rod journaled in the vertical Angle Girders. The  $6\frac{1}{2}$ " Rod also carries two Couplings carrying the Rods 3, two Double Brackets to which the Girders of the elevated chute are secured, and two Bush Wheels clamped on either side of the balance weight 4. The Rods 3 carry near their outer ends Collars, in the tapped holes of which Bolts 5 are screwed and arranged to face inward.

A 3" Strip 6 is held loosely to a Pivot Bolt and carries a Flat Bracket to which two Angle Brackets are fixed so that they catch the Bolt 5 and prevent the Rods 3 revolving. The mechanism should be very carefully adjusted so that the Angle Brackets 7 and 8 of the car release the catch and then come into position directly above the Bolts 5, which, being freed, are raised by means of the Motor. The lower edges of the Brackets 7 should be slightly higher than those of the Brackets 8. The Bolts 5 carry the car up and deposit it on the upper girders, which are normally held in a horizontal position by the Girders 9. The latter are pivoted by lock-nutted Bolts at 10 and are provided with balance weights 11 consisting of  $2\frac{1}{2}$ " Strips. A Rod 12 held in Cranks at the ends of the Girders carries Collars which are so arranged to keep the side members of the chute in alignment with the lower track.

Before setting the model in operation all parts on rotating shafts should be fixed securely. The Sprocket 2, the Couplings carrying the Rods 3 and the Bush Wheels which hold the weight 4, should all be provided with two grub screws, since they must be absolutely immovable on the horizontal  $6\frac{1}{2}$ " Rod.

Parts required :

26	of No. 2	4	of No. 9	2	of No. 17	2	of No. 26	1	of No. 43	16"	of No. 94
7	" " 3	3	" " 10	2	" " 18A	2	" " 27A	4	" " 48B	1	" " 95
3	" " 4	2	" " 11	4	" " 20A	120	" " 37	2	" " 48D	1	" " 96A
32	" " 5	13	" " 12	2	" " 22	8	" " 37A	1	" " 52	2	" " 111
2	" " 6	1	" " 12A	2	" " 24	24	" " 38	1	" " 52A	4	" " 111c
2	" " 6A	1	" " 13A					3	" " 53	1	" " 115
10	" " 8	1	" " 14					14	" " 59	2	" " 126
4	" " 8A	2	" " 15					2	" " 62	4	" " 126A
2	" " 8B	2	" " 16					4	" " 63	1	" " 147B
										1	" " 162

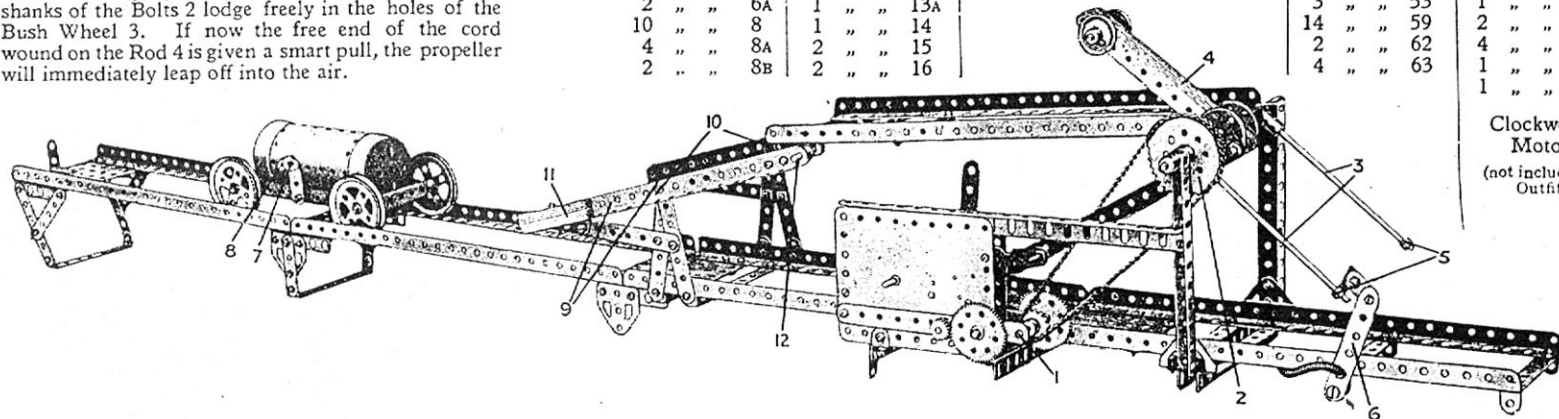

Clockwork  
Motor  
(not included in  
Outfit)



## Model No. 5.25 Travelling Crane

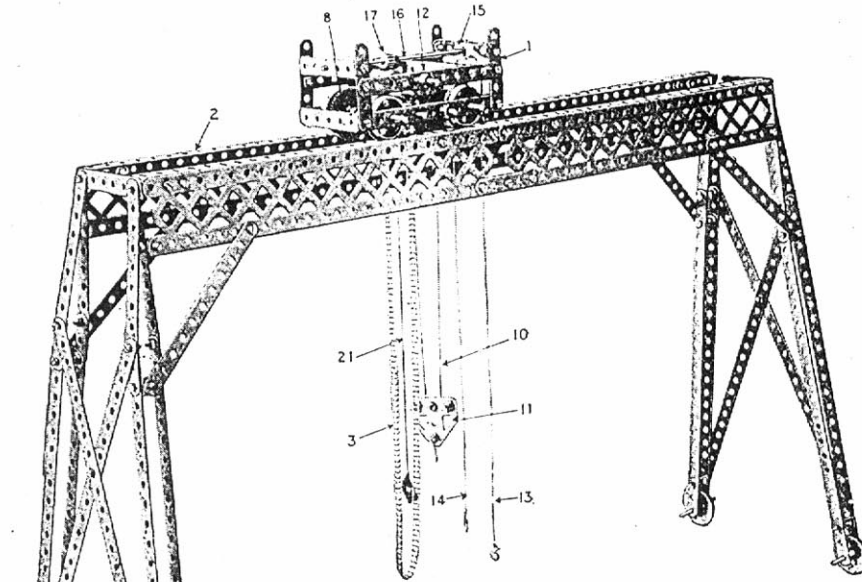

Parts required :

16 of No. 1	86 of No. 37
16 " " 2	9 " " 37A
6 " " 5	2 " " 38
4 " " 8	1 " " 40
2 " " 9	2 " " 47A
8 " " 11	5 " " 48A
4 " " 12	1 " " 57C
1 " " 14	6 " " 59
1 " " 15A	1 " " 62
4 " " 16	1 " " 63
4 " " 17	30" " 94
8 " " 20	1 " " 96
1 " " 22	4 " " 99
1 " " 23	4 " " 111C
3 " " 26	2 " " 126A
2 " " 27A	1 " " 128
1 " " 32	

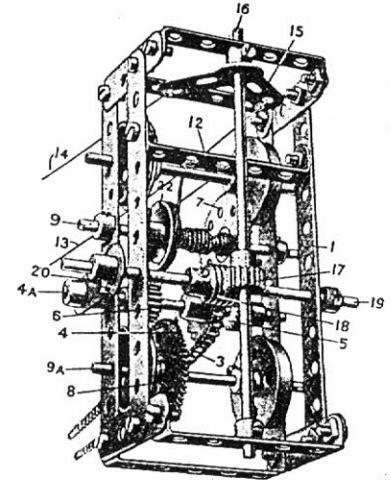
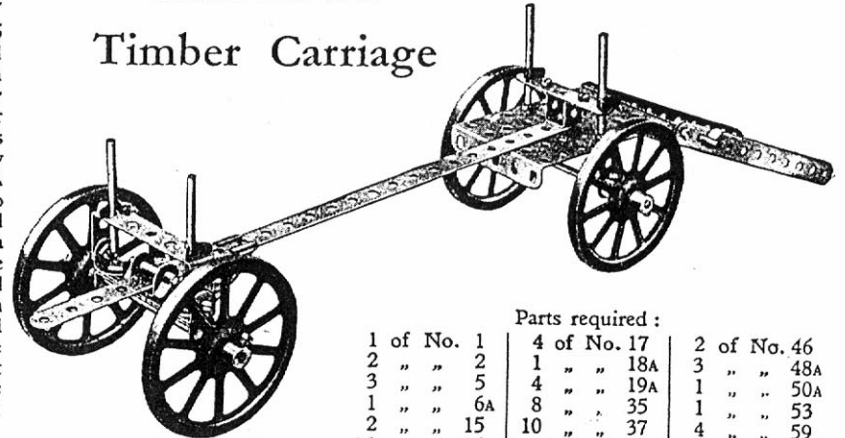

FIG. 5.25A

The carriage 1 is caused to travel on the rails 2 in either direction by the Sprocket Chain 3, which passes over a 1" Sprocket Wheel 4 on the spindle 4A on which are two Pinions 5 and 6 for engagement respectively with 57-teeth Gears 7 and 8. The Gear Wheel 7 is secured on an Axle Rod 9, upon which is coiled the winding Cord 10 passing round a 1/2" Pulley in the block 11, and being made fast to the Strip 12. The other Gear Wheel 8 is secured on the axle 9A of the travelling wheels 9A. The Pinions 5 and 6 are caused to engage respectively with the Gear Wheels 7 and 8 by sliding the Pinion Axle 4A in the carriage frame 1. This is effected by means of two Cords 13 and 14 connected to a Boss Bell Crank 15 on a Rod 16, a Pinion 17 which engages a Worm 18 in the manner of a rack. This Worm is secured to a Rod 19, which is connected by means of the Crank 20 to the Rod 4A. The latter revolves freely in the Crank 20, being held in position by a Collar on each side of the Crank. Consequently, by pulling on one or other of the Cords 13, 14, the Bell Crank is racked and the Pinions caused to engage with one or other of the toothed Wheels 7 or 8. When engaging the toothed Wheel 7 the load may be raised or lowered by pulling the Sprocket Chain 3, but when the Pinion 6 engages the toothed wheel 8, the carriage travels on the rails. The Cord 21 passes round a Pulley 22 on the winding Axle and acts as a brake.

## Model No. 5.26 Timber Carriage



Parts required :

1 of No. 1	4 of No. 17	2 of No. 46
2 " " 2	1 " " 18A	3 " " 48A
3 " " 5	4 " " 19A	1 " " 50A
1 " " 6A	8 " " 35	1 " " 53
2 " " 15	10 " " 37	4 " " 59
1 " " 16	1 " " 45	1 " " 111

## Model No. 5.27 Vertical Drill

Parts required :

2 of No. 2	1 of No. 6A	6 of No. 12
3 " " 4	2 " " 8	1 " " 14
2 " " 5	5 " " 11	1 " " 15A
1 " " 6		4 " " 16
		1 " " 17
		6 " " 20
		2 " " 21
		2 " " 22A
		4 " " 35
		39 " " 37
		6 " " 38
		1 " " 40
		1 " " 43
		1 " " 44
		1 " " 48A
		1 " " 50A
		10 " " 59
		2 " " 62
		1 " " 65
		2 " " 108
		1 " " 109
		1 " " 111
		2 " " 115
		2 " " 126A

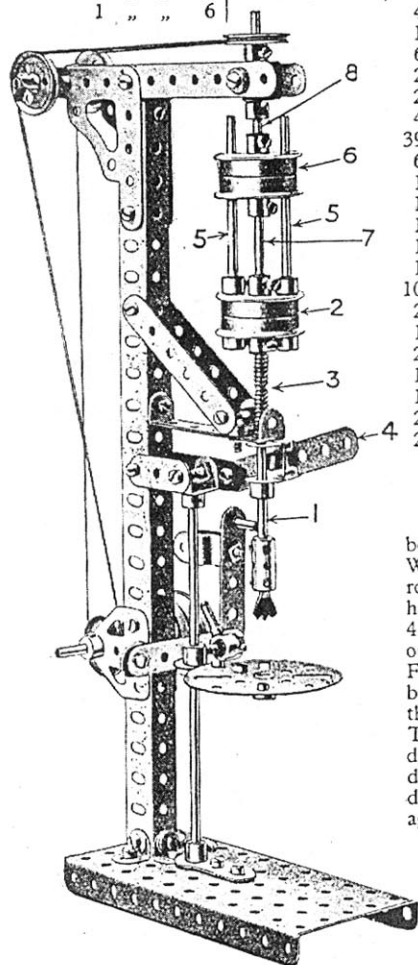

The drill Rod 1 is connected to the boss of the lower pair of Flanged Wheels 2 which are reversed, a Spring 3 round the Rod raising the drill after it has been depressed by the handle Strip 4. Bolted in the Wheels 2 are two outer Rods 5 which slide in the upper Flanged Wheels 6. The central Rod 7 is bolted in the upper Wheels and slides in the centre bosses of the lower Wheels 2. The upper Wheels 6 are bolted to the driving spindle 8 and consequently the drill is driven by the Rods 5 when the drill is depressed by the handle 4 against the Spring.

## Model No. 5.28 Giant Auto Swing

Parts required :

8 of No. 1	1 of No. 24	4 of No. 53
26 " " 2	1 " " 27A	9 " " 59
2 " " 3	1 " " 32	2 " " 62
8 " " 4	165 " " 37	28" " " 94
31 " " 5	2 " " 38	1 " " 95
12 " " 8	2 " " 48A	1 " " 96
1 " " 9	2 " " 48B	1 " " 147B
18 " " 12	4 " " 48D	
2 " " 14	4 " " 52	
4 " " 15		
1 " " 19B		

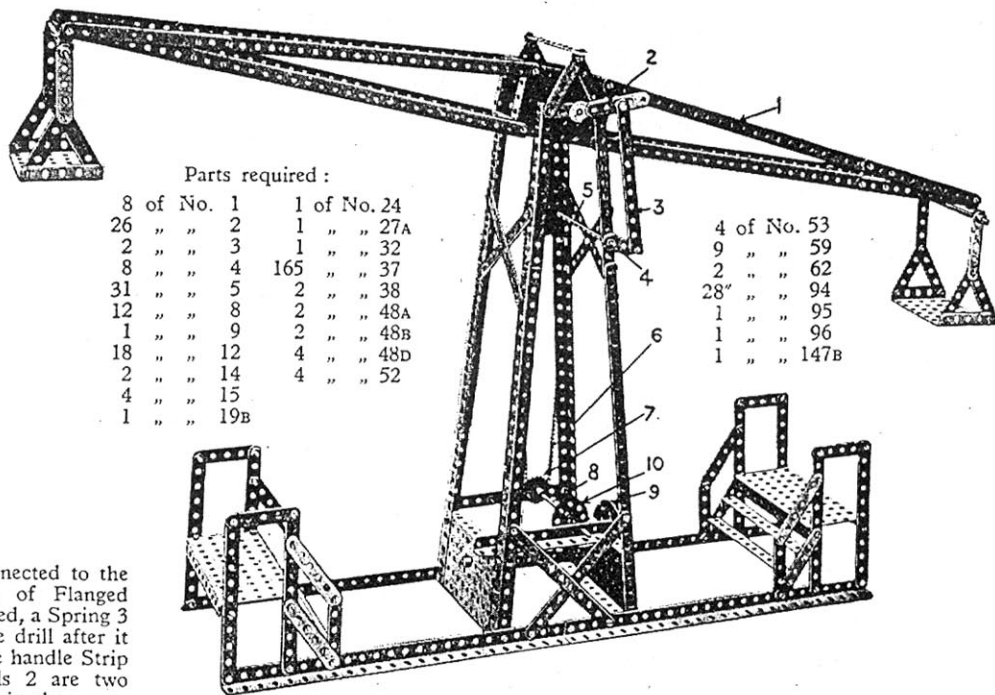

The beam 1 is rocked by means of a Crank 2 secured on the end of a Rod which forms the beam pivot and which is gripped in a Bush Wheel secured to the beam. The Crank 2 is connected by a Strip 3 to another Crank 4 on a Rod 5. On the end of this is a 2" Sprocket Wheel driven by a Chain 6 from a 1" Sprocket Wheel 7 on a Rod 8. This Rod is driven by means of a Worm on the Rod of the 3" Pulley 9 which Worm engages and drives the Gear Wheel 10 on the Rod 8. As the Crank 4 continuously rotates the link 3 causes the upper Crank 2 to oscillate and also the beam 1.

## Model No. 5.29 Beam Scales

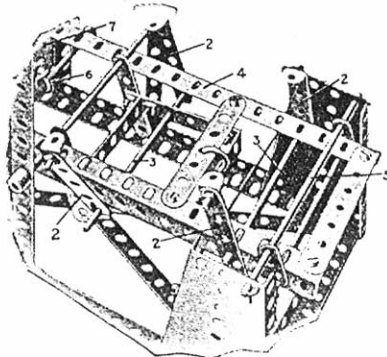
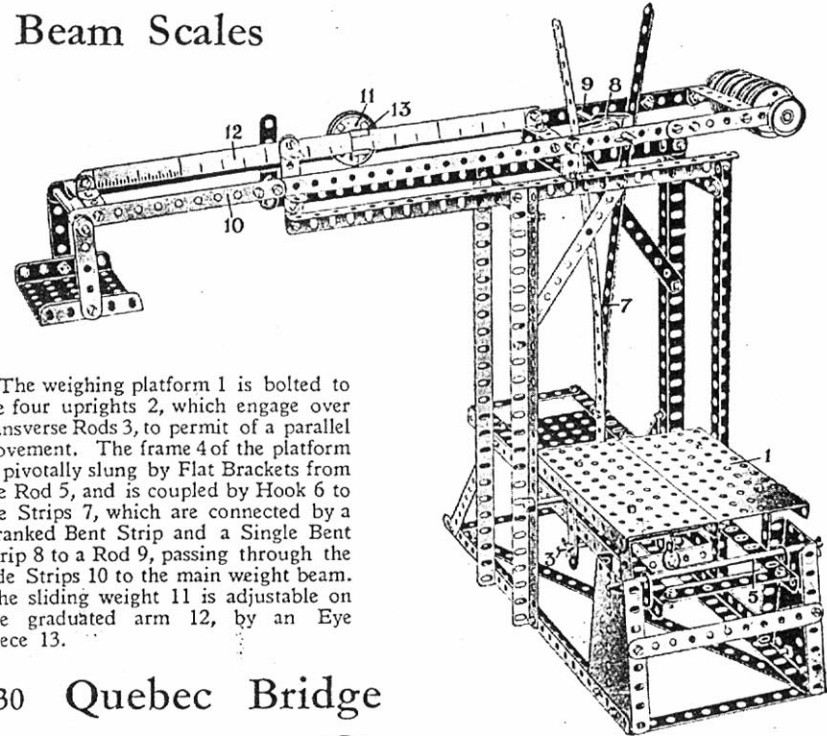

FIG. 5.29A

Parts required :

7	of No.	1
10	" "	2
8	" "	3
2	" "	4
10	" "	5
10	" "	8
2	" "	10
9	" "	12
2	" "	14
2	" "	15
4	" "	15A
2	" "	16
4	" "	20
2	" "	22
88	" "	37
1	" "	44
1	" "	46
5	" "	48A
1	" "	50A
2	" "	52
2	" "	53
2	" "	54
2	" "	57C
8	" "	59
1	" "	102



The weighing platform 1 is bolted to the four uprights 2, which engage over transverse Rods 3, to permit of a parallel movement. The frame 4 of the platform is pivotally slung by Flat Brackets 6 from the Rod 5, and is coupled by Hook 6 to the Strips 7, which are connected by a Cranked Bent Strip and a Single Bent Strip 8 to a Rod 9, passing through the side Strips 10 to the main weight beam. The sliding weight 11 is adjustable on the graduated arm 12, by an Eye Piece 13.

## Model No. 5.30 Quebec Bridge

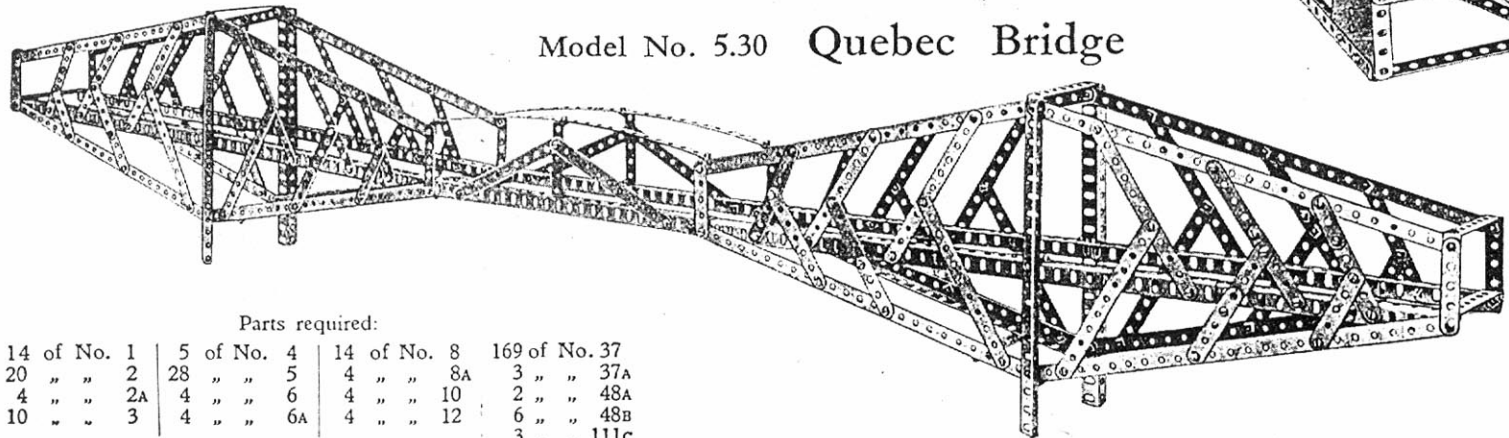

Parts required:

14	of No.	1	5	of No.	4	14	of No.	8	169	of No.	37
20	" "	2	28	" "	5	4	" "	8A	3	" "	37A
4	" "	2A	4	" "	6	4	" "	10	2	" "	48A
10	" "	3	4	" "	6A	4	" "	12	6	" "	48B
									3	" "	111c

## Model No. 5.31 Hand Operated Gantry Crane

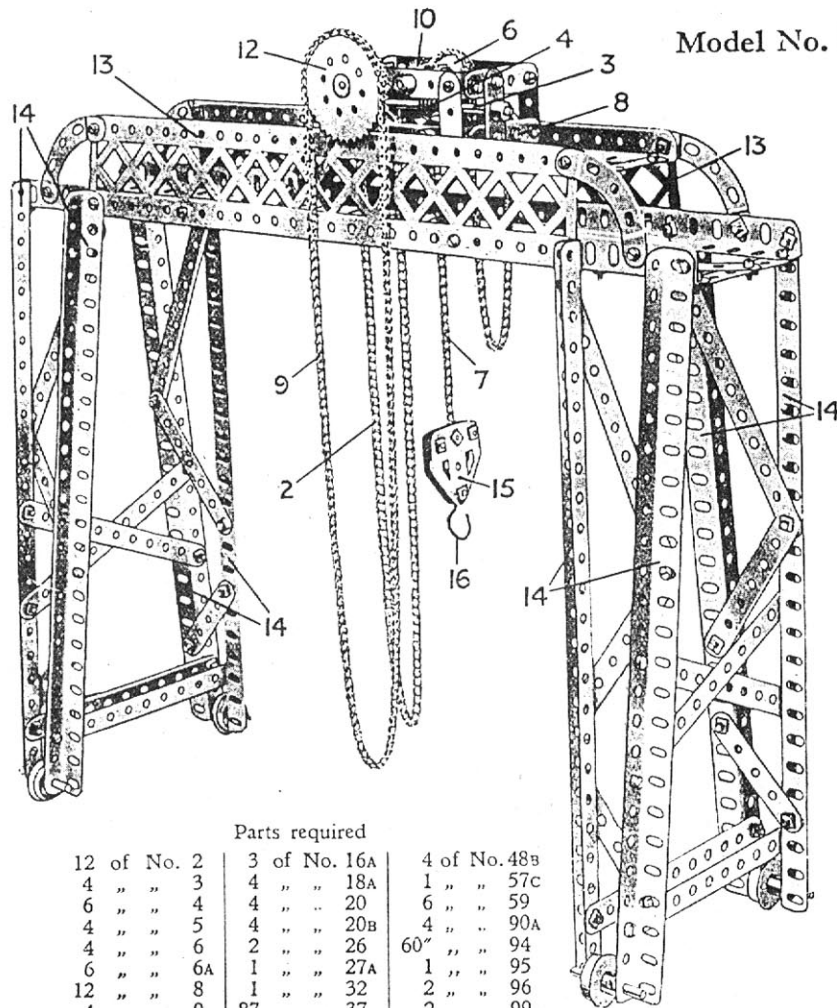

### Parts required

12	of	No. 2	3	of	No. 16A	4	of	No. 48B
4	"	3	4	"	18A	1	"	57C
6	"	4	4	"	20	6	"	59
4	"	5	4	"	20B	4	"	90A
4	"	6	2	"	26	60	"	94
6	"	6A	1	"	27A	1	"	95
12	"	8	1	"	32	2	"	96
4	"	9	87	"	37	2	"	99
1	"	15A	8	"	37A	4	"	111C
1	"	16	2	"	38	2	"	126A

The gantry consists of two  $12\frac{1}{2}$ " Angle Girders extended at each end by means of  $5\frac{1}{2}$ " Girders. Braced Girders 13 support further  $12\frac{1}{2}$ " Angle Girders that form the track along which travels the crane trolley.

The end towers comprise  $12\frac{1}{2}$ " Angle Girders 14 braced by Strips.  $1\frac{1}{2}$ " Axle Rods are journaled in the lower ends of the Girders, and carry  $\frac{1}{2}$ " Flanged Wheels that form the travelling wheels.

The construction of the trolley or traveller is shown clearly in Fig. 5.31A. Two pairs of  $3\frac{1}{2}$ " x  $\frac{1}{2}$ " Double Angle Strips are spaced apart by means of 2" Strips and  $1\frac{1}{2}$ " Strips are bolted between each pair. Two  $2\frac{1}{4}$ " Rods journaled in the Double Angle Strips carry the  $\frac{3}{4}$ " Flanged Wheels 1 and 1A. The Rod of the Wheels 1A also carries a 57-teeth Gear that meshes with the  $\frac{1}{2}$ " Pinion 10.

By hauling on the Chain 9, which is passed over the Sprocket Wheel 12, the  $\frac{1}{2}$ " Pinion 10 and the 57-teeth Gear Wheel is made to rotate, thus driving the Flanged Wheels 1A and causing the trolley to travel along the gantry.

The hoisting mechanism is operated by the chain 2 that passes over a 1" Sprocket, on the Rod of which is a Worm 4. This engages the teeth of a  $\frac{1}{2}$ " Pinion on the Rod 5 that also carries a 1" Sprocket Wheel 6. A length of Sprocket Chain 7 is placed over this Wheel, one end of it being secured between two Flat Trunnions 15 (Fig. 5.31); the other end is secured to the frame at 8. By operating the Chain 2 the load hook 16 is raised or lowered.

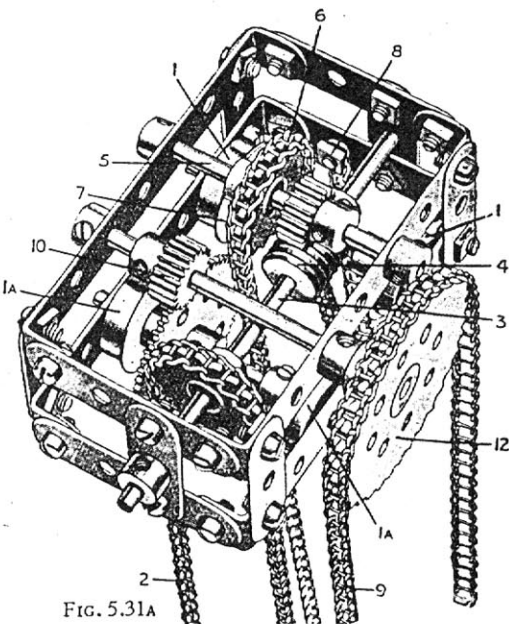
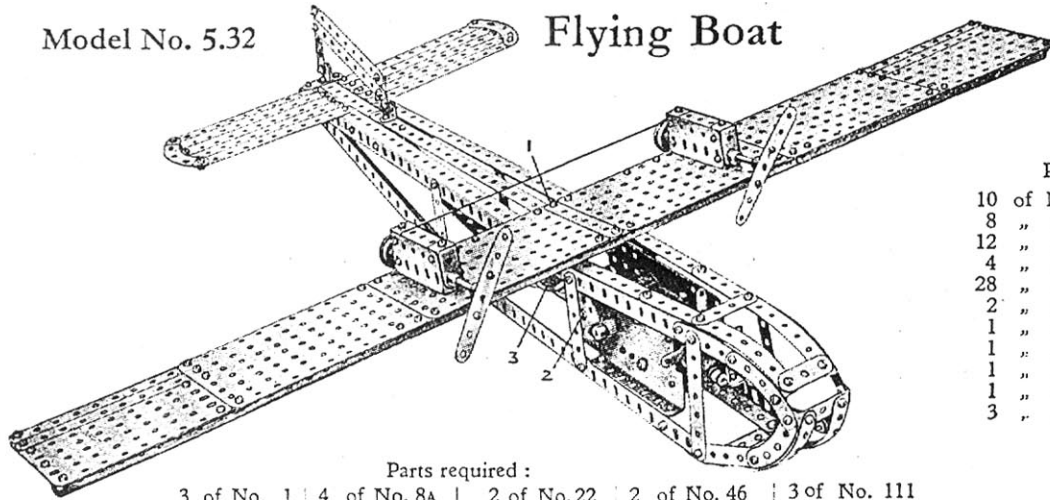

FIG. 5.31A

Model No. 5.32

## Flying Boat



Parts required :

3 of No. 1	4 of No. 8A	2 of No. 22	2 of No. 46	3 of No. 111
20 " " 2	4 " " 9	1 " " 26	1 " " 48	2 " " 111c
2 " " 2A	1 " " 9D	1 " " 27A	4 " " 52A	
5 " " 3	2 " " 10	1 " " 29	2 " " 53A	Electric
4 " " 4	8 " " 11	154 " " 37	5 " " 59	Motor
6 " " 5	8 " " 12	5 " " 37A	2 " " 62B	(not included in
2 " " 6	2 " " 15A	12 " " 38	4 " " 90	Outfit)
5 " " 6A	2 " " 16A	1 " " 40	2 " " 90A	
5 " " 8	1 " " 21	1 " " 45	4 " " 103F	

The Flat Plates of the main plane are secured to a girder consisting of one 12½" Angle Girder extended at each end by 9½" Girders and bolted along the leading edge of the plane with the projecting flange toward the tail of the model. A 2½" Angle Girder is bolted to the centre of the girder so formed and is secured, in turn, across the fuselage. The wings are held rigid by the ¾" Bolt 1, which is passed through the 12½" Strip in the centre of the fuselage but is spaced therefrom by a Collar.

The Electric Motor is fixed to the lower pair of Angle Girders by means of two Angle Brackets at the front, and two ¾" Bolts at the rear passed through the Motor Flanges and secured by Nuts below the lower faces of the Girders. The armature spindle carries a ½" Pinion meshing with a 57-teeth gear on the 2½" Rod 2, which carries a ¾" Contrate Wheel. The latter engages a Pinion on a further 2½" Rod to which the 1½" Pulley 3 is secured. Bearings for the Rod are formed by a 1½" Strip and Double Bent Strip which are bolted by Angle Brackets to the side plates of the Motor. Cord is passed round the Pulley 3 to each of the 1" Pulleys on the propeller shafts of the miniature engines.

Each of the engines consists of two 2½" Flat Girders and a 2½" × 1" Double Angle Strip held together by means of Double Brackets and fixed to the wings by similar means.

Model No. 5.33

## Belgian Water Wheel

Parts required :

10 of No. 1	1 of No. 27A
8 " " 2	82 " " 37
12 " " 5	5 " " 48A
4 " " 8	2 " " 52
28 " " 12	2 " " 53
2 " " 15	4 " " 59
1 " " 15A	1 " " 63
1 " " 16	
1 " " 21	
1 " " 24	
3 " " 26	

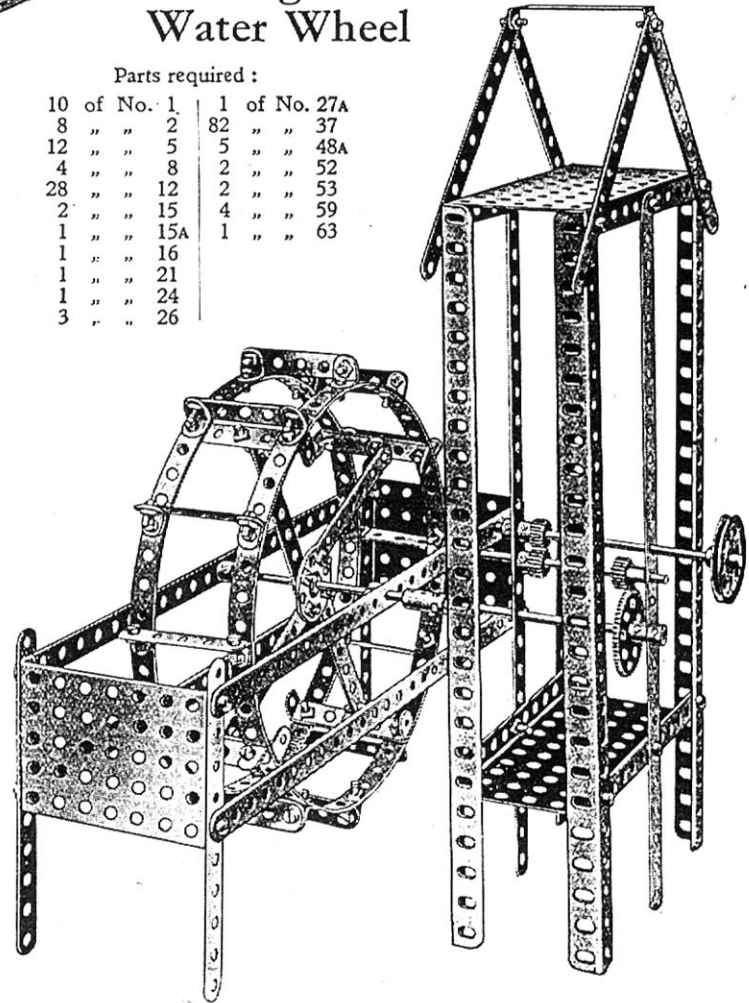

## Model No. 5.34 Oil Well-Drilling Apparatus

The drive is transmitted from the Motor armature shaft to the Rod 1 by means of two sets of 57-teeth Gears and  $\frac{1}{4}$ " Pinions. This Rod carries a  $\frac{3}{4}$ " Sprocket Wheel and 1" fast Pulley that is connected when desired to a 3" Pulley on the Rod 2, which forms the hoisting drum for the sand pump. The latter is represented by an 11 $\frac{1}{2}$ " Rod secured by a Small Fork Piece to the hoisting cord, which passes over one of the 1" loose Pulleys at the derrick head.

The  $\frac{3}{4}$ " Sprocket on the Rod 1 is connected by Sprocket Chain to a 2" Sprocket on the Rod 4. A 1" Sprocket 5 and  $\frac{1}{2}$ " fast Pulley are nipped on the other end of this Rod, the  $\frac{1}{2}$ " Pulley being connected by cord to a 1" fast Pulley on the crankshaft of the steam engine. The 1" Sprocket 5 may be connected by two different lengths of Sprocket Chain to either of the Sprockets 6 and 7. The 1" Sprocket 6 is secured to the tool hoisting drum, which is supplied with a Pawl and Ratchet 8. The cord is wound on to this shaft, carried over the remaining 1" loose Pulley at the derrick head, and attached to an End Bearing on the tool, the construction of which is clearly shown in the illustration.

The 2" Sprocket 7 is secured to the crankshaft 9, which is built up from two short Rods and two Cranks, the latter being rigidly secured together at their ends by a  $\frac{3}{4}$ " Bolt having three Nuts. The crankshaft is connected to the beam 10 by a 3 $\frac{1}{2}$ " Strip 11. The beam is pivoted at its centre on a 3 $\frac{1}{2}$ " Rod journalled in the 7 $\frac{1}{2}$ " Angle Girders 12, and a Double Bracket is attached pivotally to its inner end by means of a 1 $\frac{1}{4}$ " Rod and Collars. A 3 $\frac{1}{2}$ " Screwed Rod, turning freely between two Collars in the centre hole of this Double Bracket, passes through the end threaded hole of a Coupling 13. This Coupling carries a  $\frac{3}{8}$ " Bolt and Washer 14, behind which is clamped the tool cord when it is desired to carry out the actual digging operation.

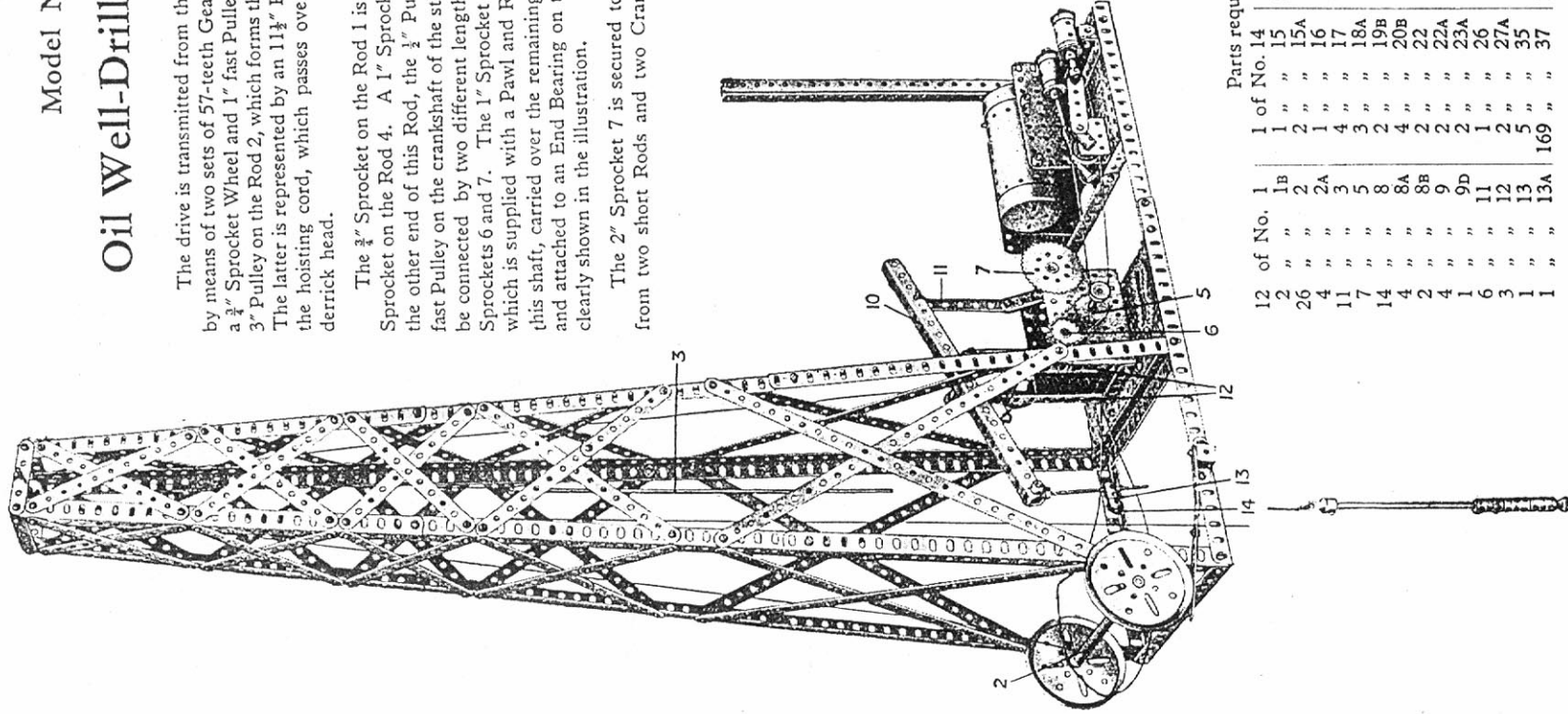

Parts required :

12 of No. 1	1 of No. 14	6 of No. 37A	2 of No. 95
2 " " 1B	1 " " 15	38 " " 38	2 " " 96
26 " " 2	2 " " 15A	40 " " 40	1 " " 96A
4 " " 2A	1 " " 16	45 " " 45	6 " " 111C
4 " " 3	4 " " 17	48A " " 48A	1 " " 115
11 " " 3	4 " " 18A	52 " " 52	1 " " 116A
7 " " 5	3 " " 18B	52A " " 52A	2 " " 126
14 " " 8	2 " " 19B	53 " " 53	1 " " 147
4 " " 8A	4 " " 20B	53A " " 53A	1 " " 148
2 " " 8B	2 " " 22	59 " " 59	1 " " 160
4 " " 9	2 " " 22A	62 " " 62	1 " " 162
4 " " 9D	2 " " 23A	63 " " 63	2 " " 163
1 " " 11	1 " " 26	65 " " 65	1 " " 165
6 " " 6	2 " " 27A	80A " " 80A	1 " " 165
3 " " 12	2 " " 35	Electric Motor	(not included in
1 " " 13	5 " " 37	169 " "	Outfit)
1 " " 13A	169 " "	29 " "	

### Model No. 5.34 Oil Well-Drilling Apparatus

(continued)

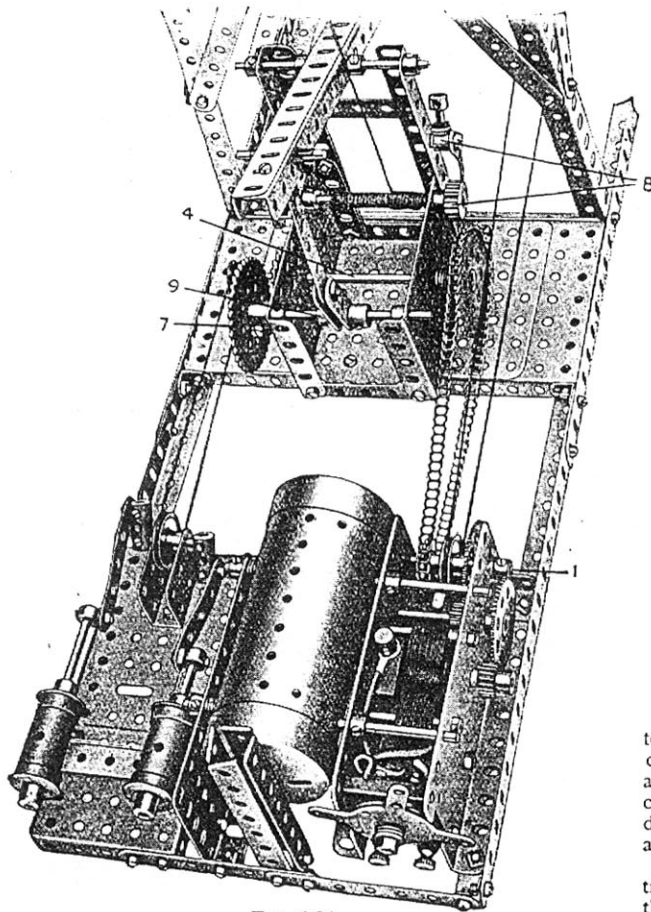
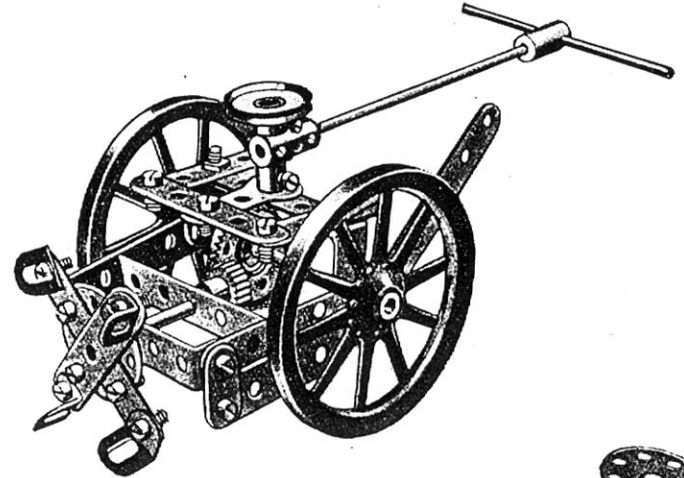

FIG. 5.34A

### Model No. 5.35 Potato Reaper

Parts required :

1	of No.	3
8	" "	5
2	" "	10
4	" "	12
1	" "	15
2	" "	16
1	" "	17
1	" "	18A
2	" "	19B
1	" "	22
1	" "	24
1	" "	26
1	" "	28
19	" "	37
1	" "	46
2	" "	48A
1	" "	59
1	" "	62
2	" "	63



### Model No. 5.36

### Map Measuring Instrument

Parts required :

2 of No. 2	2 of No. 24	5 of No. 37	1 of No. 62B
3 " " 17	2 " " 26	1 " " 48	1 " " 109
1 " " 18A	2 " " 27A	4 " " 59	1 " " 125

By rolling this model along any desired route in a map, it is possible to obtain a very close approximation of the actual distance. The dial consists of a Face Plate on which is stuck a circular disc of white cardboard, and is divided into forty equal parts representing inches, which, when compared with the scale of the map, will give the mileage. Thus, if the dial gives a reading of 10, and the scale of the map is  $\frac{1}{2}$ " to the mile, the actual distance will be 20 miles.

The Bush Wheel 1 forms the "travelling wheel," and its motion is transmitted through a gear train to the dial shaft 3. Readings are taken through the hole in the Reversed Angle Bracket 4.

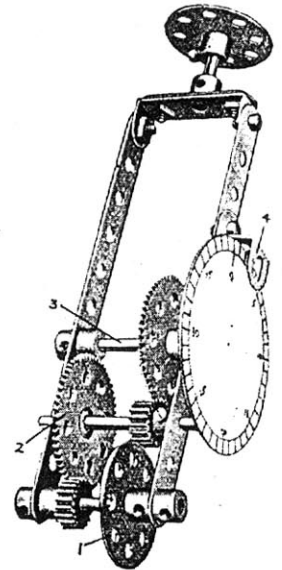

## Model No. 537

## Cable Ploughing Engine

Two 12½" Angle Girders, 1 forming the main frames, are extended at the front by the 5½" Girders 2, the complete frames being joined together at the front by the 5½" × 3½" Flat Plates 3, 3A and at the rear by a 3½" × 2½" Flanged Plate 4. Each side of the gear box and controlling platform is built up from a 3½" × 2½" Flanged Plate and a 4½" × 2½" Flat Plate. These are held rigid by the 3½" Strip 5 (shank portion cut away in Fig. 5.37A) and the 3½" × ½" Double Angle Strip 6.

The front axle pivot 7 (a Pivot Bolt) has a Bush Wheel secured to it which carries two 1" × 1" Angle Brackets 8 and two ½" × ½" Angle Brackets 9. The tool tray, which is built up of four 2½" × ½" Double Angle Strips and one 2½" Flat Girder, is secured to one of the Angle Brackets 8 by means of a 1" × ½" Angle Bracket. The front axle proper, a 3½" × ½" Double Angle Strip, carries four ½" × ½" Angle Brackets 10 and 11, the latter forming bearings for the front wheel stub axles. A 2½" Rod 12 passed through the Angle Brackets 9 and 10 forms a suitable connection for the three-point suspension system.

A ½" Pinion on the Motor armature shaft engages with a 57-teeth Gear on the Rod 13, which carries a ¾" Contrate engaging with a ½" Pinion on the Rod 14. This Rod, journalled in a 1½" × ½" Double Angle Strip 15 and in the 3½" × ½" Double Angle Strip 6, carries a Worm that meshes with a ½" Pinion on the layshaft 16. The latter is slidable in its bearings and is controlled by the lever 17 (a 3½" Strip that is pivoted at its second hole from the handle end to a ½" × ½" Angle Bracket, which, in turn, is secured to the Double Angle Strip 6, in the second hole from one end). A bolt is secured to the lever 17 so that its shank lies between two Collars secured to the layshaft. Operation of the lever causes the ½" Pinion on the layshaft to engage with either of the two gears 18 and 19 at the same time remaining in mesh with the Worm on the Rod 14.

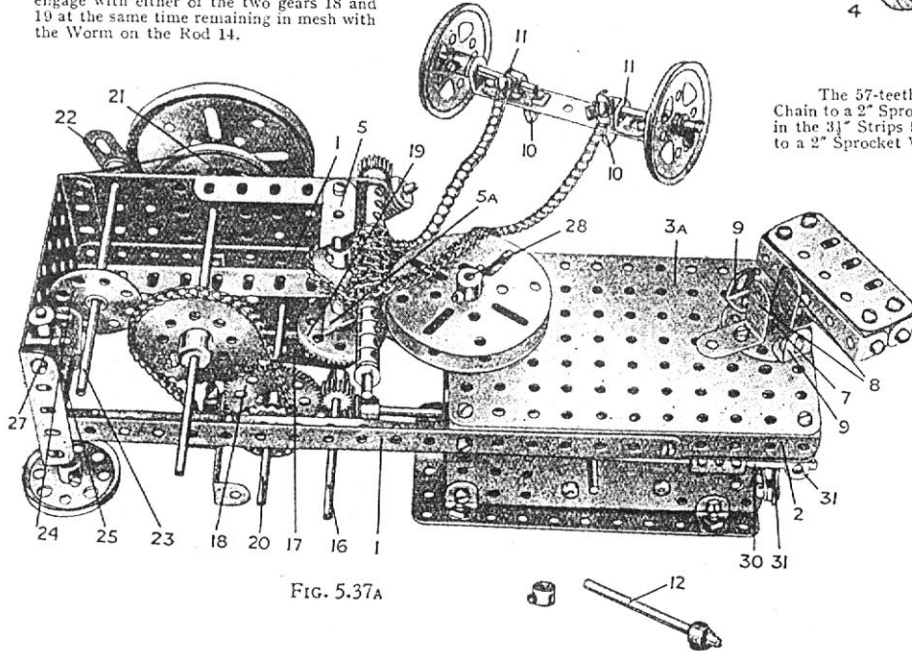
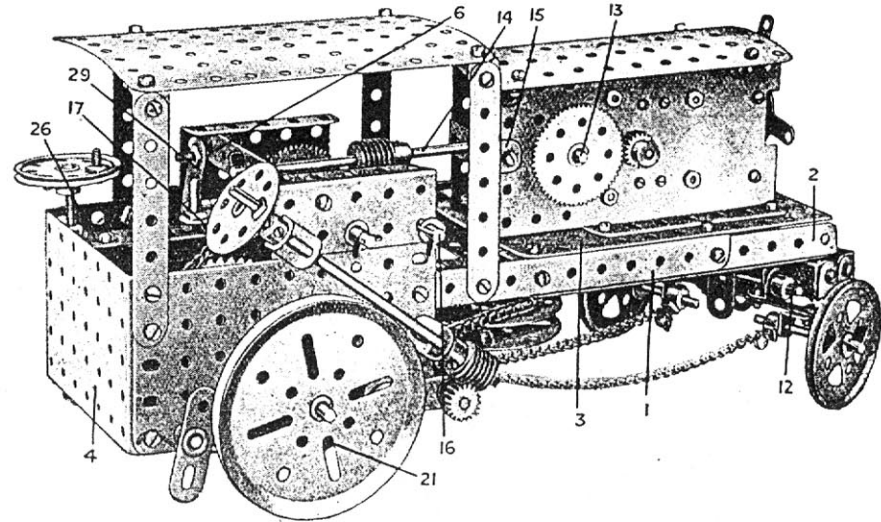

Fig. 5.37A



The 57-teeth Gear 18 is secured to a 4½" Rod 20 on which is fixed a ¾" Sprocket Wheel connected by Chain to a 2" Sprocket Wheel on the rear axle. The 1½" Contrate 19 is secured to a 2½" Rod that is journalled in the 3½" Strips 5 and 5A and has attached to it a 1" Sprocket Wheel that is connected by Sprocket Chain to a 2" Sprocket Wheel on the cable drum shaft 28.

Brake drums (2" Pulleys 21) are fitted to the rear axle and round these are passed cords that are attached at one end to the side plates of the model and at the other to Double Arm Cranks 22. The latter are secured to each end of a 4½" Rod 23 that carries a Bush Wheel 24 connected pivotally by a 1½" Strip to the Coupling 25, which has a 3½" Screwed Rod passing through its end transverse threaded bore. The Screwed Rod is journalled in the Girder 1 and Flat Bracket 26 and in the Angle Bracket 27, which is spaced by four Washers to keep the Rod in correct alignment. A suitable handle is attached consisting of a 1½" Pulley fitted with a ¾" Bolt.

The Crank 29, secured to the shaft 30, manipulates the reversing handle of the Electric Motor through the Coupling and 1½" Strip 31. The latter is lock-nutted to the reversing handle and attached loosely to the Coupling by a ½" Bolt. The shaft 30 consists of one 6½" and one 1½" Rod joined by a Coupling and is journalled in two Angle Brackets secured to the main frame.

Parts required:	1 of No. 14	2 of No. 27A	3 of No. 52A	2 of No. 96
7 of No. 3	2 " " 15	1 " " 28	3 " " 53	1 " " 103F
4 " " 6A	4 " " 15A	1 " " 29	2 " " 53A	2 " " 109
2 " " 8A	2 " " 16A	2 " " 32	16 " " 59	6 " " 111C
2 " " 9	2 " " 17	7 " " 35	1 " " 62	2 " " 115
1 " " 10	2 " " 18A	85 " " 37	2 " " 6-B	1 " " 147B
2 " " 11	4 " " 19B	4 " " 37A	6 " " 6A	
1 " " 12	4 " " 20A	21 " " 38	1 " " 70	
4 " " 12A	1 " " 21	1 " " 48	1 " " 80A	Electric Motor (not included in Outfit).
4 " " 13A	2 " " 24	4 " " 48A	34 " " 94	
	3 " " 26	2 " " 48B	2 " " 95	



## Model No. 5.38 Vertical Marine Engine

The crosshead 1 consists of two Flat Trunnions secured together by two Double Brackets, which are free to slide between  $4\frac{1}{2}$ " Strips 2 forming the crosshead guide. The latter is attached at its upper extremity to a  $\frac{1}{2}$ " x  $\frac{1}{2}$ " Angle Bracket on the bottom cylinder cover, and at its lower extremity to a  $1\frac{1}{2}$ " x  $\frac{1}{2}$ " Angle Bracket that is mounted on a Trunnion. The Strips of the guide are spaced apart by a Washer on each of the retaining Bolts. A Coupling is secured rigidly to the apex of the crosshead by Bolts, which are inserted in its upper transverse tapped bore. This Coupling is secured to the piston rod and is attached pivotally to the connecting rod by a Fork Piece that rides on two Bolts inserted in its lower transverse tapped bore.

The crankshaft is built up from two Rods on the inner ends of which Cranks are secured very rigidly. The crank pin is a  $\frac{1}{2}$ " Bolt, which is fixed rigidly by Nuts in the end holes of the Cranks and in Flat Trunnions that form the balance weights. The "big end" (a Coupling 3) is free to turn on the crank pin between the Cranks, and is attached to the lower end of the connecting rod.

The model is fitted with Stephenson's valve gear. This comprises two Eccentrics, which are mounted upon the crankshaft in such a manner that their throws are opposite, and each Eccentric is connected by a  $4\frac{1}{2}$ " Strip, to one end of an "expansion link" 4. The latter consists of two  $2\frac{1}{2}$ " large radius Curved Strips, bolted together at each end by a  $\frac{1}{2}$ " Bolt and three Nuts. On one of these Strips slides a "die block" 5 and the other is connected pivotally to a crank arm 6 by a  $2\frac{1}{2}$ " Strip. The die block is an Eye Piece, which is attached to the lower end of the valve spindle by a  $\frac{1}{2}$ " Reversed Angle Bracket and an End Bearing. The crank 6 is mounted on the "weigh shaft" 6a, to one end of which is secured a  $1\frac{1}{2}$ " Pulley carrying a "spider" (taken from a Swivel Bearing) in which works a Screwed Rod. The latter is rotated by turning the Wheel 7, so actuating the crank 6 and moving the expansion link in the die block.

The "thrust block" 8 consists of two Trunnions and one Flat Trunnion. The two former are bolted down to four Double Brackets 9, Washers spacing each Trunnion form the Double Brackets, whilst  $1\frac{1}{2}$ " Strips keep the Trunnions apart. The lower portions of the Double Brackets are clamped between pairs of  $2\frac{1}{2}$ " Strips bolted to the bed plate to keep the thrust block in position whilst the Flat Trunnion is secured in place by a  $\frac{1}{2}$ " x  $\frac{1}{2}$ " Angle Bracket. Collars fixed to the crankshaft represent the thrust collars of the actual device.

The circulating pump is represented by a Sleeve Piece 10 fitted with a  $\frac{1}{2}$ " Flanged Wheel, through which the pump plunger passes. The pump is retained in position by being pushed on to a Chimney Adaptor that is bolted to the base plate, and it is worked off the crosshead through a lever and links. The Boiler secured next to the pump represents the condenser.

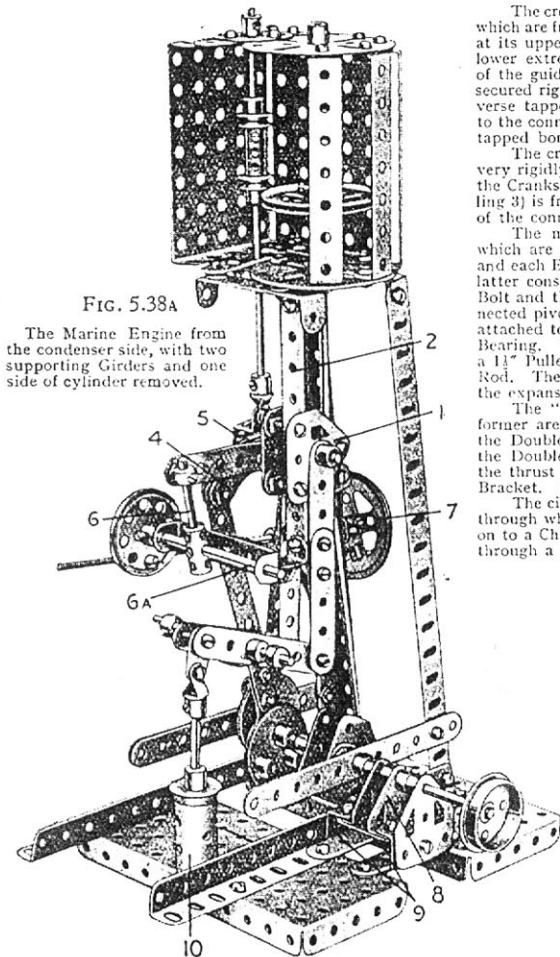
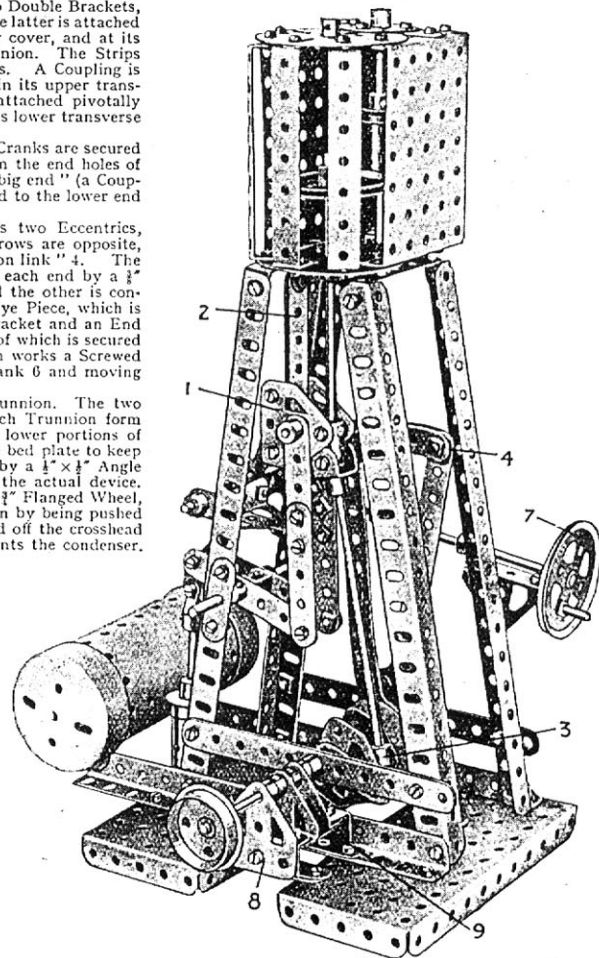

FIG. 5.38A

The Marine Engine from the condenser side, with two supporting Girders and one side of cylinder removed.



### Parts required :

4 of No. 2	1 of No. 20	2 of No. 62
4 " " 2A	2 " " 20A	4 " " 63
1 " " 3	1 " " 20B	1 " " 80A
2 " " 4	1 " " 21	2 " " 90
10 " " 5	1 " " 23	2 " " 109
4 " " 6A	1 " " 23A	2 " " 111
4 " " 8A	2 " " 24	6 " " 111c
2 " " 8B	86 " " 37	1 " " 115
1 " " 10	18 " " 37A	1 " " 116
7 " " 11	24 " " 38	1 " " 125
5 " " 12	1 " " 38	4 " " 126
1 " " 14	3 " " 48A	5 " " 126A
2 " " 15	3 " " 48B	1 " " 162
4 " " 16	1 " " 50A	1 " " 163
1 " " 16A	2 " " 52	1 " " 164
1 " " 17	3 " " 53	1 " " 165
2 " " 18A	15 " " 59	1 " " 166

## Model No. 5.39 Electric Telfer Crane

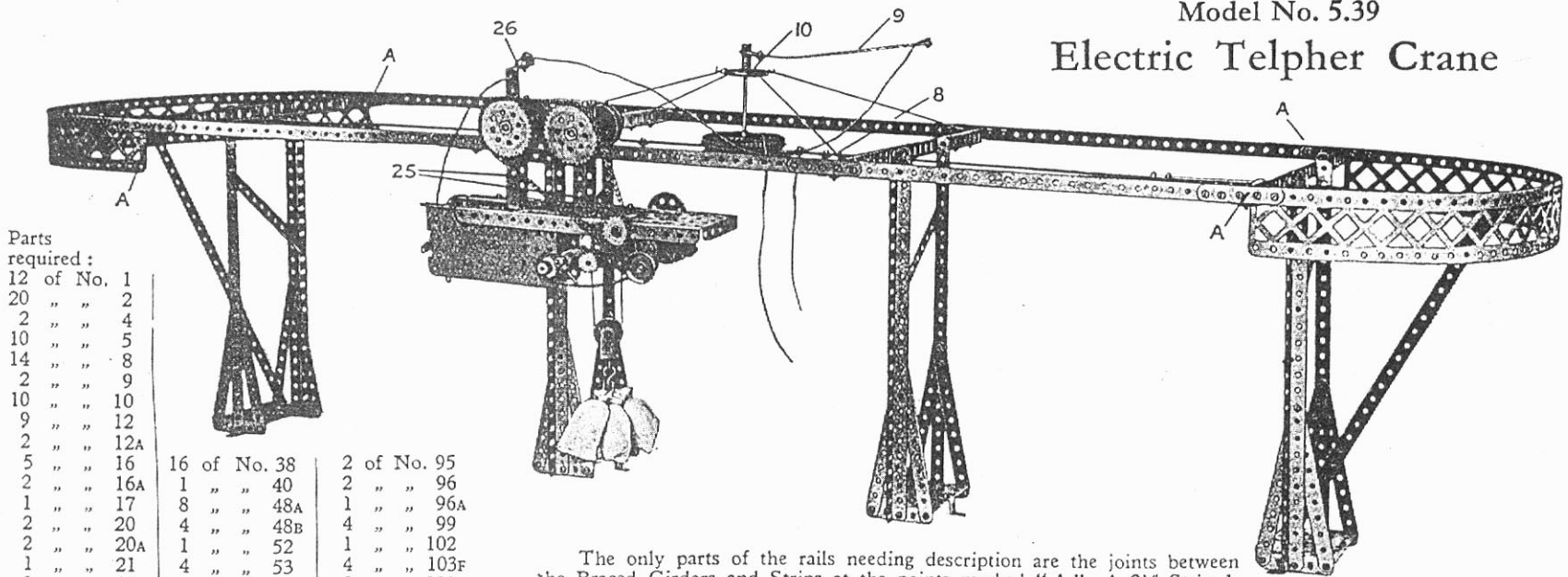

Parts  
required :

12	of No.	1
20	" "	2
2	" "	4
10	" "	5
14	" "	8
2	" "	9
10	" "	10
9	" "	12
2	" "	12A
5	" "	16
2	" "	16A
1	" "	17
2	" "	20
2	" "	20A
1	" "	21
1	" "	22
1	" "	22A
2	" "	24
2	" "	26
2	" "	27A
1	" "	29
1	" "	32
164	" "	37
3	" "	37A

16	of No.	38
1	" "	40
8	" "	48A
4	" "	48B
1	" "	52
4	" "	53
1	" "	57C
14	" "	59
1	" "	62
1	" "	63
1	" "	80A
26	" "	94

2	of No.	95
2	" "	96
1	" "	96A
4	" "	99
1	" "	102
4	" "	103F
3	" "	111
1	" "	111C
2	" "	115
4	" "	125
2	" "	142A
1	" "	147
1	" "	148
1	" "	160

Electric  
Motor  
(not included in  
Outfit)

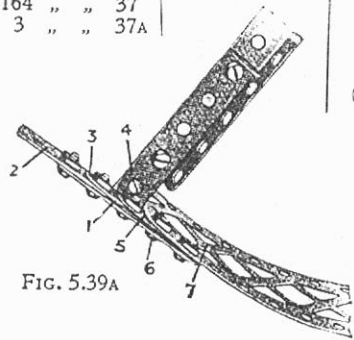

The only parts of the rails needing description are the joints between the Braced Girders and Strips at the points marked "A." A  $2\frac{1}{2}$ " Strip 1, Fig. 5.39A, is bolted to the outside of the  $12\frac{1}{2}$ " Strip 2, the latter also carrying a Flat Bracket 3 on its inner side. This Flat Bracket overlaps the end of a Double Angle Strip 4 and both are again overlapped by a second Flat Bracket 5, a Washer on the Bolt 6 spacing the Bracket 5 from the  $2\frac{1}{2}$ " Strip 1. The Braced Girder 7 is secured by the Bolt 6 and also by a second Bolt spaced also by a Washer. The complete joint is bolted to the overhanging Girder of the end support by means of the Double Angle Strip 4.

The current conductor is insulated by means of 2" Dunlop Tyres mounted on 2" Pulleys and clamped to the central  $12\frac{1}{2}$ " Strip 8 by means of two  $\frac{3}{4}$ " Bolts. These are inserted in the holes of the 2" Pulleys on each side on the Strip 8 and great care should be taken to prevent them touching the Strip. A  $3\frac{1}{2}$ " Rod nipped in the boss of the upper Pulley has attached to it a Bush Wheel 10, with a Crank swinging loosely immediately above it, but held in place by a Collar. A  $12\frac{1}{2}$ " Strip 9 is bolted to this Crank and bent upwards slightly so as to clear the electric telfer. The complete conductor is held vertical by four cords attached to the Bush Wheel 10 and tied to the two central standards.

The two  $5\frac{1}{2}$ " Angle Girders 11 of the telfer (Fig. 5.39B) are attached at one end to the flanges of the Electric Motor and at the other to the  $5\frac{1}{2}$ " x  $2\frac{1}{2}$ " Flanged Plate 12. To each side of the Plate 12, two  $2\frac{1}{2}$ " Flat Girders are bolted to form the sides of the gear box. The drive from the armature shaft of the Motor to the  $\frac{3}{4}$ " Sprocket 13 will be seen clearly from the illustration. From this Sprocket the drive is transmitted by means of Sprocket Chain to a 1" Sprocket on the lay shaft 14 of the gear box. This Rod is moved into any desired position by means of a  $3\frac{1}{2}$ " Screwed Rod 15 through the medium of the Coupling 16 and Threaded Pin 17. The latter is provided with two Nuts so that the Collar 18 may be fixed rigidly to it but still allowed to turn freely between the two Collars clamped to the Rod 14. The smooth portion of the Threaded Pin is inserted in the Coupling, but not gripped therein.

## Model No. 5.39 Electric Telpher Crane

(continued)

The  $\frac{1}{2}$ " Pinion 19 on the end of the layshaft engages with either of the 57-teeth Gears 20 and 20A. Gear 20A is fixed to the hoisting shaft, which is provided with a Pawl and Ratchet 21, the Pawl being locknutted to a  $2\frac{1}{2}$ " Strip 22. Gear 20 is nipped on one end of the Rod 23, the other end of which carries a 1" Sprocket Wheel that is connected by Sprocket Chain to the two 2" Sprockets 24 on the driving axles. The latter are supported in  $3\frac{1}{2}$ " x  $\frac{1}{2}$ " Double Angle Strips 25, which are joined together at the top by a  $3\frac{1}{2}$ " Strip. Two 1" Angle Brackets and one  $\frac{1}{2}$ " Angle Bracket 26 surmount one of the axle bearings. This is to keep the conductor wire clear of the Sprockets. The travelling wheels are built up from  $1\frac{1}{4}$ " Flanged Wheels and Bush Wheels butted together, the wide groove thus obtained being required to enable the telpher to negotiate small curves.

To wire the model the following notes will be useful. One wire is taken from a terminal of the Accumulator to the set-screw in the boss of the top Pulley of the insulator. The current runs from here to the end of the conductor arm and a wire attached to this passes through the bracket 26 and is fixed to a terminal of the Motor. The remaining terminals on the Motor and Accumulator are earthed to the frame of the model.

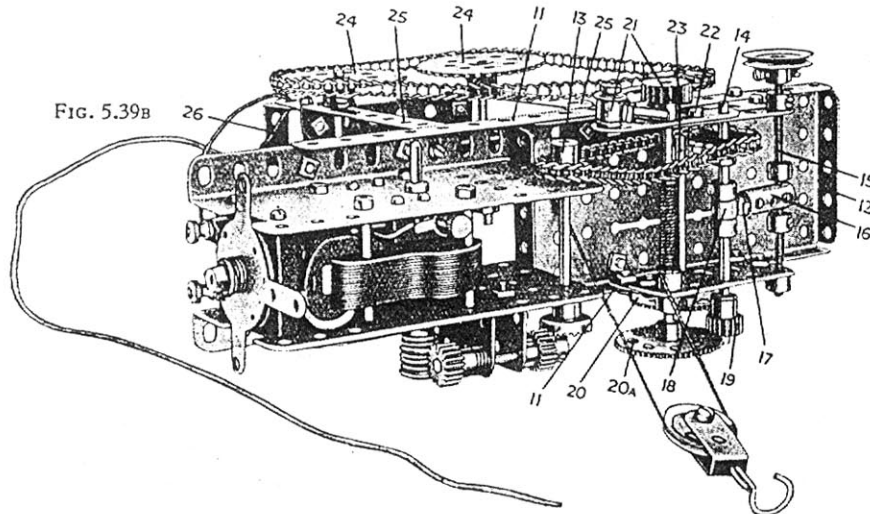

## Model No. 5.40 Delivery Van

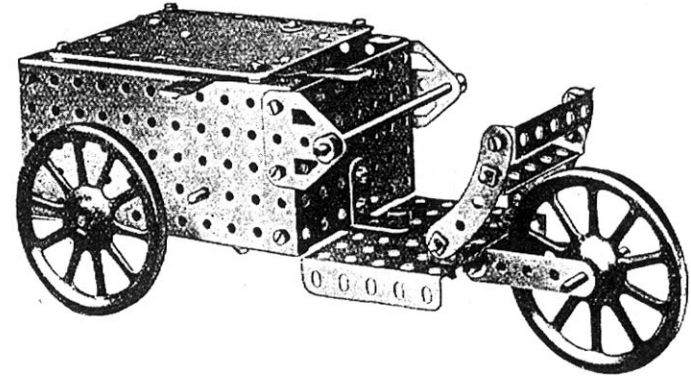

### Parts

required:

- 1 of No. 3
- 3 " " 5
- 4 " " 12
- 1 " " 12A
- 1 " " 15
- 2 " " 15A
- 1 " " 17
- 1 " " 18A
- 3 " " 19A
- 1 " " 26
- 1 " " 28
- 31 " " 37
- 9 " " 38
- 2 " " 48A
- 2 " " 52
- 3 " " 53
- 7 " " 59
- 2 " " 90
- 9" " " 94
- 2 " " 96
- 2 " " 126A

Clockwork  
Motor

(not included in  
Outfit)

A  $\frac{1}{2}$ " Pinion on the Motor driving shaft (see Fig. 5.40A) engages with a  $1\frac{1}{2}$ " Contrate Wheel that is secured to a  $3\frac{1}{2}$ " Rod journalled in the side plates of the model. This Rod carries a 1" Sprocket Wheel that is connected by Sprocket Chain to a further 1" Sprocket on the axle of the front road wheels.

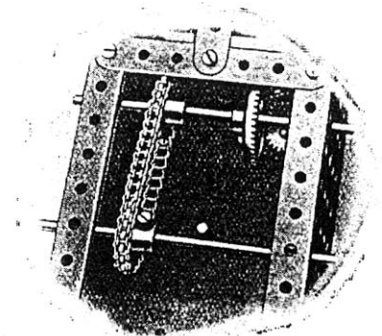
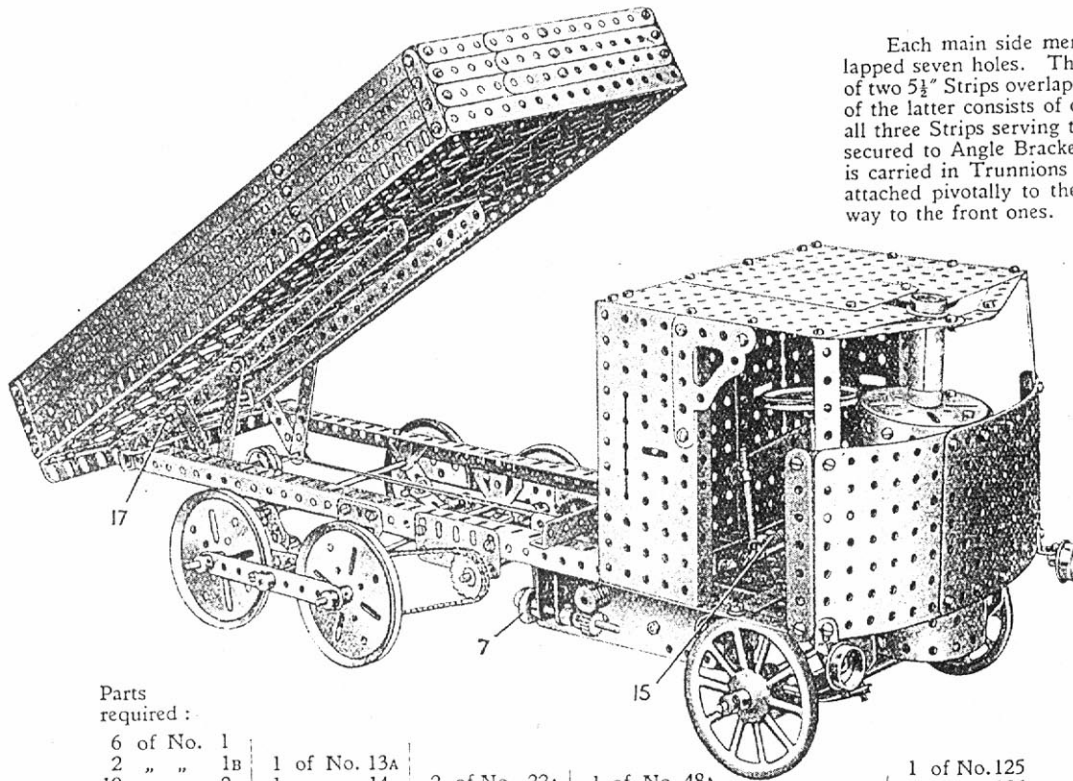

FIG. 5.40A.

## Model No. 5.41 Tipping Steam Wagon



Parts  
required :

6 of No. 1	1 of No. 13A	2 of No. 22A	1 of No. 48A	1 of No. 125
2 " " 1B	1 " " 14	1 " " 23	1 " " 48B	4 " " 126
19 " " 2	4 " " 15	1 " " 23A	2 " " 48D	4 " " 126A
4 " " 2A	3 " " 15A	3 " " 26	4 " " 52	1 " " 160
12 " " 3	5 " " 16	2 " " 27A	4 " " 52A	1 " " 162
1 " " 4	3 " " 16A	1 " " 29	2 " " 53A	1 " " 163
8 " " 5	5 " " 17	1 " " 32	1 " " 57C	1 " " 164
4 " " 6	4 " " 18A	14 " " 35	19 " " 59	2 " " 165
4 " " 6A	2 " " 19A	164 " " 37	1 " " 62B	1 " " 166
10 " " 8	4 " " 19B	10 " " 37A	5 " " 63	2 " " 111
2 " " 8B	1 " " 20A	24 " " 38	1 " " 70	4 " " 111C
4 " " 9	3 " " 20B	1 " " 40	1 " " 90	2 " " 115
7 " " 10	3 " " 22	1 " " 43	24 " " 94	1 " " 116A
21 " " 12				
4 " " 12A				

1 of No. 125
4 " " 126
4 " " 126A
1 " " 160
1 " " 162
1 " " 163
1 " " 164
2 " " 165
1 " " 166

Electric Motor  
(not included in  
Outfit)

Each main side member of the chassis consists of two 12½" Angle Girders overlapped seven holes. The front axle is duplicated for strength, each portion consisting of two 5½" Strips overlapped nine holes and bolted to one side of the leaf springs. Each of the latter consists of one 3½", one 2½" and one 1½" Strip, a ¼" Bolt passing through all three Strips serving to secure the spring to the axle. The ends of the Springs are secured to Angle Brackets, the front Angle Brackets being mounted on a Rod 1 that is carried in Trunnions bolted to the chassis, whilst the rear ones have Flat Brackets attached pivotally to them by lock-nutted bolts and mounted on a Rod in a similar way to the front ones. The Springs for the rear wheels are constructed and mounted in an exactly similar manner to the front ones.

The equalizing beams of each bogie are two 4½" Strips that are connected at their centres by 1"×1" Angle Brackets 2. Each pair of equalizing beams pivots freely about an 8" Rod 3, that is passed through Collars attached by ¾" Bolts to the Springs.

The steering gear is based on the correct Ackermann principle and is built up in the following way: The stub axles are secured in Couplings 4, which are free to turn about ¾" Bolts inserted in their centre holes and attached by double Nuts to the extremities of the front axle. The track rod (which connects the Wheels so that they turn together) is attached pivotally by means of Swivel Bearings 5, to the ends of short Rods that are held in the end bores of the Couplings. The free end of one of these Rods carries a third Swivel Bearing 6 which is connected by a Rod to a Double Arm Crank on the lower extremity of the steering column. The latter is journalled in a reinforced bearing consisting of a ½" Reversed Angle Bracket that is bolted to the floor of the cab.

The Motor armature spindle carries a Worm meshing with a ½" Pinion on a Rod that has also a ¾" Contrace Wheel 7 secured to it. The latter is in constant mesh with a ½" Pinion on a sliding Rod 8. This Rod has two further ½" Pinions, one between and the other outside the Motor side plates, and by sliding it in its bearings, the Pinions may be brought into mesh with either of the 57-teeth Gears 9 and 10. The Gear 10 is secured to a short Rod journalled in the Motor side plates and carrying also a 1" loose Pulley 11, which is retained in place on the Rod, together with a Flat Bracket, by Collars. One end of a length of cord is tied to the Flat Bracket and is passed over one of the 1" loose Pulleys 12 that are free on a Rod, which is carried by Strips attached rigidly to the underside of the tipping body. The cord then passes

## Model No. 5.41 Tipping Steam Wagon

(continued)

to the Pulley 11 back over the second Pulley 12, and is attached finally to the Rod on which the Gear 10 is secured.

The Gear 9 is mounted on a  $6\frac{1}{2}$ " Rod that passes completely through both Motor side plates and is also supported in additional bearings consisting of  $2\frac{1}{2}$ " Flat Girders bolted to the chassis members. 1" Sprocket Wheels are secured on each end of the Rod and are connected by Sprocket Chain to the 2" Sprockets on the road wheel axles. It will be seen, therefore, that by sliding the Rod 8, either the travelling or tipping movement may be effected. The sliding of the Rod is accomplished by a 2" Rod that engages between a  $\frac{1}{2}$ " loose and a  $\frac{1}{2}$ " fast Pulley, and is secured in a Coupling on a Rod 13. The latter is journaled in a  $3\frac{1}{2}$ " Double Angle Strip bolted to the chassis and carries on its other end another Coupling in which is held a Rod to serve as a lever. In order to manipulate the latter conveniently a Strip 14 that projects through the slot of the  $5\frac{1}{2}$ " x  $2\frac{1}{2}$ " Flanged Plate forming the side of the cab is attached pivotally to it by a Bolt inserted in a Collar on the upper extremity of the lever. A Spring 15 keeps the lever normally in the travelling position, so that to engage the tipping movement it is necessary to pull out the Strip against the tension of the Spring. A similar scheme is followed in the case of the Motor control switch; a  $5\frac{1}{2}$ " Strip 16 is attached pivotally to the top end of a Crank Handle, which is secured rigidly by means of a Coupling to the motor switch arm.

The tipping body pivots about a  $3\frac{1}{2}$ " Rod 17 that is passed through holes in two  $12\frac{1}{2}$ " Angle Girders bolted to the underside of the body, and also through the ends of a  $2\frac{1}{2}$ " x  $\frac{1}{2}$ " Double Angle Strip. This Double Angle Strip is secured by  $\frac{3}{8}$ " Bolts to a  $5\frac{1}{2}$ " Angle Girder spanning the end of the chassis, and is spaced therefrom by three  $2\frac{1}{2}$ " Strips.

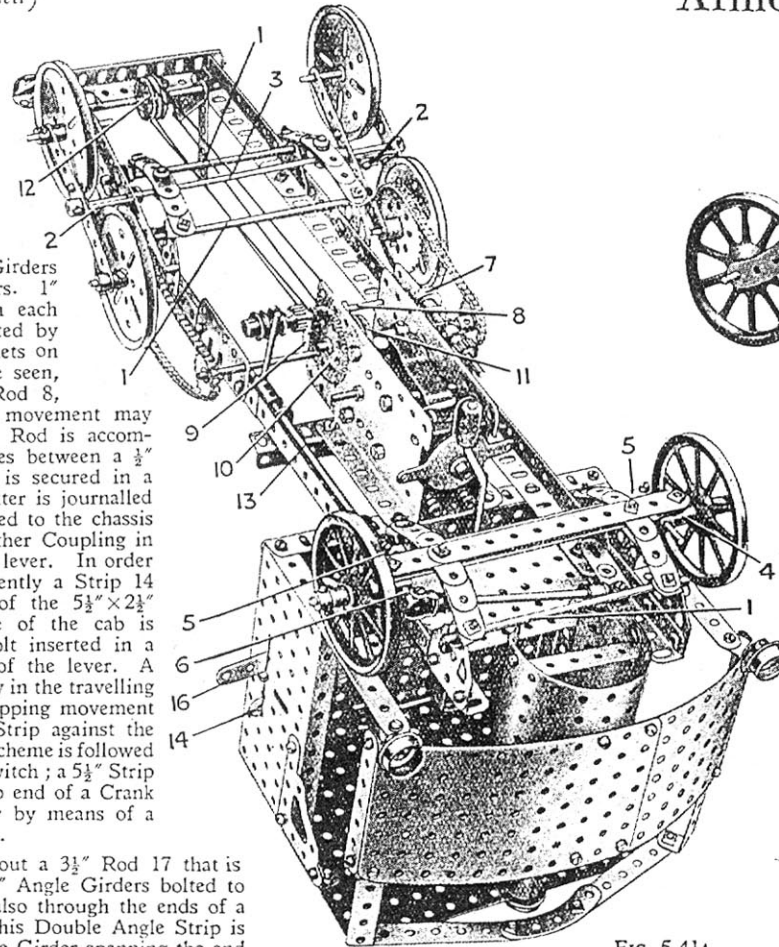
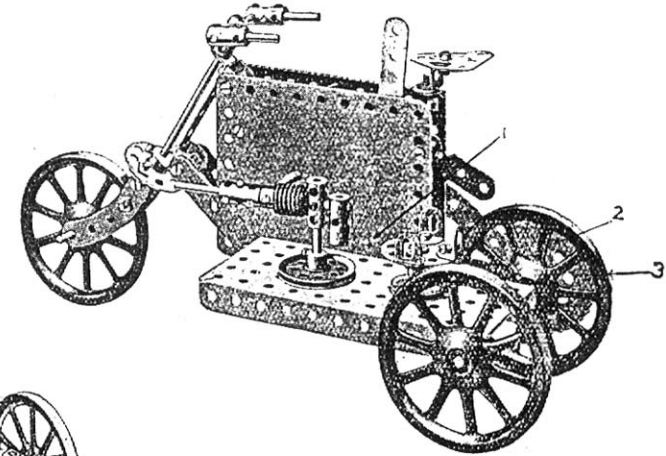

FIG. 5.41A

## Model No. 5.42 Armoured Motor Tricycle



Parts required :

2 of No. 2	4 of No. 18A	1 of No. 52
2 " " 5	3 " " 19A	1 " " 59
1 " " 9D	1 " " 21	6 " " 63
2 " " 11	3 " " 22	2 " " 90
4 " " 12	2 " " 24	1 " " 95
2 " " 12A	1 " " 32	1 " " 96
1 " " 15A	22 " " 37	1 " " 125
2 " " 16	10 " " 38	1 " " 126A
2 " " 17	1 " " 48A	

Clockwork Motor

(not included in Outfit)

This is driven from the Motor Spindle 1, a small Sprocket Wheel at the rear, not shown in the illustration, being geared by a chain to the larger Sprocket Wheel 2 bolted on the Axle Rod of the rear Wheels 3.

## Model No. 5.43

# Electric Tram Car

The external construction of the model is shown clearly in Figs. 5.43 and 5.43A.

The bells are composed of two small Flanged Wheels 1 attached to the roof of the lower deck by means of Angle Brackets, and Collars attached to a cord running through the bosses of both Wheels, form the strikes.

The seats on the upper deck are constructed as follows: backs are two sets of  $5\frac{1}{2}$ " Strips 2 connected together at the ends by means of 2" Strips, which are secured to the floor of the upper deck by means of two  $9\frac{1}{2}$ " Angle Girders 3. The seats proper are  $5\frac{1}{2}$ " Strips similar to 2 but are joined together by Flat Brackets and secured to the backs by Angle Brackets.

The construction of the bogies will be seen clearly in Fig. 5.43A the mounting of the 2" Pulleys 4 and 5 being the only part needing description. Each Pulley 4 is secured to the  $1\frac{1}{2}$ "  $\times$   $\frac{1}{2}$ " Double Angle Strip and the Trunnion on the bogie by means of  $\frac{3}{8}$ " Bolts, three Washers on each being used for spacing purposes. The second Pulley 4 is connected to two  $1\frac{1}{2}$ " Strips 6 by means of  $\frac{3}{8}$ " Bolts spaced similarly to those on the Pulley 4, and the  $1\frac{1}{2}$ " Strips 6 are bolted to the  $3\frac{1}{2}$ " Strip 7 and the  $5\frac{1}{2}$ "  $\times$   $3\frac{1}{2}$ " Flanged Plate 8. The bogie pivot, a  $\frac{3}{4}$ " Bolt, is passed through the boss of the Pulley 4 and secured in the boss of the Pulley 5.

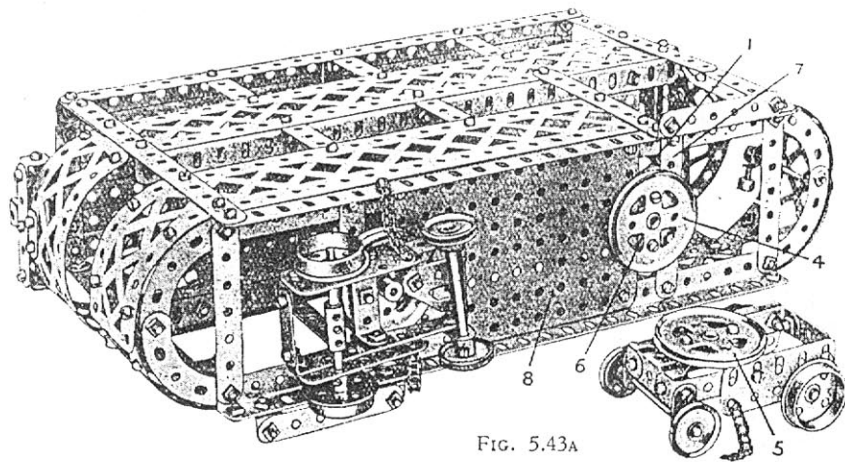
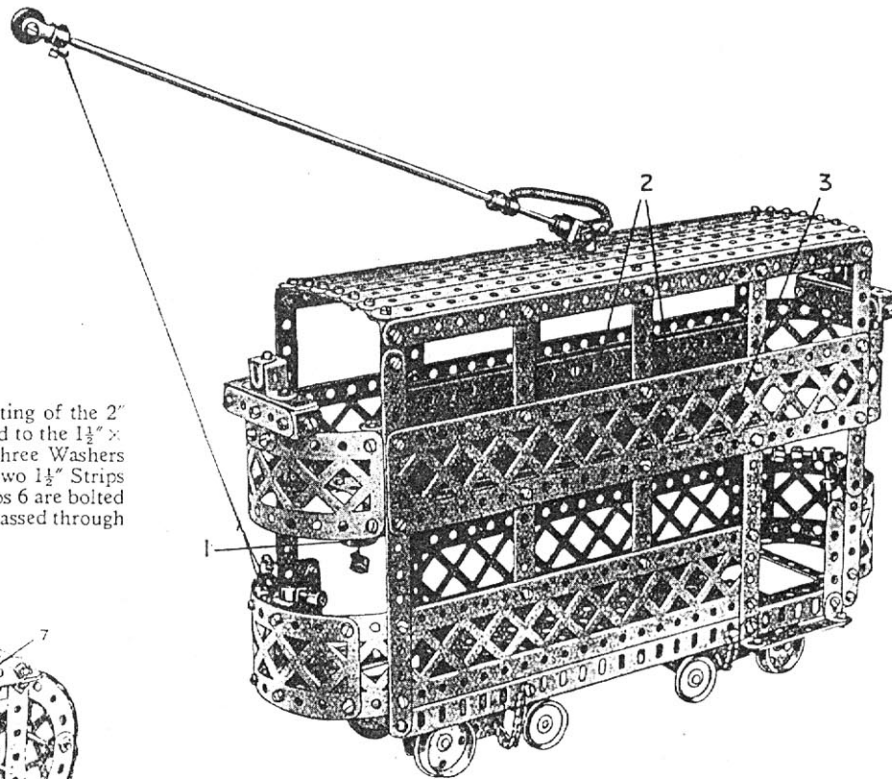

FIG. 5.43A



### Parts required:

9	of No.	1	4	of No.	11	6	of No.	37A	4	cf No.	90A
2	"	1B	20	"	12	24	"	38	8	"	94
12	"	2	1	"	13	1	"	40	4	"	99
2	"	2A	3	"	16A	1	"	43	4	"	100
7	"	3	4	"	17	2	"	45	4	"	103F
2	"	4	2	"	18A	2	"	48	3	"	111
18	"	5	4	"	20	2	"	48A	6	"	111c
4	"	6	4	"	20A	4	"	48B	2	"	115
6	"	6A	2	"	20B	3	"	52A	1	"	116
4	"	8	4	"	22	13	"	59	1	"	116A
4	"	8A	1	"	23	4	"	63	2	"	126
12	"	10	169	"	37	2	"	77	1	"	147B



## Model No. 5.45 Battle Cruiser

The hull consists of three rows of  $12\frac{1}{2}$ " and  $5\frac{1}{2}$ " Strips, the upper row being bolted to the flanges of the Sector Plates and  $5\frac{1}{2}$ "  $\times$   $2\frac{1}{2}$ " Flanged Plates which form the deck. The superstructure is built up on two  $12\frac{1}{2}$ " Angle Girders, which are spaced apart by  $1\frac{1}{2}$ " Strips and a longitudinal  $12\frac{1}{2}$ " Strip and secured by Angle Brackets to the Flanged Plates.  $2\frac{1}{2}$ " Strips are bolted vertically to support  $2\frac{1}{2}$ "  $\times$   $1\frac{1}{2}$ " Double Angle Strips, to which further Strips are secured to form the navigating bridge.

The tripod mast is placed directly behind the bridge. The mast proper, which consists of one  $6\frac{1}{2}$ " Axle Rod, is secured to the deck by a  $1\frac{1}{2}$ " Pulley Wheel and carries a Flanged Wheel and two 1" Pulleys. Two further  $6\frac{1}{2}$ " Rods are passed through holes in the Flanged Wheel and their lower ends are inserted in holes in the upper deck and secured by Spring Clips. The funnel consists of ten  $2\frac{1}{2}$ " Strips bolted in a vertical position and held together by Flat Brackets slightly bent. It is secured to the ship by Angle Brackets.

The aeroplane launching platform consists of  $2\frac{1}{2}$ " Strips bolted to a Bush Wheel, while the miniature aeroplane is built up from a 2" Rod carrying a Collar, in the tapped hole of which a Bolt is securely fixed. A Double Bracket and a  $1\frac{1}{2}$ " Strip are held on the shank of the Bolt. The tail plane is represented by a Spring Clip.

Figs. 5.45A and 5.45B show the gun turrets. The guns, which are formed from Rods, are held in position by Collars. The completed turrets pivot about  $\frac{3}{8}$ " Bolts secured to the 1" Triangular Plates and loosely attached to the Sector Plates by lock-Nuts.

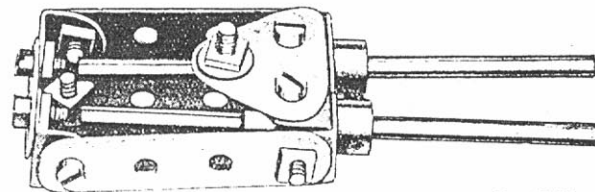

Fig. 5.45A

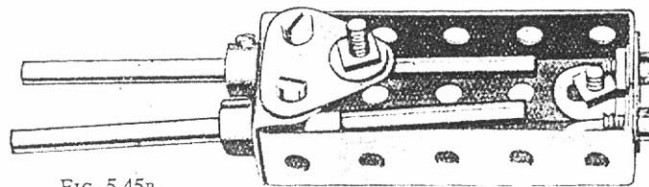
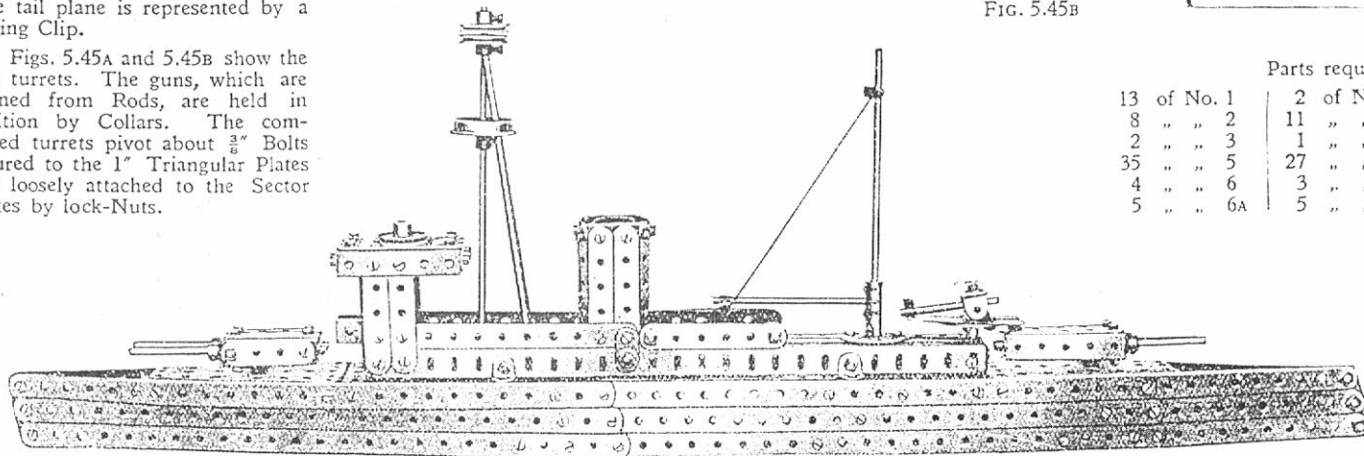

Fig. 5.45B



### Parts required :

13	of No. 1	2	of No. 8	1	of No. 18A
8	" "	11	" "	1	" "
2	" "	1	" "	1	" "
35	" "	27	" "	3	" "
4	" "	3	" "	2	" "
5	" "	5	" "	3	" "
				146	" "
				4	" "
				1	" "
				2	" "
				6	" "
				1	" "
				1	" "
				2	" "
				9	" "
				1	" "
				2	" "

### HOW TO CONTINUE.

This completes our examples of models that may be made with MECCANO Outfit No. 5 (or No. 4 and No. 4A). The next models are a little more advanced, requiring extra parts to construct them. The necessary parts are all contained in a No. 5A Accessory Outfit, the price of which may be obtained from any Meccano dealer.



## Model No. 6.1 Portable Crane

Parts required :

12	of No. 2	1	of No. 19	4	of No. 37A
3	" " 3	1	" " 21	16	" " 38
6	" " 5	5	" " 22	1	" " 40
2	" " 9	2	" " 22A	2	" " 44
16	" " 12	2	" " 23	1	" " 45
1	" " 15	1	" " 24	1	" " 48
5	" " 16	1	" " 26	2	" " 48A
4	" " 17	1	" " 27A	1	" " 53
2	" " 18A	74	" " 37	1	" " 57c

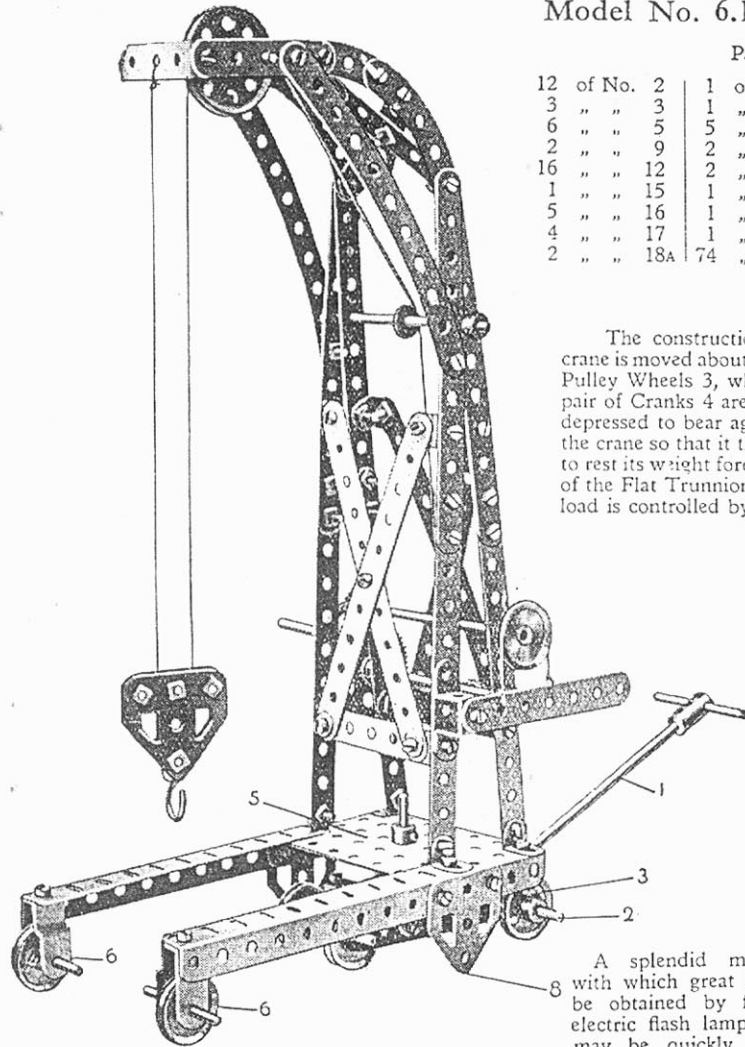

The construction of the tower is quite clear from the illustration. The crane is moved about by depressing the handle 1 carrying an Axle 2 for the 1" loose Pulley Wheels 3, which are secured in position by Collars and Set Screws. A pair of Cranks 4 are secured to the Axle 2 and are arranged when the handle is depressed to bear against the underface of the 3 1/2" x 2 1/2" Flanged Plate 5 and lift the crane so that it then runs on the Wheels 3 and 6. When the crane is brought to rest its weight forces down the Cranks 4 which raise the handle 1, and the tips 8 of the Flat Trunnions together with front Wheels 6 then support the crane. The load is controlled by a strap and lever brake.

Parts required :

1	of No. 1	1	of No. 18A
2	" " 2	1	" " 19
4	" " 4	1	" " 21
6	" " 6	3	" " 24
6	" " 8	2	" " 26
2	" " 10	1	" " 27A
6	" " 12	1	" " 29
1	" " 15		
1	" " 16		
2	" " 17		

A splendid model with which great fun may be obtained by fitting an electric flash lamp. The light may be quickly manoeuvred in any direction and enemy aircraft "spotted" at once.

FIG. 6.1A

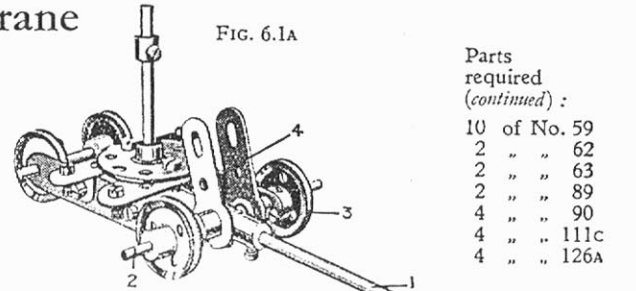

Parts required  
(continued) :

10	of No. 59
2	" " 62
2	" " 63
2	" " 89
4	" " 90
4	" " 111c
4	" " 126A

## Model No. 6.2 Searchlight

Parts required  
(continued) :

2	of No. 32
62	" " 37
3	" " 45
1	" " 46
7	" " 53
8	" " 59
1	" " 63

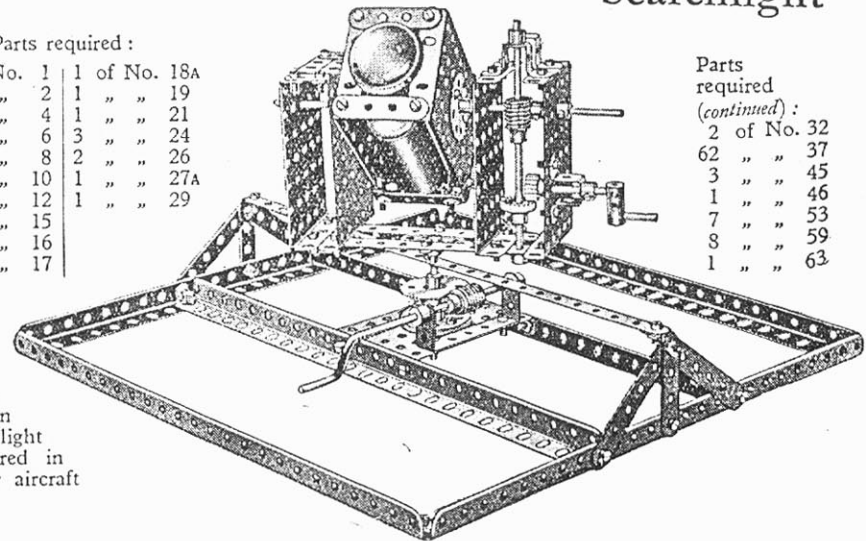

## Model No. 6.3 Punching Machine

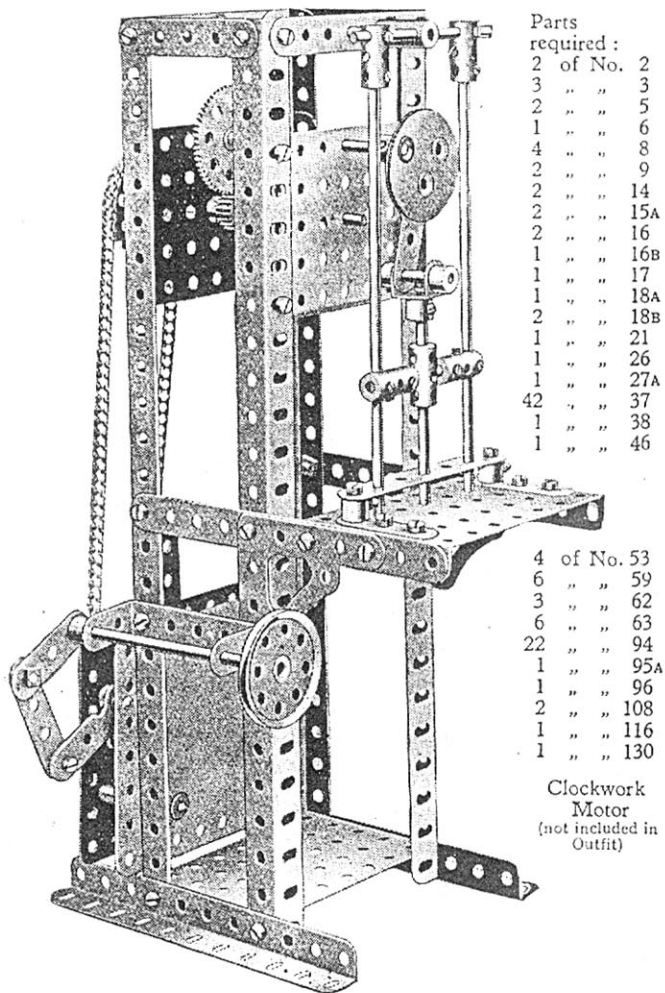

Parts required:	
2	of No. 2
3	" " 3
2	" " 5
1	" " 6
4	" " 8
2	" " 9
2	" " 14
2	" " 15A
2	" " 16
1	" " 16B
1	" " 17
1	" " 18A
2	" " 18B
1	" " 21
1	" " 26
1	" " 27A
42	" " 37
1	" " 38
1	" " 46

4	of No. 53
6	" " 59
3	" " 62
6	" " 63
22	" " 94
1	" " 95A
1	" " 96
2	" " 108
1	" " 116
1	" " 130

Clockwork  
Motor  
(not included in  
Outfit)

## Model No. 6.4 Walking Tractor

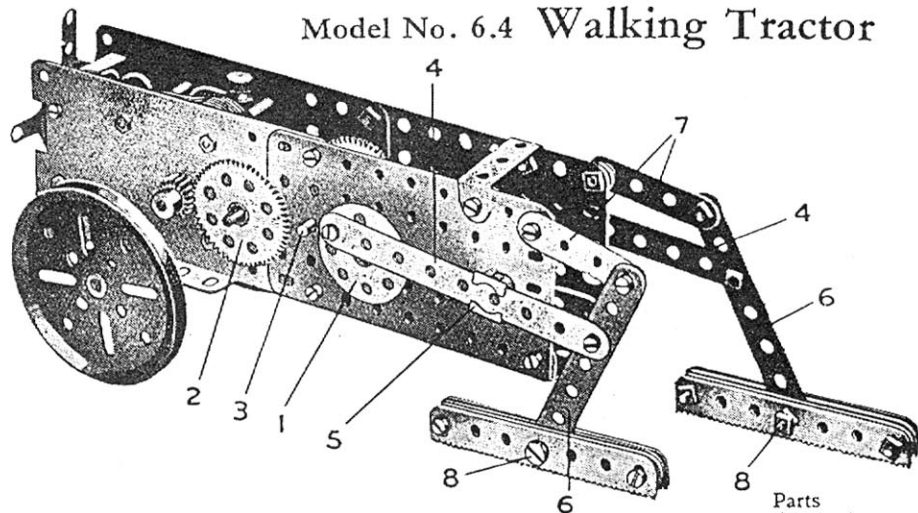

This is a model of a machine designed to travel over very rough surfaces where ordinary wheeled vehicles could not pass.

The gear train by which the motion from the Motor armature is transmitted to the "legs" of the machine, consists of three  $\frac{1}{2}$ " Pinions and three 57-teeth Gear Wheels. One of the latter can be seen at 2; the second 57-teeth Gear is secured to a 2" Rod 3 and is rotated by a  $\frac{1}{2}$ " Pinion secured to the shaft of wheel 2. The third Gear is fixed to the 2" Rod carrying the Bush Wheel 1. Another Bush Wheel is secured to the opposite end of the latter Rod, and these two Bush Wheels actuate the legs by means of connecting  $4\frac{1}{2}$ " Strips 4. The Bush Wheels should be arranged so that the pivots of the connecting Strips 4 are placed at 180 degrees to each other.

The Strips 4 slide to and fro in Eye Pieces 5, which are secured to the shanks of  $\frac{3}{8}$ " Bolts that are free to turn in the side plates of the model. The Strips are pivoted to the  $3\frac{1}{2}$ " Strips 6 forming the legs by means of Bolts and lock-Nuts and their other ends are pivoted by the same method to the Bush Wheels 1. The legs are pivoted at their upper ends to two 2" Strips 7, and the latter are pivoted to the side plates.

Each of the "shoes" consists of a  $3\frac{1}{2}$ " Rack Strip and seven  $3\frac{1}{2}$ " Strips—the latter being used to increase the weight of the shoes. The Strips 6 are inserted in the centres of the shoes and Pivot Bolts 8 are passed through their end holes. Washers should be placed on the  $\frac{1}{2}$ " Bolts securing the ends of the shoes together, so that the shoes are quite free to move about the Pivot Bolts 8.

The Motor is mounted on 3" Pulley Wheels, the axle of which is journaled through Angle Brackets bolted beneath the Motor.

Parts  
required:

Parts required:	
2	of No. 2A
16	" " 3
2	" " 6
1	" " 6A
2	" " 12
1	" " 16
2	" " 16A
1	" " 17
2	" " 19B
2	" " 24
3	" " 26
3	" " 27A
12	" " 37
2	" " 38
1	" " 48
2	" " 50A
2	" " 53A
1	" " 59
2	" " 110
4	" " 111
6	" " 111A
6	" " 111C
2	" " 147B

Electric  
Motor  
(not included in  
Outfit)

## Model No. 6.5 Robot (or Mechanical Man)

The front and back of the body are built up from four  $5\frac{1}{2}'' \times 3\frac{1}{2}''$  Flat Plates and are joined together at the sides by means of  $3\frac{1}{2}'' \times 2\frac{1}{2}''$  Flanged Plates 1 and  $5\frac{1}{2}'' \times 2\frac{1}{2}''$  Flat Plates 2. The  $5\frac{1}{2}''$  Angle Girders forming the arms have attached to them Boiler Ends, inside which are 2" Pulleys, and the "fists" so formed are attached to the arms by means of  $2\frac{1}{2}''$  Rods 3 and Collars 4. The complete arms are attached by  $\frac{1}{2}''$  Bolts to the shoulders, and an Angle Bracket and a  $\frac{1}{2}''$  Bolt 5 are used to secure each elbow to the body. The construction of the head and shoulders will be seen in Fig. 6.5A.

The  $3\frac{1}{2}'' \times 2\frac{1}{2}''$  Flanged Plates forming the head are bolted to the top ends of the  $12\frac{1}{2}''$  Girders 6. These Girders run from the top of the head to a point half way down the body, and also support the Electric Motor, which is attached by means of the  $2\frac{1}{2}''$  Flat Girders 7.

A 57-teeth Gear and  $\frac{1}{2}''$  Pinion connect the armatures spindle to the  $2\frac{1}{2}''$  Rod 8, on which is fixed a Worm 9. This engages with a  $\frac{1}{2}''$  Pinion 12 on the Rod 10, the latter also carrying two loose Couplings 11 and 11A. The Pinion 12 engages with a  $\frac{1}{2}''$  Contrate 13 on a  $1\frac{1}{2}''$  Rod journalled in the side plate of the Motor and in the lower loose Coupling 11. This Rod also carries a  $\frac{1}{2}''$  Pinion which engages with the 57-teeth Gear 14 that is mounted on a  $1\frac{1}{2}''$  Rod journalled in the Motor side plate and in the top loose Coupling 11A. The latter  $1\frac{1}{2}''$  Rod is connected to the crankshaft 15 by Sprocket Chain as shown in the illustration.

The crankshaft carries two Bush Wheels 21 that are fitted with  $\frac{1}{2}''$  Bolts on which are mounted loose Pulleys 16. These Pulleys are spaced by Washers so as to slide between the two  $12\frac{1}{2}''$  Angle Girders forming each leg. A short Rod engaging with one of the holes in the reversing handle of the Motor is fixed to the Rod holding the "ears" by means of a Coupling and held in place by two Collars. This forms an easy means of stopping and starting the model.

The Motor unit may now be fixed in place. This is accomplished by bolting the two  $12\frac{1}{2}''$  Angle Girders to the back of the body and the flanges of the Motor to the front. Two  $\frac{1}{2}''$  Bolts 23 spaced by Washers are used to secure the latter.

The feet should next be made, each being constructed similarly. A  $5\frac{1}{2}'' \times 2\frac{1}{2}''$  Flanged Plate is raised on  $5\frac{1}{2}''$  Strips as shown in Fig. 6.5B, and a  $2\frac{1}{2}'' \times 1''$  Double Angle Strip bolted to the top of the Plate carries a  $3\frac{1}{2}''$  Rod. Two  $5\frac{1}{2}''$  Angle Girders connected together by a Double Bracket are held in place on this Rod by Collars. Two  $1'' \times 1''$  Angle Brackets are bolted to the rear end of the foot as shown. One carries a  $3\frac{1}{2}''$  Rod 17, while a Swivel Bearing 18 attached to the other by a  $\frac{1}{2}''$  Bolt carries a Centre Fork 19, which is held against the ground by the Spring 20. A Flat Bracket 22, attached loosely by set-screws to the "spider" and boss of the Swivel Bearing, prevents excess movement of the Centre Fork.

The  $12\frac{1}{2}''$  Angle Girders forming the upper parts of the legs are bolted to the  $5\frac{1}{2}''$  Angle Girders of the feet and the complete legs are pivoted by Bolts and Nuts (see Standard Mechanism No. 262) immediately below the  $\frac{1}{2}''$  Bolts holding the arms. The  $3\frac{1}{2}''$  Rod 17 is connected to an  $11\frac{1}{2}''$  Rod 20 by means of a Coupling, the whole being pivoted one inch to the rear of the leg pivot as follows: A Bolt is passed through the Plate 1 and inserted in the set-screw hole of a Collar on the upper end of the Rod 20, and the Bolt is screwed home until the Collar is fast on the Rod, leaving the Bolt free to turn in the Plate. These Rods 20 ensure that the foot always remains parallel to the ground, to facilitate walking.

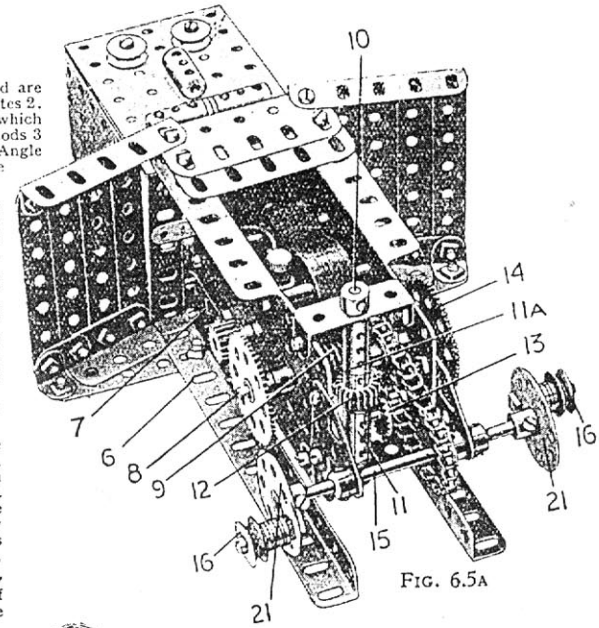

FIG. 6.5A

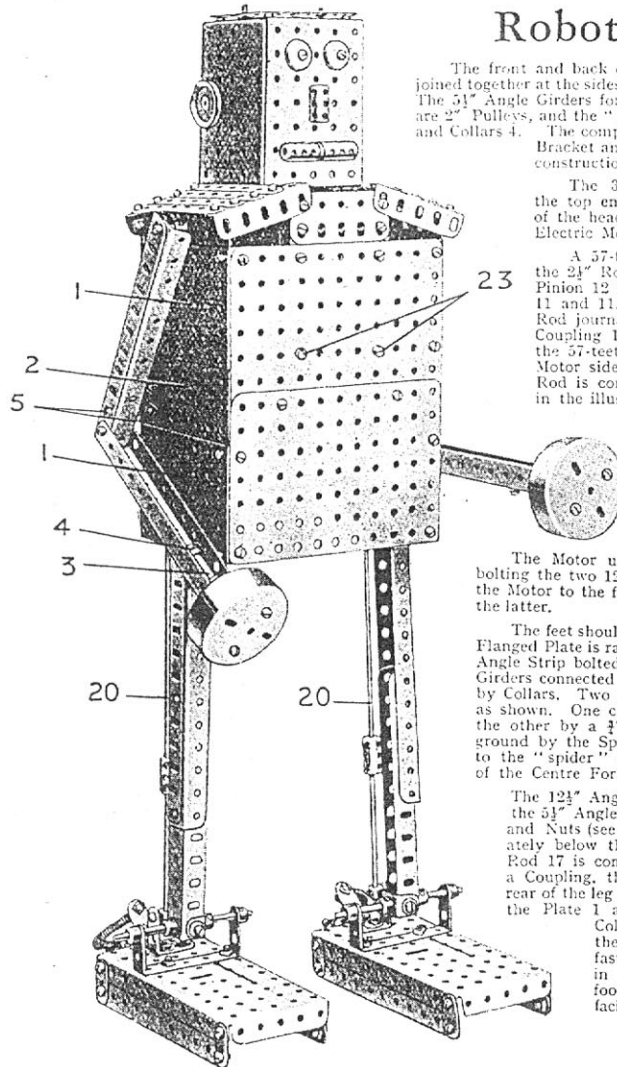
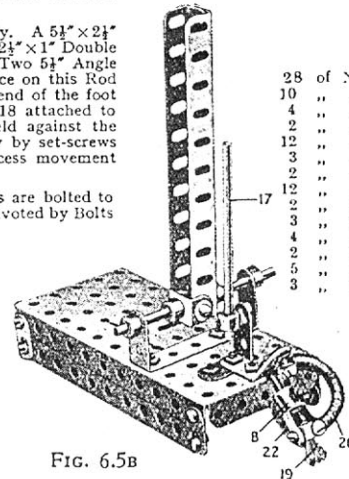

FIG. 6.5B



Parts required:

28	of	No.	2	2	of	No.	16B	7	of	No.	53
10	"	"	3	1	"	"	17	1	"	"	53A
4	"	"	8	2	"	"	18B	23	"	"	59
2	"	"	8B	2	"	"	20	8	"	"	63
12	"	"	9	4	"	"	20A	2	"	"	65
3	"	"	9D	2	"	"	22	2	"	"	70
2	"	"	9F	4	"	"	23	1	"	"	72
12	"	"	10	2	"	"	24	6	"	"	94
2	"	"	11	3	"	"	26	1	"	"	98
3	"	"	12	2	"	"	27A	1	"	"	96A
4	"	"	12A	1	"	"	29	2	"	"	103F
2	"	"	13	1	"	"	32	8	"	"	111
4	"	"	13A	1	"	"	37	4	"	"	111A
5	"	"	16	114	"	"	37A	6	"	"	111C
3	"	"	16A	15	"	"	38	2	"	"	126A
				31	"	"	43	2	"	"	182A
				2	"	"	46	2	"	"	165
				1	"	"	48				
				2	"	"	52				
				4	"	"	52A				

Electric Motor  
not included  
(Outfit)

These Models can be built with MECCANO Outfit No. 6 (or No. 5 and No. 5A)

## Model No. 6.7 Revolving Aeroplanes

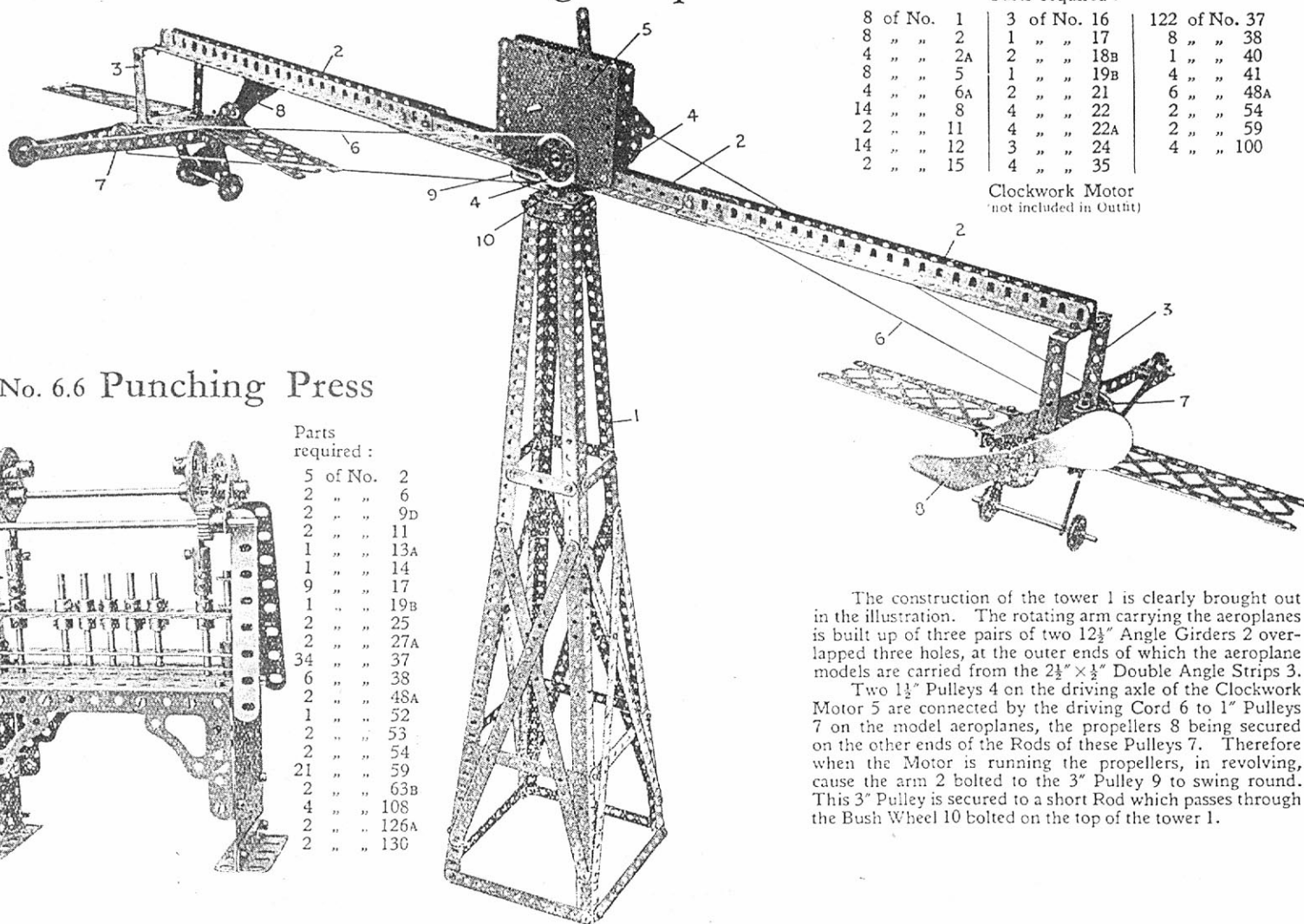

Parts required :

8 of No.	1	3 of No.	16	122 of No.	37
8 "	2	1 "	17	8 "	38
4 "	2A	2 "	18B	1 "	40
8 "	5	1 "	19B	4 "	41
4 "	6A	2 "	21	6 "	48A
14 "	8	4 "	22	2 "	54
2 "	11	4 "	22A	2 "	59
14 "	12	3 "	24	4 "	100
2 "	15	4 "	35		

Clockwork Motor  
(not included in Outfit)

## Model No. 6.6 Punching Press

Parts  
required :

5 of No.	2
2 "	6
2 "	9D
2 "	11
1 "	13A
1 "	14
9 "	17
1 "	19B
2 "	25
2 "	27A
34 "	37
6 "	38
2 "	48A
1 "	52
2 "	53
2 "	54
21 "	59
2 "	63B
4 "	108
2 "	126A
2 "	130

The construction of the tower 1 is clearly brought out in the illustration. The rotating arm carrying the aeroplanes is built up of three pairs of two  $12\frac{1}{2}$ " Angle Girders 2 overlapped three holes, at the outer ends of which the aeroplane models are carried from the  $2\frac{1}{2}$ "  $\times$   $\frac{1}{2}$ " Double Angle Strips 3.

Two  $1\frac{1}{2}$ " Pulleys 4 on the driving axle of the Clockwork Motor 5 are connected by the driving Cord 6 to 1" Pulleys 7 on the model aeroplanes, the propellers 8 being secured on the other ends of the Rods these Pulleys 7. Therefore when the Motor is running the propellers, in revolving, cause the arm 2 bolted to the 3" Pulley 9 to swing round. This 3" Pulley is secured to a short Rod which passes through the Bush Wheel 10 bolted on the top of the tower 1.

Parts required :

12	of No. 1	1	of No. 24
18	" " 2	2	" " 26
4	" " 3	1	" " 27A
4	" " 4	1	" " 32
18	" " 5	124	" " 37
4	" " 8	2	" " 40
24	" " 12	2	" " 48A
1	" " 14	2	" " 52
3	" " 16	2	" " 52A
1	" " 21	2	" " 53
2	" " 22	5	" " 59

## Model No. 6.8 Dutch Windmill

The construction of the sails 1 of the mill, will be readily followed from the illustration. They are bolted to an inner strip frame 2 and to a Bush Wheel 3 fixed on a Rod 4, on which is also mounted a Pulley Wheel 5. The driving cord passes round this Pulley Wheel to a lower Pulley Wheel 6, the driving of which will be followed from Fig. 6.8A.

The Pulley Wheel 6 is on the outer end of the Rod 7 on which is fitted a  $1\frac{1}{2}$ " Gear

Wheel 8 driven by a  $\frac{1}{2}$ " Pinion 9 on the Axle Rod 10. The Axle Rod also carries a  $\frac{1}{2}$ " Pinion 11 engaged by a Worm 12 on the driving shaft 13 which carries a driving Pulley 14.

The driving gear is enclosed in two  $3\frac{1}{2}$ " x  $2\frac{1}{2}$ " Flanged Plates 15 bolted to a Base Plate 16.

The vertical tower of the mill is made from corner Angle Girders 17 bolted to side Plates 15.

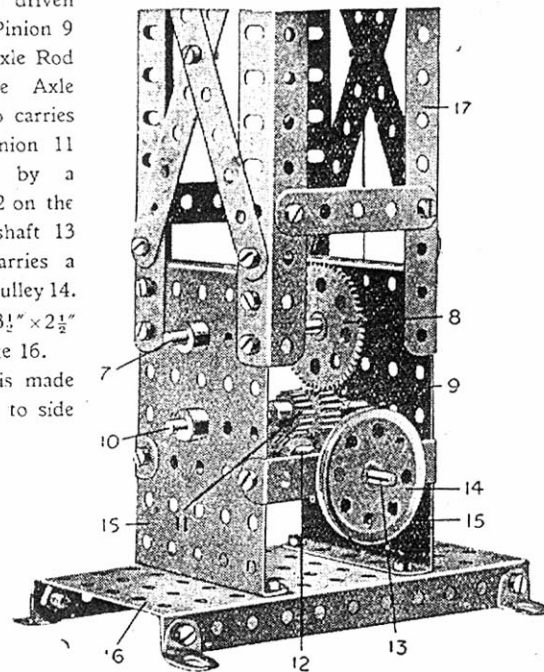
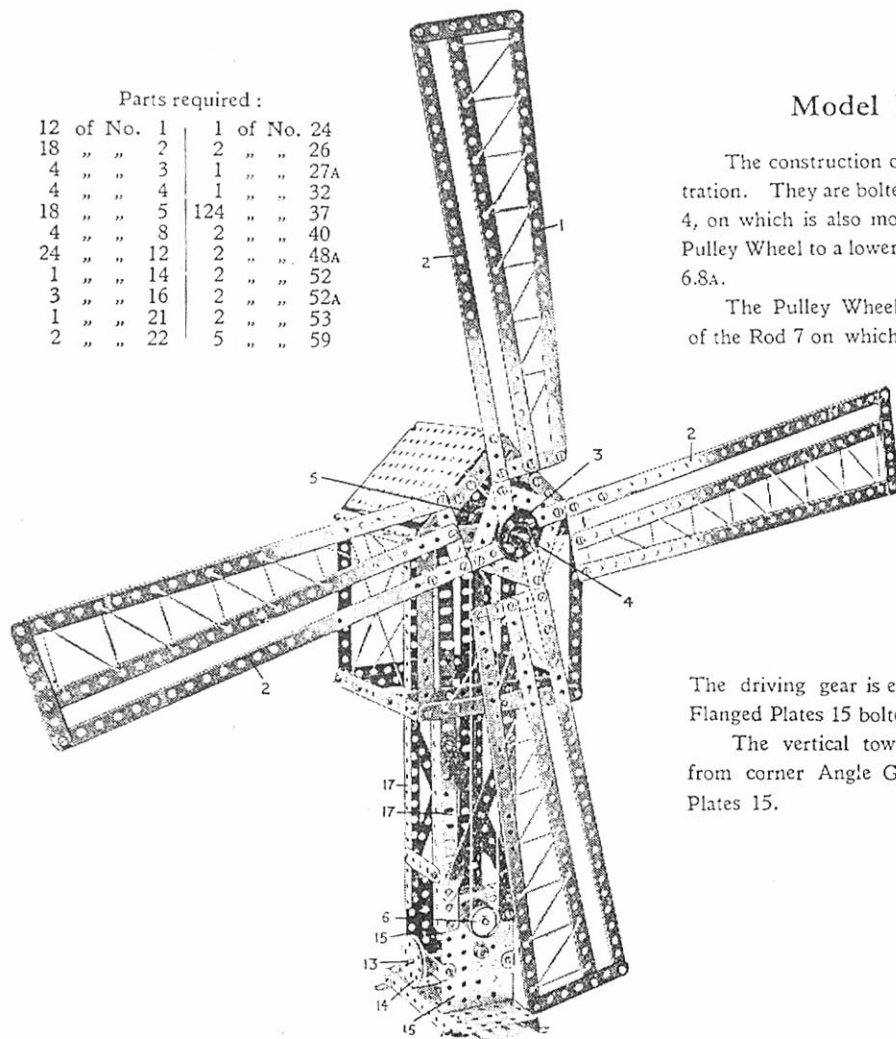

FIG. 6.8A

## Model No. 6.9 Drop Hammer

Parts required :

1 of No. 1	10 of No. 8	4 of No. 16	75 of No. 37	5 of No. 59
2 " " 1B	2 " " 9D	6 " " 20	6 " " 38	1 " " 63
4 " " 2	1 " " 11	1 " " 22A	1 " " 40	2 " " 72
1 " " 2A	1 " " 12A	2 " " 24	4 " " 48A	1 " " 95A
4 " " 3	1 " " 13	2 " " 26	2 " " 52	2 " " 97
4 " " 5	1 " " 15A	2 " " 27A	1 " " 53	4 " " 108

The construction details of this model are clearly shown in the illustration. The vertical hammer shaft is guided through  $2\frac{1}{2} \times \frac{1}{2}$ " Double Angle Strips secured in the upper framework. The operating Cord is led from a point on the shaft near the hammer-head up to a guide Pulley situated at the top of the model, and from thence down to the winding drum consisting of two Flanged Wheels butted together in the gear box.

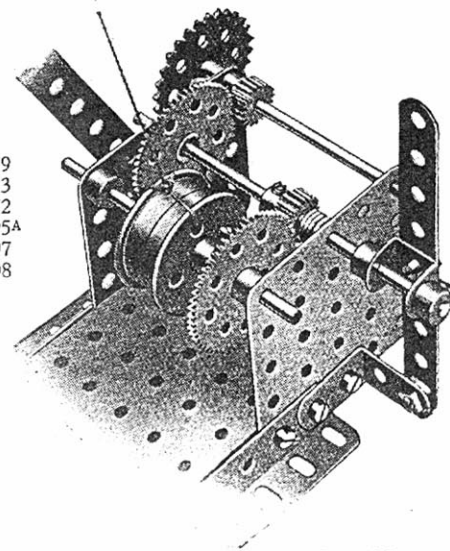
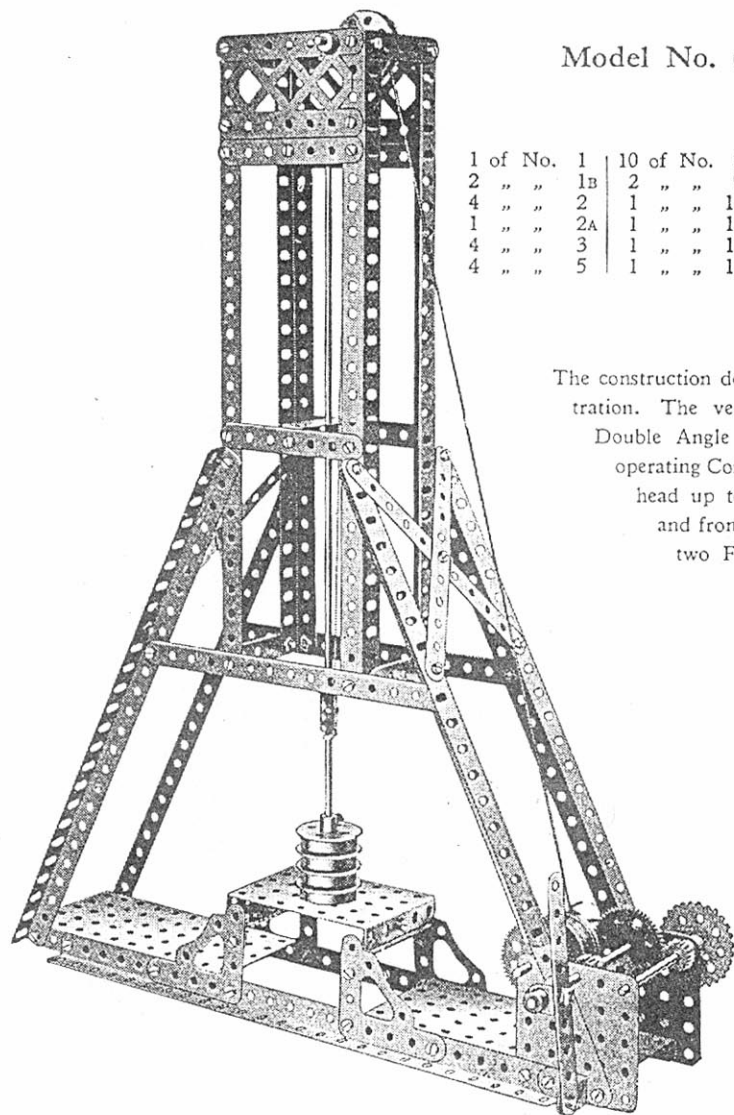

FIG. 6.9A

The Rod carrying the winding drum is rotated through a chain of reduction gearing from the driving shaft carrying a Sprocket Wheel, which may, of course, be coupled to a Meccano Motor or any other driving method. The intermediate shaft is slidable in its bearings and is controlled by the hand lever shewn in Fig. 6.9A, while its gears are so arranged that they may be easily slipped out of engagement with the driving shaft, with the result that the hammer, being released, forcibly strikes the table secured in the base of the machine. From this it will be seen that the power of the blow may be altered as desired, since the hammer may be dropped from varying heights.

### Model No. 6.10 Cantilever Bridge

Parts required :

16	of No.	1	8	of No.	6A	2	of No.	48B
16	"	"	2	8	"	14	"	90
3	"	"	3	18	"	8	"	99
4	"	"	5	8	"	2	"	100
4	"	"	6	136	"			

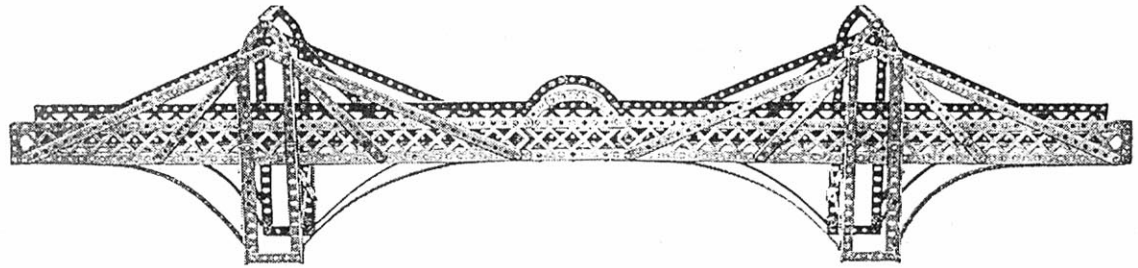

### Model No. 6.11 St. Malo Transporter Bridge

Parts required :

8	of No.	1	4	of No.	20
12	"	"	1	"	21
10	"	"	1	"	22
6	"	"	1	"	26
6	"	"	1	"	27A
6	"	"	156	"	37
16	"	"	4	"	48A
5	"	"	4	"	52
4	"	"	6	"	53
1	"	"	7	"	59
4	"	"	8	"	94
1	"	"	2	"	96
1	"	"	8	"	98
1	"	"	4	"	100

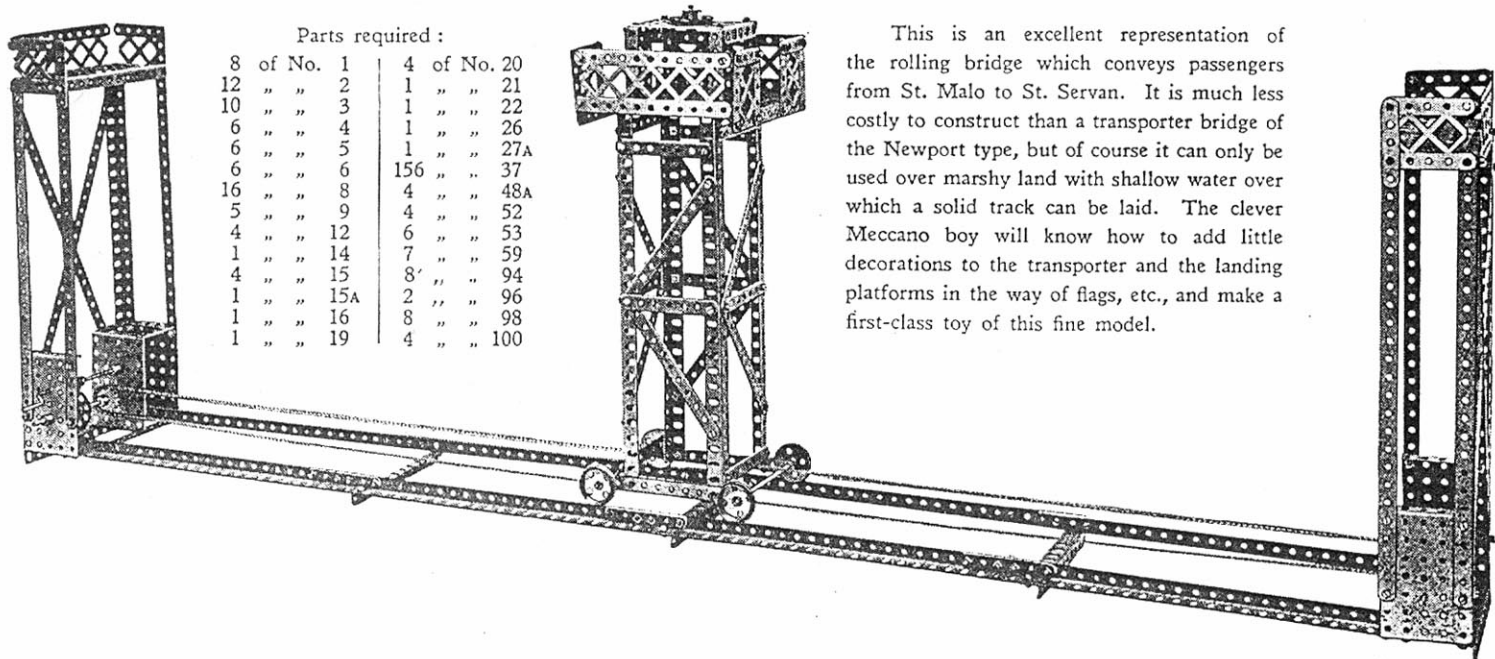

This is an excellent representation of the rolling bridge which conveys passengers from St. Malo to St. Servan. It is much less costly to construct than a transporter bridge of the Newport type, but of course it can only be used over marshy land with shallow water over which a solid track can be laid. The clever Meccano boy will know how to add little decorations to the transporter and the landing platforms in the way of flags, etc., and make a first-class toy of this fine model.

## Model No. 6.12 Roundabout

The vertical Rod 1 is driven from the Motor through the gearing shown, the final drive being taken through a Worm 4 and 57-teeth Gear Wheel. A Face Plate 2 secured to the Rod 1, carries four 1"×1" Angle Brackets, in which are journalled the inner ends of the four 6½" Rods conveying the drive to the revolving cars and galloping horses. On the ends of these Rods are secured ½" Pinions, which engage with a fixed 1½" Contrate Wheel 3. The latter is attached to the top of the central column by ½" Bolts, on the shanks of which Collars are placed for spacing purposes.

The vertical Rods 6 each carry a ¾" Contrate Wheel that is in mesh with a ¾" Pinion 7, the ends of the Rods being journalled in Couplings that are mounted loosely on the horizontal 6½" Rods. The outer ends of the latter are journalled in Double Brackets 8. The horses, which are attached pivotally by one leg to the roundabout, are caused to "gallop" by means of the Eccentrics 9. A 7½" Strip 5 operates the Motor switch.

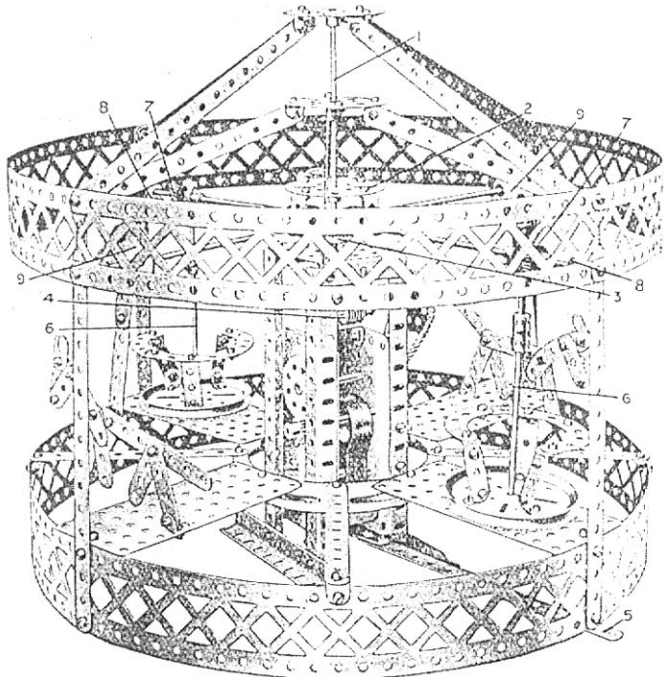

Parts required :

4	of No.	1A
9	" "	1B
4	" "	2
2	" "	3
2	" "	5
10	" "	6
8	" "	6A
2	" "	8B
4	" "	9
2	" "	9B
2	" "	9D
2	" "	10
4	" "	11
34	" "	12
4	" "	12A
1	" "	13A
4	" "	14
2	" "	15
2	" "	16A
2	" "	18A
2	" "	19B
2	" "	25
4	" "	26
2	" "	27A
1	" "	28
2	" "	29
1	" "	32
142	" "	37
6	" "	37A
8	" "	38
2	" "	48
10	" "	59
4	" "	63
4	" "	70
1	" "	72
2	" "	90
6	" "	90A
9	" "	94
1	" "	95A
1	" "	96A
8	" "	99
3	" "	109
2	" "	111A
2	" "	130
1	" "	143

Electric Motor  
(not included in Outfit)

## Model No. 6.13 Linen Winder

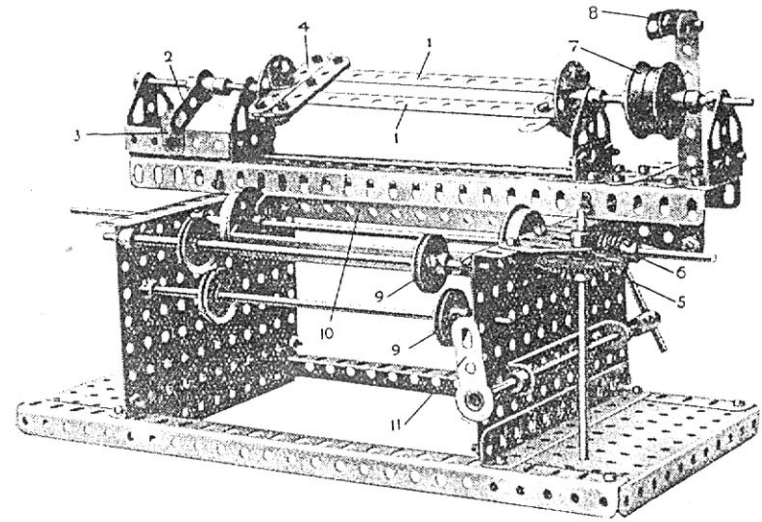

Parts required :

2	of No.	2	1 of No.	13	1 of No.	27A	2 of No.	48B
1	" "	2A	2	" "	13A	1	" "	52
8	" "	5	1	" "	14	66	" "	52A
4	" "	8	1	" "	15A	2	" "	59
4	" "	9	2	" "	16	1	" "	62
4	" "	9F	1	" "	16A	6	" "	63
6	" "	10	4	" "	20	1	" "	126A
1	" "	11	4	" "	22	1	" "	
7	" "	12	2	" "	24	1	" "	

In order to disengage the winding frame bars 1 the Crank 2 is lifted clear of the stop 3 and drawn back, this action disengaging the end cross Strips 4 from the tips of the frame bars 1 and permitting the wound linen to be removed. The Gear Wheel 5 engaging the Worm 6 forms a counter, 7 are the belt Pulleys, and 8 the belt striker operated by Crank 11; 9 are the guide Pulleys for the main linen drums 10.



## Model No. 6.14 Derricking Grab

The grab 1 is suspended by Cords 2 which pass over the Pulleys 3 and round the outer pulleys of a set of four 4 at the head of the standard 5. The cords continue down and under the outer pulleys of a set of smaller Pulleys 6 and are wound on a Crank Handle 7 at the centre of which they are connected by a Spring Clip. (Care should be taken to see that, when winding up, the double lapping of each cord on the rod occurs simultaneously, as otherwise the grab will cant over).

The grab is opened or closed by the Cord 8 which, after passing over one of two inner Pulleys at the end of the jib 9, then passes over another of the four Pulleys 4 and one of the Pulleys 6 to the Crank Handle 10.

The jib 9 is raised or lowered by the Cord 11 which is secured to the standard 5, and having passed around the outer of the two inner pulleys at the jib end is passed back and around one of the four Pulleys 4 and one of the Pulleys 6 to the Crank Handle 12. The swinging of the jib is effected from the Crank Handle 13 on the end of a rod, on which is a  $\frac{3}{8}$ " Pinion 14 engaging a Contrate Wheel 15 at the foot of the standard 5.

Gear Wheels 16 and 17 are bolted on the Crank Handles 10 and 7 and are connected by the Pinion 18. The Crank Handle 7 is fixed against longitudinal movement, but the Crank Handle 10 may be slid clear of the Pinion 18, and the Handle 7 turning the grab is raised or lowered. If the Handle 10 is slid to disengage its gear wheel from the Pinion 18 and the handle turned, the grab is opened or closed.

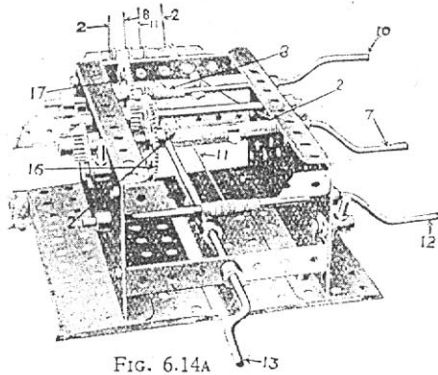
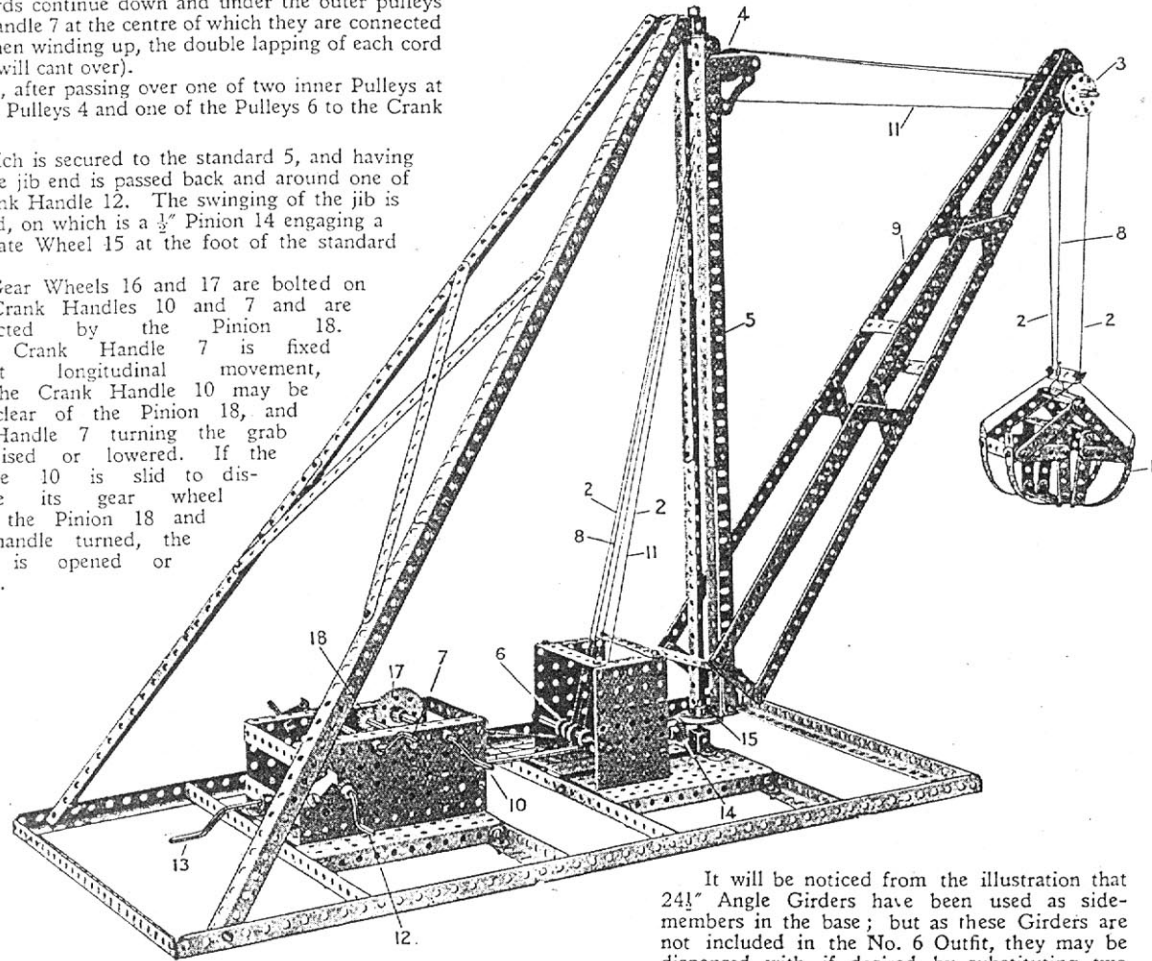

Fig. 6.14A

Parts required :

10 of No. 1	1 of No. 18A	2 of No. 44
6 " " 3	3 " " 19	4 " " 48
4 " " 4	1 " " 19s	9 " " 48A
20 " " 5	2 " " 20	5 " " 48B
4 " " 6	2 " " 22	6 " " 52
18 " " 8	3 " " 22A	2 " " 53
2 " " 9	4 " " 23	1 " " 57c
6 " " 10	2 " " 24	16 " " 59
6 " " 11	2 " " 26	1 " " 63
10 " " 12	2 " " 27A	2 " " 108
1 " " 13	1 " " 28	2 " " 115
2 " " 15A	6 " " 35	1 " " 126
3 " " 16	169 " " 37	2 " " 147A
2 " " 17	2 " " 40	2 " " 147B
	2 of No. 148	



It will be noticed from the illustration that  $2\frac{1}{2}$ " Angle Girders have been used as side-members in the base; but as these Girders are not included in the No. 6 Outfit, they may be dispensed with, if desired, by substituting two  $1\frac{1}{2}$ " Girders bolted end to end along each side of the base frame.

This Model can be built with MECCANO Outfit No. 6 (or No. 5 and No. 5A)

## Model No. 6.15 Penny-in-the-Slot Machine

The sides of the model can be removed by undoing four Nuts 1 from Bolts that are firmly secured by additional Nuts to the corner Girders. Thus the machine can be re-loaded and attention can be given to the mechanism if necessary. Each side is built up from Flat Plates bolted to  $9\frac{1}{2}$ " Angle Girders. Four  $5\frac{1}{2}$ " x  $2\frac{1}{2}$ " Flat Plates and three  $5\frac{1}{2}$ " Strips are bolted to the Girders at the back of the model.

Fig. 6.15a shows the mechanism removed from the model. Four  $12\frac{1}{2}$ " Angle Girders are spaced apart by  $2\frac{1}{2}$ " x  $\frac{1}{2}$ " Double Angle Strips and  $2\frac{1}{2}$ " Strips to form a receptacle for the match boxes. It will be seen that the Bolts are so arranged that they do not in any way interfere with the downward movement of the boxes. The  $9\frac{1}{2}$ " Strip bolted between the rear pair of Girders is clamped between two  $2\frac{1}{2}$ " Strips (see Fig. 6.15c) near its lower end.

Details of the drawer and slide are shown in Fig. 6.15b. The Bolts 2 holding the  $2\frac{1}{2}$ " Strips to the  $1\frac{1}{2}$ " x  $\frac{1}{2}$ " Double Angle Strips of the slide should be passed through the vertical  $12\frac{1}{2}$ " Angle Girders, one hole above their lower extremities. The Angle Brackets 3 form guides for the  $5\frac{1}{2}$ " x  $\frac{1}{2}$ " Double Angle Strips of the drawer. The Rack Strip 4 is secured to a  $1$ " x  $1$ " Angle Bracket and to a  $3\frac{1}{2}$ " Strip that is fixed by an Angle Bracket to the Flat Girders at the front of the drawer.

A  $\frac{1}{2}$ " Pinion 5 (Figs. 6.15a and 6.15c) is mounted on a Pivot Bolt and gripped in place by a  $\frac{1}{4}$ " Bolt. When the drawer is moved in or out, the Rack Strip engaging with the Pinion causes the latter to rotate. Normally, with the drawer closed, the Bolt 6 should be almost touching an Angle Bracket 7 (Fig. 6.15c) that is secured to a Crank on the end of a  $4\frac{1}{2}$ " Axle Rod, which also carries a second Crank to which the Flat Bracket 8 is fixed by a  $\frac{1}{4}$ " Bolt. The Cranks are so arranged that when the  $\frac{1}{4}$ " Bolt strikes the vertical Angle Girder the Angle Bracket 7 just clears the teeth of the Pinion 5. A  $4\frac{1}{2}$ " Strip is bolted to a Double Arm Crank fixed on the other extremity of the  $4\frac{1}{2}$ " Rod, and carries two  $2\frac{1}{2}$ " Strips as a balance weight. The weight is correctly adjusted by means of a Bolt and Washers. The Flat Bracket 9 is spaced from the  $4\frac{1}{2}$ " Strip by two Washers and a  $\frac{1}{4}$ " Bolt 10 carrying four Washers is bolted in the fourth hole from the end of the Strip.

The slot for the penny is shown detached from the model in Fig. 6.15b. It is secured in place by a  $1$ " Triangular Plate bolted to the upper transverse  $5\frac{1}{2}$ " Angle Girder at the front of the outer casing of the model, and also by the  $\frac{1}{4}$ " Reversed Angle Bracket shown in Fig. 6.15c. The penny is inserted between the two pairs of Girders 11 and 12 and falls between the Flat Bracket 9 (Fig. 6.15c) and the  $4\frac{1}{2}$ " Strip. The Washers on the Bolt 10 serve as a "stop," but they will not retain a halfpenny in position.

The weight of the penny raises the Crank carrying the Angle Bracket 7, but only sufficiently to allow the Bolt 6 to pass unimpeded, for the Centre Fork 13 engages the Flat Bracket 8 and prevents further movement of the Crank. The Centre Fork is held in a Coupling which is loosely attached to the model by a  $\frac{1}{4}$ " Bolt passed through its centre transverse hole, and secured by two Nuts to an Angle Bracket. The weight of the Rod 14 then returns the Centre Fork to its normal position, and as the drawer is pushed back, the Bolt 6 raises the Angle Bracket 7, which should be arranged obliquely. When the drawer is pushed right in, the next box of matches should fall into position in the drawer, and the weight 15—consisting of a piece of lead—is provided to assist the downward movement of the boxes.

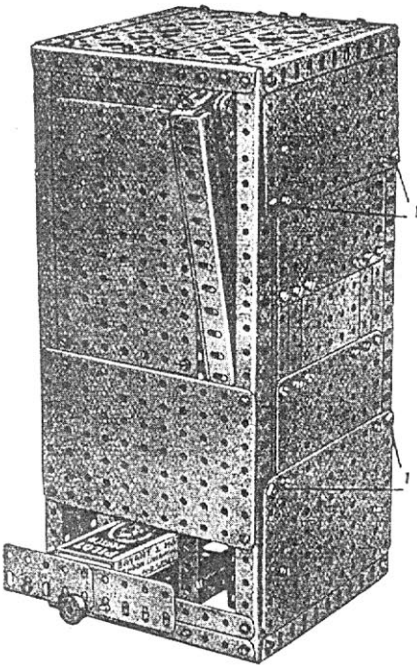

Rod 14 held in the lower transverse hole of the Coupling is forced upward by the Bolt 6 when the drawer is pulled out, and thus forces the Centre Fork 13 out of engagement with the Flat Bracket. The penny is then free to drop off the end of the lever. The weight of the Rod 14 then returns the Centre Fork to its normal position, and as the drawer is pushed back, the Bolt 6 raises the Angle Bracket 7, which should be arranged obliquely. When the drawer is pushed right in, the next box of matches should fall into position in the drawer, and the weight 15—consisting of a piece of lead—is provided to assist the downward movement of the boxes.

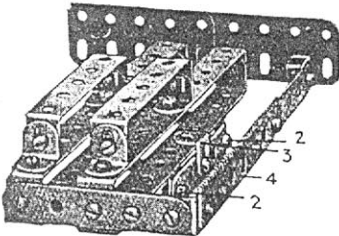

FIG. 6.15b

Parts required :			
1 of No. 1	4 of No. 10	4 of No. 48A	2 of No. 77
1 " " 1A	12 " " 12	4 " " 48D	2 " " 100
5 " " 2	1 " " 12A	4 " " 52A	5 " " 103F
1 " " 2A	1 " " 15A	4 " " 53A	1 " " 110
2 " " 3	1 " " 18B	1 " " 59	1 " " 111
11 " " 5	1 " " 23A	2 " " 62	2 " " 111A
8 " " 8	1 " " 26	1 " " 62B	2 " " 111C
8 " " 8A	170 " " 37	1 " " 63	1 " " 125
2 " " 8B	13 " " 37A	1 " " 65	1 " " 147B
8 " " 9	16 " " 38	6 " " 70	
1 " " 9F	2 " " 48	2 " " 72	

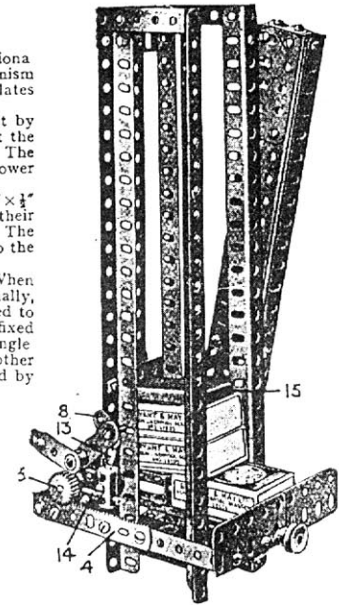

FIG. 6.15a

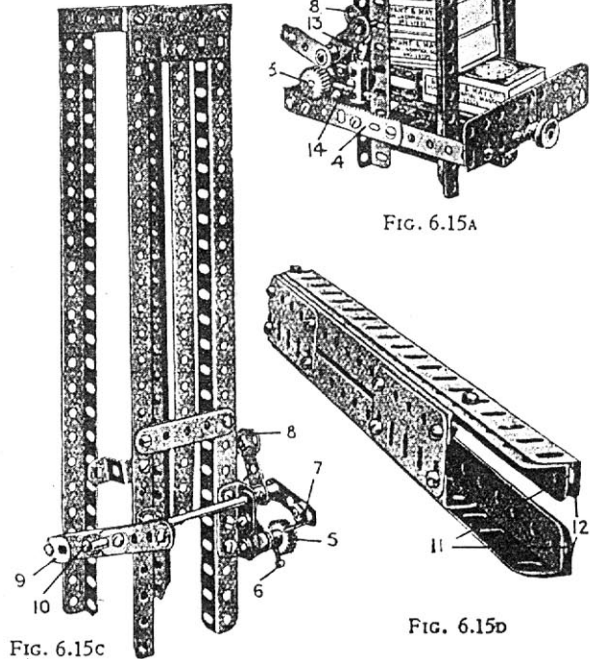

FIG. 6.15c

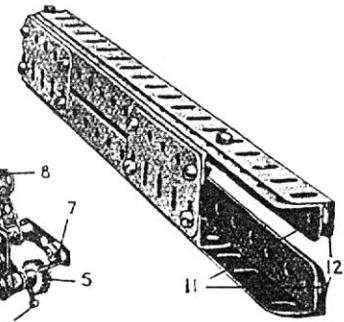
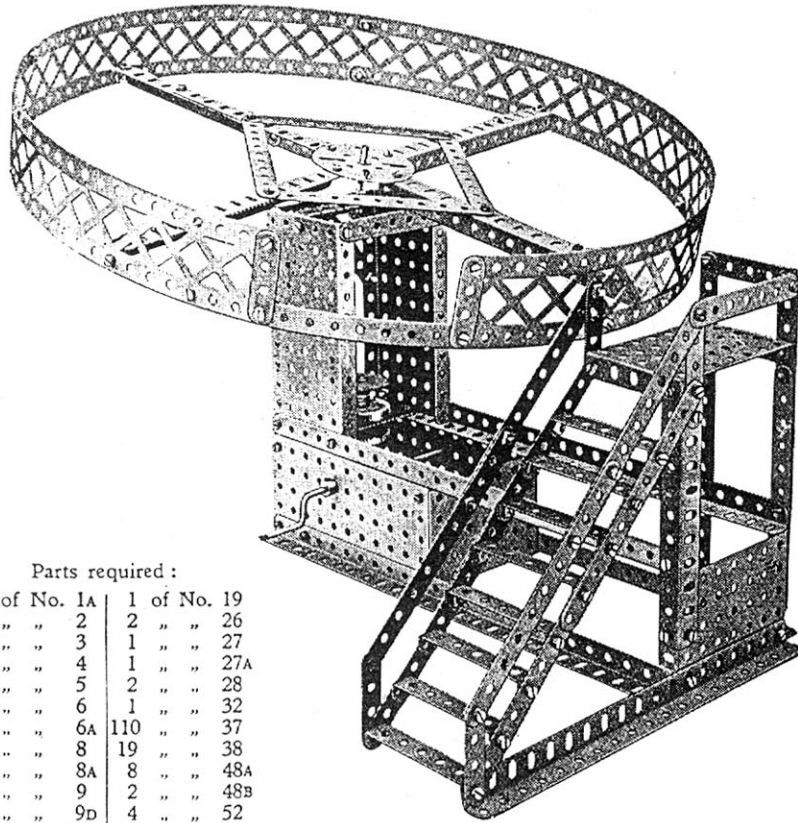

FIG. 6.15d

## Model No. 6.16 Joy Wheel



Parts required :

1	of No. 1A	1	of No. 19
16	" "	2	" "
4	" "	3	" "
2	" "	4	" "
2	" "	5	" "
5	" "	6	" "
2	" "	6A	110
4	" "	8	19
1	" "	8A	8
9	" "	9	2
1	" "	9D	4
5	" "	12	4
1	" "	14	6
1	" "	16	4
1	" "	17	1
	1 of No. 126		

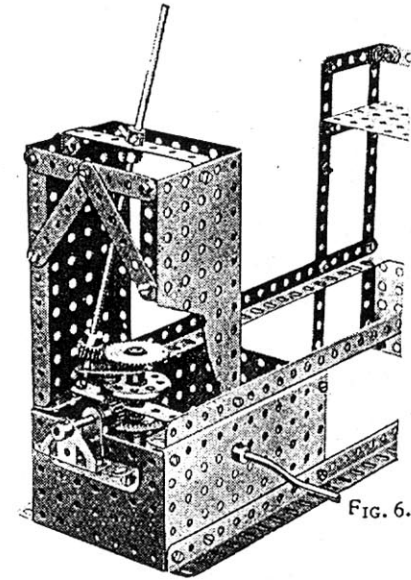

FIG. 6.16A

This model comprises a new and very interesting Meccano motion.

The Crank Handle drives by means of a Worm and 57-toothed Gear Wheel, a vertical Rod carrying two  $1\frac{1}{2}$ " Contrate Wheels and a Gear Wheel, as shown in Figure 6.16A. The lower Contrate Wheel is secured to the shaft but the upper one revolves freely upon it. The latter is driven from the fixed Contrate Wheel by means of a  $\frac{1}{2}$ " Pinion, and its direction of rotation is consequently reversed.

The end of the shaft carrying the revolving part of the model is journaled on a short Strip bolted to the upper Contrate Wheel and carries a  $\frac{1}{2}$ " Pinion which engages with the Gear Wheel secured on the vertical shaft. Thus on operation of the Crank Handle, the model revolves upon its axis, at the same time twisting slowly round with an amusing "wobble." A circular piece of carboard is cut and placed in position to represent the floor found in real "Joywheels."

# Model No. 6.17 Theodolite

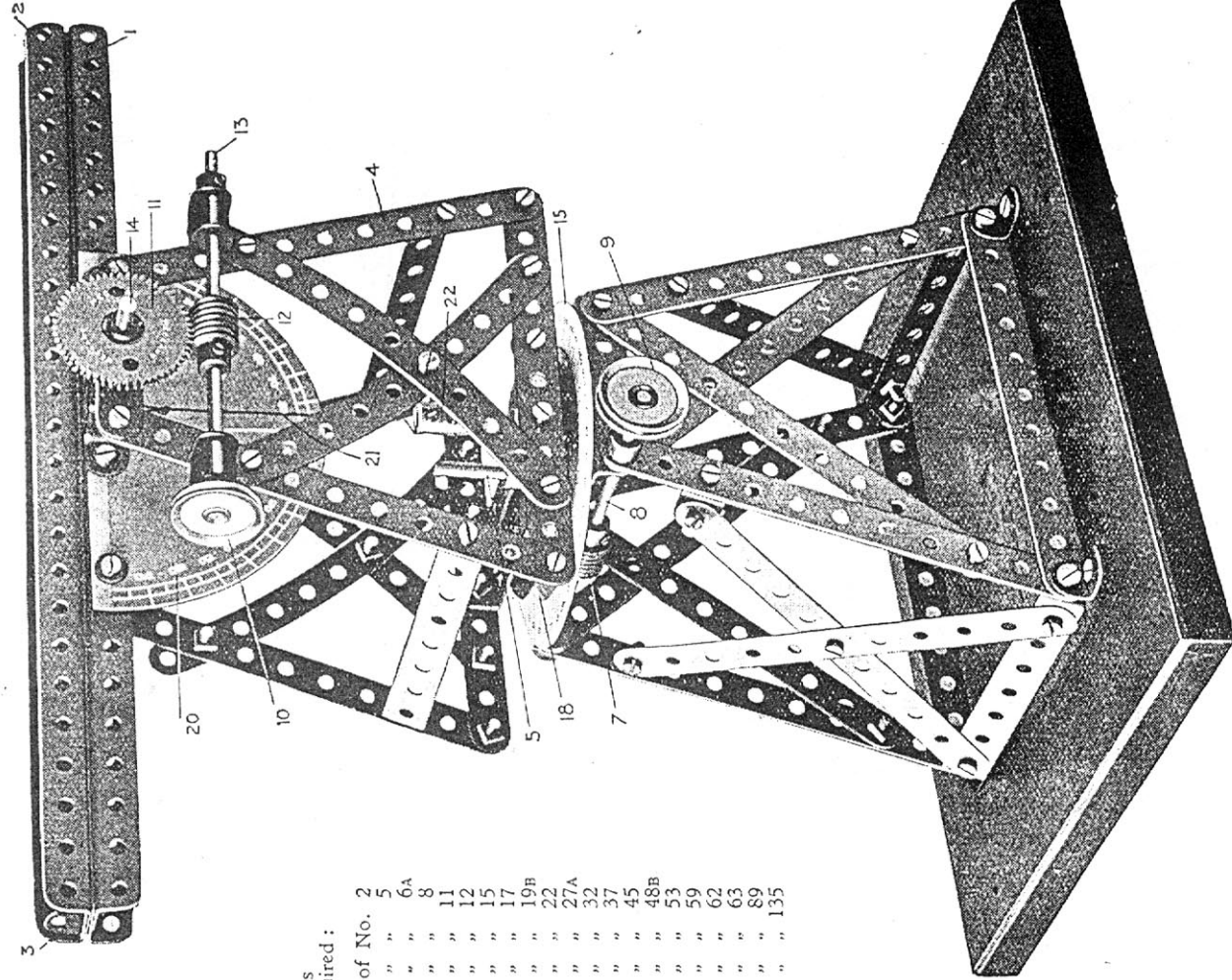

Parts  
required :

20	of No. 2
2	" 5
6	" 6A
4	" 8
2	" 11
10	" 12
3	" 15
1	" 17
1	" 19B
2	" 22
2	" 27A
2	" 32
60	" 37
1	" 45
6	" 48B
1	" 53
6	" 59
1	" 62
1	" 63
4	" 89
1	" 135

The Theodolite arm is represented by two reversed pairs of 12½" Angle Girders 1 and 2, an Angle Bracket being secured at each end to form the sights, one of which is shown at 3. A small piece of paper, with a pin hole punched in its centre, is secured over the hole in the Angle Bracket 3 and two crossed threads over that in the Angle Bracket at the other end of the arm. The arm is elevated or depressed by the Pulley 10 and the Worm 12 on the Rod 13, the Worm meshing with a 57-teeth Gear 11 on the pivot Rod 14. This Rod is secured by a Crank to the sighting arm.

The upper framework 4 is secured to a short Rod 5 by means of a 3" Pulley 18 that is secured by ½" Bolts to the transverse 3½" x ½" Double Angle Strips bolted to the bottom of the frame. A 57-teeth Gear is fitted to the lower extremity of this pivot rod and engages with the Worm 7 on the Rod 8. Hence, on turning the hand wheel 9 the swivelling structure may be rotated. A graduated disc 15, cut from the Theodolite Protractor (part No. 135) and bolted to the top of the fixed base, indicates the horizontal angular movement. The vertical movement of the sighting arm is indicated by means of the semi-circular protractor 20, also cut from part No. 135, and bolted to the lower Angle Girder 1, the correct reading being given by a "plumb line" 21. This line consists of a short length of cord looped over the Rod 14 and carrying a Coupling 22, which forms the "bob" at its lower end.

## Model No. 6.18 Automatic Weighing Machine

Parts required :

2 of No. 1	1 of No. 24	12 of No. 59
6 " " 2	2 " " 26	2 " " 62
2 " " 3	2 " " 27A	6 " " 63
6 " " 4	64 " " 37	10" " " 94
4 " " 5	2 " " 37B	1 " " " 96
4 " " 8	1 " " 43	2 " " " 99
1 " " 13	1 " " 48A	6 " " " 100
2 " " 13A	3 " " 48B	2 " " " 108
1 " " 15A	2 " " 52	
7 " " 16	1 " " 53	

The platform 1 is connected by cross Rod and Couplings 2A to a Rod 2, by means of a further Coupling, that passes through the centre of the machine guided in the  $3\frac{1}{2}$ " Double Angle Strips 3 and 3A connected to side Strips 4. At the upper end of this Rod 2 is a Bush Wheel 5, to which is connected a Cord 6 and Sprocket Chain 7. This Chain passes round a Sprocket Wheel 8 on the same spindle as the 57-toothed Gear Wheel 9 engaging a  $\frac{1}{2}$ " Pinion 10. The Pinion 10 also engages another 57-toothed Gear Wheel 10A, and this in turn a  $\frac{1}{2}$ " Pinion 11 on the spindle 12 carrying the pointer 13. The other end of the Chain is coupled by a Spring 14 to the cross piece 3A, and the pointer is thus always returned to zero immediately the load is removed from the platform.

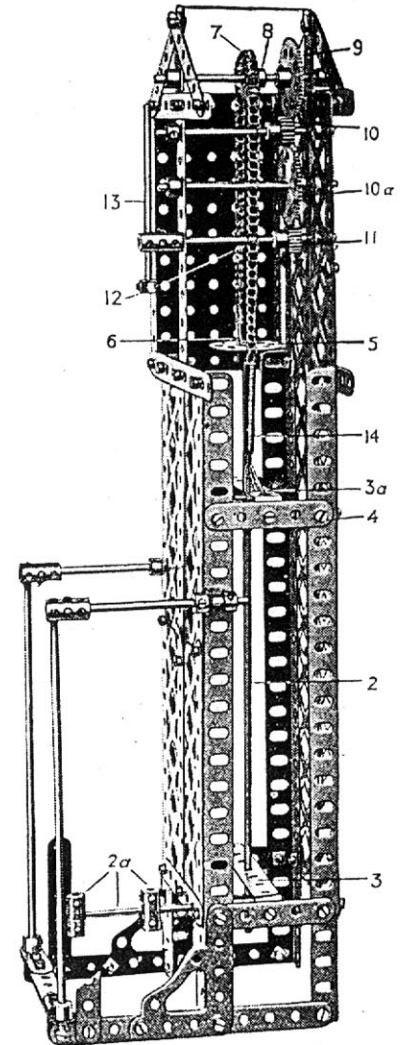
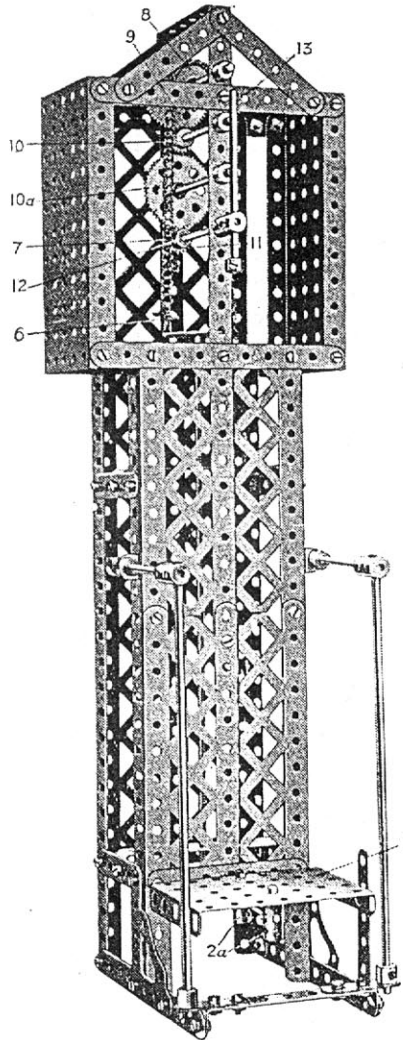

FIG. 6.18A



## Model No. 6.20 Steam Tug Boat

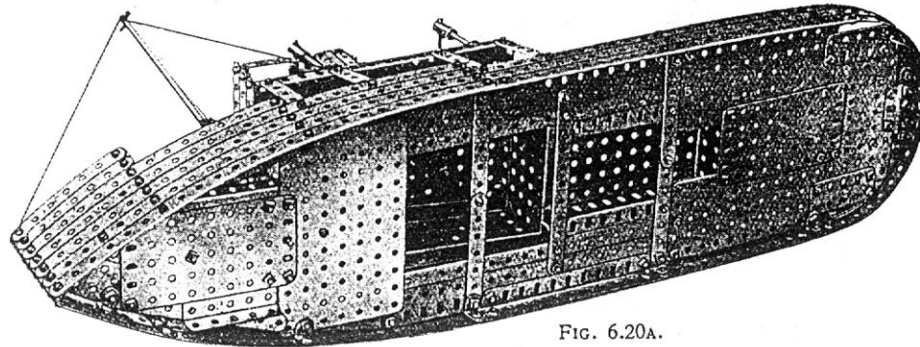

FIG. 6.20A.

Parts required :

14	of No.	1	26	of No.	12	2	of No.	52	2	of No.	62B
2	" "	1A	4	" "	12A	4	" "	52A	6	" "	63
5	" "	1B	1	" "	13	2	" "	53	2	" "	70
24	" "	2	1	" "	15	4	" "	53A	2	" "	72
4	" "	2A	1	" "	15A	6	" "	59	1	" "	76
15	" "	3	4	" "	17	2	" "	62	2	" "	90
12	" "	4	4	" "	18A				1	" "	102
17	" "	5	1	" "	18B				2	" "	103A
3	" "	6	1	" "	22A				2	" "	103F
12	" "	6A	3	" "	35				1	" "	103H
2	" "	8B	314	" "	37				5	" "	111A
8	" "	9	5	" "	38				1	" "	162B
6	" "	9D	1	" "	40				1	" "	165
4	" "	9F	2	" "	48						
10	" "	10	6	" "	48B						

The funnel comprises ten  $5\frac{1}{2}$ " Strips bolted to a Boiler, which is compressed so that the edges overlap three holes, and it is secured to the superstructure by two  $\frac{1}{2}$ "  $\times$   $\frac{1}{2}$ " and one  $1$ "  $\times$   $1$ " Angle Brackets. The sides of the superstructure each consist of a  $5\frac{1}{2}$ "  $\times$   $2\frac{1}{2}$ " Flanged Plate and a  $2\frac{1}{2}$ "  $\times$   $2\frac{1}{2}$ " Flat Plate bolted end to end with a  $7\frac{1}{2}$ " Strip secured along the bottom. A  $4\frac{1}{2}$ "  $\times$   $2\frac{1}{2}$ " Flat Plate is bolted across the end flanges of the  $5\frac{1}{2}$ "  $\times$   $2\frac{1}{2}$ " Plates at the rear, and at the forward end of the superstructure a  $3\frac{1}{2}$ "  $\times$   $2\frac{1}{2}$ " Flanged Plate and two  $3\frac{1}{2}$ "  $\times$   $\frac{1}{2}$ " Double Angle Strips are secured.

The steam whistle is represented by a Coupling which is held to the funnel by a Bolt screwed into its centre tapped hole. A Rod secured in the Coupling and passed through a hole in the deck of the superstructure, represents the steam pipe.

The mast consists of an  $11\frac{1}{2}$ " Rod extended at its lower end by a  $4\frac{1}{2}$ " Rod held in a Coupling. The latter is secured by means of a Bolt passed through the  $5\frac{1}{2}$ " Angle Girder of the bridge and inserted in its lower tapped hole, while the  $4\frac{1}{2}$ " Rod is passed through the deck of the model. A  $\frac{1}{2}$ " Bolt carries a  $1$ " loose Pulley and a "spider" (removed from a Swivel Bearing), and is screwed into the upper tapped hole of the Coupling. Four  $\frac{1}{2}$ " Bolts are screwed into the tapped bores of the "spider."

The lifeboats, of which there are two, are constructed very simply, two  $5\frac{1}{2}$ " Strips that are bolted together at each end and bent to form the gunwales, being connected by means of Flat Brackets to a lower  $4\frac{1}{2}$ " Strip that forms the keel. Each completed boat is secured to its respective davits by two short lengths of cord.

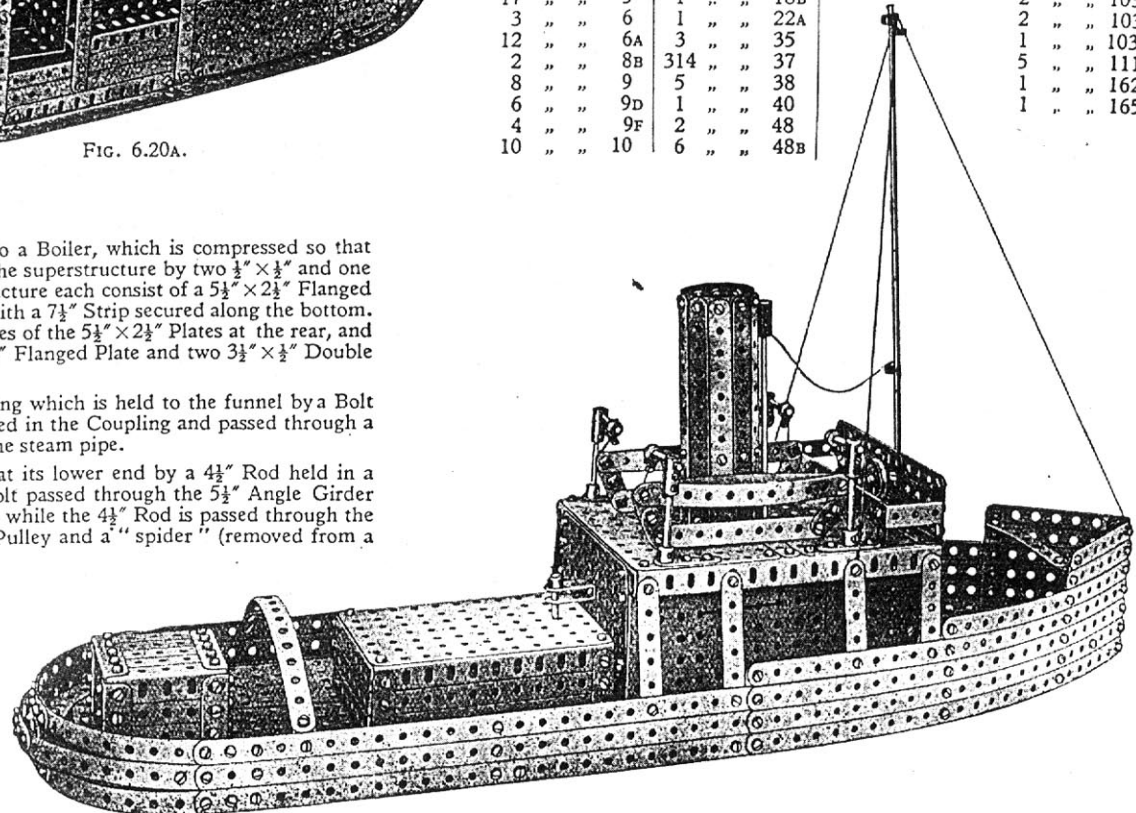

Model No. 6.21

Big Wheel

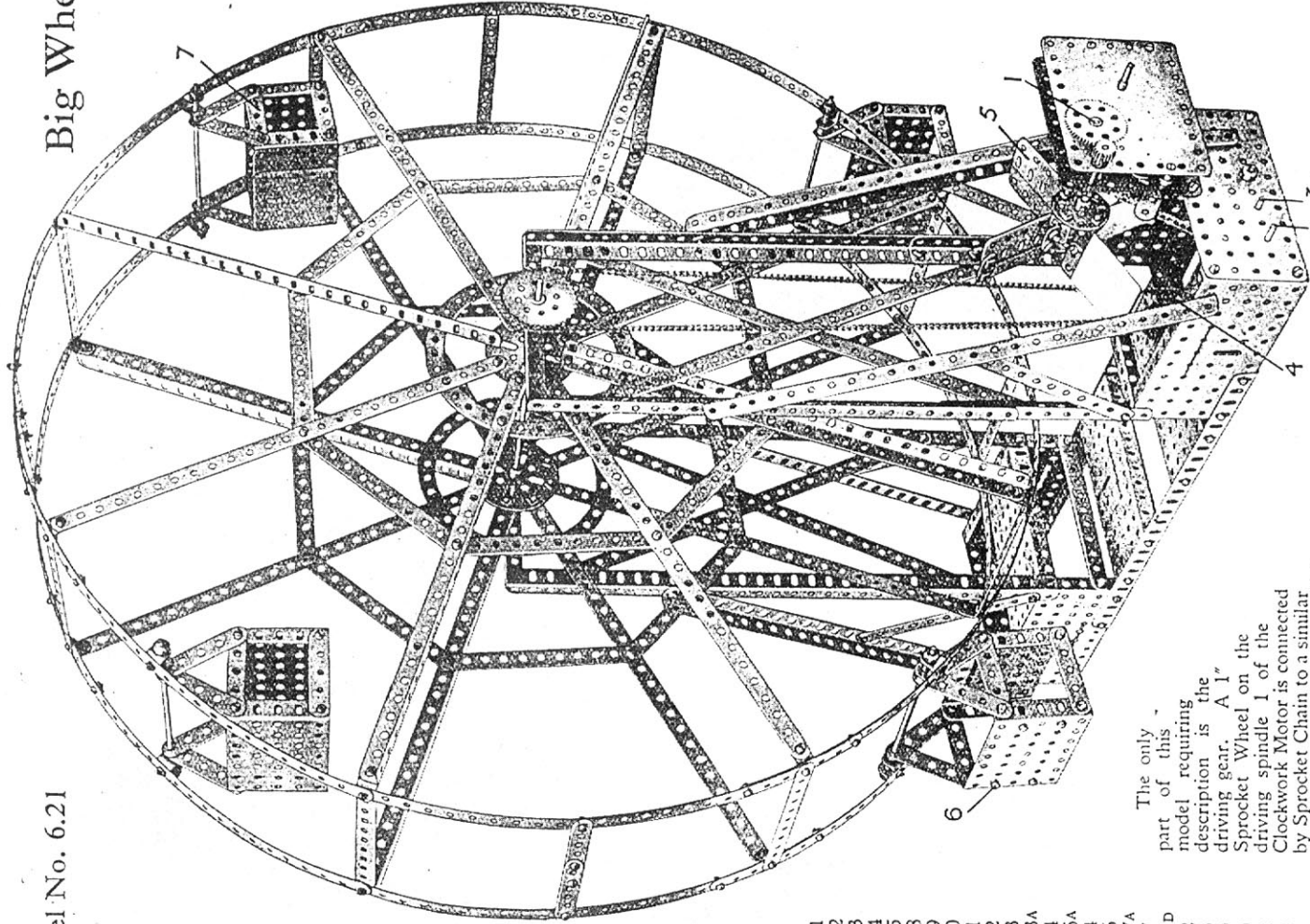

Parts required :	
28 of No.	1
26 "	2
12 "	3
3 "	4
34 "	5
18 "	8
8 "	9
4 "	10
8 "	11
12 "	12
1 "	13
1 "	13A
6 "	14
1 "	16A
1 "	24
3 "	26
3 "	27A
258 "	37
4 "	48D
6 "	52
7 "	53
21 "	59
3 "	70
2 "	72
16 "	90
50 "	94
1 "	95
2 "	96
1 "	96A
6 "	103F
2 "	109

Clockwork Motor (not included in Outfit)

The only part of this model requiring description is the driving gear. A 1" Sprocket Wheel on the driving spindle 1, of the Clockwork Motor is connected by Sprocket Chain to a similar Sprocket on a 6½" Rod 2, which also carries a ½" Pinion in mesh with another 57-teeth Gear on a second Rod 3. On the latter is a ½" Pinion in mesh with another 57-teeth Gear on a Rod carrying a ½" Sprocket Wheel 4.

The speed of the Motor is governed by a fan 5, driven through a step-up gear of 3 : 1. Two of the blades of the fan each consist of two 2½" Flat Girders whilst the other two are each composed of a 2½" Flat Girder and a Strip. The blades are covered with paper and are bolted to 1" x ½" Angle Brackets that are secured to a Bush Wheel. The car 6 has a few Strips bolted to it to balance the weight of the two 2½" x 2½" Flat Plates forming one side of the car 7.



## Model No. 6.22 Crane

Parts required :

10 of No.	1	3 of No.	27A
12 "	2	4 "	35
8 "	3	139 "	37
4 "	4	1 "	40
17 "	5	1 "	45
16 "	8	1 "	46
1 "	11	2 "	48A
9 "	12	4 "	52
2 "	13A	1 "	53
4 "	14	2 "	54
2 "	15	1 "	57C
2 "	15A	14 "	59
3 "	16	1 "	62
2 "	17	1 "	63
1 "	18A	5 "	94
8 "	20	2 "	95
2 "	21	4 "	96
2 "	22	5 "	99
2 "	22A	1 "	147A
1 "	24	1 "	147B
3 "	26	1 "	148

Electric Motor

(not included in Outfit)

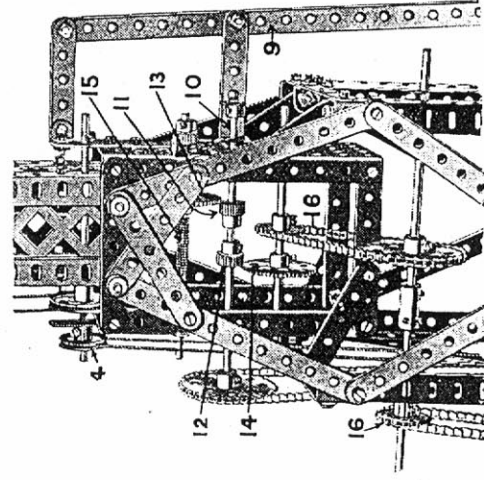
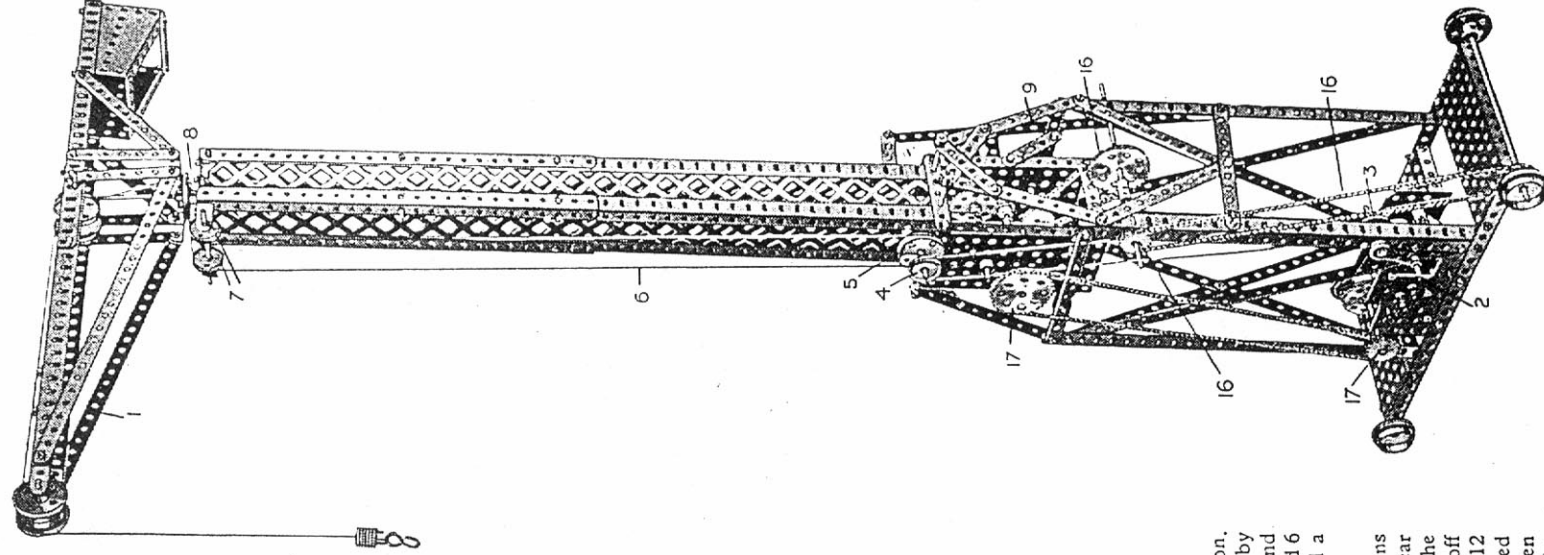

FIG. 6.22A

The frame of the model is well shown in the illustration. The swinging of the jib 1 is effected from the handle 2 by means of a Cord coupling a Pulley 3 to a Pulley 4. Round a larger Pulley 5 on the same shaft passes a continuous Cord 6 which, after winding round guide Pulley 7, passes round a Pulley 8 fixed on the central spindle of the jib.

The handle 9 slides the spindle 10 carrying two Pinions 11 and 12 so that either the Pinion 11 may engage the Gear Wheel 13 or the Pinion 12 the Gear Wheel 14. When the Pinion engages the Wheel 13 the Cord 15 is wound on or off the spindle to raise or lower the load, and when the Pinion 12 engages the Wheel 14 the traversing movement is effected through the Chain and Sprocket 16. The power is taken from the Motor by way of the 1' and 2' Sprockets 17, the latter on the spindle carrying the Pinions 11 and 12.

## Model No. 6.23 Jack Knife Bridge

## Parts required :

6	of No. 1	210	of No. 37	4	of No. 100
4	" " 1B	6	" " 38	4	" " 108
26	" " 2	1	" " 40	1	" " 109
4	" " 2A	1	" " 48A	1	" " 115
4	" " 3	2	" " 48B	4	" " 133
16	" " 6	3	" " 48D		
20	" " 8	2	" " 52		
6	" " 9	2	" " 52A		
4	" " 9D	17	" " 59		
6	" " 12	6	" " 70		
1	" " 13A	6	" " 89		
6	" " 14	80	" " 94		
1	" " 16B	1	" " 95A		
2	" " 26	4	" " 96		
2	" " 27A	1	" " 96A		
1	" " 29	4	" " 98		
1	" " 32	4	" " 99		

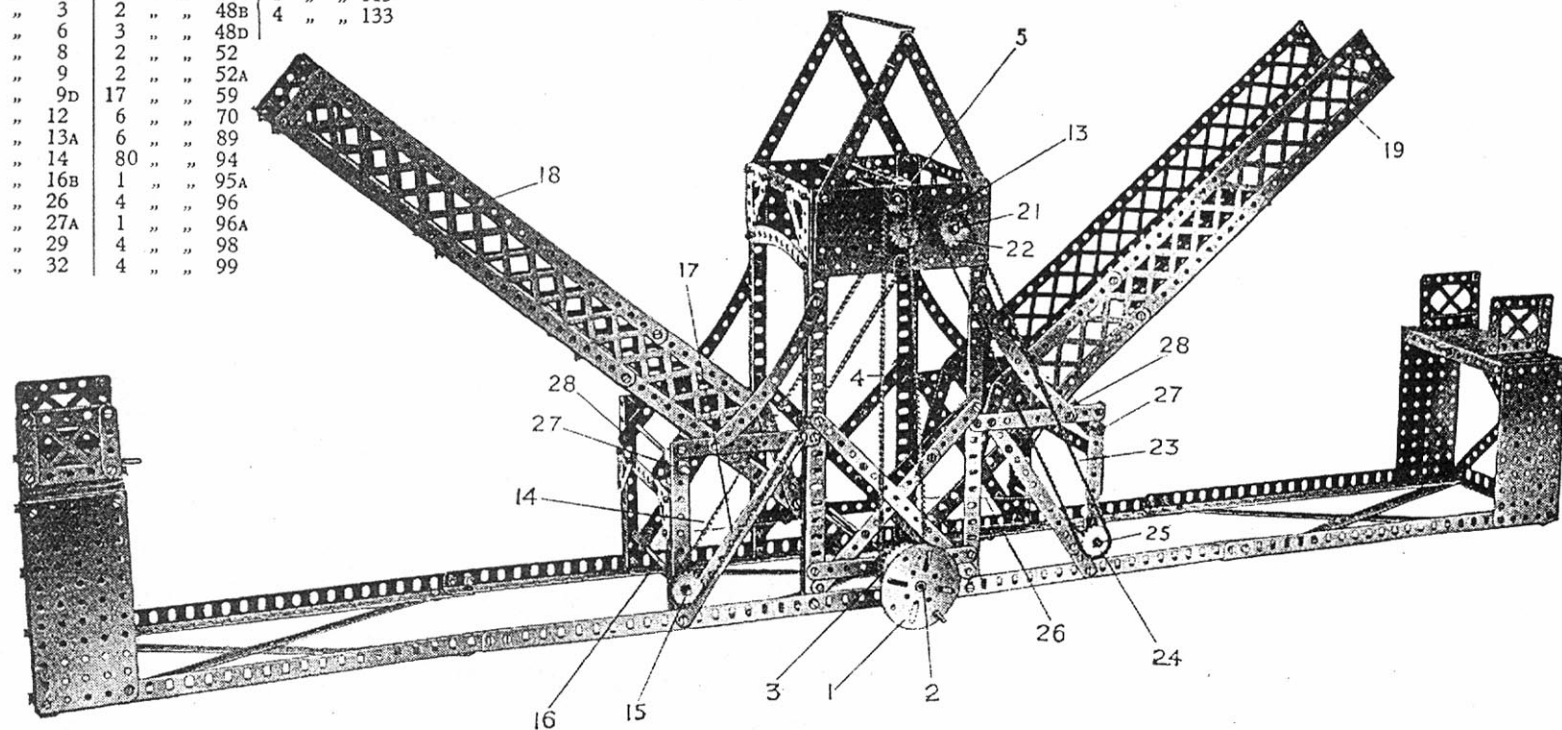

The arms of the bridge are raised or lowered by rotating the hand wheel 1. On the 8" Rod 2 of the hand wheel is mounted a 1½" Sprocket Wheel 3 which is coupled by a Chain 4 to a ¾" Sprocket Wheel 5 on a 6½" Rod 6, Fig. 6.23A. On this rod a Worm Wheel 7 drives a ½" Pinion 8 on a 3½" Rod 9, on which is a ¾" Contrate Wheel 10. This engages a ¾" Pinion 11 carried on a 3" Rod 12, on the outer end of which is a 1" Sprocket Wheel 13 connected by a Sprocket Chain 14 to a 1" Sprocket Wheel 15 on a 6½" Rod 16; on this rod a Cord 17 is wound, connected to the end of one arm 18 of the bridge. The other arm 19 is operated from a 57 toothed Gear Wheel 20 on the Rod 12 engaging a similar Wheel 29 on the 6½" Rod 21. On the end of this rod a 1" Sprocket Wheel 22 is coupled by

## Model No. 6.23 Jack Knife Bridge

(continued)

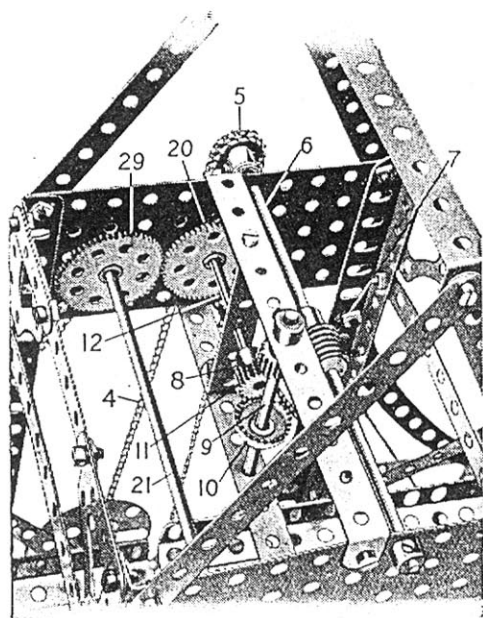

FIG. 6.23A

a Chain 23 to another 1" Sprocket Wheel 24 on the 6½" winding Rod 25, the Cord 26 from which is connected to the other arm 19 of the bridge.

The arms 18 and 19 are pivotally carried on 6½" Rods 27 by means of 3½" x 1½" Double Angle Strips 28.

## Model No. 6.24 Box Ball Alley

This model of a box ball alley gives endless amusement, apart from the actual construction.

The object is to hit one of the Strips 1, which have various number values, by means of a ball rolled along the platform 2, the ball after striking and tipping one of the Strips being returned by the tray 3 to the player. The Strips 1 are pivoted by Double Bent Strips on to a Rod 4, so that each Strip may swing independently. The upper end of each Strip is engaged by Strips 5, the ends of which are bent slightly down, as shown, so that while the Strips 1 are normally held in the position shown, when one of the Strips is struck by the ball it is deflected backward and its upper end snaps outward past the bent end of its Strip 5, which thus acts as a spring, the deflected Strip being then retained in that position until it is reset. To reset any or all of the Strips 1 a handle is formed by a Strip 6 pivoted at 7 and controlled by a tension Spring 8. A Cord 9 connects the Strip 6 to a short Strip 10 forming a Crank and bolted to a Bush Wheel 11 on an axle journalled in the side Plates 12. This axle on its interior carries two further Bush Wheels to which are secured two short Strips 13 forming Cranks, a long Double Angle Strip 14 being in turn bolted to the Strips 13. When therefore the handle 6 is pulled out against the Spring 8 the Cord 9 rotates the Bush Wheel 11 and forces out the long Double Angle Strip 14 which pushes out the Strips 1 and resets them in their normal positions. During this resetting operation the upper ends of the Strips 1 snap back beneath the bent ends of the spring Strips 5.

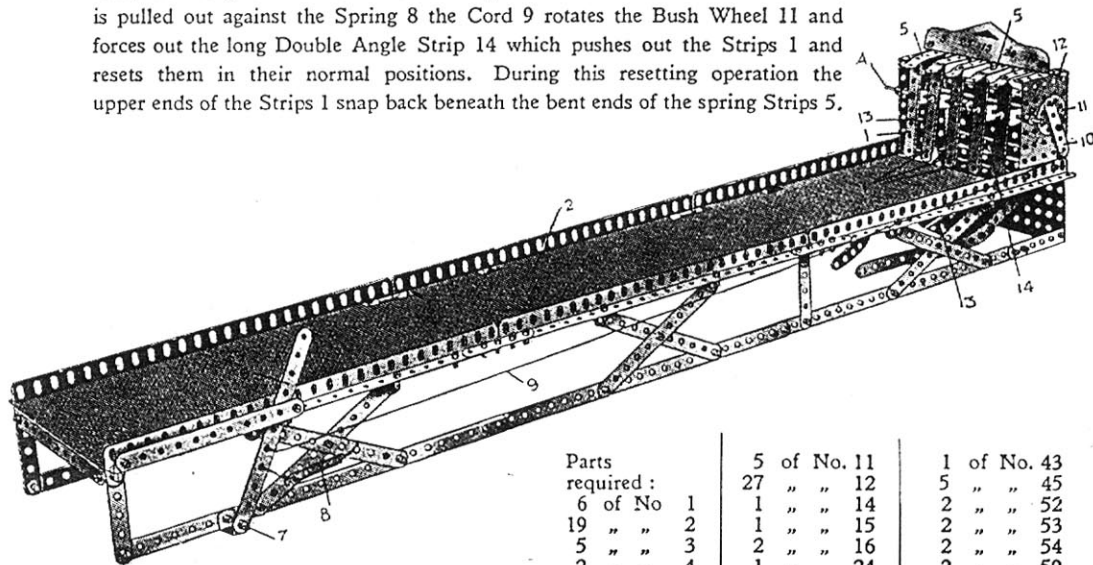

Parts required :	5 of No. 11	1 of No. 43
27 " " 12	27 " " 12	5 " " 45
6 of No. 1	1 " " 14	2 " " 52
19 " " 2	1 " " 15	2 " " 53
5 " " 3	2 " " 16	2 " " 54
2 " " 4	1 " " 24	2 " " 59
15 " " 5	8 " " 35	2 " " 62
6 " " 8	132 " " 37	1 " " 63

## Parts required :

2	of No. 3	3	of No. 15A
11	" " 5	3	" " 16
8	" " 6	2	" " 16A
6	" " 6A	1	" " 16B
12	" " 8	4	" " 17
2	" " 9B	1	" " 18A
4	" " 9D	1	" " 19B
5	" " 10	4	" " 20B
8	" " 11	2	" " 21
22	" " 12	2	" " 22
1	" " 12B	2	" " 24
1	" " 13	1	" " 25

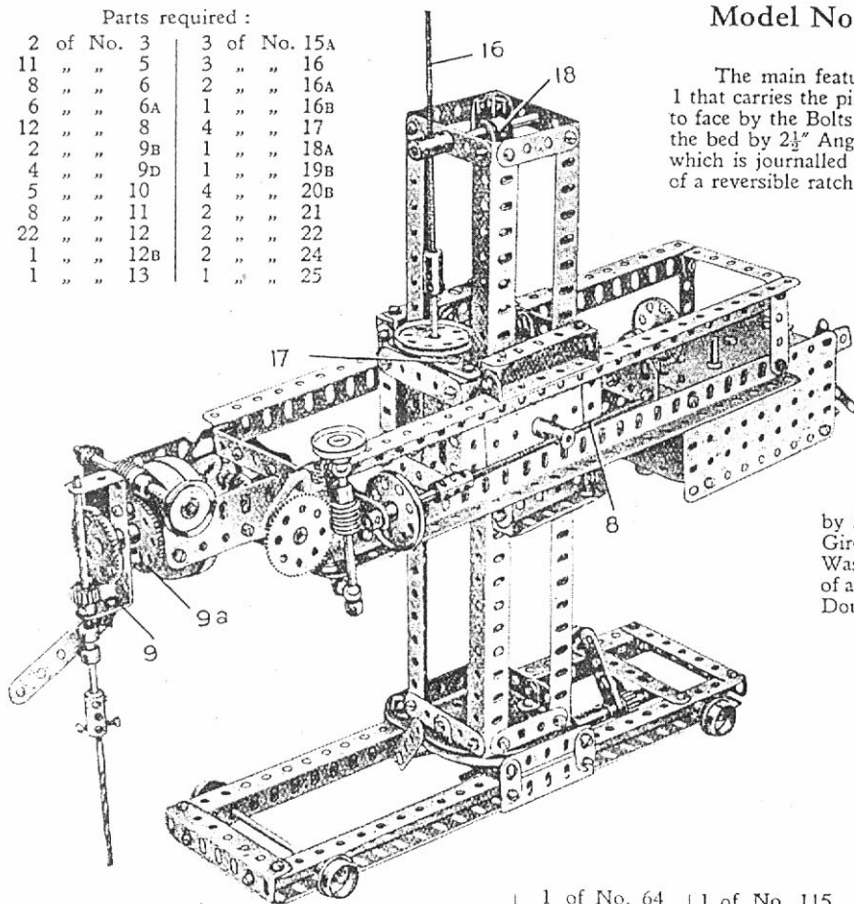

4	of No. 26	117	of No. 37	6	of No. 53
1	" " 27	7	" " 37A	2	" " 53A
3	" " 27A	35	" " 38	25	" " 59
2	" " 28	1	" " 44	1	" " 62A
2	" " 29	2	" " 46	2	" " 62B
2	" " 32	7	" " 48A	6	" " 63

1	of No. 64	1	of No. 115
1	" " 77	4	" " 126A
1	" " 80A	2	" " 136
2	" " 80B	1	" " 137
1	" " 81	1	" " 162A
2	" " 103F		Electric
2	" " 108		Motor
3	" " 111		(not included in
2	" " 111C		Outfit)

## Model No. 6.25 Universal Radial Drilling Machine

The main features of the travelling bed of the model will be apparent from Fig. 6.25A. The saddle 1 that carries the pillar and slides on the bed, consists of two  $3\frac{1}{2}'' \times 2\frac{1}{2}''$  Flanged Plates secured together face to face by the Bolts that serve to fasten a Bush Wheel 2, and it is retained in place on the side members of the bed by  $2\frac{1}{2}''$  Angle Girders. The traversing of the saddle along the bed is effected by a Screwed Rod, which is journaled in a Handrail Support 13 and works in a Threaded Boss 14; it is actuated by means of a reversible ratchet 3. This consists essentially of a 2" Strip, mounted freely on the Rod, with a  $\frac{1}{2}'' \times \frac{1}{2}''$  Angle Bracket attached pivotally to it so that the Bracket may engage with the teeth of a  $\frac{1}{2}''$  Pinion secured to the Rod, the Bracket being weighted with a Collar to ensure constant engagement. The device works equally well in either direction.

The base of the pillar is secured rigidly by  $\frac{1}{2}'' \times \frac{1}{2}''$  Angle Brackets to a 3" Pulley, which is attached to the saddle by a  $1\frac{1}{2}''$  Rod. The Rod is fixed in the boss of the Pulley and passes through the centre holes of the Flanged Plates and through the Bush Wheel 2. A 2" Screwed Rod, secured to a 2" Strip, is inserted in the set screw hole of the Bush Wheel and serves as a locking device, whereby the pillar may be locked in any desired position.

Attention should next be paid to the saddle that slides upon the pillar and carries the horizontal arm (Fig. 6.25B). The part fitting the pillar consists of two  $3\frac{1}{2}'' \times 2\frac{1}{2}''$  Flanged Plates 4 that are connected together by  $2\frac{1}{2}''$  Strips. Double Brackets 5, bolted to the flanges of the Plates, press against the Girders of the pillar, and in order that they do so efficiently, they are packed out with Washers. Each of the slides carrying the arm consists of a  $3\frac{1}{2}'' \times 2\frac{1}{2}''$  Flanged Plate 6, to the flanges of which  $2\frac{1}{2}'' \times \frac{1}{2}''$  Double Angle Strips are attached by  $\frac{1}{2}'' \times \frac{1}{2}''$  Angle Brackets.

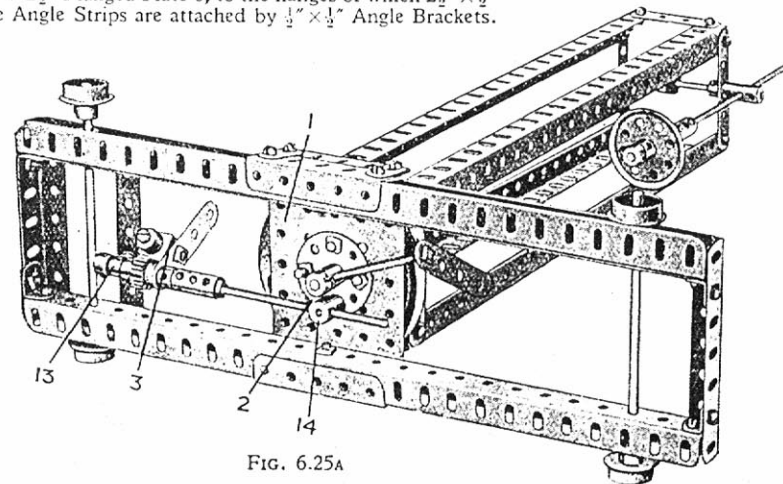

FIG. 6.25A

## Model No. 6.25 Universal Radial Drilling Machine

(continued)

A  $\frac{3}{4}$ " Bolt is secured rigidly to a  $3\frac{1}{2}$ " Strip 7, which is attached to the Plate 6 so that the shank of the Bolt passes through the centre holes of the Plates 4 and 6; the Strip 7 is spaced away from the Plate 6 by a Washer on each of its retaining Bolts, to make room for the Nut on the  $\frac{3}{4}$ " Bolt. A Bush Wheel and a locking handle (the latter consisting of a Threaded Crank, to which is bolted a  $2\frac{1}{2}$ " Strip), are then placed on the shank of the Bolt, so that by turning the locking handle, the arm may be locked and prevented from tilting. A  $\frac{3}{8}$ " Bolt serves as a pivot for the two Plates on the other side of the saddle and is inserted in a Coupling, in the tapped hole of which works the  $4\frac{1}{2}$ " Screwed Rod 8 (Fig. 6.25) that forms a means of traversing the arm. Vertical movement of the saddle upon the pillar is effected by the Screwed Rod 16, which is journaled in the Strip 17 on the saddle and works in a Coupling at the top of the Pillar.

The "drillhead" 9 is capable of being turned through a complete circle and also tilted in a vertical sense to a considerable degree; the constructional details of this portion of the model are well brought out in Fig. 6.25b. The drill head proper consists of a  $2\frac{1}{2}$ " x 1" Double Strip attached by two  $\frac{3}{4}$ " Bolts to a 57-teeth Gear 9A (Fig. 6.25b) and a Boiler End, the Gear being spaced equidistantly between the Double Angle Strip and the Boiler End by Collars on the Bolts. A Wheel Flange 10, attached to a  $2\frac{1}{2}$ " x 1" Double Angle Strip, forms a bearing for the Boiler End, over which it fits. The object of this bearing is to relieve the central shaft of strain. The shorter arms of the Double Angle Strip are attached to Double Arm Cranks, that are secured by double grub-screws to a Rod 11, the latter having secured to it a 57-teeth Gear that is in mesh with a Worm. By this gear the drill head may be tilted in a vertical direction. By turning a 1" fast Pulley the drill head may be rotated through a complete circle about the central shaft, through the medium of a Worm that is in mesh with the 57-teeth Gear 9A.

The  $11\frac{1}{2}$ " Rod 12 conveying the drive from the Motor carries a  $\frac{3}{4}$ " Contrate Wheel in mesh with a  $\frac{1}{2}$ " Pinion, which is loose on the Rod 11 and engages with a second  $\frac{3}{4}$ " Contrate. The latter is secured to a short Rod that passes through the Boiler End-Wheel Flange unit and terminates in a  $1\frac{1}{2}$ " Contrate Wheel. This Contrate drives the drill spindle, which may be moved longitudinally in its bearings in order to feed the drill into the work, and is actuated by a  $2\frac{1}{2}$ " Strip.

The Motor armature spindle carries a  $\frac{1}{2}$ " Pinion in mesh with a 57-teeth Gear on a short Rod that carries also a  $\frac{3}{4}$ " Pinion. The latter is in mesh with a 50-teeth Gear. This Gear is secured to a Rod that has at its upper end a  $\frac{1}{2}$ " Pinion, which is in mesh with a  $1\frac{1}{2}$ " Contrate on the end of the  $11\frac{1}{2}$ " Rod 12.

The Cranked Bent Strip 18 is provided for lifting purposes.

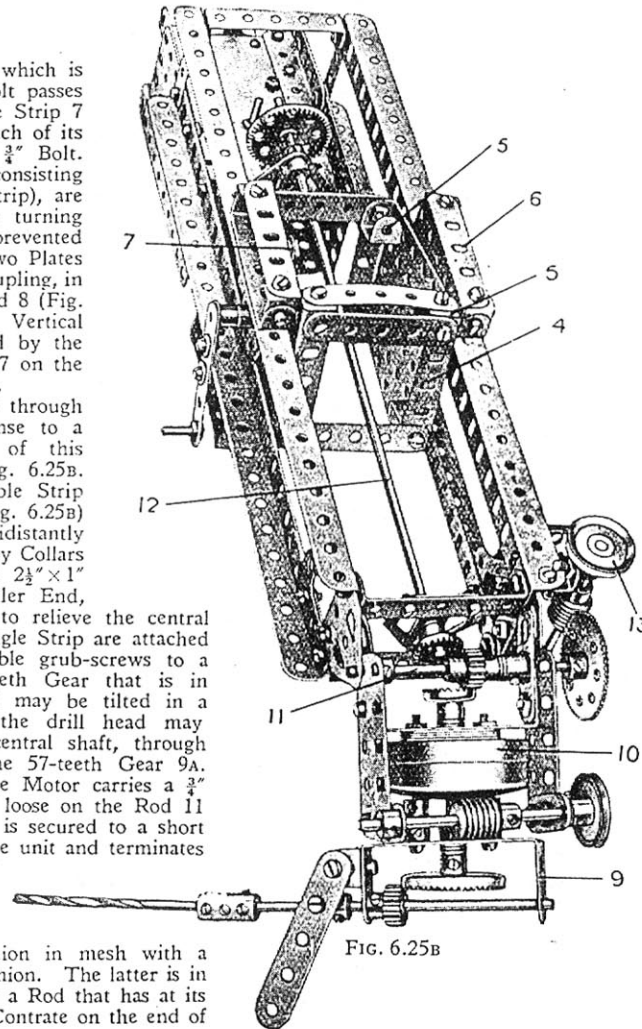
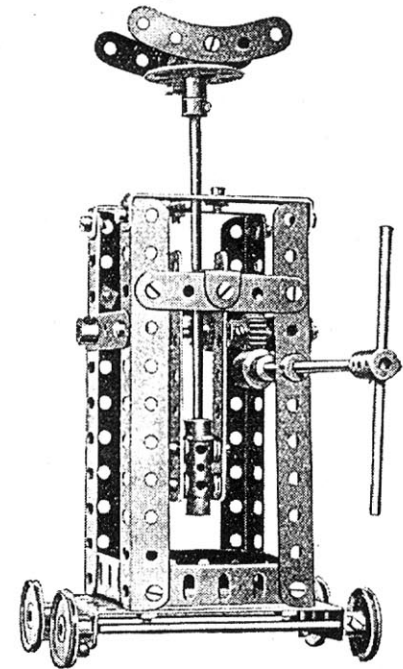

FIG. 6.25b

## Model No. 6.26

### Jack



#### Parts required :

5	of No. 5	3	of No. 26
4	" " 9	1	" " 32
4	" " 9D	32	" " 37
2	" " 12	8	" " 38
2	" " 14	3	" " 48A
2	" " 15A	1	" " 53
1	" " 16	7	" " 59
1	" " 16B	2	" " 63
4	" " 22	2	" " 90
1	" " 24	2	" " 110

## Model No. 6.27 Weighbridge

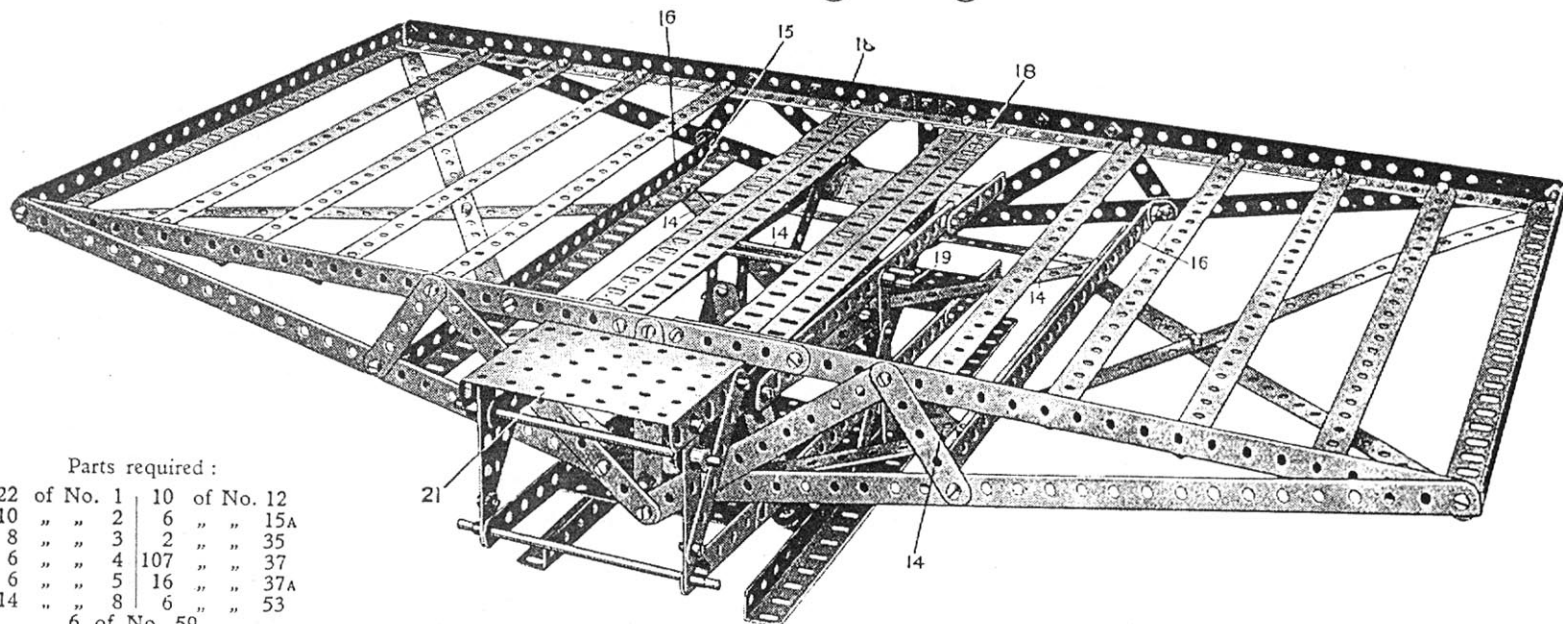

## Parts required :

22	of No. 1	10	of No. 12
10	" "	2	6 " " 15A
8	" "	3	2 " " 35
6	" "	4	107 " " 37
6	" "	5	16 " " 37A
14	" "	8	6 " " 53
		6	of No. 59

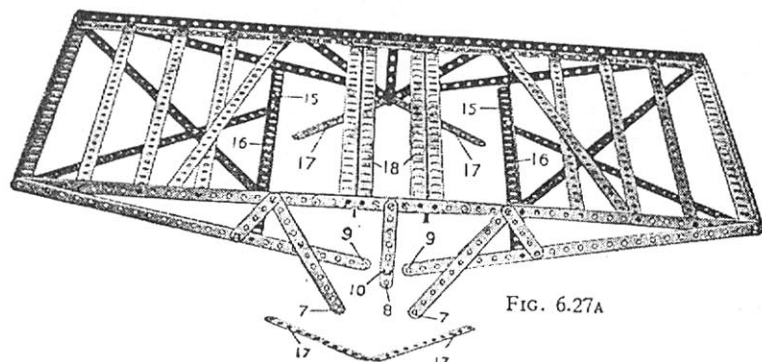

FIG. 6.27A

Begin the construction of this model by making the weigh beam, Fig. 6.27B. The side Strips 1 are bolted to the base Angle Girders 2, and in the Strips 1 are journaled the Rods 3 which form the fixed pivots of the weigh beam. The upper and lower Rods 4 are journaled in the Strips 5 and form the moving pivots of the beam. All the Rods 3 and 4 pass through perforations in the upper and lower Strips 6 of the beam. Next construct the platform, Fig. 6.27A, leaving the Strips at one side unconnected, as shown. The platform is then passed between the upper and lower parts of the weigh beam, and the unconnected Strips then bolted as follows: The ends 7 are bolted to the lowest hole 8, and the ends 9 to the Bolt

## Model No. 6.27 Weighbridge *(continued)*

10, which also carries an Angle Bracket. The outer holes 14 of the crossed  $12\frac{1}{2}$ " Strips, Fig. 6.27B, are then bolted to the same holes 15 in the Angle Girders 16 as the Strips 17. The other ends of the Strips 17 are secured to the Angle Bracket at 10. The Double Angle Girders 18 are then bolted in position, and the upper holes 19, Fig. 6.27B, are bolted to the Angle Girders 18 in the centre holes and the holes 20, Fig. 6.27B, to the Angle Girders 18 at the fifth hole from the Girder ends. The load to be weighed rests on the main platform, and the weights are placed on the small Rectangular Plate 21 at the end of the weigh beam.

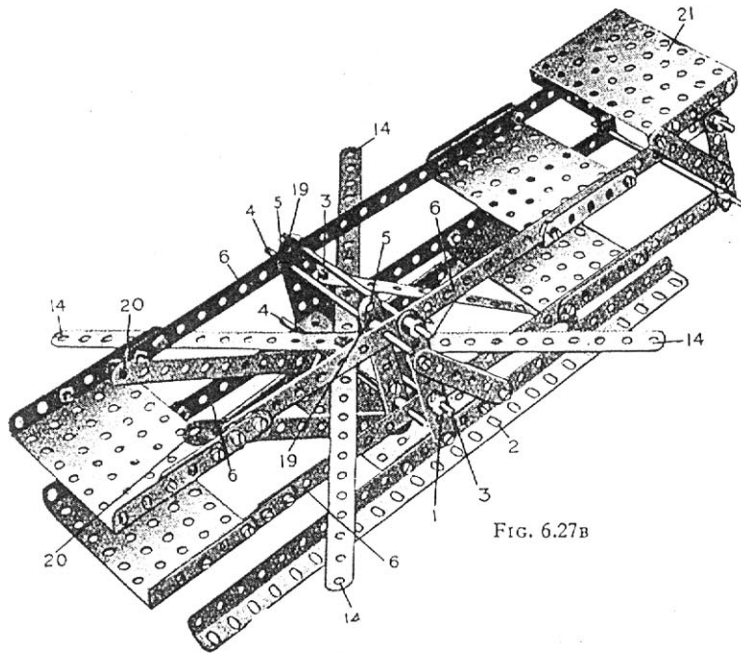
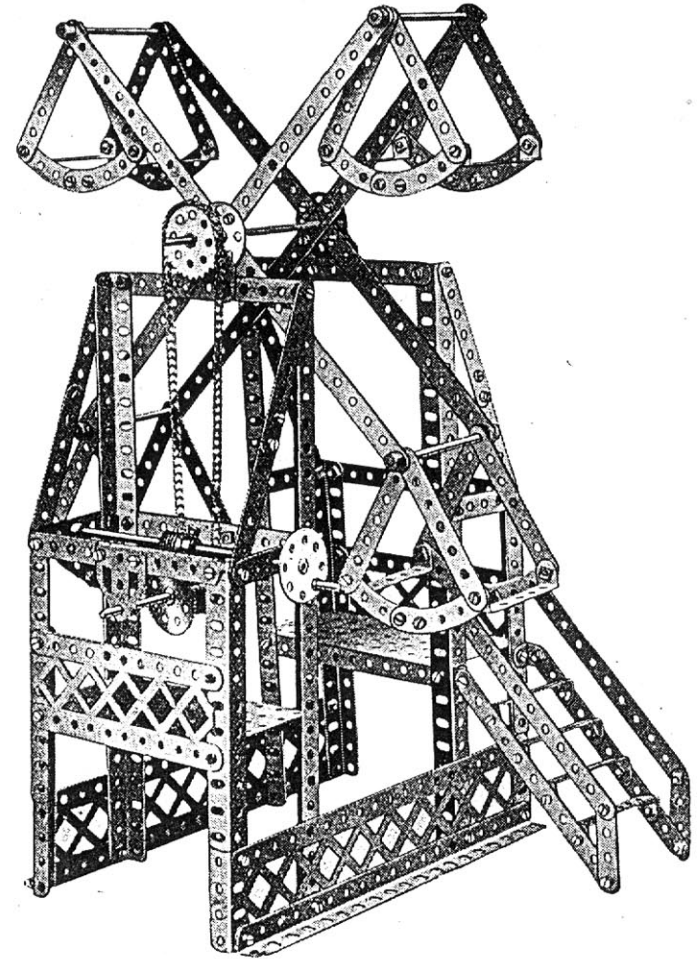

FIG. 6.27B

## Model No. 6.28 Fly Boats

Parts  
required :

4	of No.	1
9	" "	2
24	" "	3
4	" "	5
2	" "	6
4	" "	8
2	" "	8A
8	" "	9
4	" "	12
2	" "	14
5	" "	16
3	" "	24
1	" "	27A
1	" "	32
15	" "	37
24	" "	38
12	" "	48A
2	" "	52
12	" "	59
16	" "	90
18	" "	94
1	" "	95A
1	" "	96
2	" "	99A
2	" "	100
1	" "	115
4	" "	126A



# Model No. 6.29 Automatic Weighing Crane

Parts required :

8 of No	1	4 of No. 8A	2 of No. 18B	2 of No. 27A
28 "	2	12 "	19 "	1 "
2 "	2A	5 "	20 "	9 "
10 "	3	30 "	1	198 "
12 "	4	2 "	22	7 "
36 "	5	5 "	22A	1 "
2 "	6	2 "	24	1 "
2 "	6A	4 "	25	1 "
8 "	8	3 "	26	4 "
			27	48A

(continued below).

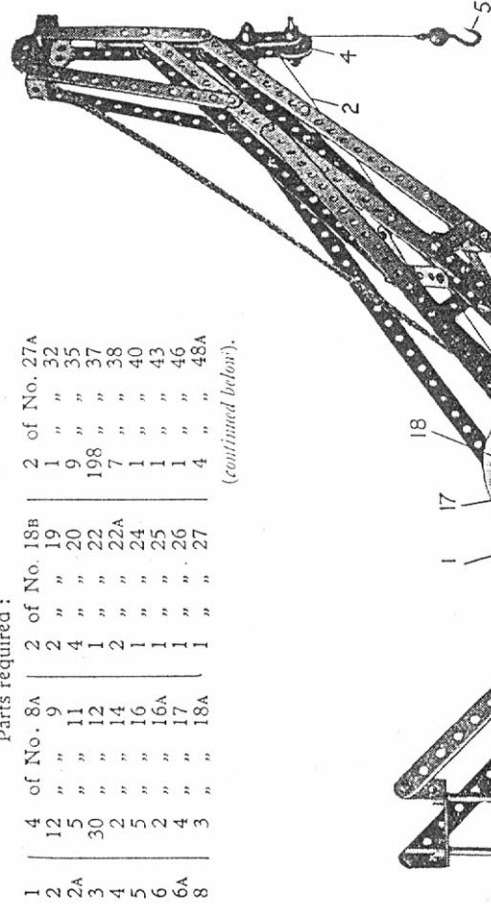

Parts required :

(continued)

3 of No.	52
2 "	52A
1 "	57C
15 "	59
3 "	62
2 "	63
1 "	70
2 "	77
27 "	94
1 "	95A
1 "	96
2 "	108
2 "	115
3 "	125
4 "	126A
1 "	137
1 "	147A
1 "	147B
1 "	148

21 of No. 117  
(not included in outfit).

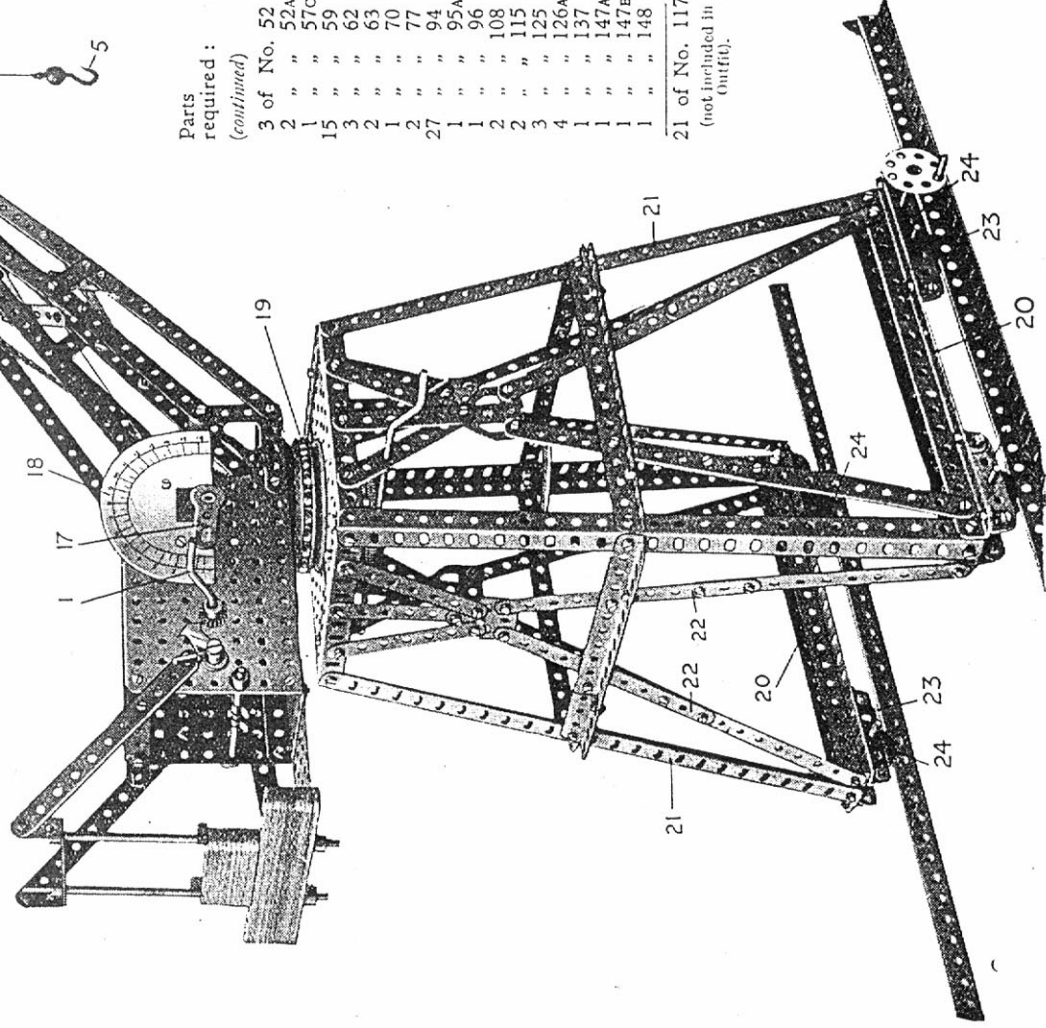



## Model No. 6.29 Automatic Weighing Crane (continued)

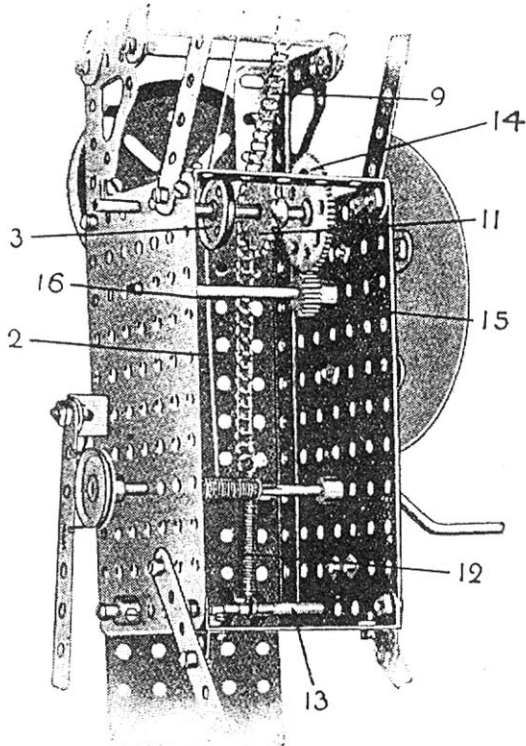

FIG. 6.29A

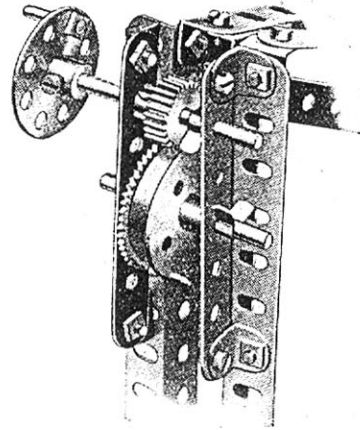

FIG. 6.29B

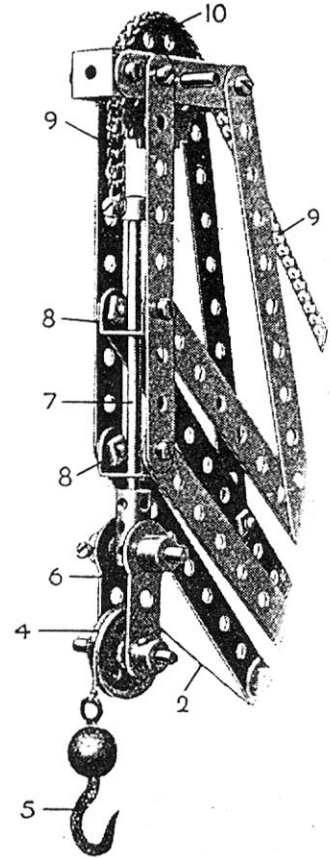

FIG. 6.29C

This is a model of a crane that, when raising a load, automatically indicates the weight carried. The load is raised or lowered by the operation of the Crank Handle 1 upon which is wound a lifting Cord 2 passing round a 1" Pulley 3 and over another 1" Pulley 4 (Fig. 6.29c) to the Loaded Hook 5. The 1" Pulley 4, which bears the weight of the load, is carried by two Cranks 6 connected to a 3½" Rod 7, slidable in two Double Brackets 8.

To the top of the rod is connected a Sprocket Chain 9 which passes over a 1½" Sprocket Wheel 10 and under a 1" Sprocket Wheel 11 (Fig. 6.29A), the other end of the Chain being connected to a Spring 12, secured to a 3½" Rod 13. Thus, when a load is being raised the weight is carried by the Rod 7 which pulls down in its bearings and consequently extends the Spring 12. In this movement, the Chain 9 rotates the Sprocket Wheel 11 and a 1½" Gear Wheel 14, on the rod of the Sprocket 11, engages a ½" Pinion 15 on a Rod 16. On the outer end of this Rod 16 is a Crank 17 that sweeps round the

graduated Dial 18 to indicate the weight of the load that is being lifted.

The construction of the remainder of the model will be clearly seen from the illustration. The Bearings 23 carrying the Flanged Wheel 24 are formed of 2½" Strips connected to the Girders 20 by Angle Brackets.

It will be noted that the crane jib is carried upon Ball Bearings 19, the Balls (Part No. 117) for which are not supplied in the No. 6 Outfit but may be obtained separately. The crane will work well without the ball bearing, but the operation is easier when such a bearing is fitted.

## Model No. 6.30 Vertical Lifting Bridge

## Parts required :

10	of No.	1	1	of No.	25
6	"	1A	2	"	26
7	"	1B	1	"	27
24	"	2	3	"	27A
1	"	2A	295	"	37
17	"	3	10	"	37A
10	"	4	11	"	38
11	"	5	2	"	40
24	"	6	2	"	44
1	"	6A	4	"	48D
26	"	8	7	"	52
8	"	8A	2	"	52A
2	"	8B	1	"	53A
18	"	9	20	"	59
2	"	9A	5	"	63
5	"	9D	5	"	70
14	"	12	4	"	99
1	"	12A	2	"	102
3	"	13A	2	"	103A
4	"	14	2	"	103F
3	"	17	3	"	111
2	"	18B	4	"	111A
4	"	20A	4	"	126
4	"	22	4	"	126A
2	"	22A	4	"	133
4	"	23	4	"	136

2 of No. 147B

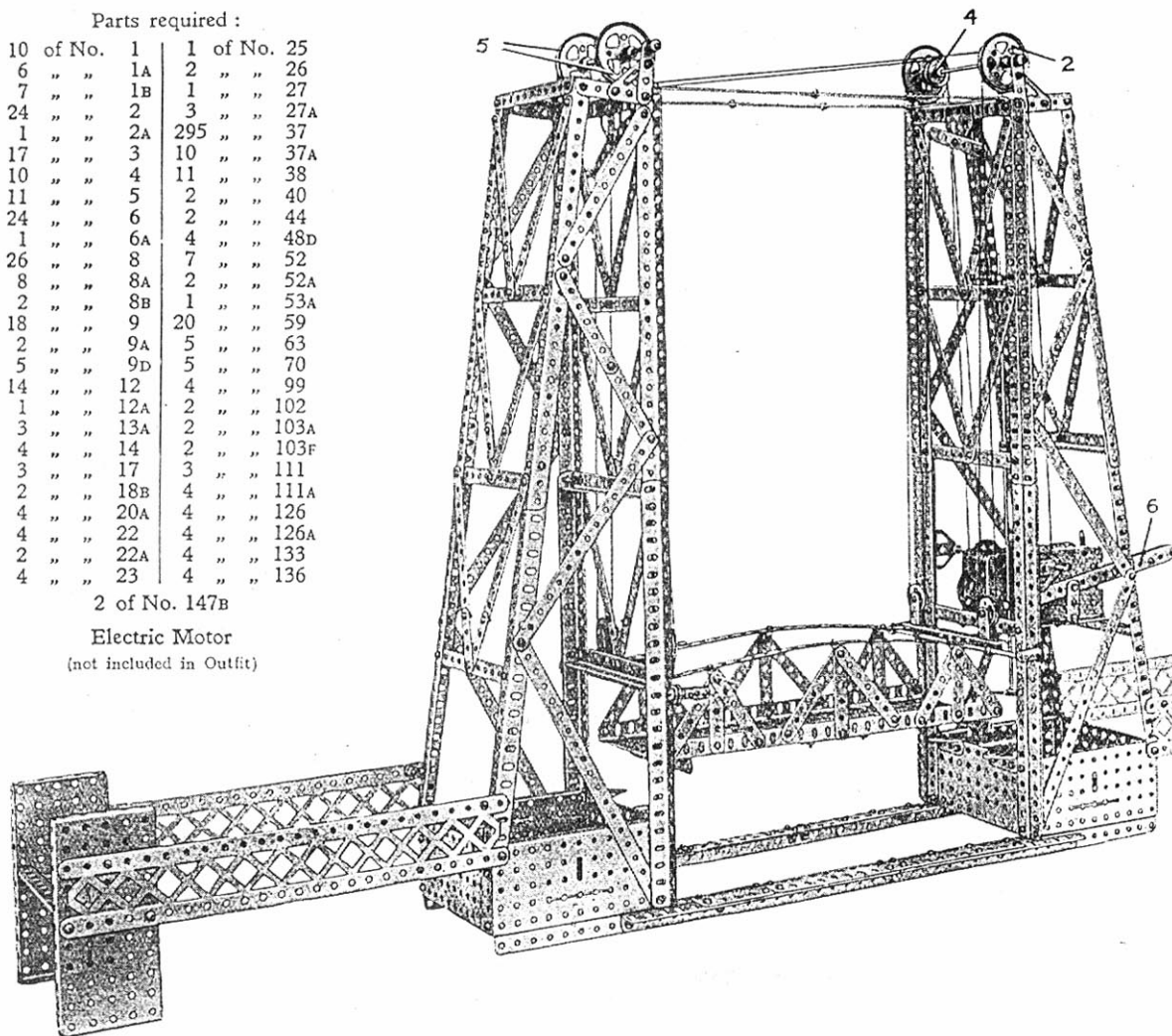
Electric Motor  
(not included in Outfit)

The lifting span of the bridge is supported on four separate "falls" of cord, each of which is attached to the hoisting winch 1. The two lengths that pass over the 2" Pulleys 2 on the top of the first tower are rove through pulley blocks on the lifting span and are then attached to a compensating lever 3. The latter is pivoted and allows for variation in the lengths of the two cords. The other two cords pass over 1" fast Pulleys 4, then under and round 2" Pulleys 5 at the head of the second tower, after which they are treated in a similar manner to the first set.

The limit switch consists of a pivoted  $7\frac{1}{2}$ " Strip 6, one end of which is attached to a Collar on the vertically-slidable Rod 7 (Fig. 6.30A), whilst its other end is attached by a

$\frac{1}{2} \times \frac{1}{2}$ " Angle Bracket to the switch arm of the Motor. This extremity of the lever carries also seven  $2\frac{1}{2}$ " Strips that act as a balance weight.  $\frac{3}{4}$ " Bolts, inserted in Collars on each end of the

Rod 7, come into contact with a  $\frac{1}{2} \times \frac{1}{2}$ " Angle Bracket 7A on the lifting span at the limits of travel of the span, and thus cut off the Motor at the right moment.

Model No. 6.30  
Vertical Lifting Bridge  
(continued)

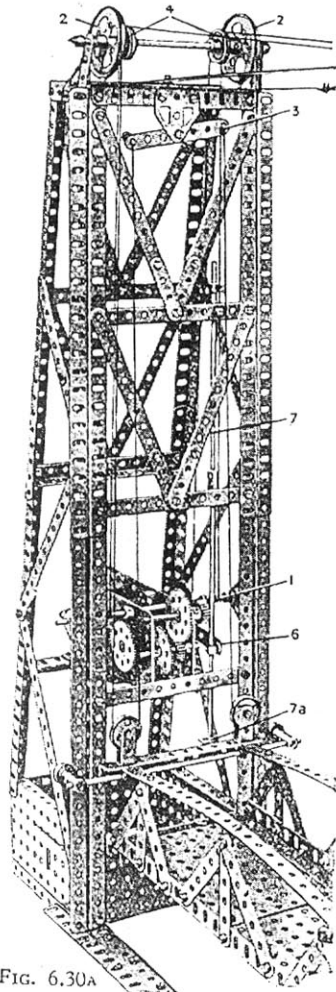
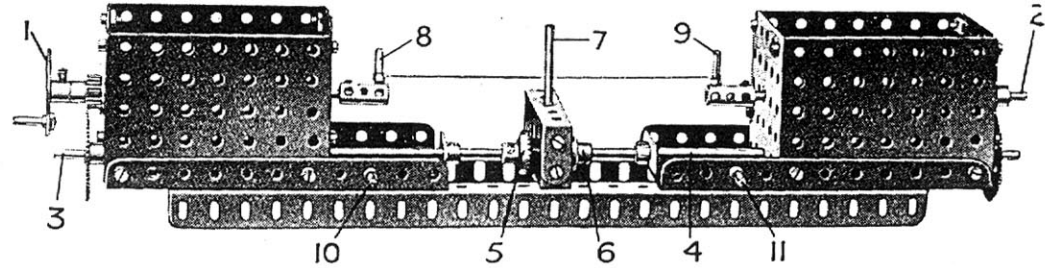

FIG. 6.30A

Parts  
required :

6	of No.	5
2	"	6A
2	"	8
2	"	12
2	"	12B
2	"	14
2	"	15A
2	"	16A
1	"	25
1	"	26
2	"	27A
2	"	29
2	"	37
3	"	37A
2	"	46
2	"	52
4	"	53
2	"	59
2	"	63
2	"	72
3	"	111
2	"	115

Model No. 6.31 Heald-Making Machine



This model converts thin lengths of wire into healds for use in Meccano looms. Two typical specimens of healds made with the machine are shown in Fig. 6.31A.

Two  $4\frac{1}{2}$ " Axle Rods are placed longitudinally in the model. One of these Rods carries a handle, composed of a Threaded Pin and Bush Wheel 1, and a  $\frac{1}{2}$ " Pinion that engages with a 57-teeth Gear Wheel secured to an 8" Rod 3.

The other  $4\frac{1}{2}$ " Rod 2 revolves in the opposite direction to the handle 1, the reverse motion being obtained in the following manner. The inner end of the 8" Rod 3 is journaled in one end of a Coupling, through the centre hole of which passes the vertical  $2\frac{1}{2}$ " Rod 7. The latter carries a  $\frac{3}{4}$ " Pinion and is journaled in the centre holes of two  $2\frac{1}{2}$ " x 1" Double Angle Strips bolted to the base Angle Girders. Another 8" Rod 4 is journaled in the opposite end of the Coupling, and this Rod is fitted with a 57-teeth Gear Wheel meshing with a  $\frac{1}{2}$ " Pinion on the Rod 2. Rods 3 and 4 are both free to revolve in the ends of

the Coupling, but the drive is transmitted from Rod 3 to Rod 4 via two  $\frac{3}{4}$ " Contrate Wheels 5 and 6 and the Pinion on Rod 7; hence the direction of rotation of Rod 4 is reversed.

Each of the two  $4\frac{1}{2}$ " Rods is fitted with a Coupling carrying a Threaded Pin 8, 9 secured at right-angles to its end; these Pins form hooks over which is slipped the loop of wire from which the heald is formed. Each Rod is also equipped with a Compression Spring that is mounted between a  $2\frac{1}{2}$ " x  $2\frac{1}{2}$ " Flat Plate (forming the inner bearing for the Rod), and a Collar on the Rod in such a way that it tends to hold the Coupling carrying the Threaded Pin against the Plate. Two  $\frac{3}{4}$ " Bolts 10 and 11 are bolted to the side of the machine to form a gauge by which the correct length of wire may be ascertained.

The healds are manufactured as follows: A piece of suitable wire, about 13" in length, is passed round the Bolts 10 and 11 and the ends twisted together with a pair of pliers to form a loop. A convenient size of wire is 26 S.W.G. (.018" in diameter).

Next the loop of wire is removed and passed over the Rod 7, and its ends slipped over the Pins 8 and 9. The hand wheel is now rotated and the loop of wire is twisted into the form of a heald, the Rod 7 forming the hole through which will pass the warp threads of the loom. As the loop of wire is twisted the  $4\frac{1}{2}$ " Rods carrying the Threaded Pins 8 and 9 are drawn slightly towards the Rod 7. This movement is allowed for by the small Compression Springs already mentioned.



FIG. 6.31A

## Model No. 6.32 Watt's Beam Engine

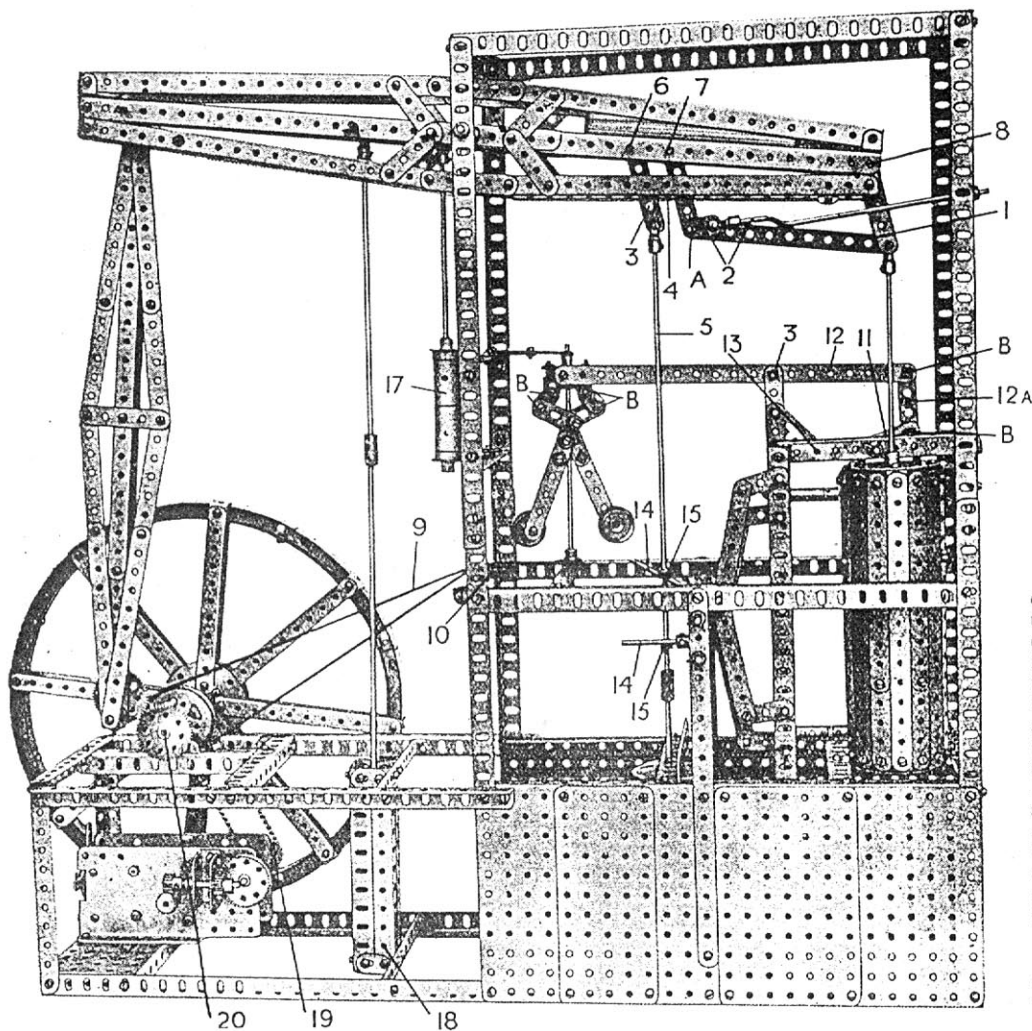

This model of James Watt's double-acting Beam Engine incorporates working reproductions of three of the great engineer's most notable achievements—sun-and-planet gear, steam governor and parallel motion—as well as a representation of a fourth—the water-cooled condenser. The 1" Sprocket Wheel 19 is connected by Sprocket Chain to a similar Sprocket in the flywheel-shaft, which is journaled in two Trunnions secured to the main frames. The piston rod is kept parallel by the parallelogram 1, the point A in which is connected by the Crank Handle and 1" Reversed Angle Bracket 2 to the framework. An extra link 3, secured to the main parallelogram by the 1½" Strip 4, is added to keep the condenser pump rod 5 perpendicular. The complete link unit is pivoted on the 2" Rods 6, 7 and 8 and held in place by Collars. In constructing the cylinder it should be noted that 1½" Strips and Flat Brackets are used at top and bottom respectively for connecting the separate Strips forming the sides. The governor, driven as shown by the Spring Cord 9 passing over the ½" loose Pulleys 10, is connected to the throttle valve 11 (a Crank carried on a 1½" Rod) by the 12½" Strip 12 and the 2" Strip 12A. A Bolt secured in the end hole of the Strip 12 slides between the two Bush Wheels on the governor, these Bush Wheels being spaced apart by means of Spring Clips held in place by ½" Bolts. All joints marked B are lock-nutted.

The condenser is shown in detail in Fig. 6.32A. It consists chiefly of two cylinders, one of which is composed of a boiler and the other 3¼ × ½" Double Angle Strips bolted round the periphery of two Bush Wheels. The main steam pipe, which is constructed from 12½" Angle Girders to form a square, is secured to latter at the bottom and at the top to two 5½" Angle Girders 13, which are bolted together in a similar manner to the main pipe. The main steam pipe in the actual engine carries the inlet and exhaust ports, these being represented in the model by 1½" Strips pivoted on 1" and 1½" Rods carried in 12½" Strips bolted inside the Angle Girders. It will be noticed in constructing the connections between the steam pipe and cylinder that the Screwed Rod used in the building of the top connection does not pass inside the cylinder as that in the bottom. The tappet Rods 14 are rocked by the Threaded Pins 15, and returned by the action of the Springs 16. The method of connecting the valves to the tappet rods will be seen clearly in Fig. 6.32A.

The sun and planet gear that is incorporated in the model is composed of two 57-teeth gears. To complete the engine a feed water pump 17 and water circulating pump 18 are fitted.

Model No. 6.32 Watt's Beam Engine (continued)

Parts required :

6	of No. 1	2	of No. 52
3	" " 1A	4	" " 52A
10	" " 1B	27"	" " 58
27	" " 2	29	" " 59
10	" " 3	3	" " 62
2	" " 4	8	" " 63
18	" " 5	2	" " 64
16	" " 6	6	" " 70
13	" " 6A	4	" " 77
26	" " 8	1	" " 80A
8	" " 8A	1	" " 81
18	" " 9	11"	" " 94
2	" " 9F	2	" " 96
8	" " 10	4	" " 109
8	" " 11	4	" " 111
31	" " 12	6	" " 111A
2	" " 12A	6	" " 111C
2	" " 12B	2	" " 115
3	" " 13	1	" " 116A
1	" " 13A	8	" " 119
5	" " 14	1	" " 125
2	" " 15	2	" " 126
1	" " 15A	1	" " 126A
5	" " 16	2	" " 128
1	" " 16A	1	" " 133
4	" " 17	1	" " 147B
4	" " 18A	1	" " 160
2	" " 18B	1	" " 162
1	" " 19	2	" " 163
1	" " 20A	1	" " 164
2	" " 20B	2	" " 165
4	" " 22	2	" " 166
2	" " 23		
1	" " 23A		
4	" " 24		
1	" " 26		
2	" " 27A		
1	" " 28		
1	" " 32		
19	" " 35		
314	" " 37		
6	" " 37A		
36	" " 38		
2	" " 43	1	of No. 2
5	" " 48A	4	" " 2A
7	" " 48B	14	" " 3
4	" " 48D	10	" " 4

Electric Motor  
(not included in Outfit)

In addition the following parts are used as the balance weight for the beam:—

1	of No. 2
4	" " 2A
14	" " 3
10	" " 4

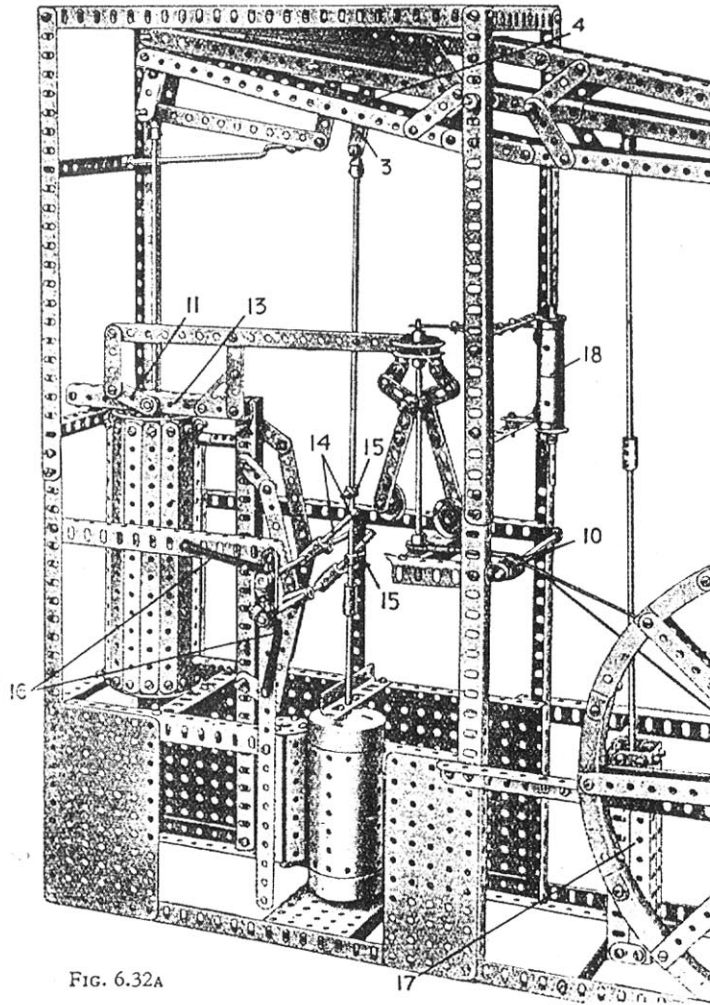

FIG. 6.32A

Model No. 6.33  
Ash Tray and Match Holder

The match-box holder is secured to the pedestal by a Fork Piece 1, and a Bush Wheel 2 carries the Wheel Flange 3, which forms the ash tray. A strip of sand paper or the roughened portion of a match-box cover may be pasted on each of the Flat Plates to facilitate the striking of the matches.

Parts required :

2	of No. 11
1	" " 19B
1	" " 24
1	" " 32
10	" " 37
2	" " 63
2	" " 72
1	" " 116
1	" " 137

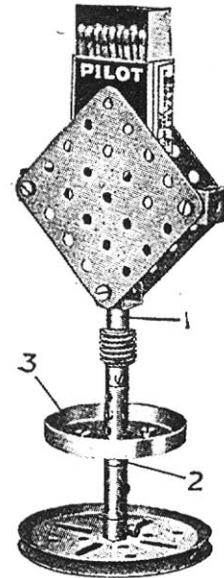

## Model No. 6.34 Lathe

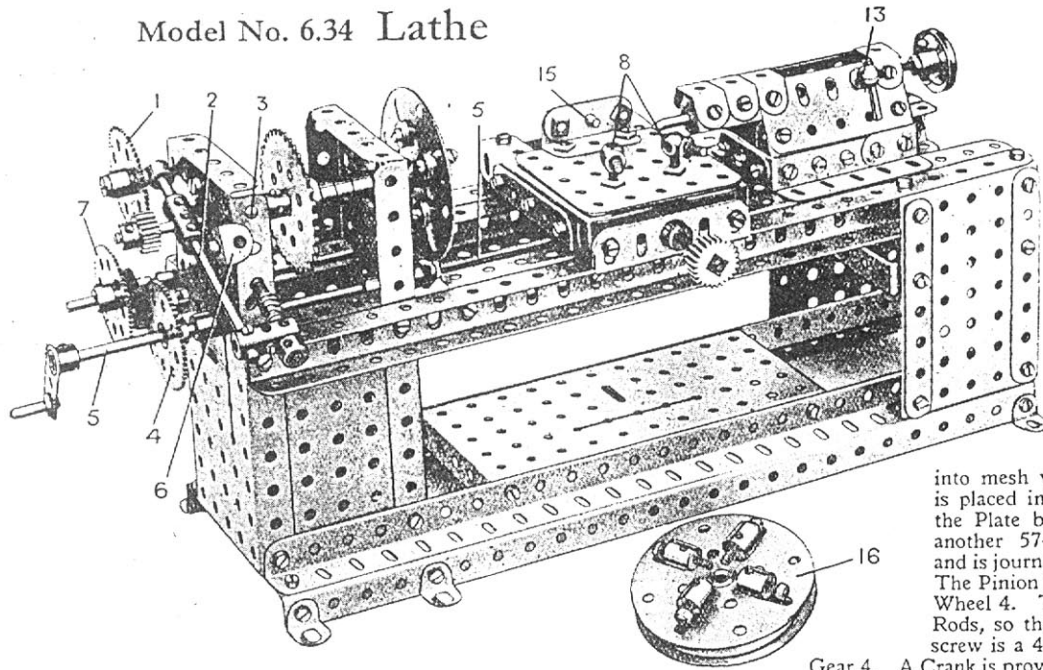

The headstock of the lathe is composed of two  $5\frac{1}{2}'' \times 2\frac{1}{2}''$  and two  $3\frac{1}{2}'' \times 2\frac{1}{2}''$  Flanged Plates. Bush Wheels, bolted to the former Plates, form reinforced bearings for the "mandrel," which carries a 2" Sprocket Wheel and is strengthened by the addition of a Coupling and Collars.

Each side of the lathe bed is built up from two  $12\frac{1}{2}''$  and two  $9\frac{1}{2}''$  Angle Girders, bolted together to form an H-section girder, and the rear end of the bed is supported by two  $3\frac{1}{2}'' \times 2\frac{1}{2}''$  Flanged Plates, which have  $3\frac{1}{2}''$  Strips bolted to them for strengthening purposes and are spaced apart by a  $3\frac{1}{2}'' \times \frac{1}{2}''$  Double Angle Strip and a  $3\frac{1}{2}'' \times 2\frac{1}{2}''$  Flanged Plate. Both the Plate and the Double Angle Strip are spaced from the side Plates by the thickness of a Washer.

The change-speed gearing for actuating the lead-screw 5 is arranged as follows: A  $\frac{1}{2}''$  Pinion on the mandrel is in continual mesh with a 57-teeth Gear Wheel 1, which is mounted freely on a Pivot Bolt on the end of a lever 2. The latter pivots and is free to slide on the mandrel, so that by placing the spring-loaded plunger on the end of the lever in the hole 3, the Gear 1 is brought into mesh with a 57-teeth Gear 4 on the lead-screw. When the plunger is placed in the hole of an  $\frac{1}{2}'' \times \frac{1}{2}''$  Angle Bracket 6 (which is spaced from the Plate by three Washers on the securing Bolt), the Gear 1 engages with another 57-teeth Gear Wheel 7 on a Rod that carries a  $\frac{1}{2}''$  Pinion and is journalled in a  $2\frac{1}{2}'' \times \frac{1}{2}''$  Double Angle Strip at the rear of the headstock. The Pinion is in mesh with an "idler" Pinion that is in mesh with the Gear Wheel 4. The Gears 4 and 7 must be carefully adjusted on their respective Rods, so that the movable Gear 1 meshes correctly with both. The lead-screw is a  $4\frac{1}{2}''$  Screwed Rod secured by a Coupling to the Rod carrying the

Gear 4. A Crank is provided to traverse the slide rest by hand if the mechanical movement is considered too fast for delicate work.

The bottom and top slides of the slide rest are shown in Figs. 6.34A and 6.34C. The portion that slides on the lathe bed (see Fig. 6.34A) consists of a  $3\frac{1}{2}'' \times 2\frac{1}{2}''$  Flanged Plate, to the flanges of which are bolted  $2\frac{1}{2}''$  Angle Girders, a  $2\frac{1}{2}''$  Strip being placed between each Girder and the flange of the Plate. Two  $3\frac{1}{2}''$  Angle Girders are secured to further  $2\frac{1}{2}''$  Girders as shown, and upon these the top slide runs. The latter—of which the underside is shown in Fig. 6.34C—is built up from two  $2\frac{1}{2}'' \times 2\frac{1}{2}''$  Flat Plates, to two sides of which duplicated  $2\frac{1}{2}''$  Flat Girders are secured by means of  $\frac{3}{4}''$  Bolts 8 and  $\frac{3}{8}''$  Bolts 9. Each pair of Flat Girders is packed away from the Plates by a  $2\frac{1}{2}''$  Strip. The top slide is pushed on to the  $3\frac{1}{2}''$  Angle Girders and the end of the feed-screw 10 inserted in the set-screw holes of a Double Arm Crank.

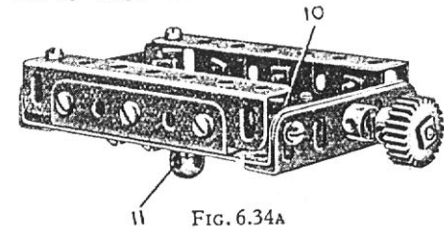

FIG. 6.34A

## Parts required :

8	of No. 3	2	of No. 15A	23	of No. 38	6	of No. 103F
6	" " 5	1	" " 16	1	" " 48A	1	" " 109
4	" " 6A	2	" " 16A	3	" " 48B	6	" " 111
8	" " 8	1	" " 18A	3	" " 52	1	" " 111A
4	" " 8A	2	" " 18B	6	" " 53	5	" " 111C
2	" " 9B	1	" " 22	16	" " 59	3	" " 115
6	" " 9D	2	" " 24	1	" " 62	1	" " 120B
3	" " 9F	2	" " 25	1	" " 62B	4	" " 136
4	" " 10	2	" " 26	5	" " 63	1	" " 147B
4	" " 11	3	" " 27A	2	" " 72	1	" " 165
9	" " 12	1	" " 35	2	" " 80B		
4	" " 12A	95	" " 37	1	" " 81		
1	" " 15	19	" " 37A	1	" " 95		

## Model No. 6.34 Lathe (continued)

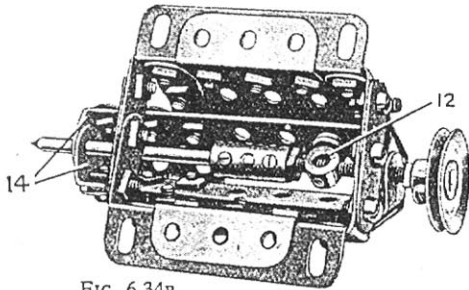

FIG. 6.34B

The tailstock is shown in Fig. 6.34b. The tailstock spindle is a  $2\frac{1}{2}$ " Rod (one end of which is turned to a point in the lathe) that is secured by a Coupling to a 2" Screwed Rod. The latter works in the tapped bores of a "spider" 12 (removed from a Swivel Bearing) that is attached to the frame of the tailstock by a Handrail Support 13 (Fig. 6.34), so that by screwing up the latter the spindle is locked. The spindle slides in two  $3\frac{1}{2} \times \frac{1}{2}$ " Double Angle Strips 14, and the complete tailstock is slidable on the lathe bed in order that work of varying lengths may be accommodated. It may be retained in the required position by passing Threaded Pins through the holes in the tailstock Girders and those in the lathe bed.

The "chuck" for holding the work to be turned, consists of a Face Plate to which four equidistantly-spaced Collars are secured by Set-screws passed through the Face Plate and inserted in their tapped bores. A  $\frac{3}{4}$ " Bolt is passed through each Collar and held in place by two Nuts, so that by turning the Nuts, the Bolts can be made to grip the work from four different directions.

A more satisfactory and stronger chuck is shown separately at 16, but this requires four Threaded Bosses while Outfit No. 6 contains only three. Two Face Plates and a Wheel Flange are clamped together by four  $\frac{1}{2}$ " Bolts, which are screwed into the Threaded Bosses. The Bosses bed into the slotted hole of the Face Plate, and are hence prevented from twisting round. One Washer and a Collar is used on the shank of each  $\frac{1}{2}$ " Bolt between the two Face Plates, and a Washer is also placed under the head of each Bolt.

The turning tool may be held in place on the top slide of the slide rest by Strips, which are placed over the shanks of the  $\frac{3}{4}$ " Bolts 8 and over the tool, so that by screwing down the Handrail Supports, the tool is clamped firmly. It is very important to see that the point of the tool is exactly on a level with the centre of the work; to achieve this it may be necessary to pack up the tool by Strips, etc. The Bolt 15 forms a "steady" when turning work of small diameter.

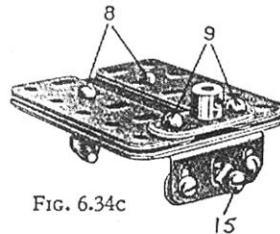
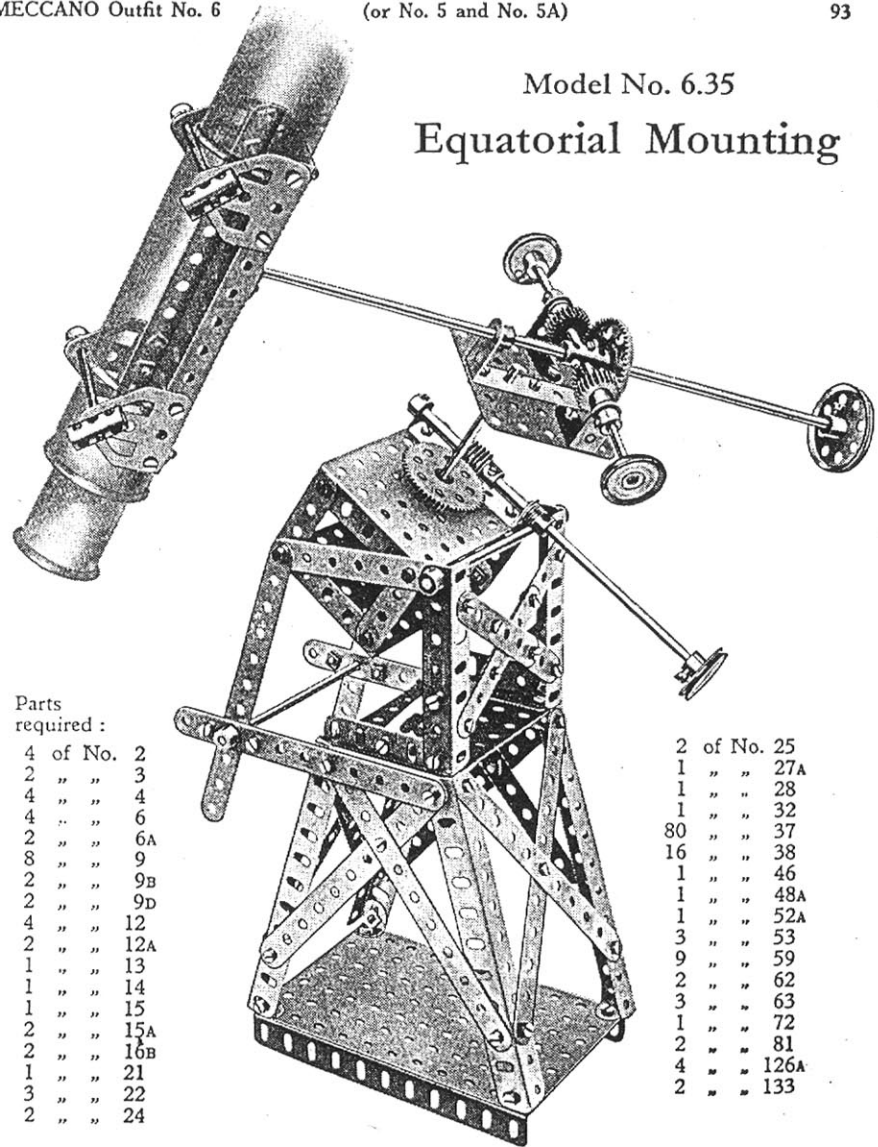

FIG. 6.34c

The complete slide rest is placed in position on the lathe-bed, and the lead-screw passed through the tapped bores of a Handrail Support 11. It is very important that there should be absolutely no slackness in the longitudinal and cross movements of the slide rest, as this will prevent accurate work being obtained, particularly in the case of metal-turning.

## Model No. 6.35 Equatorial Mounting



Parts  
required :

4	of No.	2
2	" "	3
4	" "	4
4	" "	6
2	" "	6A
8	" "	9
2	" "	9B
2	" "	9D
4	" "	12
2	" "	12A
1	" "	13
1	" "	14
1	" "	15
2	" "	15A
2	" "	16B
1	" "	21
3	" "	22
2	" "	24

2	of No.	25
1	" "	27A
1	" "	28
1	" "	32
80	" "	37
16	" "	38
1	" "	46
1	" "	48A
1	" "	52A
3	" "	53
9	" "	59
2	" "	62
3	" "	63
1	" "	72
2	" "	81
4	" "	126A
2	" "	133

## Model No. 6.36

## Radial Travelling Crane

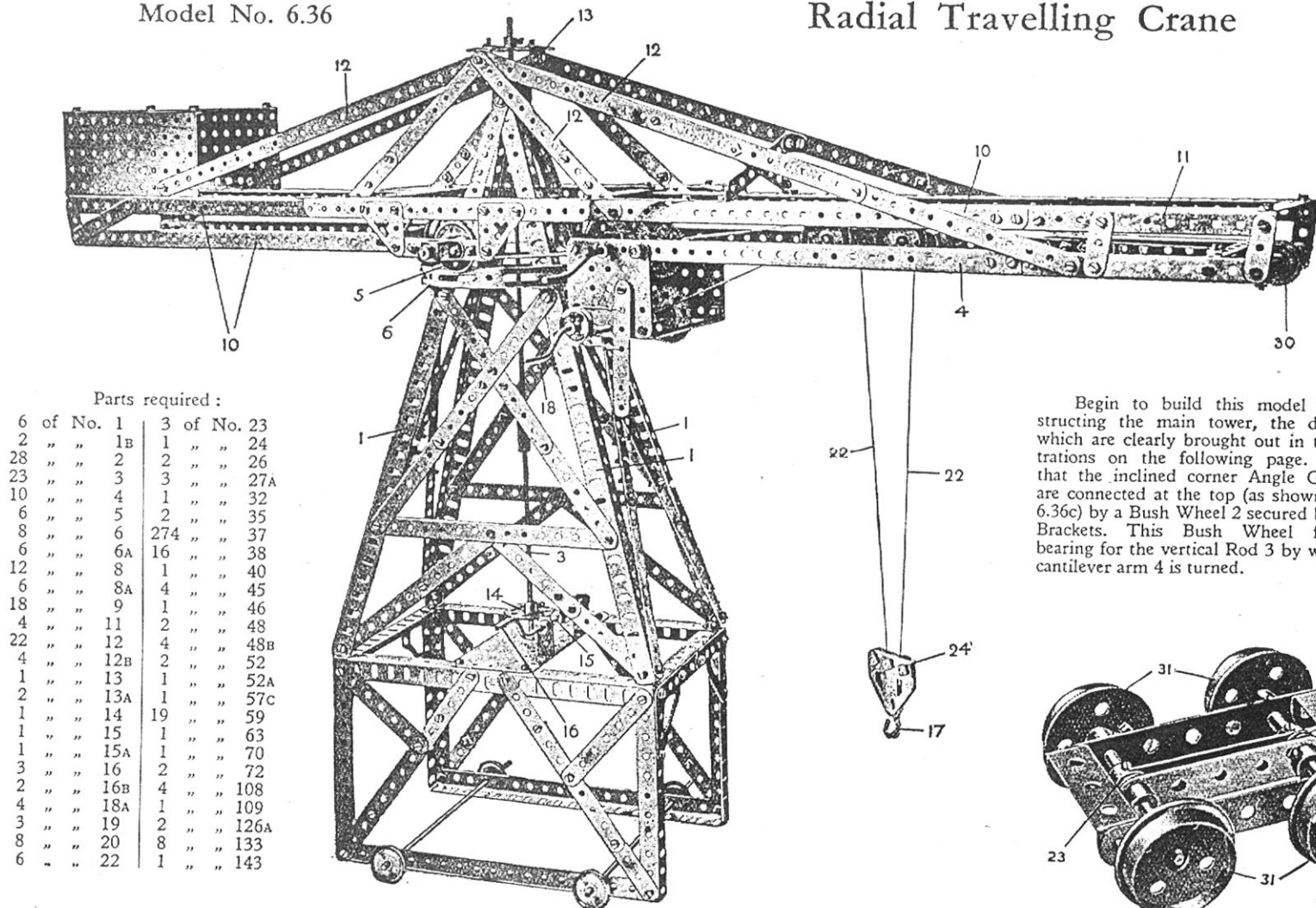

## Parts required :

of	No.	3	of	No.
6	1	3	23	
2	1B	1	24	
28	2	2	26	
23	3	3	27A	
10	4	1	32	
6	5	2	35	
8	6	274	37	
6	6A	16	38	
12	8	1	40	
6	8A	4	45	
18	9	1	46	
4	11	2	48	
22	12	4	48B	
4	12B	2	52	
1	13	1	52A	
2	13A	1	57C	
1	14	19	59	
1	15	1	63	
1	15A	1	70	
3	16	2	72	
2	16B	4	108	
4	18A	1	109	
3	19	2	126A	
8	20	8	133	
6	22	1	143	

Begin to build this model by constructing the main tower, the details of which are clearly brought out in the illustrations on the following page. Notice that the inclined corner Angle Girders 1 are connected at the top (as shown in Fig. 6.36c) by a Bush Wheel 2 secured by Angle Brackets. This Bush Wheel forms a bearing for the vertical Rod 3 by which the cantilever arm 4 is turned.

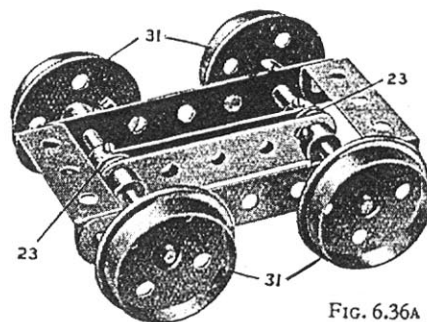

FIG. 6.36A



## Model No. 6.36 Radial Travelling Crane (continued)

The cantilever arm 4 turns on a roller bearing formed of Flanged Wheels 5, which run on a Circular Girder 6 supported by four  $\frac{1}{2}'' \times \frac{1}{2}''$  Angle Brackets bolted to the corner Girders 1. The cantilever is built up (as shown in Fig. 6.36b) from two  $9\frac{1}{2}''$  Angle Girders 8 braced by two  $5\frac{1}{2}''$  Angle Girders 9 overlapped nine holes. From these,  $12\frac{1}{2}''$  Angle Girders 10 extend at one side, and to similar Girders 10 at the other side are connected  $5\frac{1}{2}''$  Girders 11.

The inclined Strips 12 are connected at the top, by means of Angle Brackets, to a Face Plate 13 secured to the vertical Rod 3. At the foot of the Rod 3 is a 57-teeth Gear 14 engaged by a Worm Wheel 15 operated by the Crank Handle 16 and in this way the cantilever arm is swung round, the Wheels 5 riding on the Circular Girder 6.

The load carried from the Hook 17 is raised or lowered by the Crank Handle 18, a  $\frac{1}{2}''$  Pinion 19 on which engages a  $1\frac{1}{2}''$  Gear Wheel 20 on a Rod 21 on which is wound a Cord 22. This Cord passes over a  $\frac{1}{2}''$  Pulley 23 to the block 24 and back over another  $\frac{1}{2}''$  Pulley on the trolley, and is secured to the  $3\frac{1}{2}'' \times \frac{1}{2}''$  Double Angle Strip 25 at the outer end of the cantilever arm. Consequently, when the trolley is caused to travel along the cantilever arm the load remains suspended at a constant height—an important point and an interesting detail.

The trolley is caused to move to and fro along the cantilever arm by the action of the Crank Handle 26. On this a  $\frac{1}{2}''$  Pinion 27 engages a 57 teeth Gear 28 on a rod on which is wound the Cord 29, the opposite ends of which are connected to the opposite ends of the trolley. The Cord 29 passes round a Pulley 30 at the outer end of the jib. By turning the Crank Handle 26, therefore, the Cord 29 winds on and off its Rod, and moves the trolley to and fro, its Wheels 31, as shown in Fig. 6.36a running on the Angle Girders 10.

The Wheels 5 are connected to  $1\frac{1}{2}''$  Rods 5a which are journalled in Double Bent Strips 5b bolted to  $3\frac{1}{2}''$  Strips 5c carried from the Angle Girders 8 by Corner Brackets 5d.

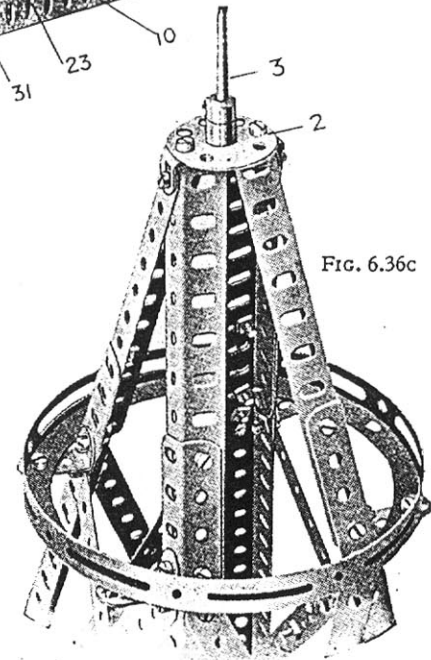
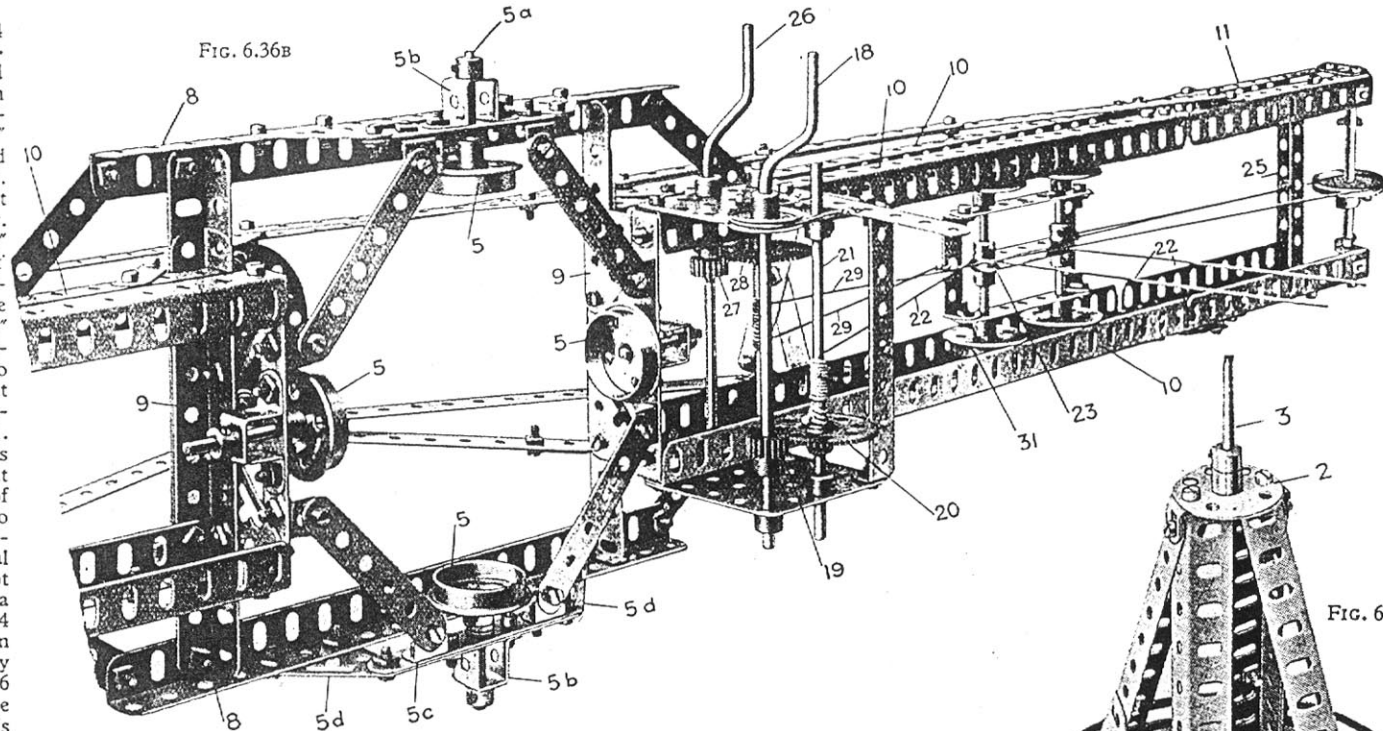

## Model No. 6.37 Mill Engine

### Parts required :

6	of No.	1	1	of No.	15	1	of No.	48B	6	of No.	70
4	"	1A	2	"	15A	1	"	50A	2	"	72
3	"	1B	4	"	16	6	"	52	2	"	76
25	"	2	1	"	16A	4	"	52A	1	"	81
1	"	2A	1	"	16B	3	"	53	46"	"	94
5	"	3	3	"	17	4	"	53A	1	"	95
3	"	4	3	"	18A	10"	"	58	2	"	96
28	"	5	4	"	20	16	"	59	1	"	96A
7	"	6	2	"	20A	4	"	62	4	"	97
12	"	6A	5	"	24	2	"	62B	8	"	99
19	"	8	1	"	26	5	"	63	2	"	99A
1	"	8A	1	"	28						
2	"	8B	300	"	37						
9	"	9	20	"	37A						
2	"	9B	8	"	38						
4	"	9F	1	"	45						
2	"	10	4	"	48						
8	"	11	7	"	48A						
29	"	12									
1	"	12A									
2	"	12B									
1	"	13									

The only parts needing description in this model are the crosshead and Corliss valve gear, both of which are seen fairly clearly in the illustrations. The Corliss valve gear is built up as follows:

The "wrist-plate" 7 (Fig. 6.37B), which consists of a Bush Wheel, is free to turn about a Pivot Bolt that is secured to the  $5\frac{1}{2} \times 3\frac{1}{2}$ " Flat Plate forming one side of the cylinder block. The links connecting the steam valve cranks 8, 8A, and the exhaust valve cranks 9, 9A, consist of 2" Strips that are attached pivotally to the wrist plate by  $\frac{3}{4}$ " Bolts. These Bolts serve also to secure a 2" Strip 10, a Nut being placed on either side of the wrist plate by  $\frac{3}{4}$ " Bolts. The eccentric on the crankshaft is connected to the wrist plate by two  $12\frac{1}{2}$ " Strips overlapped eleven holes, and attached pivotally to the Strip 10 by a Pivot Bolt, a Collar being used for spacing purposes. The two exhaust valve cranks 9 and 9A are lock-nutted direct to their respective links, the Rods on which they are mounted representing the rotary exhaust valves.

The Face Plates 12, 12A are mounted loosely on  $\frac{1}{2}$ " Rods, which are journalled in the side plates of the cylinder to represent the actual steam valves. Each "trip" 13 and 13A consists of two  $1\frac{1}{2}$ " Strips and one Flat Bracket bolted together by Set-screws to form an isosceles triangle, the apex of which is pivoted on a Threaded Pin secured to the Face Plate. A  $\frac{1}{2} \times \frac{1}{2}$ " Angle Bracket is bolted to each trip by its slotted hole. The connecting links between the wrist-plate are now slipped in place on the Threaded Pins and held in position by Collars;

the links are bent slightly to obtain sufficient clearance. Each of the two Bush Wheels 14, 14A, which turn freely on the valve rods, has an ordinary Bolt inserted in the set-screw hole and locked in place by a Nut. A 2" Strip is now bolted across the face of each Bush Wheel so that when the Strips are vertical the Bolt in the boss of 14 is pointing — to use a clock face as a comparison — to 5 o'clock, while the Bolt in the boss of 14A is pointing to 11 o'clock. The Cranks 8 and 8A, are now secured on the Rod, and a  $\frac{1}{2} \times \frac{1}{2}$ " Angle Bracket is bolted to the end hole of each. Short lengths of Spring Cord

8	of No.	100	1	of No.	128
4	"	108	1	"	130
4	"	109	2	"	137
2	"	111	2	"	147B
5	"	111A	2	"	166
6	"	111c			Electric
2	"	115			Motor
8	"	119			(not included in
4	"	126A			Outfit)

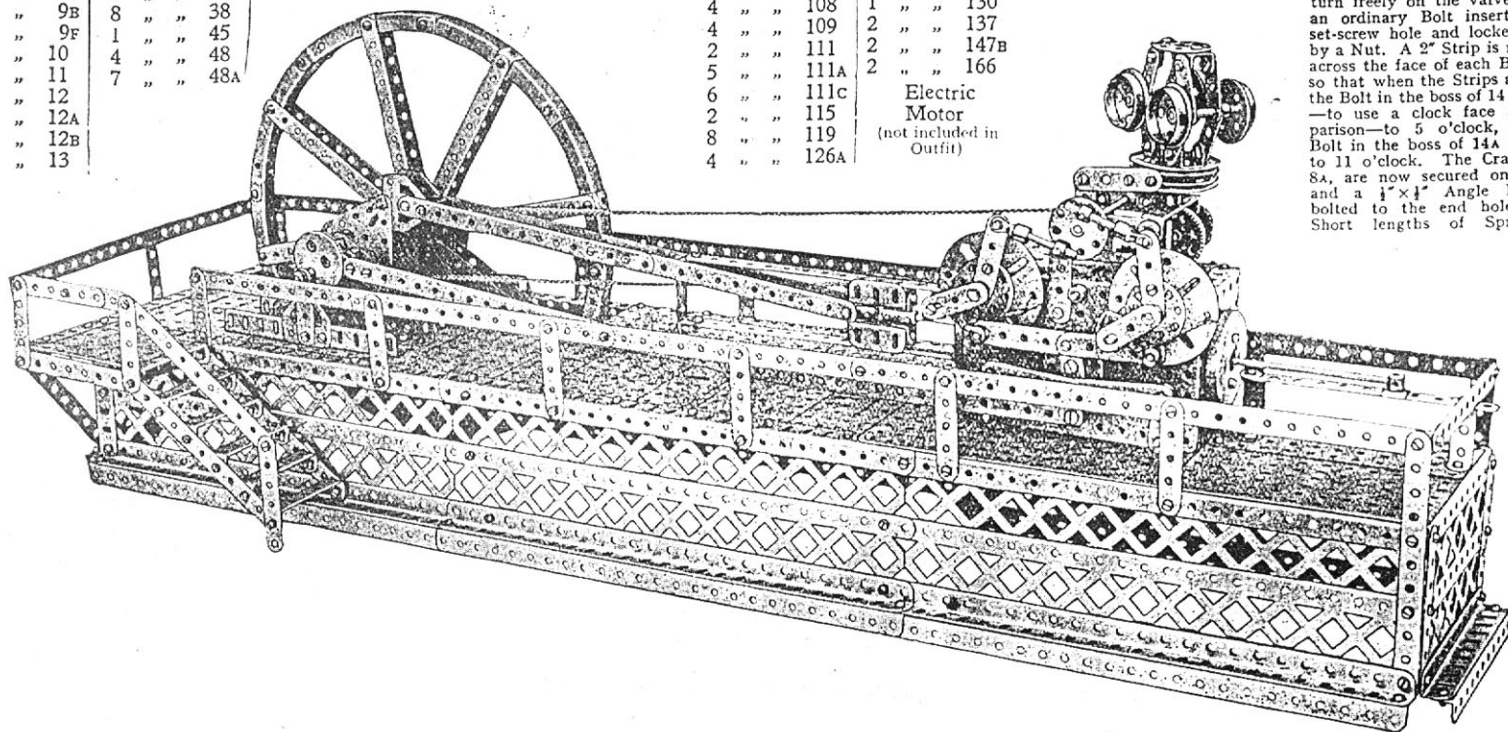

## Model No. 6.37 Mill Engine (continued)

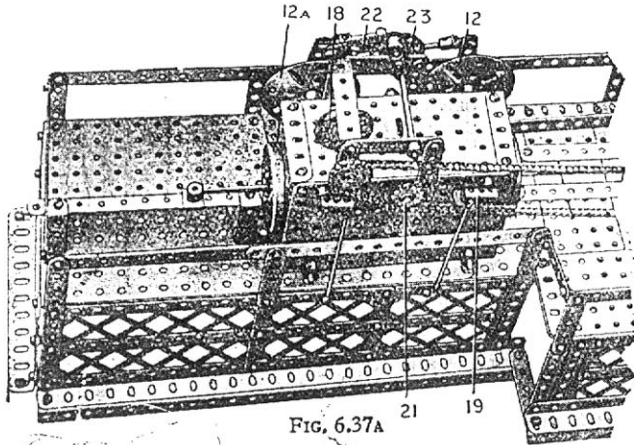

FIG. 6.37A

(continued from above)

A Boss Bell Crank is bolted to the 2" Strip 22 (Fig. 6.37A), which carries a 1" Bolt locating between the Pulleys 17, and is secured by a Coupling to a 3/4" Rod carrying a Bush Wheel 23. Two Collars are attached pivotally to the latter and are connected by 1 1/2" Rods and End Bearings to the 2" Strips on the Bush Wheels 14 and 14A.

In the illustration the Crank 8 is about to be pulled down by the Angle Bracket on the trip 13. As this downward movement continues, the trip commences to "ride up" the Bolt on the boss of the Bush Wheel 14, thus releasing the Angle Bracket on the Crank, which returns to its normal position under the influence of a length of Spring Cord that is fixed to the Coupling 19 (Fig. 6.37A). The other valve functions similarly, except that the Crank 8A is tripped in an upward direction instead of downward.

If the engine speed increases, the governor weights fly out and partially rotate the Bush Wheel 23 through the medium of the Crank 22. This alters the position of the Bolts in the bosses of the Bush Wheels relative to the trips, so that the Cranks are tripped earlier in the stroke of the piston.

By altering the position of the Rods in their respective Collars, both valves may be arranged to lift an equal amount by their trips. The Angle Brackets on the trips and Cranks 8 and 8A must be adjusted very carefully.

In constructing the crosshead the following notes will be useful. Two pairs of 1 1/2" Angle Girders 1 and four 1/2" x 1/2" Angle Brackets 2 are secured to two Couplings 3 and 4 by two 7/8" Bolts. One of these passes through the centre tapped holes of the Coupling 3 and the other through the end plain hole of the Coupling 4, and each Bolt has a Washer placed under its head. Two 1 1/2" x 1/2" Double Angle Strips 5 are next bolted to the Angle Brackets 2, thus forming two channel-shaped "shoes" that slide on the crosshead guides 6.

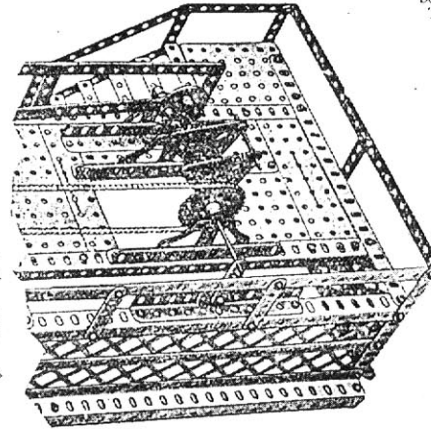

attached to the Face Plates 12 and 12A and to the trips, hold the latter against bosses of the Bush Wheels.

The 5" Rod carrying the governor is journaled in a 2 1/2" x 1/2" Double Angle Strip and in the top plate of the cylinder. The links 15 (1 1/2" Strips) supporting the governor weights, are attached pivotally at their top ends to 1/2" x 1/2" Angle Brackets that are secured to a Bush Wheel 16, while their lower extremities are attached in a similar manner to two 2" Pulleys 17, which are secured rigidly together by 1" Bolts and spaced apart by Collars. These Pulleys should be free to slide on the Rod. The drive for the governor is taken from a 2" Sprocket Wheel on the crankshaft by Sprocket Chain to a 1" Sprocket Wheel on a short Rod carrying a 1 1/2" Contrate 18 (Fig. 6.37A), that meshes with a 1" Pinion 20 on the governor shaft; a 1" Sprocket Wheel 21 (Fig. 6.37A) is used to keep the Sprocket Chain clear of the Coupling 19.

(continued below)

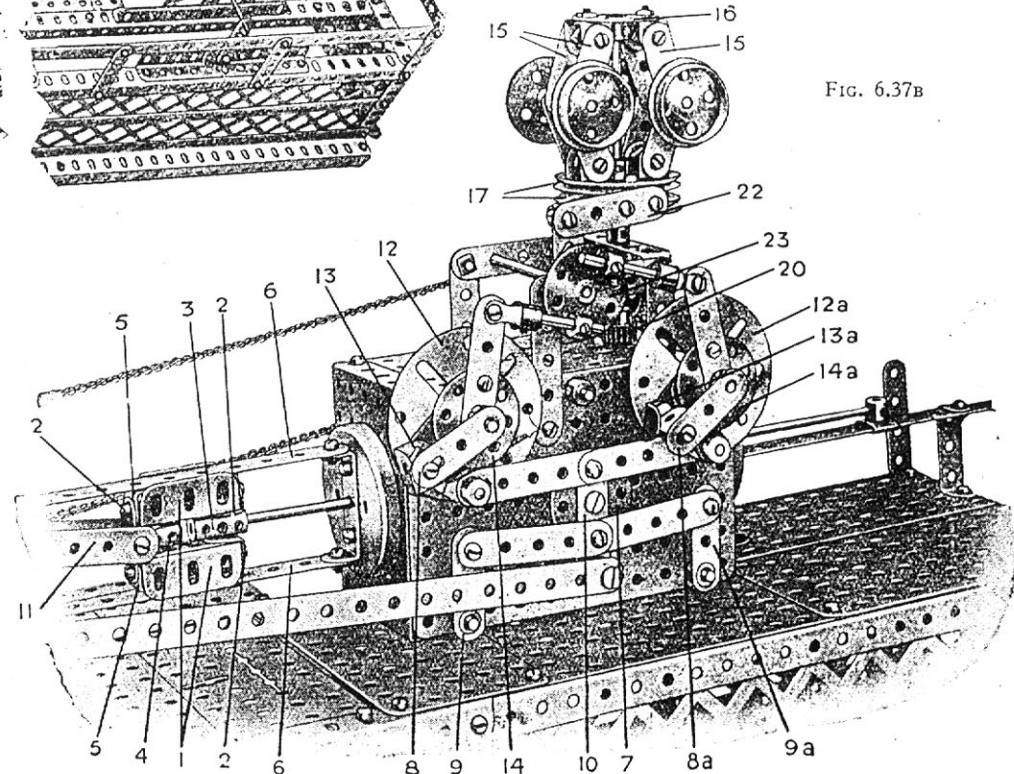

FIG. 6.37B

## Model No. 6.38 Battleship ("Revenge" Class)

Fitted with eight large swivelling Turret Guns  
and six small Guns, Control Tower, Wireless  
Aerial, Working Derrick, etc.

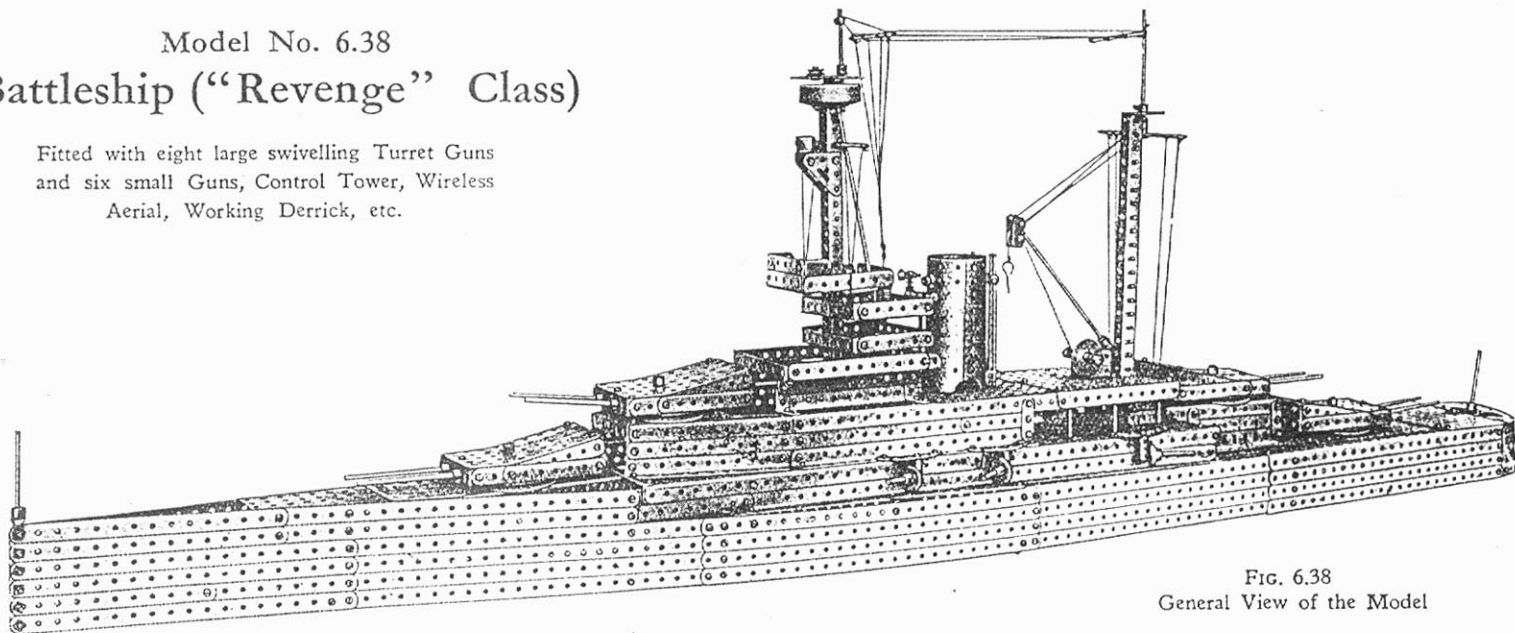

FIG. 6.38  
General View of the Model

### Parts required :

30	of No.	1	7	of No.	10	1	of No.	24	4	of No.	52A	6	of No.	103F
6	"	1A	4	"	11	1	"	27	5	"	53	1	"	109
7	"	1B	27	"	12	2	"	29	4	"	53A	3	"	111
10	"	2	6	"	12A	1	"	32	1	"	54	6	"	111A
4	"	2A	2	"	12B	19	"	35	1	"	57c	6	"	111c
16	"	3	3	"	14	314	"	37	29	"	59	2	"	115
11	"	4	2	"	15	6	"	37A	3	"	62	1	"	118
1	"	5	6	"	15A	12	"	38	8	"	63	2	"	133
16	"	6	7	"	16	1	"	40	1	"	64	4	"	136
12	"	6A	7	"	16A	3	"	45	6	"	70	1	"	143
18	"	8	2	"	16B	2	"	46	1	"	72	2	"	147B
6	"	8A	9	"	17	2	"	47	1	"	81	1	"	160
2	"	8B	4	"	18A	1	"	48	6	"	90A	1	"	162A
11	"	9	4	"	19B	14	"	48A	1	"	98	1	"	162B
2	"	9A	4	"	20B	6	"	48B	1	"	100	1	"	164
2	"	9B	4	"	22	2	"	48C	1	"	102	1	"	165
3	"	9D	2	"	23	4	"	52						

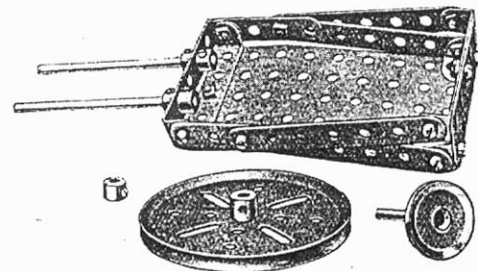

FIG. 6.38A Underneath view of one of the Gun  
Turrets dismantled.

## Model No. 6.38 Battleship ("Revenge" Class)

(continued)

The complete superstructure is shown in Fig. 6.38B. It is attached to the hull section (Fig. 6.38A) by bolting Flat Brackets 1 to the side Girders 2 of the superstructure. Additional security is effected by attaching  $\frac{1}{2}'' \times \frac{1}{2}''$  Angle Brackets 3 and the flange of a Flanged Plate 4 to the front girder of the superstructure.

The control tower (Fig. 6.38c) is secured in place by bolting the Double Bent Strip at the foot of the tower to a transverse  $7\frac{1}{2}''$  Strip 5 in the hull. It is additionally supported by a  $\frac{1}{2}'' \times \frac{1}{2}''$  Angle Bracket that is attached to the front of the tower and to the Flanged Plate 6 (Fig. 6.38B). The fire control station (a Boiler End) is secured to a Double Bent Strip that is fixed to the top of the tower.

Fig. 6.38D gives an underneath view of one of the 15" gun turrets, all of which are constructed in the same manner. It is mounted in place by passing a Rod up through the deck and through the boss of a 3"

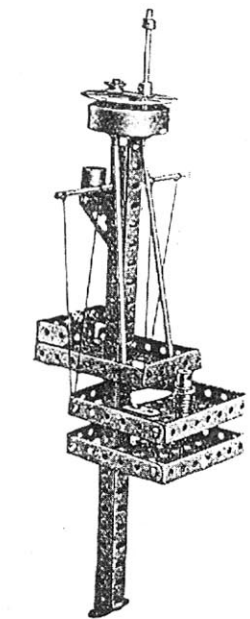

Fig. 6.38c. Control Tower.

Pulley, then placing the turret over the end of the Rod, and securing it finally by a Collar on the Rod.

Set-screws serve to secure the Coupling 7 to the tower (Fig. 6.38B) and the Collar supporting the centre escape pipe is secured in the same manner to the funnel. Set-screws are also used to attach to the funnel the Coupling that carries the "branch pipe" on the ends of which the two Syrens are mounted.

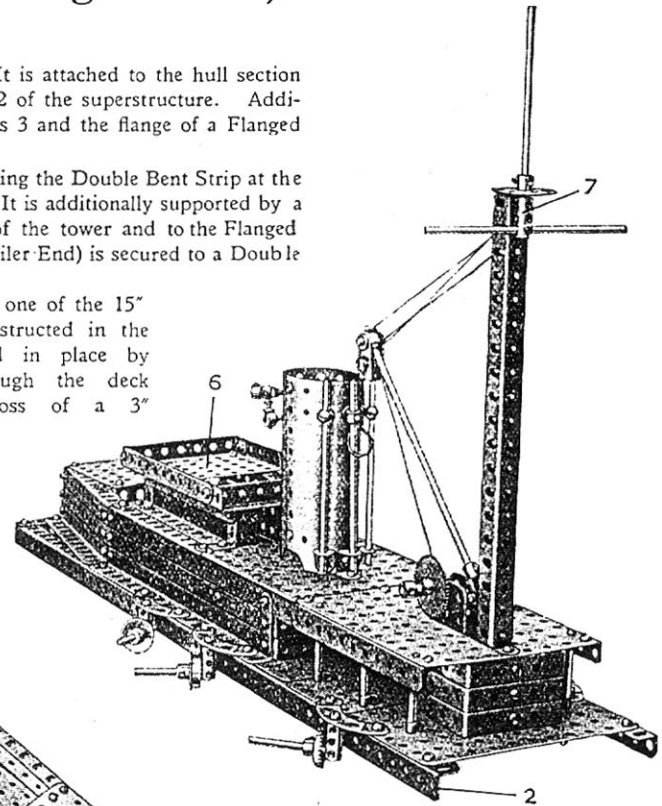
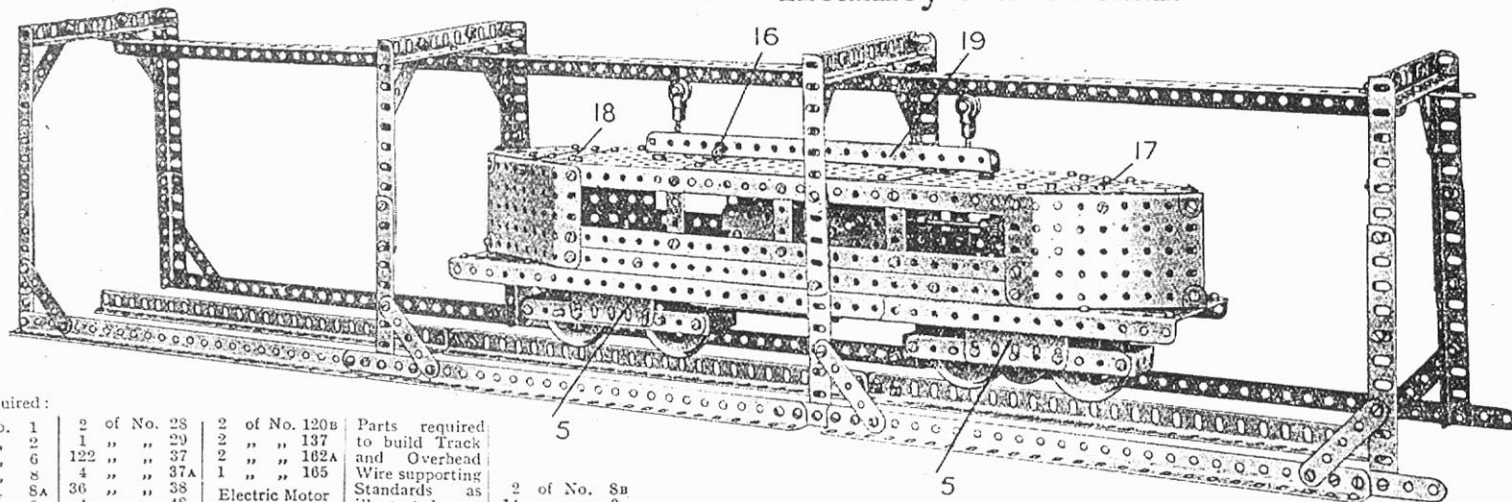

FIG. 6.38B. The Superstructure, with Foremast and top forward Gun Turret removed.

FIG. 6.38A. Semi-plan view of Hull, with Superstructure and Gun Turrets removed.

## Model No. 6.39 Kearney's Monorail



## Parts required:

2	of No. 1	2	of No. 28	2	of No. 120B	2	of No. 8B
4	" " 2	1	" " 29	2	" " 137	14	" " 9
6	" " 6	122	" " 37	2	" " 162A	2	" " 9A
8	" " 8	4	" " 37A	1	" " 165	2	" " 9B
2	" " 8A	36	" " 38	8	of No. 4	102	" " 37
4	" " 9	4	" " 48	17	" " 5		
4	" " 9D	3	" " 52A	2	" " 6		
2	" " 10	4	" " 53	3	" " 6A		
12	" " 12	4	" " 53A	12	" " 8		
1	" " 12A	12	" " 59				
1	" " 16		" " 62				
1	" " 16A		" " 62B				
1	" " 16B		" " 63				
5	" " 17		" " 76				
1	" " 18A	18	" " 84	1	of No. 182		
2	" " 18B	4	" " 96	2	" " 1570		
4	" " 20A	2	" " 96A	2	" " 1675		
2	" " 23	7	" " 103F	2	" " 1583		
1	" " 25	1	" " 116A				
1	" " 26						

Parts required to build Track and Overhead Wire supporting Standards as illustrated:—

The following parts are used for insulation purposes, but are not included in the Outfit:—

1 of No. 182  
2 " " 1570  
2 " " 1675  
2 " " 1583

Each side of the main frame of the car is composed of two  $12\frac{1}{2}$ " Angle Girders overlapping eleven holes, these sides being joined together at each end by  $3\frac{1}{2} \times 2\frac{1}{2}$ " Flanged Plates. Two  $12\frac{1}{2}$ " Angle Girders 1 are bolted to the main frames as shown in Fig. 6.39A and have secured to their ends two further  $3\frac{1}{2} \times 2\frac{1}{2}$ " Flanged Plates 2. These latter have Boiler Ends 3 attached to their under sides to form the bearings for the bogies. The Motor is carried between the main frames on the  $5\frac{1}{2}$ " Angle Girders 4.

The bogie frames are  $5\frac{1}{2}$ " Strips joined together by  $1\frac{1}{2} \times \frac{1}{2}$ " Double Angle Strips.  $2\frac{1}{2}$ " Flat Girders 5 are bolted to the sides of the bogies and attached to the Wheel Flanges 6 by  $2\frac{1}{2}$ " Angle Girders. The Boiler Ends 3 fit exactly into the Wheel Flanges and form very efficient swivel bearings. The bogie included in Fig. 6.39A is constructed similarly to that shown in Fig. 6.39B except that the latter embodies part of the driving mechanism.

Sprocket Chain connects the  $\frac{3}{4}$ " Sprocket Wheel on the Motor armature shaft to a  $1$ " Sprocket Wheel on the Rod 7. This Rod carries a  $\frac{3}{4}$ " Pinion that meshes with the  $\frac{3}{4}$ " Contrate 8, which is secured to a  $3\frac{1}{2}$ " Rod 20 journalled in the  $1 \times 1$ " Angle Bracket 9 and in a Coupling 10. A second  $3\frac{1}{2}$ " Rod 12, inserted in the end hole of this Coupling, carries a  $1\frac{1}{2}$ " Contrate that meshes with the  $\frac{1}{2}$ " Pinion 11 on the Rod 20. The Rod 12 passes through the Boiler End 3, through a Double Bent Strip and a Double Arm

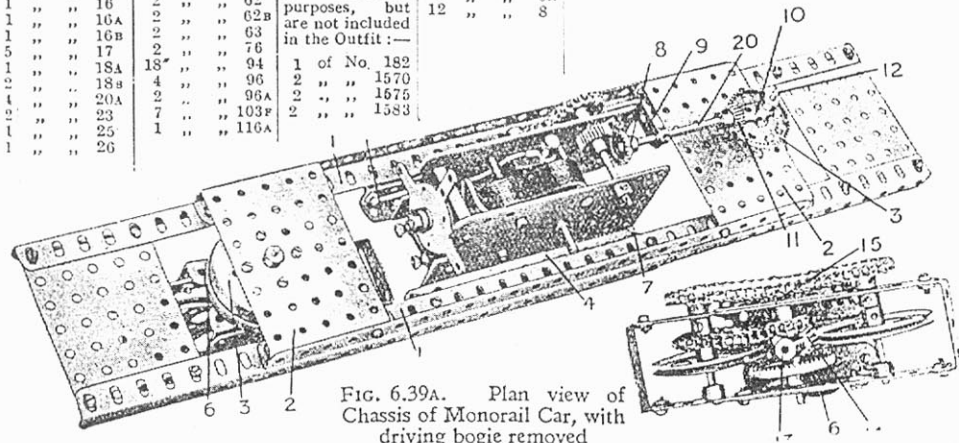

FIG. 6.39A. Plan view of Chassis of Monorail Car, with driving bogie removed

FIG. 6.39B. Underneath view of Driving Bogie of Monorail Car.

### Model No. 6.39 Kearney's Monorail (continued)

Crank bolted to the inside of the Wheel Flange 6, and enters the Coupling 13. Between this Coupling and the Wheel Flange a  $\frac{1}{2}$ " Pinion 14 is nipped on the Rod and engaged with a  $1\frac{1}{2}$ " Contrate on a 2" Rod 15. This Rod is journalled in the bogie sides and in the Coupling 13 and carries a  $\frac{3}{4}$ " Sprocket that is connected by Sprocket Chain to a 1" Sprocket Wheel on one of the driving axles. This axle is connected to the second driving axle by means of 1" Sprockets and Sprocket Chain.

The construction of the body, which is a complete unit, will be seen fairly clearly from the illustration. It should be noted however, that two  $2\frac{1}{2}$ " Flat Girders 17 are used at one end of the roof and one  $2\frac{1}{2}$ " Flat Girder and two Flat Brackets 18 at the other. Two  $\frac{1}{2}$ " loose Pulleys carried in the jaws of two Swivel Bearings form the collectors. These are free to slide on 1" spring-mounted Rods that are attached by Cranks to the Angle Girders 19. The latter are secured to the roof by 6 B.A. Bolts (part No. 1575) and insulated from the model by Insulating Bushes and Washers. These special electrical parts are not included in the Outfit and if they are not available ordinary Bolts may be used provided that they are wrapped round with insulating tape so that they do not make contact with the metal parts. When the car is on the rails the  $\frac{1}{2}$ " loose Pulleys collect the current, which is taken down the wire 16 to one of the terminals on the Motor. The other terminal is earthed to the car and the current returns through the wheels to the lower rail.

The construction of the rails will be seen fairly clearly from the illustration, but it will be noticed that the standards are all built up from different length girders. This is in order to conform with the selection of girders supplied in the Outfit, but if Strips are used in conjunction with the Girders a considerable length of rail may be constructed.

### Model No. 6.40 Machine Gun

Parts required :

1 of No. 2A	1 of No. 26
2 " " 3	17 " " 37
2 " " 5	8 " " 38
2 " " 11	1 " " 48B
5 " " 12	1 " " 50A
2 " " 12A	7 " " 59
2 " " 12B	1 " " 62A
1 " " 17	1 " " 63
1 " " 18A	1 " " 81
1 " " 18B	2 " " 109

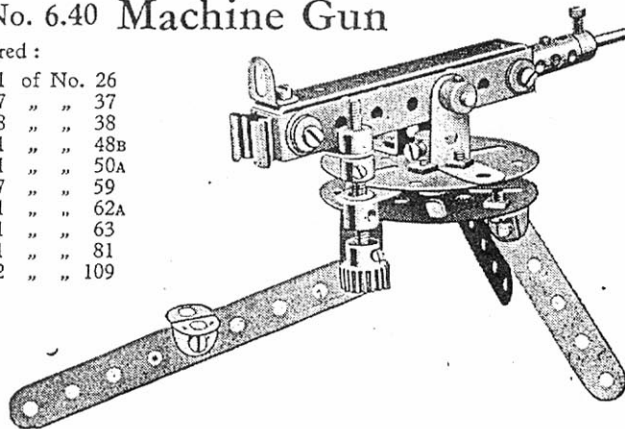

Parts required :

3 of No. 1
2 " " 2
2 " " 3
2 " " 4
3 " " 5
2 " " 6
6 " " 6A
4 " " 8
2 " " 9
4 " " 10
1 " " 11
2 " " 12

1 of No. 12A	1 of No. 18B	4 of No. 48D	1 of No. 81
3 " " 12B	8 " " 20	2 " " 52A	4 " " 90
2 " " 13	1 " " 25	6 " " 57C	10 " " 94
2 " " 14	2 " " 26	20 " " 59	3 " " 100
1 " " 15	8 " " 35	2 " " 62	2 " " 102
3 " " 16	78 " " 37	8 " " 63	2 " " 108
2 " " 16B	14 " " 38	1 " " 63B	1 " " 111
1 " " 17	1 " " 46	1 " " 64	1 " " 111A
2 " " 18A	3 " " 48	2 " " 65	2 " " 115
2 of No. 126A			

### Model No. 6.41 Platform Scales

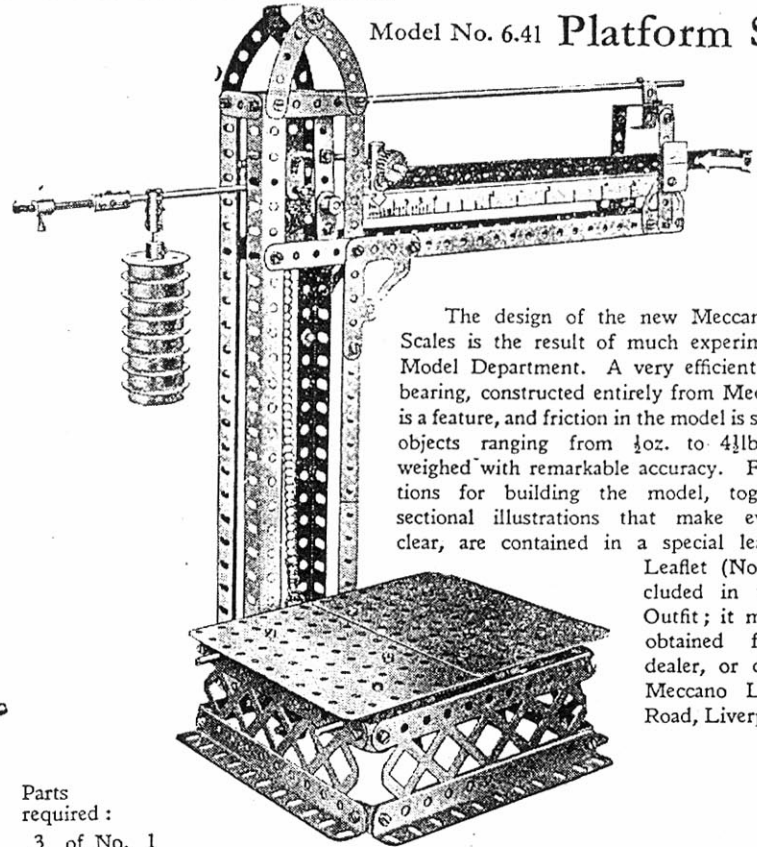

The design of the new Meccano Platform Scales is the result of much experiment in our Model Department. A very efficient knife edge bearing, constructed entirely from Meccano parts, is a feature, and friction in the model is so small that objects ranging from  $\frac{1}{4}$ oz. to 4lbs. may be weighed with remarkable accuracy. Full instructions for building the model, together with sectional illustrations that make every detail clear, are contained in a special leaflet. This

Leaflet (No. 7) is included in the No. 6 Outfit; it may also be obtained from your dealer, or direct from Meccano Ltd., Binns Road, Liverpool 13.

## Model No. 6.42 Single Cylinder Horizontal Steam Engine

Models of steam engines are always very popular with Meccano boys. This particular model is an exceptionally fine one, and it looks splendid when in motion. All necessary instructions for building the engine, together with sectional illustrations that make every detail clear, are contained in a special leaflet included in the Outfit. This Leaflet (No. 11) may also be obtained from your dealer, or direct from Meccano Ltd., Binns Road, Liverpool 13, England.

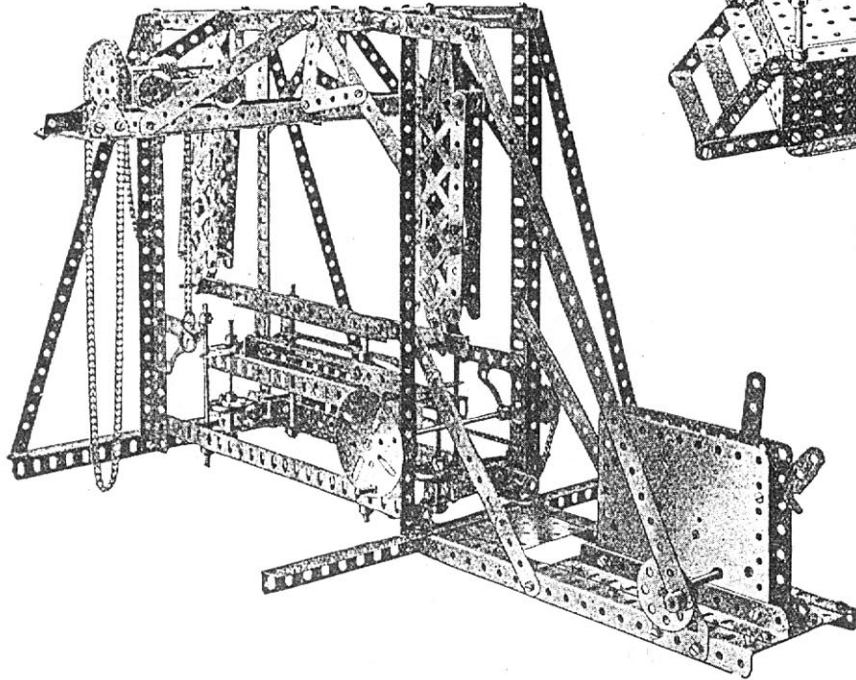
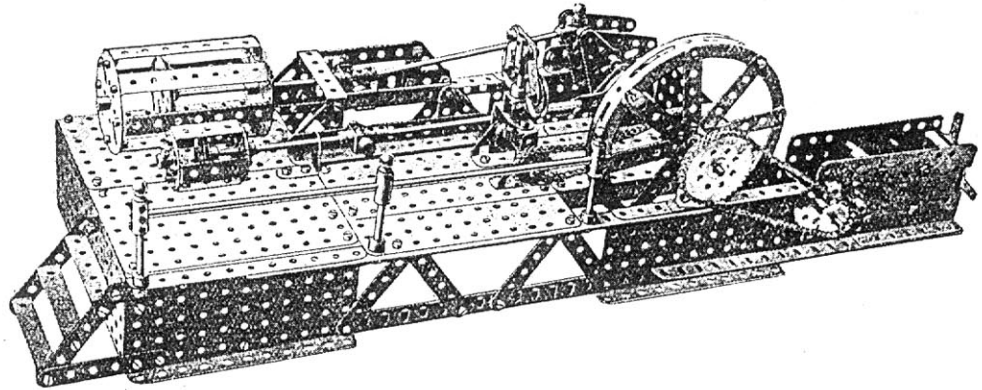

## Model No. 6.43 Stone-Sawing Machine

This is a very interesting model to construct and operate. The saw is represented by two Rack Strips, but if desired these may be substituted by a hack saw blade. The model includes a trolley that runs on overhead rails and carries a self-sustaining chain hoist. The elevation of the sawing table is adjusted by means of a hand wheel. Full instructions for building the model, together with sectional illustrations that make every detail clear, are contained in a special leaflet included in the Outfit. This Leaflet (No. 12) may also be obtained from your dealer, or direct from Meccano Ltd., Binns Road, Liverpool 13, England.



## Model No. 6.45 Bagatelle Table

### Model No. 6.44 Log-Saw

In addition to the operation of the saw, the movements of this model include the vertical adjustment of the saw frame and the to-and-fro movement of the feed carriage. Several sectional views are necessary in order to explain the construction of the Log Saw. These are included in a special instruction leaflet contained in the Outfit. The Leaflet (No. 10) may also be obtained from your dealer, or direct from Meccano Ltd., Binns Road, Liverpool 13, England.

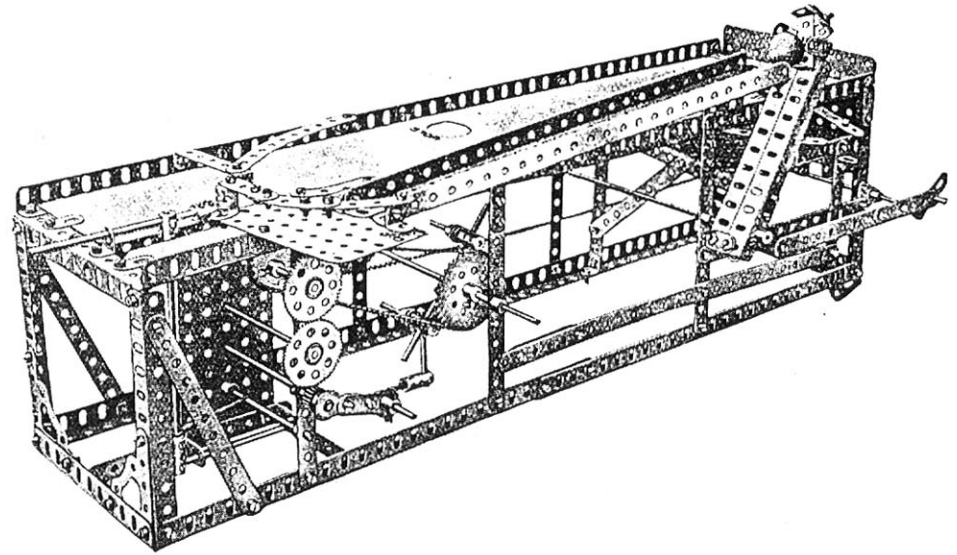
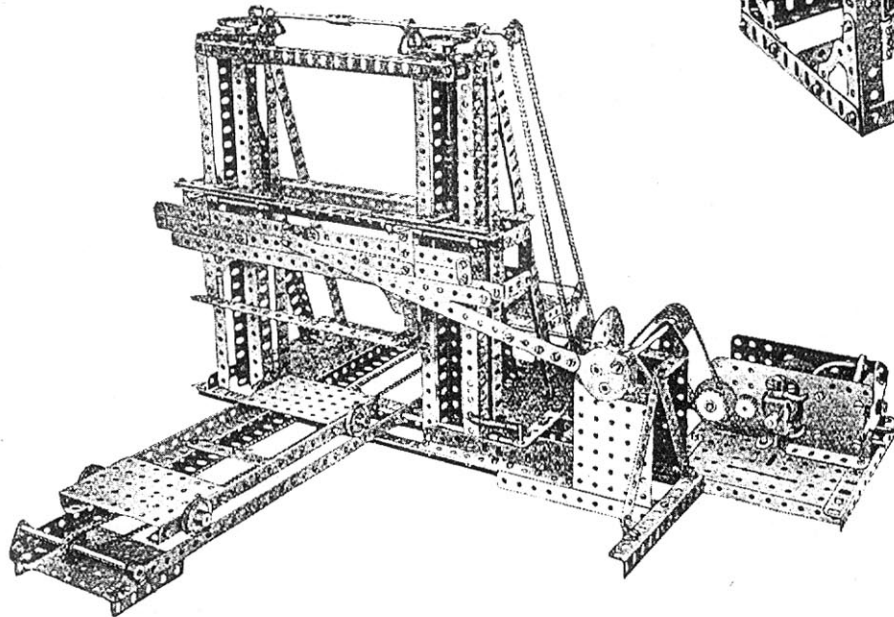

The Meccano Bagatelle Table will provide hours of fun for all members of the family. The game is played merely by turning the handle. The ball or marble is struck automatically and rolled toward the end of the table (which consists of a sheet of cardboard cut to the required shape). A number of holes are pierced in the end of the table and the score is made according to the particular hole through which the ball falls. The ball is afterwards returned to the playing end automatically. A detailed explanation of this model would require much space, and full instructions have therefore been prepared in the form of a special leaflet, which is included in the Outfit. The Leaflet (No. 9) may also be obtained from your dealer, or direct from Meccano Ltd., Binns Road, Liverpool 13, England.

It should be noted that the ball and strip of cardboard forming the table are not included in the Meccano Outfit.

## Model No. 646 Howitzer and Tractor

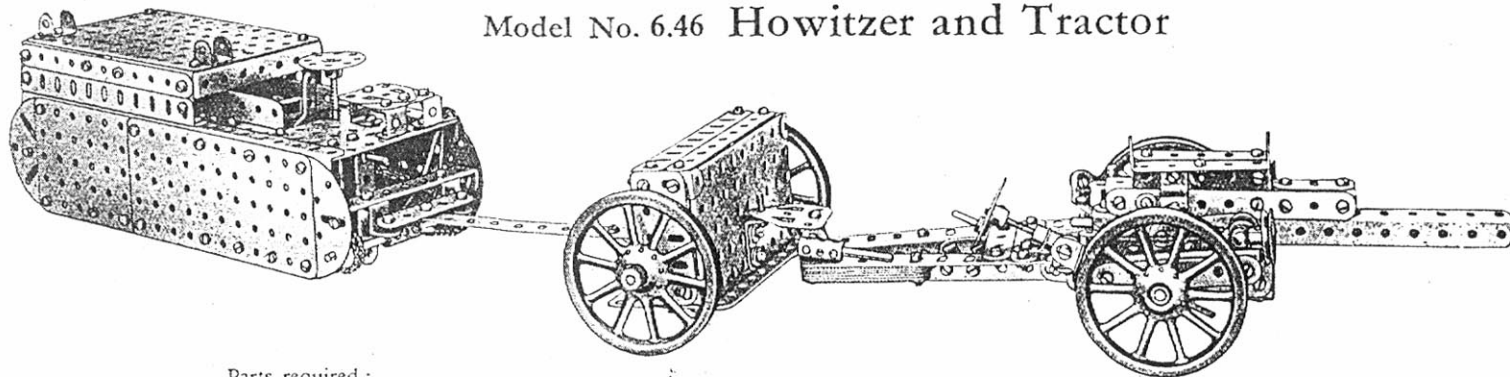

## Parts required :

5 of No. 1B	5 of No. 12A	20 of No. 38	2 of No. 95
3 " " 2	1 " " 12B	1 " " 43	1 " " 96
3 " " 2A	2 " " 13A	1 " " 48	3 " " 96A
4 " " 3	1 " " 14	2 " " 48A	2 " " 103F
2 " " 4	1 " " 16	4 " " 48B	4 " " 109
22 " " 5	3 " " 16A	1 " " 52A	5 " " 111
3 " " 6	8 " " 17	5 " " 53	6 " " 111A
1 " " 6A	3 " " 18A	3 " " 53A	5 " " 111c
2 " " 8A	4 " " 19A	29 " " 59	2 " " 115
2 " " 8B	2 " " 22	4 " " 62	4 " " 125
6 " " 9	2 " " 24	6 " " 63	4 " " 126A
2 " " 9A	2 " " 25	3 " " 64	2 " " 136
2 " " 9B	2 " " 26	4 " " 70	
6 " " 9D	2 " " 27	2 " " 72	Electric Motor
4 " " 9F	3 " " 27A	2 " " 77	(not included in Outfit)
6 " " 10	7 " " 35	2 " " 80A	
8 " " 11	165 " " 37	1 " " 80B	
25 " " 12	10 " " 37A	60 " " 94	

The illustration shows an accurate reproduction of a big gun with its ammunition carriage, or "limber," and tractor. The gun fires ammunition in the shape of Washers for a considerable distance with a remarkable degree of accuracy. It is fitted with brakes on the road wheels, fixing spade, recoil cylinder that actually functions, training apparatus and sights. The Washers used in the gun are carried in racks in the limber. The tractor, which is fitted with endless tracks and may be steered in any desired direction, is driven by an Electric Motor, making the whole a self-contained and mobile unit. There is far too much detail in the model to permit of a proper description in this Manual, and a special Instruction Leaflet has therefore been prepared. This leaflet, which describes every part of the model and is amply illustrated, is included in the No. 6 Outfit. It may also be obtained separately from any Meccano dealer or direct from Meccano Ltd., Binns Road, Liverpool 13, England. Please ask for Leaflet No. 37.

## HOW TO CONTINUE

This completes our examples of models that may be made with MECCANO Outfit No. 6. The next models are a little more advanced, requiring a number of extra parts to construct them. The necessary parts are all contained in a number 6A Accessory Outfit, the price of which may be obtained from any Meccano dealer.



## Model No. 7.2 Reaping Machine

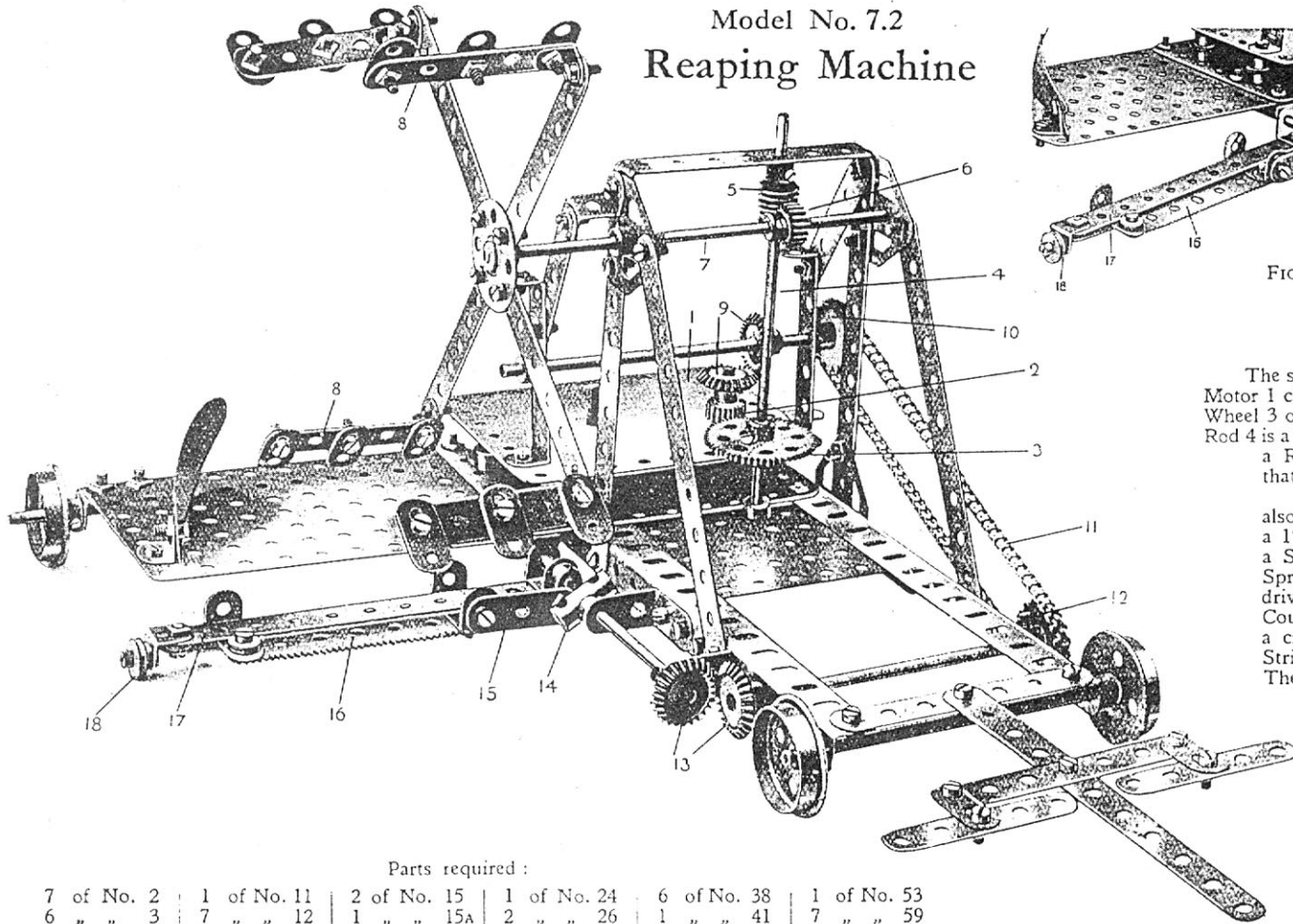

FIG. 7.2A

The spindle of the Meccano Clockwork Motor 1 carries a Pinion 2 engaging a Gear Wheel 3 on the Rod 4. At the top of this Rod 4 is a Worm 5 driving a  $\frac{1}{2}$ " Pinion 6 on a Rod 7 which carries the arms 8 that sweep towards the knife.

The driving spindle of the Motor also drives, through bevel Pinions 9, a 1" Sprocket Wheel 10 coupled by a Sprocket Chain 11 to another 1" Sprocket Wheel 12, which in turn drives through bevel Wheels 13 a Coupling 14. This Coupling acts as a crank and is connected by a  $1\frac{1}{2}$ " Strip 15 lock-nutted to the cutter 16.

The cutter is formed by a Rack Strip guided to and fro by two  $1\frac{1}{2}$ " Angle Brackets between two  $5\frac{1}{2}$ " Strips 17 spaced apart by Washers at each end. The outer end of these Strips is fitted with a  $\frac{1}{2}$ " Pulley 18 on which the cutter knife travels. The remainder of the detail of the model will be made quite clear from our illustration. When completed the model works in a very realistic manner.

Parts required :

7 of No. 2	1 of No. 11	2 of No. 15	1 of No. 24	6 of No. 38	1 of No. 53
6 " " 3	7 " " 12	1 " " 15A	2 " " 26	1 " " 41	7 " " 59
8 " " 5	2 " " 12A	2 " " 16B	1 " " 27A	1 " " 48	1 " " 63
1 " " 6A	4 " " 12B	1 " " 17	4 " " 30	2 " " 48A	16 " " 94
2 " " 8A	1 " " 13	4 " " 20	1 " " 32	1 " " 48B	1 " " 110
14 " " 10	2 " " 14	1 " " 23	66 " " 37	1 " " 52A	1 " " 125
3 of No. 126A					
Clockwork Motor					

## Model No. 7.3 Wire Covering Machine

### Parts required :

1 of No. 2	2 of No. 27A
7 " " 3	2 " " 30
2 " " 4	2 " " 32
1 " " 5	41 " " 37
2 " " 6A	17 " " 38
2 " " 8	2 " " 44
1 " " 10	1 " " 46
2 " " 12	1 " " 48
3 " " 12A	2 " " 50A
1 " " 13	4 " " 53
3 " " 15	12 " " 59
4 " " 15A	2 " " 62
1 " " 21	1 " " 63
1 " " 22	1 " " 81
2 " " 24	1 " " 106
4 " " 26	1 " " 181

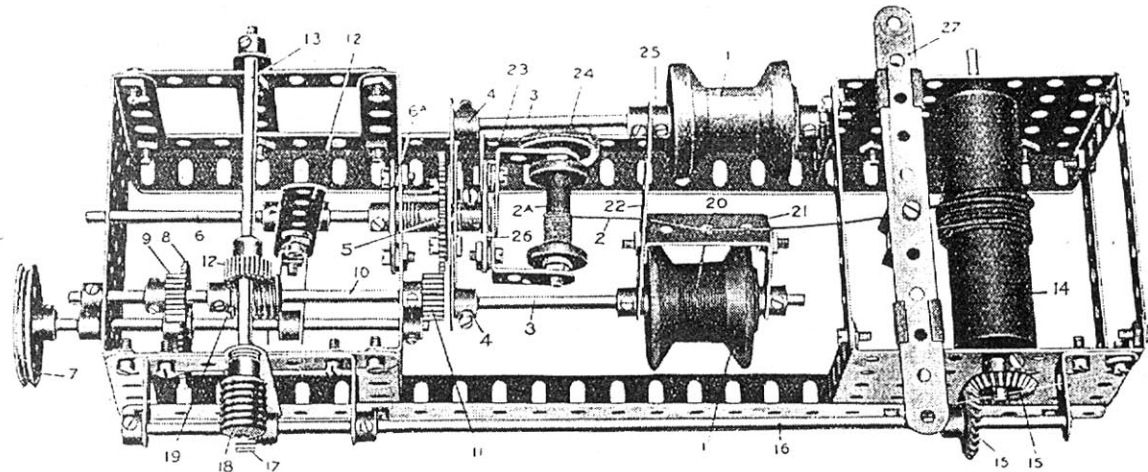

The bobbins 1, carrying the thread by means of which the wire 2 is covered, are carried in a yoke consisting of two Rods 3, secured in Cranks 4, between a  $2\frac{1}{2}$ " and  $1\frac{1}{2}$ " Strip, and bolted to a 57-toothed Gear Wheel 5, rotatable loosely on a fixed 5" Rod 6. On the Rod 6 is a Bush Wheel 6A, bolted thereto and to the frame. This holds the Rod against rotation. The bobbin 2A is carried in the two 1" Angle Brackets, forming a frame which is bolted to the Bush Wheel 26, the latter being held by its screw fixedly on the Rod 6. The yoke is rotated from the Pulley Wheel 7, a 57-toothed Gear Wheel 8, on the spindle of which drives a  $\frac{1}{2}$ " Pinion 9, on an upper 4" Rod 10, another  $\frac{1}{2}$ " Pinion 11, on the end of which engages and drives the Gear Wheel 5; this rotates the yoke. The Gear 8 is caused to engage or disengage with the Pinion 9 by a clutch mechanism operated by the handle 12. As the yoke rotates, the thread from the bobbins is wound closely round the wire 2, and in order to ensure an even wrapping of the thread on the wire, the take-up roller 14, is provided, on to which the wire as it is covered is wound. The take-up roller is driven with a very slow movement by Bevel Pinions 15, from a side Rod 16, a  $\frac{1}{2}$ " Pinion 17 on which is driven by a Worm 18, on the Rod 13. Consequently, the rotary movement of the Rod 10 drives the bobbin yoke and also operates the Worm 19 and engages the Pinion 12. The Worm 18, engaging the Pinion 17, in turn drives the take-up Roller 14, bringing the uncovered wire 2 slowly past a perforation 20 in the guide Strip 21, formed of a  $1\frac{1}{2}$ " by  $\frac{1}{2}$ " Double Angle Strip and carried from the yoke arm 22.

In order to prevent the wire 2 unwinding too freely from its bobbin 2A, a brake is provided, consisting of a cord 23, passing round a Pulley 24, on the spindle of the bobbin 2A, and connected to a Flat Bracket bolted on the Bush Wheel 26.

It will be noticed that a Collar 25 is placed on one side of the yoke Strip 22, which has the effect of setting one of the bobbins slightly to the rear of the other, and the effect of this is to give two windings round the wire, one over the other. The thread on the bobbins may be of different colours, which would give a variegated effect to the covering. In order to cause the covered wire to be wound evenly on the take-up Roller 14, a distributor is provided, consisting of a Strip 27, beneath which is bolted a Double Bracket through which the covered wire passes. By moving the Strip 27 from one side to the other, the wire winds evenly on the Wood Roller 14.

## Model No. 7.4 Locomotive and Tender (Midland, 4-2-2)

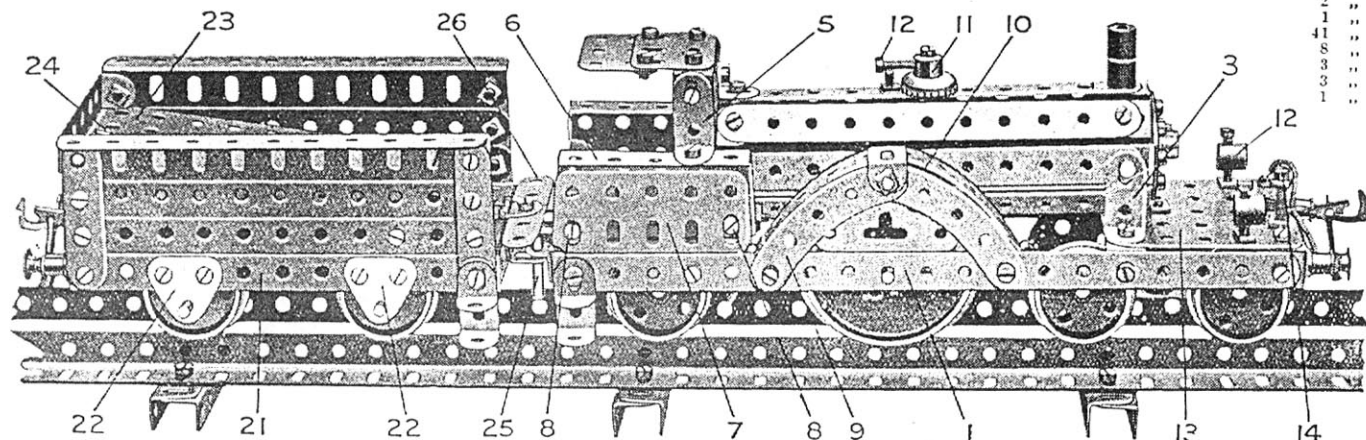

## Parts required:

2	of No.	1A	10	of No.	20
13	"	2	2	"	24
1	"	5	1	"	29
4	"	6	131	"	37
1	"	6A	11	"	38
2	"	9	2	"	46
2	"	9D	1	"	48
1	"	11	10	"	48A
41	"	12	1	"	52
8	"	12B	1	"	53A
3	"	16	2	"	58
3	"	18A	6	"	59
1	"	18B	4	"	64
			2	"	72
			4	"	77
			4	"	90
			2	"	103
			3	"	103B
			2	"	109
			4	"	111
			3	"	111A
			1	"	114
			5	"	120A
			2	"	121
			2	"	126
			2	"	133
			2	"	137

This is a well-proportioned model of an old-style Midland "single-wheeler" locomotive. The engine frame is built up from two 9½" Strips 1 joined at the points 2 (Fig. 7.4A) by 2½" × ½" Double Angle Strips, and further strengthened at each end by 2½" Angle Girders. The boiler is composed of seven 5½" Strips bolted at either end to a Bush Wheel by means of Angle Brackets. It is supported by 1" × 1" Angle Brackets 3, and an Angle Bracket secured to the lowest hole of the rear Bush Wheel is bolted at 4 (Fig. 7.4A) to the floor of the cab.

The cab roof consists of 1½" Flat Girders bolted by Angle Brackets to 1" × 1" Brackets 5. 2½" × 1" Double Angle Strips 6 and Flat Girders 7 bolted together by Angle Brackets at 8 form the sides, which, in turn, are bolted by Angle Brackets to the footplate.

The wheel covers for the main drivers are each constructed from two 2½" Curved Strips 9 and a 5½" Strip 10 bent to the same curvature. A Corner Bracket is secured in the centre as shown.

A safety valve in the centre of the boiler consists of a Contrate Wheel 11 secured by means of a ½" Bolt and carrying a further ½" Bolt 12. The smoke-stack is composed of two Threaded Bosses mounted on the shank of a ½" Bolt passing through the top Strip of the boiler. Two lamps are carried on the front of the engine-frame and consist of Threaded Bosses 12 mounted on the upturned shanks of ½" Bolts secured in the 2½" × 2½" Flat Plate 13, and gripped in position by 7/32" Bolts inserted in the tops of the bosses. A piece of Spring Cord, secured to a ½" Bolt 14, represents the front vacuum brake pipe connection.

It will be noticed from Fig. 7.4A that the front bogie consists of two 2½" Strips 15, bolted to a Double Bracket 16. It is attached to the locomotive frame by means of a ½" Bolt, secured by two Nuts on its end to the Flat Plate 13. A Compression Spring Part No. 120n is placed on the Bolt between the Double Bracket and the Base Plate. The rear trailing Wheels 17 are mounted on a ½" Rod passed through two Trunnions 18 bolted to the underside of the footplate. The Wheels are retained in their correct position by means of a Collar 19, spaced between two Washers.

The driving wheels are built up from Face Plates and Wheel Flanges, and are secured to a 3" Rod 20. They are spaced in the correct position in the centre of the frame by means of three Washers placed between the boss of each Face Plate and the sides 1 of the engine.

A 5½" × 2½" Flanged Plate 21 forms the base of the tender and the sides are each built up from two 5½" Strips and one 5½" Angle Girder. The back consists of four 2½" × ½" Double Angle Strips. The Wheels are carried on axles journalled in 1" Triangular Plates 22 bolted to the Base Plate 21. A 4½" × 2½" Flat Plate 23 is secured inside the tender by means of an Angle Bracket bolted to the back at 24, and a 2½" × ½" Double Angle Strip at the other end of the plate.

The loco. and tender are coupled together by means of a 1" Rod 25, passed through two Angle Brackets. An extension of the footplate consists of a 1½" Flat Girder and a 2½" Strip 26, bolted by means of a Hinge to the tender.

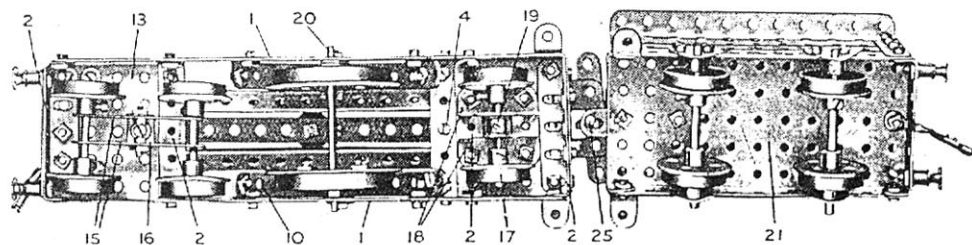

FIG. 7.4A

## Model No. 7.5 Rotary Truck Tipper

### Parts required :

9 of No. 2A	4 of No. 11	4 of No. 26	2 of No. 63
6 " " 3	8 " " 12	4 " " 27A	18 " " 94
2 " " 7A	4 " " 12A	98 " " 37	1 " " 96
5 " " 8A	2 " " 12B	4 " " 37A	3 " " 96A
8 " " 8B	4 " " 15A	8 " " 38	4 " " 111A
4 " " 9	5 " " 16A	4 " " 48D	4 " " 120B
4 " " 9D	4 " " 18A	7 " " 59	4 " " 133
2 " " 9F	4 " " 23A	4 " " 62	2 " " 145

Electric Motor

The base is built up from five  $9\frac{1}{2}$ " Angle Girders 8 bolted to  $18\frac{1}{2}$ " Angle Girders 9. The "cage" is formed by two Circular Strips 10, to each of which are bolted two  $5\frac{1}{2}$ " Angle Girders 18 that, in turn, support four  $7\frac{1}{2}$ " Angle Girders 11. Two further  $7\frac{1}{2}$ " Angle Girders 14 bolted to the lower pair of transverse Angle Girders 18 form the rail track.

To the Girders 11 are bolted four  $3\frac{1}{2}$ " Strips 16 which support two more  $7\frac{1}{2}$ " Angle Girders 19, one on each side of the cage. These Girders support spring "pads" which grip the truck while the tipping operations are in progress. Two  $5\frac{1}{2}$ " x  $\frac{1}{2}$ " Double Angle Strips 12 are connected together by bolts passed through their turned-up ends. These bolts also carry Angle Brackets 20 that are bent slightly so as to form guides for the entrance and egress of the truck. Two Cranks 13 bolted to the outer Double Angle Strip 12 carry  $1\frac{1}{2}$ " Rods. These Rods are journaled in Double Brackets bolted to the Angle Girder 19 and each carries a Compression Spring placed between the Double Brackets and the inner Double Angle Strip 12.

After passing the Rods through the Double Brackets a  $3\frac{1}{2}$ " Strip 12A is placed over their ends. A Bolt 15 passed through the Girder 19 is held loosely in position by a nut and carries an Angle Bracket locked on the bolt by a second nut. A Collar is then secured to the bolt and carries a  $\frac{1}{2}$ " Bolt 15A as shown. This completes the "gripping" device, and it will now be found that the Double Angle Strips 12 are forced by the Springs against the side of the truck. Using the Bolt 15A as a lever to turn the Bolt 15 the corner of the Angle Bracket may be brought into contact with the Strip 12A, thus drawing the "pad" 12 inwards and releasing the truck. The gripping device is duplicated on the other side of the cage.

The cage rests on four Pulleys that are mounted on Rods 5 (two  $4\frac{1}{2}$ " Rods coupled together) and journaled in  $1$ " x  $1$ " Angle Brackets bolted to the Angle Girders 8.

The Electric Motor is mounted on the base of the model, and a  $\frac{1}{2}$ " Pinion 3 on the armature spindle engages a 57-teeth Gear, the spindle of which carries on the other side of the Motor a  $\frac{1}{2}$ " Pinion engaging a further 57-teeth Gear. The Rod of this latter Gear carries a  $\frac{1}{2}$ " Pinion meshing with another 57-teeth Gear 6, on the Rod of which is a further  $\frac{1}{2}$ " Pinion 7 engaging a third 57-teeth Gear carried on a Rod journaled in the Motor framework. On this Rod is a  $\frac{3}{4}$ " Sprocket connected by Sprocket Chain to a  $1$ " Sprocket Wheel 4 on one of the Rods 5. The latter carries also a  $\frac{3}{4}$ " Sprocket Wheel 4 connected by Sprocket Chain to a  $\frac{3}{4}$ " Sprocket Wheel on the other Rod 5. Rotation of the Motor therefore causes the Rods 5 with their Pulleys to revolve, and the Pulleys to impart rotary movement to the cage.

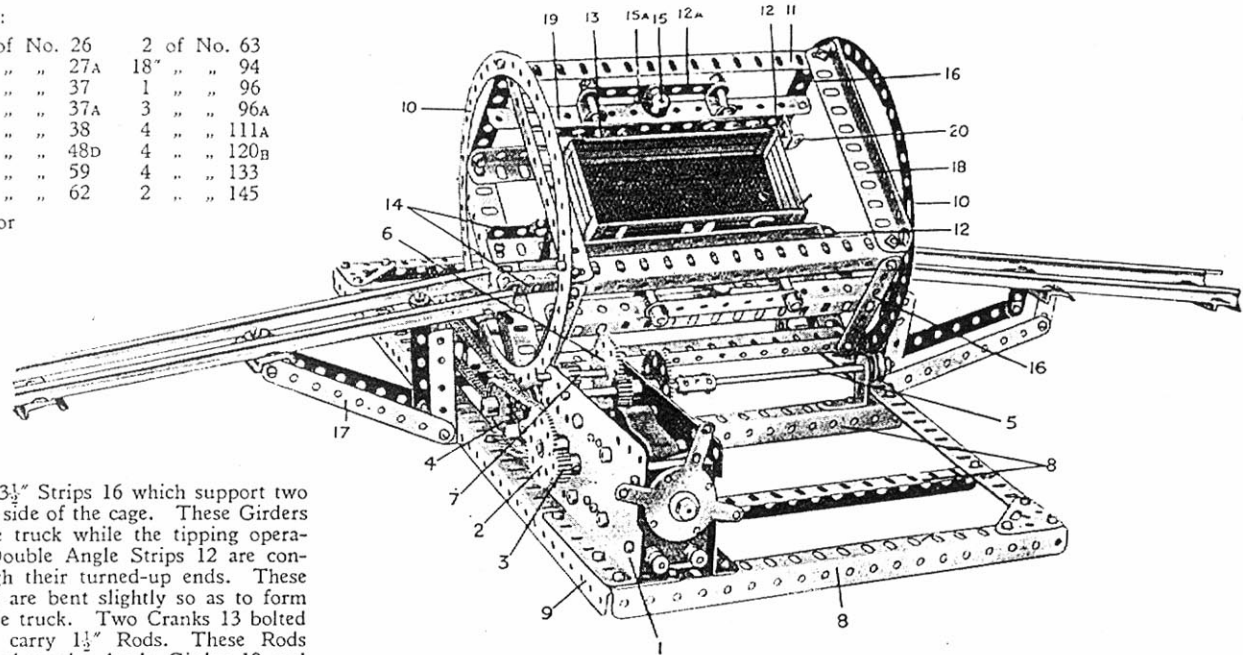

## Model No. 7.6 Motor Breakdown Crane

The jib is pivoted on a  $4\frac{1}{2}$ " Rod 12 that passes through holes in the  $12\frac{1}{2}$ " Angle Girders 10.

The movement of the jib is controlled from a hand-wheel 7 secured to a 5" Threaded Rod that passes through a Threaded Boss pivotally secured between right and left-hand Corner Angle Brackets that in turn are bolted to a  $3\frac{1}{2}$ " Angle Girder 20 at the rear end of the jib.

The lower end of the Threaded Rod passes through a Collar pivotally secured between  $1\frac{1}{2}$ " Angle Girders 4, and is held in position in the Collar by means of another Collar and two lock-Nuts, the former being placed on the Rod against the upper face of the pivoted Collar while the Nuts are placed against the lower face. When the hand-wheel 7 is turned the Threaded Boss is caused to rise or fall, carrying the jib with it, the jib being guided by the Eye Pieces 9 sliding on the Curved Strips 8. Short lengths of Sprocket Chain 21 secured to the rear of the jib carry Threaded Pins which may be placed in holes in the Curved Strips 8 and used to hold the jib securely in the required position.

The hoisting pulley block 15 is carried on the end of a  $5\frac{1}{2}$ " Rod 14 journalled in a Double Bracket 17 and in a Cranked Bent Strip, the latter being secured to a  $2\frac{1}{2}$ " Strip bolted to the underside of the  $5\frac{1}{2}$ " Angle Girders 13. The jib head Pulley is supported on a  $\frac{3}{8}$ " Bolt passed through two Corner Brackets and held in position by a Nut. Collars are placed on the Bolt each side the jib head pulley. A  $\frac{1}{2}$ " Pulley 15A is journalled in a similar manner to the 1" Pulley, but a 1" Rod is used in place of the  $\frac{3}{8}$ " Bolt. The whole pulley block is attached to the Rod 14 by a Large Fork Piece.

The load is raised or lowered by turning the handles 1, which are constructed as shown and secured to a  $5\frac{1}{2}$ " Rod carrying a  $\frac{1}{2}$ " Pinion 2 and a Ratchet Wheel 2A. The Pinion 2 engages a  $3\frac{1}{2}$ " Gear Wheel 3 secured to a  $3\frac{1}{2}$ " Rod 6 that is journalled in Double Brackets secured to the Angle Girders 10. The Rod of the Pinion 2 is journalled likewise. The winding cord is attached to the Rod 6 and passes thence over a  $\frac{1}{2}$ " Pulley (carried on a 2" Threaded Rod 14A) and over the 1" jib head Pulley, then round a  $\frac{1}{2}$ " Pulley on the Pin 16 and back over the Pulley 15A. It is attached finally to the hoisting block, which is constructed from two Single Bent Strips. A Pawl 5 is pivoted in a Double Bracket bolted to one of the Girders 10 and serves to hold the load suspended.

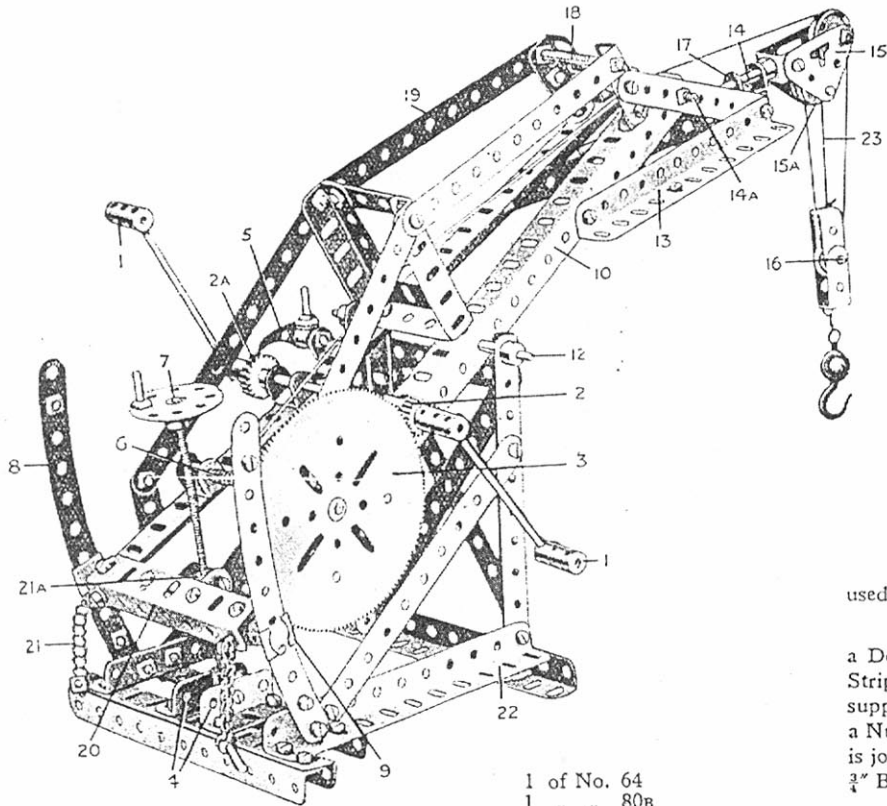

Parts required:			
8 of No. 2	1 of No. 9E	1 of No. 26	1 of No. 64
2 " " 2A	4 " " 9F	1 " " 27B	1 " " 80B
1 " " 3	6 " " 11	60 " " 37	1 " " 81
1 " " 5	7 " " 12	11 " " 37A	2 " " 89
1 " " 6	1 " " 15	5 " " 38	4" " " 94
2 " " 6A	2 " " 15A	1 " " 40	2 " " 102
2 " " 8	3 " " 16	1 " " 44	1 " " 111
9 " " 9	1 " " 18B	2 " " 50A	2 " " 111A
1 " " 9A	1 " " 22A	1 " " 57B	4 " " 115
1 " " 9B	3 " " 23	13 " " 59	1 " " 116
2 " " 9D	1 " " 24	4 " " 63	2 " " 133
			1 " " 147A
			1 " " 147B
			1 " " 148



## Model No. 7.7 Boat-Lowering Gear

Parts required :

10 of No. 1A	2 of No. 12	6 of No. 23	2 of No. 48B	3 of No. 109
2 " " 2A	1 " " 12A	4 " " 26	5 " " 52A	1 " " 115
6 " " 3	2 " " 12B	2 " " 27A	6 " " 53	2 " " 126
7 " " 5	1 " " 13	2 " " 31	2 " " 57C	2 " " 126A
8 " " 6	2 " " 13A	2 " " 32	13 " " 59	4 " " 129
2 " " 7A	1 " " 15	142 " " 37	2 " " 62	4 " " 147B
2 " " 9	3 " " 16	14 " " 38	2 " " 63	
2 " " 9D	2 " " 16A	1 " " 40	8 " " 90	
3 " " 11	1 " " 18A	5 " " 48A	4 " " 102	

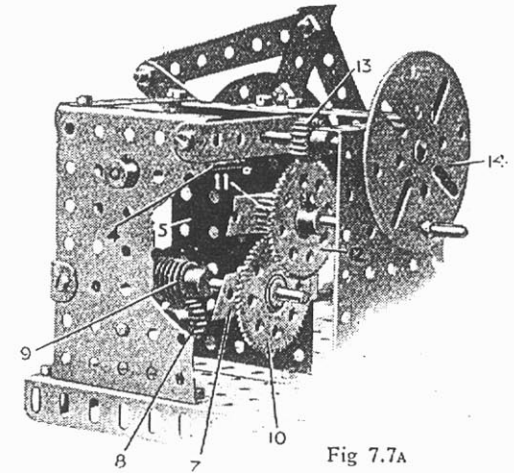
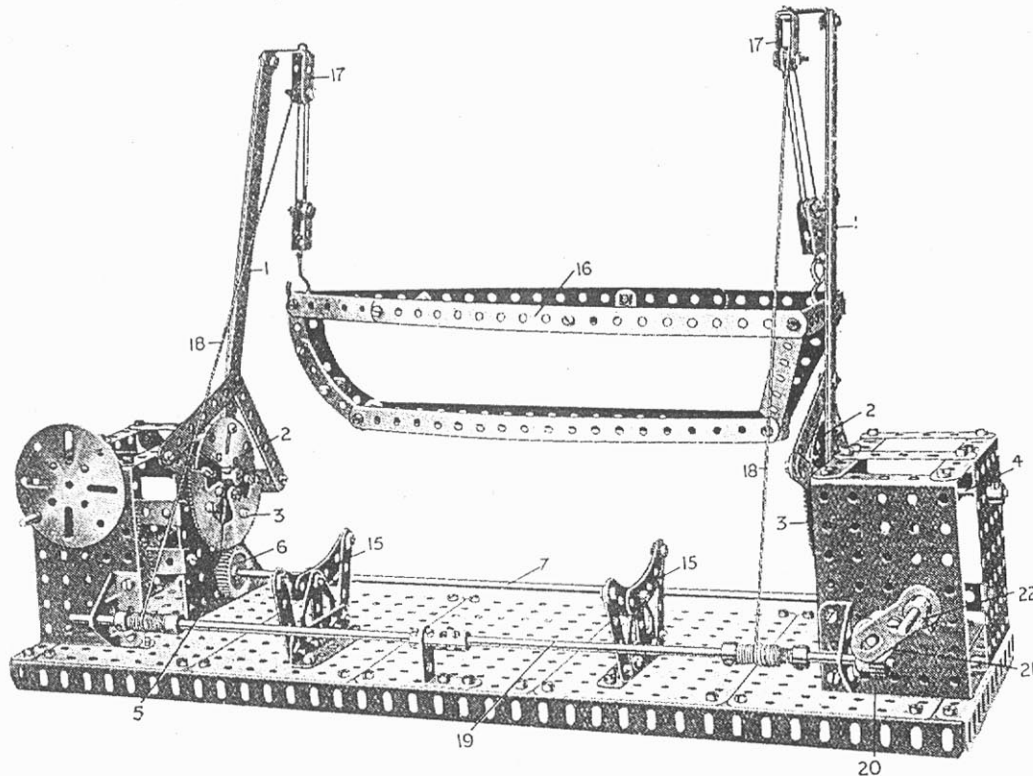

Fig 7.7A

The davit arms 1 are connected to Face Plates 2 to which are bolted two Rack Segments 3 forming the usual geared quadrants. The davit arms are secured to Rods 4 journalled in the Flanged Plates 5, the Rack Segments 3 being engaged and driven by 1" Gear Wheels 6 on an Axle Rod 7. This Rod 7 carries a Pinion 8, Fig. 7.7A, driven by a worm 9 and a Rod, to which is secured a 1½" Gear Wheel 10. This is driven by a ½" Pinion 11 on a Rod to which is also secured a 1½" Gear Wheel 12 driven by a ½" Pinion 14 rotated by a hand wheel formed by a Face Plate 14. As the hand wheel is rotated, the davit arms are raised outward when launching the boat 16 or inward when it is desired to deposit the boat on the chocks 15.

The boat 16 is raised or lowered from the blocks 17 by the ropes 18 which wind on to a Rod 19. On this Rod is secured a ½" Pinion 20 engaged by a Worm 21 which is rotated by the Crank Handle 22 formed of two Cranks bolted together, and in this way the boat may be lowered over the ship's side.



## Model No. 7.8 Crazy Driver

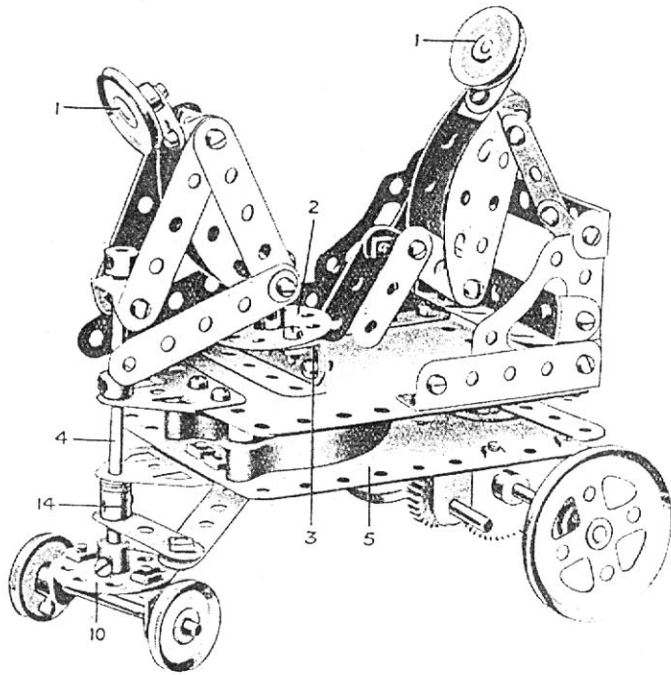

wheels being turned first to the right and then to the left alternately, so causing the model to perform some very amusing antics.

### Parts required :

1 of No. 4	4 of No. 11	1 of No. 18B	2 of No. 30	3 of No. 59
8 " " 5	1 " " 12	2 " " 20A	44 " " 37	1 " " 62
7 " " 6A	4 " " 12A	4 " " 22	4 " " 37A	4 " " 90A
1 " " 9B	1 " " 15A	3 " " 24	13 " " 38	2 " " 108
4 " " 9D	2 " " 16	1 " " 25	1 " " 48	6 " " 111c
3 " " 10	1 " " 16A	1 " " 27	3 " " 48B	2 " " 126A

Clockwork Motor.

The Strips forming the body and legs of the " driver " are bolted to a Fork Piece secured to a short Rod which, in turn, is secured to the boss of a Bush Wheel. This Bush Wheel is connected to the Motor by means of two  $3\frac{1}{2}$ " Angle Girders bolted together as shown.

The Motor actuates the rear wheels through a Bevel Wheel 6 secured to the driving spindle of the Motor and engaging the Bevel 7 on the Rod 8 (Fig. 7.8A). This Rod also carries a  $\frac{1}{4}$ " Pinion engaging a 50-teeth Gear Wheel 9 secured to the axle of the rear wheels.

The steering column 4 carries at its lower end a Bush Wheel 10 to which is secured a  $1\frac{1}{2} \times \frac{1}{2}$ " Double Angle Strip that forms a support for the  $2\frac{1}{2}$ " front axle. The steering is controlled as follows : two  $1\frac{1}{2}$ " Strips 11 are bolted together by three Bolts, and two Washers are placed on each Bolt between the Strips for spacing purposes. The link thus formed fits over the Motor key shaft, and when the Motor is set in motion the link will be rotated slowly with the keyshaft. One end of the link carries a Collar 13 which is secured on the link Bolt in place of a Nut. A 3" Strip 12 is pivoted on a Bolt that is secured in one of the tapped holes in the Collar 13 and its other end is attached pivotally to the end of a Crank 14 that is secured to the steering column. Hence, when the Motor is started, the link 11 rotates slowly and imparts motion to the Strip 12 which, in turn, influences the steering column, resulting in the front

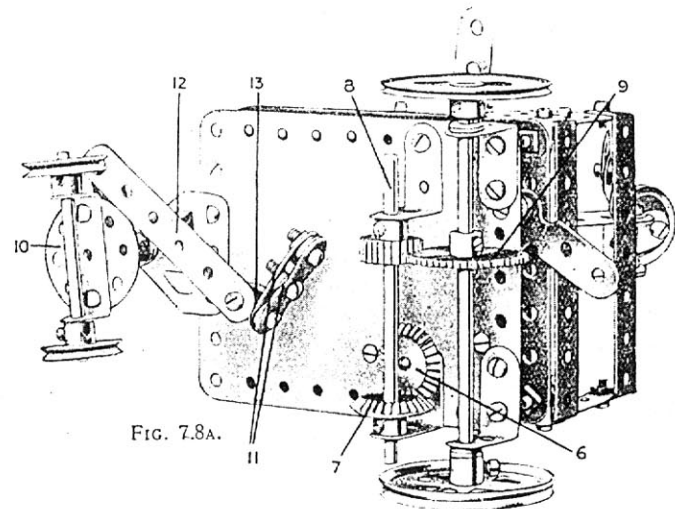
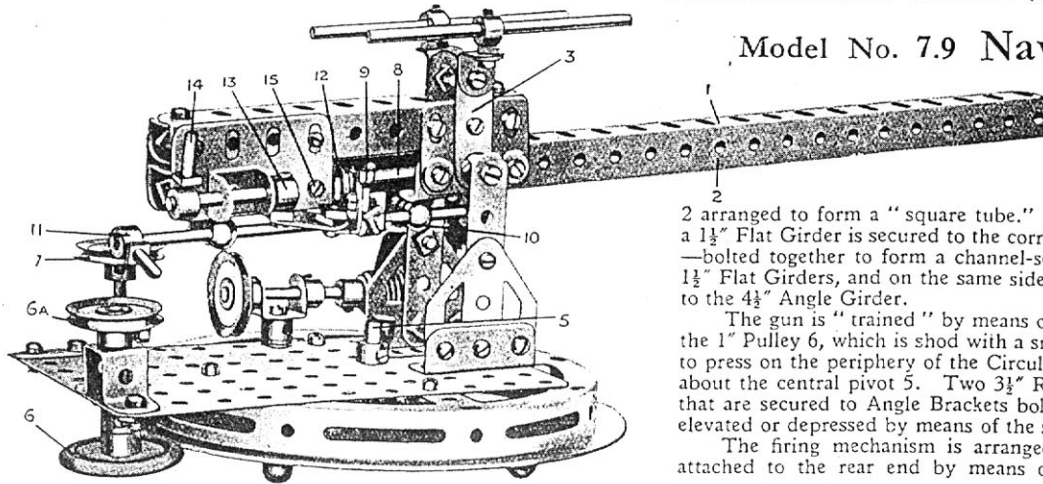

FIG. 7.8A.

## Model No. 7.9 Naval 4.7" Gun



This model represents a small but formidable type of weapon to be found on most ships of war. It will fire "shells"—in the form of Washers—quite a respectable distance.

The "barrel" of the gun is composed of a  $12\frac{1}{2}$ " Angle Girder 1 and a  $9\frac{1}{2}$ " Angle Girder 2 arranged to form a "square tube." A  $4\frac{1}{2}$ " Flat Girder is bolted to one end of the  $12\frac{1}{2}$ " Girder and a  $1\frac{1}{2}$ " Flat Girder is secured to the corresponding end of the  $9\frac{1}{2}$ " Angle Girder. Two  $4\frac{1}{2}$ " Angle Girders—bolted together to form a channel-section girder—are next secured to the top edges of the  $4\frac{1}{2}$ " and  $1\frac{1}{2}$ " Flat Girders, and on the same side of the barrel as the  $1\frac{1}{2}$ " Flat Girder a 2" Flat Girder is attached to the  $4\frac{1}{2}$ " Angle Girder.

The gun is "trained" by means of the 1" fast Pulley 6A mounted at the top end of a Rod carrying the 1" Pulley 6, which is shod with a small Rubber Ring (part No. 155). The Rubber Ring is arranged to press on the periphery of the Circular Plate, so that by turning the Pulley 6 the entire gun is moved about the central pivot 5. Two  $3\frac{1}{2}$ " Rods—representing the telescopic sights—are mounted in Collars that are secured to Angle Brackets bolted to the top ends of the Cranks 3. The barrel of the gun is elevated or depressed by means of the simple mechanism that is controlled from the Pulley 4.

The firing mechanism is arranged as follows. An  $11\frac{1}{2}$ " Rod 8 is placed inside the barrel and attached to the rear end by means of a Coupling. This Coupling is secured to the 2" and  $4\frac{1}{2}$ " Flat

Girders by Bolts that are passed through the holes of the Flat Girders and inserted in the tapped holes of the Coupling, and the latter is spaced from the Flat Girders by two Washers on each retaining Bolt. The loading mechanism consists of a Bolt 10 locked by a Nut in the tapped hole of a collar, which is secured to a rod that is free to turn and slide in its bearings, formed by two Handrail Supports. The Rod is fitted with a handle 11.

The trigger mechanism is assembled as follows. A Hinge secured by the Bolt 15 to the front hole of the 2" Girder has a Flat Bracket secured to it by the slotted hole, two Washers being placed on the retaining bolt between the Flat Bracket and the Hinge. A  $\frac{1}{2}$ " x  $\frac{1}{2}$ " Angle Bracket 12 is secured in the round hole of the Flat Bracket, and is connected pivotally by means of a second Flat Bracket to the Collar 13. This Collar is secured to a short Rod carrying the handle 14, by means of which the Rod may be moved to and fro in the Double Bracket forming its bearings.

To load the gun, the Washer forming the projectile is placed on the front end of the  $11\frac{1}{2}$ " Rod 8 and the barrel of the gun tilted up to allow it to slide down the Rod to the Compression Springs 9. Next the handle 11 is pushed away from the operator, turned so that the head of the Bolt 10 engages with the Washer, and then pulled back—or toward the operator—so that the Washer compresses the Spring 9. Previous to this, however, the handle 14 controlling the trigger should be pulled toward the operator. The handle may now be pushed outward so that the Flat Bracket engages with the Washer. The gun is now ready for firing.

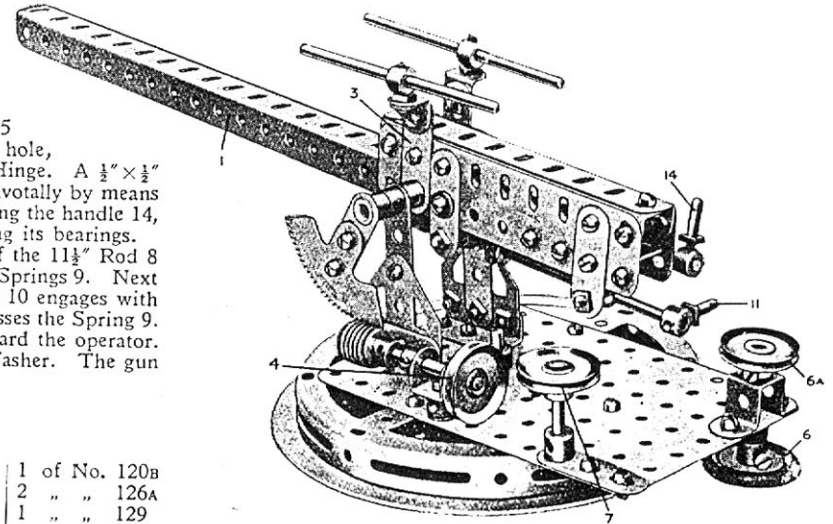
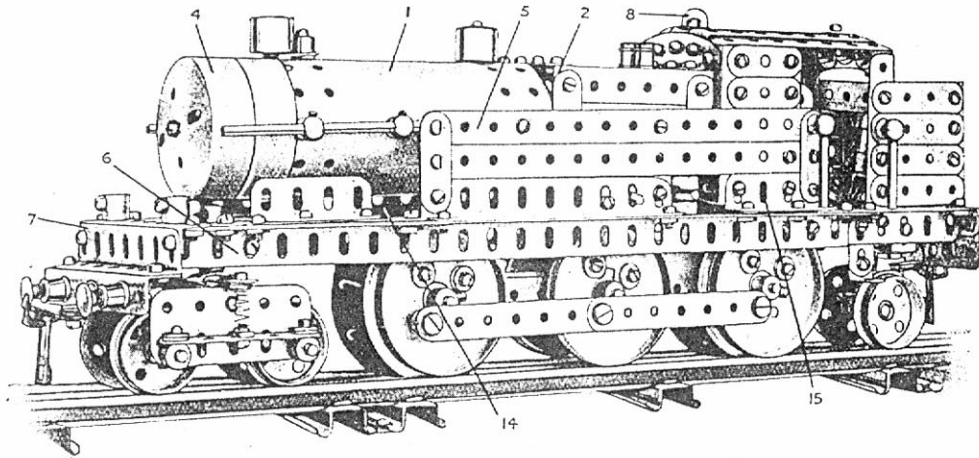

FIG. 7.9A

### Parts required :

2 of No. 5	2 of No. 11	1 of No. 18A	16 of No. 38	1 of No. 103G	1 of No. 120B
2 " " 6A	3 " " 12	3 " " 18B	1 " " 45	1 " " 103H	2 " " 126A
1 " " 8	1 " " 13	4 " " 22	1 " " 52A	1 " " 111A	1 " " 129
1 " " 8A	1 " " 15A	1 " " 24	10 " " 59	1 " " 111c	6 " " 136
2 " " 9A	2 " " 16	1 " " 32	4 " " 62	1 " " 114	1 " " 146
2 " " 9F	1 " " 16A	53 " " 37	1 " " 63	2 " " 115	1 " " 155
2 " " 10	1 " " 17	2 " " 37A	1 " " 103c	1 " " 118	

## Model No. 7.10 Clockwork Pacific Tank Locomotive



The frame of the locomotive is shown in Fig. 7.10A and it will be seen that each side member comprises a  $12\frac{1}{2}$ " Angle Girder extended by a  $3\frac{1}{2}$ " Girder, while  $3\frac{1}{2}$ " Girders are bolted to the ends, additional Girders 7 being attached at the front of the frame to form the front buffer beam. The buffer beam at the rear of the engine comprises a  $3\frac{1}{2}$ " Flat Girder.

A  $7\frac{1}{2}$ " Angle Girder 14 is bolted to the right-hand side of the main frame and to each of its ends a  $1\frac{1}{2}$ " Strip is secured in a vertical position. Two  $7\frac{1}{2}$ " Strips bolted to these complete the right-hand side tank. The left-hand tank 5 is constructed similarly, with the exception that  $4\frac{1}{2}$ " and 2" Girders are used in place of the  $7\frac{1}{2}$ " Girder, so that an aperture is formed to receive the winding key of the Clockwork Motor.

To complete the cab, Angle Girders 16 (Fig. 7.10A) are bolted to the Girders 14 and 15, and  $2\frac{1}{2}$ " Strips are secured two holes further back, while  $1\frac{1}{2}$ " Strips hold the Strips and Girders the correct distance apart. The roof is composed of four  $3\frac{1}{2} \times \frac{1}{2}$ " Double Angle Strips and one  $3\frac{1}{2}$ " Strip bolted to two  $2\frac{1}{2}$ " large radius curved Strips, one of which is bolted between the tops of the girders 16 whilst the other is bolted across two 3" Girders 17. The  $3\frac{1}{2}$ " Strip in the centre of the roof is supported by Angle Brackets; this Strip is so arranged to obtain a slot through which may protrude the reversing lever 8 of the Clockwork Motor. Four 2" Strips form each side of the coal bunker and two Girder Brackets bolted to their ends form the rear, the space between these Girders being filled in by a 2" Strip.

### Parts required :

4	of No. 1B	2	of No. 16A	4	of No. 109
5	" " 3	4	" " 17	3	" " 111
7	" " 4	5	" " 18A	1	" " 111A
5	" " 5	6	" " 20	1	" " 111c
11	" " 6	2	" " 24	1	" " 115
9	" " 6A	1	" " 25	6	" " 120A
2	" " 8	156	" " 37	2	" " 120B
1	" " 8B	8	" " 37A	2	" " 121
3	" " 9	25	" " 38	8	" " 136
6	" " 9B	5	" " 48B	6	" " 137
2	" " 9C	2	" " 50A	8	" " 147B
2	" " 9D	25	" " 59	2	" " 161
2	" " 9E	5	" " 62B	1	" " 162
3	" " 10	2	" " 64	2	" " 164
8	" " 12	3	" " 90	1	" " 166
1	" " 12A	1	" " 103D		
2	" " 12B	2	" " 103E		
4	" " 16	2	" " 103F		

Clockwork  
Motor

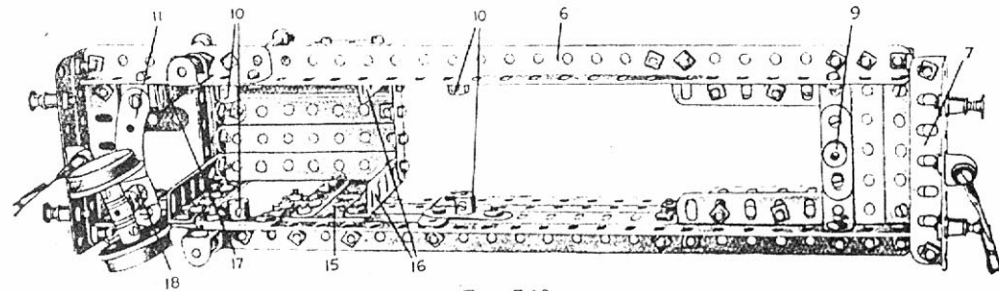

FIG. 7.10A

## Model No. 7.10 Clockwork Pacific Tank Locomotive *(continued)*

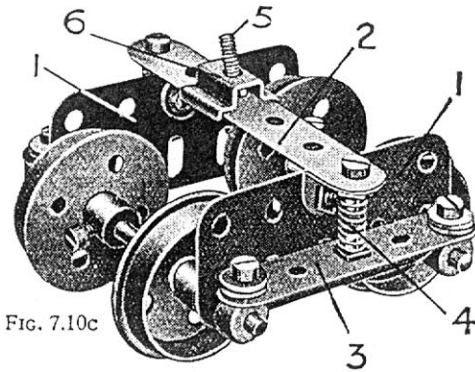

FIG. 7.10c

The firebox top consists of two 3" Angle Girders 2 spaced apart by 2" Strips. Two 3" Strips are secured to the latter between the Girders and on these is mounted the Ross pop safety valve, which consists of two outer "sleeves" removed from Meccano Spring Buffers, and held in place by means of Pivot Bolts. Each side of the firebox consists of two horizontal 3" Strips secured at their ends to vertical 1½" Strips which, in turn, are bolted to the Girders 2. The completed firebox is held in position by means of an Angle Bracket bolted to the cab, and Flat Brackets secured to the Boiler 1.

The Boiler is secured in position by Bolts passed through the side tanks, and rests on two 2" Angle Girders bolted to 3" Flat Girders that, in turn, are secured to the side frames of the locomotive. Two Chimney Adaptors are mounted on the Boiler, one being inverted to form the steam dome while the other, which represents the chimney, is secured to the Boiler by a Flat Bracket and ½" Bolt carrying a Collar. The smoke-box 4 is formed from two Boiler Ends held together by a ¾" Bolt passed through their centres.

Fig. 7.10b shows the power unit. This consists of a Clockwork Motor, the drive being taken from the pinion on the driving shaft by a ¾" Pinion 12 on the Axle of the rear pair of driving wheels. A 7½" Strip is bolted to each side plate of the Motor to form a journal for the axle of the front driving wheels, and two 5½" Angle Girders are also secured in position to give extra strength. The centre pair of wheels are not provided with flanges, Bush Wheels being substituted for the Face Plates, thus allowing the loco to negotiate sharper curves than would otherwise be possible. The Motor is held in position by Axle Rods passed through the Double Arm Cranks 10 (Fig. 7.10a) so that the reversing lever 8 (Fig. 7.10) passes through the cab top. A 1½" Strip is bolted to the brake lever and an End Bearing connected pivotally to its extremity carries an Axle Rod which, after passing through a 1" × 1" Angle Bracket secured to the coal bunker, is fitted with a Collar to form a control knob.

The rear pony truck consists of two 1½" Flanged Wheels mounted on a 1½" Rod that is passed through a Collar. A Threaded Pin gripped in the tapped hole of this Collar is secured in the boss of an Eye Piece 18 (Fig. 7.10a) and is spaced from same by a Collar. The Eye Piece slides on the 2½" Curved Strip 11. The front bogie forms the subject of Standard Mechanism No. 219, which is reproduced at Fig. 7.10c. This illustration shows an old-style Eye Piece at 6, but a new part should be used. The improved pattern is shown in Fig. 7.10.

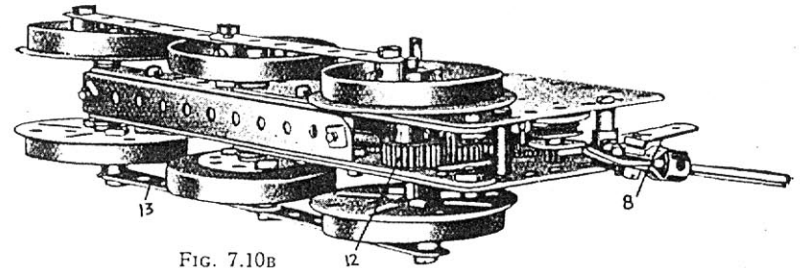

FIG. 7.10b

## Model No. 7.11 Warehouse

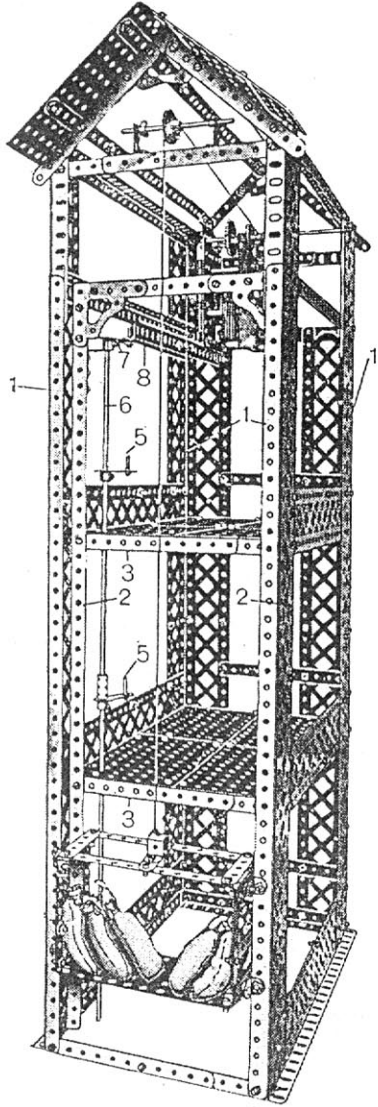
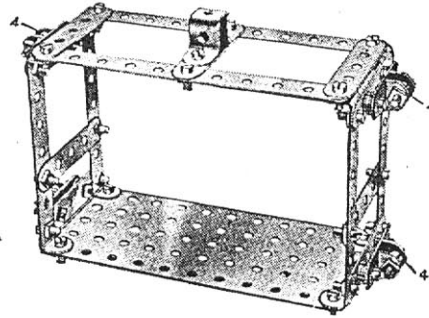

FIG. 7.11A



Commence this model by building the framework.  $2\frac{1}{2}$ " Angle Girders are used to form the corner uprights 1 with  $5\frac{1}{2}$ " Angle Girders overlapped eight holes at the top. Two  $2\frac{1}{2}$ " Angle Girders 2 are also used to carry the front portion of the warehouse floors, the latter being bolted to two  $5\frac{1}{2}$ " Angle Girders 3 overlapped eight holes and connected across to the two inner Angle Girders 2. Two similar  $5\frac{1}{2}$ " Angle Girders are bolted to the back of the framework, to carry the other end of each of the floors. The floor is formed of four  $5\frac{1}{2}$ "  $\times$   $3\frac{1}{2}$ " Flat Plates bolted together and bolted in the centre to a  $5\frac{1}{2}$ " Flat Girder on the underside—the two outer ends being bolted to the Angle Girders 3. The horizontal side-strips are formed of  $1\frac{1}{2}$ " Strips to which are bolted the brace Girder Strips.

Fig. 7.11A shows the construction of the cage. This is guided by bolt heads 4, at each side riding along the inwardly turned flanges of the Angle Girders 2. The Bolts are attached to Angle Brackets, which are secured to a  $1\frac{1}{2}$ " Strip, this latter being secured to the side-strips of the cage, spaced with three Washers to take up the play between the cage and the upright Girders 2.

Fig. 7.11B shows the position of the Motor, and this may be started and stopped from the control Crank Handles 5, one on each floor of the warehouse. These Crank Handles are fixed on a vertical Rod 6 composed of two  $11\frac{1}{2}$ " Rods connected by a Coupling. A Crank 7 is secured to the upper end of this Rod and is connected by a  $5\frac{1}{2}$ " Angle Girder and Strip 8 to the operating lever of the Motor.

$1" \times 1"$  Angle Brackets, secured to the sides of the warehouse by Strips, form the bearings for the upper and lower ends of the vertical Rod.

When the Motor is wired up to the Accumulator, the elevator is ready to be operated.

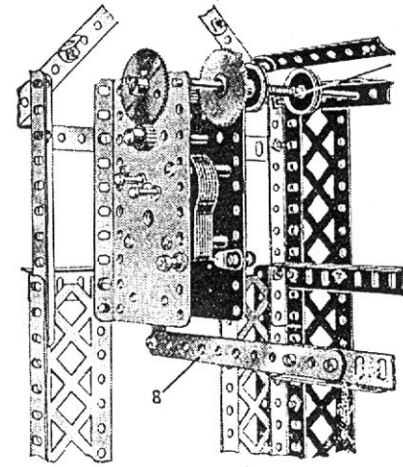

FIG. 7.11B

## Parts required :

18	of No.	1	2	of No.	13	1	of No.	59
21	"	2	1	"	14	4	"	62
9	"	5	1	"	16	1	"	63
1	"	6	3	"	22	3	"	70
4	"	6A	2	"	35	18	"	99
6	"	7	240	"	37	4	"	100
6	"	8	30	"	38	2	"	103
23	"	9	1	"	45	4	"	108
16	"	12	1	"	46	4	"	115
2	"	12A	8	"	52A			

Electric Motor

## Model No. 7.12 Field Gun

Parts required :

1 of No. 2	2 of No. 11	52 of No. 37	4 of No. 103
24 " " 3	9 " " 12	4 " " 37A	6 " " 111c
2 " " 4	1 " " 12A	20 " " 38	1 " " 114
1 " " 5	1 " " 14	2 " " 43	2 " " 115
1 " " 6	4 " " 17	9 " " 59	1 " " 116A
1 " " 6A	2 " " 18B	1 " " 63	2 " " 118
4 " " 8B	5 " " 24	1 " " 64	1 " " 160
2 " " 9	1 " " 26	4 " " 72	
4 " " 9F	1 " " 27A	1 " " 81	

This gun has a quick-firing action and will fire twelve Meccano Steel Balls at one loading. Fig. 7.12A shows the barrel and firing mechanism, with one side removed.

Each side of the magazine chamber is built up from two  $2\frac{1}{2}'' \times 2\frac{1}{2}''$  Flat Plates with corners overlapping. The two upper Plates have two  $1\frac{1}{2}''$  Angle Girders 10 and one Channel Bearing 1 bolted to them and the bottom Plates are joined together by a Double Bracket. The barrel consists of two  $7\frac{1}{2}''$  Angle Girders secured together to form a channel by two Bolts in the two end inner holes only. The end Bolt secures a Double Bracket inside the barrel and the recoil chamber 11 is held rigidly by the other.

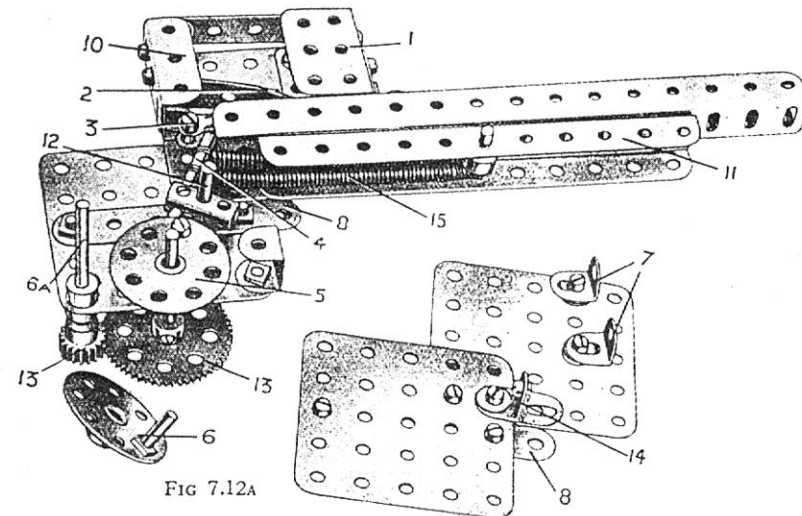
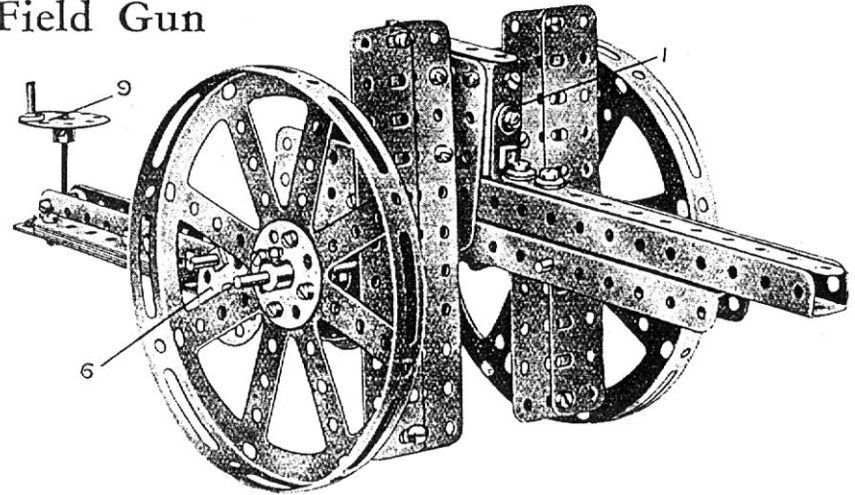

FIG 7.12A



The Double Bracket inside the barrel carries a 2" Rod on which is secured a Small Fork Piece 3 carrying a  $\frac{3}{8}''$  Bolt. A second 2" Rod 4, working freely in the jaws of the Small Fork Piece, is secured to a Coupling that is pivoted on the Rod 12. The action of the model is as follows. On turning the Bush Wheel 6, which is secured to the Rod 6A, the Bush Wheel 5 is rotated through the gears 13. The latter Bush Wheel carries in one of its holes a  $\frac{3}{8}''$  Bolt that catches the Rod 4 and pulls back the Small Fork Piece 3, with the plunger attached, against the action of the Springs 15. The plunger is now clear of the space formed by the 2" Strip 2 and the end of the Channel Bearing 1 and this movement allows a single Steel Ball to fall from the magazine chamber to a position directly in front of the plunger. On continuing the movement of the hand wheel 6 the Bolt in the Bush Wheel 5 disengages itself from the Rod 4, thereby allowing the plunger to strike the "shell" and so shoot it from the gun.

The 8" Rod that carries the road wheels is journaled in the end holes of the 3" Strips 8, and axle covers are provided by bolting a  $1\frac{1}{2}''$  Angle Girder on each side of the gun to the  $\frac{1}{2}'' \times \frac{1}{2}''$  Angle Brackets 14. The Angle Brackets 7 form supports for the shields, which are built up from  $5\frac{1}{2}''$  Flat Girders.

The trailing girder is built up from two  $7\frac{1}{2}''$  Angle Girders joined together at the far end by means of a  $1\frac{1}{2}''$  Strip and secured at the near end to the lower holes of the magazine chamber. A 2" Threaded Rod surmounted by the Bush Wheel 9 and working in a Threaded Boss, which is secured to the  $7\frac{1}{2}''$  Angle Girders by Bolts and spaced by Washers, forms the elevating apparatus. When the gun is assembled a  $5\frac{1}{2}''$  Strip should be placed along the top of the barrel and secured to the magazine chamber by a  $1'' \times 1''$  Angle Bracket.

## Model No. 7.13 Mantel Clock

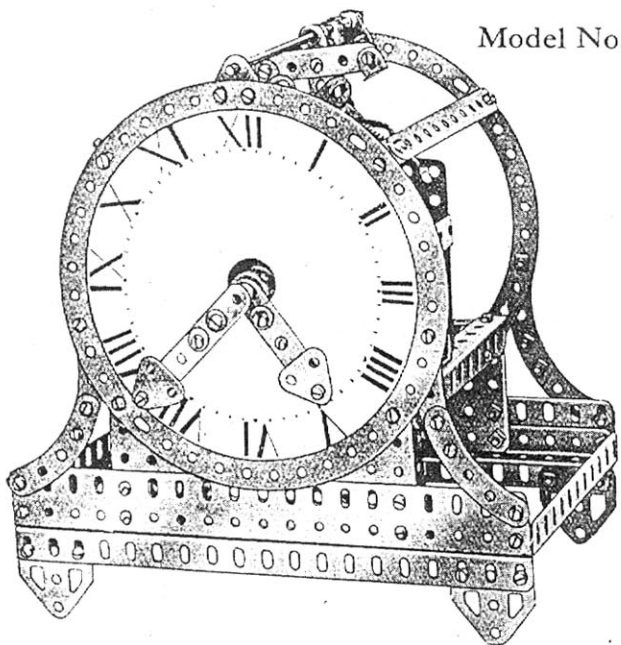

### Parts required :

2 of No. 2	3 of No. 25	3 of No. 62
1 " " 3	2 " " 26	2 " " 63
2 " " 4	3 " " 27	2 " " 70
2 " " 5	3 " " 27A	4 " " 77
4 " " 8A	1 " " 30A	8 " " 90
8 " " 9	1 " " 30C	2 " " 103A
1 " " 9F	4 " " 31	1 " " 109
8 " " 10	1 " " 32	2 " " 111c
11 " " 12	1 " " 35	6 " " 126A
1 " " 13A	95 " " 37	1 " " 136
1 " " 14	2 " " 37A	2 " " 145
1 " " 15	13 " " 38	1 " " 171
1 " " 16	2 " " 48	
1 " " 16B	1 " " 52	Clockwork Motor
3 " " 17	1 " " 52A	
2 " " 18A	12 " " 59	

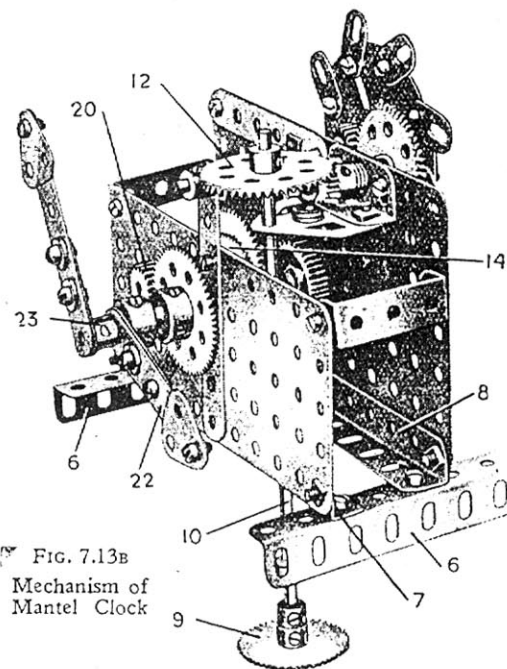

FIG. 7.13B  
Mechanism of  
Mantel Clock

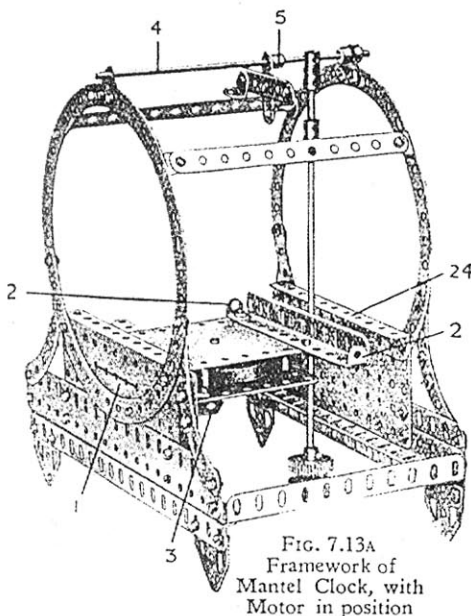

FIG. 7.13A  
Framework of  
Mantel Clock, with  
Motor in position

This clock will keep good time for four hours at a single winding of the Clockwork Motor. The framework of the model will be seen fairly clearly in Fig. 7.13A. The Clockwork Motor is secured rigidly to the  $5\frac{1}{2} \times 2\frac{1}{2}$ " Flanged Plate 1 by means of a  $5\frac{1}{2}$ " Angle Girder. A second  $5\frac{1}{2}$ " Angle Girder, shown fitted with Angle Brackets 2 and bolted to the rear edge of the Motor, will be secured later to the mechanism framework. The Motor is also fitted with a Flat Trunnion 3, which is secured so as to allow the three centre holes to be in alignment with the Motor driving shaft.

The pendulum is weighted with two 1" Gears and is attached to the Rod 4 by a Coupling. Rod 4 also carries the pallet, which consists of a Crank 5 that carries a  $2\frac{1}{2}$ " Strip fitted with Angle Brackets.

The mechanism housing (Fig. 7.13B) is composed of one  $5\frac{1}{2} \times 2\frac{1}{2}$ " and one  $5\frac{1}{2} \times 3\frac{1}{2}$ " Flat Plates connected

together by two  $1\frac{1}{2} \times \frac{1}{2}$ " Double Angle Strips and secured to the  $5\frac{1}{2}$ " Angle Girders 6 by the Angle Brackets 7 and Girder 8.

A  $\frac{3}{4}$ " Pinion on the Motor driving shaft engages with the 50-teeth Gear 9 secured to a 6" Rod 10. This Rod is journalled at its lower end in the centre hole of the Flat Trunnion 3 and carries a Worm 11 (Fig. 7.13c) and a  $1\frac{1}{2}$ " Bevel Gear 12. The latter meshes with a  $\frac{1}{2}$ " Bevel Gear secured to a short rod that is journalled in the Handrail Support 13 and in the mechanism side plate, and the 57-teeth Gear on this Rod meshes with a  $\frac{1}{2}$ " Pinion on the escapement shaft. The escapement consists of a Face Plate with Flat Brackets set round its circumference as shown in the illustration.

The Worm 11 engages with the 57-teeth Gear 14. This is free on the Rod 21, and has bolted



### Model No. 7.13 Mantel Clock (continued)

to it an Angle Bracket, the flat edge of which engages with the arms of the Spring Clip 15. In this way is obtained a neat friction clutch that enables the hands of the clock to be set without the gears moving. A 1" Gear also secured to the clutch Rod 21 engages with a second 1" Gear on the Rod 16. This Rod carries a  $\frac{1}{2}$ " Pinion that engages with the 50-teeth Gear 17 on the Rod 18. A further reduction Gear consisting of a  $\frac{1}{2}$ " Pinion and a 50-teeth Gear connects this Rod to the shaft 19, which carries a  $\frac{1}{2}$ " Pinion 20 outside the  $5\frac{1}{2}$ " x  $2\frac{1}{2}$ " Flat Plate.

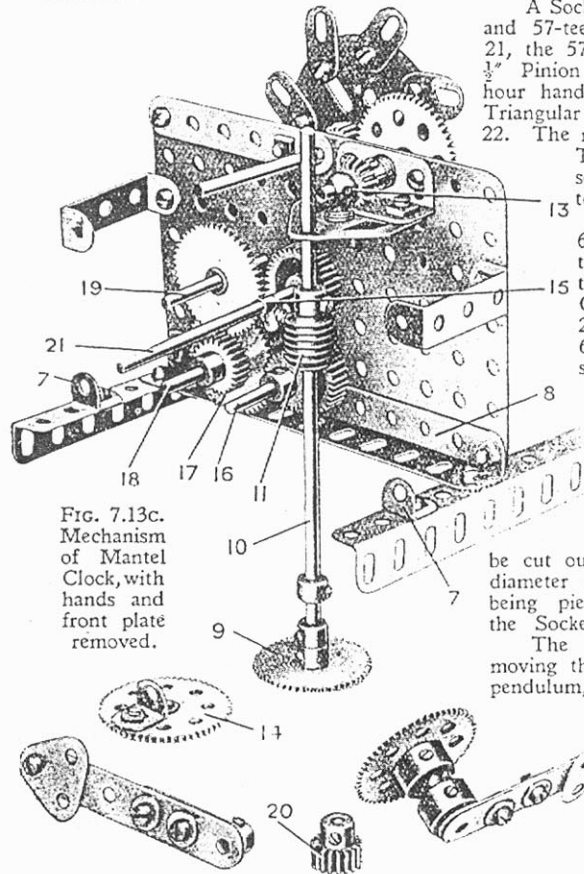

FIG. 7.13c. Mechanism of Mantel Clock, with hands and front plate removed.

A Socket Coupling secured to a Crank and 57-teeth Gear is free on the Rod 21, the 57-teeth Gear engaging with the  $\frac{1}{2}$ " Pinion 20. The Crank carries the hour hand, which is composed of a 1" Triangular Plate attached to the  $2\frac{1}{2}$ " Strip 22. The minute hand, a 3" Strip and 1" Triangular Plate, is carried on a second Crank 23, that is secured to the Rod 21.

The  $5\frac{1}{2}$ " Angle Girders 6 are bolted in position across the frame of the clock between the Plate 1 and the Angle Girder 24 and the Angle Brackets 2 are bolted to the Girders 6. The Crank 5 of the pallet should be ripped on the Rod 4 so that the Angle Brackets on the  $2\frac{1}{2}$ " Strip engage with the escapement teeth. The Angle Brackets need careful adjustment to obtain the best results.

A clock face should now be cut out of stiff white card the same diameter as the Circular Strip, a hole being pierced in the centre to allow the Socket Coupling to revolve freely. The clock may be regulated by moving the 1" Gears on the end of the pendulum, lowering them if the clock is fast and raising them if it is found to lose time.

### Model No. 7.14 Clockwork Motor Tractor

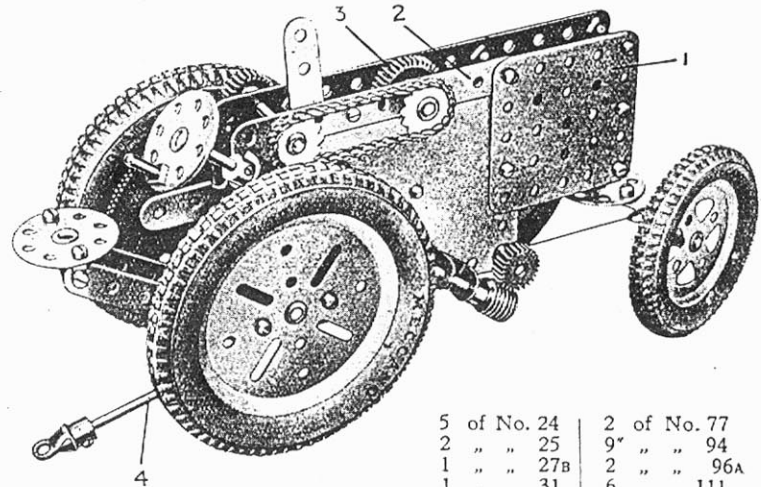

	5 of No. 24	2 of No. 77
	2 " " 25	9 " " 94
	1 " " 27B	2 " " 96A
	1 " " 31	6 " " 111
	1 " " 32	1 " " 115
	30 " " 37	2 " " 142A
	12 " " 38	2 " " 142B
	1 " " 48A	2 " " 147B
	9 " " 59	1 " " 166
	1 " " 63	
	2 " " 72	
		Clockwork Motor
Parts required :	1 of No. 14	
	1 " " 15A	
	1 " " 16	
2 of No. 2	1 " " 16A	
2 " " 3	4 " " 18A	
4 " " 11	2 " " 19B	
4 " " 12	2 " " 20A	

This tiny tractor is driven by the Clockwork Motor and is capable of exerting tremendous power. It has been tested to pull 10 stone a distance of 8 to 10 feet.

The front axle (a  $2\frac{1}{2}$ " x  $\frac{1}{2}$ " Double Angle Strip) is pivoted on a  $2\frac{1}{2}$ " Rod that is carried in Double Brackets attached to the Motor by means of the  $2\frac{1}{2}$ " x  $2\frac{1}{2}$ " Flat Plates 1 and the  $5\frac{1}{2}$ " Strips 2. The steering is similar to Standard Mechanism No. 166 except that cord is used instead of Sprocket Chain. The driver's seat is a Bush Wheel secured by Angle Brackets to two  $3\frac{1}{2}$ " Strips that in turn are attached to the Motor side plates by 1" Triangular Plates.

The drive for the rear wheels is taken from a 1" Gear 3 meshing with the main driving gear of the Motor and carried on a  $1\frac{1}{2}$ " Rod journalled in the Motor side plates. This Rod carries a  $\frac{1}{2}$ " Sprocket Wheel connected by Sprocket Chain to a second  $\frac{1}{2}$ " Sprocket that is nipped on a short Rod carrying a  $\frac{1}{2}$ " Pinion. The latter engages with a  $3\frac{1}{2}$ " Gear that is secured by double set-screws to the rear axle. It should be noted that to secure a more positive grip on the rear axle the 3" Pulleys, in addition to being secured by set-screws, are each connected by two  $\frac{1}{2}$ " Bolts to a Bush Wheel that also is secured to the Rod by two set-screws.

The draw-bar is composed of a  $\frac{1}{2}$ " Rod 4 carrying an End Bearing and pivoted on a short Rod in the bottom row of holes in the side plates.

## Model No. 7.15 Racing Seaplane

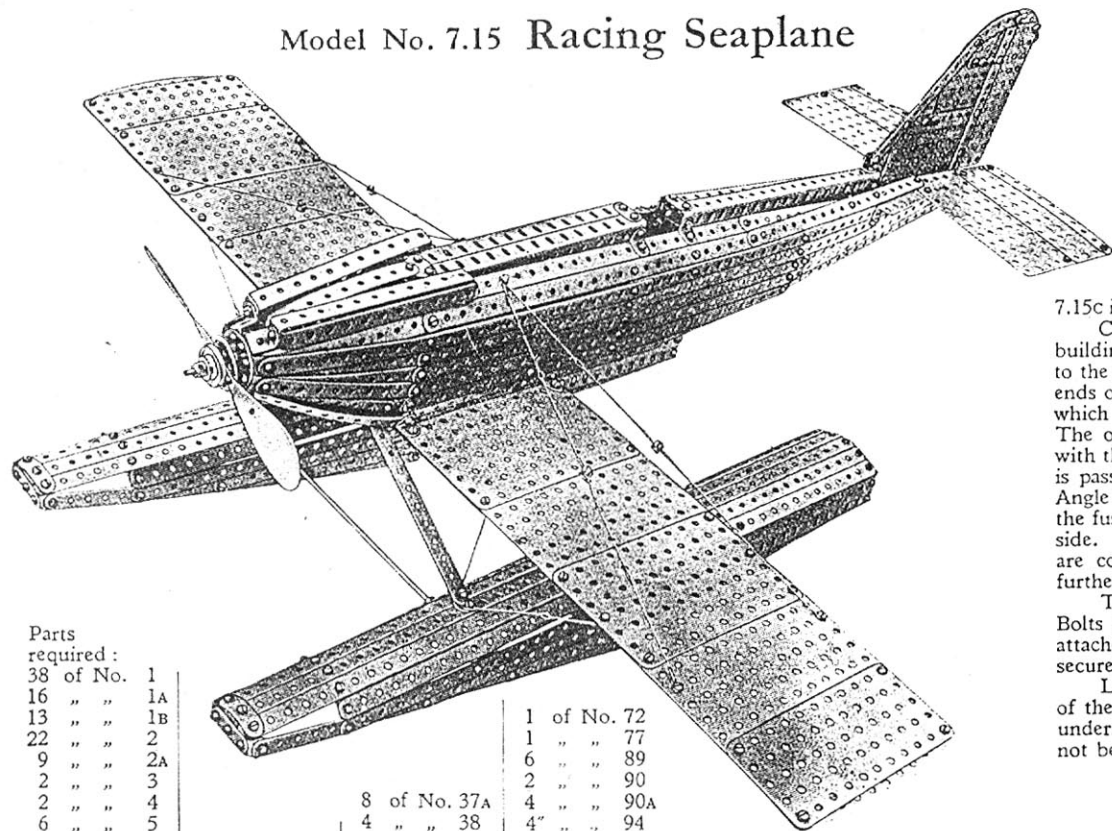

Parts  
required :

38	of No.	1				1	of No.	72
16	" "	1A				1	" "	77
13	" "	1B				6	" "	89
22	" "	2				2	" "	90
9	" "	2A				4	" "	90A
2	" "	3				4	" "	94
2	" "	4				2	" "	96A
6	" "	5				18	" "	101
1	" "	6	2	of No.	13	2	" "	103A
6	" "	6A	1	" "	14	4	" "	103B
2	" "	8A	1	" "	17	1	" "	103H
4	" "	8B	1	" "	18A	2	" "	109
2	" "	9	1	" "	18B	4	" "	111
2	" "	9A	1	" "	22A	8	" "	111C
2	" "	9D	1	" "	23A	1	" "	125
4	" "	9F	2	" "	24	10	" "	140
8	" "	10	2	" "	30	4	" "	
75	" "	12	360	" "	37	7	" "	

Electric Motor

The graceful lines of a high-speed seaplane have been well brought out in this model, which represents the Supermarine Racing Seaplane S.6. The shape of the streamlined fuselage has been reproduced as closely as possible, and the large fin and stepped floats are additional features that add to the interest of the model. The propeller is driven by a Meccano Electric Motor incorporated in the fuselage.

Fig. 7.15D shows the underside of the model, whilst Fig 7.15B illustrates the fuselage with one side removed to disclose internal details. Fig.

7.15C is the engine unit.

Construction of the model should be commenced by building the fuselage, which should be fairly clear on referring to the illustrations, particularly Fig. 7.15A and 7.15B. The rear ends of the fuselage sides are drawn together by the  $\frac{3}{4}$ " Bolts 1 which pass through a  $7\frac{1}{2}$ " Strip that serves to support the fin. The other points at which Bolts are inserted should be clear with the exception, perhaps, of the point 2. In this case a Bolt is passed through the end hole of the  $12\frac{1}{2}$ " Strip, through the Angle Bracket that is secured to the Face Plate in the nose of the fuselage, and lastly through the Flat Bracket on the fuselage side. The Face Plate mentioned above is one of two that are connected rigidly together by  $2\frac{1}{2}$ " Angle Girders, which further serve as a means of attachment to the side-members.

The Motor is mounted in place in the fuselage by passing Bolts through the holes 3 and through  $\frac{1}{2} \times \frac{1}{2}$ " Angle Brackets attached to the Motor flanges. The Universal Coupling 4 is secured to the propeller shaft.

Little difficulty should be experienced in the construction of the floats as their general features are fairly apparent in the underneath view of the model (Fig. 7.15D). One point that may not be quite clear, however is the fact that the Strips forming

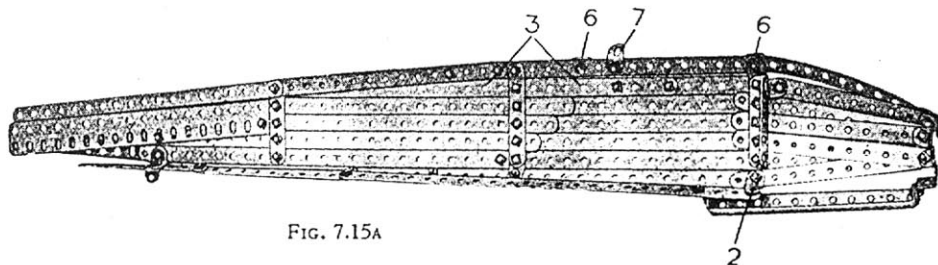
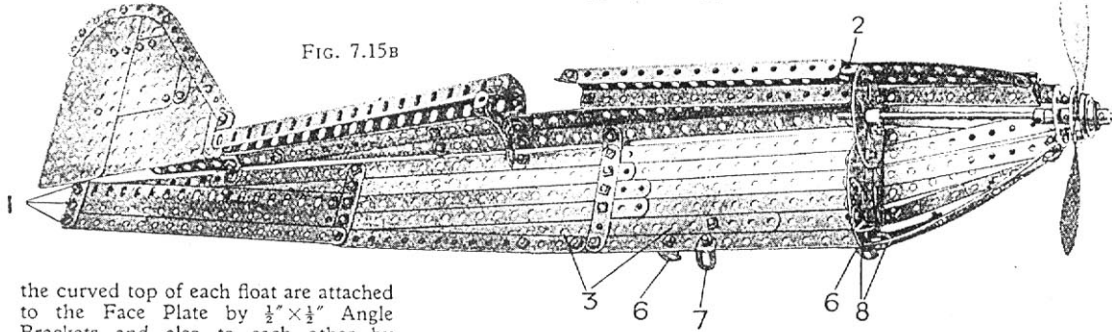

FIG. 7.15A

## Model No. 7.15 Racing Seaplane (continued)

FIG. 7.15B



the curved top of each float are attached to the Face Plate by  $\frac{1}{2}'' \times \frac{1}{2}''$  Angle Brackets and also to each other by Flat Brackets. The rear ends of the Strips are attached by  $\frac{1}{2}'' \times \frac{1}{2}''$  Angle Brackets to a  $2\frac{1}{2}''$  small radius Curved Strip, which in turn is bolted to a  $2\frac{1}{2}''$  Flat Girder forming the back of the float.

Each of the rear struts 5 connecting the fuselage to the floats, is bolted to a  $\frac{1}{2}'' \times \frac{1}{2}''$  Angle Bracket secured to the top of the float by a  $\frac{3}{4}''$  Bolt 5A, which is screwed into a Collar on an  $11\frac{1}{2}''$  Rod. This Rod, together with the corresponding one at the front end of the floats, is secured in Double Arm Cranks that are bolted to the sides of the floats.

The main plane is attached to the fuselage by the  $\frac{1}{2}'' \times \frac{1}{2}''$  Angle Brackets 6, and the float struts are

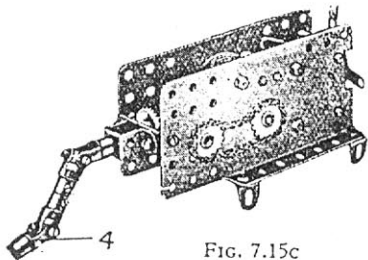
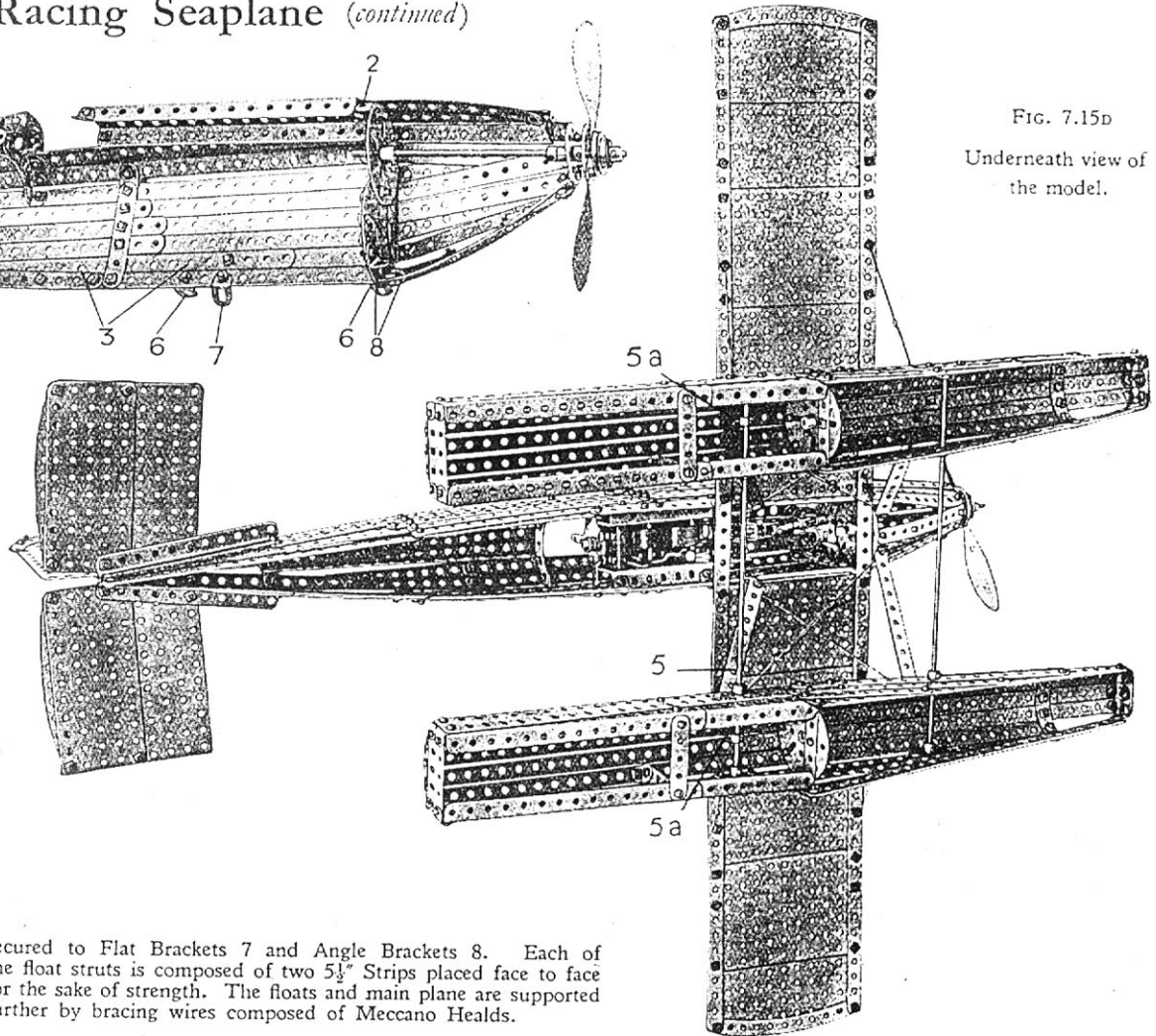

FIG. 7.15C

FIG. 7.15D  
Underneath view of the model.



secured to Flat Brackets 7 and Angle Brackets 8. Each of the float struts is composed of two  $5\frac{1}{2}''$  Strips placed face to face for the sake of strength. The floats and main plane are supported further by bracing wires composed of Meccano Healds.

## Model No. 7.16 4-2-2 Locomotive and Tender

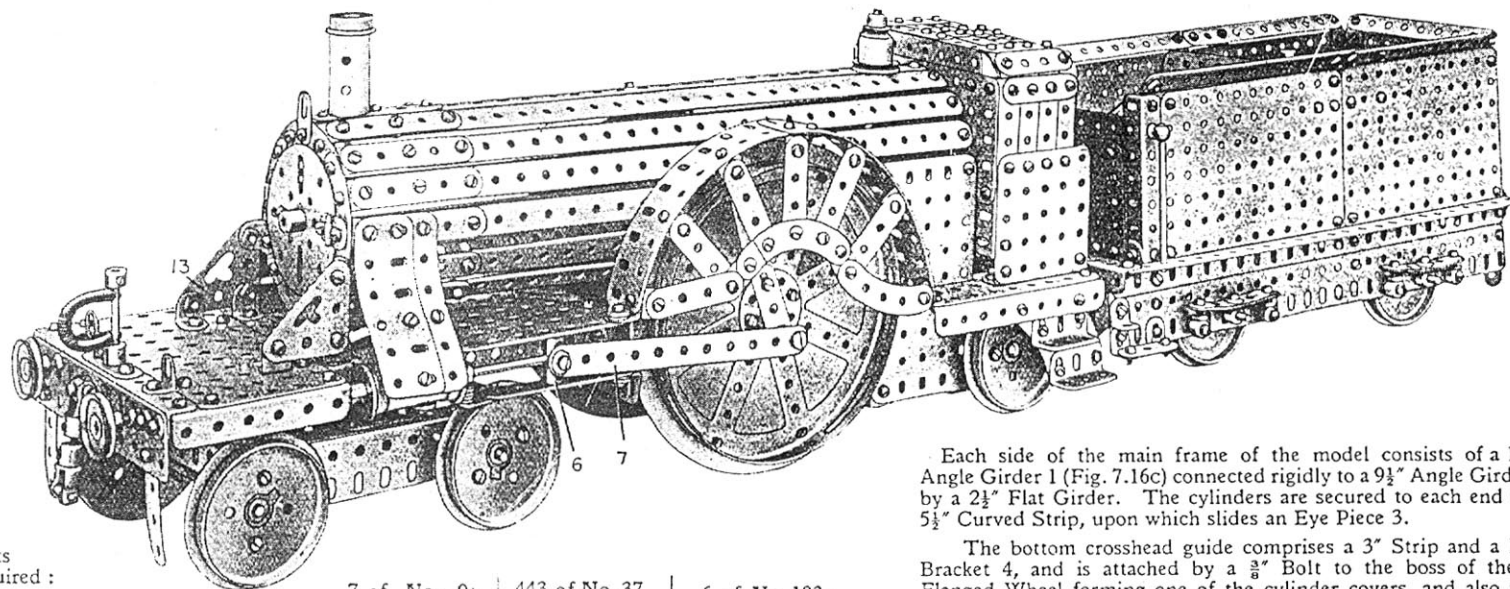

Parts  
required :

13 of No. 1	33 of No. 5
2 " " 1B	28 " " 6
4 " " 2	6 " " 6A
5 " " 2A	4 " " 8
12 " " 3	2 " " 8A
2 " " 4	8 " " 9

7 of No. 9A	443 of No. 37	6 of No. 103E
4 " " 9B	40 " " 38	7 " " 103F
2 " " 9C	4 " " 43	11 " " 109
2 " " 9D	2 " " 48B	3 " " 111
4 " " 9F	1 " " 50A	12 " " 111A
29 " " 10	7 " " 52A	10 " " 111c
2 " " 11	6 " " 53A	1 " " 114
74 " " 12	2 " " 55A	5 " " 115
4 " " 15A	25 " " 59	4 " " 116A
2 " " 16	2 " " 62	2 " " 118
1 " " 16A	1 " " 62B	3 " " 125
4 " " 16B	4 " " 63	2 " " 126
3 " " 17	1 " " 70	2 " " 126A
3 " " 18A	2 " " 72	2 " " 133
1 " " 20	1 " " 81	2 " " 136
5 " " 20B	1 " " 89	10 " " 137
5 " " 22	4 " " 90	2 " " 146
1 " " 23A	10 " " 90A	2 " " 147B
2 " " 24	7 " " 103	3 " " 163
2 " " 26	2 " " 103B	2 " " 164
2 " " 27A	4 " " 103c	
1 " " 27B	1 " " 103D	Electric Motor

Each side of the main frame of the model consists of a 12½" Angle Girder 1 (Fig. 7.16c) connected rigidly to a 9½" Angle Girder 2 by a 2½" Flat Girder. The cylinders are secured to each end of a 5½" Curved Strip, upon which slides an Eye Piece 3.

The bottom crosshead guide comprises a 3" Strip and a Flat Bracket 4, and is attached by a ⅜" Bolt to the boss of the ¾" Flanged Wheel forming one of the cylinder covers, and also to a transverse 5½" Angle Girder. Five Washers are used to space the guide the correct distances from the Flanged Wheel, and two

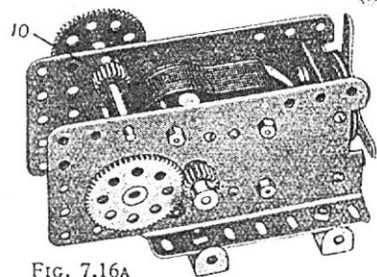

FIG. 7.16A

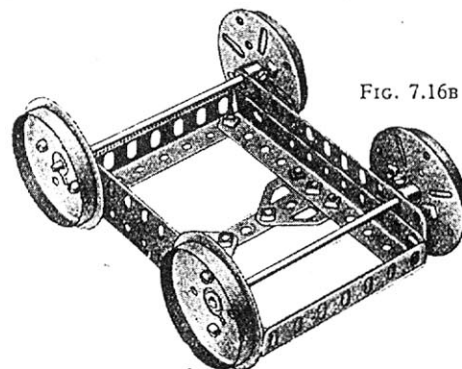

FIG. 7.16B

## Model No. 7.16 4-2-2 Locomotive and Tender (continued)

Washers space the  $5\frac{1}{2}$ " Angle Girder from each of the Angle Brackets by which it is attached to the main frame. The top crosshead guide is formed by the end of a  $5\frac{1}{2}$ "  $\times$   $3\frac{1}{2}$ " Flat Plate 5, which is bolted across the top of the main frame and is packed up therefrom by five  $3\frac{1}{2}$ " Strips on each side. A Coupling 6, which is secured to the end of the piston rod and slides freely between the crosshead guides, represents the crosshead, to one end of which the connecting rod 7 (Fig. 7.16) is attached.

The Motor is held in place in the main frame by Bolts, which pass through holes 8 in the  $4\frac{1}{2}$ "  $\times$   $2\frac{1}{2}$ " Flat Plates 9 and through the ends of  $3\frac{1}{2}$ "  $\times$   $\frac{1}{2}$ " Double Angle Strips on the Motor. When the Motor is secured in place, the  $\frac{1}{2}$ " Pinion 10 (Fig. 7.16a) should mesh with the  $3\frac{1}{2}$ " Gear Wheel on the driving wheel axle. The steps 11 are secured in place by  $\frac{1}{4}$ " Bolts and are spaced away from the Girder to which they are attached, by Collars on the shanks of the Bolts.

The construction of the bogie should be quite plain from Fig. 7.16e. It is mounted pivotally on the bogie pin (a 1" Rod), which is secured in the boss of the Eye Piece 3, and the lateral movement of the latter upon the Curved Strip is controlled by means of Springs. The trailing wheels are secured to an axle that is journalled freely in the slotted holes of 2" Slotted Strips 12.

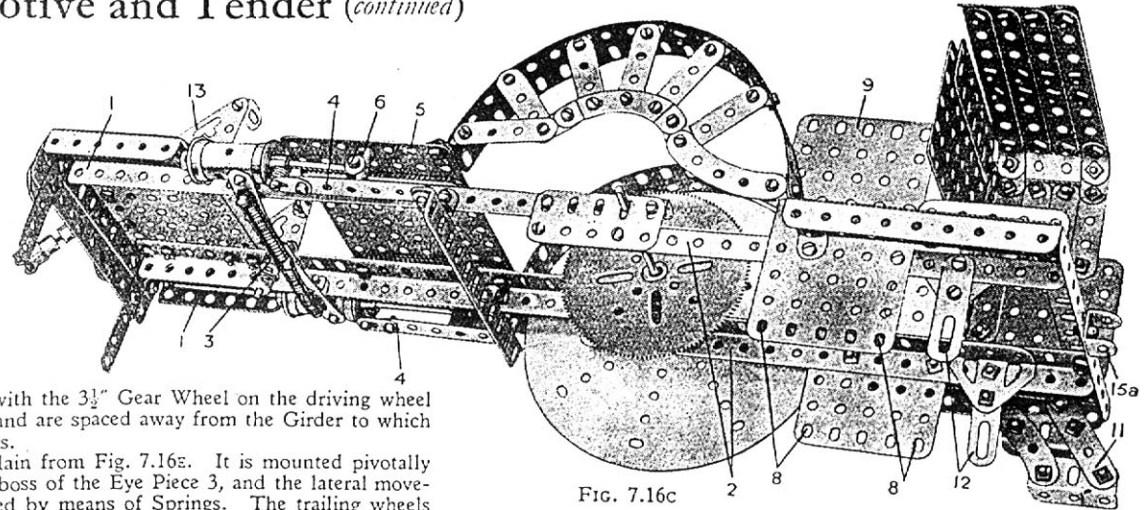

FIG. 7.16c

The smokebox end of the boiler is attached to Corner Brackets 13 and the firebox end is secured to the  $4\frac{1}{2}$ "  $\times$   $2\frac{1}{2}$ " Flat Plates 9. Before mounting the boiler in position, the chimney and the safety valve should be attached. In the case of the former, a Chimney Adaptor is secured to the top of the smokebox by a 2" Screwed Rod. The Sleeve Piece forming the chimney is then pushed on to the Chimney Adaptor, and a  $\frac{3}{4}$ " Flanged Wheel is fixed on the end of the Screwed Rod to form the chimney cap.

The tender is shown dismantled in Fig. 7.16d; one side has been removed and reversed (Fig. 7.16e) to show its

interior construction. The two portions may be constructed as indicated and then placed together so that the lettered holes coincide (a with a', b with b', and so on). The front plate of the tender has a sliding door, which consists of a  $2\frac{1}{2}$ " Flat Girder 14 sliding between two pairs of  $2\frac{1}{2}$ " Flat Girders, each pair being spaced apart by a  $2\frac{1}{2}$ " Strip.

The locomotive and tender are connected together by passing a short Rod through the Double Brackets 15, 15A. This Rod is held in place by Collars. The 6-volt Accumulator may be accommodated in the tender, thus making the model entirely self-contained; the bottom of the Accumulator rests on the Angle Girders 16.

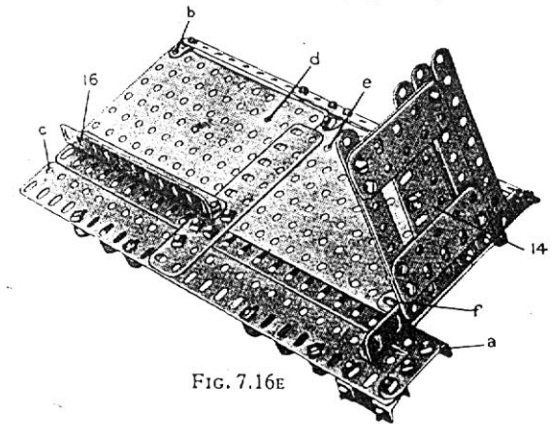

FIG. 7.16e

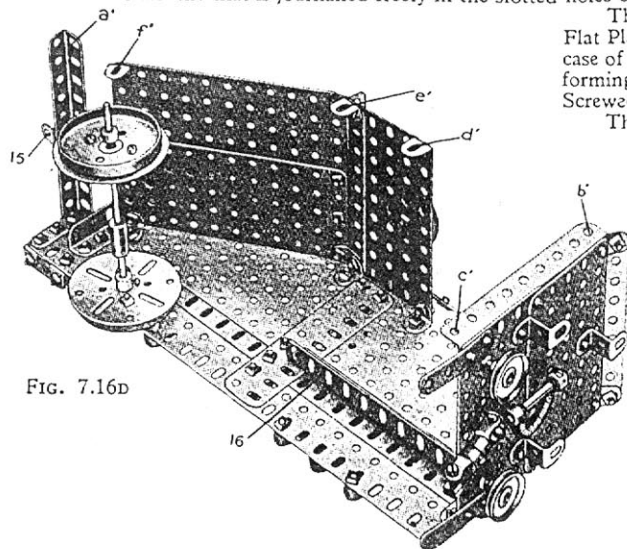

FIG. 7.16d

This Model can be built with MECCANO Outfit No. 7 (or No. 6 and No. 6A)

## Model No. 7.17

## Eiffel-Tower

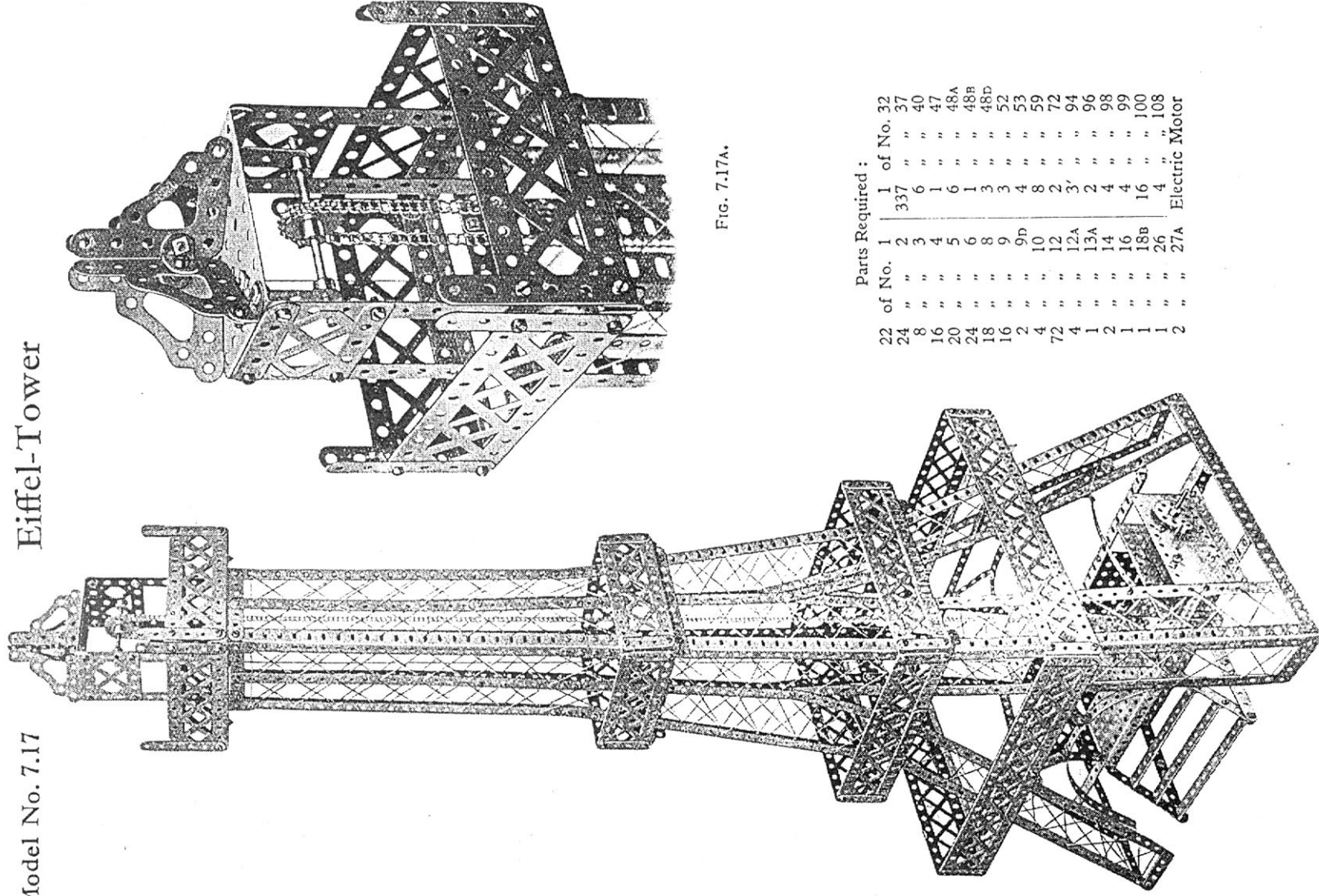

FIG. 7.17A.

Parts Required :

22	of No. 1	1	of No. 32
24	" 2	337	" 37
8	" 3	6	" 40
16	" 4	1	" 47
20	" 5	6	" 48A
24	" 6	1	" 48B
18	" 8	3	" 48D
16	" 9	3	" 52
2	" 9d	4	" 53
4	" 10	8	" 59
72	" 12	2	" 72
4	" 12A	3'	" 94
1	" 13A	2	" 96
2	" 14	4	" 98
1	" 16	4	" 99
1	" 18B	16	" 100
1	" 26	4	" 108
2	" 27A		Electric Motor

### Model No. 7.17 Eiffel-Tower (continued)

Parts required :

1	of No.	5
4	" "	7A
2	" "	9D
4	" "	9F
2	" "	16
54	" "	37
4	" "	52A
2	" "	62B
4	" "	70
2	" "	103D
4	" "	103H

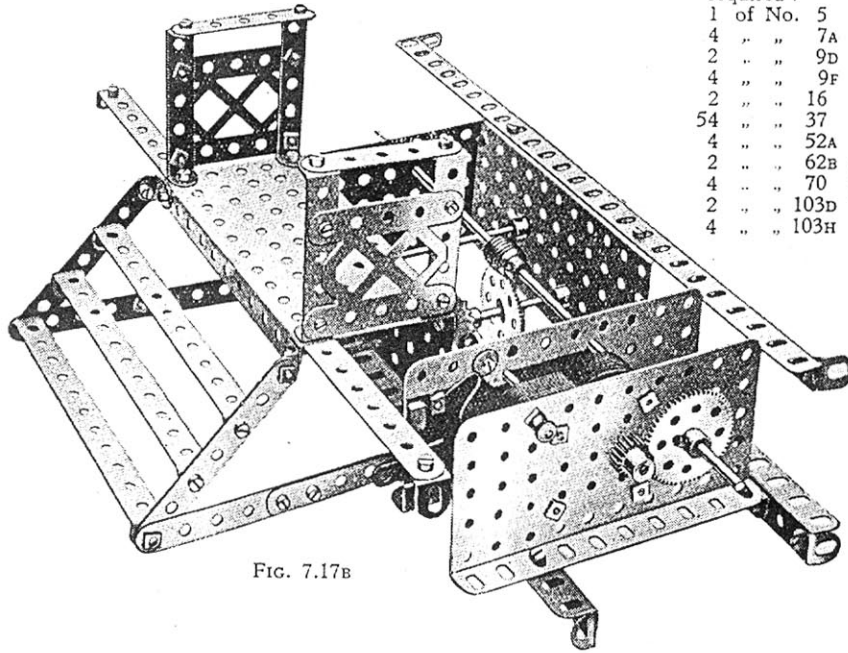
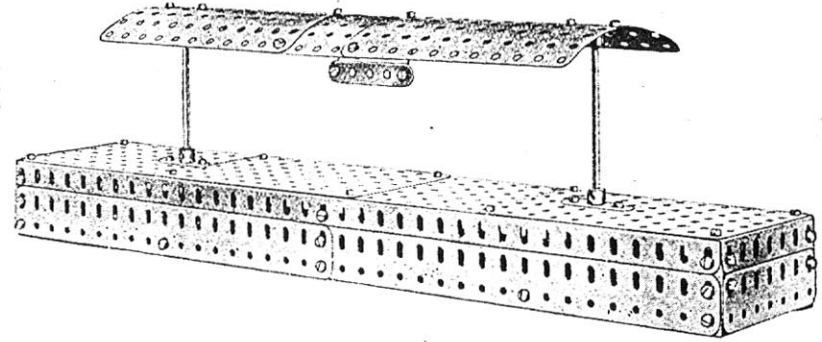

FIG. 7.17B

The construction of the tower may be followed from the illustrations. The lift carriage is built up from two  $3\frac{1}{2}'' \times 2\frac{1}{2}''$  Flanged Plates and two  $2\frac{1}{2}'' \times 2\frac{1}{2}''$  Flat Plates and runs on a length of cord which acts as a guide line. This cord is secured to the top of the tower and to a transverse Rod in the base, and passes through holes in the Plates of the lift. The operation of the lift is effected by means of a length of Sprocket Chain passing round the 1" Sprocket Wheel situated in the top of the tower, Fig. 7.17A, and round a similar wheel in the base, Fig. 7.17B. The ends of the chain are secured to the lift. The lower Sprocket Wheel is operated through worm gearing from the Electric Motor, Fig. 7.17B.

### Model No. 7.18 Railway Island Platform



### Model No. 7.19 The Tilters

Parts required :

The lances 1 pivoted at 2 are raised into position by the Cords 3 and the figures caused to advance together by the Chains 4 on turning the Handle 5.

The Cords 3, instead of being tied where indicated in the illustration, should, after aim, be made fast to some part of the moving figures.

2	of No.	3	1	of No.	15A
4	" "	4	5	" "	16
22	" "	5	1	" "	19
2	" "	7	10	" "	22
2	" "	8B	2	" "	22A
10	" "	10	2	" "	31
2	" "	11	73	" "	37
10	" "	12	2	" "	37A
2	" "	13	4	" "	38
			1	" "	46
			1	" "	47
			2	" "	52
			2	" "	54
			8	" "	59
			6	" "	90
			50	" "	94
			4	" "	96
			2	" "	126A
			4	" "	133

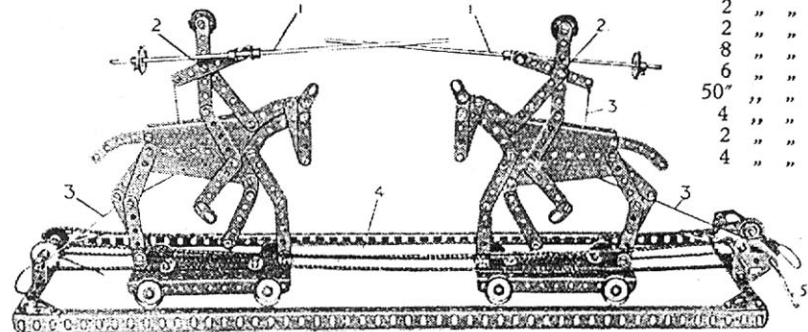

## Model No. 7.20 Funicular Railway

The inclined rails are made from four sets of  $2\frac{1}{2}$ " Angle Girders and  $9\frac{1}{2}$ " Girders butted together and connected by 3" Strips. The loading platform consists of three  $5\frac{1}{2}$ " $\times$  $3\frac{1}{2}$ " Flat Plates and one  $5\frac{1}{2}$ " $\times$  $2\frac{1}{2}$ " Flat Plate, and is supported by the  $12\frac{1}{2}$ " Girders 6 and uprights 7. The side girders 2 in the base of the model are each formed from one  $2\frac{1}{2}$ ", one  $12\frac{1}{2}$ " and one 3" Girders overlapped two holes each.

The cars 8 are connected to the Chains 9 which pass over Sprocket Wheels 10, 2" diameter at the top and 1" at the bottom. They move in opposite directions so that the weight of the descending car assists the other car to ascend. This is effected by driving a 3" Sprocket Wheel 11, Fig. 7.20A, from the Motor, the 8" Rod 12 of the Sprocket Wheel 11 carrying a 1" Sprocket 13 which is coupled by the Chain 14 to a similar Sprocket 15 on the 3" Rod 16. The Rod 12 is coupled to another 8" Rod 17 by a pair of  $\frac{1}{2}$ " Pinions 18 in order to obtain a reversed rotation, and a 1" Sprocket Wheel 19 on the Rod 17 is coupled by a Chain 20 to another 1" Sprocket Wheel 21 on a 3" Rod 22 which drives the Chain of the other car. In this way, opposite movement of the two cars is always taking place.

The cars, having reached their destinations, are returned by reversing the Motor.

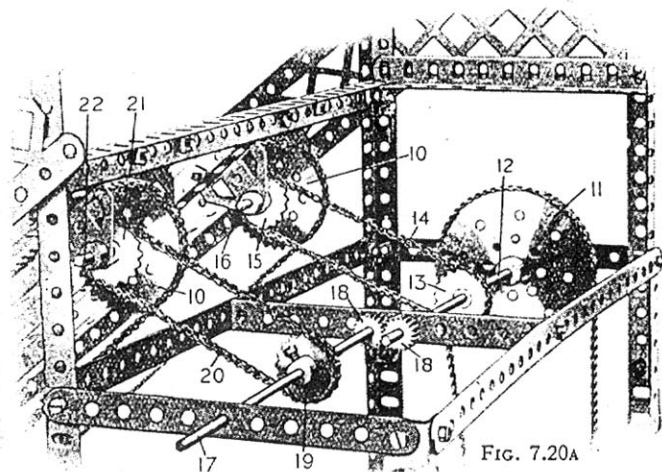
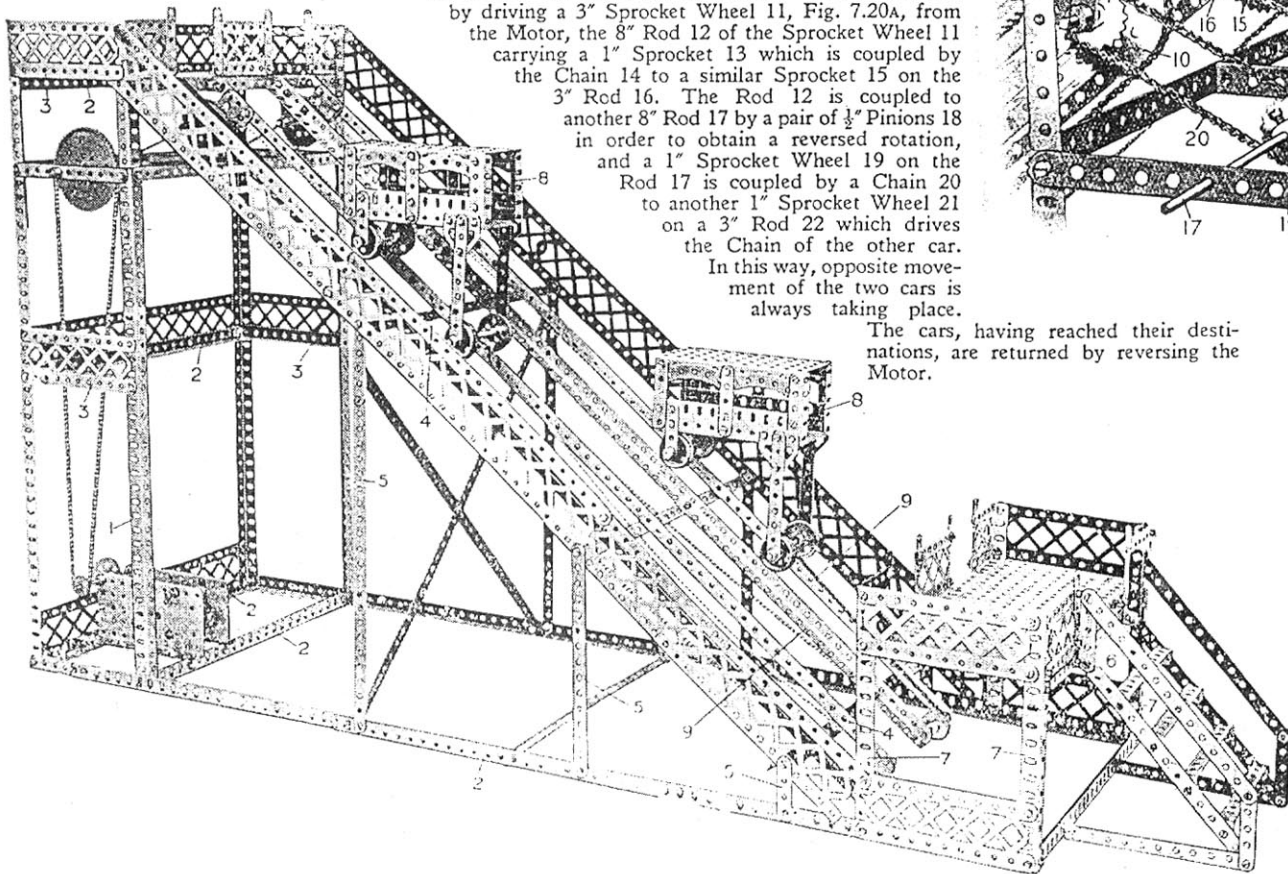

Fig. 7.20A



### Parts required :

9	of No. 1	4	of No. 26
4	" " 1B	3	" " 27A
6	" " 2A	274	" " 37
4	" " 2A	5	" " 48D
4	" " 4	4	" " 52
26	" " 5	6	" " 52A
6	" " 6	19	" " 59
6	" " 7	2	" " 70
4	" " 7A	8	" " 90
13	" " 8	160"	" " 94
4	" " 8A	2	" " 95
4	" " 8B	1	" " 95B
8	" " 9	6	" " 96
2	" " 9B	1	" " 96A
2	" " 9C	5	" " 97
4	" " 9D	4	" " 98
38	" " 12	9	" " 99
2	" " 13A	8	" " 100
9	" " 16	4	" " 103
2	" " 17	8	" " 126A
8	" " 20		

Electric Motor





These Models can be built with MECCANO Outfit No. 7 (or No. 6 and No. 6A)

## Model No. 7.22 Hammerhead Crane

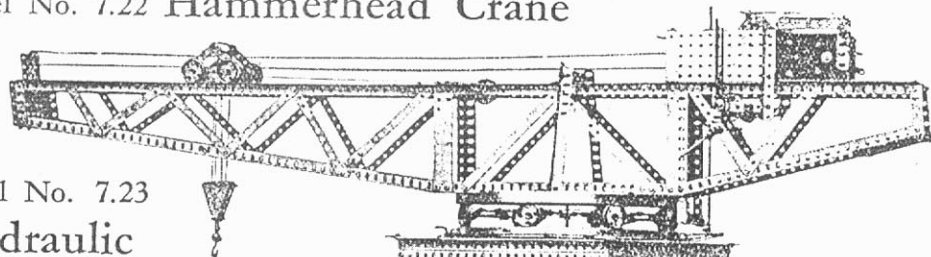

## Model No. 7.23 Hydraulic Crane

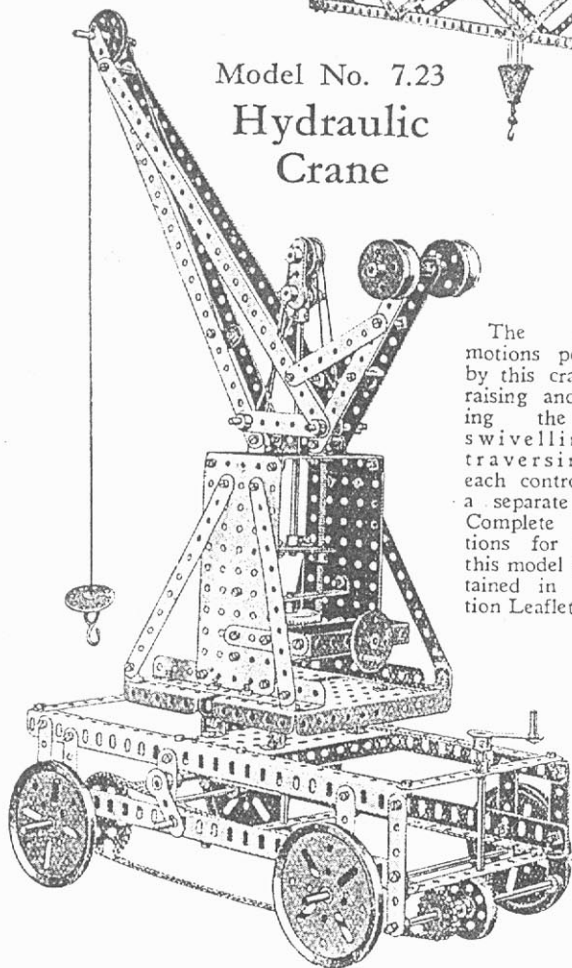

The different motions performed by this crane, viz., raising and lowering the load, swivelling, and traversing, are each controlled by a separate handle. Complete instructions for building this model are contained in Instruction Leaflet No. 25.

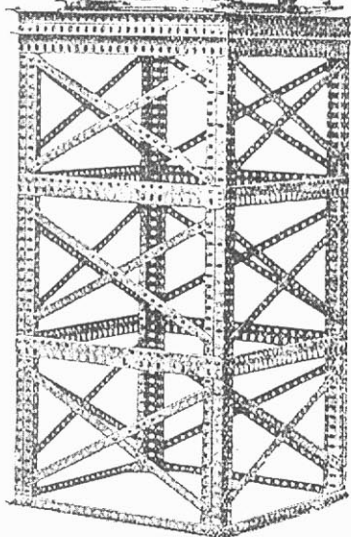

This is a powerful model of a type of massive crane used in shipyards and harbours. Complete instructions for building this model are contained in Instruction Leaflet No. 29.

## Model No. 7.24 Automatic Warehouse Lift

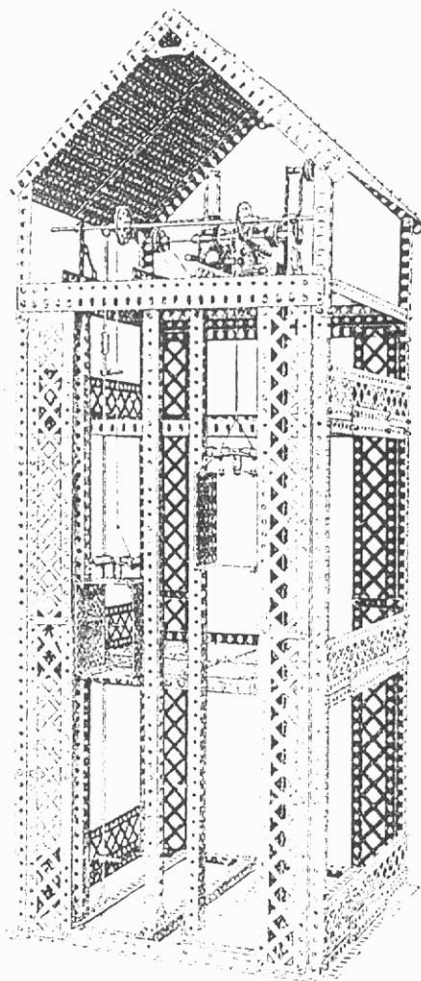

This is a model of special interest. It incorporates two cages which are operated automatically in such a manner that, as one rises, the other falls. Complete instructions for building this model are contained in Instruction Leaflet No. 31.

## Model No. 7.25 Electrically Driven Traction Engine

This well-designed model is extremely powerful. It will easily haul a load more than ten times its own weight. Complete instructions for building this model are contained in Instruction Leaflet No. 22.

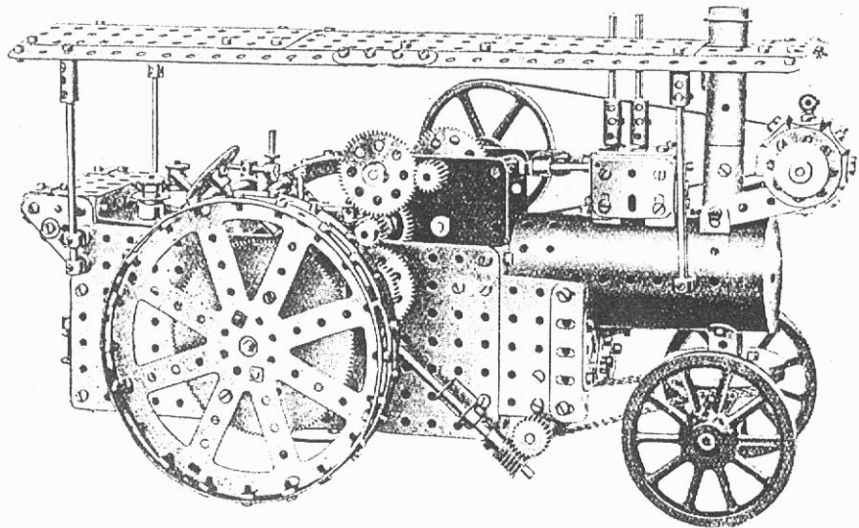

## Model No. 7.27 Revolving Crane

This crane is realistic in appearance and very efficient in operation. An interesting feature is the luffing mechanism. Complete instructions for building this model are contained in Instruction Leaflet No. 18.

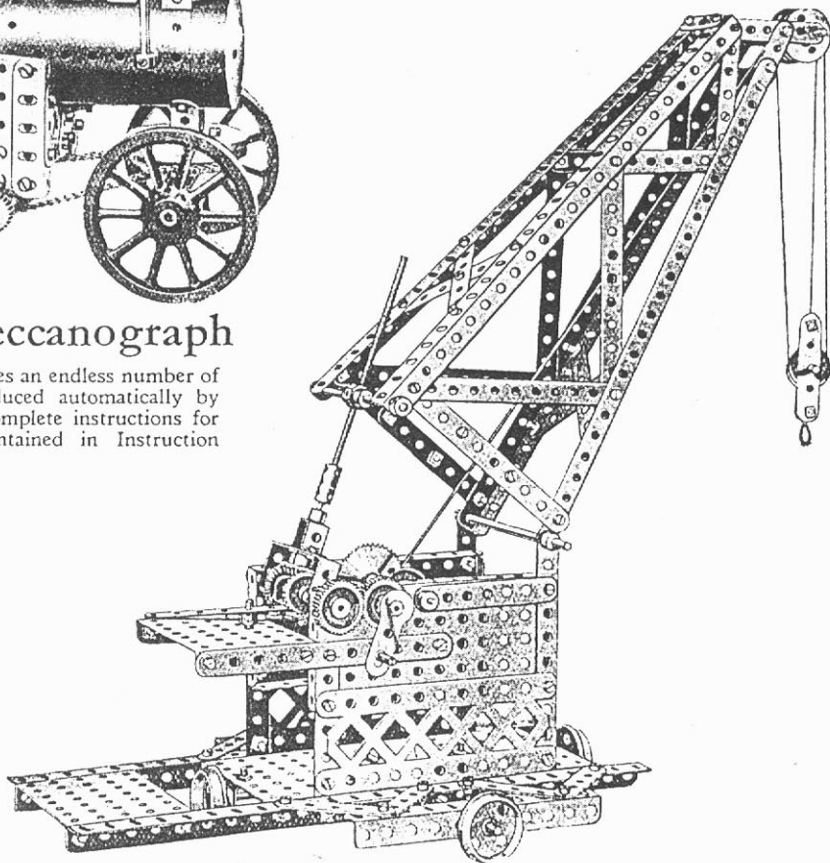

## Model No. 7.26 Meccanograph

The Meccanograph enables an endless number of exquisite designs to be produced automatically by simply turning a handle. Complete instructions for building this model are contained in Instruction Leaflet No. 13.

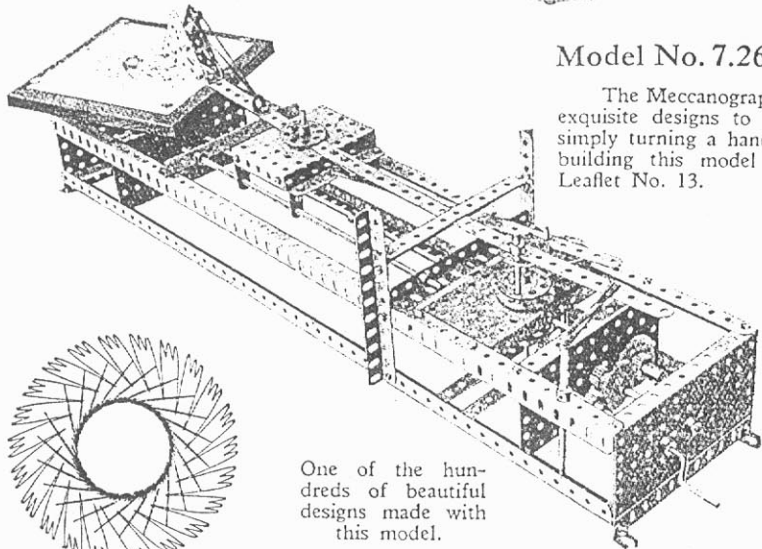

One of the hundreds of beautiful designs made with this model.

## Model No. 7.29

## Travelling Gantry Crane

By manipulating the various clutch levers the Electric motor is caused to raise or lower the load on the Hook, draw the trolley along the rails at the top of the gantry and drive the whole crane along on its travelling wheels. Complete instructions for building the model are contained in Instruction Leaflet No. 24.

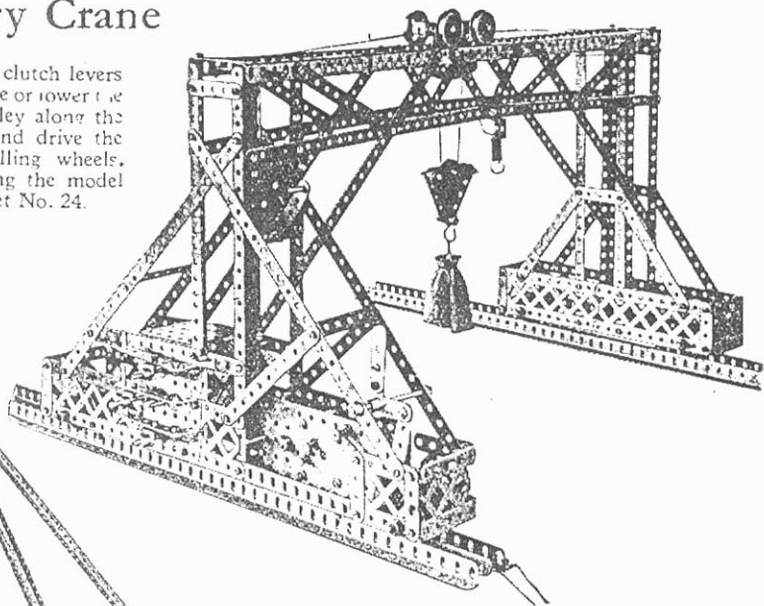

## Model No. 7.30

## Electric Mobile Crane

This is a realistic model of a very useful type of crane that is invaluable in large warehouses, railway sidings, etc. The portability of its prototype is as great or even greater than a motor vehicle of the same size. Complete instructions for building this model are contained in Instruction Leaflet No. 20.

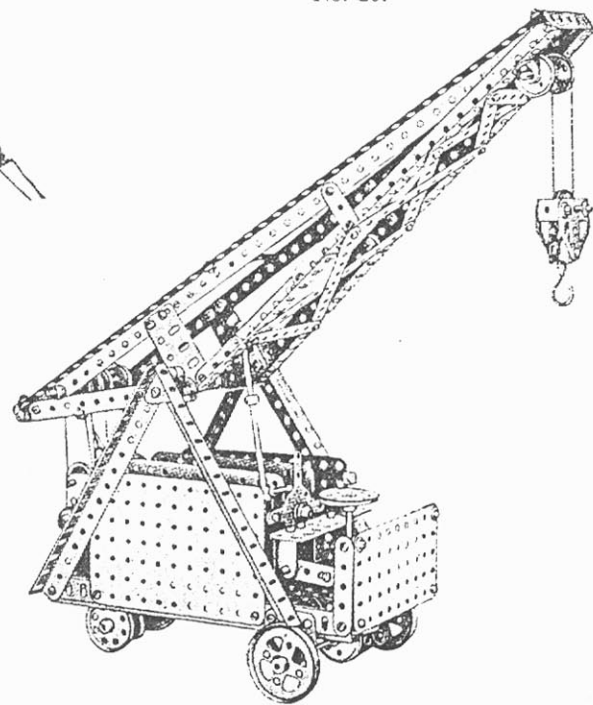

## Model No. 7.28

Scotch Type  
Electric  
Derrick Crane

This model is built to a scale of  $\frac{3}{4}$  in. to 1 ft. and the arrangement of the mechanism closely resembles that adopted in its prototype. Complete instructions for building this model are contained in Instruction Leaflet No. 36.

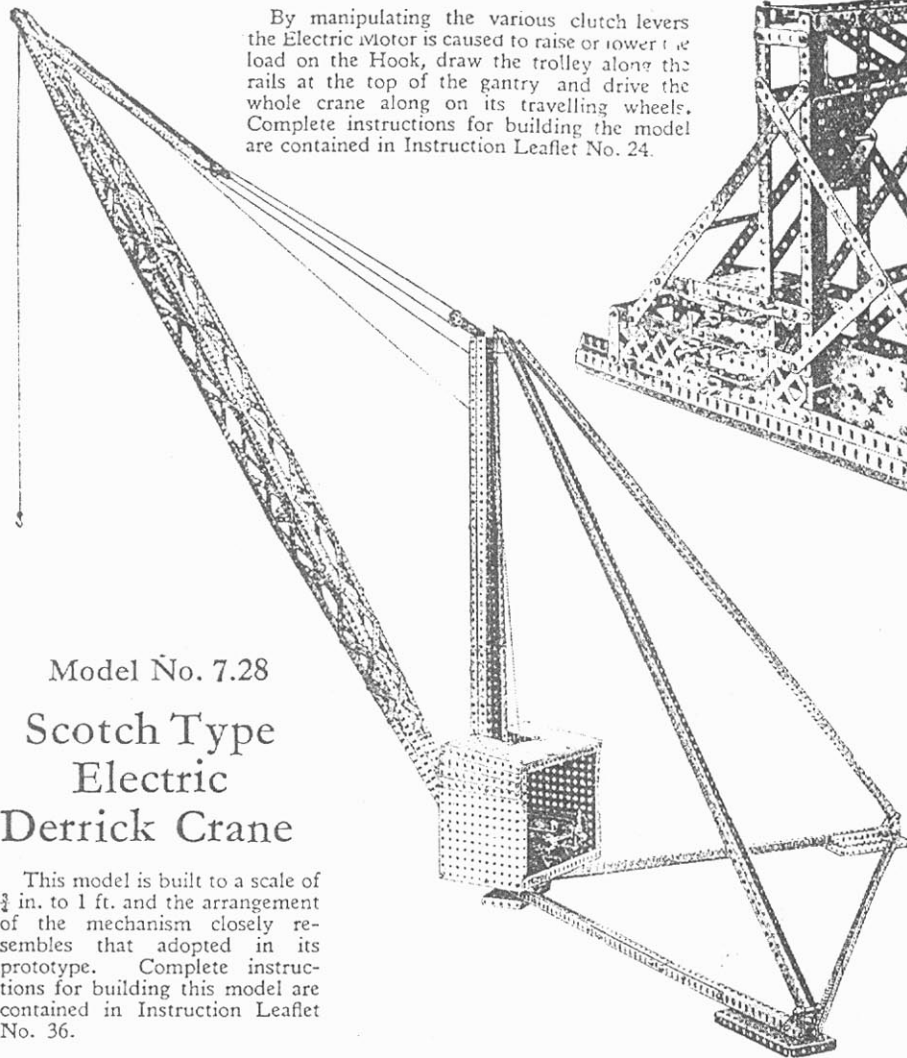

Model No. 7.31

## Travelling Bucket Dredger

This is an ideal model to use in conjunction with your Hornby miniature railway. It can be used to load goods wagons with sand, grain, etc. Complete instructions for building this model are contained in Instruction Leaflet No. 5.

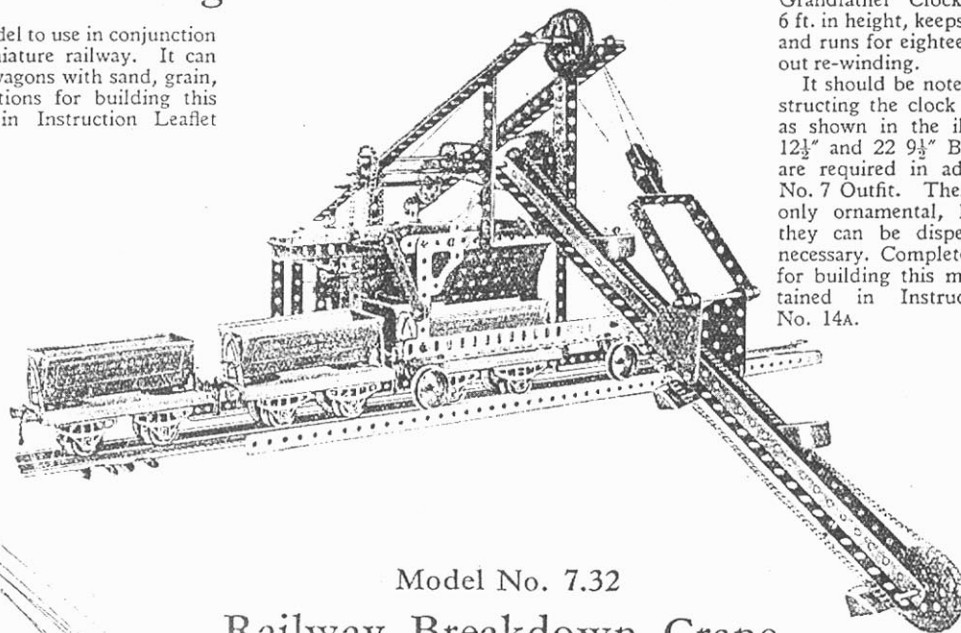

Model No. 7.32

## Railway Breakdown Crane

This very realistic model represents a heavy type of crane designed to run under its own power on standard railway lines. All the important features of its prototype are reproduced and the model is capable of four distinct movements, i.e., the hoisting and lowering of the pulley block, slewing, luffing and travelling. Complete instructions for building the model are contained in Instruction Leaflet No. 30.

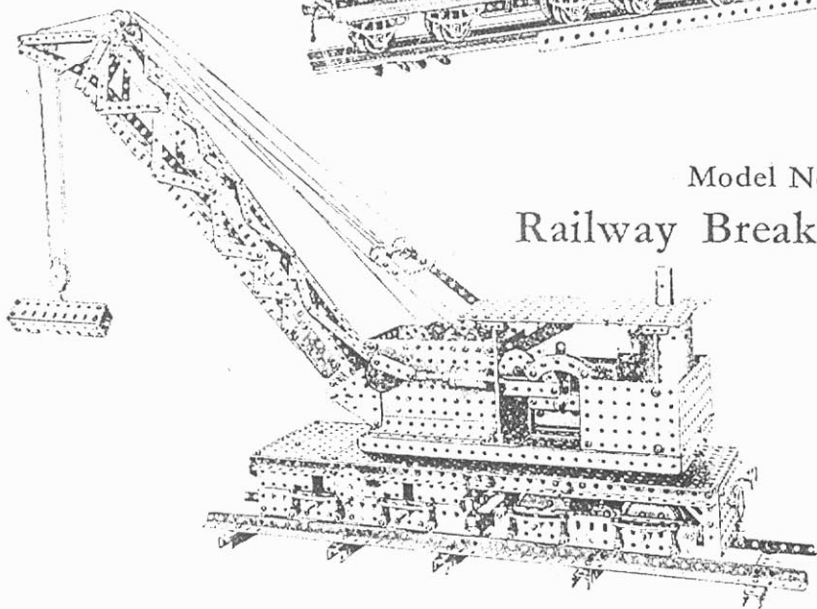

## Model No. 7.33 Grandfather Clock

This new Meccano model of a Grandfather Clock stands over 6 ft. in height, keeps perfect time, and runs for eighteen hours without re-winding.

It should be noted that in constructing the clock frame exactly as shown in the illustration, 20 12 1/2" and 22 9 1/2" Braced Girders are required in addition to the No. 7 Outfit. These Girders are only ornamental, however, and they can be dispensed with if necessary. Complete instructions for building this model are contained in Instruction Leaflet No. 14A.

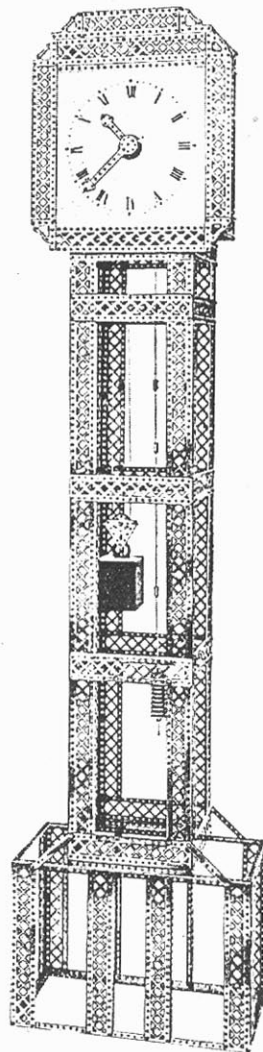

Model No. 7.34  
Automatic Reversing  
Transporter  
Bridge

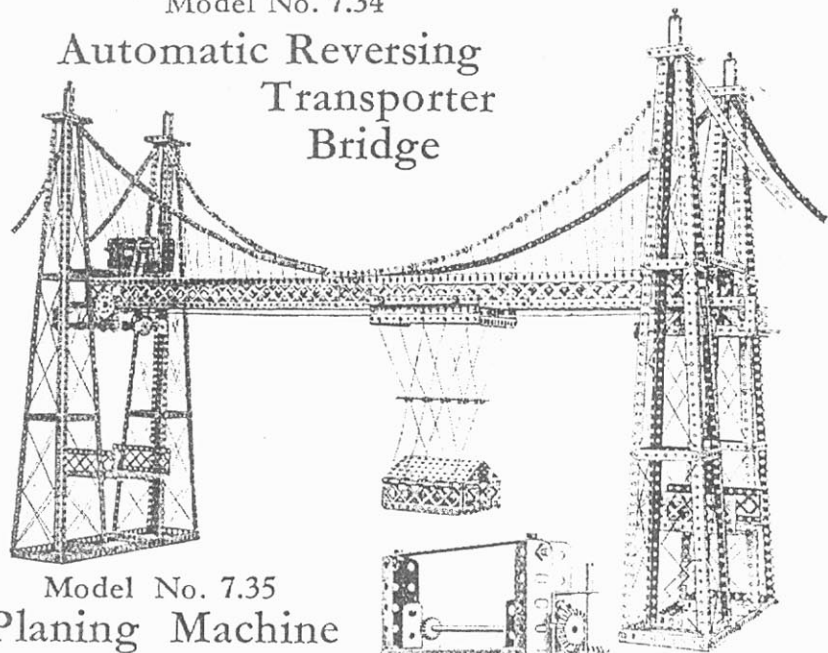

Model No. 7.35  
Planing Machine

The movements in this model comprise the reciprocating motion of the work table and the vertical and horizontal movements of the tool. Complete instructions for building this model are contained in Instruction Leaflet No. 17.

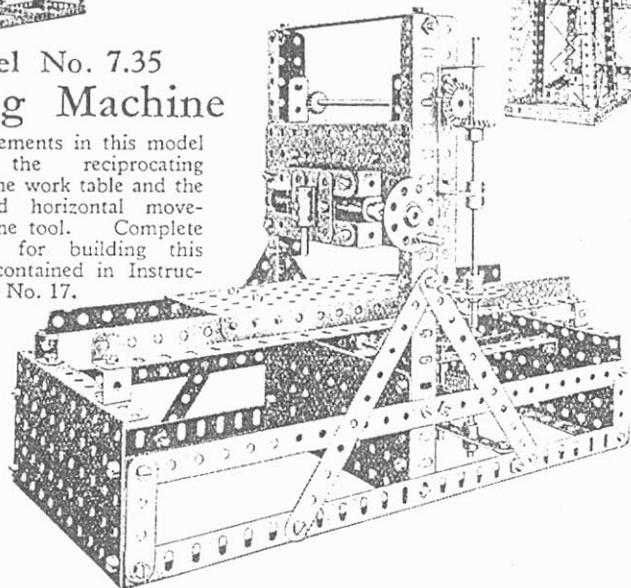

The design of this imposing model is based on that of the famous transporter bridge that spans the River Mersey between Runcorn and Widnes. Complete instructions for building this model are contained in Instruction Leaflet No. 21.

Model No. 7.36  
Level-  
Luffing  
Automatic  
Grabbing Crane

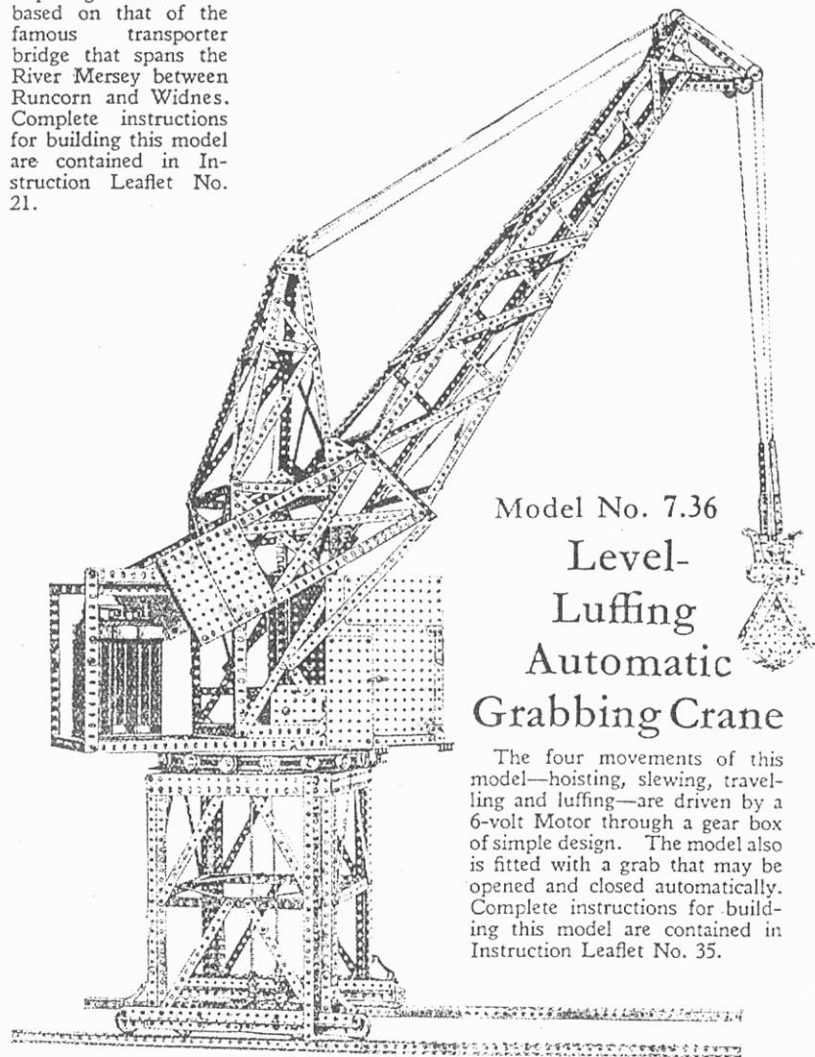

The four movements of this model—hoisting, slewing, traveling and luffing—are driven by a 6-volt Motor through a gear box of simple design. The model also is fitted with a grab that may be opened and closed automatically. Complete instructions for building this model are contained in Instruction Leaflet No. 35.

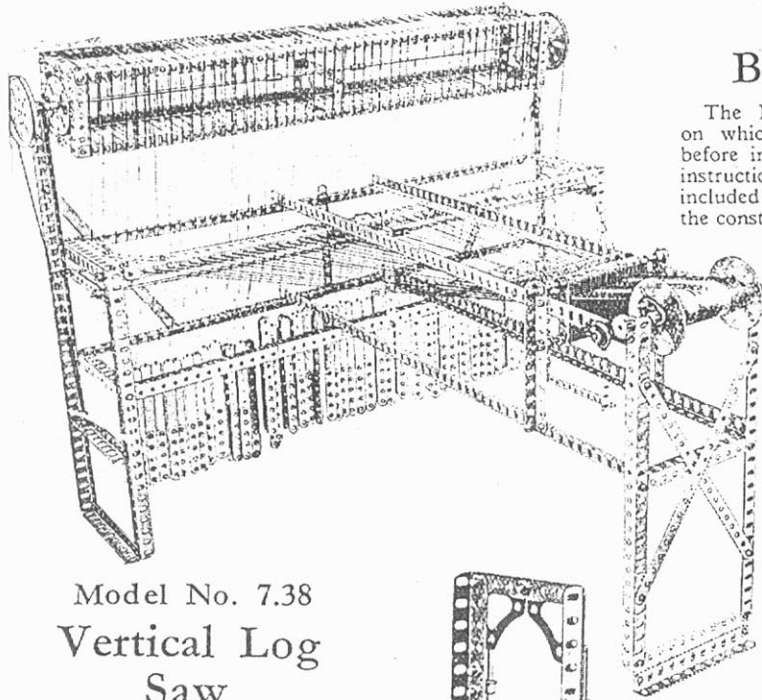

### Model No. 7.37 Beaming Frame

The Beaming Frame is the apparatus on which the Beam must be prepared before insertion in the Loom. Complete instructions for building this model are included in Leaflet No. 16A, which describes the construction of the Meccano Loom.

### Model No. 7.38 Vertical Log Saw

This is a model of a machine used in sawmills for sawing logs into planks. Complete instructions for building this model are contained in Instruction Leaflet No. 23.

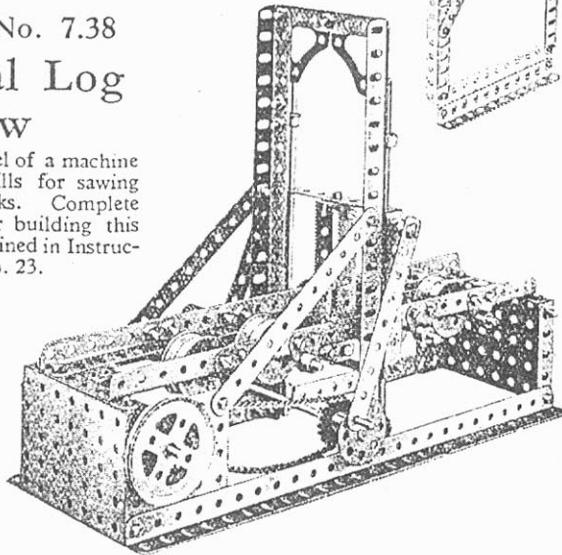

### Model No. 7.39 Loom

The Meccano Loom, which is considered by many to be the greatest Meccano achievement, has recently been rebuilt and re-designed. The model operates exactly like a real loom, the shedding motion of the heald frames, the rocking of the slay and reed, the oscillation of the picking sticks, and the "take-up" of the woven material all taking place with perfect accuracy. Complete instructions for building this model are contained in Instruction Leaflet No. 16A.

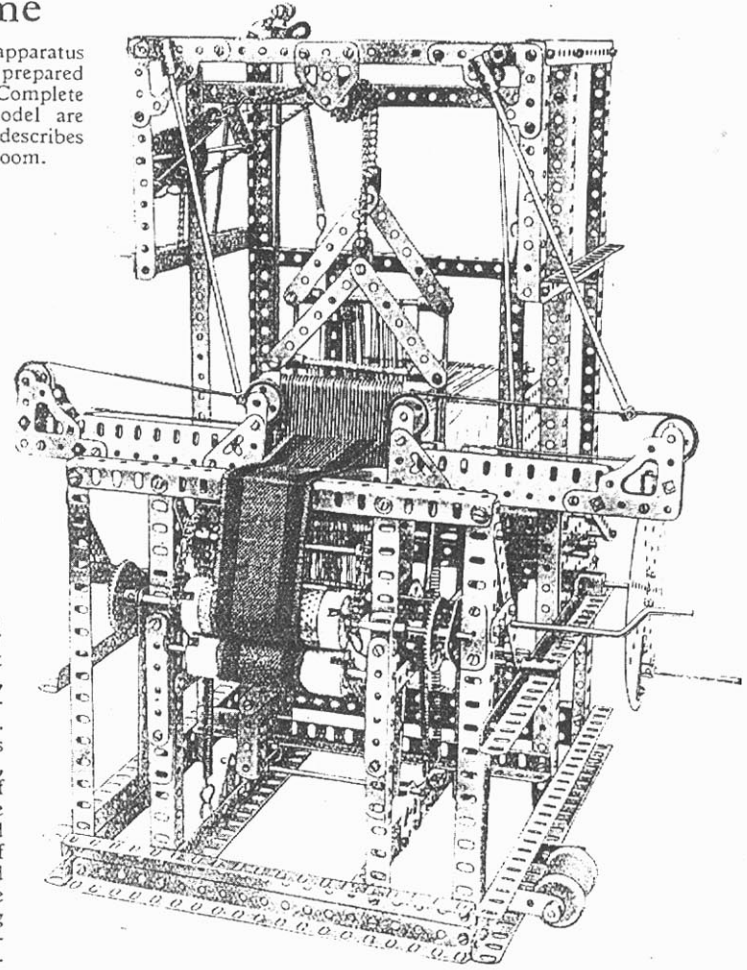

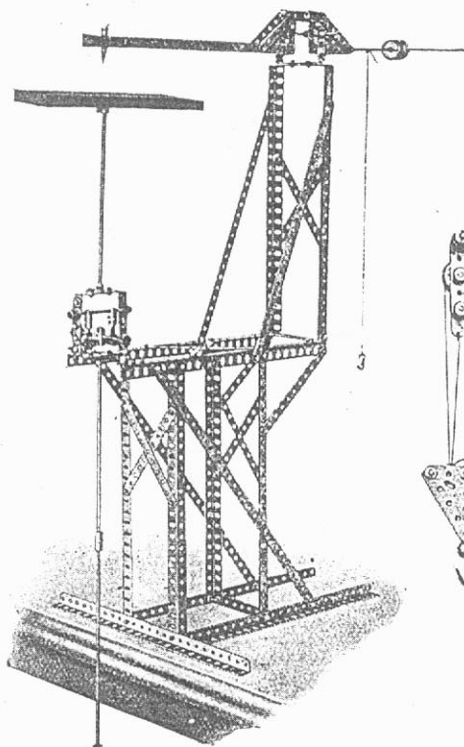

### Model No. 7.41 Stiff-Leg Derrick

The Meccano Stiff-Leg Derrick is an accurate reproduction of one of the most useful types of crane. Complete instructions for building this model are contained in Instruction Leaflet No. 6.

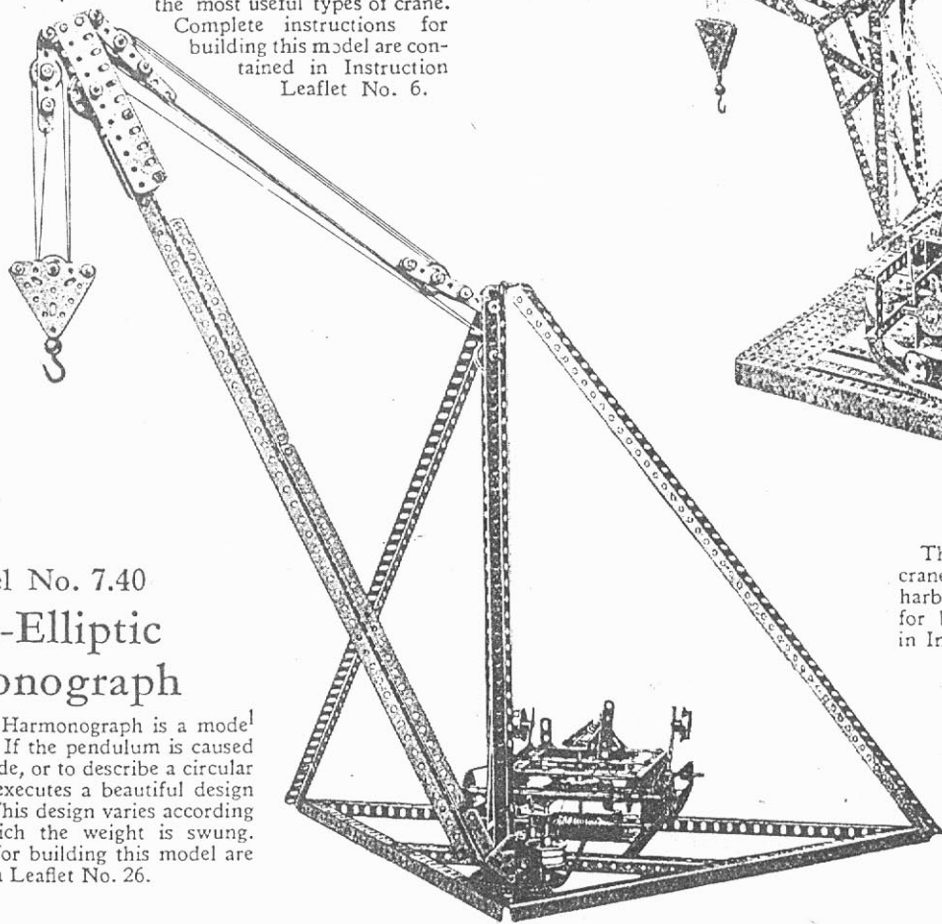

### Model No. 7.42 Pontoon Crane

This is a model of a giant floating crane of the type used in docks and harbours, etc. Complete instructions for building this model are contained in Instruction Leaflet No. 28.

### Model No. 7.40 Twin-Elliptic Harmonograph

The Twin-elliptic Harmonograph is a model of very great interest. If the pendulum is caused to swing from side to side, or to describe a circular movement, the pencil executes a beautiful design on a sheet of paper. This design varies according to the manner in which the weight is swung. Complete instructions for building this model are contained in Instruction Leaflet No. 26.





### Model No. 7.43 Motor Cycle and Sidecar

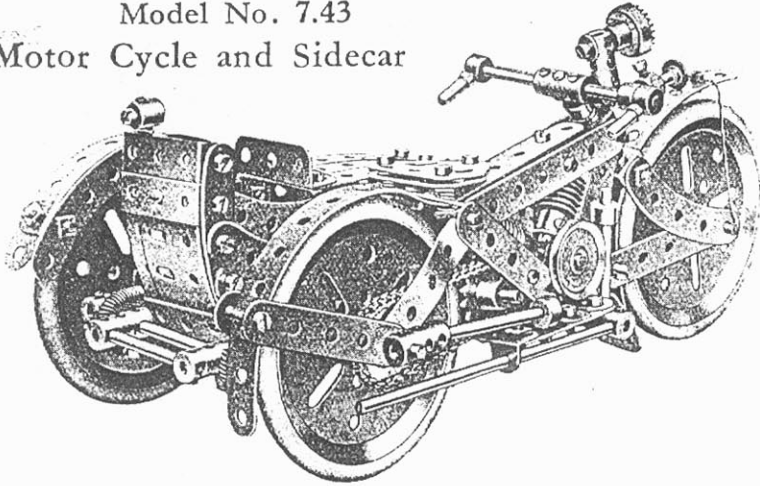

This model is an excellent example of Meccano miniature engineering, and affords a remarkable testimonial to the adaptability of the system. Complete instructions for building this model are contained in Instruction Leaflet No. 3.

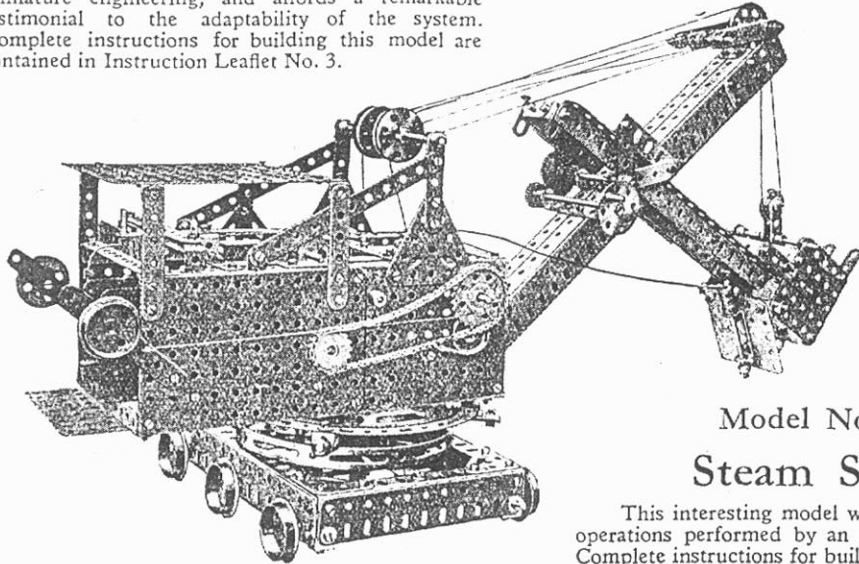

### Model No. 7.44 Steam Shovel

This interesting model will carry out all the operations performed by an actual steam navvy. Complete instructions for building this model are contained in Instruction Leaflet No. 19.

### Model No. 7.45 Ship Coaler

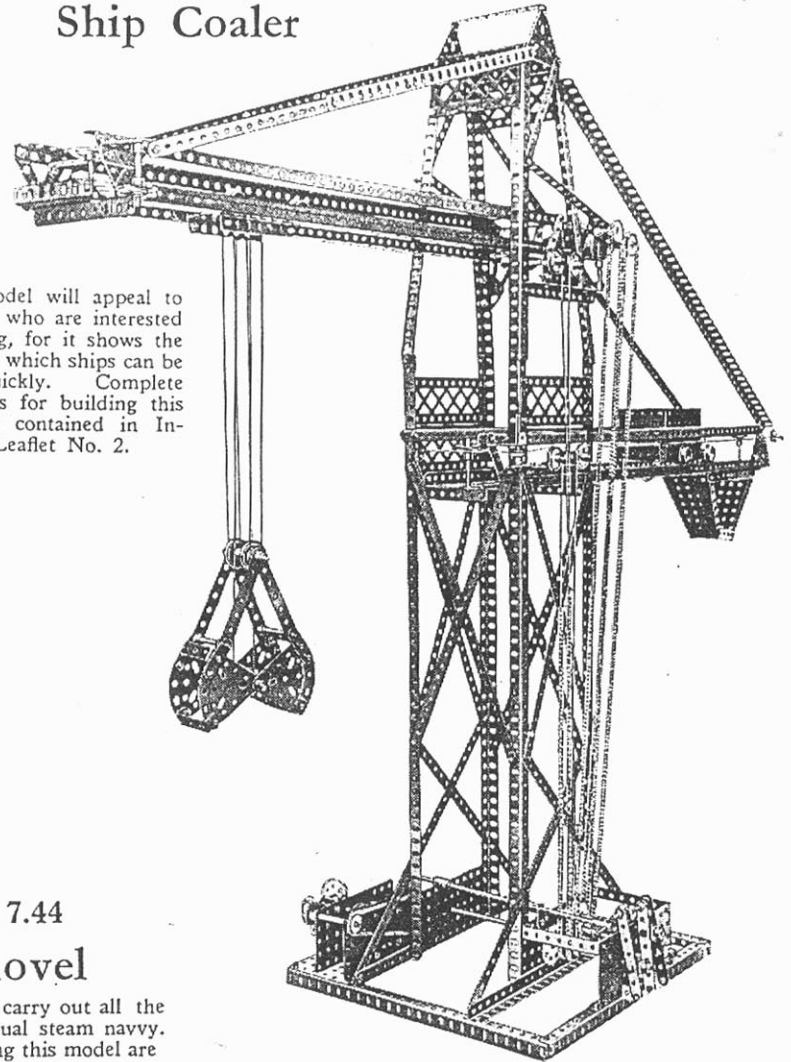

This model will appeal to most boys who are interested in shipping, for it shows the manner by which ships can be coaled quickly. Complete instructions for building this model are contained in Instruction Leaflet No. 2.

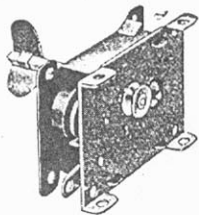

Magic Clockwork Motor

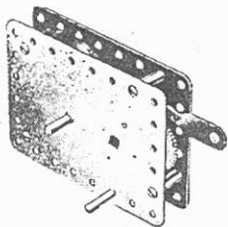

No. 1 Clockwork Motor

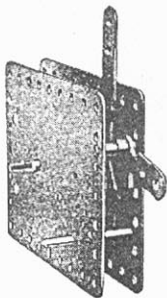

No. 2 Clockwork Motor



Resistance Controller

# MECCANO

POWER UNITS FOR OPERATING MECCANO MODELS

If you want to obtain the fullest enjoyment from the Meccano hobby you should operate your models by means of one of the Meccano power units described on this page. You push over the control lever of the Clockwork or Electric Motor and immediately your Crane, Motor Car, Ship Coaler or Windmill commences to work in exactly the same manner as its prototype in real life.

The side plates and bases of each Motor are pierced with the standard Meccano equidistant holes, which enables the Motor to be built into any Meccano model in the exact position required.

## MECCANO CLOCKWORK MOTORS

These are the finest clockwork Motors obtainable for driving models. They have exceptional power and length of run and their gears are cut with such precision as to make them perfectly smooth and steady in operation.

**MAGIC CLOCKWORK MOTOR.** A fine Motor specially designed to drive with ease any of the X Series models and also many of the smaller types of Meccano models. It is non-reversing.

**No. 1 CLOCKWORK MOTOR.** An efficient and long-running Motor fitted with a brake lever. It is non-reversing.

**No. 1a. CLOCKWORK MOTOR.** This Motor is more powerful than the No. 1 Motor and is fitted with reversing motion. It has start, stop and reverse levers.

**No. 2 CLOCKWORK MOTOR.** This is a Motor of super quality. Brake and reverse levers enable the Motor to be started, stopped or reversed, as required.

## MECCANO ELECTRIC MOTORS

The four Meccano Electric Motors detailed below provide smooth-running power units for the operation of Meccano models. The 6-volt Motors may be operated either from a 6-volt Accumulator, or through a Transformer direct from the mains providing that the supply is alternating current. They cannot be run satisfactorily from dry cells. The 20-volt Motors are most conveniently operated through a 20-volt Transformer from alternating current supply mains.

**No. E1 Electric Motor (6-volt).** Non-reversing.

**No. E6 Electric Motor (6-volt).** Reversing.

**No. E120 Electric Motor (20-volt).** Non-reversing.

**No. E20B Electric Motor (20-volt).** Reversing.

## MECCANO TRANSFORMERS

A Meccano Transformer provides a convenient and safe means of driving a Meccano Electric Motor from the mains supply where this is alternating current.

There are six Transformers in the series, all of which are available for the following A.C. supplies:—100/110 volts, 50 cycles; 200/225 volts, 50 cycles; 225/250 volts, 50 cycles. Any of the Transformers can be specially wound for supplies other than these at a small extra charge. When ordering a Transformer the voltage and frequency of the supply must always be stated.

**No. T6 Transformer (Output 25 VA at 9 volts) for 6-volt Electric Motors.** Fitted with 5 stud speed regulator.

**No. T6M Transformer (Output 25 VA at 9 volts) for 6-volt Electric Motors.** This is similar to No. T6, but is not fitted with a speed regulator.

**No. T6A Transformer (Output 40 VA at 9 $\frac{3}{4}$  volts) for 6-volt Electric Motors.** Fitted with speed regulator and separate circuit for supplying current for eighteen 3 $\frac{1}{2}$ -volt lamps.

**No. T20 Transformer (Output 20 VA at 20 volts) for 20-volt Electric Motors.** Fitted with 5-stud speed regulator.

**No. T20M Transformer (Output 20 VA at 20 volts) for 20-volt Electric Motors.** This is similar to No. T20, but is not fitted with speed regulator.

**No. T20A Transformer (Output 35 VA at 20 $\frac{3}{4}$  volts) for 20-volt Electric Motors.** Fitted with speed regulator and output sockets for lighting lamps.

## RESISTANCE CONTROLLERS

These Controllers enable the speed of Meccano 6-volt and 20-volt Motors and Hornby 6-volt and 20-volt Electric Trains to be regulated as desired.

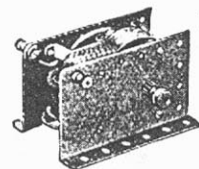

No. E1 Electric Motor (6-volt)

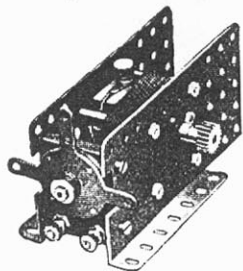

No. E6 Electric Motor (6-volt)

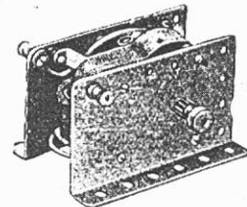

No. E1/20 Electric Motor (20-volt)

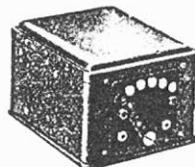

No. T20 Transformer

Ask your dealer for a complete price list

# CONTENTS OF OUTFITS

No.	DESCRIPTION OF PART.	00	00A	0	0A	1	1A	2	2A	3	3A	4	4A	5	5A	6	6A	7
1	Perforated Strips, 1 1/2"	..	..	..	..	..	..	..	..	..	..	..	..	..	..	..	..	..
1A	" "	..	..	..	4	4	6	10	..	10	..	10	6	16	14	30	8	38
1B	" "	..	..	..	..	..	..	..	..	..	..	..	..	..	..	..	..	..
2	" "	..	..	..	..	..	..	..	..	..	..	..	..	..	..	..	..	..
2A	" "	..	..	..	..	..	..	..	..	..	..	..	..	..	..	..	..	..
3	" "	..	..	..	..	..	..	..	..	..	..	..	..	..	..	..	..	..
3A	" "	..	..	..	..	..	..	..	..	..	..	..	..	..	..	..	..	..
4	" "	..	..	..	..	..	..	..	..	..	..	..	..	..	..	..	..	..
4A	" "	..	..	..	..	..	..	..	..	..	..	..	..	..	..	..	..	..
5	" "	..	..	..	..	..	..	..	..	..	..	..	..	..	..	..	..	..
5A	" "	..	..	..	..	..	..	..	..	..	..	..	..	..	..	..	..	..
6	" "	..	..	..	..	..	..	..	..	..	..	..	..	..	..	..	..	..
6A	" "	..	..	..	..	..	..	..	..	..	..	..	..	..	..	..	..	..
7	Angle Girders, 2 1/2"	..	..	..	..	..	..	..	..	..	..	..	..	..	..	..	..	..
7A	" "	..	..	..	..	..	..	..	..	..	..	..	..	..	..	..	..	..
8	" "	..	..	..	..	..	..	..	..	..	..	..	..	..	..	..	..	..
8A	" "	..	..	..	..	..	..	..	..	..	..	..	..	..	..	..	..	..
8B	" "	..	..	..	..	..	..	..	..	..	..	..	..	..	..	..	..	..
9	" "	..	..	..	..	..	..	..	..	..	..	..	..	..	..	..	..	..
9A	" "	..	..	..	..	..	..	..	..	..	..	..	..	..	..	..	..	..
9B	" "	..	..	..	..	..	..	..	..	..	..	..	..	..	..	..	..	..
9C	" "	..	..	..	..	..	..	..	..	..	..	..	..	..	..	..	..	..
9D	" "	..	..	..	..	..	..	..	..	..	..	..	..	..	..	..	..	..
9E	" "	..	..	..	..	..	..	..	..	..	..	..	..	..	..	..	..	..
9F	" "	..	..	..	..	..	..	..	..	..	..	..	..	..	..	..	..	..
10	Flat Brackets	..	..	..	..	..	..	..	..	..	..	..	..	..	..	..	..	..
11	Double Brackets	..	..	..	..	..	..	..	..	..	..	..	..	..	..	..	..	..
12	Angle Brackets, 1" x 1"	..	..	..	..	..	..	..	..	..	..	..	..	..	..	..	..	..
12A	" "	..	..	..	..	..	..	..	..	..	..	..	..	..	..	..	..	..
12B	" "	..	..	..	..	..	..	..	..	..	..	..	..	..	..	..	..	..
13	Axle Rods, 1 1/2"	..	..	..	..	..	..	..	..	..	..	..	..	..	..	..	..	..
13A	" "	..	..	..	..	..	..	..	..	..	..	..	..	..	..	..	..	..
14	" "	..	..	..	..	..	..	..	..	..	..	..	..	..	..	..	..	..
15	" "	..	..	..	..	..	..	..	..	..	..	..	..	..	..	..	..	..
15A	" "	..	..	..	..	..	..	..	..	..	..	..	..	..	..	..	..	..
16	" "	..	..	..	..	..	..	..	..	..	..	..	..	..	..	..	..	..
16A	" "	..	..	..	..	..	..	..	..	..	..	..	..	..	..	..	..	..
16B	" "	..	..	..	..	..	..	..	..	..	..	..	..	..	..	..	..	..
17	" "	..	..	..	..	..	..	..	..	..	..	..	..	..	..	..	..	..
18	" "	..	..	..	..	..	..	..	..	..	..	..	..	..	..	..	..	..
18A	" "	..	..	..	..	..	..	..	..	..	..	..	..	..	..	..	..	..
18B	" "	..	..	..	..	..	..	..	..	..	..	..	..	..	..	..	..	..
19	Crank Handles (3" shaft)	..	..	..	..	..	..	..	..	..	..	..	..	..	..	..	..	..
19A	" "	..	..	..	..	..	..	..	..	..	..	..	..	..	..	..	..	..
19B	" "	..	..	..	..	..	..	..	..	..	..	..	..	..	..	..	..	..
20	Pulley Wheels, 3"	..	..	..	..	..	..	..	..	..	..	..	..	..	..	..	..	..
20A	" "	..	..	..	..	..	..	..	..	..	..	..	..	..	..	..	..	..
20B	" "	..	..	..	..	..	..	..	..	..	..	..	..	..	..	..	..	..
21	Pulley Wheels, 2"	..	..	..	..	..	..	..	..	..	..	..	..	..	..	..	..	..
21A	" "	..	..	..	..	..	..	..	..	..	..	..	..	..	..	..	..	..
22	" "	..	..	..	..	..	..	..	..	..	..	..	..	..	..	..	..	..
22A	" "	..	..	..	..	..	..	..	..	..	..	..	..	..	..	..	..	..
23	" "	..	..	..	..	..	..	..	..	..	..	..	..	..	..	..	..	..
23A	" "	..	..	..	..	..	..	..	..	..	..	..	..	..	..	..	..	..
24	Bush Wheels	..	..	..	..	..	..	..	..	..	..	..	..	..	..	..	..	..
25	Pinion Wheels, 1 1/2" diam., wide	..	..	..	..	..	..	..	..	..	..	..	..	..	..	..	..	..
25A	" "	..	..	..	..	..	..	..	..	..	..	..	..	..	..	..	..	..
26	" "	..	..	..	..	..	..	..	..	..	..	..	..	..	..	..	..	..
26A	" "	..	..	..	..	..	..	..	..	..	..	..	..	..	..	..	..	..
27	Gear Wheels, 50-teeth	..	..	..	..	..	..	..	..	..	..	..	..	..	..	..	..	..
27A	" "	..	..	..	..	..	..	..	..	..	..	..	..	..	..	..	..	..
27B	" "	..	..	..	..	..	..	..	..	..	..	..	..	..	..	..	..	..
28	Contrate Wheels, 1 1/2" (3/4" diam.)	..	..	..	..	..	..	..	..	..	..	..	..	..	..	..	..	..
29	Bevel Gears, 1 1/2"	..	..	..	..	..	..	..	..	..	..	..	..	..	..	..	..	..
30	" "	..	..	..	..	..	..	..	..	..	..	..	..	..	..	..	..	..
30A	" "	..	..	..	..	..	..	..	..	..	..	..	..	..	..	..	..	..
30C	" "	..	..	..	..	..	..	..	..	..	..	..	..	..	..	..	..	..
31	Gear Wheels, 1", 98-teeth	..	..	..	..	..	..	..	..	..	..	..	..	..	..	..	..	..
32	Worms	..	..	..	..	..	..	..	..	..	..	..	..	..	..	..	..	..
34	Spanners	..	..	..	..	..	..	..	..	..	..	..	..	..	..	..	..	..
35	Spring Clips	..	..	..	..	..	..	..	..	..	..	..	..	..	..	..	..	..
36	Screw Drivers	..	..	..	..	..	..	..	..	..	..	..	..	..	..	..	..	..
36A	" "	..	..	..	..	..	..	..	..	..	..	..	..	..	..	..	..	..
36B	" "	..	..	..	..	..	..	..	..	..	..	..	..	..	..	..	..	..
37	Nuts and Bolts, 7/32"	..	..	..	..	..	..	..	..	..	..	..	..	..	..	..	..	..
37A	" "	..	..	..	..	..	..	..	..	..	..	..	..	..	..	..	..	..
38	Washers	..	..	..	..	..	..	..	..	..	..	..	..	..	..	..	..	..
40	Hanks of Cord	..	..	..	..	..	..	..	..	..	..	..	..	..	..	..	..	..
41	Propeller Blades	..	..	..	..	..	..	..	..	..	..	..	..	..	..	..	..	..
43	Spring	..	..	..	..	..	..	..	..	..	..	..	..	..	..	..	..	..
44	Cranked Bent Strips	..	..	..	..	..	..	..	..	..	..	..	..	..	..	..	..	..
45	Double Bent Strips	..	..	..	..	..	..	..	..	..	..	..	..	..	..	..	..	..
46	Double Angle Strips, 2 1/2" x 1 1/4"	..	..	..	..	..	..	..	..	..	..	..	..	..	..	..	..	..
47	" "	..	..	..	..	..	..	..	..	..	..	..	..	..	..	..	..	..
47A	" "	..	..	..	..	..	..	..	..	..	..	..	..	..	..	..	..	..
48	" "	..	..	..	..	..	..	..	..	..	..	..	..	..	..	..	..	..
48A	" "	..	..	..	..	..	..	..	..	..	..	..	..	..	..	..	..	..

(CONTINUED OVERLEAF)

## Contents of Outfits—(Continued).

No.	DESCRIPTION OF PART.	00	00A	0	0A	1	1A	2	2A	3	3A	4	4A	5	5A	6	6A	7
48n	Double Angle Strips, 3½" x 1½"	...	...	...	...	...	...	...	...	...	...	...	...	...	...	...	...	...
48C	" " " 4½" x 1½"	...	...	...	...	...	...	...	...	...	...	...	...	...	...	...	...	...
48D	" " " 5½" x 1½"	...	...	...	...	...	...	...	...	...	...	...	...	...	...	...	...	...
50A	" Pieces, with boss	...	...	...	...	...	...	...	...	...	...	...	...	...	...	...	...	...
52	Perforated Flanged Plates, 5½" x 2½"	...	...	...	...	...	...	...	...	...	...	...	...	...	...	...	...	...
52A	Flat Plates, 5½" x 2½"	...	...	...	...	...	...	...	...	...	...	...	...	...	...	...	...	...
53	Perforated Flanged Plates, 3½" x 2½"	...	...	...	...	...	...	...	...	...	...	...	...	...	...	...	...	...
53A	Flat Plates, 4½" x 2½"	...	...	...	...	...	...	...	...	...	...	...	...	...	...	...	...	...
54	Perforated Flanged Sector Plates	...	...	...	...	...	...	...	...	...	...	...	...	...	...	...	...	...
55A	Strips, slotted, 2"	...	...	...	...	...	...	...	...	...	...	...	...	...	...	...	...	...
57B	Hooks, Loaded (Large)	...	...	...	...	...	...	...	...	...	...	...	...	...	...	...	...	...
57C	(Small)	...	...	...	...	...	...	...	...	...	...	...	...	...	...	...	...	...
58	Spring Cord, 40" lengths	...	...	...	...	...	...	...	...	...	...	...	...	...	...	...	...	...
58A	Coupling Screws for Spring Cord	...	...	...	...	...	...	...	...	...	...	...	...	...	...	...	...	...
59	Collars with Set Screws	...	...	...	...	...	...	...	...	...	...	...	...	...	...	...	...	...
59A	Cranks ...	...	...	...	...	...	...	...	...	...	...	...	...	...	...	...	...	...
62A	Threaded Cranks	...	...	...	...	...	...	...	...	...	...	...	...	...	...	...	...	...
62B	Double Arm Cranks	...	...	...	...	...	...	...	...	...	...	...	...	...	...	...	...	...
63	Couplings ...	...	...	...	...	...	...	...	...	...	...	...	...	...	...	...	...	...
63B	Strip Couplings	...	...	...	...	...	...	...	...	...	...	...	...	...	...	...	...	...
64	Threaded Bosses	...	...	...	...	...	...	...	...	...	...	...	...	...	...	...	...	...
65	Centre Forks	...	...	...	...	...	...	...	...	...	...	...	...	...	...	...	...	...
70	Flat Plates, 5½" x 2½"	...	...	...	...	...	...	...	...	...	...	...	...	...	...	...	...	...
72	Flat Plates, 2½" x 2"	...	...	...	...	...	...	...	...	...	...	...	...	...	...	...	...	...
76	Triangular Plates, 2½"	...	...	...	...	...	...	...	...	...	...	...	...	...	...	...	...	...
77	" " " 1½"	...	...	...	...	...	...	...	...	...	...	...	...	...	...	...	...	...
78	Screwed Rods, 11½"	...	...	...	...	...	...	...	...	...	...	...	...	...	...	...	...	...
80	" " " 5"	...	...	...	...	...	...	...	...	...	...	...	...	...	...	...	...	...
80A	" " " 3½"	...	...	...	...	...	...	...	...	...	...	...	...	...	...	...	...	...
80B	" " " 4"	...	...	...	...	...	...	...	...	...	...	...	...	...	...	...	...	...
81	" " " 2"	...	...	...	...	...	...	...	...	...	...	...	...	...	...	...	...	...
82	" " " 1"	...	...	...	...	...	...	...	...	...	...	...	...	...	...	...	...	...
89	Curved Strips, 6½", 10" radius	...	...	...	...	...	...	...	...	...	...	...	...	...	...	...	...	...
90	" " " 2½", large "	...	...	...	...	...	...	...	...	...	...	...	...	...	...	...	...	...
90A	Sprocket Chain ...	...	...	...	...	...	...	...	...	...	...	...	...	...	...	...	...	...
94	" " " 1"	...	...	...	...	...	...	...	...	...	...	...	...	...	...	...	...	...
95	" " " 1½"	...	...	...	...	...	...	...	...	...	...	...	...	...	...	...	...	...
95A	" " " 1"	...	...	...	...	...	...	...	...	...	...	...	...	...	...	...	...	...
95B	" " " 1"	...	...	...	...	...	...	...	...	...	...	...	...	...	...	...	...	...
96	" " " 3"	...	...	...	...	...	...	...	...	...	...	...	...	...	...	...	...	...
96A	" " " 2"	...	...	...	...	...	...	...	...	...	...	...	...	...	...	...	...	...
97	Braced Girders, 3½"	...	...	...	...	...	...	...	...	...	...	...	...	...	...	...	...	...
98	" " " 2½"	...	...	...	...	...	...	...	...	...	...	...	...	...	...	...	...	...
99	" " " 9"	...	...	...	...	...	...	...	...	...	...	...	...	...	...	...	...	...
99A	" " " 7"	...	...	...	...	...	...	...	...	...	...	...	...	...	...	...	...	...
99B	" " " 5½"	...	...	...	...	...	...	...	...	...	...	...	...	...	...	...	...	...
100	" " " 5"	...	...	...	...	...	...	...	...	...	...	...	...	...	...	...	...	...
101	Heads for Looms	...	...	...	...	...	...	...	...	...	...	...	...	...	...	...	...	...
102	Single Bent Strips	...	...	...	...	...	...	...	...	...	...	...	...	...	...	...	...	...
103	Flat Girders, 5½"	...	...	...	...	...	...	...	...	...	...	...	...	...	...	...	...	...
103A	" " " 4½"	...	...	...	...	...	...	...	...	...	...	...	...	...	...	...	...	...
103B	" " " 12"	...	...	...	...	...	...	...	...	...	...	...	...	...	...	...	...	...
103C	" " " 3½"	...	...	...	...	...	...	...	...	...	...	...	...	...	...	...	...	...
103D	" " " 3"	...	...	...	...	...	...	...	...	...	...	...	...	...	...	...	...	...
103E	" " " 2½"	...	...	...	...	...	...	...	...	...	...	...	...	...	...	...	...	...
103F	" " " 2"	...	...	...	...	...	...	...	...	...	...	...	...	...	...	...	...	...
103G	" " " 1½"	...	...	...	...	...	...	...	...	...	...	...	...	...	...	...	...	...
103H	" " " 1"	...	...	...	...	...	...	...	...	...	...	...	...	...	...	...	...	...
103K	" " " 7½"	...	...	...	...	...	...	...	...	...	...	...	...	...	...	...	...	...
104	Shuttles for Looms	...	...	...	...	...	...	...	...	...	...	...	...	...	...	...	...	...
105	Reed Hooks	...	...	...	...	...	...	...	...	...	...	...	...	...	...	...	...	...
106	Wood Rollers	...	...	...	...	...	...	...	...	...	...	...	...	...	...	...	...	...
106A	Sand	...	...	...	...	...	...	...	...	...	...	...	...	...	...	...	...	...
107	Designing Tables	...	...	...	...	...	...	...	...	...	...	...	...	...	...	...	...	...
108	Architraves ...	...	...	...	...	...	...	...	...	...	...	...	...	...	...	...	...	...
109	Face Plates, 2½"	...	...	...	...	...	...	...	...	...	...	...	...	...	...	...	...	...
110	Rack Strips, 3½"	...	...	...	...	...	...	...	...	...	...	...	...	...	...	...	...	...
111	Bolts, 1"	...	...	...	...	...	...	...	...	...	...	...	...	...	...	...	...	...
111A	" " " 1"	...	...	...	...	...	...	...	...	...	...	...	...	...	...	...	...	...
111C	" " " 1"	...	...	...	...	...	...	...	...	...	...	...	...	...	...	...	...	...
114	Hinges ...	...	...	...	...	...	...	...	...	...	...	...	...	...	...	...	...	...
115	Threaded Pins	...	...	...	...	...	...	...	...	...	...	...	...	...	...	...	...	...
116	Fork Pieces	...	...	...	...	...	...	...	...	...	...	...	...	...	...	...	...	...
116A	Small Fork Pieces	...	...	...	...	...	...	...	...	...	...	...	...	...	...	...	...	...
118	Hub Discs (5½" diam.)	...	...	...	...	...	...	...	...	...	...	...	...	...	...	...	...	...
119	Channel Segments (8 to circle)	...	...	...	...	...	...	...	...	...	...	...	...	...	...	...	...	...
120A	Spring Buffers	...	...	...	...	...	...	...	...	...	...	...	...	...	...	...	...	...
120B	Compression Springs	...	...	...	...	...	...	...	...	...	...	...	...	...	...	...	...	...
121	Train Couplings	...	...	...	...	...	...	...	...	...	...	...	...	...	...	...	...	...

[CONTINUED OVERLEAF

Contents of Outfits—(Continued).

No.	DESCRIPTION OF PART.	00	00A	0	0A	1	1A	2	2A	3	3A	4	4A	5	5A	6	6A	7		
124	Reversed Angle Brackets, 1"	...	...	...	...	...	...	...	...	...	...	...	...	...	...	...	...	...	4	
125	Trunnions "	1	1	2	...	2	2	4	...	4	...	4	...	4	4	4	5	0	0	
126	Flat Trunnions "	2	2	2	...	2	2	2	...	2	2	4	...	4	4	4	3	8	4	
128A	Bess Bell Cranks	2	2	2	...	2	2	2	...	2	2	4	...	4	4	4	3	8	2	
128	Rack Segments (3" diam.)	...	...	...	...	...	...	...	...	...	...	...	...	...	...	...	...	...	4	
129	Eccentrics, Triple Throw	...	...	...	...	...	...	...	...	...	...	...	...	...	...	...	...	...	4	
130	Dredger Buckets	...	...	...	...	...	...	...	...	...	...	...	...	...	...	...	...	...	4	
131	Flywheels, 2½"	...	...	...	...	...	...	...	...	...	...	...	...	...	...	...	...	...	2	
132	Corner Brackets	...	...	...	...	...	...	...	...	...	...	...	...	...	...	...	...	...	2	
133	Theodolite Protractors	...	...	...	...	...	...	...	...	...	...	...	...	...	...	...	...	...	5	
135	Handrail Supports	...	...	...	...	...	...	...	...	...	...	...	...	...	...	...	...	...	1	
136	Wheel Flanges	...	...	...	...	...	...	...	...	...	...	...	...	...	...	...	...	...	1	
137	Universal Couplings	...	...	...	...	...	...	...	...	...	...	...	...	...	...	...	...	...	4	
140	Wire Lines	...	...	...	...	...	...	...	...	...	...	...	...	...	...	...	...	...	4	
141	Rubber Rings, 3" diam.	...	...	...	...	...	...	...	...	...	...	...	...	...	...	...	...	...	2	
142	Motor Tyres, 3", internal diam.	...	...	...	...	...	...	...	...	...	...	...	...	...	...	...	...	...	1	
142A	Circular Girders (5½" diam.)	...	...	...	...	...	...	...	...	...	...	...	...	...	...	...	...	...	3	
143	Dog Clutches	...	...	...	...	...	...	...	...	...	...	...	...	...	...	...	...	...	4	
144	Circular Strips (7½" diam. overall)	...	...	...	...	...	...	...	...	...	...	...	...	...	...	...	...	...	1	
145	Plates, 6"	...	...	...	...	...	...	...	...	...	...	...	...	...	...	...	...	...	1	
146	Pawls	...	...	...	...	...	...	...	...	...	...	...	...	...	...	...	...	...	2	
147A	Pivot Bolts with two Nuts	...	...	...	...	...	...	...	...	...	...	...	...	...	...	...	...	...	0	
147B	Ratchet Wheels	...	...	...	...	...	...	...	...	...	...	...	...	...	...	...	...	...	2	
148	Rubber Rings, ¾"	...	...	...	...	...	...	...	...	...	...	...	...	...	...	...	...	...	4	
155	Fans, 2" diam.	...	...	...	...	...	...	...	...	...	...	...	...	...	...	...	...	...	2	
157	Channel Bearings, 1½" x 1" x 1"	...	...	...	...	...	...	...	...	...	...	...	...	...	...	...	...	...	0	
160	Gridler Brackets, 3" x 1" x 1"	...	...	...	...	...	...	...	...	...	...	...	...	...	...	...	...	...	1	
161	Boilers, complete with Ends	...	...	...	...	...	...	...	...	...	...	...	...	...	...	...	...	...	1	
162	Boiler Ends	...	...	...	...	...	...	...	...	...	...	...	...	...	...	...	...	...	1	
162A	Sleeve Pieces	...	...	...	...	...	...	...	...	...	...	...	...	...	...	...	...	...	2	
163	Chimney Adaptors	...	...	...	...	...	...	...	...	...	...	...	...	...	...	...	...	...	1	
164	Swivel Bearings	...	...	...	...	...	...	...	...	...	...	...	...	...	...	...	...	...	1	
165	End "	...	...	...	...	...	...	...	...	...	...	...	...	...	...	...	...	...	1	
166	Ball "	...	...	...	...	...	...	...	...	...	...	...	...	...	...	...	...	...	1	
168	Eccentrics, 1" throw	...	...	...	...	...	...	...	...	...	...	...	...	...	...	...	...	...	1	
170	Socket Couplings	...	...	...	...	...	...	...	...	...	...	...	...	...	...	...	...	...	3	
171	Pendulum Connections	...	...	...	...	...	...	...	...	...	...	...	...	...	...	...	...	...	1	
172	Bobbins	...	...	...	...	...	...	...	...	...	...	...	...	...	...	...	...	...	2	
181	Bushes, Insulating	...	...	...	...	...	...	...	...	...	...	...	...	...	...	...	...	...	2	
182	Terminals	...	...	...	...	...	...	...	...	...	...	...	...	...	...	...	...	...	1	
1563	Washers, Insulating	...	...	...	...	...	...	...	...	...	...	...	...	...	...	...	...	...	3	
1570	6 B.A. Bolts	...	...	...	...	...	...	...	...	...	...	...	...	...	...	...	...	...	0	
1575	Nuts	...	...	...	...	...	...	...	...	...	...	...	...	...	...	...	...	...	0	
1583	Clockwork Motor No. 2	...	...	...	...	...	...	...	...	...	...	...	...	...	...	...	...	...	1	
	Electric Motor No. F.6 (6 volt)	...	...	...	...	...	...	...	...	...	...	...	...	...	...	...	...	...	1	
	Instruction Leaflets																			
No.	1A—Motor Chassis	...	...	...	...	...	...	...	...	...	...	...	...	...	...	...	...	...	...	1
	2—High-speed Ship-Coaler	...	...	...	...	...	...	...	...	...	...	...	...	...	...	...	...	...	...	1
	3—Motor Cycle and Sidecar	...	...	...	...	...	...	...	...	...	...	...	...	...	...	...	...	...	...	1
	5—Dredget...	...	...	...	...	...	...	...	...	...	...	...	...	...	...	...	...	...	...	1
	6—Stiff Leg Derrick	...	...	...	...	...	...	...	...	...	...	...	...	...	...	...	...	...	...	1
	7—Platform Scales	...	...	...	...	...	...	...	...	...	...	...	...	...	...	...	...	...	...	1
	9—Bagatelle Table	...	...	...	...	...	...	...	...	...	...	...	...	...	...	...	...	...	...	1
	10—Log Saw	...	...	...	...	...	...	...	...	...	...	...	...	...	...	...	...	...	...	1
	11—Horizontal Steam Engine	...	...	...	...	...	...	...	...	...	...	...	...	...	...	...	...	...	...	1
	12—Stone-sawing Machine	...	...	...	...	...	...	...	...	...	...	...	...	...	...	...	...	...	...	1
	13—Meccanograph	...	...	...	...	...	...	...	...	...	...	...	...	...	...	...	...	...	...	1
	14A—New Grandfather Clock	...	...	...	...	...	...	...	...	...	...	...	...	...	...	...	...	...	...	1
	16A—New Loom	...	...	...	...	...	...	...	...	...	...	...	...	...	...	...	...	...	...	1
	17—Planing Machine	...	...	...	...	...	...	...	...	...	...	...	...	...	...	...	...	...	...	1
	18—Revolving Crane	...	...	...	...	...	...	...	...	...	...	...	...	...	...	...	...	...	...	1
	19—Steam Shovel	...	...	...	...	...	...	...	...	...	...	...	...	...	...	...	...	...	...	1
	20—Electric Mobile Crane	...	...	...	...	...	...	...	...	...	...	...	...	...	...	...	...	...	...	1
	21—Transporter Bridge	...	...	...	...	...	...	...	...	...	...	...	...	...	...	...	...	...	...	1
	22—Traction Engine	...	...	...	...	...	...	...	...	...	...	...	...	...	...	...	...	...	...	1
	23—Vertical Log Saw	...	...	...	...	...	...	...	...	...	...	...	...	...	...	...	...	...	...	1
	24—Travelling Gantry Crane	...	...	...	...	...	...	...	...	...	...	...	...	...	...	...	...	...	...	1
	25—Hydraulic Crane	...	...	...	...	...	...	...	...	...	...	...	...	...	...	...	...	...	...	1
	26—Twin-elliptic Harmonograph	...	...	...	...	...	...	...	...	...	...	...	...	...	...	...	...	...	...	1
	28—Pontoon Crane	...	...	...	...	...	...	...	...	...	...	...	...	...	...	...	...	...	...	1
	29—Hammerhead Crane	...	...	...	...	...	...	...	...	...	...	...	...	...	...	...	...	...	...	1
	30—Breakdown Crane	...	...	...	...	...	...	...	...	...	...	...	...	...	...	...	...	...	...	1
	31—Warehouse	...	...	...	...	...	...	...	...	...	...	...	...	...	...	...	...	...	...	1
	35—Automatic Grabbing Crane	...	...	...	...	...	...	...	...	...	...	...	...	...	...	...	...	...	...	1
	36—Electric Derrick Crane	...	...	...	...	...	...	...	...	...	...	...	...	...	...	...	...	...	...	1
	37—Howitzer Limber and Tractor	...	...	...	...	...	...	...	...	...	...	...	...	...	...	...	...	...	...	1

Full instructions for building a fine range of models are included with each Outfit.

# MECCANO

# MAGAZINE



The *Meccano Magazine* is the Meccano boy's newspaper. It is published monthly, and each issue contains details of splendid new Meccano models and new ideas for operating Hornby model railways. Interesting competitions, and first details of all new parts and accessories appear in its pages. It is the official organ of the Meccano Guild and the Hornby Railway Company, of which organisations many thousands of boys in all parts of the world are members. No Meccano or Hornby Train enthusiast should miss any of its issues.

The *Meccano Magazine* appeals to every boy, for it deals with Engineering in all its branches—Railways, Aviation, Ships, Motor Cars, Hydro-electric Schemes, Bridges, Cranes, etc. Specially attractive articles are devoted to Model Railways and Model Speed Boats, and to Home Experiments in Electricity and Chemistry. Other sections deal with Books of interest to boys—Stamps, New Inventions, etc.

The publishing date of the Magazine is the 1st of each month. If you are not already a reader, write to the Editor for full particulars, or order a copy from your Meccano dealer or newsagent.



The World's Best Magazine for Boys

# INDEX TO MODELS

Description	Model No.	Description	Model No.	Description	Model No.	Description	Model No.
Aeroplane, Revolving ...	6.7	Crane, Scotch type Electric		Locomotive and Tender ...	7.4 ; 7.16	Searchlight ...	4.30 ; 6.2
Armoured Motor Tricycle ...	5.42	Derrick ...	7.28	Clockwork Pacific		Sextant and Theodolite ...	4.34
Ash Tray and Match Holder ...	6.33	" Swivelling and Luffing Jib	4.53	" Tank ...	7.10	Sheer Legs ...	4.18
Automatic Fire Escape ...	7.1	" Travelling ...	5.25	" Electric ...	6.19	Ship Coaler ...	7.45
" Racer... ..	5.24	" Gantry ...	5.16 ; 7.29	" 0-4-0 Shunting ...	4.32	Shovel, Steam ...	4.61
" Reversing ...		Crazy Driver ...	7.8	" Stephenson's Rocket	4.37	Sighting Apparatus ...	6.21
" Transporter Bridge ...	7.34	Croquet, Table ...	4.18	Log Saw ...	6.44	Signal, Three-arm ...	4.12
" Warehouse Lift ...	7.24	Crossbow, Mechanical ...	4.36	Loom ...	7.39	Single Cylinder Horizontal Steam	
" Weighing Machine ...	6.18			Lorry, Motor ...	4.39	Engine ...	6.42
		Delivery Van ...	5.40	Machine Gun ...	6.40	Skein Winder ...	5.11
Bagatelle Table ...	6.45	Derricking Grab ...	6.14	Mantel Clock ...	7.13	Spooling Machine ...	5.1
Bale Lifter ...	4.41	Diplodocus ...	4.22	Map Measuring Instrument ...	5.36	Spring Balance ...	4.58
Battle Cruiser ...	5.45	Distance Indicator ...	4.5 ; 5.18	Measuring Machine ...	5.12	" Scales ...	5.17
Battleship... ..	6.38	Drill, Breast ...	4.13	Meccanograph ...	7.26	St. Malo Transporter Bridge ...	6.11
Beaming Frame ...	7.37	Drop Hammer ...	6.9	Mill Engine ...	6.37	Steam Engine, Under type ...	4.40
Beam Scales ...	5.29	Dutch Windmill ...	6.8	Motor 'Bus ...	4.28	" Shovel ...	7.44
Belgian Water Wheel ...	5.33			" Car ...	5.2 ; 5.15	" Tug Boat ...	6.20
Big Wheel... ..	6.21	Eiffel Tower ...	7.17	" " Ancient ...	4.50	" Wagon ...	5.41
Boat-Lowering Gear ...	7.7	Electric Mobile Crane ...	7.30	" " Armoured ...	5.20	" Winch ...	4.2
Box Ball Alley ...	6.24	" Telpher ...	5.30	" Chassis ...	7.21	Stiff Leg Derrick ...	7.41
Brewer's Dray ...	5.19	Equatorial Mounting ...	6.35	" Cycle and Sidecar ...	7.43	Stone Sawing Machine ...	6.43
Bridge Swing ...	4.8	Fertiliser Distributing Cart ...	5.7	" Plough ...	5.4	Submarine ...	4.65
Butter Churn ...	4.17	" Field Gun ...	7.12	Mouse Trap ...	5.22	Swing, Alternating ...	4.31
		" " and Carriage ...	5.8			Telpher Span ...	4.51
Cabin Monoplane... ..	5.3	" Fire Watertower ...	5.5	Oil Well Drilling Apparatus ...	5.34	The Tilters ...	7.19
Cable Ploughing Engine... ..	5.37	" Fly Boats ...	8.28	Opisometer ...	4.44	Theodolite ...	6.17
" Railway ...	4.27	" Flying Boat ...	5.32			Timber Carriage ...	5.26
Cake Walk ...	4.56	" Machine ...	4.48	Penny-in-the-Slot Machine ...	6.15	Traction Engine, Electrically-	
Cantilever Bridge ...	6.10	Fret Saw ...	5.9	" driven ...	4.1	" Tram Car, Electric ...	5.43
Car, Trotting ...	4.14	Funicular Railway ...	7.20	" Pistol, Spring ...	5.6	Travelling Bucket Dredger or	
Catapult ...	4.47			" Pit Head Gear ...	5.14	" Conveyor ...	7.31
Char-à-Banc ...	5.10	Geometrical Apparatus ...	4.26	" Planing Machine ...	7.35	Trailer ...	4.63
Clay Modelling Machine ...	4.23	Giant Auto Swing ...	5.28	" Platform Scales ...	6.41	Truck Weighing Machine ...	5.44
Clockwork Motor Tractor ...	7.14	Gong, Automatic... ..	4.29	" Potato Chopper ...	4.35	Twin Elliptic Harmonograph ...	7.40
Coal Tipper ...	4.55	Grandfather Clock, Improved	7.33	" " Reaper ...	6.35		
Crane ...	6.22	Gun, Anti-Aircraft ...	1.118	" Press, Bale ...	4.24	Universal Radial Drilling	
" Automatic Weighing	6.29	" Naval 4.7" ...	7.9	" Power ...	4.42	" Machine... ..	6.25
" Electric Mobile ...	7.30	" Naval Quick-firing... ..	4.46	" Punch, Conductor's ...	4.20	Vertical Drill ...	5.27
" " Telpher ...	5.39			" Punching Machine ...	6.3	" " Lifting Bridge ...	6.30
" Elevated Jib ...	4.60	Hammerhead Crane ...	7.22	" Puzzle ...	4.11	" " Log Saw... ..	7.38
" Gantry ...	4.66	" Hammer, Treadle ...	4.49	Quebec Bridge ...	5.30	" " Marine Engine ...	5.38
" Girder ...	4.38	" " Trip ...	4.54			Wagon, Steam ...	4.62
" Hammerhead ...	7.22	" Heald-making Machine ...	6.31	Racing Seaplane ...	7.15	" Tipping Motor ...	4.33
" Hand-Operated Gantry ...	5.31	" Helicopter Toy ...	5.23	Railway Breakdown Crane ...	7.32	Walking Tractor ...	6.4
" Hydraulic ...	7.23	" Howitzer and Tractor ...	6.46	" Island Platform ...	7.18	Warehouse ...	4.15 ; 7.11
" Level Luffing Automatic		" Inclined Delivery Chute... ..	4.19	Reaping Machine... ..	7.2	Watt's Beam Engine ...	6.32
" Grabbing... ..	7.36	" Indicator, Speed ...	5.13	" Robot ...	6.5	Weather Vane ...	4.25
" Level Luffing Jib ...	4.45	" Invalid Chair ...	6.26	" Rotary Truck Tipper ...	7.5	Weighbridge ...	6.27
" Motor Breakdown ...	4.43 ; 7.6	" Jack ...	6.23	" Roundabout ...	6.12	Windmill ...	4.7
" Pontoon ...	7.42	" " Knife Bridge ...	6.16	Saw, Automatic ...	4.21	Wire Covering Machine ...	7.3
" Portable ...	6.1	" Joy Wheel ...	6.39	" " Band ...	4.3	" Rope Maker ...	4.59
" Radial Travelling ...	6.38	" Kearney's Monorail ...	6.34	" " Bench ...	4.52		
" Railway Breakdown ...	7.32	" Lathe ...	4.4	" " Swing ...	4.6	Yacht ...	4.9
" Revolving ...	7.27	" " Elliptical ...	6.13				
" Rotating ...	4.64						

Patents and Designs  
Great Britain

680,416      682,208  
682,209

# MECCANO

THE TOY THAT MADE ENGINEERING FAMOUS

Millions of Boys in every country throughout the world play with Meccano.  
These are the Meccano Factories and distributing centres.

Patents and Designs  
Great Britain

682,934	733,541
683,011	733,542
698,054	740,413
718,404	767,865
718,731	777,900

Canadian Office and Warehouse:  
Meccano Ltd.,  
187-189, Church Street, Toronto.

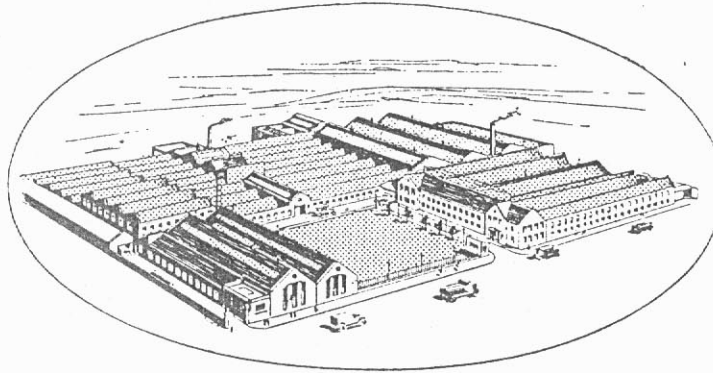
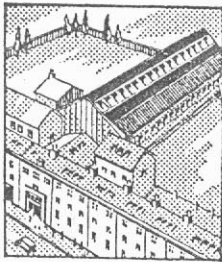

Meccano G.m.b.H.,  
Düsseldorf, Kasernenstr 18



Head Office and Factory :  
BINNS ROAD, LIVERPOOL 13.

Meccano Agencies :

London Office and Warehouse :  
Meccano Ltd.,  
Walnut Tree Walk,  
Kennington Road, London, S.E.11

Amsterdam  
Asuncion  
Auckland  
Barcelona  
Basle  
Batavia  
Bogota  
Bombay  
Brussels

Buenos Aires  
Calcutta  
Cape Town  
Caracas  
Colombo  
Durban  
Genoa  
Guayaquil  
Helsingfors

Hong Kong  
Iquitos  
Istanbul  
Johannesburg  
Karachi  
Mexico  
Monte Video  
Nairobi  
Oslo

Rangoon  
Rio de Janeiro  
Sao Paulo  
Shanghai  
Stockholm  
Sydney  
Trinidad  
Valparaiso  
Vienna

Paris Office :  
Meccano (France) Ltd.,  
78-80, Rue Rébeval,  
Paris, XIXe.  
Factory : Bobigny (Seine).