

MECCANO

INSTRUCTIONS FOR No. 2 OUTFIT

Prices
Great Britain 1/3
Australia 2/6
New Zealand 2/-
South Africa 2/6
Canada 45c

No.
37.2

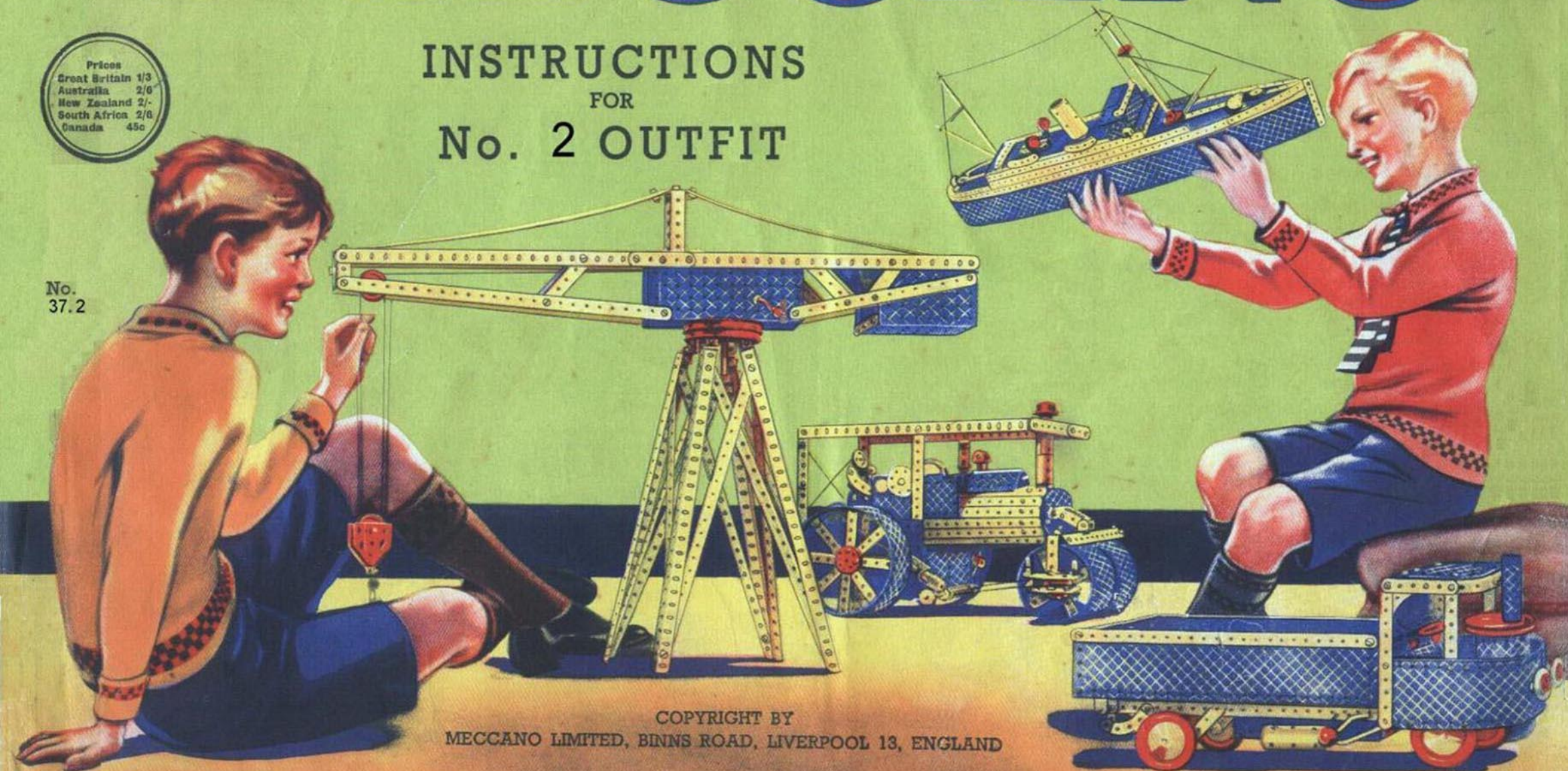

COPYRIGHT BY
MECCANO LIMITED, BINNS ROAD, LIVERPOOL 13, ENGLAND

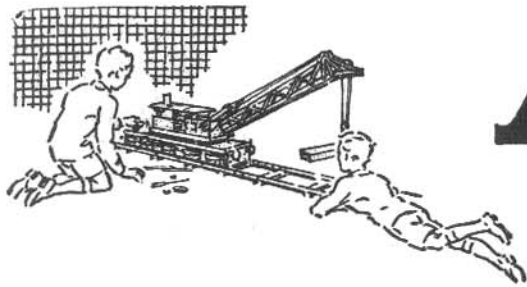

MECCANO

Real Engineering in Miniature

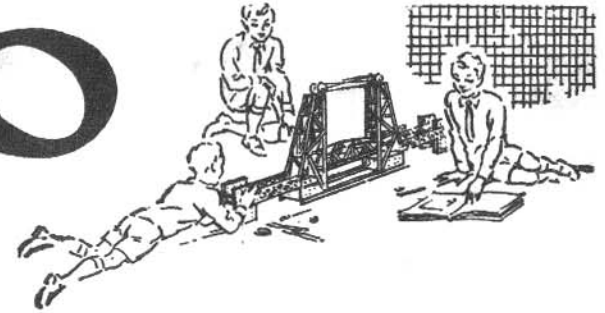

MODEL-BUILDING WITH MECCANO

There is no limit to the number of models that can be built with Meccano—Cranes, Clocks, Motor Cars, Aeroplanes, Machine Tools, Locomotives—in fact everything that interests boys. A screwdriver and a spanner, both of which are provided in each Outfit, are the only tools necessary.

When you have built all the models illustrated in the Manuals of Instruction the fun is not over, but is just beginning. Now comes the chance to make use of your own ideas. First of all, re-build some of the models with small changes in construction that may occur to you; then try building models entirely of your own design. In doing this you will feel the real thrill of the engineer and the inventor.

HOW TO BUILD UP YOUR OUTFIT

Meccano is sold in 11 different Outfits, ranging from No. 0 to No. 10. Each Outfit from No. 1 upwards can be converted into the one next larger by the purchase of an Accessory Outfit. Thus Meccano No. 1 Outfit can be converted into No. 2 Outfit by adding to it a No. 1a Accessory Outfit. No. 2a Outfit would then convert it into a No. 3, and so on. In this way, no matter with which Outfit you begin, you can build it up by degrees until you have a No. 10 Outfit.

All Meccano parts are of the same high quality and finish, but the larger Outfits contain a greater quantity and variety, making possible the construction of more elaborate models.

Special Note.—The Meccano Plates (Flanged, Flat, Curved, etc.) are shown in the Manuals with diagonal white lines. In the new Meccano Outfits these parts are plain.

Several of the illustrations in this Manual show how miniature figures and various small articles can be introduced to add realism to the models. These are not included in the Outfit. Many of them are Meccano Dinky Toys that can be bought separately from your Meccano dealer.

THE "MECCANO MAGAZINE"

The "Meccano Magazine" is published specially for Meccano boys. Every month it describes and illustrates new Meccano models for Outfits of all sizes, and deals with suggestions from readers for new Meccano parts and for new methods of using the existing parts.

There are model-building competitions specially

planned to give an equal chance to the owners of small and large Outfits. In addition, there are splendid articles on such subjects as Railways, Famous Engineers and Inventors, Electricity, Chemistry, Bridges, Cranes and Aeroplanes, and special sections dealing with the latest Engineering, Aviation and Shipping News. Other pages deal with Stamp Collecting, and Books of interest to boys; and a feature of outstanding popularity is the section devoted to short articles from readers.

If you are not already a reader write to the Editor for full particulars, or order a copy from your Meccano dealer, or from any newsagent.

THE MECCANO GUILD

Every owner of a Meccano Outfit should join the Meccano Guild. This is a world-wide organisation, started at the request of Meccano boys. Its primary object is to bring boys together and to make them feel that they are all members of a great brotherhood, each trying to help others to get the very best out of life. Its members are in constant touch with Headquarters, giving news of their activities and being guided in their hobbies and interests. Write for full particulars and an application form to the Secretary, Meccano Guild, Binns Road, Liverpool 13.

Clubs founded and established under the guidance of the Guild Secretary provide Meccano boys with opportunities of enjoying to the utmost the fun of model-building. Each has its Leader, Secretary, Treasurer and other officials. With the exception of the Leader, all the officials are boys, and as far as possible the proceedings of the clubs are conducted by boys.

MECCANO SERVICE

The service of Meccano does not end with selling an Outfit and an Instruction Manual. If ever you are in any difficulty with your models, or if you want advice on anything connected with this great hobby, write to us. We receive hundreds of interesting letters from boys in all parts of the world, and each of these is answered personally by one of our staff of experienced experts.

Whatever your problem may be, write to us about it. Do not hesitate. We shall be delighted to help you in any way possible.

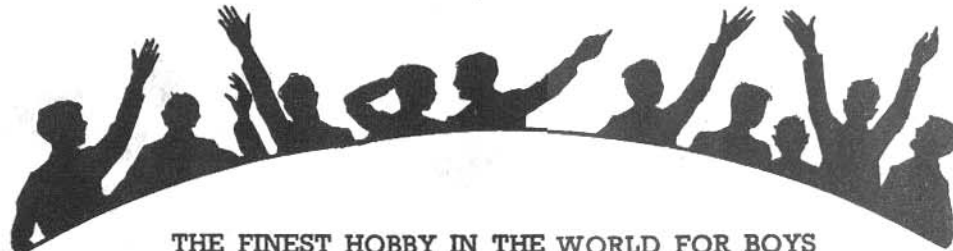

THE FINEST HOBBY IN THE WORLD FOR BOYS

HOW TO COMMENCE THE FUN

THE MOST FASCINATING OF ALL HOBBIES

Meccano model-building is the most fascinating of all hobbies, because it never becomes dull. There is always something new to be done. First of all there is the fun of building a new model, and watching it take shape as part after part is added. Then, when the model is complete, comes the thrill of setting it to work just like the real structure it represents, by means of a Meccano Motor. This wonderful process can be repeated indefinitely, for there is no end to the number of Meccano models that can be built. Another point is that models built with Meccano are real engineering structures in miniature, and the keen model-builder has wonderful opportunities for learning the working of machines and mechanisms of all kinds. So he acquires practical engineering knowledge without special study.

It is so simple to build Meccano models that operations can be started as soon as the first Outfit is opened. Different boys build in different ways, but in the end they all reach the same splendid results. The following hints are given with the object of showing boys who are just commencing the wonderful Meccano hobby how to obtain the greatest possible fun.

A FEW USEFUL HINTS

It will be noticed that with each model shown in this Manual of Instructions is given a list of the parts required to build it. For the first few models it is a good plan to lay out on the table all the parts required for the one it is proposed to build, and put the remainder of the Outfit on one side. To help you to pick out the correct parts for your model a complete list of Meccano parts is given at the back of this Manual, and all the principal parts are illustrated. In the list the parts are all numbered, and in most cases their measurements are given. There is no need, however, to measure the parts to find out which is which, as the size is easily found from the number of holes. All Meccano holes are spaced $\frac{1}{2}$ " apart, so that by counting two holes to the inch the size of a part can be found at once. For instance, Part No. 2 is listed as a $5\frac{1}{2}$ " Perforated Strip, so you look in your Outfit for a Strip with eleven holes. Similarly No. 192 is a $5\frac{1}{2}$ " \times $2\frac{1}{2}$ " Flexible Plate, so you look for a Flexible Plate eleven holes in length and five holes in width. By the time a few models have been built the names of the parts will have become familiar.

Beginners sometimes wonder which section of a model should be built first. There cannot be any definite rule for this, as it depends on the design of the model. In stationary models the base usually should be built first. In most of the smaller models a $5\frac{1}{2}$ " \times $2\frac{1}{2}$ " Flanged Plate forms an important part of the structure, and often the best plan is to start building by bolting parts to this Plate. For other models a good general rule is that the sections that form supports for a number of other parts should be built first.

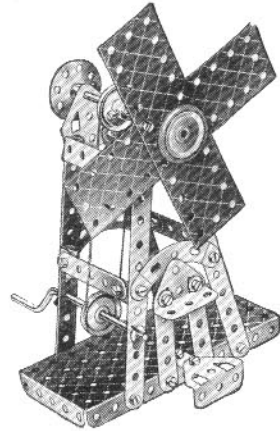

Windmill

THE IMPORTANCE OF "LOCK-NUTTING"

In building models in which Rods revolve in the holes of other parts it is important to make sure that such holes are exactly in line with one another. This can be done very easily by pushing through the holes a long Rod before the Bolts holding the various parts are tightened up.

In some models it is necessary to join certain parts together, so that, although they cannot come apart, they are free to pivot or move in relation to one another. To do this the parts are bolted together as usual, but the Nut is not screwed up tightly, so that the parts are not gripped. Then, to prevent the Nut from unscrewing, a second Nut is screwed up tightly against it, the first, meanwhile, being held with a spanner. This method of using a second Nut is known as lock-nutting, and it is employed in a large number of Meccano models.

During the construction of a model it is best to screw up the Nuts with the fingers, followed by just a light turn with the screwdriver, leaving the final tightening with spanner and screwdriver until all the parts are connected up.

MOTORS AND GEARING

Models can be operated by means of either Meccano Clockwork or Electric Motors.

The Clockwork Motors have the advantage of being self-contained and extremely simple. If only a small amount of power is needed, the model may be driven direct from the driving spindle of the Motor or through a belt running over two pulleys of the same size, giving what is described as a 1:1 (one-to-one) ratio. Greater power can be obtained by a reduction in the speed of the drive, which can be produced in a simple manner by connecting a small pulley on the Motor to a larger pulley by means of a belt. Thus if a 1" Pulley is made to drive a 3" Pulley, a reduction ratio of approximately 1:3 is obtained. This means that the driven shaft will take about three times the load that the driving shaft would handle, but will rotate at only one-third of the speed. Rubber bands are better than Cord for driving belts for most purposes.

The Electric Motors have the advantage of giving long continuous runs. Their speed is much higher than that of the Clockwork Motors, and this makes it possible to employ higher reduction ratios and thus obtain greater power.

With the larger Outfits, belt drive can be replaced with advantage by gearing. To operate a slow-moving model demanding great power, such as a traction engine, gears that will provide a considerable reduction must be used. For example, a Worm meshed with a $\frac{1}{2}$ " Pinion will give a 1:19 reduction; while a Worm meshed with a 57-teeth Gear will give a 1:57 reduction.

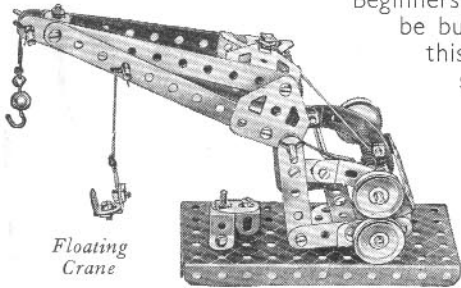

Floating Crane

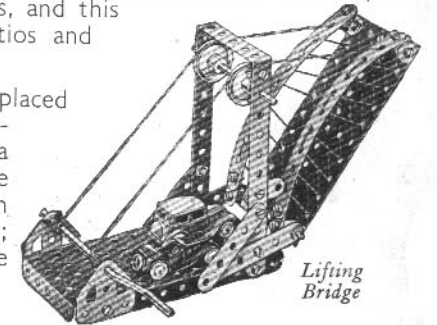

Lifting Bridge

O.1 HAND CART

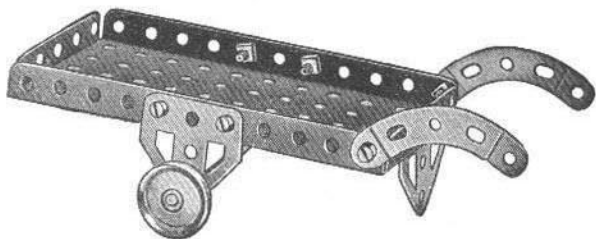

Parts required

1 of No. 16	1 of No. 52	2 of No. 126a
2 " " 22	2 " " 90a	2 " " 155a
8 " " 37	1 " " 126	

O.2 SLEDGE

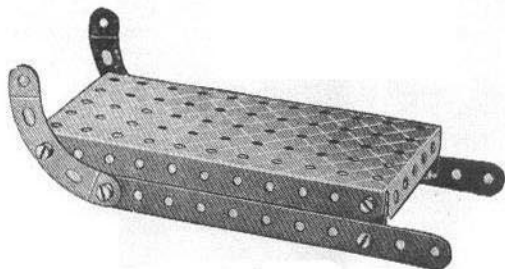

Parts required

2 of No. 2	1 of No. 52
2 " " 10	2 " " 90a
8 " " 37	

O.3 FLAT TRUCK

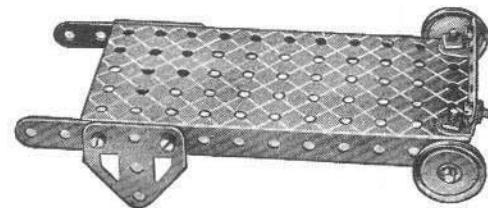

Parts required

2 of No. 5	2 of No. 22	1 of No. 90a
2 " " 12	8 " " 37	2 " " 126a
1 " " 16	1 " " 52	2 " " 155a

O.4 DOCKSIDE CRANE

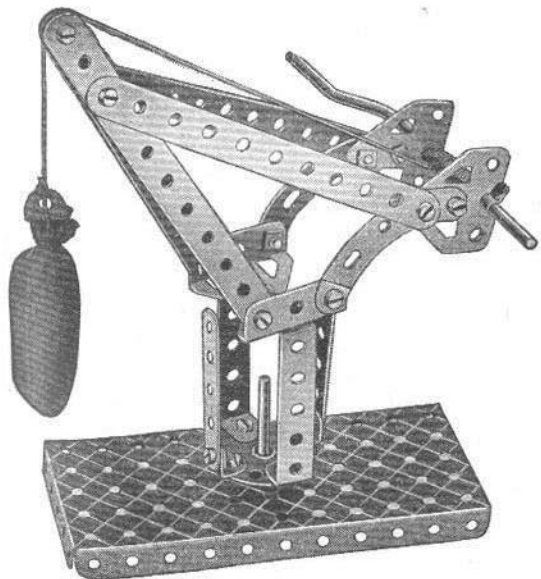

Parts required

4 of No. 2
2 " " 5
3 " " 12
1 " " 17
1 " " 19s
1 " " 22
1 " " 24
2 " " 35
18 " " 37
2 " " 37a
2 " " 38
2 " " 48a
1 " " 52
2 " " 90a
2 " " 111c
2 " " 126
2 " " 126a

O.5 SWING

Parts required

4 of No. 2
2 " " 5
18 " " 37
2 " " 38
1 " " 48a
1 " " 52
2 " " 126
2 " " 126a

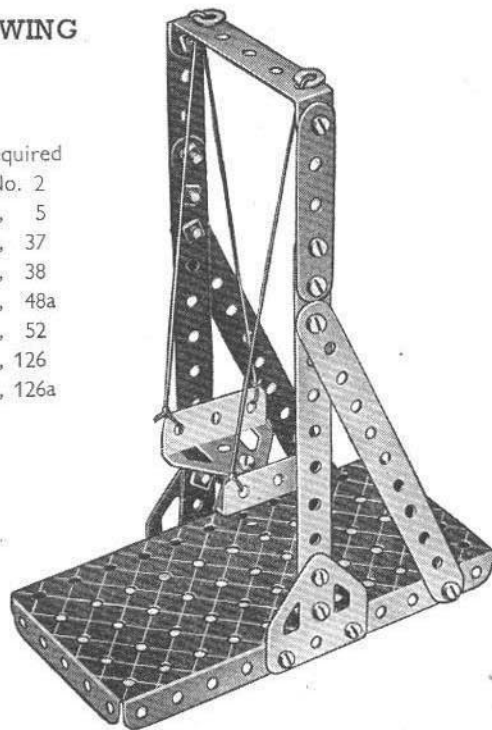

O.6 ELEVATOR

Parts required

4 of No. 2	2 of No. 48a
2 " " 5	1 " " 52
1 " " 16	2 " " 126
1 " " 19s	2 " " 126a
1 " " 22	
4 " " 35	
15 " " 37	

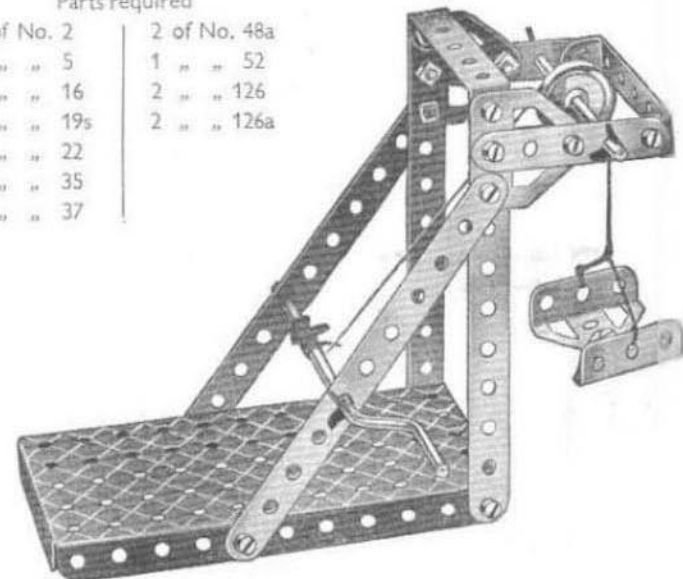

O.7 GARDEN SEAT



- Parts required
 4 of No. 2
 2 " " 5
 10 " " 37
 2 " " 48a
 1 " " 52

O.8 COUNTER SCALES

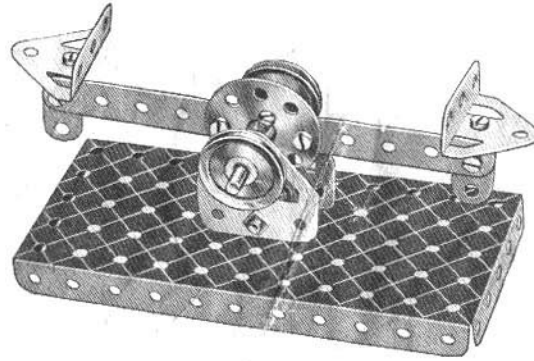

- Parts required
- | | | |
|------------|-------------|-------------|
| 1 of No. 2 | 2 of No. 22 | 1 of No. 52 |
| 2 " " 10 | 1 " " 24 | 2 " " 126 |
| 4 " " 12 | 9 " " 37 | 2 " " 126a |
| 1 " " 17 | 2 " " 38 | |

O.9 COSTER'S BARROW

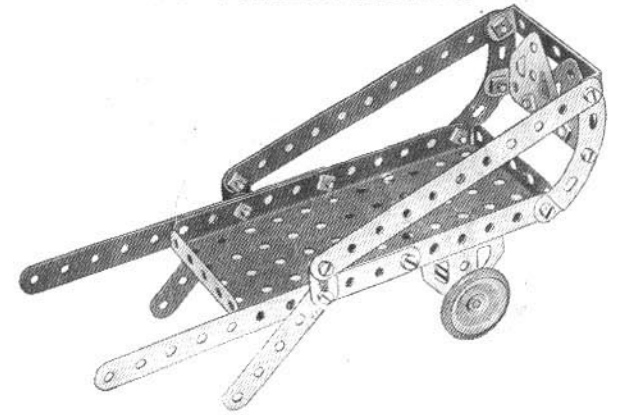

- Parts required
- | | | |
|------------|-------------|--------------|
| 4 of No. 2 | 2 of No. 22 | 2 of No. 90a |
| 2 " " 5 | 16 " " 37 | 2 " " 126 |
| 2 " " 10 | 2 " " 48a | 2 " " 126a |
| 1 " " 16 | 1 " " 52 | 2 " " 155a |

O.10 SIGNAL

- Parts required
 2 of No. 2
 2 " " 5
 1 " " 10
 3 " " 12
 1 " " 17
 1 " " 22
 2 " " 35
 11 " " 37
 3 " " 37a
 2 " " 38
 1 " " 52
 2 " " 90a
 2 " " 111c
 2 " " 126

Fix the signal arm to the post in such a manner that the arm is free to move, by means of Bolt 1, which is lock-nutted. The Bolt is passed through the Strips forming the signal post and the signal arm, and a Nut is placed on it and screwed up sufficiently to hold the Bolt in place. The first Nut is then held with a Spanner while a second Nut is screwed tightly up against it. The lever by which the signal is moved is also secured with Bolt 1a similarly lock-nutted.

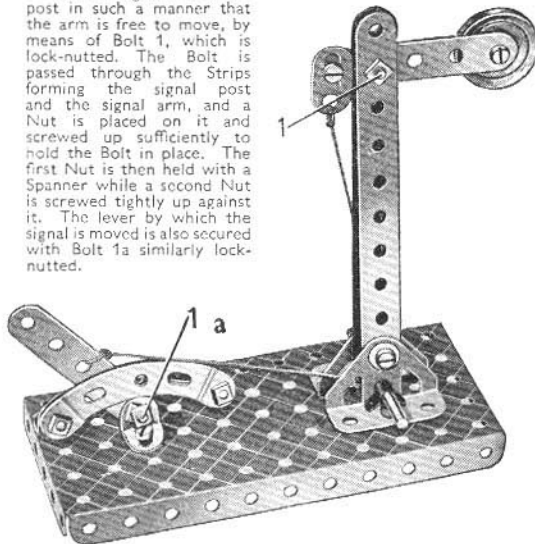

O.11 SCALES

- Parts required
 3 of No. 2
 1 " " 17
 1 " " 24
 2 " " 35
 10 " " 37
 1 " " 52
 2 " " 126
 2 " " 126a

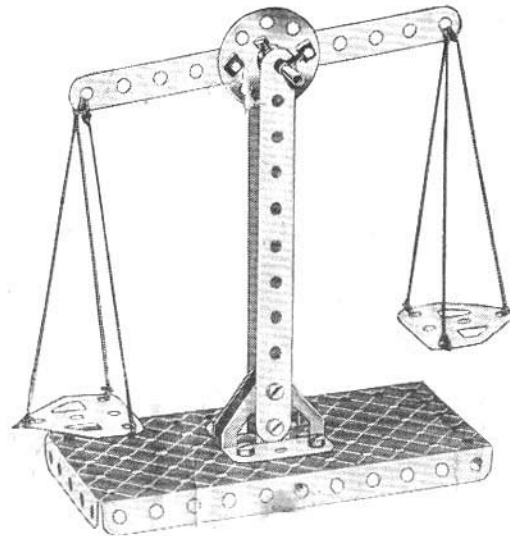

O.12 ELECTRIC TRUCK

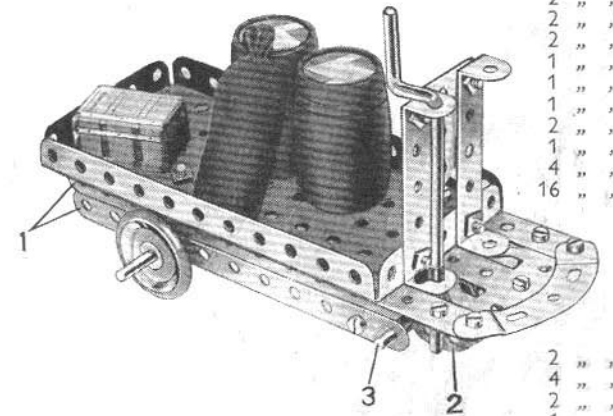

- Parts required
- | | |
|------------|----------|
| 4 of No. 2 | 2 " " 5 |
| 2 " " 10 | 2 " " 12 |
| 1 " " 16 | 1 " " 17 |
| 1 " " 19s | 1 " " 22 |
| 2 " " 24 | 4 " " 35 |
| 16 " " 37 | |
| 2 " " 37a | |
| 4 " " 38 | |
| 2 " " 48a | |
| 1 " " 52 | |
| 2 " " 90a | |
| 2 " " 111c | |
| 2 " " 126 | |
| 2 " " 126a | |
| 2 " " 155a | |

The two 5 1/2" Strips 1 are fastened to the Flanged Plate by two Trunnions secured to the Plate on the underneath side. A Bush Wheel 2 is fixed on the Axle Rod 3, which passes through the end holes of the 5 1/2" Strips that form the sides of the truck frame.

O.13 ACROBAT

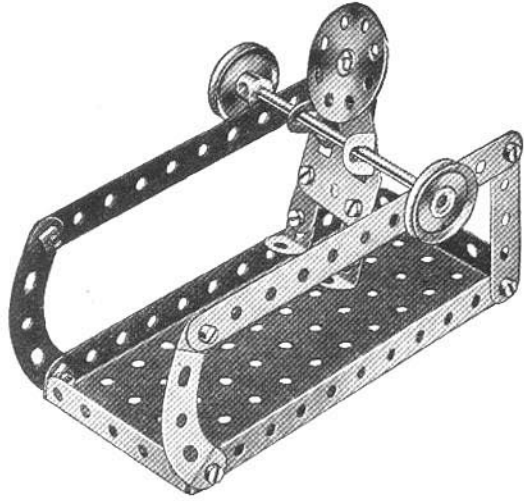

Parts required

2 of No. 2
2 " " 5
3 " " 10
4 " " 12
1 " " 16
2 " " 22
1 " " 24
15 " " 37
1 " " 52
2 " " 90a
1 " " 111c
1 " " 126a

O.14 BATTLESHIP

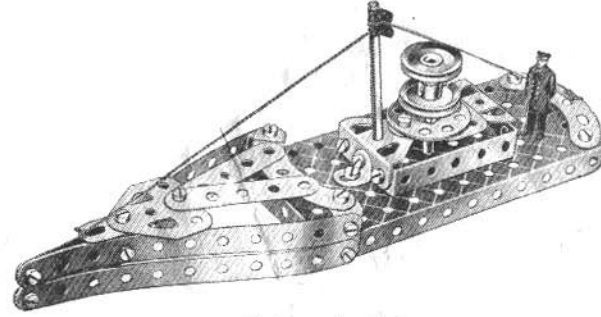

Parts required

4 of No. 2	2 of No. 22	1 of No. 52
2 " " 5	1 " " 24	2 " " 90a
3 " " 10	3 " " 35	1 " " 111c
4 " " 12	18 " " 37	2 " " 126
1 " " 16	1 " " 37a	2 " " 126a
1 " " 17	2 " " 48a	

O.15 ESKIMO BOY AND SLEDGE

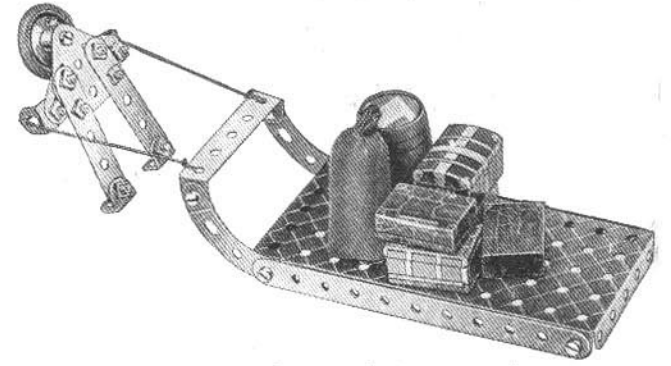

Parts required

2 of No. 2	1 of No. 22	2 of No. 90a
2 " " 5	14 " " 37	1 " " 111c
2 " " 10	1 " " 48a	1 " " 126a
4 " " 12	1 " " 52	1 " " 155a

O.16 SKIER

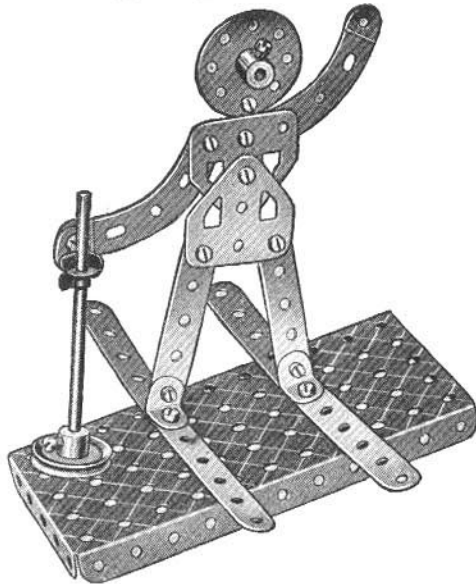

Parts required

2 of No. 2
2 " " 5
1 " " 10
3 " " 12
1 " " 16
1 " " 22
1 " " 24
2 " " 35
11 " " 37
1 " " 52
2 " " 90a
2 " " 126a

O.17 LEVEL CROSSING BARRIER

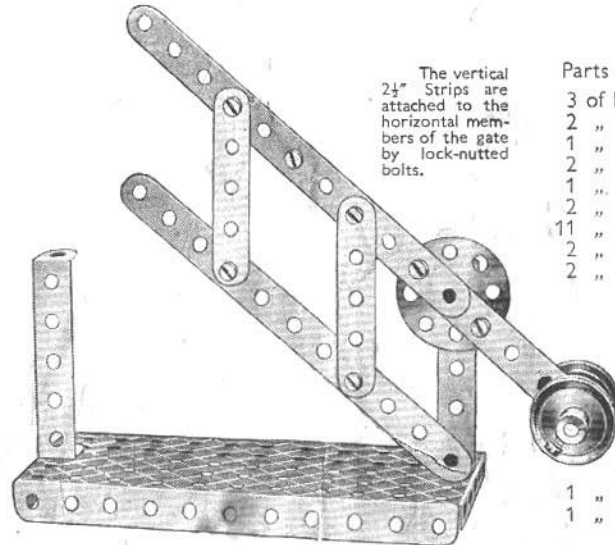

The vertical 2 1/2" Strips are attached to the horizontal members of the gate by lock-nutted bolts.

Parts required

3 of No. 2
2 " " 5
1 " " 17
2 " " 22
1 " " 24
2 " " 35
11 " " 37
2 " " 37a
2 " " 48a
1 " " 52
1 " " 111c

O.18 SWING BOAT

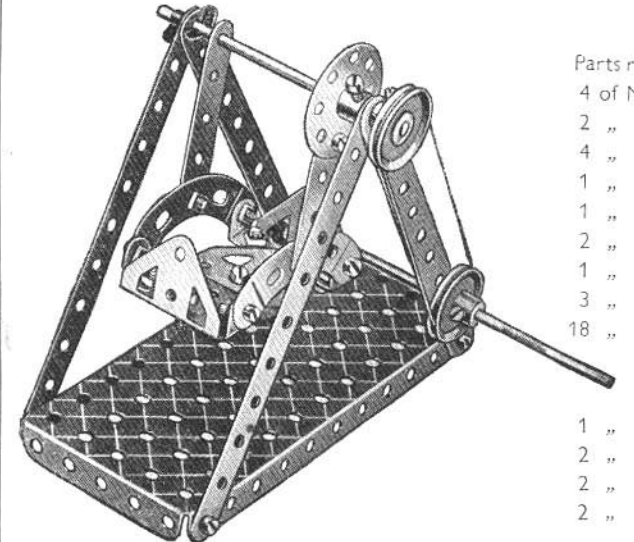

Parts required

4 of No. 2
2 " " 5
4 " " 12
1 " " 16
1 " " 19s
2 " " 22
1 " " 24
3 " " 35
18 " " 37
1 " " 52
2 " " 90a
2 " " 126
2 " " 126a

O.19 TRAPEZE ARTIST

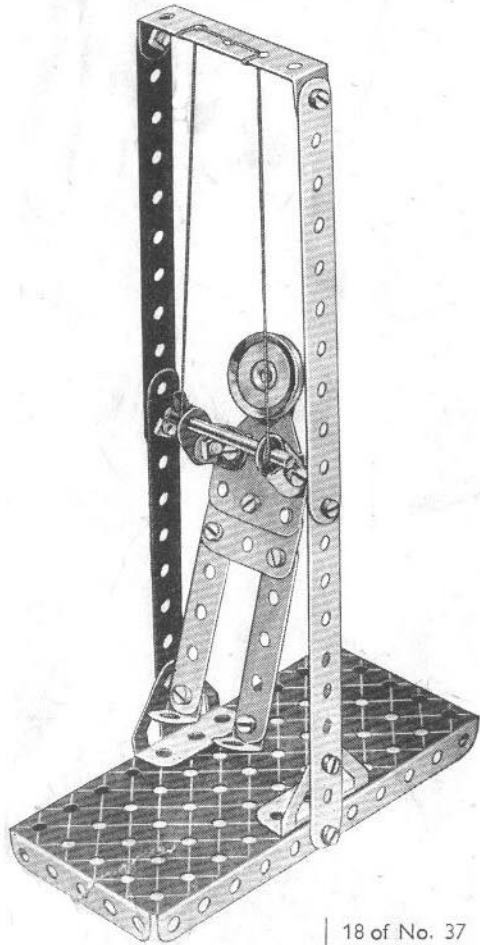

		18 of No. 37
Parts required	4 of No. 12	1 " " 48a
4 of No. 2	1 " " 17	1 " " 52
2 " " 5	1 " " 22	1 " " 111c
3 " " 10	2 " " 35	2 " " 126
		2 " " 126a

O.20 SAILING BOAT

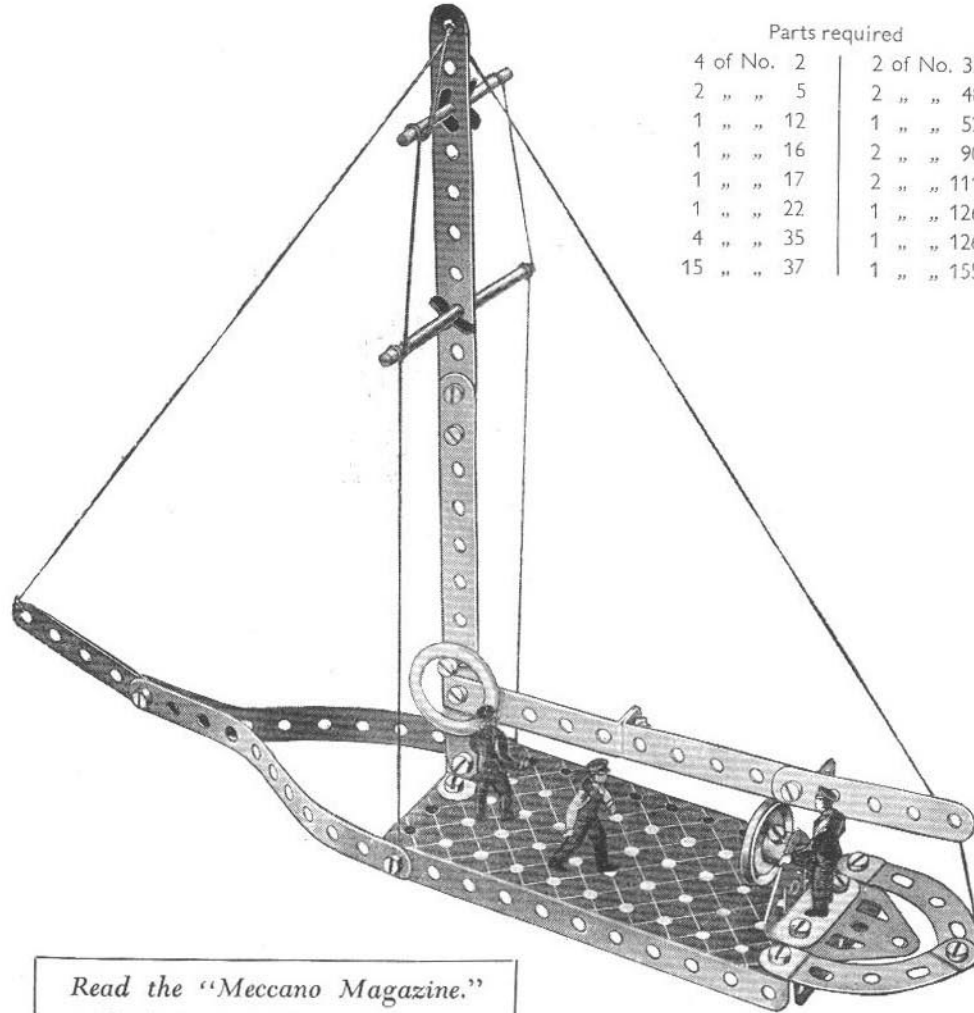

Parts required	
4 of No. 2	2 of No. 37a
2 " " 5	2 " " 48a
1 " " 12	1 " " 52
1 " " 16	2 " " 90a
1 " " 17	2 " " 111c
1 " " 22	1 " " 126
4 " " 35	1 " " 126a
15 " " 37	1 " " 155a

Read the "Meccano Magazine," published monthly. Ask your dealer for full particulars.

O.21 DERRICK CRANE

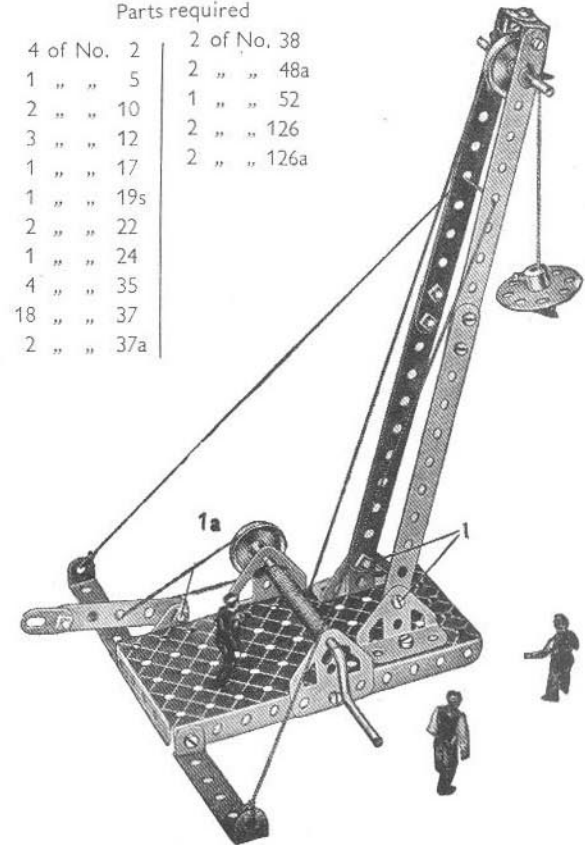

Parts required	
4 of No. 2	2 of No. 38
1 " " 5	2 " " 48a
2 " " 10	1 " " 52
3 " " 12	2 " " 126
1 " " 17	2 " " 126a
1 " " 19s	
2 " " 22	
1 " " 24	
4 " " 35	
18 " " 37	
2 " " 37a	

The construction of the model is commenced by bolting the Trunnions and Flat Trunnions that support the jib and Crank Handle respectively, to the 5½" x 2½" Flanged Plate that forms the base of the model. The jib is then assembled and fastened to the Trunnions by means of the lock-nutted Bolts 1. The brake lever is a 2½" Strip extended by a Flat Bracket, and is fastened to a second Flat Bracket bolted to the Flanged Plate by means of a Bolt 1a the nut of which is left sufficiently loose to allow the Strip to move. A length of Cord is fastened to the lever and then passed round the 1" Pulley on the Crank Handle.

O.22 STATIONARY STEAM ENGINE

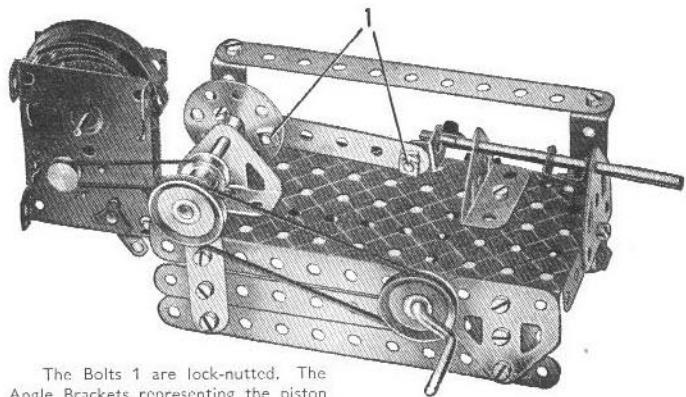

The Bolts 1 are lock-nutted. The Angle Brackets representing the piston are clamped to the Rod by a Nut and Bolt fastened in their elongated holes.

Parts required

4 of No. 2
2 " " 5
3 " " 12
1 " " 16
1 " " 17
1 " " 19s
2 " " 22
1 " " 24
3 " " 35
18 " " 37
2 " " 37a
1 " " 38
2 " " 48a
1 " " 52

2 of No. 126
2 " " 126a
Magic Motor

Parts required

3 of No. 2
2 " " 5
1 " " 10

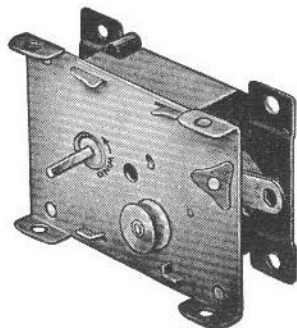
THE MECCANO
MAGIC MOTOR

The greatest thrill in Meccano model-building is experienced when a model is set to work by means of a Meccano *Magic Motor*. The illustrations on this page show how the *Magic Motor* can be fitted without any difficulty to No. O Outfit models of various types. Fit the model you have just built with one of these wonderful Motors, and enjoy the fun of watching it work just like the real thing!

Parts required

4 of No. 2
2 " " 5
4 " " 12
1 " " 16
1 " " 19s
2 " " 22
1 " " 24
4 " " 35
18 " " 37
2 " " 37a
2 " " 38
1 " " 48a
1 " " 52
2 " " 90a

2 of No. 111c
2 " " 126
2 " " 126a
Magic Motor

1 of No. 52
2 " " 90a
2 " " 126
2 " " 126a

O.23 MECHANICAL HAMMER

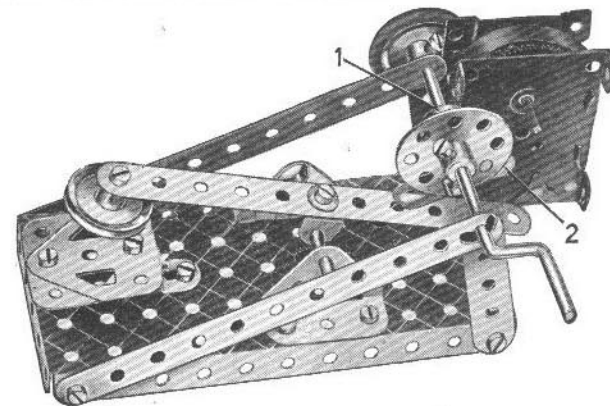

The $\frac{1}{2}$ " fast Pulley 1 is driven from the pulley 2 on the *Magic Motor* by the Driving Band supplied with the Motor.

4 of No. 12

1 " " 17
1 " " 19s
2 " " 22
1 " " 24
3 " " 35
15 " " 37
1 " " 38
1 " " 52
1 " " 111c
2 " " 126
2 " " 126a
1 " " 155a

Magic Motor

O.25 WINDMILL

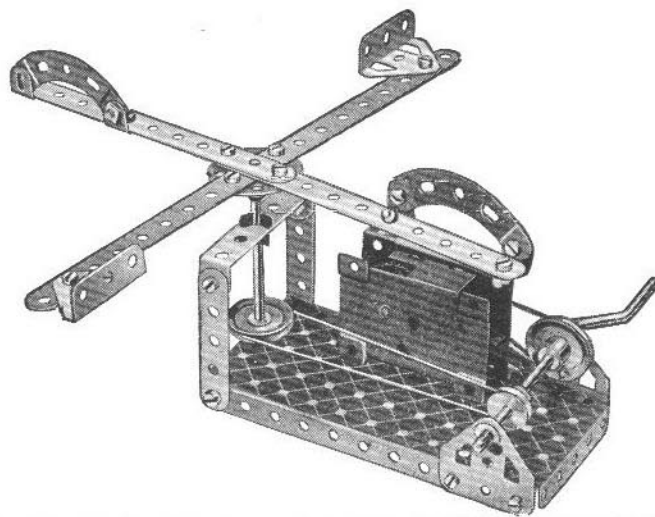

A Driving Band connects the pulley of the *Magic Motor* to a 1" Pulley fastened on the Crank Handle. The Crank Handle carries also a $\frac{1}{2}$ " Pulley, which is connected by a second Driving Band with a further 1" Pulley fixed to the Rod on which the sails are mounted.

Parts required

4 of No. 2
2 " " 5
1 " " 16
1 " " 19s
2 " " 22
1 " " 24
3 " " 35
18 " " 37
2 " " 38
2 " " 48a

Magic Motor

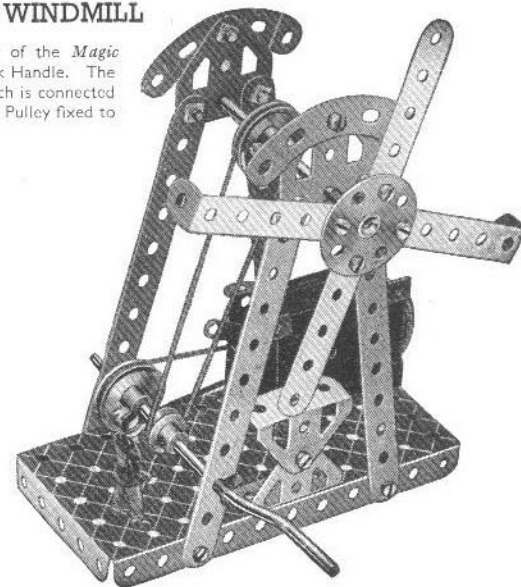

1.1 PORTER'S TRUCK

The bearings for the axle are Flat Trunnions fastened on the insides of the Flexible Plates, and the axle is a 3 1/4" Rod that carries two 1" Pulleys fitted with Rubber Rings.

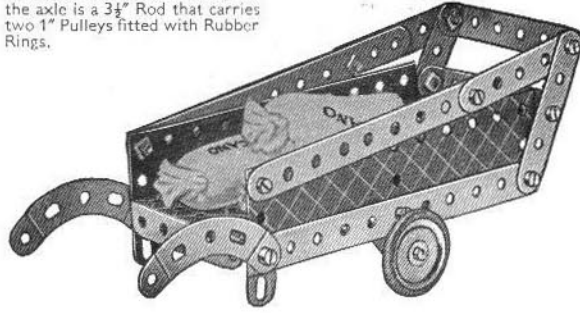

Parts required

4 of No. 2
4 " " 5
2 " " 10
1 " " 16
2 " " 22
14 " " 37
2 " " 38
2 " " 48a
1 " " 52
2 " " 90a
2 " " 126a
2 " " 155a
2 " " 189

1.2 BATTLESHIP

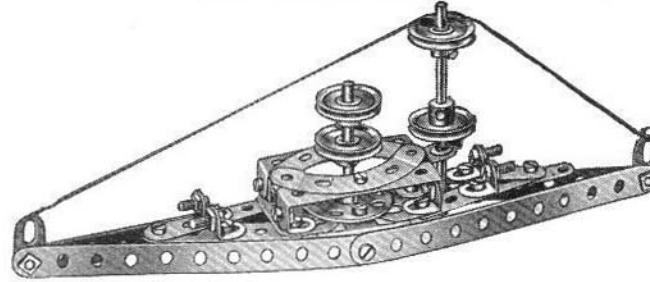

Parts required

4 of No. 2	1 of No. 17	4 of No. 37a	4 of No. 111c
4 " " 5	4 " " 22	2 " " 38	1 " " 125
4 " " 10	1 " " 24	1 " " 40	2 " " 126
8 " " 12	3 " " 35	2 " " 48a	2 " " 126a
1 " " 16	24 " " 37	2 " " 90a	

1.3 WINDMILL

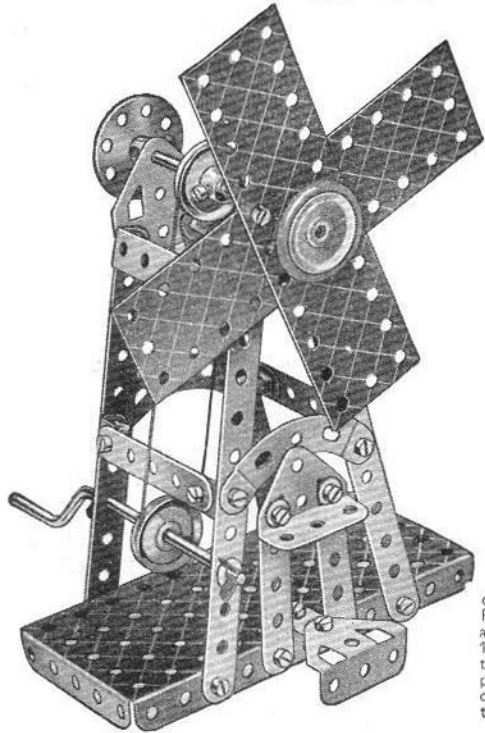

The sails are gripped on the 3 1/4" Rod by the 1" Pulley (with Rubber Ring) at the front and another 1" Pulley at the back of the sails. The Pulleys are pressed against the faces of the sails and locked on the Rod.

Parts required

4 of No. 2
4 " " 5
1 " " 10
4 " " 12
1 " " 16
1 " " 19s
4 " " 22
1 " " 24
3 " " 35
24 " " 37
4 " " 38
1 " " 40
2 " " 48a
1 " " 52
2 " " 90a
2 " " 126
2 " " 126a
1 " " 155a
2 " " 189

1.4 SCALES

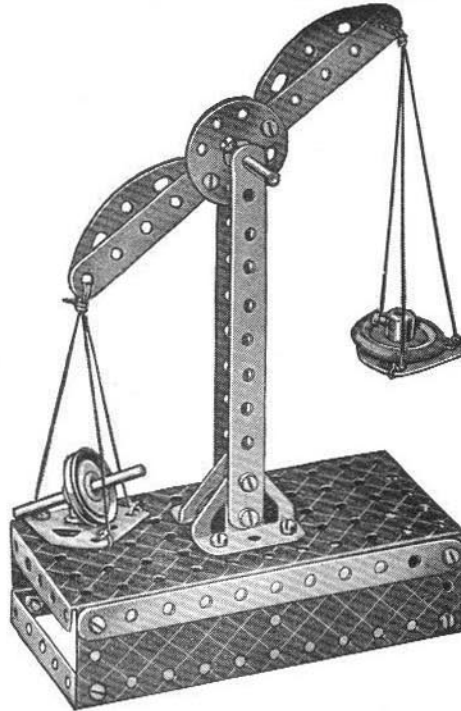

Parts required

4 of No. 2
2 " " 5
2 " " 17
2 " " 22
1 " " 24
19 " " 37
1 " " 38
1 " " 40
2 " " 48a
1 " " 52
2 " " 90a
1 " " 111c
2 " " 126
2 " " 126a
1 " " 155a
2 " " 189

1.5 GYMNAST

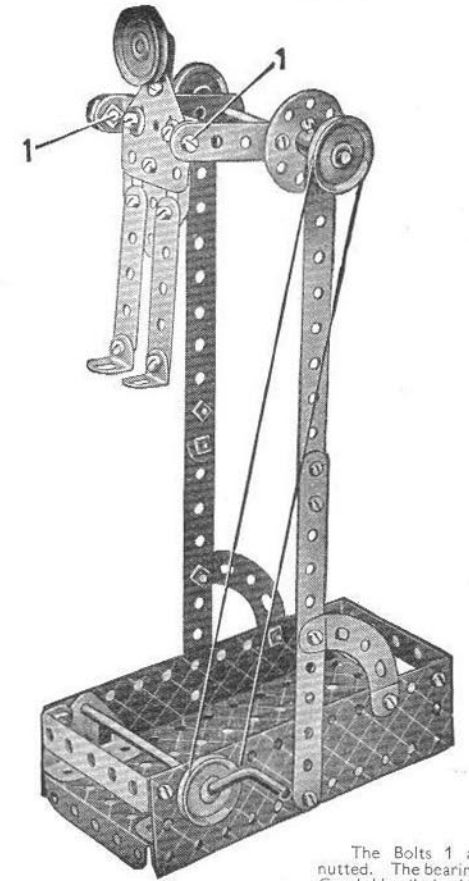

The Bolts 1 are lock-nutted. The bearings for the Crank Handle in the Flexible Plates are reinforced by Trunnions bolted to the Flanged Plate.

Parts required

4 of No. 2	1 of No. 24	1 of No. 52
4 " " 5	2 " " 35	2 " " 90a
1 " " 10	24 " " 37	4 " " 111c
4 " " 12	5 " " 37a	2 " " 126
1 " " 16	4 " " 38	2 " " 126a
1 " " 19s	1 " " 40	2 " " 189
4 " " 22	2 " " 48a	

1.6 LUMBER WAGON

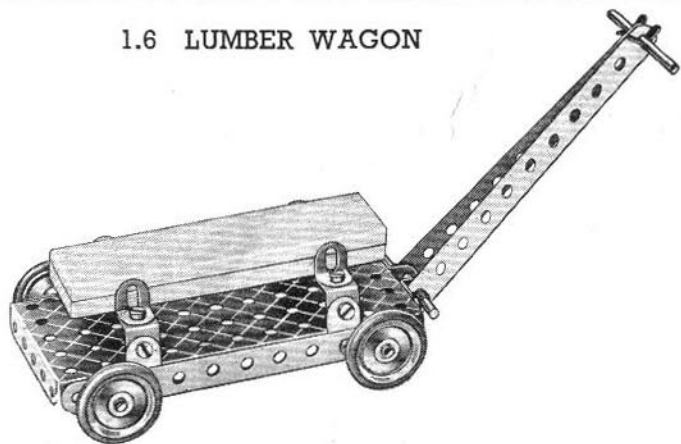

Parts required

4 of No. 2	2 of No. 16	4 of No. 35	1 of No. 52
4 " " 10	2 " " 17	14 " " 37	4 " " 155a
6 " " 12	4 " " 22	2 " " 48a	

1.7 TABLE

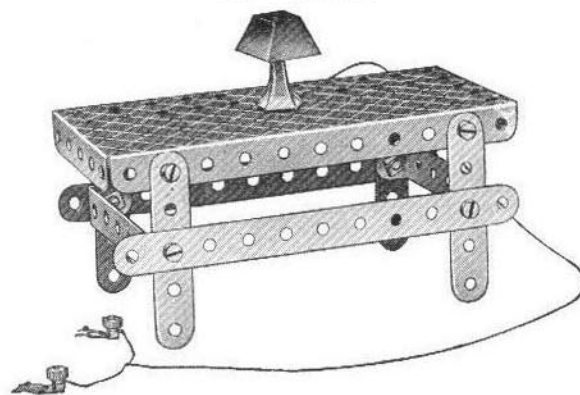

Parts required

2 of No. 2	8 of No. 37	1 of No. 52
4 " " 5	2 " " 48a	

The model is shown with a Stand Lamp from a Meccano Lighting Set.

1.8 BUFFER STOPS

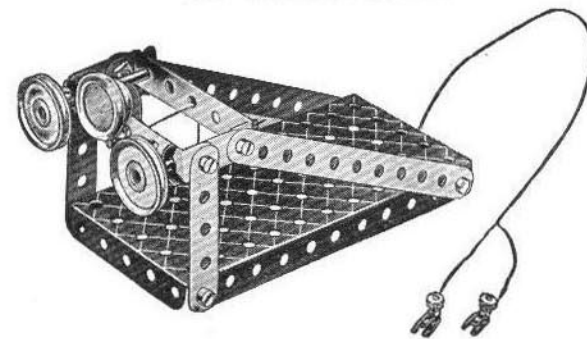

Parts required

2 of No. 2	2 of No. 17	9 of No. 37
2 " " 5	2 " " 22	2 " " 48a
3 " " 10	4 " " 35	1 " " 52

The model is fitted with a Spot light from a Meccano Lighting Set.

1.9 AEROPLANE

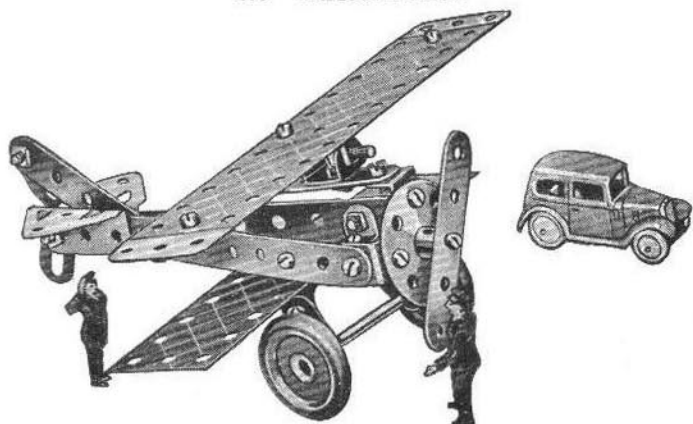

Parts required

2 of No. 2	1 of No. 17	2 of No. 37a	2 of No. 126
3 " " 5	2 " " 22	1 " " 38	2 " " 126a
4 " " 10	1 " " 24	3 " " 111c	2 " " 155a
8 " " 12	17 " " 37	1 " " 125	2 " " 189

1.10 "KIDDIE KAR"

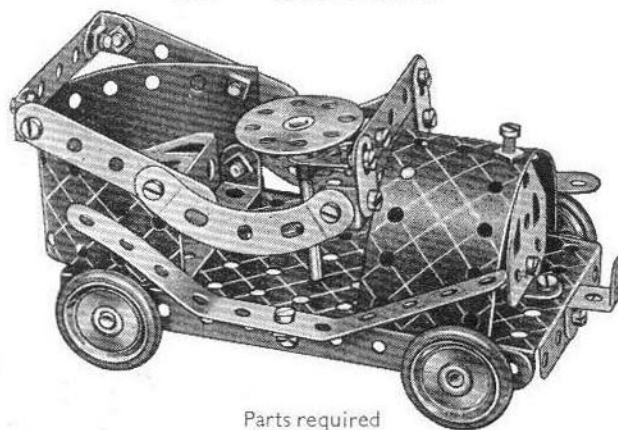

Parts required

4 of No. 2	1 of No. 17	3 of No. 37a	1 of No. 125
4 " " 5	4 " " 22	2 " " 48a	2 " " 126
3 " " 10	1 " " 24	1 " " 52	1 " " 126a
7 " " 12	1 " " 35	2 " " 90a	4 " " 155a
2 " " 16	24 " " 37	2 " " 111c	2 " " 189

Two Trunnions overlapped one hole, and fastened to the Flanged Plate by an Angle Bracket, form the seat.

1.11 WATCH STAND

Parts required

4 of No. 2
2 " " 12
19 " " 37
1 " " 38
1 " " 52
1 " " 57c
2 " " 90a
1 " " 126
2 " " 126a

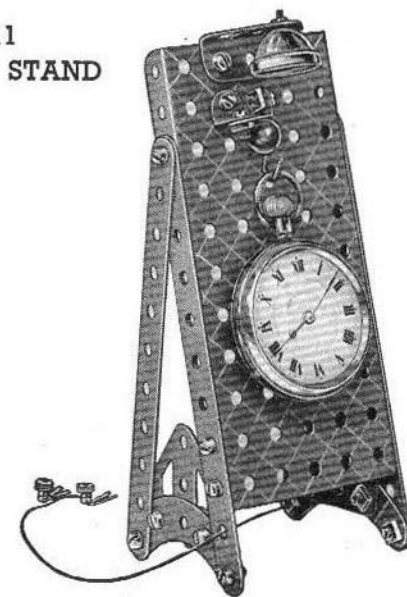

A good example of the use of the Meccano Lighting Set.

1.12 BAGGAGE TRUCK

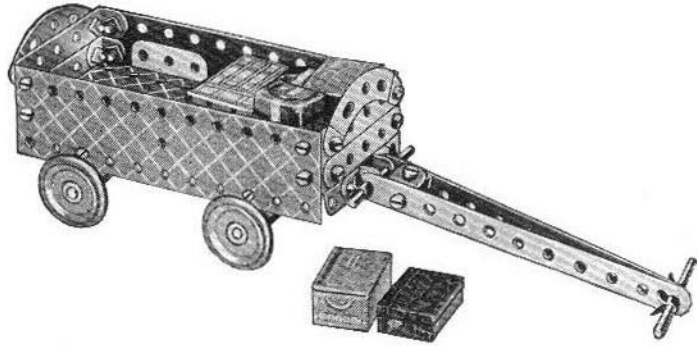

Parts required

2 of No. 2	4 of No. 35	2 of No. 90a
2 " " 5	1 " " 37	1 " " 111c
8 " " 12	1 " " 37a	2 " " 126
2 " " 16	2 " " 38	2 " " 126a
2 " " 17	2 " " 48a	4 " " 155a
4 " " 22	1 " " 52	2 " " 189

1.13 RACING SEAPLANE

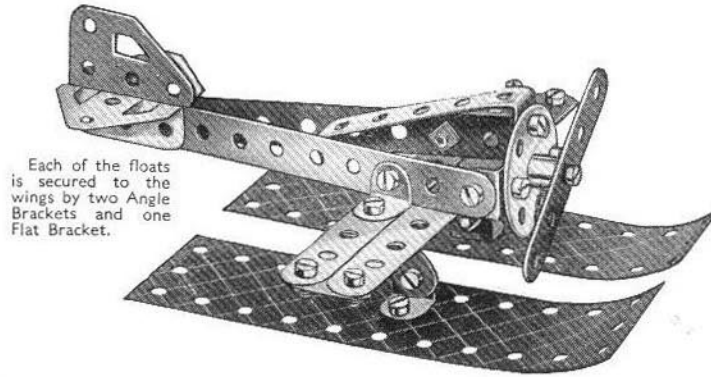

Each of the floats is secured to the wings by two Angle Brackets and one Flat Bracket.

Parts required

3 of No. 2	1 of No. 24	2 of No. 111c
3 " " 5	19 " " 37	2 " " 126
4 " " 10	1 " " 37a	1 " " 126a
8 " " 12	1 " " 48a	2 " " 189

1.14 SLEDGE

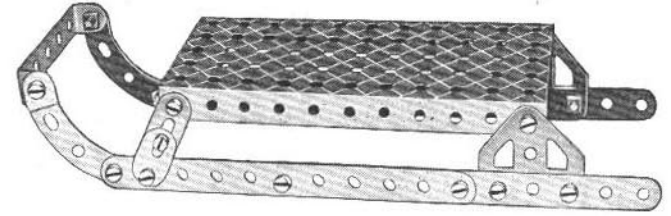

Parts required

4 of No. 2	1 of No. 48a	2 of No. 126a
4 " " 10	1 " " 52	
20 " " 37	2 " " 90a	

1.15 BAND SAW

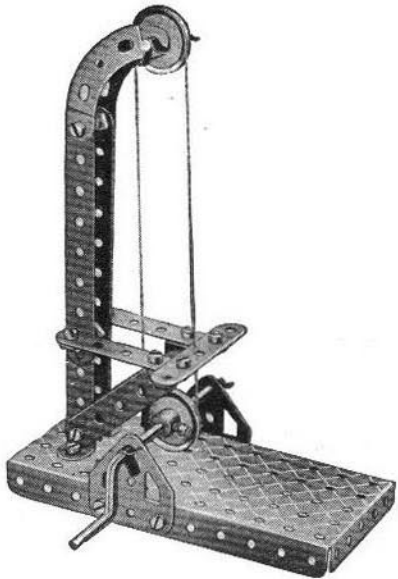

Parts required

2 of No. 2
4 " " 5
6 " " 12
1 " " 17
1 " " 19s
2 " " 22
4 " " 35
19 " " 37
1 " " 40
1 " " 52
2 " " 90a
2 " " 126a

1.16 CIRCULAR SAW

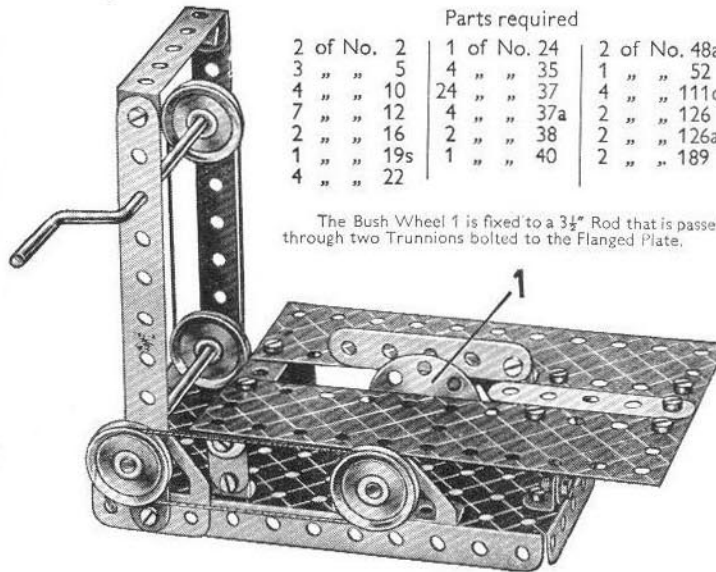

Parts required

2 of No. 2	1 of No. 24	2 of No. 48a
3 " " 5	4 " " 35	1 " " 52
4 " " 10	24 " " 37	4 " " 111c
7 " " 12	4 " " 37a	2 " " 126
2 " " 16	2 " " 38	2 " " 126a
1 " " 19s	1 " " 40	2 " " 189
4 " " 22		

The Bush Wheel 1 is fixed to a 3/4" Rod that is passed through two Trunnions bolted to the Flanged Plate.

1.17 DRILL

Parts required

4 of No. 2
3 " " 5
8 " " 12
1 " " 16
1 " " 17
1 " " 19s
4 " " 22
4 " " 35
20 " " 37
4 " " 38
1 " " 40
1 " " 52
2 " " 126
2 " " 126a

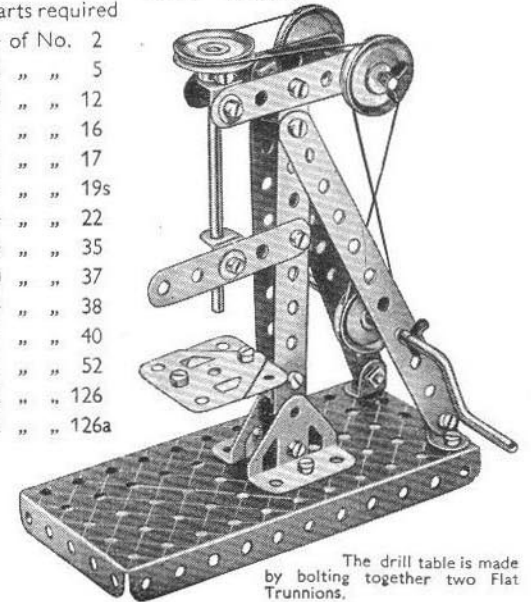

The drill table is made by bolting together two Flat Trunnions.

1.18 TRIP HAMMER

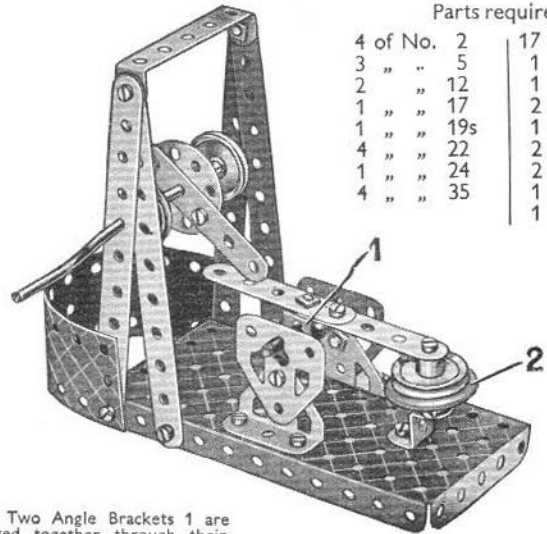

Parts required

4 of No. 2	17 of No. 37
3 " " 5	1 " " 48a
2 " " 12	1 " " 52
1 " " 17	2 " " 111c
1 " " 19s	1 " " 125
4 " " 22	2 " " 126
1 " " 24	2 " " 126a
4 " " 35	1 " " 155a
	1 " " 189

Two Angle Brackets 1 are bolted together through their holes and also are bolted to two 2 1/2" Strips to form a double bracket. The 1" fast Pulley 2 is fitted with a 1" Rubber Ring.

1.19 STEAM LAUNCH

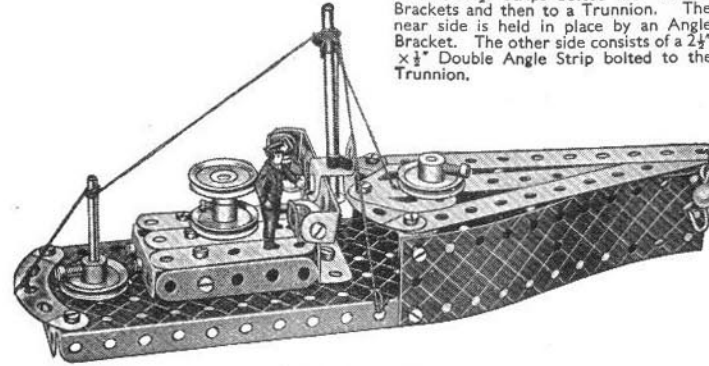

The top of the deck-house consists of three 2 1/2" Strips bolted first to Flat Brackets and then to a Trunnion. The rear side is held in place by an Angle Bracket. The other side consists of a 2 1/2" x 1/2" Double Angle Strip bolted to the Trunnion.

Parts required

3 of No. 2	4 of No. 22	1 of No. 52	2 of No. 126a
4 " " 5	4 " " 35	1 " " 57c	2 " " 189
3 " " 10	23 " " 37	2 " " 90a	
8 " " 12	4 " " 38	2 " " 111c	
1 " " 16	1 " " 40	1 " " 125	
2 " " 17	2 " " 48a	2 " " 126	

1.20 COASTER

The Bolts 1 are lock-nutted. The rear axle Rod is pushed through the end hole of the Curved Strip 2.

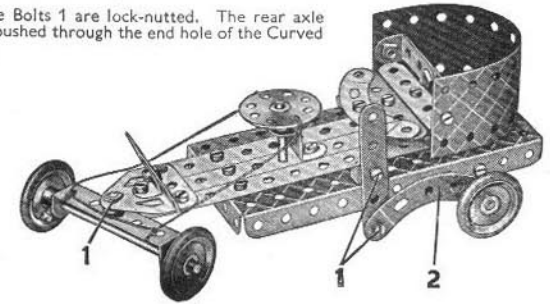

Parts required

3 of No. 2	1 of No. 35	2 of No. 90a
4 " " 5	20 " " 37	2 " " 111c
5 " " 12	4 " " 37a	1 " " 125
2 " " 16	4 " " 38	2 " " 126
1 " " 17	1 " " 40	2 " " 126a
4 " " 22	2 " " 48a	4 " " 155a
1 " " 24	1 " " 52	1 " " 189

1.21 LIFTING BRIDGE

The Bolts 1, on which the bridge span pivots, are lock-nutted.

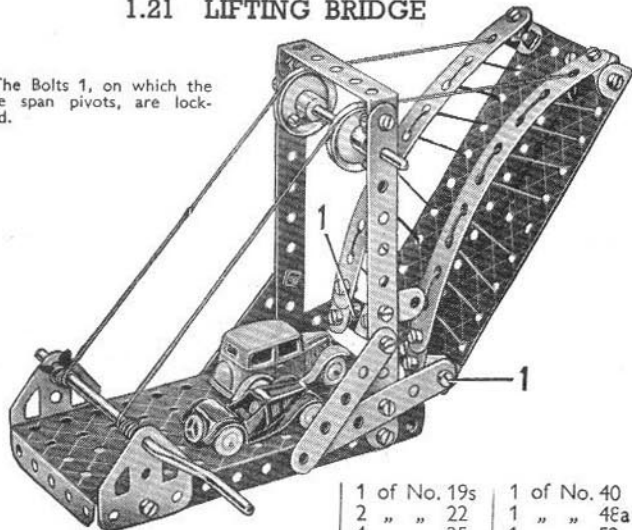

Parts required	3 of No. 10	1 of No. 19s	1 of No. 40
4 of No. 2	8 " " 12	2 " " 22	1 " " 48a
4 " " 5	2 " " 16	4 " " 35	1 " " 52
		24 " " 37	3 " " 111c
		5 " " 37a	2 " " 126a
		4 " " 38	2 " " 189

1.22 HAND TRUCK

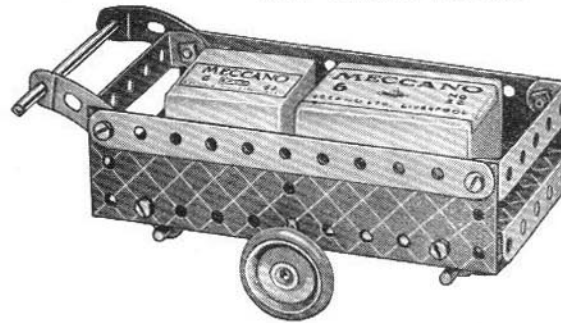

Parts required

2 of No. 2
2 " " 10
8 " " 12
2 " " 16
2 " " 17
4 " " 22
3 " " 35
14 " " 37
2 " " 48a
1 " " 52
2 " " 90a
2 " " 155a
2 " " 189

The bearings on the 3 1/2" Rod are Flat Brackets, and the front and rear axle bearings are reversed angle brackets built up from Angle Brackets. The right-hand 1" Pulley on the 3 1/2" Rod is loose on the Rod, but is retained in place by a Spring Clip. The front and rear 1" Pulleys are fixed on their respective 2" Rods.

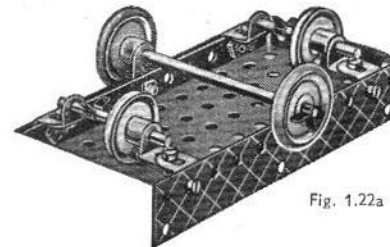
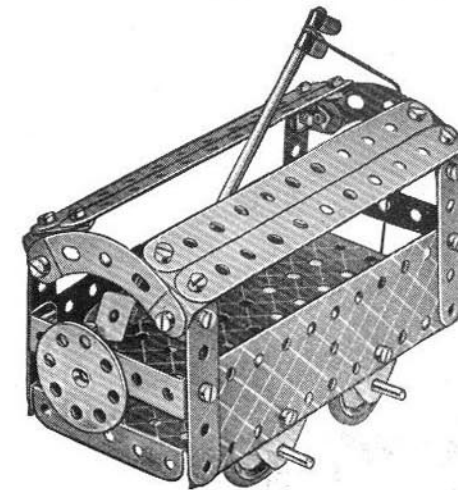

Fig. 1.22a

1.23 TROLLEY BUS



Parts required	4 of No. 2
	4 " " 5
	8 " " 10
	4 " " 12
	2 " " 16
	1 " " 19s
	4 " " 22
	1 " " 24
	4 " " 35
	24 " " 37
	1 " " 37a
	4 " " 38
	1 " " 40
	2 " " 48a
	1 " " 52
	2 " " 90a
	2 " " 111c
	1 " " 125
	2 " " 126
	2 " " 126a
	4 " " 155a
	2 " " 189

The Reversed Angle Bracket that holds the trolley is fixed in position by a Bolt passed through the slot in the Bracket, then through two Washers, and into the boss of the Bush Wheel.

1.24 HAY CART

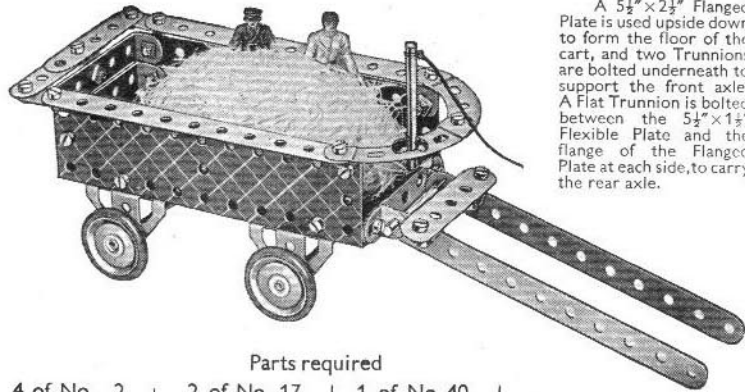

A $5\frac{1}{2}'' \times 2\frac{1}{2}''$ Flanged Plate is used upside down to form the floor of the cart, and two Trunnions are bolted underneath to support the front axle. A Flat Trunnion is bolted between the $5\frac{1}{2}'' \times 1\frac{1}{2}''$ Flexible Plate and the flange of the Flanged Plate at each side, to carry the rear axle.

Parts required

4 of No. 2	2 of No. 17	1 of No. 40	
3 " " 5	4 " " 22	2 " " 48a	2 of No. 126
2 " " 10	4 " " 35	1 " " 52	2 " " 126a
7 " " 12	24 " " 37	2 " " 90a	4 " " 155a
2 " " 16	1 " " 37a	1 " " 111c	2 " " 189

1.25 MOTOR LORRY

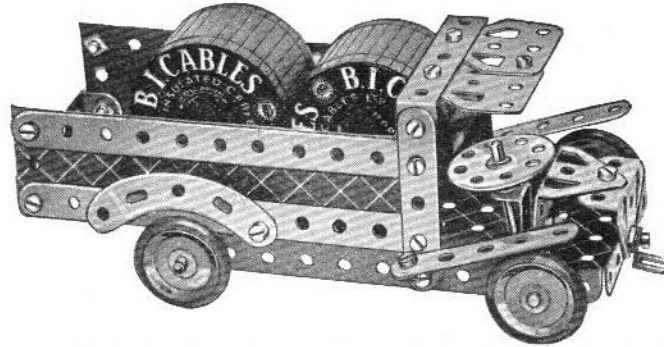

The $2\frac{1}{2}''$ Curved Strips representing the rear mudguards are each fastened to the sides by a $\frac{3}{8}''$ Bolt and Nut, with a Spring Clip between the mudguards and the $5\frac{1}{2}''$ Strip to form a distance piece.

Parts required

4 of No. 2	1 of No. 17	19 of No. 37	2 of No. 90a	2 of No. 126a
4 " " 5	4 " " 22	4 " " 37a	3 " " 111c	4 " " 155a
3 " " 12	1 " " 24	2 " " 48a	1 " " 125	2 " " 189
2 " " 16	2 " " 35	1 " " 52	2 " " 126	

1.26 HOSPITAL TROLLEY

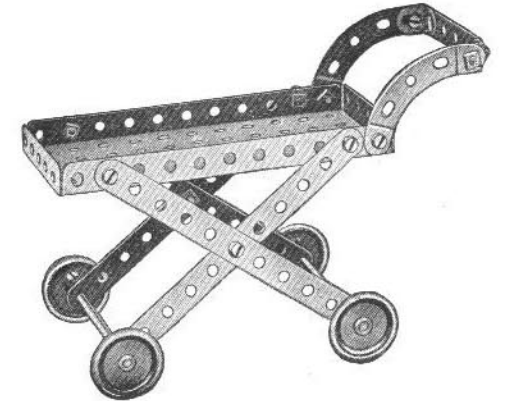

Parts required

4 of No. 2
1 " " 5
2 " " 12
2 " " 16
4 " " 22
12 " " 37
1 " " 52
2 " " 90a
4 " " 155a

1.27 STAMPING MILL

The anvil 1 is made up of two Trunnions bolted together. When the Crank Handle is rotated, the Flat Brackets bolted to the Bush Wheel strike the centre $1''$ Pulley on the hammer shaft and cause it to rise and fall.

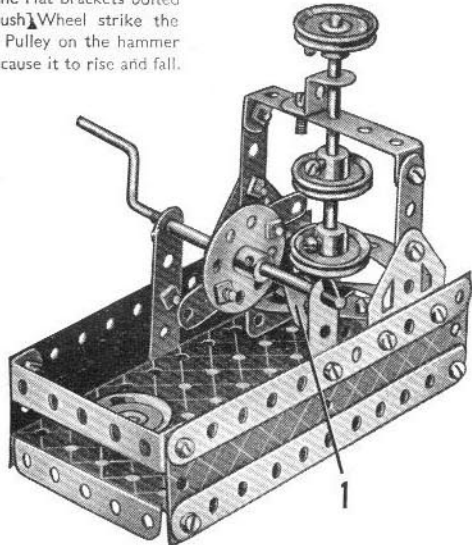

Parts required

4 of No. 2
4 " " 5
4 " " 10
5 " " 12
1 " " 16
1 " " 19s
4 " " 22
1 " " 24
2 " " 35
24 " " 37
3 " " 37a
2 " " 48a
1 " " 52
1 " " 90a
4 " " 111c
1 " " 125
2 " " 126
2 " " 126a
2 " " 189

1.28 FLYING BOATS

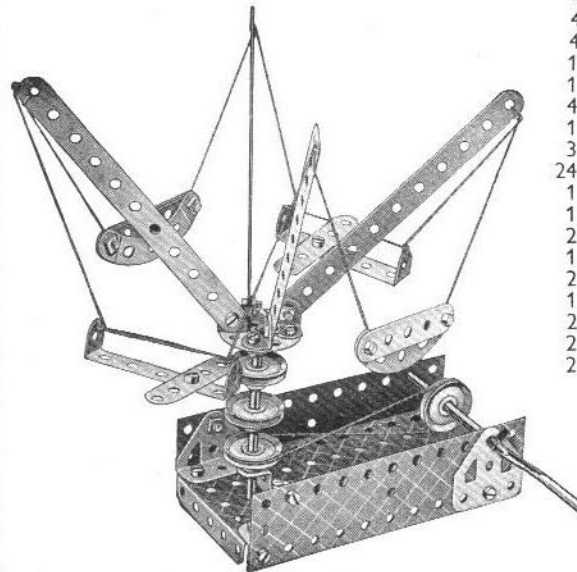

Parts required

4 of No. 2
4 " " 5
4 " " 12
1 " " 16
1 " " 19s
4 " " 22
1 " " 24
3 " " 35
24 " " 37
1 " " 38
1 " " 40
2 " " 48a
1 " " 52
2 " " 90a
1 " " 125
2 " " 126
2 " " 126a
2 " " 189

1.29 HAND CAR

The Bolts 1 on which the $5\frac{1}{2}''$ Strips are pivoted, are lock-nutted. The $2\frac{1}{2}''$ small radius Curved Strips are fixed to Angle Brackets bolted to the $5\frac{1}{2}'' \times 2\frac{1}{2}''$ Flanged Plate.

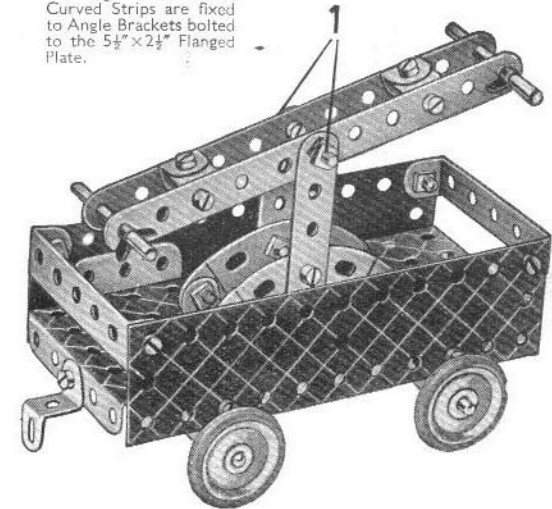

Parts required

2 of No. 2
2 " " 5
8 " " 12
2 " " 16
2 " " 17
4 " " 22
4 " " 35
23 " " 37
4 " " 37a
4 " " 38
2 " " 48a
1 " " 52
2 " " 90a
2 " " 111c
1 " " 125
2 " " 126
2 " " 126a
4 " " 155a
2 " " 189

1.30 MONOPLANE

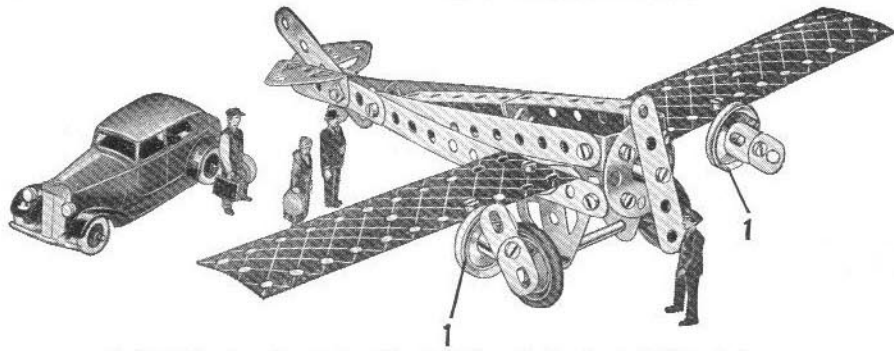

The fast Pulleys 1 are fixed to Angle Brackets fastened to the wing by $\frac{3}{8}$ " Bolts, which are passed through the Angle Brackets, and held in the bosses of the Pulleys. The set screws of the Pulleys hold also a second Bolt on which the propellers are mounted.

Parts required

4 of No.	2
4 "	5
4 "	10
8 "	12
1 "	16
4 "	22
1 "	24
2 "	35
20 "	37
3 "	37a
2 "	48a
1 "	57c
4 "	111c
2 "	126
2 "	126a
2 "	155a
2 "	189

1.31 FLOATING CRANE

Parts required	
4 of No.	2
4 "	5
4 "	10
7 "	12
2 "	16
2 "	17
1 "	19s
4 "	22
1 "	24
4 "	35
24 "	37
4 "	37a
4 "	38
1 "	40
2 "	48a
1 "	52
1 "	57c
2 of No.	90a
3 "	111c
1 "	125
2 "	126
2 "	126a

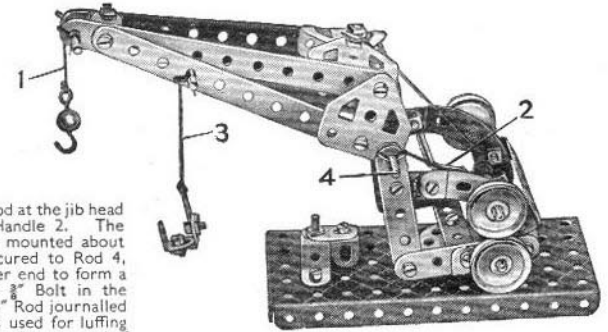

The Cord 1 passes over the Rod at the jib head and is fastened to the Crank Handle 2. The other Cord 3 passes over a Rod mounted about halfway along the jib, and is secured to Rod 4, which has a 1" Pulley at the other end to form a handle. The Cord tied to the $\frac{3}{8}$ " Bolt in the Trunnions is taken around the $3\frac{1}{2}$ " Rod journalled above the Crank Handle, and is used for luffing the jib by turning the 1" Pulley at the rear end of the Rod. Two Angle Brackets and a Flat Bracket form the hook on Cord 3.

1.32 POWER PRESS

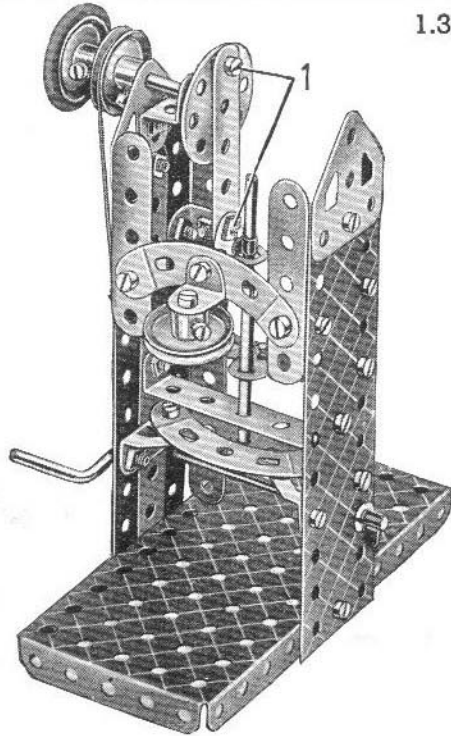

Parts required

4 of No.	2
4 "	5
1 "	10
6 "	12
1 "	16
1 "	17
1 "	19s
4 "	22
1 "	24
3 "	35
24 "	37
5 "	37a
1 "	38
1 "	40
2 "	48a
1 "	52
2 "	90a
4 "	111c
1 "	125
2 "	126
2 "	126a
1 "	155a
2 "	189

The Bolts 1 are lock-nutted, and the Angle Bracket at the lower end of the $2\frac{1}{2}$ " Strip has a $4\frac{1}{2}$ " Rod in its elongated hole, where it is held by means of two Spring Clips.

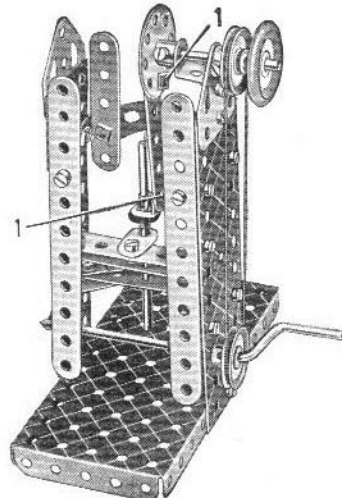
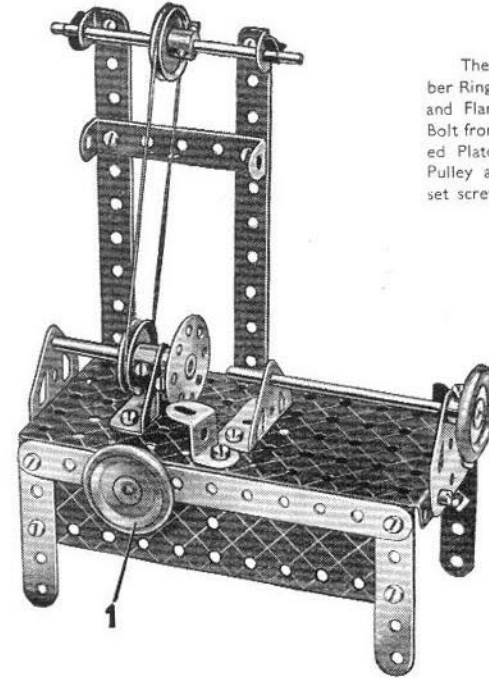

Fig. 1.32a

1.33 LATHE



The 1" fast Pulley with Rubber Ring 1 is secured to the Strip and Flanged Plate by passing a Bolt from the inside of the Flanged Plate into the boss of the Pulley and then tightening the set screw.

Parts required

4 of No.	2
4 "	5
2 "	12
2 "	16
1 "	17
4 "	22
1 "	24
3 "	35
22 "	37
1 "	40
1 "	48a
1 "	52
1 "	111c
1 "	125
2 "	126
2 "	126a
2 "	155a
2 "	189

1.34 MECHANICAL SHOVEL

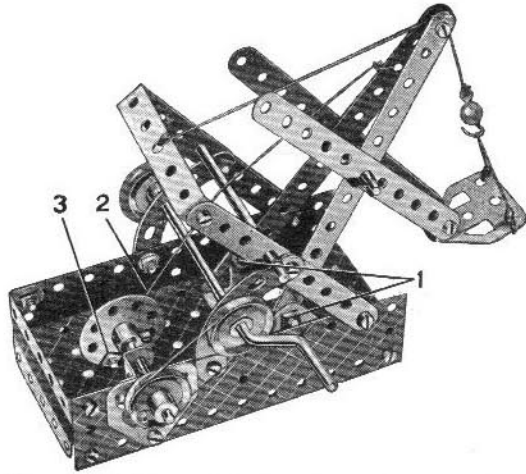

The Bolts 1, on which the jib pivots, are lock-nutted. The shovel arm is pivoted on a 2" Rod and the shovel is supported by a Cord that passes over the $\frac{3}{8}$ " Bolt at the jib head and is fastened to a $2\frac{1}{2}$ " x $\frac{1}{2}$ " Double Angle Strip as shown. The Cord 2 is fastened to the jib and then passes over a $3\frac{1}{2}$ " Rod journalled in the holes above the $2\frac{1}{2}$ " Curved Strips, and is attached to a Flat Bracket fastened by the lock-nutted Bolt 3 to the Bush Wheel.

When the Crank Handle is rotated, the Bush Wheel imparts a digging motion to the jib and shovel arm.

Parts required	
4 of No.	2
4 "	5
1 "	10
2 "	12
1 "	16
2 "	17
1 "	19s
3 "	22
1 "	24
4 "	35
4 "	37a
4 "	38
1 "	40
2 "	48a
1 "	52
1 "	57c
2 "	90a
4 "	111c
1 "	125
2 "	126
2 "	126a
1 "	155a
2 "	189

1.35 TELPHER SPAN

The anchoring piece 1 consists of two Trunnions bolted together, and a hook, which is made of two Angle Brackets fastened to them. A 2" Rod carrying a 1" fast Pulley is journalled in the Trunnions. The anchoring piece is hooked on a picture rail or other suitable support, and the Cord 2, which can be of any length, is passed round the 1" Pulleys as shown. When the Crank Handle is rotated, the car moves either backward or forward.

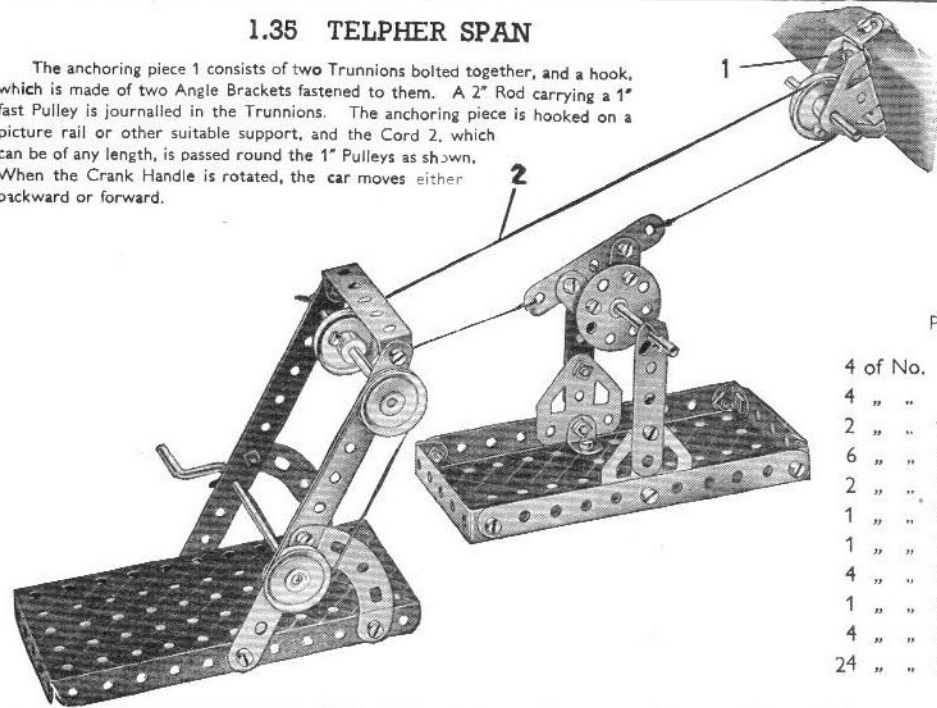

Parts required	
4 of No.	2
4 "	5
2 "	10
6 "	12
2 "	16
1 "	17
1 "	19s
4 "	22
1 "	24
4 "	35
24 "	37
4 of No.	37a
4 "	38
1 "	40
2 "	48a
1 "	52
2 "	90a
4 "	111c
2 "	126
2 "	126a
2 "	189

1.36 LAND YACHT

The Bush Wheel is secured to the $5\frac{1}{2}$ " x $2\frac{1}{2}$ " Flanged Plate by a $\frac{3}{8}$ " Bolt passed through the Plate and locked in the boss of the Bush Wheel. The 2" Rod journalled in the $5\frac{1}{2}$ " x $1\frac{1}{2}$ " Flexible Plates carries at its centre a 1" Pulley (with Rubber Ring), which is made fast to the Rod.

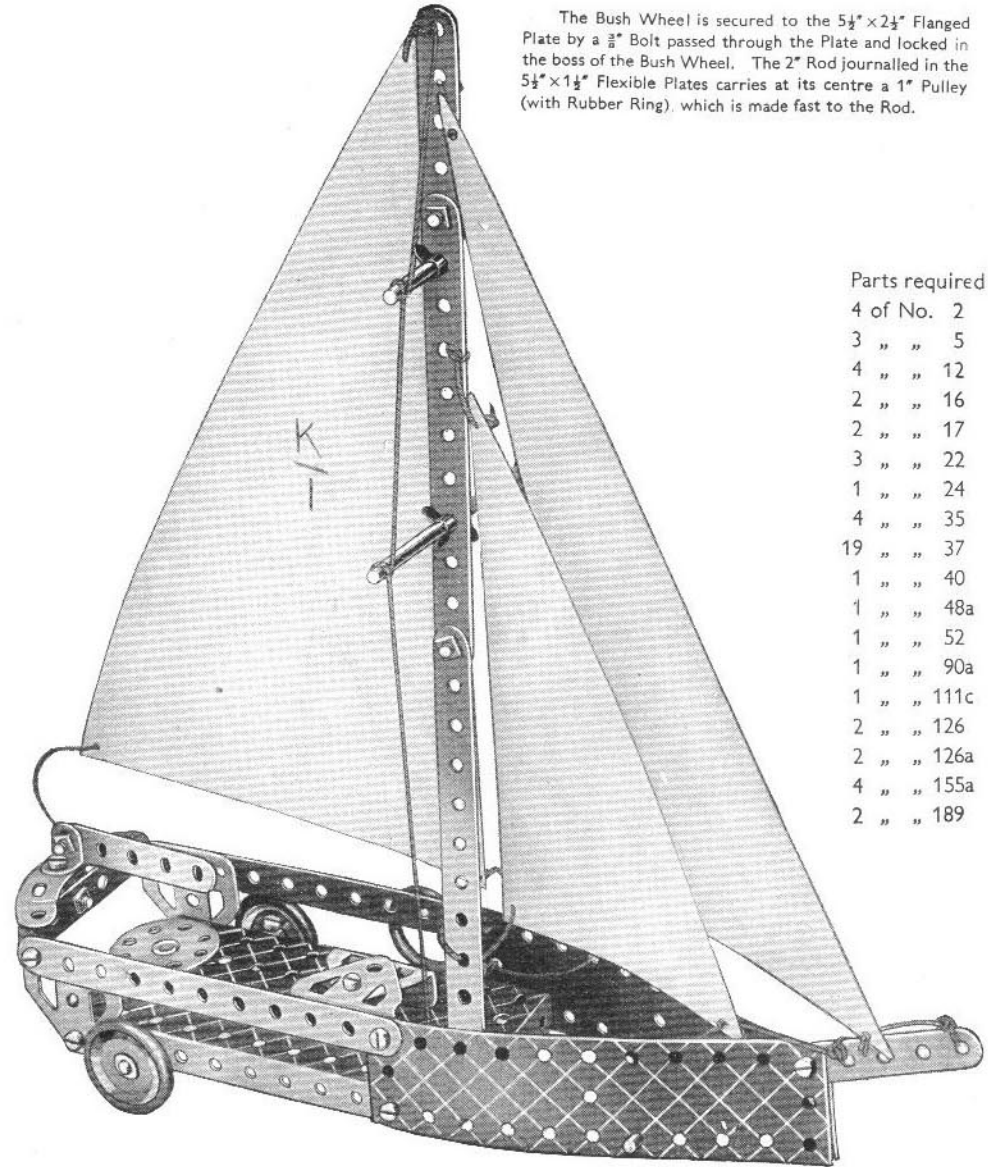

Parts required	
4 of No.	2
3 "	5
4 "	12
2 "	16
2 "	17
3 "	22
1 "	24
4 "	35
19 "	37
1 "	40
1 "	48a
1 "	52
1 "	90a
1 "	111c
2 "	126
2 "	126a
4 "	155a
2 "	189

1.37 RAILWAY BREAKDOWN CRANE

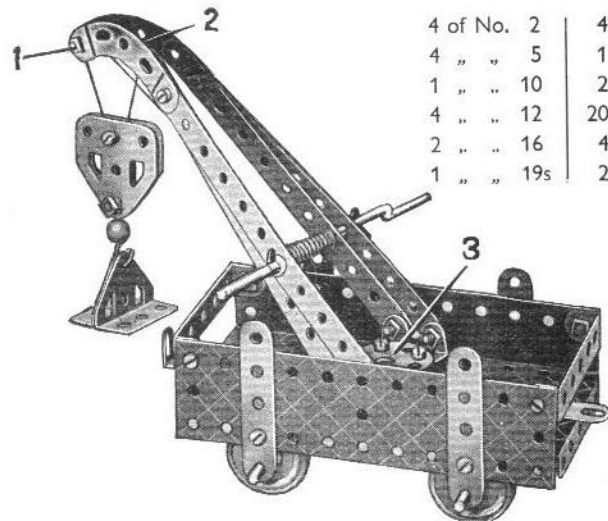

Parts required

4 of No. 2	4 of No. 22	1 of No. 40	1 of No. 125
4 " " 5	1 " " 24	2 " " 48a	2 " " 126
1 " " 10	2 " " 35	1 " " 52	2 " " 126a
4 " " 12	20 " " 37	1 " " 57c	4 " " 155a
2 " " 16	4 " " 37a	2 " " 90a	2 " " 189
1 " " 19s	2 " " 38	4 " " 111c	

The hoisting cord is secured to the Crank Handle, and then led over the $\frac{3}{8}$ " Bolt 1. It is then passed through the pulley block and fastened to the jib at 2. The jib is attached to the Bush Wheel 3 by means of Angle Brackets and the complete unit is pivoted as follows. A $\frac{3}{8}$ " Bolt is passed through the $5\frac{1}{2}$ " \times $2\frac{1}{2}$ " Flanged Plate, and is secured in the boss of the Bush Wheel by its set screw.

1.38 FIRE ENGINE

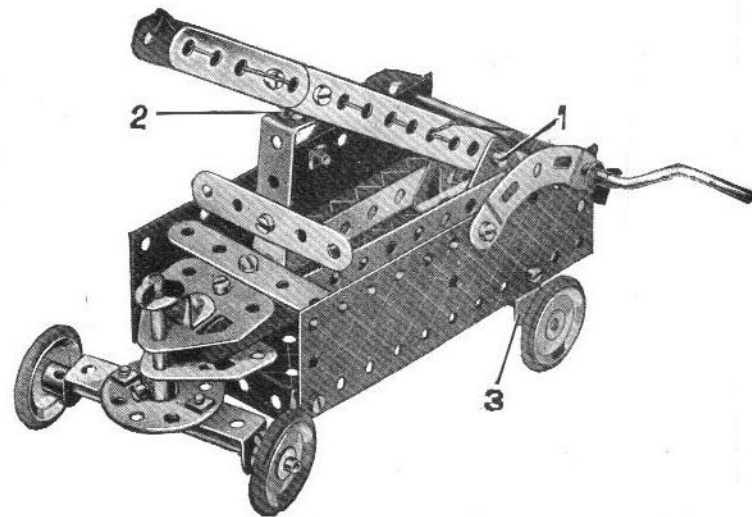

Parts required

4 of No. 2	2 of No. 38
4 " " 5	1 " " 40
3 " " 10	2 " " 48a
5 " " 12	1 " " 52
2 " " 16	2 " " 90a
1 " " 17	2 " " 111c
1 " " 19s	1 " " 125
4 " " 22	2 " " 126
1 " " 24	2 " " 126a
4 " " 35	4 " " 155a
24 " " 37	2 " " 189
4 " " 37a	

Bolts 1 are lock-nutted. The sides of the ladder are held together by two Angle Brackets 2, which are bolted together to form a double bracket. The rear axle bearings 3 are Flat Brackets bolted inside the flange of the Flanged Plate. The Cord from the Crank Handle is tied in the fourth hole up the ladder so that when the Handle is turned it causes the ladder to lift.

1.39 DERRICK CRANE

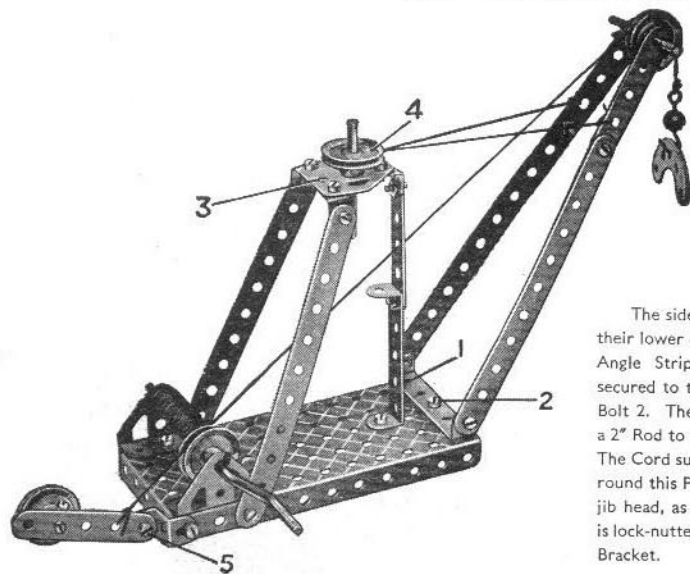

Parts required

4 of No. 2
4 " " 5
3 " " 12
2 " " 17
1 " " 19s
4 " " 22
4 " " 35
19 " " 37
4 " " 37a
1 " " 40
2 " " 48a
1 " " 52
1 " " 57c
2 " " 90a
1 " " 111c
1 " " 125
2 " " 126
1 " " 126a

The sides of the jib are bolted at their lower ends to a $2\frac{1}{2}$ " \times $\frac{1}{2}$ " Double Angle Strip 1, which is pivotally secured to the base by a lock-nutted Bolt 2. The Flat Trunnion 3 carries a 2" Rod to which is fitted a Pulley 4. The Cord supporting the jib is passed round this Pulley and attached to the jib head, as shown. The band brake is lock-nutted at 5 to a Reversed Angle Bracket.

1.40 TRAVELLING CRANE

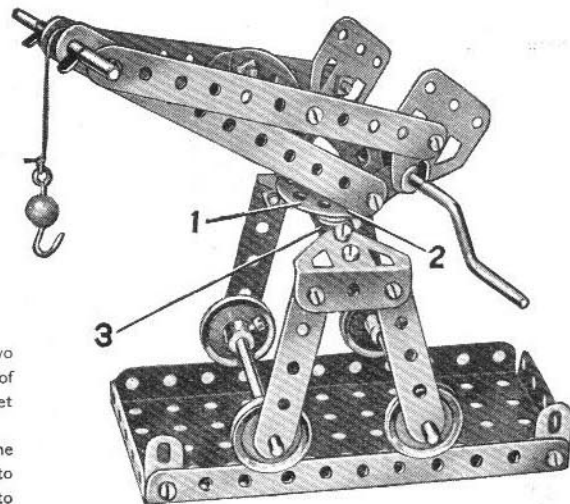

Parts required

4 of No. 2	20 of No. 37
4 " " 5	4 " " 38
4 " " 10	1 " " 40
2 " " 12	1 " " 48a
2 " " 16	1 " " 52
1 " " 17	1 " " 57c
1 " " 19s	2 " " 90a
4 " " 22	1 " " 111c
1 " " 24	2 " " 126
4 " " 35	2 " " 126a

The sides of the jib are secured to the Bush Wheel 1 by two Angle Brackets 2. A $\frac{3}{8}$ " Bolt is passed through the underneath side of Double Angle Strip 3 into the boss of the Bush Wheel 1 and the set screw is then tightened.

The Flat Trunnions at the lower end of the jib support the Crank Handle, which also passes through Flat Brackets bolted to the Angle Brackets 2 on the Bush Wheel 1. The Cord is fastened to the Crank Handle, and passes over the 2" Rod at the jib head.

1.41 RAILWAY TRUCK

Parts required

4 of No. 2	4 of No. 38
4 " " 5	2 " " 48a
2 " " 10	1 " " 52
8 " " 12	4 " " 111c
2 " " 16	1 " " 125
4 " " 22	2 " " 126
24 " " 37	2 " " 126a
4 " " 37a	2 " " 189

The axle bearings 1 are Flat Trunnions and Trunnions are used for the bearings 2, which fit underneath the Flanged Plate in the manner shown in the underneath view of the model Side Tipping Wagon (1.46).

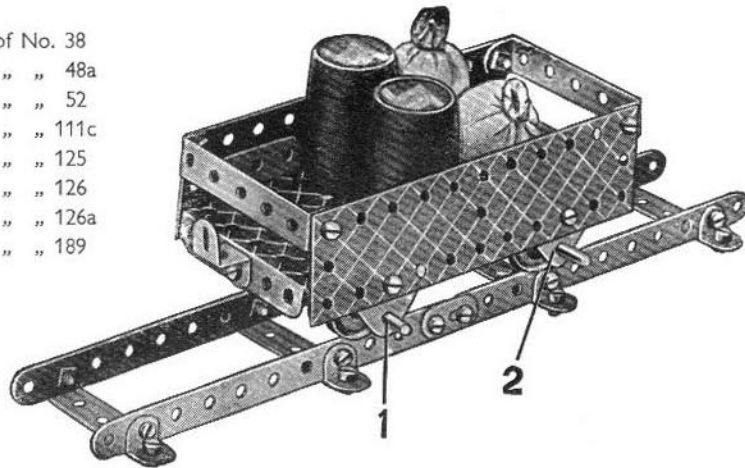

1.42 OPEN TRAMCAR

Parts required

2 of No. 5	1 of No. 40
4 " " 10	2 " " 48a
7 " " 12	1 " " 52
2 " " 16	2 " " 90a
1 " " 19s	4 " " 111c
4 " " 22	1 " " 125
1 " " 24	2 " " 126
4 " " 35	2 " " 126a
24 " " 37	4 " " 155a
3 " " 37a	2 " " 189

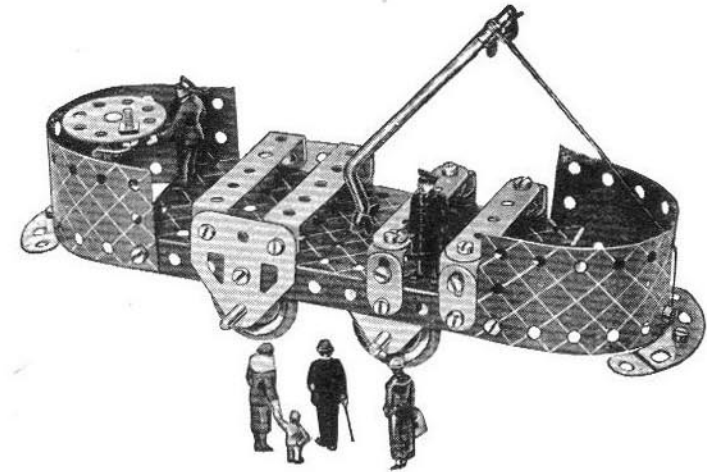

1.43 PITHEAD GEAR

Parts required

4 of No. 2	4 of No. 38
4 " " 5	1 " " 40
4 " " 10	2 " " 48a
2 " " 12	1 " " 52
1 " " 16	1 " " 90a
1 " " 19s	4 " " 111c
4 " " 22	2 " " 126
4 " " 35	2 " " 126a
20 " " 37	2 " " 189
4 " " 37a	

A Cord is taken from each side of the lift cage over the 1" Pulleys and secured to each end of the Crank Handle. The Cords must both be the same length otherwise the lift will tilt.

The two guides for the lift consist of two pieces of Cord fastened to the Washers 1. The Cords are then passed through holes in the Double Angle Strip, through two corresponding holes in the lift cage 2, and then through the two corresponding holes in the Flanged Plate. Two more Washers are tied to the Cords beneath the Flanged Plate to keep the Cords tight. The lift cage 2 is made up of two Trunnions.

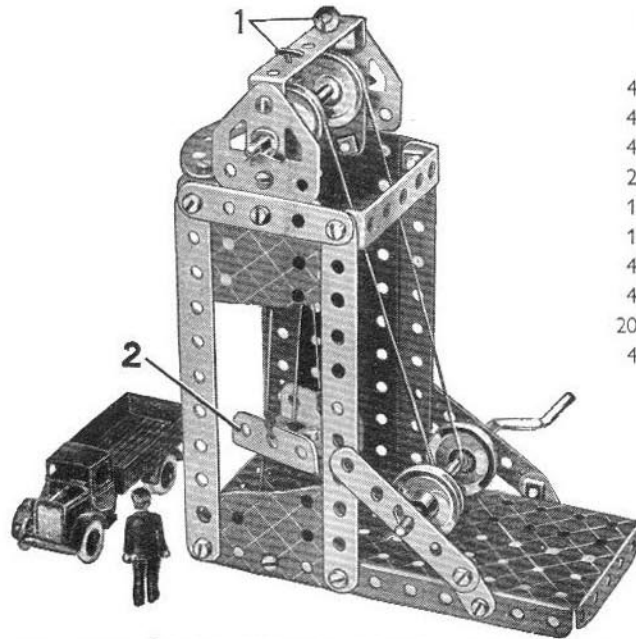

1.44 DOCKSIDE CRANE

Parts required

4 of No. 2	4 of No. 38
4 " " 5	1 " " 40
2 " " 10	2 " " 48a
4 " " 12	1 " " 52
1 " " 16	1 " " 57c
2 " " 17	2 " " 90a
1 " " 19s	4 " " 111c
4 " " 22	1 " " 125
1 " " 24	2 " " 126
4 " " 35	2 " " 126a
24 " " 37	2 " " 155a
4 " " 37a	2 " " 189

The Rod 1 passes through the bosses of the Bush Wheel 2 and the 1" Pulley, and is held in position by a Spring Clip underneath the Flanged Plate. The set screw of the Bush Wheel 2 is tightened on the Rod.

The 5 1/2" Strips that form the jib are extended at the head by 2 1/4" x 1/2" Double Angle Strips, in which a 2" Rod is journaled.

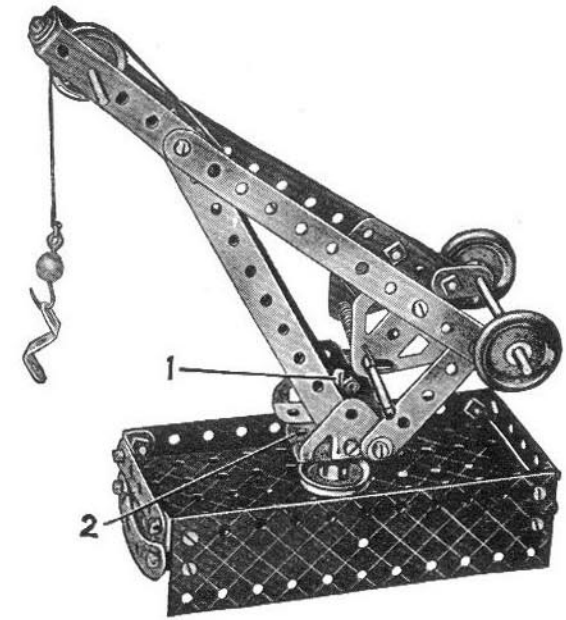

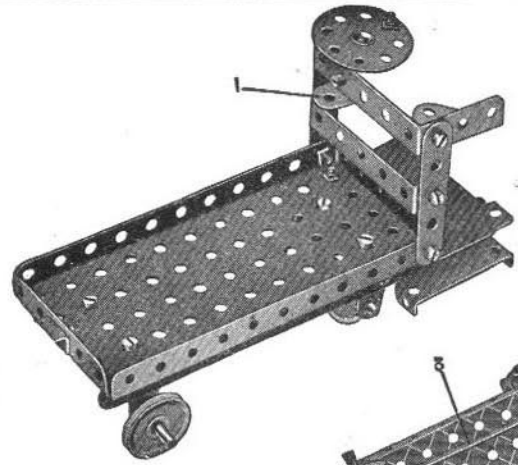

The steering wheel, a Bush Wheel, is secured to the Reversed Angle Bracket 1 by means of a $\frac{3}{8}$ " Bolt. Fig. 1.45a shows how the *Magic Motor* is mounted to drive the front wheels. The front wheel axle is journalled in two Flat Brackets bolted to the $5\frac{1}{2}$ " Strips 2 and 3.

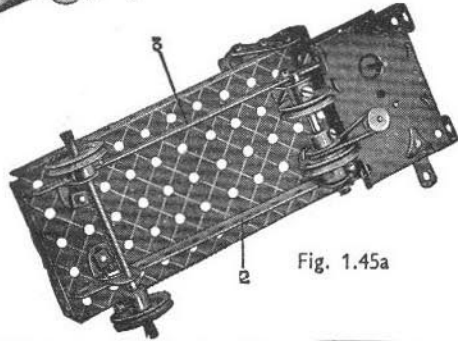

Fig. 1.45a

1.45 ELECTRIC TRUCK

Parts required

2 of No. 2	4 of No. 22
2 " " 5	1 " " 24
4 " " 10	1 " " 37
4 " " 12	2 " " 48a
1 " " 16	1 " " 52
1 " " 17	1 " " 111c
	1 " " 125
	1 " " 126
	1 <i>Magic Motor</i>

1.46 SIDE TIPPING WAGON

Parts required

3 of No. 2	2 of No. 90a
4 " " 5	4 " " 111c
4 " " 10	1 " " 125
7 " " 12	2 " " 126
2 " " 16	2 " " 126a
1 " " 17	4 " " 155a
4 " " 22	2 " " 189
1 " " 24	1 <i>Magic Motor</i>
24 " " 37	
4 " " 37a	
3 " " 38	
2 " " 48a	
1 " " 52	

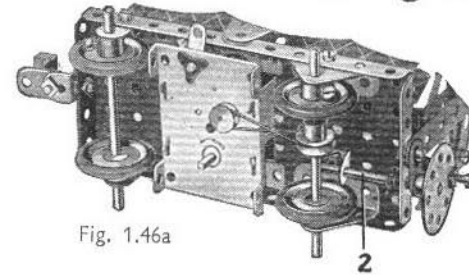
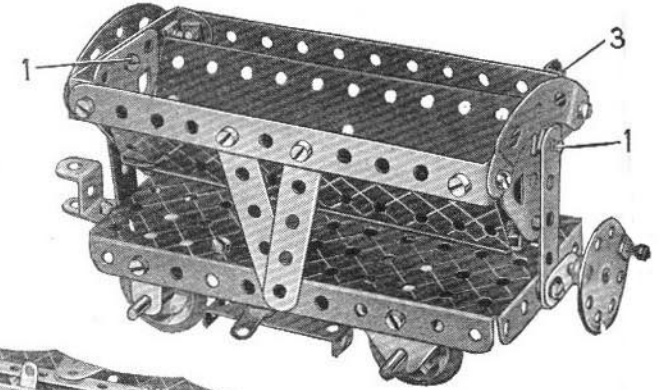
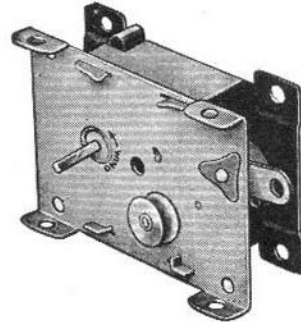

Fig. 1.46a

Each of the Bolts 1 is lock-nutted. A piece of Cord is fastened to the Rod 2 (Fig. 1.46a) wrapped round it two or three times, and then is taken through the hole in the Flanged Plate above the Rod and secured to the Angle Bracket 3.

By turning the Bush Wheel the container is tipped sideways.

THE MECCANO *MAGIC MOTOR*

The greatest thrill in Meccano model-building is experienced when a model is set to work by means of a Meccano *Magic Motor*. The illustrations on this page show how the *Magic Motor* can be fitted without any difficulty to No. 1 Outfit models of various types. Fit the model you have just built with one of these wonderful Motors, and enjoy the fun of watching it work just like the real thing!

The left-hand $2\frac{1}{2}$ " Strip that supports the swing is connected to the Crank Handle by passing the set screw of the 1" Pulley Wheel 2 through the hole in an Angle Bracket bolted to the Strip and then into the boss of the Pulley. Bolt 1 on the Bush Wheel is fitted with lock-nuts.

The Bolts 1 are lock-nutted. The Rod 2 is secured to an Angle Bracket by means of two Spring Clips 3. The model is driven by a *Magic Motor* bolted to the $5\frac{1}{2}$ " x $2\frac{1}{2}$ " Flanged Plate. The pulley of the Motor is connected to a 1in. fast Pulley on the crankshaft of the engine by a Driving Band.

1.47 MECHANICAL SWING

Parts required

4 of No. 2
2 " " 5
2 " " 10
3 " " 12
1 " " 16
1 " " 19s
2 " " 22
1 " " 24
4 " " 35
15 " " 37
2 " " 37a
4 " " 38
1 " " 40
2 " " 48a
1 " " 52
1 " " 111c
1 " " 125
2 " " 126
2 " " 189
1 <i>Magic Motor</i>

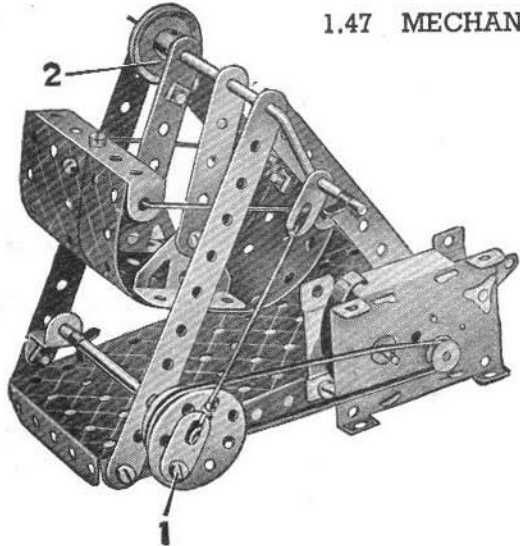

1.48

HORIZONTAL STEAM ENGINE

Parts required

3 of No. 2
4 " " 5
2 " " 12
1 " " 16
1 " " 17
4 " " 22
1 " " 24
4 " " 35
24 " " 37
2 " " 37a
3 " " 38
1 " " 38a
1 " " 52
1 " " 111c
1 " " 125
2 " " 126
2 " " 126a
2 " " 189
1 <i>Magic Motor</i>

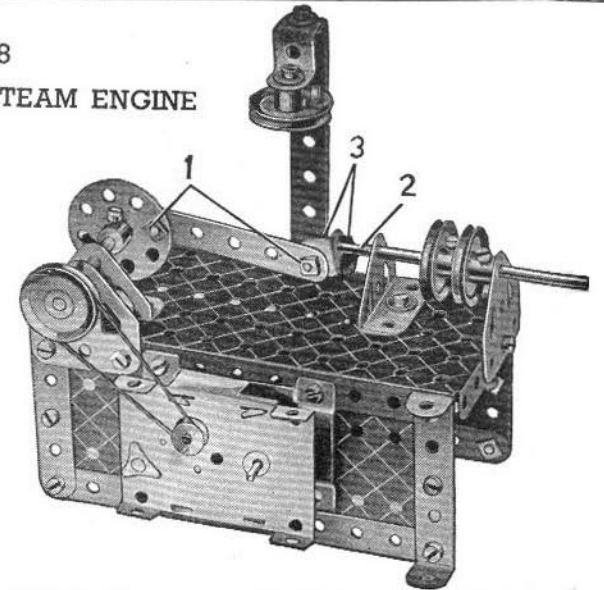

2.1 RAILWAY FOOTBRIDGE

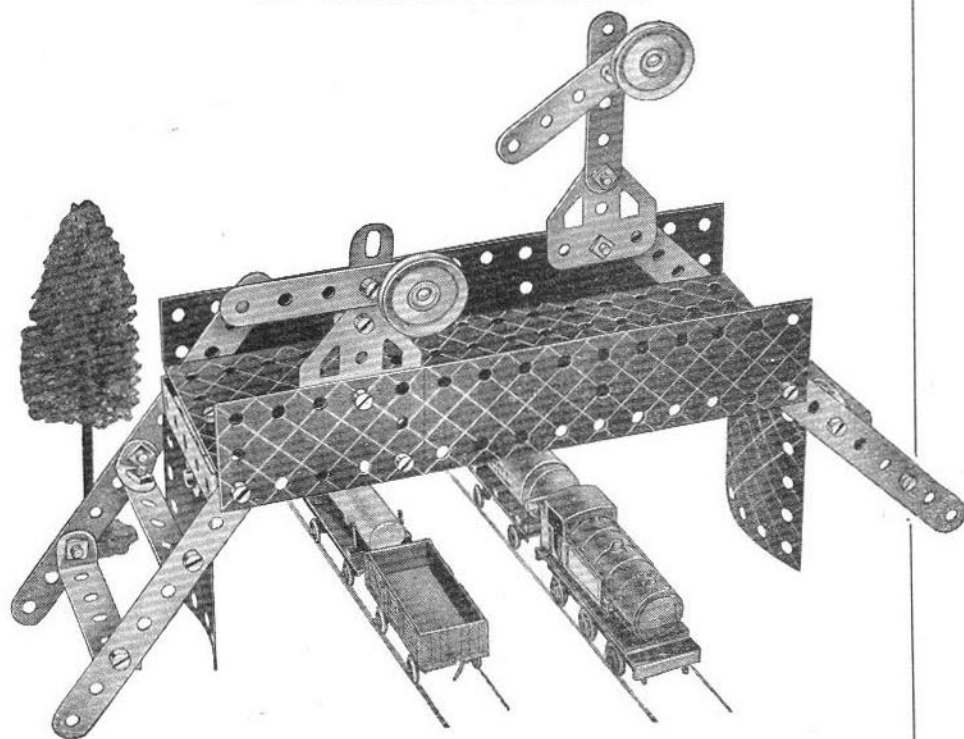

Parts required

4 of No. 2	2 of No. 22	1 of No. 52	2 of No. 188
6 " " 5	32 " " 37	2 " " 111c	2 " " 189
2 " " 10	2 " " 37a	2 " " 126	1 " " 190
6 " " 12	2 " " 48a	2 " " 126a	2 " " 200

The span of the bridge is a $5\frac{1}{2}'' \times 2\frac{1}{2}''$ Flanged Plate, extended by a $2\frac{1}{2}'' \times 2\frac{1}{2}''$ Flexible Plate. Trunnions are bolted to each end of the span, and have $1\frac{1}{8}''$ radius Curved Plates fastened to them. The sides of the approach stairways are $5\frac{1}{2}''$ Strips. They are joined across by $2\frac{1}{2}'' \times \frac{1}{2}''$ Double Angle Strips and $2\frac{1}{2}''$ Strips fitted with Angle Brackets at each end.

The signals are supported on Flat Trunnions bolted to the sides of the bridge. The smaller of the two signal posts is formed by two Flat Brackets, and the larger one is a $2\frac{1}{2}''$ Strip. The signal arms are $2\frac{1}{2}''$ Strips bolted to the posts in the second holes from one end. They are fitted at their shorter ends with $1''$ Pulleys, representing the spectacles, which are held in place by $\frac{3}{8}''$ Bolts passed through the Strips and inserted in their bosses.

2.2 LAWN MOWER

The "cutter" is made by bolting an Angle Bracket at each end of a Reversed Angle Bracket 1 and then sliding an Axle Rod through the free holes of the Brackets. The two Pulleys 2 are fixed to the Rod and pushed tightly against the "cutter" to make it rotate with the Rod as the wheels revolve. The wheels are $1''$ Pulleys fitted with Rubber Rings.

Parts required

4 of No. 2	2 of No. 90a
4 " " 5	1 " " 125
4 " " 10	2 " " 126
6 " " 12	2 " " 155a
1 " " 16	2 " " 200
4 " " 22	
25 " " 37	
4 " " 38	
2 " " 48a	

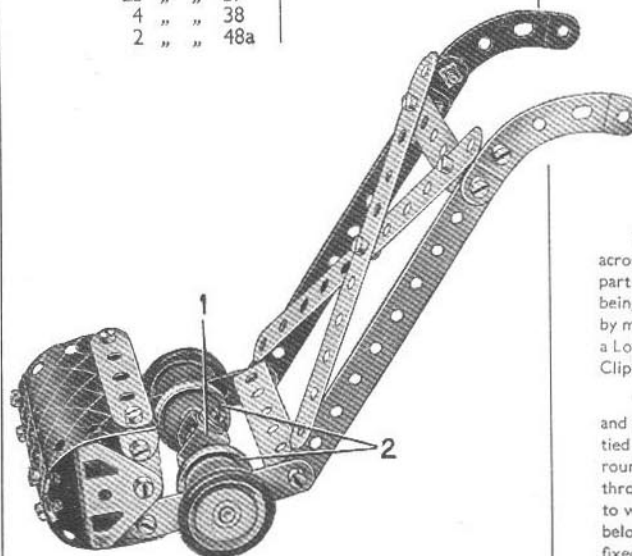

2.3 FLOATING CRANE

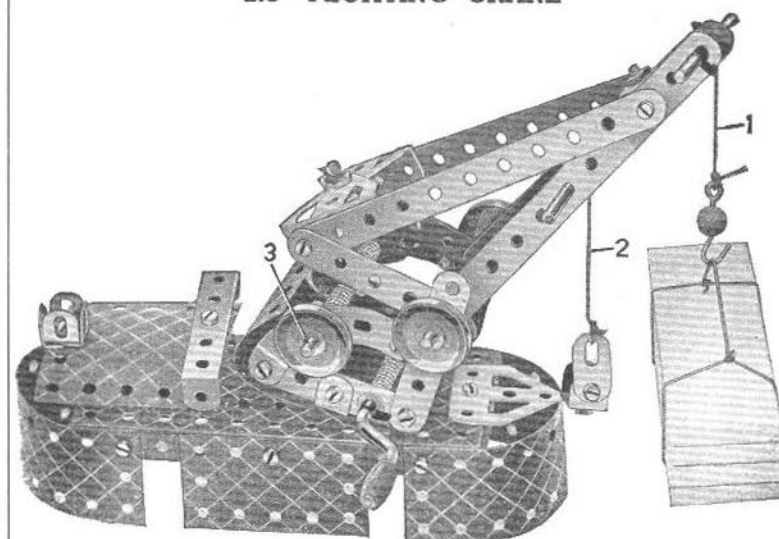

Parts required

4 of No. 2	4 of No. 22	2 of No. 48a	1 of No. 126a
6 " " 5	1 " " 24	1 " " 52	1 " " 176
3 " " 10	4 " " 35	1 " " 57c	2 " " 188
8 " " 12	29 " " 37	2 " " 90a	2 " " 189
2 " " 16	3 " " 37a	4 " " 111c	1 " " 199
2 " " 17	4 " " 38	1 " " 125	1 " " 200
1 " " 19g	1 " " 40	2 " " 126	

The jib consists of $5\frac{1}{2}''$ Strips and $2\frac{1}{2}''$ Strips. At its upper end these are joined across by Angle Brackets, and at its lower end by Trunnions. Each side of the lower part of the crane consists of $2\frac{1}{2}''$ Strips and small radius Curved Strips, the two sides being connected by $2\frac{1}{2}'' \times \frac{1}{2}''$ Double Angle Strips. The jib is pivoted to this structure by means of a $3\frac{1}{2}''$ Rod, which carries at each end a $1''$ Pulley. The Cord 1 fitted with a Loaded Hook, is passed over a $2''$ Rod held in place in the jib by means of Spring Clips and is then wound around the Crank Handle.

The Cord 2 passes over a Rod held in place in the jib by an Anchoring Spring, and is then wound around the Rod that forms the pivot for the jib. A third Cord is tied to a Bolt fastened in the two Trunnions at the base of the jib, and is wound round Rod 3. This Cord controls the luffing motion of the crane. A $\frac{3}{8}''$ Bolt passes through the Flanged Plate and is held by a set screw in the boss of the Bush Wheel to which the jib is fastened. The Bush Wheel is bolted to the Double Angle Strip below the Rod 3. The roof of the cabin is bolted to a $\frac{1}{2}''$ Reversed Angle Bracket fixed to the Flanged Plate.

2.4 AUTOGIRO

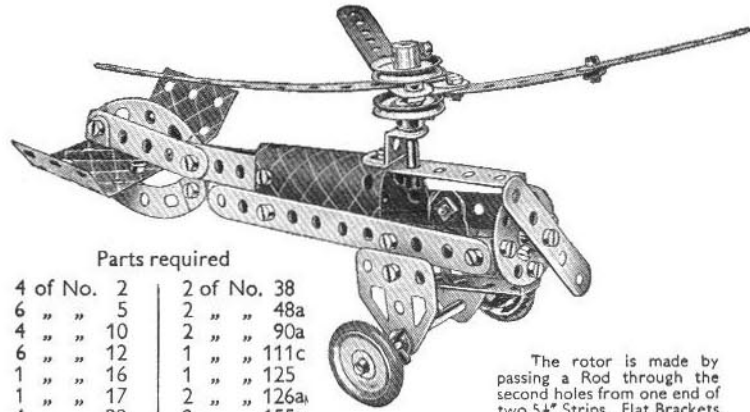

Parts required

4 of No. 2	2 of No. 38
6 " " 5	2 " " 48a
4 " " 10	2 " " 90a
6 " " 12	1 " " 111c
1 " " 16	1 " " 125
1 " " 17	2 " " 126a
4 " " 22	2 " " 155a
1 " " 24	2 " " 188
3 " " 35	1 " " 199
25 " " 37	

The rotor is made by passing a Rod through the second holes from one end of two 5 1/2" Strips. Flat Brackets are bolted to the short ends of the Strips and the third blade of the rotor is fixed to them as shown.

2.6 GAS ENGINE

Parts required

1 of No. 2	1 of No. 19g	4 of No. 35
3 " " 5	4 " " 22	39 " " 37
4 " " 10	1 " " 24	3 " " 37a
8 " " 12		4 " " 38
2 " " 16		1 " " 40
1 " " 17		2 " " 48a
		1 " " 52
		1 " " 90a
		1 " " 111c
		1 " " 125
		2 " " 126
		1 " " 126a
		1 " " 155a
		1 " " 176
		1 " " 187
		2 " " 188
		2 " " 189
		1 " " 190
		2 " " 200

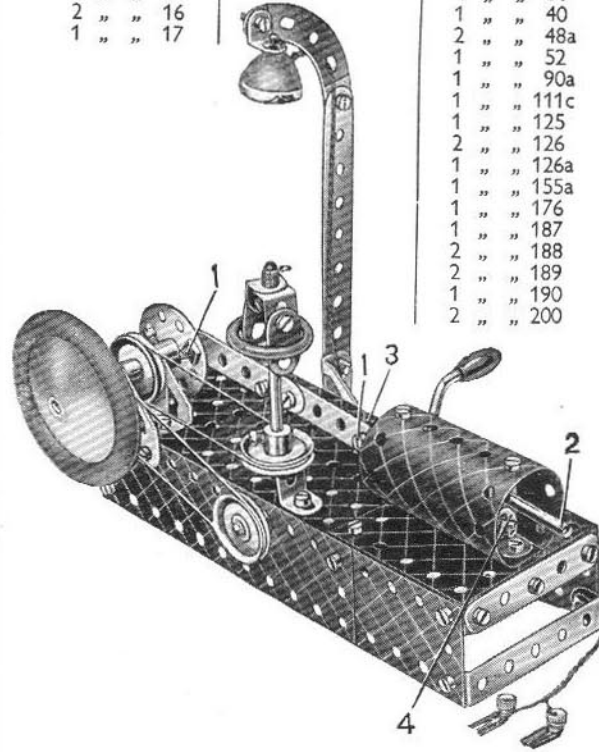

The bearings on the Rod representing the crankshaft are a Flat Trunnion and a Trunnion. The crankshaft carries a Road Wheel and a 1" Pulley at one end, a second 1" Pulley between the bearings, and a Bush Wheel at its other end.

The connecting rod is fastened to the Bush Wheel and to an Angle Bracket 3 by a lock-nutted Bolt 1. The Rod 2 is held in the Angle Bracket 3 by means of Spring Clips, one on each side. An Angle Bracket 4, carrying a Flat Bracket, is bolted inside the cylinder, and a similar arrangement is fitted at the other end. These form bearings for the Rod 2.

The model is operated by the Crank Handle, which carries also a 1" Pulley connected to one of the 1" Pulleys on the crankshaft by a belt of Cord. A second Cord drives the governor, which is mounted on a 3 1/2" Rod journalled in the 5 1/2 x 2 1/2" Flanged Plate and a Reversed Angle Bracket.

The model is fitted with a Spotlight from the Meccano Lighting Set, current being supplied by a 4.5-volt pocket-lamp battery housed in the base of the model.

2.7 RACING CAR

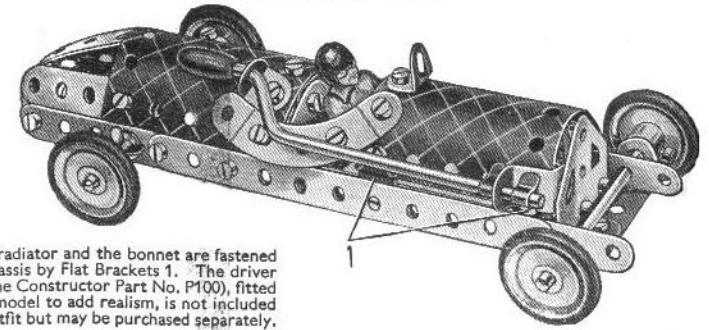

The radiator and the bonnet are fastened to the chassis by Flat Brackets 1. The driver (Aeroplane Constructor Part No. P100), fitted into the model to add realism, is not included in the Outfit but may be purchased separately.

Parts required

4 of No. 2	1 of No. 19g	2 of No. 38	1 of No. 126a
5 " " 5	4 " " 22	1 " " 48a	4 " " 155a
4 " " 10	4 " " 35	2 " " 90a	1 " " 199
8 " " 12	30 " " 37	1 " " 125	1 " " 200
2 " " 16	1 " " 37a	1 " " 126	

2.5 ANTI-AIRCRAFT GUN

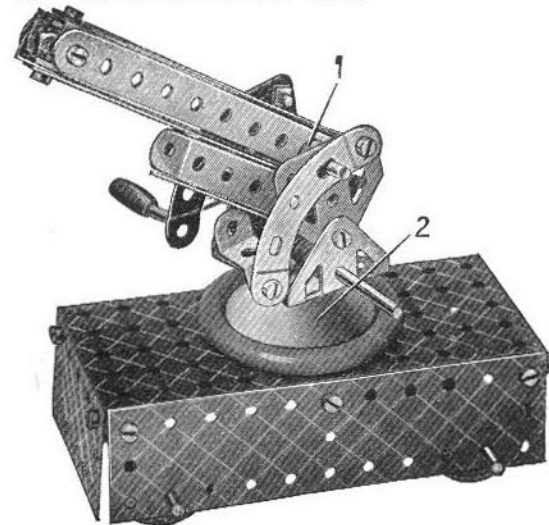

Parts required

4 of No. 2
1 " " 5
6 " " 12
2 " " 16
2 " " 17
1 " " 19g
4 " " 22
1 " " 24
3 " " 35
26 " " 37
4 " " 38
2 " " 48a
1 " " 52
2 " " 90a
1 " " 125
2 " " 126
2 " " 126a
4 " " 155a
1 " " 176
1 " " 187
2 " " 188
2 " " 189

One end of a piece of Cord is fastened to the Crank Handle. It is wound round the Handle a few times and its other end is then fastened to the end of the gun. The two Trunnions are bolted to a Bush Wheel fixed on a 2" Rod that passes through the Road Wheel 2 and the Flanged Plate and is held in place by an Anchoring Spring. The Spring Clips at 1 space the gun barrel from the Flat Trunnions.

2.8 LOW WING MONOPLANE

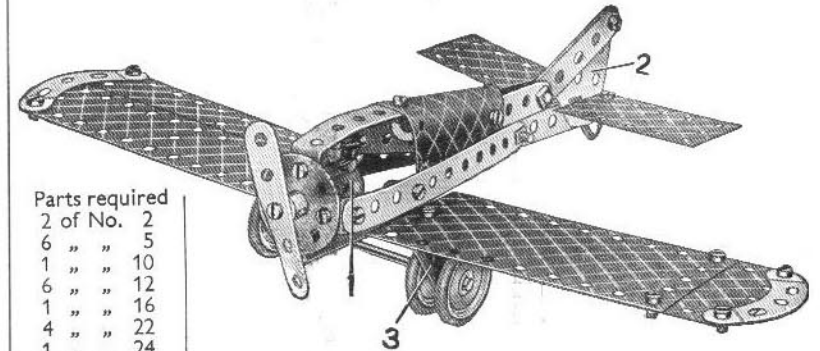

Parts required

2 of No. 2	2 of No. 126	2 of No. 189
6 " " 5	1 " " 126a	1 " " 190
1 " " 10	4 " " 155a	1 " " 191
6 " " 12	2 " " 188	1 " " 199
1 " " 16		
4 " " 22		
1 " " 24		
23 " " 37		
2 " " 37a		
2 " " 38		
2 " " 48a		
2 " " 90a		
3 " " 111c		

The pilot 1 (Aeroplane Constructor Part No. P100) is not included in the Outfit, but may be bought separately. The fin 2 is a Flat Trunnion, and it is clamped between the two 2 1/2" Strips. The bearings 3 for the axle of the landing wheels are Trunnions, bolted to the wings. The wings are attached to the fuselage by Angle Brackets.

2.9 SETTEE

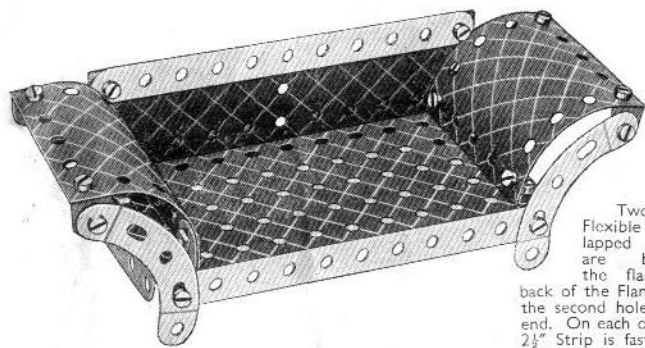

Two $5\frac{1}{2}'' \times 1\frac{1}{2}''$ Flexible Plates overlapped two holes are bolted to the flange at the back of the Flanged Plate in the second holes from each end. On each of the Bolts a $2\frac{1}{2}''$ Strip is fastened by its end hole, and the other end of the Strip is bolted to the turned down ends of the $2\frac{1}{2}''$ Double Angle Strips under the arm rests.

$2\frac{1}{2}''$ Strips are bolted behind the $5\frac{1}{2}'' \times 1\frac{1}{2}''$ Flexible Plates at each end to form the back legs.

Parts required

2 of No. 2	24 of No. 37	2 of No. 90a
4 " " 5	2 " " 48a	2 " " 189
4 " " 12	1 " " 52	2 " " 200

2.11 TRAVELLING CRANE

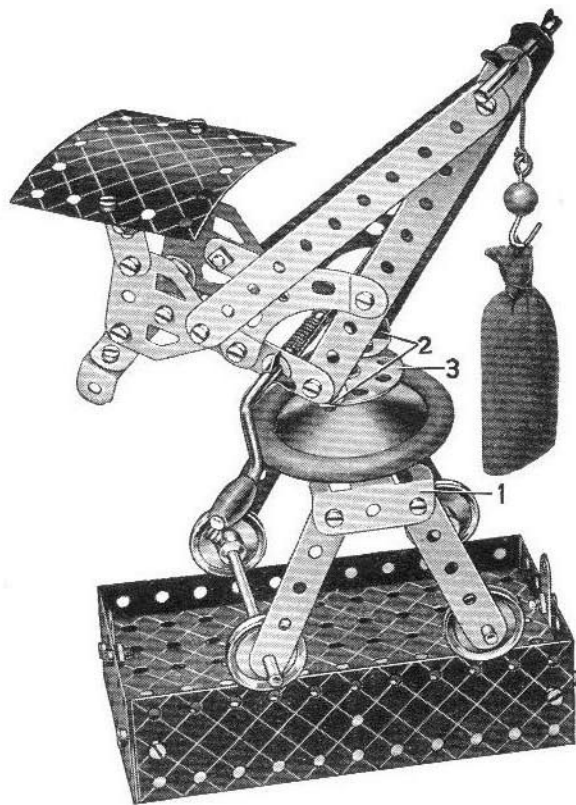

Parts required

4 of No. 2	1 of No. 19g	3 of No. 38	2 of No. 111c
6 " " 5	4 " " 22	1 " " 40	2 " " 126
4 " " 10	1 " " 24	2 " " 48a	2 " " 126a
6 " " 12	4 " " 35	1 " " 52	1 " " 176
2 " " 16	38 " " 37	1 " " 57c	1 " " 187
2 " " 17	2 " " 37a	2 " " 90a	2 " " 188
	2 of No. 189		1 of No. 200

A 2" Rod is secured in the boss of the Bush Wheel 3. It then passes through the Road Wheel and through the centre of a $2\frac{1}{2}'' \times \frac{1}{2}''$ Double Angle Strip bolted between the two Trunnions 1. A Washer and a Cord Anchoring Spring are pushed on to the Rod to hold it in position. The crane jib is attached to the Bush Wheel by the Angle Brackets 2.

2.12 CATTLE TRUCK

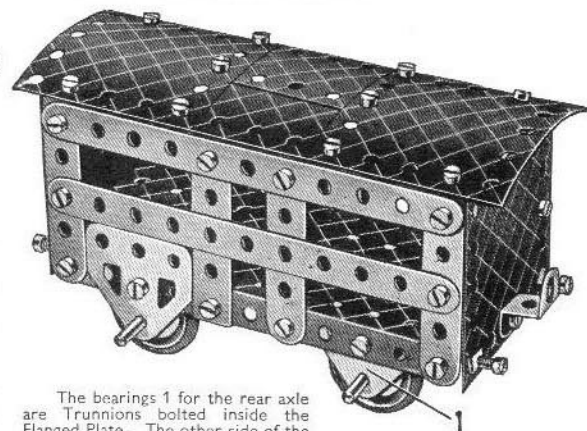

Parts required

4 of No. 2
6 " " 5
4 " " 10
5 " " 12
2 " " 16
4 " " 22
38 " " 37
8 " " 37a
4 " " 38
2 " " 48a
1 " " 52
4 " " 111c
1 " " 125
2 " " 126
2 " " 126a
4 " " 155a
2 " " 188
2 " " 190
2 " " 200

The bearings 1 for the rear axle are Trunnions bolted inside the Flanged Plate. The other side of the truck is constructed in a similar manner to the side shown in the illustration.

2.10 ROLL TOP DESK

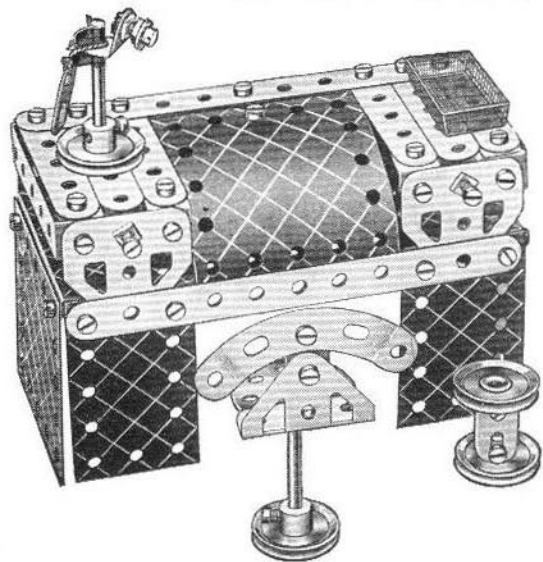

Parts required

2 of No. 2
6 " " 5
4 " " 10
7 " " 12
2 " " 17
4 " " 22
1 " " 24
3 " " 35
38 " " 37
5 " " 37a
1 " " 38
2 " " 48a
1 " " 52
1 " " 90a
3 " " 111c
1 " " 126
2 " " 126a
2 " " 188
1 " " 189
2 " " 190
1 " " 200

2.13 PIANO

A $5\frac{1}{2}'' \times 2\frac{1}{2}''$ Flanged Plate is used for the upper part of the back and to each end of this a $2\frac{1}{2}''$ Strip is bolted to form the rear legs.

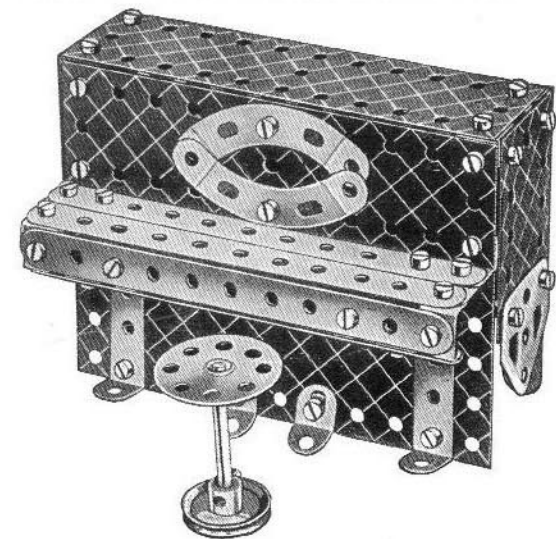

Parts required

4 of No. 2
4 " " 5
4 " " 10
8 " " 12
1 " " 17
1 " " 22
1 " " 24
38 " " 37
4 " " 38
2 " " 48a
1 " " 52
2 " " 90a
2 " " 126
2 " " 126a
2 " " 188
2 " " 189
1 " " 190
1 " " 191

2.14 MOTOR VAN

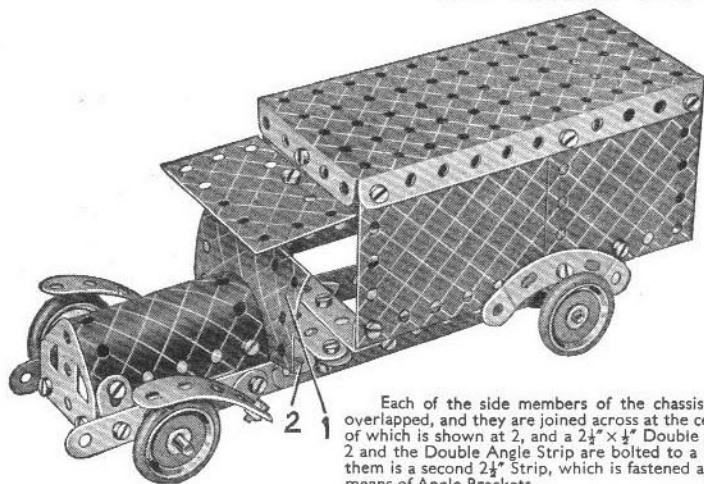

Each of the side members of the chassis consists of two $5\frac{1}{2}$ " Strips overlapped, and they are joined across at the centre by two $2\frac{1}{2}$ " Strips, one of which is shown at 2, and a $2\frac{1}{2}$ " x $\frac{1}{2}$ " Double Angle Strip. The $2\frac{1}{2}$ " Strip 2 and the Double Angle Strip are bolted to a Flat Trunnion and between them is a second $2\frac{1}{2}$ " Strip, which is fastened at each end to the chassis by means of Angle Brackets.

The Plate 1 is fastened to an Angle Bracket that is bolted to Strip 2. The body is fixed to the chassis by a Double Angle Strip and an Angle Bracket.

Parts required

4 of No. 2
4 " " 5
4 " " 10
8 " " 12
2 " " 16
4 " " 22
4 " " 35
40 " " 37
4 " " 38
2 " " 48a
1 " " 52
2 " " 90a
1 " " 126
2 " " 126a
4 " " 155a
2 " " 188
2 " " 189
2 " " 190
1 " " 191
1 " " 199

2.16 STEAMSHIP

Parts required

4 of No. 2
6 " " 5
1 " " 12
2 " " 16
2 " " 17
4 " " 22
1 " " 24
4 " " 35
34 " " 37
1 " " 40
2 " " 48a
1 " " 52
1 " " 125
2 " " 126
2 " " 188
2 " " 189
1 " " 190

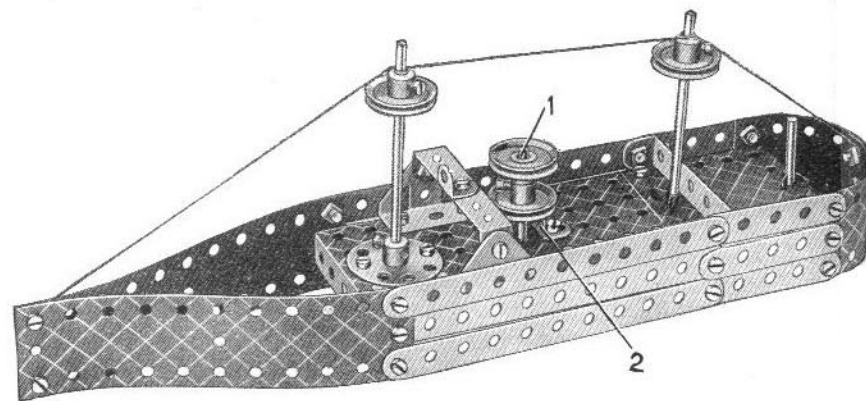

The deck of the model is a $5\frac{1}{2}$ " x $2\frac{1}{2}$ " Flanged Plate extended by a $2\frac{1}{2}$ " x $2\frac{1}{2}$ " Flexible Plate. A $2\frac{1}{2}$ " x $\frac{1}{2}$ " Double Angle Strip fitted with an Angle Bracket represents the bridge, and it is supported by two Trunnions bolted to the deck. The funnel consists of a Rod 1 fitted with two 1 " fast Pulleys. The Rod passes through the hole in a Reversed Angle Bracket 2 and then through the Flanged Plate.

2.15 RAILWAY BREAKDOWN CRANE

Parts required

4 of No. 2
6 " " 5
4 " " 10
3 " " 12
2 " " 16
1 " " 17
1 " " 19g
4 " " 22
1 " " 24
2 " " 35
39 " " 37
3 " " 37a
3 " " 38
1 " " 40
2 " " 48a
1 " " 52
1 " " 57c
2 " " 90a
3 " " 111c
2 " " 126
2 " " 126a
1 " " 155a
1 " " 176
1 " " 187

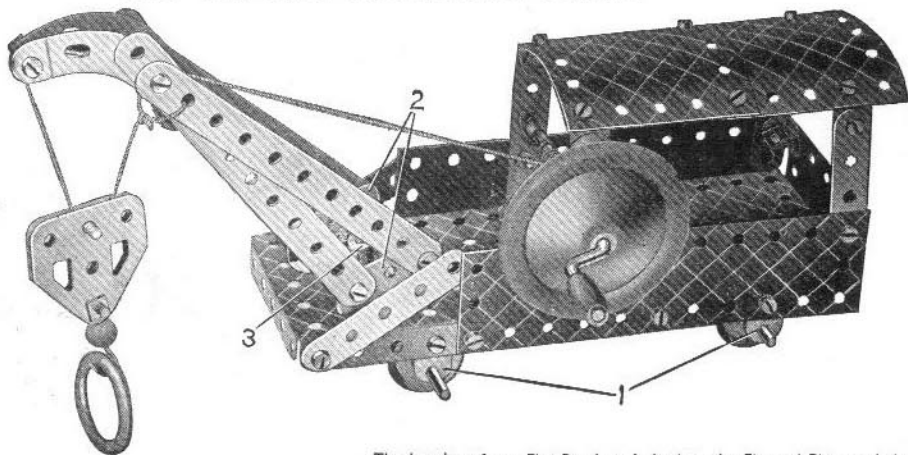

The bearings 1 are Flat Brackets bolted to the Flanged Plate and the Flexible Plates respectively. The jib is fastened to two Trunnions 2, which are bolted to the Bush Wheel 3. A 2 " Rod is secured in the boss of the Bush Wheel 3. It then passes through a hole in the Flanged Plate, and is held in position by a Spring Clip underneath the Plate.

1 of No. 188
2 " " 189
1 " " 190
2 " " 200

2.17

BATHROOM SUITE

Parts required

4 of No. 2
6 " " 5
4 " " 10
8 " " 12
1 " " 24
40 " " 37
6 " " 37a
2 " " 38
2 " " 48a
1 " " 52
2 " " 90a
4 " " 111c
1 " " 125
2 " " 126
2 " " 126a
2 " " 188
2 " " 189
1 " " 190
1 " " 191
1 " " 199
1 " " 200

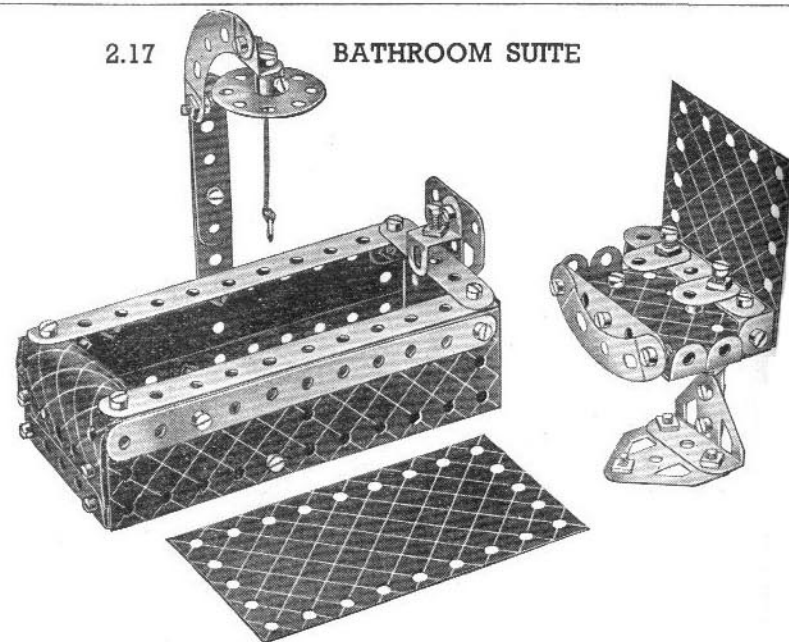

2.18 WHEELBARROW

A $5\frac{1}{2}'' \times 2\frac{1}{2}''$ Flanged Plate is used upside down for the floor of the barrow, and two $5\frac{1}{2}''$ Strips overlapped six holes form the shafts.

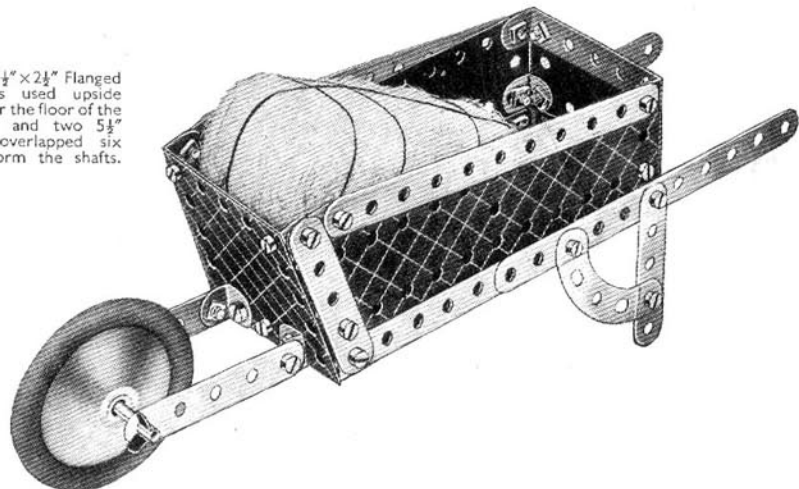

Parts required

4 of No. 2
6 " " 5
2 " " 10
4 " " 12
1 " " 17
2 " " 35
29 " " 37
2 " " 48a
1 " " 52
2 " " 90a
1 " " 187
1 " " 188
2 " " 189
1 " " 190

2.19 ROAD BRIDGE

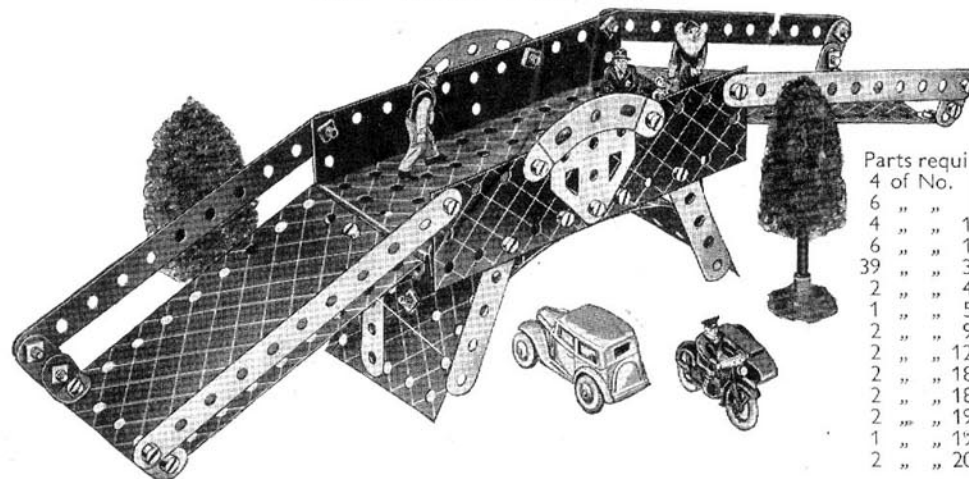

Parts required

4 of No. 2
6 " " 5
4 " " 10
6 " " 12
39 " " 37
2 " " 48a
1 " " 52
2 " " 90a
2 " " 126a
2 " " 188
2 " " 189
2 " " 190
1 " " 191
2 " " 200

2.20 GARDEN HAMMOCK

The Cord by which the back of the hammock is suspended is tied to the rear ends of the Double Angle Strips 1. The seat, which consists of two $2\frac{1}{2}'' \times 2\frac{1}{2}''$ Flexible Plates, is attached to the back of the hammock by two Trunnions.

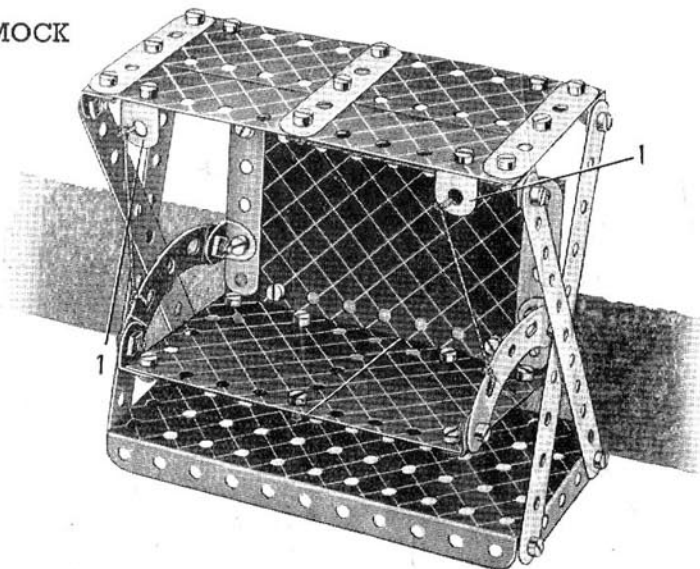

Parts required

4 of No. 2	1 of No. 52
5 " " 5	2 " " 90a
8 " " 12	2 " " 126
38 " " 37	2 " " 189
1 " " 40	2 " " 190
2 " " 48a	1 " " 191

2.21 DRAGLINE EXCAVATOR

Parts required

4 of No. 2	3 of No. 22	1 of No. 48a	1 of No. 176
6 " " 5	1 " " 24	1 " " 52	1 " " 187
2 " " 10	4 " " 35	1 " " 57c	2 " " 188
8 " " 12	40 " " 37	2 " " 90a	2 " " 189
1 " " 16	4 " " 37a	2 " " 111c	2 " " 190
2 " " 17	1 " " 38	2 " " 126	1 " " 199
1 " " 19g	1 " " 40	2 " " 126a	2 " " 200

The Cord 1 is wound round the Crank Handle about 12 times, then one end of it is fastened to a small Loaded Hook and the other end to the Cord on the bucket.

A Curved Strip is pivoted by a $\frac{3}{8}''$ Bolt through one of its ends, in the position of Bolt 2, but on the rear side of the model. A $1''$ Pulley is attached to the other end of the Curved Strip with a $\frac{3}{8}''$ Bolt to act as a weight. A loop of Cord is fastened through the slotted hole next to the bottom of the Strip, and then passes round the $1''$ Pulley 3 on the shaft of the Bush Wheel, to act as a brake band. The Cord should be long enough to allow the Strip to lie nearly horizontal.

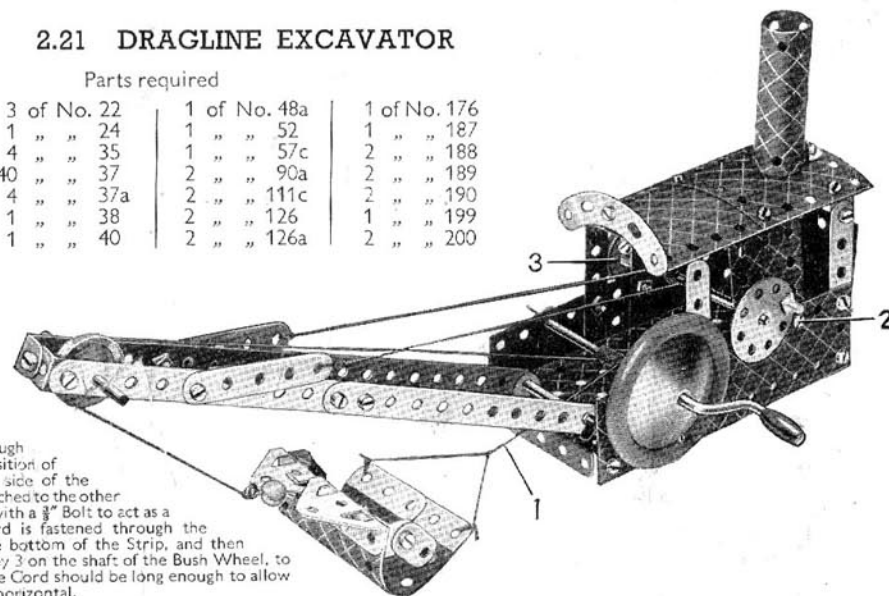

The greatest thrill in Meccano model-building is experienced when a model is set to work by means of a Meccano Motor. The illustrations below show how the Meccano *Magic Motor* can be fitted without any difficulty to No. 2 Outfit models of various types. Fit the model you have just built with one of these wonderful Motors, and enjoy the fun of watching it work just like the real thing.

2.22 LUMBER TRUCK AND HORSE

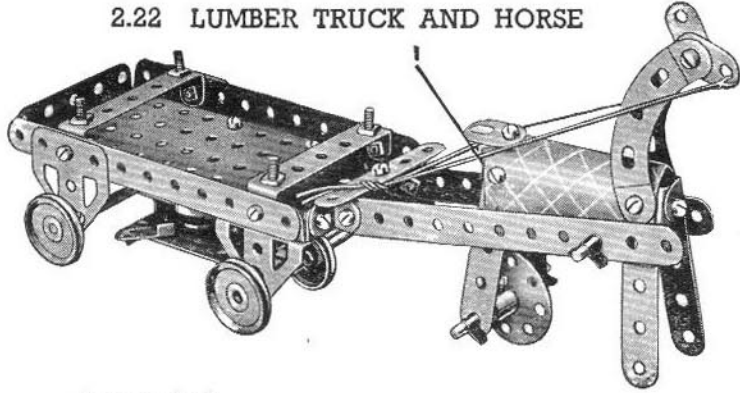

Parts required

4 of No. 2	4 of No. 37a
5 " " 5	2 " " 48a
3 " " 10	1 " " 52
5 " " 12	2 " " 9Ca
2 " " 16	4 " " 111c
2 " " 17	2 " " 126
4 " " 22	2 " " 126a
1 " " 24	4 " " 155a
4 " " 35	1 " " 199
23 " " 37	1 <i>Magic Motor</i>

A *Magic Motor* is mounted beneath the cart and the Driving Band is taken from the pulley on the Motor to a $\frac{1}{2}$ " fast Pulley (supplied with the Motor) fastened on the $3\frac{1}{2}$ " Rod that forms the front axle.

The forelegs of the horse are held together by means of two Angle Brackets bolted in the positions shown. This construction is duplicated at 1 for the hind-legs. The forelegs of the horse are held clear of the ground by means of the reins.

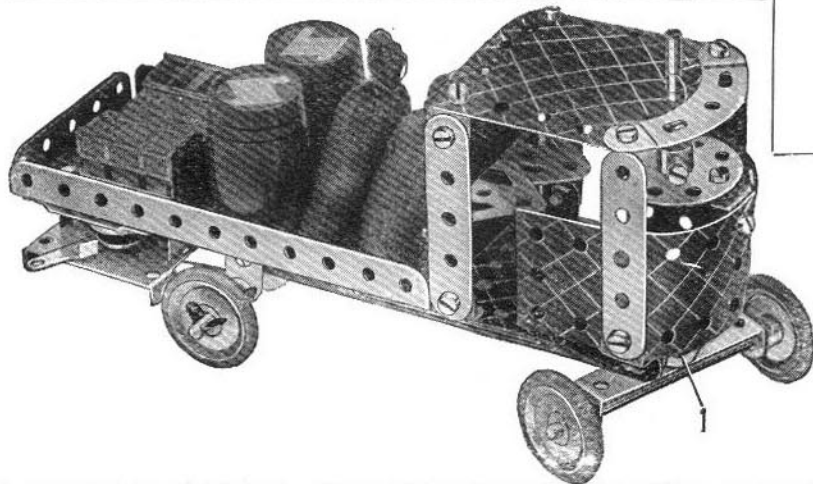

2.23 DRILLING MACHINE

Parts required

2 of No. 2	1 " " 10	1 " " 12	1 " " 16	2 " " 17	4 " " 22	1 " " 24	4 " " 35	22 " " 37	2 " " 37a	1 " " 40	1 " " 48a	1 " " 52	1 " " 111c	2 " " 126	2 " " 126a	1 " " 190
1 <i>Magic Motor</i>																

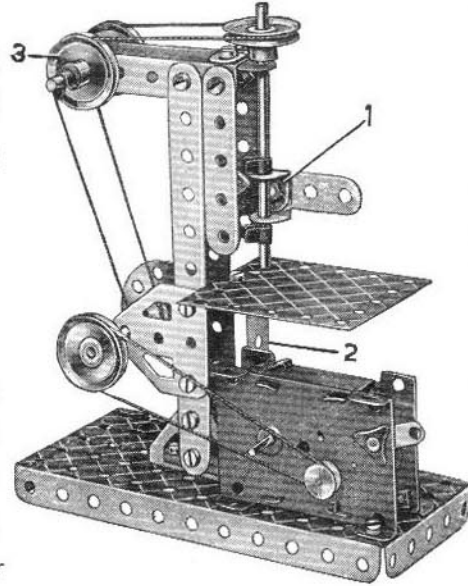

The horizontal $2\frac{1}{2}$ " Strips at the top of the drill are joined together, and also to the vertical $2\frac{1}{2}$ " Strips, by means of Angle Brackets. The lower bearings 1 are two Angle Brackets bolted to a $2\frac{1}{2}$ " Strip and the Rod forming the drill is journaled in these, and in a Flat Bracket at its upper end. A $2\frac{1}{2}$ " x $2\frac{1}{2}$ " Flexible Plate is supported by a Double Angle Strip 2, and represents the table.

The drive is taken from the Motor to the 1" Pulley on the lower shaft. A second Driving Band passes round the $\frac{1}{2}$ " fast Pulley supplied with the Motor, round the two Pulleys at 3, and finally round the 1" Pulley fastened on the vertical drill shaft.

2.25 STEAM WAGON

Parts required

2 of No. 2	4 of No. 35	2 of No. 126
6 " " 5	31 " " 37	4 " " 155a
2 " " 10	1 " " 37a	1 " " 188
8 " " 12	4 " " 38	1 " " 189
2 " " 16	2 " " 48a	1 " " 190
1 " " 17	1 " " 52	1 " " 200
4 " " 22	1 " " 90a	1 <i>Magic Motor</i>
1 " " 24	1 " " 125	

2.24 BEAM ENGINE

Parts required

4 of No. 2	2 " " 5	2 " " 10	6 " " 12	2 " " 16	1 " " 17	1 " " 19g	4 " " 22	1 " " 24	4 " " 35	31 " " 37	4 " " 37a	4 " " 38	1 " " 52	2 " " 90a	2 " " 111c	1 " " 126	1 " " 126a	1 " " 176	1 " " 187	2 " " 188	2 " " 189	1 " " 191	
1 <i>Magic Motor</i>																							

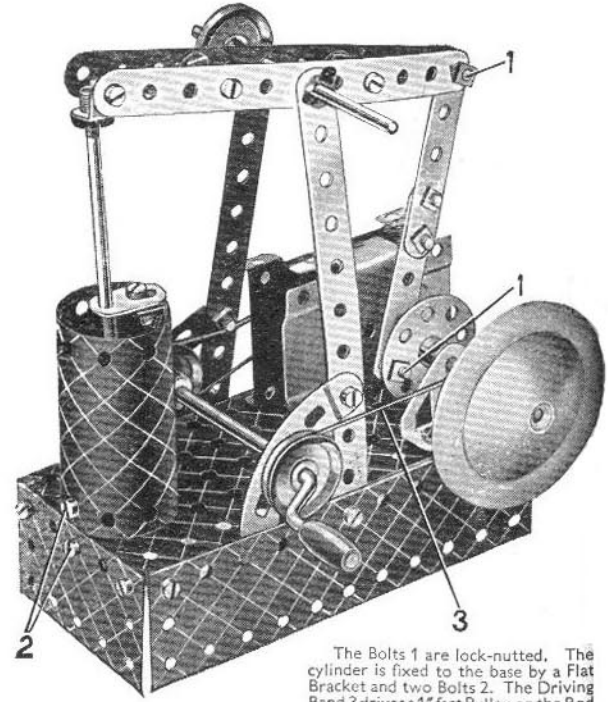

The Bolts 1 are lock-nutted. The cylinder is fixed to the base by a Flat Bracket and two Bolts 2. The Driving Band 3 drives a 1" fast Pulley on the Rod on which the Road Wheel is fastened.

The front axle is carried in a $2\frac{1}{2}$ " x $\frac{1}{2}$ " Double Angle Strip that is pivoted to a Reversed Angle Bracket fastened to a $2\frac{1}{2}$ " Strip below the cab by means of the lock-nutted Bolt 1, which is tightened up sufficiently to hold the two front wheels in position when running along. The rear axle is a $3\frac{1}{2}$ " Rod and it carries a $\frac{1}{2}$ " fast Pulley supplied with the *Magic Motor*.

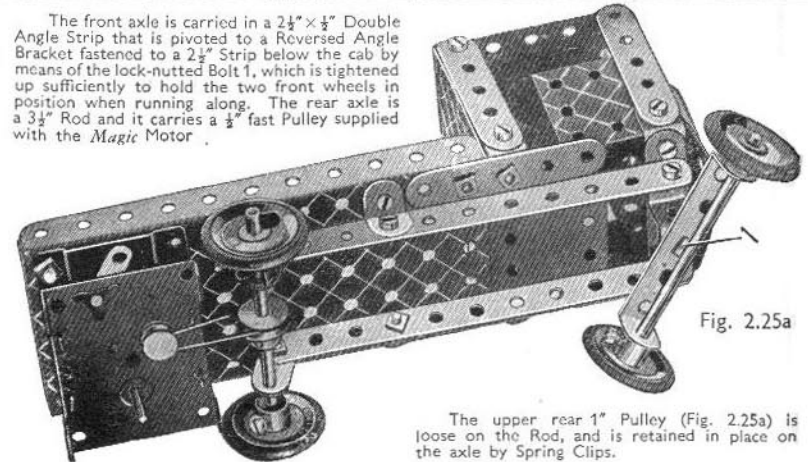

Fig. 2.25a

The upper rear 1" Pulley (Fig. 2.25a) is loose on the Rod, and is retained in place on the axle by Spring Clips.

If you want to obtain the fullest enjoyment from the Meccano hobby you should operate your models by means of one of the Meccano Motors described on this page. You push over the control lever of the clockwork or electric Motor and immediately your Crane,

Motor Car, Ship Coaler or Windmill commences to work in exactly the same manner as its prototype in real life.

Each Motor is pierced with the standard Meccano equidistant holes.

MECCANO CLOCKWORK MOTORS

These are the finest clockwork motors obtainable for model driving. They have exceptional power and length of run and their gears are cut with such precision as to make them perfectly smooth and steady in operation.

Meccano Clockwork Motors are especially suitable for small models built with a limited range of parts. They are extremely simple to operate and have the advantage of being self contained.

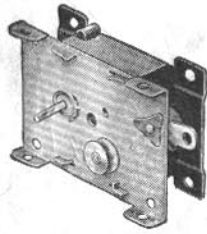

THE MECCANO MAGIC MOTOR

The Meccano *Magic* Motor is well designed and strongly constructed, and is fitted with a powerful spring giving a long and steady run. It is non-reversing. Each *Magic* Motor is supplied with a separate $\frac{1}{4}$ " fast Pulley and three pairs of Driving Bands of different lengths. It is capable of driving all light models built with the smaller Outfits.

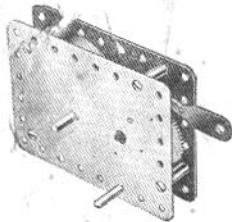

No. 1 Clockwork Motor

This strongly built and efficient Motor is fitted with a powerful spring that gives a long and steady run, and is exceptionally smooth in action. The Motor is provided with a conveniently-placed brake lever by means of which it can be started and stopped. The Motor is of the non-reversing type.

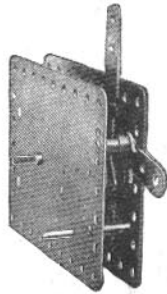

No. 2 Clockwork Motor.

No. 1a Clockwork Motor

This Motor is more powerful than the No. 1 Motor and is fitted with reversing motion. It has brake and reverse levers.

No. 2 Clockwork Motor

This is a Motor of super quality. Brake and reverse levers enable it to be started, stopped or reversed, as required.

MECCANO ELECTRIC MOTORS

The four Meccano Electric Motors shown here have been designed specially to provide smooth-running power units for the operation of Meccano models. The 6-volt Motors may be operated through a Meccano Transformer direct from the mains, providing that the supply is alternating current, or from a 6-volt accumulator. The 20-volt Motors are operated through a 20-volt Transformer from alternating current supply mains.

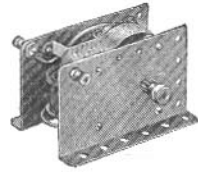

No. E1 Electric Motor (6 volt)

This is a highly efficient Motor (non-reversing) that will give excellent service. It can be operated through a 9-volt Meccano Transformer from the mains, providing that the supply is alternating current, or from a 6-volt accumulator.

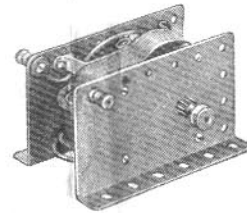

No. E120 Electric Motor (20 volt)

The E120 Electric Motor is a very reliable and smooth-running power unit. It is operated through a Meccano 20-volt Transformer from alternating current supply mains. Non-reversing.

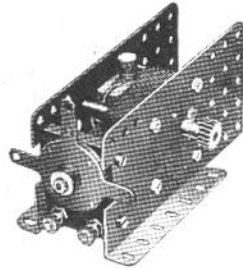

No. E6 Electric Motor (6 volt)

This fine Motor is fitted with reversing motion and provided with stopping and starting controls. It can be operated through a 9-volt Meccano Transformer from the mains, providing that the supply is alternating current, or from a 6-volt accumulator.

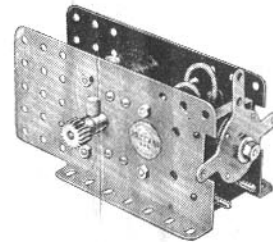

No. E20b Electric Motor (20 volt)

This 20-volt Electric Motor is an extremely efficient power unit, fitted with reversing motion and provided with stopping and starting controls. It is operated through a Meccano 20-volt Transformer from alternating current supply mains.

MECCANO TRANSFORMERS

There are six Transformers in the series, as described below, all of which are available for the following A.C. supplies:—100/110 volts, 50 cycles; 200/225 volts, 50 cycles; 225/250 volts, 50 cycles. Any of the Transformers can be specially wound for supplies other than these at a small extra charge. When ordering a Transformer the voltage and frequency of the supply must always be stated.

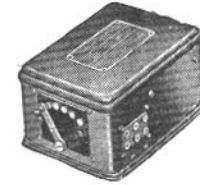

No. T20A Transformer

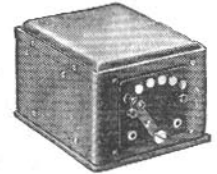

No. T6 Transformer

FOR 20-volt ELECTRIC MOTORS

No. T20A TRANSFORMER (Output 35 VA at 20 $\frac{3}{4}$ volts). Has two separate circuits at 20 volts, one of which is controlled by a 5-stud speed regulator, and a third circuit at 3 $\frac{1}{2}$ volts for lighting up to 18 lamps.

No. T20 TRANSFORMER (Output 20 VA at 20 volts). Has one 20-volt circuit controlled by a 5-stud speed regulator.

No. T20M TRANSFORMER (Output 20 VA at 20 volts). This Transformer is provided with one 20-volt circuit, but is not fitted with speed regulator.

FOR 6-volt ELECTRIC MOTORS

No. T6A TRANSFORMER (Output 40 VA at 9 $\frac{3}{4}$ volts). Has two separate circuits at 9 volts, one of which is controlled by a 5-stud speed regulator, and a third circuit at 3 $\frac{1}{2}$ volts for lighting up to 18 lamps.

No. T6 TRANSFORMER (Output 25 VA at 9 volts). Has one 9-volt circuit and is fitted with a 5-stud speed regulator.

No. T6M TRANSFORMER (Output 25 VA at 9 volts). Has one 9-volt circuit, but is not fitted with a speed regulator.

Resistance Controllers

By means of these Controllers the speed of Meccano 6-volt and 20-volt Motors can be regulated exactly as desired.

Ask your dealer for the latest Meccano Price List

BUILD BIGGER AND BETTER MODELS

When you have built all the models shown in this Manual you will be keen to build bigger and more elaborate models. Your next step is to purchase a Meccano No. 2a Accessory Outfit containing all the parts required to convert your No. 2 into a No. 3 Outfit. You will then be able to build the full range of No. 3 Outfit models, a selection of which is illustrated on this page and opposite.

If you prefer to do so, you can build up and develop your Outfit quite easily by adding various parts to it from time to time. The model-building possibilities of the Meccano System are limitless, and the more Meccano parts you have the bigger and better the models you will be able to build.

Ask your dealer to post to you regularly the latest Meccano parts lists and other Meccano literature.

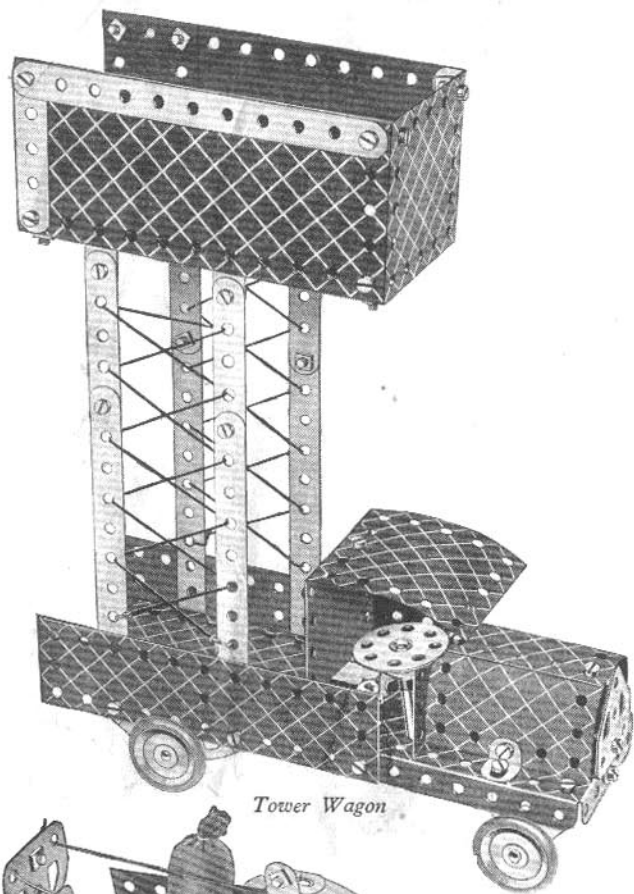

Tower Wagon

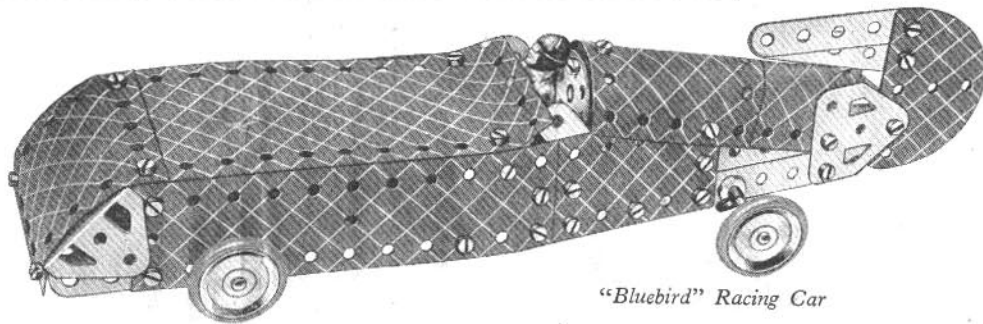

"Bluebird" Racing Car

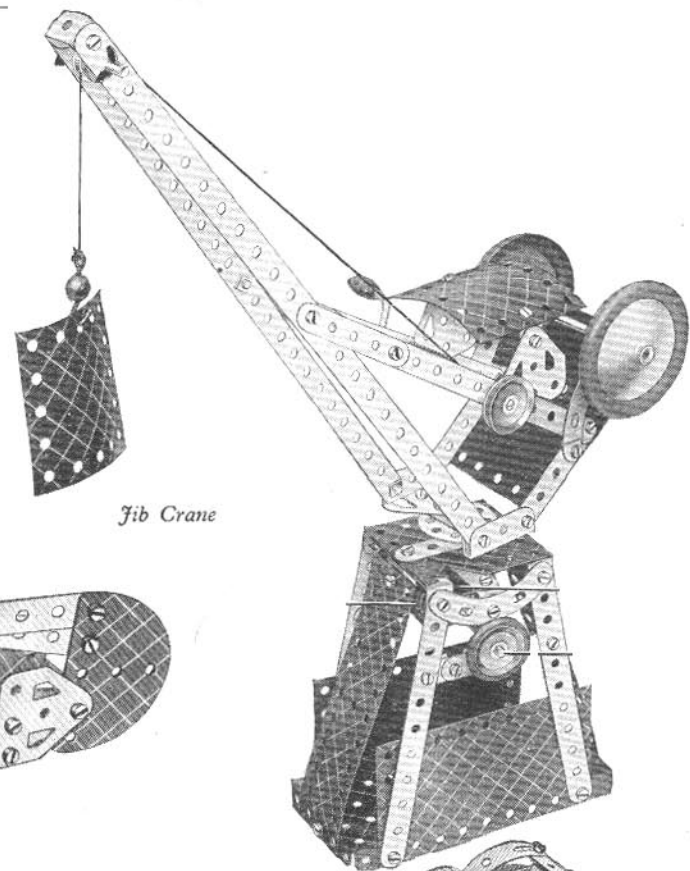

Jib Crane

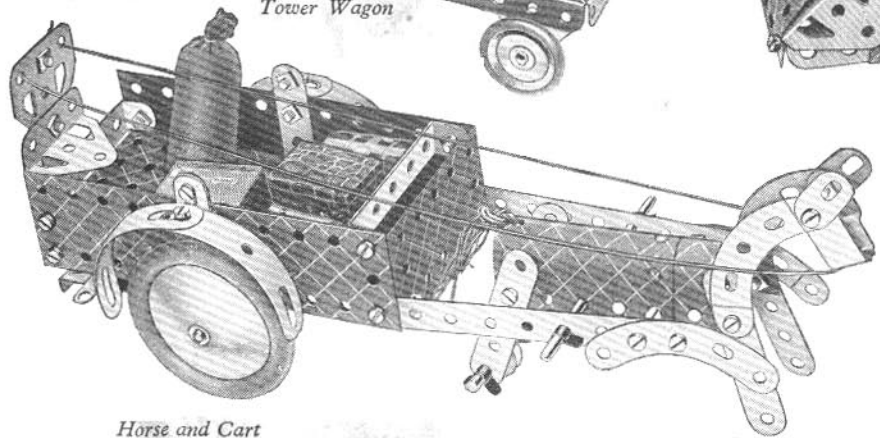

Horse and Cart

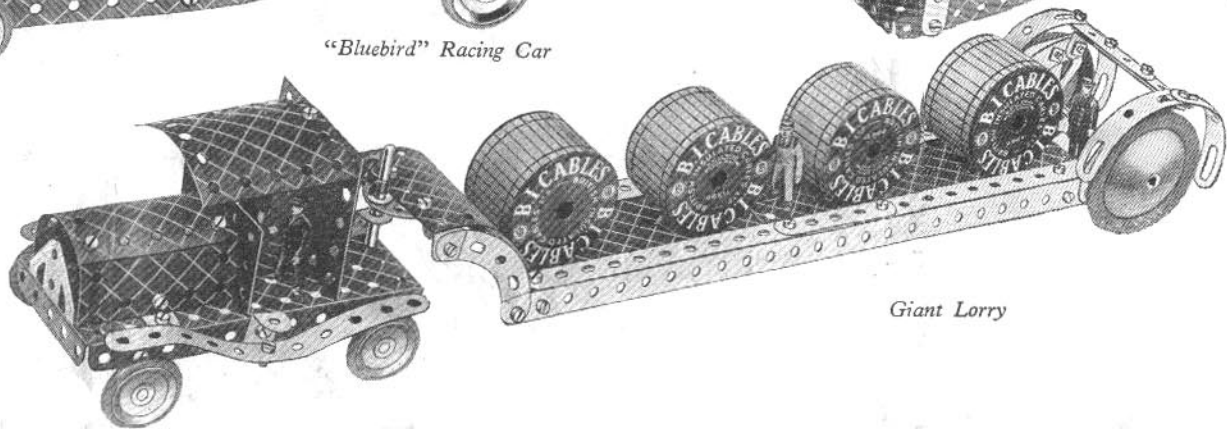

Giant Lorry

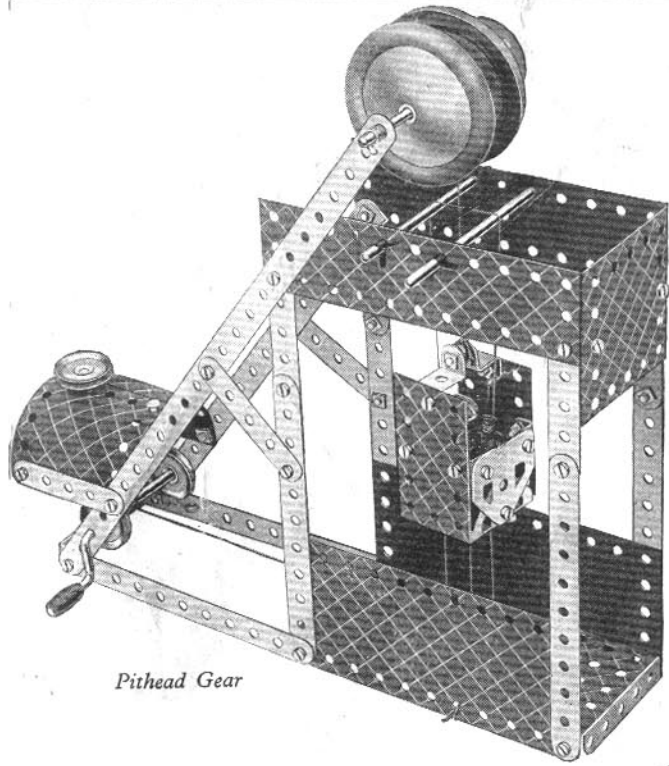

Pithead Gear

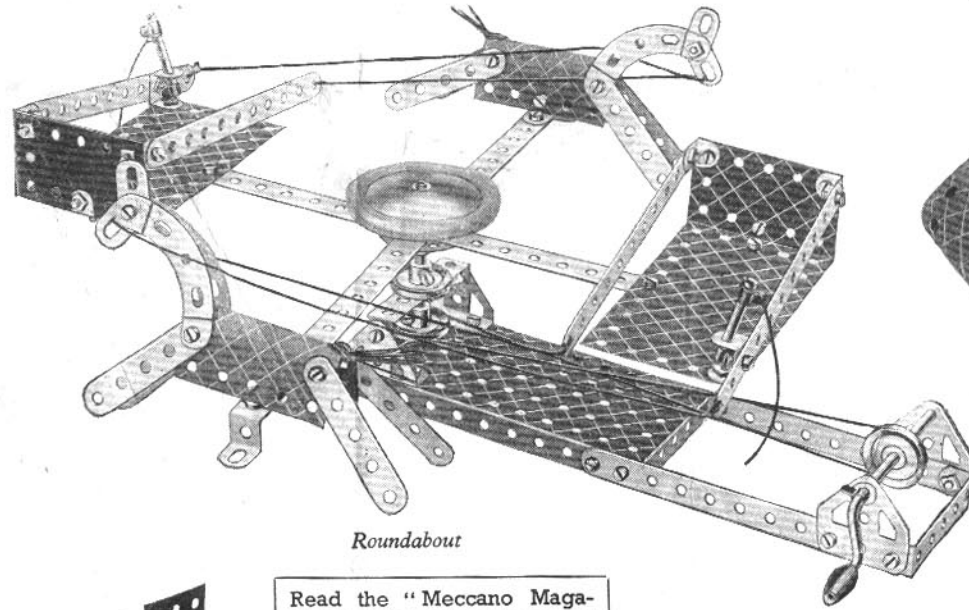

Roundabout

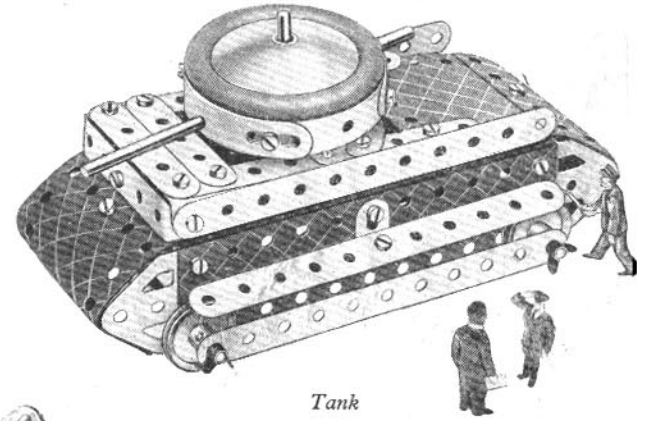

Tank

Read the "Meccano Magazine." Place a regular order now with your Meccano dealer or newsagent.

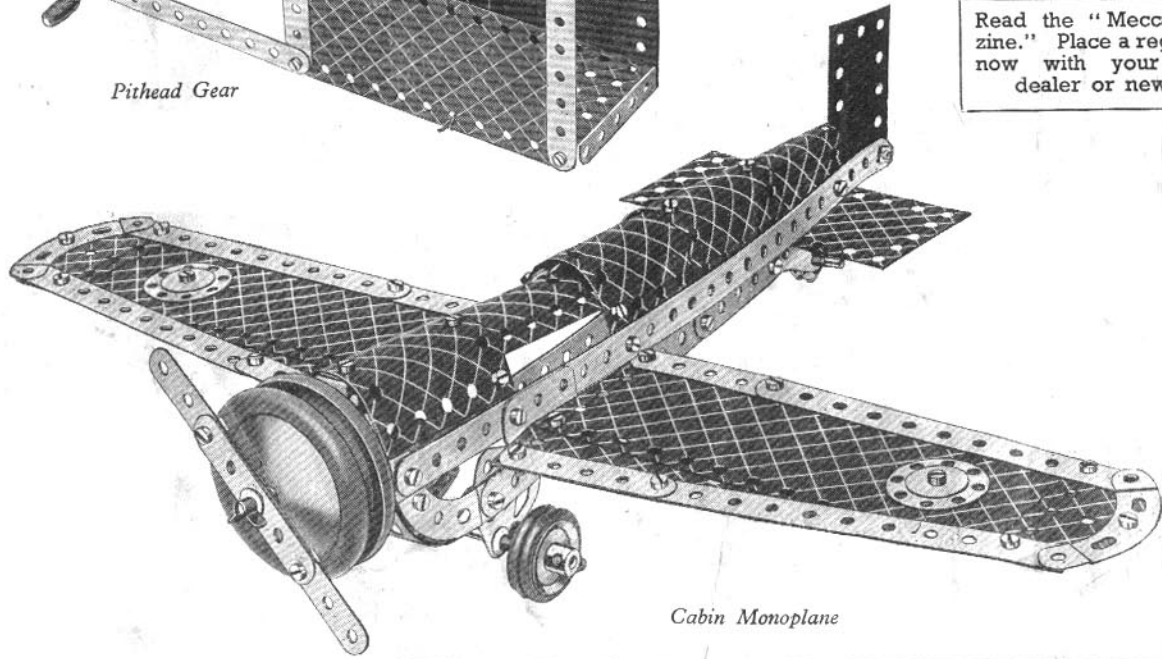

Cabin Monoplane

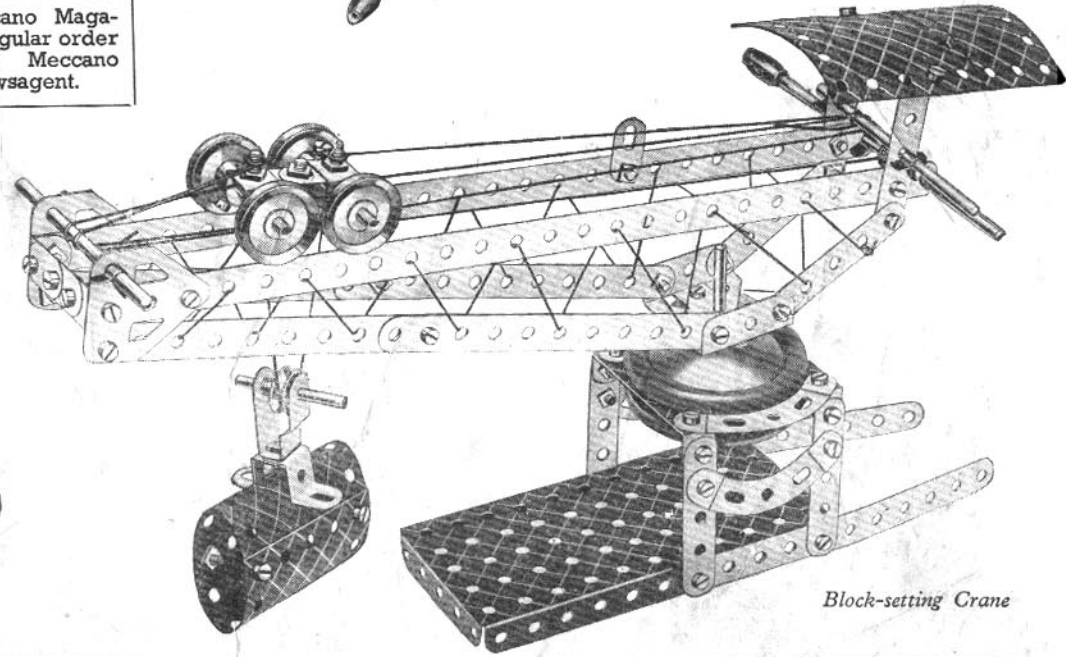

Block-setting Crane

MECCANO PARTS

3
Perforated Strips

No. 1. 12 9 1/2" long
1a. 4 1/2" long
2. 4 1/2" long
2a. 4 1/2" long

3. 3" long
4. 2 1/2" long
5. 2 1/2" long
6a. 2 1/2" long

9b
Angle Girders

7. 24 1/2" long
7a. 18 1/2" long
8. 13 1/2" long
8a. 9 1/2" long
9. 5 1/2" long
9a. 4 1/2" long
9b. 4 1/2" long
9c. 4 1/2" long
9d. 2 1/2" long
9e. 2 1/2" long
9f. 1 1/2" long

10. Flat Brackets
11. Double Brackets
12. Angle Brackets, 1 1/2" x 1 1/2"
12a. 1" x 1"
12b. 1" x 1"
12c. Obtuse Angle Brackets, 1 1/2" x 1"

13
Axle Rods

13a. 8 3/4" long
14. 6 3/4" long
15. 5 3/4" long
15a. 4 3/4" long
15b. 4 3/4" long

16. 3 1/2" long
16a. 2 1/2" long
16b. 2 1/2" long
17. 2 1/2" long
18a. 1 3/4" long
18b. 1 3/4" long

19h
Crank Handles, 3 1/2" with Erinoid grip
19h. 3 1/2" without
19s. 3 1/2" without

19a. Wheels, 3" diam., with set-screws
20. Flanged Wheels, 1 1/2" diam.
20b. " " " "

19c
Pulley Wheels

19b. 3" diam. with centre boss & set-screw
19c. 6" " " " "
20a. 2" " " " "
21. 1 1/2" " " " "
22. 1 1/2" " " " " "
22a. 1 1/2" " " " " and grub-screw
23. 1 1/2" " " " " "
23. 1 1/2" " " " " "

24. Bush Wheels

26a
Pinion Wheels, 2" diam., 1" face
25. " " " "
25a. " " " "
25b. " " " "
26. " " " "
26a. " " " "
26b. " " " "

27
Gear Wheels

27. 50 teeth, to gear with 2" pinion
27a. 57 " " " " "
27b. 133 " " " " (3 1/2" diam.)
27c. 95 " " " " (2 1/2" diam.)

28. Contrate Wheels, 1 1/2" diam.
29. " " " " "

30
Bevel Gears, 7, 26 teeth
30a. 7 teeth
30b. 26 teeth
30c. 1 1/2", 16 " " " used together
30c. 1 1/2", 48 " " " "

31
Gear Wheels, 1", 38 teeth
32
Worms

34. Spanners
34b. Box Spanners

35
Spring Clips ... box of 20
35a. " " " " box of 30
36. Screwdrivers
36a. " Extra Long
36b. " Special

37. Nuts and Bolts, 3/16" ... box of 12
37a. " " " " " " " box of 50
37b. Bolts, 3/16" ... box of 50
37c. Nuts and Bolts, 1/8" ... box of 50
37d. " " " " " " " box of 144
38. Washers ... pkt. of 20
38s. " " " " box of 60

40. Hanks of Cord

41. Propeller Blades

43. Springs

44. Cranked Bent Strips
45. Double Double Angle Strips, 2 1/2" x 1"
46. " " " " 2 1/2" x 1"
47. " " " " 2 1/2" x 1"
47a. " " " " 2 1/2" x 1"
48. " " " " 1 1/2" x 1"
48a. " " " " 2 1/2" x 1"
48b. " " " " 3 1/2" x 1"
48c. " " " " 4 1/2" x 1"
48d. " " " " 5 1/2" x 1"

50a. Eye Pieces, with boss

51. Flanged Plates, 2 1/2" x 1 1/2"
52. " " 5 1/2" x 2 1/2"
52a. Flat Plates, 5 1/2" x 2 1/2"
53. Flanged Plates, 3 1/2" x 2 1/2"
53a. Flat Plates, 4 1/2" x 2 1/2"

54a. Flanged Sector Plates, 4 1/2" long

55. Perforated Strips, slotted, 5 1/2" long
55a. " " " " 2" long

57. Hooks
57a. Scientific
57b. Loaded, Large
57c. Loaded, Small

58. Spring Cord, 40" Length
58a. Coupling Screws for Spring Cord
58b. Hooks for Spring Cord

59. Collars, with grub-screws

61. Windmill Sails

62
Cranked Bent Strips
62a
Threaded Cranks
62b
Double Arm Cranks

63
Couplings
63a
Octagonal Couplings
63b
Strip Couplings
63c
Threaded Couplings

64
Threaded Bosses
65
Centre Forks

66 & 67
Weights, 50 grammes
67. 25 " "

68. Woodscrews, 1/2" "
69. Set Screws
69a. Grub Screws, 1/4" "
69b. " " " 3/8" "
69c. " " " 1/2" "

70
Flat Plates, 5 1/2" x 2 1/2"
72. " " 2 1/2" x 2 1/2"
73. " " 3" x 1 1/2"
76. Triangular Plates, 2 1/2" "
77. " " 1"

80a
Screwed Rods
78. 11 1/2" 80b. 4 1/2" "
79. 8" 80c. 3 1/2" "
79a. 6" 81. 2" "
80. 5" 82. 1" "
80a. 3 1/2" "

89
5 1/2" Curved Strips, 10" radius
89a. 3" " " " cranked, 1 1/2" radius
4" to circle " " " "

89b
4" Curved Strips, cranked, 4 1/2" radius, 8 to circle

90
2 1/2" Curved Strips, 2 3/8" radius
90a. 2 1/2" " " " cranked, 1 1/2" radius, 4 to circle

94
Sprocket Chain, per 10" length
95. " " " " " " " wheels, 36 teeth, 2" diam.
95a. " " " " " " " 28 " " 1 1/2" " "
95b. " " " " " " " 56 " " 3" " "
96. " " " " " " " 18 " " 1" " "
96a. " " " " " " " 14 " " 3/4" " "

99
Braced Girders

97. 3 1/2" long
97a. 3 1/2" "
98. 2 1/2" "
99. 12 1/2" "

99a. 9 1/2" long
99b. 7 1/2" "
100. 5 1/2" "
100a. 4 1/2" "

101
Healds, for looms
102
Single Bent Strips

103b
Flat Girders
103. 5 1/2" long
103a. 9 1/2" "
103b. 12 1/2" "
103c. 4 1/2" "
103d. 3 1/2" "

103e. 3" long
103f. 2 1/2" "
103g. 2 1/2" "
103h. 1 1/2" "
103k. 7 1/2" "

104
Shuttles, for looms
105
Reed Hooks, for looms

106. Wood Rollers
106a. Sand Rollers
107. Tables for designing machines

108
Architraves
109
Face Plates, 2 1/2" diam.

110
Rack Strips, 3 1/2" long
110a. 6 1/2" "
110b. " " " " "
111a. Bolts, 3/8" " 111c. Bolts, 1/2" "
111b. " " " " " " " 1 1/4" "

113
Girder Frames

114
Hinges
115
Threaded Pins
116
Fork Pieces, Large
116a. " " Small
117. Steel Balls, 3/8" diam.

118
Hub Discs, 5 1/2" diam.

MECCANO PARTS

120. Buffers
120b. Compression Springs
- 120a. Spring Buffers



121. Train Couplings
122. Miniature Loaded Sacks



123. Cone Pulleys
124. Reversed Angle Brackets, 1"
125. " "



126. Trunnions
126a. Flat Trunnions



127. Simple Bell Cranks
128. Boss Bell Cranks



129. Rack Segments, 3" diam.



130. Eccentrics, Triple Throw



131. Dredger Buckets
132. Flywheels, 2 1/2" diam.



133. Corner Brackets, 1 1/2"
133a. " "



134. Crank Shafts, 1" stroke
135. Theodolite Protractors



136. Handrail Supports
136a. Handrail Couplings
137. Wheel Flanges



- No. 138. Ships' Funnels
138a-z. " " Raked



139. Flanged Brackets (right)
139a. " (left)



140. Universal Couplings
141. Wire Lines (for clock weights)



142. Rubber Rings (to fit 3" diam. rims)
142a. Motor Tyres (to fit 2" diam. rims)
142b. " " " 3" " "
142c. " " " 1" " "
142d. " " " 1 1/2" " "



143. Circular Girders, 5 1/2" diam.



144. Dog Clutches



145. Circular Strips, 7 1/2" diam. overall
146. " Plates, 6" " "
146a. " " 4" " "



147. Pawls, with Pivot Bolt and Nuts
147a. Pawls
147b. Pivot Bolts with 2 Nuts
147c. Pawls without boss
148. Ratchet Wheels



149. Collecting Shoes for Electric Locos
150. Crane Grabs

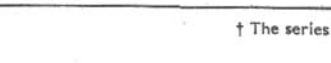

- No. 151. Pulley Blocks, Single Sheave
152. " " Two " "
153. " " Three " "



- 154a. Corner Angle Brackets, 1/2" (right-hand)
154b. Corner Angle Brackets, 1/2" (left-hand)
155. Rubber Rings (for 1" Pulleys)
155a. " " " Black White

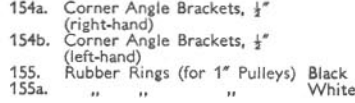

156. Pointers (with boss), 2 1/2" overall



157. Fans, 2" diam.
158a. Signal Arms, Home
158b. " " Distant



160. Channel Bearings, 1 1/2" x 1" x 1/2"
161. Girder Brackets, 2" x 1" x 1/2"

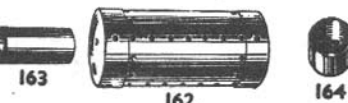

162. Boilers, complete, with ends
162a. " " Ends
162b. " " without ends
163. Sleeve Pieces
164. Chimney Adaptors



165. Swivel Bearings
166. End "

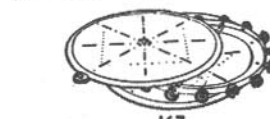

167. Geared Roller Bearings
167a. Roller Races, geared, 192 teeth
167b. Ring Frames for Rollers
167c. Pinions for Roller Bearings (16 teeth)

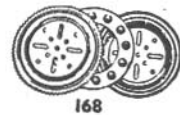

- No. 168. Ball Bearings, 4" diam.
168a. " Races, flanged discs
168b. " " toothed
168c. " Casings, complete with balls



169. Digger Buckets



170. Eccentrics, 1/2" throw
171. Socket Couplings



172. Pendulum Connections
173. Rail Adaptors



174. Grease Cups



175. Flexible Coupling Units



176. Anchoring Springs for Cord

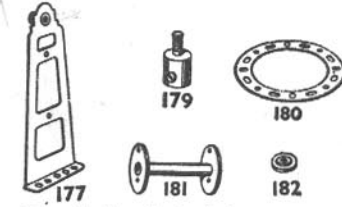

177. Shafting Standards, Large
178. " " Small
179. Rod Sockets
180. Toothed Gear Rings, 3 1/2" diam.
181. Bobbins
182. Insulating Bushes
182a. Insulating Washers

183. Lamp Holders
184a. 2 1/2-volt Lamps
184b. 3 1/2 " " "
184c. 6-volt Lamps
184d. 10 " " "
184e. 20 " " "

- No. 185. Steering Wheels, 1 1/2" diam.
186. Driving Bands, 2 1/2" (Light)
186a. " " 6" " "
186b. " " 10" " "
186c. " " 10" (Heavy)
186d. " " 15" " "
186e. " " 20" " "
187. Road Wheels



192. Flexible Plates.
188. 2 1/2" x 1 1/4" "
189. 5 1/2" x 1 1/4" "
190. 2 1/2" x 2 1/2" "
190a. 3 1/2" x 2 1/2" "
191. 4 1/2" x 2 1/4" "
192. 5 1/2" x 2 1/4" "
Strip Plates.
196. 9 1/2" x 2 1/4" "
197. 12 1/2" x 2 1/4" "

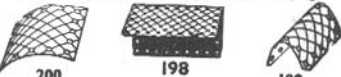

198. Hinged Flat Plates, 4 1/2" x 2 1/4" "
199. Curved Plates, U-Section 2 1/4" x 2 1/4" x 1/4" "
200. " " 2 1/2" x 2 1/2", 1 1/4" radius



201. Lamps with Flex (3 1/2 volts)
202. Angle Brackets (for Headlamps)
203. Headlamps
203a. Headlamp Rims
203b. " Bodies
204. " Nuts
205. " Glasses
206. Lampshades
207. Lamp Bases
207a. Lamp with Standard and Flex
208. Battery Tags and Studs
208a. Washers for Battery Studs
210. Nuts for Battery Studs

- 211a. Helical Gear 1/2" { Can only be used together
211b. " " 1 1/2" "

212. Rod and Strip Connectors
213. Rod Connectors



214. Semi-Circular Plates 2 1/4" "
215. Formed Slotted Strips 3" "

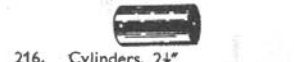

216. Cylinders, 2 1/2" "
217a. Discs, 1 1/2" "
217b. Discs 1" "

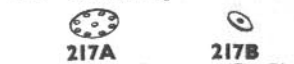



HORNBY SCALE MODEL OF
"Princess Elizabeth" -
MIGHTY L.M.S.R. WORLD
RECORD-BREAKER

*Driver Clarke
says
"It's fine!"*

**FITTED WITH 20-VOLT
AUTO-REVERSING MOTOR**

Four hundred miles non-stop from Glasgow to London at an average of 70 m.p.h., with a 260-ton load! This remarkable feat was performed by L.M.S.R. Locomotive "*Princess Elizabeth*" in charge of Driver T. J. Clarke, and it set up a world record.

Think of the thrill of owning a model of such an engine; not merely a perfect reproduction in miniature, but one having the same qualities of power, speed and efficiency! This is now made possible by the latest product of Meccano Limited—the magnificent Hornby scale model locomotive "*Princess Elizabeth*" illustrated above, driven by a 20-volt electric motor, and fitted with the Hornby Remote Control.

Playing the great game of railways with any of the world-famous Hornby Trains is fine fun. The performance and durability of the Hornby Electric Trains place them in a class entirely their own, while Hornby Clockwork Trains are the longest-running spring-driven locomotives in the world.

Ask your dealer for the latest complete catalogue of Hornby Trains, Rolling Stock and Accessories.

MANUFACTURED BY MECCANO LTD., LIVERPOOL.

HORNBY TRAINS