

MECCANO

INSTRUCTIONS FOR No. 4 OUTFIT

Prices
Great Britain 1/3
Australia 2/6
New Zealand 2/-
South Africa 2/8
Canada 45c

No.
37.4

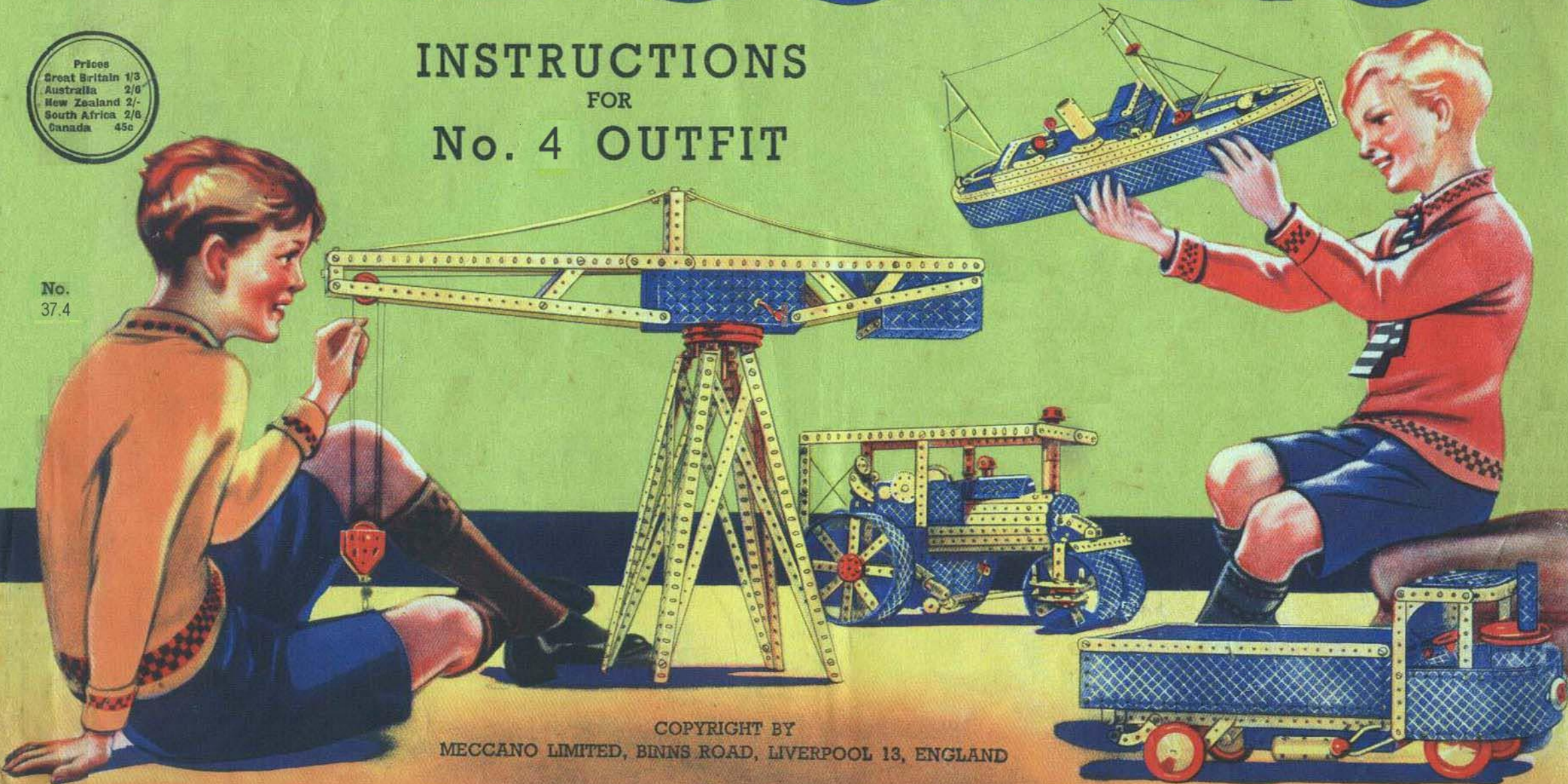

COPYRIGHT BY
MECCANO LIMITED, BINNS ROAD, LIVERPOOL 13, ENGLAND

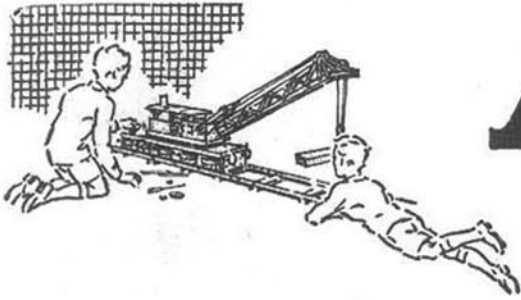

MECCANO

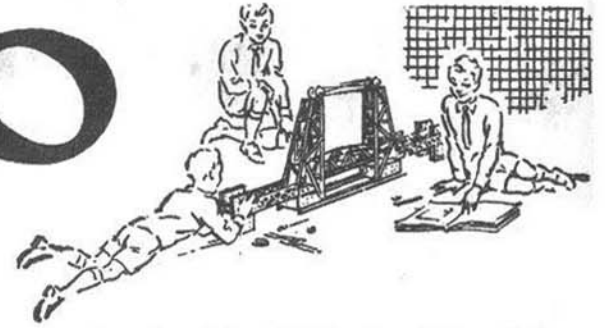

Real Engineering in Miniature

MODEL-BUILDING WITH MECCANO

There is no limit to the number of models that can be built with Meccano—Cranes, Clocks, Motor Cars, Aeroplanes, Machine Tools, Locomotives—in fact everything that interests boys. A screwdriver and a spanner, both of which are provided in each Outfit, are the only tools necessary.

When you have built all the models illustrated in the Manuals of Instruction the fun is not over, but is just beginning. Now comes the chance to make use of your own ideas. First of all, re-build some of the models with small changes in construction that may occur to you; then try building models entirely of your own design. In doing this you will feel the real thrill of the engineer and the inventor.

HOW TO BUILD UP YOUR OUTFIT

Meccano is sold in 11 different Outfits, ranging from No. 0 to No. 10. Each Outfit from No. 1 upwards can be converted into the one next larger by the purchase of an Accessory Outfit. Thus Meccano No. 1 Outfit can be converted into No. 2 Outfit by adding to it a No. 1a Accessory Outfit. No. 2a Outfit would then convert it into a No. 3, and so on. In this way, no matter with which Outfit you begin, you can build it up by degrees until you have a No. 10 Outfit.

All Meccano parts are of the same high quality and finish, but the larger Outfits contain a greater quantity and variety, making possible the construction of more elaborate models.

Special Note.—The Meccano Plates (Flanged, Flat, Curved, etc.) are shown in the Manuals with diagonal white lines. In the new Meccano Outfits these parts are plain.

Several of the illustrations in this Manual show how miniature figures and various small articles can be introduced to add realism to the models. These are not included in the Outfit. Many of them are Meccano Dinky Toys that can be bought separately from your Meccano dealer.

THE "MECCANO MAGAZINE"

The "Meccano Magazine" is published specially for Meccano boys. Every month it describes and illustrates new Meccano models for Outfits of all sizes, and deals with suggestions from readers for new Meccano parts and for new methods of using the existing parts.

There are model-building competitions specially

planned to give an equal chance to the owners of small and large Outfits. In addition, there are splendid articles on such subjects as Railways, Famous Engineers and Inventors, Electricity, Chemistry, Bridges, Cranes and Aeroplanes, and special sections dealing with the latest Engineering, Aviation and Shipping News. Other pages deal with Stamp Collecting, and Books of interest to boys; and a feature of outstanding popularity is the section devoted to short articles from readers.

If you are not already a reader write to the Editor for full particulars, or order a copy from your Meccano dealer, or from any newsagent.

THE MECCANO GUILD

Every owner of a Meccano Outfit should join the Meccano Guild. This is a world-wide organisation, started at the request of Meccano boys. Its primary object is to bring boys together and to make them feel that they are all members of a great brotherhood, each trying to help others to get the very best out of life. Its members are in constant touch with Headquarters, giving news of their activities and being guided in their hobbies and interests. Write for full particulars and an application form to the Secretary, Meccano Guild, Binns Road, Liverpool 13.

Clubs founded and established under the guidance of the Guild Secretary provide Meccano boys with opportunities of enjoying to the utmost the fun of model-building. Each has its Leader, Secretary, Treasurer and other officials. With the exception of the Leader, all the officials are boys, and as far as possible the proceedings of the clubs are conducted by boys.

MECCANO SERVICE

The service of Meccano does not end with selling an Outfit and an Instruction Manual. If ever you are in any difficulty with your models, or if you want advice on anything connected with this great hobby, write to us. We receive hundreds of interesting letters from boys in all parts of the world, and each of these is answered personally by one of our staff of experienced experts.

Whatever your problem may be, write to us about it. Do not hesitate. We shall be delighted to help you in any way possible.

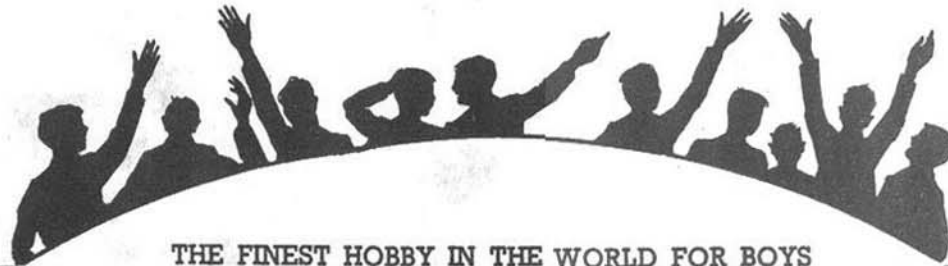

THE FINEST HOBBY IN THE WORLD FOR BOYS

HOW TO COMMENCE THE FUN

THE MOST FASCINATING OF ALL HOBBIES

Meccano model-building is the most fascinating of all hobbies, because it never becomes dull. There is always something new to be done. First of all there is the fun of building a new model, and watching it take shape as part after part is added. Then, when the model is complete, comes the thrill of setting it to work just like the real structure it represents, by means of a Meccano Motor. This wonderful process can be repeated indefinitely, for there is no end to the number of Meccano models that can be built. Another point is that models built with Meccano are real engineering structures in miniature, and the keen model-builder has wonderful opportunities for learning the working of machines and mechanisms of all kinds. So he acquires practical engineering knowledge without special study.

It is so simple to build Meccano models that operations can be started as soon as the first Outfit is opened. Different boys build in different ways, but in the end they all reach the same splendid results. The following hints are given with the object of showing boys who are just commencing the wonderful Meccano hobby how to obtain the greatest possible fun.

A FEW USEFUL HINTS

It will be noticed that with each model shown in this Manual of Instructions is given a list of the parts required to build it. For the first few models it is a good plan to lay out on the table all the parts required for the one it is proposed to build, and put the remainder of the Outfit on one side. To help you to pick out the correct parts for your model a complete list of Meccano parts is given at the back of this Manual, and all the principal parts are illustrated. In the list the parts are all numbered, and in most cases their measurements are given. There is no need, however, to measure the parts to find out which is which, as the size is easily found from the number of holes. All Meccano holes are spaced $\frac{1}{2}$ " apart, so that by counting two holes to the inch the size of a part can be found at once. For instance, Part No. 2 is listed as a $5\frac{1}{2}$ " Perforated Strip, so you look in your Outfit for a Strip with eleven holes. Similarly No. 192 is a $5\frac{1}{2}$ " \times $2\frac{1}{2}$ " Flexible Plate, so you look for a Flexible Plate eleven holes in length and five holes in width. By the time a few models have been built the names of the parts will have become familiar.

Beginners sometimes wonder which section of a model should be built first. There cannot be any definite rule for this, as it depends on the design of the model. In stationary models the base usually should be built first. In most of the smaller models a $5\frac{1}{2}$ " \times $2\frac{1}{2}$ " Flanged Plate forms an important part of the structure, and often the best plan is to start building by bolting parts to this Plate. For other models a good general rule is that the sections that form supports for a number of other parts should be built first.

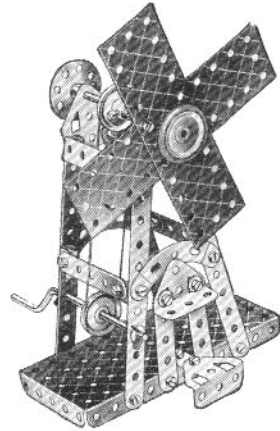

Windmill

THE IMPORTANCE OF "LOCK-NUTTING"

In building models in which Rods revolve in the holes of other parts it is important to make sure that such holes are exactly in line with one another. This can be done very easily by pushing through the holes a long Rod before the Bolts holding the various parts are tightened up.

In some models it is necessary to join certain parts together, so that, although they cannot come apart, they are free to pivot or move in relation to one another. To do this the parts are bolted together as usual, but the Nut is not screwed up tightly, so that the parts are not gripped. Then, to prevent the Nut from unscrewing, a second Nut is screwed up tightly against it, the first, meanwhile, being held with a spanner. This method of using a second Nut is known as lock-nutting, and it is employed in a large number of Meccano models.

During the construction of a model it is best to screw up the Nuts with the fingers, followed by just a light turn with the screwdriver, leaving the final tightening with spanner and screwdriver until all the parts are connected up.

MOTORS AND GEARING

Models can be operated by means of either Meccano Clockwork or Electric Motors.

The Clockwork Motors have the advantage of being self-contained and extremely simple. If only a small amount of power is needed, the model may be driven direct from the driving spindle of the Motor or through a belt running over two pulleys of the same size, giving what is described as a 1:1 (one-to-one) ratio. Greater power can be obtained by a reduction in the speed of the drive, which can be produced in a simple manner by connecting a small pulley on the Motor to a larger pulley by means of a belt. Thus if a 1" Pulley is made to drive a 3" Pulley, a reduction ratio of approximately 1:3 is obtained. This means that the driven shaft will take about three times the load that the driving shaft would handle, but will rotate at only one-third of the speed. Rubber bands are better than Cord for driving belts for most purposes.

The Electric Motors have the advantage of giving long continuous runs. Their speed is much higher than that of the Clockwork Motors, and this makes it possible to employ higher reduction ratios and thus obtain greater power.

With the larger Outfits, belt drive can be replaced with advantage by gearing. To operate a slow-moving model demanding great power, such as a traction engine, gears that will provide a considerable reduction must be used. For example, a Worm meshed with a $\frac{1}{2}$ " Pinion will give a 1:19 reduction; while a Worm meshed with a 57-teeth Gear will give a 1:57 reduction.

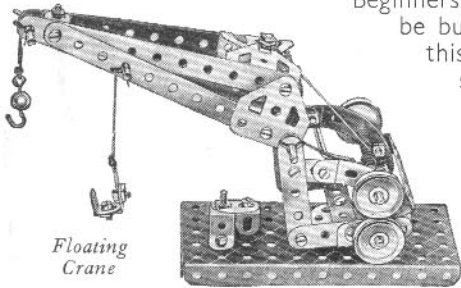

Floating Crane

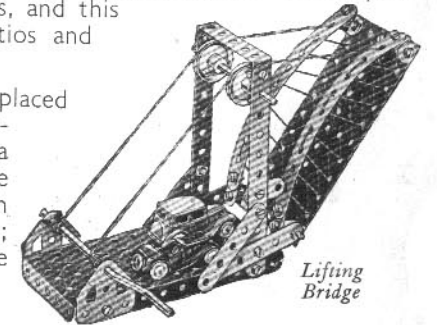

Lifting Bridge

O.1 HAND CART

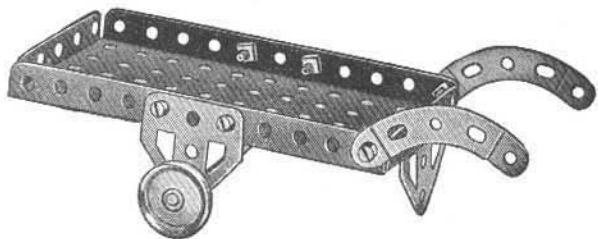

Parts required		
1 of No. 16	1 of No. 52	2 of No. 126a
2 " " 22	2 " " 90a	2 " " 155a
8 " " 37	1 " " 126	

O.2 SLEDGE



Parts required		
2 of No. 2	8 of No. 37	2 of No. 90a
2 " " 10	1 " " 52	

O.3 FLAT TRUCK

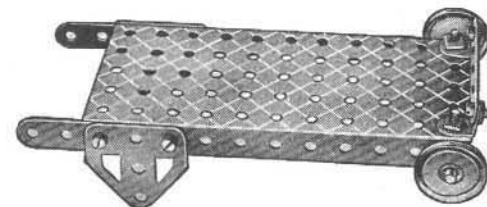

Parts required		
2 of No. 5	2 of No. 22	1 of No. 90a
2 " " 12	8 " " 37	2 " " 126a
1 " " 16	1 " " 52	2 " " 155a

O.4 DOCKSIDE CRANE

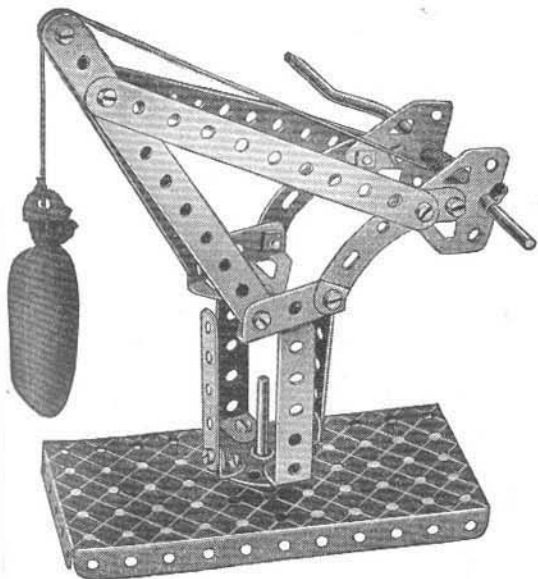

Parts required	
4 of No. 2	
2 " " 5	
3 " " 12	
1 " " 17	
1 " " 19s	
1 " " 22	
1 " " 24	
2 " " 35	
18 " " 37	
2 " " 37a	
2 " " 38	
2 " " 48a	
1 " " 52	
2 " " 90a	
2 " " 111c	
2 " " 126	
2 " " 126a	

O.5 SWING

Parts required	
4 of No. 2	
2 " " 5	
18 " " 37	
2 " " 38	
1 " " 48a	
1 " " 52	
2 " " 126	
2 " " 126a	

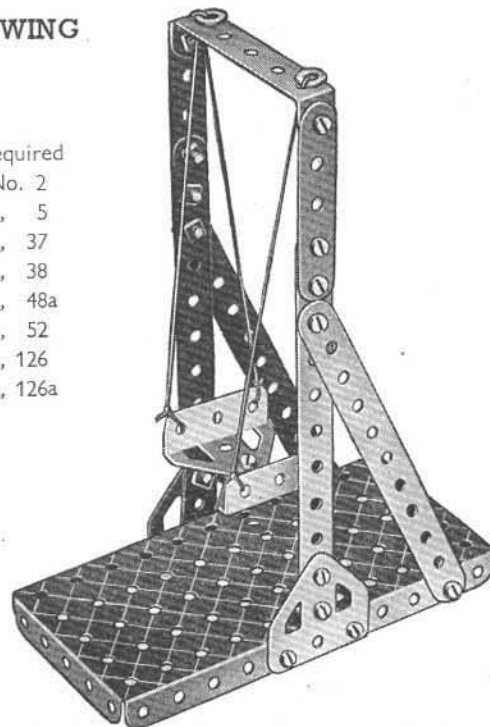

O.6 ELEVATOR

Parts required	
4 of No. 2	2 of No. 48a
2 " " 5	1 " " 52
1 " " 16	2 " " 126
1 " " 19s	2 " " 126a
1 " " 22	
4 " " 35	
15 " " 37	

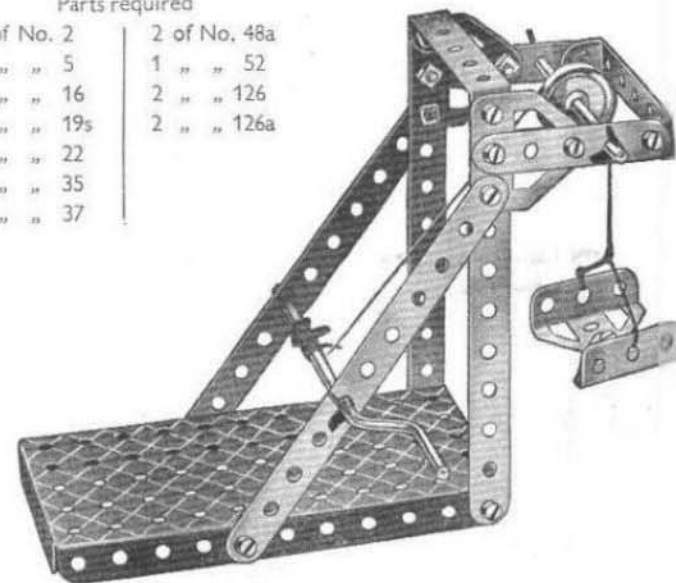

O.7 GARDEN SEAT



- Parts required
- 4 of No. 2
 - 2 " " 5
 - 10 " " 37
 - 2 " " 48a
 - 1 " " 52

O.8 COUNTER SCALES

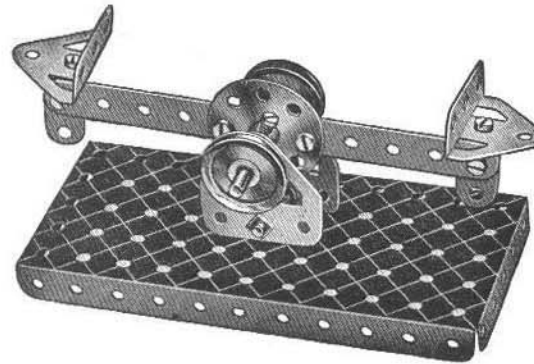

- Parts required
- | | | |
|------------|-------------|-------------|
| 1 of No. 2 | 2 of No. 22 | 1 of No. 52 |
| 2 " " 10 | 1 " " 24 | 2 " " 126 |
| 4 " " 12 | 9 " " 37 | 2 " " 126a |
| 1 " " 17 | 2 " " 38 | |

O.9 COSTER'S BARROW

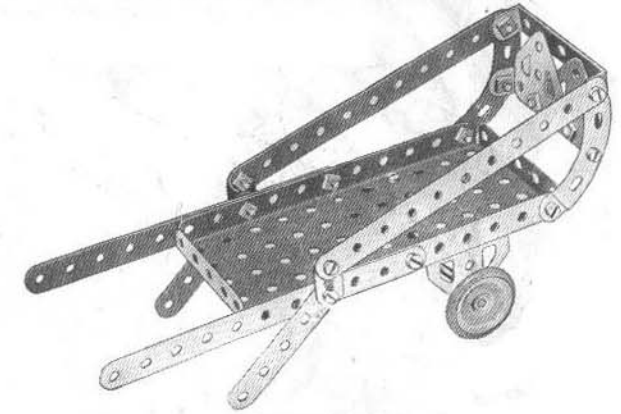

- Parts required
- | | | |
|------------|-------------|--------------|
| 4 of No. 2 | 2 of No. 22 | 2 of No. 90a |
| 2 " " 5 | 16 " " 37 | 2 " " 126 |
| 2 " " 10 | 2 " " 48a | 2 " " 126a |
| 1 " " 16 | 1 " " 52 | 2 " " 155a |

O.10 SIGNAL

- Parts required
- 2 of No. 2
 - 2 " " 5
 - 1 " " 10
 - 3 " " 12
 - 1 " " 17
 - 1 " " 22
 - 2 " " 35
 - 11 " " 37
 - 3 " " 37a
 - 2 " " 38
 - 1 " " 52
 - 2 " " 90a
 - 2 " " 111c
 - 2 " " 126

Fix the signal arm to the post in such a manner that the arm is free to move, by means of Bolt 1, which is lock-nutted. The Bolt is passed through the Strips forming the signal post and the signal arm, and a Nut is placed on it and screwed up sufficiently to hold the Bolt in place. The first Nut is then held with a Spanner while a second Nut is screwed tightly up against it. The lever by which the signal is moved is also secured with Bolt 1a similarly lock-nutted.

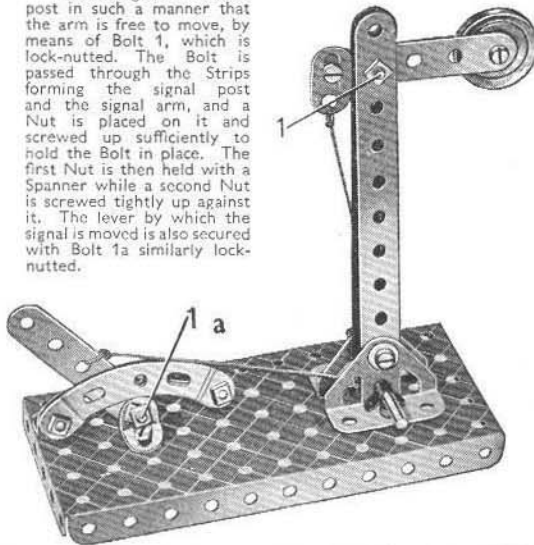

O.11 RADIAL CRANE

The wheeled bogie that carries the boom and jib is formed from two Curved Strips and two Flat Brackets. The $\frac{3}{4}$ " Bolts 2 pass through the Flat Brackets and are gripped in the bosses of the 1" Pulleys. Bearings for the Crank Handle are provided by Flat Trunnions. The Bolt 1 is lock-nutted.

- Parts required
- | | | |
|------------|---------------|---------------|
| 4 of No. 2 | 19 of No. 37a | 2 of No. 126a |
| 2 " " 5 | 18 " " 37b | 2 " " 155a |
| 3 " " 10 | 2 " " 38 | |
| 4 " " 12 | 2 " " 48a | |
| 1 " " 17 | 1 " " 52 | |
| 1 " " 19s | 2 " " 90a | |
| 2 " " 22 | 2 " " 111c | |
| 1 " " 24 | 1 " " 126 | |
| 4 " " 35 | | |

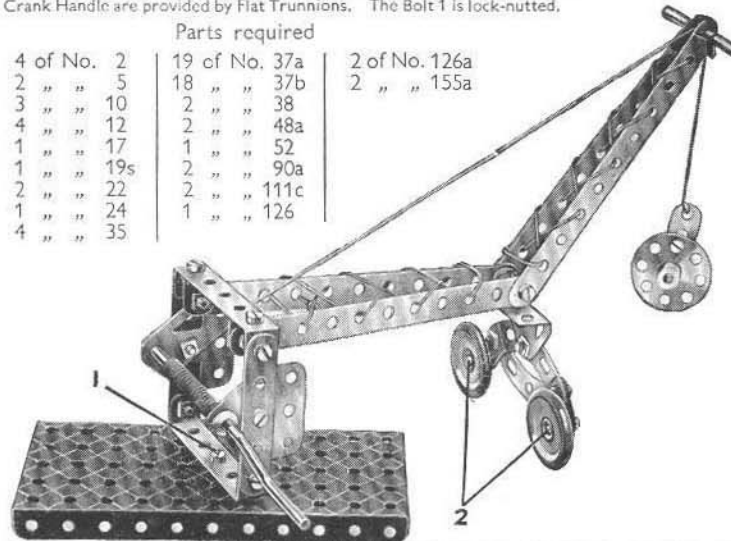

O.12 ELECTRIC TRUCK

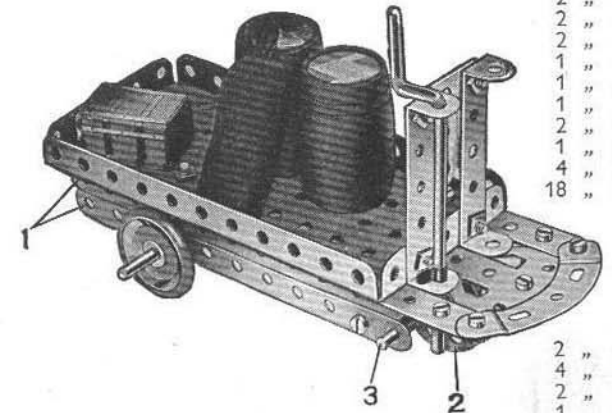

- Parts required
- 4 of No. 2
 - 2 " " 5
 - 2 " " 10
 - 2 " " 12
 - 1 " " 16
 - 1 " " 17
 - 1 " " 19s
 - 2 " " 22
 - 1 " " 24
 - 4 " " 35
 - 18 " " 37
 - 2 " " 37a
 - 4 " " 38
 - 2 " " 48a
 - 1 " " 52
 - 2 " " 90a
 - 2 " " 111c
 - 2 " " 126
 - 2 " " 126a
 - 2 " " 155a

The two $5\frac{1}{4}$ " Strips 1 are fastened to the Flanged Plate by two Trunnions secured to the Plate on the underneath side. A Bush Wheel 2 is fixed on the Axle Rod 3, which passes through the end holes of the $5\frac{1}{4}$ " Strips that form the sides of the truck frame.

O.13 ACROBAT

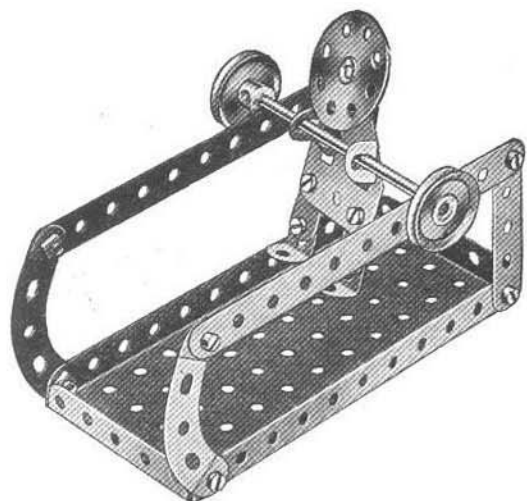

Parts required

2	of No. 2
2	" " 5
3	" " 10
4	" " 12
1	" " 16
2	" " 22
1	" " 24
15	" " 37
1	" " 52
2	" " 90a
1	" " 111c
1	" " 126a

O.14 BATTLESHIP

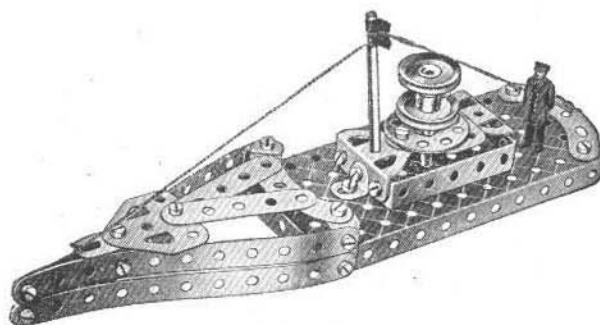

Parts required

4	of No. 2	2	of No. 22	1	of No. 52
2	" " 5	1	" " 24	2	" " 90a
3	" " 10	3	" " 35	1	" " 111c
4	" " 12	18	" " 37	2	" " 126
1	" " 16	1	" " 37a	2	" " 126a
1	" " 17	2	" " 48a		

O.15 ESKIMO BOY AND SLEDGE

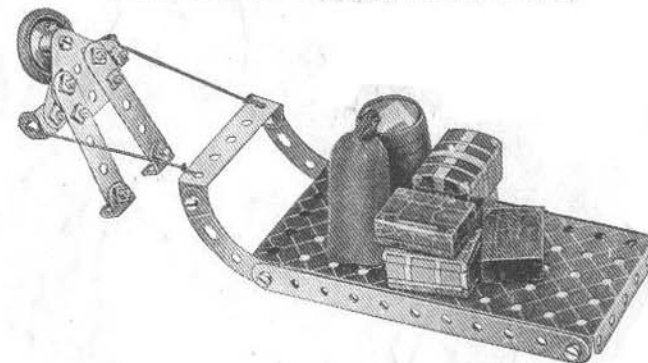

Parts required

2	of No. 2	1	of No. 22	2	of No. 90a
2	" " 5	14	" " 37	1	" " 111c
2	" " 10	1	" " 48a	1	" " 126a
4	" " 12	1	" " 52	1	" " 155a

O.16 SKIER

Parts required

2	of No. 2
2	" " 5
1	" " 10
3	" " 12
1	" " 16
1	" " 22
1	" " 24
2	" " 35
11	" " 37
1	" " 52
2	" " 90a
2	" " 126a

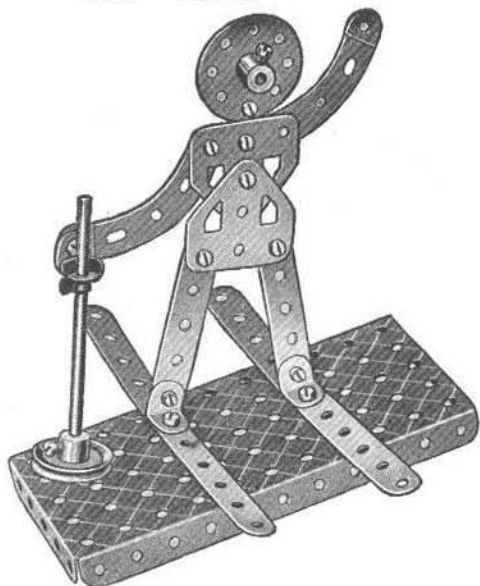

O.17 LEVEL CROSSING BARRIER

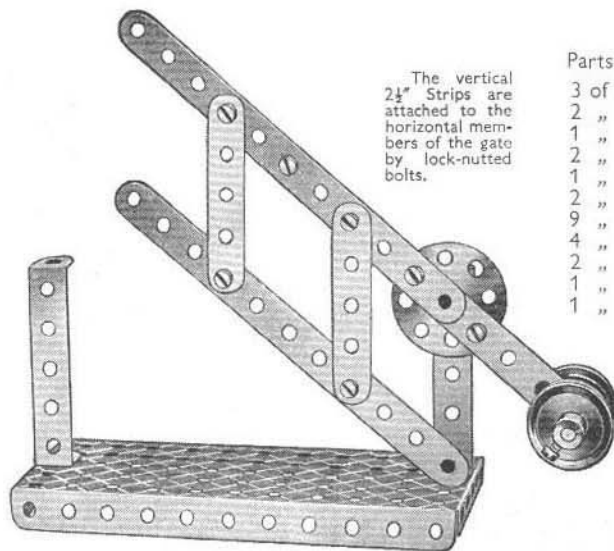

The vertical $2\frac{1}{2}$ " Strips are attached to the horizontal members of the gate by lock-nutted bolts.

Parts required

3	of No. 2
2	" " 5
1	" " 17
2	" " 22
1	" " 24
2	" " 35
9	" " 37
4	" " 37a
2	" " 48a
1	" " 52
1	" " 111c

O.18 SWING BOAT

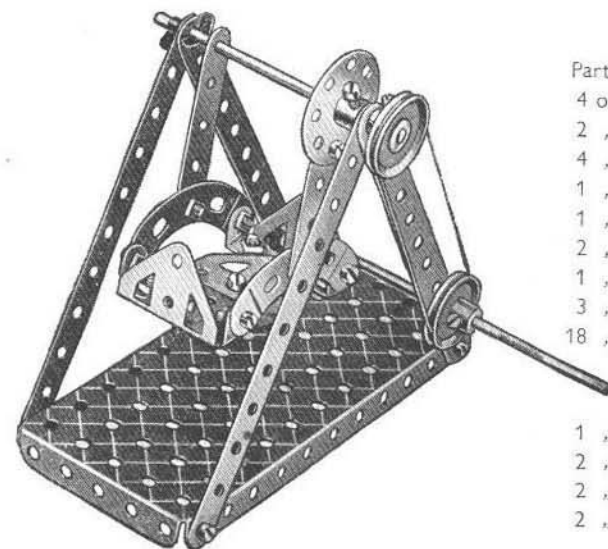

Parts required

4	of No. 2
2	" " 5
4	" " 12
1	" " 16
1	" " 19s
2	" " 22
1	" " 24
3	" " 35
18	" " 37
1	" " 52
2	" " 90a
2	" " 126
2	" " 126a

O.19 TRAPEZE ARTIST

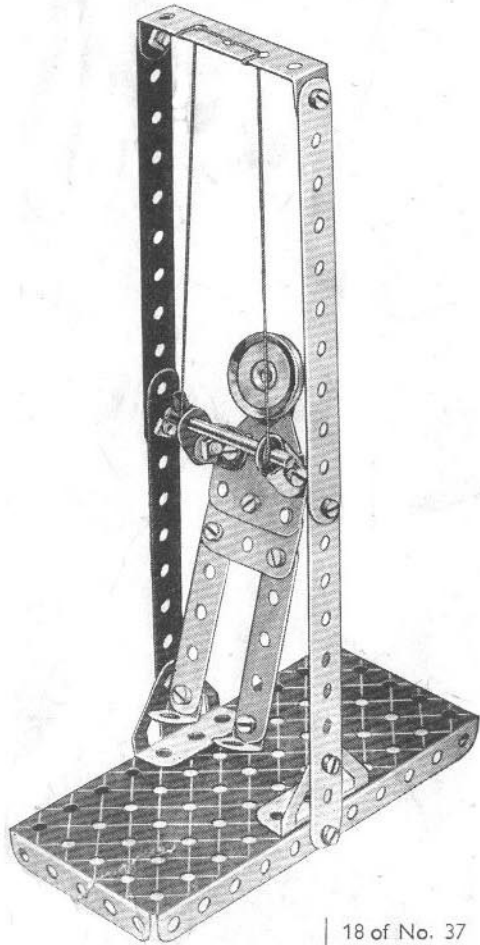

		18 of No. 37
Parts required	4 of No. 12	1 " " 48a
4 of No. 2	1 " " 17	1 " " 52
2 " " 5	1 " " 22	1 " " 111c
3 " " 10	2 " " 35	2 " " 126
		2 " " 126a

O.20 SAILING BOAT

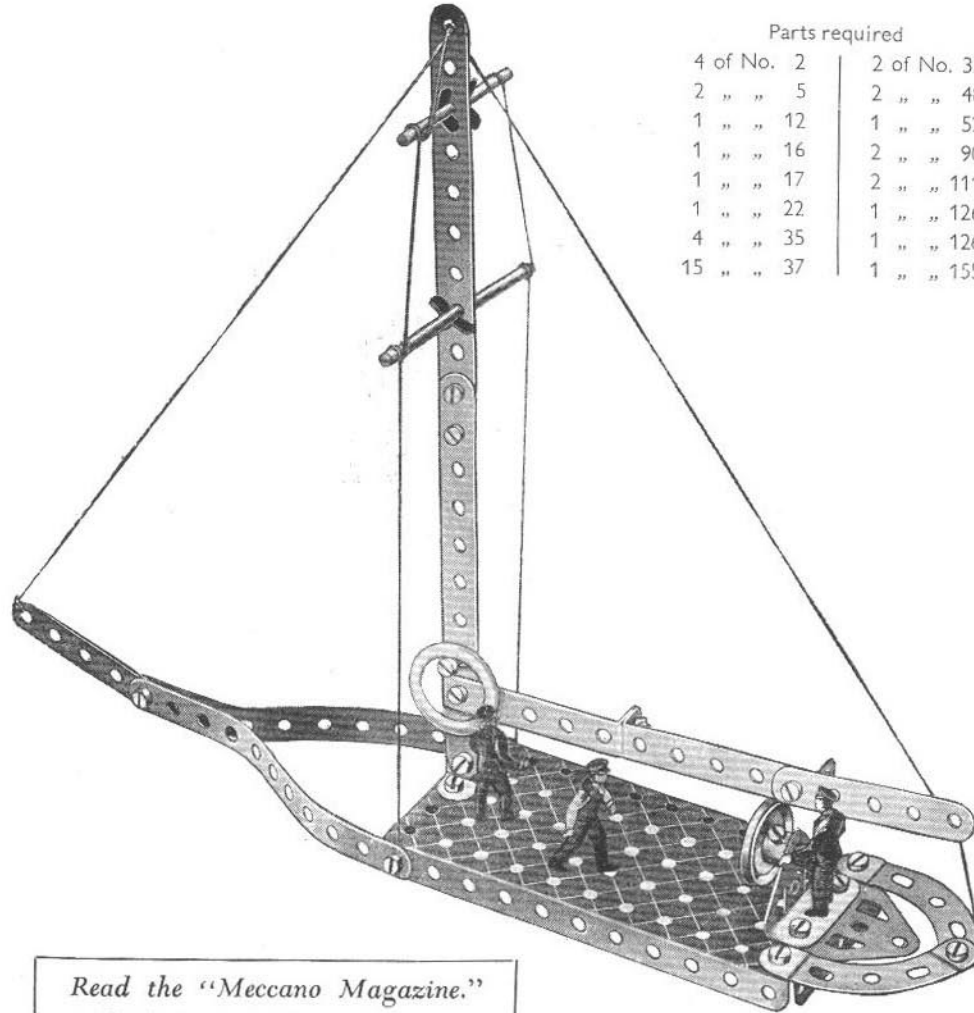

Parts required	
4 of No. 2	2 of No. 37a
2 " " 5	2 " " 48a
1 " " 12	1 " " 52
1 " " 16	2 " " 90a
1 " " 17	2 " " 111c
1 " " 22	1 " " 126
4 " " 35	1 " " 126a
15 " " 37	1 " " 155a

Read the "Meccano Magazine," published monthly. Ask your dealer for full particulars.

O.21 DERRICK CRANE

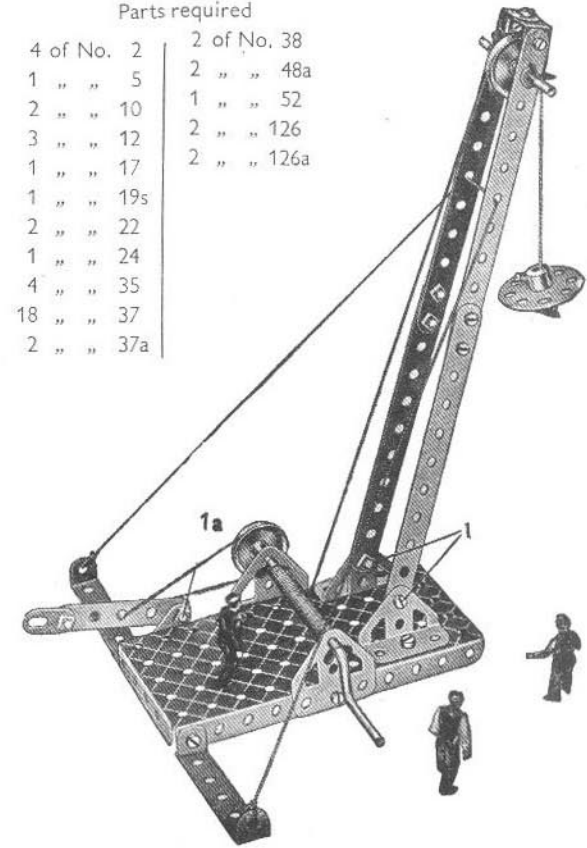

Parts required	
4 of No. 2	2 of No. 38
1 " " 5	2 " " 48a
2 " " 10	1 " " 52
3 " " 12	2 " " 126
1 " " 17	2 " " 126a
1 " " 19s	
2 " " 22	
1 " " 24	
4 " " 35	
18 " " 37	
2 " " 37a	

The construction of the model is commenced by bolting the Trunnions and Flat Trunnions that support the jib and Crank Handle respectively, to the 5½" x 2½" Flanged Plate that forms the base of the model. The jib is then assembled and fastened to the Trunnions by means of the lock-nutted Bolts 1. The brake lever is a 2½" Strip extended by a Flat Bracket, and is fastened to a second Flat Bracket bolted to the Flanged Plate by means of a Bolt 1a the nut of which is left sufficiently loose to allow the Strip to move. A length of Cord is fastened to the lever and then passed round the 1" Pulley on the Crank Handle.

O.22 STATIONARY STEAM ENGINE

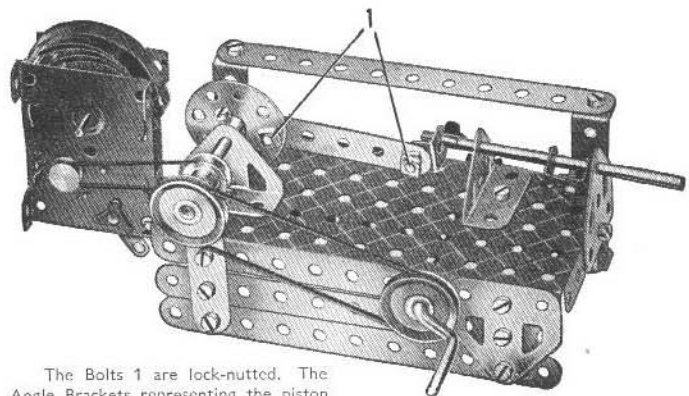

The Bolts 1 are lock-nutted. The Angle Brackets representing the piston are clamped to the Rod by a Nut and Bolt fastened in their elongated holes.

Parts required

4 of No. 2
2 " " 5
3 " " 12
1 " " 16
1 " " 17
1 " " 19s
2 " " 22
1 " " 24
3 " " 35
18 " " 37
2 " " 37a
1 " " 38
2 " " 48a
1 " " 52

2 of No. 126
2 " " 126a
Magic Motor

Parts required

3 of No. 2
2 " " 5
1 " " 10

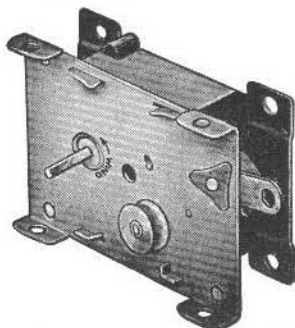
THE MECCANO
MAGIC MOTOR

The greatest thrill in Meccano model-building is experienced when a model is set to work by means of a Meccano *Magic Motor*. The illustrations on this page show how the *Magic Motor* can be fitted without any difficulty to No. O Outfit models of various types. Fit the model you have just built with one of these wonderful Motors, and enjoy the fun of watching it work just like the real thing!

2 of No. 111c
2 " " 126
2 " " 126a
Magic Motor

1 of No. 52
2 " " 90a
2 " " 126
2 " " 126a

O.23 MECHANICAL HAMMER

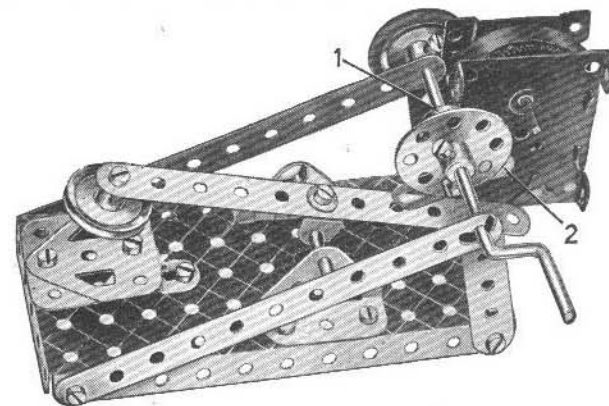

The $\frac{1}{2}$ " fast Pulley 1 is driven from the pulley 2 on the *Magic Motor* by the Driving Band supplied with the Motor.

4 of No. 12

1 " " 17
1 " " 19s
2 " " 22
1 " " 24
3 " " 35
15 " " 37
1 " " 38
1 " " 52
1 " " 111c
2 " " 126
2 " " 126a
1 " " 155a
Magic Motor

O.24 MERRY-GO-ROUND

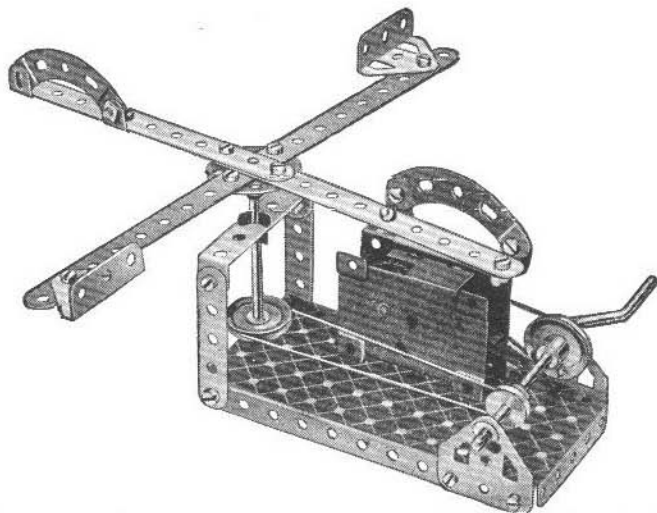

Parts required

4 of No. 2
2 " " 5
4 " " 12
1 " " 16
1 " " 19s
2 " " 22
1 " " 24
4 " " 35
18 " " 37
2 " " 37a
2 " " 38
1 " " 48a
1 " " 52
2 " " 90a

2 of No. 111c
2 " " 126
2 " " 126a
Magic Motor

1 of No. 52
2 " " 90a
2 " " 126
2 " " 126a

O.25 WINDMILL

A Driving Band connects the pulley of the *Magic Motor* to a $1\frac{1}{2}$ " Pulley fastened on the Crank Handle. The Crank Handle carries also a $\frac{1}{2}$ " Pulley, which is connected by a second Driving Band with a further $1\frac{1}{2}$ " Pulley fixed to the Rod on which the sails are mounted.

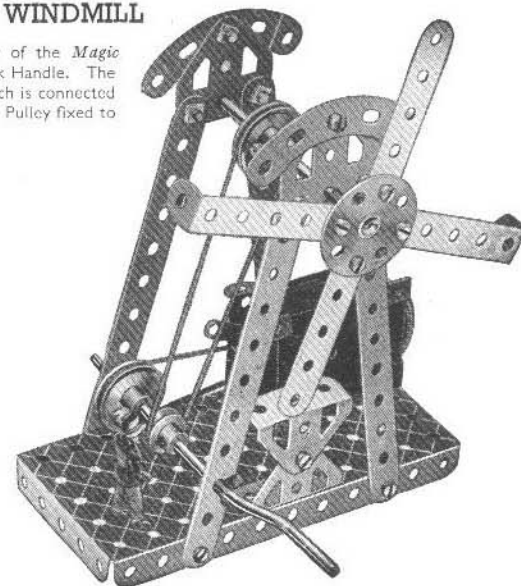

Parts required

4 of No. 2
2 " " 5
1 " " 16
1 " " 19s
2 " " 22
1 " " 24
3 " " 35
18 " " 37
2 " " 38
2 " " 48a
Magic Motor

1.1 PORTER'S TRUCK

The bearings for the axle are Flat Trunnions fastened on the insides of the Flexible Plates, and the axle is a 3/4" Rod that carries two 1" Pulleys fitted with Rubber Rings.

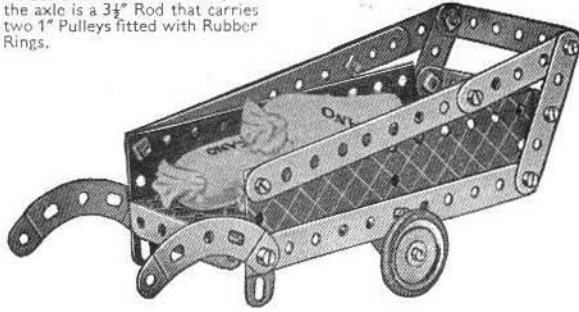

Parts required

4 of No. 2
4 " " 5
2 " " 10
1 " " 16
2 " " 22
14 " " 37
2 " " 38
2 " " 48a
1 " " 52
2 " " 90a
2 " " 126a
2 " " 155a
2 " " 189

1.2 BATTLESHIP

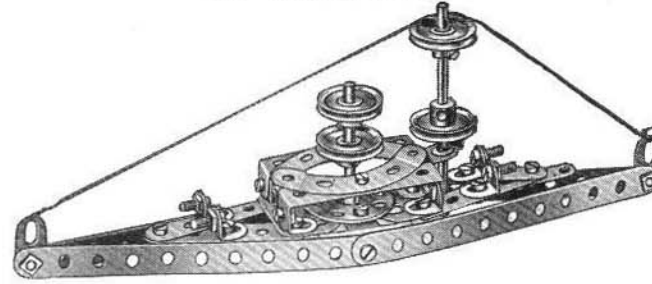

Parts required

4 of No. 2	1 of No. 17	4 of No. 37a	4 of No. 111c
4 " " 5	4 " " 22	2 " " 38	1 " " 125
4 " " 10	1 " " 24	1 " " 40	2 " " 126
8 " " 12	3 " " 35	2 " " 48a	2 " " 126a
1 " " 16	24 " " 37	2 " " 90a	

1.3 WINDMILL

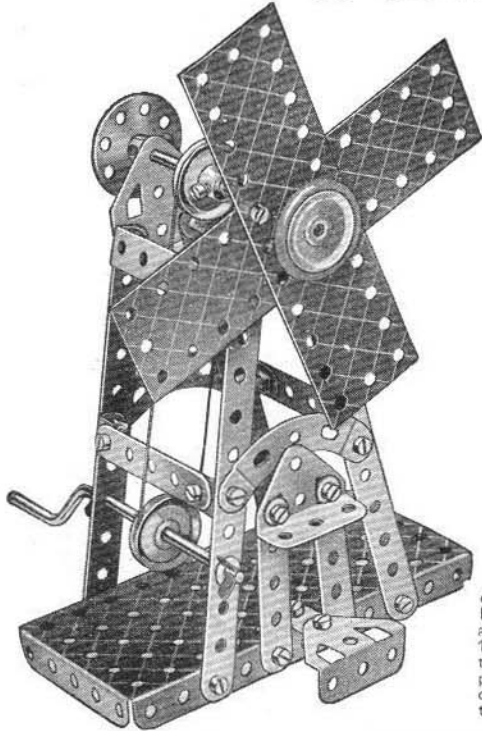

The sails are gripped on the 3/4" Rod by the 1" Pulley (with Rubber Ring) at the front and another 1" Pulley at the back of the sails. The Pulleys are pressed against the faces of the sails and locked on the Rod.

Parts required

4 of No. 2
4 " " 5
1 " " 10
4 " " 12
1 " " 16
1 " " 19s
4 " " 22
1 " " 24
3 " " 35
24 " " 37
4 " " 38
1 " " 40
2 " " 48a
1 " " 52
2 " " 90a
2 " " 126
2 " " 126a
1 " " 155a
2 " " 189

1.4 SCALES

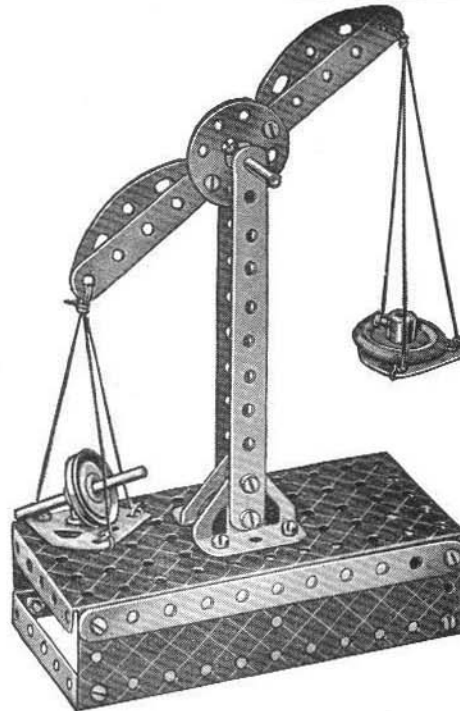

Parts required

4 of No. 2
2 " " 5
2 " " 17
2 " " 22
1 " " 24
19 " " 37
1 " " 38
1 " " 40
2 " " 48a
1 " " 52
2 " " 90a
1 " " 111c
2 " " 126
2 " " 126a
1 " " 155a
2 " " 189

1.5 GYMNAST

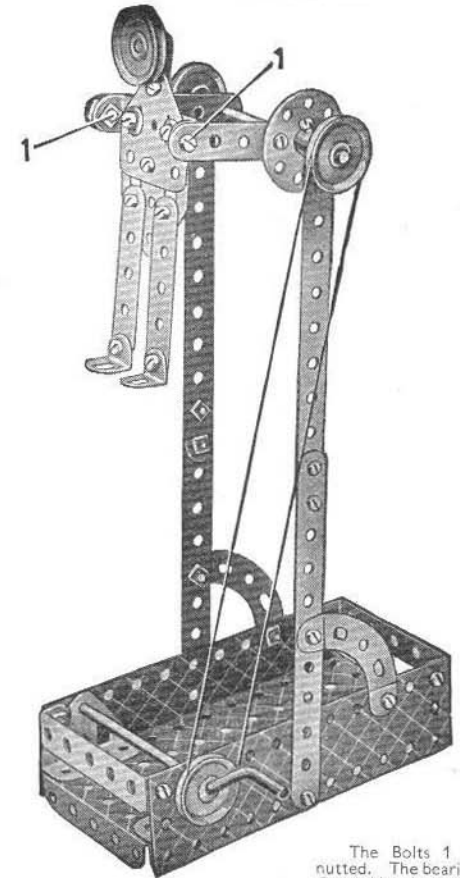

The Bolts 1 are lock-nutted. The bearings for the Crank Handle in the Flexible Plates are reinforced by Trunnions bolted to the Flanged Plate.

Parts required

4 of No. 2	1 of No. 24	1 of No. 52
4 " " 5	2 " " 35	2 " " 90a
1 " " 10	24 " " 37	4 " " 111c
4 " " 12	5 " " 37a	2 " " 126
1 " " 16	4 " " 38	2 " " 126a
1 " " 19s	1 " " 40	2 " " 189
4 " " 22	2 " " 48a	

1.6 LUMBER WAGON

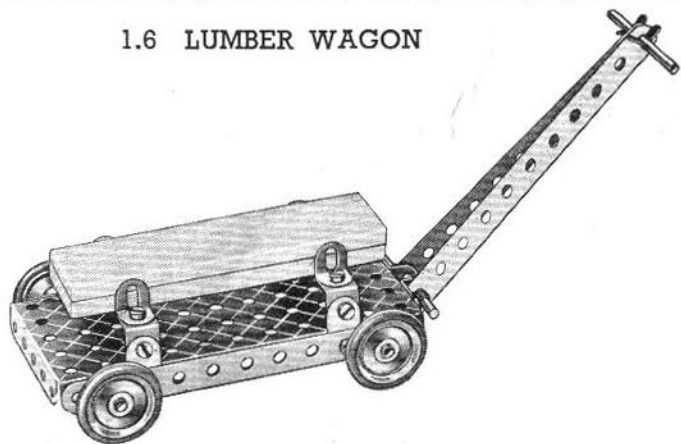

Parts required

4 of No. 2	2 of No. 16	4 of No. 35	1 of No. 52
4 " " 10	2 " " 17	14 " " 37	4 " " 155a
6 " " 12	4 " " 22	2 " " 48a	

1.7 TABLE

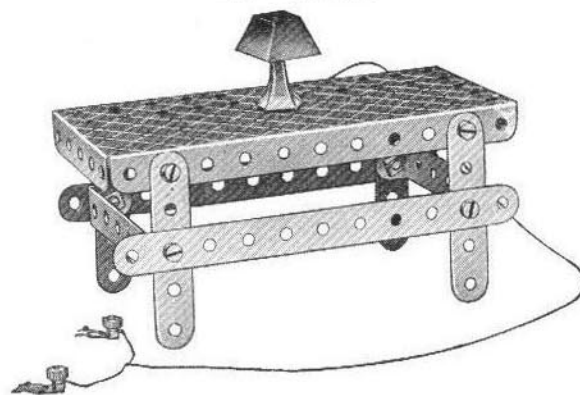

Parts required

2 of No. 2	8 of No. 37	1 of No. 52
4 " " 5	2 " " 48a	

The model is shown with a Stand Lamp from a Meccano Lighting Set.

1.8 BUFFER STOPS

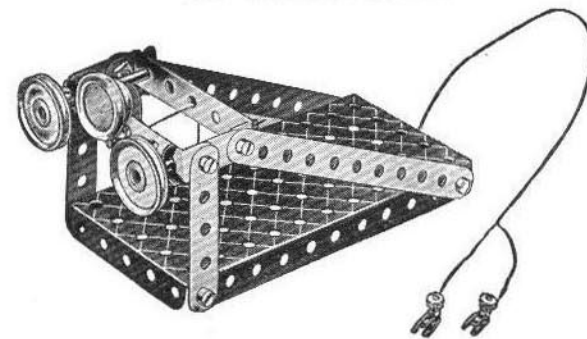

Parts required

2 of No. 2	2 of No. 17	9 of No. 37
2 " " 5	2 " " 22	2 " " 48a
3 " " 10	4 " " 35	1 " " 52

The model is fitted with a Spot light from a Meccano Lighting Set.

1.9 AEROPLANE

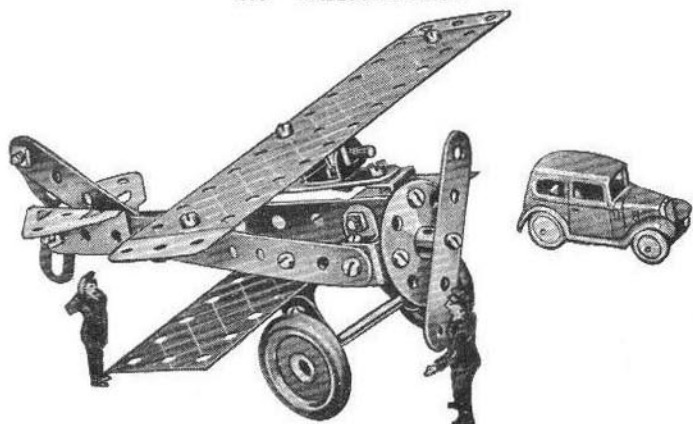

Parts required

2 of No. 2	1 of No. 17	2 of No. 37a	2 of No. 126
3 " " 5	2 " " 22	1 " " 38	2 " " 126a
4 " " 10	1 " " 24	3 " " 111c	2 " " 155a
8 " " 12	17 " " 37	1 " " 125	2 " " 189

1.10 "KIDDIE KAR"

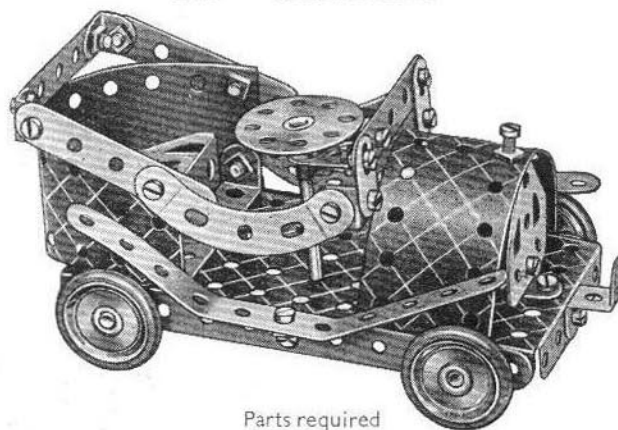

Parts required

4 of No. 2	1 of No. 17	3 of No. 37a	1 of No. 125
4 " " 5	4 " " 22	2 " " 48a	2 " " 126
3 " " 10	1 " " 24	1 " " 52	1 " " 126a
7 " " 12	1 " " 35	2 " " 90a	4 " " 155a
2 " " 16	24 " " 37	2 " " 111c	2 " " 189

Two Trunnions overlapped one hole, and fastened to the Flanged Plate by an Angle Bracket, form the seat.

1.11 WATCH STAND

Parts required

4 of No. 2
2 " " 12
19 " " 37
1 " " 38
1 " " 52
1 " " 57c
2 " " 90a
1 " " 126
2 " " 126a

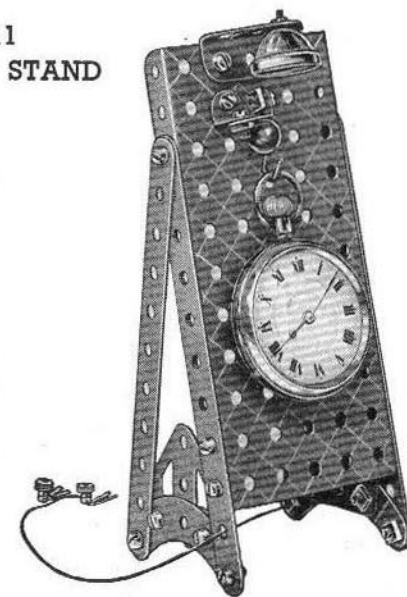

A good example of the use of the Meccano Lighting Set.

1.12 BAGGAGE TRUCK

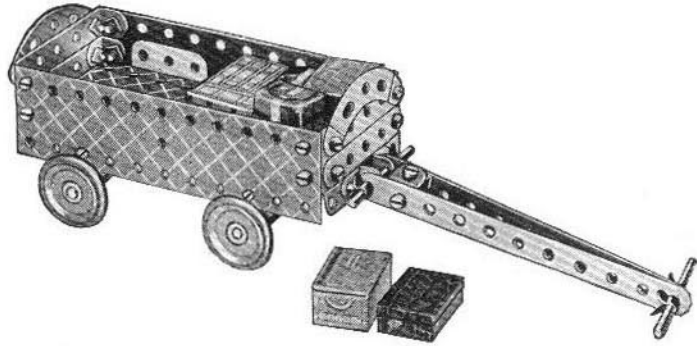

Parts required

2 of No. 2	4 of No. 35	2 of No. 90a
2 " " 5	1 " " 37	1 " " 111c
8 " " 12	1 " " 37a	2 " " 126
2 " " 16	2 " " 38	2 " " 126a
2 " " 17	2 " " 48a	4 " " 155a
4 " " 22	1 " " 52	2 " " 189

1.13 RACING SEAPLANE

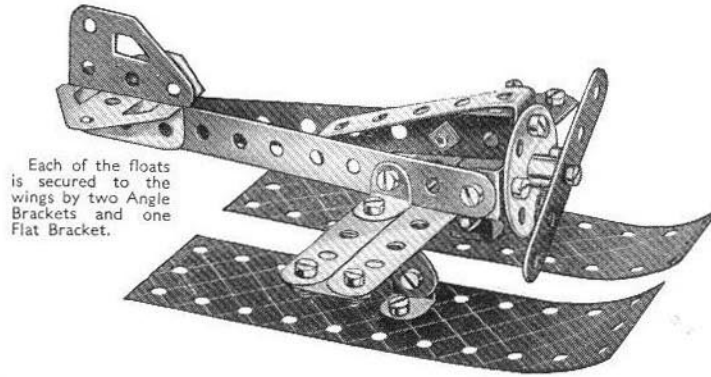

Each of the floats is secured to the wings by two Angle Brackets and one Flat Bracket.

Parts required

3 of No. 2	1 of No. 24	2 of No. 111c
3 " " 5	19 " " 37	2 " " 126
4 " " 10	1 " " 37a	1 " " 126a
8 " " 12	1 " " 48a	2 " " 189

1.14 SLEDGE

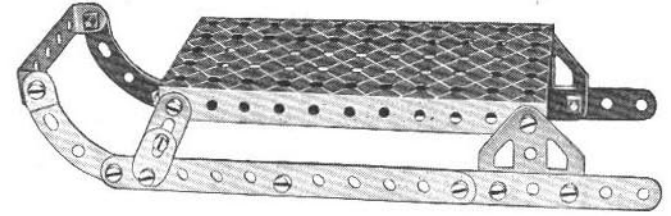

Parts required

4 of No. 2	1 of No. 48a	2 of No. 126a
4 " " 10	1 " " 52	
20 " " 37	2 " " 90a	

1.15 BAND SAW

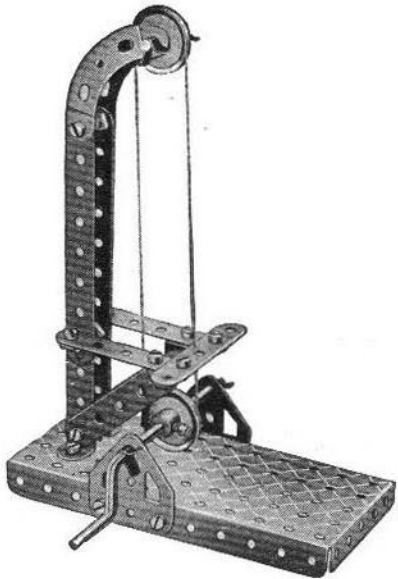

Parts required

2 of No. 2
4 " " 5
6 " " 12
1 " " 17
1 " " 19s
2 " " 22
4 " " 35
19 " " 37
1 " " 40
1 " " 52
2 " " 90a
2 " " 126a

1.16 CIRCULAR SAW

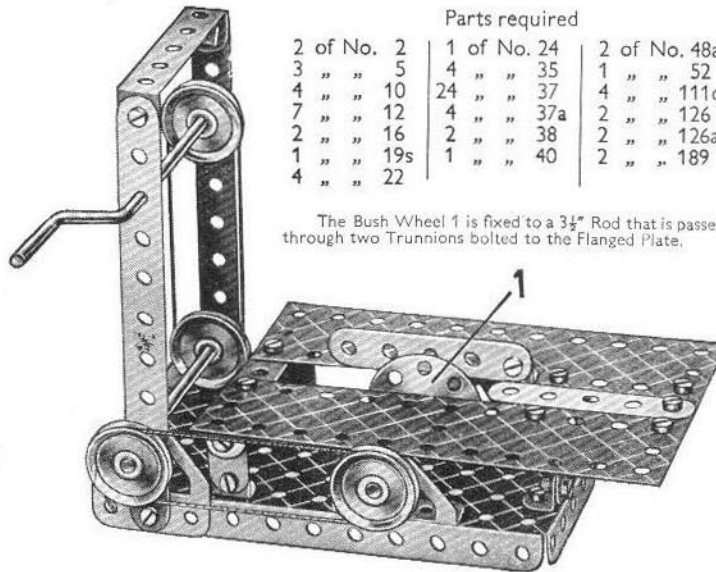

Parts required

2 of No. 2	1 of No. 24	2 of No. 48a
3 " " 5	4 " " 35	1 " " 52
4 " " 10	24 " " 37	4 " " 111c
7 " " 12	4 " " 37a	2 " " 126
2 " " 16	2 " " 38	2 " " 126a
1 " " 19s	1 " " 40	2 " " 189
4 " " 22		

The Bush Wheel 1 is fixed to a 3/4" Rod that is passed through two Trunnions bolted to the Flanged Plate.

1.17 DRILL

Parts required

4 of No. 2
3 " " 5
8 " " 12
1 " " 16
1 " " 17
1 " " 19s
4 " " 22
4 " " 35
20 " " 37
4 " " 38
1 " " 40
1 " " 52
2 " " 126
2 " " 126a

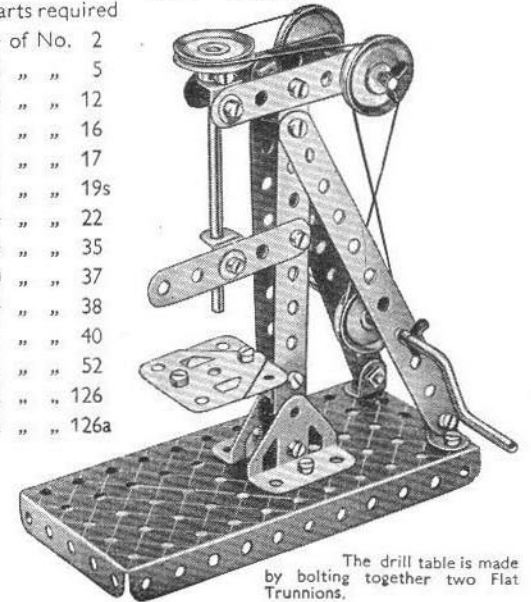

The drill table is made by bolting together two Flat Trunnions.

1.18 TRIP HAMMER

Parts required

4 of No. 2	17 of No. 37
3 " " 5	1 " " 48a
2 " " 12	1 " " 52
1 " " 17	2 " " 111c
1 " " 19s	1 " " 125
4 " " 22	2 " " 126
1 " " 24	2 " " 126a
4 " " 35	1 " " 155a
	1 " " 189

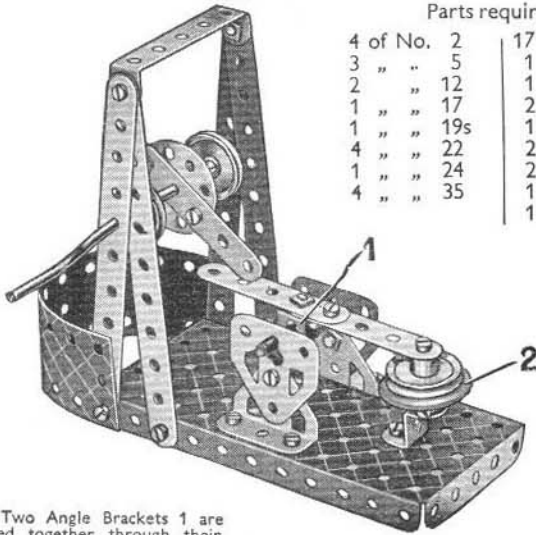

Two Angle Brackets 1 are bolted together through their holes and also are bolted to two 2 1/2" Strips to form a double bracket. The 1" fast Pulley 2 is fitted with a 1" Rubber Ring.

1.19 STEAM LAUNCH

The top of the deck-house consists of three 2 1/2" Strips bolted first to Flat Brackets and then to a Trunnion. The rear side is held in place by an Angle Bracket. The other side consists of a 2 1/2" x 1" Double Angle Strip bolted to the Trunnion.

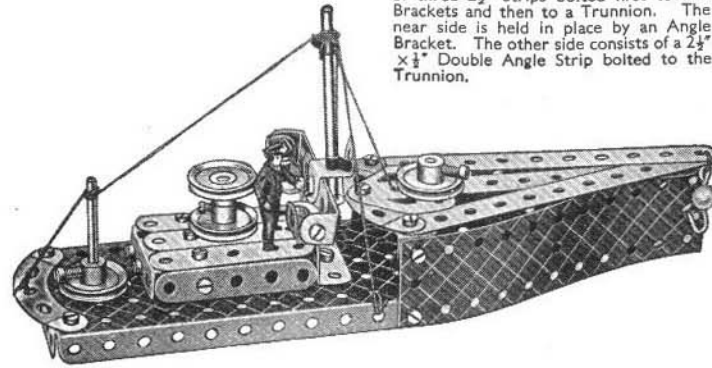

Parts required

3 of No. 2	4 of No. 22	1 of No. 52	2 of No. 126a
4 " " 5	4 " " 35	1 " " 57c	2 " " 189
3 " " 10	23 " " 37	2 " " 90a	
8 " " 12	4 " " 38	2 " " 111c	
1 " " 16	1 " " 40	1 " " 125	
2 " " 17	2 " " 48a	2 " " 126	

1.20 COASTER

The Bolts 1 are lock-nutted. The rear axle Rod is pushed through the end hole of the Curved Strip 2.

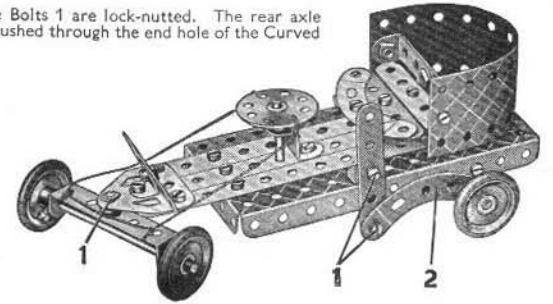

Parts required

3 of No. 2	1 of No. 35	2 of No. 90a
4 " " 5	20 " " 37	2 " " 111c
5 " " 12	4 " " 37a	1 " " 125
2 " " 16	4 " " 38	2 " " 126
1 " " 17	1 " " 40	2 " " 126a
4 " " 22	2 " " 48a	4 " " 155a
1 " " 24	1 " " 52	1 " " 189

1.21 LIFTING BRIDGE

The Bolts 1, on which the bridge span pivots, are lock-nutted.

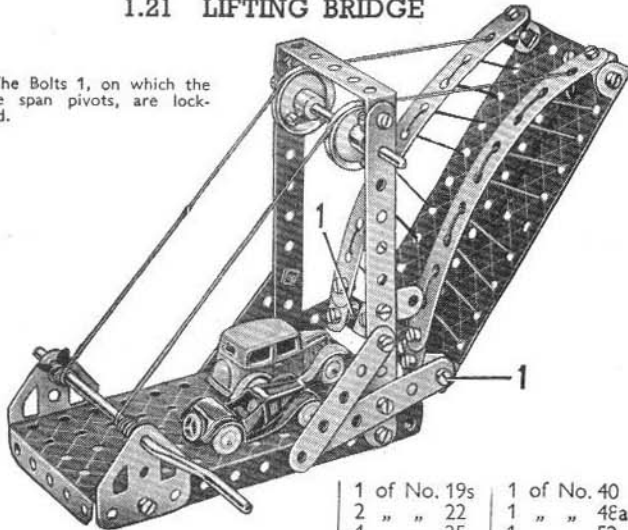

Parts required	3 of No. 10	1 of No. 19s	1 of No. 40
4 of No. 2	8 " " 12	2 " " 22	1 " " 48a
4 " " 5	2 " " 16	4 " " 35	1 " " 52
		24 " " 37	3 " " 111c
		5 " " 37a	2 " " 126a
		4 " " 38	2 " " 189

1.22 HAND TRUCK

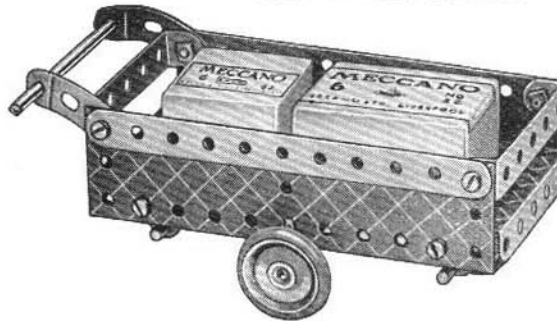

Parts required

2 of No. 2
2 " " 10
8 " " 12
2 " " 16
2 " " 17
4 " " 22
3 " " 35
14 " " 37
2 " " 48a
1 " " 52
2 " " 90a
2 " " 155a
2 " " 189

The bearings on the 3 1/2" Rod are Flat Brackets, and the front and rear axle bearings are reversed angle brackets built up from Angle Brackets. The right-hand 1" Pulley on the 3 1/2" Rod is loose on the Rod, but is retained in place by a Spring Clip. The front and rear 1" Pulleys are fixed on their respective 2" Rods.

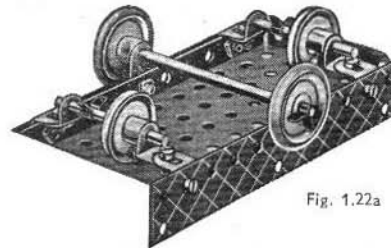
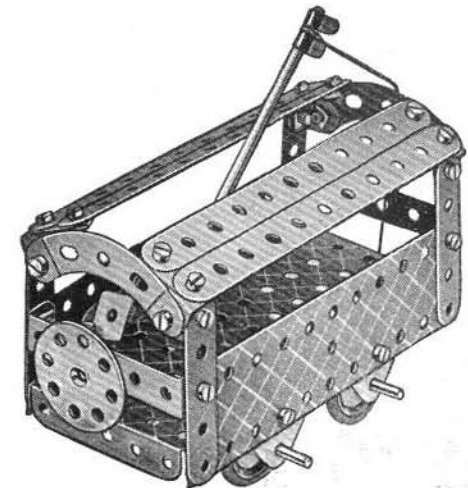

Fig. 1.22a

1.23 TROLLEY BUS



Parts required

4 of No. 2
4 " " 5
4 " " 10
8 " " 12
2 " " 16
1 " " 19s
4 " " 22
1 " " 24
4 " " 35
24 " " 37
1 " " 37a
4 " " 38
1 " " 40
2 " " 48a
1 " " 52
2 " " 90a
2 " " 111c
1 " " 125
2 " " 126
2 " " 126a
4 " " 155a
2 " " 189

The Reversed Angle Bracket that holds the trolley is fixed in position by a Bolt passed through the slot in the Bracket, then through two Washers, and into the boss of the Bush Wheel.

1.24 HAY CART

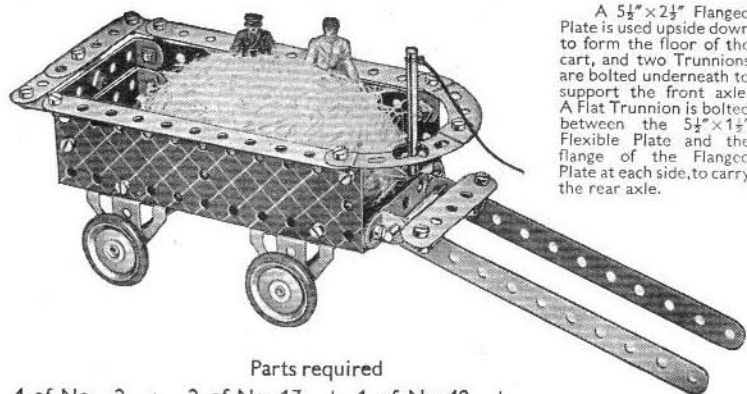

A $5\frac{1}{2}'' \times 2\frac{1}{2}''$ Flanged Plate is used upside down to form the floor of the cart, and two Trunnions are bolted underneath to support the front axle. A Flat Trunnion is bolted between the $5\frac{1}{2}'' \times 1\frac{1}{2}''$ Flexible Plate and the flange of the Flanged Plate at each side, to carry the rear axle.

Parts required

4 of No. 2	2 of No. 17	1 of No. 40	
3 " " 5	4 " " 22	2 " " 48a	2 of No. 126
2 " " 10	4 " " 35	1 " " 52	2 " " 126a
7 " " 12	24 " " 37	2 " " 90a	4 " " 155a
2 " " 16	1 " " 37a	1 " " 111c	2 " " 189

1.25 MOTOR LORRY

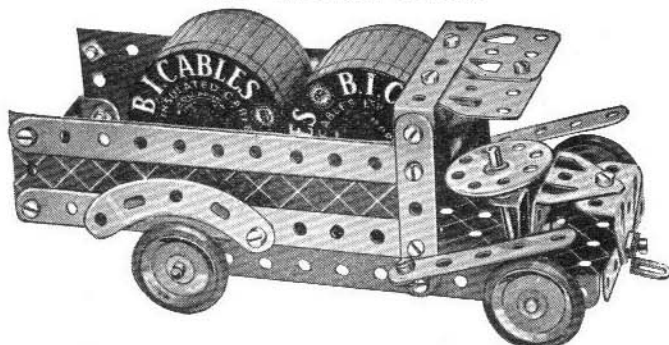

The $2\frac{1}{2}''$ Curved Strips representing the rear mudguards are each fastened to the sides by a $\frac{3}{8}''$ Bolt and Nut, with a Spring Clip between the mudguards and the $5\frac{1}{2}''$ Strip to form a distance piece.

Parts required

4 of No. 2	1 of No. 17	19 of No. 37	2 of No. 90a	2 of No. 126a
4 " " 5	4 " " 22	4 " " 37a	3 " " 111c	4 " " 155a
3 " " 12	1 " " 24	2 " " 48a	1 " " 125	2 " " 189
2 " " 16	2 " " 35	1 " " 52	2 " " 126	

1.26 HOSPITAL TROLLEY

Parts required

4 of No. 2
1 " " 5
2 " " 12
2 " " 16
4 " " 22
12 " " 37
1 " " 52
2 " " 90a
4 " " 155a

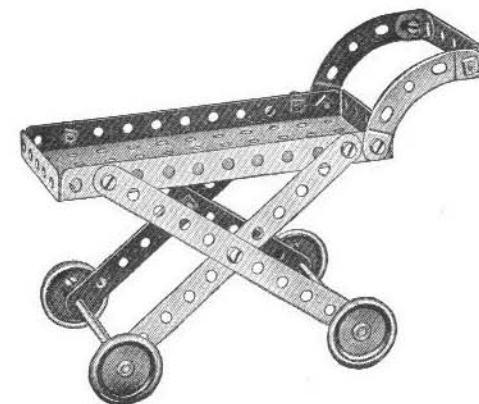

1.27 STAMPING MILL

The anvil 1 is made up of two Trunnions bolted together. When the Crank Handle is rotated, the Flat Brackets bolted to the Bush Wheel strike the centre 1" Pulley on the hammer shaft and cause it to rise and fall.

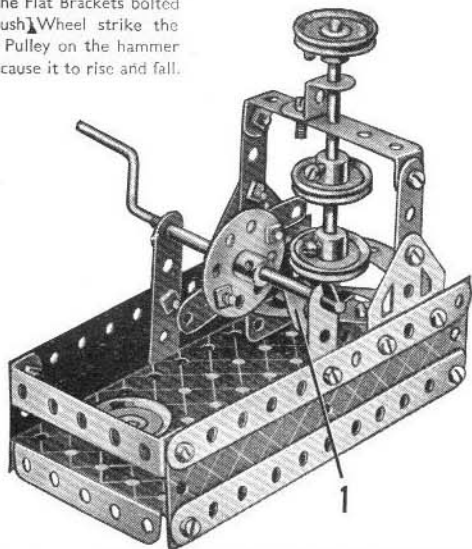

Parts required

4 of No. 2
4 " " 5
4 " " 10
5 " " 12
1 " " 16
1 " " 19s
1 " " 22
4 " " 24
2 " " 35
24 " " 37
3 " " 37a
2 " " 48a
1 " " 52
1 " " 90a
4 " " 111c
1 " " 125
2 " " 126
2 " " 126a
2 " " 189

1.28 FLYING BOATS

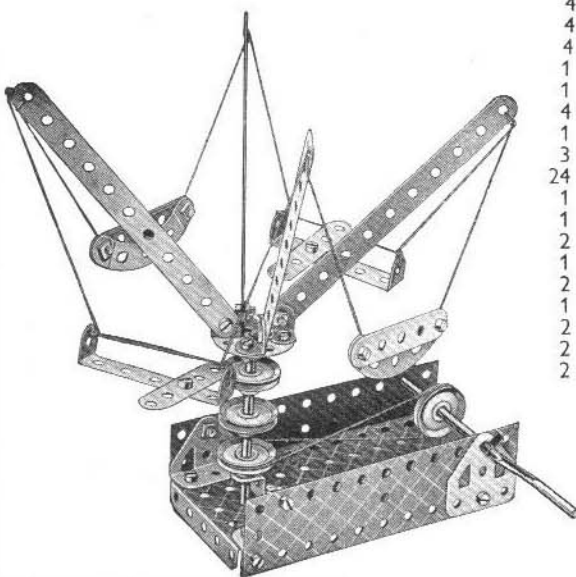

Parts required

4 of No. 2
4 " " 5
4 " " 12
1 " " 16
1 " " 19s
4 " " 22
1 " " 24
3 " " 35
24 " " 37
1 " " 38
1 " " 40
2 " " 48a
1 " " 52
2 " " 90a
1 " " 125
2 " " 126
2 " " 126a
2 " " 189

1.29 HAND CAR

The Bolts 1 on which the $5\frac{1}{2}''$ Strips are pivoted, are lock-nutted. The $2\frac{1}{2}''$ small radius Curved Strips are fixed to Angle Brackets bolted to the $5\frac{1}{2}'' \times 2\frac{1}{2}''$ Flanged Plate.

Parts required

2 of No. 2
2 " " 5
8 " " 12
2 " " 16
2 " " 17
4 " " 22
4 " " 35
23 " " 37
4 " " 37a
4 " " 38
2 " " 48a
1 " " 52
2 " " 90a
2 " " 111c
1 " " 125
2 " " 126
2 " " 126a
4 " " 155a
2 " " 189

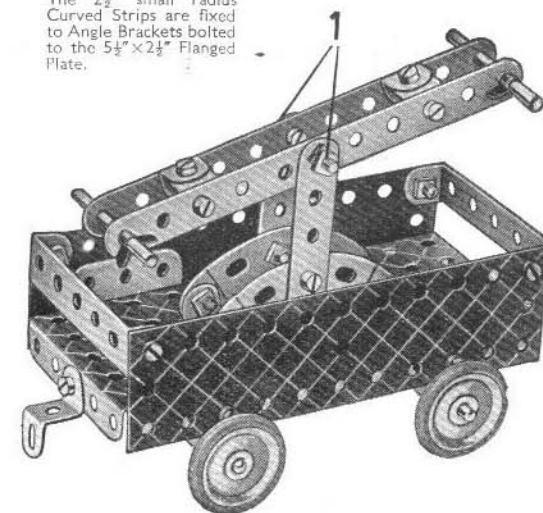

1.30 MONOPLANE

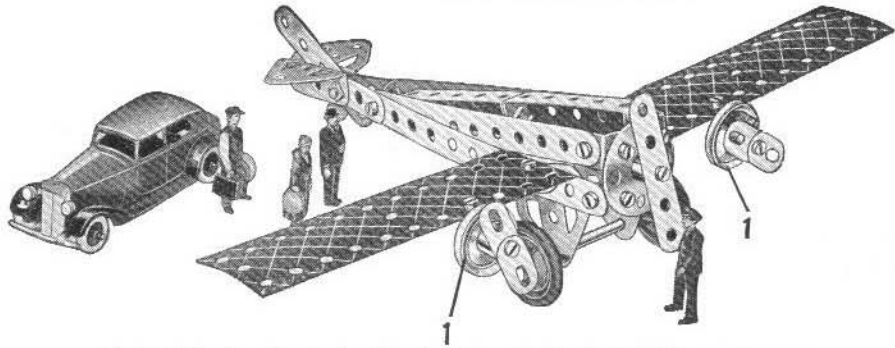

The fast Pulleys 1 are fixed to Angle Brackets fastened to the wing by $\frac{3}{8}$ " Bolts, which are passed through the Angle Brackets, and held in the bosses of the Pulleys. The set screws of the Pulleys hold also a second Bolt on which the propellers are mounted.

Parts required

4 of No.	2
4 "	5
4 "	10
8 "	12
1 "	16
4 "	22
1 "	24
2 "	35
20 "	37
3 "	37a
2 "	48a
1 "	57c
4 "	111c
2 "	126
2 "	126a
2 "	155a
2 "	189

1.31 FLOATING CRANE

Parts required

4 of No.	2	2 of No.	90a
4 "	5	3 "	111c
4 "	10	1 "	125
7 "	12	2 "	126
2 "	16	2 "	126a
2 "	17		
1 "	19s		
4 "	22		
1 "	24		
4 "	35		
24 "	37		
4 "	37a		
4 "	38		
1 "	40		
2 "	48a		
1 "	52		
1 "	57c		

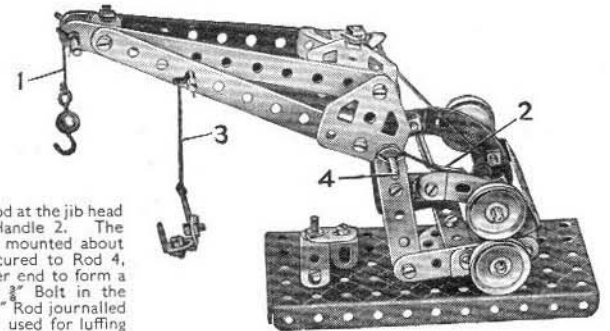

The Cord 1 passes over the Rod at the jib head and is fastened to the Crank Handle 2. The other Cord 3 passes over a Rod mounted about halfway along the jib, and is secured to Rod 4, which has a 1" Pulley at the other end to form a handle. The Cord tied to the $\frac{3}{8}$ " Bolt in the Trunnions is taken around the $3\frac{1}{2}$ " Rod journalled above the Crank Handle, and is used for luffing the jib by turning the 1" Pulley at the rear end of the Rod. Two Angle Brackets and a Flat Bracket form the hook on Cord 3.

1.32 POWER PRESS

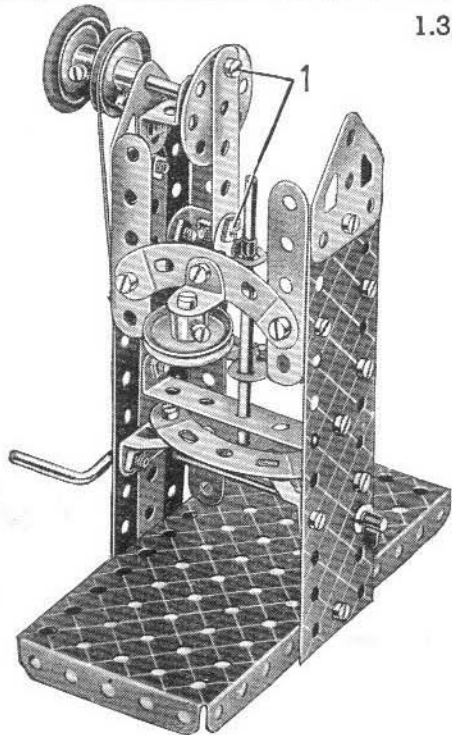

Parts required

4 of No.	2
4 "	5
1 "	10
6 "	12
1 "	16
1 "	17
1 "	19s
4 "	22
1 "	24
3 "	35
24 "	37
5 "	37a
1 "	38
1 "	40
2 "	48a
1 "	52
2 "	90a
4 "	111c
1 "	125
2 "	126
2 "	126a
1 "	155a
2 "	189

The Bolts 1 are lock-nutted, and the Angle Bracket at the lower end of the $2\frac{1}{2}$ " Strip has a $4\frac{1}{2}$ " Rod in its elongated hole, where it is held by means of two Spring Clips.

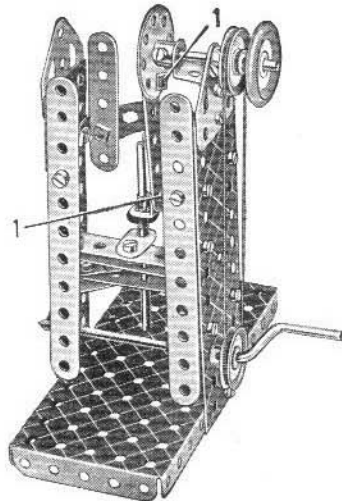
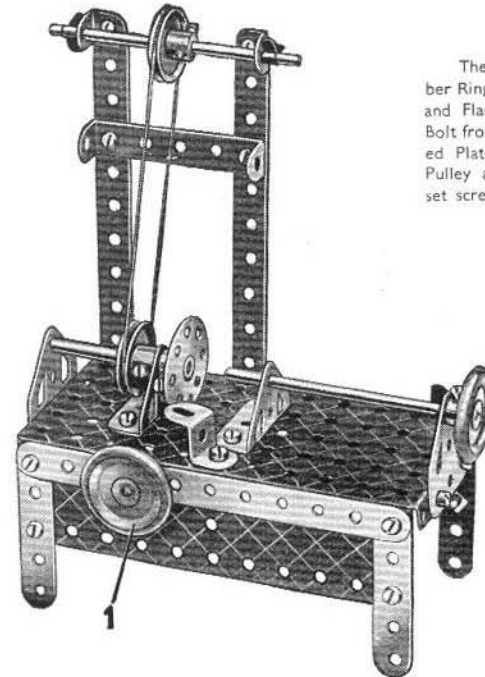

Fig. 1.32a

1.33 LATHE



The 1" fast Pulley with Rubber Ring 1 is secured to the Strip and Flanged Plate by passing a Bolt from the inside of the Flanged Plate into the boss of the Pulley and then tightening the set screw.

Parts required

4 of No.	2
4 "	5
2 "	12
2 "	16
1 "	17
4 "	22
1 "	24
3 "	35
22 "	37
1 "	40
1 "	48a
1 "	52
1 "	111c
1 "	125
2 "	126
2 "	126a
2 "	155a
2 "	189

1.34 MECHANICAL SHOVEL

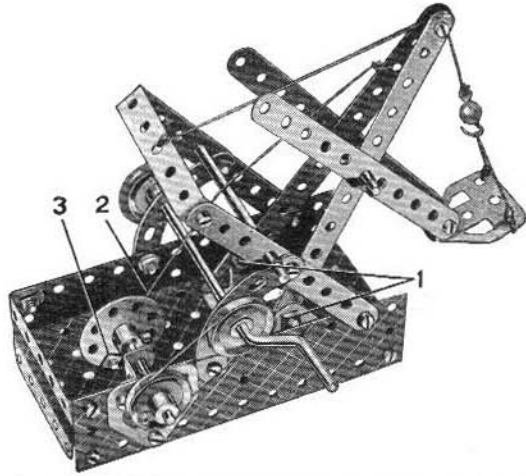

The Bolts 1, on which the jib pivots, are lock-nutted. The shovel arm is pivoted on a 2" Rod and the shovel is supported by a Cord that passes over the $\frac{3}{8}$ " Bolt at the jib head and is fastened to a $2\frac{1}{2}$ " x $\frac{1}{2}$ " Double Angle Strip as shown. The Cord 2 is fastened to the jib and then passes over a $3\frac{1}{2}$ " Rod journalled in the holes above the $2\frac{1}{2}$ " Curved Strips, and is attached to a Flat Bracket fastened by the lock-nutted Bolt 3 to the Bush Wheel.

When the Crank Handle is rotated, the Bush Wheel imparts a digging motion to the jib and shovel arm.

Parts required	
4 of No.	2
4 "	5
1 "	10
2 "	12
1 "	16
2 "	17
1 "	19s
3 "	22
1 "	24
4 "	35
24 "	37
4 "	37a
4 "	38
1 "	40
2 "	48a
1 "	52
1 "	57c
2 "	90a
4 "	111c
1 "	125
2 "	126
2 "	126a
1 "	155a
2 "	189

1.35 TELPHER SPAN

The anchoring piece 1 consists of two Trunnions bolted together, and a hook, which is made of two Angle Brackets fastened to them. A 2" Rod carrying a 1" fast Pulley is journalled in the Trunnions. The anchoring piece is hooked on a picture rail or other suitable support, and the Cord 2, which can be of any length, is passed round the 1" Pulleys as shown. When the Crank Handle is rotated, the car moves either backward or forward.

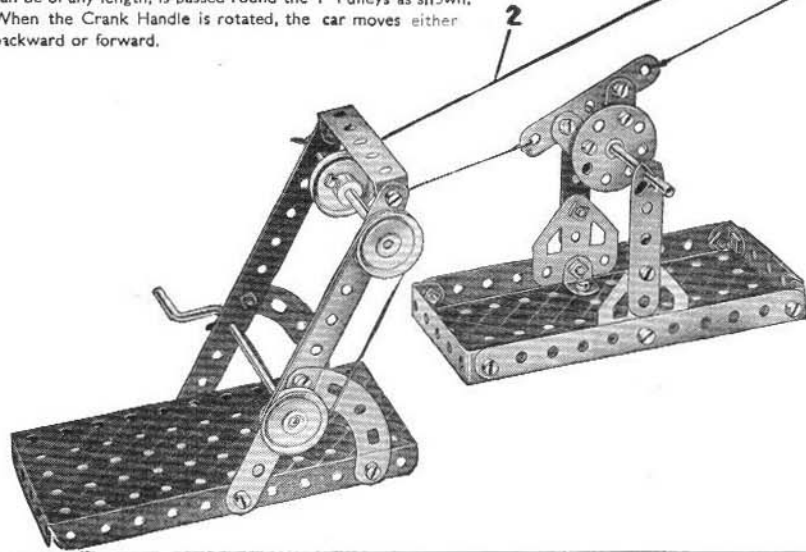
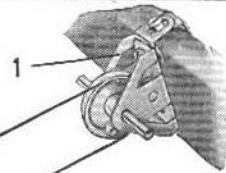

Parts required	
4 of No.	2
4 "	5
2 "	10
6 "	12
2 "	16
1 "	17
1 "	19s
4 "	22
1 "	24
4 "	35
24 "	37
4 of No.	37a
4 "	38
1 "	40
2 "	48a
1 "	52
2 "	90a
4 "	111c
2 "	126
2 "	126a
2 "	189

1.36 LAND YACHT

The Bush Wheel is secured to the $5\frac{1}{2}$ " x $2\frac{1}{2}$ " Flanged Plate by a $\frac{3}{8}$ " Bolt passed through the Plate and locked in the boss of the Bush Wheel. The 2" Rod journalled in the $5\frac{1}{2}$ " x $1\frac{1}{2}$ " Flexible Plates carries at its centre a 1" Pulley (with Rubber Ring) which is made fast to the Rod.

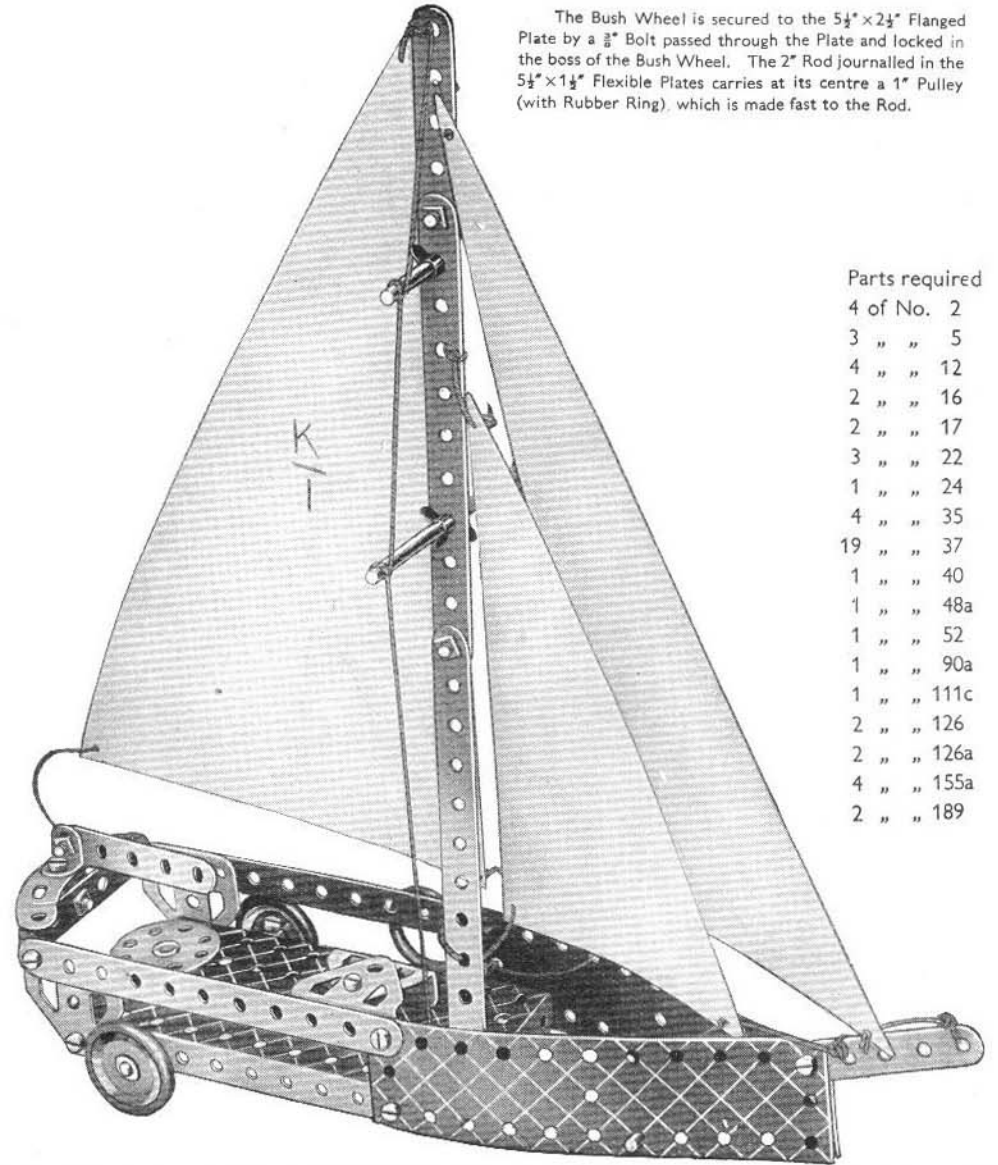

Parts required	
4 of No.	2
3 "	5
4 "	12
2 "	16
2 "	17
3 "	22
1 "	24
4 "	35
19 "	37
1 "	40
1 "	48a
1 "	52
1 "	90a
1 "	111c
2 "	126
2 "	126a
4 "	155a
2 "	189

1.37 RAILWAY BREAKDOWN CRANE

Parts required

4 of No. 2	4 of No. 22	1 of No. 40	1 of No. 125
4 " " 5	1 " " 24	2 " " 48a	2 " " 126
1 " " 10	2 " " 35	1 " " 52	2 " " 126a
4 " " 12	20 " " 37	1 " " 57c	4 " " 155a
2 " " 16	4 " " 37a	2 " " 90a	2 " " 189
1 " " 19s	2 " " 38	4 " " 111c	

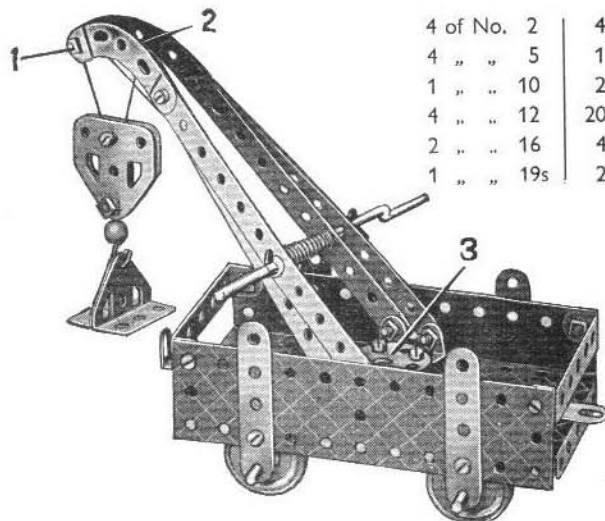

The hoisting cord is secured to the Crank Handle, and then led over the $\frac{3}{8}$ " Bolt 1. It is then passed through the pulley block and fastened to the jib at 2. The jib is attached to the Bush Wheel 3 by means of Angle Brackets and the complete unit is pivoted as follows. A $\frac{3}{8}$ " Bolt is passed through the $5\frac{1}{2}$ " x $2\frac{1}{2}$ " Flanged Plate, and is secured in the boss of the Bush Wheel by its set screw.

1.38 FIRE ENGINE

Parts required

4 of No. 2	2 of No. 38
4 " " 5	1 " " 40
3 " " 10	2 " " 48a
5 " " 12	1 " " 52
2 " " 16	2 " " 90a
1 " " 17	2 " " 111c
1 " " 19s	1 " " 125
4 " " 22	2 " " 126
1 " " 24	2 " " 126a
4 " " 35	4 " " 155a
24 " " 37	2 " " 189
4 " " 37a	

Bolts 1 are lock-nutted. The sides of the ladder are held together by two Angle Brackets 2, which are bolted together to form a double bracket. The rear axle bearings 3 are Flat Brackets bolted inside the flange of the Flanged Plate. The Cord from the Crank Handle is tied in the fourth hole up the ladder so that when the Handle is turned it causes the ladder to lift.

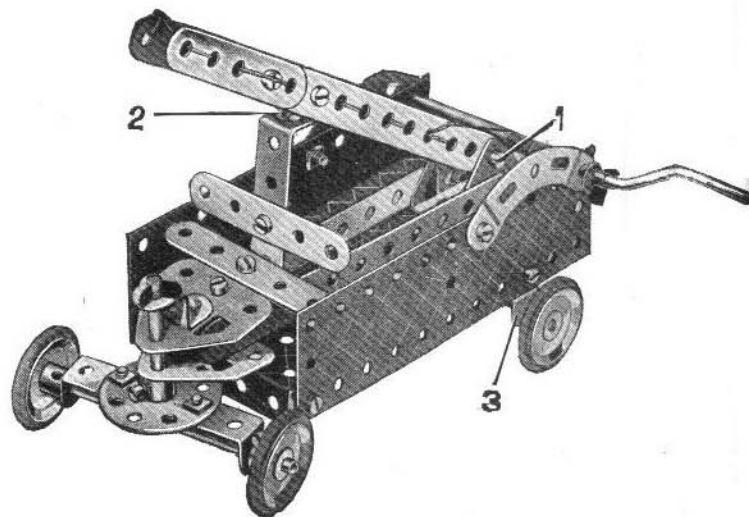

1.39 DERRICK CRANE

Parts required

4 of No. 2
4 " " 5
3 " " 12
2 " " 17
1 " " 19s
4 " " 22
4 " " 35
19 " " 37
4 " " 37a
1 " " 40
2 " " 48a
1 " " 52
1 " " 57c
2 " " 90a
1 " " 111c
1 " " 125
2 " " 126
1 " " 126a

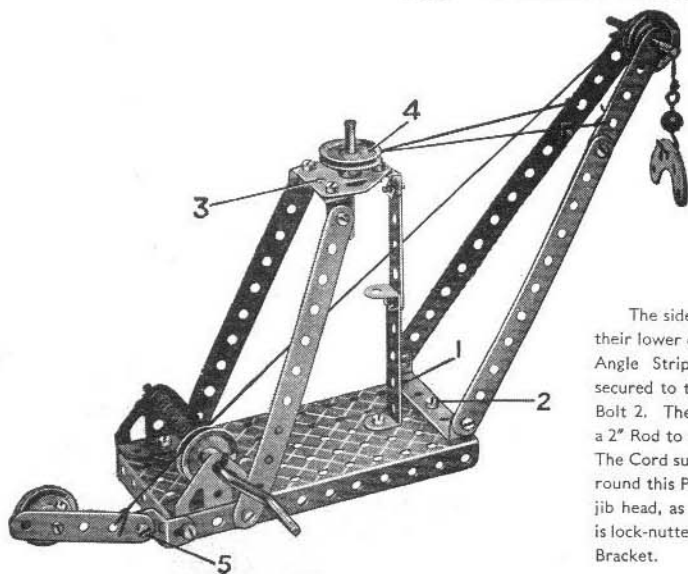

The sides of the jib are bolted at their lower ends to a $2\frac{1}{2}$ " x $\frac{1}{2}$ " Double Angle Strip 1, which is pivotally secured to the base by a lock-nutted Bolt 2. The Flat Trunnion 3 carries a 2" Rod to which is fitted a Pulley 4. The Cord supporting the jib is passed round this Pulley and attached to the jib head, as shown. The band brake is lock-nutted at 5 to a Reversed Angle Bracket.

1.40 TRAVELLING CRANE

Parts required

4 of No. 2	20 of No. 37
4 " " 5	4 " " 38
4 " " 10	1 " " 40
2 " " 12	1 " " 48a
2 " " 16	1 " " 52
1 " " 17	1 " " 57c
1 " " 19s	2 " " 90a
4 " " 22	1 " " 111c
1 " " 24	2 " " 126
4 " " 35	2 " " 126a

The sides of the jib are secured to the Bush Wheel 1 by two Angle Brackets 2. A $\frac{3}{8}$ " Bolt is passed from the underneath side of Double Angle Strip 3 into the boss of the Bush Wheel 1 and the set screw is then tightened.

The Flat Trunnions at the lower end of the jib support the Crank Handle, which also passes through Flat Brackets bolted to the Angle Brackets 2 on the Bush Wheel 1. The Cord is fastened to the Crank Handle, and passes over the 2" Rod at the jib head.

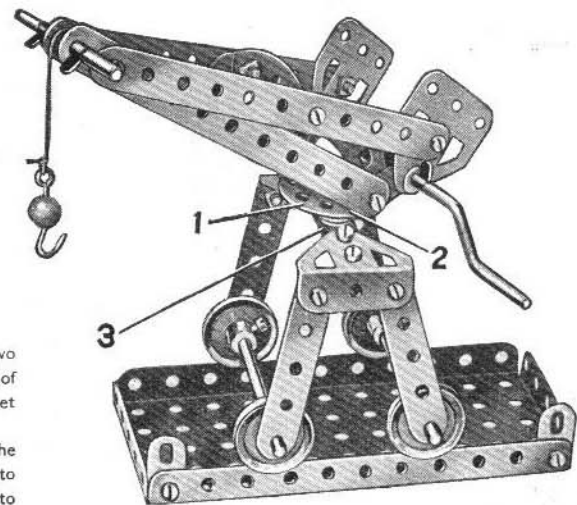

1.41 RAILWAY TRUCK

Parts required

4 of No. 2	4 of No. 38
4 " " 5	2 " " 48a
2 " " 10	1 " " 52
8 " " 12	4 " " 111c
2 " " 16	1 " " 125
4 " " 22	2 " " 126
24 " " 37	2 " " 126a
4 " " 37a	2 " " 189

The axle bearings 1 are Flat Trunnions and Trunnions are used for the bearings 2, which fit underneath the Flanged Plate in the manner shown in the underneath view of the model Side Tipping Wagon (1.46).

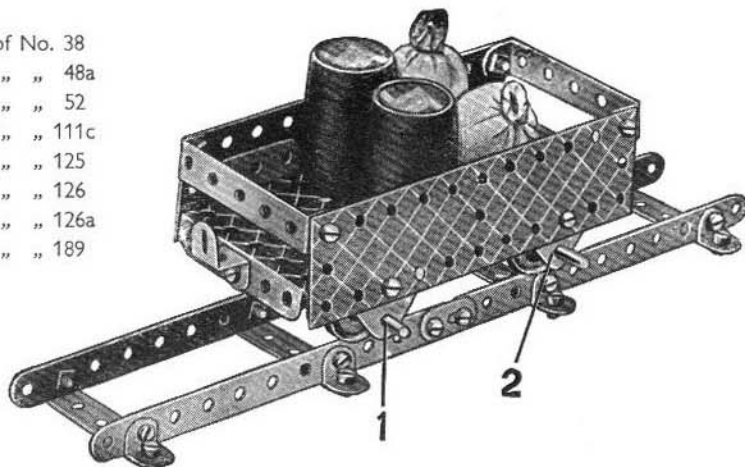

1.42 OPEN TRAMCAR

Parts required

2 of No. 5	1 of No. 40
4 " " 10	2 " " 48a
7 " " 12	1 " " 52
2 " " 16	2 " " 90a
1 " " 19s	4 " " 111c
4 " " 22	1 " " 125
1 " " 24	2 " " 126
4 " " 35	2 " " 126a
24 " " 37	4 " " 155a
3 " " 37a	2 " " 189

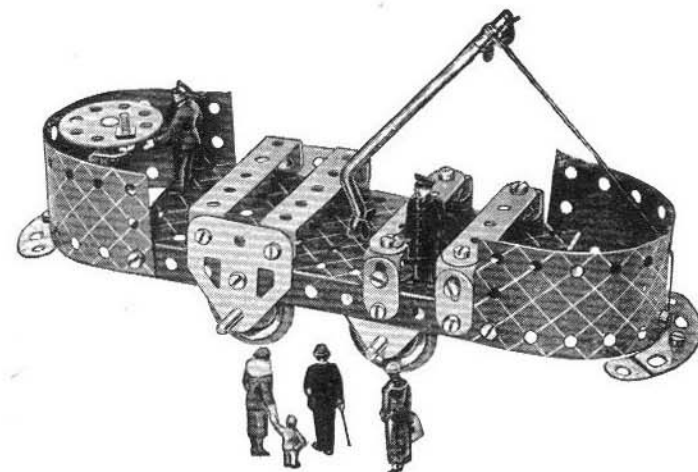

1.43 PITHEAD GEAR

Parts required

4 of No. 2	4 of No. 38
4 " " 5	1 " " 40
4 " " 10	2 " " 48a
2 " " 12	1 " " 52
1 " " 16	1 " " 90a
1 " " 19s	4 " " 111c
4 " " 22	2 " " 126
4 " " 35	2 " " 126a
20 " " 37	2 " " 189
4 " " 37a	

A Cord is taken from each side of the lift cage over the 1" Pulleys and secured to each end of the Crank Handle. The Cords must both be the same length otherwise the lift will tilt.

The two guides for the lift consist of two pieces of Cord fastened to the Washers 1. The Cords are then passed through holes in the Double Angle Strip, through two corresponding holes in the lift cage 2, and then through the two corresponding holes in the Flanged Plate. Two more Washers are tied to the Cords beneath the Flanged Plate to keep the Cords tight. The lift cage 2 is made up of two Trunnions.

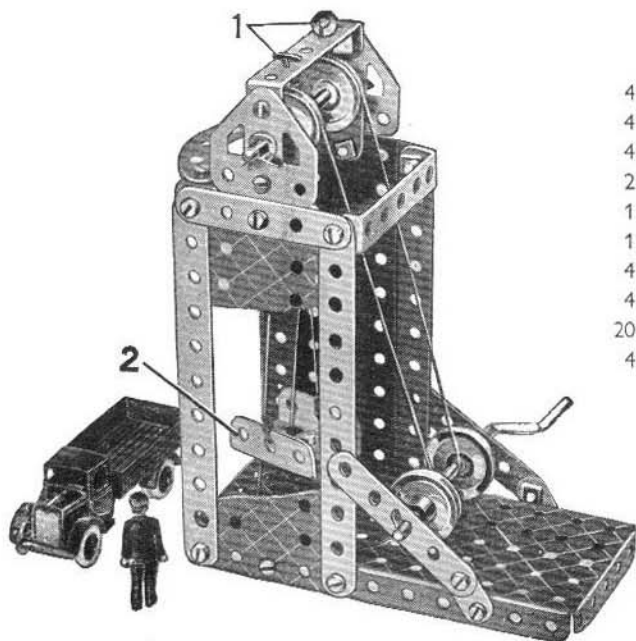

1.44 DOCKSIDE CRANE

Parts required

4 of No. 2	4 of No. 38
4 " " 5	1 " " 40
2 " " 10	2 " " 48a
4 " " 12	1 " " 52
1 " " 16	1 " " 57c
2 " " 17	2 " " 90a
1 " " 19s	4 " " 111c
4 " " 22	1 " " 125
1 " " 24	2 " " 126
4 " " 35	2 " " 126a
24 " " 37	2 " " 155a
4 " " 37a	2 " " 189

The Rod 1 passes through the bosses of the Bush Wheel 2 and the 1" Pulley, and is held in position by a Spring Clip underneath the Flanged Plate. The set screw of the Bush Wheel 2 is tightened on the Rod.

The 5 1/2" Strips that form the jib are extended at the head by 2 1/2" x 1/2" Double Angle Strips, in which a 2" Rod is journaled.

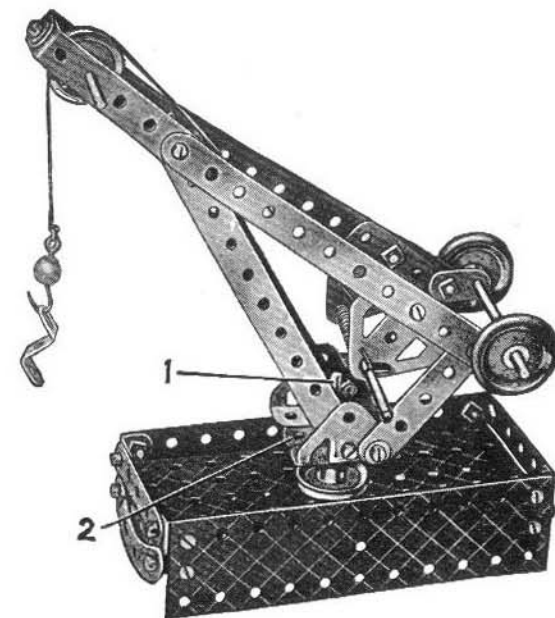

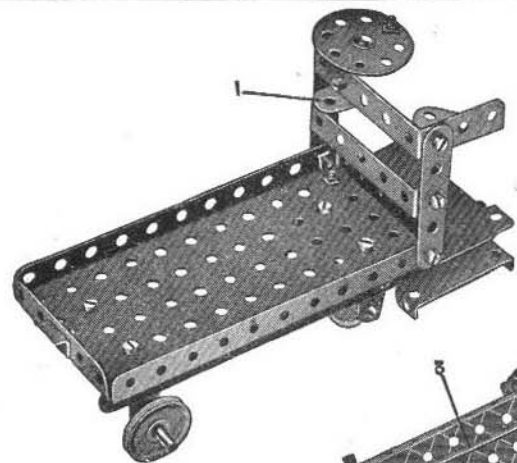

The steering wheel, a Bush Wheel, is secured to the Reversed Angle Bracket 1 by means of a $\frac{3}{8}$ " Bolt. Fig. 1.45a shows how the *Magic Motor* is mounted to drive the front wheels. The front wheel axle is journalled in two Flat Brackets bolted to the $5\frac{1}{4}$ " Strips 2 and 3.

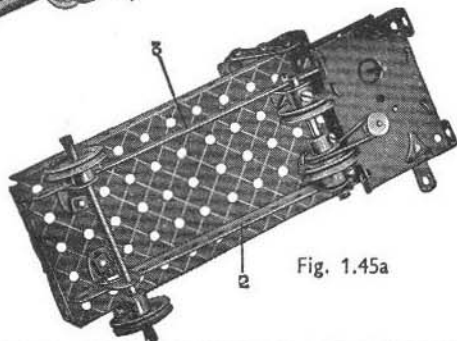

Fig. 1.45a

1.45 ELECTRIC TRUCK

Parts required

2 of No. 2	4 of No. 22
2 " " 5	1 " " 24
4 " " 10	18 " " 37
4 " " 12	2 " " 48a
1 " " 16	1 " " 52
1 " " 17	1 " " 111c
	1 " " 125
	1 " " 126
	1 <i>Magic Motor</i>

1.46 SIDE TIPPING WAGON

Parts required

3 of No. 2	2 of No. 90a
4 " " 5	4 " " 111c
4 " " 10	1 " " 125
7 " " 12	2 " " 126
2 " " 16	2 " " 126a
1 " " 17	4 " " 155a
4 " " 22	2 " " 189
1 " " 24	1 <i>Magic Motor</i>
24 " " 37	
4 " " 37a	
3 " " 38	
2 " " 48a	
1 " " 52	

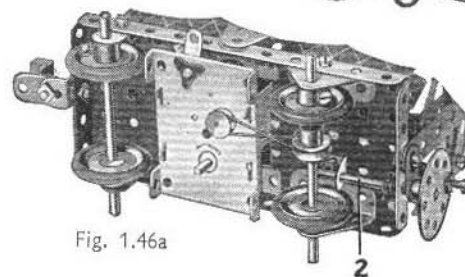
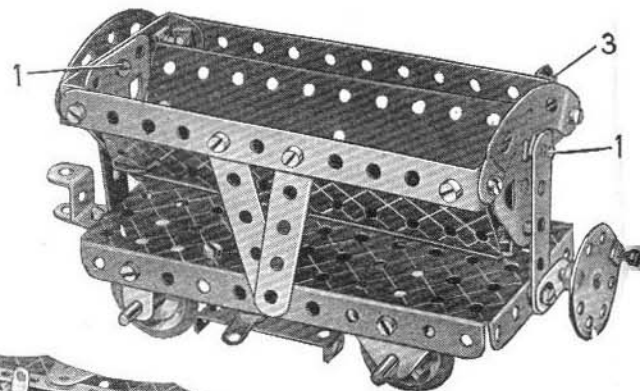
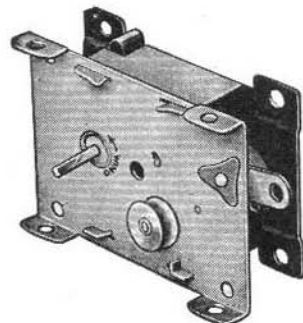

Fig. 1.46a

Each of the Bolts 1 is lock-nutted. A piece of Cord is fastened to the Rod 2 (Fig. 1.46a) wrapped round it two or three times, and then is taken through the hole in the Flanged Plate above the Rod and secured to the Angle Bracket 3.

By turning the Bush Wheel the container is tipped sideways.

THE MECCANO MAGIC MOTOR



The greatest thrill in Meccano model-building is experienced when a model is set to work by means of a Meccano *Magic Motor*. The illustrations on this page show how the *Magic Motor* can be fitted without any difficulty to No. 1 Outfit models of various types. Fit the model you have just built with one of these wonderful Motors, and enjoy the fun of watching it work just like the real thing!

The left-hand $2\frac{1}{4}$ " Strip that supports the swing is connected to the Crank Handle by passing the set screw of the 1" Pulley Wheel 2 through the hole in an Angle Bracket bolted to the Strip and then into the boss of the Pulley. Bolt 1 on the Bush Wheel is fitted with lock-nuts.

The Bolts 1 are lock-nutted. The Rod 2 is secured to an Angle Bracket by means of two Spring Clips 3. The model is driven by a *Magic Motor* bolted to the $5\frac{1}{4}$ " x $2\frac{1}{2}$ " Flanged Plate. The pulley of the Motor is connected to a 1in. fast Pulley on the crankshaft of the engine by a Driving Band.

1.47 MECHANICAL SWING

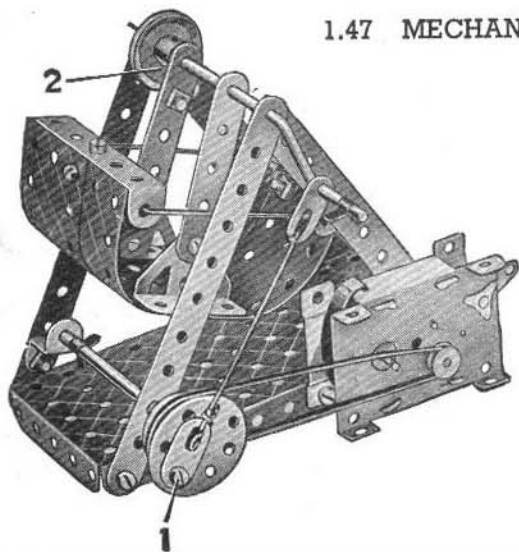

Parts required

4 of No. 2
2 " " 5
2 " " 10
3 " " 12
1 " " 16
1 " " 19s
2 " " 22
1 " " 24
4 " " 35
15 " " 37
2 " " 37a
4 " " 38
1 " " 40
2 " " 48a
1 " " 52
1 " " 111c
1 " " 125
2 " " 126
2 " " 189
1 <i>Magic Motor</i>

1.48 HORIZONTAL STEAM ENGINE

Parts required

3 of No. 2
4 " " 5
2 " " 12
1 " " 16
1 " " 17
4 " " 22
1 " " 24
4 " " 35
24 " " 37
2 " " 37a
3 " " 38
1 " " 38a
1 " " 52
1 " " 111c
1 " " 125
2 " " 126
2 " " 126a
2 " " 189
1 <i>Magic Motor</i>

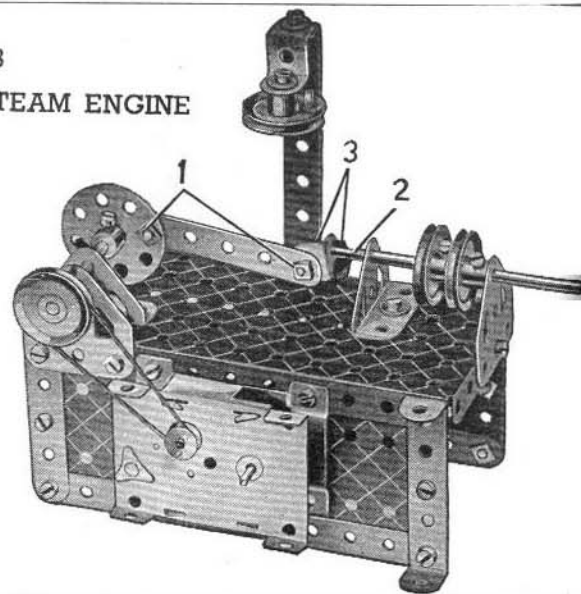

2.1 RAILWAY FOOTBRIDGE

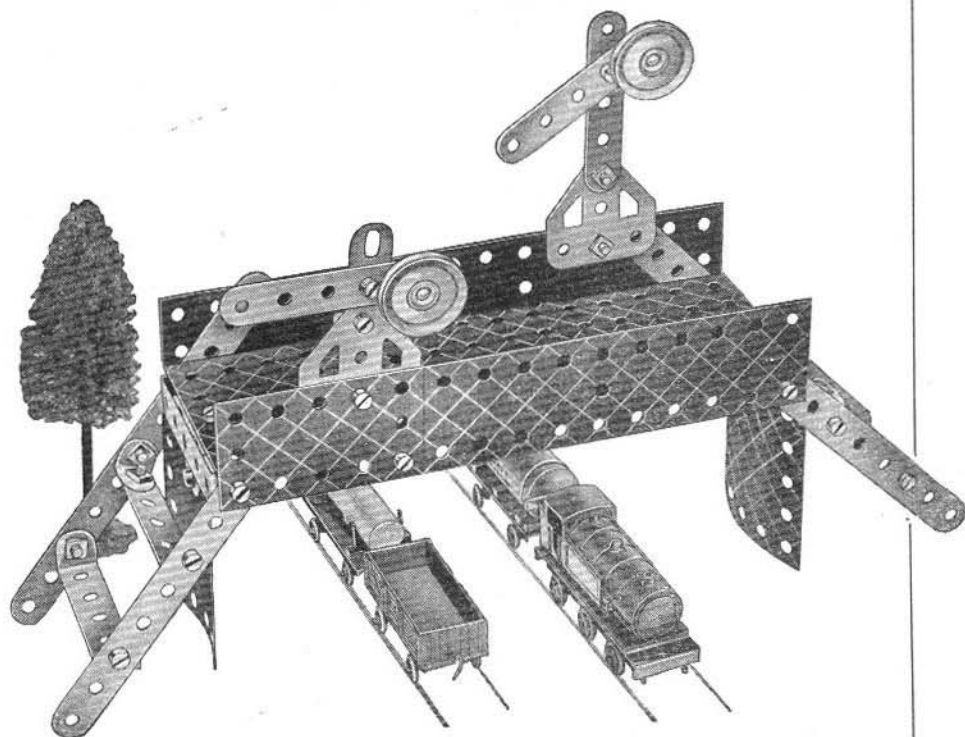

Parts required

4 of No. 2	2 of No. 22	1 of No. 52	2 of No. 188
6 " " 5	32 " " 37	2 " " 111c	2 " " 189
2 " " 10	2 " " 37a	2 " " 126	1 " " 190
6 " " 12	2 " " 48a	2 " " 126a	2 " " 200

The span of the bridge is a $5\frac{1}{2} \times 2\frac{1}{2}$ " Flanged Plate, extended by a $2\frac{1}{2} \times 2\frac{1}{2}$ " Flexible Plate. Trunnions are bolted to each end of the span, and have $1\frac{1}{8}$ " radius Curved Plates fastened to them. The sides of the approach stairways are $5\frac{1}{2}$ " Strips. They are joined across by $2\frac{1}{2} \times \frac{1}{4}$ " Double Angle Strips and $2\frac{1}{2}$ " Strips fitted with Angle Brackets at each end.

The signals are supported on Flat Trunnions bolted to the sides of the bridge. The smaller of the two signal posts is formed by two Flat Brackets, and the larger one is a $2\frac{1}{2}$ " Strip. The signal arms are $2\frac{1}{2}$ " Strips bolted to the posts in the second holes from one end. They are fitted at their shorter ends with 1" Pulleys, representing the spectacles, which are held in place by $\frac{3}{8}$ " Bolts passed through the Strips and inserted in their bosses.

2.2 LAWN MOWER

The "cutter" is made by bolting an Angle Bracket at each end of a Reversed Angle Bracket 1 and then sliding an Axle Rod through the free holes of the Brackets. The two Pulleys 2 are fixed to the Rod and pushed tightly against the "cutter" to make it rotate with the Rod as the wheels revolve. The wheels are 1" Pulleys fitted with Rubber Rings.

Parts required

4 of No. 2	2 of No. 90a
4 " " 5	1 " " 125
4 " " 10	2 " " 126
6 " " 12	2 " " 155a
1 " " 16	2 " " 200
4 " " 22	
25 " " 37	
4 " " 38	
2 " " 48a	

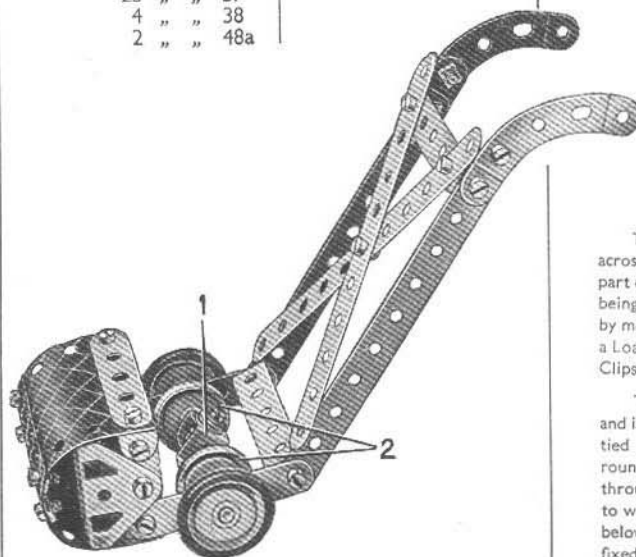

2.3 FLOATING CRANE

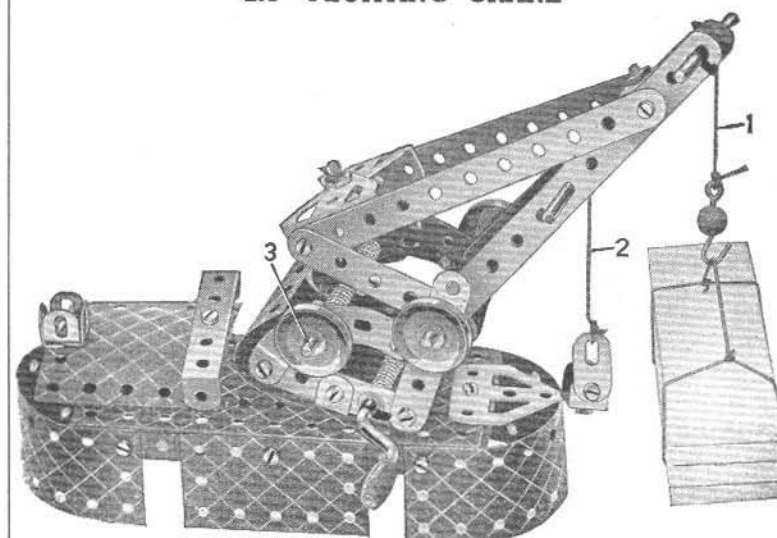

Parts required

4 of No. 2	4 of No. 22	2 of No. 48a	1 of No. 126a
6 " " 5	1 " " 24	1 " " 52	1 " " 176
3 " " 10	4 " " 35	1 " " 57c	2 " " 188
8 " " 12	29 " " 37	2 " " 90a	2 " " 189
2 " " 16	3 " " 37a	4 " " 111c	1 " " 199
2 " " 17	4 " " 38	1 " " 125	1 " " 200
1 " " 19g	1 " " 40	2 " " 126	

The jib consists of $5\frac{1}{2}$ " Strips and $2\frac{1}{2}$ " Strips. At its upper end these are joined across by Angle Brackets, and at its lower end by Trunnions. Each side of the lower part of the crane consists of $2\frac{1}{2}$ " Strips and small radius Curved Strips, the two sides being connected by $2\frac{1}{2} \times \frac{1}{4}$ " Double Angle Strips. The jib is pivoted to this structure by means of a $3\frac{1}{2}$ " Rod, which carries at each end a 1" Pulley. The Cord 1 fitted with a Loaded Hook, is passed over a 2" Rod held in place in the jib by means of Spring Clips and is then wound around the Crank Handle.

The Cord 2 passes over a Rod held in place in the jib by an Anchoring Spring, and is then wound around the Rod that forms the pivot for the jib. A third Cord is tied to a Bolt fastened in the two Trunnions at the base of the jib, and is wound round Rod 3. This Cord controls the luffing motion of the crane. A $\frac{3}{8}$ " Bolt passes through the Flanged Plate and is held by a set screw in the boss of the Bush Wheel to which the jib is fastened. The Bush Wheel is bolted to the Double Angle Strip below the Rod 3. The roof of the cabin is bolted to a $\frac{1}{2}$ " Reversed Angle Bracket fixed to the Flanged Plate.

2.4 AUTOGIRO

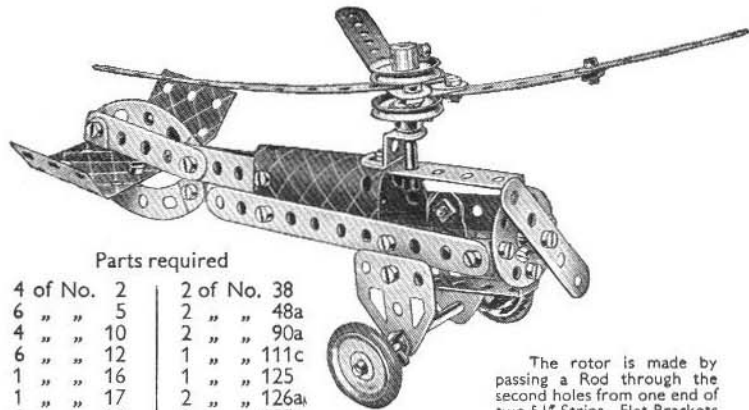

Parts required

4 of No. 2	2 of No. 38
6 " " 5	2 " " 48a
4 " " 10	2 " " 90a
6 " " 12	1 " " 111c
1 " " 16	1 " " 125
1 " " 17	2 " " 126a
4 " " 22	2 " " 155a
1 " " 24	2 " " 188
3 " " 35	1 " " 199
25 " " 37	

The rotor is made by passing a Rod through the second holes from one end of two 5½" Strips. Flat Brackets are bolted to the short ends of the Strips and the third blade of the rotor is fixed to them as shown.

2.6 GAS ENGINE

Parts required

1 of No. 2	1 of No. 19g	4 of No. 35
3 " " 5	4 " " 22	39 " " 37
4 " " 10	1 " " 24	3 " " 37a
8 " " 12		4 " " 38
2 " " 16		2 " " 40
1 " " 17		2 " " 48a
		1 " " 52
		1 " " 90a
		1 " " 111c
		1 " " 125
		2 " " 126
		1 " " 126a
		1 " " 155a
		1 " " 176
		1 " " 187
		2 " " 188
		2 " " 189
		1 " " 190
		2 " " 200

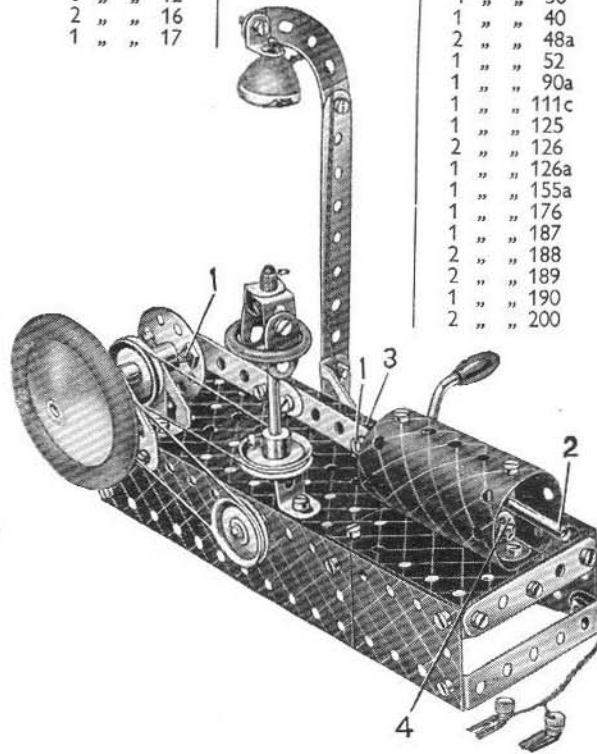

The bearings on the Rod representing the crankshaft are a Flat Trunnion and a Trunnion. The crankshaft carries a Road Wheel and a 1" Pulley at one end, a second 1" Pulley between the bearings, and a Bush Wheel at its other end.

The connecting rod is fastened to the Bush Wheel and to an Angle Bracket 3 by a lock-nutted Bolt 1. The Rod 2 is held in the Angle Bracket 3 by means of Spring Clips, one on each side. An Angle Bracket 4, carrying a Flat Bracket, is bolted inside the cylinder, and a similar arrangement is fitted at the other end. These form bearings for the Rod 2.

The model is operated by the Crank Handle, which carries also a 1" Pulley connected to one of the 1" Pulleys on the crankshaft by a belt of Cord. A second Cord drives the governor, which is mounted on a 3½" Rod journalled in the 5½ x 2½" Flanged Plate and a Reversed Angle Bracket.

The model is fitted with a Spotlight from the Meccano Lighting Set, current being supplied by a 4.5-volt pocket-lamp battery housed in the base of the model.

2.7 RACING CAR

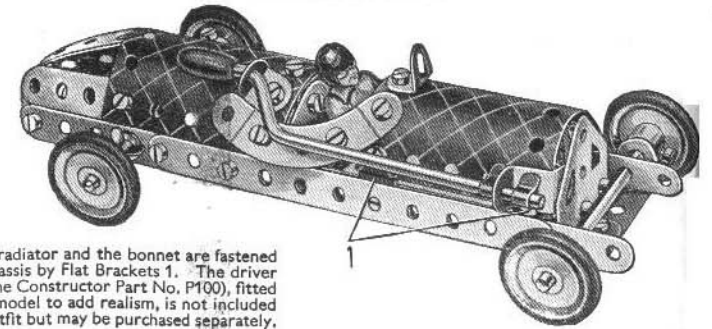

The radiator and the bonnet are fastened to the chassis by Flat Brackets 1. The driver (Aeroplane Constructor Part No. P100), fitted into the model to add realism, is not included in the Outfit but may be purchased separately.

Parts required

4 of No. 2	1 of No. 19g	2 of No. 38	1 of No. 126a
5 " " 5	4 " " 22	1 " " 48a	4 " " 155a
4 " " 10	4 " " 35	2 " " 90a	1 " " 199
8 " " 12	30 " " 37	1 " " 125	1 " " 200
2 " " 16	1 " " 37a	1 " " 126	

2.5 ANTI-AIRCRAFT GUN

Parts required

4 of No. 2
1 " " 5
6 " " 12
2 " " 16
2 " " 17
1 " " 19g
4 " " 22
1 " " 24
3 " " 35
26 " " 37
4 " " 38
2 " " 48a
1 " " 52
2 " " 90a
1 " " 125
2 " " 126
2 " " 126a
4 " " 155a
1 " " 176
1 " " 187
2 " " 188
2 " " 189

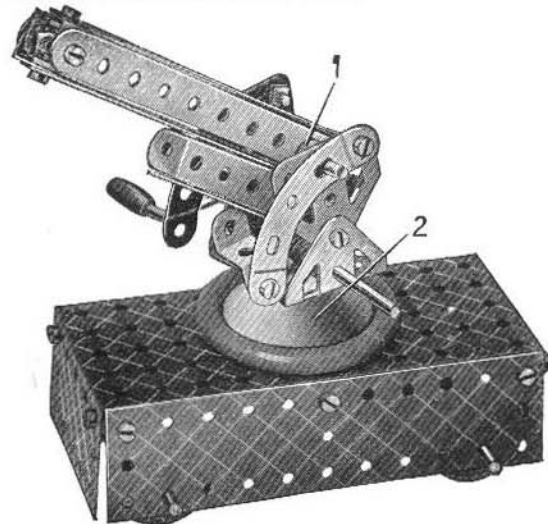

One end of a piece of Cord is fastened to the Crank Handle. It is wound round the Handle 1 few times and its other end is then fastened to the end of the gun. The two Trunnions are bolted to a Bush Wheel fixed on a 2" Rod that passes through the Road Wheel 2 and the Flanged Plate and is held in place by an Anchoring Spring. The Spring Clips at 1 space the gun barrel from the Flat Trunnions.

2.8 LOW WING MONOPLANE

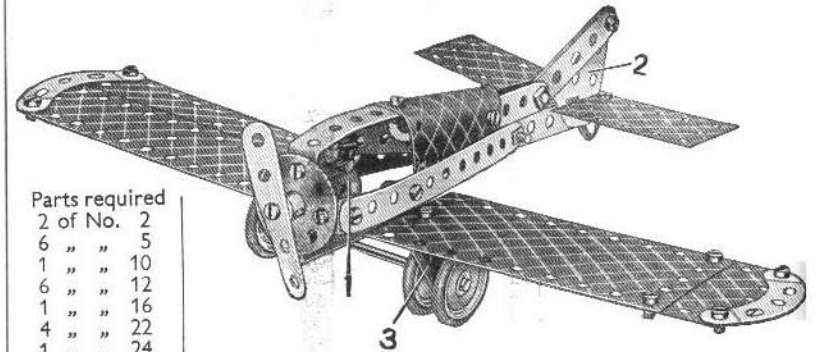

Parts required

2 of No. 2		
6 " " 5		
1 " " 10		
6 " " 12		
1 " " 16		
1 " " 17		
4 " " 22		
1 " " 24		
23 " " 37		
2 " " 37a	2 of No. 126	2 of No. 189
2 " " 38	1 " " 126a	1 " " 190
2 " " 48a	4 " " 155a	1 " " 191
2 " " 90a	2 " " 188	1 " " 199
3 " " 111c		

The pilot 1 (Aeroplane Constructor Part No. P100) is not included in the Outfit, but may be bought separately. The fin 2 is a Flat Trunnion, and it is clamped between the two 2½" Strips. The bearings 3 for the axle of the landing wheels are Trunnions, bolted to the wings. The wings are attached to the fuselage by Angle Brackets.

2.9 SETTEE

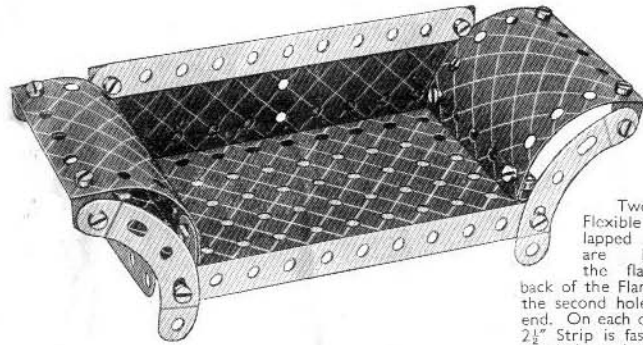

Two $5\frac{1}{2}'' \times 1\frac{1}{2}''$ Flexible Plates overlapped two holes are bolted to the flange at the back of the Flanged Plate in the second holes from each end. On each of the Bolts a $2\frac{1}{2}''$ Strip is fastened by its end hole, and the other end of the Strip is bolted to the turned down ends of the $2\frac{1}{2}''$ Double Angle Strips under the arm rests.

$2\frac{1}{2}''$ Strips are bolted behind the $5\frac{1}{2}'' \times 1\frac{1}{2}''$ Flexible Plates at each end to form the back legs.

Parts required

2 of No. 2	24 of No. 37	2 of No. 90a
4 " " 5	2 " " 48a	2 " " 189
4 " " 12	1 " " 52	2 " " 200

2.11 TRAVELLING CRANE

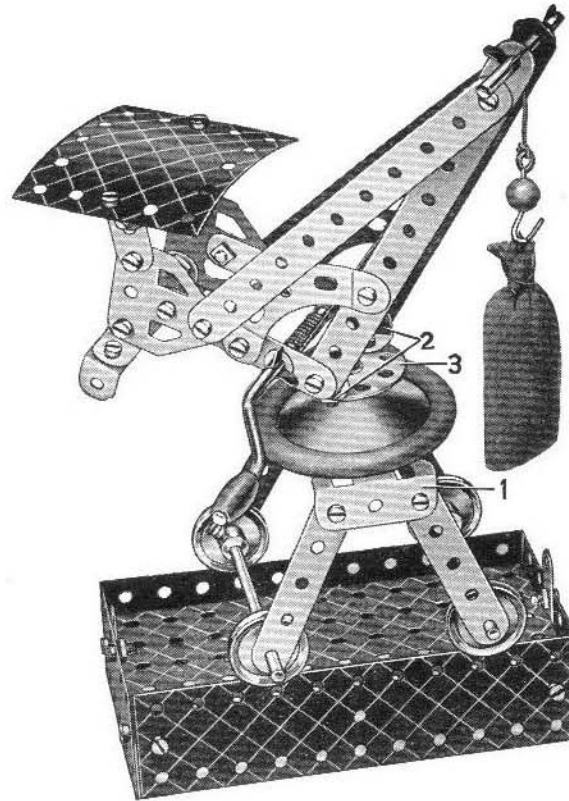

Parts required

4 of No. 2	1 of No. 19g	3 of No. 38	2 of No. 111c
6 " " 5	4 " " 22	1 " " 40	2 " " 126
4 " " 10	1 " " 24	2 " " 48a	2 " " 126a
6 " " 12	4 " " 35	1 " " 52	1 " " 176
2 " " 16	38 " " 37	1 " " 57c	1 " " 187
2 " " 17	2 " " 37a	2 " " 90a	2 " " 188
2 of No. 189		1 of No. 200	

A 2" Rod is secured in the boss of the Bush Wheel 3. It then passes through the Road Wheel and through the centre of a $2\frac{1}{2}'' \times \frac{1}{2}''$ Double Angle Strip bolted between the two Trunnions 1. A Washer and a Cord Anchoring Spring are pushed on to the Rod to hold it in position. The crane jib is attached to the Bush Wheel by the Angle Brackets 2.

2.12 CATTLE TRUCK

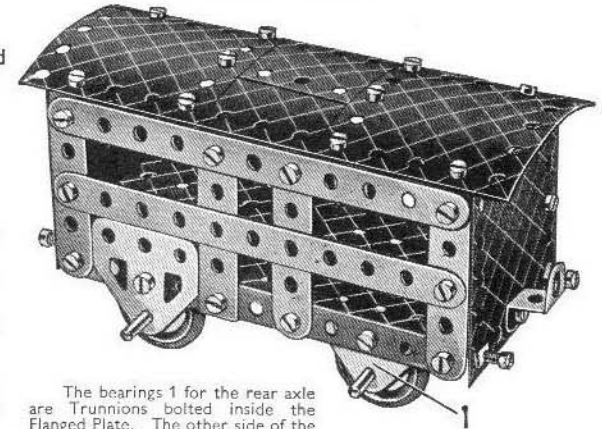

Parts required

4 of No. 2	2
6 " " 5	5
4 " " 10	10
5 " " 12	12
2 " " 16	16
4 " " 22	22
38 " " 37	37
8 " " 37a	37a
4 " " 38	38
2 " " 48a	48a
1 " " 52	52
4 " " 111c	111c
1 " " 125	125
2 " " 126	126
2 " " 126a	126a
4 " " 155a	155a
2 " " 188	188
2 " " 190	190
2 " " 200	200

The bearings 1 for the rear axle are Trunnions bolted inside the Flanged Plate. The other side of the truck is constructed in a similar manner to the side shown in the illustration.

2.10 ROLL TOP DESK

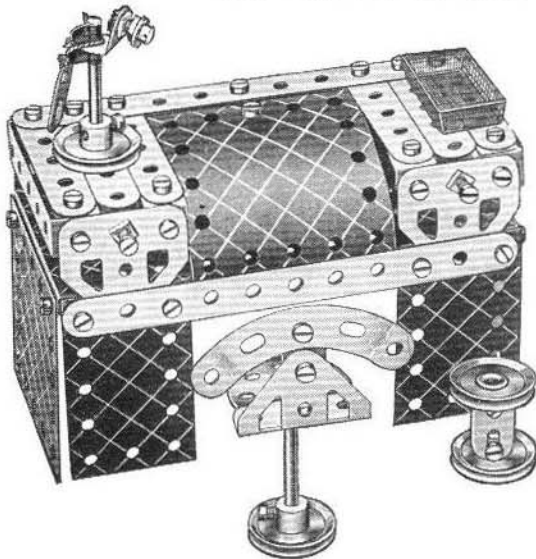

Parts required

2 of No. 2	2
6 " " 5	5
4 " " 10	10
7 " " 12	12
2 " " 17	17
4 " " 22	22
1 " " 24	24
3 " " 35	35
38 " " 37	37
5 " " 37a	37a
1 " " 38	38
2 " " 48a	48a
1 " " 52	52
1 " " 90a	90a
3 " " 111c	111c
1 " " 126	126
2 " " 126a	126a
2 " " 188	188
1 " " 189	189
2 " " 190	190
1 " " 200	200

2.13 PIANO

A $5\frac{1}{2}'' \times 2\frac{1}{2}''$ Flanged Plate is used for the upper part of the back and to each end of this a $2\frac{1}{2}''$ Strip is bolted to form the rear legs.

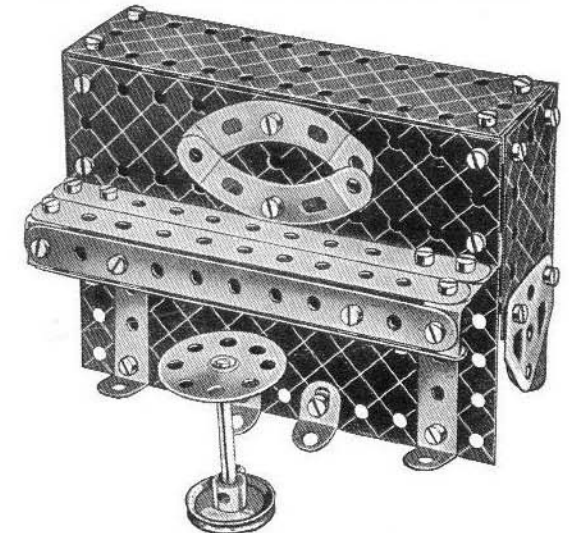

Parts required

4 of No. 2	2
4 " " 5	5
4 " " 10	10
8 " " 12	12
1 " " 17	17
1 " " 22	22
1 " " 24	24
38 " " 37	37
4 " " 38	38
2 " " 48a	48a
1 " " 52	52
2 " " 90a	90a
2 " " 126	126
2 " " 126a	126a
2 " " 188	188
2 " " 189	189
1 " " 190	190
1 " " 191	191

2.14 MOTOR VAN

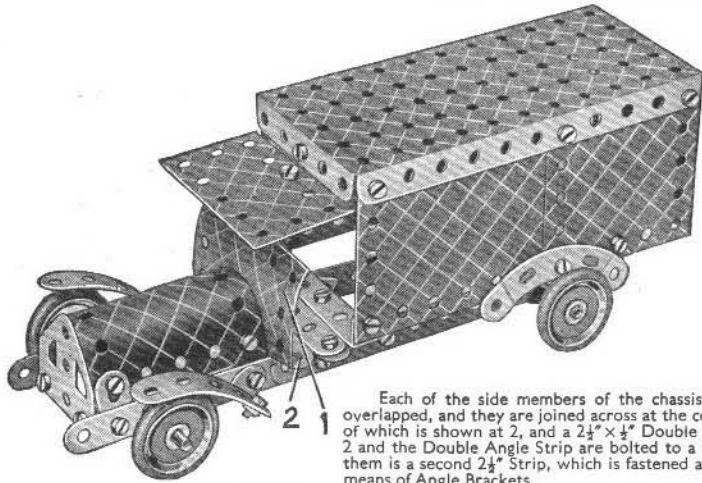

Each of the side members of the chassis consists of two $5\frac{1}{2}$ " Strips overlapped, and they are joined across at the centre by two $2\frac{1}{2}$ " Strips, one of which is shown at 2, and a $2\frac{1}{2}$ " x $\frac{1}{2}$ " Double Angle Strip. The $2\frac{1}{2}$ " Strip 2 and the Double Angle Strip are bolted to a Flat Trunnion and between them is a second $2\frac{1}{2}$ " Strip, which is fastened at each end to the chassis by means of Angle Brackets.

The Plate 1 is fastened to an Angle Bracket that is bolted to Strip 2. The body is fixed to the chassis by a Double Angle Strip and an Angle Bracket.

Parts required

4 of No. 2
4 " " 5
4 " " 10
8 " " 12
2 " " 16
4 " " 22
4 " " 35
40 " " 37
4 " " 38
2 " " 48a
1 " " 52
2 " " 90a
1 " " 126
2 " " 126a
4 " " 155a
2 " " 188
2 " " 189
2 " " 190
1 " " 191
1 " " 199

2.16 STEAMSHIP

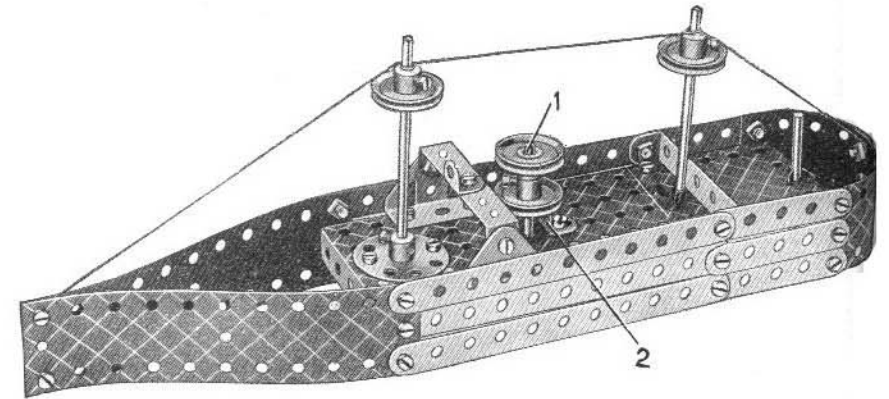

The deck of the model is a $5\frac{1}{2}$ " x $2\frac{1}{2}$ " Flanged Plate extended by a $2\frac{1}{2}$ " x $2\frac{1}{2}$ " Flexible Plate. A $2\frac{1}{2}$ " x $\frac{1}{2}$ " Double Angle Strip fitted with an Angle Bracket represents the bridge, and it is supported by two Trunnions bolted to the deck. The funnel consists of a Rod 1 fitted with two 1" fast Pulleys. The Rod passes through the hole in a Reversed Angle Bracket 2 and then through the Flanged Plate.

Parts required

4 of No. 2
6 " " 5
1 " " 12
2 " " 16
2 " " 17
4 " " 22
1 " " 24
4 " " 35
34 " " 37
1 " " 40
2 " " 48a
1 " " 52
1 " " 125
2 " " 126
2 " " 188
2 " " 189
1 " " 190

2.15 RAILWAY BREAKDOWN CRANE

Parts required

4 of No. 2
6 " " 5
4 " " 10
3 " " 12
2 " " 16
1 " " 17
1 " " 19g
4 " " 22
1 " " 24
2 " " 35
39 " " 37
3 " " 37a
3 " " 38
1 " " 40
2 " " 48a
1 " " 52
1 " " 57c
2 " " 90a
3 " " 111c
2 " " 126
2 " " 126a
1 " " 155a
1 " " 176
1 " " 187

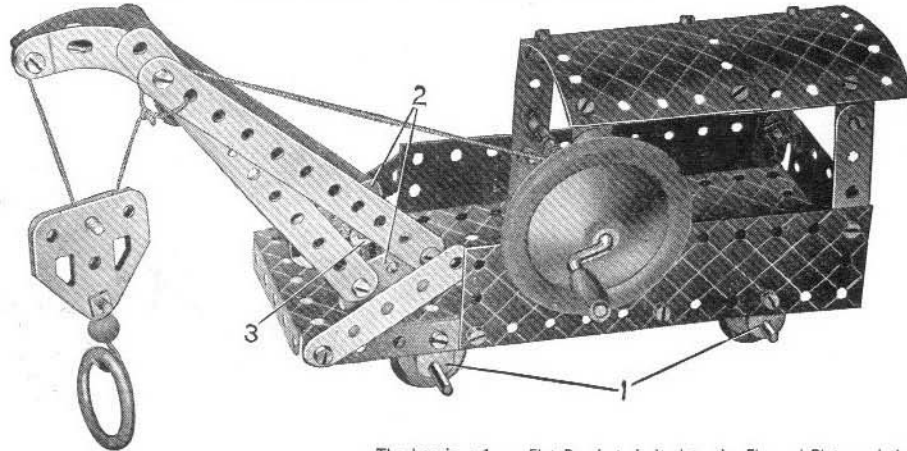

1 of No. 188
2 " " 189
1 " " 190
2 " " 200

The bearings 1 are Flat Brackets bolted to the Flanged Plate and the Flexible Plates respectively. The jib is fastened to two Trunnions 2, which are bolted to the Bush Wheel 3. A 2" Rod is secured in the boss of the Bush Wheel 3. It then passes through a hole in the Flanged Plate, and is held in position by a Spring Clip underneath the Plate.

2.17

BATHROOM SUITE

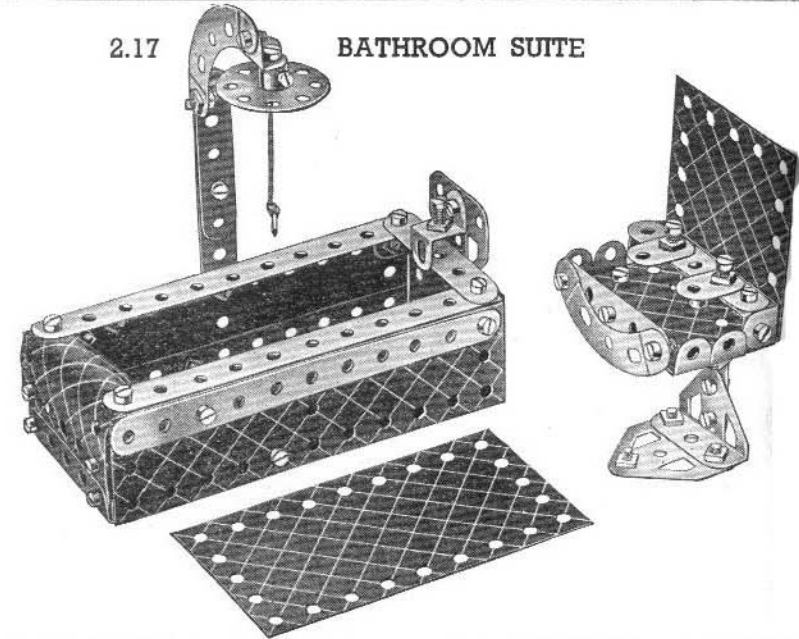

Parts required

4 of No. 2
6 " " 5
4 " " 10
8 " " 12
1 " " 24
40 " " 37
6 " " 37a
2 " " 38
2 " " 48a
1 " " 52
2 " " 90a
4 " " 111c
1 " " 125
2 " " 126
2 " " 126a
2 " " 188
2 " " 189
1 " " 190
1 " " 191
1 " " 199
1 " " 200

2.18 WHEELBARROW

A $5\frac{1}{2}'' \times 2\frac{1}{2}''$ Flanged Plate is used upside down for the floor of the barrow, and two $5\frac{1}{2}''$ Strips overlapped six holes form the shafts.

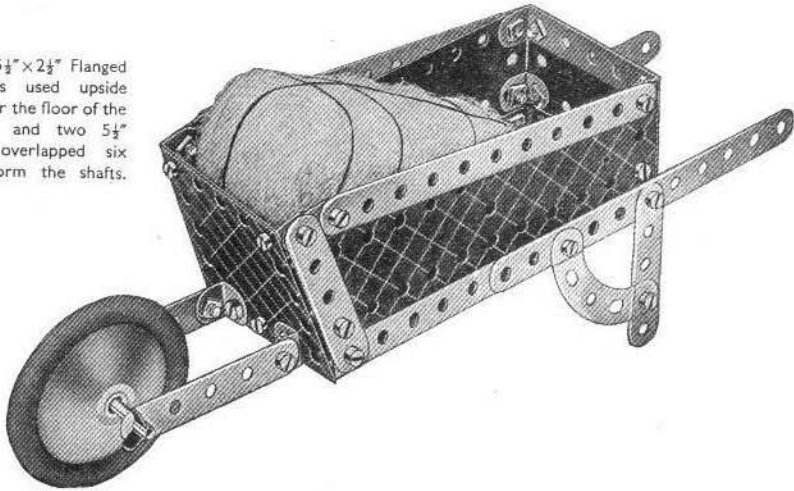

Parts required

4 of No. 2
6 " " 5
2 " " 10
4 " " 12
1 " " 17
2 " " 35
29 " " 37
2 " " 48a
1 " " 52
2 " " 90a
1 " " 187
1 " " 188
2 " " 189
1 " " 190

2.19 ROAD BRIDGE

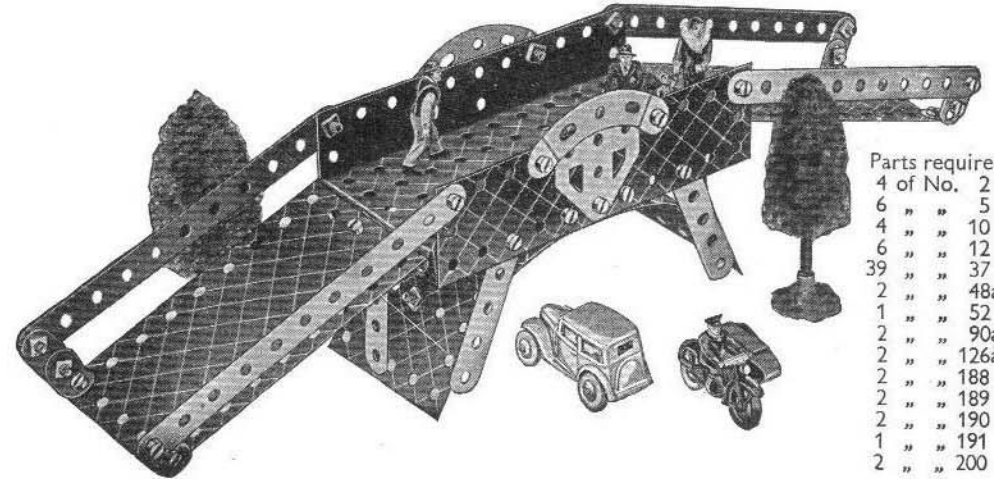

Parts required

4 of No. 2
6 " " 5
4 " " 10
6 " " 12
39 " " 37
2 " " 48a
1 " " 52
2 " " 90a
2 " " 126a
2 " " 188
2 " " 189
2 " " 190
1 " " 191
2 " " 200

2.20 GARDEN HAMMOCK

The Cord by which the back of the hammock is suspended is tied to the rear ends of the Double Angle Strips 1. The seat, which consists of two $2\frac{1}{2}'' \times 2\frac{1}{2}''$ Flexible Plates, is attached to the back of the hammock by two Trunnions.

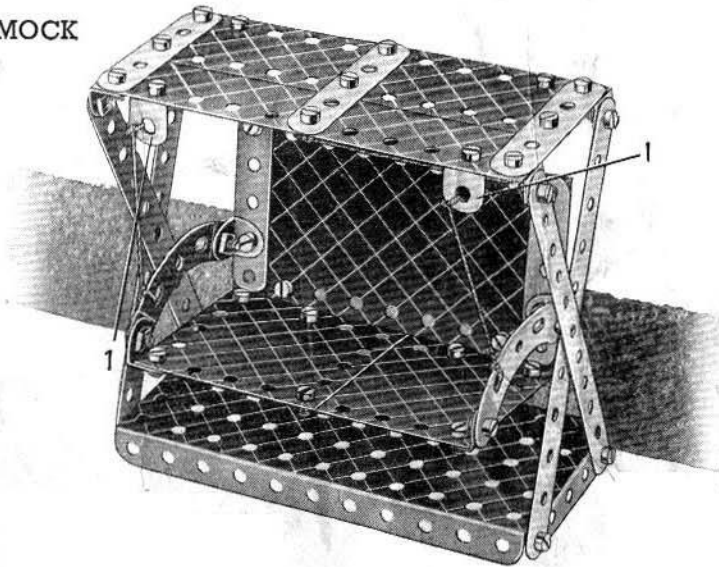

Parts required

4 of No. 2	1 of No. 52
5 " " 5	2 " " 90a
8 " " 12	2 " " 126
38 " " 37	2 " " 189
1 " " 40	2 " " 190
2 " " 48a	1 " " 191

2.21 DRAGLINE EXCAVATOR

Parts required

4 of No. 2	3 of No. 22	1 of No. 48a	1 of No. 176
6 " " 5	1 " " 24	1 " " 52	1 " " 187
2 " " 10	4 " " 35	1 " " 57c	2 " " 188
8 " " 12	4 " " 37	2 " " 90a	2 " " 189
1 " " 16	4 " " 37a	2 " " 111c	2 " " 190
2 " " 17	1 " " 38	2 " " 126	1 " " 199
1 " " 19g	1 " " 40	2 " " 126a	2 " " 200

The Cord 1 is wound round the Crank Handle about 12 times then one end of it is fastened to a small Loaded Hook and the other end to the Cord on the bucket.

A Curved Strip is pivoted by a $\frac{3}{8}''$ Bolt through one of its ends in the position of Bolt 2 but on the rear side of the model. A $1''$ Pulley is attached to the other end of the Curved Strip, with a $\frac{3}{8}''$ Bolt to act as a weight. A loop of Cord is fastened through the slotted hole next to the bottom of the Strip, and then passes round the $1''$ Pulley 3 on the shaft of the Bush Wheel, to act as a brake band. The Cord should be long enough to allow the Strip to lie nearly horizontal.

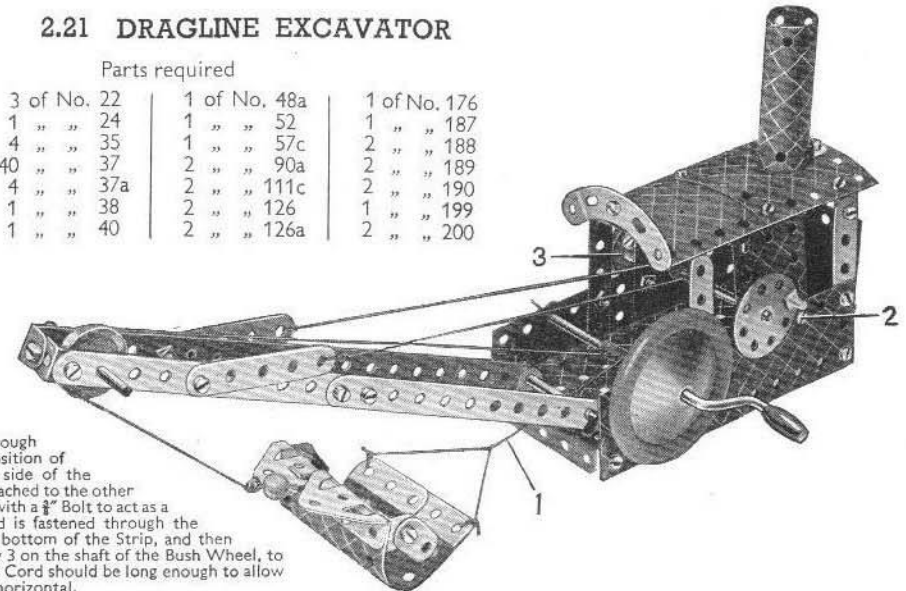

The greatest thrill in Meccano model-building is experienced when a model is set to work by means of a Meccano Motor. The illustrations below show how the Meccano *Magic* Motor can be fitted without any difficulty to No. 2 Outfit models of various types. Fit the model you have just built with one of these wonderful Motors, and enjoy the fun of watching it work just like the real thing.

2.22 LUMBER TRUCK AND HORSE

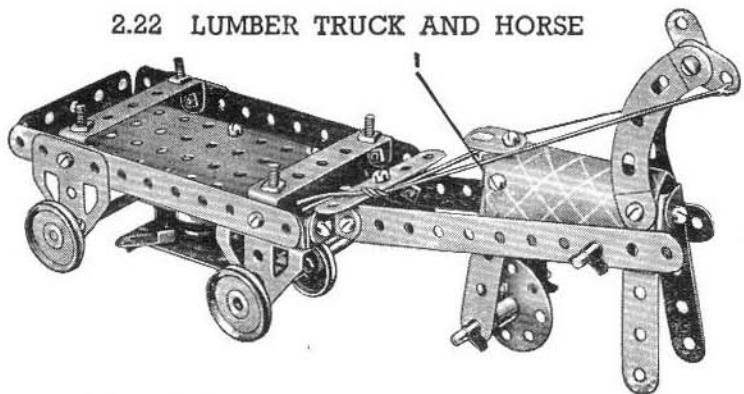

Parts required

4 of No. 2	4 of No. 37a
5 " " 5	2 " " 48a
3 " " 10	1 " " 52
5 " " 12	2 " " 90a
2 " " 16	4 " " 111c
2 " " 17	2 " " 126
4 " " 22	2 " " 126a
1 " " 24	4 " " 155a
4 " " 35	1 " " 199
23 " " 37	1 <i>Magic</i> Motor

A *Magic* Motor is mounted beneath the cart and the Driving Band is taken from the pulley on the Motor to a $\frac{1}{2}$ " fast Pulley (supplied with the Motor) fastened on the $3\frac{1}{2}$ " Rod that forms the front axle.

The forelegs of the horse are held together by means of two Angle Brackets bolted in the positions shown. This construction is duplicated at 1 for the hind-legs. The forelegs of the horse are held clear of the ground by means of the reins.

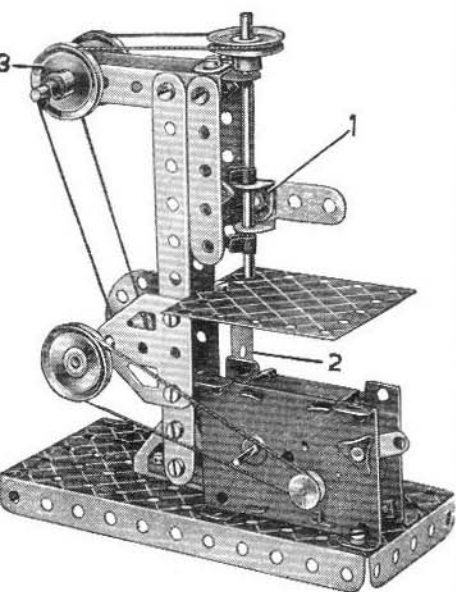
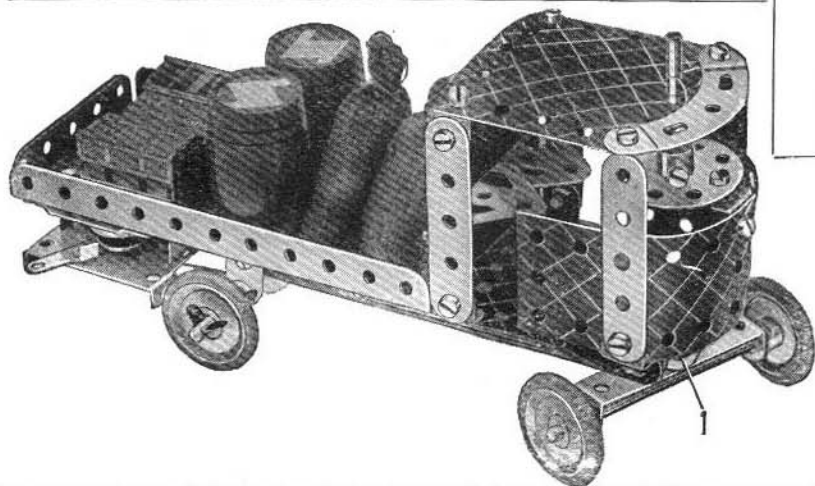

2.23 DRILLING MACHINE

Parts required

2 of No. 2	4 of No. 37a
5 " " 5	1 " " 40
1 " " 10	1 " " 48a
5 " " 12	1 " " 52
1 " " 16	1 " " 111c
2 " " 17	2 " " 126
4 " " 22	2 " " 126a
1 " " 24	1 " " 190
4 " " 35	1 <i>Magic</i> Motor
22 " " 37	
2 " " 37a	

The horizontal $2\frac{1}{2}$ " Strips at the top of the drill are joined together, and also to the vertical $2\frac{1}{2}$ " Strips, by means of Angle Brackets. The lower bearings 1 are two Angle Brackets bolted to a $2\frac{1}{2}$ " Strip and the Rod forming the drill is journaled in these, and in a Flat Bracket at its upper end. A $2\frac{1}{2}$ " x $2\frac{1}{2}$ " Flexible Plate is supported by a Double Angle Strip 2, and represents the table.

The drive is taken from the Motor to the 1" Pulley on the lower shaft. A second Driving Band passes round the $\frac{1}{2}$ " fast Pulley supplied with the Motor, round the two Pulleys at 3, and finally round the 1" Pulley fastened on the vertical drill shaft.

2.25 STEAM WAGON

Parts required

2 of No. 2	4 of No. 35	2 of No. 126
6 " " 5	31 " " 37	4 " " 155a
2 " " 10	1 " " 37a	1 " " 188
8 " " 12	4 " " 38	1 " " 189
2 " " 16	2 " " 48a	1 " " 190
1 " " 17	1 " " 52	1 " " 200
4 " " 22	1 " " 90a	1 <i>Magic</i> Motor
1 " " 24	1 " " 125	

2.24 BEAM ENGINE

Parts required

4 of No. 2	2 of No. 5
2 " " 10	2 " " 12
6 " " 12	2 " " 16
2 " " 17	1 " " 19g
1 " " 22	4 " " 22
4 " " 24	1 " " 24
1 " " 35	4 " " 35
31 " " 37	4 " " 37a
4 " " 38	4 " " 52
1 " " 90a	2 " " 111c
2 " " 126	1 " " 126
1 " " 126a	1 " " 176
1 " " 187	1 " " 188
2 " " 189	2 " " 189
1 " " 191	1 <i>Magic</i> Motor

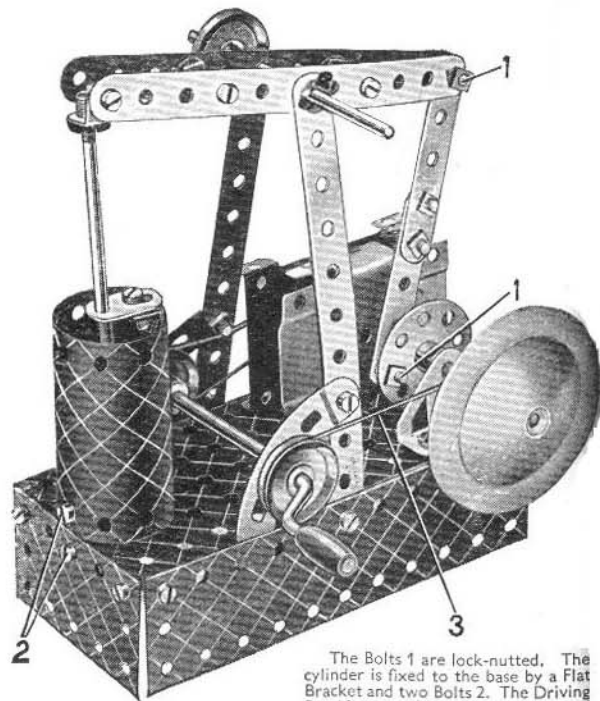

The Bolts 1 are lock-nutted. The cylinder is fixed to the base by a Flat Bracket and two Bolts 2. The Driving Band 3 drives a 1" fast Pulley on the Rod on which the Road Wheel is fastened.

The front axle is carried in a $2\frac{1}{2}$ " x $\frac{1}{2}$ " Double Angle Strip that is pivoted to a Reversed Angle Bracket fastened to a $2\frac{1}{2}$ " Strip below the cab by means of the lock-nutted Bolt 1, which is tightened up sufficiently to hold the two front wheels in position when running along. The rear axle is a $3\frac{1}{2}$ " Rod and it carries a $\frac{1}{2}$ " fast Pulley supplied with the *Magic* Motor.

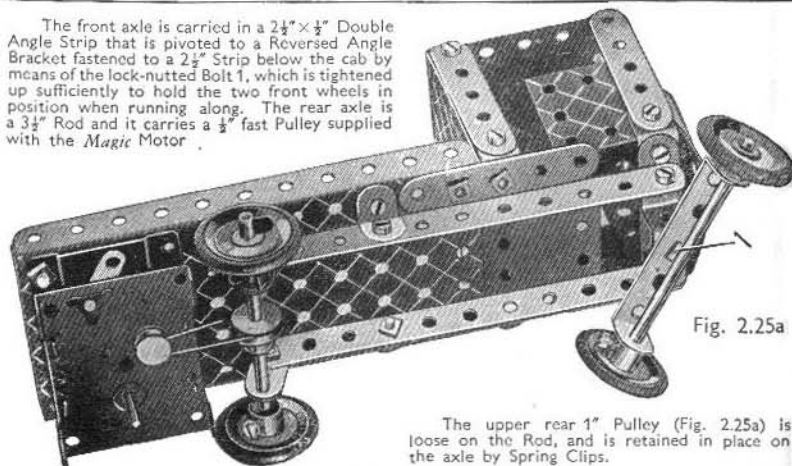
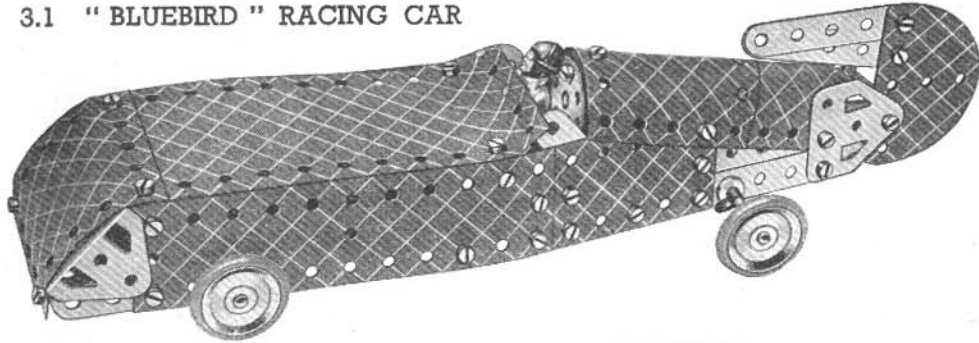

Fig. 2.25a

The upper rear 1" Pulley (Fig. 2.25a) is loose on the Rod, and is retained in place on the axle by Spring Clips.

3.1 "BLUEBIRD" RACING CAR



The $5\frac{1}{2}'' \times 2\frac{1}{2}''$ Flanged Plate is used for the front end of the chassis, and the two $5\frac{1}{2}'' \times 1\frac{1}{2}''$ Flexible Plates are bolted on each side in the third hole from the front end of the chassis. The two $5\frac{1}{2}''$ Strips forming the rear end of the chassis overlap the $5\frac{1}{2}'' \times 1\frac{1}{2}''$ Flexible Plates one hole.

Parts required			
2 of No. 2	2 of No. 35	2 of No. 126	1 of No. 192
6 " " 5	39 " " 37	2 " " 126a	2 " " 199
2 " " 10	4 " " 38	4 " " 155a	1 " " 200
3 " " 12	1 " " 48a	2 " " 188	2 " " 214
2 " " 16	1 " " 52	2 " " 189	1 " " 217a
4 " " 22			

3.2 AIRCRAFT CARRIER

Flat Trunnions are used to fasten the $5\frac{1}{2}'' \times 2\frac{1}{2}''$ Flanged Plate to the Strips that form the sides.

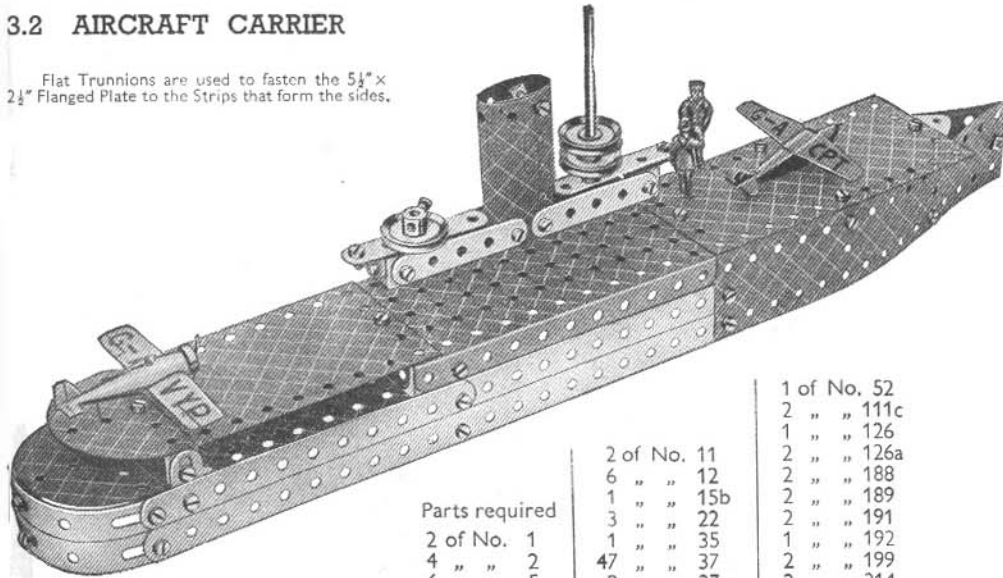

Parts required			
2 of No. 1	2 of No. 11	1 of No. 52	2 of No. 111c
4 " " 2	6 " " 12	1 " " 126	1 " " 126a
6 " " 5	1 " " 15b	2 " " 126a	2 " " 188
4 " " 10	3 " " 22	2 " " 189	2 " " 191
	1 " " 35	1 " " 192	1 " " 199
	47 " " 37	2 " " 199	2 " " 214
	2 " " 37a	2 " " 214	4 " " 215
	1 " " 48a		

3.3 MARINE ENGINE

Parts required

2 of No. 1
4 " " 2
5 " " 5
8 " " 12
2 " " 15b
3 " " 16
3 " " 22
1 " " 24
4 " " 35
47 " " 37
9 " " 37a
6 " " 38
2 " " 48a
1 " " 52
3 " " 90a
3 " " 111c
2 " " 125
2 " " 126
1 " " 126a
1 " " 155a
2 " " 187
2 " " 188
2 " " 189
1 " " 190
1 " " 191
2 " " 199
2 " " 200
1 " " 212
1 " " 213
2 " " 217a

Bolts 1 are lock-nutted. The Bolts 3 are $\frac{3}{8}''$ long and are lock-nutted twice as shown. The $2\frac{1}{2}''$ Strips 4 must be quite free to move when the crankshaft is rotated.

The left-hand piston rod is held by two Spring Clips, one at each side of the Angle Bracket pivotally fastened by the Bolts 1. Inside the cylinder the Rods slide through holes in a $2\frac{1}{2}''$ Strip and a Trunnion 2. In order to show the construction clearly part of the cylinder has been cut away in the illustration.

The Rod carrying two $1''$ Pulleys passes through the centre hole in the outer $1\frac{1}{2}''$ Disc. A $\frac{1}{2}'' \times \frac{1}{2}''$ Angle Bracket is bolted to the Disc in such a position that when the Disc is turned the Angle Bracket engages with a Spring Clip on the Rod. It is important that all nuts and bolts are made quite secure with the Spanner and Screwdriver.

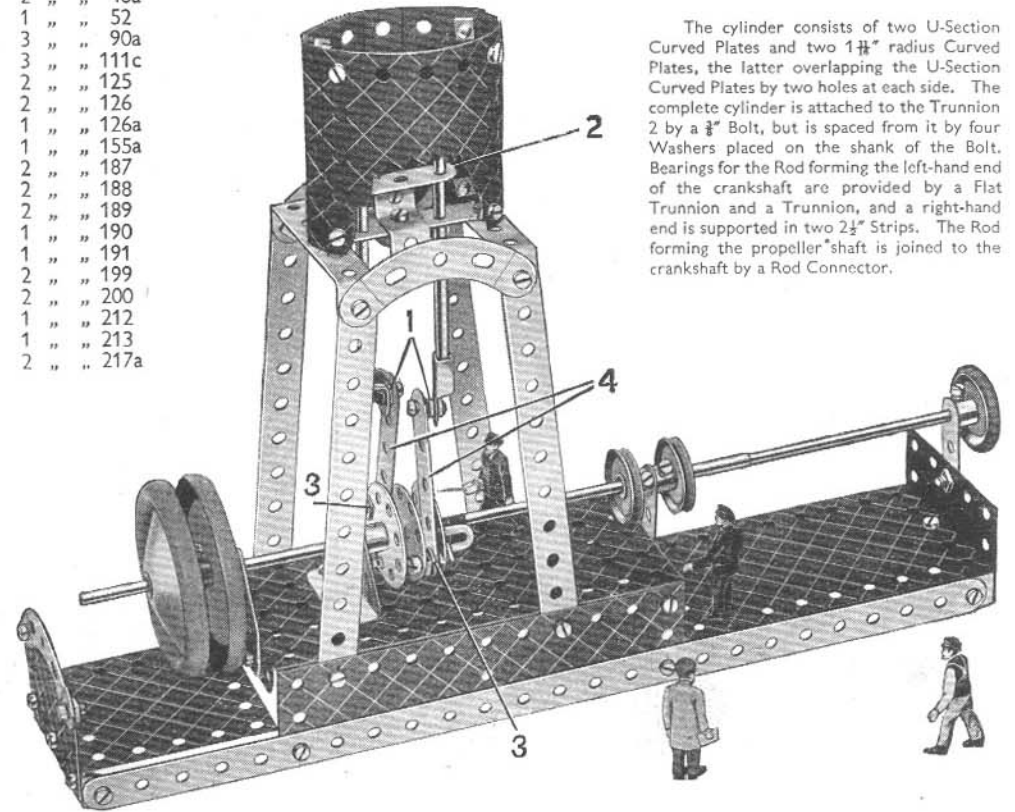

The cylinder consists of two U-Section Curved Plates and two $1\frac{1}{4}''$ radius Curved Plates, the latter overlapping the U-Section Curved Plates by two holes at each side. The complete cylinder is attached to the Trunnion 2 by a $\frac{3}{8}''$ Bolt, but is spaced from it by four Washers placed on the shank of the Bolt. Bearings for the Rod forming the left-hand end of the crankshaft are provided by a Flat Trunnion and a Trunnion, and a right-hand end is supported in two $2\frac{1}{2}''$ Strips. The Rod forming the propeller shaft is joined to the crankshaft by a Rod Connector.

3.4 SWIVELLING JIB CRANE

A 1" fast Pulley 1 is fastened to the lower end of a 2" Rod, which passes into and is held in the boss of the Bush Wheel. The Pulley rests on the tyre of Pulley Wheel 2, which is fastened on Rod 3. When the Rod 3 is rotated the jib is caused to swivel. Bearings for Rod 3 are formed by Flat Brackets, which are bolted through their elongated holes to the 2½" Strips shown in the illustration. The roof of the cab is fastened by means of Angle Brackets to two Flat Trunnions, and these in turn are bolted to the compound Strips bracing the jib.

Parts required		
2 of No. 1	1 of No. 18a	4 of No. 90a
6 " " 2	1 " " 19g	4 " " 111c
9 " " 5	4 " " 22	2 " " 126
4 " " 10	1 " " 23	2 " " 126a
1 " " 11	1 " " 24	2 " " 155a
8 " " 12	4 " " 35	1 " " 176
2 " " 16	50 " " 37	2 " " 187
1 " " 17	4 " " 37a	2 " " 188
	3 " " 38	2 " " 189
	1 " " 40	1 " " 190
	2 " " 48a	2 " " 191
	1 " " 52	1 " " 199
	1 " " 57c	2 " " 200

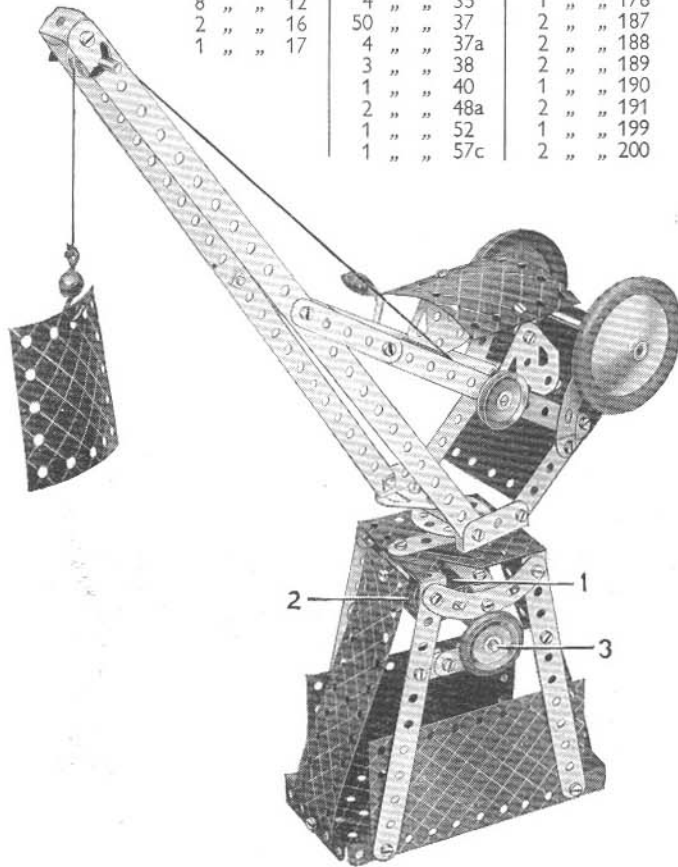

3.5 NOAH'S ARK

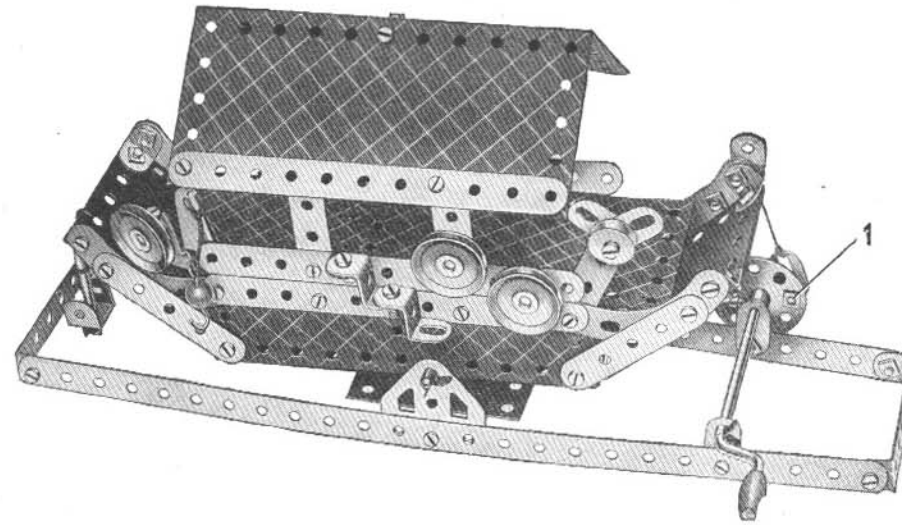

Parts required			
2 of No. 1	1 of No. 18a	1 of No. 40	2 of No. 126
6 " " 2	1 " " 19g	1 " " 44	2 " " 126a
9 " " 5	3 " " 22	2 " " 48a	1 " " 176
5 " " 10	1 " " 23	1 " " 52	2 " " 188
2 " " 11	1 " " 24	1 " " 57c	2 " " 189
8 " " 12	6 " " 35	4 " " 90a	2 " " 190
1 " " 16	50 " " 37	5 " " 111c	2 " " 191
1 " " 17	3 " " 37a	2 " " 125	2 " " 192

A 5½" × 2½" Flanged Plate is used for the bottom of the ark and 5½" × 2½" Flexible Plates and 5½" Strips form the sides. The deck is fastened to the sides by ½" × ½" Angle Brackets.

The ark is pivoted on a 3½" Rod journalled in Flat Trunnions, the Rod passing through the flanges of the baseplate at the fifth holes from the end near the Crank Handle. The Crank Handle carries a Bush Wheel, and to this a Flat Bracket is lock-nutted at 1. A length of Cord is attached to the free hole of the Flat Bracket and is then tied to a Double Bracket bolted to the side of the ark. When the Crank Handle is rotated, the downward motion of the Flat Bracket causes one end of the ark to be pulled down, but as the Flat Bracket rises again, the ark returns to its original position.

3.6 SWING

Two 2½" Strips overlapped one hole are bolted to the tops of the 12½" Strips by ½" × ½" Angle Brackets.

Parts required			
2 of No. 1	2 of No. 48a		
6 " " 5	1 " " 52		
2 " " 10	2 " " 90a		
8 " " 12	2 " " 126		
34 " " 37	2 " " 190		
1 " " 40	2 " " 191		

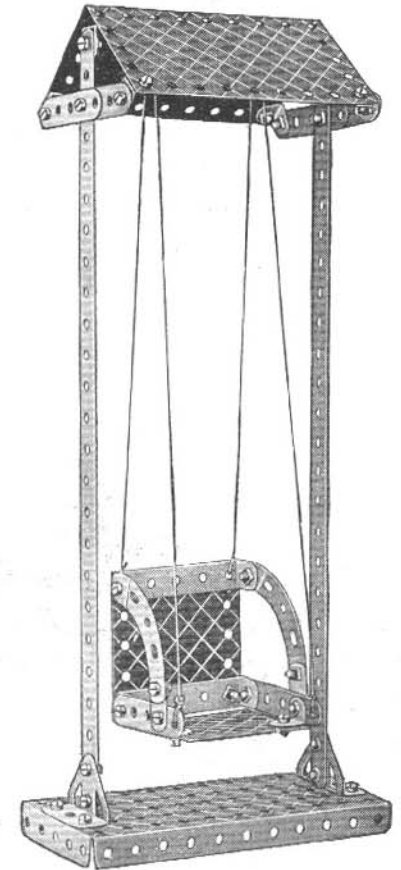

3.7 DENTIST'S CHAIR

Parts required

4 of No. 2	1 of No. 52
8 " " 5	3 " " 90a
2 " " 10	1 " " 190
4 " " 12	1 " " 191
1 " " 24	1 " " 200
38 " " 37	Lighting Set
1 " " 37a	(Not included in
1 " " 48a	Outfit)



This model is fitted with a Spotlight from the Meccano Lighting Set.

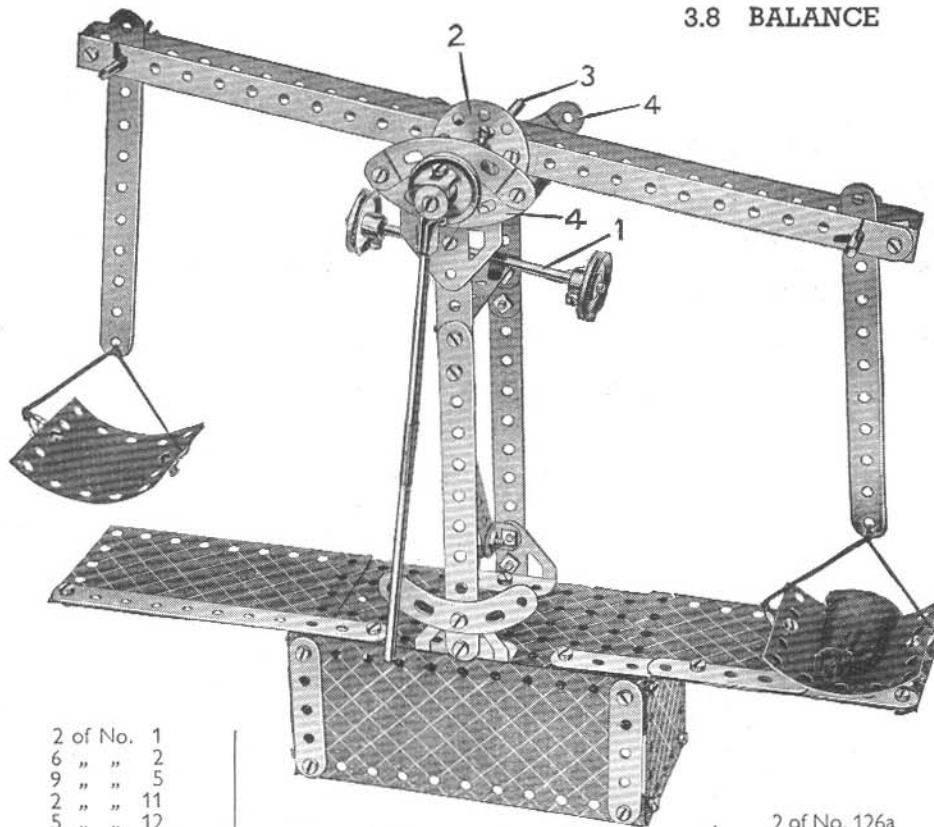

3.8 BALANCE

2 of No. 1
6 " " 2
9 " " 5
2 " " 11
5 " " 12
2 " " 15b
2 " " 16
4 " " 17
2 " " 22
1 " " 24
6 " " 35
50 " " 37

Parts required

4 of No. 37a	1 of No. 52
5 " " 38	4 " " 90a
1 " " 40	4 " " 111c
1 " " 44	1 " " 125
2 " " 48a	2 " " 126

2 of No. 126a
2 " " 190
2 " " 191
2 " " 192
2 " " 200
1 " " 212
1 " " 213
2 " " 215

One of the 12½" Strips that form the beam of the balance is bolted across a Bush Wheel 2. The 3½" Rod 3 that is locked in the boss of the Bush Wheel rests on the two Curved Strips 4.

The Rod 1, by which the balance is adjusted, is pushed through the two holes of a Cranked Bent Strip fastened to the Bush Wheel 2 by a Reversed Angle Bracket. The 5½" Strips from which the scale pans are suspended are pivoted at their upper ends on 2" Rods, which are passed through holes in the 12½" Strips of the beam.

3.9 TOWER WAGON

A Cranked Bent Strip 1 is bolted in a horizontal position in the centre of the Flanged Plate, and a 2½" Curved Strip is bolted on top of it by the centre hole to form a seat. A Reversed Angle Bracket 2 is then bolted in one of the elongated holes of the Curved Strip to form a bearing for the Rod carrying the Bush Wheel.

Parts required

6 of No. 2	2
6 " " 5	5
1 " " 10	10
2 " " 11	11
8 " " 12	12
2 " " 16	16
1 " " 18a	18a
4 " " 22	22
1 " " 24	24
1 " " 35	35
50 " " 37	37
5 " " 37a	37a
4 " " 38	38
1 " " 40	40
1 " " 44	44
2 " " 48a	48a
1 " " 52	52
3 " " 90a	90a
5 " " 111c	111c
2 " " 125	125
2 " " 126	126
1 " " 126a	126a
4 " " 155a	155a
2 " " 188	188
2 " " 189	189
2 " " 190	190
2 " " 191	191
2 " " 192	192
2 " " 199	199
1 " " 200	200

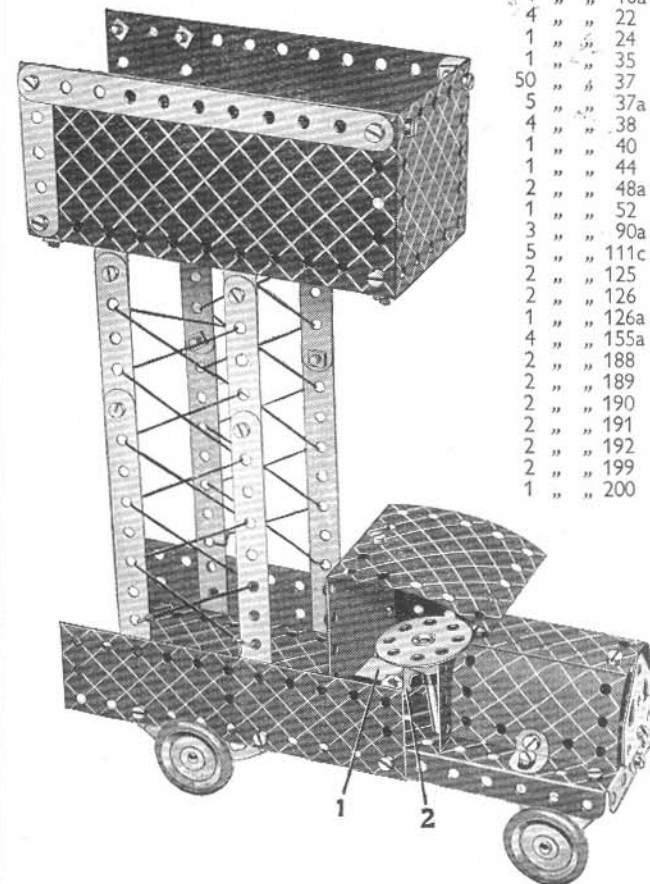

3.10 ELECTRIC GENERATING SET

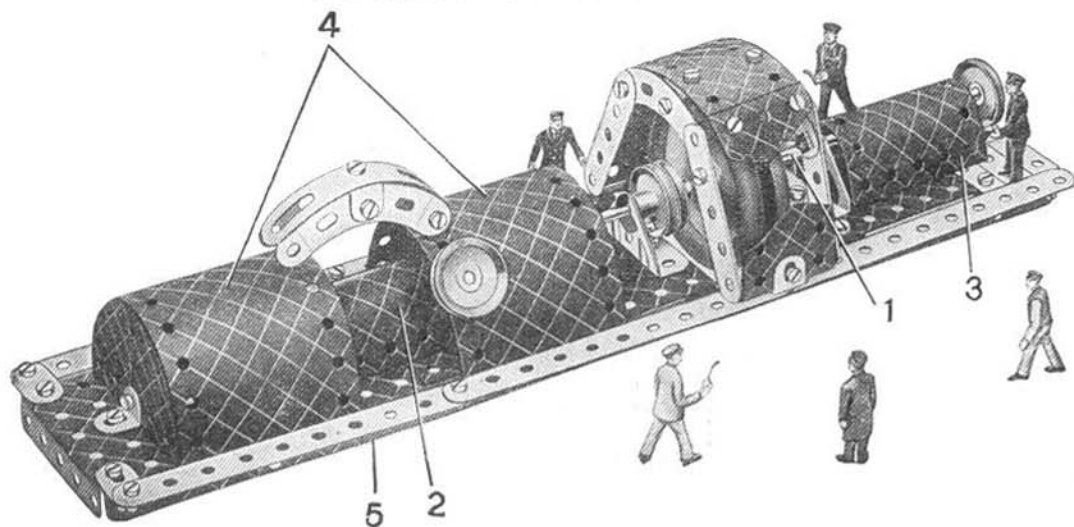

The base is constructed by bolting two $12\frac{1}{2}$ " Strips to the flanges of a $5\frac{1}{2}$ " x $2\frac{1}{2}$ " Flanged Plate 5, and joining them at their free ends by a $2\frac{1}{2}$ " x $\frac{1}{2}$ " Double Angle Strip. The space between the $12\frac{1}{2}$ " Strips is then filled in by Flexible Plates and $2\frac{1}{2}$ " Strips. The Rods that form the shaft of the machine are joined together at 1 by a Rod Connector. The bearings are formed by two Trunnions. In the illustration part of the Flexible Plate has been cut away to show the structure of the armature and the commutator. The commutator consists of two 1" Pulleys and the armature of two Road Wheels, the bosses of which are placed in contact with each other.

The connecting pipe is formed from two $2\frac{1}{2}$ " Curved Strips and one 3" Formed Slotted Strip joined together at their centre holes by a Double Bracket, and is fastened to the turbine by means of an Angle Bracket. The U-Section Curved Plate 2 is held by a Spring Clip slipped on the upper end of a 2" Rod. One end of the Rod is passed through the middle hole in the top of the Plate, and its other end is then pushed through the Flexible Plate forming the base. The Rod is held by a Spring Clip underneath the Plate. The U-Section Curved Plate 3 is fixed to the base by an Angle Bracket on the rear side of the model. The two Flexible Plates 4 are bolted to the flanges of the $5\frac{1}{2}$ " x $2\frac{1}{2}$ " Flanged Plate 5. The 1" Pulley representing the steam control is held by a $\frac{1}{2}$ " Bolt, which passes through a hole in one of the Flexible Plates 4, and is locked in the boss of the Pulley.

Parts required			
2 of No. 1	1 of No. 16	1 of No. 52	1 of No. 189
6 " " 2	1 " " 18a	4 " " 90a	1 " " 190
8 " " 5	4 " " 22	1 " " 111c	1 " " 191
3 " " 10	4 " " 35	2 " " 125	2 " " 192
2 " " 11	50 " " 37	2 " " 126	2 " " 199
8 " " 12	1 " " 38	2 " " 187	1 " " 213
1 " " 15b	2 " " 48a	1 " " 188	2 " " 214
	1 of No. 215		

3.11 TROTTING CAR

The seat of the car consists of two $2\frac{1}{2}$ " x $1\frac{1}{2}$ " Flexible Plates, overlapped two holes, and it carries at each end a Trunnion. The 3" Formed Slotted Strips that form the mudguards are supported by Reversed Angle Brackets 2, which are spaced from the Flexible Plate by three Washers. The axle consists of two 2" Rods joined by a Rod Connector, and is journalled in the Trunnions.

Each of the horses is built up as follows. Four $2\frac{1}{2}$ " Strips are bolted to a U-Section Curved Plate in the positions shown to form the legs, and two $2\frac{1}{2}$ " small radius Curved Strips represent the neck. A Rod is pushed through the centre holes of the U-Section Curved Plates and is supported in the end holes of the shafts. Two $3\frac{1}{2}$ " Rods carrying 1" Pulleys at each of their ends are journalled in the end holes of two of the forelegs, and two of the hind-legs of the horses, as shown.

The driver's body is made with two Flat Trunnions, which are bolted together and then fitted with $2\frac{1}{2}$ " x $\frac{1}{2}$ " Double Angle Strips to represent legs. The Bolt that fixes the Cranked Bent Strip to the body holds also a Flat Bracket that supports a $1\frac{1}{2}$ " Disc representing the head. An Angle Bracket bolted to the Disc secures a Bush Wheel that has a $\frac{3}{8}$ " Bolt fixed in its boss by the set-screw.

The whip is a 2" Rod held by Spring Clips in a Double Bracket, and the lash is attached to it by a Cord Anchoring Spring. The reins are fastened to the Flat Brackets that form the horses' heads, and also to the Double Bracket to which the whip is fixed. Short lengths of Cord fastened to the U-Section Curved Plates represent the horses' tails.

Parts required

4 of No. 2	33 of No. 37	1 of No. 176
8 " " 5	2 " " 37a	2 " " 187
5 " " 10	6 " " 38	2 " " 188
1 " " 11	1 " " 40	2 " " 199
1 " " 12	1 " " 44	1 " " 213
1 " " 15b	2 " " 48a	4 " " 215
2 " " 16	4 " " 90a	1 " " 217a
2 " " 17	3 " " 111c	
1 " " 18a	2 " " 125	
4 " " 22	2 " " 126	
1 " " 24	2 " " 126a	
6 " " 35	4 " " 155a	

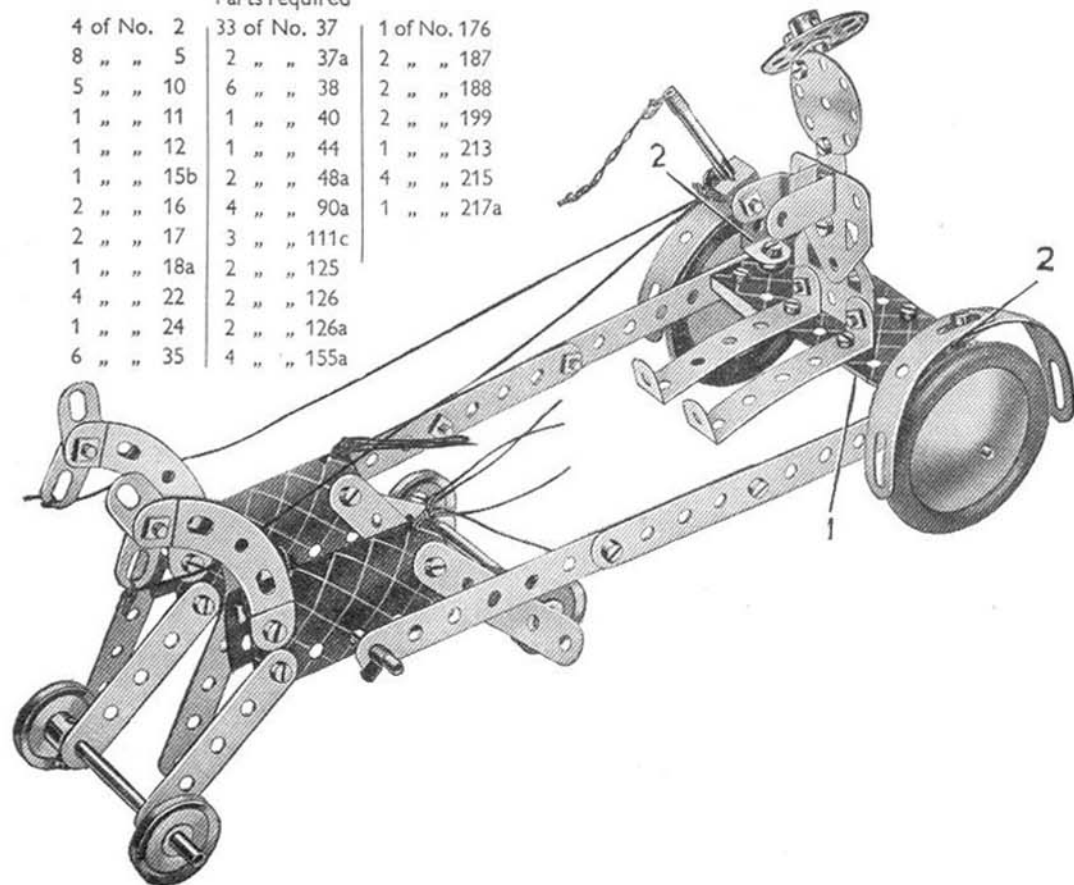

3.12 STEAM TRACTOR AND TRAILER

The steering column, a $3\frac{1}{2}$ " Rod, is supported in the holes of a Double Bracket and a Reversed Angle Bracket bolted to the side of the cab. Cord is wound round the lower part of the Rod and its ends are tied to the $2\frac{1}{2}$ " x $\frac{1}{2}$ " Double Angle Strip that carries the front axle. Care must be taken that the Cord is wound tightly round the Rod, or it will slip when the steering wheel is rotated. The Rod 2 is supported in holes in the Flexible Plates that form the sides of the cab.

The Bush Wheel that forms the front of the boiler has two Angle Brackets bolted to it and a Rod passes through the free holes of these Brackets to hold the Bush Wheel in position. This Rod is joined by a Rod Connector to a 2" Rod that forms the chimney. The roof of the cab consists of a $5\frac{1}{2}$ " x $2\frac{1}{2}$ " Flexible Plate, and is held in position by Spring Clips placed on the two Rods that pass through it. The Flat Brackets 3 are bolted in the centre holes of the $2\frac{1}{2}$ " Curved Strips. The Bolts 1 are lock-nutted in position and the wheels turn freely on them.

Parts required

4 of No. 2	1 of No. 23	2 of No. 90a	2 of No.191
9 " " 5	1 " " 21	4 " " 111c	1 " " 192
5 " " 10	4 " " 35	2 " " 125	2 " " 199
2 " " 11	45 " " 37	2 " " 126	2 " " 200
8 " " 12	6 " " 37a	2 " " 126a	1 " " 212
2 " " 15b	6 " " 38	3 " " 155a	1 " " 213
2 " " 16	1 " " 40	1 " " 176	1 " " 214
2 " " 17	1 " " 44	2 " " 187	2 " " 217a
1 " " 18a	2 " " 48a	2 " " 188	2 " " 217b
4 " " 22	1 " " 52	2 " " 190	

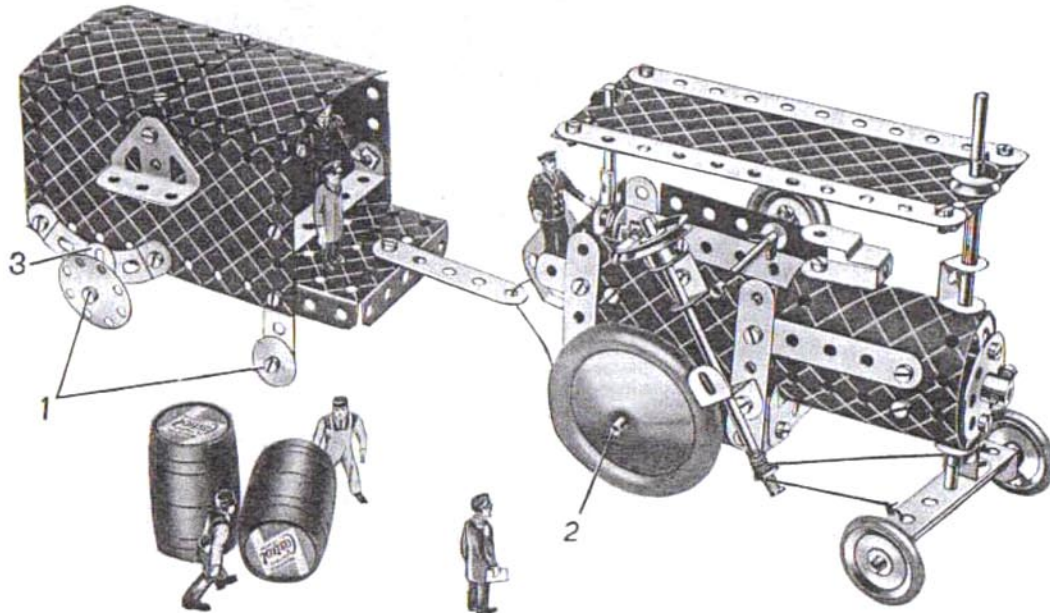

3.13 Do.X. FLYING BOAT

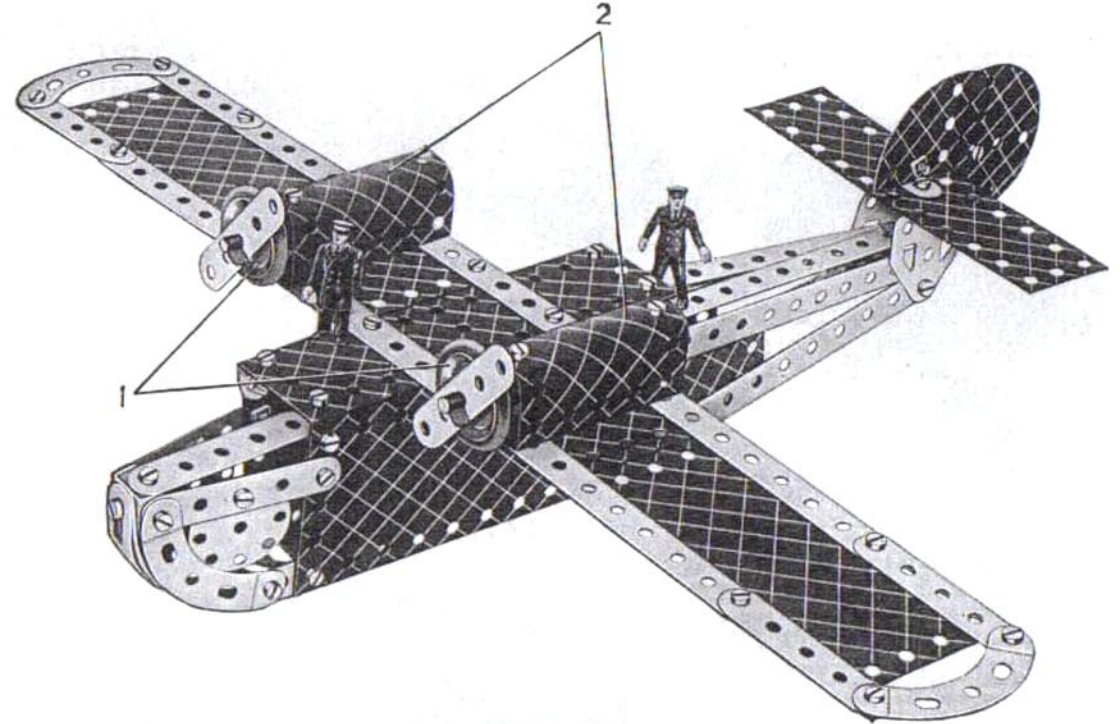

Parts required

2 of No. 1	2 of No. 22	1 of No.125	2 of No 191
6 " " 2	4 " " 35	2 " " 126	2 " " 192
9 " " 5	50 " " 37	2 " " 126a	2 " " 199
2 " " 10	6 " " 37a	2 " " 155a	2 " " 214
2 " " 11	2 " " 48a	2 " " 188	2 " " 215
8 " " 12	4 " " 90a	2 " " 189	2 " " 217a
2 " " 16	6 " " 111c	2 " " 190	

The construction of the fuselage is clear from the illustration. The Strips and Curved Strips forming the nose of the machine are all fastened at their free ends to a Double Bracket. The engines 1 are 1" fast Pulleys and the engine nacelles 2 are U-section Curved Plates, which are fastened to the wings by $\frac{1}{2}$ " x $\frac{1}{2}$ " Angle Brackets. Bearings for the propeller shafts which are $3\frac{1}{2}$ " Rods are formed by the holes in the turned-up ends of $2\frac{1}{2}$ " Double Angle Strips. These Double Angle Strip are supported by the Bolts that can be seen in the centre holes of the U-Section Curved Plates.

The tail assembly is supported on two Flat Trunnions, which are joined, at the centre holes in their ends at the top, by a Double Bracket. A $5\frac{1}{2}$ " x $1\frac{1}{2}$ " Flexible Plate representing the tail plane is bolted to the free hole of the Double Bracket. The Bolt that holds the tail plane carries also an Angle Bracket, and two $2\frac{1}{2}$ " Semi-Circular Flat Plates are fastened to this to form the rudder.

3.14 GIANT LORRY

The bonnet is made up of two U-Section Curved Plates overlapped three holes and attached to the $5\frac{1}{2}'' \times 2\frac{1}{2}''$ Flanged Plate by two Angle Brackets. The front of the cabin is a $2\frac{1}{2}'' \times 1\frac{1}{2}''$ Flexible Plate, which is attached to the chassis by a Reversed Angle Bracket. Bearings for the $3\frac{1}{2}''$ Rods forming the front and rear axles are provided by Flat Brackets bolted to the flanges of the Flanged Plate.

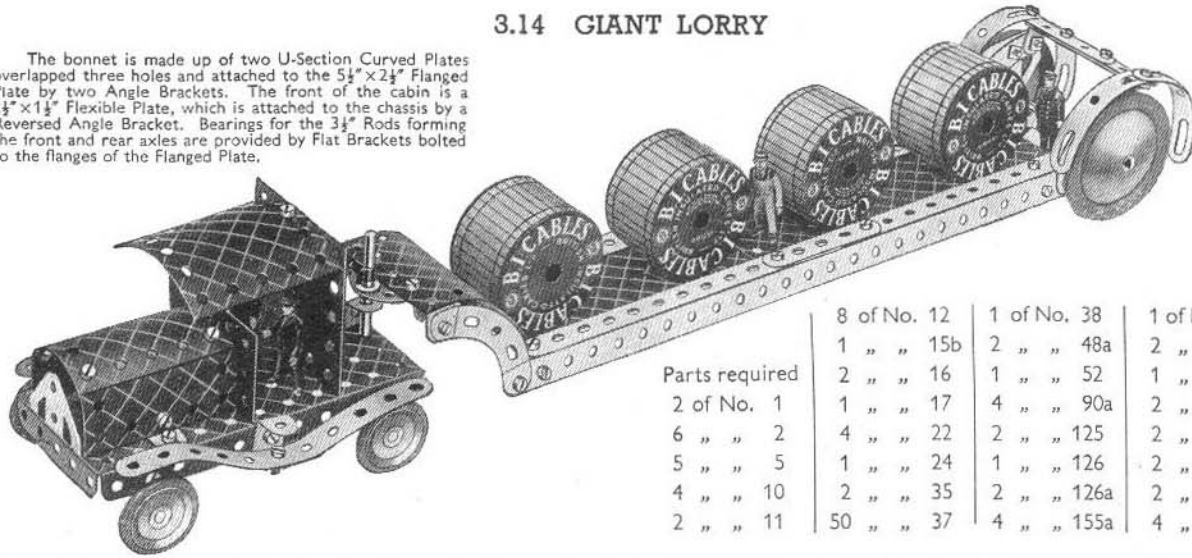

Parts required	8 of No. 12	1 of No. 38	1 of No. 176
2 of No. 1	1 " " 15b	2 " " 48a	2 " " 187
6 " " 2	2 " " 16	1 " " 52	1 " " 188
5 " " 5	1 " " 17	4 " " 90a	2 " " 190
4 " " 10	4 " " 22	2 " " 125	2 " " 192
2 " " 11	1 " " 24	1 " " 126	2 " " 199
	2 " " 35	2 " " 126a	2 " " 200
	50 " " 37	4 " " 155a	4 " " 215

3.15 BATTLE CRUISER

Bolts 1 fasten the Strips to a Flat Trunnion so that the Strips are held rigid. Trunnion 2, which holds the rear gun, is fastened by a $\frac{1}{2}'' \times \frac{1}{2}''$ Angle Bracket to the centre hole of $2\frac{1}{2}'' \times \frac{1}{2}''$ Double Angle Strip 3. The forward guns also are held by a Trunnion, but this is fastened to a Double Bracket that in turn is bolted to the $5\frac{1}{2}'' \times 2\frac{1}{2}''$ Flanged Plate.

The base of the turret is formed by a Bush Wheel, which is bolted to the deck. A $3\frac{1}{2}''$ Rod is fastened in the boss of the Bush Wheel, and two Road Wheels are placed on it as shown.

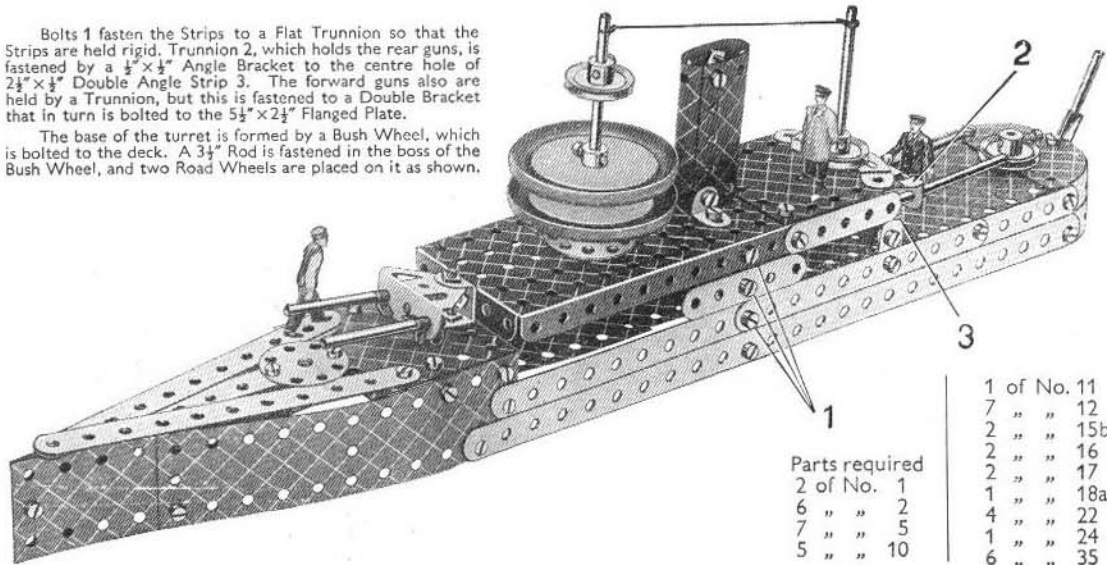

Parts required	1 of No. 11
2 of No. 1	7 " " 12
6 " " 2	2 " " 15b
7 " " 5	2 " " 16
5 " " 10	2 " " 17
	1 " " 18a
	4 " " 22
	1 " " 24
	6 " " 35

50 of No. 37	6 " " 37a
1 " " 40	2 " " 48a
2 " " 52	1 " " 90a
1 " " 111c	6 " " 111c
2 " " 126	2 " " 126
2 " " 126a	2 " " 126a
1 " " 176	1 " " 176
2 " " 187	2 " " 187
2 " " 188	2 " " 188
2 " " 189	2 " " 189
2 " " 190	2 " " 190
1 " " 191	1 " " 191
1 " " 192	1 " " 192
1 " " 199	1 " " 199
2 " " 200	2 " " 200
1 " " 212	1 " " 212
1 " " 214	1 " " 214
4 " " 215	4 " " 215
1 " " 217a	1 " " 217a
1 " " 217b	1 " " 217b

3.16 NAVAL GUN

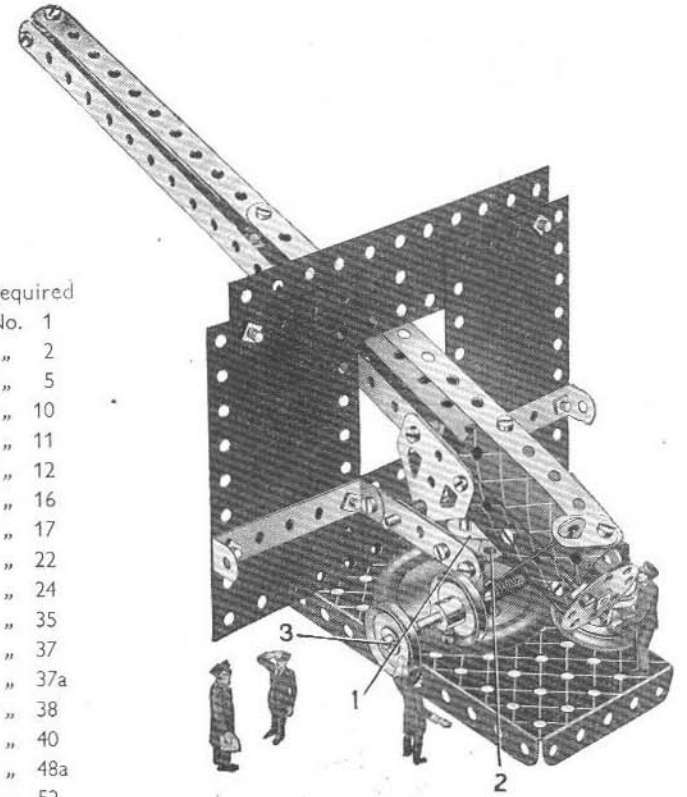

Parts required	2 of No. 1
5 " " 2	3 " " 5
3 " " 10	2 " " 11
2 " " 12	1 " " 16
2 " " 17	4 " " 22
4 " " 22	1 " " 24
1 " " 24	4 " " 35
4 " " 35	28 " " 37
2 " " 37	2 " " 37a
5 " " 38	5 " " 38
1 " " 40	1 " " 40
2 " " 48a	2 " " 48a
1 " " 52	2 " " 52
2 " " 111c	2 " " 111c
2 " " 126	2 " " 126
2 " " 126a	2 " " 126a
1 " " 155a	1 " " 155a
1 " " 176	1 " " 176
1 " " 187	1 " " 187
1 " " 188	1 " " 188
1 " " 189	1 " " 189
2 " " 191	2 " " 191
2 " " 199	2 " " 199
1 " " 217a	1 " " 217a

The Flexible Plates forming the gun shield are fastened by means of Double Angle Strips and $2\frac{1}{2}''$ Strips to two Trunnions 1. The Trunnions are bolted to Bush Wheel 2. A 2" Rod held in the boss of the Bush Wheel passes through a Road Wheel and the centre hole of the $5\frac{1}{2}'' \times 2\frac{1}{2}''$ Flanged Plate. The Rod is fastened underneath the Flanged Plate by a Cord Anchoring Spring so that the gun is free to swivel.

The elevation of the gun is controlled by Rod 3. Cord is wound round the Rod, then passed through the hole of a Flat Bracket fastened at the rear end of the gun, and knotted to a Washer as shown. The $1\frac{1}{2}''$ Disc at the end of the gun is fastened by an Angle Bracket to the U-Section Curved Plates representing the breech.

3.17 FIRE-ENGINE

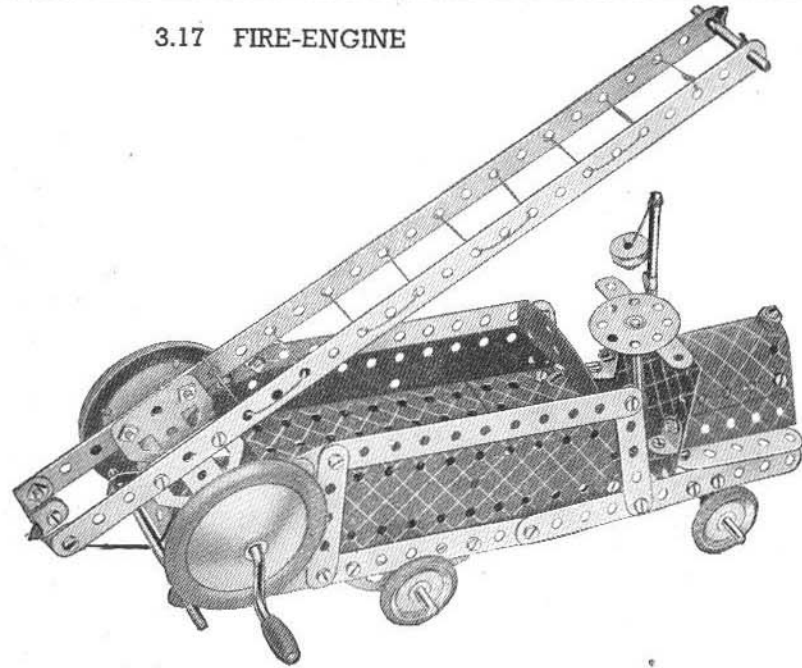

Parts required

2 of No. 1	2 of No. 125
6 " " 2	2 " " 126
8 " " 5	2 " " 126a
5 " " 10	4 " " 155a
2 " " 11	1 " " 176
7 " " 12	2 " " 187
2 " " 15b	2 " " 188
2 " " 16	2 " " 189
1 " " 17	2 " " 190
1 " " 19g	1 " " 192
4 " " 22	1 " " 199
1 " " 23	1 " " 212
1 " " 24	1 " " 214
6 " " 35	
50 " " 37	
6 " " 37a	
5 " " 38	
1 " " 40	
2 " " 48a	
1 " " 52	
4 " " 90a	
6 " " 111c	

Two Flat Trunnions are bolted to the bottom of the ladder, and the shaft of the Crank Handle shown in Fig. 3.17a passes through the holes at their narrow ends. The bonnet, which is formed from a U-Section Curved Plate and two 2½" x 1½" Flexible Plates, is fastened to the frame by Reversed Angle Brackets. These latter also support the 2½" Strips at the side of the bonnet.

The 3½" Rod representing the steering column passes through the free hole of a Flat Bracket bolted to the dashboard, then through a hole in the Flexible Plate at the bottom of the cab. It is fastened in position by a Cord Anchoring Spring.

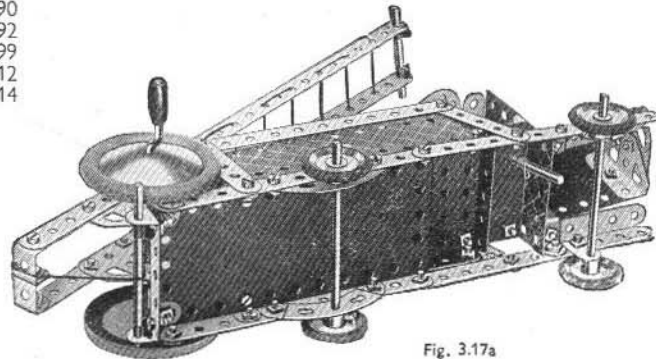
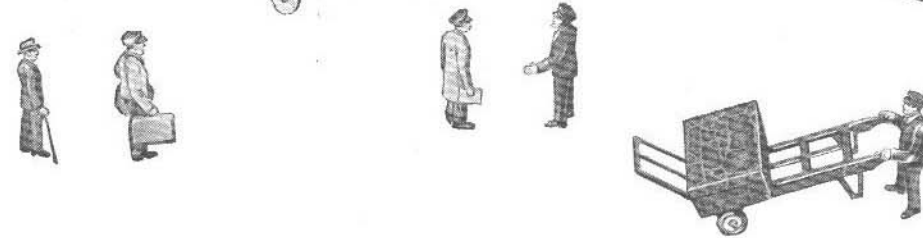
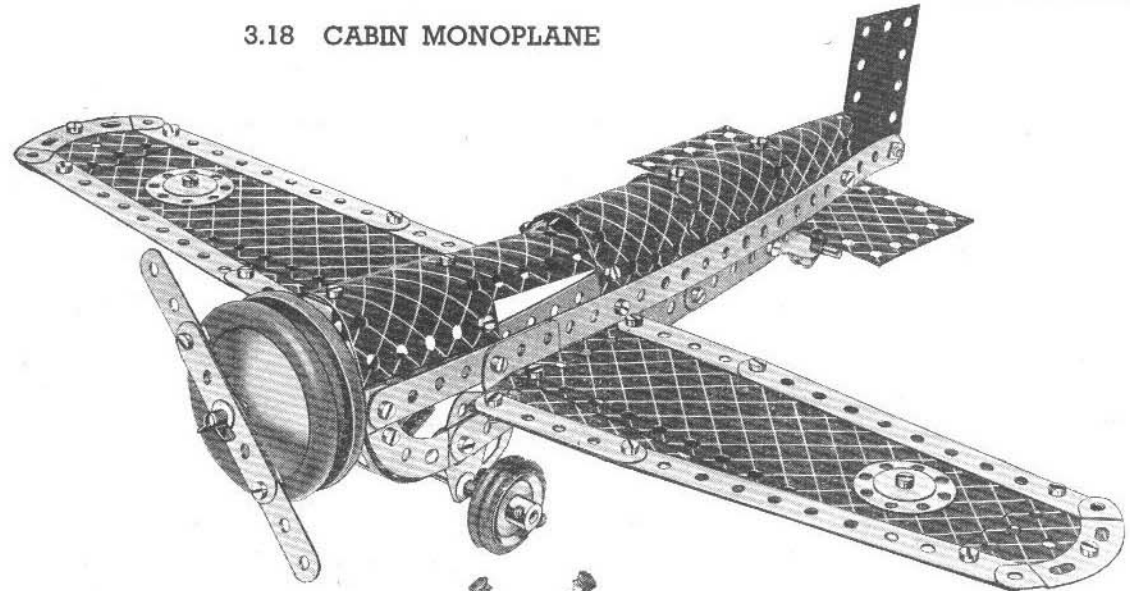

Fig. 3.17a

3.18 CABIN MONOPLANE



Parts required

2 of No. 1	4 of No. 22	4 of No. 90a	2 of No. 190
6 " " 2	1 " " 23	6 " " 111c	1 " " 191
9 " " 5	1 " " 24	2 " " 125	2 " " 192
5 " " 10	5 " " 35	2 " " 126	2 " " 199
1 " " 11	50 " " 37	2 " " 126a	2 " " 200
8 " " 12	6 " " 37a	4 " " 155a	2 " " 214
1 " " 16	5 " " 38	2 " " 187	2 " " 215
1 " " 17	1 " " 44	2 " " 188	2 " " 217a
1 " " 18a	2 " " 48a	2 " " 189	2 " " 217b

The engine and propeller are attached by fastening a Bush Wheel to the nose of the fuselage by two Angle Brackets. A 2" Rod is locked in the boss of the Bush Wheel and forms the support for the Road Wheels and the compound strip representing the propeller.

The wings are attached to the fuselage by ½" x ½" Angle Brackets and Trunnions. The tail wheel is supported on a 1½" Rod journalled in the holes of a Cranked Bent Strip fastened to the fuselage by a Double Bracket.

The Rod on which the double landing wheels are mounted passes through the holes in the narrow ends of two Flat Trunnions bolted to the fuselage.

3.19 BLOCK-SETTING CRANE

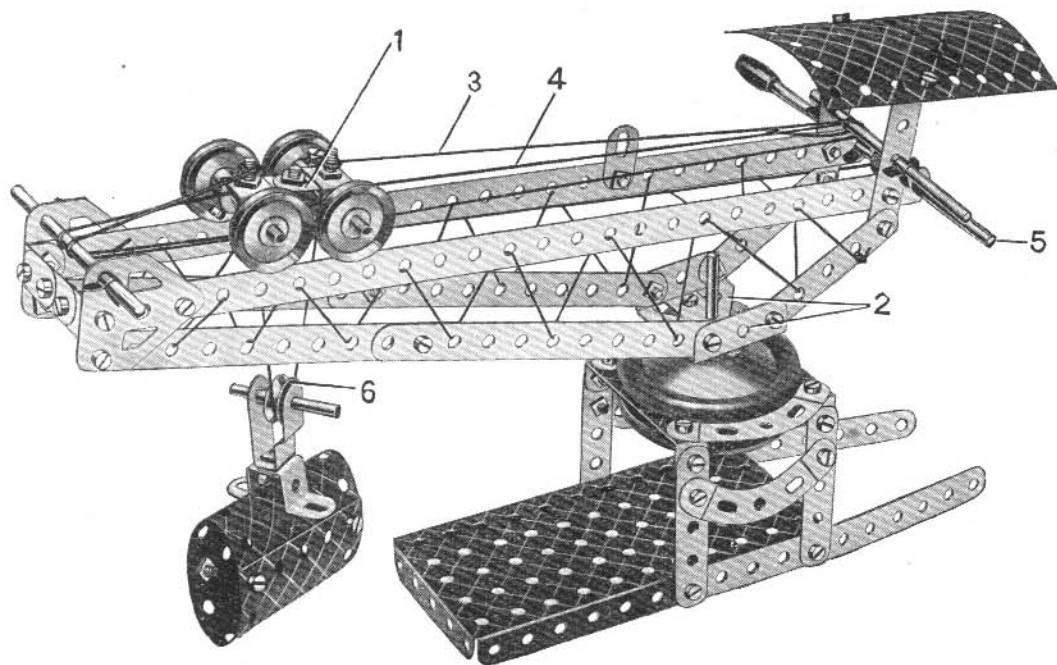

Parts required	
2 of No. 1	4 of No. 37a
6 " " 2	6 " " 38
8 " " 5	1 " " 40
5 " " 10	1 " " 44
2 " " 11	2 " " 48a
4 " " 12	1 " " 52
1 " " 15b	4 " " 90a
2 " " 16	4 " " 111c
2 " " 17	2 " " 125
1 " " 18a	2 " " 126
1 " " 19g	2 " " 126a
4 " " 22	1 " " 176
1 " " 23	2 " " 187
1 " " 24	2 " " 188
6 " " 35	2 " " 199
50 " " 37	2 " " 200

The travelling bogie 1 consists of two Flat Brackets bolted together by their elongated holes, and at each end of it Double Brackets are fastened by $\frac{3}{8}$ " Bolts. Two 2" Rods are pushed through the Double Brackets and carry 1" fast Pulleys spaced so that their grooves fit on the two $12\frac{1}{2}$ " Strips that form the top of the jib. The Trunnions 2 at the base of the jib, are secured to a Bush Wheel mounted on a Rod held in the bosses of two Road Wheels. The Road Wheels are placed one above and one below the $2\frac{1}{2}$ " x $1\frac{1}{2}$ " Flexible Plates, that form the top of the tower.

Cord 3 is first fastened to the $\frac{3}{8}$ " Bolt at the rear end of the travelling bogie, and then wound three times around the Crank Handle. It is then led around the Rod journalled in the Flat Trunnion at the front end of the jib, and brought back and tied to another $\frac{3}{8}$ " Bolt at the front of the bogie.

Cord 4 is first fastened to Rod 5, which is passed through the end holes of the $12\frac{1}{2}$ " Strips, and then over the rear axle of the bogie. It is then passed around the $\frac{1}{2}$ " Pulley 6, led over the front axle of the bogie, around the Rod at the front end of the jib, and finally tied to the bogie. The $\frac{1}{2}$ " loose Pulley 6 and its Rod are held in the Cranked Bent Strip by a Cord Anchoring Spring.

3.20 PITHEAD GEAR

Parts required

2 of No. 1
6 " " 2
8 " " 5
1 " " 10
1 " " 11
7 " " 12
1 " " 15b
2 " " 16
1 " " 18a
1 " " 19g
4 " " 22
1 " " 24
6 " " 35
41 " " 37
1 " " 37a
6 " " 38
1 " " 40
2 " " 48a
1 " " 52
2 " " 111c
2 " " 125
2 " " 126
2 " " 126a
1 " " 176
2 " " 187
2 " " 188
2 " " 189
1 " " 190
2 " " 192
2 " " 200
1 " " 214

A $3\frac{1}{2}$ " Rod is journalled in the top holes of the $12\frac{1}{2}$ " Strips. Between the two Road Wheels on this Rod is a 1" fast Pulley, over which the cord controlling the cage passes. A Cord Anchoring Spring is pushed on one end of the Rod, and a Bush Wheel is fixed to the other end. The cage is built up from Trunnions and Flat Trunnions, and the $2\frac{1}{2}$ " x $1\frac{1}{2}$ " Flexible Plates that form its sides are fastened to the Flat Trunnions by Angle Brackets.

A $\frac{3}{8}$ " Bolt is passed through the holes of Reversed Angle Brackets bolted to the top of the cage, and Washers are placed on its shank for spacing purposes.

The guides 1 for the cage consist of a piece of Cord, which is passed over two Rods as shown and then led downward and through two holes in the Flanged Plate that forms the base. Washers are tied to each end of the Cord underneath the Plate, to maintain it in tension.

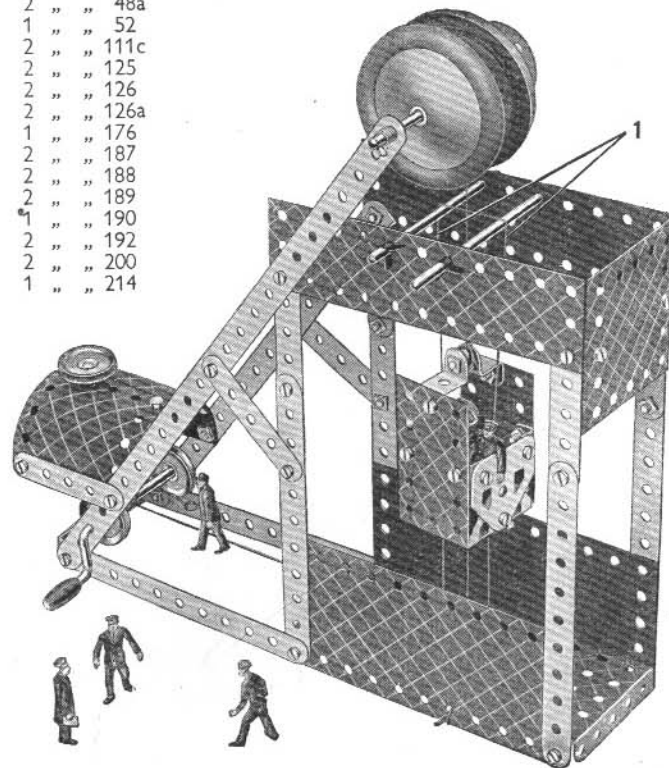

3.21 TANK

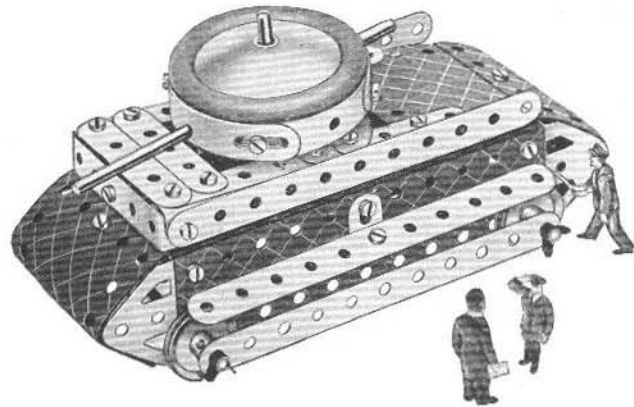

Construction of the gun turret is commenced by bolting a $2\frac{1}{2}$ " Strip across a Bush Wheel. Four 3" Formed Slotted Strips are bolted together to form a circle and fastened to the $2\frac{1}{2}$ " Strip by means of Angle Brackets. Next two Angle Brackets are bolted to the Bush Wheel in the positions shown in Fig. 3.21a. Two Rods are pushed through holes in the Formed Slotted Strips and through the free holes of the Angle Brackets, and are fastened in position by means of Spring Clips. The turret is held in place by a $3\frac{1}{2}$ " Rod that is locked in the boss of the Bush Wheel and then passed through the $5\frac{1}{2}$ " x $2\frac{1}{2}$ " Flanged Plate and through a hole in a Reversed Angle Bracket. A Cord Anchoring Spring is then screwed on to it to hold it in position. To complete the turret a Road Wheel is fastened on the upper end of the $3\frac{1}{2}$ " Rod. The Reversed Angle Bracket is bolted to the $5\frac{1}{2}$ " x $2\frac{1}{2}$ " Flanged Plate.

The *Magic Motor* is bolted to the Flanged Plate, and the drive is taken to the back axle by means of a Driving Band.

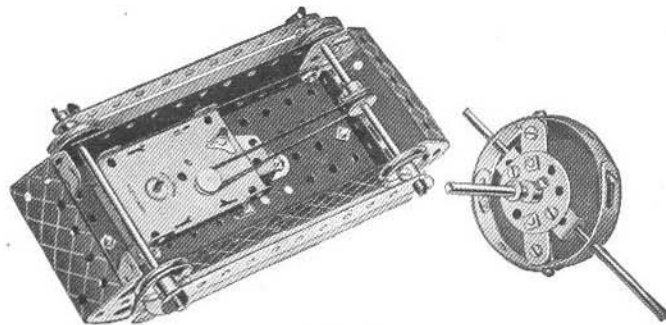

Fig. 3.21a

Parts required

6 of No. 2
7 " " 5
2 " " 10
8 " " 12
2 " " 15b
2 " " 16
1 " " 17
4 " " 22
1 " " 24
6 " " 35
40 " " 37
1 " " 38
1 " " 48a
1 " " 52
1 " " 90a
1 " " 125
2 " " 126
2 " " 126a
1 " " 176
1 " " 187
2 " " 189
1 " " 190
2 " " 199
4 " " 215
1 <i>Magic Motor</i>

Parts required

2 of No. 2	2 of No. 48a
7 " " 5	1 " " 52
2 " " 10	4 " " 90a
2 " " 12	1 " " 125
2 " " 16	1 " " 126
1 " " 17	1 " " 126a
1 " " 23	2 " " 187
4 " " 35	1 " " 188
35 " " 37	2 " " 189
2 " " 38	2 " " 199
1 " " 40	4 " " 215
1 " " 44	1 <i>Magic Motor</i>

3.22 HORSE AND CART

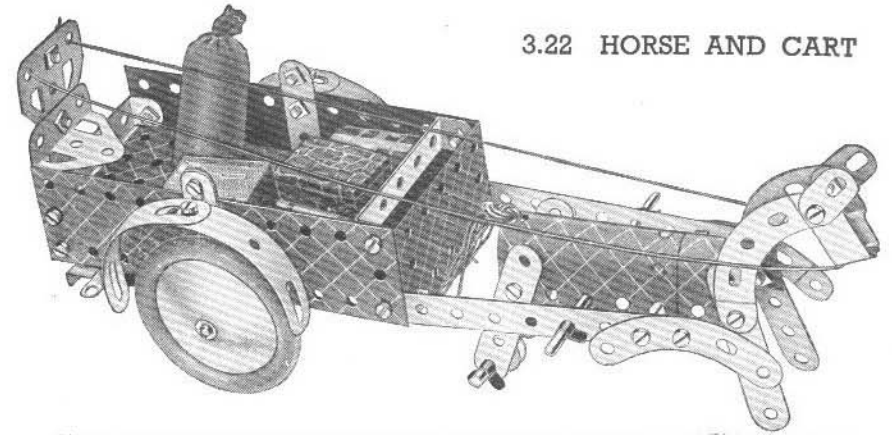

The model is driven by a *Magic Motor* fastened underneath the $5\frac{1}{2}$ " x $2\frac{1}{2}$ " Flanged Plate that forms the bottom of the cart. The drive is taken by a Driving Band from the pulley of the Motor to a $\frac{1}{2}$ " fast Pulley on the back axle. A $\frac{1}{2}$ " Loose Pulley is fitted on a 2" Rod journalled in the bottom holes of the Strips forming the legs of the horse, so that the model will travel smoothly along the ground.

3.23 ROUNDABOUT

Parts required	
2 of No. 1	4 of No. 37a
6 " " 2	4 " " 38
8 " " 5	1 " " 40
4 " " 10	2 " " 48a
2 " " 11	1 " " 52
8 " " 12	4 " " 90a
1 " " 16	4 " " 111c
1 " " 17	2 " " 125
1 " " 18a	2 " " 126
1 " " 19g	2 " " 126a
4 " " 22	1 " " 187
1 " " 24	2 " " 188
6 " " 35	2 " " 191
50 " " 37	2 " " 199

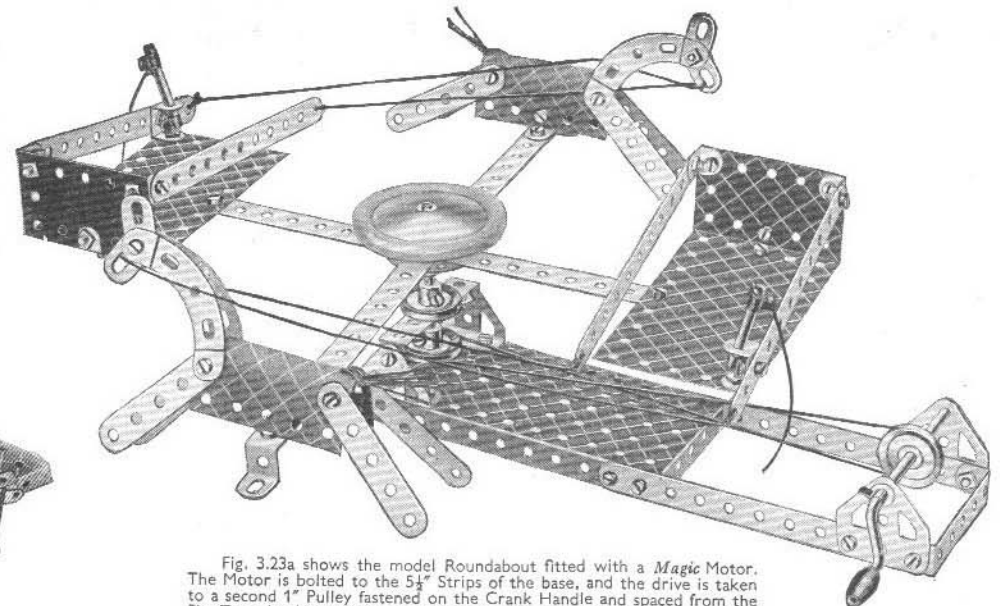

Fig. 3.23a shows the model Roundabout fitted with a *Magic Motor*. The Motor is bolted to the $5\frac{1}{2}$ " Strips of the base, and the drive is taken to a second 1" Pulley fastened on the Crank Handle and spaced from the Flat Trunnion by a Spring Clip and a Washer. This Pulley is removed from the end of the pivot rod of the roundabout underneath the $5\frac{1}{2}$ " x $2\frac{1}{2}$ " Flanged Plate.

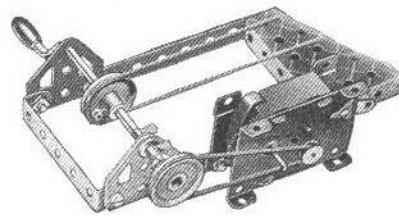

Fig. 3.23a

3.24 WINDMILL PUMP

Up and down motion of the pumping shaft is obtained from a crank fastened to the end of the Crank Handle. The crank is formed by securing an Angle Bracket to the boss of a 1" Pulley, two Washers being used between the Bracket and the boss. A 2½" Strip is pivoted to the crank and to the pumping beam, the other end of which is pivotally attached to a Double Bracket on the pump rod. The Bolts 1 are lock-nutted. The 1" Pulley on the Crank Handle is connected by a belt of Cord to the shaft carrying the sails. The *Magic Motor* is bolted by its flanges to the baseplate, and the drive is taken from the pulley of the Motor to a ½" Pulley fixed on the shaft of the Crank Handle, if desired the Motor may be dispensed with and the model operated by hand.

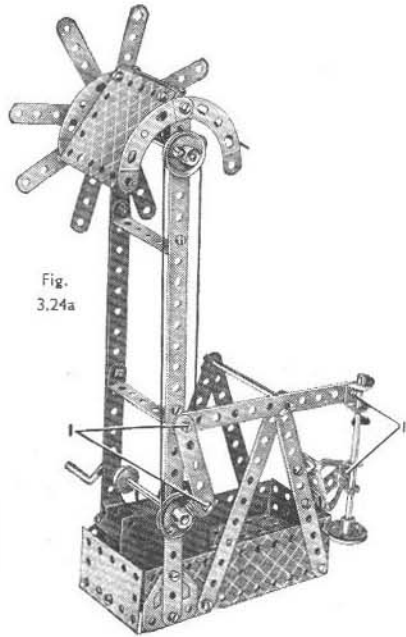
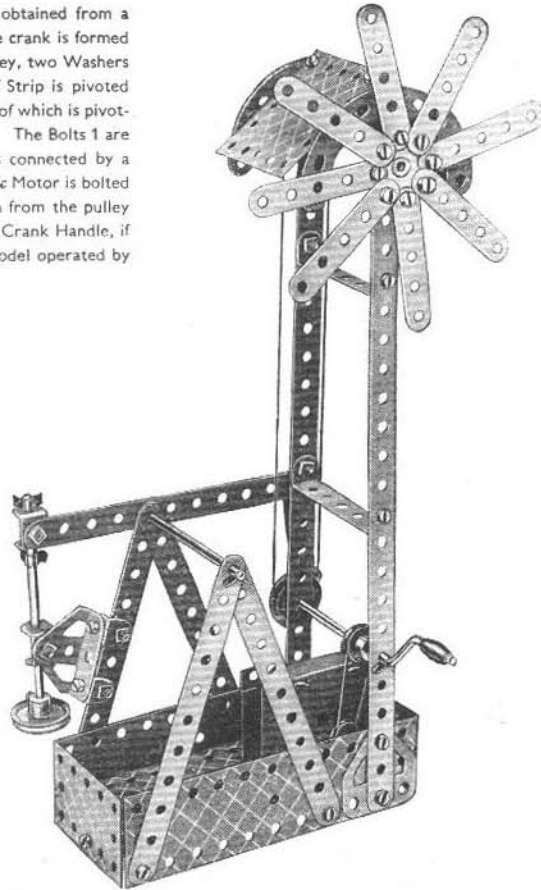

Fig. 3.24a



Parts required	
2 of No. 1	2 of No. 11
5 " " 2	7 " " 12
9 " " 5	1 " " 15b

2 of No. 16	2 of No. 48a
1 " " 19g	1 " " 52
3 " " 22	4 " " 90a
1 " " 24	1 " " 126
4 " " 35	2 " " 126a
39 " " 37	2 " " 188
3 " " 37a	2 " " 189
2 " " 38	2 " " 190
1 " " 40	1 <i>Magic Motor</i>

3.25 TRACTOR AND HARROW

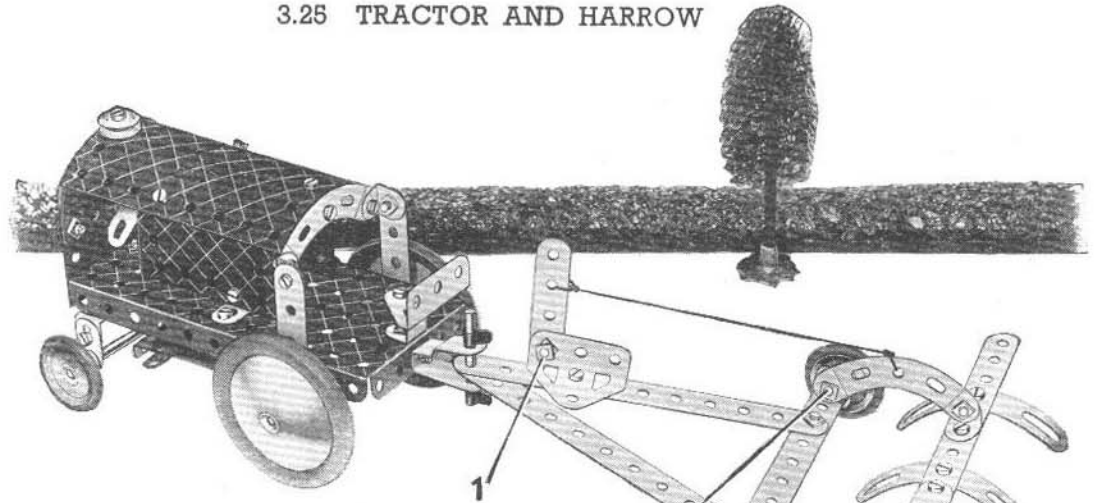

The rear axle is passed through the bottom holes of two 2½" Strips that are bolted to the flanges of the 5" x 2½" Flanged Plate forming the chassis. The construction of the bonnet and radiator is clearly shown in the illustration.

The fan consists of two Flat Brackets held against the head of a ¾" Bolt by a Nut. The ¾" Bolt is fastened to the radiator by means of two more Nuts. The engine itself is represented by two U-Section Curved Plates, bolted together so that they overlap two holes, and then fastened to the Flanged Plate by two Angle Brackets.

The wheels of the harrow are held by ¾" Bolts in Reversed Angle Brackets at each end of a 5½" Strip. Small radius Curved Strips are fastened to the Reversed Angle Brackets by lock-nutted Bolts, and Cord is attached to the centre hole of one of these and also to the operating lever, which is held by lock-nuts to a Trunnion. By moving the lever forward the harrow may be raised from the ground when not in use.

The Bolts 1 shown in both illustrations are lock-nutted.

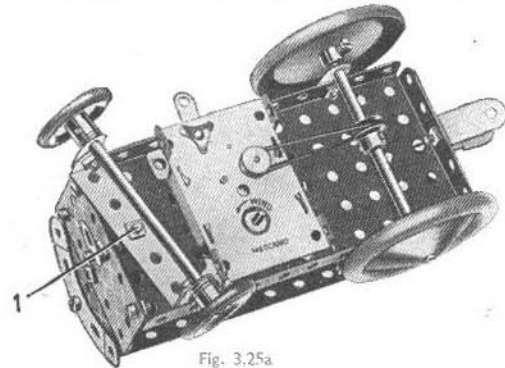
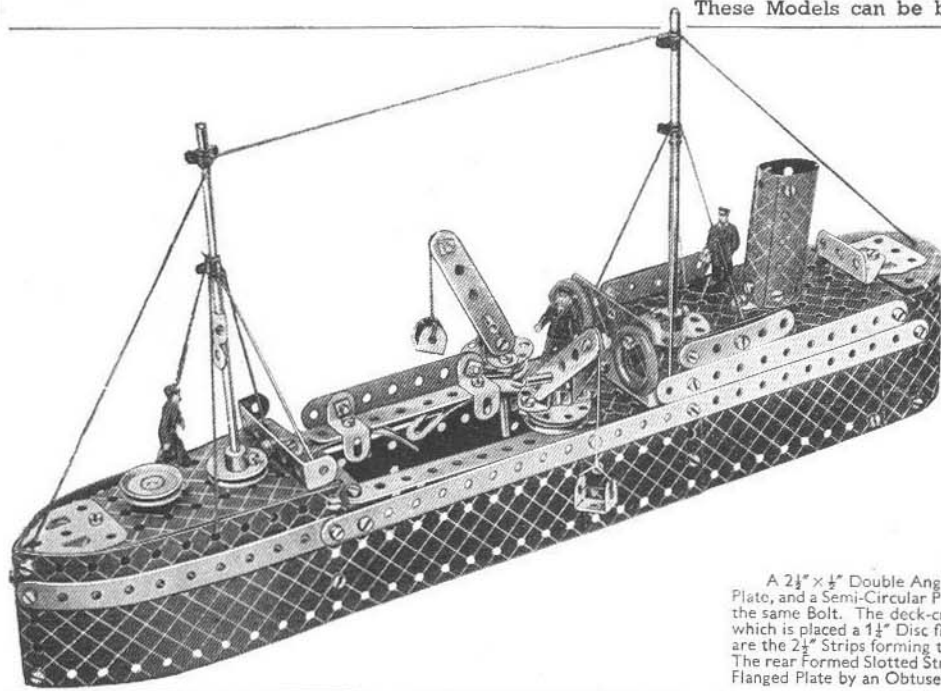

Fig. 3.25a

Parts required	4 of No. 22	2 of No. 125
5 of No. 2	1 " " 23	2 " " 126
3 " " 5	2 " " 35	4 " " 155a
2 " " 11	46 " " 37	2 " " 187
8 " " 12	10 " " 37a	1 " " 188
2 " " 16	6 " " 38	2 " " 199
1 " " 18a	1 " " 44	2 " " 200
	1 " " 48a	1 " " 214
	1 " " 52	4 " " 215
	4 " " 90a	1 <i>Magic Motor</i>
	5 " " 111c	



4.1 DREDGER

Parts required

2 of No. 1	1 of No. 51
6 " " 2	1 " " 52
2 " " 3	1 " " 54a
9 " " 5	5 " " 111c
4 " " 10	2 " " 125
2 " " 11	1 " " 126
8 " " 12	2 " " 126a
2 " " 12c	2 " " 155a
4 " " 16	2 " " 188
2 " " 17	2 " " 189
2 " " 18a	2 " " 190
4 " " 22	2 " " 191
1 " " 24	2 " " 192
8 " " 35	2 " " 199
70 " " 37	2 " " 200
6 " " 37a	1 " " 212
4 " " 38	1 " " 213
1 " " 40	2 " " 214
3 " " 48a	2 " " 215
	2 " " 217a

A $2\frac{1}{2}'' \times \frac{1}{2}''$ Double Angle Strip is bolted to the front flange of the $5\frac{1}{2}'' \times 2\frac{1}{2}''$ Flanged Plate, and a Semi-Circular Plate is held between the flange and the Double Angle Strip by the same Bolt. The deck-cranes each consist of a 1" Pulley fastened to a 2" Rod, above which is placed a $1\frac{1}{2}''$ Disc fitted with Angle Brackets. Bolted to these, and lock-nutted, are the $2\frac{1}{2}''$ Strips forming the jib. The complete units are held in place by Spring Clips. The rear Formed Slotted Strip of the hopper bridge is fastened to the front of the $2\frac{1}{2}'' \times 1\frac{1}{2}''$ Flanged Plate by an Obtuse Angle Bracket.

4.2 SUBMARINE

Parts required

4 of No. 1	4 of No. 48a
3 " " 5	1 " " 52
1 " " 11	2 " " 54a
2 " " 12	2 " " 125
1 " " 15b	2 " " 126
3 " " 16	2 " " 126a
1 " " 17	2 " " 188
1 " " 18a	2 " " 189
1 " " 18b	2 " " 190
4 " " 22	2 " " 191
1 " " 24	2 " " 192
5 " " 35	1 " " 198
64 " " 37	1 " " 199
1 " " 40	1 " " 212
1 " " 44	1 " " 213
1 " " 48	1 " " 217a

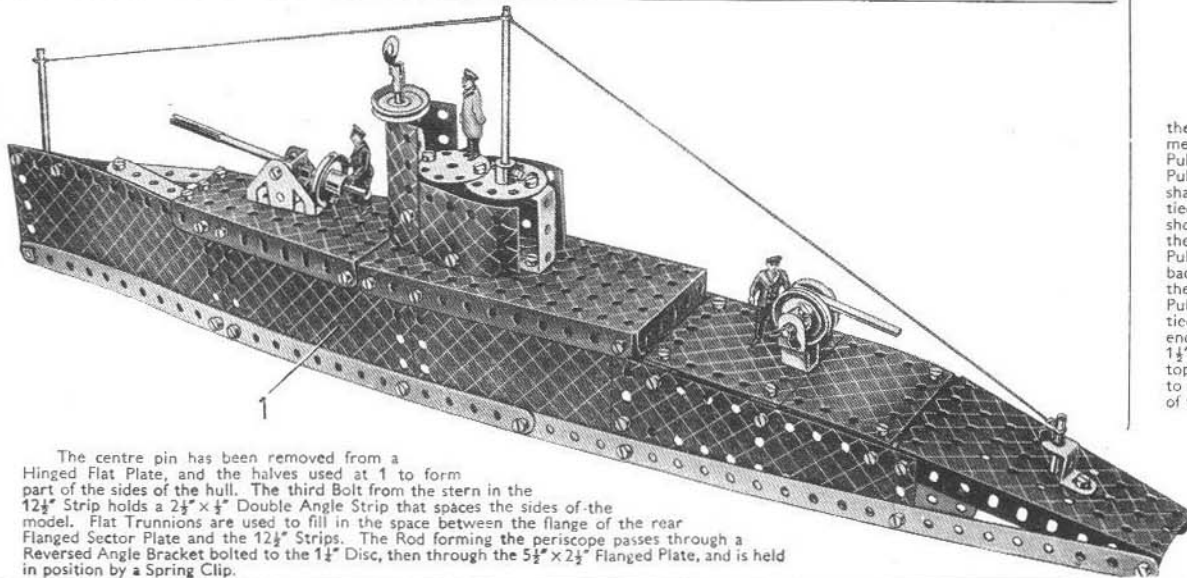

The centre pin has been removed from a Hinged Flat Plate, and the halves used at 1 to form part of the sides of the hull. The third Bolt from the stern in the $12\frac{1}{2}''$ Strip holds a $2\frac{1}{2}'' \times \frac{1}{2}''$ Double Angle Strip that spaces the sides of the model. Flat Trunnions are used to fill in the space between the flange of the rear Flanged Sector Plate and the $12\frac{1}{2}''$ Strips. The Rod forming the periscope passes through a Reversed Angle Bracket bolted to the $1\frac{1}{2}''$ Disc, then through the $5\frac{1}{2}'' \times 2\frac{1}{2}''$ Flanged Plate, and is held in position by a Spring Clip.

4.3 TELPHER SPAN

Parts required

4 of No. 1	4 of No. 22
6 " " 2	1 " " 23
1 " " 3	1 " " 24
8 " " 5	6 " " 35
2 " " 11	55 " " 37
6 " " 12	2 " " 38
4 " " 12c	1 " " 40
2 " " 16	1 " " 48
1 " " 17	2 " " 48a
1 " " 18a	1 " " 52
2 " " 19b	2 " " 54a
1 " " 19g	2 " " 90a
	2 " " 126
	2 " " 126a
	1 " " 176
	2 " " 191
	1 " " 198

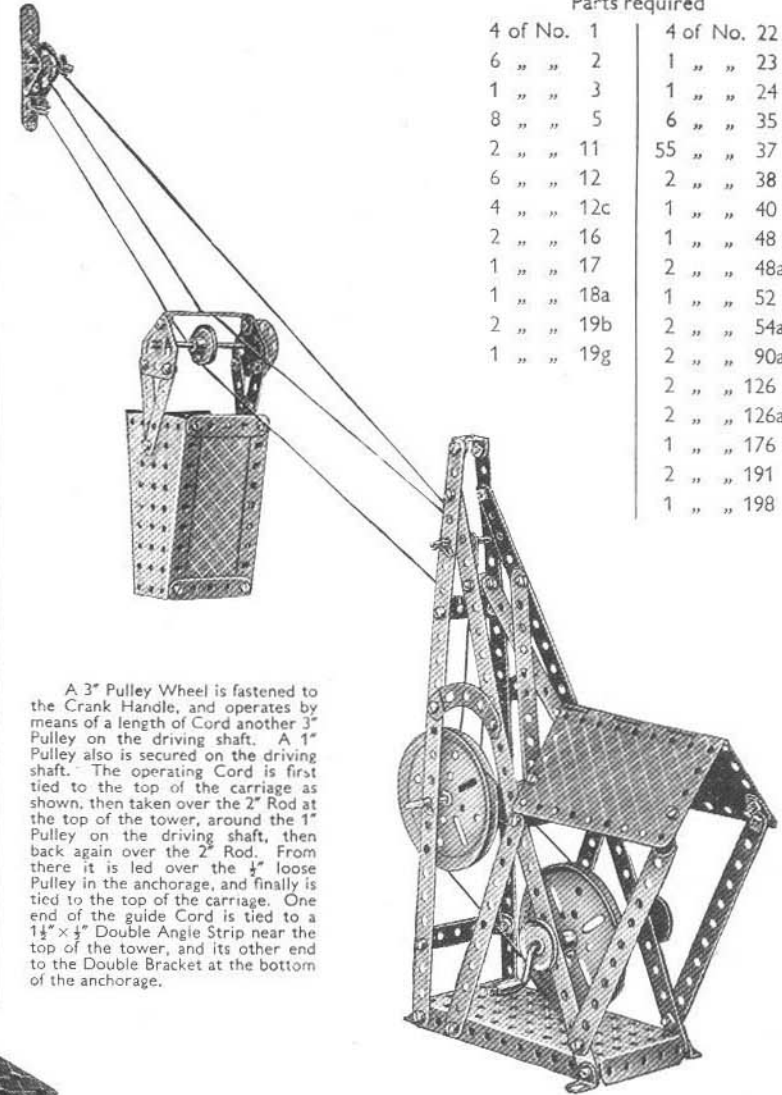

A 3" Pulley Wheel is fastened to the Crank Handle, and operates by means of a length of Cord another 3" Pulley on the driving shaft. A 1" Pulley also is secured on the driving shaft. The operating Cord is first tied to the top of the carriage as shown, then taken over the 2" Rod at the top of the tower, around the 1" Pulley on the driving shaft, then back again over the 2" Rod. From there it is led over the $\frac{1}{2}''$ loose Pulley in the anchorage, and finally is tied to the top of the carriage. One end of the guide Cord is tied to a $1\frac{1}{2}'' \times \frac{1}{2}''$ Double Angle Strip near the top of the tower, and its other end to the Double Bracket at the bottom of the anchorage.

4.4 SPORTS CAR

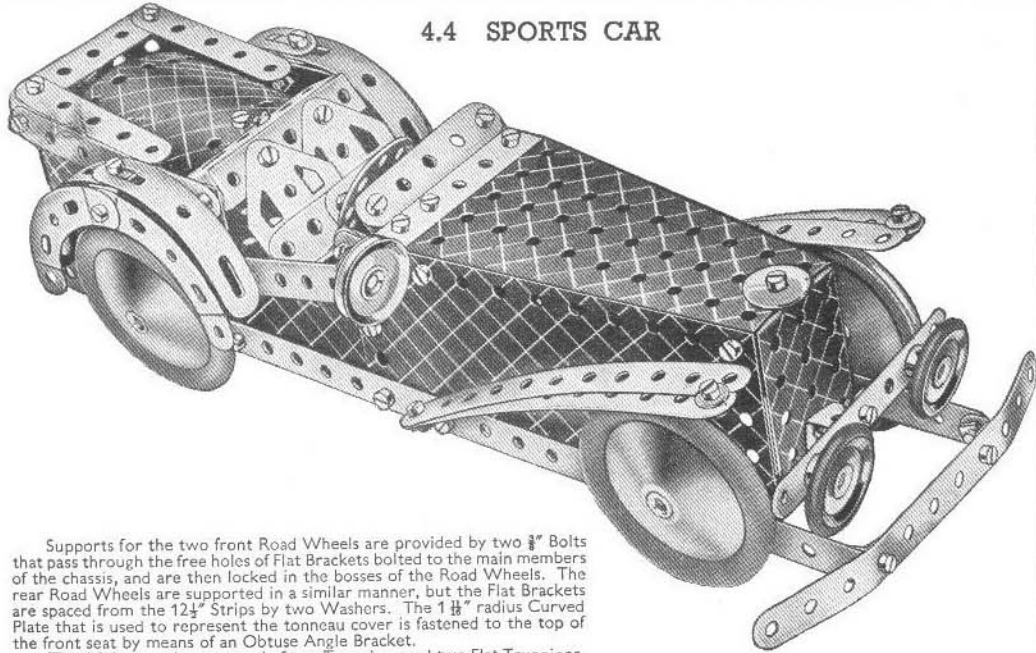

Supports for the two front Road Wheels are provided by two $\frac{3}{8}$ " Bolts that pass through the free holes of Flat Brackets bolted to the main members of the chassis, and are then locked in the bosses of the Road Wheels. The rear Road Wheels are supported in a similar manner, but the Flat Brackets are spaced from the $12\frac{1}{2}$ " Strips by two Washers. The $1\frac{1}{2}$ " radius Curved Plate that is used to represent the tonneau cover is fastened to the top of the front seat by means of an Obtuse Angle Bracket.

The driving seat is composed of two Trunnions and two Flat Trunnions, and these are bolted to the $2\frac{1}{2}$ " x $\frac{1}{2}$ " Double Angle Strip supported by the sides of the car.

The steering wheel is a Bush Wheel fastened to a $1\frac{1}{2}$ " Rod that is secured by two Spring Clips in an Angle Bracket bolted under the scuttle.

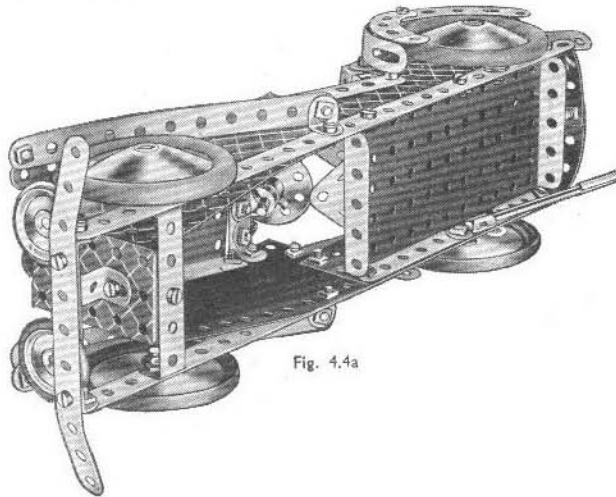

Fig. 4.4a

Parts required

2 of No. 1	1 of No. 52
5 " " 2	1 " " 54a
1 " " 3	4 " " 90a
9 " " 5	6 " " 111c
4 " " 10	2 " " 125
2 " " 11	2 " " 126
6 " " 12	2 " " 126a
3 " " 12c	2 " " 155a
1 " " 16	4 " " 187
1 " " 18b	2 " " 188
3 " " 22	2 " " 190
1 " " 24	2 " " 192
2 " " 35	2 " " 199
66 " " 37	1 " " 200
7 " " 38	1 " " 212
1 " " 44	1 " " 213
6 " " 48a	4 " " 215
1 " " 51	2 " " 217a

4.5 EARLY TYPE OF STEAMSHIP

Parts required

4 of No. 1	2 of No. 126a
5 " " 2	4 " " 155a
5 " " 5	2 " " 187
1 " " 10	2 " " 188
2 " " 11	2 " " 189
7 " " 12	4 " " 190
2 " " 15b	2 " " 191
4 " " 16	2 " " 192
1 " " 17	1 " " 199
1 " " 18a	2 " " 200
2 " " 22	1 " " 213
1 " " 23	2 " " 214
6 " " 35	4 " " 215
75 " " 37	2 " " 217a
6 " " 37a	2 " " 217b
5 " " 38	
1 " " 40	
5 " " 48a	
1 " " 51	
1 " " 52	
2 " " 54a	
4 " " 90a	
4 " " 111c	
2 " " 125	
2 " " 126	

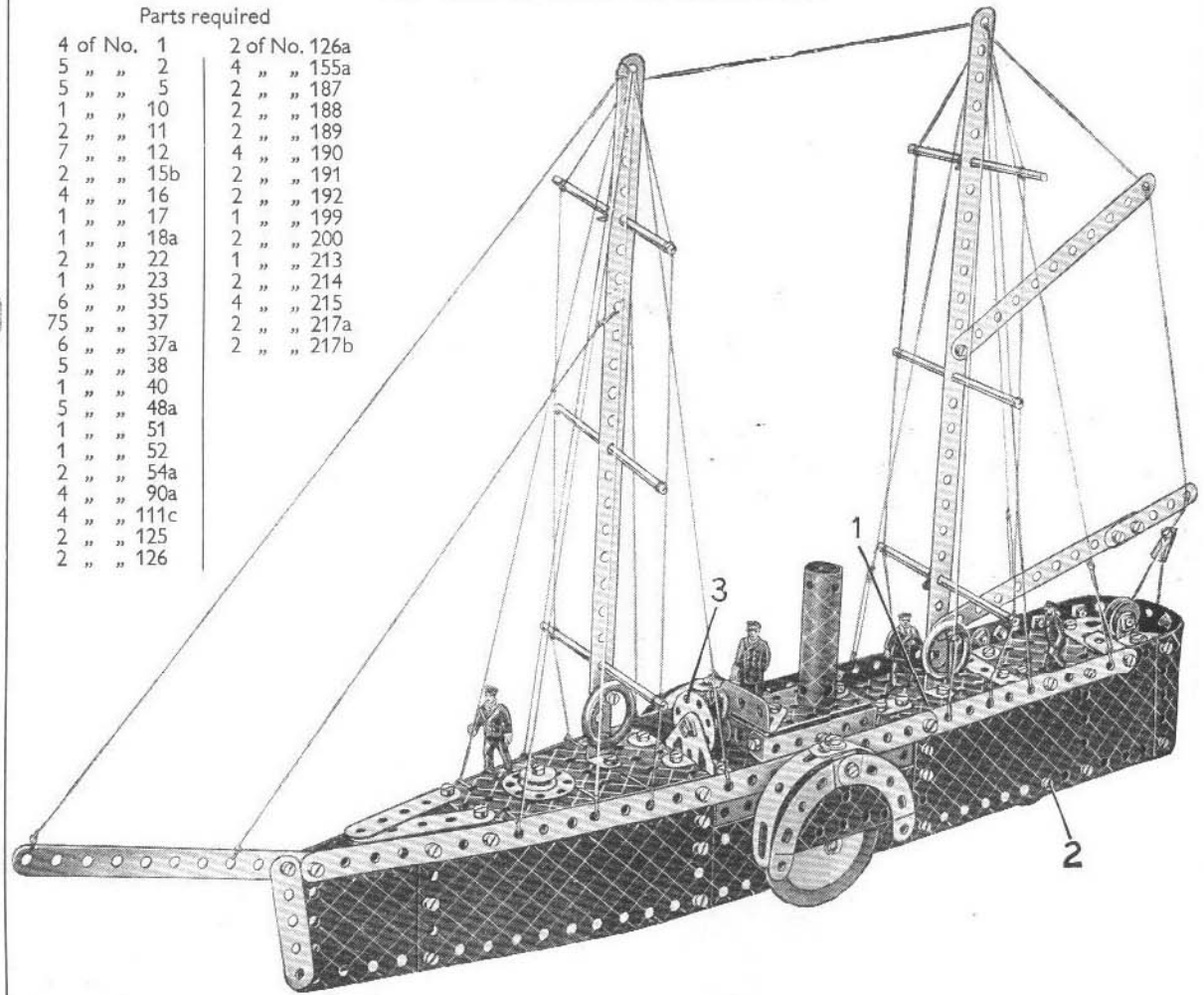

The foredeck consists of a Flanged Sector Plate bolted to the $12\frac{1}{2}$ " Strips that are placed along the sides of the deck. A $5\frac{1}{2}$ " x $2\frac{1}{2}$ " Flanged Plate is used for the central portion of the deck and to the rear end of this a Flanged Sector Plate 1 is fastened by a Flat Bracket. A $2\frac{1}{2}$ " x $\frac{1}{2}$ " Double Angle Strip is bolted across the Flanged Sector Plate and to the sides of the vessel. Two $2\frac{1}{2}$ " x $1\frac{1}{2}$ " Flexible Plates, overlapped one hole, are bolted to the rear end of the Flanged Sector Plate.

The vessel runs on Road Wheels mounted on a compound rod consisting of a $1\frac{1}{2}$ " and a 2" Rod joined by a Rod Connector, which is journalled in the sides of the hull as shown, and also on 1" Pulleys fitted with Rubber Rings supported inside the hull on $\frac{3}{8}$ " Bolts 2. The Bolts 2 pass through holes in the Flexible Plates forming the sides of the ship and are locked in the bosses of the Pulleys. A $1\frac{1}{4}$ " Disc 3 is lock-nutted to a Trunnion to form the wheel.

4.6 DRILLING MACHINE

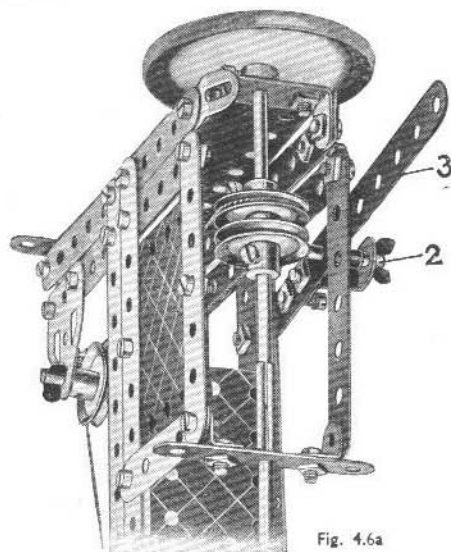
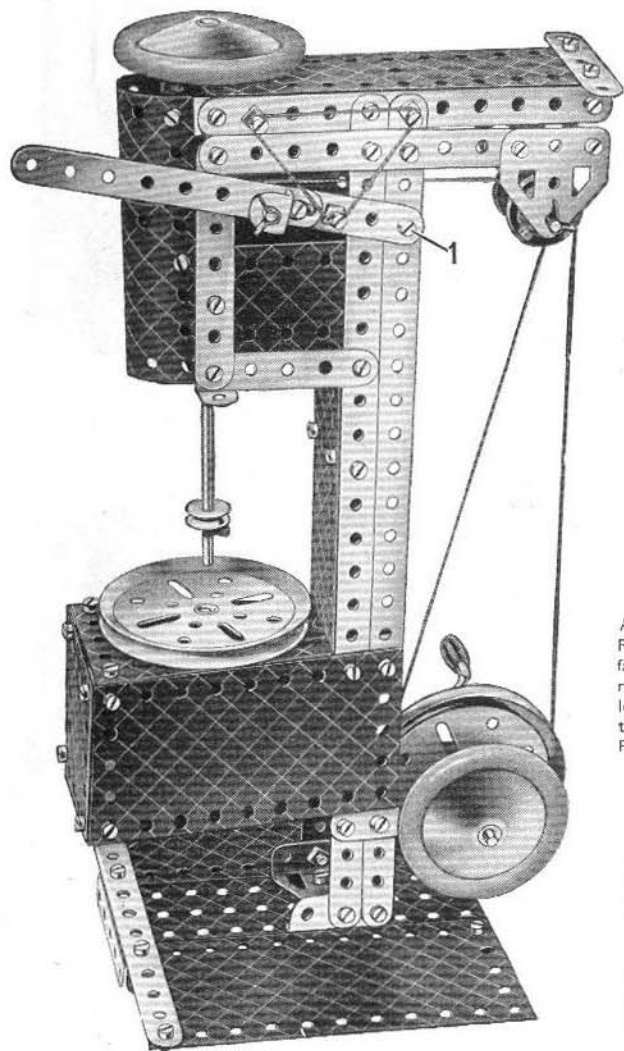

Fig. 4.6a

The height of the drill is controlled by the lever 3 (Fig. 4.6a). A 2" Rod 2, passed through a hole in the Strip 3 and through a hole in a Reversed Angle Bracket bolted to the Strip, engages between two 1" fast Pulleys on the shaft of the drill. A Driving Band, which is arranged as shown, holds the lever at its maximum height. The Bolt 1 is lock-nutted. The drill table is held in position by a 3/4" Bolt, that passes through the Flanged Sector Plate and is then locked in the boss of the Pulley.

Parts required		
4 of No. 1	4 of No. 22	2 of No.126
6 " " 2	1 " " 23	2 " " 126a
2 " " 3	6 " " 35	2 " " 187
7 " " 5	71 " " 37	1 " " 188
8 " " 12	7 " " 37a	2 " " 189
2 " " 12c	1 " " 48	2 " " 190
1 " " 15b	1 " " 48a	2 " " 191
1 " " 16	1 " " 52	2 " " 192
2 " " 17	1 " " 54a	2 " " 199
2 " " 19b	4 " " 111c	1 " " 213
1 " " 19g	1 " " 125	

4.7 GIANT EXCAVATOR

The Cord 1 is fastened to a Crank Handle journalled in holes in the sides of the cab, and after passing round the 2 1/2" x 1/2" Double Angle Strip above the cabin is tied to the jib at 2. This Cord controls the luffing movement of the jib. The Cord 3 is tied to the bucket and is passed over the 1" Pulley Wheel 5 and then wound round Rod 6. By turning the handle 7 on the Bush Wheel 7 the bucket is raised or lowered.

The bucket arm is pivoted on Rod 4, which passes through holes in the 12 1/2" Strips forming the jib and the bucket arm. Road Wheels fastened at each end of Rod 4 retain it in position.

A 3" Pulley Wheel 8 is bolted to the base by two Bolts, and a Flanged Sector Plate 9, to which the cab is fastened, is similarly attached to the upper 3" Pulley. A 1 1/2" Rod is held in the boss of Pulley Wheel 8, and the Pulley attached to Flanged Sector Plate 9 is retained in position by a Spring Clip so that the superstructure is free to swivel on the Rod. The control cab is built up on the flanges of the Flanged Sector Plate, and the platform around the cab is composed of two 5 1/2" x 2 1/2" Flexible Plates, which are bolted underneath the Flanged Sector Plate 9.

The wheels on which the model runs are free to rotate on pairs of 3 1/2" Rods. The front pair are joined by a Rod Connector and the rear pair by a Rod and Strip Connector.

Parts required

4 of No. 1	1 of No.176
6 " " 2	4 " " 187
5 " " 5	2 " " 188
4 " " 10	2 " " 189
1 " " 11	4 " " 190
6 " " 12	2 " " 191
4 " " 12c	2 " " 192
1 " " 15b	2 " " 200
4 " " 16	1 " " 212
2 " " 17	1 " " 213
1 " " 18a	1 " " 214
2 " " 19b	
1 " " 19g	
5 " " 22	
1 " " 24	
8 " " 35	
73 " " 37	
5 " " 37a	
4 " " 38	
1 " " 40	
1 " " 48	
6 " " 48a	
1 " " 52	
1 " " 54a	
5 " " 111c	
2 " " 126	
2 " " 126a	
4 " " 155a	

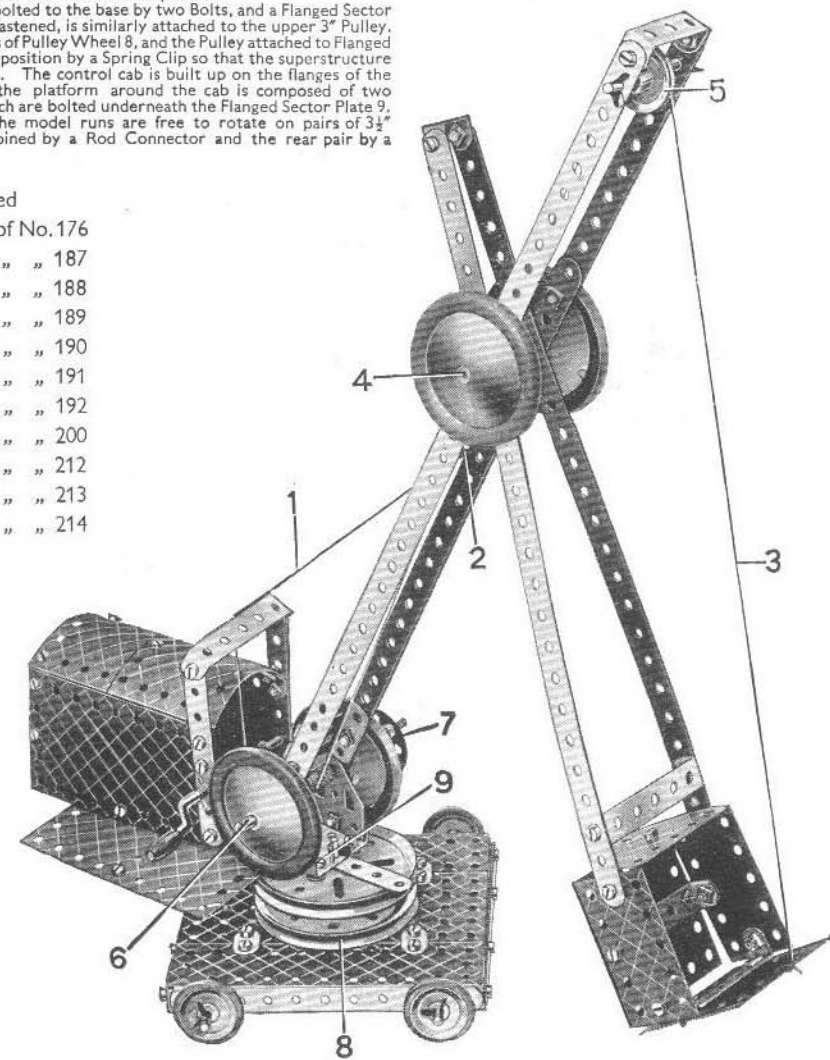

4.8 ELEVATED JIB CRANE

The superstructure of the model is pivoted on a Rod held in the boss of the 3" Pulley. Bearings for this Rod are provided by two $2\frac{1}{2} \times \frac{1}{2}$ " Double Angle Strips, one of which is bolted halfway down the Flanged Sector Plates and the other at the top.

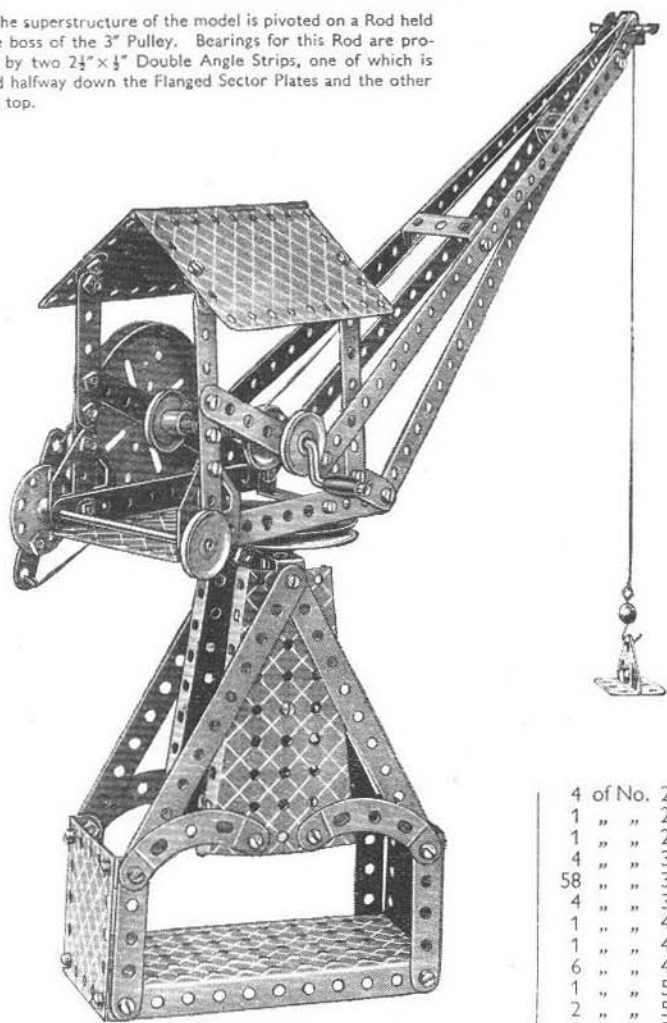

Parts required	
4 of No. 1	2 of No. 12
8 " " 2	3 " " 12c
1 " " 3	2 " " 16
9 " " 5	1 " " 18a
1 " " 11	2 " " 19b
	1 " " 19g

4 of No. 22
1 " " 23
1 " " 24
4 " " 35
58 " " 37
4 " " 38
1 " " 40
1 " " 48
6 " " 48a
1 " " 52
2 " " 54a
1 " " 57c
4 " " 90a
2 " " 126
2 " " 126a
1 " " 176
3 " " 190
1 " " 198

Parts required			
4 of No. 1	8 of No. 38		
6 " " 2	1 " " 40		
9 " " 5	1 " " 44		
1 " " 10	1 " " 48		
1 " " 11	4 " " 48a		
6 " " 12	1 " " 51		
4 " " 12c	1 " " 52		
1 " " 15b	2 " " 54a		
3 " " 16	1 " " 57c		
1 " " 18a	4 " " 90a		
1 " " 18b	4 " " 111c		
2 " " 19b	2 " " 126a		
1 " " 19g	3 " " 187		
5 " " 22	1 " " 188		
1 " " 23	2 " " 189		
1 " " 24	4 " " 190		
8 " " 35	2 " " 200		
64 " " 37	1 " " 212		
6 " " 37a	2 " " 217a		

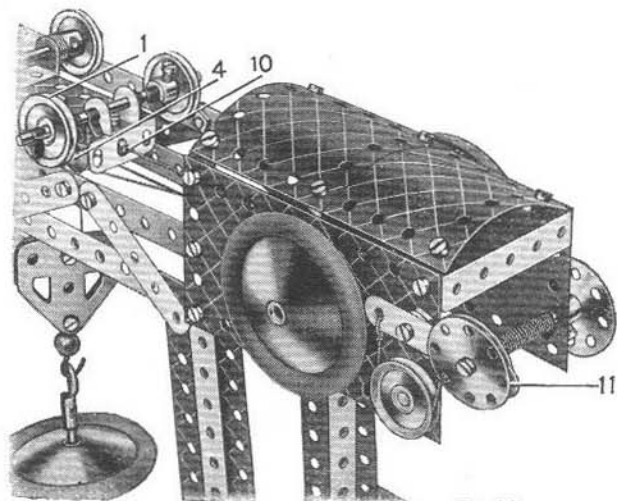
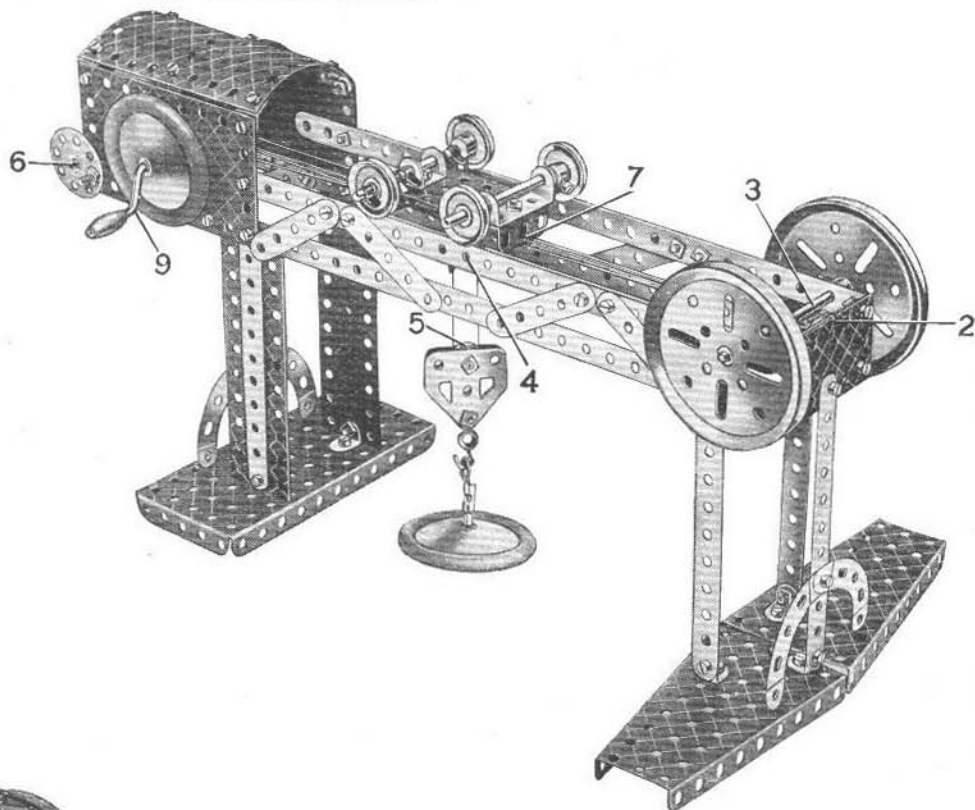

Fig. 4.9a

4.9 GANTRY CRANE



The sides of the cabin each consist of two $2\frac{1}{2} \times 2\frac{1}{2}$ " Flexible Plates overlapped one hole. The top of the cabin, which consists of two $1\frac{1}{2}$ " radius Curved Plates, is attached to the sides by means of Obtuse Angle Brackets at each corner as shown.

The hoisting carriage is a $2\frac{1}{2} \times 1\frac{1}{2}$ " Flanged Plate 7. Bearings for one of the $3\frac{1}{2}$ " Rods carrying the 1" Pulley Wheels are provided by the holes in the turned up ends of a $1\frac{1}{2} \times \frac{1}{2}$ " Double Angle Strip, and for the other Rod by the holes in a Double Bracket. The Bolt 1 (Fig. 4.9a) secures a Cranked Bent Strip 4 vertically to the underside of the Flanged Plate 7. A 1" Rod passes through the lower holes of the Cranked Bent Strip and is held in position by Spring Clips.

Two Flat Trunnions form the pulley block. They are fastened together at their wide ends by a $\frac{3}{4}$ " Bolt, which carries a $\frac{1}{2}$ " loose Pulley 5 on its shank between the two Flat Trunnions.

The Cord that operates the hoisting carriage 7 is tied at 10. It is then passed round Rod 3, which carries the two 3" Pulleys, and is taken to the Crank Handle 9. The Cord is wound round the Crank Handle several times to enable it to grip the shaft, and finally is tied to the rear end of the carriage. The hoisting cord is tied to Rod 6 fitted with a Bush Wheel, and wound round it several times. It is then taken over the 1" Rod held in the Cranked Bent Strip 4, round Pulley 5, back over the 1" Rod, and tied at 2. Strip 11 is the lever of a band brake, the cord of which passes around a 1 Pulley on Rod 6.

4.10 TANK LOCOMOTIVE

The construction of the model is commenced by building the chassis as shown in Fig. 4.10a. The Flat Brackets 1 must be bolted to the 12½ Strips 2 before the Flanged Sector Plate 3 is fitted. The 1½ Discs 5 rotate on ⅜ Bolts lock-nutted in the end holes of two 2½ small radius Curved Strips, which are bolted to the 12½ Strips forming the side members of the frame.

The top of the cab consists of two 1# radius Curved Plates, overlapped three holes and fastened by an Angle

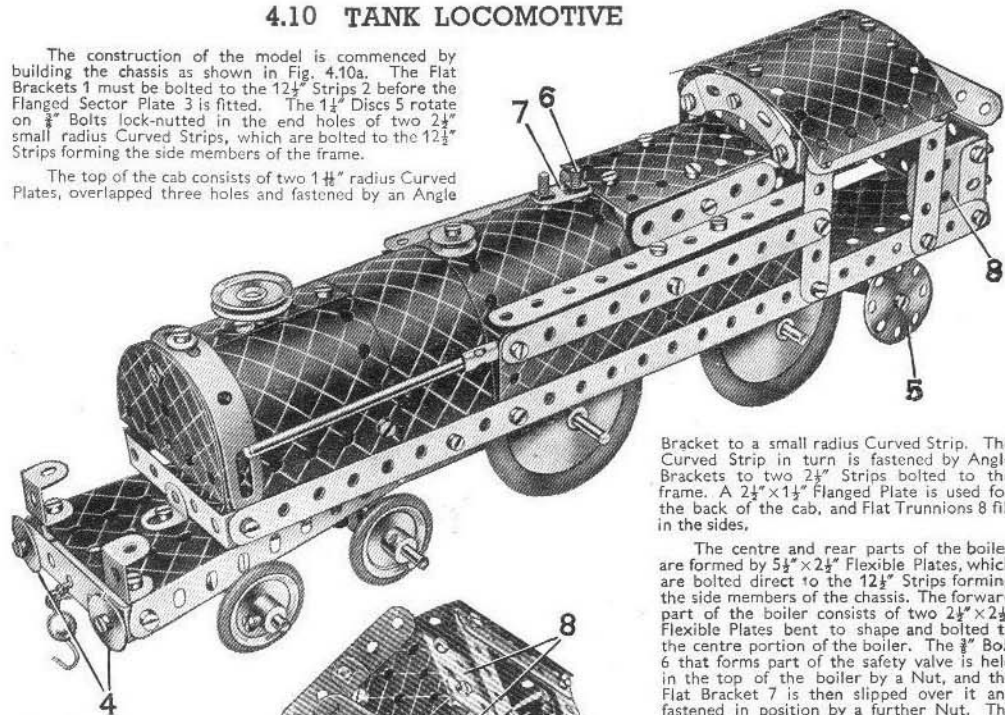

Bracket to a small radius Curved Strip. The Curved Strip in turn is fastened by Angle Brackets to two 2½ Strips bolted to the frame. A 2½×1½ Flanged Plate is used for the back of the cab, and Flat Trunnions 8 fill in the sides.

The centre and rear parts of the boiler are formed by 5½×2½ Flexible Plates, which are bolted direct to the 12½ Strips forming the side members of the chassis. The forward part of the boiler consists of two 2½×2½ Flexible Plates bent to shape and bolted to the centre portion of the boiler. The ⅜ Bolt 6 that forms part of the safety valve is held in the top of the boiler by a Nut, and the Flat Bracket 7 is then slipped over it and fastened in position by a further Nut. The buffers 4 are lock-nutted to a 2½×½ Double Angle Strip bolted to the flanges of the Flanged Sector Plate 3.

Fig. 4.10a

Parts required

4 of No. 1	
5 " " 2	
9 " " 5	
5 " " 10	1 of No. 44
2 " " 11	1 " " 48
6 " " 12	4 " " 48a
4 " " 12c	1 " " 51
1 " " 15b	1 " " 54a
4 " " 16	1 " " 57c
5 " " 22	4 of No. 187
1 " " 23	2 " " 188
4 " " 35	3 " " 90a
70 " " 37	5 " " 111c
9 " " 37a	2 " " 125
7 " " 38	2 " " 126
	2 " " 192
	2 " " 190
	2 " " 192
	2 " " 192
	2 " " 200
	2 " " 212
	1 of No. 214
	2 " " 215
	2 " " 217a
	2 " " 217b

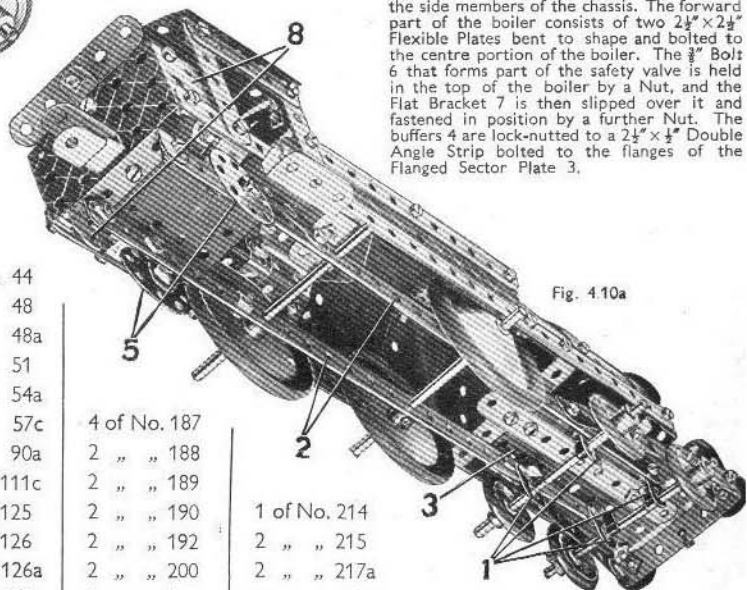

4.11 HAMMERHEAD CRANE

The jib of the crane is bolted to the upper 3" Pulley, and the lower 3" Pulley is bolted to two 2½×½ Double Angle Strips fastened to the narrow ends of the Flanged Sector Plates. A 1½ Rod is secured in the boss of the upper Pulley, but is free to rotate in the boss of the lower Pulley. A Bush Wheel fastened to the lower end of the Rod retains the jib in place.

The four Road Wheels are fastened to a 4" Rod that passes through the holes of two Flat Trunnions bolted to the 2½ small radius Curved Strips.

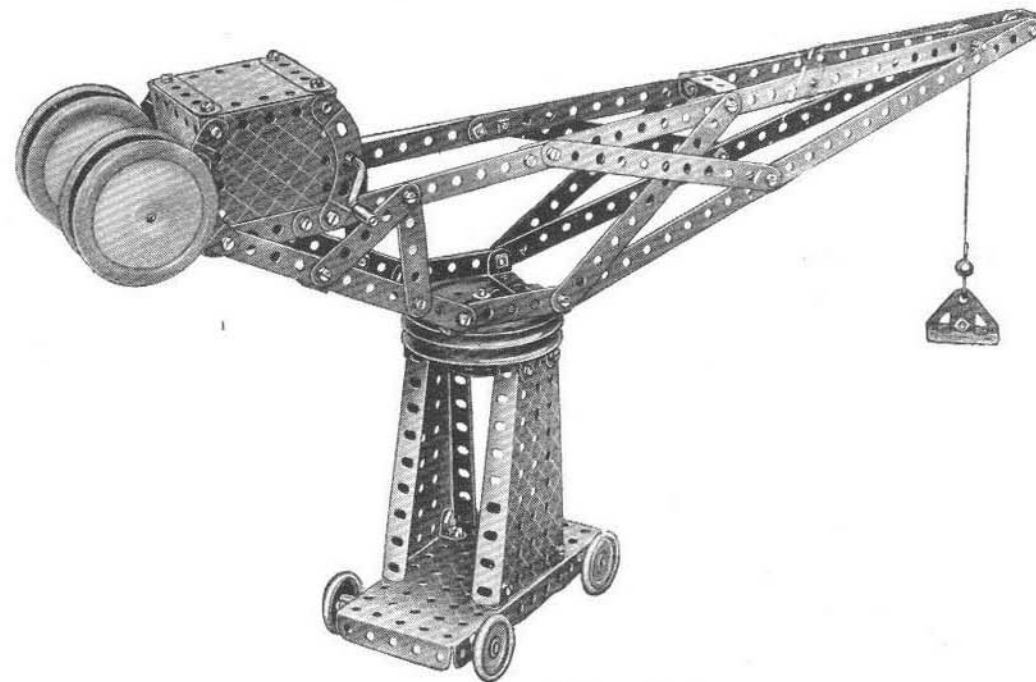

Parts required

4 of No. 1	2 of No. 18a	55 of No. 37	4 of No. 90a
8 " " 2	2 " " 19b	1 " " 40	2 " " 126
9 " " 5	1 " " 19g	1 " " 48	2 " " 126a
1 " " 11	4 " " 22	6 " " 48a	4 " " 155a
8 " " 12	1 " " 23	1 " " 52	1 " " 176
1 " " 15b	1 " " 24	2 " " 54a	4 " " 187
2 " " 16	4 " " 35	1 " " 57c	4 " " 190

4.12 FIGHTING BIPLANE

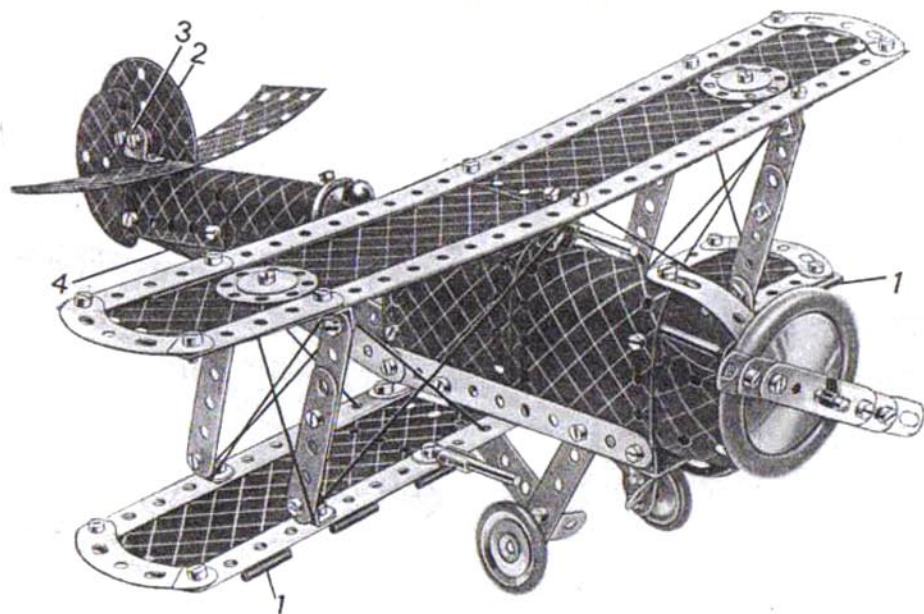

		Parts required		
of No. 1	1 of No. 16	1 of No. 40	1 of No. 187	1 of No. 212
" " 2	2 " " 17	1 " " 48	2 " " 188	2 " " 214
" " 3	1 " " 18a	4 " " 48a	1 " " 189	2 " " 215
" " 5	4 " " 22	4 " " 90a	4 " " 190	2 " " 217a
" " 10	6 " " 35	5 " " 111c	2 " " 191	2 " " 217b
" " 11	74 " " 37	2 " " 125	2 " " 192	
" " 12	1 " " 37a	2 " " 126a	1 " " 198	
" " 12c	5 " " 38	2 " " 155a	2 " " 199	

The two 3" Formed Slotted Strips that can be seen in the illustration, one forming the top and one the under side of the fuselage, are joined end to end by a Bolt through their slotted holes. The Bolt holds also a Reversed Angle Bracket at the nose, and an Obtuse Angle Bracket, which is outside the nose. The 3 1/4" Rod that forms the propeller shaft passes through the free hole of the Obtuse Angle Bracket, through the unoccupied part of the slots in the 3" Formed Slotted Strips, through the hole of the Reversed Angle Bracket. The Rod is held in position by Spring Clips. The centre pin of a Hinged Flat Plate has been withdrawn, and the two parts used as flat plates 1, to form part of the lower wing. The Semilar Plate 2 is fastened to the fuselage by means of a Double Bracket 3, and is spaced from the inside of the Bracket by three Spacers. Flat Trunnions are used for the sides of the cockpit. The 1" fast Pulleys forming the front and the back of the cockpit are fastened by a Bolt passing through the top of the U-Section Curved Plates and into the tapped hole of the boss.

4.13 RAILWAY FOOTBRIDGE

The Bolts 1 are lock-nutted. The right-hand signal is operated by the Cord 3, which passes underneath the bridge and around the rear end of Rod 5, and is tied to the Flat Bracket on the lever arm. The other end of the Cord is tied to Strip 4, so that if the lever is pushed forward the signal arm rises to a horizontal position. The 2 1/4" Strip 2 is held by the Bolts that hold the small radius Curved Strips, and it retains the lever 4 in whatever position it is placed. The 2" Rod on which the levers pivot is journaled in the centre hole of the 2 1/4" Strip 2, and in the lower hole of a Reversed Angle Bracket bolted to the rear Cranked Curved Strip. The left-hand Trunnion that supports the lever frame is fastened to the bottom of the step by a Cranked Bent Strip, the top of which can just be seen in the illustration. The other Trunnion forms a guide for the operating Cords. The 1" Pulleys are fastened to the signal arms by 3/8" Bolts, which pass through the end hole of the Strips and are locked in the bosses of the Pulleys.

The centre pin has been withdrawn from a Hinged Flat Plate and the two halves used as flat plates at 6 for the floor of the span. Two 5 1/2" x 1 1/4" Flexible Plates fill in the space between them.

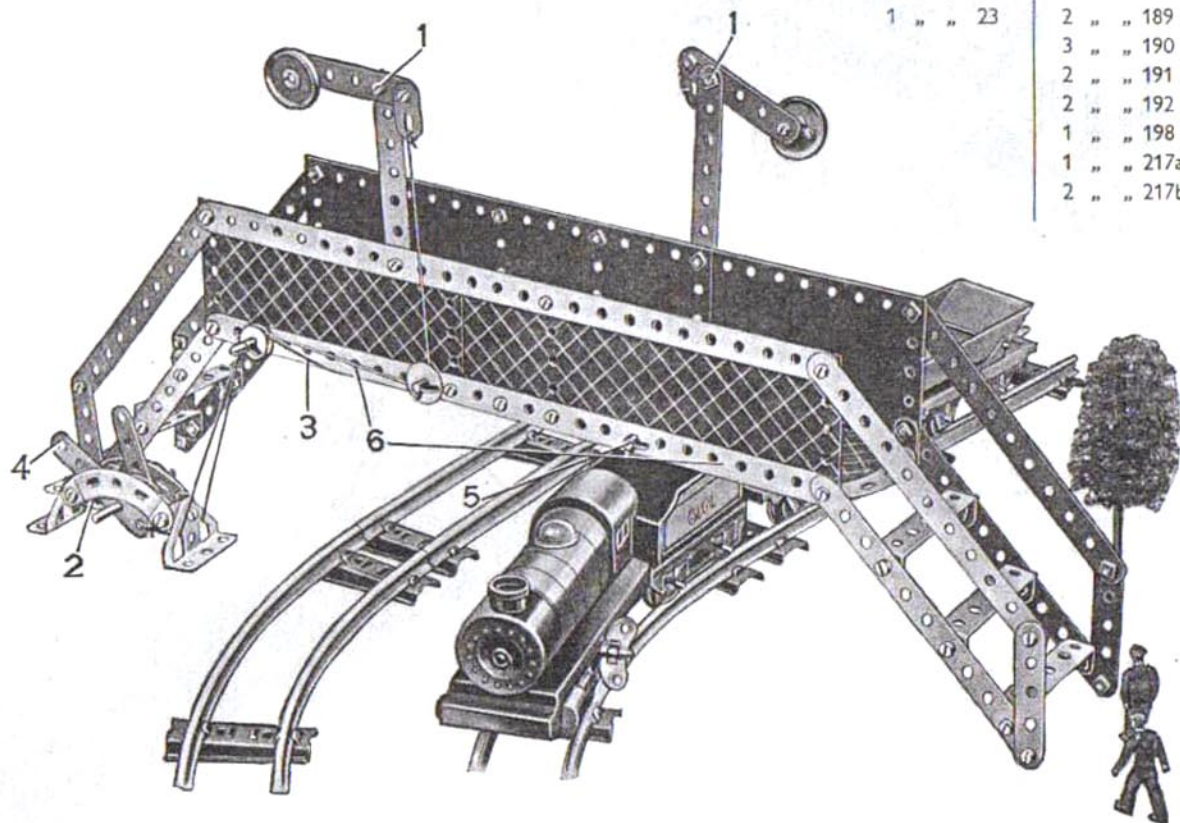

Parts required

4 of No. 1	8 of No. 35
8 " " 2	64 " " 37
2 " " 3	2 " " 37a
9 " " 5	2 " " 38
2 " " 10	1 " " 40
2 " " 11	1 " " 44
6 " " 12	6 " " 48a
1 " " 15b	4 " " 90a
2 " " 16	2 " " 111c
1 " " 17	1 " " 125
2 " " 22	2 " " 126
1 " " 23	2 " " 189
	3 " " 190
	2 " " 191
	2 " " 192
	1 " " 198
	1 " " 217a
	2 " " 217b

4.14 LIFTING BRIDGE

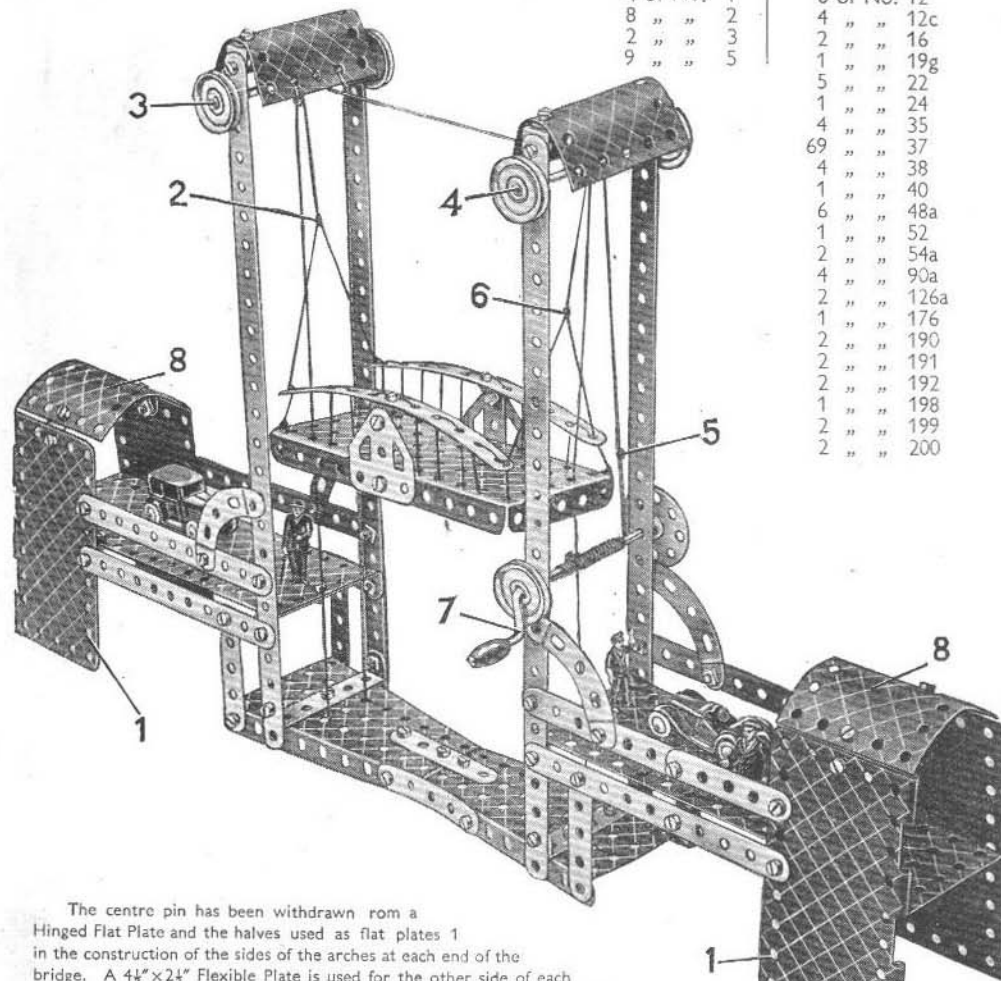

Parts required

4 of No.	1	6 of No.	12
8 "	2	4 "	12c
2 "	3	2 "	16
9 "	5	1 "	19g
		5 "	22
		1 "	24
		4 "	35
		69 "	37
		4 "	38
		1 "	40
		6 "	48a
		1 "	52
		2 "	54a
		4 "	90a
		2 "	126a
		1 "	176
		2 "	190
		2 "	191
		2 "	192
		1 "	198
		2 "	199
		2 "	200

The centre pin has been withdrawn from a Hinged Flat Plate and the halves used as flat plates 1 in the construction of the sides of the arches at each end of the bridge. A $4\frac{1}{2}'' \times 2\frac{1}{2}''$ Flexible Plate is used for the other side of each arch, and the $1\frac{1}{8}''$ radius Curved Plates 8 that form their tops are held in position by Obtuse Angle Brackets. The two U-Section Curved Plates bolted at the head of the towers are spaced away from the $2\frac{1}{2}'' \times \frac{1}{2}''$ Double Angle Strips that support them by two Washers. Crank Handle 7 which controls the raising and lowering of the bridge, is retained in position in the sides of the right hand tower by a Bush Wheel and a 1" Pulley. Cord is wound round the shaft of Crank Handle 7, and at 5 a second length of Cord is knotted to it, and both are led over the Rod 4. One of the Cords is led downward and is tied at 6 to the Cords supporting the span; while the other is passed over Rod 3 and is tied at 2 to the other supporting Cords. Guide Cords are tied to Rods 3 and 4, and after passing through holes in the $5\frac{1}{2}'' \times 2\frac{1}{2}''$ Flanged Plate are fastened to the two Flanged Sector Plates forming the base.

4.15 RACING CAR

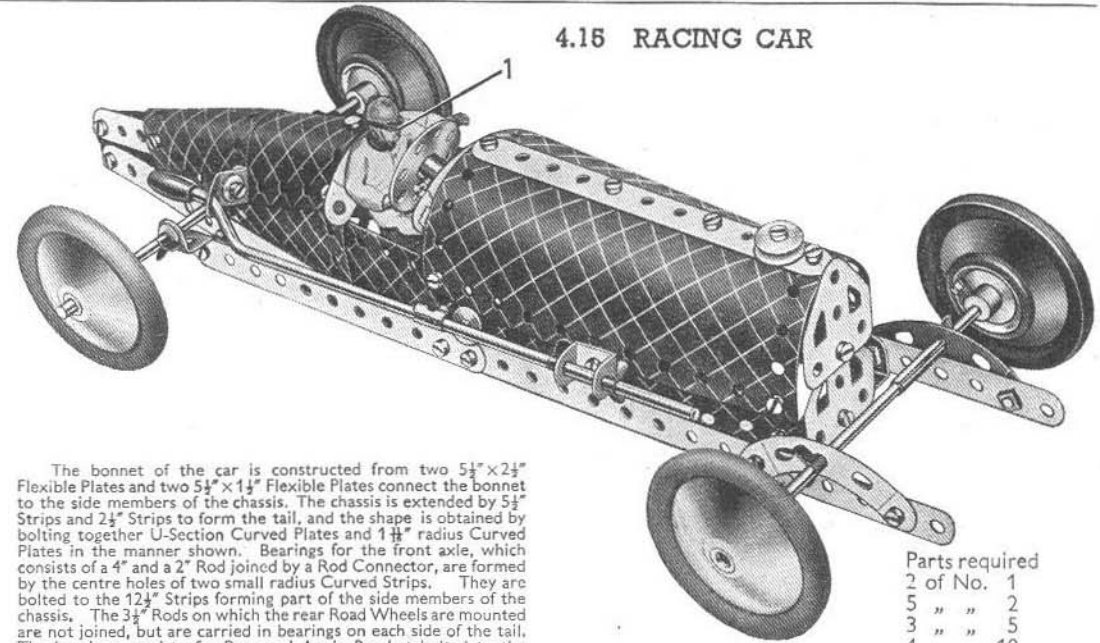

The bonnet of the car is constructed from two $5\frac{1}{2}'' \times 2\frac{1}{2}''$ Flexible Plates and two $5\frac{1}{2}'' \times 1\frac{1}{2}''$ Flexible Plates connect the bonnet to the side members of the chassis. The chassis is extended by $5\frac{1}{2}''$ Strips and $2\frac{1}{2}''$ Strips to form the tail, and the shape is obtained by bolting together U-Section Curved Plates and $1\frac{1}{8}''$ radius Curved Plates in the manner shown. Bearings for the front axle, which consists of a 4" and a 2" Rod joined by a Rod Connector, are formed by the centre holes of two small radius Curved Strips. They are bolted to the $12\frac{1}{2}''$ Strips forming part of the side members of the chassis. The $3\frac{1}{2}''$ Rods on which the rear Road Wheels are mounted are not joined, but are carried in bearings on each side of the tail. The bearings consist of a Reversed Angle Bracket bolted to the chassis and a Flat Bracket fastened to the side of the car. The Rods are held in position by Spring Clips. The Driver 1 (Motor Car Constructor Part No. A1100) is not included in the Outfit, but can be purchased separately if required.

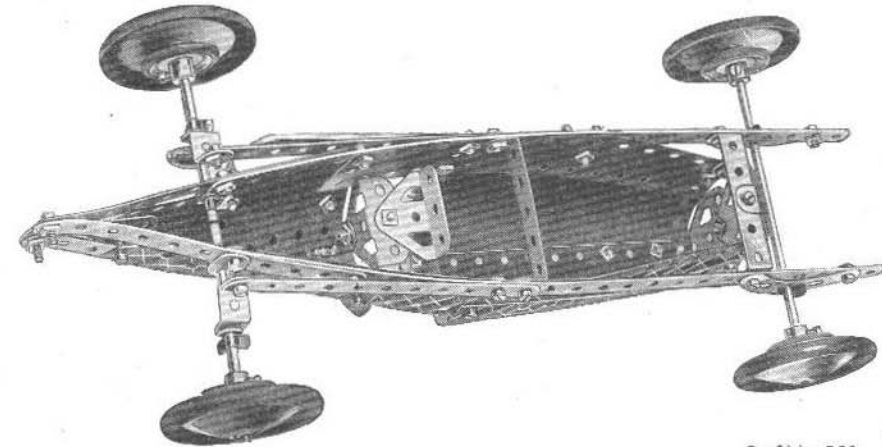
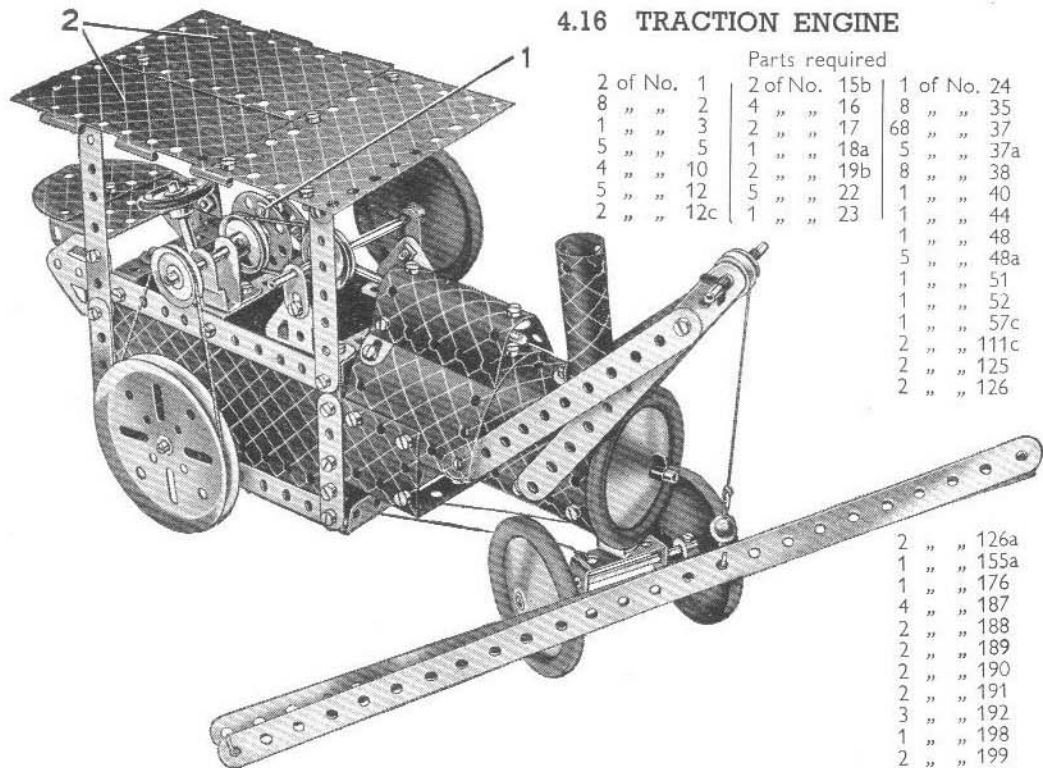

Fig. 4.15a

Parts required

2 of No.	1
5 "	2
3 "	5
4 "	10
1 "	11
4 "	12
1 "	12c
2 "	15b
2 "	16
1 "	17
1 "	19g
4 "	22
1 "	23
1 "	24
8 "	35
42 "	37
2 "	37a
7 "	38
1 "	48
2 "	48a
4 "	90a
4 "	111c
2 "	125
2 "	126
2 "	126a
4 "	155a
4 "	187
2 "	188
2 "	189
2 "	192
1 "	213

4.16 TRACTION ENGINE



Parts required		
2 of No. 1	2 of No. 15b	1 of No. 24
8 " " 2	4 " " 16	8 " " 35
1 " " 3	2 " " 17	68 " " 37
5 " " 5	1 " " 18a	5 " " 37a
4 " " 10	2 " " 19b	8 " " 38
5 " " 12	5 " " 22	1 " " 40
2 " " 12c	1 " " 23	1 " " 44
		1 " " 48
		5 " " 48a
		1 " " 51
		1 " " 52
		1 " " 57c
		2 " " 111c
		2 " " 125
		2 " " 126

2 " " 126a
1 " " 155a
1 " " 176
4 " " 187
2 " " 188
2 " " 189
2 " " 190
2 " " 191
3 " " 192
1 " " 198
2 " " 199
1 " " 200
1 " " 212
1 " " 213
1 " " 214
2 " " 215
1 " " 217b

The cylinder consists of a U-Section Curved Plate, fastened to the boiler by the Obtuse Angle Brackets. Bearings for the piston rod are formed by the holes of two Angle Brackets, which are held in place by the Bolts that can be seen at the top of the cylinder. The Bolts 1, which pass through a connecting rod consisting of two Flat Brackets, are lock-nutted. A U-Section Curved Plate, bent so that its ends overlap one hole, is used for the chimney. The centre pin of a Hinged Flat Plate has been removed and the two parts used as flat plates 2 in the construction of the roof of the cab.

The $1\frac{1}{2}'' \times \frac{1}{2}''$ Double Angle Strip that supports the front axle is pivotally attached by a lock-nutted Bolt, to the centre hole of a double bent strip, which consists of two Reversed Angle Brackets. The Cord controlling the steering is wound twice around the lower end of the steering column.

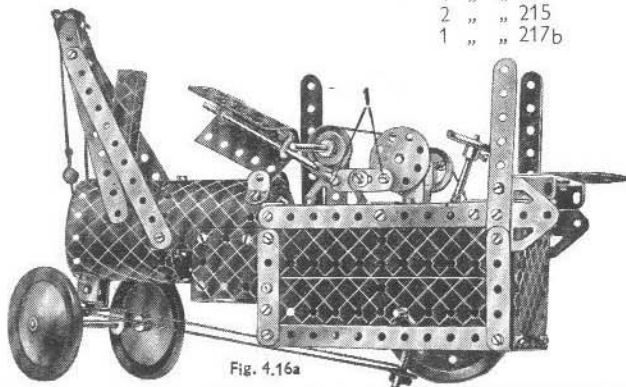
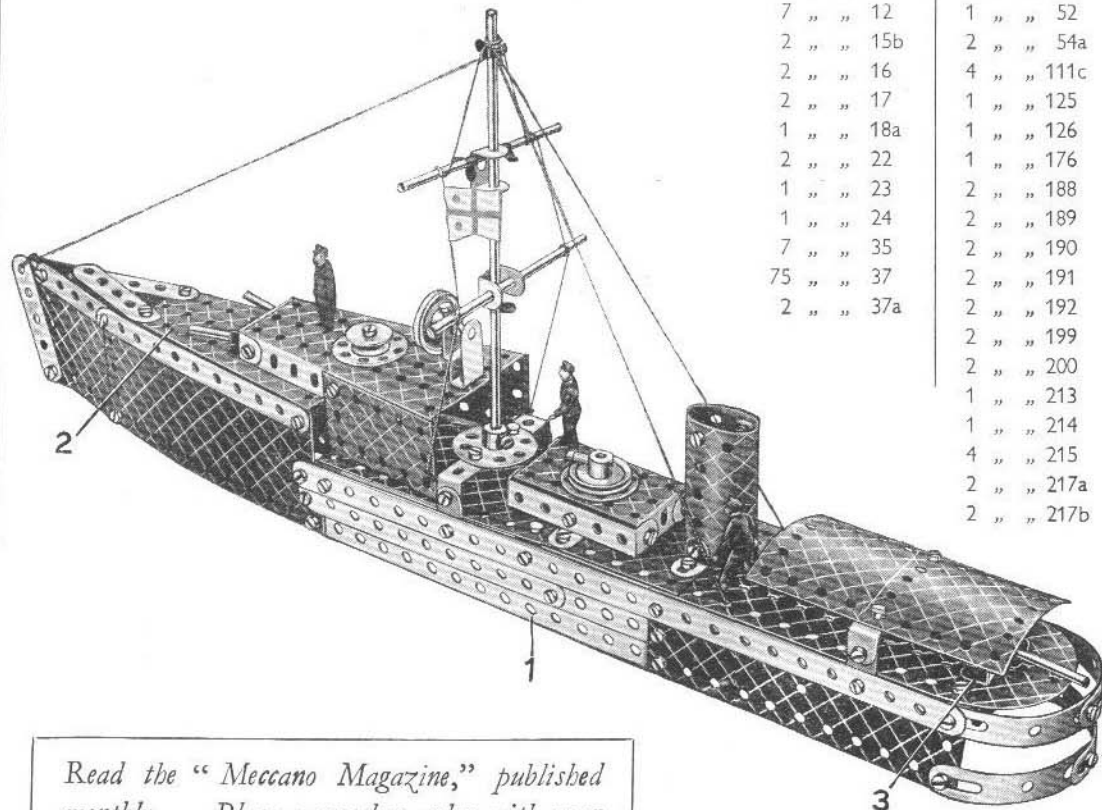

Fig. 4.16a

4.17 RIVER GUN-BOAT

Each side of the forward part of the ship consists of a $2\frac{1}{2}'' \times 2\frac{1}{2}''$ and a $5\frac{1}{2}'' \times 2\frac{1}{2}''$ Flexible Plate. These are bolted to the $12\frac{1}{2}''$ Strip 1 and to the Flanged Sector Plate 2. The funnel is represented by two U-Section Curved Plates bent so that their ends overlap two holes at each side, and it is fastened to the deck by two Angle Brackets. The forward gun turret, also a Flanged Sector Plate, is fastened to the raised portion of the deck by means of an $\frac{1}{2}'' \times \frac{1}{2}''$ Angle Bracket. The guns are represented by two 2" Rods, held by Spring Clips in the holes of a $1\frac{1}{2}'' \times \frac{1}{2}''$ Double Angle Strip bolted to the narrow end of the Flanged Sector Plate 2. A $1\frac{1}{2}''$ Rod, held by a Spring Clip and a Cord Anchoring Spring in a Trunnion 3, forms the rear gun. The gun in front of the funnel is held in place by a $\frac{3}{8}''$ Bolt passed through the centre hole of the Flanged Plate and locked in the boss of the Pulley by the $\frac{3}{8}''$ Bolt representing the gun barrel.



Parts required

4 of No. 1	1 of No. 40
4 " " 2	1 " " 44
8 " " 5	1 " " 48
4 " " 10	5 " " 48a
2 " " 11	1 " " 51
7 " " 12	1 " " 52
2 " " 15b	2 " " 54a
2 " " 16	4 " " 111c
2 " " 17	1 " " 125
1 " " 18a	1 " " 126
2 " " 22	1 " " 176
1 " " 23	2 " " 188
1 " " 24	2 " " 189
7 " " 35	2 " " 190
75 " " 37	2 " " 191
2 " " 37a	2 " " 192
	2 " " 199
	2 " " 200
	1 " " 213
	1 " " 214
	4 " " 215
	2 " " 217a
	2 " " 217b

Read the "Meccano Magazine," published monthly. Place a regular order with your Meccano dealer or newsagent today.

4.18 SIX-WHEELED STEAM WAGON

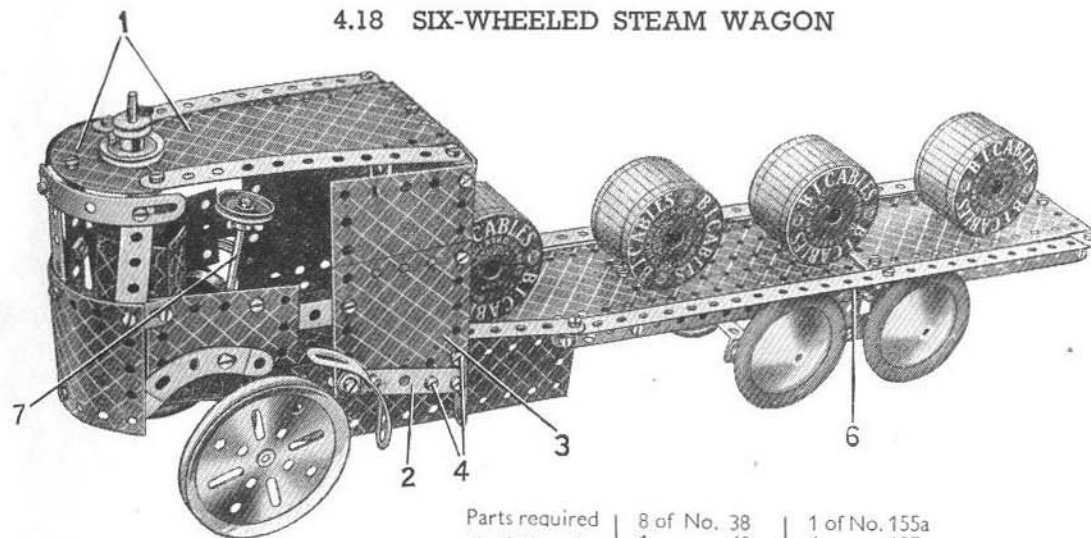

Parts required		8 of No. 38	1 of No. 155a
4 of No. 1		1 " " 48	4 " " 187
8 " " 2		6 " " 48a	2 " " 188
2 " " 3		1 " " 51	2 " " 189
6 " " 5		1 " " 52	4 " " 190
4 " " 10		1 " " 54a	2 " " 191
2 " " 11		4 " " 90a	2 " " 192
8 " " 12		2 " " 111c	2 " " 199
2 " " 12c		2 " " 125	2 " " 200
2 " " 15b		1 " " 126	1 " " 214
4 " " 16		2 " " 126a	4 " " 215
2 " " 19b			
5 " " 22			
1 " " 23			
1 " " 24			
8 " " 35			
75 " " 37			
2 " " 37a			

In Fig. 4.18a the top of the cab has been removed to show the construction of the boiler and steering wheel. The boiler consists of two U-Section Curved Plates fastened by a $1\frac{1}{2}'' \times \frac{1}{2}''$ Double Angle Strip to the Flanged Sector Plate forming the bottom of the cab. The two 1" Pulleys seen in Fig. 4.18a are fixed to the steering column 7, which passes through the bottom of the cab and is held in the boss of a Bush Wheel carrying a $2\frac{1}{2}'' \times \frac{1}{2}''$ Double Angle Strip. The holes in the turned down ends of the Double Angle Strip support the 4" Rod that forms the front axle. The method of attaching the chimney to the two Plates 1 is shown in Fig. 4.18c. The Bolts 4 pass through a Flat Bracket behind Plate 3, thus securing the Strip 2 to the Plate. The 1" Pulley with Rubber Ring represents the top of the boiler.

Fig. 4.18b shows the construction of the rear wheel bogie. The bogie is attached to the wagon by a Rod 5, which passes through the holes in the $12\frac{1}{2}''$ Strips 6 and through the upper holes in the Flat Trunnions bolted to the bogie. The Rod is held in position by Spring Clips.

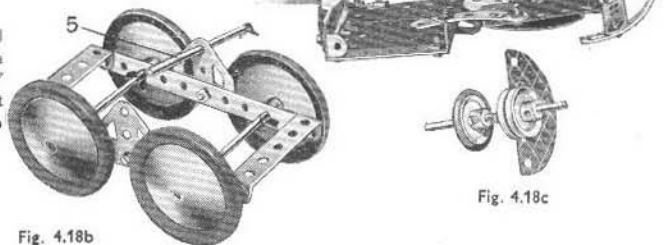
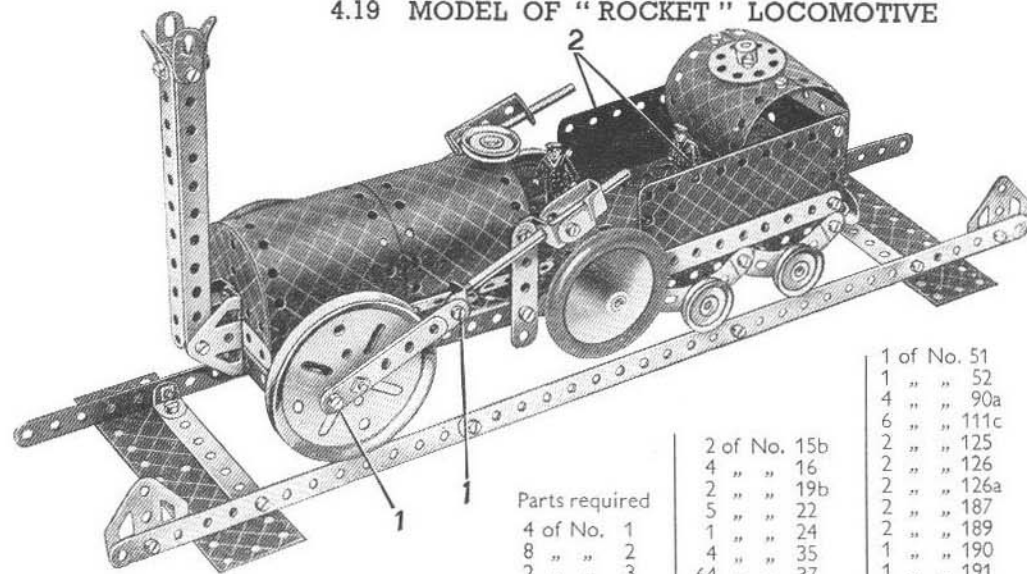

Fig. 4.18b

Fig. 4.18c

4.19 MODEL OF "ROCKET" LOCOMOTIVE



Parts required		1 of No. 51
4 of No. 1		1 " " 52
8 " " 2		4 " " 90a
2 " " 3		6 " " 111c
9 " " 5		2 " " 125
4 " " 10		2 " " 126
1 " " 11		2 " " 187
8 " " 12		2 " " 189
4 " " 12c		1 " " 190
	2 of No. 15b	1 " " 191
	4 " " 16	2 " " 192
	2 " " 19b	1 " " 198
	5 " " 22	2 " " 200
	1 " " 24	2 " " 214
	4 " " 35	2 " " 217b
	1 " " 37	
	12 " " 37a	
	8 " " 38	
	1 " " 44	
	1 " " 48	
	2 " " 48a	

The pin has been removed from a Hinged Flat Plate and the halves used as flat plates 2, to form the sides of the tender. The chassis of the engine consists of a $5\frac{1}{2}'' \times 2\frac{1}{2}''$ and a $2\frac{1}{2}'' \times 1\frac{1}{2}''$ Flanged Plate, fastened together by two $2\frac{1}{2}''$ Strips. Two $5\frac{1}{2}'' \times 2\frac{1}{2}''$ Flexible Plates bolted to $5\frac{1}{2}''$ Strips form the boiler, and are fastened to the $5\frac{1}{2}'' \times 2\frac{1}{2}''$ Flanged Plate by Obtuse Angle Brackets, two of which can be seen in Fig. 4.19a. Semi-Circular Plates form the ends of the boiler.

The four $5\frac{1}{2}''$ Strips that represent the chimney are joined together at the top by a Double Bracket and an Angle Bracket. The Chimney is bolted to two Trunnions, secured to the chassis and to the boiler front. Bearings for the piston rods are formed on one side by a $1\frac{1}{2}'' \times \frac{1}{2}''$ Double Angle Strip and a Reversed Angle Bracket, and on the other side by a Cranked Bent Strip and a Reversed Angle Bracket. The Bolts 1 on the connecting rods are lock-nutted, and the piston rods are retained in position by Spring Clips placed on each side of the Angle Brackets. The $\frac{3}{4}''$ Discs representing buffers are fastened against the heads of the $\frac{3}{4}''$ Bolts, which are lock-nutted to the Flexible Plate forming the back of the tender.

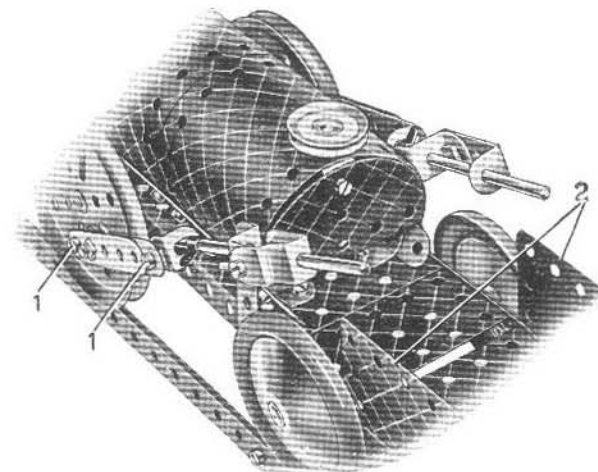
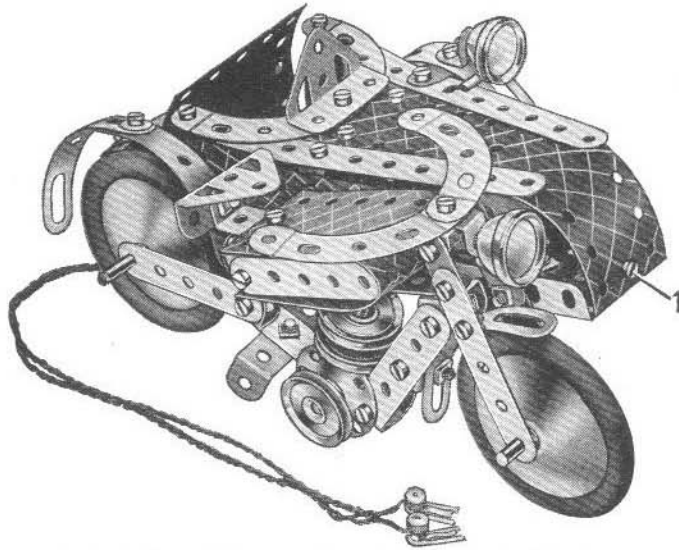

Fig. 4.19a

4.20 MOTOR CYCLE AND SIDECAR



Parts required		
5 of No.	2	1 of No. 54a
1 " "	3	4 " " 90a
8 " "	5	1 " " 111c
5 " "	10	1 " " 125
2 " "	11	2 " " 126
8 " "	12	2 " " 126a
1 " "	12c	3 " " 187
1 " "	16	2 " " 188
2 " "	17	2 " " 189
1 " "	18a	1 " " 190
3 " "	22	2 " " 199
1 " "	25	1 " " 200
51 " "	37	2 " " 214
2 " "	38	4 " " 215
1 " "	48	2 " " 217a
3 " "	48a	Lighting Set (Not included in Outfit)

The $5\frac{1}{2} \times 1\frac{1}{2}$ " Flexible Plate that forms the front of the sidecar is bolted at 1 to a $2\frac{1}{2} \times \frac{1}{2}$ " Double Angle Strip, which is fastened by Bolt 2 to the $4\frac{1}{2}$ " Flanged Sector Plate forming the bottom of the sidecar. The Bolts 3 pass through the Flexible Plates and also through a $2\frac{1}{2} \times \frac{1}{2}$ " Double Angle Strip.

The engine cylinder consists of two 1" Pulleys mounted on a 2" Rod, one end of which is journalled in the Strip 4 that forms the top of the frame. The other end of the Rod is held between the two Bolts that fasten the $1\frac{1}{4}$ " Discs to the frame.

The model is fitted with two Spotlights taken from a Meccano Lighting Set. These are fastened by the Angle Brackets supplied with the Lighting Set, to the handlebars and sidecar mudguard. The battery for supplying current for the Spotlights can be concealed in the sidecar.

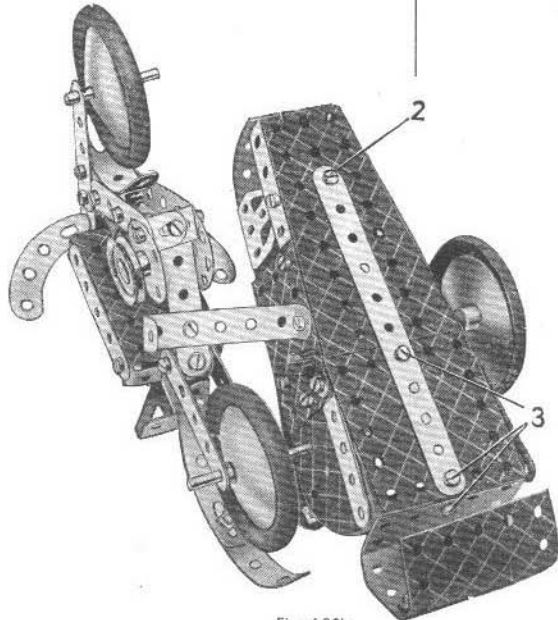

Fig. 4.20b

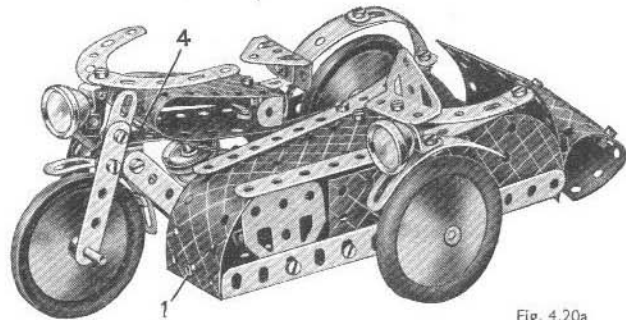
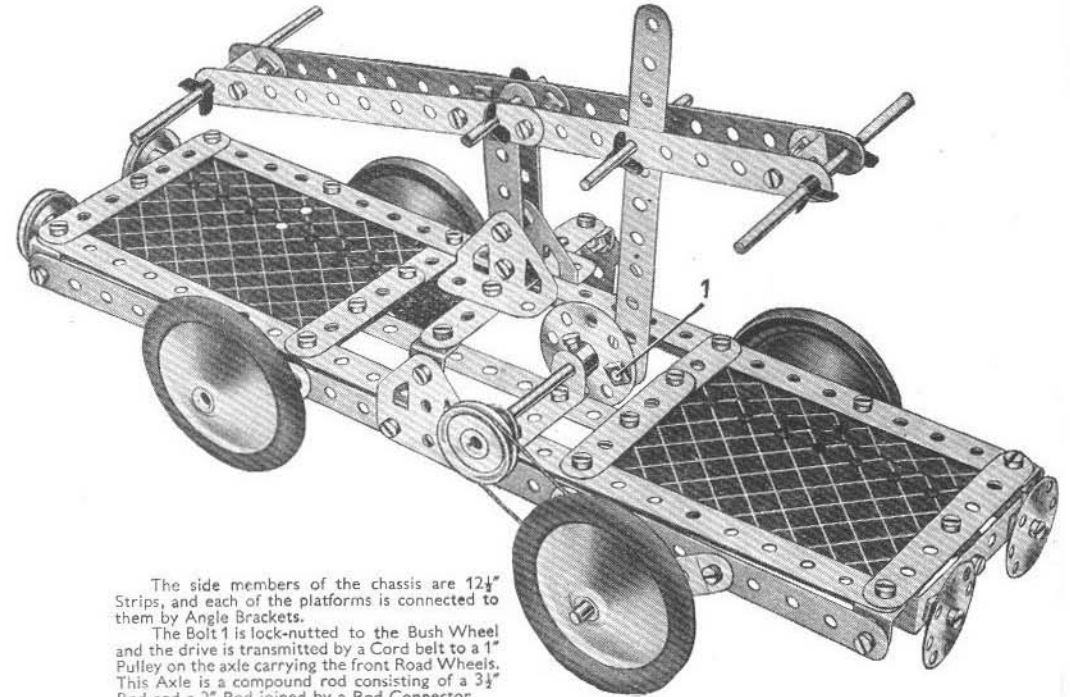

Fig. 4.20a

4.21 HAND TROLLEY CAR



The side members of the chassis are $12\frac{1}{2}$ " Strips, and each of the platforms is connected to them by Angle Brackets.

The Bolt 1 is lock-nutted to the Bush Wheel and the drive is transmitted by a Cord belt to a 1" Pulley on the axle carrying the front Road Wheels. This Axle is a compound rod consisting of a $3\frac{1}{2}$ " Rod and a 2" Rod joined by a Rod Connector.

Parts required			
4 of No.	1	2 of No. 18a	4 of No. 90a
6 " "	2	4 " " 22	4 " " 111c
2 " "	3	1 " " 24	2 " " 126
8 " "	5	8 " " 35	2 " " 126a
2 " "	11	54 " " 37	4 " " 187
8 " "	12	7 " " 37a	4 " " 190
1 " "	15b	2 " " 38	2 " " 191
3 " "	16	1 " " 48	1 " " 213
2 " "	17	2 " " 48a	2 " " 217a

4.22 HORIZONTAL STEAM ENGINE

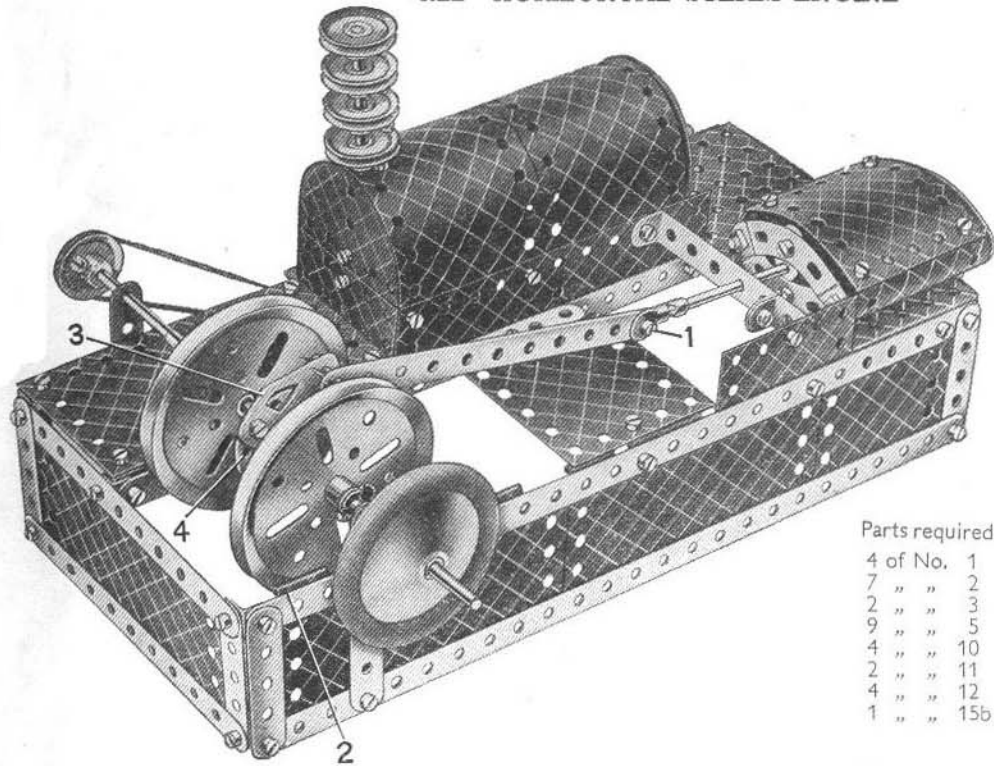

Parts required

4 of No.	1
7 " "	2
2 " "	3
9 " "	5
4 " "	10
2 " "	11
4 " "	12
1 " "	15b

3 of No.	16
1 " "	17
1 " "	18b
2 " "	19b
5 " "	22
1 " "	24
6 " "	35
75 " "	37
6 " "	37a
3 " "	38
6 " "	48a
1 " "	51
1 " "	52
4 " "	90a
6 " "	111c
2 " "	125
2 " "	126
2 " "	126a
1 " "	176
1 " "	187
2 " "	188
2 " "	189
4 " "	190
2 " "	191
2 " "	192
1 " "	198
2 " "	199
2 " "	200
1 " "	212
1 " "	213
2 " "	214
1 " "	217a
1	1 Magic Motor

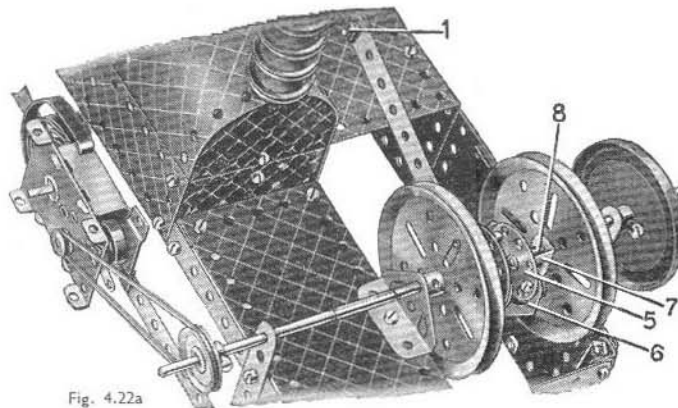
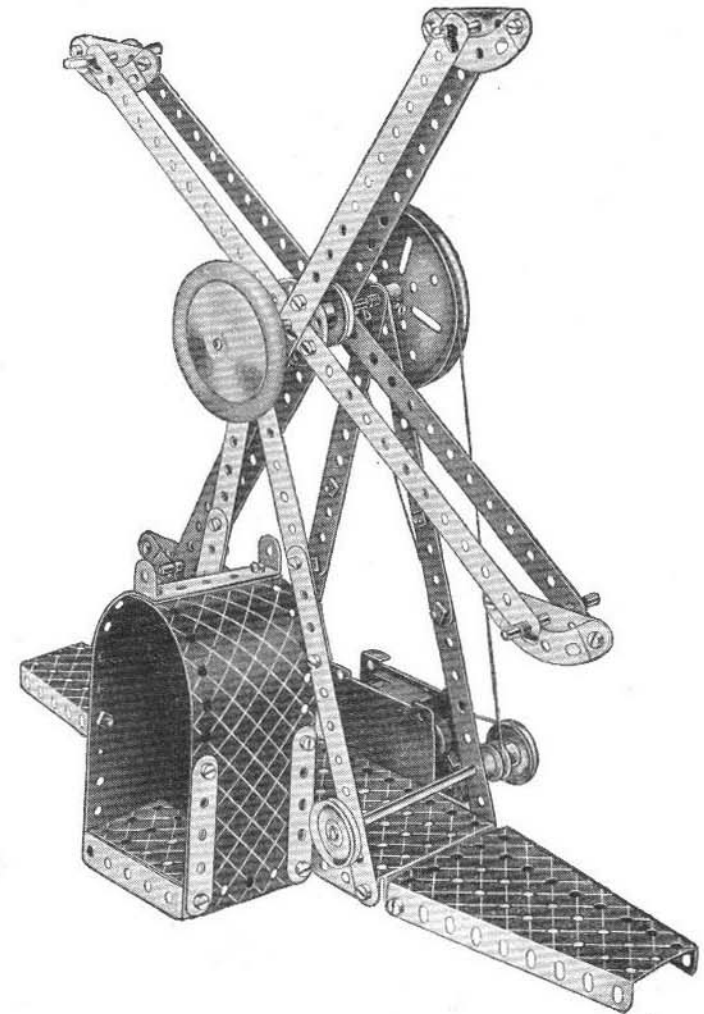

Fig. 4.22a

The Bolt 1 is lock-nutted. The centre pin is withdrawn from a Hinged Flat Plate and the two halves used as flat plates at 2. The Flat Trunnion 3 is bolted to Bush Wheel 4 and forms one web of the crank. The Bush Wheel is fastened to a 2" Rod, which carries also a 3" Pulley, and a Rod Connector joins this Rod to a 3½" Rod that transmits the drive from the Magic Motor. The other web of the crank is made by bolting a 1½" Disc 5 to a Flat Trunnion 6, one of the bolts holding also a Reversed Angle Bracket 7. A Spring Clip 8 is fixed in position so that when the crankshaft is rotated the Rod on which the 3" Pulley and the Road Wheel are fastened is rotated by the Reversed Angle Bracket 7. The cylinder is composed of two 1½" radius Curved Plates and two U-Section Curved Plates bolted together as shown, and the complete unit is fastened in position to the 5½" x 2½" Flanged Plate that forms the base.

The boiler consists of two 5½" x 2½" Flexible Plates bolted to 5½" x 1½" Flexible Plates, and its ends are closed by Semi-circular Plates and 2½" x 1½" Flexible Plates. The fire-box door is represented by a Trunnion. The chimney is a 4" Rod fitted with 1" Pulleys, and is held in place by a Cord Anchoring Spring. Fig. 4.22a shows the arrangement for driving the model with a Magic Motor.

4.23 FLYBOATS



Parts required

4 of No.	1
8 " "	2
8 " "	5
2 " "	15b
2 " "	17
2 " "	18a
1 " "	19b
3 " "	22
1 " "	24
8 " "	35
44 " "	37
1 " "	40
6 " "	48a
1 " "	51
1 " "	52
2 " "	54a
4 " "	90a
1 " "	176
1 " "	187
2 " "	192
1	1 Magic Motor

The Magic Motor is bolted to the flange of the 5½" x 2½" Flanged Plate, and the drive is taken from the pulley of the Motor to a 1" Pulley fastened on a Rod journalled in the 12½" Strips that support the main shaft. A ½" fast Pulley also is secured on this Rod, and drives through a belt of Cord a 3" Pulley on the main shaft. The arms that support the boats are bolted to a Bush Wheel fastened on the main shaft. Each of the boats consists of a 2½" Strip and a 2½" small radius Curved Strip bolted together.

4.M24 MOTOR LORRY

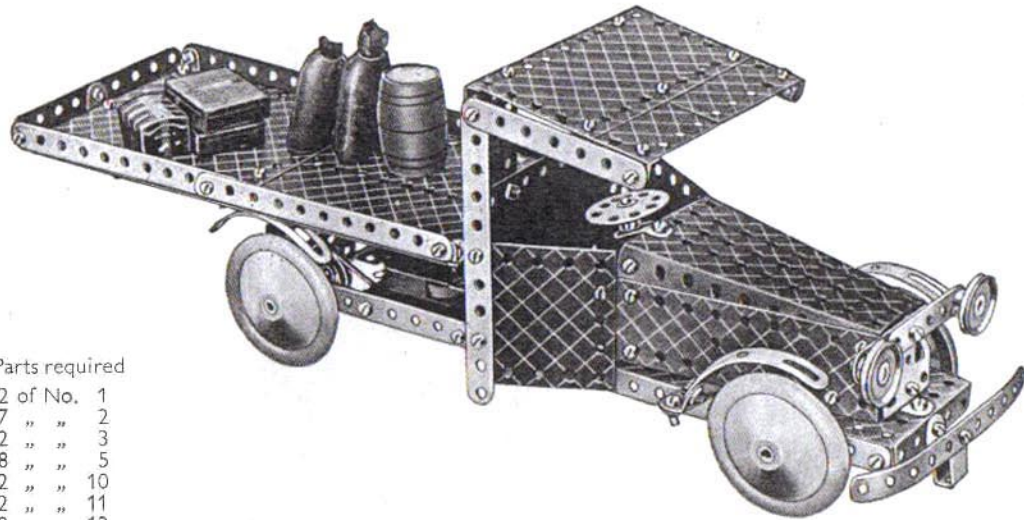

Parts required

2 of No.	1
7 " "	2
2 " "	3
8 " "	5
2 " "	10
2 " "	11
8 " "	12
3 " "	12c
2 " "	15b
1 " "	16
3 " "	22
1 " "	24
5 " "	35
75 " "	37
2 " "	37a
5 " "	38
1 " "	44
1 " "	48
4 " "	48a
1 " "	52
2 " "	54a
4 " "	111c
2 " "	125
2 " "	126
1 " "	126a
4 " "	187
2 " "	188
2 " "	189
4 " "	190
2 " "	191
2 " "	192
1 " "	198
4 " "	215
1 Magic Motor	

The chassis of the model consists of two 12½" Strips bolted to a 5½" × 2½" Flanged Plate and secured at their free ends by a 2½" × ½" Double Angle Strip. Both the front and rear axles are journaled directly in the chassis. The Magic Motor is attached by its flanges to one of the 12½" Strips, and the drive is taken through a Driving Band from the pulley of the Motor to a 1" fast Pulley fastened on the back axle of the lorry.

The platform is fixed to the end of the chassis by two 2½" × ½" Double Angle Strips, the end of which can be seen in Fig. 4.M20a and also to the back of the cab by a 1½" × ½" Double Angle Strip. The front bumper consists of a 5½" Strip curved to shape and fastened by a Cranked Bent Strip to the 5½" × 2½" Flanged Plate forming the front of the chassis. The head-lamps, which are 1" Fulleys, are fixed in place by ½" Bolts pushed through the 2½" Strips into the bosses of the Pulleys and held by the setscrews.

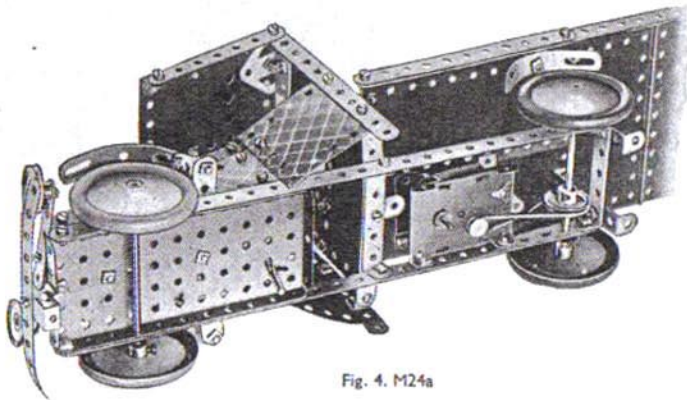
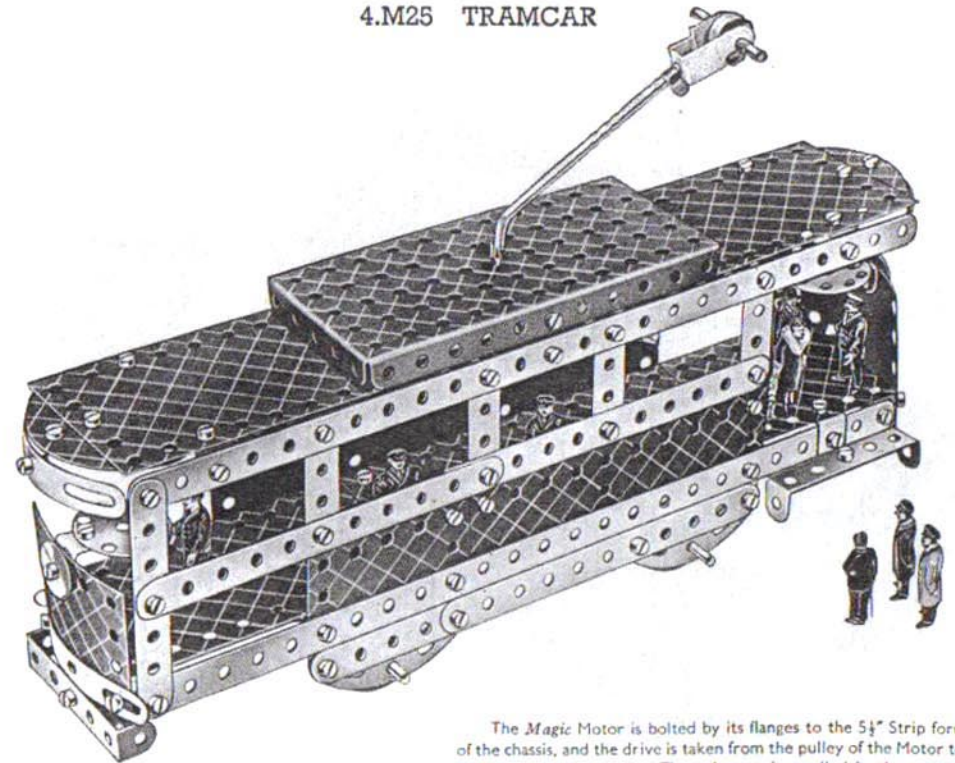

Fig. 4. M24a

4.M25 TRAMCAR



Parts required

4 of No.	1	4 of No.	38	2 of No.	200
8 " "	2	1 " "	44	2 " "	214
2 " "	3	6 " "	48a	4 " "	215
9 " "	5	1 " "	52	2 " "	217a
5 " "	10	4 " "	90a	2 " "	217b
4 " "	12	6 " "	111c	1 Magic Motor	
4 " "	12c	2 " "	125		
2 " "	16	2 " "	126		
1 " "	18a	4 " "	155a		
1 " "	19g	1 " "	176		
4 " "	22	2 " "	188		
1 " "	23	2 " "	189		
5 " "	35	1 " "	190		
75 " "	37	2 " "	191		
16 " "	37a	2 " "	192		

The Magic Motor is bolted by its flanges to the 5½" Strip forming part of the chassis, and the drive is taken from the pulley of the Motor to a ½" fast Pulley on the rear axle. The axles are journaled in the centre holes of 2½" small radius Curved Strips bolted to the chassis. A Crank Handle is used for the trolley. The current "pick-up" is a ½" loose Pulley. It is supported on a 1½" Rod that passes through the holes of a Cranked Bent Strip fastened at the end of the Crank Handle by a Cord Anchoring Spring and a Spring Clip.

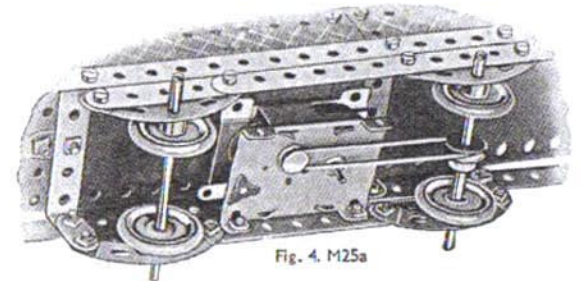

Fig. 4. M25a

If you want to obtain the fullest enjoyment from the Meccano hobby you should operate your models by means of one of the Meccano Motors described on this page. You push over the control lever of the clockwork or electric Motor and immediately your Crane,

Motor Car, Ship Coaler or Windmill commences to work in exactly the same manner as its prototype in real life.

Each Motor is pierced with the standard Meccano equidistant holes.

MECCANO CLOCKWORK MOTORS

These are the finest clockwork motors obtainable for model driving. They have exceptional power and length of run and their gears are cut with such precision as to make them perfectly smooth and steady in operation.

Meccano Clockwork Motors are especially suitable for small models built with a limited range of parts. They are extremely simple to operate and have the advantage of being self contained.

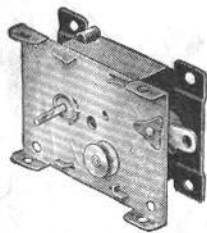

THE MECCANO MAGIC MOTOR

The Meccano *Magic* Motor is well designed and strongly constructed, and is fitted with a powerful spring giving a long and steady run. It is non-reversing. Each *Magic* Motor is supplied with a separate $\frac{1}{2}$ " fast Pulley and three pairs of Driving Bands of different lengths. It is capable of driving all light models built with the smaller Outfits.

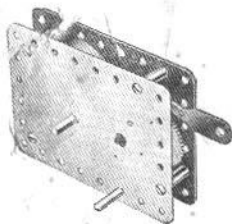

No. 1 Clockwork Motor

This strongly built and efficient Motor is fitted with a powerful spring that gives a long and steady run, and is exceptionally smooth in action. The Motor is provided with a conveniently-placed brake lever by means of which it can be started and stopped. The Motor is of the non-reversing type.

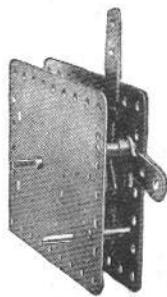

No. 2 Clockwork Motor.

No. 1a Clockwork Motor

This Motor is more powerful than the No. 1 Motor and is fitted with reversing motion. It has brake and reverse levers.

No. 2 Clockwork Motor

This is a Motor of super quality. Brake and reverse levers enable it to be started, stopped or reversed, as required.

MECCANO ELECTRIC MOTORS

The four Meccano Electric Motors shown here have been designed specially to provide smooth-running power units for the operation of Meccano models. The 6-volt Motors may be operated through a Meccano Transformer direct from the mains, providing that the supply is alternating current, or from a 6-volt accumulator. The 20-volt Motors are operated through a 20-volt Transformer from alternating current supply mains.

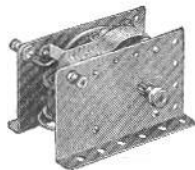

No. E1 Electric Motor (6 volt)

This is a highly efficient Motor (non-reversing) that will give excellent service. It can be operated through a 9-volt Meccano Transformer from the mains, providing that the supply is alternating current, or from a 6-volt accumulator.

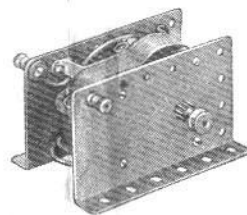

No. E120 Electric Motor (20 volt)

The E120 Electric Motor is a very reliable and smooth-running power unit. It is operated through a Meccano 20-volt Transformer from alternating current supply mains. Non-reversing.

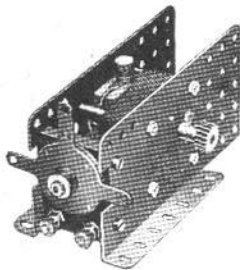

No. E6 Electric Motor (6 volt)

This fine Motor is fitted with reversing motion and provided with stopping and starting controls. It can be operated through a 9-volt Meccano Transformer from the mains, providing that the supply is alternating current, or from a 6-volt accumulator.

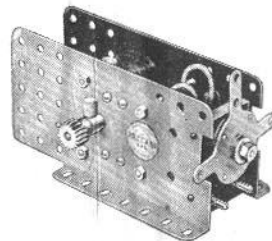

No. E20b Electric Motor (20 volt)

This 20-volt Electric Motor is an extremely efficient power unit, fitted with reversing motion and provided with stopping and starting controls. It is operated through a Meccano 20-volt Transformer from alternating current supply mains.

MECCANO TRANSFORMERS

There are six Transformers in the series, as described below, all of which are available for the following A.C. supplies:—100/110 volts, 50 cycles; 200/225 volts, 50 cycles; 225/250 volts, 50 cycles. Any of the Transformers can be specially wound for supplies other than these at a small extra charge. When ordering a Transformer the voltage and frequency of the supply must always be stated.

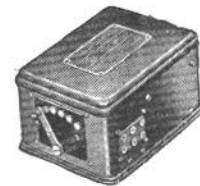

No. T20A Transformer

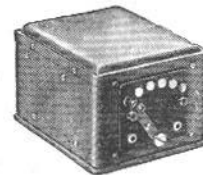

No. T6 Transformer

FOR 20-volt ELECTRIC MOTORS

No. T20A TRANSFORMER (Output 35 VA at 20 $\frac{3}{4}$ volts). Has two separate circuits at 20 volts, one of which is controlled by a 5-stud speed regulator, and a third circuit at 3 $\frac{1}{2}$ volts for lighting up to 18 lamps.

No. T20 TRANSFORMER (Output 20 VA at 20 volts). Has one 20-volt circuit controlled by a 5-stud speed regulator.

No. T20M TRANSFORMER (Output 20 VA at 20 volts). This Transformer is provided with one 20-volt circuit, but is not fitted with speed regulator.

FOR 6-volt ELECTRIC MOTORS

No. T6A TRANSFORMER (Output 40 VA at 9 $\frac{3}{4}$ volts). Has two separate circuits at 9 volts, one of which is controlled by a 5-stud speed regulator, and a third circuit at 3 $\frac{1}{2}$ volts for lighting up to 18 lamps.

No. T6 TRANSFORMER (Output 25 VA at 9 volts). Has one 9-volt circuit and is fitted with a 5-stud speed regulator.

No. T6M TRANSFORMER (Output 25 VA at 9 volts). Has one 9-volt circuit, but is not fitted with a speed regulator.

Resistance Controllers

By means of these Controllers the speed of Meccano 6-volt and 20-volt Motors can be regulated exactly as desired.

Ask your dealer for the latest Meccano Price List

BUILD BIGGER AND BETTER MODELS

When you have built all the models shown in this Manual you will be keen to build bigger and more elaborate models. Your next step is to purchase a Meccano No. 4a Accessory Outfit containing all the parts required to convert your No. 4 into a No. 5 Outfit. You will then be able to build the full range of No. 5 Outfit Models, a selection of which is illustrated on this page and opposite.

If you prefer to do so, you can build up and develop your Outfit quite easily by adding various parts to it from time to time. The model-building possibilities of the Meccano System are limitless, and the more Meccano parts you have the bigger and better the models you will be able to build.

Ask your dealer to post to you regularly the latest Meccano parts lists and other Meccano literature.

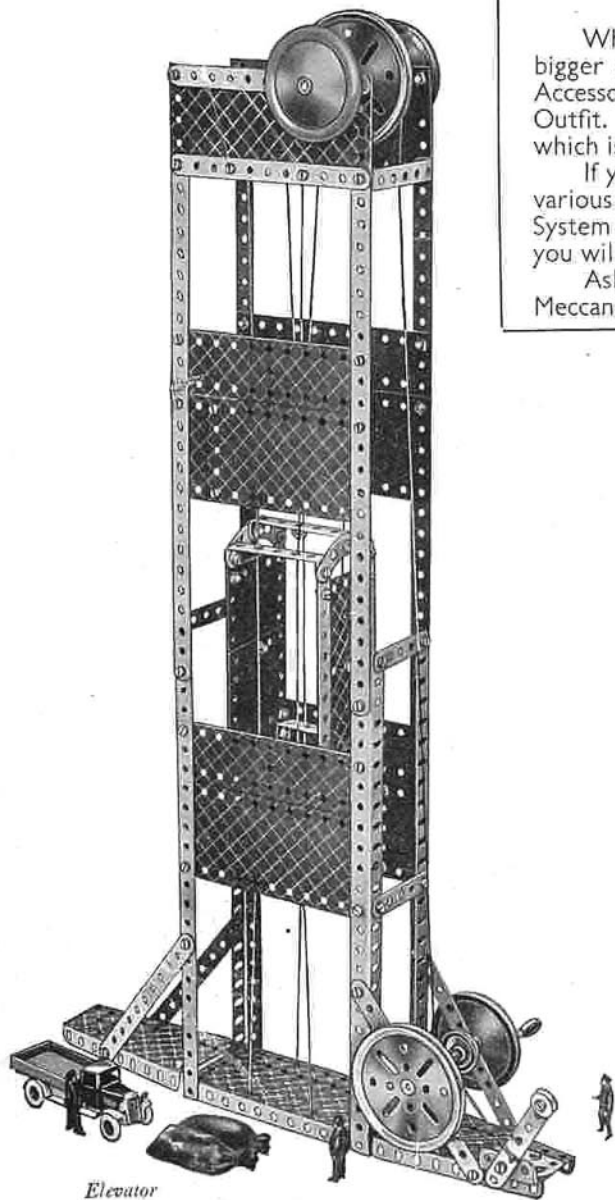
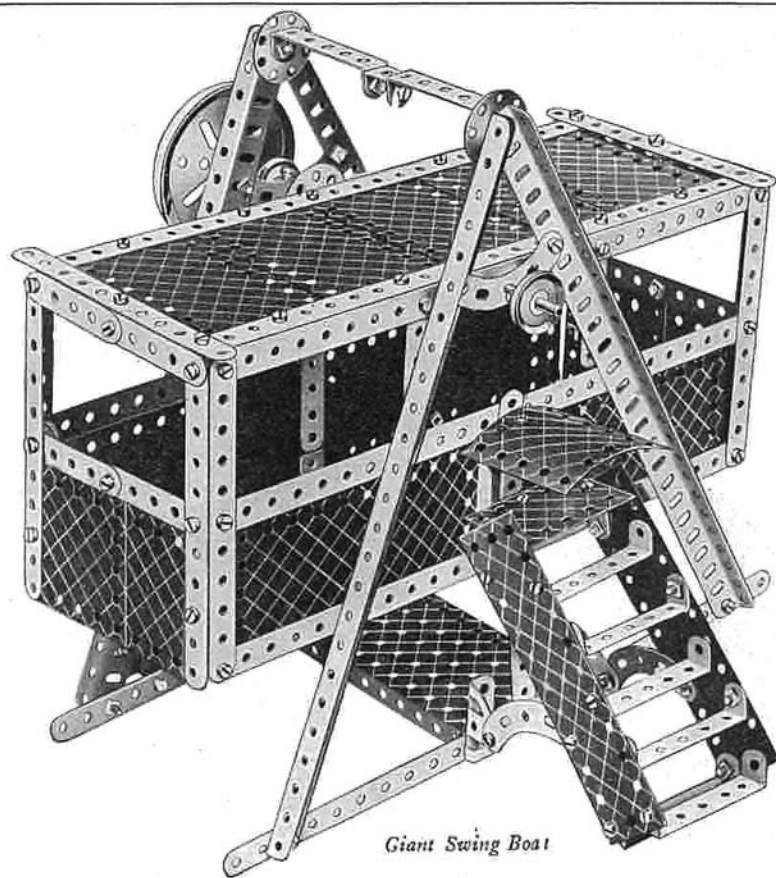
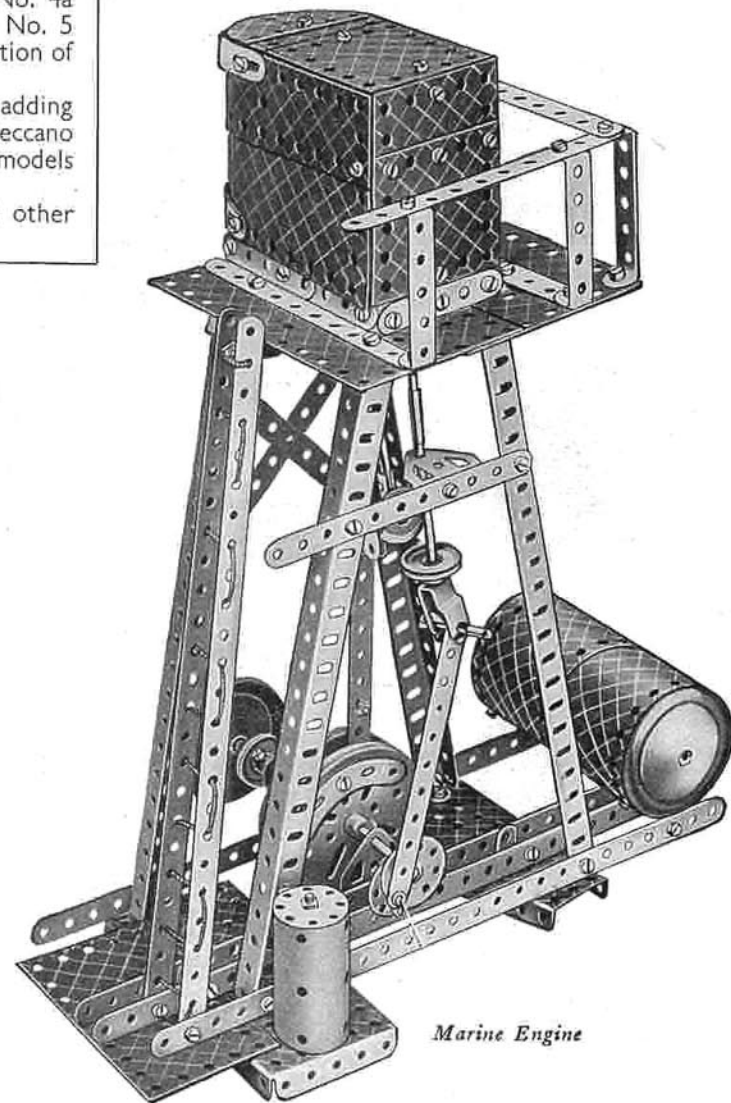
*Elevator**Giant Swing Boat**Marine Engine*

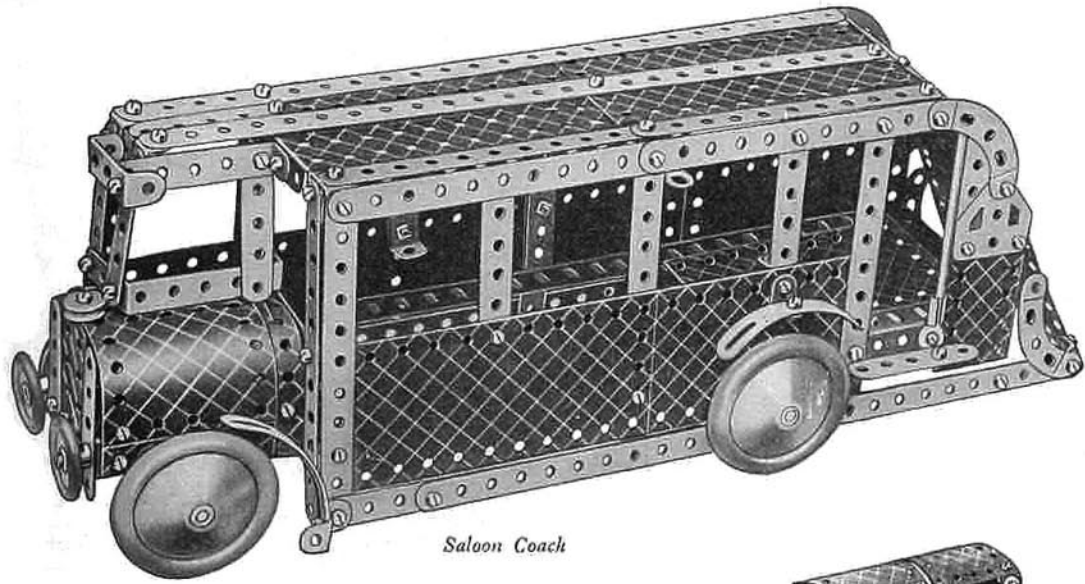

Saloon Coach

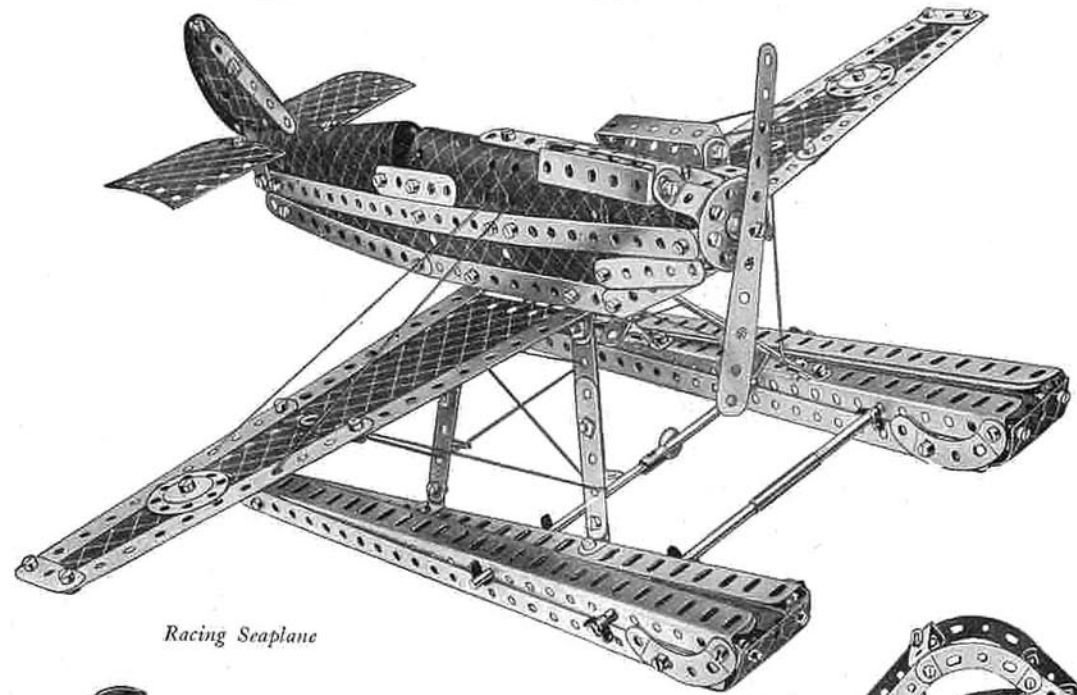

Racing Seaplane

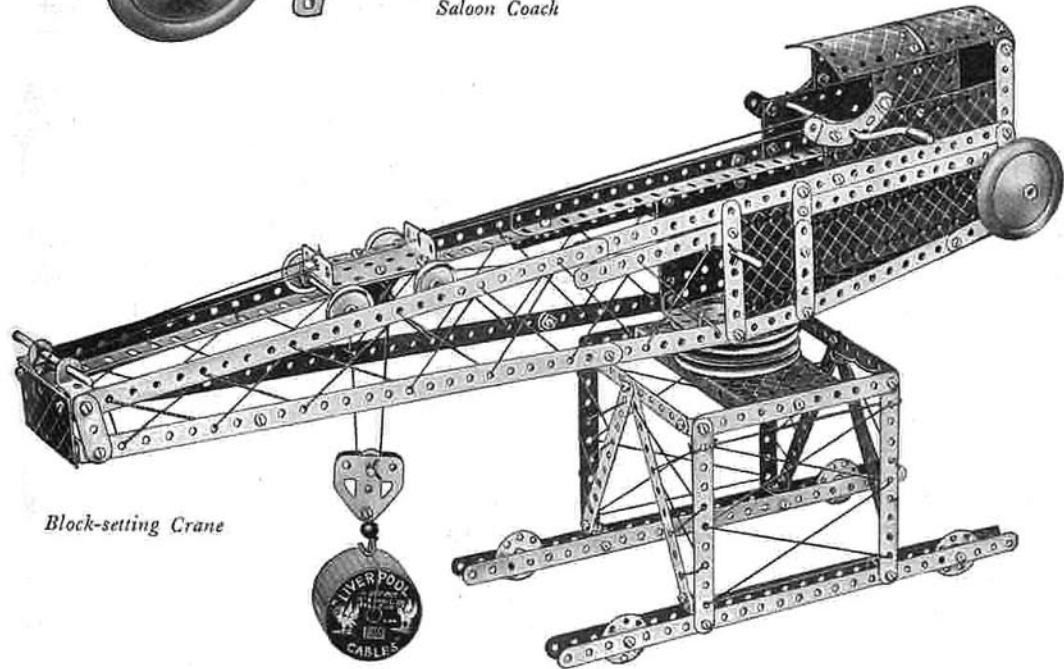

Block-setting Crane

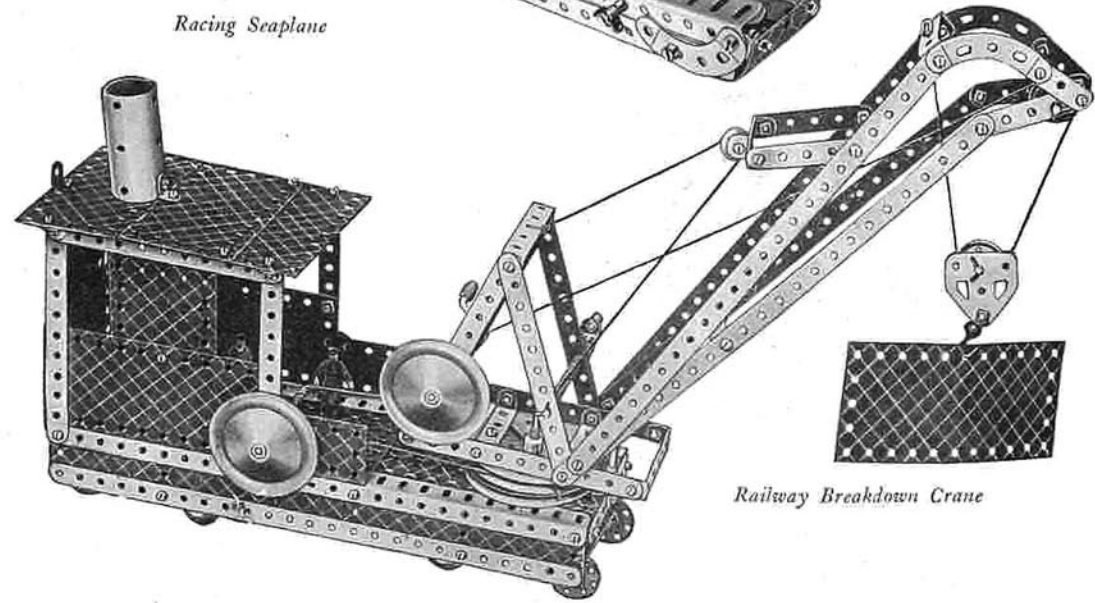

Railway Breakdown Crane

Here are a few simple and interesting movements showing how easily real mechanisms can be reproduced with Meccano.

STRAP AND LEVER BRAKE

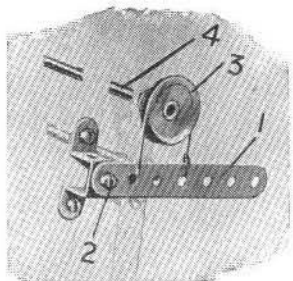

This device will be found very useful as a quick emergency hand-brake. Although it is the simplest of such devices, it is also one of the most valuable and can be used in a great variety of models.

INTERMITTENT ROTARY MOTION

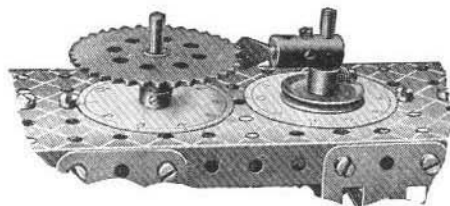

Intermittent rotary motion can be obtained by means of the above device. Such an arrangement is useful in revolution counters, measuring machines, etc. In addition to mechanisms that give true intermittent motion, different types of cams that convert a regular rotary motion into a constant or intermittent reciprocating motion can be constructed.

PAWL AND RATCHET MOVEMENT

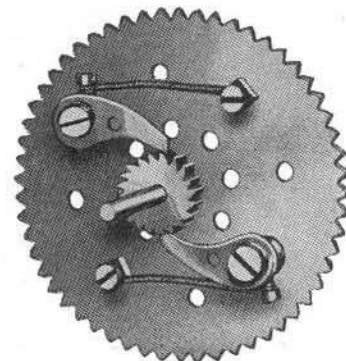

By means of this device it is possible to construct certain types of automatic brakes and free wheels. The illustration shows the method of building up a free-wheel unit.

GRABS

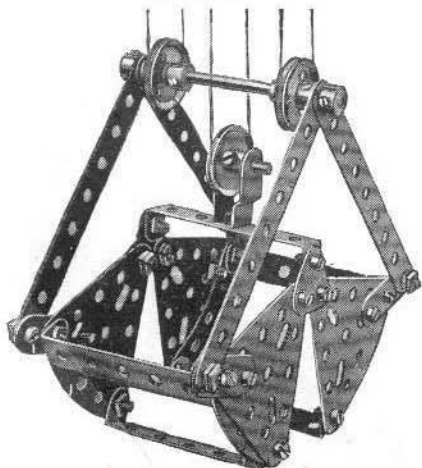

Here is a typical example of the many kinds of grab that can be constructed from Meccano. If the grab is fitted to a model crane or ship-coaler, all its movements can be controlled from an operating box built into the frame of the model. The outer sides of the jaws may be filled in with cardboard and the grab can then be used to pick up loads of sand, grain, marbles, etc.

BIG END FOR MECCANO CRANKSHAFT

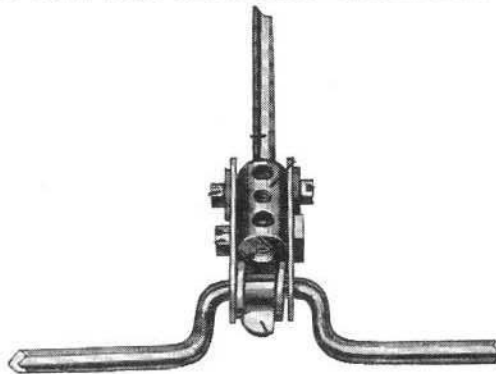

A Spring Clip is first clipped on to the centre of the cranked portion of the Crankshaft, and on each side of this is carried a Washer. On the outside of each of the Washers is placed a $1\frac{1}{2}$ " Strip, and these are connected together by means of a Coupling. A $\frac{1}{2}$ " Bolt passes completely through the two $1\frac{1}{2}$ " Strips at their centre holes and also through the inner transverse tapped hole of the Coupling. The outer tapped holes are fitted with Set-Screws, under the heads of which a Washer is placed.

STRAP AND SCREW BRAKE

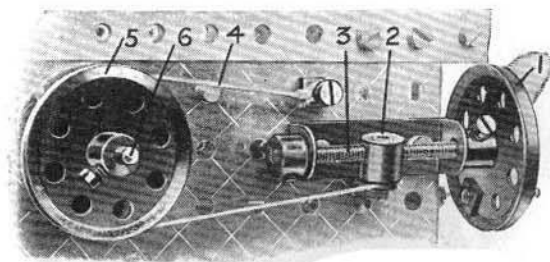

The type of brake shown above is used to apply a constant retarding effect to a rotating shaft. It can thus be utilised in a crane to prevent the load from falling back when the winding spindle is released. An advantage of the brake is that the speed of the shaft to which it is applied can be varied as required; the retarding action of the brake cannot vary when once set unless the hand wheel is turned.

WORM AND PINION BEARING

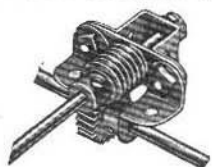

The compact rear axle drive unit illustrated above is intended chiefly for use in small models of motor cars. Two Corner Angle Brackets are secured by Bolts passing through their elongated holes to a $1\frac{1}{2}$ " Strip, to which a Double Bent Strip also is secured. The Rod carrying the Worm is passed through the centre hole of the Strips and held in position by a Collar.

The driven Rod is journaled in the Corner Angle Brackets and carries a Pinion that engages with the Worm.

A feature of this bearing that should not be overlooked is that the useful gear ratio of 25:1 is provided by employing a $\frac{5}{8}$ " Pinion.

GEARS

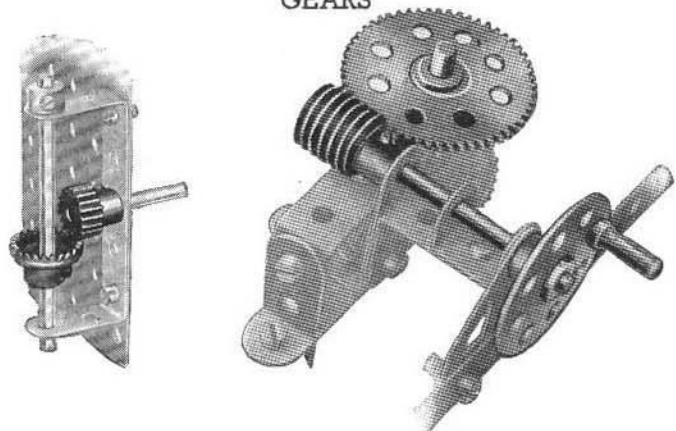

The Meccano system includes a wide range of Gear Wheels, Bevel Gears, Pinion Wheels, Contrate Wheels and Worms in various sizes. All manner of interesting movements can be obtained by the use of these gears.

How a drive can be transmitted from a vertical to a horizontal shaft or vice versa, is shown on the left. On the right the Worm engaged with a Gear Wheel, gives a very great reduction in shaft speed.

BELT AND CHAIN DRIVES

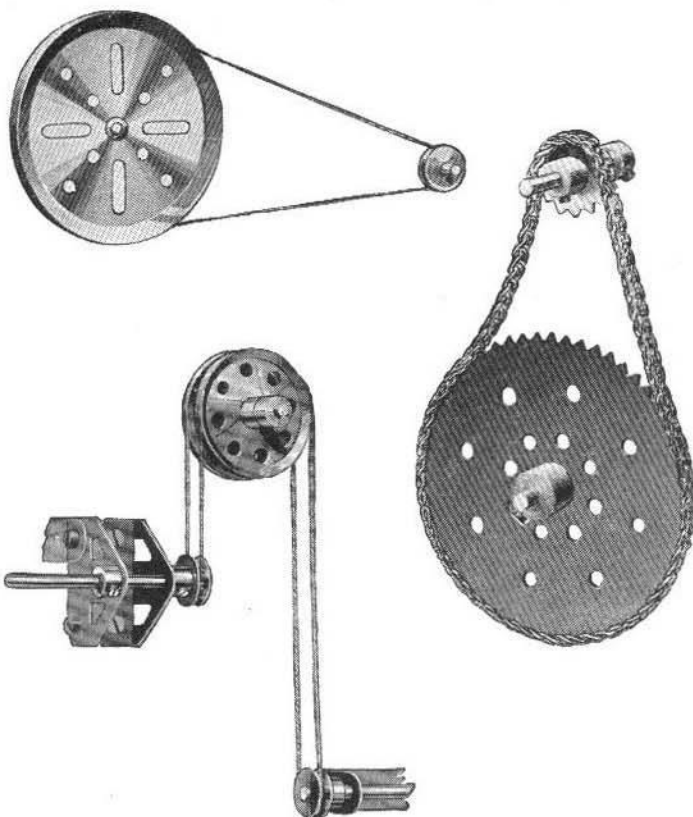

Above we show examples of belt and chain drive. The movements illustrated require no explanation excepting, perhaps, the lower belt drive, which shows a simple method for transmitting the drive from one shaft to another when the shafts are not in line.

Cords usually take the place of belts in Meccano models but miniature belting can be made from strips of canvas, indiarubber, etc., in which case Flanged Wheels should be used instead of grooved Pulleys.

EPICYCLIC TRANSMISSION GEAR

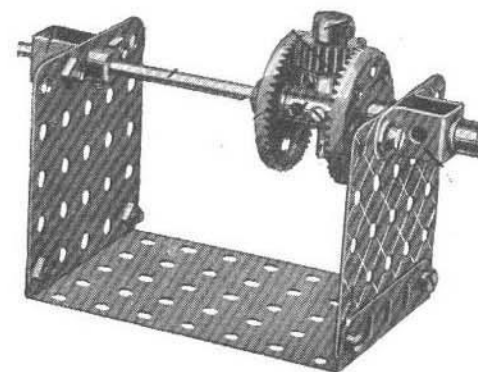

Practically every type of mechanical power transmission gear can be reproduced with Meccano.

The device illustrated is designed to provide a gear ratio between two shafts mounted in direct line with one another. Its chief merit lies in the compactness of its construction and lack of external bearings.

STEERING GEARS

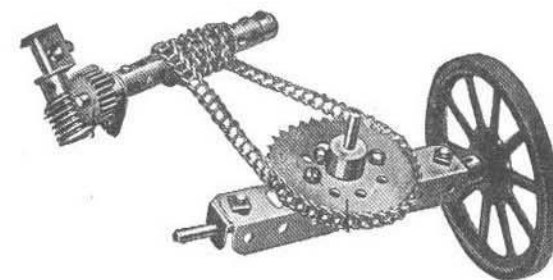

The various types of steering mechanism commonly in use on vehicles of all descriptions can readily be reproduced with Meccano.

In the example illustrated, the road wheels are controlled by an endless Sprocket Chain operated by a Worm and Pinion mechanism,

No.	Description	0	1	1a	2	2a	3	3a	4	4a	5	5a	6	6a	7	7a	8	8a	9	9a	10
95	Sprocket Wheels, 2"																				
95a	" " 1"																				
95b	" " 3"																				
96	" " 1"																				
96a	" " 1"																				
100	Braced Girders, 5"																				
102	Single Bent Strips																				
103	Flat Girders, 5"																				
103a	" " 12"																				
103b	" " 4"																				
103c	" " 3"																				
103d	" " 3"																				
103e	" " 2"																				
103f	" " 2"																				
103g	" " 1"																				
103h	" " 7"																				
103k	" " 7"																				
108	Architraves																				
109	Face Plates, 2 1/2" diam.																				
110	Rack Strips, 3 1/2"																				
111	Bolts, 3/8"																				
111a	" " "																				
111c	" " "																				
114	Hinges																				
115	Threaded Pins																				
116	Fork Pieces, Large																				
116a	" " Small																				
117	Steel Balls, 1/8" diam.																				
118	Hub Discs, 5 1/2" diam.																				
120b	Compression Springs																				
124	Reversed Angle Brackets, 1"																				
125	" " 1/2"																				
126	Trunnions																				
126a	Flat Trunnions																				
128	Boss Bell Cranks																				
129	Rack Segments, 3" diam.																				
130	Triple Throw Eccentrics																				
132	Flywheels, 2 1/2" diam.																				
133	Corner Brackets, 1 1/2" diam.																				
133a	" " 1"																				
134	Crank Shafts, 1" stroke																				
136	Handrail Supports																				
136a	Couplings																				
137	Wheel Flanges																				
140	Universal Couplings																				
142a	Motor Tyres, 2"																				
142b	" " 3"																				
143	Circular Girders, 5 1/2" diam.																				
144	Dog Clutches																				
145	Circular Strips, 7 1/2" diam.																				
146	" " Plates, 6" diam.																				
146a	" " 4" diam.																				
147a	Pawls																				
147b	Pivot Bolt with 2 Nuts																				
147c	Pawls without Boss																				
154a	Corner Angle Brackets, 1/2" RH;																				
154b	" " LH;																				
155a	Rubber Rings, for 1" pulley																				
157	Fans, 2" diam.																				
160	Channel Bearings, 1 1/2" x 1" x 1/2"																				
161	Girder Brackets, 2" x 1" x 1/2"																				
162	Boiler with Ends, complete																				
162a	Boiler Ends																				
162b	Boilers without Ends																				
163	Sleeve Pieces																				
164	Chimney Adaptors																				
165	Swivel Bearings																				
166	End Bearings																				
167b	Ring Frames for Rollers																				
168	Ball Bearings, 4" diam.																				
169	Digger Buckets																				
170	Eccentrics, 1/2" Throw																				
171	Socket Couplings																				
175	Flexible Couplings Units																				
176	Anchoring Springs for Cord																				
179	Rod Socket																				
185	Steering Wheel, 1 1/2" diam.																				
186	Driving Bands, 2 1/2" Light																				
186a	" " 10"																				
186b	" " 10" Heavy																				
186c	" " 15"																				
186d	" " 20"																				
186e	" " "																				
187	Road Wheels																				
188	Flexible Plates, 2 1/2" x 1 1/2"																				
189	" " 2 1/2" x 1 1/2"																				
190	" " 3 1/2" x 2 1/2"																				
190a	" " 4 1/2" x 2 1/2"																				
191	" " 5 1/2" x 2 1/2"																				
192	" " 9 1/2" x 2 1/2"																				
196	Strip Plates, 12 1/2" x 2 1/2"																				
197	Hinged Flat Plates, 4 1/2" x 2 1/2"																				
198	Curved Plates, U Section, 3 1/2" x 2 1/2" x 1 1/2" radius																				
199	Curved Plates, U Section, 2 1/2" x 2 1/2" x 1 1/2" radius																				
200	Rod and Strip Connectors																				
212	Rod Connectors																				
213	Semi-Circular Plates, 2 1/2"																				
214	Formed Slotted Strips, 3"																				
215	Cylinder, 2 1/2"																				
216	Discs, 1 1/2"																				
217a	" " "																				
217b	" " "																				
219	Wheel Discs																				
A1083	Drifts																				
p52	Aeroplane Collars																				
	Clockwork Motor No. 1																				
	Electric Motor No. E120, 20-volts																				

Full instructions for building a fine range of models are included with each Outfit.

REAL ENGINEERING PARTS IN MINIATURE

Meccano parts, an illustrated list of which is given in the following pages, combine to form a complete miniature engineering system with which practically any movement known in mechanics can be correctly reproduced. New parts are always being introduced in order to keep Meccano model-building in line with the most modern engineering requirements. The greatest care is taken in the designing of these parts to ensure that they function exactly as their counterparts in actual engineering practice. Ask your dealer for the latest complete illustrated price list and ask him also to keep you advised of all new parts that are added to the system.

MECCANO PARTS

120. Buffers
120a. Spring Buffers
120b. Compression Springs
121. Train Couplings
122. Miniature Loaded Sacks
123. Cone Pulleys
124. Reversed Angle Brackets, 1"
125. " " "
126. Trunnions
126a. Flat Trunnions
127. Simple Bell Cranks
128. Boss Bell Cranks
129. Rack Segments, 3" diam.
130. Eccentrics, Triple Throw
131. Dredger Buckets
132. Flywheels, 2½" diam.
133. Corner Brackets, 1½"
133a. " " "
134. Crank Shafts, 1" stroke
135. Theodolite Protractors
136. Handrail Supports
136a. Handrail Couplings
137. Wheel Flanges

138. Ships' Funnels
138a-z. " " Raked
139. Flanged Brackets (right)
139a. " " (left)
140. Universal Couplings
141. Wire Lines (for clock weights)
142. Rubber Rings (to fit 3" diam. rims)
142a. Motor Tyres (to fit 2" diam. rims)
142b. " " " 3" " "
142c. " " " 1" " "
142d. " " " 1½" " "
143. Circular Girders, 5½" diam.
144. Dog Clutches
145. Circular Strips, 7½" diam. overall
146. " Plates, 6" " "
146a. " " 4" " "
147. Pawls, with Pivot Bolt and Nuts
147a. Pawls
147b. Pivot Bolts with 2 Nuts
147c. Pawls without boss
148. Ratchet Wheels
149. Collecting Shoes for Electric Locos
150. Crane Grabs

151. Pulley Blocks, Single Sheave
152. " " Two " "
153. " " Three " "
154. Corner Angle Brackets, ½"
(right-hand)
154b. Corner Angle Brackets, ½"
(left-hand)
155. Rubber Rings (for 1" Pulleys) Black
155a. " " " White
156. Pointers (with boss), 2½" overall
157. Fans, 2" diam.
158a. Signal Arms, Home
158b. " " Distant
160. Channel Bearings, 1½" x 1" x ½"
161. Girder Brackets, 2" x 1" x ½"
162. Boilers, complete, with ends
162a. " Ends
162b. " without ends
163. Sleeve Pieces
164. Chimney Adaptors
165. Swivel Bearings
166. End " "
167. Geared Roller Bearings
167a. Roller Races, geared, 192 teeth
167b. Ring Frames for Rollers
167c. Pinions for Roller Bearings (16 teeth)

168. Ball Bearings, 4" diam.
168a. " Races, flanged discs
168b. " " toothed
168c. " Casings, complete with balls
169. Digger Buckets
170. Eccentrics, ½" throw
171. Socket Couplings
172. Pendulum Connections
173. Rail Adaptors
174. Grease Cups
175. Flexible Coupling Units
176. Anchoring Springs for Cord
177. Shafting Standards, Large
178. " " Small
179. Rod Sockets
180. Toothed Gear Rings, 3½" diam.
181. Bobbins
182. Insulating Bushes
182a. Insulating Washers
183. Lamp Holders
183a. 2½-volt Lamps
183b. 3½ " " "
183c. 6-volt Lamps
183d. 10 " " "
183e. 20 " " "

185. Steering Wheels, 1½" diam.
186. Driving Bands, 2½" (Light)
186a. " " 6" " "
186b. " " 10" " "
186c. " " 10" (Heavy)
186d. " " 15" " "
186e. " " 20" " "
187. Road Wheels
192. Flexible Plates.
191. 4½" x 2½"
192. 5½" x 2½"
193. Strip Plates.
196. 9½" x 2½"
197. 12½" x 2½"
198. Hinged Flat Plates, 4½" x 2½"
199. Curved Plates, U-Section 2½" x 2½" x ½" radius
200. " " 2½" x 2½", 1½" radius
201. Lamps with Flex (3½ volts)
202. Angle Brackets (for Headlamps)
203. Headlamps
203a. Headlamp Rims
203b. " Bodies
204. " Nuts
205. " Glasses
206. Lampshades
207. Lamp Bases
207a. Lamp with Standard and Flex
208. Battery Tags and Studs
208a. Washers for Battery Studs
210. Nuts for Battery Studs
- 211a. Helical Gear ½" { Can only be
211b. " " 1½" used together
212. Rod and Strip Connectors
213. Rod Connectors
214. Semi-Circular Plates 2½"
215. Formed Slotted Strips 3"
216. Cylinders, 2½"
- 217a. Discs, 1½"
217b. Discs ¾"



HORNBY SCALE MODEL OF
"Princess Elizabeth"—
MIGHTY L.M.S.R. WORLD
RECORD-BREAKER

**FITTED WITH 20-VOLT
AUTO-REVERSING MOTOR**

Four hundred miles non-stop from Glasgow to London at an average of 70 m.p.h., with a 260-ton load! This remarkable feat was performed by L.M.S.R. Locomotive "Princess Elizabeth" in charge of Driver T. J. Clarke, and it set up a world record.

Think of the thrill of owning a model of such an engine; not merely a perfect reproduction in miniature, but one having the same qualities of power, speed and efficiency! This is now made possible by the latest product of Meccano Limited—the magnificent Hornby scale model locomotive "Princess Elizabeth" illustrated above, driven by a 20-volt electric motor, and fitted with the Hornby Remote Control.

Playing the great game of railways with any of the world-famous Hornby Trains is fine fun. The performance and durability of the Hornby Electric Trains place them in a class entirely their own, while Hornby Clockwork Trains are the longest-running spring-driven locomotives in the world.

Ask your dealer for the latest complete catalogue of Hornby Trains, Rolling Stock and Accessories.

MANUFACTURED BY MECCANO LTD., LIVERPOOL.

*Driver Clarke
says
"It's fine!"*

HORNBY TRAINS