

# MECCANO

INSTRUCTIONS

FOR

No. 7 and No. 8 OUTFITS

Prices  
Great Britain 1/6  
Australia 3/-  
New Zealand 2/6  
South Africa 3/-  
Canada 60c

No.  
39.7/8

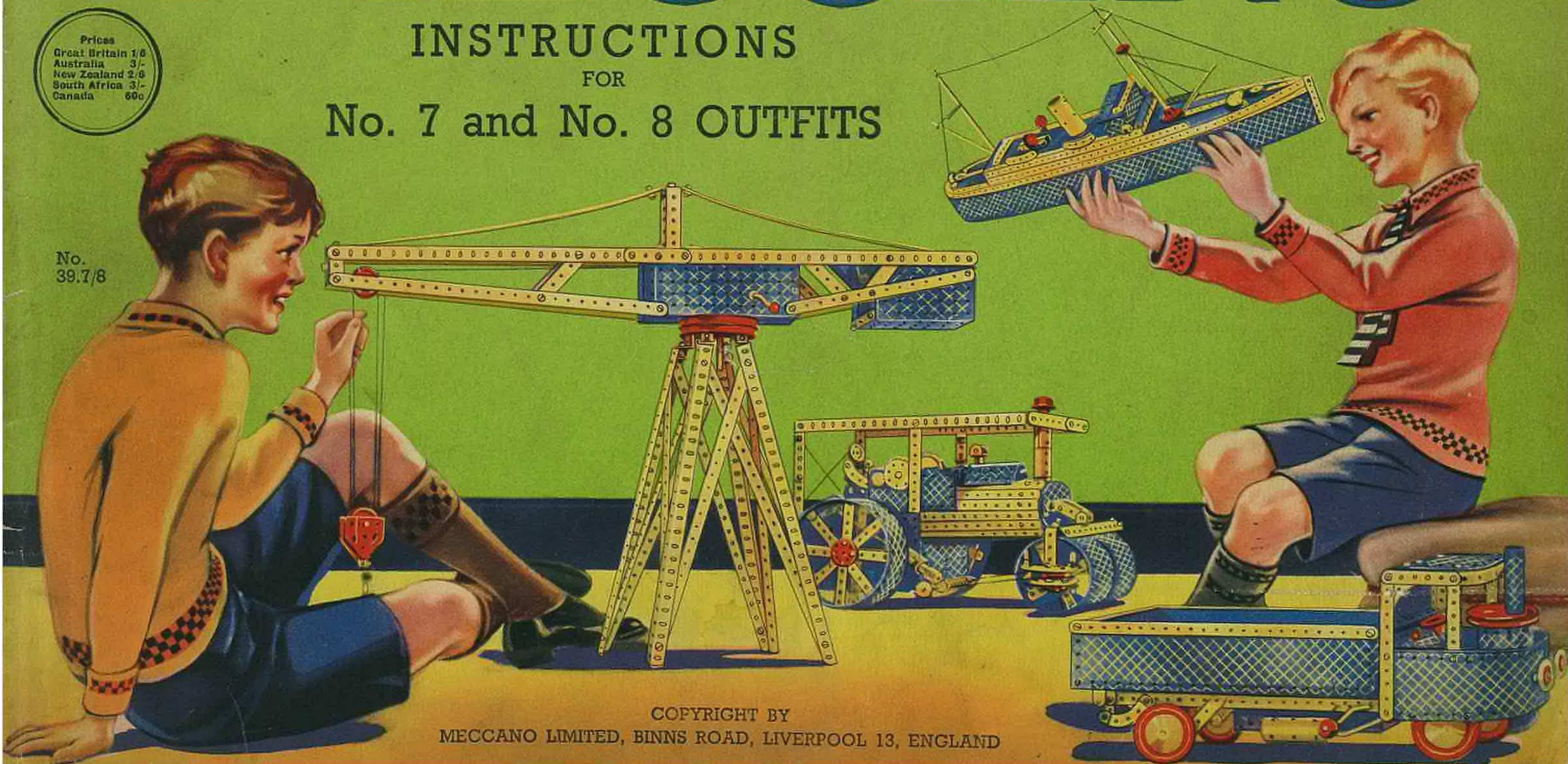

COPYRIGHT BY  
MECCANO LIMITED, BINNS ROAD, LIVERPOOL 13, ENGLAND



## 7.1 STREAMLINED PETROL TANK LORRY

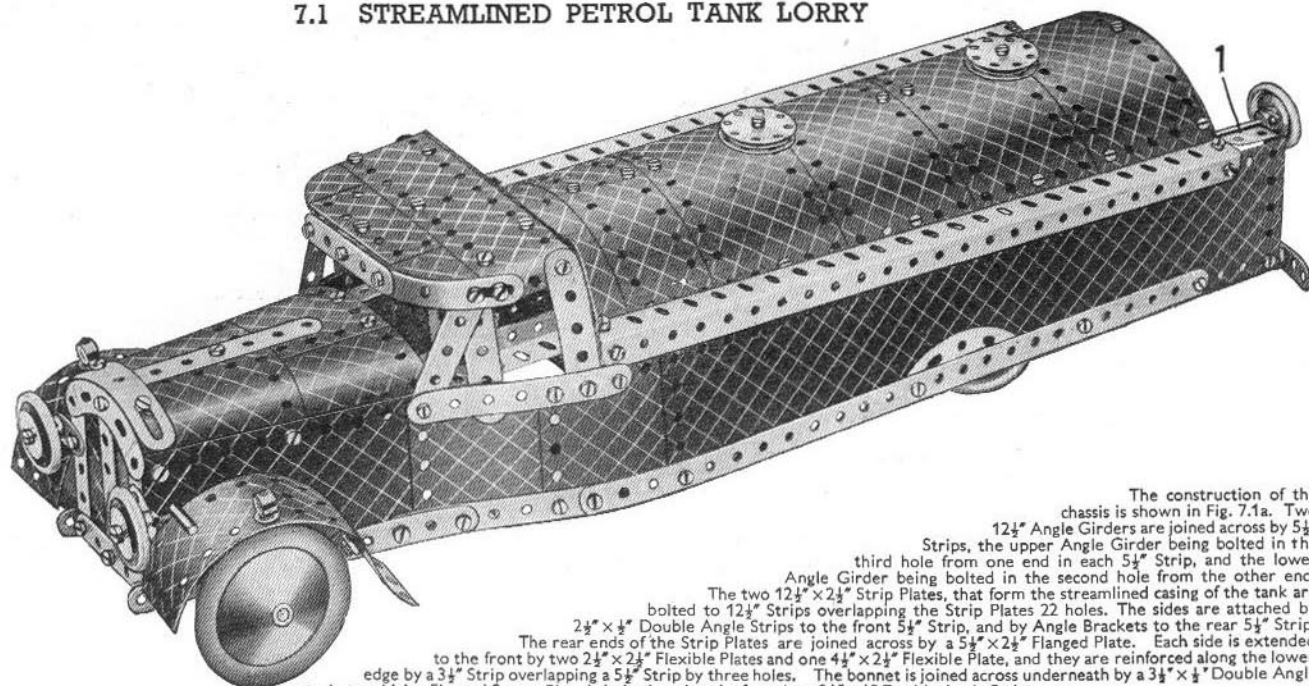

The construction of the chassis is shown in Fig. 7.1a. Two  $12\frac{1}{2}$ " Angle Girders are joined across by  $5\frac{1}{2}$ " Strips, the upper Angle Girder being bolted in the third hole from one end in each  $5\frac{1}{2}$ " Strip, and the lower Angle Girder being bolted in the second hole from the other end. The two  $12\frac{1}{2}$ " x  $2\frac{1}{2}$ " Strip Plates, that form the streamlined casing of the tank are bolted to  $12\frac{1}{2}$ " Strips overlapping the Strip Plates 22 holes. The sides are attached by  $2\frac{1}{2}$ " x  $\frac{1}{2}$ " Double Angle Strips to the front  $5\frac{1}{2}$ " Strip, and by Angle Brackets to the rear  $5\frac{1}{2}$ " Strip. The rear ends of the Strip Plates are joined across by a  $5\frac{1}{2}$ " x  $2\frac{1}{2}$ " Flanged Plate. Each side is extended to the front by two  $2\frac{1}{2}$ " x  $2\frac{1}{2}$ " Flexible Plates and one  $4\frac{1}{2}$ " x  $2\frac{1}{2}$ " Flexible Plate, and they are reinforced along the lower edge by a  $3\frac{1}{2}$ " Strip overlapping a  $5\frac{1}{2}$ " Strip by three holes. The bonnet is joined across underneath by a  $3\frac{1}{2}$ " x  $\frac{1}{2}$ " Double Angle Strip to which a Flanged Sector Plate is bolted, and at the front by a  $2\frac{1}{2}$ " x  $\frac{1}{2}$ " Double Angle Strip.

The bonnet is represented by two  $1\frac{1}{2}$ " radius Curved Plates and two  $2\frac{1}{2}$ " x  $2\frac{1}{2}$ " Flexible Plates bent to shape. The  $1\frac{1}{2}$ " radius Curved Plates overlap the  $4\frac{1}{2}$ " x  $2\frac{1}{2}$ " Flexible Plates forming the sides, by two holes and are bolted also to the Formed Slotted Strip. The Bolt holding the  $3\frac{1}{2}$ " Strip on top of the bonnet carries also a Washer, which clamps the two  $1\frac{1}{2}$ " radius Curved Plates together. The  $2\frac{1}{2}$ " x  $2\frac{1}{2}$ " Flexible Plates overlap each other by two holes. The radiator is bolted to the  $2\frac{1}{2}$ " x  $\frac{1}{2}$ " Double Angle Strip that spaces the front of the chassis. The headlamps are carried on  $\frac{1}{2}$ " Bolts passed through holes in Fishplates and locked in the bosses of the 1" Pulleys.

Two  $5\frac{1}{2}$ " x  $1\frac{1}{2}$ " Flexible Plates are bent to shape for the front mudguards and they are attached to the bonnet by Angle Brackets. A 5" Rod pushed through the sides of the bonnet also holds the mudguards in position. The roof of the cab is built up from two Semi-Circular Plates overlapped one hole, which together with a  $2\frac{1}{2}$ " x  $1\frac{1}{2}$ " Flexible Plate, are bolted to a  $5\frac{1}{2}$ " x  $1\frac{1}{2}$ " Flexible Plate. The ends of the latter are turned down, and two Formed Slotted Strips are bolted to them, one on each side, and the other ends of these Strips are joined together by a  $2\frac{1}{2}$ " Strip. The back of the cab is made by overlapping two  $2\frac{1}{2}$ " x  $1\frac{1}{2}$ " Flexible Plates, which are extended at each side by a  $1\frac{1}{2}$ " Strip, attached to them by Fishplates bolted to their lower ends.

The method of attaching the roof to the body will be clear from the illustration.

The curved part of the tank is made by bolting four  $5\frac{1}{2}$ " x  $2\frac{1}{2}$ " Flexible Plates and two  $5\frac{1}{2}$ " x  $1\frac{1}{2}$ " Flexible Plates to a  $12\frac{1}{2}$ " Strip placed across the middle of their long edges. The ends of the Flexible Plates are bolted to further  $12\frac{1}{2}$ " Strips, each corner being fitted with an Obtuse Angle Bracket. The top is then curved and the front end bolted to the ends of the  $2\frac{1}{2}$ " x  $\frac{1}{2}$ " Double Angle Strips attached to the chassis, and also to an Angle Bracket at the back of the cab. The rear end is attached to two Angle Girders which are bolted to the sides and sloped upward slightly to the cab. Here they are attached to the sides by Fishplates and to the  $1\frac{1}{2}$ " Strips previously mentioned, by Angle Brackets. Fig. 7.1b shows the construction of the rear of the tank, which is attached to the sides of the model by Angle Brackets.

The No. 1 Clockwork Motor is now bolted in position to the chassis and an  $11\frac{1}{2}$ " Rod 1, fitted at the rear end with a 1" Pulley, carries a large Fork Piece, which is lock-nutted to the brake-lever of the Motor. The drive is taken from a  $\frac{1}{2}$ " fast Pulley on the Motor shaft to a 1" fast Pulley on the 5" Rod representing the rear axle.

Bearings for each front wheel pivot are provided by 1" x 1" Angle Brackets, which are bolted to the bonnet. Each pivot is a  $\frac{3}{8}$ " Bolt having a Double Bracket and a  $1\frac{1}{2}$ " Strip securely fastened on its shank by a nut and is passed through the end hole of the 1" x 1" Angle Bracket and then lock-nutted. The tie rod is a 3" and a  $3\frac{1}{2}$ " Strip overlapped three holes and attached at each end to the  $1\frac{1}{2}$ " Strips. The Bolts 2 are lock-nutted. The front Road Wheels are carried on  $1\frac{1}{2}$ " Rods journalled in the Double Brackets and retained in place by Collars.

### Parts required

5 of No. 1
6 " " 2
6 " " 3
2 " " 4
12 " " 5
4 " " 6a
4 " " 8
6 " " 10
2 " " 11
12 " " 12
4 " " 12a
4 " " 12c
1 " " 13
2 " " 15
1 " " 15a
3 " " 18a
3 " " 20b
5 " " 22
2 " " 22a
1 " " 23a
1 " " 24
4 " " 24a
3 " " 35
131 " " 37

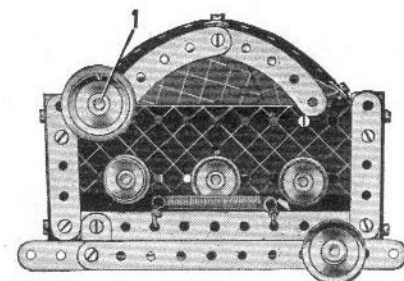

Fig. 7.1b

9 of No. 37a	1 of No. 116
8 " " 38	2 " " 125
1 " " 43	3 " " 155
1 " " 48	1 " " 186
3 " " 48a	4 " " 187
1 " " 48b	5 " " 188
1 " " 52	6 " " 189
1 " " 54	6 " " 190
4 " " 59	2 " " 191
2 " " 90	4 " " 192
3 " " 90a	2 " " 197
2 " " 111	2 " " 199
2 " " 111a	2 " " 200
6 " " 111c	2 " " 214
	3 " " 215
	1 No. 1 Clockwork Motor (Not included in Outfit)

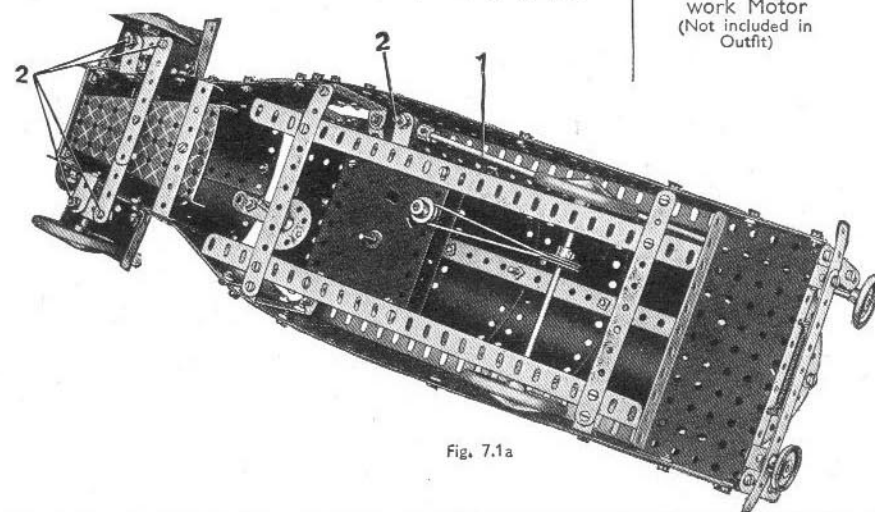
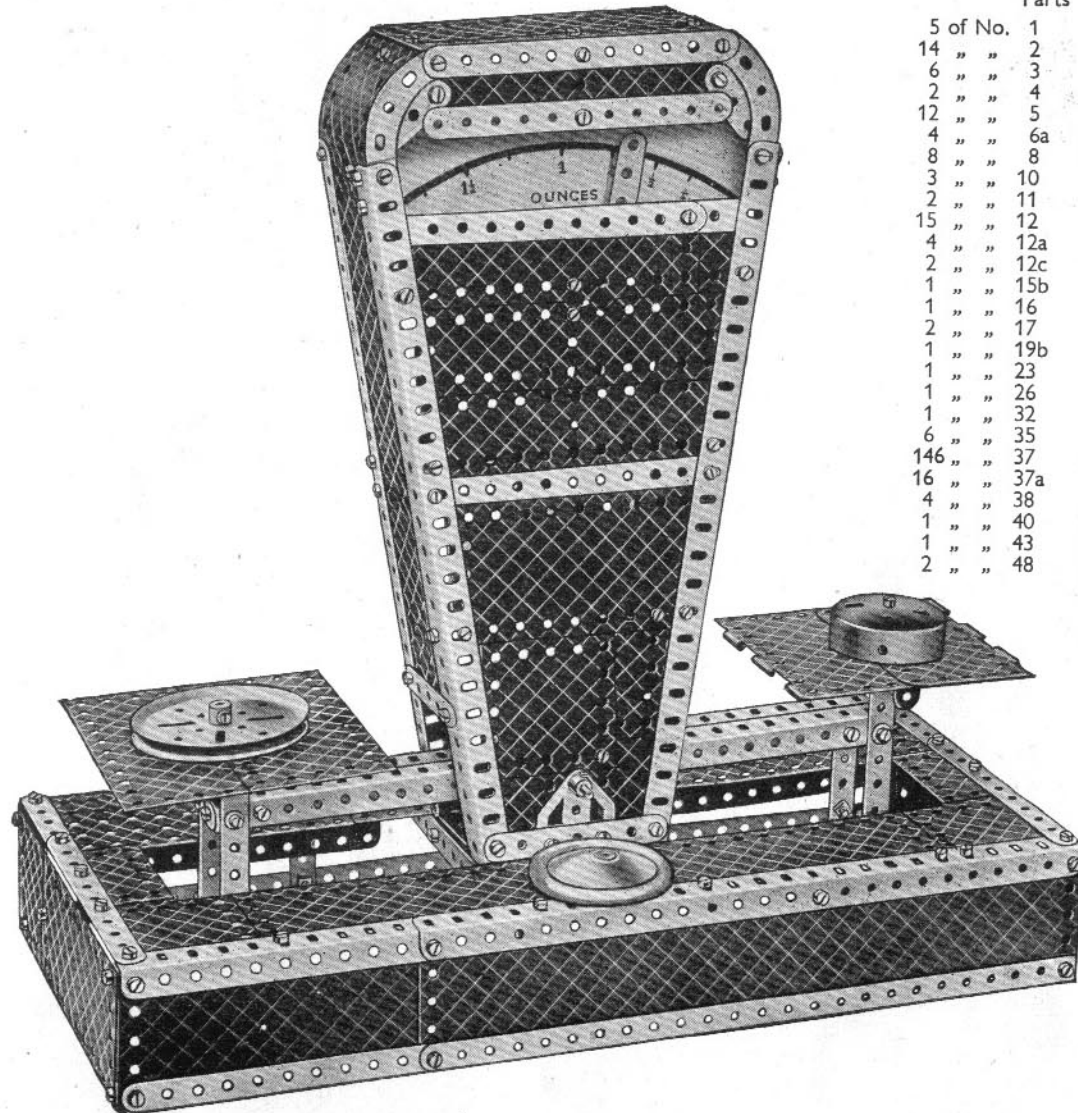

Fig. 7.1a

## 7.2 SCALES



Parts required	
5 of No. 1	2 of No. 48a
14 " " 2	1 " " 48b
6 " " 3	1 " " 51
2 " " 4	2 " " 52
12 " " 5	3 " " 53
4 " " 6a	2 " " 59
8 " " 8	1 " " 62
3 " " 10	1 " " 90
2 " " 11	4 " " 90a
15 " " 12	1 " " 111
4 " " 12a	2 " " 111a
2 " " 12c	6 " " 111c
1 " " 15b	2 " " 126
1 " " 16	2 " " 126a
2 " " 17	1 " " 162a
1 " " 19b	1 " " 187
1 " " 23	6 " " 188
1 " " 26	6 " " 189
1 " " 32	8 " " 190
6 " " 35	2 " " 191
146 " " 37	6 " " 192
16 " " 37a	2 " " 197
4 " " 38	1 " " 198
1 " " 40	2 " " 200
1 " " 43	
2 " " 48	

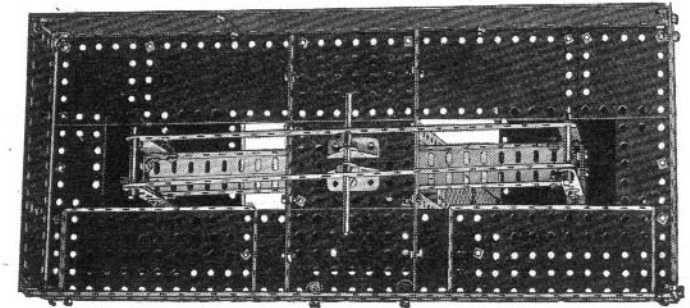

Fig. 7.2a

Construction should be commenced with the base as shown in Figs. 7.2a and 7.2b. The front consists of two Angle Girders overlapped 15 holes and two  $12\frac{1}{2}$ " Strips similarly overlapped. To these are bolted a  $12\frac{1}{2}$ " $\times$  $2\frac{1}{2}$ " Strip Plate and a  $5\frac{1}{2}$ " $\times$  $2\frac{1}{2}$ " Flexible Plate. The front and rear are joined at each end by compound strips, each consisting of a  $5\frac{1}{2}$ " Strip overlapping a  $3$ " Strip two holes. The strips are bolted to the Angle Girders and attached to the rear side by Angle Brackets.

The two sides of the base are  $5\frac{1}{2}$ " $\times$  $2\frac{1}{2}$ " and  $2\frac{1}{2}$ " $\times$  $2\frac{1}{2}$ " Flexible Plates, which are bolted together and attached to the front and rear by four Angle Brackets. At the centre, three  $3\frac{1}{4}$ " $\times$  $2\frac{1}{2}$ " Flanged Plates are joined together by bolting their flanges to two  $5\frac{1}{2}$ " Strips (Fig. 7.2a), and the compound plate is then bolted to the Angle

Girders and to Angle Brackets fastened to the rear side. The top of the base is made by bolting a  $12\frac{1}{2}$ " $\times$  $2\frac{1}{2}$ " Strip Plate, two  $5\frac{1}{2}$ " $\times$  $2\frac{1}{2}$ " Flanged Plates and Flexible Plates of various sizes in the positions shown in Fig. 7.2a.

The front of the housing for the dial and mechanism consists of two Angle Girders joined across at the bottom by a  $3\frac{1}{2}$ " Strip and in the middle by a  $5\frac{1}{2}$ " Strip. Two  $2\frac{1}{2}$ " small radius Curved Strips are bolted to the end of the Angle Girders and are joined across by a  $5\frac{1}{2}$ " Strip. A  $5\frac{1}{2}$ " $\times$  $1\frac{1}{2}$ " Flexible Plate fitted with a  $5\frac{1}{2}$ " Strip and two  $1\frac{1}{2}$ " Strips as shown, is held by the securing Bolts of the upper  $5\frac{1}{2}$ " Strip. The space between the Angle Girder is filled in by three  $5\frac{1}{2}$ " $\times$  $1\frac{1}{2}$ ", four  $2\frac{1}{2}$ " $\times$  $1\frac{1}{2}$ " Flexible Plates, a  $4\frac{1}{2}$ " $\times$  $2\frac{1}{2}$ " Flexible Plate and a  $2\frac{1}{2}$ " $\times$  $2\frac{1}{2}$ " Flexible Plate. The framework for the rear of the dial housing is constructed in a similar manner, and is joined to the front by two  $2\frac{1}{2}$ " $\times$  $\frac{1}{2}$ " Double Angle Strips, which also attach the housing to the base. One side is filled in by a  $2\frac{1}{2}$ " Strip, a  $2\frac{1}{2}$ " $\times$  $1\frac{1}{2}$ " Flanged Plate, a  $5\frac{1}{2}$ " $\times$  $2\frac{1}{2}$ " Flexible Plate and a  $2\frac{1}{2}$ " $\times$  $2\frac{1}{2}$ " Flexible Plate.

At the other side the front and rear of the housing are joined across by three  $2\frac{1}{2}$ " Strips and by a  $4\frac{1}{2}$ " $\times$  $2\frac{1}{2}$ " Flexible Plate. The top corners are made by bolting two  $1\frac{1}{2}$ " radius Curved Plates to the Angle Girders and attaching them by Obtuse Angle Brackets to two  $5\frac{1}{2}$ " $\times$  $1\frac{1}{2}$ " Flexible Plates forming the top. The dial is carried on two Double Brackets (see Fig. 7.2b).

The beam connecting the two scale pans is shown in Figs. 7.2a and 7.2b. Two Angle Girders are joined across at each end by two  $1$ " $\times$  $1$ " Angle Brackets. A Crank is bolted at the centre of the rear Angle Girder and four compound strips each consisting of a  $2\frac{1}{2}$ " Strip overlapping a  $3\frac{1}{2}$ " Strip four holes, are pivoted to the Angle Girders in the third hole from the top ends of the compound strips. Two  $12\frac{1}{2}$ " Strips are then pivoted to the ends of the compound strips by  $2$ " Rods held in place by Spring Clips. The Angle Girders are pivoted on a  $3\frac{1}{2}$ " Rod that is held in the boss of the Crank and is passed through holes in two Flat Trunnions bolted to the base of the dial casing.

The  $12\frac{1}{2}$ " Strips are pivoted on a  $4$ " Rod that is passed through holes in Fishplates bolted to Trunnions. The Trunnions in turn are bolted to the centre  $3\frac{1}{2}$ " $\times$  $2\frac{1}{2}$ " Flanged Plate of the base. The left-hand scale pan is attached by Angle Brackets

(Continued on next page).

(Continued from previous page)

and the right-hand scale pan 2, which consists of the halves of a Hinged Flat Plate is fastened to a  $3\frac{1}{2}'' \times \frac{1}{2}''$  and a  $1\frac{1}{2}'' \times \frac{1}{2}''$  Double Angle Strip. The method of making the pointer is shown in Fig. 7.2b. A Worm fixed on the  $1\frac{1}{2}''$  Strip, and a  $\frac{1}{2}''$  Pinion secured on the  $2\frac{1}{2}''$  large radius Curved Strip act as counterweights. The pointer is pivotally mounted on a  $\frac{1}{2}''$  Bolt. Cord is tied to the pointer, led over a  $\frac{1}{2}''$  loose Pulley on a  $\frac{3}{4}''$  Bolt, and finally is tied to a  $\frac{3}{8}''$  Bolt fastened to the rear Angle Girder of the beam. One end of a Spring is fastened to the dial casing and its other end is attached to the beam at the point shown in Fig. 7.2b

Bolts 1 and 3 should all be lock-nutted. The dial can be made of white card and can be calibrated by placing objects of known weight on the left-hand scale pan, and marking on the dial the position taken up by the pointer. The 3" Pulley, Road Wheel and Boiler End represent weights and are not fastened to the model.

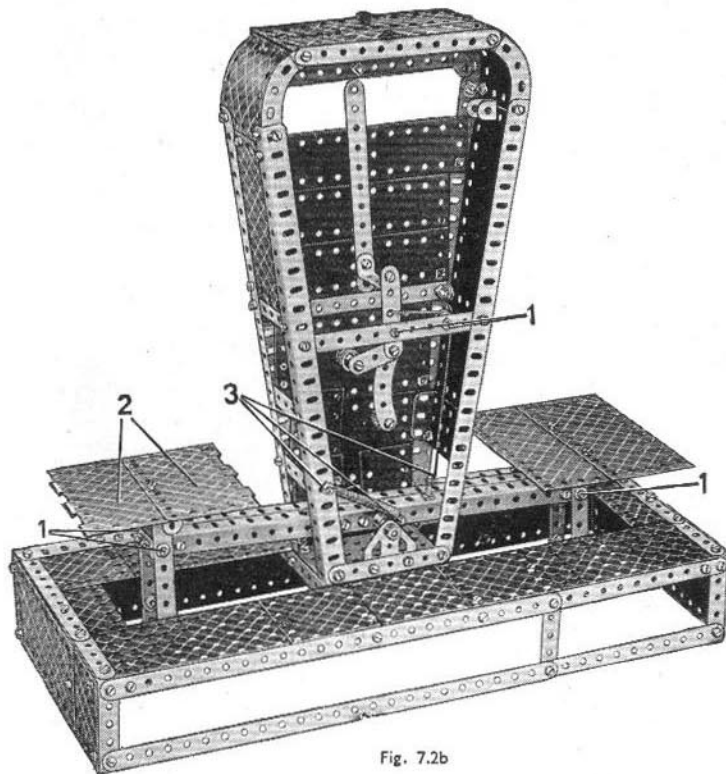
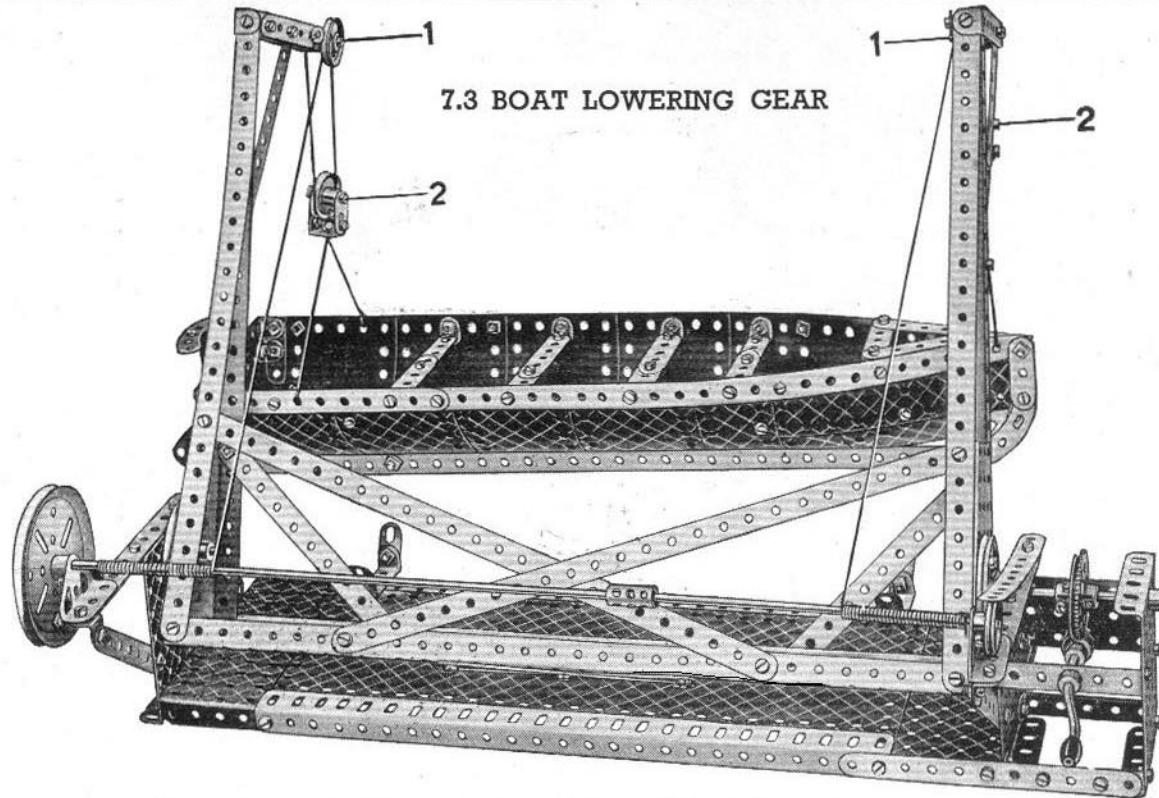

Fig. 7.2b

### 7.3 BOAT LOWERING GEAR



The base of the model consists of two  $5\frac{1}{2}'' \times 2\frac{1}{2}''$  Flanged Plates joined by two  $12\frac{1}{2}''$  Angle Girders and two  $12\frac{1}{2}'' \times 2\frac{1}{2}''$  Strip Plates overlapped one row of holes along their long edges. The Strip Plates are clamped between the Angle Girders and the  $5\frac{1}{2}'' \times 2\frac{1}{2}''$  Flanged Plates. At the left-hand end of the base is a  $3\frac{1}{2}'' \times 2\frac{1}{2}''$  Flanged Plate, which carries two  $5\frac{1}{4}''$  Strips bolted face to face to the upper flange of the Flanged Plate. The end of the double strip is supported by a  $3\frac{1}{4}''$  Strip bolted to an Angle Bracket, the Bolt holding the Angle Bracket carrying also a Trunnion that forms a bearing for a compound rod.

The right-hand side of the base carries two  $3\frac{1}{2}'' \times 2\frac{1}{2}''$  Flanged Plates spaced apart by three  $2\frac{1}{2}'' \times \frac{1}{2}''$  Double Angle Strips and a  $2\frac{1}{2}'' \times 1\frac{1}{2}''$  Flanged Plate. A  $5\frac{1}{2}''$  Strip bolted to one of the Double Angle Strips and to the  $5\frac{1}{4}'' \times 2\frac{1}{2}''$  Flanged Plates, ensures rigidity. The inner  $3\frac{1}{2}'' \times 2\frac{1}{2}''$  Flanged Plate carries a similar bearing to the left-hand  $3\frac{1}{2}'' \times 2\frac{1}{2}''$  Flanged Plate, and is fitted with a  $5\frac{1}{2}''$  Strip bolted as shown in the illustration, which acts as a friction brake.

The  $12\frac{1}{2}''$  Strips and Angle Girders forming the uprights of the davits are bolted to Flanged Sector Plates, and the Compound Angle Girders forming the base of the frame are braced by  $5\frac{1}{2}''$  Strips. The members carrying the 1" loose Pulleys on Bolts 1 each consist of a  $3\frac{1}{2}'' \times \frac{1}{2}''$  Double Angle Strip and a  $2\frac{1}{2}'' \times \frac{1}{2}''$  Double Angle Strip extended by a  $2\frac{1}{2}''$  Strip and an Angle Bracket. The  $\frac{3}{8}''$  Bolts 1 are lock-nutted. A Crank is bolted on the inside of each Flanged Sector Plate, and a 2" Pulley is bolted in a corresponding position on the outside. A  $1\frac{1}{2}''$  Rod locked in the bosses of the left-hand 2" Pulley and Crank, passes through the  $3\frac{1}{2}'' \times 2\frac{1}{2}''$  Flanged Plate, and is retained by a Collar. A  $3\frac{1}{2}''$  Rod is fixed in the bosses of the right-hand 2" Pulley and Crank, and carries between the two Flanged Plates a 57-teeth Gear bolted to a Bush Wheel, each of the Bolts being provided with a Washer. The 57-teeth Gear meshes with a Worm carried on a Crank Handle journalled as shown.

The  $\frac{3}{8}''$  Bolts 2 in the pulley blocks each carry a 1" fast Pulley and three Washers, and are lock-nutted. The construction of the boat and the rests will be clear from the illustrations. A Flat Trunnion bolted to the bottom end of the Angle Girder of the left-hand davit, guides the stern of the boat on to the rests.

4 of No. 190	6 of No. 111c
1 " " 191	1 " " 115
4 " " 192	4 " " 125
2 " " 197	2 " " 126
1 " " 199	3 " " 126a
2 " " 214	1 " " 188
2 " " 215	3 " " 189

Parts required	
7 of No. 1	1
14 " " 2	2
6 " " 3	3
2 " " 4	4
11 " " 5	5
4 " " 6a	6a
8 " " 8	8
6 " " 10	10
2 " " 11	11
18 " " 12	12
4 " " 12c	12c
1 " " 13	13
1 " " 14	14
1 " " 16	16
1 " " 18a	18a
1 " " 19b	19b
1 " " 19g	19g
2 " " 20a	20a
3 " " 22	22
2 " " 22a	22a
1 " " 24	24
1 " " 27a	27a
1 " " 32	32
2 " " 35	35
139 " " 37	37
14 " " 37a	37a
14 " " 38	38
1 " " 40	40
2 " " 48	48
5 " " 48a	48a
2 " " 48b	48b
1 " " 51	51
2 " " 52	52
3 " " 53	53
2 " " 54	54
4 " " 59	59
2 " " 62	62
1 " " 63	63
1 " " 90	90
4 " " 90a	90a
2 " " 111	111
2 " " 111a	111a

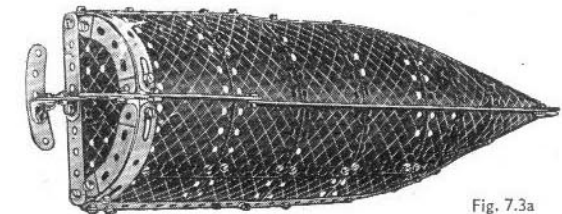

Fig. 7.3a

## 7.4 SHEERLEGS

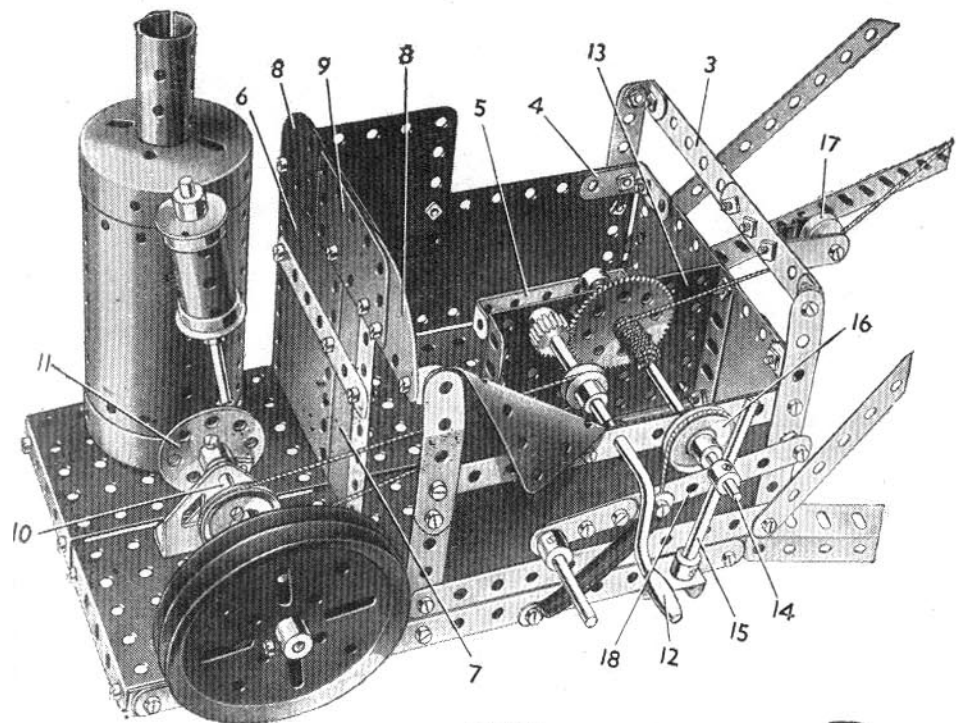

Fig. 7.4 a

The piston rod is a 4" Rod, and it is connected to the Pivot Bolt on the Bush Wheel by a Rod and Strip Connector. Bearings for the crankshaft are provided by Flat Trunnions attached to Trunnions bolted to the base, and the flywheel consists of two 3" Pulleys.

The model is operated by a 3½" Crank Handle 12. This is journaled in the side of the cab and in a 3½" x 2½" Flanged Plate 13, bolted to the front of the cab and attached by an Angle Bracket to the base. A ½" Pulley on the Crank Handle is connected by a belt of Cord to a 1" Pulley on Rod 10. The Crank Handle is also fitted with a ¼" Pinion, which can be meshed with a 57-teeth Gear on a 5" Rod 14. This Rod is free to slide in its bearings, and is controlled by a lever 15, consisting of 3½" Rod fixed in a large Fork Piece. The Fork Piece is pivoted by a ¾" Bolt to a Double Bracket bolted to the base. The lever 15 engages between a 1" Pulley 16 and a Collar locked on the Rod 14.

The fixed pulley block at the crane head (Fig. 7.4 b) is formed by 1½" Strips attached to two Flat Trunnions bolted to the legs. A 2" Pulley and a 1" loose Pulley are free to turn on a 1½" Rod mounted in the 1½" Strips and held in place by Collars.

The hoisting pulley block consists of two 2½" x ½" Double Angle Strips bolted together, and the Hook is attached by an Angle Bracket. A 2" Pulley is locked on a 1" Rod mounted in the Double Angle Strips.

(Continued on next page)

Construction of this model is begun by building the base of the cab from two 5½" x 2½" Flanged Plates extended by two 3½" x 2½" Flanged Plates. Two 12½" Angle Girders 1 are bolted to the 5½" x 2½" Flanged Plates and are connected at their outer ends by a third 12½" Angle Girder 2.

Each of the legs is made from two 12½" Angle Girders overlapped three holes, and two 12½" Strips overlapped five holes are attached to the Angle Girders by Angle Brackets to form U-section girders. The legs are attached to the Angle Girders 1 by Angle Brackets, and are bolted together at their upper ends. The tie rods are formed by three 12½" Strips overlapped seven and ten holes and are bolted to the cab and to the Double Bracket fastened to the crane head.

The sides of the cab are 5½" x 2½" Flexible Plates strengthened by 5½" and 2½" Strips, and are attached to the base by Angle Brackets. The roof is supported by four 2½" Strips bolted to the sides. Two of these Strips are connected by a compound strip 3 (Fig. 7.4 a) consisting of a 3½" and a 2½" Strip overlapped two holes and fastened to Angle Brackets. The roof is formed by three 5½" x 2½" Flexible Plates bolted together and attached to formed Slotted Strips bolted to the sides by Obtuse Angle Brackets.

The front of the cab consists of a 4½" x 2½" and a 2½" x 1½" Flexible Plate joined together and fastened to the sides by 1" x 1" Angle Brackets 4 and 2½" x ½" Double Angle Strips 5. The rear of the cab is partly filled in by a 5½" x 2½" Flexible Plate 6, a 5½" x 1½" Flexible Plate 7, two Semi-Circular Plates 8 and a 2½" x 1½" Flexible Plate 9. The Flexible Plates 6 and 7 are bolted to the base between the 3½" x 2½" and 5½" x 2½" Flanged Plates, and the Semi-Circular Plates 8 are attached to the sides of the cab by Angle Brackets. A Boiler is bolted to the base and fitted with a Chimney Adapter and Sleeve Piece to represent the chimney. A second Sleeve Piece fitted with two ¾" Flanged Wheels is lock-nutted to the Boiler to represent the cylinder of the steam engine. The crankshaft is a 3½" Rod 10 carrying a Bush Wheel 11, which is fitted with a Pivot Bolt.

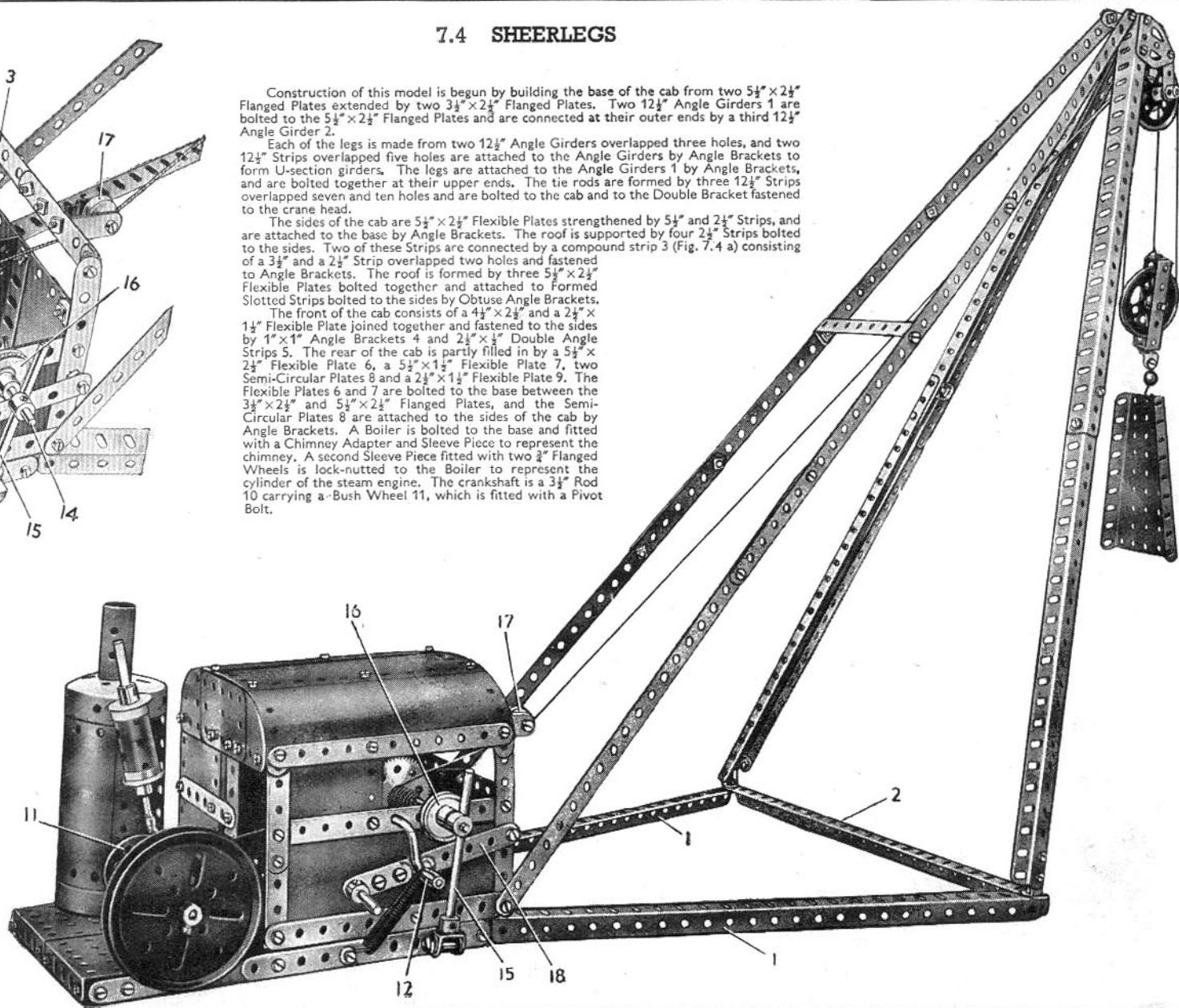

### 7.5 BUILDER'S LORRY

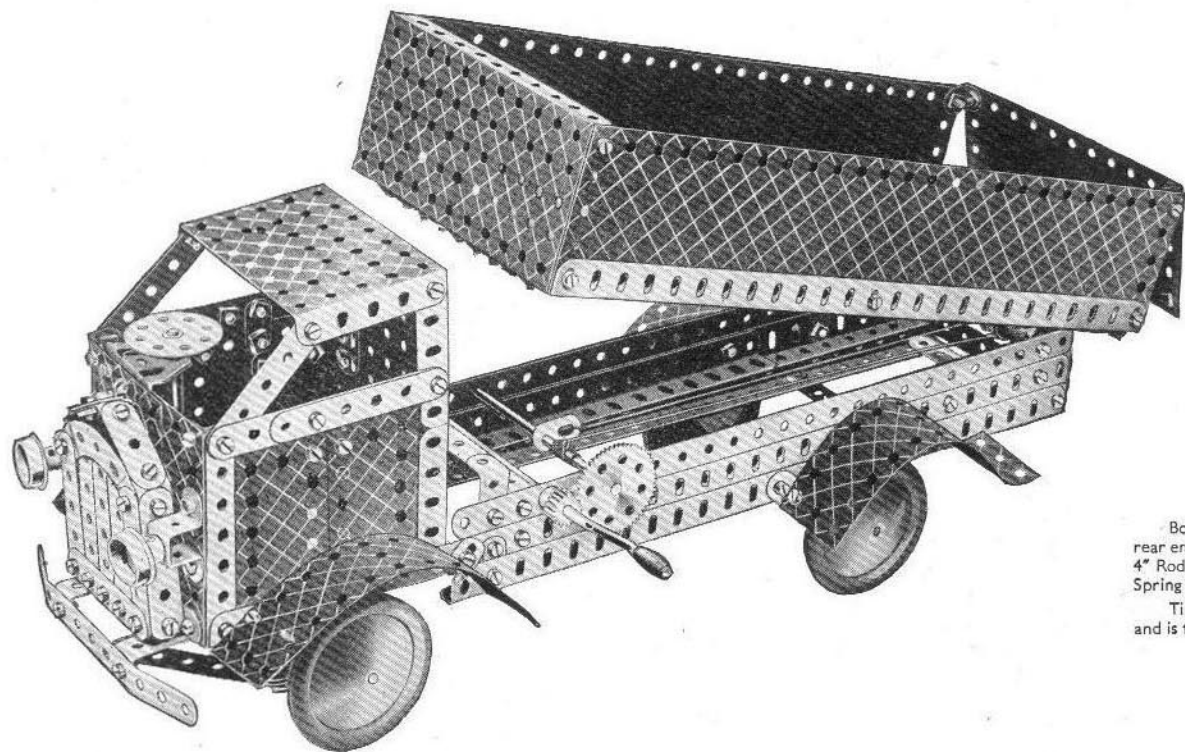

The main side members of the chassis consist of two  $1\frac{1}{2}$ " angle girders built up from  $12\frac{1}{2}$ " Angle Girders. Each member has a further  $12\frac{1}{2}$ " Angle Girder attached below it by two Fishplates, one of which is bolted in the second hole from the front end of the Angle Girder, and the other in the tenth hole from the rear end. The side members are further deepened by  $12\frac{1}{2}$ " Strips attached to them by Fishplates,  $1" \times 1"$  Angle Brackets and  $1\frac{1}{2}" \times \frac{1}{2}"$  Double Angle Strips. The Flat Trunnions are bolted at the rear end of the chassis and the  $1\frac{1}{2}" \times \frac{1}{2}"$  Double Angle Strips are bolted in the second hole from the front end of the chassis. A  $1" \times 1"$  Angle Bracket is bolted next to each Double Angle Strip, and two are also fixed in a position six holes from the rear end of the chassis. The lower Angle Girders of the side members are joined across by a  $3\frac{1}{2}" \times \frac{1}{2}"$  Double Angle Strip, and a  $3\frac{1}{2}"$  Strip. A  $2\frac{1}{2}" \times \frac{1}{2}"$  Double Angle Strip is bolted to the ends of the front pair of  $1" \times 1"$  Angle Brackets. The side members are also spanned by a  $3\frac{1}{2}" \times 2\frac{1}{2}"$  Flanged Plate forming the back of the cab, and by a  $3\frac{1}{2}"$  Strip and a  $3\frac{1}{2}" \times \frac{1}{2}"$  Double Angle Strip at the front end.

The back of the cab is completed by a second  $3\frac{1}{2}" \times 2\frac{1}{2}"$  Flanged Plate, which is attached to the first by two Fishplates, and the roof also is a  $3\frac{1}{2}" \times 2\frac{1}{2}"$  Flanged Plate. A  $2\frac{1}{2}" \times 1\frac{1}{2}"$  Flanged Plate bolted to the lower  $3\frac{1}{2}" \times 2\frac{1}{2}"$  Flanged Plate of the back of the cab represents the driving seat. Each side of the cab is filled in by three  $2\frac{1}{2}" \times 1\frac{1}{2}"$  Flexible Plates, two of which are butted together, and the third is bolted behind to reinforce the joint. The Flexible Plates are attached to the cab by two Fishplates. The front of the cab is made by overlapping four  $2\frac{1}{2}" \times 2\frac{1}{2}"$  Flexible Plates and bolting them at the bottom to the  $3\frac{1}{2}" \times \frac{1}{2}"$  Double Angle Strip spacing the chassis, and at the top to Angle Brackets. The radiator is carried on two Reversed Angle Brackets joined across by a  $2\frac{1}{2}"$  Strip. A  $5\frac{1}{2}"$  Strip represents the front bumper and is carried on the ends of two  $2\frac{1}{2}" \times \frac{1}{2}"$  Double Angle Strips.

The back axle is a  $5"$  Rod journalled in holes in two Flat Trunnions. The front stub axles are  $2"$  Rods carried in Double Brackets 2. A  $1\frac{1}{2}"$  Strip is held between the ends of each Double Bracket on a  $\frac{3}{8}"$  Bolt, which is lock-nutted to a Reversed Angle Bracket bolted to the chassis in the sixth hole from the front. The tie rod is a  $3\frac{1}{2}"$  Strip, connected to a Crank by a  $3"$  Strip. The Crank is carried on a  $5"$  Rod fitted with a Bush Wheel to represent the steering wheel.

Bolts 1 (Fig. 7.5a) are lock-nutted. The construction of the truck body is shown clearly in the illustrations. The  $5\frac{1}{2}" \times 2\frac{1}{2}"$  Flexible Plate at the rear end is fitted with Angle Brackets, which are fastened by lock-nuts to  $\frac{3}{8}"$  Bolts passed through the sides of the body. The body is pivoted on a  $4"$  Rod passed through holes in Flat Trunnions and a  $2\frac{1}{2}" \times \frac{1}{2}"$  Double Angle Strip bolted underneath the body. The Rod is held in place by four Spring Clips.

Tipping is carried out by turning the Crank Handle. The Cord is tied to a Cord Anchoring Spring on the  $4\frac{1}{2}"$  Rod carrying the 57-teeth Gear, and is then led around a  $\frac{1}{2}"$  loose Pulley on a  $1\frac{1}{2}"$  Rod in a Stepped Bent Strip, and finally is tied to a Fishplate on the  $4\frac{1}{2}"$  Rod.

Parts required	
11 of No. 1	4 of No. 12a
4 " " 2	3 " " 12c
6 " " 3	2 " " 15
2 " " 4	1 " " 15a
12 " " 5	1 " " 15b
4 " " 6a	2 " " 17
8 " " 8	1 " " 18a
11 " " 10	1 " " 19h
2 " " 11	2 " " 20b
14 " " 12	1 " " 23
1 of No. 24	2 of No. 48
1 " " 26	4 " " 48a
1 " " 27a	2 " " 48b
11 " " 35	1 " " 51
148 " " 37	1 " " 52
12 " " 37a	3 " " 53
6 " " 38	3 " " 59
1 " " 40	1 " " 62
1 " " 44	1 " " 90a
2 " " 45	1 " " 111a
6 of No. 111c	
4 " " 125	
1 " " 126	
4 " " 126a	
1 " " 176	
4 " " 187	
6 " " 188	
4 " " 189	
4 " " 190	
1 " " 192	
2 " " 197	

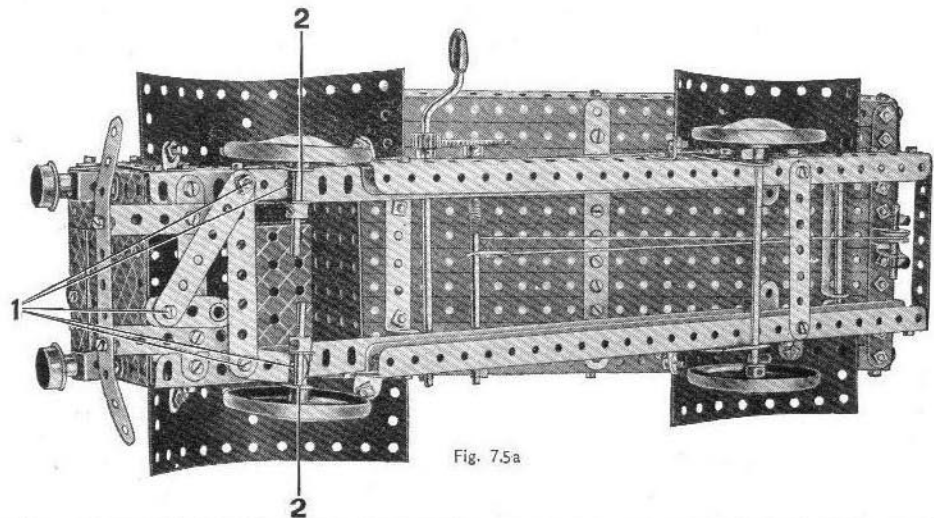
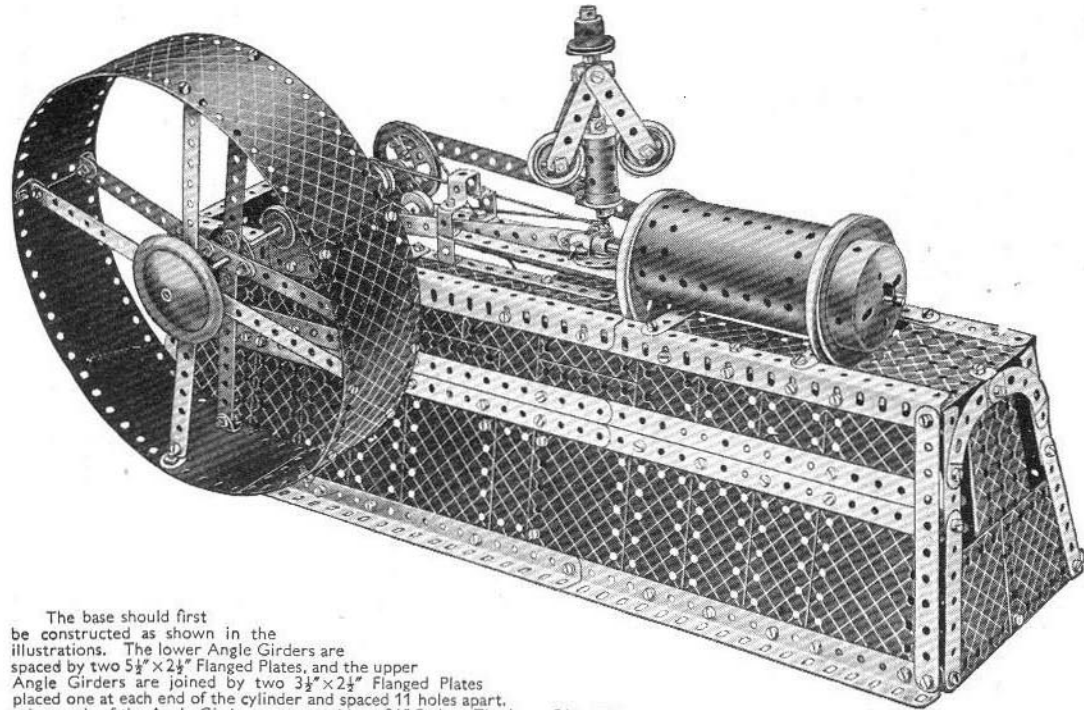

Fig. 7.5a

## 7.6 HORIZONTAL STEAM ENGINE



The base should first be constructed as shown in the illustrations. The lower Angle Girders are spaced by two  $5\frac{1}{2}'' \times 2\frac{1}{2}''$  Flanged Plates, and the upper Angle Girders are joined by two  $3\frac{1}{2}'' \times 2\frac{1}{2}''$  Flanged Plates placed one at each end of the cylinder and spaced 11 holes apart. The other ends of the Angle Girders are spaced by a  $3\frac{1}{2}''$  Strip. The inner  $3\frac{1}{2}'' \times 2\frac{1}{2}''$  Flanged Plate is extended on each side of the connecting rod by compound plates, which are made from two  $2\frac{1}{2}'' \times 1\frac{1}{2}''$  Flexible Plates overlapped two holes, and are reinforced round the edges with  $5\frac{1}{2}''$  and  $1\frac{1}{2}''$  Strips. This forms the bed-plate.

The Boiler that represents the cylinder of the engine, is opened out slightly and its edges are joined together by an Obtuse Angle Bracket. The  $2\frac{1}{2}''$  Cylinder representing the valve chest is carried on two Bolts, which have two Washers on their shanks for spacing purposes. The cylinder is bolted to a  $3\frac{1}{2}''$  Strip and a compound strip consisting of two  $3''$  Strips overlapped five holes. The ends of these Strips are clamped between the Angle Girder and  $2\frac{1}{2}''$  Strips below the valve chest. The rear end of the cylinder is represented by a  $3''$  Pulley and a Boiler End, both of which are carried on a  $1\frac{1}{2}''$  Rod that is held by Spring Clips in a  $1\frac{1}{2}'' \times \frac{1}{2}''$  Double Angle Strip bolted inside the cylinder.

The other end of the cylinder is carried by two Angle Brackets bolted to Reversed Angle Brackets, which in turn are fastened to the  $3\frac{1}{2}'' \times 2\frac{1}{2}''$  Flanged Plate. Each Bolt holding the Angle Brackets carries also a  $5\frac{1}{2}''$  Strip and a Washer. The free ends of the  $5\frac{1}{2}''$  Strips are bolted between Double Brackets (see Fig. 7.6a), the lower pair of which is bolted to the bed-plate, while the upper pair is joined by a Double Bent Strip. This construction forms the slide for the crosshead.

Each web of the crankshaft consists of three  $2\frac{1}{2}''$  Strips fastened together in the form of a triangle and bolted to a Crank, the Bolt holding also a  $1\frac{1}{2}''$  Strip. The Cranks are secured on the ends of a  $2''$  Rod and a  $5''$  Rod respectively, and a  $2''$  Rod is passed through the end holes of the  $1\frac{1}{2}''$  Strips and retained in place by Collars and  $\frac{3}{8}''$  Flanged Wheels. Bearings for the crankshaft are supplied by Trunnions and Flat Trunnions. The  $2''$  member of the crankshaft carries a  $1''$  Pulley and a  $2''$  Pulley, while the  $5''$  member is fitted with a  $1''$  Pulley, the built-up fly-wheel and a Road Wheel.

The crosshead 1 consists of two Wheel Discs spaced apart by two Washers and mounted on a  $\frac{3}{8}''$  Bolt. Three other Washers are used to space the Wheel Discs from the boss of the large Fork Piece. The connecting rod is pivoted on a  $1''$  Rod that has eight Washers placed on it for spacing purposes. Bolt 3 on the slide valve connecting rod is lock-nutted.

The governor shaft is a  $6\frac{1}{2}''$  Rod. The  $2\frac{1}{2}''$  Strips are pivoted on Bolts screwed into a Coupling, and the  $\frac{1}{2}''$  Bolts 2 are lock-nutted. Bearings for the governor shaft are supplied by a Double Bent Strip and the  $3\frac{1}{2}'' \times 2\frac{1}{2}''$  Flanged Plate.

The model is driven by a No. 1 Clockwork Motor. The drive is taken from a  $1''$  Pulley on a  $1\frac{1}{2}''$  Rod in the Motor side plates to the  $2''$  Pulley on the crankshaft. The drive to the governor is taken from a  $1''$  Pulley on the crankshaft to the shaft of the governor.

## Parts required

8 of No. 1	2 of No. 17	12 of No. 37a	2 of No. 111a	1 of No. 187
18 " " 2	2 " " 18a	26 " " 38	6 " " 111c	6 " " 188
6 " " 3	1 " " 18b	2 " " 45	1 " " 116	6 " " 189
2 " " 4	2 " " 19b	1 " " 48	3 " " 125	8 " " 190
12 " " 5	1 " " 20a	4 " " 48a	2 " " 126	2 " " 191
4 " " 6a	4 " " 20b	1 " " 48b	2 " " 126a	6 " " 192
8 " " 8	4 " " 22	2 " " 52	1 " " 147b	2 " " 197
2 " " 10	2 " " 22a	2 " " 53	2 " " 155	1 " " 212
4 " " 11	4 " " 24	2 " " 54	1 " " 162a	1 " " 216
12 " " 12	1 " " 24a	4 " " 59	1 " " 162b	1 No. 1 Clockwork Motor
1 " " 12c	1 " " 26	2 " " 62	1 " " 163	(Not included in Outfit).
1 " " 14	1 " " 27a	1 " " 63	1 " " 164	
2 " " 15	5 " " 35	2 " " 80c	2 " " 186	
1 " " 15a	148 " " 37	4 " " 90a		

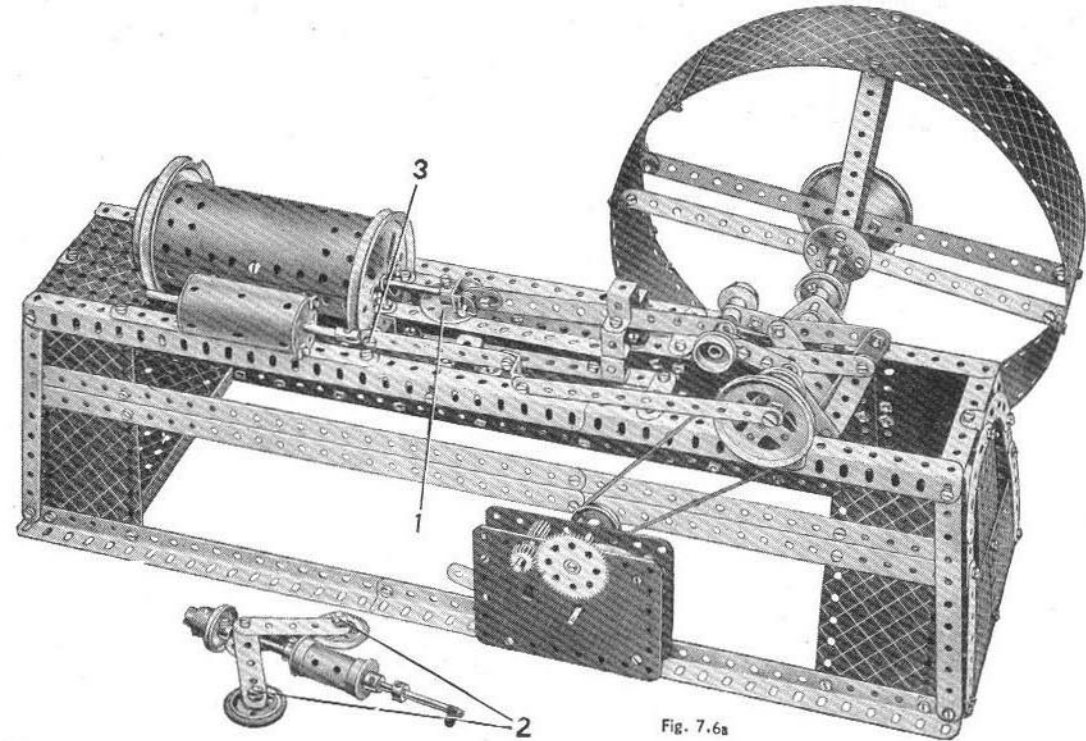

Fig. 7.6a



## 7.7 COASTAL PATROL BOAT

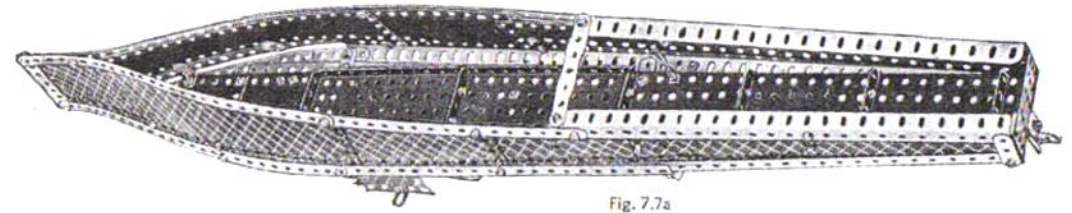
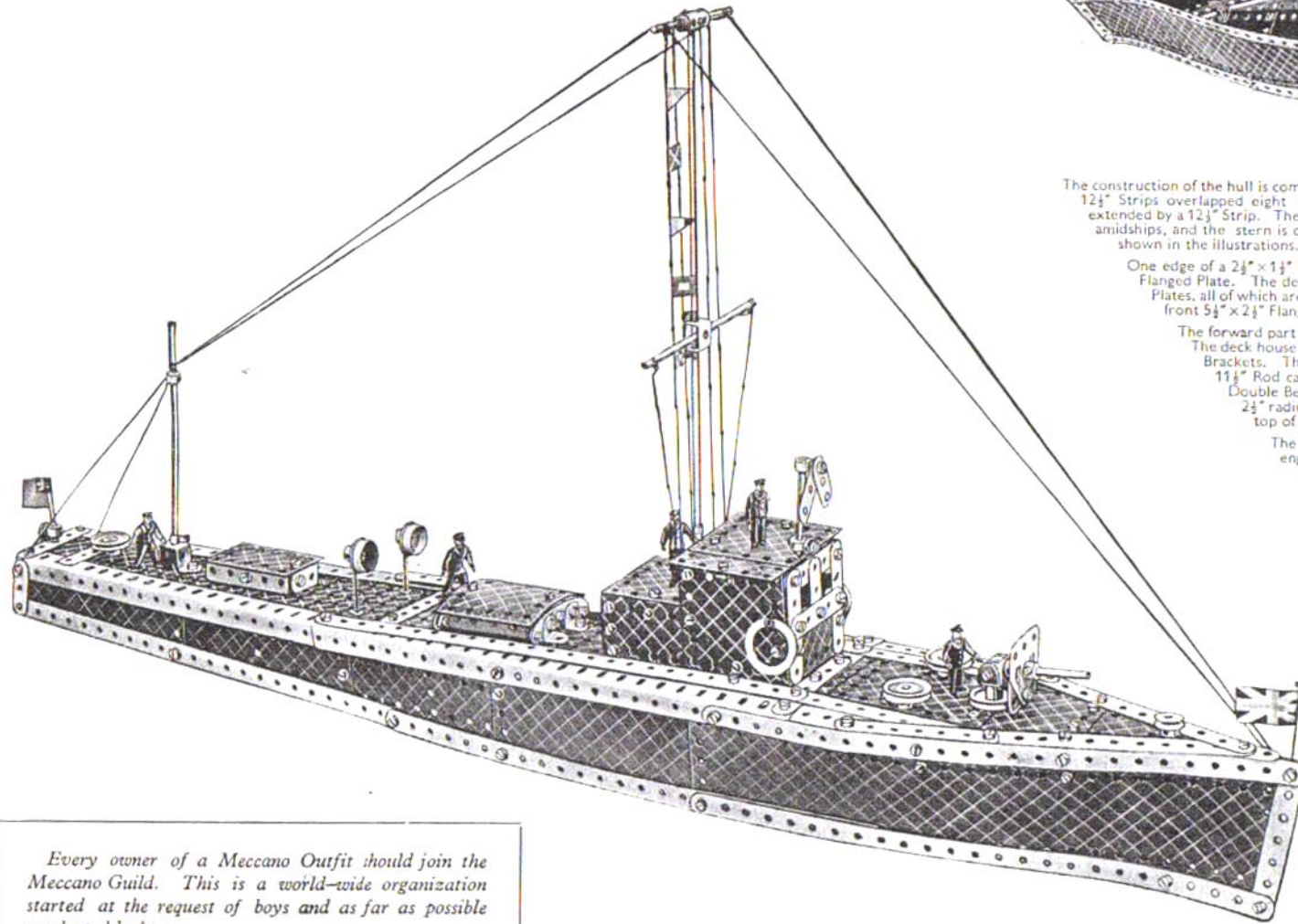

Fig. 7.7a

The construction of the hull is commenced by making the framework of the sides. The Angle Girders at the bottom are extended by two 12½" Strips overlapped eight holes, and the two Angle Girders forming part of each side of the deck are overlapped six holes and extended by a 12½" Strip. The sides are bolted together, the Bolts holding also two 3½" Strips. A 3½" Strip connects the Angle Girders amidships, and the stern is completed with a 2½" x 1½" Flanged Plate. The sides are filled in by Strip Plates and Flexible Plates as shown in the illustrations.

One edge of a 2½" x 1½" Flexible Plate is bolted to a 2½" Strip across the stern and its other edge to a 2½" Strip and a 3½" x 2½" Flanged Plate. The deck is extended from this to the bows by two further 3½" x 2½" Flanged Plates and two 5½" x 2½" Flanged Plates, all of which are bolted together by their flanges. The third 3½" x 2½" Flanged Plate is supported by a 3½" Strip, and the front 5½" x 2½" Flanged Plate is supported by two 3" Strips overlapped three holes.

The forward part of the deck consists of three 2½" x 2½" Flexible Plates, and a 2½" x 1½" Flexible Plate bolted as shown. The deck house is built up from Flexible Plates of various sizes, joined together by 2½" x ½" Double Angle Strips and Angle Brackets. The rear of the deck house is completed with 2½" x ½" Double Angle Strips. The forward wireless mast is an 11½" Rod carried in a Rod and Strip Connector, and the rear mast is a 5" Rod held by Spring Clips in holes in a Double Bent Strip and a 3½" x 2½" Flanged Plate. The amidship hatch is built of 2½" x ½" Double Angle Strips and 2½" radius Curved Strips, and the after hatch is a 2" x 1" and a 2½" x ½" Double Angle Strip bolted together. The top of the hatch is held in place by a ½" Bolt.

The forward gun shield consists of two Flat Trunnions, and an Angle Bracket is bolted to them so that it engages with the groove of the 1" Pulley forming the swivel.

### Parts required

8 of No. 1	4 of No. 22	2 of No. 90
4 " " 2	1 " " 23a	1 " " 111
6 " " 3	4 " " 35	2 " " 111a
2 " " 4	123 " " 37	6 " " 111c
10 " " 5	5 " " 37a	1 " " 116
4 " " 6a	9 " " 38	2 " " 126a
6 " " 8	1 " " 40	2 " " 155a
4 " " 10	1 " " 45	6 " " 188
2 " " 11	1 " " 46	6 " " 189
18 " " 12	8 " " 48a	8 " " 190
1 " " 13	1 " " 51	2 " " 192
1 " " 14	2 " " 52	2 " " 197
1 " " 15	3 " " 53	1 " " 200
2 " " 17	5 " " 59	1 " " 212
3 " " 18a	1 " " 63	1 " " 213
2 " " 20b	2 " " 80c	

Every owner of a Meccano Outfit should join the Meccano Guild. This is a world-wide organization started at the request of boys and as far as possible conducted by boys.

Write for full particulars and an application form to the Meccano Guild Secretary, Binns Road, Liverpool, 13.

## 7.8 RADIAL TRAVELLING CRANE

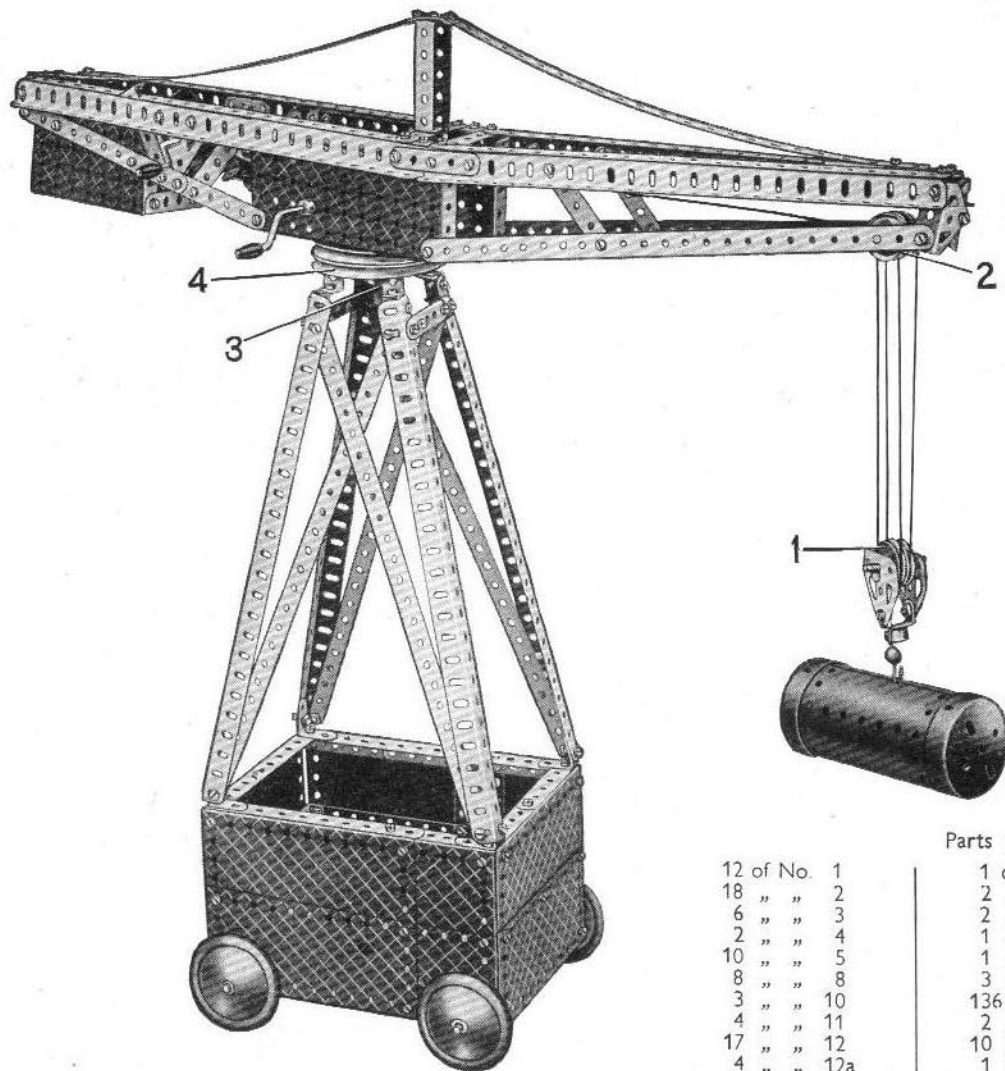

Construction should be commenced with the base of the model, which is shown in Fig. 7.8a with one side removed in order to reveal its internal details. The sides are built up from Flexible Plates and Strips of various sizes, the Plates used for the short sides being reinforced by  $5\frac{1}{2}$ " Strips at the centre. The sides are connected together by Angle Brackets, and a tie rod made by bolting a  $3\frac{1}{2}$ "  $\times$   $\frac{1}{2}$ ", a  $2\frac{1}{2}$ "  $\times$   $\frac{1}{2}$ " and a  $1\frac{1}{2}$ "  $\times$   $\frac{1}{2}$ " Double Angle Strip together, is used to brace the short sides.

The tower supporting the jib consists of four  $12\frac{1}{2}$ " Angle Girders, attached by  $1"$   $\times$   $1"$  Angle Brackets to the base and braced by  $12\frac{1}{2}$ " Strips on each side. The Angle Girders are joined across at the top by two compound strips consisting of two  $5\frac{1}{2}$ " Strips overlapped four holes. The lower  $3"$  Pulley 4, which forms the bearing for the jib, has four Reversed Angle Brackets bolted to it, and these in turn are bolted to Double Brackets fastened to the ends of the Angle Girders of the tower.

The jib is shown in Fig. 7.8b with one of the tie rods removed. Each side consists of two  $12\frac{1}{2}$ " Angle Girders bolted to a  $5\frac{1}{2}$ "  $\times$   $2\frac{1}{2}$ " Flanged Plate. A  $12\frac{1}{2}$ " Strip is bolted to the front end of the Flanged Plate and a compound strip consisting of a  $5\frac{1}{2}$ " and a  $3\frac{1}{2}$ " Strip is bolted to its rear end. The  $12\frac{1}{2}$ " Strip is joined to the front Angle Girder by a Trunnion and the compound strip is attached to the rear Angle Girder by an Angle Bracket. The Strips and Angle Girders are braced by two  $2\frac{1}{2}$ "  $\times$   $\frac{1}{2}$ " Double Angle Strips and a  $2\frac{1}{2}$ " Strip.

The sides of the jib are connected together at the front by the Trunnions, at the centre by two  $2\frac{1}{2}$ " Strips, and at the rear by two  $2\frac{1}{2}$ "  $\times$   $\frac{1}{2}$ " Double Angle Strips. The box at the rear end of the jib consists of three  $3\frac{1}{2}$ "  $\times$   $2\frac{1}{2}$ " Flanged Plates and a  $2\frac{1}{2}$ "  $\times$   $2\frac{1}{2}$ " Flexible Plate, and is bolted to the compound strips bracing the Angle Girders. A  $3"$  Pulley is bolted to the flanges of the  $5\frac{1}{2}$ "  $\times$   $2\frac{1}{2}$ " Flanged Plates. The  $3\frac{1}{2}"$  Rod 3 is locked in the boss of Pulley 4 and carries a Collar and a 57-teeth Gear. A Worm fastened on the large Crank Handle meshes with the 57-teeth Gear, so that by turning the Crank Handle the jib is made to swivel.

The small Crank Handle is passed through holes in two Flat Trunnions bolted to the jib, and it carries a Cord Anchoring Spring. The  $1\frac{1}{2}"$  Rod at the jib head carries two  $1"$  fast Pulleys, spaced apart by three Washers, Pulley 2 being free on the Rod. The hoisting pulley block 1 carries two  $1"$  loose Pulleys spaced apart by Washers. Cord is tied to the Cord Anchoring Spring and then led over  $1"$  Pulley 2 and around  $1"$  Pulley. It is then passed around the second  $1"$  Pulley in the jib, around the other  $1"$  Pulley in the hoisting pulley block, and finally is tied to the jib.

The axles for the Road Wheels are compound rods, one consisting of two  $3\frac{1}{2}"$  Rods joined by a Rod Connector, and the other of  $3\frac{1}{2}"$  Rod and a  $4"$  Rod joined by a Rod Connector.

## Parts required

12 of No. 1	1 of No. 19h	3 of No. 59
18 " " 2	2 " " 22	2 " " 111c
6 " " 3	2 " " 22a	1 " " 116
2 " " 4	1 " " 27a	4 " " 125
10 " " 5	1 " " 32	2 " " 126
8 " " 8	3 " " 35	4 " " 126a
3 " " 10	136 " " 37	1 " " 162
4 " " 11	2 " " 37a	1 " " 176
17 " " 12	10 " " 38	4 " " 187
4 " " 12a	1 " " 40	2 " " 188
2 " " 12c	1 " " 48	5 " " 190
1 " " 15b	9 " " 48a	2 " " 191
4 " " 16	1 " " 48b	6 " " 192
2 " " 18a	2 " " 52	2 " " 213
2 " " 19b	3 " " 53	
1 " " 19g	1 " " 57c	

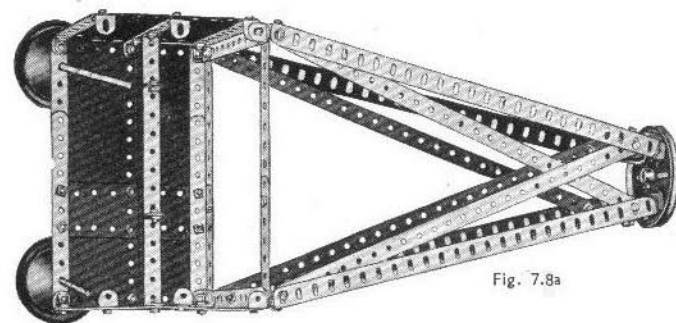

Fig. 7.8a

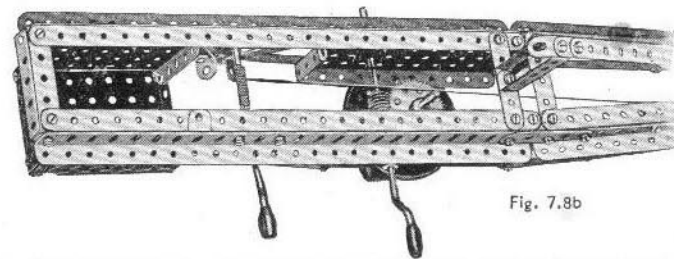
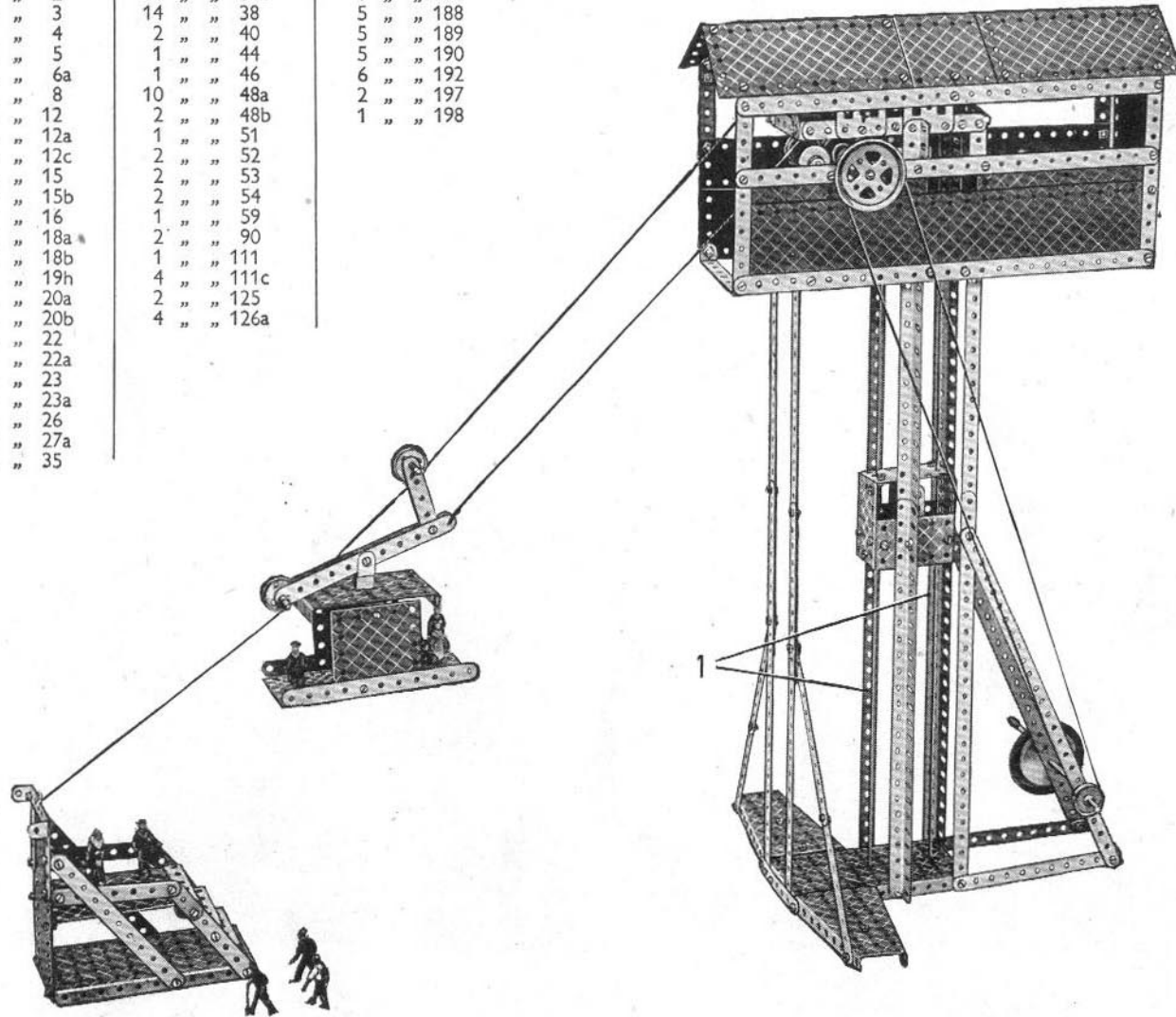

Fig. 7.8b

### 7.9 TELPHER RAILWAY AND ELEVATOR

Parts required

12 of No. 1	150 of No. 37	2 of No. 163
18 " " 2	6 " " 37a	1 " " 187
2 " " 3	14 " " 38	5 " " 188
2 " " 4	2 " " 40	5 " " 189
9 " " 5	1 " " 44	5 " " 190
4 " " 6a	1 " " 46	6 " " 192
8 " " 8	10 " " 48a	2 " " 197
18 " " 12	2 " " 48b	1 " " 198
3 " " 12a	1 " " 51	
6 " " 12c	2 " " 52	
2 " " 15	2 " " 53	
1 " " 15b	2 " " 54	
2 " " 16	1 " " 59	
1 " " 18a	2 " " 90	
1 " " 18b	1 " " 111	
1 " " 19h	4 " " 111c	
1 " " 20a	2 " " 125	
4 " " 20b	4 " " 126a	
2 " " 22		
2 " " 22a		
1 " " 23		
1 " " 23a		
1 " " 26		
1 " " 27a		
7 " " 35		



The control cabin is supported on four main pillars each made from two Angle Girders overlapped three holes. Additional support is supplied by two compound strips made by overlapping two 12½" Strips 11 holes, and bolting them to two 2½" Strips overlapped three holes and attached by Angle Brackets to the base of the cabin. The supports are braced by 12½" Strips and 9½" compound strips.

The 12½" x 2½" Strip Plates forming the sides of the cabin are attached to the rear pair of Angle Girders by Reversed Angle Brackets, and to the front pair of Angle Girders by Angle Brackets. The sides are spaced at the ends by 3½" x ½" Double Angle Strips.

The roof consists of a Hinged Flat Plate extended on each side by 5½" x 2½" Flexible Plates, each of these overlapping the Hinged Flat Plate by two holes. The roof is attached to the sides by Obtuse Angle Brackets, and the back of the cabin, which consists of a 5½" x 2½" and a 5½" x 1½" Flexible Plate, is attached by two 1" x 1" Angle Brackets.

The 5½" Strips carrying the 1" Pulleys of the carriage are pivoted on a lock-nutted ¾" Bolt, which carries a Collar and two Washers for spacing purposes and is supported by a Stepped Bent Strip. The ¾" Bolt at the junction of the 2½" Strips carries five Washers on its shank, to space the Strips apart.

Fig. 7.9a shows the cab with the roof removed to reveal the arrangement of the hoisting drums. The guide cords for the elevator are tied at 1, and the guide cord for the carriage is tied to an Obtuse Angle Bracket 2. Cord is tied around a ½" loose Pulley fastened to a 1" x 1" Angle Bracket on the lift, and then passes over a 1" fast Pulley and a ½" fast Pulley at the top of the shaft and finally is wound around hoisting drum 3. A second Cord is tied to the carriage and is wound around hoisting drum 4.

A Crank Handle passed through holes in the 12½" Strips bracing the Angle Girders carries a 1" fast Pulley that is connected by a belt of Cord to a 2" Pulley fastened on the 5" Rod carrying hoisting drum 3. A 57-teeth Gear on this Rod meshes with a ½" Pinion on the 5" Rod of hoisting drum 4. In order to ensure that the lift reaches the top of the shaft at the same time as the carriage, the carriage Cord should be three times the length of the lift Cord.

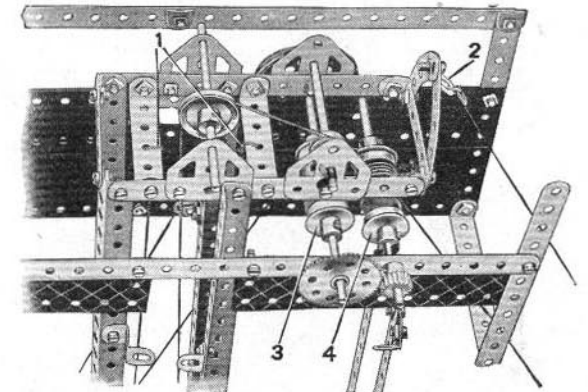
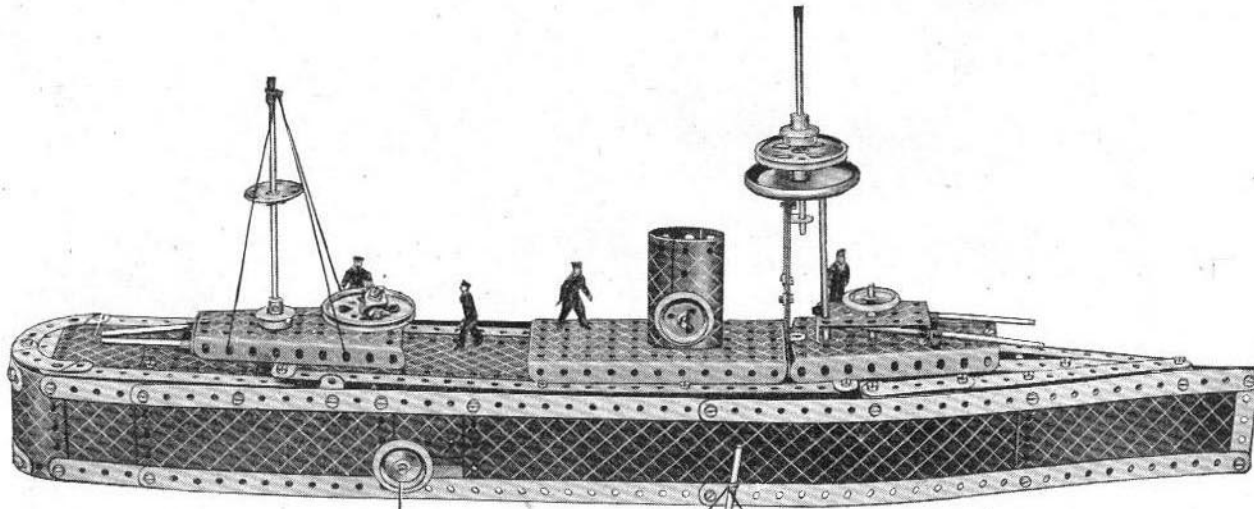

Fig. 7.9a

### 7.10 EXPLODING SHIP



This is an amusing model with which great fun can be obtained. It includes a battleship and a small submarine. The battleship is caused to "explode" by firing a torpedo from the submarine so that it strikes a 1" Pulley set in the side of the ship. The torpedo is represented by a Coupling and is ejected from a tube passing through the centre of the submarine. When the "torpedo" strikes the 1" Pulley an arm is released inside the ship, and this springs upward and throws off the superstructure, thus providing the effect of an explosion.

The hull of the vessel is first constructed as shown in Figs. 7.10c and 7.10d. The sides, which are formed by Strips and Flexible Plates, are spaced apart at the stern by a 3½" x 2½" Flanged Plate, and at the front by a 2½" Strip. The rounded stern is formed by two 1¼" radius Curved Plates overlapped one hole and strengthened by two Formed Slotted Strips.

Two Angle Girders are secured inside the ship by means of 3½" x 2½" Double Angle Strips, and on these is carried the mechanism for "exploding" the ship. This consists essentially of an arm 2 (Fig. 7.10a) pivoted at one end and actuated by a Driving Band 4.

The arm 2 consists of two 5½" Strips, which are joined at one end by a 2½" x ½" and a 2½" x 1" Double Angle Strip, and pivoted at the other end on a 3½" Rod. The Rod is journaled at each end in a Double Bracket bolted to one of the Angle Girders. The arm 2 carries also a ½" fast Pulley 9, which is secured on a ⅜" Bolt passed through the centre hole of the 2½" x ½" Double Angle Strip. A Double Bent Strip is bolted to the 2½" x 1" Double Angle Strip to form a handle.

The Driving Band 4 is first fastened through one of the holes at the end of the arm 2, and its other end is slipped between a Fishplate and the 5½" Strip 5. The Fishplate is held by the Bolt 6, and is spaced from the Strip 5 by two Washers. The Flat Trunnion 8 is fastened to the centre of one of the 3½" x ½" Double Angle Strips joining the two Angle Girders, and it serves as a stop for the arm 2. If desired, a percussion cap, such as is used in toy pistols, can be placed on the Flat Trunnion 8, in such a position that it is exploded on impact with the ½" Pulley 9.

(Continued on next page)

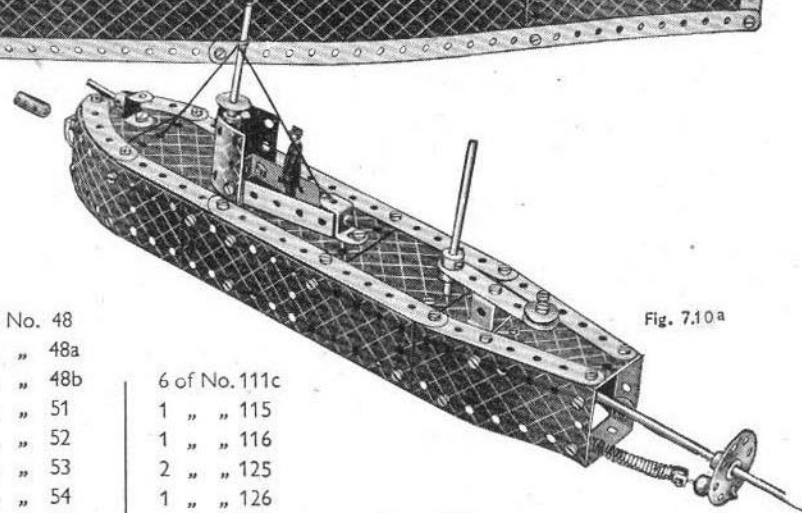

Fig. 7.10a

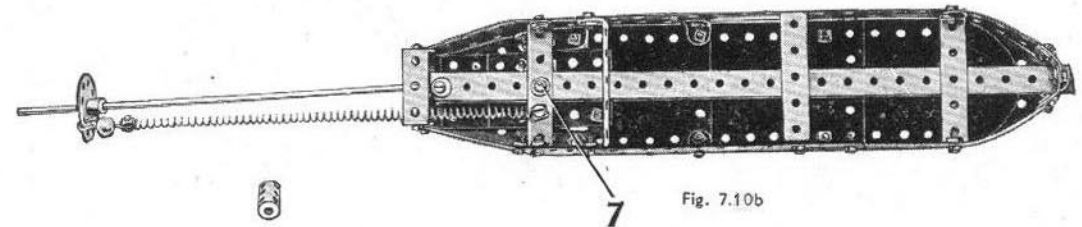

Fig. 7.10b

Parts required

10 of No. 1	1 of No. 18b			
11 " " 2	2 " " 20a			
5 " " 3	2 " " 20b			
2 " " 4	2 " " 22	2 of No. 48		
12 " " 5	2 " " 22a	8 " " 48a		
2 " " 6a	1 " " 23	2 " " 48b	6 of No. 111c	
4 " " 8	1 " " 23a	1 " " 51	1 " " 115	
7 " " 10	1 " " 24	1 " " 52	1 " " 116	
4 " " 11	1 " " 24a	1 " " 53	2 " " 125	
18 " " 12	14 " " 35	2 " " 54	1 " " 126	
5 " " 12c	144 " " 37	1 " " 57c	1 " " 126a	1 No. of 191
1 " " 13	9 " " 37a	6 " " 59	4 " " 155	5 " " 192
1 " " 14	19 " " 38	1 " " 62	1 " " 176	2 " " 197
2 " " 15	1 " " 38d	1 " " 63	1 " " 186b	2 " " 199
3 " " 15a	1 " " 40	2 " " 90	1 " " 187	2 " " 200
2 " " 15b	1 " " 43	2 " " 90a	6 " " 188	1 " " 213
4 " " 16	2 " " 45	1 " " 111	6 " " 189	1 " " 214
3 " " 18a	1 " " 46	2 " " 111a	6 " " 190	2 " " 215

(Continued from previous page)

When set ready for "exploding" the ship the arm 2 is held by a catch, which can be seen in Fig. 7.10c consisting of an Angle Bracket bolted to the centre hole of a Crank. The Crank is secured on a  $3\frac{1}{2}$ " Rod 3, journalled in a Trunnion and a Reversed Angle Bracket and it is capable of about  $\frac{1}{4}$ " lateral movement. This movement allows the Angle Bracket on to the Crank to be slipped over one of the  $5\frac{1}{2}$ " Strips forming the arm 2, to hold it in position. When the 1" Pulley 1 on the outer end of the Rod 3 is struck, however, the arm is released.

The superstructure is carried on a frame formed by securing two  $12\frac{1}{2}$ " Strips together at each end by a  $3\frac{1}{2}$ " Strip. The rear half of the frame is filled in by a  $5\frac{1}{2}$ " $\times$  $2\frac{1}{2}$ " Flexible Plate, supported by means of Fish-plates. Two Fishplates, projecting inwards, are also bolted to the front part of the frame, to form a support for part of the superstructure. The frame is supported at the rear on two  $5\frac{1}{2}$ " Strips projecting from the stern deck, and at the front by a  $1\frac{1}{2}$ " Strip, which is bolted to the  $3\frac{1}{2}$ " Strip spacing the sides. The Bolt holding the  $1\frac{1}{2}$ " Strip carries also an Angle Bracket, which prevents the frame slipping out of position. In assembling the various units the first part of the superstructure to be placed in position is the forward gun turret. This consists of a Flanged Sector Plate, to which a  $2\frac{1}{2}$ " $\times$  $1\frac{1}{2}$ " Flanged Plate is attached by means of a  $1\frac{1}{2}$ " Rod. The Rod carries at its upper end a 1" Pulley complete with Rubber Ring, and at its lower end a Spring Clip. Each of the guns is represented by a  $3\frac{1}{2}$ " Rod, and is secured in position through the front flange of the  $2\frac{1}{2}$ " $\times$  $1\frac{1}{2}$ " Flanged Plate by two Spring Clips. The gun turret is placed so that it rests partly on the frame and partly on the forward deck.

Directly behind the gun turret there is a  $5\frac{1}{2}$ " $\times$  $2\frac{1}{2}$ " Flanged Plate, to the front flange of which is fastened a  $2\frac{1}{2}$ " $\times$  $1\frac{1}{2}$ " Flexible Plate. Each of the Bolts holding the Flexible Plate carries also a compound strip consisting of two  $2\frac{1}{2}$ " Strips overlapped two holes. The compound strips are joined at their upper ends, a double bracket, consisting of two  $\frac{1}{2}$ " $\times$  $\frac{1}{2}$ " Angle Brackets, being held by the same Bolt. The two free holes of the double bracket form the bearings for the 5" Rod representing the forward mast, which carries, above the double bracket, a Road Wheel, a 2" Pulley and a  $\frac{3}{4}$ " Flanged Wheel.

The funnel is constructed from two U-Section Curved Plates, the ends of which overlap one hole, and it stands at the centre of the  $5\frac{1}{2}$ " $\times$  $2\frac{1}{2}$ " Flanged Plate. A  $1\frac{1}{2}$ " Rod passing through the lower end of the funnel carries at each end a 1" loose Pulley complete with Rubber Ring, the Pulleys being prevented from slipping off the Rod by two Spring Clips. These Pulleys represent rafts.

The rear gun turret consists of a Flanged Sector Plate, across the narrow end of which a  $1\frac{1}{2}$ " Strip is secured by an Angle Bracket. The two 4" Rods forming the guns are passed through the end holes of the  $1\frac{1}{2}$ " Strip, and locked in position by Spring Clips. The barrel of the anti-aircraft gun is a  $\frac{3}{4}$ " Bolt, which is mounted on an Angle Bracket fixed to a  $1\frac{1}{2}$ " Rod by an Obtuse Angle Bracket. The  $1\frac{1}{2}$ " Rod passes through the Flanged Sector Plate, and carries a 2" Pulley that forms the base for the gun. The mizzen mast is a 6 $\frac{1}{2}$ " Rod, rigidly secured to the Flanged Sector Plate by a Collar and a  $\frac{3}{4}$ " Flanged Wheel.

The main deck of the submarine, an underneath view of which is shown in Fig. 7.10b consists of three  $2\frac{1}{2}$ " $\times$  $2\frac{1}{2}$ " Flexible Plates and one  $2\frac{1}{2}$ " $\times$  $1\frac{1}{2}$ " Flexible Plate, bolted end to end. The deck is extended to the rear by two  $2\frac{1}{2}$ " $\times$  $1\frac{1}{2}$ " Flexible Plates and to the front by a Semi-Circular Plate. Strips of various sizes are bolted round the edge of the deck.

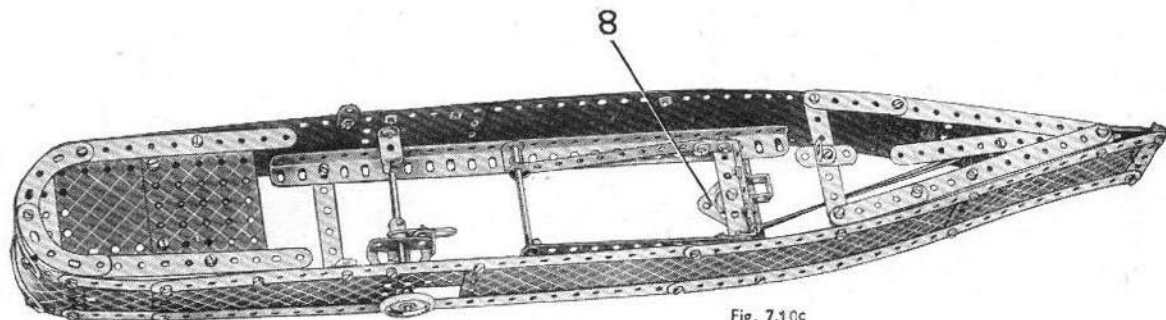

Fig. 7.10c

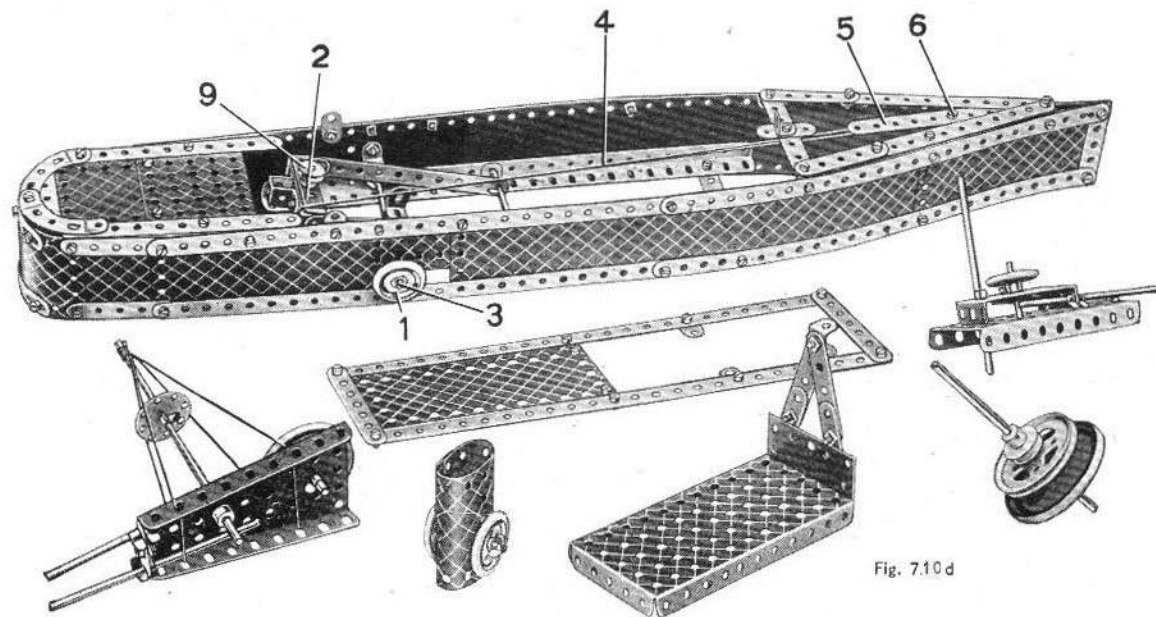

Fig. 7.10d

The conning tower is a  $2\frac{1}{2}$ " $\times$  $1\frac{1}{2}$ " Flexible Plate bent to shape and secured to the deck by two  $2\frac{1}{2}$ " $\times$  $\frac{1}{2}$ " Double Angle Strips and a Reversed Angle Bracket. A  $3\frac{1}{2}$ " Rod used for the periscope is fastened inside the conning tower by a Collar. At its upper end the Rod carries a second Collar, upon which rests a  $\frac{3}{4}$ " Washer. The latter is prevented from coming off the Rod by Cord. The quick-firer in the bows is formed by a 1" Rod, which is held in the boss of a large Fork Piece bolted to the deck.

The sides of the submarine are constructed from  $5\frac{1}{2}$ " $\times$  $1\frac{1}{2}$ " and  $2\frac{1}{2}$ " $\times$  $1\frac{1}{2}$ " Flexible Plates braced across the bottom by  $2\frac{1}{2}$ " $\times$  $\frac{1}{2}$ " Double Angle Strips as shown in Fig. 7.10b and secured in position by Angle Brackets. Angle Girders joined by Double Brackets form the torpedo tube, and are secured in position by the Bolt 7. An  $11\frac{1}{2}$ " Rod slides in the centre holes of the two Double Brackets joining the Angle Girders and carries a Collar at its inner end. At the outer end of the  $11\frac{1}{2}$ " Rod a Bush Wheel is fastened, and this is secured by a small Loaded Hook to one end of a Spring, the other end of which is bolted under the submarine.

When the  $11\frac{1}{2}$ " Rod is pulled out to its fullest extent it is prevented from shooting back under the action of the Spring by a  $3\frac{1}{2}$ " Rod, which slips down in front of it. The  $3\frac{1}{2}$ " Rod is secured through a  $2\frac{1}{2}$ " Strip by two Collars as shown in the illustration, and can be lifted out of the path of the  $11\frac{1}{2}$ " Rod by depressing the  $\frac{1}{2}$ " Pulley at the other end of the  $2\frac{1}{2}$ " Strip.

## 7.11 COAL ELEVATOR

The frame of the shaft consists of four compound angle girders, spaced apart at their ends by  $5\frac{1}{2}$ " Strips. Each compound girder is made from two  $12\frac{1}{2}$ " Angle Girders bolted together overlapping 14 holes. The base of the shaft is extended as shown by two  $12\frac{1}{2}$ " Strips, between the outer ends of which is bolted a  $5\frac{1}{2}$ " $\times$  $2\frac{1}{2}$ " Flanged Plate. Two more  $12\frac{1}{2}$ " Strips forming rails on which the coal trucks run, are secured to the centre of the Flanged Plate by Angle Brackets. At their other ends the rails are supported by Fishplates and Angle Brackets attached to a  $3\frac{1}{2}$ " Strip, which is fixed to the base by Reversed Angle Brackets.

The extension of the base on one side of the shaft is made by two  $3\frac{1}{2}$ " $\times$  $2\frac{1}{2}$ " Flanged Plates. These support a third  $3\frac{1}{2}$ " $\times$  $2\frac{1}{2}$ " Flanged Plate in which a Crank Handle is journalled as shown. The other bearing for the Crank Handle is provided by a  $2\frac{1}{2}$ " $\times$  $1$ " Double Angle Strip, which is secured to the  $12\frac{1}{2}$ " Strip Plates by a  $2\frac{1}{2}$ " $\times$  $\frac{1}{2}$ " Double Angle Strip.

Between the two Double Angle Strips, the Crank Handle carries a 2" Pulley, which is connected by Cord to a 1" Pulley on a compound rod consisting of a  $4\frac{1}{2}$ " and a 2" Rod joined by a Coupling. This rod is journalled in the  $5\frac{1}{2}$ " Strips at the top of the shaft. A  $6\frac{1}{2}$ " Rod journalled in two Flat Trunnions as shown carries a 57-teeth Gear, which meshes with a  $\frac{1}{2}$ " Pinion on the compound rod. The  $6\frac{1}{2}$ " Rod carries at its centre a Cord Anchoring Spring, to which a length of Cord is tied. The Cord is then wound around the Rod several times and secured to the top of the truck platform the constructional details of which are shown in Fig. 7.11a. The Bolts 1 are lock-nutted, and when the projecting  $2\frac{1}{2}$ " Strips make contact with the  $5\frac{1}{2}$ " Strip that is secured to the elevator shaft just below the chute, the rails and wagon tip up and the coal is fed on to the chute.

The chute is a Flanged Sector Plate, and it is pivoted on a 5" Rod supported by two Reversed Angle Brackets. The angle at which the chute rests is controlled by a large Crank Handle journalled in the  $5\frac{1}{2}$ " Strip at the top of the shaft. Cord is tied to the shaft of the Crank Handle, taken over the  $\frac{1}{2}$ " loose Pulley at the top of the elevator shaft and finally is tied to the front of the Flanged Sector Plate. The  $\frac{1}{2}$ " loose Pulley is held on a  $1\frac{1}{2}$ " Rod journalled in the end holes of two  $2\frac{1}{2}$ " Strips fixed to the top of the shaft by a Double Bracket. The motor is represented by two Boiler Ends, which are bolted to a  $2\frac{1}{2}$ " $\times$  $1\frac{1}{2}$ " Flanged Plate that can be seen in Fig. 7.11b. A  $3\frac{1}{2}$ " Rod is passed through the centres of the Boiler Ends, and is held in position by a  $\frac{1}{2}$ " fast Pulley and a  $\frac{3}{4}$ " Flanged Wheel. A Driving Band connects the  $\frac{1}{2}$ " fast Pulley to a 1" Pulley on the  $6\frac{1}{2}$ " Rod.

The Coal Truck is used to demonstrate the model and is an item of Hornby Rolling Stock.

Parts required	
10 of No. 1	7 of No. 48a
18 " " 2	2 " " 48b
4 " " 3	1 " " 51
2 " " 4	2 " " 52
12 " " 5	3 " " 53
4 " " 6a	1 " " 54
8 " " 8	3 " " 59
8 " " 10	1 " " 63
1 " " 11	2 " " 90a
10 " " 12	4 " " 111c
3 " " 12a	4 " " 125
1 " " 14	2 " " 126
2 " " 15	4 " " 126a
1 " " 15a	2 " " 162a
1 " " 16	1 " " 176
1 " " 17	1 " " 186
1 " " 18a	1 " " 188
1 " " 19g	6 " " 189
1 " " 19h	2 " " 190
1 " " 20a	6 " " 192
1 " " 20b	2 " " 197
5 " " 22	
1 " " 23	
1 " " 23a	
1 " " 26	
1 " " 27a	
7 " " 35	
146 " " 37	
6 " " 37a	
6 " " 38	
1 " " 40	
1 " " 46	
2 " " 48	

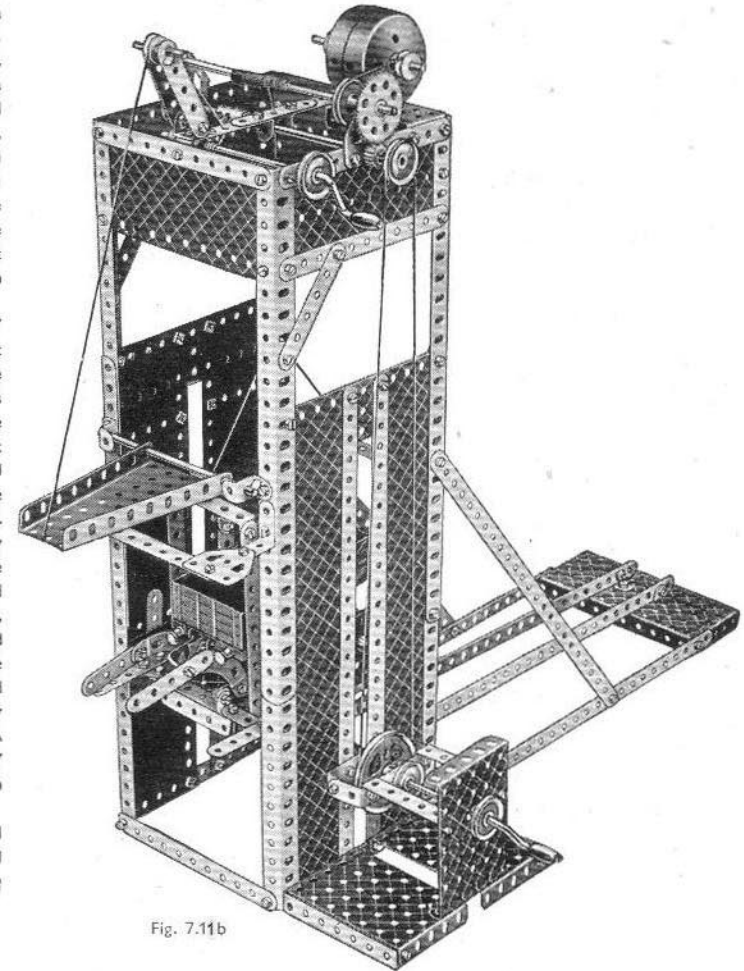
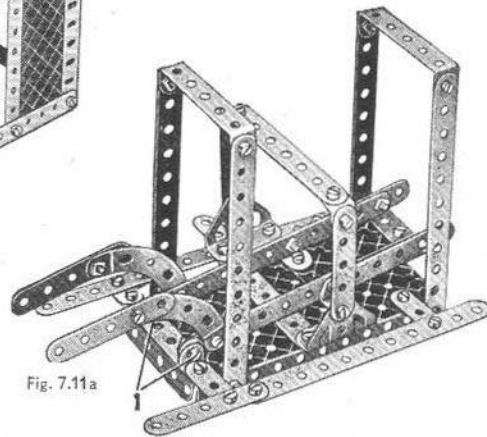
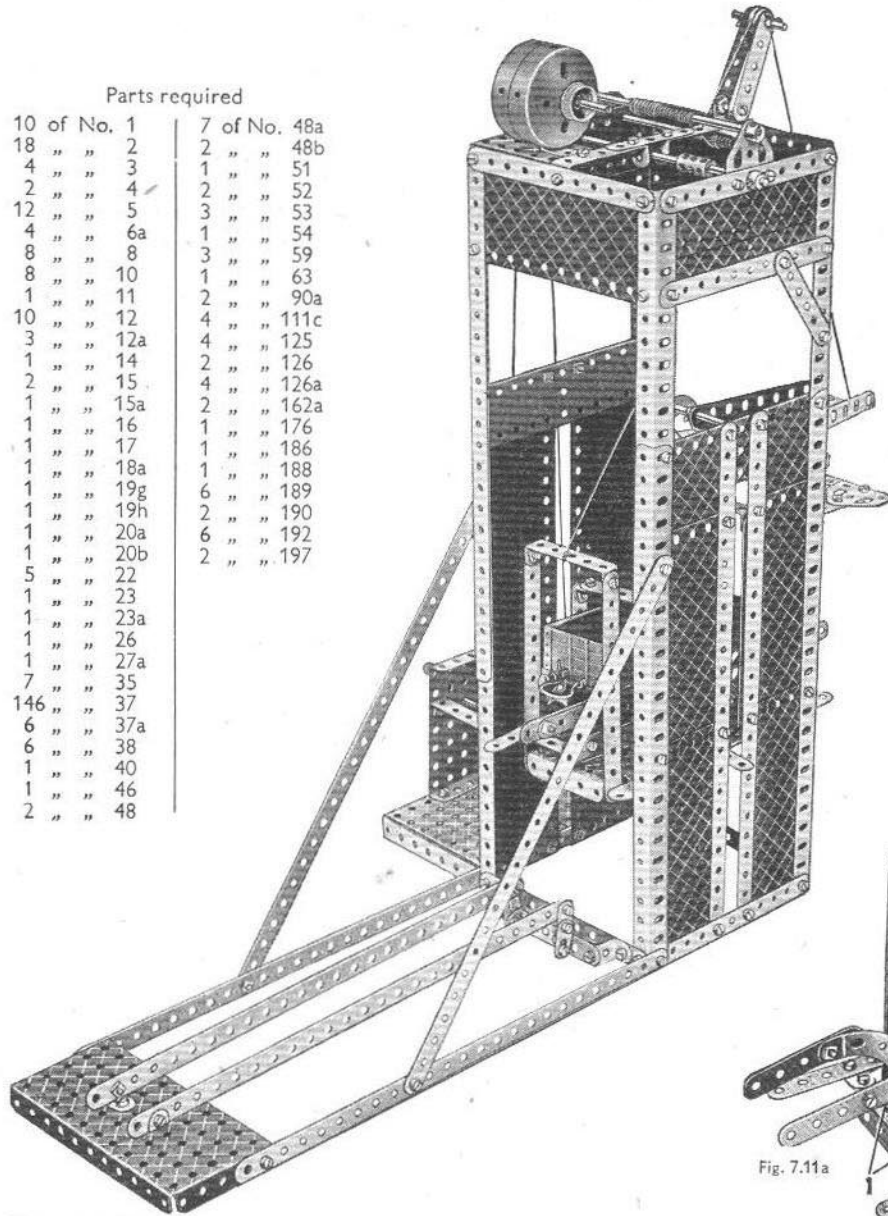

### 7.12 DIESEL GENERATOR

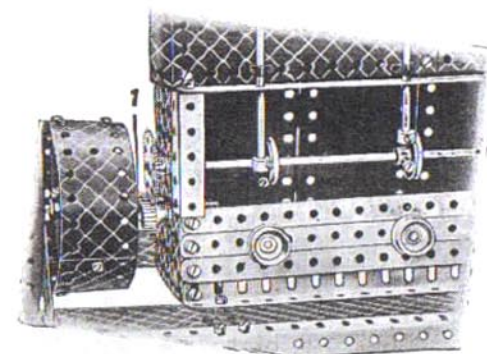
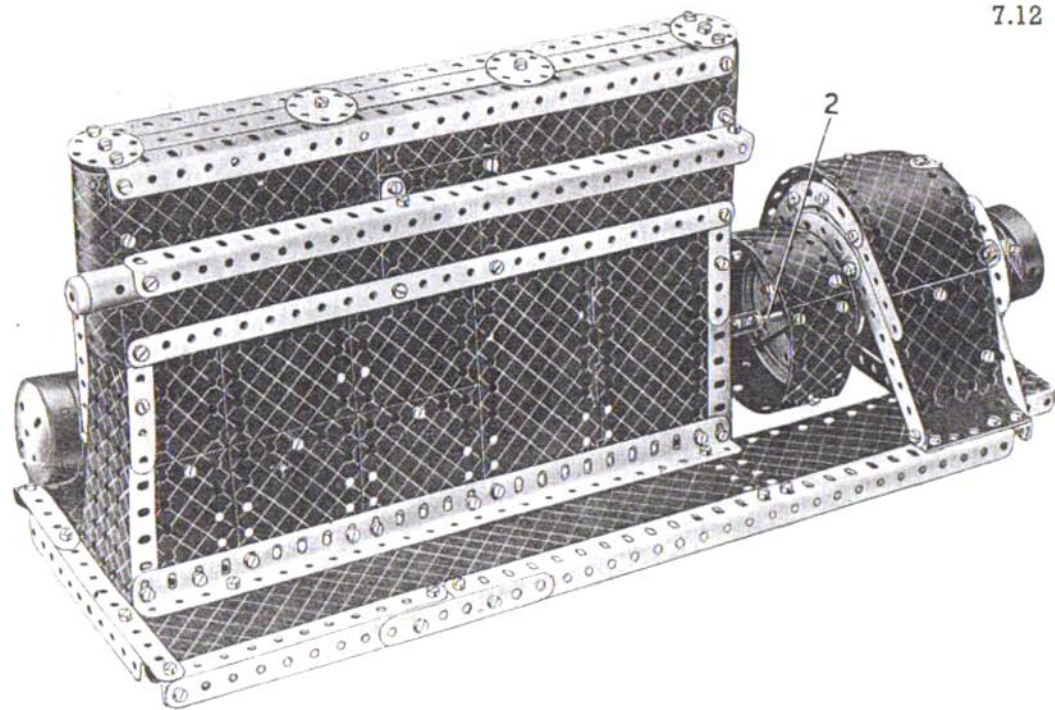

Fig. 7.12a

Parts required			
12 of No. 1	2 of No. 20a		
18 " " 2	4 " " 20b		
3 " " 3	4 " " 22		
2 " " 4	2 " " 22a		
8 " " 5	1 " " 23a		
3 " " 6a	1 " " 24		
8 " " 8	2 " " 26		
2 " " 10	1 " " 27a		
2 " " 11	8 " " 35		
14 " " 12	140 " " 37		
4 " " 12a	7 " " 37a		
1 " " 12c	3 " " 38		
1 " " 13	1 " " 40		
1 " " 14	1 " " 45		
2 " " 15	9 " " 48a		
2 " " 15a	2 " " 48b		
1 " " 17	1 " " 51		
2 " " 19b	2 " " 52		
2 of No. 54a	1 of No. 115	2 of No. 187	
4 " " 59	2 " " 126	6 " " 188	
1 " " 63	1 " " 126a	6 " " 189	
2 " " 90	1 " " 147b	8 " " 190	
3 " " 90a	1 " " 162	2 " " 191	
2 " " 111	1 " " 163	6 " " 192	
2 " " 111a	1 " " 164	2 " " 197	
6 " " 111c	1 " " 176	1 " " 198	
			2 of No. 199
			2 " " 200
			4 " " 217a

The lower part of the engine crankcase is built up by joining the flanges of two Flanged Sector Plates at their wide ends by two Angle Girders. The front flanges of the two Sector Plates are also joined by three 12½" Strips, which can be seen in Fig. 7.12b. The rear side is filled in with a Hinged Flat Plate, four 2½" x 2½" Flexible Plates and two 2½" x 1½" Flexible Plates. The crank case side shown in Fig. 7.12b consists of five 12½" Strips bolted between two 2½" x ½" Double Angle Strips fixed to the Flanged Sector Plates by Angle Brackets.

The Cords representing the railings on the inspection gallery are tied between 1½" Strips supported by 1" x 1" Angle Brackets. The cylinder block is constructed from Flexible Plates of various sizes arranged as shown.

The push rods are represented by 4" and 4½" Rods, and each is supported by two Spring Clips. The method by which the Rods are actuated is shown in Fig. 7.12a. Each of the Rods carries at its lower end a Collar, and a ¼" Bolt in the tapped hole of a 1" Pulley bears against the Collar when the 11½" Rod carrying the Pulleys is turned. The positions of the ¼" Bolts in the four Pulleys are adjusted so that the push rods rise one after the other. At the fly-wheel end the 11½" Rod passes through the Flanged Sector Plate and is fitted with a 57-teeth Gear, and at its other end it is journaled in a Double Bracket. The Double Bracket is secured to a 5½" Strip, the lower end of which is bolted to the front Angle Girder joining the Flanged Sector Plates.

The rim of the fly-wheel is built up from two 5½" x 1½" Flexible Plates and a 2½" x 1½" Flexible Plate overlapping each other one hole, and is secured to a 3" Pulley by two 3½" x ½" Double Angle Strips. The compound rod 2 carrying the fly-wheel consists of a 6½" Rod and a 2" Rod, and is journaled at one end in the Flanged Sector Plate and at the other end in a Flat Trunnion. The Flat Trunnion is supported by a Trunnion 3 from a 5½" x 2½" Flanged Plate bolted to the base. The Rod of the fly-wheel carries at its end a ¼" Pinion 1, which meshes with a second ¼" Pinion that is held loosely on the shank of a ¾" Bolt lock-nutted to the Flanged Sector Plate. The second ¼" Pinion meshes also with the 57-teeth Gear at the end of the 11½" Rod carrying the 1" Pulleys.

The armature of the generator is a 3" Pulley and two 2" Pulleys. Each of the 2" Pulleys has two 2½" x ½" Double Angle Strips bolted to its inner face, which serve to space it from the 3" Pulley. Two Road Wheels with their bosses touching, are used for the commutator. The armature and commutator are covered by a casing built up from Flexible Plates and two U-Section Curved Plates.

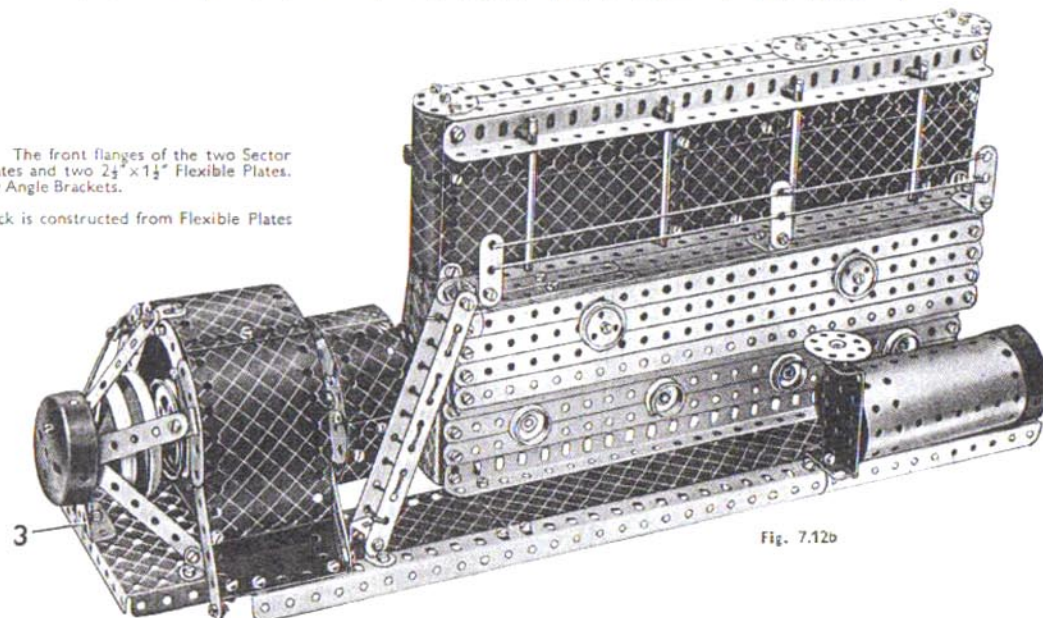
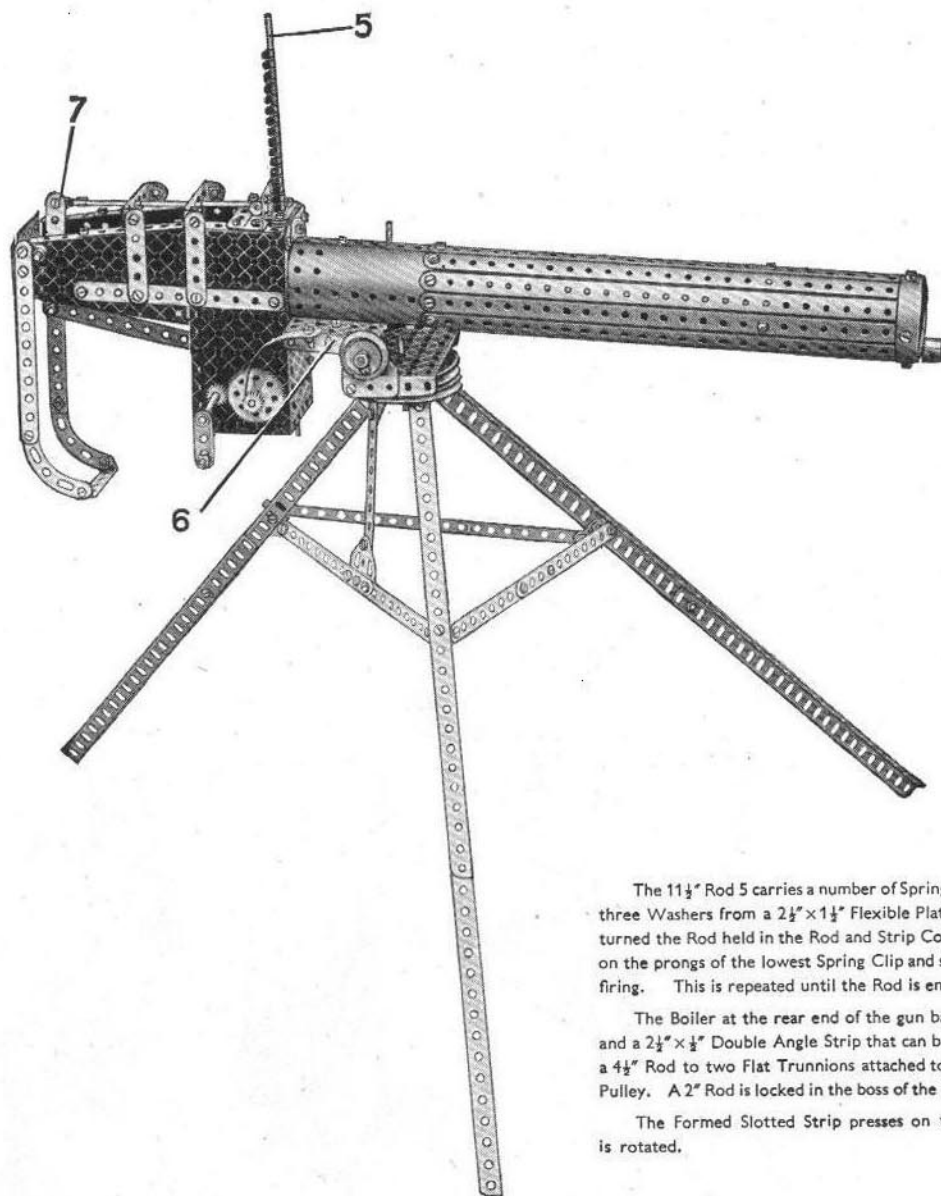

Fig. 7.12b



### 7.13 MACHINE GUN

The tripod stand is first constructed. Two of the three legs consist of two Angle Girders bolted together overlapping 10 holes, and the Girders of the third leg overlap three holes. At their upper ends the legs are secured to a 3" Pulley by Obtuse Angle Brackets, and are braced by compound strips, each formed by bolting two 5½" Strips together overlapping four holes.

The breech and barrel of the gun, are built up as separate units and then bolted together. The construction of the breech is commenced by fastening a Flanged Sector Plate to a 5½"×2½" Flanged Plate by means of a 5½" Strip as shown in Fig. 7.13a. A second similar unit is then constructed, but the opposite way round. The front flanges of the two 5½"×2½" Flanged Plates are then joined by a 2½" Strip, and the rear ends of the two Sector Plates are connected by two 1"×1" Angle Brackets and a 2½"×1½" Flexible Plate. Two 2½" Strips are bolted to each side of the casing, their upper ends supporting the 2½"×½" Double Angle Strips that form bearings for the 5" Rod held in Rod and Strip Connector 7.

A 3½" Rod is journaled in the right-hand side plate of the breech and also in a 3½"×2½" Flanged Plate fixed between the two 5½"×2½" Flanged Plates. On the end of the Rod a Bush Wheel 2 is fixed, and to the latter three 5½" Strips 1 are pivotally secured by a lock-nutted ⅜" Bolt. The free ends of Strips 1 are slipped on to the shank of a Pivot Bolt, and spaced by three Washers from the lock-nuts that hold the 3½" Strip 3. The Strip 3 is pivoted on a 3½" Rod 4, a Crank being secured to the Strip to prevent it from sliding. The 5" Rod connected to Strip 3 by Rod and Strip Connector 7 carries at its forward end a Coupling, from the front of which protrude two Bolts.

The 11½" Rod 5 carries a number of Spring Clips, and it passes through the centre hole of a 1½" Strip that is spaced (at each end) by three Washers from a 2½"×1½" Flexible Plate bolted between the two 5½"×2½" Flanged Plates. When the built-up crank handle is turned the Rod held in the Rod and Strip Connector 7 moves forward, and the two Bolts in the Coupling at the end of the Rod catch on the prongs of the lowest Spring Clip and shoot it off the 11½" Rod 5. The Rod drops until the next Spring Clip is in position for firing. This is repeated until the Rod is empty of Spring Clips.

The Boiler at the rear end of the gun barrel is fixed to the breech by a 2½"×1" Double Angle Strip, a 3½"×2½" Flanged Plate 6 and a 2½"×½" Double Angle Strip that can be seen at the front of the breech in Fig. 7.11a. The Flanged Plate 6 is pivotally secured by a 4½" Rod to two Flat Trunnions attached to the flanges of a second 3½"×2½" Flanged Plate, to the underside of which is bolted a 3" Pulley. A 2" Rod is locked in the boss of the Pulley and its lower end passes through the centre of the 3" Pulley attached to the tripod.

The Formed Slotted Strip presses on the teeth of the ½" Pinion and produces the noise of a machine gun when the handle is rotated.

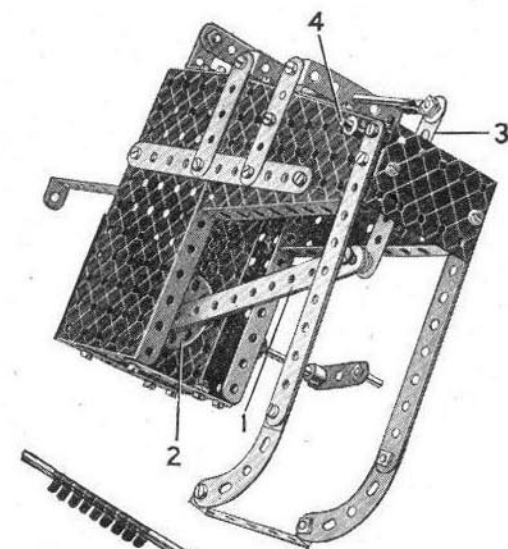

Fig. 7.13a

#### Parts required

12 of No. 1		
18 " " 2		
1 " " 3		
10 " " 5	2 of No. 26	
1 " " 6a	1 " " 27a	
6 " " 8	18 " " 35	
1 " " 10	110 " " 37	1 of No. 111a
3 " " 12	4 " " 37a	3 " " 111c
4 " " 12a	18 " " 38	1 " " 115
6 " " 12c	1 " " 46	1 " " 126
1 " " 13	6 " " 48a	3 " " 126a
2 " " 15	1 " " 51	1 " " 147b
1 " " 15a	2 " " 52	2 " " 155
2 " " 16	3 " " 53	1 " " 162
2 " " 17	2 " " 54	1 " " 164
2 " " 19b	4 " " 59	2 " " 188
2 " " 22	2 " " 62	1 " " 190
1 " " 24	2 " " 63	1 " " 212
	4 " " 90a	1 " " 215



### 7.14 CANADIAN PACIFIC RAILWAY LOCOMOTIVE

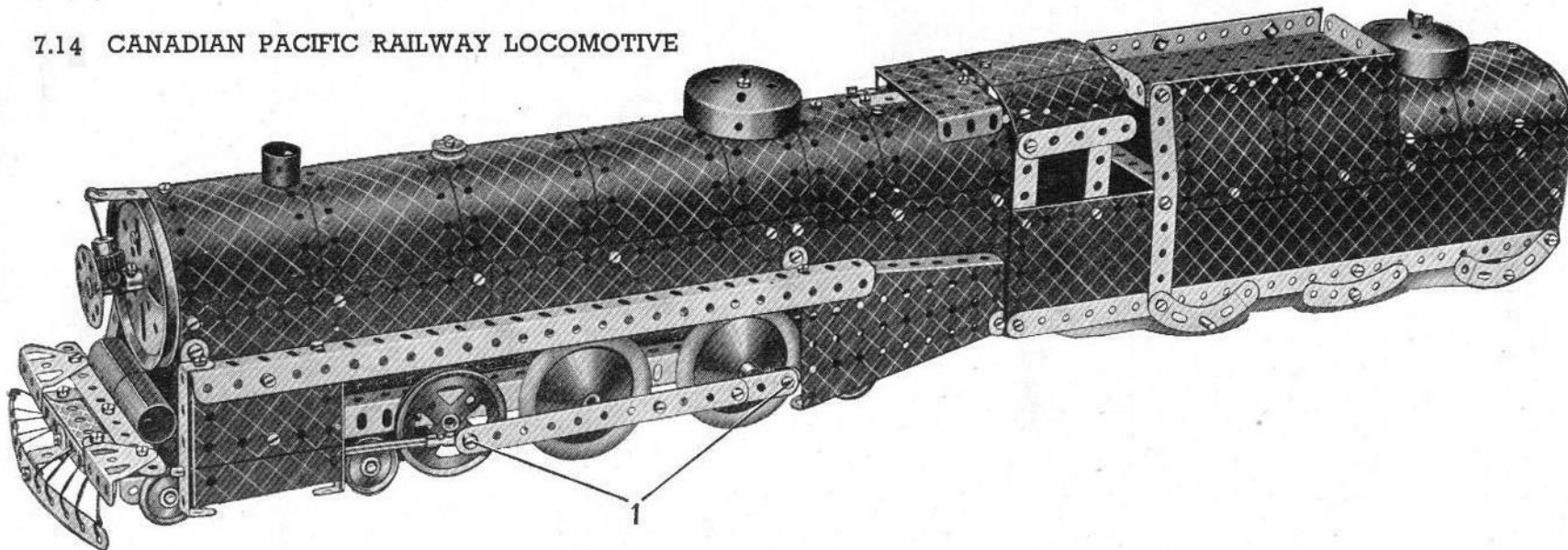

Parts required

11 of No.	1	7 of No.	48a
11	2	2	48b
4	3	1	51
2	4	2	52
11	5	3	53
4	6a	2	54
8	8	2	59
12	10	1	63
2	11	2	90
15	12	4	90a
1	12a	1	111
6	12c	2	111a
2	15	4	111c
2	15a	1	125
2	15b	2	126
3	16	4	126a
1	17	2	162a
2	18a	2	163
1	18b	1	164
1	19b	1	186
2	20a	4	187
4	20b	6	188
4	22	6	189
2	22a	6	190
1	23	2	191
1	23a	4	192
1	24	2	197
1	26	2	199
2	35	2	200
148	37	2	213
11	37a	2	214
26	38		

Each side member of the locomotive and tender consists of three  $12\frac{1}{2}$ " Angle Girders, the one at the front overlapping nine holes and the rear Angle Girder overlapping seven holes. The side members are joined at the rear by a  $3\frac{1}{2}$ "  $\times$   $\frac{1}{2}$ " Double Angle Strip and a  $2\frac{1}{2}$ " Strip and a  $3\frac{1}{2}$ "  $\times$   $2\frac{1}{2}$ " Flanged Plate below the cab. At the front of the chassis is bolted a second  $3\frac{1}{2}$ "  $\times$   $2\frac{1}{2}$ " Flanged Plate.

The boiler is made from four  $5\frac{1}{2}$ "  $\times$   $2\frac{1}{2}$ " and two  $5\frac{1}{2}$ "  $\times$   $1\frac{1}{2}$ " Flexible Plates, which are bolted across their centres to a compound strip consisting of a  $12\frac{1}{2}$ " Strip overlapping a  $5\frac{1}{2}$ " Strip five holes. The upper part of the fire-box is represented by two  $2\frac{1}{2}$ "  $\times$   $2\frac{1}{2}$ " Flexible Plates and a  $2\frac{1}{2}$ "  $\times$   $1\frac{1}{2}$ " Flanged Plate. The sides of the boiler are extended along each edge by two  $5\frac{1}{2}$ "  $\times$   $1\frac{1}{2}$ " and two  $2\frac{1}{2}$ "  $\times$   $1\frac{1}{2}$ " Flexible Plates, the securing Bolts holding also a  $12\frac{1}{2}$ " and a  $5\frac{1}{2}$ " Strip overlapped five holes. The lower edges of the Flexible Plates are then bolted to further compound strips, each consisting of a  $12\frac{1}{2}$ " and a  $3\frac{1}{2}$ " Strip overlapped one hole. A  $1\frac{1}{2}$ " Strip is bolted to the compound strips at the front end of the boiler, another  $1\frac{1}{2}$ " Strip is bolted at a distance of 20 holes from it, and a Fishplate is placed midway between them. The front of the boiler is a  $3$ " Pulley bolted to a  $2\frac{1}{2}$ "  $\times$   $\frac{1}{2}$ " Double Angle Strip. Two compound strips comprising  $5\frac{1}{2}$ " Strips and  $12\frac{1}{2}$ " Strips overlapped five holes, extend the boiler on each side. The complete unit is attached to the chassis by four Obtuse Angle Brackets.

The sides of the tender and cab are made by  $12\frac{1}{2}$ "  $\times$   $2\frac{1}{2}$ " Strip Plates bolted to the  $3\frac{1}{2}$ "  $\times$   $2\frac{1}{2}$ " Flanged Plate in the centre of the chassis. At the rear end the Strip Plates are attached to a  $3\frac{1}{2}$ "  $\times$   $\frac{1}{2}$ " Double Angle Strip and a  $3\frac{1}{2}$ "  $\times$   $2\frac{1}{2}$ " Flanged Plate that forms the back of the tender. Two  $1\frac{1}{2}$ " radius Curved Plates overlapped three holes form the roof of the cab, and they are attached by a  $\frac{1}{2}$ " Bolt that carries three Washers on its shank, to a Fishplate fixed to the fire-box. The roof is attached by Obtuse Angle Brackets to the  $2\frac{1}{2}$ " Strips forming the sides.

The coal bunker is represented by a  $5\frac{1}{2}$ "  $\times$   $2\frac{1}{2}$ " Flanged Plate bolted flanges upward to four  $2\frac{1}{2}$ "  $\times$   $2\frac{1}{2}$ " Flexible Plates, and two  $5\frac{1}{2}$ " Strips. Two  $4\frac{1}{2}$ "  $\times$   $2\frac{1}{2}$ " Flexible Plates attached to the sides and back of the tender by Fishplates and a  $2\frac{1}{2}$ "  $\times$   $\frac{1}{2}$ " Double Angle Strip respectively, represent the water tank.

The  $1\frac{1}{2}$ " Rod that holds the Boiler End to the tender passes through one of the Flexible Plates, and through a hole in a Fishplate bolted to the rear  $4\frac{1}{2}$ "  $\times$   $2\frac{1}{2}$ " Flexible Plate. A ladder giving access to the coal bunker (Fig. 7.14a) consists of two  $3\frac{1}{2}$ " Strips, which are joined across at the top by two Angle Brackets. Six Angle Brackets provide the rungs.

The front bogie carriage is a  $5\frac{1}{2}$ "  $\times$   $2\frac{1}{2}$ " Flanged Plate attached to the chassis by two Flat Trunnions, and the  $1$ " Pulleys are mounted on two  $3\frac{1}{2}$ " Rods. The  $2$ " Pulleys are fastened on a compound rod consisting of a  $2$ " Rod and a  $1\frac{1}{2}$ " Rod joined together by a Coupling. Axles for the front and rear Road Wheels are provided by a  $4$ " Rod and a  $4\frac{1}{2}$ " Rod respectively. A Collar is fixed on each end of the  $4\frac{1}{2}$ " Rod and a Bolt carrying an Angle Bracket and three Washers is screwed into its tapped hole. Each connecting rod is lock-nutted to the Angle Bracket as shown at 1, and also to a Rod and Strip Connector carrying a  $5$ " Rod. The  $5$ " Rods represent the piston rods and are free to slide in holes in  $2\frac{1}{2}$ "  $\times$   $\frac{1}{2}$ " Double Angle Strips forming the ends of the cylinders. The  $\frac{1}{2}$ " fast Pulley on the axle of the front Road Wheels is connected by a Driving Band to the Coupling on the compound rod.

The rear bogie wheels below the cab are  $1$ " loose Pulleys lock-nutted to Fishplates. The Bolts are  $\frac{1}{2}$ " long and carry two Washers on their shanks.

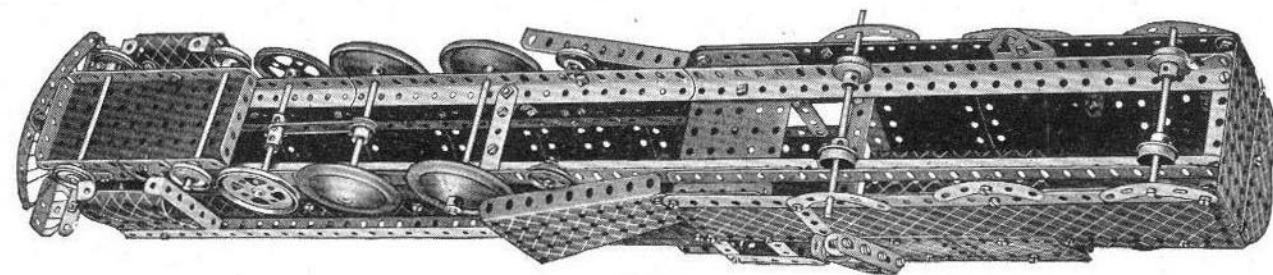

Fig. 7.14a

## 7.15 BEAM BRIDGE

The base is built by bolting two  $5\frac{1}{2}'' \times 2\frac{1}{2}''$  Flexible Plates to two  $5\frac{1}{2}'' \times 2\frac{1}{2}''$  Flanged Plates. The ends of the Flanged Plates are then joined across by compound strips consisting of two  $5\frac{1}{2}''$  Strips overlapped five holes. The remaining sides of the base are made by overlapping a  $5\frac{1}{2}'' \times 2\frac{1}{2}''$  Flexible Plate and a  $4\frac{1}{2}'' \times 2\frac{1}{2}''$  Flexible Plate by three holes. The sides are joined together at the lower corners by Angle Brackets. Two  $5\frac{1}{2}'' \times 1\frac{1}{2}''$ , two  $2\frac{1}{2}'' \times 2\frac{1}{2}''$  and one  $2\frac{1}{2}'' \times 1\frac{1}{2}''$  Flexible Plate are bolted together and fastened to the  $5\frac{1}{2}'' \times 2\frac{1}{2}''$  Flanged Plates in the positions shown in Fig. 7.15a. Supports for the beam are provided by four  $12\frac{1}{2}''$  Angle Girders bolted to each corner of the base. At their upper ends pairs of Angle Girders are bolted to the flanges of two Flanged Sector Plates as shown, and three  $12\frac{1}{2}''$  Strips are also attached to the Angle Girders by Fishplates.

The span of the bridge is made by joining two  $12\frac{1}{2}''$  Angle Girders at their ends and centres by three  $5\frac{1}{2}''$  Strips, and two  $12\frac{1}{2}''$  Strip Plates form the roadway. The upper Angle Girders of the span are joined across by four  $5\frac{1}{2}''$  Strips, and are connected to the lower Angle Girders by three  $5\frac{1}{2}''$  Strips, a  $2\frac{1}{2}''$  Strip in the manner shown. The lower side members of the beam consist of compound strips made by overlapping two  $12\frac{1}{2}''$  Strips by 15 holes, and joining them at the rear end by a  $3\frac{1}{2}'' \times 2\frac{1}{2}''$  Flanged Plate, and at the front end and middle by  $3\frac{1}{2}'' \times \frac{1}{2}''$  Double Angle Strips. The upper side members are  $12\frac{1}{2}''$  Strips, and they are connected at their centres by two  $2\frac{1}{2}'' \times 1\frac{1}{2}''$  Flexible Plates overlapped three holes, and Angle Brackets. At the front end the upper and lower side members are joined by 3" Strips, to which is bolted a  $3\frac{1}{2}'' \times 2\frac{1}{2}''$  Flanged Plate. At the rear end the side members are joined by  $3\frac{1}{2}''$  Strips extended one hole by the flanges of a  $3\frac{1}{2}'' \times 2\frac{1}{2}''$  Flanged Plate. The side members are connected also by a series of  $2\frac{1}{2}''$  Strips.

On one side the span is pivoted by a  $\frac{3}{8}''$  lock-nutted Bolt to a Trunnion, and on the other side it is pivoted on a  $3\frac{1}{2}''$  Rod, which passes through a second Trunnion and the centre hole in a  $2\frac{1}{2}'' \times 1\frac{1}{2}''$  Flanged Plate attached to the base by two  $1'' \times 1''$  Angle Brackets. The Rod carries a 57-teeth Gear, a 1" Pulley fitted with Rubber Ring and a Bush Wheel. The Bush Wheel has a  $2\frac{1}{2}''$  Strip bolted across it, and a  $12\frac{1}{2}''$  Strip is connected to the end of the  $2\frac{1}{2}''$  Strip and the 3" Pulley by lock-nutted Bolts 3. A large Crank Handle connected by a Coupling to a 2" Rod, carries a Worm and two 1" Pulleys fitted with Rubber Rings. The Crank Handle is passed through holes in the Angle Girders forming the beam supports, and the Worm meshes with the 57-teeth Gear. By turning the Crank Handle the span can be raised or lowered.

The counterweight at the rear of the beam is a Boiler attached to the lower  $3\frac{1}{2}'' \times 2\frac{1}{2}''$  Flanged Plate by Angle Brackets. Cranks bolted to the beam have an  $11\frac{1}{2}''$  Rod locked in their bosses. The Rod passes through the centre holes in the Flanged Sector Plates of the beam supports and it carries two Road Wheels and the 3" Pulley. The beam is connected to the span by two  $12\frac{1}{2}''$  Strips 2, the upper ends of which are pivoted in the third holes

on a  $6\frac{1}{2}''$  Rod passed through two  $2\frac{1}{2}'' \times \frac{1}{2}''$  Double Angle Strips bolted to the front end of the beam. The lower ends of  $12\frac{1}{2}''$  Strips 2 are pivoted on  $\frac{3}{8}''$  Bolts 1, which are lock-nutted to the span and carry Collars on their shanks to hold the  $12\frac{1}{2}''$  Strips in position.

The landing jetty consists of Flexible Plates of various sizes joined together by Double Angle Strips and Angle Brackets. The stairways are built up from Strips and Double Angle Strips and are bolted to the jetty. Two 3" Screwed Rods lock-nutted to the  $2\frac{1}{2}'' \times 2\frac{1}{2}''$  Flexible Plates forming part of the platform, have Cord tied between them to represent rails. Two Fishplates are bolted to the edge of the jetty to act as stops when the bridge reaches a horizontal position.

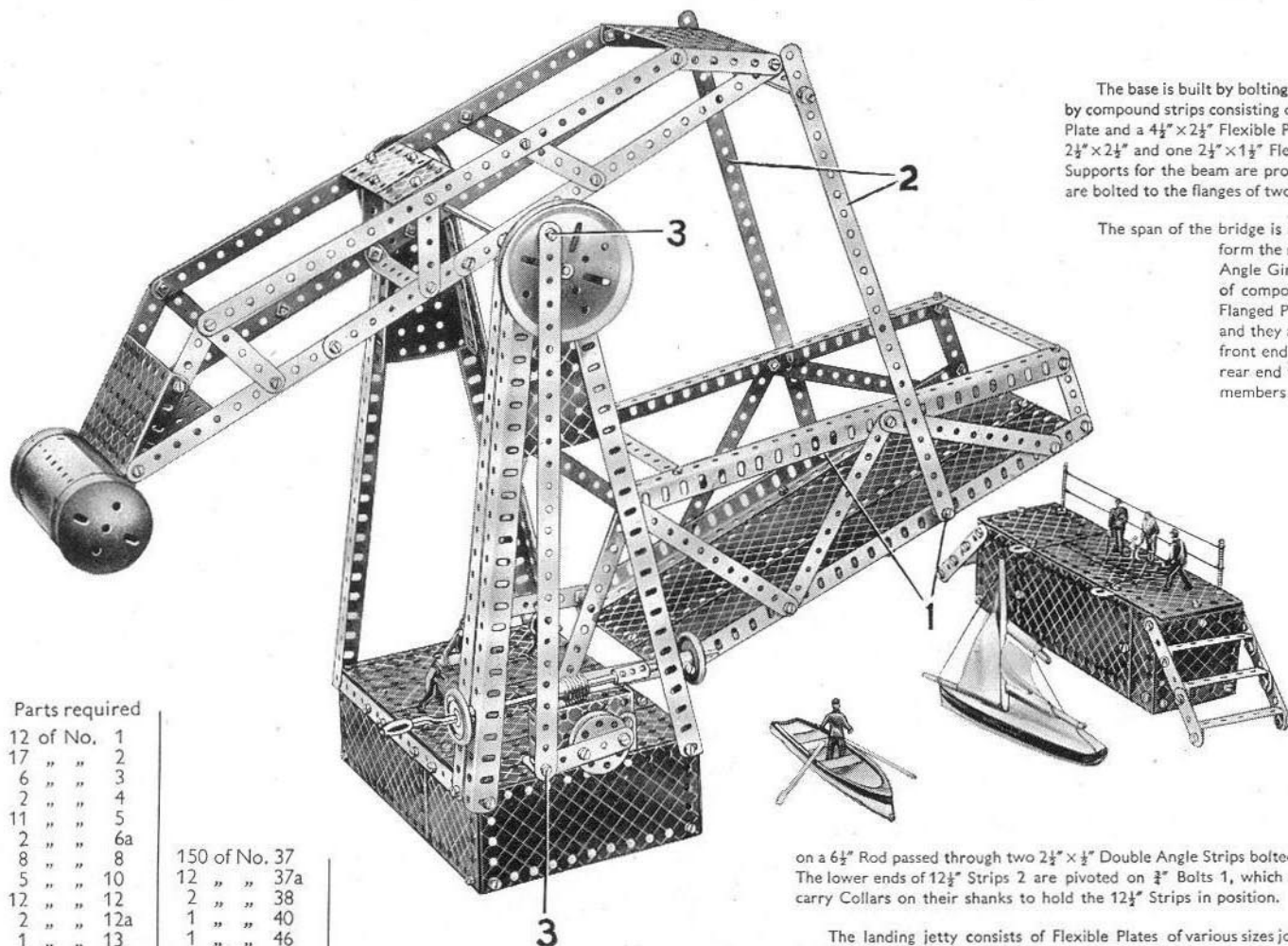

## Parts required

12	of No.	1
17	" "	2
6	" "	3
2	" "	4
11	" "	5
2	" "	6a
8	" "	8
5	" "	10
12	" "	12
2	" "	12a
1	" "	13
1	" "	14
1	" "	16
1	" "	17
1	" "	19b
1	" "	19h
3	" "	22
1	" "	24
1	" "	27a
1	" "	32
150	of No.	37
12	" "	37a
2	" "	38
1	" "	40
1	" "	46
10	" "	48a
2	" "	48b
1	" "	51
2	" "	52
3	" "	53
2	" "	54
4	" "	59
2	" "	62
1	" "	63

2	of No.	80c
2	" "	111
3	" "	111c
2	" "	126
3	" "	155
1	" "	162
2	" "	187
5	" "	188
4	of No.	189
8	" "	190
2	" "	191
6	" "	192
2	" "	197

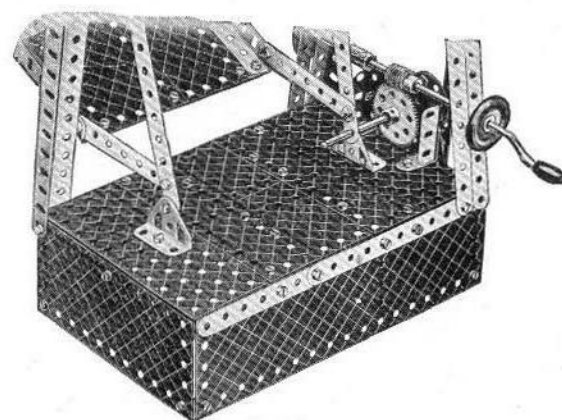
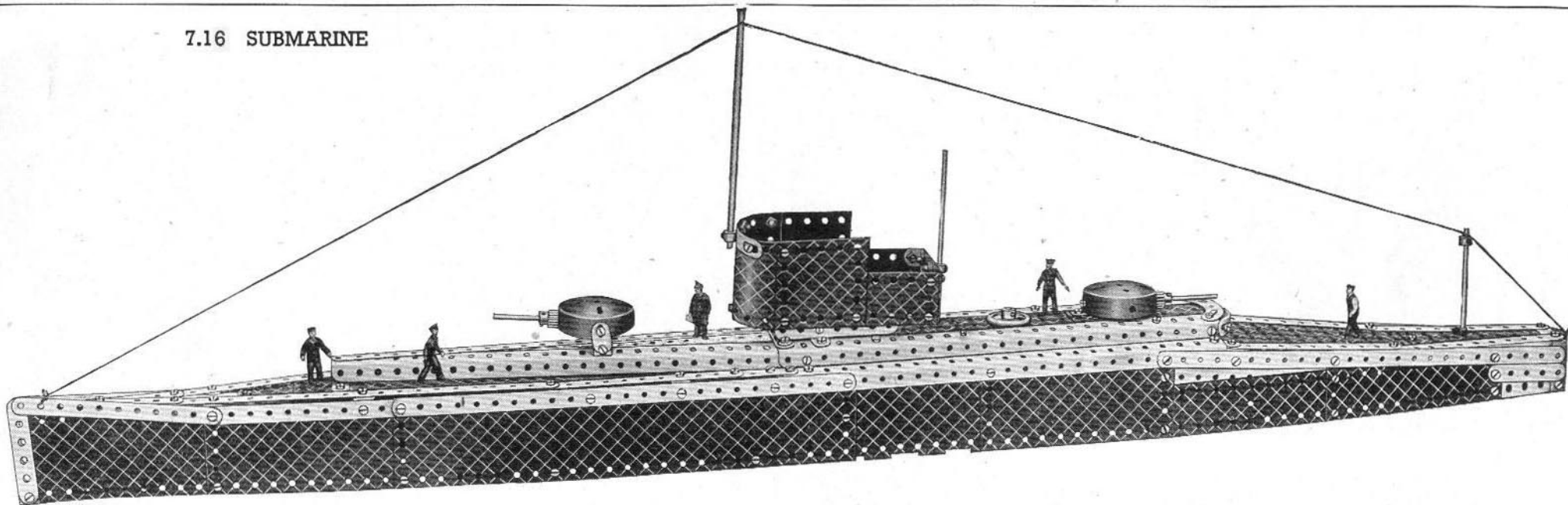

Fig. 7.15a

7.16 SUBMARINE



Construction of the hull is commenced by bolting a  $12\frac{1}{2}$ " Strip Plate, a  $5\frac{1}{2}$ " $\times$  $2\frac{1}{2}$ " Flexible Plate and a flat plate 1 to a  $12\frac{1}{2}$ " Angle Girder, to form part of each side. The flat plates 1 are obtained by removing the centre pin from a Hinged Flat Plate. The sides are extended towards the bows by  $5\frac{1}{2}$ " $\times$  $2\frac{1}{2}$ " Flexible Plates, and towards the stern by  $5\frac{1}{2}$ " $\times$  $1\frac{1}{2}$ " Flexible Plates. The sides are joined across by two  $3\frac{1}{2}$ " $\times$  $\frac{1}{2}$ " Double Angle Strips, a  $3\frac{1}{2}$ " $\times$  $2\frac{1}{2}$ " Flanged Plate and a Flanged Sector Plate (see Fig. 7.16a). The stern is completed by a  $2\frac{1}{2}$ " $\times$  $1\frac{1}{2}$ " Flexible Plate.

The sides of the main deck consist of Angle Girders bolted in the positions shown. The pair of Angle Girders tapering toward the bows are supported by a Double Bent Strip, and those carrying the conning tower are attached by Angle Brackets. The tapered portion of the deck is filled in with a  $12\frac{1}{2}$ " Strip and two  $5\frac{1}{2}$ " Strips, which are bolted to a  $2\frac{1}{2}$ " Strip under the conning tower, and from this point the deck towards the stern consists of a  $2\frac{1}{2}$ " $\times$  $2\frac{1}{2}$ " Flexible Plate, a  $5\frac{1}{2}$ " $\times$  $2\frac{1}{2}$ " Flanged Plate, a second  $2\frac{1}{2}$ " $\times$  $2\frac{1}{2}$ " Flexible Plate, and finally a Semi-Circular Plate. The rear decking consists of a  $5\frac{1}{2}$ " $\times$  $2\frac{1}{2}$ " Flanged Plate and a Flanged Sector Plate supported by  $5\frac{1}{2}$ " Strips, which are attached to the sides by Angle Brackets. The forward deck consists of a  $3\frac{1}{2}$ " $\times$  $2\frac{1}{2}$ " Flanged Plate and several Flexible Plates supported by  $5\frac{1}{2}$ " Strips.

Two  $1\frac{1}{8}$ " radius Curved Plates overlapped one hole and bolted to two  $2\frac{1}{2}$ " $\times$  $2\frac{1}{2}$ " Flexible Plates, form the forward part of the conning tower. The Flexible Plates are bolted to a  $2\frac{1}{2}$ " $\times$  $1\frac{1}{2}$ " Flanged Plate. The floor is filled in by bolting a Semi-Circular Plate to a  $2\frac{1}{2}$ " $\times$  $2\frac{1}{2}$ " Flexible Plate, and then overlapping the Flexible Plate three holes with a  $3\frac{1}{2}$ " $\times$  $2\frac{1}{2}$ " Flanged Plate. The Flanged Plate is bolted to a  $2\frac{1}{2}$ " $\times$  $\frac{1}{2}$ " Double Angle Strip that supports the stern end of the conning tower. The latter is fixed to the vessel by bolting it to Reversed Angle Brackets fastened to the Angle Girders of the deck. The forward gun turret is carried by Fishplates, which are bolted to Double Brackets. The rear gun turret is attached to the deck by an Angle Bracket.

Parts required	
5 of No. 1	3 of No. 35
18 " " 2	146 " " 37
5 " " 3	7 " " 38
2 " " 4	1 " " 40
8 " " 5	1 " " 45
1 " " 6a	2 " " 48a
6 " " 8	2 " " 48b
5 " " 10	1 " " 51
2 " " 11	2 " " 52
17 " " 12	3 " " 53
2 " " 12c	2 " " 54
1 " " 14	3 " " 59
1 " " 15	1 " " 90a
2 " " 16	1 " " 111c
1 " " 17	2 " " 125
1 " " 22	1 " " 155
2 " " 26	2 " " 162a
	6 of No.188
	4 " " 189
	8 " " 190
	1 " " 191
	6 " " 192
	2 " " 197
	1 " " 198
	2 " " 200
	2 " " 214
	2 " " 215

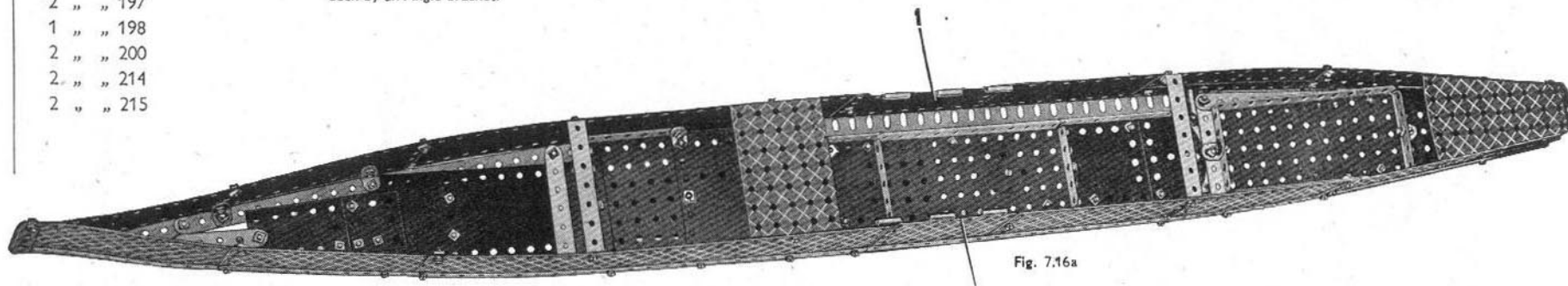

Fig. 7.16a

## 7.17 PENNY-IN-THE-SLOT MACHINE

## Parts required

11	of No.	1
17	" "	2
6	" "	3
8	" "	5
3	" "	6a
8	" "	8
5	" "	10
8	" "	12
3	" "	12a
3	" "	12c
1	" "	14
4	" "	16
1	" "	20b
4	" "	35
97	" "	37
9	" "	37a
4	" "	38
2	" "	48
4	" "	48a
1	" "	48b
2	" "	52
3	" "	53
2	" "	54
2	" "	59
1	" "	63
2	" "	111a
6	" "	111c
2	" "	126
5	" "	188
6	" "	189
2	" "	190
1	" "	191
6	" "	192
2	" "	197
1	" "	198
1	" "	199
1	" "	213

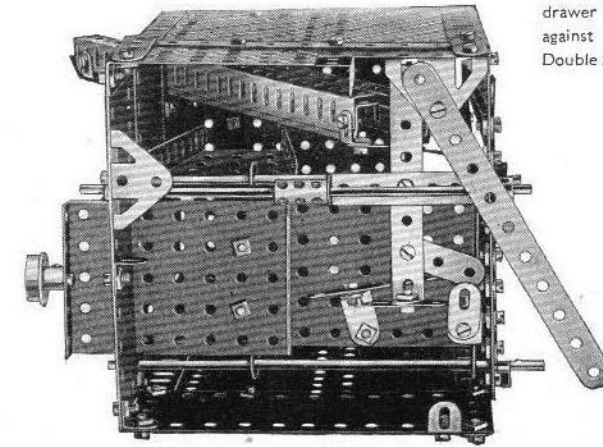
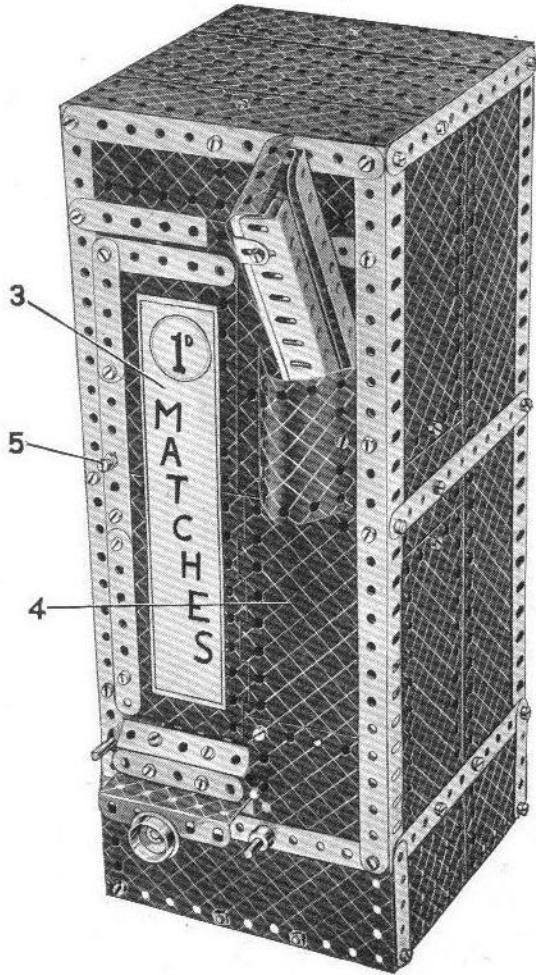

Fig. 7.17b

The framework of the model consists of four Angle Girders joined at the top and bottom by  $5\frac{1}{2}$ " Strips. Each of the Angle Girders is extended downwards by a  $2\frac{1}{2}$ " Strip. The sides are covered in by Flexible Plates, Strip Plates and Flat Plates of various sizes and the back by  $12\frac{1}{2}$ " Strips. A  $5\frac{1}{2}$ "  $\times$   $2\frac{1}{2}$ " Flanged Plate is secured across the top (Fig. 7.17a) and the remaining space at each side is filled in by  $5\frac{1}{2}$ "  $\times$   $1\frac{1}{2}$ " Flexible Plates. The latter are fastened to the sides by  $1"$   $\times$   $1"$  Angle Brackets.

The front of the model is fitted with an inspection door 3. This consists of one half of the Hinged Flat Plate 4, extended upward by a  $4\frac{1}{2}$ "  $\times$   $2\frac{1}{2}$ " Flexible Plate. When closed the door can be locked by means of a Fishplate lock-nutted to the end of the  $\frac{1}{2}"$  Bolt 5.

The drawer is constructed as shown in Fig. 7.17c. It consists essentially of two  $3\frac{1}{2}"$   $\times$   $2\frac{1}{2}"$  Flanged Plates, which are fastened together by two  $2\frac{1}{2}"$   $\times$   $\frac{1}{2}"$  Double Angle Strips. A  $2\frac{1}{2}"$  Strip and a  $2\frac{1}{2}"$   $\times$   $\frac{1}{2}"$  Double Angle Strip, secured together by Obtuse Angle Brackets are bolted to the front ends of the two  $2\frac{1}{2}"$   $\times$   $\frac{1}{2}"$  Double Angle Strips. A knob is provided by a  $\frac{3}{8}"$  Flanged Wheel, which is held on the shank of a  $\frac{3}{8}"$  Bolt. To the free flange of the rear  $3\frac{1}{2}"$   $\times$   $2\frac{1}{2}"$  Flanged Plate is bolted a  $1\frac{1}{2}"$   $\times$   $\frac{1}{2}"$  Double Angle Strip, carrying a Fishplate at its lower end.

Each of the flanges of the rear Flanged Plate carry also a  $3\frac{1}{2}"$  Strip, and through the end holes of these Strips pass the two shafts on which the drawer slides. One of these shafts is formed by a  $6\frac{1}{2}"$  Rod and the other by a compound rod consisting of two  $3\frac{1}{2}"$  Rods, and their ends can be seen protruding from the back of the model in Fig. 7.17a. The two  $3\frac{1}{2}"$  Rods forming the shaft 2 are joined by a Rod Connector.

When pushed in the drawer is locked owing to the Fishplate that is attached to the rear end of the drawer by the  $1\frac{1}{2}"$   $\times$   $\frac{1}{2}"$  Double Angle Strip catching against the Fishplates on the end of a  $3\frac{1}{2}"$   $\times$   $\frac{1}{2}"$  Double Angle Strip. The latter carries also a  $1\frac{1}{2}"$  Strip

that forms a stop, and is bolted at its centre to a  $2\frac{1}{2}"$   $\times$   $\frac{1}{2}"$  Double Angle Strip that is pivoted on a Rod. When a penny is dropped down the chute provided, it falls on to the free end of the  $3\frac{1}{2}"$   $\times$   $\frac{1}{2}"$  Double Angle Strip. The Fishplates on the other end of the latter are thus raised clear of the Fishplate attached to the drawer.

The chute is shown in Fig. 7.17a and consists of two compound girders joined by  $1\frac{1}{2}"$  Strips and Angle Brackets. Each of the compound girders is constructed from two Angle Girders, which are bolted together by their elongated holes in such a manner that a space wide enough to receive a penny is left between the sides perforated with round holes. At the top the chute is held in position by a  $\frac{3}{8}"$  Bolt, and at the bottom by a  $1\frac{1}{2}"$   $\times$   $\frac{1}{2}"$  Double Angle Strip.

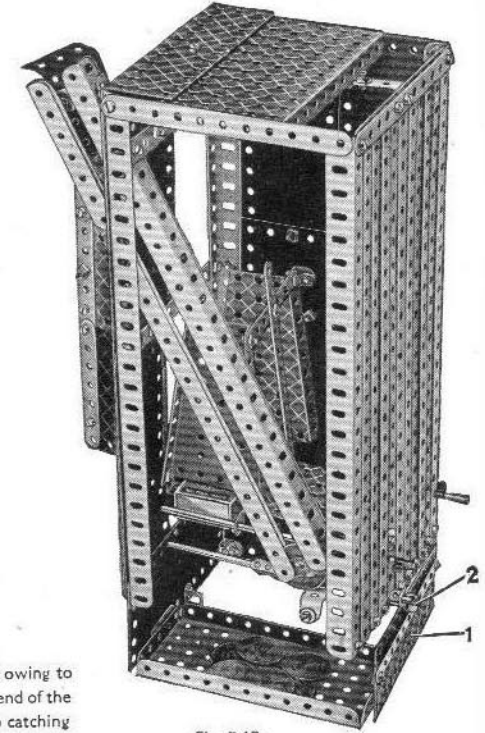

Fig. 7.17a

(Continued on next page)

### 7.18 TUG BOAT

(Continued from previous page)

The pennies are collected in a tray formed by a  $5\frac{1}{2}'' \times 2\frac{1}{2}''$  Flanged Plate (Fig. 7.17a), which is reached by means of the door 1. This is constructed from two  $5\frac{1}{2}'' \times 1\frac{1}{2}''$  Flexible Plates overlapped two holes, and is suspended from a  $\frac{3}{8}''$  Bolt that is fastened through a Fishplate bolted to the back of the model. The door is prevented from slipping off the Bolt by a Collar.

The  $5\frac{1}{2}'' \times 2\frac{1}{2}''$  Flanged Plate is supported at its forward end by a Trunnion bolted to the casing, and at its rear end by a  $5\frac{1}{2}''$  Strip. The Strip is secured in position by a Trunnion and an Angle Bracket, as shown in Fig. 7.17b.

The match boxes are stacked between two Flanged Sector Plates, which can be seen in Fig. 7.17a, and when the drawer is pushed inwards, a box automatically falls into position.

The Sector Plates are joined by a  $3\frac{1}{2}''$  Strip and are bolted by their flanges to the front and side of the machine. The match boxes are prevented from falling out of the slide by a  $5\frac{1}{2}''$  Strip fastened to the centre of the  $3\frac{1}{2}''$  Strip.

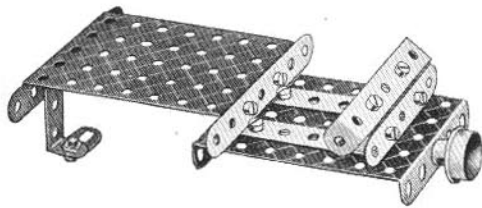
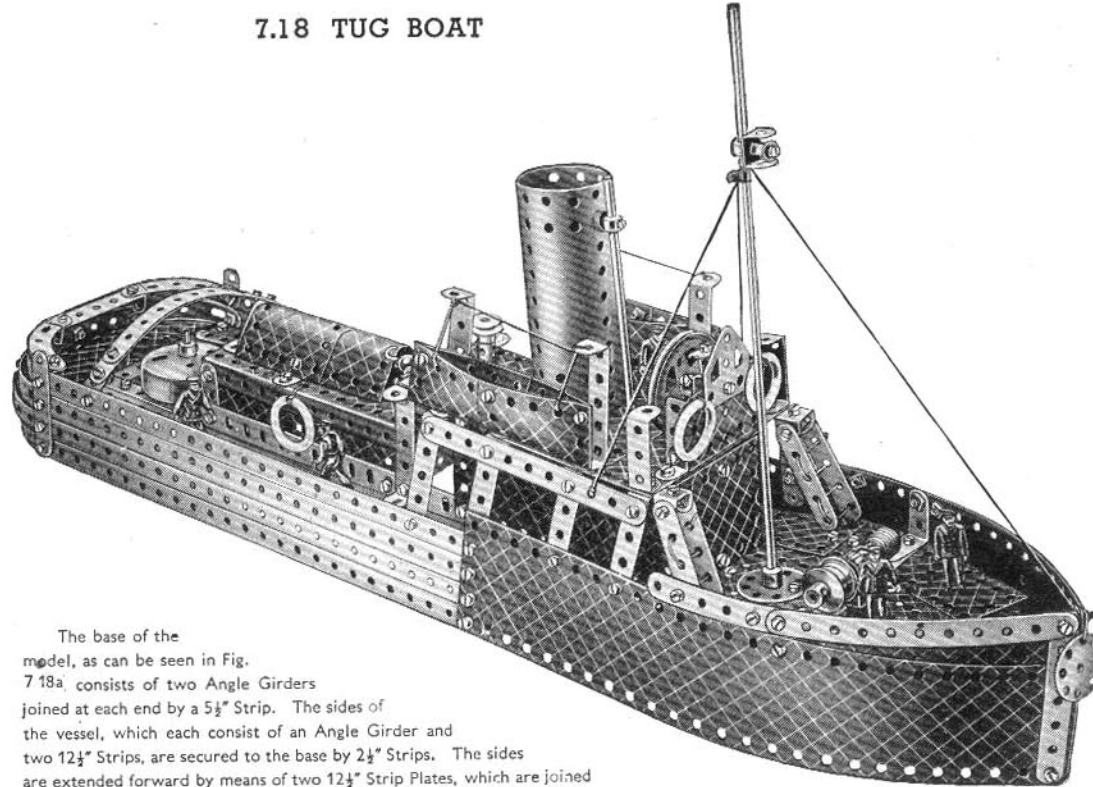

Fig. 7.17c



The base of the model, as can be seen in Fig. 7.18a, consists of two Angle Girders joined at each end by a  $5\frac{1}{2}''$  Strip. The sides of the vessel, which each consist of an Angle Girder and two  $12\frac{1}{2}''$  Strips, are secured to the base by  $2\frac{1}{2}''$  Strips. The sides are extended forward by means of two  $12\frac{1}{2}''$  Strip Plates, which are joined at the front by two Angle Brackets.

The aft deck is filled in with a  $2\frac{1}{2}'' \times 2\frac{1}{2}''$  Flexible Plate and two Semi-Circular Plates, and the fore deck with Flexible Plates of various sizes and two  $3\frac{1}{2}'' \times 2\frac{1}{2}''$  Flanged Plates (Fig. 7.18a). Six  $12\frac{1}{2}''$  Strips form the centre deck, and they are supported between two  $5\frac{1}{2}''$  Strips bolted to the top Angle Girders. Two  $12\frac{1}{2}''$  Angle Girders bolted lengthways along the centre deck form the base for the cabin and the bridge.

The cabin is constructed by bolting  $5\frac{1}{2}'' \times 1\frac{1}{2}''$  Flexible Plates to the Angle Girders in the positions shown. A  $5\frac{1}{2}'' \times 2\frac{1}{2}''$  Flanged Plate carrying two U-Section Curved Plates is then fastened to the Flexible Plates to form the roof. A second  $5\frac{1}{2}'' \times 2\frac{1}{2}''$  Flanged Plate extended by two  $4\frac{1}{2}'' \times 2\frac{1}{2}''$  Flexible Plates overlapped two holes, is used for the bridge. It is supported from the Angle Girders bolted to the deck by two  $5\frac{1}{2}'' \times 2\frac{1}{2}''$  Flexible Plates and two  $2\frac{1}{2}'' \times \frac{1}{2}''$  Double Angle Strips. The wheel is represented by a 2" Pulley, and is fastened by a large Fork Piece to a  $2\frac{1}{2}'' \times 1\frac{1}{2}''$  Flanged Plate secured to the bridge by Angle Brackets. In its boss the Fork Piece holds a  $\frac{3}{8}''$  Bolt carrying a  $\frac{3}{8}''$  Washer to represent the compass.

Parts required

11 of No.	1	1 of No.	44
14 " "	2	2 " "	48
6 " "	3	9 " "	48a
2 " "	4	2 " "	48b
12 " "	5	1 " "	51
2 " "	6a	2 " "	52
6 " "	8	3 " "	53
4 " "	10	1 " "	57c
4 " "	11	6 " "	59
17 " "	12	1 " "	63
2 " "	12a	2 " "	90
4 " "	12c	2 " "	90a
1 " "	13	2 " "	111a
1 " "	15	6 " "	111c
1 " "	16	1 " "	116
2 " "	17	1 " "	125
1 " "	18a	1 " "	126
1 " "	20a	1 " "	126a
2 " "	20b	4 " "	155
1 " "	23a	1 " "	162a
1 " "	24	1 " "	162b
1 " "	24a	6 " "	188
1 " "	26	6 " "	189
1 " "	32	8 " "	190
3 " "	35	2 " "	191
150 " "	37	2 " "	192
6 " "	37a	2 " "	197
10 " "	38	2 " "	199
1 " "	38d	2 " "	214
1 " "	40	6 " "	215

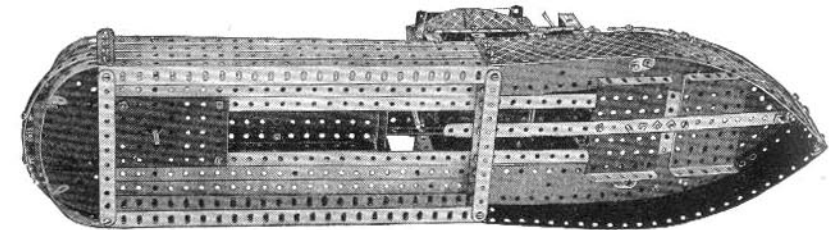
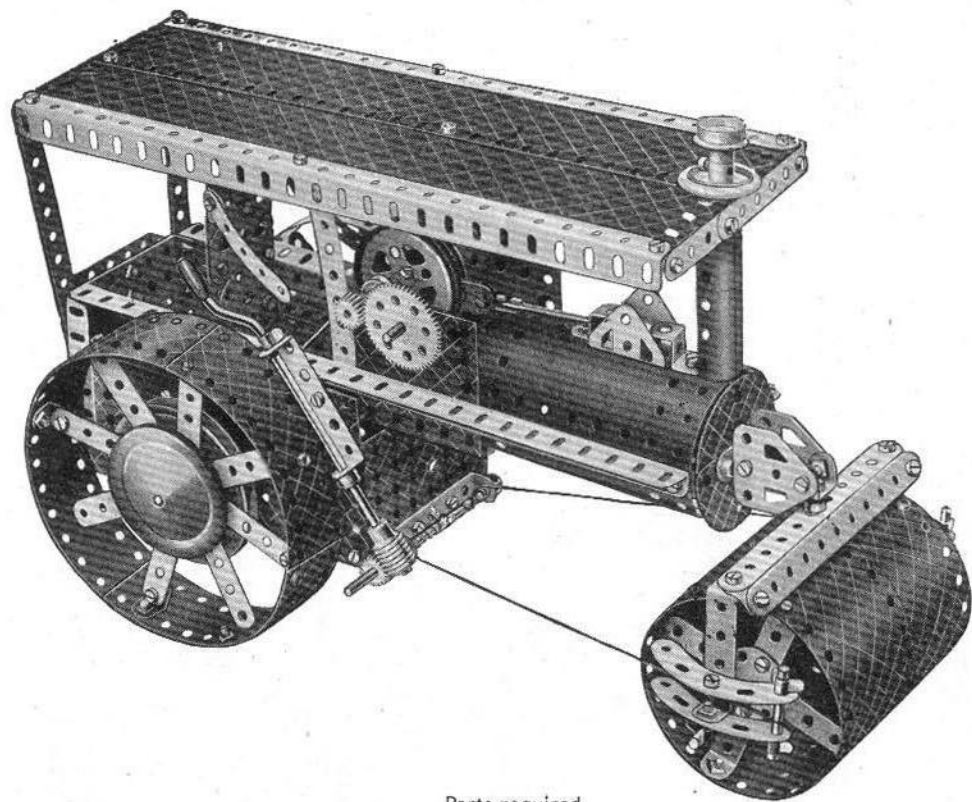

Fig. 7.18a

## 7.19 STEAM ROLLER



Parts required					
12 of No. 2	1 of No. 15a	2 of No. 26	2 of No. 48b	2 of No. 125	6 of No. 188
4 " " 3	2 " " 16	1 " " 27a	1 " " 51	2 " " 126	6 " " 189
2 " " 4	2 " " 17	1 " " 32	2 " " 52	4 " " 126a	4 " " 190
12 " " 5	3 " " 18a	11 " " 35	3 " " 53	1 " " 147b	4 " " 192
4 " " 8	2 " " 19b	140 " " 37	6 " " 59	1 " " 155	2 " " 197
1 " " 10	1 " " 19h	7 " " 37a	1 " " 63	1 " " 162b	1 " " 198
2 " " 11	2 " " 20a	14 " " 38	2 " " 90	2 " " 163	1 " " 200
18 " " 12	1 " " 20b	1 " " 40	4 " " 90a	1 " " 164	1 " " 212
2 " " 12c	2 " " 22	1 " " 44	2 " " 111	1 " " 176	2 " " 214
1 " " 14	1 " " 22a	1 " " 45	2 " " 111c	1 " " 186	
1 " " 15	1 " " 23a	1 " " 45	2 " " 111c	1 " " 186	
	3 " " 24a	7 " " 48a	1 " " 116	3 " " 187	

The construction of the model is commenced by opening out a Boiler to such an extent that two Semi-Circular Plates bolted together overlapping one hole will just fit inside its end. An Angle Girder is then bolted along each side of the Boiler and a  $3\frac{1}{2} \times 2\frac{1}{2}$ " Flanged Plate is fastened to it by a  $2\frac{1}{2} \times \frac{1}{2}$ " Double Angle Strip, placed directly behind the Boiler. A second  $3\frac{1}{2} \times 2\frac{1}{2}$ " Flanged Plate is secured lengthways across the bottom of the first, and to the flanges of the second Plate are bolted the halves of a Hinged Plate that form the sides of the cab. Another  $3\frac{1}{2} \times 2\frac{1}{2}$ " Flanged Plate is bolted to the rear ends of the two Angle Girder, to form the back of the cab. A  $2\frac{1}{2} \times 1\frac{1}{2}$ " Flanged Plate carrying a  $1\frac{1}{16}$ " radius Curved Plate is fastened to the back of the cab by a  $\frac{3}{8}$ " Bolt, as shown in Fig. 7.19a.

The construction and arrangement of the crankshaft and cylinder is clear from the illustration. The  $\frac{1}{2}$ " fast Pulley on the crankshaft is driven from a 1" fast Pulley on the back axle by means of a Driving Band. The connecting rod is a  $2\frac{1}{2}$ " Strip pivoted on a  $\frac{3}{8}$ " Bolt 1.

The back axle consists of two  $3\frac{1}{2}$ " Rods joined by a Coupling, and each of the rear wheels is built up by bolting  $5\frac{1}{2}$ " and  $2\frac{1}{2}$ " Strips across a 3" Pulley to form spokes. The rim, which consists of three  $5\frac{1}{2} \times 1\frac{1}{2}$ " Flexible Plates and two  $2\frac{1}{2} \times 1\frac{1}{2}$ " Flexible Plates bolted end to end, is then fastened to the ends of the  $5\frac{1}{2}$ " Strips by Angle Brackets. One of the back wheels with rim removed is shown in Fig. 7.19a.

(Continued on next page)

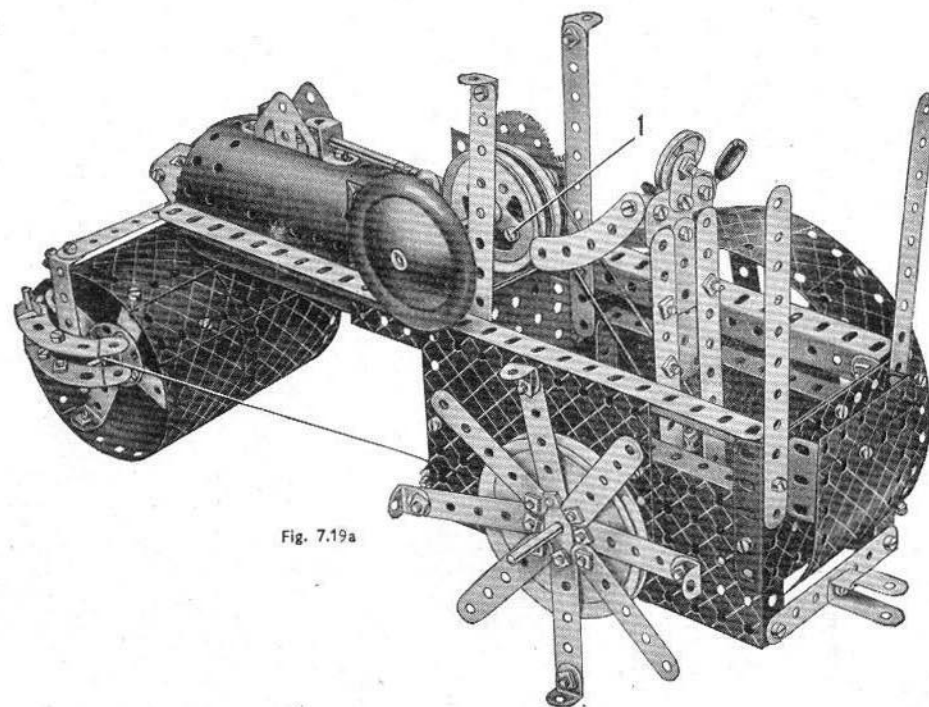

Fig. 7.19a

### 7.20 SWING BOATS

(Continued from previous page)

The roller is constructed from four  $5\frac{1}{2}'' \times 2\frac{1}{4}''$  Flexible Plates and two  $2\frac{1}{2}'' \times 1\frac{1}{2}''$  Flexible Plates, and is mounted on an axle passed through the centres of two Wheel Discs, which are secured inside the roller by  $3\frac{1}{2}'' \times \frac{1}{2}''$  Double Angle Strips. The axle is supported by two Double Angle Strips, that are secured at their upper ends to a  $5\frac{1}{2}''$  Strip. The  $5\frac{1}{2}''$  Strip is held by a lock-nutted Pivot Bolt passed through the boss of the large Fork Piece. This latter is secured by a Double Bent Strip and two Flat Trunnions to the Semi-Circular Plates, which are fastened in the front of the Boiler by a  $2\frac{1}{2}'' \times \frac{1}{2}''$  Double Angle Strip.

The canopy consists of two  $12\frac{1}{2}''$  Strip Plates and two Angle Girders and is supported from the cab by  $5\frac{1}{2}''$  Strips. The chimney is represented by two Sleeve Pieces joined by a Chimney Adaptor, and is held in position by a  $5''$  Rod passed through their centres. The Rod carries also a  $\frac{3}{4}''$  Flanged Wheel and a  $1''$  Pulley above the canopy.

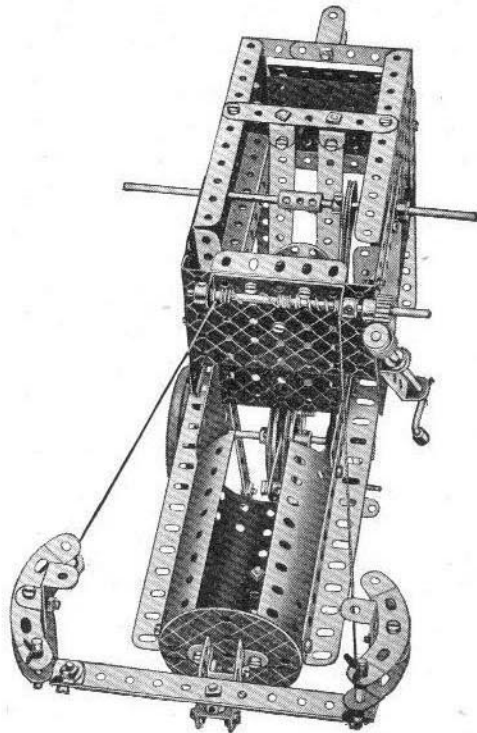
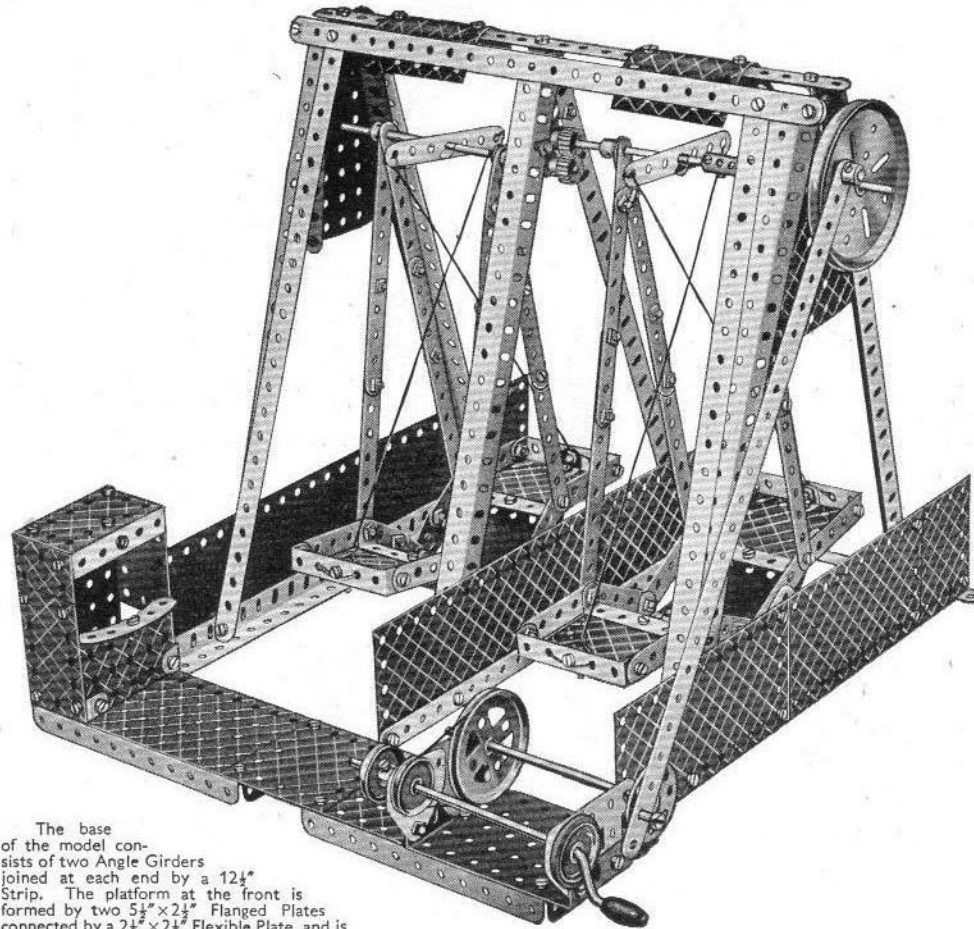

Fig. 7.19b



The base of the model consists of two Angle Girders joined at each end by a  $12\frac{1}{2}''$  Strip. The platform at the front is formed by two  $5\frac{1}{2}'' \times 2\frac{1}{4}''$  Flanged Plates connected by a  $2\frac{1}{2}'' \times 2\frac{1}{4}''$  Flexible Plate, and is secured to the base by four Angle Brackets.

The outer ends of the two shafts holding the swing boats are journaled in Flanged Sector Plates bolted to the Angle Girder uprights, which are joined across their upper ends by  $12\frac{1}{2}''$  Strips as shown. The inner ends of the Rods are journaled in Fishplates bolted to the centre pair of Angle Girder uprights. The angle at which the Fishplates are set should be adjusted so that two  $\frac{1}{2}''$  Pinions on the inner ends of the Rods mesh accurately.

The right-hand Rod carries outside the Flanged Sector Plate a  $3''$  Pulley, and to this is fastened a Threaded Pin that is connected by a  $12\frac{1}{2}''$  Strip to a Pivot Bolt secured by lock-nuts to a Bush Wheel. The Bush Wheel is held on a  $4\frac{1}{2}''$  Rod journaled in two Flat Trunnions, which are fastened to the flanges of a  $3\frac{1}{2}'' \times 2\frac{1}{4}''$  Flanged Plate bolted to the base. A  $2''$  Pulley on the  $4\frac{1}{2}''$  Rod is connected by a Driving Band to a  $1''$  Pulley on a Crank Handle, which is journaled in two further Flat Trunnions bolted to the flanges of the  $3\frac{1}{2}'' \times 2\frac{1}{4}''$  Flanged Plate.

The back of the paybox is formed by a  $3\frac{1}{2}'' \times 2\frac{1}{4}''$  Flanged Plate, and its front by a  $2\frac{1}{2}'' \times 1\frac{1}{2}''$  Flanged Plate. The sides and top are filled in with  $2\frac{1}{2}'' \times 1\frac{1}{2}''$  Flexible Plates.

Fig. 7.20a shows the model fitted with a No. 1a Clockwork Motor. The Motor is bolted to the side of the base, and the driving shaft is replaced by a  $3\frac{1}{2}''$  Rod. A  $\frac{3}{4}''$  Sprocket Wheel on the end of the Rod is connected by Sprocket Chain to a  $3''$  Sprocket Wheel on a  $6\frac{1}{2}''$  Rod that replaces the Crank Handle.

Parts required	
8 of No. 1	2 of No. 48
16 " " 2	10 " " 48a
2 " " 3	2 " " 48b
2 " " 4	1 " " 51
12 " " 5	2 " " 52
4 " " 6a	2 " " 53
8 " " 8	2 " " 54
4 " " 10	6 " " 59
16 " " 12	2 " " 62
1 " " 14	1 " " 63
2 " " 15a	1 " " 90
1 " " 16	4 " " 90a
1 " " 19b	4 " " 111c
1 " " 19h	1 " " 115
1 " " 20a	4 " " 126a
5 " " 22	1 " " 147b
1 " " 24	2 " " 155
2 " " 26	1 " " 186
4 " " 35	4 " " 188
130 " " 37	8 " " 190
4 " " 37a	2 " " 192
8 " " 38	2 " " 197
1 " " 46	2 " " 199

2 of No. 200

For model Swing Boats fitted with No. 1a Clockwork Motor

Additional parts required:

\*1 No. 1a Clockwork Motor.

\*1 of No. 14

1 " " 16

\*1 " " 94

\*1 " " 95b

\*1 " " 96a

Parts not required:

1 of No. 19h

1 " " 22

1 " " 155

\*Not included in Outfit.

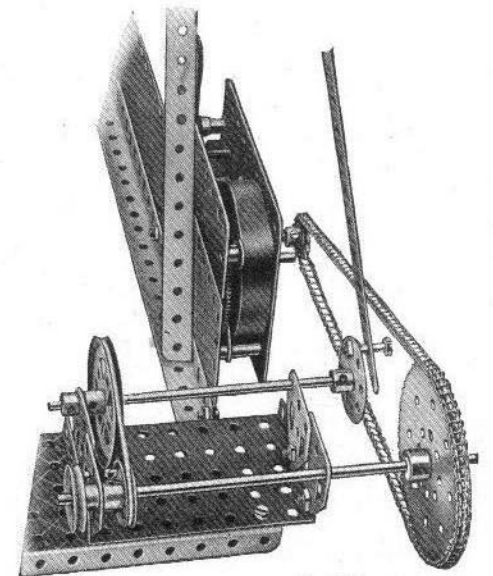
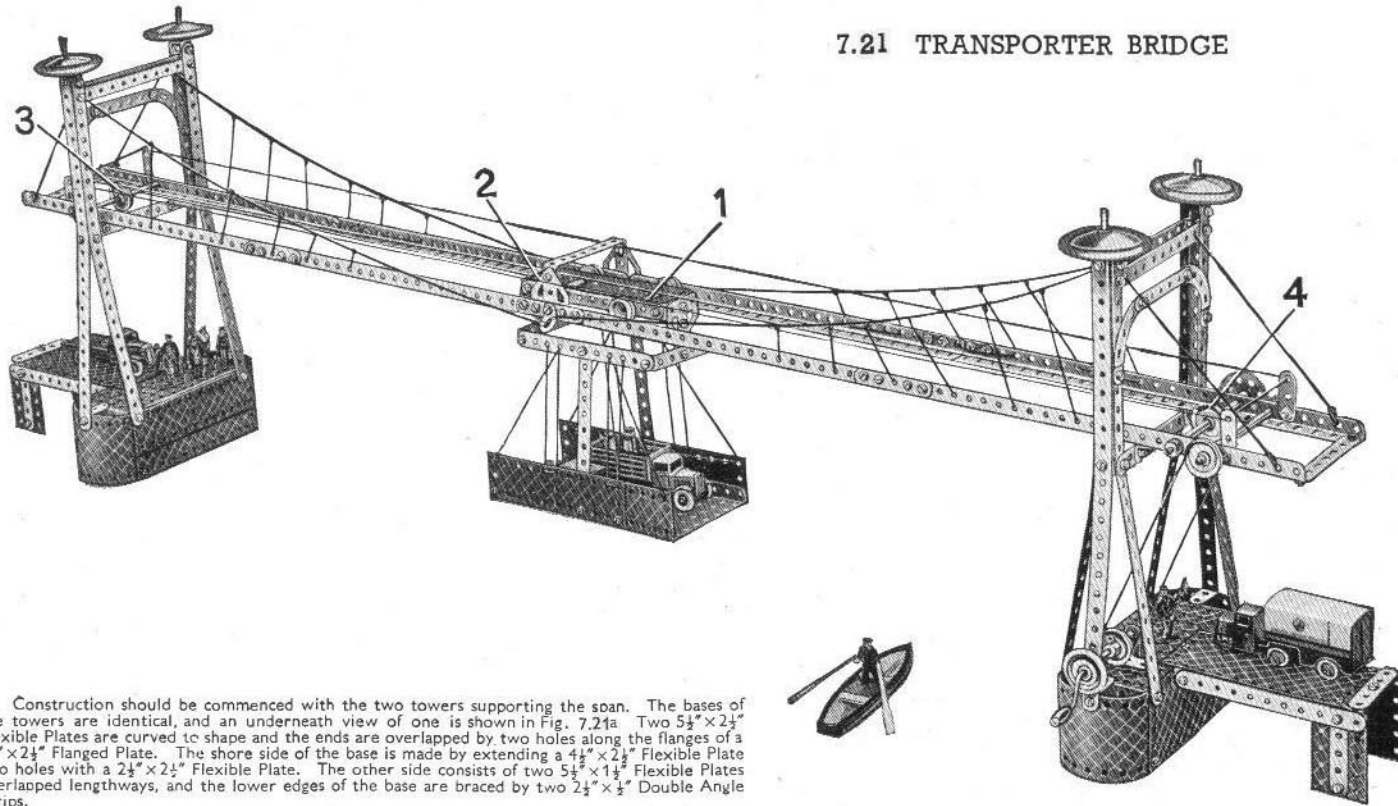

Fig. 7.20a

## 7.21 TRANSPORTER BRIDGE



Construction should be commenced with the two towers supporting the span. The bases of the towers are identical, and an underneath view of one is shown in Fig. 7.21a. Two  $5\frac{1}{2}'' \times 2\frac{1}{2}''$  Flexible Plates are curved to shape and the ends are overlapped by two holes along the flanges of a  $5\frac{1}{2}'' \times 2\frac{1}{2}''$  Flanged Plate. The shore side of the base is made by extending a  $4\frac{1}{2}'' \times 2\frac{1}{2}''$  Flexible Plate two holes with a  $2\frac{1}{2}'' \times 2\frac{1}{2}''$  Flexible Plate. The other side consists of two  $5\frac{1}{2}'' \times 1\frac{1}{2}''$  Flexible Plates overlapped lengthways, and the lower edges of the base are braced by two  $2\frac{1}{2}'' \times \frac{1}{2}''$  Double Angle Strips.

Each approach roadway is a  $5\frac{1}{2}'' \times 2\frac{1}{2}''$  Flexible Plate extended one hole by a  $2\frac{1}{2}'' \times 1\frac{1}{2}''$  Flexible Plate the securing Bolts carrying also a  $2\frac{1}{2}'' \times \frac{1}{2}''$  Double Angle Strip. A second  $2\frac{1}{2}'' \times \frac{1}{2}''$  Double Angle Strip is bolted near the inner end of the  $5\frac{1}{2}'' \times 2\frac{1}{2}''$  Flexible Plate, and is connected to the other Double Angle Strip by  $5\frac{1}{2}''$  Strips. The approach roadways are supported at the shore ends by  $2\frac{1}{2}'' \times 1\frac{1}{2}''$  Flexible Plates reinforced by  $2\frac{1}{2}''$  Strips.

Each tower is made as follows. Two  $12\frac{1}{2}''$  Strips are bolted at the top ends to a Double Bracket, and a third  $12\frac{1}{2}''$  Strip is attached to them by an Angle Bracket. In a position 12 holes from the top, the  $12\frac{1}{2}''$  Strips are bolted to a Double Bracket made from two Angle Brackets, and their lower ends are splayed out and bolted to the base. The towers at each end of the bridge are joined across by three  $5\frac{1}{2}''$  Strips, and an archway made from two  $2\frac{1}{2}''$  small radius Curved Strips and a  $3''$  Strip, is added. At the top of each tower a Road Wheel is carried on a  $1\frac{1}{2}''$  Rod, which is held in place by a Spring Clip.

Each side of the span consists of four  $12\frac{1}{2}''$  Angle Girders joined together with  $2\frac{1}{2}''$  Strips, and they are connected at each end by  $3\frac{1}{2}''$  Strips, and at the centre by a  $3\frac{1}{2}'' \times \frac{1}{2}''$  Double Angle Strip bolted to Flat Trunnions. Angle Brackets connect the span to the lower  $5\frac{1}{2}''$  Strips in the towers.

The bogie supporting the carriage consists of two  $5\frac{1}{2}''$  Strips joined across at each end by  $1\frac{1}{2}'' \times \frac{1}{2}''$  Double Angle Strips, which are fitted with Flat Trunnions. Fishplates bolted to the Flat Trunnions support the carriage. A Crank Handle carrying two  $1''$  Pulleys is journalled in the right-hand tower, and the drive is taken from the inner Pulley to a third Pulley fastened on a  $5''$  Rod in the span. A  $\frac{1}{2}''$  Pinion on this Rod meshes with a 57-teeth Gear secured to a second  $5''$  Rod. The operating Cord 1 for the carriage is tied to Flat Trunnion 2, led around  $1''$  loose Pulley 3 on a  $4\frac{1}{2}''$  Rod, and around  $1''$  fast Pulley 4 on the second  $5''$  Rod. Finally it is tied to one end of a Spring, the other end of which is carried on a Pivot Bolt lock-nutted to a Reversed Angle Bracket bolted to the travelling bogie. The Spring is used to tension the operating Cord 1.

Parts required		
12 of No. 1	1 of No. 19g	3 of No. 53
16 " " 2	4 " " 20b	2 " " 59
2 " " 3	4 " " 22	4 " " 90a
2 " " 4	1 " " 22a	4 " " 111c
12 " " 5	1 " " 26	1 " " 125
4 " " 6a	1 " " 27a	1 " " 126
8 " " 8	8 " " 35	4 " " 126a
2 " " 10	142 " " 37	1 " " 147b
4 " " 11	4 " " 37a	1 " " 155
16 " " 12	5 " " 38	4 " " 187
4 " " 12a	3 " " 40	6 " " 188
2 " " 12c	1 " " 43	6 " " 189
2 " " 15	2 " " 48	4 " " 190
1 " " 15a	10 " " 48a	2 " " 191
2 " " 17	1 " " 48b	2 " " 192
4 " " 18a	2 " " 52	

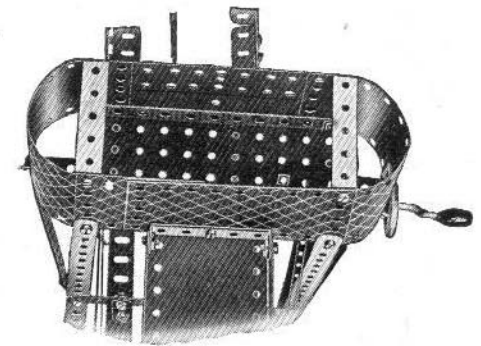
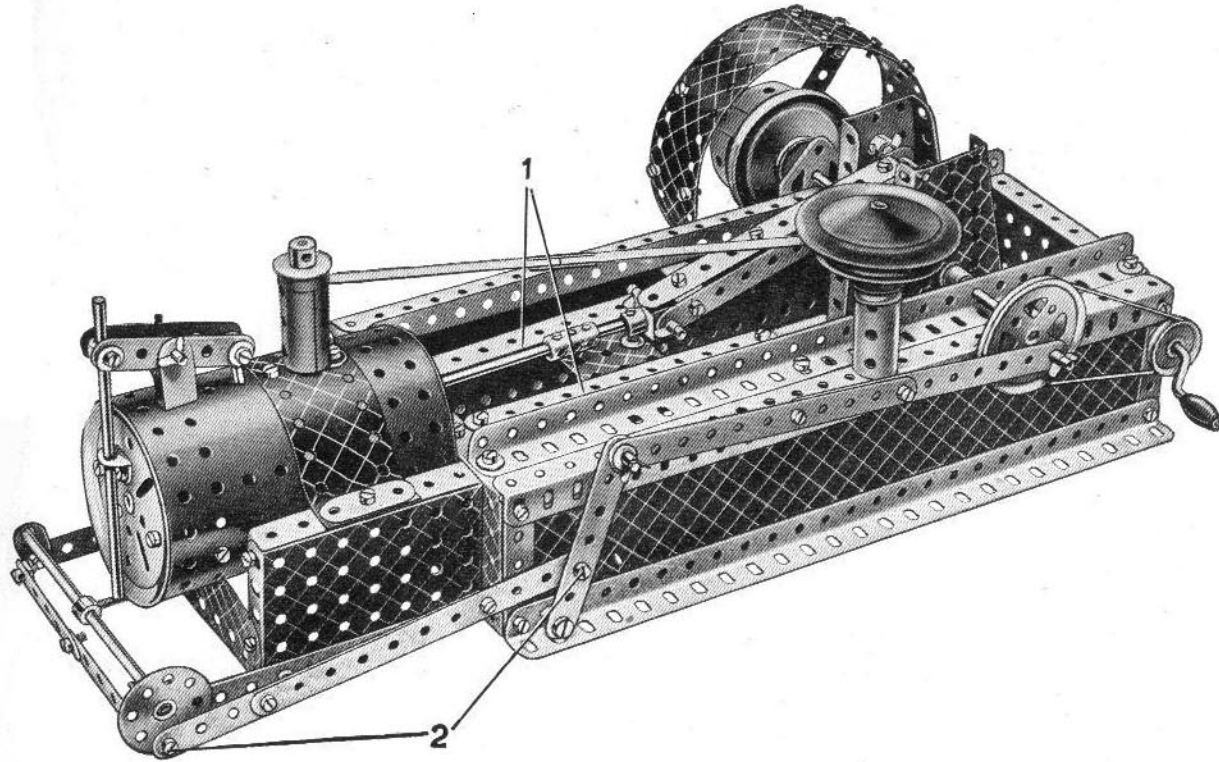

Fig. 7.21a



### 7.22 GAS ENGINE



A base for the model is provided by four  $12\frac{1}{2}$ " Angle Girders bolted at each end to two  $5\frac{1}{2}$ " $\times$  $2\frac{1}{4}$ " Flanged Plates. Further Angle Girders bolted to the upper flanges of the Flanged Plates provide bearings for the crankshaft. Each slide 1 is made by bolting two  $5\frac{1}{2}$ " Strips to a Fishplate, which is attached to the flange of the  $5\frac{1}{2}$ " $\times$  $2\frac{1}{4}$ " Flanged Plate in front of the cylinder. At their free ends the  $5\frac{1}{2}$ " Strips are bolted to a  $1\frac{1}{2}$ " Strip, which is fixed to one of the upper Angle Girders (see Fig. 7.22a). The securing Bolts each carry a Washer on their shanks in order to space the  $5\frac{1}{2}$ " Strips apart.

The cylinder is a Boiler opened out so that it will fit round the rims of the 3" Pulleys forming the cylinder ends. The 3" Pulley at the crankshaft end of the cylinder is bolted to the  $5\frac{1}{2}$ " $\times$  $2\frac{1}{4}$ " Flanged Plate, and the other 3" Pulley is attached to the Boiler by two  $1$ " $\times$  $1$ " Angle Brackets. A  $5\frac{1}{2}$ " $\times$  $1\frac{1}{2}$ " Flexible Plate is bolted to the Boiler, and is attached at each end to two  $3\frac{1}{2}$ " $\times$  $\frac{1}{2}$ " Double Angle Strips. The latter are bolted to  $3\frac{1}{2}$ " $\times$  $2\frac{1}{2}$ " Flanged Plates that in turn are fastened to the  $5\frac{1}{2}$ " $\times$  $2\frac{1}{4}$ " Flanged Plate. The cylinder inlet port is a Sleeve Piece fitted with a  $\frac{3}{8}$ " Flanged Wheel, and the valve stem is a  $1\frac{1}{2}$ " Rod held in a Collar pivoted between  $2\frac{1}{2}$ " Strips. The valve tappet is a  $4\frac{1}{2}$ " Rod also held in a Collar.

The crankshaft consists of a 2" Rod and a 5" Rod fitted with Flanged Sector Plates to represent the crank webs. The 2" Rod is held in the boss of a Crank bolted on the outside of one of the Flanged Sector Plates, and the 5" Rod is held in the boss of a 57-teeth Gear bolted on the inside of the other Flanged Sector Plate. The Flanged Sector Plates are connected by a 2" Rod, which is passed through the boss of a Crank and is held in place by a Collar and a  $\frac{3}{8}$ " Flanged Wheel. The connecting rod is made by bolting two  $5\frac{1}{2}$ " Strips and two 3" Strips overlapped two holes, to two Double Brackets. The large Fork Piece, to which the  $2\frac{1}{2}$ " $\times$  $1\frac{1}{2}$ " Flanged Plate forming the crosshead is bolted, is spaced from the crosshead by three Washers.

The piston rod consists of a  $4\frac{1}{2}$ " Rod joined to a  $1\frac{1}{2}$ " Rod by a Coupling, and the flywheel is made by bolting two compound strips consisting of two  $2\frac{1}{4}$ " Strips overlapped one hole, to a 2" Pulley. Three  $5\frac{1}{2}$ " $\times$  $1\frac{1}{2}$ " Flexible Plates and a  $2\frac{1}{2}$ " $\times$  $1\frac{1}{2}$ " Flexible Plate are bolted together and attached by Angle Brackets to the ends of the  $2\frac{1}{4}$ " Strips.

The Bolts 2 are lock-nutted. The Collar on the 5" Rod carrying the Bush Wheel is fitted with a  $\frac{3}{8}$ " Bolt that actuates the valve tappet.

#### Parts required

12 of No. 2	2 of No. 12a	2 of No. 20a	1 of No. 44	1 of No. 80c	2 of No. 163
1 " " 3	2 " " 15	3 " " 20b	2 " " 48b	1 " " 111	1 " " 186
2 " " 4	3 " " 15a	2 " " 22	1 " " 51	1 " " 111a	2 " " 187
12 " " 5	1 " " 15b	1 " " 24	2 " " 52	1 " " 111c	3 " " 188
4 " " 6a	2 " " 17	1 " " 27a	2 " " 53	2 " " 115	4 " " 189
6 " " 8	3 " " 18a	12 " " 35	2 " " 54	1 " " 116	2 " " 197
4 " " 10	1 " " 18b	92 " " 37	6 " " 59	2 " " 126a	1 " " 213
3 " " 11	2 " " 19b	3 " " 37a	2 " " 62	1 " " 147b	
8 " " 12	1 " " 19g	26 " " 38	1 " " 63	1 " " 162	

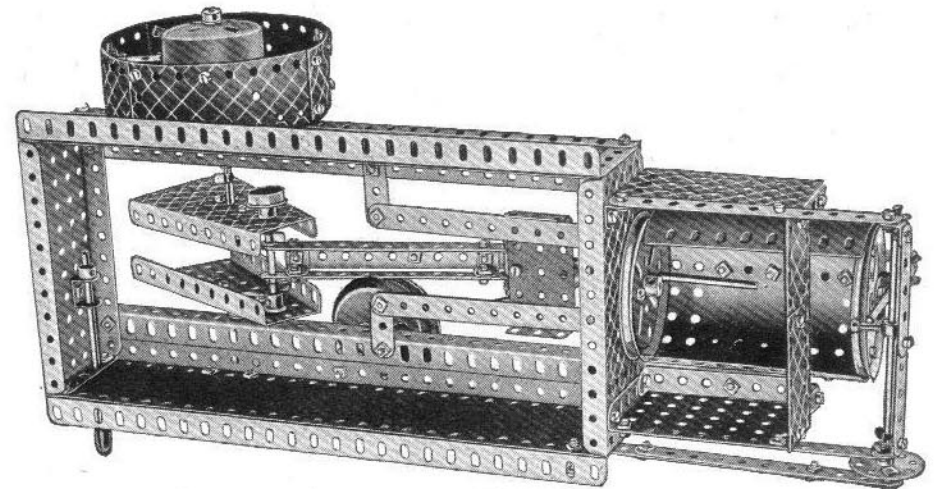

Fig. 7.22a

### 7.23 PITHEAD GEAR

The base of the model is built up from two compound girders joined at one end by a  $3\frac{1}{2}'' \times \frac{1}{2}''$  Double Angle Strip, and at the other by a  $3\frac{1}{2}'' \times 2\frac{1}{2}''$  Flanged Plate. Each of the compound girders consists of two Angle Girders bolted together overlapping 11 holes.

The corners of the pit shaft nearest to the control cabin are each formed by two Angle Girders, which are secured together also overlapping 11 holes. The lower ends of these compound girders are bolted to the base. Each of the other two corners of the pit shaft are formed by a  $12\frac{1}{2}''$  Strip, bolted to the base and extended upwards by a  $5\frac{1}{2}''$  Strip. The Angle Girders and Strips are secured together at the top by  $5\frac{1}{2}''$  Strips and a  $3\frac{1}{2}'' \times \frac{1}{2}''$  Double Angle Strip.

The cage is constructed by bolting a Flanged Sector Plate to each flange of a  $3\frac{1}{2}'' \times 2\frac{1}{2}''$  Flanged Plate. The open sides of the cage are filled in by  $4\frac{1}{2}'' \times 2\frac{1}{2}''$  Flexible Plates, which are bolted to  $3\frac{1}{2}''$  Strips secured across the flanges of the Flanged Sector Plates. Two Angle Brackets are bolted to the outer side of each Flanged Sector Plate to receive the guide Cord.

Each guide Cord is tied to a  $4\frac{1}{2}''$  Rod journalled in the sides of the base, then led through a hole in the  $5\frac{1}{2}''$  Strip secured across the top of the pit shaft, and tied to a Washer. The sides of the control cabin are formed by two  $5\frac{1}{2}'' \times 2\frac{1}{2}''$  Flanged Plates bolted to the base. A Hinged Flat Plate is used for the roof, and at each side is fastened by an Obtuse Angle Bracket to a  $5\frac{1}{2}''$  Strip bolted to the base.

A  $5''$  Rod is journalled in the two  $5\frac{1}{2}'' \times 2\frac{1}{2}''$  Flanged Plates, and at one end it carries a  $3''$  Pulley and at the other a Bush Wheel. The  $3''$  Pulley is fitted with a Crank, in the boss of which a  $1\frac{1}{4}''$  Rod is locked to form a handle. The Bush Wheel carries a Threaded Pin in one of its holes, and over this is slipped a Rod and Strip Connector, in the other end of which is a  $3\frac{1}{2}''$  Rod. This Rod is free to slide in and out of a cylinder made by pressing a  $\frac{3}{8}''$  Flanged Wheel over each end of a Sleeve Piece. Between the two Flanged Plates the  $4\frac{1}{2}''$  Rod carries two Road Wheels and a Coupling, the latter forming the winding drum. Cord is tied to the Coupling and taken over a  $3''$  Pulley at the top of the shaft, then led around a  $1''$  Pulley held on a  $2''$  Rod at the top of the cage, and finally is tied to the  $5\frac{1}{2}''$  Strip at the shaft head.

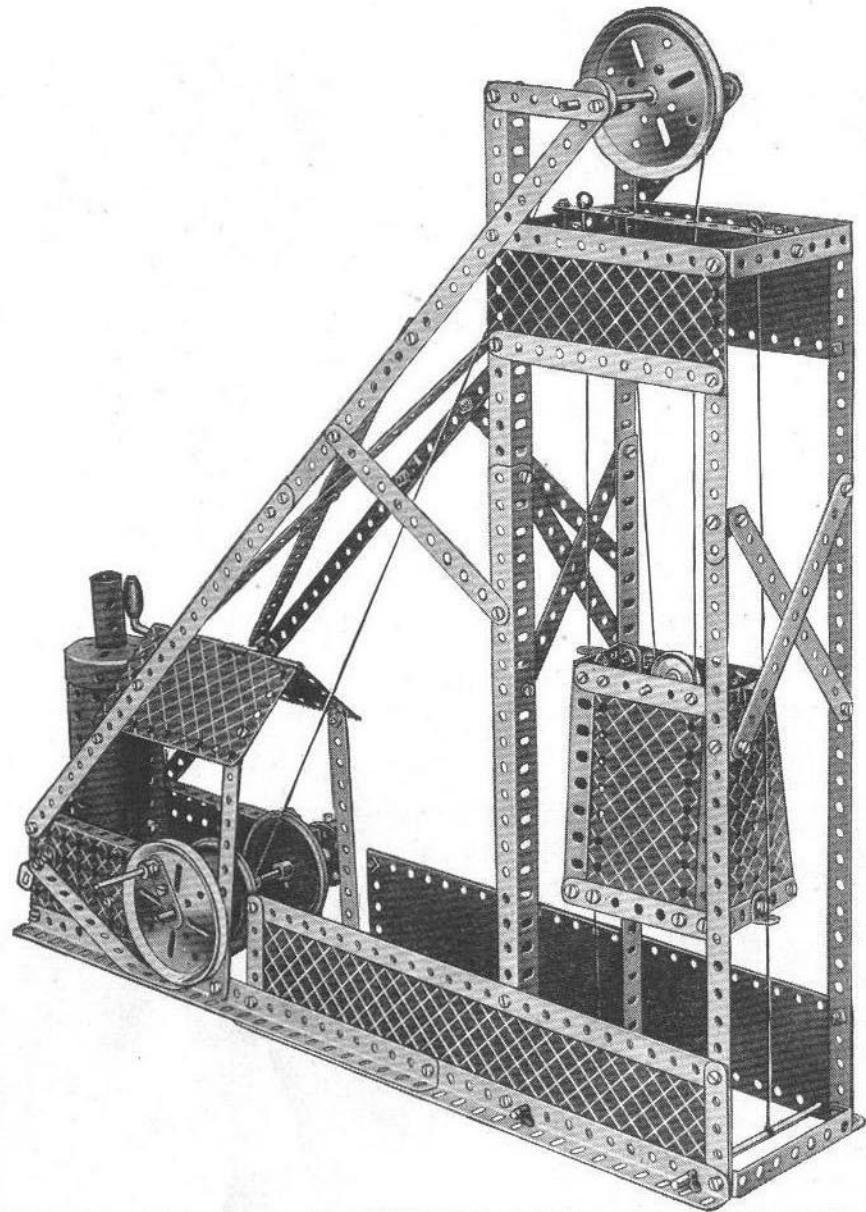

Parts required		
10 of No. 1	4 of No. 20b	1 of No. 63
16 " " 2	1 " " 22	1 " " 111a
5 " " 3	1 " " 24	1 " " 115
2 " " 4	6 " " 35	1 " " 125
4 " " 5	103 " " 37	1 " " 162a
8 " " 8	2 " " 37a	1 " " 162b
15 " " 12	18 " " 38	2 " " 163
2 " " 12c	1 " " 40	1 " " 164
1 " " 15	2 " " 48b	2 " " 187
3 " " 15a	2 " " 52	2 " " 191
1 " " 16	3 " " 53	2 " " 192
1 " " 17	2 " " 54	2 " " 197
1 " " 18a	3 " " 59	1 " " 198
2 " " 19b	1 " " 62	1 " " 212
1 " " 19g		

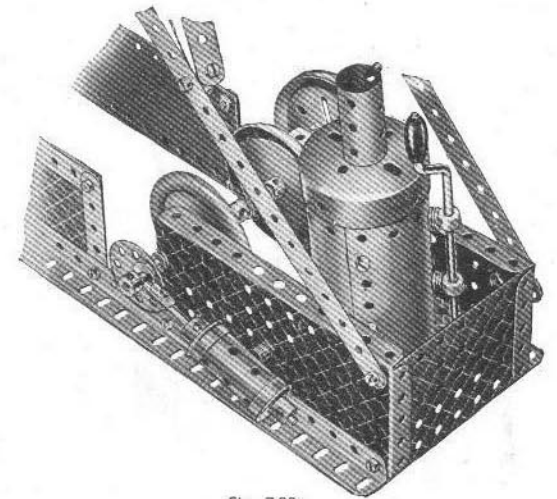

Fig. 7.23a

### 7.24 ARMY LORRY

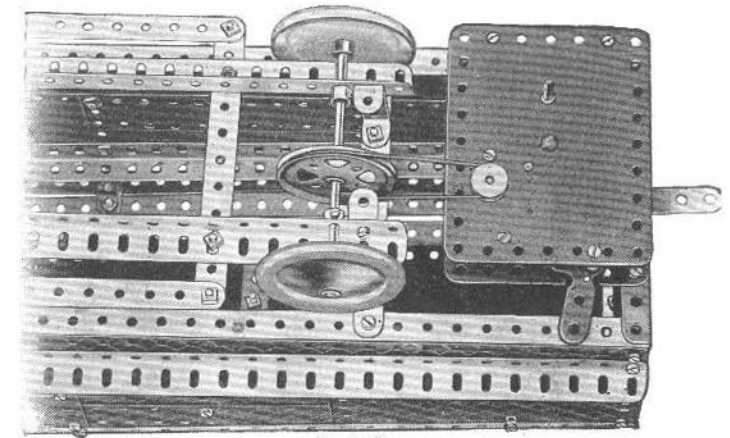
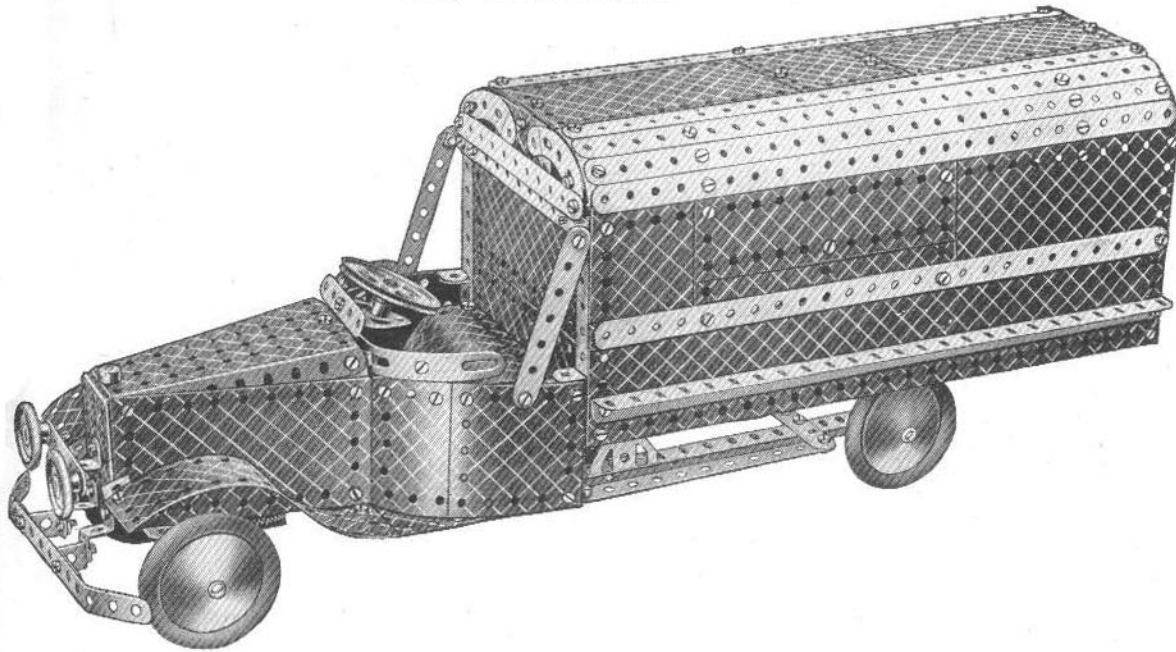

Fig. 7.24b

Parts required

10	of No.	1
12	" "	2
6	" "	3
	" "	5
3	" "	6a
8	" "	8
10	" "	10
3	" "	11
11	" "	12
2	" "	12a
6	" "	12c
1	" "	15
1	" "	15a
2	" "	18a
1	" "	20a
2	" "	22
1	" "	26
1	" "	27a
2	" "	35
150	" "	37
12	" "	37a
8	" "	38
2	" "	48
4	" "	48a
1	" "	48b
1	" "	51
2	" "	52
2	" "	54

6	of No.	59
1	" "	80c
2	" "	90a
6	" "	111c
4	" "	125
2	" "	126
3	" "	126a
1	" "	147b
2	" "	155
4	" "	187

2	of No.	188
6	" "	189
5	" "	190
2	" "	191
6	" "	192
2	" "	197
1	" "	198
2	" "	199
2	" "	200
6	" "	215

For model Army Lorry fitted with No. 1a Clockwork Motor

Additional parts required

*1 No. 1 Clockwork Motor	1 of No. 23a
1 of No. 20a	*3 " " 37
	1 " " 186

\*Not included in Outfit

Two  $12\frac{1}{2}$ " Angle Girders bolted to a  $5\frac{1}{2}$ " x  $2\frac{1}{2}$ " Flanged Plate form the main part of the chassis of the model. The Flanged Plate is extended to the front by a Flanged Sector Plate, and the floor of the cab is formed by two  $5\frac{1}{2}$ " x  $2\frac{1}{2}$ " Flexible Plates placed across the  $5\frac{1}{2}$ " x  $2\frac{1}{2}$ " Flanged Plate. The bonnet is built up by bolting two  $4\frac{1}{2}$ " x  $2\frac{1}{2}$ " Flexible Plates to the flanges of the Flanged Sector Plate. One end of a second Flanged Sector Plate is fixed to the front of the bonnet, and its other end is attached by Fishplates to the rear of the bonnet. The radiator carrying the bumper and headlamps is held in place by a 3" Screwed Rod with a Collar locked to the top of it, and a Nut underneath.

Each side of the cab is represented by a  $1\frac{1}{8}$ " radius Curved Plate overlapping a  $2\frac{1}{2}$ " x  $2\frac{1}{2}$ " Flexible Plate by two holes. The  $1\frac{1}{8}$ " radius Curved Plate is attached to the bonnet by an Obtuse Angle Bracket, and the  $2\frac{1}{2}$ " x  $2\frac{1}{2}$ " Flexible Plate is bolted to a  $2\frac{1}{2}$ " x  $\frac{1}{2}$ " Double Angle Strip, which in turn is fastened to the floor of the cab. Formed Slotted Strips are bolted to a  $2\frac{1}{2}$ " x  $1\frac{1}{2}$ " Flexible Plate and then attached by Fishplates to the sides of the cab. A  $2\frac{1}{2}$ " Strip is bolted to an Obtuse Angle Bracket to form a wind-shield and a Flat Trunnion attached by an Angle Bracket to the  $2\frac{1}{2}$ " Strip, provides a bearing for the steering column.

Each side of the body consists of a  $12\frac{1}{2}$ " x  $2\frac{1}{2}$ " Strip Plate, to which are bolted two Angle Girders and a  $12\frac{1}{2}$ " Strip. Flexible Plates of various sizes extend the sides upward, and the upper edge of each side is reinforced by a further  $12\frac{1}{2}$ " Angle Girder. The sides are joined across by three  $5\frac{1}{2}$ " Strips at the lower edge, by a  $5\frac{1}{2}$ " x  $2\frac{1}{2}$ " Flanged Plate at the rear, and by Formed Slotted Strips joined by  $3\frac{1}{2}$ " Strips at the upper corners.

The body is attached to the rear of the chassis by  $1\frac{1}{2}$ " x  $\frac{1}{2}$ " Double Angle Strips, and at the front it is held by a  $3\frac{1}{2}$ " x  $\frac{1}{2}$ " Double Angle Strip and Trunnions. The back of the cab is filled in by a Hinged Flat Plate and the seat is made by bolting two U-Section Curved Plates together and attaching them to the Hinged Flat Plate by Angle Brackets.

Fig. 7.24a shows the steering mechanism. The upper  $\frac{3}{8}$ " Bolt forming the wheel pivot carries a  $1\frac{1}{2}$ " Strip, a Double Bracket, and a second  $1\frac{1}{2}$ " Strip at right angles to the first, on its shank. All these parts are locked in place by a nut, and the Bolt is then passed through a hole in a Flat Trunnion and fitted with lock-nuts. The lower  $\frac{3}{8}$ " Bolt carries a  $1\frac{1}{2}$ " Strip and a Double Bracket. The tie rod is a  $3\frac{1}{2}$ " Strip pivotally attached to the  $1\frac{1}{2}$ " Strips by lock-nutted Bolts 1.

Steering is obtained by meshing a  $\frac{1}{2}$ " Pinion on the steering column with a 57-teeth Gear carried on a Pivot Bolt. The 57-teeth Gear is connected by a  $2\frac{1}{2}$ " Strip to the second  $1\frac{1}{2}$ " Strip on the upper  $\frac{3}{8}$ " Bolt. The Bolts 2 are lock-nutted.

Fig. 7.24b shows the method of attaching a No. 1a Clockwork Motor to this model. The Motor is bolted to the rear of the chassis and the drive is taken from a  $\frac{1}{2}$ " fast Pulley on the driving shaft to a 2" Pulley on the back axle.

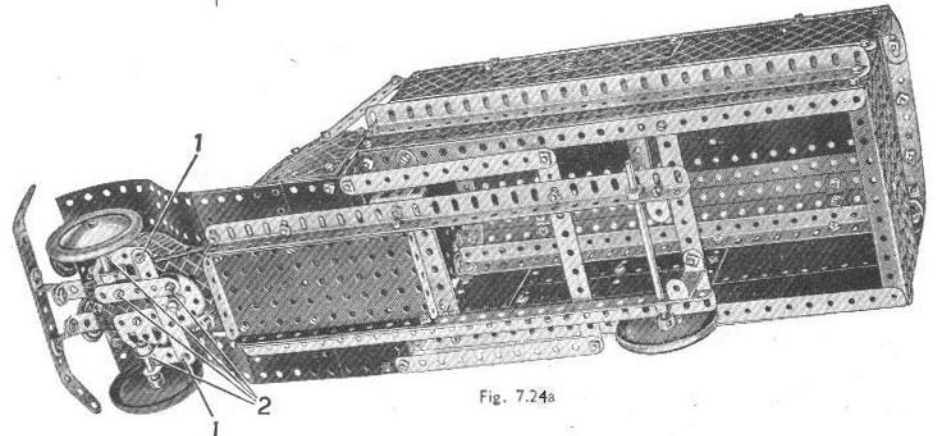

Fig. 7.24a

## 7.25 WINDMILL PUMP

The base for the windmill is constructed by bolting two  $5\frac{1}{2}'' \times 2\frac{1}{2}''$  Flanged Plates together by their long flanges. The four compound girders forming the tower each consist of two  $12\frac{1}{2}''$  Angle Girders overlapped two holes and are bolted one at each corner of the base and braced across by  $12\frac{1}{2}''$  Strips. The roof of the windmill is represented by a Hinged Flat Plate, and is secured by Angle Brackets to the ends of two  $2\frac{1}{2}''$  Strips, each of which is bolted across a pair of Angle Girders.

In Fig. 7.25a, one half of the Hinged Flat Plate is thrown back to show the bearing for the main shaft. The latter is a 5" Rod, and at one end it carries a  $\frac{1}{2}''$  Pinion, and at its other end a 3" Pulley that supports the sails. The  $\frac{1}{2}''$  Pinion meshes with a 57-teeth gear on a  $4\frac{1}{2}''$  Rod journalled directly below the 5" Rod. The  $4\frac{1}{2}''$  Rod carries also two 1" Pulleys, which are connected by Cord to two more 1" Pulleys on a  $3\frac{1}{2}''$  Rod journalled midway up the tower. A 2" Pulley on the  $3\frac{1}{2}''$  Rod is driven by Cord from a 1" Pulley on a large Crank Handle. The Crank Handle is extended by a  $1\frac{1}{2}''$  Rod, using a Rod Connector, and is journalled in the two right-hand Angle Girders. The  $3\frac{1}{2}''$  Rod journalled midway up the tower carries at its inner end a Bush Wheel, to which a  $5\frac{1}{2}''$  Strip is connected by a Threaded Pin, the other end of the Strip being pivotally attached to a beam, consisting of three  $5\frac{1}{2}''$  Strips secured together by Double Brackets. The other end of the beam is connected to a pump as shown in Fig. 7.25a.

Each of the sails is attached to the 3" Pulley by a  $2\frac{1}{2}''$  Strip, and six of them are represented by  $5\frac{1}{2}'' \times 2\frac{1}{2}''$  Flexible Plates. The remaining two sails are each constructed by bolting a  $2\frac{1}{2}'' \times 2\frac{1}{2}''$  Flexible Plate to a  $4\frac{1}{2}'' \times 2\frac{1}{2}''$  Flexible Plate overlapping three holes.

The inspection platform is formed by four  $5\frac{1}{2}'' \times 1\frac{1}{2}''$  Flexible Plates and is secured to the framework by small radius Curved Strips and Angle Brackets. The steps are represented by Cord threaded through compound strips, each of which consists of three  $5\frac{1}{2}''$  Strips.

Fig. 7.25b shows the Windmill Pump fitted with an E120 Electric Motor. The Motor is bolted to a  $3\frac{1}{2}'' \times 2\frac{1}{2}''$  Flanged Plate, which is connected to the base of the model by a  $3\frac{1}{2}'' \times \frac{1}{2}''$  Double Angle Strip.

The drive is taken from the armature shaft through a  $\frac{1}{2}''$  Pinion and a 57-teeth Gear fastened on a  $1\frac{1}{2}''$  Rod. This Rod carries also  $\frac{1}{2}''$  fast Pulley 1, from which the drive is taken to a 2" Pulley.

## Parts required

12 of No. 1	12 of No. 37a	6 of No. 192
12 " " 2	20 " " 38	2 " " 197
4 " " 3	1 " " 40	1 " " 198
2 " " 4	2 " " 45	1 " " 213
12 " " 5	2 " " 48	
2 " " 6a	1 " " 48b	
8 " " 8	2 " " 52	
4 " " 10	1 " " 53	
2 " " 11	2 " " 54a	
14 " " 12	4 " " 59	
2 " " 12a	1 " " 62	
1 " " 15	1 " " 63	
2 " " 15a	2 " " 90	
1 " " 15b	4 " " 90a	
1 " " 16	2 " " 111a	
4 " " 18a	6 " " 111c	
1 " " 19b	2 " " 115	
1 " " 19h	1 " " 116	
1 " " 20a	2 " " 126a	
2 " " 20b	1 " " 162a	
5 " " 22	1 " " 162b	
1 " " 22a	1 " " 163	
1 " " 24	1 " " 164	
1 " " 26	1 " " 187	
1 " " 27a	4 " " 189	
7 " " 35	4 " " 190	
134 " " 37	2 " " 191	

For model Windmill Pump fitted with E120 Electric Motor:

Additional parts required:  
\*1 E120 Electric Motor.

1 of No. 14  
\*1 " " 18a  
1 " " 19b  
1 " " 26  
\*1 " " 27a  
2 " " 35  
1 " " 37  
1 " " 48a  
1 " " 48b  
1 " " 53  
\*1 " " 63

Parts not required:  
1 of No. 19h  
1 " " 59  
1 " " 213  
\*Not included in Outfit.

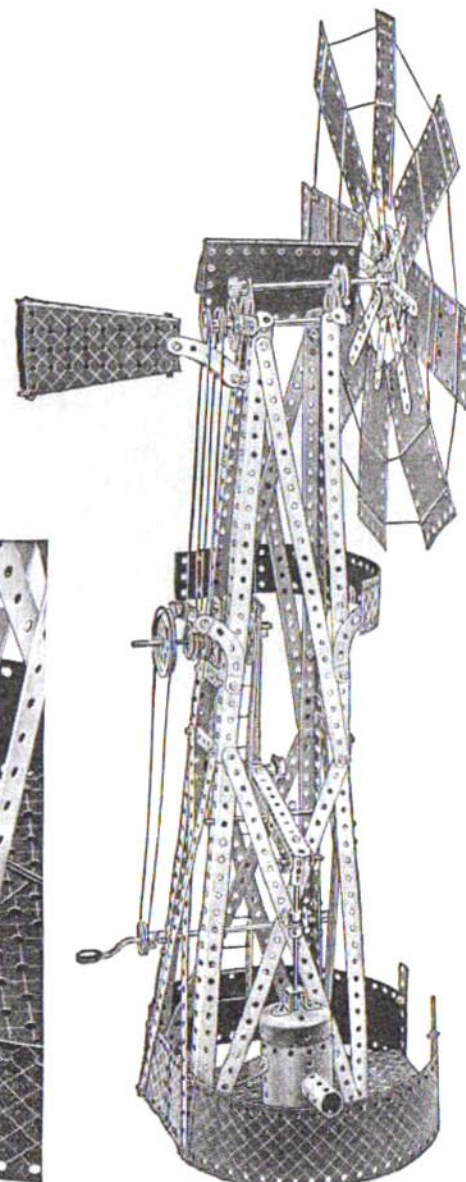
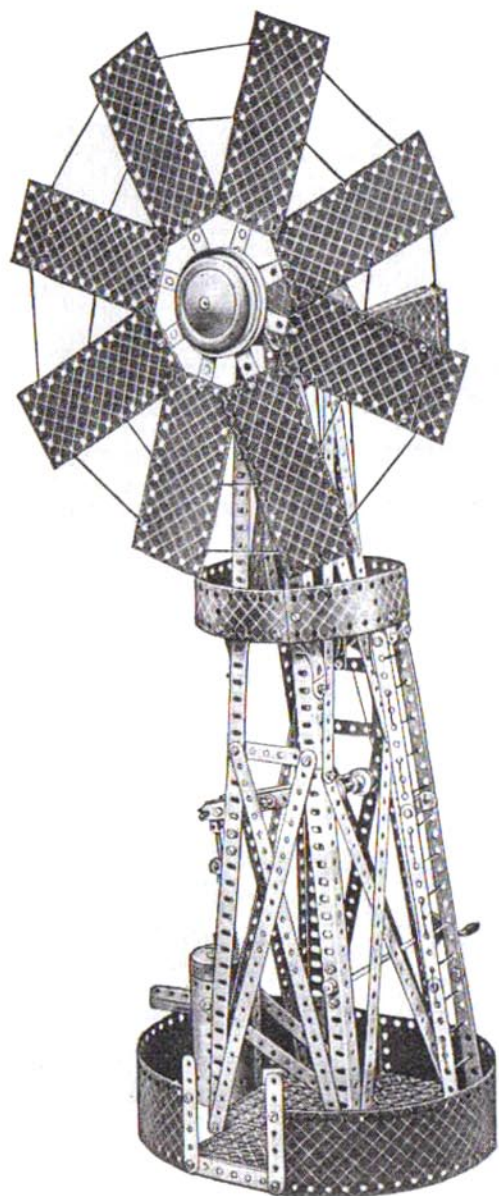
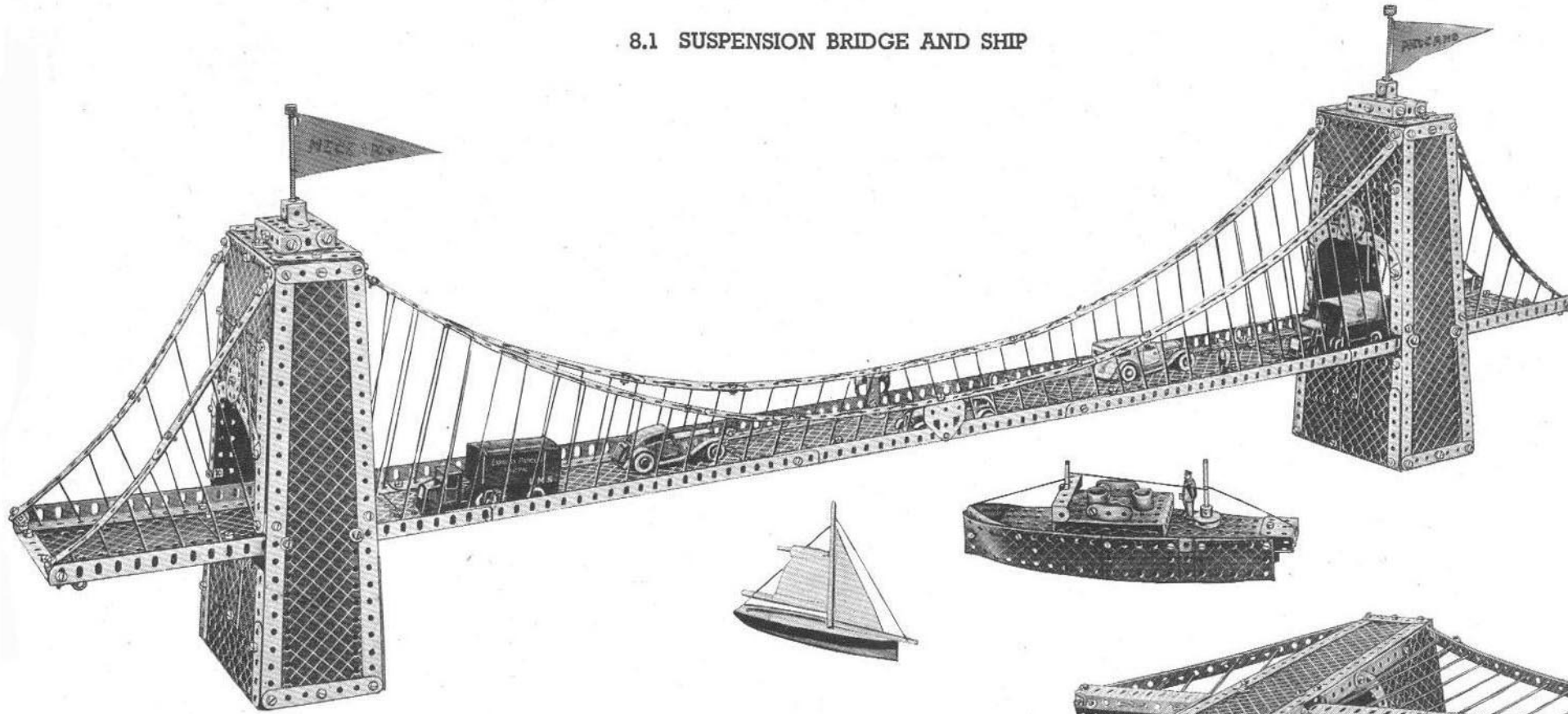

Fig. 7.25b

Fig. 7.25a

### 8.1 SUSPENSION BRIDGE AND SHIP



Parts required			
	of No.		
14	1	2	48c
18	2	2	48d
6	2a	2	51
4	3	2	52
6	4	5	53
18	5	2	54
1	6	10	59
6	6a	2	80c
10	8	4	90
4	9	4	90a
4	10	3	111
2	11	6	111a
25	12	2	111c
8	12c	4	126
2	16	3	126a
2	20b	1	160
4	24	2	164
1	26	8	188
1	35	8	189
220	37	10	190
16	37a	6	191
15	38	12	192
3	40	6	197
2	45	1	198
2	48	2	214
6	48a		
3	48b		

The model should be commenced by building the towers. These are almost identical, and their construction will be clear with reference to the illustrations. The halves of a Hinged Flat Plate are used in the construction of their bases and the top of each tower is attached to the sides by a  $4\frac{1}{2} \times \frac{1}{2}$ " Double Angle Strip.

The sides of the span each consist of five  $12\frac{1}{2}$ " Angle Girders overlapped by three holes, and they are connected by six  $4\frac{1}{2}$ " Strips. The roadway is made by two  $12\frac{1}{2} \times 2\frac{1}{2}$ " Strip Plates and seven  $5\frac{1}{2} \times 2\frac{1}{2}$ " Flexible Plates, all of which are bolted end to end, and also to the  $4\frac{1}{2}$ " Strips spacing the side members. Six  $5\frac{1}{2} \times 1\frac{1}{2}$ ", four  $5\frac{1}{2} \times 2\frac{1}{2}$ ", and one  $4\frac{1}{2} \times 2\frac{1}{2}$ " Flexible Plates are used to complete the remainder of the roadway. The span is attached to the towers by two Trunnions, one of which is seen in Fig. 8.1a.

The main suspension cables are each formed by three  $12\frac{1}{2}$ " Strips joined together by two  $5\frac{1}{2}$ " Strips to make a compound strip  $41\frac{1}{2}$ " in length. They are attached to the towers by Obtuse Angle Brackets, and to the centre of the span by  $1\frac{1}{2} \times \frac{1}{2}$ " Double Angle Strips. Cord is threaded through holes in the compound strips and the span to represent the hangers.

Each side of the boat is made with one  $5\frac{1}{2} \times 1\frac{1}{2}$ " and two  $2\frac{1}{2} \times 1\frac{1}{2}$ " Flexible Plates, and a Semi-Circular Plate, bolted to two Flanged Sector Plates. The raised bows are formed by two  $5\frac{1}{2}$ " Strips, and the upper deck, a  $3\frac{1}{2} \times 2\frac{1}{2}$ " Flanged Plate, is held in place by the  $\frac{3}{8}$ " Bolts that hold also the funnels. The bridge is made up of two  $2\frac{1}{2} \times \frac{1}{2}$ " Double Angle Strips bolted together at one end, and held by a Spring Clip on the  $3\frac{1}{2}$ " Rod representing the mast. A  $\frac{1}{2}$ " Pinion is locked on the lower end of this Rod to hold it in position, and Flanged Wheels locked on each side of the Flanged Sector Plate hold the aft mast.

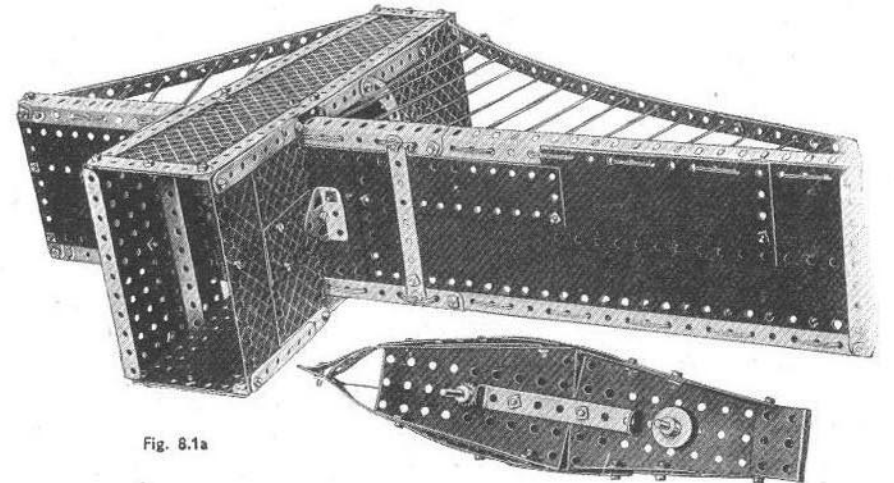
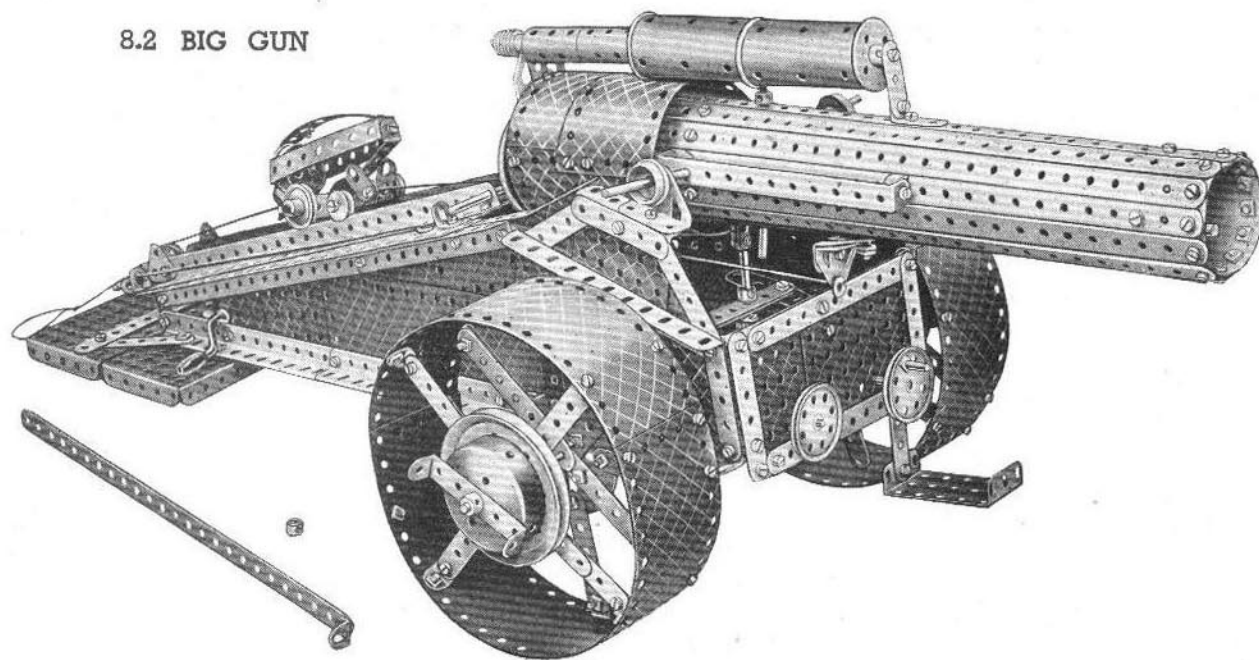

Fig. 8.1a

## 8.2 BIG GUN



This model is a realistic miniature reproduction of a modern big gun, and will actually fire Collars, Washers or similar Meccano missiles. The model is commenced by building the chassis, which consists of two side members each made as follows. Two  $12\frac{1}{2}$ " Angle Girders are overlapped 12 holes, and are bolted to a  $12\frac{1}{2}$ "  $\times$   $2\frac{1}{2}$ " Strip Plate and a  $2\frac{1}{2}$ " Strip at the front end, and to a Flanged Sector Plate five holes from the rear end. A second compound angle girder is made by overlapping a  $12\frac{1}{2}$ " Angle Girder and a  $5\frac{1}{2}$ " Angle Girder by eight holes. This is joined to the rear end of the first compound angle girder and is sloped upward.

A  $5\frac{1}{2}$ " Angle Girder is bolted to the upper front corner of the  $12\frac{1}{2}$ "  $\times$   $2\frac{1}{2}$ " Strip Plate and is sloped upward, finally being joined to the upper compound angle girder by a Fishplate. Two  $5\frac{1}{2}$ "  $\times$   $1\frac{1}{2}$ " Flexible Plates are bolted to the  $5\frac{1}{2}$ " Angle Girders of the side members as shown. The supports for the gun barrel are each made by bolting a  $3\frac{1}{2}$ "  $\times$   $2\frac{1}{2}$ " Flanged Plate and two  $2\frac{1}{2}$ "  $\times$   $1\frac{1}{2}$ " Flexible Plates to the front  $5\frac{1}{2}$ " Angle Girder. Two  $2\frac{1}{2}$ " Strips, also bolted to the  $5\frac{1}{2}$ " Angle Girder, are sloped up to the  $3\frac{1}{2}$ "  $\times$   $2\frac{1}{2}$ " Flanged Plate, and their ends are clamped between another  $2\frac{1}{2}$ " Strip and the Flanged Plate. A Trunnion is then bolted to the upper flange of the Flanged Plate. The side members are further strengthened by bolting a  $12\frac{1}{2}$ " Angle Girder to the upper  $12\frac{1}{2}$ " Angle Girder. The inner Angle Girder is then extended to the  $3\frac{1}{2}$ "  $\times$   $2\frac{1}{2}$ " Flanged Plate by a  $5\frac{1}{2}$ " Strip suitably shaped.

The side members are now connected together. At the front a framework of two compound strips joined by 3" Strips is made. The compound strips consist of two  $5\frac{1}{2}$ " Strips overlapped 10 holes. A  $3\frac{1}{2}$ "  $\times$   $2\frac{1}{2}$ " Flanged Plate and a  $2\frac{1}{2}$ "  $\times$   $1\frac{1}{2}$ " Flanged Plate fill in the framework, which is then attached to the Angle Girders of the side members by Angle Brackets. The two  $3\frac{1}{2}$ "  $\times$   $2\frac{1}{2}$ " Flanged Plates of the sides are joined at the centre holes of their lower flanges by a  $5\frac{1}{2}$ " Strip, placed one at each side of the flanges. Two  $3\frac{1}{2}$ " Strips overlapped by five holes are bolted across the inner pair of  $12\frac{1}{2}$ " Angle Girders in the positions shown in Fig. 8.2c. At the rear end the sides are joined by a  $1\frac{1}{2}$ " Strip.

The two  $5\frac{1}{2}$ "  $\times$   $2\frac{1}{2}$ " Flanged Plates that form the bed-plate are bolted together and fastened to the sides by  $2\frac{1}{2}$ " Strips. The carriage that carries the shells up the chassis to the breech runs on rails made of two Angle Girders, which are bolted as shown in Fig. 8.2c. Stops at the rear end of the rails are provided by two 1" Triangular Plates. Two  $1\frac{1}{2}$ "  $\times$   $\frac{1}{2}$ " Double Angle Strips joined by a 3" Strip are bolted to the  $3\frac{1}{2}$ "  $\times$   $2\frac{1}{2}$ " Flanged Plate at the front of the gun chassis the 3" Strip being used to provide bearings for the barrel elevating mechanism.

The hubs of the wheels are formed by a Face Plate and a 3" Pulley. On the right-hand wheel (Fig. 8.2c) two compound strips, consisting of a  $3\frac{1}{2}$ " Strip overlapping a  $4\frac{1}{2}$ " Strip by three holes, are bolted across the Face Plate. The other spokes are formed by four  $2\frac{1}{2}$ " Strips also bolted to the Face Plate. In the left-hand wheel,  $4\frac{1}{2}$ " Strips overlapped five holes form the main spokes. The spokes bolted to the 3" Pulleys are formed by  $5\frac{1}{2}$ " Strips overlapped nine holes. The rim of each wheel is made by curving two  $12\frac{1}{2}$ "  $\times$   $2\frac{1}{2}$ " Strip Plates and overlapping them by four holes at each end. The main spokes are then attached to the rim by Angle Brackets.

The wheels are carried on an axle journalled in the seventh hole from the front ends of the lower compound girders of the sides. The axle is formed by joining a  $6\frac{1}{2}$ " Rod to an 8" Rod by a Coupling.

The axle is prevented from moving from side to side in its bearings by Collars. The Boiler Ends representing the hub caps and the  $2\frac{1}{2}$ "  $\times$   $\frac{1}{2}$ " Double Angle Strips representing the drag links, are held in place by Collars.

The shell carriage is made from a  $2\frac{1}{2}$ "  $\times$   $\frac{1}{2}$ " and a  $2\frac{1}{2}$ "  $\times$   $1\frac{1}{2}$ " Double Angle Strip bolted together, and Fishplates form a rest for the shell. The 1" Pulleys are carried on an axle made by joining a  $1\frac{1}{2}$ " Rod and a 1" Rod with a Rod Connector. The Pulleys are held on the axle by Spring Clips. The  $\frac{1}{2}$ " loose Pulleys are carried on  $\frac{1}{2}$ " Bolts, which are lock-nutted to the Double Angle Strips.

The carriage is operated by the small Crank Handle journalled in the Flanged Sector Plates of the chassis. Cord is tied to the front end of the carriage, and is then led around a compound rod at the front end of the rails. This Rod consists of a  $1\frac{1}{2}$ " Rod and a 2" Rod joined by a Rod Connector. The Cord is then wound several times around the Crank Handle and is passed around the 1" loose Pulley on the  $3\frac{1}{2}$ " Rod at the rear end of the rails. Finally it is tied to the rear end of the carriage. The shell shown in Fig. 8.2c consists of four  $3\frac{1}{2}$ "  $\times$   $\frac{1}{2}$ " Double Angle Strips bolted to a  $1\frac{1}{2}$ " Flanged Wheel.

The gun barrel is next constructed and is shown partly assembled in Fig. 8.2a in order to show its details. First of all the  $12\frac{1}{2}$ " Strips carrying the recoil shock absorber, the Trunnions 3 and the two  $5\frac{1}{2}$ "  $\times$   $\frac{1}{2}$ " Double Angle Strips, are bolted to the Boiler, overlapping it by three holes. The  $12\frac{1}{2}$ " Strip carrying Trunnion 3 is duplicated for strength. The  $12\frac{1}{2}$ " Strips at the sides carry Reversed Angle Brackets, and the Bolt holding the Reversed Angle Bracket on the rear side of the gun barrel carries also a Crank. A  $3\frac{1}{2}$ " Rod is held in the boss of the Cranks and its end passes through the end transverse bore of a Coupling. In a position five holes from the  $3\frac{1}{2}$ " Rod, but at right angles to it, is a  $3\frac{1}{2}$ " compound rod, held in place by Collars. This Rod consists of two  $1\frac{1}{2}$ " Rods held in the longitudinal bore of a Coupling. The central transverse bore of this Coupling is left free, and the  $11\frac{1}{2}$ " Rod is passed through it and into the longitudinal bore of the rear Coupling. The set screws in both Couplings are then tightened to hold the  $11\frac{1}{2}$ " Rod rigidly in place. A  $5\frac{1}{2}$ " Strip is bolted in a position eight holes from the front end of the barrel and is bent upward slightly at one end as shown.

The Pivot Bolt 1 passes through the third hole from the free end of the  $5\frac{1}{2}$ " Strip and through the two  $12\frac{1}{2}$ " Strips. It carries the Trunnions 3. The  $5\frac{1}{2}$ "  $\times$   $\frac{1}{2}$ " Double Angle Strips are attached to the side  $12\frac{1}{2}$ " Strips, and the 1"  $\times$  1" Angle Bracket carrying the  $1\frac{1}{2}$ " Strip also is added.

(Continued on next page)

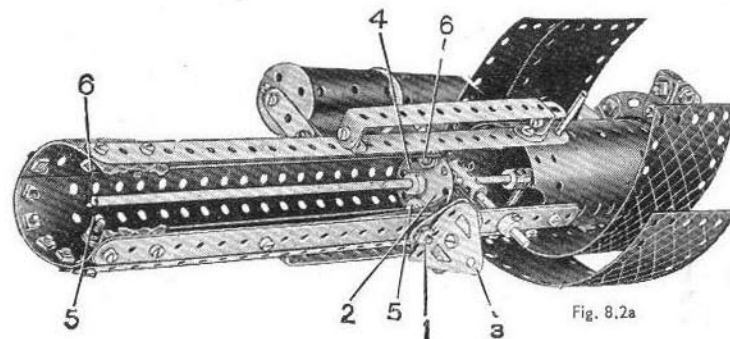
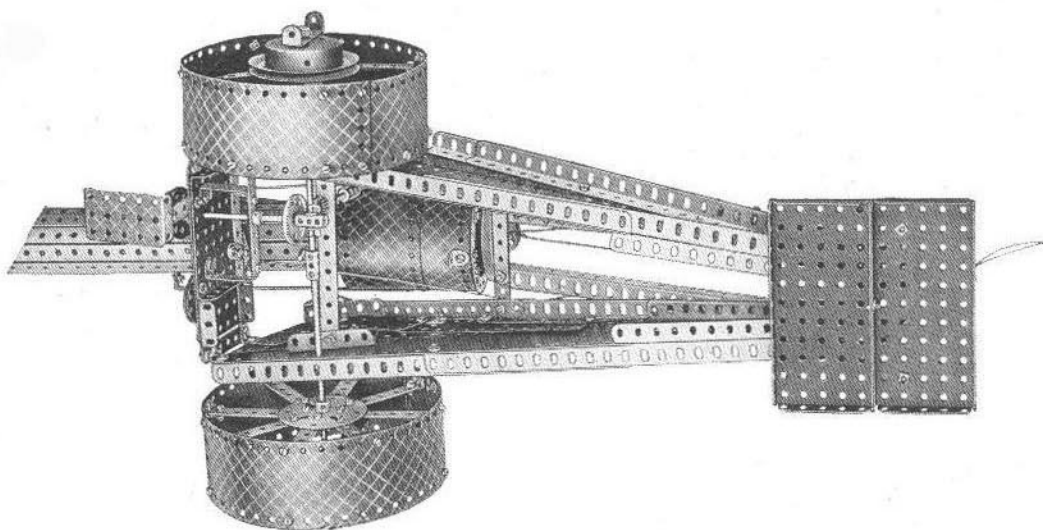

Fig. 8.2a



Parts required									
14 of No. 1	1 of No. 12a	2 of No. 21	1 of No. 45	2 of No. 77	1 of No. 162				
18 " " 2	1 " " 13	2 " " 22	1 " " 46	1 " " 80a	2 " " 163				
6 " " 2a	1 " " 13a	1 " " 22a	2 " " 48	2 " " 80c	2 " " 164				
4 " " 3	1 " " 14	2 " " 23	3 " " 48a	4 " " 90a	1 " " 165				
3 " " 4	1 " " 15b	1 " " 24a	4 " " 48b	2 " " 109	2 " " 186b				
18 " " 5	4 " " 16	1 " " 26	2 " " 48d	1 " " 111	1 " " 187				
2 " " 6	2 " " 17	1 " " 28	2 " " 51	6 " " 111a	4 " " 188				
4 " " 6a	4 " " 18a	1 " " 32	2 " " 52	6 " " 111c	6 " " 189				
10 " " 8	2 " " 18b	6 " " 35	3 " " 53	1 " " 115	4 " " 192				
4 " " 9	2 " " 19b	209 " " 37	2 " " 54	2 " " 125	6 " " 197				
12 " " 10	1 " " 19g	13 " " 37a	10 " " 59	4 " " 126	2 " " 213				
2 " " 11	4 " " 20	14 " " 38	2 " " 62	1 " " 126a	2 " " 216				
34 " " 12	2 " " 20b	1 " " 40	5 " " 63	1 " " 147b					

(Continued from previous page)

Fig. 8.2b

Two  $5\frac{1}{2} \times 1\frac{1}{2}$ " Flexible Plates are overlapped one hole at one end. They are then curved round and the ends overlapped by nine holes. The cylinder thus formed is bolted to the front ends of the  $12\frac{1}{2}$ " Strips. The  $\frac{3}{8}$ " Bolts 5 and 6 carry 10" Driving Bands clamped between Washers on these Bolts at the back of the Disc. The other ends of the Driving Bands are clamped at the front end of the barrel between the Flexible Plates and the  $12\frac{1}{2}$ " Strips, one on each side of the barrel. The Wheel Disc is kept steady on the  $11\frac{1}{2}$ " Rod by a Double Bent Strip held by the  $\frac{3}{8}$ " Bolts. The remaining  $12\frac{1}{2}$ " Strips are then added to complete the barrel.

The breech is built up as a separate unit and bolted in position when complete. Two pairs of  $5\frac{1}{2} \times 2\frac{1}{2}$ " Flexible Plates are overlapped two holes on their long edges. The two compound plates so formed are curved to form a cylinder, and are bolted together so that they overlap each other one hole at each end. Four  $2\frac{1}{2}$ " small radius Curved Strips bolted together in a circle are attached to the cylinder by two Angle Brackets. The Bolt holding the upper Angle Bracket carries also a Flat Trunnion. The door is a Road Wheel fastened to a Double Bracket by a  $\frac{1}{2}$ " Bolt locked in the boss of the Road Wheel, and is carried on two 2" Strips, one of which is made from two  $1\frac{1}{2}$ " Strips. The 2" Strips are extended by Fishplates, which are pivotally attached to another Double Bracket by a lock-nutted  $\frac{3}{8}$ " Bolt. The breech is slid into position over the Boiler so that the horizontal  $3\frac{1}{2}$ " Rod passes through holes in the Flexible Plates. Bolts secure the breech to the Reversed Angle Brackets.

The recoil shock absorbing unit is built as follows. A  $1\frac{1}{2}$ " Flanged Wheel is fastened to the top hole of the  $1\frac{1}{2}$ " Strip by a  $\frac{3}{8}$ " Bolt locked in the boss of the Flanged Wheel. A  $2\frac{1}{2}$ " Cylinder is then pushed on the flange of this Wheel and another  $1\frac{1}{2}$ " Flanged Wheel is pushed in the other end of the Cylinder. A 3" Screwed Rod is then locked in the boss of this second Flanged Wheel and another  $2\frac{1}{2}$ " Cylinder is passed over this Rod, then a third Flanged Wheel (flange first), and finally a Collar is screwed on the protruding portion of the Screwed Rod by its tapped hole. This Collar tightens the Flanged Wheels up against the Cylinder. The Screwed Rod is then further fastened by another 3" Screwed Rod that is screwed in the remaining part of the tapped hole of the Collar. Two Sleeve Pieces joined together by a Chimney Adaptor are passed over this second Screwed Rod, which then passes through the top hole of the Flat Trunnion at the rear of the gun barrel. A Worm is then locked on the remaining portion of the Screwed Rod and holds the whole assembly in place.

The gun barrel is pivotally mounted on the chassis by passing Rods fitted with  $\frac{3}{8}$ " Flanged Wheels through the Trunnions and into the sides of the gun barrel as shown.

The elevation of the barrel is controlled by a screw mechanism. A "spider" from a Swivel Bearing is pivotally attached by a lock-nutted Bolt to the breech and carries a  $3\frac{1}{2}$ " Screwed Rod, which is joined by a Coupling to a 2" Rod, journalled in the double  $5\frac{1}{2}$ " Strips. A  $\frac{1}{2}$ " Pinion on the Rod meshes with a  $1\frac{1}{2}$ " Contrate Wheel operated by a hand wheel. The 4" Rod carrying the Contrate Wheel is free to turn in the longitudinal bore of a Coupling, which is held in place on the wheel axle by two Spring Clips and Washers.

The gun is loaded by pushing the Wheel Disc 2 and the missile 4 down the gun barrel with the ramrod until it catches the  $5\frac{1}{2}$ " Strip. The gun is fired by pulling the firing lanyard tied to one of the Trunnions 3. Pivot Bolt 1 pulls the  $5\frac{1}{2}$ " Strip out of contact with Wheel Disc 4, which ejects the missile with considerable force. The  $5\frac{1}{2}$ " Strip should not be bent up enough for the end to catch in the holes of the Wheel Disc, otherwise the firing mechanism will be difficult to release.

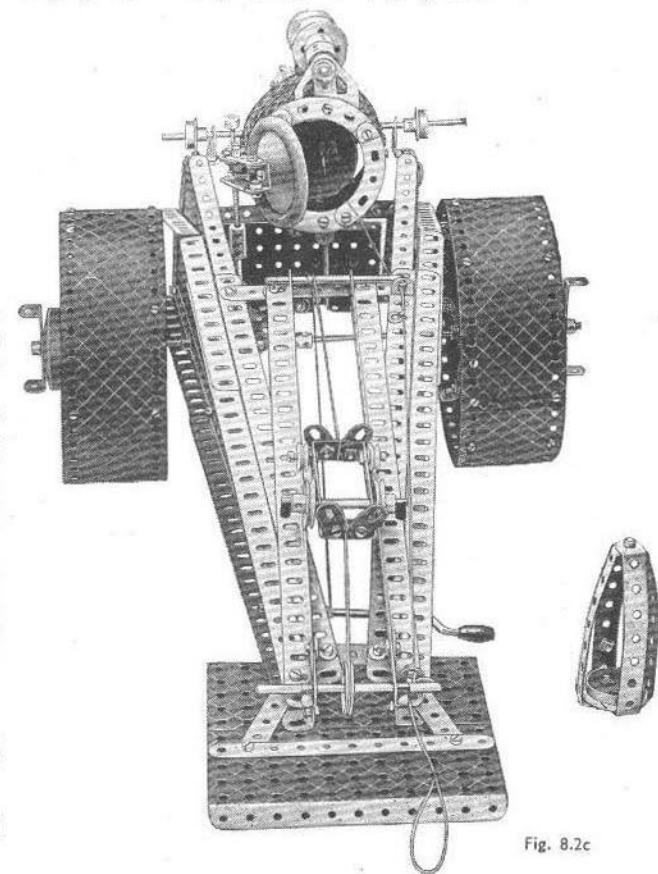
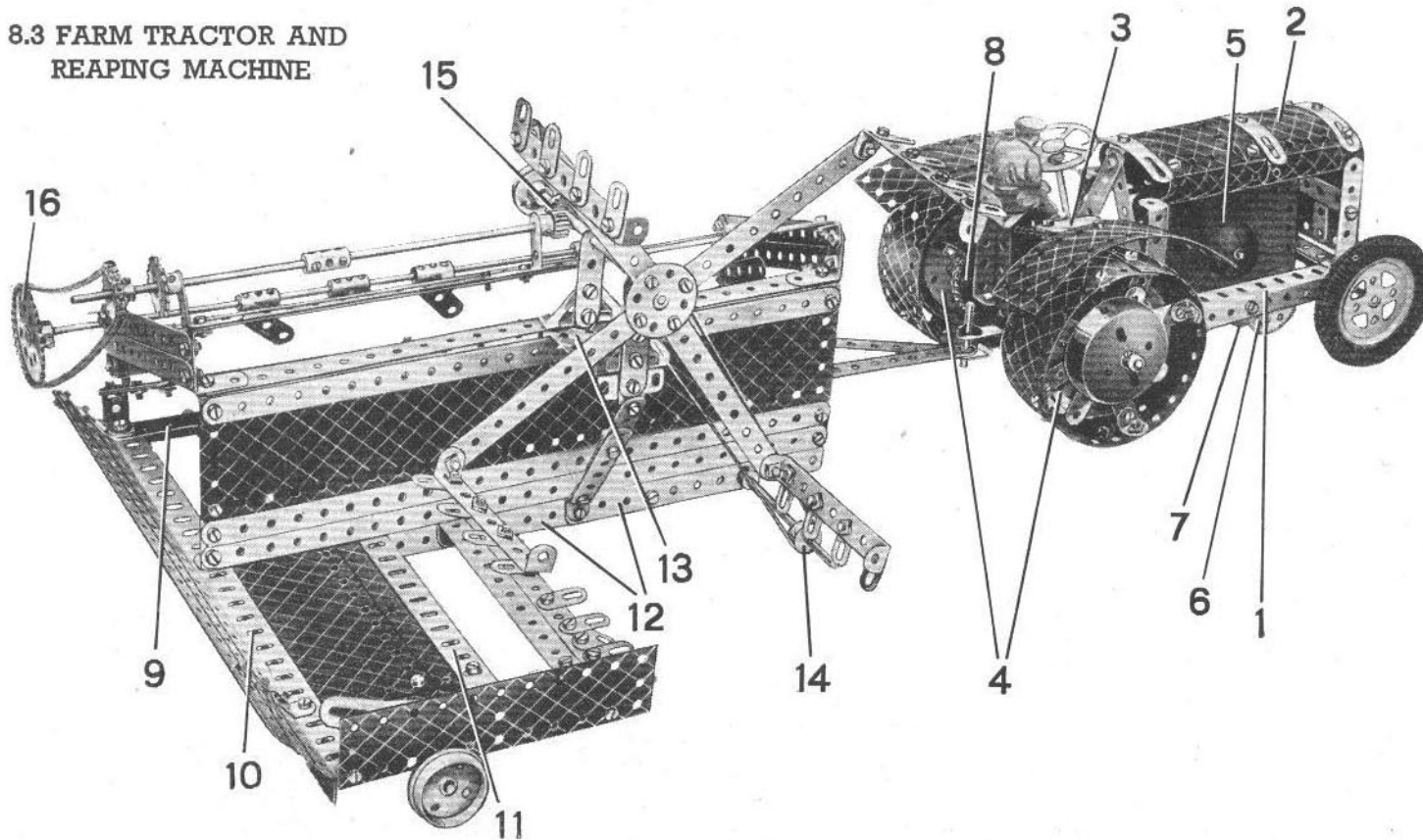

Fig. 8.2c

### 8.3 FARM TRACTOR AND REAPING MACHINE



One of the most ingenious machines now available for agricultural work is the reaping and binding machine. This machine automatically reaps and binds the corn into sheaves and is capable of doing in one hour an amount of work that would occupy a man working with ordinary tools for several days.

The illustration to the left shows the Meccano model reaper and binder complete with farm tractor. The tractor, an underneath view of which is shown in Fig. 8.3a is constructed first. The chassis for this consists of two  $5\frac{1}{2}$ " Angle Girders 1, joined at the front by a  $2\frac{1}{2}$ "  $\times$   $\frac{1}{2}$ " Double Angle Strip and at the rear by a  $3\frac{1}{2}$ "  $\times$   $2\frac{1}{2}$ " Flanged Plate. The Flanged Plate overlaps the Angle Girders two holes.

The Clockwork Motor, which is indicated at 5, is secured to the left-hand side member of the chassis by a  $1"$   $\times$   $\frac{1}{2}"$  and a  $\frac{1}{2}"$   $\times$   $\frac{1}{2}"$  Angle Bracket, the brake lever being at the rear. A  $\frac{1}{2}"$  Pinion on the driving shaft of the Motor meshes with a 57-teeth Gear carried on a  $1\frac{1}{2}"$  Rod journalled in the Motor side plates. A second  $\frac{1}{2}"$  Pinion 7, on the other end of the  $1\frac{1}{2}"$  Rod, meshes with a 57-teeth Gear 6 on a 2" Rod also journalled in the side plates of the Motor. The drive is taken from a  $\frac{3}{4}"$  Sprocket Wheel on the free end of the 2" Rod, to a 2" Sprocket Wheel on the rear axle by means of Sprocket Chain.

A  $6\frac{1}{2}"$  Rod is used for the rear axle, and its bearings are provided by the holes in the turned up ends of a  $2\frac{1}{2}"$   $\times$   $\frac{1}{2}"$  Double Angle Strip bolted across the  $3\frac{1}{2}"$   $\times$   $2\frac{1}{2}"$  Flanged Plate. The rim of each of the rear wheels is formed by two  $5\frac{1}{2}"$   $\times$   $1\frac{1}{2}"$  and one  $2\frac{1}{2}"$   $\times$   $1\frac{1}{2}"$  Flexible Plate, each overlapped one hole and secured to a 3" Pulley 4 by  $2\frac{1}{2}"$  Strips and Angle Brackets.

On its outer side each 3" Pulley carries a Crank, in the boss of which is locked a 1" Rod. A Boiler End representing a hub cap is slipped on the end of this Rod, and fastened in position by a Collar.

(Continued on next page)

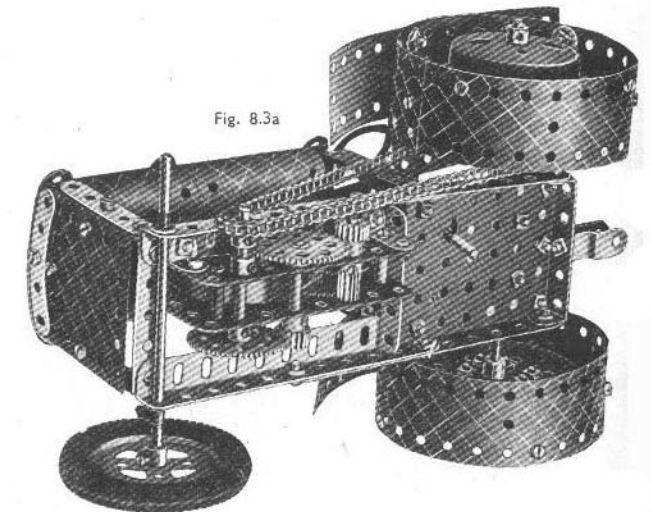

Fig. 8.3a

Parts required						
11 of No. 1	2 of No. 11	2 of No. 16	3 of No. 26	1 of No. 48c	1 of No. 96a	2 of No. 190
11 " " 2	17 " " 12	1 " " 17	2 " " 27a	2 " " 48d	6 " " 111c	1 " " 192
5 " " 2a	6 " " 12a	2 " " 18a	1 " " 29	1 " " 51	3 " " 126	6 " " 197
5 " " 3	2 " " 12b	2 " " 18b	6 " " 35	1 " " 53	2 " " 126a	2 " " 199
3 " " 4	7 " " 12c	2 " " 19b	187 " " 37	10 " " 59	2 " " 142a	5 " " 200
18 " " 5	1 " " 13	1 " " 20	6 " " 37a	2 " " 62	2 " " 162a	2 " " 212
2 " " 6	1 " " 13a	4 " " 20a	11 " " 38	5 " " 63	1 " " 163	4 " " 215
6 " " 6a	2 " " 14	2 " " 22	1 " " 44	1 " " 90	1 " " 185	
3 " " 8	4 " " 15	1 " " 23a	2 " " 48	1 " " 94	1 " " 186a	
4 " " 9	2 " " 15a	2 " " 24	9 " " 48a	2 " " 95	3 " " 188	
20 " " 10	2 " " 15b	3 " " 24a	6 " " 48b	2 " " 96	8 " " 189	

No. 1 Clockwork Motor. (Not included in Outfit)



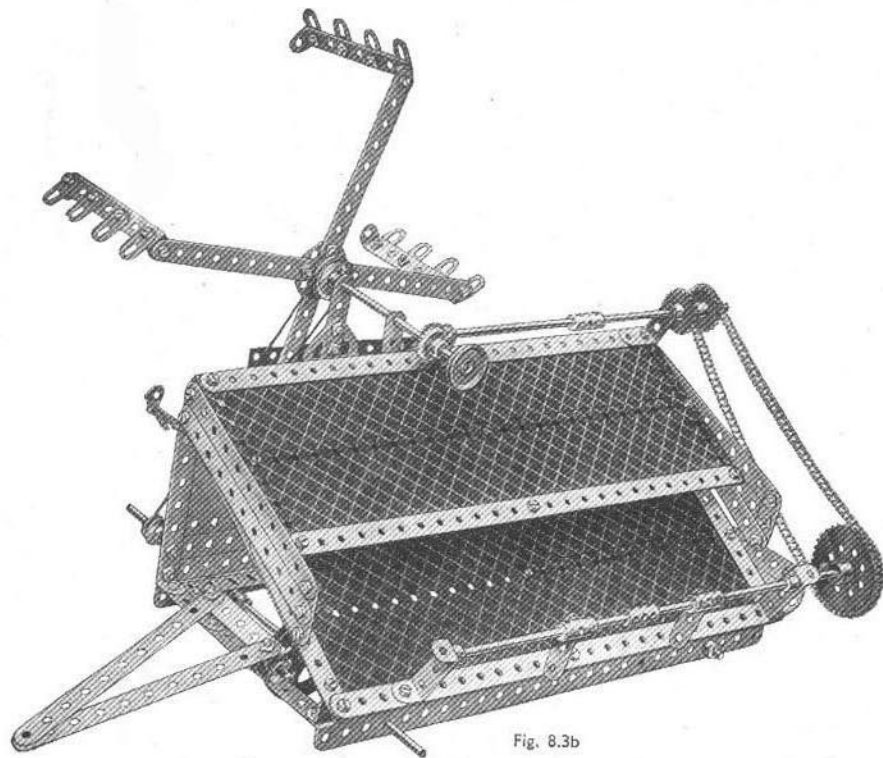

Fig. 8.3b

*Read the "Meccano Magazine" published monthly. Place a regular order with your Meccano dealer or newsagent to-day.*

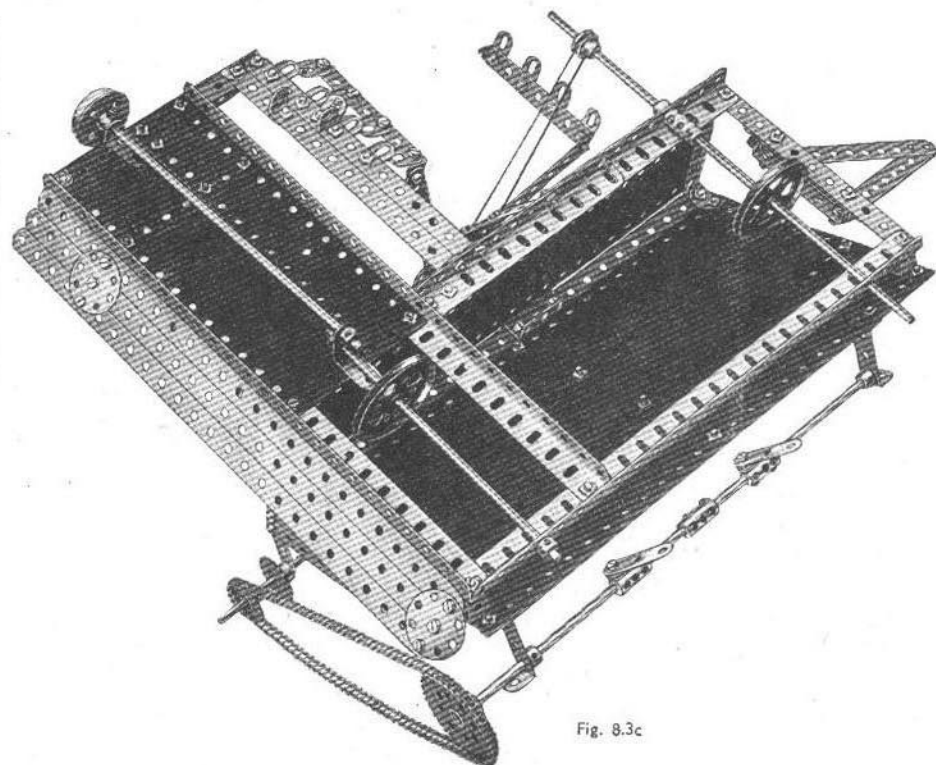

Fig. 8.3c

The flap, from under which the sheaves of corn are ejected, is represented by two 12½" Strip Plates bolted together with their long edges overlapping one hole. The flap is held in place by 1" x 1" Angle Brackets, and 12½" Strips are bolted along its edges.

The ½" Pinion 15 is fixed on the end of a compound rod, built up from two 4" Rods and journalled in the end holes of two 1" x 1" Angle Brackets seen in Fig. 8.3b. A 1" Sprocket Wheel on the end of the compound rod is connected by Sprocket Chain to a 2" Sprocket Wheel on the Rod carrying the ejectors, which are each constructed by bolting a 1½" Strip to a Coupling.

The Pinion 15 meshes with a ½" Contrate Wheel on the 5" Rod carrying the reaping blades. The bearings for the Rod are provided by a 2" Strip at the inner end, and a 2½" Strip at the outer end. Each of the Strips is secured by a Trunnion to the 2½" x 1½" Flanged Plate 13, which is bolted to the 12½" Strip joining the upper ends of the 3½" x ½" Double Angle Strips. The Flanged Plate 13 is also braced from the Angle Girder 12 by a 4" compound strip and two Obtuse Angle Brackets.

The rotating arms are 3½" x ½" Double Angle Strips, to each of which four Fishplates are bolted. The Double Angle Strips are attached by 4½" Strips to a Bush Wheel on the end of the 5" Rod. A 1" fast Pulley on this Rod is connected by a Driving Band to a ½" Pulley on the front axle of the reaper. This axle is formed by an 11½" Rod journalled in the Angle Girders 12 and 9, and it carries at its centre a 2" Pulley. A 1½" Flanged Wheel and a 2" Pulley are used for the rear wheels, and they are fixed on separate Rods as shown in Fig. 8.3c.

The reaper is attached to the tractor by passing a Rod through a Stepped Bent Strip at the back of the tractor, and also through the end holes of two 5½" Strips secured to the reaper.

*(Continued from previous page)*

The radiator is formed by a 2½" x 2½" Flexible Plate, which is secured by a 2½" x ½" Double Angle Strip and two 2½" Strips to the Double Angle Strip connecting the side members of the chassis. The bonnet is formed by three 1 11/16" radius Curved Plates 2, bolted over a 5½" x ½" Double Angle Strip, and extended round each side by two U-Section Curved Plates. The 5½" x ½" Double Angle Strip is fixed by one of its ends to the radiator and by its other end to two 2½" Strips, which are supported from the chassis by Angle Brackets and 2½" x ½" Double Angle Strips.

The construction of the reaper is commenced by joining two 12½" Angle Girders 10 and 11 by a 3½" Strip at one end, and at the other end by another 12½" Angle Girder 9. A compound girder consisting of two 5½" Angle Girders 12 is fastened to the two 12½" Angle Girders 10 and 11 by a 4½" Strip. The forward 5½" Angle Girder 12 and the 12½" Angle Girder 9 are joined at their free ends by a 5½" Strip. Three 12½" Strips, which are fixed together by two Wheel Discs, are fastened to the Angle Girder 10 by Obtuse Angle Brackets.

The 12½" Strips and the 12½" Strip Plate, which are shown in the main illustration forming the side of the enclosed part of the machine, are supported at each end by a 3½" x ½" Double Angle Strip. The upper ends of the Double Angle Strips are joined by a 12½" Strip, the Bolts holding also two Obtuse Angle Brackets, which are secured by compound strips to two Double Brackets, fixed one at each end of the Angle Girder 9. Each of the compound strips consists of a 5½" and a 1½" Strip secured end to end, and the space between them is filled by three 12½" Strip Plates.

### 8.4 MILITARY TANK

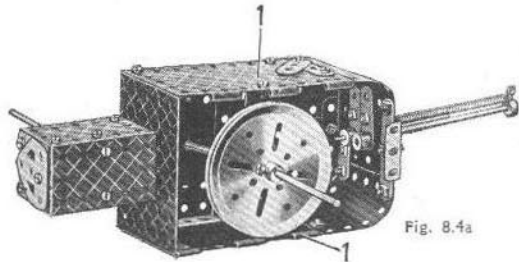
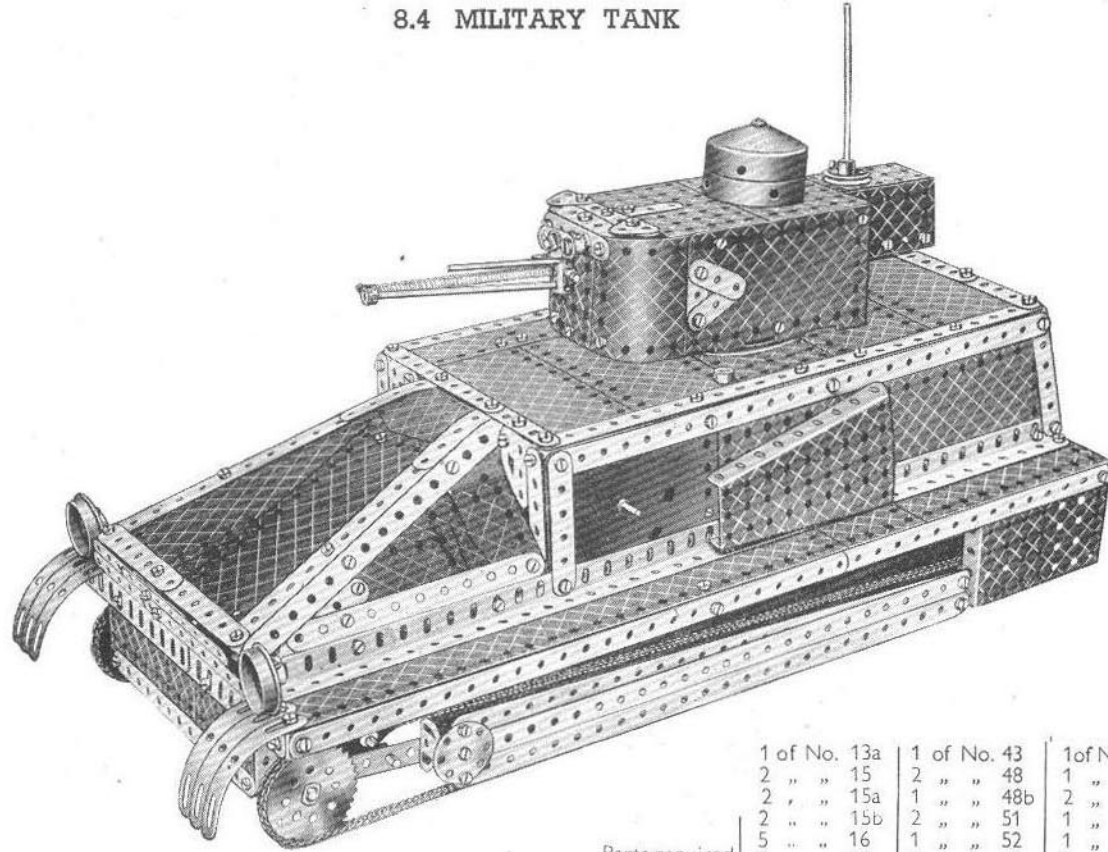

Fig. 8.4a

	1 of No. 13a	1 of No. 43	1 of No. 155
	2 " " 15	2 " " 48	1 " " 160
	2 " " 15a	1 " " 48b	2 " " 162a
	2 " " 15b	2 " " 51	1 " " 163
	5 " " 16	1 " " 52	1 " " 164
	2 " " 17	5 " " 53	1 " " 186b
	14 of No. 1	1 " " 54	1 " " 187a
	15 " " 2	1 " " 59	7 " " 188
	6 " " 2a	2 " " 62	7 " " 189
	5 " " 3	4 " " 63	9 " " 190
	5 " " 4	2 " " 77	2 " " 191
	16 " " 5	1 " " 80a	12 " " 192
	2 " " 6	1 " " 94	5 " " 197
	6 " " 6a	2 " " 95	1 " " 198
	10 " " 8	2 " " 96	1 " " 212
	4 " " 9	3 " " 111	6 " " 215
	4 " " 10	2 " " 111a	1 " " 216
	28 " " 12	2 " " 111c	1 No. 1 Clock-
	1 " " 12a	192 " " 37	work Motor. (Not
	2 " " 12b	9 " " 37a	included in Outfit).
	8 " " 12c	17 " " 38	4 " " 126a
		1 " " 147b	

The side members of the chassis each consist of two 12½" Angle Girders overlapped 11 holes and bolted in the third hole from each end of two 9½" compound angle girders. A 12½"×2½" Strip Plate overlaps a 5½"×2½" Flexible Plate by five holes, and a compound plate of this kind is then bolted to each side member one hole from the rear end. A 5½"×1½" Flexible Plate overlapping four holes, extends the 12½"×2½" Strip Plate to the front. Two 12½" Angle Girders extended by 5½" Strips are bolted one to each lower edge of the 12½"×2½" Strip Plates and 5½"×2½" Flexible Plates, and 2½" Strips bolted to the end of the upper Angle Girders are also attached to the 5½" Strips.

At the front end of the side members a 5½" Strip is bolted in the fourth hole from the front end of each 12½"×2½" Strip Plate and is sloped upward slightly and attached to a 2" Strip. The upper edges of the Flexible Plates at the rear of the tank are clamped between the 5½" Angle Girders spacing the rear of the chassis and two 5½" Strips that overlap each other by nine holes. The Bolts holding these Strips carry also a 5½"×1½" Flexible Plate and a 2½"×2½" Flexible Plate overlapped three holes.

The superstructure is carried on two side members, which are made by overlapping 12½" Angle Girders by 11 holes. On the rear side of the model a 12½"×2½" Strip Plate is bolted to the side member. A 3½" Rod fitted at one end with a Rod and Strip Connector, and at the other end with a Collar, passes through one of the Flexible Plates of the top, and is lock-nutted to the brake lever of the Clockwork Motor.

The rear end of the body is completed by bolting a 2½"×2½" and a 5½"×2½" Flexible Plate to a compound strip and attaching the unit to the top by Angle Brackets. The sloping front is now added and reference to the illustrations will make this part of the construction clear.

A 1½" Flanged Wheel is screwed on to the shank of a ¼" Bolt, the set-screw being tightened so that the Flanged Wheel is locked in place.

The exhaust unit, part of which can be seen in Fig. 8.4b, is built by pushing the flange of a Flanged Wheel into the end of a 2½" Cylinder, which is then bolted to the chassis. A large Crank Handle carries a Collar and a Sleeve Piece fitted with a Chimney Adaptor. A 1" Pulley fitted with a Rubber Ring clamps the Sleeve Piece in place, and the shaft of the Crank Handle is passed through the 2½" Cylinder and is locked in the boss of the Flanged Wheel.

The sides of the revolving gun turret consist of two flat plates 1, obtained by removing the centre pin from a Hinged Flat Plate. The plates are joined at the rear and upper edges by 3½"×2½" Flanged Plates. The method of arranging the gun will be clear from Fig. 8.4a. A 1½" Strip fitted with an Angle Bracket is held by a Collar against the head of a Pivot Bolt, the latter being lock-nutted to the upper 2½" Strip. When the Coupling is pulled backwards into the loaded position the 1½" Strip engages with the Coupling. A 3½"×½" Double Angle Strip is bolted in the centre holes of the flat plates and is fitted with a Bush Wheel, in the boss of which is secured a 4" Rod that carries two Spring Clips and a 3" Pulley.

Additional Sprocket Chain to that supplied with the Outfit is required to make the creeper tracks on which the model runs, but as the model functions satisfactorily without them, the tracks may be omitted if necessary.

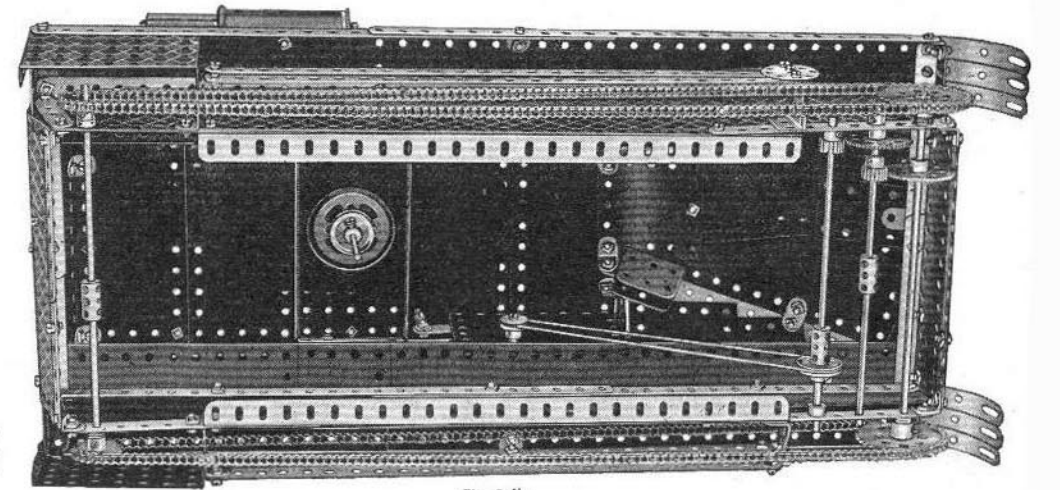

Fig. 8.4b

### 8.5 GRABBING CRANE

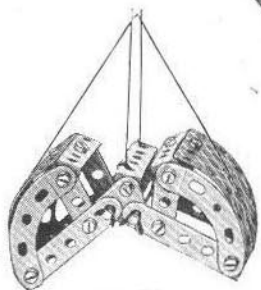
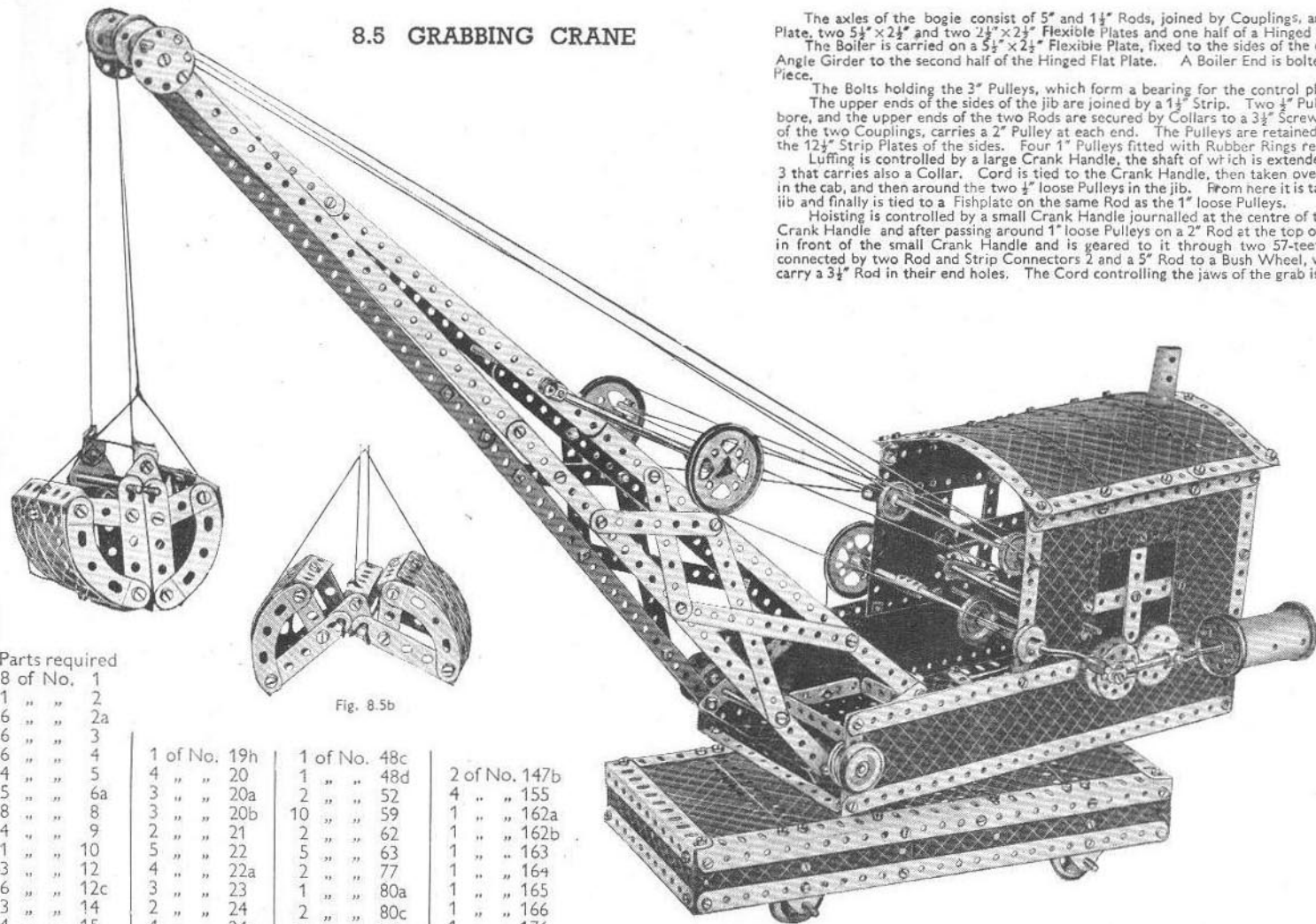

Fig. 8.5b

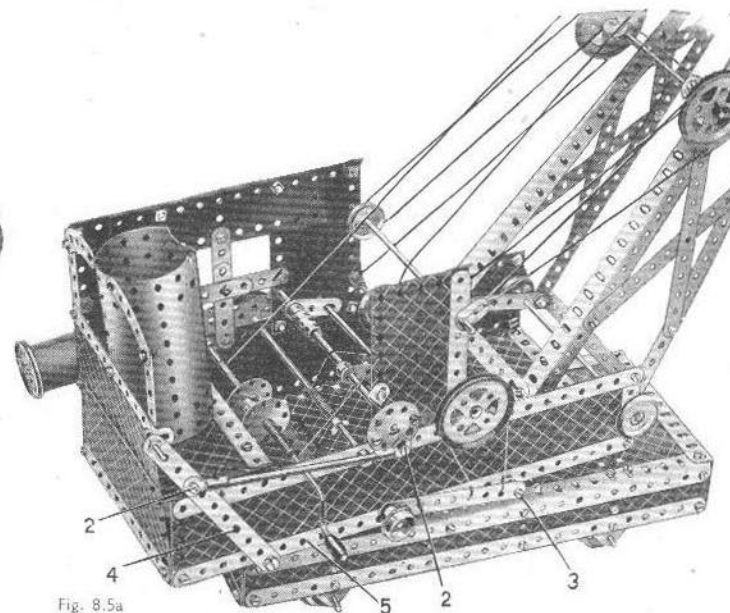

Fig. 8.5a

Parts required			
8 of No.	1		
1 " "	2		
6 " "	2a		
6 " "	3		
26 " "	4		
14 " "	5		
5 " "	6a		
8 " "	8		
4 " "	9		
1 " "	10		
13 " "	12		
6 " "	12c		
3 " "	14		
4 " "	15		
4 " "	15a		
1 " "	15b		
4 " "	16		
4 " "	17		
2 " "	18a		
2 " "	19b		
1 " "	19g		
1 of No.	19h	1 of No.	48c
4 " "	20	1 " "	48d
3 " "	20a	2 " "	52
3 " "	20b	10 " "	59
2 " "	21	2 " "	62
5 " "	22	5 " "	63
4 " "	22a	2 " "	77
3 " "	23	1 " "	80a
2 " "	24	2 " "	80c
4 " "	24a	2 " "	90
2 " "	27a	4 " "	90a
15 " "	35	2 " "	111
186 " "	37	6 " "	111a
18 " "	37a	6 " "	111c
26 " "	38	12 " "	192
2 " "	40	2 " "	197
5 " "	48a	4 " "	198
4 " "		1 " "	
4 of No.	200	2 of No.	147b
2 " "	212	4 " "	155
1 " "	216	1 " "	162a
		1 " "	162b
		1 " "	163
		1 " "	164
		1 " "	165
		1 " "	166
		1 " "	176
		7 " "	188
		8 " "	189
		2 " "	190
		4 " "	191
		12 " "	192
		2 " "	197
		1 " "	198

The axles of the bogie consist of 5" and 1½" Rods, joined by Couplings, and are journalled in Flat Trunnions. The floor of the cab is made from a 5½" x 2½" Flanged Plate, two 5½" x 2½" and two 2½" x 2½" Flexible Plates and one half of a Hinged Flat Plate.

The Boiler is carried on a 5½" x 2½" Flexible Plate, fixed to the sides of the cab by a 5½" x ½" Double Angle Strip. The front edge of the Flexible Plate is fastened by a 5½" Angle Girder to the second half of the Hinged Flat Plate. A Boiler End is bolted underneath the roof by the same Bolt that holds the Chimney Adaptor carrying the Sleeve Piece.

The Bolts holding the 3" Pulleys, which form a bearing for the control platform, carry Collars on their shanks between the faces of the Pulleys and the Plates. The upper ends of the sides of the jib are joined by a 1½" Strip. Two ½" Pulleys are each fastened by a ¾" Bolt to a Coupling, which carries a 4½" Rod in its longitudinal bore, and the upper ends of the two Rods are secured by Collars to a 3½" Screwed Rod passing through the sides of the jib. A 5" Rod journalled in the lower transverse bores of the two Couplings, carries a 2" Pulley at each end. The Pulleys are retained in position by Spring Clips. The jib is pivoted at its base on a 6½" Rod, which passes through the 12½" Strip Plates of the sides. Four 1" Pulleys fitted with Rubber Rings retain the Rod in position.

Luffing is controlled by a large Crank Handle, the shaft of which is extended by a 2" Rod. This Rod is controlled by a band brake, the lever of which is pivoted on a Bolt 3 that carries also a Collar. Cord is tied to the Crank Handle, then taken over one of two 2" Pulleys attached to the jib as shown, around a 1" loose Pulley on the 6½" Rod in the cab, and then around the two ½" loose Pulleys in the jib. From here it is taken around the second 1" loose Pulley in the cab, back around the remaining 2" Pulley in the jib and finally is tied to a Fishplate on the same Rod as the 1" loose Pulleys.

Hoisting is controlled by a small Crank Handle journalled at the centre of the cab, the shaft of the Crank Handle being extended by a 3½" Rod. Two Cords are tied to the Crank Handle and after passing around 1" loose Pulleys on a 2" Rod at the top of the jib, they are attached to a 2½" x ½" Double Angle Strip on the grab. A 6½" Rod is journalled in front of the small Crank Handle and is geared to it through two 57-teeth Gears. Grabbing is controlled by a 5½" Strip 4. The Strip is pivoted at its lower end and is connected by two Rod and Strip Connectors 2 and a 5" Rod to a Bush Wheel, which is locked on the end of a 6½" compound rod. Two Cranks are fixed on this rod and they carry a 3½" Rod in their end holes. The Cord controlling the jaws of the grab is tied to the 6½" Rod previously mentioned, and then is threaded over the 6½" compound rod and under the 3½" Rod. It is then taken over a ½" loose Pulley on the 2" Rod at the jib-head and tied to the two Cords fastened to the jaws of the grab. When the Strip 4 is moved backwards the grab operating Cord is depressed by the 3½" Rod, and as a result the grab opens.

8.6 FIRE-ENGINE

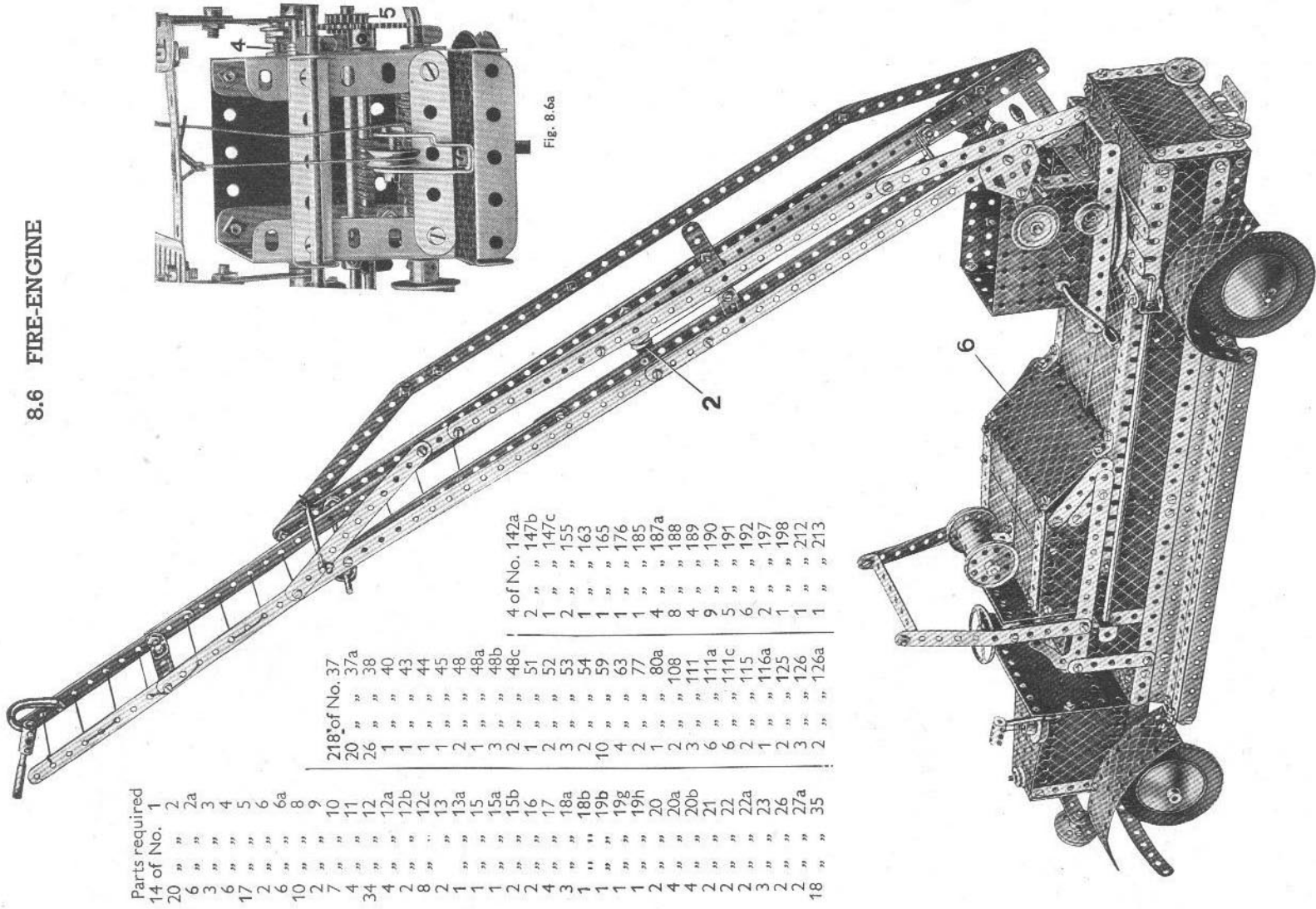

Parts required

14 of No. 1	218 of No. 37
20 " 2	20 " 37a
6 " 3	26 " 38
6 " 4	1 " 40
17 " 5	1 " 43
6 " 6	1 " 44
6 " 6a	1 " 45
10 " 8	2 " 48
2 " 9	1 " 48a
7 " 10	3 " 48b
4 " 11	2 " 48c
4 " 12	1 " 51
34 " 12a	2 " 52
2 " 12b	3 " 53
8 " 12c	2 " 54
2 " 13	10 " 59
2 " 13a	1 " 63
1 " 15	4 " 77
1 " 15a	2 " 80a
1 " 15b	1 " 108
2 " 16	3 " 111
4 " 17	6 " 111a
3 " 18a	2 " 111c
1 " 18b	2 " 115
1 " 19b	1 " 116a
1 " 19g	2 " 125
1 " 19h	3 " 126
2 " 20	2 " 126a
4 " 20a	1 " 142a
4 " 20b	2 " 147b
2 " 21	1 " 147c
2 " 22	2 " 155
2 " 22a	2 " 163
3 " 23	1 " 165
2 " 26	1 " 176
2 " 27a	1 " 185
18 " 35	4 " 187a
	8 " 188
	4 " 189
	9 " 190
	5 " 191
	6 " 192
	2 " 197
	1 " 198
	1 " 212
	1 " 213

Fig. 8.6a

The chassis consists of a 5 1/2" x 2 1/2" Flanged Plate, extended to the rear by two 12 1/2" Angle Girders joined at their free ends by a 5 1/2" Strip. Two side members, each formed by a 12 1/2" and a 5 1/2" Angle Girder, are secured to two 5 1/2" Strips bolted across the main member of the chassis by Angle Brackets. The bonnet is constructed by joining the flanges of two Flanged Sector Plates by means of 4 1/2" x 2 1/2" Flexible Plates, the lower Flanged Sector Plate being bolted in position to the 5 1/2" x 2 1/2" Flanged Plate forming the forward end of the chassis.

The radiator is a 2 1/2" x 1 1/2" Flanged Plate fixed between the narrow ends of the Flanged Sector Plates by a 3 1/2" Screwed Rod. The latter carries at its upper end a 3/8" loose Pulley representing the radiator cap. Two 1 1/2" Flanged Wheels are used for the headlights, and each is secured by a 1/2" Bolt in the end hole of a 3 1/2" compound strip, consisting of two 2 1/2" Strips overlapped three holes and bolted across the centre of the radiator. Two Reversed Angle Brackets fixed at the lower end of the radiator form the supports for the front bumper, which is made from two 5 1/2" Strips overlapped five holes and curved backward slightly at each end.

Two 4 1/2" x 2 1/2" Flexible Plates overlapped three holes are used for the front of the cab and are secured to the sides of the bonnet by two 1" x 1" Angle Brackets. A Rod and Strip Connector carrying a 1 1/2" Rod is bolted to the upper Flexible Plate in the position shown in Fig. 8.6c, the 1 1/2" Rod having a Coupling locked on its end. A 3/8" Flanged Wheel representing a gong is suspended by Cord from the free end of the Coupling. The floor is formed by two 2 1/2" x 2 1/2" Flexible Plates fastened between the side members of the chassis.

Each side of the body of the fire-engine consists of three 5 1/2" x 2 1/2" Flexible Plates bolted to a side member of the chassis. Two 12 1/2" Angle Girders are bolted along the upper edges of the sides, and the space between them is filled in by two 12 1/2" Strip Plates. The pump behind the driving seat is built up from Flexible Plates of various sizes held in position by Angle Brackets. The flat plate 6 is obtained by removing the centre pin from a Hinged Flat Plate.

The front wheel leaf springs are each constructed from a 2 1/2", a 3 1/2", and a 4 1/2" Strip, secured together by a Bolt and fastened to the 5 1/2" x 2 1/2" Flanged Plate of the chassis by Angle Brackets. The 2" Pulleys are held loosely on 1 1/2" Rods fastened in the bosses of two small Fork Pieces, one of which is obtained by loosening the set-screws of a Swivel Bearing and removing the "spider." The Pulleys are fitted with Rubber Tyres, and Conical Discs are secured against their outer faces by Collars. The two Fork Pieces are fastened by Pivot Bolts to two Couplings, which in turn are fastened to the leaf springs.

(Continued on next page)

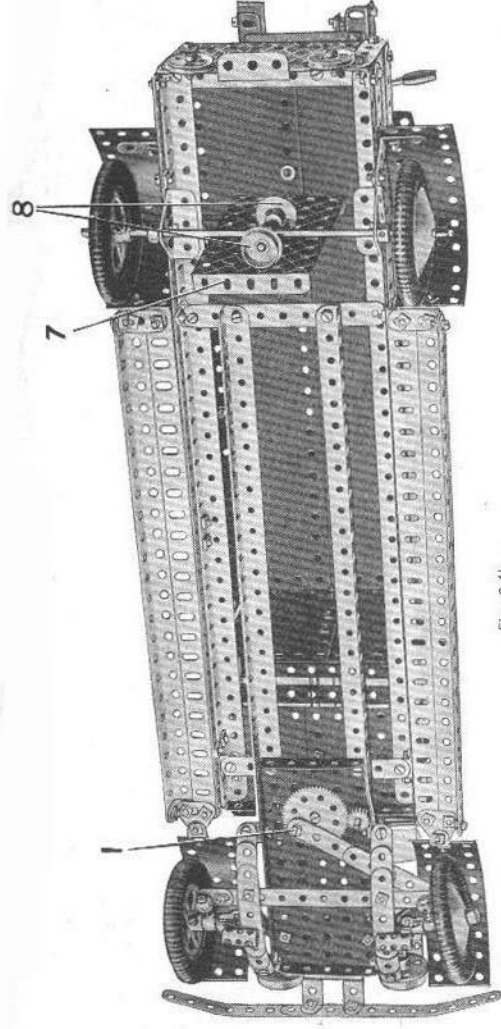

Fig. 8.6b

*Continued from previous page*

Each of the Fork Pieces carries also a  $\frac{3}{4}$ " Bolt fitted with a Collar, in one of the tapped holes of its boss. The two Collars are joined by a compound strip, consisting of a  $5\frac{1}{2}$ " Strip and a Fishplate, the lower Bolt (see Fig. 8.6b) carrying also a 4" strip formed by a 3" and a  $1\frac{1}{2}$ " Strip. The free end of the  $1\frac{1}{2}$ " strip is secured by a lock-nutted Bolt 1 to a 57-teeth Gear, loosely held on a  $\frac{3}{8}$ " Bolt fastened to the  $5\frac{1}{2}$ " x  $2\frac{1}{2}$ " Flanged Plate. The 57-teeth Gear meshes with a  $\frac{3}{8}$ " Pinion at the lower end of the 5" Rod representing the steering column. At its upper end this Rod carries a Steering Wheel, and it is journalled in an Angle Bracket bolted to the front of the cab.

The rear axle, an 8" Rod, is journalled in the holes at the narrow ends of two Trunnions bolted to the sides of the body. It carries at each end a 2" Pulley fitted with Rubber Tyre and Conical Disc, and in the centre a Collar. A Threaded Pin, on the plain shank of which is locked a  $\frac{3}{4}$ " Flanged Wheel 8, is screwed into each tapped hole of the Collar. A  $3\frac{1}{2}$ " x  $2\frac{1}{2}$ " Flanged Plate 7 is suspended by Cord in such a position that as the rear axle revolves the two Flanged Wheels 8 strike the centre of it, thus providing an automatic gong.

A view of the ladder base is shown in Fig. 8.6a. This is built up by fastening two  $3\frac{1}{2}$ " x  $2\frac{1}{2}$ " Flanged Plates to a  $5\frac{1}{2}$ " x  $2\frac{1}{2}$ " Flanged Plate by  $3\frac{1}{4}$ " x  $\frac{1}{2}$ " Double Angle Strips. The front flanges of the two smaller Plates are joined by a  $2\frac{1}{2}$ " x  $2\frac{1}{2}$ " Flexible Plate, and the rear flanges by a  $2\frac{1}{2}$ " Strip and a  $2\frac{1}{2}$ " x  $\frac{1}{2}$ " Double Angle Strip. A 3" Pulley fastened underneath the base by two  $\frac{3}{8}$ " Bolts, carries in its boss a Rod, which passes through the platform of the fire-engine and is secured below it by a Collar.

The fixed ladder consists of two  $12\frac{1}{2}$ " Angle Girders joined at each end by a 3" Strip, and extended upwards by two  $12\frac{1}{2}$ " Strips. The guard rails for the fixed ladder each consist of a  $12\frac{1}{2}$ " Strip and three  $5\frac{1}{2}$ " Strips secured at each end to the sides of the ladder. Two  $1\frac{1}{4}$ " x  $\frac{1}{2}$ " Double Angle Strips are placed midway up the fixed ladder, and two Fishplates 3 are bolted to them, but spaced from them by two Washers.

The extending ladder, which slides between the Double Angle Strips and the Fishplates, consists of two compound strips joined at the top and bottom by 2" Strips and Angle Brackets. Each of the compound strips is formed by two  $12\frac{1}{2}$ " Strips and one  $5\frac{1}{2}$ " Strip bolted end to end. The rungs of the extending ladder are represented by Cord threaded through the holes in the Strips forming the sides of the ladder. The nozzle at the top of the ladder is constructed by fastening a 1" Rod in the central bore of a Coupling. The Rod carries a Rod Connector at its end, and a Spring, secured in position as shown in Fig. 8.6c, is used for the hosepipe.

The mechanism for controlling the angle of the ladder, and also the raising and lowering of the extension ladder, is situated in the base. A Large Crank Handle, journalled in the forward end of the two  $3\frac{1}{2}$ " x  $2\frac{1}{2}$ " Flanged Plates, carries at its end a  $\frac{1}{2}$ " Pinion 5. This meshes with a 57-teeth Gear on a  $3\frac{1}{2}$ " Rod also journalled in the side plates of the base. Cord is attached to the  $3\frac{1}{2}$ " Rod by means of a Cord Anchoring Spring then taken around a  $\frac{3}{8}$ " loose Pulley, and finally tied to the 3" Strip at the bottom of the fixed ladder (Fig. 8.6a). The  $\frac{1}{2}$ " loose Pulley is held on a  $\frac{3}{8}$ " Bolt passed through the arms of a Stepped Bent Strip bolted to the base.

To prevent the ladder slipping back when raised, a Pawl engages the  $\frac{1}{2}$ " Pinion 5. The Pawl is held loosely by lock-nuts at the end of the  $\frac{1}{2}$ " Bolt 4, which is fastened to the right-hand side of the base in such a position that the end of the Pawl just rests on the top of the Pinion.

The extending ladder is controlled by a small Crank Handle journalled in the rear of the base side plates and carrying at its end a  $\frac{3}{4}$ " Flanged Wheel, which is seen in Fig. 8.6c. Cord is tied to the shaft of the Crank Handle, wound around it several times and then taken over the  $\frac{1}{2}$ " loose Pulley 2 to be tied to the bottom of the extending ladder.

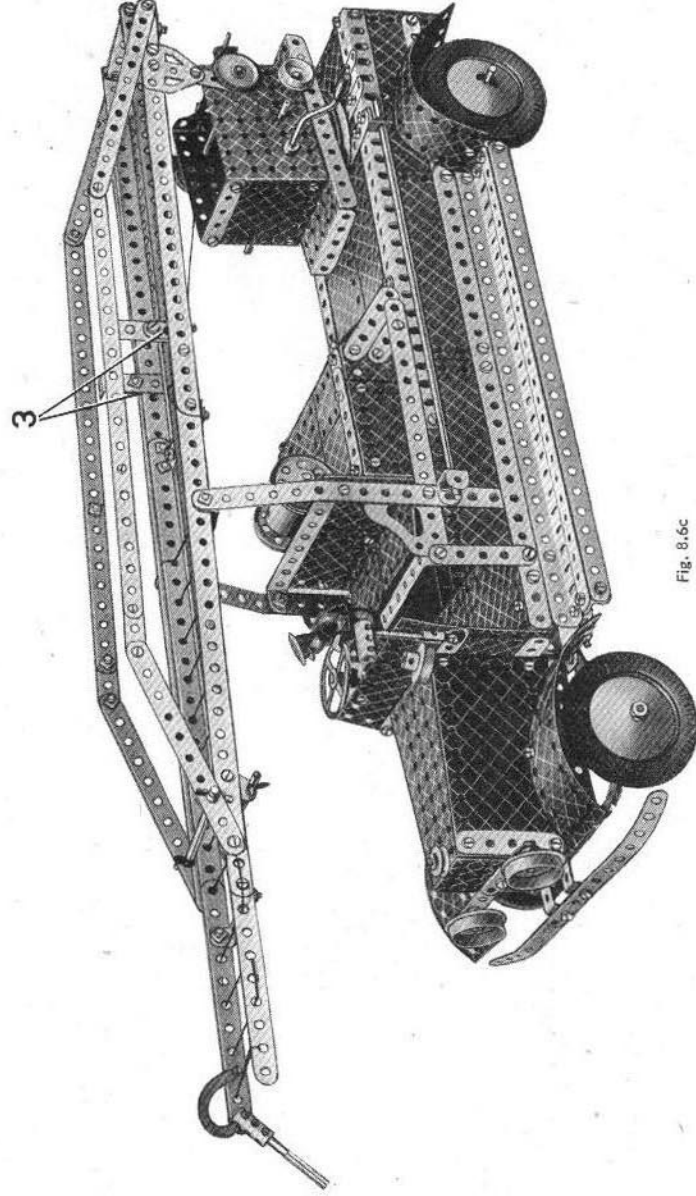
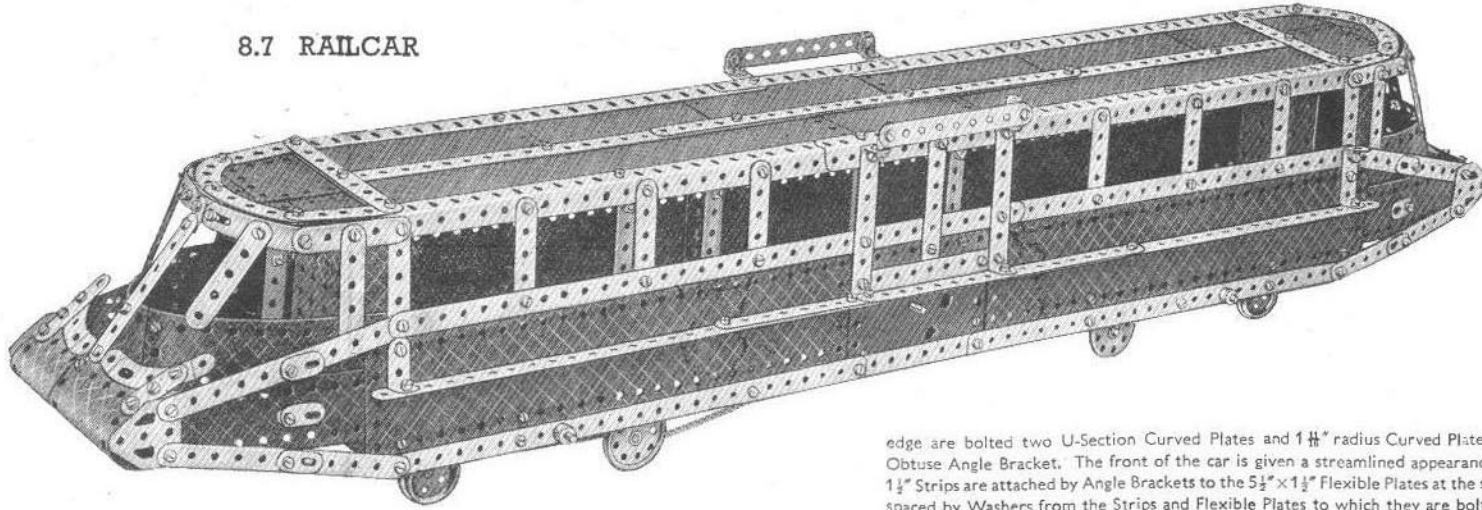

Fig. 8.6c

## 8.7 RAILCAR



The side members of the chassis are each built up from two  $12\frac{1}{2}$ " Angle Girders and one  $5\frac{1}{2}$ " Angle Girder, and are joined at their ends by  $5\frac{1}{2}$ " Angle Girders. The sides of the car are similar in construction, except that in the side not shown in the main illustration, the Motor is replaced by a  $5\frac{1}{2}$ "  $\times$   $2\frac{1}{2}$ " Flexible Plate. The sides are secured to the chassis by  $2\frac{1}{2}$ " and  $5\frac{1}{2}$ " Strips, and a rail is fastened along each of them. The rails are each built up from three  $12\frac{1}{2}$ " Strips overlapped eight holes, and are secured in position at the forward end by  $1\frac{1}{2}$ "  $\times$   $\frac{1}{2}$ " Double Angle Strips, and at the rear by  $1$ "  $\times$   $\frac{1}{2}$ " Angle Brackets.

The ends of the railcar are similar in construction, so that a description of one will suffice. Two  $5\frac{1}{2}$ "  $\times$   $1\frac{1}{2}$ " Flexible Plates are bolted to the sides of the car, and joined at their forward edges by a  $2\frac{1}{2}$ "  $\times$   $1\frac{1}{2}$ " Flexible Plate. Two more  $5\frac{1}{2}$ "  $\times$   $1\frac{1}{2}$ " Flexible Plates are secured to the sides by  $5\frac{1}{2}$ " Strips as shown in the illustration, the Bolts holding also two Flat Trunnions. A  $4\frac{1}{2}$ "  $\times$   $2\frac{1}{2}$ " Flexible Plate is fastened by Angle Brackets underneath each end, and to its forward edge of the Curved Plates are attached to the  $2\frac{1}{2}$ "  $\times$   $1\frac{1}{2}$ " Flexible Plate by an

Obtuse Angle Bracket. The front of the car is given a streamlined appearance by two small radius Curved Strips, fastened by  $1\frac{1}{2}$ " Strips to the U-Section Curved Plates. The  $1\frac{1}{2}$ " Strips are attached by Angle Brackets to the  $5\frac{1}{2}$ "  $\times$   $1\frac{1}{2}$ " Flexible Plates at the sides of the nose. The three louvres at each side of the nose are represented by Fishplates spaced by Washers from the Strips and Flexible Plates to which they are bolted.

The  $5\frac{1}{2}$ " Strips holding the sides in position, serve also to support the frame of the roof, which consists of two compound girders similar to those used in the chassis, joined at each end by a  $4\frac{1}{2}$ " Strip. The roof is divided down the middle by a compound strip built up from three  $12\frac{1}{2}$ " Strips, and one half is filled in by two  $12\frac{1}{2}$ "  $\times$   $2\frac{1}{2}$ " Strip Plates and one  $4\frac{1}{2}$ "  $\times$   $2\frac{1}{2}$ " Flexible Plate. The other side is filled in by five  $5\frac{1}{2}$ "  $\times$   $2\frac{1}{2}$ " Flexible Plates and one  $2\frac{1}{2}$ "  $\times$   $2\frac{1}{2}$ " Flexible Plate. The roof is extended at each end by a  $2\frac{1}{2}$ "  $\times$   $2\frac{1}{2}$ " and a  $2\frac{1}{2}$ "  $\times$   $1\frac{1}{2}$ " Flexible Plate and a Semi-Circular Plate, and is rimmed with two  $2\frac{1}{2}$ " Strips and two large radius Curved Strips. The curved front of the roof is represented by  $2\frac{1}{2}$ " Strips and  $3$ " Formed Slotted Strips, the latter being connected at the front by two Obtuse Angle Brackets. The Bolt joining the two Obtuse Angle Brackets holds also a third Obtuse Angle Bracket that is fastened by a  $3\frac{1}{2}$ " Strip to the front of the nose.

The indicator boards at each side of the roof are formed by  $4\frac{1}{2}$ " Strips, each secured by Angle Brackets to the ends of two  $3\frac{1}{2}$ "  $\times$   $\frac{1}{2}$ " Double Angle Strips bolted to the sides of the car.

Each bogie is a  $5\frac{1}{2}$ "  $\times$   $2\frac{1}{2}$ " Flanged Plate, to the centre of which are bolted two Trunnions to receive the  $6\frac{1}{2}$ " Rod on which the bogie pivots. The four wheels are held on the ends of  $3\frac{1}{2}$ " Rods passed through the ends of the Flanged Plates, and are represented by  $1\frac{1}{2}$ " Flanged Wheels, Bush Wheels and  $1\frac{1}{2}$ " Pulleys arranged as shown in Fig. 8.7a.

A  $\frac{1}{2}$ " Pinion on the driving shaft of the Motor meshes with a 57-teeth Gear on a  $2$ " Rod journalled in the Motor side plates, the Rod carrying also a  $\frac{1}{2}$ " Sprocket Wheel that is connected by Chain to a  $1$ " Sprocket Wheel on the rear axle of the front bogie.

## Parts required

14 of No. 1	2 of No. 21	1 of No. 111c
20 " " 2	2 " " 24	4 " " 126
6 " " 2a	1 " " 26	4 " " 126a
4 " " 3	1 " " 27a	1 " " 166
5 " " 4	1 " " 35	8 " " 188
18 " " 5	209 " " 37	8 " " 189
4 " " 6a	1 " " 37a	3 " " 190
10 " " 8	26 " " 38	3 " " 191
4 " " 9	2 " " 48	6 " " 192
16 " " 10	4 " " 48b	6 " " 197
18 " " 12	2 " " 52	2 " " 199
2 " " 12b	2 " " 53	2 " " 200
6 " " 12c	10 " " 59	2 " " 214
2 " " 14	4 " " 90	4 " " 215
1 " " 15	4 " " 90a	No. 1 Clock-work
4 " " 16	1 " " 94	Motor.
1 " " 17	1 " " 96	(Not included in Outfit).
4 " " 20	1 " " 96a	

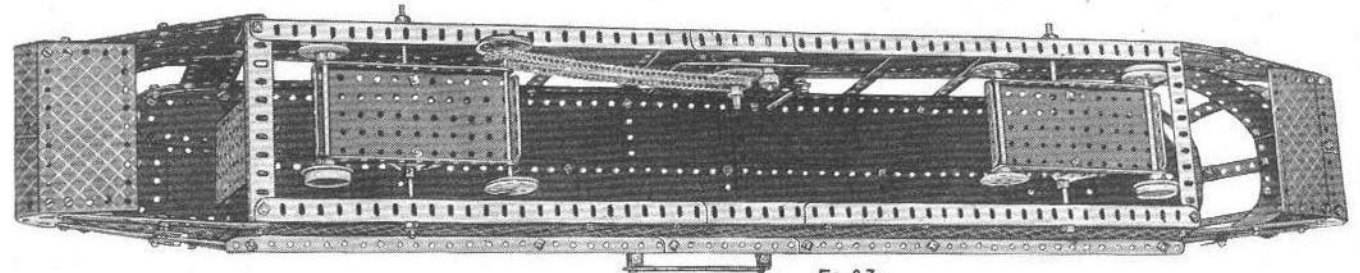
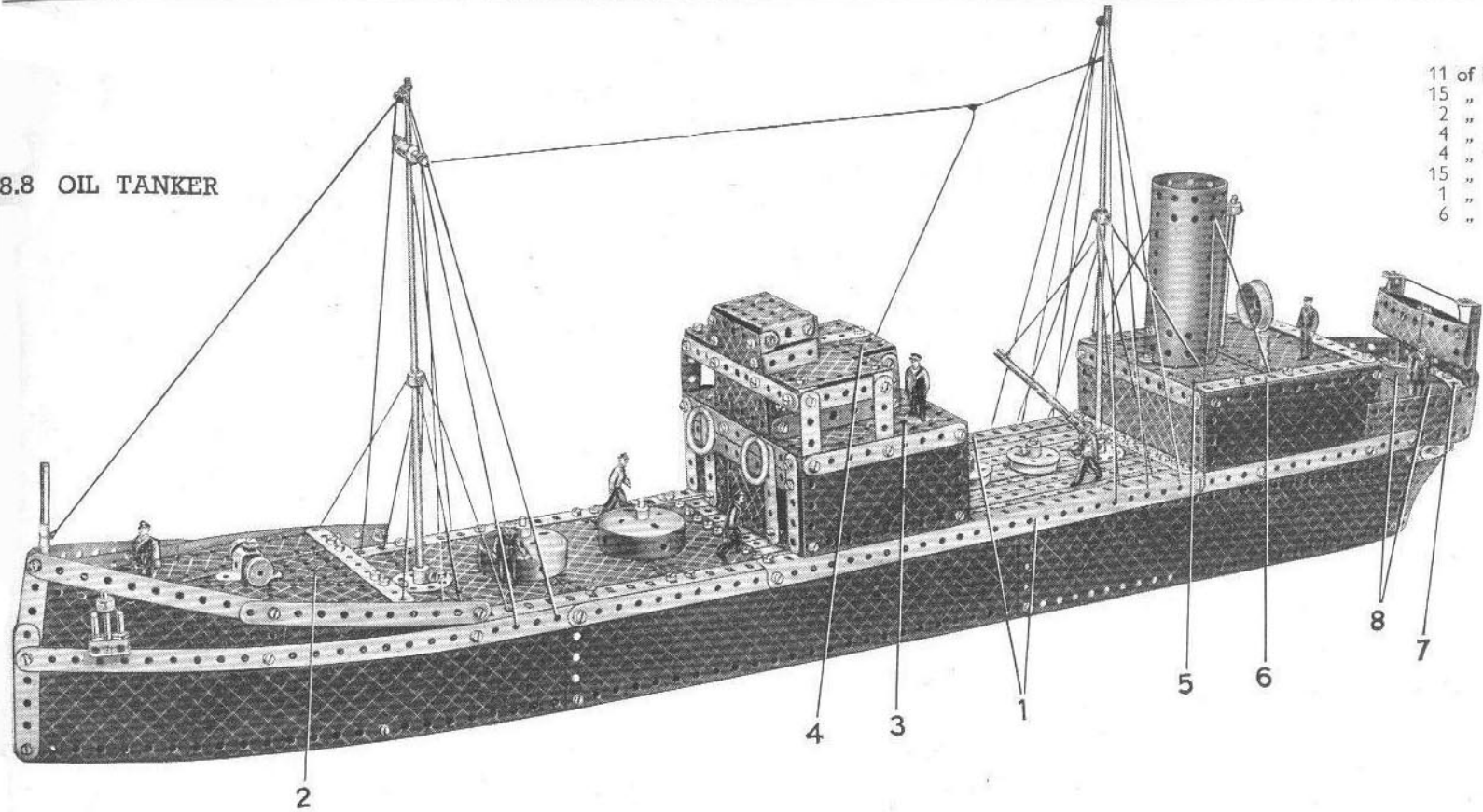

Fig. 8.7a

8.8 OIL TANKER



11	of No.	1
15	" "	2
2	" "	2a
4	" "	3
4	" "	4
15	" "	5
1	" "	6
6	" "	6a

Parts required

10	of No.	8	1	of No.	48c
4	" "	9	1	" "	51
5	" "	10	2	" "	52
18	" "	12	2	" "	53
2	" "	12b	1	" "	54
5	" "	12c	7	" "	59
2	" "	13	5	" "	63
1	" "	15a	2	" "	80c
1	" "	16	4	" "	90
3	" "	17	2	" "	111
2	" "	18a	3	" "	111c
2	" "	18b	2	" "	115
4	" "	20	1	" "	126a
1	" "	23	2	" "	155
1	" "	23a	1	" "	162
2	" "	24	8	" "	188
5	" "	35	8	" "	189
205	" "	37	6	" "	190
11	" "	37a	3	" "	191
20	" "	38	11	" "	192
1	" "	40	6	" "	197
1	" "	45	2	" "	199
2	" "	48	2	" "	212
8	" "	48a	2	" "	214
2	" "	48b	8	" "	215

Each side of the ship is formed by three  $12\frac{1}{2}$ " Strip Plates bolted end to end overlapping one hole. Two  $12\frac{1}{2}$ " Angle Girders are bolted along the lower edges of the sides as shown in Fig. 8.8a and are joined at the rear by a  $5\frac{1}{2}$ " Strip. Two  $12\frac{1}{2}$ " Angle Girders 1 also are bolted along the upper edges of the sides, and connected at one end by a  $5\frac{1}{2}$ " Strip and at the other end by a  $5\frac{1}{2}$ " x  $2\frac{1}{2}$ " Flexible Plate. The Angle Girders and  $12\frac{1}{2}$ " Strips forming part of the deck behind the bridge are bolted between the Flexible Plate and the  $5\frac{1}{2}$ " Strip.

The deck in front of the bridge consists of three  $5\frac{1}{2}$ " x  $2\frac{1}{2}$ " Flexible Plates (including the one already mentioned) and one  $5\frac{1}{2}$ " x  $1\frac{1}{2}$ " Flexible Plate. These are bolted at each end to a  $12\frac{1}{2}$ " Angle Girder fixed to the side of the ship. A  $5\frac{1}{2}$ " Angle Girder is fastened across the front part of this deck, and the raised fore deck is attached to it by Angle Brackets. The fore deck is constructed by bolting a  $3\frac{1}{2}$ " x  $2\frac{1}{2}$ " Flanged Plate 2 across the broad end of a Flanged Sector Plate. A  $5\frac{1}{2}$ " x  $1\frac{1}{2}$ " Flexible Plate also is secured to each side of the Flanged Plate 2 and sloped inward towards the front.

A  $5\frac{1}{2}$ " x  $2\frac{1}{2}$ " Flanged Plate 5 and a  $5\frac{1}{2}$ " x  $2\frac{1}{2}$ " Flexible Plate joined together by two  $5\frac{1}{2}$ " Angle Girders 6, form the roof of the aft cabin and are supported from the sides by two  $5\frac{1}{2}$ " x  $2\frac{1}{2}$ " Flexible Plates. The front of the cabin also is formed by a  $5\frac{1}{2}$ " x  $2\frac{1}{2}$ " Flexible Plate, and the back by a  $5\frac{1}{2}$ " x  $1\frac{1}{2}$ " Flexible Plate. The aft deck consists of a  $5\frac{1}{2}$ " x  $2\frac{1}{2}$ " Flexible Plate, to which are bolted a  $2\frac{1}{2}$ " x  $2\frac{1}{2}$ " Flexible Plate, and two Semi-Circular Plates. The rounded shape of the stern is obtained by bolting four  $2\frac{1}{2}$ " large radius Curved Strips together each overlapping two holes.

The base of the wheelhouse is made by fastening two  $4\frac{1}{2}$ " x  $2\frac{1}{2}$ " Flexible Plates to the Angle Girders 1 by Angle Brackets, and joining the Flexible Plates across the top by the Flanged Plate 3 and a  $5\frac{1}{2}$ " x  $2\frac{1}{2}$ " Flexible Plate. Two  $2\frac{1}{2}$ " Strips are bolted to each  $4\frac{1}{2}$ " x  $2\frac{1}{2}$ " Flexible Plate and are connected at their upper ends by  $2\frac{1}{2}$ " x  $\frac{1}{2}$ " Double Angle Strips, each of the Bolts holding also one Angle Bracket. A  $5\frac{1}{2}$ " x  $2\frac{1}{2}$ " Flexible Plate is bolted across each Angle Bracket, and the front ends of the two Double Angle Strips are joined by a  $5\frac{1}{2}$ " Strip.

A  $2\frac{1}{2}$ " x  $2\frac{1}{2}$ " Flexible Plate is bolted to the  $5\frac{1}{2}$ " Strip, the Bolts also passing through one flange of a  $3\frac{1}{2}$ " x  $2\frac{1}{2}$ " Flanged Plate 4, the sides of which are extended downwards by  $3\frac{1}{2}$ " Strips and  $2\frac{1}{2}$ " x  $\frac{1}{2}$ " Double Angle Strips. A  $2\frac{1}{2}$ " x  $1\frac{1}{2}$ " Flanged Plate is secured to the upper end of the  $2\frac{1}{2}$ " x  $2\frac{1}{2}$ " Flexible Plate by a  $2\frac{1}{2}$ " x  $\frac{1}{2}$ " Double Angle Strip, and its sides are extended downwards by  $1\frac{1}{2}$ " x  $\frac{1}{2}$ " Double Angle Strips, the rear ends of which are joined by a  $2\frac{1}{2}$ " Strip.

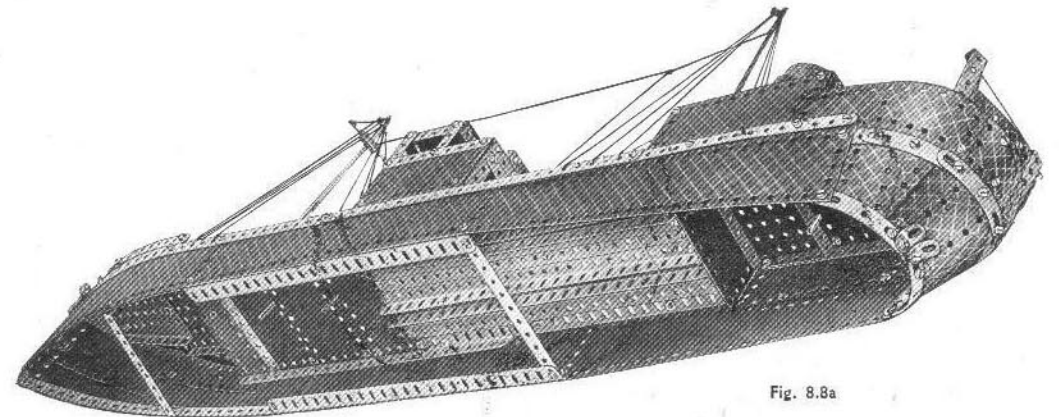

Fig. 8.8a

## 8.9 DERRICK CRANE

## Parts required

14 of No.	1	2 of No.	40	1 of No.	162a
20 "	"	1 "	44	1 "	162b
6 "	"	1 "	46	2 "	163
5 "	"	2 "	48	2 "	164
6 "	"	9 "	48a	1 "	165
12 "	"	2 "	48b	1 "	166
2 "	"	2 "	48c	1 "	176
10 "	"	2 "	51	1 "	187
8 "	"	2 "	52	2 "	188
8 "	"	5 "	53	6 "	190
33 "	"	1 "	57b	3 "	191
1 "	"	9 "	59	6 "	192
4 "	"	6 "	63	6 "	197
2 "	"	1 "	80a	1 "	198
3 "	"	2 "	80c	6 "	200
3 "	"	1 "	94	2 "	212
3 "	"	1 "	96	1 "	213
1 "	"	1 "	96a	1 "	216
2 "	"	2 "	109	1 No. 1 Clock-	
3 "	"	1 "	111	work Motor (not	
1 "	"	2 "	111a	included in Outfit	
1 "	"	6 "	111c		
3 "	"	2 "	115		
2 "	"	1 "	125		
1 "	"	2 "	126		
4 "	"	3 "	126a		
3 "	"	2 "	147b		
1 "	"				
2 "	"				
4 "	"				
3 "	"				
1 "	"				
12 "	"				
220 "	"				
18 "	"				
26 "	"				

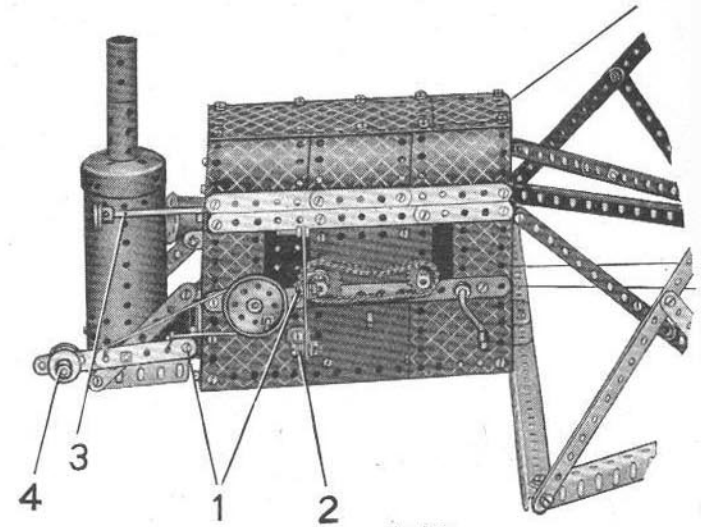
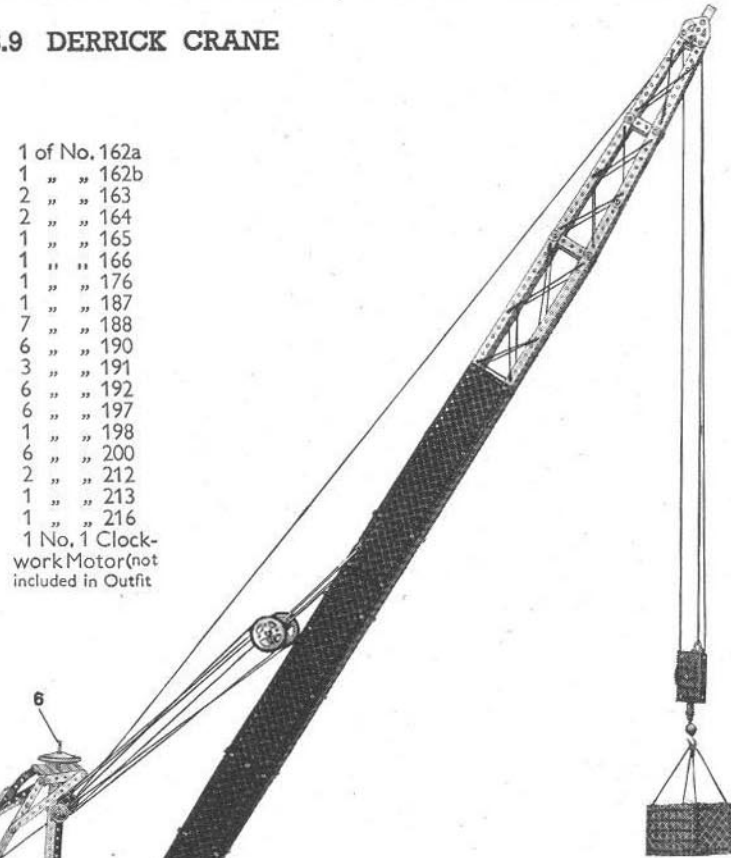
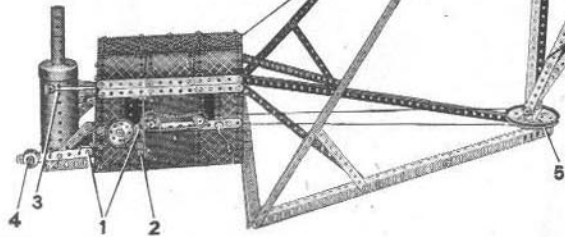

Fig. 8.9a

Each of the two forward sides of the triangular base consists of two  $12\frac{1}{2}$ " Angle Girders overlapped 10 holes, and the rear side consists of two Angle Girders overlapped seven holes. In the boss of a Face Plate bolted to the forward corner of the base is locked an  $11\frac{1}{2}$ " Rod, which is extended upwards by a second  $11\frac{1}{2}$ " Rod 6. A 3" Pulley 5, across the centre of which is bolted a  $2\frac{1}{2}$ " x  $\frac{1}{4}$ " Double Angle Strip, is then placed on the compound rod. A compound angle girder consisting of two  $12\frac{1}{2}$ " Angle Girders overlapped 10 holes is bolted to each end of the Double Angle Strip, and the two compound girders are joined at their upper ends by a second  $2\frac{1}{2}$ " x  $\frac{1}{4}$ " Double Angle Strip. The Rod 6 is journaled at the top in the centre hole of a  $3\frac{1}{2}$ " x  $2\frac{1}{2}$ " Flanged Plate, which is supported by compound strips from the rear of the base

(Continued on next page)

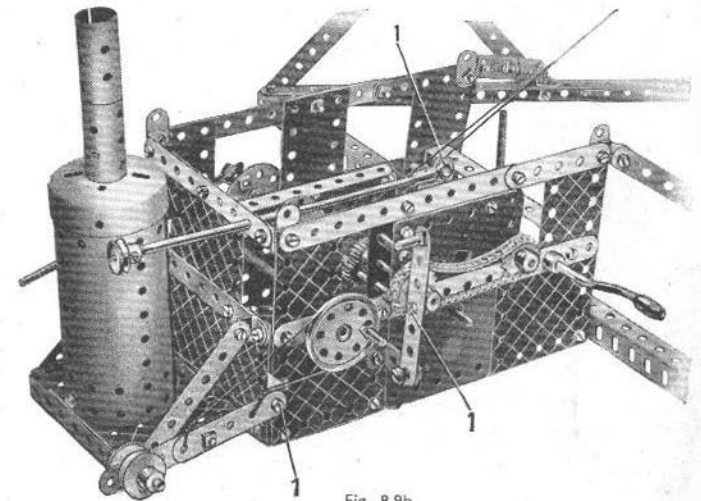

Fig. 8.9b



(Continued from previous page)

The centre part of the jib is constructed from 12½" Strip Plates and Flexible Plates of various sizes as shown, and fastened together by Angle Brackets, 2½" × 1" and 2½" × ½" Double Angle Strips. Two 12½" Strips are bolted to each side of the jib at the lower end, and they are pivoted by their end holes on two 1½" Rods, which are fastened in the longitudinal bore of a Coupling on the Rod 6. For the tapered upper end of the jib 12½" and 5½" Strips are used, and they are assembled as shown in Fig. 8.9d. Two Flat Trunnions, bolted at the top of the jib and spaced apart by a Stepped Bent Strip, form the bearing for a 2" Rod carrying two 1" loose Pulleys.

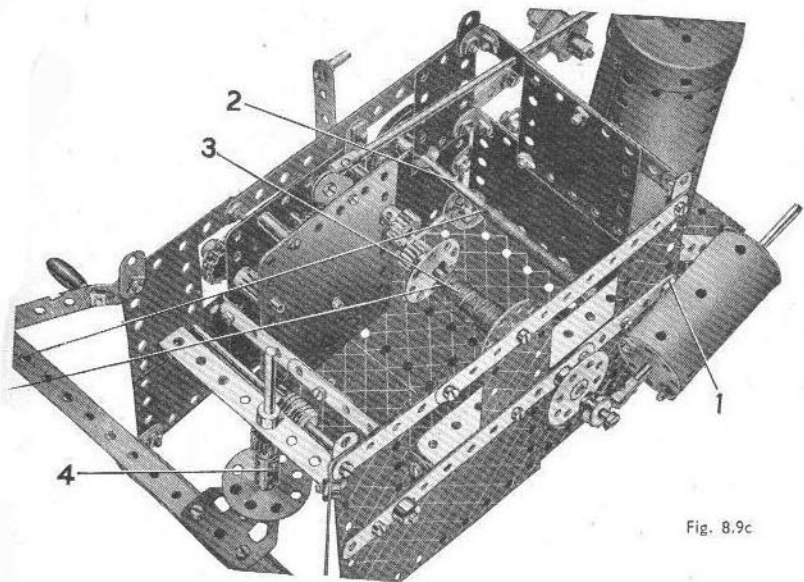

Fig. 8.9c

The pulley block casing consists of two 2½" × 1½" Flanged Plates fastened together by their flanges, and a Large Loaded Hook is secured to its lower end by an End Bearing. A ¾" Bolt fastened through the centre holes of the two Plates carries on its shank a 2" Pulley, round which the operating Cord passes.

The cab is built up as a separate unit and then attached to the base. The floor consists of a Hinged Flat Plate and two 2½" × 1½" Flexible Plates, and the Clockwork Motor, which is fastened to it by an Angle Bracket, forms part of one side of the cab. The remainder of this side of the cab is formed by 2½" × 2½" and a 2½" × 1½" Flexible Plate, which are bolted to the Motor and also are fastened to the floor by Angle Brackets.

To facilitate starting and stopping of the Motor when it is covered in, a 6½" Rod 3 (Fig. 8.9a) that carries at its end a ½" fast Pulley, is attached to the brake lever by a Rod and Strip Connector.

A 5½" × 2½" Flanged Plate overlapped five holes with a 4½" × 2½" Flexible Plate is used for the other side of the cab, and it is secured to the base by one of its longer flanges. The Flanged Plate and Flexible Plate are extended upwards by 2½" × 1½" Flexible Plates, between which spaces are left to represent the windows.

The top of the roof is constructed by bolting together a 5½" × 2½" Flexible Plate and a 2½" × 2½" Flexible Plate overlapping one hole, and it is attached by six 1 11/16" radius Curved Plates to Fishplates bolted to the sides of the cab.

A 4½" × 2½" Flexible Plate, to the upper end of which is bolted a 2½" × 2½" Flexible Plate is secured at the back of the cab by Angle Brackets. A 3½" × 2½" Flanged Plate is fastened to the 4½" × 2½" Flexible Plate by a 3½" × ½" Double Angle Strip, and also by 3½" Strips and Angle Brackets. A Boiler is attached by two Angle Brackets to the centre of the Flanged Plate, and a Boiler End, to which a Chimney Adaptor is bolted, is placed on its upper end.

A Sleeve Piece is then pushed on to the Chimney Adaptor and extended upwards by a second Sleeve Piece using a second Chimney Adaptor.

The 4½" Rod 3 (Fig. 8.9c) on which the Cord attached to the top of the pulley block is wound, is journalled at one end in one of the Motor side plates and at its other end in the side of the cab. Outside the cab the Rod carries a Bush Wheel and a Pivot Bolt fastened through one of the holes in the Wheel is connected by a Rod and Strip Connector to a 4½" Rod. This Rod slides in the centre holes of two Wheel Discs fastened at each end of a 2½" Cylinder by two 3" Screwed Rods. The cylinder is secured to the side of the cab by a lock-nutted ¾" Bolt, indicated at 1 in Fig. 8.9c.

At the Motor end the Rod 3 carries a ½" Pinion, which meshes with another ½" Pinion on a 2" Rod journalled in the side plates of the Motor. A 1" Sprocket Wheel is locked on the outer end of the 2" Rod, and is connected by Sprocket Chain to a ¾" Sprocket Wheel on the driving shaft of the Motor. As the Motor is non-reversing, the pulley block must be allowed to fall under its own weight, and to do this the two ½" Pinions are thrown out of mesh by moving the 2" Rod about ¼" to one side. For this purpose a 3½" Strip is pivotally attached by a Pivot Bolt 2 (Fig. 8.9a) to a 1" × ½" Angle Bracket bolted to the side of the cab. A ¾" Bolt is fastened through the centre hole of the 3½" Strip is lock-nutted to an Angle Bracket on the 2" Rod and held in place by a collar. A handle is provided at the top of the lever by a Threaded Pin.

The Cord tied to the Rod 3 (Fig. 8.9c) is taken over one of the 1" Pulleys at the top of the jib, around the 2" Pulley in the pulley block and then over the second 1" Pulley at the top of the jib. Finally it is tied to an Angle Bracket bolted to the upper end of the pulley block.

Luffing of the jib is controlled by a 5" Rod 2 (Fig. 8.9c) journalled in the sides of the cab and carrying at one end a handle built up from a 1½" Pulley Wheel and a Threaded Pin. A length of Cord is passed around the 1½" Pulley and is tied at each end to a compound 4" strip, which is pivotally attached to a Reversed Angle Bracket bolted to the cab. The 4" Strip is weighted at its upper end by two ¾" Flanged Wheels 4 (Fig. 8.9a). The Cord is tied to a Cord Anchoring Spring on the Rod 2, wound around it several times, and then is taken alternately through a pulley block attached to the jib, and a pulley block at the head of the jib post. The free end of the Cord is tied to a Fishplate bolted to the jib post.

The mechanism for slewing the jib is shown in Fig. 8.9c. A large Crank Handle extended by a 1" Rod is journalled in the sides of the cab, and a Worm is fastened at its centre. The Worm meshes with a ½" Pinion on a 4" Rod held in a Flat Trunnion and also in the centre hole of a 4½" × ½" Double Angle Strip bolted between the sides of the cab. The 4" Rod is fastened in position by a Bush Wheel and a Collar and carries a Coupling 4 (Fig. 8.9c). Cord is wound a few turns on the Coupling 4, led one and a half turns around the 3" Pulley 5 at the base of the jib post, and the two ends are then tied together.

*Meccano Paris can be purchased separately from your Meccano dealer. Ask him for the latest price list.*

Fig. 8.9d

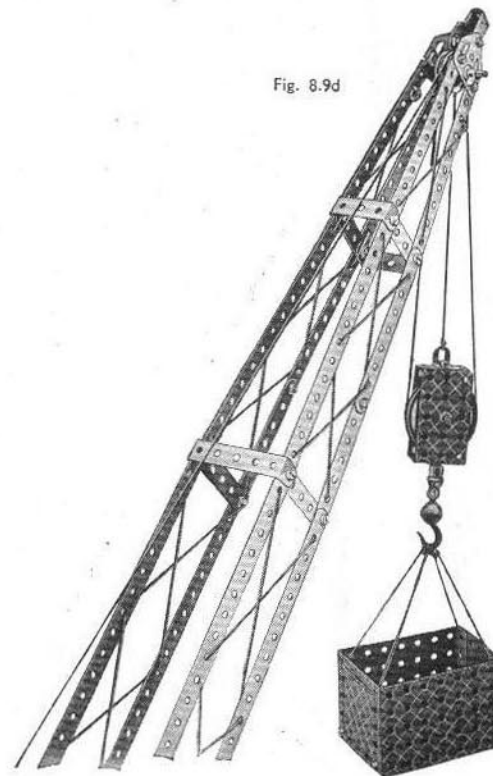

## 8.10 "SILVER JUBILEE" TRAIN

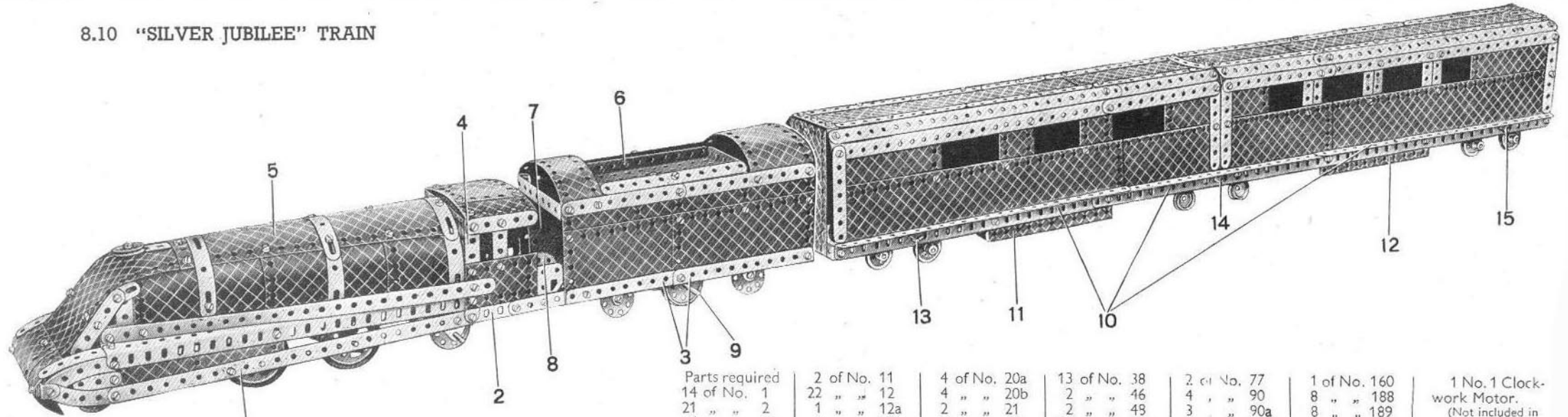

The engine chassis is made by bolting two  $12\frac{1}{2}$ " Strips 1 to a  $3\frac{1}{2}$ " x  $2\frac{1}{2}$ " Flanged Plate 2 and then attaching two  $12\frac{1}{2}$ " Angle Girders to the Flanged Plates by Fishplates. The Angle Girders and Strips are joined together by  $5\frac{1}{2}$ " x  $1\frac{1}{2}$ " Flexible Plate, and the front end of the chassis is extended by  $2\frac{1}{2}$ " large radius Curved Strips and  $1\frac{1}{2}$ " Strips. The Curved Strips on each side are joined by a  $3\frac{1}{2}$ " x  $\frac{1}{2}$ " Double Angle Strip.

The top of the boiler is made by overlapping a  $4\frac{1}{2}$ " x  $2\frac{1}{2}$ " Flexible Plate two holes with a  $5\frac{1}{2}$ " x  $2\frac{1}{2}$ " Flexible Plate 5, and then extending the latter to the front with a second  $5\frac{1}{2}$ " x  $2\frac{1}{2}$ " Flexible Plate.

Eight  $1\frac{1}{4}$ " radius Curved Plates are then bolted to the boiler top, and a  $4\frac{1}{2}$ " x  $2\frac{1}{2}$ " and a  $2\frac{1}{2}$ " x  $2\frac{1}{2}$ " Flexible Plate are bent to shape and bolted to the top at the fire-box end. Formed Slotted Strips are bolted round the boiler in the positions shown, and double  $12\frac{1}{2}$ " Strips are bolted to each side of the boiler to clamp all the parts in place. At the rear the  $12\frac{1}{2}$ " Strips are attached to a  $3\frac{1}{2}$ " x  $2\frac{1}{2}$ " Flanged Plate 4, and at the front they are joined by Angle Brackets to the  $12\frac{1}{2}$ " Angle Girders. The front  $5\frac{1}{2}$ " x  $2\frac{1}{2}$ " Flexible Plate is bent downwards and is bolted to two U-Section Curved Plates, which overlap each other by three holes. The Bolts holding the U-Section Curved Plates to the  $3\frac{1}{2}$ " x  $\frac{1}{2}$ " Double Angle Strip carry two Washers on their shanks for spacing purposes.

Two  $2\frac{1}{2}$ " small radius Curved Strips are bolted to  $3\frac{1}{2}$ " x  $2\frac{1}{2}$ " Flanged Plate 4 to form the curved part below the roof of the cab. The front bogie is mounted on a  $3\frac{1}{2}$ " Rod held in the bosses of two Cranks attached to  $12\frac{1}{2}$ " Strips 1, and the  $1\frac{1}{4}$ " Flanged Wheels are carried on Pivot Bolts.

The sides of the tender are built on compound angle girders, each of which consists of two  $5\frac{1}{2}$ " Angle Girders 3 overlapping by three holes. The rear side of the tender is formed by a  $5\frac{1}{2}$ " x  $2\frac{1}{2}$ " and a  $5\frac{1}{2}$ " x  $1\frac{1}{2}$ " Flexible Plate and a No. 1 Clockwork Motor 7. At the rear the sides are joined by a  $3\frac{1}{2}$ " x  $2\frac{1}{2}$ " Flanged Plate, a  $2\frac{1}{2}$ " x  $1\frac{1}{2}$ " Flexible Plate and a Channel Bearing, and at the front they are connected by a  $3\frac{1}{2}$ " x  $\frac{1}{2}$ " Double Angle Strip. The coal bunker is a  $5\frac{1}{2}$ " x  $2\frac{1}{2}$ " Flanged Plate 6 bolted to a  $3\frac{1}{2}$ " x  $\frac{1}{2}$ " Double Angle Strip.

The drive is taken from a  $\frac{1}{2}$ " Pinion on the driving shaft of the Motor through a 57-teeth Gear 8. A  $\frac{3}{8}$ " Sprocket Wheel is connected to a  $1\frac{1}{2}$ " Sprocket Wheel on the axle 9 of the  $1\frac{1}{2}$ " Pulleys. The Wheel Discs on  $\frac{1}{2}$ " Bolts are held in place by Collars.

The coach is built up on the  $12\frac{1}{2}$ " Angle Girders 10, which overlap, and reference to the illustrations will make clear the construction of its sides and roof. A  $5\frac{1}{2}$ " x  $2\frac{1}{2}$ " Flanged Plate and a  $5\frac{1}{2}$ " x  $1\frac{1}{2}$ " Flexible Plate are used for the accumulator box 11, and at 12 two  $5\frac{1}{2}$ " x  $1\frac{1}{2}$ " Flexible Plates are used. The  $4\frac{1}{2}$ " Rods 13, 14 and 15 are used for pivoting the bogies. The Rods 13 and 15 pass through Double Brackets but Rod 14 is journalled in a  $2\frac{1}{2}$ " x  $\frac{1}{2}$ " Double Angle Strip.

Parts required	2 of No. 11	4 of No. 20a	13 of No. 38	2 of No. 77	1 of No. 160
14 of No. 1	22 " " 12	4 " " 20b	2 " " 46	4 " " 90	8 " " 188
21 " " 2	1 " " 12a	2 " " 21	2 " " 49	3 " " 90a	8 " " 189
4 " " 2a	1 " " 12b	5 " " 22	10 " " 48a	1 " " 94	8 " " 190
6 " " 3	8 " " 12c	4 " " 22a	6 " " 48b	1 " " 96	6 " " 191
6 " " 4	1 " " 15	2 " " 24	2 " " 51	1 " " 96a	12 " " 192
18 " " 5	4 " " 15a	4 " " 24a	2 " " 52	4 " " 111a	6 " " 197
2 " " 6	1 " " 15b	2 " " 26	5 " " 53	3 " " 111c	1 " " 198
6 " " 6a	4 " " 16	1 " " 27a	1 " " 54	1 " " 115	2 " " 199
8 " " 8	3 " " 17	13 " " 35	8 " " 59	1 " " 116a	8 " " 200
4 " " 9	2 " " 18a	216 " " 37	2 " " 62	4 " " 126a	8 " " 215
20 " " 10	2 " " 20	3 " " 37a	2 " " 63	1 " " 147b	

1 No. 1 Clockwork Motor.  
(Not included in Outfit.)

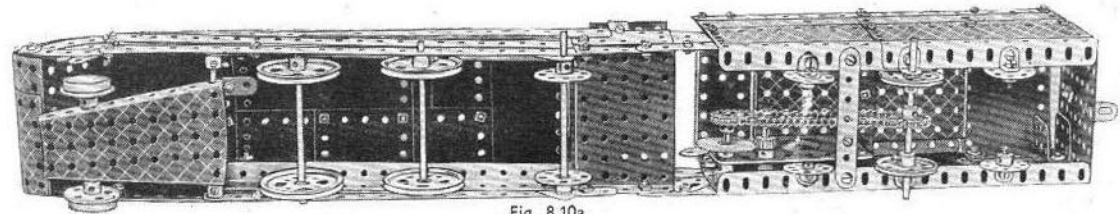

Fig. 8.10a

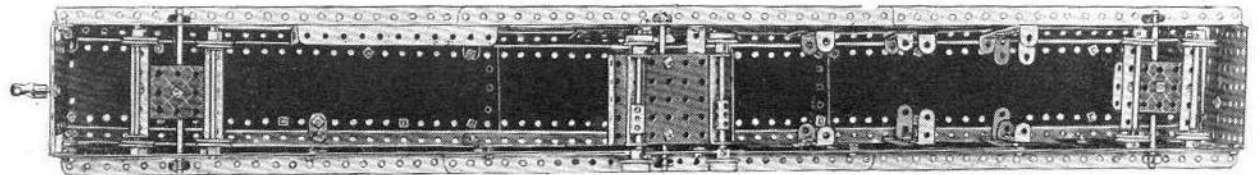
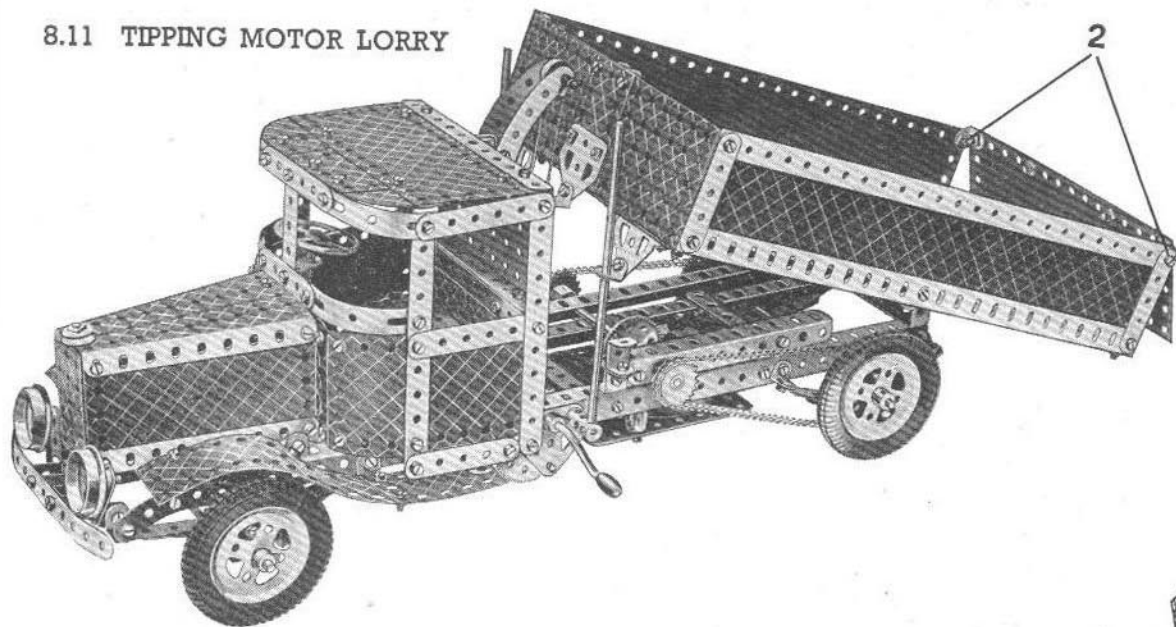

Fig. 8.10b

### 8.11 TIPPING MOTOR LORRY



Parts required

4 of No. 1	25 of No. 12	1 of No. 23a	1 of No. 80c
19 " " 2	2 " " 12a	3 " " 26	4 " " 90
5 " " 2a	2 " " 12b	2 " " 27a	1 " " 94
5 " " 3	2 " " 14	1 " " 28	2 " " 95
6 " " 4	2 " " 15	6 " " 35	2 " " 96
12 " " 5	1 " " 15a	205 " " 37	3 " " 111
1 " " 6	2 " " 15b	16 " " 37a	2 " " 111a
4 " " 6a	4 " " 16	26 " " 38	6 " " 111c
6 " " 8	1 " " 17	1 " " 40	1 " " 116a
2 " " 9	2 " " 18a	2 " " 45	1 " " 120b
6 " " 10	2 " " 18b	2 " " 48a	4 " " 125
5 " " 11	1 " " 19h	4 " " 48b	4 " " 126
	2 " " 20	2 " " 48d	3 " " 126a
	4 " " 20a	1 " " 51	4 " " 142a
	1 " " 23	2 " " 51	2 " " 147b
		2 " " 52	1 " " 165
		2 " " 53	1 " " 176
		2 " " 54	1 " " 185
		9 " " 59	7 " " 188
		5 " " 63	4 " " 189
			4 " " 191
			3 " " 192
			5 " " 197
			1 " " 212
			2 " " 214
			4 " " 215
			1 No. 1 Clock-work Motor (not included in Outfit)

The construction of the model is commenced with the chassis, which consists of two compound girders, each made by bolting two 12½" Angle Girders together overlapping fifteen holes. The two compound girders are joined at the forward end by a 3½" Strip and at the rear end by a 3½" × ½" Double Angle Strip. The bonnet is built up by joining the flanges of two Flanged Sector Plates by 4½" × 2½" Flexible Plates. The lower Sector Plate is bolted to the 3½" Strips joining the side members of the chassis. A 2½" × 1½" Flanged Plate is fixed between the narrow ends of the two Flanged Sector Plates by a 3" Screwed Rod to represent the radiator.

The back of the cab is formed by two 5½" × 2½" Flanged Plates fastened together by their longer flanges, the lower one being bolted direct to the chassis. A 4½" × 2½" Flexible Plate is used for each side of the cab. It is bolted at the rear to the lower Flanged Plate, and at the front is connected by a 2½" × 1½" Flexible Plate to the bonnet.

Each of the front leaf springs is constructed from a 2½", 3½", 4½" and a 5½" Strip, and is fastened to the chassis by a Double Bracket at its front end and by an Angle Bracket at the rear. Two 2" Pulleys fitted with Rubber Tyres are used for the front wheels, and each is loosely held by a Collar on a 1½" Rod, which is fastened by a ¾" Bolt in the boss of a Small Fork Piece. The Small Fork Piece is connected by a Pivot Bolt to the end tapped hole of a Coupling, which is secured by its other end to one of the leaf springs. One of the Fork Pieces is taken from a Swivel Bearing.

Each of the ¾" Bolts used for fastening the 1½" rods to the Small Fork Pieces, carries a Collar locked against its head. The two Collars are joined by a compound 6" strip, one of the Bolts holding also a 3½" Strip, which is secured at its other end to the 57-teeth Gear by the lock-nutted Bolt 1. This Gear meshes with a ½" Pinion on the lower end of the 3½" Rod representing the steering column. The Bolts fastened to the 57-teeth Gear allow it to turn only half a revolution.

The rear wheels are fastened on a compound 7" rod, built from two 3½" Rods and journalled at each end in a 1" × 1" Angle Bracket bolted to one of the leaf springs. Each of these consists of a 2½", a 3½" and a 4½" Strip, and is secured to the chassis by Angle Brackets. The rear axle bears two 2" Sprocket Wheels, connected by Sprocket Chain to two 1" Sprocket Wheels on a 5" Rod journalled in two 5½" Angle Girders secured to the chassis. The 5" Rod carries at its centre a 1½" Contrate Wheel that meshes with a ½" Pinion on the driving shaft of the Motor, which is secured underneath the chassis by two 3½" × ½" Double Angle Strips. The brake lever of the Motor is extended by a Fishplate 2 (Fig. 8.11a), which is fastened by a Rod and Strip Connector to a 2" Rod, that protrudes through a Flat Trunnion bolted to the side of the chassis. The body of the lorry is constructed on a frame consisting of two 12½" Angle Girders joined at each end by a compound 7½" strip made by bolting two 5½" Strips together overlapping seven holes. The frame is filled in by three 12½" × 2½" Strip Plates, two more of which are bolted to the Angle Girders to form the sides. Two guide Rods are fixed behind the cab as shown in the illustrations, and Angle Brackets secured to the body by Trunnions are used for the slides. The Bolts 2, used to hold the tailboard in position, are lock-nutted.

The Crank Handle that controls the raising and lowering of the body of the wagon is journalled in two Flat Trunnions bolted to the sides of the chassis, and is prevented from turning freely by a Compression Spring. A ½" Pinion on the shaft of the Crank Handle meshes with a 57-teeth Gear on a 5" Rod that also is journalled in the two Flat Trunnions. Cord is tied to a Cord Anchoring Spring on this Rod and wound around it several times. The Cord is then led over a ½" Pulley at the head of a small jib behind the cab, and finally is tied to the front of the body of the lorry.

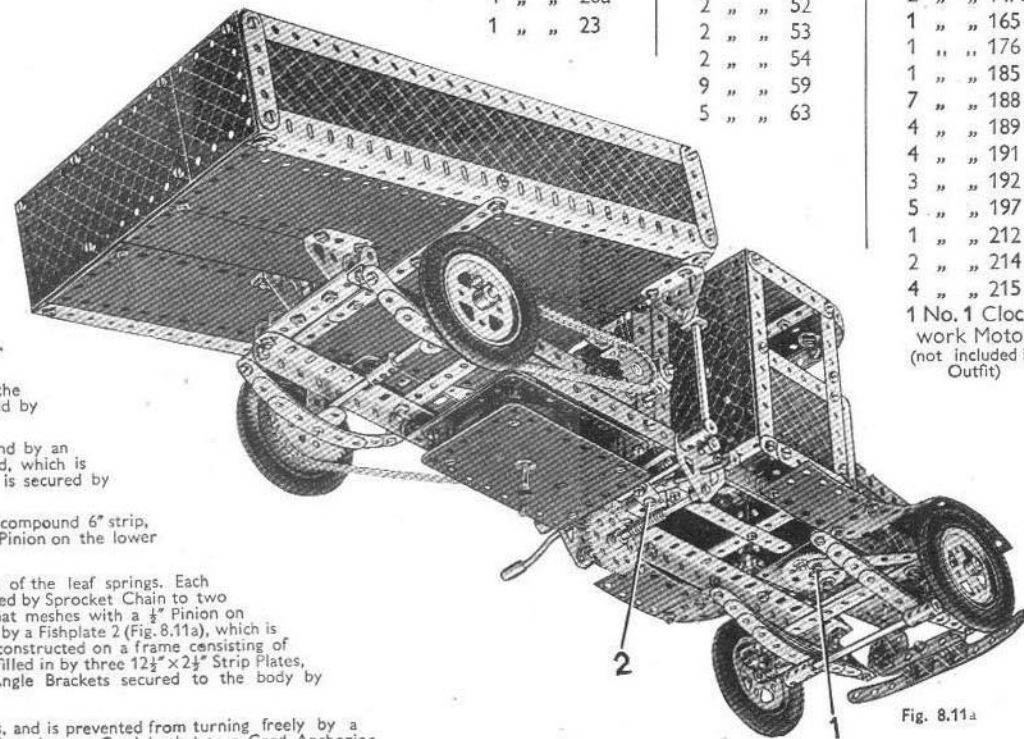
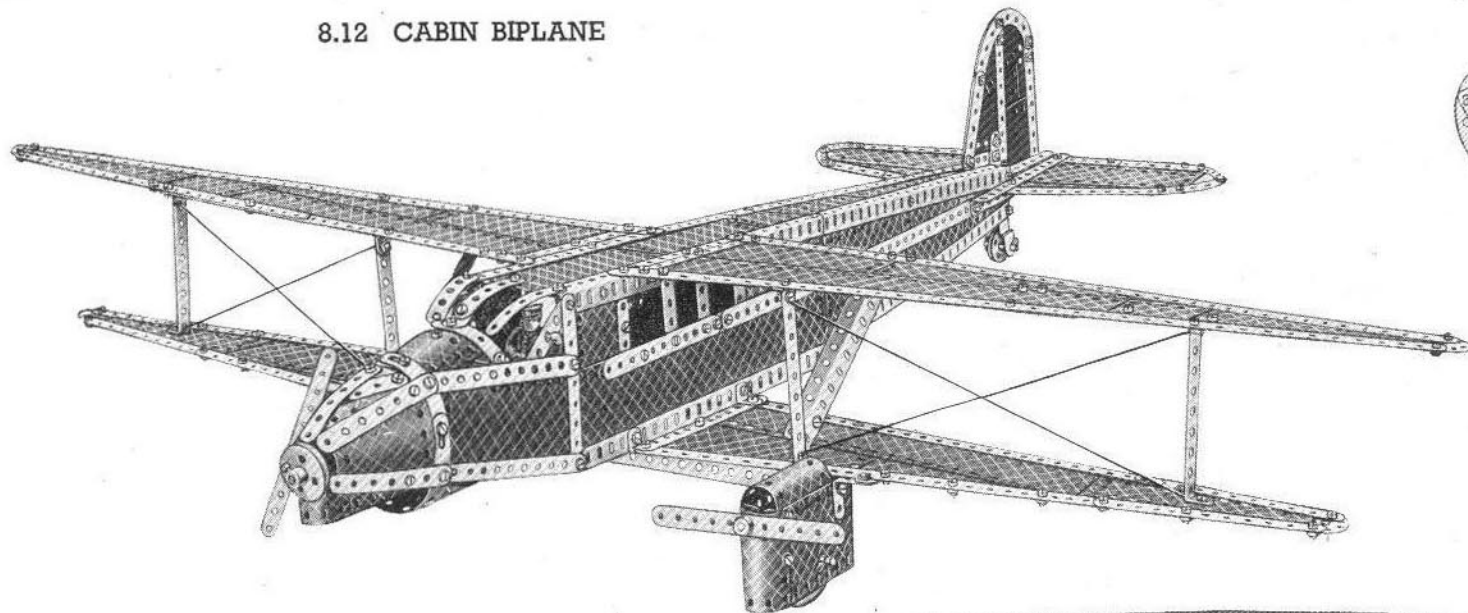

Fig. 8.11a

## 8.12 CABIN BIPLANE



The fuselage of the aeroplane comprises four compound girders, each consisting of two  $12\frac{1}{2}$ " Angle Girders secured together by  $12\frac{1}{2}$ " Strip Plates and Flexible Plates of various sizes.

The sides of the cockpit are formed by  $5\frac{1}{2}$ "  $\times$   $2\frac{1}{2}$ " Flexible Plates, and it is covered in at the front by  $1\frac{1}{8}$ " radius Curved Plates. The  $5\frac{1}{2}$ "  $\times$   $2\frac{1}{2}$ " Flexible Plates are braced along their edges by  $5\frac{1}{2}$ " Strips, the ends of which are joined by a circle of four Formed Slotted Strips. The nose consists of two more  $1\frac{1}{8}$ " radius Curved Plates, which are braced by  $3$ " and  $3\frac{1}{2}$ " Strips. The  $1\frac{1}{8}$ " Flanged Wheel protruding from the nose is locked on the end of a  $1\frac{1}{2}$ " Rod, which is prevented from slipping out of position by a  $1$ " fast Pulley complete with Rubber Ring fitted just inside the nose of the plane.

Each of the lower wings is formed by a  $12\frac{1}{2}$ " Strip Plate and a  $5\frac{1}{2}$ "  $\times$   $2\frac{1}{2}$ " and two  $5\frac{1}{2}$ "  $\times$   $1\frac{1}{2}$ " Flexible Plates, all of which are bolted to a frame consisting of two compound strips secured at one end to a Wheel Disc and at the other end to a  $5\frac{1}{2}$ " Strip. The  $5\frac{1}{2}$ " Strip is fastened to the fuselage by Angle Brackets, and the wings are also braced by two  $12\frac{1}{2}$ " Angle Girders, which are bolted across the underside of the fuselage as shown in Fig. 8.12a.

The engine nacelle and wheel casing are built up by joining the flanges of two  $3\frac{1}{2}$ "  $\times$   $2\frac{1}{2}$ " Flanged Plates with Fishplates. A U-Section Curved Plate is bolted to the front of the two Flanged Plates and a second U-Section Curved Plate is fastened to their upper edges to form the starboard engine, the port engine being completed with  $2\frac{1}{2}$ "  $\times$   $2\frac{1}{2}$ " Flexible Plates. The propeller is a  $5\frac{1}{2}$ " Strip secured by a Collar on the plain shank of a Threaded Pin, which is fastened through the upper end of the forward U-Section Curved Plate. The landing wheel is a  $2$ " Pulley fitted with a Rubber Tyre and it is carried on a  $2$ " Rod journalled in the two Flanged Plates.

The complete unit is attached by a  $3\frac{1}{2}$ "  $\times$   $\frac{1}{2}$ " Double Angle Strip to the rear  $12\frac{1}{2}$ " Angle Girder bracing the lower wing, and by a  $1$ "  $\times$   $1$ " Angle Bracket to the forward  $12\frac{1}{2}$ " Angle Girder.

The upper wings each consist of  $12\frac{1}{2}$ " Strip Plates and Flexible Plates of various sizes. These are bolted to a frame consisting of two compound strips joined at one end by a Wheel Disc and bolted at the other end to the top of the fuselage.

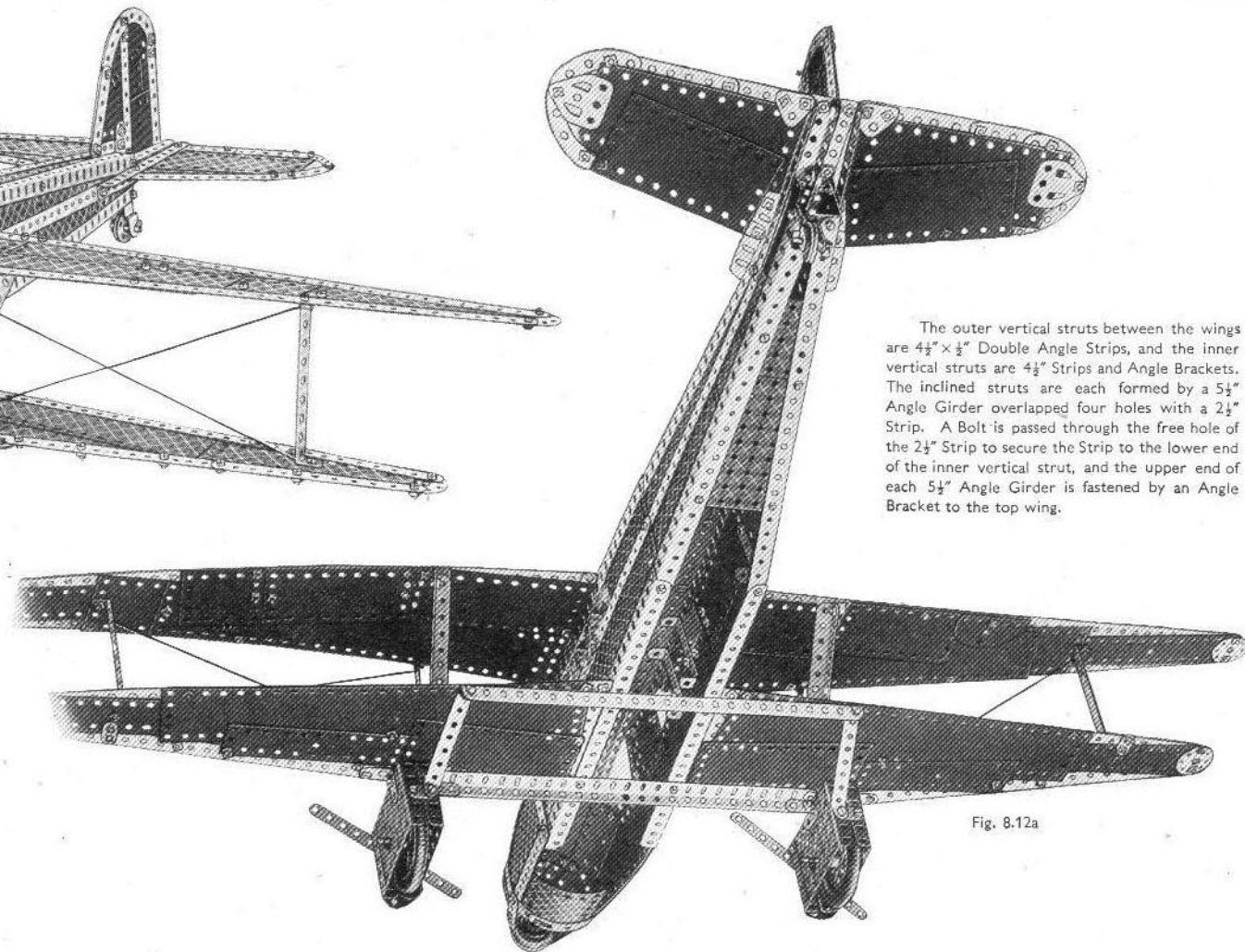

The outer vertical struts between the wings are  $4\frac{1}{2}$ "  $\times$   $\frac{1}{2}$ " Double Angle Strips, and the inner vertical struts are  $4\frac{1}{2}$ " Strips and Angle Brackets. The inclined struts are each formed by a  $5\frac{1}{2}$ " Angle Girder overlapped four holes with a  $2\frac{1}{2}$ " Strip. A Bolt is passed through the free hole of the  $2\frac{1}{2}$ " Strip to secure the Strip to the lower end of the inner vertical strut, and the upper end of each  $5\frac{1}{2}$ " Angle Girder is fastened by an Angle Bracket to the top wing.

Fig. 8.12a

Parts required	2 of No. 6	2 of No. 12b	1 of No. 22a	4 of No. 48a	2 of No. 77	2 of No. 142a	6 of No. 197
14 of No. 1	4 " " 6a	2 " " 17	4 " " 24a	4 " " 48b	4 " " 90	1 " " 155	2 " " 199
21 " " 2	10 " " 8	1 " " 18a	6 " " 35	2 " " 48c	4 " " 90a	8 " " 188	6 " " 200
6 " " 2a	4 " " 9	1 " " 18b	213 " " 37	2 " " 51	2 " " 111a	6 " " 189	2 " " 214
6 " " 3	18 " " 10	1 " " 20	6 " " 37a	4 " " 53	4 " " 111c	10 " " 190	8 " " 215
6 " " 4	13 " " 12	2 " " 20a	15 " " 38	2 " " 54	2 " " 115	6 " " 191	
15 " " 5	4 " " 12a	1 " " 22	1 " " 44	2 " " 59	2 " " 126a	12 " " 192	

### 8.13 STREAMLINED CAR

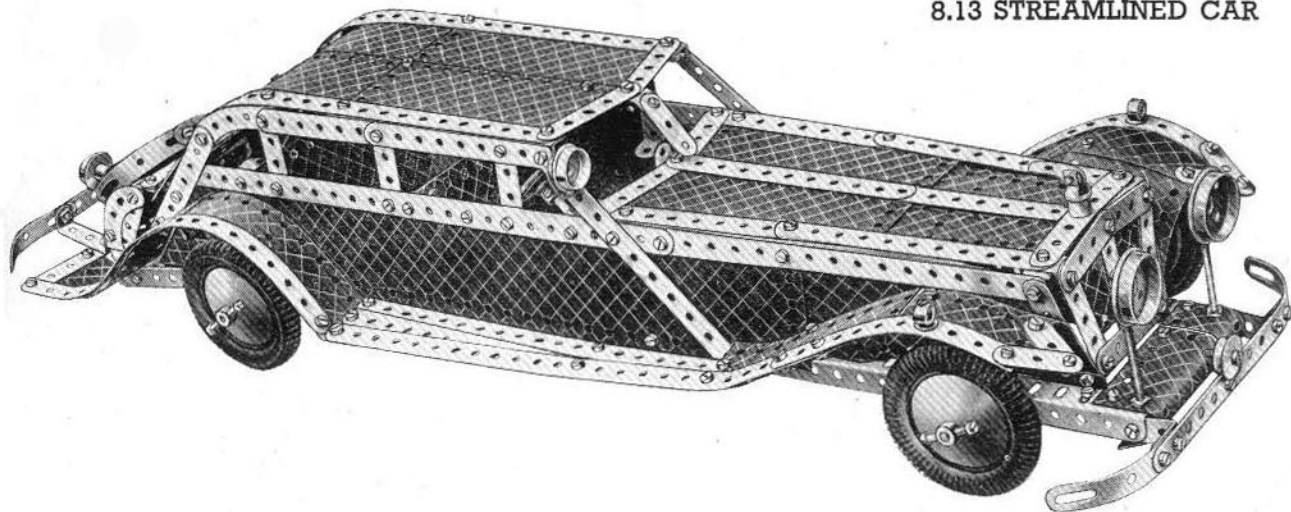

The front part of the chassis consists of two 12½" Angle Girders, one of which is bolted to the No. 1 Clockwork Motor. The other Angle Girder is attached to the Clockwork Motor by one Fishplate. The Angle Girders are joined together at the front end by two U-Section Curved Plates overlapped three holes, and five holes from the rear end the Angle Girders are joined by a 3½" Strip. A 5¼" x ½" Double Angle Strip is attached by Angle Brackets as shown, and 12½" Strips are bolted to its ends to form the bottom of the sides of the body.

Each side of the body comprises two 12½" x 2½" Strip Plates overlapped 19 holes, the front Strip Plate being raised up one hole, and extended to the front by a 5½" x 2½" Flexible Plate.

The rear seat is made from two 4½" x 2½" Flexible Plates, the lower Flexible Plate being attached to the sides by Double Brackets, and the front seat is a Hinged Flat Plate attached to the 12½" Angle Girders by Double Brackets. The backs of both seats are attached to the sides by Angle Brackets.

The top of the bonnet is made from a framework of compound strips consisting of 5½" and 4½" Strips, which are joined by a 3½" Strip at the front and two 2½" Strips at the rear. The top is filled in by 5½" x 1½" and 5½" x 2½" Flexible Plates, and is attached to the sides of the bonnet by Angle Brackets. The radiator also is a framework of Strips built up from 2½" and 2" Strips and filled in by a 2½" x 1½" Flexible Plate. Compound strips 20" in length are bolted to the sides of the body and to them are attached the roof supports consisting of two 3" Strips and four 2½" x ½" Double Angle Strips.

The roof consists of two 5½" x 2½" and two 4½" x 2½" Flexible Plates bolted together, and 12½" Strips bent to shape are bolted to each long edge of the compound plate so formed. The luggage compartment is shown in Fig. 8.13b. It consists of two Formed Slotted Strips bolted to two 1½" radius Curved Plates and to a 4½" Strip at the top edge. Bolted to the lower ends of the Formed Slotted Strips is a compound strip consisting of two 3½" Strips overlapped three holes. Each side of the body is extended by a 3" Strip and a Semi-Circular Plate. A 2½" small radius Curved Strip bolted to a 2½" Strip and attached to the 3" Strip by a Fishplate, forms each side of the luggage compartment.

The rear mudguards are 5½" x 1½" Flexible Plates bolted to 5½" Strips, and they are carried on 3½" Strips bolted to the 1½" x ½" Double Angle Strips that support the rear bumper. The running boards are made by bolting two 12½" Strips and a 5½" Strip to each rear mudguard, and after bending to shape they are bolted to the front mudguards. Each front mudguard consists of a 5½" x 1½" and a 2½" x 1½" Flexible Plates overlapped one hole. The running boards are attached to the sides of the body by 1½" x ½" Angle Brackets, and the front mudguards are bolted to 1½" radius Curved Plates, which in turn are bolted to the bonnet. The front bumper is carried on 1" x 1" Angle Brackets, and the headlamps, which are 1½" Flanged Wheels, are fixed by their set screws to the ends of 3" Screwed Rods, lock-nutted to the chassis.

The Steering Wheel is fastened on a 3½" Rod that is held by Spring Clips in a Trunnion. The rear wheel axles are 1½" Rods held in the bosses of Cranks bolted to the sides of the body. The 2" Pulleys are spaced from the Cranks by Collars, and are retained in position by the Collars fitted with ¾" and ½" Bolts that hold the Conical Discs in place.

A ½" fast Pulley is fastened on the 1½" Rod that carries the 57-teeth Gear, and it is connected by a Driving Band to the 1" Pulley fixed on the 8" Rod that forms the front axle.

#### Parts required

12	of No.	1
19	" "	2
5	" "	2a
6	" "	3
6	" "	4
18	" "	5
2	" "	6
5	" "	6a
2	" "	8
5	" "	10
4	" "	11
27	" "	12
2	" "	12a
2	" "	12b
3	" "	12c
1	" "	13a
1	" "	16
3	" "	18a
2	" "	20
4	" "	20a
2	" "	20b
1	" "	22
1	" "	23
1	" "	23a
1	" "	24a
1	" "	26
1	" "	27a
4	" "	35
187	" "	37
12	" "	37a
11	" "	38
2	" "	38d

Fig. 8.13b

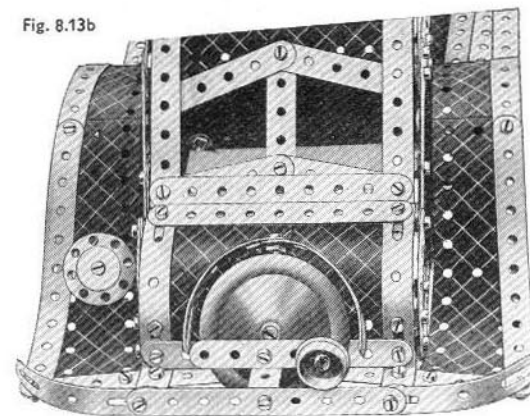

2	of No.	48
4	" "	48a
1	" "	48d
10	" "	59
2	" "	62
2	" "	80c
2	" "	90
2	" "	90a
2	" "	111
6	" "	111a
6	" "	111c
1	" "	125

1	of No.	126
4	" "	142a
1	" "	147c
1	" "	166
1	" "	185
1	" "	186
1	" "	187
4	" "	187a
3	" "	188
8	" "	189
4	" "	191
6	" "	192

4	of No.	197
1	" "	198
2	" "	199
4	" "	200
2	" "	214
8	" "	215
No. 1 Clockwork Motor.		
(Not included in Outfit)		

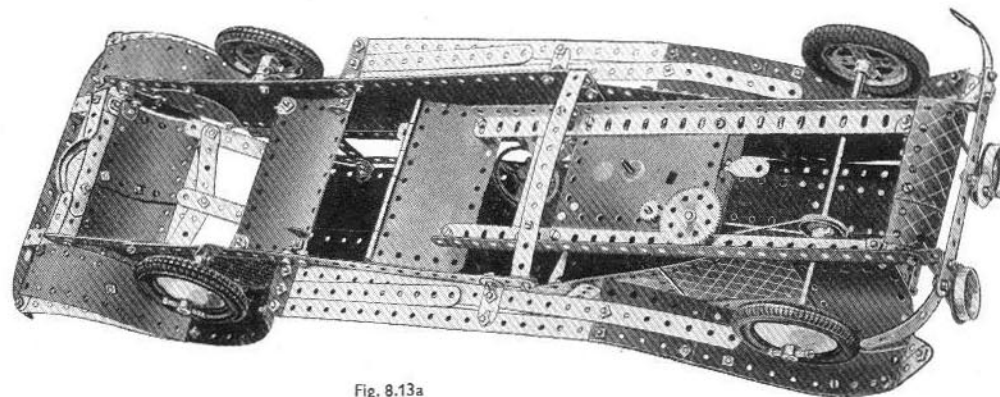
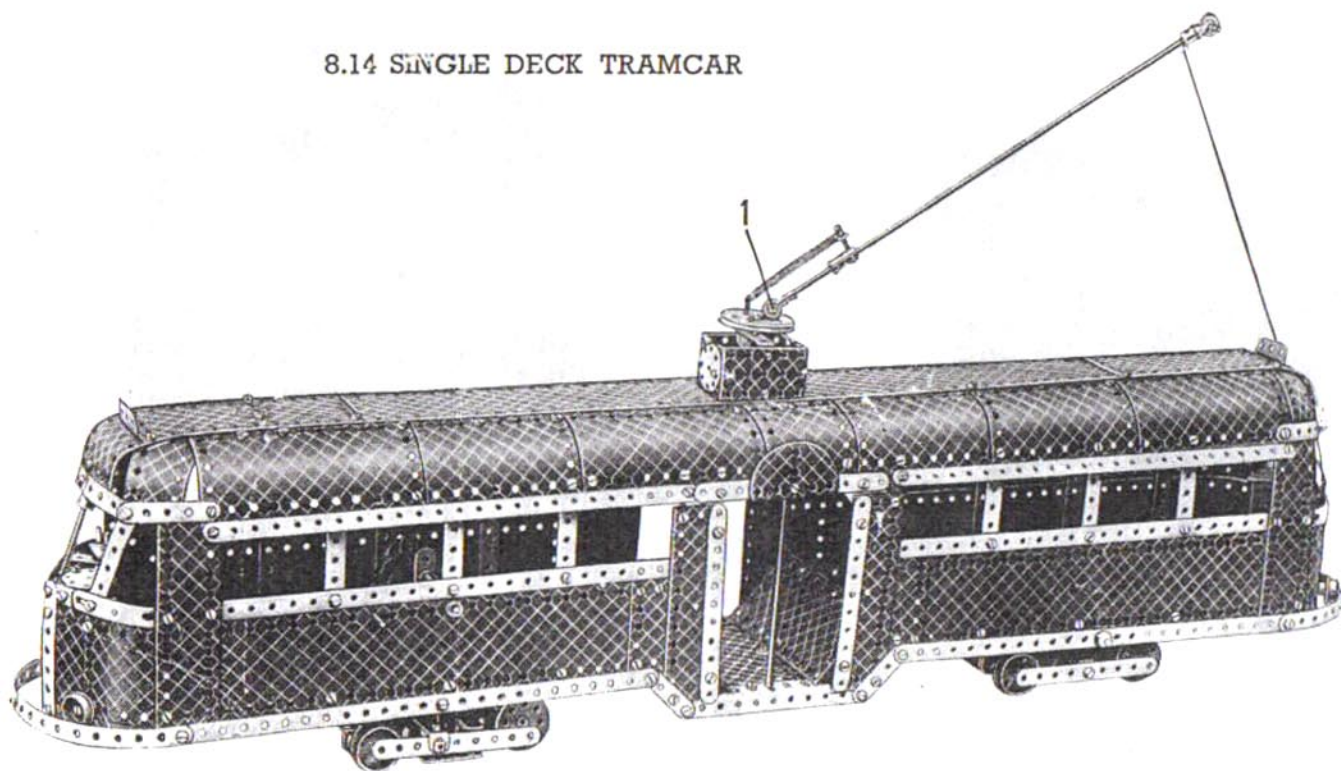

Fig. 8.13a

## 8.14 SINGLE DECK TRAMCAR



The chassis consists of two side members made by joining two  $12\frac{1}{2}$ " Angle Girders to a  $5\frac{1}{2}$ " Angle Girder by  $2\frac{1}{2}$ " Strips. The  $5\frac{1}{2}$ " Angle Girders of each side member are connected by a  $5\frac{1}{2}$ " x  $2\frac{1}{2}$ " Flanged Plate, and the  $12\frac{1}{2}$ " Angle Girders are joined by  $5\frac{1}{2}$ " Strips at their free ends. The next step is to make two compound Angle Girders by overlapping two  $12\frac{1}{2}$ " Angle Girders by seven holes with a third  $12\frac{1}{2}$ " Angle Girder. The compound angle girders are then connected to the chassis by six  $5\frac{1}{2}$ " Strips on one side, and on the other side by four  $5\frac{1}{2}$ " Strips and two  $3\frac{1}{2}$ " x  $\frac{1}{2}$ " Double Angle Strips.

The sides are formed by four  $12\frac{1}{2}$ " x  $2\frac{1}{2}$ " Strip Plates, all of which are extended towards the centre of the car by  $2\frac{1}{2}$ " x  $2\frac{1}{2}$ " Flexible Plates. At the other ends of the  $12\frac{1}{2}$ " x  $2\frac{1}{2}$ " Strip Plates,  $5\frac{1}{2}$ " x  $1\frac{1}{2}$ " Flexible Plates are bolted to the  $12\frac{1}{2}$ " Angle Girders of the chassis and roof. Further  $5\frac{1}{2}$ " x  $1\frac{1}{2}$ " Flexible Plates bolted to  $5\frac{1}{2}$ " Strips form the sides of the central entrance, and are extended to the Angle Girders of the roof by Flat Brackets and Flat Trunnions, the Flat Trunnions on each side being joined together by  $5\frac{1}{2}$ " Strips to form the top of the entrance.

The windows are edged with  $12\frac{1}{2}$ " Strips, those at the top being attached to the roof by Obtuse Angle Brackets. At the lower edges of the sides  $12\frac{1}{2}$ " Strips are bolted to the  $2\frac{1}{2}$ " Strips of the chassis and are joined at their other ends by two sets of compound strips. The shorter compound strip is made by bolting Formed Slotted Strips to  $2\frac{1}{2}$ " Strips, and then joining the  $2\frac{1}{2}$ " Strips together with Obtuse Angle Brackets. The bumpers are made by bolting two  $5\frac{1}{2}$ " Strips together and curving them to shape.

The sides are extended at the front by  $1\frac{1}{8}$ " radius Curved Plates lengthened by overlapping them two holes with  $2\frac{1}{2}$ " x  $2\frac{1}{2}$ " Flexible Plates. The compound plates are joined to the Formed Slotted Strips and  $2\frac{1}{2}$ " Strips by Flat Brackets. A  $3\frac{1}{2}$ " Strip is bolted to each of the  $2\frac{1}{2}$ " Strips and to the  $2\frac{1}{2}$ " x  $2\frac{1}{2}$ " Flexible Plates. Formed Slotted Strips bolted to  $2\frac{1}{2}$ " Strips extend the front Flexible Plates and Curved Plates, and are attached by the  $2\frac{1}{2}$ " Strips to the upper ends of the  $3\frac{1}{2}$ " Strips.

The top of the roof consists of two  $12\frac{1}{2}$ " x  $2\frac{1}{2}$ " Strip Plates bolted to the inner sides of a  $3\frac{1}{2}$ " x  $2\frac{1}{2}$ " Flanged Plate. The  $12\frac{1}{2}$ " x  $2\frac{1}{2}$ " Strip Plates are extended by  $5\frac{1}{2}$ " x  $2\frac{1}{2}$ " Flexible Plates, which overlap the former by one hole.

## Parts required

12 of No. 1	3 of No. 22	2 of No. 111
21 " " 2	1 " " 23	5 " " 111a
5 " " 2a	1 " " 23a	6 " " 111c
4 " " 3	2 " " 24	2 " " 115
6 " " 4	2 " " 26	1 " " 116a
18 " " 5	2 " " 27a	4 " " 126
2 " " 6	4 " " 35	4 " " 126a
5 " " 6a	220 " " 37	2 " " 147b
10 " " 8	18 " " 37a	1 " " 166
4 " " 9	26 " " 38	1 " " 176
17 " " 10	1 " " 40	1 " " 186
10 " " 12	1 " " 43	6 " " 188
3 " " 12a	2 " " 46	8 " " 189
2 " " 12b	1 " " 48	7 " " 190
8 " " 12c	5 " " 48b	6 " " 191
1 " " 13	1 " " 48c	10 " " 192
3 " " 14	2 " " 48d	6 " " 197
2 " " 15	2 " " 51	8 " " 200
2 " " 15a	2 " " 52	1 " " 212
2 " " 15b	5 " " 53	2 " " 214
3 " " 16	9 " " 59	8 " " 215
5 " " 17	2 " " 62	2 " " 216
1 " " 18b	4 " " 63	4 " " 217a
4 " " 20	1 " " 94	1 E6 Electric Motor
1 " " 20a	1 " " 96	(Not included in Outfit)
4 " " 20b	1 " " 96a	
2 " " 21	2 " " 108	

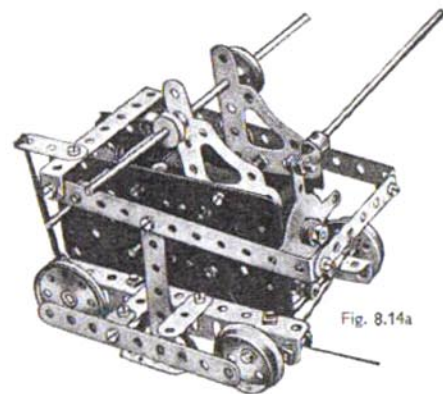

Fig. 8.14a

(Continued on next page)

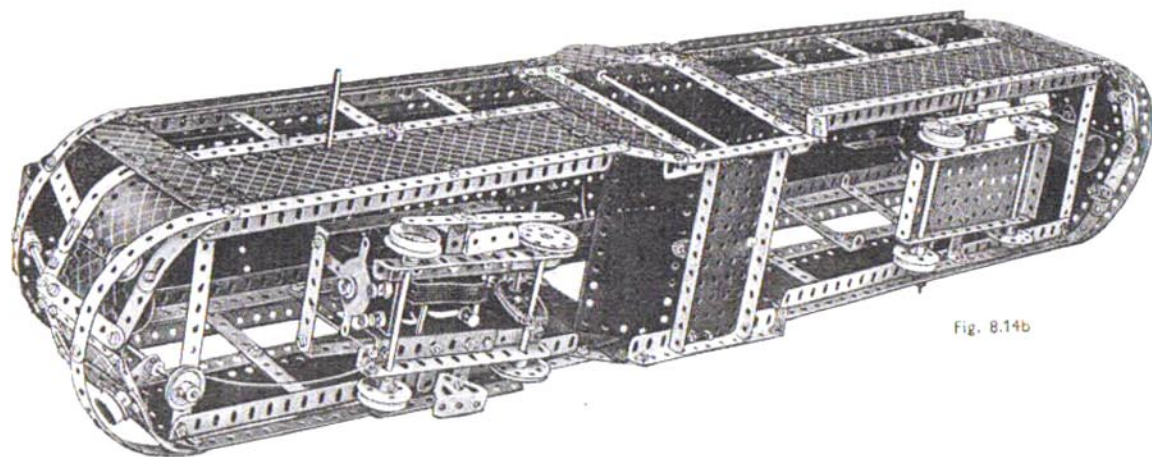

Fig. 8.14b

Continued from previous page

The curved sides of the roof are each made by bolting a  $1\frac{1}{2}$ " radius Curved Plate to the  $3\frac{1}{2}$ " x  $2\frac{1}{2}$ " Flanged Plate, and then bolting three  $5\frac{1}{2}$ " x  $2\frac{1}{2}$ " and three  $4\frac{1}{2}$ " x  $2\frac{1}{2}$ " Flexible Plates to the upper  $12\frac{1}{2}$ " Angle Girders of the sides. The Flexible Plates are joined to the Strip Plates of the roof in the following manner. Two  $3\frac{1}{2}$ " x  $2\frac{1}{2}$ " Flanged Plates are bolted to the Strip Plates and Flexible Plates on each side of the centre Flanged Plate, but spaced equally apart, and to them are bolted the  $5\frac{1}{2}$ " x  $2\frac{1}{2}$ " and  $4\frac{1}{2}$ " x  $2\frac{1}{2}$ " Flexible Plates. At the rear end of the roof additional support for the Flexible Plates is provided by two  $3\frac{1}{2}$ " x  $\frac{1}{2}$ " Double Angle Strips. The curved front of the roof is obtained by extending the  $5\frac{1}{2}$ " x  $2\frac{1}{2}$ " Flexible Plates by  $1\frac{1}{2}$ " radius Curved Plates, the remaining space being filled in with  $2\frac{1}{2}$ " x  $1\frac{1}{2}$ " Flexible Plates. Destination boards are made by Trunnions.

The compound angle girders of the roof are joined at the ends by compound strips, made by bolting  $2\frac{1}{2}$ " Strips end to end and curving them to form a  $2\frac{1}{2}$ " x  $1\frac{1}{2}$ " Flanged Plates are joined together by bolting  $1\frac{1}{4}$ " Discs to their flanges. A  $1\frac{1}{2}$ " x  $\frac{1}{2}$ " Double Angle Strip is then bolted to the Flanged Plates and a Pivot Bolt, carrying a 2" Pulley, is lock-nutted in its centre hole. A Rod and Strip Connector lock-nutted at 1" to an Angle Bracket, carries a compound rod consisting of an  $11\frac{1}{2}$ " Rod joined to a 2" Rod by a Coupling. The Rod carries at its other end a small Fork Piece, in the end of which is retained a 1" Rod carrying a  $\frac{1}{2}$ " loose Pulley. A  $\frac{3}{4}$ " Bolt has a Spring held against its head by a Nut, and is screwed into the Coupling. The other end of the Spring is held on a second  $\frac{3}{4}$ " Bolt lock-nutted to the 2" Pulley. The complete unit is attached to the roof by two  $1\frac{1}{2}$ " x  $1\frac{1}{2}$ " Angle Brackets.

The window bars in the control cab at the rear end of the body are formed by two 3" Strips and a 2" Rod held in the longitudinal bore of a Coupling. The dummy brake handle is a Crank fitted with a Threaded Pin, and is held by a  $\frac{3}{4}$ " Bolt to a  $1\frac{1}{2}$ " x  $1\frac{1}{2}$ " Angle Bracket fastened to the front of the cab. The speed control box is a  $2\frac{1}{2}$ " Cylinder, to which a  $1\frac{1}{4}$ " Disc is attached by a  $1\frac{1}{2}$ " x  $\frac{1}{2}$ " Angle Bracket.

The windows in the control cab at the front of the tramcar are the same as those at the rear, but a Strip is omitted to allow access to the brake control handle, which consists of a Crank fitted with a Threaded Pin and is secured on a  $4\frac{1}{2}$ " Rod. The Rod is journalled in a  $2\frac{1}{2}$ " x  $1\frac{1}{2}$ " Double Angle Strip, and is retained in place by a Collar. At its lower end the Rod carries a Cord Anchoring Spring and a 1" Pulley (see Fig. 8.14b). The body is completed by fitting the  $3\frac{1}{2}$ " Flanged Wheels to represent headlights, and by attaching  $5\frac{1}{2}$ " x  $2\frac{1}{2}$ " Flexible Plates to the  $5\frac{1}{2}$ " x  $2\frac{1}{2}$ " Flanged Plate of the chassis by Obtuse Angle Brackets. The  $6\frac{1}{2}$ " Rods forming hand rails in the entrance are secured at their upper ends in Collars held by the same Bolts that hold the Semi-Circular Plates.

Figs 8.14a and 8.14c show the construction of the front driving bogie. An E20B Electric Motor is bolted by its flanges to two  $5\frac{1}{2}$ " Angle Girders.

The axle carrying the  $1\frac{1}{2}$ " Flanged Wheels is a 4" Rod, the Flanged Wheels being spaced from the  $5\frac{1}{2}$ " Angle Girders by three Washers. The other axle is a  $3\frac{1}{2}$ " Rod, and carries a  $\frac{3}{4}$ " Sprocket between the Angle Girders. The wheel guards are  $4\frac{1}{2}$ " Strips attached by Angle Brackets to  $1\frac{1}{2}$ " Strips. The gear train is arranged in the following manner.

A  $\frac{3}{4}$ " Pinion is secured on the armature shaft and meshes with a 57-teeth Gear fastened on a 2" Rod journalled in the Motor side plates, but spaced from them by three Washers. This Rod carries between the Motor side plates a  $\frac{1}{2}$ " Pinion that meshes with another 57-teeth Gear fastened on a  $3\frac{1}{2}$ " Rod, which carries also a 1" Sprocket Wheel. The Sprocket Wheel is connected by a short length of Sprocket Chain to the  $\frac{3}{4}$ " Sprocket Wheel on the driving axle. A line brake is fitted to the driving unit and it consists of two  $5\frac{1}{2}$ " x  $\frac{1}{2}$ " Double Angle Strips joined at one end by a  $3\frac{1}{2}$ " x  $\frac{1}{2}$ " Double Angle Strip and at the other end by a  $3\frac{1}{2}$ " Strip. The frame so formed is pivoted on a  $3\frac{1}{2}$ " Rod, and is prevented from sliding by two Collars, while side play in the Rod is prevented by two Spring Clips. The brake shoes are Trunnions bolted to 3" Strips pivoted to lock-nutted Bolts 2, and are held clear of the ground by a Driving Band (Fig. 8.14c). The Architraves are bolted to the Motor side plates, and to fit the bogie in the car a  $6\frac{1}{2}$ " Rod is passed through the  $12\frac{1}{2}$ " x  $2\frac{1}{2}$ " Strip Plates of the sides and through the second holes from the top of the Architraves. A  $\frac{1}{2}$ " Pulley and a 1" Pulley prevent the driving unit from sliding from side to side, and Collars retain the  $6\frac{1}{2}$ " Rod in position.

To facilitate operation of the Motor switch a  $4\frac{1}{2}$ " Rod is held in an End Bearing lock-nutted to the switch lever of the Motor, and also passes through one side of the model. A short length of Cord is tied to the  $3\frac{1}{2}$ " Strip of the brake operating frame and is passed around a Pivot Bolt lock-nutted to one of the  $5\frac{1}{2}$ " Angle Girders (Fig. 8.14a). It is then tied to the Cord Anchoring Spring on the Rod carrying the brake control handle. When the brake handle is rotated the Cord pulls the  $3\frac{1}{2}$ " Strip downward and the Trunnions make contact with the ground.

The rear bogie is constructed from a  $5\frac{1}{2}$ " x  $2\frac{1}{2}$ " Flanged Plate, to which are attached by the same Bolts, a  $4\frac{1}{2}$ " x  $\frac{1}{2}$ " Double Angle Strip and a  $2\frac{1}{2}$ " x  $1\frac{1}{2}$ " Double Angle Strip. Two  $4\frac{1}{2}$ " Strips are bolted one to each end of the  $4\frac{1}{2}$ " x  $\frac{1}{2}$ " Double Angle Strip (Fig. 8.14c). The wheel axles are 4" Rods, and the  $1\frac{1}{2}$ " Flanged Wheels and Bush Wheels are spaced from the Flanged Plate by Washers. The bogie is pivoted on a compound rod consisting of a 5" Rod joined to a 2" Rod by a Coupling. The compound rod is journalled in the lower  $12\frac{1}{2}$ " Strips of the sides and is held in place by Collars.

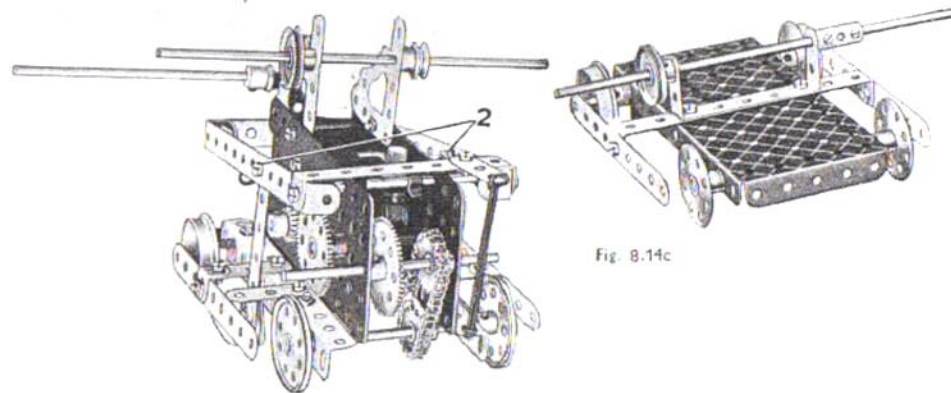
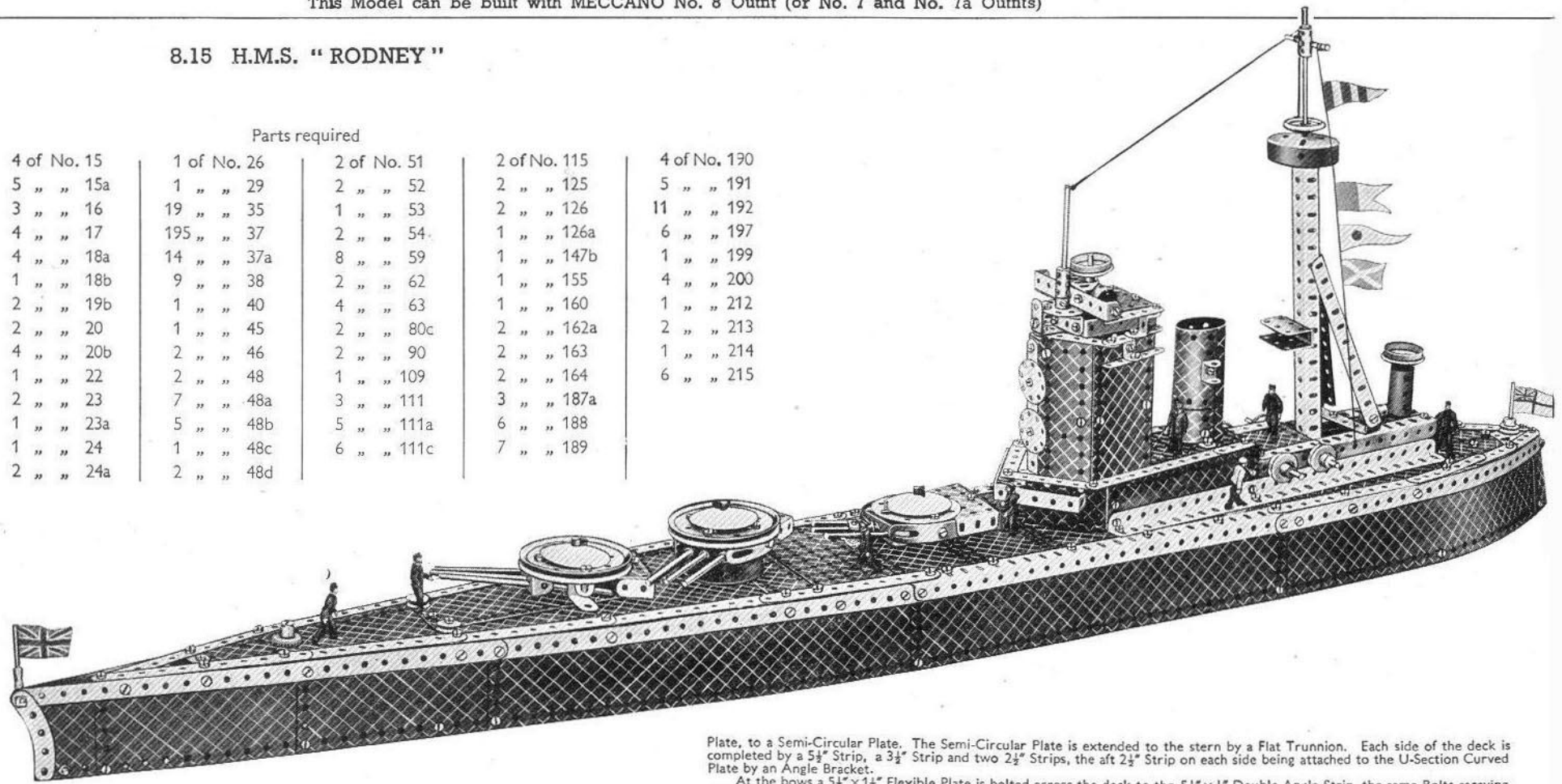

Fig. 8.14c

## 8.15 H.M.S. "RODNEY"

## Parts required

8 of No. 1	4 of No. 15	1 of No. 26	2 of No. 51	2 of No. 115	4 of No. 190
15 " " 2	5 " " 15a	1 " " 29	2 " " 52	2 " " 125	5 " " 191
2 " " 3	3 " " 16	19 " " 35	1 " " 53	2 " " 126	11 " " 192
2 " " 4	4 " " 17	195 " " 37	2 " " 54	1 " " 126a	6 " " 197
15 " " 5	4 " " 18a	14 " " 37a	8 " " 59	1 " " 147b	1 " " 199
3 " " 6a	1 " " 18b	9 " " 38	2 " " 62	1 " " 155	4 " " 200
8 " " 8	2 " " 19b	1 " " 40	4 " " 63	1 " " 160	1 " " 212
3 " " 9	2 " " 20	1 " " 45	2 " " 80c	2 " " 162a	2 " " 213
4 " " 11	4 " " 20b	2 " " 46	2 " " 90	2 " " 163	1 " " 214
25 " " 12	1 " " 22	2 " " 48	1 " " 109	2 " " 164	6 " " 215
4 " " 12a	2 " " 23	7 " " 48a	3 " " 111	3 " " 187a	
2 " " 12b	1 " " 23a	5 " " 48b	5 " " 111a	6 " " 188	
4 " " 12c	1 " " 24	1 " " 48c	6 " " 111c	7 " " 189	
1 " " 14	2 " " 24a	2 " " 48d			



Construction of the hull should be commenced by making the sides. Three  $12\frac{1}{2} \times 2\frac{1}{2}$ " Strip Plates are bolted end to end to the centre Plate a  $12\frac{1}{2}$ " Angle Girder is bolted. Each side is further extended by two  $5\frac{1}{2} \times 2\frac{1}{2}$ " Flexible Plates and a  $2\frac{1}{2} \times 2\frac{1}{2}$ " Flexible Plate. The sides are strengthened by  $12\frac{1}{2}$ " Strips bolted along the upper edges of the Strip and Flexible Plates, and the lower edges of the Flexible Plates are bolted to  $12\frac{1}{2}$ " Strips. The  $12\frac{1}{2} \times 2\frac{1}{2}$ " Strip Plates are joined together at the rear by a U-Section Curved Plate, which is arranged so that it slopes towards the deck. The lower edges of the side Plates are joined by a  $5\frac{1}{2} \times \frac{1}{2}$ " Double Angle Strip and by a  $2\frac{1}{2} \times \frac{1}{2}$ " Double Angle Strip.

At the bows the ends of the front  $12\frac{1}{2}$ " Strips are bolted together, the Bolt carrying also two  $2\frac{1}{2}$ " large radius Curved Strips. The upper edges of the sides are joined by two  $5\frac{1}{2} \times 2\frac{1}{2}$ " Flanged Plates; one of which is bolted to the aft  $12\frac{1}{2}$ " Strips directly behind the  $12\frac{1}{2}$ " Angle Girder, and the other to the  $12\frac{1}{2}$ " Strips in front of the  $12\frac{1}{2}$ " Angle Girders. Additional stays are formed by a  $5\frac{1}{2} \times \frac{1}{2}$ ", a  $4\frac{1}{2} \times \frac{1}{2}$ " and a  $3\frac{1}{2} \times \frac{1}{2}$ " Double Angle Strip bolted as shown in Fig. 8.15a.

In a position 10 holes from the bows of the model two  $1 \times 1$ " Angle Brackets are bolted to the sides and to each other. The portion of the deck between the two  $5\frac{1}{2} \times 2\frac{1}{2}$ " Flanged Plates, which supports the superstructure, is filled in by five  $5\frac{1}{2} \times 2\frac{1}{2}$ " Flexible Plates. At the stern two Flanged Sector Plates are bolted one to each side, with their narrow ends to the stern. A  $2\frac{1}{2} \times 1\frac{1}{2}$ " Flexible Plate is bolted to each Flanged Sector Plate and the other ends of the two are bolted together with a  $2\frac{1}{2} \times 2\frac{1}{2}$ " Flexible

Plate, to a Semi-Circular Plate. The Semi-Circular Plate is extended to the stern by a Flat Trunnion. Each side of the deck is completed by a  $5\frac{1}{2}$ " Strip, a  $3\frac{1}{2}$ " Strip and two  $2\frac{1}{2}$ " Strips, the aft  $2\frac{1}{2}$ " Strip on each side being attached to the U-Section Curved Plate by an Angle Bracket.

At the bows a  $5\frac{1}{2} \times 1\frac{1}{2}$ " Flexible Plate is bolted across the deck to the  $5\frac{1}{2} \times \frac{1}{2}$ " Double Angle Strip, the same Bolts carrying also two  $5\frac{1}{2} \times 2\frac{1}{2}$ " Flexible Plates. The other ends of the  $5\frac{1}{2} \times 2\frac{1}{2}$ " Flexible Plates are bolted together with two  $4\frac{1}{2} \times 2\frac{1}{2}$ " Flexible Plates, to the  $4\frac{1}{2} \times \frac{1}{2}$ " Double Angle Strip spacing the deck. The  $4\frac{1}{2} \times 2\frac{1}{2}$ " Flexible Plates are overlapped three holes, and their other ends are supported by the  $3\frac{1}{2} \times \frac{1}{2}$ " Double Angle Strips of the deck. A  $4\frac{1}{2} \times 2\frac{1}{2}$ " Flexible Plate extended by a  $2\frac{1}{2} \times 1\frac{1}{2}$ " Flexible Plate, is bolted to the rear Flexible Plates, and the  $2\frac{1}{2} \times 1\frac{1}{2}$ " Flexible Plate is bolted to the  $1 \times 1$ " Angle Brackets. The sides of the deck are completed on each side by five  $5\frac{1}{2}$ " Strips.

The gun turrets are free to swivel. The two outside gun turrets are pivoted on Rods held in the bosses of Cranks, and the Rod of the centre gun turret is journaled in a Double Bent Strip. The  $\frac{1}{2}$ " loose Pulleys are fastened to the deck by  $\frac{3}{8}$ " Bolts, and the  $\frac{3}{4}$ " Contrate Wheel is held by a Pivot Bolt. The flag mast in the bows is a  $1\frac{1}{2}$ " Rod held in a Rod and Strip Connector, and the rear mast is a  $3\frac{1}{2}$ " Rod held in place by a  $\frac{1}{2}$ " fast Pulley and a  $\frac{1}{2}$ " Pinion.

The superstructure of the deck is built on two  $12\frac{1}{2}$ " Angle Girders, to each of which is bolted a  $5\frac{1}{2} \times 1\frac{1}{2}$ " Flexible Plate. Further  $12\frac{1}{2}$ " Angle Girders are fixed to the  $5\frac{1}{2} \times 1\frac{1}{2}$ " Flexible Plates above the first Angle Girders and at the rear end are bolted to a  $2\frac{1}{2} \times 1\frac{1}{2}$ " Flanged Plate. Just forward of the mast a  $2\frac{1}{2} \times 2\frac{1}{2}$ " Flexible Plate reinforced by two  $2\frac{1}{2}$ " Strips is bolted. The front of the superstructure is joined by a  $5\frac{1}{2} \times 1\frac{1}{2}$ " Flexible Plate curved to shape.

The control tower consists of two  $4\frac{1}{2} \times 2\frac{1}{2}$ " Flexible Plates attached at the rear to a  $5\frac{1}{2} \times 1\frac{1}{2}$ " Flexible Plate by Angle Brackets, and fixed at the front to two  $5\frac{1}{2} \times 1\frac{1}{2}$ " Flexible Plates by Obtuse Angle Brackets. The control tower is then bolted by the front  $5\frac{1}{2} \times 1\frac{1}{2}$ " Flexible Plates to the superstructure. The aft  $5\frac{1}{2} \times 1\frac{1}{2}$ " Flexible Plate is bolted to a  $3\frac{1}{2} \times 2\frac{1}{2}$ " Flanged Plate that in turn is fastened to the upper  $12\frac{1}{2}$ " Angle Girders by two  $\frac{3}{4}$ " Bolts.

(Continued on next page)



(Continued from previous page)

The top of the control tower is built as follows. A  $2\frac{1}{2}$ " Strip and a  $3\frac{1}{2}$ "  $\times$   $\frac{1}{2}$ " Double Angle Strip are bolted across the shorter ends of a  $2\frac{1}{2}$ "  $\times$   $1\frac{1}{2}$ " Flexible Plate, the Bolts holding also a second  $3\frac{1}{2}$ "  $\times$   $\frac{1}{2}$ " Double Angle Strip bolted along the length of the Flexible Plate. The ends of the first mentioned  $3\frac{1}{2}$ "  $\times$   $\frac{1}{2}$ " Double Angle Strip and the  $2\frac{1}{2}$ " Strip are joined by further  $2\frac{1}{2}$ " Strips. Two  $2\frac{1}{2}$ "  $\times$   $\frac{1}{2}$ " Double Angle Strips are then joined at one end by a Trunnion, and at the other end by a  $1\frac{1}{2}$ " Strip, the Trunnion being bolted to one of the  $3\frac{1}{2}$ "  $\times$   $\frac{1}{2}$ " Double Angle Strips. A Bush Wheel also is fixed to the Double Angle Strip, and a third  $3\frac{1}{2}$ "  $\times$   $\frac{1}{2}$ " Double Angle Strip is bolted to the top Double Angle Strip to form the bridge (see Fig. 8.15b). A Trunnion is bolted to the bridge and it carries a  $1\frac{1}{2}$ " Rod to which is fastened a  $1\frac{1}{4}$ " Flanged Wheel. The Rod passes through a Sleeve Piece and is retained in position by a Collar inside the Sleeve Piece.

A  $3\frac{1}{2}$ " Rod held in the boss of the Bush Wheel forms the wireless mast, and is fitted with a Coupling.

A fourth  $3\frac{1}{2}$ "  $\times$   $\frac{1}{2}$ " Double Angle Strip has two  $2\frac{1}{2}$ " Strips bolted to it at one end. The Bolt carries also a  $1$ "  $\times$   $1$ " Angle Bracket attached to the second  $3\frac{1}{2}$ "  $\times$   $\frac{1}{2}$ " Double Angle Strip bolted to the  $2\frac{1}{2}$ "  $\times$   $1\frac{1}{2}$ " Flexible Plate. The two  $2\frac{1}{2}$ " Strips are extended around the top of the control tower by further  $2\frac{1}{2}$ " Strips fitted with Reversed Angle Brackets in their centre holes, the Brackets being arranged so that their other ends are clamped between the  $2\frac{1}{2}$ " Strips bolted to the  $2\frac{1}{2}$ "  $\times$   $1\frac{1}{2}$ " Flexible Plate. Double Brackets carry  $2\frac{1}{2}$ " Strips as shown. The complete unit is now ready for bolting in position. The Double Brackets are bolted to the  $4\frac{1}{2}$ "  $\times$   $2\frac{1}{2}$ " Flexible Plates, and the lowest  $3\frac{1}{2}$ "  $\times$   $\frac{1}{2}$ " Double Angle Strip is bolted at its rear end to the  $5\frac{1}{2}$ "  $\times$   $1\frac{1}{2}$ " Flexible Plate, and at its front end to a  $5\frac{1}{2}$ " Strip attached to the front of the superstructure. A  $1$ "  $\times$   $1$ " Angle Bracket bolted to this  $5\frac{1}{2}$ " Strip carries two  $3$ " Strips and an Angle Bracket, to which two  $2\frac{1}{2}$ "  $\times$   $\frac{1}{2}$ " Double Angle Strips are bolted as shown. A  $5\frac{1}{2}$ " Strip is bolted to the end of each  $3$ " Strip and is clamped to the  $3\frac{1}{2}$ "  $\times$   $2\frac{1}{2}$ " Flanged Plate by a  $1\frac{1}{4}$ " Strip.

The funnel consists of four  $1\frac{1}{4}$ " radius Curved Plates, pairs of which overlap each other by three holes and are bolted together, the upper Bolts carrying also Double Brackets; the funnel is fastened to the deck by two Angle Brackets. The rear guns are formed by two  $4\frac{1}{2}$ " Rods which are pushed through holes in the upper  $12\frac{1}{2}$ " Angle Girders and are held in place by the  $\frac{3}{4}$ " Flanged Wheels that form the gun shields.

At the after end of this deck is a Coupling fastened on a  $3$ " Screwed Rod lock-nutted to the  $2\frac{1}{2}$ "  $\times$   $1\frac{1}{2}$ " Flanged Plate. Behind the Coupling is a Sleeve Piece fitted with Chimney Adaptors. A  $3$ " Screwed Rod, which has a  $1\frac{1}{4}$ " Flanged Wheel secured to it, is passed through the Chimney Adaptor and also through a hole in the deck, and is held in place by a nut.

The two  $5\frac{1}{2}$ " Angle Girders bracing the mast are bolted to a  $2\frac{1}{2}$ "  $\times$   $\frac{1}{2}$ " Double Angle Strip that in turn is fastened to the upper deck. The main mast consists of two  $12\frac{1}{2}$ " Angle Girders bolted together in the form of a U-section girder, to the upper end of which a  $5\frac{1}{2}$ " Angle Girder is then bolted to make a box girder. The upper part of the mast is a  $6\frac{1}{2}$ " Rod held in a Collar fastened inside the mast, the Rod carrying a Boiler End and a  $1$ " Pulley fitted with a Rubber Ring. At the top of the Rod is a Coupling that holds a  $2$ " Rod in its centre transverse bore. A  $1$ " Rod is held in the unoccupied part of the longitudinal bore. A Channel Bearing is bolted to the mast, and after the superstructure has been placed in position the mast is passed through the opening in the deck and is bolted to the flange of the rear  $5\frac{1}{2}$ "  $\times$   $2\frac{1}{2}$ " Flanged Plate.

An underneath view of the gun turrets is shown in Fig. 8.15b. The forward gun turret is shown on the left, and is made by bolting a  $2\frac{1}{2}$ "  $\times$   $1\frac{1}{2}$ " Flexible Plate to a  $3$ " Pulley, to which two Formed Slotted Strips are attached by Angle Brackets.

The barrels of the guns are carried in a  $1\frac{1}{2}$ "  $\times$   $\frac{1}{2}$ " Double Angle Strip, and are held in Angle Brackets by Spring Clips. The Angle Brackets are spaced from the  $3$ " Pulley by Collar placed on the shanks of the Bolts. A  $2\frac{1}{2}$ "  $\times$   $1$ " Double Angle Strip forms the rear of the turret. The central gun barrel is a  $2$ " Rod joined by a Rod Connector to a Threaded Pin, and the other gun barrels are  $5$ " Rods. A  $2$ " Rod is locked in the boss of the  $3$ " Pulley and is fitted in the boss of the Crank bolted to the main deck. The Conical Disc is held in place by a Spring Clip.

The centre gun turret and its guns are identical in construction to that already described, but this turret is carried on a  $3\frac{1}{2}$ " Rod locked in the boss of the  $3$ " Pulley. The Rod is passed through the centre hole of a Boiler End and through holes in the Double Bent Strip and deck, and is retained in position by a Collar underneath the deck.

The rear gun turret is shown on the right (Fig. 8.15b) and is made by bolting a  $2\frac{1}{2}$ "  $\times$   $1\frac{1}{2}$ " Flanged Plate in the slotted hole of a Face Plate. A  $2\frac{1}{2}$ "  $\times$   $\frac{1}{2}$ " Double Angle Strip is attached by an Angle Bracket to the rear edge of the Flanged Plate. Two Formed Slotted Strips are fixed by Angle Brackets to the Face Plate, and two  $1$ "  $\times$   $\frac{1}{2}$ " Angle Brackets bolted together by a  $\frac{3}{4}$ " Bolt are attached to the Face Plate by a second Angle Bracket, the Bolt carrying three Washers on its shank for spacing purposes. The centre gun is made by joining a  $1\frac{1}{2}$ " Rod to the  $\frac{3}{4}$ " Bolt by a Coupling. The turret is pivoted on a  $1\frac{1}{2}$ " Rod passed into the boss of the Crank.

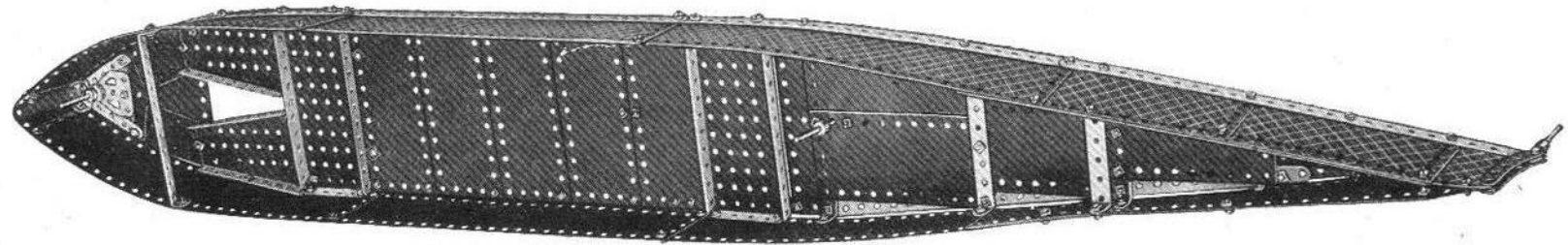

Fig. 8.15a

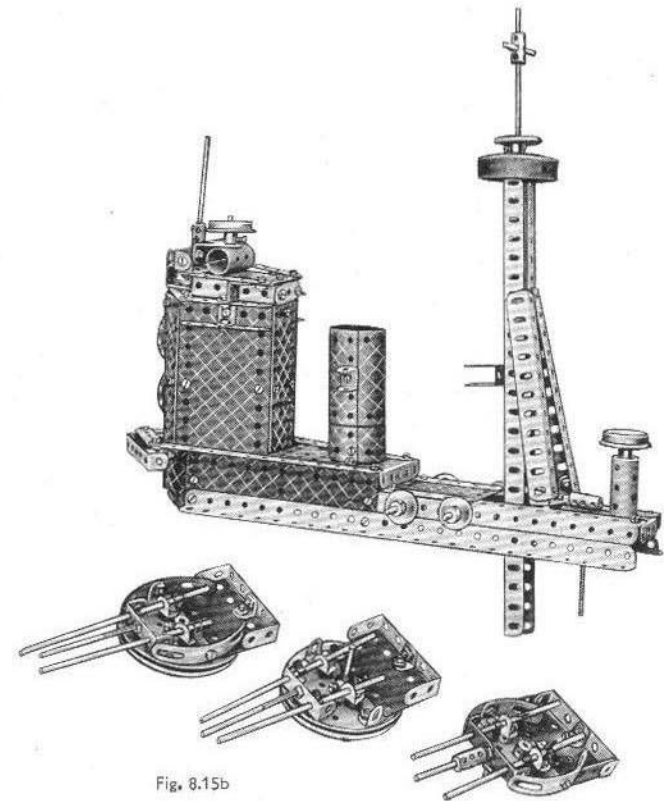
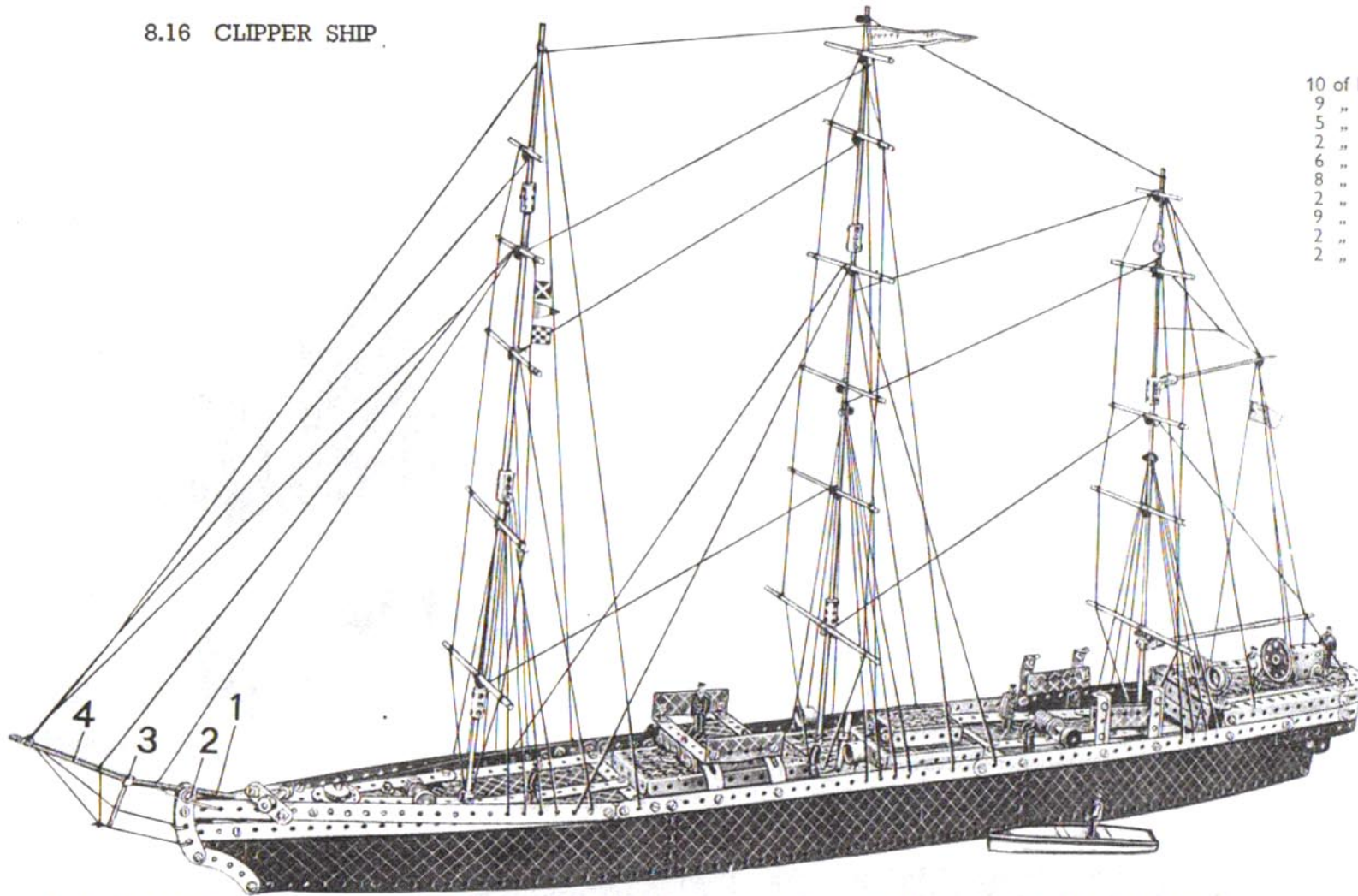

Fig. 8.15b

## 8.16 CLIPPER SHIP



## Parts required

10 of No.	1	5 of No.	16
9 "	2	5 "	17
5 "	2a	4 "	18a
2 "	3	1 "	19g
6 "	4	1 "	19h
8 "	5	2 "	20b
2 "	6a	1 "	21
9 "	8	2 "	23
2 "	9	1 "	23a
2 "	10	1 "	24
		1 "	26
		1 "	32
		19 "	35
		150 "	37
		13 "	37a
		13 "	38
		3 "	40
		4 "	48a
		2 "	48b
		2 "	51
		2 "	52
		1 "	53
		8 "	59
		1 "	62
		6 "	63
		1 "	77
		2 "	80c
		4 "	90
		2 "	90a
		3 "	111
		5 "	111a
		3 "	111c
		2 "	115
		1 "	116a
		1 "	126a
		1 "	160
		2 "	164
		2 "	165
		1 "	176
		8 "	188
		4 "	189
		1 "	190
		4 "	192
		6 "	197
		1 "	198
		1 "	212
		2 "	213
		1 "	214
		8 "	215
		1 "	217a
		1 "	217b
		5 "	15a
		2 "	15b
3 of No.	11		
16 "	12		
2 "	12b		
2 "	13		
1 "	13a		
3 "	14		
4 "	15		
5 "	15a		
2 "	15b		

The sides of the vessel each consist of three  $12\frac{1}{2}$ " Strip Plates bolted end to end and joined at the centre by  $4\frac{1}{2}$ " Strips. The Strip Plates are strengthened by bolting  $12\frac{1}{2}$ " Strips along their upper edges.

The rudder is a Flat Trunnion secured to the sides of the ship between two  $2\frac{1}{2}$ " $\times$  $1\frac{1}{2}$ " Flexible Plates, and the rounded stern is formed by two  $5\frac{1}{2}$ " $\times$  $1\frac{1}{2}$ " Flexible Plates overlapped one hole and bolted to the  $12\frac{1}{2}$ " Strip Plates.

The centre deck is composed of seven  $12\frac{1}{2}$ " Angle Girders, which are bolted between the two  $4\frac{1}{2}$ " Strips bracing the sides of the ship, and it is extended to the rear by a Hinged Flat Plate and two  $5\frac{1}{2}$ " $\times$  $2\frac{1}{2}$ " Flexible Plates. The raised aft deck is formed by a  $5\frac{1}{2}$ " $\times$  $2\frac{1}{2}$ " Flanged Plate, to the edges of which are bolted two  $5\frac{1}{2}$ " Angle Girders, and it is supported by Flat Brackets from the sides of the ship.

Two  $5\frac{1}{2}$ " $\times$  $2\frac{1}{2}$ " Flexible Plates overlapped two holes and extended to the front by two  $5\frac{1}{2}$ " $\times$  $1\frac{1}{2}$ " Flexible Plates, form the fore deck. The Flexible Plates are braced round the edges by  $5\frac{1}{2}$ " Strips, and are fastened to the sides of the ship by Angle Brackets.

A  $5\frac{1}{2}$ " $\times$  $2\frac{1}{2}$ " Flanged Plate secured to the deck by Angle Brackets, is used for the base of the bridge, and a  $2\frac{1}{2}$ " $\times$  $1\frac{1}{2}$ " Flanged Plate is fastened to the centre of it by two more Angle Brackets. A  $2\frac{1}{2}$ " $\times$  $2\frac{1}{2}$ " Flexible Plate is bolted to the top of the smaller Flanged Plate, the Bolts holding also two  $3\frac{1}{2}$ " Strips. The latter are each connected to the sides of the ship by two Formed Slotted Strips. Two U-Section Curved Plates, secured in position by Angle Brackets, are used to represent the inverted lifeboats at each side of the bridge.

The bowsprit is formed by two 3" Screwed Rods 1 and 4, which are each screwed into a tapped hole of the Collar 3. The Screwed Rod 1 is supported in a Collar fastened between two large radius Curved Strips in the bows by the Bolts 2.



Fig. 8.16

### 8.17 GIANT SWING BOAT

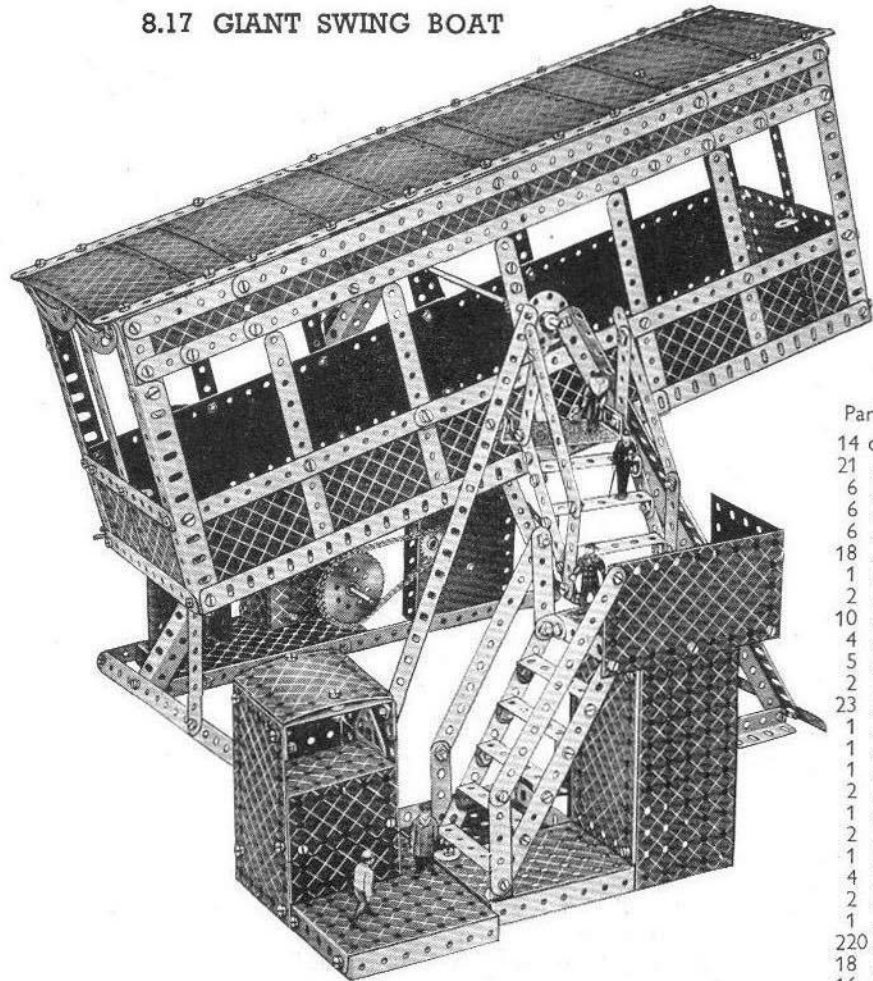

Parts required			
14 of No. 1	1	1 of No. 43	
21 " " 2	2	2 " " 46	
6 " " 2a	2a	2 " " 48	
6 " " 3	3	10 " " 48a	
6 " " 4	4	3 " " 48b	
6 " " 4	4	2 " " 48c	
18 " " 5	5	2 " " 48d	
1 " " 6	6	2 " " 51	
2 " " 6a	6a	2 " " 52	
10 " " 8	8	5 " " 53	
4 " " 9	9	2 " " 54	
5 " " 10	10	8 " " 59	
2 " " 11	11	2 " " 62	
23 " " 12	12	4 " " 63	
1 " " 12a	12a	2 " " 80c	
1 " " 13	13	4 " " 90a	
1 " " 14	14	1 " " 94	
2 " " 15	15	1 " " 95	
1 " " 15b	15b	1 " " 96a	
2 " " 17	17	2 " " 109	
1 " " 24	24	3 " " 111	
4 " " 24a	24a	6 " " 111a	
2 " " 26	26	6 " " 111c	
1 " " 27a	27a	1 " " 115	
220 " " 37	37	1 " " 120b	
18 " " 37a	37a	1 " " 126	
16 " " 38	38	2 " " 126a	
		1 " " 147b	
		1 " " 162a	
		1 " " 162b	
		1 " " 163	
		1 " " 164	
		1 " " 166	
		7 " " 188	
		8 " " 189	
		10 " " 190	
		5 " " 191	
		12 " " 192	
		6 " " 197	
		1 " " 200	
		1 " " 216	
		No. 1 Clockwork Motor	
		(Not included in Outfit)	

The floor of the boat is formed by four  $12\frac{1}{2} \times 2\frac{1}{2}$ " Strip Plates, which are supported by a compound strip made from two 3" Strips. The boat is pivotally mounted on an  $11\frac{1}{2}$ " Rod locked in the bosses of two Cranks bolted to the roof supports as shown. The  $11\frac{1}{2}$ " Rod is journaled in the centre holes of Wheel Discs, which are bolted to the  $12\frac{1}{2}$ " Angle Girders that act as supports. The 3" stepped Curved Strips shown in the illustrations should be replaced by  $2\frac{1}{2}$ " small radius Curved Strips.

The back of the pay-box is formed by a  $2\frac{1}{2} \times 2\frac{1}{2}$ " and a  $2\frac{1}{2} \times 1\frac{1}{2}$ " Flexible Plate joined by a Flat Trunnion.

The operating mechanism is housed between two Flanged Sector Plates, which are attached to the base by two  $1\frac{1}{2} \times \frac{1}{2}$ " Double Angle Strips and are bolted to two  $2\frac{1}{2} \times 1\frac{1}{2}$ " Flexible Plates. Sprocket Chain connects the  $\frac{3}{4}$ " Sprocket Wheel on the driving shaft of the No. 1 Clockwork Motor to a 2" Sprocket Wheel fastened on a 4" Rod, which carries two Collars and a  $\frac{1}{2}$ " Pinion between the

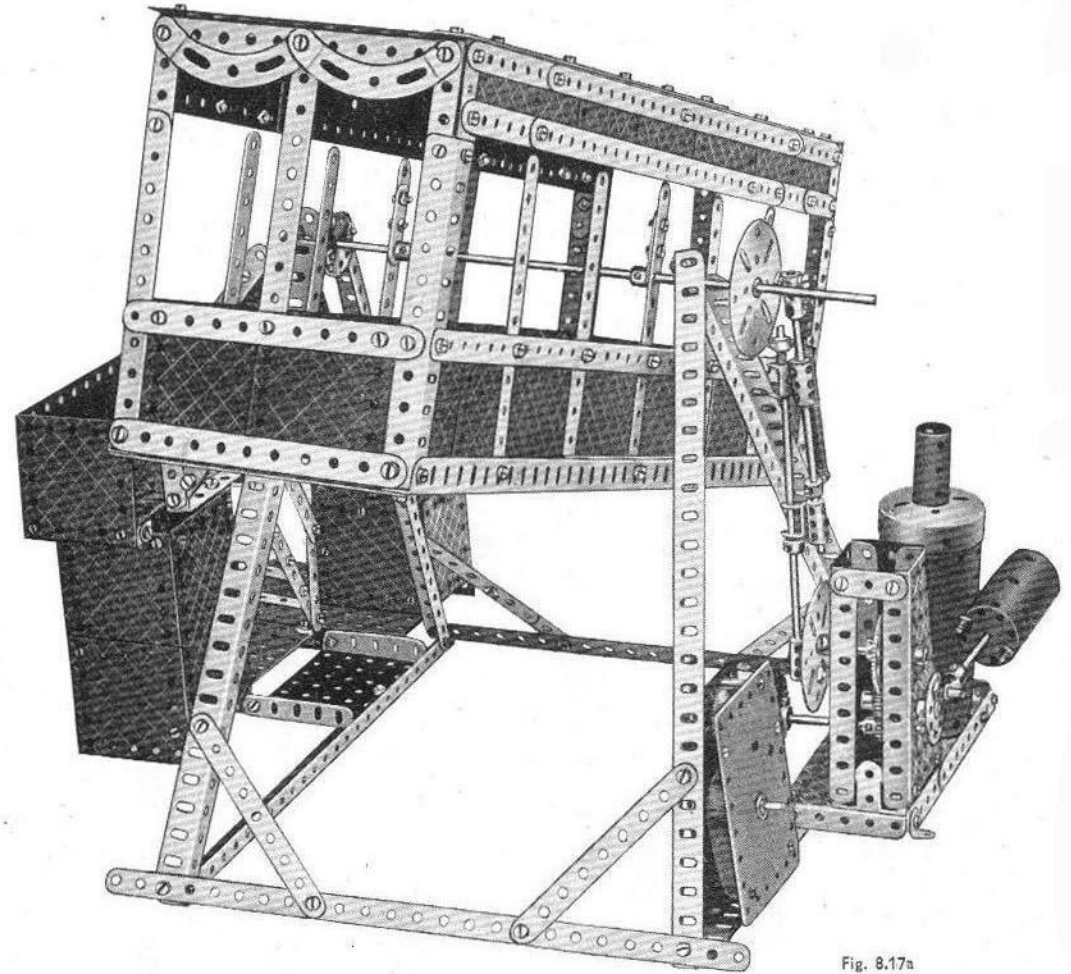
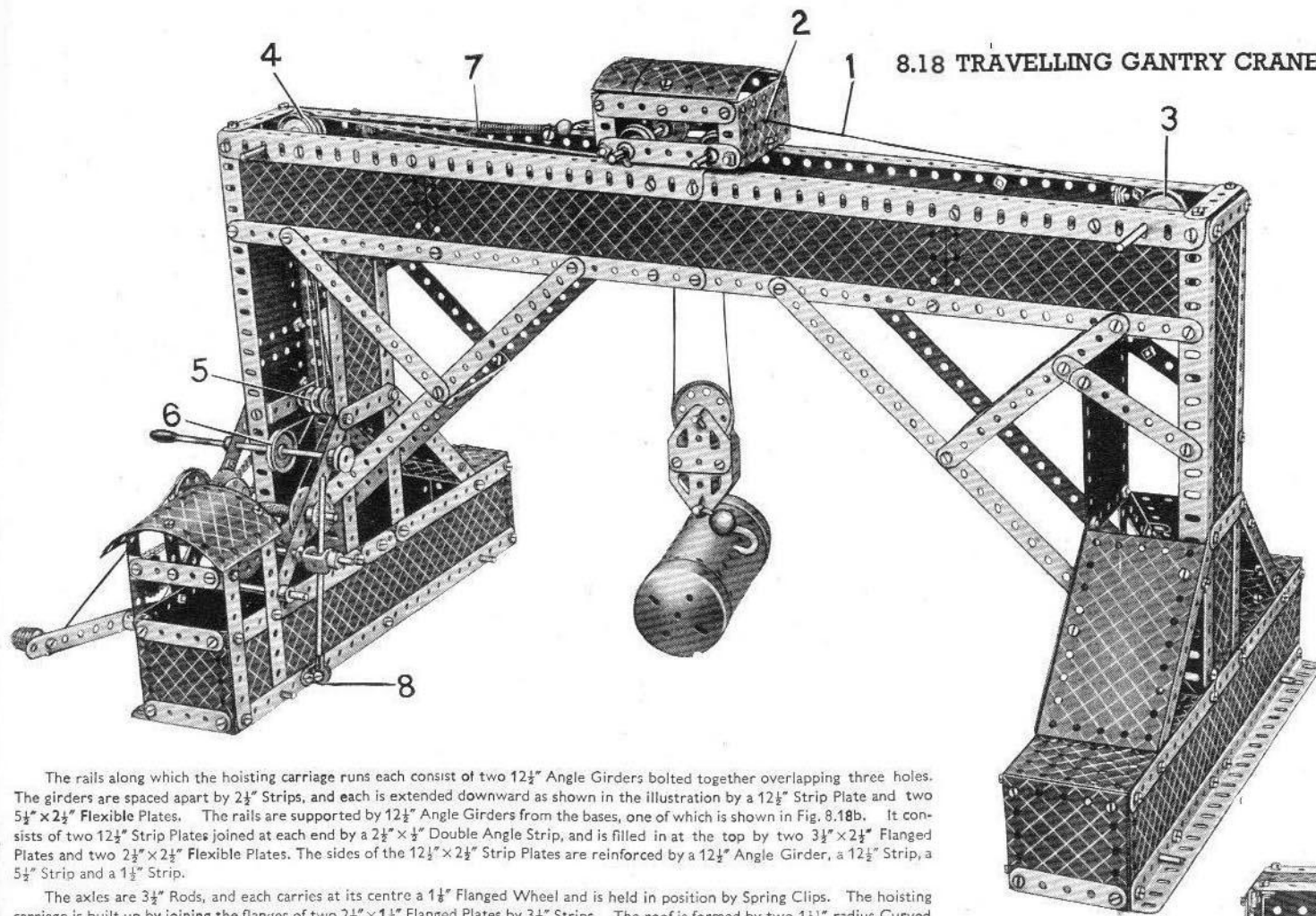

Fig. 8.17a

Flanged Sector Plates. Above this Rod is a 2" Rod, on which is a  $\frac{1}{2}$ " Pinion that meshes with the first  $\frac{1}{2}$ " Pinion, and a Collar. Outside the Flanged Sector Plates on the same Rod is a Bush Wheel fitted with a Threaded Pin to which the piston rod is connected.

A second 2" Rod carries a 57-teeth Gear and a Face Plate as shown. A Coupling, in the longitudinal bore of which is a  $6\frac{1}{2}$ " Rod, is carried on a  $\frac{3}{4}$ " Bolt lock-nutted to one of the inner holes of the Face Plate. A 5" Rod fitted with three Couplings and a Collar is pivoted to a Pivot Bolt on a second Face Plate. The lower Couplings carry Double Brackets, which slide between two Collars on the  $6\frac{1}{2}$ " Rod. A Compression Spring is placed between the upper Double Bracket and Collar, and the Collar on the 5" Rod is connected to the upper Collar on the  $6\frac{1}{2}$ " Rod by a Spring. When the model is in operation the Spring and Compression Spring absorb the jerky reciprocating movements of the Rods.

## 8.18 TRAVELLING GANTRY CRANE



14	of No.	1
20	" "	2
5	" "	2a
5	" "	3
3	" "	4
18	" "	5
2	" "	6
6	" "	6a
10	" "	8
3	" "	11
25	" "	12
1	" "	12a
4	" "	12c
2	" "	15
4	" "	15a
2	" "	15b
3	" "	16
1	" "	17
3	" "	18a
1	" "	19g
4	" "	20
4	" "	20b

## Parts required

2	of No.	21
4	" "	22
3	" "	22a
3	" "	23
1	" "	23a
2	" "	24a
2	" "	26
2	" "	27a
1	" "	29
1	" "	32
19	" "	35
198	" "	37
7	" "	37a
21	" "	38
1	" "	40
1	" "	43
9	" "	48a
1	" "	48b
2	" "	51
2	" "	53
1	" "	57b
1	" "	57c

10	of No.	59
1	" "	94
1	" "	96
1	" "	96a
1	" "	111
2	" "	111a
3	" "	111c
2	" "	126
4	" "	126a
1	" "	147b
1	" "	162
1	" "	176
7	" "	190
5	" "	191
8	" "	192
6	" "	197
4	" "	200
1	" "	212
1	" "	213

No. 1 Clockwork  
Motor (Not  
included in Outfit)

The rails along which the hoisting carriage runs each consist of two  $12\frac{1}{2}$ " Angle Girders bolted together overlapping three holes. The girders are spaced apart by  $2\frac{1}{2}$ " Strips, and each is extended downward as shown in the illustration by a  $12\frac{1}{2}$ " Strip Plate and two  $5\frac{1}{2}$ "  $\times$   $2\frac{1}{2}$ " Flexible Plates. The rails are supported by  $12\frac{1}{2}$ " Angle Girders from the bases, one of which is shown in Fig. 8.18b. It consists of two  $12\frac{1}{2}$ " Strip Plates joined at each end by a  $2\frac{1}{2}$ "  $\times$   $\frac{1}{2}$ " Double Angle Strip, and is filled in at the top by two  $3\frac{1}{2}$ "  $\times$   $2\frac{1}{2}$ " Flanged Plates and two  $2\frac{1}{2}$ "  $\times$   $2\frac{1}{2}$ " Flexible Plates. The sides of the  $12\frac{1}{2}$ "  $\times$   $2\frac{1}{2}$ " Strip Plates are reinforced by a  $12\frac{1}{2}$ " Angle Girder, a  $12\frac{1}{2}$ " Strip, a  $5\frac{1}{2}$ " Strip and a  $1\frac{1}{2}$ " Strip.

The axles are  $3\frac{1}{2}$ " Rods, and each carries at its centre a  $1\frac{1}{2}$ " Flanged Wheel and is held in position by Spring Clips. The hoisting carriage is built up by joining the flanges of two  $2\frac{1}{2}$ "  $\times$   $1\frac{1}{2}$ " Flanged Plates by  $3\frac{1}{2}$ " Strips. The roof is formed by two  $1\frac{1}{2}$ " radius Curved Plates overlapped three holes, and is secured in position by Obtuse Angle Brackets. A  $3\frac{1}{2}$ "  $\times$   $\frac{1}{2}$ " Double Angle Strip is bolted between the two Flanged Plates as shown in Fig. 8.18a and two Trunnions are fastened to its centre. A  $1\frac{1}{2}$ " Rod, which carries two 1" loose Pulleys, is secured by Collars in the holes at the narrow ends of the Trunnions.

Fig. 8.18c shows the arrangement of the Motor and gearing. The Motor is bolted to one of the supporting  $12\frac{1}{2}$ " Angle Girders and a  $\frac{3}{4}$ " Sprocket is locked on the end of its driving shaft. This Sprocket Wheel is connected by Chain to a 1" Sprocket Wheel on a  $4\frac{1}{2}$ " Rod journalled as shown. The Rod carries at its centre a  $\frac{1}{2}$ " Pinion, which meshes with a 57-teeth Gear on a 5" Rod that can be seen in Fig. 8.18c. The Rod is capable of about  $\frac{1}{4}$ " lateral movement, so that the 57-teeth Gear can be moved into or out of mesh with the  $\frac{1}{2}$ " Pinion. The position of the Rod carrying the 57-teeth Gear is controlled by a second 5" Rod, which is pivoted at 8, and held at its upper end in a Double Bracket, secured on the first 5" Rod by two Collars.

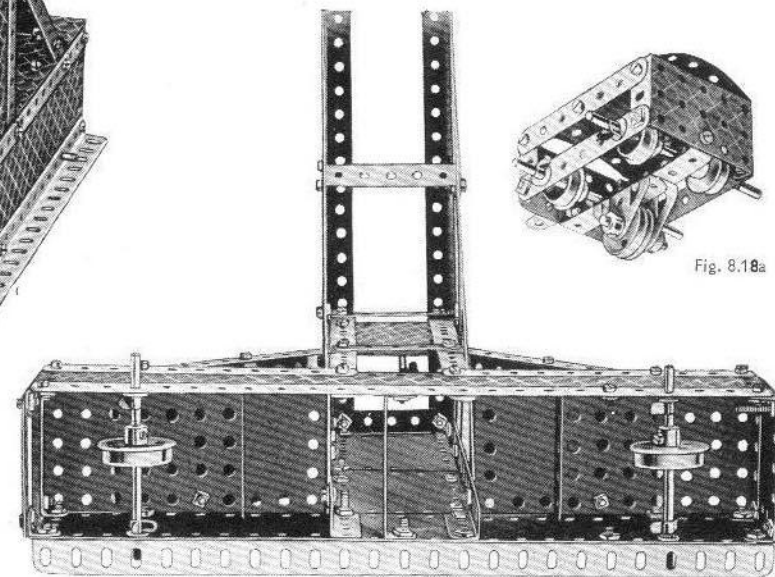

Fig. 8.18a

Fig. 8.18b

(Continued on next page)

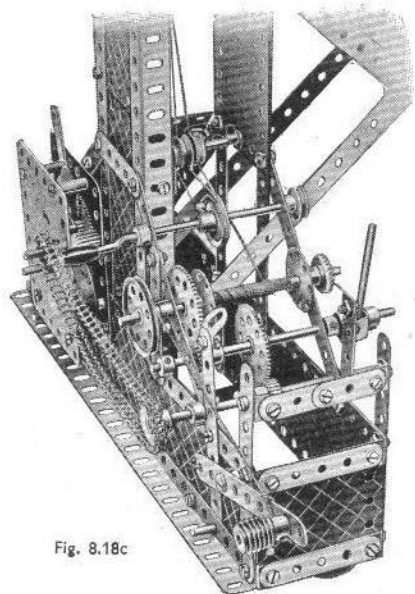
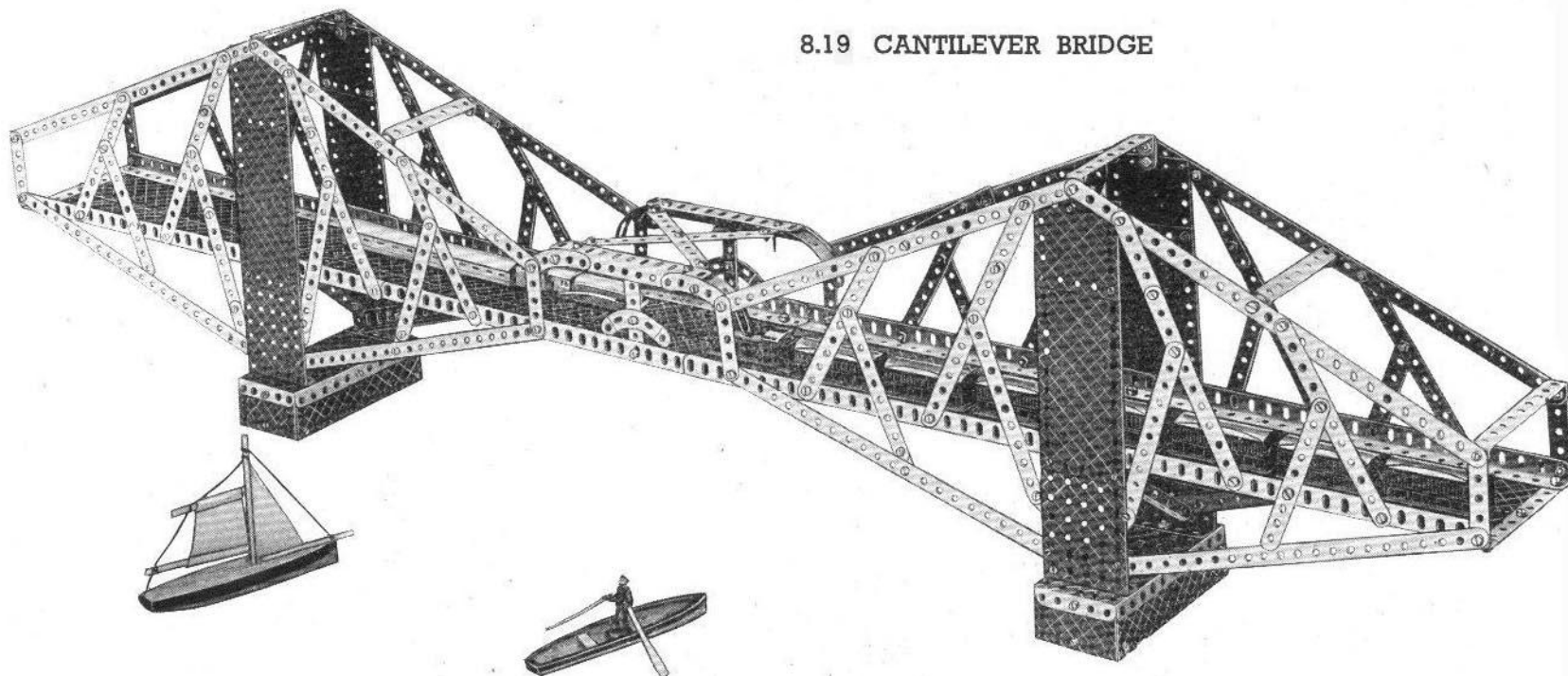

Fig. 8.18c

(Continued from previous page)

In addition to the 57-teeth Gear the 5" Rod carries also a  $\frac{1}{2}$ " Pinion that meshes with a 57-teeth Gear on the  $4\frac{1}{2}$ " Rod that can be seen in Fig. 8.18c carrying a  $1\frac{1}{2}$ " Pulley at its end. Cord is tied to a Cord Anchoring Spring on the  $4\frac{1}{2}$ " Rod, wound around it several times, then passed under one of the  $\frac{1}{2}$ " Pulleys 5 and over the centre 1" Pulley 4. It is then taken around one of the Pulleys under the hoisting carriage, through the pulley block and over the second 1" Pulley under the hoisting carriage. Finally it is tied to the right-hand end of the gantry.

The Cord 1 controls the movement of the carriage and is tied to the  $2\frac{1}{2}$ " x  $1\frac{1}{2}$ " Flanged Plate at 2, taken over the Pulleys 3 and 4 and then around the 1" Pulley 6 on the Crank Handle. It is then tied to the end of the Spring 7, which is attached by a Loaded Hook to a 1" x 1" Angle Bracket bolted to the side of the hoisting carriage.



### 8.19 CANTILEVER BRIDGE

The roadway of the bridge consists of Strip and Flexible Plates bolted to a framework consisting of two compound girders joined by  $4\frac{1}{2}$ " Strips. The girders each comprise four  $12\frac{1}{2}$ " and one  $5\frac{1}{2}$ " Angle Girders. Two  $12\frac{1}{2}$ " x  $2\frac{1}{2}$ " Strip Plates are used for each end and also the centre of the roadway, and the remaining spaces are filled by six  $5\frac{1}{2}$ " x  $2\frac{1}{2}$ " Flexible Plates.

Each pier is built up on a base consisting of a  $5\frac{1}{2}$ " x  $2\frac{1}{2}$ " Flanged Plate, to the longer flanges of which are bolted  $5\frac{1}{2}$ " x  $1\frac{1}{2}$ " Flexible Plates, and to the shorter flanges  $2\frac{1}{2}$ " x  $1\frac{1}{2}$ " Flexible Plates. The lower ends of the Flexible Plates are joined by  $2\frac{1}{2}$ " x  $\frac{1}{2}$ " Double Angle Strips. Two  $3\frac{1}{2}$ " x  $2\frac{1}{2}$ " Flanged Plates are attached by their flanges one hole from each end of the  $5\frac{1}{2}$ " x  $2\frac{1}{2}$ " Flanged Plate, and are extended upward by  $5\frac{1}{2}$ " x  $2\frac{1}{2}$ " and  $2\frac{1}{2}$ " x  $2\frac{1}{2}$ " Flexible Plates.

The lower ends of the piers are connected to the span by means of  $12\frac{1}{2}$ " Strips and  $12\frac{1}{2}$ " Angle Girders, the ends of which are bolted direct to the sides of the roadway. A  $2\frac{1}{2}$ " x  $\frac{1}{2}$ " Double Angle Strip is fastened by Fishplates across the top of each tower, the Bolts holding also  $12\frac{1}{2}$ " Strips bolted at their lower ends to  $2\frac{1}{2}$ " vertical Strips attached to the sides of the roadway. The cantilevers thus formed are braced by Strips of various sizes arranged as shown.

The connecting span between the two cantilevers is formed by two  $5\frac{1}{2}$ " Angle Girders, braced across by  $5\frac{1}{2}$ " x  $\frac{1}{2}$ " Double Angle Strips and Fishplates. At each of its ends the span is secured by  $2\frac{1}{2}$ " large radius Curved Strips to the ends of the  $2\frac{1}{2}$ " vertical Strips bolted to the sides of the roadway. A 3" Formed Slotted Strip also is bolted to each end of the  $5\frac{1}{2}$ " Angle Girders.

#### Parts required

14 of No. 1	198 of No. 37	6 of No. 111a
21 " " 2	8 " " 37a	2 " " 111c
6 " " 2a	6 " " 48a	4 " " 126a
4 " " 3	6 " " 48b	4 " " 188
5 " " 4	2 " " 48c	4 " " 189
17 " " 5	2 " " 48d	4 " " 190
2 " " 6	2 " " 52	10 " " 192
6 " " 6a	4 " " 53	6 " " 197
10 " " 8	8 " " 59	4 " " 215
4 " " 9	4 " " 90	
12 " " 10	2 " " 90a	

## 8.20 STEAM TRACTOR AND TRAILER

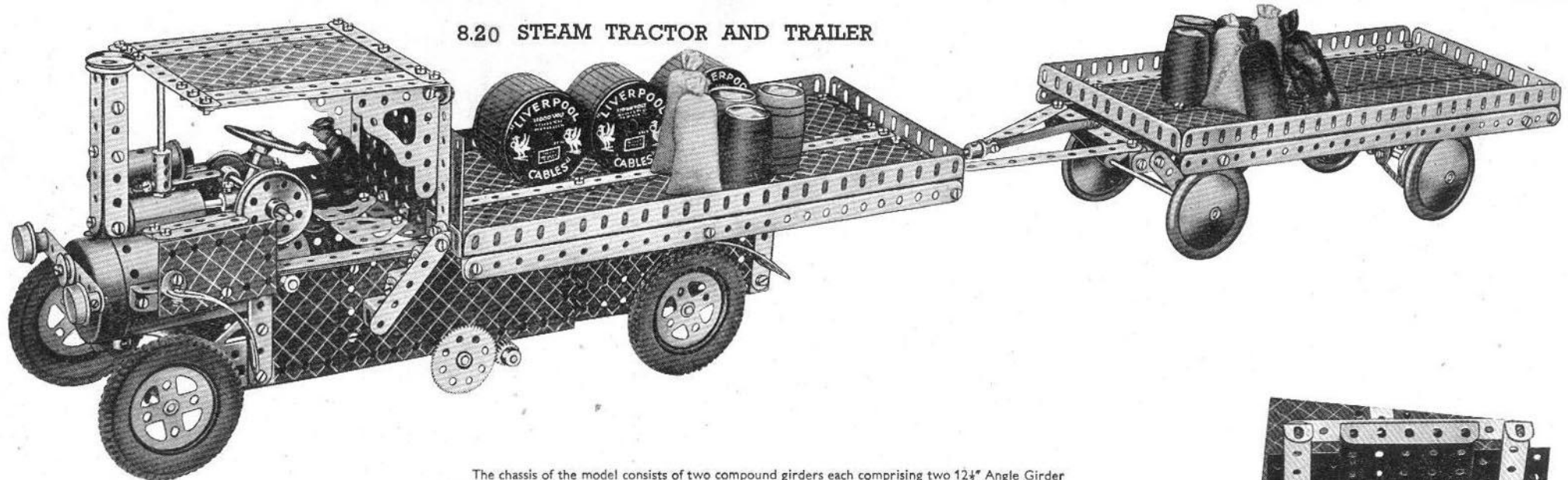

Parts required	
7 of No. 1	1 of No. 23
8 " " 2	1 " " 24
5 " " 2a	2 " " 26
6 " " 3	1 " " 27a
2 " " 4	1 " " 32
15 " " 5	9 " " 35
2 " " 6	164 " " 37
2 " " 6a	13 " " 37a
8 " " 8	26 " " 38
4 " " 9	1 " " 40
4 " " 10	1 " " 43
5 " " 11	1 " " 46
3 " " 12	4 " " 48a
35 " " 12a	3 " " 48b
2 " " 12b	2 " " 48d
3 " " 15	2 " " 52
2 " " 15a	2 " " 53
4 " " 16	9 " " 59
4 " " 17	5 " " 63
2 " " 18a	1 " " 80a
1 " " 18b	1 " " 94
1 " " 20	1 " " 95
4 " " 20a	1 " " 96a
4 " " 20b	2 " " 108
2 " " 21	1 " " 109
2 " " 22	5 " " 111a
	No. 1 Clockwork Motor (Not included in Outfit)

No. 1 Clockwork Motor (Not included in Outfit)

The chassis of the model consists of two compound girders each comprising two  $12\frac{1}{2}$ " Angle Girder overlapped 20 holes. These are spaced apart at the rear by a  $2\frac{1}{2}$ "  $\times$   $\frac{1}{2}$ " Double Angle Strip, and at the front by a Boiler. The side members of the chassis are extended downward by two  $5\frac{1}{2}$ "  $\times$   $2\frac{1}{2}$ " Flanged Plates, along the lower flanges of which are bolted two  $12\frac{1}{2}$ " Strips as shown in Fig. 8.20d. The space between the  $12\frac{1}{2}$ " Strips and Angle Girders is filled in with  $5\frac{1}{2}$ "  $\times$   $2\frac{1}{2}$ " and  $2\frac{1}{2}$ "  $\times$   $2\frac{1}{2}$ " Flexible Plates.

A  $3\frac{1}{2}$ "  $\times$   $2\frac{1}{2}$ " Flanged Plate and two  $2\frac{1}{2}$ "  $\times$   $1\frac{1}{2}$ " Flexible Plates are used for the back of the cab, and it is secured to the chassis by a  $5\frac{1}{2}$ " Angle Girder. For the roof a  $4\frac{1}{2}$ " Strip is bolted across each end of a  $5\frac{1}{2}$ "  $\times$   $2\frac{1}{2}$ " Flexible Plate and the ends of the Strip are joined by four  $5\frac{1}{2}$ " Strips. The roof is fixed in position by Angle Brackets and two corner gussets, and is supported at the front by a 2" Rod secured at its lower end in a Coupling fastened by a Bolt to the cylinder. The cylinder is represented by a Sleeve Piece bolted to the top of the Boiler, and a  $1\frac{1}{2}$ " Rod is used for the piston rod. The Rod is connected by a Small Fork Piece to a  $3\frac{1}{2}$ " Rod journalled in a Double Bracket bolted to the Boiler. The  $3\frac{1}{2}$ " Rod carries at one end a 1" fast Pulley, and at its other end two  $1\frac{1}{2}$ " Pulleys represent the fly-wheel.

The water tanks at each side of the Boiler are constructed by securing 2" Strips on one side and  $2\frac{1}{2}$ " Strips on the other, to a  $2\frac{1}{2}$ "  $\times$   $1\frac{1}{2}$ " Flexible Plate by  $1$ "  $\times$   $1$ " Angle Brackets, and they are attached to the chassis by  $\frac{1}{2}$ "  $\times$   $\frac{1}{2}$ " Angle Brackets. The chimney, removed from the Boiler, is shown in Fig. 8.20b. It consists of four  $3\frac{1}{2}$ " Strips joined by Double Brackets and Angle Brackets, and it carries a 1" fast Pulley at its upper end. The Pulley is locked on the end of a 2" Rod fixed inside the chimney by a Collar. The chimney is held in place by a Chimney Adaptor, which is bolted to the lower end of the chimney and then pushed into the end of the cylinder.

One side of the cab is left open, and is fitted with three Reversed Angle Brackets to represent steps; the other side is closed in by a  $3\frac{1}{2}$ "  $\times$   $2\frac{1}{2}$ " Flanged Plate. The Plate is fastened by an Angle Bracket to the right-hand water tank, and one of its flanges is bolted to the back of the cab. The platform of the wagon is built up by joining a  $12\frac{1}{2}$ " Angle Girder to each end of the  $5\frac{1}{2}$ " Angle Girder holding the back of the cab in position. The free ends of the two  $12\frac{1}{2}$ " Angle Girders are connected by a second  $5\frac{1}{2}$ " Angle Girder and the space between them is filled by two  $12\frac{1}{2}$ "  $\times$   $2\frac{1}{2}$ " Strip Plates and a  $12\frac{1}{2}$ " Strip. Each side of the platform is extended downward by a  $12\frac{1}{2}$ " Strip, and the rear end is extended by a  $5\frac{1}{2}$ "  $\times$   $\frac{1}{2}$ " Double Angle Strip.

(Continued on next page)

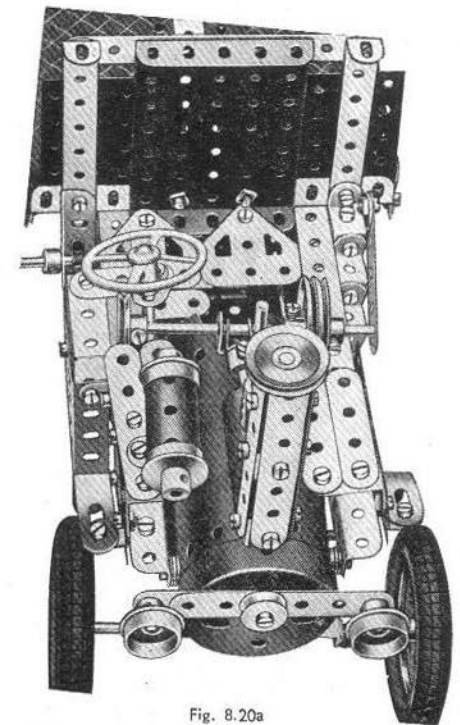

Fig. 8.20a

(Continued from previous page)

The front wheels are secured on the ends of a 5" Rod journalled in the ends of a  $2\frac{1}{2}" \times \frac{1}{2}"$  Double Angle Strip, which is attached by a Pivot Bolt to the underside of the Boiler. The steering column, a 5" Rod, is journalled at its upper end in a Fishplate secured to the side of the cab by a  $1\frac{1}{2}"$  Strip and a Channel Bearing, and at its lower end in an Angle Bracket, and it carries a Worm (see Fig. 8.20d). The Worm meshes with a  $\frac{1}{2}"$  Pinion on a  $3\frac{1}{2}"$  Rod journalled in two Flat Trunnions bolted to the chassis, the Rod carrying also two Couplings. Cord is wound around the two Couplings and each of its ends is tied to the Double Angle Strip supporting the front axle.

The Clockwork Motor is suspended by Angle Brackets underneath the tractor in the position shown, and its driving shaft is removed and replaced by a  $3\frac{1}{2}"$  Rod. A  $\frac{1}{2}"$  Pinion on the end of this Rod meshes with a 57-teeth Gear on a second  $3\frac{1}{2}"$  Rod journalled in the Motor side plates. A  $\frac{3}{4}"$  Sprocket Wheel on the last mentioned  $3\frac{1}{2}"$  Rod is connected by Chain to a 2" Sprocket Wheel on the rear axle. The axle is a  $4\frac{1}{2}"$  Rod journalled in the sides of the chassis, and it carries at each end a 2" Pulley fitted with a Rubber Tyre.

The trailer is built up on a frame consisting of two  $12\frac{1}{2}"$  Angle Girders joined at each end by  $5\frac{1}{2}"$  Angle Girders. The floor of the trailer is formed by two  $12\frac{1}{2}" \times 2\frac{1}{2}"$  Strip Plates, overlapped one hole along their sides and bolted between the two  $5\frac{1}{2}"$  Angle Girders. The two  $12\frac{1}{2}"$  Angle Girders are extended downward by two  $12\frac{1}{2}"$  Strips, which are fastened in position by Angle Brackets and joined at the rear by a  $5\frac{1}{2}" \times \frac{1}{2}"$  Double Angle Strip.

The rear axle, a 5" Rod, is journalled at each end in the end holes of two  $2\frac{1}{2}"$  Strips fastened under-

neath the trailer, and is fitted with a band brake. A  $2\frac{1}{2}" \times 1"$  Double Angle Strip is fastened by Angle Brackets to the  $2\frac{1}{2}"$  Strips forming the left-hand bearing for the axle, and a  $1\frac{1}{2}"$  Strip is bolted to its forward end. A Coupling is next screwed through its central tapped hole on to the centre of a  $3\frac{1}{2}"$  Screwed Rod, which is then journalled in the ends of the Double Angle Strip and fitted with lock-nuts at 1. Another Coupling carrying a Threaded Pin for a handle is then locked on the other end of the Screwed Rod. A length of Sprocket Chain is fastened by a Bolt to one of the end holes of the first Coupling, passed over the brake drum on the axle and finally is fastened to the upper end of the  $1\frac{1}{2}"$  Strip. The brake drum is constructed by fastening a Bush Wheel and a  $1\frac{1}{8}"$  Flanged Wheel on the axle so that they press against each other.

The bearings for the front axle are provided by the end holes of  $2\frac{1}{2}"$  Strips, bolted at their upper ends to a frame consisting of two  $4\frac{1}{2}"$  Strips joined at their ends by a  $3\frac{1}{2}" \times \frac{1}{2}"$  Double Angle Strip. A  $3\frac{1}{2}"$  Strip, to the centre of which is bolted a Boiler End, is secured by  $\frac{1}{2}"$  Bolts between the two Double Angle Strips, but is spaced from each of them by a Collar and three Washers. A 1" Rod locked in the boss of a Face Plate bolted under the trailer, passes through the centre hole of the Boiler End, and is secured in position by a Collar.

Two  $5\frac{1}{2}"$  Strips are fastened to the front of the wheel frame by a  $3\frac{1}{2}" \times \frac{1}{2}"$  Double Angle Strip, and their forward ends are bolted together, the Bolt holding also an Angle Bracket. A 2" Rod carrying at its end a Large Fork Piece, is passed through the Angle Bracket and secured by an End Bearing and a Spring to the  $3\frac{1}{2}" \times \frac{1}{2}"$  Double Angle Strip. The Large Fork Piece is connected at the rear of the steam wagon by a Rod and Spring Clip.

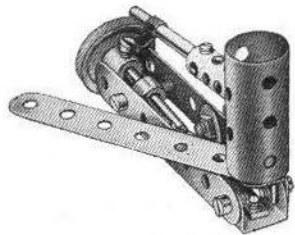

Fig. 8.20b

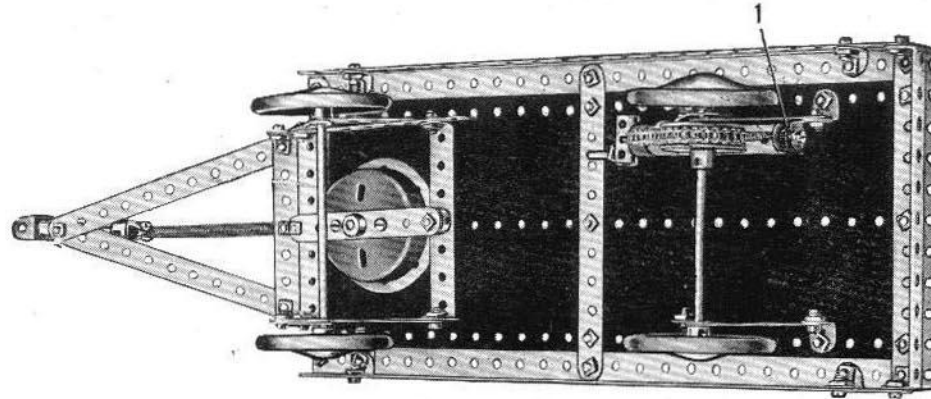

Fig. 8.20c

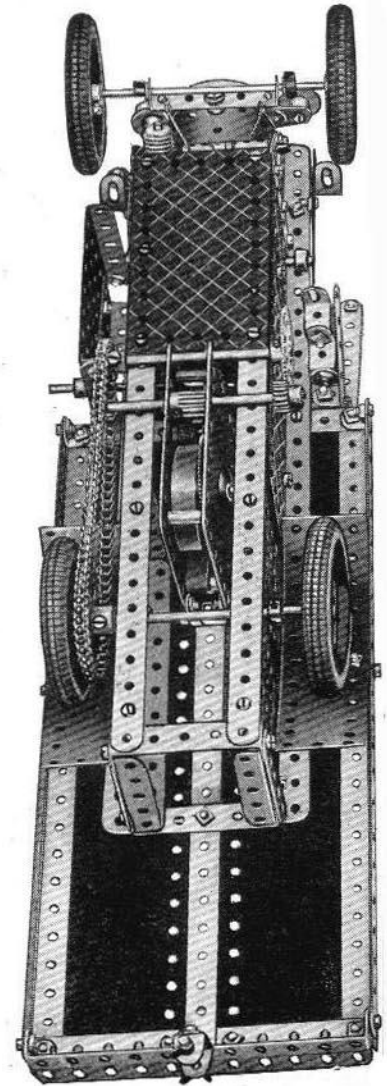
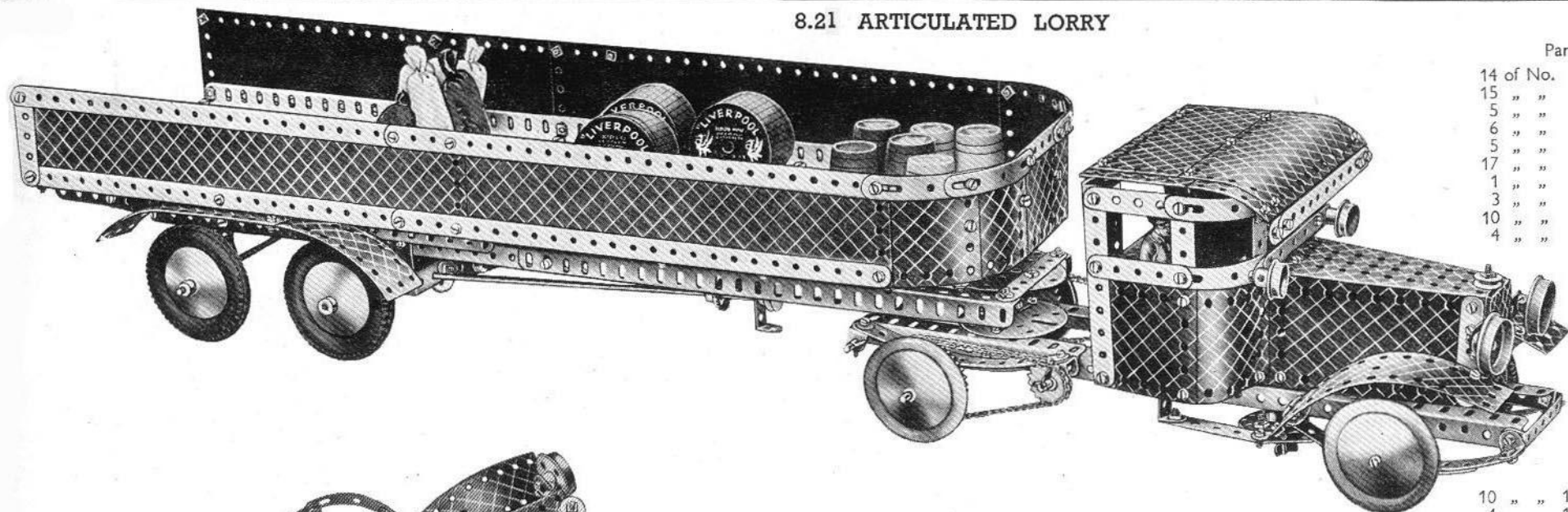

Fig. 8.20d

## 8.21 ARTICULATED LORRY



## Parts required

14 of No.	1	1 of No.	29
15 " "	2	7 " "	35
5 " "	2a	220 " "	37
6 " "	3	13 " "	37a
5 " "	4	26 " "	38
17 " "	5	1 " "	45
1 " "	6	1 " "	48
3 " "	6a	5 " "	48a
10 " "	8	2 " "	48b
4 " "	9	1 " "	48d
		1 " "	51
		2 " "	52
		2 " "	54
		10 " "	59
		2 " "	62
		5 " "	63
		1 " "	80a
		1 " "	94
		2 " "	95
		2 " "	96
		2 " "	109
		3 " "	111
		5 " "	111a
		6 " "	111c
10 " "	10	2 " "	115
4 " "	11	1 " "	116a
16 " "	12	4 " "	125
4 " "	12a	2 " "	126a
6 " "	12c	4 " "	142a
1 " "	13	2 " "	147b
1 " "	13a	1 " "	160
1 " "	14	1 " "	166
2 " "	15	1 " "	185
1 " "	15a	4 " "	187
2 " "	15b	4 " "	187a
3 " "	16	6 " "	188
2 " "	17	8 " "	189
3 " "	18a	8 " "	190
2 " "	20	5 " "	191
4 " "	20a	11 " "	192
2 " "	20b	4 " "	197
1 " "	21	6 " "	200
1 " "	22	1 " "	213
1 " "	23	8 " "	215
1 " "	23a		
3 " "	26	No. 1 Clockwork	
1 " "	27a	Motor (Not	
1 " "	28	included in Outfit.)	

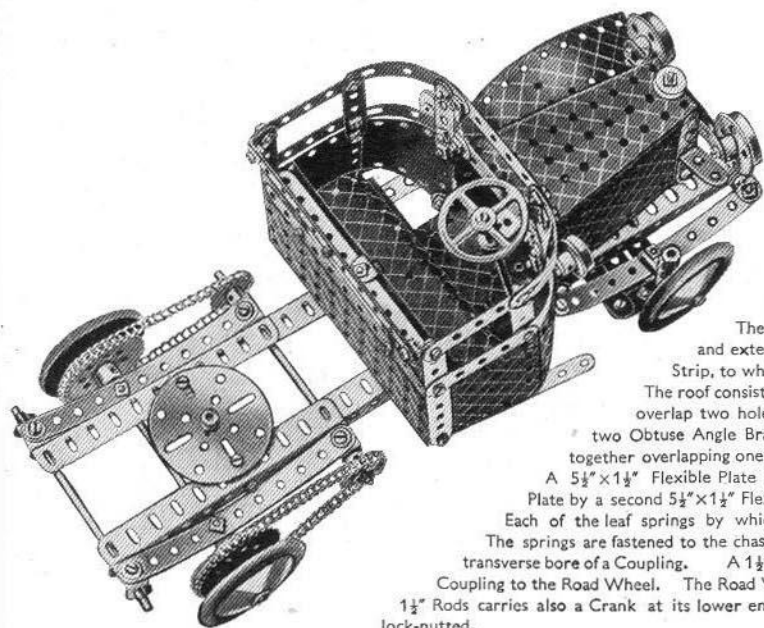

Fig. 8.21a

The power unit of the lorry is first constructed. The chassis for this consists of two  $12\frac{1}{2}$ " Angle Girders joined at the front by a  $2\frac{1}{2}$ "  $\times$   $\frac{1}{2}$ " Double Angle Strip and extended to the rear by two  $5\frac{1}{2}$ " Angle Girders. The bonnet is built up by joining the flanges of two Flanged Sector Plates by  $4\frac{1}{2}$ "  $\times$   $2\frac{1}{2}$ " Flexible Plates, the lower Flanged Sector Plate being bolted to the chassis as shown. The radiator is formed by a  $2\frac{1}{2}$ "  $\times$   $1\frac{1}{2}$ " Flanged Plate secured between the Flanged Sector Plates by a  $3\frac{1}{2}$ " Screwed Rod. The headlights are represented by two  $1\frac{1}{2}$ " Flanged Wheels, each of which is secured to a  $1$ "  $\times$   $1$ " Angle Bracket by a  $\frac{3}{8}$ " Bolt. The Angle Brackets are bolted to the sides of the bonnet so that the headlights protrude outwards.

The back of the cab is formed by a  $5\frac{1}{2}$ "  $\times$   $2\frac{1}{2}$ " Flanged Plate bolted by one of its longer flanges to the  $12\frac{1}{2}$ " Angle Girders and extended upwards at each end by a  $2\frac{1}{2}$ "  $\times$   $1\frac{1}{2}$ " Flexible Plate. The upper ends of the Flexible Plates are joined by a  $5\frac{1}{2}$ " Strip, to which the roof of the cab is fastened by two Angle Brackets.

The roof consists of two  $5\frac{1}{2}$ "  $\times$   $2\frac{1}{2}$ " Flexible Plates bolted together and extended to one side by two  $2\frac{1}{2}$ "  $\times$   $1\frac{1}{2}$ " Flexible Plates, which overlap two holes with the larger Flexible Plates. Two  $5\frac{1}{2}$ " Strips overlapped 10 holes are secured to the front of the roof by two Obtuse Angle Brackets. The sides of the cab are each formed by a  $1\frac{1}{4}$ " radius Curved Plate and a  $2\frac{1}{2}$ "  $\times$   $2\frac{1}{2}$ " Flexible Plate bolted together overlapping one hole.

A  $5\frac{1}{2}$ "  $\times$   $1\frac{1}{2}$ " Flexible Plate curved slightly is used for the seat inside the cab, and it is fastened to the upper flange of the  $5\frac{1}{2}$ "  $\times$   $2\frac{1}{2}$ " Flanged Plate by a second  $5\frac{1}{2}$ "  $\times$   $1\frac{1}{2}$ " Flexible Plate and Angle Brackets.

Each of the leaf springs by which the front Road Wheels are supported consists of a  $5\frac{1}{2}$ ",  $3\frac{1}{2}$ " and a  $2\frac{1}{2}$ " Strip secured together by a centre Bolt. The springs are fastened to the chassis at each end by Angle Brackets. Each of the centre Bolts of the leaf springs passes at its upper end through the end transverse bore of a Coupling. A  $1\frac{1}{2}$ " Rod that is slipped through the remaining end transverse bore of the Coupling, is connected by means of a second Coupling to the Road Wheel. The Road Wheel is held on the shank of a  $\frac{3}{8}$ " Bolt screwed into one of the tapped holes of the second Coupling. Each of the

$1\frac{1}{2}$ " Rods carries also a Crank at its lower end, and these are joined by a compound strip consisting of two  $2\frac{1}{2}$ " Strips bolted end to end, the Bolts 2 being lock-nutted.

One of the Cranks is bolted to a  $2$ " Strip, the other end of which is attached to a  $3$ " Strip by a lock-nutted Bolt 1. The  $3$ " Strip is connected by a Threaded Pin to a  $1\frac{1}{2}$ " Pulley secured at the lower end of the steering column, as shown in Fig. 8.21c. The steering column is a  $4$ " Rod journalled in one of the  $12\frac{1}{2}$ " Angle Girders and also in the end hole of a  $1\frac{1}{2}$ " Strip bolted to the upper Flanged Sector Plate of the bonnet.

(Continued on next page)



(Continued from previous page)

Each of the rear leaf springs is formed by a  $5\frac{1}{2}$ " and a  $3\frac{1}{2}$ " Strip secured together at their centre holes by a Bolt, which holds also an Angle Bracket. The two Angle Brackets form the bearings for the rear axle, a  $6\frac{1}{2}$ " Rod. The springs are joined to the chassis by two Rods pushed through the sides of the Angle Girders and also through Double Brackets bolted to the ends of the springs, as shown in the illustrations. Two 2" Sprocket Wheels on the rear axle are connected to two 1" Sprocket Wheels on the forward rod fastening the springs to the chassis. The rod consists of a  $3\frac{1}{2}$ " and a 2" Rod joined by a Rod Connector.

A Face Plate is bolted between the two side members of the chassis in the position shown in Fig. 8.21a to form part of the swivel for the trailer.

The trailer is built up on a base consisting of two angle girders joined at each end and also in the centre by compound strips. Each of the angle girders consists of two  $12\frac{1}{2}$ " Angle Girders bolted end to end overlapping four holes. The end compound strips joining the girders are connected across the centre by  $12\frac{1}{2}$ " Strips (see Fig. 8.21d). The floor of the trailer is then filled in with Flexible Plates of various sizes and a  $5\frac{1}{2}$ " x  $2\frac{1}{2}$ " Flanged Plate.

Two  $12\frac{1}{2}$ " Strip Plates, overlapped four holes and bolted to the sides of the  $12\frac{1}{2}$ " Angle Girders are used for each side of the trailer, and the front is formed by one  $2\frac{1}{2}$ " x  $2\frac{1}{2}$ " Flexible Plate and four  $1\frac{1}{8}$ " radius Curved Plates.

The No. 1 Clockwork Motor is secured under the trailer with its winding spindle protruding upwards, and a 4" Rod is attached to the brake lever by a Small Fork Piece. The Rod passes through an Angle Bracket fastened underneath the trailer and carries at its end a Collar in the tapped hole of which is screwed a Threaded Pin.

Two  $12\frac{1}{2}$ " Angle Girders are fastened underneath the trailer by Reversed Angle Brackets and are joined at the front by a  $3\frac{1}{2}$ " Strip. A Face Plate is bolted underneath the  $3\frac{1}{2}$ " Strip to form the upper part of the trailer swivel and in its boss a  $1\frac{1}{2}$ " Rod is locked.

The two  $12\frac{1}{2}$ " Angle Girders are each extended to the rear by a  $12\frac{1}{2}$ " Strip, the two Strips being secured to the floor of the trailer by Double Angle Strips and  $5\frac{1}{2}$ " Angle Girders. The front axle, which consists of a  $4\frac{1}{2}$ " and a  $3\frac{1}{2}$ " Rod joined by a Coupling, is journalled in holes at the narrow ends of two Flat Trunnions supported by the  $12\frac{1}{2}$ " Strips, and it carries a  $1\frac{1}{2}$ " Contrate Wheel at its centre. The Contrate meshes with a  $\frac{1}{2}$ " Pinion held on a 2" Rod journalled as shown in Fig. 8.21c. The 2" Rod carries also a 57-teeth Gear that meshes with a second  $\frac{1}{2}$ " Pinion on the end of an  $11\frac{1}{2}$ " Rod driven from the Motor through a  $\frac{3}{4}$ " Contrate Wheel and a  $\frac{1}{2}$ " Pinion. The  $11\frac{1}{2}$ " Rod is journalled at its forward end in the centre hole of a  $1\frac{1}{2}$ " x  $\frac{1}{2}$ " Double Angle Strip bolted to the Motor side plate, and is prevented from slipping out of position by a  $\frac{1}{2}$ " fast Pulley.

The rear axle is an 8" Rod, and is journalled at each end in a  $1\frac{1}{2}$ " strip bolted to the  $12\frac{1}{2}$ " Strip. Each  $1\frac{1}{2}$ " strip is built up from two Fishplates bolted end to end. The rear mudguards consist of two  $5\frac{1}{2}$ " x  $1\frac{1}{2}$ " Flexible Plates overlapped four holes and bolted underneath the trailer, their ends being curved down slightly.

The coupling hook consists of a Channel Bearing bolted underneath the back of the trailer and extended to the rear by an Angle Bracket.

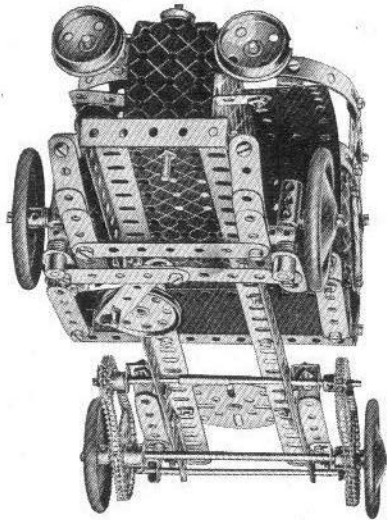

Fig. 8.21b

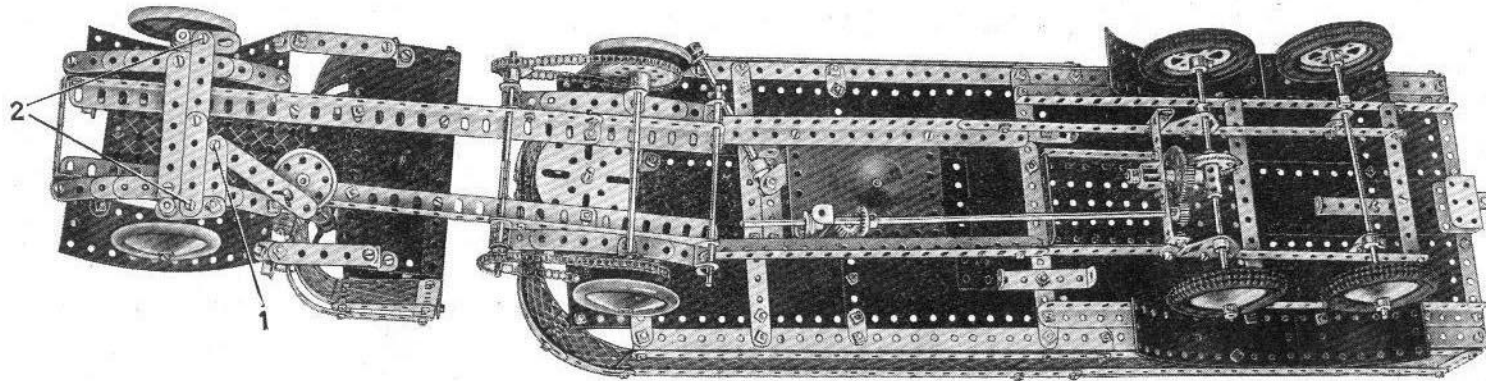

Fig. 8.21c

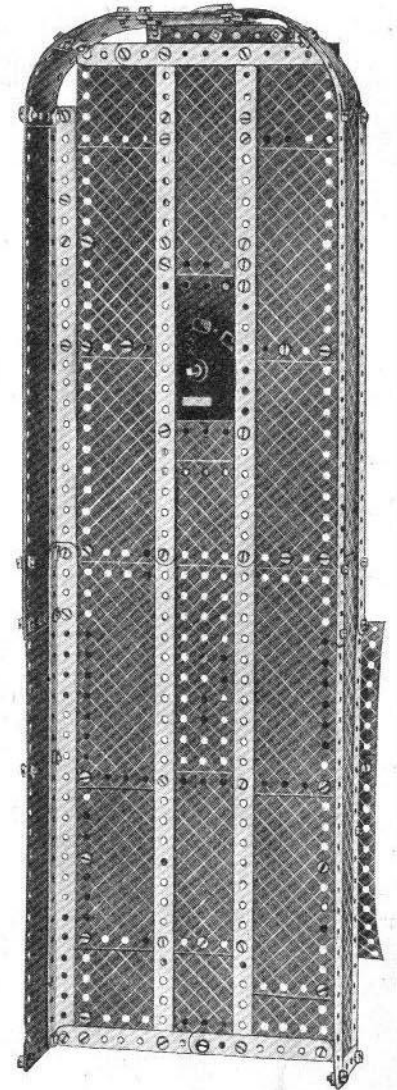
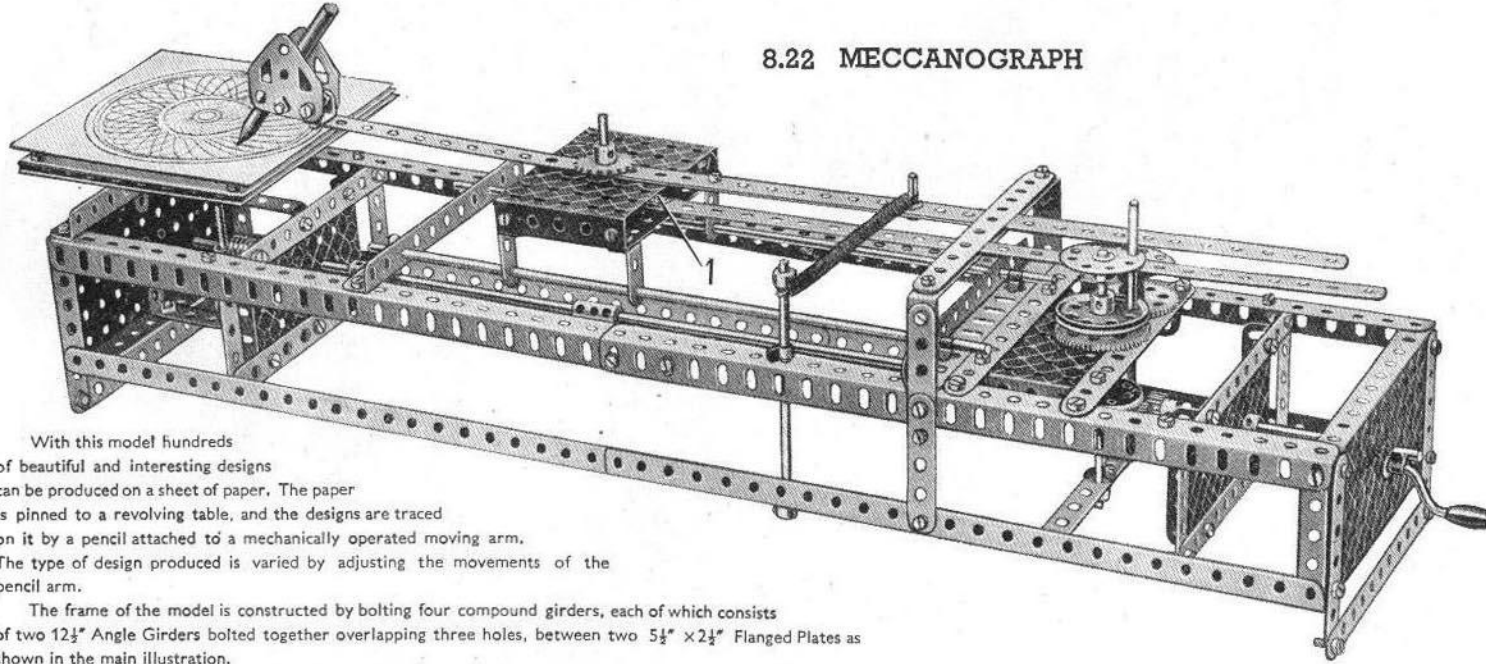

Fig. 8.21d

## 8.22 MECCANOGRAPH



With this model hundreds of beautiful and interesting designs can be produced on a sheet of paper. The paper is pinned to a revolving table, and the designs are traced on it by a pencil attached to a mechanically operated moving arm. The type of design produced is varied by adjusting the movements of the pencil arm.

The frame of the model is constructed by bolting four compound girders, each of which consists of two  $12\frac{1}{2}$ " Angle Girders bolted together overlapping three holes, between two  $5\frac{1}{2}$ " x  $2\frac{1}{2}$ " Flanged Plates as shown in the main illustration.

The large Crank Handle, by which the machine is operated, is journaled in the centre hole of one of the  $5\frac{1}{2}$ " x  $2\frac{1}{2}$ " Flanged Plates, and also in the centre hole of a  $3\frac{1}{2}$ " x  $2\frac{1}{2}$ " Flanged Plate secured to the frame by two  $2\frac{1}{2}$ " x  $\frac{1}{2}$ " Double Angle Strips and  $5\frac{1}{2}$ " Strips. The Crank Handle carries at its end a  $\frac{1}{2}$ " Pinion, which meshes with a second  $\frac{1}{2}$ " Pinion on a compound 24" rod. This rod is journaled in the two Flanged Plates already mentioned, and also in two similar Flanged Plates situated at the other end of the model. At the latter end the compound rod carries a Worm that meshes with a  $\frac{1}{2}$ " Pinion on a vertical 4" Rod, the bearings for which are provided by the centre holes of two  $3\frac{1}{2}$ " x  $\frac{1}{2}$ " Double Angle Strips bolted between the two Flanged Plates. A Face Plate is locked on the upper end of the Rod and to it are bolted the two  $5\frac{1}{2}$ " x  $2\frac{1}{2}$ " Flexible Plates forming the table.

The  $\frac{1}{2}$ " Pinion on the Crank Handle meshes also with a  $1\frac{1}{2}$ " Contrate Wheel on a  $4\frac{1}{2}$ " Rod, which is journaled in a  $5\frac{1}{2}$ " Strip bolted to the lower members of the frame and in a  $3\frac{1}{2}$ " x  $2\frac{1}{2}$ " Flanged Plate secured between the upper members of the frame by two  $5\frac{1}{2}$ " Strips. The  $4\frac{1}{2}$ " Rod carries, above the Flanged Plate, a 57-teeth Gear 2, a  $1\frac{1}{2}$ " Pulley and a Bush Wheel. A  $3\frac{1}{2}$ " Rod 5 passes through holes in the Bush Wheel and the  $1\frac{1}{2}$ " Pulley, and the rear end of the pencil arm is held against the Rod by a Spring as shown in the illustration above.

The pencil arm is formed by two  $12\frac{1}{2}$ " Strips overlapped 13 holes, and it is pivoted 12 holes from its forward end on a 2" Rod that passes through the centre holes of two  $3\frac{1}{2}$ " x  $2\frac{1}{2}$ " Flanged Plates. The two Plates are fastened together by their flanges, and to their undersides are bolted two  $2\frac{1}{2}$ " x 1" Double Angle Strips that slide on two  $11\frac{1}{2}$ " Rods journaled at each end in a  $5\frac{1}{2}$ " Angle Girder bolted to the sides of the frame. The pencil is gripped between two Flat Trunnions secured to the end of the arm by a Double Bracket. The  $5\frac{1}{2}$ " Strip 1 (Fig. 8.22a) and a  $5\frac{1}{2}$ " x  $1\frac{1}{2}$ " Double Angle Strip through which the pencil arm passes, are bent apart so that the arm does not jam.

The 57-teeth Gear 2 meshes with a second 57-teeth Gear 3 on a  $3\frac{1}{2}$ " Rod journaled in a similar fashion to the  $4\frac{1}{2}$ " Rods and carrying a Bush Wheel at its upper end. A Threaded Pin 4 is fastened through one of the holes of the Bush Wheel, and its plain shank carries a  $12\frac{1}{2}$ " Strip, the forward end of which is lock-nutted at 1 (see general view of model) to the sliding carriage.

The pattern obtained may be varied by altering the hole of the  $12\frac{1}{2}$ " Strip through which the Threaded Pin passes, or by using two or more Rods at 5. A few experiments with the Rods and arms in different positions will show the combinations that produce the most interesting and beautiful designs.

		Parts required	
3 of No. 1	1	1 of No. 17	4 of No. 48a
11 " " 2		1 " " 19h	2 " " 48b
4 " " 3		1 " " 21	1 " " 48d
4 " " 5		2 " " 24	2 " " 52
8 " " 8		3 " " 26	5 " " 53
3 " " 9		2 " " 27a	10 " " 59
1 " " 11		1 " " 28	3 " " 63
2 " " 13		1 " " 32	1 " " 96
1 " " 13a		7 " " 35	1 " " 109
1 " " 14		99 " " 37	2 " " 111c
1 " " 15		3 " " 37a	2 " " 115
2 " " 15a		15 " " 38	2 " " 126a
2 " " 15b		1 " " 43	2 " " 192
2 " " 16		2 " " 46	

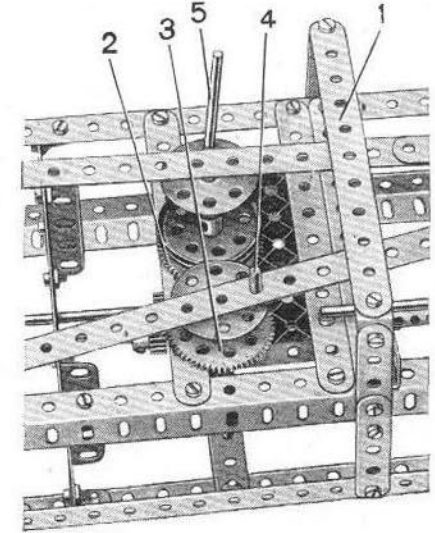
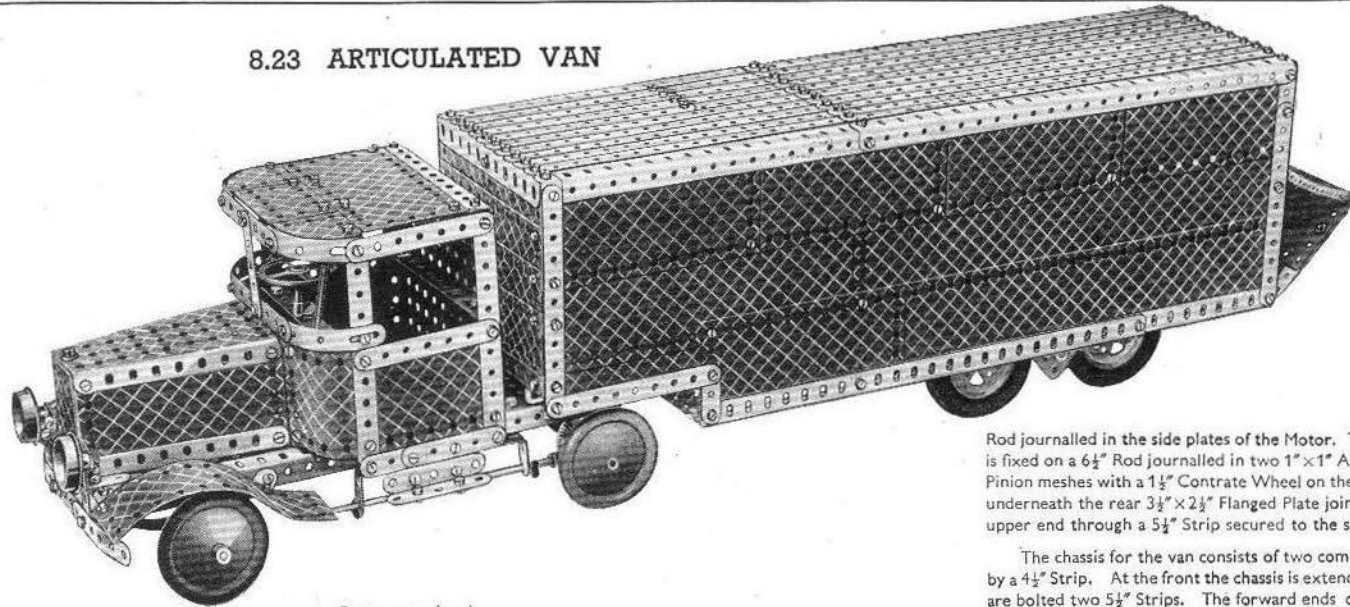

Fig. 8.22a

### 8.23 ARTICULATED VAN



Parts required	
14 of No. 1	13 of No. 10
21 " " 2	28 " " 12
6 " " 2a	6 " " 12a
6 " " 3	4 " " 12c
5 " " 4	1 " " 14
18 " " 5	3 " " 15
1 " " 6	3 " " 15a
2 " " 6a	1 " " 17
10 " " 8	3 " " 18a
4 " " 9	2 " " 20
4 of No. 20a	2 of No. 48
1 " " 24	1 " " 48c
1 " " 26	2 " " 48d
1 " " 27a	2 " " 51
1 " " 28	2 " " 52
1 " " 29	3 " " 53
6 " " 35	2 " " 54
220 " " 37	10 " " 59
15 " " 37a	2 " " 63
26 " " 38	1 " " 90
1 of No. 94	1 " " 109
1 " " 111	2 " " 111a
6 " " 111a	6 " " 111c
1 " " 116a	1 " " 116c
2 " " 126	4 " " 142a
2 " " 147b	2 " " 147b
1 " " 166	1 " " 185
1 " " 185	4 " " 187
4 " " 187	2 " " 188
2 " " 188	7 " " 189
4 " " 190	4 " " 190
6 " " 191	6 " " 191
12 " " 192	6 " " 197
6 " " 197	1 " " 198
1 " " 198	2 " " 214
2 " " 214	4 " " 215

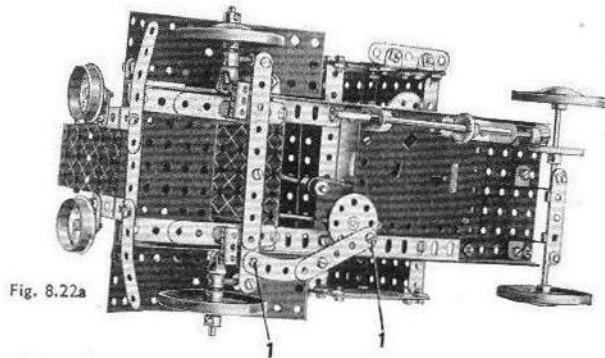

Fig. 8.22a

No. 1 Clockwork Motor (Not included in Outfit)

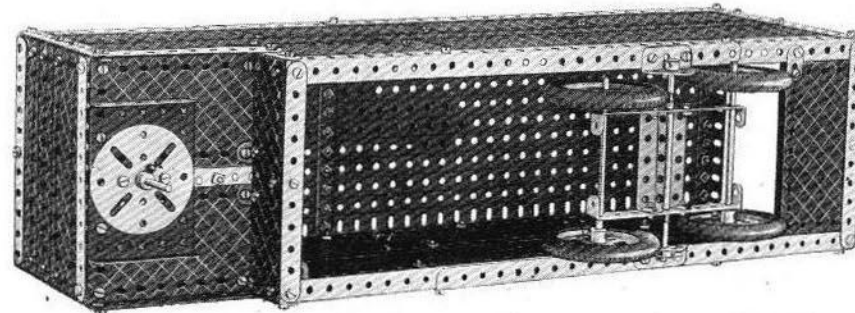

Fig. 8.23b

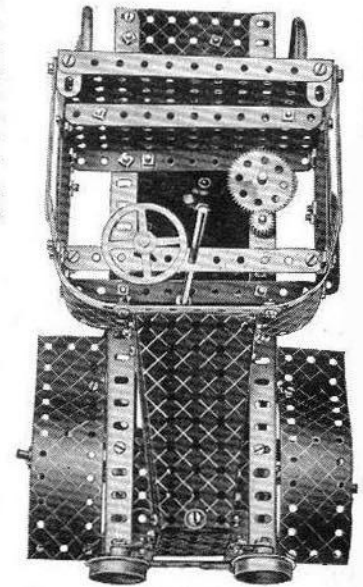

Fig. 8.23c

The power unit is first built up, construction being commenced with the chassis consisting of two 12½" Angle Girders joined at each end by a 3½" × 2½" Flanged Plate. On its forward end is mounted the bonnet, which is made joining the flanges of two Flanged Sector Plates with 4½" × 2½" Flexible Plates, a 2½" × 1½" Flanged Plate being bolted between the narrow ends of the two Sector Plates to represent the radiator. A 1" × 1" Angle Bracket carrying a Fishplate by the slotted hole, is bolted at each side of the radiator, and the headlamps, 1½" Flanged Wheels, are secured to the Fishplate by ¾" Bolts.

The leaf springs are built up from 2½" and 4½" Strips, and each carries at its centre a Coupling spaced from the spring by six Washers. Two Pivot Bolts are screwed into the end tapped holes of the Couplings, one carrying a Small Fork Piece and the other an End Bearing. A 1½" Rod is locked in the bosses of the Small Fork Piece and the End Bearing by ¾" Bolts to form the stub axles. A Collar is locked against the head of each ¾" Bolt and the two are joined by a compound 5½" strip, which is connected by a 2½" Strip and a 2½" large radius Curved Strip to a Bush Wheel locked on the end of a 4½" Rod representing the steering column. The Bolts are lock-nutted.

The No. 1 Clockwork Motor is secured to the chassis underneath the cab, and a ½" Pinion is fastened on its driving shaft. The Pinion meshes with a 57-teeth Gear fixed on a 1½" Rod journaled in the side plates of the Motor. The Rod carries at its lower end a ½" Pinion that meshes with a ¾" Contrate. The Contrate Wheel is fixed on a 6½" Rod journaled in two 1" × 1" Angle Brackets bolted one at each end of the Motor, and it carries at its rear end a ½" Pinion. This Pinion meshes with a 1½" Contrate Wheel on the 5" Rod forming the back axle. The 5" Rod is journaled in two 1½" × ½" Double Angle Strips bolted underneath the rear 3½" × 2½" Flanged Plate joining the side members of the chassis. For starting and stopping the Motor, a 5" Rod passing at its upper end through a 5½" Strip secured to the sides of the cab, is fastened to the Motor brake lever by two Collars.

The chassis for the van consists of two compound girders made by overlapping two 12½" Angle Girders 17 holes and joining them at each end by a 4½" Strip. At the front the chassis is extended upwards by two 1½" Strips, to the upper ends of which are bolted two 5½" Strips. The forward ends of the latter are joined by a 5½" Strip, and the space between them is filled in by two 4½" × 2½" Flexible Plates and a 3½" × 2½" Flanged Plate. A Face Plate, in the boss of which is locked a 1½" Rod, is bolted underneath the Flanged Plate, and the lower end of the Rod passes through the Flanged Plate at the rear of the cab to provide a coupling between the two units.

The top of the body is constructed from 12½" and 5½" Strips bolted over a frame formed by joining the ends of two 20½" compound angle girders by two 5½" Angle Girders. The roof is supported from the chassis by 5½" Strips at the front and by 6½" strips at the rear, and the sides are filled in with Flexible and Strip Plates as shown. A Hinged Flat Plate is bolted by one of its sides to the rear of the chassis, the other side being extended by two 2½" × 2½" Flexible Plates and a 2½" × 1½" Flexible Plate to form the flap at the rear of the van. The flap is supported from the sides of the van by two lengths of Sprocket Chain.

The two rear axles are 4½" Rods journaled in the ends of two 4½" × ½" Double Angle Strips bolted at their centres to the flanges of a 2½" × 1½" Flanged Plate. The Flanged Plate is pivoted on a 5" Rod, bearings for which are provided by two Trunnions bolted underneath the chassis.

## 8.24 LIFEBOAT AND TRACTOR

The construction of the model is commenced with the tractor, the chassis of which is built up as follows. Two girders, each consisting of two  $5\frac{1}{2}$ " Angle Girders overlapped three holes, are joined at their forward ends by a  $3\frac{1}{2}$ " Strip, and at the rear ends by a  $3\frac{1}{2}$ "  $\times$   $2\frac{1}{2}$ " Flanged Plate and a  $3\frac{1}{2}$ "  $\times$   $\frac{1}{2}$ " Double Angle Strip. Each side member of the chassis is extended upwards by a  $5\frac{1}{2}$ " Strip, and to these are bolted the sides of the bonnet. The Clockwork Motor together with a  $2\frac{1}{2}$ "  $\times$   $1\frac{1}{2}$ " Flexible Plate forms one side of the bonnet, and two  $2\frac{1}{2}$ "  $\times$   $2\frac{1}{2}$ " Flexible Plates and one  $2\frac{1}{2}$ "  $\times$   $1\frac{1}{2}$ " Flexible Plate form the other side. Three  $1\frac{3}{8}$ " radius Curved Plates bolted end to end are used for the top of the bonnet. At the rear end the Curved Plates are supported by a  $3\frac{1}{2}$ "  $\times$   $\frac{1}{2}$ " Double Angle Strip from a  $3\frac{1}{2}$ " Strip bolted across the chassis, and at the front they are secured by a  $1"$   $\times$   $1"$  Angle Bracket to the radiator. The last-mentioned is represented by a  $2\frac{1}{2}$ "  $\times$   $2\frac{1}{2}$ " Flexible Plate, the lower end of which is secured by an Angle Bracket to a  $3\frac{1}{2}$ " Strip bolted across the chassis.

The headlamps,  $\frac{3}{8}"$  Flanged Wheels, are fastened by  $\frac{3}{16}"$  Bolts to Fishplates fixed to the radiator. The bumper in

(Continued on next page)

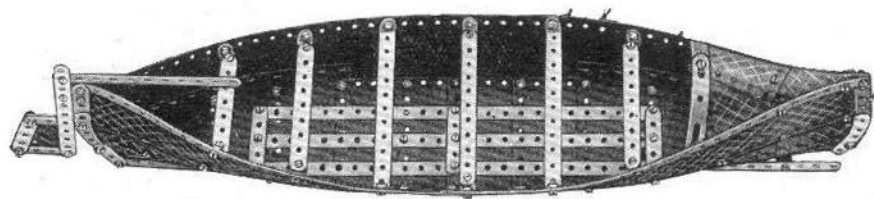
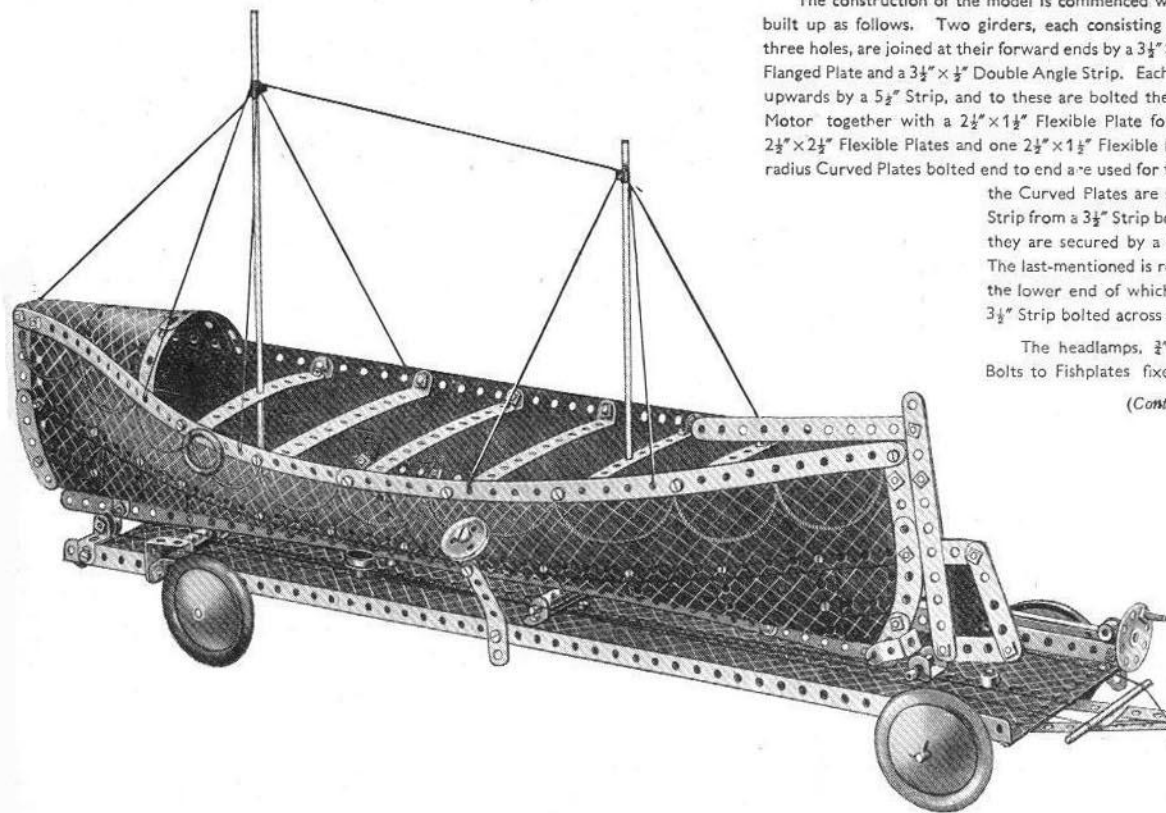

Fig. 8.24c

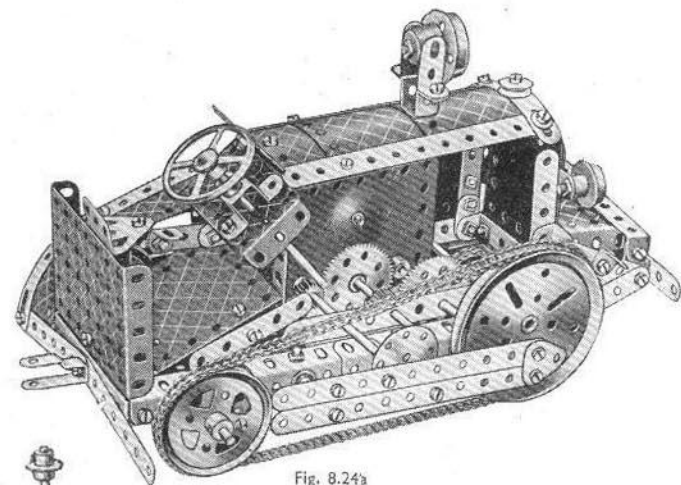

Fig. 8.24a

Parts required	2 of No. 6	6 of No. 12a	2 of No. 15b	4 of No. 20a	2 of No. 27a	5 of No. 111a
11 of No. 1	6 " " 6a	2 " " 12b	4 " " 16	4 " " 20b	12 " " 35	6 " " 111c
21 " " 2	4 " " 8	1 " " 12c	3 " " 17	2 " " 22a	10 " " 37	1 " " 115
6 " " 2a	4 " " 9	2 " " 13	3 " " 18a	1 " " 90a	26 " " 37a	1 " " 120b
5 " " 3	8 " " 10	2 " " 14	1 " " 18b	1 " " 94	2 " " 38	2 " " 125
6 " " 4	3 " " 11	4 " " 15	2 " " 19b	1 " " 96	2 " " 38d	3 " " 126
18 " " 5	29 " " 12	1 " " 15a	1 " " 20	1 " " 96a	2 " " 40	2 " " 147b
				1 " " 109	1 " " 44	4 " " 155
				3 " " 111	3 " " 45	1 " " 164
					4 " " 48a	1 " " 165
					6 " " 48b	1 " " 185
					1 " " 48c	4 " " 187
					2 " " 48d	7 " " 188
					2 " " 51	6 " " 189
					2 " " 53	4 " " 190
					1 " " 57c	5 " " 191
					10 " " 59	10 " " 192
					2 " " 62	6 " " 197
					6 " " 63	2 " " 199
					2 " " 77	6 " " 200
					1 " " 80a	2 " " 212
					4 " " 90	1 " " 213
					1 " " 90a	7 " " 215
					1 " " 94	
					1 " " 96	
					1 " " 96a	
					1 " " 109	
					3 " " 111	
						No. 1 Clockwork Motor (Not included in Outfit)

(Continued from previous page)

front of the radiator is constructed by securing two  $3\frac{1}{2}'' \times \frac{1}{2}''$  Double Angle Strips to a  $2\frac{1}{2}'' \times 1\frac{1}{2}''$  Flanged Plate and fastening them to the chassis and to Double Brackets attached to the side of the bonnet, by  $2\frac{1}{2}''$  Strips. The front of the bumper is extended downwards by a  $5\frac{1}{2}''$  Strip curved slightly at the ends.

The searchlight on the top of the bonnet is represented by a  $1\frac{1}{2}''$  Flanged Wheel secured by a  $\frac{3}{8}''$  Bolt to a Chimney Adaptor. The Chimney Adaptor is held between two  $1'' \times \frac{1}{2}''$  Angle Brackets bolted to the ends of a Double Bent Strip fastened to the top of the bonnet. The exhaust pipe and air intake valve for use when the tractor is partially submerged in the sea are formed by a  $5''$  and a  $4''$  Rod respectively. The Rods are secured by Collars to the sides of the bonnet, and at its upper end each Rod carries a  $\frac{3}{4}''$  Washer locked between two Collars. A  $3\frac{1}{2}'' \times 2\frac{1}{2}''$  Flanged Plate is used for the back of the cab and is fastened to the chassis by an Angle Bracket. Just in front of the Flanged Plate is bolted a  $2\frac{1}{2}'' \times \frac{1}{2}''$  Double Angle Strip, which supports at its upper end the Trunnion forming the driver's seat.

The Steering Wheel is locked on the upper end of a  $4''$  Rod held in the centre hole of a Double Bent Strip and also in a  $2\frac{1}{2}'' \times 1\frac{1}{2}''$  Flanged Plate to which the Double Bent Strip is bolted. The Flanged Plate is fastened in position between the sides of the bonnet. The brake lever of the Motor is extended by a  $1\frac{1}{2}''$  Strip, at the end of which an Angle Bracket is fixed to represent a pedal.

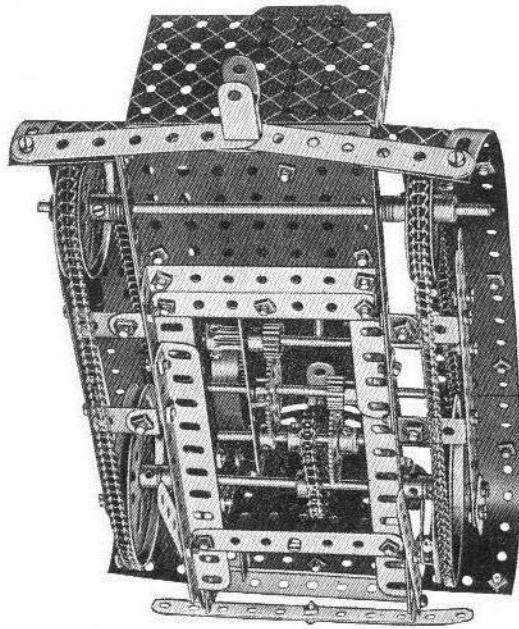

Fig. 8.24d

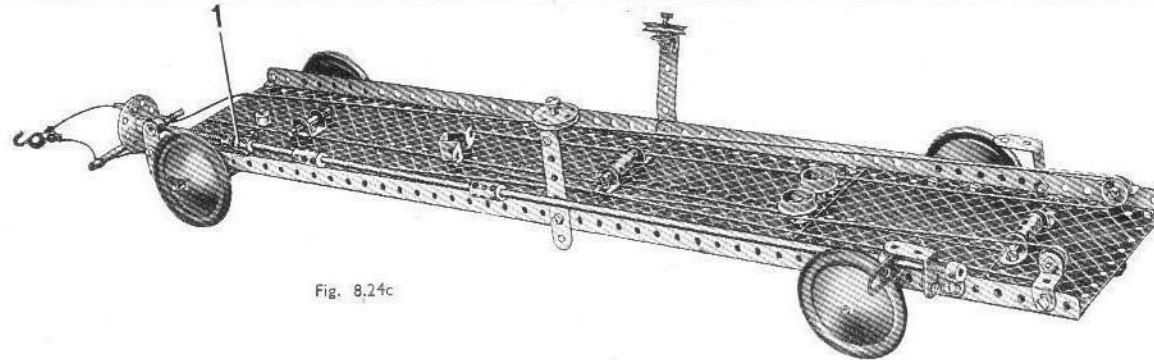

Fig. 8.24c

The driving shaft of the Motor is removed and a  $3\frac{1}{2}''$  Rod, carrying a  $\frac{1}{2}''$  Pinion is inserted in its place. The Pinion meshes with a 57-teeth Gear on a  $3\frac{1}{2}''$  Rod journalled in the Motor side plate and the right-hand side of the bonnet. The drive is then taken through a second  $\frac{1}{2}''$  Pinion and 57-teeth Gear to a Rod carrying at its centre a  $\frac{3}{4}''$  Sprocket Wheel, which is connected by Sprocket Chain to a  $1''$  Sprocket Wheel on the front axle.

The  $3''$  Pulleys on the front axle, and the four  $2''$  Pulleys on the rear axle are joined by Sprocket Chain, which represents the creeper track. The tracks are covered in on each side by a mudguard built up from two  $5\frac{1}{2}'' \times 1\frac{1}{2}''$  Flexible Plates and a  $2\frac{1}{2}'' \times 1\frac{1}{2}''$  Flexible Plate. The mudguards are braced by  $5\frac{1}{2}''$  and  $2\frac{1}{2}''$  Strips, and are shaped at the ends by Formed Slotted Strips. They are bolted at the rear to two  $3\frac{1}{2}''$  Strips secured to the chassis and at the front they are fastened by Angle Brackets to the bumper supports.

The chassis or the lifeboat carriage is built up by joining two compound girders made by bolting two  $12\frac{1}{4}''$  Angle Girders end to end, by a  $5\frac{1}{2}''$  Strip at each end. The floor of the carriage is filled in by two  $12\frac{1}{4}''$  Strip Plates and four  $5\frac{1}{2}'' \times 2\frac{1}{2}''$  Flexible Plates, and along its centre are fixed four supports or rollers for the lifeboat. The first of these consists of a  $1\frac{1}{2}''$  Rod secured by two Spring Clips in a Double Bracket bolted to the floor of the carriage. The second and fourth are identical and consist of a Coupling that is supported between two Angle Brackets by a  $1\frac{1}{2}''$

Rod. The third roller is of different construction and is formed by two  $\frac{3}{4}''$  Flanged Wheels secured to the carriage by lock-nutted  $\frac{1}{2}''$  Bolts, at a distance of  $1''$  apart. The lifeboat is prevented from falling over sideways by two  $1''$  loose Pulleys, which are fastened by Pivot Bolts to two Angle Brackets fixed to the sides of the carriage by  $3''$  Strips. The  $3''$  Strips are curved outwards slightly to allow the boat to rest on the rollers.

The front Road Wheels of the carriage are held by Spring Clips on the end of a  $2''$  Rod fastened by a Rod and Strip Connector to a  $4\frac{1}{2}''$  Strip bolted to a Face Plate. A  $1''$  Rod locked in the boss of the Face Plate passes through the floor of the carriage and is secured by a Collar. Two  $5\frac{1}{4}''$  Strips bolted to the Face Plate are fastened by a  $1\frac{1}{2}''$  Rod to a Stepped Bent Strip bolted at the rear of the tractor.

The rear Road Wheels of the carriage are held on the ends of a  $6\frac{1}{2}''$  Rod, bearings for which are provided by two Trunnions bolted under the carriage. The left hand rear wheel is fitted with a brake of the screw-on type constructed as follows. A  $3\frac{1}{2}''$  Screwed Rod fitted with lock-nuts at 1, is connected by a Swivel Bearing to a compound  $18\frac{1}{2}''$  rod, consisting of a  $2''$ ,  $5''$  and an  $11\frac{1}{2}''$  Rod joined by Couplings. The Screwed Rod passes through the tapped hole of the boss of a Crank bolted to the carriage, and the compound rod is journalled at its rear end in a  $1'' \times 1''$  Angle Bracket secured to the chassis of the carriage by an Angle Bracket. The rod is prevented from slipping by a Collar, and is fitted with a Compression Spring between the  $1'' \times 1''$  Angle Bracket and the Collar. The compound rod also is fitted with a Crank, so that when the built-up handle at the end of the Screwed Rod is turned in an anti-clockwise direction the Crank presses against the rim of the Road Wheel, and prevents it from turning.

The construction of the lifeboat itself is clear from the various illustrations.

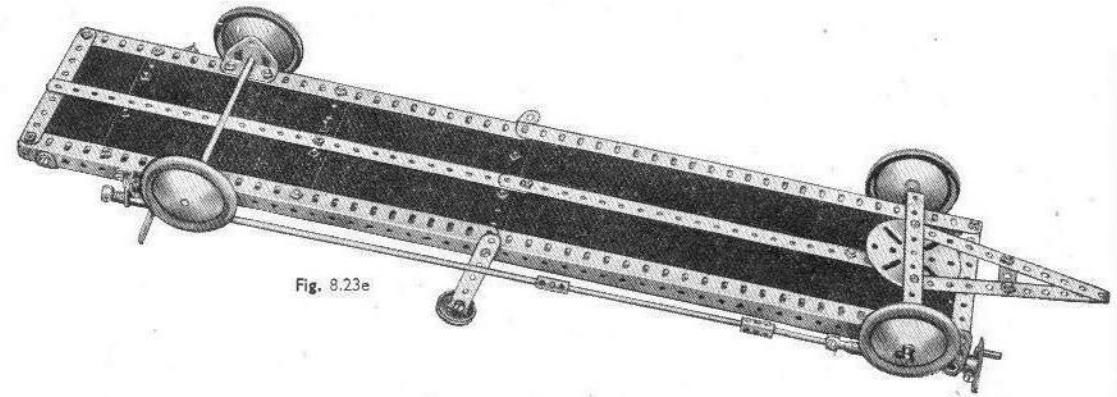
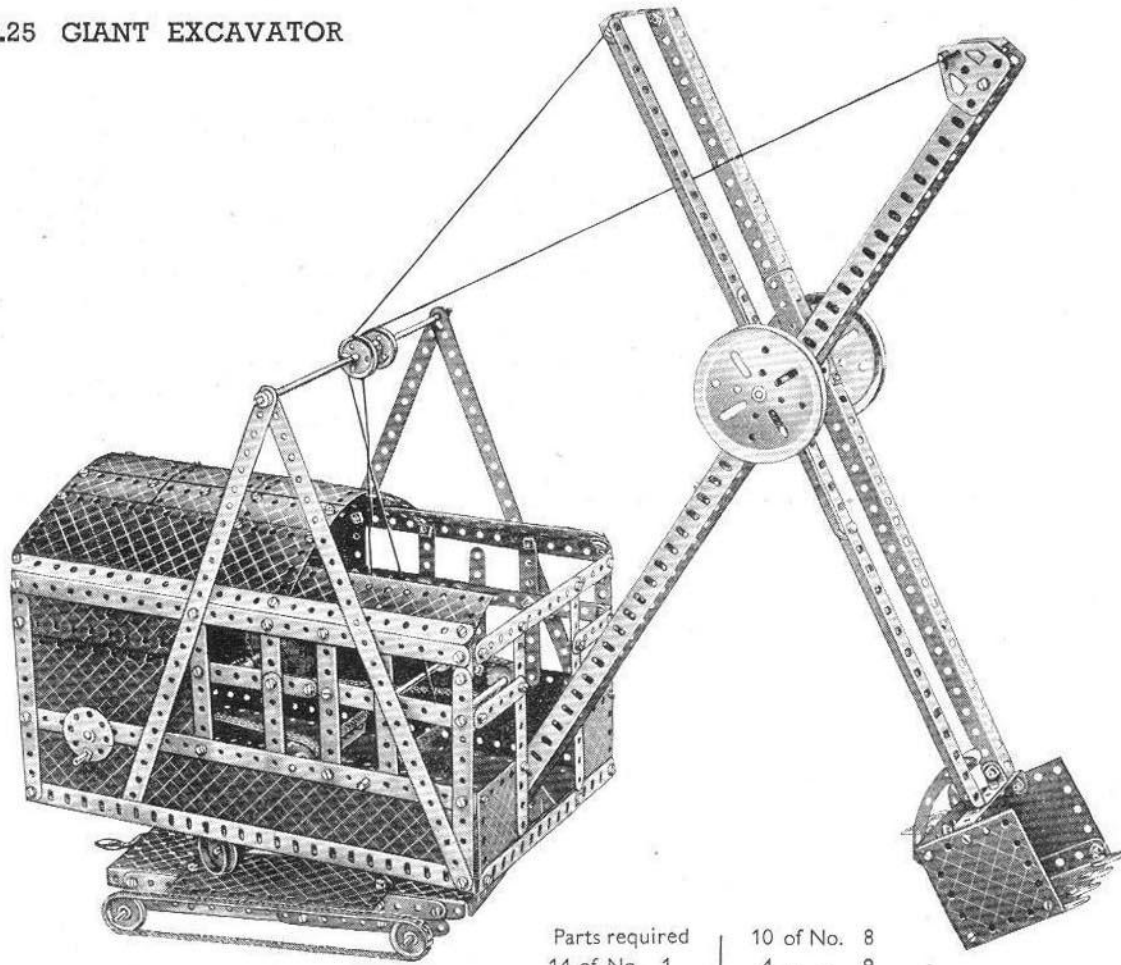

Fig. 8.23e

## 8.25 GIANT EXCAVATOR



Parts required	10 of No. 8	
14 of No. 1	4 " " 9	
20 " " 2	12 " " 10	
5 " " 2a	8 " " 12	4 of No. 15a
6 " " 3	4 " " 12c	2 " " 15b
12 " " 5	1 " " 13a	4 " " 16
2 " " 6	1 " " 14	2 " " 17
2 " " 6a	1 " " 15	2 " " 19b

1 of No. 19g
1 " " 19h
4 " " 20
4 " " 22
2 " " 22a
1 " " 24
3 " " 24a
1 " " 26
1 " " 28
15 " " 35
200 " " 37
1 " " 37a
12 " " 38
1 " " 40
1 " " 48
1 " " 48a
2 " " 48b
2 " " 48d
2 " " 52
4 " " 53
6 " " 59
6 " " 63
1 " " 90
1 " " 94
2 " " 95
2 " " 96
2 " " 109
5 " " 111a
1 " " 115
3 " " 126
2 " " 126a
6 " " 188
6 " " 189
7 " " 190
3 " " 191
8 " " 192
4 " " 197
3 " " 200
2 " " 215

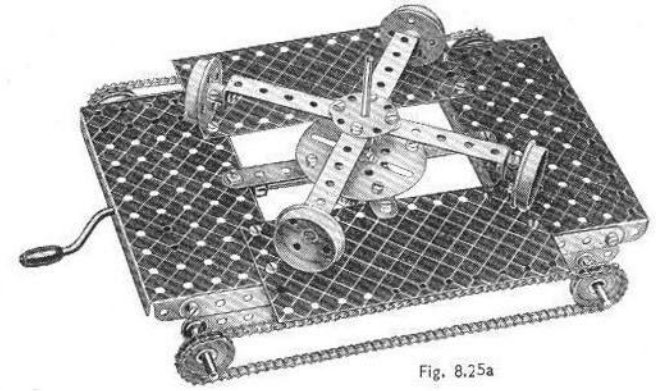

Fig. 8.25a

Construction should be commenced by building up the control cabin as shown in Fig. 8.25b. The base is made by joining two  $12\frac{1}{2}$ " Angle Girders together at each end by a compound angle girder consisting of two  $5\frac{1}{2}$ " Angle Girders overlapped seven holes. Four  $12\frac{1}{2}$ " Strips are then bolted along the middle of the base to the compound angle girders the inner pair of Strips being fastened three holes apart. The spaces between the outer pair of  $12\frac{1}{2}$ " Strips and the sides are filled in with  $12\frac{1}{2}$ " x  $2\frac{1}{2}$ " Strip Plates, and the space between the inner pair of  $12\frac{1}{2}$ " Strips is filled in with two  $5\frac{1}{2}$ " x  $2\frac{1}{2}$ " Flexible Plates bolted so that a square gap is left in the floor. Two compound strips each consisting of two  $5\frac{1}{2}$ " Strips overlapping by seven holes, are next bolted across the base to the two  $12\frac{1}{2}$ " Angle Girders and are arranged so that they reinforce the sides of the square opening. The opening is then filled in by bolting a Face Plate to the two compound strips.

The sides of the control cabin are next built up on the Angle Girders of the base. The cross-bars of the windows are made by overlapping a  $4\frac{1}{2}$ " Strip and a  $3\frac{1}{2}$ " Strip one hole and bolting them in the position shown. The vertical bars are next added. Each side is completed by bolting the "A" frames, consisting of two  $12\frac{1}{2}$ " Strips, in place. At their upper ends these Strips carry a 5" Rod and a 4" Rod joined together by a Coupling. This compound rod is fitted with two 1" loose Pulleys, placed one at each side of the Coupling and held in place against the Coupling by Spring Clips.

The rear of the control cabin is built by first making a compound plate from three  $4\frac{1}{2}$ " x  $2\frac{1}{2}$ " Flexible Plates. Two  $4\frac{1}{2}$ " x  $2\frac{1}{2}$ " Flexible Plates are overlapped two holes on their long edges. A third  $4\frac{1}{2}$ " x  $2\frac{1}{2}$ " Flexible Plate is bolted to the other two but overlaps them by one hole. The complete plate is bolted to two  $3\frac{1}{2}$ " x  $2\frac{1}{2}$ " Flanged Plates by its longest edge, with an equal amount of overlap at each side of the Flanged Plates. The latter are bolted by their flanges to one side of the control cabin, and the  $4\frac{1}{2}$ " x  $2\frac{1}{2}$ " Flexible Plates are attached to the other side of the cabin by an Angle Bracket at the top. The bottom edge of the lower  $4\frac{1}{2}$ " x  $2\frac{1}{2}$ " Flexible Plate is bolted to a compound angle girder of the base. One end of a compound

(Continued on next page)

(Continued from previous page)

strip is attached to the edge of the top  $4\frac{1}{2}'' \times 2\frac{1}{2}''$  Flexible Plate, and its other end is attached to the side by an Angle Bracket. This compound strip consists of a  $5\frac{1}{2}''$  Strip extended by a  $2\frac{1}{2}''$  Strip. The back is extended to the roof by three  $2\frac{1}{2}'' \times 1\frac{1}{2}''$  Flexible Plates, bolted together as shown and strengthened at the top by a Curved Strip, to each end of which a  $2\frac{1}{2}''$  Strip extended by a  $1\frac{1}{2}''$  Strip is bolted.

The front of the cabin consists of two  $2\frac{1}{2}'' \times 2\frac{1}{2}''$  Flexible Plates bolted to the compound angle girder of the base, and  $5\frac{1}{2}''$  and  $2\frac{1}{2}''$  Strips fixed in the positions shown. A gap is left in the front of the control cabin to accommodate the jib.

Three  $1\frac{1}{2}''$  radius Curved Plates are bolted at each side to a  $5\frac{1}{2}'' \times 1\frac{1}{2}''$  Flexible Plate and a  $2\frac{1}{2}'' \times 1\frac{1}{2}''$  Flexible Plate overlapping one hole. Compound plates consisting of a  $5\frac{1}{2}'' \times 2\frac{1}{2}''$  Flexible Plate and a  $2\frac{1}{2}'' \times 2\frac{1}{2}''$  Flexible Plate are bolted to the other Flexible Plates, and the roof so formed is curved and bolted to two  $12\frac{1}{2}''$  Strips attached to the sides by Obtuse Angle Brackets. Two  $5\frac{1}{2}'' \times 1\frac{1}{2}''$  Flexible Plates also bolted to the  $12\frac{1}{2}''$  Strips extend the roof to the front.

The Rods by which the movements of the jib and shovel arm are controlled are next fitted. The rear Rod is 4" long and is passed through the side of the control cabin and through a hole in a  $3\frac{1}{2}'' \times 2\frac{1}{2}''$  Flanged Plate bolted inside the cab (see Fig. 8.25b). It carries outside the cab a Bush Wheel fitted with a Threaded Pin, and a 2" Sprocket Wheel between the side and the  $3\frac{1}{2}'' \times 2\frac{1}{2}''$  Flanged Plate. A Coupling retains the Rod in position. Next to this Rod is a small Crank Handle, which is journaled in the other side of the cabin and is extended by joining to it a  $3\frac{1}{2}''$  Rod with a Coupling. The Crank Handle carries a 2" Sprocket Wheel. The Sprocket Wheel on the rear Rod is connected by a Sprocket Chain to a 1" Sprocket fastened on an 8" Rod journaled in the sides of the control cabin. This Rod forms the winding drum for the Cord controlling the shovel arm.

The 2" Sprocket Wheel on the Crank Handle is connected by Sprocket Chain to a second 1" Sprocket Wheel on a compound rod made by joining a  $6\frac{1}{2}''$  Rod to a 2" Rod by a Coupling. This rod forms the winding drum for the cord controlling the jib.

The next step is to construct the travelling base on which the model runs. This is made by overlapping  $5\frac{1}{2}''$  Strips by five holes to make two compound strips, and then bolting them to the end flanges of two  $5\frac{1}{2}'' \times 2\frac{1}{2}''$  Flanged Plates as shown. The Flanged Plates are joined also by two  $5\frac{1}{2}'' \times 2\frac{1}{2}''$  Flexible Plates that form the platform on which the superstructure swivels. A  $3\frac{1}{2}''$  Strip and a  $5\frac{1}{2}''$  Strip are bolted across the opening in the base and to them is fastened a Face Plate.

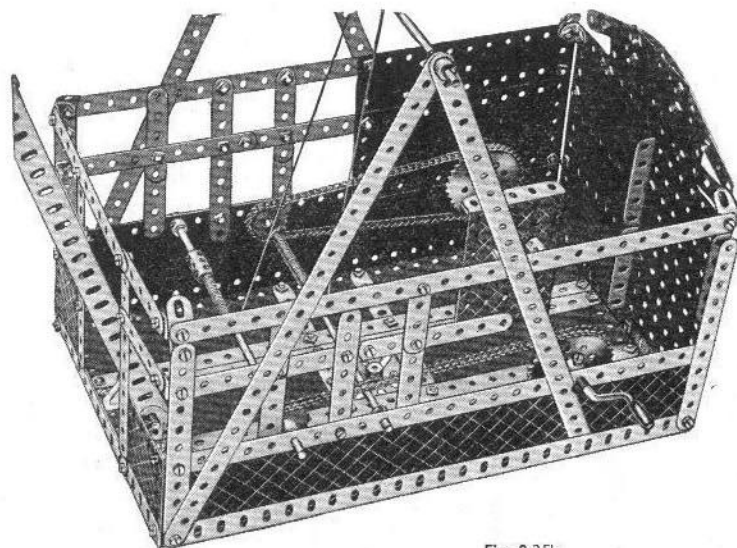

Fig. 8.25b

A  $3\frac{1}{2}''$  Rod passes through the boss of the Face Plate and a  $1\frac{1}{2}''$  Contrate Wheel is fastened to it underneath the base. The Contrate Wheel meshes with a  $\frac{1}{2}''$  Pinion, secured on the end of a large Crank Handle, which passes through holes in the flanges of the left-hand Flanged Plate and is retained in position by a Collar. The Contrate Wheel is kept in constant mesh with the  $\frac{1}{2}''$  Pinion by a Collar fastened on the  $3\frac{1}{2}''$  Rod on the opposite side of the Face Plate. The axles of the 1" Pulleys are journaled in the end holes of two compound strips made by overlapping a  $4\frac{1}{2}''$  Strip and a  $5\frac{1}{2}''$  Strip by three holes. They are attached to the other compound strips by Fishplates. The axles of the 1" Pulleys are compound rods each consisting of a

$3\frac{1}{2}''$  Rod connected to a  $4\frac{1}{2}''$  Rod by a Coupling. The 1" Pulleys are spaced from the compound strips by a Washer and Spring Clip.

The creeper tracks are formed by Sprocket Chain passed round the 1" Pulleys, and additional Chain to that provided in the Outfit is required if these are fitted.

Efficient swivelling is obtained by using the built-up roller bearing unit shown in Fig. 8.25a. This consists of two  $5\frac{1}{2}'' \times \frac{1}{2}''$  Double Angle Strips bolted to a Wheel Disc as shown, care being taken to align the centre holes before tightening the Nuts. The  $\frac{1}{2}''$  Flanged Wheels are carried on  $\frac{1}{2}''$  Bolts held sufficiently loose to allow the Flanged Wheels to revolve freely. The control cabin is then fitted. The roller bearing unit is placed on the  $3\frac{1}{2}''$  Rod of the travelling base and the Rod is passed through the boss of the Face Plate underneath the control cabin. The set-screw of the Face Plate is then tightened up. When the large Crank Handle of the base is turned the complete superstructure is made to swivel.

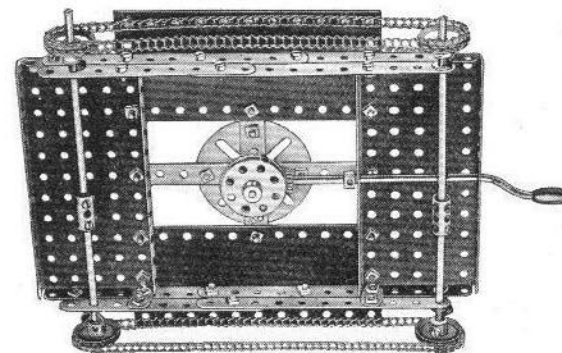

Fig. 8.25c

To complete the construction of the model the jib and shovel arm are constructed. The jib consists of a U-section girder built up as follows. Pairs of  $12\frac{1}{2}''$  Angle Girders are overlapped by six holes, and the members thus formed are joined at each end by Fishplates. Two Flat Trunnions are bolted at the top end of the jib, and a  $1\frac{1}{2}''$  Rod is held in place by Spring Clips. In a position 17 holes from the top end of the jib two Wheel Discs are bolted, one at each side of the jib. The jib is now pivoted in the control cabin on a 2" Rod, which is retained in position by Spring Clips in two Trunnions bolted to the floor.

The shovel arm comprises two members each consisting of two  $12\frac{1}{2}''$  Angle Girders overlapped 12 holes. The members are joined together at their upper ends by a  $2\frac{1}{2}'' \times \frac{1}{2}''$  Double Angle Strip and at the bucket end by a  $1\frac{1}{2}'' \times \frac{1}{2}''$  Double Angle Strip. The digger bucket is made by bolting two  $2\frac{1}{2}'' \times 2\frac{1}{2}''$  Flexible Plates to the flanges of a  $3\frac{1}{2}'' \times 2\frac{1}{2}''$  Flanged Plate to form the sides. The back consists of a  $2\frac{1}{2}'' \times 2\frac{1}{2}''$  Flexible Plate and a  $2\frac{1}{2}'' \times 1\frac{1}{2}''$  Flexible Plate overlapped one hole and bolted to a  $3\frac{1}{2}'' \times \frac{1}{2}''$  Double Angle Strip, that in turn is fastened to the sides. A second  $3\frac{1}{2}'' \times \frac{1}{2}''$  Double Angle Strip is bolted across the top of the bucket and to it is fastened the  $1\frac{1}{2}'' \times \frac{1}{2}''$  Double Angle Strip of the shovel arm. The "tines" or teeth of the digging edge are four Fishplates bolted to the edge of the  $3\frac{1}{2}'' \times 2\frac{1}{2}''$  Flanged Plate. Two Formed Slotted Strips and a Trunnion are bolted to the back of the digger bucket.

The shovel arm is pivoted in the eighteenth holes from the top end, on a  $4\frac{1}{2}''$  Rod that passes through the central holes of the Wheel Discs bolted to the jib. The Rod is held in place in the Wheel Discs by Spring Clips, and two 3" Pulleys, one at each end of the Rod, hold the shovel arm in position.

The model is now ready to be fitted with operating Cords. The Cord controlling the jib is wound around the 8" Rod in the control cabin and is led over one of the 1" loose Pulleys above the cabin. It is then tied to the  $1\frac{1}{2}''$  Rod at the jib head. A second Cord is wound around the compound rod in the control cabin and also is led over a 1" loose Pulley. Finally it is tied to the  $2\frac{1}{2}'' \times \frac{1}{2}''$  Double Angle Strip at the top end of the shovel arm.





No.	Description	0	1	1a	2	2a	3	3a	4	4a	5	5a	6	6a	7	7a	8	8a	9	9a	10
95	Sprocket Wheels, 2"																				2
95a	" " 1 1/2"																				2
95b	" " 3"																				2
96	" " 1 1/2"																				2
96a	" " 1 1/2"																				2
100	Braced Girders, 5 1/2"																				4
102	Single Bent Strips																				4
103	Flat Girders, 5 1/2"																				4
103a	" " 12 1/2"																				4
103b	" " 4 1/2"																				4
103c	" " 3 1/2"																				4
103d	" " 3 1/2"																				4
103e	" " 2 1/2"																				4
103f	" " 2 1/2"																				4
103g	" " 1 1/2"																				4
103h	" " 1 1/2"																				4
103k	" " 7 1/2"																				4
108	Architraves																				2
109	Face Plates, 2 1/2" diam.																				2
110	Rack Strips, 3 1/2"																				2
111	Bolts, 3/8"																				2
111a	" " 3/8"																				2
111b	" " 3/8"																				2
111c	" " 3/8"																				2
114	Hinges																				2
115	Threaded Pins																				2
116	Fork Pieces, Large																				2
116a	" " Small																				2
117	Steel Balls, 3/8" diam.																				2
118	Hub Discs, 5 1/2" diam.																				2
120b	Compression Springs																				2
124	Reversed Angle Brackets, 1 1/2"																				2
125	" " 1 1/2"																				2
126	Trunnions																				2
126a	Flat Trunnions																				2
128	Boss Bell Cranks																				2
129	Rack Segments, 3" diam.																				2
130	Triple Throw Eccentrics																				2
132	Flywheels, 2 1/2" diam.																				2
133	Corner Brackets, 1 1/2"																				2
133a	" " 1 1/2"																				2
134	Crank Shafts, 1" stroke																				2
136	Handrail Supports																				2
136a	Handrail Couplings																				2
137	Wheel Flanges																				2
140	Universal Couplings																				2
142a	Motor Tyres, 2"																				2
142b	" " 3"																				2
143	Circular Girders, 5 1/2" diam.																				2
144	Dog Clutches																				2
145	Circular Strips, 7 1/2" diam.																				2
146	" " Plates, 6" diam.																				2
146a	" " 4" diam.																				2
147a	Pawls																				2
147b	Pivot Bolt with 2 Nuts																				2
147c	Pawls without Boss																				2
154a	Corner Angle Brackets, 3/4" R.H.																				2
154b	" " L.H.																				2
155a	Rubber Rings, for 1" pulley																				2
157	Fans, 2" diam.																				2
160	Channel Bearings, 1 1/2" x 1" x 1/2"																				2
161	Girder Brackets, 2" x 1" x 1/2"																				2
162	Boiler with Ends, complete																				2
162a	Boiler Ends																				2
162b	Boilers without Ends																				2
163	Sleeve Pieces																				2
164	Chimney Adaptors																				2
165	Swivel Bearings																				2
166	End Bearings																				2
167a	Ring Frames for Rollers																				2
167b	Ball Bearings, 4" diam.																				2
169	Digger Buckets																				2
170	Eccentrics, 3/4" Throw																				2
171	Socket Couplings																				2
175	Flexible Couplings Units																				2
176	Anchoring Springs for Cord																				2
179	Rod Socket																				2
185	Steering Wheel, 1 1/2" diam.																				2
186	Driving Bands, 2 1/2" Light																				2
186a	" " 10"																				2
186b	" " 10" Heavy																				2
186c	" " 15"																				2
186d	" " 20"																				2
186e	Road Wheels																				2
188	Flexible Plates, 2 1/2" x 1 1/2"																				2
189	" " 5 1/2" x 1 1/2"																				2
190	" " 3 1/2" x 2 1/2"																				2
190a	" " 4 1/2" x 2 1/2"																				2
191	" " 5 1/2" x 2 1/2"																				2
192	" " 6 1/2" x 2 1/2"																				2
196	Strip Plates, 1 1/2" x 2 1/2"																				2
197	" " 1 1/2" x 2 1/2"																				2
198	Hinged Flat Plates, 4 1/2" x 2 1/2"																				2
199	Curved Plates, U Section, 2 1/2" x 2 1/2" x 3/8" radius																				2
200	Curved Plates, 2 1/2" x 2 1/2" x 1 1/2" radius																				2
212	Rod and Strip Connectors																				2
213	Rod Connectors																				2
214	Semi-Circular Plates, 2 1/2"																				2
215	Formed Slotted Strips, 3"																				2
216	Cylinder, 2 1/2"																				2
217a	Discs, 1 1/2"																				2
217b	" " 3/8"																				2
219	Wheel Discs																				2
A1083	Drifts																				2
PS2	Aeroplane Collars																				2
	Clockwork Motor No. 1																				2
	Electric Motor No. E120, 20-volts																				2

Full instructions for building a fine range of models are included with each Outfit.

**REAL ENGINEERING PARTS IN MINIATURE**

Meccano parts, an illustrated list of which is given in the following pages, combine to form a complete miniature engineering system with which practically any movement known in mechanics can be correctly reproduced. New parts are always being introduced in order to keep Meccano model-building in line with the most modern engineering requirements. The greatest care is taken in the designing of these parts to ensure that they function exactly as their counterparts in actual engineering practice. Ask your dealer for the latest complete illustrated price list and ask him also to keep you advised of all new parts that are added to the system.

# MECCANO PARTS

120. Buffers  
120b. Compression Springs
- 120a. Spring Buffers
121. Train Couplings
122. Miniature Loaded Sacks
123. Cone Pulleys
124. Reversed Angle Brackets, 1"
125. " " "
126. Trunnions
- 126a. Flat Trunnions
127. Simple Bell Cranks
128. Boss Bell Cranks
129. Rack Segments, 3" diam.
130. Eccentrics, Triple Throw
131. Dredger Buckets
132. Flywheels, 2 1/2" diam.
133. Corner Brackets, 1 1/2"
- 133a. " " "
134. Crank Shafts, 1" stroke
135. Theodolite Protractors
136. Handrail Supports
- 136a. Handrail Couplings
137. Wheel Flanges
138. Ships' Funnels
- 138a-z. " " Raked
139. Flanged Brackets (right)
- 139a. " " (left)
140. Universal Couplings
141. Wire Lines (for clock weights)
142. Rubber Rings (to fit 3" diam. rims)
- 142a. Motor Tyres (to fit 2" diam. rims)
- 142b. " " " 3" " "
- 142c. " " " 1" " "
- 142d. " " " 1 1/2" " "
143. Circular Girders, 5 1/2" diam.
144. Dog Clutches
145. Circular Strips, 7 1/2" diam. overall
146. " Plates, 6" " "
- 146a. " " 4" " "
147. Pawls, with Pivot Bolt and Nuts
- 147a. Pawls
- 147b. Pivot Bolts with 2 Nuts
- 147c. Pawls without boss
148. Ratchet Wheels
149. Collecting Shoes for Electric Locos
150. Crane Grabs

151. Pulley Blocks, Single Sheave
152. " " Two " "
153. " " Three " "
- 154a. Corner Angle Brackets, 1/2" (right-hand)
- 154b. Corner Angle Brackets, 1/2" (left-hand)
155. Rubber Rings (for 1" Pulleys) Black White
- 155a. " " " "
156. Pointers (with boss), 2 1/2" overall
157. Fans, 2" diam.
- 158a. Signal Arms, Home
- 158b. " " Distant
160. Channel Bearings, 1 1/2" x 1" x 1/2"
161. Girder Brackets, 2" x 1" x 1/2"
162. Boilers, complete, with ends
- 162a. " Ends
- 162b. " without ends
163. Sleeve Pieces
164. Chimney Adaptors
165. Swivel Bearings
166. End " "
167. Geared Roller Bearings
- 167a. Roller Races, geared, 192 teeth
- 167b. Ring Frames for Rollers
- 167c. Pinions for Roller Bearings (16 teeth)

168. Ball Bearings, 4" diam.
- 168a. " Races, flanged discs
- 168b. " " toothed " "
- 168c. " Casings, complete with balls
169. Digger Buckets
170. Eccentrics, 1/2" throw
171. Socket Couplings
172. Pendulum Connections
173. Rail Adaptors
174. Grease Cups
175. Flexible Coupling Units
176. Anchoring Springs for Cord
177. Shafting Standards, Large
178. " " Small
179. Rod Sockets
180. Toothed Gear Rings, 3 1/2" diam.
181. Bobbins
182. Insulating Bushes
- 182a. Insulating Washers
183. Lamp Holders
- 184a. 2 1/2-volt Lamps
- 184b. 3 1/2 " " "
- 184c. 6-volt Lamps
- 184d. 10 " " "
- 184e. 20 " " "

185. Steering Wheels, 1 1/2" diam.
186. Driving Bands, 2 1/2" (Light)
- 186a. " " 6" " "
- 186b. " " 10" " "
- 186c. " " 10" (Heavy) " "
- 186d. " " 15" " "
- 186e. " " 20" " "
187. Road Wheels
192. Flexible Plates.
197. Strip Plates.
191. 4 1/2" x 2 1/2"
192. 5 1/2" x 2 1/2"
188. 2 1/2" x 1 1/2"
189. 5 1/2" x 1 1/2"
190. 2 1/2" x 2 1/2"
- 190a. 3 1/2" x 2 1/2"
196. 9 1/2" x 2 1/2"
199. Curved Plates, U-Section 2 1/2" x 2 1/2" x 1/8" radius
200. " " 2 1/2" x 2 1/2", 1 1/8" radius
198. Hinged Flat Plates, 4 1/2" x 2 1/2"
199. " " " " " " " "
200. " " " " " " " "
201. Lamps with Flex (3 1/2 volts)
202. Angle Brackets (for Headlamps)
203. Headlamps
- 203a. Headlamp Rims
- 203b. " Bodies
204. " Nuts
205. " Glasses
206. Lampshades
207. Lamp Bases
- 207a. Lamp with Standard and Flex
208. Battery Tags and Studs
- 208a. Washers for Battery Studs
210. Nuts for Battery Studs
- 211a. Helical Gear 1/2" { Can only be used together
- 211b. " " 1 1/2" " " }
212. Rod and Strip Connectors
213. Rod Connectors
214. Semi-Circular Plates 2 1/2"
215. Formed Slotted Strips 3"
216. Cylinders, 2 1/2"
- 217a. Discs, 1 1/2"
- 217b. Discs 3/4"



HORNBY SCALE MODEL OF  
*"Princess Elizabeth"* -  
MIGHTY L.M.S.R. WORLD  
RECORD-BREAKER

*Driver Clarke  
says  
"It's fine!"*

**FITTED WITH 20-VOLT  
AUTO-REVERSING MOTOR**

Four hundred miles non-stop from Glasgow to London at an average of 70 m.p.h., with a 260-ton load! This remarkable feat was performed by L.M.S.R. Locomotive "*Princess Elizabeth*" in charge of Driver T. J. Clarke, and it set up a world record.

Think of the thrill of owning a model of such an engine; not merely a perfect reproduction in miniature, but one having the same qualities of power, speed and efficiency! This is now made possible by the latest product of Meccano Limited—the magnificent Hornby scale model locomotive "*Princess Elizabeth*" illustrated above, driven by a 20-volt electric motor, and fitted with the Hornby Remote Control.

Playing the great game of railways with any of the world-famous Hornby Trains is fine fun. The performance and durability of the Hornby Electric Trains place them in a class entirely their own, while Hornby Clockwork Trains are the longest-running spring-driven locomotives in the world.

Ask your dealer for the latest complete catalogue of Hornby Trains, Rolling Stock and Accessories.

**HORNBY TRAINS**

MANUFACTURED BY MECCANO LTD., LIVERPOOL.