

MECCANO

INSTRUCTIONS FOR No. 6 OUTFIT

Prices	
Great Britain	1/3
Australia	2/6
New Zealand	2/-
South Africa	2/8
Canada	45c

No.
40.6

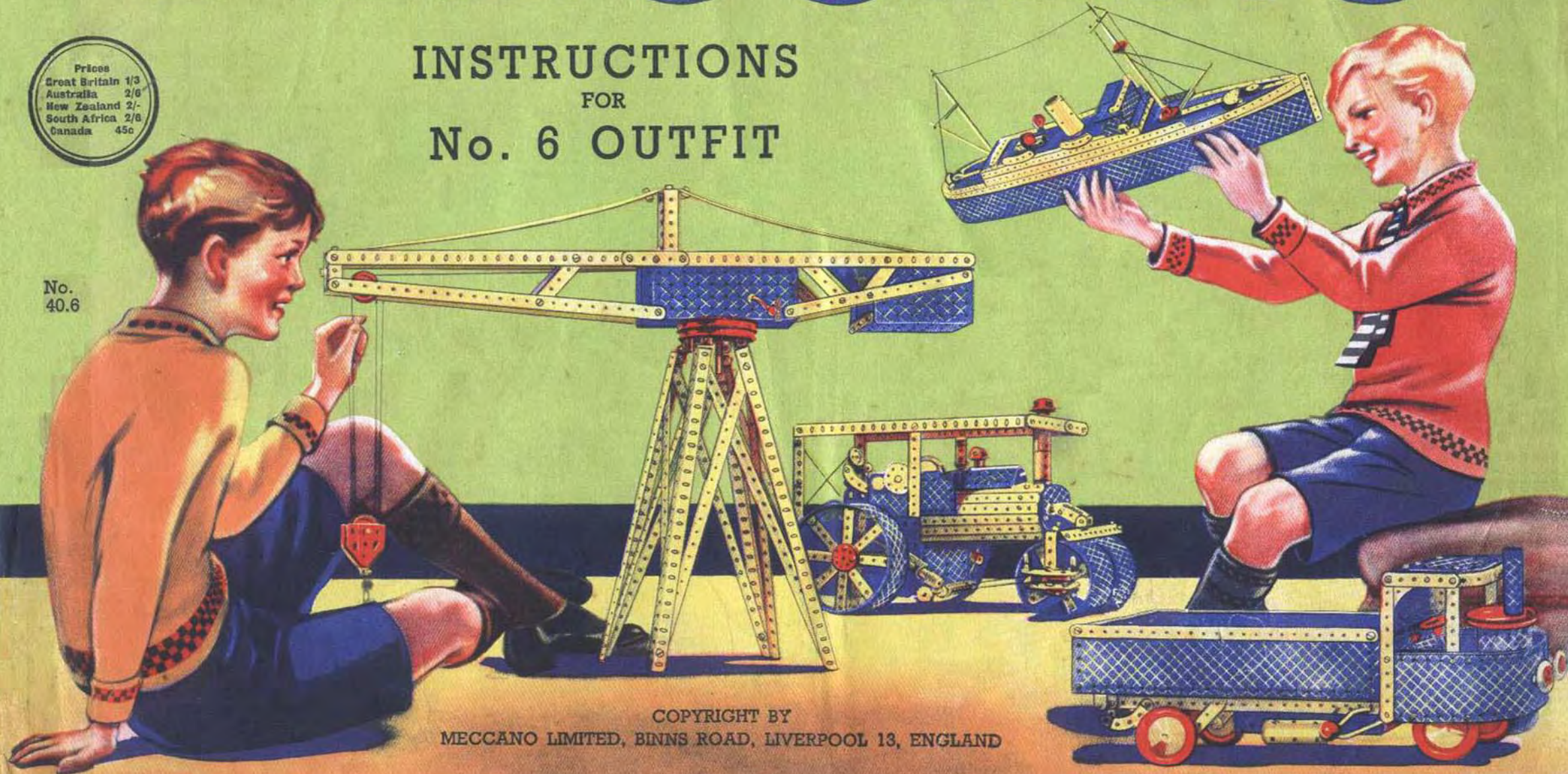

COPYRIGHT BY
MECCANO LIMITED, BINNS ROAD, LIVERPOOL 13, ENGLAND

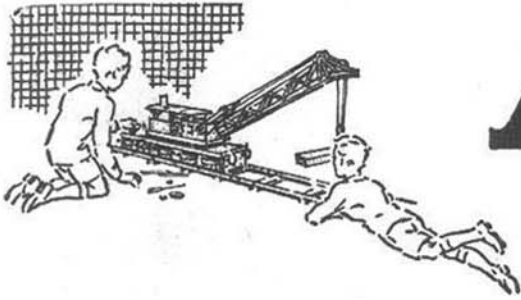

MECCANO

Real Engineering in Miniature

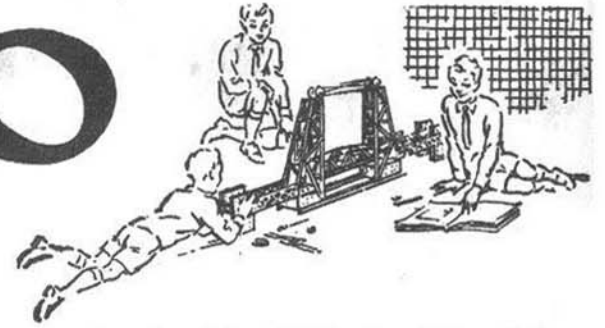

MODEL-BUILDING WITH MECCANO

There is no limit to the number of models that can be built with Meccano—Cranes, Clocks, Motor Cars, Aeroplanes, Machine Tools, Locomotives—in fact everything that interests boys. A screwdriver and a spanner, both of which are provided in each Outfit, are the only tools necessary.

When you have built all the models illustrated in the Manuals of Instruction the fun is not over, but is just beginning. Now comes the chance to make use of your own ideas. First of all, re-build some of the models with small changes in construction that may occur to you; then try building models entirely of your own design. In doing this you will feel the real thrill of the engineer and the inventor.

HOW TO BUILD UP YOUR OUTFIT

Meccano is sold in 11 different Outfits, ranging from No. 0 to No. 10. Each Outfit from No. 1 upwards can be converted into the one next larger by the purchase of an Accessory Outfit. Thus Meccano No. 1 Outfit can be converted into No. 2 Outfit by adding to it a No. 1a Accessory Outfit. No. 2a Outfit would then convert it into a No. 3, and so on. In this way, no matter with which Outfit you begin, you can build it up by degrees until you have a No. 10 Outfit.

All Meccano parts are of the same high quality and finish, but the larger Outfits contain a greater quantity and variety, making possible the construction of more elaborate models.

Special Note.—The Meccano Plates (Flanged, Flat, Curved, etc.) are shown in the Manuals with diagonal white lines. In the new Meccano Outfits these parts are plain.

Several of the illustrations in this Manual show how miniature figures and various small articles can be introduced to add realism to the models. These are not included in the Outfit. Many of them are Meccano Dinky Toys that can be bought separately from your Meccano dealer.

THE "MECCANO MAGAZINE"

The "Meccano Magazine" is published specially for Meccano boys. Every month it describes and illustrates new Meccano models for Outfits of all sizes, and deals with suggestions from readers for new Meccano parts and for new methods of using the existing parts.

There are model-building competitions specially

planned to give an equal chance to the owners of small and large Outfits. In addition, there are splendid articles on such subjects as Railways, Famous Engineers and Inventors, Electricity, Chemistry, Bridges, Cranes and Aeroplanes, and special sections dealing with the latest Engineering, Aviation and Shipping News. Other pages deal with Stamp Collecting, and Books of interest to boys; and a feature of outstanding popularity is the section devoted to short articles from readers.

If you are not already a reader write to the Editor for full particulars, or order a copy from your Meccano dealer, or from any newsagent.

THE MECCANO GUILD

Every owner of a Meccano Outfit should join the Meccano Guild. This is a world-wide organisation, started at the request of Meccano boys. Its primary object is to bring boys together and to make them feel that they are all members of a great brotherhood, each trying to help others to get the very best out of life. Its members are in constant touch with Headquarters, giving news of their activities and being guided in their hobbies and interests. Write for full particulars and an application form to the Secretary, Meccano Guild, Binns Road, Liverpool 13.

Clubs founded and established under the guidance of the Guild Secretary provide Meccano boys with opportunities of enjoying to the utmost the fun of model-building. Each has its Leader, Secretary, Treasurer and other officials. With the exception of the Leader, all the officials are boys, and as far as possible the proceedings of the clubs are conducted by boys.

MECCANO SERVICE

The service of Meccano does not end with selling an Outfit and an Instruction Manual. If ever you are in any difficulty with your models, or if you want advice on anything connected with this great hobby, write to us. We receive hundreds of interesting letters from boys in all parts of the world, and each of these is answered personally by one of our staff of experienced experts.

Whatever your problem may be, write to us about it. Do not hesitate. We shall be delighted to help you in any way possible.

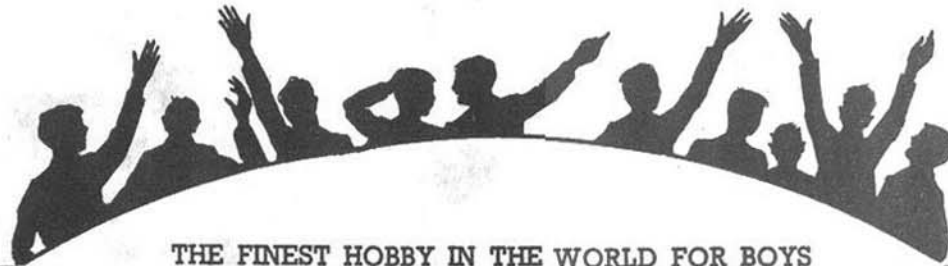

THE FINEST HOBBY IN THE WORLD FOR BOYS

HOW TO COMMENCE THE FUN

THE MOST FASCINATING OF ALL HOBBIES

Meccano model-building is the most fascinating of all hobbies, because it never becomes dull. There is always something new to be done. First of all there is the fun of building a new model, and watching it take shape as part after part is added. Then, when the model is complete, comes the thrill of setting it to work just like the real structure it represents, by means of a Meccano Motor. This wonderful process can be repeated indefinitely, for there is no end to the number of Meccano models that can be built. Another point is that models built with Meccano are real engineering structures in miniature, and the keen model-builder has wonderful opportunities for learning the working of machines and mechanisms of all kinds. So he acquires practical engineering knowledge without special study.

It is so simple to build Meccano models that operations can be started as soon as the first Outfit is opened. Different boys build in different ways, but in the end they all reach the same splendid results. The following hints are given with the object of showing boys who are just commencing the wonderful Meccano hobby how to obtain the greatest possible fun.

A FEW USEFUL HINTS

It will be noticed that with each model shown in this Manual of Instructions is given a list of the parts required to build it. For the first few models it is a good plan to lay out on the table all the parts required for the one it is proposed to build, and put the remainder of the Outfit on one side. To help you to pick out the correct parts for your model a complete list of Meccano parts is given at the back of this Manual, and all the principal parts are illustrated. In the list the parts are all numbered, and in most cases their measurements are given. There is no need, however, to measure the parts to find out which is which, as the size is easily found from the number of holes. All Meccano holes are spaced $\frac{1}{2}$ " apart, so that by counting two holes to the inch the size of a part can be found at once. For instance, Part No. 2 is listed as a $5\frac{1}{2}$ " Perforated Strip, so you look in your Outfit for a Strip with eleven holes. Similarly No. 192 is a $5\frac{1}{2}$ " \times $2\frac{1}{2}$ " Flexible Plate, so you look for a Flexible Plate eleven holes in length and five holes in width. By the time a few models have been built the names of the parts will have become familiar.

Beginners sometimes wonder which section of a model should be built first. There cannot be any definite rule for this, as it depends on the design of the model. In stationary models the base usually should be built first. In most of the smaller models a $5\frac{1}{2}$ " \times $2\frac{1}{2}$ " Flanged Plate forms an important part of the structure, and often the best plan is to start building by bolting parts to this Plate. For other models a good general rule is that the sections that form supports for a number of other parts should be built first.

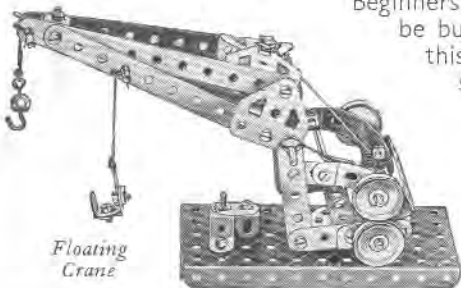

Floating Crane

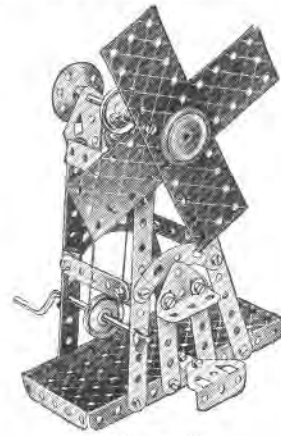

Windmill

THE IMPORTANCE OF "LOCK-NUTTING"

In building models in which Rods revolve in the holes of other parts it is important to make sure that such holes are exactly in line with one another. This can be done very easily by pushing through the holes a long Rod before the Bolts holding the various parts are tightened up.

In some models it is necessary to join certain parts together, so that, although they cannot come apart, they are free to pivot or move in relation to one another. To do this the parts are bolted together as usual, but the Nut is not screwed up tightly, so that the parts are not gripped. Then, to prevent the Nut from unscrewing, a second Nut is screwed up tightly against it, the first, meanwhile, being held with a spanner. This method of using a second Nut is known as lock-nutting, and it is employed in a large number of Meccano models.

During the construction of a model it is best to screw up the Nuts with the fingers, followed by just a light turn with the screwdriver, leaving the final tightening with spanner and screwdriver until all the parts are connected up.

MOTORS AND GEARING

Models can be operated by means of either Meccano Clockwork or Electric Motors.

The Clockwork Motors have the advantage of being self-contained and extremely simple. If only a small amount of power is needed, the model may be driven direct from the driving spindle of the Motor or through a belt running over two pulleys of the same size, giving what is described as a 1:1 (one-to-one) ratio. Greater power can be obtained by a reduction in the speed of the drive, which can be produced in a simple manner by connecting a small pulley on the Motor to a larger pulley by means of a belt. Thus if a 1" Pulley is made to drive a 3" Pulley, a reduction ratio of approximately 1:3 is obtained. This means that the driven shaft will take about three times the load that the driving shaft would handle, but will rotate at only one-third of the speed. Rubber bands are better than Cord for driving belts for most purposes.

The Electric Motors have the advantage of giving long continuous runs. Their speed is much higher than that of the Clockwork Motors, and this makes it possible to employ higher reduction ratios and thus obtain greater power.

With the larger Outfits, belt drive can be replaced with advantage by gearing. To operate a slow-moving model demanding great power, such as a traction engine, gears that will provide a considerable reduction must be used. For example, a Worm meshed with a $\frac{1}{2}$ " Pinion will give a 1:19 reduction; while a Worm meshed with a 57-teeth Gear will give a 1:57 reduction.

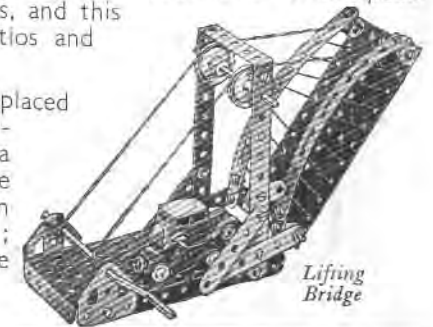

Lifting Bridge

O.1 HAND CART

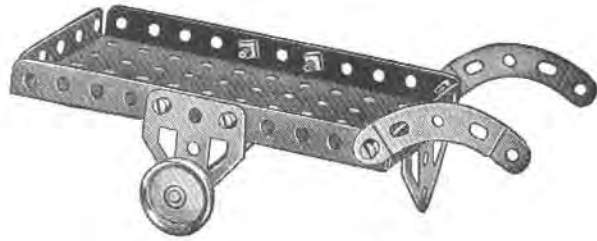

Parts required		
1 of No. 16	1 of No. 52	2 of No. 126a
2 " " 22	2 " " 90a	2 " " 155a
8 " " 37	1 " " 126	

O.2 COSTER'S BARROW



Parts required		
2 of No. 10	1 of No. 52	
1 " " 16	2 " " 90a	
2 " " 22	2 " " 126	
16 " " 37	2 " " 126a	
2 " " 5	2 " " 155a	
4 of No. 2		
2 " " 5		

O.3 FLAT TRUCK

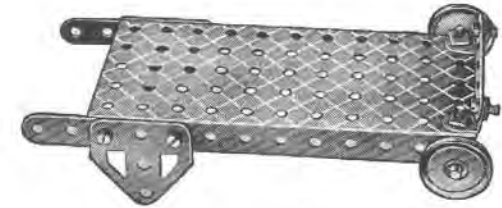

Parts required		
2 of No. 5	2 of No. 22	1 of No. 90a
2 " " 12	8 " " 37	2 " " 126a
1 " " 16	1 " " 52	2 " " 155a

O.4 DOCKSIDE CRANE

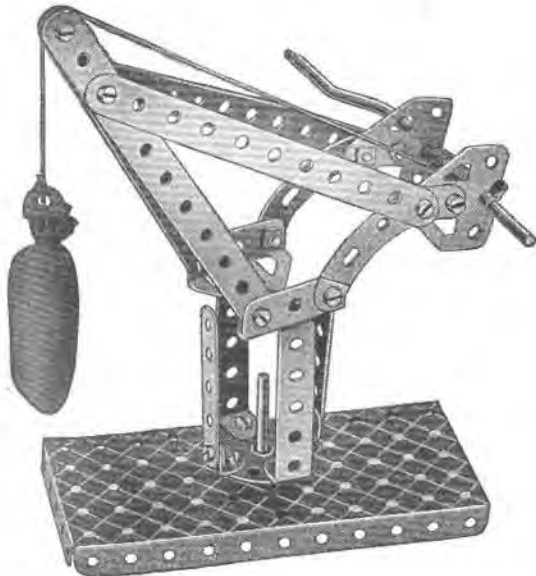

Parts required	
4 of No. 2	
2 " " 5	
3 " " 12	
1 " " 17	
1 " " 19s	
1 " " 22	
1 " " 24	
2 " " 35	
18 " " 37	
2 " " 37a	
2 " " 38	
2 " " 48a	
1 " " 52	
2 " " 90a	
2 " " 111c	
2 " " 126	
2 " " 126a	

O.5 SWING

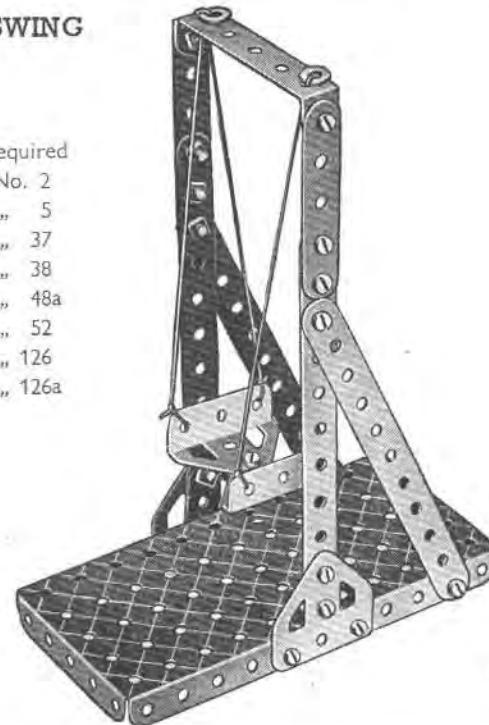

Parts required	
4 of No. 2	
2 " " 5	
18 " " 37	
2 " " 38	
1 " " 48a	
1 " " 52	
2 " " 126	
2 " " 126a	

O.6 ELEVATOR

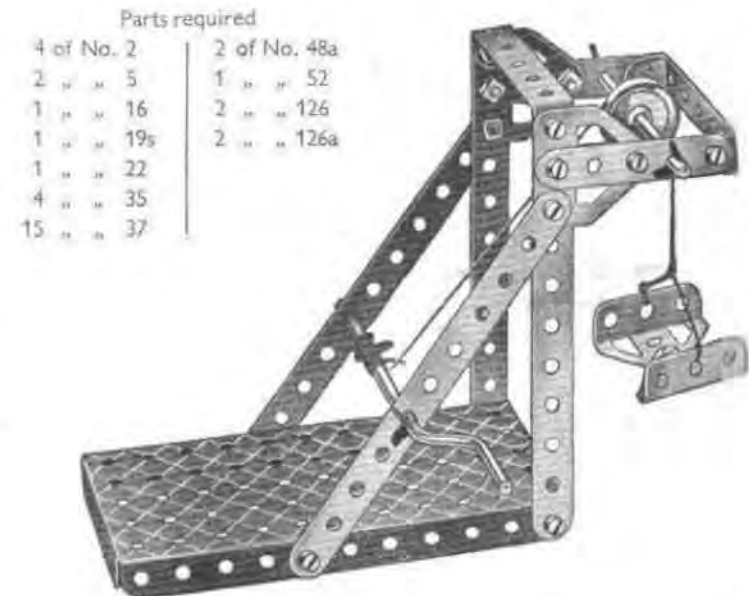

Parts required	
4 of No. 2	2 of No. 48a
2 " " 5	1 " " 52
1 " " 16	2 " " 126
1 " " 19s	2 " " 126a
1 " " 22	
4 " " 35	
15 " " 37	

O.7 GARDEN SEAT



Parts required

4 of No. 2
2 " " 5
10 " " 37
2 " " 48a
1 " " 52

O.8 COUNTER SCALES

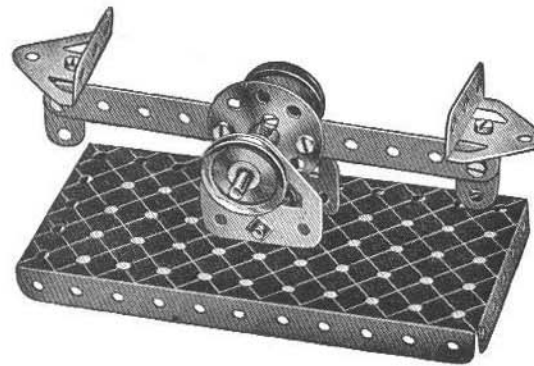

Parts required

1 of No. 2	2 of No. 22	1 of No. 52
2 " " 10	1 " " 24	2 " " 126
4 " " 12	9 " " 37	2 " " 126a
1 " " 17	2 " " 38	

O.9 ESKIMO BOY AND SLEDGE

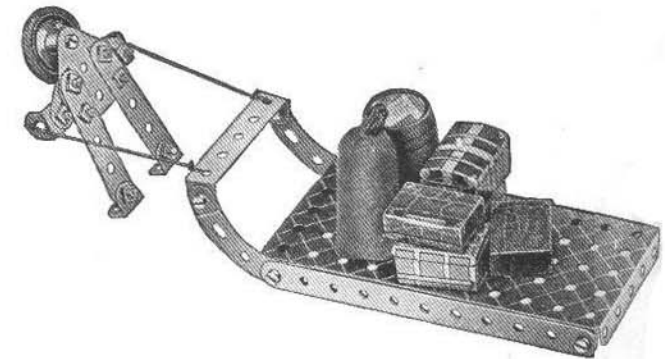

Parts required

2 of No. 2	1 of No. 22	2 of No. 90a
2 " " 5	14 " " 37	1 " " 111c
2 " " 10	1 " " 48a	1 " " 126a
4 " " 12	1 " " 52	1 " " 155a

O.10 SIGNAL

Parts required

2 of No. 2
2 " " 5
1 " " 10
3 " " 12
1 " " 17
1 " " 22
2 " " 35
11 " " 37
3 " " 37a
2 " " 38
1 " " 52
2 " " 90a
2 " " 111c
2 " " 126

Fix the signal arm to the post in such a manner that the arm is free to move, by means of Bolt 1, which is lock-nutted. The Bolt is passed through the Strips forming the signal post and the signal arm, and a Nut is placed on it and screwed up sufficiently to hold the Bolt in place. The first Nut is then held with a Spanner while a second Nut is screwed tightly up against it. The lever by which the signal is moved is also secured with Bolt 1a similarly lock-nutted.

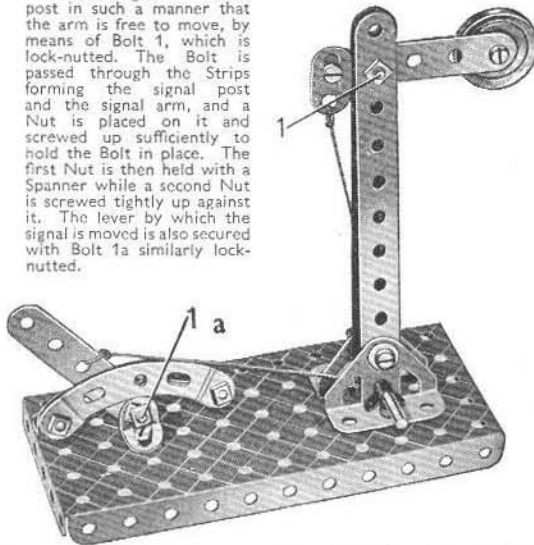

O.11 RADIAL CRANE

The wheeled bogie that carries the boom and jib is formed from two Curved Strips and two Flat Brackets. The $\frac{3}{4}$ " Bolts 2 pass through the Flat Brackets and are gripped in the bosses of the 1" Pulleys. Bearings for the Crank Handle are provided by Flat Trunnions. The Bolt 1 is lock-nutted.

Parts required

4 of No. 2	19 of No. 37a	2 of No. 126a
2 " " 5	18 " " 37b	2 " " 155a
3 " " 10	2 " " 38	
4 " " 12	2 " " 48a	
1 " " 17	1 " " 52	
1 " " 19s	2 " " 90a	
2 " " 22	2 " " 111c	
1 " " 24	1 " " 126	
4 " " 35		

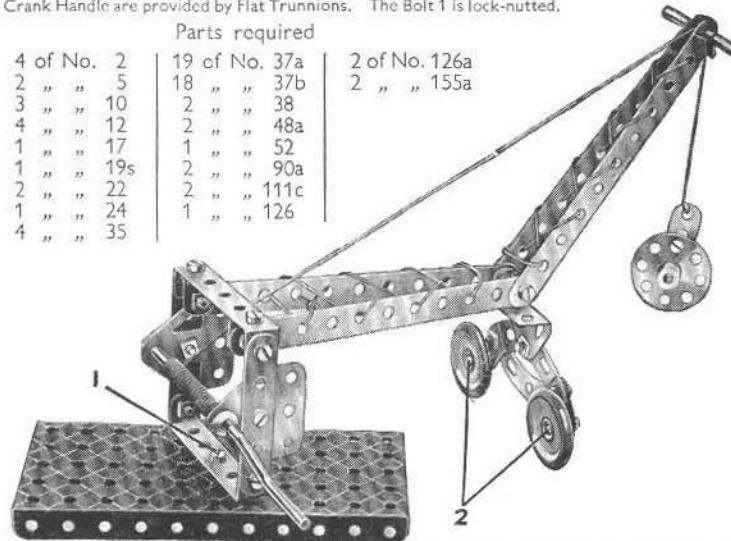

O.12 ELECTRIC TRUCK

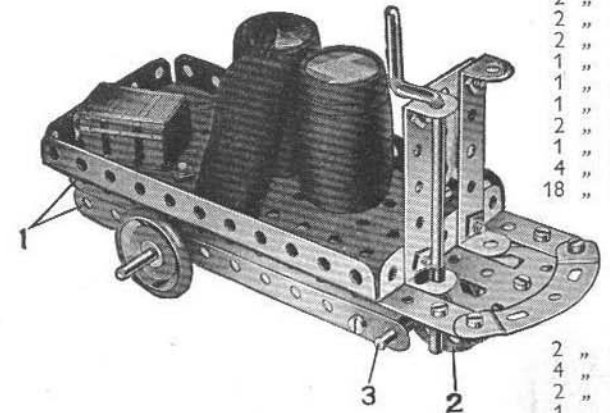

Parts required

4 of No. 2
2 " " 5
2 " " 10
2 " " 12
1 " " 16
1 " " 17
1 " " 19s
2 " " 22
1 " " 24
4 " " 35
18 " " 37
2 " " 37a
4 " " 38
2 " " 48a
1 " " 52
2 " " 90a
2 " " 111c
2 " " 126
2 " " 126a
2 " " 155a

The two $5\frac{1}{2}$ " Strips 1 are fastened to the Flanged Plate by two Trunnions secured to the Plate on the underneath side. A Bush Wheel 2 is fixed on the Axle Rod 3, which passes through the end holes of the $5\frac{1}{2}$ " Strips that form the sides of the truck frame.

O.13 ACROBAT

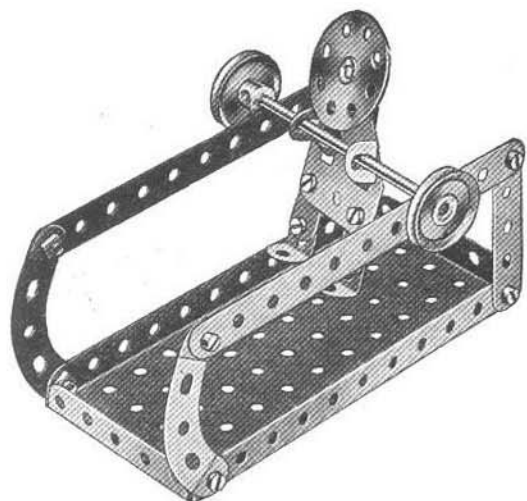

Parts required

2	of No.	2
2	" "	5
3	" "	10
4	" "	12
1	" "	16
2	" "	22
1	" "	24
15	" "	37
1	" "	52
2	" "	90a
1	" "	111c
1	" "	126a

O.14 BATTLESHIP

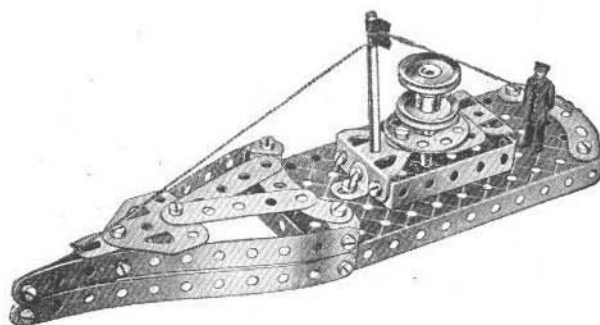

Parts required

4	of No.	2	2	of No.	22	1	of No.	52
2	" "	5	1	" "	24	2	" "	90a
3	" "	10	3	" "	35	1	" "	111c
4	" "	12	18	" "	37	2	" "	126
1	" "	16	1	" "	37a	2	" "	126a
1	" "	17	2	" "	48a			

O.15 SCALES

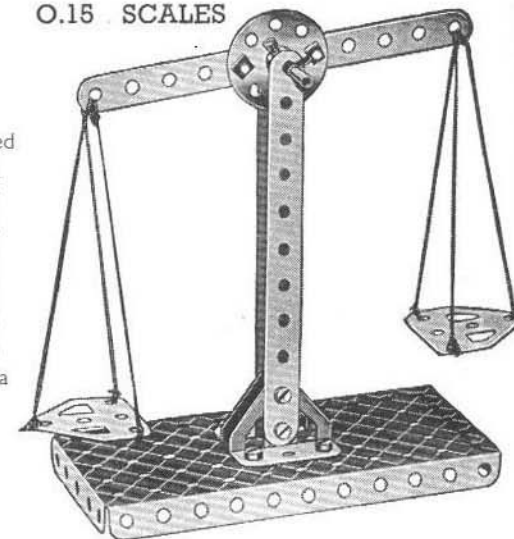

Parts required

3	of No.	2
1	" "	17
1	" "	24
2	" "	35
10	" "	37
1	" "	52
2	" "	126
2	" "	126a

O.16 SKIER

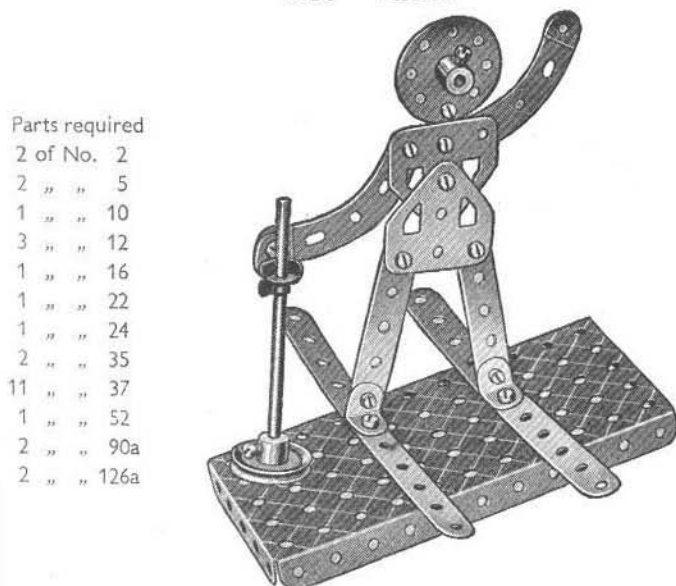

Parts required

2	of No.	2
2	" "	5
1	" "	10
3	" "	12
1	" "	16
1	" "	22
1	" "	24
2	" "	35
11	" "	37
1	" "	52
2	" "	90a
2	" "	126a

O.17 LEVEL CROSSING BARRIER

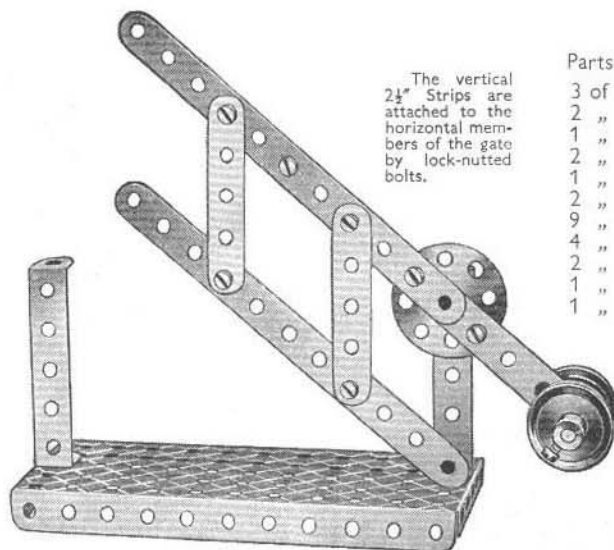

The vertical $2\frac{1}{2}$ " Strips are attached to the horizontal members of the gate by lock-nutted bolts.

Parts required

3	of No.	2
2	" "	5
1	" "	17
2	" "	22
1	" "	24
2	" "	35
9	" "	37
4	" "	37a
2	" "	48a
1	" "	52
1	" "	111c

O.18 SWING BOAT

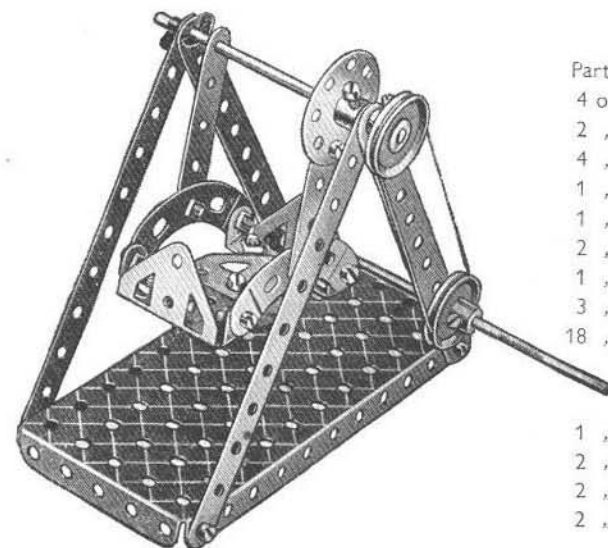

Parts required

4	of No.	2
2	" "	5
4	" "	12
1	" "	16
1	" "	19s
2	" "	22
1	" "	24
3	" "	35
18	" "	37
1	" "	52
2	" "	90a
2	" "	126
2	" "	126a

O.19 DOCKSIDE CRANE

Two Trunnions 1 form the top of the tower and a $\frac{3}{4}$ " Bolt passed through the holes in their pointed ends and into the boss of a Bush Wheel, forms the pivot for the jib. The Flat Trunnions are connected to the Bush Wheel by Angle Brackets. The $\frac{3}{4}$ " Bolt 2 that connects the $5\frac{1}{2}$ " strips of the jib is fitted with lock-nuts.

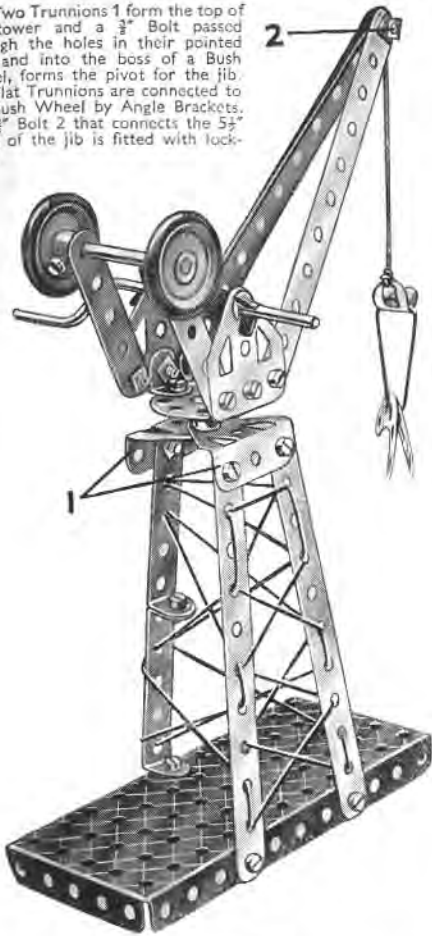

Parts required		
4 of No. 2	1 of No. 24	1 of No. 52
2 " " 5	2 " " 35	2 " " 90a
3 " " 12	17 " " 37a	2 " " 111c
1 " " 17	15 " " 37b	2 " " 126
1 " " 19s	2 " " 38	2 " " 126a
2 " " 22	2 " " 48a	2 " " 155a

O.20 SAILING BOAT

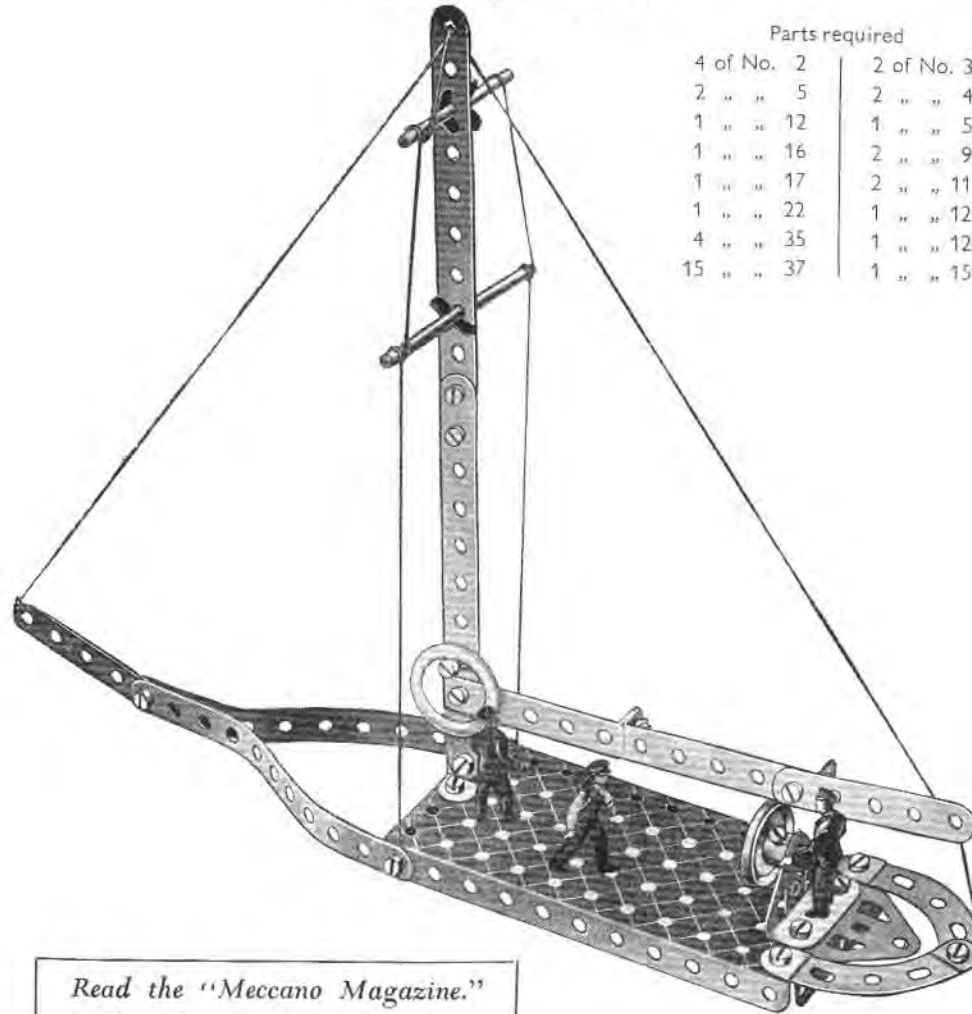

Parts required	
4 of No. 2	2 of No. 37a
2 " " 5	2 " " 48a
1 " " 12	1 " " 52
1 " " 16	2 " " 90a
1 " " 17	2 " " 111c
1 " " 22	1 " " 126
4 " " 35	1 " " 126a
15 " " 37	1 " " 155a

Read the "Meccano Magazine" published monthly. Ask your dealer for full particulars.

O.21 DERRICK CRANE

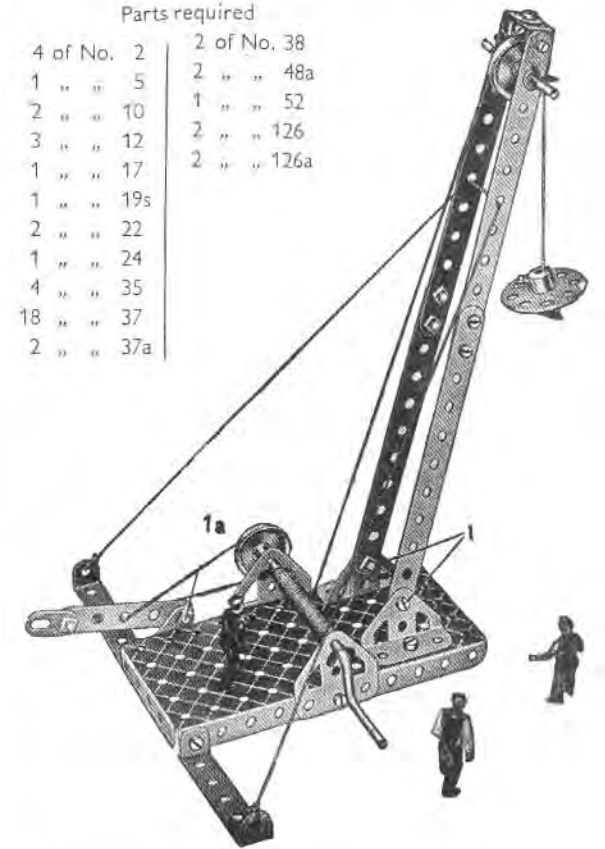

Parts required	
4 of No. 2	2 of No. 38
1 " " 5	2 " " 48a
2 " " 10	1 " " 52
3 " " 12	2 " " 126
1 " " 17	2 " " 126a
1 " " 19s	
2 " " 22	
1 " " 24	
4 " " 35	
18 " " 37	
2 " " 37a	

The construction of the model is commenced by bolting the Trunnions and Flat Trunnions that support the jib and Crank Handle respectively, to the $5\frac{1}{2}$ " x $2\frac{1}{2}$ " Flanged Plate that forms the base of the model. The jib is then assembled and fastened to the Trunnions by means of the lock-nutted Bolts 1. The brake lever is a $2\frac{1}{2}$ " Strip extended by a Flat Bracket, and is fastened to a second Flat Bracket bolted to the Flanged Plate by means of Bolt 1a the nut of which is left sufficiently loose to allow the Strip to move. A length of Cord is fastened to the lever and then passed round the 1" Pulley on the Crank Handle.

O.22 STATIONARY STEAM ENGINE

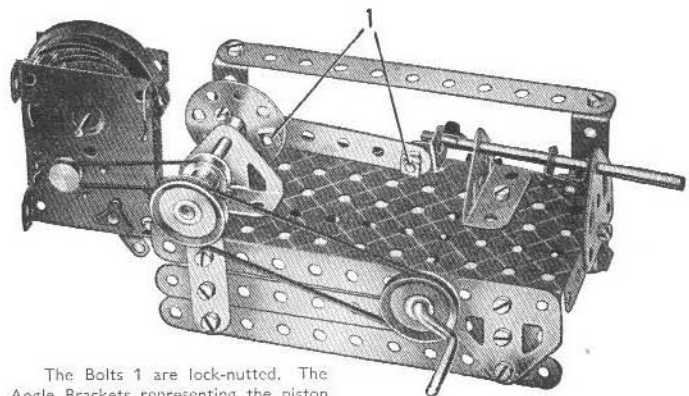

The Bolts 1 are lock-nutted. The Angle Brackets representing the piston are clamped to the Rod by a Nut and Bolt fastened in their elongated holes.

Parts required

4 of No. 2
2 " " 5
3 " " 12
1 " " 16
1 " " 17
1 " " 19s
2 " " 22
1 " " 24
3 " " 35
18 " " 37
2 " " 37a
1 " " 38
2 " " 48a
1 " " 52

2 of No. 126
2 " " 126a
Magic Motor

Parts required

3 of No. 2
2 " " 5
1 " " 10

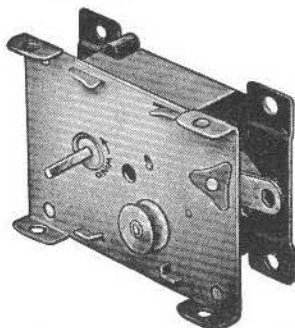
THE MECCANO
MAGIC MOTOR

The greatest thrill in Meccano model-building is experienced when a model is set to work by means of a Meccano *Magic Motor*. The illustrations on this page show how the *Magic Motor* can be fitted without any difficulty to No. O Outfit models of various types. Fit the model you have just built with one of these wonderful Motors, and enjoy the fun of watching it work just like the real thing!

2 of No. 111c
2 " " 126
2 " " 126a
Magic Motor

1 of No. 52
2 " " 90a
2 " " 126
2 " " 126a

O.23 MECHANICAL HAMMER

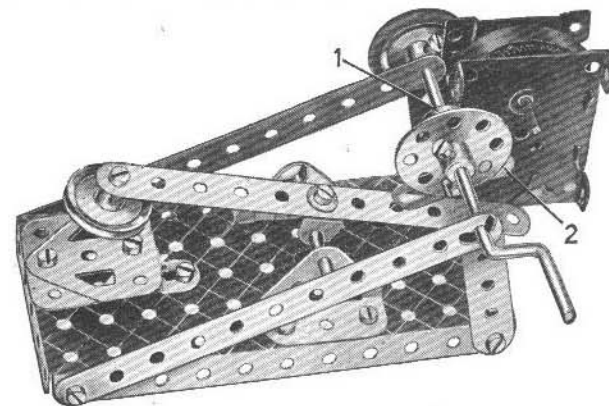

The $\frac{1}{2}$ " fast Pulley 1 is driven from the pulley 2 on the *Magic Motor* by the Driving Band supplied with the Motor.

4 of No. 12

1 " " 17
1 " " 19s
2 " " 22
1 " " 24
3 " " 35
15 " " 37
1 " " 38
1 " " 52
1 " " 111c
2 " " 126
2 " " 126a
1 " " 155a
Magic Motor

O.24 MERRY-GO-ROUND

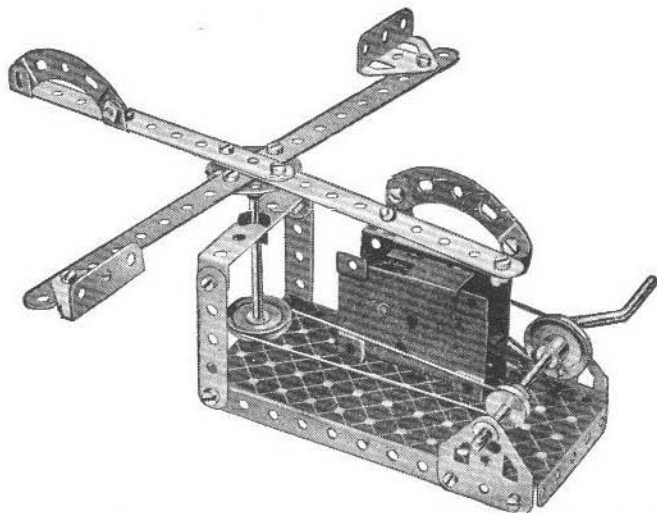

Parts required

4 of No. 2
2 " " 5
4 " " 12
1 " " 16
1 " " 19s
2 " " 22
1 " " 24
4 " " 35
18 " " 37
2 " " 37a
2 " " 38
1 " " 48a
1 " " 52
2 " " 90a

2 of No. 111c
2 " " 126
2 " " 126a
Magic Motor

1 of No. 52
2 " " 90a
2 " " 126
2 " " 126a

O.25 WINDMILL

A Driving Band connects the pulley of the *Magic Motor* to a $1\frac{1}{2}$ " Pulley fastened on the Crank Handle. The Crank Handle carries also a $\frac{1}{2}$ " Pulley, which is connected by a second Driving Band with a further $1\frac{1}{2}$ " Pulley fixed to the Rod on which the sails are mounted.

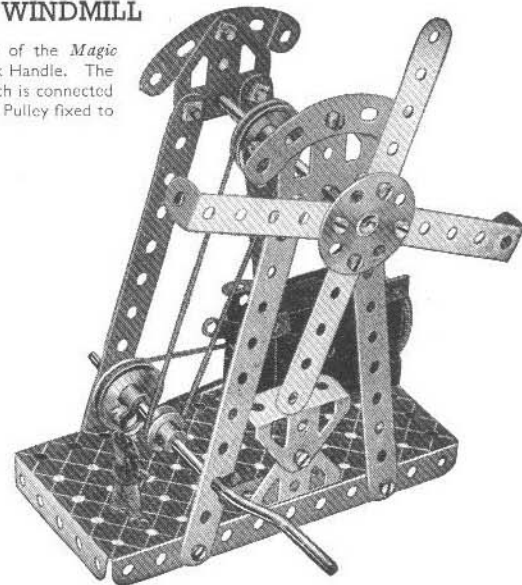

Parts required

4 of No. 2
2 " " 5
1 " " 16
1 " " 19s
2 " " 22
1 " " 24
3 " " 35
18 " " 37
2 " " 38
2 " " 48a
Magic Motor

1.1 PORTER'S TRUCK

The bearings for the axle are Flat Trunnions fastened on the insides of the Flexible Plates, and the axle is a 3/4" Rod that carries two 1" Pulleys fitted with Rubber Rings.

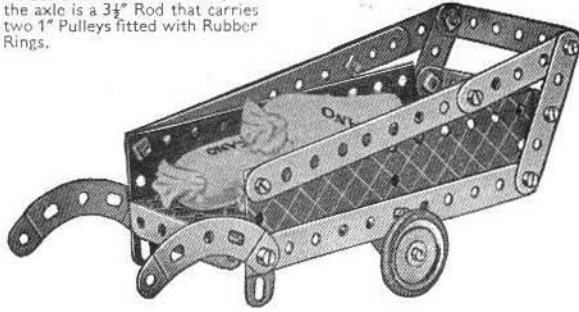

Parts required

4 of No. 2
4 " " 5
2 " " 10
1 " " 16
2 " " 22
14 " " 37
2 " " 38
2 " " 48a
1 " " 52
2 " " 90a
2 " " 126a
2 " " 155a
2 " " 189

1.2 BATTLESHIP

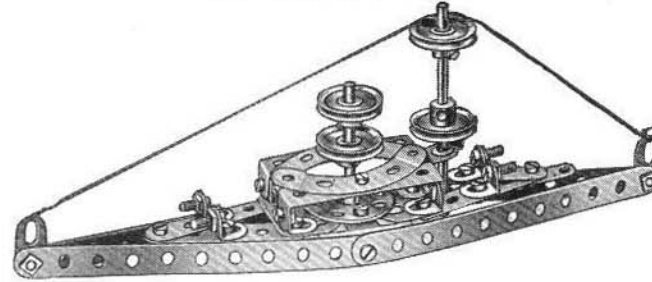

Parts required

4 of No. 2	1 of No. 17	4 of No. 37a	4 of No. 111c
4 " " 5	4 " " 22	2 " " 38	1 " " 125
4 " " 10	1 " " 24	1 " " 40	2 " " 126
8 " " 12	3 " " 35	2 " " 48a	2 " " 126a
1 " " 16	24 " " 37	2 " " 90a	

1.3 WINDMILL

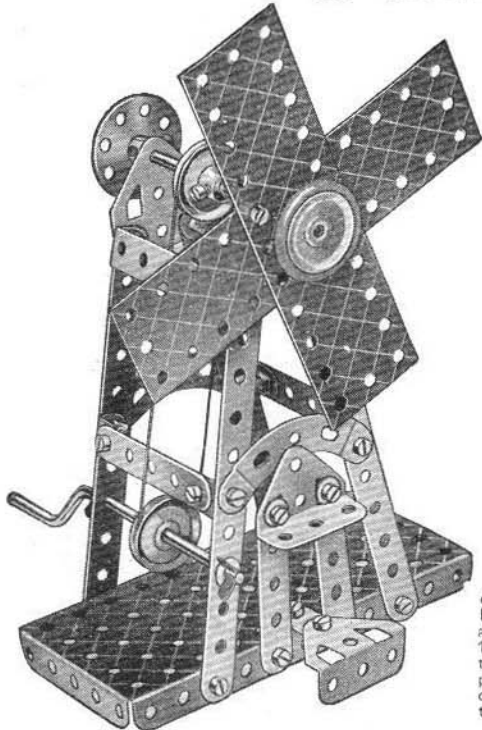

The sails are gripped on the 3/4" Rod by the 1" Pulley (with Rubber Ring) at the front and another 1" Pulley at the back of the sails. The Pulleys are pressed against the faces of the sails and locked on the Rod.

Parts required

4 of No. 2
4 " " 5
1 " " 10
4 " " 12
1 " " 16
1 " " 19s
4 " " 22
1 " " 24
3 " " 35
24 " " 37
4 " " 38
1 " " 40
2 " " 48a
1 " " 52
2 " " 90a
2 " " 126
2 " " 126a
1 " " 155a
2 " " 189

1.4 SCALES

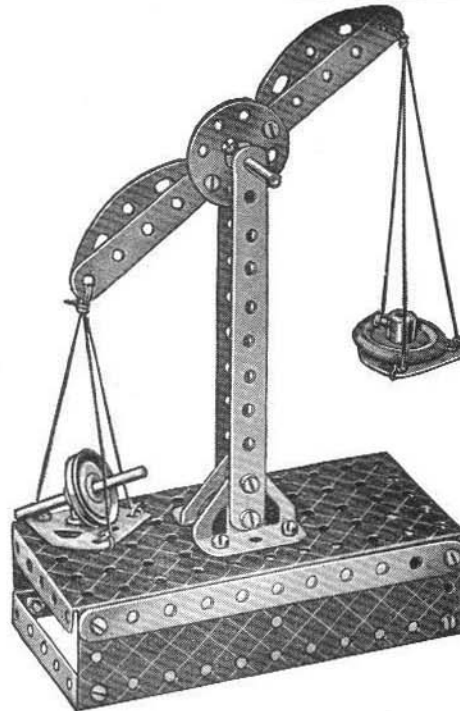

Parts required

4 of No. 2
2 " " 5
2 " " 17
2 " " 22
1 " " 24
19 " " 37
1 " " 38
1 " " 40
2 " " 48a
1 " " 52
2 " " 90a
1 " " 111c
2 " " 126
2 " " 126a
1 " " 155a
2 " " 189

1.5 GYMNAST

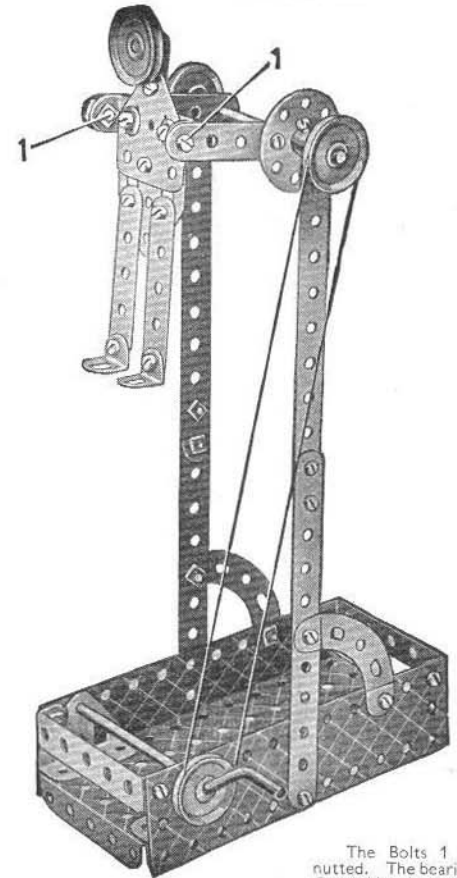

The Bolts 1 are lock-nutted. The bearings for the Crank Handle in the Flexible Plates are reinforced by Trunnions bolted to the Flanged Plate.

Parts required

4 of No. 2	1 of No. 24	1 of No. 52
4 " " 5	2 " " 35	2 " " 90a
1 " " 10	24 " " 37	4 " " 111c
4 " " 12	5 " " 37a	2 " " 126
1 " " 16	4 " " 38	2 " " 126a
1 " " 19s	1 " " 40	2 " " 189
4 " " 22	2 " " 48a	

1.6 LETTER BALANCE

The Bolts 1 are lock-nutted. The 2" Bolt 2 is passed through the hole of the Angle Bracket and then locked in the boss of the 1" Pulley.

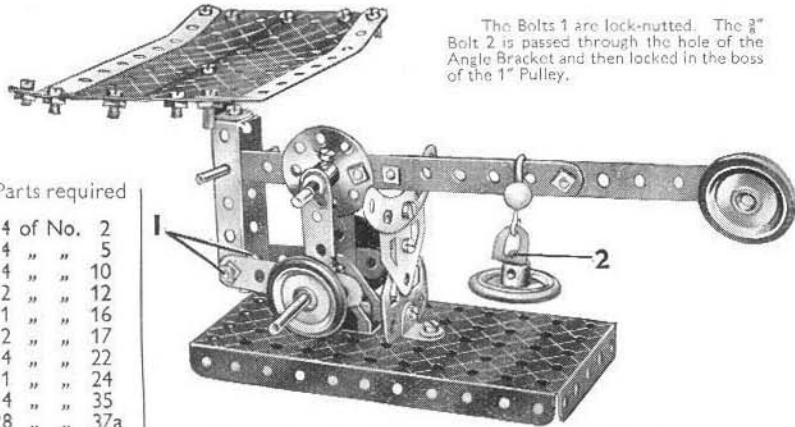

Parts required

4	of No.	2
4	" "	5
4	" "	10
2	" "	12
1	" "	16
2	" "	17
4	" "	22
1	" "	24
4	" "	35
28	" "	37a
24	" "	37b
4	" "	38
2	" "	48a

1	of No.	52	4	of No.	111c	2	of No.	126a
1	" "	57c	1	" "	125	4	" "	155a
1	" "	90a	2	" "	126	2	" "	189

1.7 TABLE

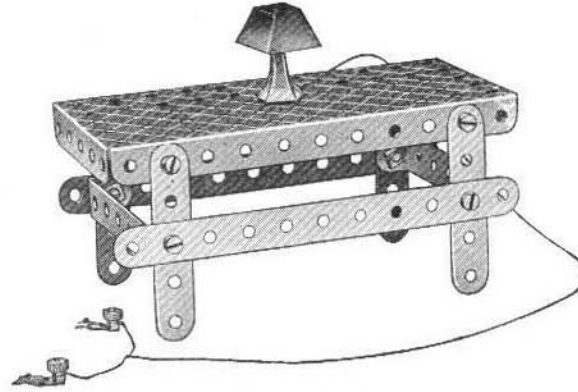

Parts required

2	of No.	2	8	of No.	37	1	of No.	52
4	" "	5	2	" "	48a			

The model is shown with a Stand Lamp from a Meccano Lighting Set.

1.8 BUFFER STOPS

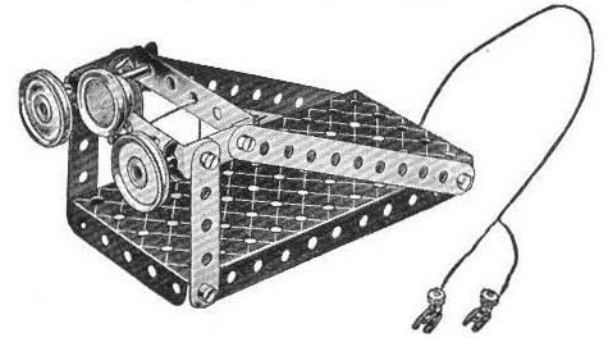

Parts required

2	of No.	2	2	of No.	17	9	of No.	37
2	" "	5	2	" "	22	2	" "	48a
3	" "	10	4	" "	35	1	" "	52

The model is fitted with a Spot light from a Meccano Lighting Set.

1.9 AEROPLANE

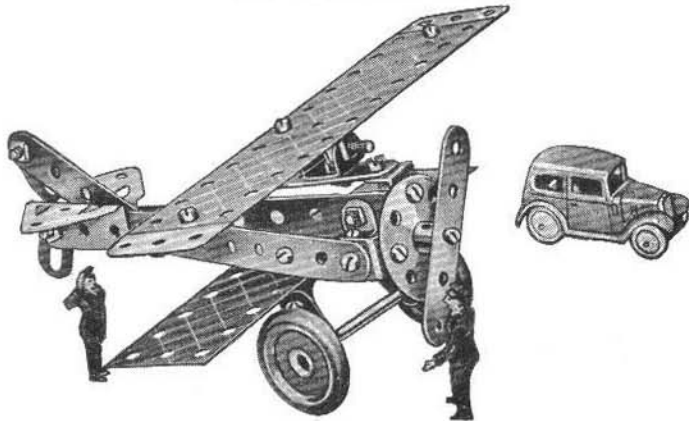

Parts required

2	of No.	2	1	of No.	17	2	of No.	37a	2	of No.	126
3	" "	5	2	" "	22	1	" "	38	2	" "	126a
4	" "	10	1	" "	24	3	" "	111c	2	" "	155a
8	" "	12	17	" "	37	1	" "	125	2	" "	189

1.10 "KIDDIE KAR"

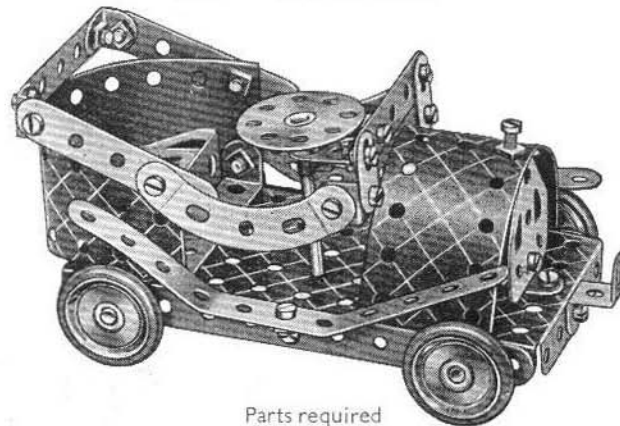

Parts required

4	of No.	2	1	of No.	17	3	of No.	37a	1	of No.	125
4	" "	5	4	" "	22	2	" "	48a	2	" "	126
3	" "	10	1	" "	24	1	" "	52	1	" "	126a
7	" "	12	1	" "	35	2	" "	90a	4	" "	155a
2	" "	16	24	" "	37	2	" "	111c	2	" "	189

Two Trunnions overlapped one hole, and fastened to the Flanged Plate by an Angle Bracket, form the seat.

1.11 WATCH STAND

Parts required

4	of No.	2
2	" "	12
19	" "	37
1	" "	38
1	" "	52
1	" "	57c
2	" "	90a
1	" "	126
2	" "	126a

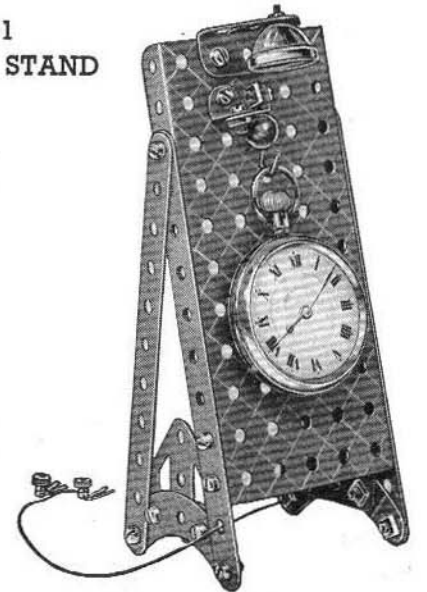

A good example of the use of the Meccano Lighting Set.

1.12 BAGGAGE TRUCK

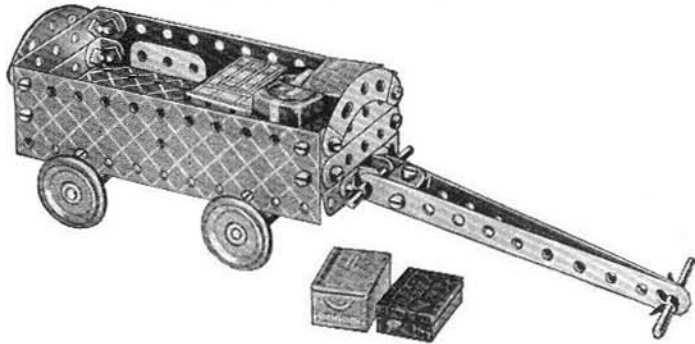

Parts required		
2 of No. 2	4 of No. 35	2 of No. 90a
2 " " 5	24 " " 37	1 " " 111c
8 " " 12	1 " " 37a	2 " " 126
2 " " 16	2 " " 38	2 " " 126a
2 " " 17	2 " " 48a	4 " " 155a
4 " " 22	1 " " 52	2 " " 189

1.13 RACING SEAPLANE

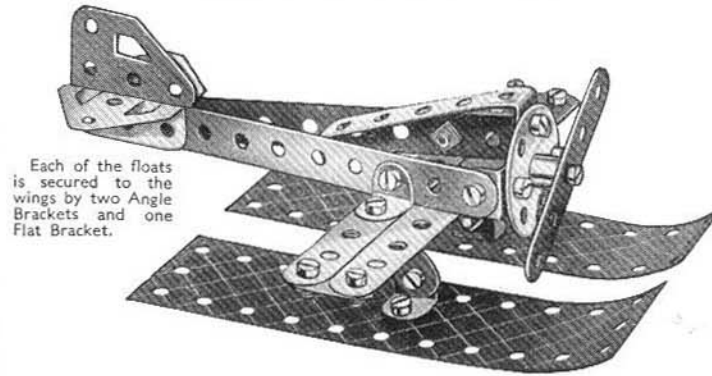

Each of the floats is secured to the wings by two Angle Brackets and one Flat Bracket.

Parts required		
3 of No. 2	1 of No. 24	2 of No. 111c
3 " " 5	19 " " 37	2 " " 126
4 " " 10	1 " " 37a	1 " " 126a
8 " " 12	1 " " 48a	2 " " 189

1.14 CHILD'S PRAM

Flat Trunnions bolted between the Flexible Plates and the Flanged Plate provide bearings for the rear axle. Angle Brackets bolted under the Flanged Plate form the bearings for the front axle. The body of the "baby" consists of two Trunnions, and its arms and legs are Flat Brackets. Its head is fixed in place by a Reversed Angle Bracket.

Parts required	
4 of No. 2	5
4 " " 5	10
4 " " 10	12
2 " " 16	22
4 " " 22	24
1 " " 37a	37b
22 " " 37b	38
4 " " 38	48a
2 " " 48a	52
1 " " 52	90a
2 " " 90a	

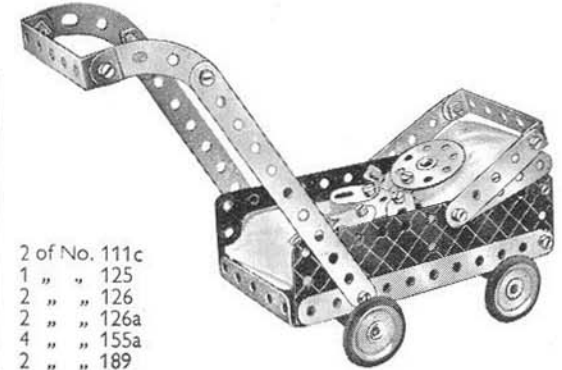

2 of No. 111c	
1 " " 125	126
2 " " 126	126a
4 " " 126a	155a
2 " " 155a	189

1.15 BAND SAW

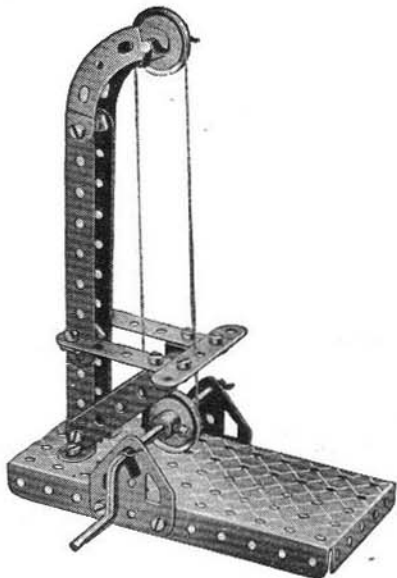

Parts required	
2 of No. 2	
4 " " 5	
6 " " 12	
1 " " 17	
1 " " 19s	
2 " " 22	
4 " " 35	
19 " " 37	
1 " " 40	
1 " " 52	
2 " " 90a	
2 " " 126a	

1.16 CIRCULAR SAW

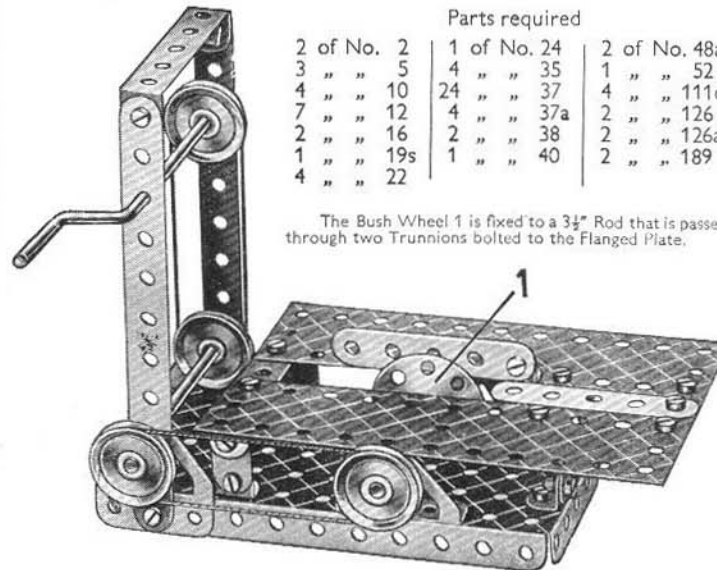

The Bush Wheel 1 is fixed to a 3/8" Rod that is passed through two Trunnions bolted to the Flanged Plate.

Parts required		
2 of No. 2	1 of No. 24	2 of No. 48a
3 " " 5	4 " " 35	1 " " 52
4 " " 10	24 " " 37	4 " " 111c
7 " " 12	4 " " 37a	2 " " 126
2 " " 16	2 " " 38	2 " " 126a
1 " " 19s	1 " " 40	2 " " 189
4 " " 22		

1.17 DRILL

Parts required	
4 of No. 2	
3 " " 5	
8 " " 12	
1 " " 16	
1 " " 17	
1 " " 19s	
4 " " 22	
4 " " 35	
20 " " 37	
4 " " 38	
1 " " 40	
1 " " 52	
2 " " 126	
2 " " 126a	

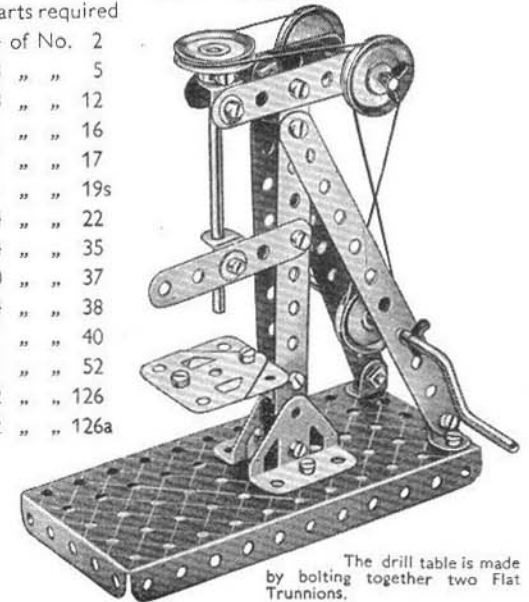

The drill table is made by bolting together two Flat Trunnions.

1.18 TRIP HAMMER

Parts required

4 of No. 2	17 of No. 37
3 " " 5	1 " " 48a
2 " " 12	1 " " 52
1 " " 17	2 " " 111c
1 " " 19s	1 " " 125
4 " " 22	2 " " 126
1 " " 24	2 " " 126a
4 " " 35	1 " " 155a
	1 " " 189

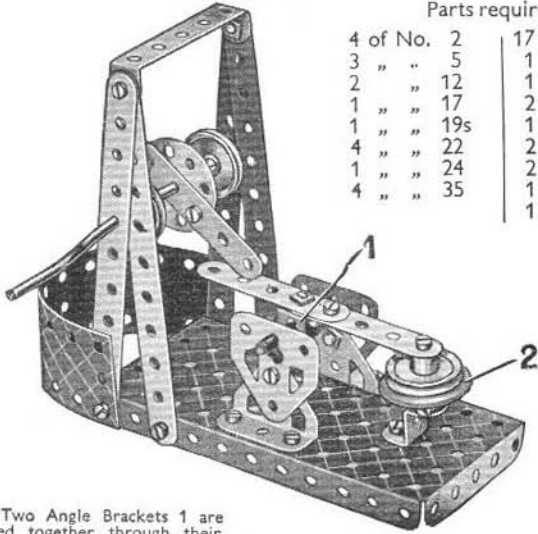

Two Angle Brackets 1 are bolted together through their holes and also are bolted to two 2½" Strips to form a double bracket. The 1" fast Pulley 2 is fitted with a 1" Rubber Ring.

1.19 STEAM LAUNCH

The top of the deck-house consists of three 2½" Strips bolted first to Flat Brackets and then to a Trunnion. The rear side is held in place by an Angle Bracket. The other side consists of a 2½" x ½" Double Angle Strip bolted to the Trunnion.

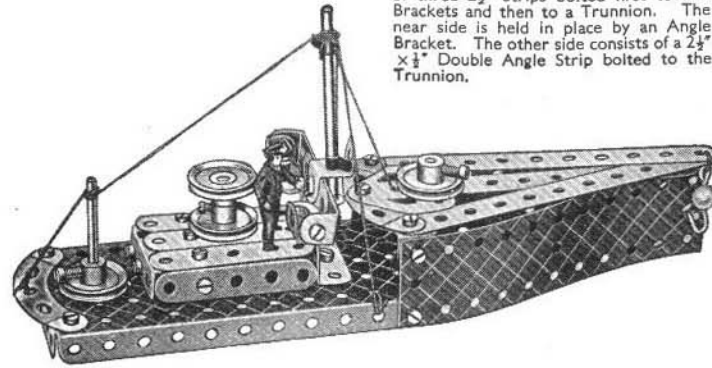

Parts required

3 of No. 2	4 of No. 22	1 of No. 52	2 of No. 126a
4 " " 5	4 " " 35	1 " " 57c	2 " " 189
3 " " 10	23 " " 37	2 " " 90a	
8 " " 12	4 " " 38	2 " " 111c	
1 " " 16	1 " " 40	1 " " 125	
2 " " 17	2 " " 48a	2 " " 126	

1.20 COASTER

The Bolts 1 are lock-nutted. The rear axle Rod is pushed through the end hole of the Curved Strip 2.

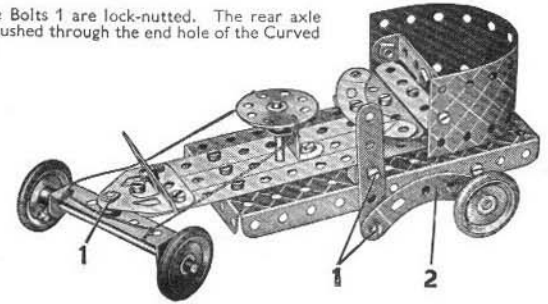

Parts required

3 of No. 2	1 of No. 35	2 of No. 90a
4 " " 5	20 " " 37	2 " " 111c
5 " " 12	4 " " 37a	1 " " 125
2 " " 16	4 " " 38	2 " " 126
1 " " 17	1 " " 40	2 " " 126a
4 " " 22	2 " " 48a	4 " " 155a
1 " " 24	1 " " 52	1 " " 189

1.21 LIFTING BRIDGE

The Bolts 1, on which the bridge span pivots, are lock-nutted.

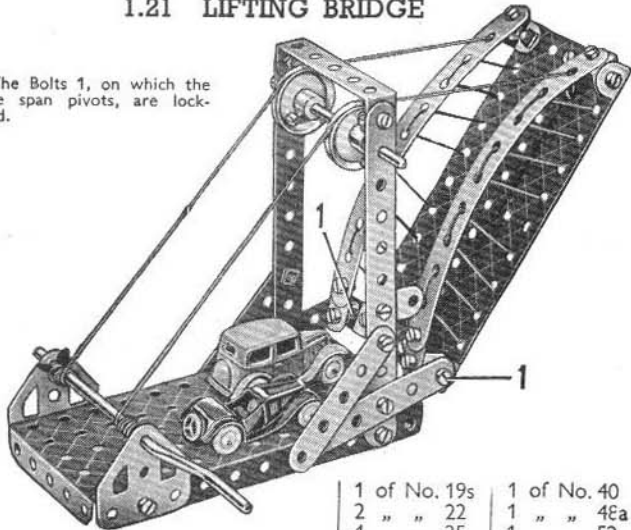

Parts required	3 of No. 10	1 of No. 19s	1 of No. 40
4 of No. 2	8 " " 12	2 " " 22	1 " " 48a
4 " " 5	2 " " 16	4 " " 35	1 " " 52
		24 " " 37	3 " " 111c
		5 " " 37a	2 " " 126a
		4 " " 38	2 " " 189

1.22 HAND TRUCK

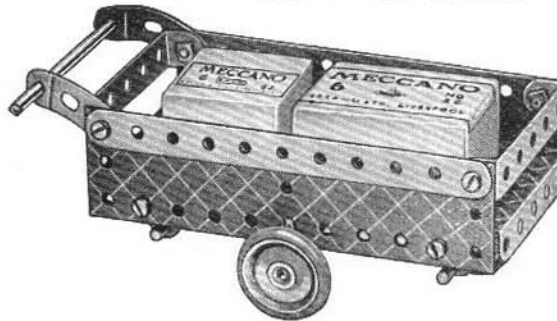

Parts required

2 of No. 2
2 " " 10
8 " " 12
2 " " 16
2 " " 17
4 " " 22
3 " " 35
14 " " 37
2 " " 48a
1 " " 52
2 " " 90a
2 " " 155a
2 " " 189

The bearings on the 3½" Rod are Flat Brackets, and the front and rear axle bearings are reversed angle brackets built up from Angle Brackets. The right-hand 1" Pulley on the 3½" Rod is loose on the Rod, but is retained in place by a Spring Clip. The front and rear 1" Pulleys are fixed on their respective 2" Rods.

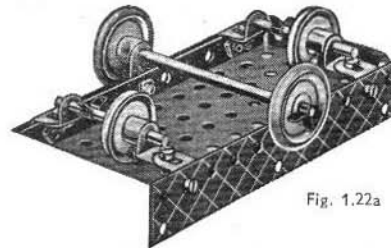
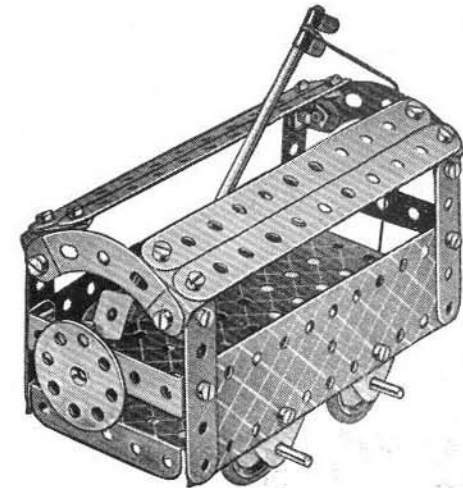

Fig. 1.22a

1.23 TROLLEY BUS



Parts required

4 of No. 2
4 " " 5
4 " " 10
8 " " 12
2 " " 16
1 " " 19s
4 " " 22
1 " " 24
4 " " 35
24 " " 37
1 " " 37a
4 " " 38
1 " " 40
2 " " 48a
1 " " 52
2 " " 90a
2 " " 111c
1 " " 125
2 " " 126
2 " " 126a
4 " " 155a
2 " " 189

The Reversed Angle Bracket that holds the trolley is fixed in position by a Bolt passed through the slot in the Bracket, then through two Washers, and into the boss of the Bush Wheel.

1.24 HAY CART

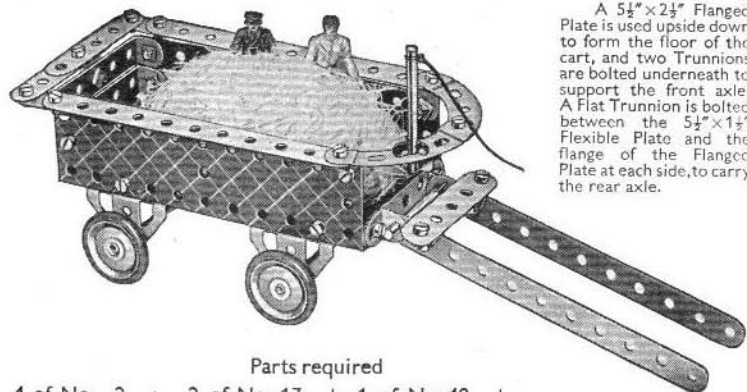

A $5\frac{1}{2}'' \times 2\frac{1}{2}''$ Flanged Plate is used upside down to form the floor of the cart, and two Trunnions are bolted underneath to support the front axle. A Flat Trunnion is bolted between the $5\frac{1}{2}'' \times 1\frac{1}{2}''$ Flexible Plate and the flange of the Flanged Plate at each side, to carry the rear axle.

Parts required

4 of No. 2	2 of No. 17	1 of No. 40	
3 " " 5	4 " " 22	2 " " 48a	2 of No. 126
2 " " 10	4 " " 35	1 " " 52	2 " " 126a
7 " " 12	24 " " 37	2 " " 90a	4 " " 155a
2 " " 16	1 " " 37a	1 " " 111c	2 " " 189

1.25 MOTOR LORRY

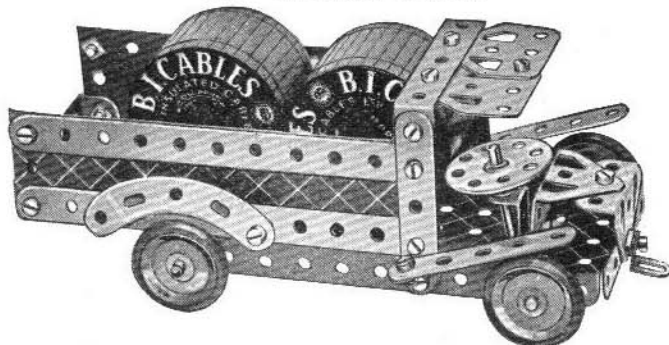

The $2\frac{1}{2}''$ Curved Strips representing the rear mudguards are each fastened to the sides by a $\frac{3}{8}''$ Bolt and Nut, with a Spring Clip between the mudguards and the $5\frac{1}{2}''$ Strip to form a distance piece.

Parts required

4 of No. 2	1 of No. 17	19 of No. 37	2 of No. 90a	2 of No. 126a
4 " " 5	4 " " 22	4 " " 37a	3 " " 111c	4 " " 155a
3 " " 12	1 " " 24	2 " " 48a	1 " " 125	2 " " 189
2 " " 16	2 " " 35	1 " " 52	2 " " 126	

1.26 HOSPITAL TROLLEY

Parts required

4 of No. 2
1 " " 5
2 " " 12
2 " " 16
4 " " 22
12 " " 37
1 " " 52
2 " " 90a
4 " " 155a

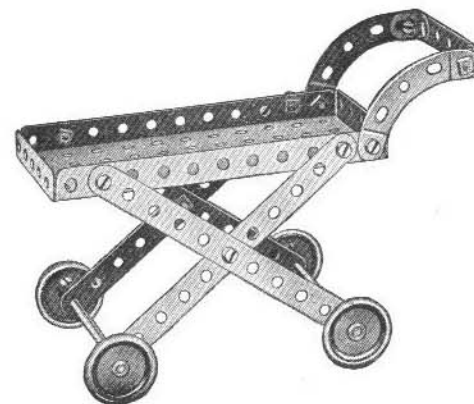

1.27 STAMPING MILL

The anvil 1 is made up of two Trunnions bolted together. When the Crank Handle is rotated, the Flat Brackets bolted to the Bush Wheel strike the centre 1" Pulley on the hammer shaft and cause it to rise and fall.

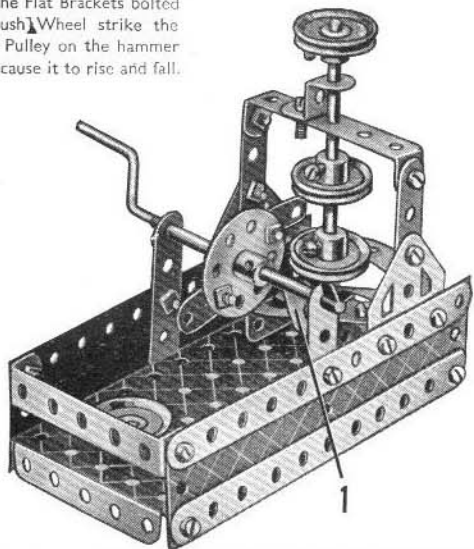

Parts required

4 of No. 2
4 " " 5
4 " " 10
5 " " 12
1 " " 16
1 " " 19s
1 " " 22
4 " " 24
1 " " 37
2 " " 35
24 " " 37
3 " " 37a
2 " " 48a
1 " " 52
1 " " 90a
4 " " 111c
1 " " 125
2 " " 126
2 " " 126a
2 " " 189

1.28 FLYING BOATS

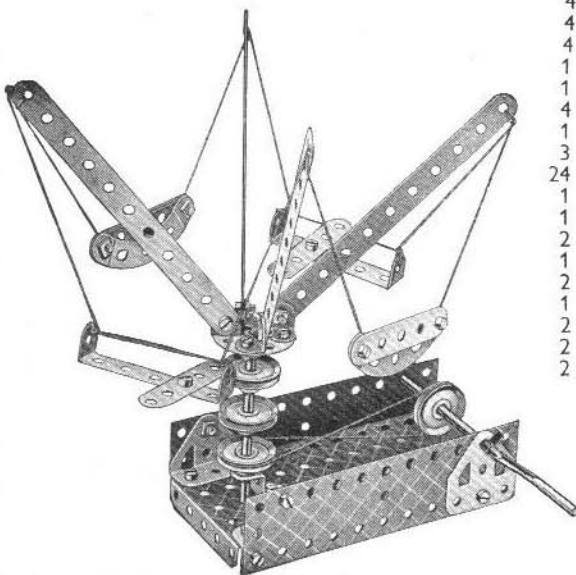

Parts required

4 of No. 2
4 " " 5
4 " " 12
1 " " 16
1 " " 19s
4 " " 22
1 " " 24
3 " " 35
24 " " 37
1 " " 38
1 " " 40
2 " " 48a
1 " " 52
2 " " 90a
1 " " 125
1 " " 126
2 " " 126a
2 " " 189

1.29 HAND CAR

The Bolts 1 on which the $5\frac{1}{2}''$ Strips are pivoted, are lock-nutted. The $2\frac{1}{2}''$ small radius Curved Strips are fixed to Angle Brackets bolted to the $5\frac{1}{2}'' \times 2\frac{1}{2}''$ Flanged Plate.

Parts required

2 of No. 2
2 " " 5
8 " " 12
2 " " 16
2 " " 17
4 " " 22
4 " " 35
23 " " 37
4 " " 37a
4 " " 38
2 " " 48a
1 " " 52
2 " " 90a
2 " " 111c
1 " " 125
2 " " 126
2 " " 126a
4 " " 155a
2 " " 189

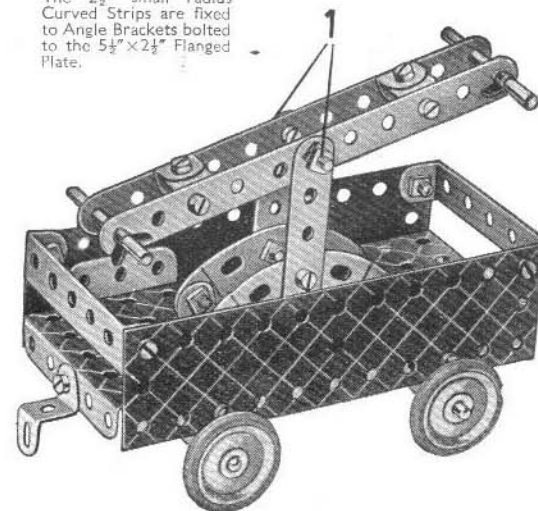

1.30 MONOPLANE

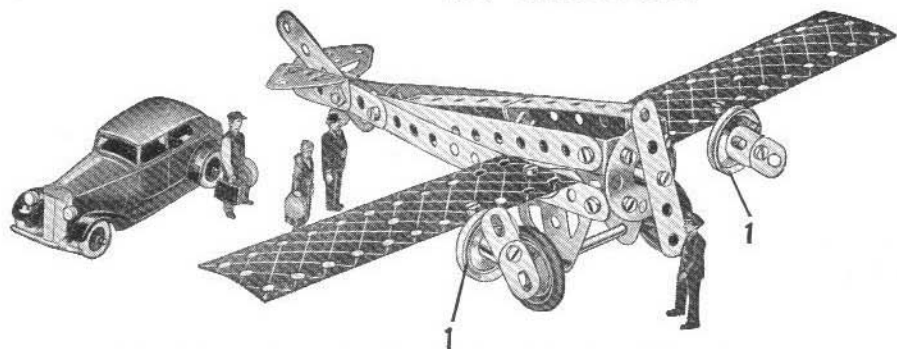

The fast Pulleys 1 are fixed to Angle Brackets fastened to the wing by $\frac{3}{8}$ " Bolts, which are passed through the Angle Brackets, and held in the bosses of the Pulleys. The set screws of the Pulleys hold also a second Bolt on which the propellers are mounted.

Parts required

4 of No.	2
4 "	5
4 "	10
8 "	12
1 "	16
4 "	22
1 "	24
2 "	35
20 "	37
3 "	37a
2 "	48a
1 "	57c
4 "	111c
2 "	126
2 "	126a
2 "	155a
2 "	189

1.31 FLOATING CRANE

Parts required	
4 of No.	2
4 "	5
4 "	10
7 "	12
2 "	16
2 "	17
1 "	19s
4 "	22
1 "	24
4 "	35
24 "	37
4 "	37a
4 "	38
1 "	40
2 "	48a
1 "	52
1 "	57c
2 of No.	90a
3 "	111c
1 "	125
2 "	126
2 "	126a

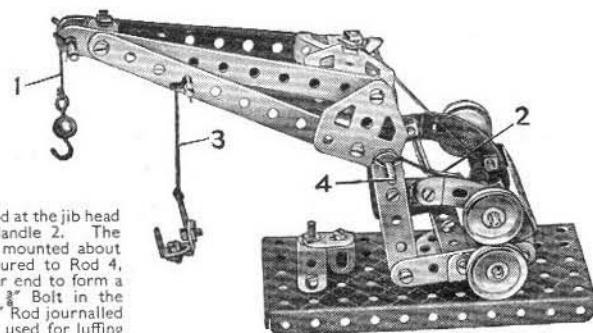

The Cord 1 passes over the Rod at the jib head and is fastened to the Crank Handle 2. The other Cord 3 passes over a Rod mounted about halfway along the jib, and is secured to Rod 4, which has a 1" Pulley at the other end to form a handle. The Cord tied to the $\frac{3}{8}$ " Bolt in the Trunnions is taken around the $3\frac{1}{2}$ " Rod journalled above the Crank Handle, and is used for luffing the jib by turning the 1" Pulley at the rear end of the Rod. Two Angle Brackets and a Flat Bracket form the hook on Cord 3.

1.32 POWER PRESS

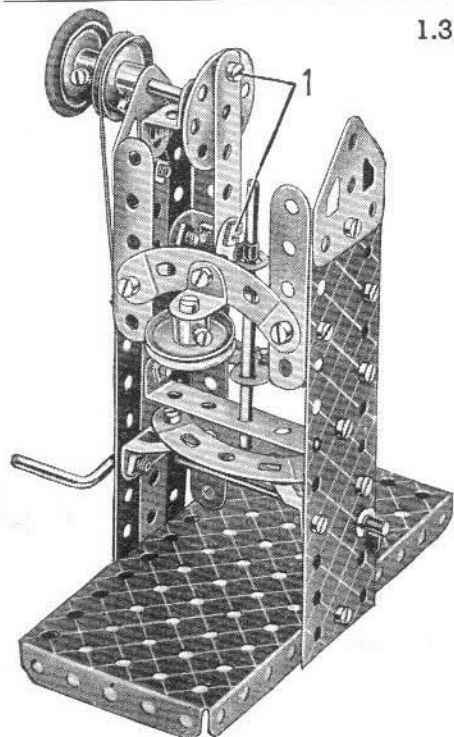

Parts required

4 of No.	2
4 "	5
1 "	10
6 "	12
1 "	16
1 "	17
1 "	19s
4 "	22
1 "	24
3 "	35
24 "	37
5 "	37a
1 "	38
1 "	40
2 "	48a
1 "	52
2 "	90a
4 "	111c
1 "	125
2 "	126
2 "	126a
1 "	155a
2 "	189

The Bolts 1 are lock-nutted, and the Angle Bracket at the lower end of the $2\frac{1}{2}$ " Strip has a $4\frac{1}{2}$ " Rod in its elongated hole, where it is held by means of two Spring Clips.

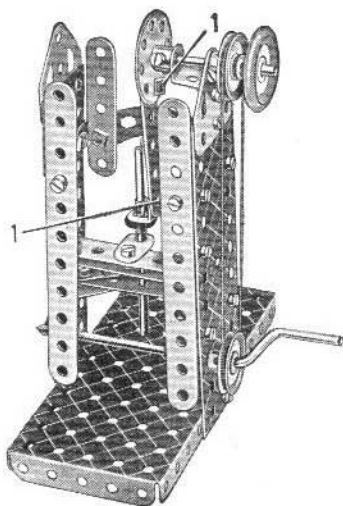
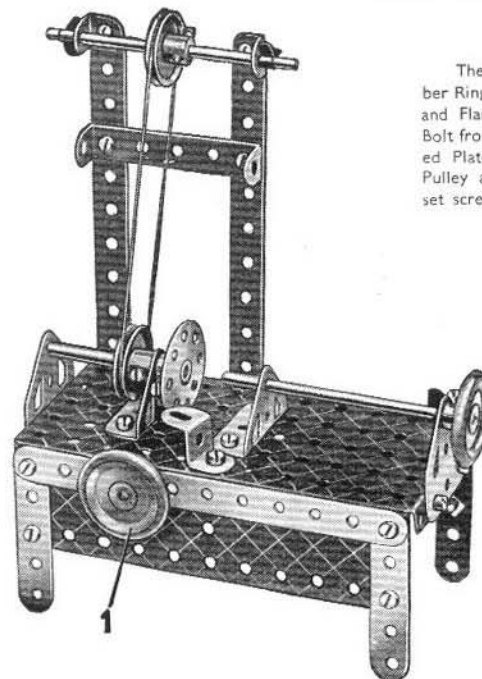

Fig. 1.32a

1.33 LATHE



The 1" fast Pulley with Rubber Ring 1 is secured to the Strip and Flanged Plate by passing a Bolt from the inside of the Flanged Plate into the boss of the Pulley and then tightening the set screw.

Parts required

4 of No.	2
4 "	5
2 "	12
2 "	16
1 "	17
4 "	22
1 "	24
3 "	35
22 "	37
1 "	40
1 "	48a
1 "	52
1 "	111c
1 "	125
2 "	126
2 "	126a
2 "	155a
2 "	189

1.34 MECHANICAL SHOVEL

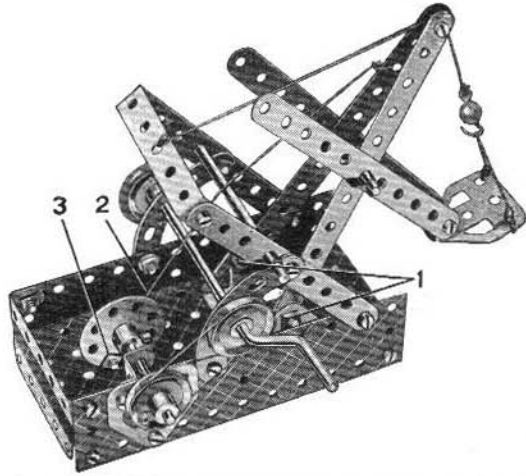

The Bolts 1, on which the jib pivots, are lock-nutted. The shovel arm is pivoted on a 2" Rod and the shovel is supported by a Cord that passes over the $\frac{3}{8}$ " Bolt at the jib head and is fastened to a $2\frac{1}{2}$ " x $\frac{1}{2}$ " Double Angle Strip as shown. The Cord 2 is fastened to the jib and then passes over a $3\frac{1}{2}$ " Rod journalled in the holes above the $2\frac{1}{2}$ " Curved Strips, and is attached to a Flat Bracket fastened by the lock-nutted Bolt 3 to the Bush Wheel.

When the Crank Handle is rotated, the Bush Wheel imparts a digging motion to the jib and shovel arm.

Parts required	
4 of No.	2
4 "	5
1 "	10
2 "	12
1 "	16
2 "	17
1 "	19s
3 "	22
1 "	24
4 "	35
24 "	37
4 "	37a
4 "	38
1 "	40
2 "	48a
1 "	52
1 "	57c
2 "	90a
4 "	111c
1 "	125
2 "	126
2 "	126a
1 "	155a
2 "	189

1.35 TELPHER SPAN

The anchoring piece 1 consists of two Trunnions bolted together, and a hook, which is made of two Angle Brackets fastened to them. A 2" Rod carrying a 1" fast Pulley is journalled in the Trunnions. The anchoring piece is hooked on a picture rail or other suitable support, and the Cord 2, which can be of any length, is passed round the 1" Pulleys as shown. When the Crank Handle is rotated, the car moves either backward or forward.

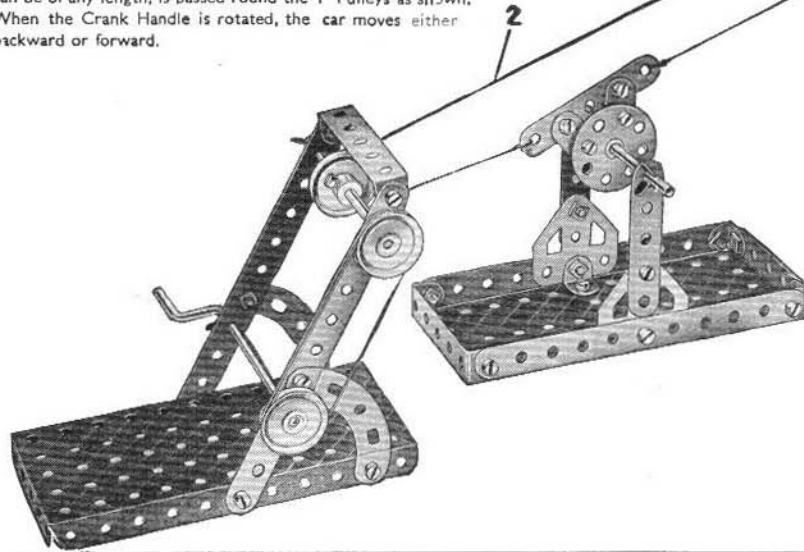
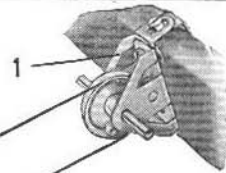

Parts required

4 of No.	2	4 of No.	37a
4 "	5	4 "	38
2 "	10	1 "	40
6 "	12	2 "	48a
2 "	16	1 "	52
1 "	17	2 "	90a
1 "	19s	4 "	111c
4 "	22	2 "	126
1 "	24	2 "	126a
4 "	35	2 "	189
24 "	37		

1.36 LAND YACHT

The Bush Wheel is secured to the $5\frac{1}{2}$ " x $2\frac{1}{2}$ " Flanged Plate by a $\frac{3}{8}$ " Bolt passed through the Plate and locked in the boss of the Bush Wheel. The 2" Rod journalled in the $5\frac{1}{2}$ " x $1\frac{1}{2}$ " Flexible Plates carries at its centre a 1" Pulley (with Rubber Ring) which is made fast to the Rod.

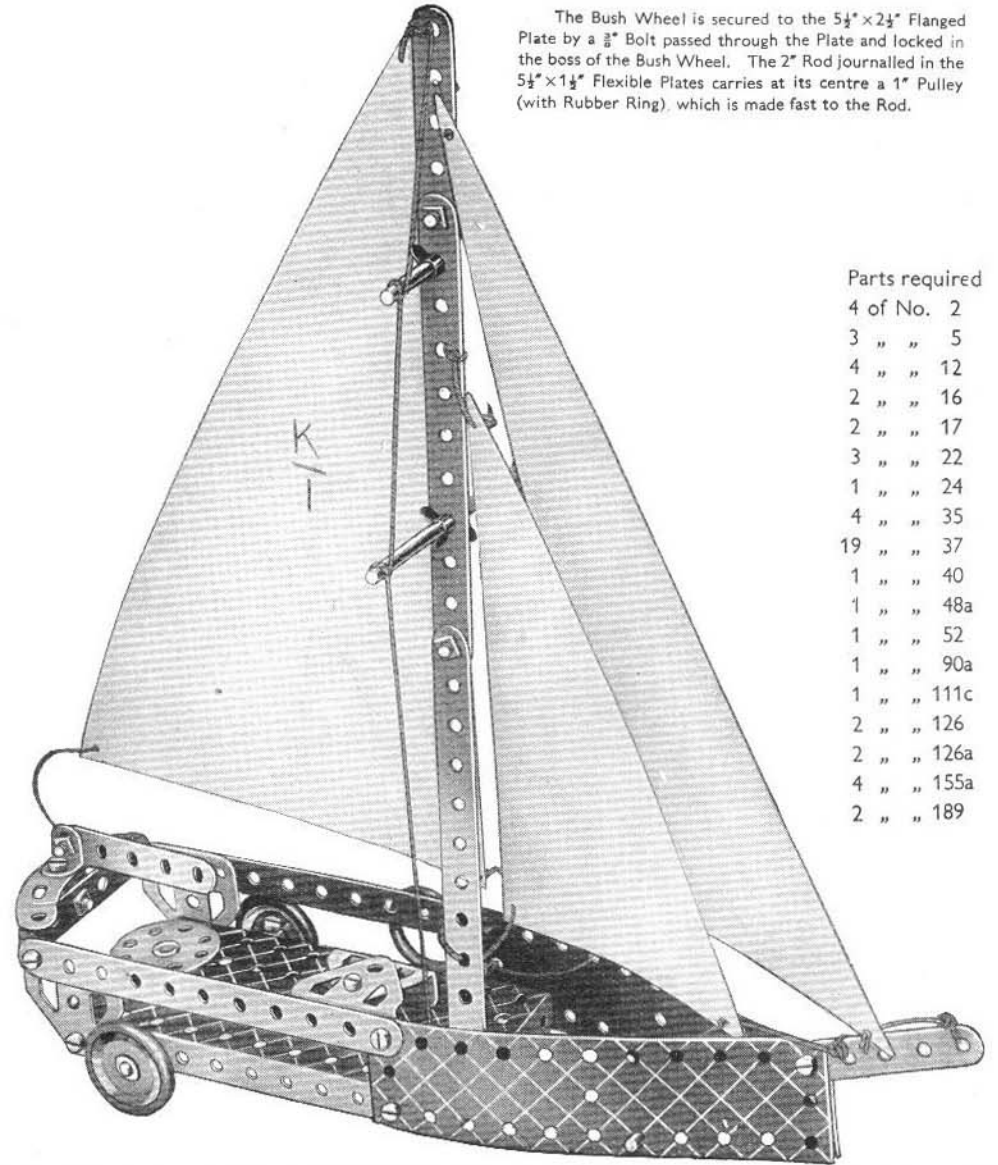

Parts required

4 of No.	2
3 "	5
4 "	12
2 "	16
2 "	17
3 "	22
1 "	24
4 "	35
19 "	37
1 "	40
1 "	48a
1 "	52
1 "	90a
1 "	111c
2 "	126
2 "	126a
4 "	155a
2 "	189

1.37 RAILWAY BREAKDOWN CRANE

Parts required

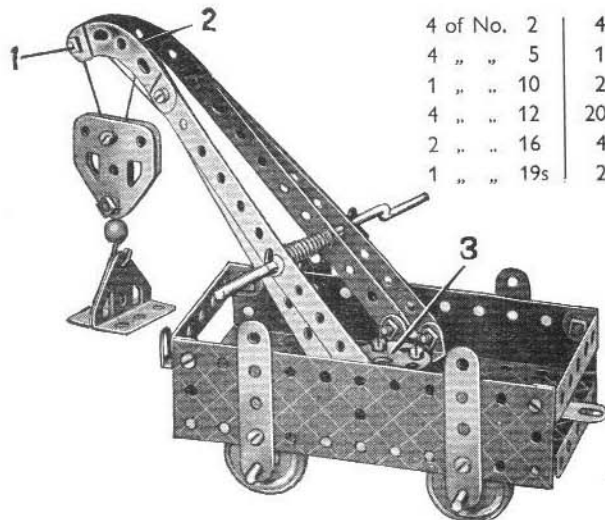

4 of No. 2	4 of No. 22	1 of No. 40	1 of No. 125
4 " " 5	1 " " 24	2 " " 48a	2 " " 126
1 " " 10	2 " " 35	1 " " 52	2 " " 126a
4 " " 12	20 " " 37	1 " " 57c	4 " " 155a
2 " " 16	4 " " 37a	2 " " 90a	2 " " 189
1 " " 19s	2 " " 38	4 " " 111c	

The hoisting cord is secured to the Crank Handle, and then led over the $\frac{3}{8}$ " Bolt 1. It is then passed through the pulley block and fastened to the jib at 2. The jib is attached to the Bush Wheel 3 by means of Angle Brackets and the complete unit is pivoted as follows. A $\frac{3}{8}$ " Bolt is passed through the $5\frac{1}{2}$ " x $2\frac{1}{2}$ " Flanged Plate, and is secured in the boss of the Bush Wheel by its set screw.

1.38 FIRE ENGINE

Parts required

4 of No. 2	2 of No. 38
4 " " 5	1 " " 40
3 " " 10	2 " " 48a
5 " " 12	1 " " 52
2 " " 16	2 " " 90a
1 " " 17	2 " " 111c
1 " " 19s	1 " " 125
4 " " 22	2 " " 126
1 " " 24	2 " " 126a
4 " " 35	4 " " 155a
24 " " 37	2 " " 189
4 " " 37a	

Bolts 1 are lock-nutted. The sides of the ladder are held together by two Angle Brackets 2, which are bolted together to form a double bracket. The rear axle bearings 3 are Flat Brackets bolted inside the flange of the Flanged Plate. The Cord from the Crank Handle is tied in the fourth hole up the ladder so that when the Handle is turned it causes the ladder to lift.

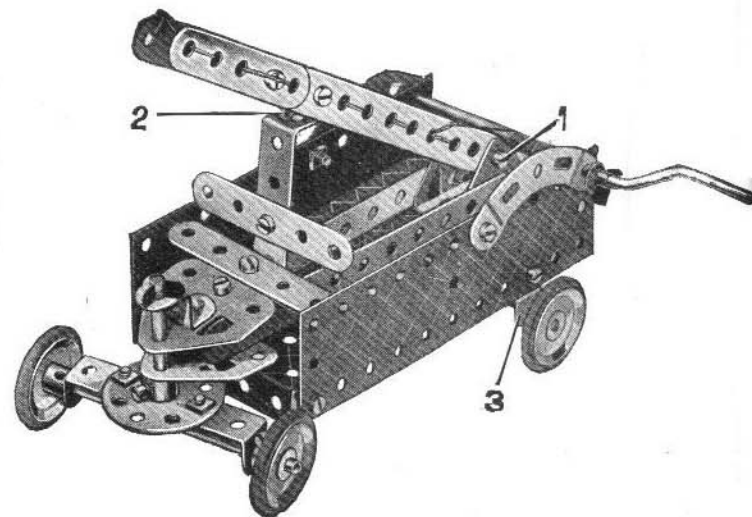

1.39 DERRICK CRANE

Parts required

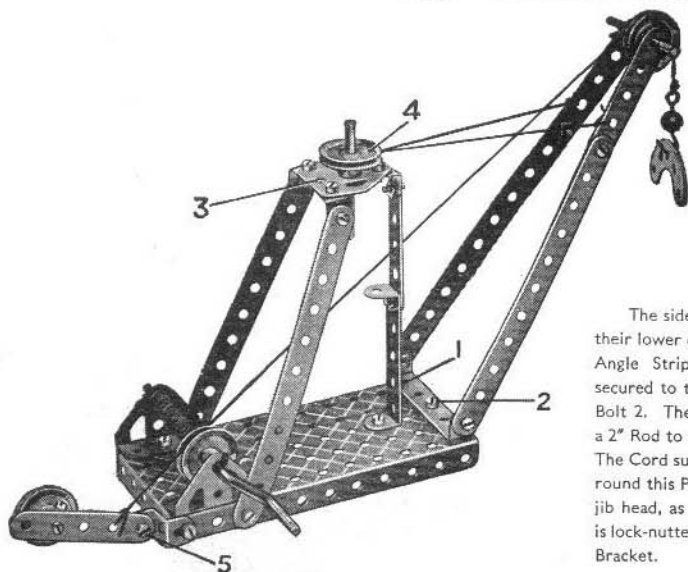

The sides of the jib are bolted at their lower ends to a $2\frac{1}{2}$ " x $\frac{1}{2}$ " Double Angle Strip 1, which is pivotally secured to the base by a lock-nutted Bolt 2. The Flat Trunnion 3 carries a 2" Rod to which is fitted a Pulley 4. The Cord supporting the jib is passed round this Pulley and attached to the jib head, as shown. The band brake is lock-nutted at 5 to a Reversed Angle Bracket.

4 of No. 2
4 " " 5
3 " " 12
2 " " 17
1 " " 19s
4 " " 22
4 " " 35
19 " " 37
4 " " 37a
1 " " 40
2 " " 48a
1 " " 52
1 " " 57c
2 " " 90a
1 " " 111c
1 " " 125
2 " " 126
1 " " 126a

1.40 TRAVELLING CRANE

Parts required

4 of No. 2	20 of No. 37
4 " " 5	4 " " 38
4 " " 10	1 " " 40
2 " " 12	1 " " 48a
2 " " 16	1 " " 52
1 " " 17	1 " " 57c
1 " " 19s	2 " " 90a
4 " " 22	1 " " 111c
1 " " 24	2 " " 126
4 " " 35	2 " " 126a

The sides of the jib are secured to the Bush Wheel 1 by two Angle Brackets 2. A $\frac{3}{8}$ " Bolt is passed from the underneath side of Double Angle Strip 3 into the boss of the Bush Wheel 1 and the set screw is then tightened.

The Flat Trunnions at the lower end of the jib support the Crank Handle, which also passes through Flat Brackets bolted to the Angle Brackets 2 on the Bush Wheel 1. The Cord is fastened to the Crank Handle, and passes over the 2" Rod at the jib head.

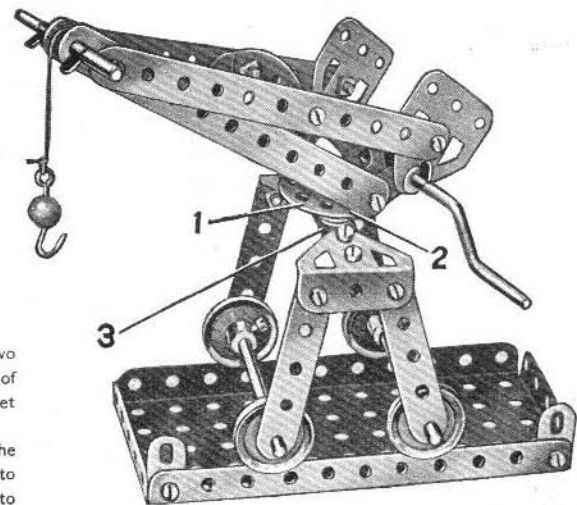

1.41 RAILWAY TRUCK

Parts required

4 of No. 2	4 of No. 38
4 " " 5	2 " " 48a
2 " " 10	1 " " 52
8 " " 12	4 " " 111c
2 " " 16	1 " " 125
4 " " 22	2 " " 126
24 " " 37	2 " " 126a
4 " " 37a	2 " " 189

The axle bearings 1 are Flat Trunnions and Trunnions are used for the bearings 2, which fit underneath the Flanged Plate in the manner shown in the underneath view of the model Side Tipping Wagon (1.46).

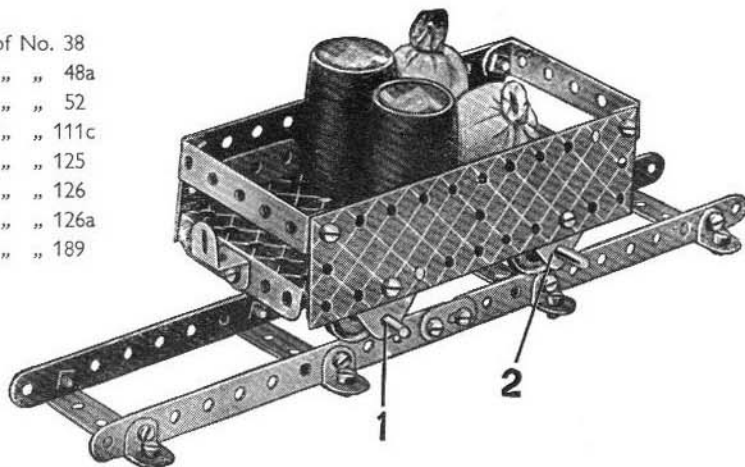

1.42 OPEN TRAMCAR

Parts required

2 of No. 5	1 of No. 40
4 " " 10	2 " " 48a
7 " " 12	1 " " 52
2 " " 16	2 " " 90a
1 " " 19s	4 " " 111c
4 " " 22	1 " " 125
1 " " 24	2 " " 126
4 " " 35	2 " " 126a
24 " " 37	4 " " 155a
3 " " 37a	2 " " 189

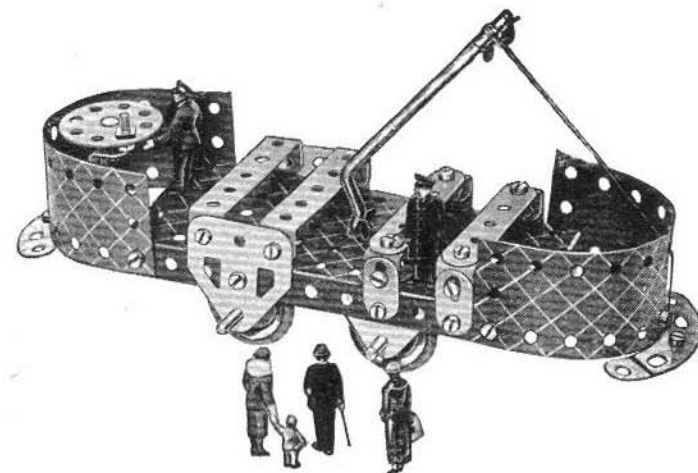

1.43 PITHEAD GEAR

Parts required

4 of No. 2	4 of No. 38
4 " " 5	1 " " 40
4 " " 10	2 " " 48a
2 " " 12	1 " " 52
1 " " 16	1 " " 90a
1 " " 19s	4 " " 111c
4 " " 22	2 " " 126
4 " " 35	2 " " 126a
20 " " 37	2 " " 189
4 " " 37a	

A Cord is taken from each side of the lift cage over the 1" Pulleys and secured to each end of the Crank Handle. The Cords must both be the same length otherwise the lift will tilt.

The two guides for the lift consist of two pieces of Cord fastened to the Washers 1. The Cords are then passed through holes in the Double Angle Strip, through two corresponding holes in the lift cage 2, and then through the two corresponding holes in the Flanged Plate. Two more Washers are tied to the Cords beneath the Flanged Plate to keep the Cords tight. The lift cage 2 is made up of two Trunnions.

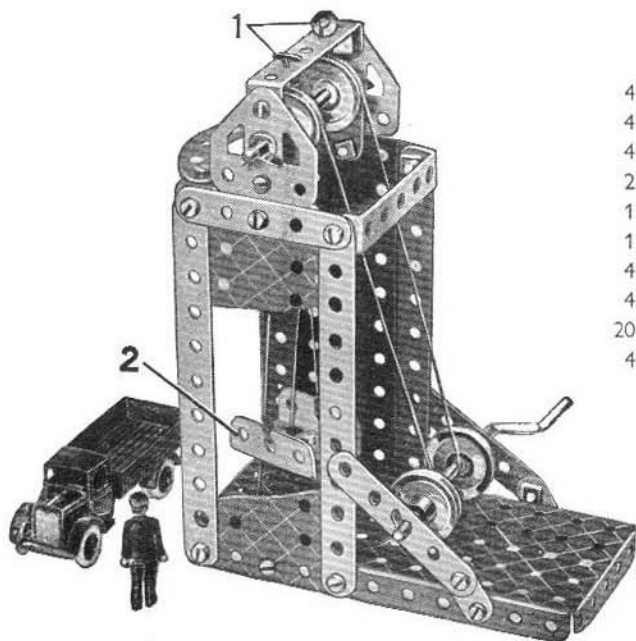

1.44 DOCKSIDE CRANE

Parts required

4 of No. 2	4 of No. 38
4 " " 5	1 " " 40
2 " " 10	2 " " 48a
4 " " 12	1 " " 52
1 " " 16	1 " " 57c
2 " " 17	2 " " 90a
1 " " 19s	4 " " 111c
4 " " 22	1 " " 125
1 " " 24	2 " " 126
4 " " 35	2 " " 126a
24 " " 37	2 " " 155a
4 " " 37a	2 " " 189

The Rod 1 passes through the bosses of the Bush Wheel 2 and the 1" Pulley, and is held in position by a Spring Clip underneath the Flanged Plate. The set screw of the Bush Wheel 2 is tightened on the Rod.

The 5 1/2" Strips that form the jib are extended at the head by 2 1/2" x 1/2" Double Angle Strips, in which a 2" Rod is journaled.

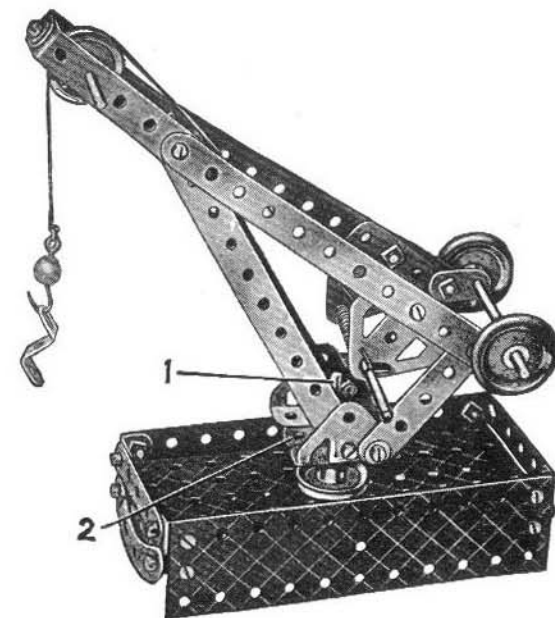

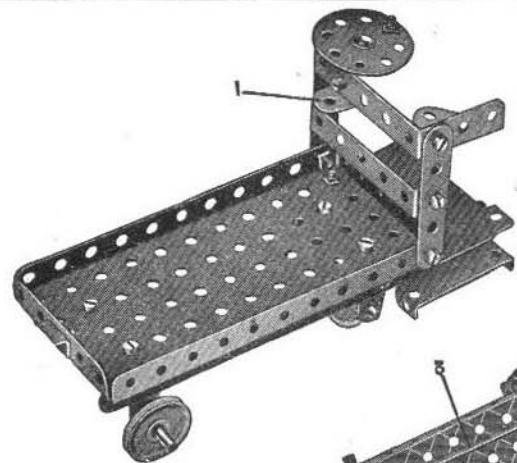

The steering wheel, a Bush Wheel, is secured to the Reversed Angle Bracket 1 by means of a $\frac{3}{8}$ " Bolt. Fig. 1.45a shows how the *Magic Motor* is mounted to drive the front wheels. The front wheel axle is journalled in two Flat Brackets bolted to the $5\frac{1}{4}$ " Strips 2 and 3.

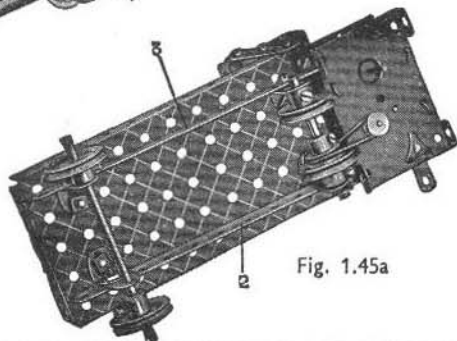

Fig. 1.45a

1.45 ELECTRIC TRUCK

Parts required

2 of No. 2	4 of No. 22
2 " " 5	1 " " 24
4 " " 10	18 " " 37
4 " " 12	2 " " 48a
1 " " 16	1 " " 52
1 " " 17	1 " " 111c
	1 " " 125
	1 " " 126
	1 <i>Magic Motor</i>

1.46 SIDE TIPPING WAGON

Parts required

3 of No. 2	2 of No. 90a
4 " " 5	4 " " 111c
4 " " 10	1 " " 125
7 " " 12	2 " " 126
2 " " 16	2 " " 126a
1 " " 17	4 " " 155a
4 " " 22	2 " " 189
1 " " 24	1 <i>Magic Motor</i>
24 " " 37	
4 " " 37a	
3 " " 38	
2 " " 48a	
1 " " 52	

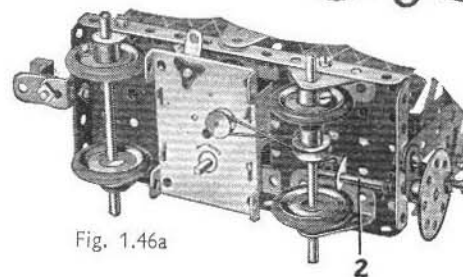
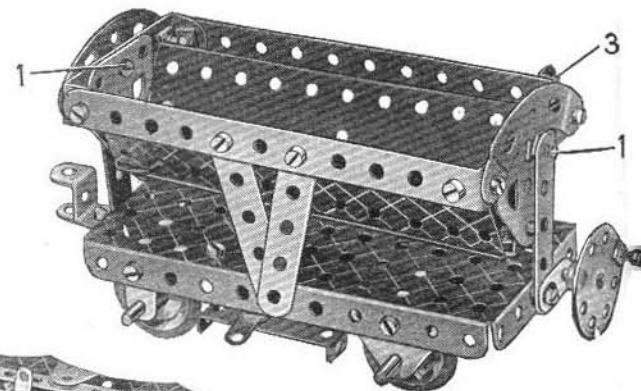
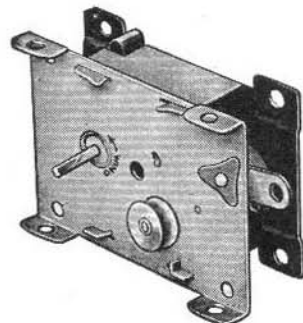

Fig. 1.46a

Each of the Bolts 1 is lock-nutted. A piece of Cord is fastened to the Rod 2 (Fig. 1.46a) wrapped round it two or three times, and then is taken through the hole in the Flanged Plate above the Rod and secured to the Angle Bracket 3.

By turning the Bush Wheel the container is tipped sideways.

THE MECCANO MAGIC MOTOR



The greatest thrill in Meccano model-building is experienced when a model is set to work by means of a Meccano *Magic Motor*. The illustrations on this page show how the *Magic Motor* can be fitted without any difficulty to No. 1 Outfit models of various types. Fit the model you have just built with one of these wonderful Motors, and enjoy the fun of watching it work just like the real thing!

The left-hand $2\frac{1}{4}$ " Strip that supports the swing is connected to the Crank Handle by passing the set screw of the 1" Pulley Wheel 2 through the hole in an Angle Bracket bolted to the Strip and then into the boss of the Pulley. Bolt 1 on the Bush Wheel is fitted with lock-nuts.

The Bolts 1 are lock-nutted. The Rod 2 is secured to an Angle Bracket by means of two Spring Clips 3. The model is driven by a *Magic Motor* bolted to the $5\frac{1}{4}$ " x $2\frac{1}{4}$ " Flanged Plate. The pulley of the Motor is connected to a 1in. fast Pulley on the crankshaft of the engine by a Driving Band.

1.47 MECHANICAL SWING

Parts required

4 of No. 2
2 " " 5
2 " " 10
3 " " 12
1 " " 16
1 " " 19s
2 " " 22
1 " " 24
4 " " 35
15 " " 37
2 " " 37a
4 " " 38
1 " " 40
2 " " 48a
1 " " 52
1 " " 111c
1 " " 125
2 " " 126
2 " " 189
1 <i>Magic Motor</i>

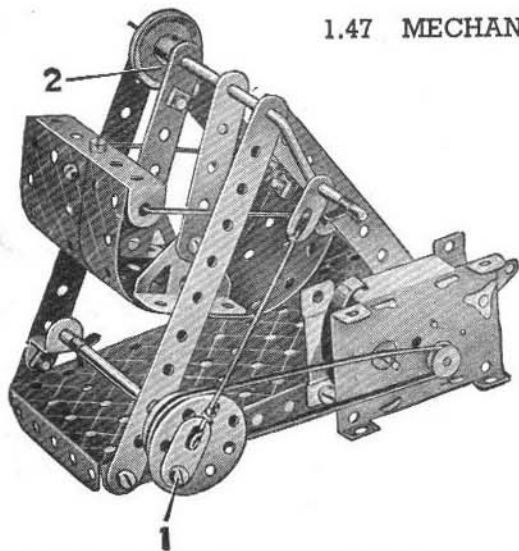

1.48 HORIZONTAL STEAM ENGINE

Parts required

3 of No. 2
4 " " 5
2 " " 12
1 " " 16
1 " " 17
4 " " 22
1 " " 24
4 " " 35
24 " " 37
2 " " 37a
3 " " 38
1 " " 38a
1 " " 52
1 " " 111c
1 " " 125
2 " " 126
2 " " 126a
2 " " 189
1 <i>Magic Motor</i>

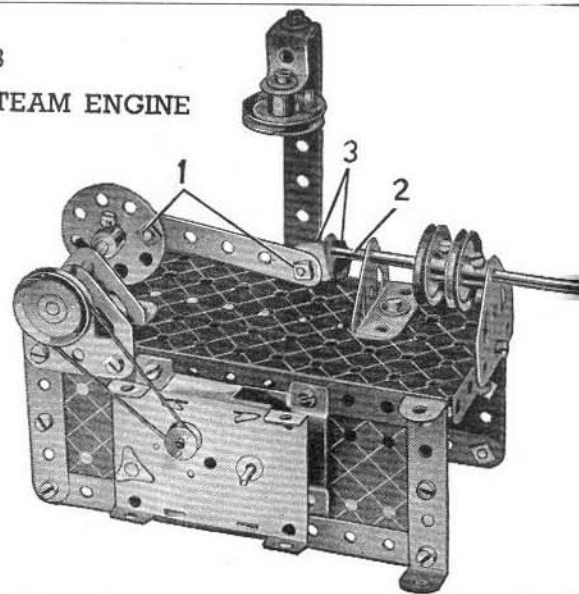

2.1 RAILWAY FOOTBRIDGE

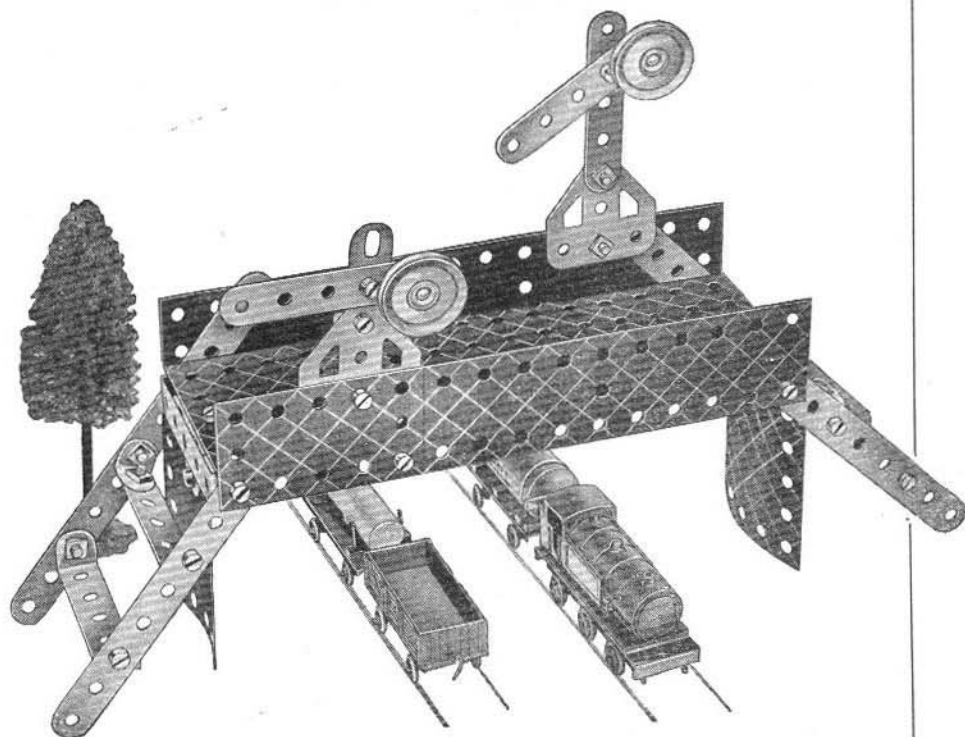

Parts required

4 of No. 2	2 of No. 22	1 of No. 52	2 of No. 188
6 " " 5	32 " " 37	2 " " 111c	2 " " 189
2 " " 10	2 " " 37a	2 " " 126	1 " " 190
6 " " 12	2 " " 48a	2 " " 126a	2 " " 200

The span of the bridge is a $5\frac{1}{2} \times 2\frac{1}{2}$ " Flanged Plate, extended by a $2\frac{1}{2} \times 2\frac{1}{2}$ " Flexible Plate. Trunnions are bolted to each end of the span, and have $1\frac{1}{8}$ " radius Curved Plates fastened to them. The sides of the approach stairways are $5\frac{1}{2}$ " Strips. They are joined across by $2\frac{1}{2} \times \frac{1}{4}$ " Double Angle Strips and $2\frac{1}{2}$ " Strips fitted with Angle Brackets at each end.

The signals are supported on Flat Trunnions bolted to the sides of the bridge. The smaller of the two signal posts is formed by two Flat Brackets, and the larger one is a $2\frac{1}{2}$ " Strip. The signal arms are $2\frac{1}{2}$ " Strips bolted to the posts in the second holes from one end. They are fitted at their shorter ends with 1" Pulleys, representing the spectacles, which are held in place by $\frac{3}{8}$ " Bolts passed through the Strips and inserted in their bosses.

2.2 LAWN MOWER

The "cutter" is made by bolting an Angle Bracket at each end of a Reversed Angle Bracket 1 and then sliding an Axle Rod through the free holes of the Brackets. The two Pulleys 2 are fixed to the Rod and pushed tightly against the "cutter" to make it rotate with the Rod as the wheels revolve. The wheels are 1" Pulleys fitted with Rubber Rings.

Parts required

4 of No. 2	2 of No. 90a
4 " " 5	1 " " 125
4 " " 10	2 " " 126
6 " " 12	2 " " 155a
1 " " 16	2 " " 200
4 " " 22	
25 " " 37	
4 " " 38	
2 " " 48a	

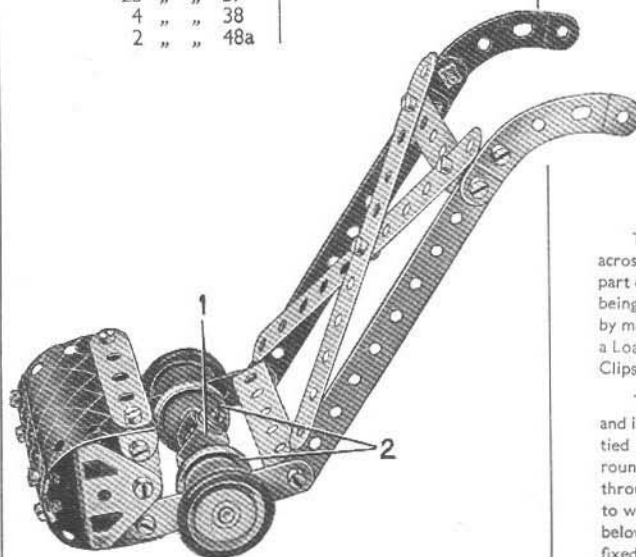

2.3 FLOATING CRANE

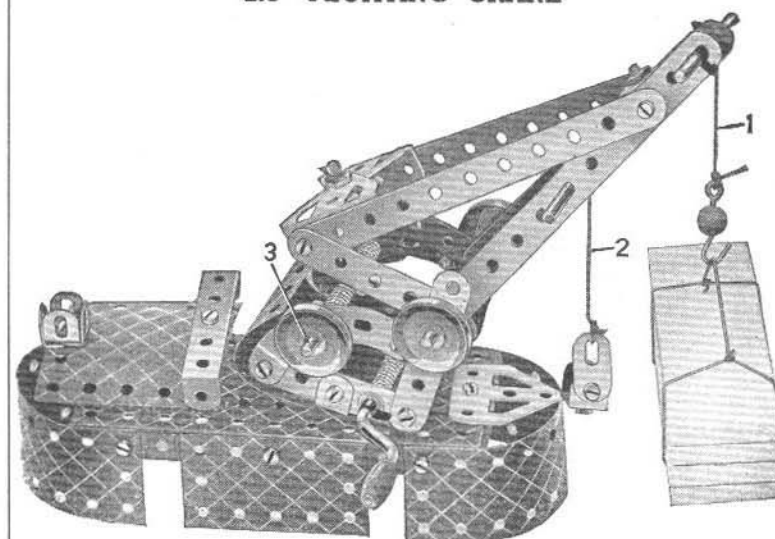

Parts required

4 of No. 2	4 of No. 22	2 of No. 48a	1 of No. 126a
6 " " 5	1 " " 24	1 " " 52	1 " " 176
3 " " 10	4 " " 35	1 " " 57c	2 " " 188
8 " " 12	29 " " 37	2 " " 90a	2 " " 189
2 " " 16	3 " " 37a	4 " " 111c	1 " " 199
2 " " 17	4 " " 38	1 " " 125	1 " " 200
1 " " 19g	1 " " 40	2 " " 126	

The jib consists of $5\frac{1}{2}$ " Strips and $2\frac{1}{2}$ " Strips. At its upper end these are joined across by Angle Brackets, and at its lower end by Trunnions. Each side of the lower part of the crane consists of $2\frac{1}{2}$ " Strips and small radius Curved Strips, the two sides being connected by $2\frac{1}{2} \times \frac{1}{4}$ " Double Angle Strips. The jib is pivoted to this structure by means of a $3\frac{1}{2}$ " Rod, which carries at each end a 1" Pulley. The Cord 1 fitted with a Loaded Hook, is passed over a 2" Rod held in place in the jib by means of Spring Clips and is then wound around the Crank Handle.

The Cord 2 passes over a Rod held in place in the jib by an Anchoring Spring, and is then wound around the Rod that forms the pivot for the jib. A third Cord is tied to a Bolt fastened in the two Trunnions at the base of the jib, and is wound round Rod 3. This Cord controls the luffing motion of the crane. A $\frac{3}{8}$ " Bolt passes through the Flanged Plate and is held by a set screw in the boss of the Bush Wheel to which the jib is fastened. The Bush Wheel is bolted to the Double Angle Strip below the Rod 3. The roof of the cabin is bolted to a $\frac{1}{2}$ " Reversed Angle Bracket fixed to the Flanged Plate.

2.4 AUTOGIRO

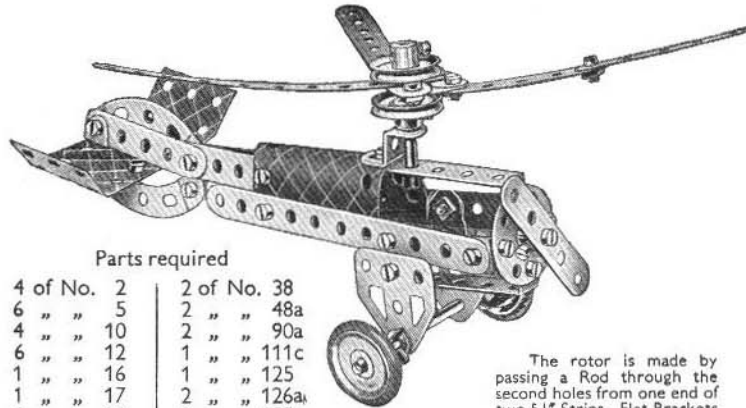

Parts required

4 of No. 2	2 of No. 38
6 " " 5	2 " " 48a
4 " " 10	2 " " 90a
6 " " 12	1 " " 111c
1 " " 16	1 " " 125
1 " " 17	2 " " 126a
4 " " 22	2 " " 155a
1 " " 24	2 " " 188
3 " " 35	1 " " 199
25 " " 37	

The rotor is made by passing a Rod through the second holes from one end of two 5½" Strips. Flat Brackets are bolted to the short ends of the Strips and the third blade of the rotor is fixed to them as shown.

2.5 ANTI-AIRCRAFT GUN

Parts required

4 of No. 2
1 " " 5
6 " " 12
2 " " 16
2 " " 17
1 " " 19g
4 " " 22
1 " " 24
3 " " 35
26 " " 37
4 " " 38
2 " " 48a
1 " " 52
2 " " 90a
1 " " 125
2 " " 126
2 " " 126a
4 " " 155a
1 " " 176
1 " " 187
2 " " 188
2 " " 189

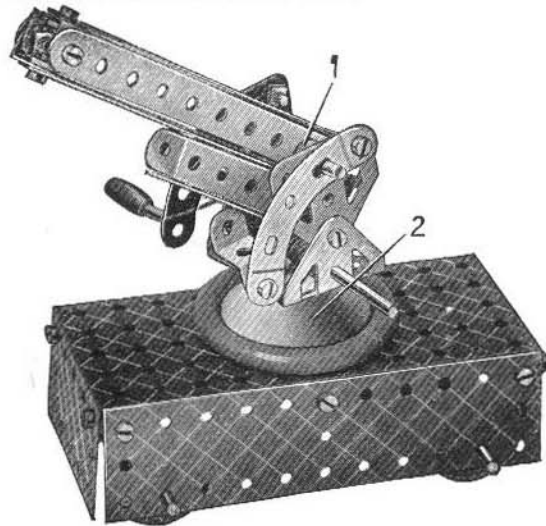

One end of a piece of Cord is fastened to the Crank Handle. It is wound round the Handle 1 few times and its other end is then fastened to the end of the gun. The two Trunnions are bolted to a Bush Wheel fixed on a 2" Rod that passes through the Road Wheel 2 and the Flanged Plate and is held in place by an Anchoring Spring. The Spring Clips at 1 space the gun barrel from the Flat Trunnions.

2.6 GAS ENGINE

Parts required

1 of No. 2	1 of No. 19g	4 of No. 35
3 " " 5	4 " " 22	39 " " 37
4 " " 10	1 " " 24	3 " " 37a
8 " " 12		4 " " 38
2 " " 16		1 " " 40
1 " " 17		2 " " 48a
		1 " " 52
		1 " " 90a
		1 " " 111c
		1 " " 125
		2 " " 126
		1 " " 126a
		1 " " 155a
		1 " " 176
		1 " " 187
		2 " " 188
		2 " " 189
		1 " " 190
		2 " " 200

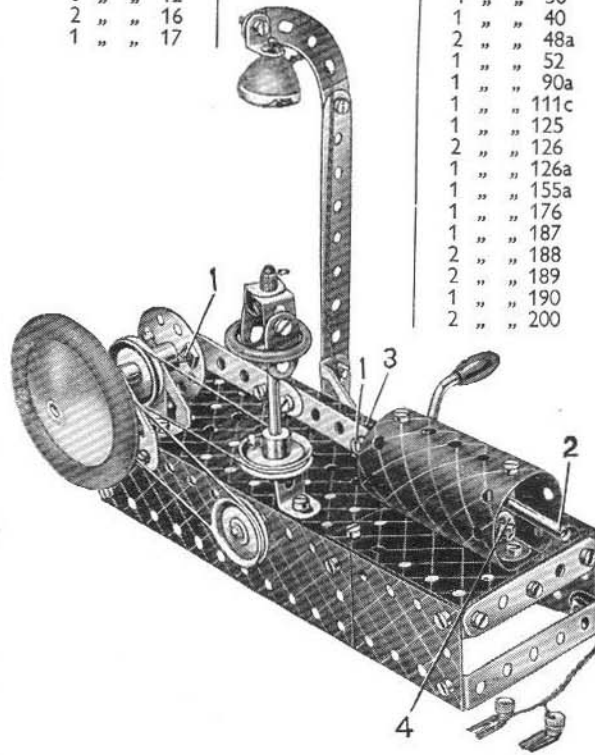

The bearings on the Rod representing the crankshaft are a Flat Trunnion and a Trunnion. The crankshaft carries a Road Wheel and a 1" Pulley at one end, a second 1" Pulley between the bearings, and a Bush Wheel at its other end.

The connecting rod is fastened to the Bush Wheel and to an Angle Bracket 3 by a lock-nutted Bolt 1. The Rod 2 is held in the Angle Bracket 3 by means of Spring Clips, one on each side. An Angle Bracket 4, carrying a Flat Bracket, is bolted inside the cylinder, and a similar arrangement is fitted at the other end. These form bearings for the Rod 2.

The model is operated by the Crank Handle, which carries also a 1" Pulley connected to one of the 1" Pulleys on the crankshaft by a belt of Cord. A second Cord drives the governor, which is mounted on a 3½" Rod journalled in the 5½" x 2½" Flanged Plate and a Reversed Angle Bracket.

The model is fitted with a Spotlight from the Meccano Lighting Set, current being supplied by a 4.5-volt pocket-lamp battery housed in the base of the model.

2.7 RACING CAR

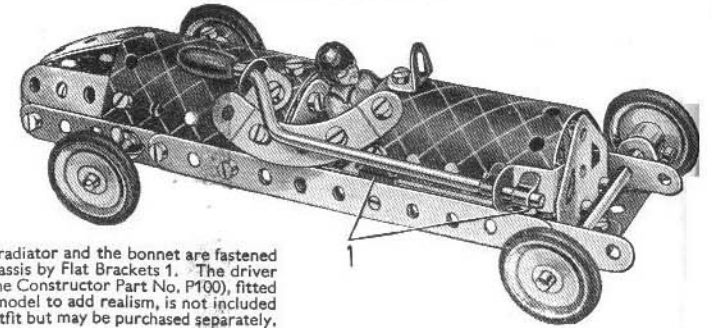

The radiator and the bonnet are fastened to the chassis by Flat Brackets 1. The driver (Aeroplane Constructor Part No. P100), fitted into the model to add realism, is not included in the Outfit but may be purchased separately.

Parts required

4 of No. 2	1 of No. 19g	2 of No. 38	1 of No. 126a
5 " " 5	4 " " 22	1 " " 48a	4 " " 155a
4 " " 10	4 " " 35	2 " " 90a	1 " " 199
8 " " 12	30 " " 37	1 " " 125	1 " " 200
2 " " 16	1 " " 37a	1 " " 126	

2.8 LOW WING MONOPLANE

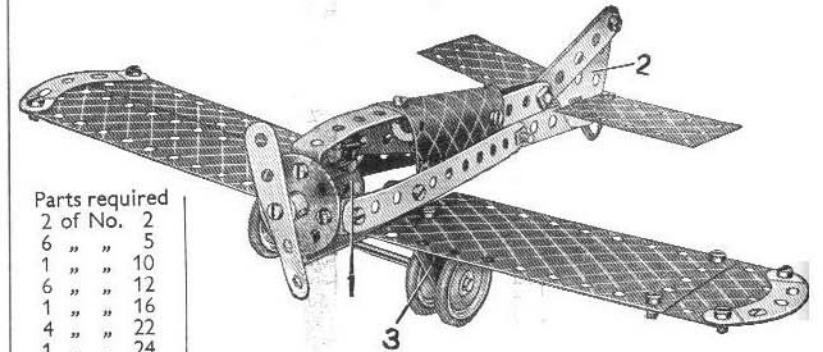

Parts required

2 of No. 2		
6 " " 5		
1 " " 10		
6 " " 12		
1 " " 16		
4 " " 22		
1 " " 24		
23 " " 37		
2 " " 37a	2 of No. 126	2 of No. 189
2 " " 38	1 " " 126a	1 " " 190
2 " " 48a	4 " " 155a	1 " " 191
2 " " 90a	2 " " 188	1 " " 199
3 " " 111c		

The pilot 1 (Aeroplane Constructor Part No. P100) is not included in the Outfit, but may be bought separately. The fin 2 is a Flat Trunnion, and it is clamped between the two 2½" Strips. The bearings 3 for the axle of the landing wheels are Trunnions, bolted to the wings. The wings are attached to the fuselage by Angle Brackets.

2.9 "THUNDERBOLT" SPEED CAR

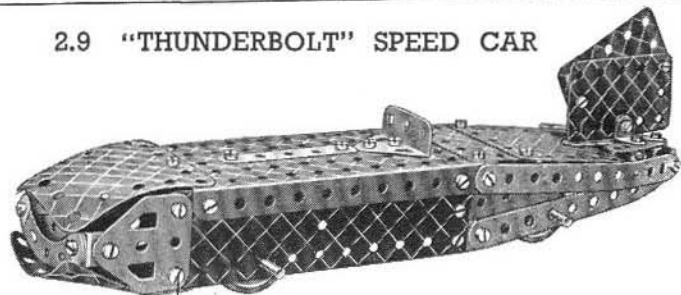

Parts required	
4 of No. 2	1 of No. 52
6 " " 5	2 " " 90a
2 " " 10	1 " " 126
4 " " 12	2 " " 126a
2 " " 16	4 " " 155a
4 " " 22	2 " " 188
39 " " 37a	2 " " 189
39 " " 37b	2 " " 190
4 " " 38	2 " " 200
2 " " 48a	

A $5\frac{1}{2} \times 2\frac{1}{2}$ " Flanged Plate, extended at the front by a $1\frac{1}{8}$ " radius Curved Plate and at the rear by two $2\frac{1}{2} \times 2\frac{1}{2}$ " Flexible Plates, forms the top of the car. The rear part of each side is formed by two $5\frac{1}{2}$ " Strips and a $2\frac{1}{2}$ " Strip, the former being connected together at the tail by Angle Brackets. Bolts 1 hold a $2\frac{1}{2} \times \frac{1}{2}$ " Double Angle Strip that carries the $1\frac{1}{8}$ " radius Curved Plate forming the underside of the front cowling.

2.10 ROLL TOP DESK

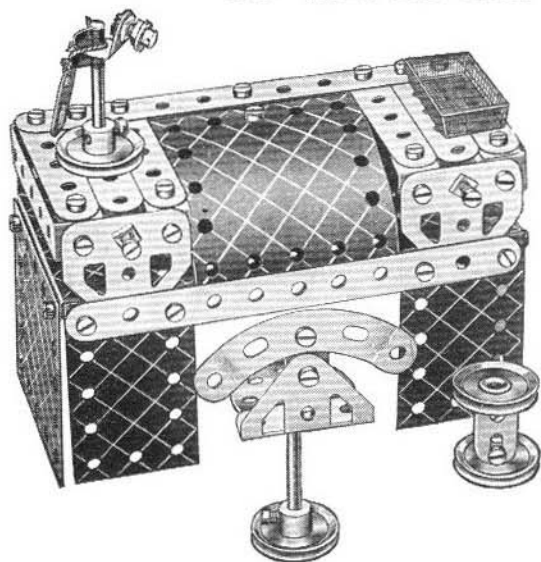

Parts required	
2 of No. 2	
6 " " 5	
4 " " 10	
7 " " 12	
2 " " 17	
4 " " 22	
1 " " 24	
3 " " 35	
38 " " 37	
5 " " 37a	
1 " " 38	
2 " " 48a	
1 " " 52	
1 " " 90a	
3 " " 111c	
1 " " 126	
2 " " 126a	
2 " " 188	
1 " " 189	
2 " " 190	
1 " " 200	

2.11 TRAVELLING CRANE

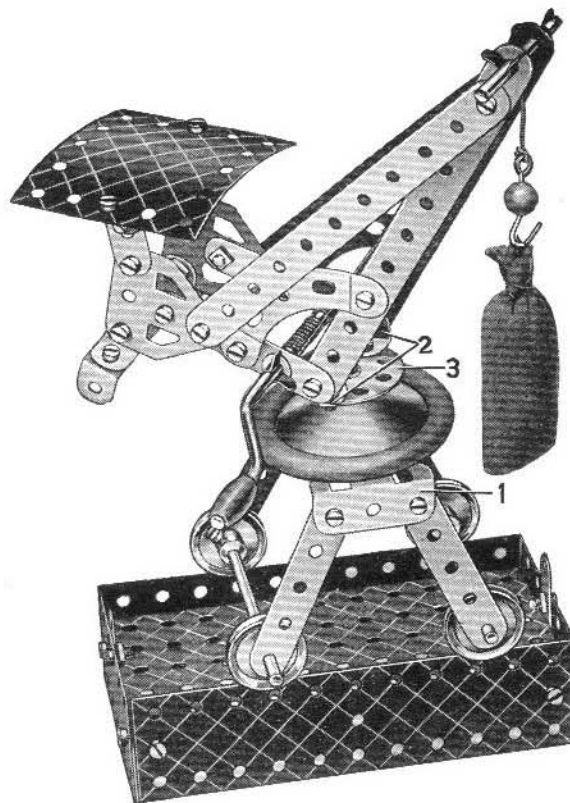

Parts required			
4 of No. 2	1 of No. 19g	3 of No. 38	2 of No. 111c
6 " " 5	4 " " 22	1 " " 40	2 " " 126
4 " " 10	1 " " 24	2 " " 48a	2 " " 126a
6 " " 12	4 " " 35	1 " " 52	1 " " 176
2 " " 16	38 " " 37	1 " " 57c	1 " " 187
2 " " 17	2 " " 37a	2 " " 90a	2 " " 188
	2 of No. 189		1 of No. 200

A 2" Rod is secured in the boss of the Bush Wheel 3. It then passes through the Road Wheel and through the centre of a $2\frac{1}{2} \times \frac{1}{2}$ " Double Angle Strip bolted between the two Trunnions 1. A Washer and a Cord Anchoring Spring are pushed on to the Rod to hold it in position. The crane jib is attached to the Bush Wheel by the Angle Brackets 2.

2.12 CATTLE TRUCK

Parts required	
4 of No. 2	
6 " " 5	
4 " " 10	
5 " " 12	
2 " " 16	
4 " " 22	
38 " " 37	
8 " " 37a	
4 " " 38	
2 " " 48a	
1 " " 52	
4 " " 111c	
1 " " 125	
2 " " 126	
2 " " 126a	
4 " " 155a	
2 " " 188	
2 " " 190	
2 " " 200	

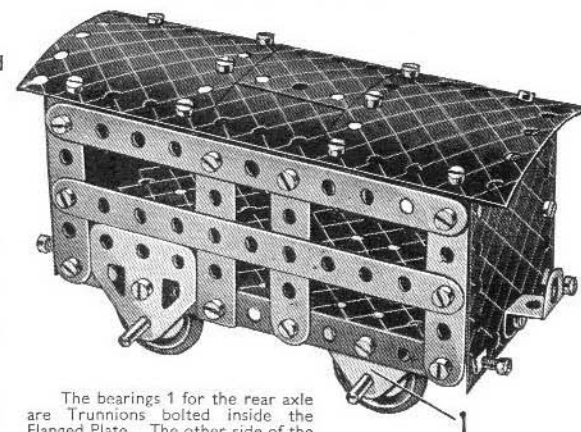

The bearings 1 for the rear axle are Trunnions bolted inside the Flanged Plate. The other side of the truck is constructed in a similar manner to the side shown in the illustration.

2.13 PIANO

Parts required	
4 of No. 2	
4 " " 5	
4 " " 10	
8 " " 12	
1 " " 17	
1 " " 22	
1 " " 24	
38 " " 37	
4 " " 38	
2 " " 48a	
1 " " 52	
2 " " 90a	
2 " " 126	
2 " " 126a	
2 " " 188	
2 " " 189	
1 " " 190	
1 " " 191	

A $5\frac{1}{2} \times 2\frac{1}{2}$ " Flanged Plate is used for the upper part of the back and to each end of this a $2\frac{1}{2}$ " Strip is bolted to form the rear legs.

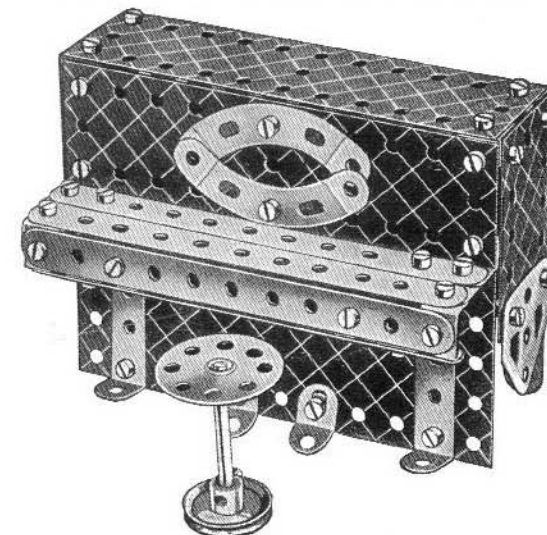

2.14 MOTOR VAN

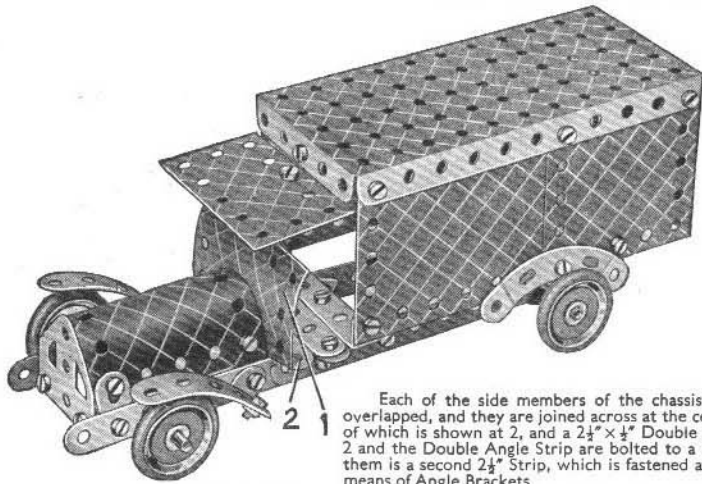

Each of the side members of the chassis consists of two 5½" Strips overlapped, and they are joined across at the centre by two 2½" Strips, one of which is shown at 2, and a 2½" x ½" Double Angle Strip. The 2½" Strip 2 and the Double Angle Strip are bolted to a Flat Trunnion and between them is a second 2½" Strip, which is fastened at each end to the chassis by means of Angle Brackets.

The Plate 1 is fastened to an Angle Bracket that is bolted to Strip 2. The body is fixed to the chassis by a Double Angle Strip and an Angle Bracket.

Parts required

4 of No. 2
4 " " 5
4 " " 10
8 " " 12
2 " " 16
4 " " 22
4 " " 35
40 " " 37
4 " " 38
2 " " 48a
1 " " 52
2 " " 90a
1 " " 126
2 " " 126a
4 " " 155a
2 " " 188
2 " " 189
2 " " 190
1 " " 191
1 " " 199

2.16 STEAMSHIP

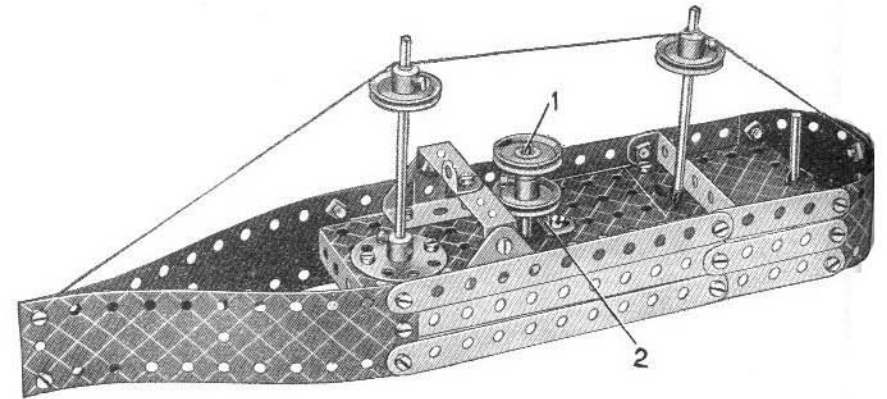

Parts required

4 of No. 2
6 " " 5
1 " " 12
2 " " 16
2 " " 17
4 " " 22
1 " " 24
4 " " 35
34 " " 37
1 " " 40
2 " " 48a
1 " " 52
1 " " 125
2 " " 126
2 " " 188
2 " " 189
1 " " 190

The deck of the model is a 5½" x 2½" Flanged Plate extended by a 2½" x 2½" Flexible Plate. A 2½" x ½" Double Angle Strip fitted with an Angle Bracket represents the bridge, and it is supported by two Trunnions bolted to the deck. The funnel consists of a Rod 1 fitted with two 1" fast Pulleys. The Rod passes through the hole in a Reversed Angle Bracket 2 and then through the Flanged Plate.

2.15 RAILWAY BREAKDOWN CRANE

Parts required

4 of No. 2
6 " " 5
4 " " 10
3 " " 12
2 " " 16
1 " " 17
1 " " 19g
4 " " 22
1 " " 24
2 " " 35
39 " " 37
3 " " 37a
3 " " 38
1 " " 40
2 " " 48a
1 " " 52
1 " " 57c
2 " " 90a
3 " " 111c
2 " " 126
2 " " 126a
1 " " 155a
1 " " 176
1 " " 187

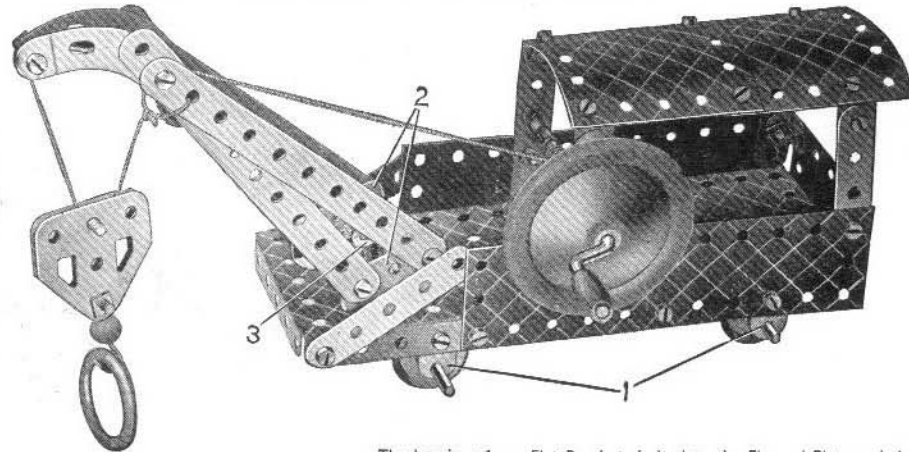

1 of No. 188
2 " " 189
1 " " 190
2 " " 200

The bearings 1 are Flat Brackets bolted to the Flanged Plate and the Flexible Plates respectively. The jib is fastened to two Trunnions 2, which are bolted to the Bush Wheel 3. A 2" Rod is secured in the boss of the Bush Wheel 3. It then passes through a hole in the Flanged Plate, and is held in position by a Spring Clip underneath the Plate.

2.17 BATHROOM SUITE

Parts required

4 of No. 2
6 " " 5
4 " " 10
8 " " 12
1 " " 24
40 " " 37
6 " " 37a
2 " " 38
2 " " 48a
1 " " 52
2 " " 90a
4 " " 111c
1 " " 125
2 " " 126
2 " " 126a
2 " " 188
2 " " 189
1 " " 190
1 " " 191
1 " " 199
1 " " 200

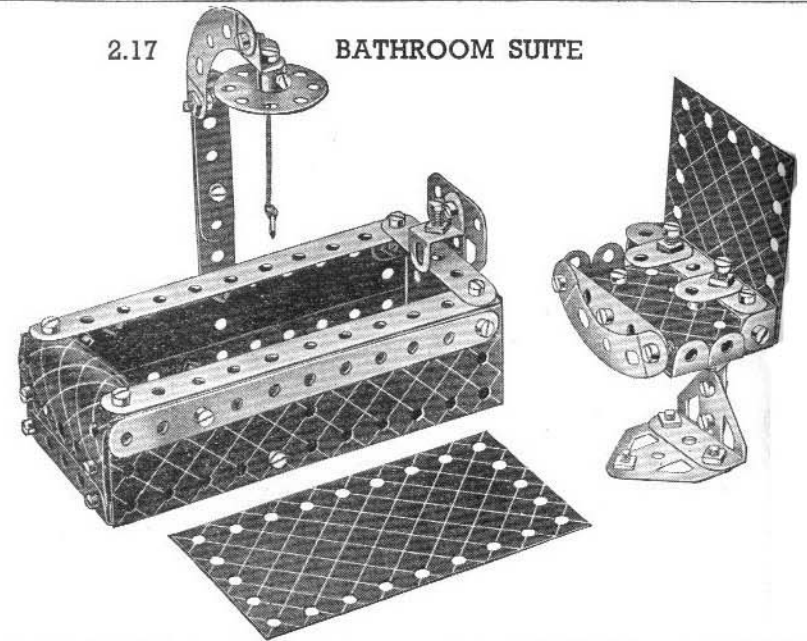

2.18 WHEELBARROW

A $5\frac{1}{2}'' \times 2\frac{1}{2}''$ Flanged Plate is used upside down for the floor of the barrow, and two $5\frac{1}{2}''$ Strips overlapped six holes form the shafts.

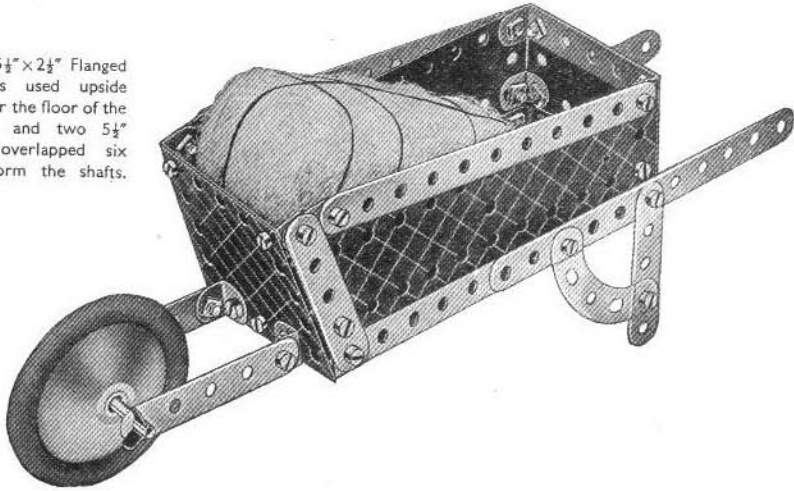

Parts required

4 of No. 2
6 " " 5
2 " " 10
4 " " 12
1 " " 17
2 " " 35
29 " " 37
2 " " 48a
1 " " 52
2 " " 90a
1 " " 187
1 " " 188
2 " " 189
1 " " 190

2.20 ROAD BRIDGE

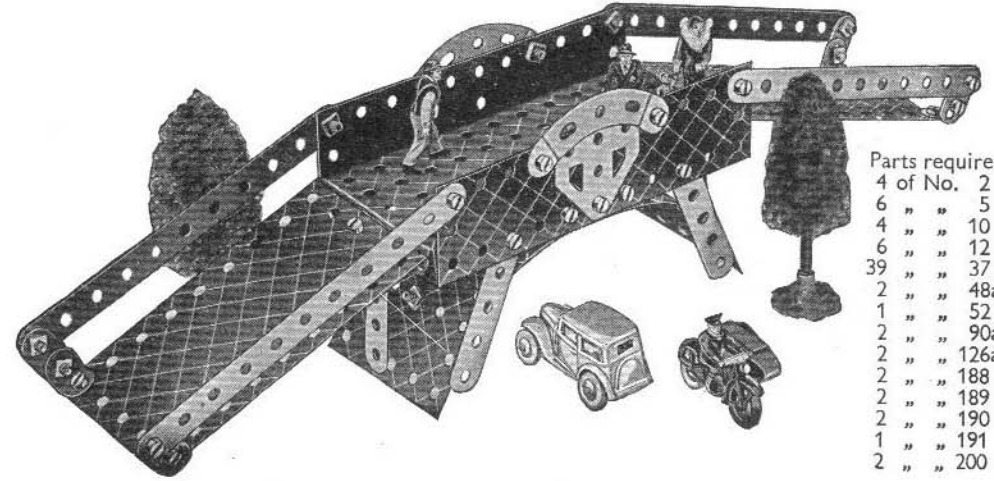

Parts required

4 of No. 2
6 " " 5
4 " " 10
6 " " 12
39 " " 37
2 " " 48a
1 " " 52
2 " " 90a
2 " " 126a
2 " " 188
2 " " 189
2 " " 190
1 " " 191
2 " " 200

2.19 CANAL BRIDGE

Parts required

4 of No. 2
6 " " 5
4 " " 10
4 " " 12
1 " " 16
1 " " 19g
4 " " 22
1 " " 24
41 " " 37a
39 " " 37b

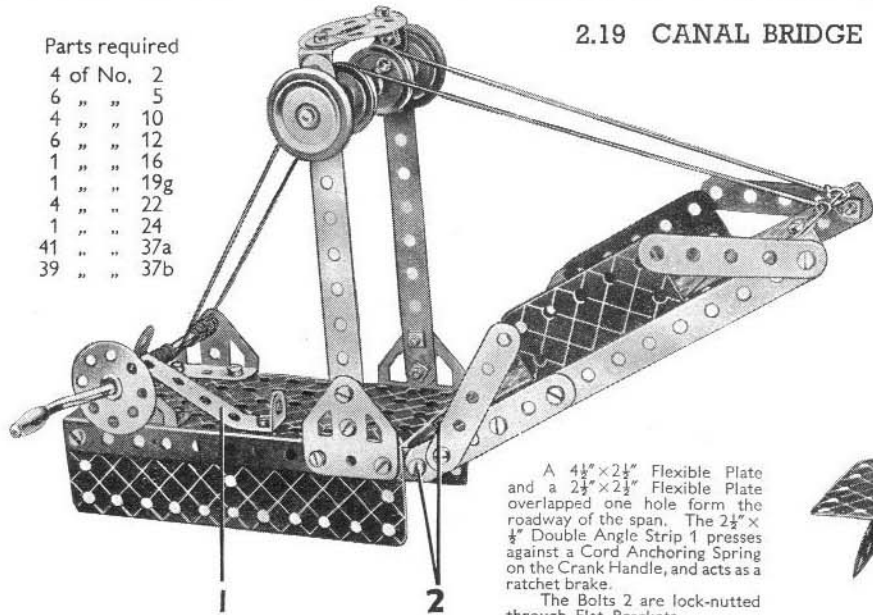

A $4\frac{1}{2}'' \times 2\frac{1}{2}''$ Flexible Plate and a $2\frac{1}{2}'' \times 2\frac{1}{2}''$ Flexible Plate overlapped one hole form the roadway of the span. The $2\frac{1}{2}'' \times \frac{1}{2}''$ Double Angle Strip 1 presses against a Cord Anchoring Spring on the Crank Handle, and acts as a ratchet brake.

The Bolts 2 are lock-nutted through Flat Brackets.

Parts required (continued)

2 of No. 38
2 " " 48a
1 " " 52
2 " " 90a
2 " " 126
2 " " 126a
2 " " 155a
1 " " 176
2 " " 188
2 " " 189
2 " " 190
1 " " 191
1 " " 199
1 " " 200

2.21 DRAGLINE EXCAVATOR

Parts required

4 of No. 2	3 of No. 22	1 of No. 48a	1 of No. 176
6 " " 5	1 " " 24	1 " " 52	1 " " 187
2 " " 10	4 " " 35	1 " " 57c	2 " " 188
8 " " 12	40 " " 37	2 " " 90a	2 " " 189
1 " " 16	4 " " 37a	2 " " 111c	2 " " 190
2 " " 17	1 " " 38	2 " " 126	1 " " 199
1 " " 19g	1 " " 40	2 " " 126a	2 " " 200

The Cord 1 is wound round the Crank Handle about 12 times then one end of it is fastened to a small Loaded Hook and the other end to the Cord on the bucket.

A Curved Strip is pivoted by a $\frac{3}{8}''$ Bolt through one of its ends in the position of Bolt 2 but on the rear side of the model. A 1" Pulley is attached to the other end of the Curved Strip, with a $\frac{3}{8}''$ Bolt to act as a weight. A loop of Cord is fastened through the slotted hole next to the bottom of the Strip, and then passes round the 1" Pulley 3 on the shaft of the Bush Wheel, to act as a brake band. The Cord should be long enough to allow the Strip to lie nearly horizontal.

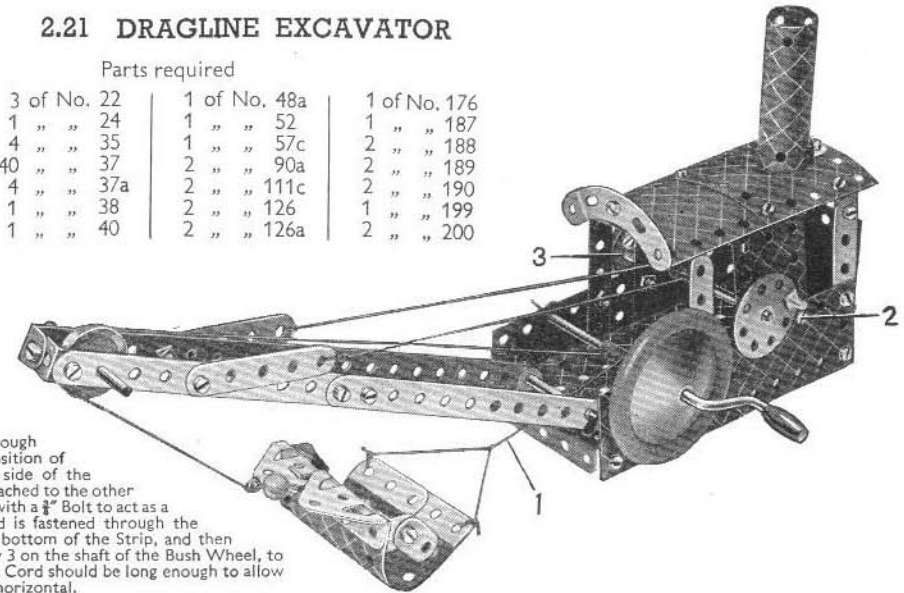

The greatest thrill in Meccano model-building is experienced when a model is set to work by means of a Meccano Motor. The illustrations below show how the Meccano *Magic* Motor can be fitted without any difficulty to No. 2 Outfit models of various types. Fit the model you have just built with one of these wonderful Motors, and enjoy the fun of watching it work just like the real thing.

2.22 LUMBER TRUCK AND HORSE

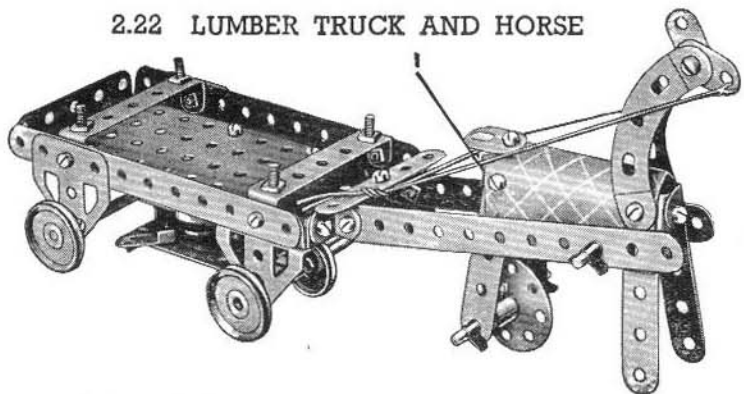

Parts required

4 of No. 2	4 of No. 37a
5 " " 5	2 " " 48a
3 " " 10	1 " " 52
5 " " 12	2 " " 90a
2 " " 16	4 " " 111c
2 " " 17	2 " " 126
4 " " 22	2 " " 126a
1 " " 24	4 " " 155a
4 " " 35	1 " " 199
23 " " 37	1 <i>Magic</i> Motor

A *Magic* Motor is mounted beneath the cart and the Driving Band is taken from the pulley on the Motor to a $\frac{1}{2}$ " fast Pulley (supplied with the Motor) fastened on the $3\frac{1}{2}$ " Rod that forms the front axle.

The forelegs of the horse are held together by means of two Angle Brackets bolted in the positions shown. This construction is duplicated at 1 for the hind-legs. The forelegs of the horse are held clear of the ground by means of the reins.

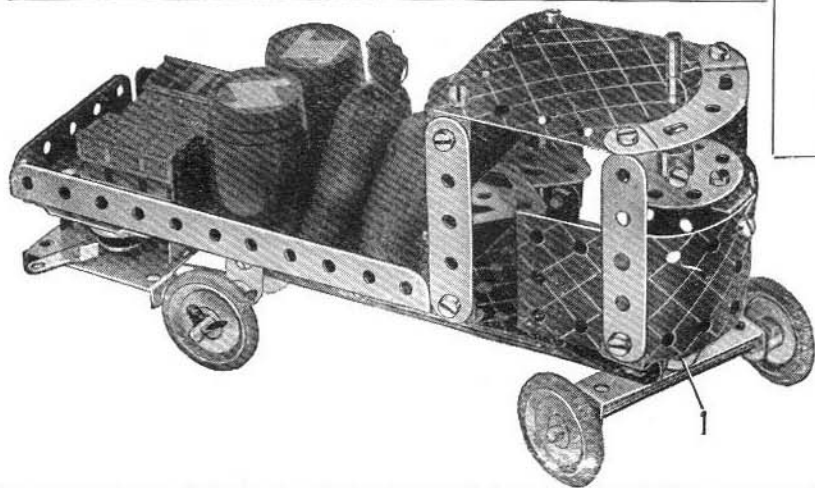

2.23 DRILLING MACHINE

Parts required

2 of No. 2	1 " " 40
5 " " 5	1 " " 48a
1 " " 10	1 " " 52
5 " " 12	1 " " 111c
1 " " 16	2 " " 126
2 " " 17	2 " " 126a
4 " " 22	1 " " 190
1 " " 24	1 <i>Magic</i> Motor
4 " " 35	
22 " " 37	
2 " " 37a	

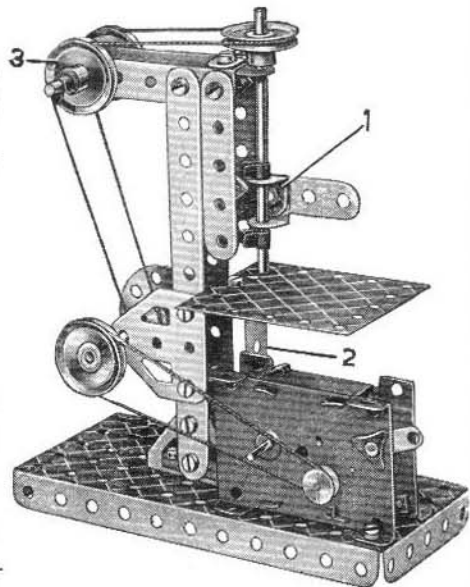

The horizontal $2\frac{1}{2}$ " Strips at the top of the drill are joined together, and also to the vertical $2\frac{1}{2}$ " Strips, by means of Angle Brackets. The lower bearings 1 are two Angle Brackets bolted to a $2\frac{1}{2}$ " Strip and the Rod forming the drill is journaled in these, and in a Flat Bracket at its upper end. A $2\frac{1}{2}$ " x $2\frac{1}{2}$ " Flexible Plate is supported by a Double Angle Strip 2, and represents the table.

The drive is taken from the Motor to the 1" Pulley on the lower shaft. A second Driving Band passes round the $\frac{1}{2}$ " fast Pulley supplied with the Motor, round the two Pulleys at 3, and finally round the 1" Pulley fastened on the vertical drill shaft.

2.25 STEAM WAGON

Parts required

2 of No. 2	4 of No. 35	2 of No. 126
6 " " 5	31 " " 37	4 " " 155a
2 " " 10	1 " " 37a	1 " " 188
8 " " 12	4 " " 38	1 " " 189
2 " " 16	2 " " 48a	1 " " 190
1 " " 17	1 " " 52	1 " " 200
4 " " 22	1 " " 90a	1 <i>Magic</i> Motor
1 " " 24	1 " " 125	

2.24 BEAM ENGINE

Parts required

4 of No. 2	2 " " 5
2 " " 10	6 " " 12
2 " " 16	1 " " 17
1 " " 17	4 " " 19g
1 " " 24	1 " " 22
4 " " 35	1 " " 24
31 " " 37	4 " " 35
4 " " 37a	4 " " 37
4 " " 38	4 " " 38
1 " " 52	2 " " 90a
2 " " 90a	2 " " 111c
1 " " 111c	1 " " 126
1 " " 126	1 " " 126a
1 " " 176	1 " " 176
1 " " 187	2 " " 188
2 " " 188	2 " " 189
2 " " 189	1 " " 191
1 " " 191	1 <i>Magic</i> Motor

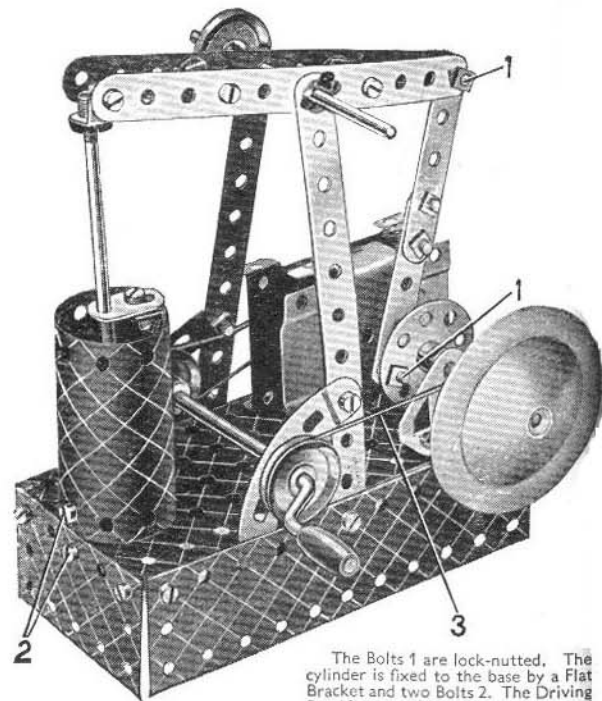

The Bolts 1 are lock-nutted. The cylinder is fixed to the base by a Flat Bracket and two Bolts 2. The Driving Band 3 drives a 1" fast Pulley on the Rod on which the Road Wheel is fastened.

The front axle is carried in a $2\frac{1}{2}$ " x $\frac{1}{2}$ " Double Angle Strip that is pivoted to a Reversed Angle Bracket fastened to a $2\frac{1}{2}$ " Strip below the cab by means of the lock-nutted Bolt 1, which is tightened up sufficiently to hold the two front wheels in position when running along. The rear axle is a $3\frac{1}{2}$ " Rod and it carries a $\frac{1}{2}$ " fast Pulley supplied with the *Magic* Motor.

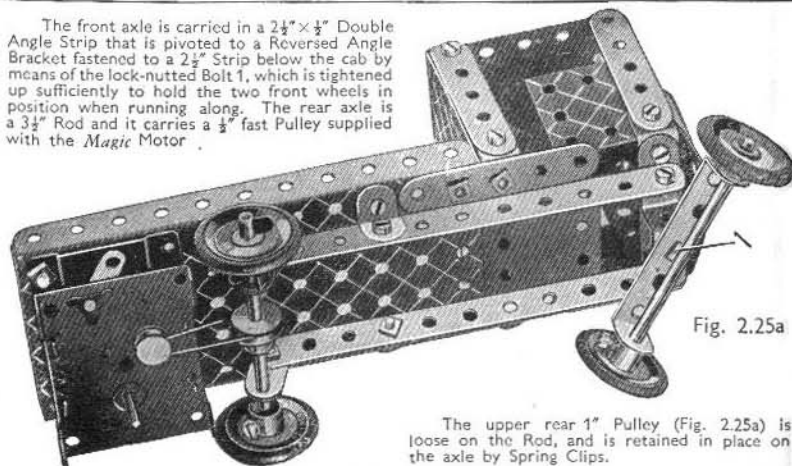
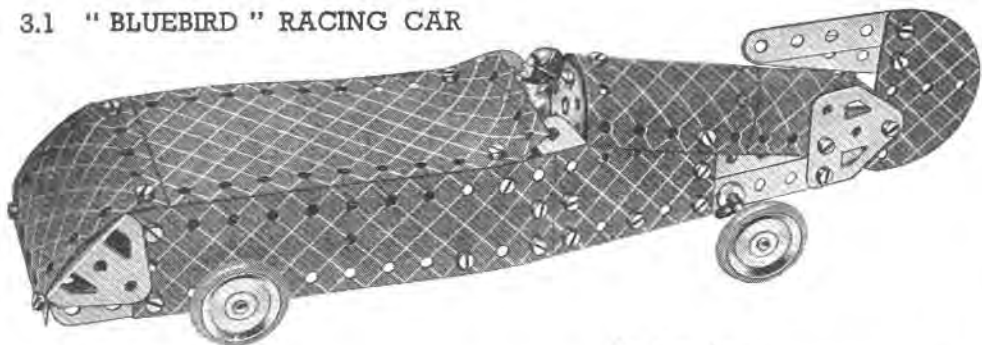

Fig. 2.25a

The upper rear 1" Pulley (Fig. 2.25a) is loose on the Rod, and is retained in place on the axle by Spring Clips.

3.1 "BLUEBIRD" RACING CAR



The $5\frac{1}{2}'' \times 24''$ Flanged Plate is used for the front end of the chassis, and the two $5\frac{1}{2}'' \times 1\frac{1}{2}''$ Flexible Plates are bolted on each side in the third hole from the front end of the chassis. The two $5\frac{1}{2}''$ Strips forming the rear end of the chassis overlap the $5\frac{1}{2}'' \times 1\frac{1}{2}''$ Flexible Plates one hole.

Parts required			
2 of No. 2	2 of No. 35	2 of No. 126	1 of No. 192
6 " " 5	39 " " 37	2 " " 126a	2 " " 199
2 " " 10	4 " " 38	4 " " 155a	1 " " 200
3 " " 12	1 " " 48a	2 " " 188	2 " " 214
2 " " 16	1 " " 52	2 " " 189	1 " " 217a
4 " " 22			

3.2 AIRCRAFT CARRIER

Flat Trunnions are used to fasten the $5\frac{1}{2}'' \times 24''$ Flanged Plate to the Strips that form the sides.

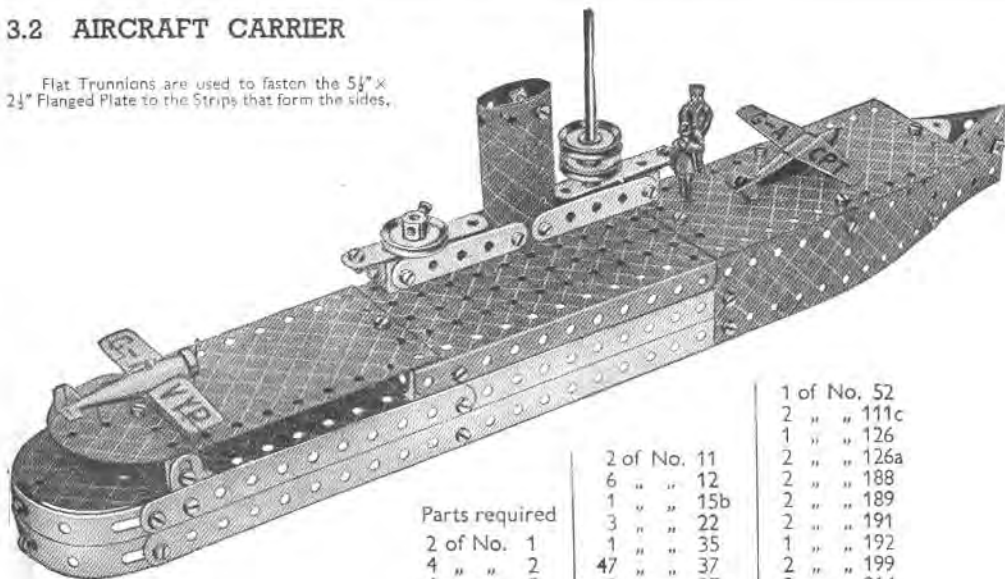

Parts required			
2 of No. 1	2 of No. 11	1 of No. 52	
4 " " 2	6 " " 12	2 " " 111c	
6 " " 5	1 " " 15b	1 " " 126	
4 " " 10	3 " " 22	2 " " 126a	
	1 " " 35	2 " " 188	
	47 " " 37	2 " " 189	
	2 " " 37a	1 " " 191	
	1 " " 48a	1 " " 192	
		2 " " 199	
		2 " " 214	
		4 " " 215	

3.3 MARINE ENGINE

Parts required

2 of No. 1
4 " " 2
5 " " 5
8 " " 12
2 " " 15b
3 " " 16
3 " " 22
1 " " 24
4 " " 35
47 " " 37
9 " " 37a
6 " " 38
2 " " 48a
1 " " 52
3 " " 90a
3 " " 111c
2 " " 125
2 " " 126
1 " " 126a
1 " " 155a
2 " " 187
2 " " 188
2 " " 189
1 " " 190
1 " " 191
2 " " 199
2 " " 200
1 " " 212
1 " " 213
2 " " 217a

Bolts 1 are lock-nutted. The Bolts 3 are $\frac{3}{8}''$ long and are lock-nutted twice as shown. The $2\frac{1}{2}''$ Strips 4 must be quite free to move when the crankshaft is rotated.

The left-hand piston rod is held by two Spring Clips, one at each side of the Angle Bracket pivotally fastened by the Bolts 1. Inside the cylinder the Rods slide through holes in a $2\frac{1}{2}''$ Strip and a Trunnion 2. In order to show the construction clearly part of the cylinder has been cut away in the illustration.

The Rod carrying two $1''$ Pulleys passes through the centre hole in the outer $1\frac{1}{4}''$ Disc. A $\frac{3}{8}'' \times \frac{1}{2}''$ Angle Bracket is bolted to the Disc in such a position that when the Disc is turned the Angle Bracket engages with a Spring Clip on the Rod. It is important that all nuts and bolts are made quite secure with the Spanner and Screwdriver.

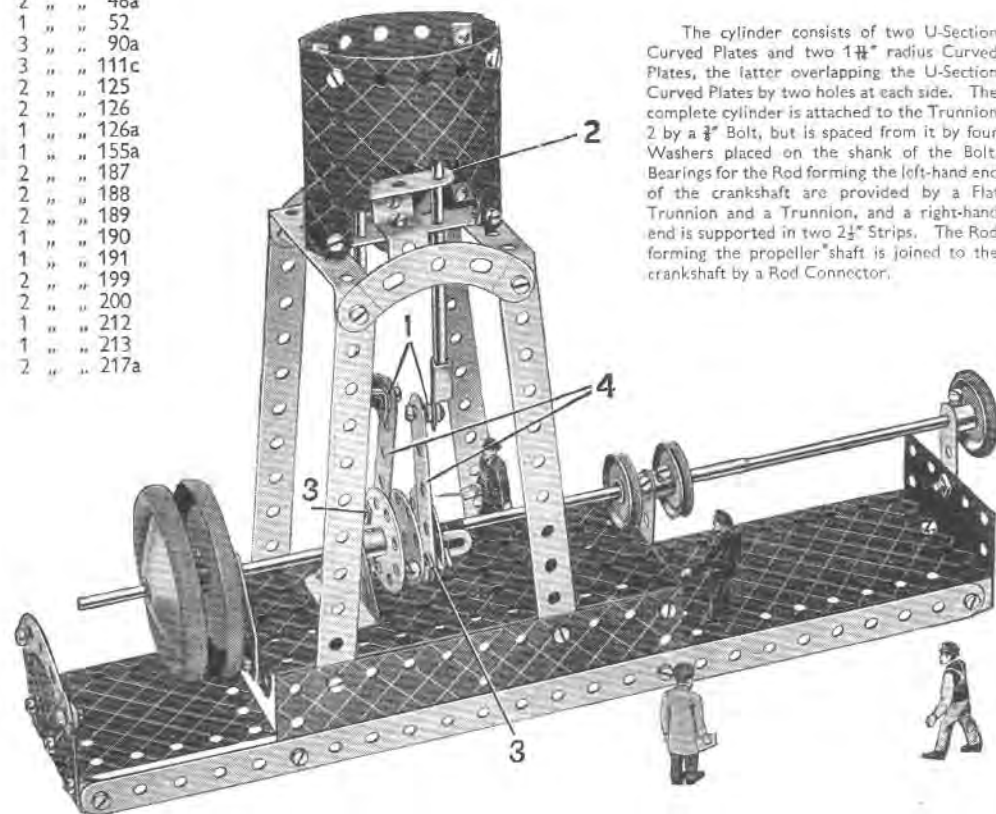

The cylinder consists of two U-Section Curved Plates and two $1\frac{1}{4}''$ radius Curved Plates, the latter overlapping the U-Section Curved Plates by two holes at each side. The complete cylinder is attached to the Trunnion 2 by a $\frac{3}{8}''$ Bolt, but is spaced from it by four Washers placed on the shank of the Bolt. Bearings for the Rod forming the left-hand end of the crankshaft are provided by a Flat Trunnion and a Trunnion, and a right-hand end is supported in two $2\frac{1}{2}''$ Strips. The Rod forming the propeller shaft is joined to the crankshaft by a Rod Connector.

3.4 SWIVELLING JIB CRANE

A 1" fast Pulley 1 is fastened to the lower end of a 2" Rod, which passes into and is held in the boss of the Bush Wheel. The Pulley rests on the tyre of Pulley Wheel 2, which is fastened on Rod 3. When the Rod 3 is rotated the jib is caused to swivel. Bearings for Rod 3 are formed by Flat Brackets, which are bolted through their elongated holes to the 2½" Strips shown in the illustration. The roof of the cab is fastened by means of Angle Brackets to two Flat Trunnions, and these in turn are bolted to the compound Strips bracing the jib.

Parts required		
2 of No. 1	1 of No. 18a	4 of No. 90a
6 " " 2	1 " " 19g	4 " " 111c
9 " " 5	4 " " 22	2 " " 126
4 " " 10	1 " " 23	2 " " 126a
1 " " 11	1 " " 24	2 " " 155a
8 " " 12	4 " " 35	1 " " 176
2 " " 16	50 " " 37	2 " " 187
1 " " 17	4 " " 37a	2 " " 188
	3 " " 38	2 " " 189
	1 " " 40	1 " " 190
	2 " " 48a	2 " " 191
	1 " " 52	1 " " 199
	1 " " 57c	2 " " 200

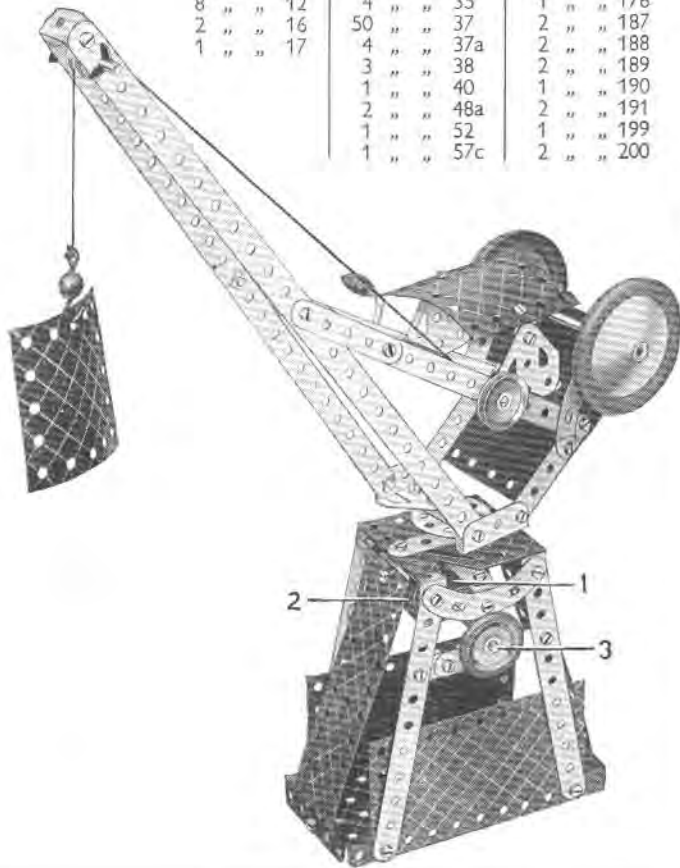

3.5 NOAH'S ARK

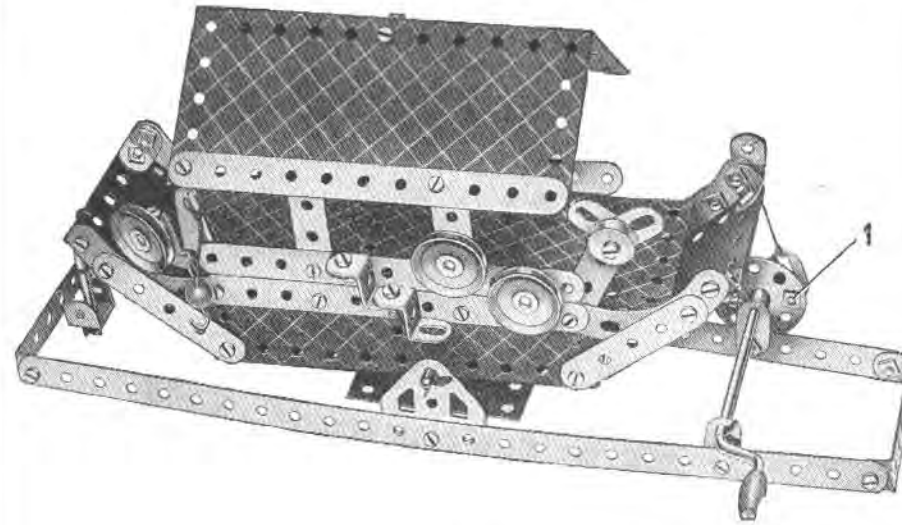

Parts required			
2 of No. 1	1 of No. 18a	1 of No. 40	2 of No. 126
6 " " 2	1 " " 19g	1 " " 44	2 " " 126a
9 " " 5	3 " " 22	2 " " 48a	1 " " 176
5 " " 10	1 " " 23	1 " " 52	2 " " 188
2 " " 11	1 " " 24	1 " " 57c	2 " " 189
8 " " 12	6 " " 35	4 " " 90a	2 " " 190
1 " " 16	50 " " 37	5 " " 111c	2 " " 191
1 " " 17	3 " " 37a	2 " " 125	2 " " 192

A 5½" x 2½" Flanged Plate is used for the bottom of the ark and 5½" x 2½" Flexible Plates and 5½" Strips form the sides. The deck is fastened to the sides by ½" x ¼" Angle Brackets.

The ark is pivoted on a 3½" Rod journalled in Flat Trunnions, the Rod passing through the flanges of the baseplate at the fifth holes from the end near the Crank Handle. The Crank Handle carries a Bush Wheel, and to this a Flat Bracket is lock-nutted at 1. A length of Cord is attached to the free hole of the Flat Bracket and is then tied to a Double Bracket bolted to the side of the ark. When the Crank Handle is rotated, the downward motion of the Flat Bracket causes one end of the ark to be pulled down, but as the Flat Bracket rises again, the ark returns to its original position.

3.6 SWING

Two 2½" Strips overlapped one hole are bolted to the tops of the 12½" Strips by ½" x ¼" Angle Brackets.

Parts required	
2 of No. 1	2 of No. 48a
6 " " 5	1 " " 52
2 " " 10	2 " " 90a
8 " " 12	2 " " 126
34 " " 37	2 " " 190
1 " " 40	2 " " 191

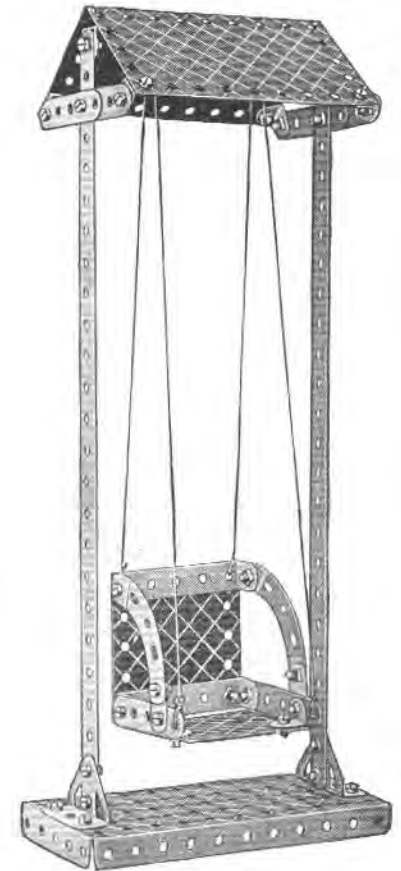

3.7 DENTIST'S CHAIR

Parts required

4 of No. 2	1 of No. 52
8 " " 5	3 " " 90a
2 " " 10	1 " " 190
4 " " 12	1 " " 191
1 " " 24	1 " " 200
38 " " 37	Lighting Set
1 " " 37a	(Not included in
1 " " 48a	Outfit)



This model is fitted with a Spotlight from the Meccano Lighting Set.

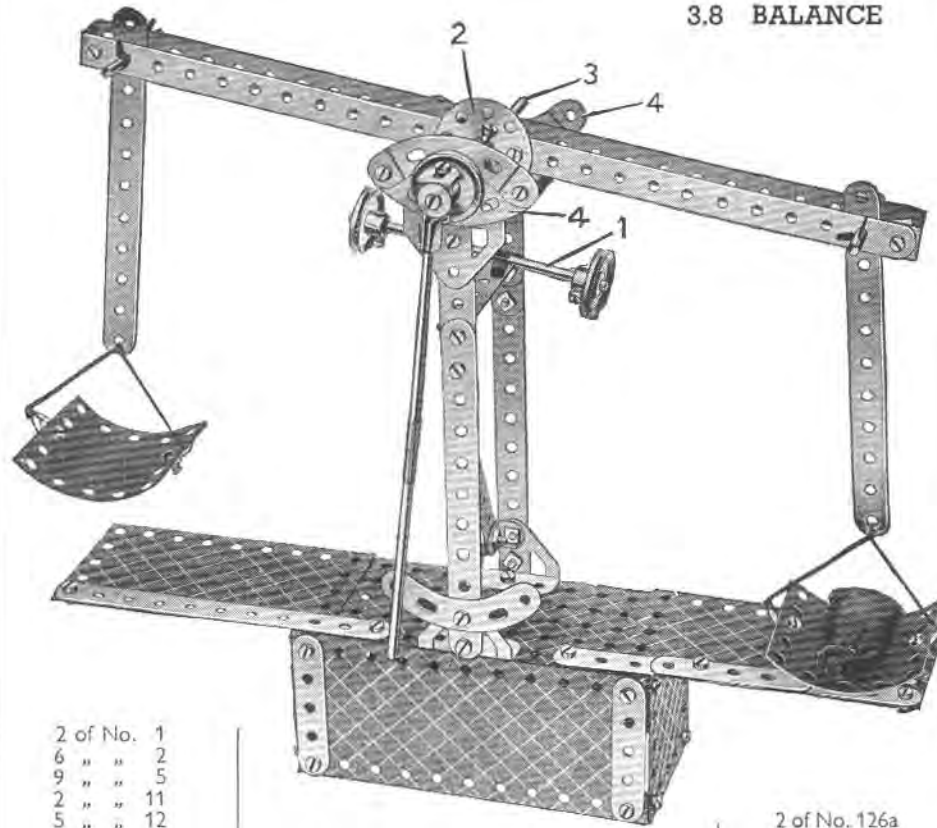

3.8 BALANCE

2 of No. 1
6 " " 2
9 " " 5
2 " " 11
5 " " 12
2 " " 15b
2 " " 16
2 " " 17
4 " " 22
1 " " 24
6 " " 35
50 " " 37

Parts required

4 of No. 37a	1 of No. 52
5 " " 38	4 " " 90a
1 " " 40	4 " " 111c
1 " " 44	1 " " 125
2 " " 48a	2 " " 126

2 of No. 126a
2 " " 190
2 " " 191
2 " " 192
2 " " 200
1 " " 212
1 " " 213
2 " " 215

One of the 12½" Strips that form the beam of the balance is bolted across a Bush Wheel 2. The 3¼" Rod 3 that is locked in the boss of the Bush Wheel rests on the two Curved Strips 4.

The Rod 1, by which the balance is adjusted, is pushed through the two holes of a Cranked Bent Strip (fastened to the Bush Wheel 2 by a Reversed Angle Bracket). The 5½" Strips from which the scale pans are suspended are pivoted at their upper ends on 2" Rods, which are passed through holes in the 12½" Strips of the beam.

3.9 TOWER WAGON

A Cranked Bent Strip 1 is bolted in a horizontal position in the centre of the Flanged Plate, and a 2½" Curved Strip is bolted on top of it by the centre hole to form a seat. A Reversed Angle Bracket 2 is then bolted in one of the elongated holes of the Curved Strip to form a bearing for the Rod carrying the Bush Wheel.

Parts required

6 of No. 2
6 " " 5
1 " " 10
2 " " 11
8 " " 12
2 " " 16
1 " " 18a
4 " " 22
1 " " 24
1 " " 35
50 " " 37
5 " " 37a
4 " " 38
1 " " 40
1 " " 44
2 " " 48a
1 " " 52
3 " " 90a
5 " " 111c
2 " " 125
2 " " 126
1 " " 126a
4 " " 155a
2 " " 188
2 " " 189
2 " " 190
2 " " 191
2 " " 192
2 " " 199
1 " " 200

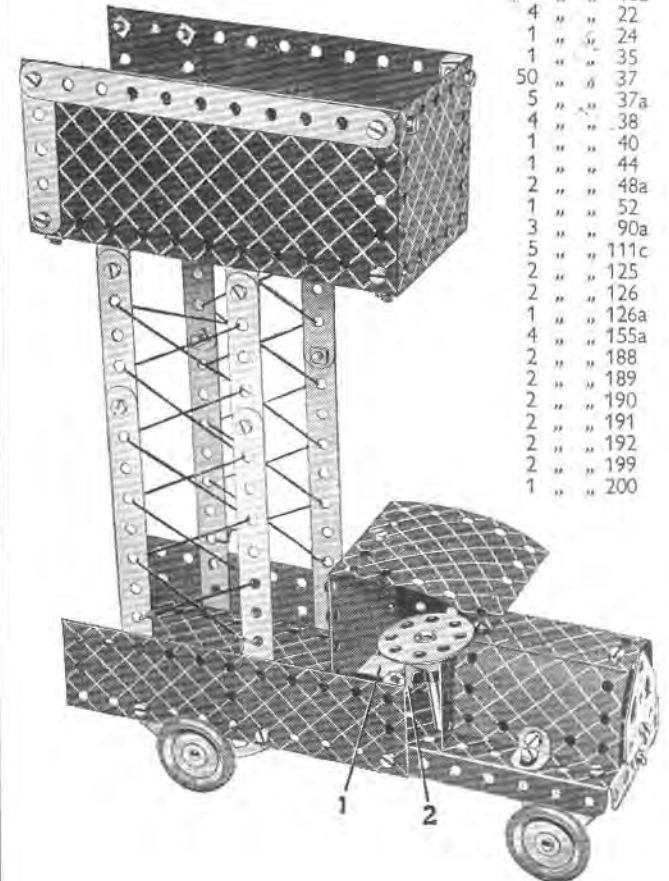

3.10 ELECTRIC GENERATING SET

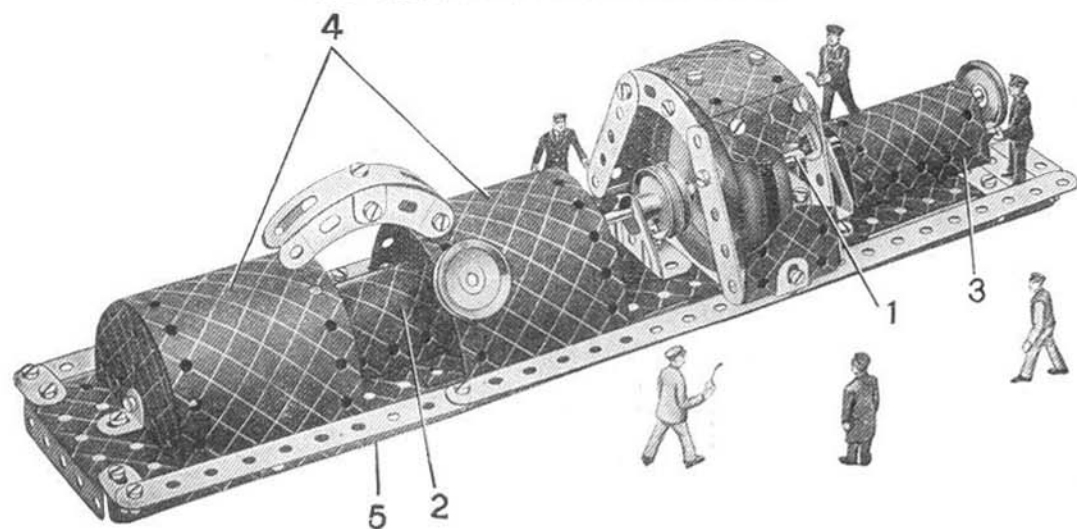

The base is constructed by bolting two $12\frac{1}{2}$ " Strips to the flanges of a $5\frac{1}{2}$ " x $2\frac{1}{2}$ " Flanged Plate 5, and joining them at their free ends by a $2\frac{1}{2}$ " x $\frac{1}{2}$ " Double Angle Strip. The space between the $12\frac{1}{2}$ " Strips is then filled in by Flexible Plates and $2\frac{1}{2}$ " Strips. The Rods that form the shaft of the machine are joined together at 1 by a Rod Connector. The bearings are formed by two Trunnions. In the illustration part of the Flexible Plate has been cut away to show the structure of the armature and the commutator. The commutator consists of two 1" Pulleys and the armature of two Road Wheels, the bosses of which are placed in contact with each other.

The connecting pipe is formed from two $2\frac{1}{2}$ " Curved Strips and one 3" Formed Slotted Strip joined together at their centre holes by a Double Bracket, and is fastened to the turbine by means of an Angle Bracket. The U-Section Curved Plate 2 is held by a Spring Clip slipped on the upper end of a 2" Rod. One end of the Rod is passed through the middle hole in the top of the Plate, and its other end is then pushed through the Flexible Plate forming the base. The Rod is held by a Spring Clip underneath the Plate. The U-Section Curved Plate 3 is fixed to the base by an Angle Bracket on the rear side of the model. The two Flexible Plates 4 are bolted to the flanges of the $5\frac{1}{2}$ " x $2\frac{1}{2}$ " Flanged Plate 5. The 1" Pulley representing the steam control is held by a $\frac{1}{2}$ " Bolt, which passes through a hole in one of the Flexible Plates 4, and is locked in the boss of the Pulley.

Parts required			
2 of No. 1	1 of No. 16	1 of No. 52	1 of No. 189
6 " " 2	1 " " 18a	4 " " 90a	1 " " 190
8 " " 5	4 " " 22	1 " " 111c	1 " " 191
3 " " 10	4 " " 35	2 " " 125	2 " " 192
2 " " 11	50 " " 37	2 " " 126	2 " " 199
8 " " 12	1 " " 38	2 " " 187	1 " " 213
1 " " 15b	2 " " 48a	1 " " 188	2 " " 214
	1 of No. 215		

3.11 TROTTING CAR

The seat of the car consists of two $2\frac{1}{2}$ " x $1\frac{1}{2}$ " Flexible Plates, overlapped two holes, and it carries at each end a Trunnion. The 3" Formed Slotted Strips that form the mudguards are supported by Reversed Angle Brackets 2, which are spaced from the Flexible Plate by three Washers. The axle consists of two 2" Rods joined by a Rod Connector, and is journalled in the Trunnions.

Each of the horses is built up as follows. Four $2\frac{1}{2}$ " Strips are bolted to a U-Section Curved Plate in the positions shown to form the legs, and two $2\frac{1}{2}$ " small radius Curved Strips represent the neck. A Rod is pushed through the centre holes of the U-Section Curved Plates and is supported in the end holes of the shafts. Two $3\frac{1}{2}$ " Rods carrying 1" Pulleys at each of their ends are journalled in the end holes of two of the forelegs, and two of the hind-legs of the horses, as shown.

The driver's body is made with two Flat Trunnions, which are bolted together and then fitted with $2\frac{1}{2}$ " x $\frac{1}{2}$ " Double Angle Strips to represent legs. The Bolt that fixes the Cranked Bent Strip to the body holds also a Flat Bracket that supports a $1\frac{1}{2}$ " Disc representing the head. An Angle Bracket bolted to the Disc secures a Bush Wheel that has a $\frac{3}{8}$ " Bolt fixed in its boss by the set-screw.

The whip is a 2" Rod held by Spring Clips in a Double Bracket, and the lash is attached to it by a Cord Anchoring Spring. The reins are fastened to the Flat Brackets that form the horses' heads, and also to the Double Bracket to which the whip is fixed. Short lengths of Cord fastened to the U-Section Curved Plates represent the horses' tails.

Parts required

4 of No. 2	33 of No. 37	1 of No. 176
8 " " 5	2 " " 37a	2 " " 187
5 " " 10	6 " " 38	2 " " 188
1 " " 11	1 " " 40	2 " " 199
1 " " 12	1 " " 44	1 " " 213
1 " " 15b	2 " " 48a	4 " " 215
2 " " 16	4 " " 90a	1 " " 217a
2 " " 17	3 " " 111c	
1 " " 18a	2 " " 125	
4 " " 22	2 " " 126	
1 " " 24	2 " " 126a	
6 " " 35	4 " " 155a	

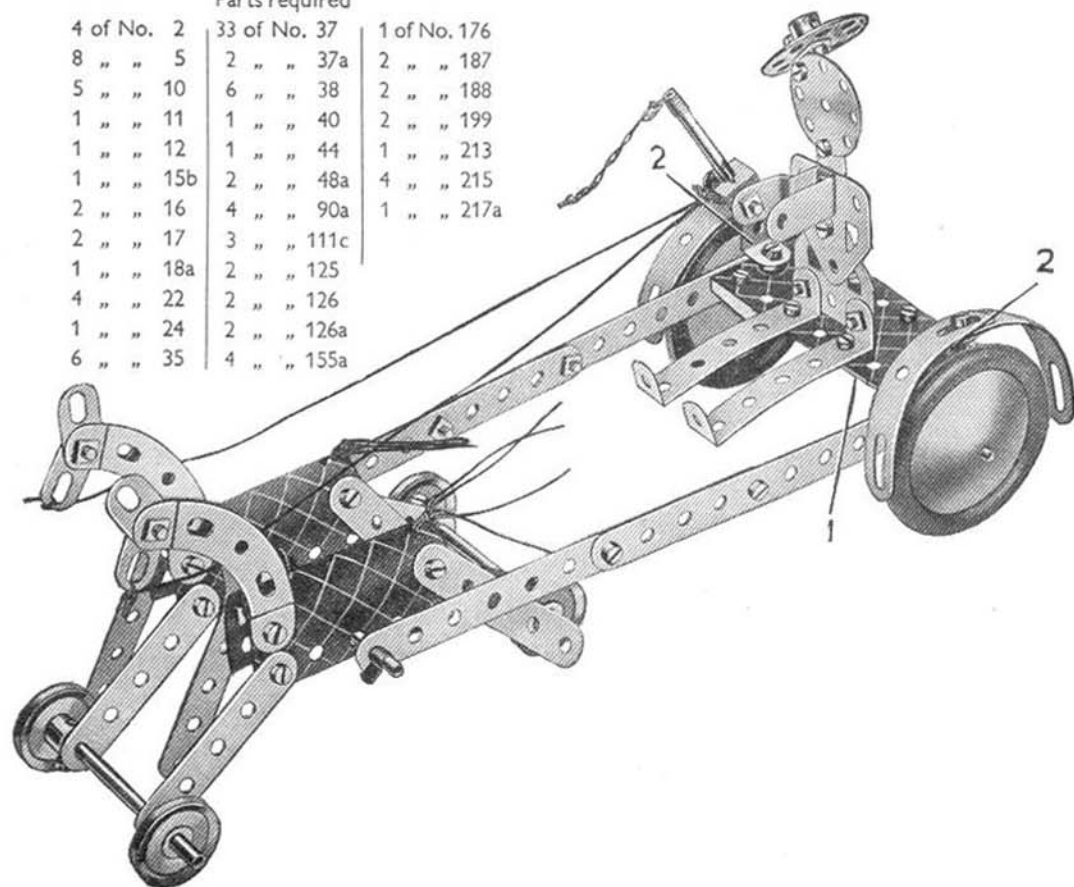

3.12 STEAM TRACTOR AND TRAILER

The steering column, a $3\frac{1}{2}$ " Rod, is supported in the holes of a Double Bracket and a Reversed Angle Bracket bolted to the side of the cab. Cord is wound round the lower part of the Rod and its ends are tied to the $2\frac{1}{2}$ " x $\frac{1}{2}$ " Double Angle Strip that carries the front axle. Care must be taken that the Cord is wound tightly round the Rod, or it will slip when the steering wheel is rotated. The Rod 2 is supported in holes in the Flexible Plates that form the sides of the cab.

The Bush Wheel that forms the front of the boiler has two Angle Brackets bolted to it and a Rod passes through the free holes of these Brackets to hold the Bush Wheel in position. This Rod is joined by a Rod Connector to a 2" Rod that forms the chimney. The roof of the cab consists of a $5\frac{1}{2}$ " x $2\frac{1}{2}$ " Flexible Plate, and is held in position by Spring Clips placed on the two Rods that pass through it. The Flat Brackets 3 are bolted in the centre holes of the $2\frac{1}{2}$ " Curved Strips. The Bolts 1 are lock-nutted in position and the wheels turn freely on them.

Parts required

4 of No. 2	1 of No. 23	2 of No. 90a	2 of No. 191
9 " " 5	1 " " 24	4 " " 111c	1 " " 192
5 " " 10	4 " " 35	2 " " 125	2 " " 199
2 " " 11	43 " " 37	2 " " 126	2 " " 200
8 " " 12	8 " " 37a	2 " " 126a	1 " " 212
2 " " 15b	6 " " 38	3 " " 155a	1 " " 213
2 " " 16	1 " " 40	1 " " 176	1 " " 214
2 " " 17	1 " " 44	2 " " 187	2 " " 217a
1 " " 18a	2 " " 48a	2 " " 188	2 " " 217b
4 " " 22	1 " " 52	2 " " 190	

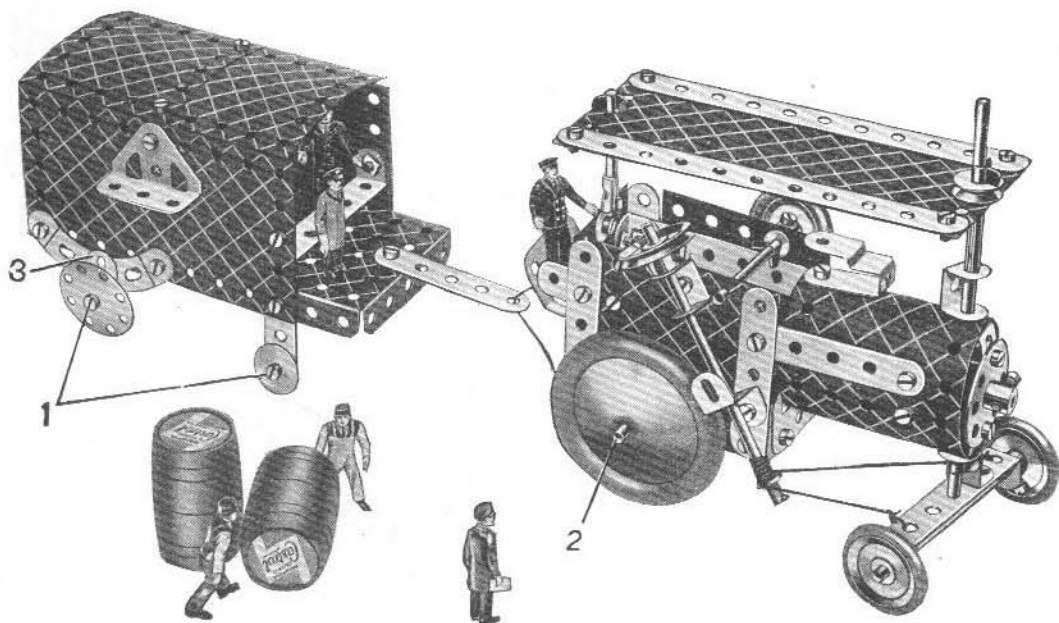

3.13 MECHANICAL HORSE AND TRAILER

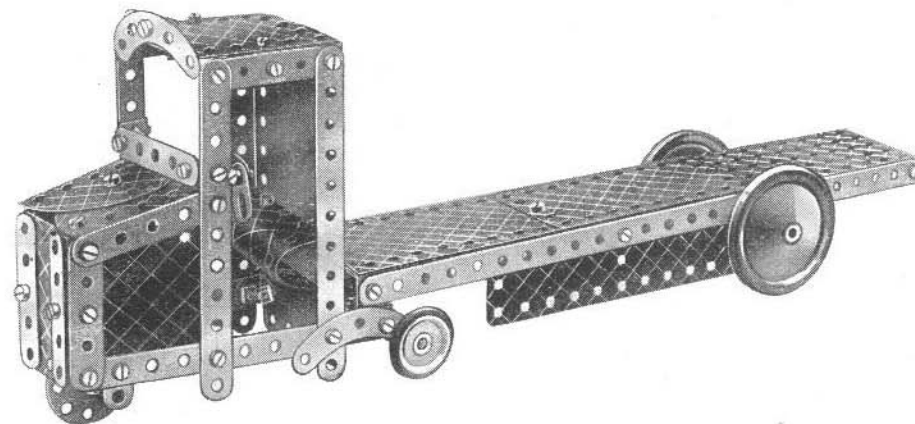

The chassis of the mechanical horse is built up on two $5\frac{1}{2}$ " Strips, extended at the rear by $2\frac{1}{2}$ " Curved Strips that provide bearings for the rear axle. The method of building up the bonnet and cab is clear from the illustration. The rear ends of the $5\frac{1}{2}$ " Strips are joined by a Curved Strip and two Double Brackets. At the centre of the Curved Strip is bolted a $1\frac{1}{2}$ " Disc, through which passes a $1\frac{1}{2}$ " Rod 1. This Rod engages in the centre hole of the Plate at the front of the trailer, and is retained in place by a Spring Clip and a Cord Anchoring Spring. A 1" Pulley and two Washers space the end of the trailer from the $1\frac{1}{2}$ " Disc. Bearings for the rear axle are provided by Flat Trunnions.

Parts required

2 of No. 1	4 of No. 90a
6 " " 2	6 " " 111c
9 " " 5	2 " " 125
4 " " 10	2 " " 126
2 " " 11	2 " " 126a
8 " " 12	2 " " 155a
2 " " 16	1 " " 176
1 " " 17	2 " " 187
1 " " 18a	1 " " 188
3 " " 22	2 " " 189
1 " " 24	2 " " 190
4 " " 35	2 " " 191
56 " " 37a	1 " " 192
50 " " 37b	1 " " 199
2 " " 38	1 " " 200
2 " " 48a	2 " " 214
1 " " 52	1 " " 217a

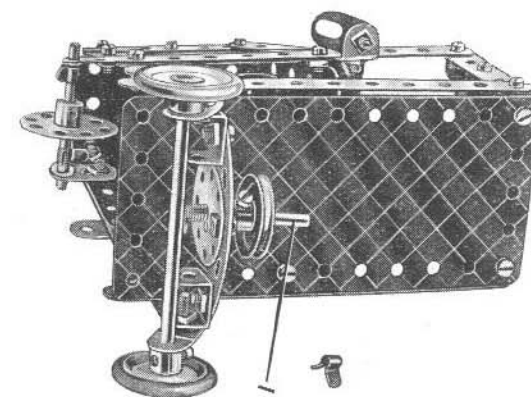

3.14 GIANT LORRY

The bonnet is made up of two U-Section Curved Plates overlapped three holes and attached to the $5\frac{1}{2}'' \times 2\frac{1}{2}''$ Flanged Plate by two Angle Brackets. The front of the cabin is a $2\frac{1}{2}'' \times 1\frac{1}{2}''$ Flexible Plate, which is attached to the chassis by a Reversed Angle Bracket. Bearings for the $3\frac{1}{2}''$ Rods forming the front and rear axles are provided by Flat Brackets bolted to the flanges of the Flanged Plate.

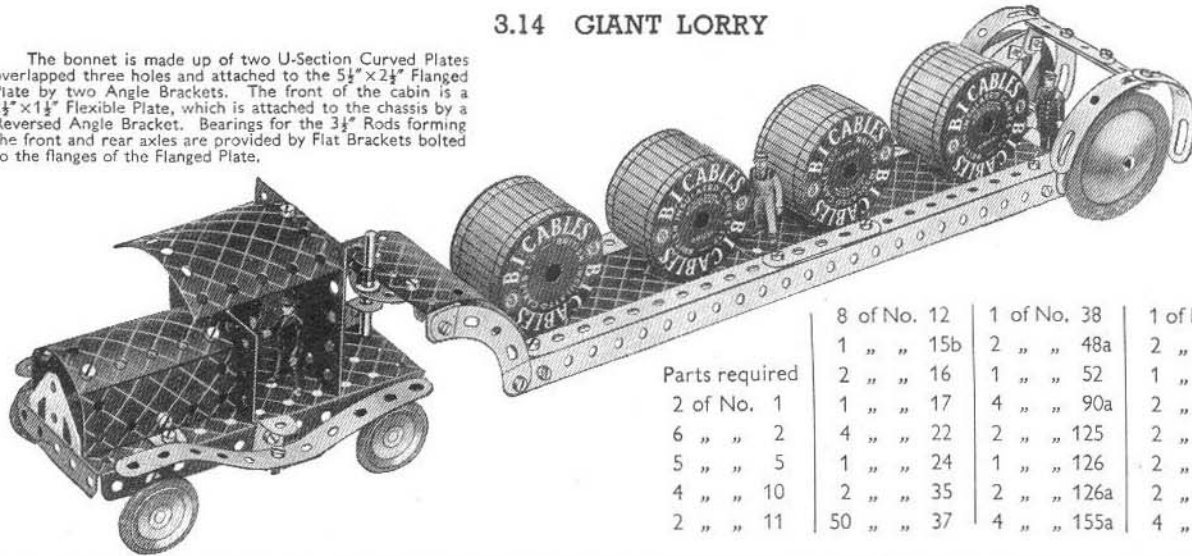

Parts required	8 of No. 12	1 of No. 38	1 of No. 176
2 of No. 1	1 " " 15b	2 " " 48a	2 " " 187
6 " " 2	2 " " 16	1 " " 52	1 " " 188
5 " " 5	1 " " 17	4 " " 90a	2 " " 190
4 " " 10	4 " " 22	2 " " 125	2 " " 192
2 " " 11	1 " " 24	1 " " 126	2 " " 199
	2 " " 35	2 " " 126a	2 " " 200
	50 " " 37	4 " " 155a	4 " " 215

3.15 BATTLE CRUISER

Bolts 1 fasten the Strips to a Flat Trunnion so that the Strips are held rigid. Trunnion 2, which holds the rear gun, is fastened by a $\frac{1}{2}'' \times \frac{1}{2}''$ Angle Bracket to the centre hole of $2\frac{1}{2}'' \times \frac{1}{2}''$ Double Angle Strip 3. The forward guns also are held by a Trunnion, but this is fastened to a Double Bracket that in turn is bolted to the $5\frac{1}{2}'' \times 2\frac{1}{2}''$ Flanged Plate.

The base of the turret is formed by a Bush Wheel, which is bolted to the deck. A $3\frac{1}{2}''$ Rod is fastened in the boss of the Bush Wheel, and two Road Wheels are placed on it as shown.

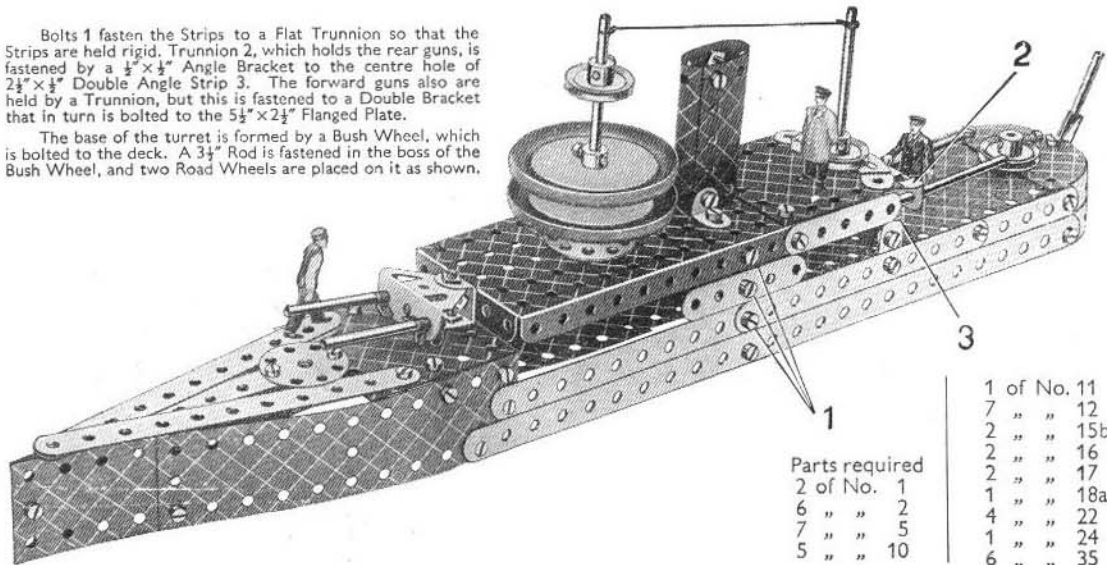

Parts required	1 of No. 11
2 of No. 1	7 " " 12
6 " " 2	2 " " 15b
7 " " 5	2 " " 16
5 " " 10	2 " " 17
	1 " " 18a
	4 " " 22
	1 " " 24
	6 " " 35

50 of No. 37	6 " " 37a
1 " " 40	2 " " 48a
2 " " 52	1 " " 90a
1 " " 90a	6 " " 111c
6 " " 111c	2 " " 126
2 " " 126	2 " " 126a
2 " " 126a	1 " " 176
1 " " 176	2 " " 187
2 " " 187	2 " " 188
2 " " 188	2 " " 189
2 " " 189	2 " " 190
2 " " 190	1 " " 191
1 " " 191	1 " " 192
1 " " 192	1 " " 199
1 " " 199	2 " " 200
2 " " 200	1 " " 212
2 " " 212	1 " " 214
1 " " 214	4 " " 215
4 " " 215	1 " " 217a
1 " " 217a	1 " " 217b
1 " " 217b	

3.16 NAVAL GUN

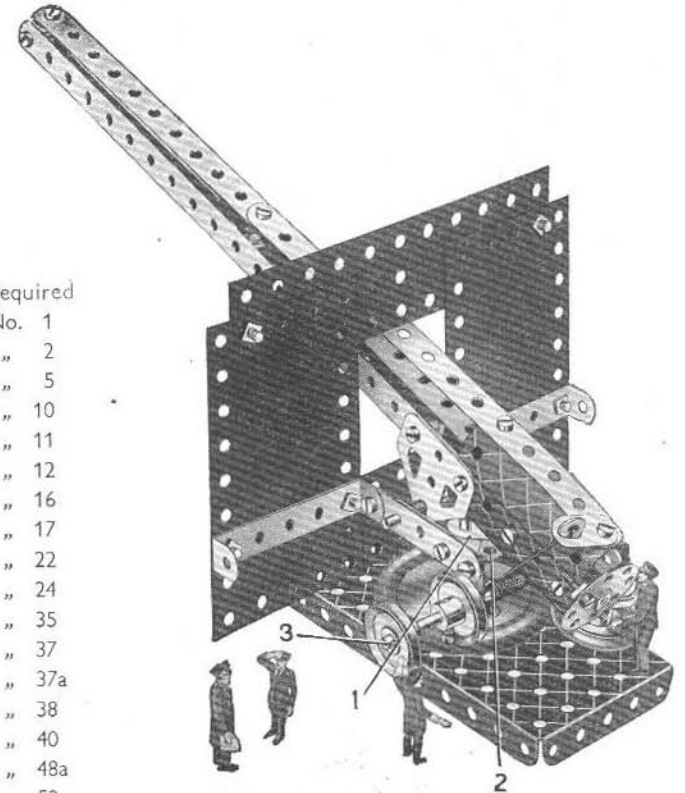

Parts required	2 of No. 1
5 " " 2	3 " " 5
3 " " 10	2 " " 11
2 " " 12	1 " " 16
1 " " 16	2 " " 17
2 " " 17	4 " " 22
4 " " 22	1 " " 24
1 " " 24	4 " " 35
4 " " 35	28 " " 37
28 " " 37	2 " " 37a
2 " " 37a	5 " " 38
5 " " 38	1 " " 40
1 " " 40	2 " " 48a
2 " " 48a	1 " " 52
1 " " 52	2 " " 111c
2 " " 111c	2 " " 126
2 " " 126	2 " " 126a
2 " " 126a	1 " " 155a
1 " " 155a	1 " " 176
1 " " 176	1 " " 187
1 " " 187	1 " " 188
1 " " 188	1 " " 189
1 " " 189	2 " " 191
2 " " 191	2 " " 199
2 " " 199	1 " " 217a
1 " " 217a	

The Flexible Plates forming the gun shield are fastened by means of Double Angle Strips and $2\frac{1}{2}''$ Strips to two Trunnions 1. The Trunnions are bolted to Bush Wheel 2. A 2" Rod held in the boss of the Bush Wheel passes through a Road Wheel and the centre hole of the $5\frac{1}{2}'' \times 2\frac{1}{2}''$ Flanged Plates. The Rod is fastened underneath the Flanged Plate by a Cord Anchoring Spring so that the gun is free to swivel.

The elevation of the gun is controlled by Rod 3. Cord is wound round the Rod, then passed through the hole of a Flat Bracket fastened at the rear end of the gun, and knotted to a Washer as shown. The $1\frac{1}{2}''$ Disc at the end of the gun is fastened by an Angle Bracket to the U-Section Curved Plates representing the breech.

3.17 FIRE-ENGINE

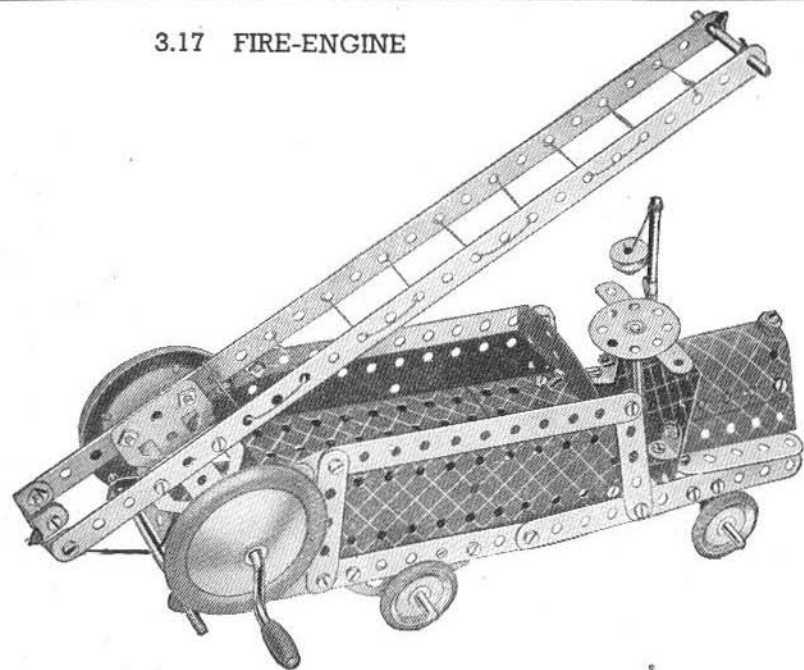

Parts required

2 of No. 1	2 of No. 125
6 " " 2	2 " " 126
8 " " 5	2 " " 126a
5 " " 10	4 " " 155a
2 " " 11	1 " " 176
7 " " 12	2 " " 187
2 " " 15b	2 " " 188
2 " " 16	2 " " 189
1 " " 17	2 " " 190
1 " " 19g	1 " " 192
4 " " 22	1 " " 199
1 " " 23	1 " " 212
1 " " 24	1 " " 214
6 " " 35	
50 " " 37	
6 " " 37a	
5 " " 38	
1 " " 40	
2 " " 48a	
1 " " 52	
4 " " 90a	
6 " " 111c	

Two Flat Trunnions are bolted to the bottom of the ladder, and the shaft of the Crank Handle shown in Fig. 3.17a passes through the holes at their narrow ends. The bonnet, which is formed from a U-Section Curved Plate and two $2\frac{1}{2}'' \times 1\frac{1}{2}''$ Flexible Plates, is fastened to the frame by Reversed Angle Brackets. These latter also support the $2\frac{1}{2}''$ Strips at the side of the bonnet.

The $3\frac{1}{2}''$ Rod representing the steering column passes through the free hole of a Flat Bracket bolted to the dashboard, then through a hole in the Flexible Plate at the bottom of the cab. It is fastened in position by a Cord Anchoring Spring.

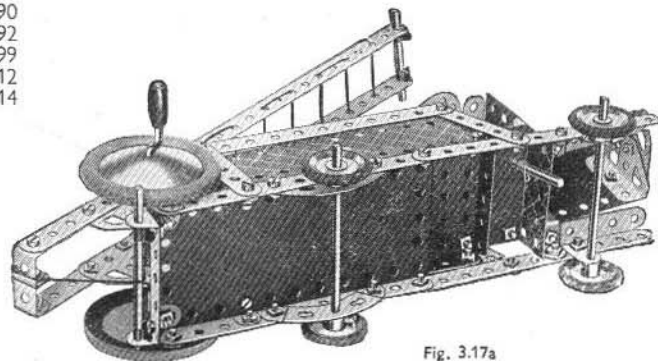
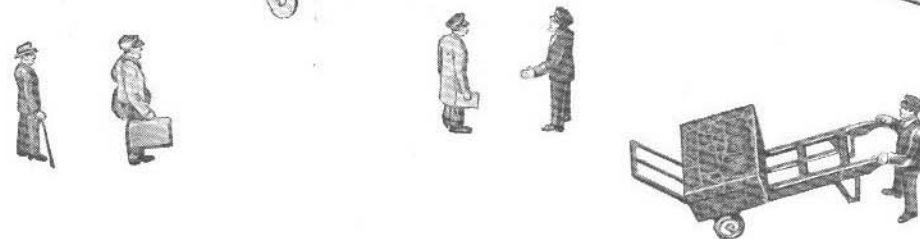
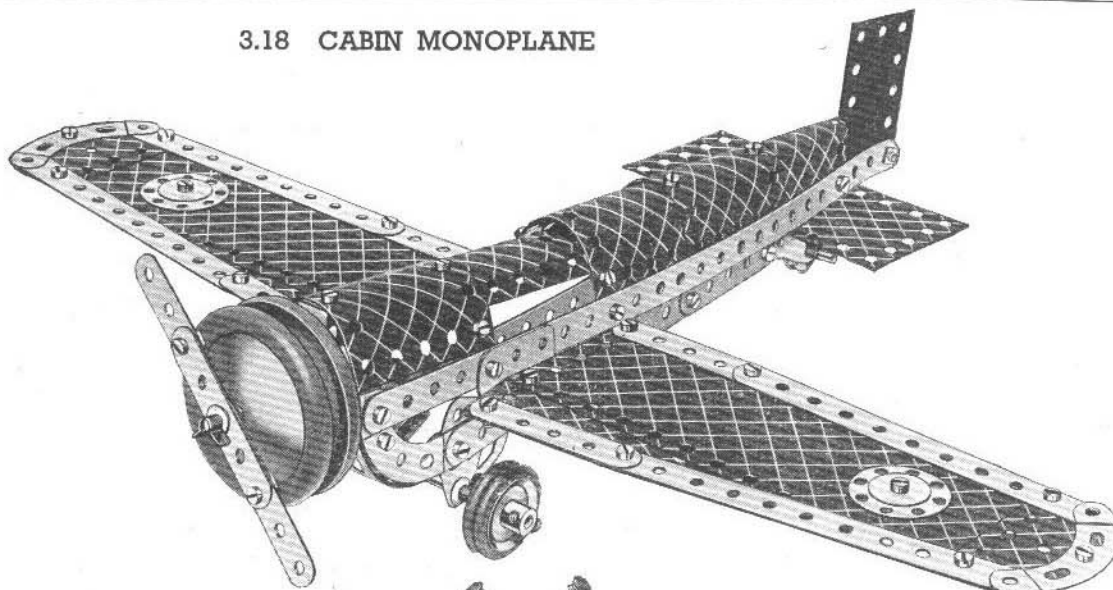

Fig. 3.17a

3.18 CABIN MONOPLANE



Parts required

2 of No. 1	4 of No. 22	4 of No. 90a	2 of No. 190
6 " " 2	1 " " 23	6 " " 111c	1 " " 191
9 " " 5	1 " " 24	2 " " 125	2 " " 192
5 " " 10	5 " " 35	2 " " 126	2 " " 199
1 " " 11	50 " " 37	2 " " 126a	2 " " 200
8 " " 12	6 " " 37a	4 " " 155a	2 " " 214
1 " " 16	5 " " 38	2 " " 187	2 " " 215
1 " " 17	1 " " 44	2 " " 188	2 " " 217a
1 " " 18a	2 " " 48a	2 " " 189	2 " " 217b

The engine and propeller are attached by fastening a Bush Wheel to the nose of the fuselage by two Angle Brackets. A $2''$ Rod is locked in the boss of the Bush Wheel and forms the support for the Road Wheels and the compound strip representing the propeller.

The wings are attached to the fuselage by $\frac{1}{2}'' \times \frac{1}{2}''$ Angle Brackets and Trunnions. The tail wheel is supported on a $1\frac{1}{2}''$ Rod journalled in the holes of a Cranked Bent Strip fastened to the fuselage by a Double Bracket.

The Rod on which the double landing wheels are mounted passes through the holes in the narrow ends of two Flat Trunnions bolted to the fuselage.

3.19 BLOCK-SETTING CRANE

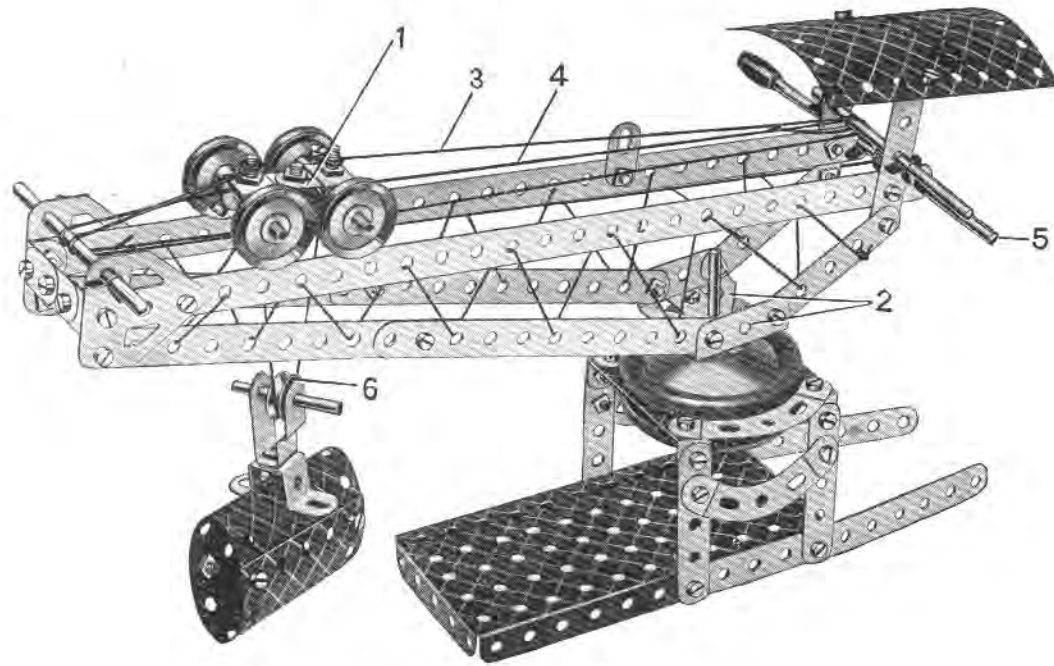

Parts required			
2 of No. 1	4 of No. 37a	6 of No. 38	1 " " 40
6 " " 2	1 " " 44	1 " " 48a	1 " " 52
8 " " 5	4 " " 90a	4 " " 111c	2 " " 125
5 " " 10	2 " " 126	2 " " 126a	1 " " 176
2 " " 11	2 " " 187	2 " " 188	2 " " 189
2 " " 12	1 " " 190	2 " " 192	2 " " 200
1 " " 15b	2 " " 199	2 " " 200	
2 " " 16			
2 " " 17			
1 " " 18a			
1 " " 19g			
4 " " 22			
1 " " 23			
1 " " 24			
6 " " 35			
50 " " 37			

The travelling bogie 1 consists of two Flat Brackets bolted together by their elongated holes, and at each end of it Double Brackets are fastened by $\frac{3}{8}$ " Bolts. Two 2" Rods are pushed through the Double Brackets and carry 1" fast Pulleys spaced so that their grooves fit on the two $12\frac{1}{2}$ " Strips that form the top of the jib. The Trunnions 2 at the base of the jib, are secured to a Bush Wheel mounted on a Rod held in the bosses of two Road Wheels. The Road Wheels are placed one above and one below the $2\frac{1}{2}$ " x $1\frac{1}{2}$ " Flexible Plates, that form the top of the tower.

Cord 3 is first fastened to the $\frac{3}{8}$ " Bolt at the rear end of the travelling bogie, and then wound three times around the Crank Handle. It is then led around the Rod journalled in the Flat Trunnion at the front end of the jib, and brought back and tied to another $\frac{3}{8}$ " Bolt at the front of the bogie.

Cord 4 is first fastened to Rod 5, which is passed through the end holes of the $12\frac{1}{2}$ " Strips, and then over the rear axle of the bogie. It is then passed around the $\frac{1}{2}$ " Pulley 6, led over the front axle of the bogie, around the Rod at the front end of the jib, and finally tied to the bogie. The $\frac{1}{2}$ " loose Pulley 6 and its Rod are held in the Cranked Bent Strip by a Cord Anchoring Spring.

3.20 PITHEAD GEAR

Parts required

2 of No. 1	6 " " 2
8 " " 5	1 " " 10
1 " " 11	7 " " 12
1 " " 15b	2 " " 16
1 " " 18a	1 " " 19g
1 " " 22	1 " " 24
6 " " 35	41 " " 37
1 " " 37a	6 " " 38
2 " " 40	1 " " 48a
1 " " 52	2 " " 111c
2 " " 125	2 " " 126
2 " " 126a	2 " " 176
1 " " 187	2 " " 188
2 " " 189	1 " " 190
2 " " 192	2 " " 200
2 " " 200	1 " " 214

A $3\frac{1}{2}$ " Rod is journalled in the top holes of the $12\frac{1}{2}$ " Strips. Between the two Road Wheels on this Rod is a 1" fast Pulley, over which the cord controlling the cage passes. A Cord Anchoring Spring is pushed on one end of the Rod, and a Bush Wheel is fixed to the other end. The cage is built up from Trunnions and Flat Trunnions, and the $2\frac{1}{2}$ " x $1\frac{1}{2}$ " Flexible Plates that form its sides are fastened to the Flat Trunnions by Angle Brackets.

A $\frac{3}{8}$ " Bolt is passed through the holes of Reversed Angle Brackets bolted to the top of the cage, and Washers are placed on its shank for spacing purposes.

The guides 1 for the cage consist of a piece of Cord, which is passed over two Rods as shown and then led downward and through two holes in the Flanged Plate that forms the base. Washers are tied to each end of the Cord underneath the Plate, to maintain it in tension.

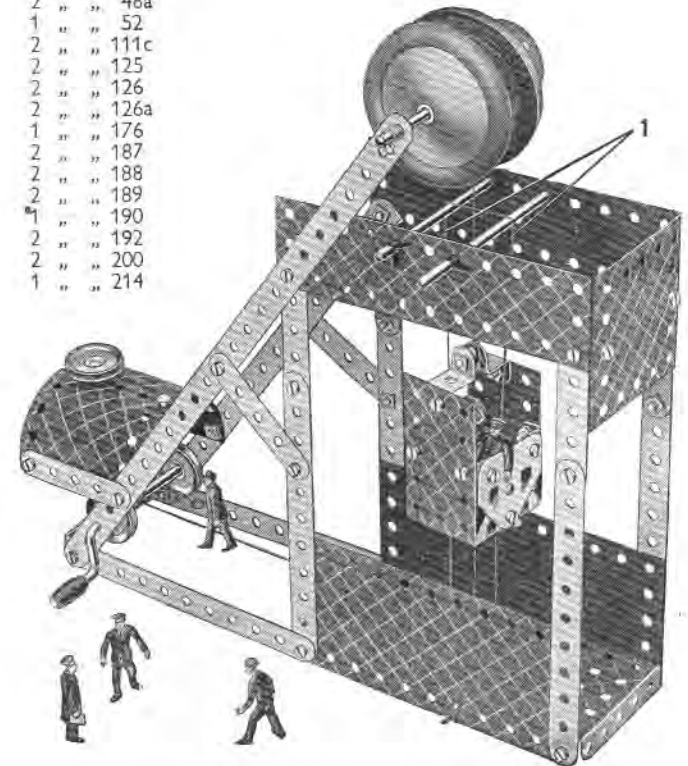

3.21 TANK

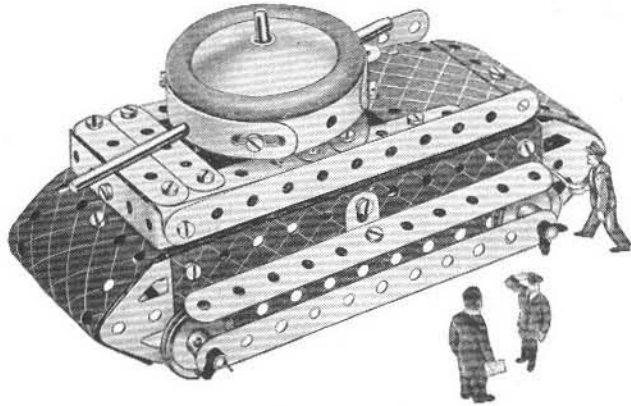

Construction of the gun turret is commenced by bolting a $2\frac{1}{2}$ " Strip across a Bush Wheel. Four 3" Formed Slotted Strips are bolted together to form a circle and fastened to the $2\frac{1}{2}$ " Strip by means of Angle Brackets. Next two Angle Brackets are bolted to the Bush Wheel in the positions shown in Fig. 3.21a. Two Rods are pushed through holes in the Formed Slotted Strips and through the free holes of the Angle Brackets, and are fastened in position by means of Spring Clips. The turret is held in place by a $3\frac{1}{2}$ " Rod that is locked in the boss of the Bush Wheel and then passed through the $5\frac{1}{2}$ " x $2\frac{1}{2}$ " Flanged Plate and through a hole in a Reversed Angle Bracket. A Cord Anchoring Spring is then screwed on to it to hold it in position. To complete the turret a Road Wheel is fastened on the upper end of the $3\frac{1}{2}$ " Rod. The Reversed Angle Bracket is bolted to the $5\frac{1}{2}$ " x $2\frac{1}{2}$ " Flanged Plate.

The *Magic Motor* is bolted to the Flanged Plate, and the drive is taken to the back axle by means of a Driving Band.

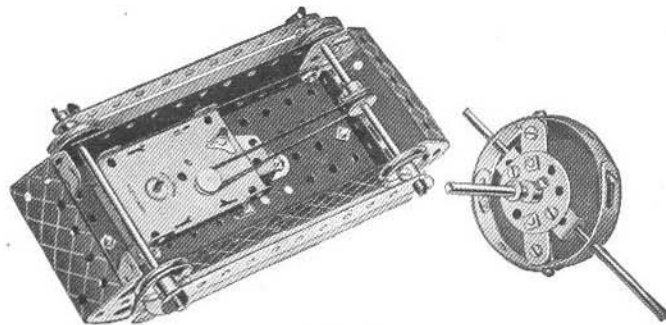

Fig. 3.21a

Parts required

6 of No. 2
7 " " 5
2 " " 10
8 " " 12
2 " " 15b
2 " " 16
1 " " 17
4 " " 22
1 " " 24
6 " " 35
40 " " 37
1 " " 38
1 " " 48a
1 " " 52
1 " " 90a
1 " " 125
2 " " 126
2 " " 126a
1 " " 176
1 " " 187
2 " " 189
1 " " 190
2 " " 199
4 " " 215
1 <i>Magic Motor</i>

Parts required

2 of No. 2	2 of No. 48a
7 " " 5	1 " " 52
2 " " 10	4 " " 90a
2 " " 12	1 " " 125
2 " " 16	1 " " 126
1 " " 17	1 " " 126a
1 " " 23	2 " " 187
4 " " 35	1 " " 188
35 " " 37	2 " " 189
2 " " 38	2 " " 199
1 " " 40	4 " " 215
1 " " 44	1 <i>Magic Motor</i>

3.22 HORSE AND CART

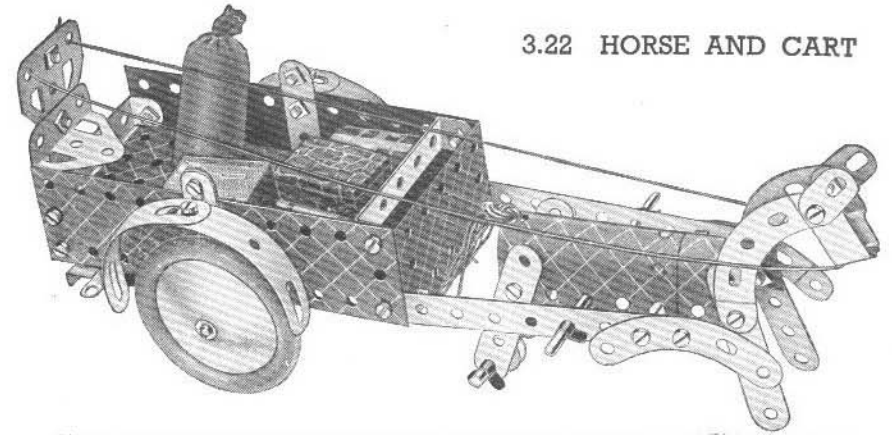

The model is driven by a *Magic Motor* fastened underneath the $5\frac{1}{2}$ " x $2\frac{1}{2}$ " Flanged Plate that forms the bottom of the cart. The drive is taken by a Driving Band from the pulley of the Motor to a $\frac{1}{2}$ " fast Pulley on the back axle. A $\frac{1}{2}$ " Loose Pulley is fitted on a 2" Rod journalled in the bottom holes of the Strips forming the legs of the horse, so that the model will travel smoothly along the ground.

3.23 ROUNDABOUT

Parts required	
2 of No. 1	4 of No. 37a
6 " " 2	4 " " 38
8 " " 5	1 " " 40
4 " " 10	2 " " 48a
2 " " 11	1 " " 52
8 " " 12	4 " " 90a
1 " " 16	4 " " 111c
1 " " 17	2 " " 125
1 " " 18a	2 " " 126
1 " " 19g	2 " " 126a
4 " " 22	1 " " 187
1 " " 24	2 " " 188
6 " " 35	2 " " 191
50 " " 37	2 " " 199

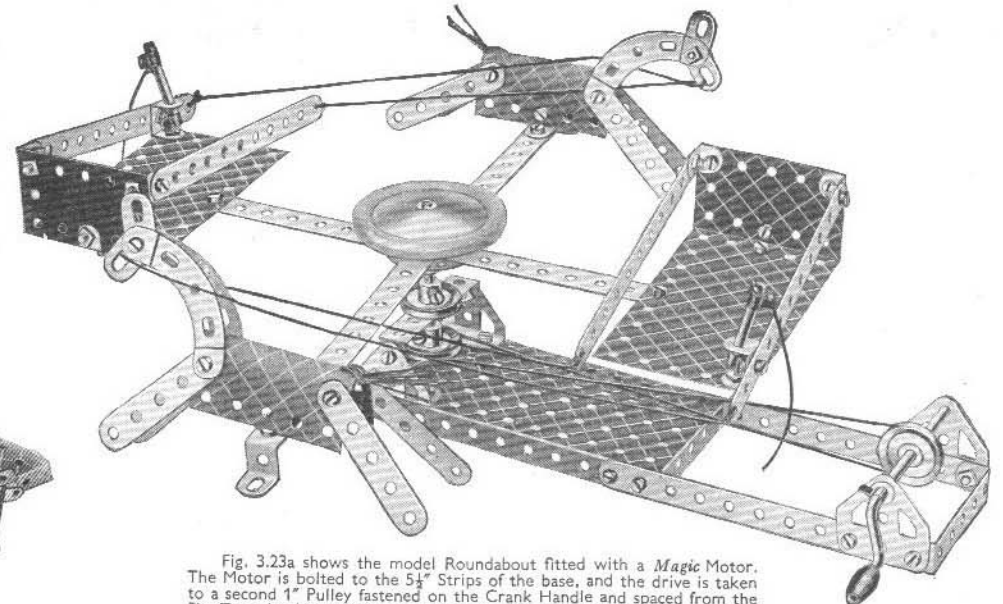

Fig. 3.23a shows the model Roundabout fitted with a *Magic Motor*. The Motor is bolted to the $5\frac{1}{2}$ " Strips of the base, and the drive is taken to a second 1" Pulley fastened on the Crank Handle and spaced from the Flat Trunnion by a Spring Clip and a Washer. This Pulley is removed from the end of the pivot rod of the roundabout underneath the $5\frac{1}{2}$ " x $2\frac{1}{2}$ " Flanged Plate.

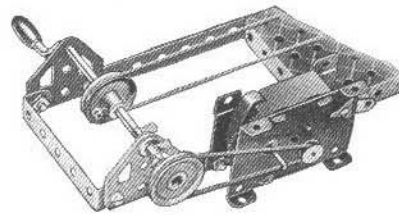

Fig. 3.23a

3.24 WINDMILL PUMP

Up and down motion of the pumping shaft is obtained from a crank fastened to the end of the Crank Handle. The crank is formed by securing an Angle Bracket to the boss of a 1" Pulley, two Washers being used between the Bracket and the boss. A 2½" Strip is pivoted to the crank and to the pumping beam, the other end of which is pivotally attached to a Double Bracket on the pump rod. The Bolts 1 are lock-nutted. The 1" Pulley on the Crank Handle is connected by a belt of Cord to the shaft carrying the sails. The *Magic Motor* is bolted by its flanges to the baseplate, and the drive is taken from the pulley of the Motor to a ½" Pulley fixed on the shaft of the Crank Handle, if desired the Motor may be dispensed with and the model operated by hand.

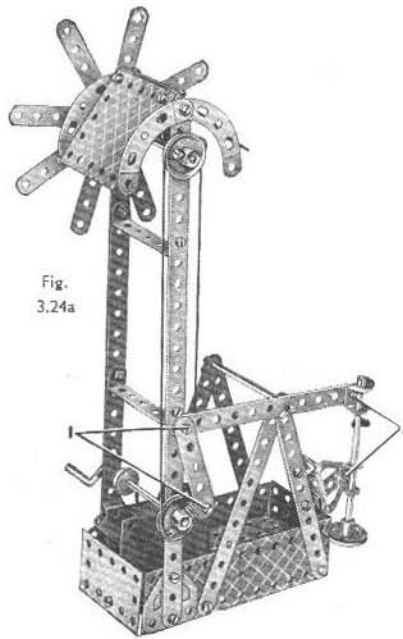
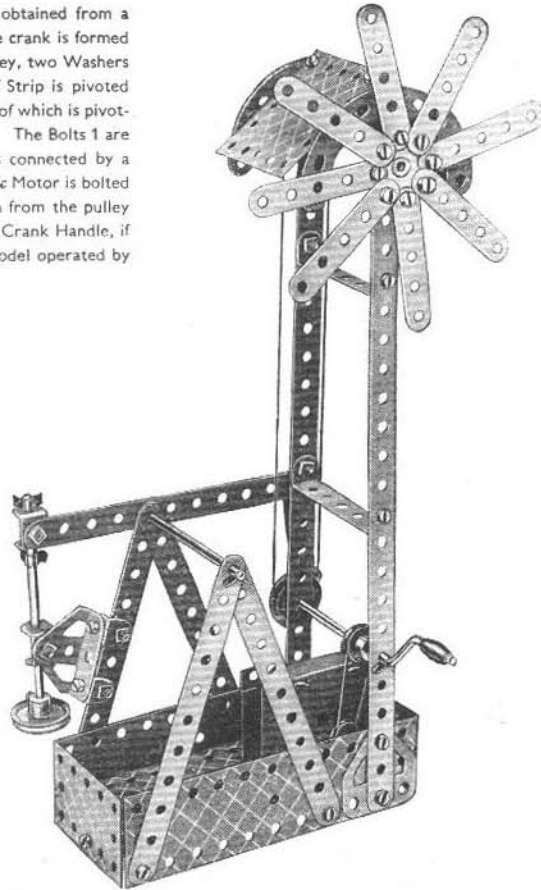

Fig. 3.24a



Parts required	
2 of No. 1	2 of No. 11
5 " " 2	7 " " 12
9 " " 5	1 " " 15b

2 of No. 16	2 of No. 48a
1 " " 19g	1 " " 52
3 " " 22	4 " " 90a
1 " " 24	1 " " 126
4 " " 35	2 " " 126a
39 " " 37	2 " " 188
3 " " 37a	2 " " 189
2 " " 38	2 " " 190
1 " " 40	1 <i>Magic Motor</i>

3.25 TRACTOR AND HARROW

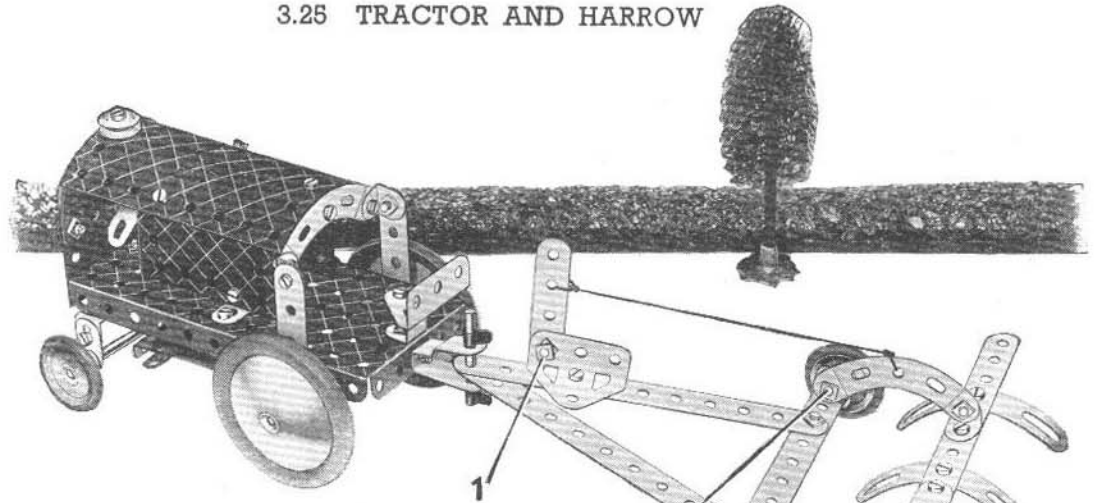

The rear axle is passed through the bottom holes of two 2½" Strips that are bolted to the flanges of the 5" x 2½" Flanged Plate forming the chassis. The construction of the bonnet and radiator is clearly shown in the illustration.

The fan consists of two Flat Brackets held against the head of a ¾" Bolt by a Nut. The ¾" Bolt is fastened to the radiator by means of two more Nuts. The engine itself is represented by two U-Section Curved Plates, bolted together so that they overlap two holes, and then fastened to the Flanged Plate by two Angle Brackets.

The wheels of the harrow are held by ¾" Bolts in Reversed Angle Brackets at each end of a 5½" Strip. Small radius Curved Strips are fastened to the Reversed Angle Brackets by lock-nutted Bolts, and Cord is attached to the centre hole of one of these and also to the operating lever, which is held by lock-nuts to a Trunnion. By moving the lever forward the harrow may be raised from the ground when not in use.

The Bolts 1 shown in both illustrations are lock-nutted.

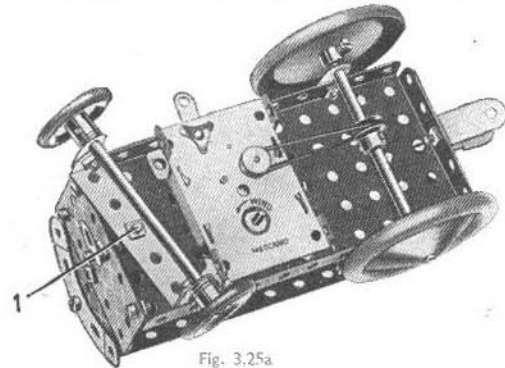
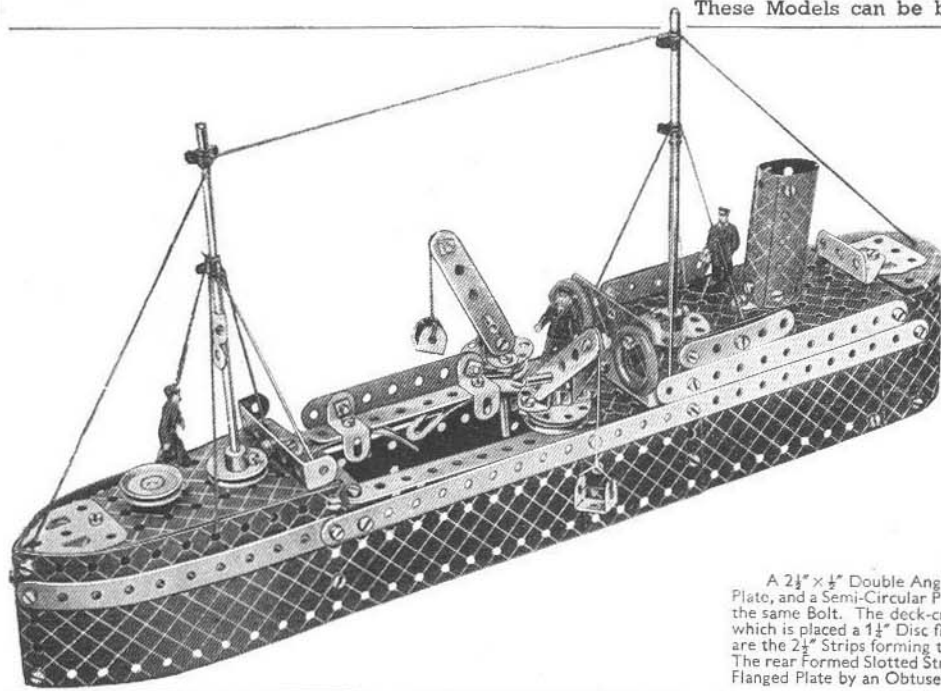

Fig. 3.25a

Parts required	4 of No. 22	2 of No. 125
5 of No. 2	1 " " 23	2 " " 126
3 " " 5	2 " " 35	4 " " 155a
2 " " 11	46 " " 37	2 " " 187
8 " " 12	10 " " 37a	1 " " 188
2 " " 16	6 " " 38	2 " " 199
1 " " 18a	1 " " 44	2 " " 200
	1 " " 48a	1 " " 214
	1 " " 52	4 " " 215
	4 " " 90a	1 <i>Magic Motor</i>
	5 " " 111c	



4.1 DREDGER

Parts required

2 of No. 1	1 of No. 51
6 " " 2	1 " " 52
2 " " 3	1 " " 54a
9 " " 5	5 " " 111c
4 " " 10	2 " " 125
2 " " 11	1 " " 126
8 " " 12	2 " " 126a
2 " " 12c	2 " " 155a
4 " " 16	2 " " 188
2 " " 17	2 " " 189
2 " " 18a	2 " " 190
4 " " 22	2 " " 191
1 " " 24	2 " " 192
8 " " 35	2 " " 199
70 " " 37	2 " " 200
6 " " 37a	1 " " 212
4 " " 38	1 " " 213
1 " " 40	2 " " 214
3 " " 48a	2 " " 215
	2 " " 217a

A $2\frac{1}{2}'' \times \frac{1}{2}''$ Double Angle Strip is bolted to the front flange of the $5\frac{1}{2}'' \times 2\frac{1}{2}''$ Flanged Plate, and a Semi-Circular Plate is held between the flange and the Double Angle Strip by the same Bolt. The deck-cranes each consist of a 1" Pulley fastened to a 2" Rod, above which is placed a $1\frac{1}{2}''$ Disc fitted with Angle Brackets. Bolted to these, and lock-nutted, are the $2\frac{1}{2}''$ Strips forming the jib. The complete units are held in place by Spring Clips. The rear Formed Slotted Strip of the hopper bridge is fastened to the front of the $2\frac{1}{2}'' \times 1\frac{1}{2}''$ Flanged Plate by an Obtuse Angle Bracket.

4.2 SUBMARINE

Parts required

4 of No. 1	4 of No. 48a
3 " " 5	1 " " 52
1 " " 11	2 " " 54a
2 " " 12	2 " " 125
1 " " 15b	2 " " 126
3 " " 16	2 " " 126a
1 " " 17	2 " " 188
1 " " 18a	2 " " 189
1 " " 18b	2 " " 190
4 " " 22	2 " " 191
1 " " 24	2 " " 192
5 " " 35	1 " " 198
64 " " 37	1 " " 199
1 " " 40	1 " " 212
1 " " 44	1 " " 213
1 " " 48	1 " " 217a

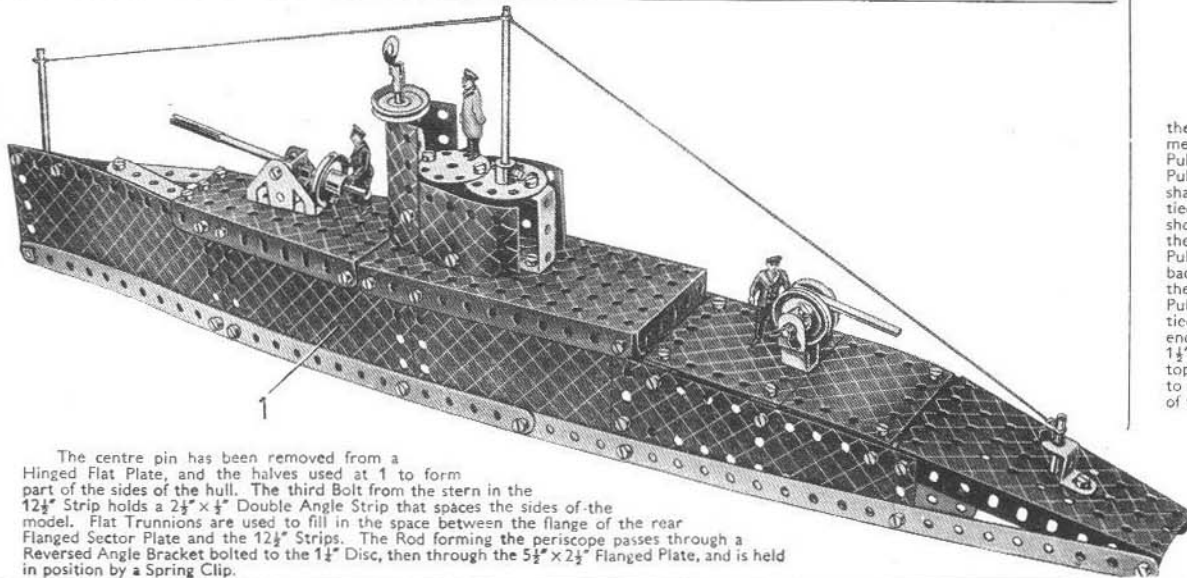

The centre pin has been removed from a Hinged Flat Plate, and the halves used at 1 to form part of the sides of the hull. The third Bolt from the stern in the $12\frac{1}{2}''$ Strip holds a $2\frac{1}{2}'' \times \frac{1}{2}''$ Double Angle Strip that spaces the sides of the model. Flat Trunnions are used to fill in the space between the flange of the rear Flanged Sector Plate and the $12\frac{1}{2}''$ Strips. The Rod forming the periscope passes through a Reversed Angle Bracket bolted to the $1\frac{1}{2}''$ Disc, then through the $5\frac{1}{2}'' \times 2\frac{1}{2}''$ Flanged Plate, and is held in position by a Spring Clip.

4.3 TELPHER SPAN

Parts required

4 of No. 1	4 of No. 22
6 " " 2	1 " " 23
1 " " 3	1 " " 24
8 " " 5	6 " " 35
2 " " 11	55 " " 37
6 " " 12	2 " " 38
4 " " 12c	1 " " 40
2 " " 16	1 " " 48
1 " " 17	2 " " 48a
1 " " 18a	1 " " 52
2 " " 19b	2 " " 54a
1 " " 19g	2 " " 90a
	2 " " 126
	2 " " 126a
	1 " " 176
	2 " " 191
	1 " " 198

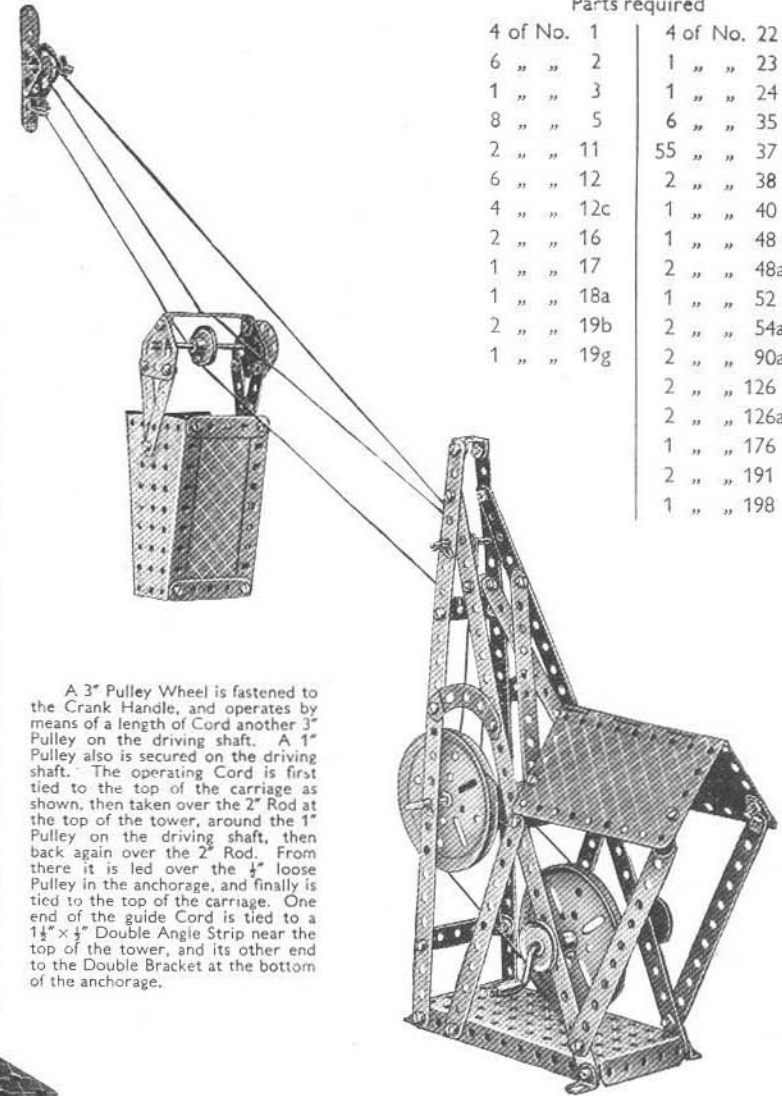

A 3" Pulley Wheel is fastened to the Crank Handle, and operates by means of a length of Cord another 3" Pulley on the driving shaft. A 1" Pulley also is secured on the driving shaft. The operating Cord is first tied to the top of the carriage as shown, then taken over the 2" Rod at the top of the tower, around the 1" Pulley on the driving shaft, then back again over the 2" Rod. From there it is led over the $\frac{1}{2}''$ loose Pulley in the anchorage, and finally is tied to the top of the carriage. One end of the guide Cord is tied to a $1\frac{1}{2}'' \times \frac{1}{2}''$ Double Angle Strip near the top of the tower, and its other end to the Double Bracket at the bottom of the anchorage.

4.4 SPORTS CAR

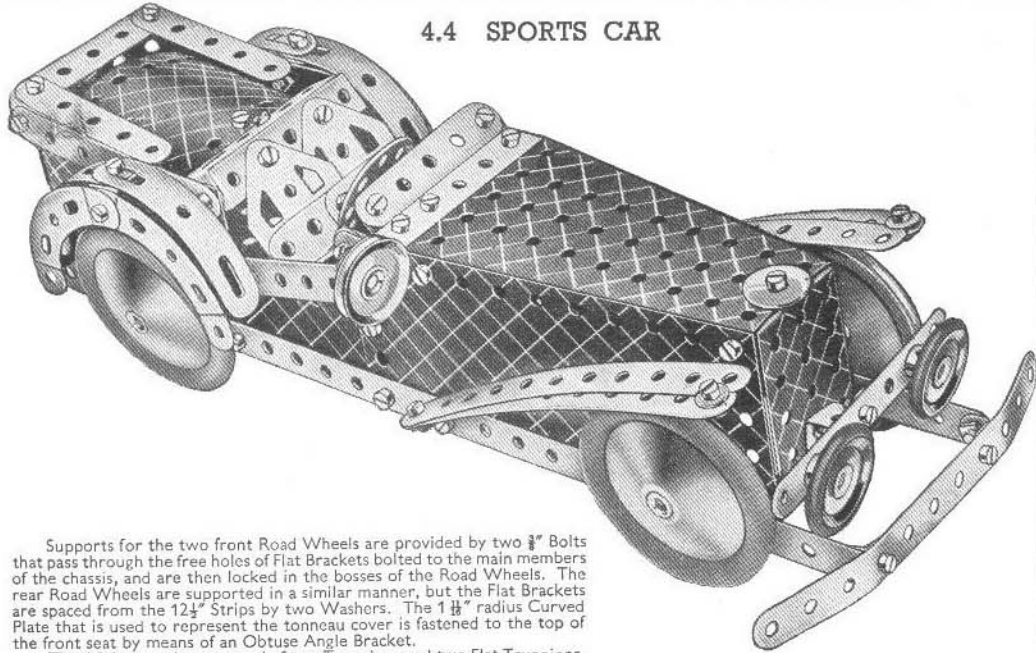

Supports for the two front Road Wheels are provided by two $\frac{3}{8}$ " Bolts that pass through the free holes of Flat Brackets bolted to the main members of the chassis, and are then locked in the bosses of the Road Wheels. The rear Road Wheels are supported in a similar manner, but the Flat Brackets are spaced from the $12\frac{1}{2}$ " Strips by two Washers. The $1\frac{1}{2}$ " radius Curved Plate that is used to represent the tonneau cover is fastened to the top of the front seat by means of an Obtuse Angle Bracket.

The driving seat is composed of two Trunnions and two Flat Trunnions, and these are bolted to the $2\frac{1}{2}$ " x $\frac{1}{2}$ " Double Angle Strip supported by the sides of the car.

The steering wheel is a Bush Wheel fastened to a $1\frac{1}{2}$ " Rod that is secured by two Spring Clips in an Angle Bracket bolted under the scuttle.

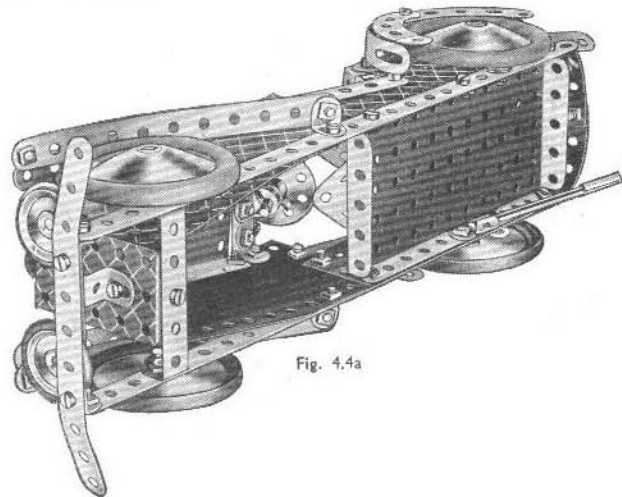
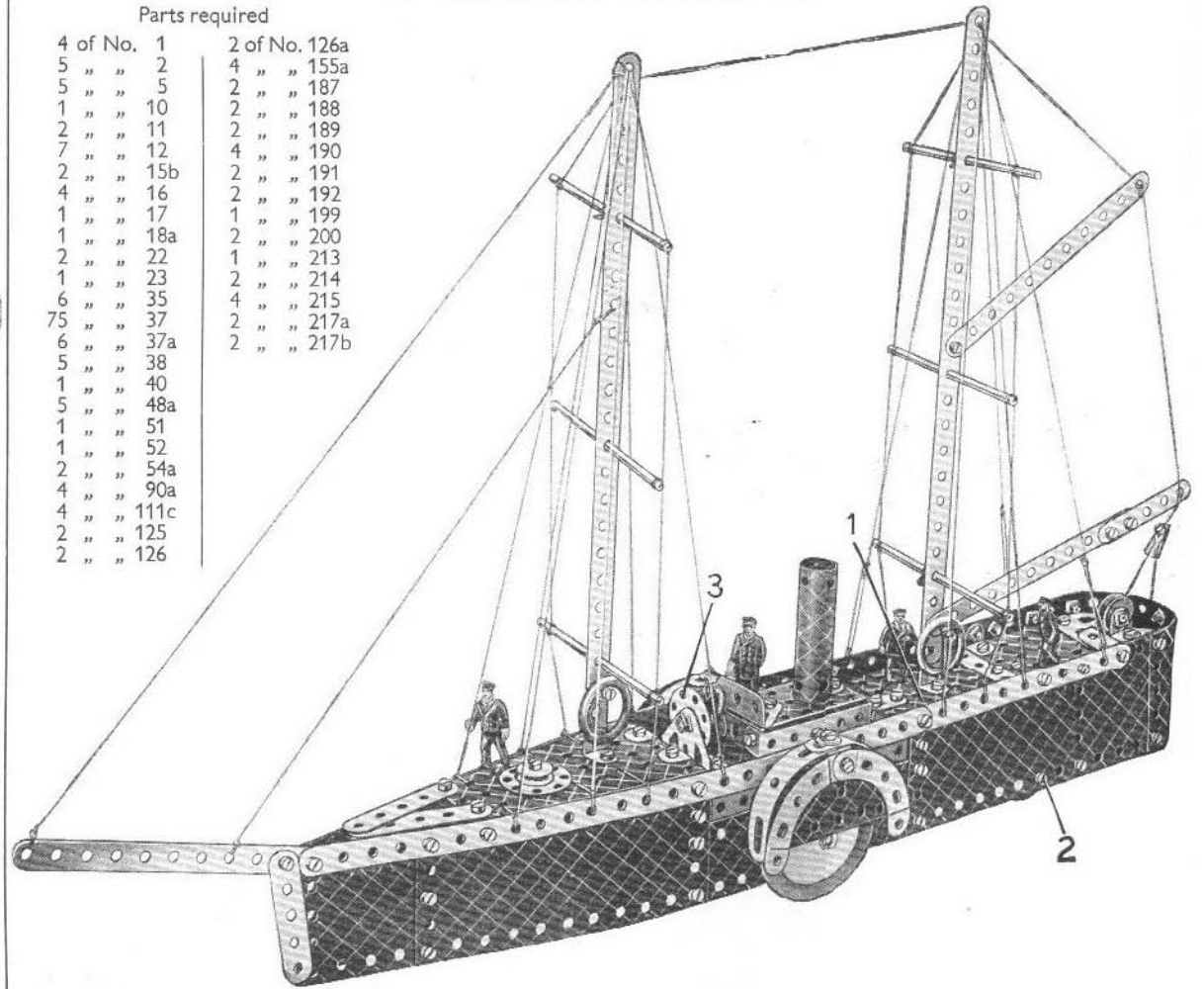

Fig. 4.4a

Parts required

2 of No. 1	1 of No. 52
5 " " 2	1 " " 54a
1 " " 3	4 " " 90a
9 " " 5	6 " " 111c
4 " " 10	2 " " 125
2 " " 11	2 " " 126
6 " " 12	2 " " 126a
3 " " 12c	2 " " 155a
1 " " 16	4 " " 187
1 " " 18b	2 " " 188
3 " " 22	2 " " 190
1 " " 24	2 " " 192
2 " " 35	2 " " 199
66 " " 37	1 " " 200
7 " " 38	1 " " 212
1 " " 44	1 " " 213
6 " " 48a	4 " " 215
1 " " 51	2 " " 217a

4.5 EARLY TYPE OF STEAMSHIP



Parts required

4 of No. 1	2 of No. 126a
5 " " 2	4 " " 155a
5 " " 5	2 " " 187
1 " " 10	2 " " 188
2 " " 11	2 " " 189
7 " " 12	4 " " 190
2 " " 15b	2 " " 191
4 " " 16	2 " " 192
1 " " 17	1 " " 199
1 " " 18a	2 " " 200
2 " " 22	1 " " 213
1 " " 23	2 " " 214
6 " " 35	4 " " 215
75 " " 37	2 " " 217a
6 " " 37a	2 " " 217b
5 " " 38	
1 " " 40	
5 " " 48a	
1 " " 51	
1 " " 52	
2 " " 54a	
4 " " 90a	
4 " " 111c	
2 " " 125	
2 " " 126	

The foredeck consists of a Flanged Sector Plate bolted to the $12\frac{1}{2}$ " Strips that are placed along the sides of the deck. A $5\frac{1}{2}$ " x $2\frac{1}{2}$ " Flanged Plate is used for the central portion of the deck and to the rear end of this a Flanged Sector Plate 1 is fastened by a Flat Bracket. A $2\frac{1}{2}$ " x $\frac{1}{2}$ " Double Angle Strip is bolted across the Flanged Sector Plate and to the sides of the vessel. Two $2\frac{1}{2}$ " x $1\frac{1}{2}$ " Flexible Plates, overlapped one hole, are bolted to the rear end of the Flanged Sector Plate.

The vessel runs on Road Wheels mounted on a compound rod consisting of a $1\frac{1}{2}$ " and a $2\frac{1}{2}$ " Rod joined by a Rod Connector, which is journalled in the sides of the hull as shown, and also on $1\frac{1}{2}$ " Pulleys fitted with Rubber Rings supported inside the hull on $\frac{3}{8}$ " Bolts 2. The Bolts 2 pass through holes in the Flexible Plates forming the sides of the ship and are locked in the bosses of the Pulleys. A $1\frac{1}{4}$ " Disc 3 is lock-nutted to a Trunnion to form the wheel.

4.6 DRILLING MACHINE

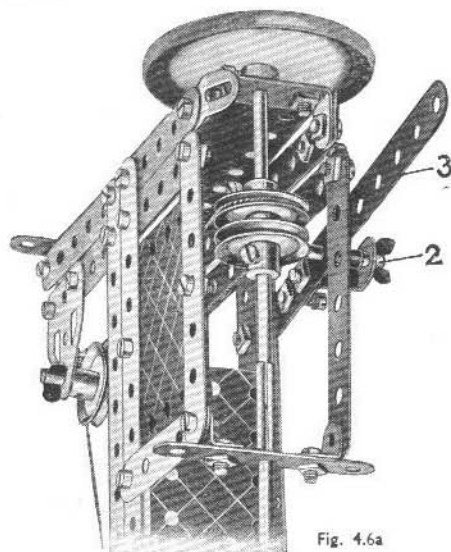
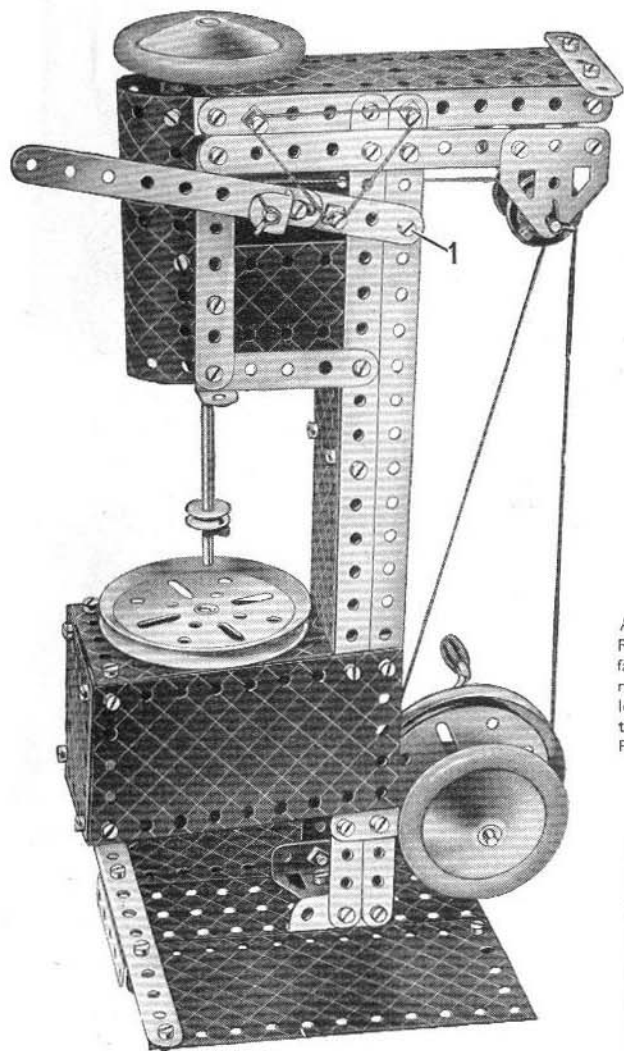

Fig. 4.6a

The height of the drill is controlled by the lever 3 (Fig. 4.6a). A 2" Rod 2, passed through a hole in the Strip 3 and through a hole in a Reversed Angle Bracket bolted to the Strip, engages between two 1" fast Pulleys on the shaft of the drill. A Driving Band, which is arranged as shown, holds the lever at its maximum height. The Bolt 1 is lock-nutted. The drill table is held in position by a $\frac{3}{8}$ " Bolt, that passes through the Flanged Sector Plate and is then locked in the boss of the Pulley.

Parts required		
4 of No. 1	4 of No. 22	2 of No.126
6 " " 2	1 " " 23	2 " " 126a
2 " " 3	6 " " 35	2 " " 187
7 " " 5	71 " " 37	1 " " 188
8 " " 12	7 " " 37a	2 " " 189
2 " " 12c	1 " " 48	2 " " 190
1 " " 15b	1 " " 48a	2 " " 191
1 " " 16	1 " " 52	2 " " 192
2 " " 17	1 " " 54a	2 " " 199
2 " " 19b	4 " " 111c	1 " " 213
1 " " 19g	1 " " 125	

4.7 GIANT EXCAVATOR

The Cord 1 is fastened to a Crank Handle journalled in holes in the sides of the cab, and after passing round the 2 $\frac{1}{2}$ " x $\frac{1}{2}$ " Double Angle Strip above the cabin is tied to the jib at 2. This Cord controls the luffing movement of the jib. The Cord 3 is tied to the bucket and is passed over the 1" Pulley Wheel 5 and then wound round Rod 6. By turning the handle 7 on the Bush Wheel 7 the bucket is raised or lowered.

The bucket arm is pivoted on Rod 4, which passes through holes in the 12 $\frac{1}{2}$ " Strips forming the jib and the bucket arm. Road Wheels fastened at each end of Rod 4 retain it in position.

A 3" Pulley Wheel 8 is bolted to the base by two Bolts, and a Flanged Sector Plate 9, to which the cab is fastened, is similarly attached to the upper 3" Pulley. A 1 $\frac{1}{2}$ " Rod is held in the boss of Pulley Wheel 8, and the Pulley attached to Flanged Sector Plate 9 is retained in position by a Spring Clip so that the superstructure is free to swivel on the Rod. The control cab is built up on the flanges of the Flanged Sector Plate, and the platform around the cab is composed of two 5 $\frac{1}{2}$ " x 2 $\frac{1}{2}$ " Flexible Plates, which are bolted underneath the Flanged Sector Plate 9.

The wheels on which the model runs are free to rotate on pairs of 3 $\frac{1}{2}$ " Rods. The front pair are joined by a Rod Connector and the rear pair by a Rod and Strip Connector.

Parts required

4 of No. 1	1 of No.176
6 " " 2	4 " " 187
5 " " 5	2 " " 188
4 " " 10	2 " " 189
1 " " 11	4 " " 190
6 " " 12	2 " " 191
4 " " 12c	2 " " 192
1 " " 15b	2 " " 200
4 " " 16	1 " " 212
2 " " 17	1 " " 213
1 " " 18a	1 " " 214
2 " " 19b	
1 " " 19g	
5 " " 22	
1 " " 24	
8 " " 35	
73 " " 37	
5 " " 37a	
4 " " 38	
1 " " 40	
1 " " 48	
6 " " 48a	
1 " " 52	
1 " " 54a	
5 " " 111c	
2 " " 126	
2 " " 126a	
4 " " 155a	

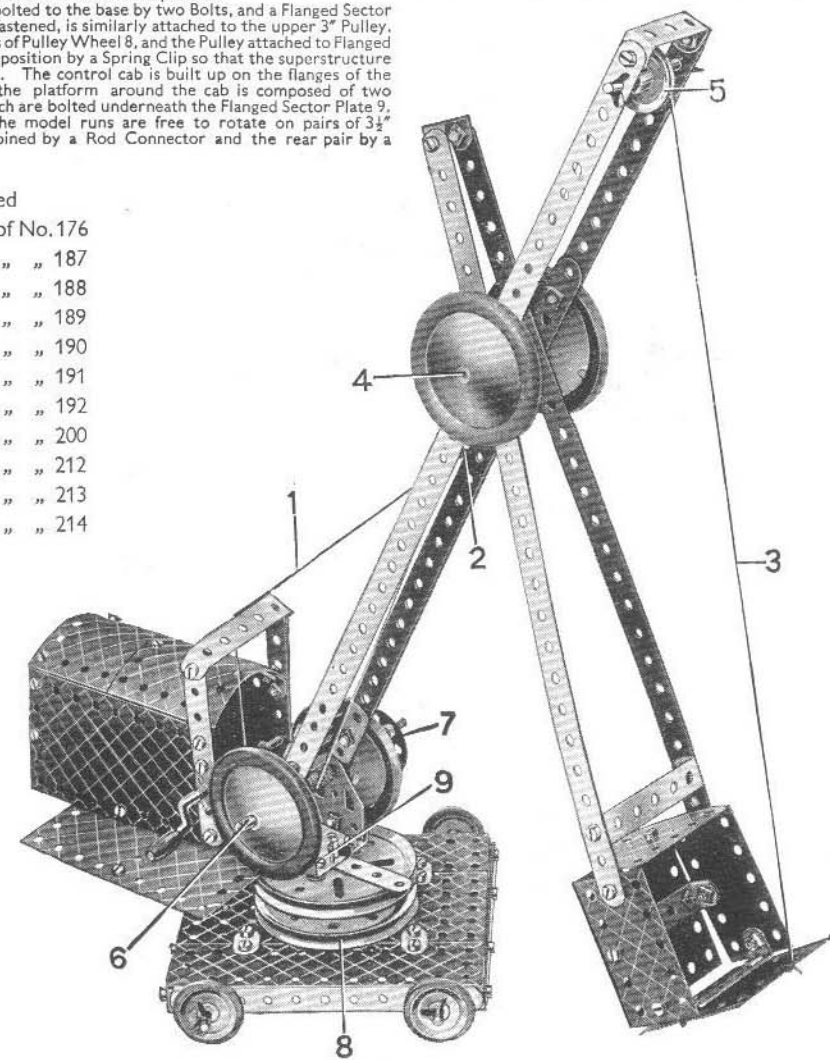

4.8 ELEVATED JIB CRANE

The superstructure of the model is pivoted on a Rod held in the boss of the 3" Pulley. Bearings for this Rod are provided by two $2\frac{1}{2} \times \frac{1}{2}$ " Double Angle Strips, one of which is bolted halfway down the Flanged Sector Plates and the other at the top.

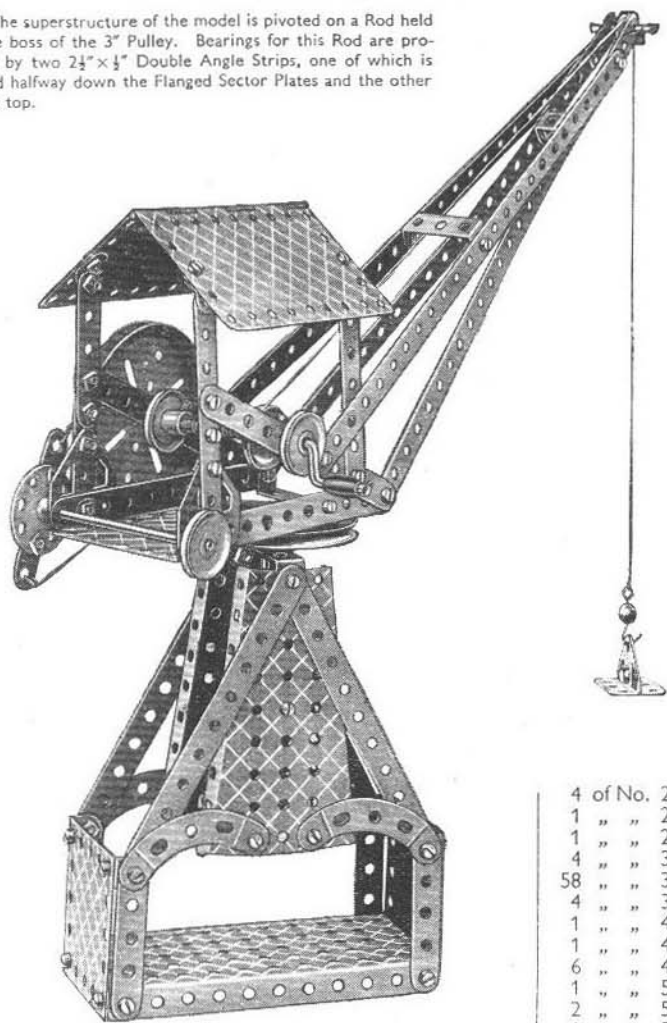

Parts required	
4 of No. 1	2 of No. 12
8 " " 2	3 " " 12c
1 " " 3	2 " " 16
9 " " 5	1 " " 18a
1 " " 11	2 " " 19b
	3 " " 190
	1 " " 19g

4 of No. 22
1 " " 23
1 " " 24
4 " " 35
58 " " 37
4 " " 38
1 " " 40
1 " " 48
6 " " 48a
1 " " 52
2 " " 54a
1 " " 57c
4 " " 90a
2 " " 126
2 " " 126a
1 " " 176
3 " " 190
1 " " 198

Parts required			
4 of No. 1	8 of No. 38		
6 " " 2	1 " " 40		
9 " " 5	1 " " 44		
1 " " 10	1 " " 48		
1 " " 11	4 " " 48a		
6 " " 12	1 " " 51		
4 " " 12c	1 " " 52		
1 " " 15b	2 " " 54a		
3 " " 16	1 " " 57c		
1 " " 18a	4 " " 90a		
1 " " 18b	4 " " 111c		
2 " " 19b	2 " " 126a		
1 " " 19g	3 " " 187		
5 " " 22	1 " " 188		
1 " " 23	2 " " 189		
1 " " 24	4 " " 190		
8 " " 35	2 " " 200		
64 " " 37	1 " " 212		
6 " " 37a	2 " " 217a		

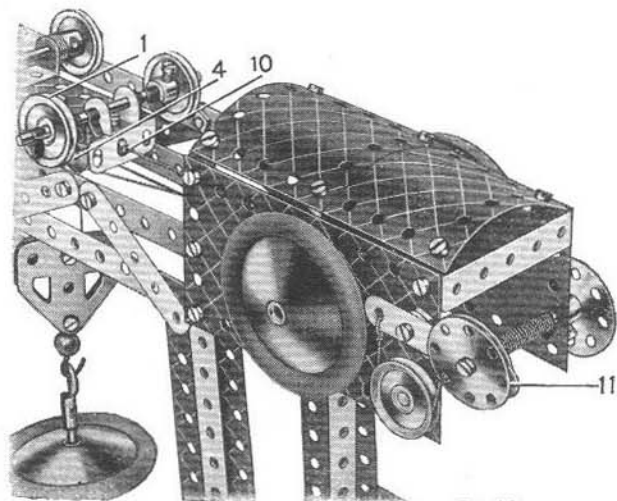
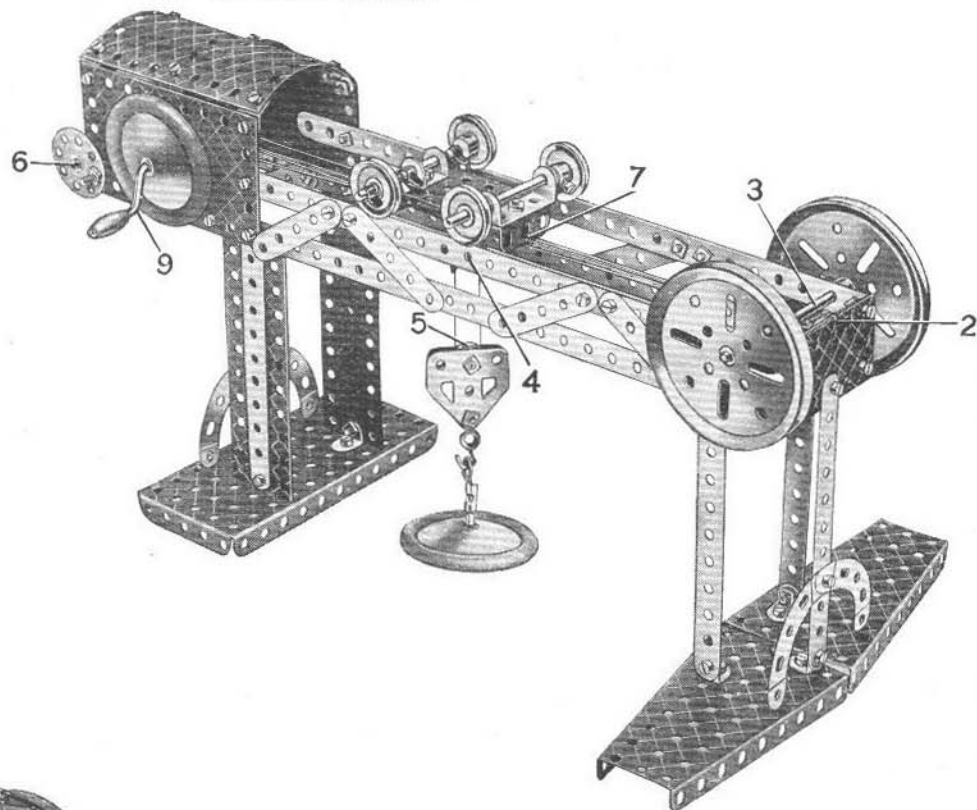

Fig. 4.9a

4.9 GANTRY CRANE



The sides of the cabin each consist of two $2\frac{1}{2} \times 2\frac{1}{2}$ " Flexible Plates overlapped one hole. The top of the cabin, which consists of two $1\frac{1}{2}$ " radius Curved Plates, is attached to the sides by means of Obtuse Angle Brackets at each corner as shown.

The hoisting carriage is a $2\frac{1}{2} \times 1\frac{1}{2}$ " Flanged Plate 7. Bearings for one of the $3\frac{1}{2}$ " Rods carrying the 1" Pulley Wheels are provided by the holes in the turned up ends of a $1\frac{1}{2} \times \frac{1}{2}$ " Double Angle Strip, and for the other Rod by the holes in a Double Bracket. The Bolt 1 (Fig. 4.9a) secures a Cranked Bent Strip 4 vertically to the underside of the Flanged Plate 7. A 1" Rod passes through the lower holes of the Cranked Bent Strip and is held in position by Spring Clips.

Two Flat Trunnions form the pulley block. They are fastened together at their wide ends by a $\frac{3}{8}$ " Bolt, which carries a $\frac{1}{2}$ " loose Pulley 5 on its shank between the two Flat Trunnions.

The Cord that operates the hoisting carriage 7 is tied at 10. It is then passed round Rod 3, which carries the two 3" Pulleys, and is taken to the Crank Handle 9. The Cord is wound round the Crank Handle several times to enable it to grip the shaft, and finally is tied to the rear end of the carriage. The hoisting cord is tied to Rod 6 fitted with a Bush Wheel, and wound round it several times. It is then taken over the 1" Rod held in the Cranked Bent Strip 4, round Pulley 5, back over the 1" Rod, and tied at 2. Strip 11 is the lever of a band brake, the cord of which passes around a 1 Pulley on Rod 6.

4.10 MECHANICAL DIGGER

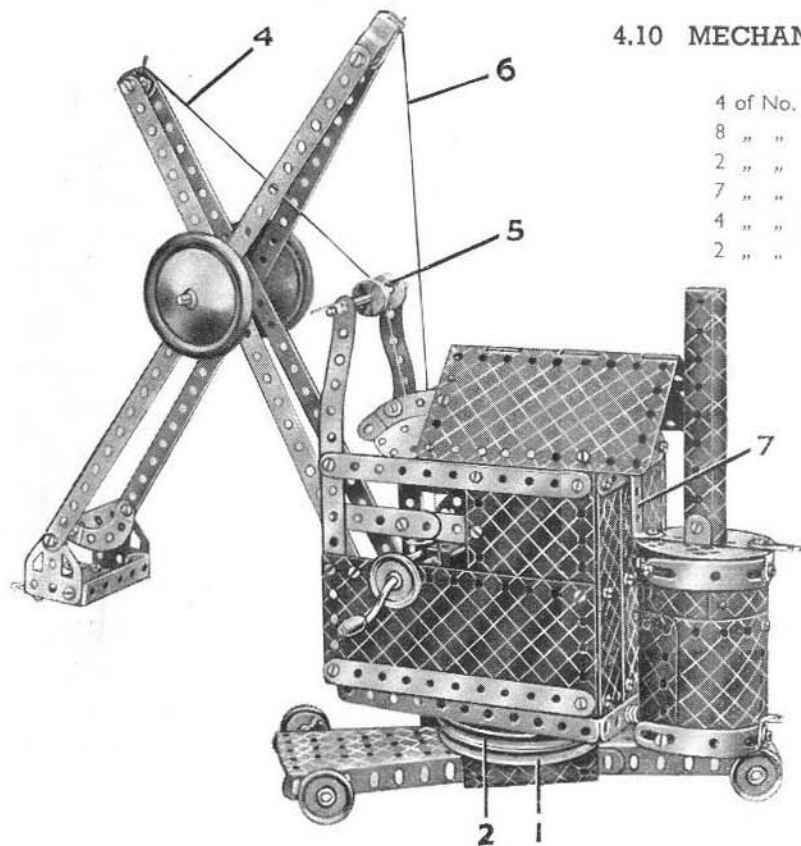

Parts required

4 of No. 1	7 of No. 12	1 of No. 51	1 of No. 212
8 " " 2	4 " " 12c	1 " " 52	1 " " 213
2 " " 3	2 " " 15b	2 " " 54a	2 " " 214
7 " " 5	3 " " 16	3 " " 90a	4 " " 215
4 " " 10	2 " " 17	5 " " 111c	2 " " 217a
2 " " 11	2 " " 19b	2 " " 125	2 " " 217b
	1 " " 19g	2 " " 126	
	5 " " 22	2 " " 126a	
	1 " " 23	1 " " 176	
	1 " " 24	3 " " 187	
	8 " " 35	2 " " 188	
	81 " " 37a	2 " " 189	
	75 " " 37b	4 " " 190	
	7 " " 38	2 " " 191	
	1 " " 40	2 " " 192	
	1 " " 44	1 " " 198	
	1 " " 48	2 " " 199	
	5 " " 48a	2 " " 200	

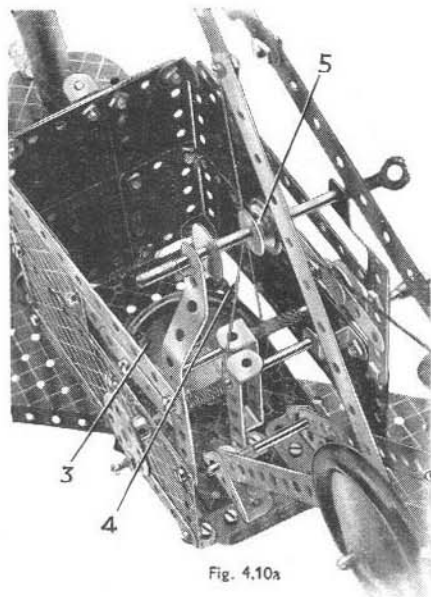

Fig. 4.10a

The bogie is constructed from two Flanged Sector Plates, the flanges of which are connected by two $2\frac{1}{2}$ " Strips. A gap of $\frac{1}{2}$ " is left between the ends of the Plates. A 3" Pulley 1 is then bolted boss downwards, to the Flanged Sector Plates by two $\frac{3}{8}$ " Bolts.

A 2" Rod is locked in the boss of Pulley 1, and on it is placed Pulley 2, boss downward. The base of the cab (Fig. 4.10a) is a $5\frac{1}{2}$ " x $2\frac{1}{2}$ " Flanged Plate, which rests on Pulley 2 and is retained on the 2" Rod by a Road Wheel 3.

The construction of the cab is clear from the illustrations. The boiler comprises a cylinder built up from two $1\frac{1}{4}$ " radius Curved Plates, a $4\frac{1}{2}$ " x $2\frac{1}{2}$ " Flexible Plate, and two $5\frac{1}{2}$ " x $1\frac{1}{2}$ " Flexible Plates. The edges of the cylinder are strengthened with Formed Slotted Strips. Semi-Circular Plates are attached to the top of the boiler by a $2\frac{1}{2}$ " x $\frac{1}{2}$ " Double Angle Strip. The Chimney is a $4\frac{1}{2}$ " x $2\frac{1}{2}$ " Flexible Plate rolled into a tube and fixed in place by a Double Bracket. The boiler is fastened to the back of the cab by a $1\frac{1}{2}$ " x $\frac{1}{2}$ " Double Angle Strip 7 at the top, and by a $\frac{3}{8}$ " Bolt at the bottom, where it is spaced from the cab by three Washers.

The Cord 4 is taken over the $\frac{1}{2}$ " Pulley 5 and tied to the Double Bracket at the top of the jib. This $\frac{1}{2}$ " Pulley 5 is clamped loosely between the two $\frac{3}{4}$ " Discs by two Spring Clips to form a deep-grooved pulley.

The Cord 6 is wound around the Crank Handle and is tied to the Cranked Bent Strip at the top of the dipper stick.

4.11 HAMMERHEAD CRANE

The jib of the crane is bolted to the upper 3" Pulley, and the lower 3" Pulley is bolted to two $2\frac{1}{2}$ " x $\frac{1}{2}$ " Double Angle Strips fastened to the narrow ends of the Flanged Sector Plates. A $1\frac{1}{2}$ " Rod is secured in the boss of the upper Pulley, but is free to rotate in the boss of the lower Pulley. A Bush Wheel fastened to the lower end of the Rod retains the jib in place.

The four Road Wheels are fastened to a 4" Rod that passes through the holes of two Flat Trunnions bolted to the $2\frac{1}{2}$ " small radius Curved Strips.

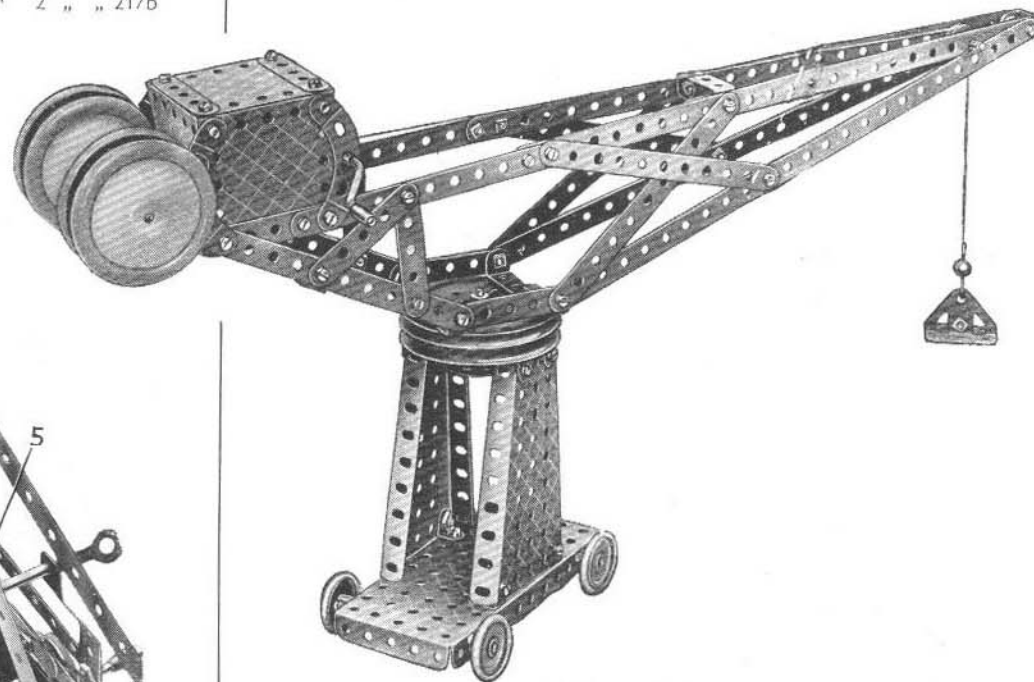

Parts required

4 of No. 1	2 of No. 18a	55 of No. 37	4 of No. 90a
8 " " 2	2 " " 19b	1 " " 40	2 " " 126
9 " " 5	1 " " 19g	1 " " 48	2 " " 126a
1 " " 11	4 " " 22	6 " " 48a	4 " " 155a
8 " " 12	1 " " 23	1 " " 52	1 " " 176
1 " " 15b	1 " " 24	2 " " 54a	4 " " 187
2 " " 16	4 " " 35	1 " " 57c	4 " " 190

4.12 FIGHTING BIPLANE

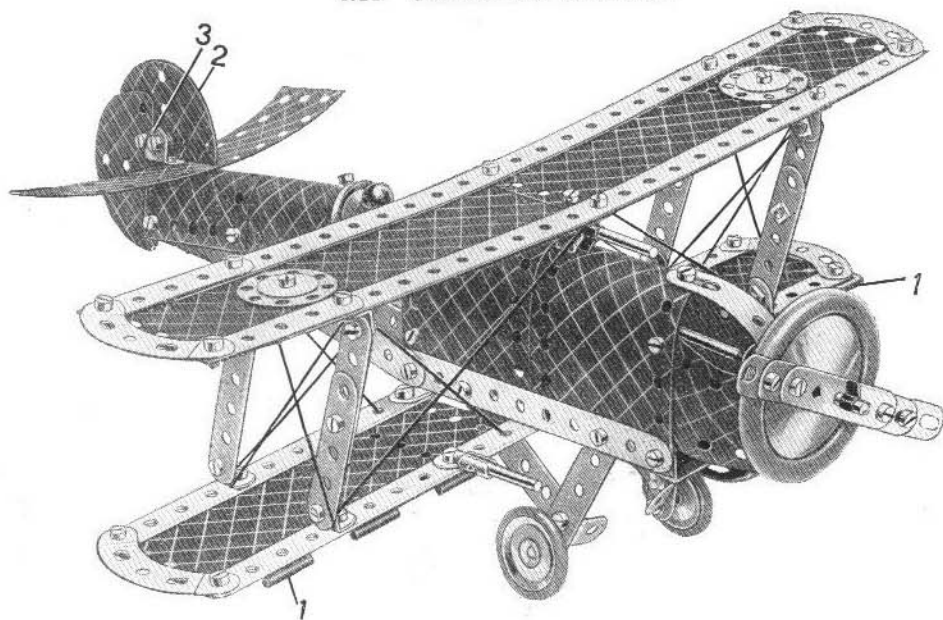

Parts required				
4 of No. 1	1 of No. 16	1 of No. 40	1 of No. 187	1 of No. 212
6 " " 2	2 " " 17	1 " " 48	2 " " 188	2 " " 214
2 " " 3	1 " " 18a	4 " " 48a	1 " " 189	2 " " 215
9 " " 5	4 " " 22	4 " " 90a	4 " " 190	2 " " 217a
4 " " 10	6 " " 35	5 " " 111c	2 " " 191	2 " " 217b
2 " " 11	74 " " 37	2 " " 125	2 " " 192	
8 " " 12	1 " " 37a	2 " " 126a	1 " " 198	
3 " " 12c	5 " " 38	2 " " 155a	2 " " 199	

The two 3" Formed Slotted Strips that can be seen in the illustration, one forming the top and one the underside of the nose of the plane, are joined end to end by a Bolt through their slotted holes. The Bolt holds also a Reversed Angle Bracket inside the nose, and an Obtuse Angle Bracket, which is outside the nose. The 3½" Rod that forms the propeller shaft passes through the free hole of the Obtuse Angle Bracket, through the unoccupied part of the slots in the 3" Formed Slotted Strips, and through the hole of the Reversed Angle Bracket. The Rod is held in position by Spring Clips. The centre pin of a Hinged Flat Plate has been withdrawn, and the two parts used as flat plates 1, to form part of the lower wing. The Semi-Circular Plate 2 is fastened to the fuselage by means of a Double Bracket 3, and is spaced from the inside of the Bracket by three Washers. Flat Trunnions are used for the sides of the cockpit. The 1" fast Pulleys forming the front and the back of the cockpit are each fastened by a Bolt passing through the top of the U-Section Curved Plates and into the tapped hole of the boss.

4.13 TANK LOCOMOTIVE

The construction of the model is commenced by building the chassis as shown in Fig. 4.10a. The Flat Brackets 1 must be bolted to the 12½" Strips 2 before the Flanged Sector Plate 3 is fitted. The 1½" Discs 5 rotate on ½" Bolts lock-nutted in the end holes of two 2½" small radius Curved Strips, which are bolted to the 12½" Strips forming the side members of the frame.

The top of the cab consists of two 1" radius Curved Plates, overlapped three holes and fastened by an Angle

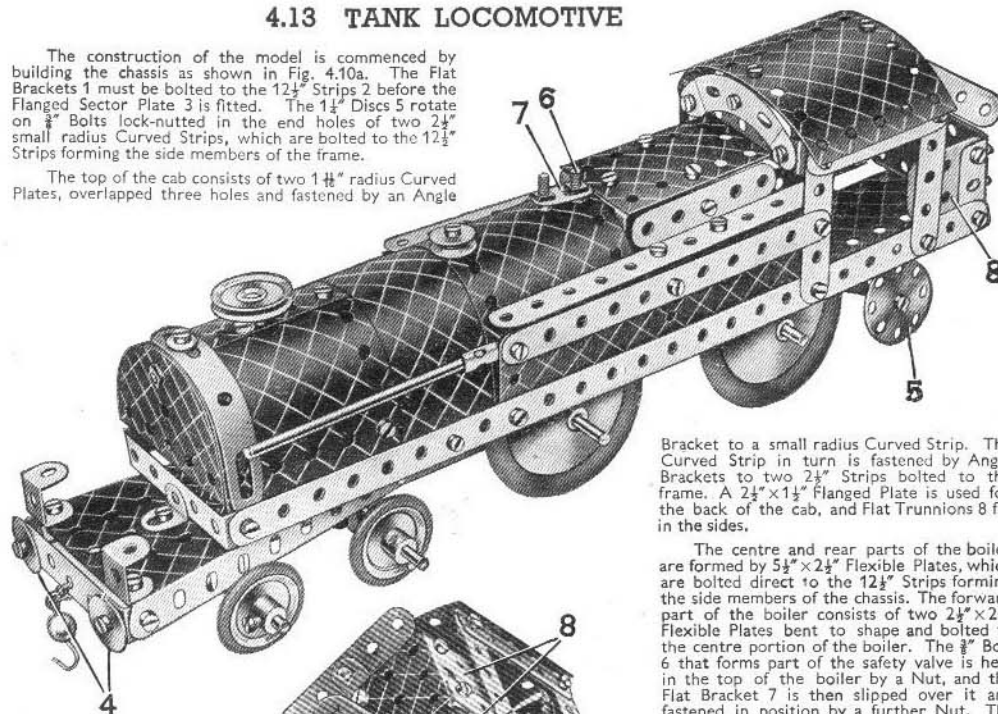

Bracket to a small radius Curved Strip. The Curved Strip in turn is fastened by Angle Brackets to two 2½" Strips bolted to the frame. A 2½" x 1½" Flanged Plate is used for the back of the cab, and Flat Trunnions 8 fill in the sides.

The centre and rear parts of the boiler are formed by 5½" x 2½" Flexible Plates, which are bolted direct to the 12½" Strips forming the side members of the chassis. The forward part of the boiler consists of two 2½" x 2½" Flexible Plates bent to shape and bolted to the centre portion of the boiler. The ½" Bolt 6 that forms part of the safety valve is held in the top of the boiler by a Nut, and the Flat Bracket 7 is then slipped over it and fastened in position by a further Nut. The buffers 4 are lock-nutted to a 2½" x ½" Double Angle Strip bolted to the flanges of the Flanged Sector Plate 3.

Parts required	
4 of No. 1	1 of No. 44
5 " " 2	1 " " 48
9 " " 5	4 " " 48a
5 " " 10	1 " " 51
2 " " 11	1 " " 54a
6 " " 12	1 " " 57c
4 " " 12c	4 of No. 187
1 " " 15b	2 " " 188
4 " " 16	2 " " 189
5 " " 22	2 " " 190
1 " " 23	2 " " 192
4 " " 35	2 " " 200
70 " " 37	2 " " 126
9 " " 37a	2 " " 126a
7 " " 38	4 " " 155a
	1 " " 212
	1 of No. 214
	2 " " 215
	2 " " 217a
	2 " " 217b

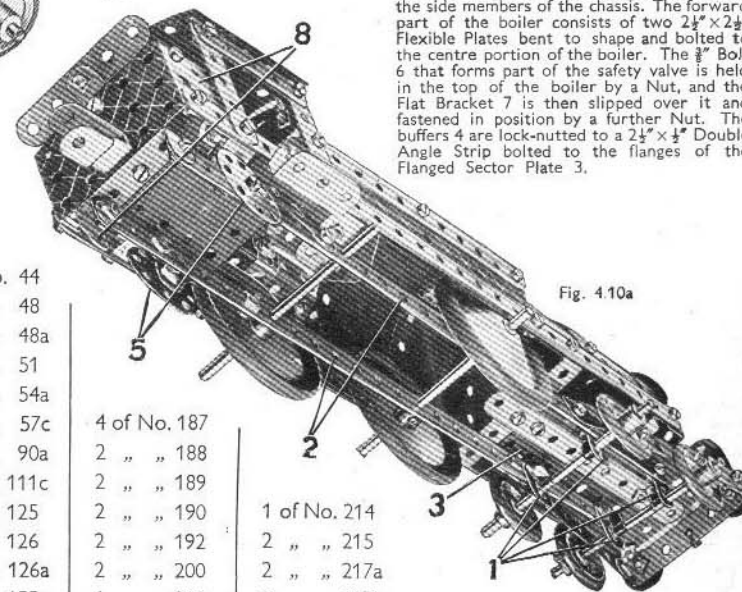
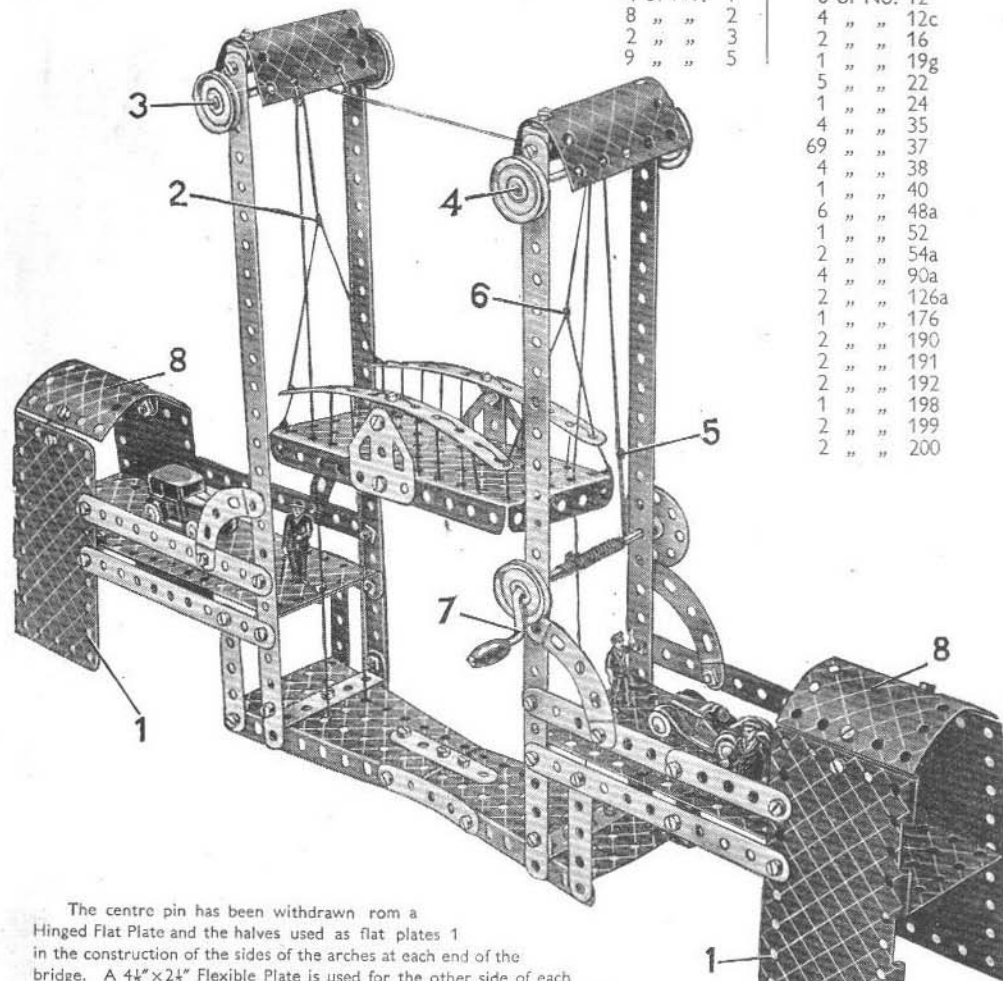

Fig. 4.10a

4.14 LIFTING BRIDGE



Parts required

4 of No.	1	6 of No.	12
8 "	2	4 "	12c
2 "	3	2 "	16
9 "	5	1 "	19g
		5 "	22
		1 "	24
		4 "	35
		69 "	37
		4 "	38
		1 "	40
		6 "	48a
		1 "	52
		2 "	54a
		4 "	90a
		2 "	126a
		1 "	176
		2 "	190
		2 "	191
		2 "	192
		1 "	198
		2 "	199
		2 "	200

The centre pin has been withdrawn from a Hinged Flat Plate and the halves used as flat plates 1 in the construction of the sides of the arches at each end of the bridge. A $4\frac{1}{2}'' \times 2\frac{1}{2}''$ Flexible Plate is used for the other side of each arch, and the $1\frac{1}{8}''$ radius Curved Plates 8 that form their tops are held in position by Obtuse Angle Brackets. The two U-Section Curved Plates bolted at the head of the towers are spaced away from the $2\frac{1}{2}'' \times \frac{1}{2}''$ Double Angle Strips that support them by two Washers. Crank Handle 7 which controls the raising and lowering of the bridge, is retained in position in the sides of the right hand tower by a Bush Wheel and a 1" Pulley. Cord is wound round the shaft of Crank Handle 7, and at 5 a second length of Cord is knotted to it, and both are led over the Rod 4. One of the Cords is led downward and is tied at 6 to the Cords supporting the span; while the other is passed over Rod 3 and is tied at 2 to the other supporting Cords. Guide Cords are tied to Rods 3 and 4, and after passing through holes in the $5\frac{1}{2}'' \times 2\frac{1}{2}''$ Flanged Plate are fastened to the two Flanged Sector Plates forming the base.

4.15 RACING CAR

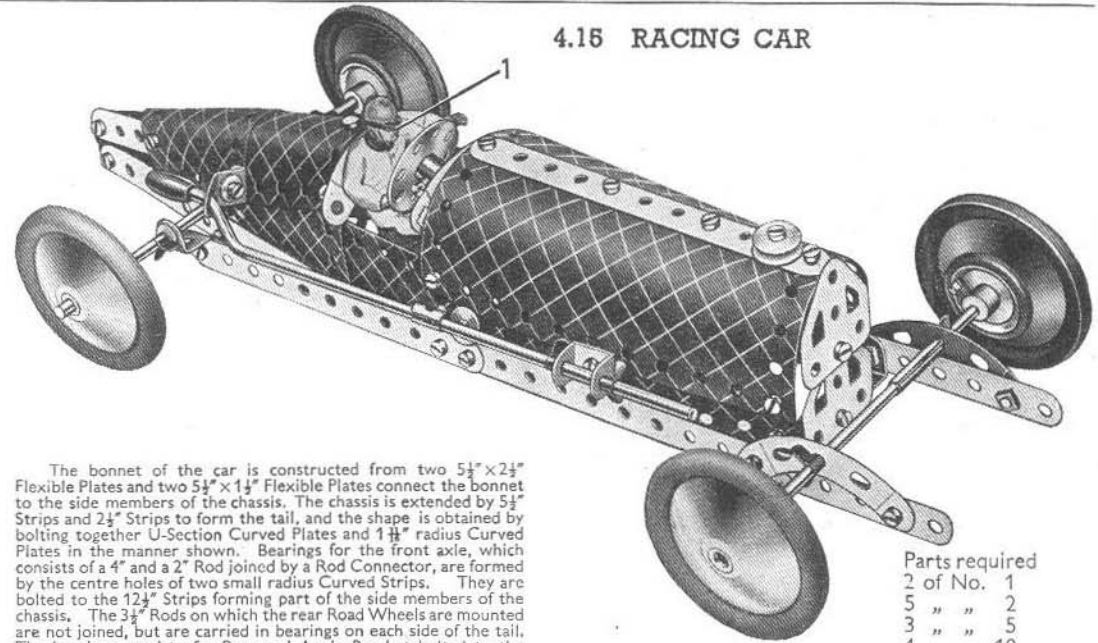

The bonnet of the car is constructed from two $5\frac{1}{2}'' \times 2\frac{1}{2}''$ Flexible Plates and two $5\frac{1}{2}'' \times 1\frac{1}{2}''$ Flexible Plates connect the bonnet to the side members of the chassis. The chassis is extended by $5\frac{1}{2}''$ Strips and $2\frac{1}{2}''$ Strips to form the tail, and the shape is obtained by bolting together U-Section Curved Plates and $1\frac{1}{8}''$ radius Curved Plates in the manner shown. Bearings for the front axle, which consists of a 4" and a 2" Rod joined by a Rod Connector, are formed by the centre holes of two small radius Curved Strips. They are bolted to the $12\frac{1}{2}''$ Strips forming part of the side members of the chassis. The $3\frac{1}{2}''$ Rods on which the rear Road Wheels are mounted are not joined, but are carried in bearings on each side of the tail. The bearings consist of a Reversed Angle Bracket bolted to the chassis and a Flat Bracket fastened to the side of the car. The Rods are held in position by Spring Clips. The Driver 1 (Motor Car Constructor Part No. A1100) is not included in the Outfit, but can be purchased separately if required.

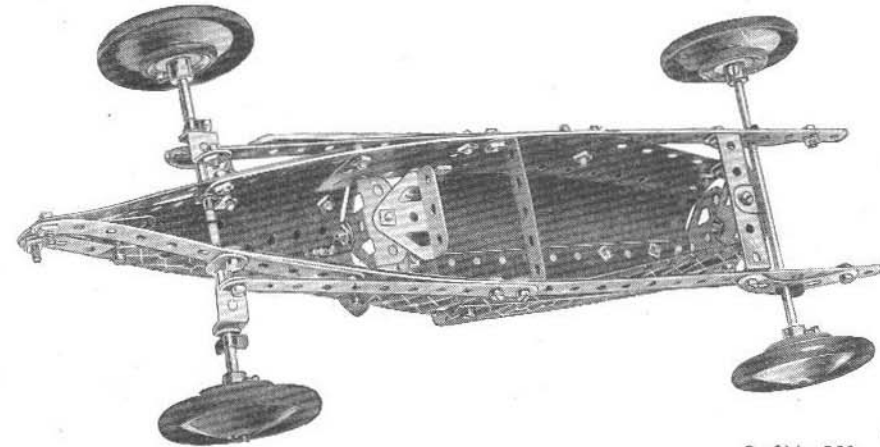

Parts required

2 of No.	1
5 "	2
3 "	5
4 "	10
1 "	11
4 "	12
1 "	12c
2 "	15b
2 "	16
1 "	17
1 "	19g
4 "	22
1 "	23
1 "	24
8 "	35
42 "	37
2 "	37a
7 "	38
1 "	48
2 "	48a
4 "	90a
4 "	111c
2 "	125
2 "	126
2 "	126a
4 "	155a
4 "	187
2 "	188
2 "	189
2 "	192
1 "	213

Fig. 4.15a

2 of No. 200
1 " " 212
1 " " 213

4.16 TRACTION ENGINE

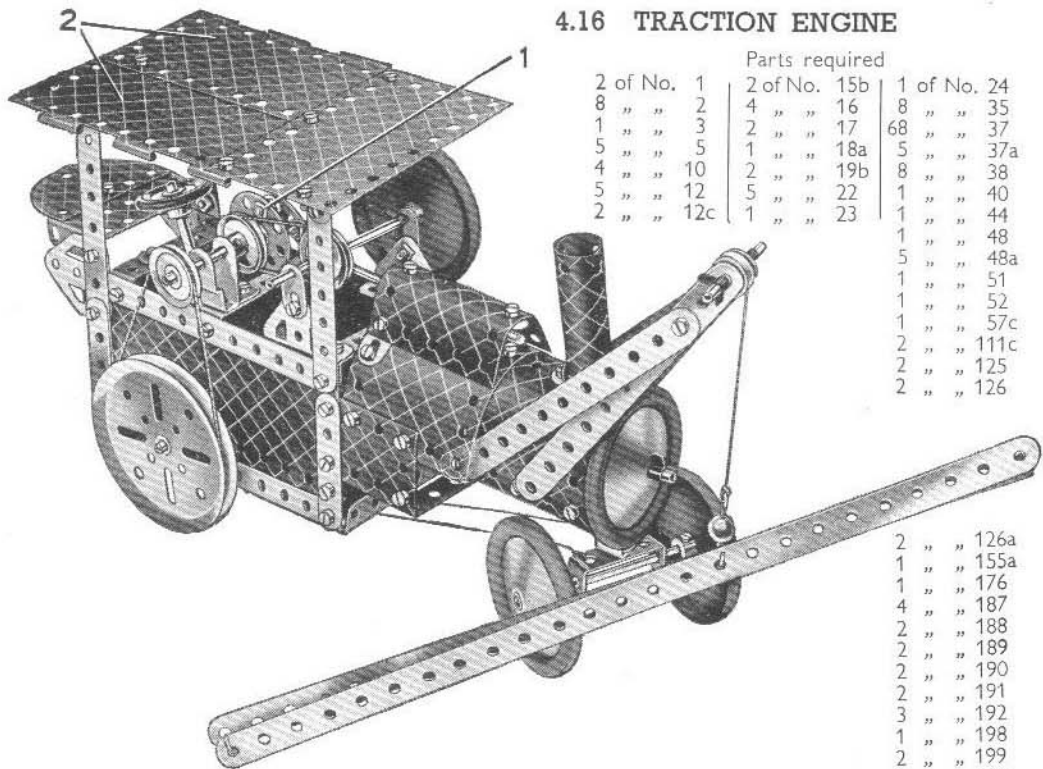

Parts required		
2 of No. 1	2 of No. 15b	1 of No. 24
8 " " 2	4 " " 16	8 " " 35
1 " " 3	2 " " 17	68 " " 37
5 " " 5	1 " " 18a	5 " " 37a
4 " " 10	2 " " 19b	8 " " 38
5 " " 12	5 " " 22	1 " " 40
2 " " 12c	1 " " 23	1 " " 44
		1 " " 48
		5 " " 48a
		1 " " 51
		1 " " 52
		1 " " 57c
		2 " " 111c
		2 " " 125
		2 " " 126

2 " " 126a
1 " " 155a
1 " " 176
4 " " 187
2 " " 188
2 " " 189
2 " " 190
2 " " 191
3 " " 192
1 " " 198
2 " " 199
1 " " 200
1 " " 212
1 " " 213
1 " " 214
2 " " 215
1 " " 217b

The cylinder consists of a U-Section Curved Plate, fastened to the boiler by the Obtuse Angle Brackets. Bearings for the piston rod are formed by the holes of two Angle Brackets, which are held in place by the Bolts that can be seen at the top of the cylinder. The Bolts 1, which pass through a connecting rod consisting of two Flat Brackets, are lock-nutted. A U-Section Curved Plate, bent so that its ends overlap one hole, is used for the chimney. The centre pin of a Hinged Flat Plate has been removed and the two parts used as flat plates 2 in the construction of the roof of the cab.

The $1\frac{1}{2}'' \times \frac{1}{2}''$ Double Angle Strip that supports the front axle is pivotally attached by a lock-nutted Bolt, to the centre hole of a double bent strip, which consists of two Reversed Angle Brackets. The Cord controlling the steering is wound twice around the lower end of the steering column.

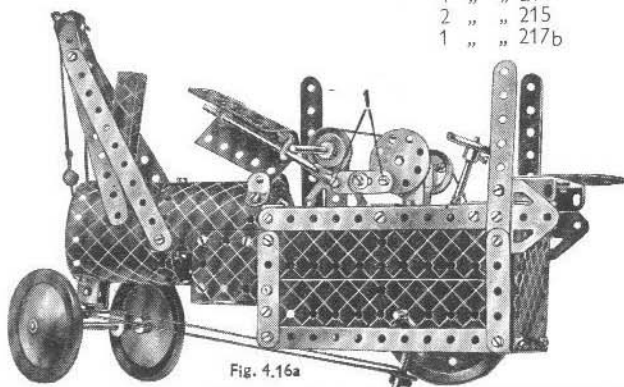
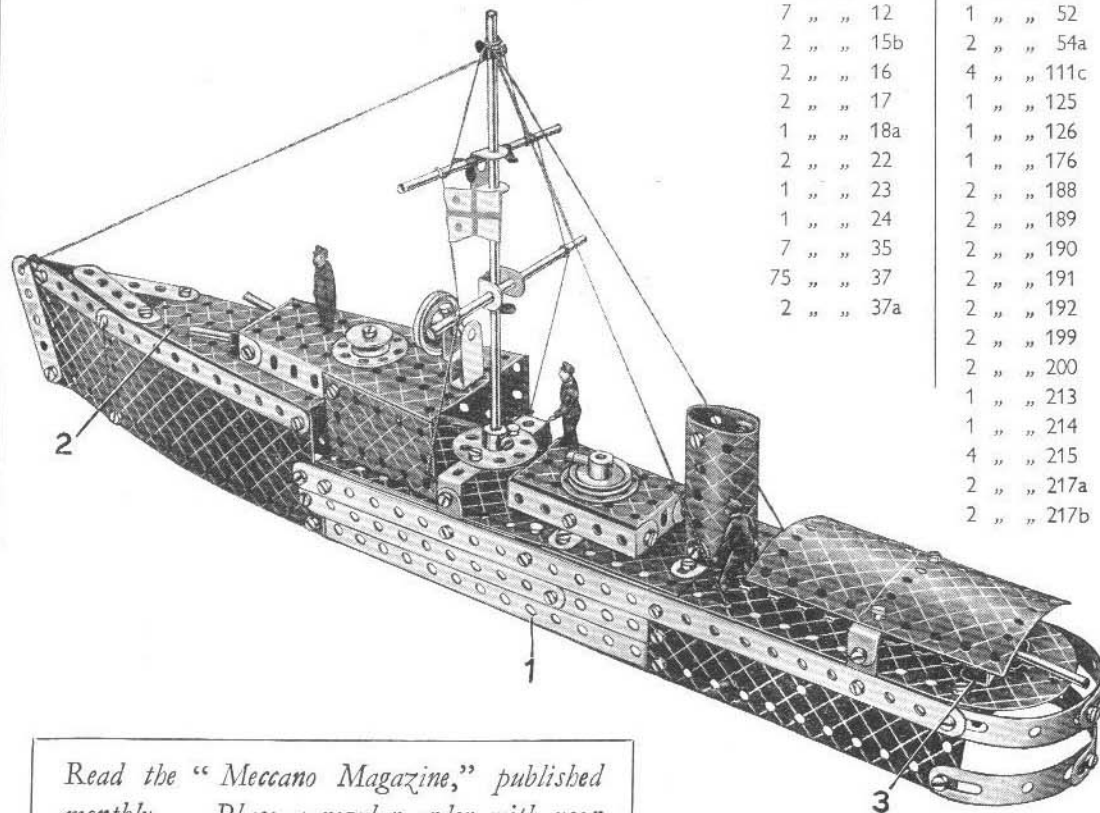

Fig. 4.16a

4.17 RIVER GUN-BOAT

Each side of the forward part of the ship consists of a $2\frac{1}{2}'' \times 2\frac{1}{2}''$ and a $5\frac{1}{2}'' \times 2\frac{1}{2}''$ Flexible Plate. These are bolted to the $12\frac{1}{2}''$ Strip 1 and to the Flanged Sector Plate 2. The funnel is represented by two U-Section Curved Plates bent so that their ends overlap two holes at each side, and it is fastened to the deck by two Angle Brackets. The forward gun turret, also a Flanged Sector Plate, is fastened to the raised portion of the deck by means of an $\frac{1}{2}'' \times \frac{1}{2}''$ Angle Bracket. The guns are represented by two 2" Rods, held by Spring Clips in the holes of a $1\frac{1}{2}'' \times \frac{1}{2}''$ Double Angle Strip bolted to the narrow end of the Flanged Sector Plate 2. A $1\frac{1}{2}''$ Rod, held by a Spring Clip and a Cord Anchoring Spring in a Trunnion 3, forms the rear gun. The gun in front of the funnel is held in place by a $\frac{3}{8}''$ Bolt passed through the centre hole of the Flanged Plate and locked in the boss of the Pulley by the $\frac{3}{8}''$ Bolt representing the gun barrel.



Parts required		
4 of No. 1	1 of No. 40	
4 " " 2	1 " " 44	
8 " " 5	1 " " 48	
4 " " 10	5 " " 48a	
2 " " 11	1 " " 51	
7 " " 12	1 " " 52	
2 " " 15b	2 " " 54a	
2 " " 16	4 " " 111c	
2 " " 17	1 " " 125	
1 " " 18a	1 " " 126	
2 " " 22	1 " " 176	
1 " " 23	2 " " 188	
1 " " 24	2 " " 189	
7 " " 35	2 " " 190	
75 " " 37	2 " " 191	
2 " " 37a	2 " " 192	
	2 " " 199	
	2 " " 200	
	1 " " 213	
	1 " " 214	
	4 " " 215	
	2 " " 217a	
	2 " " 217b	

Read the "Meccano Magazine," published monthly. Place a regular order with your Meccano dealer or newsagent today.

4.18 SIX-WHEELED STEAM WAGON

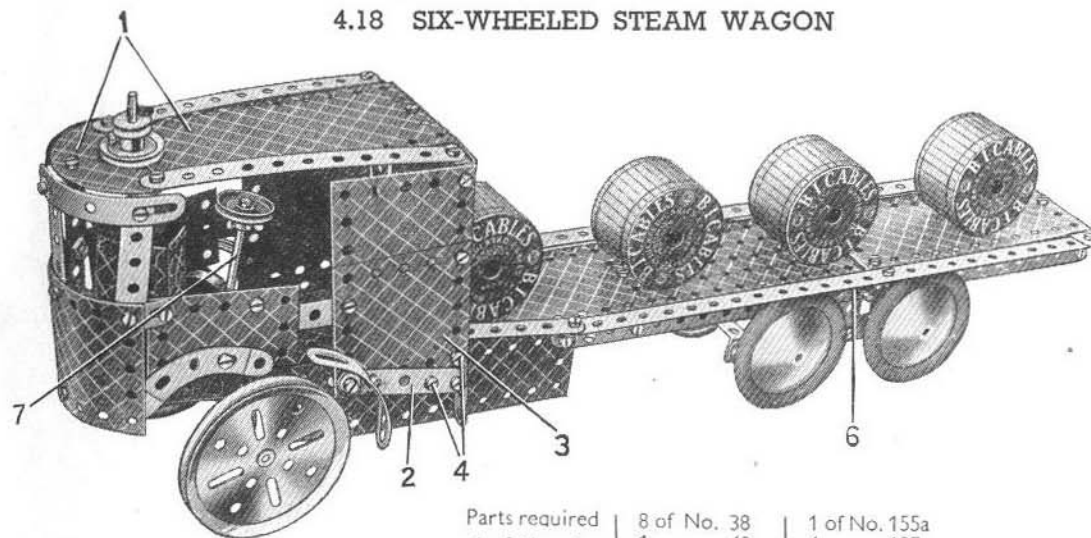

Parts required		8 of No. 38	1 of No. 155a
4 of No. 1	1 " " 48	4 " " 187	
8 " " 2	6 " " 48a	2 " " 188	
2 " " 3	1 " " 51	2 " " 189	
6 " " 5	1 " " 52	4 " " 190	
4 " " 10	1 " " 54a	2 " " 191	
2 " " 11	4 " " 90a	2 " " 192	
8 " " 12	2 " " 111c	2 " " 199	
2 " " 12c	2 " " 125	2 " " 200	
2 " " 15b	1 " " 126	1 " " 214	
4 " " 16	2 " " 126a	4 " " 215	
2 " " 19b			
5 " " 22			
1 " " 23			
1 " " 24			
8 " " 35			
75 " " 37			
2 " " 37a			

In Fig. 4.18a the top of the cab has been removed to show the construction of the boiler and steering wheel. The boiler consists of two U-Section Curved Plates fastened by a $1\frac{1}{2}'' \times \frac{1}{2}''$ Double Angle Strip to the Flanged Sector Plate forming the bottom of the cab. The two 1" Pulleys seen in Fig. 4.18a are fixed to the steering column 7, which passes through the bottom of the cab and is held in the boss of a Bush Wheel carrying a $2\frac{1}{2}'' \times \frac{1}{2}''$ Double Angle Strip. The holes in the turned down ends of the Double Angle Strip support the 4" Rod that forms the front axle. The method of attaching the chimney to the two Plates 1 is shown in Fig. 4.18c. The Bolts 4 pass through a Flat Bracket behind Plate 3, thus securing the Strip 2 to the Plate. The 1" Pulley with Rubber Ring represents the top of the boiler.

Fig. 4.18b shows the construction of the rear wheel bogie. The bogie is attached to the wagon by a Rod 5, which passes through the holes in the $12\frac{1}{2}''$ Strips 6 and through the upper holes in the Flat Trunnions bolted to the bogie. The Rod is held in position by Spring Clips.

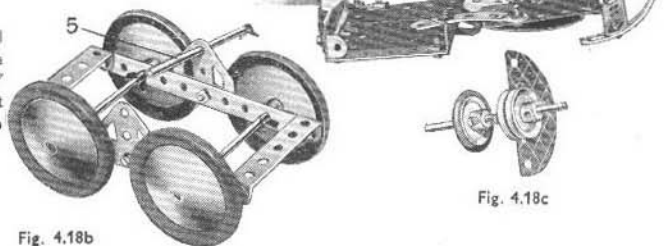
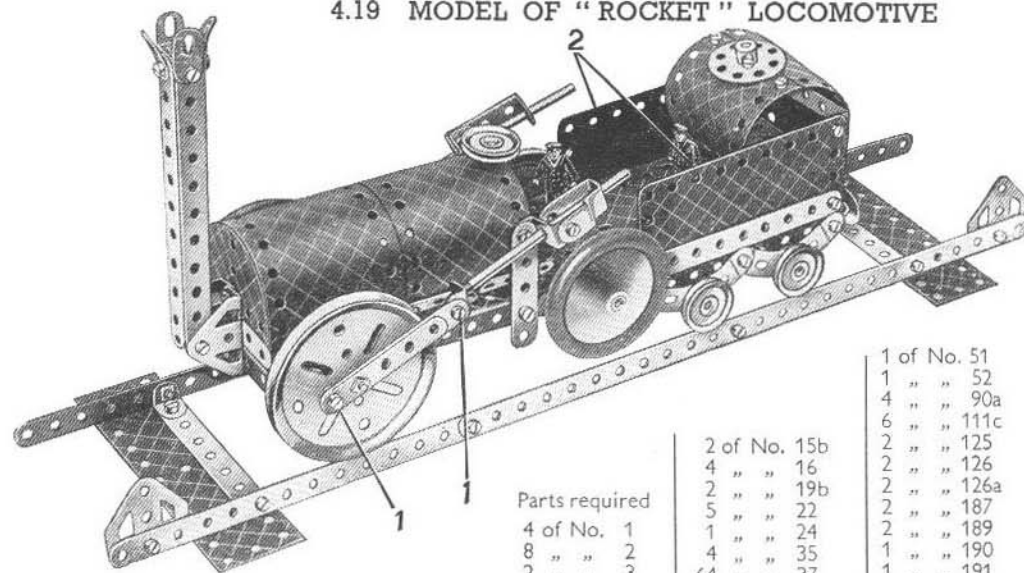

Fig. 4.18b

Fig. 4.18c

4.19 MODEL OF "ROCKET" LOCOMOTIVE



Parts required		2 of No. 15b	1 of No. 51
4 of No. 1	4 " " 16	2 " " 19b	1 " " 52
8 " " 2	5 " " 22	2 " " 22	4 " " 90a
2 " " 3	1 " " 24	4 " " 35	6 " " 111c
9 " " 5	1 " " 37	12 " " 37a	2 " " 125
4 " " 10	8 " " 38	1 " " 44	2 " " 126
1 " " 11	1 " " 48	2 " " 48	2 " " 187
8 " " 12	2 " " 48a	2 " " 189	1 " " 190
4 " " 12c		1 " " 191	2 " " 192
		2 " " 198	1 " " 198
		2 " " 200	2 " " 200
		2 " " 214	2 " " 214
		2 " " 217b	

The pin has been removed from a Hinged Flat Plate and the halves used as flat plates 2, to form the sides of the tender. The chassis of the engine consists of a $5\frac{1}{2}'' \times 2\frac{1}{2}''$ and a $2\frac{1}{2}'' \times 1\frac{1}{2}''$ Flanged Plate, fastened together by two $2\frac{1}{2}''$ Strips. Two $5\frac{1}{2}'' \times 2\frac{1}{2}''$ Flexible Plates bolted to $5\frac{1}{2}''$ Strips form the boiler, and are fastened to the $5\frac{1}{2}'' \times 2\frac{1}{2}''$ Flanged Plate by Obtuse Angle Brackets, two of which can be seen in Fig. 4.19a. Semi-Circular Plates form the ends of the boiler.

The four $5\frac{1}{2}''$ Strips that represent the chimney are joined together at the top by a Double Bracket and an Angle Bracket. The Chimney is bolted to two Trunnions, secured to the chassis and to the boiler front. Bearings for the piston rods are formed on one side by a $1\frac{1}{2}'' \times \frac{1}{2}''$ Double Angle Strip and a Reversed Angle Bracket, and on the other side by a Cranked Bent Strip and a Reversed Angle Bracket. The Bolts 1 on the connecting rods are lock-nutted, and the piston rods are retained in position by Spring Clips placed on each side of the Angle Brackets. The $\frac{3}{4}''$ Discs representing buffers are fastened against the heads of the $\frac{3}{4}''$ Bolts, which are lock-nutted to the Flexible Plate forming the back of the tender.

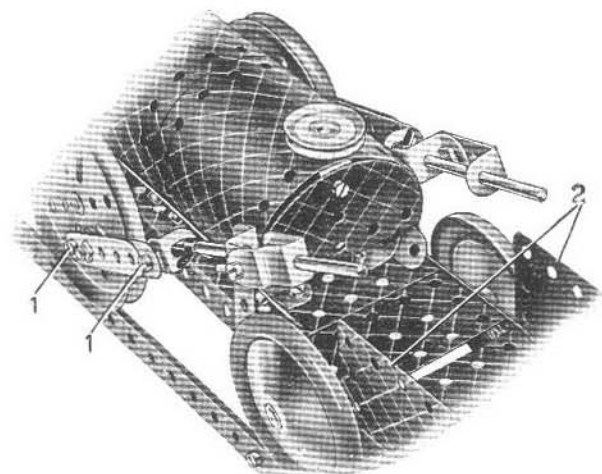
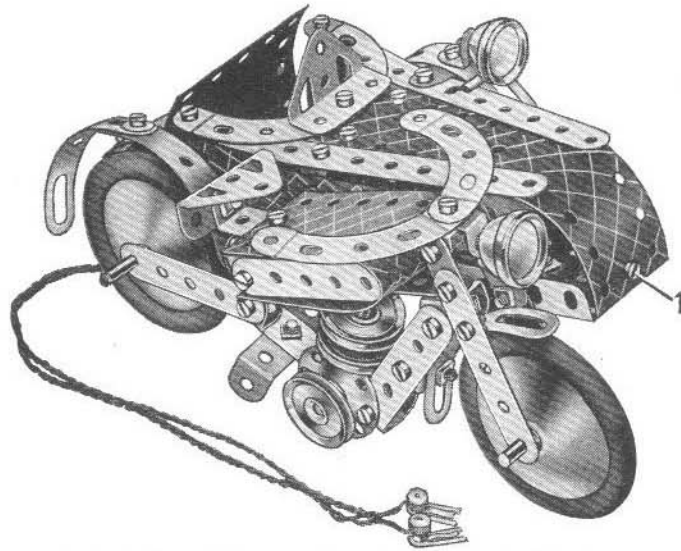

Fig. 4.19a

4.20 MOTOR CYCLE AND SIDECAR



Parts required		
5 of No.	2	1 of No. 54a
1 " "	3	4 " " 90a
8 " "	5	1 " " 111c
5 " "	10	1 " " 125
2 " "	11	2 " " 126
8 " "	12	2 " " 126a
1 " "	12c	3 " " 187
1 " "	16	2 " " 188
2 " "	17	2 " " 189
1 " "	18a	1 " " 190
3 " "	22	2 " " 199
1 " "	25	1 " " 200
51 " "	37	2 " " 214
2 " "	38	4 " " 215
1 " "	48	2 " " 217a
3 " "	48a	Lighting Set (Not included in Outfit)

The $5\frac{1}{2} \times 1\frac{1}{2}$ " Flexible Plate that forms the front of the sidecar is bolted at 1 to a $2\frac{1}{2} \times \frac{1}{2}$ " Double Angle Strip, which is fastened by Bolt 2 to the $4\frac{1}{2}$ " Flanged Sector Plate forming the bottom of the sidecar. The Bolts 3 pass through the Flexible Plates and also through a $2\frac{1}{2} \times \frac{1}{2}$ " Double Angle Strip.

The engine cylinder consists of two 1" Pulleys mounted on a 2" Rod, one end of which is journalled in the Strip 4 that forms the top of the frame. The other end of the Rod is held between the two Bolts that fasten the $1\frac{1}{4}$ " Discs to the frame.

The model is fitted with two Spotlights taken from a Meccano Lighting Set. These are fastened by the Angle Brackets supplied with the Lighting Set, to the handlebars and sidecar mudguard. The battery for supplying current for the Spotlights can be concealed in the sidecar.

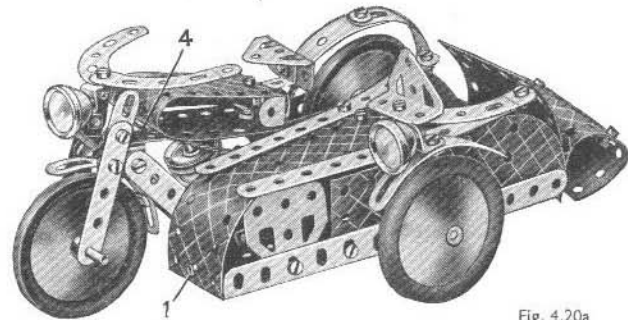

Fig. 4.20a

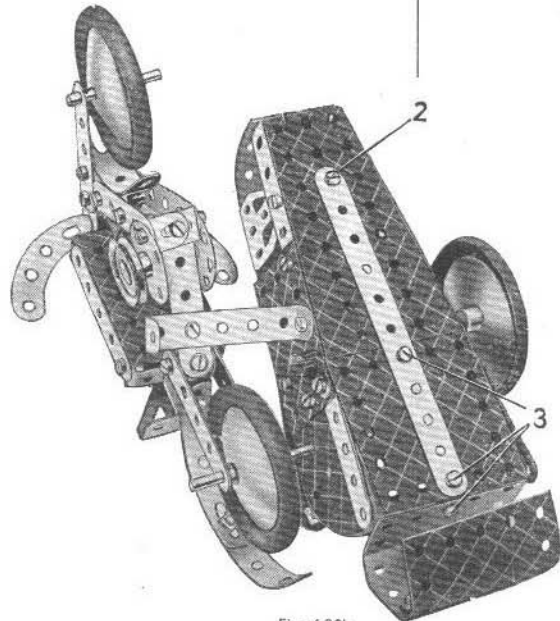
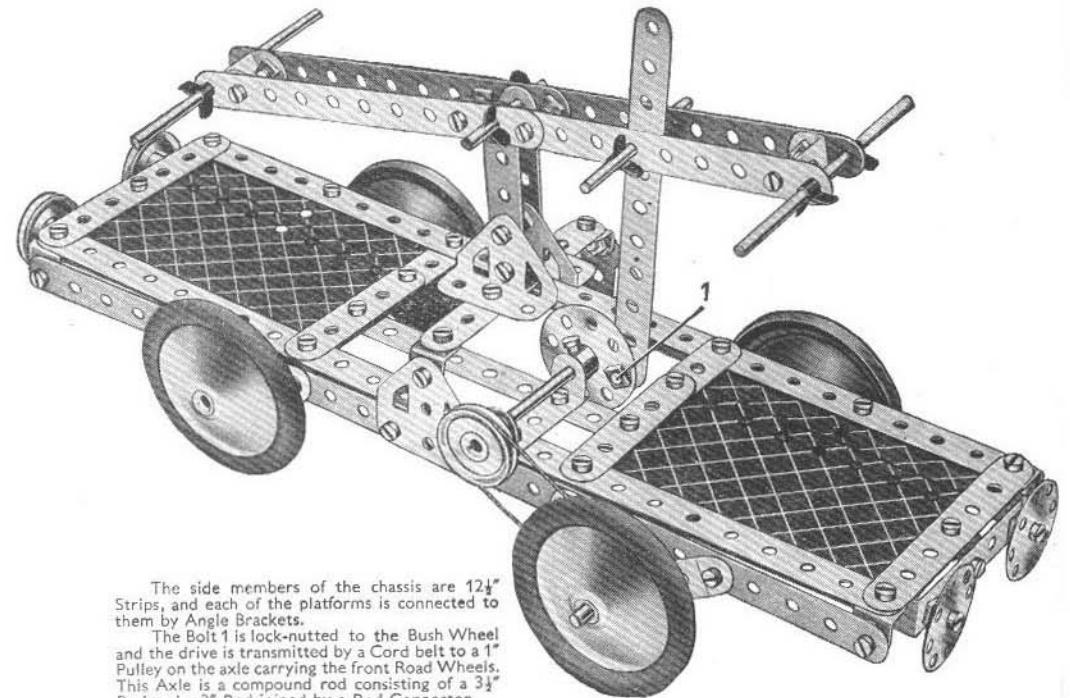

Fig. 4.20b

4.21 HAND TROLLEY CAR



The side members of the chassis are $12\frac{1}{2}$ " Strips, and each of the platforms is connected to them by Angle Brackets.

The Bolt 1 is lock-nutted to the Bush Wheel and the drive is transmitted by a Cord belt to a 1" Pulley on the axle carrying the front Road Wheels. This Axle is a compound rod consisting of a $3\frac{1}{2}$ " Rod and a 2" Rod joined by a Rod Connector.

Parts required			
4 of No.	1	2 of No. 18a	4 of No. 90a
6 " "	2	4 " " 22	4 " " 111c
2 " "	3	1 " " 24	2 " " 126
8 " "	5	8 " " 35	2 " " 126a
2 " "	11	54 " " 37	4 " " 187
8 " "	12	7 " " 37a	4 " " 190
1 " "	15b	2 " " 38	2 " " 191
3 " "	16	1 " " 48	1 " " 213
2 " "	17	2 " " 48a	2 " " 217a

4.22 HORIZONTAL STEAM ENGINE

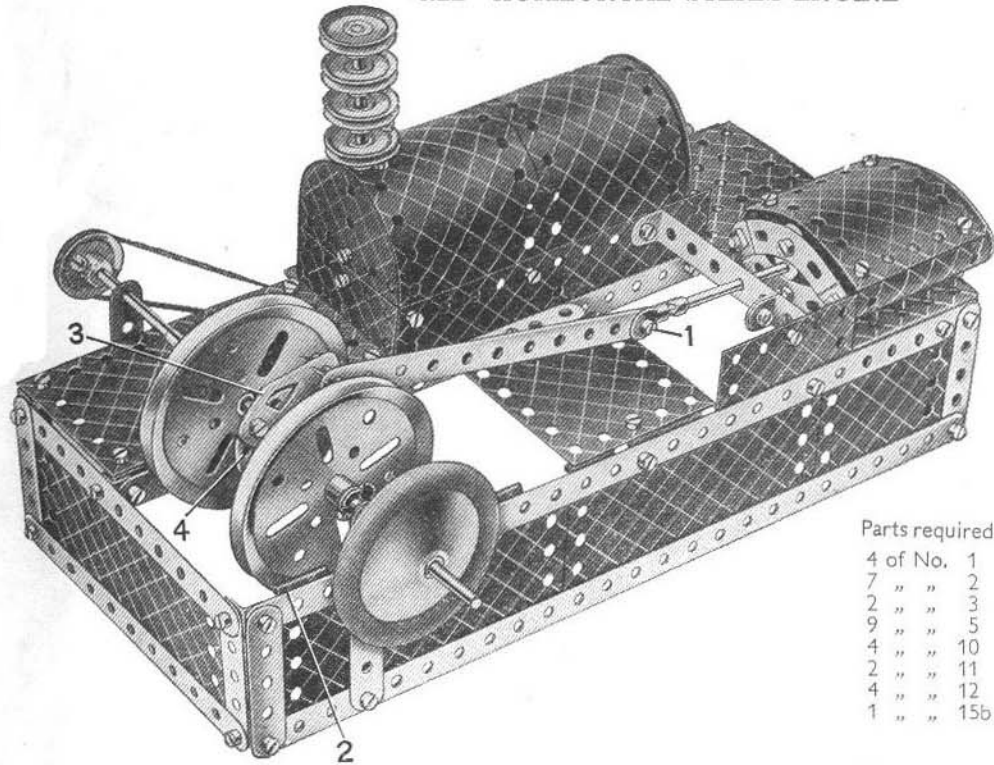

Parts required

- 4 of No. 1
- 7 " " 2
- 2 " " 3
- 9 " " 5
- 4 " " 10
- 2 " " 11
- 4 " " 12
- 1 " " 15b

- 3 of No. 16
- 1 " " 17
- 1 " " 18b
- 2 " " 19b
- 5 " " 22
- 1 " " 24
- 6 " " 35
- 75 " " 37
- 6 " " 37a
- 3 " " 38
- 6 " " 48a
- 1 " " 51
- 1 " " 52
- 4 " " 90a
- 6 " " 111c
- 2 " " 125
- 2 " " 126
- 2 " " 126a
- 1 " " 176
- 1 " " 187
- 2 " " 188
- 2 " " 189
- 4 " " 190
- 2 " " 191
- 2 " " 192
- 1 " " 198
- 2 " " 199
- 2 " " 200
- 1 " " 212
- 1 " " 213
- 2 " " 214
- 1 " " 217a
- 1 Magic Motor

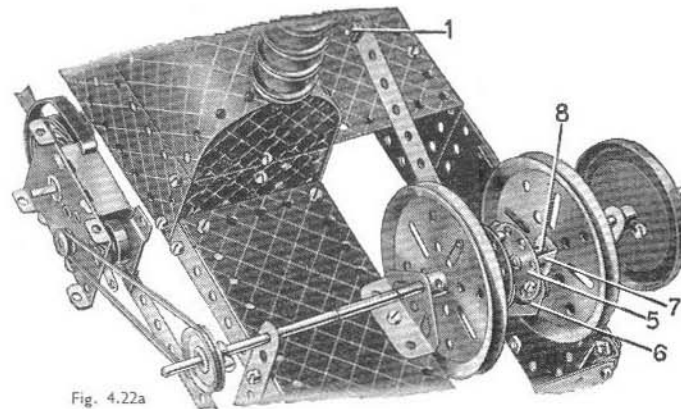
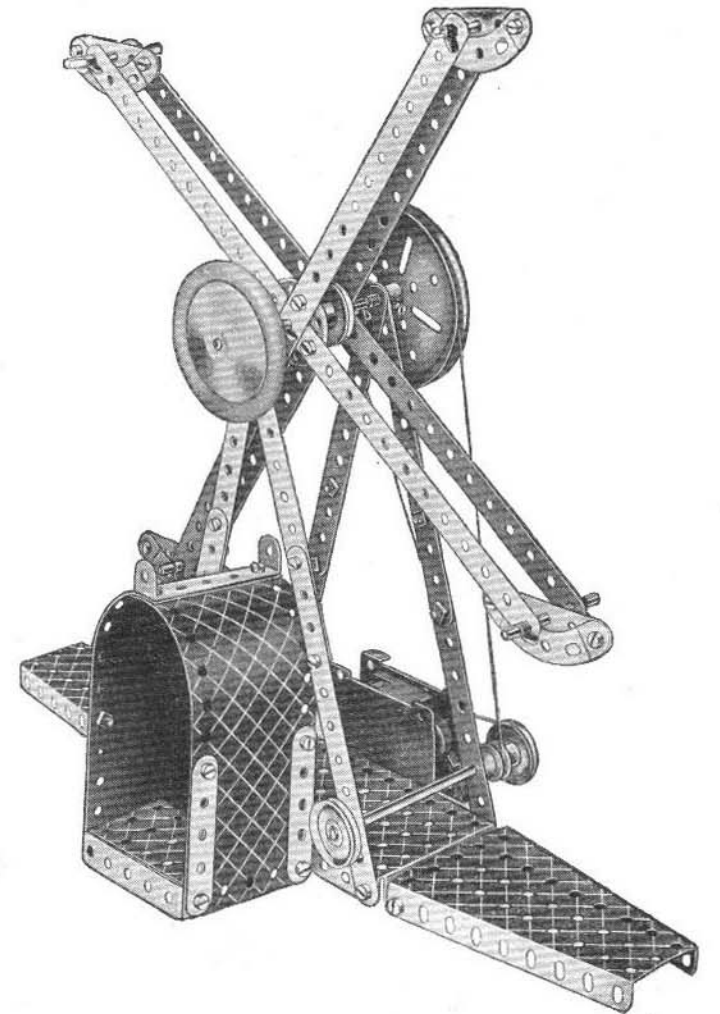

Fig. 4.22a

The Bolt 1 is lock-nutted. The centre pin is withdrawn from a Hinged Flat Plate and the two halves used as flat plates at 2. The Flat Trunnion 3 is bolted to Bush Wheel 4 and forms one web of the crank. The Bush Wheel is fastened to a 2" Rod, which carries also a 3" Pulley, and a Rod Connector joins this Rod to a 3½" Rod that transmits the drive from the Magic Motor. The other web of the crank is made by bolting a 1½" Disc 5 to a Flat Trunnion 6, one of the bolts holding also a Reversed Angle Bracket 7. A Spring Clip 8 is fixed in position so that when the crankshaft is rotated the Rod on which the 3" Pulley and the Rod Wheel are fastened is rotated by the Reversed Angle Bracket 7. The cylinder is composed of two 1½" radius Curved Plates and two U-Section Curved Plates bolted together as shown, and the complete unit is fastened in position to the 5½" x 2½" Flanged Plate that forms the base.

The boiler consists of two 5½" x 2½" Flexible Plates bolted to 5½" x 1½" Flexible Plates, and its ends are closed by Semi-circular Plates and 2½" x 1½" Flexible Plates. The fire-box door is represented by a Trunnion. The chimney is a 4" Rod fitted with 1" Pulleys, and is held in place by a Cord Anchoring Spring. Fig. 4.22a shows the arrangement for driving the model with a Magic Motor.

4.23 FLYBOATS



Parts required

- 4 of No. 1
- 8 " " 2
- 8 " " 5
- 2 " " 15b
- 2 " " 17
- 2 " " 18a
- 1 " " 19b
- 3 " " 22
- 1 " " 24
- 8 " " 35
- 44 " " 37
- 1 " " 40
- 6 " " 48a
- 1 " " 51
- 1 " " 52
- 2 " " 54a
- 4 " " 90a
- 1 " " 176
- 1 " " 187
- 2 " " 192
- 1 Magic Motor

The Magic Motor is bolted to the flange of the 5½" x 2½" Flanged Plate, and the drive is taken from the pulley of the Motor to a 1" Pulley fastened on a Rod journalled in the 12½" Strips that support the main shaft. A ½" fast Pulley also is secured on this Rod, and drives through a belt of Cord a 3" Pulley on the main shaft. The arms that support the boats are bolted to a Bush Wheel fastened on the main shaft. Each of the boats consists of a 2½" Strip and a 2½" small radius Curved Strip bolted together.

4.24 MOTOR LORRY

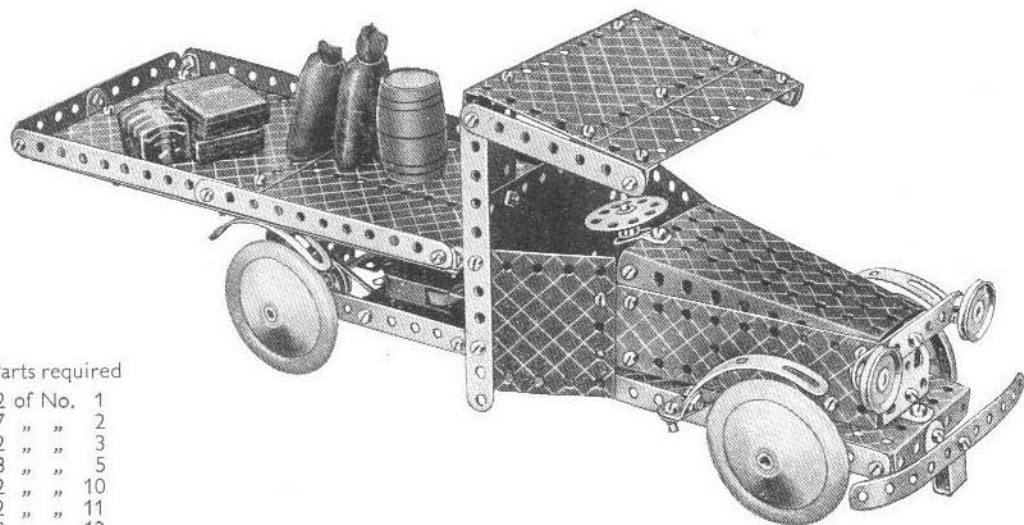

Parts required

2	of No.	1
7	" "	2
2	" "	3
8	" "	5
2	" "	10
2	" "	11
8	" "	12
3	" "	12c
2	" "	15b
1	" "	16
3	" "	22
1	" "	24
5	" "	35
75	" "	37
2	" "	37a
5	" "	38
1	" "	44
1	" "	48
4	" "	48a
1	" "	52
2	" "	54a
4	" "	111c
2	" "	125
2	" "	126
1	" "	126a
4	" "	187
2	" "	188
2	" "	189
4	" "	190
2	" "	191
2	" "	192
1	" "	198
4	" "	215
1	Magic	Motor

The chassis of the model consists of two $12\frac{1}{2}$ " Strips bolted to a $5\frac{1}{2}$ " \times $2\frac{1}{2}$ " Flanged Plate and secured at their free ends by a $2\frac{1}{2}$ " \times $\frac{1}{2}$ " Double Angle Strip. Both the front and rear axles are journalled directly in the chassis. The *Magic Motor* is attached by its flanges to one of the $12\frac{1}{2}$ " Strips, and the drive is taken through a Driving Band from the pulley of the Motor to a 1" fast Pulley fastened on the back axle of the lorry.

The platform is fixed to the end of the chassis by two $2\frac{1}{2}$ " \times $\frac{1}{2}$ " Double Angle Strips, the ends of which can be seen in Fig. 4.24a and also to the back of the cab by a $1\frac{1}{2}$ " \times $\frac{1}{2}$ " Double Angle Strip. The front bumper consists of a $5\frac{1}{2}$ " Strip curved to shape and fastened by a Cranked Bent Strip to the $5\frac{1}{2}$ " \times $2\frac{1}{2}$ " Flanged Plate forming the front of the chassis. The headlamps, which are 1" Pulleys, are fixed in place by $\frac{3}{8}$ " Bolts pushed through the $2\frac{1}{2}$ " Strips into the bosses of the Pulleys and held by the setscrews.

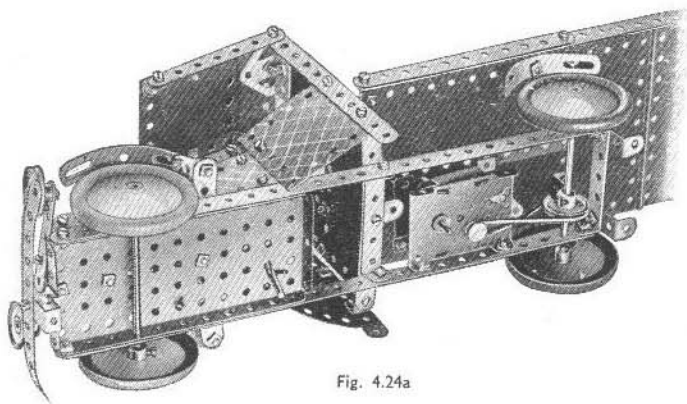
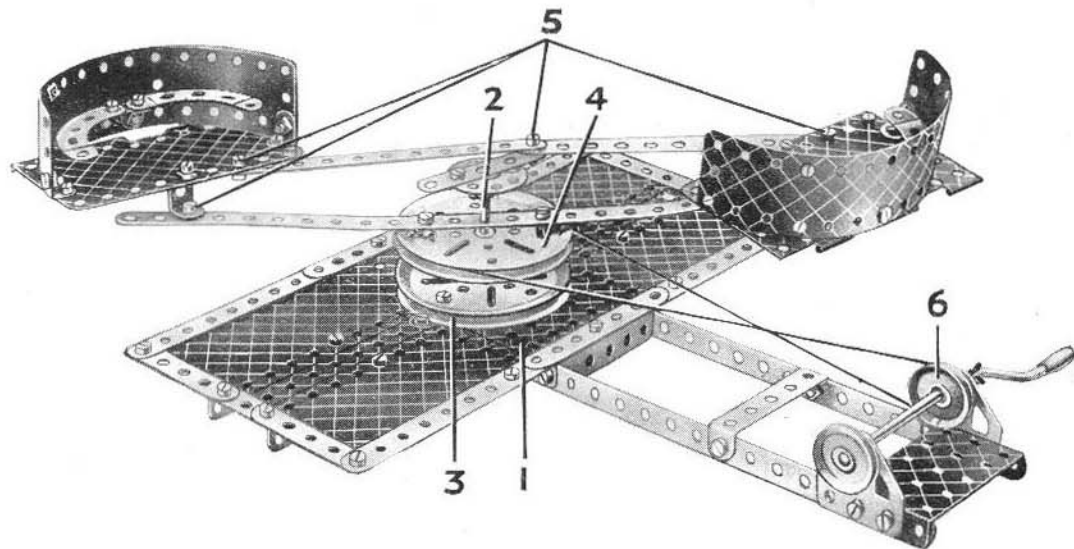

Fig. 4.24a

4.25 "WHIP" ROUNDABOUT



Parts required

3	of No.	1	52	of No.	37b
7	" "	2	8	" "	38
2	" "	3	1	" "	40
4	" "	5	1	" "	48a
4	" "	10	1	" "	51
2	" "	11	1	" "	52
6	" "	12	2	" "	54a
1	" "	17	4	" "	90a
2	" "	19b	6	" "	111c
1	" "	19g	2	" "	126a
2	" "	22	2	" "	188
1	" "	24	2	" "	189
4	" "	35	2	" "	191
65	" "	37a	2	" "	192

1 of No. 198

The base of the model is formed by a $5\frac{1}{2}$ " \times $2\frac{1}{2}$ " Flanged Plate 1 extended on each side by a Flanged Sector Plate, a $5\frac{1}{2}$ " \times $2\frac{1}{2}$ " and a $4\frac{1}{2}$ " \times $2\frac{1}{2}$ " Flexible Plate. The edges of the base are strengthened with Strips. Two $12\frac{1}{2}$ " Strips are bolted to the flanges of Plate 1 and their ends are connected by a $2\frac{1}{2}$ " \times $1\frac{1}{2}$ " Flanged Plate. Two Flat Trunnions provide bearings for a Small Crank Handle.

A 3" Pulley 3 is bolted to Flanged Plate 1 and in its boss is fixed a 2" Rod 2. A second 3" Pulley 4 is spaced from Pulley 3 by a Spring Clip and is free to turn on Rod 2. Across its face is bolted a $12\frac{1}{2}$ " Strip, the Strip being spaced from the Pulley by a Spring Clip and two Washers placed on the shank of each securing Bolt.

A Bush Wheel fitted with a $2\frac{1}{2}$ " Strip is secured on Rod 2 in the position shown, the end of the Strip being connected to the cars by $5\frac{1}{2}$ " Strips. All the Bolts 5 are lock-nutted.

The 1" Pulley 6 mounted on the Crank Handle, drives Pulley 4 through a belt of Cord.

5.1 RACING SEAPLANE

Parts required

8	of No.	1
14	" "	2
2	" "	3
12	" "	5
2	" "	6a
4	" "	8
4	" "	12
2	" "	12a
4	" "	12c
1	" "	15a
2	" "	15b
1	" "	16
1	" "	24
8	" "	35
85	" "	37
6	" "	37a
4	" "	38
1	" "	40

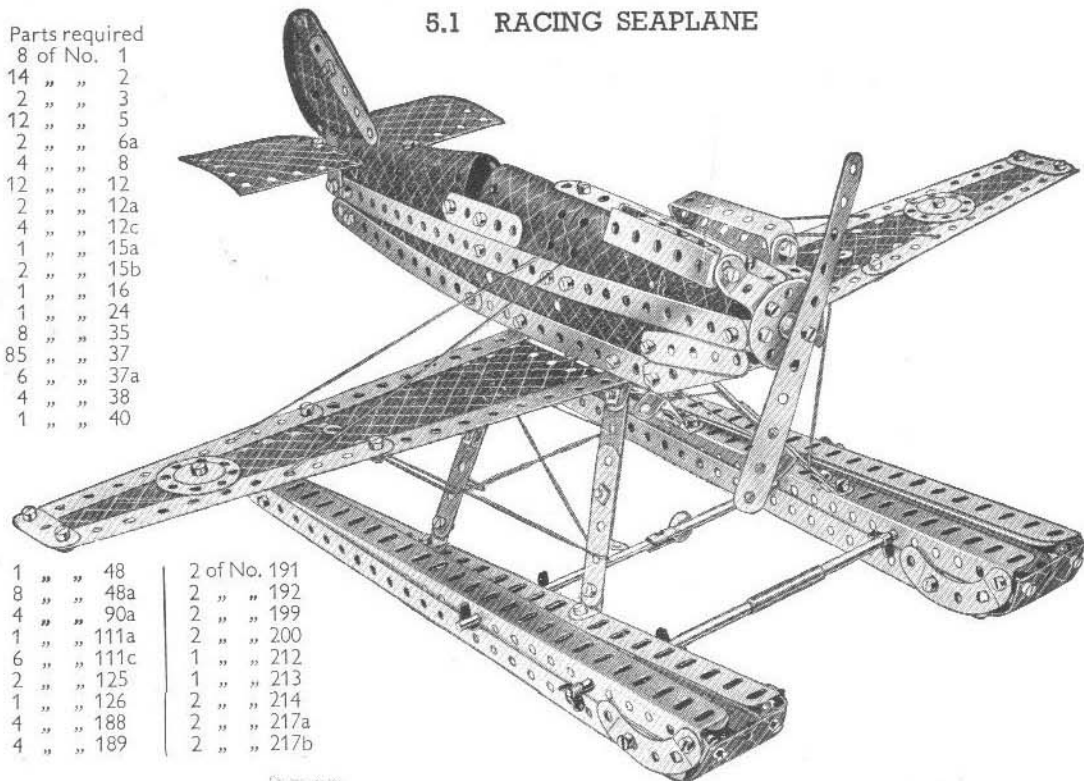

1	" "	48	2	of No.	191
8	" "	48a	2	" "	192
4	" "	90a	2	" "	199
1	" "	111a	2	" "	200
6	" "	111c	1	" "	212
2	" "	125	1	" "	213
1	" "	126	2	" "	214
4	" "	188	2	" "	217a
4	" "	189	2	" "	217b

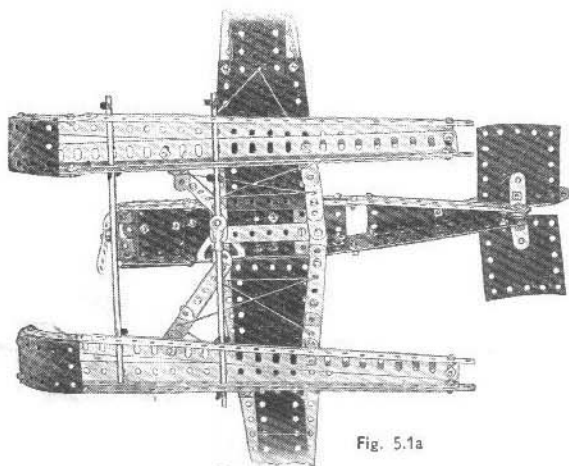
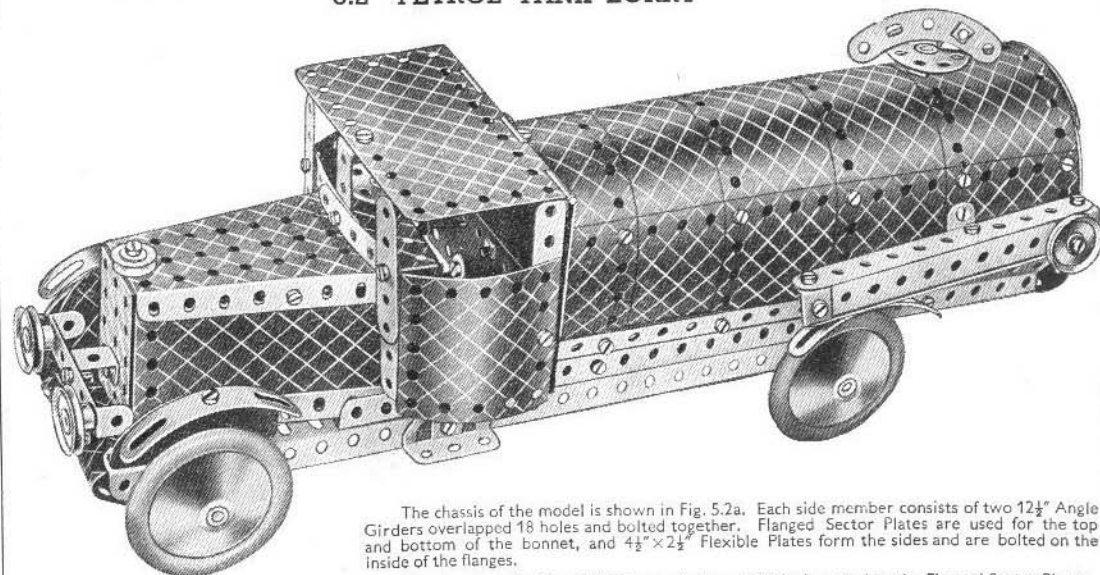

Fig. 5.1a

A $2\frac{1}{2}'' \times 1\frac{1}{2}''$ Flexible Plate is bolted to Angle Brackets underneath the nose, but it is removed in Fig. 5.1a to show the construction of the fuselage. The rudder is bolted to a $3\frac{1}{2}''$ Strip, which is held upright between four spacing Washers (two on each side) on the $\frac{1}{2}''$ Bolt that holds the $12\frac{1}{2}''$ Strips together at the tail.

The leading edge of the wing is fastened to the fuselage by a Trunion, and the trailing edge is fixed to a $1\frac{1}{2}'' \times \frac{1}{2}''$ Double Angle Strip that spaces the underside of the fuselage. The floats are attached by Obtuse Angle Brackets bolted to the wings. The front tie rod of the floats is made up of two 4" Rods joined by a Rod Connector, and the rear tie rod consists of a $4\frac{1}{2}''$ Rod and a $3\frac{1}{2}''$ Rod joined by a Rod and Strip Connector. A $12\frac{1}{2}''$ Strip is bolted between the two $12\frac{1}{2}''$ Angle Girders that form the top of each float.

5.2 PETROL TANK LORRY



The chassis of the model is shown in Fig. 5.2a. Each side member consists of two $12\frac{1}{2}''$ Angle Girders overlapped 18 holes and bolted together. Flanged Sector Plates are used for the top and bottom of the bonnet, and $4\frac{1}{2}'' \times 2\frac{1}{2}''$ Flexible Plates form the sides and are bolted on the inside of the flanges.

The steering wheel is a $1\frac{1}{2}''$ Disc carried on a Bolt lock-nutted to the Flanged Sector Plate.

The roof and back of the cab consist of a Hinged Flat Plate and two $2\frac{1}{2}'' \times 1\frac{1}{2}''$ Flexible Plates overlapped one hole. The cab is fastened to the chassis by Angle Brackets, and to the bonnet by the $1\frac{1}{2}'' \times \frac{1}{2}''$ Double Angle Strip that forms the central division of the windscreen.

In Fig. 5.2a the tank is opened out to show its construction. The top of the tank consists of four $5\frac{1}{2}'' \times 2\frac{1}{2}''$ Flexible Plates and a $5\frac{1}{2}'' \times 1\frac{1}{2}''$ Flexible Plate. It is extended on the rear side by two $5\frac{1}{2}'' \times 1\frac{1}{2}''$ Flexible Plates, and $12\frac{1}{2}''$ Strips are bolted to each longitudinal edge. The complete tank is attached to the Angle Girders by four Obtuse Angle Brackets. The tank filler cap is a Bush Wheel fitted with a $2\frac{1}{2}''$ small radius Curved Strip, and is fastened to the shank of the $\frac{1}{2}''$ Bolt at the top of the tank.

Parts required

7	of No.	2	1	of No.	52
1	" "	3	2	" "	54a
8	" "	5	4	" "	90a
4	" "	8	2	" "	111a
3	" "	11	5	" "	111c
10	" "	12	2	" "	125
2	" "	12a	2	" "	126
4	" "	12c	2	" "	126a
2	" "	15	4	" "	187
3	" "	22	4	" "	188
1	" "	22a	3	" "	189
1	" "	23	4	" "	190
1	" "	24	2	" "	191
4	" "	35	4	" "	192
80	" "	37	1	" "	198
5	" "	37a	2	" "	199
9	" "	38	2	" "	200
1	" "	48	2	" "	214
1	" "	48a	4	" "	215
1	" "	51	1	" "	217a

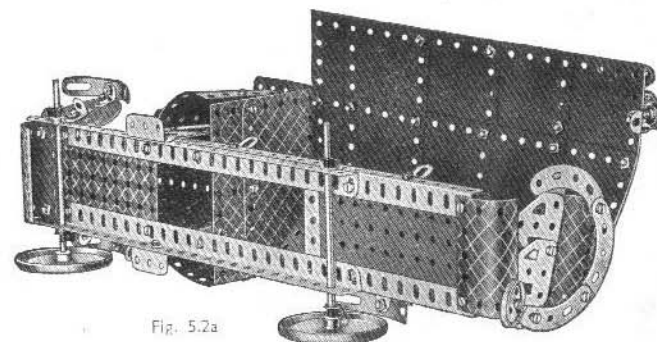
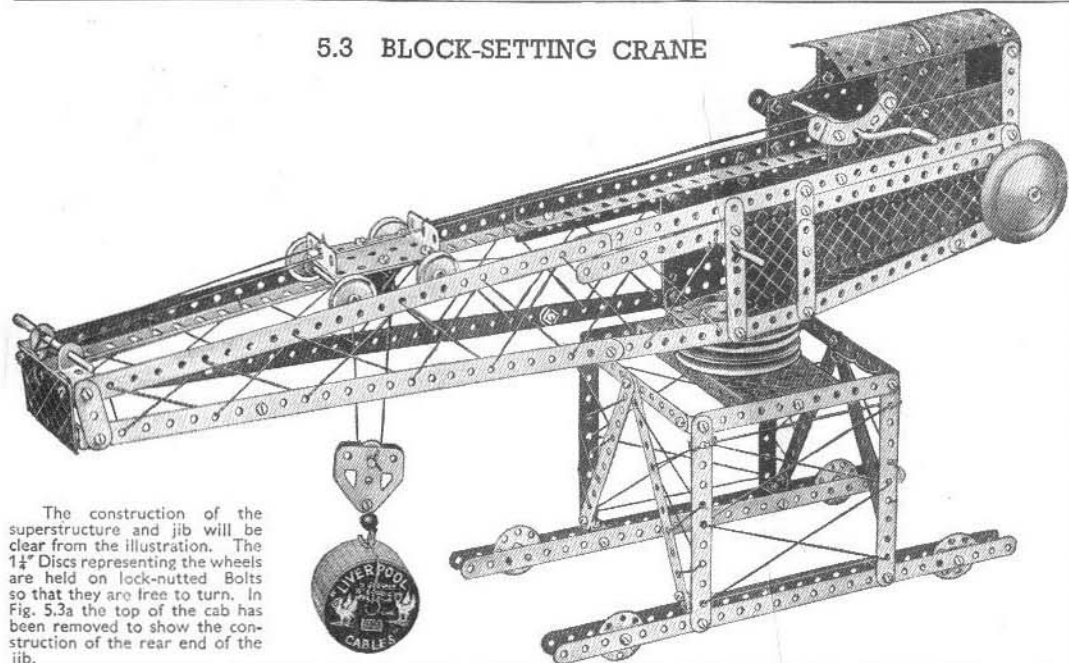

Fig. 5.2a

5.3 BLOCK-SETTING CRANE



The construction of the superstructure and jib will be clear from the illustration. The 1 1/4" Discs representing the wheels are held on lock-nutted Bolts so that they are free to turn. In Fig. 5.3a the top of the cab has been removed to show the construction of the rear end of the jib.

A 3" Pulley is bolted to the jib by two 3/8" Bolts, which hold also a 2 1/2" x 1/4" Double Angle Strip fixed along the length of the jib on the underside of the 3" Pulley, so that its ends form a bearing between the two Pulleys. A 3 1/2" Rod fastened in the boss of the upper 3" Pulley passes through the boss of the lower 3" Pulley, which is bolted to a 5 1/2" x 2 1/2" Flanged Plate forming part of the superstructure. The Rod is retained in position below the Flanged Plate as shown in Fig. 5.3b.

The hoisting carriage is shown in Fig. 5.3c; it runs on rails formed by Angle Girders at the top of the jib. A Cord is tied to the front end of the carriage, and is taken over a 3 1/2" Rod at the jib head and wound six times around the Crank Handle. It is then tied to the rear of the carriage.

A second Cord is tied to a Cord Anchoring Spring on the 3 1/2" Rod carrying the Bush Wheel and the Road Wheel. The Cord is then led around one of the 1" loose Pulleys in the carriage around the 1/2" loose Pulley in the pulley block, and back over the second 1" loose Pulley. Finally it is tied to the 2 1/2" x 1 1/2" Flexible Plate at the jib head.

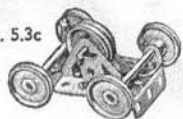
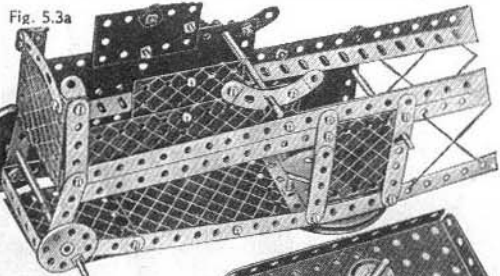
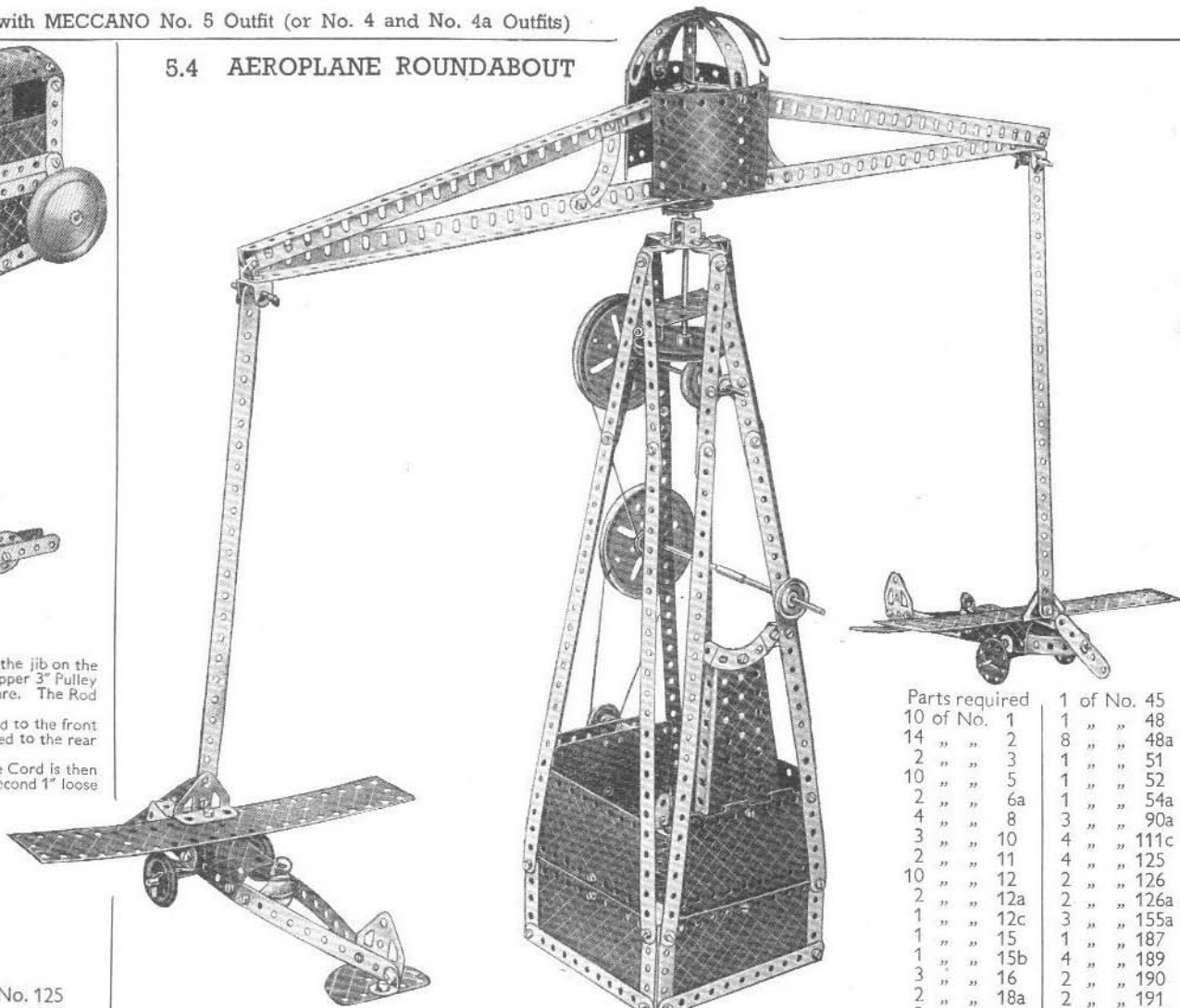

Fig. 5.3b

Parts required

10 of No. 1	2 of No. 22a	2 of No. 125
14 " " 2	1 " " 23	2 " " 126
2 " " 3	1 " " 24	2 " " 126a
12 " " 5	10 " " 35	1 " " 176
2 " " 6a	85 " " 37	1 " " 187
4 " " 8	6 " " 37a	3 " " 188
4 " " 11	11 " " 38	4 " " 189
12 " " 12	1 " " 40	4 " " 190
2 " " 12a	1 " " 45	1 " " 191
4 " " 12c	1 " " 48	2 " " 200
1 " " 15b	7 " " 48a	4 " " 217a
3 " " 16	1 " " 51	
2 " " 17	1 " " 52	
1 " " 18a	1 " " 57c	
1 " " 18b	3 " " 90a	
2 " " 19b	1 " " 111a	
1 " " 19g	6 " " 111c	
5 " " 22	1 " " 115	

5.4 AEROPLANE ROUNDABOUT



The centre pin is withdrawn from a Hinged Flat Plate and the halves are used as flat plates in the construction of the base.

The Clockwork Motor is fastened by two 1" x 1" Angle Brackets to a 5 1/2" x 2 1/2" Flanged Plate bolted inside the base. The drive is taken from a 1" fast Pulley on the driving shaft of the Motor, to a 3" Pulley fixed on a Crank Handle journaled in two of the 12 1/2" Strips of the tower.

The Crank Handle is lengthened by joining to it a 3 1/2" Rod with a Rod Connector. It carries also a 1" fast Pulley, which is connected by Cord to a second 3" Pulley mounted on a 5" Rod, bearings for which are provided by the centre holes of two 1 1/4" Strips near the top of the tower. A 1" Pulley fitted with a Rubber Ring is fastened to this Rod, inside the tower. The Rubber Ring bears against the rim of a Road Wheel fastened on the lower end of the vertical 4" Rod to which the beam carrying the aeroplanes also is fastened.

The beam consists of two 12 1/2" Angle Girders bolted to a Bush Wheel and overlapped one hole. The top Girders of the beam are joined together at the centre by an Obtuse Angle Bracket.

Parts required	1 of No. 45
10 of No. 1	1 " " 48
14 " " 2	8 " " 48a
2 " " 3	1 " " 51
10 " " 5	1 " " 52
2 " " 6a	1 " " 54a
4 " " 8	3 " " 90a
3 " " 10	4 " " 111c
2 " " 11	4 " " 125
10 " " 12	2 " " 126
2 " " 12a	2 " " 126a
1 " " 12c	3 " " 155a
1 " " 15	1 " " 187
1 " " 15b	4 " " 189
3 " " 16	2 " " 190
2 " " 18a	2 " " 191
2 " " 19b	4 " " 192
1 " " 19g	1 " " 198
4 " " 22	2 " " 199
2 " " 22a	2 " " 200
1 " " 24	1 " " 213
10 " " 35	2 " " 214
83 " " 37	4 " " 215
4 " " 37a	3 " " 217a
6 " " 38	
1 " " 40	1 No. 1 Clockwork Motor

5.5. TRAVELLING GANTRY CRANE

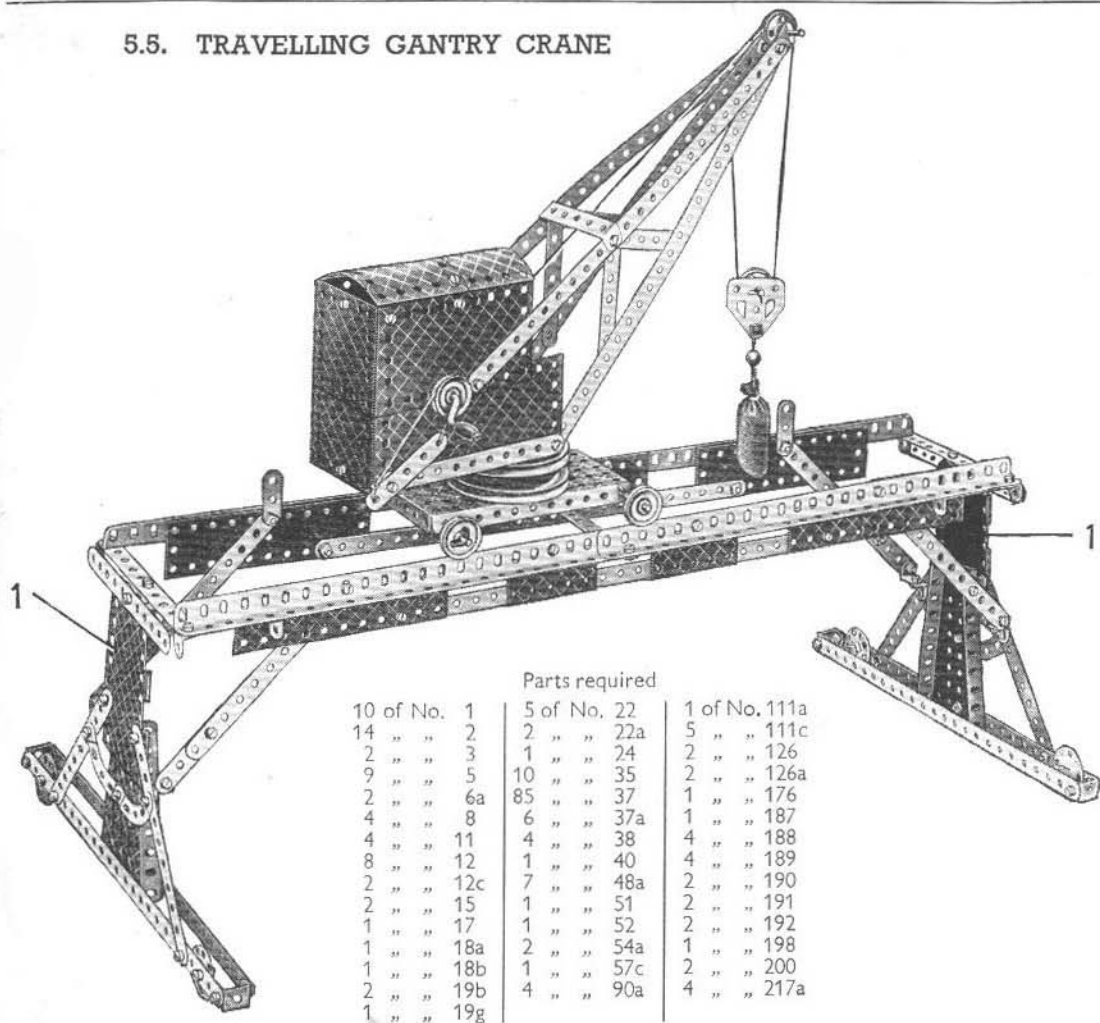

Parts required		
10 of No. 1	5 of No. 22	1 of No. 111a
14 " " 2	2 " " 22a	5 " " 111c
2 " " 3	1 " " 24	2 " " 126
9 " " 5	10 " " 35	2 " " 126a
2 " " 6a	85 " " 37	1 " " 176
4 " " 8	6 " " 37a	1 " " 187
4 " " 11	4 " " 38	4 " " 188
8 " " 12	1 " " 40	4 " " 189
2 " " 12c	7 " " 48a	2 " " 190
2 " " 15	1 " " 51	2 " " 191
1 " " 17	1 " " 52	2 " " 192
1 " " 18a	2 " " 54a	1 " " 198
1 " " 18b	1 " " 57c	2 " " 200
2 " " 19b	4 " " 90a	4 " " 217a
1 " " 19g		

The pin has been withdrawn from a Hinged Flat Plate and the halves are used as flat plates 1 in the construction of the supports for the gantry. Four 1½" Discs are fastened to the 12½" Strips by lock-nutted Bolts, so that the gantry can travel along the ground. Each of the rails along which the crane runs consists of two 12½" Angle Girders, overlapped three holes and joined across by 5½" Strips. Trunnions connect the rails to the supports. A 5½" x 2½" Flanged Plate fitted with a 3" Pulley forms the base of the crane, and the 1" Pulleys are fastened on 5" Rods journaled in the end holes of the Flanged Plate. The cab of the crane consists of Flexible Plates fastened together by 2½" x ½" Double Angle Strips, and a Crank Handle fitted with a 1" Pulley and a Road Wheel is passed through the sides. The Bolts that hold the lower 12½" Strips of the jib carry also a 2½" x 1½" Flanged Plate that has a second 3" Pulley fixed to it. A 2" Rod in the boss of this Pulley passes through the lower Pulley and Flanged Plates, and is retained in position beneath it by a Bush Wheel. A Cord is tied to a Cord Anchoring Spring on the shaft of a Crank Handle, and after passing over the 1" loose Pulleys at the jib head and in the pulley block, is fastened to the jib as shown.

5.6 SALOON COACH

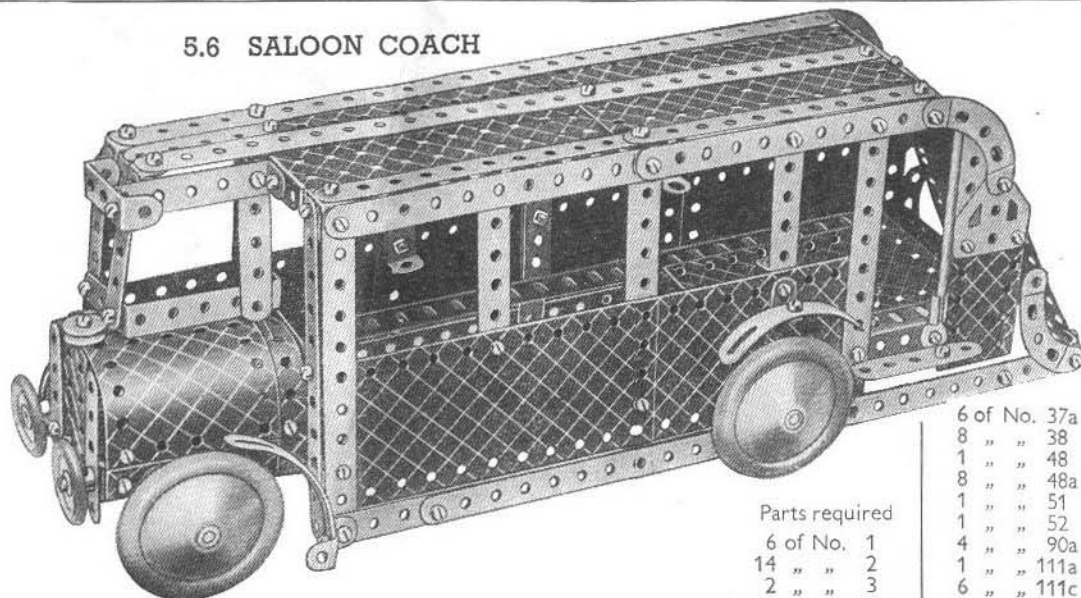

Two 12½" Angle Girders joined by 3½" Strips at each end comprise the chassis, and to this the Flexible Plates forming the sides are bolted. Supports for the roof are provided by 5½" Strips to which a 5½" x 2½" Flanged Plate and two 5½" x 1½" Flexible Plates are fastened by Angle Brackets. The curved back of the coach is formed by two 1½" radius Curved Plates, a 5½" x 1½" Flexible Plate, and a 5½" x 2½" Flexible Plate. The Flexible Plates are curved and bolted to the 1½" radius Curved Plates so that they overlap three holes.

The tail lamp is a 1" Pulley, which is secured to a Threaded Pin fastened to one of the Flexible Plates.

The bonnet is built up from two U-section Curved Plates and a 2½" x 1½" Flexible Plate. The radiator is a 2½" x 1½" Flanged Plate.

Parts required		
6 of No. 1	6 of No. 1	6 of No. 37a
14 " " 2	1 " " 2	8 " " 38
2 " " 3	1 " " 3	1 " " 48
11 " " 5	1 " " 5	8 " " 48a
2 " " 6a	1 " " 6a	1 " " 51
3 " " 8	2 " " 8	1 " " 52
2 " " 10	2 " " 10	4 " " 90a
3 " " 11	3 " " 11	1 " " 111a
12 " " 12	12 " " 12	1 " " 111c
2 " " 12c	2 " " 12c	1 " " 115
1 " " 15	1 " " 15	2 " " 125
1 " " 15a	1 " " 15a	2 " " 125a
1 " " 16	1 " " 16	2 " " 126a
3 " " 22	3 " " 22	2 " " 155a
1 " " 23	1 " " 23	4 " " 187
1 " " 35	1 " " 35	4 " " 188
85 " " 37	85 " " 37	3 " " 189
		2 " " 190
		2 " " 191
		4 " " 192
		2 " " 199
		2 " " 200
		1 " " 212
		4 " " 215

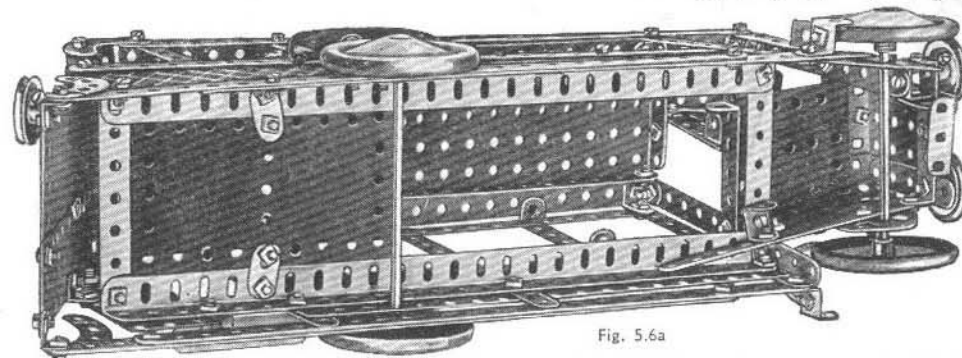

Fig. 5.6a

5.7 MERRY-GO-ROUND

A base for the model is provided by two $12\frac{1}{2}$ " Angle Girders bolted to the end flanges of a $5\frac{1}{2}$ " x $2\frac{1}{2}$ " Flanged Plate, and joined across at their other ends by a $5\frac{1}{2}$ " Strip as shown. A Double Bent Strip and a Bush Wheel are held by the same Bolts, one above and the other below the Flanged Plate; and they provide bearings for the turntable. The centre pin has been withdrawn from a Hinged Flat Plate and the halves used as flat plates at 1.

The 'horses' heads each consist of two Flat Brackets, bolted to the $2\frac{1}{2}$ " small radius Curved Strips that form their necks. The backs of the cars are $1\frac{1}{4}$ " radius Curved Plates, attached to the Flanged Sector Plates by Angle Brackets. The $12\frac{1}{2}$ " Strips used for bracing the platform are bolted to a 3" Pulley, and the central pylon is arranged so that the 4" Rod, on which the turntable pivots, passes through the centre holes of the $2\frac{1}{2}$ " x $\frac{1}{2}$ " Double Angle Strips at the ends of the $12\frac{1}{2}$ " Strips. The 3" Pulley is fastened on the Rod, and a 1" Pulley clamps the $2\frac{1}{2}$ " x $\frac{1}{2}$ " Double Angle Strips in place.

A second 3" Pulley is fastened below the first on the same Rod, and the Rod is passed through the Double Bent Strip, the $5\frac{1}{2}$ " x $2\frac{1}{2}$ " Flanged Plate and the Bush Wheel. It is retained in position by a Spring Clip.

The method of mounting the *Magic Motor* for driving the model is clear from the illustration.

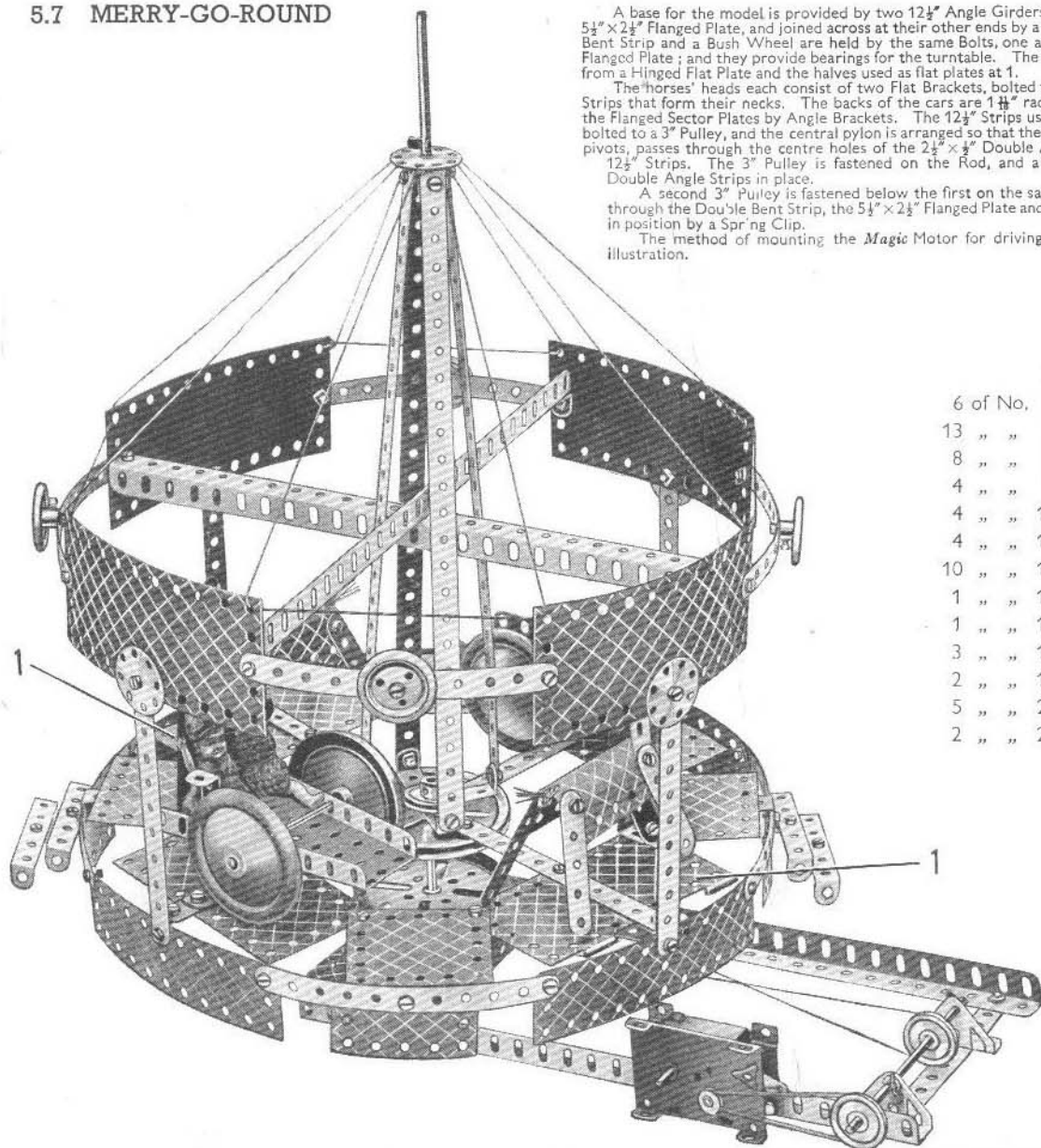

Parts required

6 of No. 1	1 of No. 24
13 " " 2	5 " " 35
8 " " 5	85 " " 37
4 " " 8	2 " " 37a
4 " " 10	2 " " 38
4 " " 11	1 " " 40
10 " " 12	1 " " 45
1 " " 15	8 " " 48a
1 " " 15b	1 " " 52
3 " " 16	2 " " 54a
2 " " 19b	4 " " 90a
5 " " 22	2 " " 111c
2 " " 22a	4 " " 125
	2 " " 126
	4 " " 155a
	4 " " 187
	4 " " 188
	4 " " 189
	4 " " 190
	2 " " 191
	4 " " 192
	1 " " 198
	2 " " 199
	2 " " 200
	4 " " 217a
	1 <i>Magic Motor</i>

5.8 GIANT SWING-BOAT

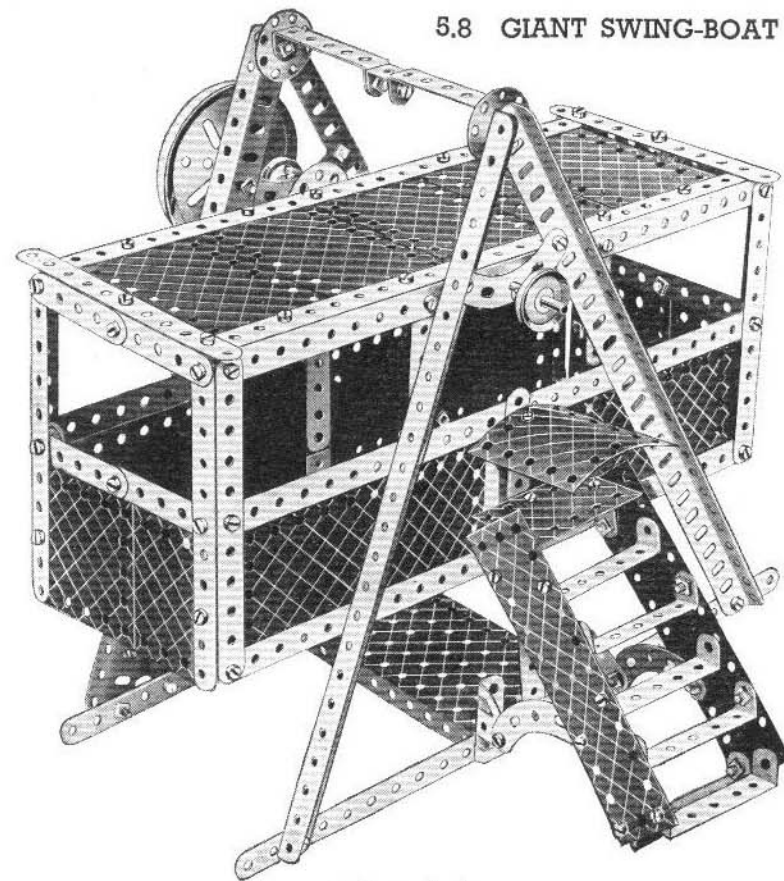

Parts required

10 of No. 1	4 of No. 22	6 of No. 111c
12 " " 2	1 " " 24	2 " " 126
2 " " 3	3 " " 35	2 " " 126a
12 " " 5	85 " " 37	1 " " 147b
4 " " 8	6 " " 37a	3 " " 188
4 " " 11	6 " " 38	2 " " 189
6 " " 12	1 " " 45	4 " " 190
2 " " 12a	8 " " 48a	2 " " 191
1 " " 15	1 " " 51	4 " " 192
1 " " 16	1 " " 52	1 " " 198
1 " " 17	2 " " 54a	1 " " 200
2 " " 19b	4 " " 90a	1 " " 213
1 " " 19g	1 " " 111a	2 " " 217a
	1 <i>Magic Motor</i>	

5.8 GIANT SWING-BOAT—continued

The main supports for the swing-boat are formed by $12\frac{1}{2}$ " Angle Girders, which are bolted to a base made by fastening two $12\frac{1}{2}$ " Strips to a $5\frac{1}{2}$ " x $2\frac{1}{2}$ " Flanged Plate. The steps are supported by two $2\frac{1}{2}$ " small radius Curved Strips, bolted to the sides of the staircase and to two Trunnions fastened to the base. The platform at the top consists of a $2\frac{1}{2}$ " x $1\frac{1}{2}$ " Flexible Plate held in position by two 1 " x 1 " Angle Brackets.

The $1\frac{1}{4}$ " radius Curved Plate is fastened to a Double Bent Strip bolted to one end of a $5\frac{1}{2}$ " Strip, the other end of which is fastened to the base.

The swing-boat is pivoted on a compound rod consisting of a 5 " Rod and a 4 " Rod joined by a Rod Connector. The compound rod is held in the boss of a Bush Wheel bolted to the side of the swing-boat.

The *Magic Motor* is bolted direct to the base. The drive is taken by a Driving Band from the small pulley of the Motor to a 1 " Pulley on the shaft of a $3\frac{1}{2}$ " Crank Handle journaled in holes in two Flanged Sector Plates. A second 1 " Pulley on the Crank Handle is connected by a Driving Band to a 3 " Pulley on a 2 " Rod journaled in the Flanged Sector Plates. A $5\frac{1}{2}$ " Strip is attached to a Pivot Bolt, and its other end is pivoted on a Bolt lock-nutted to the top 3 " Pulley. The two Flanged Sector Plates are bolted at the bottom to a $2\frac{1}{2}$ " x $1\frac{1}{2}$ " Flanged Plate and to two Double Brackets.

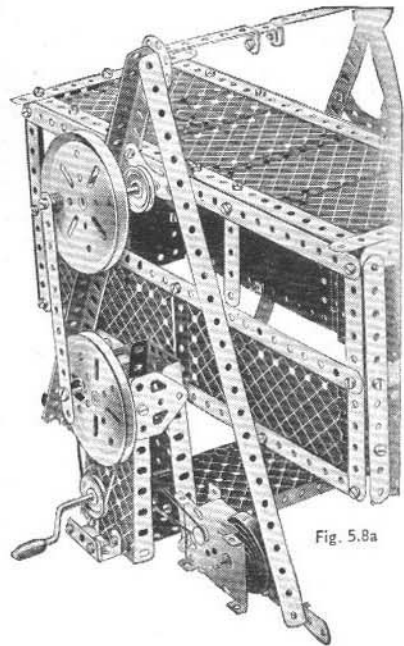
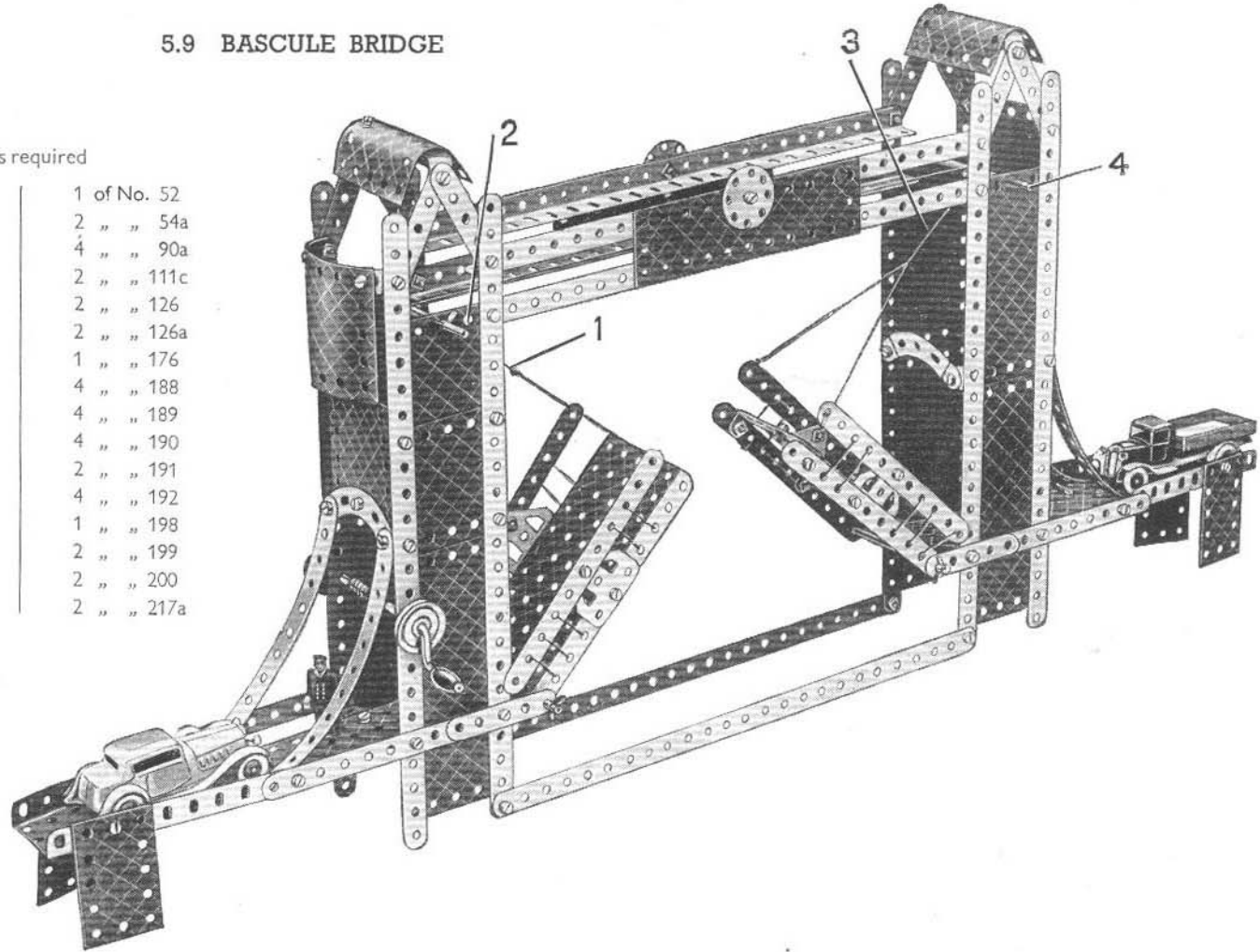

Fig. 5.8a

5.9 BASCULE BRIDGE

Parts required

10 of No. 1	1 of No. 52
14 " " 2	2 " " 54a
12 " " 5	4 " " 90a
4 " " 8	2 " " 111c
10 " " 12	2 " " 126
4 " " 12c	2 " " 126a
4 " " 16	1 " " 176
1 " " 19g	4 " " 188
2 " " 22	4 " " 189
8 " " 35	4 " " 190
84 " " 37	2 " " 191
2 " " 37a	4 " " 192
8 " " 38	1 " " 198
1 " " 40	2 " " 199
8 " " 48a	2 " " 200
1 " " 51	2 " " 217a



The centre pin has been withdrawn from a Hinged Flat Plate, and one of the halves is used in the construction of the side of one of the towers. Each of the main towers consists of four $12\frac{1}{2}$ " Strips to which are bolted Flexible Plates as shown. The $12\frac{1}{2}$ " Strips are braced across by the $2\frac{1}{2}$ " x $1\frac{1}{2}$ " Double Angle Strips that support the approach roadway, the $2\frac{1}{2}$ " small radius Curved Strips, and a further Double Angle Strip at the top of the tower. The U-Section Curved Plates are spaced from the $2\frac{1}{2}$ " x $1\frac{1}{2}$ " Double Angle Strips by three Washers. The two towers are joined across at the top by four Angle Girders, and at the bottom by two $12\frac{1}{2}$ " Strips.

Four $2\frac{1}{2}$ " Strips form bearings for the $3\frac{1}{2}$ " Rods on which the halves of the span are pivoted. The left-hand half is a $5\frac{1}{2}$ " x $2\frac{1}{2}$ " Flanged Plate fitted with Flat Trunnions and $5\frac{1}{2}$ " Strips as shown. The other half of the span is a part of the Hinged Flat Plate, and is connected to two $5\frac{1}{2}$ " Strips by a $2\frac{1}{2}$ " x $1\frac{1}{2}$ " Double Angle Strip and Angle Brackets.

The halves of the span are raised and lowered by turning a Crank Handle journaled in the sides of the left-hand tower. Cord 3 passes over Rod 4 and around Rod 2, and is then knotted to Cord 1 inside the tower. Cord 1 passes over Rod 2 and is fastened to a Cord Anchoring Spring on the Crank Handle. Cord 3 passes over Rod 4 and around Rod 2, and is then knotted to Cord 1 inside the tower.

5.10 TRAWLER

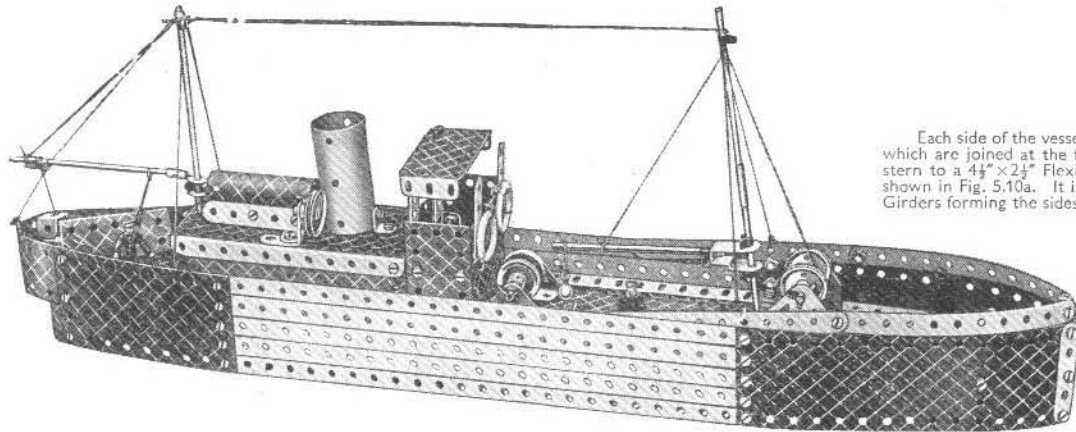

Each side of the vessel consists of three 12½" Strips and two Angle Girders, which are joined at the forward end to a 5½" x 2½" Flexible Plate, and at the stern to a 4½" x 2½" Flexible Plate. The deck of the model is constructed as shown in Fig. 5.10a. It is secured to Strips bolted between two of the Angle Girders forming the sides of the ship.

The sides of the cabin behind the bridge are attached by a 2½" x ½" Double Angle Strip and Flat Brackets to the two Angle Girders in the sides of the ship. The back of the cabin is completed with 2½" x ½" Double Angle Strips. The back of the wheelhouse, a 2½" x 2½" Flexible Plate, is bolted to the 5½" x 2½" Flanged Plate, the Bolts holding also Angle Brackets and 2½" Strips. The front of the wheelhouse is a 2½" x 1½" Flexible Plate, which is held in position by two Angle Brackets.

The funnel, a 2½" Cylinder, is fastened to the top of the cabin by an Angle Bracket.

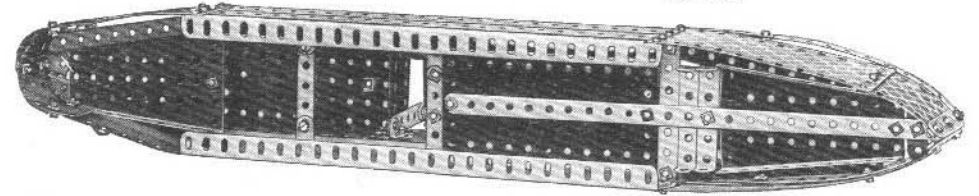
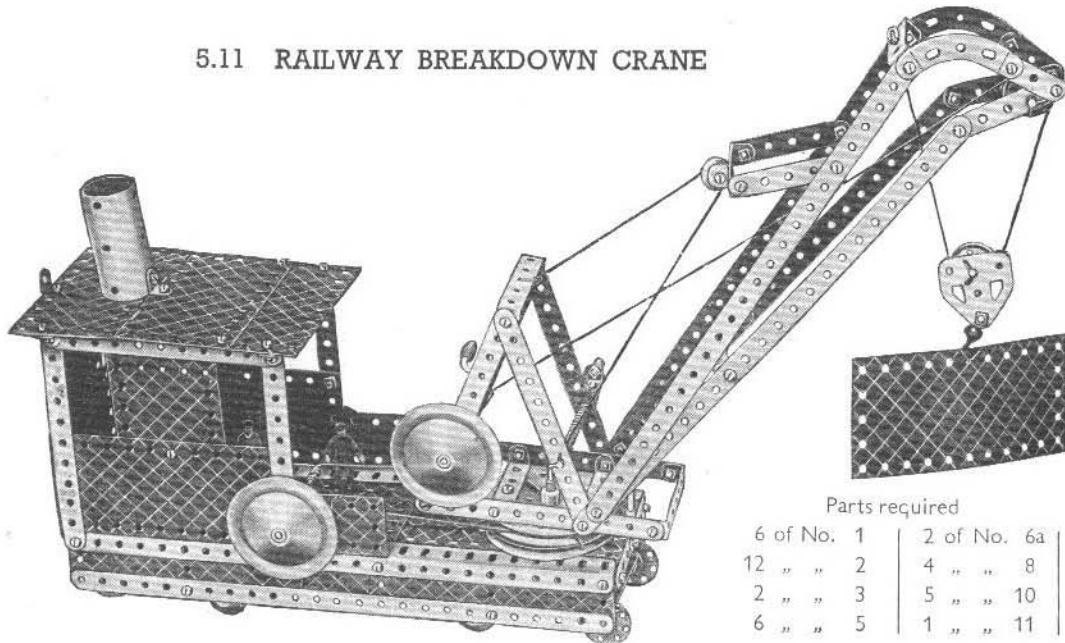

Fig. 5.10a

Parts required

7 of No. 1	1 of No. 15a	1 of No. 48	1 of No. 176
8 " " 2	2 " " 15b	5 " " 48a	4 " " 188
2 " " 3	1 " " 16	1 " " 51	3 " " 189
9 " " 5	2 " " 17	1 " " 52	4 " " 190
2 " " 6a	4 " " 22	2 " " 54a	2 " " 191
4 " " 8	2 " " 22a	1 " " 57c	3 " " 192
5 " " 10	1 " " 24	2 " " 111a	2 " " 199
1 " " 11	14 " " 35	6 " " 111c	1 " " 212
10 " " 12	85 " " 37	2 " " 125	1 " " 213
2 " " 12a	6 " " 37a	2 " " 126	1 " " 216
1 " " 12c	1 " " 40	2 " " 126a	1 " " 217a
1 " " 15	1 " " 44	2 " " 155a	

5.11 RAILWAY BREAKDOWN CRANE



Parts required

6 of No. 1	2 of No. 6a
12 " " 2	4 " " 8
2 " " 3	5 " " 10
6 " " 5	1 " " 11

10 of No. 12	1 of No. 57c
1 " " 15	2 " " 90a
4 " " 16	2 " " 111a
1 " " 17	6 " " 111c
2 " " 18a	1 " " 115
1 " " 18b	3 " " 125
2 " " 19b	2 " " 126a
1 " " 19g	1 " " 147b
5 " " 22	1 " " 176
2 " " 22a	1 " " 186a
1 " " 23	4 " " 187
1 " " 24	4 " " 188
14 " " 35	4 " " 189
79 " " 37	4 " " 190
12 " " 37a	2 " " 191
14 " " 38	4 " " 192
1 " " 40	1 " " 198
1 " " 48	1 " " 212
6 " " 48a	1 " " 216
1 " " 52	4 " " 217a
2 " " 54a	1 " " 217b

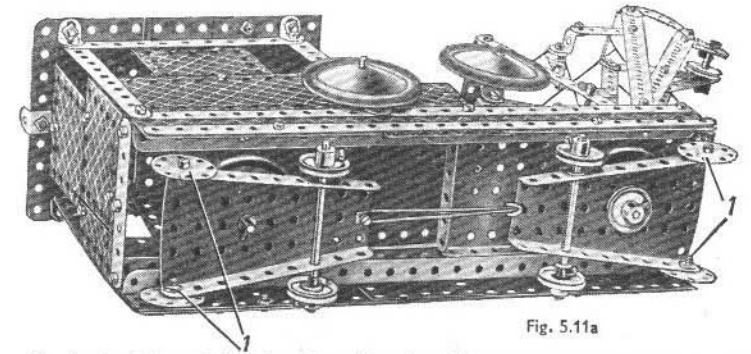

Fig. 5.11a

The chassis of the model consists of two U-section girders, built up from Angle Girders and joined at each end by 3½" Strips and Angle Brackets. A 5½" x 2½" Flanged Plate and a 5½" x 2½" Flexible Plate, overlapping one hole, are attached to the Angle Girders by Flat Brackets. The framework on which the jib is pivoted is fastened to a 3" Pulley by two ¾" Bolts, which have two Washers on their shanks for spacing purposes. The ¾" Bolts on which the jib luffs are lock-nutted.

The 3" Pulley on the jib swivels on a 3½" Rod passed through its boss, and is held in place by a Cord Anchoring Spring.

The front bogie (Fig. 5.11a) pivots on the 3½" Rod and is held between a Road Wheel and a 1" Pulley as shown. The rear bogie is similarly pivoted on a 2" Rod, bearings for which are provided by the 5½" x 2½" Flexible Plate and two 2½" Strips overlapped three holes. The bogies are connected by a Driving Band, and the Bolts 1 are lock-nutted. Luffing of the jib is controlled by the built-up crank handle, consisting of a Double Bracket fitted with an Angle Bracket that carries a Pivot Bolt. The Bolt holding the Angle Bracket clamps the Double Bracket to the Rod.

Hoisting is controlled by the Crank Handle, and the slewing movement is carried out by a belt of Cord passed around the upper 3" Pulley at the base of the jib and then wound several times around the Rod journalled in the sides of the cab.

5.12 ELECTRIC LOCOMOTIVE

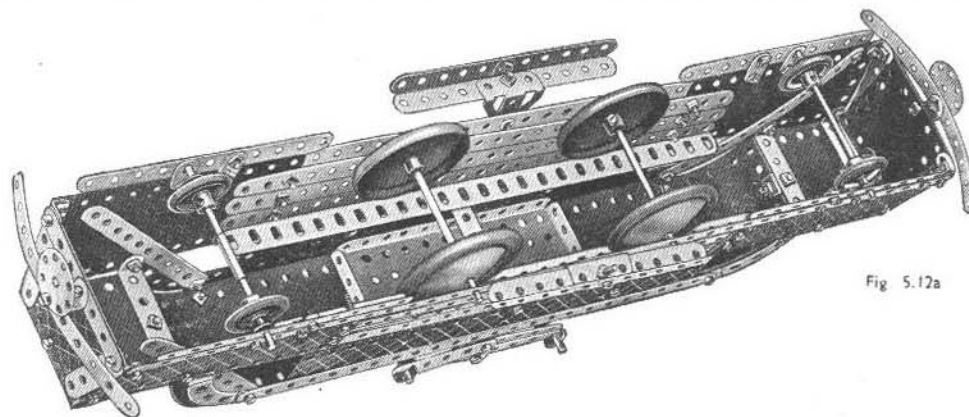
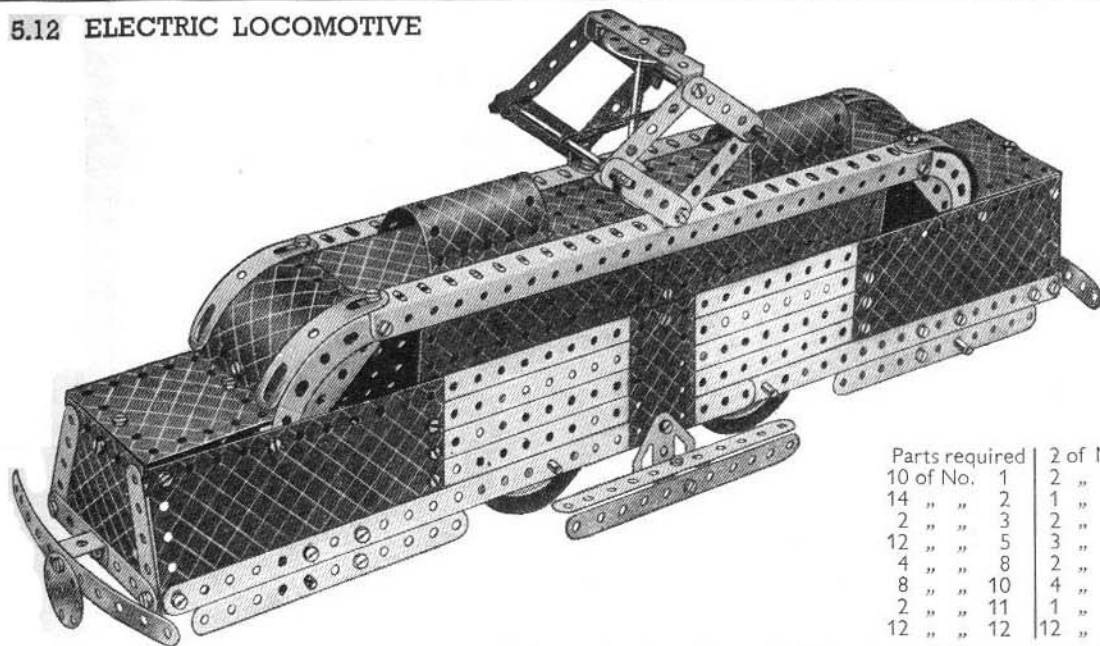

Fig. 5.12a

Parts required	2 of No. 12a	83 of No. 37	2 of No. 126	4 of No. 192
10 of No. 1	2 " " 12c	6 " " 37a	4 " " 155a	2 " " 199
14 " " 2	1 " " 15	4 " " 38	1 " " 176	2 " " 200
2 " " 3	2 " " 15b	1 " " 45	1 " " 186	1 " " 213
12 " " 5	3 " " 16	5 " " 48a	4 " " 187	4 " " 215
4 " " 8	2 " " 17	1 " " 52	2 " " 188	2 " " 217a
8 " " 10	4 " " 22	4 " " 90a	4 " " 189	
2 " " 11	1 " " 24	2 " " 111a	4 " " 190	
12 " " 12	12 " " 35	6 " " 111c	2 " " 191	

The method of constructing the sides and roof will be clear from the illustrations. The front wheel axle consists of two 2" Rods joined by a Rod Connector.

Each side of the pantograph consists of four 2½" Strips, pairs of which are lock-nutted to an Angle Bracket and a 2½" x ½" Double Angle Strip respectively. They are pivoted together on 3½" Rods, and a Driving Band is stretched between the Rods as shown. The Bush Wheel carries in its boss a 5" Rod that passes through a Double Bent Strip and the 5½" x 2½" Flanged Plate.

The two U-Section Curved Plates are attached to the roof by Obtuse Angle Brackets.

5.13 GONDOLA

The bottom of the gondola consists of a framework of two 12½" Angle Girders, joined across at each end by a 2½" Strip and Angle Brackets. A 12½" Strip is bolted in the centre hole of each of the 2½" Strips, and this supports the Flexible Plates that fill in the bottom of the model.

The model runs on 1" Pulleys fitted with Rubber Rings, which are mounted on 3½" Rods journalled as shown.

In Fig. 5.13a one of the seats, the mandoline and the gondolier have been removed to show the details of their construction. The seat fitted in the gondola in Fig. 5.13a consists of a 2½" x 1½" Flexible Plate bolted to a 2½" x ½" Double Angle Strip.

A Flat Bracket and a Double Bracket are held by a Bolt passed through the centre hole of the 1" loose Pulley representing the passenger's head, and a Flat Bracket bolted to the Trunnion is clamped between the rim of the Pulley and the other Flat Bracket to hold the Pulley in position. A ¾" Bolt passed through the centre hole of the Double Bracket is held in the boss of the Road Wheel representing the passenger's hat.

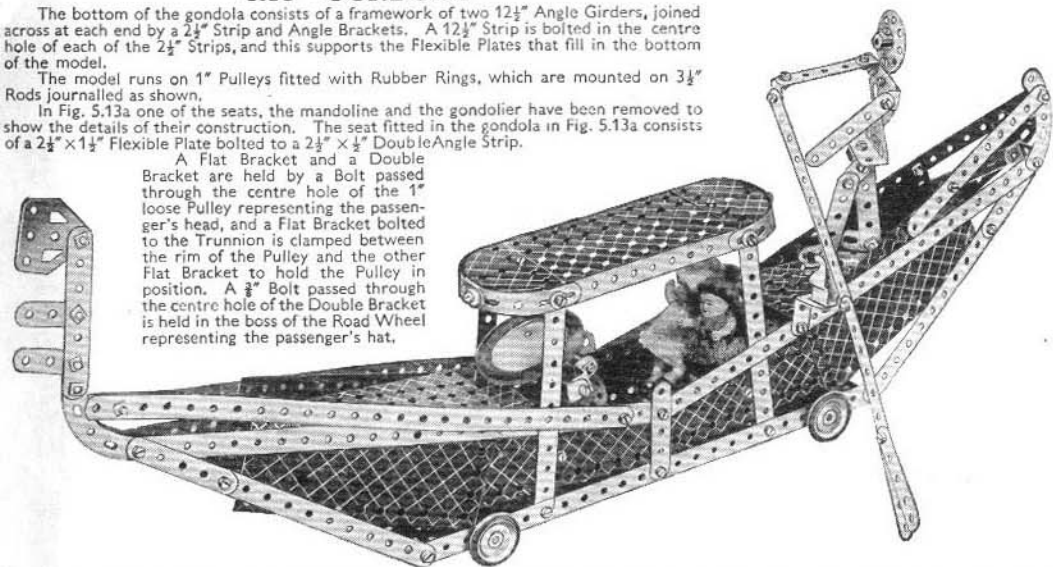

Parts required	7 of No. 1	1 of No. 51
14 " " 2	2 " " 3	1 " " 52
2 " " 3	12 " " 5	2 " " 54a
12 " " 5	2 " " 6a	4 " " 90a
2 " " 8	2 " " 8	6 " " 111c
7 " " 10	7 " " 10	1 " " 115
3 " " 11	3 " " 11	3 " " 125
5 " " 12	4 " " 12c	2 " " 126
1 " " 12a	2 " " 16	2 " " 126a
4 " " 12c	1 " " 18a	4 " " 155a
2 " " 16	4 " " 22	1 " " 187
1 " " 18a	1 " " 22a	1 " " 188
4 " " 22	1 " " 24	4 " " 189
1 " " 22a	2 " " 35	1 " " 190
1 " " 24	2 " " 37	2 " " 191
2 " " 35	6 " " 37a	4 " " 192
85 " " 37	6 " " 38	2 " " 199
6 " " 37a	1 " " 44	2 " " 214
6 " " 38	1 " " 48	4 " " 215
1 " " 44	3 " " 48a	1 " " 217a

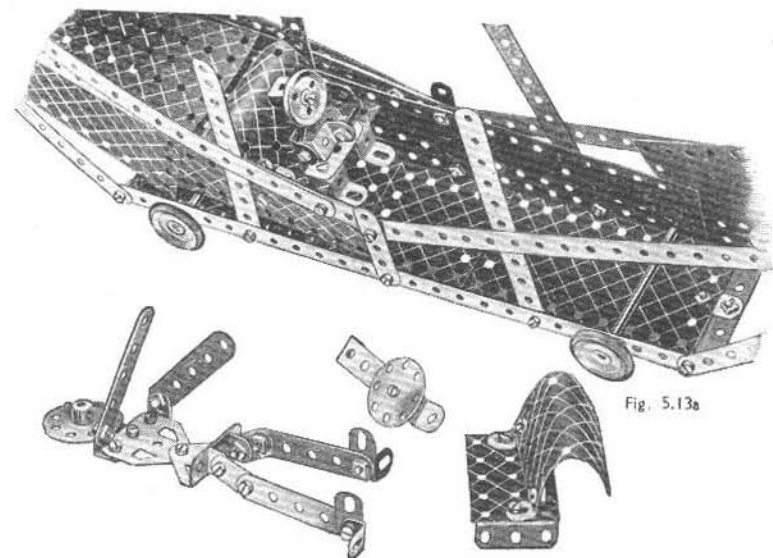

Fig. 5.13a

5.14 MARINE ENGINE

Bearings for the crankshaft are provided on the rear side by a Flat Trunnion and a Reversed Angle Bracket bolted to it, and on the other side by a second Flat Trunnion and a 1 $\frac{1}{4}$ " Disc. A 3 $\frac{1}{2}$ " Rod is held in the rear bearings by a 1" Pulley and a Spring Clip, and in the other bearings is a 2" Rod, which is retained in place by a Bush Wheel and a Spring Clip.

To the inner ends of these Rods are fastened 3" Pulleys that form the crank webs. A 2" Rod is pushed through the outer hole of one of these and then into a Reversed Angle Bracket bolted to the second Pulley. The Rod is held in place by four Spring Clips.

The main connecting rod consists of two 5 $\frac{1}{2}$ " Strips overlapped seven holes. Two 5 $\frac{1}{2}$ " Strips bolted together provide a guide for the piston rod, and the crosshead is a Double Bracket pivoted to the Connecting Rod by a 1 $\frac{1}{4}$ " Rod. Two 3 $\frac{1}{4}$ " Rods joined by a Rod Connector form the slide valve, which is held in the Cranked Bent Strip 2, by a Cord Anchoring Spring and a 1" Pulley. The 5 $\frac{1}{2}$ " Strip forming the valve connecting rod is carried on a Bolt 1 lock-nutted to the Bush Wheel.

Parts required	1 of No. 52	4 of No. 189
6 of No. 1	1 " " 54a	4 " " 190
12 " " 2	1 " " 80c	2 " " 191
1 " " 3	2 " " 111c	4 " " 192
6 " " 5	3 " " 125	1 " " 212
1 " " 6a	2 " " 126	1 " " 213
4 " " 8	2 " " 126a	1 " " 214
4 " " 11	1 " " 176	4 " " 215
11 " " 12	3 " " 187	1 " " 216
1 " " 12a	4 " " 188	2 " " 217a
2 " " 15		
3 " " 16		
2 " " 17		
2 " " 18a		
2 " " 19b		
4 " " 22		
1 " " 24		
9 " " 35		
85 " " 37		
5 " " 37a		
3 " " 38		
1 " " 44		
1 " " 48		
7 " " 48a		

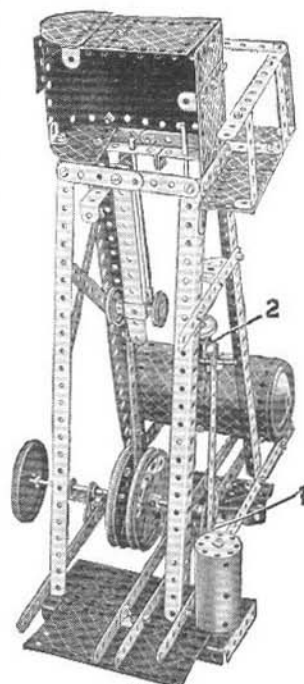
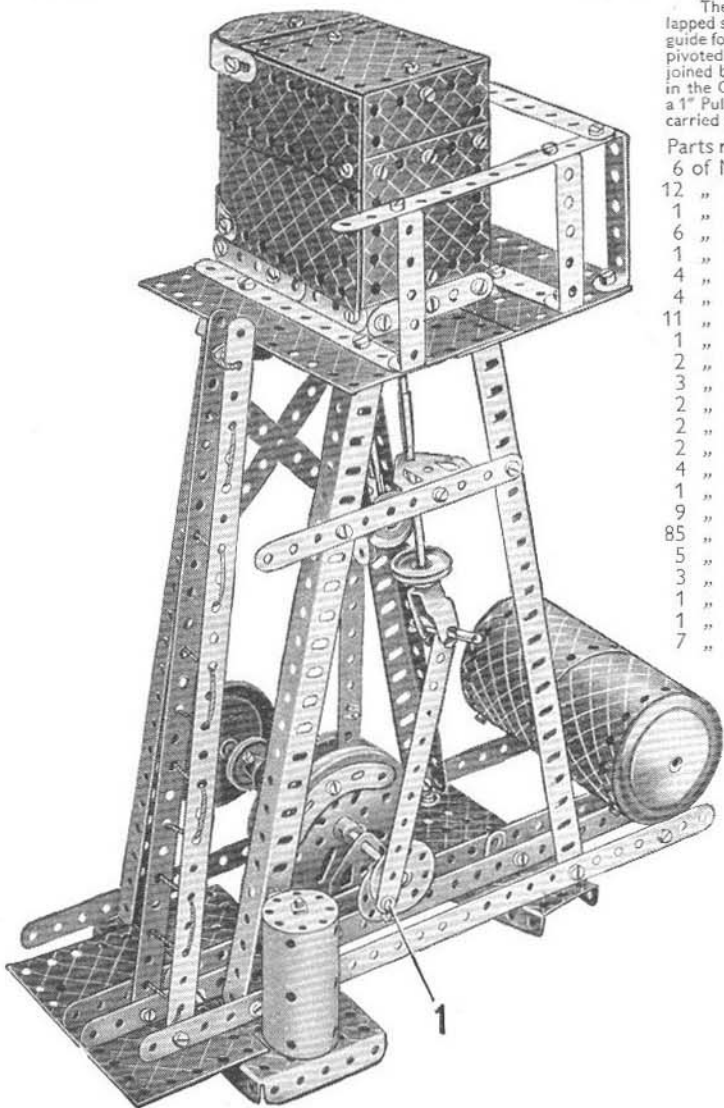
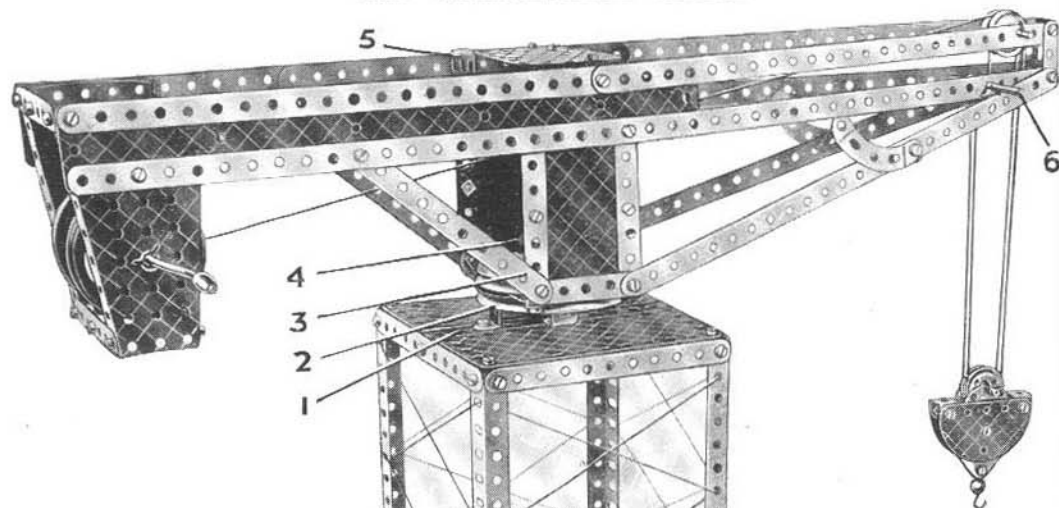

Fig. 5.14a

5.15 HAMMERHEAD CRANE



The top of the tower is filled in with a 5 $\frac{1}{2}$ " \times 2 $\frac{1}{2}$ " Flanged Plate 1 extended on each side by a 5 $\frac{1}{2}$ " \times 2 $\frac{1}{2}$ " Flexible Plate. The 3" Pulley 2 on which the jib swivels is bolted to the tower by four Reversed Angle Brackets, and in its boss is secured a 2" Rod on which the 3" Pulley 3 is free to turn. A 1" Pulley 4 fitted with a Rubber Ring is fastened at the upper end of the 2" Rod and retains the jib in position on its pivot.

The 2 $\frac{1}{2}$ " \times 1 $\frac{1}{2}$ " Flanged Plate 5 is connected to the other side of the jib by a 2 $\frac{1}{2}$ " \times 1 $\frac{1}{2}$ " Double Angle Strip, on top of which is bolted a 2 $\frac{1}{2}$ " \times 2 $\frac{1}{2}$ " Flexible Plate.

The hoisting Cord is tied to the Crank Handle journaled in the Flanged Sector Plates at the rear end of the jib. It is then taken over one of two 1" Pulleys mounted at the front end of the jib, then down and around one of the 1" loose Pulleys in the pulley block, up and over the other 1" fast Pulley in the jib and around the other 1" loose Pulley of the Pulley block. Finally it is tied to a Flat Bracket in the middle of Rod 6.

Parts required

10 of No. 1	1 of No. 51
14 " " 2	1 " " 52
2 " " 3	2 " " 54a
12 " " 5	1 " " 57c
2 " " 6a	2 " " 90a
4 " " 8	4 " " 111a
1 " " 10	1 " " 111c
4 " " 11	4 " " 125
9 " " 12	2 " " 126a
1 " " 16	1 " " 155a
1 " " 17	1 " " 176
3 " " 18a	2 " " 187
2 " " 19b	4 " " 188
1 " " 19g	4 " " 189
4 " " 22	3 " " 190
2 " " 22a	2 " " 191
10 " " 35	4 " " 192
90 " " 37a	1 " " 198
85 " " 37b	1 " " 213
9 " " 38	2 " " 214
1 " " 40	3 " " 217a
2 " " 48a	

5.16 ROWING FOUR

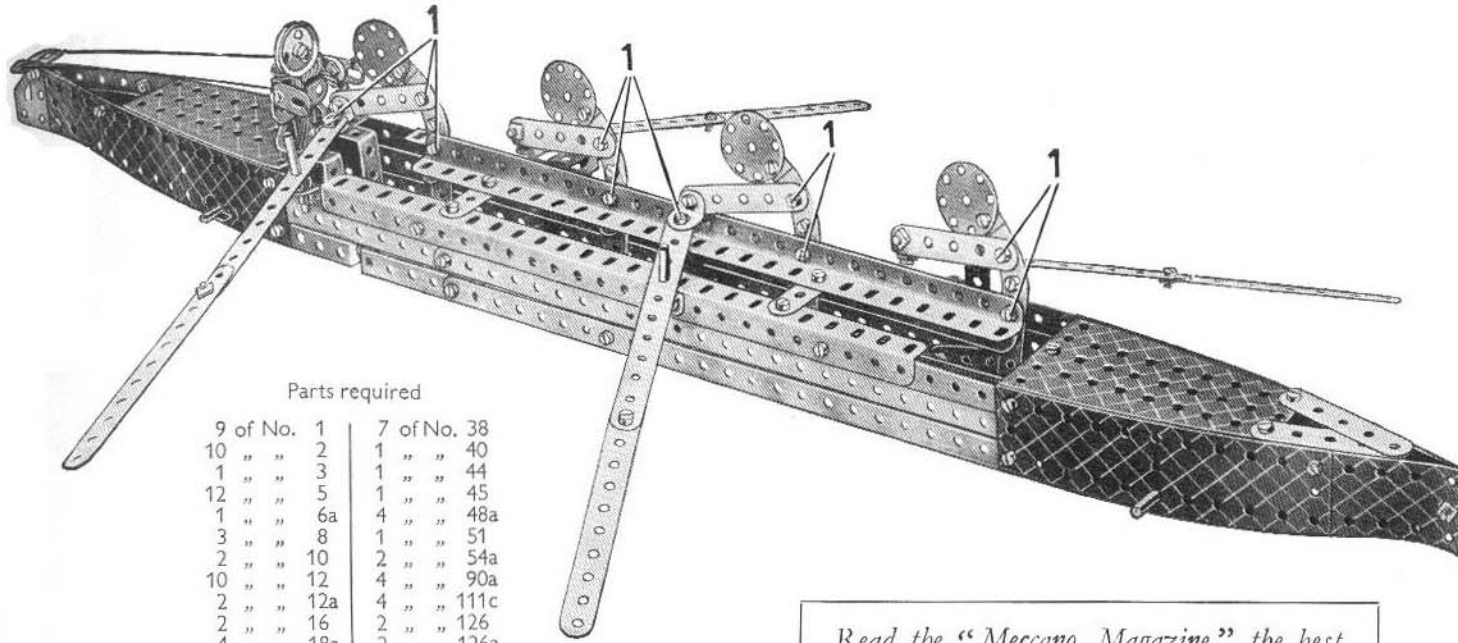

Parts required

9 of No. 1	7 of No. 38
10 " " 2	1 " " 40
1 " " 3	1 " " 44
12 " " 5	1 " " 45
1 " " 6a	4 " " 48a
3 " " 8	1 " " 51
2 " " 10	2 " " 54a
10 " " 12	4 " " 90a
2 " " 12a	4 " " 111c
2 " " 16	2 " " 126
4 " " 18a	2 " " 126a
1 " " 18b	1 " " 147b
5 " " 22	4 " " 155a
2 " " 22a	1 " " 186
1 " " 24	4 " " 188
11 " " 35	4 " " 189
77 " " 37	4 " " 217a
14 " " 37a	

Read the "Meccano Magazine" the best of all magazines for boys. Place a regular order now with your Meccano dealer or newsagent.

Each side of the boat consists of an Angle Girder extended by 12½" Strips, the one at the stern overlapping nine holes, and that at the bows overlapping eight holes. Two 5½"×1½" Flexible Plates are bolted to the 12½" Strips at the bows and stern as shown. The sides are filled in by 12½" Strips and 2½"×½" Double Angle Strips bolted to the 5½"×1½" Flexible Plates. Flanged Sector Plates form the deck and are bolted to the sides at their broad ends.

The hull is traced by a 2½"×1½" Flanged Plate bolted across it as shown in Fig. 5.16a. The rowing crew are carried on an Angle Girder bolted to two 2½" Strips fastened to the Angle Girders forming the sides. Each member of the crew consists of a 2½" small radius Curved Strip overlapping a 2½" Strip three holes. A further 2½" Strip fitted with an Angle Bracket and bolted to the "body" forms the arms, and a 1½" Disc represents the head. The four figures are pivotally attached to the Angle Girder in the positions shown. The lower end of the 2½" Strip forming part of the body of each figure is also pivotally attached to a 12½" Strip underneath the boat. The oars are pivotally attached to the Angle Brackets and they also are pivoted on 1½" Rods as shown.

The Nuts on Bolts 1 are left sufficiently loose to enable the oars to move easily, but for better working they should all be lock-nutted. To do this seven Nuts more than are included in the Outfit will be required.

The drive is taken from the Pulleys on which the model runs to the Rod carrying the Bush Wheel (Fig. 5.16a). The Bush Wheel is connected to the Pivot Bolt on the 12½" Strip by a 3½" Strip. The Pivot Bolt carries six Washers on its shank. Bolt 2 should be lock-nutted.

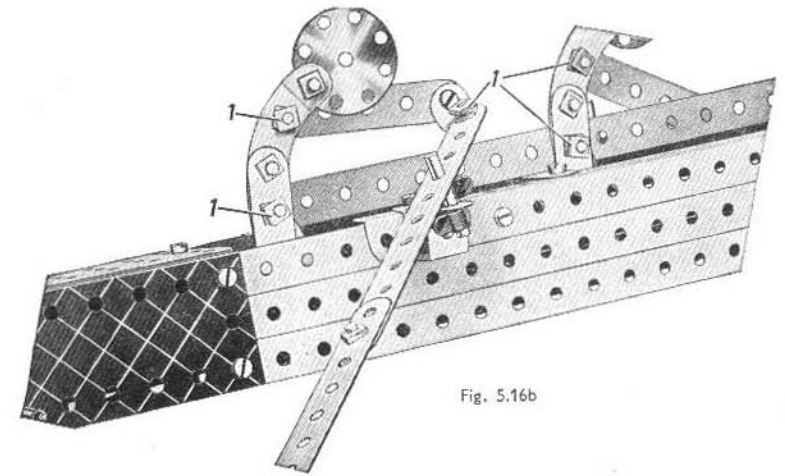

Fig. 5.16b

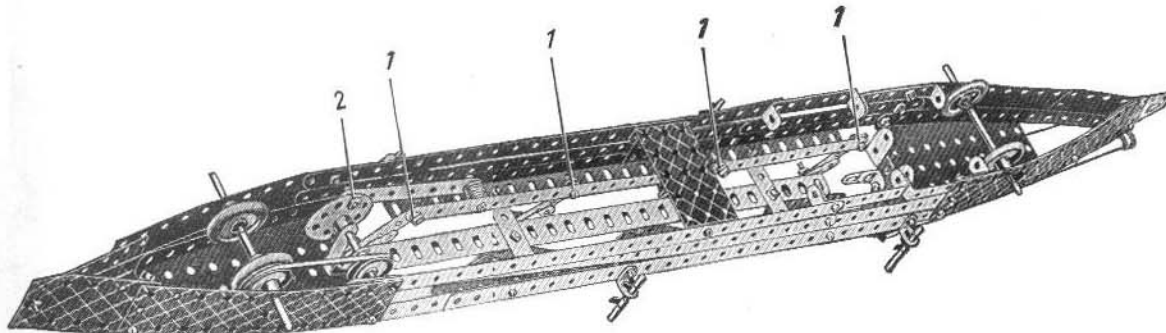
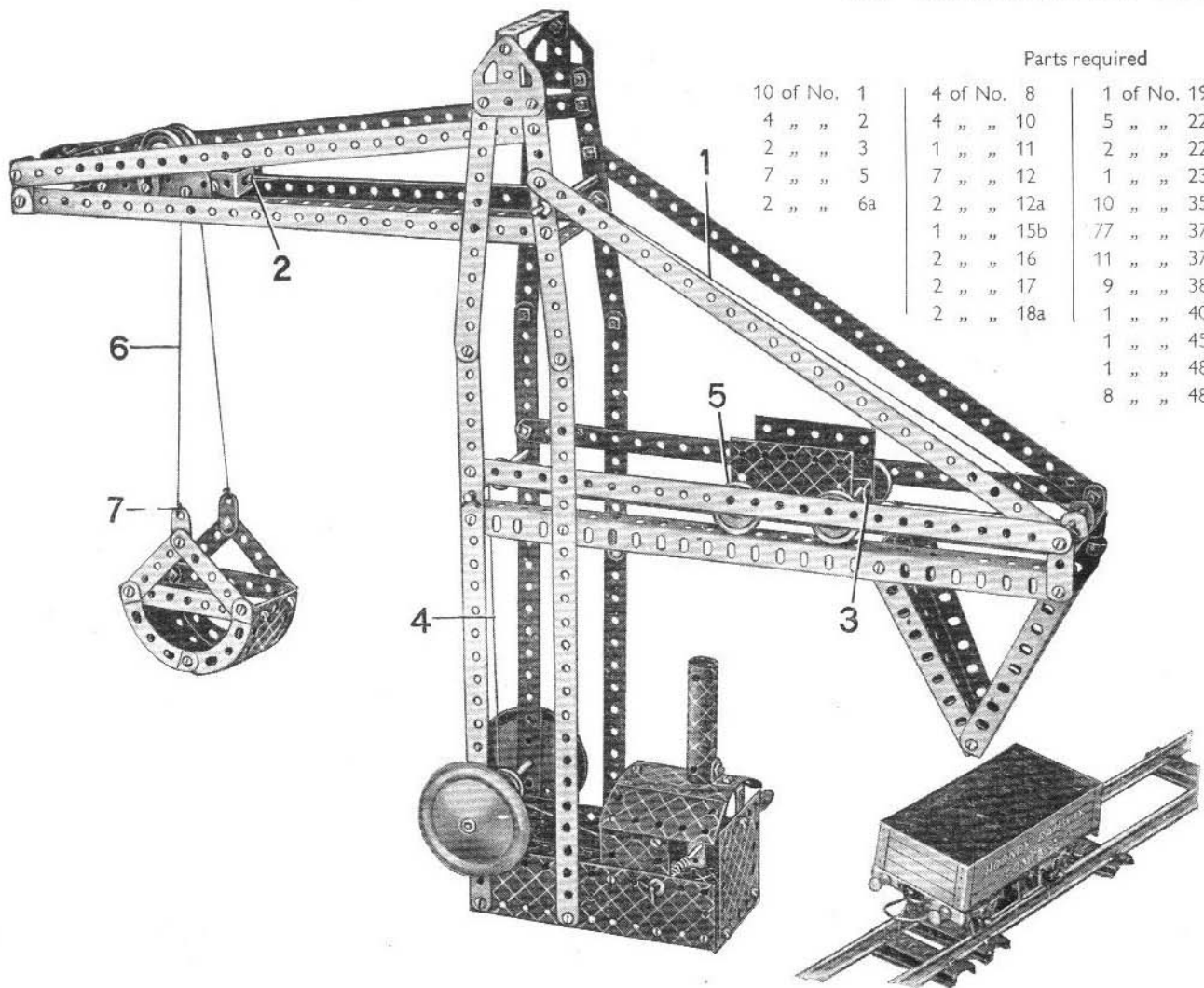

Fig. 5.16a

5.17 AUTOMATIC SHIP-COALER



Parts required

10 of No. 1	4 of No. 8	1 of No. 19g	1 of No. 51
4 " " 2	4 " " 10	5 " " 22	1 " " 52
2 " " 3	1 " " 11	2 " " 22a	2 " " 54a
7 " " 5	7 " " 12	1 " " 23	4 " " 90a
2 " " 6a	2 " " 12a	10 " " 35	5 " " 111c
	1 " " 15b	77 " " 37	4 " " 125
	2 " " 16	11 " " 37a	2 " " 126a
	2 " " 17	9 " " 38	2 " " 187
	2 " " 18a	1 " " 40	4 " " 188
		1 " " 45	3 " " 189
		1 " " 48	1 " " 190
		8 " " 48a	1 " " 199
			2 " " 200
			4 " " 217a
			2 " " 217b

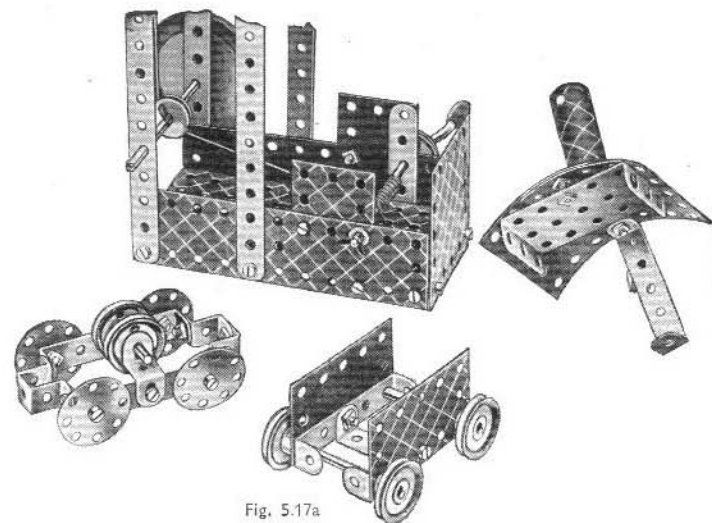

Fig. 5.17a

The construction of the control cabin, hoisting carriage and truck is shown in Fig. 5.17a. The $2\frac{1}{2} \times 1\frac{1}{2}$ " Flanged Plate is lock-nutted to the $1\frac{1}{8}$ " radius Curved Plates, which are overlapped three holes. The chimney is a U-Section Curved Plate, bent to shape. The built-up pulley on the same 4" Rod as the Road Wheels consists of two $\frac{3}{4}$ " Discs spaced by two Washers, and is retained in position by two Spring Clips.

The rails on which the grab hoist and truck run are Angle Girders. Those forming the rails or the grab hoist are bolted at their inner ends to the rear pair of $5\frac{1}{2}$ " Strips at the top of the tower, but are not connected to the second pair of Strips. This enables the hoist to travel the full length of the rails. The $1\frac{1}{4}$ " Discs that form the wheels of the grab hoist revolve on Bolts lock-nutted to the $2\frac{1}{2} \times \frac{1}{2}$ " Double Angle Strips.

The grab consists of $2\frac{1}{2}$ " small radius Curved Strips bolted to $3\frac{1}{2}$ " Strips, and the $5\frac{1}{2} \times 1\frac{1}{2}$ " Flexible Plate is attached to them by Angle Brackets.

The operating Cords are arranged as follows. Cord 1 is tied at 2 to the grab hoist, passed over a $3\frac{1}{2}$ " Rod in the tower, and then around a $1\frac{1}{2}$ " Rod held by Spring Clips in a Double Bracket. Finally it is tied to the rear of the truck at 3. Cord 4 is fastened to the truck at 5, led over a $\frac{1}{2}$ " loose Pulley on a $3\frac{1}{2}$ " Rod halfway up the tower, and around the built-up pulley on the Rod that carries the Road Wheels. It is then wound around the Crank Handle.

Cord 6 is fastened to Flat Bracket 7 on the grab, and is taken over one of the 1" loose Pulleys on the grab hoist. It then passes through the end holes of the 1×1 " Angle Brackets at the end of the jib, and is led over the second 1" loose Pulley and finally tied to the other Flat Bracket on the grab.

The length of the grab operating Cord should be adjusted so that the grab reaches the tower at the same time as the truck reaches the inner end of the rails.

5.18 RACING YACHT

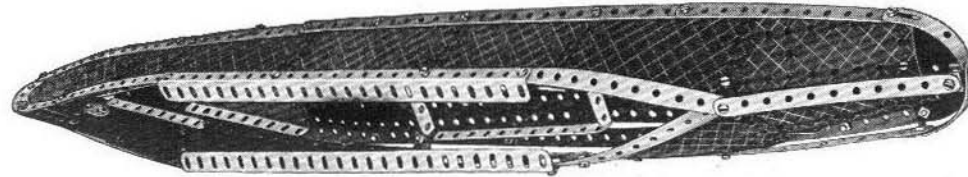

Fig. 5.18a

Construction should be commenced by building up the sides of the hull, and reference to the illustrations will make the details clear. The pin has been withdrawn from a Hinged Flat Plate, and the two parts are bolted to the Angle Girders, one at each side of the hull near the stern. The Strips along the sides of the deck are then added. They are bolted to two Flanged Sector Plates forming the forward part of the deck, and to two Angle Brackets amidships and at the stern. The Flanged Sector Plates are bolted so that the narrow end of one overlaps the broad end of the other by two holes.

Two $5\frac{1}{2}'' \times 1\frac{1}{2}''$ Flexible Plates connect the rear Flanged Sector Plate to a $5\frac{1}{2}'' \times 2\frac{1}{2}''$ Flanged Plate, to which the small boat is bolted. Two $5\frac{1}{2}''$ Strips overlapped three holes are fastened to the Flanged Plate and to a $2\frac{1}{2}''$ Strip at the stern. Two $2\frac{1}{2}'' \times 2\frac{1}{2}''$ Flexible Plates are bolted to this compound strip, together with a $2\frac{1}{2}'' \times 1\frac{1}{2}''$ Flanged Plate and two $2\frac{1}{2}'' \times 1\frac{1}{2}''$ Flexible Plates. The 1" Pulleys are secured by Bolts that pass through the deck into their bosses. The Bush Wheel is similarly fastened to the Trunnion. The small boat consists of two U-Section Curved Plates overlapped one hole and attached to the deck by an Angle Bracket.

The mast, which consists of three $12\frac{1}{2}''$ Strips, a $5\frac{1}{2}''$ Strip and a $2\frac{1}{2}''$ Strip, is fastened between two Angle Brackets by a $\frac{3}{8}''$ Bolt, on the shank of which are four Washers between the Angle Brackets. The method of rigging the model will be clear from Fig. 5.18b.

The sails can be cut from white cardboard or stiff paper. The mainsail measures $20'' \times 38'' \times 43''$. The two sails at the bows each measure $10'' \times 22'' \times 25''$. The topsail is $12'' \times 14'' \times 24''$, and is 6" in width at its widest part.

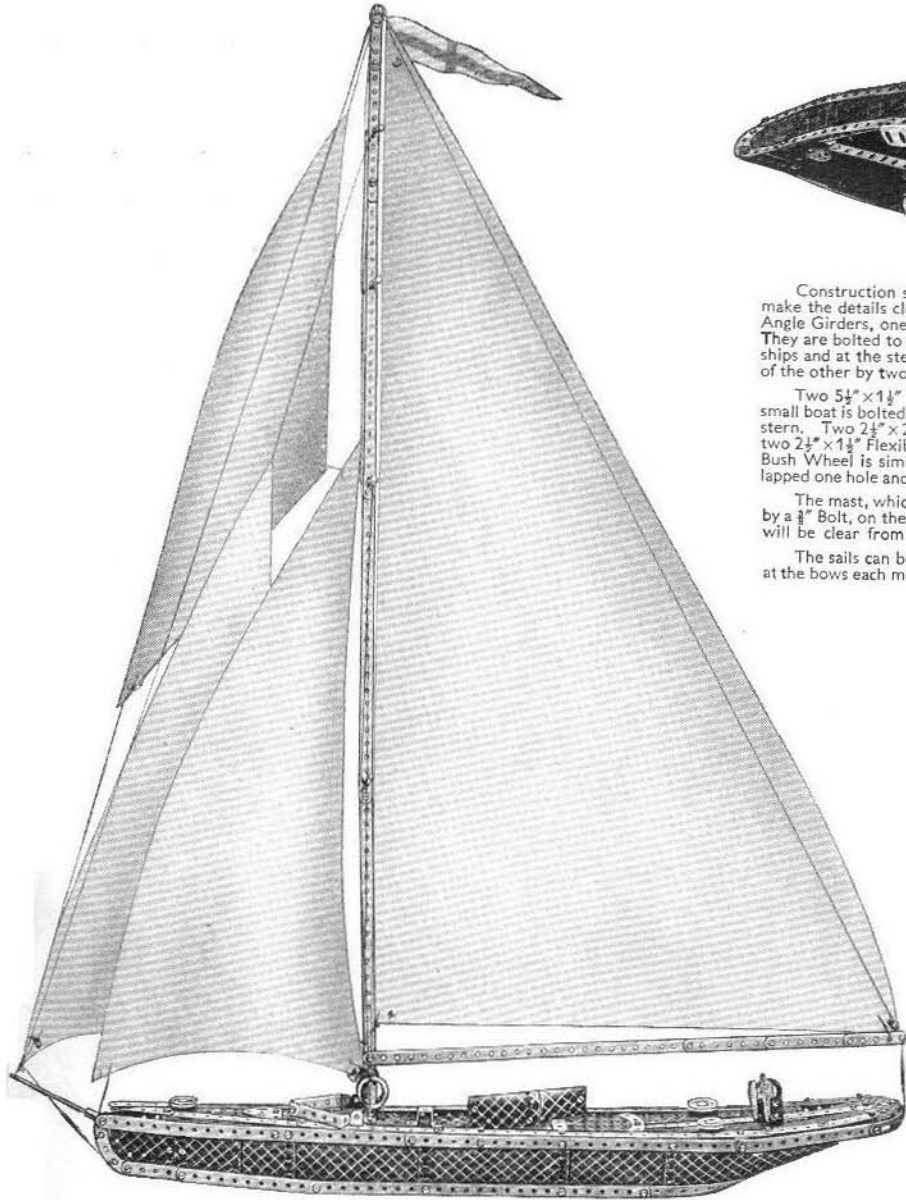

Parts required		
10 of No. 1	8 of No. 35	1 of No. 126a
14 " " 2	85 " " 37	3 " " 155a
2 " " 3	4 " " 37a	1 " " 176
12 " " 5	14 " " 38	4 " " 188
1 " " 6a	1 " " 40	4 " " 189
2 " " 8	1 " " 45	4 " " 190
2 " " 10	3 " " 48a	2 " " 191
10 " " 12	1 " " 51	4 " " 192
2 " " 12a	1 " " 52	1 " " 198
2 " " 15	2 " " 54a	2 " " 199
1 " " 15b	3 " " 90a	2 " " 200
2 " " 16	2 " " 111a	1 " " 212
3 " " 22	6 " " 111c	1 " " 214
1 " " 24	1 " " 126	2 " " 215

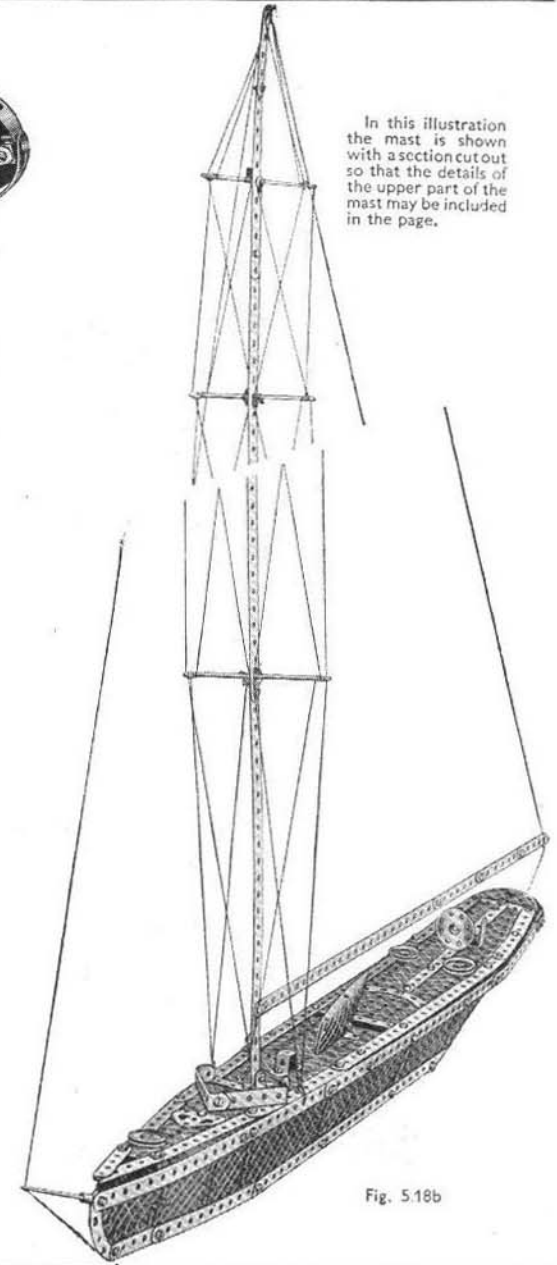

In this illustration the mast is shown with a section cutout so that the details of the upper part of the mast may be included in the page.

Fig. 5.18b

5.19 MILITARY TANK

Angle Girders form the main members of the model and the upper pair are connected by three 5½" Strips, the lower pair comprising the chassis being connected by a 5½" Strip near the front and by two 2½" Strips, overlapped one hole, at the rear. At 1 (Fig. 5.19a) the halves of a Hinged Flat Plate are used separately as flat plates. Flat Trunnions are bolted to the 2½" Strips that space the upper and lower pairs of Angle Girders at the rear of the tank, and they form part of the creeper track covers.

The revolving gun turret is shown in Fig. 5.19a. The rear gun is a 3½" Rod, which is fitted with a Reversed Angle Bracket on the inside of the Flanged Plate, and is retained in position by Spring Clips. A 5" Rod is fixed in the boss of the 3" Pulley to which the turret is bolted, and a Road Wheel is secured to its top end. The lower end of the Rod passes through the 5½" x 2½" Flanged Plate and through a Double Bent Strip. A 1" Pulley retains the complete unit in position. The Flanged Sector Plate shown in the upper illustration is bolted to a second Flanged Sector Plate, and overlaps it by eight holes.

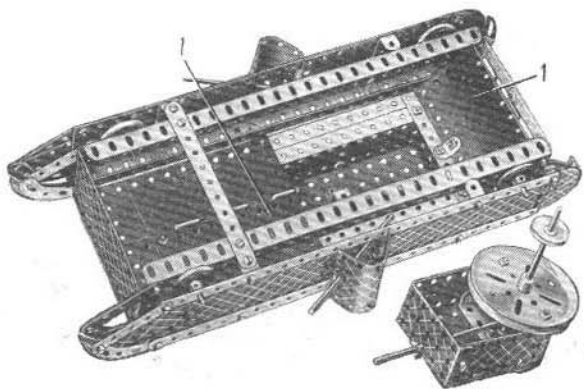

Fig. 5.19a

Parts required	
4 of No. 1	1 of No. 187
8 " " 2	3 " " 188
11 " " 5	4 " " 189
4 " " 8	3 " " 190
6 " " 12	2 " " 191
1 " " 12c	4 " " 192
2 " " 15	1 " " 198
1 " " 15b	2 " " 199
2 " " 16	2 " " 214
4 " " 18a	4 " " 215
1 " " 19b	
5 " " 22	
8 " " 35	
83 " " 37	
2 " " 38	
1 " " 45	
6 " " 48a	
1 " " 51	
1 " " 52	
2 " " 54a	
4 " " 90a	
1 " " 125	
2 " " 126	
2 " " 126a	
4 " " 155a	

5.20 DERRICK CRANE

Reference to the illustrations will make clear the construction of the base and cabin. Each side of the jib consists of three 12½" Strips, which are joined across at the lower ends by a 1½" x ½" Double Angle Strip, in the centre by a 2½" x ½" Double Angle Strip, and at the top by a Cranked Bent Strip. A 1½" Rod locked in the boss of the upper 3" Pulley passes through a second 3" Pulley bolted to the base, and is held in position by a Spring Clip. The Double Bracket at the upper ends of the 12½" Strips is lock-nutted to the 2½" x 1½" Flanged Plate.

The 5" Rod 1, which controls the swivelling of the jib, has a belt of Cord wound around it several times. The Cord is taken round the 3" Pulley at the bottom of the jib. Crank Handle 2 controls the hoisting movement. Cord is wound a few turns around the shaft of the Crank Handle, then passed under a 2" Rod at the base of the jib, and over a 1½" loose Pulley on a 1½" Rod at the top of the jib. The Cord is then led through the pulley block and tied to an Angle Bracket bolted to the jib. The 3½" Rod 3 carries a Bush Wheel, to which a Threaded Pin is fitted to form a handle for controlling the luffing movement of the jib.

Cord is tied to a Flat Bracket on the 2" Rod in the jib post and is taken around a 1" Pulley in the jib. It is then passed around a ½" loose Pulley on the 2" Rod and led over a second Pulley on the same Rod as the first 1" Pulley. Finally it is led back over the 2" Rod and wound around Rod 3.

Parts required		1 of No. 23	1 of No. 57c	1 of No. 213
10 of No. 1	1 " " 24	2 " " 90a	2 " " 217a	
10 " " 2	14 " " 35	4 " " 111c		
2 " " 3	69 " " 37	1 " " 115		
2 " " 5	6 " " 37a	2 " " 126		
3 " " 8	10 " " 38	2 " " 126a		
1 " " 10	1 " " 40	1 " " 147b		
1 " " 11	1 " " 44	1 " " 176		
6 " " 12	1 " " 48	1 " " 198		
2 " " 12a	1 " " 48a			
4 " " 12c	1 " " 51			
1 " " 15	1 " " 52			
3 " " 16	2 " " 54a			
2 " " 17				
2 " " 18a				
1 " " 18b				
2 " " 19b				
1 " " 19g				
5 " " 22				
2 " " 22a				

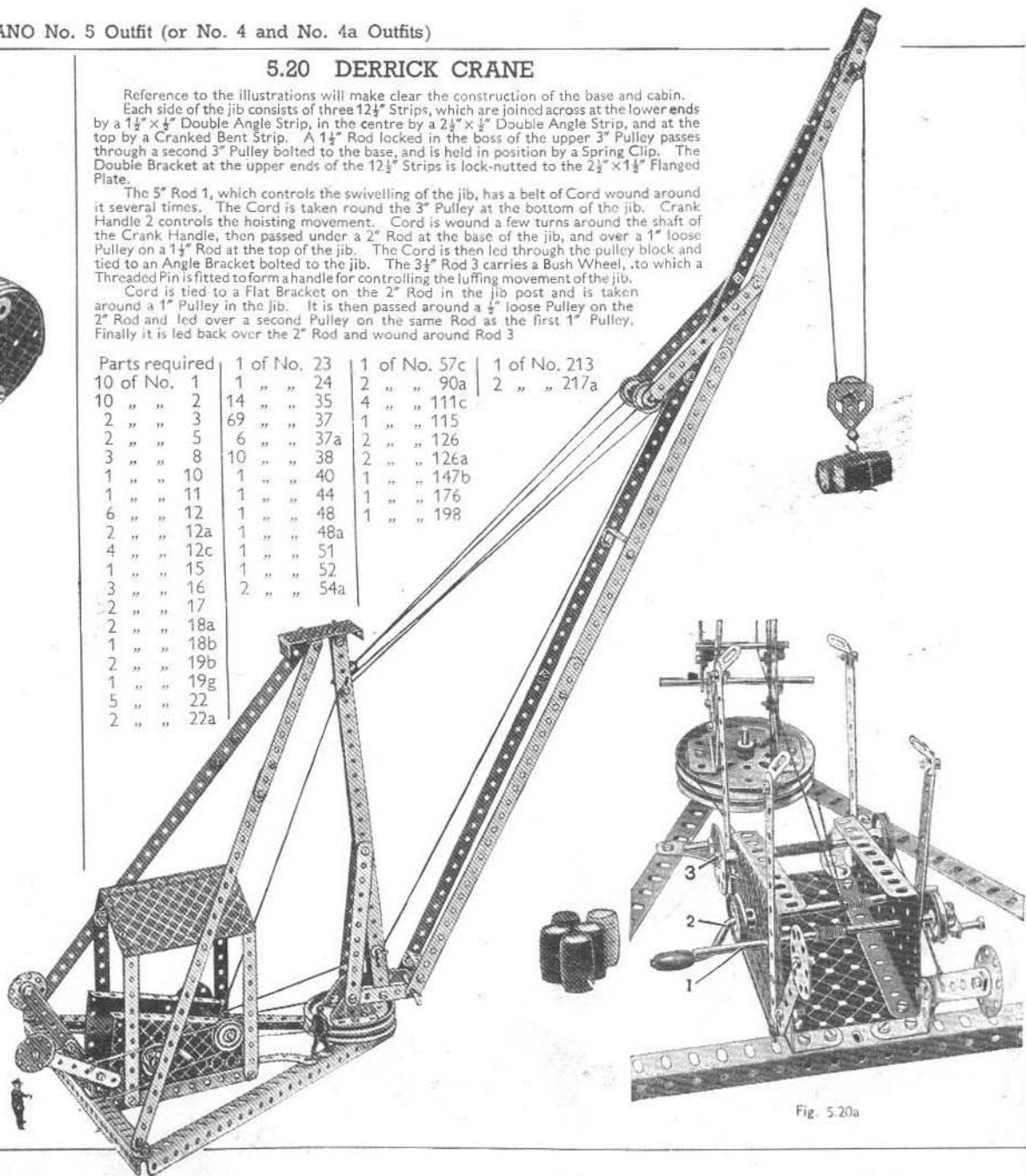
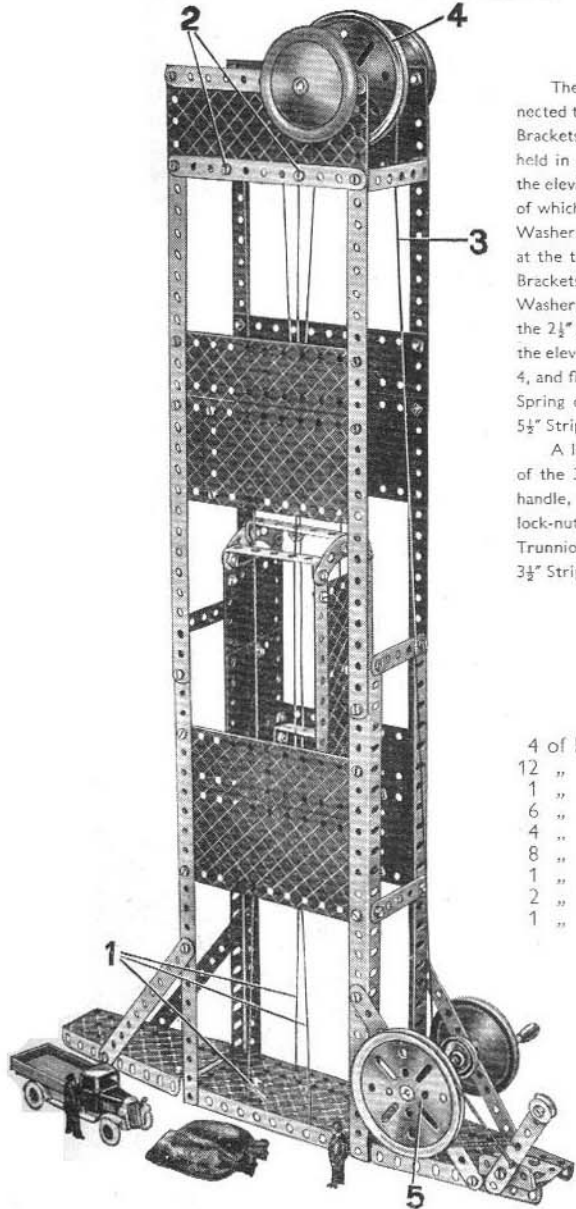

Fig. 5.20a

5.21 ELEVATOR



The two Flanged Sector Plates are connected to the $5\frac{1}{2}'' \times 2\frac{1}{2}''$ Flanged Plate by Angle Brackets, and the four $1\frac{1}{2}''$ Angle Girders are held in place by the same Bolts. Guides for the elevator are provided by four Cords, three of which are shown at 1. These are tied to Washers underneath the Flanged Plate, and at the top of the shaft are fastened to Angle Brackets held by Bolts 2. Cord 3 is tied to a Washer, and passes through the centre hole of the $2\frac{1}{4}'' \times \frac{1}{2}''$ Double Angle Strip at the top of the elevator. It then passes over the $3''$ Pulley 4, and finally is fastened to a Cord Anchoring Spring on a Crank Handle journalled in the $5\frac{1}{2}''$ Strips that brace the elevator shaft.

A length of Cord passes around the rim of the $3''$ Pulley 5 and is tied to the brake handle, which is a $3\frac{1}{2}''$ Strip. This Strip is lock-nutted to a Trunnion fastened to a Flat Trunnion. The $\frac{1}{2}''$ loose Pulley bolted to the $3\frac{1}{2}''$ Strip maintains the brake band in tension.

Parts required		Parts required	
4 of No. 1	2 of No. 22	1 of No. 23	
12 " " 2	1 " " 23	83 " " 37	
1 " " 3	2 " " 37a	2 " " 38	
6 " " 5	7 " " 38	1 " " 40	
4 " " 8	1 " " 48a	7 " " 52	
8 " " 12	2 " " 54a	2 " " 90a	
1 " " 15b	1 " " 111c	1 " " 126	
2 " " 19b	1 " " 126a	1 " " 176	
1 " " 19g	1 " " 187	3 " " 188	
	2 " " 189	4 " " 190	
	4 " " 191	2 " " 192	
	4 " " 192		

5.22 BIG WHEEL

Each rim of the wheel consists of four $1\frac{1}{2}''$ Strips bolted so that they overlap three holes. The rims are connected by $4''$ compound strips, and are secured by $6\frac{1}{2}''$ compound strips to a Bush Wheel and the inner holes of a $3''$ Pulley on the supporting shaft. The shaft consists of a $5''$ and a $4''$ Rod fastened together by a Rod Connector, and is journalled in the centre holes of two $1\frac{1}{2}''$ Discs secured to the ends of two $1\frac{1}{2}''$ Angle Girders bolted to the base. The base is formed by bolting $5\frac{1}{2}''$ Strips to the shorter flanges of a $5\frac{1}{2}'' \times 2\frac{1}{2}''$ Flanged Plate, and then extending the length of the Flanged Plate by a Flanged Sector Plate. The construction of the cars can be seen from the illustration.

The drive is taken by Cord from a $1''$ Pulley on the shaft of a Crank Handle to a $3''$ Pulley on the shaft of the wheel. The Crank Handle is journalled in the holes of a Cranked Bent Strip bolted to the Flanged Sector Plate, and also in the upper hole of a $1\frac{1}{2}'' \times \frac{1}{2}''$ Double Angle Strip fixed to the $5\frac{1}{2}'' \times 2\frac{1}{2}''$ Flanged Plate. The Flexible Plates forming the pay-box are joined together and secured to the framework of the model by $2\frac{1}{2}'' \times \frac{1}{2}''$ Double Angle Strips.

Fig. 5.22a shows the Big Wheel driven by an E120 Electric Motor. The drive is taken through a Worm meshed with a $1''$ Gear, and the $1''$ Pulley held on a Rod in the Cranked Bent Strip is driven by a Driving Band that runs on the same Rod as the $1''$ Gear, in order to give a slow drive.

Parts required		
8 of No. 1	1 of No. 24	1 of No. 125
14 " " 2	9 " " 35	2 " " 126
2 " " 3	85 " " 37	2 " " 126a
11 " " 5	3 " " 37a	1 " " 147b
2 " " 6a	12 " " 38	2 " " 187
4 " " 8	1 " " 40	4 " " 188
5 " " 10	1 " " 44	2 " " 190
4 " " 11	1 " " 48	3 " " 192
12 " " 12	4 " " 48a	2 " " 199
2 " " 12a	1 " " 51	2 " " 200
1 " " 15	1 " " 52	1 " " 213
1 " " 15b	1 " " 54a	1 " " 214
4 " " 16	3 " " 111c	2 " " 215
2 " " 19b		4 " " 217a
1 " " 19g		
3 " " 22		
2 " " 22a		
1 " " 23		

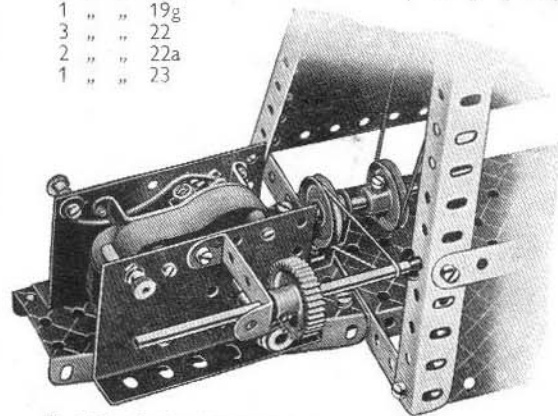
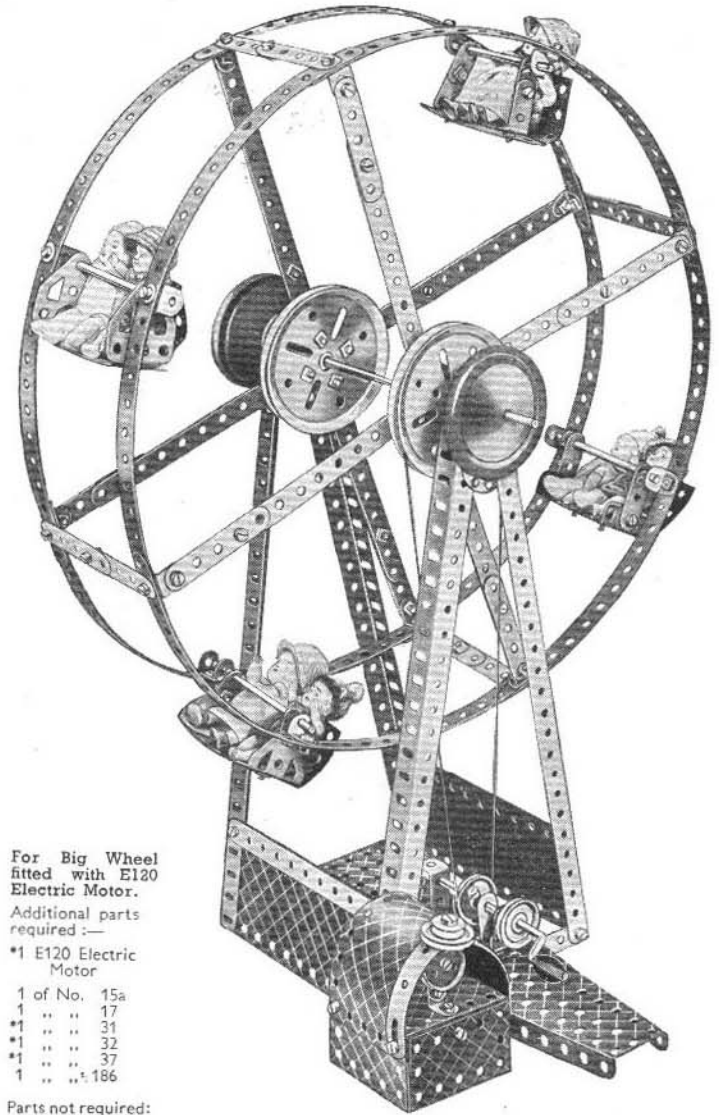

Fig. 5.22a Sectional view showing Motor fitted



For Big Wheel fitted with E120 Electric Motor.

Additional parts required:—

- *1 E120 Electric Motor
- 1 of No. 15a
- 1 " " 17
- *1 " " 31
- *1 " " 32
- *1 " " 37
- 1 " " 186

Parts not required:

- 1 of No. 19g
- *Not included in Outfit.

5.23 BEAM BRIDGE

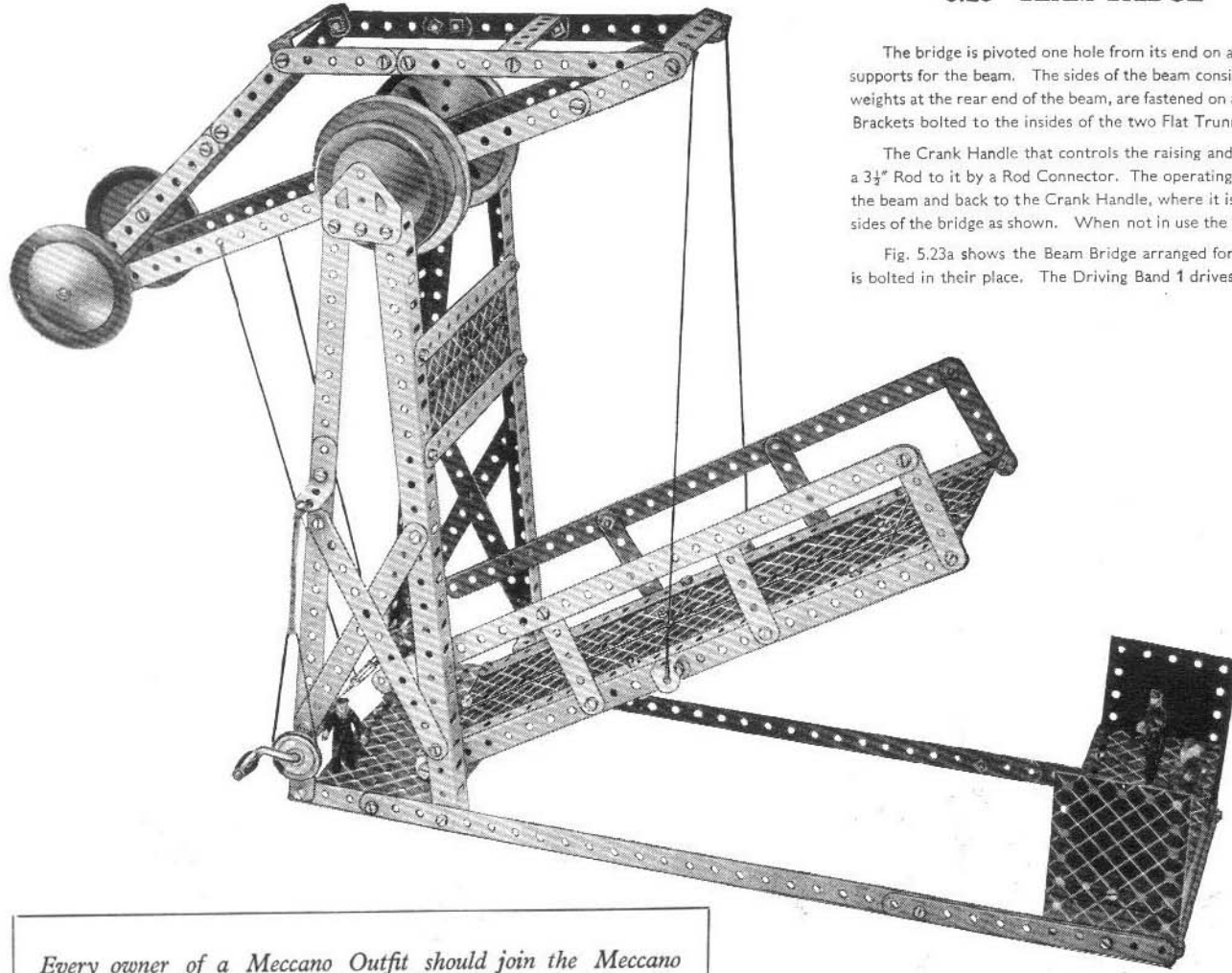

The bridge is pivoted one hole from its end on a 5" Rod, which is supported in two Reversed Angle Brackets bolted to two of the 12½" Angle Girders forming the supports for the beam. The sides of the beam consist of compound strips, and they are joined by 2½" × ½" Double Angle Strips. The Road Wheels, which act as counterweights at the rear end of the beam, are fastened on a 4" Rod. The beam is pivoted 1" out of centre to the front on a 5" Rod, which is supported in two Reversed Angle Brackets bolted to the insides of the two Flat Trunnions at the tops of the towers.

The Crank Handle that controls the raising and lowering of the bridge is journalled near the lower ends of the rear beam supports, and is lengthened by joining a 3½" Rod to it by a Rod Connector. The operating Cord is fastened to the Crank Handle by a Spring Clip, wound around its shaft several times and then taken through the beam and back to the Crank Handle, where it is again tied. Cords attached to the front end of the beam are tied to Double Brackets fastened halfway along the sides of the bridge as shown. When not in use the Crank Handle is kept stationary by a Cord band brake tensioned by a Driving Band.

Fig. 5.23a shows the Beam Bridge arranged for operation by an E20b Electric Motor. The two 5½" Strips bracing the beam supports are removed, and the Motor is bolted in their place. The Driving Band 1 drives the 1" Pulley direct from the Rod carrying the ½" Pinion.

Every owner of a Meccano Outfit should join the Meccano Guild. This is a world-wide guild for boys, started at the request of boys and as far as possible conducted by boys. Write for full particulars and an application form to the Meccano Guild Secretary, Binns Road, Liverpool, 13.

Parts required

10 of No.	1	4 of No.187
13 " "	2	2 " " 188
2 " "	3	2 " " 189
10 " "	5	4 " " 190
4 " "	8	2 " " 191
5 " "	10	4 " " 192
2 " "	11	1 " " 213
8 " "	12	
1 " "	12a	
2 " "	15	
1 " "	15b	
1 " "	16	
2 " "	19b	
1 " "	19g	
1 " "	22	
4 " "	35	
82 " "	37	
1 " "	40	
7 " "	48a	
1 " "	52	
4 " "	125	
2 " "	126a	
1 " "	186a	

For Beam Bridge fitted with E20b Electric Motor.

Additional parts required:—

*1 E20b Electric Motor

*1 of No. 15

1 " " 22

*1 " " 23a

*1 " " 32

2 " " 37

2 " " 126

1 " " 186

Parts not required:—

2 of No. 2

1 " " 19g

1 " " 186a

1 " " 213

*Not included in Outfit.

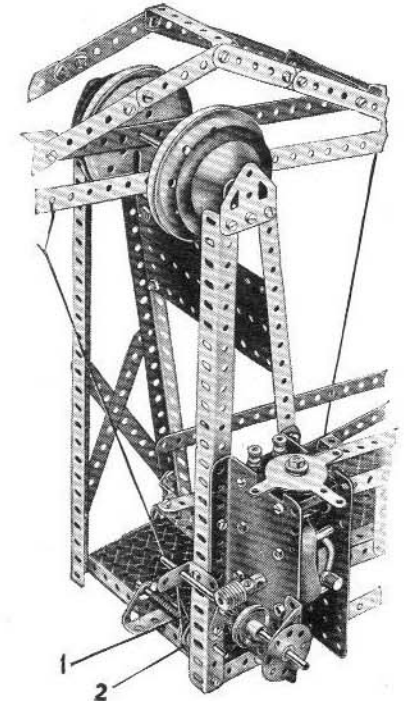

Fig. 5.23a Sectional view showing Motor fitted.

5.24 PITHEAD GEAR

The rear side of the engine house consists of a Flanged Sector Plate and a $2\frac{1}{2}'' \times 1\frac{1}{2}''$ Flanged Plate, which are bolted to an Angle Girder that forms part of the base of the model.

The $2\frac{1}{4}''$ Cylinder lock-nutted to the $5\frac{1}{2}'' \times 2\frac{1}{4}''$ Flanged Plate, is fitted at each end with $1\frac{1}{4}''$ Discs by passing a $3''$ Screwed Rod through holes in their circumferences and screwing Nuts on each end of it. The piston is a $4\frac{1}{2}''$ Rod fitted with a Rod and Strip Connector, and is retained in position by a Cord Anchoring Spring on a Threaded Pin fastened to a Bush Wheel. A $5''$ Rod is journalled in the holes of the two $2\frac{1}{2}''$ Strips at the head of the shaft, and it carries at its centre a $1''$ fast Pulley. On each side of the Pulley are a $3''$ Pulley and a Road Wheel.

A $4''$ Rod is held in place in the holes of the $5\frac{1}{2}''$ Strips by Spring Clips, and directly below this Rod, at the bottom of the shaft, is a $3\frac{1}{2}''$ Rod, which is supported in the holes of two Reversed Angle Brackets. This Rod carries a $\frac{1}{2}''$ loose Pulley between two Spring Clips. The arrangement of the Cord forming the guides for the cage can be seen in the illustration. A length of Cord is tied through one of the holes in the $1''$ loose Pulley at the top of the cage, and is passed over the $1''$ fast Pulley between the two $3''$ Pulleys at the top of the shaft. It is then wound six times around the $5''$ Rod in the engine house, and then led around the $\frac{1}{2}''$ loose Pulley. Finally the Cord is tied to another hole in the $1''$ loose Pulley.

Fig. 5.24a shows the Pithead Gear adapted for Clockwork Motor drive. The Motor is bolted to the Angle Girder at the base, and the drive is taken from the $1''$ Pulley fastened on the Motor shaft to a $1''$ Pulley on the $5''$ Rod carrying the Bush Wheel.

Parts required		Parts required		Parts required	
10 of No. 1	2 of No. 12a	5 of No. 22	1 of No. 48	2 of No. 125	
14 " " 2	4 " " 12c	1 " " 22a	7 " " 48a	1 " " 126	
2 " " 3	2 " " 15	1 " " 23	1 " " 51	1 " " 126a	
11 " " 5	1 " " 15a	1 " " 24	1 " " 52	2 " " 155a	
1 " " 6a	1 " " 15b	9 " " 35	1 " " 54a	1 " " 176	
4 " " 8	1 " " 16	85 " " 37	1 " " 80c	1 " " 186	
2 " " 10	1 " " 17	4 " " 37a	1 " " 111a	3 " " 187	
2 " " 11	2 " " 19b	10 " " 38	3 " " 111c	3 " " 188	
5 " " 12	1 " " 19g	1 " " 40	1 " " 115	4 " " 189	
				4 " " 190	
				1 " " 191	
				4 " " 192	
				1 " " 198	
				1 " " 199	
				1 " " 212	
				1 " " 216	
				2 " " 217a	

For model Pit-head Gear fitted with No. 1a or No. 2 Clockwork Motor.

Additional Parts required :-

*1 No. 1a or No. 2 Clockwork Motor

Parts not required
2 of No. 155a

* Not included in Outfit.

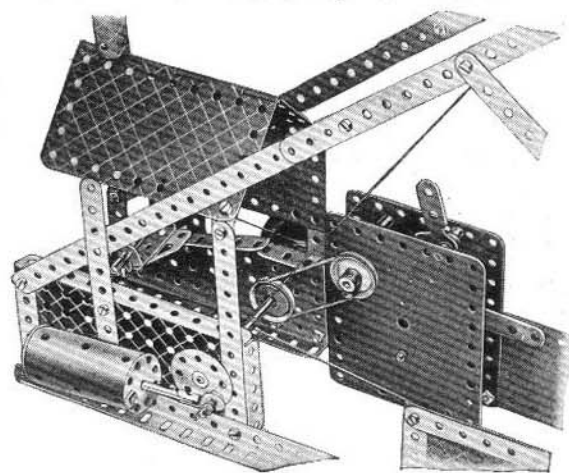
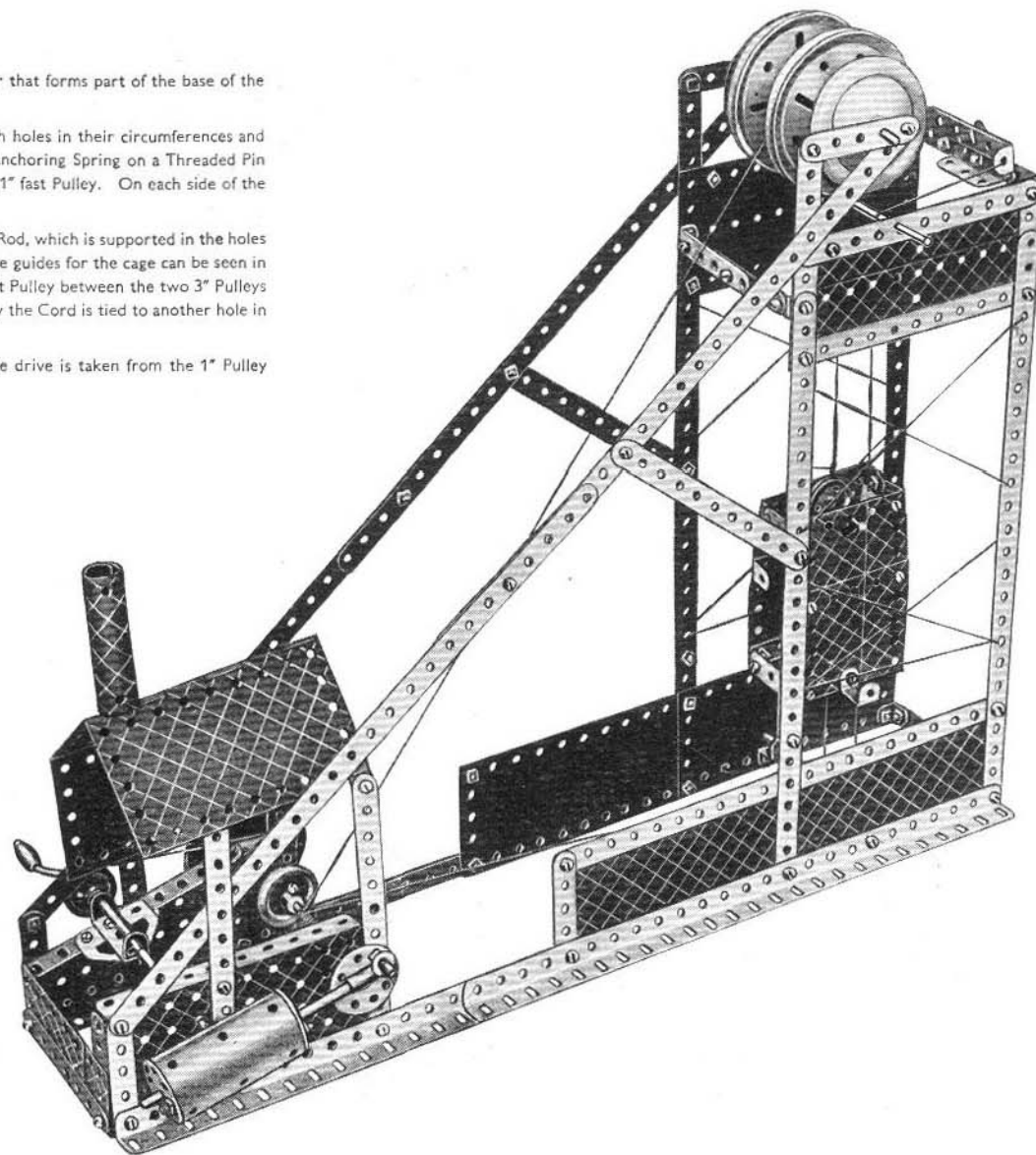
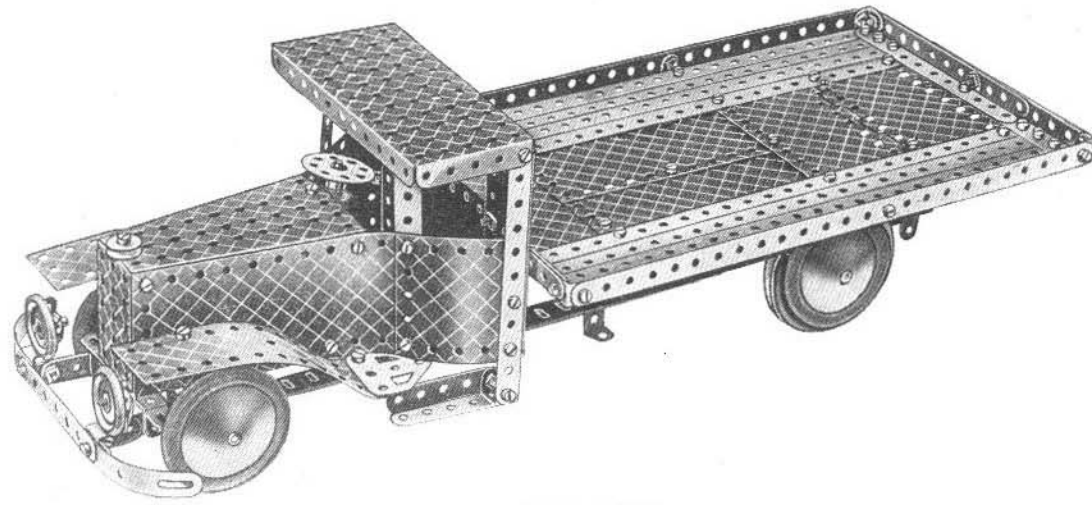

Fig. 5.24a Sectional view showing Motor fitted





5.25 MOTOR LORRY

The chassis of the lorry consists of two side members each built up from two $12\frac{1}{2}$ " Angle Girders overlapped 14 holes, and joined at each end by $2\frac{1}{2}$ " \times $\frac{1}{2}$ " Double Angle Strips. The front Road Wheels are mounted on a 5" Rod passed through the side members of the chassis, and the back Road Wheels are secured on a compound rod consisting of a $3\frac{1}{2}$ " and a $1\frac{1}{2}$ " Rod joined by a Rod Connector and journalled in a similar manner.

Flanged Sector Plates form the top and base for the bonnet and radiator. The narrow end of the bonnet is bolted to the centre hole of the $2\frac{1}{2}$ " \times $\frac{1}{2}$ " Double Angle Strip joining the forward ends of the chassis, and the wider end is attached to the centre of a $5\frac{1}{2}$ " Strip bolted across the chassis. The sides of the bonnet are $5\frac{1}{2}$ " \times $2\frac{1}{2}$ " Flexible Plates, and are bolted to the flanges of the Flanged Sector Plates. The radiator is a $2\frac{1}{2}$ " \times $1\frac{1}{2}$ " Flanged Plate, which is fastened by its flanges to the forward ends of the two Flanged Sector Plates. The radiator cap is represented by a $\frac{1}{2}$ " loose Pulley. The bumper consists of a $3\frac{1}{2}$ " Strip, to the ends of which are bolted 3" Formed Slotted Strips, and it is fastened to the front end of the chassis by 1 " \times 1 " Angle Brackets and $1\frac{1}{2}$ " Strips.

The platform of the lorry is secured to the chassis at the front by $2\frac{1}{2}$ " \times $\frac{1}{2}$ " Double Angle Strips and at the rear by Trunnions and $2\frac{1}{2}$ " Strips.

Fig. 5.25b shows the Motor Lorry fitted with a No. 1 Clockwork Motor. The Motor is held to the chassis by four Bolts, and a $\frac{1}{2}$ " fast Pulley is fastened to the Motor shaft as shown. The drive is transmitted by a Driving Band to a 1 " Pulley on the rear axle.

Parts required					
10 of No. 1	12 of No. 11	1 of No. 17	6 of No. 37a	6 of No. 111c	2 of No. 189
12 " " 2	8 " " 12	2 " " 19b	12 " " 38	2 " " 125	2 " " 191
1 " " 3	2 " " 12a	2 " " 22	8 " " 48a	2 " " 126	4 " " 192
9 " " 5	1 " " 12c	1 " " 23	1 " " 51	2 " " 126a	1 " " 198
2 " " 6a	1 " " 15	1 " " 24	1 " " 52	2 " " 155a	2 " " 200
4 " " 8	1 " " 15b	4 " " 35	2 " " 54a	4 " " 187	1 " " 213
2 " " 10	1 " " 16	85 " " 37	2 " " 111a	3 " " 188	2 " " 215

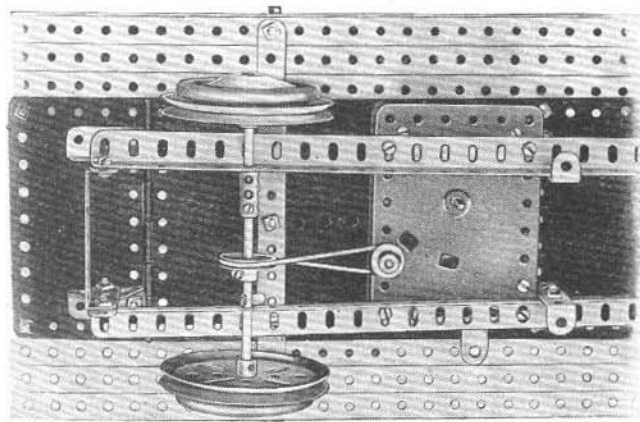

Fig. 5.25b. Sectional view showing Motor fitted.

For Motor Lorry fitted with No. 1 Clockwork Motor

Additional Parts required:—

* 1 No. 1 Clockwork Motor

- 1 of No. 22
- * 1 " " 23a
- * 4 " " 37
- * 1 " " 63
- 1 " " 186a

Parts not required
1 of No. 213

*Not included in Outfit.

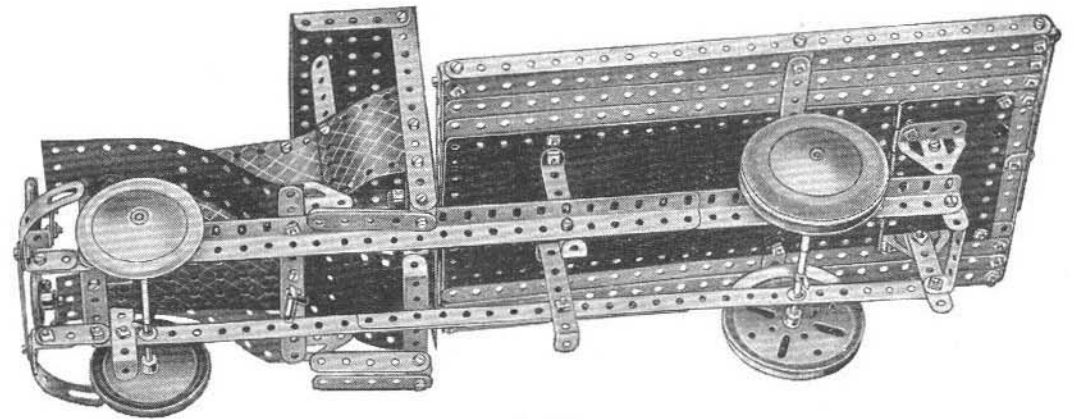
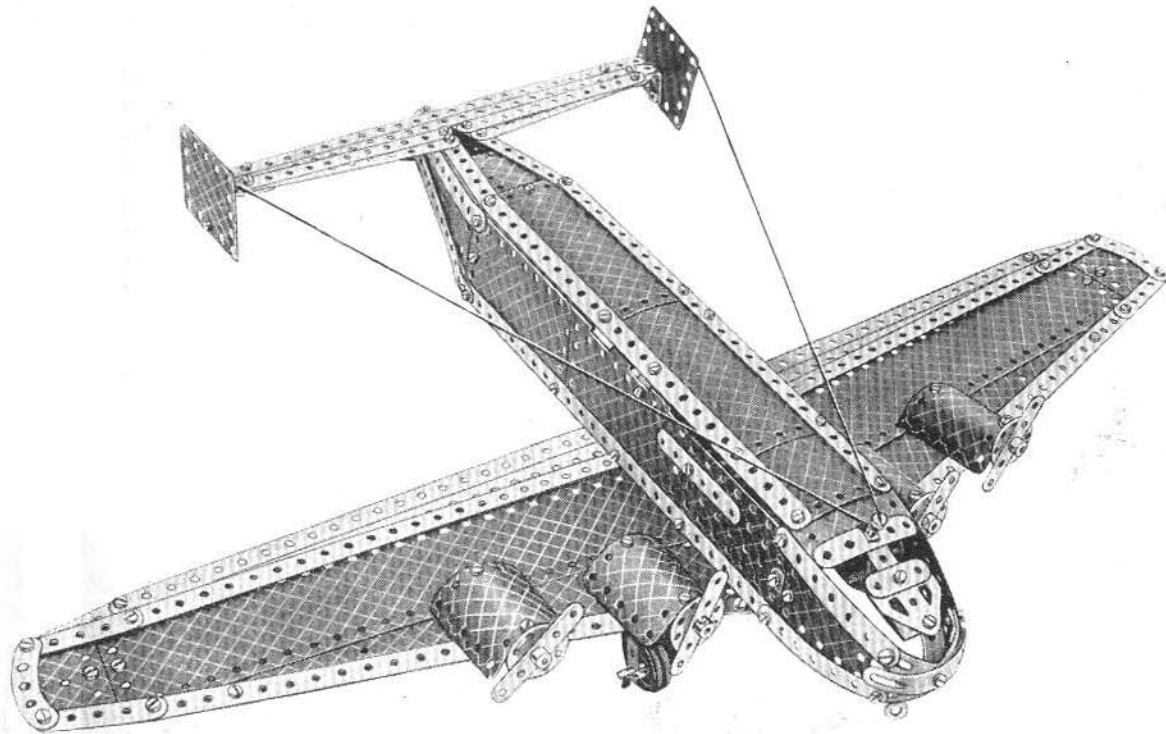

Fig. 5.25a

6.1 FOUR-ENGINE MONOPLANE



The sides of the fuselage are constructed on two 12½" Angle Girders 1, and as they are identical their construction can be followed from the illustration above. The fuselage top is connected to the sides by Obtuse Angle Brackets. The tail of the fuselage is tapered to a point with 5½" Strips and 5½" × 1½" Flexible Plates, the upper Strips being joined by two Angle Brackets. Two 3½" Strips and a 2½" × 1½" Flexible Plate form each side of the forward part of the fuselage and the nose is made up of four Formed Slotted Strips bolted together through their centre holes.

Three 12½" Strips form the trailing edge of each wing, and the leading edge also is a 12½" Strip. These are lengthened with 2½" Strips and are connected by a 2½" Curved Strip at the tip, the framework so formed being filled in with a 12½" Strip Plate, a 5½" × 2½" and a 5½" × 1½" Flexible Plate. A Semi-Circular Plate completes the tip.

The engine nacelles are 1 1/8" radius Curved Plates and 2½" × 2½" Flexible Plates, which are connected to the wings by Reversed Angle Brackets. A 1¼" Disc is attached to the front of each nacelle by an Angle Bracket. The shanks of the 5/8" Bolts 2 form propeller shafts on which the propellers, 2½" Strips, are retained by Collars.

U-Section Curved Plates bolted underneath the wings form supports for 2½" Curved Strips, which provide bearings for the landing wheel axles. The axles are 1½" Rods, and each carries two 1" Pulleys.

A direction-finding aerial is represented by Rod and Strip Connector 3 mounted on a Threaded Pin.

Parts required			
12 of No. 1	3 of No. 18a	2 of No. 90	4 of No. 189
10 " " 2	4 " " 22	4 " " 90a	5 " " 190
4 " " 3	1 " " 23	1 " " 111	2 " " 191
2 " " 4	7 " " 35	2 " " 111a	4 " " 192
11 " " 5	108 " " 37a	6 " " 111c	2 " " 197
2 " " 6a	99 " " 37b	1 " " 115	1 " " 198
2 " " 8	3 " " 38	4 " " 125	2 " " 199
6 " " 10	1 " " 40	3 " " 126a	2 " " 200
6 " " 12	2 " " 48a	1 " " 147b	1 " " 212
2 " " 12a	2 " " 53	4 " " 155a	2 " " 214
6 " " 12c	4 " " 59	4 " " 188	4 " " 215
4 of No. 217a			

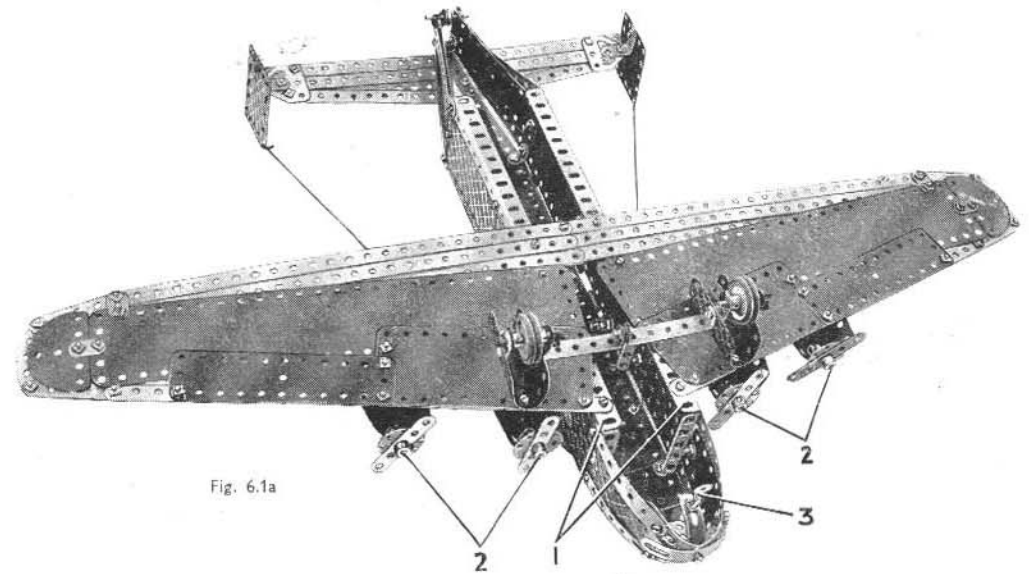
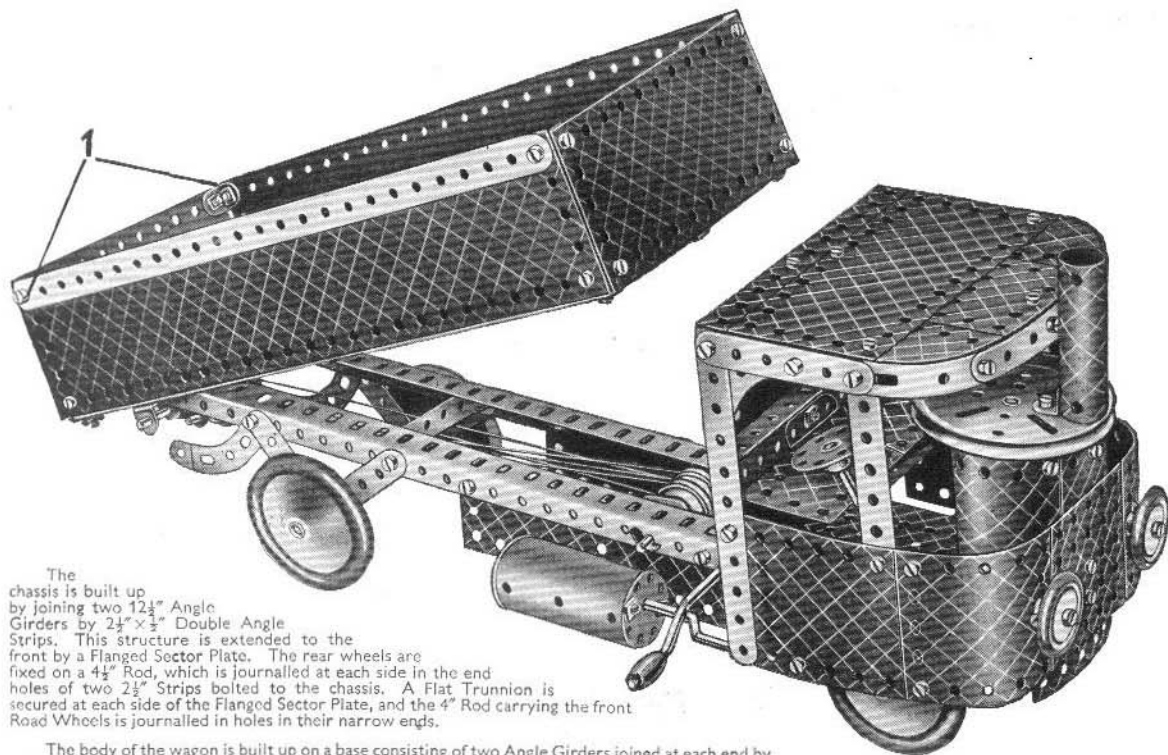

Fig. 6.1a



The chassis is built up by joining two $12\frac{1}{2}$ " Angle Girders by $2\frac{1}{2}$ " x $\frac{1}{2}$ " Double Angle Strips. This structure is extended to the front by a Flanged Sector Plate. The rear wheels are fixed on a $4\frac{1}{2}$ " Rod, which is journalled at each side in the end holes of two $2\frac{1}{2}$ " Strips bolted to the chassis. A Flat Trunnion is secured at each side of the Flanged Sector Plate, and the $4\frac{1}{2}$ " Rod carrying the front Road Wheels is journalled in holes in their narrow ends.

The body of the wagon is built up on a base consisting of two Angle Girders joined at each end by a $5\frac{1}{2}$ " Strip. The bottom is filled in with $12\frac{1}{2}$ " Strips bolted between the two $5\frac{1}{2}$ " Strips. Two $12\frac{1}{2}$ " Strip Plates 1 bolted to the Angle Girders form the sides, and a $5\frac{1}{2}$ " x $2\frac{1}{2}$ " Flexible Plate is secured by four Angle Brackets to the front end. $3\frac{1}{2}$ " Bolts 1, which hold two Angle Brackets supporting the rear $5\frac{1}{2}$ " x $2\frac{1}{2}$ " Flexible Plate, are lock-nutted, and this end of the body is free to swing open when the body is tipped.

The body of the wagon is pivoted on a $5\frac{1}{2}$ " Rod, which passes through holes in the Angle Girders forming the chassis and through two Double Brackets bolted beneath the body.

The tipping mechanism is shown in Fig. 6.2a. A $3\frac{1}{2}$ " Rod is passed through the Angle Girders forming the sides of the chassis, and it carries between the Angle Girders a Flat Bracket, a $1\frac{1}{2}$ " fast Pulley, a $1\frac{1}{2}$ " loose Pulley and a $\frac{1}{2}$ " loose Pulley, all of which are held on the Rod by Spring Clips.

The Pulleys at the rear end of the body are carried on a $2\frac{1}{2}$ " Rod passed through holes in $1\frac{1}{2}$ " x $1\frac{1}{2}$ " Angle Brackets. The $2\frac{1}{2}$ " Rod carries a Collar, a $1\frac{1}{2}$ " fast Pulley, a $1\frac{1}{2}$ " loose Pulley and a $\frac{1}{2}$ " fast Pulley.

The Cord is tied to a Cord Anchoring Spring on the Crank Handle. It is then taken over the Rods and Pulleys in the following order — Over the front Rod, rear Rod, $\frac{1}{2}$ " loose Pulley (front), $1\frac{1}{2}$ " fast Pulley (rear), $1\frac{1}{2}$ " loose Pulley (front), $1\frac{1}{2}$ " loose Pulley (rear), $1\frac{1}{2}$ " fast Pulley (front), $\frac{1}{2}$ " fast Pulley (rear). Finally it is tied to the Flat Bracket on the front Rod.

Several of the Flexible Plates have been removed from the model in Fig. 6.26 to show the construction of the cab. The back consists of a $5\frac{1}{2}$ " x $2\frac{1}{2}$ " Flanged Plate, which is bolted to the chassis by one of its flanges, and is extended upwards by a flat plate 2 obtained by removing the centre pin from a Hinged Flat Plate. The front of the cab is formed by a $3\frac{1}{2}$ " x $2\frac{1}{2}$ " Flanged Plate attached to the Flanged Sector Plate by an Angle Bracket, and each side consists of a $4\frac{1}{2}$ " x $2\frac{1}{2}$ " Flexible Plate and a $2\frac{1}{2}$ " x $2\frac{1}{2}$ "

6.2 TIPPING STEAM WAGON

		Parts required			
11 of No. 1	2 of No. 15b	99 of No. 37	2 of No. 111a	2 of No. 191	
10 " " 2	2 " " 16	10 " " 37a	4 " " 111c	3 " " 192	
1 " " 3	1 " " 17	7 " " 38	1 " " 125	2 " " 197	
2 " " 4	1 " " 19b	1 " " 40	1 " " 126	1 " " 198	
8 " " 5	1 " " 19g	3 " " 48a	2 " " 126a	2 " " 199	
4 " " 8	1 " " 19h	2 " " 48b	2 " " 155a	2 " " 200	
1 " " 10	5 " " 22	1 " " 52	1 " " 176	2 " " 214	
3 " " 11	2 " " 22a	1 " " 53	1 " " 186	2 " " 215	
13 " " 12	1 " " 23	1 " " 54a	4 " " 187	1 " " 216	
2 " " 12a	1 " " 23a	2 " " 59	4 " " 188	2 " " 217a	
1 " " 15	1 " " 24	2 " " 80c	3 " " 189	2 " " 217b	
1 " " 15a	14 " " 35	4 " " 90a	3 " " 190		

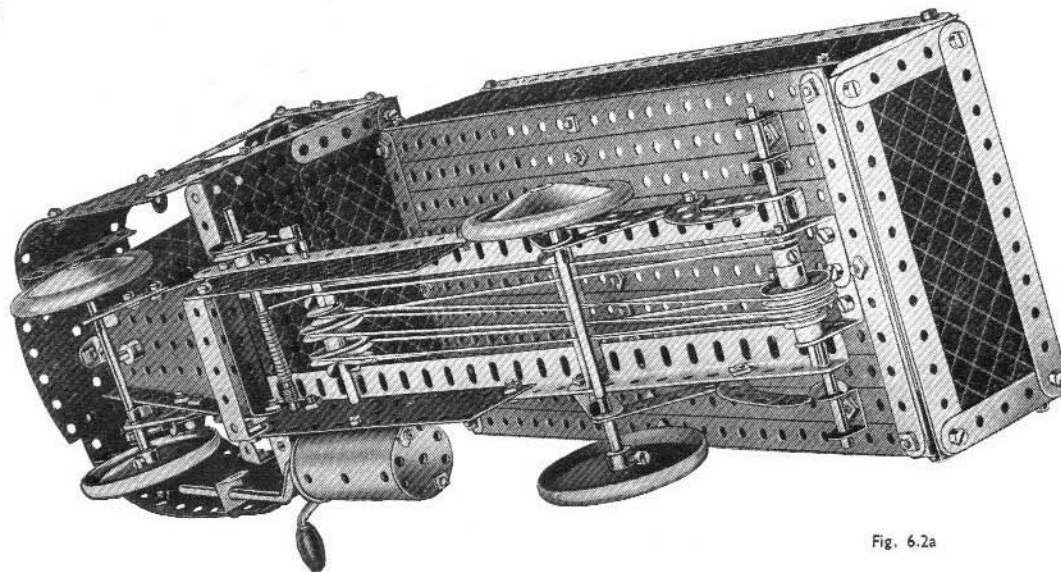

Fig. 6.2a

(Continued on next page)

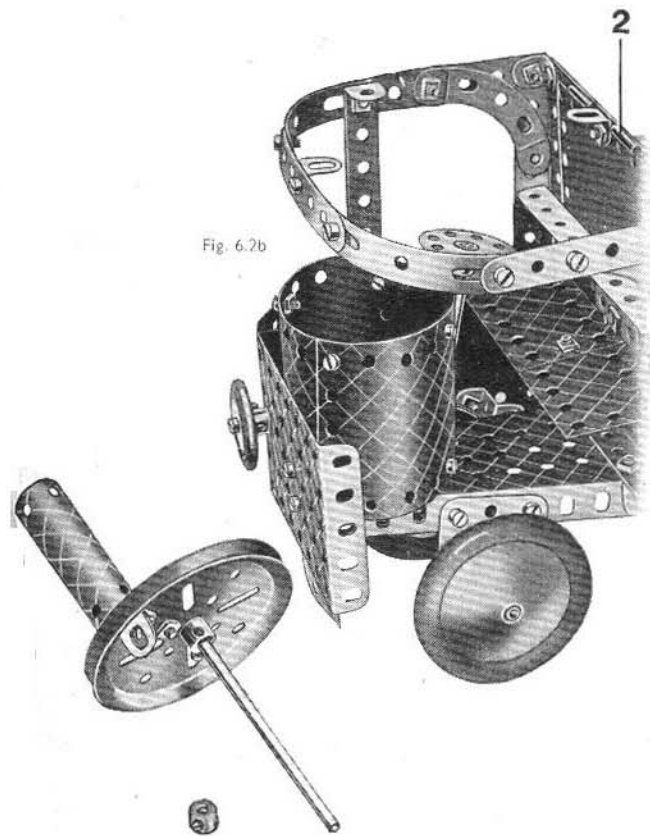

Fig. 6.2b

(Continued from previous page)

Flexible Plate, overlapped three holes and bolted together. The sides are secured at the forward end to the $3\frac{1}{2}'' \times 2\frac{1}{2}''$ Flanged Plate, and at the rear to the shorter flanges of the $5\frac{1}{2}'' \times 2\frac{1}{2}''$ Flanged Plate. The seat is represented by two $2\frac{1}{2}'' \times 1\frac{1}{2}''$ Flexible Plates attached to the $5\frac{1}{2}'' \times 2\frac{1}{2}''$ Flanged Plate by a Trunnion.

The steering wheel is formed by a Bush Wheel locked on the end of a 4" Rod, which passes through a Double Bracket and is fastened in position by two Spring Clips. The Double Bracket is bolted to one of the flanges of the Flanged Sector Plate.

The Boiler is constructed from two U-Section Curved Plates and two $1\frac{1}{4}''$ radius Curved Plates, and is bolted to the $3\frac{1}{2}'' \times 2\frac{1}{2}''$ Flanged Plate at the front of the cab. The top of the cab consists of a $5\frac{1}{2}'' \times 1\frac{1}{2}''$ Flexible Plate and a $5\frac{1}{2}'' \times 2\frac{1}{2}''$ Flexible Plate, bolted together overlapping two holes, and then secured to the flat plate 2 by an Angle Bracket. The two Flexible Plates are extended to the front by a $2\frac{1}{2}'' \times 1\frac{1}{2}''$ Flexible Plate and two Semi-Circular Plates.

6.3 MARKET GARDENER'S VAN

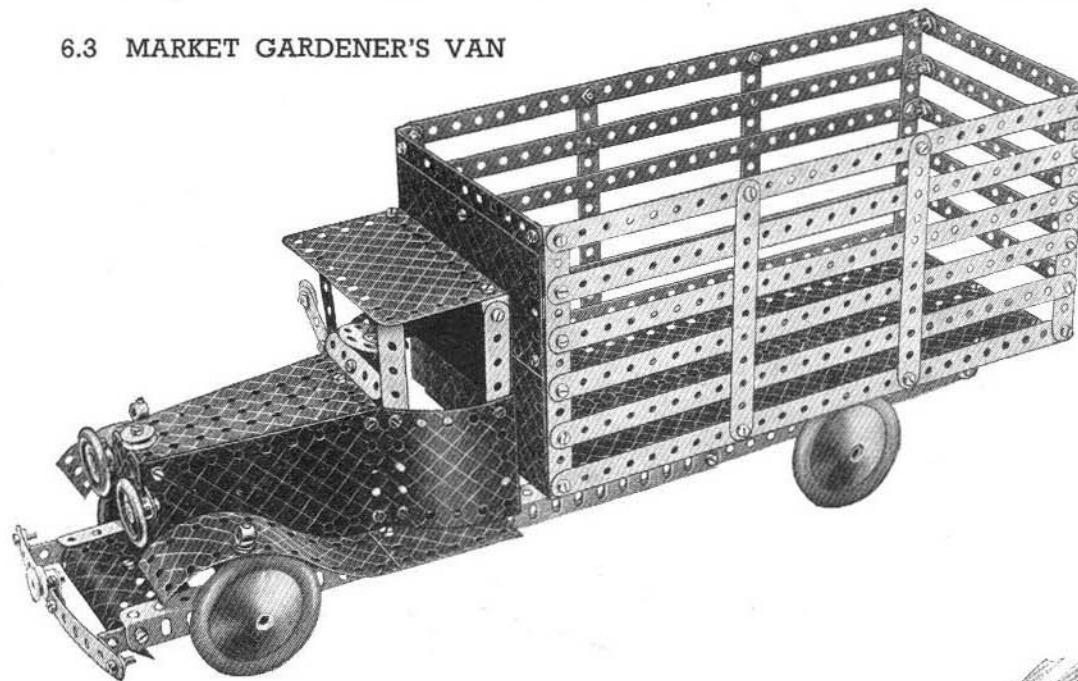

Parts required

12 of No.	1	9 of No.	38
14 "	2	1 "	51
2 "	3	1 "	52
2 "	4	2 "	54a
6 "	5	2 "	59
2 "	6a	6 "	111c
4 "	8	2 "	125
2 "	10	2 "	126
2 "	11	2 "	126a
16 "	12	2 "	155a
2 "	12a	4 "	187
6 "	12c	2 "	188
2 "	15	3 "	189
2 "	15b	2 "	191
2 "	22	1 "	192
1 "	23	2 "	197
1 "	23a	1 "	198
1 "	24	1 "	199
7 "	35	2 "	200
105 "	37	1 "	217b
1 "	37a		

The chassis of the model consists of two $12\frac{1}{2}''$ Angle Girders joined across by $3\frac{1}{2}''$ Strips and extended at the rear by $12\frac{1}{2}''$ Strips. The $12\frac{1}{2}''$ Strips overlap the Angle Girders by 12 holes. The front Road Wheels are fastened on a 5" Rod journalled directly in the sides of the chassis. The back axle, another 5" Rod, passes through the holes of two Flat Trunnions bolted to the $12\frac{1}{2}''$ Strip forming the rear of the chassis.

The body of the van is built up on a framework consisting of two $12\frac{1}{2}''$ Angle Girders, joined at one end by a $5\frac{1}{2}''$ Strip and at the other end by a $5\frac{1}{2}'' \times 2\frac{1}{2}''$ Flanged Plate. At intervals along the sides of the Angle Girders $5\frac{1}{2}''$ Strips are bolted, and to them $12\frac{1}{2}''$ Strips are secured horizontally. The body is fixed to the chassis by two $\frac{1}{2}''$ Reversed Angle Brackets at the front and by two Trunnions at the back.

The sides of the bonnet are formed by $4\frac{1}{2}'' \times 2\frac{1}{2}''$ Flexible Plates, which are bolted to a Flanged Sector Plate secured to the two $3\frac{1}{2}''$ Strips bracing the chassis. Another Flanged Sector Plate forms the top of the bonnet, and is fastened to the $4\frac{1}{2}'' \times 2\frac{1}{2}''$ Flexible Plates. The radiator, a $2\frac{1}{2}'' \times 1\frac{1}{2}''$ Flanged Plate, is bolted to the Flanged Sector Plates forming the top and base of the bonnet. The doors of the cab itself consist of two $1\frac{1}{4}''$ radius Curved Plates, which are fastened to the sides of the bonnet by Obtuse Angle Brackets. A Hinged Flat Plate forms the roof and back of the cab, and it is secured by Angle Brackets to two $2\frac{1}{2}''$ Strips bolted to the doors. The front of the roof rests on the ends of two $2\frac{1}{2}''$ Strips bolted to the doors just behind the bonnet.

The mudguards are constructed by bending $5\frac{1}{2}'' \times 1\frac{1}{2}''$ Flexible Plates to shape and bolting their ends to the chassis. They are supported at the forward ends by a 4" Rod journalled in the sides of the bonnet and fastened in position by Spring Clips.

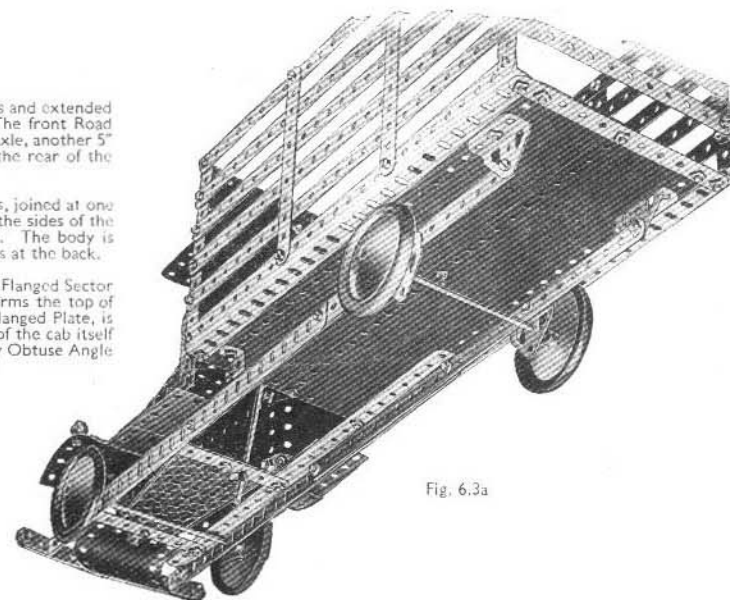
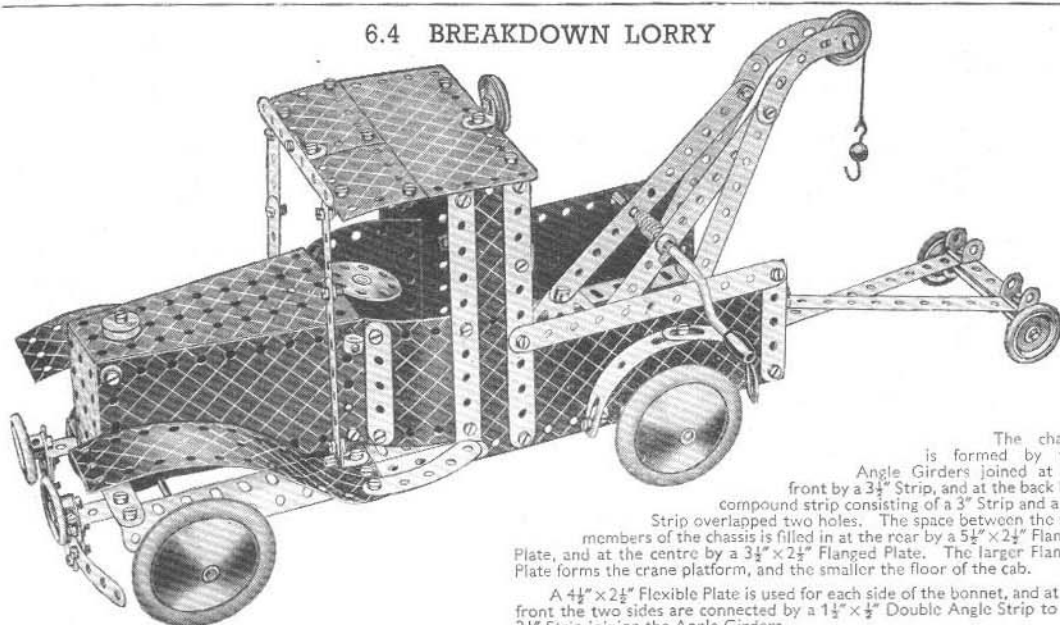

Fig. 6.3a

6.4 BREAKDOWN LORRY



The chassis is formed by two Angle Girders joined at the front by a $3\frac{1}{2}$ " Strip, and at the back by a compound strip consisting of a 3" Strip and a $1\frac{1}{2}$ " Strip overlapped two holes. The space between the side members of the chassis is filled in at the rear by a $5\frac{1}{2}$ " x $2\frac{1}{2}$ " Flanged Plate, and at the centre by a $3\frac{1}{2}$ " x $2\frac{1}{2}$ " Flanged Plate. The larger Flanged Plate forms the crane platform, and the smaller the floor of the cab.

A $4\frac{1}{2}$ " x $2\frac{1}{2}$ " Flexible Plate is used for each side of the bonnet, and at the front the two sides are connected by a $1\frac{1}{2}$ " x $\frac{1}{2}$ " Double Angle Strip to the $3\frac{1}{2}$ " Strip joining the Angle Girders.

The sides of the cab consist of $5\frac{1}{2}$ " x $1\frac{1}{2}$ " Flexible Plates, bolted to the chassis, a $3\frac{1}{2}$ " x $2\frac{1}{2}$ " Flanged Plate being bolted between them to form the lower part of the back. Two $2\frac{1}{2}$ " x $1\frac{1}{2}$ " Flexible Plates are fastened to a $3\frac{1}{2}$ " x $\frac{1}{2}$ " Double Angle Strip to fill in the rest of the back, but a small space is left for the window.

The centre pin is withdrawn from a Hinged Flat Plate and one of the halves is used as a flat plate in the construction of the roof. The flat plate is secured by Angle Brackets to the sides of the cab.

Both the front and the rear Road Wheels are fastened on 5" Rods passed through holes in Flat Trunnions bolted to the sides of the chassis.

The steering wheel is a Bush Wheel fastened on a $3\frac{1}{2}$ " Rod passed through a Reversed Angle Bracket bolted to the top of the bonnet. The Rod also passes through the $3\frac{1}{2}$ " x $2\frac{1}{2}$ " Flanged Plate forming the floor of the cab.

Parts required

13 of No. 2	1 of No. 48a	4 of No. 126a
4 " " 3	1 " " 48b	1 " " 147b
1 " " 4	1 " " 51	4 " " 155a
8 " " 5	1 " " 52	1 " " 176
2 " " 6a	2 " " 53	4 " " 187
2 " " 8	1 " " 54a	4 " " 188
6 " " 10	1 " " 57c	4 " " 189
2 " " 11	3 " " 59	2 " " 191
12 " " 12	2 " " 90	2 " " 192
2 " " 12a	2 " " 90a	1 " " 198
4 " " 12c	3 " " 111c	2 " " 200
2 " " 15	1 " " 125	4 " " 215
1 " " 15a	2 " " 126	
2 " " 16		
1 " " 18b		
1 " " 19g		
5 " " 22		
1 " " 22a		
1 " " 23		
1 " " 24		
5 " " 35		
101 " " 37		
1 " " 37a		
6 " " 38		
1 " " 40		
1 " " 44		
1 " " 48		

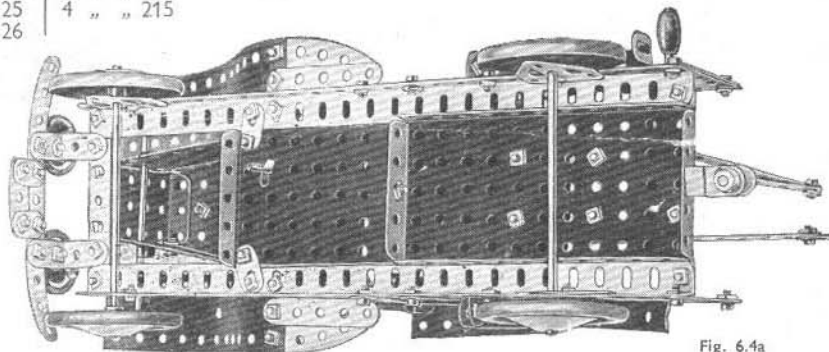
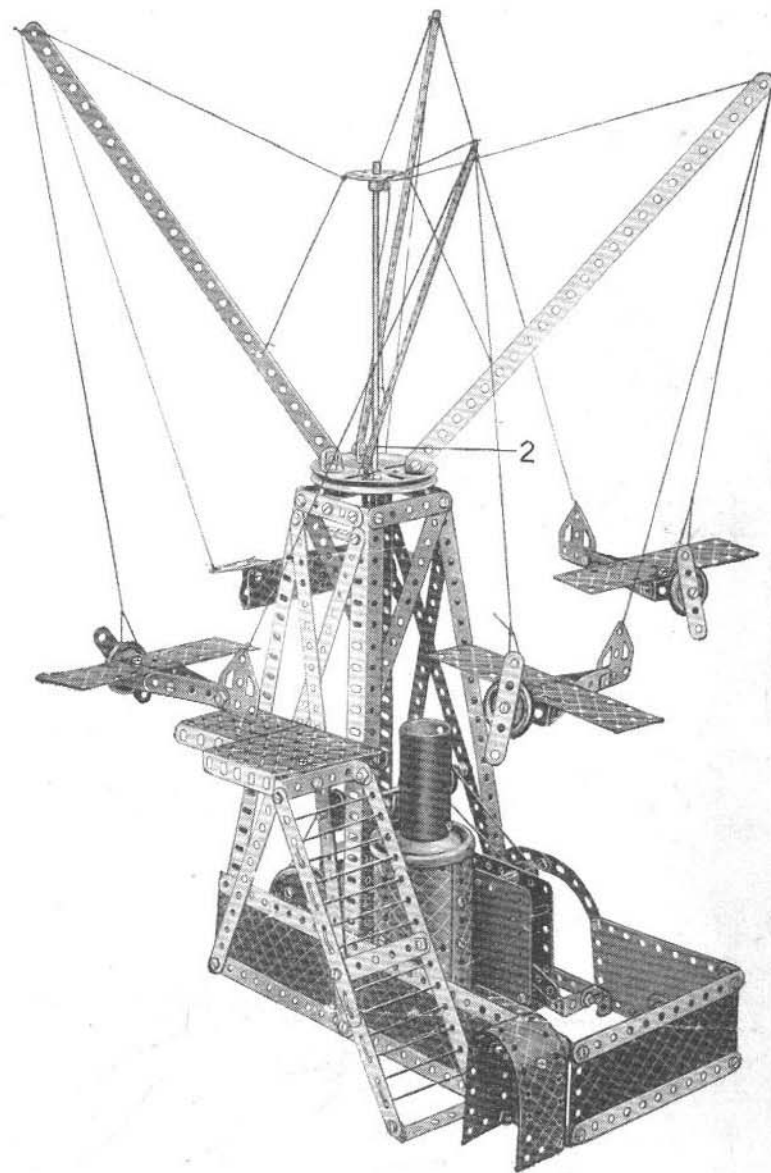

Fig. 6.4a

6.5 HIGH FLYERS



6.5 HIGH-FLYERS

A base for the model is provided by bolting two 12½" Strips to the Angle Girders that form the tower. Two 5½" Strips are bolted to the Angle Girders across their lower ends, and between them is fixed a 5½" × 2¼" Flanged Plate. The Flanged Plate is extended on the inside by a 3½" × 2½" Flanged Plate attached to it by a Flat Bracket. The 3½" × 2½" Flanged Plate is attached also to one of the 12½" Strips of the base by a 1" × 1" Angle Bracket and a Double Bracket.

The boiler consists of two 5½" × 2¼" Flexible Plates bolted together and extended by two 1⅞" radius Curved Plates. They are then curved to shape and their ends are bolted together. The boiler is fixed to the side of the model. The Road Wheel is fastened on a 3" Screwed Rod, which is lock-nutted to a Flat Bracket bolted to a 1" × 1" Angle Bracket inside the boiler. The 2½" Cylinder carries an Angle Bracket on its inside, and is fitted on to the Screwed Rod, where it is held in place by a Nut.

The No. 1 Clockwork Motor is fastened by Double Brackets to the 5½" × 2¼" Flanged Plate and the 3½" × 2½" Flanged Plate. The drive is taken by a Driving Band from a ½" fast Pulley on the driving shaft of the Motor, to a 1" fast Pulley on a 5" Rod journalled in the sides of the tower. This Rod carries also a second 1" Pulley, which is connected by a Driving Band to a 3" Pulley on the 3½" Rod carrying the Pulley 1 (Fig. 6.5a). Pulley 1 is fitted with a Rubber Ring, which is in contact with the rim of the Road Wheel at the bottom of the main shaft. The arms carrying the aeroplanes are fastened by Angle Brackets to a 3" Pulley on the main shaft, and are supported by Cords. The main shaft consists of an 11½" Rod and a 6½" Rod joined by a Rod Connector 2.

The construction of three of the aeroplanes will be clear from the illustration. The fuselage of the aeroplane partly hidden by the tower consists of two U-section Curved Plates bolted together at the tail. A 1" loose Pulley is attached to the fuselage by an Angle Bracket to form the engine. The wing is made of two 5½" Strips bolted to an Angle Bracket and to a Double Bracket fastened to the sides of the fuselage.

Parts required	
11 of No. 1	1 of No. 52
12 " " 2	2 " " 53
4 " " 3	1 " " 54a
2 " " 4	4 " " 59
12 " " 5	1 " " 80c
1 " " 6a	2 " " 90a
4 " " 8	2 " " 111
3 " " 10	2 " " 111a
4 " " 11	6 " " 111c
15 " " 12	2 " " 126
2 " " 12a	4 " " 126a
1 " " 13	4 " " 155a
1 " " 14	2 " " 186
1 " " 15	2 " " 187
1 " " 16	3 " " 188
2 " " 19b	3 " " 189
5 " " 22	1 " " 191
2 " " 22a	4 " " 192
1 " " 23a	1 " " 197
1 " " 24	2 " " 199
105 " " 37	2 " " 200
6 " " 37a	1 " " 213
4 " " 38	1 " " 216
2 " " 40	1 No. 1 Clockwork Motor
2 " " 48	
8 " " 48a	

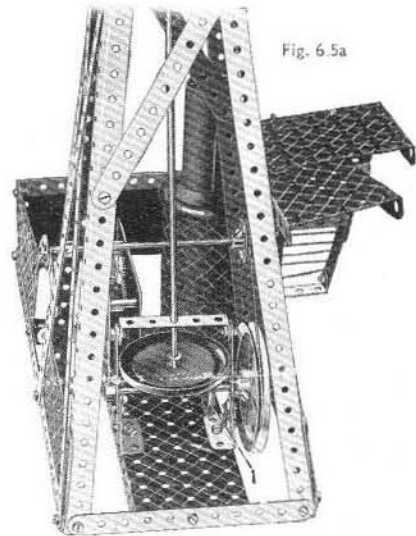

Fig. 6.5a

6.6. FURNITURE VAN

The construction of the model is commenced by building the van body, the base of which consists of two 12½" Angle Girders joined at each end by a 5½" Strip. The lower part of each side comprises 12½" Strip Plates and different sized Flexible Plates, and the two flat plates 1 form the upper part of the sides. The flat plates 1 are obtained by removing the centre pin from a Hinged Flat Plate and using the two halves separately. Each half is bolted over a framework of 12½" Strips and 5½" Strips, which can be seen in Fig. 6.6a. The top is constructed from 12½" Strips bolted at each end to 5½" Strips connected to the frame. The bonnet unit consists of two Flanged Sector Plates, the flanges of which are joined by 4½" × 2½" Flexible Plates. The radiator is bolted in position to the two Flanged Sector Plates, the upper Bolt being ⅝" long and carrying a ½" loose Pulley to represent the radiator cap. The lower Flanged Sector Plate is bolted to a 3½" × 2¼" Flanged Plate, which is secured to the chassis.

The front bumper is fastened by two Reversed Angle Brackets to the ends of two 3½" × ½" Double Angle Strips fixed under the bonnet. The headlights are represented by 1" fast Pulleys on the shanks of two ⅝" Bolts, which are passed through a 2½" × ½" Double Angle Strip bolted to the radiator. Running boards are represented by 2½" × 1½" Flexible Plates bolted to the 3½" × 2¼" Flanged Plate, and they provide supports for the front mudguards. The latter each consist of two formed Slotted Strips coupled together by Flat Brackets, and they are secured to the running board by Angle Brackets.

The seat inside the cab is made with two U-Section Curved Plates connected by Flat Brackets and attached by an Angle Bracket to the back of the seat, which consists of a 3½" × 2¼" Flanged Plate extended by a 2½" × 2¼" Flexible Plate.



Fig. 6.6a

Parts required		
12 of No. 1	1 of No. 24	6 of No. 111c
13 " " 2	1 " " 35	2 " " 125
3 " " 3	103 " " 37	2 " " 155a
2 " " 4	8 " " 37a	4 " " 187
12 " " 5	5 " " 38	4 " " 188
4 " " 8	1 " " 48a	4 " " 189
8 " " 10	2 " " 48b	5 " " 190
2 " " 11	1 " " 51	2 " " 191
13 " " 12	1 " " 52	4 " " 192
1 " " 12a	2 " " 53	2 " " 197
1 " " 14	2 " " 54a	1 " " 198
1 " " 15	4 " " 59	2 " " 199
1 " " 18a	2 " " 90a	2 " " 200
2 " " 22	2 " " 111	2 " " 214
1 " " 23	2 " " 111a	4 " " 215

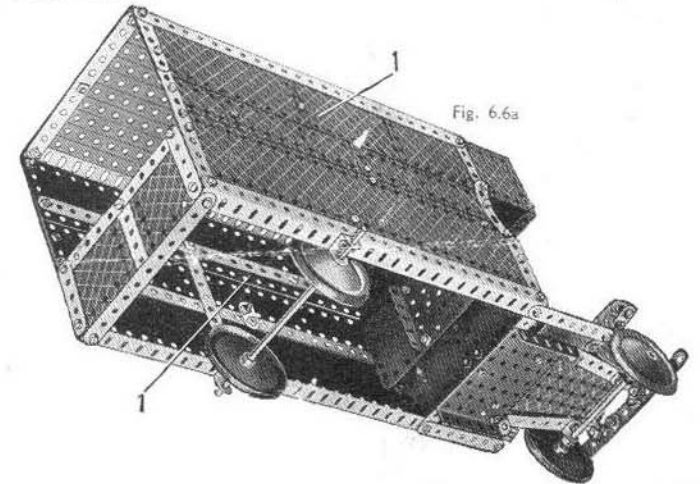

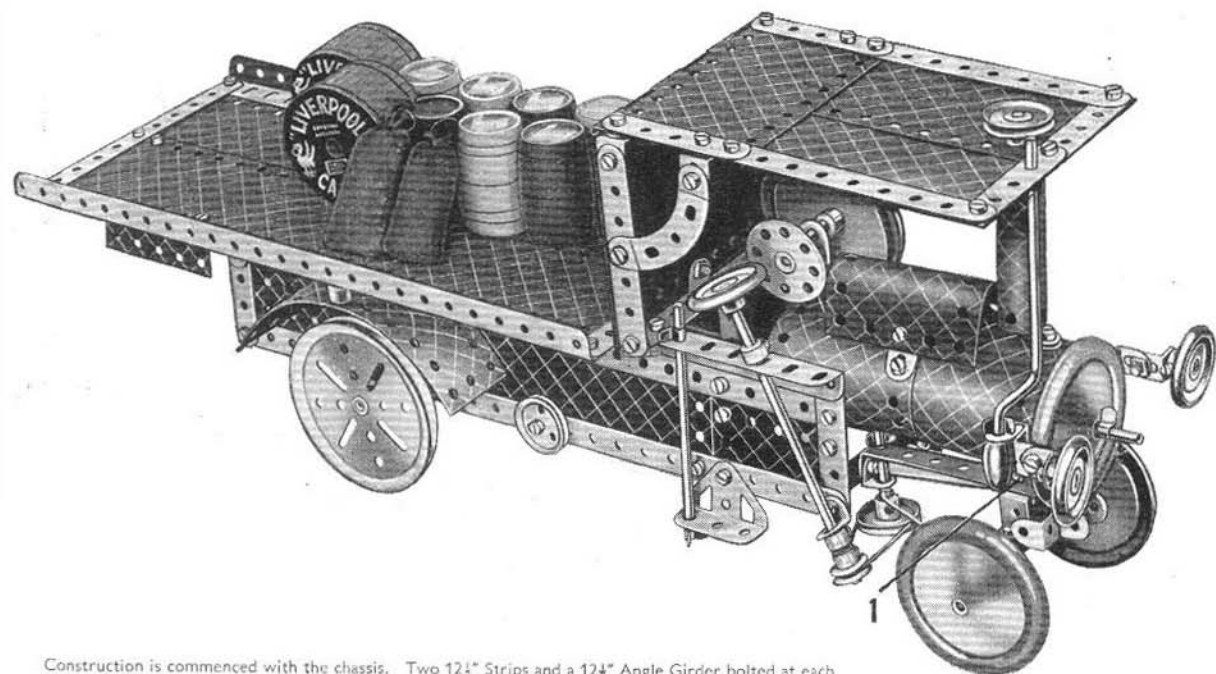

6.7 STEAM WAGON

Parts required

4 of No. 1	1 of No. 17	1 of No. 44	1 of No. 126
5 " " 2	1 " " 18a	1 " " 45	3 " " 155a
3 " " 3	2 " " 19b	1 " " 48	1 " " 186
1 " " 4	1 " " 19g	3 " " 48a	4 " " 187
12 " " 5	5 " " 22	1 " " 48b	4 " " 188
4 " " 8	1 " " 22a	1 " " 51	2 " " 189
3 " " 10	1 " " 23	2 " " 53	4 " " 190
4 " " 11	1 " " 23a	4 " " 59	2 " " 191
12 " " 12	1 " " 24	1 " " 80c	4 " " 192
2 " " 12a	8 " " 35	2 " " 90a	2 " " 197
5 " " 12c	101 " " 37	2 " " 111	1 " " 198
1 " " 13	4 " " 37a	2 " " 111c	2 " " 199
2 " " 15	8 " " 38	2 " " 125	2 " " 200
2 " " 15b	1 " " 40		

Construction is commenced with the chassis. Two $12\frac{1}{2}$ " Strips and a $12\frac{1}{2}$ " Angle Girder bolted at each end to two $2\frac{1}{2}$ " Strips form each side member. The sides of the chassis are filled in with Flexible Plates and two Flanged Plates. The side members of the chassis are then joined together, at the rear by $2\frac{1}{2}$ " Strips and at the front by a $2\frac{1}{2}$ " \times $2\frac{1}{2}$ " Double Angle Strip. The platform is bolted to the chassis by two $1"$ \times $1"$ Angle Brackets at the rear. At the front end it is bolted to a Flat Bracket attached to two $2\frac{1}{2}$ " Strips, which are overlapped one hole and bolted to the Angle Girders forming the side members of the chassis.

The boiler consists of two $4\frac{1}{2}$ " \times $2\frac{1}{2}$ " Flexible Plates extended by two $1\frac{1}{4}$ " radius Curved Plates and bent to shape, the end being joined together by two Obtuse Angle Brackets. The boiler front is a Road Wheel carried on an $11\frac{1}{2}$ " Rod, which is held by a Spring Clip in a $2\frac{1}{2}$ " \times $2\frac{1}{2}$ " Double Angle Strip. The chimney is a U-Section Curved Plate bent to shape, and is attached as follows. A $3"$ Screwed Rod is lock-nutted at one end to a Flat Bracket bolted to the boiler, and passed up the centre of the chimney. The free end of the Screwed Rod projects through the roof of the cab and is held in the boss of a $1"$ Pulley.

The rear part of the roof is formed by a Hinged Flat Plate, extended at the back of the cab by two $2\frac{1}{2}$ " \times $2\frac{1}{2}$ " Flexible Plates. These are attached to the platform body by an Angle Bracket, which is held by the same Bolt as the Flat Bracket already mentioned. The Angle Brackets bolted to the $3\frac{1}{2}$ " Strips at the side of the cab are spaced from the Hinged Flat Plate by two Washers.

The front axle is mounted in the following manner. A Double Bracket is fastened by Obtuse Angle Brackets to the underside of the boiler, and a $3\frac{1}{2}$ " \times $2\frac{1}{2}$ " Double Angle Strip is bolted to it and to the Double Angle Strip spacing the front of the chassis. To the Double Angle Strip a Double Bent Strip carrying the front axle support is lock-nutted by Bolt 1.

The steering column is journaled in the Angle Girder at the side of the cab, and also in an Angle Bracket. The $\frac{3}{4}"$ Pulley on the lower end of the steering column is connected to a $1"$ Pulley held on a $1\frac{1}{2}"$ Rod, by a Driving Band. Cord is wound several times around the $1\frac{1}{2}"$ Rod, and is tied at each end to the $2\frac{1}{2}"$ \times $2\frac{1}{2}"$ Double Angle Strip supporting the front axle.

The rear mudguards are held by $\frac{1}{2}"$ Bolts, and are spaced from the platform by a Collar and two Washers. The rear wheels are $3"$ Pulleys fastened on the ends of a $5"$ Rod.

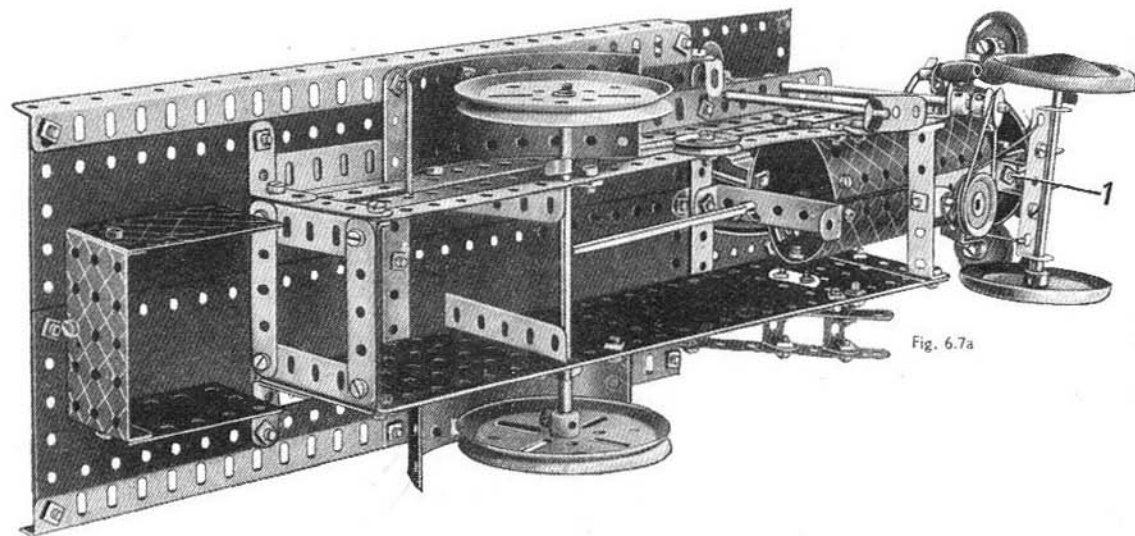
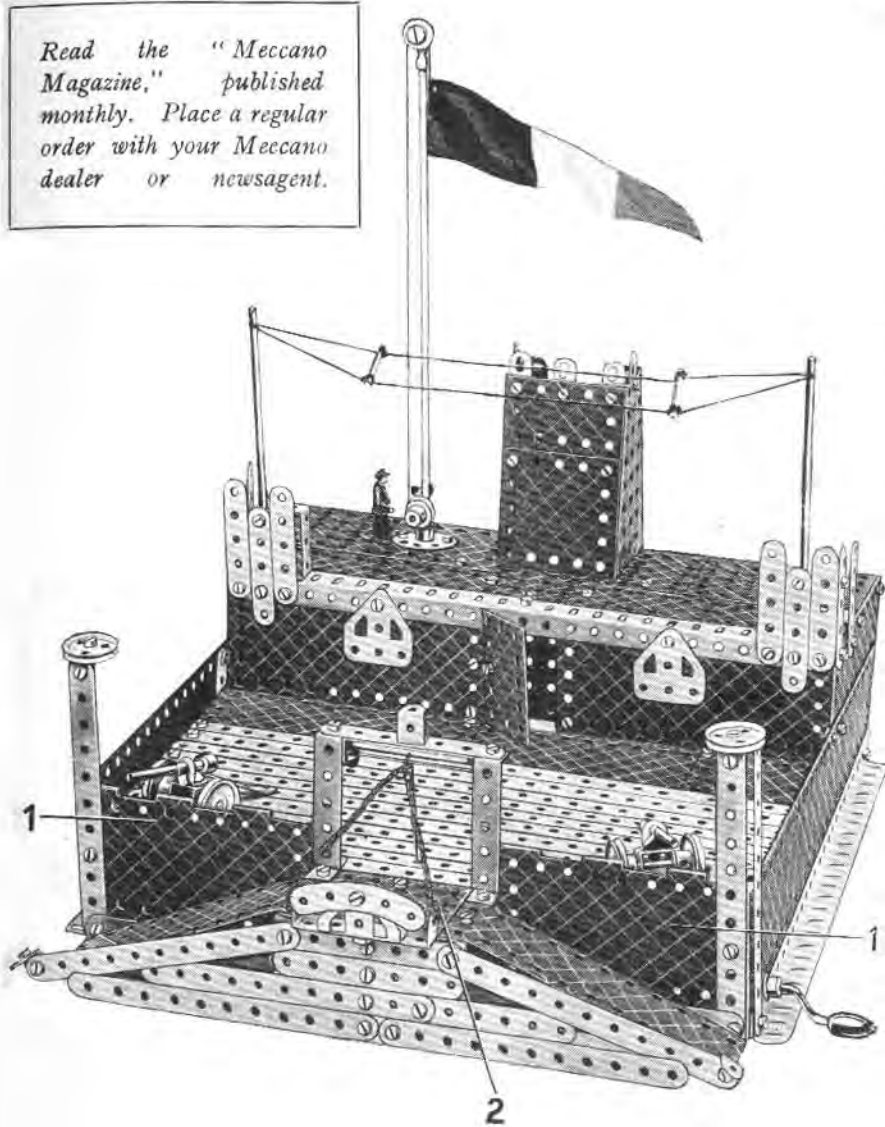

Fig. 6.7a

6.8 FOREIGN LEGION FORT



Read the "Meccano Magazine," published monthly. Place a regular order with your Meccano dealer or newsagent.

12 of No. 1	4 of No. 18a	2 of No. 54a
11 " " 2	1 " " 19h	4 " " 59
4 " " 3	4 " " 22	1 " " 90
1 " " 4	2 " " 22a	6 " " 111c
12 " " 5	1 " " 23	2 " " 125
2 " " 6a	1 " " 23a	2 " " 126
4 " " 8	1 " " 24	4 " " 126a
7 " " 10	10 " " 35	1 " " 147b
4 " " 11	105 " " 37	4 " " 188
16 " " 12	6 " " 37a	4 " " 189
2 " " 12a	12 " " 38	3 " " 190
1 " " 12c	1 " " 40	2 " " 191
1 " " 13	2 " " 48	4 " " 192
1 " " 14	7 " " 48a	2 " " 197
2 " " 15	1 " " 51	1 " " 198
2 " " 16	1 " " 52	1 " " 212
2 " " 17	2 " " 53	1 " " 213
	2 of No. 214	

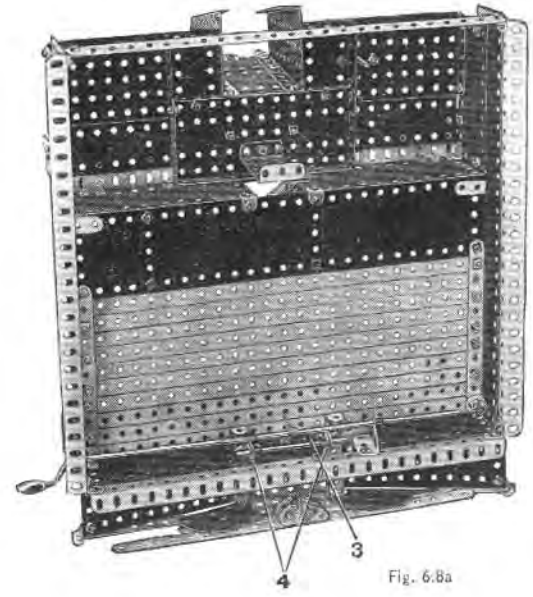

Fig. 6.8a

The base of the fort consists of two Angle Girders joined at each end by Angle Brackets to 12½" Strips. Two 12½" × 2½" Strip Plates are bolted to the Angle Girders to form the sides. The 12½" Strips that form the floor of the court-yard are bolted to 5½" Strips attached by Angle Brackets to the 12½" × 2½" Strip Plates. Reference to the illustrations will make clear the construction of the barrack rooms.

The observation tower is formed by two Flanged Sector Plates, the front flanges of which are joined by a 2½" × 2½" and a 2½" × 1½" Flexible Plate. The Flanged Sector Plates are bolted to the 5½" × 2½" Flanged Plate forming the centre part of the roof. An 11½" Rod is used for the flag mast and is held upright in the boss of a Bush Wheel bolted to the roof. The Cord for raising and lowering the flag passes around a ½" fast Pulley at the bottom of the pole and a ½" loose Pulley at the top. The ½" fast Pulley is held on the shank of a ¼" Bolt passed through a Double Bracket on the 11½" Rod, and the ½" loose Pulley is carried on a Pivot Bolt lock-nutted to a Rod and Strip Connector at the top of the Rod. The Rods forming the wireless masts are held in Collars bolted to the 2½" Strips at the corners of the roof.

The centre pin is removed from a Hinged Flat Plate, and the halves are used as flat plates 1 in the construction of the front of the fort. The approach roadways are formed by 5½" × 1½" Flexible Plates bolted to the 2½" Strips fastened to the front 12½" Strip of the court-yard. The Strips at the front of the fort are supported by two Flat Trunnions (see Fig. 6.8a).

A 2½" × 2½" Flexible Plate 2 is used for the drawbridge, and to its rear end is bolted a 2½" × ½" Double Angle Strip 3, which is pivoted on a 3½" Rod journalled in two Angle Brackets 4. The operation of raising and lowering the drawbridge is controlled by a Crank Handle, to the shaft of which a 6½" Rod is attached by a Rod Connector. Cord is wound around the 6½" Rod, led over a 3½" Rod at the top of the gateway, and finally is tied to the front of the drawbridge.

6.9 TRAMCAR

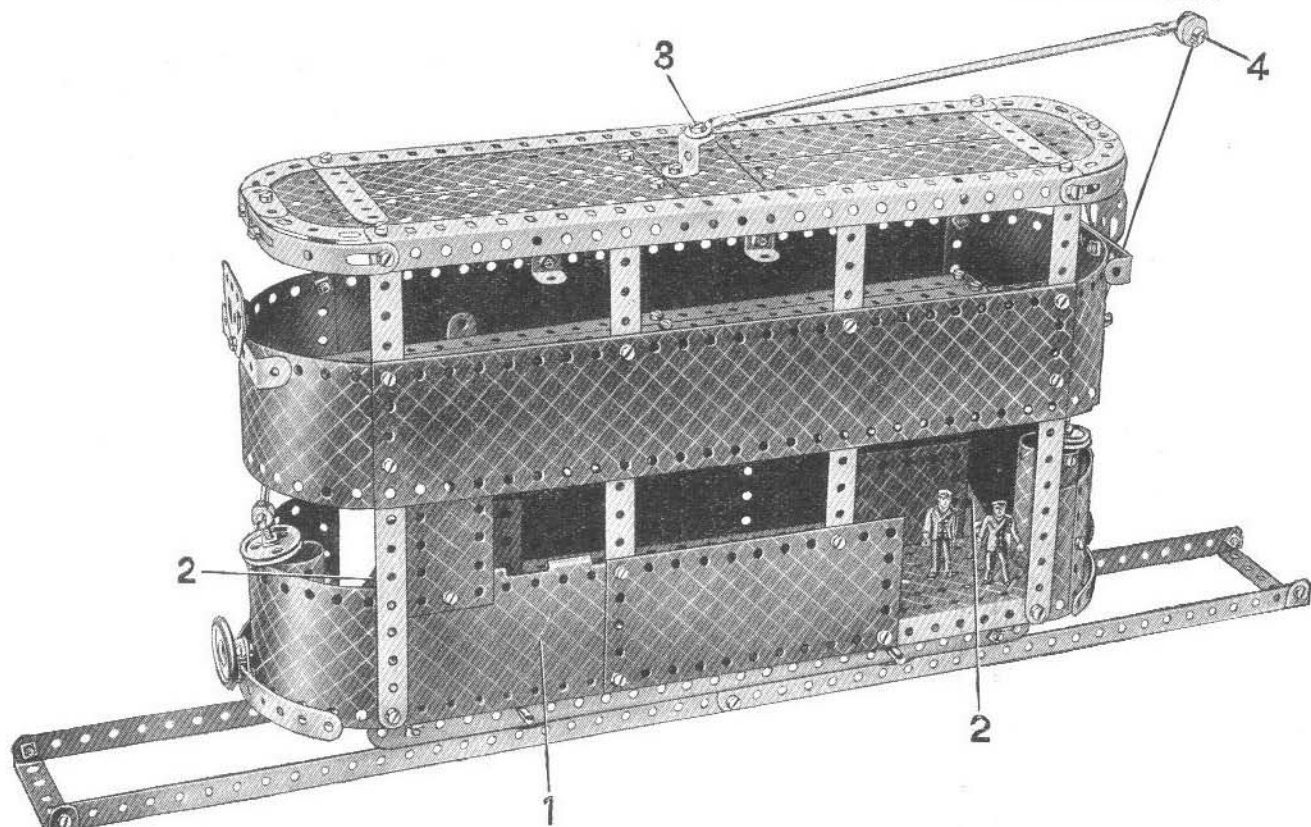

Parts required

11 of No. 1	9 of No. 12	4 of No. 35	1 of No. 52	3 of No. 125	2 of No. 197
13 " " 2	2 " " 12c	103 " " 37	2 " " 53	2 " " 126a	1 " " 198
3 " " 3	1 " " 13	8 " " 37a	2 " " 54a	1 " " 155a	2 " " 199
2 " " 4	2 " " 16	10 " " 38	2 " " 59	4 " " 188	2 " " 200
11 " " 5	2 " " 18a	1 " " 48	2 " " 80c	4 " " 189	2 " " 212
2 " " 6a	5 " " 22	6 " " 48a	1 " " 90	6 " " 190	2 " " 214
4 " " 8	2 " " 22a	1 " " 48b	4 " " 90a	2 " " 191	4 " " 215
6 " " 10	1 " " 23	1 " " 51	6 " " 111c	4 " " 192	4 " " 217a
					1 of No. 217b

Construction is commenced with the chassis as shown in Fig. 6.9a. Two $12\frac{1}{2}$ " Strips are connected by Angle Brackets to two Angle Girders, and the last named are joined across at each end by compound strips consisting of two $2\frac{1}{2}$ " Strips overlapped two holes. The bottom is filled in by bolting a $3\frac{1}{2}$ " \times $2\frac{1}{2}$ " Flanged Plate by its flange to the lower Angle Girder, and a $5\frac{1}{2}$ " \times $2\frac{1}{2}$ " Flanged Plate to the other Angle Girder. A Flanged Sector Plate and a $5\frac{1}{2}$ " Strip are bolted to the $3\frac{1}{2}$ " \times $2\frac{1}{2}$ " Flanged Plate, and two further $5\frac{1}{2}$ " Strips are attached by Reversed Angle Brackets, one to the $5\frac{1}{2}$ " \times $2\frac{1}{2}$ " Flanged Plate, and the other to the compound strip that spaces the Angle Girders.

The sides of the car are next added. One half of a Hinged Flat Plate is used at 1, and the other half is used in a similar position on the opposite side of the model. Five $5\frac{1}{2}$ " Strips carry the upper deck, and $2\frac{1}{2}$ " Strips and Double Angle Strips support the roof. The $5\frac{1}{2}$ " Strips 2 are bolted to $2\frac{1}{2}$ " \times $2\frac{1}{2}$ " Flexible Plates, which in turn are fastened to the floor of the tramcar.

The upper deck consists of five $12\frac{1}{2}$ " Strips, three of which are bolted to one side of a $3\frac{1}{2}$ " \times $4\frac{1}{2}$ " Double Angle Strip, while the other two are fastened to a Flat Bracket that is attached to the Double Angle Strip. The floor is filled in with $2\frac{1}{2}$ " \times $2\frac{1}{2}$ " Flexible Plates, with a Flanged Sector Plate at the front end and a $2\frac{1}{2}$ " \times $1\frac{1}{2}$ " Flanged Plate at the rear end.

U-Section Curved Plates are attached by Obtuse Angle Brackets to each end of the tram to represent the speed control boxes, the securing Bolts holding also an Angle Bracket. Two 3" Screwed Rods are each fitted with a 1" loose Pulley, and Collars with $1\frac{1}{2}$ " Rods locked in them are fixed on the upper end of each Screwed Rod to form the control switch.

A Reversed Angle Bracket is bolted to a $3\frac{1}{2}$ " \times $2\frac{1}{2}$ " Flanged Plate in the roof of the tram and a Rod and Strip Connector is attached by lock-nutted Bolt 3 to its other end. A second Rod and Strip Connector is carried at the end of the $11\frac{1}{2}$ " Rod forming the trolley, and a $\frac{1}{2}$ " loose Pulley is attached by lock-nutted Bolt 4.

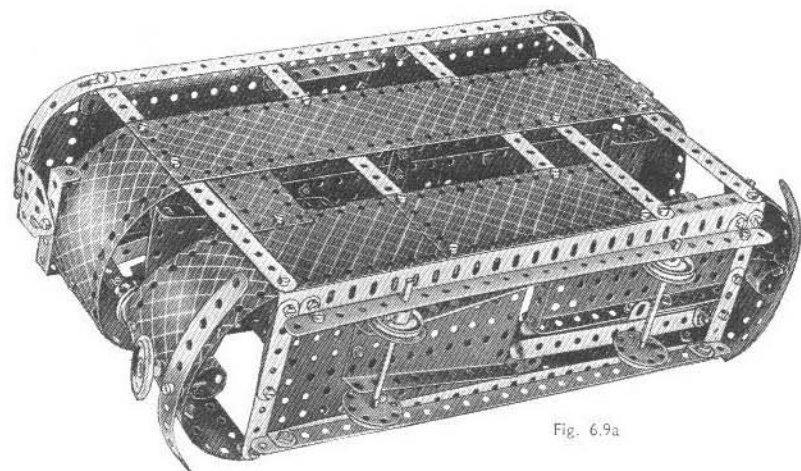
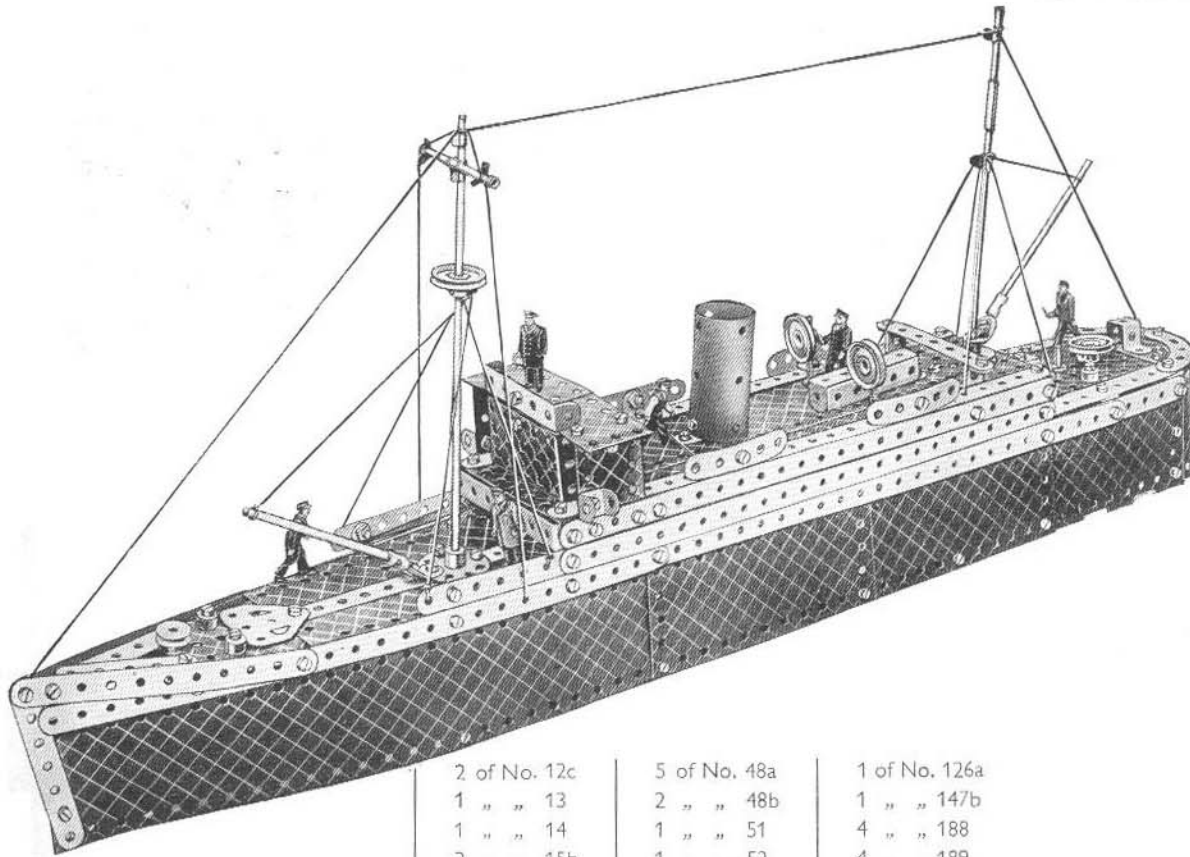

Fig. 6.9a

6.10 LINER



Construction of the model is commenced by connecting two Angle Girders together by $5\frac{1}{2}$ " Strips in the manner shown in Fig. 6.10a. Each side consists of a $12\frac{1}{2}$ " \times $2\frac{1}{2}$ " Strip Plate overlapping the Angle Girder 10 holes, and two $5\frac{1}{2}$ " \times $2\frac{1}{2}$ " Flexible Plates also bolted to the Angle Girder. The hull is extended rearwards at 1 (Fig. 6.10a) by the halves of a Hinged Flat Plate from which the centre pin has been withdrawn. The stern consists of two $5\frac{1}{2}$ " \times $1\frac{1}{2}$ " Flexible Plates, overlapped and bolted together along their long sides and fastened to the flat plates 1. The $12\frac{1}{2}$ " \times $2\frac{1}{2}$ " Strip Plates are connected together at their free ends, the Bolt holding also two $3\frac{1}{2}$ " Strips. The two compound strips consisting of two $12\frac{1}{2}$ " Strips and a $2\frac{1}{2}$ " Strip, which extend the full length of the ship on each side, are bolted to flat plates 1 and sloped upwards. The ends of the strips are clamped at the bows by the $5\frac{1}{2}$ " Strips.

The $12\frac{1}{2}$ " Strips forming the sides of the superstructure are fastened to the sides of the ship at each end by $2\frac{1}{2}$ " Strips. The boat deck is filled in at each end by a $3\frac{1}{2}$ " \times $2\frac{1}{2}$ " Flanged Plate, and the centre portion, consisting of Flexible Plates bolted together as shown in Fig. 6.10a, is bolted to two $12\frac{1}{2}$ " Strips, which in turn are fastened to the $3\frac{1}{2}$ " \times $2\frac{1}{2}$ " Flanged Plates. The ventilators are represented by 1" fast Pulleys, which are secured on the ends of 3" Screwed Rods fastened to the deck by Nuts in the following manner. The Screwed Rods are inserted in one of the tapped holes in the boss of each Pulley, and the set screw is tightened up against the end of the Screwed Rod.

The front of the wheelhouse consists of a $2\frac{1}{2}$ " \times $1\frac{1}{2}$ " Flanged Plate, secured by an Angle Bracket to the two $2\frac{1}{2}$ " \times $1\frac{1}{2}$ " Flexible Plates forming the roof. A $2\frac{1}{2}$ " \times $1\frac{1}{2}$ " Flexible Plate is used also for each of the side supports for the wheelhouse, and the roof is fastened to them by two Trunnions.

The foredeck is formed by a Flanged Sector Plate, extended to the rear by two $5\frac{1}{2}$ " \times $1\frac{1}{2}$ " Flexible Plates and a $5\frac{1}{2}$ " Strip. The Flexible Plates are secured by 1 " \times 1 " Angle Brackets bolted to $\frac{1}{2}$ " \times $\frac{1}{2}$ " Angle Brackets to the $3\frac{1}{2}$ " \times $2\frac{1}{2}$ " Flanged Plate forming the base of the wheelhouse.

The aft deck consists of a $5\frac{1}{2}$ " \times $2\frac{1}{2}$ " Flanged Plate fixed to the boat deck by a $2\frac{1}{2}$ " \times $\frac{1}{2}$ " Double Angle Strip, and to the stern by a Semi-Circular Plate. The spaces between the $5\frac{1}{2}$ " \times $2\frac{1}{2}$ " Flanged Plate and the sides of the ship are filled in by $5\frac{1}{2}$ " Strips. The Semi-Circular Plate and the $2\frac{1}{2}$ " small radius Curved Strips are fastened to the stern of the ship by an Angle Bracket.

	2 of No. 12c	5 of No. 48a	1 of No. 126a
	1 " " 13	2 " " 48b	1 " " 147b
	1 " " 14	1 " " 51	4 " " 188
	2 " " 15b	1 " " 52	4 " " 189
	2 " " 17	2 " " 53	4 " " 190
Parts required	5 " " 22	1 " " 54a	2 " " 191
10 of No. 1	1 " " 23a	4 " " 59	4 " " 192
9 " " 2	1 " " 24	2 " " 80c	2 " " 197
3 " " 3	7 " " 35	2 " " 90a	1 " " 198
12 " " 5	98 " " 37	2 " " 111a	2 " " 212
2 " " 8	10 " " 37a	6 " " 111c	1 " " 213
2 " " 10	3 " " 38	1 " " 115	1 " " 214
4 " " 11	1 " " 40	2 " " 125	1 " " 216
14 " " 12	1 " " 45	2 " " 126	
2 " " 12a			

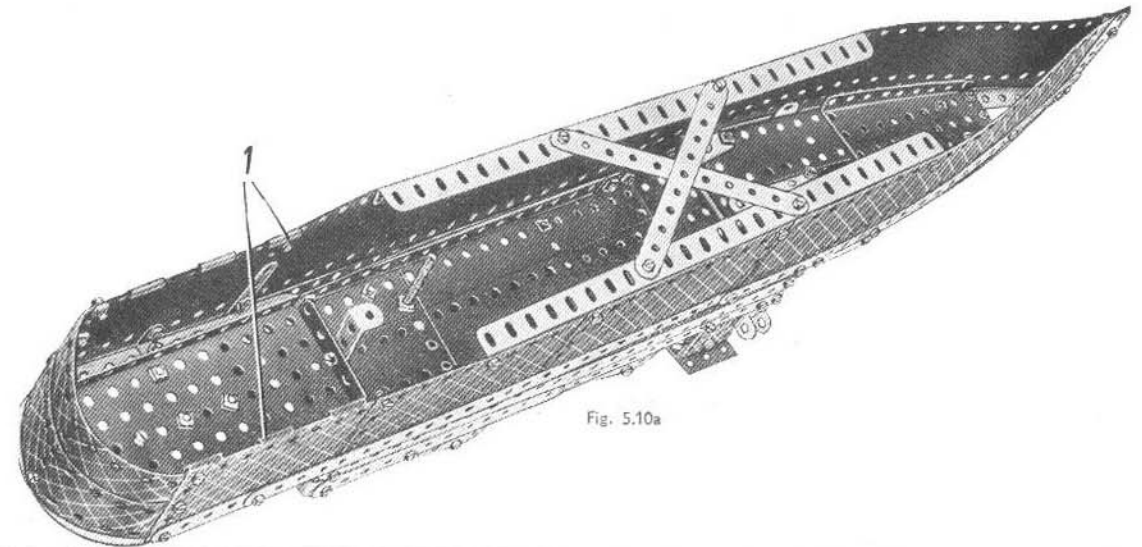
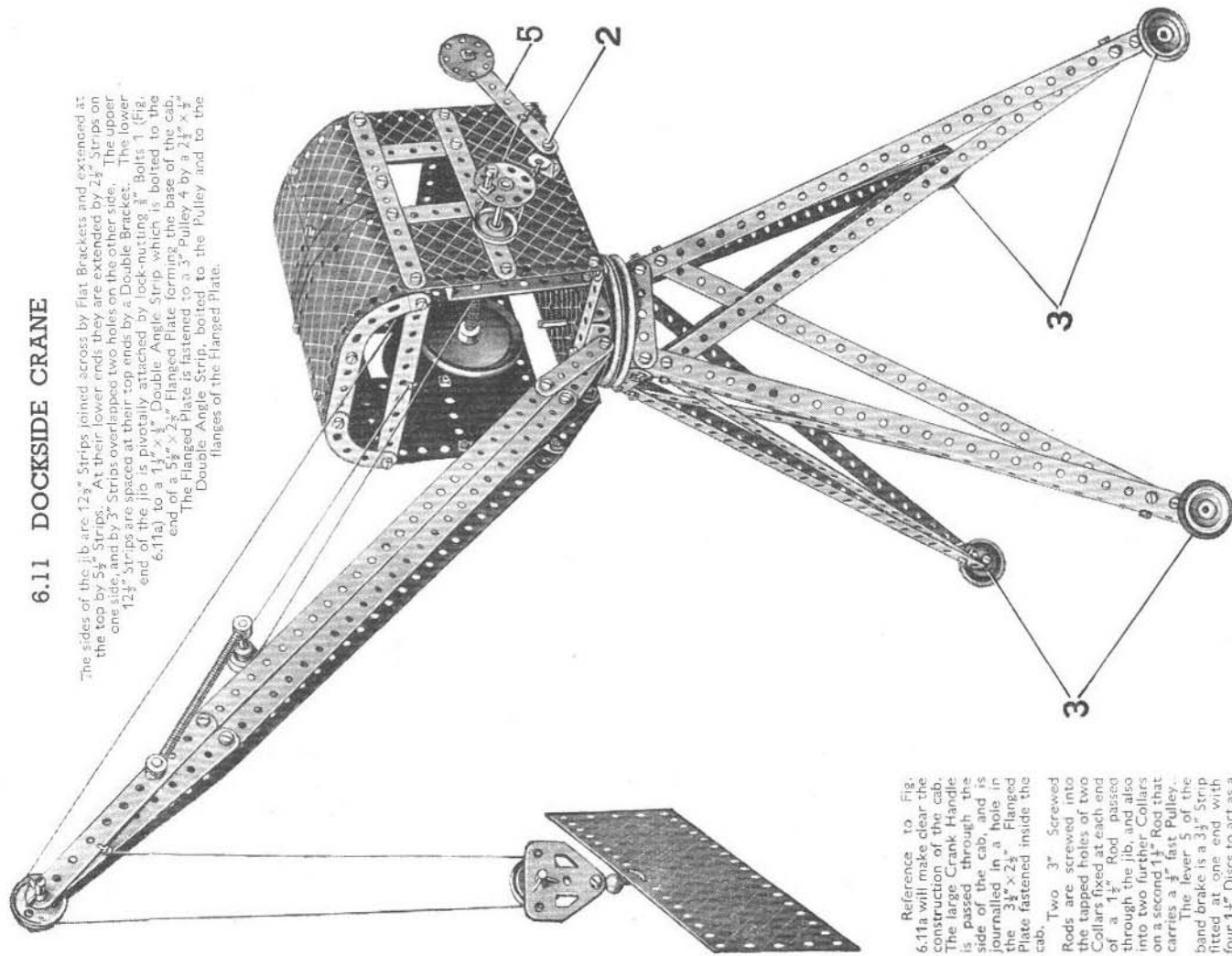

Fig. 5.10a

6.11 DOCKSIDE CRANE



The sides of the jib are 12 $\frac{3}{4}$ " Strips joined across by Flat Brackets and extended at the top by 5 $\frac{1}{2}$ " Strips. At their lower ends they are extended by 2 $\frac{1}{2}$ " Strips on one side, and by 3" Strips overlapped two holes on the other side. The upper 12 $\frac{3}{4}$ " Strips are spaced at their top ends by a Double Bracket. The lower end of the jib is pivotally attached by lock-nutting $\frac{3}{8}$ " Bolt 1 (Fig. 6.11a) to a 1 $\frac{1}{2}$ " x $\frac{1}{2}$ " Double Angle Strip which is bolted to the end of a 5 $\frac{1}{2}$ " x 2 $\frac{1}{2}$ " Flanged Plate forming the base of the cab. The Flanged Plate is fastened to a 3" Pulley 4 by a 2 $\frac{1}{2}$ " x $\frac{3}{4}$ " Double Angle Strip, bolted to the Pulley and to the flanges of the Flanged Plate.

Reference to Fig. 6.11a will make clear the construction of the cab. The large Crank Handle is passed through the side of the cab, and is journalled in a hole in the 3 $\frac{1}{2}$ " x 2 $\frac{1}{2}$ " Flanged Plate fastened inside the cab.

Two 3" Screwed Rods are screwed into the tapped holes of two Collars fixed at each end of a 1 $\frac{1}{2}$ " Rod passed through the jib, and also into two further Collars on a second 1 $\frac{1}{2}$ " Rod that carries a $\frac{3}{8}$ " fast Pulley. The lever 5 of the band brake is a 3 $\frac{1}{2}$ " Strip fitted at one end with four 1 $\frac{1}{4}$ " Discs to act as a counterweight. The

other end of the Strip is pivoted on a lock-nutted $\frac{3}{8}$ " Bolt 2, which carries two Washers on its shank for spacing purposes. Cord is tied to Strip 5, led around a 1" Pulley on a Rod passed through the side of the cab, and finally tied to a Reversed Angle Bracket. The super-structure is free to swivel on a 2" Rod, which is locked in the boss of the lower 3" Pulley but is free in the boss of 3" Pulley 4. The 1" Pulleys 3, fitted with Rubber Rings, are attached by $\frac{3}{8}$ " Bolts to Obtuse Angle Brackets at the base of the legs. The Bolts carry two Washers on their shanks for spacing purposes.

Luffing is controlled by a Cord that is first wound around the 5" Rod carrying the Bush Wheel, then passed around the $\frac{3}{8}$ " fast Pulley in the jib, and finally tied to the 5 $\frac{1}{2}$ " Strip at the front of the cab.

The hoisting movement is controlled by a second Cord that is wound around the Crank Handle, then passed over the 5 $\frac{1}{2}$ " Strip previously mentioned, and over a 1" loose Pulley on a 2" Rod at the jib-head. It is then led over a 1" loose Pulley in the pulley block and finally tied to the jib.

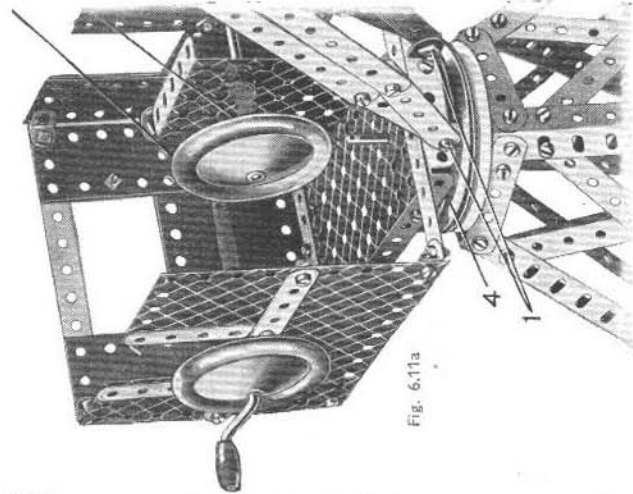

Fig. 6.11a

12 of No. 1	1 of No. 19h	2 of No. 80c
13 "	5 "	2 "
1 "	2 "	2 "
2 "	1 "	6 "
12 "	1 "	1 "
4 "	7 "	2 "
4 "	91 "	1 "
1 "	7 "	4 "
12 "	14 "	2 "
6 "	1 "	4 "
1 "	1 "	2 "
2 "	1 "	3 "
2 "	1 "	2 "
1 "	1 "	4 "
2 "	4 "	4 "
	1 of No. 217b	

6.12 EIFFEL TOWER

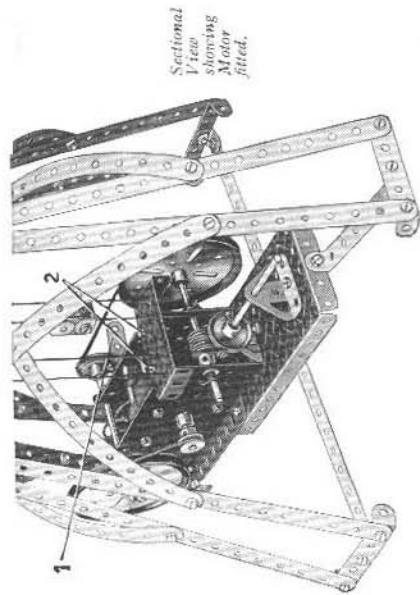
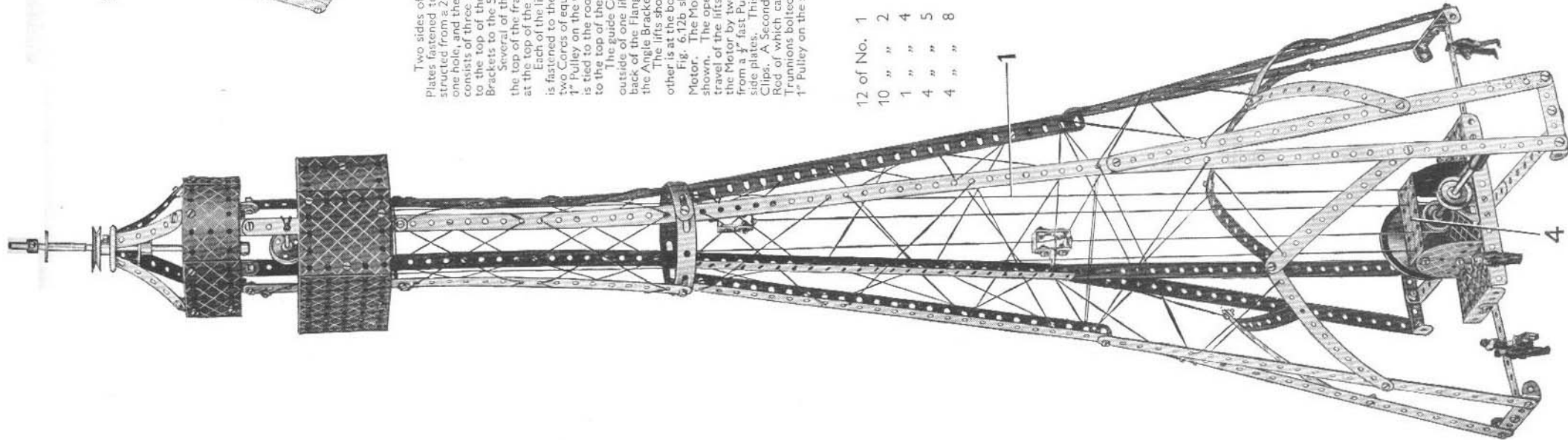

Fig. 6.12b

Two sides of the lower platform at the top of the tower are formed by $3\frac{1}{2}'' \times 2\frac{1}{2}''$ Flanged Plates fastened to the frame by Reversed Angle Brackets. The other two sides are each constructed from a $2\frac{1}{2}'' \times 2\frac{1}{2}''$ Flexible Plate and a $2\frac{1}{2}'' \times 1\frac{1}{2}''$ Flexible Plate bolted together overlapping one hole, and they also are secured to the frame by Reversed Angle Brackets. The top platform consists of three $5\frac{1}{2}'' \times 1\frac{1}{2}''$ Flexible Plates bolted together and attached by $1'' \times 1''$ Angle Brackets to the top of the frame. Four $2\frac{1}{2}''$ Strips are curved slightly and fastened by Obtuse Angle Brackets to the $5\frac{1}{2}'' \times 1\frac{1}{2}''$ Flexible Plates.

Several of the Flexible Plates have been removed in Fig. 6.12a to show the construction of the top of the frame and the arrangement of the Pulleys and Bush Wheel on the compound rod at the top of the tower.

Each of the lifts consists of two Double Brackets joined by Flat Brackets, and an Angle Bracket is fastened to the side of each lift to receive the guide Cord 1. The operating cable consists of two Cords of equal length. The first of these is tied to the bottom of one lift, taken around the $1''$ Pulley on the Crank Handle and then tied to the bottom of the other lift. The second Cord is tied to the roof of the other lift, taken over the $1''$ Pulley at the top of the tower and then tied to the top of the first lift.

The guide Cord is anchored to a Washer 2, and is pushed through the Angle Bracket on the outside of one lift, then taken through the end holes of the $2\frac{1}{2}'' \times 1\frac{1}{2}''$ Flanged Plate 4, across the back of the Flanged Plate, to similar holes on the other side. It then passes upwards through the Angle Bracket of the second lift to the top of the model, where it is secured to Bolt 3. The lifts should be spaced on the Cord so that when one reaches the top of the tower the other is at the bottom.

Fig. 6.12b shows the model Eiffel Tower arranged for operation with an E20B Electric Motor. The Motor is bolted to the $5\frac{1}{2}'' \times 2\frac{1}{2}''$ Flanged Plate at the foot of the tower in the manner shown. The operating switch of the Motor is extended by a $2\frac{1}{2}''$ Strip 1 so that the direction of travel of the lifts may easily be reversed. The $2\frac{1}{2}'' \times 1\frac{1}{2}''$ Flanged Plate is attached to the top of the Motor by two Angle Brackets, which are bolted at 2. The drive is taken by a Driving Band from a $\frac{1}{2}''$ fast Pulley on the Motor shaft to a $3''$ Pulley fastened on a Rod journalled in the Motor side plates. This Rod carries also a $1''$ fast Pulley at its other end and is held in place by Spring Clips. A Second Driving Band transmits the drive from the $1''$ Pulley to another $3''$ Pulley, the Rod of which carries a Worm that meshes with a $\frac{1}{2}''$ Pinion on a Rod journalled in holes in Trunnions bolted to the baseplate. The Cord to which the lifts are fastened is passed around a $1''$ Pulley on the same Rod as the $\frac{1}{2}''$ Pinion.

12 of No.	1
10 "	2
1 "	4
4 "	5
4 "	8

Parts required

4 of No.	10
4 "	11
6 "	12
2 "	12a
4 "	12c
1 "	15
1 "	15b
2 "	19b
*1 "	32
1 "	186a
*1 "	E20B Electric Motor.
Parts not required:	
1 of No.	187
2 "	214
*Not included in Outfit.	

For model Eiffel Tower fitted with E20B Electric Motor.

Additional parts required:	
1 of No.	5
1 "	15
1 "	15b
2 "	19b
*1 "	32
1 "	186a
*1 "	E20B Electric Motor.
Parts not required:	
1 of No.	187
2 "	214
*Not included in Outfit.	

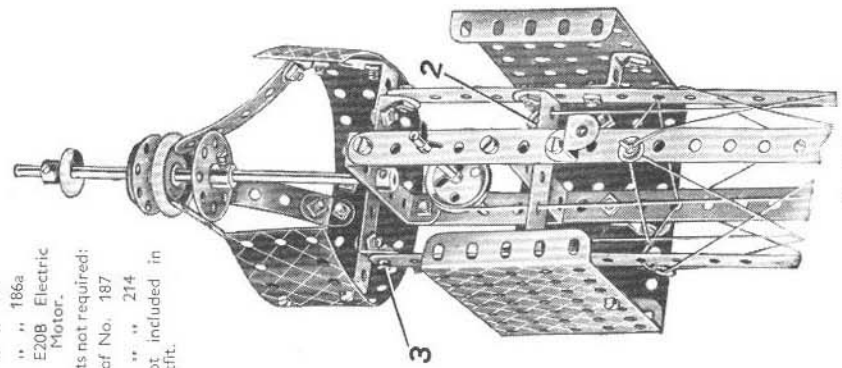

Fig. 6.12a

6.13 MECHANICAL HORSE AND TRAILER

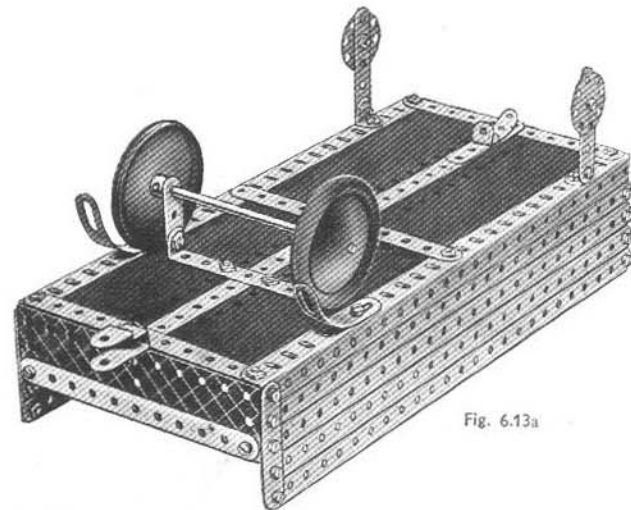
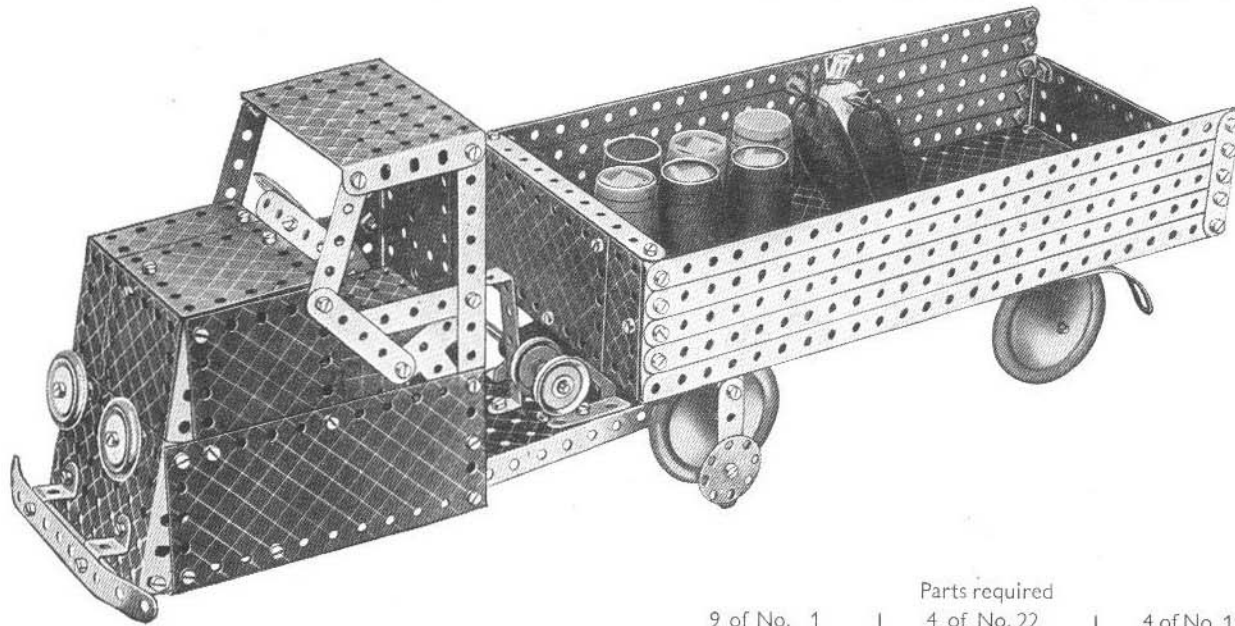

Fig. 6.13a

9 of No.	1
10 " "	2
3 " "	3
2 " "	4
12 " "	5
2 " "	6a
2 " "	8
2 " "	10
16 " "	12
2 " "	12a
3 " "	12c
2 " "	15
1 " "	15a
1 " "	16
1 " "	19b
1 " "	19g

Parts required

4 of No.	22
1 " "	24
5 " "	35
105 " "	37
6 " "	37a
4 " "	38
1 " "	44
1 " "	48
5 " "	48a
2 " "	48b
1 " "	51
1 " "	52
2 " "	53
2 " "	90
2 " "	111
2 " "	111a

4 of No.	111c
4 " "	125
2 " "	126
3 " "	126a
1 " "	147b
2 " "	155a
4 " "	187
4 " "	188
4 " "	189
6 " "	190
2 " "	191
2 " "	192
2 " "	197
2 " "	215
2 " "	217a
2 " "	217b

The cab and bonnet of the mechanical horse are first constructed, and are built up on a base consisting of two $5\frac{1}{2}'' \times 2\frac{1}{2}''$ Strips bolted to the flanges of a $3\frac{1}{2}'' \times 2\frac{1}{2}''$ Flanged Plate. Two $5\frac{1}{2}'' \times 2\frac{1}{2}''$ Flexible Plates are bolted to the $5\frac{1}{2}''$ Strips so that the Strips are extended one hole beyond the edge of the Flexible Plates, thus allowing the $3\frac{1}{2}'' \times 2\frac{1}{2}''$ Flanged Plate representing the radiator to be sloped backwards and bolted to the Flexible Plates. Two $3''$ Strips are bolted inside the flanges of the $3\frac{1}{2}'' \times 2\frac{1}{2}''$ Flanged Plate and they overlap the flanges two holes. Two $5\frac{1}{2}'' \times 2\frac{1}{2}''$ Strips overlap the rear ends of the $5\frac{1}{2}'' \times 2\frac{1}{2}''$ Flexible Plates by three holes, and $1'' \times 1''$ Angle Brackets are bolted to the lower rear corners of the two Flexible Plates for the purpose of holding the back in position.

Each side of the bonnet is completed by bolting a $2\frac{1}{2}'' \times 2\frac{1}{2}''$ Flexible Plate to the $3''$ Strip and also to the $5\frac{1}{2}'' \times 2\frac{1}{2}''$ Flexible Plate. The upper rear corners of the $2\frac{1}{2}'' \times 2\frac{1}{2}''$ Flexible Plates are joined across by a $3\frac{1}{2}'' \times \frac{1}{2}''$ Double Angle Strip, each Bolt holding also a $2\frac{1}{2}'' \times 1\frac{1}{2}''$ Flexible Plate and two $2\frac{1}{2}''$ Strips. One of the $2\frac{1}{2}''$ Strips is bolted to a Flat Trunnion and the $2\frac{1}{2}'' \times 2\frac{1}{2}''$ Flexible Plate, and the other is used to support the $3\frac{1}{2}'' \times 2\frac{1}{2}''$ Flanged Plate that represents the roof of the cab.

The upper part of the radiator is completed by two $2\frac{1}{2}'' \times 2\frac{1}{2}''$ Flexible Plates overlapped three holes. They are attached to the $3\frac{1}{2}'' \times 2\frac{1}{2}''$ Flanged Plate by the $\frac{1}{2}''$ Bolts that hold in place the $1''$ Pulleys and $\frac{3}{8}''$ Discs representing the headlamps. Two further $2\frac{1}{2}'' \times 2\frac{1}{2}''$ Flexible Plates are attached by an Angle Bracket to those previously mentioned, and are bolted also to the $3\frac{1}{2}'' \times \frac{1}{2}''$ Double Angle Strip spacing the sides of the bonnet.

The back of the cab consists of two $2\frac{1}{2}'' \times 1\frac{1}{2}''$ Flexible Plates overlapped three holes and bolted to the $1'' \times 1''$ Angle Brackets. The upper portion of the back is completed by overlapping three $5\frac{1}{2}'' \times 1\frac{1}{2}''$ Flexible Plates along their long edges and bolting them at their top ends to a $3\frac{1}{2}''$ Strip and to Angle Brackets.

The driving seat is a $2\frac{1}{2}'' \times 1\frac{1}{2}''$ Flanged Plate attached to the back of the cab by an Angle Bracket.

The steering wheel is a Bush Wheel held on a $4\frac{1}{2}''$ Rod. The Rod is passed through the hole of an Obtuse Angle Bracket bolted to the $3\frac{1}{2}'' \times \frac{1}{2}''$ Double Angle Strip. It is held by a Spring Clip in the hole of a Flat Bracket, which is bolted to an Angle Bracket fastened to the side of the bonnet.

The single front wheel is a $3''$ Pulley, which is free to turn on a $3\frac{1}{2}''$ Rod, and is retained in position by two Spring Clips. The Rod is journaled in holes in two Reversed Angle Brackets bolted to the sides of the bonnet.

The rear part of the chassis is a $5\frac{1}{2}'' \times 2\frac{1}{2}''$ Flanged Plate, and it carries a ramp built as follows. Two Trunnions are bolted to the Flanged Plate, and a $3\frac{1}{2}''$ Strip and a $2\frac{1}{2}''$ Strip are bolted to each Trunnion as shown in Fig. 6.13c. The $2\frac{1}{2}''$ Strips are extended by $2\frac{1}{2}''$ large radius Curved Strips, which are bolted also to a $1\frac{1}{2}'' \times \frac{1}{2}''$ Double Angle Strip fixed to the $5\frac{1}{2}'' \times 2\frac{1}{2}''$ Flanged Plate. A Flat Trunnion is attached to an Obtuse Angle Bracket held by the same Bolt as the $1\frac{1}{2}'' \times \frac{1}{2}''$ Double Angle Strip. The Crank Handle is passed through holes in the $2\frac{1}{2}''$ Strips forming the ramp, and two $1''$ Pulleys are secured to it, one on each side of the rear $2\frac{1}{2}''$ Strip. The $1''$ Pulleys are fitted with $\frac{3}{8}''$ Bolts, which are used to allow the trailer to be unhitched from the power unit. The $2\frac{1}{2}'' \times \frac{1}{2}''$ Double Angle Strip at the end of the ramp acts as a stop for the trailer.

(Continued on next page)

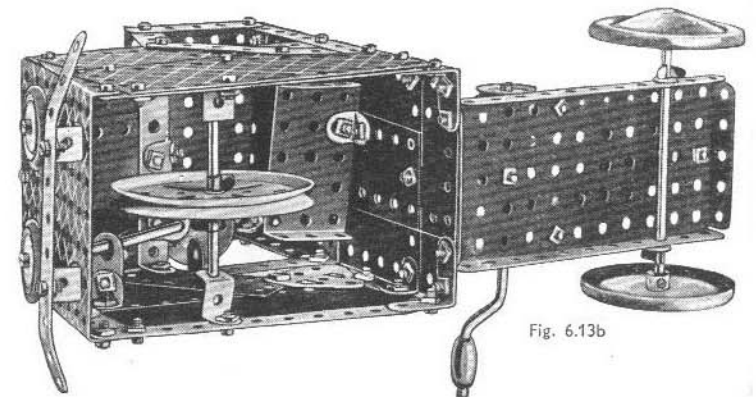

Fig. 6.13b

(Continued from previous page)

An underneath view of the trailer is shown in Fig. 6.13a. Its main members are 12½" Angle Girders, joined across by a 5½" Strip at each end. At the centre a 12½" Strip is bolted across the 5½" Strips, and the floor is filled in with two 12½" Strip Plates. Each of the sides is built up from four 12½" Strips, bolted at the rear end to a 2½" Strip and at the front end to a 2½"×4" Double Angle Strip. The front end of the trailer consists of two 4½"×2½" Flexible Plates overlapped seven holes, and attached by Angle Brackets to the bottom and sides. The rear end is a 5½"×1½" Flexible Plate fixed to a 5½" Strip and attached to the sides by Angle Brackets, and the rear coupling hook is a Cranked Bent Strip bolted to a Flat Bracket.

The rear Road Wheels are carried on a 4½" Rod journalled in 1½" Strips bolted to a 3½"×½" Double Angle Strip. The front wheels are 1½" Discs bolted to 2½" Strips attached by Angle Brackets to the Angle Girders.

The 2½" Strip seen underneath the trailer in Fig. 6.13a, is fitted with an Angle Bracket, which engages with the Flat Trunnion forming part of the ramp on the mechanical horse.

When the Crank Handle is turned the ¾" Bolt in the boss of the Pulley lifts the front of the trailer and releases the Angle Bracket from behind the Flat Trunnion.

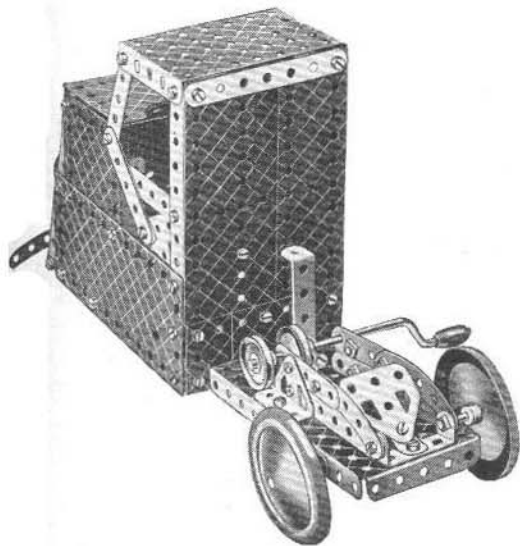
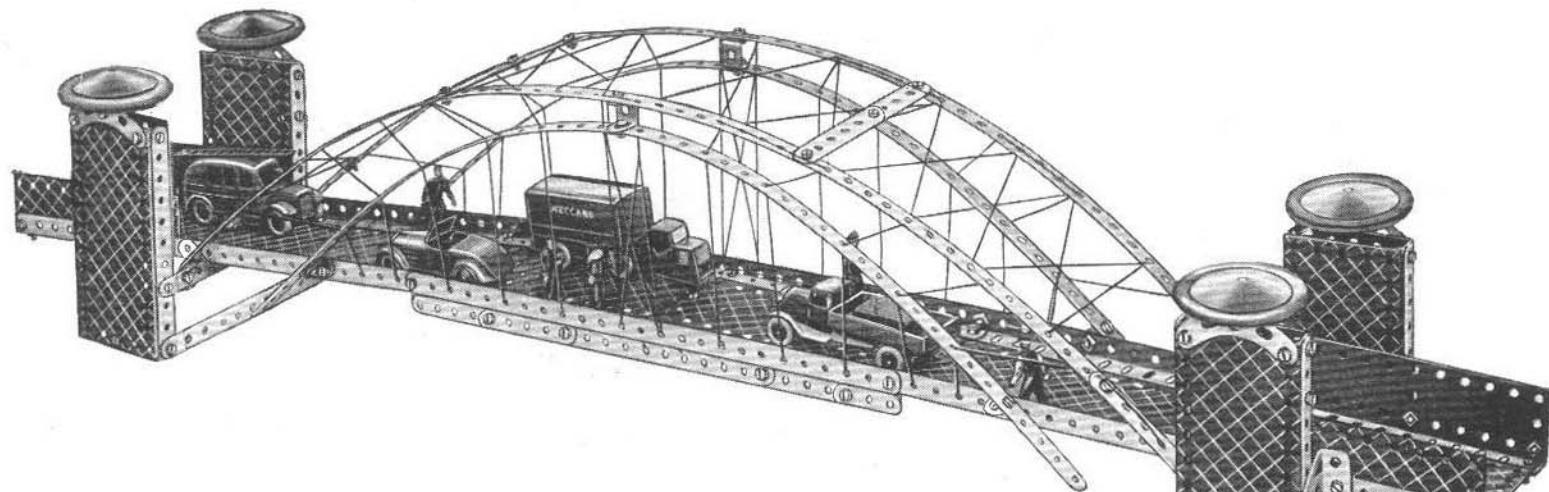

Fig. 6.13c

6.14 SYDNEY HARBOUR BRIDGE



Each of the towers consists of two 5½" Strips joined across by 2½"×½" Double Angle Strips, between which 5½"×2½" Flexible Plates are bolted on the outside face, and on the inside face 2½"×2½" Flexible Plates are attached by Angle Brackets. A 2½" small radius Curved Strip bolted to the upper 2½"×½" Double Angle Strip carries an Angle Bracket, to which a Road Wheel is attached by a ¾" Bolt. The pairs of towers at each end of the bridge are joined across by three 5½" Strips.

Each side of the span consists of two Angle Girders joined together by two 12½" Strips arranged in the form of an angle girder. The two sides are connected by 3½"×2½" Flanged Plates held by the same Bolts as the 12½" Strips, and also by a 3½"×½" Double Angle Strip at the centre. The roadway at the centre of the span is represented by two 4½"×2½" Flexible Plates overlapped one hole and bolted between the 3½"×2½" Flanged Plates. The remainder of the roadway consists of 12½"×2½" Strip Plates, attached to the 3½"×2½" Flanged Plates at one end and clamped between Flat Brackets and the Angle Girders at the other end. The sides of the approach roadways are 5½"×1½" Flexible Plates bolted to the Angle Girders of the span. The completed span is attached to each pair of towers by a Trunnion bolted in the position shown in the illustration.

The top of the suspension arch on each side consists of two 12½" Strips, bolted together and extended at each end by a 2½" Strip. An Obtuse Angle Bracket and an Angle Bracket are bolted to the end of the 2½" Strip, the Angle Bracket being attached to the span and the Obtuse Angle Bracket to the upper 5½" Strip spacing the towers. The inside of the arch is made of two 12½" Strips fixed by Angle Brackets to the sides of the roadway and connected by a Double Bracket to the other arch at its centre.

The arches on each side are braced across by compound strips, each of which consists of a 3½" Strip and a 3" Strip overlapped three holes. The model is completed by adding the roadway suspension cables, which are represented by Cord and are arranged as shown in the illustration.

Parts required

12 of No. 1	16 of No. 12	2 of No. 111a
14 " " 2	4 " " 12c	6 " " 111c
2 " " 3	103 " " 37	2 " " 126
2 " " 4	6 " " 37a	4 " " 187
10 " " 5	8 " " 48a	4 " " 189
2 " " 6a	1 " " 48b	4 " " 190
4 " " 8	2 " " 53	2 " " 191
4 " " 10	4 " " 90a	4 " " 192
2 " " 11	2 " " 111	2 " " 197

6.15 GALLEON

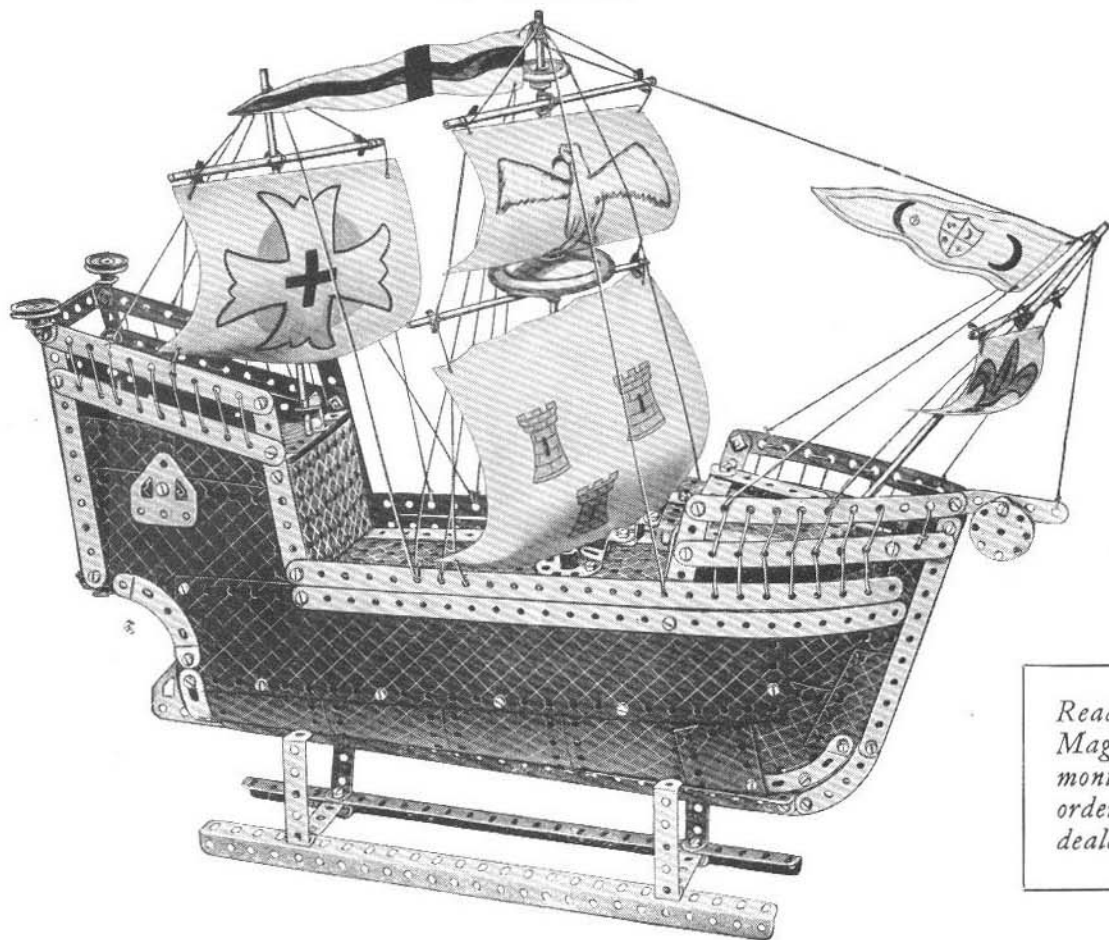

Read the "Meccano Magazine," published monthly. Place a regular order with your Meccano dealer or newsagent.

Parts required

6 of No. 1	13 of No. 12	3 of No. 22	2 of No. 48	2 of No. 90	4 of No. 188	2 of No. 199
14 " " 2	1 " " 12c	1 " " 24	7 " " 48a	4 " " 90a	3 " " 189	2 " " 200
3 " " 3	1 " " 13	13 " " 35	2 " " 48b	3 " " 111c	4 " " 190	1 " " 212
2 " " 4	1 " " 14	104 " " 37	1 " " 51	4 " " 125	2 " " 191	2 " " 213
12 " " 5	2 " " 15	1 " " 37a	1 " " 52	3 " " 126a	4 " " 192	2 " " 214
2 " " 6a	1 " " 15a	4 " " 38	2 " " 53	1 " " 155a	2 " " 197	2 " " 215
4 " " 8	1 " " 15b	2 " " 40	1 " " 54a	1 " " 187	1 " " 198	2 " " 217a
5 " " 10	3 " " 16					

Construction is commenced by bolting four $5\frac{1}{2}'' \times 2\frac{1}{2}''$ Flexible Plates and one $5\frac{1}{2}'' \times 1\frac{1}{2}''$ Flexible Plate to one of the two Angle Girders forming the keel of the vessel, as shown in Fig. 6.15b. Two Formed Slotted Strips also are bolted to the Angle Girders at the stern. The $5\frac{1}{2}'' \times 2\frac{1}{2}''$ Flexible Plates are extended on the rear side of the model by two $5\frac{1}{2}'' \times 1\frac{1}{2}''$ Flexible Plates overlapping each other one hole. Two $12\frac{1}{2}'' \times 2\frac{1}{2}''$ Strip Plates are then bolted to each side of the model in the positions shown, and the sides are curved up and joined across at the stern by two $2\frac{1}{2}''$ Strips overlapped one hole, and by Angle Brackets.

The keel is extended at the bows by $2\frac{1}{2}''$ large radius Curved Strips and by two $5\frac{1}{2}''$ Strips fastened together by Angle Brackets. The stern is filled in by two Semi-Circular Plates, which are bolted to a $2\frac{1}{2}'' \times 1\frac{1}{2}''$ Flanged Plate and attached by a Flat Bracket to the $2\frac{1}{2}''$ Strips spacing the sides, the Bolt holding also two $1\frac{1}{4}''$ radius Curved Plates.

One half of a Hinged Flat Plate is used for one side of the poop, and the other half is used for the poop deck, and is bolted to a $3\frac{1}{2}'' \times \frac{1}{2}''$ Double Angle Strip.

The main deck consists of a $3\frac{1}{2}'' \times 2\frac{1}{2}''$ Flanged Plate bolted across the ship just in front of the forecabin, and to it two $12\frac{1}{2}''$ Strips are bolted one on each side. These Strips support a $5\frac{1}{2}'' \times 2\frac{1}{2}''$ Flanged Plate by means of Angle Brackets.

The forecabin is spaced across by a $3\frac{1}{2}'' \times \frac{1}{2}''$ Double Angle Strip, to which is bolted a Flanged Sector Plate forming the deck, and two $1\frac{1}{2}'' \times \frac{1}{2}''$ Double Angle Strips. The $5\frac{1}{2}''$ Strips forming the rails of the forward deck are bolted to the ends of $1\frac{1}{2}''$ Strips extending the bows. The bows are completed by bolting one U-Section Curved Plate to the $5\frac{1}{2}''$ Strips forming the sides of the upper deck, and another U-Section Curved Plate to the $2\frac{1}{2}''$ small radius Curved Strips near the keel.

The mainmast is an $11\frac{1}{2}''$ Rod held in the boss of a Bush Wheel bolted to the $3\frac{1}{2}'' \times 2\frac{1}{2}''$ Flanged Plate forming part of the deck, and it carries a $5''$ Rod and a $4\frac{1}{2}''$ Rod, which represent spars. The mast on the poop is a $5''$ Rod joined to a $3\frac{1}{2}''$ Rod by a Rod Connector. It is passed through a hole in a Reversed Angle Bracket bolted to the poop, and through a hole in the deck, and is held in position by Spring Clips. This mast carries a $3\frac{1}{2}''$ Rod as a spar.

(Continued on next page)

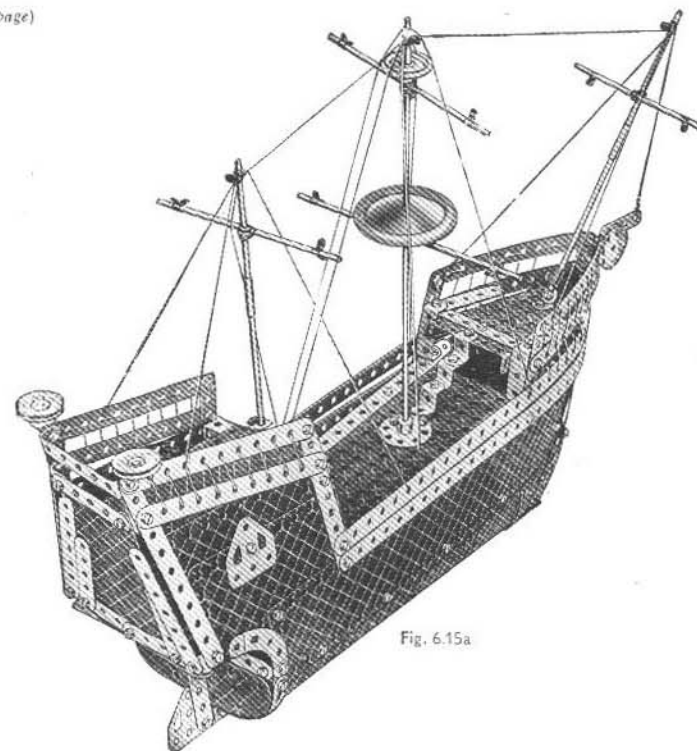

Fig. 6.15a

(Continued from previous page)

The forward mast also is a 5" Rod joined to a 3½" Rod by a Rod Connector, and it is mounted in a Rod and Strip Connector attached to the Flanged Sector Plate by an Obtuse Angle Bracket. The spars are fastened to the mast by Cord, and the method of rigging the model is shown in Fig. 6.15a.

The sails and pennant can be cut from white cardboard or stiff paper. The topsail is 5" long at its upper edge, 5½" long at its lower edge, and 3½" wide. The mainsail is 5½" long, broadening to 6½" at its lower edge, and 5" in width. The foresail is 3½" long, broadening to 4", and 2½" wide, and the sail on the after mast is 5" in length broadening to 5½" and is 4½" in width. The pennant is 6" long and 1" wide.

The model is carried on a stand made by joining two 12½" Angle Girders across by 2½" x ¼" Double Angle Strips. Four 2½" x ½" Double Angle Strips are bolted to the Angle Girders in an upright position, and they are bent inward slightly so that the keel of the galleon can rest on their ends.

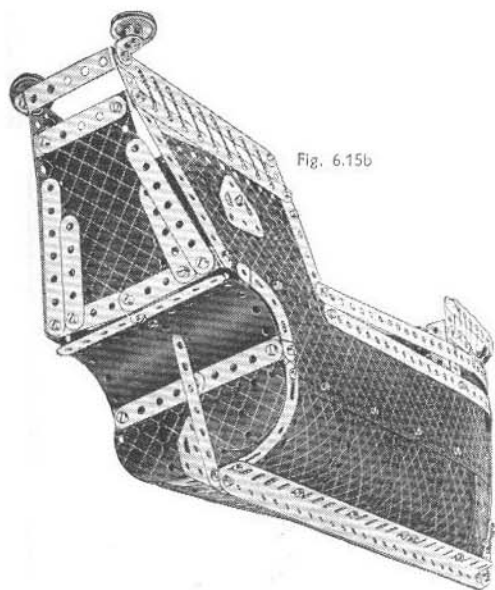
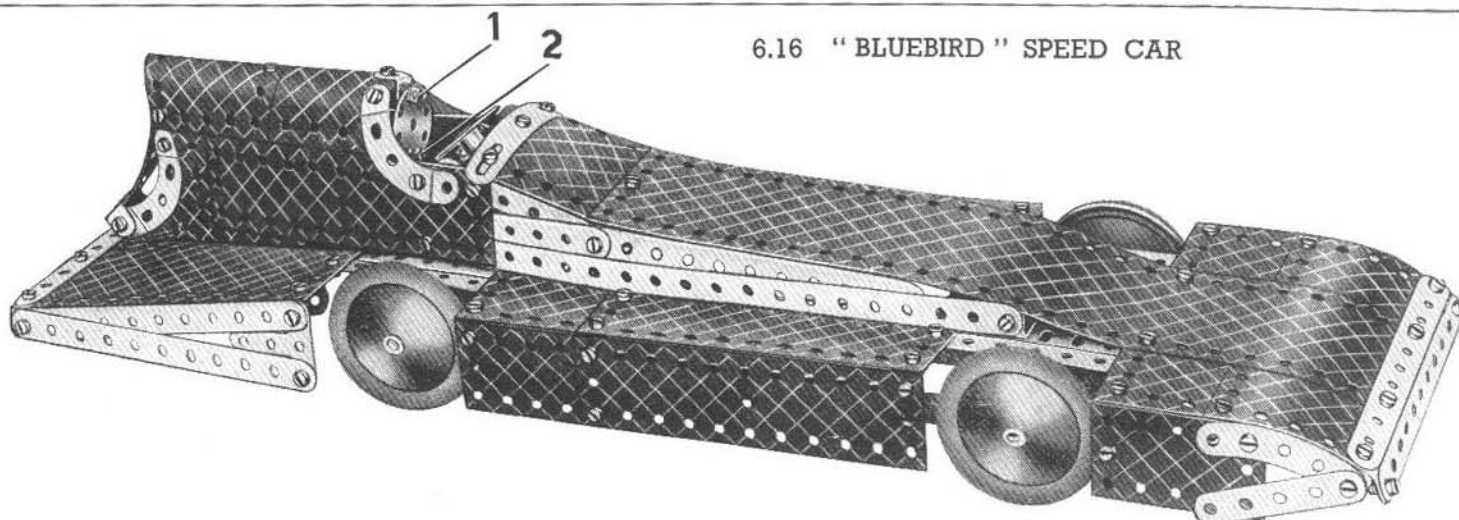

Fig. 6.15b



6.16 "BLUEBIRD" SPEED CAR

The chassis is built up as shown in Fig. 6.16a. It consists of four Angle Girders, pairs of which are joined across at the rear end by Flat Trunnions, and at the front by 1½" Strips bolted in the fourth holes from the front ends of the Angle Girders. These form bearings for the axles. The lower Angle Girders or side members are joined together at the rear by a 2½" Strip, and at the front by a 3½" x 2½" Flanged Plate. The upper Angle Girders are joined across by three 5½" Strips, two of which are bolted five holes from the rear ends and seven holes from the front ends of the Angle Girders respectively, to form supports for the streamlined casing between the wheels.

Two 12½" Strips overlapping the chassis 13 holes extend the tail of the car, which consists of two Flanged Sector Plates bolted by the flanges of their broad ends to a 2½" x ¼" Double Angle Strip on one edge, and to an Angle Bracket on the other edge. The narrow ends of the two Flanged Sector Plates are spaced one hole apart, and are bolted in the second hole in their flanges to a 5½" Strip. Two 2½" small radius Curved Strips and a 2½" Strip are bolted to a Double Bracket and fixed as shown. Two U-Section Curved Plates overlapped one hole also are bolted to the Flanged Sector Plates, and are joined to the 5½" x 1½" Flexible Plates by 2½" small radius Curved Strips.

Two 5½" x 2½" Flexible Plates are bolted between the two 5½" Strips to form the rear wheel fairings, and the 5½" Strips forming the sides are bolted to a Flat Trunnion and a Double Bracket. The engine and cockpit fairing consists of a 12½" x 2½" Strip Plate and a 2½" x 2½" Flexible Plate, bolted at the join to a 2½" x ½" Double Angle Strip. The last named is joined in turn to two 5½" Strips that fill in the side of the fairing. The method of building up the streamlined radiator will be clear from the general view of the model.

The front and rear axles are 5" Rods held in place by Collars. They carry a 1" Pulley, fitted with Rubber Ring, and a Road Wheel at each end.

The headrest is a 1½" Disc lock-nutted to Bolt 1. Bolt 2 holds in place a second 1½" Disc, which in turn is bolted at right angles to a third Disc 3 by means of a Reversed Angle Bracket.

Parts required

4 of No. 1	1 of No. 24	4 of No.126a
12 " " 2	95 " " 37	4 " " 155a
4 " " 3	1 " " 37a	4 " " 187
2 " " 4	2 " " 48	4 " " 188
6 " " 5	5 " " 48a	4 " " 189
2 " " 6a	1 " " 53	5 " " 190
4 " " 8	2 " " 54a	4 " " 192
3 " " 11	4 " " 59	1 " " 197
14 " " 12	2 " " 90	2 " " 199
1 " " 12a	4 " " 90a	2 " " 200
2 " " 12c	1 " " 111c	1 " " 215
2 " " 15	1 " " 125	3 " " 217a
4 " " 22	2 " " 126	

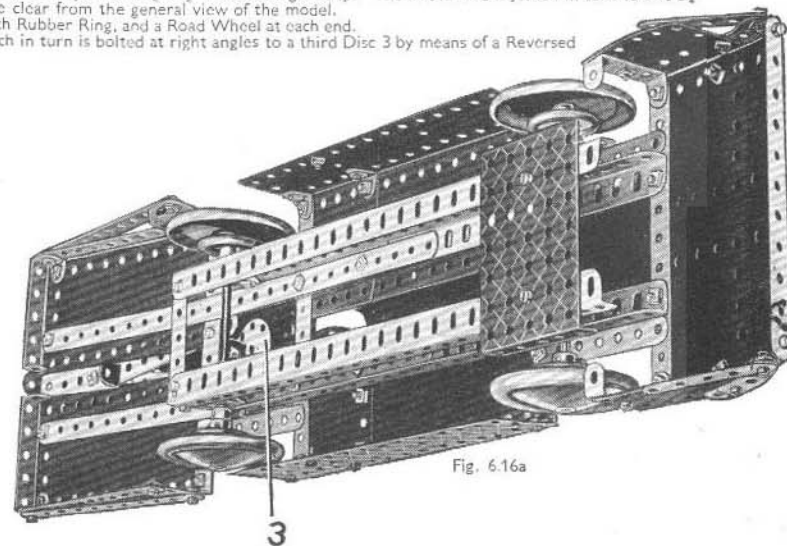

Fig. 6.16a

6.17 WINDMILL

The corners of the main frame are four Angle Girders, connected at their lower ends by $5\frac{1}{2}$ " Strips and at their upper ends by $2\frac{1}{2}$ " Strips. The sides are filled in with $12\frac{1}{2}$ " \times $2\frac{1}{2}$ " Strip Plates, and at the front Flexible Plates are used in order to leave a space for the doorway. A $3\frac{1}{2}$ " \times $2\frac{1}{2}$ " Flanged Plate fastened to the front $5\frac{1}{2}$ " Strip by Angle Brackets forms a platform in front of the doorway.

The top portion of the windmill is constructed as follows. Two Flanged Sector Plates are bolted together at right angles by their flanges at the narrow end. Two $5\frac{1}{2}$ " \times $2\frac{1}{2}$ " Flexible Plates are then bolted across the flanges at the wide ends of the Flanged Sector Plates. The lower corners of the $4\frac{1}{2}$ " \times $2\frac{1}{2}$ " Flexible Plates are braced across by $2\frac{1}{2}$ " \times $\frac{1}{2}$ " Double Angle Strips, the Bolts holding also $2\frac{1}{2}$ " small radius Curved Strips, which in turn are bolted to the upper ends of the Angle Girders forming the corners of the main frame.

A superstructure (Fig. 6.17a) is erected at the rear to hold the directional vanes. It is constructed by fastening two compound strips, each consisting of a $5\frac{1}{2}$ " and a $2\frac{1}{2}$ " Strip, to the back $5\frac{1}{2}$ " \times $2\frac{1}{2}$ " Flexible Plate by a $1\frac{1}{2}$ " \times $\frac{1}{2}$ " Double Angle Strip. The compound strips are braced by two $2\frac{1}{2}$ " large radius Curved Strips, also fastened to the $5\frac{1}{2}$ " \times $2\frac{1}{2}$ " Flexible Plate by a $1\frac{1}{2}$ " \times $\frac{1}{2}$ " Double Angle Strip. A 2" Rod, journaled in the end holes of the compound strips, carries at its end a Bush Wheel, to which are bolted $2\frac{1}{2}$ " Strips representing the vanes.

The construction of the sails, and the manner in which they are mounted, are clear from the illustration.

A Crank Handle journaled as shown in Fig. 6.17a carries on its shaft a 1" Pulley, that is connected by a Driving Band to another 1" Pulley on a 5" Rod midway up the frame. A $\frac{1}{2}$ " fast Pulley, also on the 5" Rod, is connected by Cord to the 3" Pulley on the shaft of the sails, and a 1" Pulley on this shaft is connected by a Driving Band with the 2" Rod carrying the directional vanes.

Fig. 6.17b shows the Windmill arranged for drive with an E120 Electric Motor. The Motor is bolted by one of its flanges to the $5\frac{1}{2}$ " \times $2\frac{1}{2}$ " Flanged Plate in the base of the model, and its other flange is attached by an Angle Bracket to the $5\frac{1}{2}$ " Strip bracing the sides. The drive is taken from the pinion of the Motor to a 57-teeth Gear on a Rod journaled in the Motor side plates. A $\frac{1}{2}$ " fast Pulley on this Rod transmits the drive through a belt of Cord to the 3" Pulley half-way up the mill.

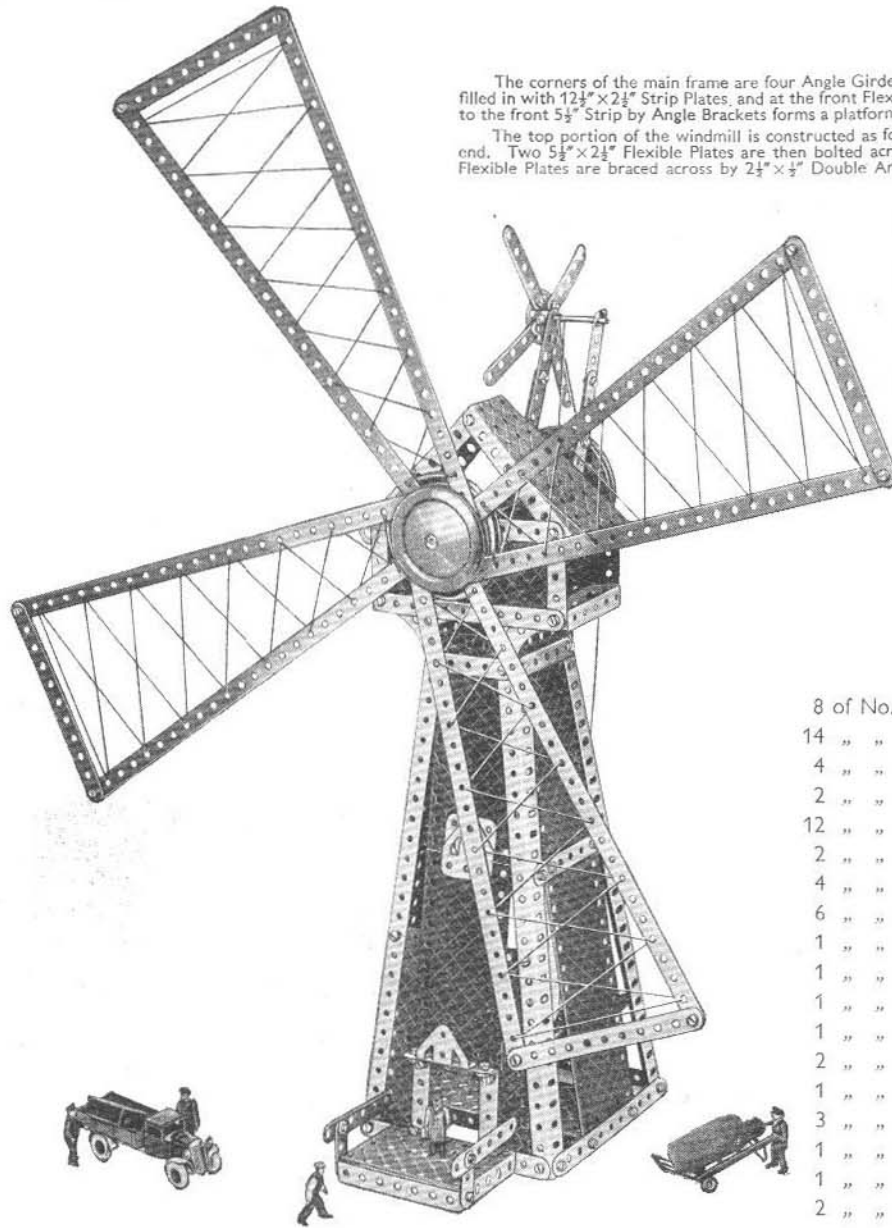

Parts required

8 of No. 1	92 of No. 37	1 of No. 186a
14 " " 2	4 " " 37a	1 " " 187
4 " " 3	2 " " 38	2 " " 189
2 " " 4	1 " " 40	4 " " 192
12 " " 5	1 " " 48	2 " " 197
2 " " 6a	5 " " 48a	
4 " " 8	2 " " 48b	For model Wind-
6 " " 12	1 " " 51	mill fitted with
1 " " 12a	1 " " 52	E120 Electric
1 " " 13	1 " " 53	Motor:—
1 " " 15	2 " " 54a	Additional parts
1 " " 17	4 " " 59	required:—
2 " " 19b	2 " " 90	1 of No. 16
1 " " 19g	4 " " 90a	*1 " " 19b
3 " " 22	4 " " 111c	*1 " " 27a
1 " " 23a	1 " " 126	*1 E120 Electric
1 " " 24	2 " " 126a	Motor
2 " " 35	1 " " 186	Parts not required:

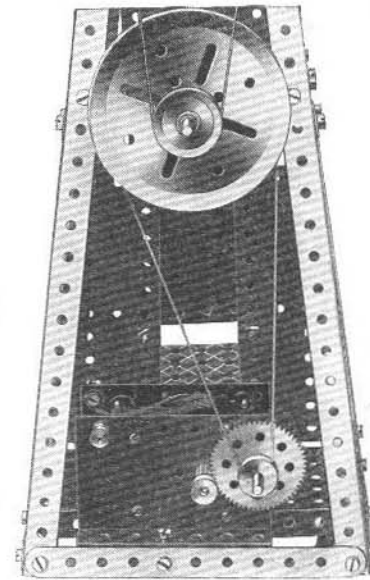

Fig. 6.17b

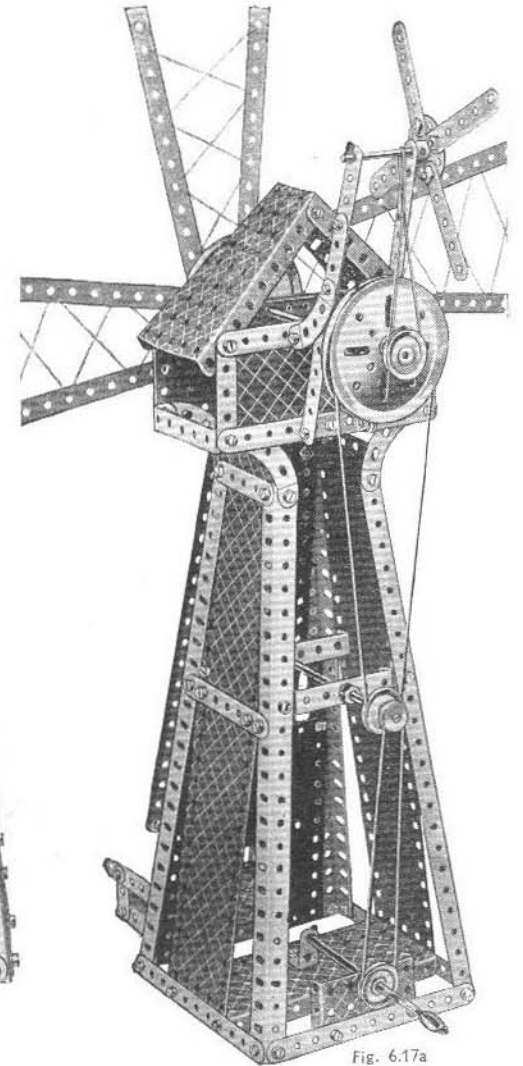

Fig. 6.17a

6.18 FLYBOATS

The base consists of two $12\frac{1}{2}'' \times 2\frac{1}{2}''$ Strip Plates, joined at each end by $5\frac{1}{2}'' \times 2\frac{1}{2}''$ Flexible Plates and strengthened by $5\frac{1}{2}''$ Strips bolted to the ends of the base. Four Angle Girders are bolted to the base as shown in the illustration, and pairs of them are joined at the top by compound strips, each of which consists of two $5\frac{1}{2}''$ Strips overlapped five holes. The Angle Girders are braced across by $12\frac{1}{2}''$ Strips.

The centre pin is withdrawn from a Hinged Flat Plate and the halves are used as flat plates 3. The $12\frac{1}{2}''$ Strips 1 and 2 form the supports for the carriages. The Strips 2 are bolted across a Bush Wheel mounted on the $6\frac{1}{2}''$ Rod forming the main shaft. Strips 1 are bolted across a $3''$ Pulley also secured on the $6\frac{1}{2}''$ Rod.

Two of the carriages are made by fastening $2\frac{1}{2}'' \times \frac{1}{2}''$ Double Angle Strips inside the flanges of a $3\frac{1}{2}'' \times 2\frac{1}{2}''$ Flanged Plate. Two $3''$ Strips and two $3\frac{1}{2}''$ Strips are then bolted to the ends of the $2\frac{1}{2}'' \times \frac{1}{2}''$ Double Angle Strips. A $4''$ Rod passes through the holes in these Strips and through the end holes of the $12\frac{1}{2}''$ Strips 1 and 2. A back is provided by a U-Section Curved Plate bolted to the rear of the $3\frac{1}{2}'' \times 2\frac{1}{2}''$ Flanged Plate, and the sides are formed by $2\frac{1}{2}''$ small radius Curved Strips.

The base of each of the other two carriages is a Flanged Sector Plate. The sides consist of $2\frac{1}{2}'' \times 1\frac{1}{2}''$ Flexible Plates, and bearings for the $3\frac{1}{2}''$ Rods on which the carriages are supported are provided by the end holes of $2\frac{1}{2}''$ Strips, bolted to the flanges of the Flanged Sector Plate. The back is formed by two Flat Trunnions fixed to a $2\frac{1}{2}'' \times \frac{1}{2}''$ Double Angle Strip secured between the flanges of the Flanged Sector Plate.

The Crank Handle (Fig. 6.18a) by which the carriages are set in motion, is journalled in the $12\frac{1}{2}'' \times 2\frac{1}{2}''$ Strip Plate forming the rear side of the base, and also in a $1'' \times 1''$ Angle Bracket. The $1'' \times 1''$ Angle Bracket is bolted to the half of a Hinged Flat Plate used in the construction of the left-hand platform. The drive is taken by Cord from a $1''$ Pulley on the shaft of the Crank Handle to a $3''$ Pulley on the main shaft.

The pay-box consists of a $5\frac{1}{2}'' \times 1\frac{1}{2}''$ Flexible Plate bent to shape, and is secured to the base by a $1\frac{1}{2}'' \times \frac{1}{2}''$ Double Angle Strip. The counter is formed by a Trunnion, and is fastened in position by Angle Brackets.

Fig. 6.18b shows the model fitted with a No. 1a or No. 2 Clockwork Motor. The Motor is bolted to the base of the model, and the drive is taken from a $\frac{1}{2}''$ Pinion on the Motor shaft through a 57-teeth Gear fastened on a Rod journalled in the Motor side-plates. The Rod carries also a $\frac{1}{2}''$ fast Pulley 1. A driving band connects the $\frac{1}{2}''$ fast Pulley 1 to the $3''$ Pulley.

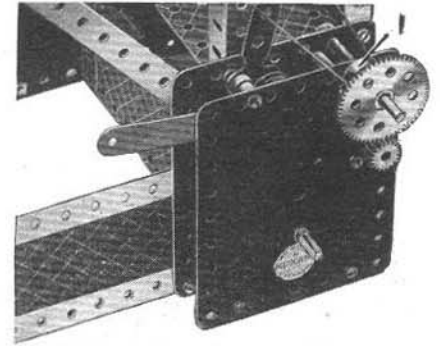
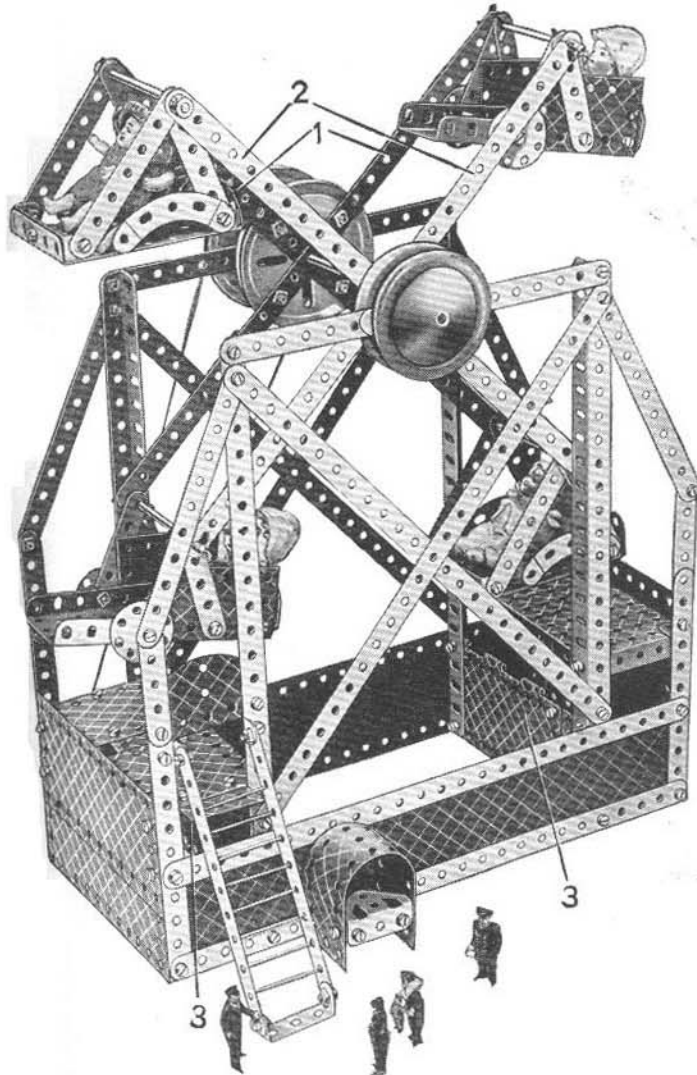

Fig. 6.18b Sectional view showing Motor fitted.

Parts required

12 of No. 1	1 of No. 23a	6 of No. 111c
14 " " 2	1 " " 24	1 " " 126
4 " " 3	14 " " 35	4 " " 126a
2 " " 4	105 " " 37	2 " " 187
12 " " 5	6 " " 37a	4 " " 188
2 " " 6a	8 " " 38	2 " " 189
4 " " 8	1 " " 40	4 " " 190
8 " " 12	2 " " 48	4 " " 192
1 " " 12a	8 " " 48a	2 " " 197
1 " " 14	2 " " 48b	1 " " 198
2 " " 15b	1 " " 52	2 " " 199
2 " " 16	2 " " 53	1 " " 214
2 " " 19b	2 " " 54a	4 " " 217a
1 " " 19g	3 " " 59	
3 " " 22	4 " " 90a	

For Model Flyboats fitted with No. 1a or No. 2 Clockwork Motor

Additional parts required:—

*1 of No. 16a

*1 " " 26

*1 " " 27a

6 " " 38

1 " " 59

*1 No. 1a or No. 2 Clockwork Motor

Parts not required:—

1 of No. 12a

1 " " 19g

2 " " 22

* Not included in Outfit

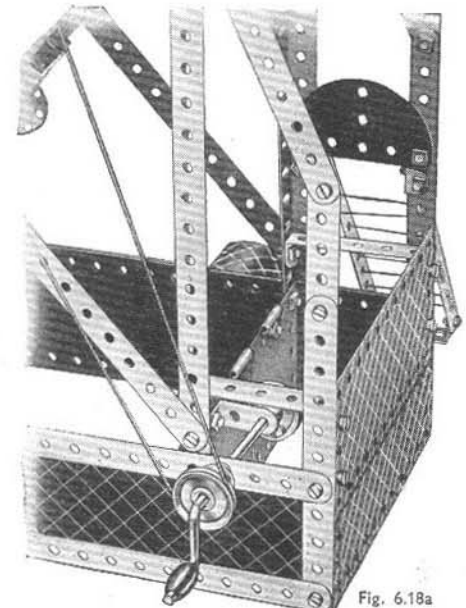

Fig. 6.18a

6.19 GIANT DRAGLINE

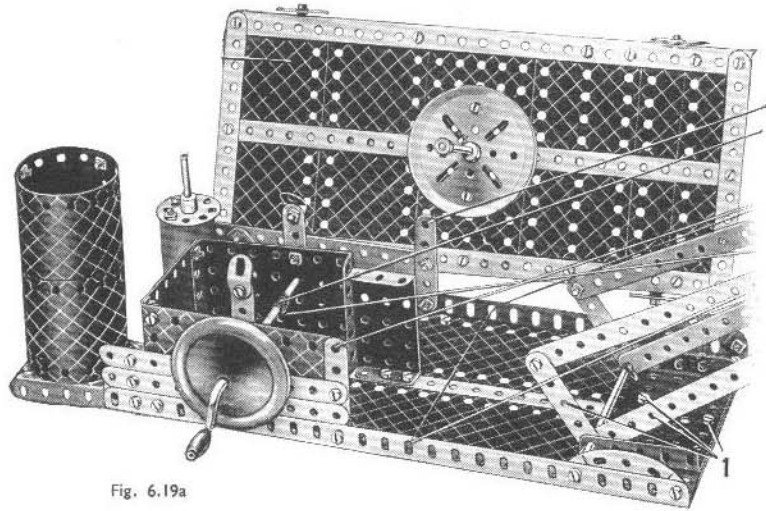
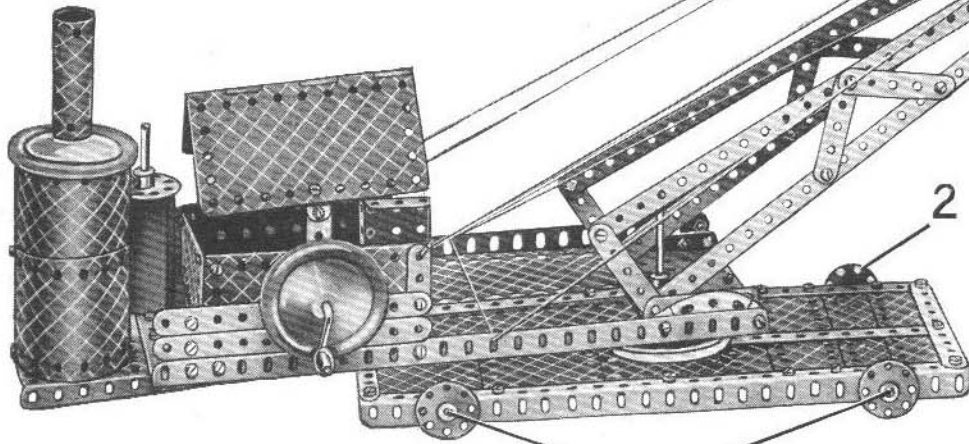

Fig. 6.19a

12 of No. 1	1 of No. 24
12 " " 2	5 " " 35
2 " " 3	97 " " 37
8 " " 5	14 " " 37a
2 " " 6a	7 " " 38
4 " " 8	1 " " 40
2 " " 10	2 " " 48
2 " " 11	3 " " 48a
3 " " 12	1 " " 48b
2 " " 12c	1 " " 51
1 " " 14	1 " " 52
1 " " 15	2 " " 53
2 " " 15b	2 " " 54a
2 " " 16	1 " " 57c
1 " " 17	
1 " " 18b	
2 " " 19b	
1 " " 19h	
4 " " 22	
2 " " 22a	

Parts required

3 of No. 59	4 of No. 189	2 of No. 200
1 " " 80c	4 " " 190	1 " " 216
2 " " 90a	4 " " 192	4 " " 217a
2 " " 111a	2 " " 197	
6 " " 111c	1 " " 198	
4 " " 125	1 " " 199	
4 " " 126a		
1 " " 147b		
2 " " 187		



2

For Model Drag-line fitted with E20B Electric Motor.

Additional parts required:—

1 of No. 16
1 " " 23a
*1 " " 32
1 " " 126
1 " " 186a
*E20B Electric Motor

Parts not required:—

2 of No. 12
2 " " 12c
1 " " 19h
4 " " 37
1 " " 48b
1 " " 53
4 " " 190
1 " " 198
*Not included in Outfit

The base is constructed by joining two Angle Girders at each end by a $5\frac{1}{2}$ " Strip. It is then filled in by a $5\frac{1}{2}$ " \times $2\frac{1}{2}$ " Flanged Plate and different sized Flexible Plates. The Bolts 2 carrying the $1\frac{1}{2}$ " Discs are lock-nutted. A 3" Pulley Wheel is bolted to the centre of the $5\frac{1}{2}$ " \times $2\frac{1}{2}$ " Flanged Plate. The control platform is built up in a similar manner to the base, but is filled in by two $12\frac{1}{2}$ " Strip Plates. A 3" Pulley is secured under the forward end of the platform by four Reversed Angle Brackets, which are held by the Bolts shown at 1. A 4" Rod is passed through the upper 3" Pulley, and its lower end is gripped in the 3" Pulley bolted to the base. The platform, therefore, is free to swivel, but is retained in position on the Rod by a Collar.

The near side of the cab (Fig. 6.19a) consists of two $2\frac{1}{2}$ " \times $2\frac{1}{2}$ " Flexible Plates, overlapped one hole and fastened to the Angle Girder at the edge of the platform. The rear side of the cab is formed by a $3\frac{1}{2}$ " \times $2\frac{1}{2}$ " Flanged Plate and a $2\frac{1}{2}$ " \times $1\frac{1}{2}$ " Flanged Plate. The $3\frac{1}{2}$ " \times $2\frac{1}{2}$ " Flanged Plate is secured to the base by a $3\frac{1}{2}$ " \times $\frac{1}{2}$ " Double Angle Strip, and the $2\frac{1}{2}$ " \times $1\frac{1}{2}$ " Flanged Plate is bolted in position by its flange. A Hinged Flat Plate is used for the roof, and it is attached by Obtuse Angle Brackets to two $1\frac{1}{2}$ " Strips bolted to the sides. The boiler consists of two $5\frac{1}{2}$ " \times $2\frac{1}{2}$ " Flexible Plates and two $1\frac{1}{8}$ " radius Curved Plates.

The chimney is formed by bending a U-Section Curved Plate so that the two ends overlap. A Bolt is fastened through the overlapping portions, and carries also an Angle Bracket inside the chimney. A $6\frac{1}{2}$ " Rod, on the end of which is a Spring Clip, is slipped through the Angle Bracket and locked in the boss of a Road Wheel. The Wheel is placed over the boiler, and the lower end of the $6\frac{1}{2}$ " Rod passes through a Flanged Sector Plate, which is bolted at the rear of the base. The Rod is held in position by another Spring Clip.

(Continued on next page)

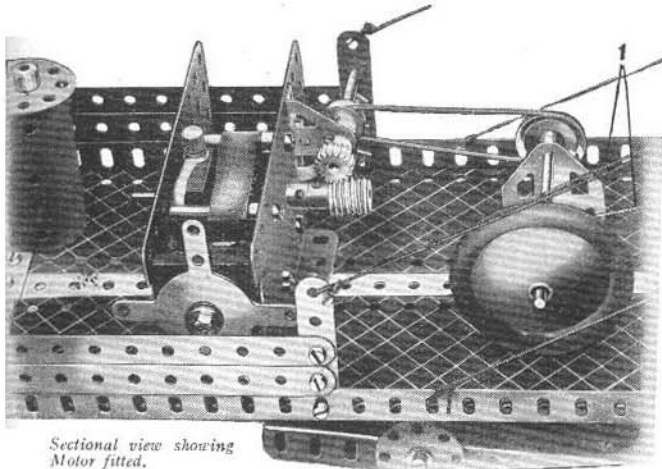

Sectional view showing Motor fitted.

Fig. 6.19b

(Continued from previous page)

The jib is constructed from 12½" Strips bolted end to end. It is pivoted at its lower end on a 4" Rod journalled in the flanges of a 3½" x 2½" Flanged Plate held by Bolts 1. The jib is held at an angle of about 30 degrees by Cord, which is tied to the cab and then taken over a 1" fast Pulley on a 2" Rod journalled in the jib. From there the Cord is led through holes in the Angle Girders forming the sides of the platform, over a 1" Pulley on the other end of the 2" Rod, and finally is tied to the cab.

The Crank Handle held in the sides of the cab controls the movement of the bucket. Cord is wound a few times round the shaft of the Crank Handle and then is taken over a 4½" Rod in the jib and tied to the front of the bucket. The other end of the Cord is led around a 1" fast Pulley on a Rod at the end of the jib, and through the pulley block at the back of the bucket. It is then tied to a Flat Bracket carried on the 2" Rod journalled in the jib.

Fig. 6.19b shows the Giant Dragline fitted with an E20B Electric Motor. The Motor is bolted by its flanges to the 12½" Strip running the length of the control platform, and is fixed to one of the sides by an Angle Bracket. The Flat Trunnions used as bearings for the Rod controlling the bucket are taken from the sides of the platform and are replaced by 1½" Strips. The drive is taken through a Worm on the driving shaft of the Motor to a ½" Pinion fastened on a 2½" Rod. Bearings for this Rod are provided by a 2½" Strip fixed to the side of the platform, and by a Trunnion bolted to the sideplate of the Motor. The Rod carries also a ½" fast Pulley, which is connected by a Driving Band to a 1" Pulley on the 3½" Rod, journalled in the Flat Trunnions. The Cord 1 controls the movement of the bucket.

6.20 TRAIN FERRY

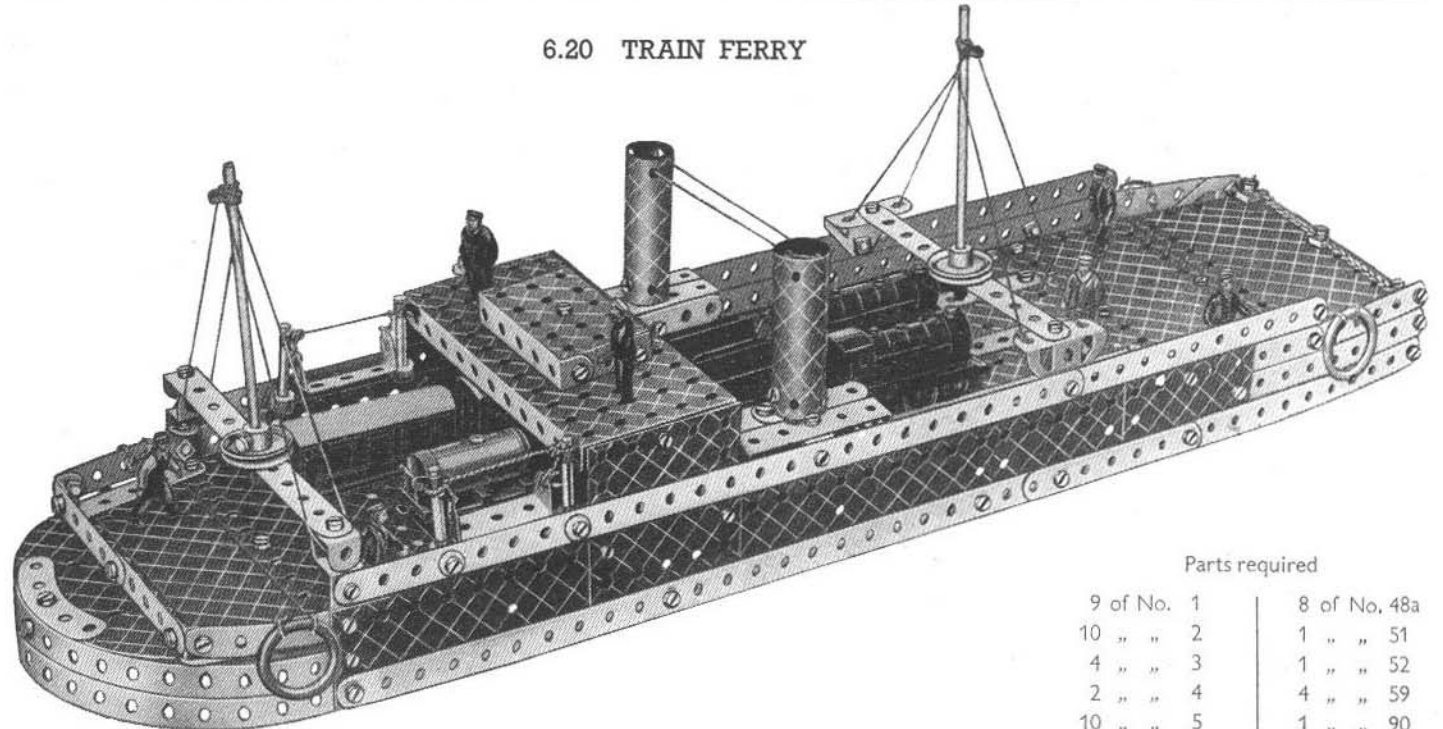

Construction is commenced by bolting 12½" Angle Girders together to make two 17½" compound angle girders, and then connecting them by two 5½" Strips. The sides of the ship consist mainly of 5½" x 1½" and 2½" x 1½" Flexible Plates, and are bolted to the framework and strengthened at the bottom by 12½" Strips.

The bows are formed by bending 12½" Strips to shape and bolting them to the sides of the ship. At the stern the sides are extended by means of Strips, and are joined across by 2½" Strips to form a square end. Fig. 6.20a shows the layout of the Flexible Plates and Strip Plates forming the deck.

A 5½" x 2½" Flanged Plate is used for the bridge, and is supported by two 2½" x 2½" Flexible Plates bolted to the sides. The twin funnels are made from U-Section Curved Plates. The supports to which the funnels are bolted are built up from 2½" x ½" Double Angle Strips and 2½" Strips attached to a 1" x 1" Angle Bracket, the complete assembly being attached to the sides of the vessel by Double Brackets.

Parts required

9 of No. 1	8 of No. 48a
10 " " 2	1 " " 51
4 " " 3	1 " " 52
2 " " 4	4 " " 59
10 " " 5	1 " " 90
4 " " 8	1 " " 111
7 " " 10	3 " " 111c
4 " " 11	2 " " 125
9 " " 12	2 " " 126
2 " " 12a	2 " " 126a
2 " " 15	4 " " 155a
4 " " 18a	4 " " 188
2 " " 22	4 " " 189
8 " " 35	2 " " 190
93 " " 37	2 " " 191
7 " " 37a	2 " " 192
9 " " 38	2 " " 197
1 " " 40	2 " " 199
2 " " 48	2 " " 214

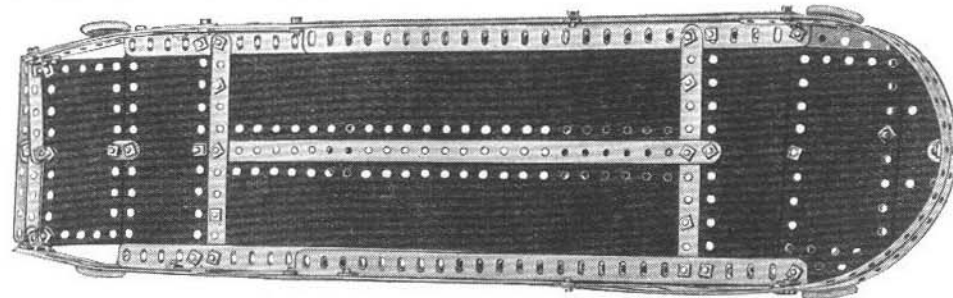
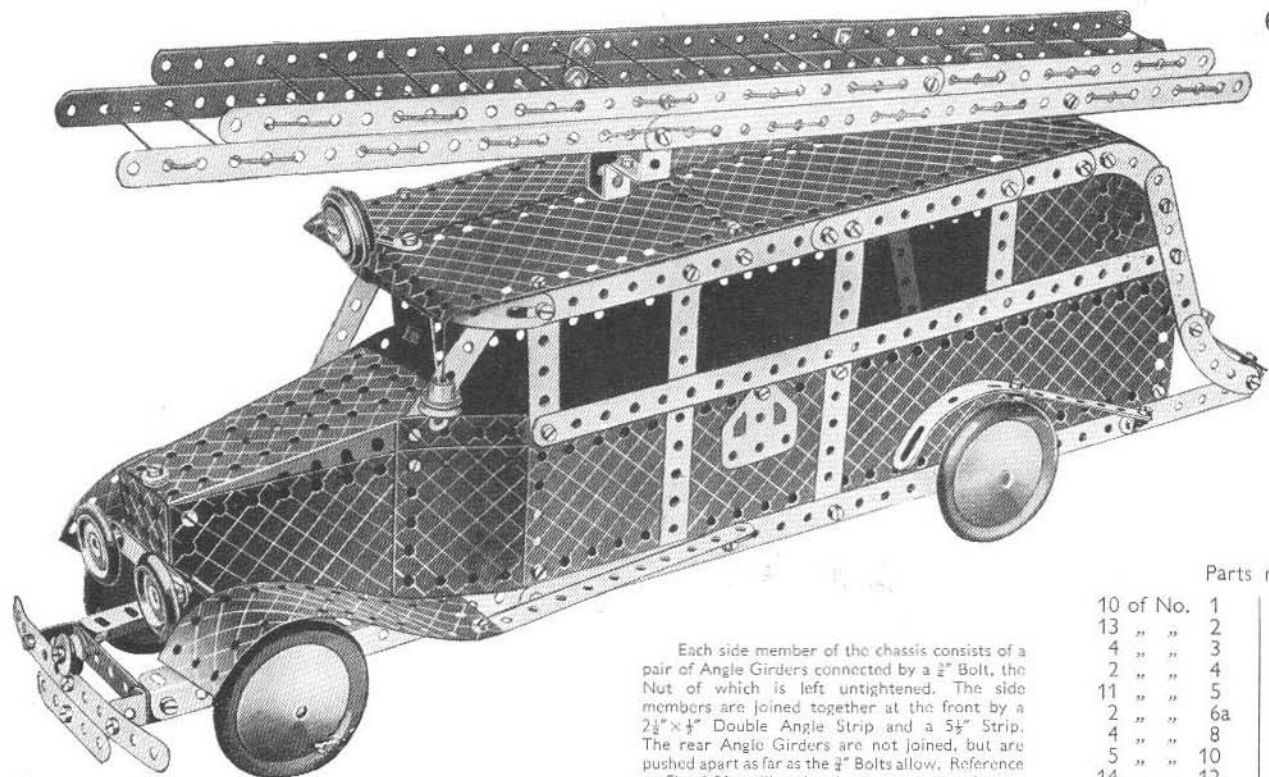

Fig. 6.20a



Each side member of the chassis consists of a pair of Angle Girders connected by a $\frac{1}{2}$ " Bolt, the Nut of which is left untightened. The side members are joined together at the front by a $2\frac{1}{2}$ " \times $\frac{1}{2}$ " Double Angle Strip and a $5\frac{1}{2}$ " Strip. The rear Angle Girders are not joined, but are pushed apart as far as the $\frac{1}{2}$ " Bolts allow. Reference to Fig. 6.21a will make the arrangement clear.

The sides of the body consist of $12\frac{1}{2}$ " \times $2\frac{1}{2}$ " Strip Plates, and are attached by Flat Brackets to the rear Angle Girders. The roof is formed by four $5\frac{1}{2}$ " \times $2\frac{1}{2}$ " Flexible Plates, and is secured by Angle Brackets to the compound strips forming the top of the windows. The curved back is obtained by bending Flexible Plates to the correct shape and fastening them to a framework of Strips.

The sides of the bonnet are each represented by a $4\frac{1}{2}$ " \times $2\frac{1}{2}$ " Flexible Plate, and are secured to the body of the fire-engine by $2\frac{1}{2}$ " \times $2\frac{1}{2}$ " Flexible Plates and $2\frac{1}{2}$ " \times $1\frac{1}{2}$ " Flexible Plates. The last named are bolted to the $12\frac{1}{2}$ " \times $2\frac{1}{2}$ " Strip Plates forming the sides of the body. A Flanged Sector Plate forms the top of the bonnet, and is secured by the flanges of its narrow end to the two

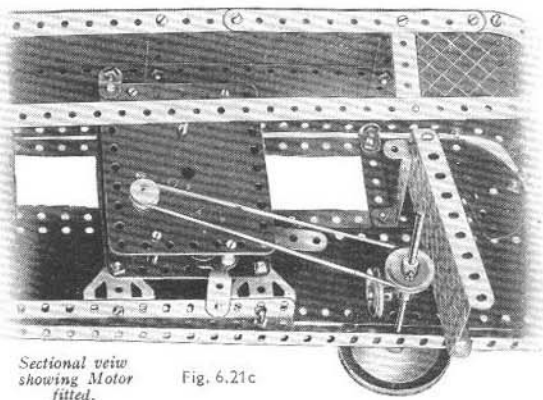

Sectional view showing Motor fitted.

Fig. 6.21c

6.21 STREAMLINED FIRE ENGINE

$4\frac{1}{2}$ " \times $2\frac{1}{2}$ " Flexible Plates. At its wide end it is fastened to the $2\frac{1}{2}$ " \times $1\frac{1}{2}$ " Flexible Plates secured to the body. The radiator is represented by a $2\frac{1}{2}$ " \times $1\frac{1}{2}$ " Flanged Plate bolted to the front end of the Flanged Sector Plate. The Bolt carries two Washers above the Flanged Sector Plate to represent the radiator cap.

Two 1" fast Pulleys are used for the headlights, and they are secured to a $2\frac{1}{2}$ " Strip fixed by $\frac{1}{2}$ " Bolts to the $2\frac{1}{2}$ " \times $1\frac{1}{2}$ " Flanged Plate forming the radiator. The $\frac{3}{8}$ " Bolts pass through the end holes of the $2\frac{1}{2}$ " Strip, and are locked in the bosses of the 1" Pulleys. The front bumper is represented by a $5\frac{1}{2}$ " Strip extended downward by a $2\frac{1}{2}$ " Strip. It is fastened in position to the $2\frac{1}{2}$ " \times $\frac{1}{2}$ " Double Angle Strip at the front of the chassis by two Reversed Angle Brackets.

The Road Wheels are held on 5" Rods journalled in the sides of the chassis. The front mudguards are each formed by a $5\frac{1}{2}$ " \times $1\frac{1}{2}$ " Flexible Plate bolted to the $5\frac{1}{2}$ " Strip joining the side members of the chassis. A $3\frac{1}{2}$ " Strip extended by a Formed Slotted Strip and secured by an Angle Bracket to the side of the body, is used for each of the rear mudguards.

The rear 5" Rod carries a Collar between the side members of the chassis. A Pivot Bolt, which carries a 1" fast Pulley 2 against its head, is screwed into the tapped hole of the Collar, thus holding it in position on the Rod. A Flanged Sector Plate 1 is loosely suspended from a $2\frac{1}{2}$ " \times $\frac{1}{2}$ " Double Angle Strip 3 by a lock-nutted $\frac{3}{8}$ " Bolt. When the rear Road Wheels revolve, the Pulley 2 strikes the Flanged Sector Plate 1, and thus provides an automatic gong.

(Continued on next page)

Parts required

10 of No. 1	1 of No. 51
13 " " 2	1 " " 53
4 " " 3	2 " " 54a
2 " " 4	4 " " 59
11 " " 5	2 " " 90
2 " " 6a	4 " " 90a
4 " " 8	2 " " 111
5 " " 10	2 " " 111a
14 " " 12	6 " " 111c
2 " " 12a	1 " " 115
4 " " 12c	2 " " 125
2 " " 15	2 " " 126a
1 " " 15b	1 " " 147b
2 " " 17	3 " " 155a
1 " " 19g	4 " " 187
3 " " 22	3 " " 188
2 " " 22a	4 " " 189
1 " " 23	6 " " 190
1 " " 23a	2 " " 191
6 " " 35	4 " " 192
105 " " 37	2 " " 197
4 " " 37a	2 " " 200
7 " " 38	2 " " 214
2 " " 40	4 " " 215
1 " " 45	2 " " 217a
3 " " 48a	2 " " 217b

For Model Fire-Engine fitted with No. 2 Clockwork Motor.

Additional parts required :-

- 1 of No. 12
- 1 " " 22
- * 1 " " 23a
- * 6 " " 37
- 2 " " 126
- 1 " " 186b
- * 1 No. 2 Clockwork Motor.

* Not included in Outfit.

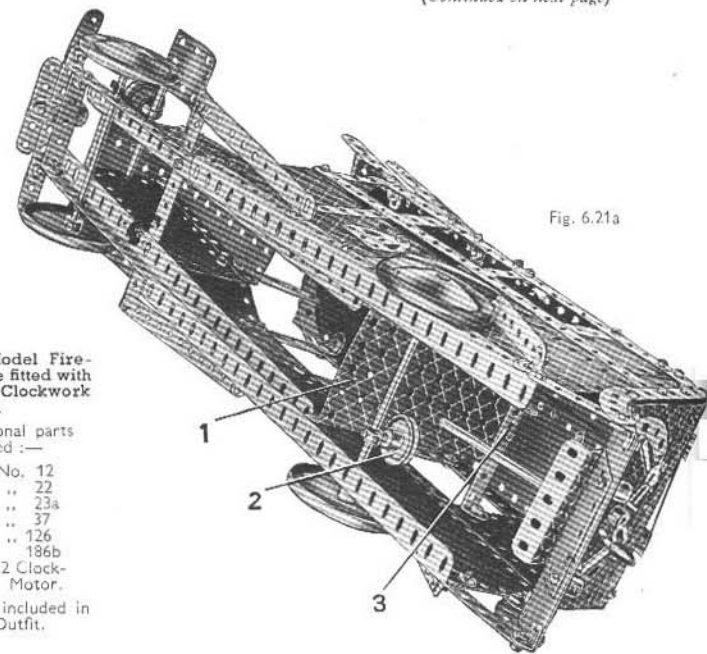

Fig. 6.21a

(Continued from previous page)

The fixed escape ladder consists of two pairs of compound strips, each built up from two 12½" Strips bolted together overlapping eight holes. The escape is attached to the roof of the car at the rear by a 2½" × ½" Double Angle Strip, and at the front by a compound bracket, which is built up by attaching 1" × 1" Angle Brackets to the ends of a Double Bent Strip. The extension escape is built up from two pairs of compound strips each consisting of two 12½" Strips overlapping 13 holes. The extension ladder is fastened to the fixed part of the escape by Flat Brackets. The rungs of the ladders are represented by Cord threaded through the holes in the Strips.

The searchlight at the front of the fire-engine is made by placing a ½" Disc, a 1" loose Pulley fitted with a Rubber Ring, a 1¼" Disc, and a second 1" loose Pulley on the shank of a ¾" Bolt. The complete unit is then fastened to the roof by a compound bracket consisting of two Obtuse Angle Brackets bolted together.

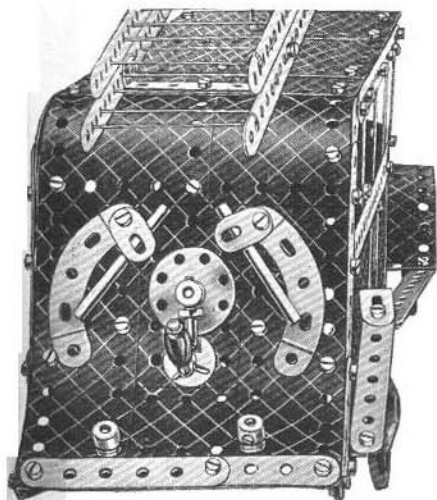
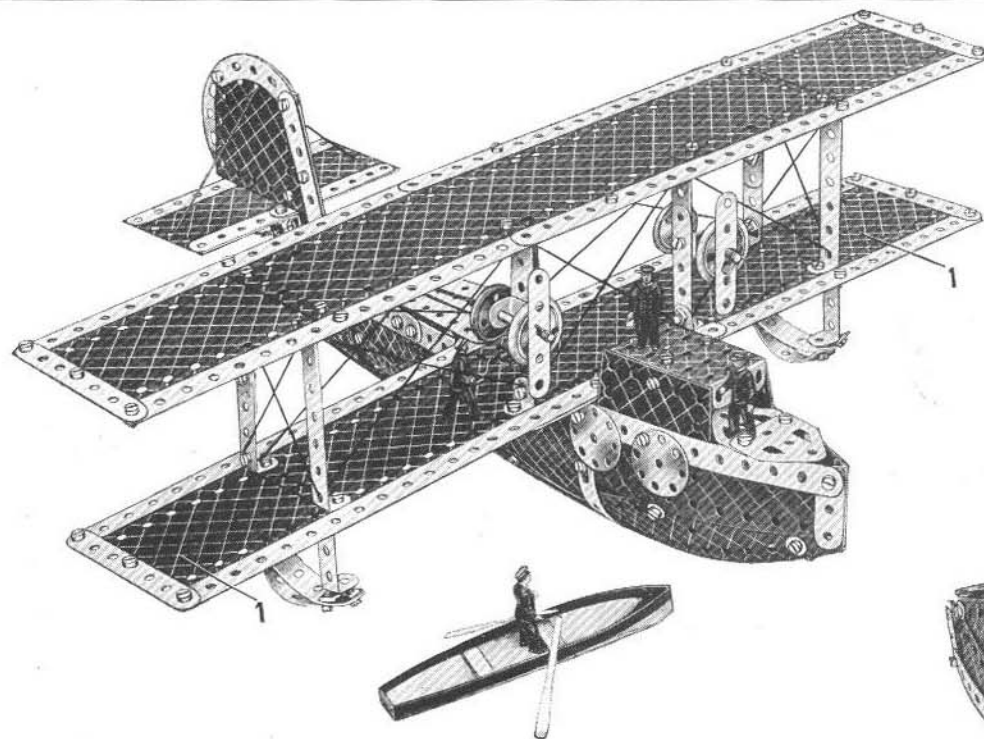

Fig. 6.21b



6.22 TWIN-ENGINE FLYING BOAT

The uselage is built up from Flexible Plates, and as each side is identical, reference to the illustrations will make the construction clear.

The lower wing consists of a 12½" × 2½" Strip Plate, extended at each end by the flat plates 1, and it is framed by 12½" and 3½" Strips. The flat plates 1 are obtained by removing the centre pin from a Hinged Flat Plate. The wing is attached by Angle Brackets to the sides of the fuselage. The top wing is constructed in a similar manner, except that the 12½" × 2½" Strip Plate is extended by 4½" × 2½" Flexible Plates and not by the halves of a Hinged Flat Plate. It is braced from the lower wing by 3½" × ½" Double Angle Strips, and by double angle strips built up from Strips and Angle Brackets. The propellers are supported on 2" Rods journalled in Double Brackets bolted to the inner wing supports.

The control cabin is constructed by bolting two 2½" × 1½" Flexible Plates to the sides of the fuselage in front of the wings, and then joining them across at the top by a 2½" × 1½" Flanged Plate.

A 5½" × 2½" Flexible Plate is used for the tailplane and is secured by Angle Brackets to two 2½" large radius Curved Strips bolted to the end of the fuselage. The rudder is formed by two 2½" × 2½" Flexible Plates, which are attached to the tailplane by an Angle Bracket. The rudder is given a curved outline by bolting to it 2½" small radius Curved Strips.

Parts required

11 of No. 1	4 of No. 35	1 of No. 125
11 " " 2	102 " " 37	2 " " 126a
4 " " 3	9 " " 37a	2 " " 155a
2 " " 4	14 " " 38	4 " " 188
12 " " 5	1 " " 40	4 " " 189
2 " " 6a	2 " " 48	2 " " 190
10 " " 10	3 " " 48a	2 " " 191
4 " " 11	2 " " 48b	3 " " 192
14 " " 12	1 " " 51	2 " " 197
1 " " 12a	2 " " 90	1 " " 198
3 " " 12c	4 " " 90a	2 " " 199
2 " " 17	2 " " 111	2 " " 200
2 " " 22	1 " " 111a	4 " " 215
2 " " 22a	6 " " 111c	4 " " 217a

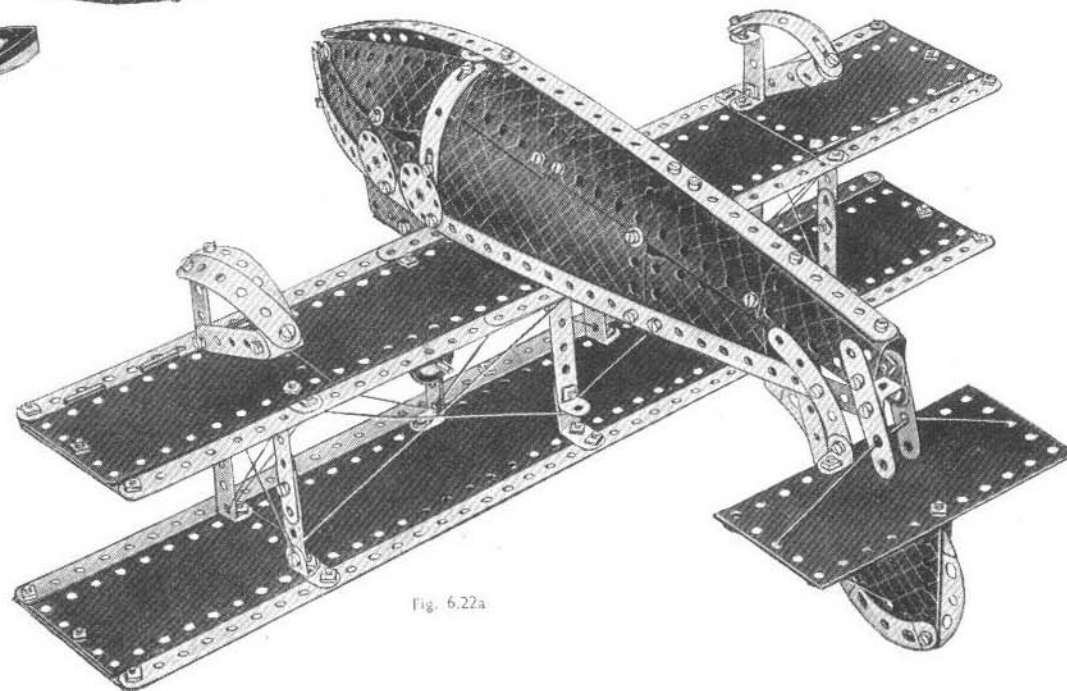

Fig. 6.22a

6.23 FRETWORK MACHINE



Parts required

12	of No.	1
14	" "	2
4	" "	3
8	" "	5
2	" "	6a
4	" "	8
2	" "	10
7	" "	12
2	" "	12a
1	" "	14
1	" "	15a
1	" "	17
2	" "	19b
4	" "	22
1	" "	24
1	" "	35
83	" "	37
8	" "	37a
13	" "	38
1	" "	45
1	" "	48
6	" "	48a
1	" "	51
1	" "	52
2	" "	53
2	" "	54a
4	" "	59
1	" "	80c
2	" "	111a
6	" "	111c
1	" "	115
2	" "	126
4	" "	126a
1	" "	147b

2	of No.	187
4	" "	188
4	" "	189
2	" "	191
2	" "	197

For Model Fret Machine fitted with E120 Electric Motor :-

Additional parts required :-

2	of No.	10
1	" "	15
*1	" "	27
*1	" "	32
1	" "	186a
*1	E120	Electric Motor

Parts not required :-

1	of No.	2
1	" "	17
1	" "	24
2	" "	37a
2	" "	38
2	" "	111a

*Not included in Outfit

The main framework of the model consists of four 12½" Angle Girders joined across at their lower ends by compound strips consisting of two 5½" Strips. The Strips spacing the sides are overlapped two holes, and those spacing the front and rear are overlapped four holes.

The base is extended downwards by 5½"×1½" and 2½"×1½" Flexible Plates, which are joined at the corners by Angle Brackets bolted at the rear of the model. At the top the Angle Girders are spaced at the front and rear by 5½" Strips, and at the sides by 12½" Strips, which are bolted so that they extend five holes to the front of the table. Four 12½" Strips are bolted to the frame of the base and to the upper 5½" and 12½" Strips, and a supplementary framework to support the operating handle is also added (see Fig. 6.23a).

The table is shown complete in the front view of the model, and in Fig. 6.23a one of the 12½"×2½" Strip Plates has been removed. A 5½"×2½" Flanged Plate is bolted across the 12½" Strips at the sides of the table. The two 12½"×2½" Strip Plates are bolted to the Flanged Plate and joined by Angle Brackets to the ends of the 12½" Strips, the Bolts carrying also two Flat Trunnions. The table is extended to the front by a 2½"×1½" Flanged Plate, which is bolted to a 5½" Strip and to the ends of two 2½"×½" Double Angle Strips. The side extensions are Flanged Sector Plates, each of which is attached to the frame by a Flat Bracket, a 3½" Strip and a 12½" Strip. A 2½"×½" Double Angle Strip provides additional support underneath.

The saw frame consists of two long arms, each consisting of two 12½" Strips bolted together. One of the arms is bolted between two 3½"×2½" Flanged Plates, and the other is lock-nutted at its end to an N-shaped piece, consisting of two 2½" Strips and two 3½" Strips braced across by a 2½" Strip in the manner shown. A tensioning device for the saw blade consists of a Double Bent Strip lock-nutted to the upper arm. A 3" Screwed Rod is passed through holes in the Double Bent Strip and a Collar is screwed on each of its ends.

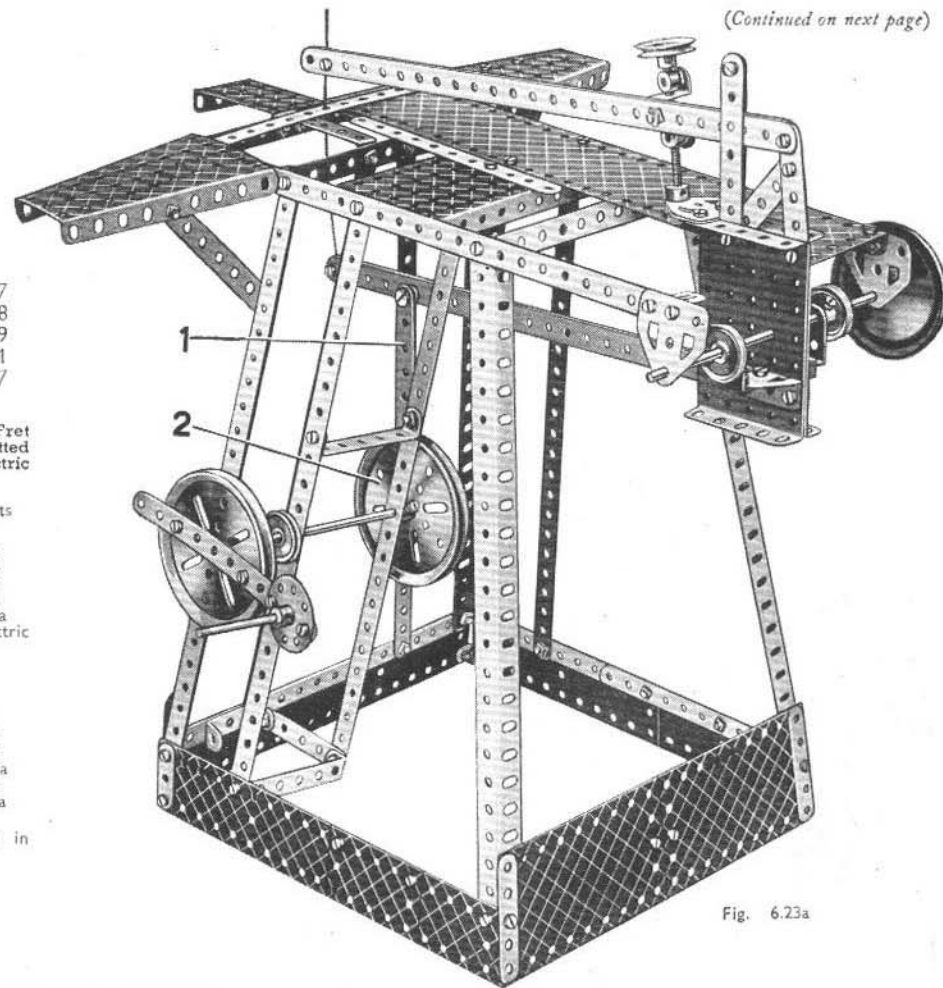

(Continued on next page)

Fig. 6.23a

(Continued from previous page)

The shanks of two Bolts in the end holes of the Double Bent Strip engage in the plain holes of the Collars. The Screwed Rod passes also through a hole in two Flat Trunnions bolted to the flanges of the $3\frac{1}{2}'' \times 2\frac{1}{4}''$ Flanged Plates, and two Collars are held by their grub screws on the Screwed Rod on each side of the Flat Trunnions.

A $6\frac{1}{2}''$ Rod is passed through the end holes of $1'' \times 1''$ Angle Brackets attached to Trunnions bolted to the $3\frac{1}{2}'' \times 2\frac{1}{4}''$ Flanged Plates, and is journalled in the two Flat Trunnions as shown.

The handle for operating the machine is constructed by fastening a $2''$ Rod in the boss of a Bush Wheel that is attached to a $5\frac{1}{2}''$ Strip. The Strip in turn is bolted across a $3''$ Pulley held on the end of a $4\frac{1}{2}''$ Rod journalled in two $12\frac{1}{2}''$ Strips. On its other end the $4\frac{1}{2}''$ Rod carries another $3''$ Pulley 2, which is pivotally connected by a $5\frac{1}{2}''$ Strip 1 to the lower arm of the frame. The lower end of the $5\frac{1}{2}''$ Strip is pivoted on a Threaded Pin and is held in place by a Spring Clip; its upper end being pivoted on a Pivot Bolt lock-nutted to the lower arm of the saw frame. The Pivot Bolt carries six Washers on its shank.

Fig. 6.23b shows the model fitted with an E120 Electric Motor. The Motor is bolted to the framework of the model by two Bolts, and the drive is taken from a Worm on the Motor shaft through a 50-teeth Gear. The 50-teeth Gear is secured on a Rod journalled in holes in two Flat Brackets. A Driving Band connects the $1''$ fast Pulley on this Rod to the $3''$ Pulley above.

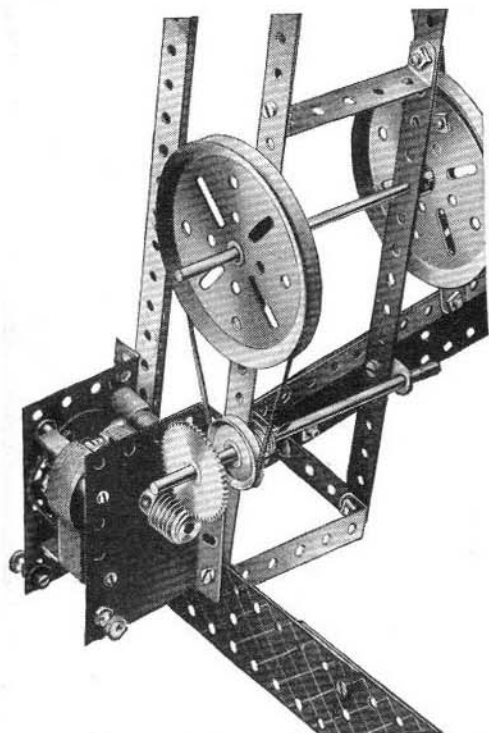

Sectional View Showing Motor Fitted.

Fig. 6.23b

6.24 BATTERY LOCOMOTIVE

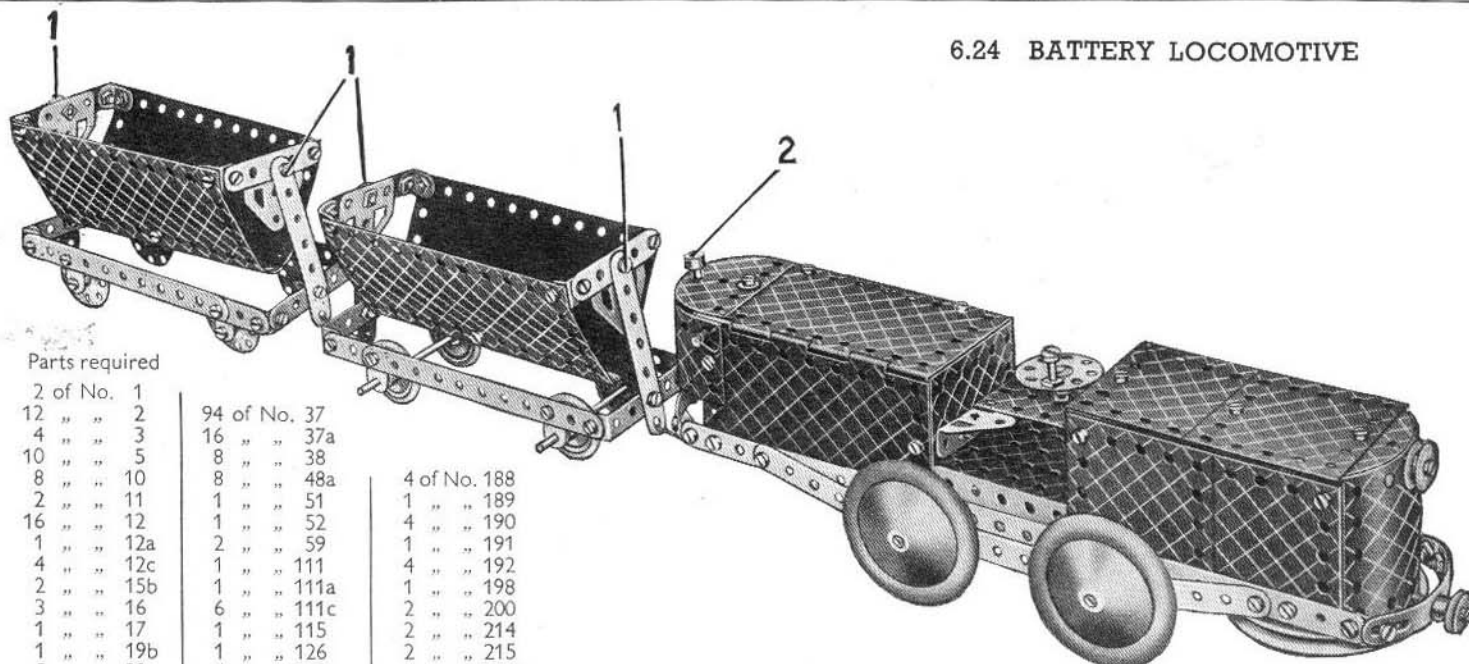

Parts required

2 of No. 1	94 of No. 37	4 of No. 188
12 " " 2	16 " " 37a	1 " " 189
4 " " 3	8 " " 38	4 " " 190
10 " " 5	8 " " 48a	1 " " 191
8 " " 10	2 " " 51	4 " " 192
2 " " 11	1 " " 52	1 " " 198
16 " " 12	2 " " 59	2 " " 200
1 " " 12a	1 " " 111	2 " " 214
4 " " 12c	1 " " 111a	2 " " 215
2 " " 15b	1 " " 111c	4 " " 217a
3 " " 16	1 " " 115	1 " " 217b
1 " " 17	1 " " 126	1 No. 1
1 " " 19b	4 " " 126a	Clockwork
5 " " 22	1 " " 147b	Motor
1 " " 23	4 " " 155a	
1 " " 23a	1 " " 186	
1 " " 24	4 " " 187	
2 " " 35		

The construction of the chassis of the locomotive will be clear from Fig. 6.24a. The $12\frac{1}{2}''$ Strips are spaced at each end by $2\frac{1}{2}'' \times \frac{1}{2}''$ Double Angle Strips, the one at the front having a $3''$ Pulley bolted to it by a $\frac{3}{4}''$ Bolt passed through its boss.

The top and side of the rear part of the locomotive are completed by bolting a Hinged Flat Plate to one of the $12\frac{1}{2}''$ Strips forming the chassis and then attaching the Plate by Angle Brackets to the side shown in Fig. 6.24a.

A $5\frac{1}{2}'' \times 2\frac{1}{4}''$ Flanged Plate forms the floor of the centre portion of the locomotive, and a $2\frac{1}{2}'' \times 1\frac{1}{2}''$ Flanged Plate, bolted to two $2\frac{1}{2}'' \times \frac{1}{2}''$ Double Angle Strips that space the sides, carries a Threaded Pin in its centre hole. A Bush Wheel carrying a Pivot Bolt is fastened to the Threaded Pin to form a control handle. The top of the front of the locomotive is fastened to $2\frac{1}{2}'' \times \frac{3}{4}''$ Double Angle Strips, and the curved front and rear portions are then added.

The method of fixing the Clockwork Motor in position is shown in Fig. 6.24a. It is attached to the chassis by two Angle Brackets, and is supported also by a $3\frac{1}{2}''$ Rod pushed through the side plates of the locomotive and through the corner holes of the Clockwork Motor.

Collar 2 is fastened on a $2''$ Rod, which is connected to the brake lever of the Motor. The connection is made by a Bolt passed through the hole in the brake lever and lock-nutted in the tapped hole of a Collar, which also is fastened on the Rod.

The sides of the chassis of each truck consist of two $5\frac{1}{2}''$ Strips overlapped nine holes, and in the front truck the two sides are joined across by $2\frac{1}{2}'' \times \frac{3}{4}''$ Double Angle Strips at each end. In the rear truck the sides of the chassis are joined by $2\frac{1}{2}''$ Strips and Angle Brackets. The two $5\frac{1}{2}'' \times 2\frac{1}{4}''$ Flexible Plates forming the sides of the container of each truck are joined together at the bottom by a Double Bracket bolted to a $5\frac{1}{2}''$ Strip.

The Bolts 1 are lock-nutted to the $2\frac{1}{2}''$ Strips, and the $1\frac{1}{2}''$ Discs forming the wheels of the rear truck are lock-nutted to $\frac{3}{4}''$ Bolts, which have two Washers on their shanks for spacing purposes.

Fig. 6.24a

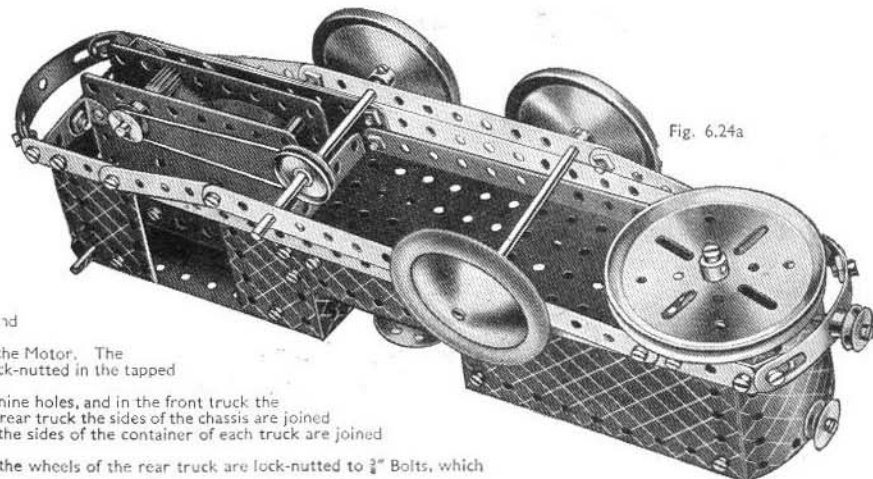

6.25 TOWER WAGON

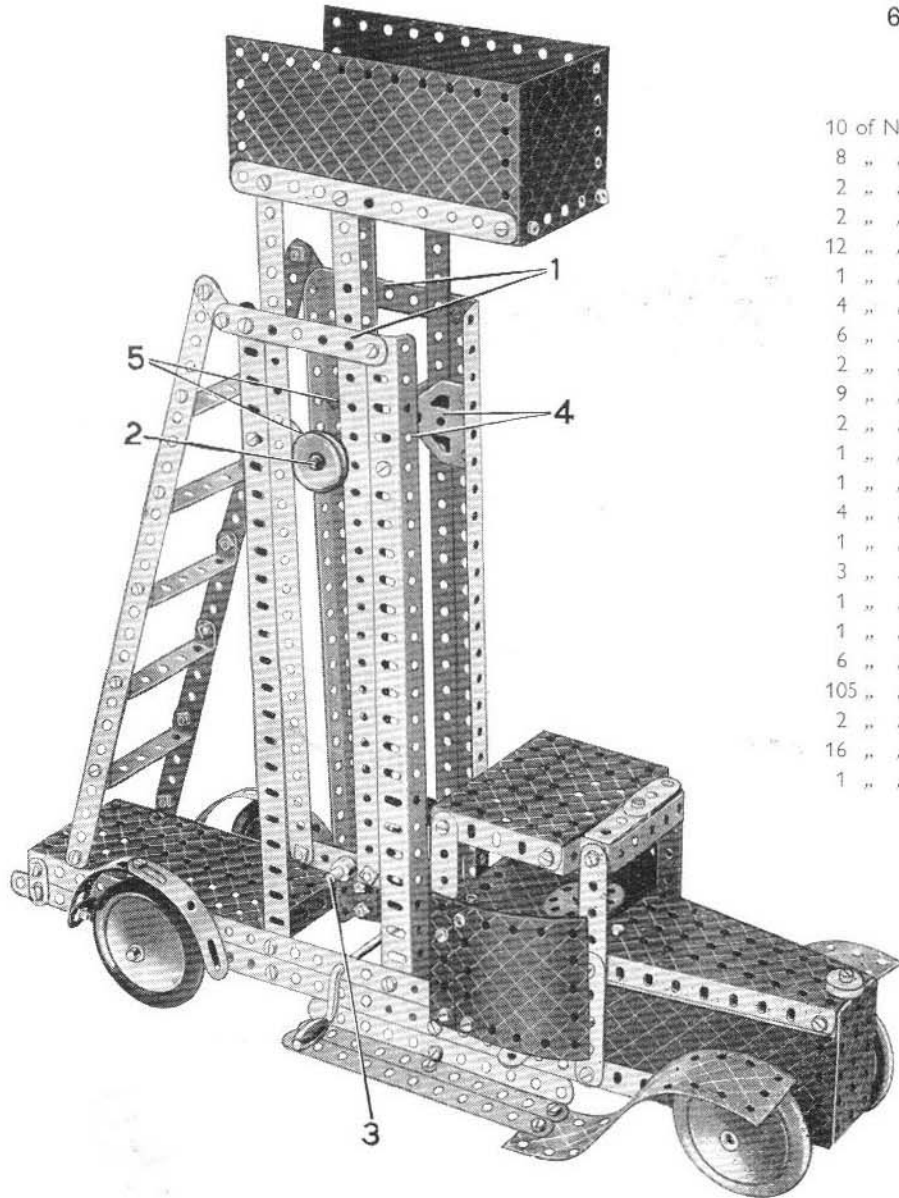

Parts required

10 of No.	1	1 of No.	48
8 " "	2	8 " "	48a
2 " "	3	1 " "	48b
2 " "	4	1 " "	51
12 " "	5	1 " "	52
1 " "	6a	2 " "	53
4 " "	8	2 " "	54a
6 " "	10	4 " "	59
2 " "	11	2 " "	111c
9 " "	12	4 " "	125
2 " "	12a	4 " "	126a
1 " "	12c	1 " "	176
1 " "	15	1 " "	186b
4 " "	16	4 " "	187
1 " "	19g	4 " "	188
3 " "	22	2 " "	189
1 " "	23	1 " "	190
1 " "	24	2 " "	191
6 " "	35	3 " "	192
105 " "	37	1 " "	199
2 " "	37a	2 " "	200
16 " "	38	4 " "	215
1 " "	40		

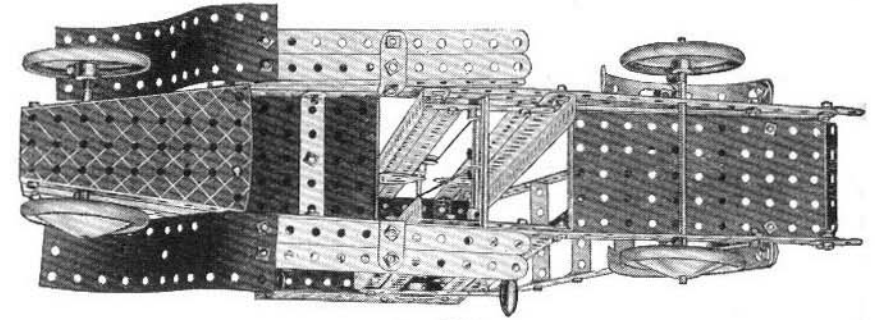

Fig. 6.25a

Each side member of the chassis consists of two $12\frac{1}{2}$ " Strips secured together by Flat Brackets. The side members are joined at the rear by a $5\frac{1}{2}$ " \times $2\frac{1}{2}$ " Flanged Plate, and at the front by a Flanged Sector Plate. The bonnet is built up by bolting $4\frac{1}{2}$ " \times $2\frac{1}{2}$ " Flexible Plates to the flanges of the Flanged Sector Plate and then fastening another Flanged Sector Plate to their upper ends. The radiator, a $2\frac{1}{2}$ " \times $1\frac{1}{2}$ " Flanged Plate, is bolted in position between the ends of the Flanged Sector Plates, the upper Bolt being $\frac{3}{8}$ " long and carrying a $\frac{1}{2}$ " loose Pulley to represent the radiator cap.

A $3\frac{1}{2}$ " \times $2\frac{1}{2}$ " Flanged Plate forms the base for the cab, and is secured to the chassis by a $2\frac{1}{2}$ " \times $\frac{1}{2}$ " Double Angle Strip (Fig. 6.25a). The back of the cab consists of two $2\frac{1}{2}$ " \times $1\frac{1}{2}$ " Flexible Plates, overlapped three holes and supported by Angle Brackets between two $5\frac{1}{2}$ " Strips bolted to the flanges of the $3\frac{1}{2}$ " \times $2\frac{1}{2}$ " Flanged Plate. Each of the doors is constructed by bolting a $2\frac{1}{2}$ " \times $1\frac{1}{2}$ " Flexible Plate to the lower end of one of the $5\frac{1}{2}$ " Strips fastened to the $3\frac{1}{2}$ " \times $2\frac{1}{2}$ " Flanged Plate. A $1\frac{1}{8}$ " radius Curved Plate is then bolted to the $2\frac{1}{2}$ " \times $1\frac{1}{2}$ " Flexible Plate, overlapping it two holes, each Bolt carrying two Washers between the Flexible and Curved Plates. A second $3\frac{1}{2}$ " \times $2\frac{1}{2}$ " Flanged Plate is fixed to the upper ends of the $5\frac{1}{2}$ " Strips, and is secured by Reversed Angle Brackets to two more $5\frac{1}{2}$ " Strips bolted to the chassis.

The front Road Wheels are fixed on a $3\frac{1}{2}$ " Rod journalled in the flanges of the lower Flanged Sector Plate, and the 5" Rod carrying the rear Road Wheels passes through the lower $12\frac{1}{2}$ " Strips.

The framework inside which the tower slides consists of four Angle Girders, which are bolted to the chassis as shown in the illustration and are joined at the top by the Strips 1. Each side of the tower is built up from $12\frac{1}{2}$ " Strips connected at the bottom by a 3" Strip, and bolted at their upper ends to the stand. To prevent the $12\frac{1}{2}$ " Strips from sliding too freely, Flat Trunnions are fastened to the Angle Girders at 4. The Crank Handle for raising and lowering the tower is journalled in the upper $12\frac{1}{2}$ " Strips of the chassis. It carries at its end a 1" Pulley, which is connected by a Driving Band to one of the Pulleys 5 on the $3\frac{1}{2}$ " Rod 2. Cord is fastened to a Cord Anchoring Spring on Rod 2, and its other end is tied to the centre of the $3\frac{1}{2}$ " Rod 3.

The ladder is constructed by bolting $2\frac{1}{2}$ " \times $\frac{1}{2}$ " Double Angle Strips between two $12\frac{1}{2}$ " Strips. The latter are fastened at their lower ends to the $5\frac{1}{2}$ " \times $2\frac{1}{2}$ " Flanged Plate by Angle Brackets, and at their upper ends they are attached to two Flat Brackets bolted to Strips 1.

If you want to obtain the fullest enjoyment from the Meccano hobby you should operate your models by means of one of the Meccano Motors described on this page. You push over the control lever of the clockwork or electric Motor and immediately your Crane,

Motor Car, Ship Cooler or Windmill commences to work in exactly the same manner as its prototype in real life.

Each Motor is specially designed for building into Meccano models.

MECCANO CLOCKWORK MOTORS

These are the finest clockwork motors obtainable for model driving. They have exceptional power and length of run and their gears are cut with such precision as to make them perfectly smooth and steady in operation.

Meccano Clockwork Motors are specially suitable for small models built with a limited range of parts. They are extremely simple to operate and have the advantage of being self contained.

THE MECCANO MAGIC MOTOR

The Meccano Magic Motor is well designed and strongly constructed, and is fitted with a powerful spring giving a long and steady run. It is non-reversing. Each Motor is supplied with a separate $\frac{1}{4}$ " fast Pulley and three pairs of Driving Bands of different lengths.

A Magic Motor is the best power unit for driving small models built from Outfits Nos. 0 to 5. The larger Clockwork Motors, No. 1, No. 1a and No. 2, and the various Electric Motors, are more suitable for driving the heavier models built from Outfits 5 to 10.

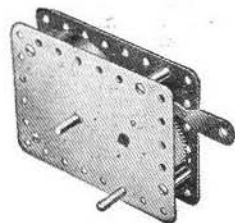
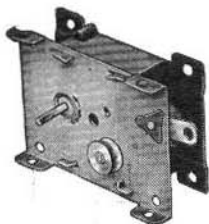

No. 1 Clockwork Motor

This strongly built and efficient Motor is fitted with a powerful spring that gives a long and steady run, and is exceptionally smooth in action. The Motor is provided with a conveniently-placed brake lever by means of which it can be started and stopped. The Motor is of the non-reversing type.

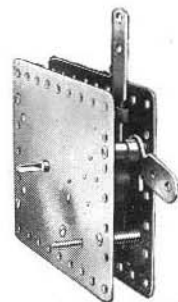

No. 2 Clockwork Motor

No. 1a Clockwork Motor

This Motor is more powerful than the No. 1 Motor and is fitted with reversing motion. It has brake and reverse levers.

No. 2 Clockwork Motor

This is a Motor of super quality. Brake and reverse levers enable it to be started, stopped or reversed, as required.

MECCANO ELECTRIC MOTORS

The Meccano Electric Motors shown here have been designed specially to provide smooth-running power units for the operation of Meccano models.

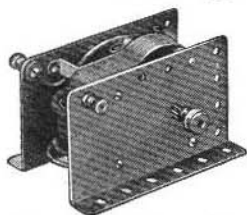

No. E1 Electric Motor (6 volt)

This Motor (non-reversing) will give excellent service. It is operated through a Meccano T6A, T6 or T6M Transformer from alternating current mains, or from a 6-volt accumulator.

No. E120 Electric Motor (20volt)

The E120 Electric Motor is operated through a Meccano T20A, T20, or T20M Transformer from alternating current supply mains. Non-reversing.

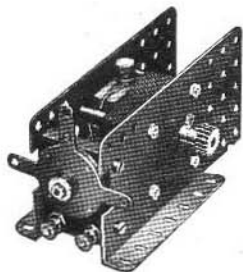

No. E6 Electric Motor (6 volt)

This fine Motor is fitted with reversing motion and provided with stopping and starting controls. It can be operated through a Meccano T6A, T6 or T6M Transformer from the mains (alternating current) or from a 6-volt accumulator.



No. E06 Electric Motor (6 volt)

This strongly-built non-reversing Motor of the all-enclosed type will drive all the models built from Outfits up to No. 5, and also some of the lighter models built from Outfits 6 to 8. It can be operated through a Meccano T6A, T6 or T6M Transformer from the mains, providing the supply is alternating current, or from a 6-volt accumulator.

No. E020 Electric Motor (20 volt)

The E020 is a powerful non-reversing Motor of similar construction to the E06 Motor illustrated above. It is designed to work from alternating current mains supply through a Meccano T20A, T20 or T20M Transformer.

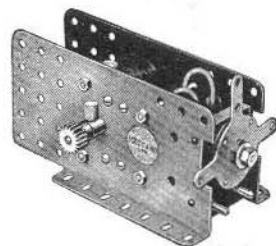

No. E20b Electric Motor (20 volt)

This 20-volt Electric Motor is an extremely efficient power unit fitted with reversing motion and provided with stopping and starting controls. It is operated through a Meccano T20A, T20 or T20M Transformer from alternating current supply mains.

MECCANO TRANSFORMERS

There are six Transformers in the series, as described below, all of which are available for the following A.C. supplies:—100/110 volts, 50 cycles; 200/225 volts, 50 cycles; 225/250 volts, 50 cycles. Any of the Transformers can be specially wound for supplies other than these at a small extra charge. When ordering a Transformer the voltage and frequency of the supply must always be stated.



No. T20A Transformer



No. T6 Transformer

FOR 20-volt ELECTRIC MOTORS

No. T20A TRANSFORMER (Output 35 VA at 20/3½ volts). Has two separate circuits at 20 volts, one of which is controlled by a 5-stud speed regulator and a third circuit at 3½ volts for lighting up to 14 lamps.

No. T20 TRANSFORMER (Output 20 VA at 20-volts). Has one 20-volt circuit controlled by a 5-stud speed regulator.

No. T20M TRANSFORMER (Output 20 VA at 20-volts). This Transformer is provided with one 20-volt circuit but is not fitted with speed regulator.

FOR 6-volt ELECTRIC MOTORS

No. T6A TRANSFORMER (Output 40 VA at 9/3½ volts). Has two separate circuits at 9-volts, one of which is controlled by a 5-stud speed regulator and a third circuit at 3½ volts for lighting up to 18 lamps.

No. T6 TRANSFORMER (Output 25 VA at 9 volts). Has one 9-volt circuit and is fitted with a 5-stud speed regulator.

No. T6M TRANSFORMER (Output 25 VA at 9 volts). Has one 9-volt circuit, but is not fitted with a speed regulator.

Resistance Controllers

By means of these Controllers the speed of Meccano 6-volt and 20-volt Motors can be regulated exactly as desired.

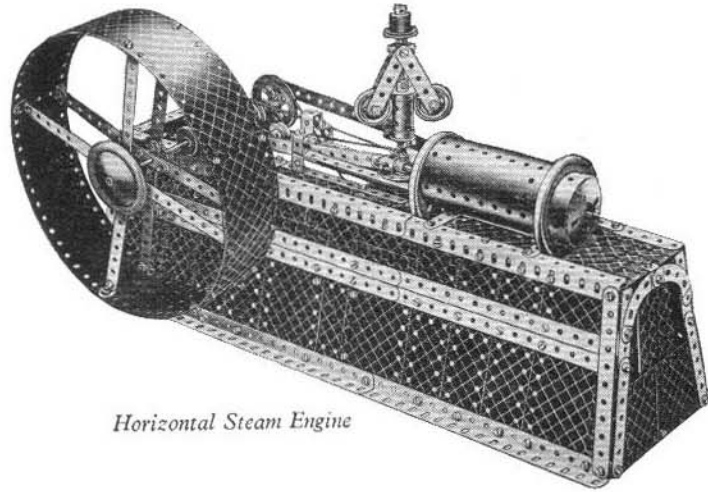
*Horizontal Steam Engine***BUILD BIGGER AND BETTER MODELS.**

When you have built all the models shown in this Manual you will be keen to build bigger and more elaborate models. Your next step is to purchase a Meccano No. 6a Accessory Outfit containing all the parts required to convert your No. 6 into a No. 7 Outfit. You will thus be able to build the full range of No. 7 Outfit models, a selection of which is illustrated on this page and opposite.

If you prefer to do so, you can build up and develop your Outfit quite easily by adding various parts to it from time to time. The model-building possibilities of the Meccano System are limitless, and the more Meccano parts you have, the bigger and better the models you will be able to build.

Ask your dealer to post to you regularly the latest Meccano parts lists and other Meccano literature.

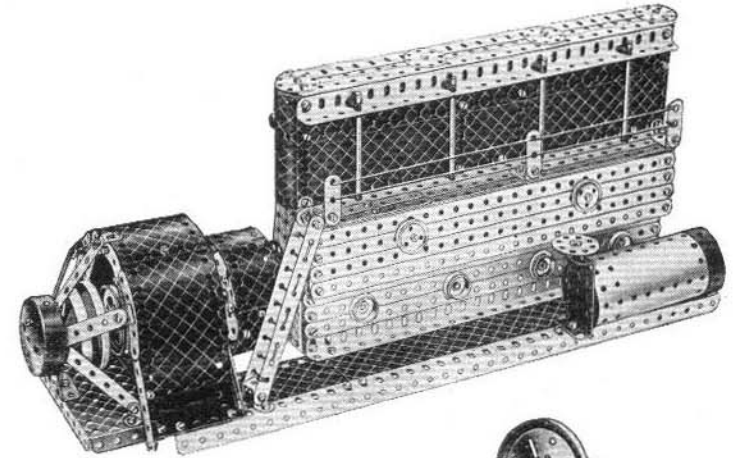
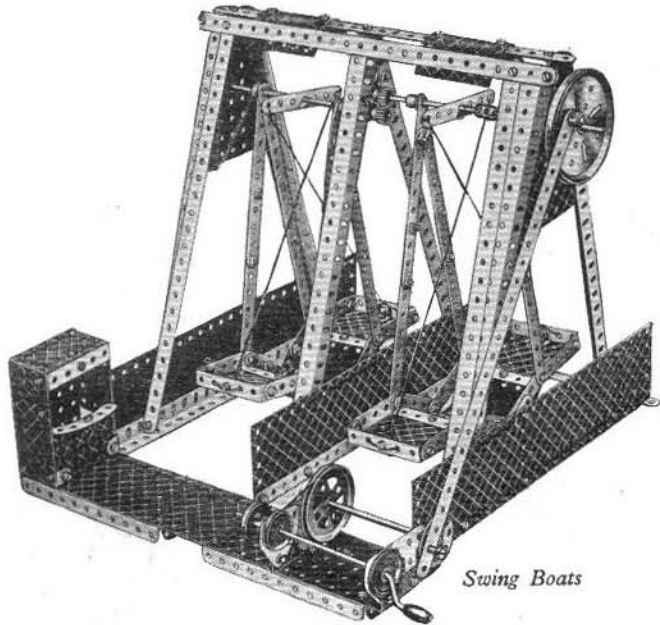
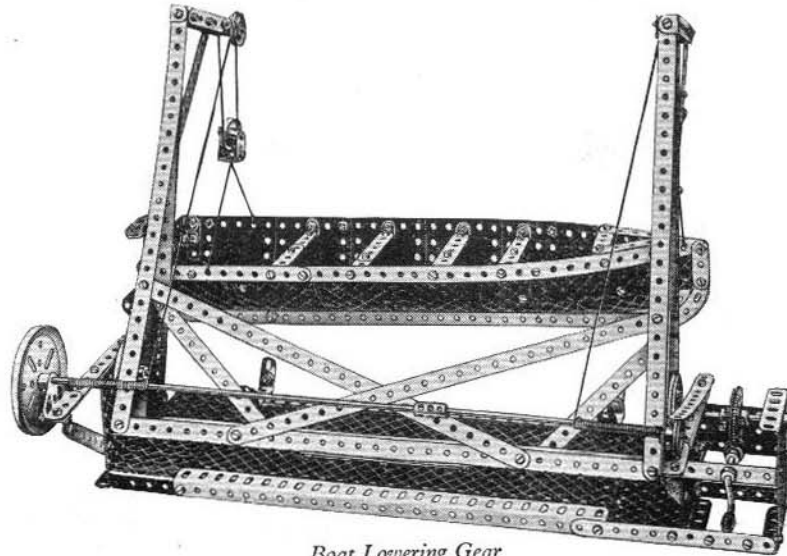
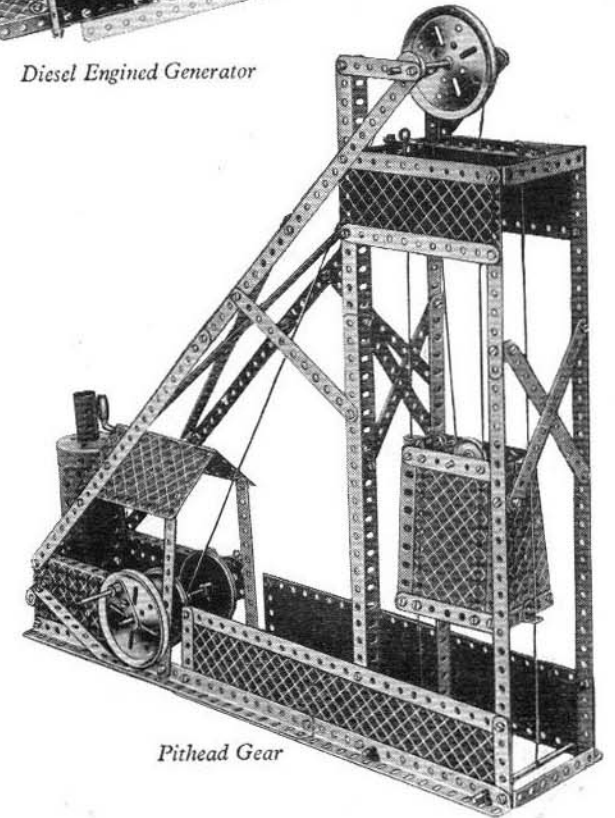
*Diesel Engine Generator**Swing Boats**Boat Lowering Gear**Pithead Gear*

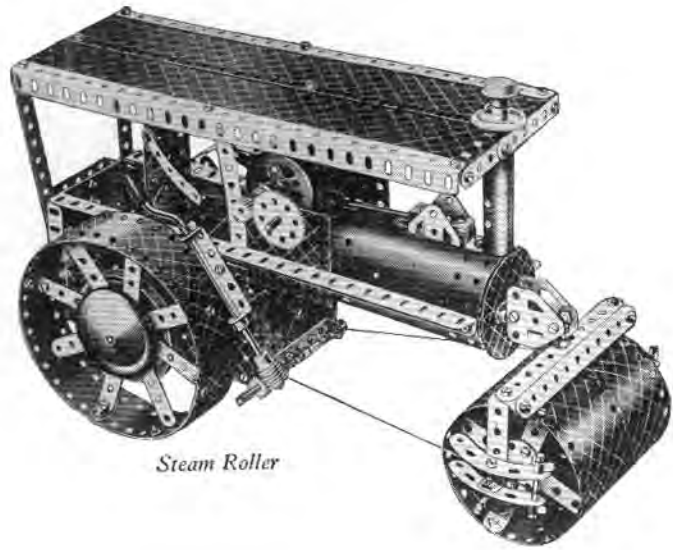

Steam Roller

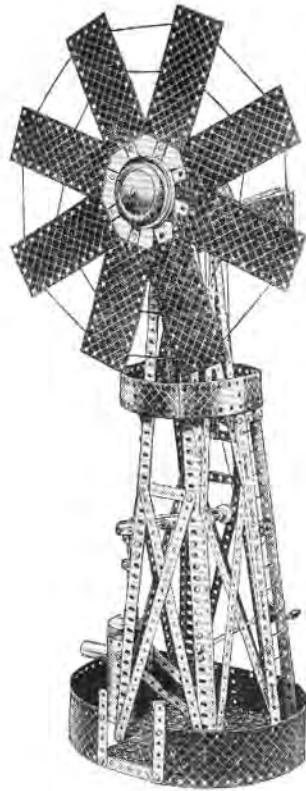

Windmill Pump

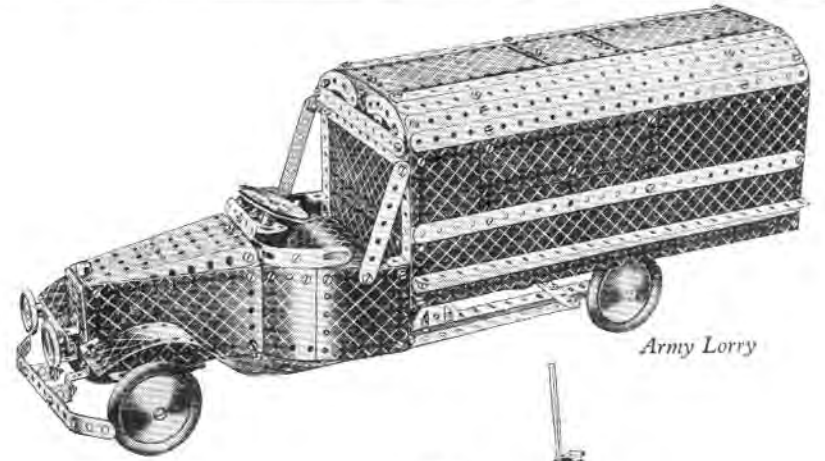

Army Lorry

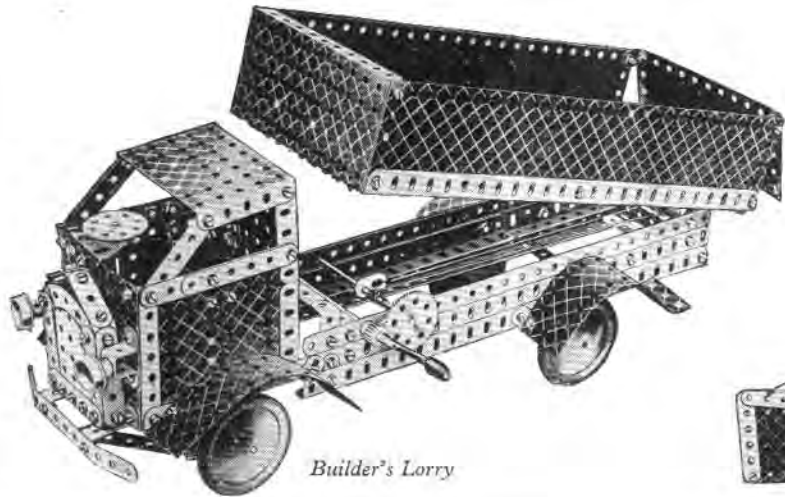

Builder's Lorry

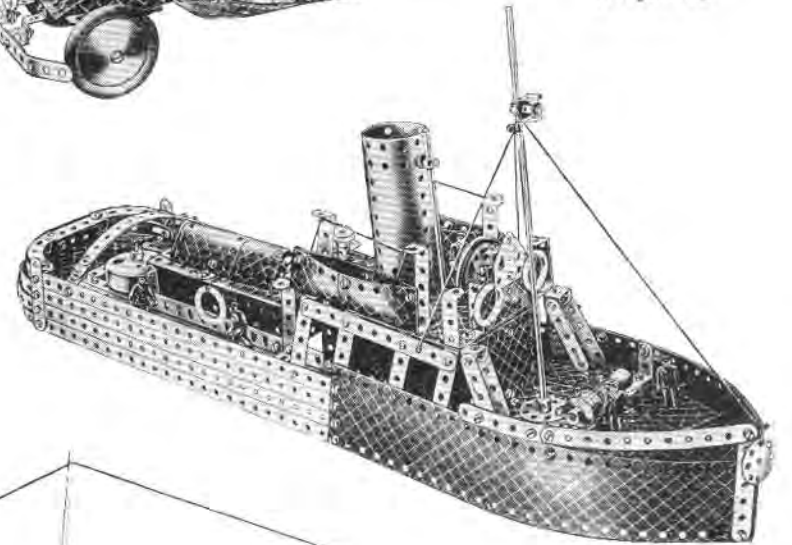

Tug Boat

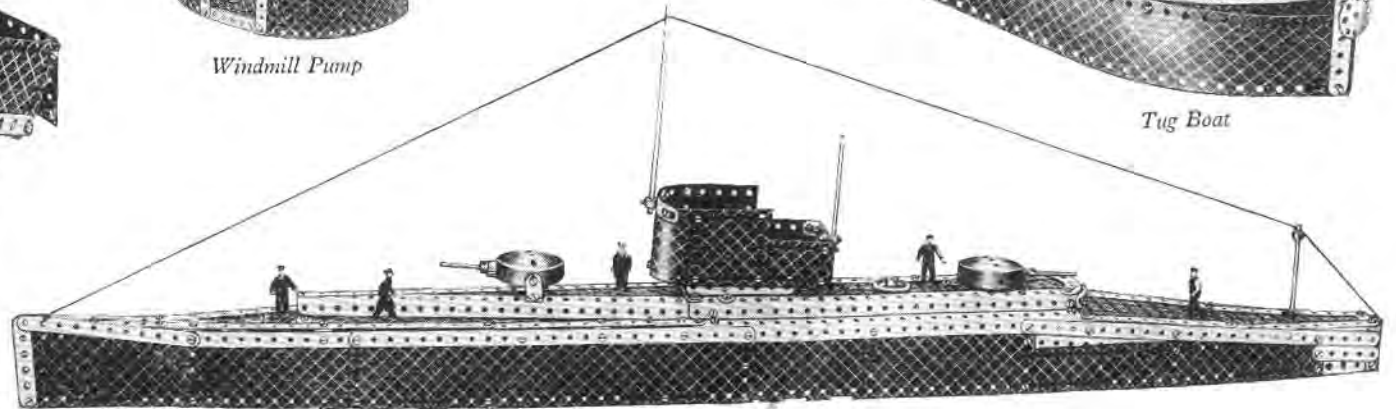

Submarine

Here are a few simple and interesting movements showing how easily real mechanisms can be reproduced with Meccano.

STRAP AND LEVER BRAKE

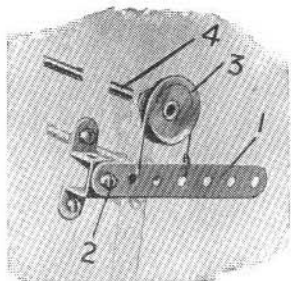

This device will be found very useful as a quick emergency hand-brake. Although it is the simplest of such devices, it is also one of the most valuable and can be used in a great variety of models.

INTERMITTENT ROTARY MOTION

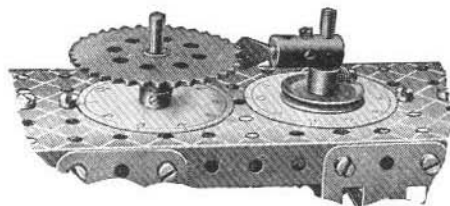

Intermittent rotary motion can be obtained by means of the above device. Such an arrangement is useful in revolution counters, measuring machines, etc. In addition to mechanisms that give true intermittent motion, different types of cams that convert a regular rotary motion into a constant or intermittent reciprocating motion can be constructed.

PAWL AND RATCHET MOVEMENT

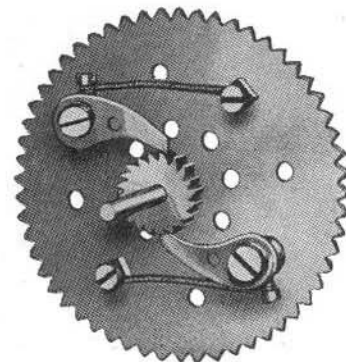

By means of this device it is possible to construct certain types of automatic brakes and free wheels. The illustration shows the method of building up a free-wheel unit.

GRABS

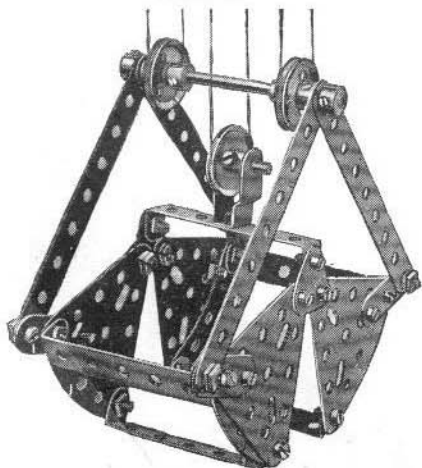

Here is a typical example of the many kinds of grab that can be constructed from Meccano. If the grab is fitted to a model crane or ship-coaler, all its movements can be controlled from an operating box built into the frame of the model. The outer sides of the jaws may be filled in with cardboard and the grab can then be used to pick up loads of sand, grain, marbles, etc.

BIG END FOR MECCANO CRANKSHAFT

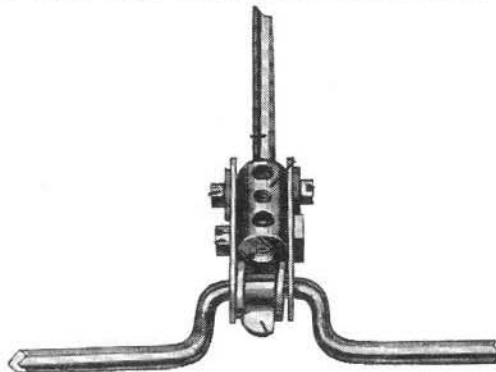

A Spring Clip is first clipped on to the centre of the cranked portion of the Crankshaft, and on each side of this is carried a Washer. On the outside of each of the Washers is placed a $1\frac{1}{2}$ " Strip, and these are connected together by means of a Coupling. A $\frac{1}{2}$ " Bolt passes completely through the two $1\frac{1}{2}$ " Strips at their centre holes and also through the inner transverse tapped hole of the Coupling. The outer tapped holes are fitted with Set-Screws, under the heads of which a Washer is placed.

STRAP AND SCREW BRAKE

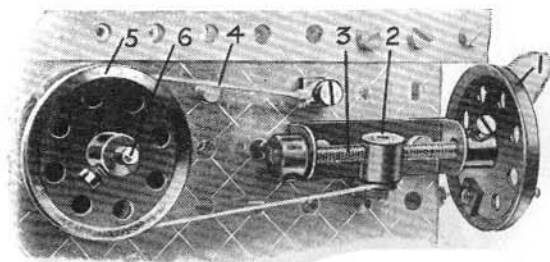

The type of brake shown above is used to apply a constant retarding effect to a rotating shaft. It can thus be utilised in a crane to prevent the load from falling back when the winding spindle is released. An advantage of the brake is that the speed of the shaft to which it is applied can be varied as required; the retarding action of the brake cannot vary when once set unless the hand wheel is turned.

WORM AND PINION BEARING

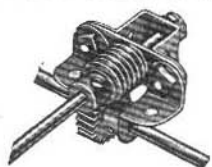

The compact rear axle drive unit illustrated above is intended chiefly for use in small models of motor cars. Two Corner Angle Brackets are secured by Bolts passing through their elongated holes to a $1\frac{1}{2}$ " Strip, to which a Double Bent Strip also is secured. The Rod carrying the Worm is passed through the centre hole of the Strips and held in position by a Collar.

The driven Rod is journaled in the Corner Angle Brackets and carries a Pinion that engages with the Worm.

A feature of this bearing that should not be overlooked is that the useful gear ratio of 25:1 is provided by employing a $\frac{5}{8}$ " Pinion.

GEARS

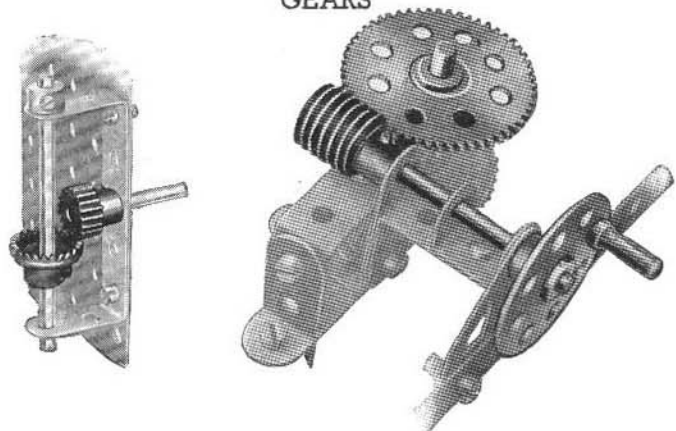

The Meccano system includes a wide range of Gear Wheels, Bevel Gears, Pinion Wheels, Contrate Wheels and Worms in various sizes. All manner of interesting movements can be obtained by the use of these gears.

How a drive can be transmitted from a vertical to a horizontal shaft or vice versa, is shown on the left. On the right the Worm engaged with a Gear Wheel, gives a very great reduction in shaft speed.

BELT AND CHAIN DRIVES

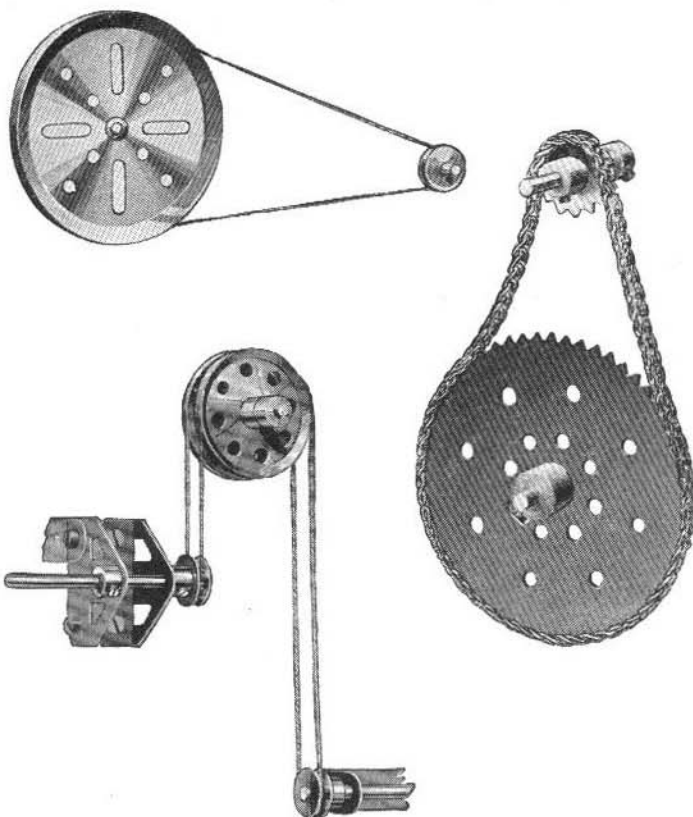

Above we show examples of belt and chain drive. The movements illustrated require no explanation excepting, perhaps, the lower belt drive, which shows a simple method for transmitting the drive from one shaft to another when the shafts are not in line.

Cords usually take the place of belts in Meccano models but miniature belting can be made from strips of canvas, indiarubber, etc., in which case Flanged Wheels should be used instead of grooved Pulleys.

EPICYCLIC TRANSMISSION GEAR

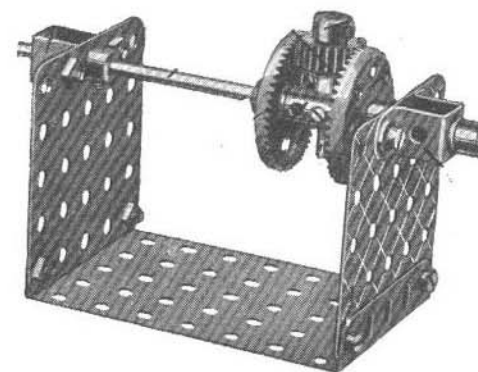

Practically every type of mechanical power transmission gear can be reproduced with Meccano.

The device illustrated is designed to provide a gear ratio between two shafts mounted in direct line with one another. Its chief merit lies in the compactness of its construction and lack of external bearings.

STEERING GEARS

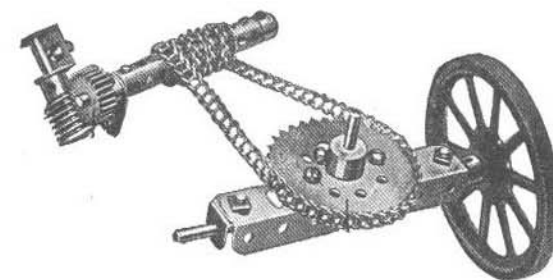

The various types of steering mechanism commonly in use on vehicles of all descriptions can readily be reproduced with Meccano.

In the example illustrated, the road wheels are controlled by an endless Sprocket Chain operated by a Worm and Pinion mechanism,

MECCANO PARTS

120. Buffers
120b. Compression Springs
- 120a. Spring Buffers
121. Train Couplings
122. Miniature Loaded Sacks
123. Cone Pulleys
124. Reversed Angle Brackets, 1"
125. " " "
126. Trunnions
126a. Flat Trunnions
127. Simple Bell Cranks
128. Boss Bell Cranks
129. Rack Segments, 3" diam.
130. Eccentrics, Triple Throw
131. Dredger Buckets
132. Flywheels, 2 1/2" diam.
133. Corner Brackets, 1 1/2"
133a. " " "
134. Crank Shafts, 1" stroke
135. Theodolite Protractors
136. Handrail Supports
136a. Handrail Couplings
137. Wheel Flanges

138. Ships' Funnels
138a-z. " " Raked
139. Flanged Brackets (right)
139a. " " (left)
140. Universal Couplings
141. Wire Lines (for clock weights)
142. Rubber Rings (to fit 3" diam. rims)
142a. Motor Tyres (to fit 2" diam. rims)
142b. " " " 3" " "
142c. " " " 1" " "
142d. " " " 1 1/2" " "
143. Circular Girders, 5 1/2" diam.
144. Dog Clutches
145. Circular Strips, 7 1/2" diam. overall
146. " Plates, 6" " "
146a. " " 4" " "
147. Pawls, with Pivot Bolt and Nuts
147a. Pawls
147b. Pivot Bolts with 2 Nuts
147c. Pawls without boss
148. Ratchet Wheels
149. Collecting Shoes for Electric Locomotives
150. Crane Grabs

151. Pulley Blocks, Single Sheave
152. " " Two " "
153. " " Three " "
154. Corner Angle Brackets, 1/2" (right-hand)
154b. Corner Angle Brackets, 1/2" (left-hand)
155. Rubber Rings (for 1" Pulleys) Black
155a. " " " White
156. Pointers (with boss), 2 1/2" overall
157. Fans, 2" diam.
158a. Signal Arms, Home
158b. " " Distant
160. Channel Bearings, 1 1/2" x 1" x 1/2"
161. Girder Brackets, 2" x 1" x 1/2"
162. Boilers, complete, with ends
162a. " Ends
162b. " without ends
163. Sleeve Pieces
164. Chimney Adaptors
165. Swivel Bearings
166. End " "
167. Geared Roller Bearings
167a. Roller Races, geared, 192 teeth
167b. Ring Frames for Rollers
167c. Pinions for Roller Bearings (16 teeth)

168. Ball Bearings, 4" diam.
168a. " Races, flanged discs
168b. " " toothed " "
168c. " Casings, complete with balls
169. Digger Buckets
170. Eccentrics, 1/2" throw
171. Socket Couplings
172. Pendulum Connections
173. Rail Adaptors
174. Grease Cups
175. Flexible Coupling Units
176. Anchoring Springs for Cord
177. Shafting Standards, Large
178. " " Small
179. Rod Sockets
180. Toothed Gear Rings, 3 1/2" diam.
181. Bobbins
182. Insulating Bushes
182a. Insulating Washers
183. Lamp Holders
183a. 2 1/2-volt Lamps
183b. 3 1/2 " " "
184. 6-volt Lamps
184c. 10 " " "
184d. 20 " " "

185. Steering Wheels, 1 1/2" diam.
186. Driving Bands, 2 1/2" (Light)
186a. " " 6" " "
186b. " " 10" " "
186c. " " 10" (Heavy) " "
186d. " " 15" " "
186e. " " 20" " "
187. Road Wheels
192. Flexible Plates.
192a. 4 1/2" x 2 1/2"
192b. 5 1/2" x 2 1/2"
192c. Strip Plates, 2 1/2" x 2 1/2"
192d. 9 1/2" x 2 1/2"
192e. 12 1/2" x 2 1/2"
198. Hinged Flat Plates, 4 1/2" x 2 1/2"
199. Curved Plates, U-Section 2 1/2" x 2 1/2" x 1/4" radius
200. " " 2 1/2" x 2 1/2", 1 1/4" radius
201. Lamps with Flex (3 1/2 volts)
202. Angle Brackets (for Headlamps)
203. Headlamps
203a. Headlamp Rims
203b. " Bodies
204. " Nuts
205. " Glasses
206. Lampshades
207. Lamp Bases
207a. Lamp with Standard and Flex
208. Battery Tags and Studs
208a. Washers for Battery Studs
210. Nuts for Battery Studs
- 211a. Helical Gear 1/2" { Can only be used together
211b. " " 1 1/2" }
212. Rod and Strip Connectors
213. Rod Connectors
215. Semi-Circular Plates 2 1/2"
215a. Formed Slotted Strips 3"
- 217a. Discs, 1 1/2"
217b. Discs 1 1/2"



HORNBY SCALE MODEL OF
"Princess Elizabeth"—
MIGHTY L.M.S.R. WORLD
RECORD-BREAKER

**FITTED WITH 20-VOLT
AUTO-REVERSING MOTOR**

Four hundred miles non-stop from Glasgow to London at an average of 70 m.p.h., with a 260-ton load! This remarkable feat was performed by L.M.S.R. Locomotive "Princess Elizabeth" in charge of Driver T. J. Clarke, and it set up a world record.

Think of the thrill of owning a model of such an engine; not merely a perfect reproduction in miniature, but one having the same qualities of power, speed and efficiency! This is now made possible by the latest product of Meccano Limited—the magnificent Hornby scale model locomotive "Princess Elizabeth" illustrated above, driven by a 20-volt electric motor, and fitted with the Hornby Remote Control.

Playing the great game of railways with any of the world-famous Hornby Trains is fine fun. The performance and durability of the Hornby Electric Trains place them in a class entirely their own, while Hornby Clockwork Trains are the longest-running spring-driven locomotives in the world.

Ask your dealer for the latest complete catalogue of Hornby Trains, Rolling Stock and Accessories.

MANUFACTURED BY MECCANO LTD., LIVERPOOL.

*Driver Clarke
says
"It's fine!"*

HORNBY TRAINS