

# MECCANO

INSTRUCTIONS FOR  
No. 2 OUTFIT

No.  
46.2

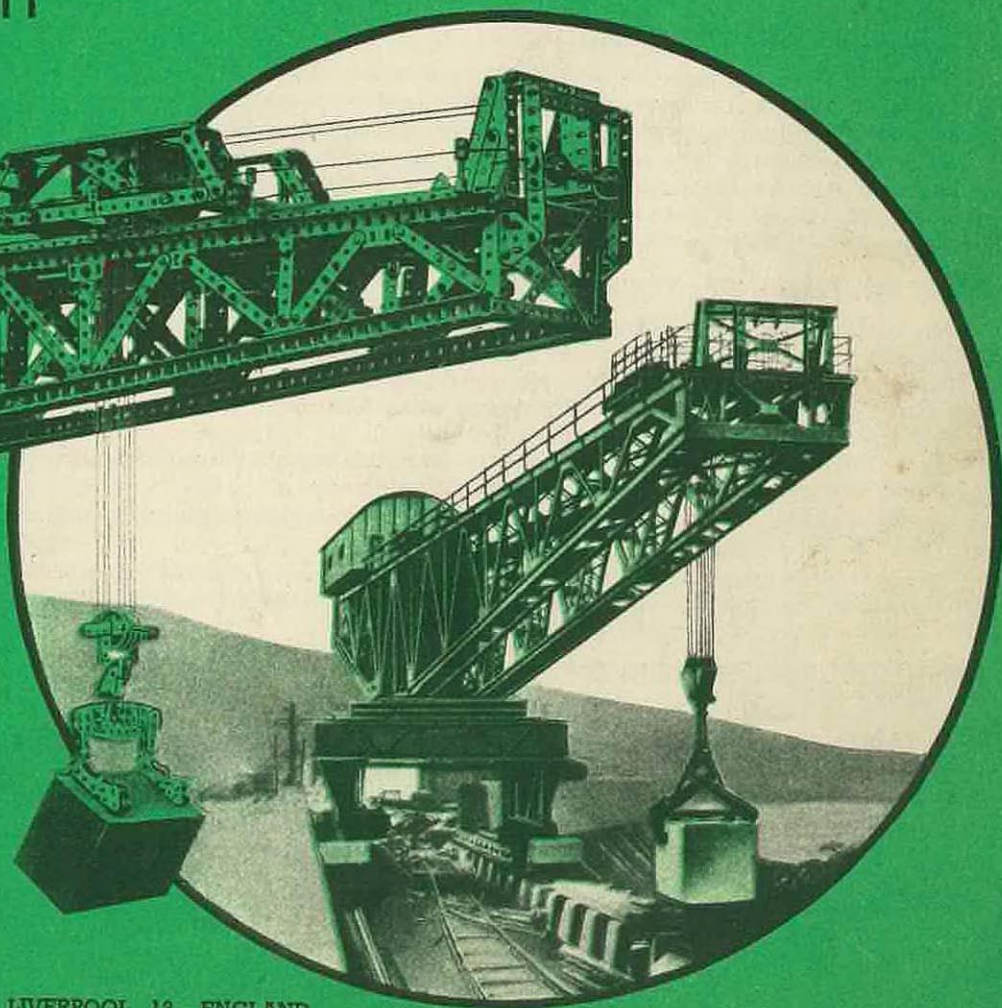

COPYRIGHT BY MECCANO LIMITED, BINNS ROAD, LIVERPOOL 13, ENGLAND

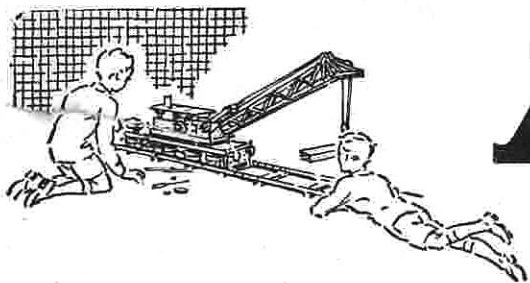

# MECCANO

*Real Engineering in Miniature*

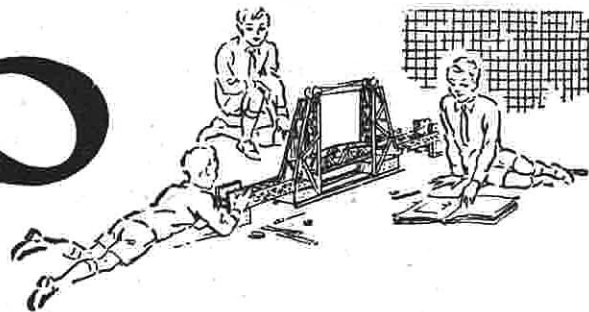

## MODEL-BUILDING WITH MECCANO

There is no limit to the number of models that can be built with Meccano—Cranes, Clocks, Motor Cars, Aeroplanes, Machine Tools, Locomotives—in fact everything that interests boys. A screwdriver and a spanner, both of which are provided in each Outfit, are the only tools necessary.

When you have built all the models illustrated in the Manuals of Instruction the fun is not over, but is just beginning. Now comes the chance to make use of your own ideas. First of all, re-build some of the models with small changes in construction that may occur to you; then try building models entirely of your own design. In doing this you will feel the real thrill of the engineer and the inventor.

## HOW TO BUILD UP YOUR OUTFIT

Meccano is sold in 11 different Outfits, ranging from No. 0 to No. 10. Each Outfit from No. 1 upwards can be converted into the one next larger by the purchase of an Accessory Outfit. Thus Meccano No. 1 Outfit can be converted into No. 2 Outfit by adding to it a No. 1a Accessory Outfit. No. 2a Outfit would then convert it into a No. 3, and so on. In this way, no matter with which Outfit you begin, you can build it up by degrees until you have a No. 10 Outfit.

All Meccano parts are of the same high quality and finish, but the larger Outfits contain a greater quantity and variety, making possible the construction of more elaborate models.

**Special Note.**—The Meccano Plates (Flanged, Flat, Curved, etc.) are shown in the Manuals with diagonal white lines. In the new Meccano Outfits these parts are plain.

Several of the illustrations in this Manual show how miniature figures and various small articles can be introduced to add realism to the models. These are not included in the Outfit. Many of them are Meccano Dinky Toys that can be bought separately from your Meccano dealer.

## THE "MECCANO MAGAZINE"

The "Meccano Magazine" is published specially for Meccano boys. Every month it describes and illustrates new Meccano models for Outfits of all sizes, and deals with suggestions from readers for new Meccano parts and for new methods of using the existing parts.

There are model-building competitions specially

planned to give an equal chance to the owners of small and large Outfits. In addition, there are splendid articles on such subjects as Railways, Famous Engineers and Inventors, Electricity, Chemistry, Bridges, Cranes and Aeroplanes, and special sections dealing with the latest Engineering, Aviation and Shipping News. Other pages deal with Stamp Collecting, and Books of interest to boys; and a feature of outstanding popularity is the section devoted to short articles from readers.

If you are not already a reader write to the Editor for full particulars, or order a copy from your Meccano dealer, or from any newsagent.

## THE MECCANO GUILD

Every owner of a Meccano Outfit should join the Meccano Guild. This is a world-wide organisation, started at the request of Meccano boys. Its primary object is to bring boys together and to make them feel that they are all members of a great brotherhood, each trying to help others to get the very best out of life. Its members are in constant touch with Headquarters, giving news of their activities and being guided in their hobbies and interests. Write for full particulars and an application form to the Secretary, Meccano Guild, Binns Road, Liverpool 13.

Clubs founded and established under the guidance of the Guild Secretary provide Meccano boys with opportunities of enjoying to the utmost the fun of model-building. Each has its Leader, Secretary, Treasurer and other officials. With the exception of the Leader, all the officials are boys, and as far as possible the proceedings of the clubs are conducted by boys.

## MECCANO SERVICE

The service of Meccano does not end with selling an Outfit and an Instruction Manual. If ever you are in any difficulty with your models, or if you want advice on anything connected with this great hobby, write to us. We receive hundreds of interesting letters from boys in all parts of the world, and each of these is answered personally by one of our staff of experienced experts.

Whatever your problem may be, write to us about it. Do not hesitate. We shall be delighted to help you in any way possible.



THE FINEST HOBBY IN THE WORLD FOR BOYS

## HOW TO BEGIN THE FUN

### THE MOST FASCINATING OF ALL HOBBIES

Meccano model-building is the most fascinating of all hobbies, because it never becomes dull. There is always something new to be done. First of all there is the fun of building a new model, and watching it take shape as part after part is added. Then, when the model is complete, comes the thrill of setting it to work just like the real structure it represents, by means of a Meccano Motor. This wonderful process can be repeated indefinitely, for there is no end to the number of Meccano models that can be built. Another point is that models built with Meccano are real engineering structures in miniature, and the keen model-builder has wonderful opportunities for learning the working of machines and mechanisms of all kinds. So he acquires practical engineering knowledge without special study.

It is so simple to build Meccano models that operations can be started as soon as the first Outfit is opened. Different boys build in different ways, but in the end they all reach the same splendid results. The following hints are given with the object of showing boys who are just starting the wonderful Meccano hobby how to get the greatest possible fun.

### A FEW USEFUL HINTS

It will be noticed that with each model shown in this Manual of Instructions is given a list of the parts required to build it. For the first few models it is a good plan to lay out on the table all the parts required for the one it is proposed to build, and put the remainder of the Outfit on one side. To help you to pick out the correct parts for your model a complete list of Meccano parts is given at the back of this Manual, and all the principal parts are illustrated. In the list the parts are all numbered, and in most cases, their measurements are given. There is no need, however, to measure the parts to find out which is which, as the size is easily found from the number of holes. All Meccano holes are spaced  $\frac{1}{2}$ " apart, so that by counting two holes to the inch the size of a part can be found at once. For instance, Part No. 2 is listed as a  $5\frac{1}{2}$ " Perforated Strip, so you look in your Outfit for a Strip with eleven holes. Similarly No. 192 is a  $5\frac{1}{2}$ "  $\times$   $2\frac{1}{2}$ " Flexible Plate, so you look for a Flexible Plate eleven holes in length and five holes in width. By the time a few models have been built the names of the parts will have become familiar.

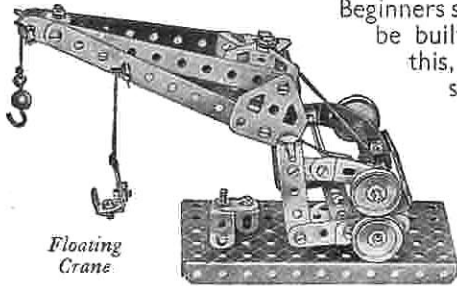

*Floating  
Crane*

Beginners sometimes wonder which section of a model should be built first. There cannot be any definite rule for this, as it depends on the design of the model. In stationary models the base usually should be built first. In most of the smaller models a  $5\frac{1}{2}$ "  $\times$   $2\frac{1}{2}$ " Flanged Plate forms an important part of the structure, and often the best plan is to start building by bolting parts to this Plate. For other models a good general rule is that the sections that form supports for a number of other parts should be built first.

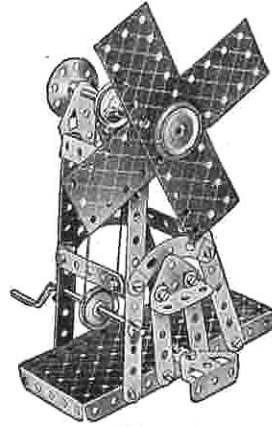

*Windmill*

### THE IMPORTANCE OF "LOCK-NUTTING"

In building models in which Rods revolve in the holes of other parts it is important to make sure that such holes are exactly in line with one another. This can be done very easily by pushing through the holes a Drift, Part No. 36c, before the Bolts holding the various parts are tightened up.

In some models it is necessary to join certain parts together so that, although they cannot come apart, they are free to pivot or move in relation to one another. To do this the parts are bolted together as usual but the nut is not screwed up tightly, so that the parts are not gripped. Then, to prevent the nut from unscrewing, a second nut is screwed up tightly against it, the first nut being held with a spanner. This method of using a second nut is known as lock-nutting.

During the construction of a model it is best to screw up the nuts with the fingers, followed by just a light turn with the screwdriver, leaving the final tightening with spanner and screwdriver until all the parts are connected up.

### MOTORS AND GEARING

Models can be operated by means of either clockwork or electric motors.

Clockwork motors have the advantage of being self-contained and extremely simple, if only a small amount of power is needed, the model may be driven direct from the driving spindle of the motor or through a belt running over two pulleys of the same size, giving what is described as a 1:1 (one-to-one) ratio. Greater power can be obtained by a reduction in the speed of the drive, which can be produced in a simple manner by connecting a small pulley on the motor to a larger pulley by means of a belt. Thus if a 1" Pulley is made to drive a 3" Pulley, a reduction ratio of approximately 1:3 is obtained. This means that the driven shaft will take about three times the load that the driving shaft would handle, but will rotate at only one-third of the speed. Rubber bands are better than Cord for driving belts for most purposes.

Electric motors have the advantage of giving long continuous runs. Their speed is much higher than that of clockwork motors, and this makes it possible to employ higher reduction ratios and thus obtain greater power.

With the larger Outfits, belt drive can be replaced with advantage by gearing. To operate a slow moving model demanding great power, such as a traction engine, gears that will provide a considerable reduction must be used. For example, a Worm meshed with a  $\frac{1}{2}$ " Pinion will give 1:19 reduction; while a Worm meshed with a 57-teeth Gear will give a 1:57 reduction.

Certain Meccano Clockwork and Electric Motors will be available during 1946. Ask your dealer for particulars.

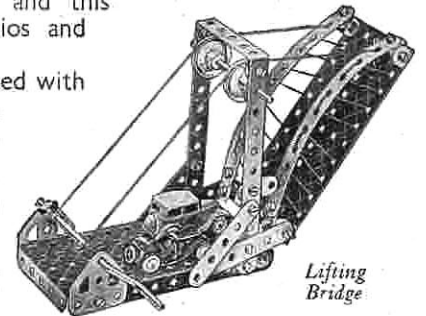

*Lifting  
Bridge*

## 1.1 PORTER'S TRUCK

The bearings for the axle are Flat Trunnions fastened on the insides of the Flexible Plates, and the axle is a 3/4" Rod that carries two 1" Pulleys fitted with Rubber Rings.

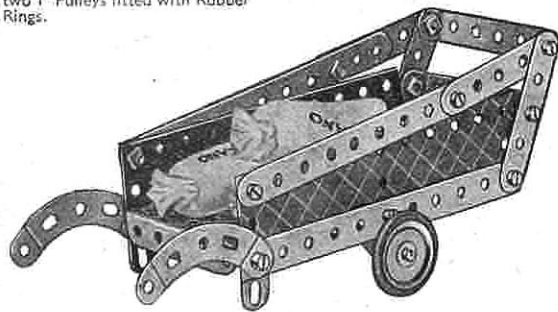

## Parts required

4 of No. 2
4 " " 5
2 " " 10
1 " " 16
2 " " 22
14 " " 37
2 " " 38
2 " " 48a
1 " " 52
2 " " 90a
2 " " 126a
2 " " 155
2 " " 189

## 1.2 BATTLESHIP

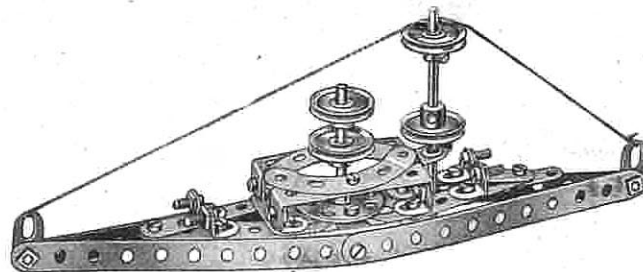

## Parts required

4 of No. 2	1 of No. 17	4 of No. 37a	4 of No. 111c
4 " " 5	4 " " 22	2 " " 38	1 " " 125
4 " " 10	1 " " 24	1 " " 40	2 " " 126
8 " " 12	3 " " 35	2 " " 48a	2 " " 126a
1 " " 16	24 " " 37	2 " " 90a	

## 1.3 WINDMILL

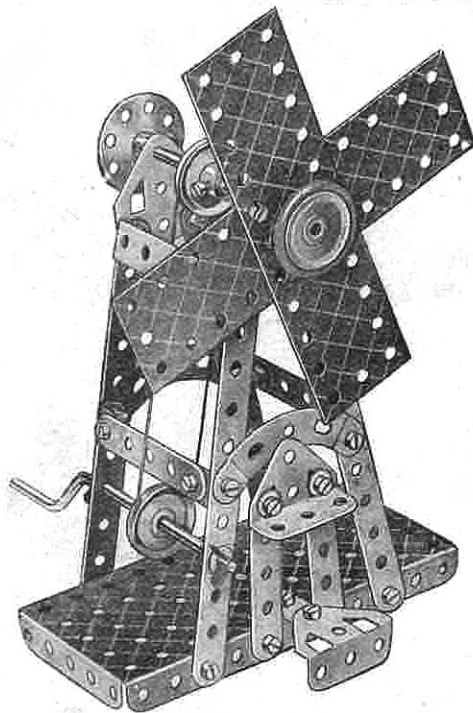

## Parts required

4 of No. 2
4 " " 5
1 " " 10
4 " " 12
1 " " 16
1 " " 19s
4 " " 22
1 " " 24
3 " " 35
24 " " 37
4 " " 38
1 " " 40
2 " " 48a
1 " " 52
2 " " 90a
2 " " 126
2 " " 126a
1 " " 155
2 " " 189

The sails are gripped on the 3/4" Rod by the 1" Pulley (with Rubber Ring) at the front and another 1" Pulley at the back of the sails. The Pulleys are pressed against the faces of the sails and locked on the Rod.

## 1.4 SCALES

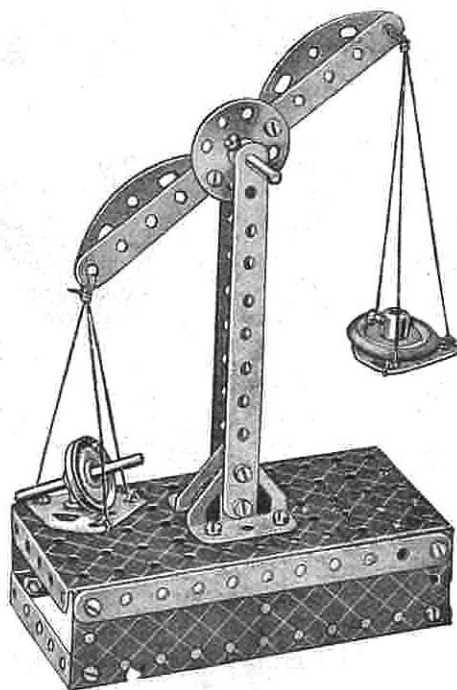

## Parts required

4 of No. 2
2 " " 5
2 " " 17
2 " " 22
1 " " 24
19 " " 37
1 " " 38
1 " " 40
2 " " 48a
1 " " 52
2 " " 90a
1 " " 111c
2 " " 126
2 " " 126a
1 " " 155
2 " " 189

## 1.5 GYMNAST

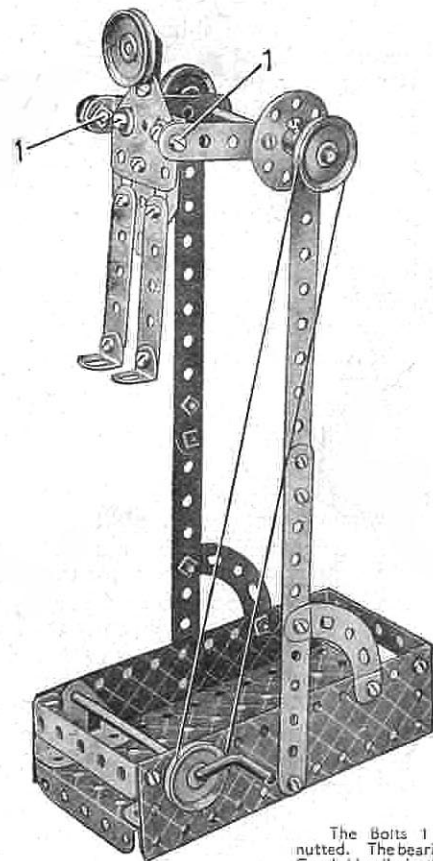

The Bolts 1 are lock-nutted. The bearings for the Crank Handle in the Flexible Plates are reinforced by Trunnions bolted to the Flanged Plate.

## Parts required

4 of No. 2	1 of No. 24	1 of No. 52
4 " " 5	2 " " 35	2 " " 90a
1 " " 10	24 " " 37	4 " " 111c
4 " " 12	5 " " 37a	2 " " 126
1 " " 16	4 " " 38	2 " " 126a
1 " " 19s	1 " " 40	2 " " 189
4 " " 22	2 " " 48a	

### 1.6 LETTER BALANCE

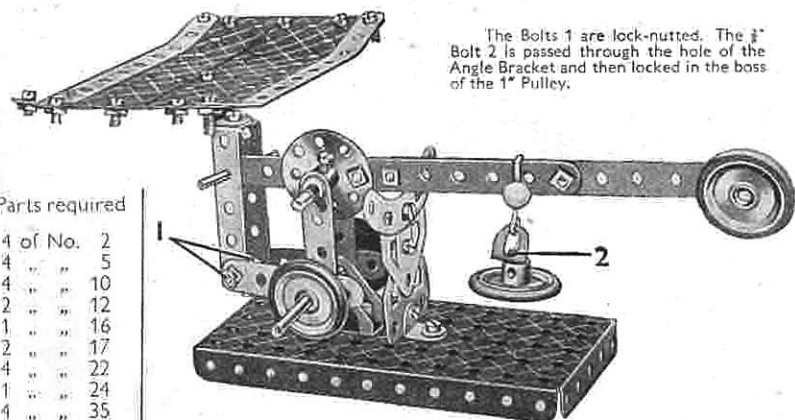

The Bolts 1 are lock-nutted. The 3" Bolt 2 is passed through the hole of the Angle Bracket and then locked in the boss of the 1" Pulley.

Parts required

4 of No. 2	1 of No. 52	4 of No. 111c	2 of No. 126a
4 " " 5	1 " " 57c	1 " " 125	4 " " 155
4 " " 10	1 " " 90a	2 " " 125	2 " " 189
2 " " 12			
1 " " 16			
2 " " 17			
4 " " 22			
1 " " 24			
4 " " 35			
28 " " 37			
24 " " 37a			
4 " " 38			
2 " " 48a			

### 1.7 TABLE

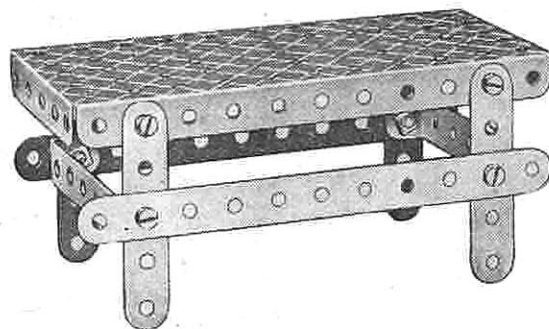

Parts required

2 of No. 2	8 of No. 37	1 of No. 52
4 " " 5	2 " " 48a	

### 1.8 BUFFER STOPS

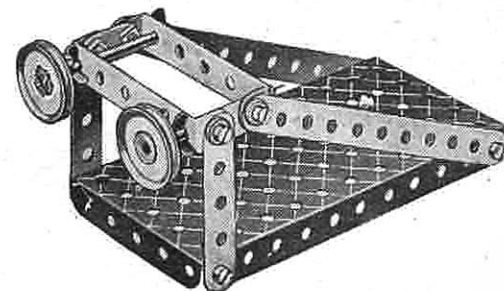

Parts required

2 of No. 2	2 of No. 17	8 of No. 37
2 " " 5	2 " " 22	4 " " 38
2 " " 10	4 " " 35	2 " " 48a
		1 " " 52

### 1.9 AEROPLANE

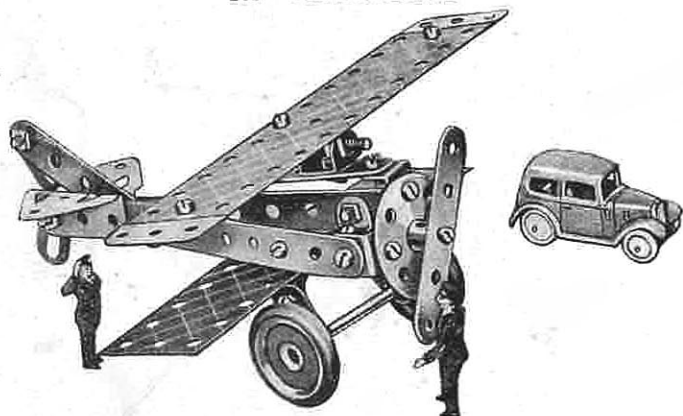

Parts required

2 of No. 2	1 of No. 17	2 of No. 37a	2 of No. 126
3 " " 5	2 " " 22	1 " " 38	2 " " 126a
4 " " 10	1 " " 24	3 " " 111c	2 " " 155
8 " " 12	17 " " 37	1 " " 125	2 " " 189

### 1.10 "KIDDIE KAR"

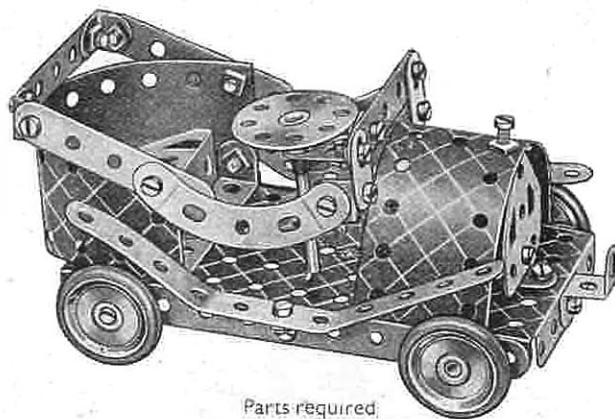

Parts required

4 of No. 2	1 of No. 17	3 of No. 37a	1 of No. 125
4 " " 5	4 " " 22	2 " " 48a	2 " " 126
3 " " 10	1 " " 24	1 " " 52	1 " " 126a
7 " " 12	1 " " 35	2 " " 90a	4 " " 155
2 " " 16	24 " " 37	2 " " 111c	2 " " 189

Two Trunnions overlapped one hole, and fastened to the Flanged Plate by an Angle Bracket, form the seat.

### 1.11 WATCH STAND

Parts required

4 of No. 2
2 " " 12
17 " " 37
1 " " 38
1 " " 52
1 " " 57c
2 " " 90a
2 " " 126a

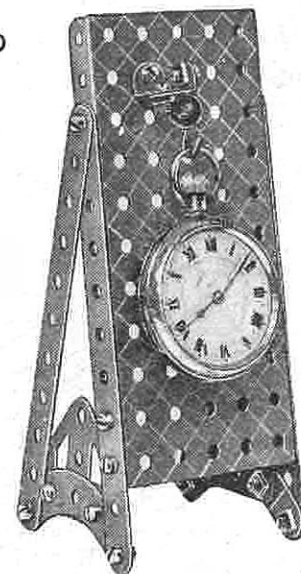

## 1.12 BAGGAGE TRUCK

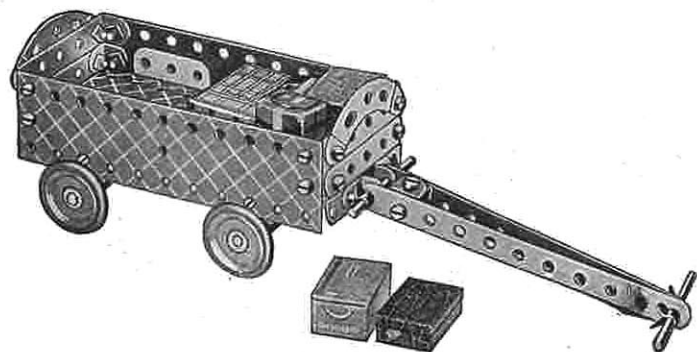

## Parts required

2 of No. 2	4 of No. 35	2 of No. 90a
2 " " 5	24 " " 37	1 " " 111c
8 " " 12	1 " " 37a	2 " " 126
2 " " 16	2 " " 38	2 " " 126a
2 " " 17	2 " " 48a	4 " " 155
4 " " 22	1 " " 52	2 " " 189

## 1.13 RACING SEAPLANE

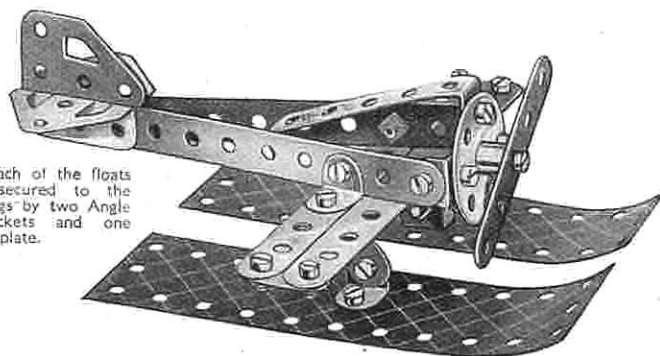

Each of the floats is secured to the wings by two Angle Brackets and one Fishplate.

## Parts required

3 of No. 2	1 of No. 24	2 of No. 111c
3 " " 5	19 " " 37	2 " " 126
4 " " 10	1 " " 37a	1 " " 126a
8 " " 12	1 " " 48a	2 " " 189

## 1.14 CHILD'S PRAM

Flat Trunnions bolted between the Flexible Plates and the Flanged Plate provide bearings for the rear axle. Angle Brackets bolted under the Flanged Plate form the bearings for the front axle. The body of the "baby" consists of two Trunnions, and its arms and legs are Fishplates. Its head is fixed in place by a Reversed Angle Bracket.

## Parts required

4 of No. 2	2 of No. 111c
4 " " 5	1 " " 125
4 " " 10	2 " " 126
4 " " 12	2 " " 126a
2 " " 16	4 " " 155
4 " " 22	2 " " 189
1 " " 24	
24 " " 37	
22 " " 37a	
4 " " 38	
2 " " 48a	
1 " " 52	
2 " " 90a	

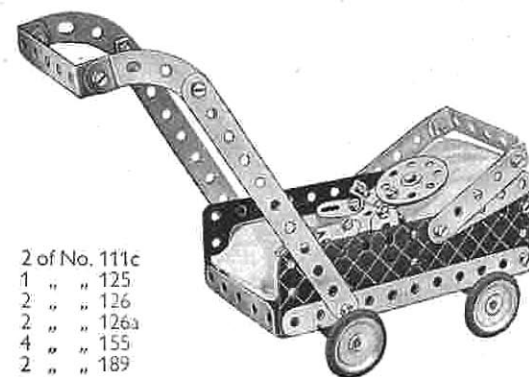

## 1.15 BAND SAW

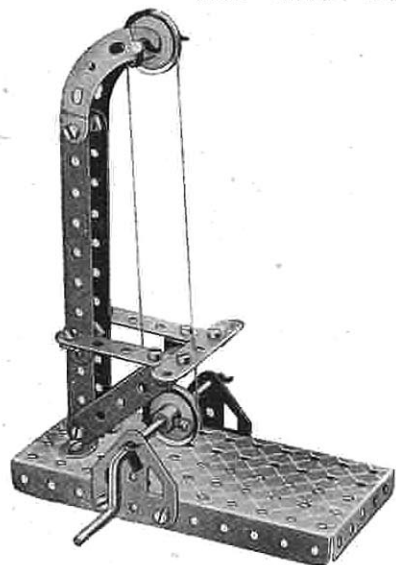

## Parts required

2 of No. 2
4 " " 5
6 " " 12
1 " " 17
1 " " 19s
2 " " 22
4 " " 35
19 " " 37
1 " " 40
1 " " 52
2 " " 90a
2 " " 126a

## 1.16 CIRCULAR SAW

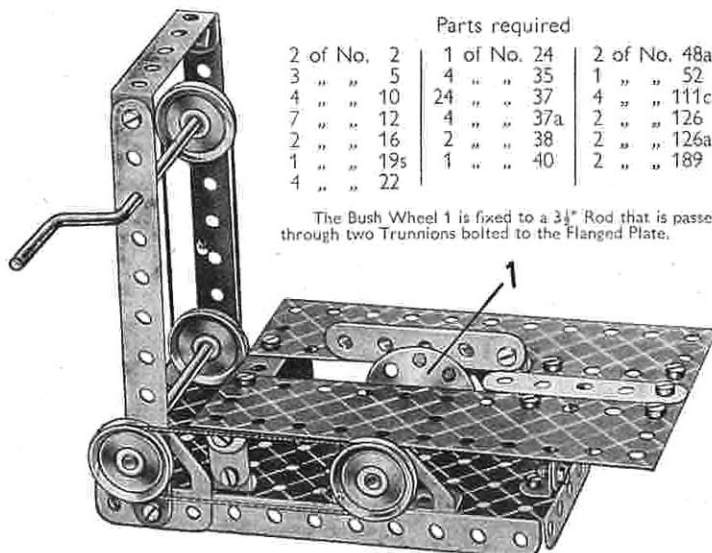

## Parts required

2 of No. 2	1 of No. 24	2 of No. 48a
3 " " 5	4 " " 35	1 " " 52
4 " " 10	24 " " 37	4 " " 111c
7 " " 12	4 " " 37a	2 " " 126
2 " " 16	2 " " 38	2 " " 126a
1 " " 19s	1 " " 40	2 " " 189
4 " " 22		

The Bush Wheel 1 is fixed to a  $3\frac{1}{4}$ " Rod that is passed through two Trunnions bolted to the Flanged Plate.

## 1.17 DRILL

## Parts required

4 of No. 2
3 " " 5
8 " " 12
1 " " 16
1 " " 17
1 " " 19s
4 " " 22
4 " " 35
20 " " 37
4 " " 38
1 " " 40
1 " " 52
2 " " 126
2 " " 126a

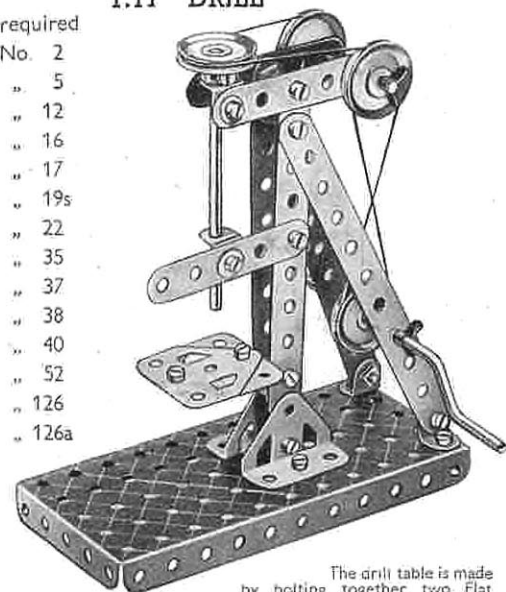

The drill table is made by bolting together two Flat Trunnions.

### 1.18 TRIP HAMMER

Parts required

4 of No. 2	17 of No. 37
3 " " 5	1 " " 48a
2 " " 12	1 " " 52
1 " " 17	2 " " 111c
1 " " 19s	1 " " 125
4 " " 22	2 " " 126
1 " " 24	2 " " 126a
4 " " 35	1 " " 155
	1 " " 189

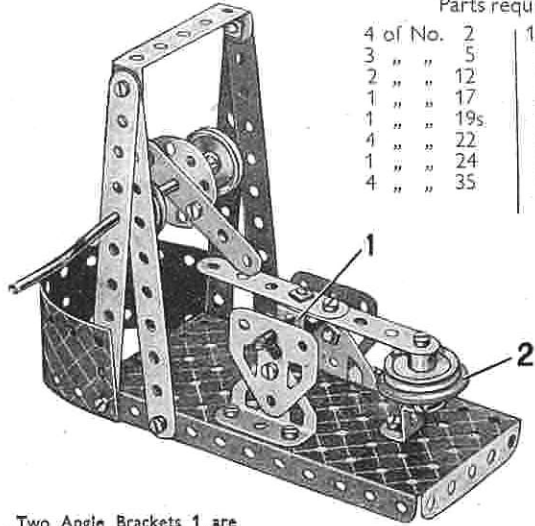

Two Angle Brackets 1 are bolted together through their holes and also are bolted to two 2 1/2" Strips to form a double bracket. The 1" fast Pulley 2 is fitted with a 1" Rubber Ring.

### 1.19 STEAM LAUNCH

The top of the deck-house consists of three 2 1/2" Strips bolted first to Fish-plates and then to a Trunnion. The rear side is held in place by an Angle Bracket. The other side consists of a 2 1/2" x 1/2" Double Angle Strip bolted to the Trunnion.

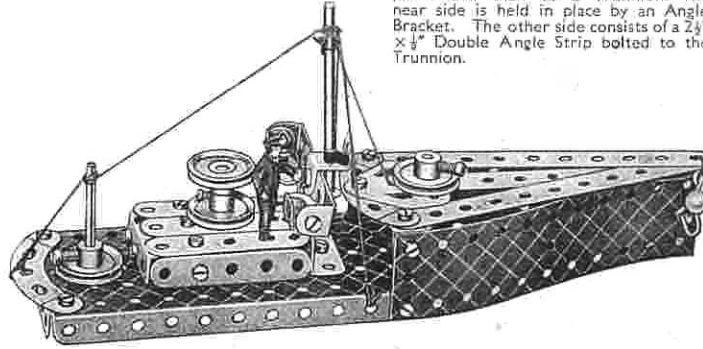

Parts required

3 of No. 2	4 of No. 22	1 of No. 52	2 of No. 126a
4 " " 5	4 " " 35	1 " " 57c	2 " " 189
3 " " 10	23 " " 37	2 " " 90a	
8 " " 12	4 " " 38	2 " " 111c	
1 " " 16	1 " " 40	2 " " 125	
2 " " 17	2 " " 48a	2 " " 126	

### 1.20 COASTER

The Bolts 1 are lock-nutted. The rear axle Rod is pushed through the end hole of the Curved Strip 2.

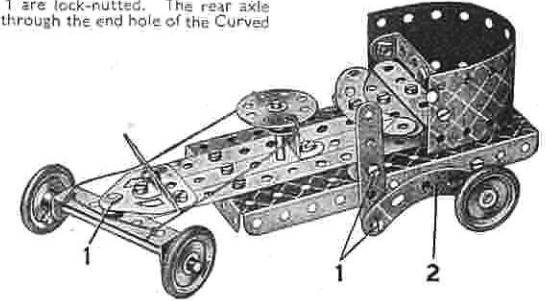

Parts required

3 of No. 2	1 of No. 35	2 of No. 90a
4 " " 5	20 " " 37	2 " " 111c
5 " " 12	4 " " 37a	1 " " 125
2 " " 16	4 " " 38	2 " " 126
1 " " 17	1 " " 40	2 " " 126a
4 " " 22	2 " " 48a	4 " " 155
1 " " 24	1 " " 52	1 " " 189

### 1.21 LIFTING BRIDGE

The Bolts 1, on which the bridge span pivots, are lock-nutted.

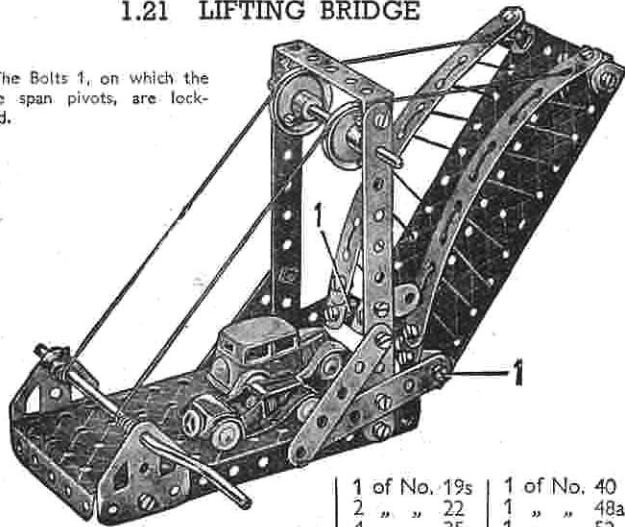

Parts required	3 of No. 10	1 of No. 19s	1 of No. 40
4 of No. 2	8 " " 12	2 " " 22	1 " " 48a
4 " " 5	2 " " 16	4 " " 35	1 " " 52
		24 " " 37	3 " " 111c
		5 " " 37a	2 " " 126a
		4 " " 38	2 " " 189

### 1.22 HAND TRUCK

Parts required

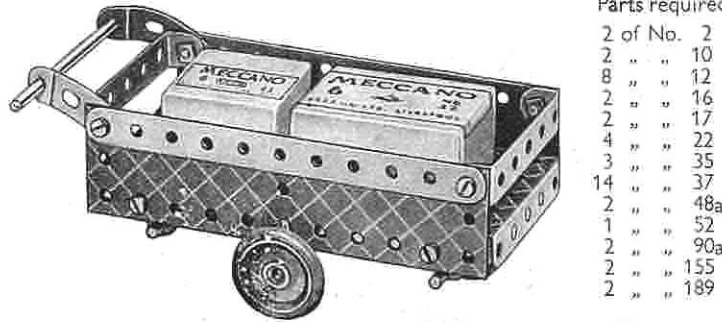

2 of No. 2
2 " " 10
8 " " 12
2 " " 16
2 " " 17
4 " " 22
3 " " 35
14 " " 37
2 " " 48a
1 " " 52
2 " " 90a
2 " " 155
2 " " 189

The bearings for the 3/8" Rod are Fishplates, and the front and rear axle bearings are reversed angle brackets built up from Angle Brackets. The right-hand 1" Pulley on the 3/8" Rod is loose on the Rod, but is retained in place by a Spring Clip. The front and rear 1" Pulleys are fixed on their respective 2" Rods.

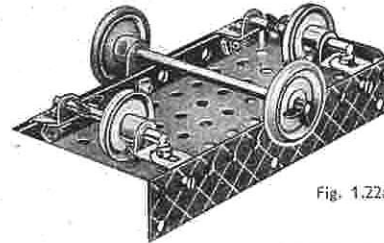
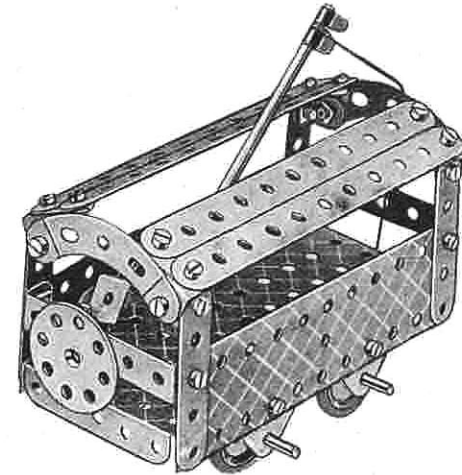

Fig. 1.22a

### 1.23 TROLLEY BUS

Parts required



4 of No. 2
4 " " 5
4 " " 10
8 " " 12
2 " " 16
1 " " 19s
4 " " 22
1 " " 24
4 " " 35
24 " " 37
1 " " 37a
4 " " 38
1 " " 40
2 " " 48a
1 " " 52
2 " " 90a
2 " " 111c
1 " " 125
2 " " 126
2 " " 126a
4 " " 155
2 " " 189

The Reversed Angle Bracket that holds the trolley is fixed in position by a Bolt passed through the slot in the Bracket, then through two Washers, and into the boss of the Bush Wheel.

## 1.24 HAY CART

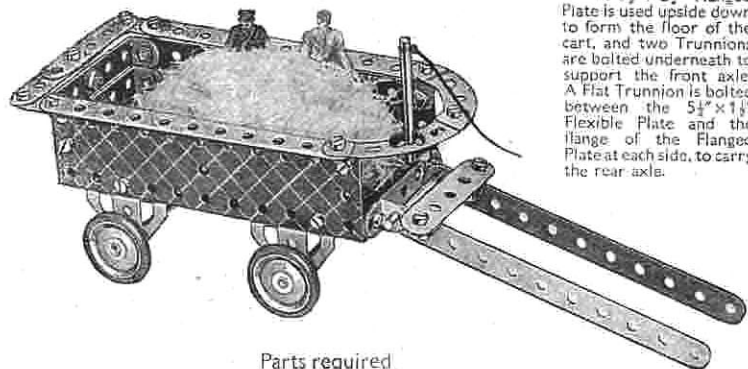

A  $5\frac{1}{2}'' \times 2\frac{1}{2}''$  Flanged Plate is used upside down to form the floor of the cart, and two Trunnions are bolted underneath to support the front axle. A Flat Trunnion is bolted between the  $5\frac{1}{2}'' \times 1\frac{1}{2}''$  Flexible Plate and the flange of the Flanged Plate at each side, to carry the rear axle.

## Parts required

4 of No. 2	2 of No. 17	1 of No. 40	
3 " " 5	4 " " 22	2 " " 48a	2 of No. 126
2 " " 10	4 " " 35	1 " " 52	2 " " 126a
7 " " 12	24 " " 37	2 " " 90a	4 " " 155
2 " " 16	1 " " 37a	1 " " 111c	2 " " 189

## 1.25 MOTOR LORRY

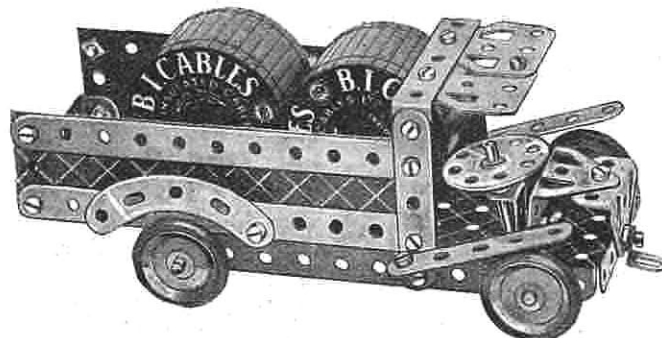

The  $2\frac{1}{2}''$  Curved Strips representing the rear mudguards are each fastened to the sides by a  $\frac{3}{4}''$  Bolt and nut, with a Spring Clip between the mudguards and the  $5\frac{1}{2}''$  Strip to form a distance piece.

## Parts required

4 of No. 2	1 of No. 17	19 of No. 37	2 of No. 90a	2 of No. 126a
4 " " 5	4 " " 22	4 " " 37a	3 " " 111c	4 " " 155
3 " " 12	1 " " 24	2 " " 48a	1 " " 125	2 " " 189
2 " " 16	2 " " 35	1 " " 52	2 " " 126	

## 1.27 STAMPING MILL

The anvil 1 is made up of two Trunnions bolted together. When the Crank Handle is rotated, the Fishplates bolted to the Bush Wheel strike the centre  $1''$  Pulley on the hammer shaft and cause it to rise and fall.

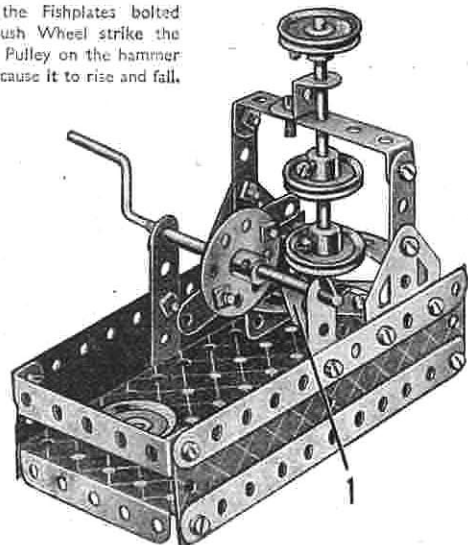

## Parts required

4 of No. 2
4 " " 5
4 " " 10
5 " " 12
1 " " 16
1 " " 19s
4 " " 22
1 " " 24
2 " " 35
24 " " 37
3 " " 37a
2 " " 48a
1 " " 52
1 " " 90a
4 " " 111c
1 " " 125
2 " " 126
2 " " 126a
2 " " 189

## 1.28 FLYING BOATS

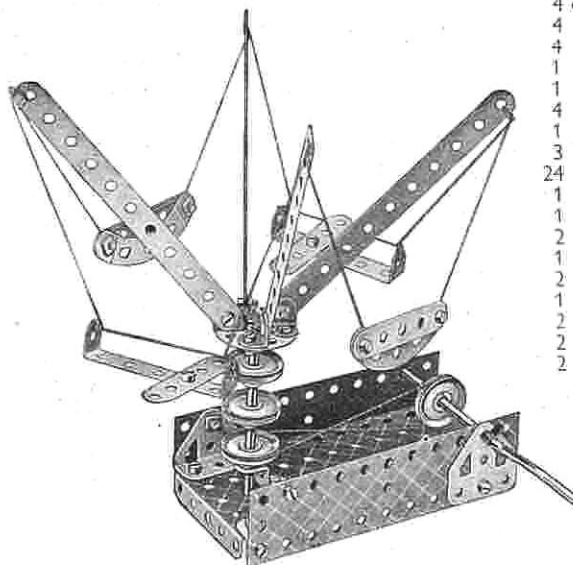

## Parts required

4 of No. 2
4 " " 5
4 " " 12
1 " " 16
1 " " 19s
4 " " 22
1 " " 24
3 " " 35
24 " " 37
1 " " 38
1 " " 40
2 " " 48a
1 " " 52
2 " " 90a
1 " " 125
2 " " 126
2 " " 126a
2 " " 189

## 1.26 HOSPITAL TROLLEY

## Parts required

4 of No. 2
1 " " 5
2 " " 12
2 " " 16
4 " " 22
12 " " 37
1 " " 52
2 " " 90a
4 " " 155

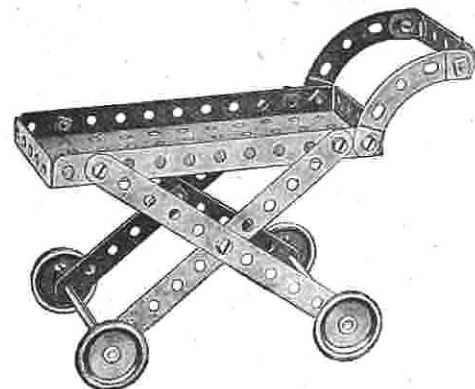

## 1.29 HAND CAR

The Bolts 1 on which the  $5\frac{1}{2}''$  Strips are pivoted, are lock-nutted. The  $2\frac{1}{2}''$  small radius Curved Strips are fixed to Angle Brackets bolted to the  $5\frac{1}{2}'' \times 2\frac{1}{2}''$  Flanged Plate.

## Parts required

2 of No. 2
2 " " 5
8 " " 12
2 " " 16
2 " " 17
4 " " 22
4 " " 35
23 " " 37
4 " " 37a
4 " " 38
2 " " 48a
1 " " 52
2 " " 90a
2 " " 111c
1 " " 125
2 " " 126
2 " " 126a
4 " " 155
2 " " 189

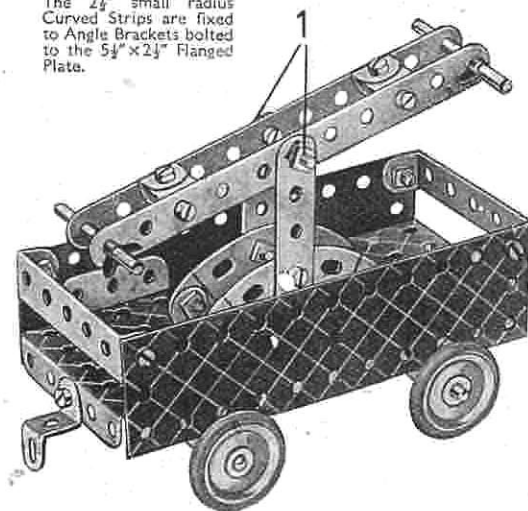



### 1.30 MONOPLANE

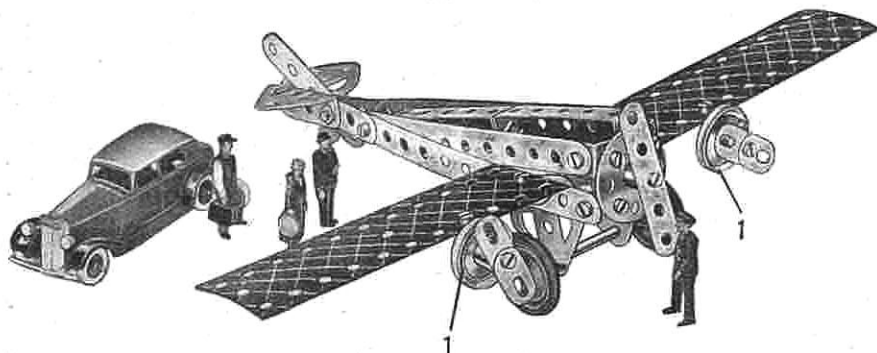

The fast Pulleys 1 are fixed to Angle Brackets fastened to the wing by  $\frac{1}{2}$ " Bolts, which are passed through the Angle Brackets, and held in the bosses of the Pulleys. The set screws of the Pulleys hold also a second Bolt on which the propellers are mounted.

#### Parts required

4 of No.	2
4 "	5
4 "	10
8 "	12
1 "	16
1 "	17
4 "	22
1 "	24
2 "	35
20 "	37
3 "	37a
2 "	48a
1 "	57c
4 "	111c
2 "	126
2 "	126a
2 "	155
2 "	189

### 1.31 FLOATING CRANE

#### Parts required

4 of No.	2	2 of No.	90a
4 "	5	3 "	111c
4 "	10	1 "	125
7 "	12	2 "	126
2 "	16	2 "	126a
2 "	17		
1 "	19s		
4 "	22		
1 "	24		
4 "	35		
1 "	37		
4 "	37a		
4 "	38		
1 "	40		
2 "	48a		
1 "	52		
1 "	57c		

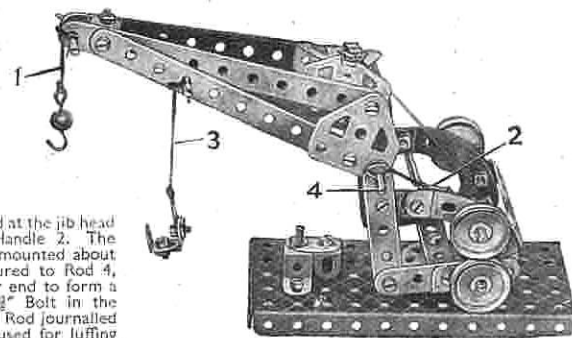

The Cord 1 passes over the Rod at the jib head and is fastened to the Crank Handle 2. The other Cord 3 passes over a Rod mounted about halfway along the jib, and is secured to Rod 4, which has a 1" Pulley at the other end to form a handle. The Cord tied to the  $\frac{1}{2}$ " Bolt in the Trunnions is taken around the  $\frac{3}{4}$ " Rod journalled above the Crank Handle, and is used for luffing the jib by turning the 1" Pulley at the rear end of the Rod. Two Angle Brackets and a Fishplate form the hook on Cord 3.

### 1.32 POWER PRESS

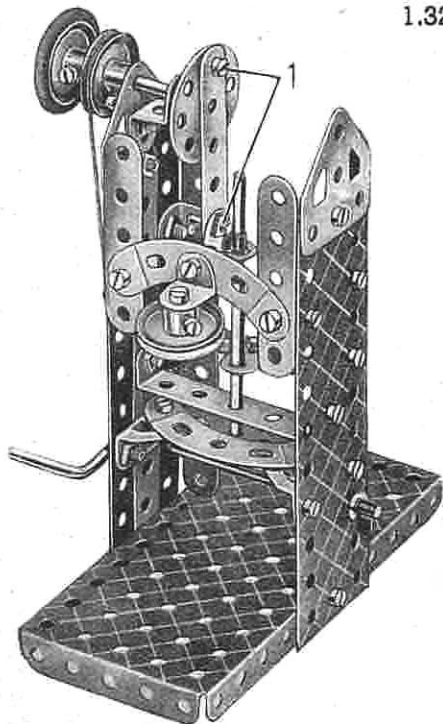

#### Parts required

4 of No.	2
4 "	5
1 "	10
6 "	12
1 "	16
1 "	17
1 "	19s
4 "	22
1 "	24
3 "	35
24 "	37
5 "	37a
1 "	38
1 "	40
2 "	48a
1 "	52
2 "	90a
4 "	111c
1 "	125
2 "	126
2 "	126a
1 "	155
2 "	189

The Bolts 1 are lock-nutted, and the Angle Bracket at the lower end of the 2 $\frac{1}{2}$ " Strip has a  $\frac{1}{2}$ " Rod in its elongated hole, where it is held by means of two Spring Clips.

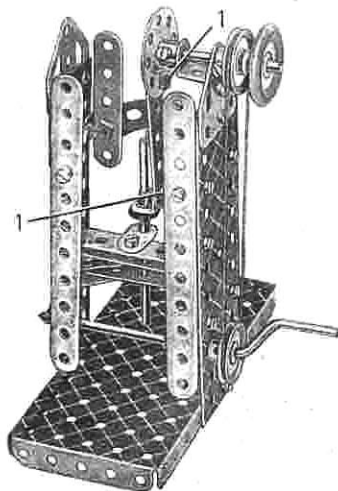
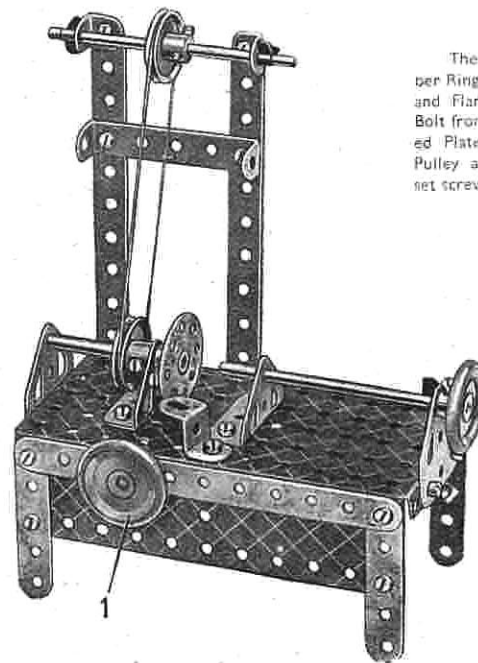

Fig. 1.32a

### 1.33 LATHE



The 1" fast Pulley with Rubber Ring 1 is secured to the Strip and Flanged Plate by passing a Bolt from the inside of the Flanged Plate into the boss of the Pulley and then tightening the set screw.

#### Parts required

4 of No.	2
4 "	5
2 "	12
2 "	16
1 "	17
4 "	22
1 "	24
3 "	35
22 "	37
1 "	40
1 "	48a
1 "	52
1 "	111c
1 "	125
2 "	126
2 "	126a
2 "	155
2 "	189

## 2.1 RAILWAY FOOTBRIDGE

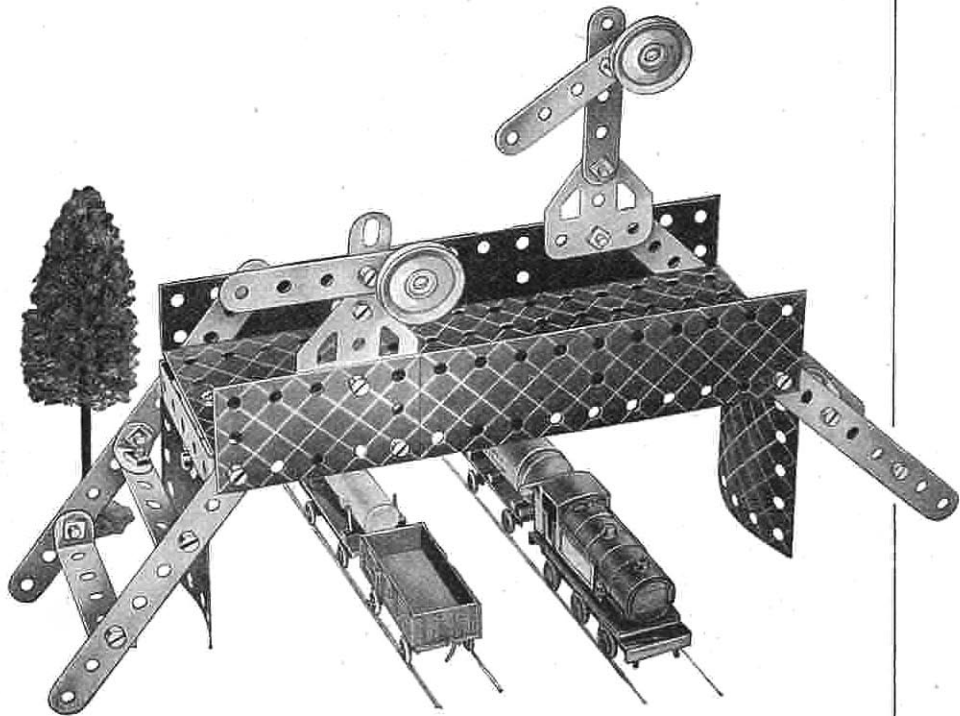

Parts required

4 of No. 2	2 of No. 22	1 of No. 52	2 of No. 188
6 " " 5	32 " " 37	2 " " 111c	2 " " 189
2 " " 10	2 " " 37a	2 " " 126	1 " " 190
6 " " 12	2 " " 48a	2 " " 126a	2 " " 200

The span of the bridge is a  $5\frac{1}{2}'' \times 2\frac{1}{2}''$  Flanged Plate, extended by a  $2\frac{1}{2}'' \times 2\frac{1}{2}''$  Flexible Plate. Trunnions are bolted to each end of the span, and have  $1\frac{1}{4}''$  radius Curved Plates fastened to them. The sides of the approach stairways are  $5\frac{1}{2}''$  Strips. They are joined across by  $2\frac{1}{2}'' \times \frac{1}{2}''$  Double Angle Strips and  $2\frac{1}{2}''$  Strips fitted with Angle Brackets at each end.

The signals are supported on Flat Trunnions bolted to the sides of the bridge. The smaller of the two signal posts is formed by two Fishplates, and the larger one is a  $2\frac{1}{2}''$  Strip. The signal arms are  $2\frac{1}{2}''$  Strips bolted to the posts in the second holes from one end. They are fitted at their shorter ends with  $1''$  Pulleys, representing the spectacles, which are held in place by  $\frac{1}{8}''$  Bolts passed through the Strips and inserted in their bosses.

## 2.2 LAWN MOWER

The "cutter" is made by bolting an Angle Bracket at each end of a Reversed Angle Bracket 1 and then sliding an Axle Rod through the free holes of the Brackets. The two Pulleys 2 are fixed to the Rod and pushed tightly against the "cutter" to make it rotate with the Rod as the wheels revolve. The wheels are  $1''$  Pulleys fitted with Rubber Rings.

Parts required

4 of No. 2	2 of No. 90e
4 " " 5	1 " " 125
4 " " 10	2 " " 126
6 " " 12	2 " " 155
1 " " 16	2 " " 200
4 " " 22	
25 " " 37	
4 " " 38	
2 " " 48a	

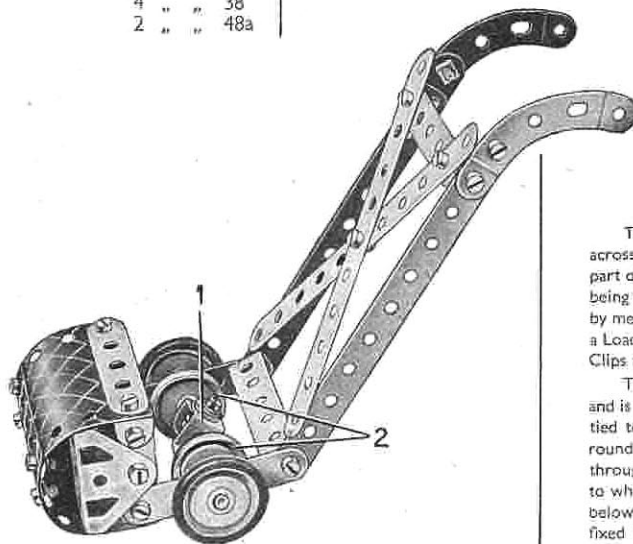

## 2.3 FLOATING CRANE

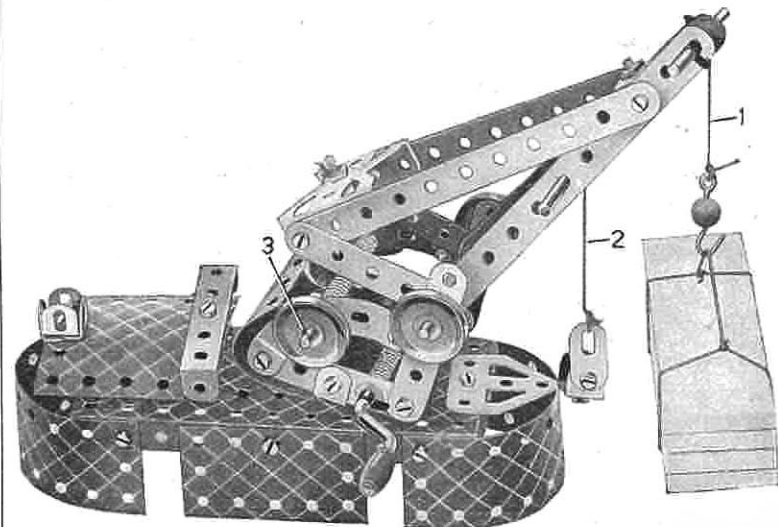

Parts required

4 of No. 2	4 of No. 22	2 of No. 48a	1 of No. 126a
6 " " 5	1 " " 24	1 " " 52	1 " " 176
3 " " 10	4 " " 35	1 " " 57c	2 " " 188
8 " " 12	29 " " 37	2 " " 90a	2 " " 189
2 " " 16	3 " " 37a	4 " " 111c	1 " " 199
2 " " 17	4 " " 38	1 " " 125	1 " " 200
1 " " 19g	1 " " 40	2 " " 126	

The jib consists of  $5\frac{1}{2}''$  Strips and  $2\frac{1}{2}''$  Strips. At its upper end these are joined across by Angle Brackets, and at its lower end by Trunnions. Each side of the lower part of the crane consists of  $2\frac{1}{2}''$  Strips and small radius Curved Strips, the two sides being connected by  $2\frac{1}{2}'' \times \frac{1}{2}''$  Double Angle Strips. The jib is pivoted to this structure by means of a  $3\frac{1}{2}''$  Rod, which carries at each end a  $1''$  Pulley. The Cord 1 fitted with a Loaded Hook, is passed over a  $2''$  Rod held in place in the jib by means of Spring Clips and is then wound around the Crank Handle.

The Cord 2 passes over a Rod held in the jib by a Cord Anchoring Spring, and is then wound around the Rod that forms the pivot for the jib. A third Cord is tied to a Bolt fastened in the two Trunnions at the base of the jib, and is wound round Rod 3. This Cord controls the luffing motion of the crane. A  $\frac{1}{8}''$  Bolt passes through the Flanged Plate and is held by a set screw in the boss of the Bush Wheel to which the jib is fastened. The Bush Wheel is bolted to the Double Angle Strip below the Rod 3. The roof of the cabin is bolted to a  $\frac{1}{2}''$  Reversed Angle Bracket fixed to the Flanged Plate.

### 2.4 AUTOGIRO

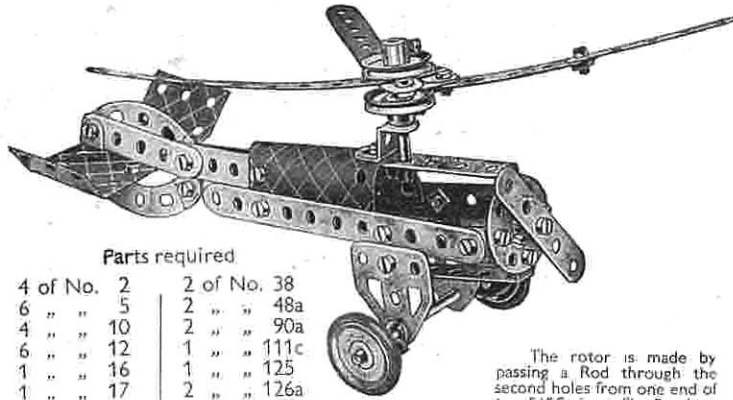

**Parts required**

4 of No. 2	2 of No. 38
6 " " 5	2 " " 48a
4 " " 10	2 " " 90a
6 " " 12	1 " " 111c
1 " " 16	1 " " 125
1 " " 17	2 " " 126a
4 " " 22	2 " " 155
1 " " 24	2 " " 188
3 " " 35	1 " " 199
25 " " 37	

The rotor is made by passing a Rod through the second hole from one end of two 5½" Strips. Flat Brackets are bolted to the short ends of the Strips and the third blade of the rotor is fixed to them as shown

### 2.6 GAS ENGINE

**Parts required**

3 of No. 5	3 of No. 37	1 of No. 126a
4 " " 10	3 " " 37a	1 " " 155
8 " " 12	4 " " 38	1 " " 176
2 " " 16	1 " " 40	1 " " 187
1 " " 17	2 " " 48a	2 " " 188
1 " " 19g	1 " " 52	2 " " 189
4 " " 22	1 " " 111c	1 " " 190
1 " " 24	1 " " 125	2 " " 200
4 " " 35	1 " " 126	

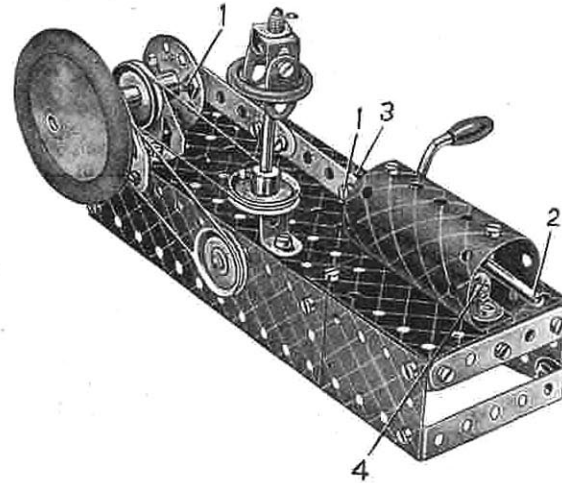

The bearings for the Rod representing the crankshaft are a Flat Trunnion and a Trunnion. The crankshaft carries a Road Wheel and a 1" Pulley at one end, a second 1" Pulley between the bearings, and a Bush Wheel at its other end.

The connecting rod is fastened to the Bush Wheel and to an Angle Bracket 3 by lock-nutted Bolts 1. The Rod 2 is held in the Angle Bracket 3 by means of Spring Clips, one on each side. An Angle Bracket 4, carrying a Fishplate, is bolted inside the cylinder, and a similar arrangement is fitted at the other end. These form bearings for the Rod 2.

The model is operated by the Crank Handle, which carries also a 1" Pulley connected to one of the 1" Pulleys on the crankshaft by a belt of Cord. A second Cord drives the governor, which is mounted on a 3½" Rod journalled in the 5½" x 2½" Flanged Plate and a Reversed Angle Bracket.

### 2.7 RACING CAR

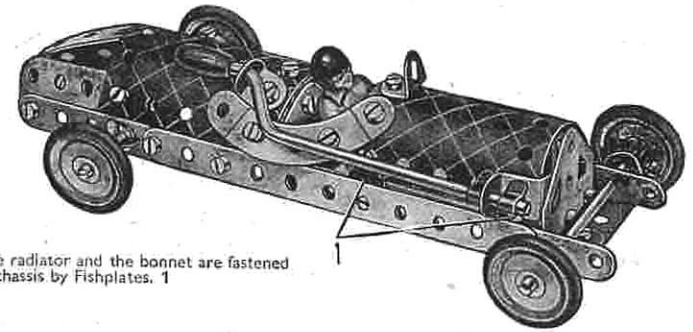

The radiator and the bonnet are fastened to the chassis by Fishplates. 1

**Parts required**

4 of No. 2	1 of No. 19g	2 of No. 38	1 of No. 126a
5 " " 5	4 " " 22	1 " " 48a	4 " " 155
4 " " 10	4 " " 35	2 " " 90a	1 " " 199
8 " " 12	30 " " 37	1 " " 125	1 " " 200
2 " " 16	1 " " 37a	1 " " 126	

### 2.5 ANTI-AIRCRAFT GUN

**Parts required**

4 of No. 2
1 " " 5
6 " " 12
2 " " 16
2 " " 17
1 " " 19g
4 " " 22
1 " " 24
3 " " 35
26 " " 37
4 " " 38
2 " " 48a
1 " " 52
2 " " 90a
1 " " 125
2 " " 126
2 " " 126a
4 " " 155
1 " " 176
1 " " 187
2 " " 188
2 " " 189

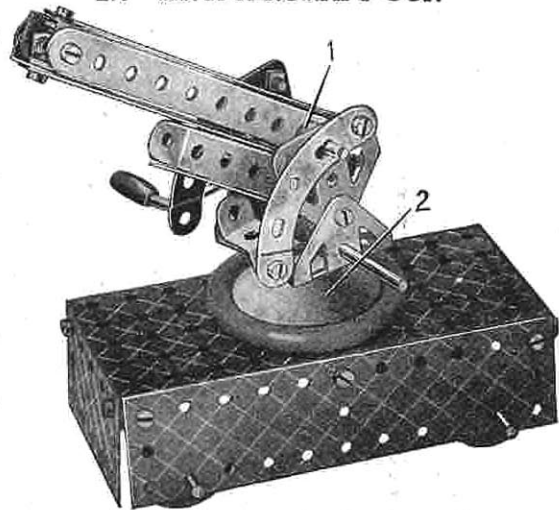

One end of a piece of Cord is fastened to the Crank Handle. It is wound round the Handle a few times and its other end is then fastened to the end of the gun. The two Trunnions are bolted to a Bush Wheel fixed on a 2" Rod that passes through the Road Wheel 2 and the Flanged Plate and is held in place by an Anchoring Spring. The Spring Clips at 1 space the gun barrel from the Flat Trunnions.

### 2.8 LOW WING MONOPLANE

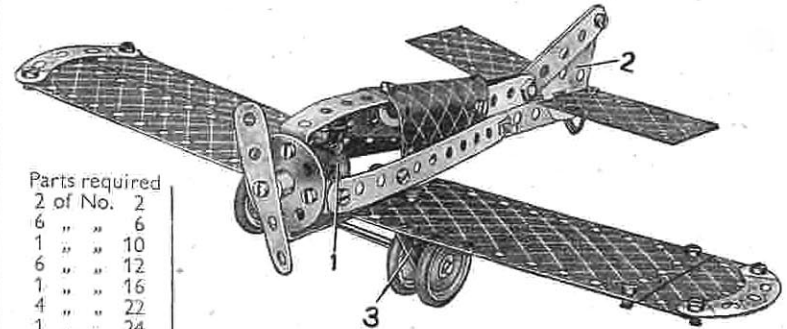

**Parts required**

2 of No. 2	2 of No. 126	2 of No. 189
6 " " 6	1 " " 126a	1 " " 190
1 " " 10	4 " " 155	1 " " 191
6 " " 12	2 " " 188	1 " " 199
1 " " 16		
4 " " 22		
1 " " 24		
23 " " 37		
2 " " 37a		
2 " " 38		
2 " " 48a		
2 " " 90a		
3 " " 111c		

The fin 2 is a Flat Trunnion, and it is clamped between the two 2½" Strips. The bearings 3 for the axle of the landing wheels are Trunnions, bolted to the wings. The wings are attached to the fuselage by Angle Brackets.

## 2.9 "THUNDERBOLT" SPEED CAR

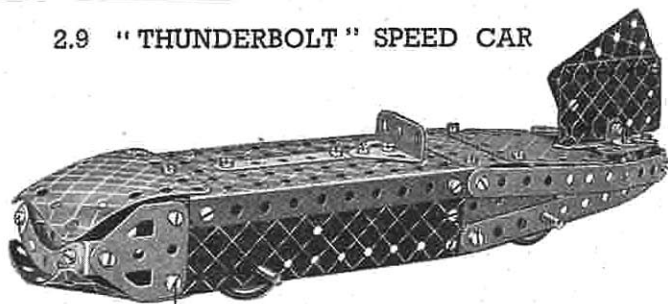

## Parts required

4 of No. 2	1 of No. 52
6 " " 5	2 " " 90a
2 " " 10	1 " " 126
4 " " 12	2 " " 126a
2 " " 16	4 " " 155
4 " " 22	2 " " 188
39 " " 37	2 " " 189
38 " " 37a	2 " " 190
4 " " 38	2 " " 200
2 " " 48a	

A  $5\frac{1}{2} \times 2\frac{1}{2}$ " Flanged Plate extended at the front by a  $1\frac{1}{8}$ " radius Curved Plate and at the rear by two  $2\frac{1}{2} \times 2\frac{1}{2}$ " Flexible Plates, forms the top of the car. The rear part of each side is formed by two  $5\frac{1}{2}$ " Strips and a  $2\frac{1}{2}$ " Strip, the former being connected together at the tail by Angle Brackets. Bolts 1 hold a  $2\frac{1}{2} \times \frac{1}{2}$ " Double Angle Strip that carries the  $1\frac{1}{8}$ " radius Curved Plate forming the underside of the front cowling.

## 2.10 ROLL TOP DESK

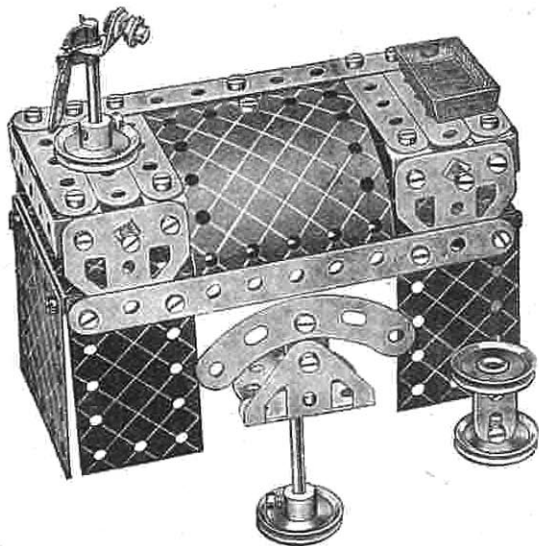

## Parts required

2 of No. 2	
6 " " 5	
4 " " 10	
7 " " 12	
2 " " 17	
4 " " 22	
1 " " 24	
3 " " 35	
38 " " 37	
5 " " 37a	
1 " " 38	
2 " " 48a	
1 " " 52	
1 " " 90a	
3 " " 111c	
1 " " 126	
2 " " 126a	
2 " " 188	
1 " " 189	
2 " " 190	
1 " " 200	

## 2.11 TRAVELLING CRANE

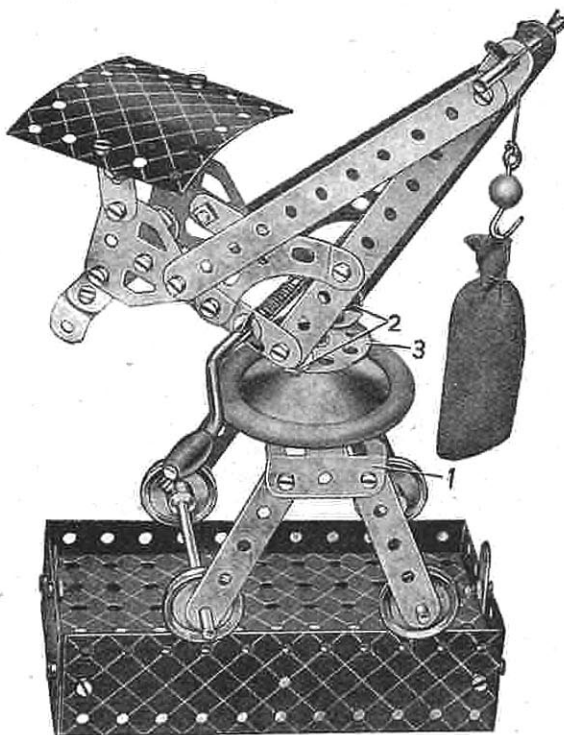

## Parts required

4 of No. 2	1 of No. 19g	3 of No. 38	2 of No. 111c
6 " " 5	4 " " 22	1 " " 40	2 " " 126
4 " " 10	1 " " 24	2 " " 48a	2 " " 126a
6 " " 12	4 " " 35	1 " " 52	1 " " 176
2 " " 16	38 " " 37	1 " " 57c	1 " " 187
2 " " 17	2 " " 37a	2 " " 90a	2 " " 188
	2 of No. 189		1 of No. 200

A 2" Rod is secured in the boss of the Bush Wheel 3. It then passes through the Road Wheel and through the centre of a  $2\frac{1}{2} \times \frac{1}{2}$ " Double Angle Strip bolted between the two Trunnions 1. A Washer and a Cord Anchoring Spring are pushed on to the Rod to hold it in position. The crane jib is attached to the Bush Wheel by the Angle Brackets 2.

## 2.12 CATTLE TRUCK

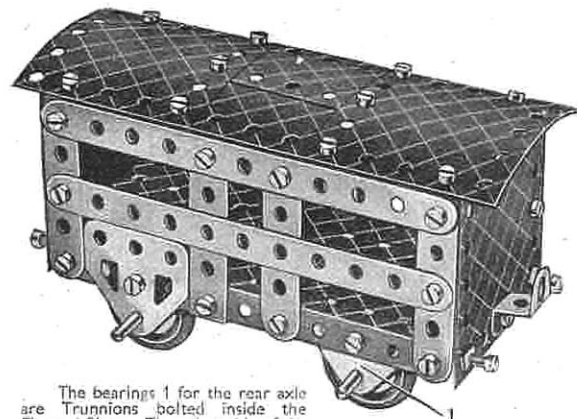

## Parts required

4 of No. 2
6 " " 5
4 " " 10
5 " " 12
2 " " 16
4 " " 22
38 " " 37
8 " " 37a
4 " " 38
2 " " 48a
1 " " 52
4 " " 111c
1 " " 125
2 " " 126
2 " " 126a
4 " " 155
2 " " 188
2 " " 190
2 " " 200

The bearings 1 for the rear axle are Trunnions bolted inside the Flanged Plate. The other side of the truck is constructed in a similar manner to the side shown in the illustration.

## 2.13 PIANO

A  $5\frac{1}{2} \times 2\frac{1}{2}$ " Flanged Plate is used for the upper part of the back and to each end of this a  $2\frac{1}{2}$ " Strip is bolted to form the rear legs.

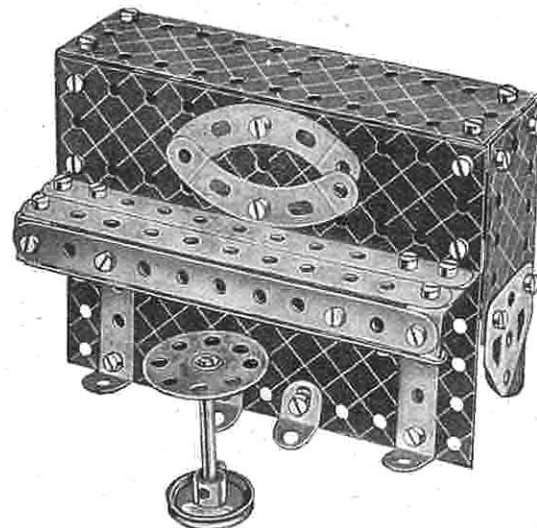

## Parts required

4 of No. 2
4 " " 5
4 " " 10
8 " " 12
1 " " 17
1 " " 22
1 " " 24
38 " " 37
4 " " 38
2 " " 48a
1 " " 52
2 " " 90a
2 " " 126
2 " " 126a
2 " " 188
2 " " 189
1 " " 190
1 " " 191

### 2.14 MOTOR VAN

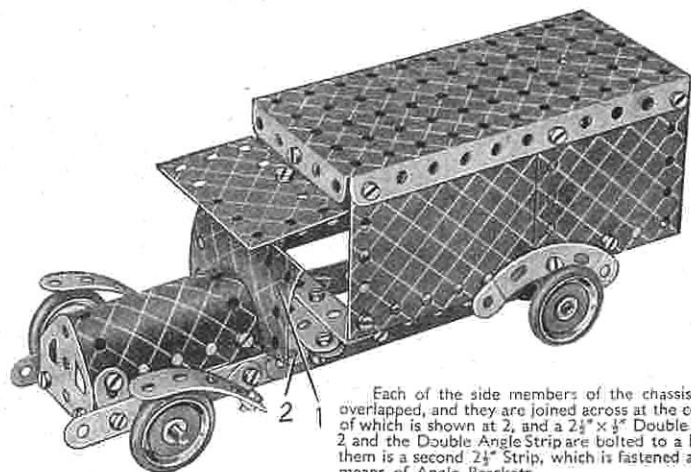

Each of the side members of the chassis consists of two  $5\frac{1}{2}''$  Strips overlapped, and they are joined across at the centre by two  $2\frac{1}{2}''$  Strips, one of which is shown at 2, and a  $2\frac{1}{2}'' \times \frac{1}{2}''$  Double Angle Strip. The  $2\frac{1}{2}''$  Strip 2 and the Double Angle Strip are bolted to a Flat Trunnion, and between them is a second  $2\frac{1}{2}''$  Strip, which is fastened at each end to the chassis by means of Angle Brackets.

The Plate 1 is fastened to an Angle Bracket that is bolted to Strip 2. The body is fixed to the chassis by a Double Angle Strip and an Angle Bracket.

#### Parts required

4	of No.	2
4	" "	5
4	" "	10
8	" "	12
2	" "	16
4	" "	22
4	" "	35
10	" "	37
4	" "	38
2	" "	48a
1	" "	52
2	" "	90a
1	" "	126
2	" "	126a
4	" "	155
2	" "	188
2	" "	189
2	" "	190
1	" "	191
1	" "	199

### 2.16 STEAMSHIP

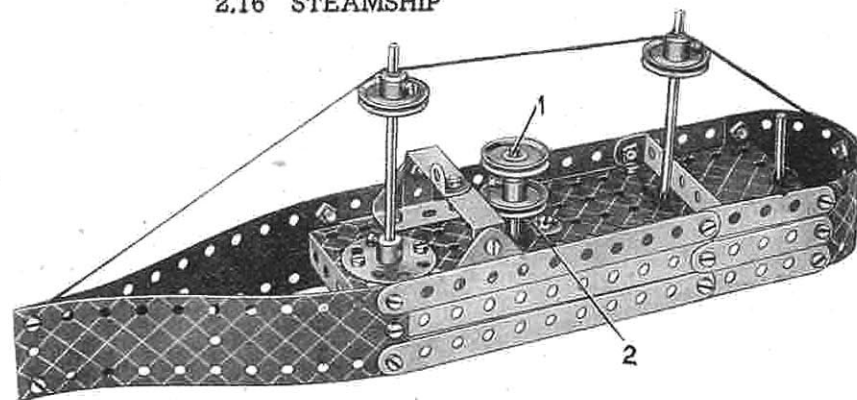

#### Parts required

4	of No.	2
6	" "	5
1	" "	12
2	" "	16
2	" "	17
4	" "	22
1	" "	24
4	" "	35
34	" "	37
1	" "	40
2	" "	48a
1	" "	52
1	" "	125
2	" "	126
2	" "	188
2	" "	189
1	" "	190

The deck of the model is a  $5\frac{1}{2}'' \times 2\frac{1}{2}''$  Flanged Plate extended by a  $2\frac{1}{2}'' \times 2\frac{1}{2}''$  Flexible Plate. A  $2\frac{1}{2}'' \times \frac{1}{2}''$  Double Angle Strip fitted with an Angle Bracket represents the bridge, and it is supported by two Trunnions bolted to the deck. The funnel consists of a Rod 1 fitted with two 1" fast Pulleys. The Rod passes through the hole in a Reversed Angle Bracket 2 and then through the Flanged Plate.

### 2.15 RAILWAY BREAKDOWN CRANE

#### Parts required

4	of No.	2
6	" "	5
4	" "	10
3	" "	12
2	" "	16
1	" "	17
1	" "	19g
4	" "	22
1	" "	24
2	" "	35
39	" "	37
3	" "	37a
3	" "	38
1	" "	40
2	" "	48a
1	" "	52
1	" "	57c
2	" "	90a
3	" "	111c
2	" "	126
2	" "	126a
1	" "	155
1	" "	176
1	" "	187

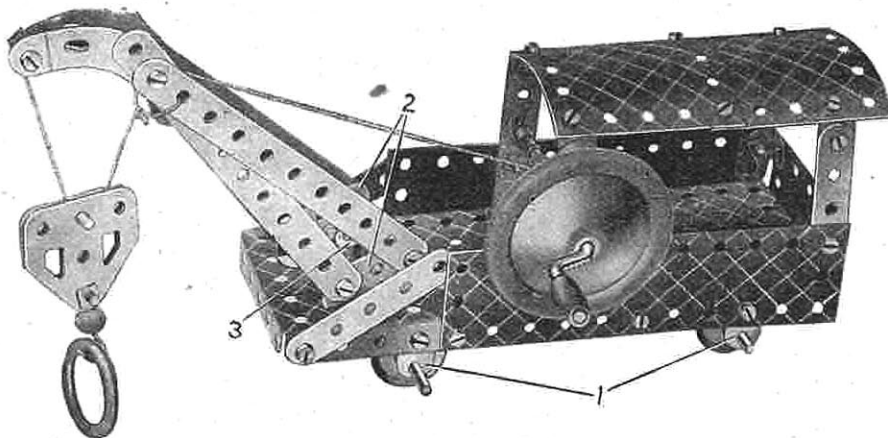

1	of No.	188
2	" "	189
1	" "	190
2	" "	200

The bearings 1 are Fishplates bolted to the Flanged Plate and the Flexible Plates respectively. The jib is fastened to two Trunnions 2, which are bolted to the Bush Wheel 3. A 2" Rod is secured in the boss of the Bush Wheel 3. It then passes through a hole in the Flanged Plate, and is held in position by a Spring Clip underneath the Plate.

### 2.17 BATHROOM SUITE

#### Parts required

4	of No.	2
6	" "	5
4	" "	10
8	" "	12
1	" "	24
40	" "	37
6	" "	37a
2	" "	38
2	" "	48a
1	" "	52
2	" "	90a
4	" "	111c
1	" "	125
2	" "	126
2	" "	126a
2	" "	188
2	" "	189
1	" "	190
1	" "	191
1	" "	199
1	" "	200

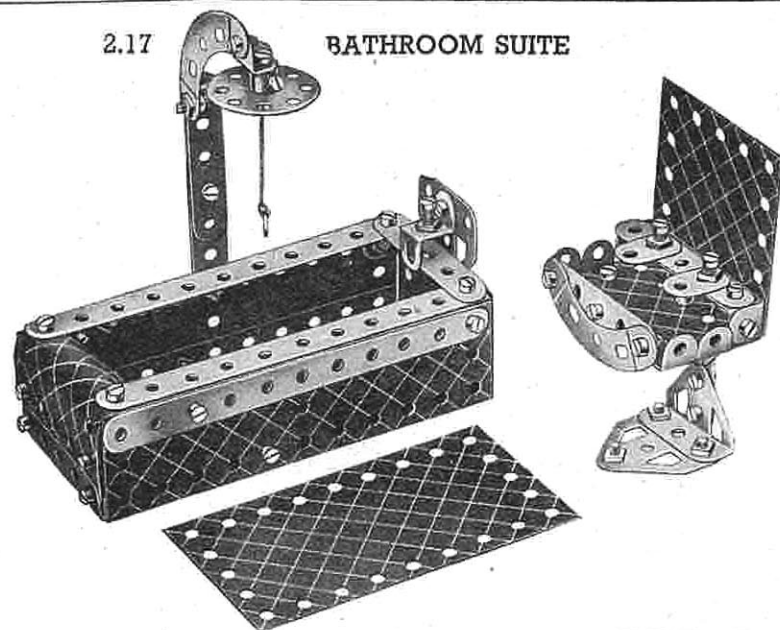

## 2.18 WHEELBARROW

A  $5\frac{1}{2}'' \times 2\frac{1}{2}''$  Flanged Plate is used upside down for the floor of the barrow, and two  $5\frac{1}{2}''$  Strips overlapped six holes form the shafts.

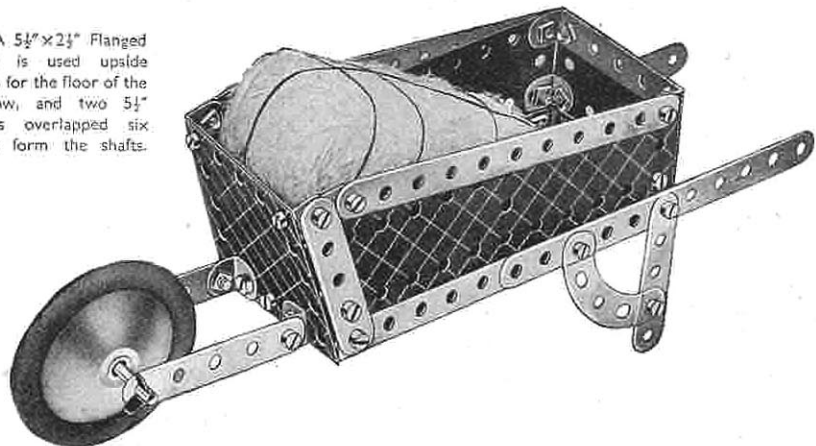

## Parts required

4 of No. 2
6 " " 5
2 " " 10
4 " " 12
1 " " 17
2 " " 35
29 " " 37
2 " " 48a
1 " " 52
2 " " 90a
1 " " 187
1 " " 188
2 " " 189
1 " " 190

## 2.20 ROAD BRIDGE

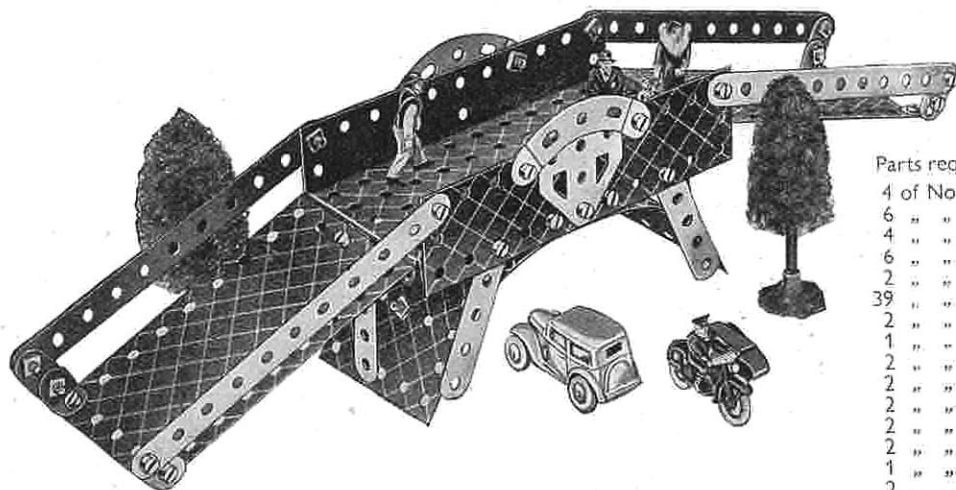

## Parts required

4 of No. 2
6 " " 5
4 " " 10
6 " " 12
2 " " 16
39 " " 37
2 " " 48a
1 " " 52
2 " " 90a
2 " " 126a
2 " " 188
2 " " 189
2 " " 190
1 " " 191
2 " " 200

## Parts required

4 of No. 2
6 " " 5
4 " " 10
6 " " 12
1 " " 16
1 " " 19g
4 " " 22
1 " " 24
39 " " 37
2 " " 37a

## 2.19 CANAL BRIDGE

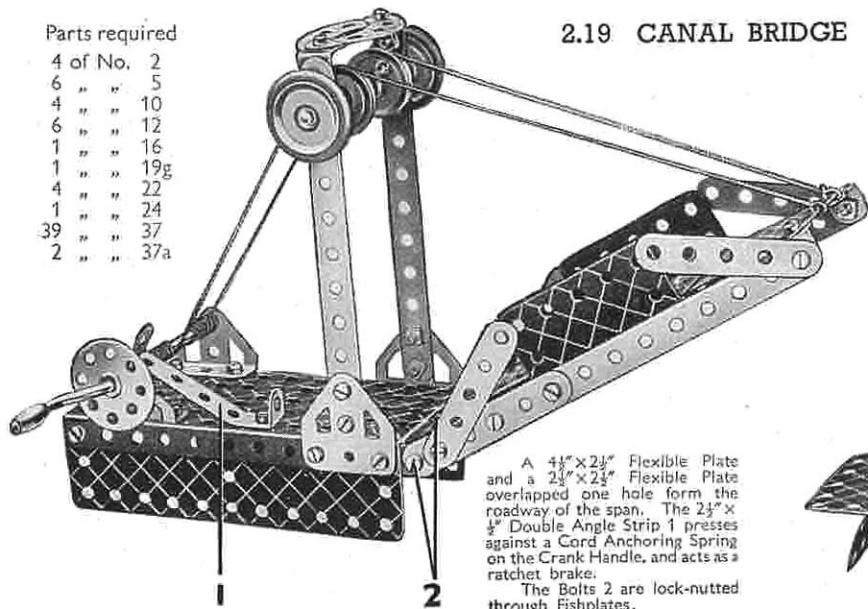

A  $4\frac{1}{2}'' \times 2\frac{1}{2}''$  Flexible Plate and a  $2\frac{1}{2}'' \times 2\frac{1}{2}''$  Flexible Plate overlapped one hole form the roadway of the span. The  $2\frac{1}{2}'' \times \frac{1}{2}''$  Double Angle Strip 1 presses against a Cord Anchoring Spring on the Crank Handle, and acts as a ratchet brake.

The Bolts 2 are lock-nutted through Fishplates.

Parts required  
(continued)

2 of No. 38
2 " " 48a
1 " " 52
2 " " 90a
2 " " 126
2 " " 126a
2 " " 155
1 " " 176
2 " " 188
2 " " 189
2 " " 190
1 " " 191
1 " " 199
1 " " 200

## 2.21 DRAGLINE EXCAVATOR

## Parts required

4 of No. 2	3 of No. 22	1 of No. 48a	1 of No. 176
6 " " 5	1 " " 24	1 " " 52	1 " " 187
2 " " 10	4 " " 35	1 " " 57c	2 " " 188
8 " " 12	40 " " 37	2 " " 90a	2 " " 189
1 " " 16	4 " " 37a	2 " " 111c	2 " " 190
2 " " 17	1 " " 38	2 " " 126	1 " " 199
1 " " 19g	1 " " 40	2 " " 126a	2 " " 200

The Cord 1 is wound round the Crank Handle about 12 times then one end of it is fastened to a small Loaded Hook and the other end to the Cord on the bucket.

A Curved Strip is pivoted by a  $\frac{1}{2}''$  Bolt through one of its ends in the position of Bolt 2 but on the rear side of the model. A 1" Pulley is attached to the other end of the Curved Strip, with a  $\frac{1}{2}''$  Bolt to act as a weight. A loop of Cord is fastened through the slotted hole next to the bottom of the Strip, and then passes round the 1" Pulley 3 on the shaft of the Bush Wheel, to act as a brake band. The Cord should be long enough to allow the Strip to lie nearly horizontal.

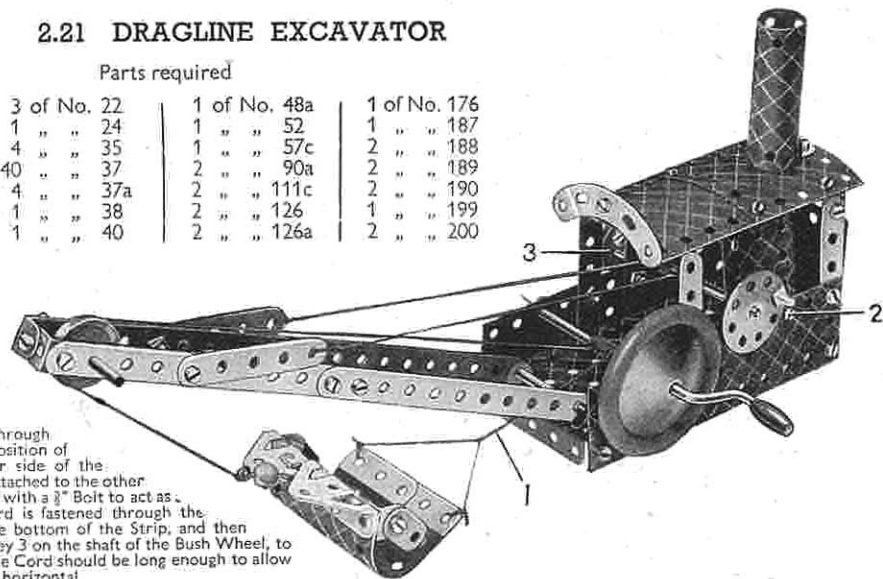

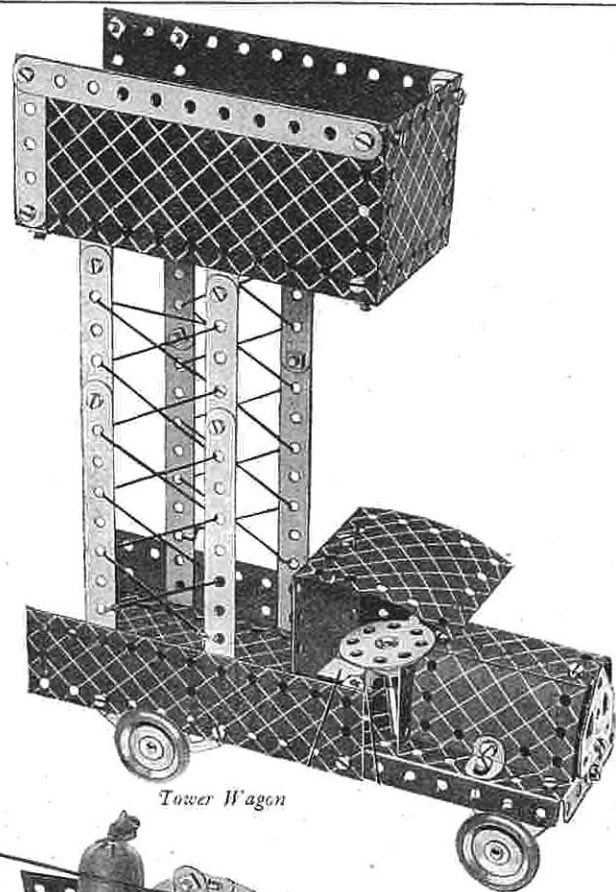
*Tower Wagon*

### BUILD BIGGER AND BETTER MODELS

When you have built all the models shown in this Manual you will be keen to build bigger and more elaborate models. Your next step is to purchase a Meccano No. 2a Accessory Outfit containing all the parts required to convert your No. 2 into a No. 3 Outfit. You will then be able to build the full range of No. 3 Outfit models, a selection of which is illustrated on this and the following page.

If you prefer to do so, you can build up and develop your Outfit quite easily by adding various parts to it from time to time. The model-building possibilities of the Meccano System are unlimited, and the more Meccano parts you have the bigger and better the models you will be able to build.

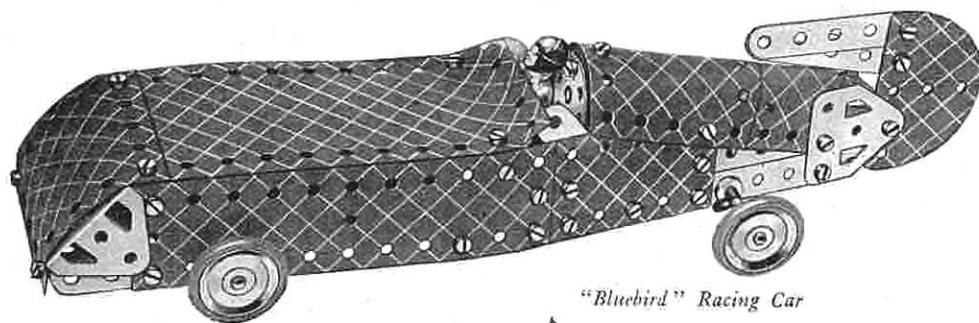
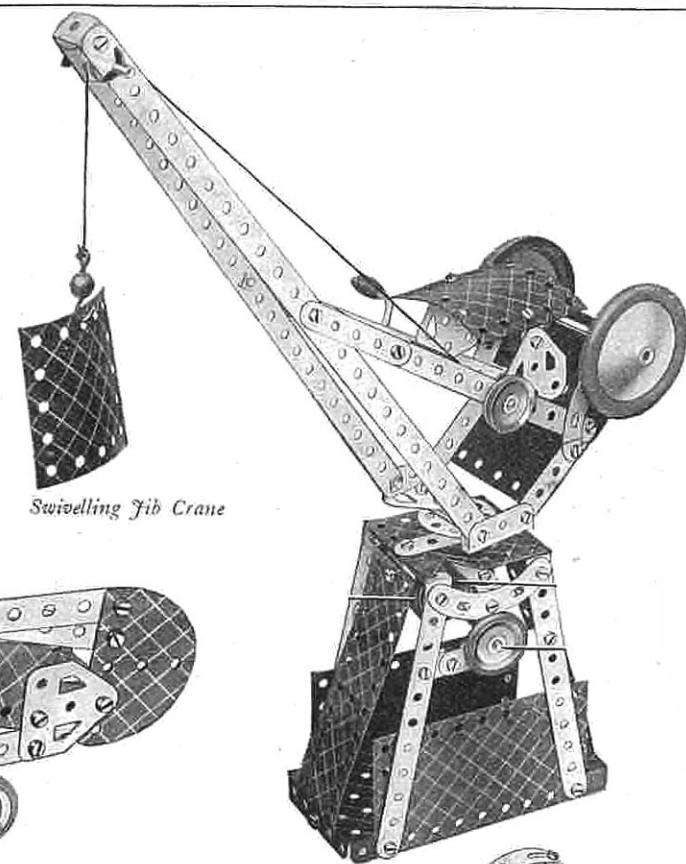
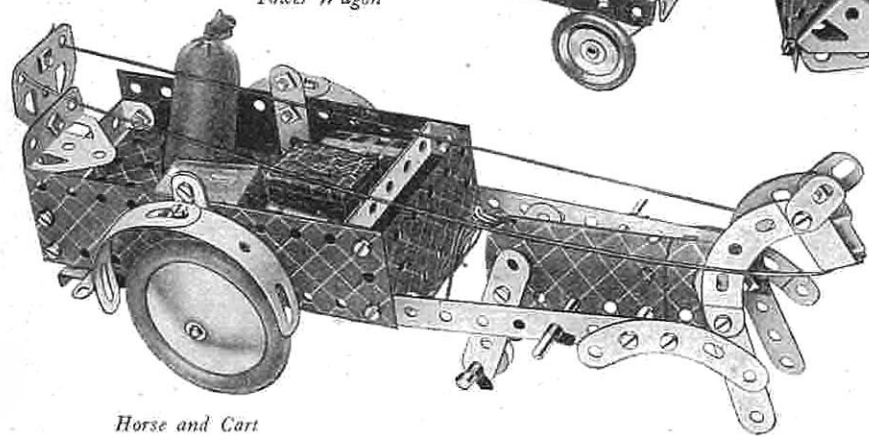
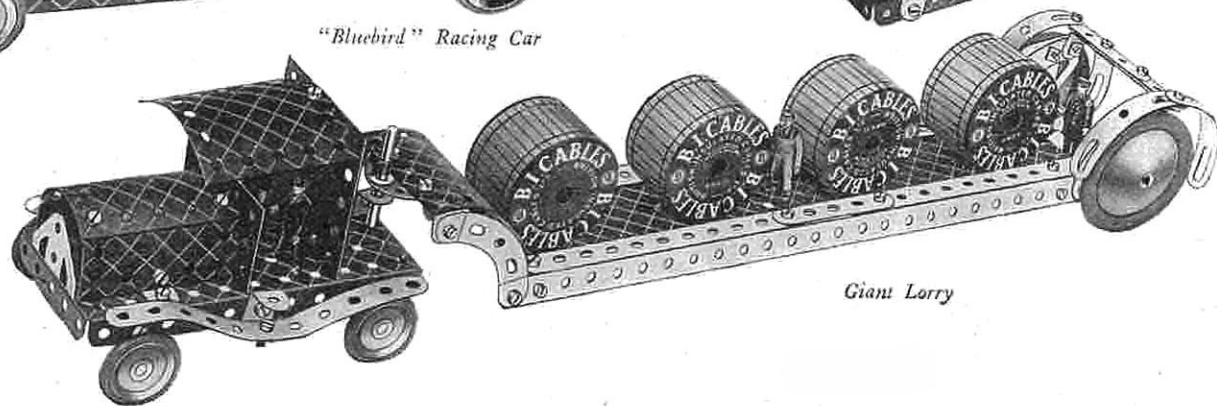
*"Bluebird" Racing Car**Swivelling Jib Crane**Horse and Cart**Giant Lorry*

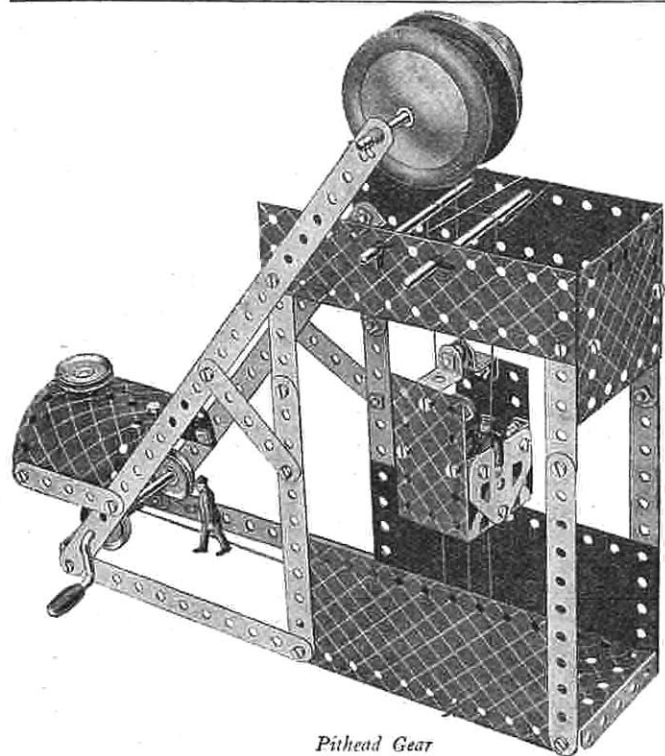
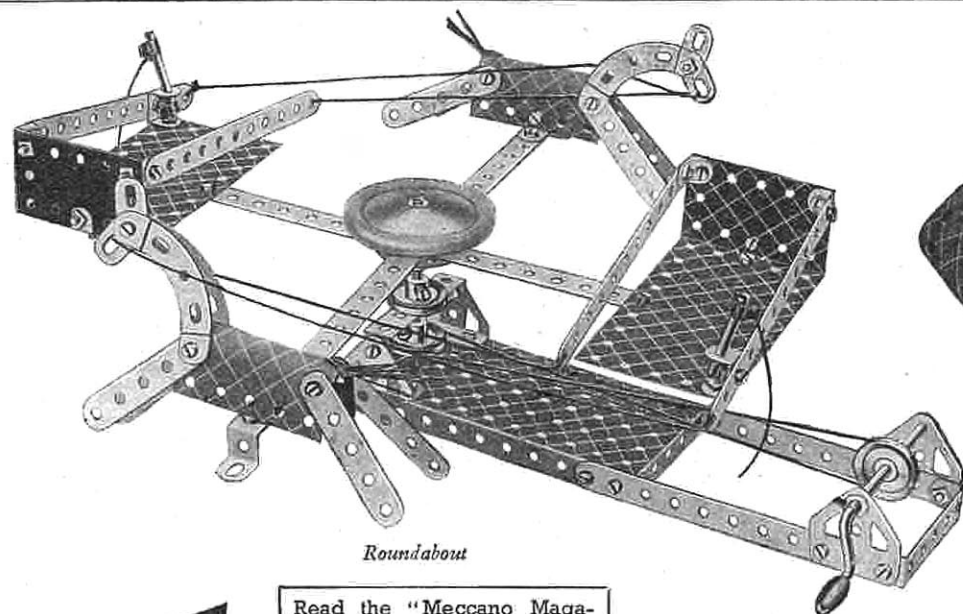
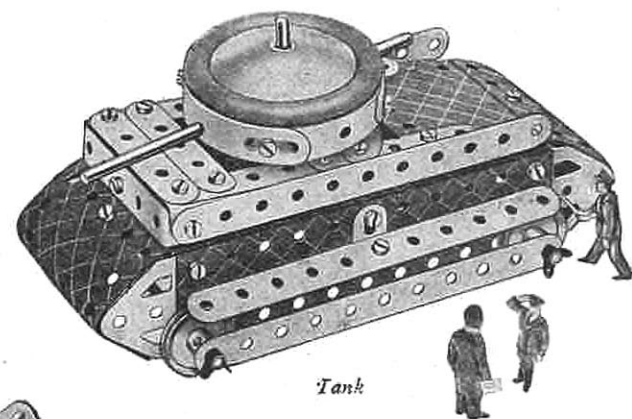
*Pithead Gear**Roundabout**Tank*

Read the "Meccano Magazine." Place a regular order now with your Meccano dealer or newsagent.

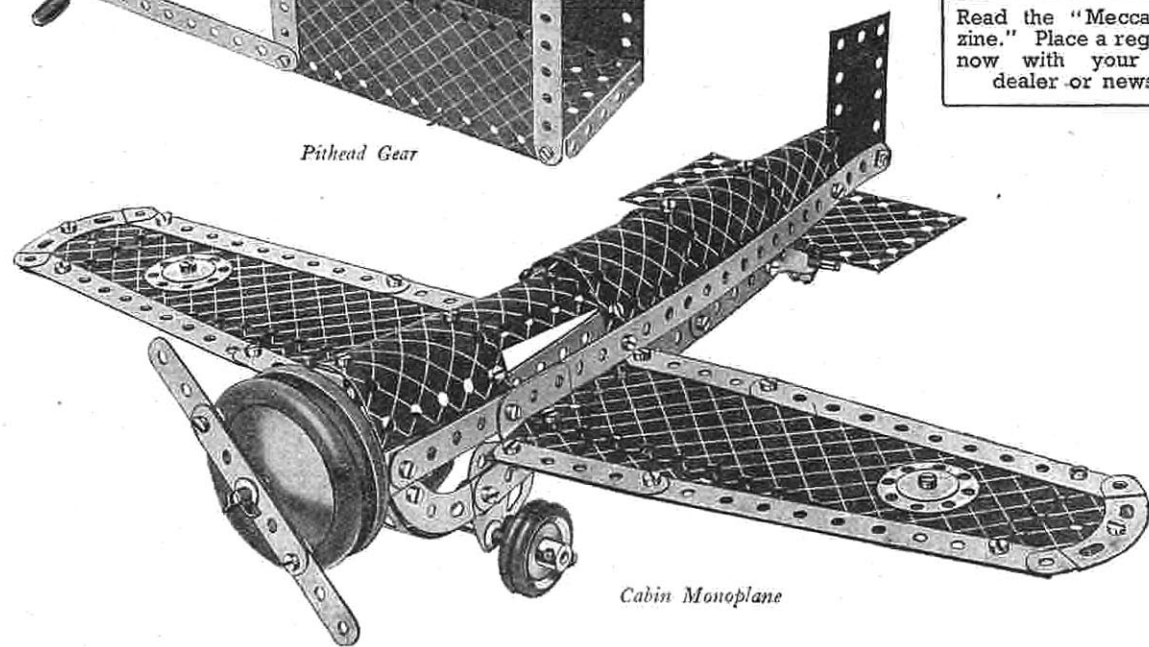
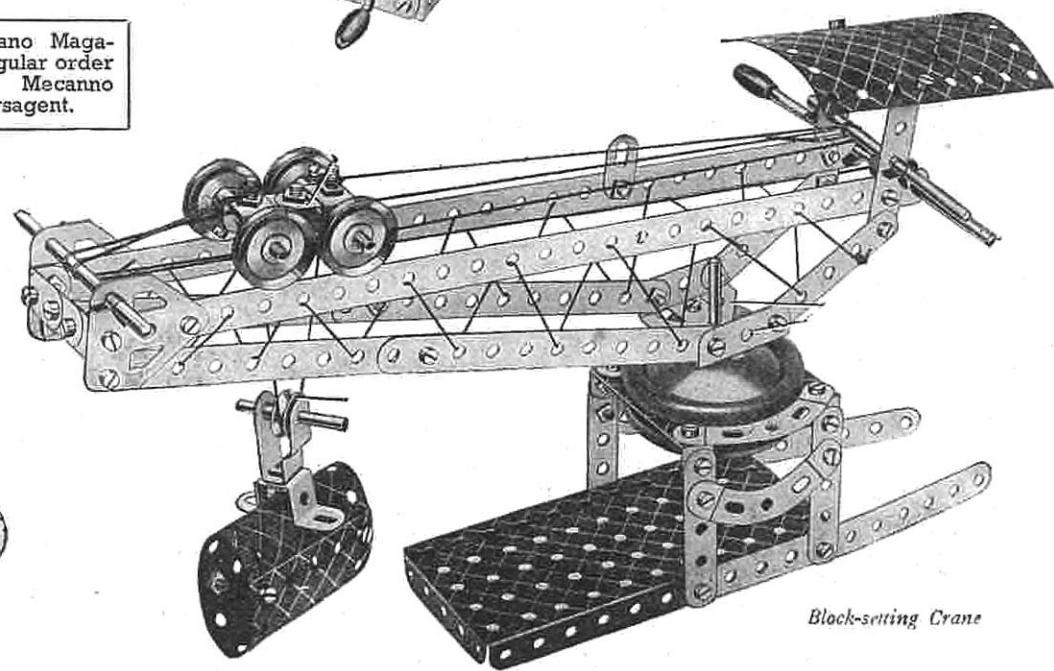
*Cabin Monoplane**Block-setting Crane*





## CONTENTS OF MECCANO OUTFITS (Continued)

No.	Description	0	1	1a	2	2a	3	3a	4	4a	5	5a	6	6a	7	7a	8	8a	9	9a	10
89	Curved Strips, 5 $\frac{1}{2}$ "	..	..	..	..	..	..	..	..	..	..	..	..	..	..	..	..	..	..	..	..
89a	" " Stepped	..	..	..	..	..	..	..	..	..	..	..	..	..	..	..	..	..	..	..	..
89b	" " " "	..	..	..	..	..	..	..	..	..	..	..	..	..	..	..	..	..	..	..	..
90	" " " "	..	..	..	..	..	..	..	..	..	..	..	..	..	..	..	..	..	..	..	..
90a	" " " "	..	..	..	..	..	..	..	..	..	..	..	..	..	..	..	..	..	..	..	..
94	Sprocket Chain, 30" lengths	..	..	..	..	..	..	..	..	..	..	..	..	..	..	..	..	..	..	..	..
95	Sprocket Wheel, 2"	..	..	..	..	..	..	..	..	..	..	..	..	..	..	..	..	..	..	..	..
95a	" " " "	..	..	..	..	..	..	..	..	..	..	..	..	..	..	..	..	..	..	..	..
95b	" " " "	..	..	..	..	..	..	..	..	..	..	..	..	..	..	..	..	..	..	..	..
96	" " " "	..	..	..	..	..	..	..	..	..	..	..	..	..	..	..	..	..	..	..	..
96a	" " " "	..	..	..	..	..	..	..	..	..	..	..	..	..	..	..	..	..	..	..	..
100	Bread Girders, 5 $\frac{1}{2}$ "	..	..	..	..	..	..	..	..	..	..	..	..	..	..	..	..	..	..	..	..
102	Single Bent Strips	..	..	..	..	..	..	..	..	..	..	..	..	..	..	..	..	..	..	..	..
103	Flat Girders, 5 $\frac{1}{2}$ "	..	..	..	..	..	..	..	..	..	..	..	..	..	..	..	..	..	..	..	..
103a	" " " "	..	..	..	..	..	..	..	..	..	..	..	..	..	..	..	..	..	..	..	..
103b	" " " "	..	..	..	..	..	..	..	..	..	..	..	..	..	..	..	..	..	..	..	..
103c	" " " "	..	..	..	..	..	..	..	..	..	..	..	..	..	..	..	..	..	..	..	..
103d	" " " "	..	..	..	..	..	..	..	..	..	..	..	..	..	..	..	..	..	..	..	..
103e	" " " "	..	..	..	..	..	..	..	..	..	..	..	..	..	..	..	..	..	..	..	..
103f	" " " "	..	..	..	..	..	..	..	..	..	..	..	..	..	..	..	..	..	..	..	..
103g	" " " "	..	..	..	..	..	..	..	..	..	..	..	..	..	..	..	..	..	..	..	..
103h	" " " "	..	..	..	..	..	..	..	..	..	..	..	..	..	..	..	..	..	..	..	..
103k	" " " "	..	..	..	..	..	..	..	..	..	..	..	..	..	..	..	..	..	..	..	..
103K	" " " "	..	..	..	..	..	..	..	..	..	..	..	..	..	..	..	..	..	..	..	..
108	Corner Gaskets	..	..	..	..	..	..	..	..	..	..	..	..	..	..	..	..	..	..	..	..
109	Face Plates, 2 $\frac{1}{2}$ " diam.	..	..	..	..	..	..	..	..	..	..	..	..	..	..	..	..	..	..	..	..
110	Rack Strips, 3 $\frac{1}{2}$ "	..	..	..	..	..	..	..	..	..	..	..	..	..	..	..	..	..	..	..	..
111	Bolts, $\frac{3}{8}$ "	..	..	..	..	..	..	..	..	..	..	..	..	..	..	..	..	..	..	..	..
111a	" " " "	..	..	..	..	..	..	..	..	..	..	..	..	..	..	..	..	..	..	..	..
111c	" " " "	..	..	..	..	..	..	..	..	..	..	..	..	..	..	..	..	..	..	..	..
114	Hinges	..	..	..	..	..	..	..	..	..	..	..	..	..	..	..	..	..	..	..	..
115	Threaded Pins	..	..	..	..	..	..	..	..	..	..	..	..	..	..	..	..	..	..	..	..
116	Fork Pieces, Large	..	..	..	..	..	..	..	..	..	..	..	..	..	..	..	..	..	..	..	..
116a	" " " "	..	..	..	..	..	..	..	..	..	..	..	..	..	..	..	..	..	..	..	..
117	Steel Balls, $\frac{3}{8}$ " diam.	..	..	..	..	..	..	..	..	..	..	..	..	..	..	..	..	..	..	..	..
118	Hub Discs, 5 $\frac{1}{2}$ " diam.	..	..	..	..	..	..	..	..	..	..	..	..	..	..	..	..	..	..	..	..
120b	Compression Springs	..	..	..	..	..	..	..	..	..	..	..	..	..	..	..	..	..	..	..	..
124	Reversed Angle Brackets, 1"	..	..	..	..	..	..	..	..	..	..	..	..	..	..	..	..	..	..	..	..
125	" " " "	..	..	..	..	..	..	..	..	..	..	..	..	..	..	..	..	..	..	..	..
126	Trunnions	..	..	..	..	..	..	..	..	..	..	..	..	..	..	..	..	..	..	..	..
126a	" " " "	..	..	..	..	..	..	..	..	..	..	..	..	..	..	..	..	..	..	..	..
128	Ball Trunnions	..	..	..	..	..	..	..	..	..	..	..	..	..	..	..	..	..	..	..	..
129	Flat Cranks, with boss	..	..	..	..	..	..	..	..	..	..	..	..	..	..	..	..	..	..	..	..
130	Toothed Segments, 1 $\frac{1}{2}$ " rad.	..	..	..	..	..	..	..	..	..	..	..	..	..	..	..	..	..	..	..	..
130	Eccentrics, Triple Throw, $\frac{1}{2}$ "	..	..	..	..	..	..	..	..	..	..	..	..	..	..	..	..	..	..	..	..
130a	" " " "	..	..	..	..	..	..	..	..	..	..	..	..	..	..	..	..	..	..	..	..
132	Flywheels, 2 $\frac{1}{2}$ " diam.	..	..	..	..	..	..	..	..	..	..	..	..	..	..	..	..	..	..	..	..
133	Corner Brackets, 1 $\frac{1}{2}$ " diam.	..	..	..	..	..	..	..	..	..	..	..	..	..	..	..	..	..	..	..	..
133a	" " " "	..	..	..	..	..	..	..	..	..	..	..	..	..	..	..	..	..	..	..	..
134	Crank Shafts, 1" stroke	..	..	..	..	..	..	..	..	..	..	..	..	..	..	..	..	..	..	..	..
136	Handrail Supports	..	..	..	..	..	..	..	..	..	..	..	..	..	..	..	..	..	..	..	..
136a	" " " "	..	..	..	..	..	..	..	..	..	..	..	..	..	..	..	..	..	..	..	..
137	Wheel Flanges	..	..	..	..	..	..	..	..	..	..	..	..	..	..	..	..	..	..	..	..
140	Universal Couplings	..	..	..	..	..	..	..	..	..	..	..	..	..	..	..	..	..	..	..	..
142a	Motor Tyres, 3"	..	..	..	..	..	..	..	..	..	..	..	..	..	..	..	..	..	..	..	..
142b	" " " "	..	..	..	..	..	..	..	..	..	..	..	..	..	..	..	..	..	..	..	..
143	Circular Girders, 5 $\frac{1}{2}$ " diam.	..	..	..	..	..	..	..	..	..	..	..	..	..	..	..	..	..	..	..	..
144	Dog Clutches	..	..	..	..	..	..	..	..	..	..	..	..	..	..	..	..	..	..	..	..
145	Circular Strips, 7 $\frac{1}{2}$ " diam.	..	..	..	..	..	..	..	..	..	..	..	..	..	..	..	..	..	..	..	..
146	" " " "	..	..	..	..	..	..	..	..	..	..	..	..	..	..	..	..	..	..	..	..
146a	" " " "	..	..	..	..	..	..	..	..	..	..	..	..	..	..	..	..	..	..	..	..
147a	Pawls	..	..	..	..	..	..	..	..	..	..	..	..	..	..	..	..	..	..	..	..
147b	Pivot Bolt with 2 Nuts	..	..	..	..	..	..	..	..	..	..	..	..	..	..	..	..	..	..	..	..
147c	Pawls without Boss	..	..	..	..	..	..	..	..	..	..	..	..	..	..	..	..	..	..	..	..
154a	Corner Angle Brackets, $\frac{1}{2}$ " L.H.	..	..	..	..	..	..	..	..	..	..	..	..	..	..	..	..	..	..	..	..
154b	" " " "	..	..	..	..	..	..	..	..	..	..	..	..	..	..	..	..	..	..	..	..
155	Rubber Rings, for 1" pulley	..	..	..	..	..	..	..	..	..	..	..	..	..	..	..	..	..	..	..	..
157	Fans, 2" diam.	..	..	..	..	..	..	..	..	..	..	..	..	..	..	..	..	..	..	..	..
160	Channel Bearings, $\frac{1}{2}$ " x $\frac{1}{2}$ " x $\frac{1}{2}$ "	..	..	..	..	..	..	..	..	..	..	..	..	..	..	..	..	..	..	..	..
161	Girder Brackets, 2" x 1 $\frac{1}{2}$ " x $\frac{1}{2}$ "	..	..	..	..	..	..	..	..	..	..	..	..	..	..	..	..	..	..	..	..
162	Boiler with Ends, complete	..	..	..	..	..	..	..	..	..	..	..	..	..	..	..	..	..	..	..	..
162a	Boiler Ends	..	..	..	..	..	..	..	..	..	..	..	..	..	..	..	..	..	..	..	..
162b	Boilers without Ends	..	..	..	..	..	..	..	..	..	..	..	..	..	..	..	..	..	..	..	..
163	Sleeve Pieces	..	..	..	..	..	..	..	..	..	..	..	..	..	..	..	..	..	..	..	..
164	Chimney Adaptors	..	..	..	..	..	..	..	..	..	..	..	..	..	..	..	..	..	..	..	..
165	Swivel Bearings	..	..	..	..	..	..	..	..	..	..	..	..	..	..	..	..	..	..	..	..
166	End Bearings	..	..	..	..	..	..	..	..	..	..	..	..	..	..	..	..	..	..	..	..
167b	Flanged Ring, 9 $\frac{1}{2}$ " diam.	..	..	..	..	..	..	..	..	..	..	..	..	..	..	..	..	..	..	..	..
168	Ball Bearings, 4 $\frac{1}{2}$ " diam.	..	..	..	..	..	..	..	..	..	..	..	..	..	..	..	..	..	..	..	..
171	Socket Couplings	..	..	..	..	..	..	..	..	..	..	..	..	..	..	..	..	..	..	..	..
175	Flexible Couplings Units	..	..	..	..	..	..	..	..	..	..	..	..	..	..	..	..	..	..	..	..
176	Anchoring Springs for Cord	..	..	..	..	..	..	..	..	..	..	..	..	..	..	..	..	..	..	..	..
179	Rod Socket	..	..	..	..	..	..	..	..	..	..	..	..	..	..	..	..	..	..	..	..
185	Steering Wheel, $\frac{1}{2}$ " diam.	..	..</																		

# MECCANO PARTS

- 3**  
Perforated Strips
- |     |                    |     |                   |                   |
|-----|--------------------|-----|-------------------|-------------------|
| No. | 12 $\frac{1}{2}$ " | No. | 3.                | 3 $\frac{1}{2}$ " |
| 1a. | 9 $\frac{1}{2}$ "  | 4.  | 3"                |                   |
| 1b. | 7 $\frac{1}{2}$ "  | 5.  | 2 $\frac{1}{2}$ " |                   |
| 2.  | 5 $\frac{1}{2}$ "  | 6.  | 2"                |                   |
| 2a. | 4 $\frac{1}{2}$ "  | 6a. | 1 $\frac{1}{2}$ " |                   |

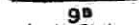

**9b**

- Angle Girders**
- |     |                    |     |                   |
|-----|--------------------|-----|-------------------|
| 7.  | 24 $\frac{1}{2}$ " | 9a. | 4 $\frac{1}{2}$ " |
| 7a. | 18 $\frac{1}{2}$ " | 9b. | 3 $\frac{1}{2}$ " |
| 8.  | 12 $\frac{1}{2}$ " | 9c. | 3"                |
| 8a. | 9 $\frac{1}{2}$ "  | 9d. | 2 $\frac{1}{2}$ " |
| 8b. | 7 $\frac{1}{2}$ "  | 9e. | 2"                |
| 9.  | 5 $\frac{1}{2}$ "  | 9f. | 1 $\frac{1}{2}$ " |



- 10** Fishplates  
**11** Double Brackets  
**12** Angle Brackets,  
12a. " "  $\frac{1}{2}$ " x  $\frac{1}{2}$ "  
12b. " "  $1$ " x  $1$ "  
12c. " "  $1$ " x  $\frac{1}{2}$ "  
**12c.** Obtuse Angle Brackets,  $\frac{1}{2}$ " x  $\frac{1}{2}$ "

- Axle Rods.**
- |      |                    |      |                   |
|------|--------------------|------|-------------------|
| 13.  | 11 $\frac{1}{2}$ " | 16.  | 3 $\frac{1}{2}$ " |
| 13a. | 8 $\frac{1}{2}$ "  | 16a. | 2 $\frac{1}{2}$ " |
| 14.  | 6 $\frac{1}{2}$ "  | 16b. | 3"                |
| 15.  | 5 $\frac{1}{2}$ "  | 17.  | 2"                |
| 15a. | 4 $\frac{1}{2}$ "  | 18a. | 1 $\frac{1}{2}$ " |
| 15b. | 4"                 | 18b. | 1"                |

- 19g.** Crank Handles, 3 $\frac{1}{2}$ " with Erinoid grip  
**19h.** " " 5 $\frac{1}{2}$ " " "  
**19s.** " " 3 $\frac{1}{2}$ " without " "

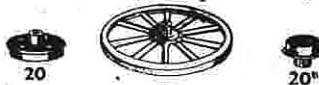

- 19a.** Spoked Wheels, 3" diam.  
**20.** Flanged Wheels, 1 $\frac{1}{2}$ " diam.  
**20b.** " " " "



- Pulleys**
- |      |                              |
|------|------------------------------|
| 19b. | 3" diam. with boss and screw |
| 19c. | 6"                           |
| 20a. | 2" " " "                     |
| 21.  | 1 $\frac{1}{2}$ " " " "      |
| 22.  | 1" " " "                     |
| 22a. | 1" " without " "             |
| 23.  | 1" " " " "                   |
| 23a. | 1" " with " "                |

- 24** Bush Wheels, 1 $\frac{1}{2}$ " diam.  
**24a.** Wheel Disc, 1 $\frac{1}{2}$ " diam., without bush

- 26b**
- |      |     |          |    |        |                 |       |    |       |
|------|-----|----------|----|--------|-----------------|-------|----|-------|
| No.  | 25. | Pinions, | 2" | diam., | $\frac{1}{4}$ " | face, | 25 | teeth |
| 25a. | "   | "        | "  | "      | "               | "     | 25 | "     |
| 25b. | "   | "        | "  | "      | "               | "     | 25 | "     |
| 26.  | "   | "        | "  | "      | "               | "     | 19 | "     |
| 26a. | "   | "        | "  | "      | "               | "     | 19 | "     |
| 26b. | "   | "        | "  | "      | "               | "     | 19 | "     |



- Gear Wheels**
- |      |     |        |                   |       |
|------|-----|--------|-------------------|-------|
| 27.  | 50  | teeth, | 1 $\frac{1}{2}$ " | diam. |
| 27a. | 57  | "      | 1 $\frac{1}{2}$ " | "     |
| 27b. | 133 | "      | 3 $\frac{1}{2}$ " | "     |
| 27c. | 95  | "      | 2 $\frac{1}{2}$ " | "     |

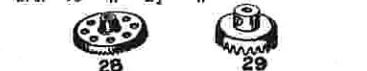

- 28.** Contrate Wheels, 1 $\frac{1}{2}$ " diam., 50 teeth  
**29.** " " " " 25 "



- 30.** Bevel Gears,  $\frac{3}{4}$ " diam., 26 teeth (for use in pairs)  
**30a.** " " " " 16 " } Can only be  
**30c.** " " " " 48 " } used together



- 31.** Gear Wheels, 1" diam.,  $\frac{1}{4}$ " face, 38 teeth  
**32.** Worms,  $\frac{1}{2}$ " diam.



- 34.** Spanners  
**34b.** Box Spanners



- 35.** Spring Clips ... box of 20  
**35a.** " " " " " box of 60  
**36.** Screwdrivers  
**36a.** " " Extra Long  
**36a.** Drift (for levering bolt holes into line)  
**37.** Nuts and Bolts,  $\frac{3}{16}$ " ... box of 12  
**37a.** Nuts ... box of 50  
**37b.** Bolts,  $\frac{3}{16}$ " ... box of 50  
**37f.** Nuts and Bolts,  $\frac{3}{16}$ " ... box of 50  
**37g.** " " " " " box of 144  
**38.** Washers ... pkt. of 20  
**38s.** " " " " " box of 60  
**38d.** " " " " " pkt. of 12  
**40.** Hanks of Cord

- 41.** Propeller Blades

- 43.** Tension Springs, 2" long
- 44.** Bent Strips, stepped  
**45.** Double Bent Strips  
**46.** Double Angle Strips, 2 $\frac{1}{2}$ " x 1"  
**47.** " " " " 2 $\frac{1}{2}$ " x 1"  
**47a.** " " " " 2 $\frac{1}{2}$ " x 1"  
**48.** " " " " 2 $\frac{1}{2}$ " x 1"  
**48a.** " " " " 2 $\frac{1}{2}$ " x 1"  
**48b.** " " " " 2 $\frac{1}{2}$ " x 1"  
**48c.** " " " " 2 $\frac{1}{2}$ " x 1"  
**48d.** " " " " 2 $\frac{1}{2}$ " x 1"

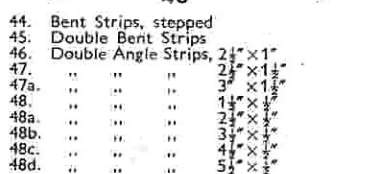

- 50.** Slide Pieces
- 51.** Flanged Plates, 2 $\frac{1}{2}$ " x 1 $\frac{1}{2}$ "  
**52.** " " " " 5 $\frac{1}{2}$ " x 2 $\frac{1}{2}$ "  
**52a.** Flat Plates, 5 $\frac{1}{2}$ " x 3 $\frac{1}{2}$ "  
**53.** Flanged Plates, 3 $\frac{1}{2}$ " x 2 $\frac{1}{2}$ "  
**53a.** Flat Plates, 4 $\frac{1}{2}$ " x 2 $\frac{1}{2}$ "



- 54.** Flanged Sector Plates, 4 $\frac{1}{2}$ " long

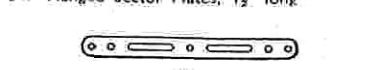

- 55.** Perforated Strips, slotted, 5 $\frac{1}{2}$ " long  
**55a.** " " " " 2 $\frac{1}{2}$ " long



- 57b.** Hooks, Loaded, Large  
**57c.** " " " Small



- 58.** Spring Cord, 40" Length  
**58a.** Coupling Screws for Spring Cord  
**58b.** Hooks for Spring Cord



- 59.** Collars, with screws



- 61.** Windmill Sails

- 62.** Cranks  
**62a.** Threaded Cranks  
**62b.** Double Arm Cranks

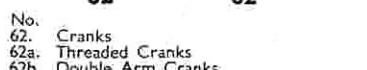

- 63.** Couplings  
**63b.** Strip Couplings  
**63c.** Threaded Couplings



- 64.** Threaded Bosses  
**65.** Centre Forks

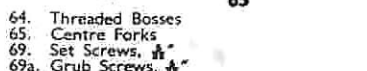

- 69.** Set Screws,  $\frac{1}{4}$ "  
**69a.** Grub Screws,  $\frac{1}{4}$ "  
**69b.** " " " "  $\frac{3}{8}$ "  
**69c.** " " " "  $\frac{1}{2}$ "



- 70.** Flat Plates, 5 $\frac{1}{2}$ " x 2 $\frac{1}{2}$ "  
**72.** " " " " 2 $\frac{1}{2}$ " x 2 $\frac{1}{2}$ "  
**73.** " " " " 3" x 1 $\frac{1}{2}$ "  
**76.** Triangular Plates, 2 $\frac{1}{2}$ "  
**77.** " " " " 1"

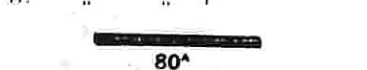

- 80a.** Screwed Rods  
**80b.** 4 $\frac{1}{2}$ "  
**80c.** 3 $\frac{1}{2}$ "  
**81.** 2"  
**82.** 1"

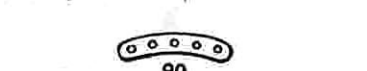

- 89.** Curved Strips, 5 $\frac{1}{2}$ ", 10" radius  
**89a.** " " " " 3", stepped, 1 $\frac{1}{2}$ " radius,  
4 to circle  
**89b.** Curved Strips, 4", stepped, 4 $\frac{1}{2}$ " radius,  
8 to circle

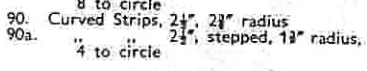

- 90.** Curved Strips, 2 $\frac{1}{2}$ ", 2 $\frac{1}{2}$ " radius  
**90a.** " " " " 2 $\frac{1}{2}$ ", stepped, 1 $\frac{1}{2}$ " radius,  
4 to circle

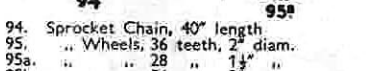

- 94.** Sprocket Chain, 40" length  
**95.** " " " " " " 36 teeth, 2" diam.  
**95a.** " " " " " " 28 " " 1 $\frac{1}{2}$ " " "  
**95b.** " " " " " " 56 " " 3" " "  
**96.** " " " " " " 18 " " 1" " "  
**96a.** " " " " " " 14 " "  $\frac{3}{4}$ " " "



- 99.** Braced Girders  
**99a.** 9 $\frac{1}{2}$ " long  
**99b.** 7 $\frac{1}{2}$ " " "  
**100.** 5 $\frac{1}{2}$ " " "  
**100a.** 4 $\frac{1}{2}$ " " "



- 101.** Healds, for looms  
**102.** Single Bent Strips



- 103.** Flat Girders  
**103a.** 5 $\frac{1}{2}$ " long  
**103b.** 9 $\frac{1}{2}$ " " "  
**103c.** 12 $\frac{1}{2}$ " " "  
**103d.** 4 $\frac{1}{2}$ " " "  
**103e.** 3" long  
**103f.** 2 $\frac{1}{2}$ " " "  
**103g.** 2" " "  
**103h.** 1 $\frac{1}{2}$ " " "  
**103i.** 7 $\frac{1}{2}$ " " "

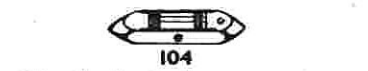

- 104.** Shuttles, for looms  
**105.** Reed Hooks, for looms

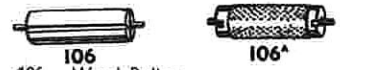

- 106.** Wood Rollers  
**106a.** Sand Rollers



- 108.** Corner Gusset  
**109.** Face Plates, 2 $\frac{1}{2}$ " diam.

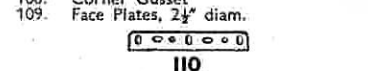

- 110.** Rack Strips, 3 $\frac{1}{2}$ " long  
**110a.** Bolts,  $\frac{1}{2}$ " " " "  
**111.** " " " " " "  $\frac{3}{8}$ " " "  
**111a.** " " " " " "  $\frac{1}{4}$ " " "



- 113.** Girder Frames



- 114.** Hinges  
**115.** Threaded Pins  
**116.** Fork Pieces, Large  
**116a.** " " Small  
**117.** Steel Balls,  $\frac{3}{8}$ " diam.

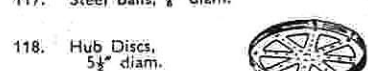

- 118.** Hub Discs, 5 $\frac{1}{2}$ " diam.

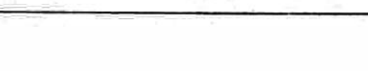

# MECCANO PARTS



No. 120b. Compression Springs,  $\frac{1}{4}$ " long



122. Miniature Loaded Sacks



123. Cone Pulleys,  $1\frac{1}{2}$ ", 1" and  $\frac{3}{4}$ " diam.



125. Reversed Angle Brackets,  $1\frac{1}{2}$ "



126. Trunnions



126a. Flat Trunnions



127. Bell Cranks



128. Bell Cranks, with Boss



129. Toothed Segments,  $1\frac{1}{2}$ " radius



130



130a

130. Eccentrics, Triple Throw,  $\frac{1}{4}$ ",  $\frac{1}{2}$ " and  $\frac{3}{4}$ "  
130a. Eccentrics, Single Throw,  $\frac{1}{4}$ "



131

131. Dredger Buckets



132

132. Flywheels,  $2\frac{1}{2}$ " diam.



133

133. Corner Brackets,  $1\frac{1}{2}$ "



133a

133a. " " " " " " " "



134

No. 134. Crank Shafts, 1" stroke



136

136. Handrail Supports



137

136a. Handrail Couplings  
137. Wheel Flanges



136A



138a

138a. Ships' Funnels



139

139. Flanged Brackets (right)  
139a. " " (left)



140

140. Universal Couplings



142

142. Rubber Rings (to fit 3" diam. rims)



142a

142a. Motor Tyres (to fit 2" diam. rims)

142b. " " " " " "

142c. " " " " " "

142d. " " " " " "



143

143. Circular Girders,  $5\frac{1}{2}$ " diam.



144

No. 144. Dog Clutches

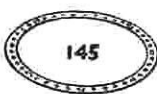

145

145. Circular Strips,  $7\frac{1}{2}$ " diam. overall

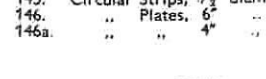

146

146. " " Plates, 6" " "

146a. " " " " " " " "



147 & 148

147. Pawls, with Pivot Bolt and Nuts  
147a. Pawls  
147b. Pivot Bolts with 2 Nuts  
147c. Pawls without boss  
148. Ratchet Wheels



151

151. Pulley Blocks, Single Sheave  
152. " " Two " "  
153. " " Three " "



154 & 154a

154a. Corner Angle Brackets,  $\frac{1}{2}$ " (right-hand)  
154b. Corner Angle Brackets,  $\frac{1}{2}$ " (left-hand)  
155. Rubber Rings (for 1" Pulleys)



157

157. Fans, 2" diam.



160

160. Channel Bearings,  $1\frac{1}{2}$ " x  $1\frac{1}{2}$ " x  $\frac{1}{2}$ "

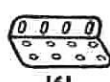

161

161. Girder Brackets, 2" x  $1\frac{1}{2}$ " x  $\frac{1}{2}$ "



163



162

No. 162. Boilers, complete, 5" long x  $2\frac{1}{4}$ " diam.

162a. " " Ends,  $2\frac{1}{4}$ " diam. x  $\frac{1}{16}$ "

162b. " " without ends,  $4\frac{1}{2}$ " long x  $2\frac{1}{4}$ " diam.

163. Sleeve Pieces,  $1\frac{1}{2}$ " long x  $\frac{1}{16}$ " diam.

164. Chimney Adaptors,  $\frac{3}{8}$ " diam. x  $\frac{1}{2}$ " high



164



165

165. Swivel Bearings



166

166. End

167b. Flanged Ring,  $9\frac{1}{2}$ " diam

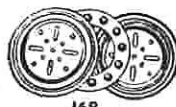

168

168. Ball Bearings, 4" diam.  
168a. " Races, flanged discs,  $3\frac{1}{2}$ " diam.  
168b. " " toothed " " 4" diam.  
168c. " Cages,  $3\frac{1}{2}$ " diam., complete with balls.



171

171. Socket Couplings

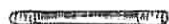

175

175. Flexible Coupling Units



176

176. Anchoring Springs for Cord



179

179. Rod Sockets

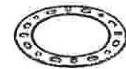

180

180. Gear Rings,  $3\frac{1}{2}$ " diam. (133 ext. teeth, 95 int.)



185

No. 185. Steering Wheels,  $1\frac{1}{2}$ " diam.

186. Driving Bands,  $2\frac{1}{2}$ " (Light)

186a. " " " " " "

186b. " " " " " "

186c. " " " " " (Heavy)

186d. " " " " " "

186e. " " " " " "

187. Road Wheels,  $2\frac{1}{2}$ " diam.

187a. Conical Disc,  $1\frac{1}{2}$ " diam.

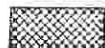

192

Flexible Plates.

188.  $2\frac{1}{2}$ " x  $1\frac{1}{2}$ "

189.  $5\frac{1}{2}$ " x  $1\frac{1}{2}$ "

190.  $3\frac{1}{2}$ " x  $2\frac{1}{2}$ "

190a.  $3\frac{1}{2}$ " x  $2\frac{1}{2}$ "



197

191.  $4\frac{1}{2}$ " x  $2\frac{1}{2}$ "

192.  $5\frac{1}{2}$ " x  $2\frac{1}{2}$ "

Strip Plates

196.  $9\frac{1}{2}$ " x  $2\frac{1}{2}$ "

197.  $12\frac{1}{2}$ " x  $2\frac{1}{2}$ "



200

198. Hinged Flat Plates,  $4\frac{1}{2}$ " x  $2\frac{1}{2}$ "



199

199. Curved Plates, U-Section

200. " " " " " " " " radius

200. " " " " " " " " radius



211A



211B

211a. Helical Gear  $\frac{1}{4}$ " | Can only be used together  
211b. " " " " " " " "



212

212. Rod and Strip Connectors



213

213. Rod Connectors



215

215. Formed Slotted Strips 3"



214

214. Semi-Circular Plates  $2\frac{1}{2}$ "



216

216. Cylinders,  $2\frac{1}{2}$ " long,  $1\frac{1}{2}$ " diam.