

# MECCANO

INSTRUCTIONS FOR  
No. 2a ACCESSORY OUTFIT

No.  
46.2a

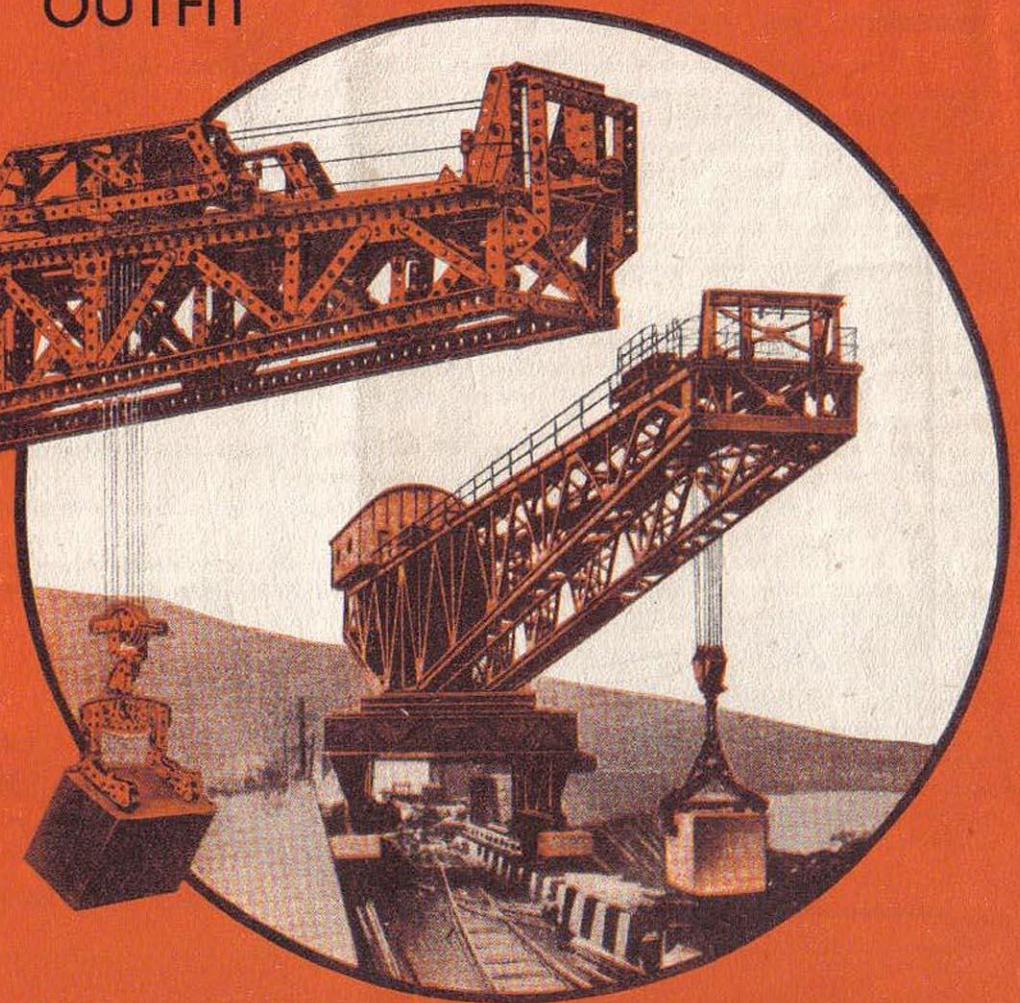

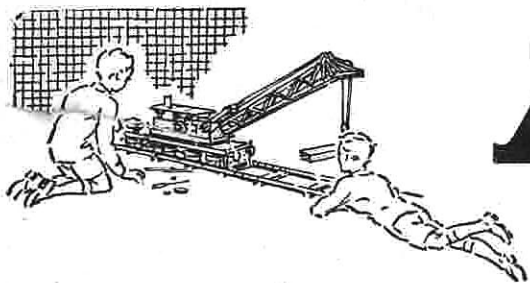

# MECCANO

*Real Engineering in Miniature*

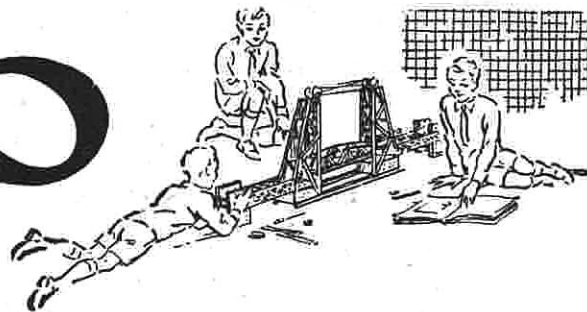

## MODEL-BUILDING WITH MECCANO

There is no limit to the number of models that can be built with Meccano—Cranes, Clocks, Motor Cars, Aeroplanes, Machine Tools, Locomotives—in fact everything that interests boys. A screwdriver and a spanner, both of which are provided in each Outfit, are the only tools necessary.

When you have built all the models illustrated in the Manuals of Instruction the fun is not over, but is just beginning. Now comes the chance to make use of your own ideas. First of all, re-build some of the models with small changes in construction that may occur to you; then try building models entirely of your own design. In doing this you will feel the real thrill of the engineer and the inventor.

## HOW TO BUILD UP YOUR OUTFIT

Meccano is sold in 11 different Outfits, ranging from No. 0 to No. 10. Each Outfit from No. 1 upwards can be converted into the one next larger by the purchase of an Accessory Outfit. Thus Meccano No. 1 Outfit can be converted into No. 2 Outfit by adding to it a No. 1a Accessory Outfit. No. 2a Outfit would then convert it into a No. 3, and so on. In this way, no matter with which Outfit you begin, you can build it up by degrees until you have a No. 10 Outfit.

All Meccano parts are of the same high quality and finish, but the larger Outfits contain a greater quantity and variety, making possible the construction of more elaborate models.

**Special Note.**—The Meccano Plates (Flanged, Flat, Curved, etc.) are shown in the Manuals with diagonal white lines. In the new Meccano Outfits these parts are plain.

Several of the illustrations in this Manual show how miniature figures and various small articles can be introduced to add realism to the models. These are not included in the Outfit. Many of them are Meccano Dinky Toys that can be bought separately from your Meccano dealer.

## THE "MECCANO MAGAZINE"

The "Meccano Magazine" is published specially for Meccano boys. Every month it describes and illustrates new Meccano models for Outfits of all sizes, and deals with suggestions from readers for new Meccano parts and for new methods of using the existing parts.

There are model-building competitions specially

planned to give an equal chance to the owners of small and large Outfits. In addition, there are splendid articles on such subjects as Railways, Famous Engineers and Inventors, Electricity, Chemistry, Bridges, Cranes and Aeroplanes, and special sections dealing with the latest Engineering, Aviation and Shipping News. Other pages deal with Stamp Collecting, and Books of interest to boys; and a feature of outstanding popularity is the section devoted to short articles from readers.

If you are not already a reader write to the Editor for full particulars, or order a copy from your Meccano dealer, or from any newsagent.

## THE MECCANO GUILD

Every owner of a Meccano Outfit should join the Meccano Guild. This is a world-wide organisation, started at the request of Meccano boys. Its primary object is to bring boys together and to make them feel that they are all members of a great brotherhood, each trying to help others to get the very best out of life. Its members are in constant touch with Headquarters, giving news of their activities and being guided in their hobbies and interests. Write for full particulars and an application form to the Secretary, Meccano Guild, Binns Road, Liverpool 13.

Clubs founded and established under the guidance of the Guild Secretary provide Meccano boys with opportunities of enjoying to the utmost the fun of model-building. Each has its Leader, Secretary, Treasurer and other officials. With the exception of the Leader, all the officials are boys, and as far as possible the proceedings of the clubs are conducted by boys.

## MECCANO SERVICE

The service of Meccano does not end with selling an Outfit and an Instruction Manual. If ever you are in any difficulty with your models, or if you want advice on anything connected with this great hobby, write to us. We receive hundreds of interesting letters from boys in all parts of the world, and each of these is answered personally by one of our staff of experienced experts.

Whatever your problem may be, write to us about it. Do not hesitate. We shall be delighted to help you in any way possible.



THE FINEST HOBBY IN THE WORLD FOR BOYS

### 3.1 "BLUEBIRD" RACING CAR

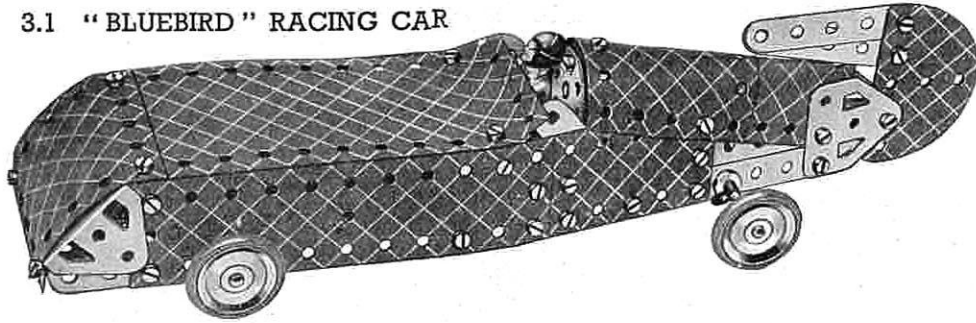

The  $5\frac{1}{2}'' \times 2\frac{3}{4}''$  Flanged Plate is used for the front end of the chassis and the two  $5\frac{1}{2}'' \times 1\frac{1}{4}''$  Flexible Plates are bolted on each side in the third hole from the front end of the chassis. The two  $5\frac{1}{2}''$  Strips forming the rear end of the chassis overlap the  $5\frac{1}{2}'' \times 1\frac{1}{4}''$  Flexible Plates one hole.

Parts required			
2 of No. 2	1 of No. 24a	2 of No. 126	1 of No. 192
6 " " 5	2 " " 35	2 " " 126a	2 " " 199
2 " " 10	39 " " 37	4 " " 155	1 " " 200
3 " " 12	4 " " 38	2 " " 188	2 " " 214
2 " " 16	1 " " 48a	2 " " 189	
4 " " 22	1 " " 52		

### 3.2 AIRCRAFT CARRIER

Flat Trunnions are used to fasten the  $5\frac{1}{2}'' \times 2\frac{3}{4}''$  Flanged Plate to the Strips that form the sides.

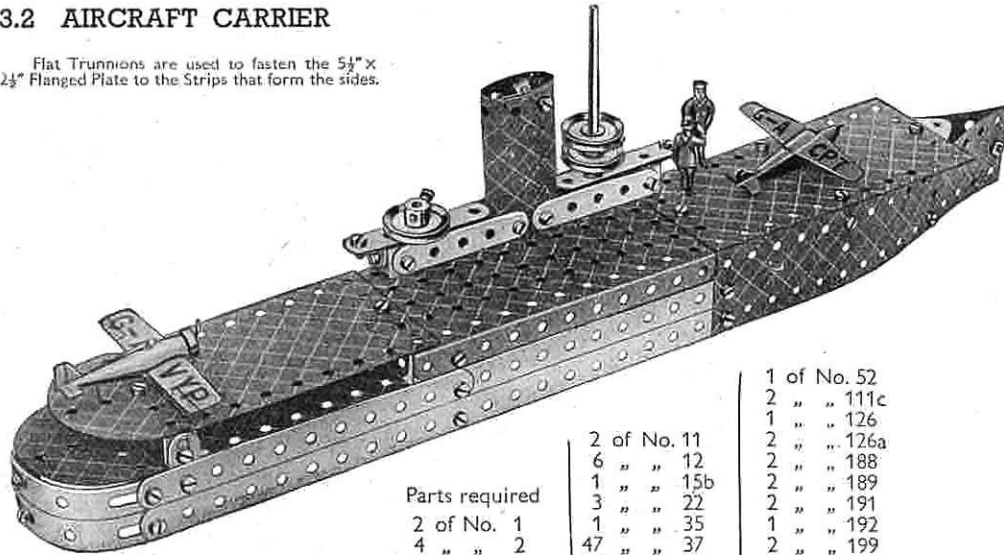

Parts required		
2 of No. 1	2 of No. 11	1 of No. 52
4 " " 2	6 " " 12	2 " " 111c
6 " " 5	1 " " 15b	1 " " 126
4 " " 10	3 " " 22	2 " " 126a
	1 " " 35	2 " " 188
	47 " " 37	2 " " 189
	2 " " 37a	2 " " 191
	1 " " 48a	1 " " 192
		2 " " 199
		2 " " 214
		4 " " 215

### 3.3 MARINE ENGINE

#### Parts required

2 of No. 1
4 " " 2
5 " " 5
8 " " 12
2 " " 15b
3 " " 16
3 " " 22
1 " " 24
2 " " 24a
4 " " 35
47 " " 37
9 " " 37a
6 " " 38
2 " " 48a
1 " " 52
3 " " 90a
3 " " 111c
2 " " 125
2 " " 126
1 " " 126a
1 " " 155
2 " " 187
2 " " 188
2 " " 189
1 " " 190
1 " " 191
2 " " 199
2 " " 200
1 " " 212
1 " " 213

Bolts 1 are lock-nutted. The Bolts 3 are  $\frac{3}{8}''$  long and are lock-nutted twice as shown. The  $2\frac{1}{2}''$  Strips 4 must be quite free to move when the crankshaft is rotated.

The left-hand piston rod is held by two Spring Clips, one at each side of the Angle Bracket pivotally fastened by the Bolts 1. Inside the cylinder the Rods slide through holes in a  $2\frac{1}{4}''$  Strip and a Trunnion 2. In order to show the construction clearly part of the cylinder has been cut away in the illustration.

The Rod carrying two 1" Pulleys passes through the centre hole in the outer Wheel Disc. A  $\frac{1}{2}'' \times \frac{1}{2}''$  Angle Bracket is bolted to the Disc in such a position that when the Disc is turned the Angle Bracket engages with a Spring Clip on the Rod. It is important that all nuts and bolts are made quite secure with the Spanner and Screwdriver.

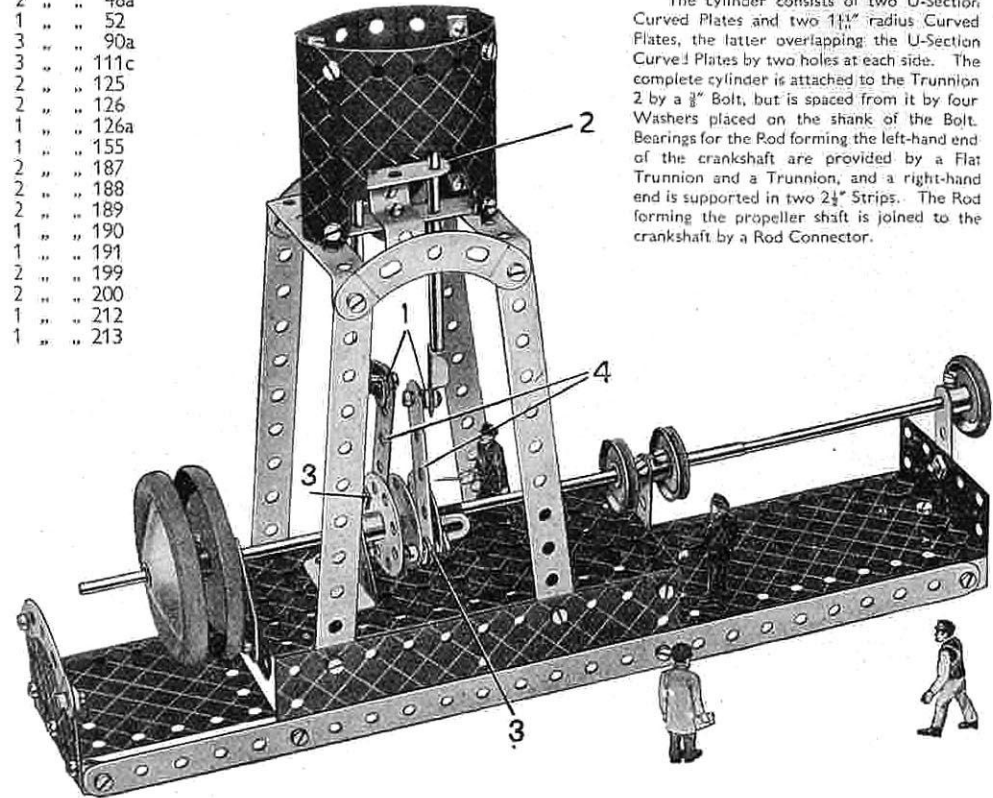

The cylinder consists of two U-Section Curved Plates and two  $1\frac{1}{4}''$  radius Curved Plates, the latter overlapping the U-Section Curved Plates by two holes at each side. The complete cylinder is attached to the Trunnion 2 by a  $\frac{3}{8}''$  Bolt, but is spaced from it by four Washers placed on the shank of the Bolt. Bearings for the Rod forming the left-hand end of the crankshaft are provided by a Flat Trunnion and a Trunnion, and a right-hand end is supported in two  $2\frac{1}{4}''$  Strips. The Rod forming the propeller shaft is joined to the crankshaft by a Rod Connector.

## 3.4 SWIVELLING JIB CRANE

A 1" fast Pulley 1 is fastened to the lower end of a 2" Rod, which passes into an is held in the boss of the Bush Wheel. The Pulley rests on the tyre of Pulley Wheel 2, which is fastened on Rod 3. When the Rod 3 is rotated the jib is caused to swivel. Supports for Rod 3 are formed by Fishplates, which are bolted through their elongated holes to the 2½" Strips shown in the illustration. The roof of the cab is fastened by means of Angle Brackets to two Flat Trunnions, and these in turn are bolted to the compound Strips bracing the jib.

## Parts required

2 of No. 1	1 of No. 18a	4 of No. 90a
6 " " 2	1 " " 19g	4 " " 111c
9 " " 5	4 " " 22	2 " " 126
4 " " 10	1 " " 23	2 " " 126a
1 " " 11	1 " " 24	2 " " 155
8 " " 12	4 " " 35	1 " " 176
2 " " 16	50 " " 37	2 " " 187
1 " " 17	4 " " 37a	2 " " 188
	3 " " 38	2 " " 189
	1 " " 40	1 " " 190
	2 " " 48a	2 " " 191
	1 " " 52	1 " " 199
	1 " " 57c	2 " " 200

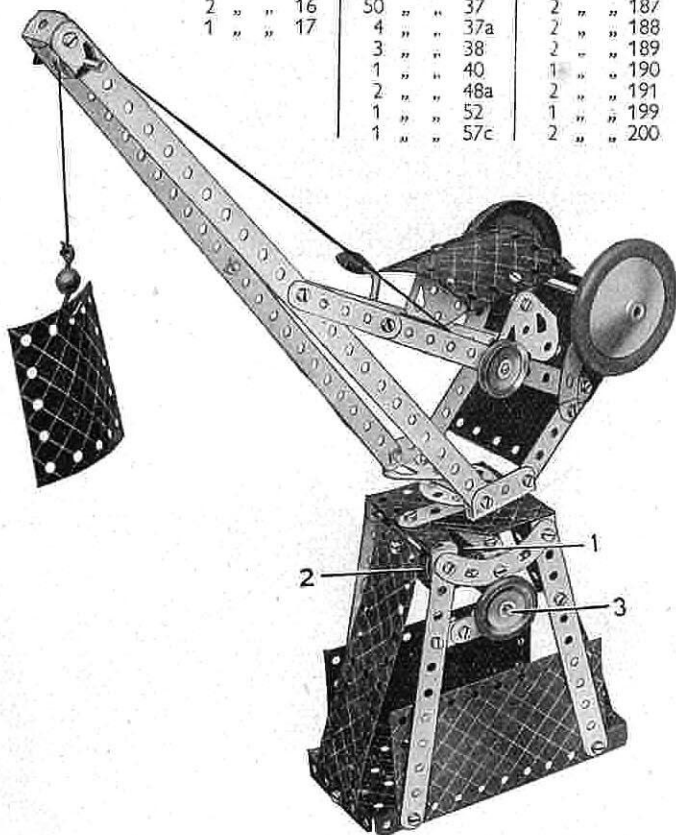

## 3.5 NOAH'S ARK

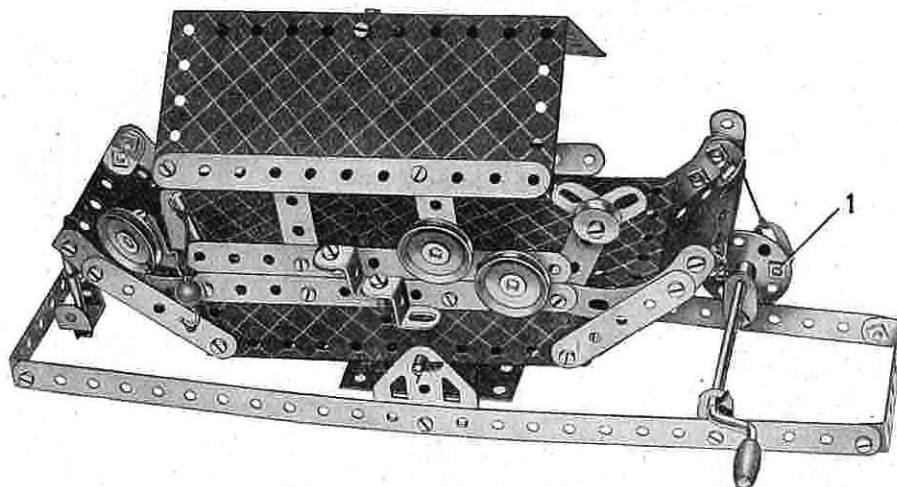

## Parts required

2 of No 1	1 of No. 18a	1 of No. 40	2 of No. 126
6 " " 2	1 " " 19g	1 " " 44	2 " " 126a
9 " " 5	3 " " 22	2 " " 48a	1 " " 176
5 " " 10	1 " " 23	1 " " 52	2 " " 188
2 " " 11	1 " " 24	1 " " 57c	2 " " 189
8 " " 12	6 " " 35	4 " " 90a	2 " " 190
1 " " 16	50 " " 37	5 " " 111c	2 " " 191
1 " " 17	3 " " 37a	2 " " 125	2 " " 192

A 5½" × 2½" Flanged Plate is used for the bottom of the ark and 5½" × 2½" Flexible Plates and 5½" Strips form the sides. The deck is fastened to the sides by ½" × ½" Angle Brackets.

The ark is pivoted on a 3½" Rod journalled in Flat Trunnions, the Rod passing through the flanges of the baseplate at the fifth holes from the end near the Crank Handle. The Crank Handle carries a Bush Wheel, and to this a Fishplate is lock-nutted at 1. A length of Cord is attached to the free hole of the Fishplate and is then tied to a Double Bracket bolted to the sides of the ark. When the Crank Handle is rotated, the downward motion of the Fishplate causes one end of the ark to be pulled down, but as the Fishplate rises again, the ark returns to its original position.

## 3.6 SWING

Two 2½" Strips overlapped one hole are attached to the tops of the 12½" Strips by ½" × ½" Angle Brackets.

## Parts required

2 of No. 1	2 of No. 48a
6 " " 5	1 " " 52
2 " " 10	2 " " 90a
8 " " 12	2 " " 126
34 " " 37	2 " " 190
1 " " 40	2 " " 191

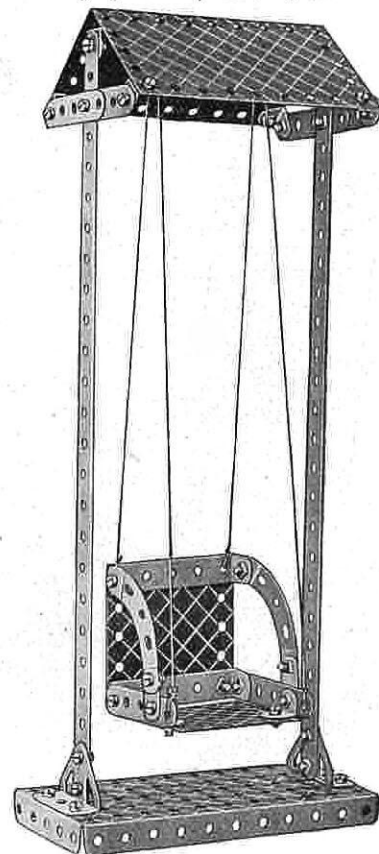

## 3.7 DENTIST'S CHAIR

## Parts required

4 of No. 2	1 of No. 48a
8 " " 5	1 " " 52
2 " " 10	2 " " 90a
3 " " 12	1 " " 190
1 " " 24	1 " " 191
36 " " 37	1 " " 200
1 " " 37a	

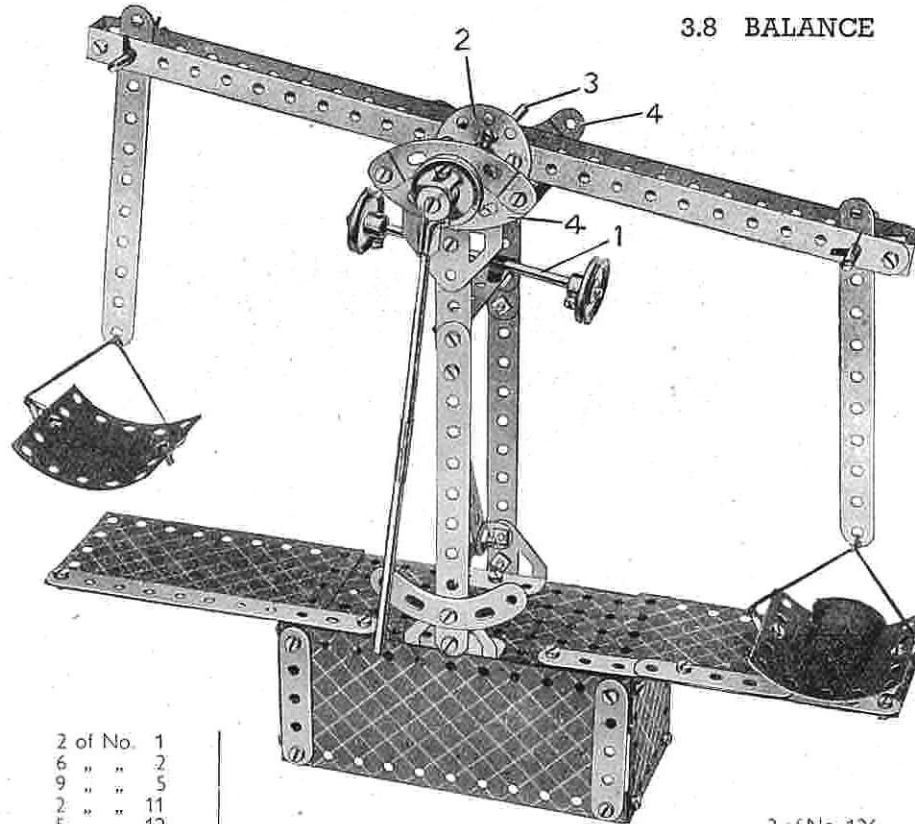
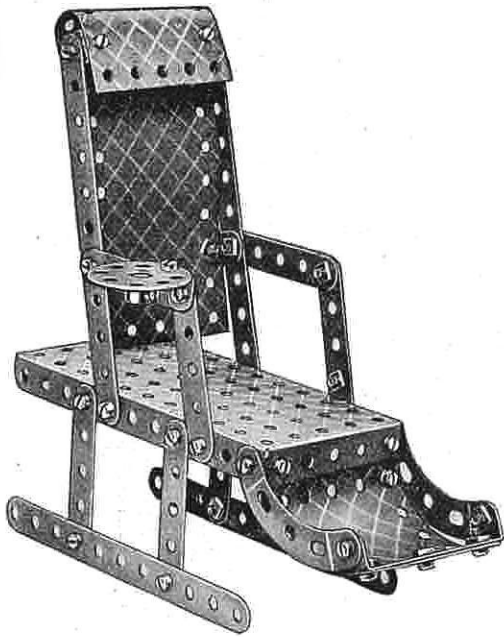

## 3.8 BALANCE

2 of No. 1
6 " " 2
9 " " 5
2 " " 11
5 " " 12
2 " " 15b
2 " " 16
2 " " 17
4 " " 22
1 " " 24
6 " " 35
50 " " 37

## Parts required

4 of No. 37a	1 of No. 52
5 " " 38	4 " " 90a
1 " " 40	4 " " 111c
1 " " 44	1 " " 125
2 " " 48a	2 " " 126

2 of No. 126a
2 " " 190
2 " " 191
2 " " 192
2 " " 200
1 " " 212
1 " " 213
2 " " 215

One of the 12½" Strips that form the beam of the balance is bolted across a Bush Wheel 2. The 3½" Rod 3 that is locked in the boss of the Bush Wheel rests on the two Curved Strips 4.

The Rod 1, by which the balance is adjusted, is pushed through the two holes of a Stepped Bent Strip fastened to the Bush Wheel 2 by a Reversed Angle Bracket. The 5½" Strips from which the scale pans are suspended are pivoted at their upper ends on 2" Rods, which are passed through holes in the 12½" Strips of the beam.

## 3.9 TOWER WAGON

A Stepped Bent Strip 1 is bolted in a horizontal position in the centre of the Flanged Plate, and a 2½" Curved Strip is bolted on top of it by the centre hole to form a seat. A Reversed Angle Bracket 2 is then bolted in one of the elongated holes of the Curved Strip to form a bearing for the Rod carrying the Bush Wheel.

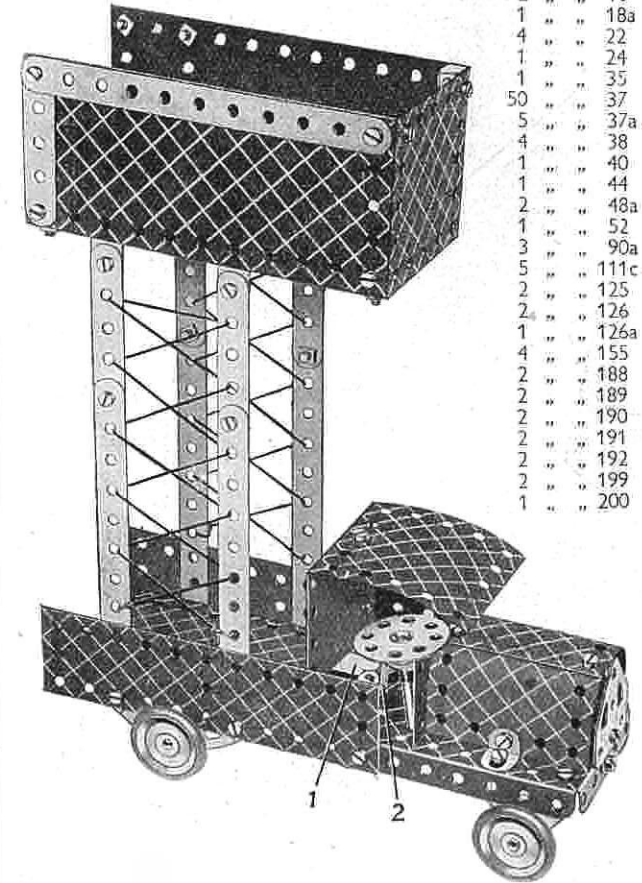

## Parts required

6 of No. 2
6 " " 5
1 " " 10
2 " " 11
8 " " 12
2 " " 16
1 " " 18a
4 " " 22
1 " " 24
1 " " 35
50 " " 37
5 " " 37a
4 " " 38
1 " " 40
1 " " 44
2 " " 48a
1 " " 52
3 " " 90a
5 " " 111c
2 " " 125
2 " " 126
1 " " 126a
4 " " 155
2 " " 188
2 " " 189
2 " " 190
2 " " 191
2 " " 192
2 " " 199
1 " " 200

## 3.10 ELECTRIC GENERATING SET

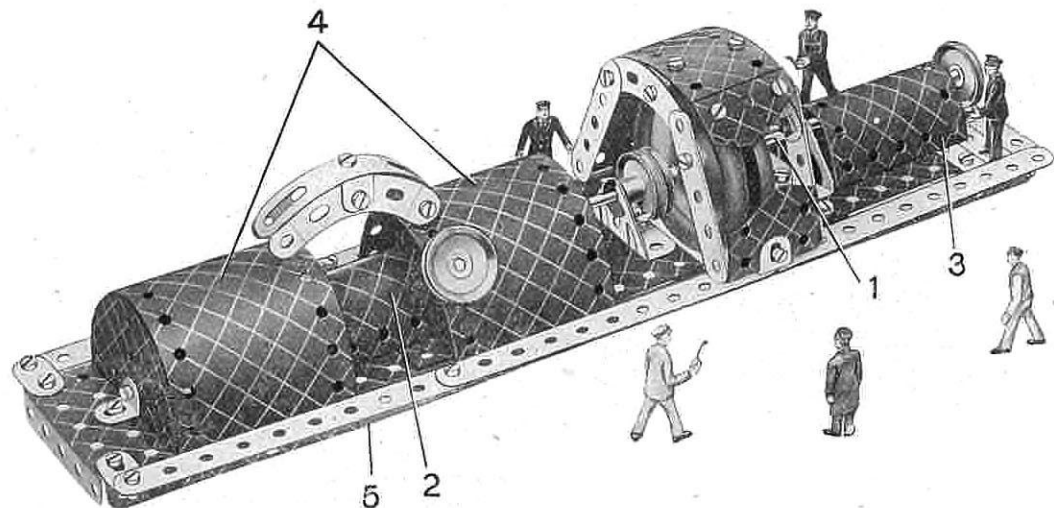

The base is constructed by bolting two 12½" Strips to the flanges of a 5½" × 2½" Flanged Plate 5, and joining them at their free ends by a 2½" × ½" Double Angle Strip. The space between the 12½" Strips is then filled in by Flexible Plates and 2½" Strips. The Rods that form the shaft of the machine are joined together at 1 by a Rod Connector. The bearings for the shaft are formed by two Trunnions. In the illustration part of the Flexible Plate has been cut away to show the structure of the armature and the commutator. The commutator consists of two 1" Pulleys and the armature of two Road Wheels, the bosses of which are placed in contact with each other.

The connecting pipe is formed from two 2½" Curved Strips and one 3" Formed Slotted Strip joined together at their centre holes by a Double Bracket, and is fastened to the turbine by means of an Angle Bracket. The U-Section Curved Plate 2 is held by a Spring Clip slipped on the upper end of a 2" Rod. One end of the Rod is passed through the middle hole in the top of the Plate, and its other end is then pushed through the Flexible Plate forming the base. The Rod is held by a Spring Clip underneath the Plate. The U-Section Curved Plate 3 is fixed to the base by an Angle Bracket on the rear side of the model. The two Flexible Plates 4 are bolted to the flanges of the 5½" × 2½" Flanged Plate 5. The 1" Pulley representing the steam control is held by a ¾" Bolt, which passes through a hole in one of the Flexible Plates 4, and is locked in the boss of the Pulley.

## Parts required

2 of No. 1	1 of No. 16	1 of No. 52	1 of No. 189
6 " " 2	1 " " 18a	4 " " 90a	1 " " 190
8 " " 5	4 " " 22	1 " " 111c	1 " " 191
3 " " 10	4 " " 35	2 " " 125	2 " " 192
2 " " 11	50 " " 37	2 " " 126	2 " " 199
8 " " 12	1 " " 38	2 " " 187	1 " " 213
1 " " 15b	2 " " 48a	1 " " 188	2 " " 214
	1 of No. 215		

## 3.11 TROTTING CAR

The seat of the car consists of two 2½" × 1½" Flexible Plates, overlapped two holes, and it carries at each end a Trunnion. The 3" Formed Slotted Strips that form the mudguards are supported by Reversed Angle Brackets 2, which are spaced from the Flexible Plate by three Washers. The axle consists of two 2" Rods joined by a Rod Connector, and is journalled in the Trunnions.

Each of the horses is built up as follows: Four 2½" Strips are bolted to a U-Section Curved Plate in the positions shown to form the legs, and two 2½" small radius Curved Strips represent the neck. A Rod is pushed through the centre holes of the U-Section Curved Plates and is supported in the end holes of the shafts. Two ¾" Rods carrying 1" Pulleys at each of their ends are journalled in the end holes of two of the forelegs and two of the hind-legs of the horses, as shown.

The driver's body is made with two Flat Trunnions, which are bolted together and then fitted with 2½" × ½" Double Angle Strips to represent legs. The Bolt that fixes the Stepped Bent Strip to the body holds also a Fishplate that supports a Wheel Disc representing the head. An Angle Bracket bolted to the Disc secures a Bush Wheel that has a ¼" Bolt fixed in its boss by its screw.

The whip is a 2" Rod held by Spring Clips in a Double Bracket, and the lash is attached to it by a Cord Anchoring Spring. The reins are fastened to the Fishplates that form the horses' heads, and also to the Double Bracket to which the whip is fixed. Short lengths of Cord fastened to the U-Section Curved Plates represent the horses' tails.

## Parts required

4 of No. 2	6 of No. 35	4 of No. 155
8 " " 5	33 " " 37	1 " " 176
5 " " 10	2 " " 37a	2 " " 187
1 " " 11	6 " " 38	2 " " 188
1 " " 12	1 " " 40	2 " " 199
1 " " 15b	1 " " 44	1 " " 213
2 " " 16	2 " " 48a	4 " " 215
2 " " 17	4 " " 90a	
1 " " 18a	3 " " 111c	
4 " " 22	2 " " 125	
1 " " 24	2 " " 126	
1 " " 24a	2 " " 126a	

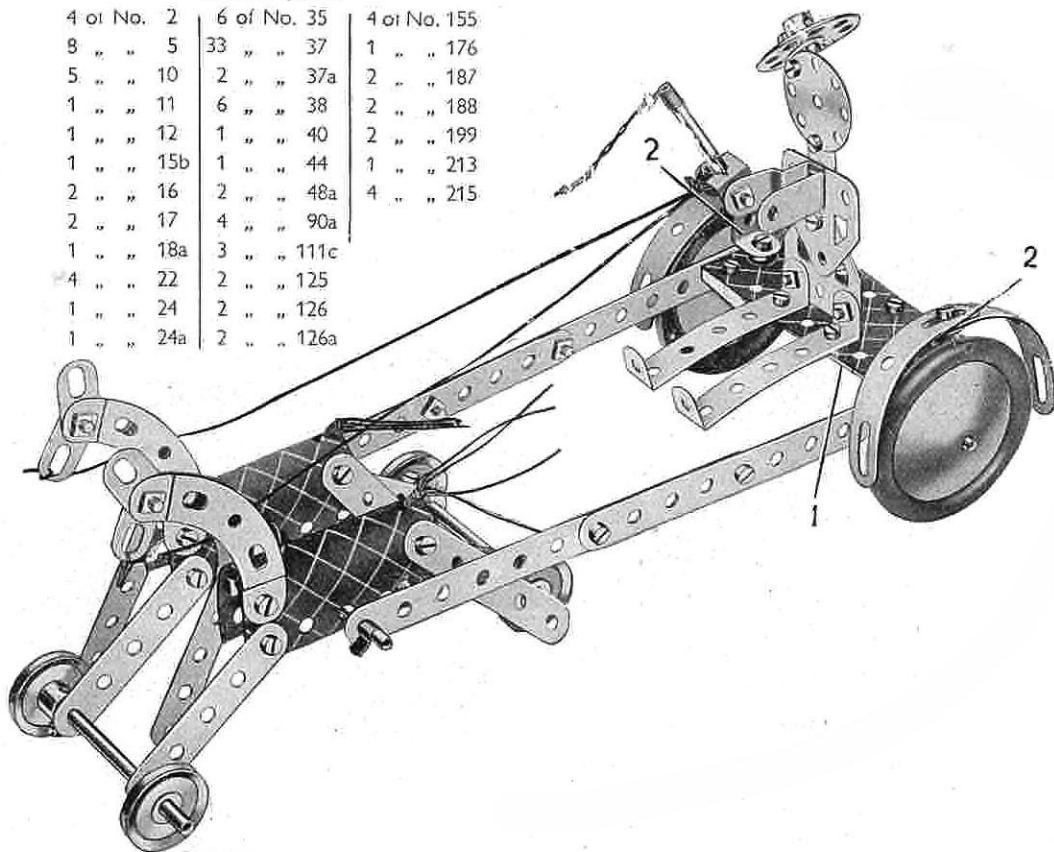

### 3.12 STEAM TRACTOR AND TRAILER

The steering column, a  $3\frac{1}{2}$ " Rod, is supported in the holes of a Double Bracket and a Reversed Angle Bracket bolted to the side of the cab. Cord is wound round the lower part of the Rod and its ends are tied to the  $2\frac{1}{2}$ " x  $\frac{1}{2}$ " Double Angle Strip that carries the front axle. Care must be taken that the Cord is wound tightly round the Rod, or it will slip when the steering wheel is rotated. The Rod 2 is supported in holes in the Flexible Plates that form the sides of the cab.

The Bush Wheel that forms the front of the boiler has two Angle Brackets bolted to it and a Rod passes through the free holes of these Brackets to hold the Bush Wheel in position. This Rod is joined by a Rod Connector to a 2" Rod that forms the chimney. The roof of the cab consists of a  $5\frac{1}{2}$ " x  $2\frac{1}{2}$ " Flexible Plate, and is held in position by Spring Clips placed on the two Rods that pass through it. The Fishplates 3 are bolted in the centre holes of the  $2\frac{1}{2}$ " Curved Strips. The Bolts 1 are locked in position and the Wheel Discs turn freely on them.

Parts required

4 of No. 2	1 of No. 23	2 of No. 48a	2 of No. 188
9 " " 5	1 " " 24	1 " " 52	2 " " 190
5 " " 10	2 " " 24a	2 " " 90a	2 " " 191
2 " " 11	4 " " 35	4 " " 111c	1 " " 192
8 " " 12	43 " " 37	2 " " 125	2 " " 199
2 " " 15b	8 " " 37a	2 " " 126	2 " " 200
2 " " 16	6 " " 38	2 " " 126a	1 " " 212
2 " " 17	2 " " 38d	3 " " 155	1 " " 213
1 " " 18a	1 " " 40	1 " " 176	1 " " 214
4 " " 22	1 " " 44	2 " " 187	

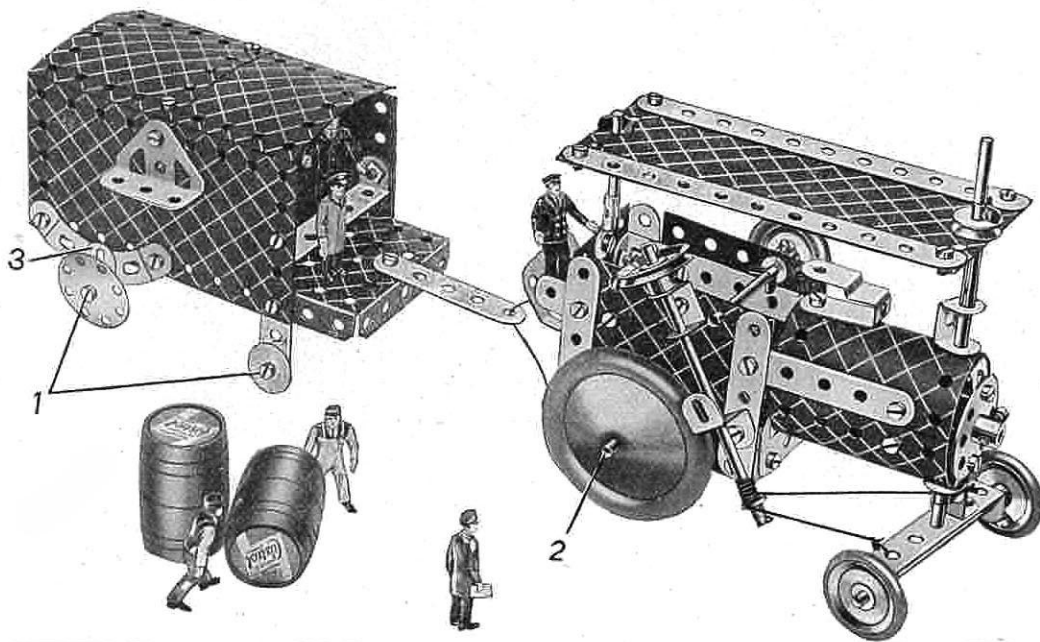

### 3.13 MECHANICAL HORSE AND TRAILER

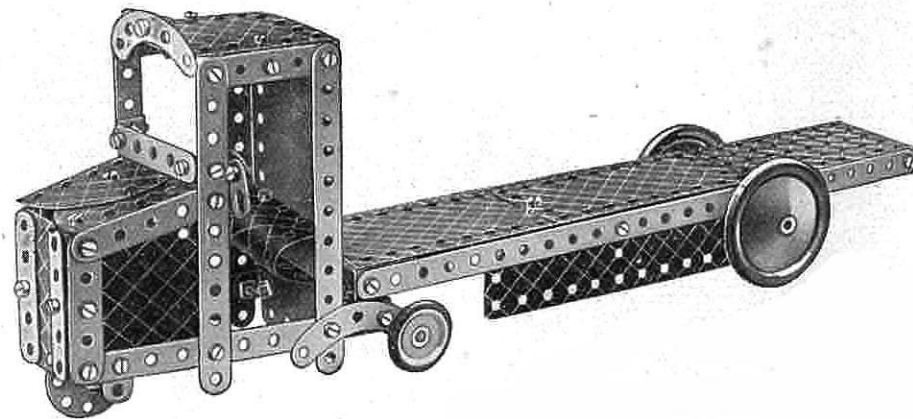

The chassis of the mechanical horse is built up on two  $5\frac{1}{2}$ " Strips extended at the rear by  $2\frac{1}{2}$ " Curved Strips that provide bearings for the rear axle. The method of building up the bonnet and cab is clear from the illustration. The rear ends of the  $5\frac{1}{2}$ " Strips are joined by a Curved Strip and two Double Brackets. At the centre of the Curved Strip is bolted a Wheel Disc through which passes a  $1\frac{1}{2}$ " Rod 1. This Rod engages in the centre hole of the Plate at the front of the trailer, and is retained in place by a Spring Clip and a Cord Anchoring Spring. A 1" Pulley and two Washers space the end of the trailer from the Wheel Disc. Bearings for the rear axle are provided by Flat Trunnions.

Parts required

2 of No. 1	1 of No. 52
6 " " 2	4 " " 90a
9 " " 5	6 " " 111c
4 " " 10	2 " " 125
2 " " 11	2 " " 126
8 " " 12	2 " " 126a
2 " " 16	2 " " 155
1 " " 17	1 " " 176
1 " " 18a	2 " " 187
3 " " 22	1 " " 188
1 " " 24	2 " " 189
1 " " 24a	2 " " 190
4 " " 35	2 " " 191
56 " " 37	1 " " 192
50 " " 37a	1 " " 199
2 " " 38	1 " " 200
2 " " 48a	2 " " 214

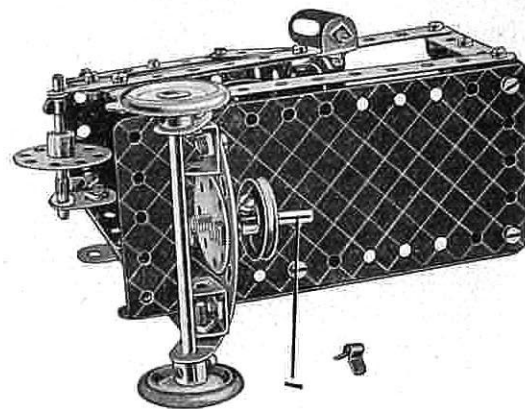

## 3.14 GIANT LORRY

The bonnet is made up of two U-Section Curved Plates overlapped three holes and attached to the  $5\frac{1}{2} \times 2\frac{1}{2}$ " Flanged Plate by two Angle Brackets. The front of the cabin is a  $2\frac{1}{2} \times 1\frac{1}{2}$ " Flexible Plate, which is attached to the chassis by a Reversed Angle Bracket. Bearings for the  $3\frac{1}{2}$ " Rods forming the front and rear axles are provided by Fishplates bolted to the flanges of the Flanged Plate.

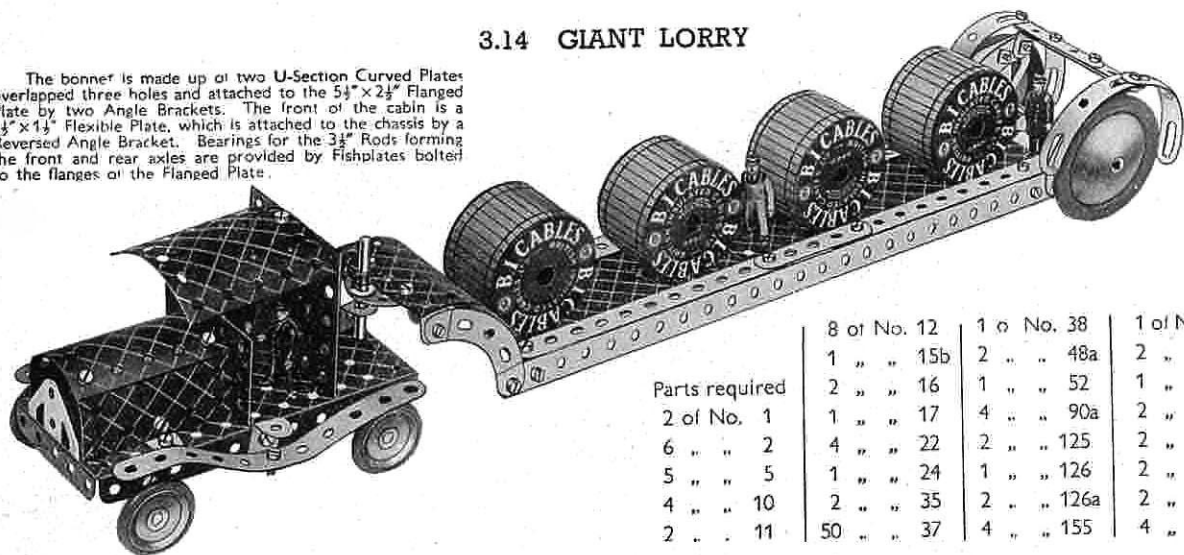

	8 of No. 12	1 of No. 38	1 of No. 176
	1 " " 15b	2 " " 48a	2 " " 187
Parts required	2 " " 16	1 " " 52	1 " " 188
2 of No. 1	1 " " 17	4 " " 90a	2 " " 190
6 " " 2	4 " " 22	2 " " 125	2 " " 192
5 " " 5	1 " " 24	1 " " 126	2 " " 199
4 " " 10	2 " " 35	2 " " 126a	2 " " 200
2 " " 11	50 " " 37	4 " " 155	4 " " 215

## 3.15 BATTLE CRUISER

Bolts 1 fasten the Strips to a Flat Trunnion so that the Strips are held rigid. Trunnion 2, which holds the rear guns, is fastened by a  $\frac{1}{2} \times \frac{1}{2}$ " Angle Bracket to the centre hole of  $2\frac{1}{2} \times \frac{1}{2}$ " Double Angle Strip 3. The forward guns also are held by a Trunnion, but this is fastened to a Double Bracket that in turn is bolted to the  $5\frac{1}{2} \times 2\frac{1}{2}$ " Flanged Plate.

The base of the turret is formed by a Bush Wheel, which is bolted to the deck. A  $3\frac{1}{2}$ " Rod is fastened in the boss of the Bush Wheel, and two Road Wheels are placed on it as shown.

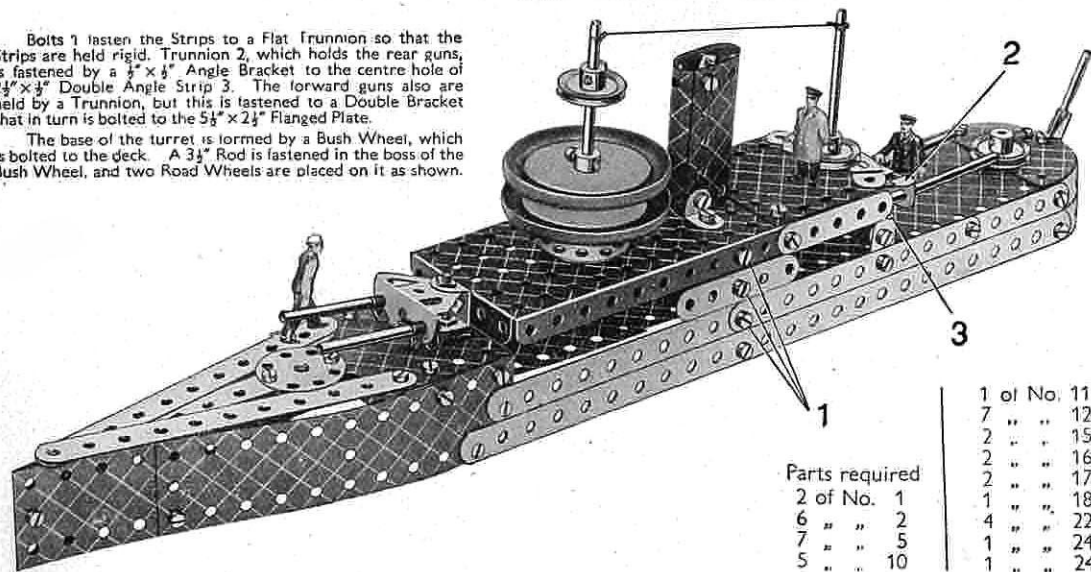

	1 of No. 11	6 of No. 35
	2 " " 12	50 " " 37
	2 " " 15b	6 " " 37a
Parts required	2 " " 16	1 " " 38d
2 of No. 1	2 " " 17	1 " " 40
6 " " 2	1 " " 18a	2 " " 48a
7 " " 5	2 " " 22	1 " " 52
5 " " 10	1 " " 24	1 " " 90a
	1 " " 24a	6 " " 111c
		2 " " 126
		2 " " 126a
		1 " " 176
		2 " " 187
		2 " " 188
		2 " " 189
		2 " " 190
		1 " " 191
		1 " " 192
		1 " " 199
		2 " " 200
		1 " " 212
		1 " " 214
		4 " " 215

## 3.16 NAVAL GUN

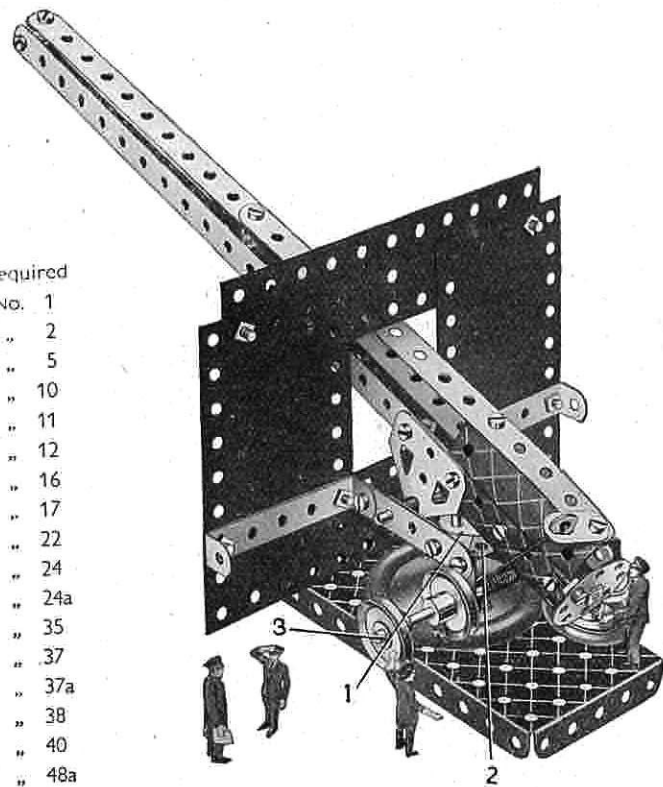

Parts required

2 of No. 1	28 " " 37
5 " " 2	2 " " 37a
3 " " 5	5 " " 38
3 " " 10	1 " " 40
2 " " 11	2 " " 48a
2 " " 12	1 " " 52
1 " " 16	2 " " 111c
2 " " 17	2 " " 126
4 " " 22	2 " " 126a
1 " " 24	1 " " 155
1 " " 24a	1 " " 176
4 " " 35	1 " " 187
2 " " 37	1 " " 187
2 " " 37a	1 " " 188
5 " " 38	1 " " 189
1 " " 40	2 " " 191
1 " " 40	2 " " 199
2 " " 48a	1 " " 200
1 " " 52	1 " " 212
2 " " 111c	1 " " 214
2 " " 126	4 " " 215
2 " " 126a	
1 " " 155	
1 " " 176	
1 " " 187	
1 " " 187	
1 " " 188	
1 " " 189	
2 " " 191	
2 " " 199	

The Flexible Plates forming the gun shield are fastened by means of Double Angle Strips and  $2\frac{1}{2}$ " Strips to two Trunnions 1. The Trunnions are bolted to Bush Wheel 2. A 2" Rod held in the boss of the Bush Wheel passes through a Road Wheel and the centre hole of the  $5\frac{1}{2} \times 2\frac{1}{2}$ " Flanged Plates. The Rod is fastened underneath the Flanged Plate by a Cord Anchoring Spring so that the gun is free to swivel.

The elevation of the gun is controlled by Rod 3. Cord is wound round the Rod, then passed through the hole of a Fishplate fastened at the rear end of the gun, and knotted to a Washer as shown. The Wheel Disc at the end of the gun is fastened by an Angle Bracket to the U-Section Curved Plates representing the breech.



### 3.17 FIRE-ENGINE

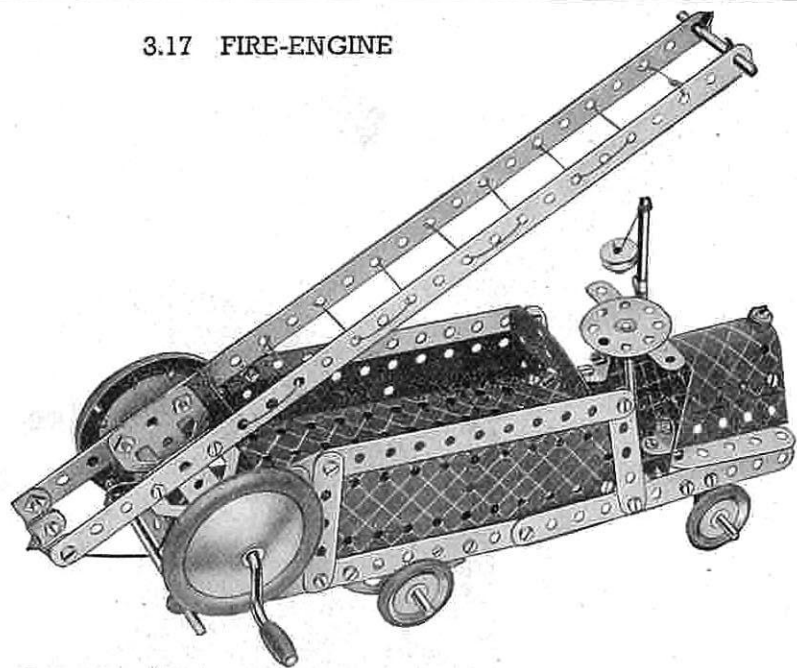

#### Parts required

2 of No. 1	2 of No. 125
6 " " 2	2 " " 126
8 " " 5	2 " " 126a
5 " " 10	4 " " 155
2 " " 11	1 " " 176
7 " " 12	2 " " 187
2 " " 15b	2 " " 188
2 " " 16	2 " " 189
1 " " 17	2 " " 190
1 " " 19g	1 " " 192
4 " " 22	1 " " 199
1 " " 23	1 " " 212
1 " " 24	1 " " 214
6 " " 35	
50 " " 37	
6 " " 37a	
5 " " 38	
1 " " 40	
2 " " 48a	
1 " " 52	
4 " " 90a	
6 " " 111c	

Two Flat Trunnions are bolted to the bottom of the ladder, and the shaft of the Crank Handle shown in Fig. 3.17a passes through the holes at their narrow ends. The bonnet, which is formed from a U-Section Curved Plate and two  $2\frac{1}{2} \times 1\frac{1}{2}$ " Flexible Plates, is fastened to the frame by Reversed Angle Brackets. These latter also support the  $2\frac{1}{2}$ " Strips at the side of the bonnet.

The  $3\frac{1}{2}$ " Rod representing the steering column passes through the free hole of a Fishplate bolted to the dashboard, then through a hole in the Flexible Plate at the bottom of the cab. It is fastened in position by a Cord Anchoring Spring.

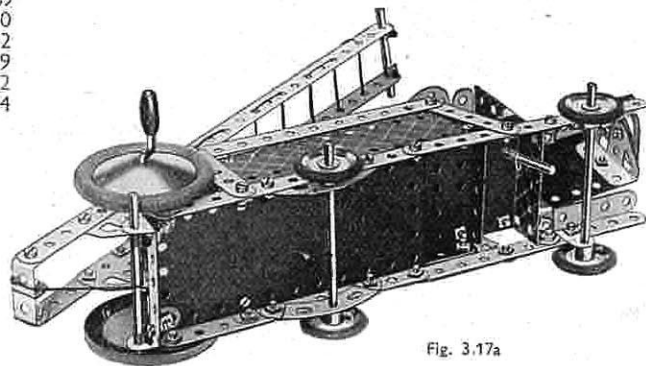
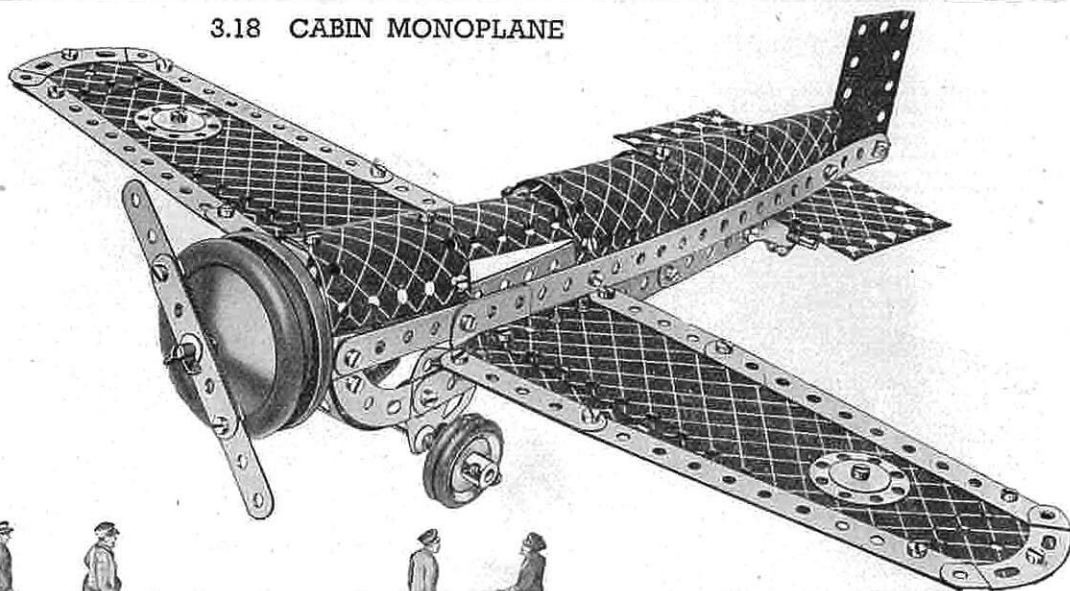

Fig. 3.17a

### 3.18 CABIN MONOPLANE



#### Parts required

2 of No. 1	4 of No. 22	1 of No. 44	2 of No. 188
6 " " 2	1 " " 23	2 " " 48a	2 " " 189
9 " " 5	1 " " 24	4 " " 90a	2 " " 190
5 " " 10	2 " " 24a	6 " " 111c	1 " " 191
1 " " 11	5 " " 35	2 " " 125	2 " " 192
8 " " 12	50 " " 37	2 " " 126	2 " " 199
1 " " 16	6 " " 37a	2 " " 126a	2 " " 200
1 " " 17	5 " " 38	4 " " 155	2 " " 214
1 " " 18a	2 " " 38d	2 " " 187	2 " " 215

The engine and propeller are attached by fastening a Bush Wheel to the nose of the fuselage by two Angle Brackets. A 2" Rod is locked in the boss of the Bush Wheel and forms the support for the Road Wheels and the compound strip representing the propeller.

The wings are attached to the fuselage by  $\frac{3}{4} \times \frac{1}{4}$ " Angle Brackets and Trunnions. The tail wheel is supported on a  $1\frac{1}{2}$ " Rod journalled in the holes of a Stepped Bent Strip fastened to the fuselage by a Double Bracket.

The Rod on which the double landing wheels are mounted passes through the holes in the narrow ends of two Flat Trunnions bolted to the fuselage.

## 3.19 BLOCK-SETTING CRANE

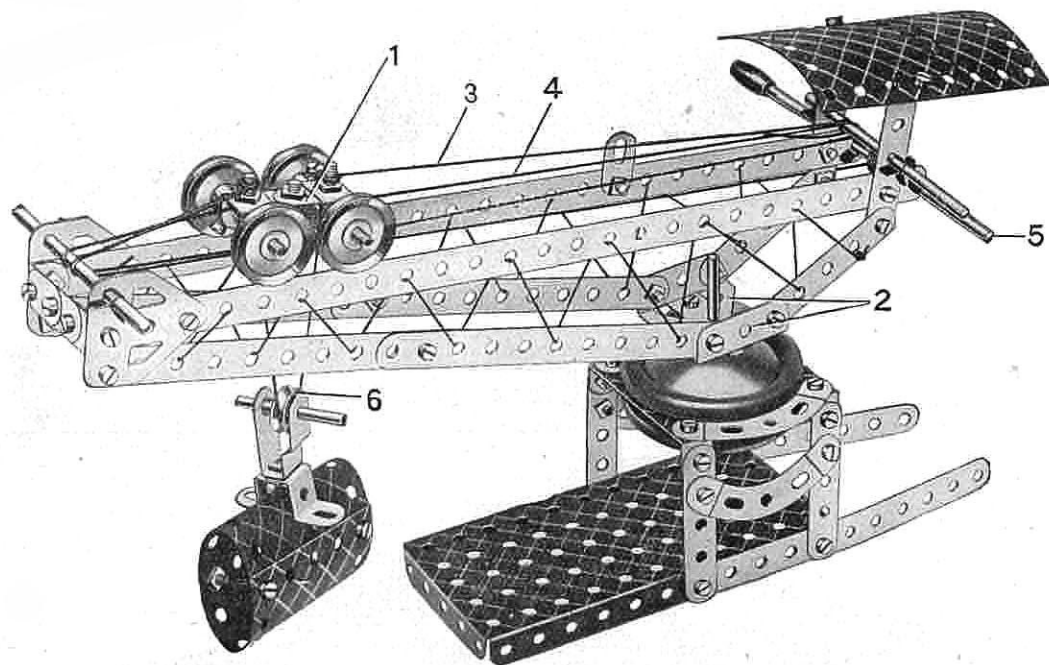

Parts required	
2 of No. 1	4 of No. 37a
6 " " 2	6 " " 38
8 " " 5	1 " " 40
5 " " 10	1 " " 44
2 " " 11	2 " " 38a
4 " " 12	1 " " 52
1 " " 15b	4 " " 90a
2 " " 16	4 " " 111c
2 " " 17	2 " " 125
1 " " 18a	2 " " 126
1 " " 19a	2 " " 126a
4 " " 22	1 " " 176
1 " " 23	2 " " 187
1 " " 24	2 " " 188
6 " " 35	2 " " 199
50 " " 37	2 " " 200

The travelling bogie 1 consists of two Fishplates bolted together by their elongated holes, and at each end of it Double Brackets are fastened by  $\frac{3}{8}$ " Bolts. Two 2" Rods are pushed through the Double Brackets and carry 1" fast Pulleys spaced so that their grooves fit on the two 12 $\frac{1}{2}$ " Strips that form the top of the jib. The Trunnions 2 at the base of the bogie are secured to a Bush Wheel mounted on a Rod held in the bosses of two Road Wheels. The Road Wheels are placed one above and one below the 2 $\frac{1}{2}$ " x 1 $\frac{1}{2}$ " Flexible Plates that form the top of the tower.

Cord 3 is first fastened to the  $\frac{3}{8}$ " Bolt at the rear end of the travelling bogie, and then wound three times around the Crank Handle. It is then led around the Rod journalled in the Flat Trunnion at the front end of the jib, and brought back and tied to another  $\frac{3}{8}$ " Bolt at the front of the bogie.

Cord 3 is first fastened to Rod 5, which is passed through the end holes of the 12 $\frac{1}{2}$ " Strips, and then over the rear axle of the bogie. It is then passed around the  $\frac{1}{2}$ " Pulley 6, led over the front axle of the bogie, around the Rod at the front end of the jib, and finally tied to the bogie. The  $\frac{1}{2}$ " loose Pulley 6 and its Rod are held in the Stepped Bent Strip by a Cord Anchoring Spring.

## 3.20 PITHEAD GEAR

## Parts required

2 of No. 1	
6 " " 2	
8 " " 5	
1 " " 10	
1 " " 11	
7 " " 12	
1 " " 15b	
2 " " 16	
1 " " 18a	
1 " " 19g	
4 " " 22	
1 " " 24	
6 " " 35	
41 " " 37	
1 " " 37a	
6 " " 38	
1 " " 40	
2 " " 48a	
1 " " 52	
2 " " 111c	
2 " " 125	
2 " " 126	
2 " " 126a	
1 " " 176	
2 " " 187	
2 " " 188	
2 " " 189	
1 " " 190	
2 " " 192	
2 " " 200	
1 " " 214	

A 3 $\frac{1}{4}$ " Rod is journalled in the top holes of the 12 $\frac{1}{2}$ " Strips. Between the two Road Wheels on this Rod is a 1" fast Pulley, over which the cord controlling the cage passes. A Cord Anchoring Spring is pushed on one end of the Rod, and a Bush Wheel is fixed to the other end. The cage is built up from Trunnions and Flat Trunnions, and the 2 $\frac{1}{2}$ " x 1 $\frac{1}{2}$ " Flexible Plates that form its sides are fastened to the Flat Trunnions by Angle Brackets.

A  $\frac{3}{8}$ " Bolt is passed through the holes of Reversed Angle Brackets bolted to the top of the cage, and Washers are placed on its shank for spacing purposes.

The guides 1 for the cage consist of a piece of Cord which is passed over two Rods as shown and then led downward and through two holes in the Flanged Plate that forms the base. Washers are tied to each end of the Cord underneath the Plate, to maintain it in tension.

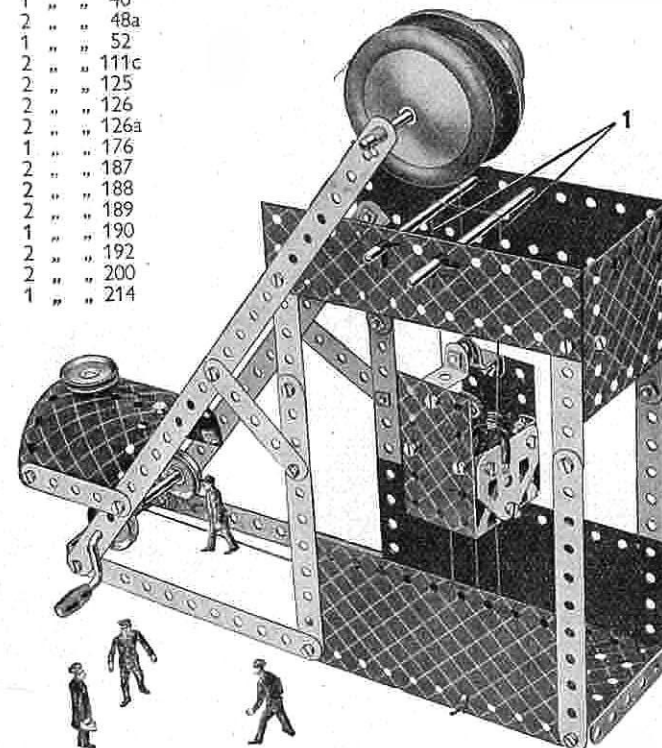

3.21 TANK

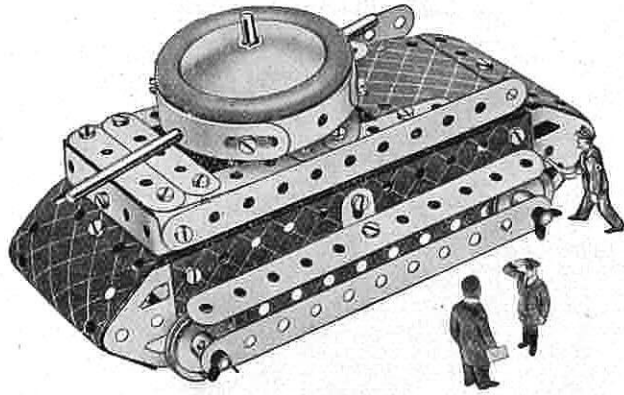

Parts required

6 of No. 2
7 " " 5
2 " " 10
8 " " 12
2 " " 15b
2 " " 16
1 " " 17
4 " " 22
1 " " 24
6 " " 35
40 " " 37
1 " " 38
1 " " 48a
1 " " 52
1 " " 90a
1 " " 125
2 " " 126
2 " " 126a
1 " " 176
1 " " 187
2 " " 189
1 " " 190
2 " " 199
4 " " 215

1 *Magic Motor* (Not included in Outfit)

Construction of the gun turret is commenced by bolting a 24" Strip across a Bush Wheel. Four 3" Formed Slotted Strips are bolted together to form a circle and fastened to the 24" Strip by means of Angle Brackets. Next two Angle Brackets are bolted to the Bush Wheel in the positions shown in Fig. 3.21a. Two Rods are pushed through holes in the Formed Slotted Strips and through the free holes of the Angle Brackets, and are fastened in position by means of Spring Clips. The turret is held in place by a 3 1/4" Rod that is locked in the boss of the Bush Wheel and then passed through the 5 1/2" x 2 1/2" Flanged Plate and through a hole in a Reversed Angle Bracket. A Cord Anchoring Spring is then screwed on to it to hold it in position. To complete the turret a Road Wheel is fastened on the upper end of the 3 1/4" Rod. The Reversed Angle Bracket is bolted to the 5 1/2" x 2 1/2" Flanged Plate.

The *Magic Motor* is bolted to the Flanged Plate, and the drive is taken to the back axle by means of a Driving Band.

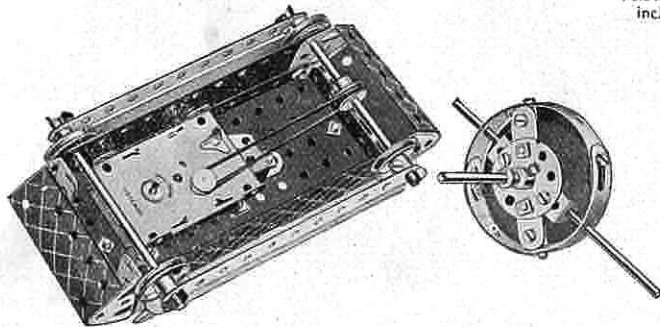
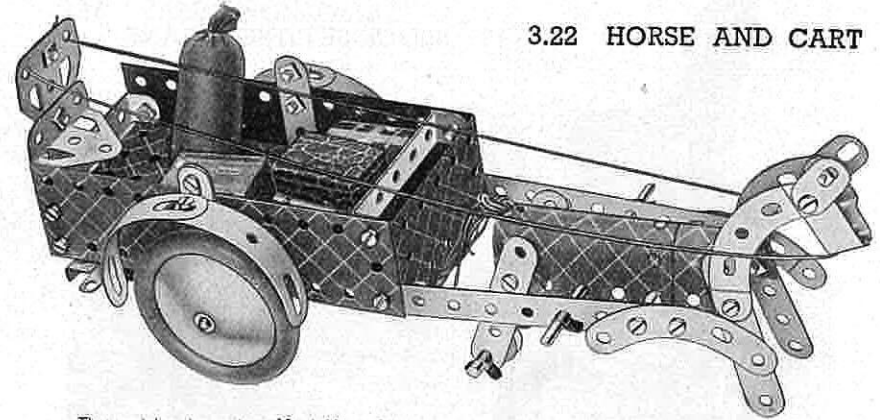

Fig. 3.21a

3.22 HORSE AND CART



The model is driven by a *Magic Motor* fastened underneath the 5 1/2" x 2 1/2" Flanged Plate that forms the bottom of the cart. The drive is taken by a Driving Band from the pulley of the Motor to a 1/2" fast Pulley on the back axle. A 1" loose Pulley is fitted on a 2" Rod journaled in the bottom holes of the Strips forming the hind-legs of the horse, so that the model will travel smoothly along the ground.

Parts required

2 of No. 2	2 of No. 48a
7 " " 5	1 " " 52
2 " " 10	4 " " 90a
2 " " 12	1 " " 125
2 " " 16	1 " " 126
1 " " 17	1 " " 126a
1 " " 23	2 " " 187
4 " " 35	1 " " 188
35 " " 37	2 " " 189
2 " " 38	2 " " 199
1 " " 40	4 " " 215
1 " " 44	1 <i>Magic Motor</i> (not included in Outfit)

3.23 ROUNDABOUT

Parts required

2 of No. 1	4 of No. 37a
6 " " 2	4 " " 38
8 " " 5	1 " " 40
4 " " 10	2 " " 38a
2 " " 11	1 " " 52
8 " " 12	4 " " 90a
1 " " 16	4 " " 111c
1 " " 17	2 " " 125
1 " " 18a	2 " " 126
1 " " 19g	2 " " 126a
4 " " 22	1 " " 187
1 " " 24	2 " " 188
6 " " 35	2 " " 191
50 " " 37	2 " " 199

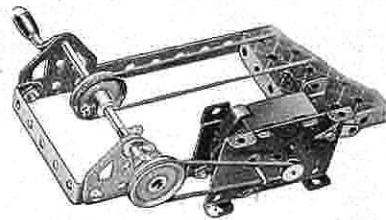

Fig. 3.23

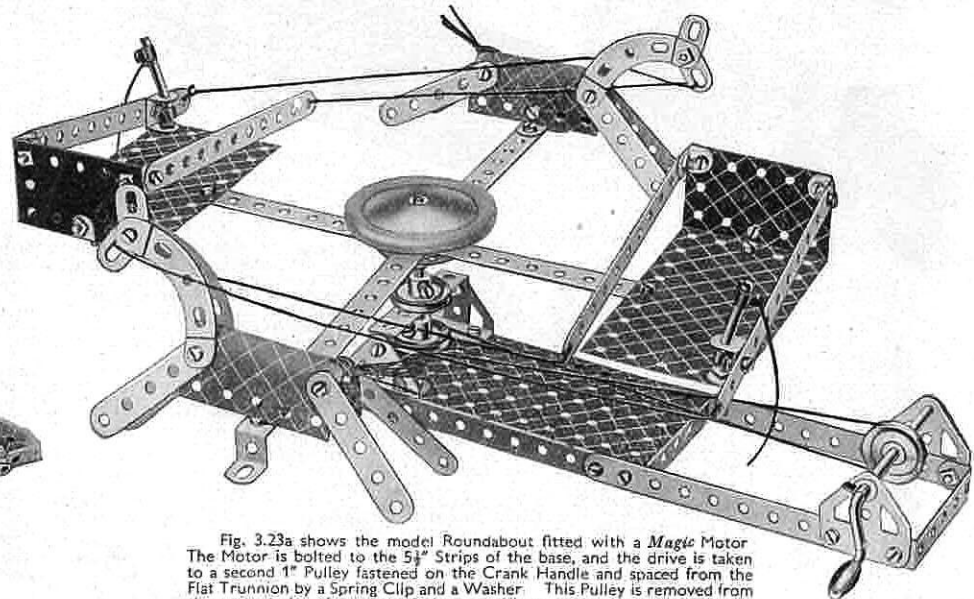

Fig. 3.23a shows the model Roundabout fitted with a *Magic Motor*. The Motor is bolted to the 5 1/2" Strips of the base, and the drive is taken to a second 1" Pulley fastened on the Crank Handle and spaced from the Flat Trunnion by a Spring Clip and a Washer. This Pulley is removed from the end of the pivot rod of the roundabout underneath the 5 1/2" x 2 1/2" Flanged Plate.

### 3.24 WINDMILL PUMP

Up and down motion of the pumping shaft is obtained from a crank fastened to the end of the Crank Handle. The crank is formed by securing an Angle Bracket to the boss of a 1" Pulley, two Washers being used between the Bracket and the boss. A 2½" Strip is pivoted to the crank and to the pumping beam, the other end of which is pivotally attached to a Double Bracket on the pump rod. The Bolts 1 are lock-nutted. The 1" Pulley on the Crank Handle is connected by a belt of Cord to the shaft carrying the sails. The *Magic Motor* is bolted by its flanges to the baseplate, and the drive is taken from the pulley of the Motor to a ½" Pulley fixed on the shaft of the Crank Handle, if desired the Motor may be dispensed with and the model operated by hand

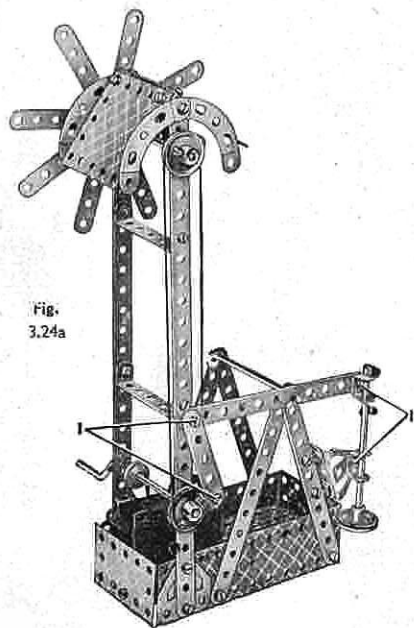
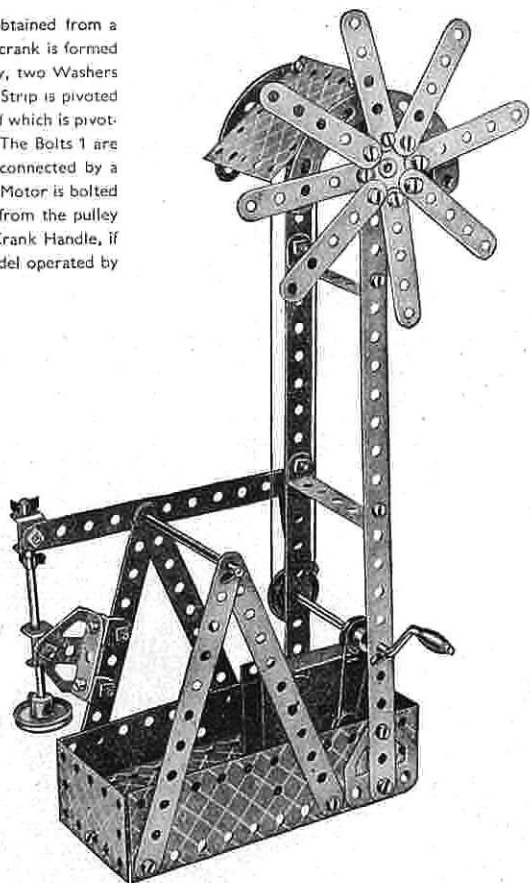
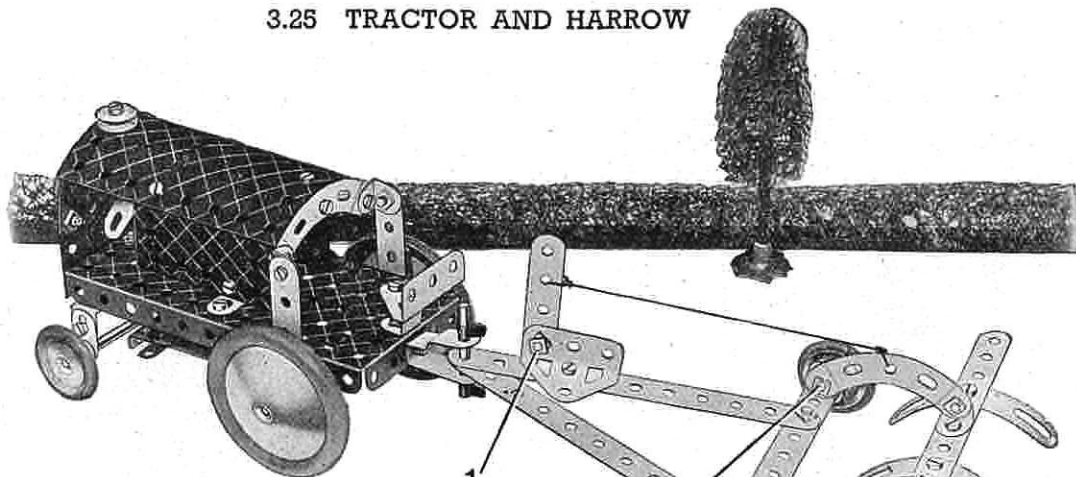

Fig. 3.24a



Parts required		2 of No. 16	2 of No. 48a
2 of No. 1	2 of No. 11	1 " " 19g	1 " " 52
5 " " 2	7 " " 12	3 " " 22	4 " " 90a
9 " " 5	1 " " 15b	1 " " 24	1 " " 126
		4 " " 35	2 " " 126a
		39 " " 37	2 " " 188
		3 " " 37a	2 " " 189
		2 " " 38	2 " " 190
		1 " " 40	1 <i>Magic Motor</i> (not included in Outfit)

### 3.25 TRACTOR AND HARROW



The rear axle is passed through the bottom holes of two 2½" Strips that are bolted to the flanges of the 5½" x 2½" Flanged Plate forming the chassis. The construction of the bonnet and radiator is clearly shown in the illustration.

The fan consists of two Fishplates held against the head of a ½" Bolt by a nut. The ½" Bolt is fastened to the radiator by means of two more nuts. The engine itself is represented by two U-Section Curved Plates, bolted together so that they overlap two holes, and then fastened to the Flanged Plate by two Angle Brackets.

The wheels of the harrow are held by ½" Bolts in Reversed Angle Brackets at each end of a 5½" Strip. Small radius Curved Strips are fastened to the Reversed Angle Brackets by lock-nutted bolts, and Cord is attached to the centre holes of one of these and also to the operating lever, which is held by lock-nuts to a Trunnion. By moving the lever forward the harrow may be raised from the ground when not in use.

The Bolts 1 shown in both illustrations are lock-nutted.

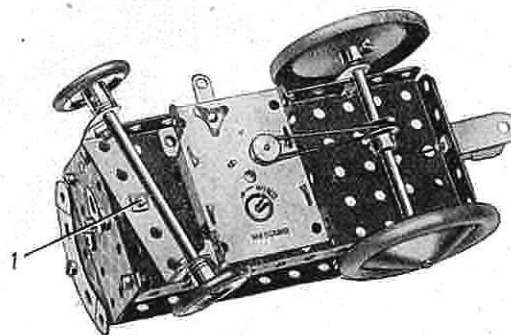
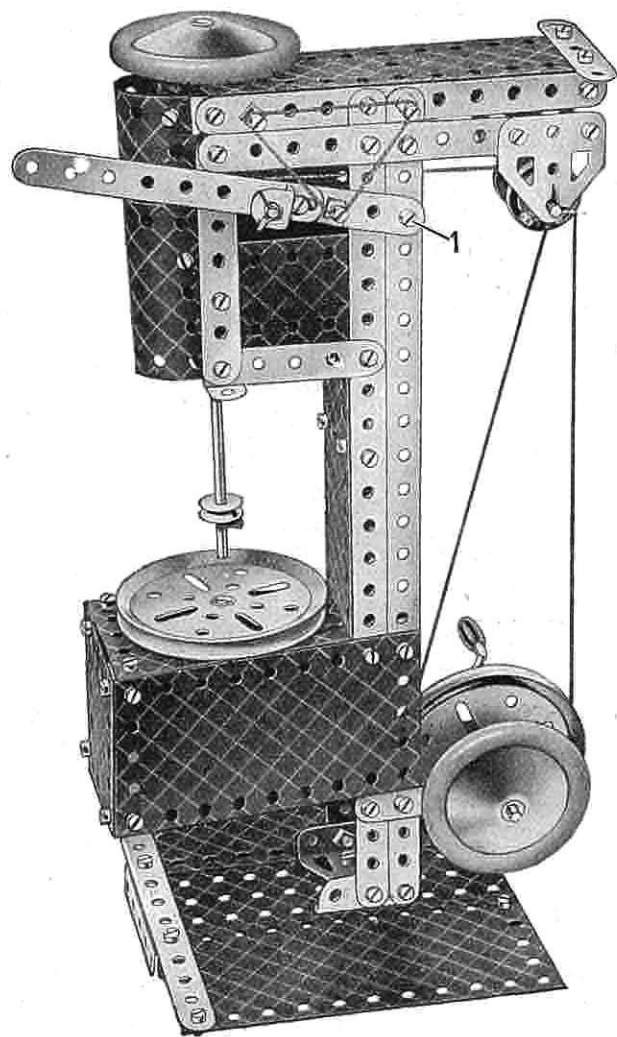

Fig. 3.25a

Parts required

5 of No. 2	4 of No. 22	2 of No. 125
3 " " 5	1 " " 23	2 " " 126
5 " " 10	2 " " 35	4 " " 155
2 " " 11	46 " " 37	2 " " 187
8 " " 12	10 " " 37a	1 " " 188
2 " " 16	6 " " 38	2 " " 199
1 " " 18a	1 " " 44	2 " " 200
	1 " " 38a	1 " " 214
	1 " " 52	4 " " 215
	4 " " 90a	1 <i>Magic Motor</i> (not included in Outfit)
	5 " " 111c	

*Drilling Machine*

### BUILD BIGGER AND BETTER MODELS

When you have built all the models shown in this Manual you will be keen to build bigger and more elaborate models. Your next step is to purchase a Meccano No. 3a Accessory Outfit containing all the parts required to convert your No. 3 into a No. 4 Outfit. You will thus be able to build the full range of No. 4 Outfit Models, a selection of which is illustrated on this page.

If you prefer to do so, you can build up and develop your Outfit quite easily by adding various parts to it from time to time. The model-building possibilities of the Meccano System are unlimited, and the more Meccano parts you have the bigger and better the models you will be able to build.

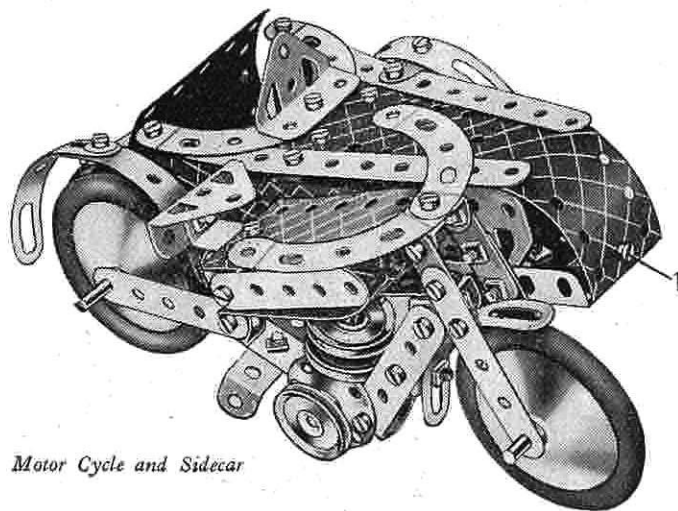
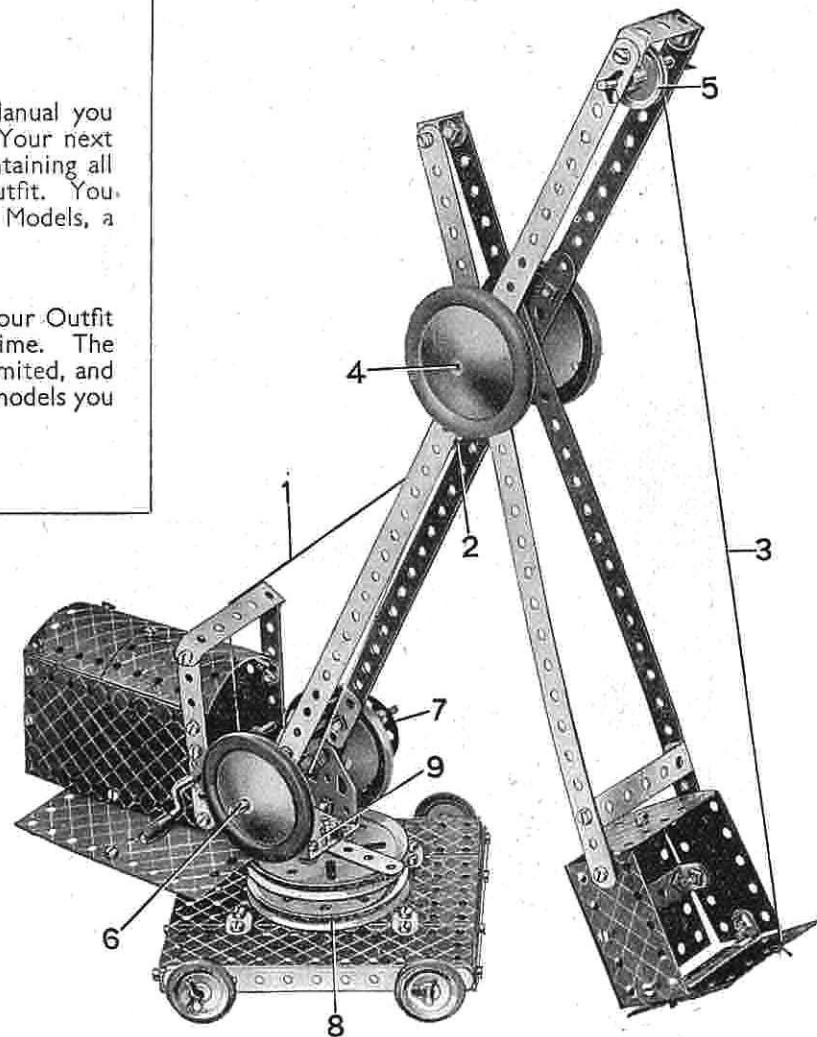
*Motor Cycle and Sidecar**Giant Excavator*

Here are a few simple and interesting movements showing how easily real mechanisms can be reproduced with Meccano.

### WORM AND PINION BEARING

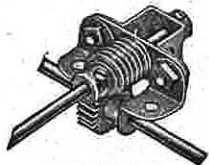

The compact rear axle drive unit illustrated above is intended chiefly for use in small models of motor cars. Two Corner Angle Brackets are secured by Bolts passing through their elongated holes to a  $1\frac{1}{2}$ " Strip, to which a Double Bent Strip also is secured. The Rod carrying the Worm is passed through the centre hole of the Strips and held in position by a Collar.

The driven Rod is journalled in the Corner Angle Brackets and carries a Pinion that engages with the Worm.

A feature of this bearing that should not be overlooked is that the useful gear ratio of 25:1 is provided by employing a  $\frac{5}{8}$ " Pinion.

### GEARS

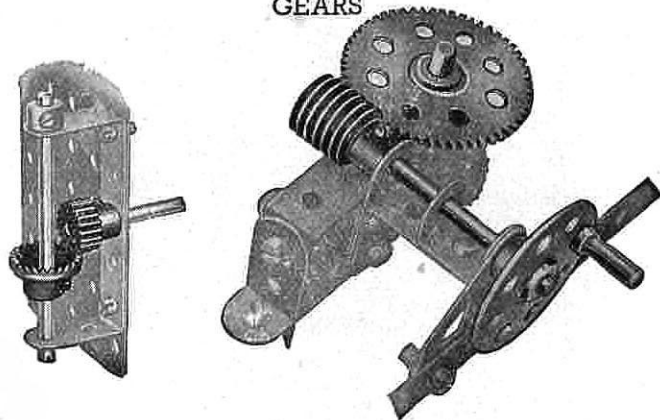

The Meccano system includes a wide range of Gear Wheels, Bevel Gears, Pinions, Contrate Wheels and Worms in various sizes. All manner of interesting movements can be obtained by the use of these gears.

How a drive can be transmitted from a vertical to a horizontal shaft, or vice versa, is shown on the left. On the right the Worm engaged with a Gear Wheel gives a very great reduction in shaft speed.

### BELT AND CHAIN DRIVES

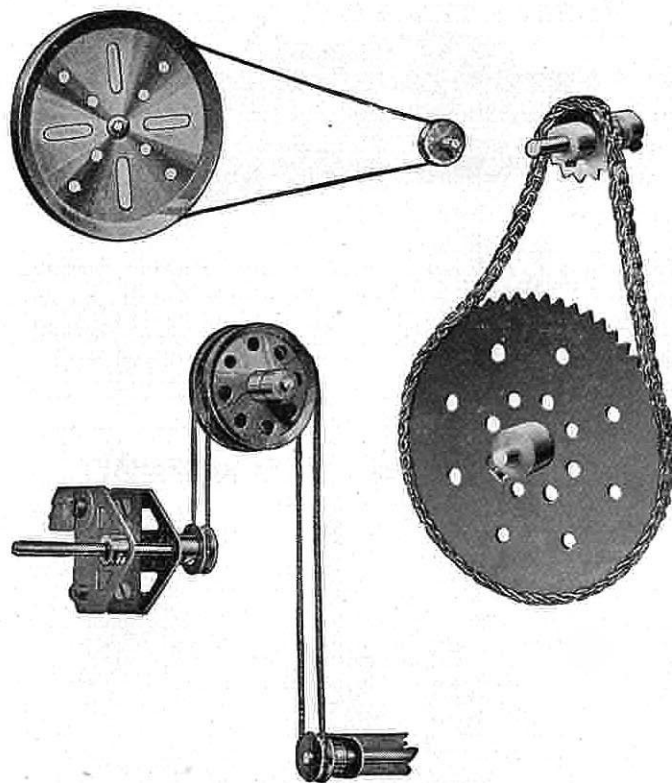

Above we show examples of belt and chain drive. The movements illustrated require no explanation excepting, perhaps, the lower belt drive, which shows a simple method for transmitting the drive from one shaft to another when the shafts are not in line.

Cords usually take the place of belts in Meccano models but miniature belting can be made from strips of canvas, indiarubber, etc., in which case Flanged Wheels should be used instead of grooved Pulleys.

### EPICYCLIC TRANSMISSION GEAR

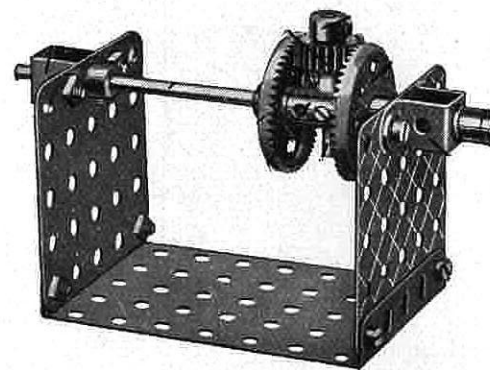

Practically every type of mechanical power transmission gear can be reproduced with Meccano.

The device illustrated is designed to provide a gear ratio between two shafts mounted in direct line with one another. Its chief merit lies in the compactness of its construction and lack of external bearings.

### STEERING GEARS

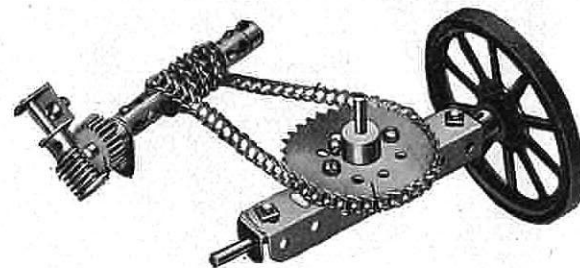

The various types of steering mechanism commonly in use on vehicles of all descriptions can readily be reproduced with Meccano.

In the example illustrated, the road wheels are controlled by an endless Sprocket Chain operated by a Worm and Pinion mechanism.



# MECCANO PARTS



No. 120b. Compression Springs,  $\frac{1}{4}$ " long



122. Miniature Loaded Sacks



123. Cone Pulleys,  $1\frac{1}{2}$ ", 1" and  $\frac{3}{4}$ " diam.



124. Reversed Angle Brackets, 1"  
125. " " " "  $\frac{1}{2}$ "



126. Trunnions



126a. Flat Trunnions



127. Bell Cranks



128. Bell Cranks, with Boss



129. Toothed Segments,  $1\frac{1}{2}$ " radius



130. Eccentrics, Triple Throw,  $\frac{1}{4}$ ",  $\frac{1}{2}$ " and  $\frac{3}{4}$ "



130a. Eccentrics, Single Throw,  $\frac{1}{4}$ "



131. Dredger Buckets



132. Flywheels, 2 $\frac{1}{2}$ " diam.



133. Corner Brackets,  $1\frac{1}{2}$ "



133a. " " " " 1"



No. 134. Crank Shafts, 1" stroke



136. Handrail Supports



136a. Handrail Couplings



137. Wheel Flanges



138a. Ships' Funnels

138<sup>a</sup>



139. Flanged Brackets (right)

139a. " " (left)

139



140. Universal Couplings

140



142. Rubber Rings (to fit 3" diam. rims)

142a. Motor Tyres (to fit 2" diam. rims)

142b. " " " " " "

142c. " " " " " "

142d. " " " " " "



142A



143. Circular Girders, 5 $\frac{1}{2}$ " diam.

143



No. 144. Dog Clutches

144

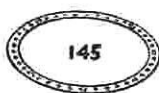

145. Circular Strips,  $7\frac{1}{2}$ " diam. overall

146. " " Plates, 6" "

146a. " " " " 4" "

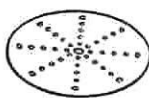

146



147. Pawls, with Pivot Bolt and Nuts

147a. Pawls

147b. Pivot Bolts with 2 Nuts

147c. Pawls without boss

148. Ratchet Wheels



151. Pulley Blocks, Single Sheave

152. " " Two "

153. " " Three "

151



154a. Corner Angle Brackets,  $\frac{1}{2}$ " (right-hand)

154b. Corner Angle Brackets,  $\frac{1}{2}$ " (left-hand)

155. Rubber Rings (for 1" Pulleys)

154<sup>a</sup> & 154<sup>b</sup>



157. Fans, 2" diam.

157



160

160. Channel Bearings,  $1\frac{1}{2}$ " x 1" x  $\frac{1}{4}$ "

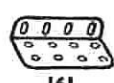

161

161. Girder Brackets, 2" x 1" x  $\frac{1}{4}$ "



163

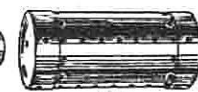

162



164

No. 162. Boilers, complete, 5" long x 2 $\frac{1}{4}$ " diam.  
162a. " " Ends, 2 $\frac{1}{4}$ " diam. x  $\frac{1}{16}$ "  
162b. " " without ends, 4 $\frac{1}{2}$ " long x 2 $\frac{1}{4}$ " diam.  
163. Sleeve Pieces, 1 $\frac{1}{2}$ " long x  $\frac{1}{16}$ " diam.  
164. Chimney Adaptors,  $\frac{3}{8}$ " diam. x  $\frac{1}{2}$ " high



165. Swivel Bearings

166. End

167b. Flanged Ring, 9 $\frac{1}{2}$ " diam



166



168

168. Ball Bearings, 4" diam.  
168a. " Races, flanged discs, 3 $\frac{1}{2}$ " diam.  
168b. " " toothed " " 4" diam.  
168c. " Cages, 3 $\frac{1}{2}$ " diam., complete with balls.



171

171. Socket Couplings



175

175. Flexible Coupling Units



176

176. Anchoring Springs for Cord



179

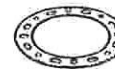

180

179. Rod Sockets  
180. Gear Rings, 3 $\frac{1}{2}$ " diam. (133 ext. teeth, 95 int.)



No. 185. Steering Wheels, 1 $\frac{1}{2}$ " diam.  
186. Driving Bands, 2 $\frac{1}{2}$ " (Light)  
186a. " " " " " "  
186b. " " " " " "  
186c. " " " " " " (Heavy)  
186d. " " " " " "  
186e. " " " " " "  
187. Road Wheels, 2 $\frac{1}{2}$ " diam.  
187a. Conical Disc, 1 $\frac{1}{2}$ " diam.



187



192

Flexible Plates.

188. 2 $\frac{1}{2}$ " x 1 $\frac{1}{2}$ "

189. 5 $\frac{1}{2}$ " x 1 $\frac{1}{2}$ "

190. 3 $\frac{1}{2}$ " x 2 $\frac{1}{2}$ "

190a. 3 $\frac{1}{2}$ " x 2 $\frac{1}{2}$ "



197

191. 4 $\frac{1}{2}$ " x 2 $\frac{1}{2}$ "

192. 5 $\frac{1}{2}$ " x 2 $\frac{1}{2}$ "

Strip Plates

196. 9 $\frac{1}{2}$ " x 2 $\frac{1}{2}$ "

197. 12 $\frac{1}{2}$ " x 2 $\frac{1}{2}$ "



200



198



199

198. Hinged Flat Plates, 4 $\frac{1}{2}$ " x 2 $\frac{1}{2}$ "  
199. Curved Plates, U-Section  
2 $\frac{1}{2}$ " x 2 $\frac{1}{2}$ " x  $\frac{1}{8}$ " radius  
200. " " " " 2 $\frac{1}{2}$ " x 2 $\frac{1}{2}$ " x 1 $\frac{1}{8}$ " radius



211A

211B

211a. Helical Gear  $\frac{1}{4}$ " | Can only be  
211b. " " " " 1 $\frac{1}{2}$ " | used together



212

212. Rod and Strip Connectors



213

213. Rod Connectors



215

214. Semi-Circular Plates 2 $\frac{1}{2}$ "  
215. Formed Slotted Strips 3"



214



216

216. Cylinders, 2 $\frac{1}{2}$ " long, 1 $\frac{1}{2}$ " diam.