

MECCANO

Registered Trade Mark



N. H. PINYON.

INSTRUCTIONS for OUTFIT No. 1

COPYRIGHT BY MECCANO LIMITED
BINNS ROAD, LIVERPOOL 13, ENGLAND

53.1

*

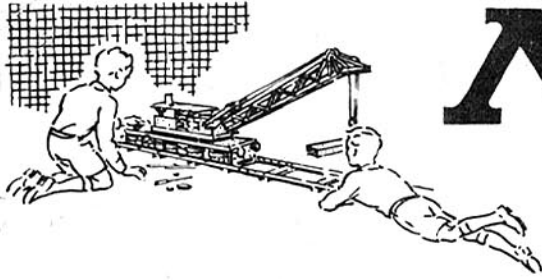

MECCANO

Registered Trade Mark

The World's Greatest Constructional Toy

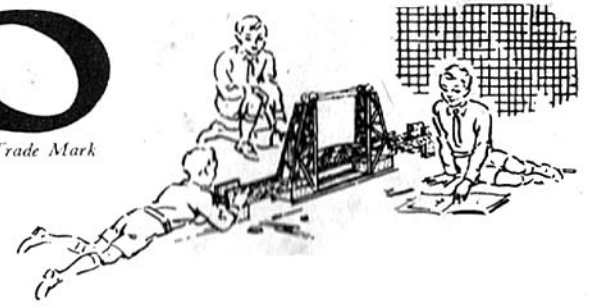

MODEL-BUILDING WITH MECCANO

There is no limit to the number of models that can be built with Meccano — Cranes, Clocks, Motor Cars, Aeroplanes, Machine Tools, Locomotives — in fact everything that interests boys. A screwdriver and a spanner, both of which are provided in each complete Outfit, are the only tools necessary.

When you have built all the models illustrated in the Books of Instructions the fun is not over, it is just beginning. Now comes the chance to make use of your own ideas. First of all, re-build some of the models with small changes in construction that may occur to you; then try building models entirely of your own design. In doing this you will enjoy the real thrill of the engineer and the inventor.

HOW TO BUILD UP YOUR OUTFIT

Meccano is sold in 12 different Outfits, ranging from No. OO to No. 10. Each Outfit can be converted into the next larger one by the purchase of an Accessory Outfit. Thus Meccano No. OO Outfit can be converted into No. O Outfit by adding to it a No. OOa Accessory Outfit. No. Oa Outfit would then convert it into a No. 1 and so on. In this way, no matter with which Outfit you begin, you can build it up by degrees until you have a complete No. 10 Outfit.

All Meccano parts are of the same high quality and finish, but the larger Outfits contain a greater quantity and variety, making possible the construction of more elaborate models.

THE 'MECCANO MAGAZINE'

The 'Meccano Magazine' is published specially for Meccano boys. Every month it describes and illustrates new Meccano models, and deals with suggestions from readers for new Meccano parts and for new methods of using the existing parts.

There are model-building competitions specially planned to give an equal chance to the owners of small and large Outfits. In addition, there are splendid articles on such subjects as Railways, Famous Engineers and Inventors, Electricity, Bridges, Cranes and Aeroplanes, and special sections dealing with the latest Engineering, Aviation, Motoring

and Shipping News. Other pages deal with Stamp Collecting, and Books of interest to boys; and a feature of outstanding popularity is the section devoted to short articles from readers.

Write to the Editor, The Meccano Magazine, Binns Road, Liverpool 13, for particulars and a specimen copy. You can order the Magazine from your Meccano dealer, or from any newsagent.

THE MECCANO GUILD

Every owner of a Meccano Outfit should join the Meccano Guild. This is a world-wide organisation, started at the request of Meccano boys. Its primary object is to bring boys together and to make them feel that they are all members of a great brotherhood, each trying to help others to get the very best out of life. Its members are in constant touch with Headquarters, giving news of their activities and being guided in their hobbies and interests. A leaflet containing full particulars of the Guild and an application form is included in this Book.

Clubs founded and established under the guidance of the Guild Secretary provide Meccano boys with opportunities of enjoying to the utmost the fun of model-building. Each has its Leader, Secretary, Treasurer and other officials. With the exception of the Leader, all the officials are boys, and as far as possible the proceedings of the clubs are conducted by boys.

MECCANO SERVICE

The service of Meccano does not end with selling an Outfit and a Book of Instructions. If ever you are in any difficulty with your models, or if you want advice on anything connected with this great hobby, write to us. We receive hundreds of interesting letters from boys in all parts of the world, and each of these is answered personally and promptly by one of our staff of experts.

Whatever your problem may be, write to us about it. We shall be delighted to help you in any way possible. Address your letters to *Information Service*.

HOW TO BEGIN THE FUN

THE MOST FASCINATING OF ALL HOBBIES

Meccano model-building is the most fascinating of all hobbies, because it never becomes dull. There is always something new to be done. First of all there is the fun of building a new model, and watching it take shape as part after part is added. Then, when the model is complete, comes the thrill of setting it to work just like the real structure it represents, by means of a Meccano Motor.

The following hints are given to show boys who are just starting the wonderful Meccano hobby how to get the greatest possible fun.

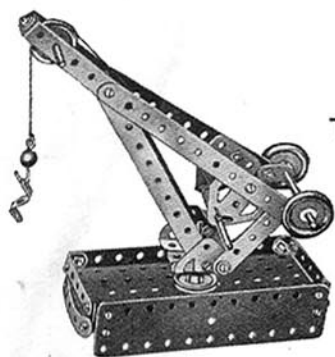

This Dockside Crane can be built with Outfit No. 1

A FEW USEFUL HINTS

It will be noticed that with each model in this Book of Instructions is given a list of the parts required to build it. For the first few models it is a good plan to lay out on the table all the parts required for the one it is proposed to build, and put the remainder of the Outfit to one side. To help you to pick out the correct parts for your model a complete list of Meccano parts is given at the back of this Book, and all the principal parts are illustrated. In the list the parts are all numbered, and in most cases their measurements are given. There is no need, however, to measure the parts to find out which is which, as the size is easily found from the number of holes. All Meccano holes are spaced $\frac{1}{2}$ " apart, so that by counting two holes to the inch the size of a part can be found at once. For instance, Part No. 2 is listed as a $5\frac{1}{2}$ " Perforated Strip, so you look in your Outfit for a Strip with eleven holes. Similarly No. 189 is a $5\frac{1}{2}$ " x $1\frac{1}{2}$ " Flexible Plate, so you look for a Flexible Plate eleven holes in length and three holes in width. By the time a few models have been built the names of the parts will have become familiar.

Beginners sometimes wonder which section of a model should be built first. There cannot be any definite rule for this, as it depends on the design of the model. In stationary models the base usually should be built first. In most of the small models a $5\frac{1}{2}$ " x $2\frac{1}{2}$ " Flanged Plate forms an important part of the structure, and often the best plan is to start building by bolting parts to this Plate. For other models a good general rule is that the sections that form supports for a number of other parts should be built first.

During the construction of a model it is best to screw up the nuts with the fingers, followed by a light turn with the screwdriver, leaving the final tightening until all the parts are connected up.

THE IMPORTANCE OF LOCK-NUTTING

In some models it is necessary to join certain parts together so that, although they cannot come apart, they are free to pivot or move in relation to one another. To do this the parts are bolted together as usual, but the nut is not screwed up tightly, so that the parts are not gripped. Then, to prevent the nut from unscrewing, a second nut is screwed up tightly against it, the first nut being held with a spanner. This method of using a second nut is known as *Lock-nutting*.

In building models in which Rods revolve in the holes of other parts it is important to make sure that such holes are exactly in line with one another. This can be done by pushing through the holes a Drift, Part No. 36c, or a Rod, before the Bolts holding the various parts are tightened up.

A Rod is usually mounted in a support or bearing so that it is free to revolve. The Rod is then said to be *Journalled* in the Strip.

DRIVING YOUR MODELS

Models can be driven by means of either clockwork or electric motors. Ask your Dealer for particulars of Meccano Clockwork and Electric Motors.

Small and light models may be driven direct from the driving pulley of the motor or through a belt running over two pulleys of the same size, giving what is known as a 1 : 1 (one-to-one) ratio. For large models it is necessary to take the drive from a small pulley on the motor shaft to a larger pulley on the driving shaft of the model. In most cases a 1" Pulley on the motor shaft and a 3" Pulley on the model shaft will be found satisfactory. This provides a reduction ratio of approximately 3 : 1.

Rubber bands are very convenient for driving belts. Sometimes, however, a rubber band of the right length is not available, and then Meccano Cord or thin string is used. To tie the Cord to form an endless belt, use the familiar reef knot.

All Outfits from No. 2 upward include a Cord Anchoring Spring, Part No. 176. This part provides a neat and positive method of fastening a length of Cord to a Rod. The Spring is placed on a Rod by pushing and turning it in such a way that its coils tend to unwind.

Flexible Plates are used for forming curved surfaces in models, but they are not intended to be bent at right angles. With careful handling a Plate can be bent to the required curve and after use straightened again.

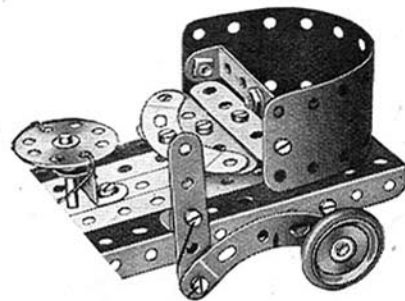

A Flexible Plate used to form a curved surface

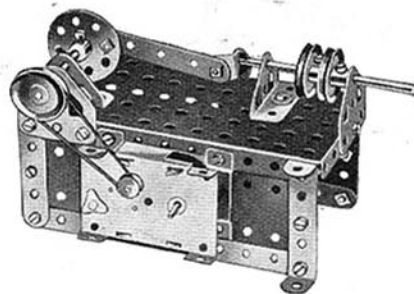

A 'Magic' Motor fitted to drive a Steam Engine

O.1 GARDEN SEAT

Parts required
 4 of No. 2
 2 " " 5
 10 " " 37*
 2 " " 48a
 1 " " 52

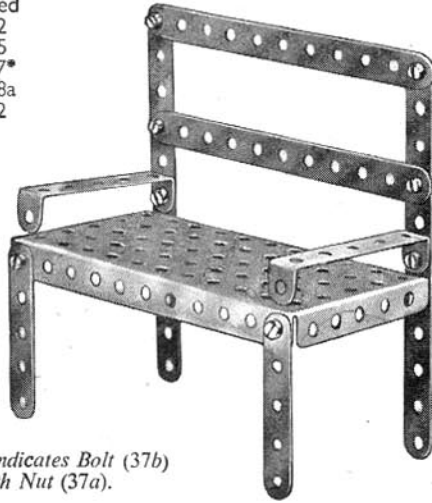

*No. 37 indicates Bolt (37b)
 fitted with Nut (37a).

O.2 FLAT TRUCK

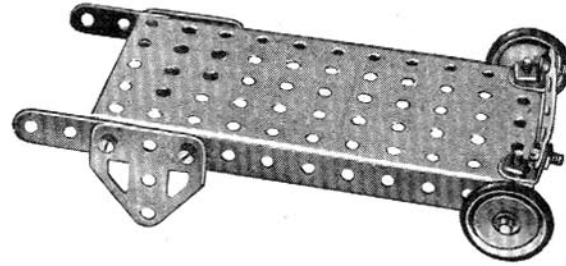

Parts required
 2 of No. 5 | 2 of No. 22 | 1 of No. 90a
 2 " " 12 | 8 " " 37 | 2 " " 126a
 1 " " 16 | 1 " " 52 | 2 " " 155

O.3 SWING BOAT

Parts required
 4 of No. 2
 2 " " 5
 4 " " 12
 1 " " 16
 1 " " 19s
 2 " " 22
 1 " " 24
 3 " " 35
 18 " " 37
 1 " " 52
 2 " " 90a
 2 " " 126
 2 " " 126a

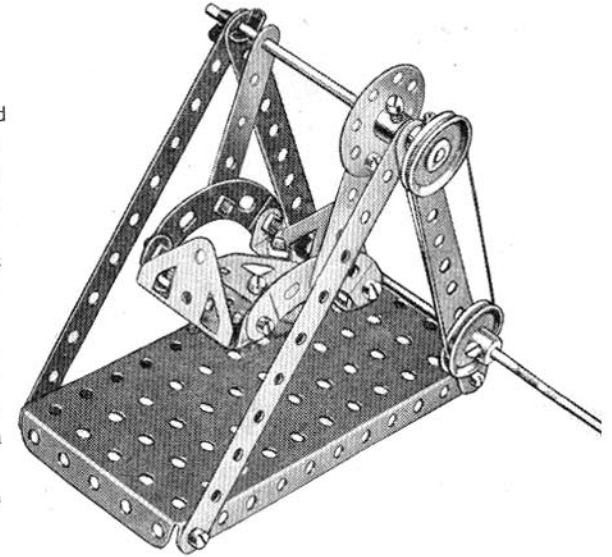

O.4 COUNTER SCALES

Parts required
 1 of No. 2 | 2 of No. 22 | 1 of No. 52
 2 " " 10 | 1 " " 24 | 2 " " 126
 4 " " 12 | 9 " " 37 | 2 " " 126a
 1 " " 17 | 2 " " 38

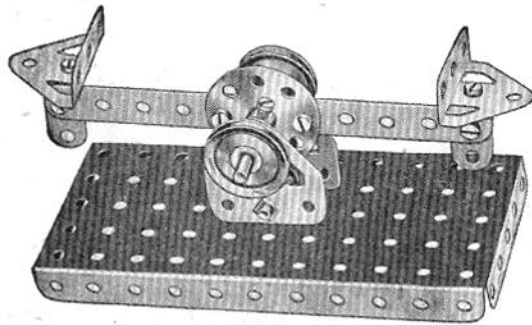

O.5 SCALES

Parts required
 3 of No. 2 | 2 of No. 35 | 2 of No. 126
 1 " " 17 | 10 " " 37 | 2 " " 126a
 1 " " 24 | 1 " " 52

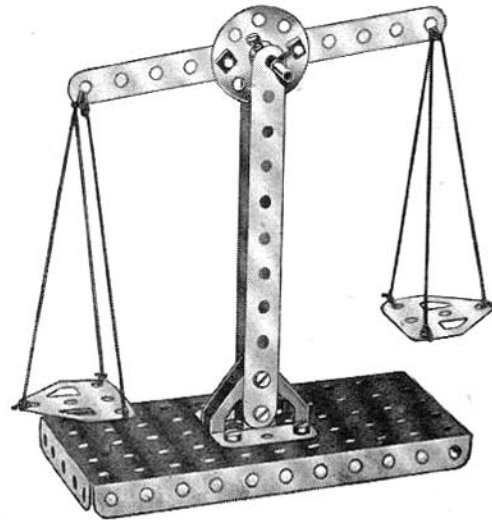

O.6 COSTER'S BARROW

Parts required
 4 of No. 2 | 2 of No. 22 | 2 of No. 90a
 2 " " 5 | 16 " " 37 | 2 " " 126
 2 " " 10 | 2 " " 48a | 2 " " 126a
 1 " " 16 | 1 " " 52 | 2 " " 155

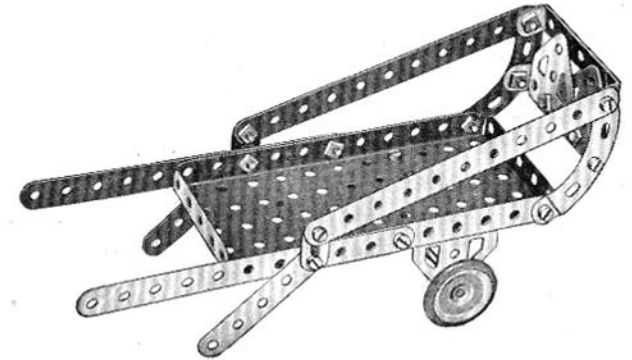

O.7 ACROBAT

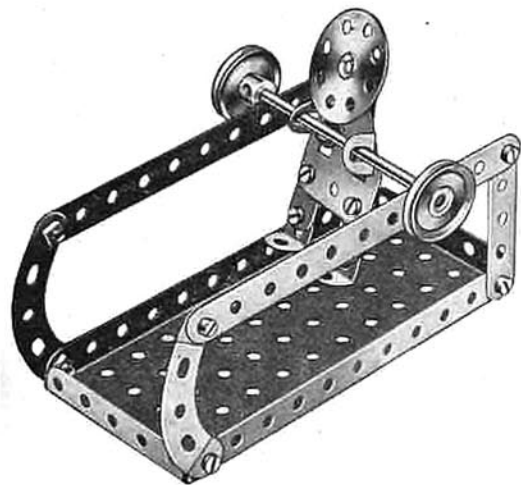

Parts required

2 of No. 2
2 " " 5
3 " " 10
4 " " 12
1 " " 16
2 " " 22
1 " " 24
15 " " 37
1 " " 52
2 " " 90a
1 " " 111c
1 " " 126a

O.8 MECHANICAL HAMMER

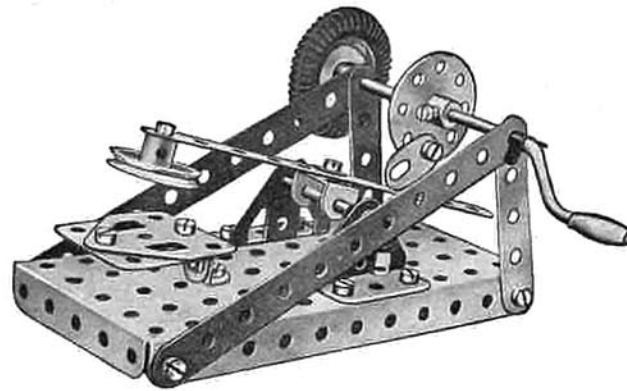

Parts required

3 of No. 2	1 of No. 17	3 of No. 35	1 of No. 111c
2 " " 5	1 " " 19s	15 " " 37	2 " " 126
1 " " 10	2 " " 22	1 " " 38	2 " " 126a
4 " " 12	1 " " 24	1 " " 52	1 " " 142c

O.9 ELECTRIC TRUCK

Parts required

4 of No. 2
2 " " 5
2 " " 10
2 " " 12
1 " " 16
1 " " 17
1 " " 19s
2 " " 22
1 " " 24
4 " " 35
17 " " 37
2 " " 37a
2 " " 38
2 " " 48a
1 " " 52
2 " " 90a
2 " " 111c
2 " " 126
2 " " 126a
2 " " 142c

The two 5½" Strips 1 on each side of the model are fastened to the Flanged Plate by two Trunnions secured to the Plate on the underneath side. A Bush Wheel 2 is fixed on the Axle Rod 3, which passes through the end holes of the 5½" Strips that form the sides of the truck frame.

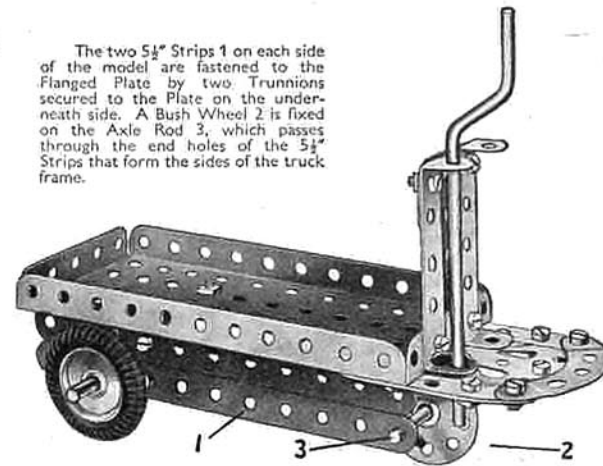

O.10 ELEVATOR

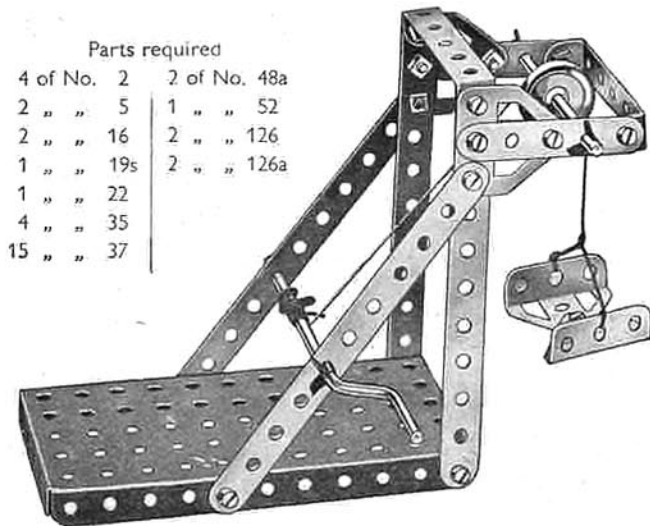

Parts required

4 of No. 2	2 of No. 48a
2 " " 5	1 " " 52
2 " " 16	2 " " 126
1 " " 19s	2 " " 126a
1 " " 22	
4 " " 35	
15 " " 37	

O.11 DOCKSIDE CRANE

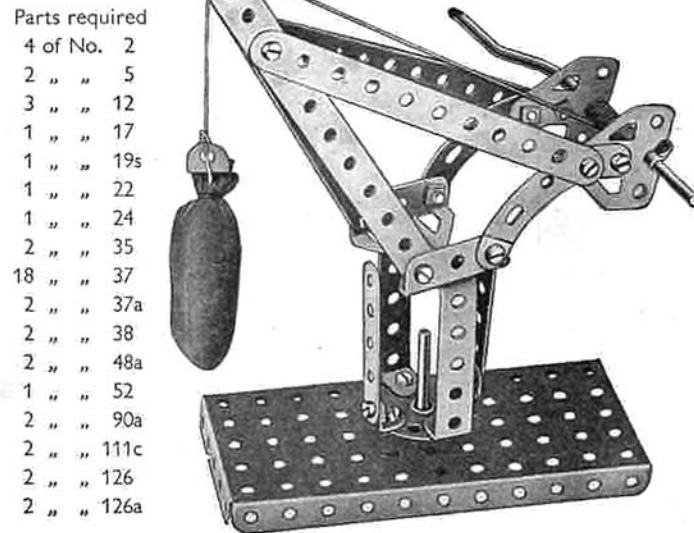

Parts required

4 of No. 2
2 " " 5
3 " " 12
1 " " 17
1 " " 19s
1 " " 22
1 " " 24
2 " " 35
18 " " 37
2 " " 37a
2 " " 38
2 " " 48a
1 " " 52
2 " " 90a
2 " " 111c
2 " " 126
2 " " 126a

O.12 BUCKING BRONCHO

The Bolts 1 are fitted with locknuts, so that the parts they attach are free to pivot. Bearings for a 2" Rod, the end of which is seen at 2, are provided by a Fishplate 3, bolted to an Angle Bracket 4, and a Trunnion 5.

Parts required

2 of No. 5
4 " " 10
1 " " 12
1 " " 17
1 " " 19s
2 " " 22
1 " " 24
4 " " 35
15 " " 37
5 " " 37a
1 " " 38
1 " " 48a
1 " " 52
2 " " 90a
2 " " 111c
2 " " 126
2 " " 126a

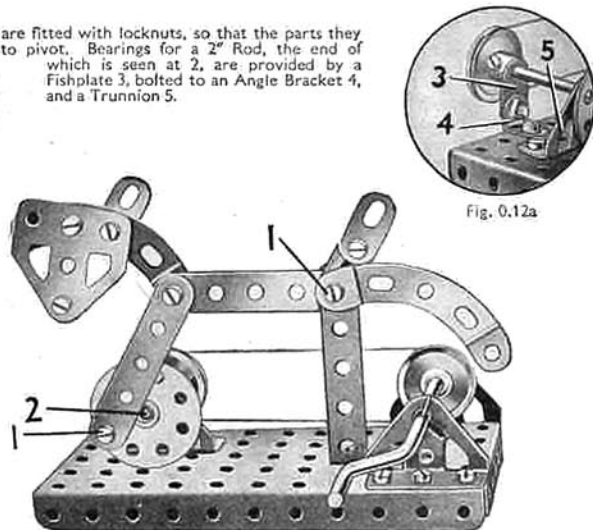
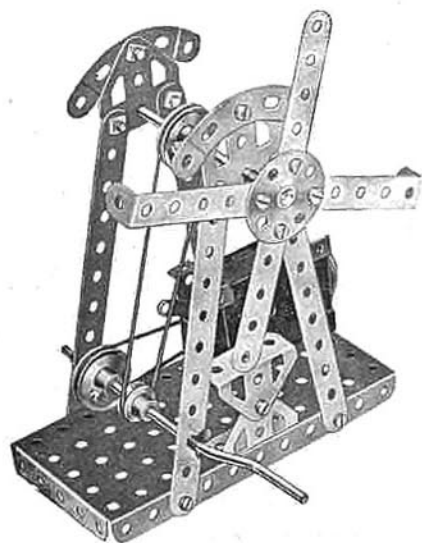

Fig. 0.12a

O.13 WINDMILL



Parts required

4 of No. 2	18 of No. 37
2 " " 5	2 " " 38
2 " " 12	2 " " 48a
1 " " 16	1 " " 52
1 " " 19s	1 " " 52
2 " " 22	2 " " 90a
1 " " 24	2 " " 126
3 " " 35	2 " " 126a

Magic Motor
(not included in Outfit)

A Driving Band connects the pulley of the *Magic Motor* to a 1" Pulley fastened on the Crank Handle. The Crank Handle carries also a $\frac{1}{2}$ " Pulley, which is connected by a second Driving Band with a further 1" Pulley fixed to the $3\frac{1}{2}$ " Rod on which the sails are mounted. The $3\frac{1}{2}$ " Rod is held in place by Spring Clips, one behind the Bush Wheel and one on its rear end. If a Motor is not used the $\frac{1}{2}$ " Pulley (supplied with Motor) is replaced by a 1" Pulley.

O.14 INVALID CARRIAGE

Parts required		
4 of No. 2	2 of No. 38	1 of No. 126
2 " " 5	2 " " 48a	2 " " 126a
2 " " 12	1 " " 52	2 " " 142c
1 " " 16	2 " " 90a	
1 " " 17	1 " " 111c	
2 " " 22		
1 " " 24		
2 " " 35		
17 " " 37		

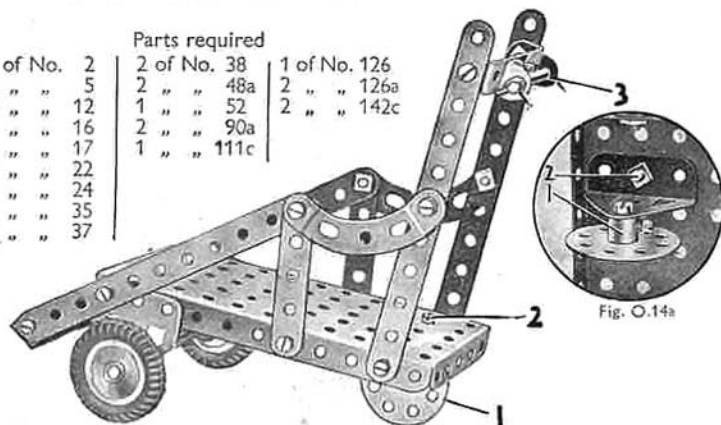

The Bush Wheel 1 is locked on a $\frac{1}{2}$ " Bolt journalled in a Trunnion attached to the Flanged Plate by the Bolt 2 (see Fig. O.14a). The handlebar 3 is held by Spring Clips in two Angle Brackets bolted to the $2\frac{1}{2}$ " x $\frac{1}{2}$ " Double Angle Strip.

O.17 DOCKSIDE CRANE

Two Trunnions 1 form the top of the tower, and a $\frac{1}{2}$ " Bolt passed through the holes in their pointed ends and into the boss of a Bush Wheel, forms the pivot for the jib. The Flat Trunnions are connected to the Bush Wheel by Angle Brackets. The $\frac{1}{2}$ " Bolt 2 that connects the $5\frac{1}{2}$ " Strips of the jib is fitted with locknuts.

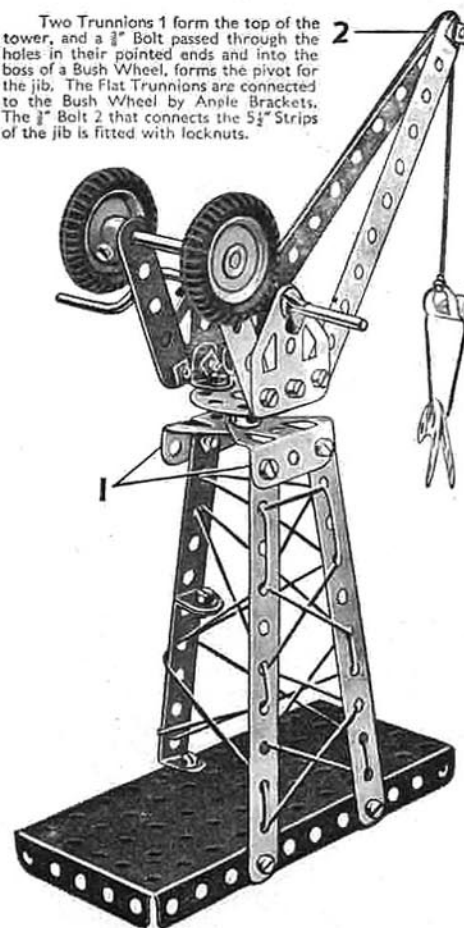

O.15 MERRY-GO-ROUND

Parts required

4 of No. 2	
2 " " 5	
4 " " 12	
1 " " 16	
1 " " 19s	
2 " " 22	
1 " " 24	
4 " " 35	
18 " " 37	
2 " " 37a	2 of No. 111c
2 " " 38	2 " " 126
1 " " 48a	2 " " 126a
1 " " 52	<i>Magic Motor</i>
2 " " 90a	(not included in Outfit)

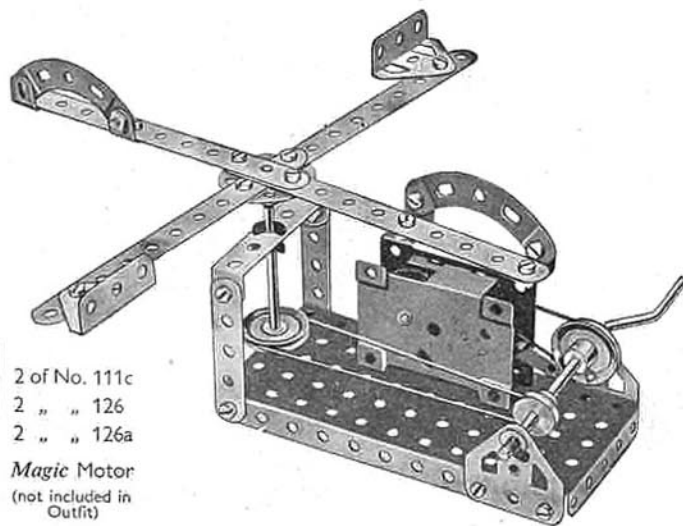

O.16 DROP HAMMER

The hammer, which is formed by the two 1" Pulleys on a $3\frac{1}{2}$ " Rod, is lifted by the Fishplates 1 as they rotate when the Crank Handle is turned. The Fishplates are bolted to a Bush Wheel fixed on the Crank Handle.

Parts required

4 of No. 2
2 " " 5
4 " " 10
1 " " 16
1 " " 19s
2 " " 22
1 " " 24
2 " " 35
18 " " 37
2 " " 37a
2 " " 38
2 " " 48a
1 " " 52
2 " " 90a
2 " " 111c
2 " " 126
2 " " 126a
2 " " 142c

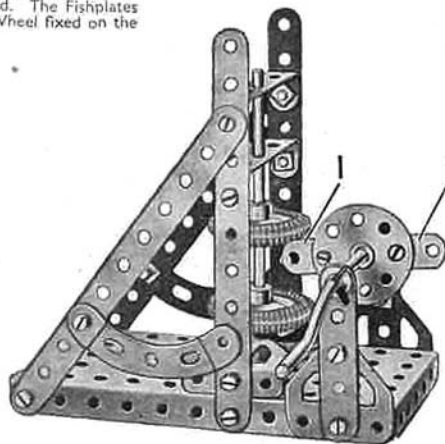

Parts required

4 of No. 2	1 of No. 24	1 of No. 52
2 " " 5	2 " " 35	2 " " 90a
3 " " 12	15 " " 37	2 " " 111c
1 " " 17	2 " " 37a	2 " " 126
1 " " 19s	2 " " 38	2 " " 126a
2 " " 22	2 " " 48a	2 " " 142c

O.18 DERRICK CRANE

Parts Required

4 of No. 2	2 of No. 38
1 " " 5	2 " " 48a
1 " " 10	1 " " 52
3 " " 12	2 " " 126
1 " " 17	2 " " 126a
1 " " 19s	
2 " " 22	
1 " " 24	
4 " " 35	
17 " " 37	
3 " " 37a	

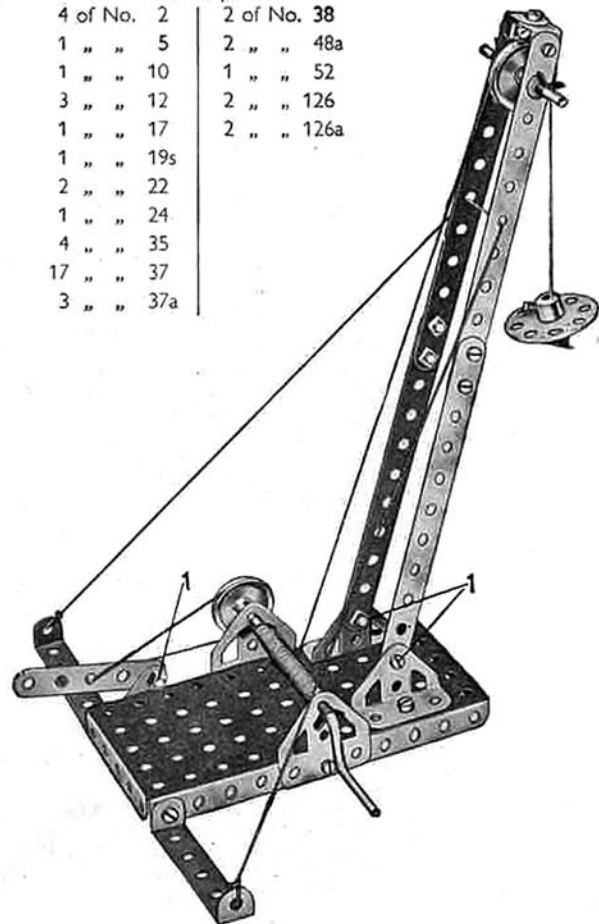

The construction of the model is commenced by bolting the Trunnions and Flat Trunnions that support the jib and Crank Handle respectively to the 5½" x 2½" Flanged Plate that forms the base of the model. The jib is then assembled and fastened to the Trunnions by means of the lock-nutted Bolts 1. The brake lever is a 2½" Strip and is fastened to a Fishplate bolted to the Flanged Plate. Bolts 1 are lock-nutted. A length of cord is fastened to the lever and then passed round the 1" Pulley on the Crank Handle.

O.19 WINDMILL PUMP

Bolts 1 are lock-nutted so that the parts they attach are free to pivot. The Curved Strip 2 is made to move up and down by a Crank, which is formed by bolting an Angle Bracket to the boss of a 1" Pulley 3. This Pulley drives by means of a cord belt another 1" Pulley on the shaft of the windmill sails.

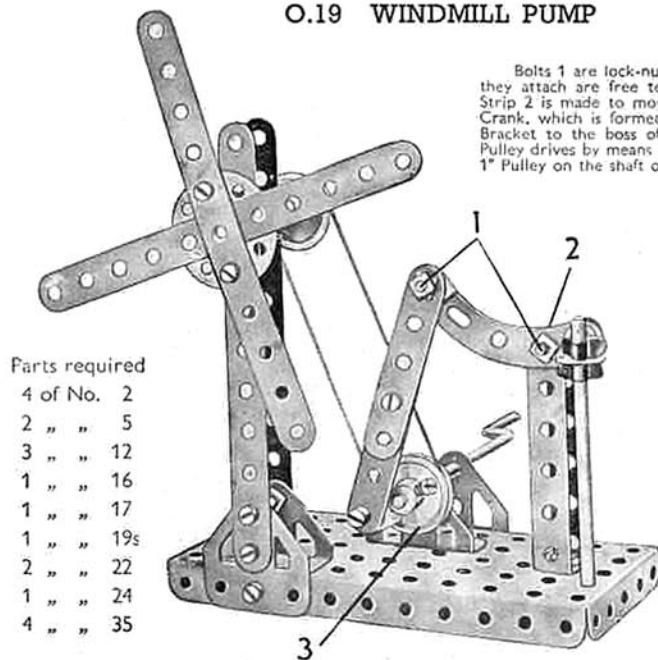

Parts required

4 of No. 2	16 of No. 37
2 " " 5	6 " " 37a
3 " " 12	2 " " 38
1 " " 16	2 " " 48a
1 " " 17	1 " " 52
1 " " 19s	1 " " 90a
2 " " 22	2 " " 111c
1 " " 24	2 " " 126
4 " " 35	2 " " 126a

O.20 PLOUGH

Parts required

4 of No. 2	2 of No. 22	1 of No. 48a
2 " " 5	1 " " 24	1 " " 90a
3 " " 10	2 " " 35	2 " " 111c
4 " " 12	12 " " 37	2 " " 126a
1 " " 16	6 " " 37a	2 " " 142c
1 " " 17	2 " " 38	

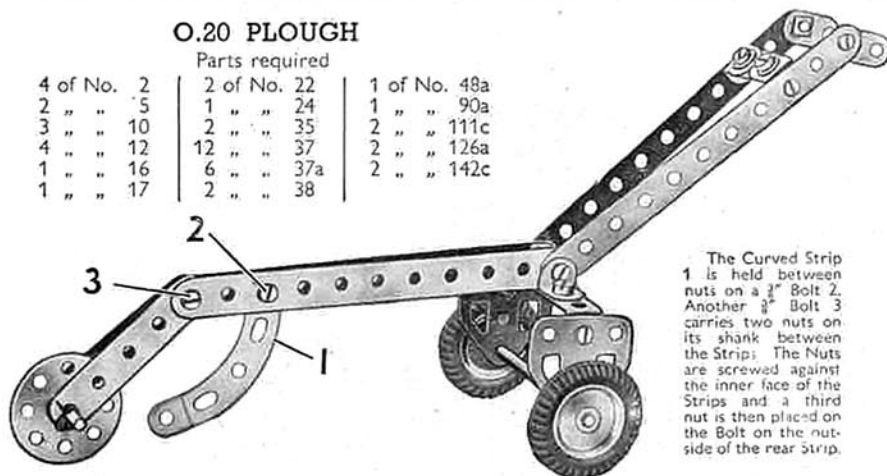

The Curved Strip 1 is held between nuts on a ½" Bolt 2. Another ½" Bolt 3 carries two nuts on its shank between the Strips. The Nuts are screwed against the inner face of the Strips and a third nut is then placed on the Bolt on the outside of the rear Strip.

O.21 PUNCHING MACHINE

Parts required

3 of No. 2	2 of No. 22	1 of No. 52
2 " " 10	1 " " 24	2 " " 126
4 " " 12	16 " " 37	2 " " 126a
1 " " 16	2 " " 37a	2 " " 142c
1 " " 17	1 " " 48a	

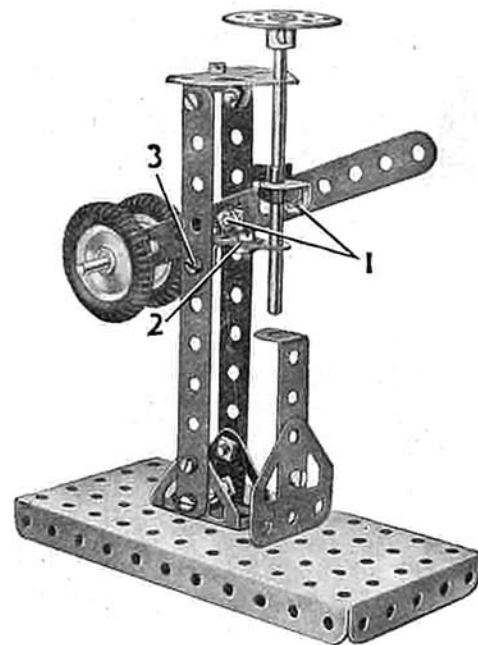

The Bolts 1 are lock-nutted. The lower bearing for the punch consists of two Fishplates 2, which are bolted together. One of them is then attached to an Angle Bracket that is fixed to one of the vertical 5½" Strips by the Bolt 3.

1.1 FLYING BOATS

Parts required

4 of No.	2
4 "	5
4 "	12
1 "	16
1 "	19s
4 "	22
1 "	24
3 "	35
24 "	37
1 "	38
1 "	40
2 "	48a
1 "	52
2 "	90a
1 "	125
2 "	126
2 "	126a
2 "	189

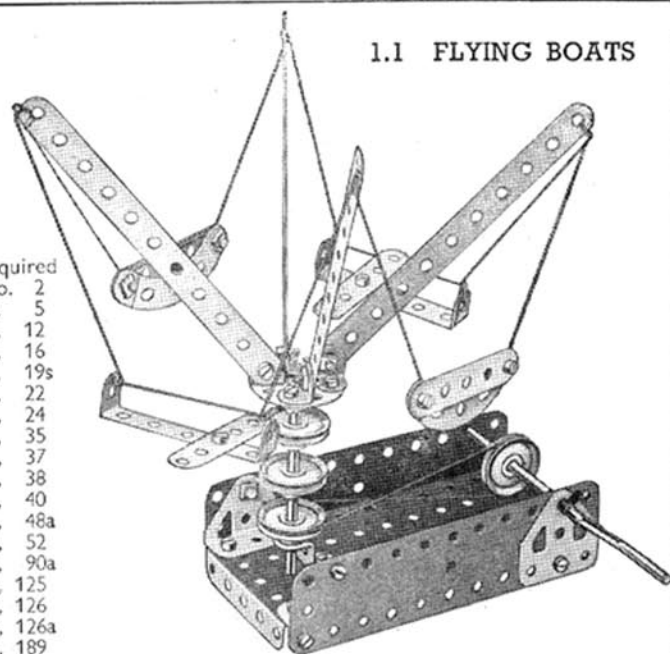

1.2 DRILL

Parts required

4 of No.	2	4 of No.	35
3 "	5	20 "	37
8 "	12	4 "	38
1 "	16	1 "	40
1 "	17	1 "	52
1 "	19s	2 "	126
4 "	22	2 "	126a

The drill table is made by bolting together two Flat Trunnions.

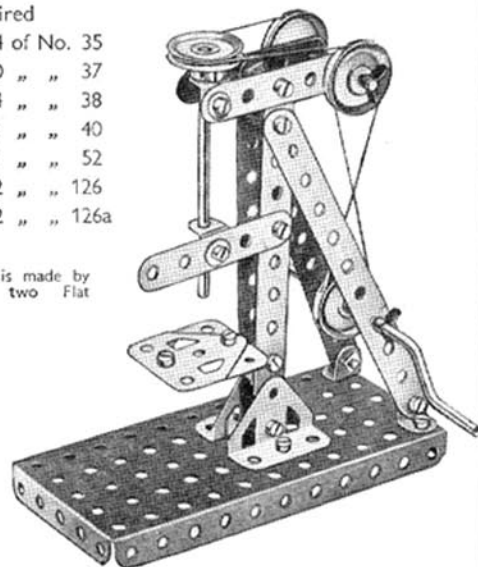

1.3 SCALES

Parts required

4 of No.	2
2 "	5
2 "	17
2 "	22
1 "	24
19 "	37
1 "	38
1 "	40
2 "	48a
1 "	52
2 "	90a
1 "	111c
2 "	126
2 "	126a
1 "	155
2 "	189

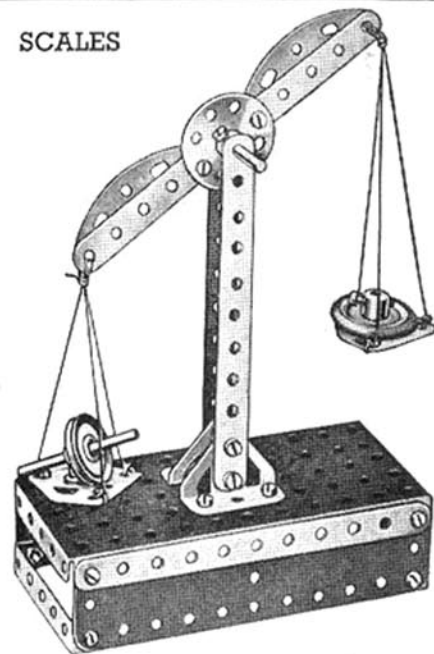

1.4 MOTOR LORRY

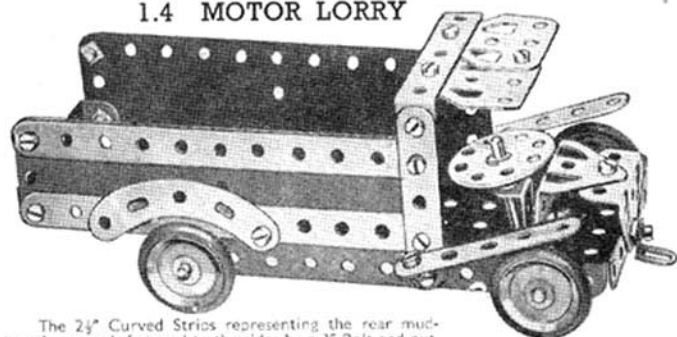

The 2½" Curved Strips representing the rear mudguards are each fastened to the sides by a ¾" Bolt and nut, with a Spring Clip between the mudguards and the 5½" Strip to form a distance piece.

Parts required

4 of No.	2	1 of No.	17	19 of No.	37	2 of No.	90a	2 of No.	126a
4 "	5	4 "	22	4 "	37a	3 "	111c	4 "	155
3 "	12	1 "	24	2 "	48a	1 "	125	2 "	189
2 "	16	2 "	35	1 "	52	2 "	126		

1.5 RACING SEAPLANE

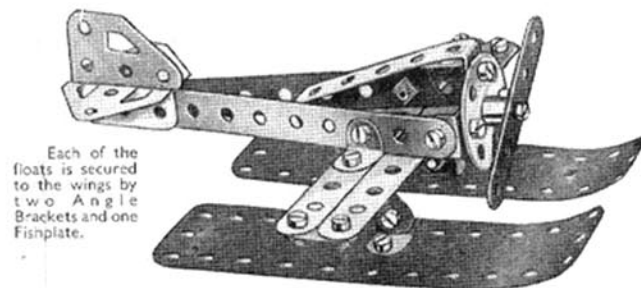

Each of the floats is secured to the wings by two Angle Brackets and one Fishplate.

Parts required

3 of No.	2	1 of No.	24	2 of No.	111c
3 "	3	19 "	37	2 "	126
4 "	10	1 "	37a	1 "	126a
8 "	12	1 "	48a	2 "	189

1.6 KIDDIE CAR

Parts required

4 of No.	2
4 "	5
3 "	10
7 "	12
2 "	16
1 "	17
1 "	22
4 "	24
1 "	35
24 "	37
3 "	37a
2 "	48a
1 "	52
2 "	90a
2 "	111c
1 "	125
2 "	126
1 "	126a
4 "	155
2 "	189

Two Trunnions overlapped one hole, and fastened to the Flanged Plate by an Angle Bracket form the seat.

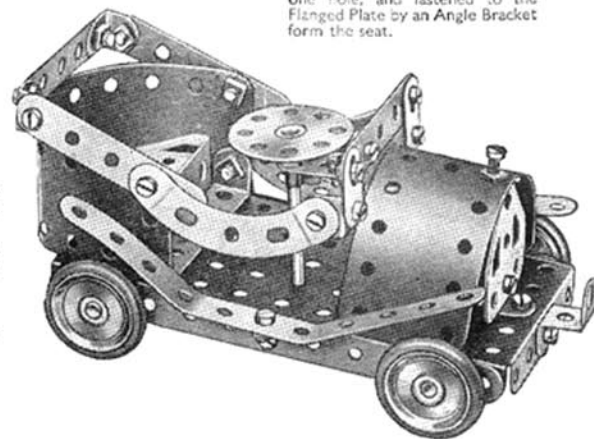

1.7 SIDE TIPPING WAGON

Parts required

3 of No. 2	3 of No. 38
4 " " 5	2 " " 48a
4 " " 10	1 " " 52
7 " " 12	2 " " 90a
2 " " 16	4 " " 111c
1 " " 17	1 " " 125
4 " " 22	2 " " 126
1 " " 24	2 " " 126a
24 " " 37	4 " " 155
4 " " 37a	2 " " 189

1 Magic Motor
(Not included in Outfit)

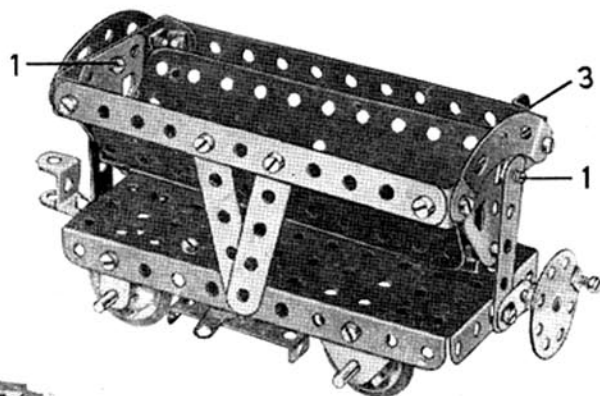

Each of the Bolts 1 is lock-nutted. A piece of Cord is fastened to the Rod 2 (Fig. 1.7a) wrapped round it two or three times, and then is taken through the hole in the Flanged Plate above the Rod and secured to the Angle Bracket 3.

By turning the Bush Wheel the container is tipped sideways.

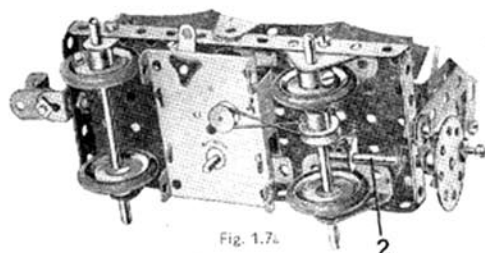

Fig. 1.7a

1.8 STAMPING MILL

The anvil 1 is made up of two Trunnions bolted together. When the Crank Handle is rotated, the Fishplates bolted to the Bush Wheel strike the centre 1" Pulley on the hammer shaft and cause it to rise and fall.

Parts required

4 of No. 2	3 of No. 37a
5 " " 5	2 " " 38
4 " " 10	2 " " 48a
4 " " 12	1 " " 52
1 " " 16	1 " " 90a
1 " " 19s	4 " " 111c
4 " " 22	1 " " 125
1 " " 24	2 " " 126
2 " " 35	2 " " 126a
24 " " 37	2 " " 189

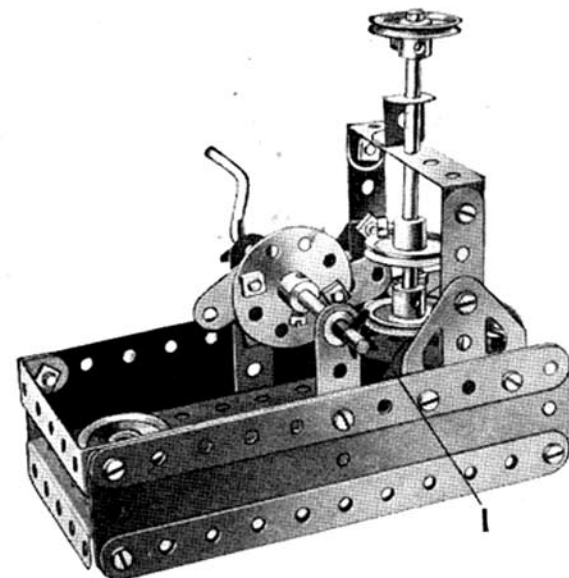

1.9 LETTER BALANCE

Parts required

4 of No. 2
4 " " 5
4 " " 10
2 " " 12
1 " " 16
2 " " 17
4 " " 22
1 " " 24
4 " " 35
24 " " 37
4 " " 37a
4 " " 38
2 " " 48a
1 " " 52
1 " " 57c
1 " " 90a
4 " " 111c
1 " " 125
2 " " 126
2 " " 126a
4 " " 155
2 " " 189

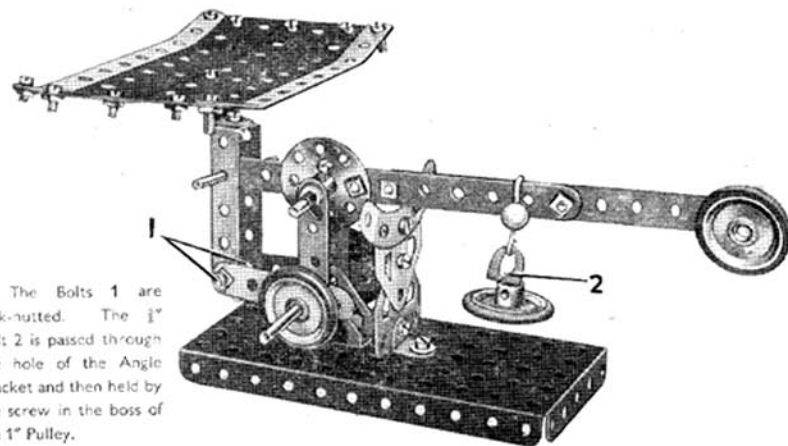

The Bolts 1 are lock-nutted. The 1/2" Bolt 2 is passed through the hole of the Angle Bracket and then held by the screw in the boss of the 1" Pulley.

1.10 RAILWAY BREAKDOWN CRANE

Parts required

4 of No. 2	4 of No. 22	1 of No. 40	1 of No. 125
4 " " 5	1 " " 24	2 " " 48a	2 " " 126
1 " " 16	2 " " 35	1 " " 52	2 " " 126a
4 " " 12	20 " " 37	1 " " 57c	4 " " 155
2 " " 16	4 " " 37a	2 " " 90a	2 " " 189
1 " " 19s	2 " " 38	4 " " 111c	

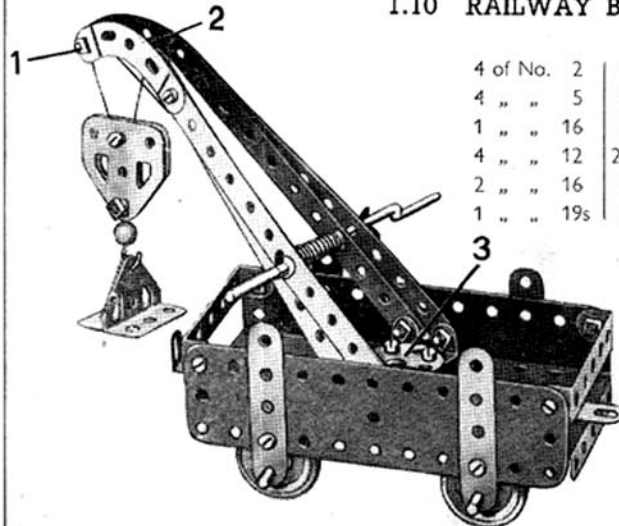

The hoisting cord is secured to the Crank Handle, and then led over the 3/8" Bolt 1. It is then passed through the pulley block and fastened to the jib at 2. The jib is attached to the Bush Wheel 3 by means of Angle Brackets and the complete unit is pivoted as follows. A 3/8" Bolt is passed through the 5 1/2" x 2 1/2" Flanged Plate from the underside, and is secured in the boss of the Bush Wheel by its set screw.

I.11 OPEN TRAMCAR

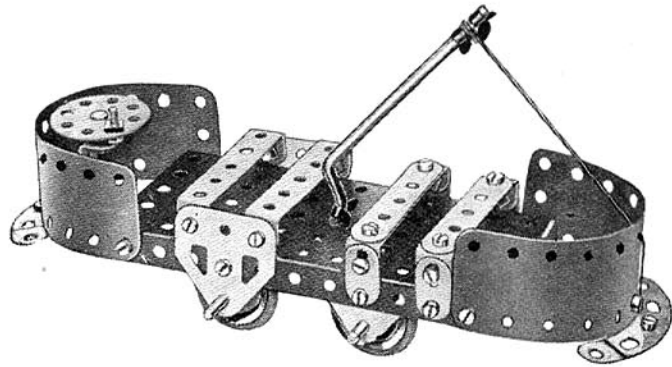

Parts Required	
2 of No. 5	1 of No. 40
4 " " 10	2 " " 48a
7 " " 12	1 " " 52
2 " " 16	2 " " 90a
1 " " 19s	4 " " 111c
4 " " 22	1 " " 125
1 " " 24	2 " " 126
4 " " 35	2 " " 126a
24 " " 37	4 " " 142c
3 " " 37a	2 " " 189

I.12 COASTER

Parts Required

3 of No. 2	4 of No. 22	1 of No. 40	2 of No. 126
4 " " 5	1 " " 24	2 " " 48a	2 " " 126a
2 " " 10	1 " " 35	1 " " 52	4 " " 155
5 " " 12	24 " " 37a	2 " " 90a	1 " " 189
2 " " 16	20 " " 37b	2 " " 111c	
1 " " 17	4 " " 38	1 " " 125	

The Bolts (1) are *lock-nutted*. The rear axle Rod is pushed through the end hole of the Curved Strip (2) and through Fishplates bolted to the Flanged Plate.

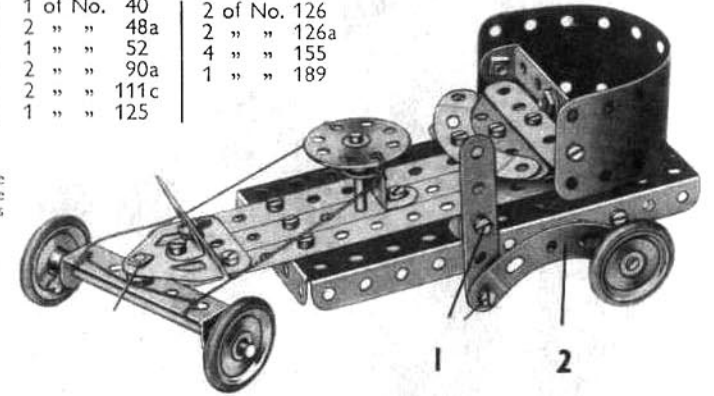

I.13 DERRICK CRANE

The jib is bolted to a Bush Wheel (1), which is fixed by its set-screw on a $\frac{3}{8}$ " Bolt passed through the Flanged Plate. The jib supporting Cord is passed round a 1" Pulley on a 2" Rod (2). This Rod is held in place by a Spring Clip placed underneath the Flat Trunnion.

The brake lever is *lock-nutted* to a $\frac{3}{8}$ " Reversed Angle Bracket (3). A brake is provided by a length of Cord passed over Pulley (4) and tied to the lever and to the Flanged Plate.

Parts Required

4 of No. 2	2 of No. 48a
4 " " 5	1 " " 52
3 " " 12	1 " " 57c
2 " " 17	1 " " 90a
1 " " 19s	2 " " 111c
4 " " 22	1 " " 125
1 " " 24	2 " " 126
4 " " 35	1 " " 126a
21 " " 37a	
20 " " 37b	
1 " " 40	

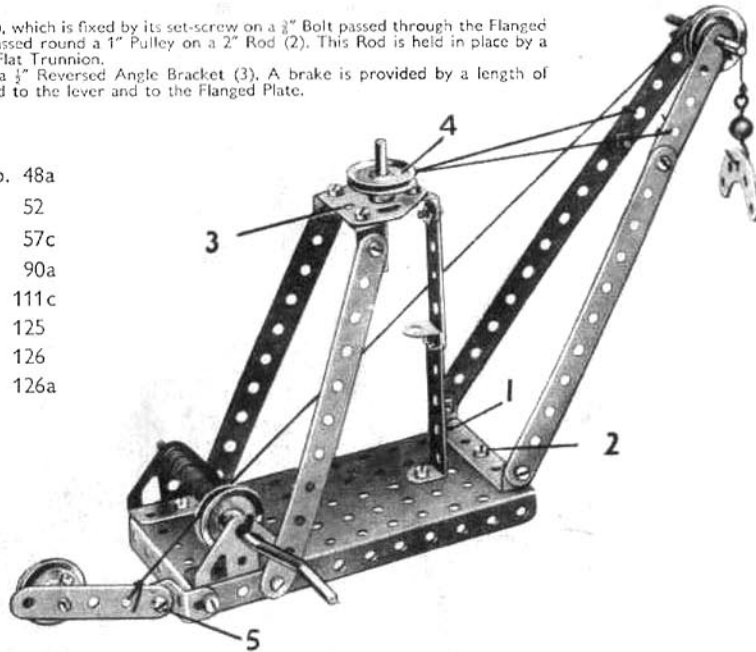

I.14 TELPHER SPAN

The anchoring piece (1) consists of two Trunnions bolted together, and a hook, which is made of two Angle Brackets, fastened to them. A 2" Rod carrying a 1" fast Pulley is journaled in the Trunnions. The anchoring piece is hooked on a picture rail or other suitable support and the Cord (2), which can be of any length, is passed round the 1" Pulleys as shown. When the Crank Handle is rotated the car moves either backward or forward.

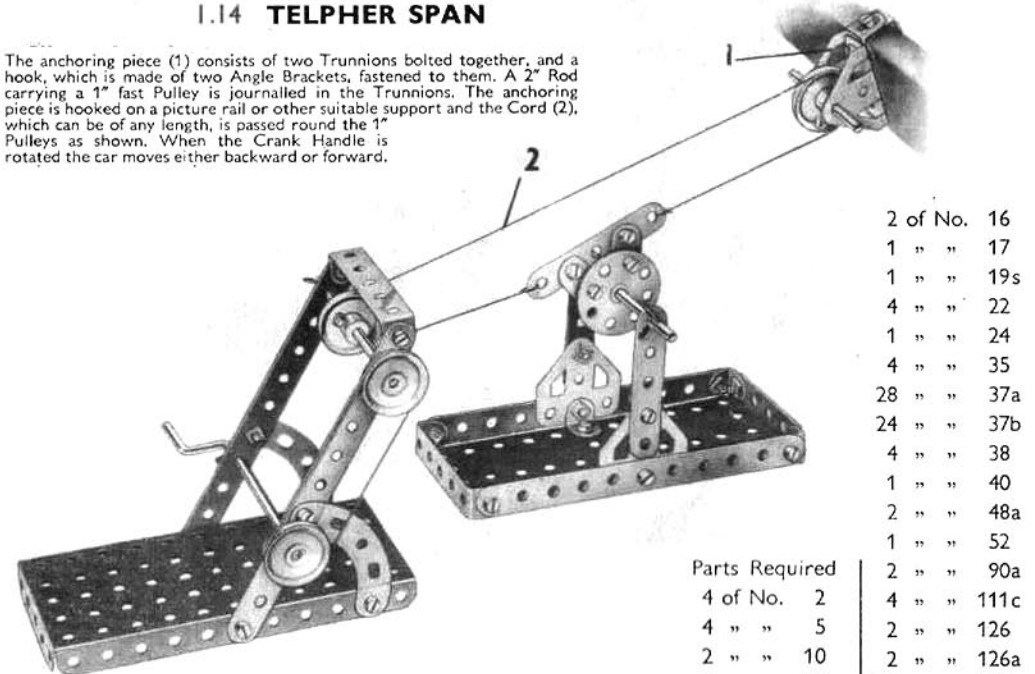

Parts Required

2 of No. 16	
1 " " 17	
1 " " 19s	
4 " " 22	
1 " " 24	
4 " " 35	
28 " " 37a	
24 " " 37b	
4 " " 38	
1 " " 40	
2 " " 48a	
1 " " 52	
2 " " 90a	
4 of No. 2	4 " " 111c
4 " " 5	2 " " 126
2 " " 10	2 " " 126a
6 " " 12	2 " " 189

I.15 MECHANICAL SHOVEL

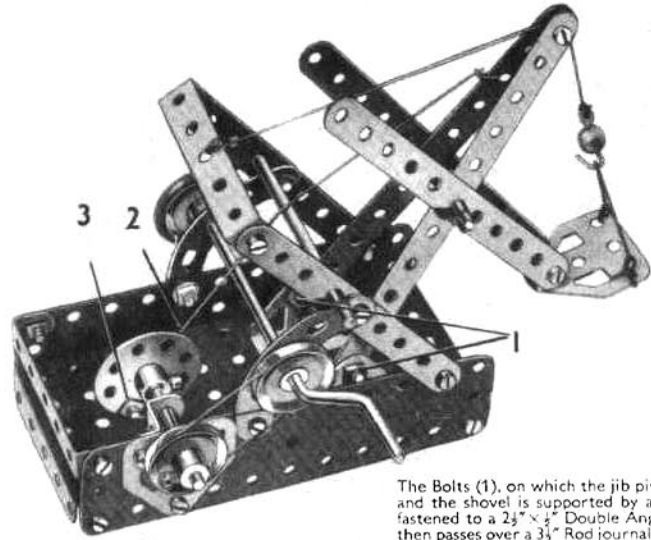

Parts Required

4 of No. 2	4 of No. 38
4 " " 5	1 " " 40
1 " " 10	2 " " 48a
2 " " 12	1 " " 52
1 " " 16	1 " " 57c
2 " " 17	2 " " 90a
1 " " 19s	4 " " 111c
3 " " 22	1 " " 125
1 " " 24	2 " " 126
28 " " 37a	2 " " 126a
24 " " 37b	1 " " 155
	2 " " 189

The Bolts (1), on which the jib pivots, are *lock-nutted*. The shovel arm is pivoted on a 2" Rod and the shovel is supported by a Cord that passes over the 1" Bolt at the jib head and is fastened to a 2 1/2" x 1/2" Double Angle Strip as shown. The Cord (2) is fastened to the jib and then passes over a 3 1/2" Rod journalled in the holes above the 2 1/2" Curved Strips, and is attached to a Fishplate fastened by the *lock-nutted* Bolt (3) to the Bush Wheel.

When the Crank Handle is rotated, the Bush Wheel imparts a digging motion to the jib and shovel arm.

I.16 LIFTING BRIDGE

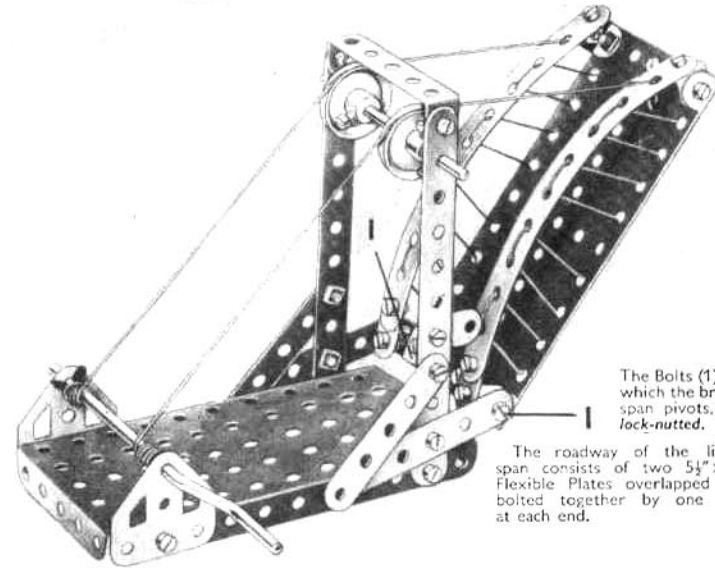

Parts Required

4 of No. 2	4 of No. 5
4 " " 5	3 " " 10
3 " " 10	8 " " 12
8 " " 12	1 " " 16
1 " " 16	1 " " 19s
1 " " 19s	2 " " 22
2 " " 22	4 " " 35
4 " " 35	29 " " 37a
29 " " 37a	24 " " 37b
24 " " 37b	4 " " 38
4 " " 38	1 " " 40
1 " " 40	1 " " 48a
1 " " 48a	1 " " 52
1 " " 52	3 " " 111c
3 " " 111c	2 " " 126a
2 " " 126a	2 " " 189
2 " " 189	

The Bolts (1), on which the bridge span pivots, are *lock-nutted*.

The roadway of the lifting span consists of two 5 1/2" x 1 1/2" Flexible Plates overlapped and bolted together by one Bolt at each end.

I.17 FIRE ENGINE

Parts Required

4 of No. 2
4 " " 5
3 " " 10
5 " " 12
2 " " 16
1 " " 17
1 " " 19s
4 " " 22
1 " " 24
4 " " 35
24 " " 37
4 " " 37a
2 " " 38
1 " " 40
2 " " 48a
1 " " 52
2 " " 90a
2 " " 111c
1 " " 125
2 " " 126
2 " " 126a
4 " " 142c
2 " " 189

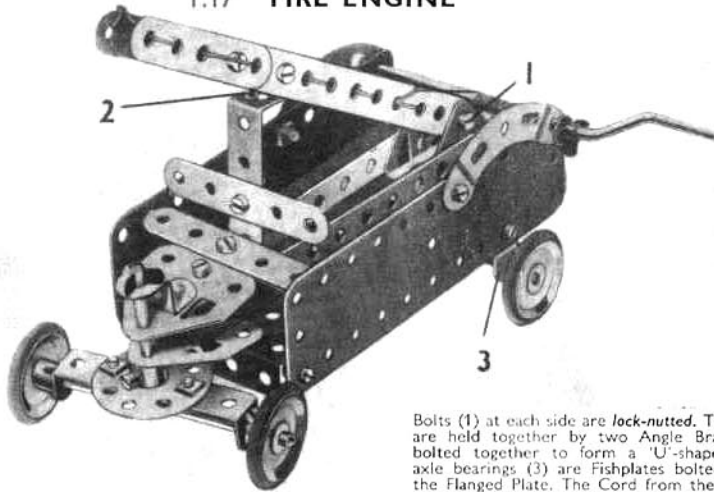

Bolts (1) at each side are *lock-nutted*. The sides of the ladder are held together by two Angle Brackets (2), which are bolted together to form a 'U'-shaped bracket. The rear axle bearings (3) are Fishplates bolted inside the flange of the Flanged Plate. The Cord from the Crank Handle is tied in the fourth hole up the ladder so that when the Handle is turned it causes the ladder to lift.

I.18 MECHANICAL SWING

The left-hand 2 1/2" Strip that supports the swing is connected to the Crank Handle by passing the set screw of the 1" Pulley (2) through a hole in an Angle Bracket bolted to the Strip and then into the boss of the Pulley. Bolt (1) on the Bush Wheel is fitted with *lock-nuts*.

Parts Required

4 of No. 2	4 of No. 38
1 " " 5	1 " " 40
2 " " 10	2 " " 48a
3 " " 12	1 " " 52
1 " " 16	1 " " 111c
1 " " 19s	1 " " 125
2 " " 22	2 " " 126
1 " " 24	2 " " 189
4 " " 35	
17 " " 37a	1 Magic Motor
15 " " 37b	(not included in
	Outfit)

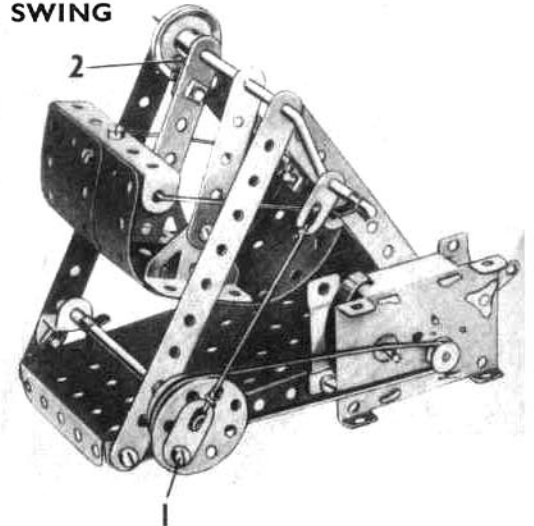

1.19 TRAVELLING CRANE

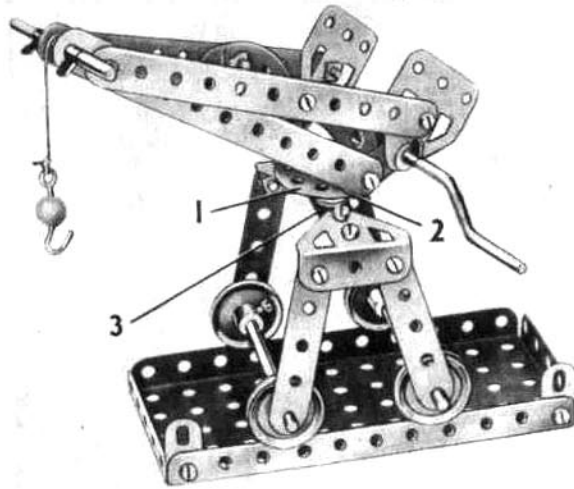

Parts Required.

4 of No. 2	20 of No. 37a
4 " " 5	20 " " 37b
4 " " 10	4 " " 38
2 " " 12	1 " " 40
2 " " 16	1 " " 48a
1 of No. 17	1 of No. 52
1 " " 19s	1 " " 57c
4 " " 22	2 " " 90a
1 " " 24	1 " " 111c
4 " " 35	2 " " 126
	2 " " 126a

The sides of the jib are secured to the Bush Wheel (1) by two Angle Brackets (2), one on each side. A $\frac{1}{2}$ " Bolt is passed from the underneath side of Double Angle Strip (3) into the boss of the Bush Wheel (1) and the set screw is then tightened. The Flat Trunnions at the lower end of the jib support the Crank Handle, which also passes through Fishplates bolted to the Angle Brackets (2) on the Bush Wheel (1). The Cord is fastened to the Crank Handle, and passes over the 2" Rod at the jib head.

1.20 CIRCULAR SAW

The Bush Wheel (1) is fixed to a $3\frac{1}{2}$ " Rod that is passed through two Trunnions bolted to the Flanged Plate.

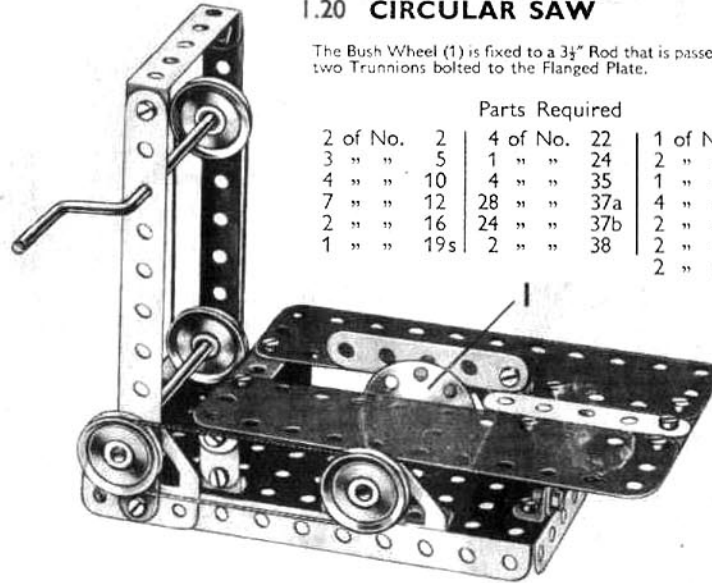

Parts Required

2 of No. 2	4 of No. 22	1 of No. 40
3 " " 5	1 " " 24	2 " " 48a
4 " " 10	4 " " 35	1 " " 52
7 " " 12	28 " " 37a	4 " " 111c
2 " " 16	24 " " 37b	2 " " 126
1 " " 19s	2 " " 38	2 " " 126a
		2 " " 189

1.21 TRIP HAMMER

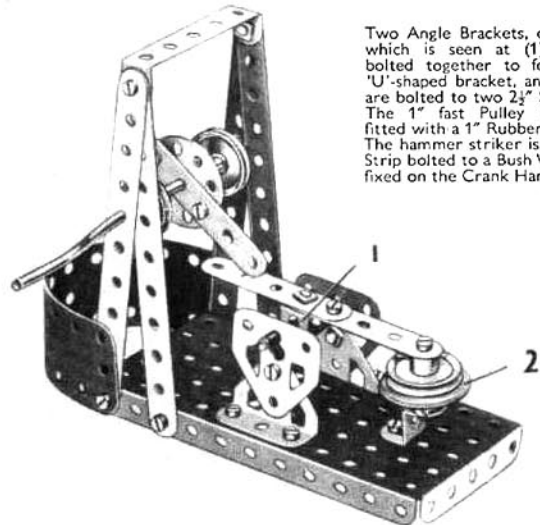

Two Angle Brackets, one of which is seen at (1), are bolted together to form a 'U'-shaped bracket, and also are bolted to two $2\frac{1}{2}$ " Strips. The 1" fast Pulley (2) is fitted with a 1" Rubber Ring. The hammer striker is a $2\frac{1}{2}$ " Strip bolted to a Bush Wheel fixed on the Crank Handle.

Parts Required

4 of No. 2
3 " " 5
2 " " 12
1 " " 17
1 " " 19s
4 " " 22
1 " " 24
4 " " 35
17 " " 37a
17 " " 37b
1 " " 48a
1 " " 52
2 " " 111c
1 " " 125
2 " " 126
2 " " 126a
1 " " 155
1 " " 189

1.22 PITHEAD GEAR

A Cord is taken from each side of the lift cage over the 1" Pulleys and secured to each end of the Crank Handle. The Cords must both be the same length, otherwise the lift will tilt.

The two guides for the lift consist of two pieces of Cord fastened to the Washers (1). The Cords are then passed through holes in the Double Angle Strip, through two corresponding holes in the lift cage (2), and then through the two corresponding holes in the Flanged Plate. Two more Washers are tied to the Cords beneath the Flanged Plate to keep the Cords tight. The lift cage (2) is made up of two Trunnions.

Note: In the illustration part of the $5\frac{1}{2}$ " x $1\frac{1}{2}$ " Flexible Plate forming one side of the tower is cut away to reveal the cage.

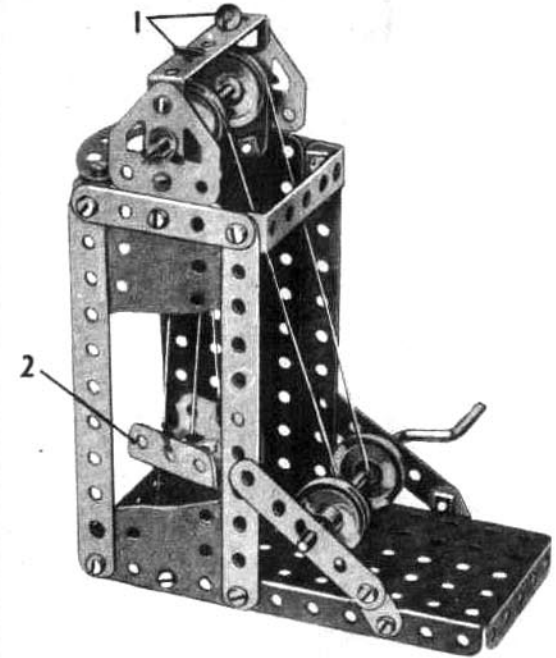

Parts Required

4 of No. 2	4 of No. 35	4 of No. 111c
4 " " 5	24 " " 37a	2 " " 126
4 " " 10	4 " " 38	2 " " 126a
2 " " 12	1 " " 40	2 " " 189
1 " " 16	2 " " 48a	
1 " " 19s	1 " " 52	
4 " " 22	1 " " 90a	

1.23 GYMNAST

The Bolts (1) are *lock-nutted*. The bearings for the Crank Handle in the Flexible Plates are reinforced by Trunnions bolted to the Flanged Plate.

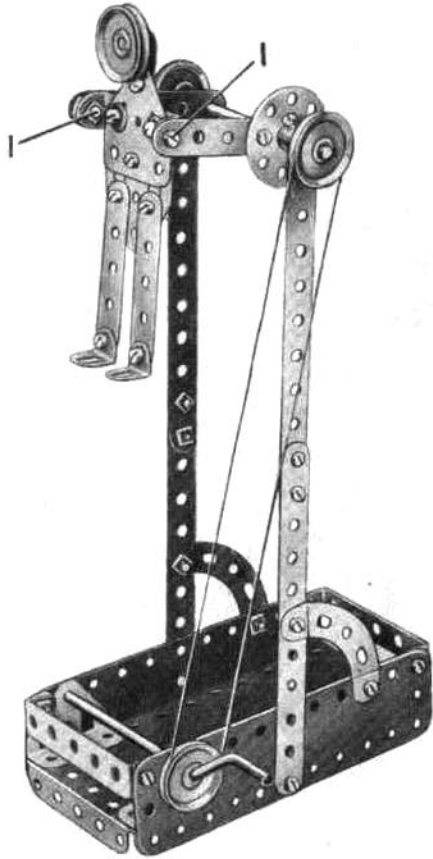

Parts Required

4 of No. 2	1 of No. 24	1 of No. 52
4 " " 5	2 " " 35	2 " " 90a
1 " " 10	24 " " 37	4 " " 111c
4 " " 12	5 " " 37a	2 " " 126
1 " " 16	4 " " 38	2 " " 126a
1 " " 19s	1 " " 40	2 " " 189
4 " " 22	2 " " 48a	

1.24 POWER PRESS

Parts Required

4 of No. 2	2
4 " " 5	5
1 " " 10	10
6 " " 12	12
1 " " 16	16
1 " " 17	17
1 " " 19s	19s
4 " " 22	22
1 " " 24	24
3 " " 35	35
29 " " 37a	37a
24 " " 37b	37b
1 " " 38	38
1 " " 40	40
2 " " 48a	48a
1 " " 52	52
2 " " 90a	90a
4 " " 111c	111c
1 " " 125	125
2 " " 126	126
2 " " 126a	126a
1 " " 155	155
2 " " 189	189

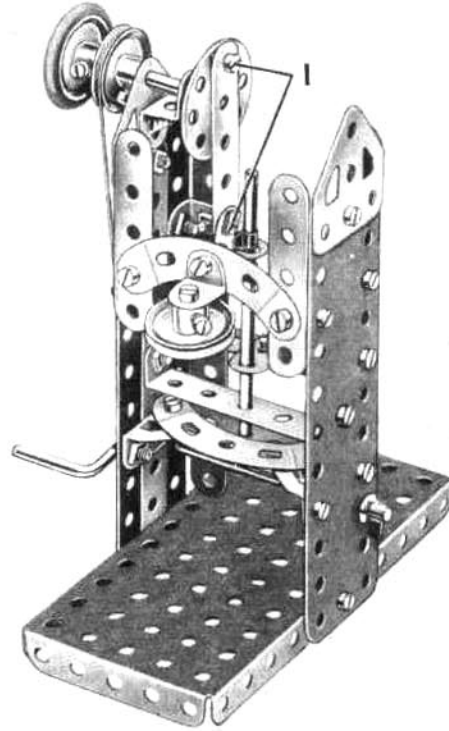

The Bolts (1) are *lock-nutted* and the Angle Bracket at the lower end of the 2½" Strip has a ¾" Rod in its elongated hole, where it is held by means of two Spring Clips.

The Rod forming the press ram moves up and down in the circular holes of a Fishplate bolted to a 2½" x ¾" Double Angle Strip and also through the centre hole of another 2½" x ¾" Double Angle Strip.

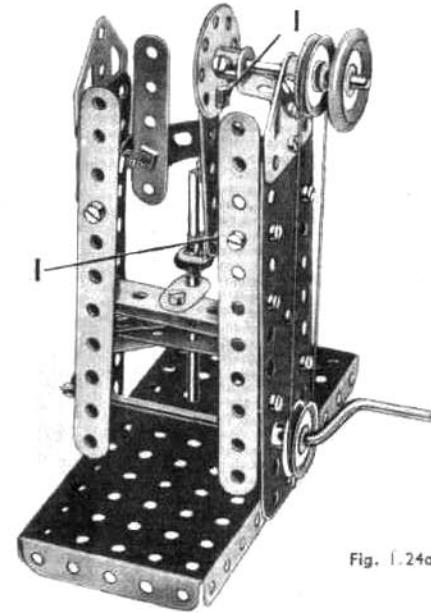
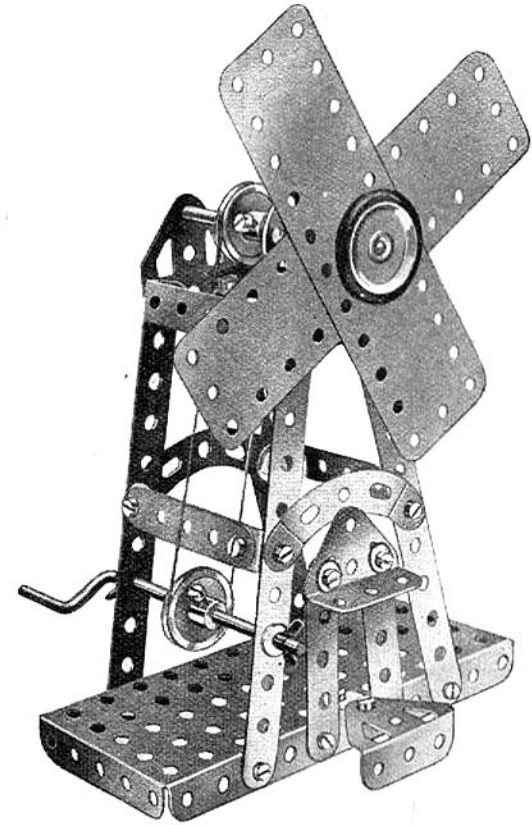

Fig. 1.24a

1.25 WINDMILL

The sails are gripped on the 3½" Rod by the 1" Pulley (with Rubber Ring) at the front and another 1" Pulley at the back of the sails. The Pulleys are pressed against the faces of the sails and locked on the Rod.



Parts Required

4 of No. 2	1 of No. 24	1 of No. 52
4 " " 5	3 " " 35	2 " " 90a
1 " " 10	24 " " 37a	2 " " 126
4 " " 12	24 " " 37b	2 " " 126a
1 " " 16	4 " " 38	1 " " 155
1 " " 19s	1 " " 40	2 " " 189
4 " " 22	2 " " 48a	

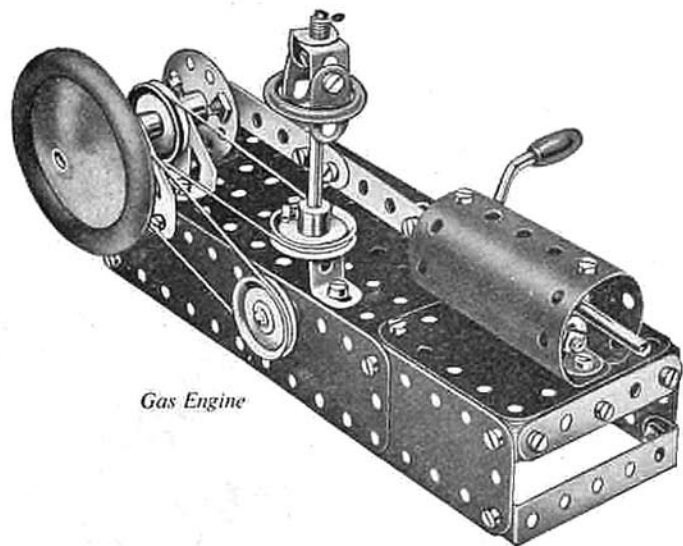
*Gas Engine*

HOW TO CONTINUE

When you have built all the models shown in this Book of Instructions, you will be keen to build bigger and more elaborate models. Your next step is to purchase a Meccano No. 1a Accessory Outfit containing all the parts required to convert your No. 1 into a No. 2 Outfit. You will then be able to build the full range of No. 2 Outfit models.

If you prefer to do so, you can build up and develop your Outfit quite easily by adding various parts to it from time to time. The model-building possibilities of the Meccano system are unlimited, and the more Meccano parts you have the bigger and better the models you will be able to build.

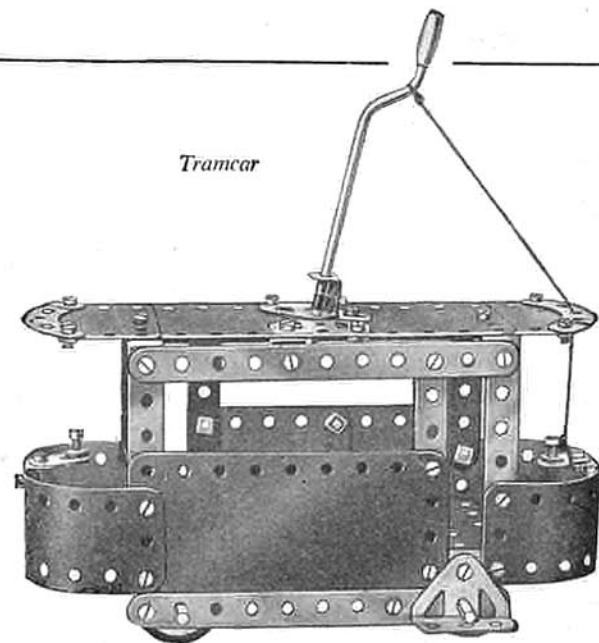
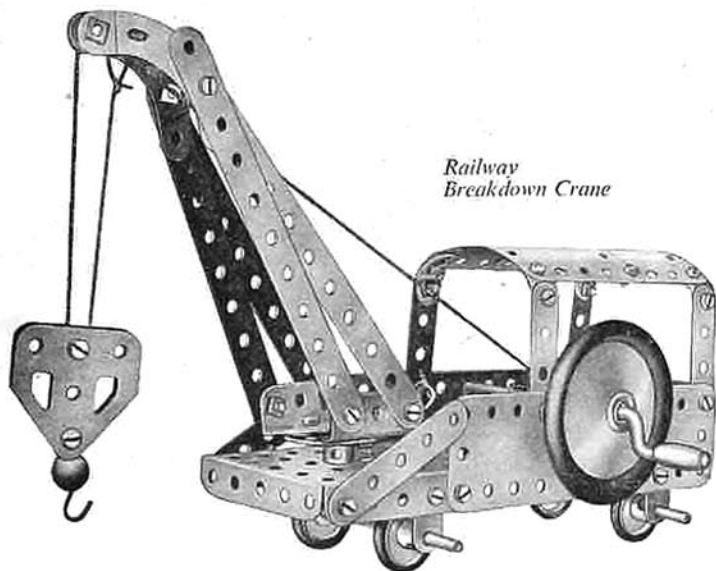
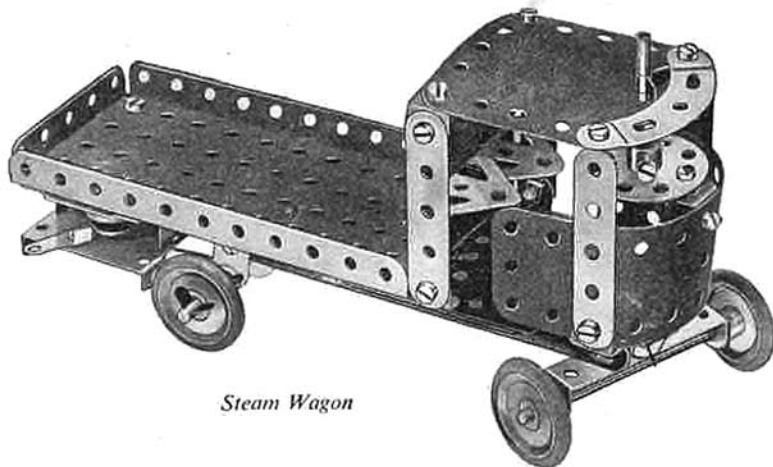
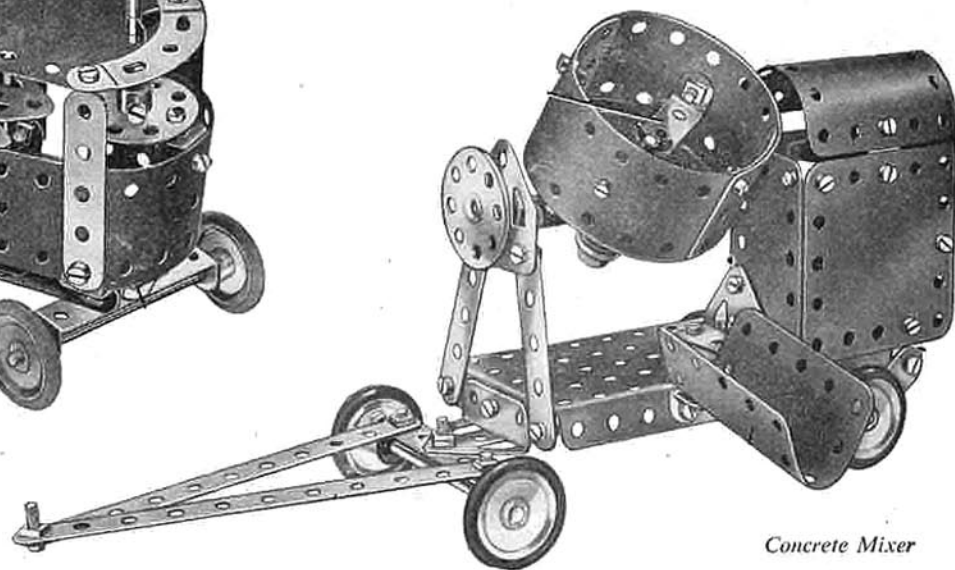
*Tramcar**Railway
Breakdown Crane**Steam Wagon**Concrete Mixer*

Here are five models selected from the range that can be built with Meccano No. 2 Outfit.

MECCANO PARTS

No. 120b. Compression Spring, $\frac{1}{4}$ " long



120^b



122

122. Loaded Sack



123



125

123. Cone Pulley, $1\frac{1}{2}$ ", 1" and $\frac{3}{4}$ " diam.
124. Reversed Angle Bracket, 1"
125. " " " " $\frac{1}{2}$ "



126

126. Trunnion



126^a

126a. Flat Trunnion



128

128. Bell Crank with Boss



130



130^a

130. Eccentric, Triple Throw, $\frac{1}{2}$ " $\frac{3}{4}$ " and $\frac{1}{2}$ "
130a. Eccentric, Single Throw, $\frac{1}{2}$ "



133



133^a

133. Corner Bracket, $1\frac{1}{2}$ "
133a. " " $1\frac{1}{4}$ "



134

No. 134. Crank Shaft, 1" stroke



136



137

136. Handrail Support
136a. Handrail Coupling
137. Wheel Flange



136^a

138a. Ship's Funnel



138^a

139. Flanged Bracket (right)
139a. " " (left)



139



140

140. Universal Coupling



142^a

142a. Motor Tyre (to fit 2" diam. rim)
142b. " " " " $\frac{3}{4}$ " " "
142c. " " " " 1" " "
142d. " " " " $1\frac{1}{2}$ " " "



143

143. Circular Girder, $5\frac{1}{2}$ " diam.



144

No. 144. Dog Clutch



145

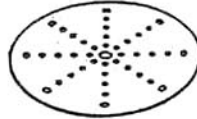

146

145. Circular Strip, $7\frac{1}{2}$ " diam. overall
146. " " Plate 6"
146a. " " " 4"



147 & 148

147. Pawl, with Pivot Bolt and Nuts
147a. Pawl
147b. Pivot Bolts with 2 Nuts
147c. Pawl without boss
148. Ratchet Wheel



151

151. Single Pulley Block
153. Triple Pulley Block



154^a & 154^b

154a. Corner Angle Bracket, $\frac{1}{2}$ " (right-hand)
154b. Corner Angle Bracket, $\frac{1}{2}$ " (left-hand)
155. Rubber Ring (for 1" Pulleys)



157

157. Fan, 2" diam.



160

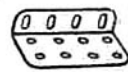

161

160. Channel Bearing, $1\frac{1}{2}$ " x $1\frac{1}{2}$ " x $\frac{1}{2}$ "
161. Girder Bracket, 2" x $1\frac{1}{2}$ " x $\frac{1}{2}$ "



163

162



164

No. 162. Boiler, complete, 5" long x $2\frac{1}{2}$ " diam.
162a. " " Ends, $2\frac{1}{2}$ " diam. x $\frac{1}{2}$ "
162b. " " without ends, $4\frac{1}{2}$ " long x $2\frac{1}{2}$ " diam.
163. Sleeve Piece, $1\frac{1}{2}$ " long x $\frac{1}{2}$ " diam.
164. Chimney Adaptor, $\frac{1}{2}$ " diam. x $\frac{1}{2}$ " high



165



166

165. Swivel Bearing
166. End
167b. Flanged Ring, $9\frac{1}{2}$ " diam.



168

168. Ball Thrust Bearing, 4" diam.
168a. " " Race, flanged disc $3\frac{1}{2}$ " diam.
168b. " " " " toothed " 4" diam.
168c. " " Cage, $3\frac{1}{2}$ " diam., complete with balls.
168d. Ball, $\frac{3}{8}$ " diam.



171

171. Socket Coupling



175

175. Flexible Coupling Unit



176

176. Anchoring Spring for Cord



179

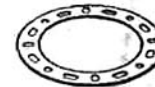

180

179. Rod Socket
180. Gear Ring, $3\frac{1}{2}$ " diam. (133 ext. teeth, 95 int.)



185



187

No. 185. Steering Wheel, $1\frac{1}{2}$ " diam.
186. Driving Band, $2\frac{1}{2}$ " (Light)
186a. " " 6" "
186b. " " 10" "
186c. " " 10" (Heavy)
186d. " " 15" "
186e. " " 20" "
187. Road Wheel, $2\frac{1}{2}$ " diam.
187a. Conical Disc, $1\frac{1}{2}$ " diam.

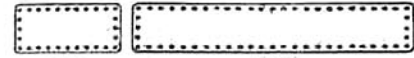

192

197

Flexible Plates
190a. $3\frac{1}{2}$ " x $2\frac{1}{2}$ "
191. $4\frac{1}{2}$ " x $2\frac{1}{2}$ "
192. $5\frac{1}{2}$ " x $2\frac{1}{2}$ "
Strip Plates
197. $12\frac{1}{2}$ " x $2\frac{1}{2}$ "

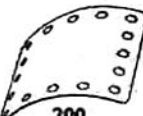

200

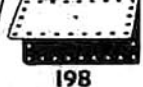

198



199

198. Hinged Flat Plate, $4\frac{1}{2}$ " x $2\frac{1}{2}$ "
199. Curved Plate, U-Section
 $2\frac{1}{2}$ " x $2\frac{1}{2}$ " x $\frac{1}{8}$ " radius
200. " " $2\frac{1}{2}$ " x $2\frac{1}{2}$ " x $1\frac{1}{8}$ " radius



211^a & 211^b

211a. Helical Gear, $\frac{1}{2}$ " (Can only be used together)
211b. " " $1\frac{1}{2}$ "



212

212. Rod and Strip Connector
213. Rod Connector



213



214



215

214. Semi-Circular Plate, $2\frac{1}{2}$ "
215. Formed Slotted Strip, 3"

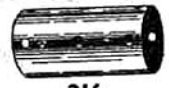

216

216. Cylinder, $2\frac{1}{2}$ " long, $1\frac{1}{2}$ " diam.