

MECCANO



INSTRUCTIONS for OUTFIT No. 2

COPYRIGHT BY MECCANO LIMITED
BINNS ROAD, LIVERPOOL 13, ENGLAND

51.2

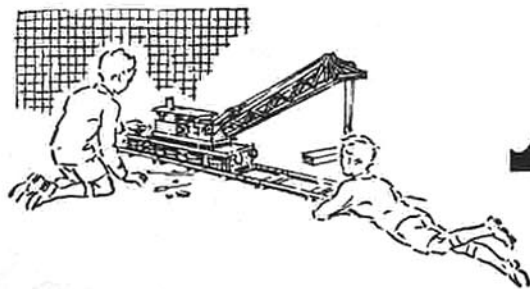

MECCANO

Real Engineering in Miniature

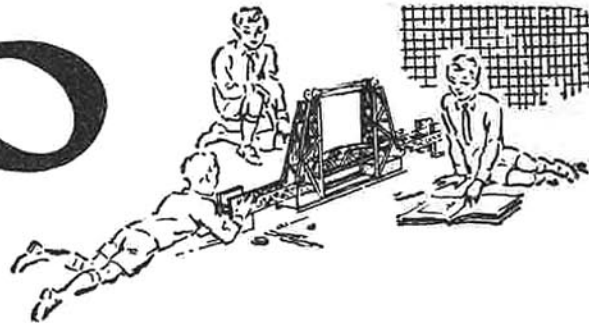

MODEL-BUILDING WITH MECCANO

There is no limit to the number of models that can be built with Meccano—Cranes, Clocks, Motor Cars, Aeroplanes, Machine Tools, Locomotives—in fact everything that interests boys. A screwdriver and a spanner, both of which are provided in each Outfit, are the only tools necessary.

When you have built all the models illustrated in the Books of Instructions the fun is not over, it is just beginning. Now comes the chance to make use of your own ideas. First of all, re-build some of the models with small changes in construction that may occur to you; then try building models entirely of your own design. In doing this you will feel the real thrill of the engineer and the inventor.

HOW TO BUILD UP YOUR OUTFIT

Meccano is sold in 11 different Outfits, ranging from No. 0 to No. 10. Each Outfit can be converted into the next larger by the purchase of an Accessory Outfit. Thus Meccano No. 0 Outfit can be converted into No. 1 Outfit by adding to it a No. 0a Accessory Outfit. No. 1a Outfit would then convert it into a No. 2 and so on. In this way, no matter with which Outfit you begin, you can build it up by degrees until you have a No. 10 Outfit.

All Meccano parts are of the same high quality and finish, but the larger Outfits contain a greater quantity and variety, making possible the construction of more elaborate models.

THE "MECCANO MAGAZINE"

The "Meccano Magazine" is published specially for Meccano boys. Every month it describes and illustrates new Meccano models for Outfits of all sizes, and deals with suggestions from readers for new Meccano parts and for new methods of using the existing parts.

There are model-building competitions specially planned to give an equal chance to the owners of small and large Outfits. In addition, there are splendid articles on such subjects as Railways, Famous Engineers and Inventors, Electricity, Bridges, Cranes and Aeroplanes, and special sections dealing with the latest Engineering, Aviation, Motoring

and Shipping News. Other pages deal with Stamp Collecting, and Books of interest to boys; and a feature of outstanding popularity is the section devoted to short articles from readers.

If you are not already a reader write to the Editor for particulars. Supplies of the Magazine are very limited owing to the paper shortage.

THE MECCANO GUILD

Every owner of a Meccano Outfit should join the Meccano Guild. This is a world-wide organisation, started at the request of Meccano boys. Its primary object is to bring boys together and to make them feel that they are all members of a great brotherhood, each trying to help others to get the very best out of life. Its members are in constant touch with Headquarters, giving news of their activities and being guided in their hobbies and interests. Write for full particulars and an application form to the Secretary, Meccano Guild, Binns Road, Liverpool 13.

Clubs founded and established under the guidance of the Guild Secretary provide Meccano boys with opportunities of enjoying to the utmost the fun of model-building. Each has its Leader, Secretary, Treasurer and other officials. With the exception of the Leader, all the officials are boys, and as far as possible the proceedings of the clubs are conducted by boys.

MECCANO SERVICE

The service of Meccano does not end with selling an Outfit and a Book of Instructions. If ever you are in any difficulty with your models, or if you want advice on anything connected with this great hobby, write to us. We receive hundreds of interesting letters from boys in all parts of the world, and each of these is answered personally by one of our staff of experienced experts.

Whatever your problem may be, write to us about it. Do not hesitate. We shall be delighted to help you in any way possible.

HOW TO BEGIN THE FUN



*This Dockside Crane
can be built with Outfit No. 1.*

THE MOST FASCINATING OF ALL HOBBIES

Meccano model-building is the most fascinating of all hobbies, because it never becomes dull. There is always something new to be done. First of all there is the fun of building a new model, and watching it take shape as part after part is added. Then, when the model is complete, comes the thrill of setting it to work just like the real structure it represents, by means of a Meccano Motor.

The following hints are given to show boys who are just starting the wonderful Meccano hobby how to get the greatest possible fun.

A FEW USEFUL HINTS

It will be noticed that with each model in this Book of Instructions is given a list of the parts required to build it. For the first few models it is a good plan to lay out on the table all the parts required for the one it is proposed to build, and put the remainder of the Outfit to one side. To help you to pick out the correct parts for your model a complete list of Meccano parts is given at the back of this Book, and all the principal parts are illustrated. In the list the parts are all numbered, and in most cases, their measurements are given. There is no need, however, to measure the parts to find out which is which, as the size is easily found from the number of holes. All Meccano holes are spaced $\frac{1}{2}$ " apart, so that by counting two holes to the inch the size of a part can be found at once. For instance, Part No. 2 is listed as a $5\frac{1}{2}$ " Perforated Strip, so you look in your Outfit for a Strip with eleven holes. Similarly No. 192 is a $5\frac{1}{2}$ " \times $1\frac{1}{2}$ " Flexible Plate, so you look for a Flexible Plate eleven holes in length and three holes in width. By the time a few models have been built the names of the parts will have become familiar.

Beginners sometimes wonder which section of a model should be built first. There cannot be any definite rule for this, as it depends on the design of the model. In stationary models the base usually should be built first. In most of the small models a $5\frac{1}{2}$ " \times $2\frac{1}{2}$ " Flanged Plate forms an important part of the structure, and often the best plan is to start building by bolting parts to this Plate. For other models a good general rule is that the sections that form supports for a number of other parts should be built first.

During the construction of a model it is best to screw up the nuts with the fingers, followed by a light turn with the screwdriver, leaving the final tightening until all the parts are connected up.

THE IMPORTANCE OF "LOCK-NUTTING"

In some models it is necessary to join certain parts together so that, although they cannot come apart, they are free to pivot or move in relation to one another. To do this the parts are bolted together as usual but the nut is not screwed up tightly, so that the parts are not gripped. Then, to prevent the nut from unscrewing, a second nut is screwed up tightly against it, the first nut being held with a spanner. This method of using a second nut is known as **Lock-nutting**.

In building models in which Rods revolve in the holes of other parts it is important to make sure that such holes are exactly in line with one another. This can be done by pushing through the holes a Drift, Part No. 36c, or a Rod, before the Bolts holding the various parts are tightened up.

A Rod is usually mounted in a support or bearing so that it is free to revolve. The Rod is then said to be **Journalled** in the Strip.

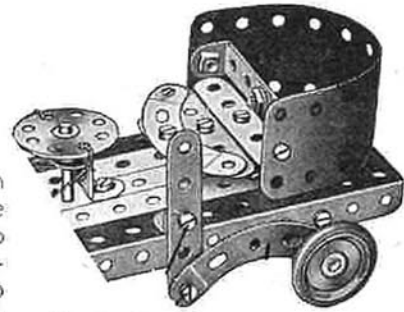

*A Flexible Plate
used to form a curved surface.*

DRIVING YOUR MODELS

Models can be driven by means of either clockwork or electric motors.

Small and light models may be driven direct from the driving pulley of the motor or through a belt running over two pulleys of the same size, giving what is known as a 1 : 1 (one-to-one) ratio. For large models it is necessary to take the drive from a small pulley on the motor shaft to a larger pulley on the driving shaft of the model. In most cases a 1" Pulley on the motor shaft and a 3" Pulley on the model shaft will be found satisfactory. This provides a reduction ratio of approximately 3 : 1.

Rubber bands are very convenient for driving belts. Sometimes, however, a rubber band of the right length is not available, and then Meccano Cord or thin string is used. To tie the Cord to form an endless belt, use the familiar reef knot.

Flexible Plates are used for forming curved surfaces in models, but they are not intended to be bent at right angles. With careful handling a Plate can be bent to the required curve and after use straightened again.

All Outfits from No. 2 upward include a Cord Anchoring Spring, Part No. 176. This part provides a neat and positive method of fastening a length of Cord to a Rod. The Spring is pushed on to a Rod or Crank Handle, by turning it in such a way that its coils tend to unwind.

Ask your dealer for particulars of Meccano Clockwork and Electric Motors.

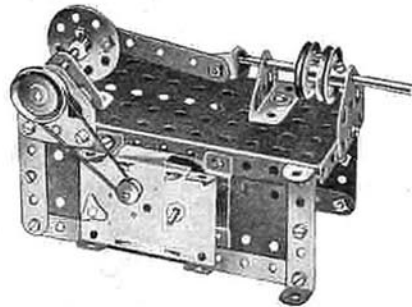

*A Magic Motor
fitted to drive a Steam Engine.*

O.1 GARDEN SEAT

Parts required
 4 of No. 2
 2 " " 5
 10 " " 37*
 2 " " 48a
 1 " " 52

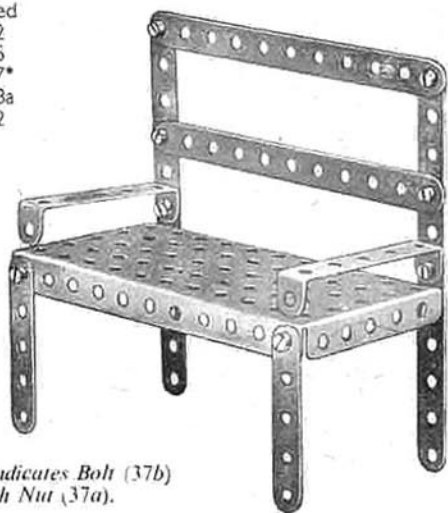

*No. 37 indicates Bolt (37b)
 fitted with Nut (37a).

O.2 FLAT TRUCK

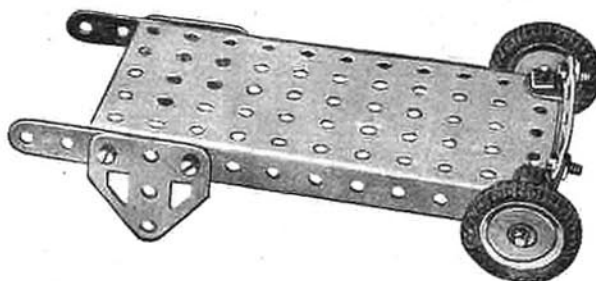

Parts required
 2 of No. 5 | 2 of No. 22 | 1 of No. 90a
 2 " " 12 | 8 " " 37 | 2 " " 126a
 1 " " 16 | 1 " " 52 | 2 " " 142c

O.5 SCALES

Parts required
 3 of No. 2 | 2 of No. 35 | 2 of No. 126
 1 " " 17 | 10 " " 37 | 2 " " 126a
 1 " " 24 | 1 " " 52

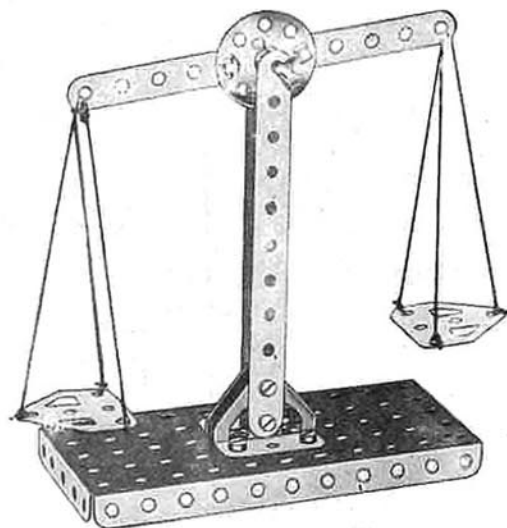

O.3 SWING BOAT

Parts required
 4 of No. 2
 2 " " 5
 4 " " 12
 1 " " 16
 1 " " 19s
 2 " " 22
 1 " " 24
 3 " " 35
 18 " " 37
 1 " " 52
 2 " " 90a
 2 " " 126
 2 " " 126a

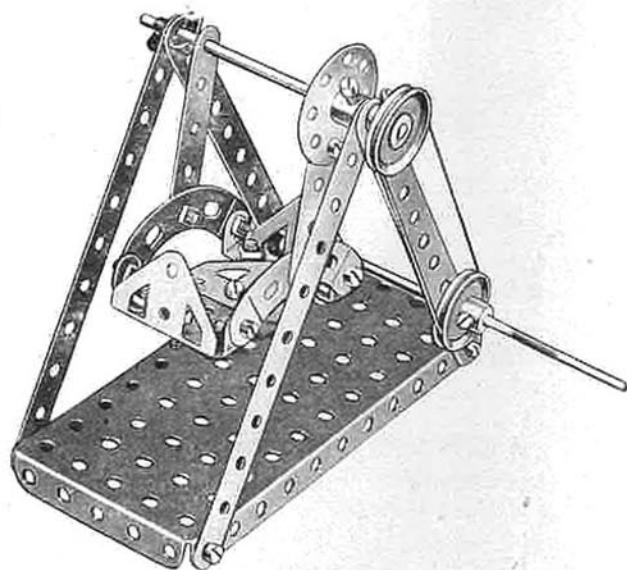

O.4 COUNTER SCALES

Parts required
 1 of No. 2 | 2 of No. 22 | 1 of No. 52
 2 " " 10 | 1 " " 24 | 2 " " 126
 4 " " 12 | 9 " " 37 | 2 " " 126a
 1 " " 17 | 2 " " 38

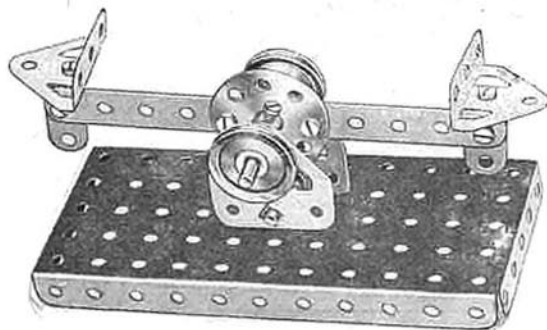

O.6 COSTER'S BARROW

Parts required
 4 of No. 2 | 2 of No. 22 | 2 of No. 90a
 2 " " 5 | 16 " " 37 | 2 " " 126
 2 " " 10 | 2 " " 48a | 2 " " 126a
 1 " " 16 | 1 " " 52 | 2 " " 142c

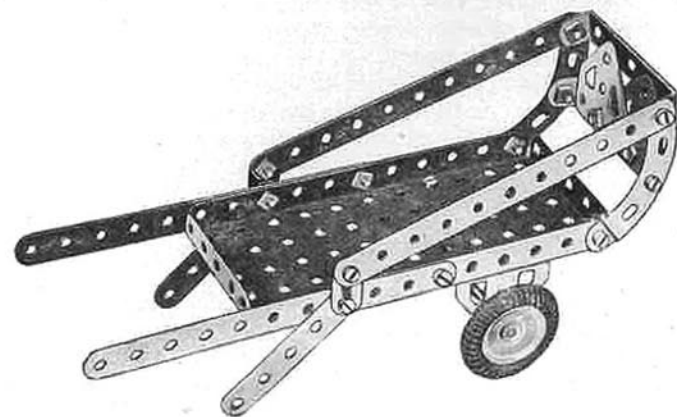

O.7 ACROBAT

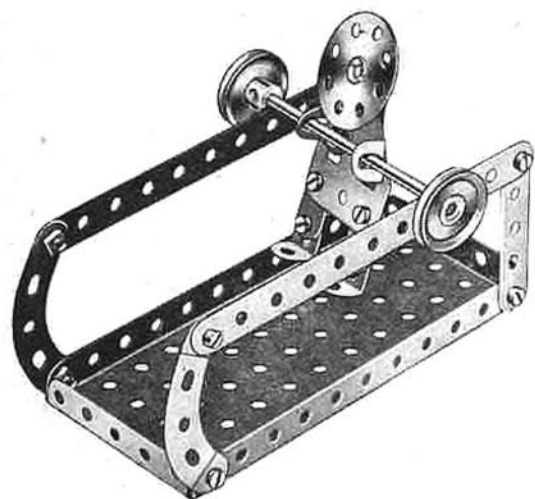

Parts required

2 of No. 2
2 " " 5
3 " " 10
4 " " 12
1 " " 16
2 " " 22
1 " " 24
15 " " 37
1 " " 52
2 " " 90a
1 " " 111c
1 " " 126a

O.8 MECHANICAL HAMMER

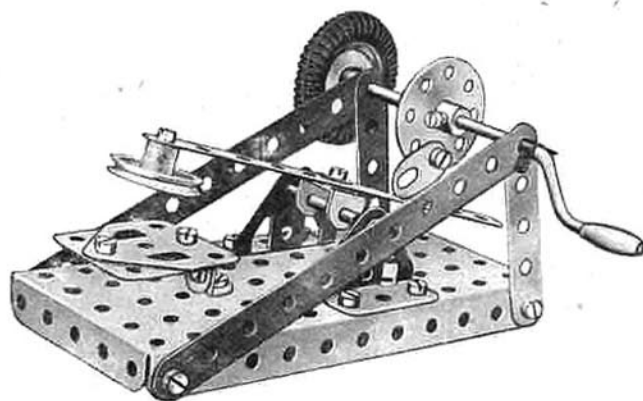

Parts required

3 of No. 2	1 of No. 17	3 of No. 35	1 of No. 111c
2 " " 5	1 " " 19s	15 " " 37	2 " " 126
1 " " 10	2 " " 22	1 " " 38	2 " " 126a
4 " " 12	1 " " 24	1 " " 52	1 " " 142c

O.9 ELECTRIC TRUCK

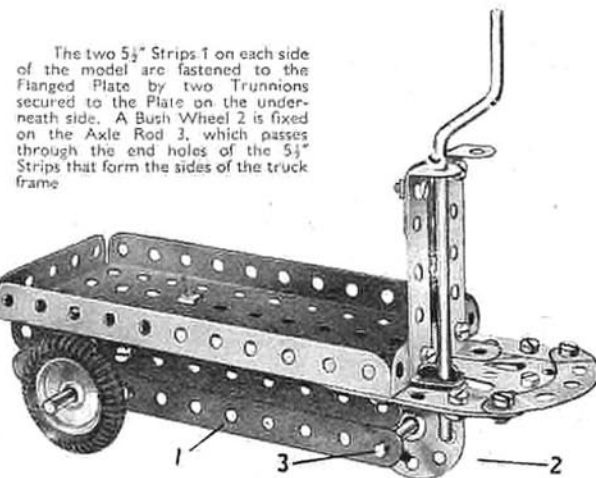

Parts required

4 of No. 2
2 " " 5
2 " " 10
2 " " 12
1 " " 16
1 " " 17
1 " " 19s
2 " " 22
1 " " 24
4 " " 35
17 " " 37
2 " " 37a
2 " " 38
2 " " 48a
1 " " 52
2 " " 90a
2 " " 111c
2 " " 126
2 " " 126a
2 " " 142c

The two 5½" Strips 1 on each side of the model are fastened to the Flanged Plate by two Trunnions secured to the Plate on the underneath side. A Bush Wheel 2 is fixed on the Axle Rod 3, which passes through the end holes of the 5½" Strips that form the sides of the truck frame

O.10 ELEVATOR

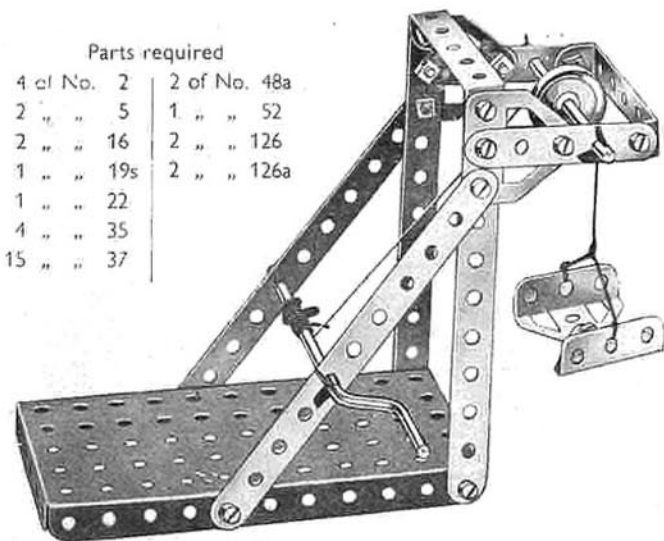

Parts required

4 of No. 2	2 of No. 48a
2 " " 5	1 " " 52
2 " " 16	2 " " 126
1 " " 19s	2 " " 126a
1 " " 22	
4 " " 35	
15 " " 37	

O.11 DOCKSIDE CRANE

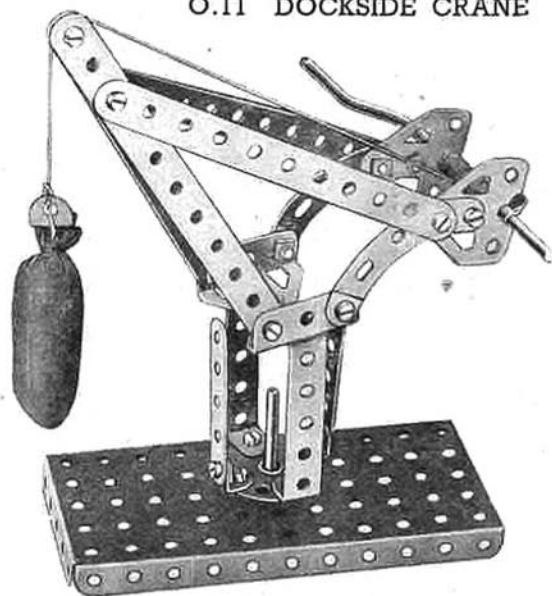

Parts required

4 of No. 2
2 " " 5
3 " " 12
1 " " 17
1 " " 19s
1 " " 22
1 " " 24
2 " " 35
18 " " 37
2 " " 37a
2 " " 38
2 " " 48a
1 " " 52
2 " " 90a
2 " " 111c
2 " " 126
2 " " 126a

O.12 BUCKING BRONCHO

The Bolts 1 are fitted with locknuts, so that the parts they attach are free to pivot. Bearings for a 2" Rod, the end of which is seen at 2, are provided by a Fishplate 3, bolted to an Angle Bracket 4, and a Trunnion 5.

Parts required

2 of No. 5
4 " " 10
1 " " 12
1 " " 17
1 " " 19s
2 " " 22
1 " " 24
4 " " 35
15 " " 37
5 " " 37a
1 " " 38
1 " " 48a
1 " " 52
2 " " 90a
2 " " 111c
2 " " 126
2 " " 126a

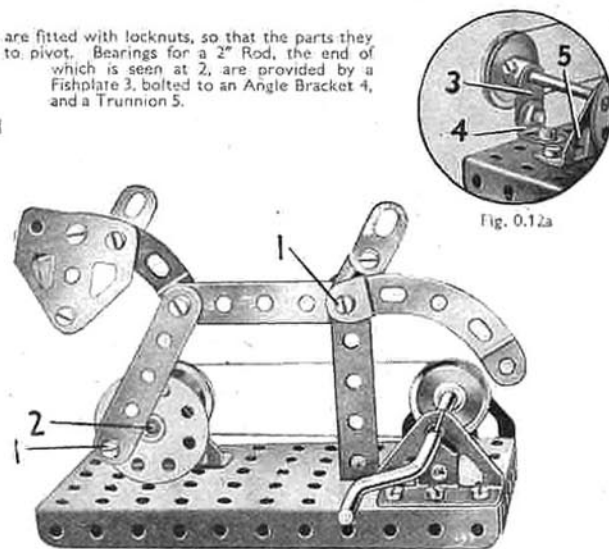
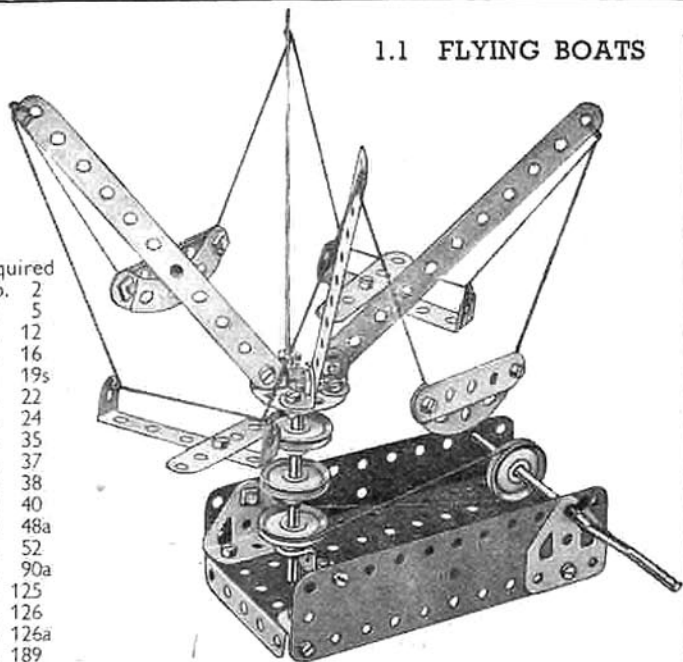

Fig. 0.12a

1.1 FLYING BOATS

Parts required

4 of No.	2
4 "	5
4 "	12
1 "	16
1 "	19s
4 "	22
1 "	24
3 "	35
24 "	37
1 "	38
1 "	40
2 "	48a
1 "	52
2 "	90a
1 "	125
2 "	126
2 "	126a
2 "	189



1.2 DRILL

Parts required

4 of No.	2	4 of No.	35
3 "	5	20 "	37
8 "	12	4 "	38
1 "	16	1 "	40
1 "	17	1 "	52
1 "	19s	2 "	126
4 "	22	2 "	126a

The drill table is made by bolting together two Flat Trunnions.

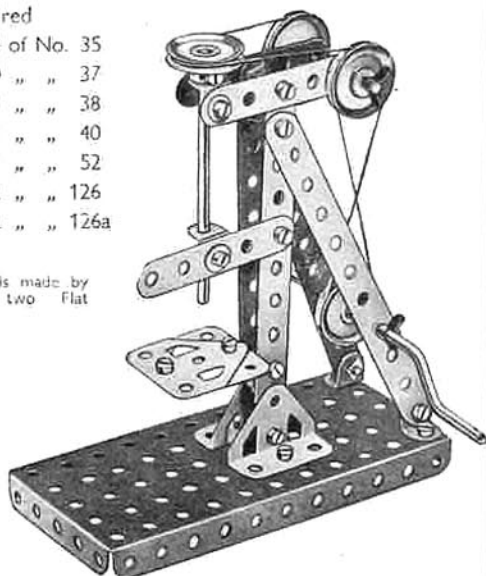

1.3 SCALES

Parts required

4 of No.	2
2 "	5
2 "	17
2 "	22
1 "	24
19 "	37
1 "	38
1 "	40
2 "	48a
1 "	52
2 "	90a
1 "	111c
2 "	126
2 "	126a
1 "	155
2 "	189

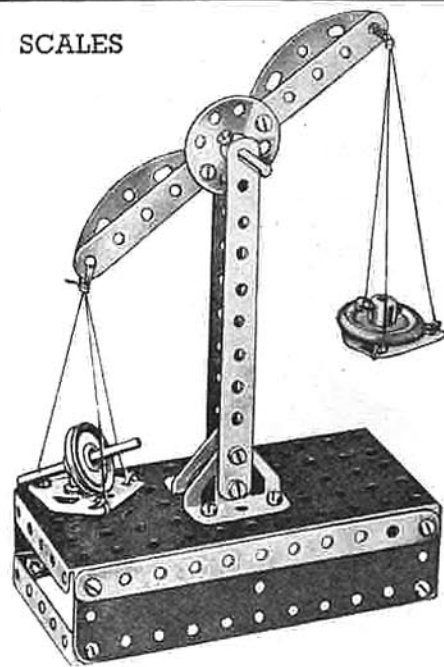

1.4 MOTOR LORRY

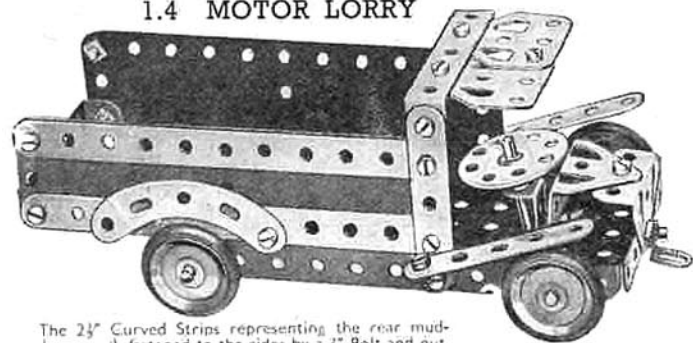

The 2 1/2" Curved Strips representing the rear mudguards are each fastened to the sides by a 1/2" Bolt and nut, with a Spring Clip between the mudguards and the 5 1/2" Strip to form a distance piece.

Parts required

4 of No.	2	1 of No.	17	19 of No.	37	2 of No.	90a	7 of No.	126a
4 "	5	4 "	22	4 "	37a	3 "	111c	1 "	155
3 "	12	1 "	24	2 "	48a	1 "	125	2 "	189
2 "	16	2 "	35	1 "	52	2 "	126		

1-5 RACING SEAPLANE

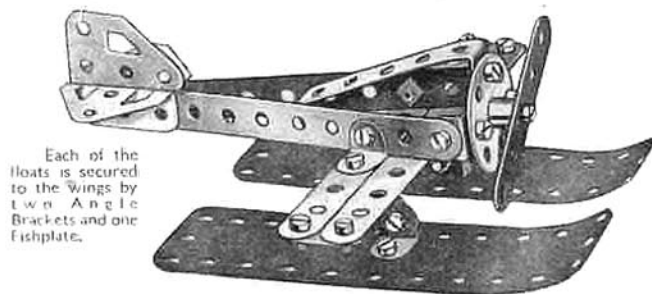

Each of the floats is secured to the wings by two Angle Brackets and one fishplate.

Parts required

3 of No.	2	1 of No.	24	2 of No.	111c
3 "	3	19 "	37	2 "	126
4 "	10	1 "	37a	1 "	126a
8 "	12	1 "	48a	2 "	189

1.6 KIDDIE CAR

Parts required

4 of No.	2
4 "	5
3 "	10
7 "	12
2 "	16
1 "	17
4 "	22
1 "	24
1 "	35
2 "	37
3 "	37a
2 "	48a
1 "	52
2 "	90a
2 "	111c
1 "	125
2 "	126
1 "	126a
4 "	155
2 "	189

Two Trunnions overlapped one hole, and fastened to the Flanged Plate by an Angle Bracket form the seat.

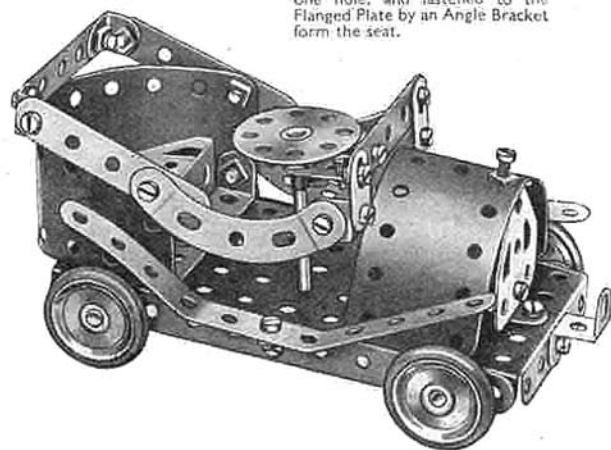

1.7 SIDE TIPPING WAGON

Parts required

3 of No. 2	3 of No. 38
4 " " 5	2 " " 48a
4 " " 10	1 " " 52
7 " " 12	2 " " 90a
2 " " 16	4 " " 111c
1 " " 17	1 " " 125
4 " " 22	2 " " 126
1 " " 24	2 " " 126a
24 " " 37	4 " " 155
4 " " 37a	2 " " 189

1 Magic Motor
(Not included in Outfit)

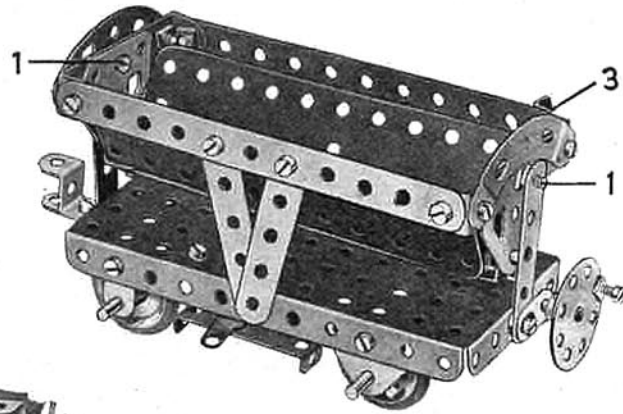

Each of the Bolts 1 is lock-nutted. A piece of Cord is fastened to the Rod 2 (Fig. 1.7a) wrapped round it two or three times, and then is taken through the hole in the Flanged Plate above the Rod and secured to the Angle Bracket 3.

By turning the Bush Wheel the container is tipped sideways.

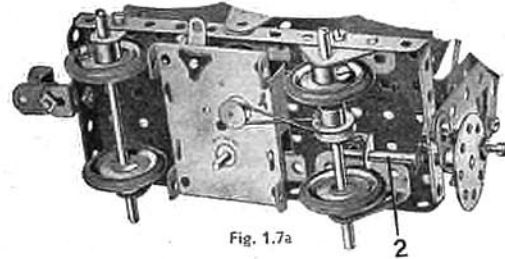

Fig. 1.7a

1.8 STAMPING MILL

The anvil 1 is made up of two Trunnions bolted together. When the Crank Handle is rotated, the Fishplates bolted to the Bush Wheel strike the centre 1" Pulley on the hammer shaft and cause it to rise and fall.

Parts required

4 of No. 2	3 of No. 37a
5 " " 5	2 " " 38
4 " " 10	2 " " 48a
4 " " 12	1 " " 52
1 " " 16	1 " " 90a
1 " " 19s	4 " " 111c
4 " " 22	1 " " 125
1 " " 24	2 " " 126
2 " " 35	2 " " 126a
24 " " 37	2 " " 189

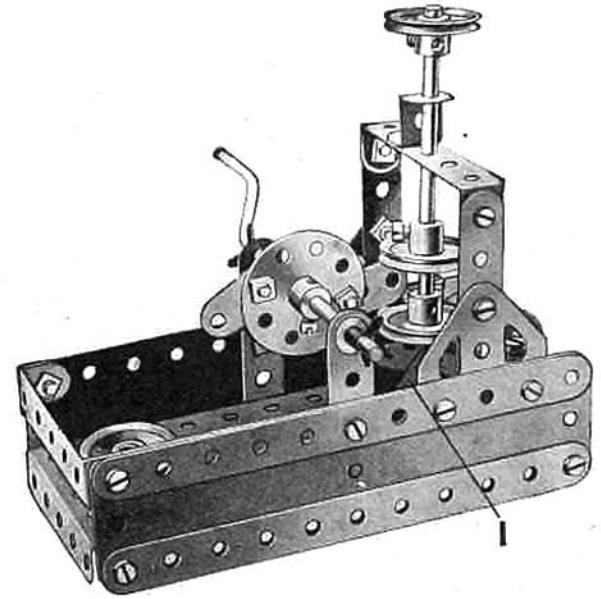

1.9 LETTER BALANCE

Parts required

4 of No. 2
4 " " 5
4 " " 10
2 " " 12
1 " " 16
2 " " 17
4 " " 22
1 " " 24
4 " " 35
24 " " 37
4 " " 37a
4 " " 38
2 " " 48a
1 " " 52
1 " " 57c
1 " " 90a
4 " " 111c
1 " " 125
2 " " 126
2 " " 126a
4 " " 155
2 " " 189

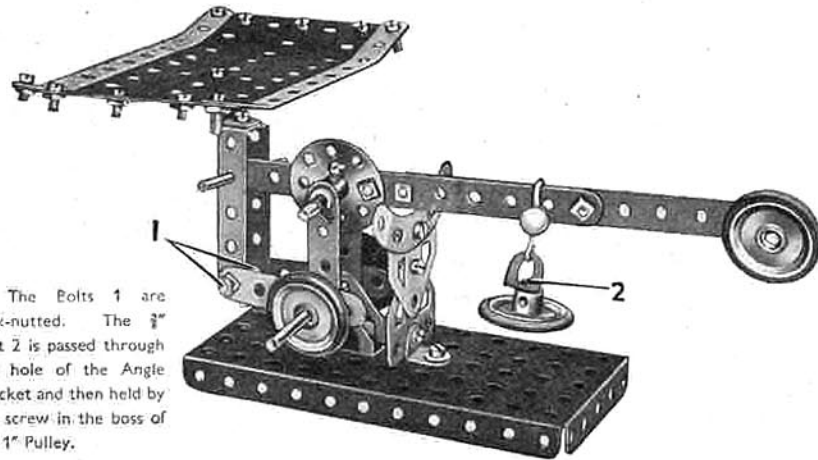

The Bolts 1 are lock-nutted. The 3/4" Bolt 2 is passed through the hole of the Angle Bracket and then held by the screw in the boss of the 1" Pulley.

1.10 RAILWAY BREAKDOWN CRANE

Parts required

4 of No. 2	4 of No. 22	1 of No. 40	1 of No. 125
4 " " 5	1 " " 24	2 " " 48a	2 " " 126
1 " " 16	2 " " 35	1 " " 52	2 " " 126a
4 " " 12	20 " " 37	1 " " 57c	4 " " 155
2 " " 16	4 " " 37a	2 " " 90a	2 " " 189
1 " " 19s	2 " " 38	4 " " 111c	

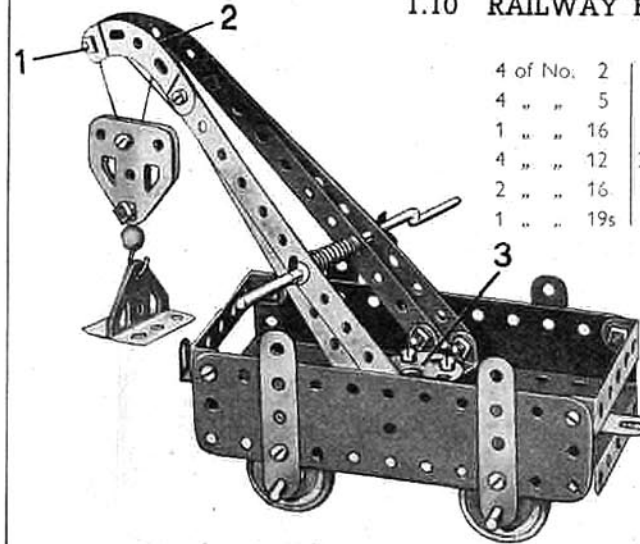

The hoisting cord is secured to the Crank Handle, and then led over the 3/4" Bolt 1. It is then passed through the pulley block and fastened to the jib at 2. The jib is attached to the Bush Wheel 3 by means of Angle Brackets and the complete unit is pivoted as follows. A 5/8" x 2 1/2" Flanged Plate from the underside, and is secured in the boss of the Bush Wheel by its set screw.

1.11 OPEN TRAMCAR

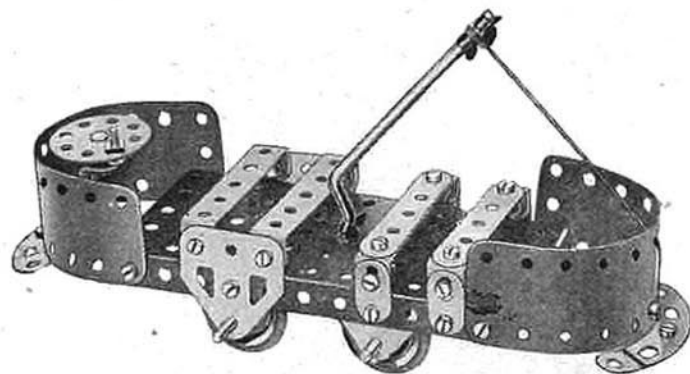

Parts required

2 of No. 5	1 of No. 40
4 " " 10	2 " " 48a
7 " " 12	1 " " 52
2 " " 16	2 " " 90a
1 " " 19s	4 " " 111c
4 " " 22	1 " " 125
1 " " 24	2 " " 126
4 " " 35	2 " " 126a
24 " " 37	4 " " 155
3 " " 37a	2 " " 189

1.12 COASTER

Parts required

3 of No. 2	1 of No. 24	2 of No. 90a
4 " " 5	1 " " 35	2 " " 111c
2 " " 10	20 " " 37	1 " " 125
5 " " 12	4 " " 37a	2 " " 126
2 " " 16	4 " " 38	2 " " 126a
1 " " 17	1 " " 40	4 " " 155
4 " " 22	2 " " 48a	1 " " 189
	1 " " 52	

The Bolts 1 are lock-nutted. The rear axle Rod is pushed through the end hole of the Curved Strip 2 and through Fishplates bolted to the Flanged Plate.

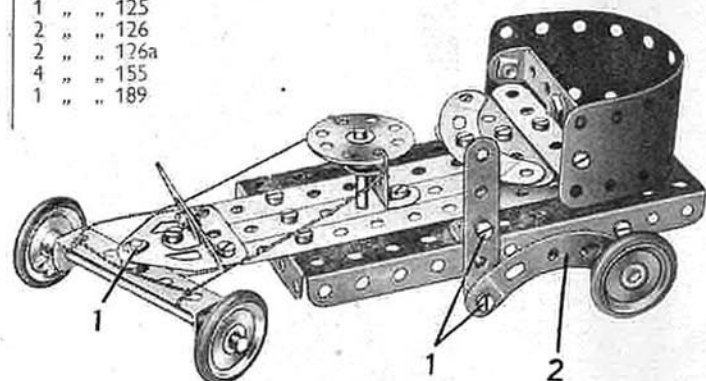

1.13 DERRICK CRANE

Parts required

4 of No. 2	2 of No. 90a
4 " " 5	1 " " 111c
3 " " 12	1 " " 125
2 " " 17	2 " " 126
1 " " 19s	1 " " 126a
4 " " 22	
4 " " 35	
19 " " 37	
4 " " 37a	
1 " " 40	
2 " " 48a	
1 " " 52	
1 " " 57c	

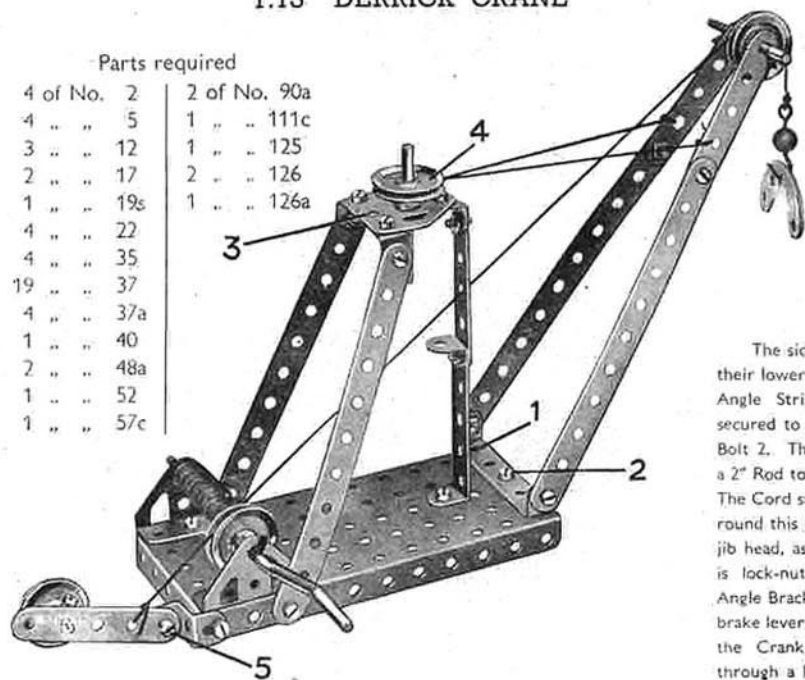

The sides of the jib are bolted at their lower ends to a 2½" x ½" Double Angle Strip 1, which is pivotally secured to the base by a lock-nutted Bolt 2. The Flat Trunnion 3 carries a 2" Rod to which is fitted a Pulley 4. The Cord supporting the jib is passed round this Pulley and attached to the jib head, as shown. The band brake is lock-nutted at 5 to a Reversed Angle Bracket. A Cord is tied to the brake lever, passed over the Pulley on the Crank Handle and then tied through a hole in the Flanged Plate.

1.14 TELPHER SPAN

Parts required

4 of No. 2	4 of No. 35	2 of No. 90a
4 " " 5	24 " " 37	4 " " 111c
2 " " 10	4 " " 37a	2 " " 126
6 " " 12	4 " " 38	2 " " 126a
2 " " 16	1 " " 40	2 " " 189
1 " " 17	2 " " 48a	
1 " " 19s	1 " " 52	
4 " " 22		
1 " " 24		

The anchoring piece 1 consists of two Trunnions bolted together, and a hook, which is made of two Angle Brackets fastened

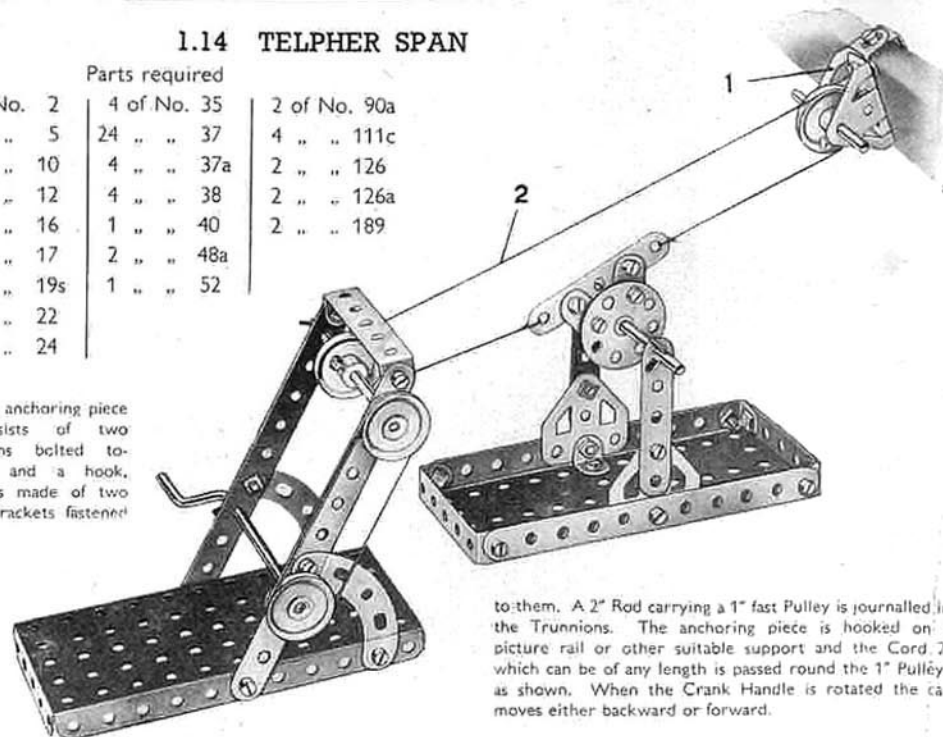

to them. A 2" Rod carrying a 1" fast Pulley is journaled in the Trunnions. The anchoring piece is hooked on a picture rail or other suitable support and the Cord 2, which can be of any length is passed round the 1" Pulleys as shown. When the Crank Handle is rotated the car moves either backward or forward.

1.15 MECHANICAL SHOVEL

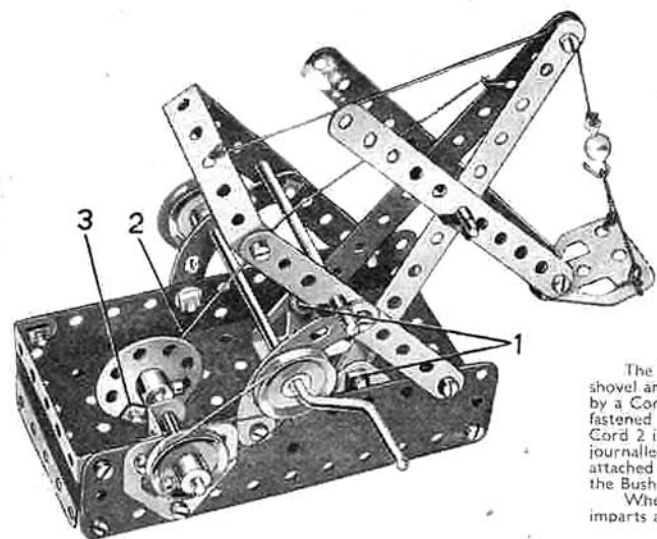

Parts required	
4 of No. 2	4 of No. 38
4 " " 5	1 " " 40
1 " " 10	2 " " 48a
2 " " 12	1 " " 52
1 " " 16	1 " " 57c
2 " " 17	2 " " 90a
1 " " 19s	4 " " 111c
3 " " 22	1 " " 125
1 " " 24	2 " " 126
24 " " 37	2 " " 126a
4 " " 37a	4 " " 155
	2 " " 189

The Bolts 1, on which the jib pivots, are lock-nutted. The shovel arm is pivoted on a 2" Rod and the shovel is supported by a Cord that passes over the 1/2" Bolt at the jib head and is fastened to a 2 1/2" x 1/2" Double Angle Strip as shown. The Cord 2 is fastened to the jib and then passes over a 3 1/2" Rod journalled in the holes above the 2 1/2" Curved Strips, and is attached to a Fishplate fastened by the lock-nutted Bolt 3 to the Bush Wheel.

When the Crank Handle is rotated, the Bush Wheel imparts a digging motion to the jib and shovel arm.

1.16 LIFTING BRIDGE

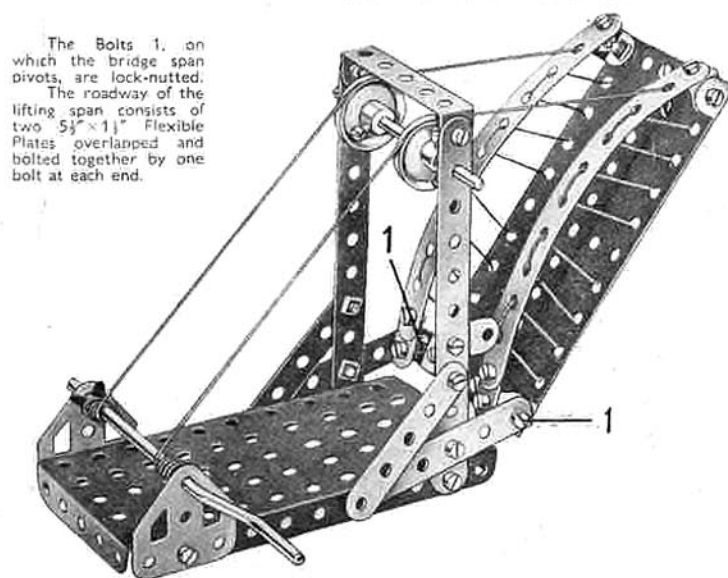

The Bolts 1, on which the bridge span pivots, are lock-nutted. The roadway of the lifting span consists of two 5 1/2" x 1 1/2" Flexible Plates overlapped and bolted together by one bolt at each end.

Parts required	
4 of No. 2	
4 " " 5	
3 " " 10	
8 " " 12	
1 " " 16	
1 " " 19s	
2 " " 22	
4 " " 35	
24 " " 37	
5 " " 37a	
4 " " 38	
1 " " 40	
1 " " 48a	
1 " " 52	
3 " " 111c	
2 " " 126a	
2 " " 189	

1.17 FIRE ENGINE

Parts required	
4 of No. 2	
4 " " 5	
3 " " 10	
5 " " 12	
2 " " 16	
1 " " 17	
1 " " 19s	
4 " " 22	
1 " " 24	
4 " " 35	
24 " " 37	
4 " " 37a	
2 " " 38	
1 " " 40	
2 " " 48a	
1 " " 52	
2 " " 90a	
2 " " 111c	
1 " " 125	
2 " " 126	
2 " " 126a	
4 " " 155	
2 " " 189	

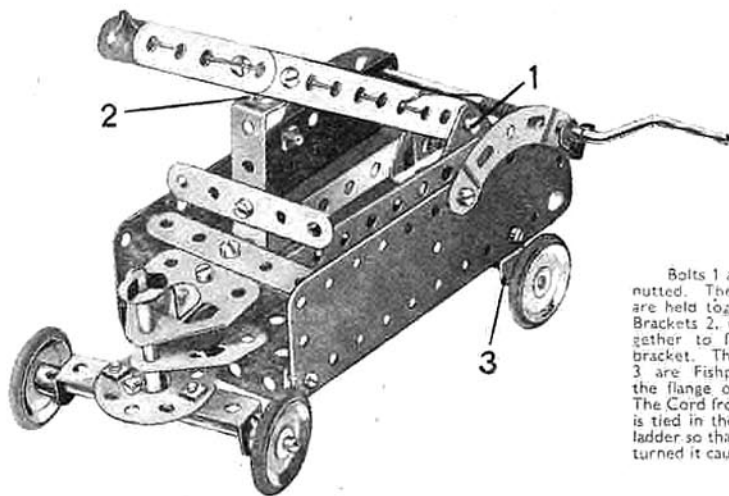

Bolts 1 at each side are lock-nutted. The sides of the ladder are held together by two Angle Brackets 2, which are bolted together to form a "U" shaped bracket. The rear axle bearings 3 are Fishplates bolted inside the flange of the Flanged Plate. The Cord from the Crank Handle is tied in the fourth hole up the ladder so that when the Handle is turned it causes the ladder to lift.

1.18 MECHANICAL SWING

The left-hand 2 1/2" Strip that supports the swing is connected to the Crank Handle by passing the set screw of the 1" Pulley 2 through the hole in an Angle Bracket bolted to the Strip and then into the Boss of the Pulley. Bolt 1 on the Bush Wheel is fitted with lock-nuts.

Parts required	
4 of No. 2	4 of No. 38
2 " " 5	1 " " 40
2 " " 10	2 " " 48a
3 " " 12	1 " " 52
1 " " 16	1 " " 111c
1 " " 19s	1 " " 125
2 " " 22	2 " " 126
1 " " 24	2 " " 189
4 " " 35	1 Magic Motor
15 " " 37	(Not included in
2 " " 37a	Outfit)

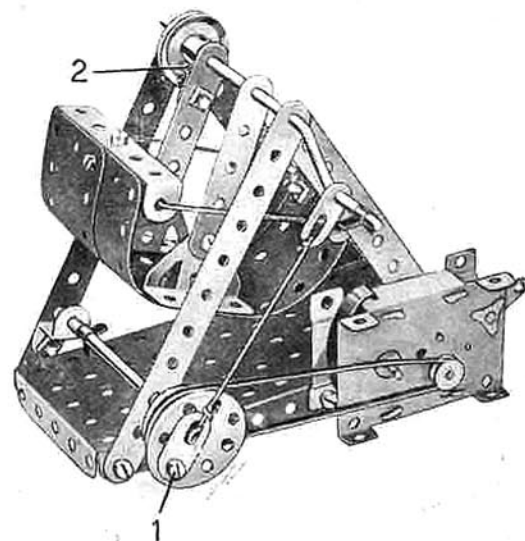

2.1 MOTOR VAN

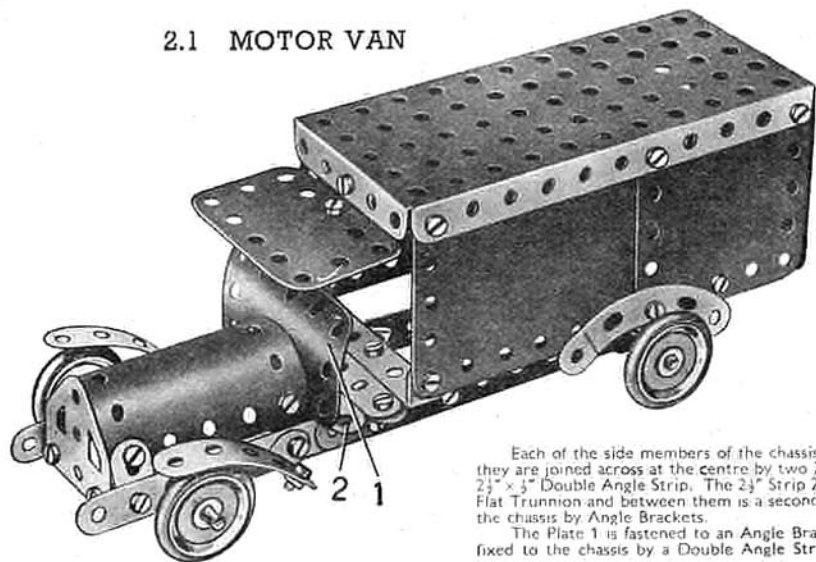

Parts required

4 of No.	2	1 of No.	52
4 " "	5	2 " "	90a
4 " "	10	1 " "	126
8 " "	12	2 " "	126a
2 " "	16	4 " "	155
4 " "	22	2 " "	188
4 " "	35	2 " "	189
40 " "	37	2 " "	190
4 " "	38	1 " "	191
2 " "	48a	1 " "	199

Each of the side members of the chassis consists of two $5\frac{1}{2}$ " Strips overlapped, and they are joined across at the centre by two $2\frac{1}{2}$ " Strips, one of which is shown at 2, and a $2\frac{1}{2}$ " x $3\frac{1}{2}$ " Double Angle Strip. The $2\frac{1}{2}$ " Strip 2 and the Double Angle Strip are bolted to a Flat Trunnion and between them is a second $2\frac{1}{2}$ " Strip, which is fastened at each end to the chassis by Angle Brackets.

The Plate 1 is fastened to an Angle Bracket that is bolted to Strip 2. The body is fixed to the chassis by a Double Angle Strip and an Angle Bracket.

2.2 SPEED CAR

A $5\frac{1}{2}$ " x $2\frac{1}{2}$ " Flanged Plate, extended at the front by a $1\frac{1}{2}$ " radius Curved Plate and at the rear by two $2\frac{1}{2}$ " x $2\frac{1}{2}$ " Flexible Plates, forms the top of the car. The rear part of each side is formed by two $5\frac{1}{2}$ " Strips and a $2\frac{1}{2}$ " Strip, the former being connected together at the tail by Angle Brackets. Bolts 1 on each side hold a $2\frac{1}{2}$ " x $\frac{1}{2}$ " Double Angle Strip that carries the $1\frac{1}{2}$ " radius Curved Plate forming the underside of the front cowling.

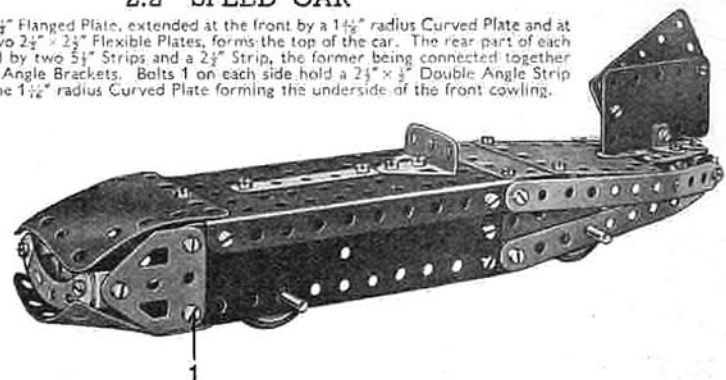

Parts required

4 of No.	2	4 of No.	22	1 of No.	52	2 of No.	188
6 " "	5	38 " "	37	2 " "	90a	2 " "	189
2 " "	10	1 " "	37a	1 " "	126	2 " "	190
4 " "	12	4 " "	38	2 " "	126a	2 " "	200
2 " "	16	2 " "	48a	4 " "	155		

Parts required

4 of No.	2
6 " "	5
4 " "	10
6 " "	12
1 " "	16
1 " "	19g
4 " "	22
1 " "	24

2.3 CANAL BRIDGE

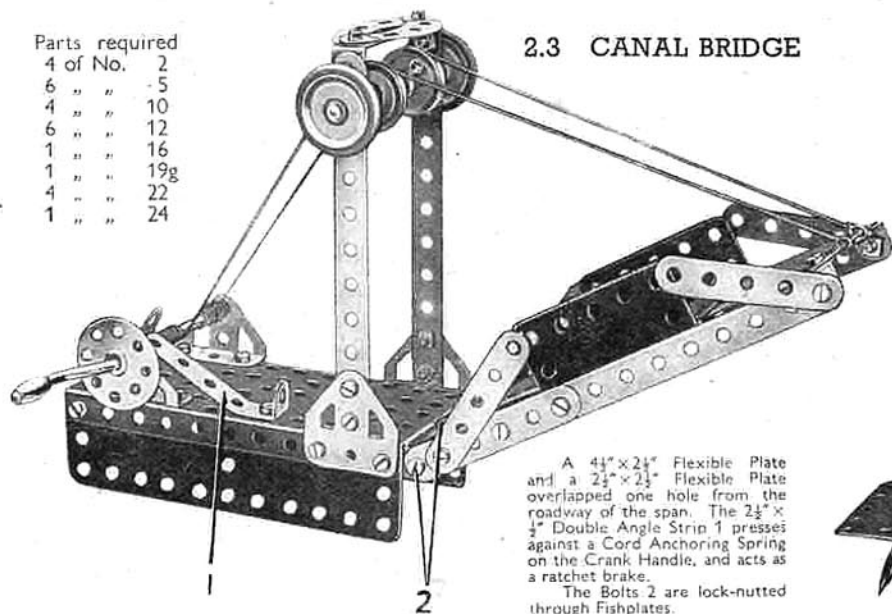

Parts required

(continued)	
39 of No.	37
2 " "	37a
2 " "	38
2 " "	48a
1 " "	52
2 " "	90a
2 " "	126
2 " "	126a
2 " "	155
1 " "	176
2 " "	188
2 " "	189
2 " "	190
1 " "	191
1 " "	199
1 " "	200

A $4\frac{1}{2}$ " x $2\frac{1}{2}$ " Flexible Plate and a $2\frac{1}{2}$ " x $2\frac{1}{2}$ " Flexible Plate overlapped one hole from the roadway of the span. The $2\frac{1}{2}$ " x $\frac{1}{2}$ " Double Angle Strip 1 presses against a Cord Anchoring Spring on the Crank Handle, and acts as a ratchet brake.

The Bolts 2 are lock-nutted through Fishplates.



2.4 DRILLING MACHINE

The horizontal $2\frac{1}{2}$ " Strips at the top of the drill are joined together, and also the vertical $2\frac{1}{2}$ " Strips, by means of Angle Brackets. The lower bearings 1 are two Angle Brackets bolted to a $2\frac{1}{2}$ " Strip, and the Rod forming the drill is journaled in these, and in a Fishplate at its upper end. A $2\frac{1}{2}$ " x $2\frac{1}{2}$ " Flexible Plate is supported by a Double Angle Strip 2, and represents the table.

The drive is taken from the Motor to the 1" Pulley on the lower shaft. A second Driving Band passes round the $\frac{1}{2}$ " fixed Pulley supplied with the Motor, which is also fixed on the lower shaft, round the two Pulleys at 3, and finally round the 1" Pulley fastened on the vertical drill shaft.

Parts required

2 of No.	2	1 of No.	24	1 of No.	111c
5 " "	5	4 " "	35	2 " "	126
1 " "	10	22 " "	37	2 " "	126a
5 " "	12	2 " "	37a	1 " "	190
1 " "	16	1 " "	40	1 Magic Motor	
2 " "	17	1 " "	48a	(Not included in Outfit)	
4 " "	22	1 " "	52		

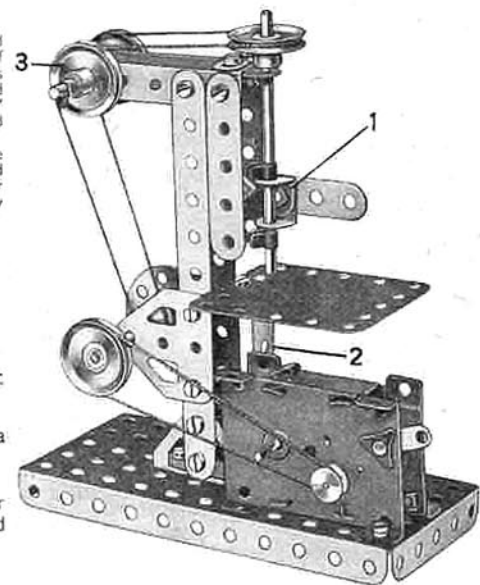

2.5 RAILWAY BREAKDOWN CRANE

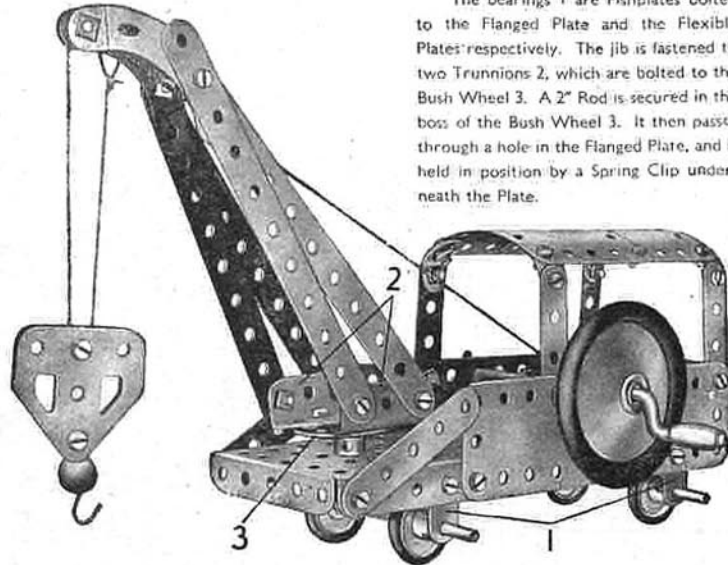

The bearings 1 are Fishplates bolted to the Flanged Plate and the Flexible Plates respectively. The jib is fastened to two Trunnions 2, which are bolted to the Bush Wheel 3. A 2" Rod is secured in the boss of the Bush Wheel 3. It then passes through a hole in the Flanged Plate, and is held in position by a Spring Clip underneath the Plate.

Parts required	
4 of No.	2
6 "	5
4 "	10
3 "	12
2 "	16
1 "	17
1 "	19g
4 "	22
1 "	24
2 "	35
39 "	37
3 "	37a
3 "	38
1 "	40
2 "	48a
1 "	52
1 "	57c
2 "	90a
3 "	111c
2 "	126
2 "	126a
1 "	155
1 "	176
1 "	187
1 "	188
2 "	189
1 "	190
2 "	200

2.6 FLOATING CRANE

The jib consists of 5 1/2" Strips and 2 1/2" Strips. At its upper end these are joined by Angle Brackets, and at its lower end by Trunnions. Each side of the lower part of the crane consists of 2 1/2" Strips and a small radius Curved Strip, the two sides being connected by a 2 1/2" x 1/2" Double Angle Strip. The jib is pivoted to this structure by means of a 3/4" Rod, which carries at each end a 1" Pulley. The Cord 1 fitted with a Loaded Hook, is passed over a 2" Rod held in place in the jib by means of Spring Clips and is then wound around the Crank Handle.

The Cord 2 passes over a Rod held in the jib by a Cord Anchoring Spring, and is then wound around the Rod that forms the pivot for the jib. A third Cord is tied to a Bolt fastened in the two Trunnions at the base of the jib, and is wound round Rod 3. This Cord controls the luffing motion of the crane. A 3/8" Bolt passes through the Flanged Plate and is held by a set screw in the boss of the Bush Wheel to which the jib is fastened. The Bush Wheel is bolted to the Double Angle Strip below the Rod 3. The roof of the cabin is bolted to a 1/2" Reversed Angle Bracket fixed to the Flanged Plate.

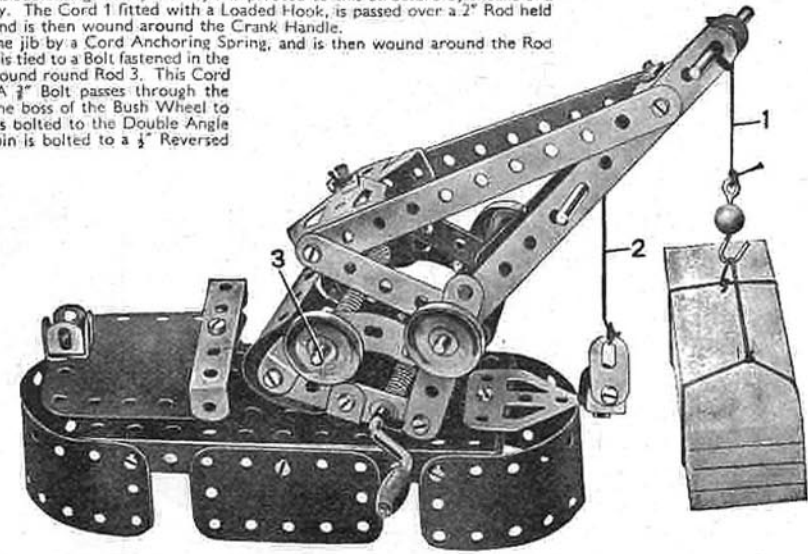

Parts required	
4 of No.	2
6 "	5
3 "	10
8 "	12
2 "	16
2 "	17
1 "	19g
4 "	22
1 "	24
4 "	35
29 "	37
4 "	37a
4 "	38
1 "	40
2 of No.	48a
1 "	52
1 "	57c
2 "	90a
4 "	111c
1 "	125
2 "	126
1 "	126a
1 "	176
2 "	188
2 "	189
1 "	199
1 "	200

2.7 RACING CAR

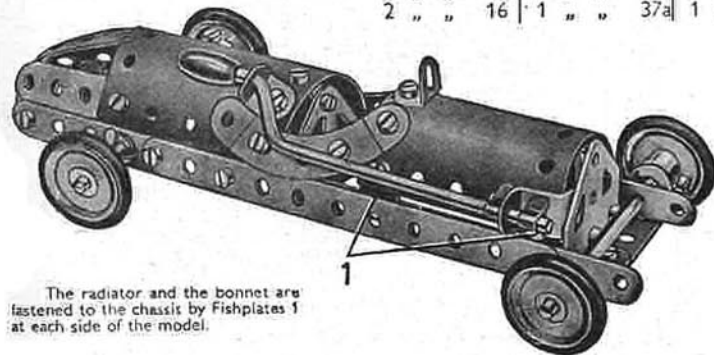

The radiator and the bonnet are fastened to the chassis by Fishplates 1 at each side of the model.

Parts required							
4 of No.	2	1 of No.	19g	2 of No.	38	1 of No.	126a
5 "	5	4 "	22	1 "	48a	4 "	155
4 "	10	4 "	35	2 "	90a	1 "	199
8 "	12	30 "	37	1 "	125	1 "	200
2 "	16	1 "	37a	1 "	126		

2.8 BACON SLICER

The base of the model consists of a Flanged Plate fitted with four 2 1/2" Strips for legs. Two 5 1/2" x 1 1/2" and two 2 1/2" x 1 1/2" Flexible Plates are bolted to the flanges of the Plate.

The guides for the sliding carriage 4 are formed by two 5 1/2" Strips attached to the Flanged Plate by Angle Brackets. The carriage consists of a 2 1/2" x 2 1/2" Flexible Plate 4 and is guided along the Strips by the Reversed Angle Bracket 1 and two Angle Brackets on the opposite side. The Angle Brackets are held in place by Bolts 5.

The cutting blade is represented by a Road Wheel fixed on a 3/4" Rod journalled in two Flat Trunnions. A Pulley on this Rod is connected by a belt of Cord to a second Pulley on the Crank Handle.

The carriage is moved backwards and forwards by a crank consisting of a Bush Wheel 6 fixed on a 2" Rod. This Rod is journalled in the Flanged Plate and in the centre hole of a Double Angle Strip fixed across the interior of the base by the Bolt 2 and another in a similar position on the opposite side. A 1" Pulley on the 2" Rod is connected by a crossed belt of Cord to a further 1" Pulley secured to the Crank Handle between the 5 1/2" Flexible Plates.

A guard for the rotating blade is provided by two Curved Strips attached to a 5 1/2" Strip 3. This Strip is fastened at one end to the Flanged Plate by a 2 1/2" Strip and a Fishplate 7, and at its other end it is attached to a 2 1/2" x 2 1/2" Flexible Plate bolted horizontally to the Flanged Plate.

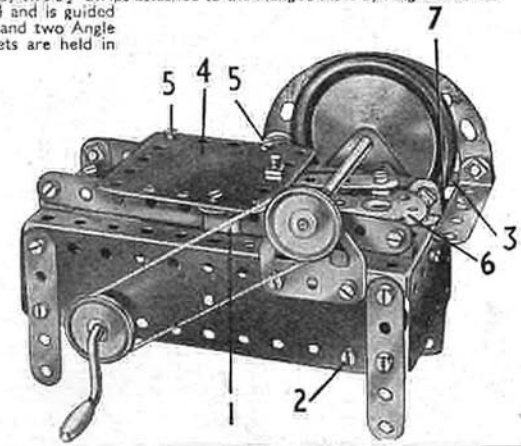

Parts required	
3 of No.	2
6 "	5
1 "	10
8 "	12
1 "	16
1 "	17
1 "	19g
4 "	22
1 "	24
2 "	35
2 "	37
36 "	37
4 "	37a
3 "	38
1 "	40
2 "	48a
1 "	52
2 "	90a
1 "	125
2 "	126a
1 "	187
2 "	188
2 "	189
2 "	190

2.9 TRAMCAR

Parts required

4 of No. 2	4 of No. 38	4 of No. 155
6 " " 5	1 " " 40	2 " " 188
2 " " 10	2 " " 48a	2 " " 189
4 " " 12	1 " " 52	2 " " 190
2 " " 16	2 " " 90a	1 " " 191
1 " " 19g	4 " " 111c	2 " " 200
4 " " 22	1 " " 125	
2 " " 35	2 " " 126	
40 " " 37	2 " " 126a	
6 " " 37a		

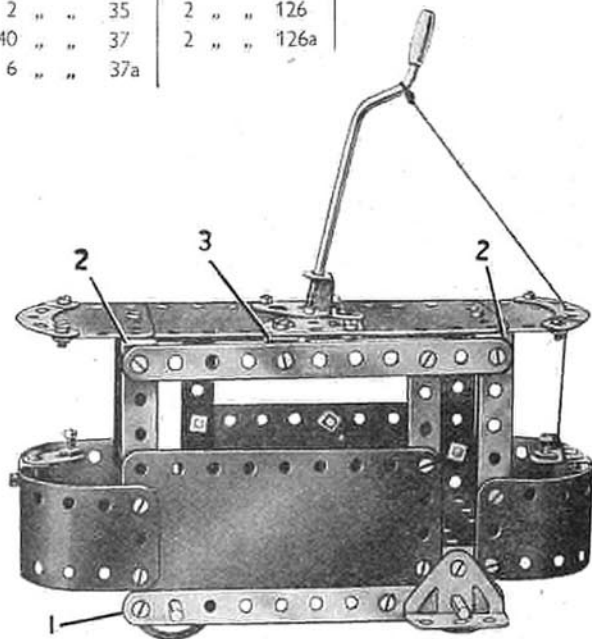

Two $5\frac{1}{2} \times 1\frac{1}{2}$ Flexible Plates are curved and bolted across the ends of a Flanged Plate to form the driving compartments at each end, and a $4\frac{1}{2} \times 2\frac{1}{2}$ Flexible Plate is used for one side of the model. This also is bolted to the Flanged Plate. The other side consists of two $1\frac{1}{2}$ radius Curved Plates, flattened and bolted in position. Both sides are strengthened by a $5\frac{1}{2}$ Strip, one of which is seen at 1.

The roof is supported on each side by three $2\frac{1}{2}$ Strips, connected at their upper ends by a $5\frac{1}{2}$ Strip. The roof is in halves, each half consisting of a $2\frac{1}{2} \times 1\frac{1}{2}$ and a $2\frac{1}{2} \times 2\frac{1}{2}$ Flexible Plate. The halves are joined at the centre by two Flat Trunnions, and the roof is secured to the Double Angle Strips 2 and Angle Brackets 3 on each side. A Crank Handle is used to represent the trolley pole and it is held in the Flat Trunnions and a Reversed Angle Bracket by Spring Clips.

The wheels are 1" Pulleys fixed on $3\frac{1}{2}$ Rods that run in holes in the sides of the model.

2.10 PETROL-ENGINE STATION TRACTOR

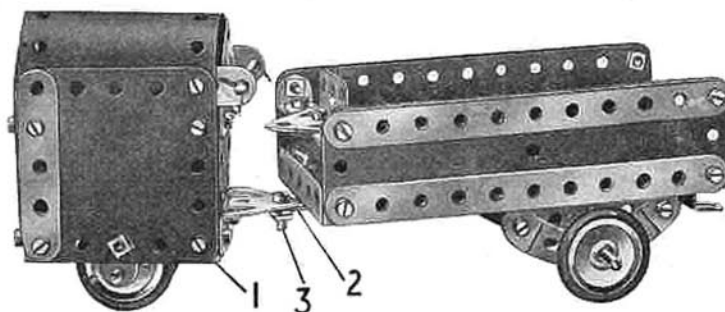

Each side of the tractor unit consists of a $2\frac{1}{2} \times 2\frac{1}{2}$ Flexible Plate bolted to a Double Angle Strip 1. A $4\frac{1}{2} \times 2\frac{1}{2}$ Flexible Plate is curved and attached to each side to form the top. The front and rear of the unit are each filled by a $2\frac{1}{2} \times 1\frac{1}{2}$ Flexible Plate and a Flat Trunnion. The front axle is mounted in two Fishplates.

The load carrier is made by bolting $5\frac{1}{2} \times 1\frac{1}{2}$ Flexible Plates to the sides of a Flanged Plate. The rear axle is carried in two Curved Strips, which are attached to $2\frac{1}{2}$ Strips and secured to the Flanged Plate by Angle Brackets.

The tractor unit and the load carrier are connected by a Trunnion bolted to the tractor and a $2\frac{1}{2}$ Strip 2 secured to the base of the load carrier. The 1" Bolt 3 is passed through holes in these parts and is fitted with lock-nuts.

Parts required

4 of No. 2	4 of No. 2
6 " " 5	6 " " 5
4 " " 10	4 " " 10
8 " " 12	8 " " 12
1 " " 16	1 " " 16
2 " " 17	2 " " 17
4 " " 22	4 " " 22
2 " " 35	2 " " 35
40 " " 37	40 " " 37
4 " " 37a	4 " " 37a
4 " " 38	4 " " 38
2 " " 48a	2 " " 48a
1 " " 52	1 " " 52
2 " " 90a	2 " " 90a
3 " " 111c	3 " " 111c
1 " " 125	1 " " 125
2 " " 126	2 " " 126
2 " " 126a	2 " " 126a
4 " " 155	4 " " 155
2 " " 188	2 " " 188
2 " " 189	2 " " 189
2 " " 190	2 " " 190
1 " " 191	1 " " 191

2.11 MECHANICAL HACKSAW

The base consists of Flexible Plates bolted to a Flanged Plate. One side is formed by a $4\frac{1}{2} \times 2\frac{1}{2}$ and a $2\frac{1}{2} \times 1\frac{1}{2}$ Flexible Plate, and the other by two $5\frac{1}{2} \times 1\frac{1}{2}$ Plates. A $2\frac{1}{2} \times 2\frac{1}{2}$ Flexible Plate is bolted to each end. The base is strengthened at each end by Double Angle Strips 1 and a $5\frac{1}{2}$ Strip on each side.

The saw is actuated by a crank formed from a Bush Wheel fixed to a $3\frac{1}{2}$ Rod. The Rod rotates in a Trunnion and a Flat Trunnion. The Trunnion is raised from the Flanged Plate by two Washers. The Rod carries a 1" Pulley 2 and a Road Wheel. The Pulley 2 is connected by a belt of Cord to a similar Pulley fixed on the Crank Handle.

The material to be sawn is clamped to the base by means of two $2\frac{1}{2}$ Strips, one of which is shown at 3.

Parts required

3 of No. 2	2	1 of No. 40
6 " " 5	5	2 " " 48a
2 " " 12	12	1 " " 52
2 " " 16	16	4 " " 111c
1 " " 19g	19g	1 " " 126
3 " " 22	22	1 " " 126a
1 " " 24	24	1 " " 187
30 " " 37	37	1 " " 188
8 " " 37a	37a	2 " " 189
4 " " 38	38	2 " " 190
	1 of No. 191	

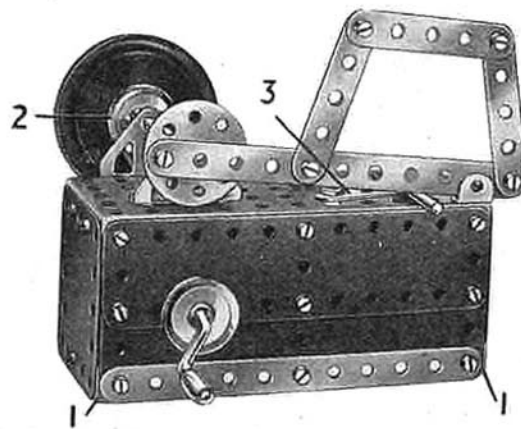

2.12 BEAM ENGINE

Parts required

4 of No. 2	1 of No. 16	3 of No. 38
4 " " 5	2 " " 17	1 " " 40
7 " " 12	1 " " 19g	1 " " 52
	3 " " 22	2 " " 90a
	1 " " 24	2 " " 111c
	4 " " 35	1 " " 126
	32 " " 37	1 " " 126a
	5 " " 37a	1 " " 176
		1 " " 187
		2 " " 188
		2 " " 189
		1 Magic Motor (Not included in Outfit)

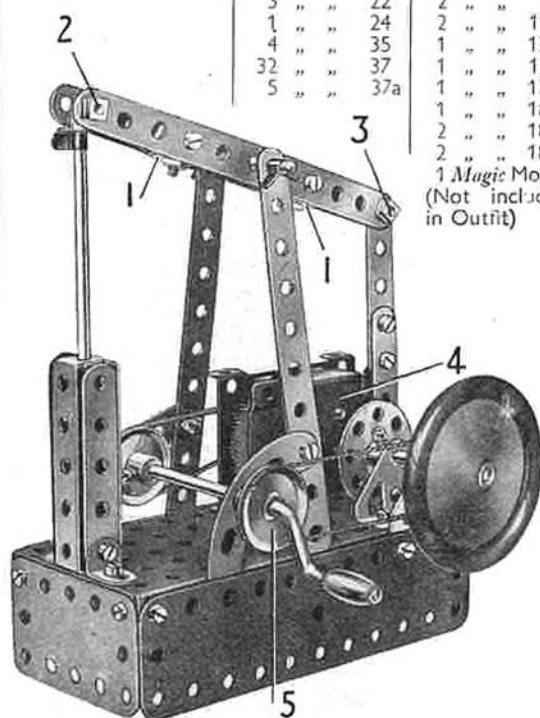

The engine bed or base consists of two $5\frac{1}{2} \times 1\frac{1}{2}$ and two $2\frac{1}{2} \times 1\frac{1}{2}$ Flexible Plates bolted to the sides of a Flanged Plate. Two $5\frac{1}{2}$ Strips form the supports for the beam, which pivots on a 2" Rod held in position by Spring Clips.

The beam is made from two $5\frac{1}{2}$ Strips held together by four Angle Brackets 1, which are bolted in pairs to form two U-shaped pieces.

The cylinder consists of two $2\frac{1}{2} \times 2\frac{1}{2}$ Double Angle Strips and two $2\frac{1}{2}$ Strips. The piston rod is a $3\frac{1}{2}$ Rod attached to the beam by an Angle Bracket, the Bolt 2 that holds the Bracket being lock-nutted. The Rod is held in the Angle Bracket by Spring Clips. The connecting rod is pivoted on a bolt lock-nutted to a Bush Wheel held on a 2" Rod journaled in a Trunnion and a Flat Trunnion. This Rod also carries a 1" Pulley and a Road Wheel. At its upper end the connecting rod is attached to the beam by the lock-nutted bolt 3.

The Magic Motor 4 is bolted to the base by its flanges, and its pulley is connected by a Driving Band to a 1" Pulley on the Crank Handle. A further 1" Pulley 5 on the Crank Handle is connected by a belt of Cord to the 2" Rod.

2.13 TRAVELLING CRANE

A 2" Rod is secured in the boss of the Bush Wheel 3. It then passes through the Road Wheel and through the centre of a 2½" x ½" Double Angle Strip bolted between the two Trunnions 1. A Washer and a Cord Anchoring Spring are pushed on to the Rod to hold it in position. The crane jib is attached to the Bush Wheel by the Angle Brackets 2.

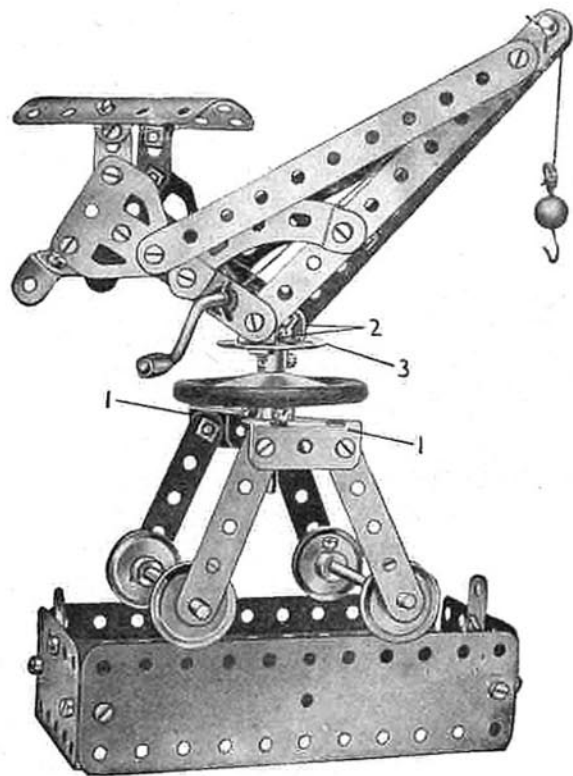

Parts required			
4 of No. 2	4 of No. 22	2 of No. 48a	1 of No. 176
6 " " 5	1 " " 24	1 " " 52	1 " " 187
4 " " 10	4 " " 35	1 " " 57c	2 " " 188
6 " " 12	38 " " 37	2 " " 90a	2 " " 189
2 " " 16	2 " " 37a	2 " " 111c	1 " " 200
2 " " 17	3 " " 38	2 " " 126	
1 " " 19g	1 " " 40	2 " " 126a	

2.14 LAWN MOWER

The "cutter" is made by bolting an Angle Bracket at each end of a Reversed Angle Rod and then sliding an Axle Rod through the free holes of the Brackets. The two Pulleys 2 are fixed to the Rod and pushed tightly against the "cutter" to make it rotate with the Rod as the wheels revolve. The wheels are 1" Pulleys fitted with Rubber Rings.

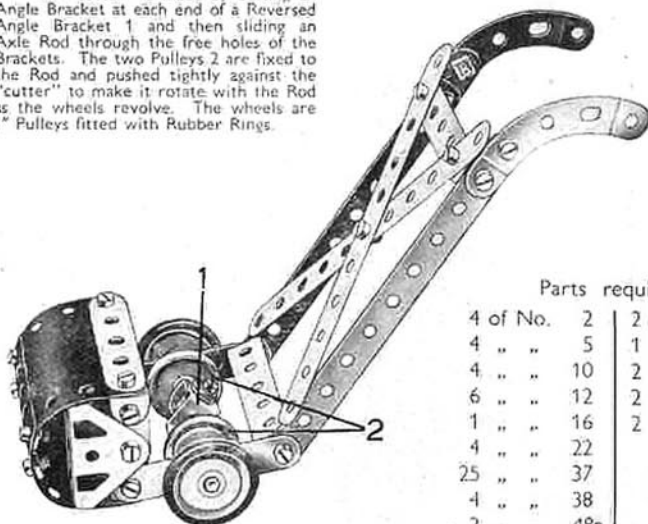

Parts required			
4 of No. 2	2 of No. 90a		
4 " " 5	1 " " 125		
4 " " 10	2 " " 126		
6 " " 12	2 " " 155		
1 " " 16	2 " " 200		
4 " " 22			
25 " " 37			
4 " " 38			
2 " " 48a			

2.15 LUMBER TRUCK AND HORSE

A Magic Motor is mounted beneath the cart, and the Driving Band is taken from the pulley on the Motor to a ½" fixed Pulley (supplied with the Motor) fastened on the 3½" Rod that forms the front axle.

The forelegs of the horse are held together by means of two Angle Brackets bolted in the positions shown. This construction is duplicated at 1 for the hind-legs. The forelegs of the horse are held clear of the ground by the reins.

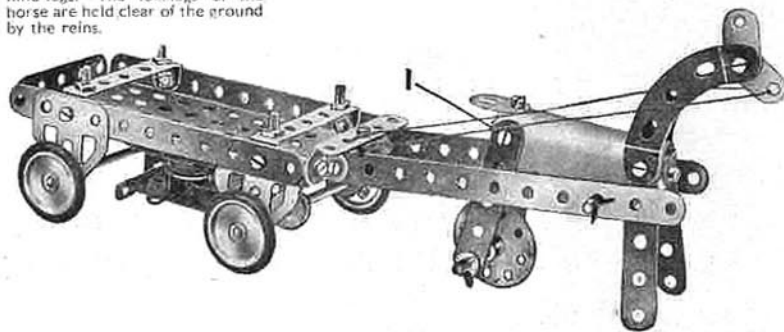

Parts required			
4 of No. 2	4 of No. 35	2 of No. 126a	
5 " " 5	23 " " 37	4 " " 155	
3 " " 10	4 " " 37a	1 " " 199	
6 " " 12	2 " " 48a	1 Magic Motor	
2 " " 16	1 " " 52	(Not included in Outfit)	
2 " " 17	2 " " 90a		
4 " " 22	4 " " 111c		
1 " " 24	2 " " 126		

2.16 PUNCHING MACHINE

Parts required	
4 of No. 2	
6 " " 5	
2 " " 10	
8 " " 12	
1 " " 16	
2 " " 17	
4 " " 22	
1 " " 24	
4 " " 35	
40 " " 37	
4 " " 37a	
3 " " 38	
2 " " 48a	
1 " " 52	
2 " " 90a	
3 " " 111c	
2 " " 126	
2 " " 126a	
4 " " 155	
1 " " 176	
2 " " 188	
2 " " 189	
1 " " 199	

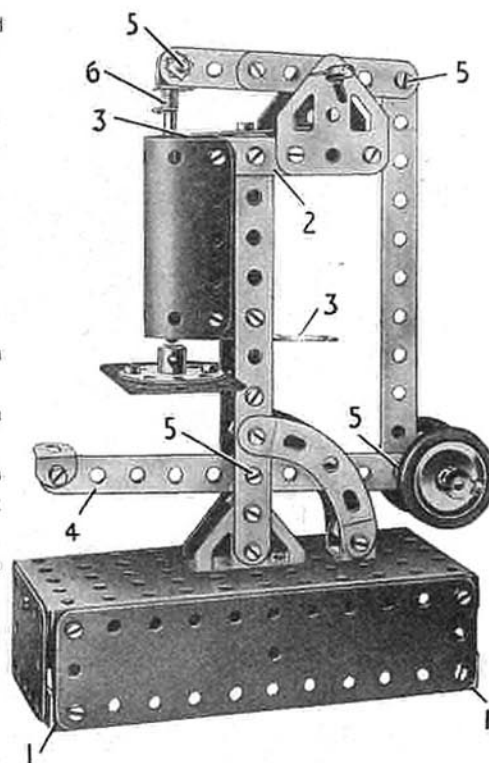

The base consists of a flanged Plate, which is edged with two 5½" x 1½" and one 2½" x 1½" Flexible Plates. The 5½" x 1½" Plates are braced together by the Double Angle Strips 1 at each end.

An upright column is formed from two 5½" Strips fastened to two Trunnions attached to the base. They are joined at their upper ends by two Angle Brackets fixed together to form a U-shaped piece. A ½" radius Curved Plate is attached to the column at the top by a 2½" Strip 2 and at its lower end by two Fishplates. The punch rod passes through holes in 2½" guide Strips 3.

Strips 2, one at each side of the machine, provide supports for two Flat Trunnions that carry a rocker arm. This is formed by two 2½" Strips overlapped three holes, and it is pivoted on a 2" Rod held in the Flat Trunnions. One end of the arm is connected by an Angle Bracket to a 3½" Rod representing the punching tool. The Rod is held in a hole of the Angle Bracket by means of a Spring Clip and a Cord Anchoring Spring 6. The rear end of the arm is connected to the foot-operated lever 4 by a 5½" Strip. The lever is weighted by four 1" Pulleys fixed on a 2" Rod.

The Bolts 5 seen at different points of the model are each lock-nutted.

The punching table is formed by a Bush Wheel bolted to a 2½" x 1½" Flexible Plate attached to the column by a Fishplate and Angle Bracket.

2.17 STEAM WAGON

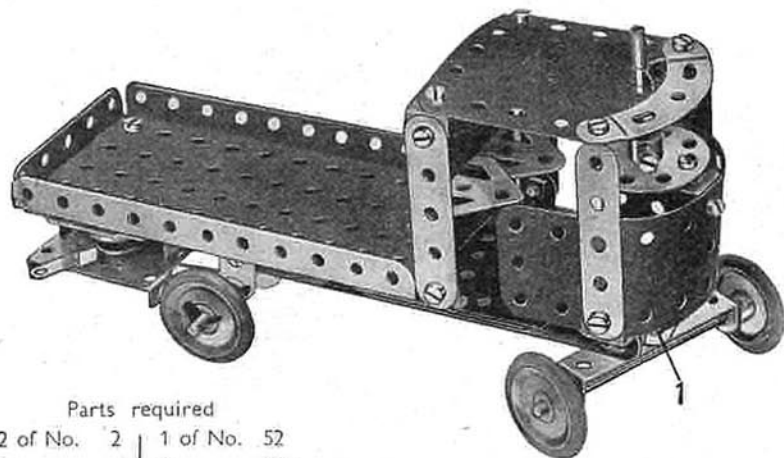

Parts required

2 of No. 2	1 of No. 52
6 " " 5	1 " " 90a
2 " " 10	1 " " 125
8 " " 12	2 " " 126
2 " " 16	4 " " 155
1 " " 17	1 " " 188
4 " " 22	1 " " 189
1 " " 24	1 " " 190
4 " " 35	1 " " 200
31 " " 37	1 Magic Motor
1 " " 37a	(Not included in Outfit)
4 " " 38	
2 " " 48a	

The front axle is carried in a $2\frac{1}{2}'' \times \frac{1}{2}''$ Double Angle Strip that is pivoted to a Reversed Angle Bracket fastened to a $2\frac{1}{2}''$ Strip below the cab by the lock-nutted Bolt 1. The Bolt is fastened sufficiently to hold the two front wheels in position when running along. The rear axle is a $3\frac{1}{2}''$ Rod and it carries a $\frac{1}{2}''$ fixed Pulley supplied with the Magic Motor.

The rear right hand 1" Pulley is loose on the Rod, and is retained in place on the axle by Spring Clips.

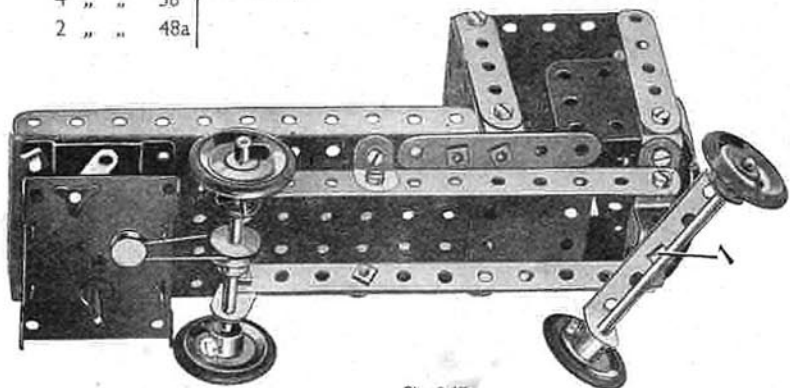

Fig. 2.17a

2.18 LETTER BALANCE

Each side of the model consists of a $5\frac{1}{2}'' \times 1\frac{1}{2}''$ Flexible Plate and two $5\frac{1}{2}''$ Strips. These are connected at the top by two Double Angle Strips. A $2\frac{1}{2}''$ Strip 3 is attached by Fishplates to one of the Double Angle Strips.

Two $2\frac{1}{2}'' \times 2\frac{1}{2}''$ Flexible Plates 1 are overlapped three holes and attached to the sides by Angle Brackets. The $2\frac{1}{2}'' \times 1\frac{1}{2}''$ Flexible Plate 2 is secured to the Double Angle Strip by an Angle Bracket. The sides and front are fastened to the base by Angle Brackets and a Trunnion.

The pointer consists of a $2\frac{1}{2}''$ Strip and a Flat Trunnion and is clamped between two 1" Pulleys fitted with Rubber Rings. These Pulleys are locked on a $3\frac{1}{2}''$ Rod journalled in the $2\frac{1}{2}''$ Strips 4 and 6.

An Angle Bracket 5 is fastened to the 2" Rod by a Spring Clip and a Cord Anchoring Spring. This Angle Bracket is connected to a Bush Wheel 7 by two $2\frac{1}{2}''$ Strips bolted together. The Bush Wheel is loose on a Rod 8 as shown. A length of Cord from the connecting strip is passed several times around the Rod fitted with the pointer. It is then passed through a Driving Band looped around the Rod 8 and tied to the Strip 4.

An indicator dial is marked on a piece of cardboard, which is then bolted in position at the front of the model.

Parts required

4 of No. 2	32 of No. 37	1 of No. 126
6 " " 5	4 " " 37a	1 " " 126a
2 " " 10	4 " " 38	2 " " 155
8 " " 12	1 " " 40	1 " " 176
2 " " 16	2 " " 48a	1 " " 186
1 " " 17	1 " " 52	1 " " 187
2 " " 22	2 " " 90a	1 " " 188
1 " " 24	2 " " 111c	2 " " 189
4 " " 35	1 " " 125	2 " " 190

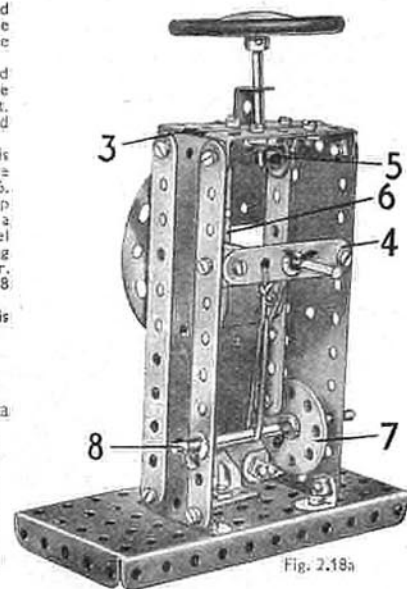
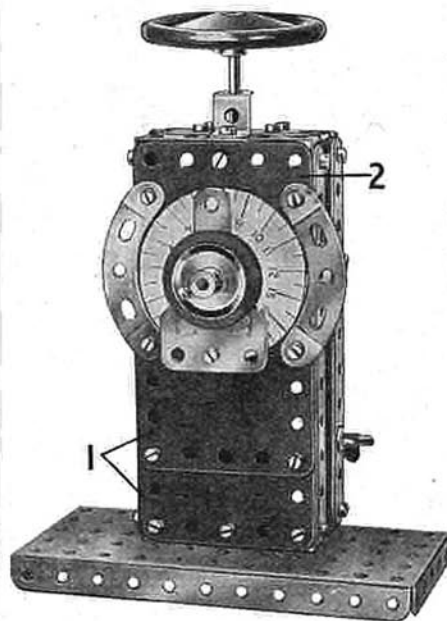

Fig. 2.18a

2.19 DRAGLINE EXCAVATOR

Parts required

4 of No. 2	1 of No. 40	2 of No. 111c	2 of No. 188
6 " " 5	1 " " 48a	2 " " 126	2 " " 189
2 " " 10	1 " " 52	2 " " 126a	2 " " 190
8 " " 12	1 " " 57c	1 " " 176	1 " " 199
1 " " 16	2 " " 90a	1 " " 187	2 " " 200
2 " " 17			
1 " " 19g			
3 " " 22			
1 " " 24			
4 " " 35			
40 " " 37			
4 " " 37a			
1 " " 38			

The Cord 1 is wound round the Crank Handle about 12 times, then one end of it is fastened to a Small Loaded Hook and the other end to the Cord on the bucket.

A Curved Strip is pivoted by a $\frac{1}{2}''$ Bolt through one of its ends in the position of Bolt 2 but on the rear side of the model. A 1" Pulley is attached with a $\frac{1}{2}''$ Bolt to the other end of the Curved Strip to act as a weight. A loop of Cord is fastened through the slotted hole next to the bottom of the Strip, and then passes round the 1" Pulley 3 on the shaft of the Bush Wheel, to act as a brake band. The Cord should be long enough to allow the Strip to lie nearly horizontal. The luffing cords are attached to two $2\frac{1}{2}''$ Strips lock-nutted to the jib.

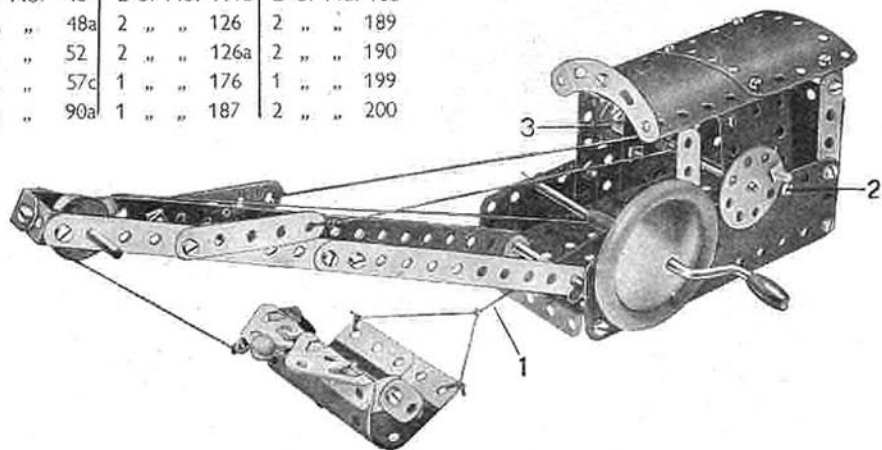

2.20 WINDMILL

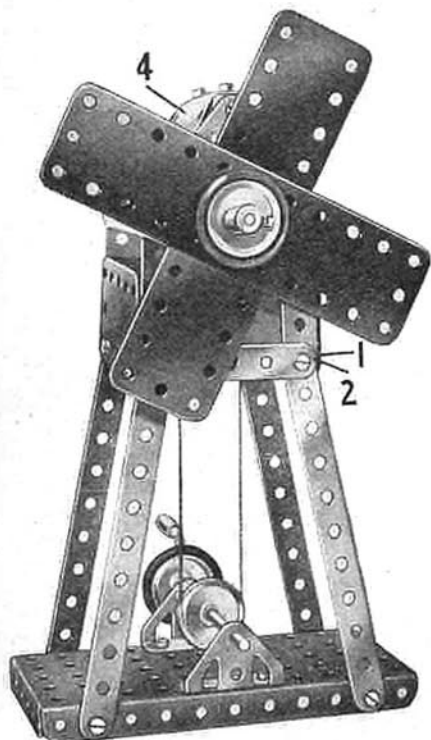

Parts required

4 of No. 2	
6 " " 5	
8 " " 12	
1 " " 16	
1 " " 19g	
4 " " 22	
1 " " 24	
2 " " 35	
32 " " 37	
3 " " 38	
1 " " 40	
2 " " 48a	
1 " " 52	
2 " " 90a	
2 " " 126	
2 " " 126a	
2 " " 155	
2 " " 188	
2 " " 189	
2 " " 190	
1 " " 199	
2 " " 200	

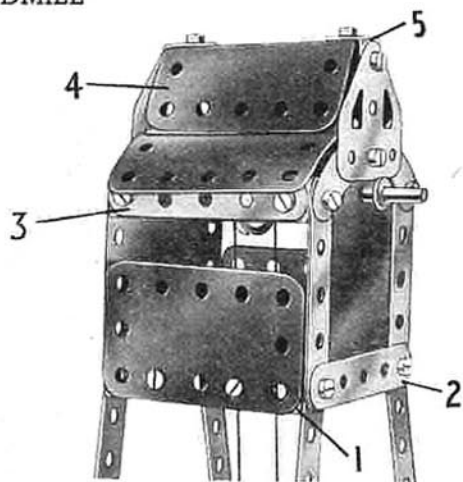

Fig. 2.20a

Four 5½" Strips bolted to the Flanged Plate forming the base are connected at their upper ends by Double Angle Strips 1 and 2½" Strips 2. A 2½" x 1½" Flexible Plate is bolted at each side, and the front and rear walls consist of 2½" x 2½" Flexible Plates. These Plates are connected together by 2½" Strips 3 attached by Angle Brackets.

The mill roof is formed by two 1½" radius Curved Plates, and is attached by two Angle Brackets to a Curved Strip bolted to each 2½" x 2½" Flexible Plate. The ¾" radius Curved Plate 4 is secured by Angle Brackets 5 to two Flat Trunnions bolted to the Curved Strips.

The sails are 5½" x 1½" Flexible Plates clamped between a 1" Pulley fitted with a Rubber Ring and a Bush Wheel. These parts are pushed tightly up against the Plates so as to grip them securely. The Pulley and Bush Wheel are locked on a 3½" Rod journalled in the 2½" x 2½" Flexible Plates. A 1" Pulley on this Rod is connected by a belt of Cord to a similar Pulley on the Crank Handle.

2.21 AUTOGIRO

Parts required

4 of No. 2	2 of No. 38
6 " " 5	2 " " 48a
4 " " 10	2 " " 90a
6 " " 12	1 " " 111c
1 " " 16	1 " " 125
1 " " 17	2 " " 126a
4 " " 22	2 " " 155
1 " " 24	2 " " 188
3 " " 35	1 " " 199
25 " " 37	

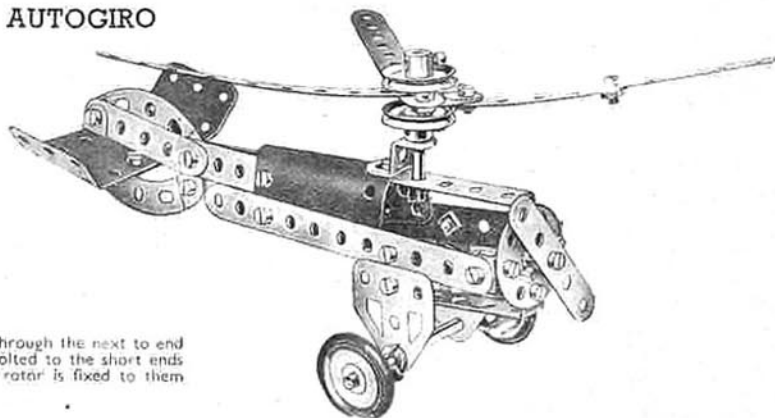

The rotor is made by passing a Rod through the next to end holes of two 5½" Strips. Fishplates are bolted to the short ends of the Strips and the third blade of the rotor is fixed to them as shown.

2.22 MOBILE CONCRETE MIXER

Parts required

2 of No. 2	1 of No. 125
5 " " 5	2 " " 126
4 " " 10	2 " " 126a
7 " " 12	4 " " 155
2 " " 16	1 " " 187
1 " " 17	2 " " 188
4 " " 22	2 " " 189
1 " " 24	1 " " 190
1 " " 35	1 " " 199
40 " " 37	1 " " 200
6 " " 37a	1 Magic Motor
3 " " 38	(Not included
2 " " 43a	in Outfit)
1 " " 52	
2 " " 90a	
4 " " 111c	

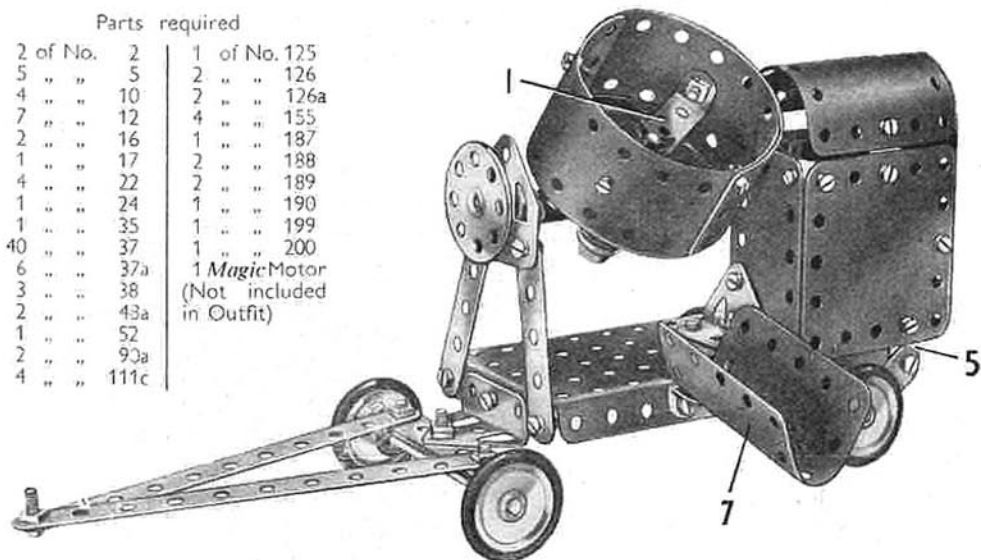

The model is built up on a Flanged Plate. The front axle is journalled in a Double Angle Strip lock-nutted to a Trunnion bolted to the Plate. The rear axle runs in two Curved Strips.

The rotating drum is made by bending two 5½" x 1½" Flexible Plates around a Road Wheel and a Double Angle Strip 1. The Road Wheel is locked on a 2" Rod journalled in the centre hole of a compound strip and a Reversed Angle Bracket 6. The compound strip consists of two 2½" Strips overlapped three holes, and an Angle Bracket is bolted to each end. One Angle Bracket is lock-nutted to the top hole of a 2½" Strip 2 and a 2½" x 1½" Flexible Plate forming part of the engine housing. The Strip 2 is attached to the base by a Trunnion.

The front support for the drum is provided by a Flat Trunnion attached to two 2½" Strips. A ¾" Bolt is locked to an Angle Bracket 3, and passes through the Trunnion. A Bush Wheel is locked to the shank of the Bolt and is used for tipping the contents of the drum into the discharge chute 7.

The Magic Motor is fastened to the base by a Fishplate and two Angle Brackets. A 2½" x 1½" Flexible Plate 4 is bolted to the flanges of the Motor, and a 2½" x 2½" Plate is secured to the base by a Fishplate 5. The top of the engine housing is formed by a Curved Plate.

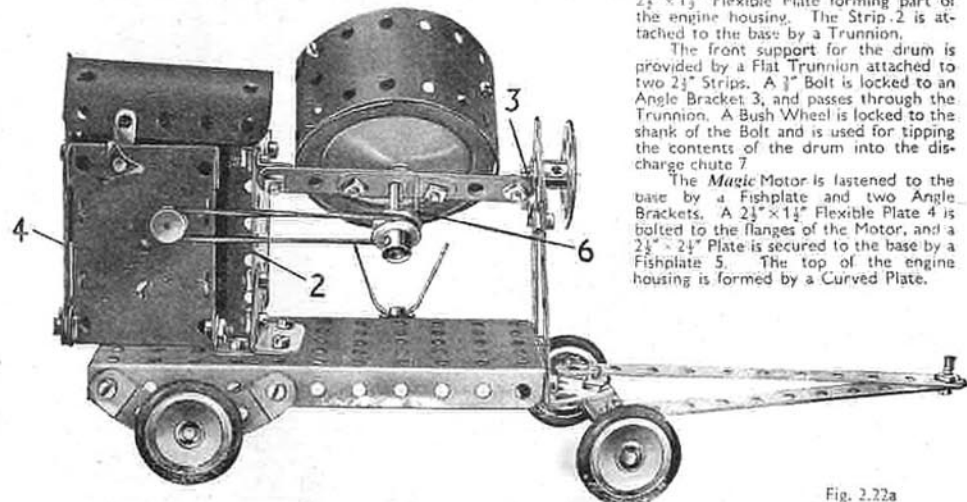

Fig. 2.22a

2.23 HORSE AND TIPPING CART

The chassis of the cart is made from two $5\frac{1}{2}$ " Strips attached at each end to a Trunnion by means of Angle Brackets. The rear axle revolves in a Double Angle Strip bolted to the rear Trunnion and the front axle in a similar Double Angle Strip lock-nutted to the other Trunnion so that it is free to pivot.

The tipping body 1 is made by bolting $5\frac{1}{2}$ " x $1\frac{1}{2}$ " Flexible Plates to the sides of a Flanged Plate. The body pivots about a 2" Rod, which passes through two Angle Brackets secured to the Flanged Plate and also through two Fishplates bolted to the chassis. A length of Cord 2 tied to the rear of the Flanged Plate is fastened to a Cord Anchoring Spring on the Crank Handle 3.

The body of the horse is formed by a U-section Curved Plate. Four $2\frac{1}{2}$ " Strips represent the legs, the front pair supporting a Bush Wheel on a 2" Rod.

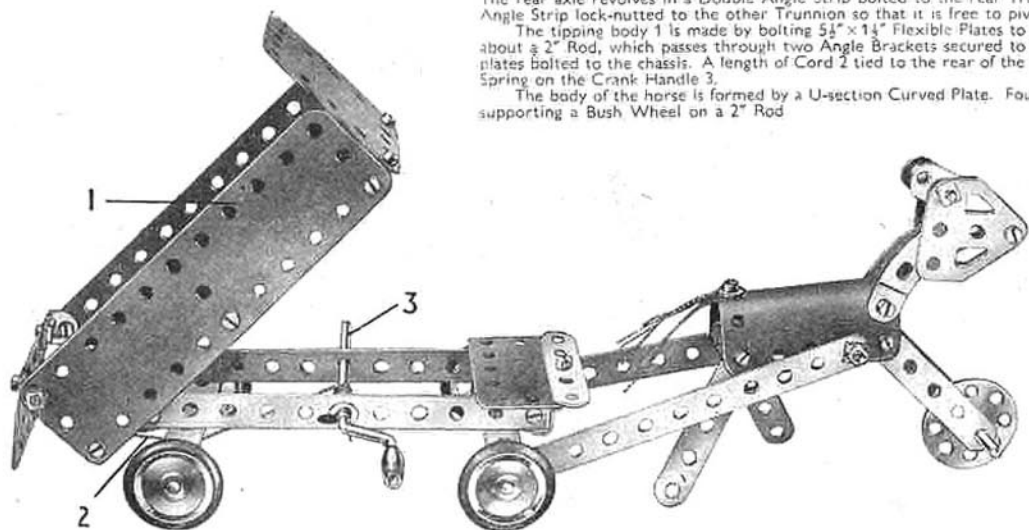

Parts required

4 of No. 2	2 of No. 48a
5 " " 5	1 " " 52
4 " " 10	2 " " 90a
8 " " 12	4 " " 111c
2 " " 16	1 " " 125
2 " " 17	2 " " 126
1 " " 19g	2 " " 126a
4 " " 22	4 " " 155
1 " " 24	1 " " 176
4 " " 35	2 " " 188
34 " " 37	2 " " 189
9 " " 37a	1 " " 190
4 " " 38	1 " " 199
1 " " 40	

2.24 ELECTRIC DELIVERY VAN

Parts required

4 of No. 2	4 of No. 27	2 of No. 48a	2 of No. 126a	1 of No. 191
6 " " 5	1 " " 24	1 " " 52	4 " " 155	1 " " 199
4 " " 10	37 " " 37	2 " " 90a	2 " " 118	2 " " 200
5 " " 12	1 " " 37a	1 " " 111c	2 " " 189	1 Magic Motor
2 " " 16	2 " " 38	2 " " 126	2 " " 190	(Not included in Outfit)

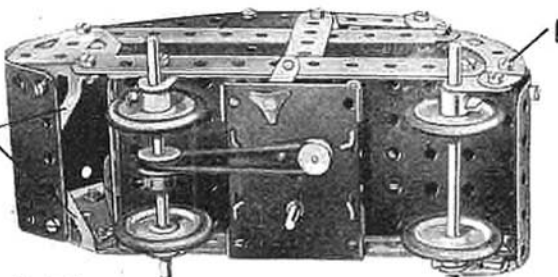
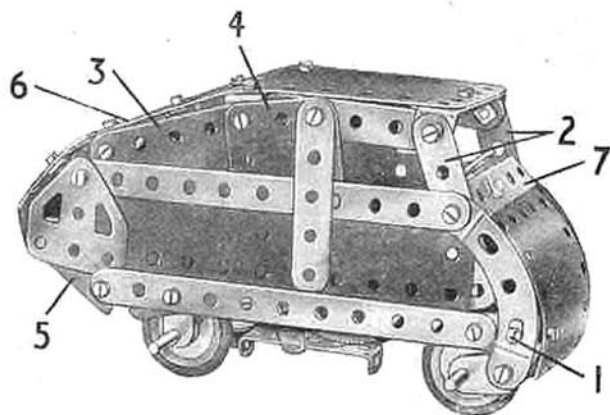

Fig. 2.24a

The Curved Strips and the $1\frac{1}{8}$ " radius Curved Plate forming the front of the model are bolted to a Flanged Plate by means of Bolts 1 at each side of the model. The upper end of the Curved Strips support a $5\frac{1}{2}$ " Strip, a $5\frac{1}{2}$ " x $1\frac{1}{2}$ " Flexible Plate, and a $2\frac{1}{2}$ " Strip 2. The Strips 2 are connected by a Double Angle Strip, to which is bolted a $4\frac{1}{2}$ " x $2\frac{1}{2}$ " Flexible Plate forming part of the roof.

Part of each side of the model is filled in by a $2\frac{1}{2}$ " x $2\frac{1}{2}$ " Flexible Plate 3 and a $2\frac{1}{2}$ " x $1\frac{1}{2}$ " Flexible Plate 4. The tail is formed by a $\frac{3}{8}$ " radius Curved Plate attached to Trunnions 5, and this is joined to the roof by a $1\frac{1}{8}$ " radius Curved Plate 6.

The rear axle is a $3\frac{1}{2}$ " Rod mounted in two Fishplates. A $\frac{1}{2}$ " Pulley on this Rod is connected by a Driving Band to a Magic Motor bolted underneath the Flanged Plate. The front axle is mounted in two Fishplates bolted to the Curved Strips.

The steering wheel is represented by a Bush Wheel, which is fastened to an Angle Bracket by a $\frac{1}{2}$ " Bolt, the Angle Bracket being secured to the Double Angle Strip 7.

2.25 GAS ENGINE.

Parts required

3 of No. 5	33 of No. 37	1 of No. 126a
4 " " 10	3 " " 37a	1 " " 155
8 " " 12	4 " " 38	1 " " 176
2 " " 16	1 " " 40	1 " " 187
1 " " 17	2 " " 48a	2 " " 188
1 " " 19g	1 " " 52	2 " " 189
4 " " 22	1 " " 111c	1 " " 190
1 " " 24	1 " " 125	2 " " 200
4 " " 35	1 " " 126	

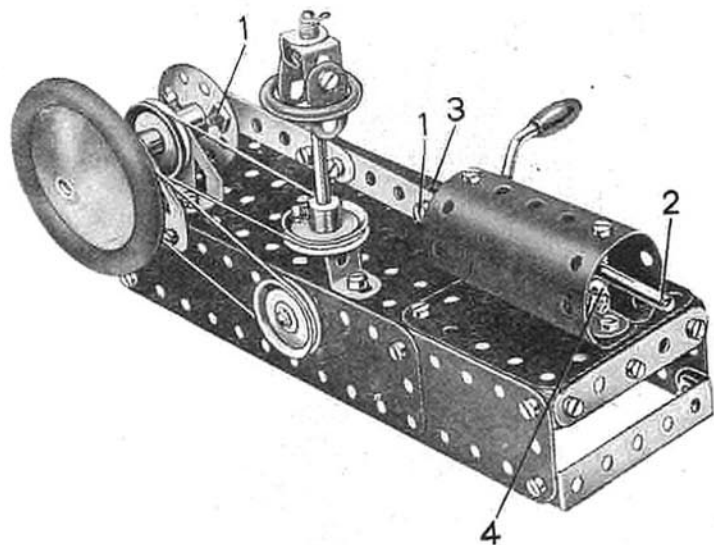

The bearings for the Rod representing the crankshaft are a Flat Trunnion and a Trunnion. The crankshaft carries a Road Wheel and a 1" Pulley at one end, a second 1" Pulley between the bearings, and a Bush Wheel at its other end.

The connecting rod is fastened to the Bush Wheel and to an Angle Bracket 3 by lock-nutted Bolts 1. The Rod 2 is held in the Angle Bracket 3 by Spring Clips, one on each side of it. An Angle Bracket 4, carrying a Fishplate, is bolted inside the cylinder, and a similar arrangement is fitted at the other end. These form bearings for the Rod 2.

The model is operated by the Crank Handle, which carries also a 1" Pulley connected to one of the 1" Pulleys on the crankshaft by a belt or Cord. A second Cord drives the governor, which is mounted on a $3\frac{1}{2}$ " Rod journaled in the $5\frac{1}{2}$ " x $2\frac{1}{2}$ " Flanged Plate and a Reversed Angle Bracket.

BUILD BIGGER AND BETTER MODELS

When you have built all the models shown in this Book of Instructions, you will be keen to build bigger and more elaborate models. Your next step is to purchase a Meccano No. 2a Accessory Outfit containing all the parts required to convert your No. 2 into a No. 3 Outfit. You will then be able to build the full range of No. 3 Outfit models, a selection of which is illustrated on this page.

If you prefer to do so, you can build up and develop your Outfit quite easily by adding various parts to it from time to time. The model-building possibilities of the Meccano System are unlimited, and the more Meccano parts you have the bigger and better the models you will be able to build.

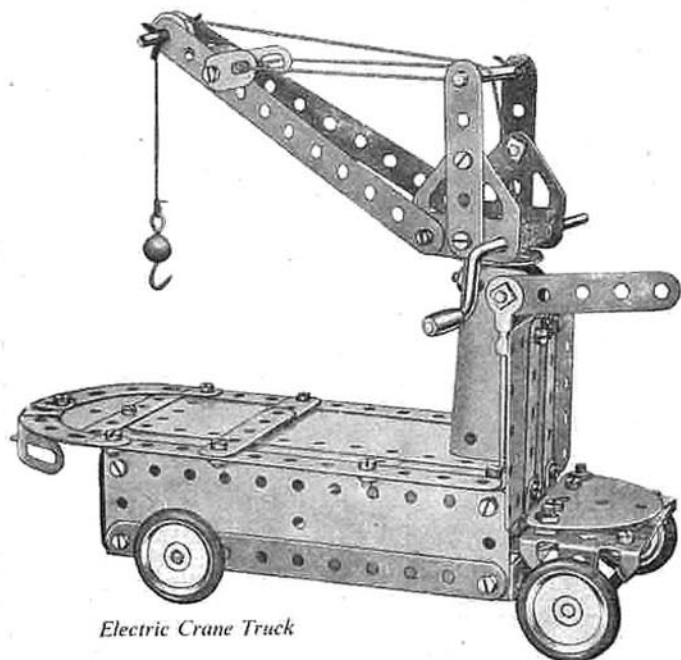
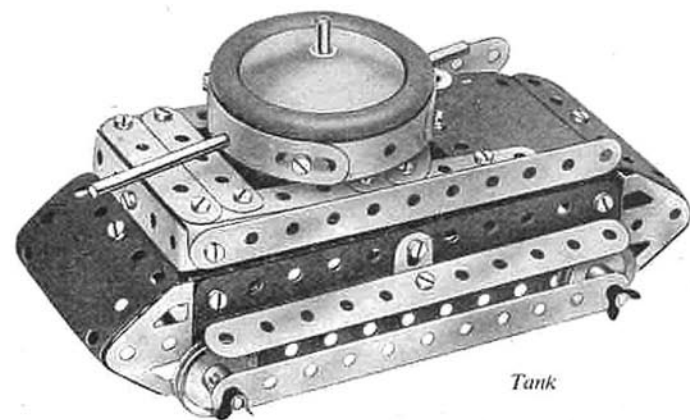
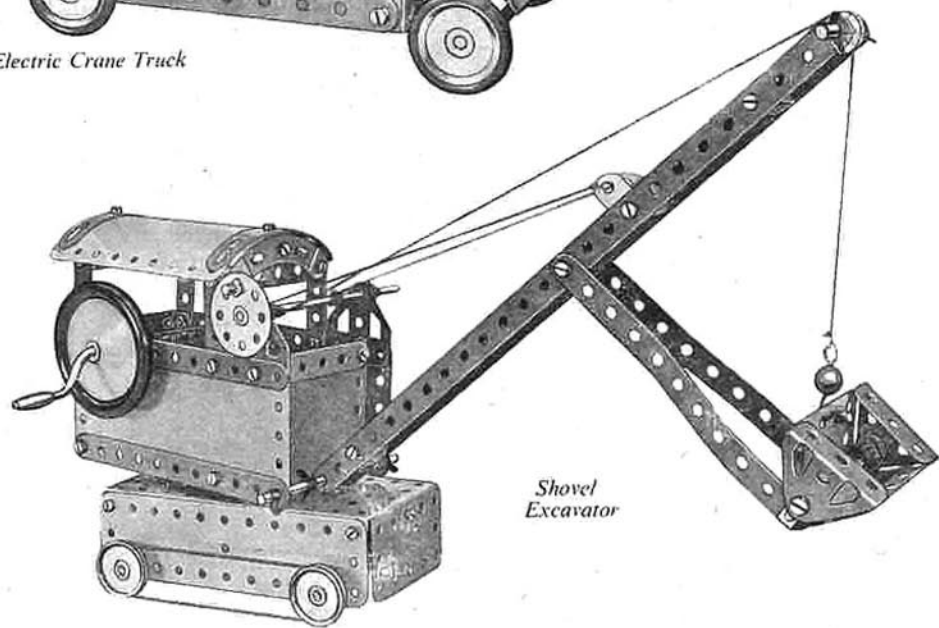
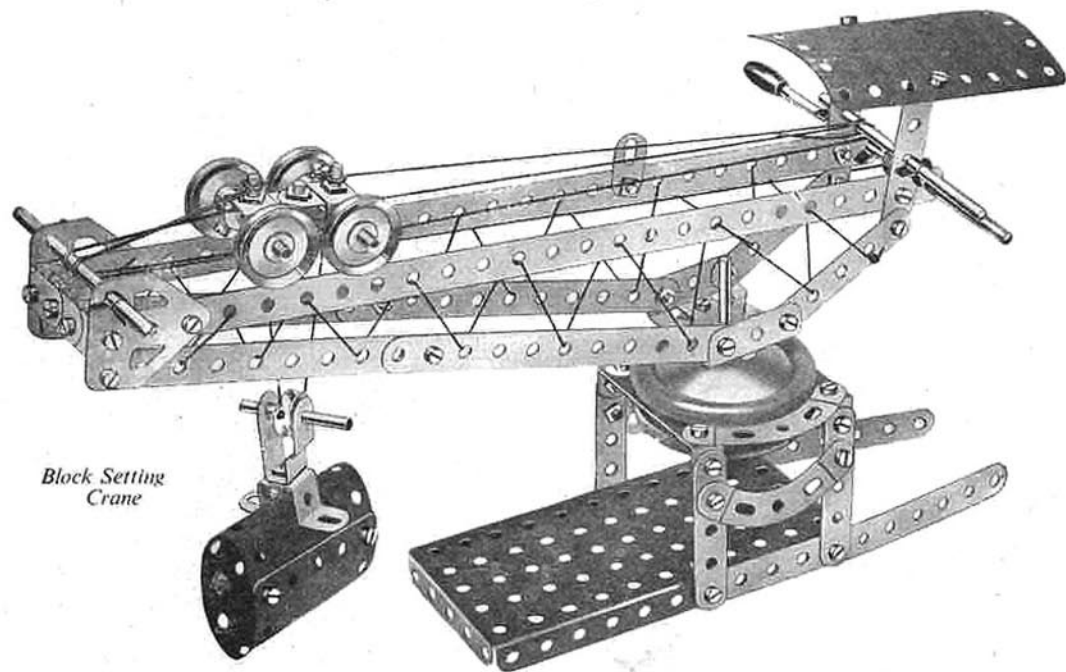
*Electric Crane Truck**Tank**Shovel
Excavator**Block Setting
Crane*

Here are a few simple and interesting movements showing how easily real mechanisms can be reproduced with Meccano.

USEFUL BAND BRAKE

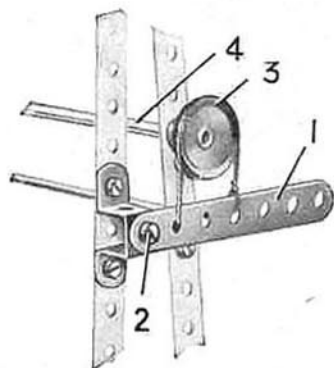

S.M.111. The brake lever consists of a $3\frac{1}{2}$ " Strip 1, pivotally attached at a suitable point on the frame of the model, to be fitted, by means of a lock-nutted $\frac{3}{8}$ " Bolt 2. The driven shaft 4 is fitted at one end with a 1" fast Pulley 3 round which a short length of cord is passed. The two ends of this Cord are secured to the brake lever at the points shown in the illustration.

If increased braking effect is desired a larger Pulley may be used in place of the 1" fast Pulley 3, the brake later 1 being attached in a lower position if necessary. Alternatively a weight can be hung from the end of the brake lever.

SIMPLE STEERING GEAR

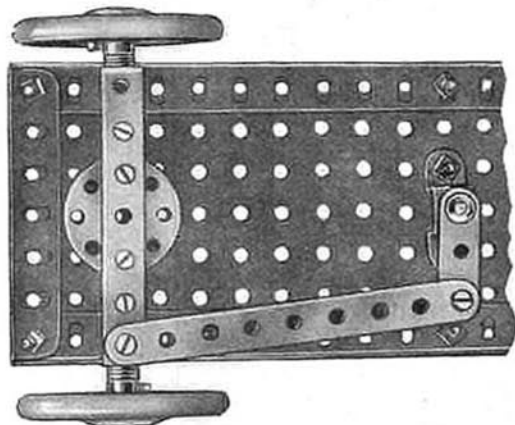

S.M.162. The simple steering gear will be found suitable for most small model vehicles.

In this example the two front wheels are mounted on separate stub axles that are secured to each end of a rigid front axle. The base of the chassis consists of two long Angle Girders connected together at the front end by a $3\frac{1}{2}$ " Angle Girder and filled in along their length by means of $5\frac{1}{2} \times 3\frac{1}{2}$ " Flat Plates.

The front axle, a $3\frac{1}{2} \times \frac{1}{2}$ " Double Angle Strip, is pivotally mounted at its centre on a Bush Wheel and short Rod. It is fitted, $\frac{1}{2}$ " from each end, with a $\frac{1}{2} \times \frac{1}{2}$ " Angle Bracket, this forming the inner bearing for its respective stub axle. The outer bearing for the axle consists of the upturned lug of the Double Angle Strip. One end of this latter part is fitted with a pivotally attached $4\frac{1}{2}$ " Strip, by means of which the front axle is linked up to a Crank fixed to the steering column.

SAFETY CATCH FOR CRANE WINDING GEAR

S.M.125. The Compression Spring 3 is mounted on the Crank Handle 1 between the Collar 4 and a Washer, and normally holds the Collar 2 against the inner side of the plate. The Collar 2 is fitted with a $\frac{3}{8}$ " Bolt; and if the Crank Handle commences to rotate, the head of this Bolt strikes against the stop 5 and prevents further movement.

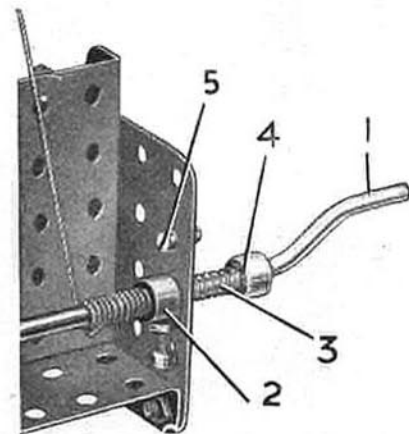

BUILT UP ROLLER BEARING

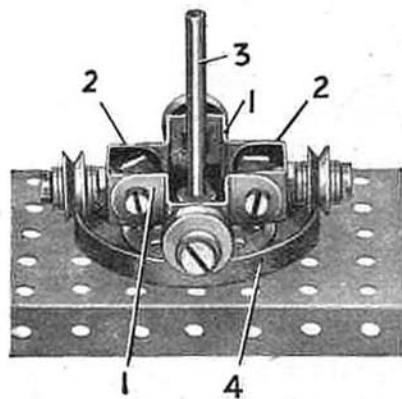

S.M.136. The spider frame is built up from Double Bent Strips 1 connected together by two Double Brackets 2. The four wheels used are represented by $\frac{1}{2}$ " loose Pulleys journalled on Pivot Bolts secured to the outer ends of the four arms of the frame. Four Washers, two on each side of the Pulleys are passed on to the shank of each of the Pivot Bolts that are attached to the Double Brackets 2. In the case of the other two Pivot Bolts, two Washers are placed against the external side only of the Pulley.

BRAKE LEVER and QUADRANT

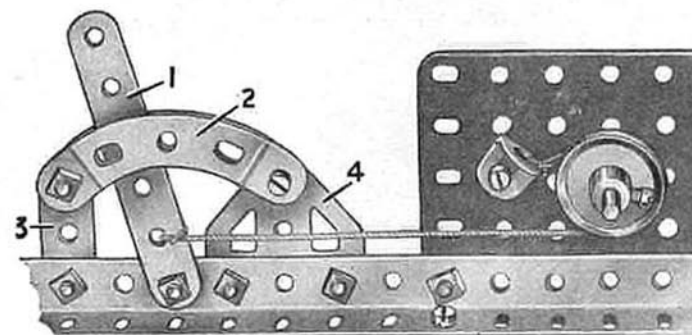

S.M.112. This mechanism is a form of band brake in which the lever 1 can be held in any position by means of the quadrant 2. In this way varying pressures can be applied to the Pulley forming the brake drum.

One end of the brake Cord is attached to a $\frac{1}{2} \times \frac{1}{2}$ " Angle Bracket bolted in a suitable position on the model. After passing round the 1" fast Pulley forming the brake drum the Cord is secured at the next to bottom hole of a 3" Strip 1. This Strip forms the brake lever, and it is secured to the frame of the model by a lock-nutted Bolt.

MECCANO PARTS

3 Perforated Strips

No.		No.	
1	12½"	3	3½"
1a	9"	4	2½"
1b	7½"	5	2"
2	5½"	6	1½"
2a	4½"	6a	1½"

9^a

9^a Angle Girders

7	24½"	9a	4½"
7a	18½"	9b	3½"
8	12½"	9c	2½"
8a	9½"	9d	2"
8b	7½"	9e	1½"
9	5½"	9f	1½"

10 Fishplate
11 Double Bracket
12 Angle Bracket, 1" x 1"
12a " " " " 1" x 1"
12b " " " " 1" x 1"
12c Obtuse Angle Bracket, 1" x 1"

17 Axle Rods

13	11½"	16	3½"
13a	8"	16a	2½"
14	6½"	16b	3"
15	5"	17	2"
15a	4½"	18a	1½"
15b	4"	18b	1"

19h Crank Handle, 3½" Shaft with grip
19h " " " " 3" " " without grip
19s " " " " 3" " " without grip

20 Spoked Wheel, 3" diam.
20 Flanged Wheel, 1½" diam.
20b " " " " " " " "

22 Pulleys

19b	3"	diam.	with boss and screw
19c	6"	"	"
20a	2"	"	"
21	1"	"	"
22	1"	"	"
22a	1"	"	without
23	½"	"	"
23a	½"	"	with

24 Bush Wheel, 1½" diam.
24a Wheel Disc, 1½" diam., without bush

26 Pinion, ¾" diam., 1" face, 25 teeth
25a " " " " " " 25 " "
25b " " " " " " 25 " "
26 " " " " " " 19 " "
26a " " " " " " 19 " "
26b " " " " " " 19 " "

27 Gear Wheels
27a 1½" diam., 50 teeth.
27b 1½" " " 57 " "
27c 2½" " " 133 " "
27c 2½" " " 95 " "

28 Contra Wheel, 1½" diam., 50 teeth
29 " " " " 25 " "

30 Bevel Gear, ¾" diam., 26 teeth (for use in pairs)
30a " " " " 16 " " Can only be used together
30c " " " " 48 " " " "

31 Gear Wheel, 1" diam., 1" face, 38 teeth
32 Worm, ½" diam.

34^a Spanner
34b Box Spanner

35 Spring Clip
36 Screwdriver
36a " " " " " " " "
36c Drift (for levering bolt holes into line)
37 Nut and Bolt, ½"
37a Nut
37b Bolt, ½"
38 Washer
38d " " " " " " " "
40 Hank of Cord

41 Propeller Blade

43 Tension Spring, 2" long

44 Bent Strip, stepped
45 Double Bent Strip
46 Double Angle Strip, 2½" x 1"
47 " " " " " " 2" x 1"
47a " " " " " " 1½" x 1"
48 " " " " " " 1½" x 1"
48a " " " " " " 2" x 1"
48b " " " " " " 2" x 1"
48c " " " " " " 2" x 1"
48d " " " " " " 2" x 1"

50 Slide Piece

52 Flanged Plate, 2½" x 1½"
53 Flat Plate, 5" x 2½"
52a Flat Plate, 5" x 3½"
53 Flanged Plate, 3" x 2½"
53a Flat Plate, 4" x 2½"

54 Flanged Sector Plate, 4½" long

55 Perforated Strip, slotted, 5½" long
55a " " " " 2" "

57^b Hook, Loaded, Large
57c " " Small

58 Spring Cord, 40" Length
58a Coupling Screw for Spring Cord
58b Hook for Spring Cord

59 Collar, with screw

61 Windmill Sail

62 Crank
62a Threaded Crank
62b Double Arm Crank

63 Coupling
63b Strip Coupling
63c Threaded Coupling

64 Threaded Boss
65 Centre Fork
69 Set Screw, ½"
69a Grub Screw, ½"
69b " " ¾"
69c " " 1"

70 Flat Plate, 5½" x 2½"
72 " " 2½" x 2½"
73 " " 3" x 1½"
76 Triangular Plate, 2½"
77 " " 1"

80^a Screwed Rods

78	11½"	80b	4½"
79	8"	80c	3"
79a	6"	81	2"
80	5"	82	1"
80a	3½"		

90 Curved Strip, 5½", 10" radius
89a " " stepped, 3", 1½" radius
89b Curved Strip, stepped, 4", 4½" radius
90 Curved Strip, 2½", 2½" radius
90a " " stepped, 2½", 1½" radius

94 Sprocket Chain, 40" length
95 " Wheel, 2" diam., 36 teeth
95a " " 1½" " 28 " "
95b " " 3" " 56 " "
96 " " 1" " 18 " "
96a " " ½" " 14 " "

99 Braced Girders

No.		No.	
97	3½" long	99a	9½" long
97a	3" " "	99b	7" " "
98	2½" " "	100	5½" " "
99	12½" " "	100a	4½" " "

101 Head, for looms
102 Single Bent Strip

103^a Flat Girders

103	5½" long	103e	3" long
103a	9½" " "	103f	2½" " "
103b	12½" " "	103g	2" " "
103c	4½" " "	103h	1½" " "
103d	3½" " "	103k	7½" " "

104 Shuttle, for looms
105 Reed Hook, for looms

106 Wood Roller
106a Sand Roller
106^a " " " "

108 Corner Gusset
109 Face Plate, 2½" diam.

110 Rack Strip, 3½" long
110a " " " " 6½" " "
111 Bolt, ½" " " " 111c. Bolt, ¾"
111a " " " " 111d. " 1½"

113 Girder Frame

114 Hinge
115 Threaded Pin
116 Fork Piece, Large
116a " " Small
117 Steel Ball, ¾" diam.

118 Hub Disc, 5½" diam.

MECCANO PARTS

No. 120b. Compression Spring, $\frac{3}{8}$ " long



122. Miniature Loaded Sack



123. Cone Pulley, $1\frac{1}{2}$ ", 1" and $\frac{3}{4}$ " diam.
124. Reversed Angle Bracket, 1"
125. " " " "



126. Trunnion
126a. Flat Trunnion



127. Bell Crank
128. Bell Crank, with Boss



129. Toothed Segment, $1\frac{1}{2}$ " radius



130. Eccentric, Triple Throw, $\frac{1}{2}$ ", $\frac{3}{4}$ " and $\frac{1}{2}$ "
130a. Eccentric, Single Throw, $\frac{1}{2}$ ", $\frac{3}{4}$ " and $\frac{1}{2}$ "



131. Dredger Bucket
132. Flywheel, 2 $\frac{1}{2}$ " diam.



133. Corner Bracket, $1\frac{1}{2}$ "
133a. " " 1"



No. 134. Crank Shaft, 1" stroke



136. Handrail Support
136a. Handrail Coupling
137. Wheel Flange



138a. Ship Funnel



139. Flanged Bracket (right)
139a. " " (left)



140. Universal Coupling



142. Rubber Ring (to fit 3" diam. rim)
142a. Motor Tyre (to fit 2" diam. rim)
142b. " " " 3" " "
142c. " " " 1" " "
142d. " " " 1 $\frac{1}{2}$ " " "



143. Circular Girder, $5\frac{1}{2}$ " diam.



No. 144. Dog Clutch



145. Circular Strip, $7\frac{1}{2}$ " diam. overall
146. " Plate 6" " "
146a. " " 4" " "

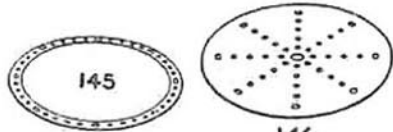

147. Pawl, with Pivot Bolt and Nuts
147a. Pawl
147b. Pivot Bolts with 2 Nuts
147c. Pawl without boss
148. Ratchet Wheel



151. Pulley Block, Single Sheave
152. " " Two " "
153. " " Three " "



154a. Corner Angle Bracket, $\frac{1}{2}$ " (right-hand)
154b. Corner Angle Bracket, $\frac{1}{2}$ " (left-hand)
155. Rubber Ring (for 1" Pulleys)

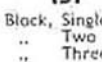

157. Fan, 2" diam.



160. Channel Bearing, $1\frac{1}{2}$ " x 1" x $\frac{1}{2}$ "
161. Girder Bracket, 2" x 1" x $\frac{1}{2}$ "



166. Flanged Ring, 9 $\frac{1}{2}$ " diam.

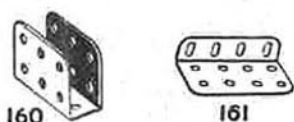

No. 162. Boiler, complete, 5" long x 2 $\frac{1}{4}$ " diam.
162a. " Ends, 2 $\frac{1}{4}$ " diam. x $\frac{1}{2}$ "
162b. " without ends, 4 $\frac{1}{2}$ " long x 2 $\frac{1}{4}$ " diam.
163. Sleeve Piece, 1 $\frac{1}{2}$ " long x $\frac{1}{2}$ " diam.
164. Chimney Adaptor, $\frac{1}{2}$ " diam. x $\frac{1}{2}$ " high

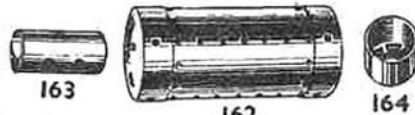

165. Swivel Bearing
166. End
167b. Flanged Ring, 9 $\frac{1}{2}$ " diam.

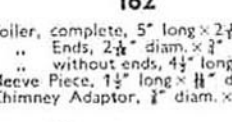

168. Ball Bearing, 4" diam.
168a. " Race, flanged disc, 3 $\frac{1}{2}$ " diam.
168b. " " toothed " 4" diam.
168c. " Cage, 3 $\frac{1}{2}$ " diam., complete with balls.

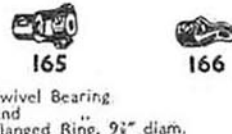

171. Socket Coupling



175. Flexible Coupling Unit

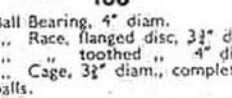

176. Anchoring Spring for Cord



179. Rod Socket
180. Gear Ring, 3 $\frac{1}{2}$ " diam. (133 ext. teeth, 95 int.)



185. Steering Wheel, 1 $\frac{1}{2}$ " diam.
186. Driving Band, 2 $\frac{1}{2}$ " (Light)
186a. " " 6" " "
186b. " " 10" " "
186c. " " 10" (heavy) " "
186d. " " 15" " "
186e. " " 20" " "
187. Road Wheel, 2 $\frac{1}{2}$ " diam.
187a. Conical Disc, 1 $\frac{1}{2}$ " diam.

192. Flexible Plates:
198. Hinged Flat Plate, 4 $\frac{1}{2}$ " x 2 $\frac{1}{2}$ "
199. Curved Plate, U-Section
200. " " 2 $\frac{1}{2}$ " x 2 $\frac{1}{2}$ " x $\frac{1}{8}$ " radius
" " 2 $\frac{1}{2}$ " x 2 $\frac{1}{2}$ " x 1 $\frac{1}{4}$ " radius

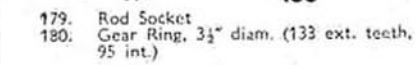

190a. 3 $\frac{1}{2}$ " x 2 $\frac{1}{2}$ "
191. 4 $\frac{1}{2}$ " x 2 $\frac{1}{2}$ "
192. 5 $\frac{1}{2}$ " x 2 $\frac{1}{2}$ "
197. 12 $\frac{1}{2}$ " x 2 $\frac{1}{2}$ "



196. 9 $\frac{1}{2}$ " x 2 $\frac{1}{2}$ "

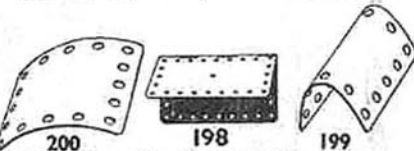

200. " " 2 $\frac{1}{2}$ " x 2 $\frac{1}{2}$ " x $\frac{1}{8}$ " radius
" " 2 $\frac{1}{2}$ " x 2 $\frac{1}{2}$ " x 1 $\frac{1}{4}$ " radius

211a. Helical Gear, $\frac{1}{2}$ "
211b. " " 1 $\frac{1}{2}$ "
Can only be used together

212. Rod and Strip Connector
213. Rod Connector

214. Semi-Circular Plate, 2 $\frac{1}{2}$ "
215. Formed Slotted Strip, 3"

216. Cylinder, 2 $\frac{1}{2}$ " long, 1 $\frac{1}{2}$ " diam.

