

# MECCANO



INSTRUCTIONS for OUTFIT No. 6

COPYRIGHT BY MECCANO LIMITED  
BINNS ROAD, LIVERPOOL 13, ENGLAND

49.6

W. H. PINYON

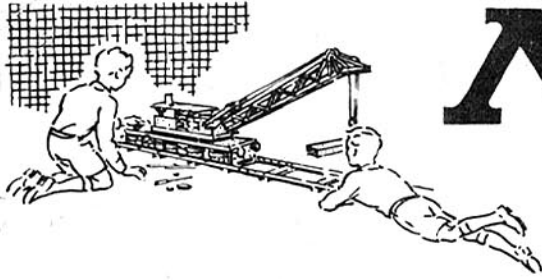

# MECCANO

Registered Trade Mark

The World's Greatest Constructional Toy



## MODEL-BUILDING WITH MECCANO

There is no limit to the number of models that can be built with Meccano — Cranes, Clocks, Motor Cars, Aeroplanes, Machine Tools, Locomotives — in fact everything that interests boys. A screwdriver and a spanner, both of which are provided in each complete Outfit, are the only tools necessary.

When you have built all the models illustrated in the Books of Instructions the fun is not over, it is just beginning. Now comes the chance to make use of your own ideas. First of all, re-build some of the models with small changes in construction that may occur to you; then try building models entirely of your own design. In doing this you will enjoy the real thrill of the engineer and the inventor.

## HOW TO BUILD UP YOUR OUTFIT

Meccano is sold in 12 different Outfits, ranging from No. OO to No. 10. Each Outfit can be converted into the next larger one by the purchase of an Accessory Outfit. Thus Meccano No. OO Outfit can be converted into No. O Outfit by adding to it a No. OOa Accessory Outfit. No. Oa Outfit would then convert it into a No. 1 and so on. In this way, no matter with which Outfit you begin, you can build it up by degrees until you have a complete No. 10 Outfit.

All Meccano parts are of the same high quality and finish, but the larger Outfits contain a greater quantity and variety, making possible the construction of more elaborate models.

## THE 'MECCANO MAGAZINE'

The 'Meccano Magazine' is published specially for Meccano boys. Every month it describes and illustrates new Meccano models, and deals with suggestions from readers for new Meccano parts and for new methods of using the existing parts.

There are model-building competitions specially planned to give an equal chance to the owners of small and large Outfits. In addition, there are splendid articles on such subjects as Railways, Famous Engineers and Inventors, Electricity, Bridges, Cranes and Aeroplanes, and special sections dealing with the latest Engineering, Aviation, Motoring

and Shipping News. Other pages deal with Stamp Collecting, and Books of interest to boys; and a feature of outstanding popularity is the section devoted to short articles from readers.

Write to the Editor, The Meccano Magazine, Binns Road, Liverpool 13, for particulars and a specimen copy. You can order the Magazine from your Meccano dealer, or from any newsagent.

## THE MECCANO GUILD

Every owner of a Meccano Outfit should join the Meccano Guild. This is a world-wide organisation, started at the request of Meccano boys. Its primary object is to bring boys together and to make them feel that they are all members of a great brotherhood, each trying to help others to get the very best out of life. Its members are in constant touch with Headquarters, giving news of their activities and being guided in their hobbies and interests. A leaflet containing full particulars of the Guild and an application form is included in this Book.

Clubs founded and established under the guidance of the Guild Secretary provide Meccano boys with opportunities of enjoying to the utmost the fun of model-building. Each has its Leader, Secretary, Treasurer and other officials. With the exception of the Leader, all the officials are boys, and as far as possible the proceedings of the clubs are conducted by boys.

## MECCANO SERVICE

The service of Meccano does not end with selling an Outfit and a Book of Instructions. If ever you are in any difficulty with your models, or if you want advice on anything connected with this great hobby, write to us. We receive hundreds of interesting letters from boys in all parts of the world, and each of these is answered personally and promptly by one of our staff of experts.

Whatever your problem may be, write to us about it. We shall be delighted to help you in any way possible. Address your letters to *Information Service*.

# HOW TO BEGIN THE FUN

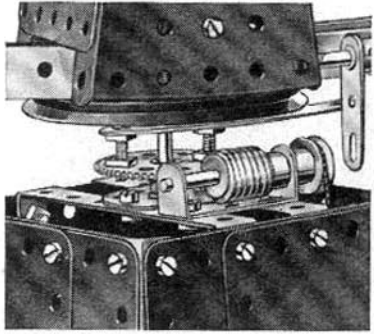

*A Worm and a 57-teeth Gear give a useful drive ratio for many models*

## THE MOST FASCINATING OF ALL HOBBIES

Meccano model-building is the most fascinating of all hobbies, because it never becomes dull. There is always something new to be done. First of all there is the fun of building a new model, and watching it take shape as part after part is added. Then, when the model is complete, comes the thrill of setting it to work just like the real structure it represents, by means of a Meccano Motor.

## A FEW USEFUL HINTS

Beginners sometimes wonder which section of a model should be built first. There cannot be any definite rule for this, as it depends on the design of the model. In stationary models the base usually should be built first. In most of the smaller models a  $5\frac{1}{2}'' \times 2\frac{1}{2}''$  Flanged Plate forms an important part of the structure, and often the best plan is to start building by bolting parts to this Plate. For other models a good general rule is that the sections that form supports for a number of other parts should be built first.

Flexible Plates are sometimes used for forming curved surfaces in models, but they are not intended to be bent at right angles. With careful handling a Plate can be bent to the required curve and after use straightened again.

All Outfits from No. 2 upward include a Cord Anchoring Spring, Part No. 176. This part provides a neat and positive method of fastening a length of Cord to a Rod. When pushing the Spring on to a Rod or Crank Handle, turn left so that its coils tend to unwind; turn it in the same direction when pulling it off the Rod.

## THE IMPORTANCE OF "LOCK-NUTTING"

In some models it is necessary to join certain parts together so that, although they cannot come apart, they are free to pivot or move in relation to one another. To do this the parts are bolted together as usual but the nut is not screwed up tightly, so that the parts are not gripped. Then, to prevent the nut from unscrewing, a second nut is screwed up tightly against it, the first nut being held with a spanner. This method of using a second nut is known as **Lock-nutting**.

A Rod is usually mounted in a support or bearing, such as a hole in a strip, so that it is free to revolve. The Rod is then said to be **journalled** in the Strip.

During the construction of a model it is best to screw up the nuts with the fingers, followed by just a light turn with the screwdriver, leaving the final tightening with spanner and screwdriver until all the parts are connected up.

## DRIVING YOUR MODELS

Models can be driven by means of either clockwork or electric motors.

Small and light models may be driven direct from the driving pulley of the motor or through a belt running over two pulleys of the same size, giving what is known as a 1 : 1 (one-to-one) ratio. For large models it is necessary to take the drive from a small pulley on the motor shaft to a larger pulley on the driving shaft of the model. In most cases a 1" Pulley on the motor shaft and a 3" Pulley on the model shaft will be found satisfactory. This provides a reduction ratio of approximately 3 : 1.

Rubber bands are very convenient for driving belts. Sometimes, however, a rubber band of the right length is not available, and then Meccano Cord or thin string is used. To tie the Cord to form an endless belt, use the familiar reef knot.

With the larger Outfits, belt drive can be replaced with advantage by gearing. To operate a slow-moving model demanding great power, such as a traction engine, gears that will provide a considerable reduction must be used. For example, a Worm meshed with a  $\frac{1}{2}''$  Pinion will give a 19 : 1 reduction; a Worm meshed with a 57-teeth Gear will give a 57 : 1 reduction.

All the models in this Book were built up and tested in our model-building department. Some of them are shown fitted with a motor, and provided that they are properly constructed the motor will drive them satisfactorily.

If the motor is to operate successfully however, there must be no excessive friction in the mechanism of the model. This can be caused by shafts and their bearings being slightly out of line, or by a belt or Cord drive being too tight. Before condemning the motor therefore, first make sure that every revolving shaft moves quite freely in its bearings, and that the bearings are in line with one another. The bearings can be brought into line by pushing through them a Drift (Part No. 36c) or a Rod, before the bolts holding the various parts are tightened up. To make the running perfectly smooth, apply a little light machine oil to every bearing or pivot on which moving parts are mounted.

The models included in this Book give a good idea of the various types of Meccano construction, and provide a guide to the building of a large number of other models with this outfit. If any difficulty should arise in planning a new model, write to Meccano Limited, Binns Road, Liverpool 13, and every possible assistance will be given.

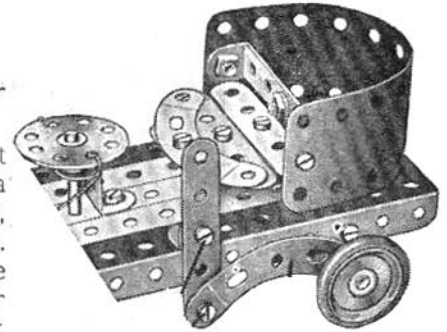

*A Flexible Plate used to form a curved surface.*

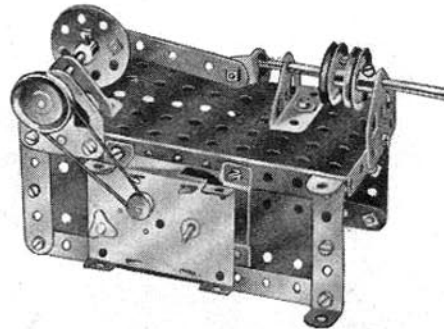

*A Magic Motor fitted to drive a Steam Engine.*

## 1.1 FLYING BOATS

Parts required

4 of No.	2
4 "	5
4 "	12
1 "	16
1 "	19s
4 "	22
1 "	24
3 "	35
24 "	37
1 "	38
1 "	40
2 "	48a
1 "	52
2 "	90a
1 "	125
2 "	126
2 "	126a
2 "	189

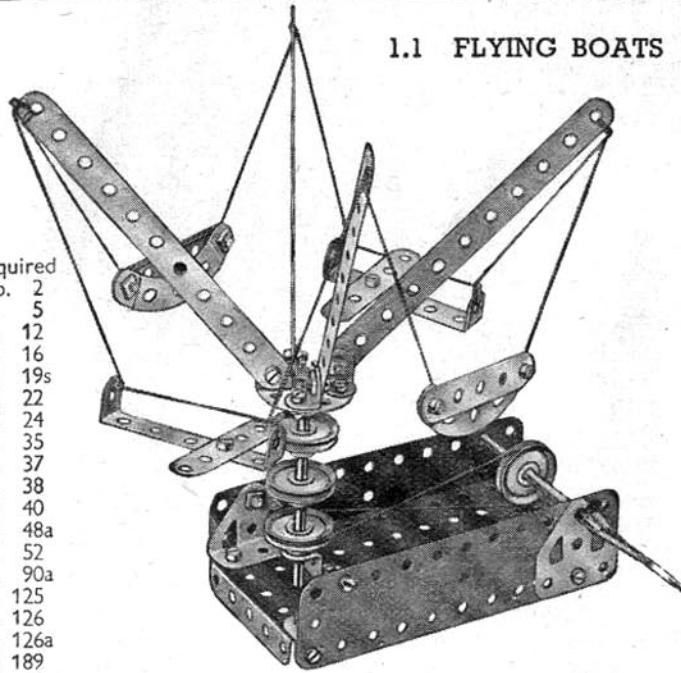

## 1.2 DRILL

## Parts required

4 of No.	2	4 of No.	35
3 "	5	20 "	37
8 "	12	4 "	38
1 "	16	1 "	40
1 "	17	1 "	52
1 "	19s	2 "	126
4 "	22	2 "	126a

The drill table is made by bolting together two Flat Trunnions.

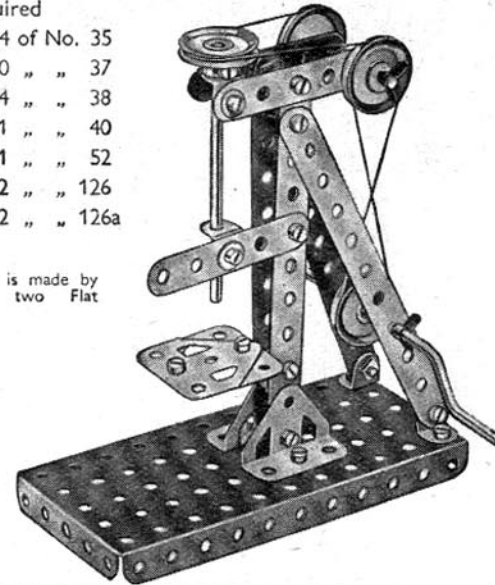

## 1.3 SCALES

## Parts required

4 of No.	2
2 "	5
2 "	17
2 "	22
1 "	24
19 "	37
1 "	38
1 "	40
2 "	48a
1 "	52
2 "	90a
1 "	111c
2 "	126
2 "	126a
1 "	155
2 "	189

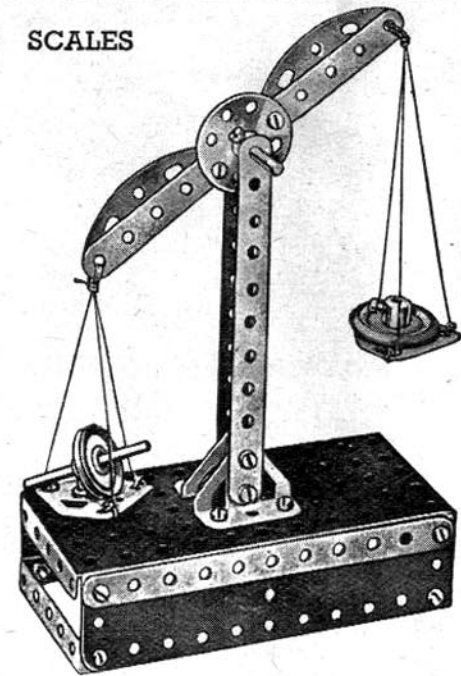

## 1.4 MOTOR LORRY

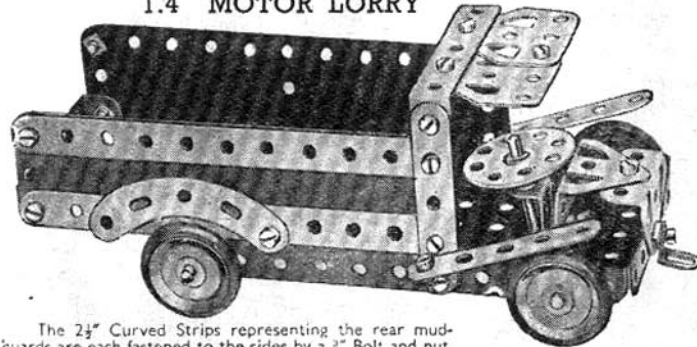

The  $2\frac{1}{2}$ " Curved Strips representing the rear mudguards are each fastened to the sides by a  $\frac{1}{4}$ " Bolt and nut, with a Spring Clip between the mudguards and the  $5\frac{1}{2}$ " Strip to form a distance piece.

## Parts required

4 of No.	2	1 of No.	17	19 of No.	37	2 of No.	90a	2 of No.	126a
4 "	5	4 "	22	4 "	37a	3 "	111c	4 "	155
3 "	12	1 "	24	2 "	48a	1 "	125	2 "	189
2 "	16	2 "	35	1 "	52	2 "	126		

## 1.5 RACING SEAPLANE

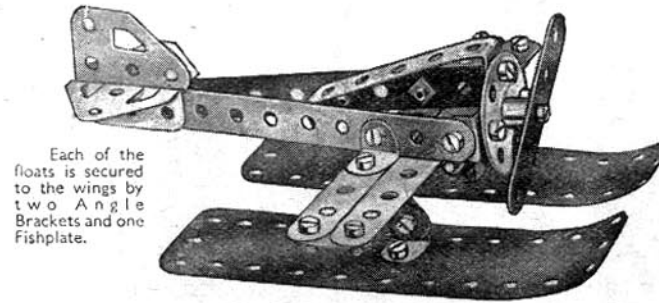

Each of the floats is secured to the wings by two Angle Brackets and one Fishplate.

## Parts required

3 of No.	2	1 of No.	24	2 of No.	111c
3 "	3	19 "	37	2 "	126
4 "	10	1 "	37a	1 "	126a
8 "	12	1 "	48a	2 "	189

## 1.6 KIDDE CAR

## Parts required

4 of No.	2
4 "	5
3 "	10
7 "	12
2 "	16
1 "	17
4 "	22
1 "	24
1 "	35
3 "	37
3 "	37a
2 "	48a
1 "	52
2 "	90a
2 "	111c
1 "	125
2 "	126
1 "	126a
4 "	155
2 "	189

Two Trunnions overlapped one hole, and fastened to the Flanged Plate by an Angle Bracket form the seat.

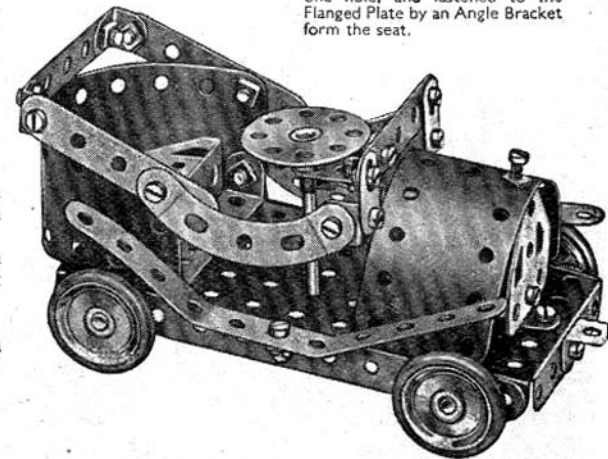

### 2.1 MOTOR VAN

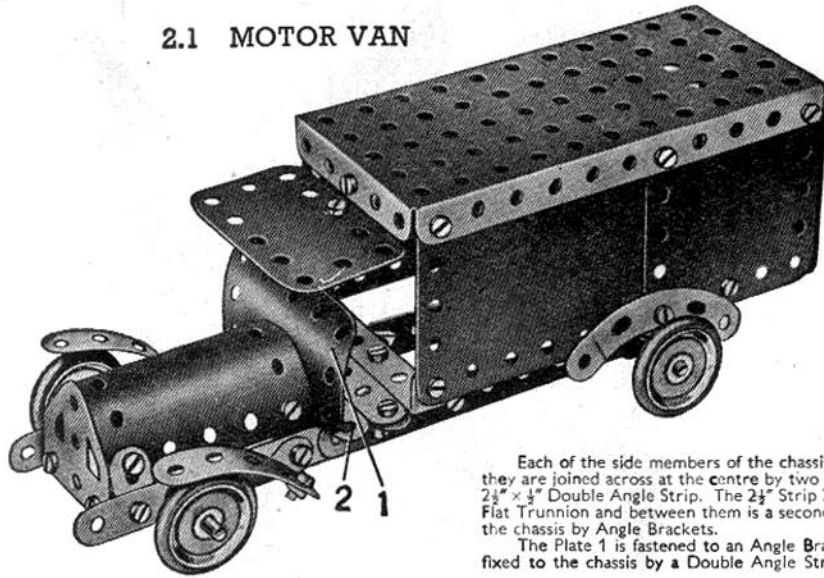

#### Parts required

4 of No. 2	1 of No. 25
4 " " 5	2 " " 90a
4 " " 10	1 " " 126
8 " " 12	2 " " 126a
2 " " 16	4 " " 155
4 " " 22	2 " " 188
4 " " 35	2 " " 189
40 " " 37	2 " " 190
4 " " 38	1 " " 191
2 " " 48a	1 " " 199

Each of the side members of the chassis consists of two  $5\frac{1}{2}$ " Strips overlapped, and they are joined across at the centre by two  $2\frac{1}{2}$ " Strips, one of which is shown at 2, and a  $2\frac{1}{2}$ " x  $\frac{1}{2}$ " Double Angle Strip. The  $2\frac{1}{2}$ " Strip 2 and the Double Angle Strip are bolted to a Flat Trunnion and between them is a second  $2\frac{1}{2}$ " Strip, which is fastened at each end to the chassis by Angle Brackets.

The Plate 1 is fastened to an Angle Bracket that is bolted to Strip 2. The body is fixed to the chassis by a Double Angle Strip and an Angle Bracket.

### 2.2 SPEED CAR

A  $5\frac{1}{2}$ " x  $2\frac{1}{2}$ " Flanged Plate, extended at the front by a  $1\frac{1}{2}$ " radius Curved Plate and at the rear by two  $2\frac{1}{2}$ " x  $2\frac{1}{2}$ " Flexible Plates, forms the top of the car. The rear part of each side is formed by two  $5\frac{1}{2}$ " Strips and a  $2\frac{1}{2}$ " Strip, the former being connected together at the tail by Angle Brackets. Bolts 1 on each side hold a  $2\frac{1}{2}$ " x  $\frac{1}{2}$ " Double Angle Strip that carries the  $1\frac{1}{2}$ " radius Curved Plate forming the underside of the front cowling.

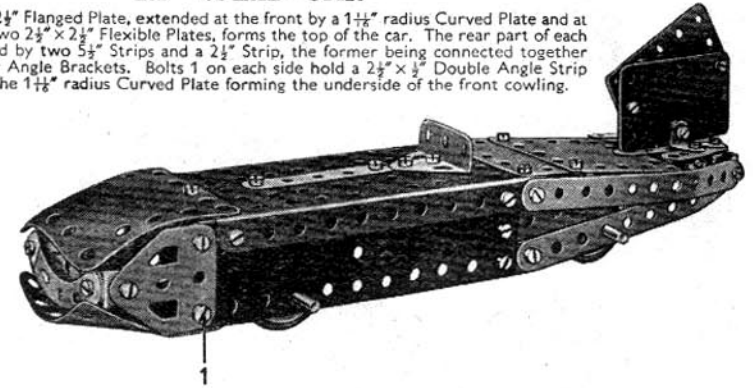

#### Parts required

4 of No. 2	4 of No. 22	1 of No. 52	2 of No. 188
6 " " 5	38 " " 37	2 " " 90a	2 " " 189
2 " " 10	1 " " 37a	1 " " 126	2 " " 190
4 " " 12	4 " " 38	2 " " 126a	2 " " 200
2 " " 16	2 " " 48a	4 " " 155	

#### Parts required

4 of No. 2
6 " " 5
4 " " 10
6 " " 12
1 " " 16
1 " " 19g
4 " " 22
1 " " 24

### 2.3 CANAL BRIDGE

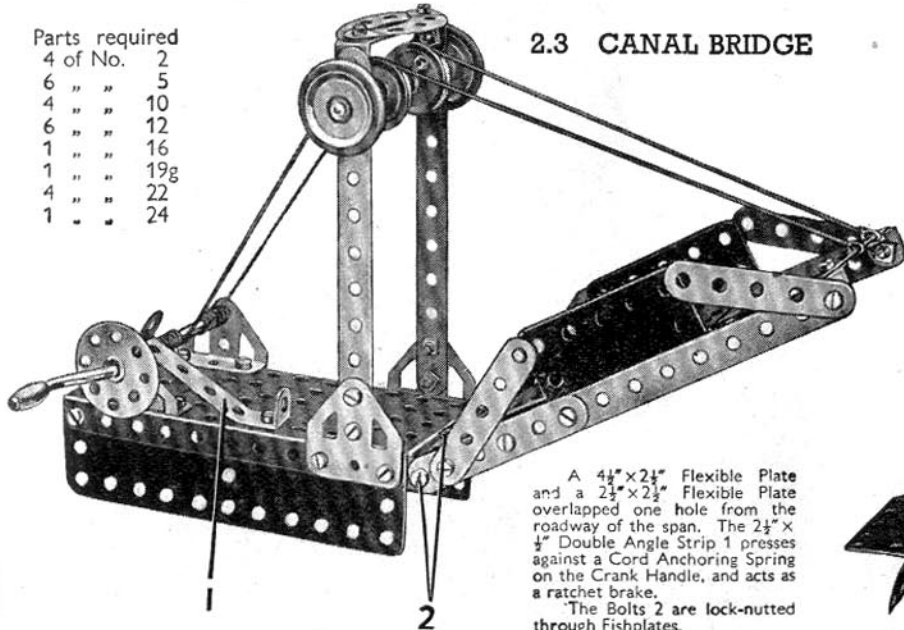

#### Parts required (continued)

39 of No. 37
2 " " 37a
2 " " 38
2 " " 48a
1 " " 52
1 " " 90a
2 " " 126
2 " " 126a
2 " " 155
1 " " 176
2 " " 188
2 " " 189
2 " " 190
1 " " 191
1 " " 199
1 " " 200

A  $4\frac{1}{2}$ " x  $2\frac{1}{2}$ " Flexible Plate and a  $2\frac{1}{2}$ " x  $2\frac{1}{2}$ " Flexible Plate overlapped one hole from the roadway of the span. The  $2\frac{1}{2}$ " x  $\frac{1}{2}$ " Double Angle Strip 1 presses against a Cord Anchoring Spring on the Crank Handle, and acts as a ratchet brake.

The Bolts 2 are lock-nutted through Fishplates.



### 2.4 DRILLING MACHINE

The horizontal  $2\frac{1}{2}$ " Strips at the top of the drill are joined together, and also the vertical  $2\frac{1}{2}$ " Strips, by means of Angle Brackets. The lower bearings 1 are two Angle Brackets attached to a  $2\frac{1}{2}$ " Strip, and the Rod forming the drill is journaled in these, and in a Fishplate at its upper end. A  $2\frac{1}{2}$ " x  $2\frac{1}{2}$ " Flexible Plate is supported by a Double Angle Strip 2, and represents the table.

The drive is taken from the Motor to the 1" Pulley on the lower shaft. A second Driving Band passes round the  $\frac{1}{2}$ " fixed Pulley supplied with the Motor, which is also fixed on the lower shaft, round the two Pulleys at 3, and finally round the 1" Pulley fastened on the vertical drill shaft.

#### Parts required

2 of No. 2	1 of No. 24	1 of No. 111c
5 " " 5	4 " " 35	2 " " 126
1 " " 10	22 " " 37	2 " " 126a
5 " " 12	2 " " 37a	1 " " 190
1 " " 16	1 " " 40	1 Magic Motor
2 " " 17	1 " " 48a	(Not included in Outfit)
4 " " 22	1 " " 52	

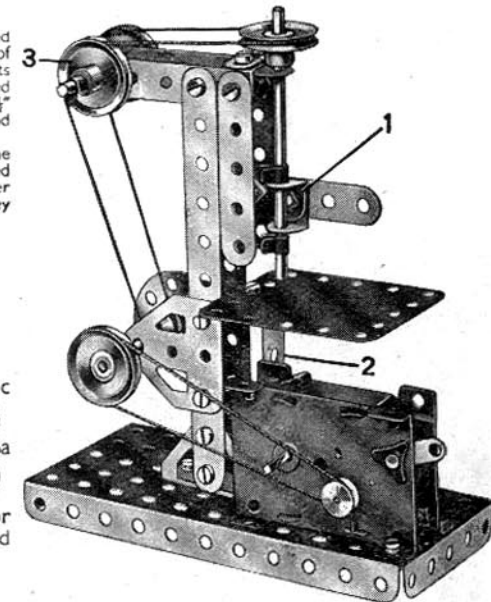

## 2.5 RAILWAY BREAKDOWN CRANE

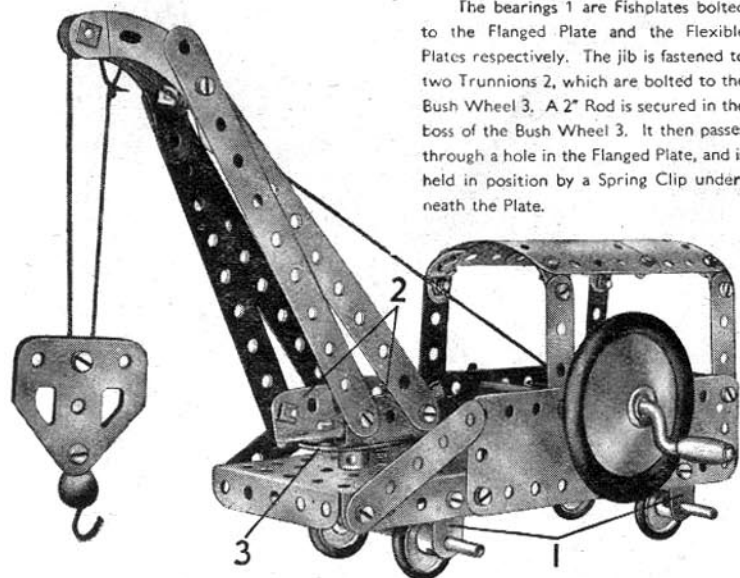

The bearings 1 are Fishplates bolted to the Flanged Plate and the Flexible Plates respectively. The jib is fastened to two Trunnions 2, which are bolted to the Bush Wheel 3. A 2" Rod is secured in the boss of the Bush Wheel 3. It then passes through a hole in the Flanged Plate, and is held in position by a Spring Clip underneath the Plate.

Parts required	
4 of No.	2
6 "	5
4 "	10
3 "	12
2 "	16
1 "	17
1 "	19g
4 "	22
1 "	24
2 "	35
39 "	37
3 "	37a
3 "	38
1 "	40
2 "	48a
1 "	52
1 "	57c
2 "	90a
3 "	111c
2 "	126
2 "	126a
1 "	155
1 "	176
1 "	187
1 "	188
2 "	189
1 "	190
2 "	200

## 2.6 FLOATING CRANE

The jib consists of 5 1/2" Strips and 2 1/2" Strips. At its upper end these are joined by Angle Brackets, and at its lower end by Trunnions. Each side of the lower part of the crane consists of 2 1/2" Strips and a small radius Curved Strip, the two sides being connected by a 2 1/2" x 1/2" Double Angle Strip. The jib is pivoted to this structure by means of a 3 1/2" Rod, which carries at each end a 1" Pulley. The Cord 1 fitted with a Loaded Hook, is passed over a 2" Rod held in place in the jib by means of Spring Clips and is then wound around the Crank Handle.

The Cord 2 passes over a Rod held in the jib by a Cord Anchoring Spring, and is then wound around the Rod that forms the pivot for the jib. A third Cord is tied to a Bolt fastened in the two Trunnions at the base of the jib, and is wound round Rod 3. This Cord controls the luffing motion of the crane. A 3/4" Bolt passes through the Flanged Plate and is held by a set screw in the boss of the Bush Wheel to which the jib is fastened. The Bush Wheel is bolted to the Double Angle Strip below the Rod 3. The roof of the cabin is bolted to a 1/2" Reversed Angle Bracket fixed to the Flanged Plate.

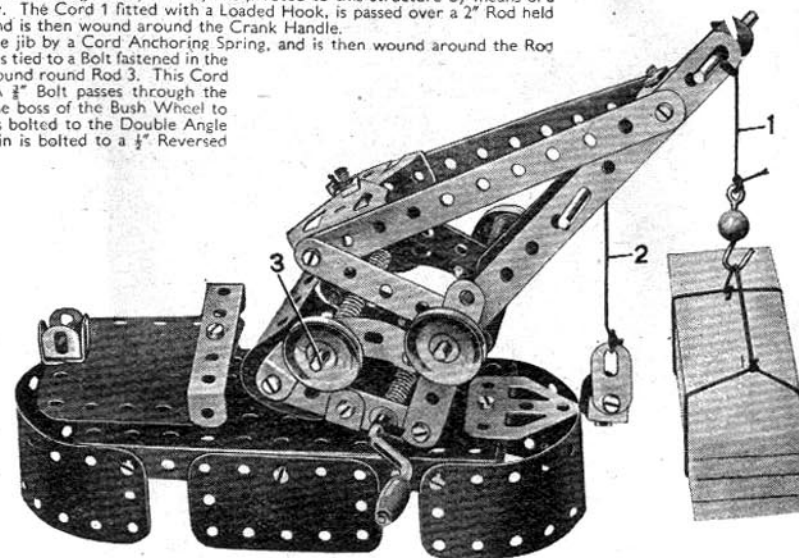

## Parts required

Parts required		Parts required	
4 of No.	2	2 of No.	48a
6 "	5	1 "	52
3 "	10	1 "	57c
8 "	12	2 "	90a
2 "	16	4 "	111c
2 "	17	1 "	125
1 "	19g	2 "	126
4 "	22	1 "	126a
1 "	24	1 "	176
4 "	35	2 "	188
29 "	37	2 "	189
4 "	37a	1 "	199
4 "	38	1 "	200
1 "	40		

## 2.7 RACING CAR

Parts required							
4 of No.	2	1 of No.	19g	2 of No.	38	1 of No.	126a
5 "	5	4 "	22	1 "	48a	4 "	155
4 "	10	4 "	35	2 "	90a	1 "	199
8 "	12	30 "	37	1 "	125	1 "	200
2 "	16	1 "	37a	1 "	126		

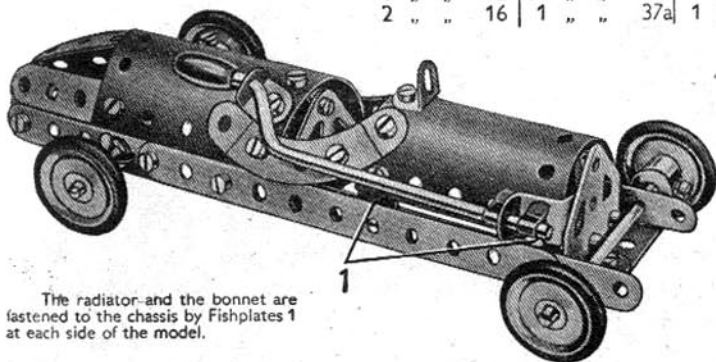

The radiator and the bonnet are fastened to the chassis by Fishplates 1 at each side of the model.

## 2.8 BACON SLICER

The base of the model consists of a Flanged Plate fitted with four 2 1/2" Strips for legs. Two 5 1/2" x 1 1/2" and two 2 1/2" x 1 1/2" Flexible Plates are bolted to the flanges of the Plate.

The guides for the sliding carriage 4 are formed by two 5 1/2" Strips attached to the Flanged Plate by Angle Brackets. The carriage consists of a 2 1/2" x 2 1/2" Flexible Plate 4 and is guided along the Strips by the Reversed Angle Bracket 1 and two Angle Brackets on the opposite side. The Angle Brackets are held in place by Bolts 5.

The cutting blade is represented by a Road Wheel fixed on a 3 1/2" Rod journaled in two Flat Trunnions. A Pulley on this Rod is connected by a belt of Cord to a second Pulley on the Crank Handle.

The carriage is moved backwards and forwards by a crank consisting of a Bush Wheel 6 fixed on a 2" Rod. This Rod is journaled in the Flanged Plate and in the centre hole of a Double Angle Strip fixed across the interior of the base by the Bolt 2 and another in a similar position on the opposite side. A 1" Pulley on the 2" Rod is connected by a crossed belt of Cord to a further 1" Pulley secured to the Crank Handle between the 5 1/2" Flexible Plates.

A guard for the rotating blade is provided by two Curved Strips attached to a 5 1/2" Strip 3. This Strip is fastened at one end to the Flanged Plate by a 2 1/2" Strip and a Fishplate 7, and at its other end it is attached to a 2 1/2" x 2 1/2" Flexible Plate bolted horizontally to the Flanged Plate.

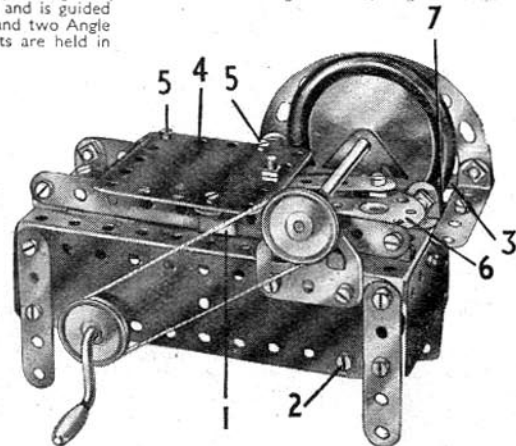

### 3.1 TOWER WAGON

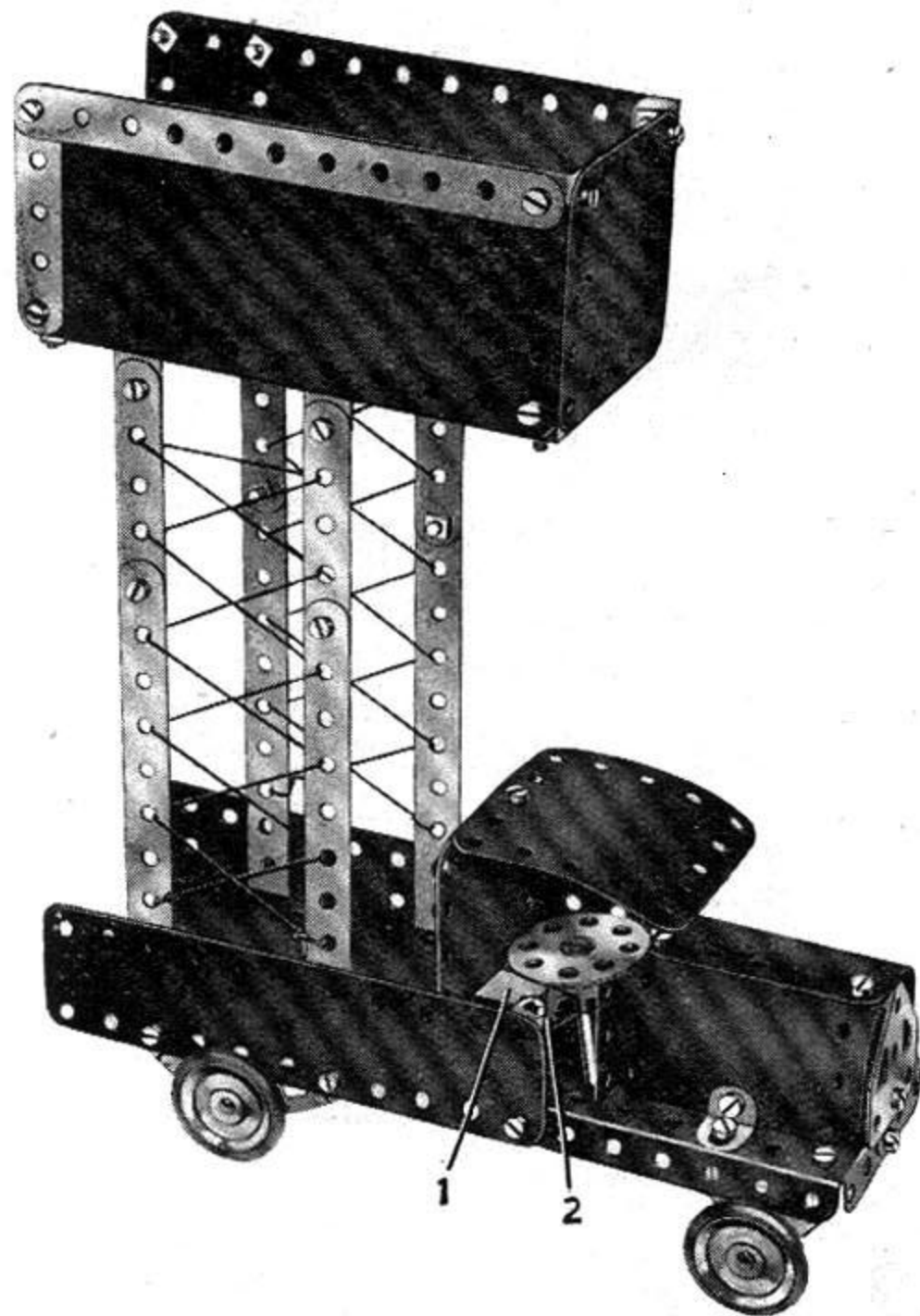

A Stepped Bent Strip 1 is bolted in a horizontal position in the centre of the Flanged Plate, and a  $2\frac{1}{2}$ " Curved Strip is bolted on top of it by the centre hole, to form a seat. A Reversed Angle Bracket 2 is then bolted in one of the elongated holes of the Curved Strip to form a bearing for the Rod carrying the Bush Wheel.

### 3.2 TANK

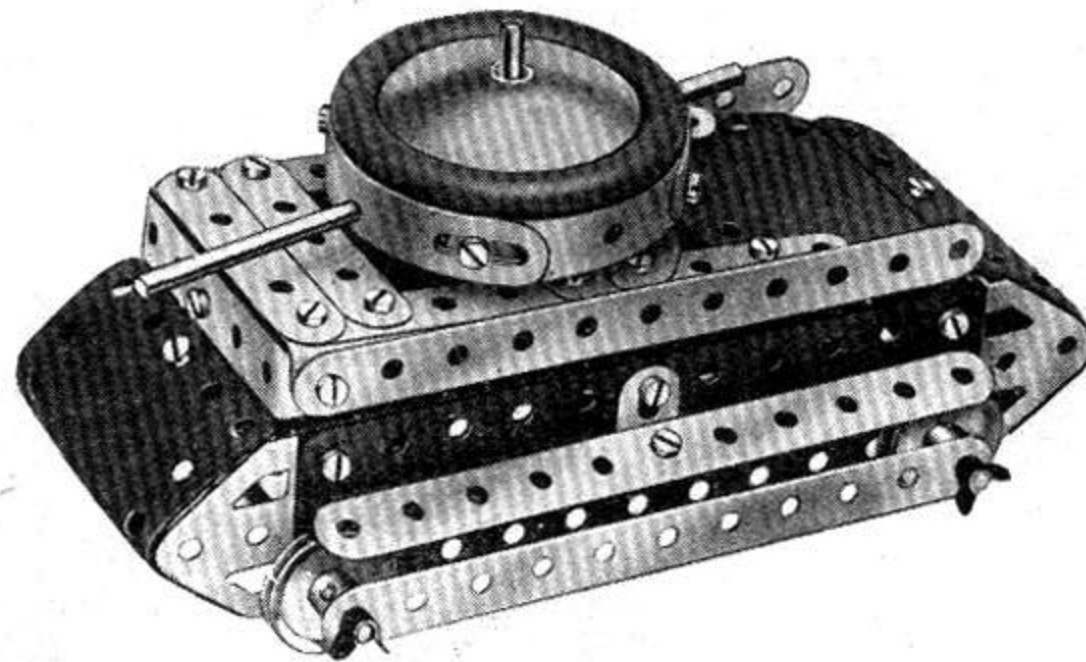

Construction of the gun turret is commenced by bolting a  $2\frac{1}{2}$ " Strip across a Bush Wheel. Four 3" Formed Slotted Strips are bolted together to form a circle and fastened to the  $2\frac{1}{2}$ " Strip by means of Angle Brackets. Next two Angle Brackets are bolted to the Bush Wheel in the positions shown in Fig. 3.2a. Two Rods are pushed through holes in the Formed Slotted Strips and through the free holes of the Angle Brackets, and are fastened in position by means of Spring Clips. The turret is held in place by a  $3\frac{1}{2}$ " Rod that is locked in the boss of the Bush Wheel and then passed through the  $5\frac{1}{2}$ " x  $2\frac{1}{2}$ " Flanged Plate and through a hole in a Reversed Angle Bracket. A Cord Anchoring Spring is then screwed on to it to hold it in position. To complete the turret a Road Wheel is fastened on the upper end of the  $3\frac{1}{2}$ " Rod. The Reversed Angle Bracket is bolted to the  $5\frac{1}{2}$ " x  $2\frac{1}{2}$ " Flanged Plate.

The *Magic Motor* is bolted to the Flanged Plate, and the drive is taken to the back axle by means of a Driving Band.

*Note:* The Motor used in this model is not included in the Outfit.

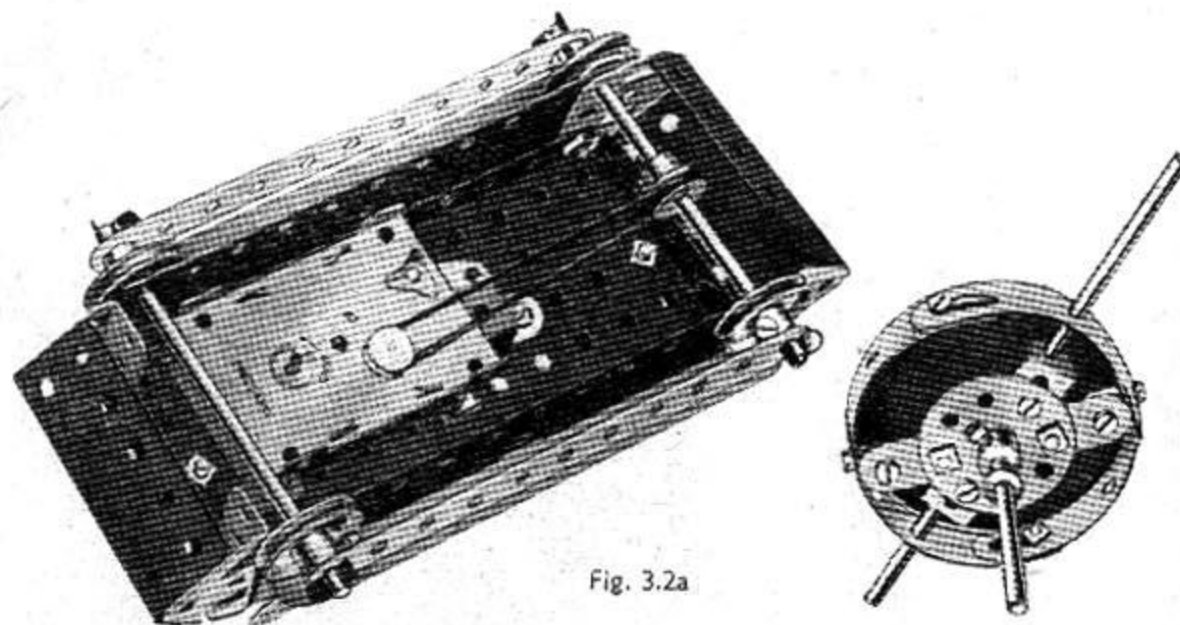

Fig. 3.2a

### 3.3 PORTABLE GARAGE CRANE

A Flanged Plate 1 is extended on each side by  $5\frac{1}{2}$ " Strips 2. The Road Wheels are locked on a  $3\frac{1}{2}$ " Rod supported in  $2\frac{1}{2}$ " Curved Strips 3 on each side of the model. The 1" Pulleys rotate on  $\frac{3}{8}$ " Bolts passed through Flat Trunnions.

The jib is built up from two  $12\frac{1}{2}$ " Strips bolted to the sides of the Flanged Plate and extended at their upper ends by Curved Strips. It is held rigid by  $5\frac{1}{2}$ " Strips fixed to the Flanged Plate and also to Semi-Circular Plates fastened to the  $12\frac{1}{2}$ " Strips.

The handle used for hauling and manoeuvring the crane truck is represented by the  $3\frac{1}{2}$ " Rod 4, fitted with a Bush Wheel to which a  $2\frac{1}{2}$ " Strip is bolted. The other end of the rod carries a Rod and Strip Connector that pivots on a Bolt between two Trunnions bolted to the Double Angle Strip 5.

The hoisting Cord is tied to a Cord Anchoring Spring on the Crank Handle and then passed over a 1" Pulley at the jib head. It passes around a  $\frac{1}{2}$ " Pulley in the pulley block and is then tied to one of the Curved Strips. The pulley block consists of a  $\frac{1}{2}$ " Pulley held between two Fishplates on a  $\frac{3}{8}$ " Bolt fitted with lock-nuts.

The brake is a belt of Cord, which is passed around a 1" Pulley on the Crank Handle and then fastened to a weighted compound strip 6. This strip is made up from two  $2\frac{1}{2}$ " Strips bolted together, and to its outer end two Wheel Discs are attached. The other end of the Strip is pivoted on a  $\frac{3}{8}$ " Bolt 7. The Bolt is fitted with lock-nuts.

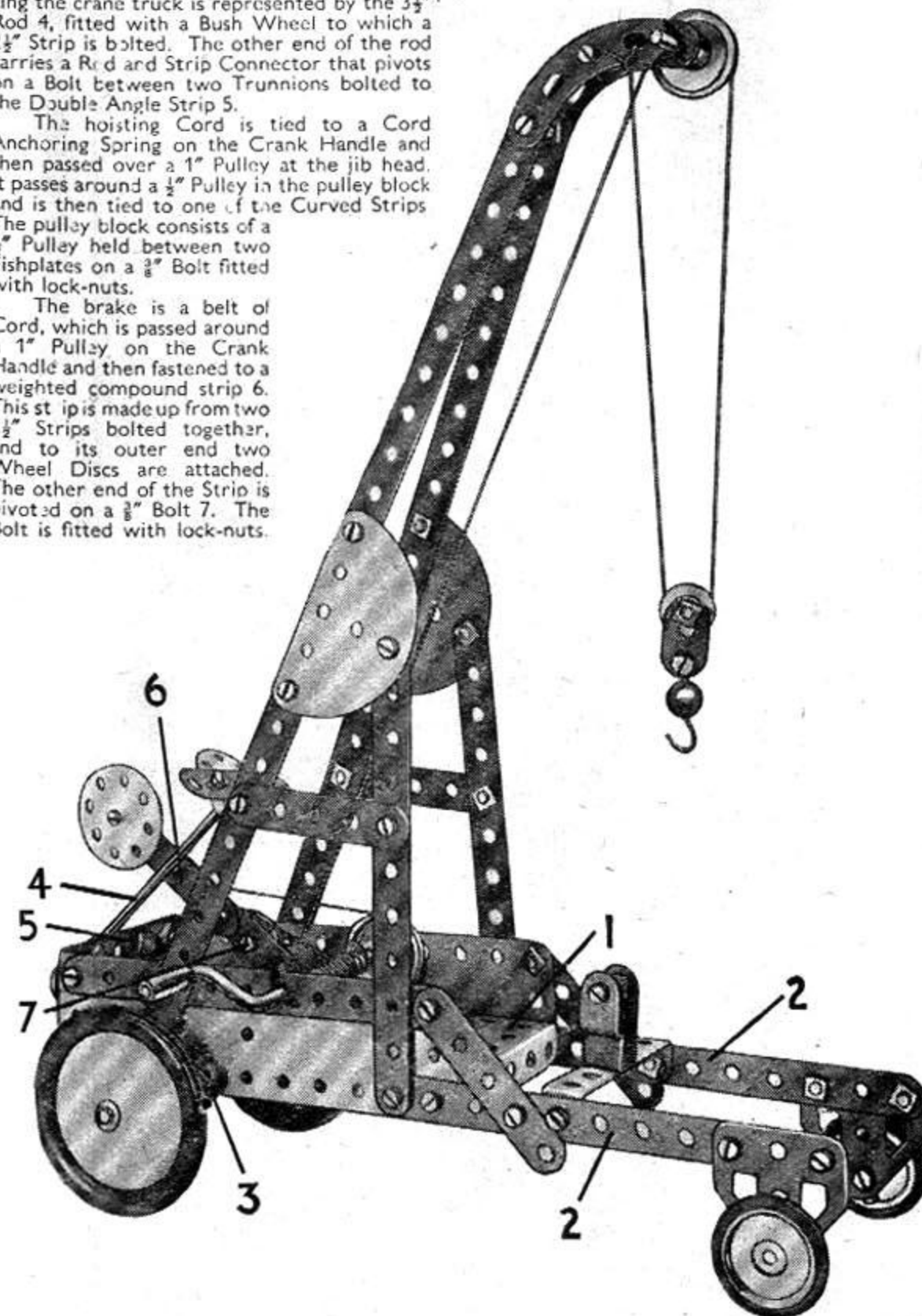

## 3.4 HORSE AND CART

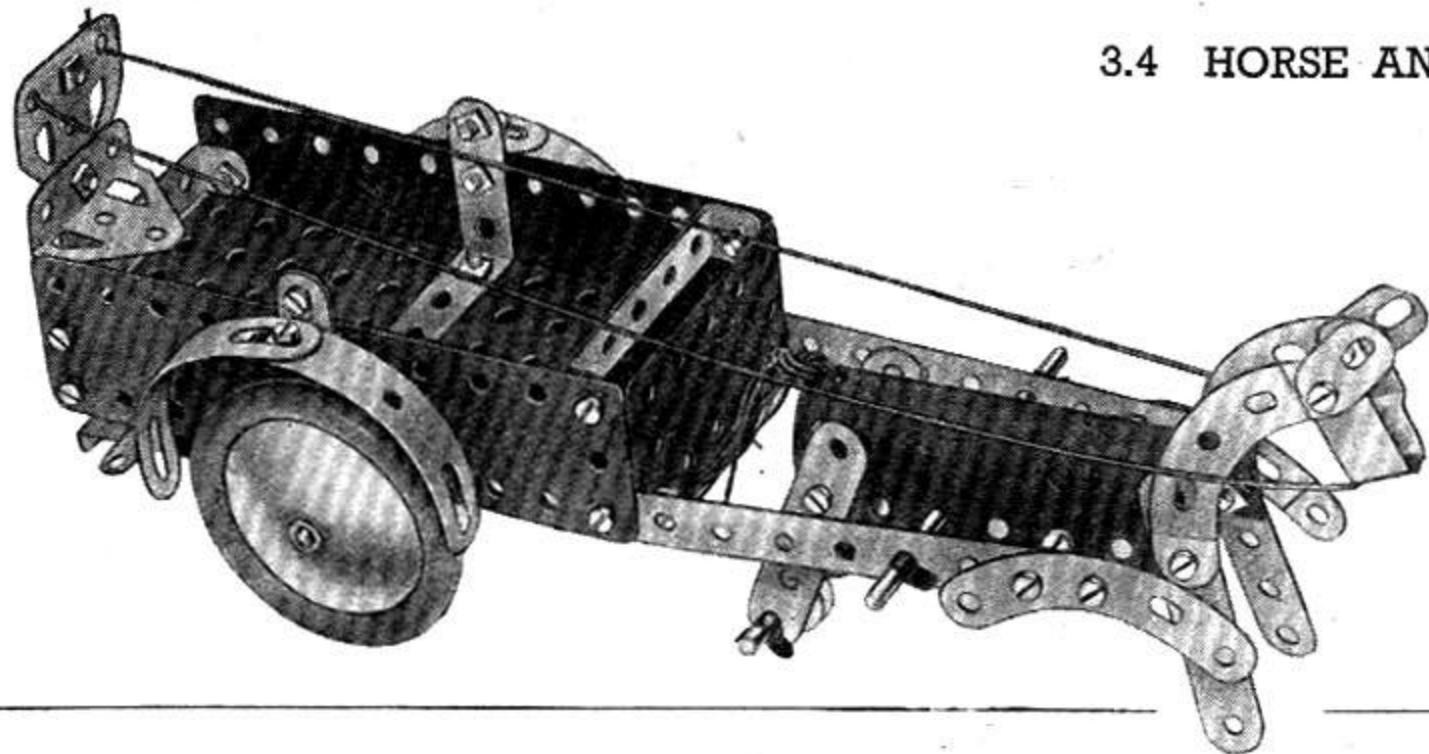

The model is driven by a *Magic* Motor fastened underneath the  $5\frac{1}{2}'' \times 2\frac{1}{2}''$  Flanged Plate that forms the bottom of the cart. The drive is taken by a Driving Band from the pulley of the Motor to a  $\frac{1}{2}''$  fast Pulley on the back axle. A  $\frac{1}{2}''$  loose Pulley is fitted on a 2'' Rod journalled in the bottom holes of the Strips forming the hind-legs of the horse, so that the model will travel smoothly along the ground.

*Note:* The Motor used in this model is not included in the Outfit.

3.5  
BLOCK-SETTING  
CRANE

The travelling bogie 1 consists of two Fishplates bolted together by their elongated holes, and at each end of it Double Brackets are fastened by  $\frac{3}{8}''$  Bolts. Two 2'' Rods are pushed through the Double Brackets and carry 1'' fast Pulleys spaced so that their grooves fit on the two  $12\frac{1}{2}''$  Strips that form the top of the jib. The Trunnions 2 at the base of the jib are secured to a Bush Wheel mounted on a Rod held in the bosses

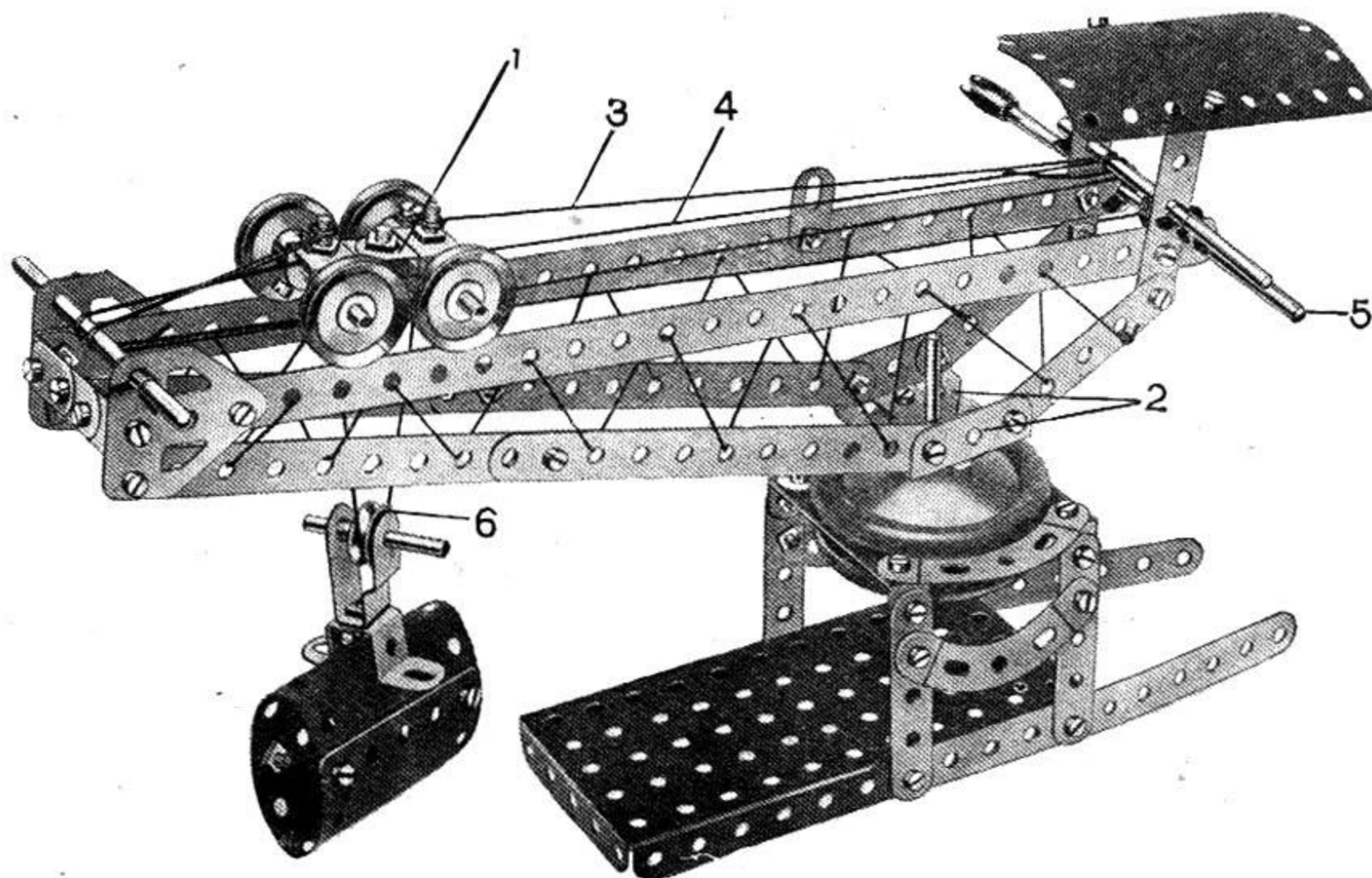

of two Road Wheels. The Road Wheels are placed one above and one below the  $2\frac{1}{2}'' \times 1\frac{1}{2}''$  Flexible Plates that form the top of the tower.

Cord 3 is first fastened to the  $\frac{3}{8}''$  Bolt at the rear end of the travelling bogie, and then wound three times around the Crank Handle. It is then led around the Rod journalled in the Flat Trunnions at the front end of the jib and brought back and tied to another  $\frac{3}{8}''$  Bolt at the front of the bogie.

Cord 4 is first fastened to Rod 5, which is passed through the end holes of the  $12\frac{1}{2}''$  Strips, and then over the rear axle of the bogie. It is then passed around the  $\frac{1}{2}''$  Pulley 6, led over the front axle of the bogie, around the Rod at the front end of the jib, and finally tied to the bogie. The  $\frac{1}{2}''$  Loose Pulley 6 and its Rod are held in the Stepped Bent Strip by a Cord Anchoring Spring.

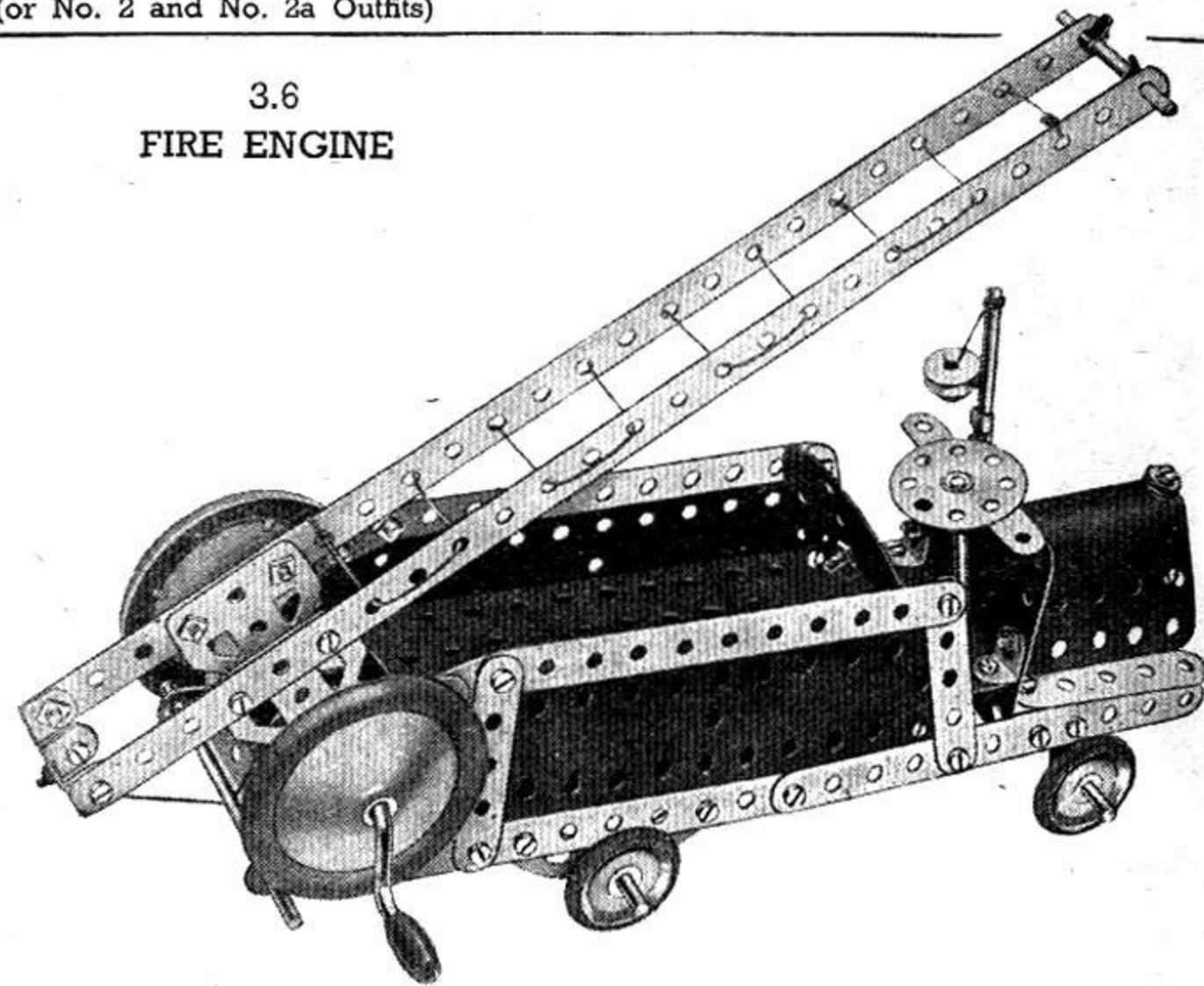
3.6  
FIRE ENGINE

Two Flat Trunnions are bolted to the bottom of the ladder, and the shaft of the Crank Handle shown in Fig. 3.6a passes through the holes at their narrow ends. The bonnet, which is formed from a U-Section Curved Plate and two  $2\frac{1}{2}'' \times 1\frac{1}{2}''$  Flexible Plates, is fastened to the frame by Reversed Angle Brackets. These latter also support the  $2\frac{1}{2}''$  Strips at the sides of the bonnet.

The  $3\frac{1}{2}''$  Rod representing the steering column passes through the free hole of a Fishplate bolted to the dashboard, then through a hole in the Flexible Plate at the bottom of the cab. It is fastened in position by a Cord Anchoring Spring.

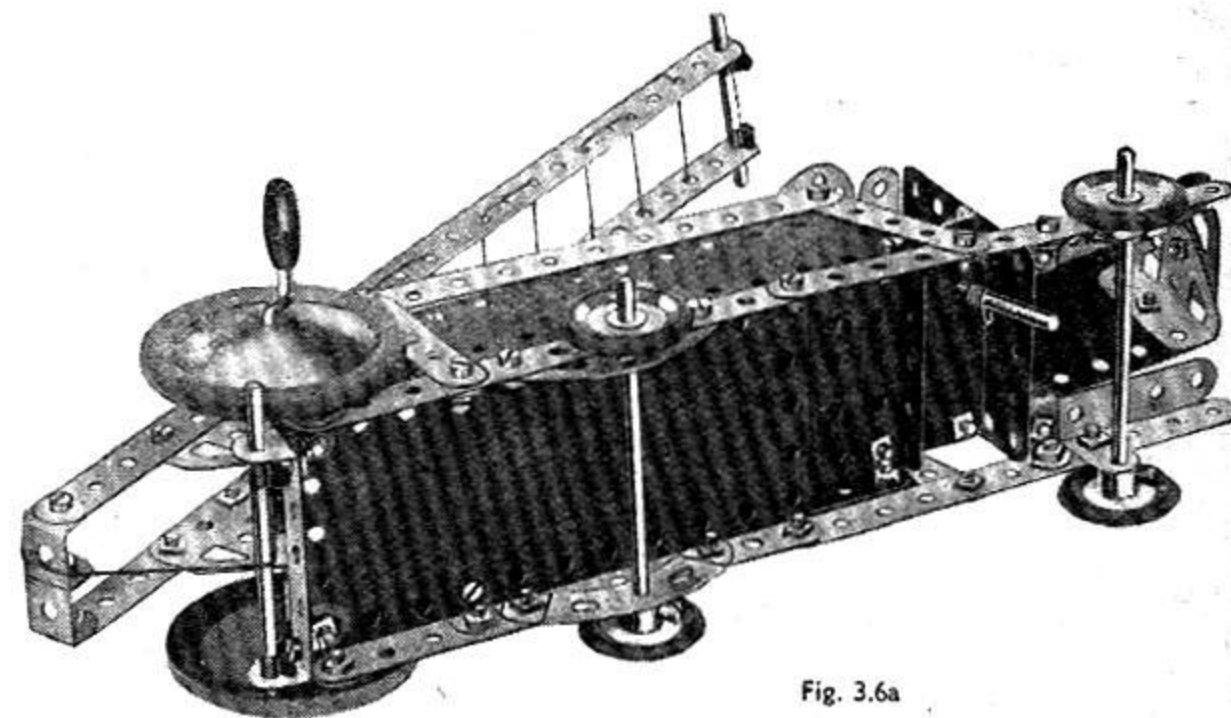

Fig. 3.6a



### 3.7 SIMPLE HAND LOOM

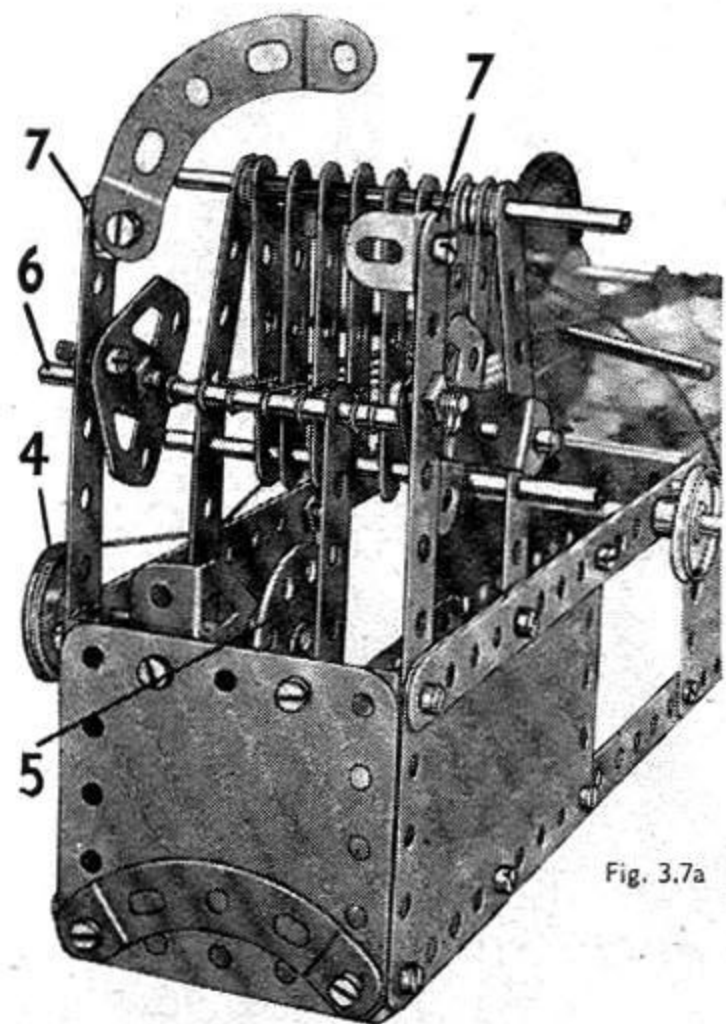
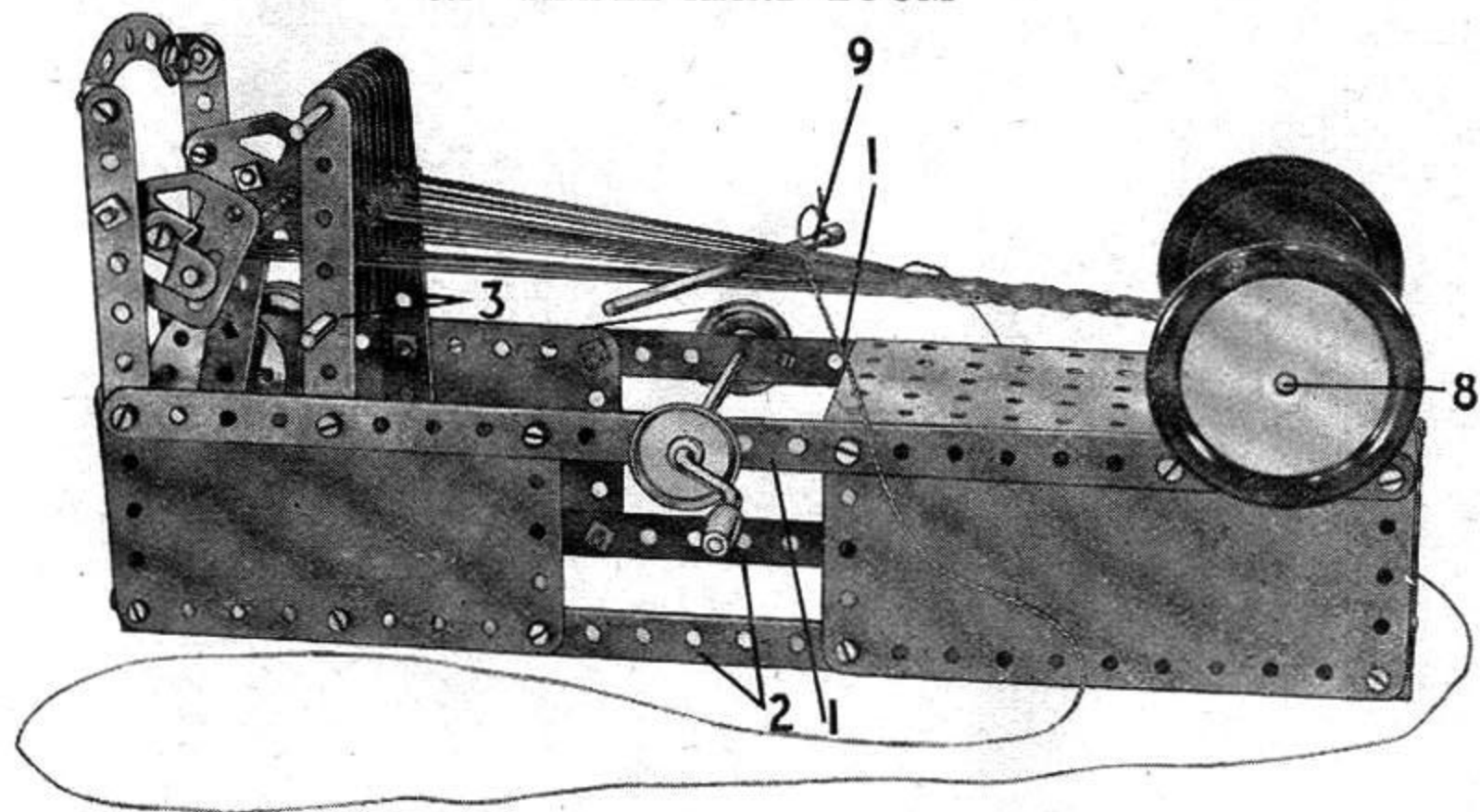

Fig. 3.7a

This interesting model is designed to demonstrate the principles of hand weaving. The base is formed by two 12 1/2" Strips 1 bolted to a Flanged Plate at one end and joined by a 2 1/2" x 1/2" Double Angle Strip at the other. Two 5 1/2" x 2 1/2" and two 4 1/2" x 2 1/2" Flexible Plates are bolted to the Strips and joined at their lower edges by the 5 1/2" Strips 2.

The 5 1/2" Strips 3 form a support for the heald frame, which consists of eight 2 1/2" Strips held by two 3 1/2" rods. The Strips are separated by Spring Clips and Washers as shown, these parts being placed between the Strips on the upper Rod.

The warp separating movement is operated from a Crank Handle. A 1" Pulley on this is connected by a belt of Cord to a similar Pulley 4, which is locked on a 2" Rod that carries also the Bush Wheel 5. A 2 1/2" Strip lock-nutted to the Bush Wheel links it with the Rod 6. This Rod is mounted in two Flat Trunnions, each fitted with a Reversed Angle Bracket. The Trunnions are free to turn on the shanks of 3/8" Bolts fastened in the Strips 7.

A 4" Rod 8 fitted with two Road Wheels passes through two Semi-Circular Plates bolted to the sides of the Flanged Plates.

A length of Cord taken from each of the 2 1/2" Strips forming the healds is tied to the Rod 8. A second set of similar Cords is taken from the Rod 8. Each of these Cords passes between the healds and is fastened to Rod 6.

To operate the model the two sets of warp threads are separated by turning the Crank Handle slightly. A length of Cord is then passed between the layers by means of the 3 1/2" Rod 9. The Crank Handle is then again turned slightly, thus changing the positions of the warp layers, and the Rod 9 is again passed through.

Cord is used in the illustrations to show the positions of the threads more clearly, but in actual operation it is better to use wool as this will give a closer and finer texture to the woven material.

### 3.8 MARINE ENGINE

Bolts 1 are lock-nutted. The Bolts 3 are 3/8" long and are lock-nutted twice as shown. The 2 1/2" Strips 4 must be quite free to move when the crankshaft is rotated.

The piston rod is held by two Spring Clips, one at each side of the Angle Bracket pivotally fastened by one of the Bolts 1. Inside the cylinder the Rods slide through holes in a 2 1/2" Strip and a Trunnion 2. In order to show the construction clearly, part of the cylinder has been cut away in the illustration.

The rod carrying two 1" Pulleys passes through the centre hole in the outer Wheel Disc. A 1/2" x 1/2" Angle Bracket is bolted to the Disc in such a position that when the Disc is turned the Angle Bracket engages with a Spring Clip on the Rod. It is important that all nuts and bolts are made quite secure with the spanner and screw-driver.

The cylinder consists of two U-Section Curved Plates, and two 1 1/8" radius Curved Plates, the latter overlapping the U-Section Curved Plates by two holes at each side. The complete cylinder is attached to the Trunnion 2 by a 3/8" Bolt, but is spaced from it by four Washers placed on the shank of the Bolt. Bearings for the Rod forming the left-hand end of the crankshaft are provided by a Flat Trunnion and a Trunnion, and the right-hand end is supported in two 2 1/2" Strips. The Rod forming the propeller shaft is joined to the crankshaft by a Rod Connector.

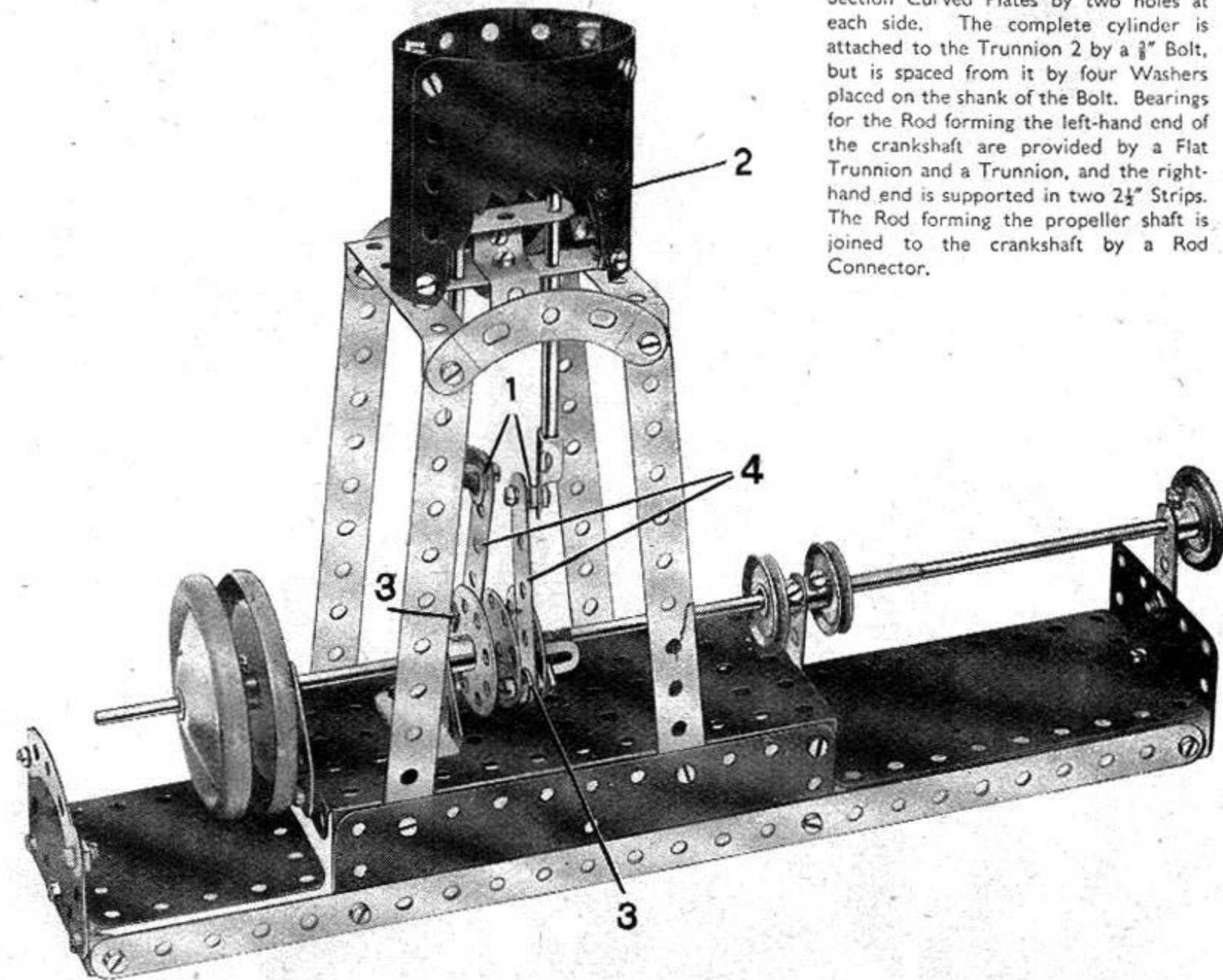

## 4.1 HAMMERHEAD CRANE

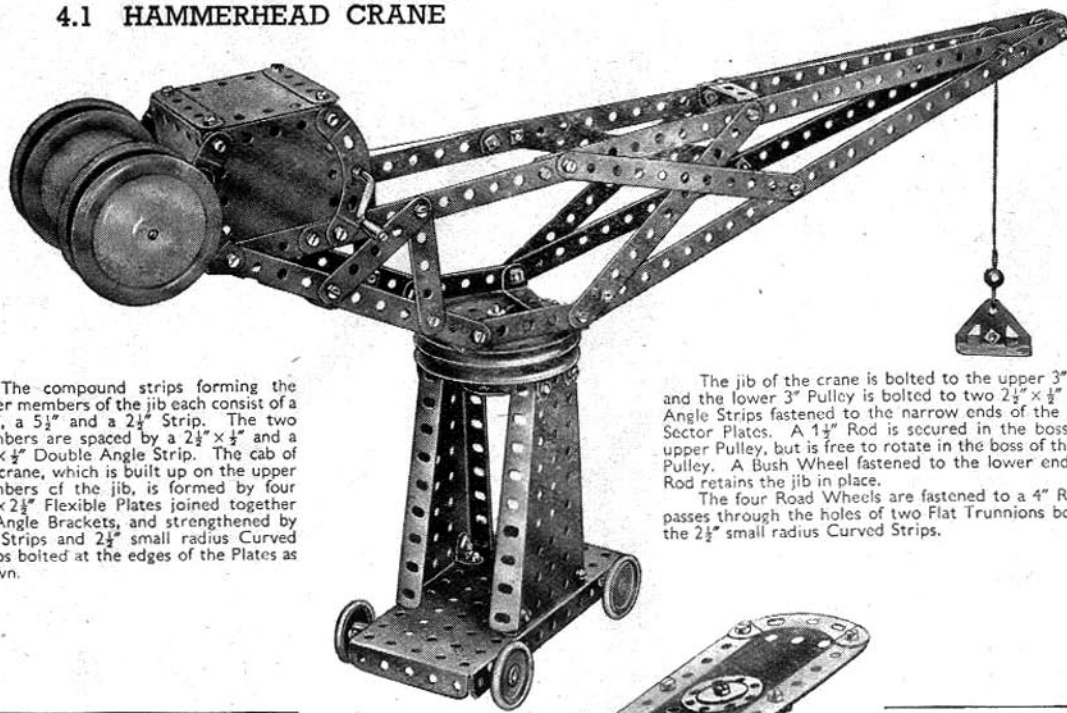

The compound strips forming the upper members of the jib each consist of a  $12\frac{1}{2}$ ", a  $5\frac{1}{2}$ " and a  $2\frac{1}{2}$ " Strip. The two members are spaced by a  $2\frac{1}{2}$ "  $\times$   $\frac{1}{2}$ " and a  $1\frac{1}{2}$ "  $\times$   $\frac{1}{2}$ " Double Angle Strip. The cab of the crane, which is built up on the upper members of the jib, is formed by four  $2\frac{1}{2}$ "  $\times$   $2\frac{1}{2}$ " Flexible Plates joined together by Angle Brackets, and strengthened by  $2\frac{1}{2}$ " Strips and  $2\frac{1}{2}$ " small radius Curved Strips bolted at the edges of the Plates as shown.

The jib of the crane is bolted to the upper 3" Pulley, and the lower 3" Pulley is bolted to two  $2\frac{1}{2}$ "  $\times$   $\frac{1}{2}$ " Double Angle Strips fastened to the narrow ends of the Flanged Sector Plates. A  $1\frac{1}{2}$ " Rod is secured in the boss of the upper Pulley, but is free to rotate in the boss of the lower Pulley. A Bush Wheel fastened to the lower end of the Rod retains the jib in place.

The four Road Wheels are fastened to a 4" Rod that passes through the holes of two Flat Trunnions bolted to the  $2\frac{1}{2}$ " small radius Curved Strips.

## 4.3 TELPHER SPAN

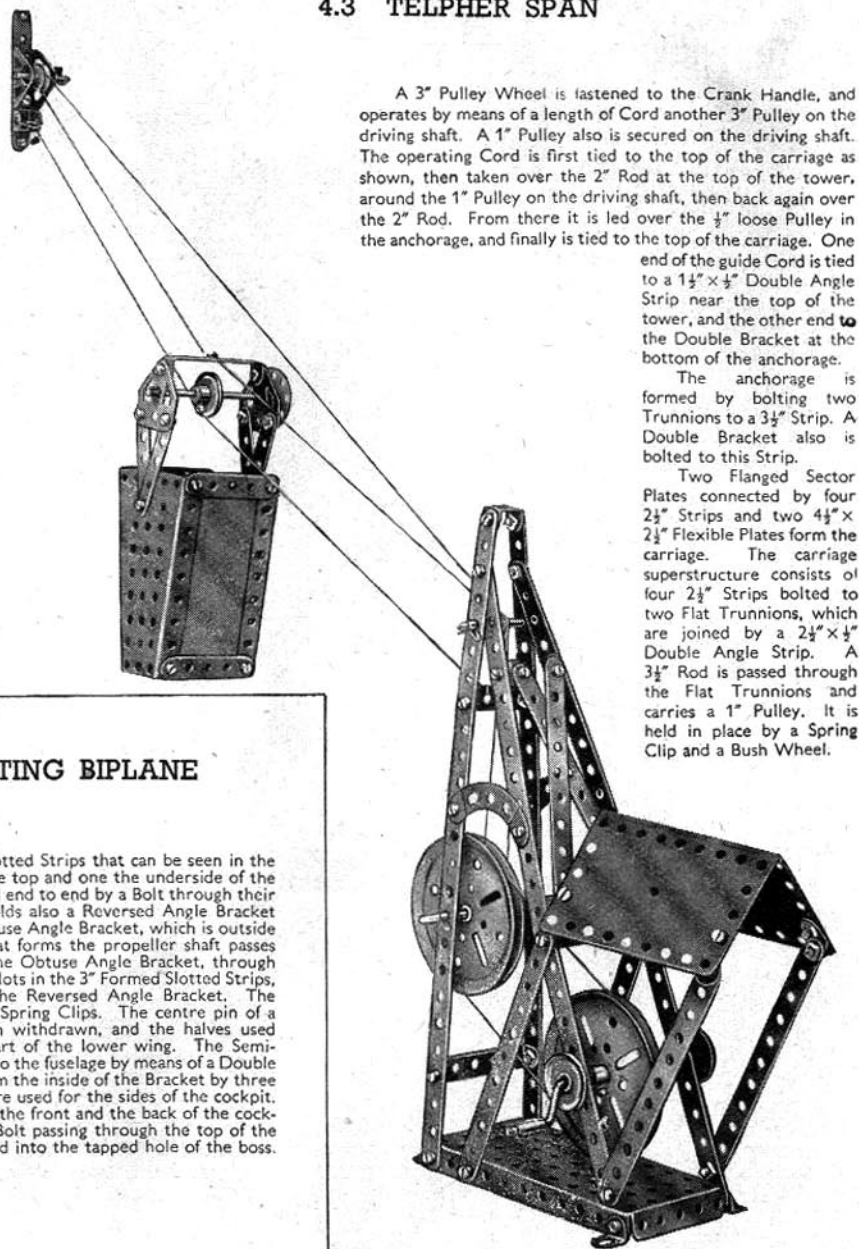

A 3" Pulley Wheel is fastened to the Crank Handle, and operates by means of a length of Cord another 3" Pulley on the driving shaft. A 1" Pulley also is secured on the driving shaft. The operating Cord is first tied to the top of the carriage as shown, then taken over the 2" Rod at the top of the tower, around the 1" Pulley on the driving shaft, then back again over the 2" Rod. From there it is led over the  $\frac{1}{2}$ " loose Pulley in the anchorage, and finally is tied to the top of the carriage. One end of the guide Cord is tied to a  $1\frac{1}{2}$ "  $\times$   $\frac{1}{2}$ " Double Angle Strip near the top of the tower, and the other end to the Double Bracket at the bottom of the anchorage.

The anchorage is formed by bolting two Trunnions to a  $3\frac{1}{2}$ " Strip. A Double Bracket also is bolted to this Strip.

Two Flanged Sector Plates connected by four  $2\frac{1}{2}$ " Strips and two  $4\frac{1}{2}$ "  $\times$   $2\frac{1}{2}$ " Flexible Plates form the carriage. The carriage superstructure consists of four  $2\frac{1}{2}$ " Strips bolted to two Flat Trunnions, which are joined by a  $2\frac{1}{2}$ "  $\times$   $\frac{1}{2}$ " Double Angle Strip. A  $3\frac{1}{2}$ " Rod is passed through the Flat Trunnions and carries a 1" Pulley. It is held in place by a Spring Clip and a Bush Wheel.

## 4.2 FIGHTING BIPLANE

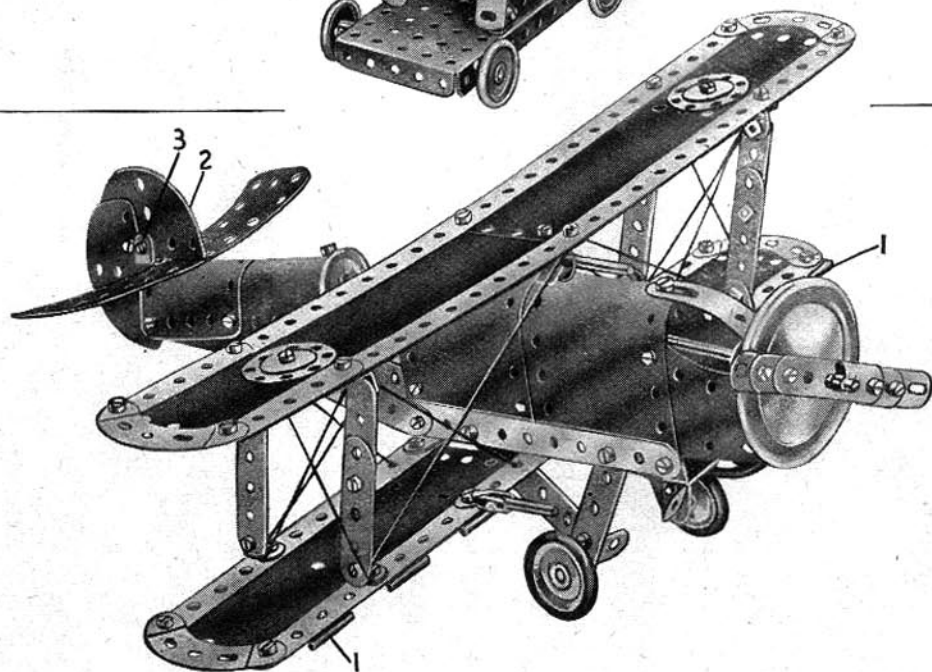

The two 3" Formed Slotted Strips that can be seen in the illustration, one forming the top and one the underside of the nose of the plane, are joined end to end by a Bolt through their slotted holes. The Bolt holds also a Reversed Angle Bracket inside the nose, and an Obtuse Angle Bracket, which is outside the nose. The  $3\frac{1}{2}$ " Rod that forms the propeller shaft passes through the free hole of the Obtuse Angle Bracket, through the unoccupied part of the slots in the 3" Formed Slotted Strips, and through the hole of the Reversed Angle Bracket. The Rod is held in position by Spring Clips. The centre pin of a Hinged Flat Plate has been withdrawn, and the halves used as flat plates 1, to form part of the lower wing. The Semi-Circular Plate 2 is fastened to the fuselage by means of a Double Bracket 3, and is spaced from the inside of the Bracket by three Washers. Flat Trunnions are used for the sides of the cockpit. The 1" fast Pulleys forming the front and the back of the cockpit are each fastened by a Bolt passing through the top of the U-Section Curved Plates and into the tapped hole of the boss.

### 4.4 MOTOR CYCLE AND SIDECAR

The  $5\frac{1}{2} \times 1\frac{1}{2}$ " Flexible Plate that forms the front of the sidcar is bolted at 1 to a  $2\frac{1}{2} \times \frac{1}{2}$ " Double Angle Strip, which is fastened by Bolt 2 (Fig. 4.4a) to the  $4\frac{1}{2}$ " Flanged Sector Plate forming the bottom of the sidcar. The Bolts 3 pass through the Flexible Plates and also through a  $2\frac{1}{2} \times \frac{1}{2}$ " Double Angle Strip.

The engine cylinder consists of two 1" Pulleys mounted on a 2" Rod, one end of which is supported in the Strip 4 (Fig. 4.4b) that forms the top of the frame. The other end of the Rod is held between the two Bolts that fasten the Wheel Discs to the frame.

The petrol tank is represented by a  $5\frac{1}{2} \times 1\frac{1}{2}$ " Flexible Plate bent to U-shape and attached to a  $1\frac{1}{2} \times \frac{1}{2}$ " Double Angle Strip by Angle Brackets. A  $2\frac{1}{2}$ " Strip is attached to the Double Angle Strip and the unit is then bolted to the Strip 4 (Fig. 4.4b). The saddle, which is a Trunnion, is also attached to this Strip by a  $\frac{1}{2}$ " Reversed Angle Bracket.

The Strip 4 carries a Double Bracket at its front end, and to this are bolted two  $2\frac{1}{2}$ " Strips. To these Strips are attached two Wheel Discs, and these are joined by a double bracket built up from two Angle Brackets (see Fig. 4.4a).

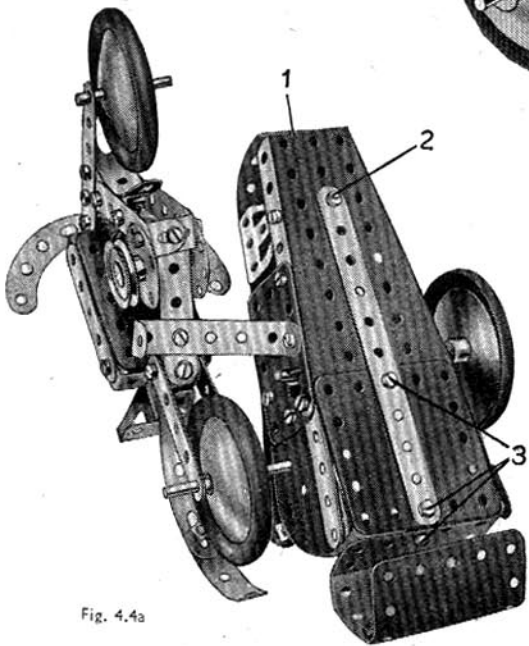
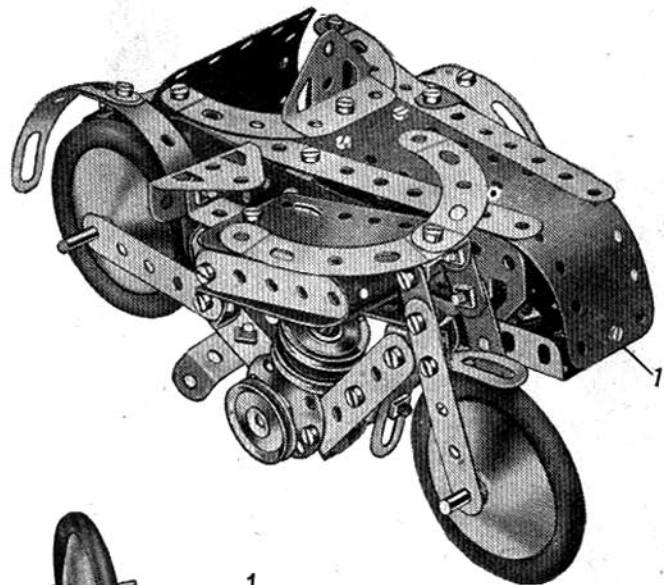

Fig. 4.4a

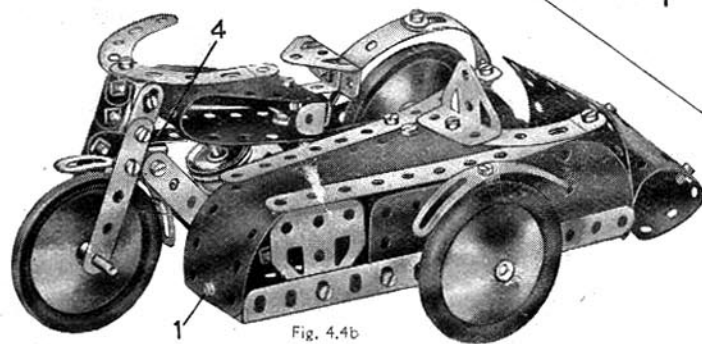
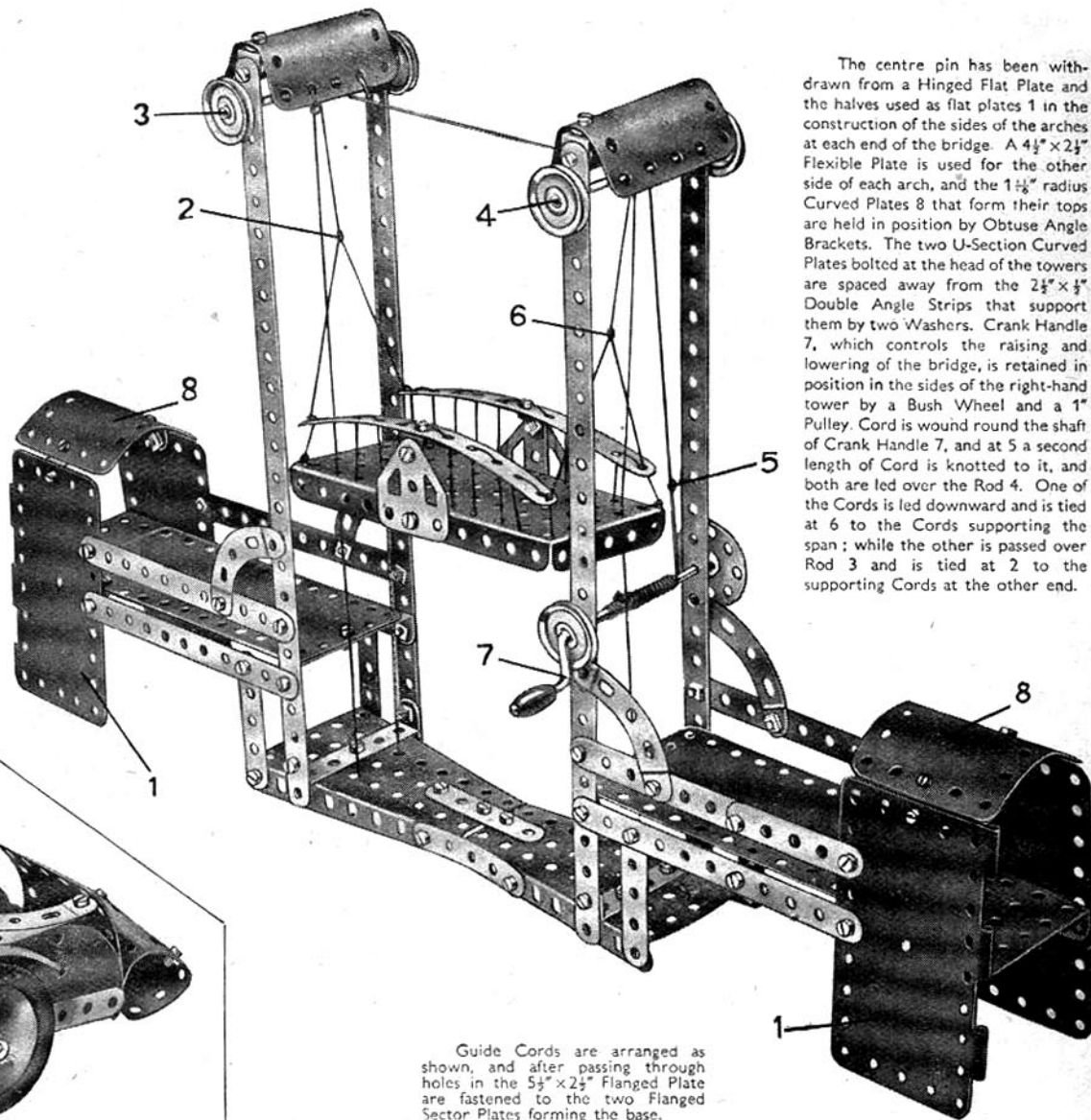

Fig. 4.4b

### 4.5 LIFTING BRIDGE



The centre pin has been withdrawn from a Hinged Flat Plate and the halves used as flat plates 1 in the construction of the sides of the arches at each end of the bridge. A  $4\frac{1}{2} \times 2\frac{1}{2}$ " Flexible Plate is used for the other side of each arch, and the  $1\frac{1}{8}$ " radius Curved Plates 8 that form their tops are held in position by Obtuse Angle Brackets. The two U-Section Curved Plates bolted at the head of the towers are spaced away from the  $2\frac{1}{2} \times \frac{1}{2}$ " Double Angle Strips that support them by two Washers. Crank Handle 7, which controls the raising and lowering of the bridge, is retained in position in the sides of the right-hand tower by a Bush Wheel and a 1" Pulley. Cord is wound round the shaft of Crank Handle 7, and at 5 a second length of Cord is knotted to it, and both are led over the Rod 4. One of the Cords is led downward and is tied at 6 to the Cords supporting the span; while the other is passed over Rod 3 and is tied at 2 to the supporting Cords at the other end.

Guide Cords are arranged as shown, and after passing through holes in the  $5\frac{1}{2} \times 2\frac{1}{2}$ " Flanged Plate are fastened to the two Flanged Sector Plates forming the base.

#### 4.6 DIESEL SHUNTING LOCOMOTIVE

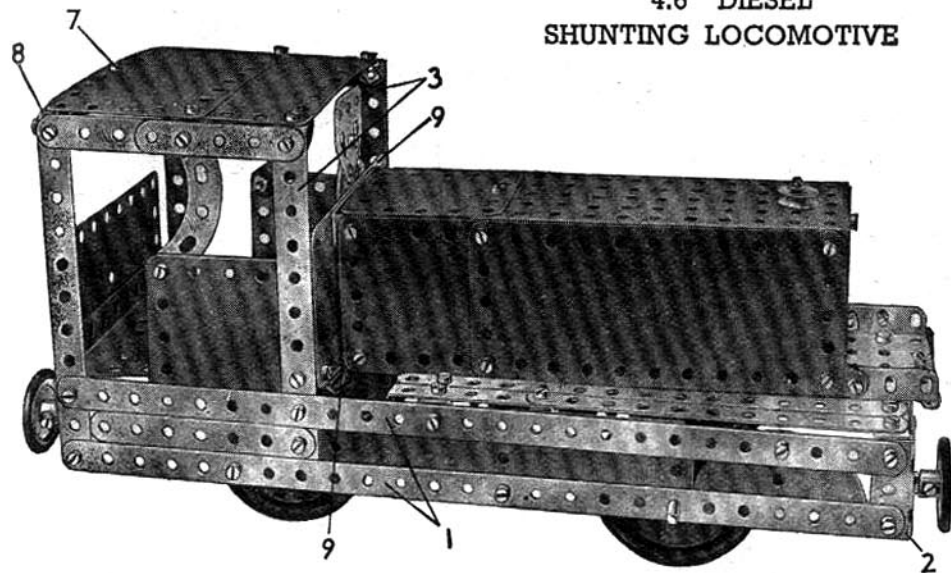

The main frames of the locomotive consist of  $12\frac{1}{2}$ " Strips 1, bolted to a  $5\frac{1}{2}$ "  $\times$   $1\frac{1}{2}$ " Flexible Plate, a Semi-Circular Plate and the Trunnions 2. The back of the cab is formed by half a Hinged Flat Plate attached to the frames by Angle Brackets. The other half of the Hinged Flat Plate is used for the front of the cab, and is fixed to the  $5\frac{1}{2}$ " Strips 3 by Angle Brackets.

The main frames are connected at the front by a  $2\frac{1}{2}$ "  $\times$   $\frac{1}{2}$ " Double Angle Strip 4 (Fig. 4.6a), a  $1\frac{1}{2}$ "  $\times$   $\frac{1}{2}$ " Double Angle Strip 5 and a  $2\frac{1}{2}$ "  $\times$   $1\frac{1}{2}$ " Flanged Plate 6. Two  $2\frac{1}{2}$ "  $\times$   $1\frac{1}{2}$ " Flexible Plates bolted together are attached to the Trunnions 2 by  $\frac{3}{8}$ " Bolts. A 1" Pulley is locked on the shank of each of these Bolts to represent the buffers.

The sides of the cab are formed by  $2\frac{1}{2}$ "  $\times$   $2\frac{1}{2}$ " Flexible Plates attached to the Strips 3 and the main frames.

The roof is made by overlapping two  $4\frac{1}{2}$ "  $\times$   $2\frac{1}{2}$ " Flexible Plates two holes. It is bolted to Angle Brackets attached to the Strips 3. A second Angle Bracket held by the Bolt 7 is bolted to a compound strip 8, consisting of two  $2\frac{1}{2}$ " Strips fastened to the sides by Angle Brackets.

Each side of the engine housing consists of a  $5\frac{1}{2}$ "  $\times$   $2\frac{1}{2}$ " and a  $2\frac{1}{2}$ "  $\times$   $2\frac{1}{2}$ " Flexible Plate. These are attached to the Flanged Plate 6 by Fishplates and to the front of the cab by Double Angle Strips 9. The top is filled in by a  $5\frac{1}{2}$ "  $\times$   $2\frac{1}{2}$ " Flanged Plate and a  $1\frac{1}{2}$ " radius Curved Plate. The radiator is formed by a second  $1\frac{1}{2}$ " radius Curved Plate.

The running plate above the wheels consists of  $5\frac{1}{2}$ " Strips bolted to the Double Angle Strips 4 and 5. The  $5\frac{1}{2}$ " Strips are extended on one side by two  $2\frac{1}{2}$ " Strips, and on the other by a  $2\frac{1}{2}$ " Strip and a  $2\frac{1}{2}$ "  $\times$   $\frac{1}{2}$ " Double Angle Strip. These Strips are supported by the Double Angle Strips 10.

The leading axle consists of a  $3\frac{1}{2}$ " and a 2" Rod joined by a Rod Connector and supported in the main frames. The rear axle is a 4" Rod free to turn in two Reversed Angle Brackets. The *Magic* Motor is bolted to one of the main frames and drives a 1" Pulley on the leading axle.

Note: The Motor used in this model is not included in the Outfit.

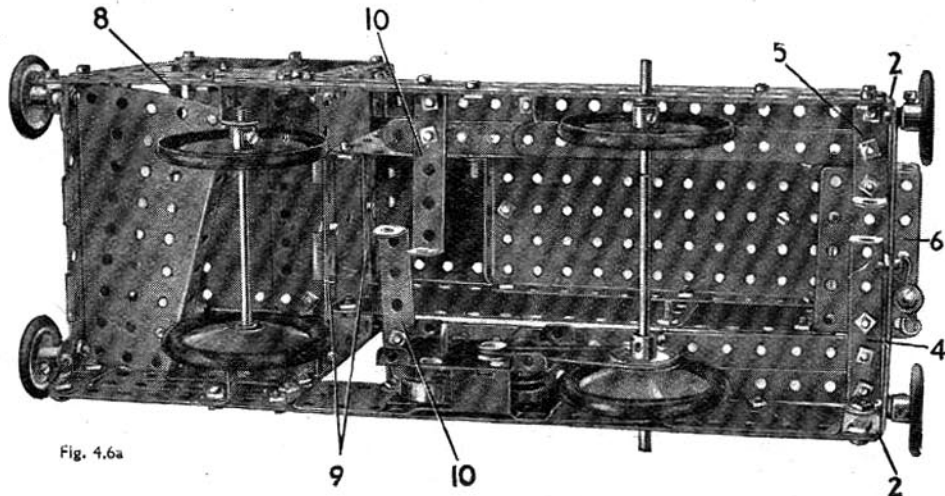
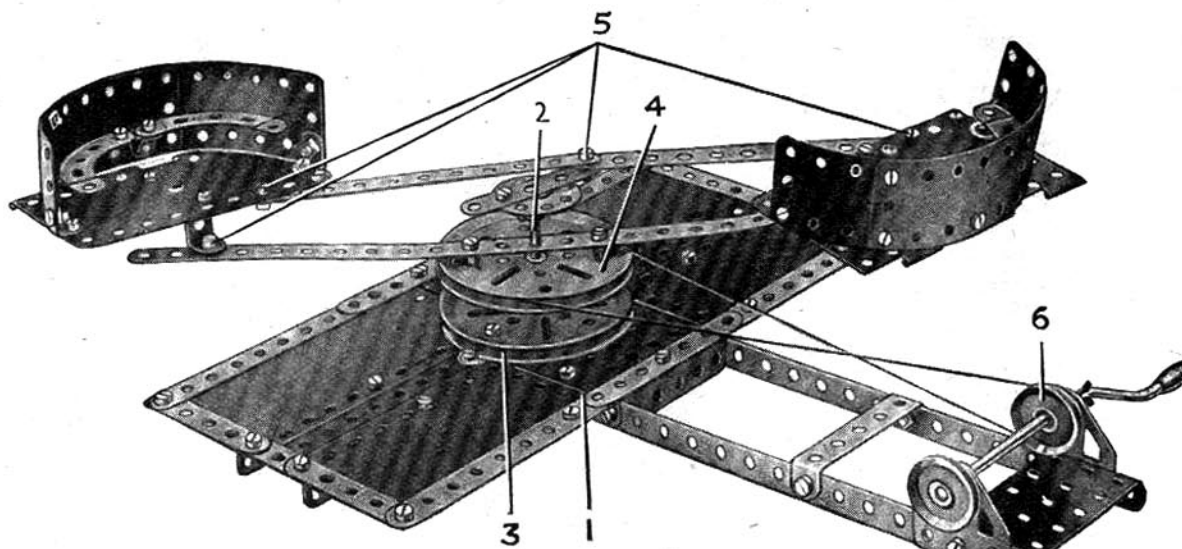

Fig. 4.6a

#### 4.7 "WHIP" ROUNDABOUT



The base of the model is formed by a  $5\frac{1}{2}$ "  $\times$   $2\frac{1}{2}$ " Flanged Plate 1 extended on each side by a Flanged Sector Plate, a  $5\frac{1}{2}$ "  $\times$   $2\frac{1}{2}$ " and a  $4\frac{1}{2}$ "  $\times$   $2\frac{1}{2}$ " Flexible Plate. The edges of the base are strengthened with Strips. Two  $12\frac{1}{2}$ " Strips are bolted to the flanges of Plate 1 and their ends are connected by a  $2\frac{1}{2}$ "  $\times$   $1\frac{1}{2}$ " Flanged Plate. Two Flat Trunnions provide bearings for a small Crank Handle.

A 3" Pulley 3 is bolted to Flanged Plate 1 and in its boss is fixed a 2" Rod 2. A second 3" Pulley 4 is spaced from Pulley 3 by a Spring Clip and is free to turn on Rod 2. Across its face is bolted a  $12\frac{1}{2}$ " Strip, the Strip being spaced from the Pulley by a Spring Clip placed on the shank of each securing Bolt.

A Bush Wheel fitted with a  $2\frac{1}{2}$ " Strip is secured on Rod 2 in the position shown, the end of the Strip being connected to the cars by  $5\frac{1}{2}$ " Strips. All the Bolts 5 are lock-nutted.

The 1" Pulley 6 mounted on the Crank Handle, drives Pulley 4 through a belt of Cord.

### 4.8 TANK LOCOMOTIVE

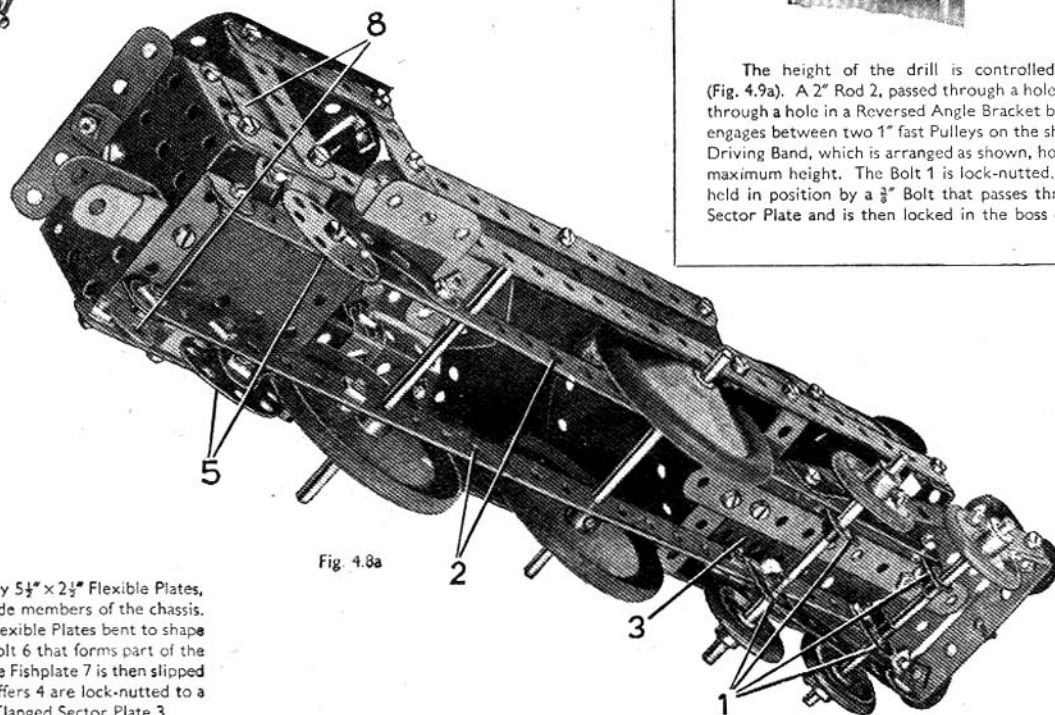
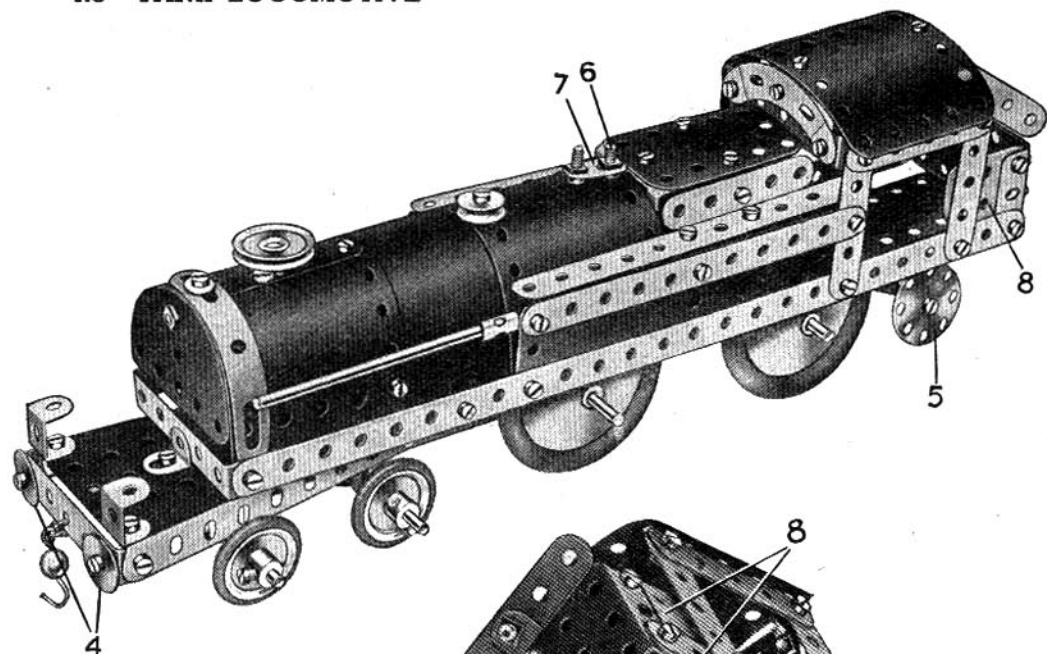

Fig. 4.8a

The construction of the model is commenced by building the chassis as shown in Fig. 4.8a. The Fishplates 1 must be bolted to the 12½" Strips 2 before the Flanged Sector Plate 3 is fitted. The Wheel Discs 5 rotate on ¾" Bolts lock-nutted in the end holes of two 2½" small radius Curved Strips, which are bolted to the 12½" Strips forming the side members of the frame.

The top of the cab consists of two 1½" radius Curved Plates, overlapped three holes and fastened by an Angle Bracket to a small radius Curved Strip. The Curved Strip in turn is fastened by Angle Brackets to two 2½" Strips bolted to the frame. A 2½" x 1½" Flanged Plate is used for the back of the cab, and Flat Trunnions 8 fill in the sides.

The centre and rear parts of the boiler are formed by 5½" x 2½" Flexible Plates, which are bolted direct to the 12½" Strips forming the side members of the chassis. The forward part of the boiler consists of two 2½" x 2½" Flexible Plates bent to shape and bolted to the centre portion of the boiler. The ¾" Bolt 6 that forms part of the safety valve is held in the top of the boiler by a nut, and the Fishplate 7 is then slipped over it and fastened in position by a further nut. The buffers 4 are lock-nutted to a 2½" x ½" Double Angle Strip bolted to the flanges of the Flanged Sector Plate 3.

### 4.9 DRILLING MACHINE

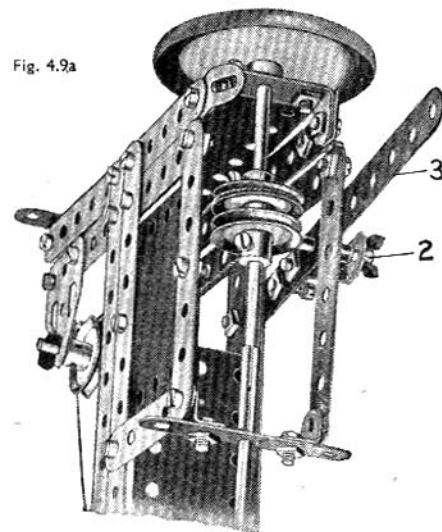
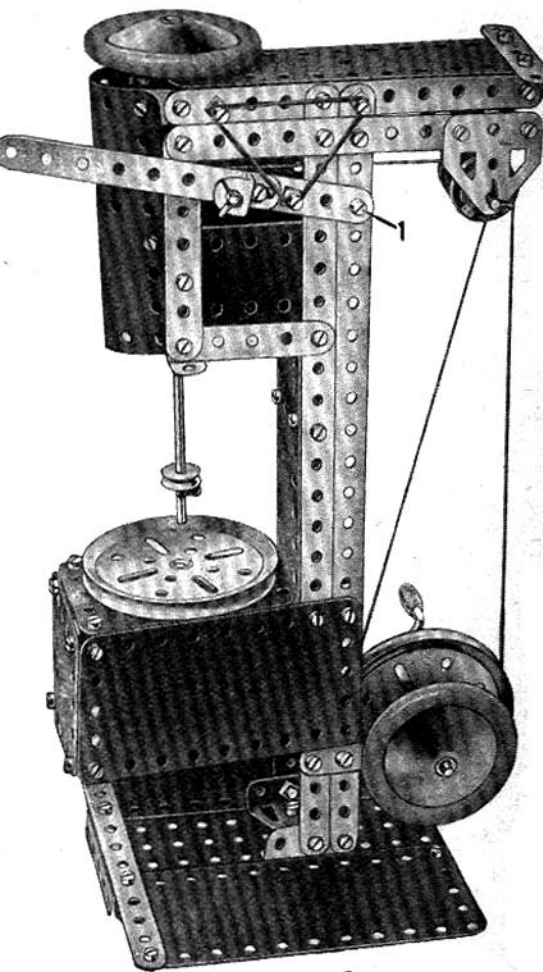

Fig. 4.9a

The height of the drill is controlled by the lever 3 (Fig. 4.9a). A 2" Rod 2, passed through a hole in the Strip 3 and through a hole in a Reversed Angle Bracket bolted to the Strip, engages between two 1" fast Pulleys on the shaft of the drill. A Driving Band, which is arranged as shown, holds the lever at its maximum height. The Bolt 1 is lock-nutted. The drill table is held in position by a ¾" Bolt that passes through the Flanged Sector Plate and is then locked in the boss of the Pulley.



A Flanged Sector Plate that supports the drilling table is bolted to the 12½" Strips that form the main column of the machine. The sides of the table are filled in by two 4½" x 2½" and one 2½" x 2½" Flexible Plates joined by Angle Brackets. Two 2½" Strips bolted to the main column provide the bearings for the Crank Handle.

### 5.1 ELEVATOR

Each side of the elevator is formed by two  $2\frac{1}{2}'' \times 2\frac{1}{2}''$  Flexible Plates joined together and bolted to two  $5\frac{1}{2}''$  Strips. A small radius Curved Strip is bolted across the upper ends of the  $5\frac{1}{2}''$  Strips, and the sides are connected at the top by three  $2\frac{1}{2}'' \times \frac{1}{2}''$  Double Angle Strips. At their lower ends the sides are joined by two  $2\frac{1}{2}'' \times \frac{1}{2}''$  Double Angle Strips.

The two Flanged Sector Plates are connected to the  $5\frac{1}{2}'' \times 2\frac{1}{2}''$  Flanged Plate by Angle Brackets, and the four  $12\frac{1}{2}''$  Angle Girders are held in place by the same bolts. Guides for the elevator are provided by four Cords, three of which are shown at 1. These are tied to Washers underneath the Flanged Plate, and at the top of the shaft are fastened to Angle Brackets held by Bolts 2 on each side. Cord 3 is tied to a Washer, and passes through the centre hole of the  $2\frac{1}{2}'' \times \frac{1}{2}''$  Double Angle Strip at the top of the elevator. It then passes over the  $3''$  Pulley 4, and finally is fastened to a Cord Anchoring Spring on a Crank Handle journalled in the  $5\frac{1}{2}''$  Strip that brace the elevator shaft.

A length of Cord passes around the rim of the  $3''$  Pulley 5 and is tied to the brake lever, which is a  $3\frac{1}{2}''$  Strip. This Strip is lock-nutted to a Trunnion fastened to a Flat Trunnion. The  $\frac{1}{2}''$  loose Pulley bolted to the  $3\frac{1}{2}''$  Strip maintains the brake band in tension.

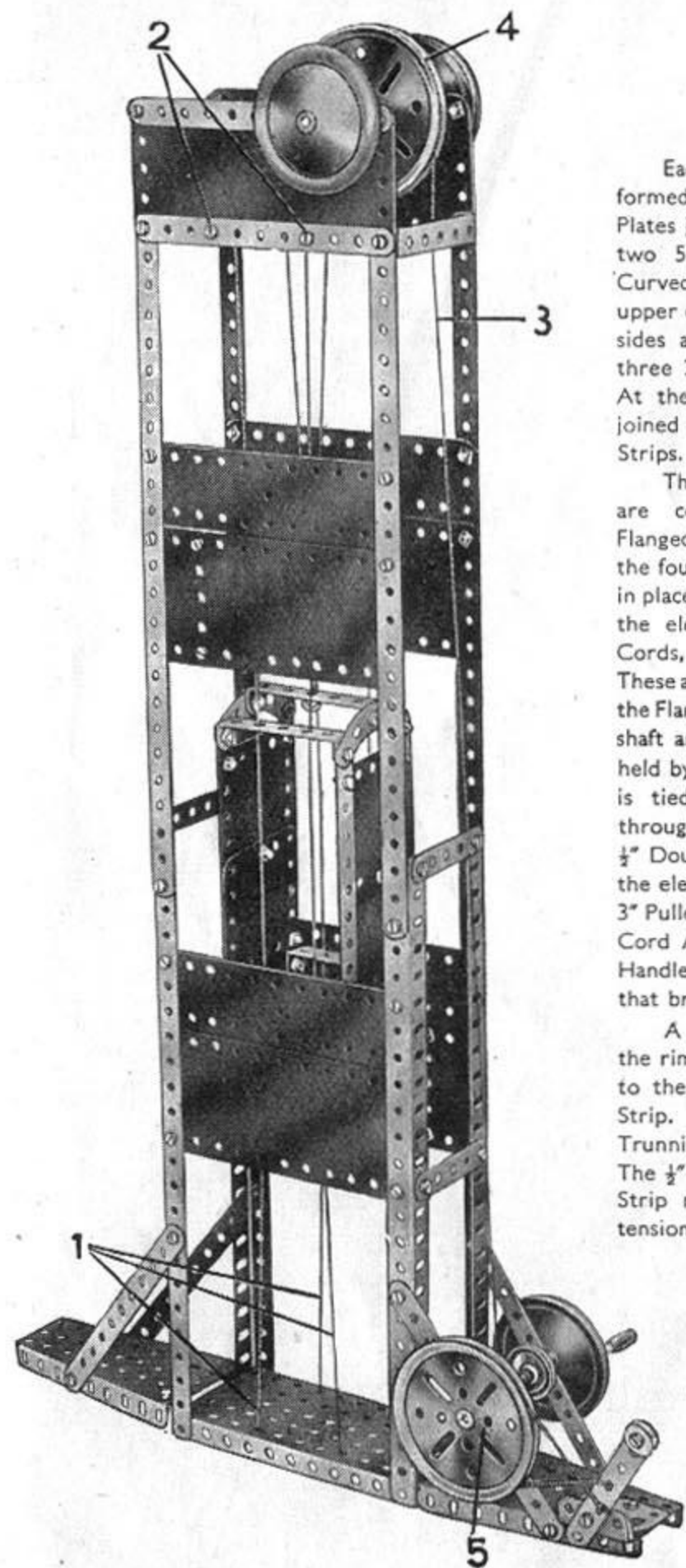

### 5.2 MOTOR LORRY

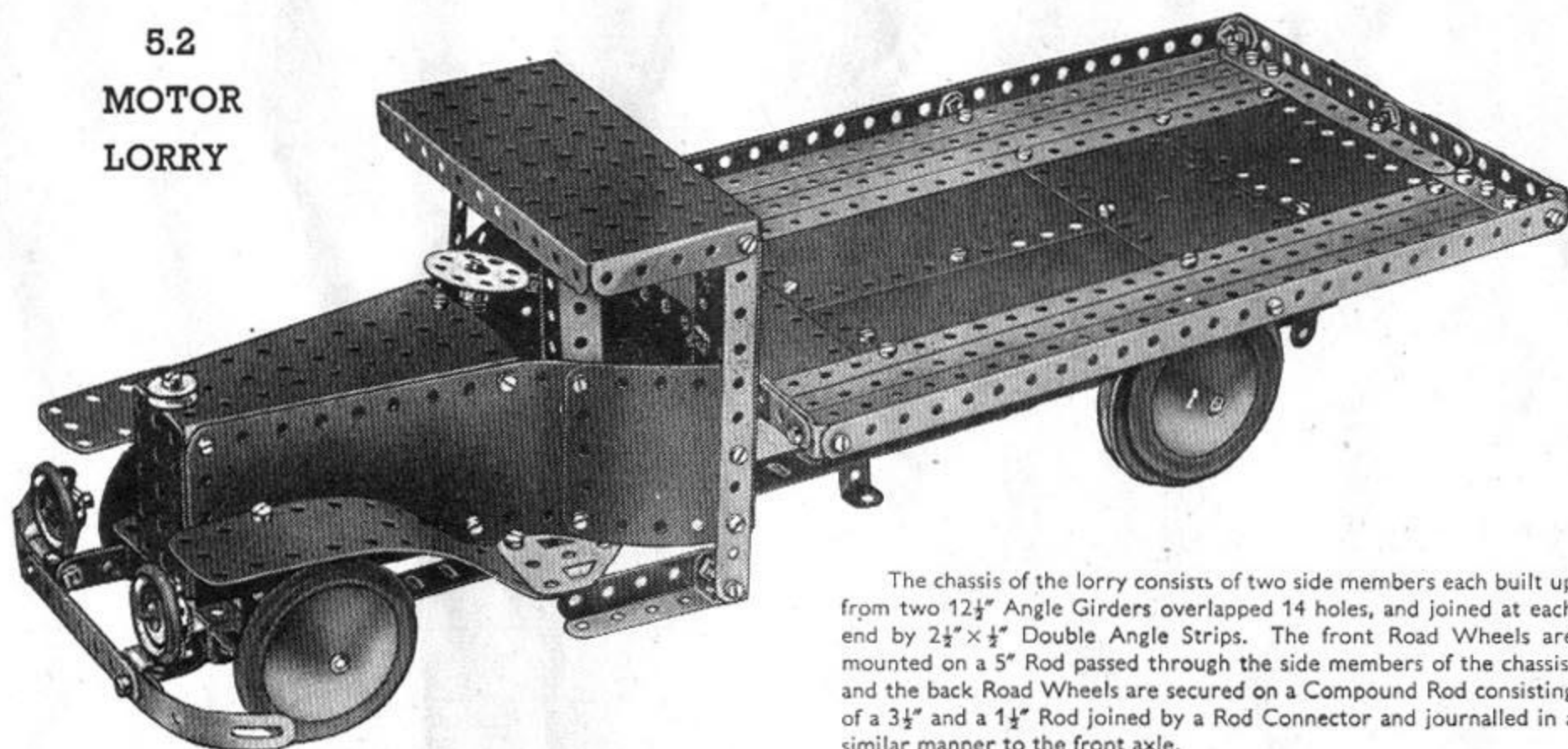

The chassis of the lorry consists of two side members each built up from two  $12\frac{1}{2}''$  Angle Girders overlapped 14 holes, and joined at each end by  $2\frac{1}{2}'' \times \frac{1}{2}''$  Double Angle Strips. The front Road Wheels are mounted on a  $5''$  Rod passed through the side members of the chassis, and the back Road Wheels are secured on a Compound Rod consisting of a  $3\frac{1}{2}''$  and a  $1\frac{1}{2}''$  Rod joined by a Rod Connector and journalled in a similar manner to the front axle.

Flanged Sector Plates form the top and base for the bonnet and radiator. The narrow end of the bonnet is bolted to the centre hole of the  $2\frac{1}{2}'' \times \frac{1}{2}''$  Double Angle Strip joining the forward ends of the chassis, and the wider end is attached to the centre of a  $5\frac{1}{2}''$  Strip bolted across the chassis. The sides of the bonnet are  $5\frac{1}{2}'' \times 2\frac{1}{2}''$  Flexible Plates, and are bolted to the flanges of the Flanged Sector Plates. The radiator is a  $2\frac{1}{2}'' \times 1\frac{1}{2}''$  Flanged Plate, which is fastened by its flanges to the forward ends of the two Flanged Sector Plates. The radiator cap is represented by a  $\frac{1}{2}''$  loose Pulley. The bumper consists of a  $3\frac{1}{2}''$  Strip, to the end of which are bolted  $3''$  Formed Slotted Strips, and it is fastened to the front end of the chassis by  $1'' \times 1''$  Angle Brackets and  $1\frac{1}{2}''$  Strips.

The headlamps are fitted to the bumper by means of Reversed Angle Brackets, and consist of  $1''$  fast Pulleys held to the Brackets by bolts. The mudguards are  $5\frac{1}{2}'' \times 1\frac{1}{2}''$  Flexible Plates, which are curved to the shape shown, and to their rear ends Flat Trunnions are attached, the pointed portions of these extending under the  $1\frac{1}{4}''$  radius Curved Plates that are used to form the sides of the driver's compartment.

The cab is formed as follows. The short Strips are bolted vertically to the cab sides to form the front supports or the cab roof and the rear supports are  $5\frac{1}{2}''$  Strips. The roof is a  $5\frac{1}{2}'' \times 2\frac{1}{2}''$  Flanged Plate, which is bolted at each end to the  $5\frac{1}{2}''$  Strips. At their lower ends each  $5\frac{1}{2}''$  Strip carries a Double Bracket, to which are bolted at right angles two  $2\frac{1}{2}''$  Strips that form the footsteps.

The platform of the lorry consists of  $12\frac{1}{2}''$  Strips and Flexible Plates. The rear central portion of the platform is a Hinged Flat Plate, and the sides are  $12\frac{1}{2}''$  Strips. Other Strips overlapped form the end. The end and sides are attached to the platform by means of Angle Brackets.

The platform is secured to the chassis at the front by  $2\frac{1}{2}'' \times \frac{1}{2}''$  Double Angle Strips and at the rear by Trunnions and  $2\frac{1}{2}''$  Strips.

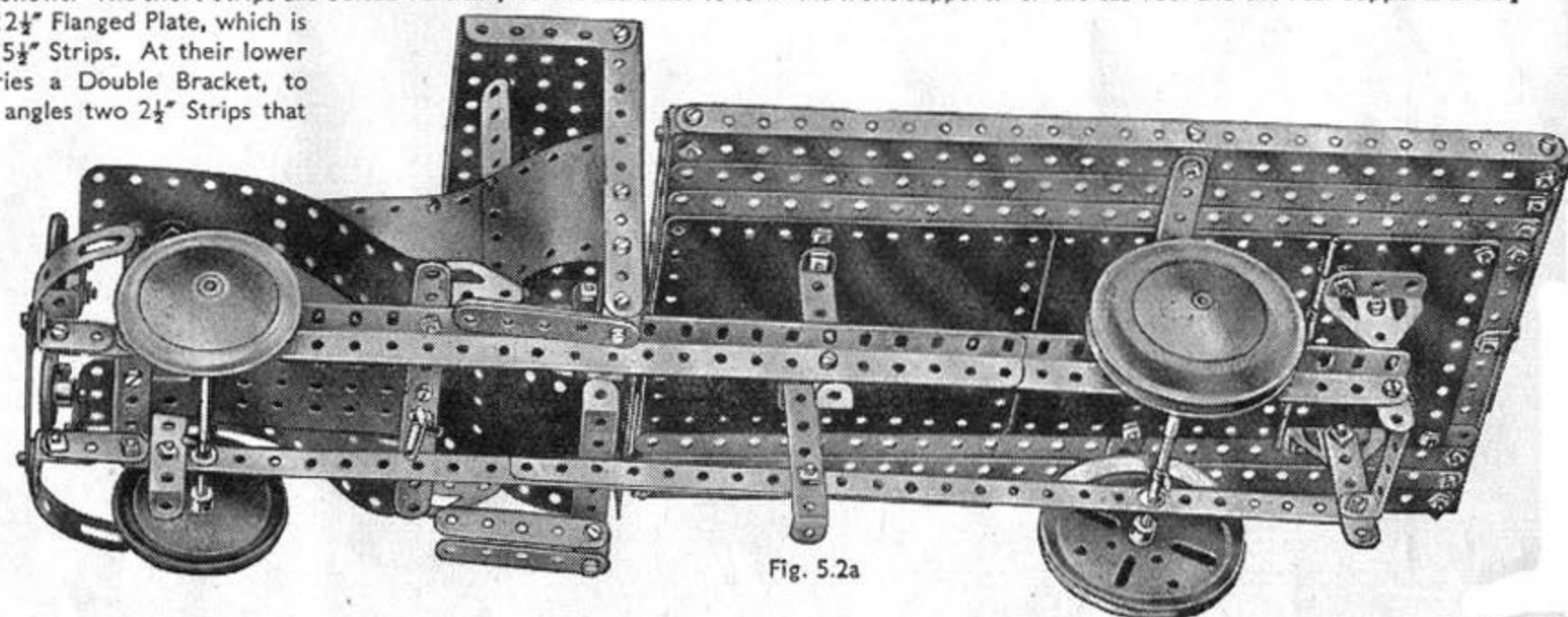

Fig. 5.2a

### 5.3 TRAVELLING GANTRY CRANE

The pin has been withdrawn from a Hinged Flat Plate and the halves are used as flat plates 1 in the construction of the supports for the gantry. Four Wheel Discs are fastened to the  $12\frac{1}{2}$ " Strips by lock-nutted bolts, so that the gantry can travel along the ground.

Each of the rails along which the crane runs consists of two  $12\frac{1}{2}$ " Angle Girders, overlapped three holes and joined across by  $5\frac{1}{2}$ " Strips. Trunnions connect the rails to the supports.

The rails are braced by four compound strips, each consisting of a  $5\frac{1}{2}$ " and a  $2\frac{1}{2}$ " Strip overlapped three holes. These strips are bolted to the rails at their upper ends, and each carries an Angle Bracket at its lower end. These Angle Brackets are bolted to further Angle Brackets fixed to the vertical supports.

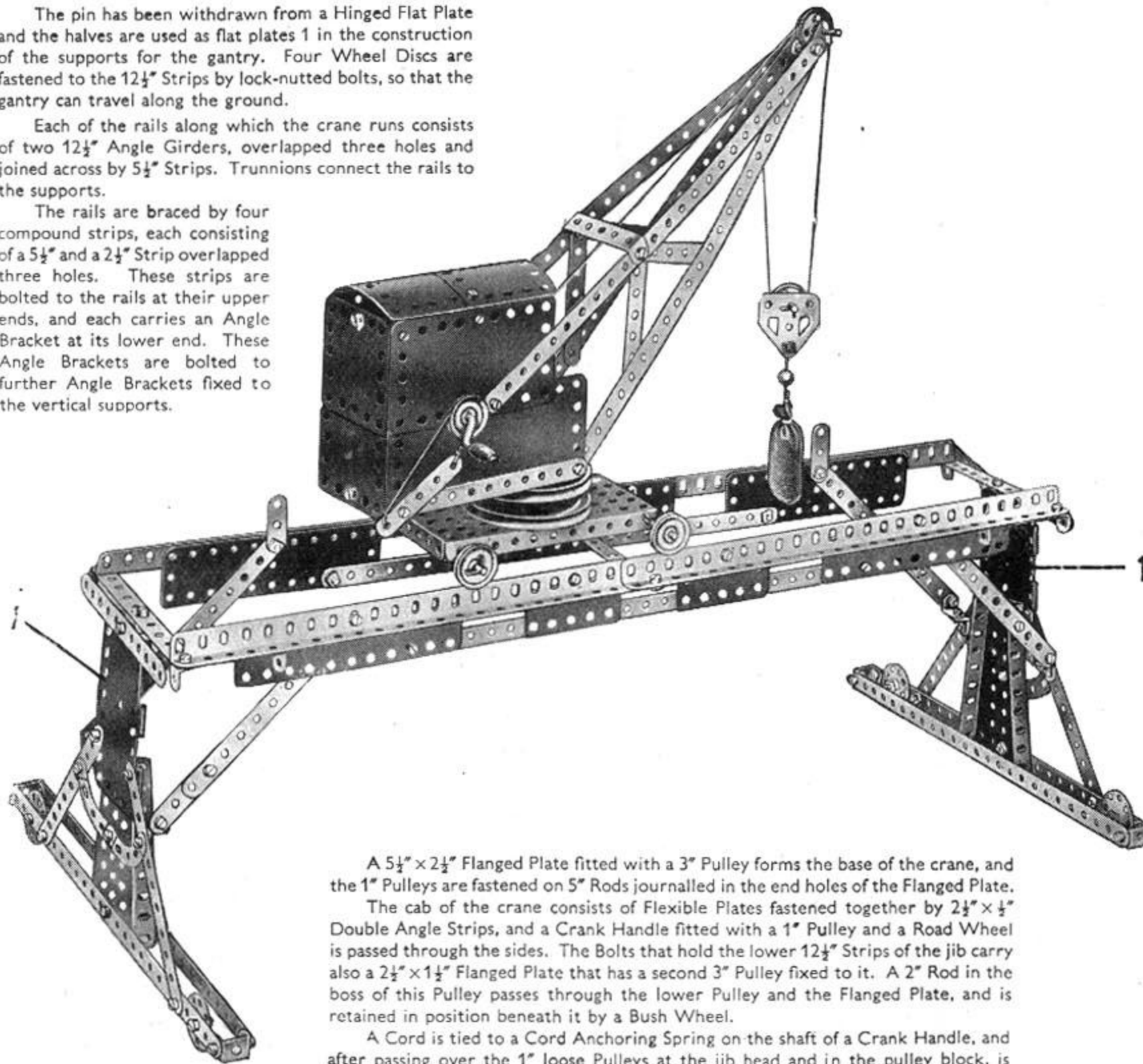

A  $5\frac{1}{2}$ " x  $2\frac{1}{2}$ " Flanged Plate fitted with a 3" Pulley forms the base of the crane, and the 1" Pulleys are fastened on 5" Rods journalled in the end holes of the Flanged Plate.

The cab of the crane consists of Flexible Plates fastened together by  $2\frac{1}{2}$ " x  $\frac{1}{2}$ " Double Angle Strips, and a Crank Handle fitted with a 1" Pulley and a Road Wheel is passed through the sides. The Bolts that hold the lower  $12\frac{1}{2}$ " Strips of the jib carry also a  $2\frac{1}{2}$ " x  $1\frac{1}{2}$ " Flanged Plate that has a second 3" Pulley fixed to it. A 2" Rod in the boss of this Pulley passes through the lower Pulley and the Flanged Plate, and is retained in position beneath it by a Bush Wheel.

A Cord is tied to a Cord Anchoring Spring on the shaft of a Crank Handle, and after passing over the 1" loose Pulleys at the jib head and in the pulley block, is fastened to the jib as shown.

Stops to limit the travel of the crane along the rails are provided by  $1\frac{1}{2}$ " Strips. These are bolted in a vertical position to the  $12\frac{1}{2}$ " Angle Girders forming the rails as shown in the illustration. The rails are extended downwards by  $5\frac{1}{2}$ " x  $1\frac{1}{2}$ " and  $2\frac{1}{2}$ " x  $1\frac{1}{2}$ " Flexible Plates. These Plates are joined along their lower edges by  $12\frac{1}{2}$ " Strips.

### 5.4 RAILWAY BREAKDOWN CRANE

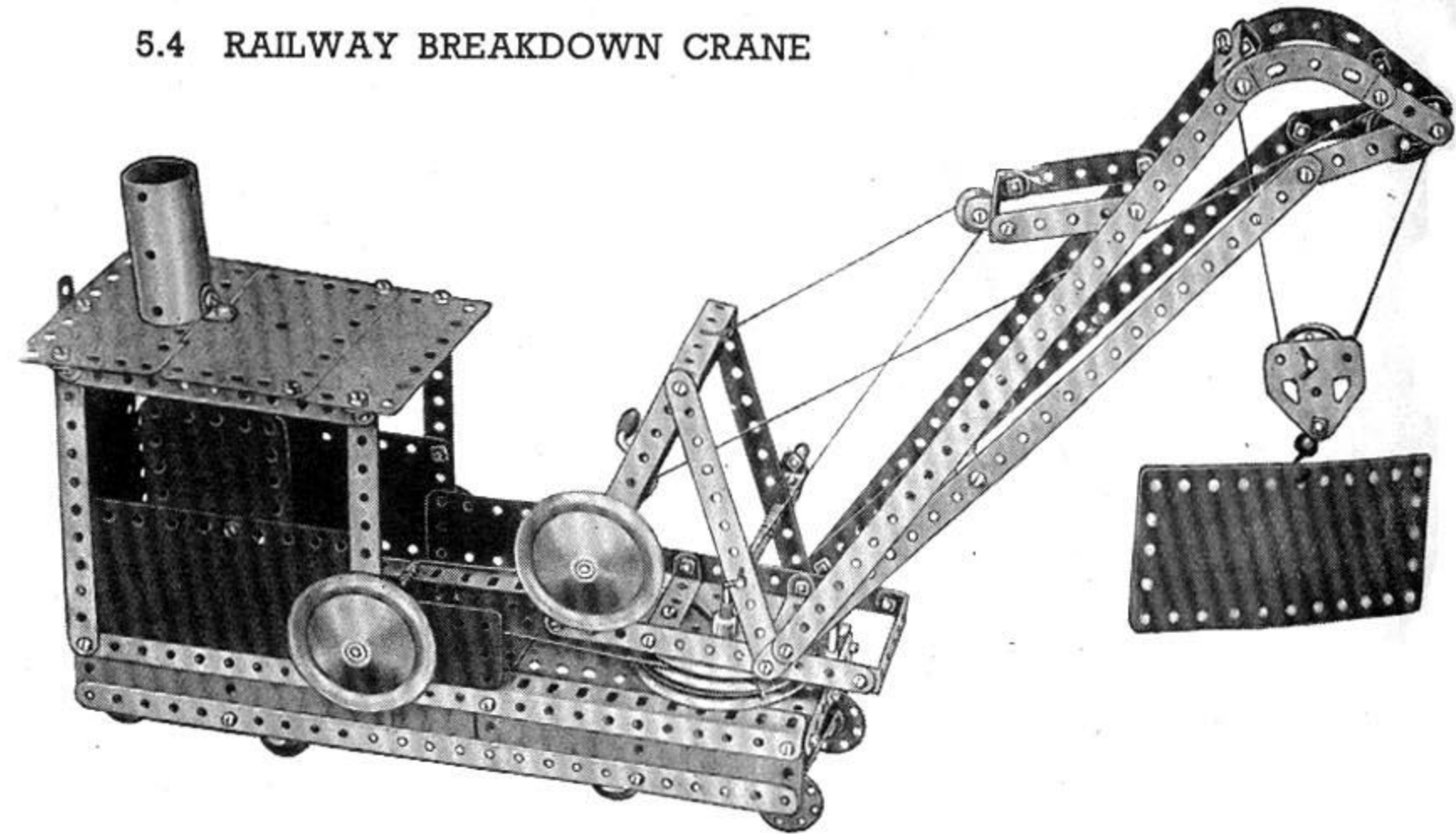

The chassis of the model consists of two U-Section girders built up from Angle Girders and joined at each end by  $3\frac{1}{2}$ " Strips and Angle Brackets. A  $5\frac{1}{2}$ " x  $2\frac{1}{2}$ " Flanged Plate and a  $5\frac{1}{2}$ " x  $2\frac{1}{2}$ " Flexible Plate, overlapping one hole, are attached to the Angle Girders by Fishplates. The framework on which the jib is pivoted is fastened to a 3" Pulley by two  $\frac{3}{8}$ " Bolts, which have two Washers on their shanks for spacing purposes. The  $\frac{3}{8}$ " Bolts on which the jib luffs are lock-nutted.

The 3" Pulley on the jib swivels on a  $3\frac{1}{2}$ " Rod passed through its boss and is held in place by a Cord Anchoring Spring.

The front bogie (Fig. 5.4a) pivots on the  $3\frac{1}{2}$ " Rod and is held between a Road Wheel and a 1" Pulley as shown. The rear bogie is similarly pivoted on a 2" Rod, bearings for which are provided by the  $5\frac{1}{2}$ " x  $2\frac{1}{2}$ " Flexible Plate and two  $2\frac{1}{2}$ " Strips

overlapped three holes. The bogies are connected by a Driving Band, and the Bolts 1 are lock-nutted. Luffing of the jib is controlled by the built-up crank handle, consisting of a Double Bracket fitted with an Angle Bracket that carries a Pivot Bolt. The Bolt holding the Angle Bracket clamps the Double Bracket to the Rod.

Hoisting is controlled by the Crank Handle, and the slewing movement is carried out by a belt of Cord passed around the upper 3" Pulley at the base of the jib and then wound several times around the Rod journalled in the sides of the cab.

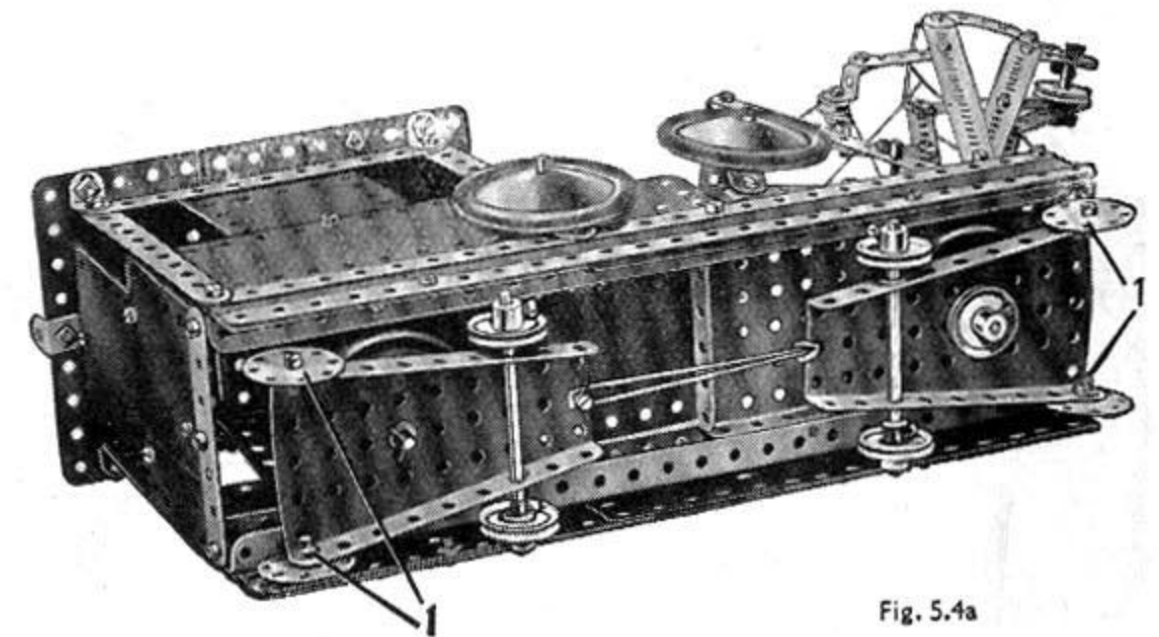
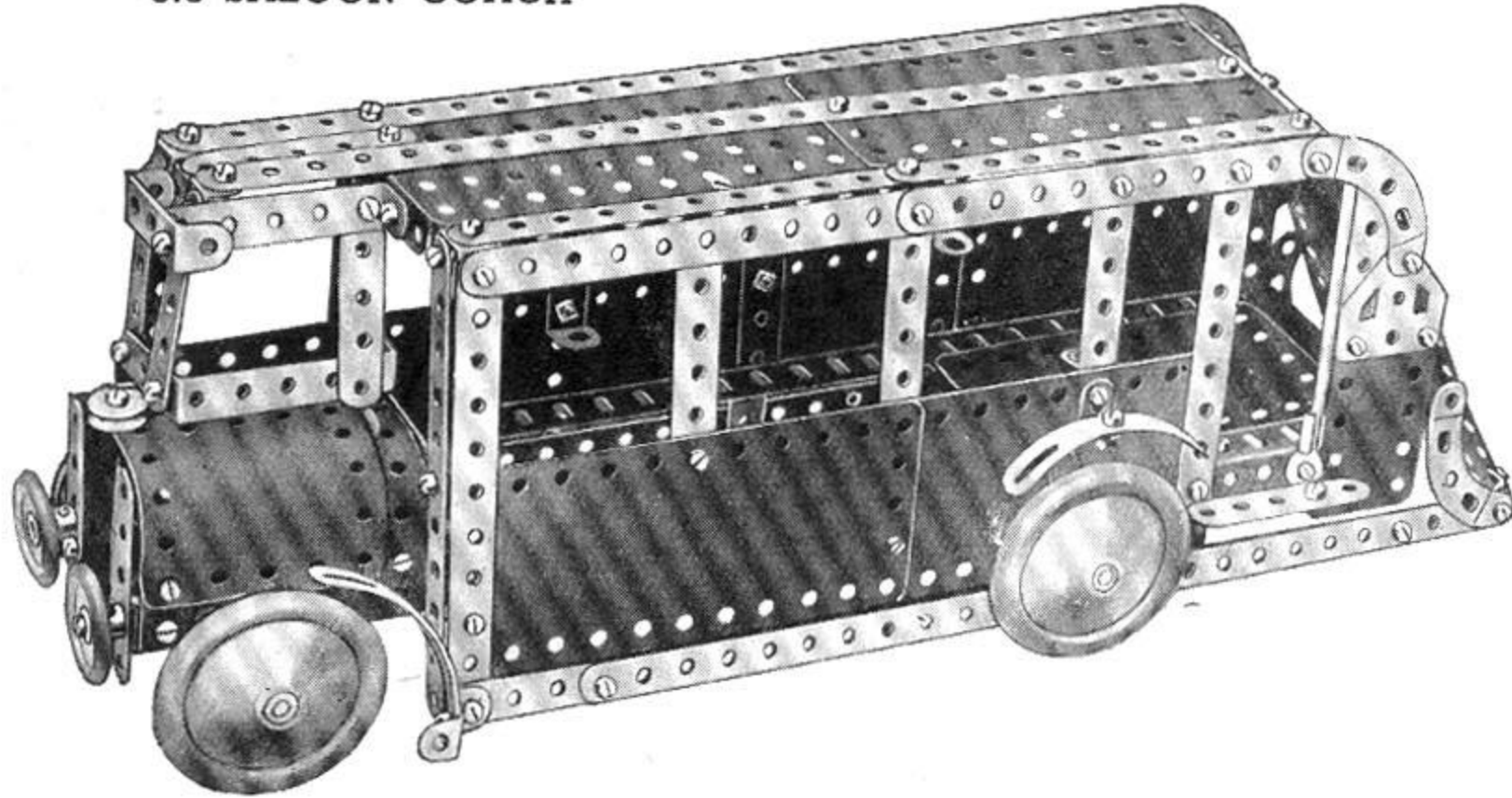

Fig. 5.4a

## 5.5 SALOON COACH



Two  $12\frac{1}{2}$ " Angle Girders joined by  $3\frac{1}{2}$ " Strips at each end comprise the chassis, and to this the Flexible Plates forming the sides are bolted. Supports for the roof are provided by  $5\frac{1}{2}$ " Strips to which a  $5\frac{1}{2}$ "  $\times$   $2\frac{1}{2}$ " Flanged Plate and two  $5\frac{1}{2}$ "  $\times$   $1\frac{1}{2}$ " Flexible Plates are fastened by Angle Brackets. The curved back of the coach is formed by two  $1\frac{1}{8}$ " radius Curved Plates, a  $5\frac{1}{2}$ "  $\times$   $1\frac{1}{2}$ " Flexible Plate, and a  $5\frac{1}{2}$ "  $\times$   $2\frac{1}{2}$ " Flexible Plate. The Flexible Plates are curved and bolted to the  $1\frac{1}{8}$ " radius Curved Plates so that they overlap three holes.

The tail lamp is a 1" Pulley, which is secured to a Threaded Pin fastened to one of the Flexible Plates (Fig. 5.5a).

The bonnet is built up from two U-Section Curved Plates and a  $2\frac{1}{2}$ "  $\times$   $1\frac{1}{2}$ " Flexible Plate. The radiator is a  $2\frac{1}{2}$ "  $\times$   $1\frac{1}{2}$ " Flanged Plate.

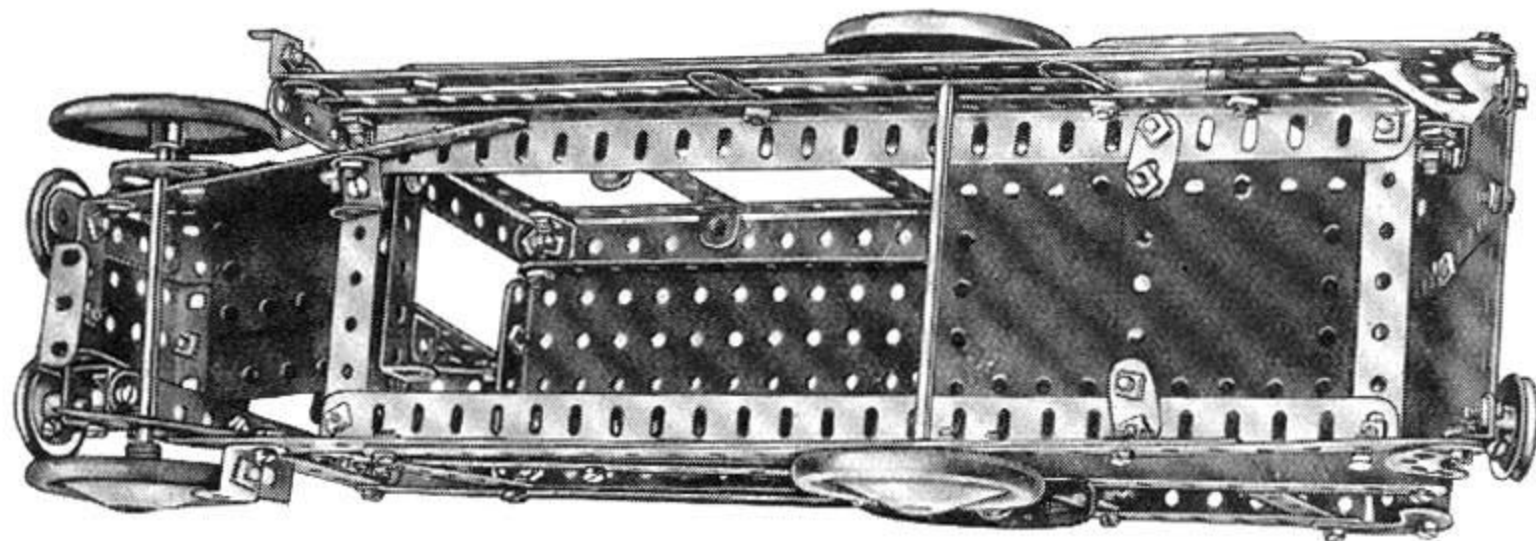

Fig. 5.5a

## 5.6 TRAVELLING CRANE

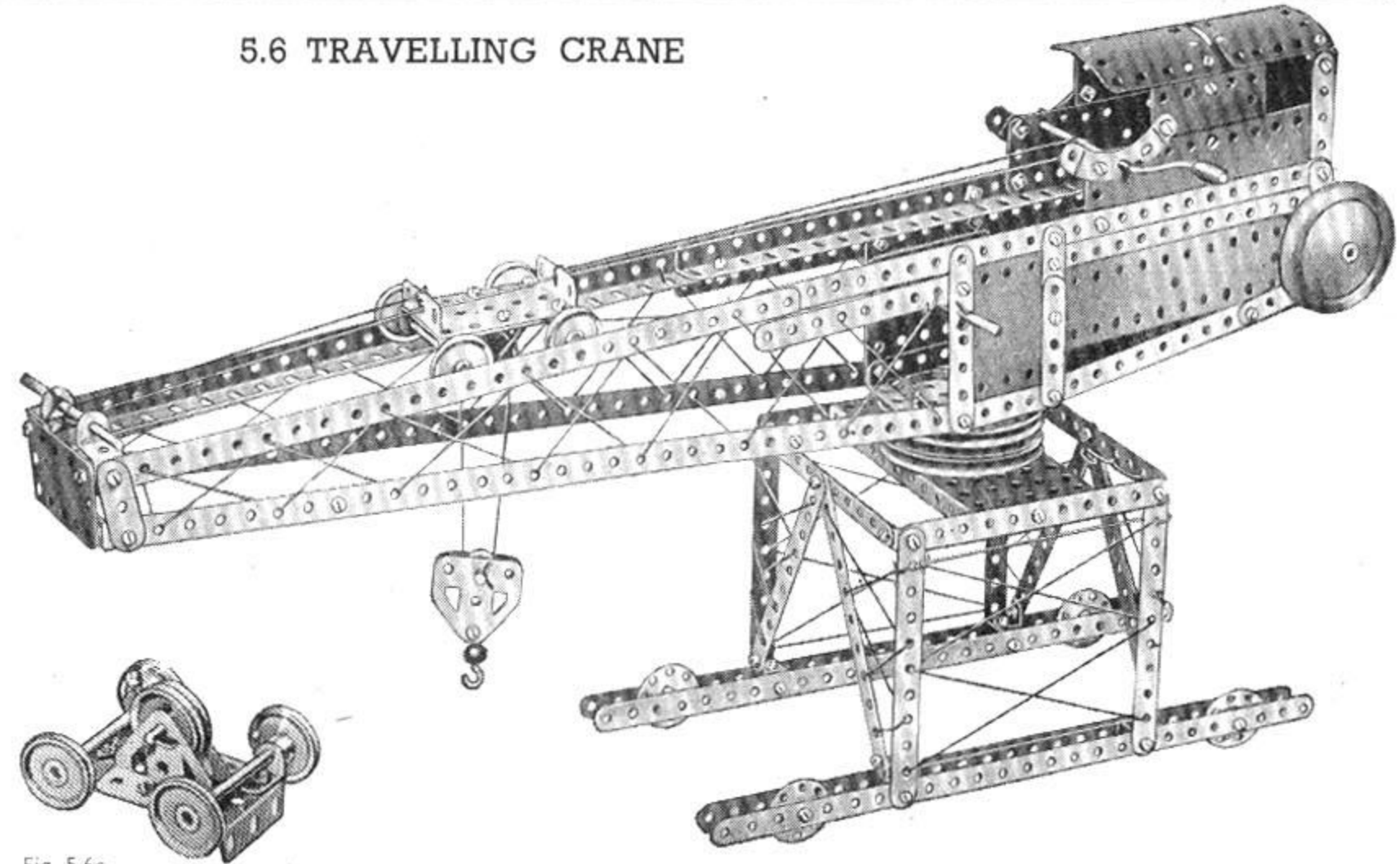

Fig. 5.6c

The construction of the superstructure and jib will be clear from the illustration. The Wheel Discs representing the wheels are held on lock-nutted bolts so that they are free to turn. In Fig. 5.6a the top of the cab has been removed to show the construction of the rear end of the jib.

A 3" Pulley is bolted to the jib by two  $\frac{3}{8}$ " Bolts, which hold also a  $2\frac{1}{2}$ "  $\times$   $\frac{1}{2}$ " Double Angle Strip fixed along the length of the jib on the underside of the 3" Pulley, so that its ends form a bearing between the two Pulleys. A  $3\frac{1}{2}$ " Rod fastened in the boss of the upper 3" Pulley passes through the boss of the lower 3" Pulley, which is bolted to a  $5\frac{1}{2}$ "  $\times$   $2\frac{1}{2}$ " Flanged Plate forming part of the superstructure. The Rod is retained in position below the Flanged Plate by a 1" Pulley as shown in Fig. 5.6b.

The hoisting carriage is shown in Fig. 5.6c; it runs on rails formed by Angle Girders at the top of the jib. A Cord is tied to the front end of the carriage, and is taken over a  $3\frac{1}{2}$ " Rod at the jib head and wound six times around the Crank Handle. It is then tied to the rear of the carriage.

A second Cord is tied to a Cord Anchoring Spring on the  $3\frac{1}{2}$ " Rod carrying the Bush Wheel and the Road Wheel. The Cord is then led around one of the 1" loose Pulleys in the carriage around the  $\frac{1}{2}$ " loose Pulley in the Pulley block and back over the second 1" loose Pulley. Finally it is tied to the  $2\frac{1}{2}$ "  $\times$   $1\frac{1}{2}$ " Flexible Plate at the jib head.

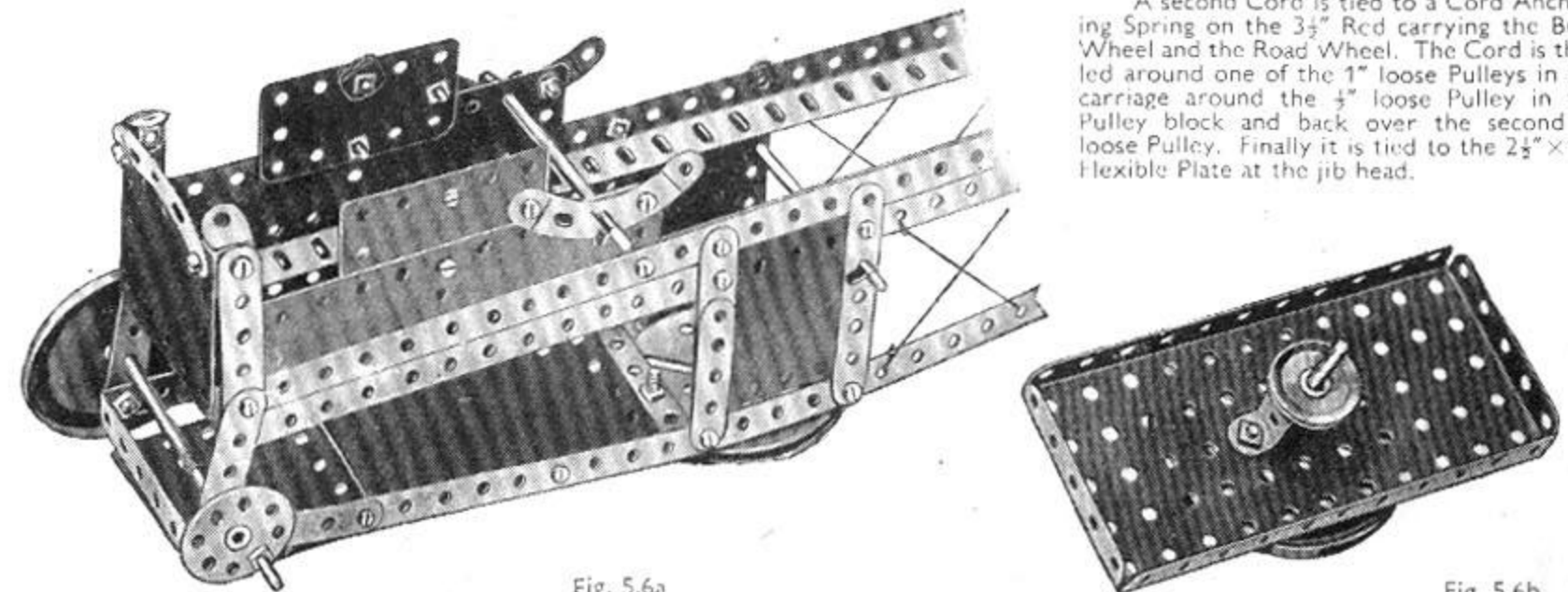

Fig. 5.6a

Fig. 5.6b



### 5.7 MILITARY TANK

Angle Girders form the main members of the model and the upper pair are connected by three  $5\frac{1}{2}$ " Strips, the lower pair comprising the chassis being connected by a  $5\frac{1}{2}$ " Strip near the front and by two  $2\frac{1}{2}$ " Strips, overlapped one hole, at the rear. At 1 (Fig. 5.7a) the two halves of a Hinged Flat Plate are used separately as flat plates. Flat Trunnions are bolted to the  $2\frac{1}{2}$ " Strips that space the upper and lower pairs of Angle Girders at the rear of the tank, and they form part of the creeper track covers.

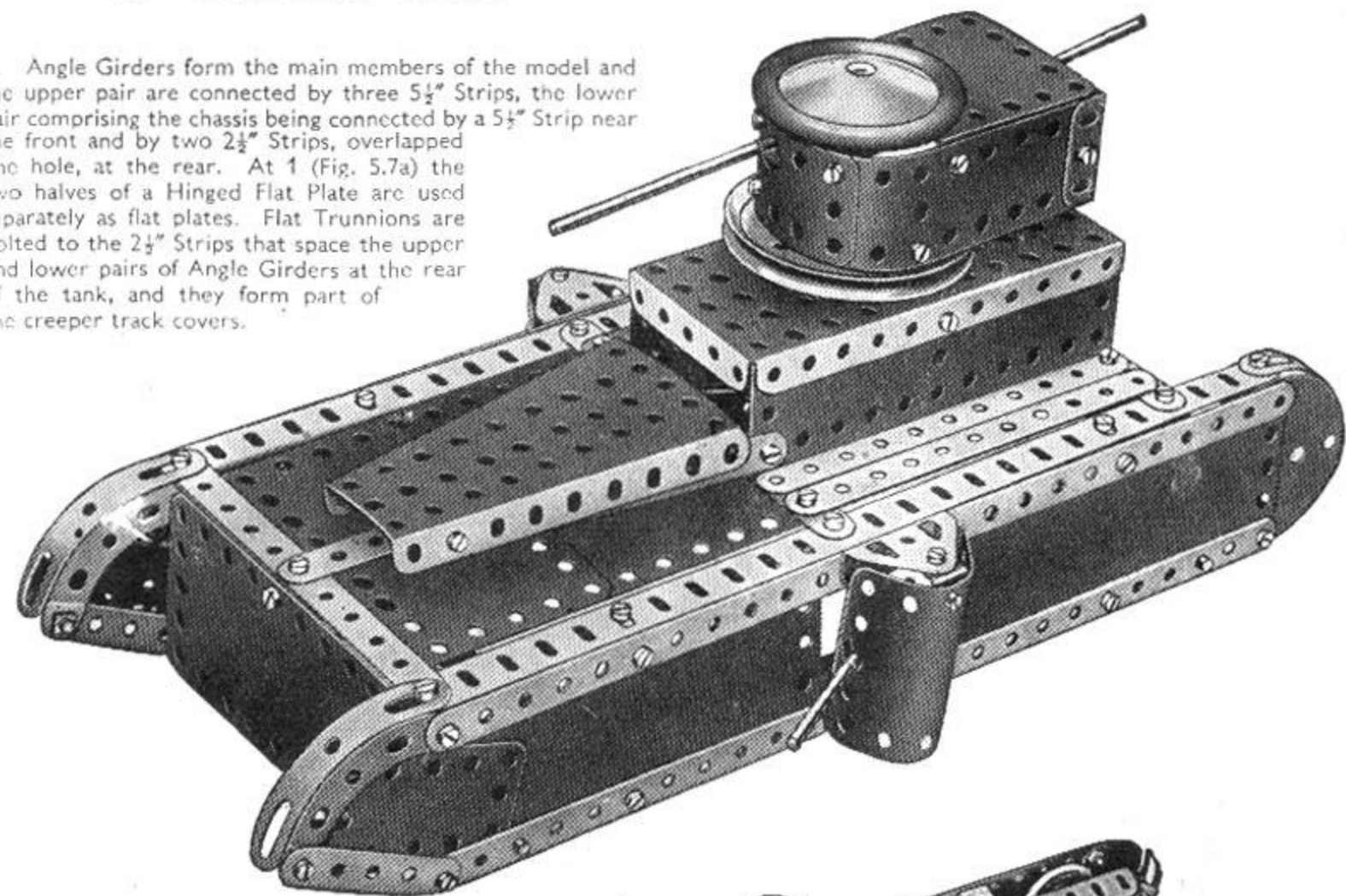

The revolving gun turret is shown in Fig. 5.7b. The rear gun is a  $3\frac{1}{2}$ " Rod, which is fitted with a Reversed Angle Bracket on the inside of the Flanged Plate, and is retained in position by Spring Clips. A 5" Rod is fixed in the boss of the 3" Pulley to which the turret is bolted, and a Road Wheel is secured to its top end. The lower end of the rod passes through the  $5\frac{1}{2}$ " x  $2\frac{1}{2}$ " Flanged Plate and through a Double Bent Strip. A 1" Pulley retains the complete unit in position. The Flanged Sector Plate shown in the general view is bolted to a second Flanged Sector Plate and overlaps it by eight holes.

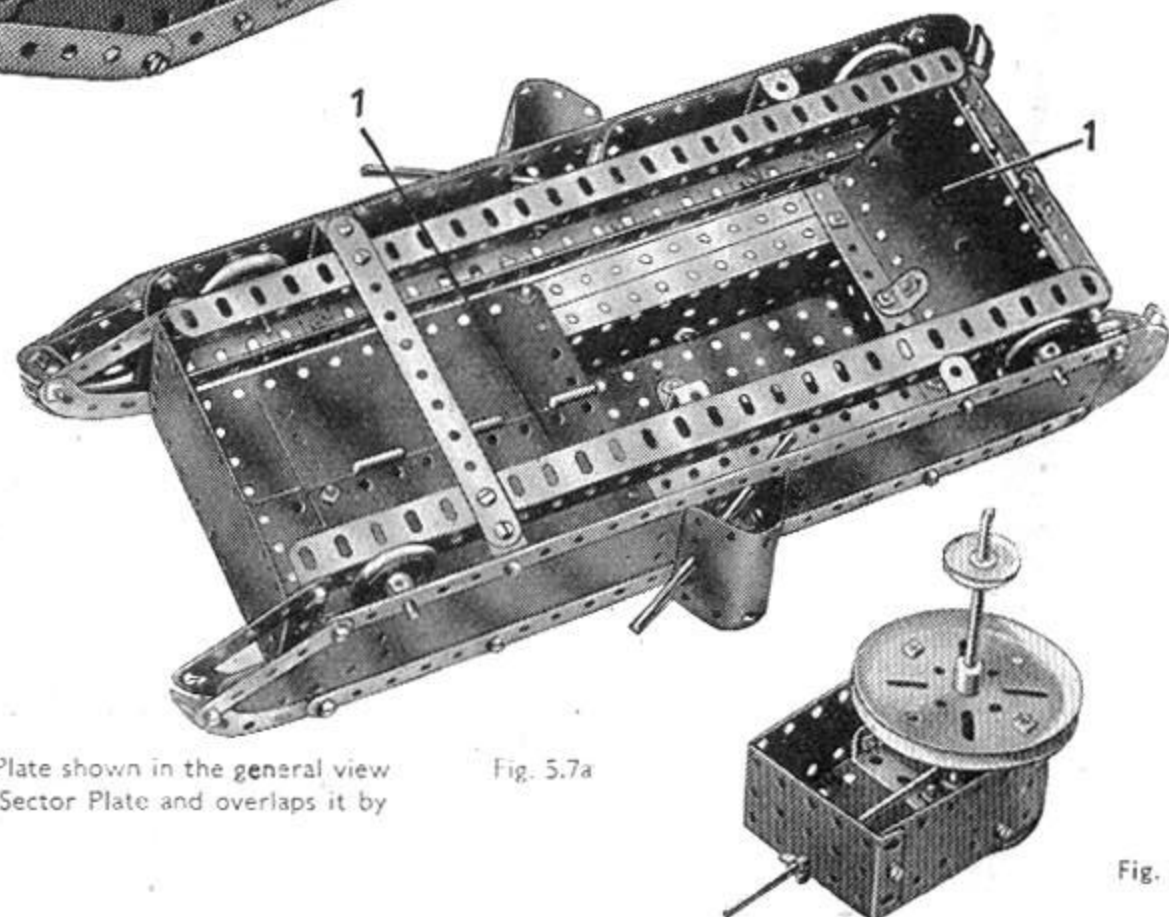
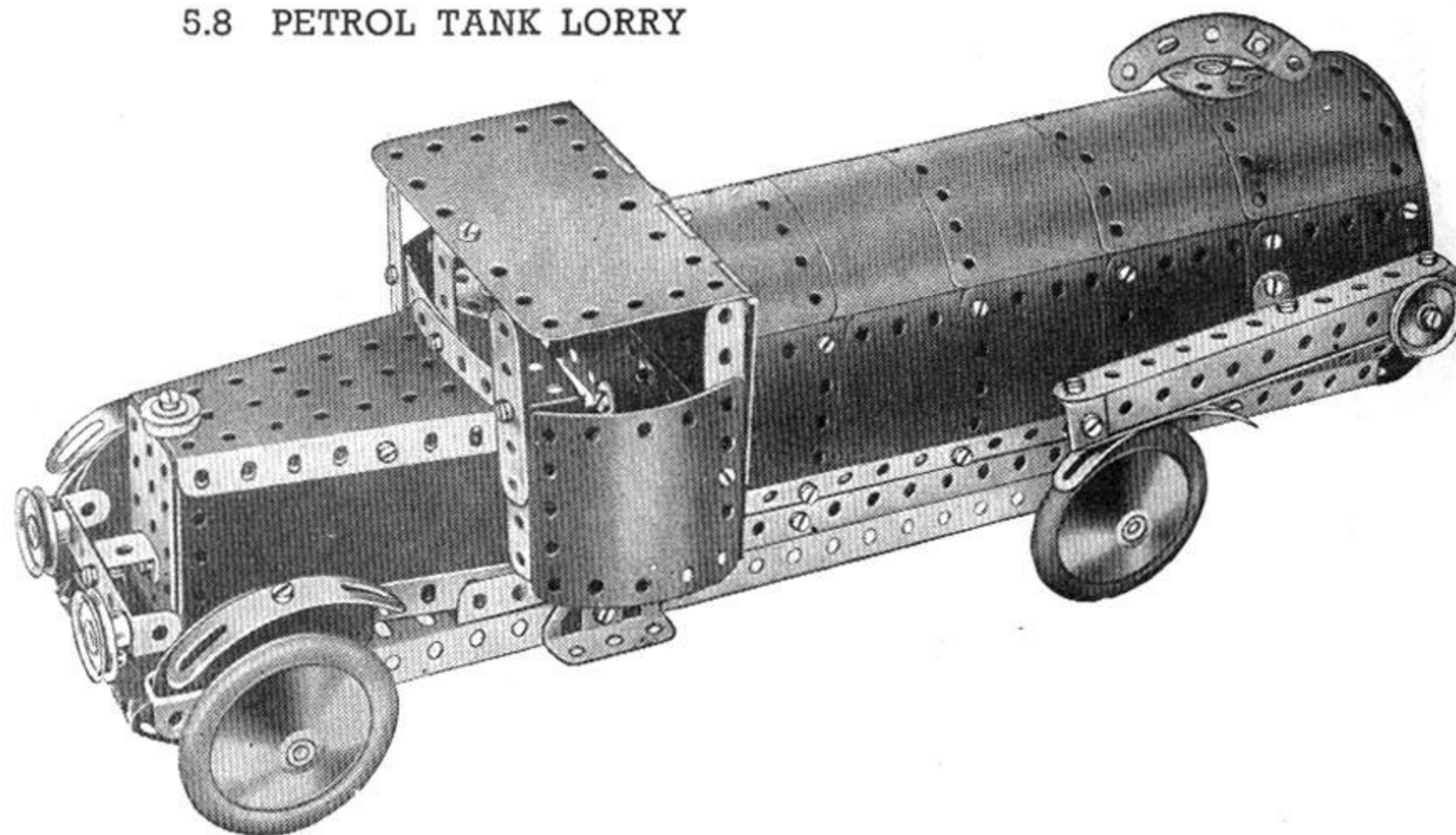

Fig. 5.7a

Fig. 5.7b

### 5.8 PETROL TANK LORRY



The chassis of the model is shown in Fig. 5.8a. Each side member consists of two  $12\frac{1}{2}$ " Angle Girders overlapped 18 holes and bolted together. Flanged Sector Plates are used for the top and bottom of the bonnet, and  $4\frac{1}{2}$ " x  $2\frac{1}{2}$ " Flexible Plates for the sides and are bolted on the inside of the flanges.

The Steering wheel is a Wheel Disc carried on a bolt lock-nutted to the Flanged Sector Plate.

The roof and back of the cab consist of a Hinged Flat Plate and two  $2\frac{1}{2}$ " x  $1\frac{1}{2}$ " Flexible Plates overlapped one hole. The cab is fastened to the chassis by Angle Brackets, and to the bonnet by the  $1\frac{1}{2}$ " x  $\frac{1}{2}$ " Double Angle Strip that forms the central division of the windscreen.

In Fig. 5.8a the tank is opened out to show its construction. The top of the tank consists of four  $5\frac{1}{2}$ " x  $2\frac{1}{2}$ " Flexible Plates and a  $5\frac{1}{2}$ " x  $1\frac{1}{2}$ " Flexible Plate. It is extended on the rear side by two  $5\frac{1}{2}$ " x  $1\frac{1}{2}$ " Flexible Plates, and  $12\frac{1}{2}$ " Strips are bolted to each longitudinal edge. The complete tank is attached to the Angle Girders by four Obtuse Angle Brackets. The tank filler cap is a Bush Wheel fitted with a  $2\frac{1}{2}$ " small radius Curved Strip, and is fastened to the shank of the  $\frac{1}{2}$ " Bolt at the top of the tank.

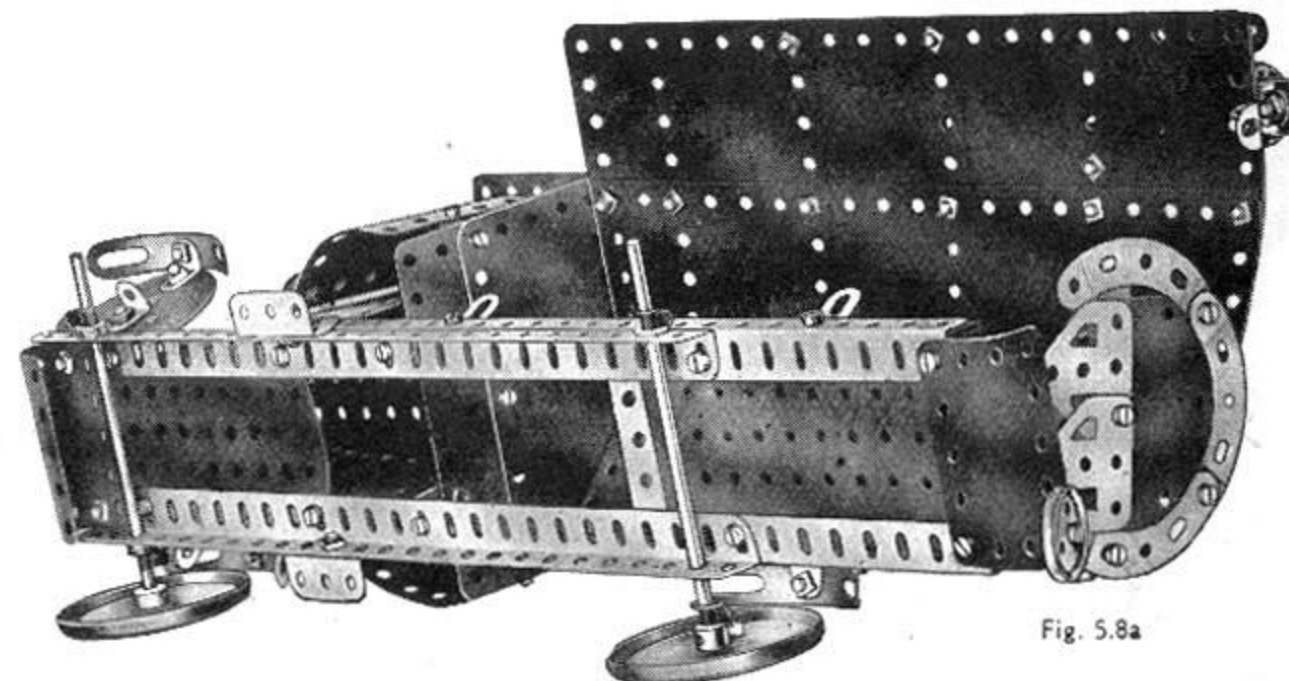
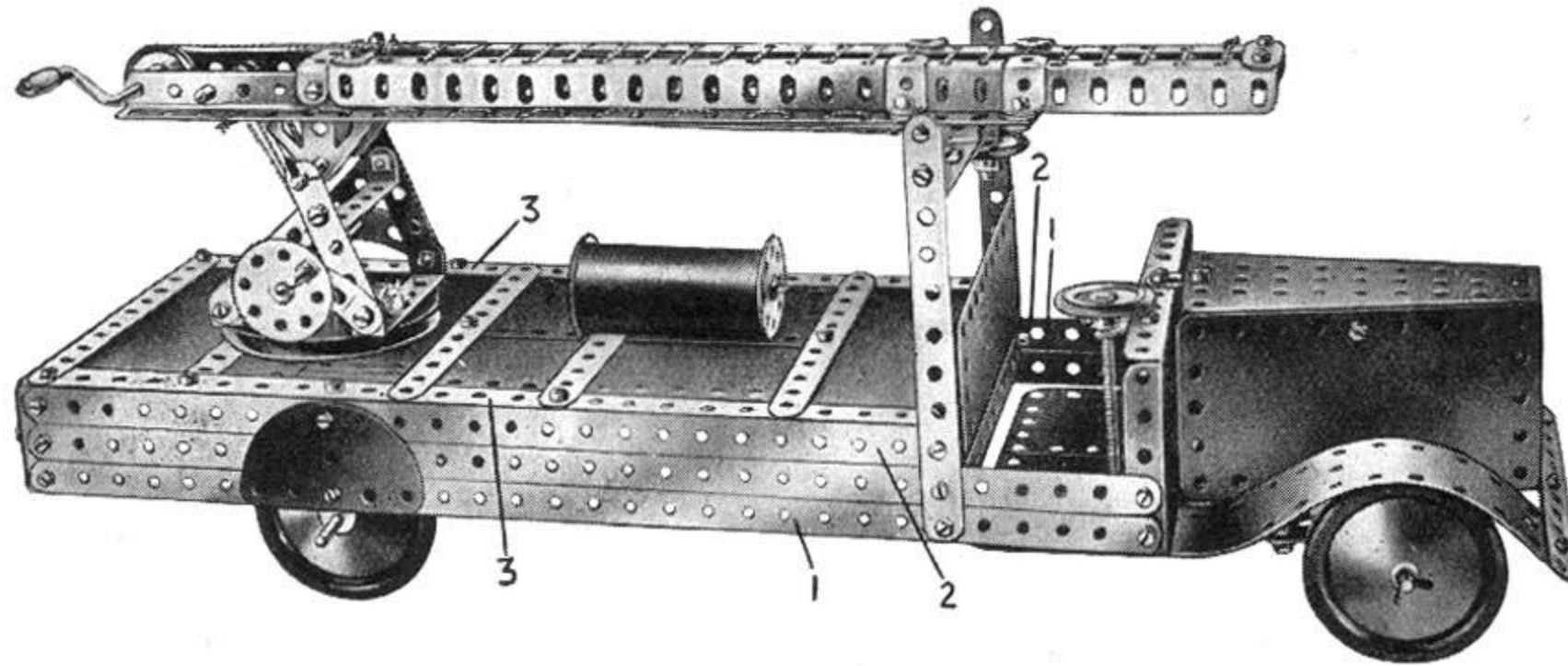

Fig. 5.8a

## 5.9 FIRE ENGINE



The body is built up on two compound Strips 1, each consisting of two  $12\frac{1}{2}$ " Strips overlapped. These are joined at the front by a Flanged Plate that forms the back of the bonnet, and a Trunnion is bolted across the ends of the Strips at the rear. The Trunnions are joined by a  $5\frac{1}{2}$ " x  $1\frac{1}{2}$ " Flexible Plate strengthened by a  $5\frac{1}{2}$ " Strip. The strips 2 are a  $12\frac{1}{2}$ " and a  $5\frac{1}{2}$ " Strip overlapped six holes. The  $12\frac{1}{2}$ " Strips 3 are attached to the sides by Angle Brackets.

The bonnet is made from two Flanged Sector Plates joined by two  $4\frac{1}{2}$ " x  $2\frac{1}{2}$ " Flexible Plates, and is secured to the  $5\frac{1}{2}$ " x  $2\frac{1}{2}$ " Flanged Plates by Fishplates. The radiator is represented by a  $2\frac{1}{2}$ " x  $1\frac{1}{2}$ " Flanged Plate.

The rear axle is formed by two  $3\frac{1}{2}$ " Rods joined together by a Rod Connector and journalled in Fishplates bolted to the chassis.

The front wheel mounting and steering arrangement is as follows. First, a  $3\frac{1}{2}$ " Strip 13 (Fig. 5.9a) is bolted securely across the underside of the bonnet. A  $2\frac{1}{2}$ " Strip 14 and a Double Bracket are then held freely by a nut on a  $\frac{3}{8}$ " Bolt, and the remaining shank of the bolt is passed through one end of the  $3\frac{1}{2}$ " Strip. A second nut is then placed on the Bolt so as to lock it firmly to the Strip, but at the same time leave the  $2\frac{1}{2}$ " Strip free to pivot. One of the Road Wheels is then fixed to a 1" Rod held by a Spring Clip in the Double Bracket. At the other

side of the model a second  $2\frac{1}{2}$ " Strip 4, a Double Bracket and a third  $2\frac{1}{2}$ " Strip 5, are assembled on a  $\frac{3}{8}$ " Bolt and held tightly with a nut. The Bolt is then lock-nutted to the end of the  $3\frac{1}{2}$ " Strip.

The free ends of the Strips 4 and 14 are now lock-nutted to the track rod 15.

The steering column is a 3" Screwed Rod journalled in Fishplates attached to the Flanged Plate. A  $2\frac{1}{2}$ " Strip 6, bent upward slightly, is fastened to the Screwed Rod by two nuts and is connected to the Strip 5 by two  $2\frac{1}{2}$ " Strips overlapped three holes. The front end of this compound strip is held between two nuts on a Bolt passed through the Strip 5. It should be noted that the Strip 5 is also bent upward slightly.

Details of the escape are shown in Fig. 5.9b. It is built up on a 3" Pulley locked on a 2" Rod. This Rod passes through the centre holes of a compound plate made by bolting the halves of a Hinged Flat Plate to the Strips 3. A 1" Pulley on the 2" Rod holds the escape in position. The Angle Girders 7 are joined at the top by a  $2\frac{1}{2}$ " Strip, and at their lower ends by the  $1\frac{1}{2}$ " x  $\frac{1}{2}$ " Double Angle Strip 8.

The extending section of the escape is made by two Angle Girders joined at each end by  $1\frac{1}{2}$ " Strips. These Girders pass over the Angle Girders 7 and slide under the Reversed Angle Brackets 9, each of which is spaced from the Girders 7 by two Washers. A length of Cord tied to the  $1\frac{1}{2}$ " Strip 10 passes around a Pulley on the Crank Handle, and around a second Pulley 11 locked on a 1" Rod journalled in a Stepped Bent Strip. This Cord is then fastened to the Strip 10.

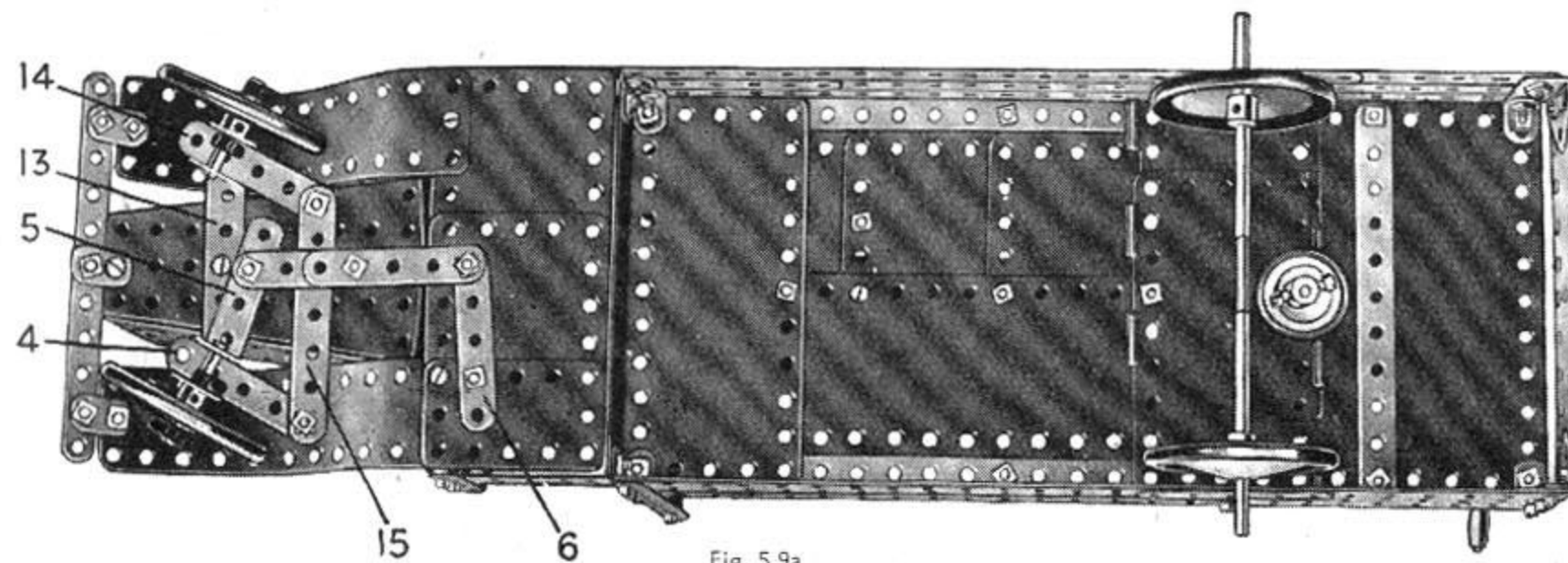

Fig. 5.9a

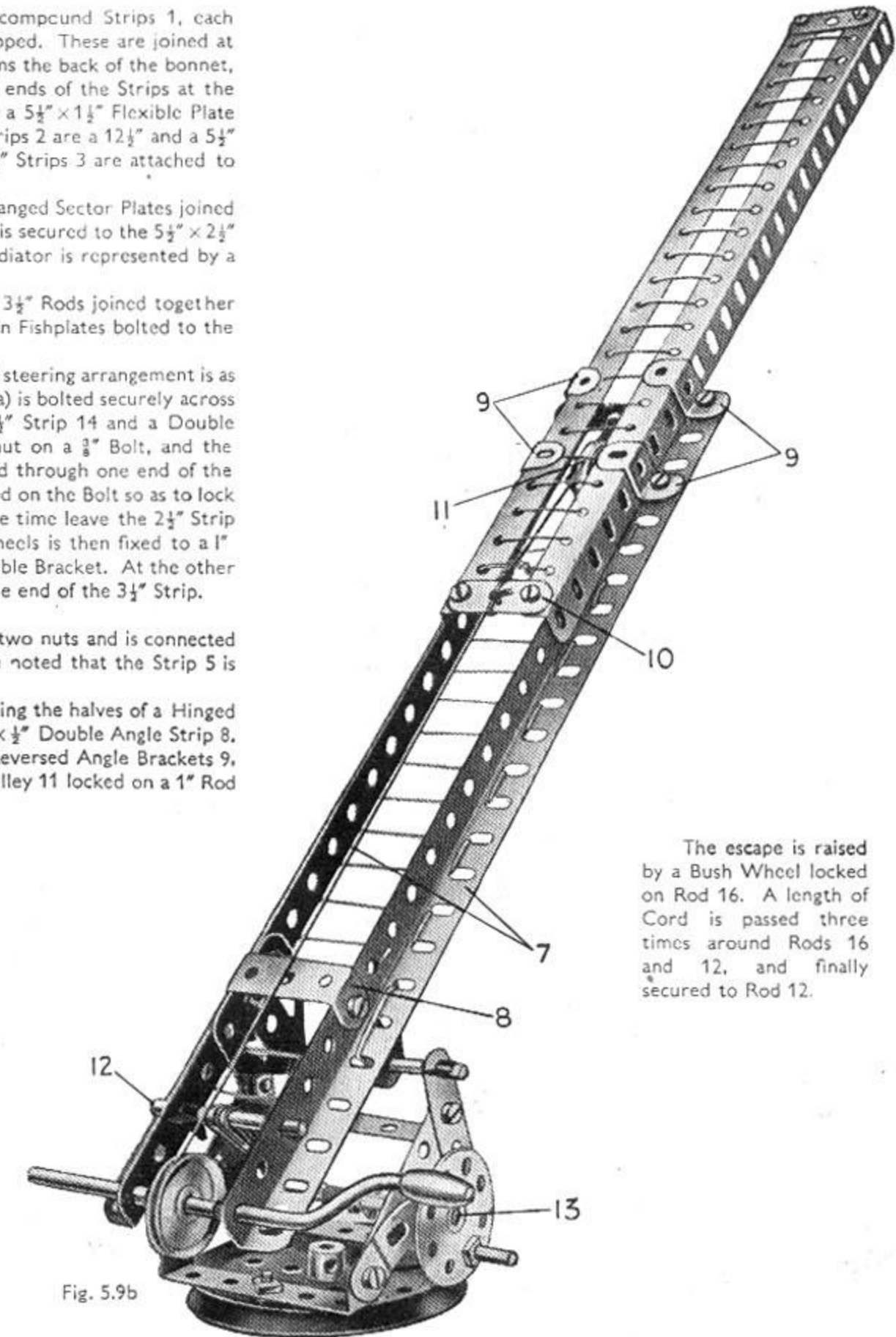
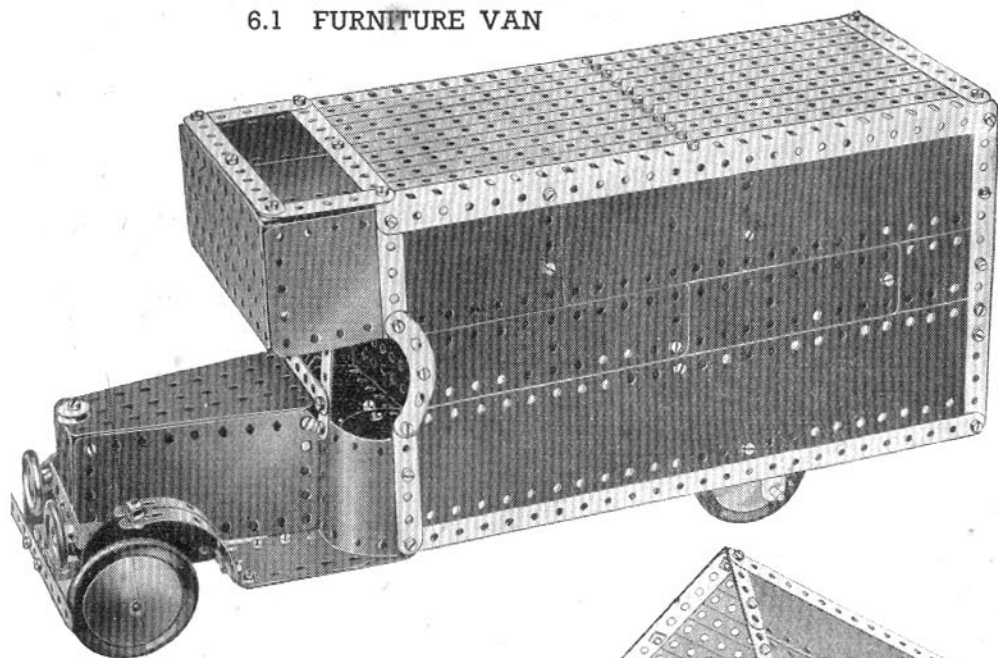

Fig. 5.9b

The escape is raised by a Bush Wheel locked on Rod 16. A length of Cord is passed three times around Rods 16 and 12, and finally secured to Rod 12.

## 6.1 FURNITURE VAN



The bonnet unit consists of two Flanged Sector Plates, the flanges of which are joined by  $4\frac{1}{2}'' \times 2\frac{1}{2}''$  Flexible Plates. The radiator is bolted in position to the two Flanged Sector Plates, the upper Bolt being  $\frac{3}{8}''$  long and carrying a  $\frac{1}{2}''$  loose Pulley to represent the radiator cap. The lower Flanged Sector Plate is bolted to a  $3\frac{1}{2}'' \times 2\frac{1}{2}''$  Flanged Plate, which is secured to the chassis.

The front bumper is fastened by two Reversed Angle Brackets to the ends of two  $3\frac{1}{2}'' \times \frac{1}{2}''$  Double Angle Strips fixed under the bonnet. The headlights are represented by  $1''$  fast Pulleys on the shanks of two  $\frac{3}{8}''$  Bolts, which are passed through a  $2\frac{1}{2}'' \times \frac{1}{2}''$  Double Angle Strip bolted to the radiator. Running boards are represented by  $2\frac{1}{2}'' \times 1\frac{1}{2}''$  Flexible Plates bolted to the  $3\frac{1}{2}'' \times 2\frac{1}{2}''$  Flanged Plate, and they provide supports for the front mudguards. The latter each consists of two Formed Slotted Strips coupled together by Fishplates and they are secured to the running board by Angle Brackets.

The seat inside the cab is made from two U-Section Curved Plates connected by Fishplates and attached by an Angle Bracket to the back of the seat, which consists of a  $3\frac{1}{2}'' \times 2\frac{1}{2}''$  Flanged Plate extended by a  $2\frac{1}{2}'' \times 2\frac{1}{2}''$  Flexible Plate.

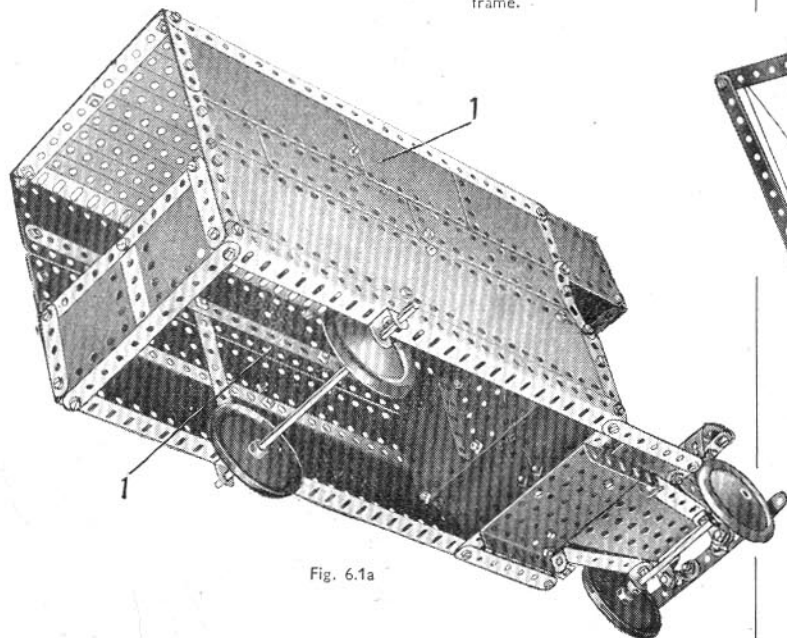

Fig. 6.1a

The construction of the model is commenced by building the van body, the base of which consists of two  $12\frac{1}{2}''$  Angle Girders joined at each end by a  $5\frac{1}{2}''$  Strip. The lower part of each side consists of a  $12\frac{1}{2}''$  Strip Plate and different sized Flexible Plates, and the two flat plates 1 form the upper part of the sides. The flat plates 1 are obtained by removing the centre pin from a Hinged Flat Plate and using the halves separately. Each side is bolted over a framework of  $12\frac{1}{2}''$  Strips and  $5\frac{1}{2}''$  Strips, which can be seen in Fig. 6.1a. The top is constructed from  $12\frac{1}{2}''$  strips clamped at each end between  $5\frac{1}{2}''$  Strips connected to the frame.

## 6.2 WINDMILL

The corners of the main frame are four Angle Girders, connected at their lower ends by  $5\frac{1}{2}''$  Strips and at their upper ends by  $2\frac{1}{2}''$  Strips. The sides are filled in with  $12\frac{1}{2}'' \times 2\frac{1}{2}''$  Strip Plates, and at the front Flexible Plates are used in order to leave a space for the doorway. A  $3\frac{1}{2}'' \times 2\frac{1}{2}''$  Flanged Plate fastened to the front  $5\frac{1}{2}''$  Strip by Angle Brackets forms a platform in front of the doorway.

The top portion of the windmill is constructed as follows: Two Flanged Sector Plates are bolted together at right angles

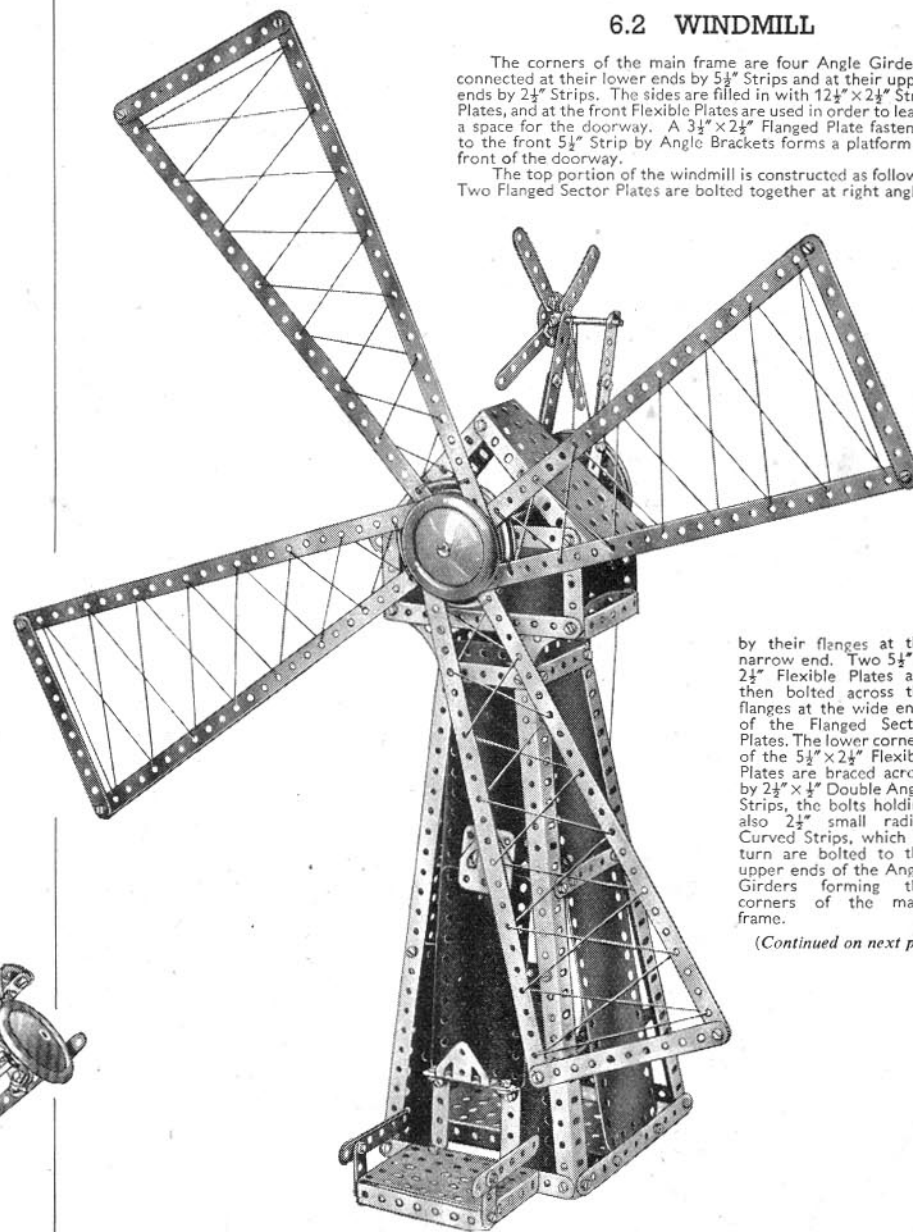

by their flanges at the narrow end. Two  $5\frac{1}{2}'' \times 2\frac{1}{2}''$  Flexible Plates are then bolted across the flanges at the wide ends of the Flanged Sector Plates. The lower corners of the  $5\frac{1}{2}'' \times 2\frac{1}{2}''$  Flexible Plates are braced across by  $2\frac{1}{2}'' \times \frac{1}{2}''$  Double Angle Strips, the bolts holding also  $2\frac{1}{2}''$  small radius Curved Strips, which in turn are bolted to the upper ends of the Angle Girders forming the corners of the main frame.

(Continued on next page)

### 6.2 WINDMILL Continued—

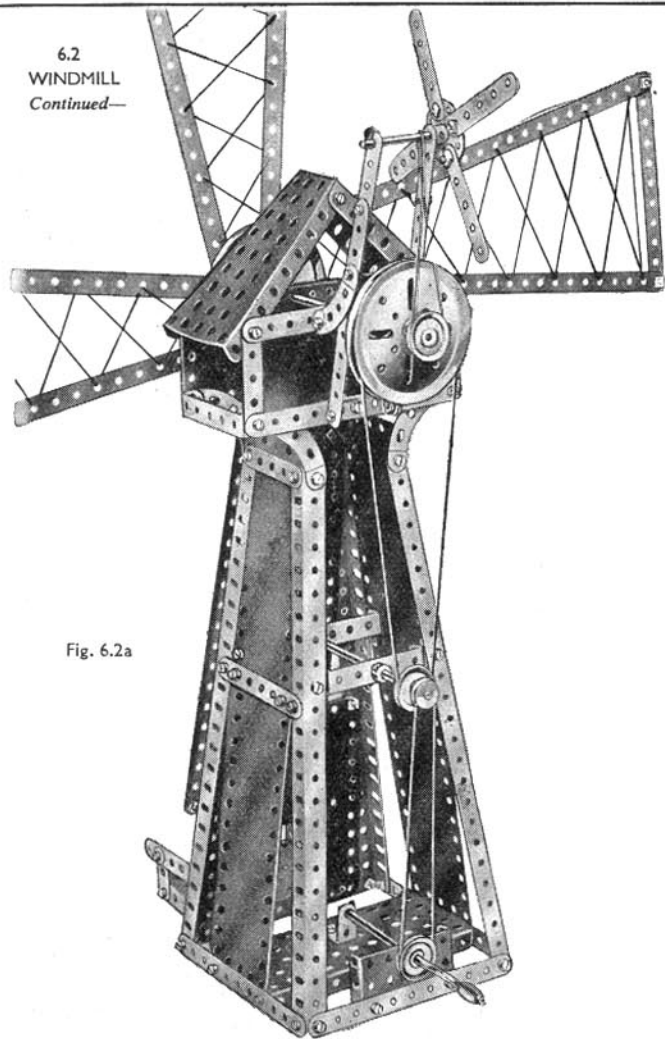

Fig. 6.2a

A superstructure (Fig. 6.2a) is erected at the rear to hold the directional vanes. It is constructed by fastening two compound strips, each consisting of a  $5\frac{1}{2}$ " and a  $2\frac{1}{2}$ " Strip, to the back  $5\frac{1}{2}$ " x  $2\frac{1}{2}$ " Flexible Plate by a  $1\frac{1}{2}$ " x  $\frac{1}{2}$ " Double Angle Strip. The compound strips are braced by two  $2\frac{1}{2}$ " Curved Strips, also fastened to the  $5\frac{1}{2}$ " x  $2\frac{1}{2}$ " Flexible Plate by a  $1\frac{1}{2}$ " x  $\frac{1}{2}$ " Double Angle Strip. A 2" Rod, journalled in the end holes of the compound strips, carries at its end a Bush Wheel, to which are bolted  $2\frac{1}{2}$ " Strips representing the vanes.

The construction of the sails, and the manner in which they are mounted are clear from the illustration.

A Crank Handle journalled as shown in Fig. 6.2a carries on its shaft a 1" Pulley that is connected by a Driving Band to a  $\frac{1}{2}$ " Pulley on a 5" Rod midway up the frame. A 1" fast Pulley, also on the 5" Rod, is connected by Cord to the 3" Pulley on the shaft of the sails, and a 1" Pulley on this shaft is connected by a Driving Band with the 2" Rod carrying the directional vanes.

### 6.3 TOWER WAGON

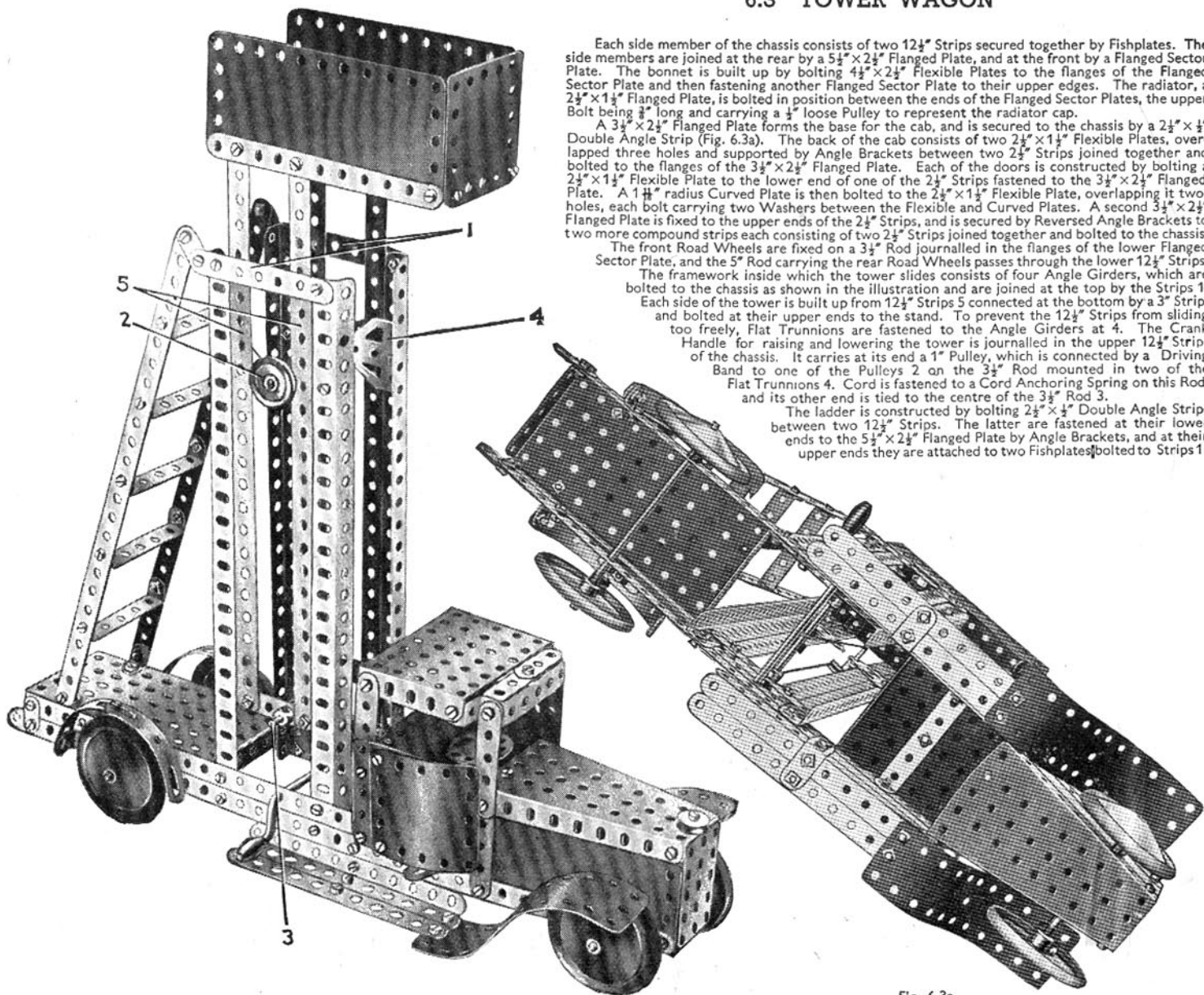

Fig. 6.3a

Each side member of the chassis consists of two  $12\frac{1}{2}$ " Strips secured together by Fishplates. The side members are joined at the rear by a  $5\frac{1}{2}$ " x  $2\frac{1}{2}$ " Flanged Plate, and at the front by a Flanged Sector Plate. The bonnet is built up by bolting  $4\frac{1}{2}$ " x  $2\frac{1}{2}$ " Flexible Plates to the flanges of the Flanged Sector Plate and then fastening another Flanged Sector Plate to their upper edges. The radiator, a  $2\frac{1}{2}$ " x  $1\frac{1}{2}$ " Flanged Plate, is bolted in position between the ends of the Flanged Sector Plates, the upper Bolt being  $\frac{3}{8}$ " long and carrying a  $\frac{1}{2}$ " loose Pulley to represent the radiator cap.

A  $3\frac{1}{2}$ " x  $2\frac{1}{2}$ " Flanged Plate forms the base for the cab, and is secured to the chassis by a  $2\frac{1}{2}$ " x  $\frac{1}{2}$ " Double Angle Strip (Fig. 6.3a). The back of the cab consists of two  $2\frac{1}{2}$ " x  $1\frac{1}{2}$ " Flexible Plates, overlapped three holes and supported by Angle Brackets between two  $2\frac{1}{2}$ " Strips joined together and bolted to the flanges of the  $3\frac{1}{2}$ " x  $2\frac{1}{2}$ " Flanged Plate. Each of the doors is constructed by bolting a  $2\frac{1}{2}$ " x  $1\frac{1}{2}$ " Flexible Plate to the lower end of one of the  $2\frac{1}{2}$ " Strips fastened to the  $3\frac{1}{2}$ " x  $2\frac{1}{2}$ " Flanged Plate. A  $1\frac{1}{8}$ " radius Curved Plate is then bolted to the  $2\frac{1}{2}$ " x  $1\frac{1}{2}$ " Flexible Plate, overlapping it two holes, each bolt carrying two Washers between the Flexible and Curved Plates. A second  $3\frac{1}{2}$ " x  $2\frac{1}{2}$ " Flanged Plate is fixed to the upper ends of the  $2\frac{1}{2}$ " Strips, and is secured by Reversed Angle Brackets to two more compound strips each consisting of two  $2\frac{1}{2}$ " Strips joined together and bolted to the chassis.

The front Road Wheels are fixed on a  $3\frac{1}{2}$ " Rod journalled in the flanges of the lower Flanged Sector Plate, and the 5" Rod carrying the rear Road Wheels passes through the lower  $12\frac{1}{2}$ " Strips.

The framework inside which the tower slides consists of four Angle Girders, which are bolted to the chassis as shown in the illustration and are joined at the top by the Strips 1.

Each side of the tower is built up from  $12\frac{1}{2}$ " Strips 5 connected at the bottom by a 3" Strip, and bolted at their upper ends to the stand. To prevent the  $12\frac{1}{2}$ " Strips from sliding too freely, Flat Trunnions are fastened to the Angle Girders at 4.

The Crank Handle for raising and lowering the tower is journalled in the upper  $12\frac{1}{2}$ " Strips of the chassis. It carries at its end a 1" Pulley, which is connected by a Driving Band to one of the Pulleys 2 on the  $3\frac{1}{2}$ " Rod mounted in two of the Flat Trunnions 4. Cord is fastened to a Cord Anchoring Spring on this Rod, and its other end is tied to the centre of the  $3\frac{1}{2}$ " Rod 3.

The ladder is constructed by bolting  $2\frac{1}{2}$ " x  $\frac{1}{2}$ " Double Angle Strips between two  $12\frac{1}{2}$ " Strips. The latter are fastened at their lower ends to the  $5\frac{1}{2}$ " x  $2\frac{1}{2}$ " Flanged Plate by Angle Brackets, and at their upper ends they are attached to two Fishplates bolted to Strips 1.

## 6.4 STREAMLINED FIRE ENGINE

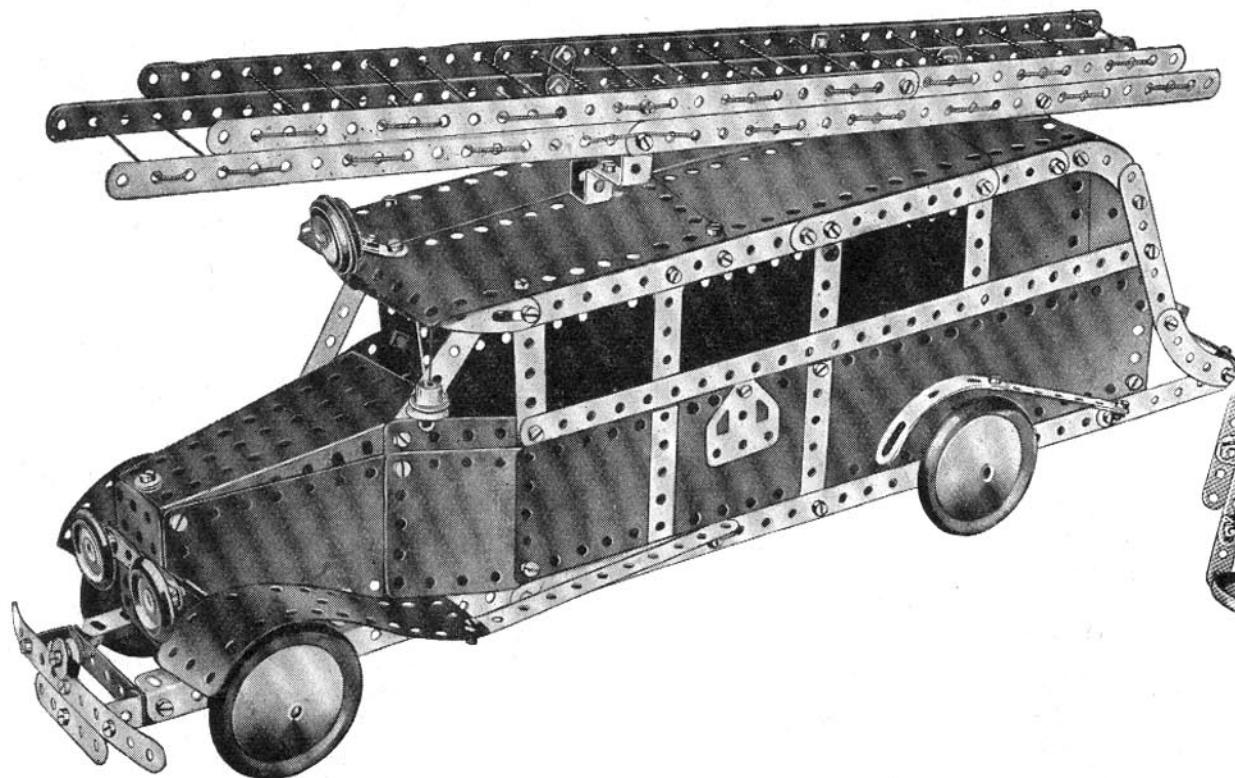

Each side member of the chassis consists of a pair of Angle Girders connected by two  $\frac{3}{8}$ " Bolts, the nuts of which are left untightened. The side members are joined together at the front by a  $2\frac{1}{2}$ "  $\times$   $1\frac{1}{2}$ " Double Angle Strip and a  $5\frac{1}{2}$ " Strip. The rear Angle Girders are not joined, but are pushed apart as far as the  $\frac{3}{8}$ " Bolts allow. Reference to Fig. 6.4a will make the arrangement clear.

The sides of the body consist of  $12\frac{1}{2}$ "  $\times$   $2\frac{1}{2}$ " Strip Plates, and are attached by Fishplates to the rear Angle Girders. The roof is formed by four  $5\frac{1}{2}$ "  $\times$   $2\frac{1}{2}$ " Flexible Plates, and is secured by Angle Brackets to the compound strips forming the tops of the windows. The curved back is obtained by bending Flexible Plates to the correct shape and fastening them to a framework of Strips.

The sides of the bonnet are each represented by a  $4\frac{1}{2}$ "  $\times$   $2\frac{1}{2}$ " Flexible Plate, and are secured to the body of the fire-engine by  $2\frac{1}{2}$ "  $\times$   $2\frac{1}{2}$ " Flexible Plates and  $2\frac{1}{2}$ "  $\times$   $1\frac{1}{2}$ " Flexible Plates. The last named are bolted to the  $12\frac{1}{2}$ "  $\times$   $2\frac{1}{2}$ " Strip Plates forming the sides of the body. A Flanged Sector Plate forms the top of the bonnet, and is secured by the flanges of its narrow end to the two  $4\frac{1}{2}$ "  $\times$   $2\frac{1}{2}$ " Flexible Plates. At its wide end it is fastened to the  $2\frac{1}{2}$ "  $\times$   $1\frac{1}{2}$ " Flexible Plates secured to the body. The radiator is represented by a  $2\frac{1}{2}$ "  $\times$   $1\frac{1}{2}$ " Flanged Plate bolted to the front end of the Flanged Sector Plate. The Bolt carries two Washers above the Flanged Sector Plate to represent the radiator cap.

Two 1" fast Pulleys are used for the headlights, and they are secured by  $\frac{3}{8}$ " Bolts to a  $2\frac{1}{2}$ " Strip fixed to the  $2\frac{1}{2}$ "  $\times$   $1\frac{1}{2}$ " Flanged Plate forming the radiator. The  $\frac{3}{8}$ " Bolts pass through the end holes of the  $2\frac{1}{2}$ " Strip, and are locked in the bosses of the 1" Pulleys. The front bumper is represented by a  $5\frac{1}{2}$ " Strip extended downward by a  $2\frac{1}{2}$ " Strip. It is fastened in position to the  $2\frac{1}{2}$ "  $\times$   $1\frac{1}{2}$ " Double Angle Strip at the front of the chassis by two Reversed Angle Brackets.

The Road Wheels are held on 5" Rods journalled in the sides of the chassis. The front mudguards are each formed by a  $5\frac{1}{2}$ "  $\times$   $1\frac{1}{2}$ " Flexible Plate bolted to the  $5\frac{1}{2}$ " Strip joining the side members of the chassis. A  $3\frac{1}{2}$ " Strip extended by a Formed Slotted Strip and secured by an Angle Bracket to the side of the body, is used for each of the rear mudguards.

The rear 5" Rod carries a Collar between the side members of the chassis. A Pivot Bolt, which carries a 1" fast Pulley 2 against its head, is screwed into the tapped hole of the Collar, thus holding it in position on the Rod. A Flanged Sector Plate 1 is loosely suspended from a  $2\frac{1}{2}$ "  $\times$   $1\frac{1}{2}$ " Double Angle Strip 3 by a lock-nutted  $\frac{3}{8}$ " Bolt. When the rear Road Wheels revolve, the Pulley 2 strikes the Flanged Sector Plate 1, and thus provides an automatic gong.

Two small radius Curved Strips each fitted with a Fishplate are bolted as shown in Fig. 6.4b to the back of the Fire Engine to represent the appliance tools. A 2" Rod is clamped between the Fishplates and the Flexible Plates.

(Continued on next page)

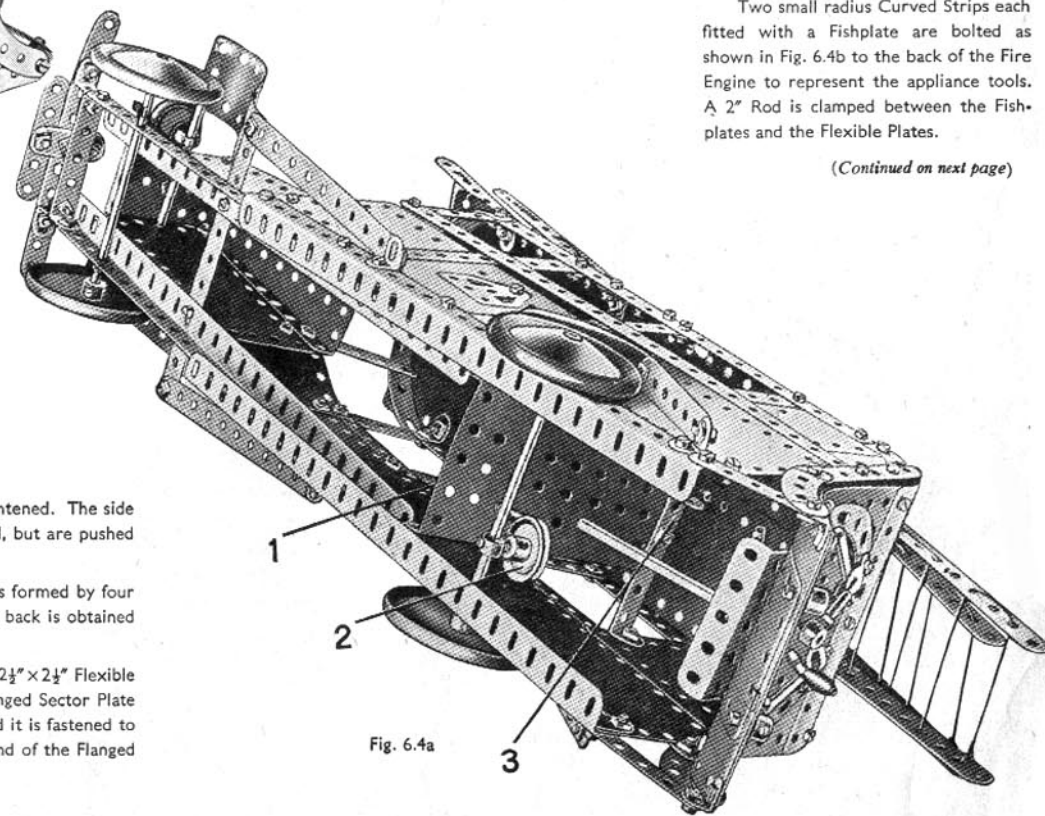

Fig. 6.4a

## 6.4 STREAMLINED FIRE ENGINE

*continued—*

The fixed escape ladder consists of two pairs of compound strips, each built up from two  $12\frac{1}{2}$ " Strips bolted together overlapping eight holes. The escape is attached to the roof of the car at the rear by a  $2\frac{1}{2}$ "  $\times$   $\frac{1}{2}$ " Double Angle Strip, and at the front by a compound bracket, which is built up by attaching  $1$ "  $\times$   $1$ " Angle Brackets to the ends of a Double Bent Strip. The extension escape is built up from two pairs of compound strips each consisting of two  $12\frac{1}{2}$ " Strips overlapping 13 holes. The extension ladder is fastened to the fixed part of the escape by Fishplates. The rungs of the ladders are represented by Cord threaded through the holes in the Strips.

The searchlight at the front of the fire-engine is made by placing a  $\frac{3}{4}$ " Washer, a  $1$ " loose Pulley fitted with a Rubber Ring, a Wheel Disc, and a second  $1$ " loose Pulley on the shank of a  $\frac{1}{2}$ " Bolt. The complete unit is then fastened to the roof by a compound bracket consisting of two Obtuse Angle Brackets bolted together.

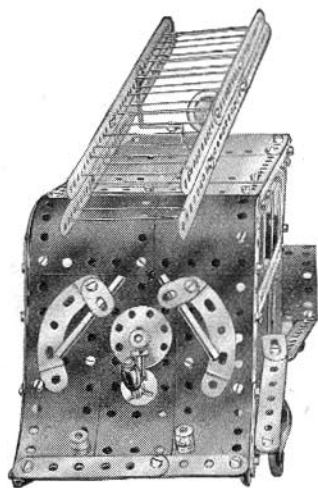
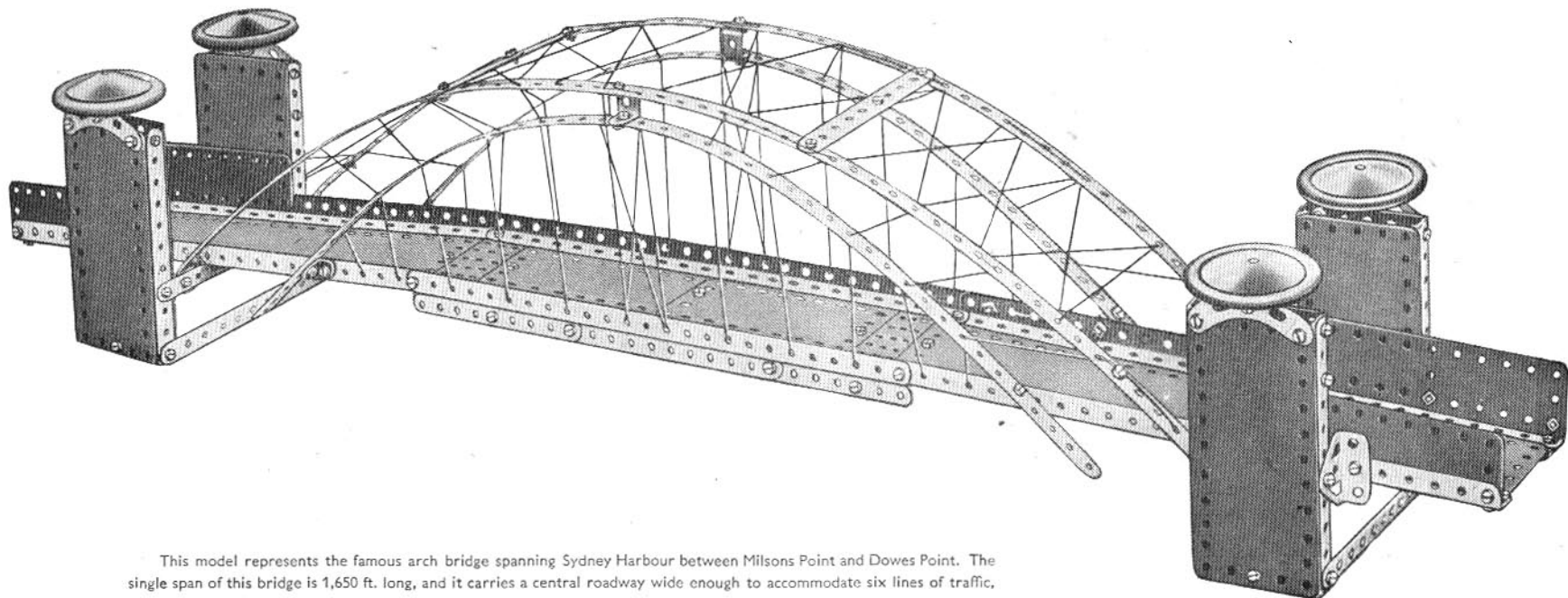

Fig. 6.4b

## 6.5 SYDNEY HARBOUR BRIDGE



This model represents the famous arch bridge spanning Sydney Harbour between Milsons Point and Dowes Point. The single span of this bridge is 1,650 ft. long, and it carries a central roadway wide enough to accommodate six lines of traffic, flanked on either side by two railway tracks and a footpath.

Each of the towers consists of two  $5\frac{1}{2}$ " Strips joined across by  $2\frac{1}{2}$ "  $\times$   $\frac{1}{2}$ " Double Angle Strips, between which  $5\frac{1}{2}$ "  $\times$   $2\frac{1}{2}$ " Flexible Plates are bolted on the outside face, and on the inside face  $2\frac{1}{2}$ "  $\times$   $2\frac{1}{2}$ " Flexible Plates are attached by Angle Brackets. A  $2\frac{1}{2}$ " small radius Curved Strip bolted to the upper  $2\frac{1}{2}$ "  $\times$   $\frac{1}{2}$ " Double Angle Strip carries an Angle Bracket, to which a Road Wheel is attached by a  $\frac{3}{8}$ " Bolt. The pairs of towers at each end of the bridge are joined across by two  $5\frac{1}{2}$ " Strips and a compound strip formed from two  $3\frac{1}{2}$ " Strips.

Each side of the span consists of two Angle Girders joined together by two  $12\frac{1}{2}$ " Strips arranged in the form of an angle girder. The two sides are connected by  $3\frac{1}{2}$ "  $\times$   $2\frac{1}{2}$ " Flanged Plates held by the same bolts as the  $12\frac{1}{2}$ " Strips, and also by a  $3\frac{1}{2}$ "  $\times$   $\frac{1}{2}$ " Double Angle Strip at the centre. The roadway at the centre of the span is represented by two  $4\frac{1}{2}$ "  $\times$   $2\frac{1}{2}$ " Flexible Plates overlapped one hole and bolted between the  $3\frac{1}{2}$ "  $\times$   $2\frac{1}{2}$ " Flanged Plates. The remainder of the roadway consists of  $12\frac{1}{2}$ "  $\times$   $2\frac{1}{2}$ " Strip Plates, attached to the  $3\frac{1}{2}$ "  $\times$   $2\frac{1}{2}$ " Flanged Plates to one end and clamped between Fishplates and the Angle Girders at the other end. The sides of the approach roadways are  $5\frac{1}{2}$ "  $\times$   $1\frac{1}{2}$ " Flexible Plates bolted to the Angle Girders of the span. The completed span is attached to each pair of towers by a Trunnion bolted in the position shown in the illustration.

The top of the suspension arch on each side consists of two  $12\frac{1}{2}$ " Strips, bolted together and extended at each end by a  $2\frac{1}{2}$ " Strip. An Obtuse Angle Bracket and an Angle Bracket are bolted to the end of the  $2\frac{1}{2}$ " Strip, the Angle Bracket being attached to the span and the Obtuse Angle Bracket to the upper  $5\frac{1}{2}$ " Strip spacing the towers. The inside of the arch is made of two  $12\frac{1}{2}$ " Strips fixed by Angle Brackets to the sides of the roadway and connected by a Double Bracket to the other arch at its centre.

The arches on each side are braced across by compound strips, each of which consists of a  $3\frac{1}{2}$ " Strip and a  $3$ " Strip overlapped three holes. The model is completed by adding the roadway suspension cables, which are represented by Cord and are arranged as shown in the illustration.

## 6.6. MECHANICAL HORSE AND TRAILER

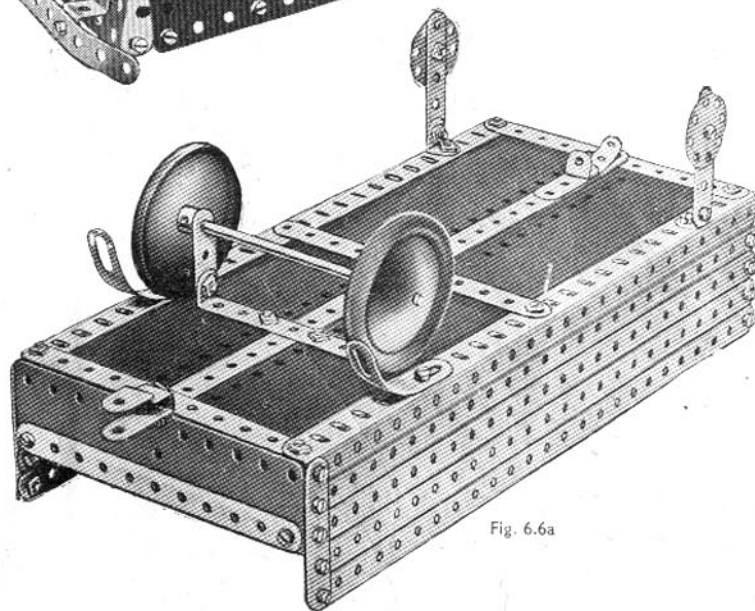
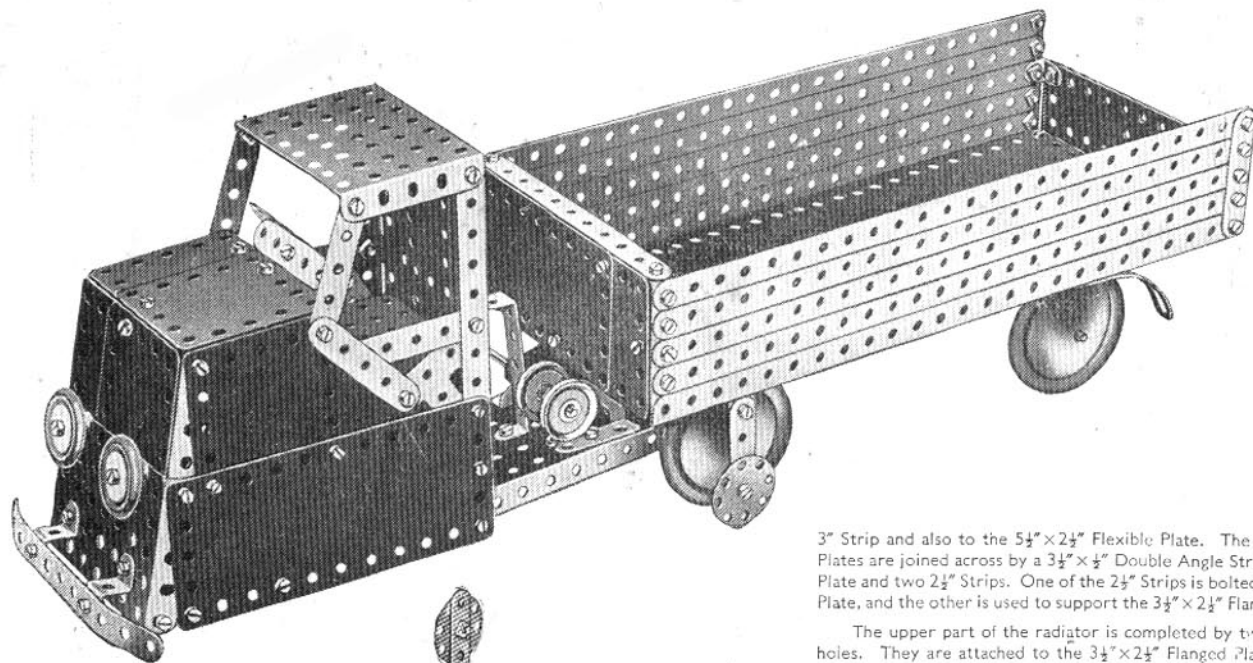

Fig. 6.6a

The cab and bonnet of the mechanical horse are first constructed, and are built up on a base consisting of two  $5\frac{1}{2}$ " Strips bolted to the flanges of a  $3\frac{1}{2}$ " x  $2\frac{1}{2}$ " Flanged Plate. Two  $5\frac{1}{2}$ " x  $2\frac{1}{2}$ " Flexible Plates are bolted to the  $5\frac{1}{2}$ " Strips so that the Strips are extended one hole beyond the edge of the Flexible Plates, thus allowing the  $3\frac{1}{2}$ " x  $2\frac{1}{2}$ " Flanged Plate representing the radiator to be sloped backwards and bolted to the Flexible Plates. Two 3" Strips are bolted inside the flanges of the  $3\frac{1}{2}$ " x  $2\frac{1}{2}$ " Flanged Plate and they overlap the flanges two holes. Two  $5\frac{1}{2}$ " Strips overlap the rear ends of the  $5\frac{1}{2}$ " x  $2\frac{1}{2}$ " Flexible Plates by three holes, and 1" x 1" Angle Brackets are bolted to the lower rear corners of the two Flexible Plates for the purpose of holding the back in position.

Each side of the bonnet is completed by bolting a  $2\frac{1}{2}$ " x  $2\frac{1}{2}$ " Flexible Plate to the 3" Strip and also to the  $5\frac{1}{2}$ " x  $2\frac{1}{2}$ " Flexible Plate. The upper rear corners of the  $2\frac{1}{2}$ " x  $2\frac{1}{2}$ " Flexible Plates are joined across by a  $3\frac{1}{2}$ " x  $\frac{1}{2}$ " Double Angle Strip, each Bolt holding also a  $2\frac{1}{2}$ " x  $1\frac{1}{2}$ " Flexible Plate and two  $2\frac{1}{2}$ " Strips. One of the  $2\frac{1}{2}$ " Strips is bolted to a Flat Trunnion and the  $2\frac{1}{2}$ " x  $1\frac{1}{2}$ " Flexible Plate, and the other is used to support the  $3\frac{1}{2}$ " x  $2\frac{1}{2}$ " Flanged Plate that represents the roof of the cab.

The upper part of the radiator is completed by two  $2\frac{1}{2}$ " x  $2\frac{1}{2}$ " Flexible Plates overlapped three holes. They are attached to the  $3\frac{1}{2}$ " x  $2\frac{1}{2}$ " Flanged Plate by the  $\frac{1}{2}$ " Bolts that hold in place the 1" Pulleys and  $\frac{3}{8}$ " Washers representing the headlamps. Two further  $2\frac{1}{2}$ " x  $2\frac{1}{2}$ " Flexible Plates are attached by an Angle Bracket to those previously mentioned, and are bolted also to the  $3\frac{1}{2}$ " x  $\frac{1}{2}$ " Double Angle Strip spacing the sides of the bonnet.

The back of the cab consists of two  $2\frac{1}{2}$ " x  $1\frac{1}{2}$ " Flexible Plates overlapped three holes and bolted to the 1" x 1" Angle Brackets. The upper portion of the back is completed by overlapping three  $5\frac{1}{2}$ " x  $1\frac{1}{2}$ " Flexible Plates along their long edges and bolting them at their top ends to a 3" Strip and to Angle Brackets.

The driving seat is a  $2\frac{1}{2}$ " x  $1\frac{1}{2}$ " Flanged Plate attached to the back of the cab by an Angle Bracket.

The steering wheel is a Bush Wheel held on a  $3\frac{1}{2}$ " Rod. The Rod is passed through the hole of an Obtuse Angle Bracket bolted to the  $3\frac{1}{2}$ " x  $\frac{1}{2}$ " Double Angle Strip. It is held by a Spring Clip in the hole of a Fishplate, which is bolted to an Angle Bracket fastened to the side of the bonnet.

The single front wheel is a 3" Pulley, which is free to turn on a  $3\frac{1}{2}$ " Rod, and is retained in position by two Spring Clips. The Rod is journalled in holes in two Reversed Angle Brackets bolted to the sides of the bonnet.

The rear part of the chassis is a  $5\frac{1}{2}$ " x  $2\frac{1}{2}$ " Flanged Plate, and it carries a ramp built as follows. Two Trunnions are bolted to the Flanged Plate, and a  $3\frac{1}{2}$ " Strip and a  $2\frac{1}{2}$ " Strip are bolted to each Trunnion as shown in Fig. 6.6c. The  $2\frac{1}{2}$ " Strips are extended by  $2\frac{1}{2}$ " large radius Curved Strips, which are bolted also to a  $1\frac{1}{2}$ " x  $\frac{1}{2}$ " Double Angle Strip fixed to the  $5\frac{1}{2}$ " x  $2\frac{1}{2}$ " Flanged Plate. A Flat Trunnion is attached to an Obtuse Angle Bracket held by the same bolt as the  $1\frac{1}{2}$ " x  $\frac{1}{2}$ " Double Angle Strip. The Crank Handle is passed through holes in the  $2\frac{1}{2}$ " Strips forming the ramp, and two 1" Pulleys are secured to it, one on each side of the rear  $2\frac{1}{2}$ " Strip. The inner 1" Pulley is fitted with a  $\frac{3}{8}$ " Bolt, which is used to allow the trailer to be unhitched from the power unit. The  $2\frac{1}{2}$ " x  $\frac{1}{2}$ " Double Angle Strip at the end of the ramp acts as a stop for the trailer.

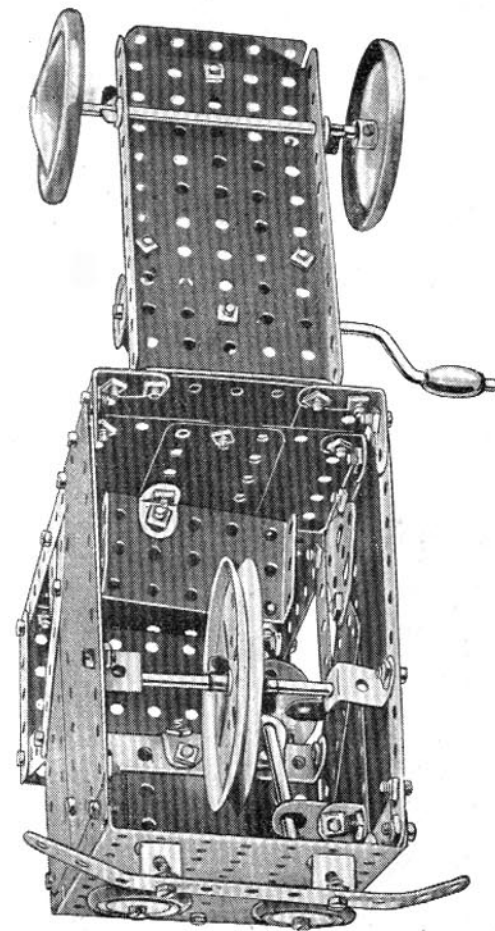

Fig. 6.6b

(Continued on next page)

## 6.6 MECHANICAL HORSE &amp; TRAILER—Continued

An underneath view of the trailer is shown in Fig. 6.6a, its main members are  $12\frac{1}{2}$ " Angle Girders, joined across by a  $5\frac{1}{2}$ " Strip at each end. At the centre a  $12\frac{1}{2}$ " Strip is bolted across the  $5\frac{1}{2}$ " Strips, and the floor is filled in with two  $12\frac{1}{2}$ " Strip Plates. Each of the sides is built up from four  $12\frac{1}{2}$ " Strips, bolted at the rear end to a  $2\frac{1}{2}$ " Strip and at the front end to a  $2\frac{1}{2}$ " x  $\frac{1}{2}$ " Double Angle Strip. The front end of the trailer consists of two  $4\frac{1}{2}$ " x  $2\frac{1}{2}$ " Flexible Plates overlapped seven holes, and attached by Angle Brackets to the bottom and sides. The rear end is a  $5\frac{1}{2}$ " x  $1\frac{1}{2}$ " Flexible Plate fixed to a  $5\frac{1}{2}$ " Strip and attached to the sides by Angle Brackets, and the rear coupling hook is a Stepped Bent Strip bolted to a Fishplate.

The rear Road Wheels are carried on a  $4\frac{1}{2}$ " Rod journalled in  $1\frac{1}{2}$ " Strips bolted to a  $3\frac{1}{2}$ " x  $\frac{1}{2}$ " Double Angle Strip. The front wheels are Wheel Discs bolted to  $2\frac{1}{2}$ " Strips attached by Angle Brackets to the Angle Girders.

The  $2\frac{1}{2}$ " Strip seen underneath the trailer in Fig. 6.6a, is fitted with an Angle Bracket, which engages with the Flat Trunnion forming part of the ramp on the mechanical horse.

When the Crank Handle is turned the  $\frac{3}{4}$ " Bolt in the boss of the inner Pulley lifts the front of the trailer and releases the Angle Bracket from behind the Flat Trunnion.

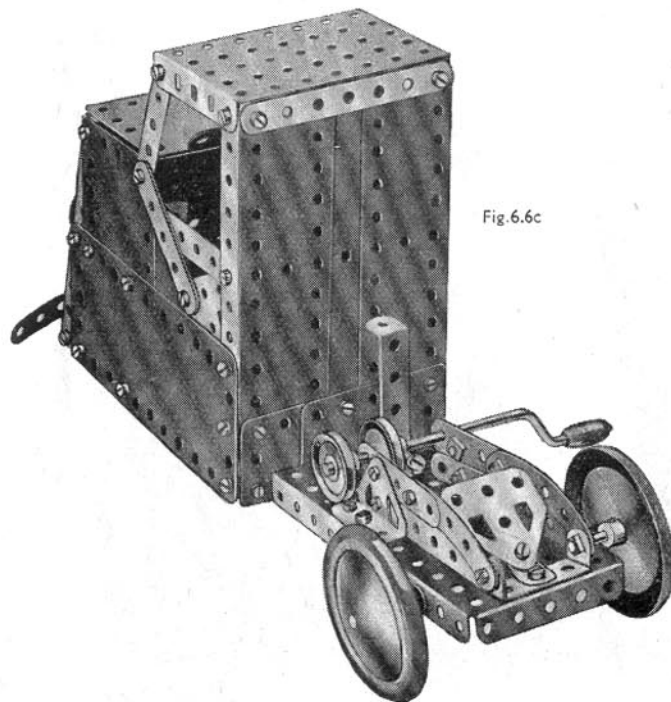
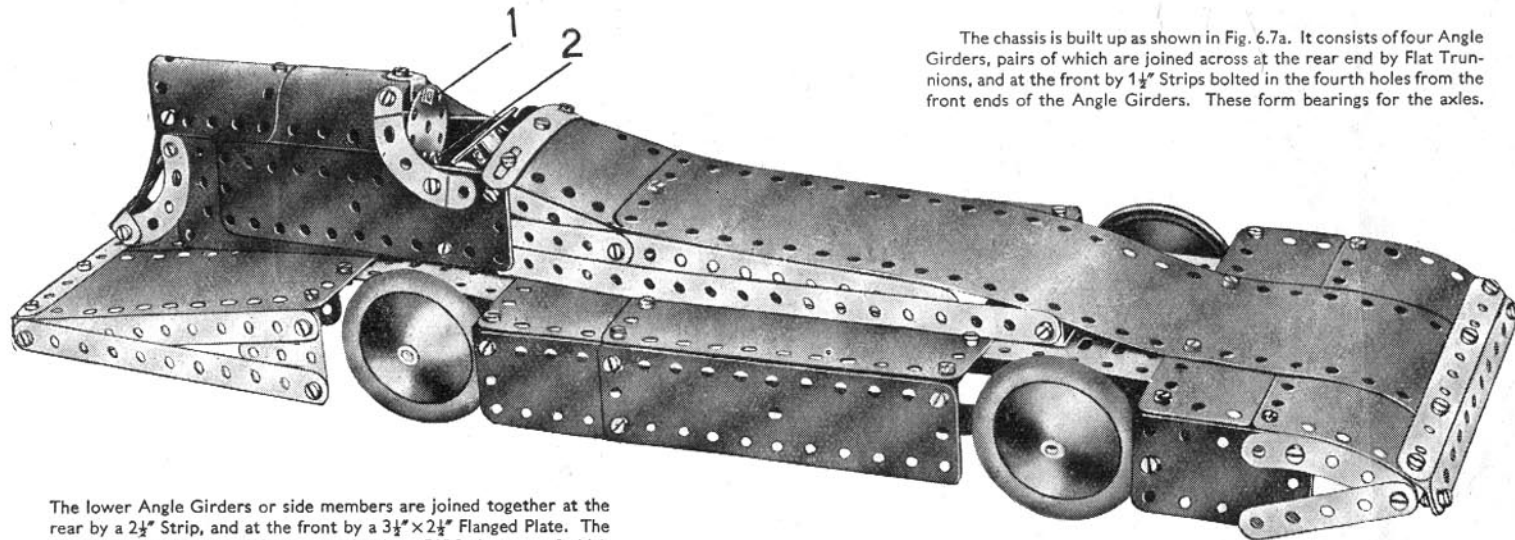

Fig. 6.6c

## 6.7 "BLUEBIRD" SPEED CAR



The chassis is built up as shown in Fig. 6.7a. It consists of four Angle Girders, pairs of which are joined across at the rear end by Flat Trunnions, and at the front by  $1\frac{1}{2}$ " Strips bolted in the fourth holes from the front ends of the Angle Girders. These form bearings for the axles.

The lower Angle Girders or side members are joined together at the rear by a  $2\frac{1}{2}$ " Strip, and at the front by a  $3\frac{1}{2}$ " x  $2\frac{1}{2}$ " Flanged Plate. The upper Angle Girders are joined across by three  $5\frac{1}{2}$ " Strips, two of which are bolted five holes from the rear ends and seven holes from the front ends of the Angle Girders respectively, to form supports for the streamlined casing between the wheels.

Two  $12\frac{1}{2}$ " Strips overlapping the chassis 13 holes extend the tail of the car, which consists of two Flanged Sector Plates bolted at their broad ends by their flanges to a  $2\frac{1}{2}$ " x  $\frac{1}{2}$ " Double Angle Strip on one edge, and to an Angle Bracket on the other edge. The narrow ends of the two Flanged Sector Plates are spaced one hole apart, and are bolted in the second hole in their flanges to a  $5\frac{1}{2}$ " Strip. Two  $2\frac{1}{2}$ " small radius Curved Strips and a  $2\frac{1}{2}$ " Strip are bolted to a Double Bracket and fixed as shown. Two U-Section Curved Plates overlapped one hole also are bolted to the Flanged Sector Plates, and are joined to the  $5\frac{1}{2}$ " x  $1\frac{1}{2}$ " Flexible Plates by  $2\frac{1}{2}$ " small radius Curved Strips.

Two  $5\frac{1}{2}$ " x  $2\frac{1}{2}$ " Flexible Plates are bolted between the two  $5\frac{1}{2}$ " Strips to form the rear wheel fairings, and the  $5\frac{1}{2}$ " Strips forming the sides are bolted to a Flat Trunnion and a Double Bracket. The engine and cockpit fairing consists of a  $12\frac{1}{2}$ " x  $2\frac{1}{2}$ " Strip Plate and a  $2\frac{1}{2}$ " x  $2\frac{1}{2}$ " Flexible Plate, bolted at the join to a  $2\frac{1}{2}$ " x  $\frac{1}{2}$ " Double Angle Strip. The last named is joined in turn to two  $5\frac{1}{2}$ " Strips that fill in the side of the fairing. The method of building up the streamlined radiator will be clear from the general view of the model.

The front and rear axles are 5" Rods held in place by Collars. They carry a 1" Pulley, fitted with Rubber Ring, and a Road Wheel at each end.

The headrest is a Wheel Disc lock-nutted to Bolt 1. Bolt 2 holds in place a second Wheel Disc, which in turn is bolted at right angles to a third Disc 3 by means of a Reversed Angle Bracket.

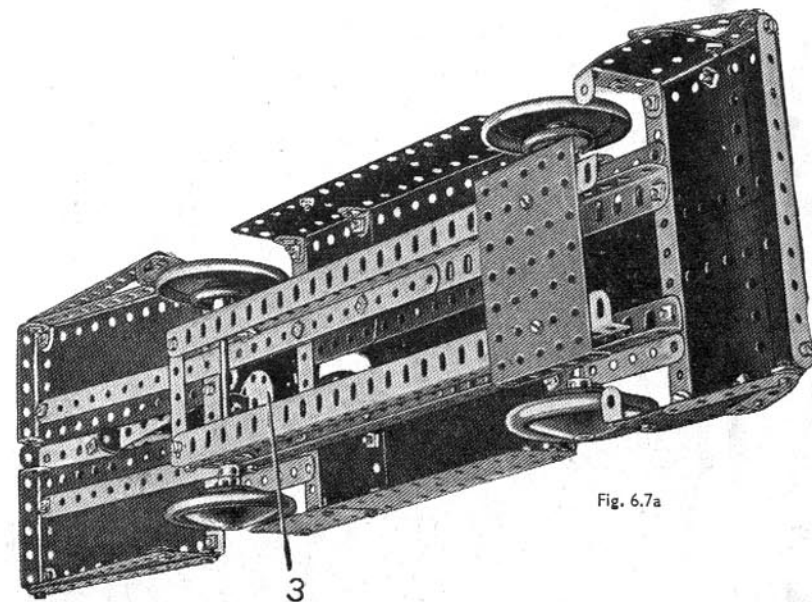

Fig. 6.7a



## 6.8 MOBILE CRANE

This model represents a type of crane frequently used in large factories and warehouses for transporting and stacking heavy goods. It is fitted with caster steering, which allows the crane to turn in a very short radius and enables it to work in confined areas.

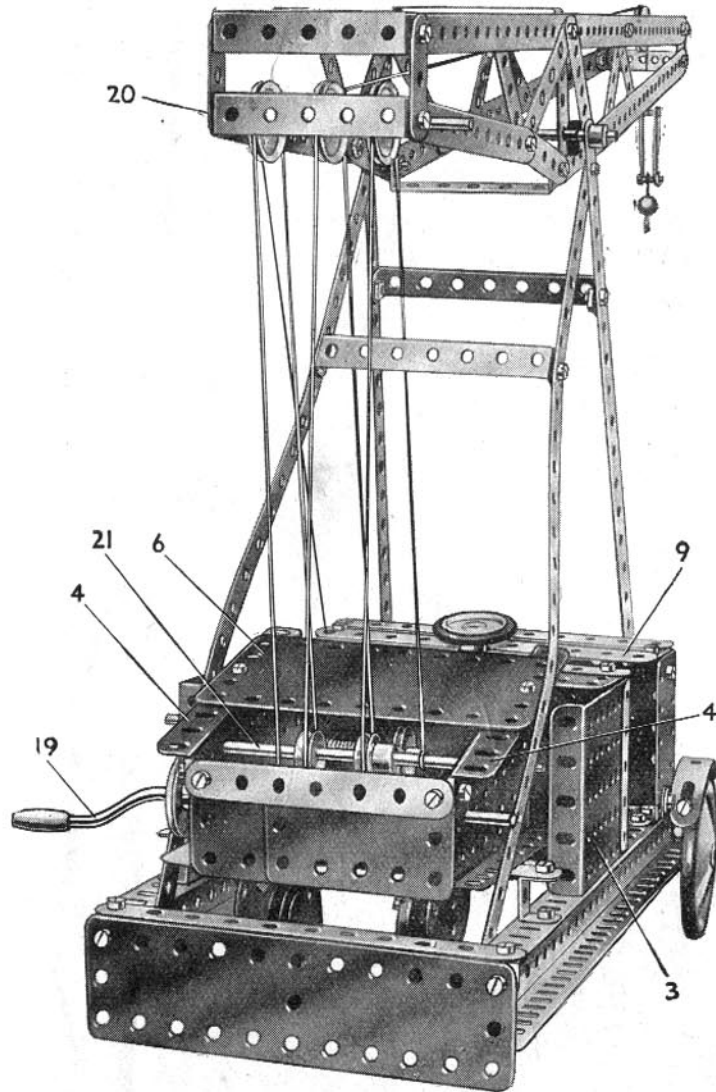
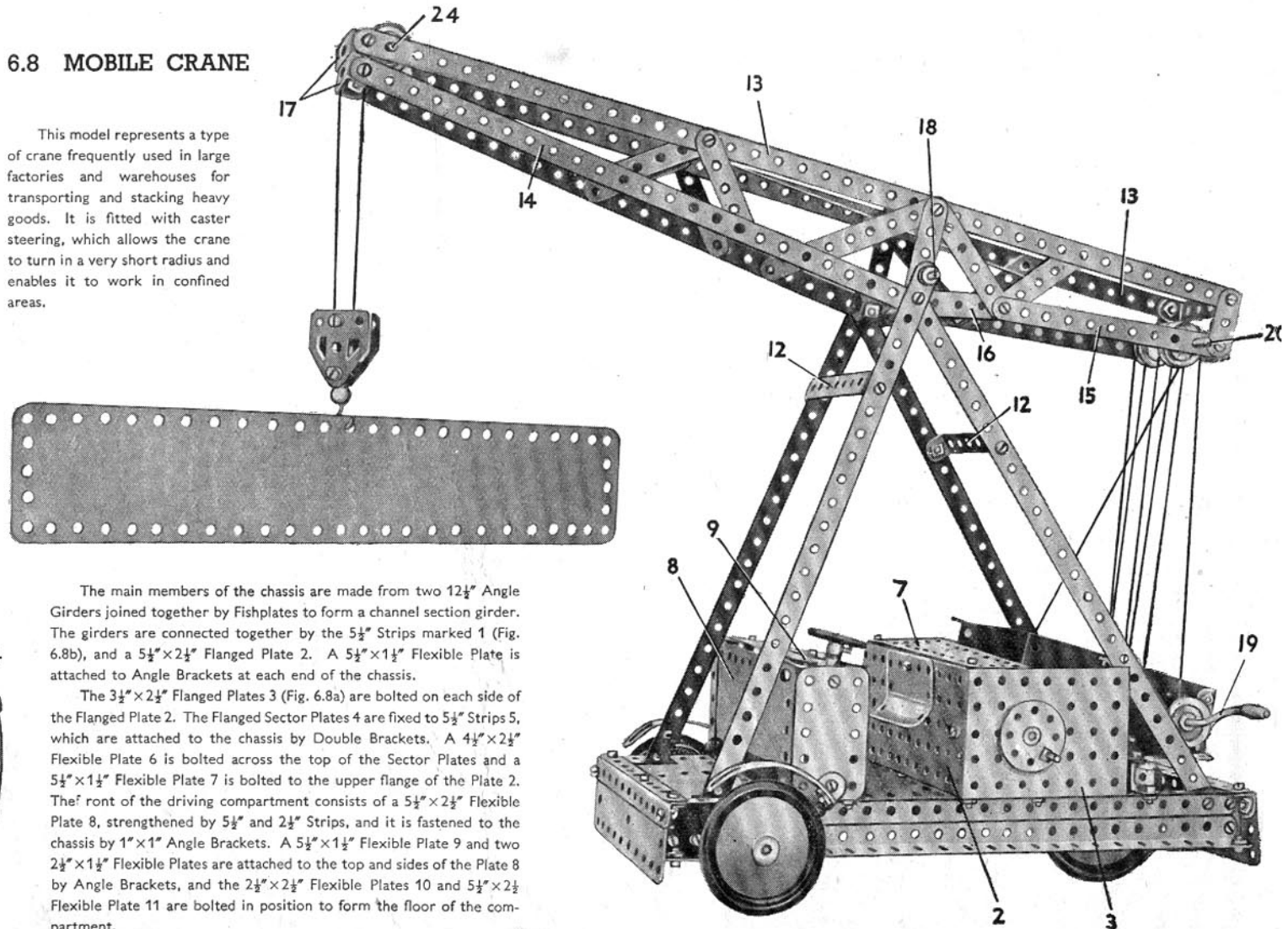

Fig. 6.8a



The main members of the chassis are made from two  $12\frac{1}{2}$ " Angle Girders joined together by Fishplates to form a channel section girder. The girders are connected together by the  $5\frac{1}{2}$ " Strips marked 1 (Fig. 6.8b), and a  $5\frac{1}{2}$ " x  $2\frac{1}{2}$ " Flanged Plate 2. A  $5\frac{1}{2}$ " x  $1\frac{1}{2}$ " Flexible Plate is attached to Angle Brackets at each end of the chassis.

The  $3\frac{1}{2}$ " x  $2\frac{1}{2}$ " Flanged Plates 3 (Fig. 6.8a) are bolted on each side of the Flanged Plate 2. The Flanged Sector Plates 4 are fixed to  $5\frac{1}{2}$ " Strips 5, which are attached to the chassis by Double Brackets. A  $4\frac{1}{2}$ " x  $2\frac{1}{2}$ " Flexible Plate 6 is bolted across the top of the Sector Plates and a  $5\frac{1}{2}$ " x  $1\frac{1}{2}$ " Flexible Plate 7 is bolted to the upper flange of the Plate 2. The front of the driving compartment consists of a  $5\frac{1}{2}$ " x  $2\frac{1}{2}$ " Flexible Plate 8, strengthened by  $5\frac{1}{2}$ " and  $2\frac{1}{2}$ " Strips, and it is fastened to the chassis by  $1$ " x  $1$ " Angle Brackets. A  $5\frac{1}{2}$ " x  $1\frac{1}{2}$ " Flexible Plate 9 and two  $2\frac{1}{2}$ " x  $1\frac{1}{2}$ " Flexible Plates are attached to the top and sides of the Plate 8 by Angle Brackets, and the  $2\frac{1}{2}$ " x  $2\frac{1}{2}$ " Flexible Plates 10 and  $5\frac{1}{2}$ " x  $2\frac{1}{2}$ " Flexible Plate 11 are bolted in position to form the floor of the compartment.

The steering caster unit is made by bolting Semi-Circular Plates to the sides of a  $2\frac{1}{2}$ " x  $1\frac{1}{2}$ " Flanged Plate. The Flanged Plate is pivotally attached to the Strip 5 by a lock-nutted Bolt. The Semi-Circular Plates form bearings for two Road Wheels locked on a  $3\frac{1}{2}$ " Rod. Steering is controlled by a  $4$ " Rod journalled in the Flexible Plate 11 and a Fishplate attached to the Plate 9. A length of Cord is lapped several times around the Rod and its ends are fastened to the sides of the caster unit. The front axle consists of a  $5\frac{1}{2}$ " Rod journalled in the main chassis girders and held in place by Spring Clips.

(Continued on next page)

## 6.8 MOBILE CRANE—Continued

The jib is supported by four  $12\frac{1}{2}$ " Strips. Two of these are bolted as shown to each side of the chassis, and connected to the pair on the opposite side by two  $3\frac{1}{2}$ "  $\times$   $\frac{1}{2}$ " Double Angle Strips 12. Each side of the jib consists of a compound strip 13, made by overlapping two  $12\frac{1}{2}$ " Strips 11 holes, a  $12\frac{1}{2}$ " Strip 14, a  $5\frac{1}{2}$ " Strip 15 and a  $2\frac{1}{2}$ " Strip 16. These Strips are bolted together and braced as shown in the illustration. The two sides are joined together at the rear and centre by  $2\frac{1}{2}$ "  $\times$   $\frac{1}{2}$ " Double Angle Strips, and at the front by the  $1\frac{1}{2}$ "  $\times$   $\frac{1}{2}$ " Double Angle Strips 17. The jib pivots about a  $4\frac{1}{2}$ " Rod 18.

The jib is luffed by means of a Cord extending from the Crank Handle 19. This Cord passes over a 1" loose Pulley on the  $3\frac{1}{2}$ " Rod 20, around a  $\frac{1}{2}$ " loose Pulley on the 4" Rod 21, and around a second 1" loose Pulley on Rod 20. It is then taken around a  $\frac{1}{2}$ " Pulley on Rod 21 and a 1" Pulley on Rod 20, and finally is tied to Rod 21.

Raising and lowering of the load is controlled by a 5" Rod 22, fitted with a Bush Wheel and Threaded Pin. This Rod is journalled in the  $3\frac{1}{2}$ "  $\times$   $2\frac{1}{2}$ " Flanged Plate and a Trunnion 23. A length of Cord from Rod 22 is passed over Rod 20, around a 1" Pulley fixed on the 2" Rod 24 and around a Pivot Bolt in the pulley block. It is then fastened to the jib head.

A simple foot brake is fitted to the Rod 22. It consists of a short length of Cord passed around a 1" Pulley 25, and tied to the  $3\frac{1}{2}$ " Strip 26. This Strip is lock-nutted to an Angle Bracket bolted to the Flanged Plate 2, and is fitted with an Angle Bracket 27 to represent the foot pedal. Normally it is held in the "on" position by the  $2\frac{1}{2}$ " Driving Band 28.

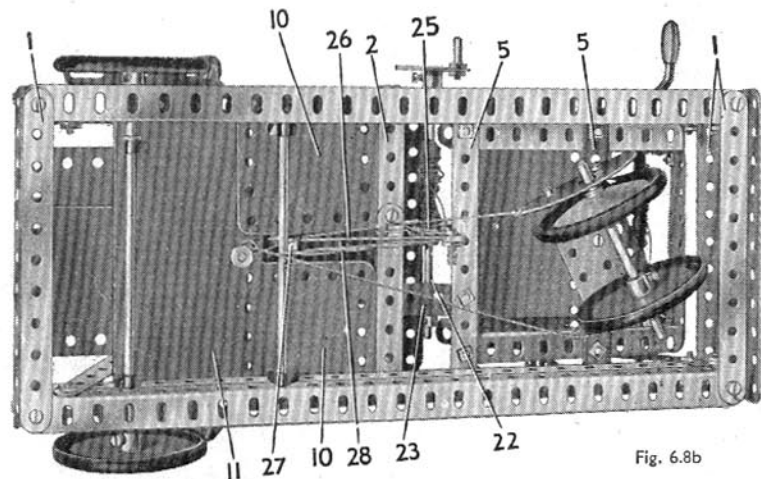
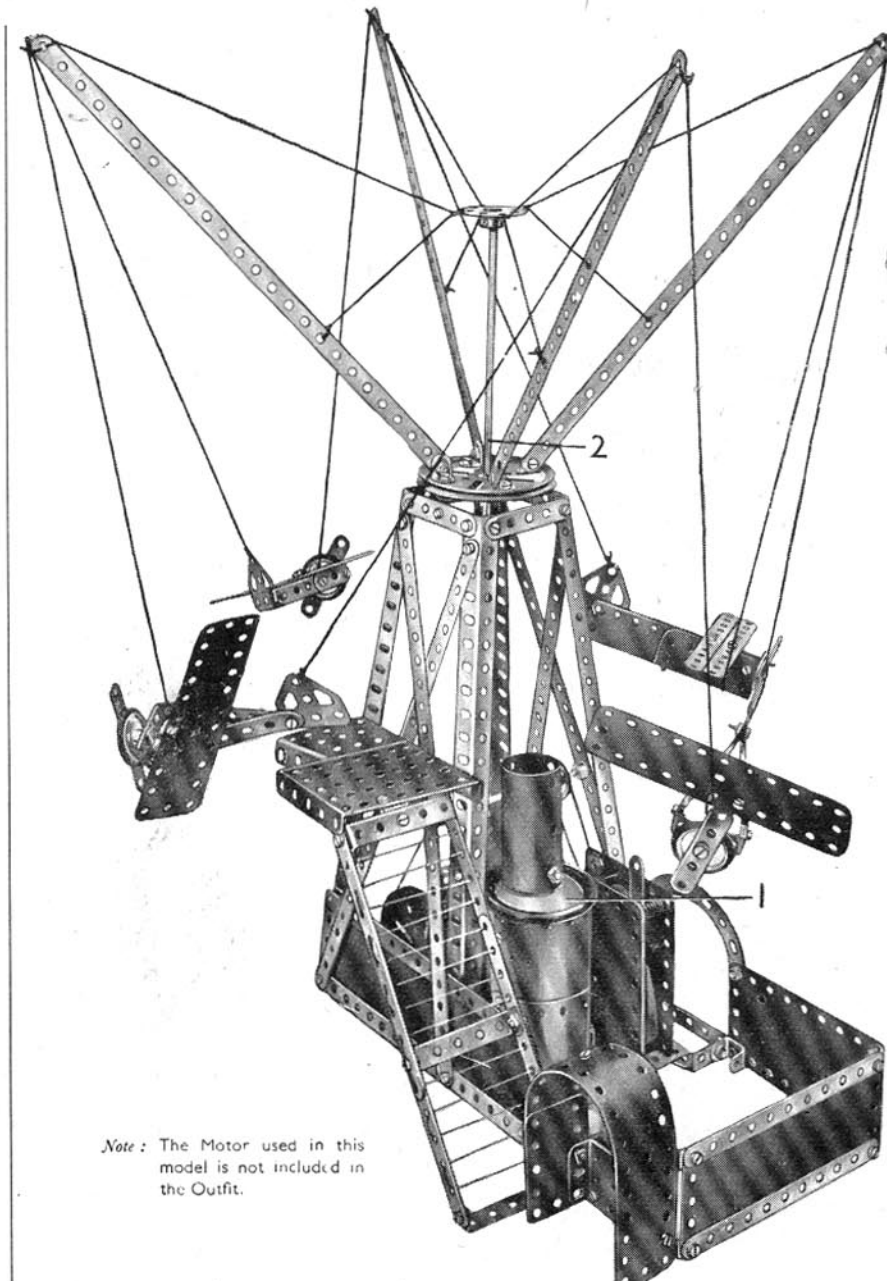

Fig. 6.8b



Note: The Motor used in this model is not included in the Outfit.

## 6.9 HIGH FLIERS

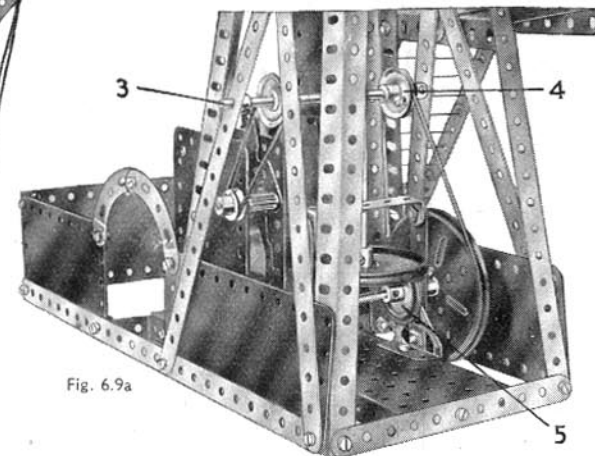

Fig. 6.9a

A base for the model is provided by bolting two  $12\frac{1}{2}$ " Strips to the Angle Girders that form the tower. Two  $5\frac{1}{2}$ " Strips are bolted to the Angle Girders across their lower ends, and between them is fixed a  $5\frac{1}{2}$ "  $\times$   $2\frac{1}{2}$ " Flanged Plate. The Flanged Plate is extended on the inside by a  $3\frac{1}{2}$ "  $\times$   $2\frac{1}{2}$ " Flanged Plate attached to it by a Fishplate. The  $3\frac{1}{2}$ "  $\times$   $2\frac{1}{2}$ " Flanged Plate is attached also to one of the  $12\frac{1}{2}$ " Strips of the base by a 1"  $\times$  1" Angle Bracket and a Double Bracket.

The boiler consists of two  $5\frac{1}{2}$ "  $\times$   $2\frac{1}{2}$ " Flexible Plates bolted together and extended by two  $1\frac{1}{2}$ " radius Curved Plates. They are then curved to shape and their ends are bolted together. The boiler is fixed to the side of the model. The Road Wheel 1 is fastened on a 3" Screwed Rod, which is lock-nutted to a Fishplate bolted to a 1"  $\times$  1" Angle Bracket inside the boiler. Inside the  $2\frac{1}{2}$ " Cylinder is an Angle Bracket which is fitted on to the Screwed Rod, where it is held in place by a nut.

The No. 1 Clockwork Motor is fastened by Double Brackets to the  $5\frac{1}{2}$ "  $\times$   $2\frac{1}{2}$ " Flanged Plate and the  $3\frac{1}{2}$ "  $\times$   $2\frac{1}{2}$ " Flanged Plate. The drive is taken by a Driving Band from a  $\frac{1}{2}$ " fast Pulley on the driving shaft of the Motor, to a 1" fast Pulley on a 5" Rod 3 journalled in the sides of the tower. This Rod carries also a second 1" Pulley 4, which is connected by a Driving Band to a 3" Pulley on the  $3\frac{1}{2}$ " Rod carrying the Pulley 5 (Fig. 6.9a). Pulley 5 is fitted with a Rubber Ring, which is in contact with the rim of the Road Wheel at the bottom of the main shaft. The arms carrying the aeroplanes are fastened by Angle Brackets to a 3" Pulley on the main shaft and are supported by Cords. The main shaft consists of an  $11\frac{1}{2}$ " Rod and a  $6\frac{1}{2}$ " Rod joined by a Rod Connector 2.

The construction of three of the aeroplanes will be clear from the illustration. The fuselage of the aeroplane partly hidden by the tower consists of two U-section Curved Plates bolted together at the tail. A 1" loose Pulley is attached to the fuselage by a Double Bracket to form the engine. The wing is made of two  $5\frac{1}{2}$ " Strips bolted to two Angle Brackets and fastened to the sides of the fuselage.

## 6.10 TRACTOR AND DUMPER WAGON

The chassis of the tractor unit is formed by bolting the  $5\frac{1}{2}$ " Strips 1 to each side of a  $5\frac{1}{2}$ " $\times$  $2\frac{1}{2}$ " Flanged Plate. The Strips 1 are connected at the front by a  $2\frac{1}{2}$ " $\times$  $\frac{1}{2}$ " Double Angle Strip, and  $5\frac{1}{2}$ " $\times$  $2\frac{1}{2}$ " Flexible Plates attached to the  $5\frac{1}{2}$ " Strips form the sides of the bonnet. The radiator is represented by a  $2\frac{1}{2}$ " $\times$  $2\frac{1}{2}$ " Flexible Plate 2 and a Semi-Circular Plate. The sides of the bonnet are joined by two  $2\frac{1}{2}$ " $\times$  $2\frac{1}{2}$ " Double Angle Strips, and the top consists of two  $5\frac{1}{2}$ " $\times$  $2\frac{1}{2}$ " and a  $4\frac{1}{2}$ " $\times$  $2\frac{1}{2}$ " Flexible Plate curved to the same radius as the Semi-Circular Plate and attached to the sides.

The driver's seat is made by bolting  $2\frac{1}{2}$ " $\times$  $1\frac{1}{2}$ " Flexible Plates to the sides of the  $5\frac{1}{2}$ " $\times$  $2\frac{1}{2}$ " Flanged Plate. The back of the seat consists of a  $2\frac{1}{2}$ " $\times$  $2\frac{1}{2}$ " Flexible Plate attached to the Double Angle Strip 3, and the seat proper is represented by a  $2\frac{1}{2}$ " $\times$  $1\frac{1}{2}$ " Flanged Plate.

The rear wheels are locked on a 5" Rod journalled in the Flat Trunnions 4 (Fig. 6.10c). The Fishplate 5 is attached to a  $3\frac{1}{2}$ " Strip lock-nutted to the chassis, so that it can be forced against a 1" Pulley fitted with a Rubber Ring on the rear axle, to act as a brake. The front axle 6 consists of a  $3\frac{1}{2}$ " and a  $2\frac{1}{2}$ " Strip overlapped three holes and secured to the chassis by a  $2\frac{1}{2}$ " $\times$  $\frac{1}{2}$ " Double Angle Strip. Two  $\frac{3}{8}$ " Bolts passed through the  $1\frac{1}{2}$ " Strips 7 and Double Brackets 8 are locked in the end holes of the strip 6 by two

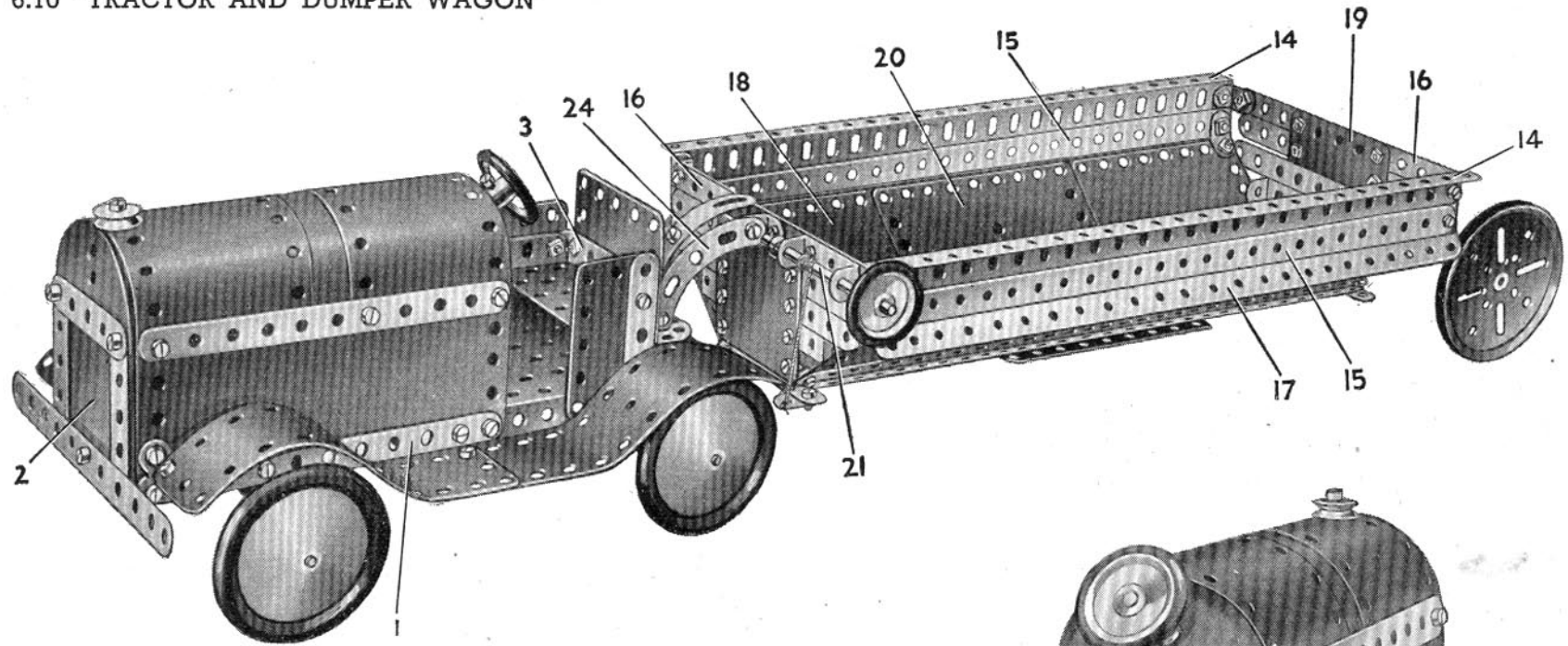

nuts. The Strips 7 are connected by lock-nuts to a compound strip 9 made from a  $3\frac{1}{2}$ " and a  $2\frac{1}{2}$ " Strip overlapped three holes. The front wheels are fixed on  $1\frac{1}{2}$ " Rods mounted in the Double Brackets 8.

The steering column is a  $6\frac{1}{2}$ " Rod journalled in the Semi-Circular Plate 10 (Fig. 6.10b) and an Angle Bracket 11. An Obtuse Angle Bracket 12, bolted to a Bush Wheel on the steering column, is fitted over a Threaded Pin 13. The Threaded Pin is fixed to an Angle Bracket attached to the strip 9.

The mudguards on each side are formed by two  $5\frac{1}{2}$ " $\times$  $1\frac{1}{2}$ " Flexible Plates joined together and attached to the chassis by Angle Brackets.

(Continued on next page)

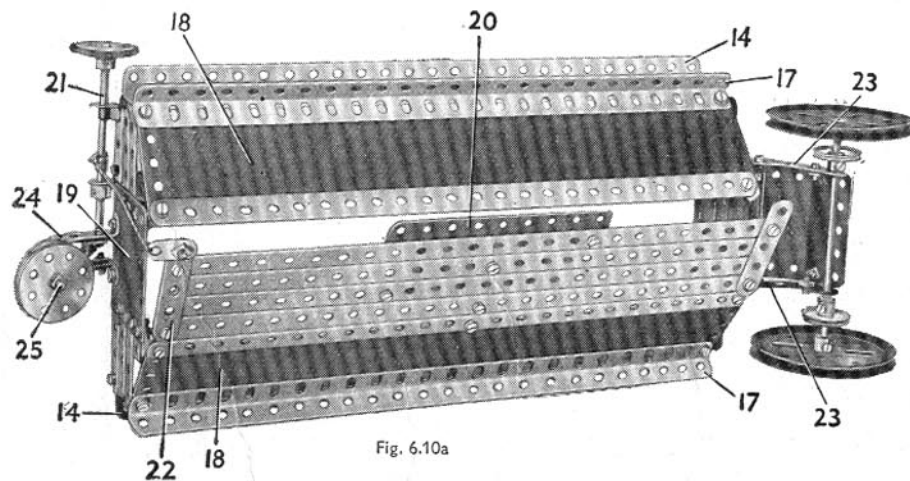

Fig. 6.10a

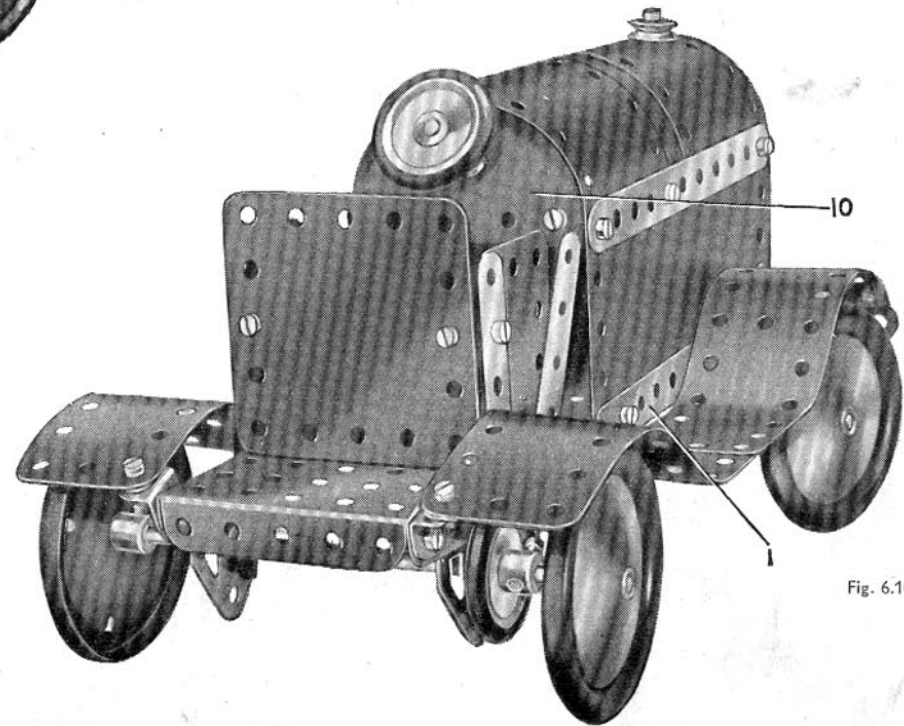

Fig. 6.10b

## 6.10 TRACTOR &amp; DUMPER WAGON—Continued

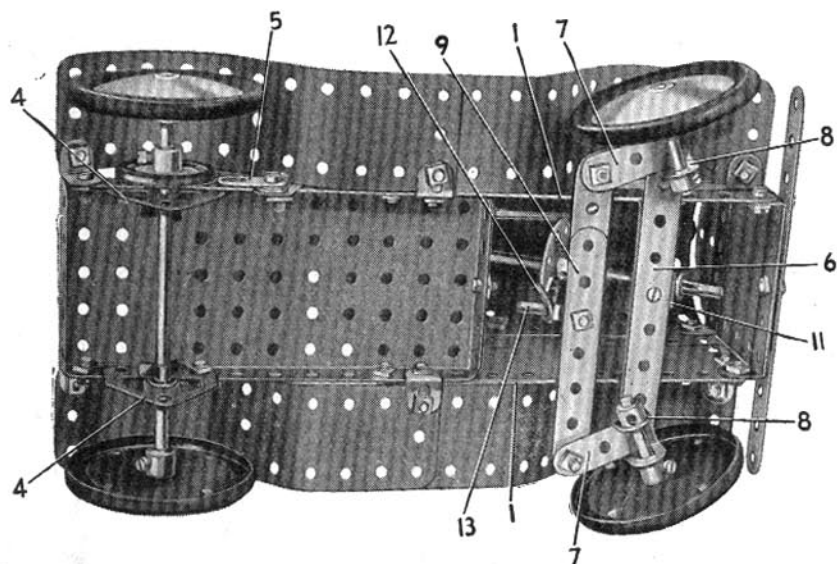

Fig. 6.10c.

The loading hopper is made by joining the  $12\frac{1}{2}$ " Angle Girders 14 to the  $12\frac{1}{2}$ " Strips 15 by Fishplates, and to the  $5\frac{1}{2}$ " Strips 16 by Angle Brackets. The Angle Girders 17 (Fig. 6.10a) and  $12\frac{1}{2}$ " Strip Plates 18 are attached to the Strips 15 by Obtuse Angle Brackets. The Plates 18 are joined to the  $2\frac{1}{2}$ "  $\times$   $2\frac{1}{2}$ " Flexible Plates 19 by Angle Brackets. Each end of the hopper is filled in by two  $5\frac{1}{2}$ " Strips and a  $3\frac{1}{2}$ "  $\times$   $\frac{1}{2}$ " Double Angle Strip bolted to the Flexible Plate 19.

The bottom of the hopper is made by bolting four  $12\frac{1}{2}$ " Strips to one half of a Hinged Flat Plate 20. The other half of this Plate is attached to the side of the hopper. The bottom can be opened or closed by operating the  $3\frac{1}{2}$ " Rod 21. A length of Cord fastened to a Cord Anchoring Spring on this Rod is tied to a Fishplate bolted to the  $2\frac{1}{2}$ " Strip 22.

The hopper runs on two 3" Pulleys locked on a 5" Rod. This Rod is journaled in the end holes of the Curved Strips 23. These Strips are fixed to Trunnions bolted to the rear end of the hopper, and a  $1\frac{1}{4}$ " radius Curved Plate is attached to them by Angle Brackets and a  $2\frac{1}{2}$ "  $\times$   $\frac{1}{2}$ " Double Angle Strip.

The hopper is pivotally connected to the tractor by the Curved Strips 24. These are attached to the hopper by two Angle Brackets, and to the tractor by a  $\frac{1}{2}$ " Bolt 25 passed through a Double Bracket and lock-nutted to the rear of the tractor. Four Wheel Discs are used for spacing purposes.

## 6.11 FLY BOATS

The base consists of two  $12\frac{1}{2}$ "  $\times$   $2\frac{1}{2}$ " Strip Plates, joined at each end by  $5\frac{1}{2}$ "  $\times$   $2\frac{1}{2}$ " Flexible Plates and strengthened by  $5\frac{1}{2}$ " Strips bolted to the ends of the base. Four Angle Girders are bolted to the base as shown in the illustration, and pairs of them are joined at the top by compound strips, each of which consists of two  $5\frac{1}{2}$ " Strips overlapped five holes. The Angle Girders are braced across by  $12\frac{1}{2}$ " Strips.

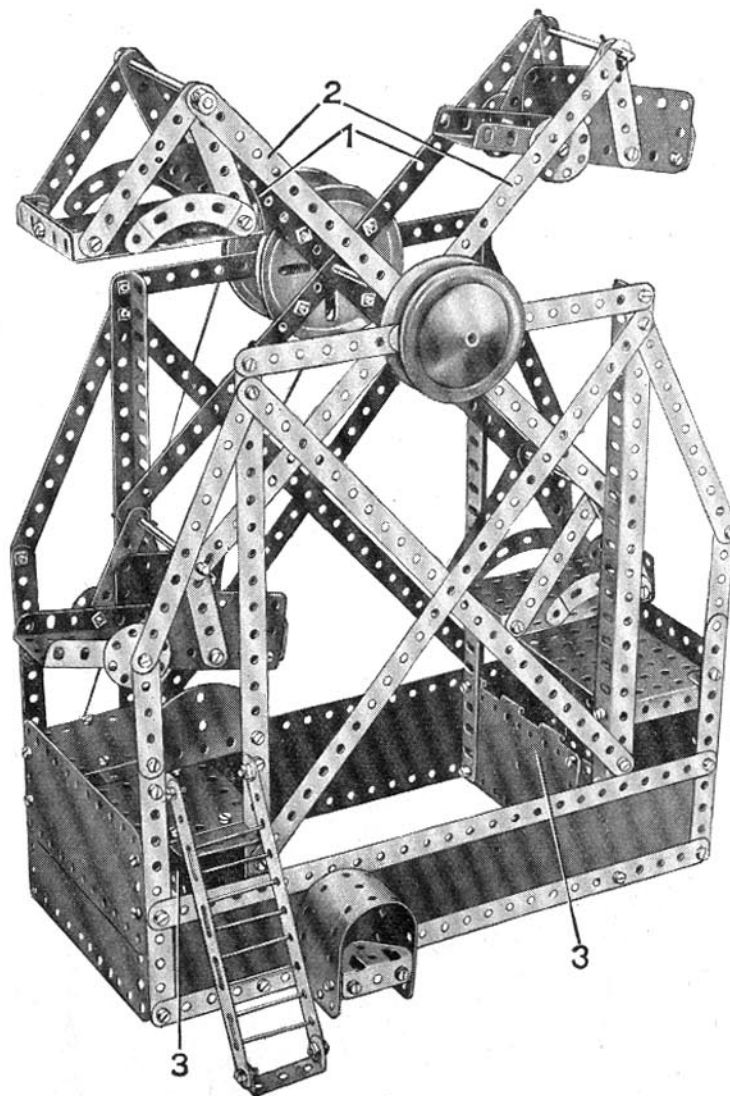

Fig. 6.11a

The centre pin is withdrawn from a Hinged Flat Plate and the halves are used as flat plates 3. The  $12\frac{1}{2}$ " Strips 1 and 2 form the supports for the carriages. The Strips 2 are bolted across a Bush Wheel mounted on the  $6\frac{1}{2}$ " Rod forming the main shaft. Strips 1 are bolted across a 3" Pulley also secured on the  $6\frac{1}{2}$ " Rod.

Two of the carriages are made by fastening  $2\frac{1}{2}$ "  $\times$   $\frac{1}{2}$ " Double Angle Strips inside the flanges of a  $3\frac{1}{2}$ "  $\times$   $2\frac{1}{2}$ " Flanged Plate. Pairs of Strips of various lengths are bolted to the ends of the Double Angle Strips. A 4" Rod passes through the holes in these Strips and through the end holes of the  $12\frac{1}{2}$ " Strips 1 and 2. A back is provided by a U-Section Curved Plate bolted to the rear of the  $3\frac{1}{2}$ "  $\times$   $2\frac{1}{2}$ " Flanged Plate, and the sides are formed by  $2\frac{1}{2}$ " small radius Curved Strips.

The base of each of the other two carriages is a Flanged Sector Plate. The sides consist of  $2\frac{1}{2}$ "  $\times$   $1\frac{1}{2}$ " Flexible Plates, and bearings for the 3" Rods on which the carriages are supported are provided by the end holes of  $2\frac{1}{2}$ " Strips, bolted to the flanges of the Flanged Sector Plate. The back is formed by two Flat Trunnions fixed to a  $2\frac{1}{2}$ "  $\times$   $\frac{1}{2}$ " Double Angle Strip secured between the flanges of the Flanged Sector Plate.

The Crank Handle (Fig. 6.11a) by which the carriages are set in motion, is journaled in the  $12\frac{1}{2}$ "  $\times$   $2\frac{1}{2}$ " Strip Plate forming the rear side of the base, and also in a  $1\frac{1}{2}$ "  $\times$   $1\frac{1}{2}$ " Angle Bracket. The  $1\frac{1}{2}$ "  $\times$   $1\frac{1}{2}$ " Angle Bracket is bolted to the half of a Hinged Flat Plate used in the construction of the left-hand platform. The drive is taken by Cord from a 1" Pulley on the shaft of the Crank Handle to a 3" Pulley on the main shaft.

The pay-box consists of a  $5\frac{1}{2}$ "  $\times$   $1\frac{1}{2}$ " Flexible Plate bent to shape, and is secured to the base by a  $1\frac{1}{2}$ "  $\times$   $\frac{1}{2}$ " Double Angle Strip. The counter is formed by a Trunnion, and is fastened in position by Angle Brackets.

## 6.12 OBSERVATION TOWER

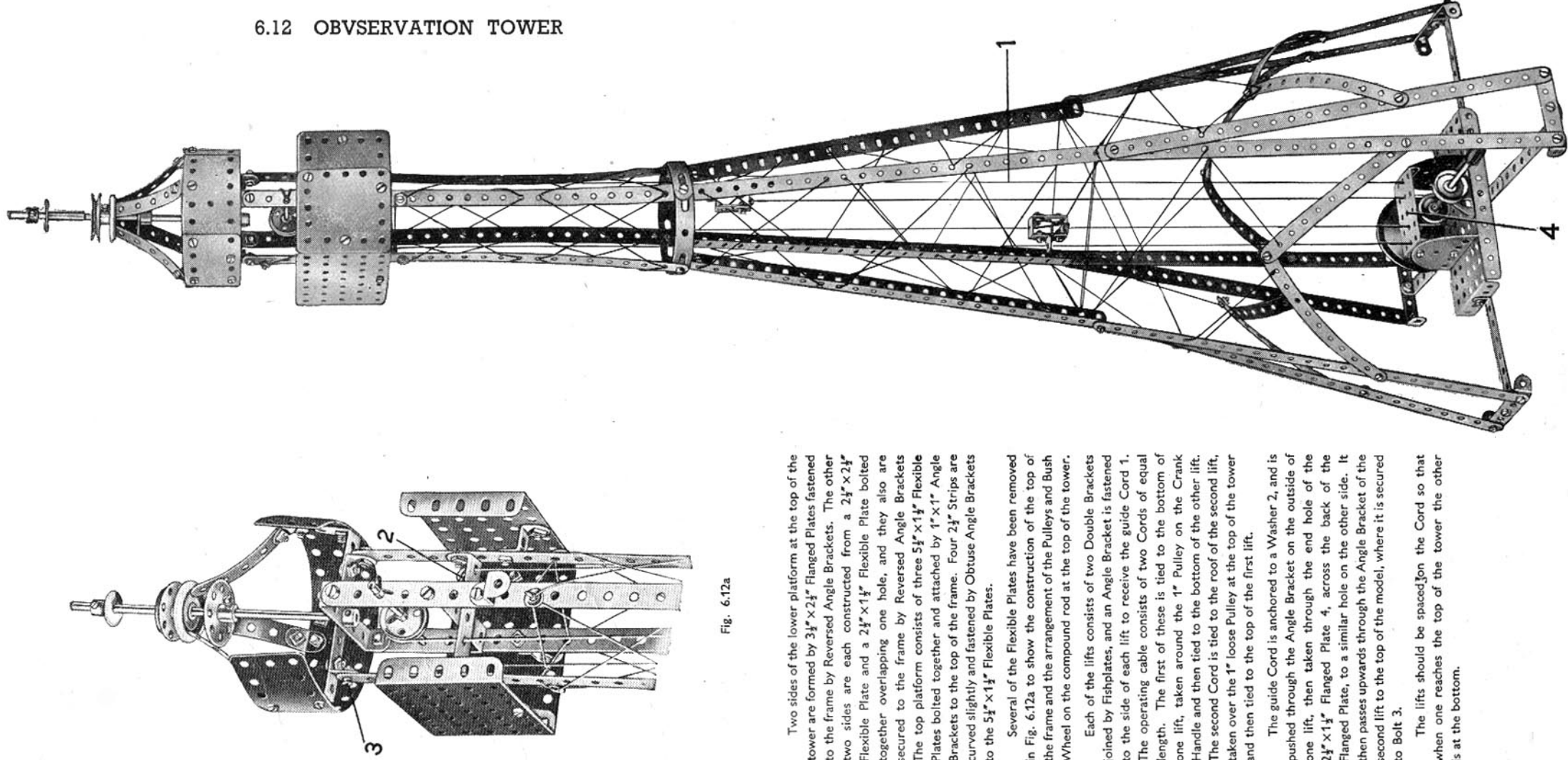

Fig. 6.12a

Two sides of the lower platform at the top of the tower are formed by  $3\frac{1}{2}'' \times 2\frac{1}{2}''$  Flanged Plates fastened to the frame by Reversed Angle Brackets. The other two sides are each constructed from a  $2\frac{1}{2}'' \times 2\frac{1}{2}''$  Flexible Plate and a  $2\frac{1}{2}'' \times 1\frac{1}{2}''$  Flexible Plate bolted together overlapping one hole, and they also are secured to the frame by Reversed Angle Brackets. The top platform consists of three  $5\frac{1}{2}'' \times 1\frac{1}{2}''$  Flexible Plates bolted together and attached by  $1'' \times 1''$  Angle Brackets to the top of the frame. Four  $2\frac{1}{2}''$  Strips are curved slightly and fastened by Obtuse Angle Brackets to the  $5\frac{1}{2}'' \times 1\frac{1}{2}''$  Flexible Plates.

Several of the Flexible Plates have been removed in Fig. 6.12a to show the construction of the top of the frame and the arrangement of the Pulleys and Bush Wheel on the compound rod at the top of the tower.

Each of the lifts consists of two Double Brackets joined by Fishplates, and an Angle Bracket is fastened to the side of each lift to receive the guide Cord 1. The operating cable consists of two Cords of equal length. The first of these is tied to the bottom of one lift, taken around the  $1''$  Pulley on the Crank Handle and then tied to the bottom of the other lift. The second Cord is tied to the roof of the second lift, taken over the  $1''$  loose Pulley at the top of the tower and then tied to the top of the first lift.

The guide Cord is anchored to a Washer 2, and is pushed through the Angle Bracket on the outside of one lift, then taken through the end hole of the  $2\frac{1}{2}'' \times 1\frac{1}{2}''$  Flanged Plate 4, across the back of the Flanged Plate, to a similar hole on the other side. It then passes upwards through the Angle Bracket of the second lift to the top of the model, where it is secured to Bolt 3.

The lifts should be spaced on the Cord so that when one reaches the top of the tower the other is at the bottom.

## 6.13 DOCKSIDE CRANE

This fine model represents a type of large travelling crane used in docks and ship-building yards. All the essential movements of the actual crane can be carried out with the model.

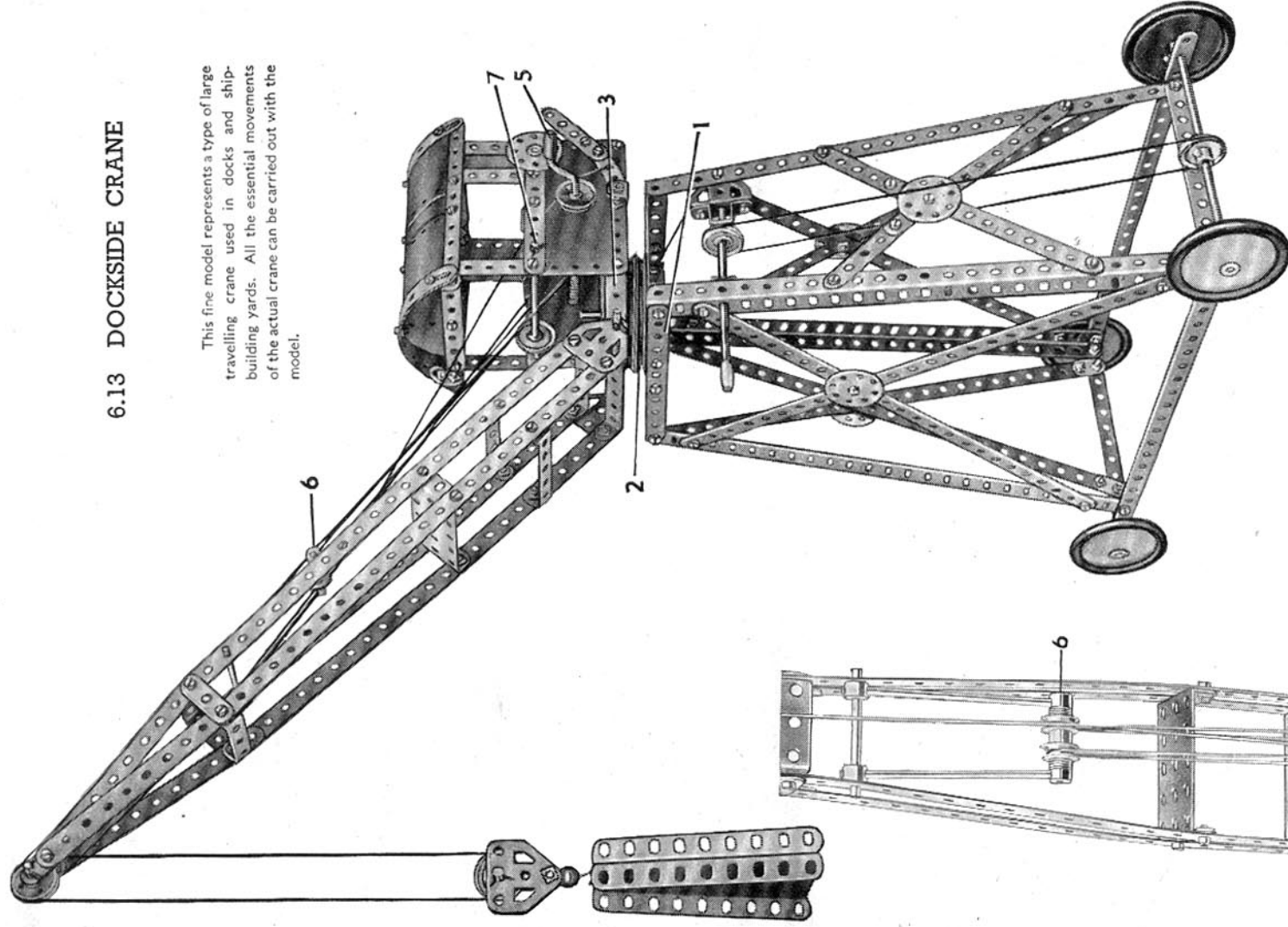
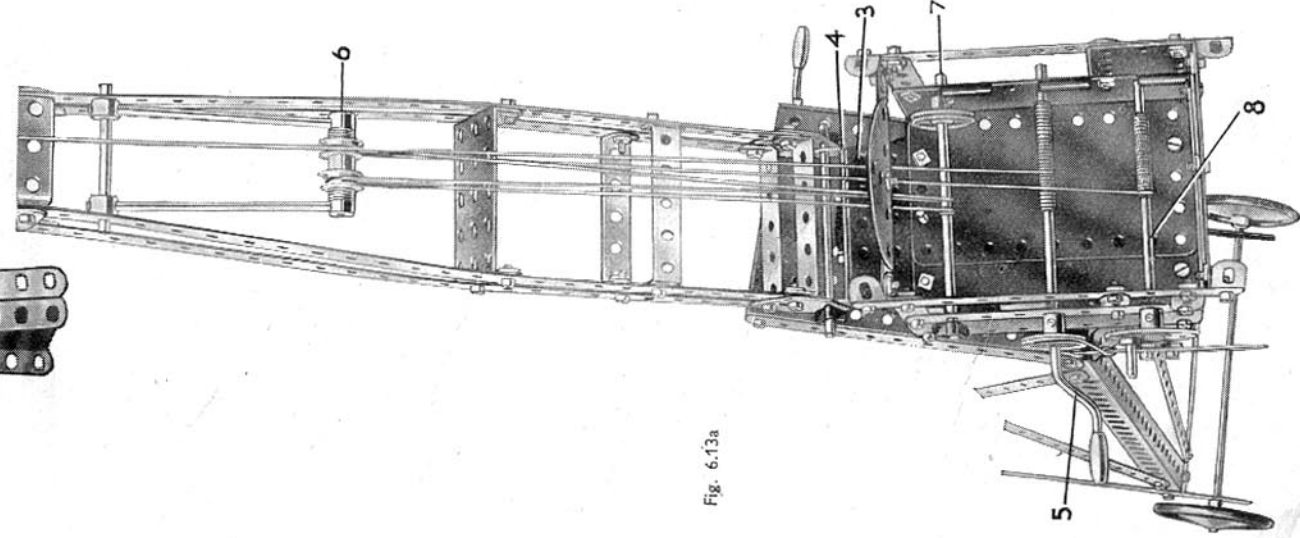

Fig. 6.13a

The top of the travelling tower consists of two  $3\frac{1}{2}$ " x  $2\frac{1}{2}$ " Flanged Plates bolted to a  $5\frac{1}{2}$ " Strip 1 on each side. The cab rotates about a 2" Rod locked in the 3" Pulley 2. The cab is built up on two  $3\frac{1}{2}$ " x  $\frac{1}{2}$ " Double Angle Strips secured to the  $5\frac{1}{2}$ " x  $2\frac{1}{2}$ " Flanged Plate 3. The sides are made by withdrawing the pin from A Hinged Flat Plate and bolting the separated halves to the Double Angle Strips. The jib is held in position by a  $3\frac{1}{2}$ " Rod passed through a  $2\frac{1}{2}$ " x  $\frac{1}{2}$ " Double Angle Strip 4 (Fig. 6.13a).

Raising and lowering of the load is controlled by a length of Cord fastened to a Cord Anchoring Spring on the Crank Handle 5. This Cord passes over a 1" loose Pulley in the jib head, around a similar Pulley in the pulley block, and is then secured to the jib head.

The jib is luffed by a length of Cord attached to the  $4\frac{1}{2}$ " Rod 8. From this Rod the Cord passes around a  $\frac{1}{2}$ " loose Pulley on the Rod 6, around the Rod 7, over a  $\frac{1}{2}$ " Pulley on Rod 6, and finally is secured to Rod 7. The Rod 6 is pivotally attached to the jib by means of two Screwed Rods screwed into the tapped holes of Collars locked on Rod 6, and also into two Collars on a 2" Rod journalled in the jib.



6.14 PITHEAD GEAR

Each side of the lower framework of the model is made by bolting the vertical 12½" Angle Girders 1 and 12½" Strips 2 to the compound strips 3. The compound strips consist of a 12½" and a 5½" Strip joined together. The sides are connected by the 5½" Strips 4 and a 5½" x 2½" Flanged Plate 5.

The tower consists of four 12½" Strips bolted to the lower framework and joined at the top by the 5½" Strips 6 and 5½" x 1½" Flexible Plates 7, which are attached to the 12½" Strips by Angle Brackets. The 3" Pulleys 8 are held between Spring Clips on a 6½" Rod mounted in 2½" Strips bolted to the top of the tower.

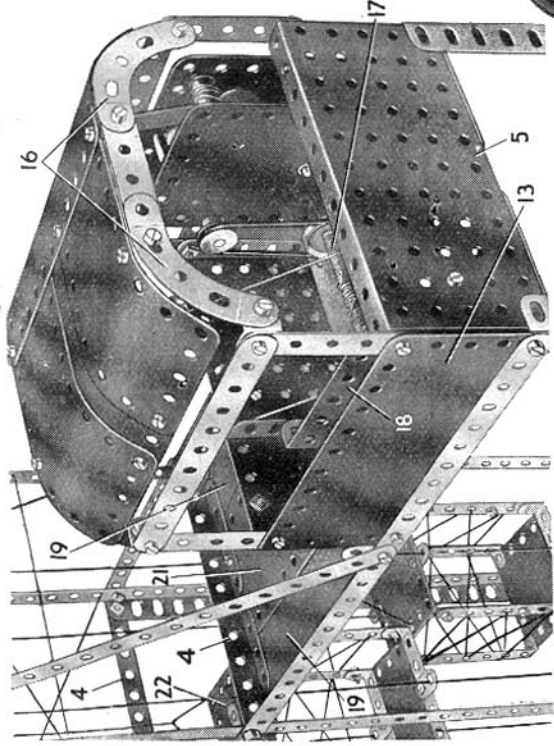
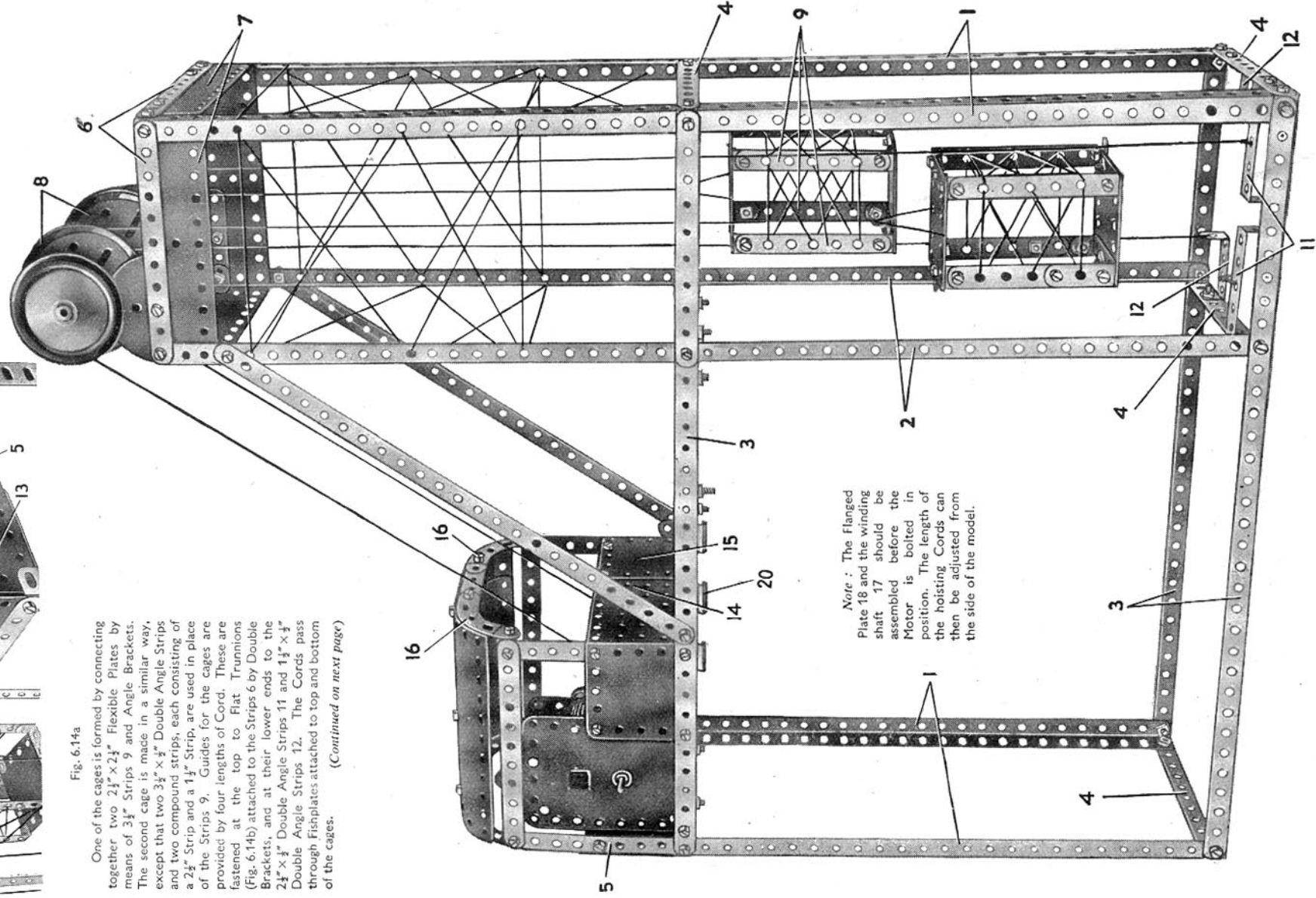

Fig. 6.14a

One of the cages is formed by connecting together two 2½" x 2½" Flexible Plates by means of 3½" Strips 9 and Angle Brackets. The second cage is made in a similar way, except that two 3½" x ½" Double Angle Strips and two compound strips, each consisting of a 2½" Strip and a 1½" Strip, are used in place of the Strip 9. Guides for the cages are provided by four lengths of Cord. These are fastened at the top to Flat Trunnions (Fig. 6.14b) attached to the Strips 6 by Double Brackets, and at their lower ends to the 2½" x ½" Double Angle Strips 11 and 1½" x ½" Double Angle Strips 12. The Cords pass through Fishplates attached to top and bottom of the cages. (Continued on next page)



Note: The Flanged Plate 18 and the winding shaft 17 should be assembled before the Motor is bolted in position. The length of the hoisting Cords can then be adjusted from the side of the model.

6.14 PITHEAD GEAR—continued

Note: The Motor used in this model is not included in the Outfit.

Fig. 6.14b

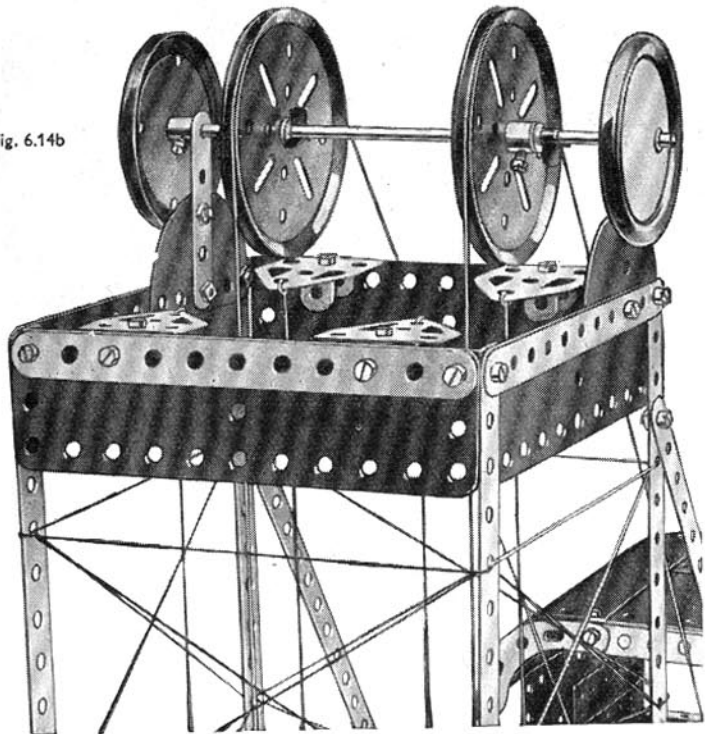

One side of the winding house consists of a  $5\frac{1}{2}'' \times 2\frac{1}{2}''$  Flexible Plate, 13, and the front is formed by the  $3\frac{1}{2}'' \times 2\frac{1}{2}''$  Flanged Plate 14 and  $2\frac{1}{2}'' \times 2\frac{1}{2}''$  Flexible Plate 15. The roof consists of a  $4\frac{1}{2}'' \times 2\frac{1}{2}''$  and three  $5\frac{1}{2}'' \times 2\frac{1}{2}''$  Flexible Plates fastened together as shown, and attached by Angle Brackets to the Curved Strips 16.

A No. 1 Clockwork Motor is bolted securely to the framework, and the drive taken from a  $\frac{1}{2}''$  Pulley on the Motor output shaft to a  $1''$  Pulley on Rod 17 (Fig. 6.14a). This Rod is journalled in the side-plate of the motor and a  $3\frac{1}{2}'' \times 2\frac{1}{2}''$  Flanged Plate 18. Lengths of Cord extending from the cages are passed over the  $3''$  Pulleys 8 and wound in opposite directions around the Rod 17, so that as one Cord is taken in the other is paid out.

"Ground level" is represented by two  $12\frac{1}{2}''$  Strip Plates 19, one half of a Hinged Flat Plate 20, and a  $4\frac{1}{2}'' \times 2\frac{1}{2}''$  Flexible Plate 21. These are attached to the Flanged Plate 5 and to two Reversed Angle Brackets, one of which is seen at 22.

6.15 STEAM WAGON

Construction is commenced with the chassis. Two  $12\frac{1}{2}''$  Strips and a  $12\frac{1}{2}''$  Angle Girder bolted at each end to two  $2\frac{1}{2}''$  Strips form each side member. The sides of the chassis are filled in with Flexible Plates and two Flanged Plates. The side members of the chassis are then joined together, at the rear by  $2\frac{1}{2}''$  Strips and at the front by a  $2\frac{1}{2}'' \times \frac{1}{2}''$  Double Angle Strip. The platform is bolted to the chassis by two  $1'' \times 1''$  Angle Brackets at the rear. At the front end it is bolted to a Fishplate attached to two  $2\frac{1}{2}''$  Strips, which are overlapped one hole and bolted to the Angle Girders forming the side members of the chassis.

The boiler consists of two  $4\frac{1}{2}'' \times 2\frac{1}{2}''$  Flexible Plates extended by two  $1\frac{1}{4}''$  radius Curved Plates and bent to shape, the ends being joined together by two Obtuse Angle Brackets. The boiler front is a Road Wheel carried on a  $11\frac{1}{2}''$  Rod, which is held by a Spring Clip in a  $2\frac{1}{2}'' \times \frac{1}{2}''$  Double Angle Strip. The chimney is a U-Section Curved Plate bent to shape, and is attached as follows. A  $3''$  Screwed Rod is lock-nutted at one end to a Fishplate bolted to the boiler, and passed up the centre of the chimney. The free end of the Screwed Rod projects through the roof of the cab and is held in the boss of a  $1''$  Pulley.

The rear part of the roof is formed by a Hinged Flat Plate, extended at the back of the cab by two  $2\frac{1}{2}'' \times 2\frac{1}{2}''$  Flexible Plates. These are attached to the platform body by an Angle Bracket, which is held by the same bolt as the Fishplate already mentioned. The Angle Brackets bolted to the  $3\frac{1}{2}''$  Strips at the side of the cab are spaced from the Hinged Flat Plate by two Washers.

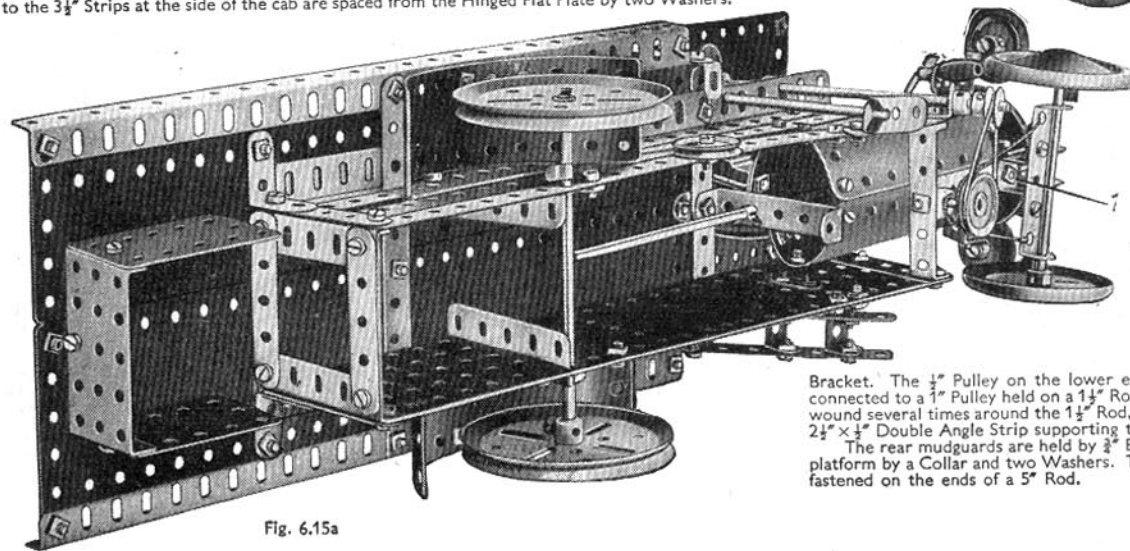
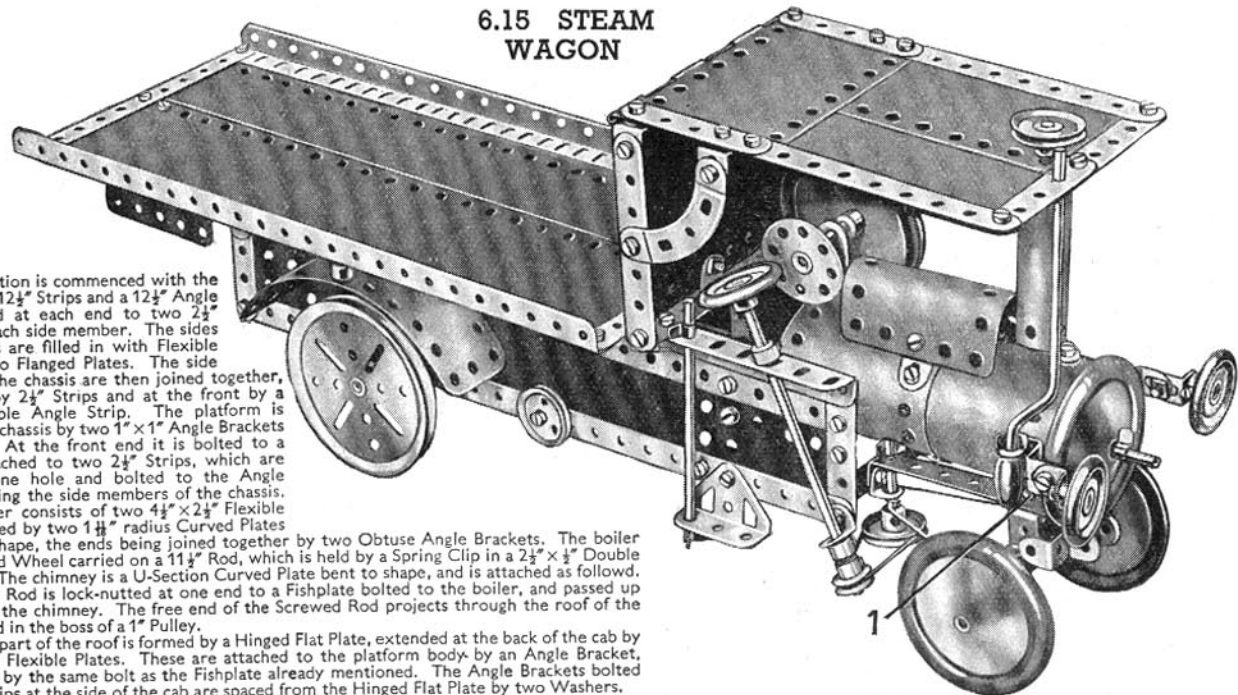

Fig. 6.15a

The front axle is mounted in the following manner. A Double Bracket is fastened by Obtuse Angle Brackets to the underside of the boiler, and a  $3\frac{1}{2}'' \times \frac{1}{2}''$  Double Angle Strip is bolted to it and to the Double Angle Strip spacing the front of the chassis. To the Double Angle Strip a Double Bent Strip carrying the front axle support is lock-nutted by Bolt 1.

The steering column is journalled in the Angle Girder at the side of the cab, and also in an Angle Bracket. The  $\frac{1}{2}''$  Pulley on the lower end of the steering column is connected to a  $\frac{1}{2}''$  Pulley held on a  $1\frac{1}{2}''$  Rod, by a Driving Band. Cord is wound several times around the  $1\frac{1}{2}''$  Rod, and is tied at each end to the  $2\frac{1}{2}'' \times \frac{1}{2}''$  Double Angle Strip supporting the front axle.

The rear mudguards are held by  $\frac{3}{4}''$  Bolts, and are spaced from the platform by a Collar and two Washers. The rear wheels are  $3''$  Pulleys fastened on the ends of a  $5''$  Rod.



6.16 SINGLE DECK BUS

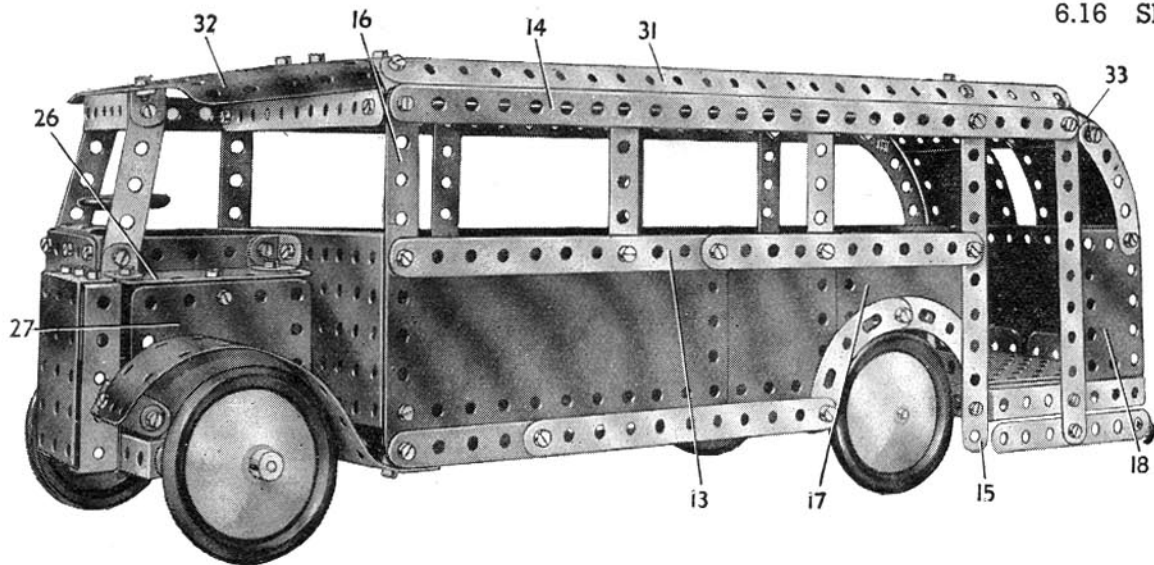

The chassis is formed by two 12 1/2" Angle Girders extended by the 5 1/2" Strips 1 (Fig. 6.16b). The Angle Girders are connected by a 2 1/2" x 1/2" Double Angle Strip at the rear, and by a 5 1/2" x 2 1/2" Flanged Plate 2. The rear platform consists of two 3 1/2" x 2 1/2" Flanged Plates and a 2 1/2" Flexible Plate bolted to the chassis members.

The off-side of the body, seen in Fig. 6.16c, is built up on a framework consisting of a compound strip 3, made by overlapping two 12 1/2" Strips 17 holes, and a 12 1/2" Strip 4 extended by a 2 1/2" Strip 5. These are bolted to a 5 1/2" Strip 6, which is attached to the chassis by a 1 1/2" x 1/2" Double Angle Strip 7, and to a 2 1/2" Strip 8. The side is filled in by a 2 1/2" x 1 1/2" Flexible Plate 9, two 4 1/2" x 2 1/2" Flexible Plates, a 5 1/2" x 1 1/2" Flexible Plate 10, and two 2 1/2" x 2 1/2" Flexible Plates 11. The 5 1/2" Strips 12 are attached to the Flexible Plates by Fishplates.

The near side of the model, seen in the general view, consists of two 5 1/2" Strips 13 and a 12 1/2" Strip 14. These are bolted to the 5 1/2" Strip 15 and 2 1/2" Strip 16, and the side is filled in by a 5 1/2" x 2 1/2" Flexible Plate, a 2 1/2" x 2 1/2" Flexible Plate, a 5 1/2" x 1 1/2" Flexible Plate 17 and a 2 1/2" x 1 1/2" Flexible Plate 18. The rear of the bus is formed by a 5 1/2" x 2 1/2" Flexible Plate attached by Angle Brackets to the Plates 11 and 18.

The front axle consists of a compound strip 19, made by overlapping a 3 1/2" and a 2 1/2" Strip three holes, and is attached to the Strips 1 by Double Brackets. The 3/8" Bolts 20 are passed through the 1 1/2" Strips 21 and two Double Brackets, and are held by lock-nuts in the end holes of the strip 19. The Strips 21 are connected by lock-nutted bolts to a compound strip 23. This strip consists of a 3 1/2" and a 2 1/2" Strip overlapped three holes. The Road Wheels are free to turn on 1 1/2" Rods held by Spring Clips in the Double Brackets.

The driver's cab is formed by a 2 1/2" x 1 1/2" Flexible Plate and a 2 1/2" x 2 1/2" Flexible Plate 25 bolted to a 2 1/2" x 1 1/2" Double Angle Strip 24. The bonnet consists of a 2 1/2" x 1 1/2" Flexible Plate 26 and a 2 1/2" x 2 1/2" Flexible Plate 27. The radiator is represented by a 2 1/2" x 1 1/2" Flanged Plate. This is fitted with a 2 1/2" x 1 1/2" Double Angle Strip on each side and is attached by a Fishplate to the Flexible Plate 26.

The steering column is a 3" Screwed Rod mounted in the Trunnions 28. A Bush Wheel fixed on the end of this Rod is fitted with a Fishplate and connected by a lock-nutted bolt to a 2 1/2" Strip. The opposite end of this Strip is placed over a 3/8" Bolt 30.

Note : The Motor used in this model is not included in the Outfit.

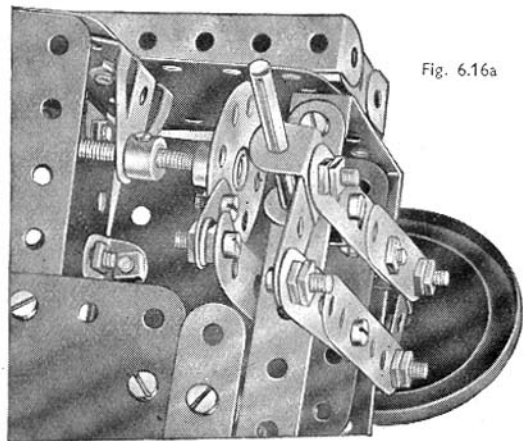

Fig. 6.16a

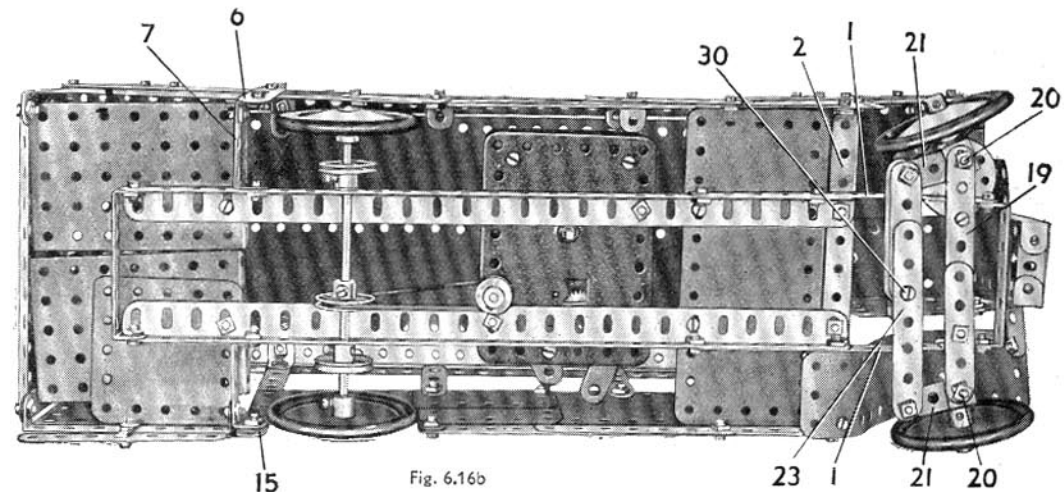

Fig. 6.16b

The 12 1/2" Strips 31 are attached by Obtuse Angle Brackets to the strips 4 and 14. The roof is formed by two 12 1/2" Strip Plates fastened by Angle Brackets to the Strips 31. A 5 1/2" x 2 1/2" Flexible Plate 32 is attached to the Strip Plates by a 2 1/2" Strip, and fastened by an Angle Bracket to the front of the driver's cab.

The curved panelling at the rear of the bus is formed by two 1 1/2" radius Curved Plates bolted to a 5 1/2" x 1 1/2" Flexible Plate 33. This Plate is attached to the 12 1/2" Strip Plates.

The model is driven by a No. 1 Clockwork Motor bolted to the chassis as shown in Fig. 6.16b. A 1" Pulley on the driving shaft of the Motor is connected by a Driving Band to a 1" Pulley on the rear axle. The rear axle consists of a 3 1/2" and a 2" Rod joined by a Rod Connector.

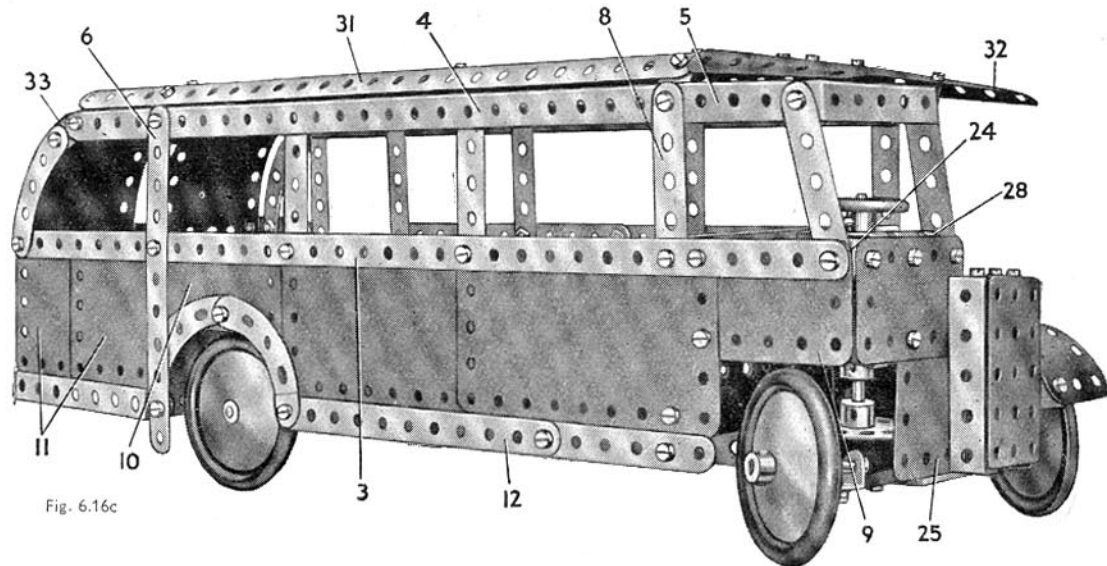

Fig. 6.16c

## 6.17 FARM TRACTOR AND HARVESTER

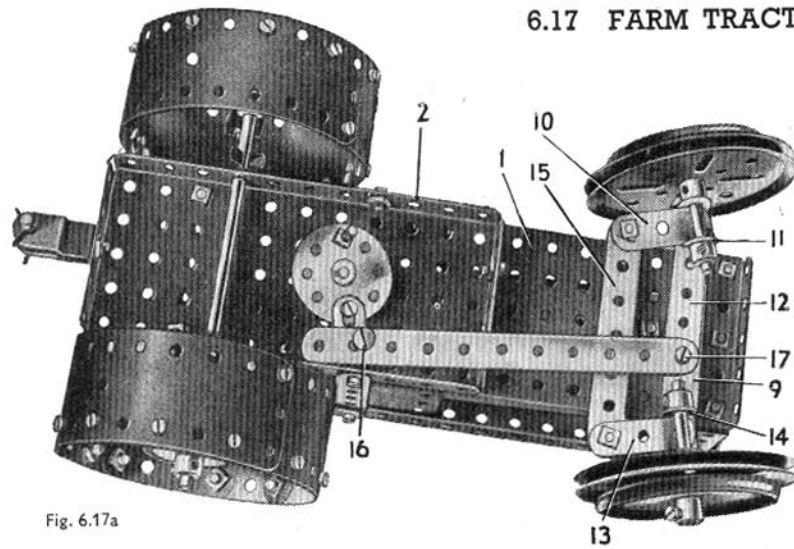
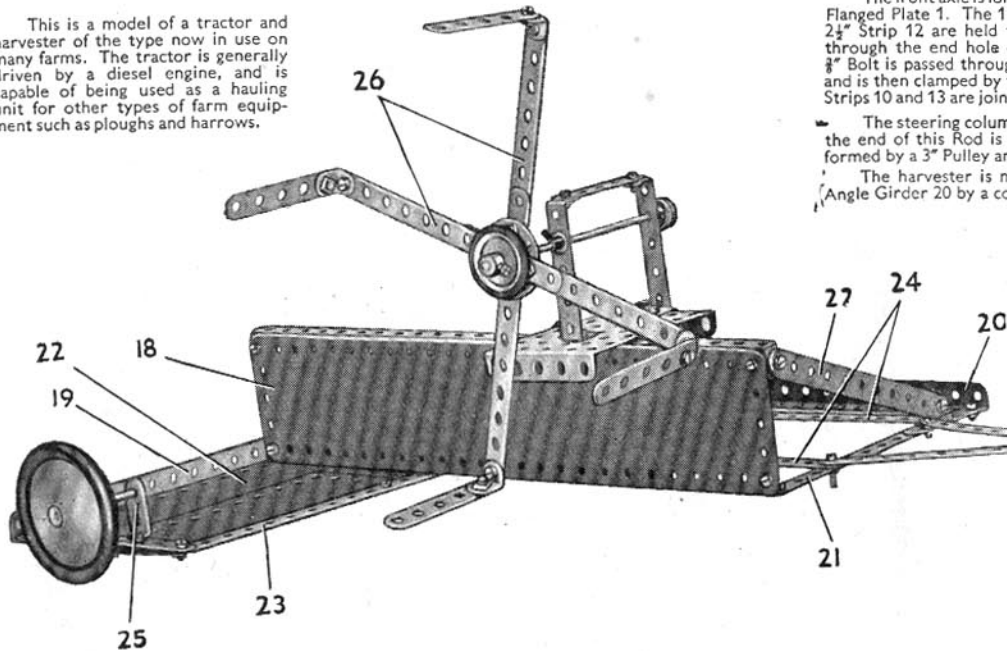

Fig. 6.17a

This is a model of a tractor and harvester of the type now in use on many farms. The tractor is generally driven by a diesel engine, and is capable of being used as a hauling unit for other types of farm equipment such as ploughs and harrows.



The tractor chassis consists of a  $3\frac{1}{2}'' \times 2\frac{1}{2}''$  Flanged Plate 1 (Fig. 6.17a) bolted to a  $5\frac{1}{2}'' \times 2\frac{1}{2}''$  Flanged Plate 2. Each side of the bonnet is formed by a  $2\frac{1}{2}'' \times \frac{1}{2}''$  Double Angle Strip 3 and a  $3''$  Strip 4. The Strips 3 and 4 are connected by a  $5\frac{1}{2}''$  Strip 5, and are joined to similar Strips on the opposite side by two  $2\frac{1}{2}'' \times \frac{1}{2}''$  Double Angle Strips (Fig. 6.17b).

The radiator consists of the  $2\frac{1}{2}''$  Strips 6 and a  $2\frac{1}{2}'' \times 1\frac{1}{2}''$  Flanged Plate 7, and the top of the bonnet is formed by a  $5\frac{1}{2}'' \times 2\frac{1}{2}''$  Flexible Plate attached to the Curved Strips 8 by Angle Brackets. The engine is represented by a U-Section Curved Plate attached to a Cylinder by means of a Double Bracket, the Cylinder being bolted to the Flanged Plate 1. The seat consists of a U-Section Curved Plate attached to the Flanged Plate 2 by  $1\frac{1}{2}'' \times \frac{1}{2}''$  Double Angle Strips.

The rear wheels are made by joining together a  $2\frac{1}{2}'' \times 1\frac{1}{2}''$  and two  $5\frac{1}{2}'' \times 1\frac{1}{2}''$  Flexible Plates, and bolting these to spokes which on one wheel consist of two  $3\frac{1}{2}'' \times \frac{1}{2}''$  Double Angle Strips, and on the other of two  $3\frac{1}{2}''$  Strips and Angle Brackets. The hubs are formed by Wheel Discs, and the wheels are clamped on a  $6\frac{1}{2}''$  Rod between a Collar and a  $1''$  Pulley fitted with a Rubber Ring.

The front axle is formed by a  $3\frac{1}{2}''$  Strip 9 (Fig. 6.17a) bolted to the Flanged Plate 1. The  $1\frac{1}{2}''$  Strip 10, the Double Bracket 11 and the  $2\frac{1}{2}''$  Strip 12 are held tightly on a  $\frac{3}{8}''$  Bolt, which is then passed through the end hole of the Strip 9 and lock-nutted. A second  $\frac{3}{8}''$  Bolt is passed through the  $1\frac{1}{2}''$  Strip 13 and Double Bracket 14, and is then clamped by two nuts in the end hole of the Strip 9. The Strips 10 and 13 are joined by lock-nuts to a  $3\frac{1}{2}''$  Strip 15.

The steering column consists of a  $4''$  Rod journalled in a Trunnion bolted to the rear Curved Strip 8, and the Flanged Plate 2. A Fishplate bolted to a Bush Wheel fixed to the end of this Rod is connected by a  $5\frac{1}{2}''$  Strip to the Strip 12. The  $5\frac{1}{2}''$  Strip is attached by means of a Pivot Bolt 16 and a lock-nutted Bolt 17. The front wheels are formed by a  $3''$  Pulley and a Road Wheel locked on  $2''$  Rods and journalled in the Double Brackets 11 and 14.

The harvester is made by bolting  $12\frac{1}{2}''$  Angle Girders to each side of a  $12\frac{1}{2}''$  Strip Plate 18. The Plate is joined to a  $12\frac{1}{2}''$  Angle Girder 19, and connected to a second  $12\frac{1}{2}''$  Strip Plate 22 and a  $2\frac{1}{2}'' \times 2\frac{1}{2}''$  and two  $5\frac{1}{2}'' \times 2\frac{1}{2}''$  Flexible Plates joined together and bolted to the  $12\frac{1}{2}''$  Strip 23. The  $12\frac{1}{2}''$  Strips 24 are then added for bracing purposes.

The harvester runs on two Road Wheels. One of these is fixed on a  $1\frac{1}{2}''$  Rod journalled in the  $1'' \times 1''$  Angle Bracket 25 and a Trunnion. The other is locked on a  $5''$  Rod, which is mounted in a Semi-Circular Plate bolted to the Angle Girder 20 and in a  $1'' \times 1''$  Angle Bracket attached to the Strip 23.

The rotating blades are formed by  $2\frac{1}{2}''$  Strips fastened by Angle Brackets to the compound strips 26. These strips consist of  $5\frac{1}{2}''$  Strips overlapped five holes and bolted to a Wheel Disc. The Wheel Disc is held tightly on a  $5''$  Rod between a Spring Clip and a  $1''$  Pulley fitted with a Rubber Ring. A  $\frac{1}{2}''$  Pulley on this Rod is connected by a Driving Band to a  $1''$  Pulley fixed on the  $5''$  Rod supporting the Road Wheel.

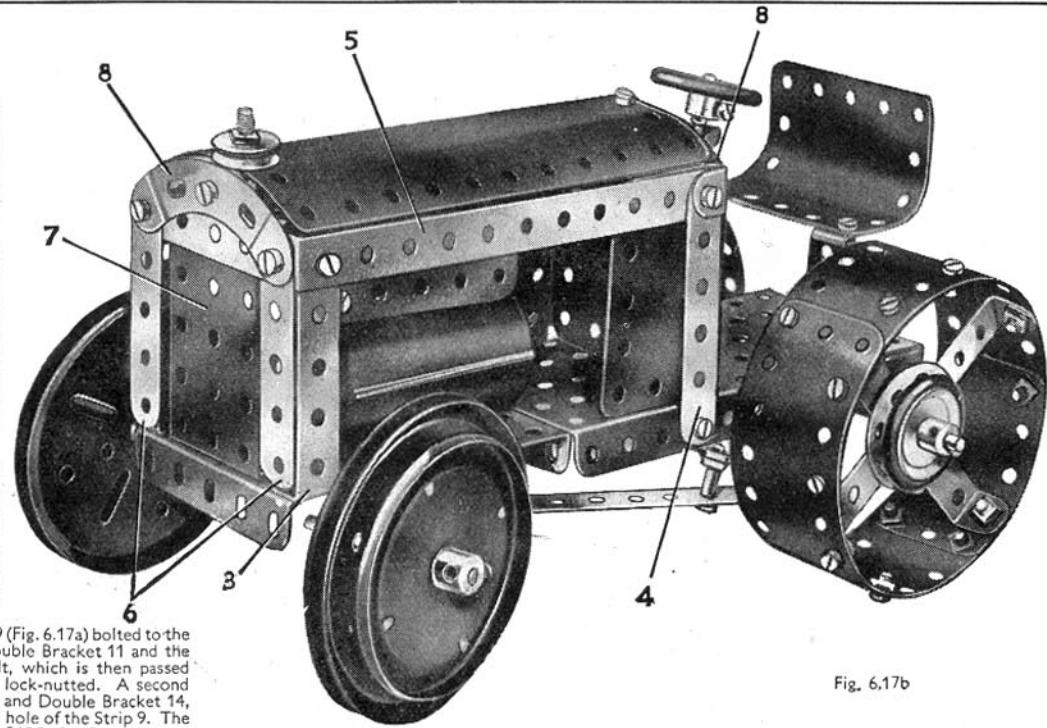
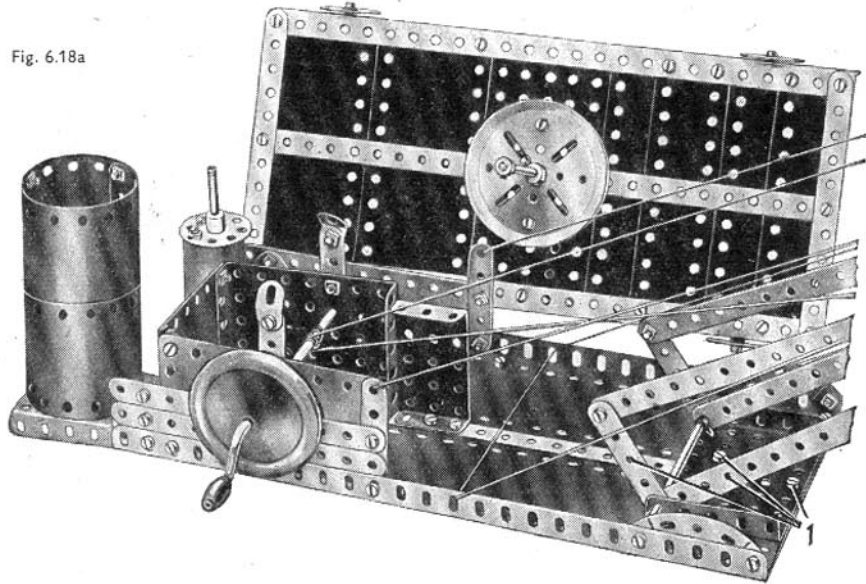
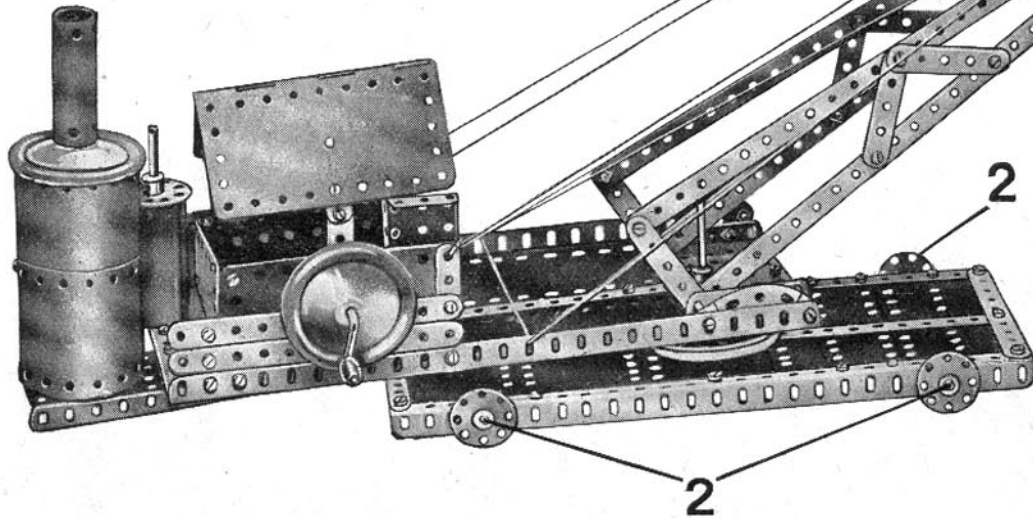

Fig. 6.17b

Fig. 6.18a



The near side of the cab (Fig. 6.18a) consists of two  $2\frac{1}{2}'' \times 2\frac{1}{2}''$  Flexible Plates, overlapped one hole and fastened to the Angle Girder at the edge of the platform. The rear side of the cab is formed by a  $3\frac{1}{2}'' \times 2\frac{1}{2}''$  Flanged Plate and a  $2\frac{1}{2}'' \times 1\frac{1}{2}''$  Flanged Plate. The  $3\frac{1}{2}'' \times 2\frac{1}{2}''$  Flanged Plate is secured to the base by a  $3\frac{1}{2}'' \times \frac{1}{2}''$  Double Angle Strip, and the  $2\frac{1}{2}'' \times 1\frac{1}{2}''$  Flanged Plate is bolted in position by its



## 6.18 GIANT DRAGLINE

The base is constructed by joining two Angle Girders at each end by a  $5\frac{1}{2}''$  Strip. It is then filled in by a  $5\frac{1}{2}'' \times 2\frac{1}{2}''$  Flanged Plate and different sized Flexible Plates. The bolts 2 carrying the Wheel Discs are lock-nutted. A  $3''$  Pulley Wheel is bolted to the centre of the  $5\frac{1}{2}'' \times 2\frac{1}{2}''$  Flanged Plate. The control platform is built up in a similar manner to the base, but is filled in by two  $12\frac{1}{2}''$  Strip Plates. A  $3''$  Pulley is secured under the forward end of the platform by four Reversed Angle Brackets, which are held by the bolts shown at 1. A  $4''$  Rod is passed through the upper  $3''$  Pulley, and its lower end is gripped in the  $3''$  Pulley bolted to the base. The platform therefore, is free to swivel, but is retained in position on the Rod by a Collar.

flange. A Hinged Flat Plate is used for the roof, and it is attached by Obtuse Angle Brackets to two  $1\frac{1}{2}''$  Strips bolted to the sides. The boiler consists of two  $5\frac{1}{2}'' \times 2\frac{1}{2}''$  Flexible Plates and two  $1\frac{1}{8}''$  radius Curved Plates.

The chimney is formed by bending a U-Section Curved Plate so that the two ends overlap. A bolt is fastened through the overlapping portions, and carries also an Angle Bracket inside the chimney. A  $6\frac{1}{2}''$  Rod, on the end of which is a Spring Clip, is slipped through the Angle Bracket and locked in the boss of a Road Wheel. The Wheel is placed over the boiler, and the lower end of the  $6\frac{1}{2}''$  Rod passes through a Flanged Sector Plate, which is bolted at the rear of the base. The Rod is held in position by another Spring Clip.

The jib is constructed from  $12\frac{1}{2}''$  Strips bolted end to end. It is pivoted at its lower end on a  $4''$  Rod journalled in the flanges of a  $3\frac{1}{2}'' \times 2\frac{1}{2}''$  Flanged Plate held by three of the bolts 1. The jib is held at an angle of about 30 degrees by Cord, which is tied to the cab and then taken over a  $1''$  fast Pulley on a  $2''$  Rod journalled in the jib. From there the Cord is led through holes in the Angle Girders forming the sides of the platform, over a  $1''$  Pulley on the other end of the  $2''$  Rod, and finally is tied to the cab.

The Crank Handle in the sides of the cab controls the movement of the bucket. Cord is wound a few times round the shaft of the Crank Handle and then is taken over a  $4\frac{1}{2}''$  Rod in the jib and tied to the front of the bucket. The other end of the Cord is led around a  $1''$  fast Pulley on a Rod at the end of the jib, and through the pulley block at the back of the bucket. It is then tied to a Fishplate carried on the  $2''$  Rod journalled in the jib.

## 6.19 LIFTING BRIDGE

Fig. 6.19a

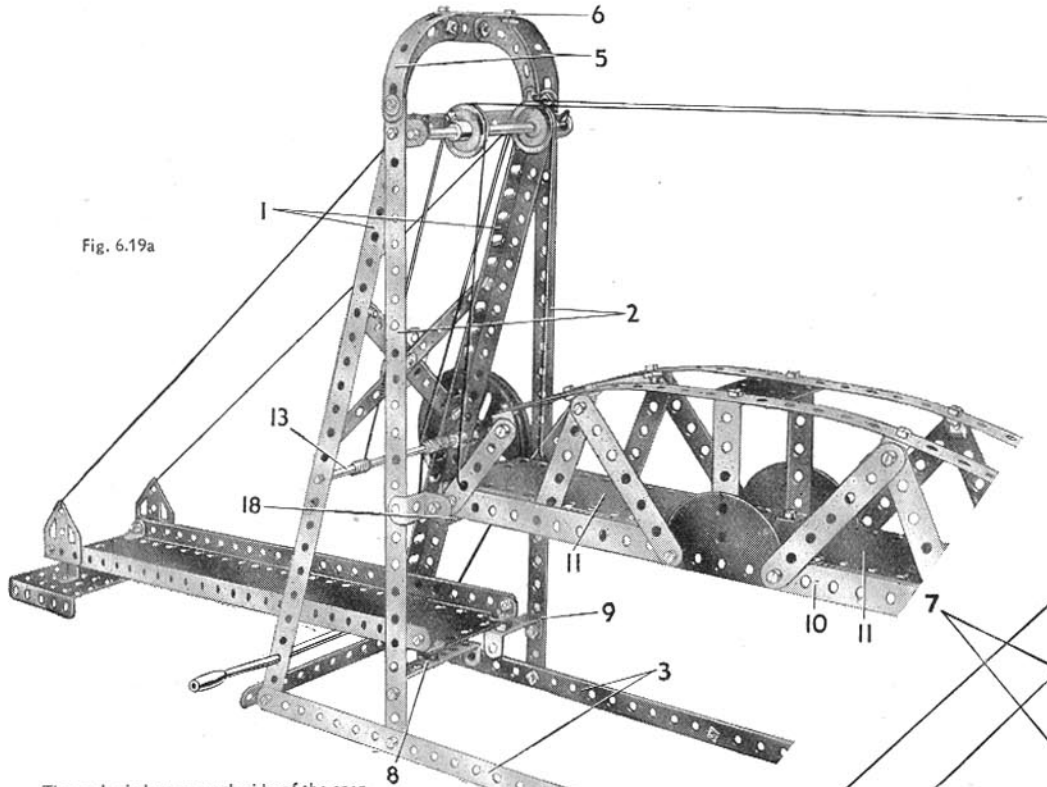

The arch girders on each side of the span are formed by two  $5\frac{1}{2}$ " Strips bolted together. These are joined by  $2\frac{1}{2} \times \frac{1}{2}$ " Double Angle Strips 12 at each end and by a  $2\frac{1}{2} \times 1\frac{1}{2}$ " Flexible Plate in the centre. The arch girders are attached to the roadway by means of a  $2\frac{1}{2} \times \frac{1}{2}$ " Double Angle Strip in the centre and a  $2\frac{1}{2}$ " Strip at each end.

A  $3\frac{1}{2} \times \frac{1}{2}$ " Double Angle Strip 18 is fastened to each end of the moving span, at one end by a Double Bent Strip and at the other by a Stepped Bent Strip. Four Reversed Angle Brackets bolted to the ends of the Double Angle Strips are free to slide on the  $12\frac{1}{2}$ " Strips 2 and provide guides for the lifting span.

The span is raised and lowered by means of a Crank Handle journalled in two of the Angle Girders 1. A 1" Pulley on the Crank Handle is connected by a Driving Band to a 3" Pulley on a 5" Rod 13. The Cords 14 extending from the Rod 13 are passed over the 1" Pulleys 15 and tied to the end of the span. The Cords 16 are fastened to the opposite end of the span, passed over the Pulleys 17 and 15, and finally tied to the Cords 14.

The towers are identical in construction and consist of two  $12\frac{1}{2}$ " Angle Girders 1, and two  $12\frac{1}{2}$ " Strips 2 (Fig. 6.19a). These are bolted to compound strips 3, made by joining two  $12\frac{1}{2}$ " Strips overlapped nine holes. The upper ends of the Angle Girders are connected by two  $2\frac{1}{2}$ " Strips joined together, and the lower ends by a  $5\frac{1}{2}$ " Strip.

The Curved Strips 4 are bolted to Obtuse Angle Brackets attached to the Angle Girders, and are connected by a  $1\frac{1}{2}$ " Strip. A Formed Slotted Strip 5 is then bolted to each side of the tower. The Slotted Strips are joined by a  $2\frac{1}{2}$ " Strip 6. Cross bracing of each tower is provided by two  $5\frac{1}{2}$ " Strips 7.

The approach roadways consist of two  $12\frac{1}{2}$ " Strips fastened to a  $12\frac{1}{2}$ " Strip Plate by Angle Brackets. They are attached to a  $2\frac{1}{2} \times \frac{1}{2}$ " Double Angle Strip 8 and a  $1\frac{1}{2} \times \frac{1}{2}$ " Double Angle Strip 9 by means of  $\frac{3}{8}$ " Bolts. A Spring Clip is placed on each Bolt to raise the level of the roadway slightly.

The central span is made by bolting a  $12\frac{1}{2}$ " Strip to each side of a  $5\frac{1}{2} \times 2\frac{1}{2}$ " Flanged Plate. One of these can be seen at 10. These Strips are joined at each end by a  $2\frac{1}{2} \times \frac{1}{2}$ " Double Angle Strip, and the  $5\frac{1}{2} \times 2\frac{1}{2}$ " Flexible Plates 11 are bolted to the Double Angle Strips and the Flanged Plate.

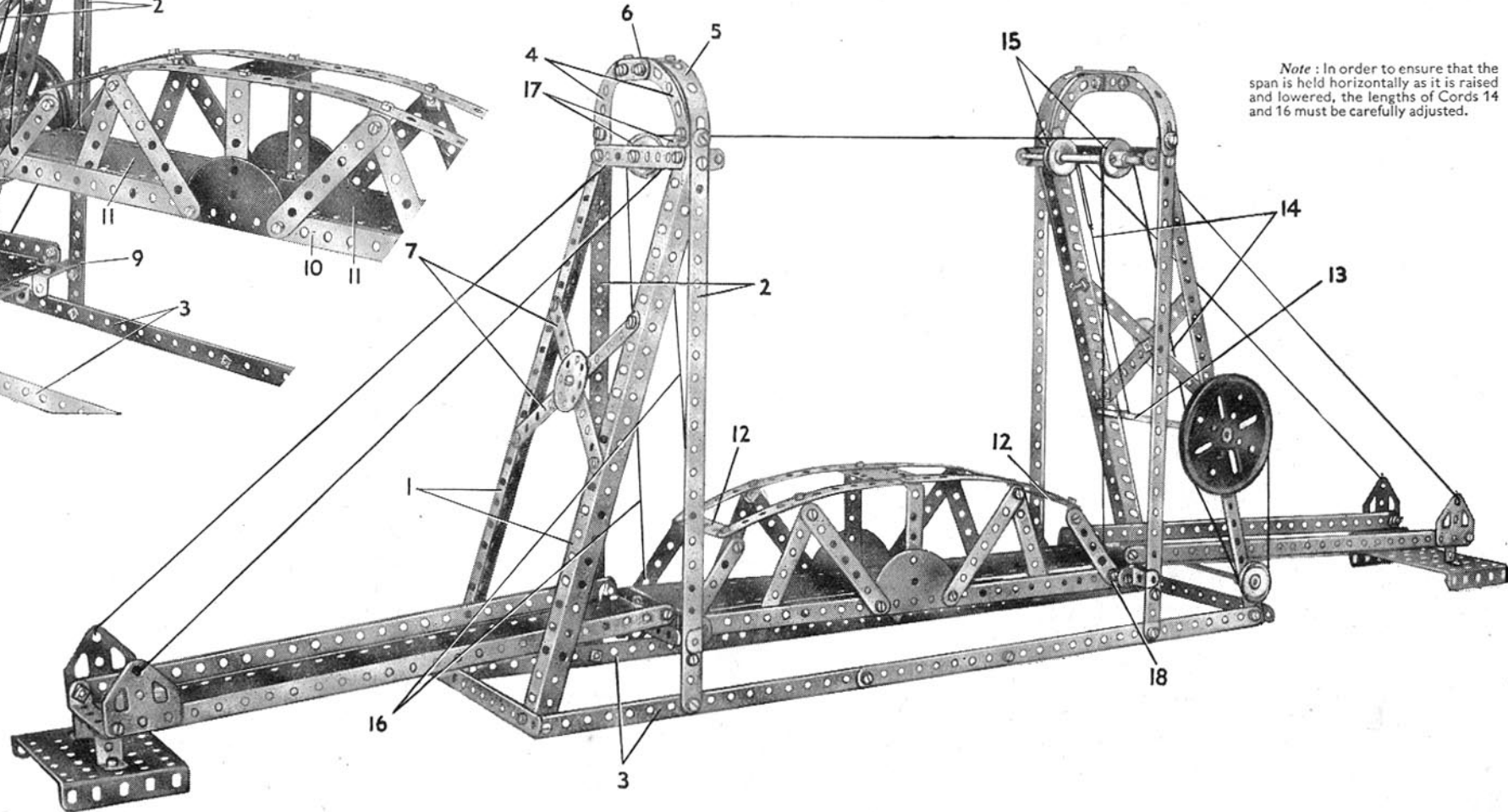

*Note:* In order to ensure that the span is held horizontally as it is raised and lowered, the lengths of Cords 14 and 16 must be carefully adjusted.

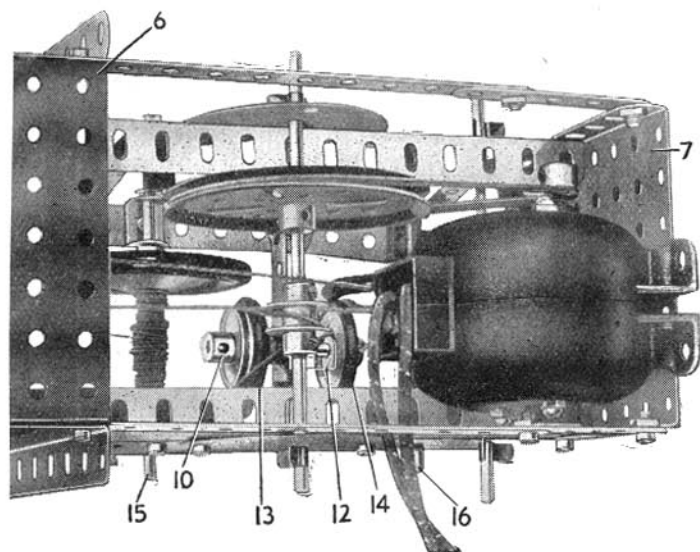

Fig. 6.20a

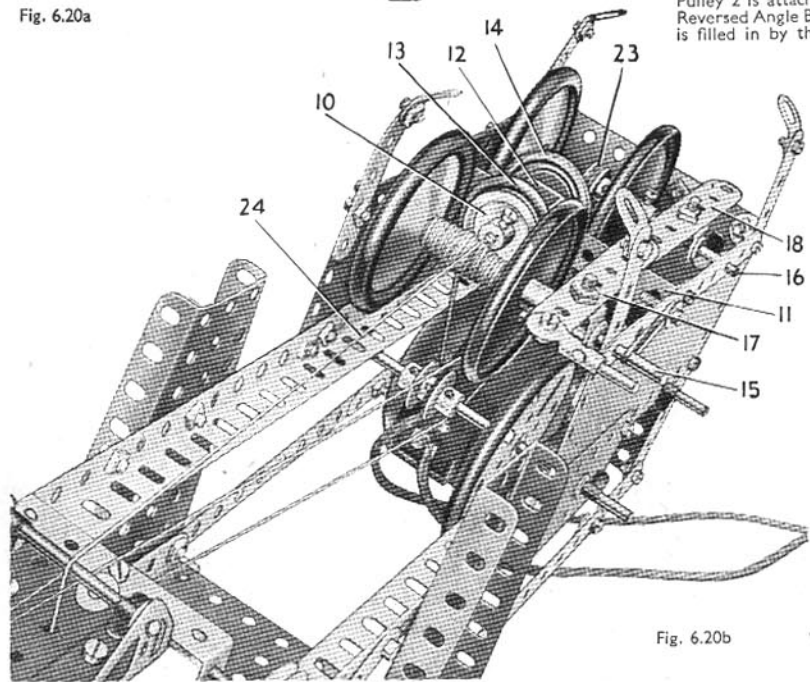

Fig. 6.20b

The tower is formed by eight  $12\frac{1}{2}$ " Strips, bolted in pairs by Angle Brackets to form four angle girders. These are joined together at the top and bottom by  $5\frac{1}{2}$ " Strips, and the  $5\frac{1}{2}$ " x  $2\frac{1}{4}$ " Flanged Plate 1 is then bolted in position. A 3" Pulley 2 is attached to the Flanged Plate by four Reversed Angle Brackets, and the top of the tower is filled in by the

separated halves of a Hinged Flat Plate and two  $5\frac{1}{2}$ " x  $1\frac{1}{2}$ " Flexible Plates bolted to the Flanged Plate 1. Each side of the jib consists of two  $12\frac{1}{2}$ " Angle Girders 3 overlapped 19 holes, two  $12\frac{1}{2}$ " Strips 4 overlapped 19 holes, and  $5\frac{1}{2}$ " and  $2\frac{1}{2}$ " Strips 5 overlapped two holes. These are bolted at the centre to Flanged Sector Plates attached to a  $3\frac{1}{2}$ " x  $2\frac{1}{4}$ " Flanged Plate 6. At the rear the sides are bolted to a  $3\frac{1}{2}$ " x  $2\frac{1}{4}$ " Flanged Plate 7 and at the front to a  $3\frac{1}{2}$ " Strip 8 and a  $3\frac{1}{2}$ " x  $\frac{1}{2}$ " Double Angle Strip 9. The jib can be slewed about a  $1\frac{1}{2}$ " Rod locked in the Pulley 2. This Rod is passed through the centre hole of the Flanged Plate 6 and is fitted with a Bush Wheel to clamp the jib in position.

The sides of the control cabin are formed by  $5\frac{1}{2}$ " x  $2\frac{1}{4}$ " Flexible Plates strengthened by  $5\frac{1}{2}$ " Strips and fixed to the Angle Girders 3. The rear of the cab consists of two  $2\frac{1}{2}$ " x  $2\frac{1}{4}$ " Flexible Plates overlapped three holes and attached to the sides by Angle Brackets. The roof is formed by two  $5\frac{1}{2}$ " x  $2\frac{1}{4}$ " Flexible Plates and is attached by Obtuse Angle Brackets to four  $2\frac{1}{2}$ " Strips bolted to the sides.

The power unit, an EQ20 Electric Motor, is bolted to the Flanged Plate 7. The drive is taken from the pulley on the motor to a 3" Pulley locked on a 5" Rod. This Rod is journalled in two Semi-Circular Plates, and is fitted with a built-up pulley consisting of two  $\frac{3}{8}$ " Washers clamped between three Collars. A 6" Driving Band on this pulley transmits the drive to a 1" Pulley 10, which is locked on a 2" Rod journalled in a  $3\frac{1}{2}$ " x  $\frac{1}{2}$ " Double Angle Strip 11 and a Double Bent Strip 12. The 2" Rod also carries two 1" Pulleys 13 and 14, each fitted with a Rubber Ring.

The  $4\frac{1}{2}$ " Rod 15 and 4" Rod 16, each fitted with two Road Wheels, are journalled in the sides of the cabin. The Road Wheels are spaced so that they can be brought into contact with the Rubber Rings on Pulleys 13 and 14 by means of the  $3\frac{1}{2}$ " Strips 17 and 18. These Strips are lock-nutted to an Angle Bracket bolted to the Double Angle Strip 11. Double Brackets lock-nutted to each of the Strips 17 and 18 are held between Spring Clips and Washers on Rods 15 and 16 respectively.

The travelling carriage consists of a  $2\frac{1}{2}$ " x  $1\frac{1}{2}$ " Flanged Plate fitted with two Trunnions, one of which is seen at 19. Two 1" Pulleys are locked on a  $3\frac{1}{2}$ " Rod journalled in a  $2\frac{1}{2}$ " x  $\frac{1}{2}$ " Double Angle Strip bolted to the Flanged Plate, and two 1" loose Pulleys are held by Spring Clips on a 5" Rod mounted in a similar manner to the  $3\frac{1}{2}$ " Rod.

The Cord 20 extending from the front of the carriage is taken around Rods 21 and 22, and passed twice around a  $\frac{1}{2}$ " Pulley 23 on Rod 16. It is then passed again around Rod 22 and fastened to the rear of the carriage. The Cord 24 which is tied to Rod 15, is taken over a  $1\frac{1}{2}$ " Rod mounted in the Trunnions 19, around a  $\frac{1}{2}$ " loose Pulley in the pulley block, and finally fastened to the travelling carriage.

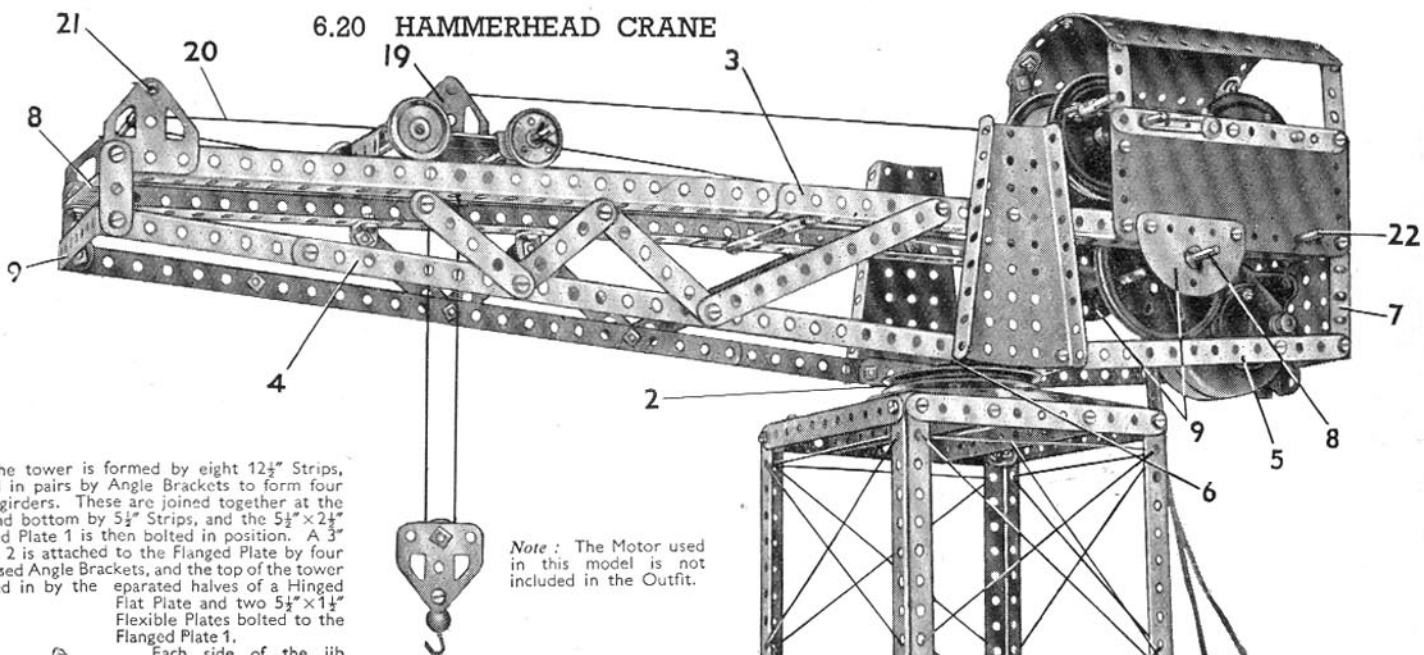

Note: The Motor used in this model is not included in the Outfit.

## 6.21 GIANT ARTICULATED LORRY

The chassis consists of two  $12\frac{1}{2}$ " Strips joined at the front by  $2\frac{1}{2}$ " x  $\frac{1}{2}$ " Double Angle Strip 1, and at the rear by two similar Double Angle Strips 2. The  $5\frac{1}{2}$ " x  $2\frac{1}{2}$ " Flanged Plate 3 is attached to the chassis by Angle Brackets.

The sides of the bonnet are formed by  $4\frac{1}{2}$ " x  $2\frac{1}{2}$ " Flexible Plates bolted to the chassis members, and the top consists of two  $1\frac{1}{8}$ " radius Curved Plates joined together and fastened to the sides by Obtuse Angle Brackets. The radiator is represented by a  $2\frac{1}{2}$ " x  $2\frac{1}{2}$ " Flexible Plate, and is attached to Angle Brackets bolted to the sides.

The back of the cab consists of two  $5\frac{1}{2}$ " x  $2\frac{1}{2}$ " Flexible Plates joined together. These are attached to the  $5\frac{1}{2}$ " Strips 4 by Angle Brackets 5 and two  $2\frac{1}{2}$ " x  $\frac{1}{2}$ " Double Angle Strips. One of the Double Angle Strips can be seen at 6. The sides of the cab are formed by a  $2\frac{1}{2}$ " x  $2\frac{1}{2}$ " and a  $2\frac{1}{2}$ " x  $1\frac{1}{2}$ " Flexible Plate overlapped two holes and attached to the Flanged Plate 3 and the Strips 4. A  $5\frac{1}{2}$ " x  $2\frac{1}{2}$ " Flexible Plate represents the roof and is bolted to the  $2\frac{1}{2}$ " x  $\frac{1}{2}$ " Double Angle Strips 7.

The front axle beam 8 (Fig. 6.21b) consists of a  $3\frac{1}{2}$ " and a  $2\frac{1}{2}$ " Strip overlapped three holes, and is attached to the chassis members by two Angle Brackets. A  $\frac{3}{8}$ " Bolt is passed through the  $1\frac{1}{2}$ " Strip 9 and the Double Bracket 10. The  $2\frac{1}{2}$ " Strip 11 is locked in position by a nut, and the Bolt passed through the end hole of the strip 8 and held by lock-nuts, so that the assembly is free to pivot.

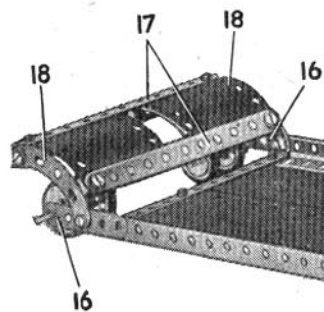

A second  $\frac{3}{8}$ " Bolt is passed through the  $1\frac{1}{2}$ " Strip 12 and Double Bracket 13, and is held in the end hole of the strip 8 by two nuts. The Strips 9 and 12 are connected by a compound strip consisting of two  $2\frac{1}{2}$ " Strips joined together.

The steering column is formed by a 4" Rod fitted with a 1" Pulley and a Bush Wheel, and is journaled in the Flanged Plate 3 and a Fishplate 14. A  $3\frac{1}{2}$ " Strip lock-nutted to the Strip 11 is connected by means of a Pivot Bolt to a Fishplate 15 bolted to the Bush Wheel. The Road Wheels are locked on  $1\frac{1}{2}$ " Rods mounted in the Double Brackets 10 and 13. Bearings for the rear axle are provided by Semi-Circular Plates attached to the chassis members. The rear axle consists of a 5" Rod and is held in place by Collars.

The main girders on each side of the semi-trailer are formed by two  $12\frac{1}{2}$ " Angle Girders overlapped 14 holes. The girders are joined together by four  $5\frac{1}{2}$ " Strips. The loading platform consists of two  $12\frac{1}{2}$ " Strips Plates and a Hinged Plate. A compound strip made by overlapping two  $12\frac{1}{2}$ " Strips is bolted in the centre of the trailer underneath the Plates forming the platform.

The trailer runs on four wheels, consisting of two 1" Pulleys and two 1" loose Pulleys. These are held on a  $6\frac{1}{2}$ " Rod journaled in the  $2\frac{1}{2}$ " Strips 16. A cover over the wheels is provided by two  $2\frac{1}{2}$ " x  $2\frac{1}{2}$ " Flexible Plates. These are bolted to the  $5\frac{1}{2}$ " Strips 17 and attached to the Curved Strips 18 by two  $1\frac{1}{2}$ " x  $\frac{1}{2}$ " Double Angle Strips.

Construction of the swan-neck of the trailer can be seen in Fig. 6.21a. The  $3\frac{1}{2}$ " x  $2\frac{1}{2}$ " Flanged Plates are connected together by  $5\frac{1}{2}$ " Strips bolted to their flanges, and are joined to the  $2\frac{1}{2}$ " Strips 19 by  $1$ " x  $1$ " Angle Brackets.

The trailer is pivotally attached to the chassis by means of a  $1\frac{1}{2}$ " Rod held in a 3" Pulley bolted to the Double Angle Strips 2. This Rod is passed through the centre hole of a  $2\frac{1}{2}$ " x  $\frac{1}{2}$ " Double Angle Strip 20.

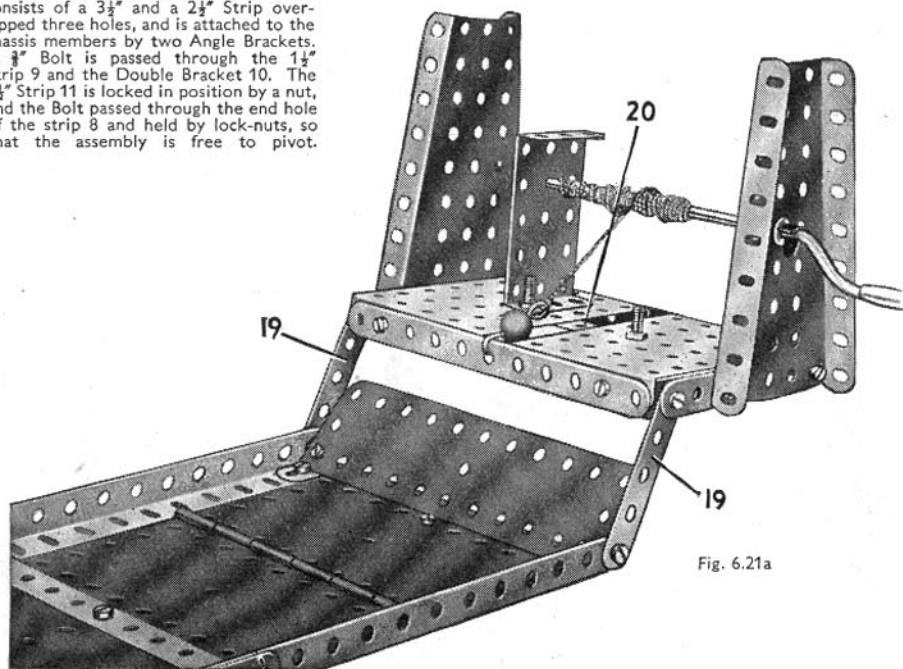

Fig. 6.21a

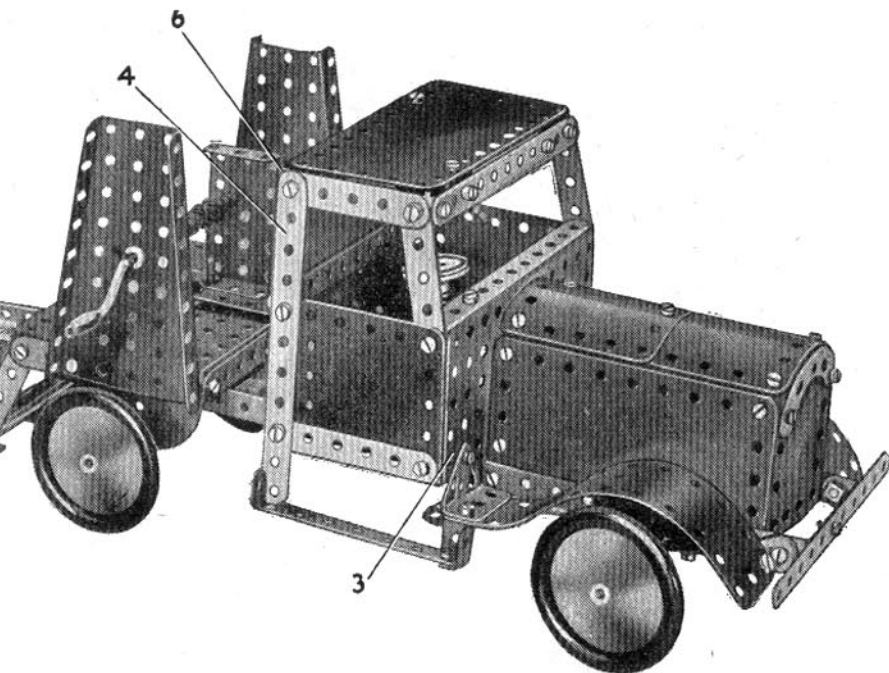
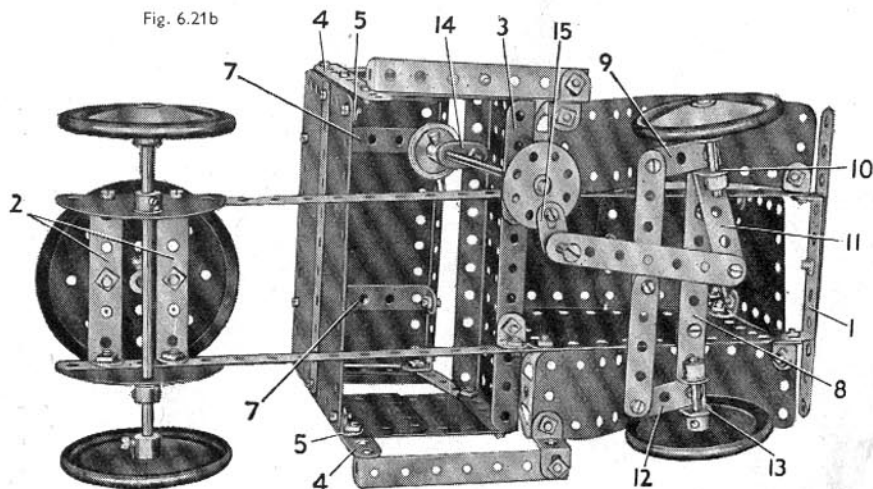

Fig. 6.21b



## 6.22 TIPPING STEAM WAGON

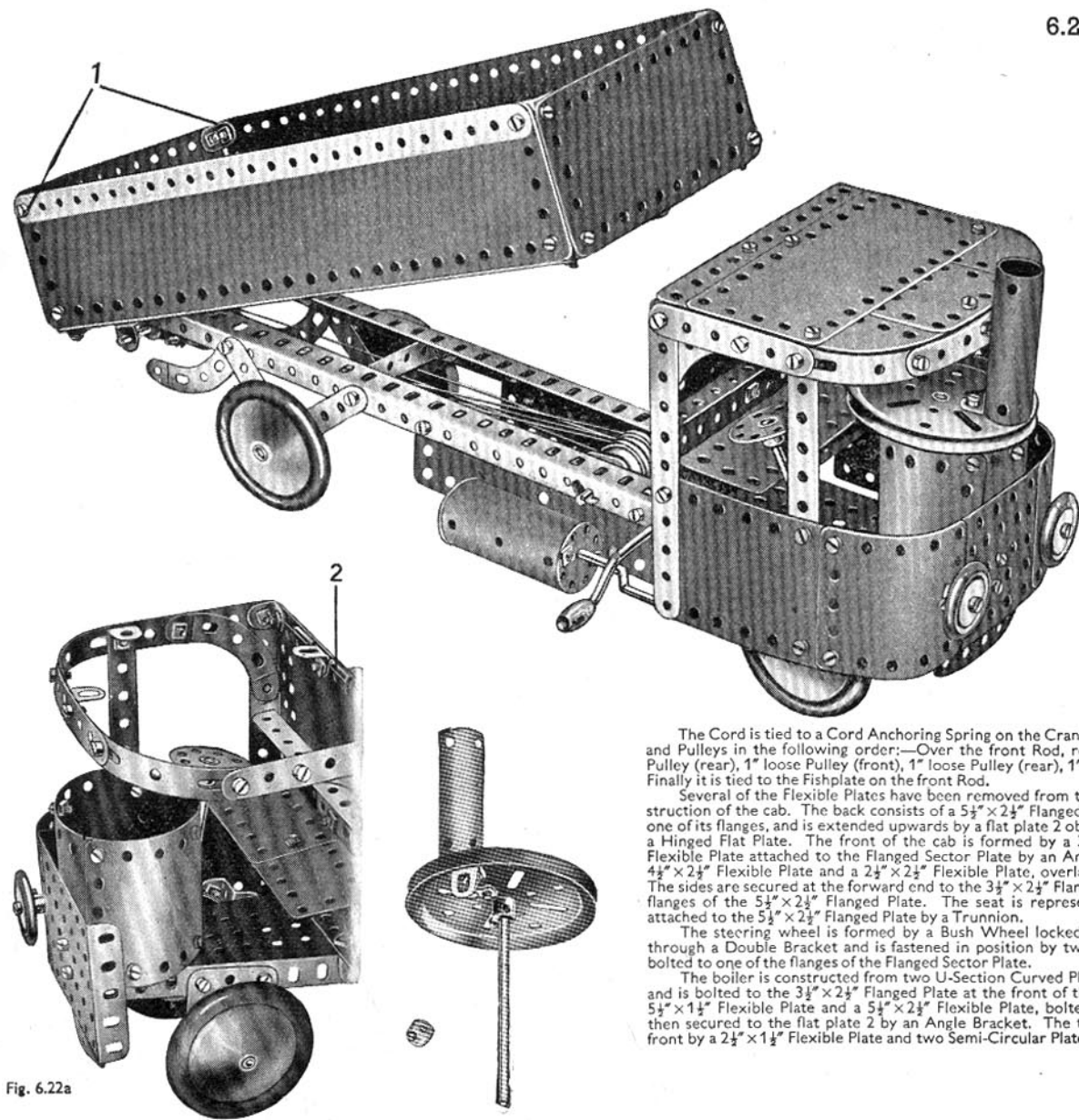

Fig. 6.22a

The chassis is built up by joining two  $12\frac{1}{2}$ " Angle Girders by  $2\frac{1}{2}$ "  $\times$   $\frac{1}{2}$ " Double Angle Strips. This structure is extended to the front by a Flanged Sector Plate. The rear wheels are fixed on a  $4\frac{1}{2}$ " Rod, which is journalled at each side in the end holes of two  $2\frac{1}{2}$ " Strips bolted to the chassis. A Flat Trunnion is secured at each side of the Flanged Sector Plate, and the 4" Rod carrying the front Road Wheels is journalled in holes in their narrow ends.

The body of the wagon is built up on a base consisting of two Angle Girders joined at each end by a  $5\frac{1}{2}$ " Strip. The bottom is filled in with  $12\frac{1}{2}$ " Strips bolted between the two  $5\frac{1}{2}$ " Strips. Two  $12\frac{1}{2}$ " Strip Plates bolted to the Angle Girders form the sides, and a  $5\frac{1}{2}$ "  $\times$   $2\frac{1}{2}$ " Flexible Plate is secured by four Angle Brackets to the front end. The  $\frac{3}{4}$ " Bolts 1, which hold two Angle Brackets supporting the rear  $5\frac{1}{2}$ "  $\times$   $2\frac{1}{2}$ " Flexible Plate, are lock-nutted, and the end of the body is free to swing open when the body is tipped.

The body of the wagon is pivoted on a 5" Rod, which passes through holes in the Angle Girders forming the chassis and through two Double Brackets bolted beneath the body.

The tipping mechanism is shown in Fig. 6.22b. A  $3\frac{1}{2}$ " Rod is passed through the Angle Girders forming the sides of the chassis, and it carries between the Angle Girders a Fishplate, a 1" fast Pulley, a 1" loose Pulley, and a  $\frac{1}{2}$ " loose Pulley, all of which are held on the Rod by Spring Clips.

The Pulleys at the rear end of the body are carried on a 2" Rod passed through holes in 1"  $\times$  1" Angle Brackets. The 2" Rod carries a Collar, a 1" fast Pulley, a 1" loose Pulley and a  $\frac{1}{2}$ " fast Pulley.

The Cord is tied to a Cord Anchoring Spring on the Crank Handle. It is then taken over the Rods and Pulleys in the following order:—Over the front Rod, rear Rod,  $\frac{1}{2}$ " loose Pulley (front), 1" fast Pulley (rear), 1" loose Pulley (front), 1" loose Pulley (rear), 1" fast Pulley (front),  $\frac{1}{2}$ " fast Pulley (rear). Finally it is tied to the Fishplate on the front Rod.

Several of the Flexible Plates have been removed from the model in Fig. 6.22a to show the construction of the cab. The back consists of a  $5\frac{1}{2}$ "  $\times$   $2\frac{1}{2}$ " Flanged Plate, which is bolted to the chassis by one of its flanges, and is extended upwards by a flat plate 2 obtained by removing the centre pin from a Hinged Flat Plate. The front of the cab is formed by a  $3\frac{1}{2}$ "  $\times$   $2\frac{1}{2}$ " Flanged Plate and a  $2\frac{1}{2}$ "  $\times$   $1\frac{1}{2}$ " Flexible Plate attached to the Flanged Sector Plate by an Angle Bracket, and each side consists of a  $4\frac{1}{2}$ "  $\times$   $2\frac{1}{2}$ " Flexible Plate and a  $2\frac{1}{2}$ "  $\times$   $2\frac{1}{2}$ " Flexible Plate, overlapped three holes and bolted together. The sides are secured at the forward end to the  $3\frac{1}{2}$ "  $\times$   $2\frac{1}{2}$ " Flanged Plate, and at the rear to the shorter flanges of the  $5\frac{1}{2}$ "  $\times$   $2\frac{1}{2}$ " Flanged Plate. The seat is represented by two  $2\frac{1}{2}$ "  $\times$   $1\frac{1}{2}$ " Flexible Plates attached to the  $5\frac{1}{2}$ "  $\times$   $2\frac{1}{2}$ " Flanged Plate by a Trunnion.

The steering wheel is formed by a Bush Wheel locked on the end of a 4" Rod, which passes through a Double Bracket and is fastened in position by two Spring Clips. The Double Bracket is bolted to one of the flanges of the Flanged Sector Plate.

The boiler is constructed from two U-Section Curved Plates and two  $1\frac{1}{4}$ " radius Curved Plates, and is bolted to the  $3\frac{1}{2}$ "  $\times$   $2\frac{1}{2}$ " Flanged Plate at the front of the cab. The top of the cab consists of a  $5\frac{1}{2}$ "  $\times$   $1\frac{1}{2}$ " Flexible Plate and a  $5\frac{1}{2}$ "  $\times$   $2\frac{1}{2}$ " Flexible Plate, bolted together overlapping two holes, and then secured to the flat plate 2 by an Angle Bracket. The two Flexible Plates are extended to the front by a  $2\frac{1}{2}$ "  $\times$   $1\frac{1}{2}$ " Flexible Plate and two Semi-Circular Plates.

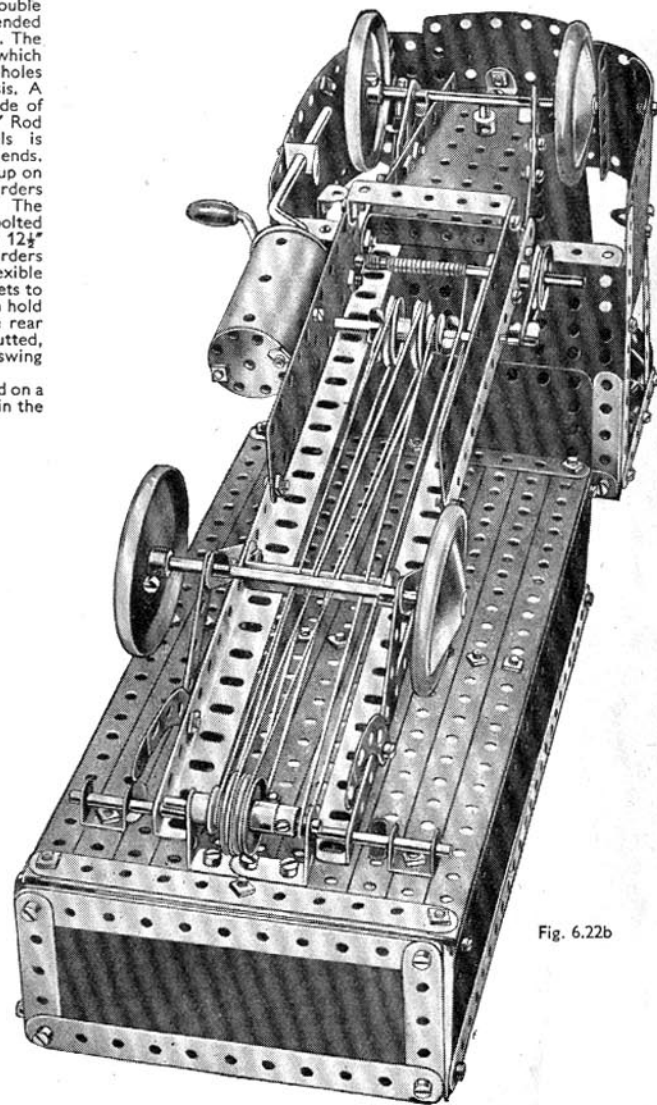

Fig. 6.22b

## 6.23 TRAMCAR

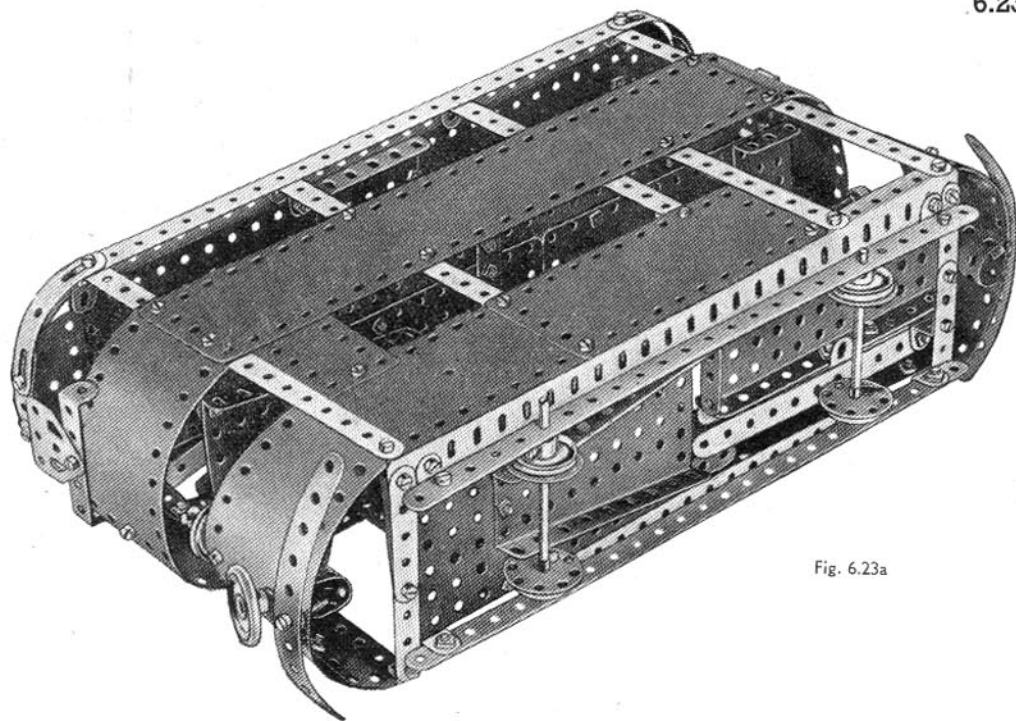

Fig. 6.23a

The upper deck consists of five  $12\frac{1}{2}$ " Strips, three of which are bolted to one side of a  $3\frac{1}{2}$ "  $\times$   $\frac{1}{2}$ " Double Angle Strip, while the other two are fastened to a Fishplate that is attached to the Double Angle Strip. The floor is filled in with  $2\frac{1}{2}$ "  $\times$   $2\frac{1}{2}$ " Flexible Plates, with a Flanged Sector Plate at the front end and a  $2\frac{1}{2}$ "  $\times$   $1\frac{1}{2}$ " Flanged Plate at the rear end.

U-Section Curved Plates are attached by Obtuse Angle Brackets to each end of the tram to represent the speed control boxes, the securing bolts holding also an Angle Bracket. Two 3" Screwed Rods are each fitted with a 1" loose Pulley, and Collars with  $1\frac{1}{2}$ " Rods locked in them are fixed on the upper end of each Screwed Rod to form the control switch.

A Reversed Angle Bracket is bolted to a  $3\frac{1}{2}$ "  $\times$   $2\frac{1}{2}$ " Flanged Plate in the roof of the tram and a Rod and Strip Connector is attached by a lock-nutted Bolt to its other lug. A second Rod and Strip Connector is carried at the end of the  $11\frac{1}{2}$ " Rod forming the trolley, and a  $\frac{1}{2}$ " loose Pulley is attached by a lock-nutted Bolt.

The roof on each side of the  $3\frac{1}{2}$ "  $\times$   $2\frac{1}{2}$ " Flanged Plate consists of two  $5\frac{1}{2}$ "  $\times$   $1\frac{1}{2}$ " Flexible Plates. These are bolted at their inner ends to the Flanged Plate, and they are extended at their outer ends by Semi-Circular Plates. The Semi-Circular Plates are edged with small radius Curved Strips as shown.

The destination indicators at each end of the tramcar are formed by Flat Trunnions bolted to  $2\frac{1}{2}$ "  $\times$   $\frac{1}{2}$ " Double Angle Strips. They are attached to the curved Flexible Plates of the upper saloon.

Construction is commenced with the chassis as shown in Fig. 6.23a. Two  $12\frac{1}{2}$ " Strips are connected by Angle Brackets to two Angle Girders, and the last named are joined across at each end by compound strips consisting of two  $2\frac{1}{2}$ " Strips overlapped two holes. The bottom is filled in by bolting a  $3\frac{1}{2}$ "  $\times$   $2\frac{1}{2}$ " Flanged Plate by its flange to the lower Angle Girder, and a  $5\frac{1}{2}$ "  $\times$   $2\frac{1}{2}$ " Flanged Plate to the other Angle Girder. A Flanged Sector Plate and a  $5\frac{1}{2}$ " Strip are bolted to the  $3\frac{1}{2}$ "  $\times$   $2\frac{1}{2}$ " Flanged Plate, and two further  $5\frac{1}{2}$ " Strips are attached by Reversed Angle Brackets, one to the  $5\frac{1}{2}$ "  $\times$   $2\frac{1}{2}$ " Flanged Plate, and the other to the compound strip that spaces the Angle Girders.

The sides of the car are next added. One half of a Hinged Flat Plate is bolted to a  $5\frac{1}{2}$ "  $\times$   $2\frac{1}{2}$ " Flexible Plate to form each side of the lower saloon. Five  $5\frac{1}{2}$ " Strips carry the upper deck, and  $2\frac{1}{2}$ " Strips and Double Angle Strips support the roof.

The wheels are fixed on 4" Rods mounted in the  $12\frac{1}{2}$ " Strips forming part of the chassis members. Each wheel consists of a Wheel Disc held against the face of a 1" Pulley by a Spring Clip placed on the axle. Washers are placed between the 1" Pulleys and the  $12\frac{1}{2}$ " Strips so that the wheels can revolve freely.

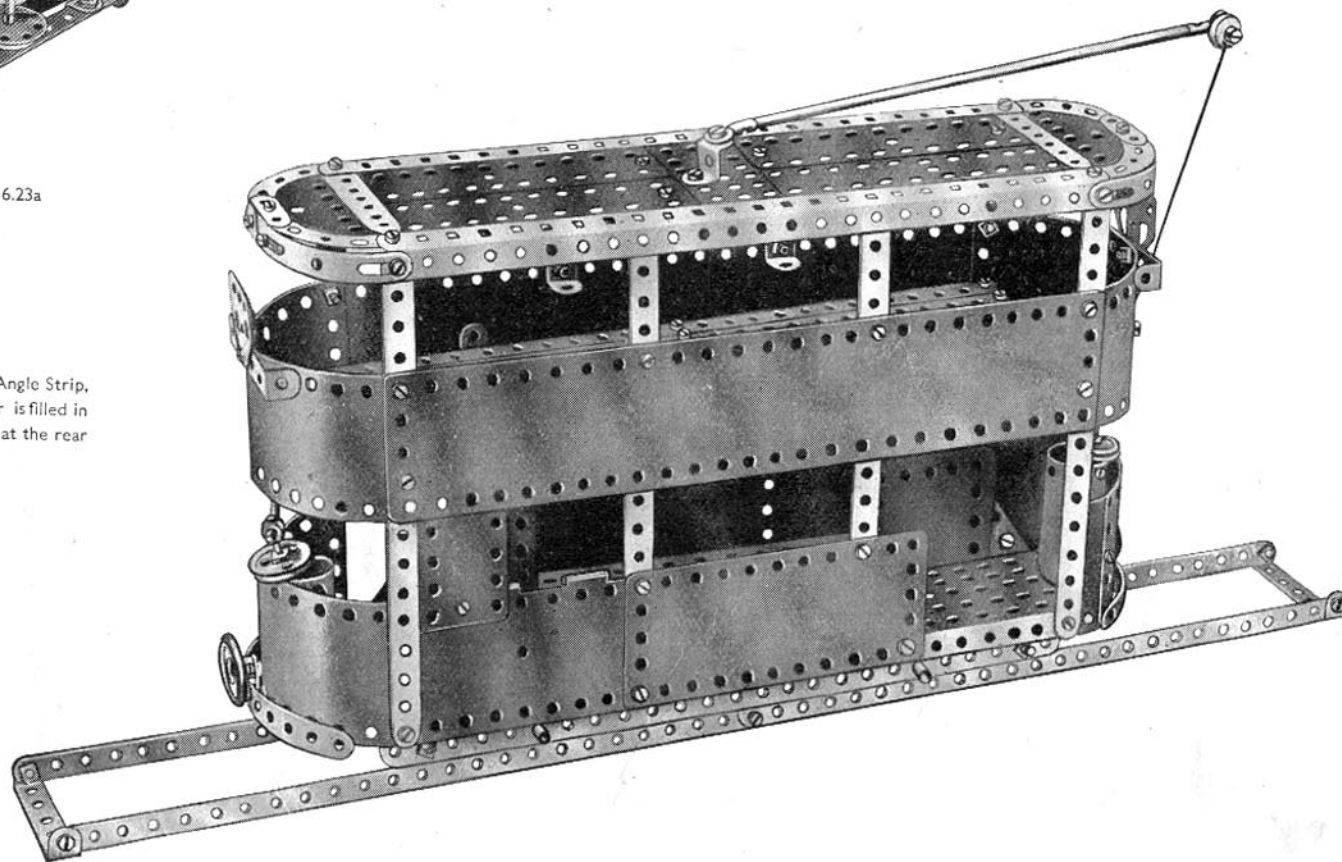



## 6.24 ROLLING LIFT BRIDGE

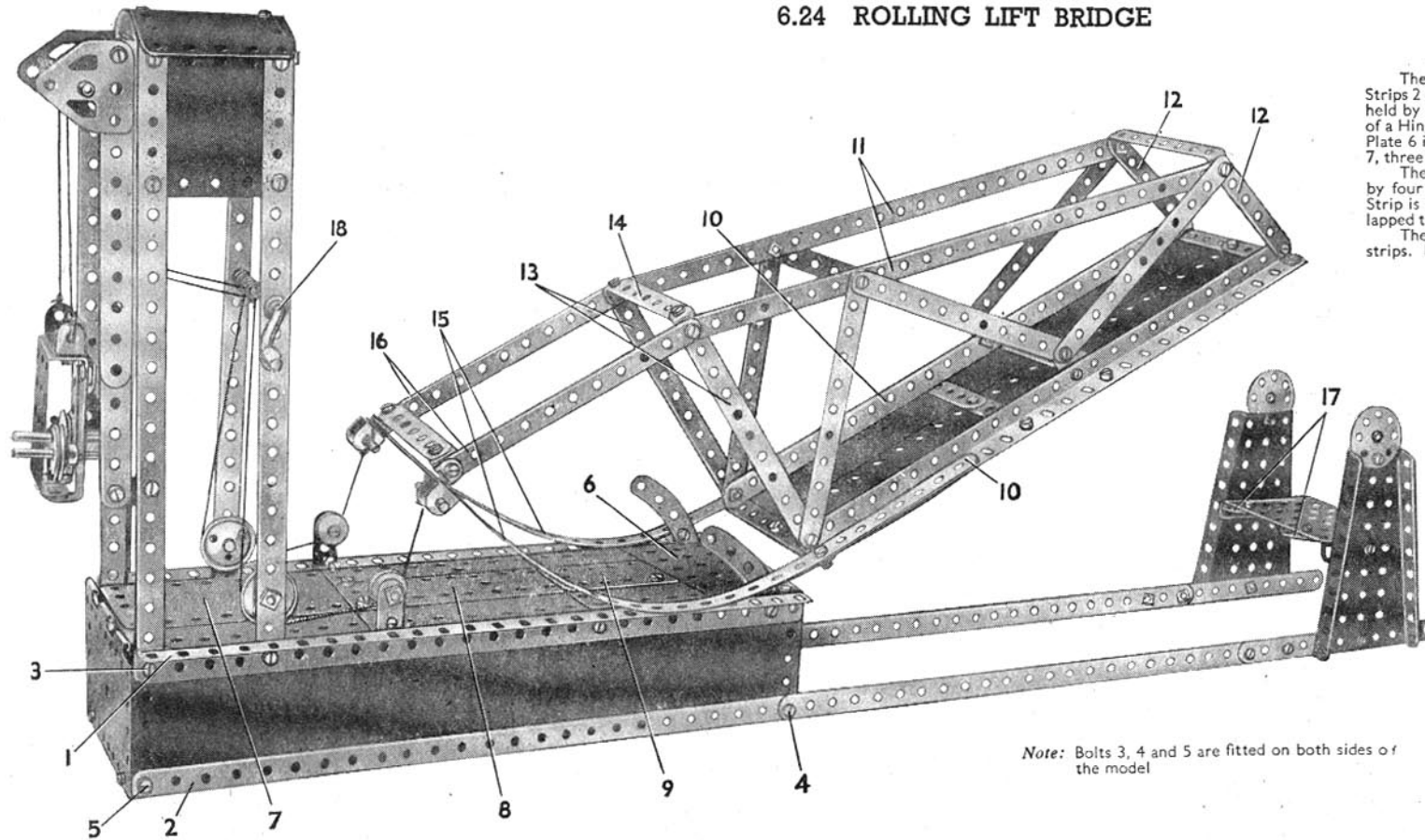

Note: Bolts 3, 4 and 5 are fitted on both sides of the model

are fastened to the 3" Strips 12 and 5½" Strips 13. Three 5½" Strips are then bolted in position on each side for bracing purposes. The Strips 11 are connected by a 3½" x ½" Double Angle Strip and a 3½" Strip 14 attached to Angle Brackets. The span rolls upon the 12½" Strips 15. These are bolted to the Angle Girders 10 and connected by Angle Brackets to the 5½" Strips 16. Guides for the rollers are provided by 2½" Curved Strips. The roadway of the lifting span is formed by four 5½" x 2½" and two 2½" x 2½" Flexible Plates.

When the bridge is in the closed position the span rests on two Flat Trunnions 17. These are attached to a 3½" x 2½" Flanged Plate bolted between two Flanged Sector Plates. The 1" loose Pulleys are free to turn on ½" Bolts locked by two nuts to the 12½" Strips forming part of the tower. The ½" Pulleys are loose on ¾" Bolts locked to 1" x 1" Angle Brackets bolted to the Angle Girders 1.

Raising and lowering of the span is operated by a Crank Handle 18. Two lengths of Cord from this pass around the 1" and ½" Pulleys and are fastened to 1½" Rods mounted in Double Brackets. The Double Brackets are bolted to the upper ends of the Strips 15.

The counter-balance weight consists of a 2½" x 1½" Flanged Plate. A 2½" x 1½" Flexible Plate is bolted to 2½" x ½" Double Angle Strips bolted to the Flanged Plate, and two 1" Pulleys are locked on 1½" Rods journalled in the Flanged Plate and the Double Angle Strips. Guides for the balance weight are provided by four 5½" Strips. Two of these are attached to each side of the tower by Fishplates. A 2½" Strip 19 fitted with two Reversed Angle Brackets is bolted to the balance weight. The Reversed Angle Brackets are free to slide between the 5½" Strips and the 12½" Strips forming the rear members of the tower.

Two lengths of Cord from the balance weight are passed over the Rod 20 and under Rod 21. They are then attached to the Crank Handle so that as the span is raised the balance weight is lowered.

The sides of the approach roadway are made by bolting the Angle Girders 1 and 12½" Strips 2 (Fig. 6.24a) to 12½" Strip Plates. The sides are joined by a 3½" x ½" Double Angle Strip held by the Bolt 3, and a 3½" Strip fastened to Angle Brackets held by the Bolt 4. One half of a Hinged Flat Plate is attached to Angle Brackets held by the Bolt 5. A 3½" x 2½" Flanged Plate 6 is then bolted in position. The roadway is filled in by two 4½" x 2½" Flexible Plates 7, three 5½" x 1½" Flexible Plates 8 and three 2½" x 1½" Flexible Plates 9.

The tower consists of four vertical 12½" Strips connected together at their upper ends by four 2½" x ½" Double Angle Strips and four 2½" x 2½" Flexible Plates. A 2½" Curved Strip is bolted in position at the front and rear of the tower, and two Curved Plates overlapped three holes are attached to the Curved Strips by Angle Brackets.

The rolling span is formed from two 12½" Angle Girders 10, joined by four 4½" compound strips. Each of these strips consists of two 2½" Strips bolted together. The 12½" Strips 11

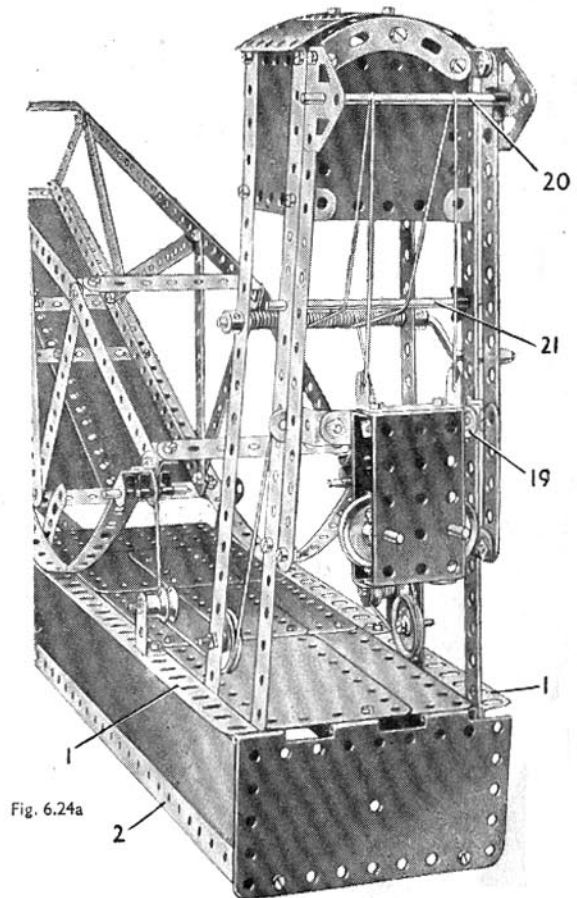
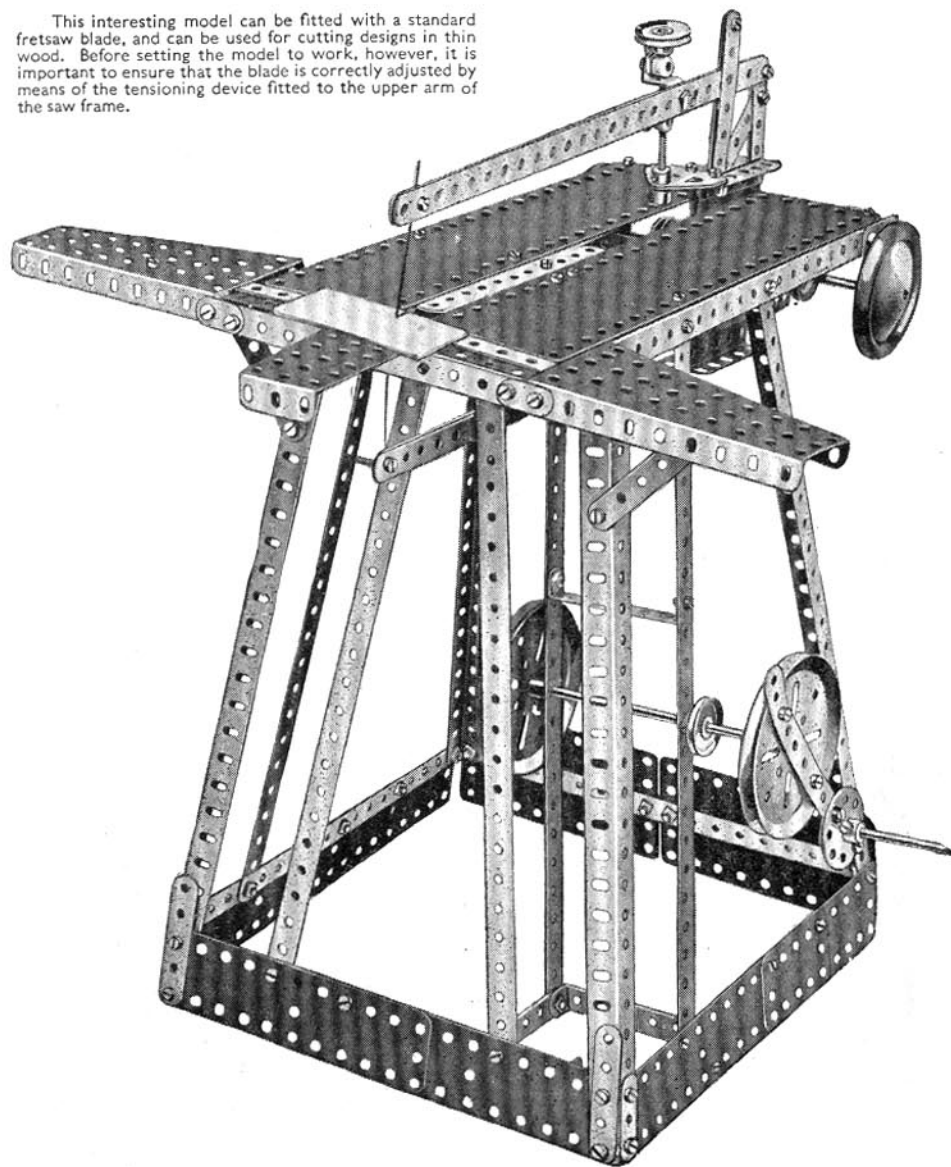

Fig. 6.24a

## 6.25 FRETWORK MACHINE

This interesting model can be fitted with a standard fretsaw blade, and can be used for cutting designs in thin wood. Before setting the model to work, however, it is important to ensure that the blade is correctly adjusted by means of the tensioning device fitted to the upper arm of the saw frame.



The main framework of the model consists of four  $12\frac{1}{2}$ " Angle Girders joined across at their lower ends by compound strips consisting of two  $5\frac{1}{2}$ " Strips. The Strips spacing the sides are overlapped two holes, and those spacing the front and rear are overlapped four holes.

The base is extended downwards by  $5\frac{1}{2}$ "  $\times$   $1\frac{1}{2}$ " and  $2\frac{1}{2}$ "  $\times$   $1\frac{1}{2}$ " Flexible Plates, which are joined at the corners by Angle Brackets bolted inside the Flexible Plate at the front of the model. At the top the Angle Girders are spaced at the front and rear by  $5\frac{1}{2}$ " Strips, and at the sides by  $12\frac{1}{2}$ " Strips, which are bolted so that they extend five holes to the front of the table. Four  $12\frac{1}{2}$ " Strips are bolted to the frame of the base and to the upper  $5\frac{1}{2}$ " and  $12\frac{1}{2}$ " Strips, and a supplementary framework to support the operating handle is also added (see Fig. 6.25a).

The table is shown complete in the front view of the model, and in Fig. 6.25a one of the  $12\frac{1}{2}$ "  $\times$   $2\frac{1}{2}$ " Strip Plates has been removed. A  $5\frac{1}{2}$ "  $\times$   $2\frac{1}{2}$ " Flanged Plate is bolted across the  $12\frac{1}{2}$ " Strips at the sides of the table. The two  $12\frac{1}{2}$ "  $\times$   $2\frac{1}{2}$ " Strip Plates are bolted to the Flanged Plate and joined by Angle Brackets to the ends of the  $12\frac{1}{2}$ " Strips, the bolts carrying also two Flat Trunnions. The table is extended to the front by a  $2\frac{1}{2}$ "  $\times$   $1\frac{1}{2}$ " Flanged Plate, which is bolted to a  $5\frac{1}{2}$ " Strip and to the ends of two  $2\frac{1}{2}$ "  $\times$   $\frac{1}{2}$ " Double Angle Strips. The side extensions are Flanged Sector Plates, each of which is attached to the frame by a Fishplate, a  $3\frac{1}{2}$ " Strip and a  $12\frac{1}{2}$ " Strip. A  $2\frac{1}{2}$ "  $\times$   $\frac{1}{2}$ " Double Angle Strip provides additional support underneath.

The saw frame consists of two long arms, each consisting of two  $12\frac{1}{2}$ " Strips bolted together. One of the arms is bolted between two  $3\frac{1}{2}$ "  $\times$   $2\frac{1}{2}$ " Flanged Plates, and the other is lock-nutted at its end to an N-shaped piece, consisting of two  $2\frac{1}{2}$ " Strips and two  $3\frac{1}{2}$ " Strips braced across by a  $2\frac{1}{2}$ " Strip in the manner shown. A tensioning device for the sawblade consists of a Double Bent Strip lock-nutted to the upper arm. A 3" Screwed Rod is passed through holes in the Double Bent Strip and a Collar is screwed on each of its ends.

The shanks of two bolts in the end holes of the Double Bent Strip engage in the plain holes of the Collars. The Screwed Rod passes also through a hole in two Flat Trunnions bolted to the flanges of the  $3\frac{1}{2}$ "  $\times$   $2\frac{1}{2}$ " Flanged Plates, and two Collars are held by their grub screws on the Screwed Rod on each side of the Flat Trunnions.

A  $6\frac{1}{2}$ " Rod is passed through the end holes of  $1"$   $\times$   $1"$  Angle Brackets attached to Trunnions bolted to the  $3\frac{1}{2}$ "  $\times$   $2\frac{1}{2}$ " Flanged Plates, and is journaled in the two Flat Trunnions as shown.

The handle for operating the machine is constructed by fastening a 2" Rod in the boss of a Bush Wheel that is attached to a  $5\frac{1}{2}$ " Strip. The Strip in turn is bolted across a 3" Pulley held on the end of a  $4\frac{1}{2}$ " Rod journaled in two  $12\frac{1}{2}$ " Strips. On its other end the  $4\frac{1}{2}$ " Rod carries another 3" Pulley 2, which is pivotally connected by a  $5\frac{1}{2}$ " Strip 1 to the lower arm of the frame. The lower end of the  $5\frac{1}{2}$ " Strip is pivoted on a Threaded Pin and is held in place by a Spring Clip; its upper end being pivoted on a Pivot Bolt lock-nutted to the lower arm of the saw frame. The Pivot Bolt carries six Washers on its shank.

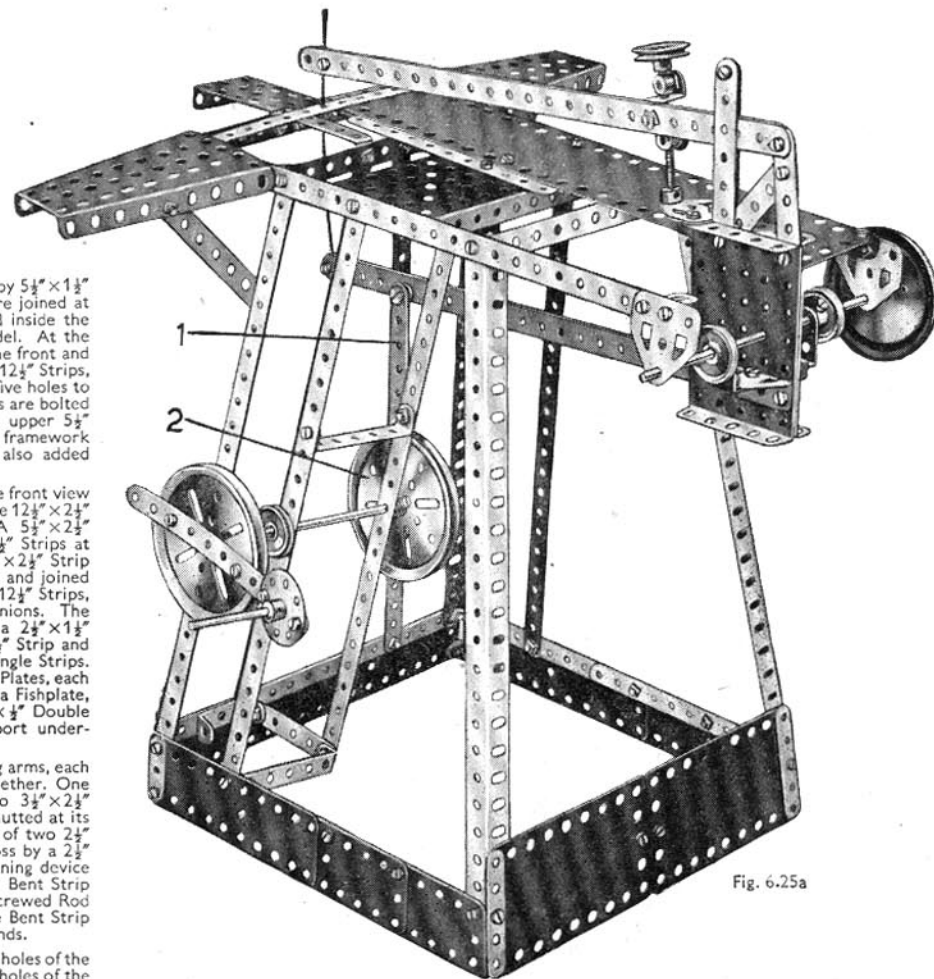
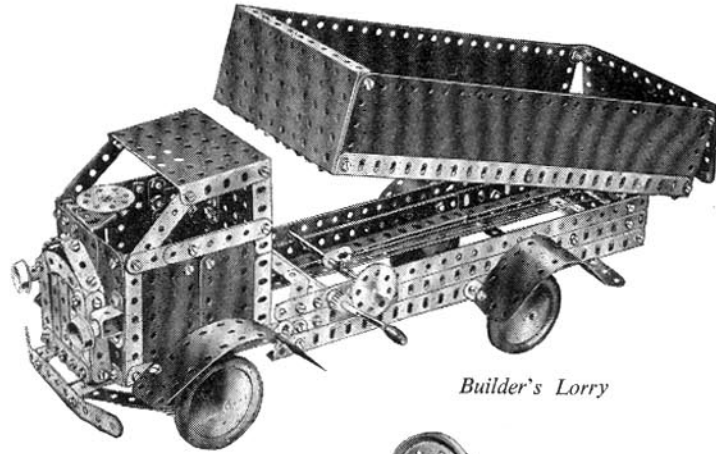
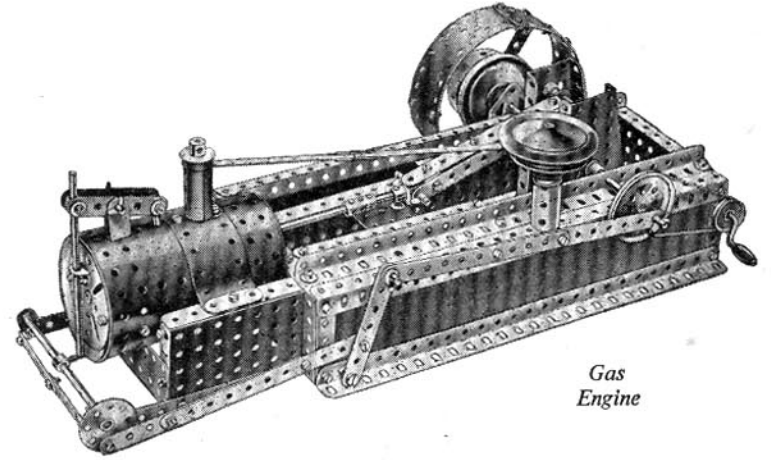
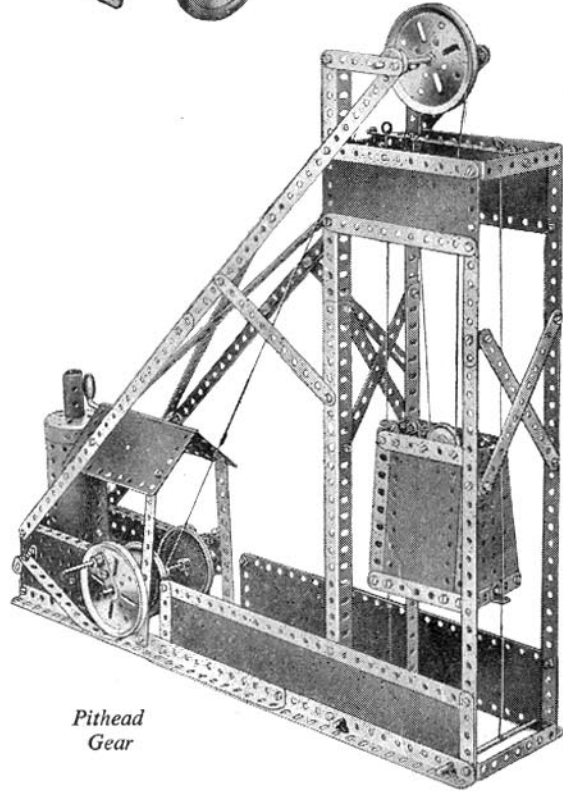
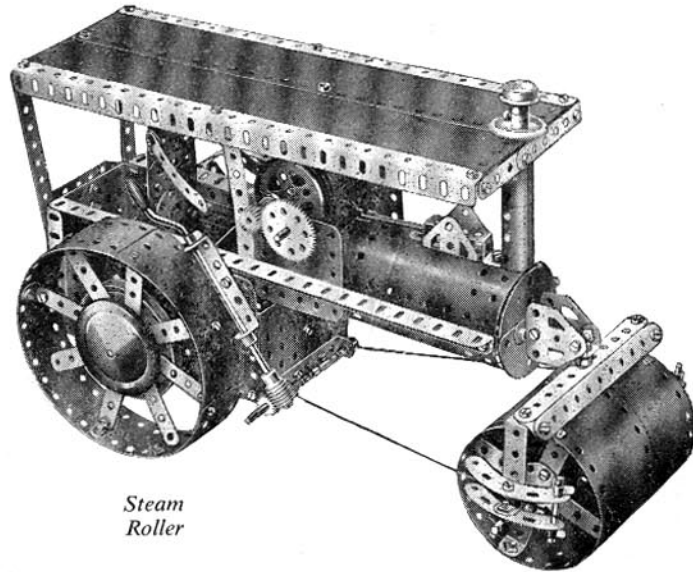
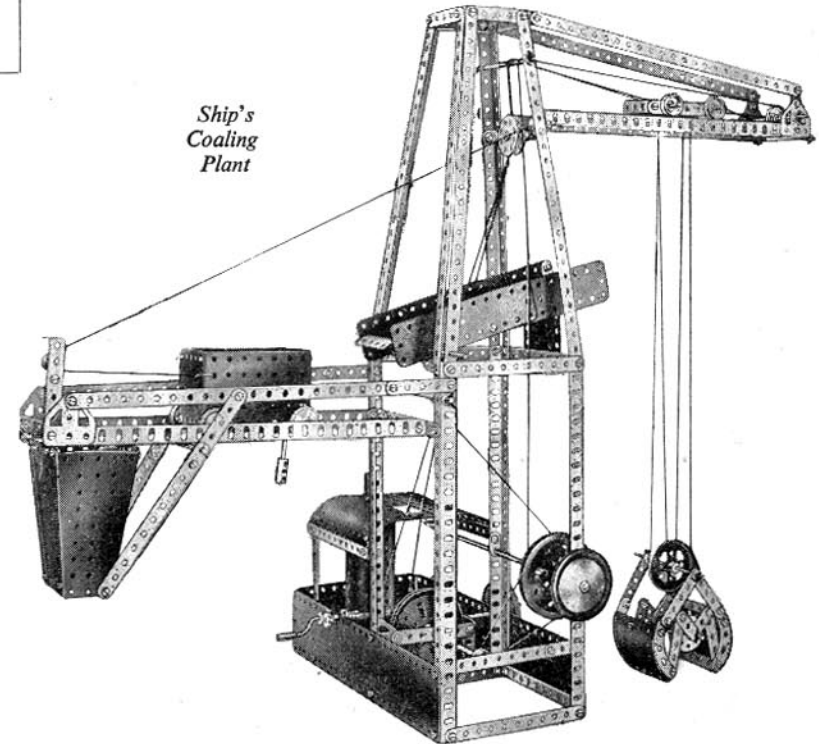

Fig. 6.25a

*Builder's Lorry***BUILD BIGGER AND BETTER MODELS**

When you have built all the models shown in this Book of Instructions, you will be keen to build bigger and more elaborate models. Your next step is to purchase a Meccano No. 6a Accessory Outfit containing all the parts required to convert your No. 6 into a No. 7 Outfit. You will then be able to build the full range of No. 7 Outfit models, a selection of which is illustrated on this page.

If you prefer to do so, you can build up and develop your Outfit quite easily by adding various parts to it from time to time. The model-building possibilities of the Meccano System are unlimited, and the more Meccano parts you have the bigger and better the models you will be able to build.

*Gas Engine**Pithead Gear**Steam Roller**Ship's Coaling Plant*

Here are a few simple and interesting movements showing how easily real mechanisms can be reproduced with Meccano.

### USEFUL BAND BRAKE

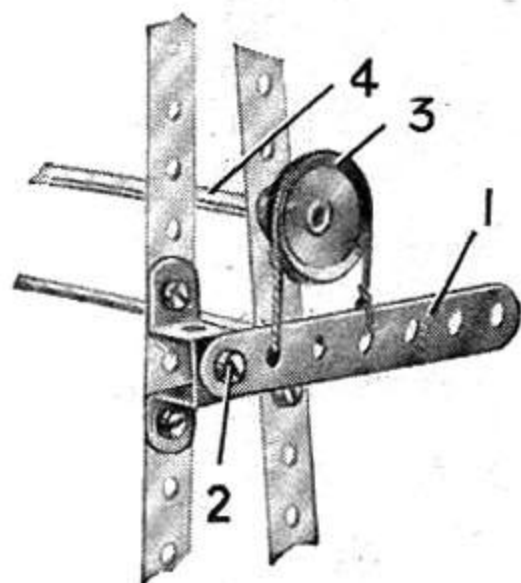

S.M.111. The brake lever consists of a  $3\frac{1}{2}$ " Strip 1, pivotally attached at a suitable point on the frame of the model, to be fitted, by means of a lock-nutted  $\frac{3}{8}$ " Bolt 2. The driven shaft 4 is fitted at one end with a 1" fast Pulley 3 round which a short length of cord is passed. The two ends of this Cord are secured to the brake lever at the points shown in the illustration.

If increased braking effect is desired a larger Pulley may be used in place of the 1" fast Pulley 3, the brake lever 1 being attached in a lower position if necessary. Alternatively a weight can be hung from the end of the brake lever.

### SIMPLE STEERING GEAR

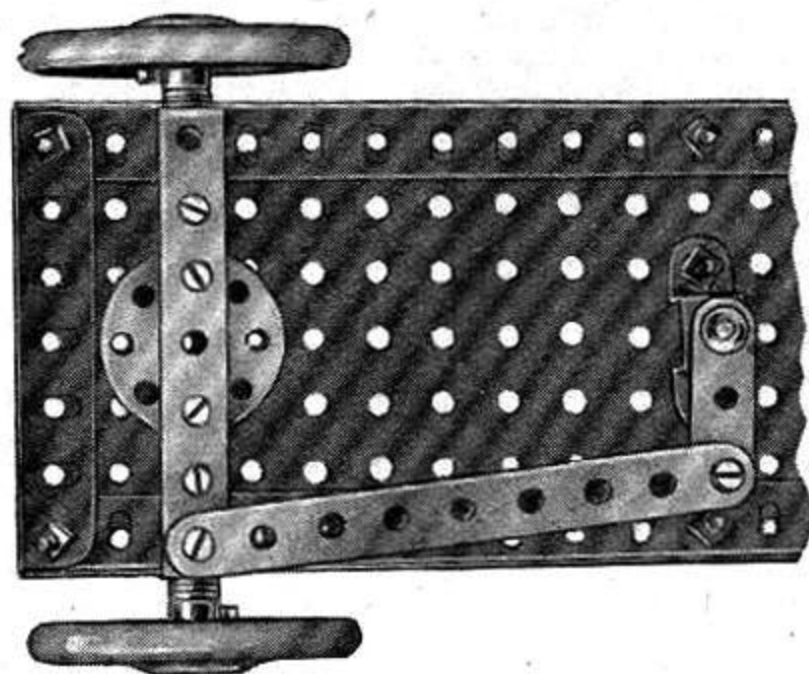

S.M.162. The simple steering gear will be found suitable for most small model vehicles.

In this example the two front wheels are mounted on separate stub axles that are secured to each end of a rigid front axle. The base of the chassis consists of two long Angle Girders connected together at the front end by a  $3\frac{1}{2}$ " Angle Girder and filled in along their length by means of  $5\frac{1}{2}$ " x  $3\frac{1}{2}$ " Flat Plates.

The front axle, a  $3\frac{1}{2}$ " x  $\frac{1}{2}$ " Double Angle Strip, is pivotally mounted at its centre on a Bush Wheel and short Rod. It is fitted,  $\frac{1}{2}$ " from each end, with a  $\frac{1}{2}$ " x  $\frac{1}{2}$ " Angle Bracket, this forming the inner bearing for its respective stub axle. The outer bearing for the axle consists of the upturned lug of the Double Angle Strip. One end of this latter part is fitted with a pivotally attached  $4\frac{1}{2}$ " Strip, by means of which the front axle is linked up to a Crank fixed to the steering column.

### SAFETY CATCH FOR CRANE WINDING GEAR

S.M.125. The Compression Spring 3 is mounted on the Crank Handle 1 between the Collar 4 and a Washer, and normally holds the Collar 2 against the inner side of the plate. The Collar 2 is fitted with a  $\frac{3}{8}$ " Bolt, and if the Crank Handle commences to rotate, the head of this Bolt strikes against the stop 5 and prevents further movement.

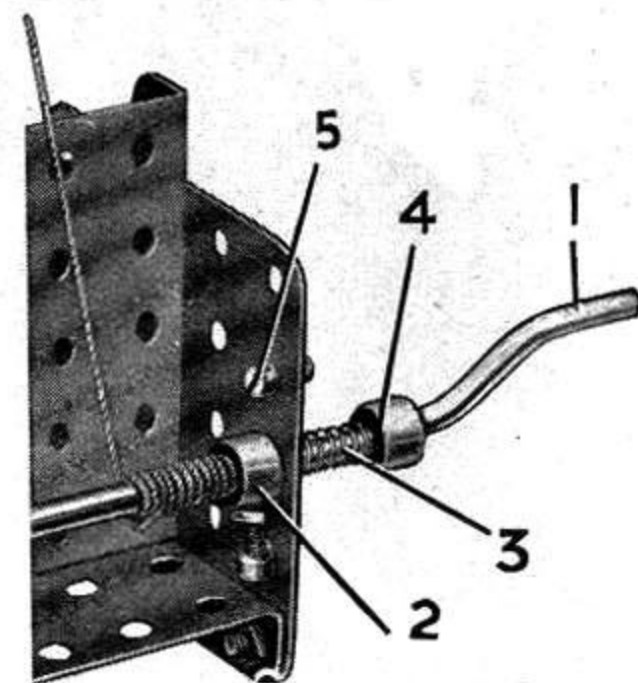

### BUILT UP ROLLER BEARING

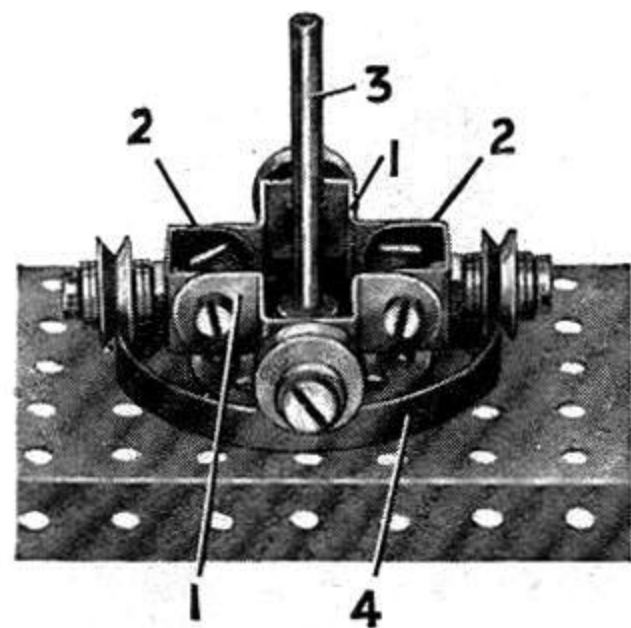

S.M.136. The spider frame is built up from Double Bent Strips 1 connected together by two Double Brackets 2. The four wheels used are represented by  $\frac{1}{2}$ " loose Pulleys journalled on Pivot Bolts secured to the outer ends of the four arms of the frame. Four Washers, two on each side of the Pulleys are passed on to the shank of each of the Pivot Bolts that are attached to the Double Brackets 2. In the case of the other two Pivot Bolts, two Washers are placed against the external side only of the Pulley.

### BRAKE LEVER and QUADRANT

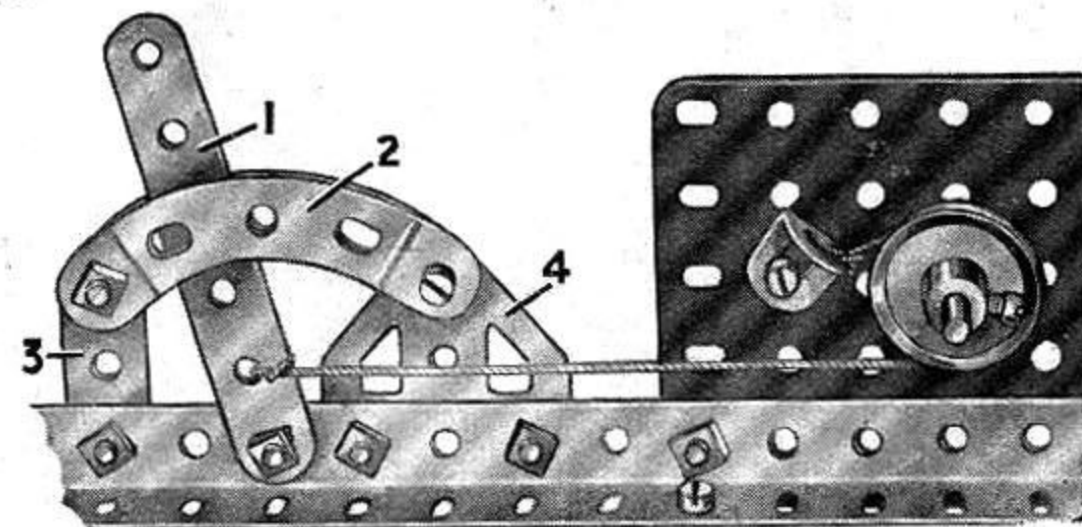

S.M.112. This mechanism is a form of band brake in which the lever 1 can be held in any position by means of the quadrant 2. In this way varying pressures can be applied to the Pulley forming the brake drum.

One end of the brake Cord is attached to a  $\frac{1}{2}$ " x  $\frac{1}{2}$ " Angle Bracket bolted in a suitable position on the model. After passing round the 1" fast Pulley forming the brake drum the Cord is secured at the next to bottom hole of a 3" Strip 1. This Strip forms the brake lever, and it is secured to the frame of the model by a lock-nutted Bolt.





# MECCANO PARTS

- 3**  
Perforated Strips
- |     |                    |     |                   |
|-----|--------------------|-----|-------------------|
| No. | 12 $\frac{1}{2}$ " | No. | 3 $\frac{3}{4}$ " |
| 1.  | 9 $\frac{1}{2}$ "  | 4.  | 3 $\frac{1}{2}$ " |
| 1a. | 7 $\frac{1}{2}$ "  | 5.  | 2 $\frac{3}{4}$ " |
| 2.  | 5 $\frac{1}{2}$ "  | 6.  | 2 $\frac{1}{2}$ " |
| 2a. | 4 $\frac{1}{2}$ "  | 6a. | 1 $\frac{1}{2}$ " |

- 9<sup>a</sup>**  
Angle Girders
- |     |                    |     |                   |
|-----|--------------------|-----|-------------------|
| 7.  | 24 $\frac{1}{2}$ " | 9a. | 4 $\frac{1}{2}$ " |
| 7a. | 18 $\frac{1}{2}$ " | 9b. | 3 $\frac{3}{4}$ " |
| 8.  | 12 $\frac{1}{2}$ " | 9c. | 3 $\frac{1}{4}$ " |
| 8a. | 9 $\frac{1}{2}$ "  | 9d. | 2 $\frac{3}{4}$ " |
| 8b. | 7 $\frac{1}{2}$ "  | 9e. | 2 $\frac{1}{4}$ " |
| 9.  | 5 $\frac{1}{2}$ "  | 9f. | 1 $\frac{1}{2}$ " |

- 10** Fishplate  
**11** Double Bracket  
**12** Angle Bracket,  $1\frac{1}{2} \times 1\frac{1}{2}$ "  
**12a** " "  $1 \times 1\frac{1}{2}$ "  
**12b** " "  $1 \times 1\frac{1}{4}$ "  
**12c** Obtuse Angle Bracket,  $\frac{1}{2} \times \frac{1}{2}$ "

- 17**  
Axle Rods
- |      |                    |      |                   |
|------|--------------------|------|-------------------|
| 13.  | 11 $\frac{1}{2}$ " | 16.  | 3 $\frac{1}{2}$ " |
| 13a. | 8 $\frac{1}{2}$ "  | 16a. | 2 $\frac{3}{4}$ " |
| 14.  | 6 $\frac{1}{2}$ "  | 16b. | 2 $\frac{1}{4}$ " |
| 15.  | 5 $\frac{1}{2}$ "  | 17.  | 2 $\frac{1}{2}$ " |
| 15a. | 4 $\frac{1}{2}$ "  | 18a. | 1 $\frac{1}{2}$ " |
| 15b. | 4 $\frac{1}{4}$ "  | 18b. | 1"                |

- 19h**  
Crank Handle,  $3\frac{1}{2}$ " Shaft with grip  
**19h.** " " 5 $\frac{1}{2}$ " " "  
**19s.** " " 3 $\frac{1}{2}$ " " without grip

- 20**  
**19<sup>a</sup>** Spoked Wheel, 3" diam.  
**20.** Flanged Wheel,  $1\frac{1}{2}$ " diam.  
**20b.** " " " "

- 22**  
**19<sup>c</sup>**  
**23<sup>a</sup>**  
**22<sup>a</sup>**  
**20<sup>a</sup>**

- 19b.** 3" diam. with boss and screw  
**19c.** 6" " " " "  
**20a.** 2" " " " "  
**21.** 1 $\frac{1}{2}$ " " " " "  
**22.** 1" " " " "  
**22a.** 1" " without " " "  
**23.**  $\frac{1}{2}$ " " " " "  
**23a.**  $\frac{1}{2}$ " " with " "

- 24** Bush Wheel,  $1\frac{1}{2}$ " diam.  
**24a.** Wheel Disc,  $1\frac{1}{2}$ " diam., without bush

- 26**  
Pinion, diam., face, teeth
- |      |   |   |    |
|------|---|---|----|
| 25.  | " | " | 25 |
| 25a. | " | " | 25 |
| 25b. | " | " | 25 |
| 26.  | " | " | 19 |
| 26a. | " | " | 19 |
| 26b. | " | " | 19 |

- 27** Gear Wheels  
**27<sup>a</sup>** 50 teeth  
**27<sup>b</sup>** 133 teeth  
**27c.** 95 teeth

- 28** Contrate Wheel,  $1\frac{1}{2}$ " diam., 50 teeth  
**29.** " " " " 25 "

- 30<sup>a</sup> & 30<sup>c</sup>** Bevel Gear,  $\frac{3}{8}$ " diam., 26 teeth (for use in pairs)  
**30a.** " " " " 16 " } Can only be  
**30c.** " " " " 48 " } used together

- 31** Gear Wheel, 1" diam.,  $\frac{1}{4}$ " face, 38 teeth  
**32** Worm,  $\frac{1}{2}$ " diam.

- 34** Spanner  
**34b.** Box Spanner

- 35** Spring Clip  
**36.** Screwdriver  
**36a.** " " " " " "  
**36c.** Drift (for levering bolt holes into line)  
**37.** Nut and Bolt,  $\frac{1}{16}$ "  
**37a.** Nut  
**37b.** Bolt,  $\frac{1}{16}$ "  
**38.** Washer  
**38d.** " " " " " "

- 40.** Hank of Cord

- 41** Propeller Blade  
**43** Tension Spring, 2" long

- 44** Bent Strip, stepped  
**45** Double Bent Strip  
**46** Double Angle Strip

- 47.** " " "  $2\frac{1}{2} \times 1\frac{1}{2}$ "  
**47a.** " " "  $3\frac{1}{2} \times 1\frac{1}{2}$ "  
**47b.** " " "  $4\frac{1}{2} \times 1\frac{1}{2}$ "  
**47c.** " " "  $5\frac{1}{2} \times 1\frac{1}{2}$ "  
**47d.** " " "  $6\frac{1}{2} \times 1\frac{1}{2}$ "  
**47e.** " " "  $7\frac{1}{2} \times 1\frac{1}{2}$ "  
**47f.** " " "  $8\frac{1}{2} \times 1\frac{1}{2}$ "  
**47g.** " " "  $9\frac{1}{2} \times 1\frac{1}{2}$ "  
**47h.** " " "  $10\frac{1}{2} \times 1\frac{1}{2}$ "  
**47i.** " " "  $11\frac{1}{2} \times 1\frac{1}{2}$ "  
**47j.** " " "  $12\frac{1}{2} \times 1\frac{1}{2}$ "

- 50** Slide Piece  
**51.** Flanged Plate,  $2\frac{1}{2} \times 1\frac{1}{2}$ "  
**52.** " " "  $5\frac{1}{2} \times 2\frac{1}{2}$ "  
**52a.** Flat Plate,  $5\frac{1}{2} \times 3$ "  
**53.** Flanged Plate,  $3\frac{1}{2} \times 2$ "  
**53a.** Flat Plate,  $4\frac{1}{2} \times 2\frac{1}{2}$ "

- 54** Flanged Sector Plate,  $4\frac{1}{2}$ " long  
**55** Perforated Strip, slotted,  $5\frac{1}{2}$ " long  
**55a.** " " " "  $2\frac{1}{2}$ " "

- 57<sup>a</sup>** Hook, Loaded, Large  
**57<sup>b</sup>** " " Small

- 58** Spring Cord, 40" Length  
**58a.** Coupling Screw for Spring Cord  
**58b.** Hook for Spring Cord

- 59** Collar, with screw

- 61** Windmill Sail  
**62** Crank  
**62a.** Threaded Crank  
**62b.** Double Arm Crank

- 63** Coupling  
**63b.** Strip Coupling  
**63c.** Threaded Coupling

- 64** Threaded Boss  
**65.** Centre Fork  
**69.** Set Screw,  $\frac{1}{16}$ "  
**69a.** Grub Screw,  $\frac{1}{16}$ "  
**69b.** " " " "  
**69c.** " " " "

- 70.** Flat Plate,  $5\frac{1}{2} \times 2\frac{1}{2}$ "  
**72.** " " "  $2\frac{1}{2} \times 2\frac{1}{2}$ "  
**73.** " " "  $3 \times 1\frac{1}{2}$ "  
**76.** Triangular Plate,  $2\frac{1}{2}$ "  
**77.** " " " 1"

- 80<sup>a</sup>** Screwed Rods  
**78.** 11 $\frac{1}{2}$ "  
**79.** 8"  
**79a.** 6"  
**80.** 5"  
**80a.** 3 $\frac{1}{2}$ "  
**80b.** 4 $\frac{1}{2}$ "  
**80c.** 3"  
**81.** 2"  
**82.** 1"

- 89.** Curved Strip,  $5\frac{1}{2}$ ", 10" radius  
**89a.** " " stepped, 3",  $1\frac{1}{2}$ " radius,  
**89b.** Curved Strip, stepped, 4",  $4\frac{1}{2}$ " radius,  
**90.** Curved Strip,  $2\frac{1}{2}$ ", 2 $\frac{1}{2}$ " radius  
**90a.** " " stepped,  $2\frac{1}{2}$ ",  $1\frac{1}{2}$ " radius,

- 94** Sprocket Chain, 40" length  
**95.** " Wheel, 2" diam. 36 teeth,  
**95a.** " " "  $1\frac{1}{2}$ " " 28 "  
**95b.** " " "  $3\frac{1}{2}$ " " 56 "  
**96.** " " " 1" " 18 "  
**96a.** " " "  $\frac{3}{4}$ " " 14 "

- 99** Braced Girders  
**97.** 3 $\frac{1}{2}$ " long  
**97a.** 3" " "  
**98.** 2 $\frac{1}{2}$ " " "  
**99.** 12 $\frac{1}{2}$ " " "  
**99a.** 9 $\frac{1}{2}$ " long  
**99b.** 7 $\frac{1}{2}$ " " "  
**100.** 5 $\frac{1}{2}$ " " "  
**100a.** 4 $\frac{1}{2}$ " " "

- 101.** Head, for looms  
**102.** Single Bent Strip  
**103<sup>a</sup>** Flat Girders  
**103.** 5 $\frac{1}{2}$ " long  
**103a.** 9 $\frac{1}{2}$ " " "  
**103b.** 12 $\frac{1}{2}$ " " "  
**103c.** 4 $\frac{1}{2}$ " " "  
**103d.** 3 $\frac{1}{2}$ " " "  
**103e.** 3" long  
**103f.** 2 $\frac{1}{2}$ " " "  
**103g.** 2" " "  
**103h.** 1 $\frac{1}{2}$ " " "  
**103k.** 7 $\frac{1}{2}$ " " "

- 101.** Head, for looms  
**102.** Single Bent Strip

- 103<sup>a</sup>** Flat Girders  
**103.** 5 $\frac{1}{2}$ " long  
**103a.** 9 $\frac{1}{2}$ " " "  
**103b.** 12 $\frac{1}{2}$ " " "  
**103c.** 4 $\frac{1}{2}$ " " "  
**103d.** 3 $\frac{1}{2}$ " " "

- 104.** Shuttle, for looms  
**105.** Reed Hook, for looms

- 106** Wood Roller  
**106a.** Sand Roller  
**106<sup>a</sup>**

- 108** Corner Gusset  
**109.** Face Plate, 2 $\frac{1}{2}$ " diam.  
**108**  
**109**

- 110** Rack Strip,  $3\frac{1}{2}$ " long  
**110a.** " " "  $6\frac{1}{2}$ " "  
**111.** Bolt,  $\frac{3}{16}$ " " "  
**111a.** " " "  $\frac{1}{8}$ " " "  
**111c.** Bolt,  $\frac{3}{16}$ " " "  
**111d.** " " "  $\frac{1}{8}$ " " "

- 113** Girder Frame  
**114** Hinge  
**115** Threaded Pin  
**116.** Fork Piece, Large  
**116a.** " " Small  
**117.** Steel Ball,  $\frac{3}{8}$ " diam.

- 118.** Hub Disc,  $5\frac{1}{2}$ " diam.  
**118**

# MECCANO PARTS

No. 120b. Compression Spring,  $\frac{3}{8}$ " long



122. Miniature Loaded Sack



123. Cone Pulley,  $1\frac{1}{2}$ ", 1" and  $\frac{3}{4}$ " diam.  
124. Reversed Angle Bracket, 1"  
125. " " "  $\frac{1}{2}$ "

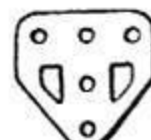

126. Trunnion 126a. Flat Trunnion

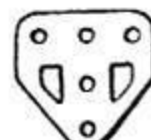

127. Bell Crank  
128. Bell Crank, with Boss



129. Toothed Segment,  $1\frac{1}{2}$ " radius

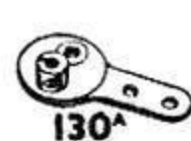
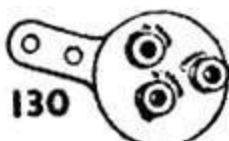

130. Eccentric, Triple Throw,  $\frac{1}{4}$ ",  $\frac{3}{8}$ " and  $\frac{1}{2}$ "  
130a. Eccentric, Single Throw,  $\frac{1}{4}$ "



131. Dredger Bucket  
132. Flywheel,  $2\frac{1}{4}$ " diam.



133. Corner Bracket,  $1\frac{1}{2}$ "  
133a. " "  $1\frac{1}{2}$ "

No. 134. Crank Shaft, 1" stroke



136. Handrail Support  
136a. Handrail Coupling  
137. Wheel Flange



138a. Ship Funnel



139. Flanged Bracket (right)  
139a. " " (left)



140. Universal Coupling



142. Rubber Ring (to fit 3" diam. rim)  
142a. Motor Tyre (to fit 2" diam. rim)  
142b. " " " 3" " "  
142c. " " " 1" " "  
142d. " " " 1 $\frac{1}{2}$ " " "



143. Circular Girder,  $5\frac{1}{2}$ " diam.

No. 144. Dog Clutch

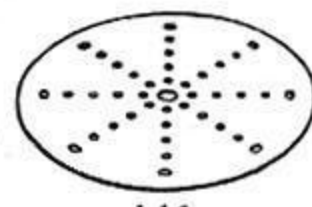
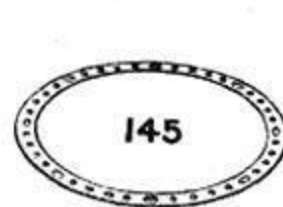

145. Circular Strip,  $7\frac{1}{2}$ " diam. overall  
146. " Plate 6" " "  
146a. " " 4" " "



147. Pawl, with Pivot Bolt and Nuts  
147a. Pawl  
147b. Pivot Bolts with 2 Nuts  
147c. Pawl without boss  
148. Ratchet Wheel



151. Pulley Block, Single Sheave  
152. " " Two " "  
153. " " Three " "



154a. Corner Angle Bracket,  $\frac{1}{2}$ " (right-hand)  
154b. Corner Angle Bracket,  $\frac{1}{2}$ " (left-hand)  
155. Rubber Ring (for 1" Pulleys)



157. Fan, 2" diam.

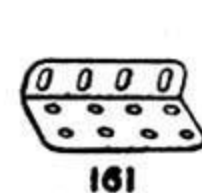

160. Channel Bearing,  $1\frac{1}{2}$ " x  $1\frac{1}{2}$ " x  $\frac{1}{2}$ "  
161. Girder Bracket, 2" x 1" x  $\frac{1}{2}$ "

No. 162. Boiler, complete, 5" long x  $2\frac{1}{4}$ " diam.  
162a. " Ends,  $2\frac{1}{4}$ " diam. x  $\frac{1}{4}$ " "  
162b. " without ends,  $4\frac{1}{2}$ " long x  $2\frac{1}{4}$ " diam.  
163. Sleeve Piece,  $1\frac{1}{2}$ " long x  $\frac{1}{4}$ " diam.  
164. Chimney Adaptor,  $\frac{3}{8}$ " diam. x  $\frac{1}{2}$ " high

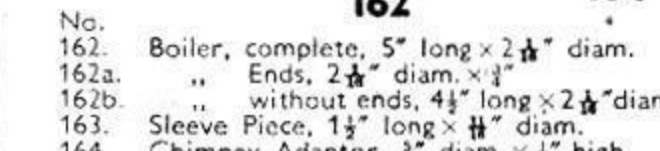

165. Swivel Bearing  
166. End  
167b. Flanged Ring,  $9\frac{3}{8}$ " diam.

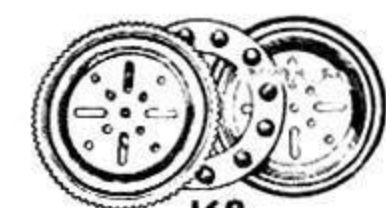

168. Ball Bearing, 4" diam.  
168a. " Race, flanged disc,  $3\frac{1}{2}$ " diam.  
168b. " " toothed " 4" diam.  
168c. " Cage,  $3\frac{1}{2}$ " diam., complete with balls.



171. Socket Coupling



175. Flexible Coupling Unit



176. Anchoring Spring for Cord

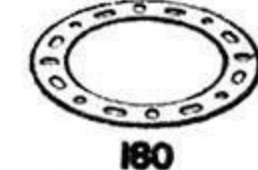

179. Rod Socket  
180. Gear Ring,  $3\frac{1}{2}$ " diam. (133 ext. teeth, 95 int.)



No. 185. Steering Wheel,  $1\frac{1}{2}$ " diam.  
186. Driving Band,  $2\frac{1}{2}$ " (Light)  
186a. " " 6" " "  
186b. " " 10" " "  
186c. " " 10" (Heavy) " "  
186d. " " 15" " "  
186e. " " 20" " "  
187. Road Wheel,  $2\frac{1}{2}$ " diam.  
187a. Conical Disc,  $1\frac{1}{8}$ " diam.

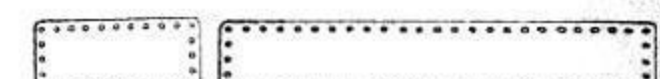

192. Flexible Plates  
190a.  $3\frac{1}{2}$ " x  $2\frac{1}{2}$ "  
191.  $4\frac{1}{2}$ " x  $2\frac{1}{2}$ "  
192.  $5\frac{1}{2}$ " x  $2\frac{1}{2}$ "  
196.  $9\frac{1}{2}$ " x  $2\frac{1}{2}$ "  
197.  $12\frac{1}{2}$ " x  $2\frac{1}{2}$ "

198. Hinged Flat Plate,  $4\frac{1}{2}$ " x  $2\frac{1}{2}$ "  
199. Curved Plate, U-Section  
200. " "  $2\frac{1}{2}$ " x  $2\frac{1}{2}$ " x  $1\frac{1}{8}$ " radius  
" "  $2\frac{1}{2}$ " x  $2\frac{1}{2}$ " x  $1\frac{1}{8}$ " radius

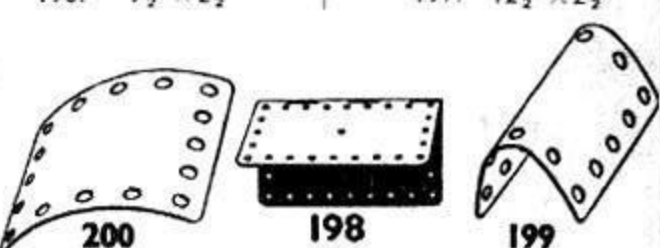

198. Hinged Flat Plate,  $4\frac{1}{2}$ " x  $2\frac{1}{2}$ "  
199. Curved Plate, U-Section  
200. " "  $2\frac{1}{2}$ " x  $2\frac{1}{2}$ " x  $1\frac{1}{8}$ " radius  
" "  $2\frac{1}{2}$ " x  $2\frac{1}{2}$ " x  $1\frac{1}{8}$ " radius



211a. Helical Gear,  $\frac{1}{2}$ "  
211b. " "  $1\frac{1}{2}$ "  
*(Can only be used together)*



212. Rod and Strip Connector  
213. Rod Connector

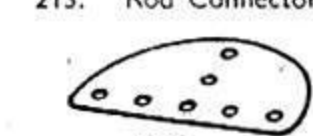

214. Semi-Circular Plate,  $2\frac{1}{2}$ "  
215. Formed Slotted Strip, 3"



216. Cylinder,  $2\frac{1}{2}$ " long,  $1\frac{1}{4}$ " diam.