

MECCANO

INSTRUCTIONS FOR
No. 3a ACCESSORY OUTFIT

No.
51.3a

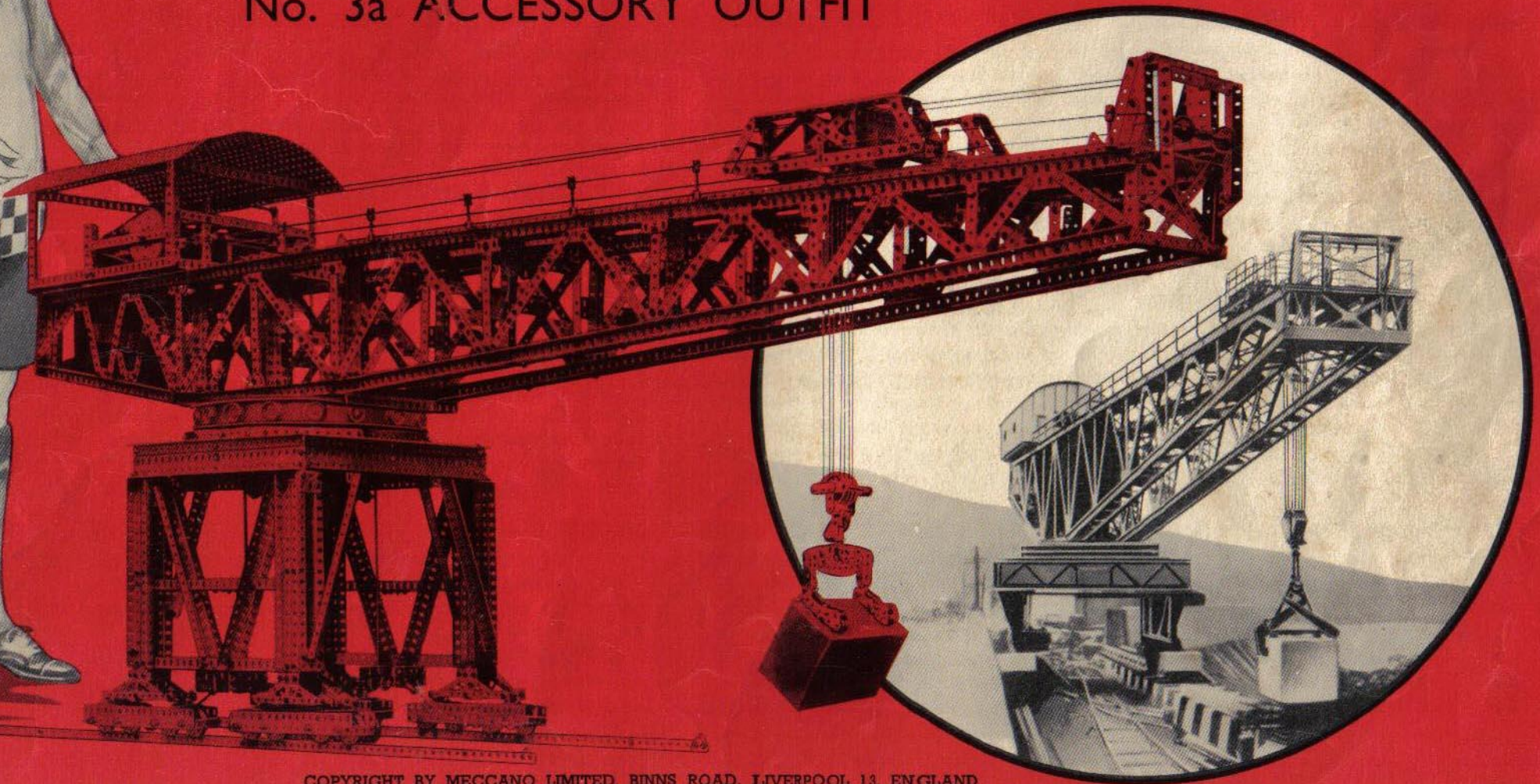

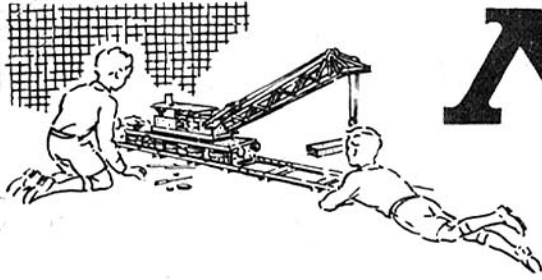

MECCANO

Registered Trade Mark

The World's Greatest Constructional Toy

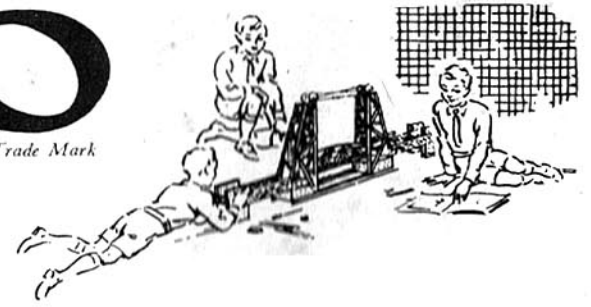

MODEL-BUILDING WITH MECCANO

There is no limit to the number of models that can be built with Meccano — Cranes, Clocks, Motor Cars, Aeroplanes, Machine Tools, Locomotives — in fact everything that interests boys. A screwdriver and a spanner, both of which are provided in each complete Outfit, are the only tools necessary.

When you have built all the models illustrated in the Books of Instructions the fun is not over, it is just beginning. Now comes the chance to make use of your own ideas. First of all, re-build some of the models with small changes in construction that may occur to you; then try building models entirely of your own design. In doing this you will enjoy the real thrill of the engineer and the inventor.

HOW TO BUILD UP YOUR OUTFIT

Meccano is sold in 12 different Outfits, ranging from No. OO to No. 10. Each Outfit can be converted into the next larger one by the purchase of an Accessory Outfit. Thus Meccano No. OO Outfit can be converted into No. O Outfit by adding to it a No. OOa Accessory Outfit. No. Oa Outfit would then convert it into a No. 1 and so on. In this way, no matter with which Outfit you begin, you can build it up by degrees until you have a complete No. 10 Outfit.

All Meccano parts are of the same high quality and finish, but the larger Outfits contain a greater quantity and variety, making possible the construction of more elaborate models.

THE 'MECCANO MAGAZINE'

The 'Meccano Magazine' is published specially for Meccano boys. Every month it describes and illustrates new Meccano models, and deals with suggestions from readers for new Meccano parts and for new methods of using the existing parts.

There are model-building competitions specially planned to give an equal chance to the owners of small and large Outfits. In addition, there are splendid articles on such subjects as Railways, Famous Engineers and Inventors, Electricity, Bridges, Cranes and Aeroplanes, and special sections dealing with the latest Engineering, Aviation, Motoring

and Shipping News. Other pages deal with Stamp Collecting, and Books of interest to boys; and a feature of outstanding popularity is the section devoted to short articles from readers.

Write to the Editor, The Meccano Magazine, Binns Road, Liverpool 13, for particulars and a specimen copy. You can order the Magazine from your Meccano dealer, or from any newsagent.

THE MECCANO GUILD

Every owner of a Meccano Outfit should join the Meccano Guild. This is a world-wide organisation, started at the request of Meccano boys. Its primary object is to bring boys together and to make them feel that they are all members of a great brotherhood, each trying to help others to get the very best out of life. Its members are in constant touch with Headquarters, giving news of their activities and being guided in their hobbies and interests. A leaflet containing full particulars of the Guild and an application form is included in this Book.

Clubs founded and established under the guidance of the Guild Secretary provide Meccano boys with opportunities of enjoying to the utmost the fun of model-building. Each has its Leader, Secretary, Treasurer and other officials. With the exception of the Leader, all the officials are boys, and as far as possible the proceedings of the clubs are conducted by boys.

MECCANO SERVICE

The service of Meccano does not end with selling an Outfit and a Book of Instructions. If ever you are in any difficulty with your models, or if you want advice on anything connected with this great hobby, write to us. We receive hundreds of interesting letters from boys in all parts of the world, and each of these is answered personally and promptly by one of our staff of experts.

Whatever your problem may be, write to us about it. We shall be delighted to help you in any way possible. Address your letters to *Information Service*.

4.1 HAMMERHEAD CRANE

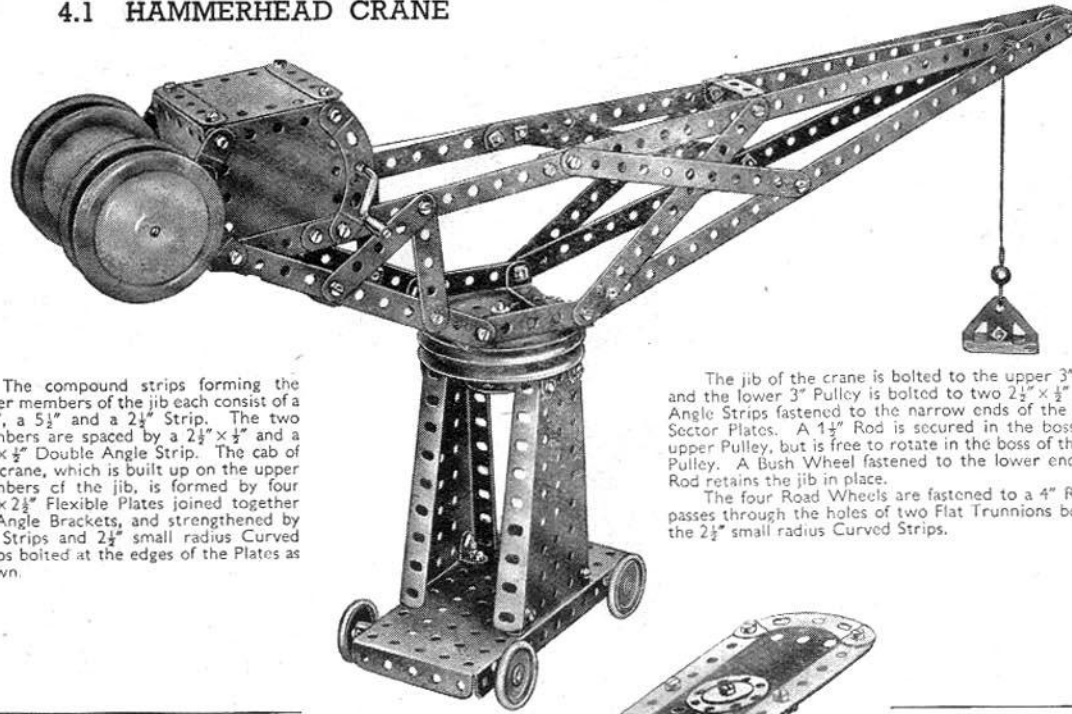

The compound strips forming the upper members of the jib each consist of a $12\frac{1}{2}$ ", a $5\frac{1}{2}$ " and a $2\frac{1}{2}$ " Strip. The two members are spaced by a $2\frac{1}{2}$ " \times $\frac{1}{2}$ " and a $1\frac{1}{2}$ " \times $\frac{1}{2}$ " Double Angle Strip. The cab of the crane, which is built up on the upper members of the jib, is formed by four $2\frac{1}{2}$ " \times $2\frac{1}{2}$ " Flexible Plates joined together by Angle Brackets, and strengthened by $2\frac{1}{2}$ " Strips and $2\frac{1}{2}$ " small radius Curved Strips bolted at the edges of the Plates as shown.

The jib of the crane is bolted to the upper 3" Pulley, and the lower 3" Pulley is bolted to two $2\frac{1}{2}$ " \times $\frac{1}{2}$ " Double Angle Strips fastened to the narrow ends of the Flanged Sector Plates. A $1\frac{1}{2}$ " Rod is secured in the boss of the upper Pulley, but is free to rotate in the boss of the lower Pulley. A Bush Wheel fastened to the lower end of the Rod retains the jib in place.

The four Road Wheels are fastened to a 4" Rod that passes through the holes of two Flat Trunnions bolted to the $2\frac{1}{2}$ " small radius Curved Strips.

4.3 TELPHER SPAN

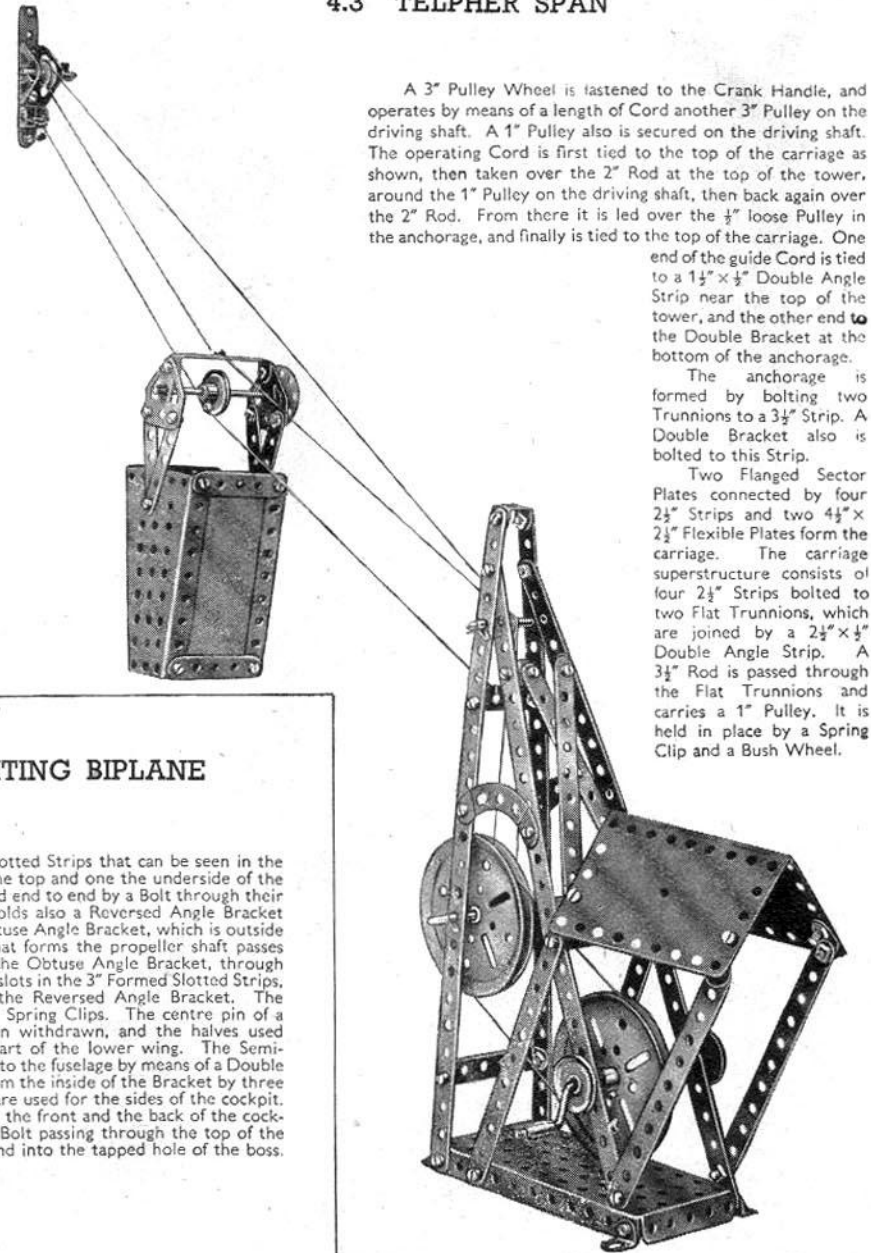

A 3" Pulley Wheel is fastened to the Crank Handle, and operates by means of a length of Cord another 3" Pulley on the driving shaft. A 1" Pulley also is secured on the driving shaft. The operating Cord is first tied to the top of the carriage as shown, then taken over the 2" Rod at the top of the tower, around the 1" Pulley on the driving shaft, then back again over the 2" Rod. From there it is led over the $\frac{1}{2}$ " loose Pulley in the anchorage, and finally is tied to the top of the carriage. One end of the guide Cord is tied to a $1\frac{1}{2}$ " \times $\frac{1}{2}$ " Double Angle Strip near the top of the tower, and the other end to the Double Bracket at the bottom of the anchorage.

The anchorage is formed by bolting two Trunnions to a $3\frac{1}{2}$ " Strip. A Double Bracket also is bolted to this Strip.

Two Flanged Sector Plates connected by four $2\frac{1}{2}$ " Strips and two $4\frac{1}{2}$ " \times $2\frac{1}{2}$ " Flexible Plates form the carriage. The carriage superstructure consists of four $2\frac{1}{2}$ " Strips bolted to two Flat Trunnions, which are joined by a $2\frac{1}{2}$ " \times $\frac{1}{2}$ " Double Angle Strip. A $3\frac{1}{2}$ " Rod is passed through the Flat Trunnions and carries a 1" Pulley. It is held in place by a Spring Clip and a Bush Wheel.

4.2 FIGHTING BIPLANE

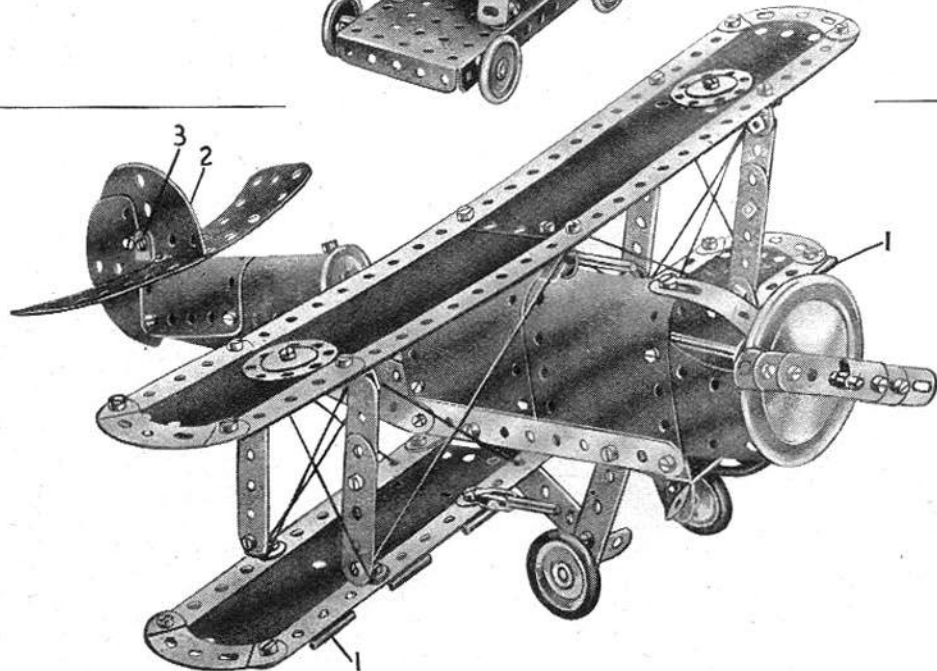

The two 3" Formed Slotted Strips that can be seen in the illustration, one forming the top and one the underside of the nose of the plane, are joined end to end by a Bolt through their slotted holes. The Bolt holds also a Reversed Angle Bracket inside the nose, and an Obtuse Angle Bracket, which is outside the nose. The $3\frac{1}{2}$ " Rod that forms the propeller shaft passes through the free hole of the Obtuse Angle Bracket, through the unoccupied part of the slots in the 3" Formed Slotted Strips, and through the hole of the Reversed Angle Bracket. The Rod is held in position by Spring Clips. The centre pin of a Hinged Flat Plate has been withdrawn, and the halves used as flat plates 1, to form part of the lower wing. The Semi-Circular Plate 2 is fastened to the fuselage by means of a Double Bracket 3, and is spaced from the inside of the Bracket by three Washers. Flat Trunnions are used for the sides of the cockpit. The 1" fast Pulleys forming the front and the back of the cockpit are each fastened by a Bolt passing through the top of the U-Section Curved Plates and into the tapped hole of the boss.

4.4 MOTOR CYCLE AND SIDECAR

The $5\frac{1}{2}'' \times 1\frac{1}{2}''$ Flexible Plate that forms the front of the sidecar is bolted at 1 to a $2\frac{1}{2}'' \times \frac{1}{2}''$ Double Angle Strip, which is fastened by Bolt 2 (Fig. 4.4a) to the $4\frac{1}{2}''$ Flanged Sector Plate forming the bottom of the sidecar. The Bolts 3 pass through the Flexible Plates and also through a $2\frac{1}{2}'' \times \frac{1}{2}''$ Double Angle Strip.

The engine cylinder consists of two 1" Pulleys mounted on a 2" Rod, one end of which is supported in the Strip 4 (Fig. 4.4b) that forms the top of the frame. The other end of the Rod is held between the two Bolts that fasten the Wheel Discs to the frame.

The petrol tank is represented by a $5\frac{1}{2}'' \times 1\frac{1}{2}''$ Flexible Plate bent to U-shape and attached to a $1\frac{1}{2}'' \times \frac{1}{2}''$ Double Angle Strip by Angle Brackets. A $2\frac{1}{2}''$ Strip is attached to the Double Angle Strip and the unit is then bolted to the Strip 4 (Fig. 4.4b). The saddle, which is a Trunnion, is also attached to this Strip by a $\frac{1}{2}''$ Reversed Angle Bracket.

The Strip 4 carries a Double Bracket at its front end, and to this are bolted two $2\frac{1}{2}''$ Strips. To these Strips are attached two Wheel Discs, and these are joined by a double bracket built up from two Angle Brackets (see Fig. 4.4a).

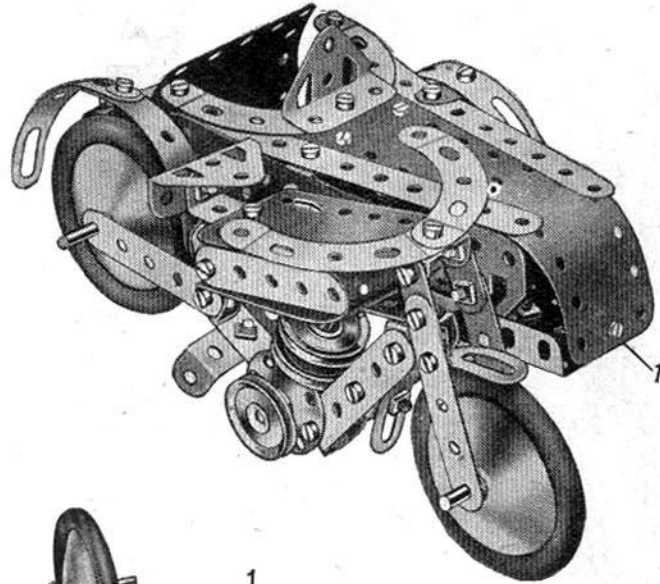

Fig. 4.4a

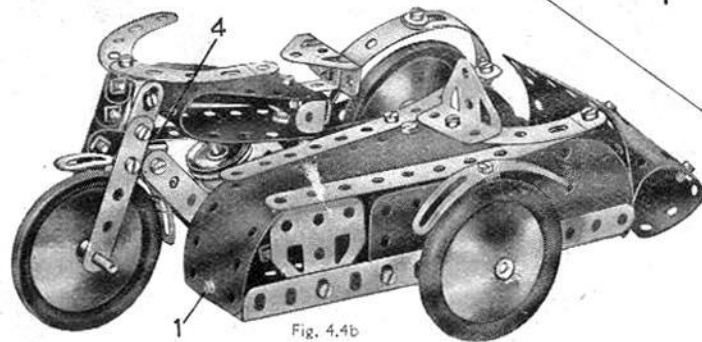
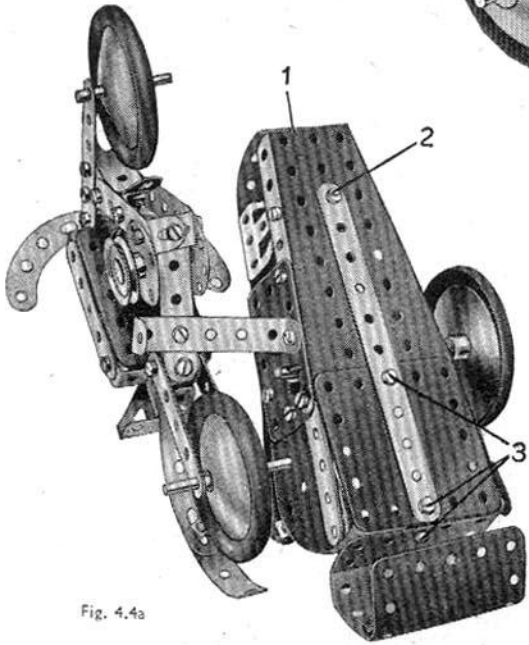
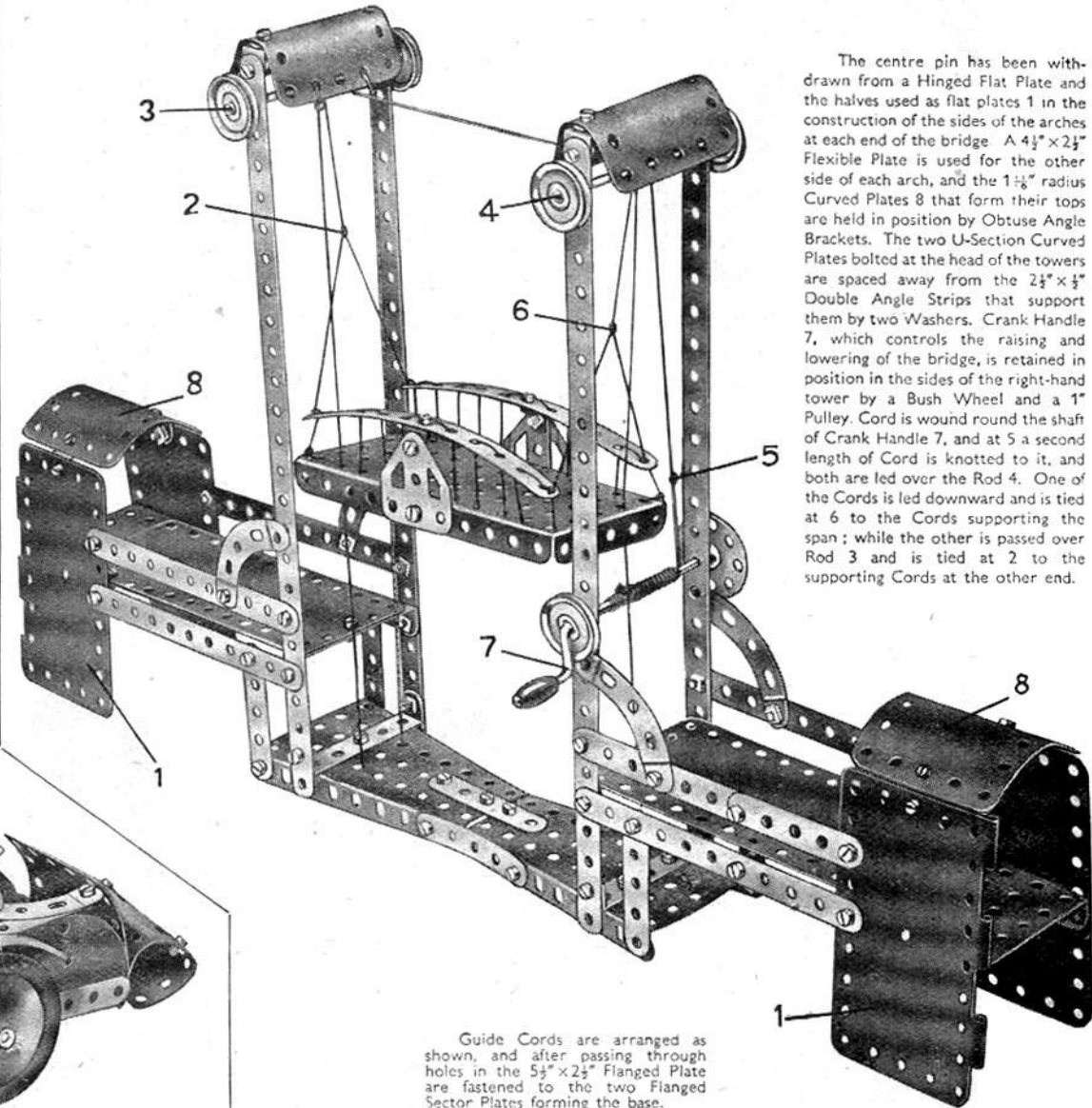

Fig. 4.4b

4.5 LIFTING BRIDGE



The centre pin has been withdrawn from a Hinged Flat Plate and the halves used as flat plates 1 in the construction of the sides of the arches at each end of the bridge. A $4\frac{1}{2}'' \times 2\frac{1}{2}''$ Flexible Plate is used for the other side of each arch, and the $1\frac{1}{2}''$ radius Curved Plates 8 that form their tops are held in position by Obtuse Angle Brackets. The two U-Section Curved Plates bolted at the head of the towers are spaced away from the $2\frac{1}{2}'' \times \frac{1}{2}''$ Double Angle Strips that support them by two Washers. Crank Handle 7, which controls the raising and lowering of the bridge, is retained in position in the sides of the right-hand tower by a Bush Wheel and a 1" Pulley. Cord is wound round the shaft of Crank Handle 7, and at 5 a second length of Cord is knotted to it, and both are led over the Rod 4. One of the Cords is led downward and is tied at 6 to the Cords supporting the span; while the other is passed over Rod 3 and is tied at 2 to the supporting Cords at the other end.

Guide Cords are arranged as shown, and after passing through holes in the $5\frac{1}{2}'' \times 2\frac{1}{2}''$ Flanged Plate are fastened to the two Flanged Sector Plates forming the base.

4.6 DIESEL SHUNTING LOCOMOTIVE

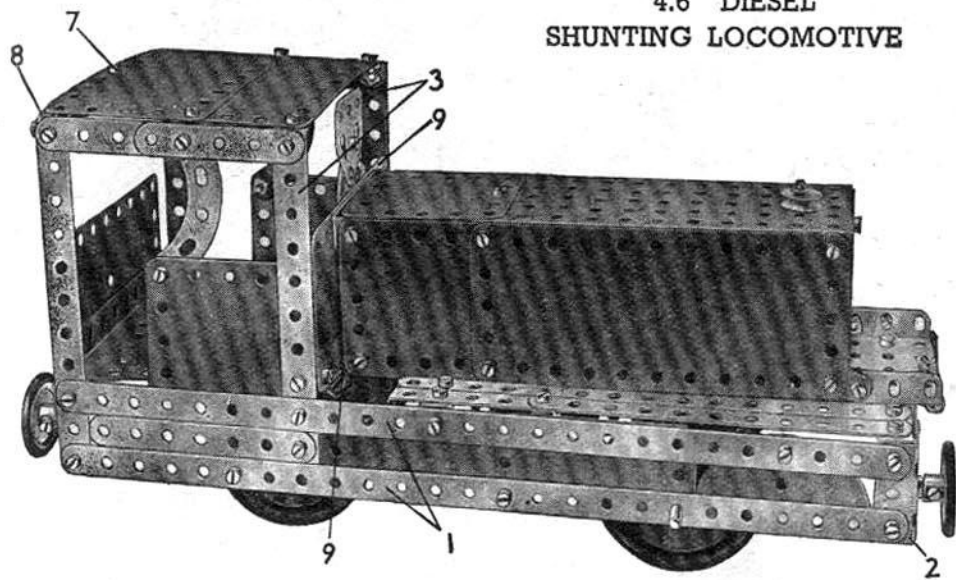

Note: The Motor used in this model is not included in the Outfit.

The main frames of the locomotive consist of $12\frac{1}{2}$ " Strips 1, bolted to a $5\frac{1}{2}$ " \times $1\frac{1}{2}$ " Flexible Plate, a Semi-Circular Plate and the Trunnions 2. The back of the cab is formed by half a Hinged Flat Plate attached to the frames by Angle Brackets. The other half of the Hinged Flat Plate is used for the front of the cab, and is fixed to the $5\frac{1}{2}$ " Strips 3 by Angle Brackets.

The main frames are connected at the front by a $2\frac{1}{2}$ " \times $\frac{1}{2}$ " Double Angle Strip 4 (Fig. 4.6a), a $1\frac{1}{2}$ " \times $\frac{1}{2}$ " Double Angle Strip 5 and a $2\frac{1}{2}$ " \times $1\frac{1}{2}$ " Flanged Plate 6. Two $2\frac{1}{2}$ " \times $1\frac{1}{2}$ " Flexible Plates bolted together are attached to the Trunnions 2 by $\frac{3}{4}$ " Bolts. A 1" Pulley is locked on the shank of each of these Bolts to represent the buffers.

The sides of the cab are formed by $2\frac{1}{2}$ " \times $2\frac{1}{2}$ " Flexible Plates attached to the Strips 3 and the main frames.

The roof is made by overlapping two $4\frac{1}{2}$ " \times $2\frac{1}{2}$ " Flexible Plates two holes. It is bolted to Angle Brackets attached to the Strips 3. A second Angle Bracket held by the Bolt 7 is bolted to a compound strip 8, consisting of two $2\frac{1}{2}$ " Strips fastened to the sides by Angle Brackets.

Each side of the engine housing consists of a $5\frac{1}{2}$ " \times $2\frac{1}{2}$ " and a $2\frac{1}{2}$ " \times $2\frac{1}{2}$ " Flexible Plate. These are attached to the Flanged Plate 6 by Fishplates and to the front of the cab by Double Angle Strips 9. The top is filled in by a $5\frac{1}{2}$ " \times $2\frac{1}{2}$ " Flanged Plate and a $1\frac{1}{2}$ " radius Curved Plate. The radiator is formed by a second $1\frac{1}{2}$ " radius Curved Plate.

The running plate above the wheels consists of $5\frac{1}{2}$ " Strips bolted to the Double Angle Strips 4 and 5. The $5\frac{1}{2}$ " Strips are extended on one side by two $2\frac{1}{2}$ " Strips, and on the other by a $2\frac{1}{2}$ " Strip and a $2\frac{1}{2}$ " \times $\frac{1}{2}$ " Double Angle Strip. These Strips are supported by the Double Angle Strips 10.

The leading axle consists of a $3\frac{1}{2}$ " and a 2" Rod joined by a Rod Connector and supported in the main frames. The rear axle is a 4" Rod free to turn in two Reversed Angle Brackets. The Magic Motor is bolted to one of the main frames and drives a 1" Pulley on the leading axle.

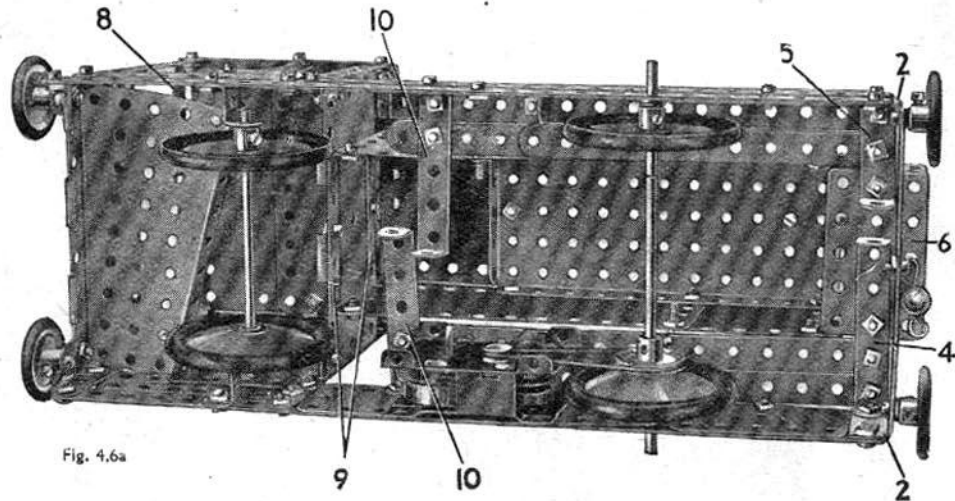
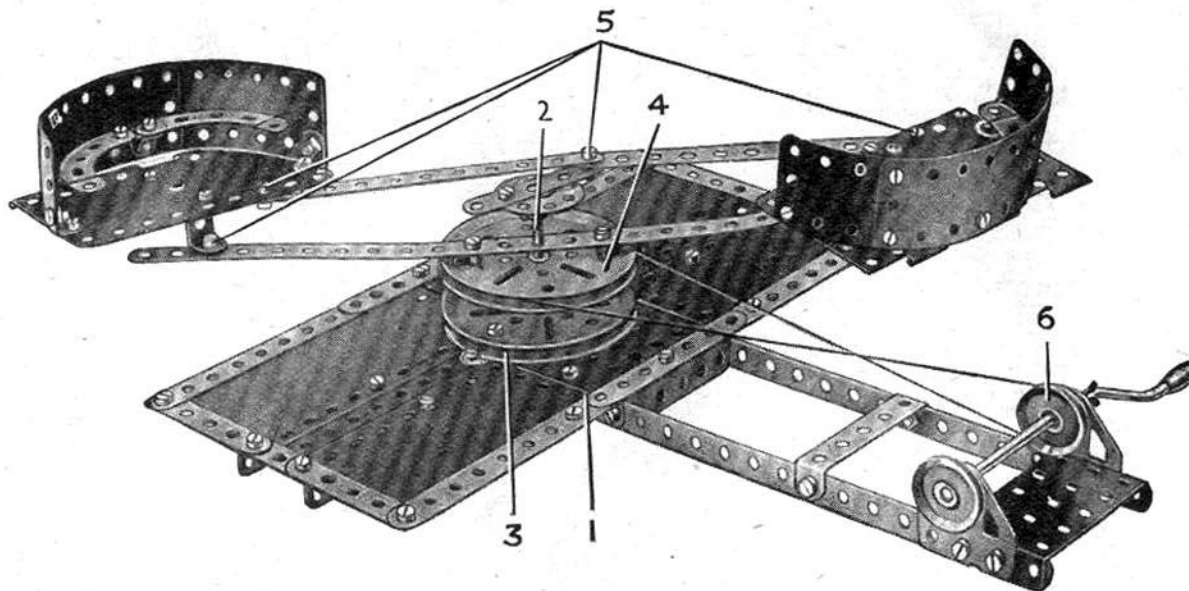

Fig. 4.6a

4.7 "WHIP" ROUNDABOUT



The base of the model is formed by a $5\frac{1}{2}$ " \times $2\frac{1}{2}$ " Flanged Plate 1 extended on each side by a Flanged Sector Plate, a $5\frac{1}{2}$ " \times $2\frac{1}{2}$ " and a $4\frac{1}{2}$ " \times $2\frac{1}{2}$ " Flexible Plate. The edges of the base are strengthened with Strips. Two $12\frac{1}{2}$ " Strips are bolted to the flanges of Plate 1 and their ends are connected by a $2\frac{1}{2}$ " \times $1\frac{1}{2}$ " Flanged Plate. Two Flat Trunnions provide bearings for a small Crank Handle.

A 3" Pulley 3 is bolted to Flanged Plate 1 and in its boss is fixed a 2" Rod 2. A second 3" Pulley 4 is spaced from Pulley 3 by a Spring Clip and is free to turn on Rod 2. Across its face is bolted a $12\frac{1}{2}$ " Strip, the Strip being spaced from the Pulley by a Spring Clip placed on the shank of each securing Bolt.

A Bush Wheel fitted with a $2\frac{1}{2}$ " Strip is secured on Rod 2 in the position shown, the end of the Strip being connected to the cars by $5\frac{1}{2}$ " Strips. All the Bolts 5 are lock-nutted.

The 1" Pulley 6 mounted on the Crank Handle, drives Pulley 4 through a belt of Cord.

4.8 TANK LOCOMOTIVE

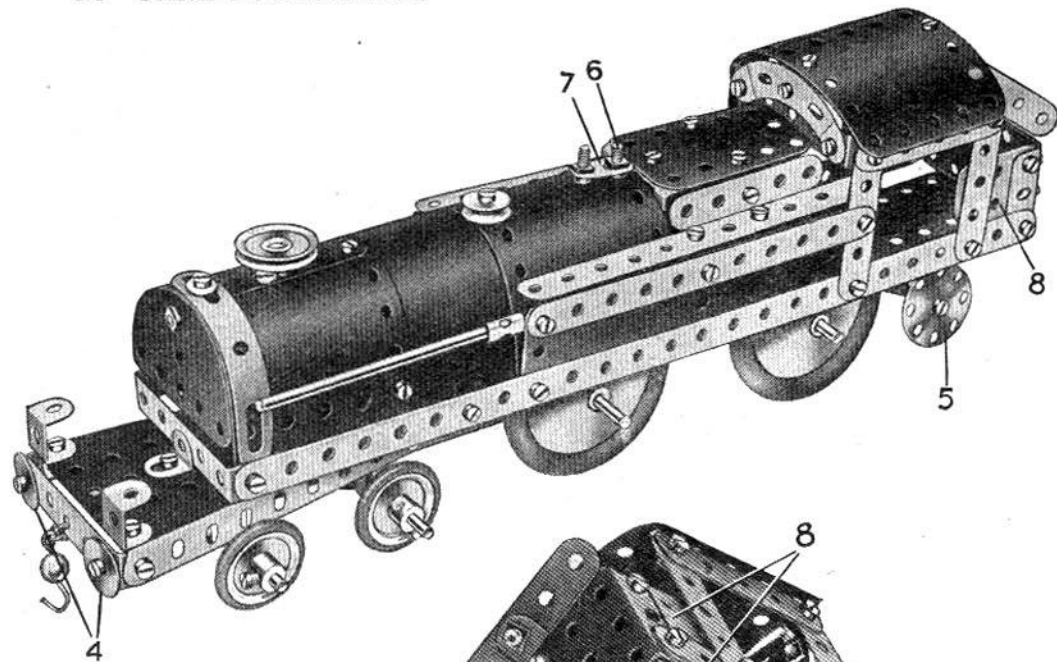

The construction of the model is commenced by building the chassis as shown in Fig. 4.8a. The Fishplates 1 must be bolted to the $12\frac{1}{2}$ " Strips 2 before the Flanged Sector Plate 3 is fitted. The Wheel Discs 5 rotate on $\frac{3}{8}$ " Bolts lock-nutted in the end holes of two $2\frac{1}{2}$ " small radius Curved Strips, which are bolted to the $12\frac{1}{2}$ " Strips forming the side members of the frame.

The top of the cab consists of two $1\frac{1}{2}$ " radius Curved Plates, overlapped three holes and fastened by an Angle Bracket to a small radius Curved Strip. The Curved Strip in turn is fastened by Angle Brackets to two $2\frac{1}{2}$ " Strips bolted to the frame. A $2\frac{1}{2}$ " x $1\frac{1}{2}$ " Flanged Plate is used for the back of the cab, and Flat Trunnions 8 fill in the sides.

The centre and rear parts of the boiler are formed by $5\frac{1}{2}$ " x $2\frac{1}{2}$ " Flexible Plates, which are bolted direct to the $12\frac{1}{2}$ " Strips forming the side members of the chassis. The forward part of the boiler consists of two $2\frac{1}{2}$ " x $2\frac{1}{2}$ " Flexible Plates bent to shape and bolted to the centre portion of the boiler. The $\frac{3}{8}$ " Bolt 6 that forms part of the safety valve is held in the top of the boiler by a nut, and the Fishplate 7 is then slipped over it and fastened in position by a further nut. The buffers 4 are lock-nutted to a $2\frac{1}{2}$ " x $\frac{1}{2}$ " Double Angle Strip bolted to the flanges of the Flanged Sector Plate 3.

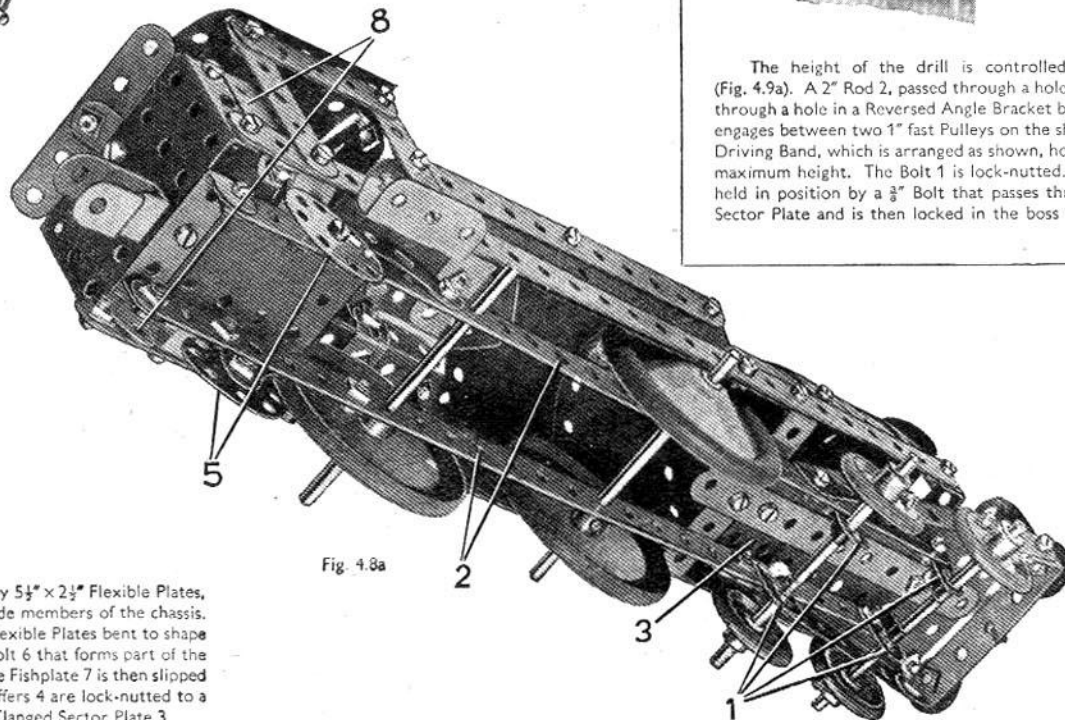

Fig. 4.8a

4.9 DRILLING MACHINE

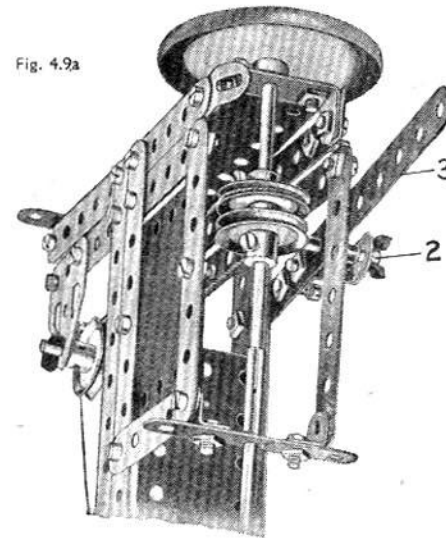
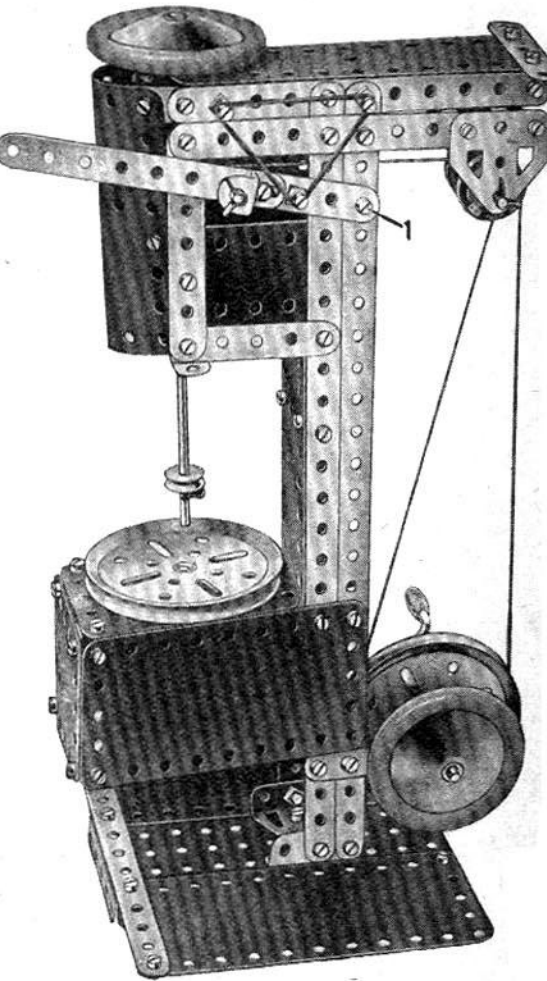

Fig. 4.9a

The height of the drill is controlled by the lever 3 (Fig. 4.9a). A 2" Rod 2, passed through a hole in the Strip 3 and through a hole in a Reversed Angle Bracket bolted to the Strip, engages between two 1" fast Pulleys on the shaft of the drill. A Driving Band, which is arranged as shown, holds the lever at its maximum height. The Bolt 1 is lock-nutted. The drill table is held in position by a $\frac{3}{8}$ " Bolt that passes through the Flanged Sector Plate and is then locked in the boss of the Pulley.



A Flanged Sector Plate that supports the drilling table is bolted to the $12\frac{1}{2}$ " Strips that form the main column of the machine. The sides of the table are filled in by two $4\frac{1}{2}$ " x $2\frac{1}{2}$ " and one $2\frac{1}{2}$ " x $2\frac{1}{2}$ " Flexible Plates joined by Angle Brackets. Two $2\frac{1}{2}$ " Strips bolted to the main column provide the bearings for the Crank Handle.

4.10 GANTRY CRANE

The sides of the cabin each consist of two $2\frac{1}{2}$ " \times $2\frac{1}{2}$ " Flexible Plates overlapped one hole. The top of the cabin, which consists of two $1\frac{1}{8}$ " radius Curved Plates, is attached to the sides by means of Obtuse Angle Brackets at each corner as shown.

The rails on which the hoisting carriage travels are two $12\frac{1}{2}$ " Strips, which are braced to the lower pair of $12\frac{1}{2}$ " Strips by $2\frac{1}{2}$ " Strips. The two sides are spaced by $2\frac{1}{2}$ " \times $\frac{1}{2}$ " Double Angle Strips and a $2\frac{1}{2}$ " \times $1\frac{1}{2}$ " Flexible Plate.

The complete span and cabin are supported at each end by $5\frac{1}{2}$ " Strips. These Strips are attached to the bases by Angle Brackets. A $5\frac{1}{2}$ " \times $2\frac{1}{2}$ " Flanged Plate forms the base at one end and two Flanged Sector Plates are used at the other end.

The hoisting carriage is a $2\frac{1}{2}$ " \times $1\frac{1}{2}$ " Flanged Plate 7. Bearings for one of the $3\frac{1}{2}$ " Rods carrying the 1" Pulleys are provided by the holes in the turned up ends of a $1\frac{1}{2}$ " \times $\frac{1}{2}$ " Double Angle Strip, and for the other Rod by the holes in a Double

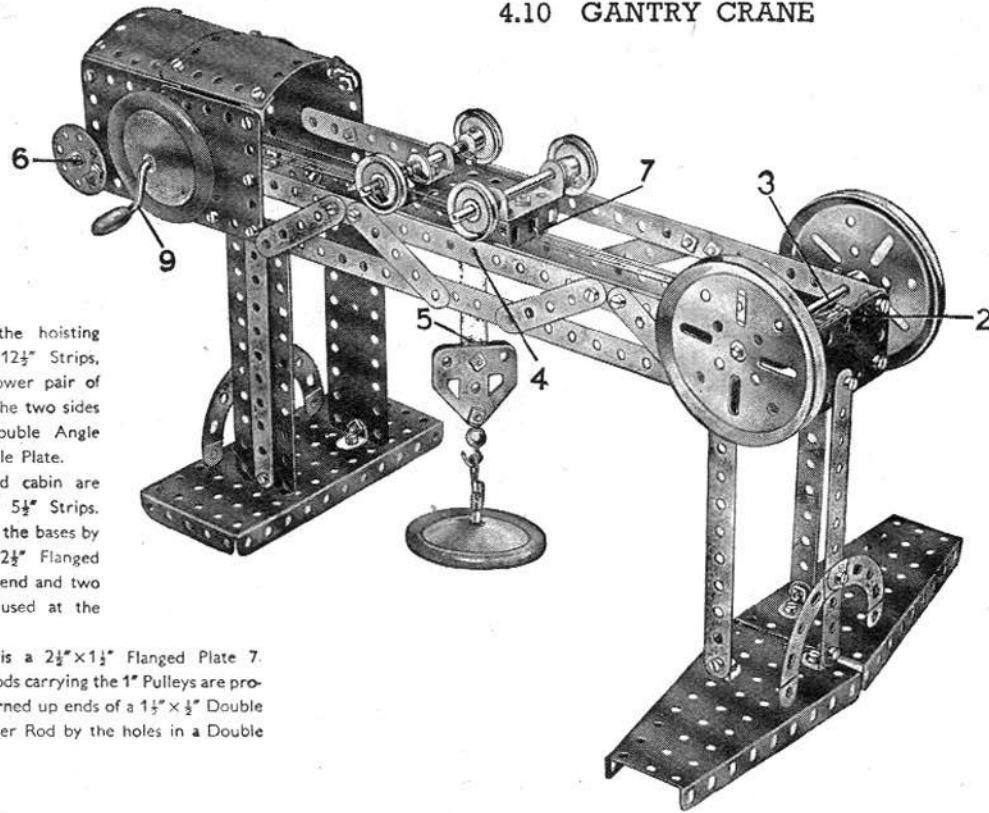

Bracket. The Bolt 1 (Fig. 4.10a) secures a Stepped Bent Strip 4 vertically to the underside of the Flanged Plate 7. A 1" Rod passes through the lower holes of the Stepped Bent Strip and is held in position by Spring Clips.

Two Flat Trunnions form the pulley block. They are fastened together at their wide ends by a $\frac{3}{8}$ " Bolt, which carries a $\frac{1}{2}$ " loose Pulley 5 on its shank between the two Flat Trunnions.

The Cord that operates the hoisting carriage 7 is tied at 10 (Fig. 4.10a). It is then passed round Rod 3, which carries the two 3" Pulleys, and is taken to the Crank Handle 9. The Cord is wound round the Crank Handle several times to enable it to grip the shaft, and finally is tied to the rear end of the carriage. The hoisting Cord is tied to Rod 7 fitted with a Bush Wheel, and wound round it several times. It is then taken over the 1" Rod held in the Stepped Bent Strip 4, round Pulley 5, back over the 1" Rod, and tied at 2. Strip 11 (Fig. 4.10a) is the lever of a band brake, the Cord of which passes around a 1" Pulley on Rod 6.

Fig. 4.10a

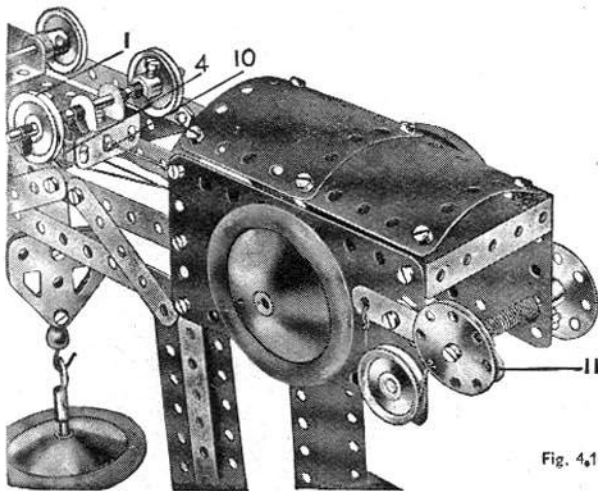

4.11 FLYBOATS

Construction is commenced by assembling four compound strips, each consisting of two $5\frac{1}{2}$ " Strips overlapped four holes. These strips form the supports for the flyboat arms and are bolted to a $5\frac{1}{2}$ " \times $2\frac{1}{2}$ " Flanged Plate that is the centre section of the base of the model. This Flanged Plate is extended at each end by a Flanged Sector Plate, each of which is attached by a $2\frac{1}{2}$ " \times $\frac{1}{2}$ " Double Angle Strip.

The pay-box and entrance is built on a $2\frac{1}{2}$ " \times $1\frac{1}{2}$ " Flanged Plate, and each side is a $5\frac{1}{2}$ " \times $2\frac{1}{2}$ " Flexible Plate strengthened by $2\frac{1}{2}$ " Strips. The unit is attached to the front side of the $5\frac{1}{2}$ " \times $2\frac{1}{2}$ " Flanged Plate by a $2\frac{1}{2}$ " \times $\frac{1}{2}$ " Double Angle Strip.

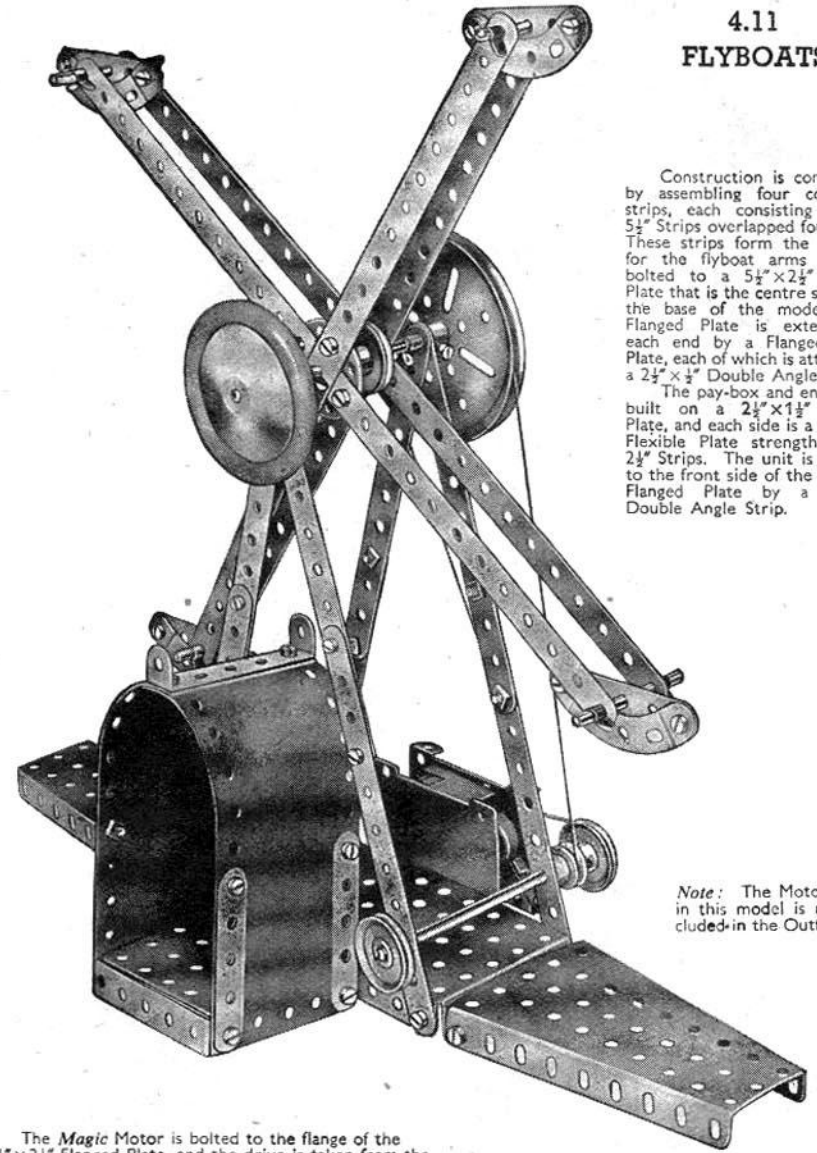

Note: The Motor used in this model is not included in the Outfit.

The Magic Motor is bolted to the flange of the $5\frac{1}{2}$ " \times $2\frac{1}{2}$ " Flanged Plate, and the drive is taken from the pulley of the Motor to a 1" Pulley fastened on a Rod journalled in the Strips that support the main shaft. A $\frac{1}{2}$ " fast Pulley also is secured on this Rod, and drives through a belt of Cord a 3" Pulley on the main shaft. The arms that support the boats are bolted to a Bush Wheel fastened on the main shaft. Each of the boats consists of a $2\frac{1}{2}$ " Strip and a $2\frac{1}{2}$ "

4.12 TRACTION ENGINE

The boiler is built up from one $5\frac{1}{2}'' \times 2\frac{1}{4}''$ and two $2\frac{1}{2}'' \times 2\frac{1}{4}''$ Flexible Plates. The ashpan consists of two $2\frac{1}{2}'' \times 1\frac{1}{2}''$ Flexible Plates one at each side of the model connected by a $2\frac{1}{2}'' \times \frac{1}{2}''$ Double Angle Strip. A Road Wheel which forms the boiler front, is held freely on a Rod by a Spring Clip.

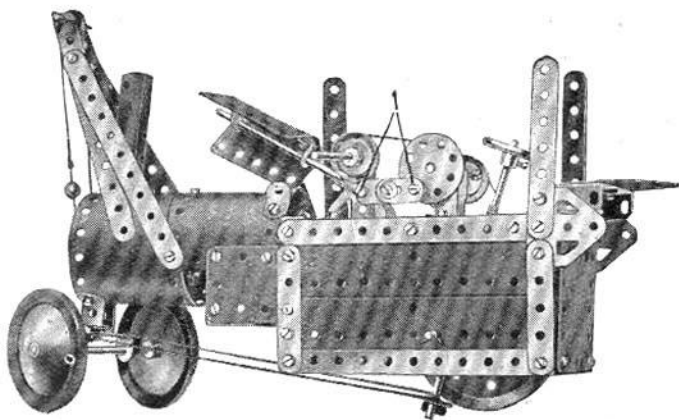
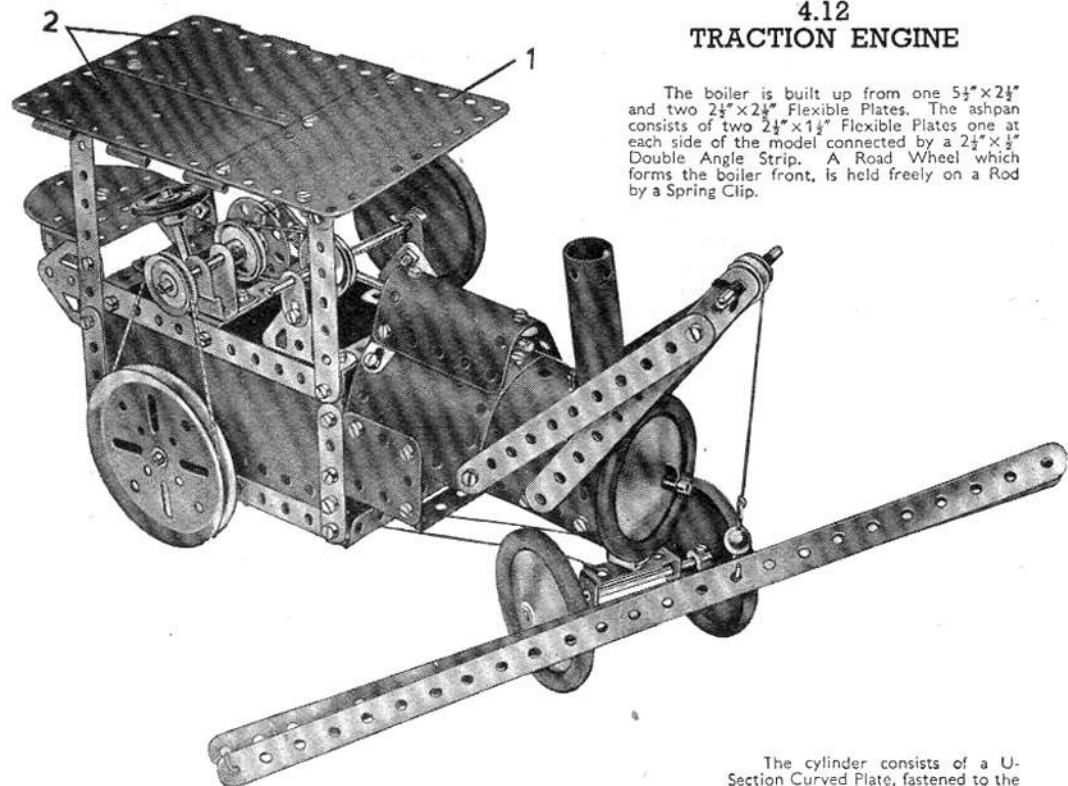

Fig. 4.12a

The cylinder consists of a U-Section Curved Plate, fastened to the boiler by Obtuse Angle Brackets. Bearings for the piston rod are formed by the holes of two Angle Brackets, which are held in place by the Bolts that can be seen at the top of the cylinder. The Bolts 1 (Fig. 4.12a) which pass through a connecting rod consisting of two Fishplates, are lock-nutted. A U-Section Curved Plate, bent so that its ends overlap one hole, is used for the chimney. The centre pin of a Hinged Flat Plate has been removed and the two parts used as flat plates 2 in the construction of the roof of the cab.

The $1\frac{1}{2}'' \times \frac{1}{2}''$ Double Angle Strip that supports the front axle is pivotally attached by a lock-nutted Bolt, to the centre hole of a double bent strip, which consists of two Reversed Angle Brackets. The Cord controlling the steering is wound twice around the lower end of the steering column.

4.13 GIANT EXCAVATOR

The Cord 1 is fastened to a Crank Handle journalled in holes in the sides of the cab, and after passing round the $2\frac{1}{2}'' \times \frac{1}{2}''$ Double Angle Strip above the cabin is tied to the jib at 2. This Cord controls the luffing movement of the jib. The Cord 3 is tied to the bucket and is passed over the 1" Pulley 5 and then wound round Rod 6. By turning the handle on the Bush Wheel 7 the bucket is raised or lowered.

The bucket arm is pivoted on Rod 4, which passes through holes in the $12\frac{1}{2}''$ Strips forming the jib and the bucket arm. Road Wheels fastened at each end of Rod 4 retain it in position.

The bucket is assembled from two $2\frac{1}{2}'' \times 1\frac{1}{2}''$ and two $2\frac{1}{2}'' \times 2\frac{1}{4}''$ Flexible Plates and one $2\frac{1}{2}'' \times 1\frac{1}{2}''$ Flanged Plate. The $2\frac{1}{2}'' \times 2\frac{1}{2}''$ Flexible Plate forming the bottom of the bucket is bolted to a $2\frac{1}{2}'' \times \frac{1}{2}''$ Double Angle Strip.

The base is a $5\frac{1}{2}'' \times 2\frac{1}{2}''$ Flanged Plate extended at each side by a $5\frac{1}{2}'' \times 1\frac{1}{2}''$ Flexible Plate attached by two Fishplates. A $5\frac{1}{2}''$ Strip is bolted across each end of the $5\frac{1}{2}'' \times 2\frac{1}{2}''$ Flanged Plate and these are joined at their outer ends by $5\frac{1}{2}''$ Strips attached by Angle Brackets.

A 3" Pulley 8 is bolted to the base by two Bolts, and a Flanged Sector Plate 9, to which the cab is fastened, is similarly attached to the upper 3" Pulley. A $1\frac{1}{2}''$ Rod is held in the boss of Pulley 8, and the Pulley attached to Flanged Sector Plate 9 is retained in position by a Spring Clip so that the superstructure is free to swivel on the Rod. The control cab is built up on the flanges of the Flanged Sector Plate and the platform around the cab is composed of two $5\frac{1}{2}'' \times 2\frac{1}{4}''$ Flexible Plates, which are bolted underneath the Flanged Sector Plate 9.

The wheels on which the model runs are free to rotate on pairs of $3\frac{1}{2}''$ Rods. The front pair are joined by a Rod Connector and the rear pair by a Rod and Strip Connector.

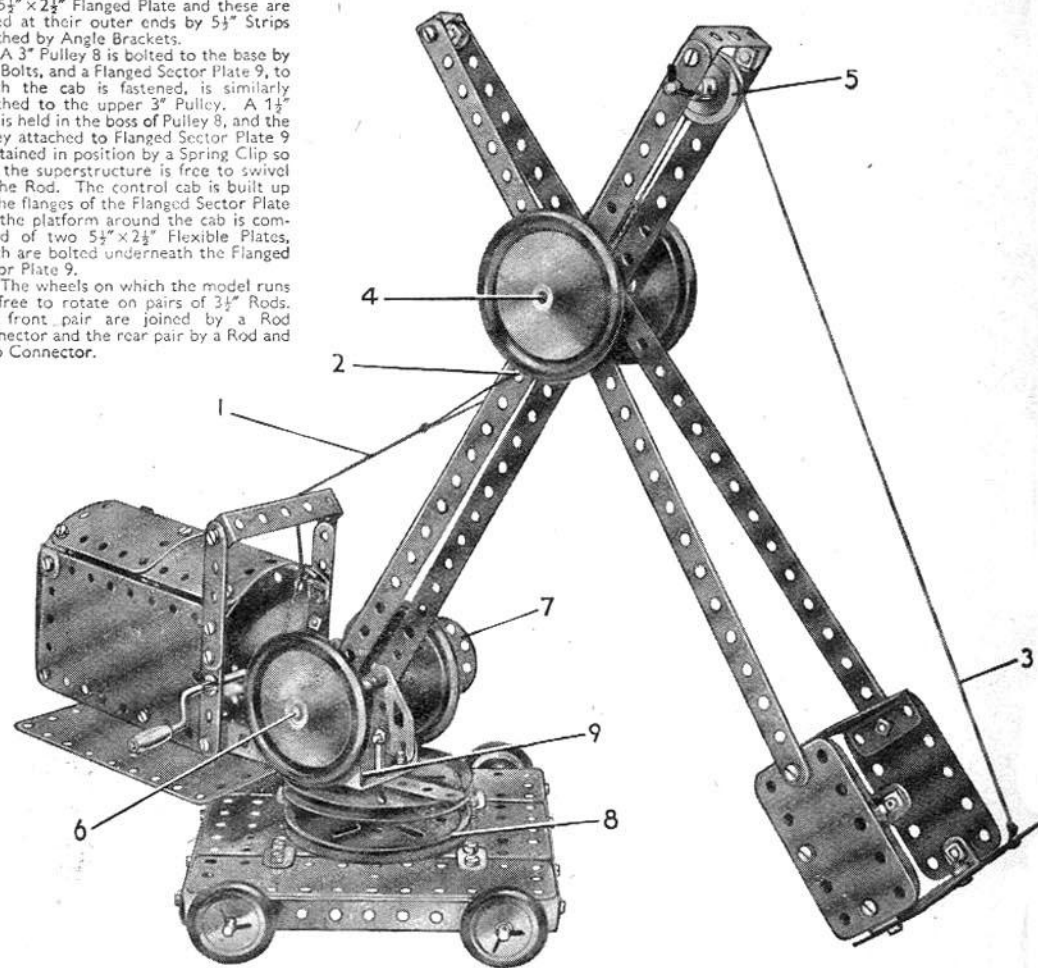

4.14 ELEVATED JIB CRANE

A 3" Pulley is attached to 5½" Strips 1 by means of two Double Angle Strips. A 4" Rod locked in this Pulley passes through a hole in a 2½"×1½" Flanged Plate bolted to the Flanged Sector Plates and a Double Angle Strip held by a Bolt 2 on each side of the tower. The tower is attached to the base by Fishplates, two of which are seen marked 6.

The jib consists of four 12½" Strips joined at their outer ends by a Double Bracket and at the inner ends by two Trunnions 3 (Fig. 4.14a) bolted together.

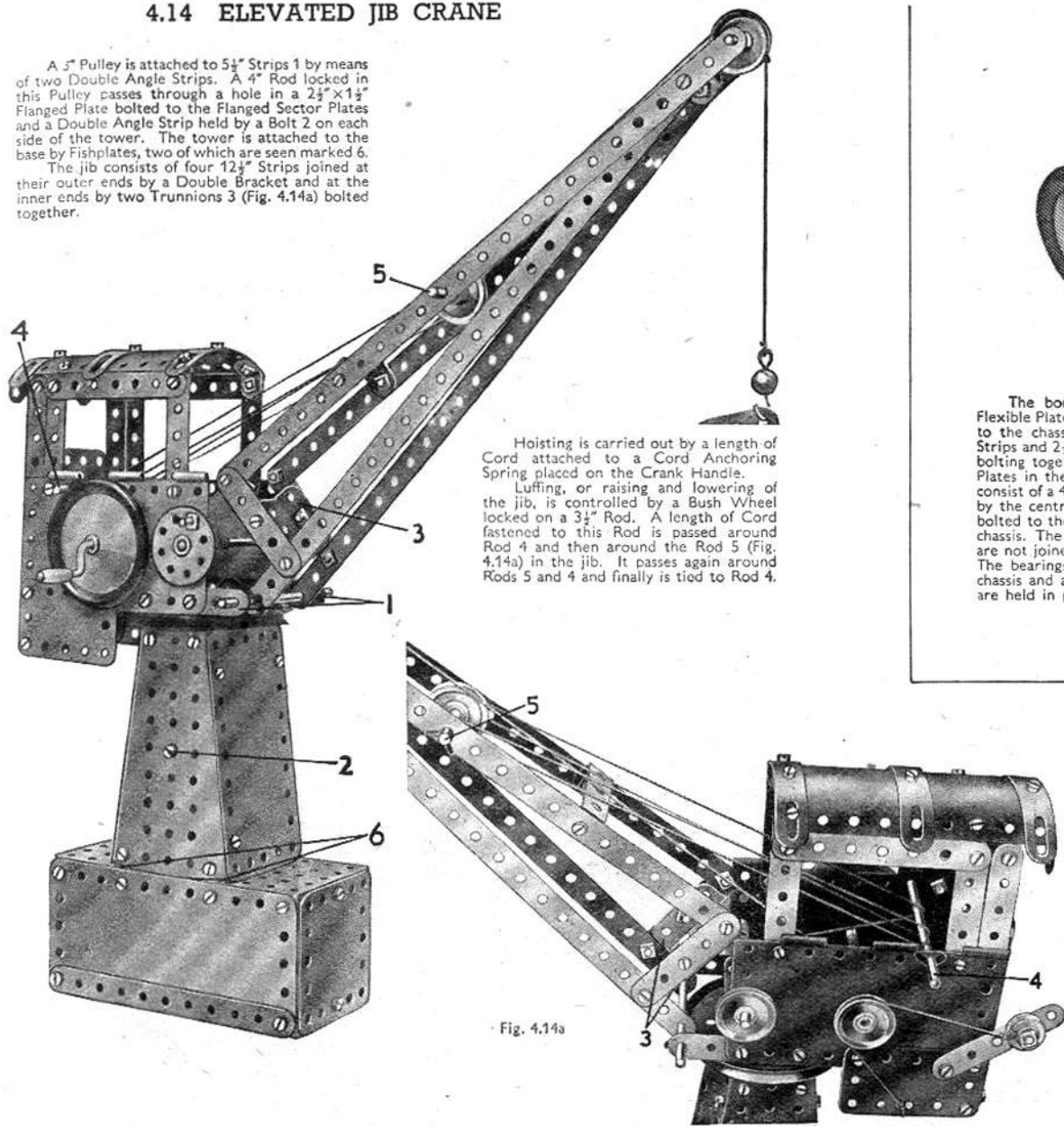

Hoisting is carried out by a length of Cord attached to a Cord Anchoring Spring placed on the Crank Handle.

Luffing, or raising and lowering of the jib, is controlled by a Bush Wheel locked on a 3½" Rod. A length of Cord fastened to this Rod is passed around Rod 4 and then around the Rod 5 (Fig. 4.14a) in the jib. It passes again around Rods 5 and 4 and finally is tied to Rod 4.

Fig. 4.14a

4.15 RACING CAR

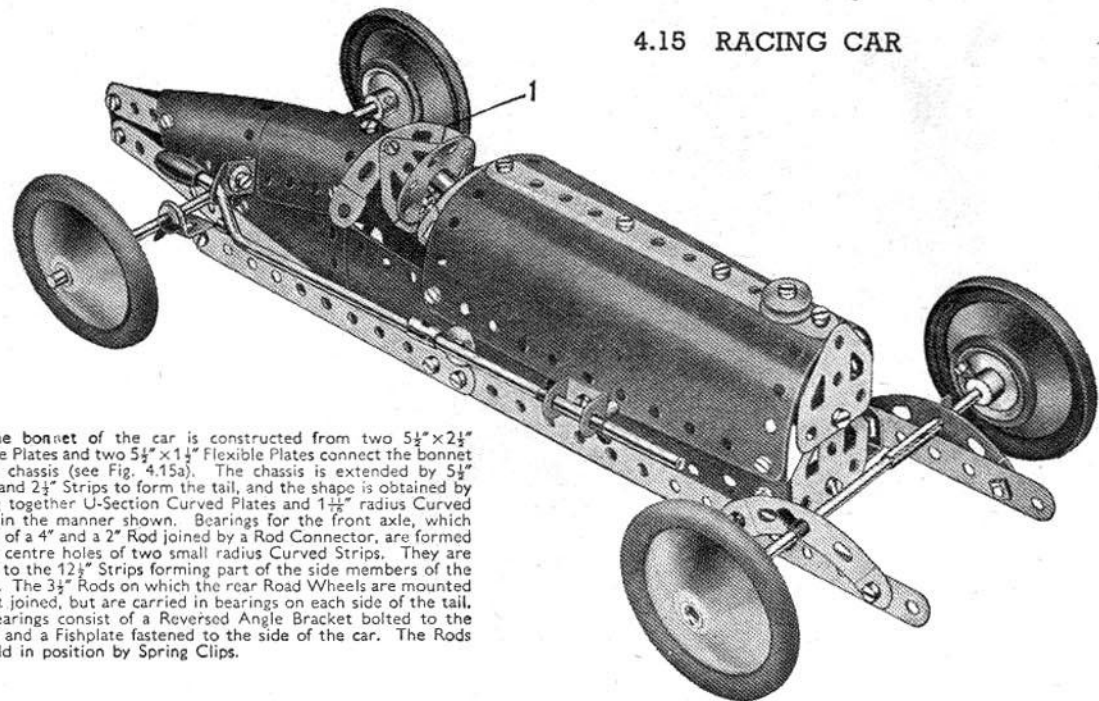

The bonnet of the car is constructed from two 5½"×2½" Flexible Plates and two 5½"×1½" Flexible Plates connect the bonnet to the chassis (see Fig. 4.15a). The chassis is extended by 5½" Strips and 2½" Strips to form the tail, and the shape is obtained by bolting together U-Section Curved Plates and 1½" radius Curved Plates in the manner shown. Bearings for the front axle, which consist of a 4" and a 2" Rod joined by a Rod Connector, are formed by the centre holes of two small radius Curved Strips. They are bolted to the 12½" Strips forming part of the side members of the chassis. The 3½" Rods on which the rear Road Wheels are mounted are not joined, but are carried in bearings on each side of the tail. The bearings consist of a Reversed Angle Bracket bolted to the chassis and a Fishplate fastened to the side of the car. The Rods are held in position by Spring Clips.

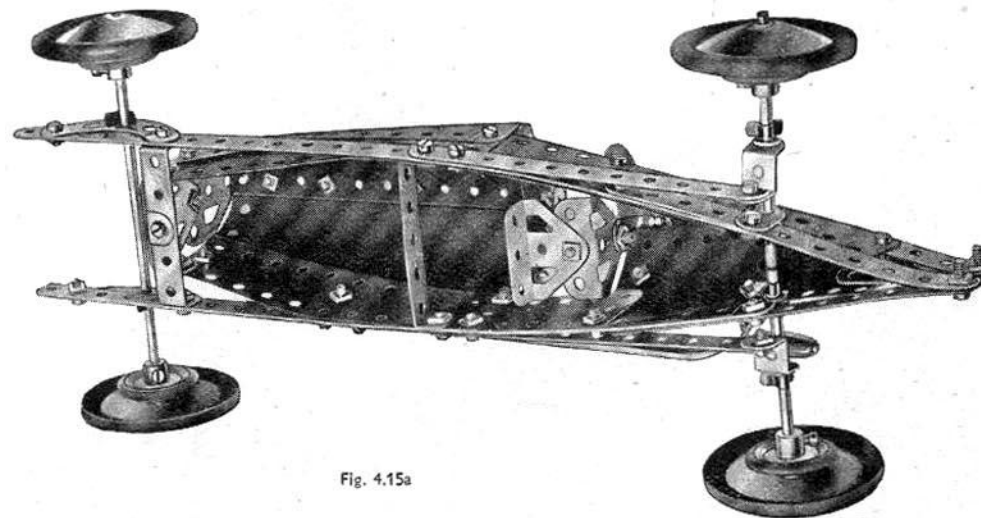
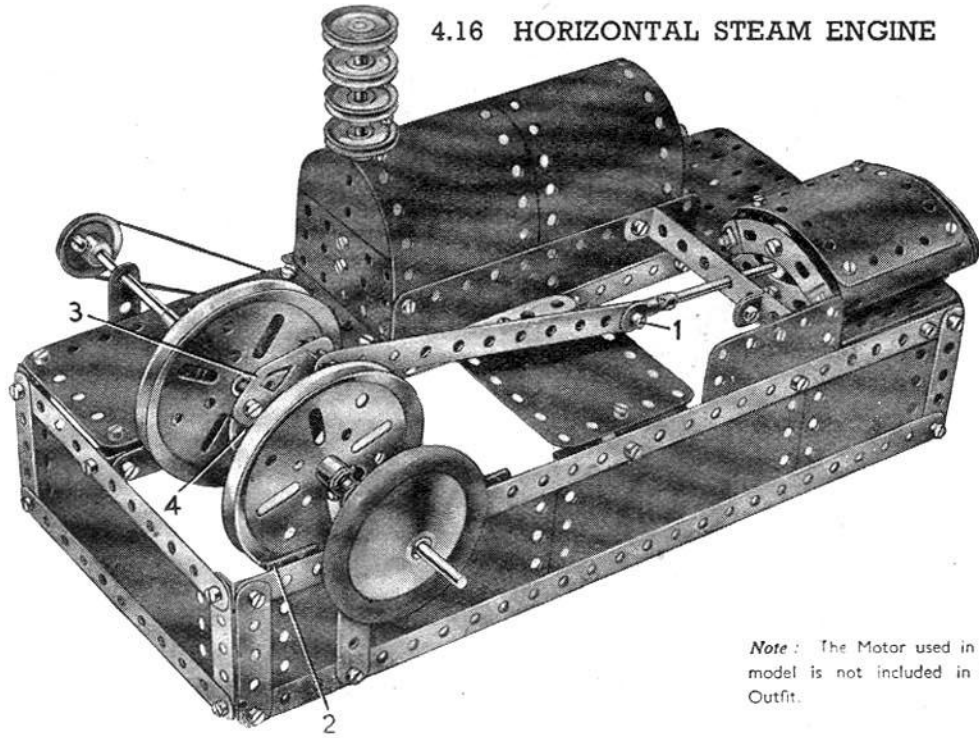

Fig. 4.15a

4.16 HORIZONTAL STEAM ENGINE



Note: The Motor used in this model is not included in this Outfit.

The Bolt 1 is lock-nutted. The centre pin is withdrawn from a Hinged Flat Plate and the halves used as flat plates at 2. The Flat Trunnion 3 is bolted to Bush Wheel 4 and forms one web of the crank. The Bush Wheel is fastened to a 2" Rod, which carries also a 3" Pulley, and a Rod Connector joins this Rod to a 3½" Rod that transmits the drive from the *Magic* Motor. The other web of the crank is made by bolting a Wheel Disc 5 (Fig. 4.16a) to a Flat Trunnion 6, one of the Bolts holding also a Reversed Angle Bracket 7. A Spring Clip 8 is fixed in position so that when the crankshaft is rotated the Rod on which the 3" Pulley and the Road Wheel are fastened are rotated by the Reversed Angle Bracket 7. The cylinder is composed of two 1½" radius Curved Plates and two U-Section Curved Plates bolted together as shown, and the complete unit is fastened in position to the 5½" x 2½" Flanged Plate that forms the base.

The boiler consists of two 5½" x 2½" Flexible Plates, bolted to 5½" x 1½" Flexible Plates, and its ends are closed by Semi-Circular Plates and a 2½" x 1½" Flexible Plate and a 2½" x 1½" Flanged Plate.

The chimney is a 4" Rod fitted with 1" Pulleys, and is held in place by a Cord Anchoring Spring. Fig. 4.16a shows the arrangement for driving the model with a *Magic* Motor.

Fig. 4.16a

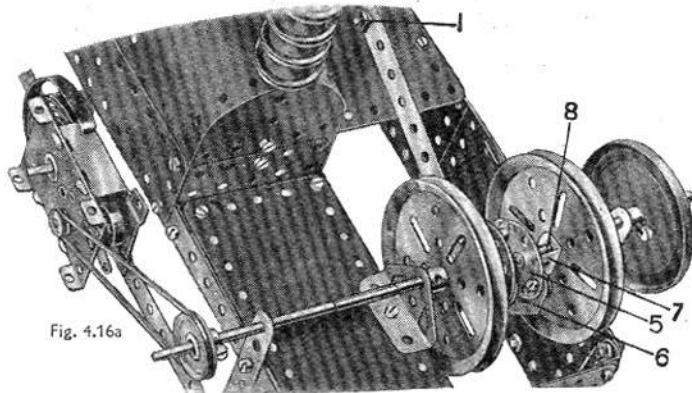

4.17 SPORTS CAR

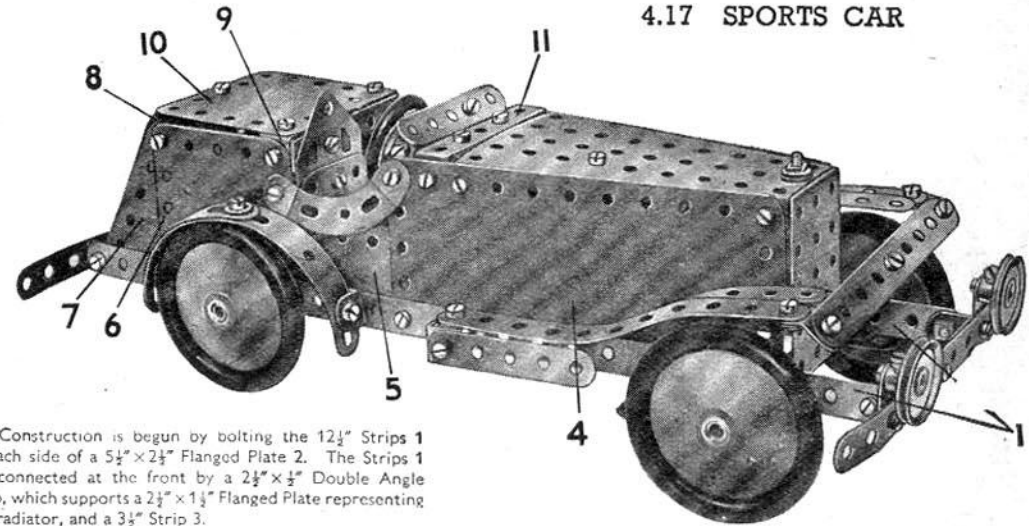

Construction is begun by bolting the 12½" Strips 1 to each side of a 5½" x 2½" Flanged Plate 2. The Strips 1 are connected at the front by a 2½" x ½" Double Angle Strip, which supports a 2½" x 1½" Flanged Plate representing the radiator, and a 3½" Strip 3.

Each side of the model consists of a 5½" x 2½" Flexible Plate 4, a 5½" x 1½" Flexible Plate 5 and a 2½" x 2½" Flexible Plate 6. A Semi-Circular Plate 7 is bolted in position at a slight angle. The sides are joined at the rear by two 2½" x ½" Double Angle Strips 8 and 9. A 2½" x 2½" Flexible Plate is bolted to the Double Angle Strip 8 and a similar Plate 10 is attached by two Angle Brackets and an Obtuse Angle Bracket.

The top of the bonnet is represented by a Flanged Sector Plate extended by a 2½" x ½" Double Angle Strip 11. The windshield consists of a 2½" Strip, and is attached to an Obtuse Angle Bracket bolted to the Double Angle Strip 11.

The steering mechanism is built up by passing the ½" Bolts 12 (Fig. 4.17a) through the end hole of the Strip 3. The Angle Brackets 13 and 2½" Strips 14 are then held tightly on the Bolts by two nuts, leaving the Bolts free to turn in the Strip 3. The Strips 14 are connected by a lock-nutted 3½" Strip 15. This Strip is fitted with an Angle Bracket held by the Bolt 16, and a ½" Bolt 17.

The steering column consists of a 4" Rod journalled in an Angle Bracket 18 and the end hole of a 1½" x ½" Double Angle Strip bolted to the top of the bonnet. The steering column is fitted with a Rod and Strip Connector and a 2½" Strip 19.

The end of this Strip engages between the Angle Bracket and the Bolt 17 on the Strip 15. The Road Wheels are locked on ½" Bolts passed through the Angle Brackets 13.

Each of the front mudguards is formed by two 5½" Strips. These are bent slightly and attached to Double Brackets bolted to the chassis. The rear mudguards consist of Formed Slotted Strips, and are fastened to the chassis by Angle Brackets. The 5½" Strips representing the front and rear bumpers are bolted to 2½" x ½" Double Angle Strips.

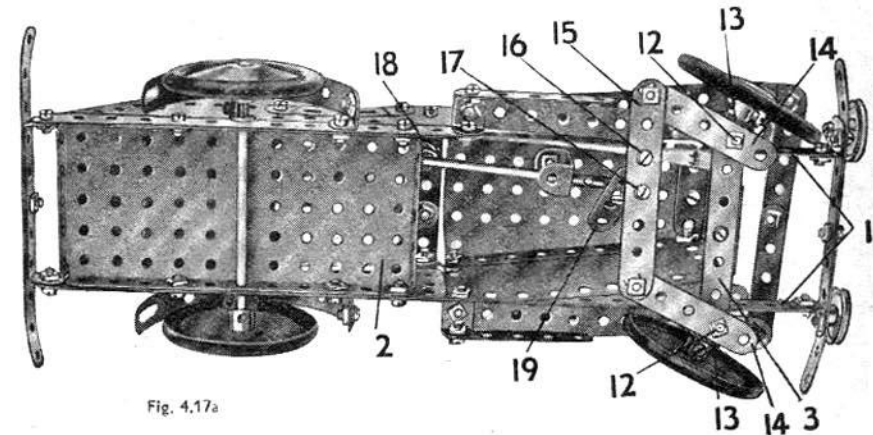

Fig. 4.17a

4.18 MECHANICAL DIGGER

The chassis is constructed from two Flanged Sector Plates, the flanges of which are connected by two $2\frac{1}{2}$ " Strips. A gap of $\frac{1}{2}$ " is left between the ends of the Plates. A 3 " Pulley 1 is then bolted boss downwards to the Flanged Sector Plates by two $\frac{3}{8}$ " Bolts.

A 2 " Rod is locked in the boss of Pulley 1, and on it is placed Pulley 2, boss upwards. The base of the cab (Fig. 4.18a) is a $5\frac{1}{2}$ " \times $2\frac{1}{2}$ " Flanged Plate, which rests on Pulley 2 and is retained on the 2 " Rod by a Road Wheel 3.

The construction of the cab is clear from the illustrations. The boiler comprises a cylinder built up from two $1\frac{1}{2}$ " radius Curved Plates, a $4\frac{1}{2}$ " \times $2\frac{1}{2}$ " Flexible Plate, and two $5\frac{1}{2}$ " \times $1\frac{1}{2}$ " Flexible Plates. The edges of the cylinder are strengthened with Formed Slotted Strips. Semi-Circular Plates are attached to the top of the boiler by a $2\frac{1}{2}$ " \times $\frac{1}{2}$ " Double Angle Strip. The boiler is fastened to the back of the cab by a $1\frac{1}{2}$ " \times $\frac{1}{2}$ "

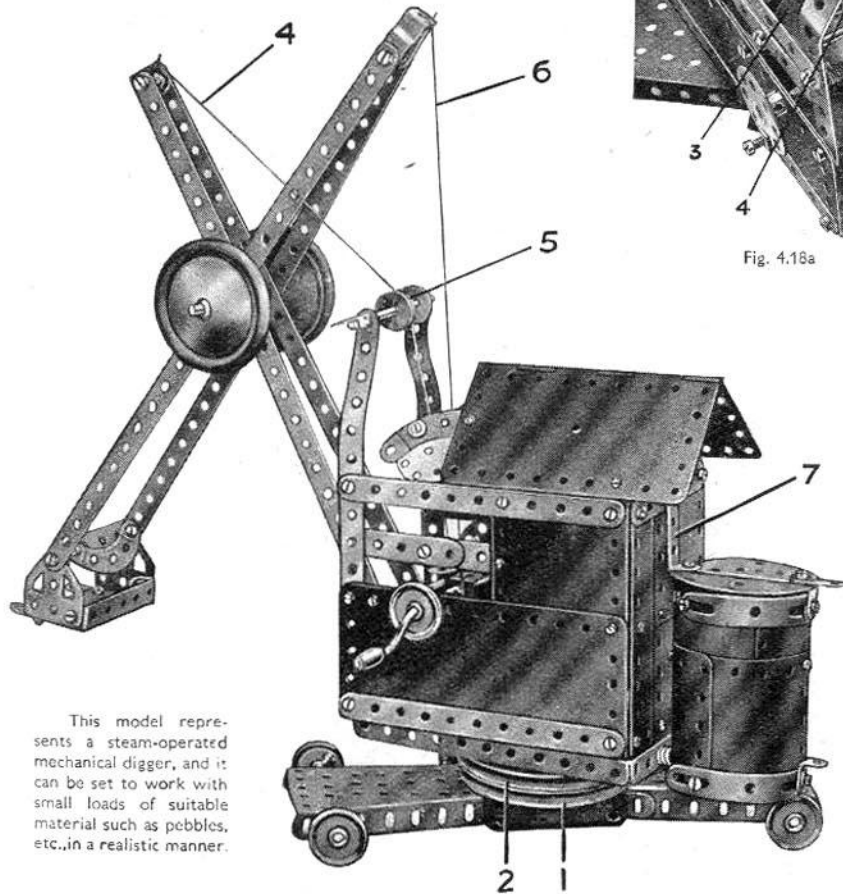

This model represents a steam-operated mechanical digger, and it can be set to work with small loads of suitable material such as pebbles, etc., in a realistic manner.

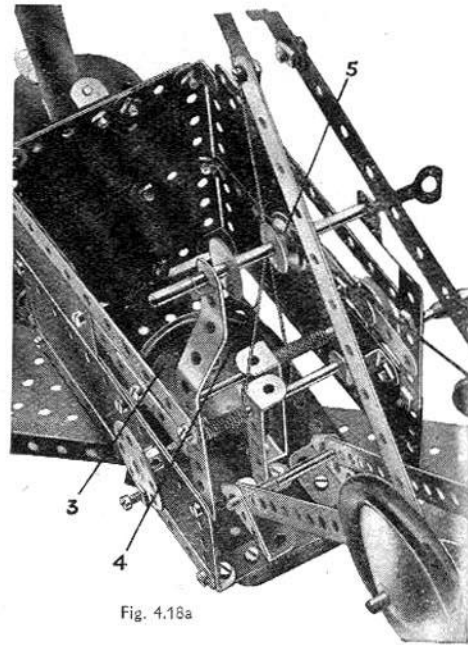

Fig. 4.18a

Double Angle Strip 7 at the top, and by a $\frac{3}{8}$ " Bolt at the bottom, where it is spaced from the cab by three Washers.

The Cord 4 is tied to a $3\frac{1}{2}$ " Rod carrying a Bush Wheel fitted with a $\frac{3}{8}$ " Bolt. It is then passed over the $\frac{1}{2}$ " Pulley 5, and tied to the Double Bracket at the top of the jib. This $\frac{1}{2}$ " Pulley 5 is clamped loosely between two $\frac{3}{8}$ " Washers by two Spring Clips to form a deep-grooved pulley.

The Cord 6 is wound around the Crank Handle and is tied to the Stepped Bent Strip at the top of the dipper stick.

4.19 MOTOR LORRY

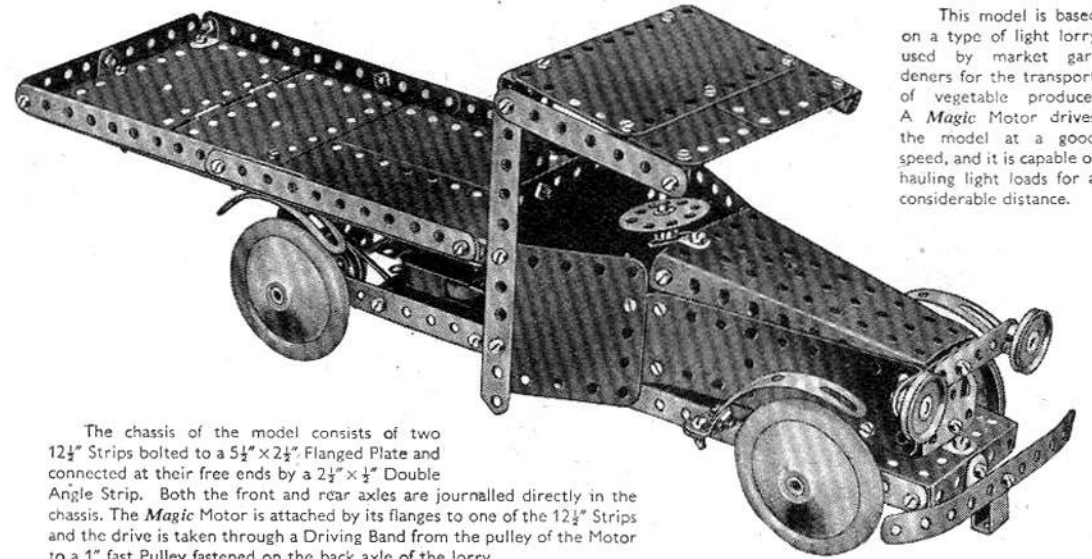

The chassis of the model consists of two $12\frac{1}{2}$ " Strips bolted to a $5\frac{1}{2}$ " \times $2\frac{1}{2}$ " Flanged Plate and connected at their free ends by a $2\frac{1}{2}$ " \times $\frac{1}{2}$ " Double Angle Strip. Both the front and rear axles are journaled directly in the chassis. The *Magic Motor* is attached by its flanges to one of the $12\frac{1}{2}$ " Strips and the drive is taken through a Driving Band from the pulley of the Motor to a 1 " fast Pulley fastened on the back axle of the lorry.

The platform is fixed to the end of the chassis by two $2\frac{1}{2}$ " \times $\frac{1}{2}$ " Double Angle Strips, the ends of which can be seen in Fig. 4.19a, and also to the back of the cab by a $1\frac{1}{2}$ " \times $\frac{1}{2}$ " Double Angle Strip. The front bumper consists of a $5\frac{1}{2}$ " Strip curved to shape and fastened by a Stepped Bent Strip to the $5\frac{1}{2}$ " \times $2\frac{1}{2}$ " Flanged Plate forming the front of the chassis. The head-lamps, which are 1 " Pulleys, are fixed in place by $\frac{3}{8}$ " Bolts pushed through the $2\frac{1}{2}$ " Strips into the bosses of the Pulleys and held by the set-screws.

Note: The Motor used in this model is not included in the Outfit.

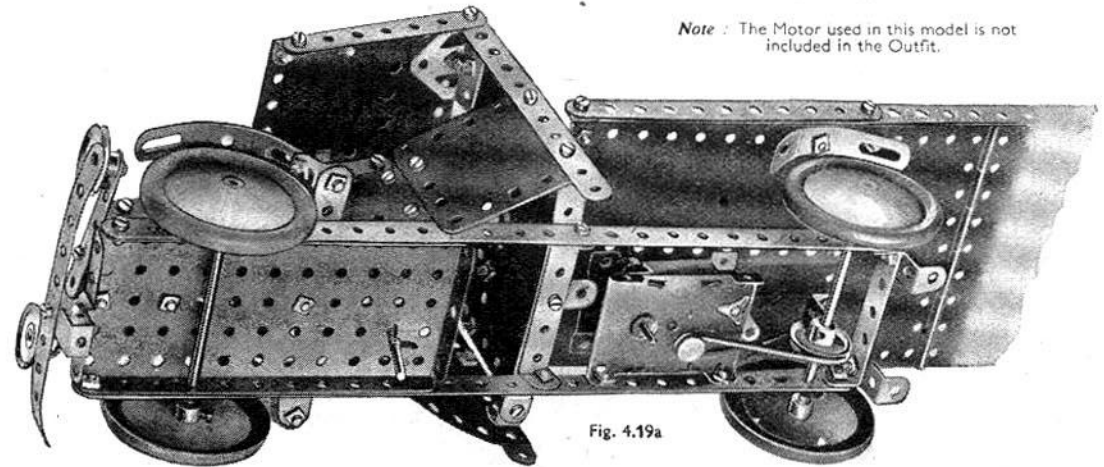

Fig. 4.19a

4.20 AUTOMATIC SLAG DUMPER

The engine house of the model is built up on a $5\frac{1}{2}'' \times 2\frac{1}{2}''$ Flanged Plate 1, extended by two compound strips, one of which is seen at 2. Each of these strips is formed from two $2\frac{1}{2}''$ Strips overlapped three holes. Two Flanged Sector Plates are bolted to the Flanged Plate to provide bearings for the winding mechanism.

Each side of the roof consists of half of a Hinged Flat Plate 3, a $5\frac{1}{2}'' \times 1\frac{1}{2}''$ Flexible Plate 4, a $2\frac{1}{2}'' \times 2\frac{1}{2}''$ Flexible Plate 5 and a $2\frac{1}{2}'' \times 1\frac{1}{2}''$ Flexible Plate 6. The roof is attached to Formed Slotted Strips bolted to the upright $5\frac{1}{2}''$ Strips.

The inclined rails for the tipping truck are formed from two $12\frac{1}{2}''$ Strips bolted to the Sector Plates. The Strips are bolted to Flat Trunnions 7, and are extended by $5\frac{1}{2}''$ Strips connected at their outer ends by a $2\frac{1}{2}'' \times \frac{1}{2}''$ Double Angle Strip. The $5\frac{1}{2}''$ Strips are supported by two $3\frac{1}{2}''$ Strips bolted at their lower ends to the centre holes of two Curved Strips. The Curved Strips are joined by a $2\frac{1}{2}'' \times \frac{1}{2}''$ Double Angle Strip, and they are connected to the Flat Trunnions 7 by $5\frac{1}{2}''$ Strips.

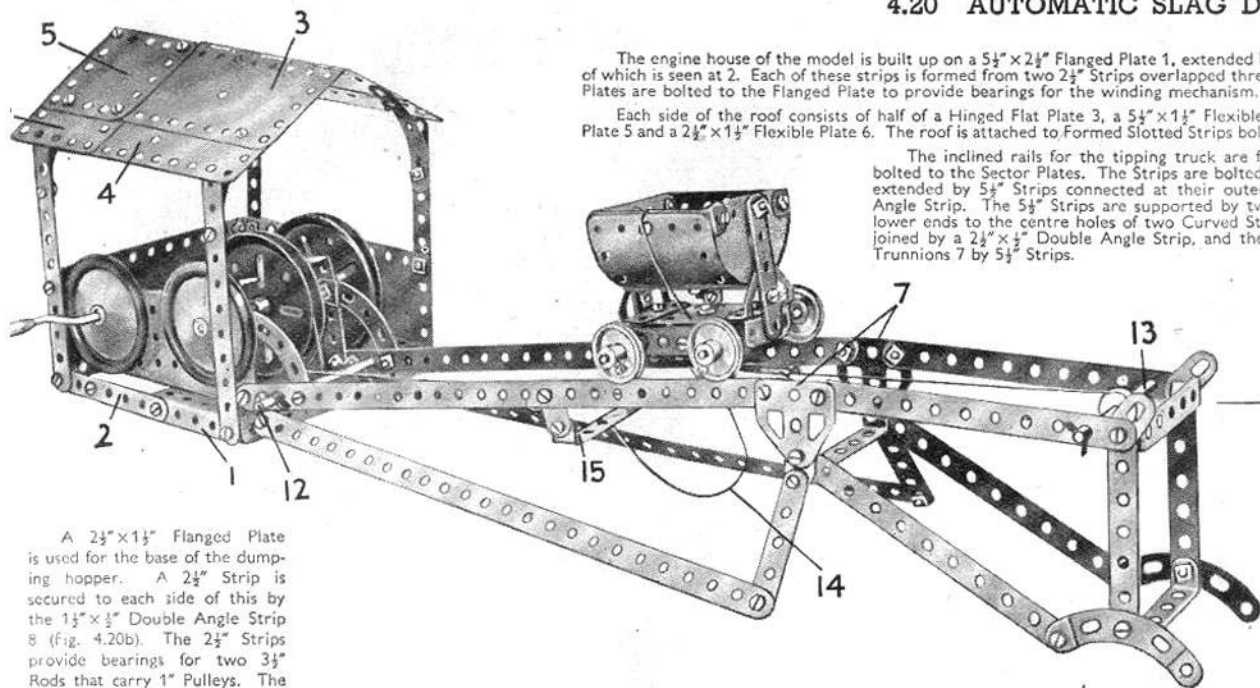

A $2\frac{1}{2}'' \times 1\frac{1}{2}''$ Flanged Plate is used for the base of the dumping hopper. A $2\frac{1}{2}''$ Strip is secured to each side of this by the $1\frac{1}{2}'' \times \frac{1}{2}''$ Double Angle Strip 8 (Fig. 4.20b). The $2\frac{1}{2}''$ Strips provide bearings for two $3\frac{1}{2}''$ Rods that carry 1" Pulleys. The ends of the hopper are Semi-Circular Plates joined by two $2\frac{1}{2}'' \times \frac{1}{2}''$ Double Angle Strips. The two $1\frac{1}{2}''$ radius Curved Plates that form the bottom and sides of the hopper are bolted to the Double Angle Strips.

The hopper is pivoted on $\frac{3}{8}''$ Bolts attached to $2\frac{1}{2}''$ Strips, which are fixed to Trunnions bolted to the $2\frac{1}{2}'' \times 1\frac{1}{2}''$ Flanged Plate.

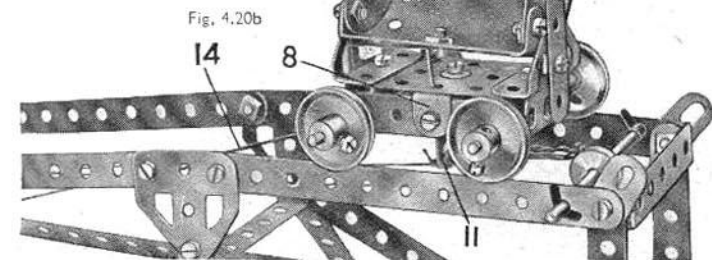

Movement of the hopper is controlled by a Crank Handle fitted with a 1" Pulley 9 (Fig. 4.20a). This Pulley is connected by a belt of Cord to a 3" Pulley fixed on a 4" Rod 10. A length of Cord fastened to a Stepped Bent Strip 11 (Fig. 4.20b) is passed around a second 3" Pulley on Rod 12, and then is taken around a $\frac{1}{2}''$ Pulley on Rod 13 and fastened to a $2\frac{1}{2}''$ Driving Band. The Driving Band is secured to the Stepped Bent Strip.

The hopper is tilted so as to discharge its contents by Cord 14 (Fig. 4.20b). This Cord is tied to a Double Angle Strip 15 and passes through a hole in the base of the hopper truck. It is then fastened to the side of the hopper. The length of this Cord is arranged so that the hopper is tipped when it reaches the limit of its travel.

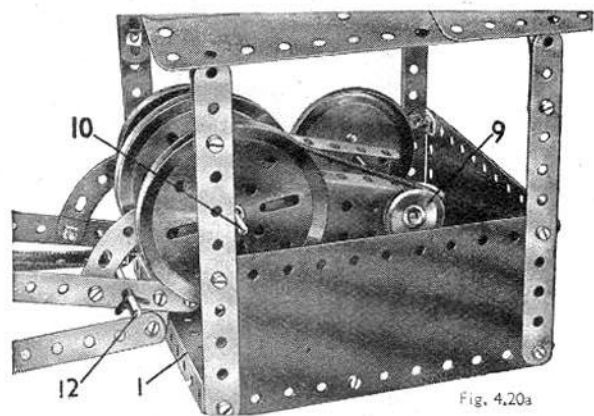
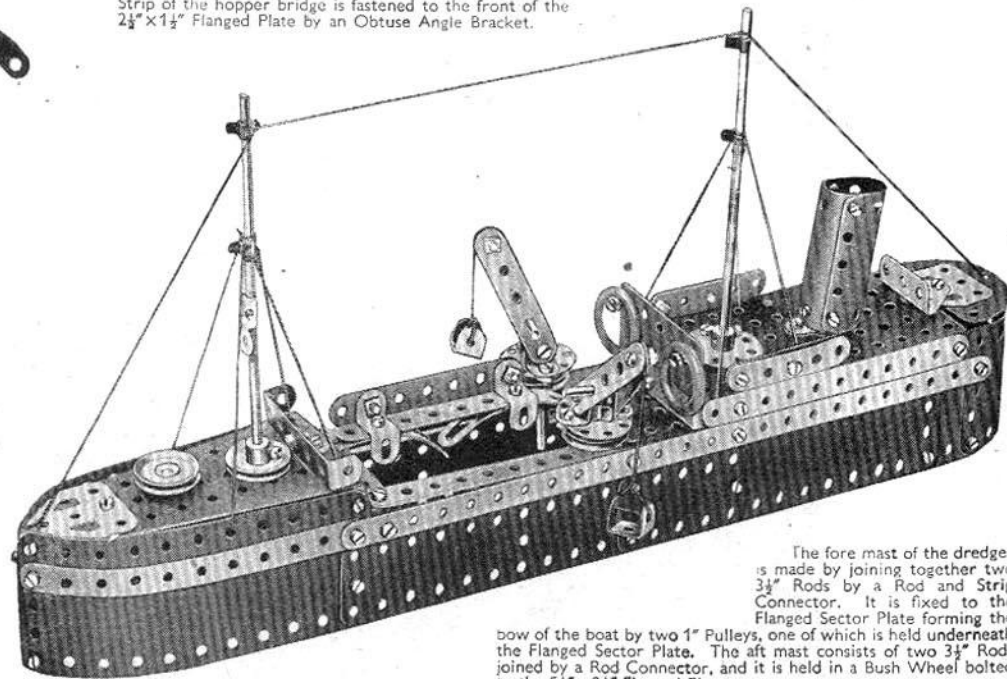

Fig. 4.20a

4.21 DREDGER

A $2\frac{1}{2}'' \times \frac{1}{2}''$ Double Angle Strip is bolted to the front flange of the $5\frac{1}{2}'' \times 2\frac{1}{2}''$ Flanged Plate, and a Semi-Circular Plate is held between the flange and the Double Angle Strip by the same Bolt. The deck-crane consists of a 1" Pulley fastened to a 2" Rod, above which is placed a Wheel Disc fitted with Angle Brackets. The complete units are held in place by Spring Clips. The rear Formed Slotted Strip of the hopper bridge is fastened to the front of the $2\frac{1}{2}'' \times 1\frac{1}{2}''$ Flanged Plate by an Obtuse Angle Bracket.



The fore mast of the dredger is made by joining together two $3\frac{1}{2}''$ Rods by a Rod and Strip Connector. It is fixed to the Flanged Sector Plate forming the bow of the boat by two 1" Pulleys, one of which is held underneath the Flanged Sector Plate. The aft mast consists of two $3\frac{1}{2}''$ Rods joined by a Rod Connector, and it is held in a Bush Wheel bolted to the $5\frac{1}{2}'' \times 2\frac{1}{2}''$ Flanged Plate.

4.22 MOTOR TRICYCLE DELIVERY VAN

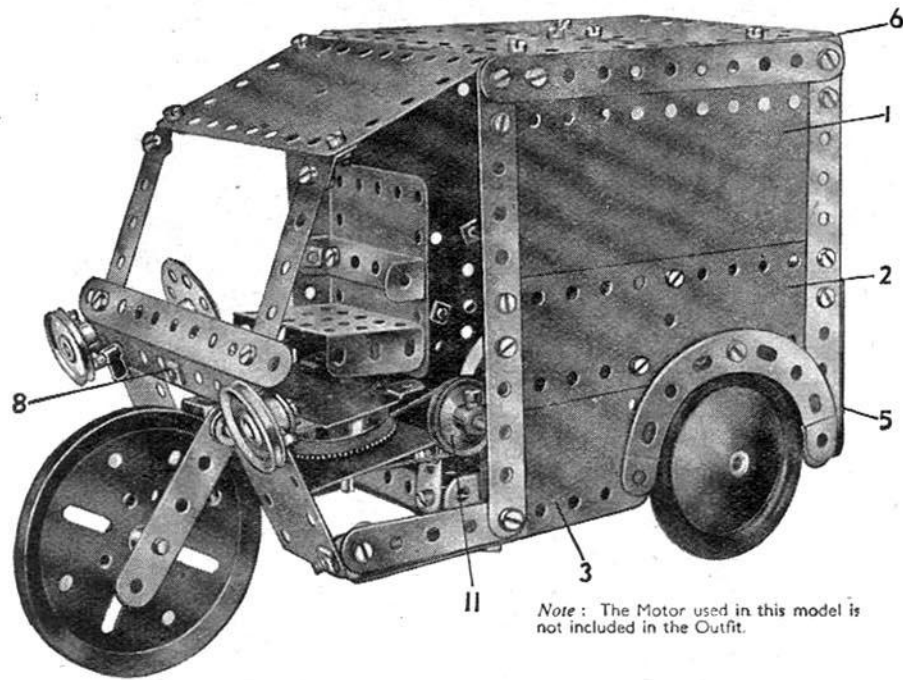

Note: The Motor used in this model is not included in the Outfit.

Each side of the van body consists of a $5\frac{1}{2}'' \times 2\frac{1}{2}''$ Flexible Plate 1, a $5\frac{1}{2}'' \times 1\frac{1}{2}''$ Plate 2 and a $2\frac{1}{2}'' \times 2\frac{1}{2}''$ Plate 3. The sides are attached to the $2\frac{1}{2}''$ Strips 4 (Fig. 4.22a) by Angle Brackets, and to a $4\frac{1}{2}'' \times 2\frac{1}{2}''$ Flexible Plate 5 by a $2\frac{1}{2}'' \times \frac{1}{2}''$ and a $1\frac{1}{2}'' \times \frac{1}{2}''$ Double Angle Strip. The Flexible Plate 5 is bolted to the Flanged Plate forming the chassis of the model.

The roof consists of a Hinged Flat Plate bolted to Angle Brackets, and a $4\frac{1}{2}'' \times 2\frac{1}{2}''$ Flexible Plate attached to $2\frac{1}{2}''$ Double Angle Strips, one of which is shown at 6. The $2\frac{1}{2}''$ Strips used for the side pillars of the wind-screen are attached to the roof and to the Strip 8 by Obtuse Angle Brackets.

The front wheel is locked on a $1''$ Rod passed through two $2\frac{1}{2}''$ Strips. These Strips are bolted to a Double Bracket.

A $\frac{3}{8}''$ Bolt is secured to the Double Bracket by the Nut 7 (Fig. 4.22b). The Bolt is then passed through an Angle Bracket fixed to the $5\frac{1}{2}''$ Strip 8, and a Fishplate 9 is locked to the Bolt by two nuts.

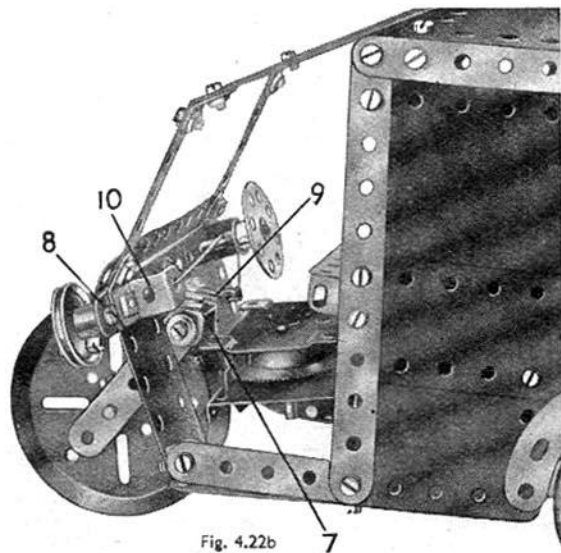

Fig. 4.22b

A Bush Wheel fixed on a $1\frac{1}{2}''$ Rod represents the steering wheel, and the Rod is passed through a Reversed Angle Bracket and the Strip 8. One end of a length of Cord is fastened to the Fishplate 9, and given several turns around the $1\frac{1}{2}''$ Rod. It is then passed through the Reversed Angle Bracket 10 and securely tied to the Fishplate.

The rear wheels are locked on a $4''$ Rod passed through holes in the sides of the $5\frac{1}{2}'' \times 2\frac{1}{2}''$ Flanged Plate.

The *Mag's* Motor is fastened to the Flanged Plate by two Fishplates, and the drive is taken from it to a $1''$ Pulley 11. This Pulley is locked on a $3\frac{1}{2}''$ Rod that rotates in Flat Trunnions secured to the Flanged Plate. A $\frac{1}{2}''$ Pulley on the same Rod is connected by a Driving Band to a $1''$ Pulley on the back axle.

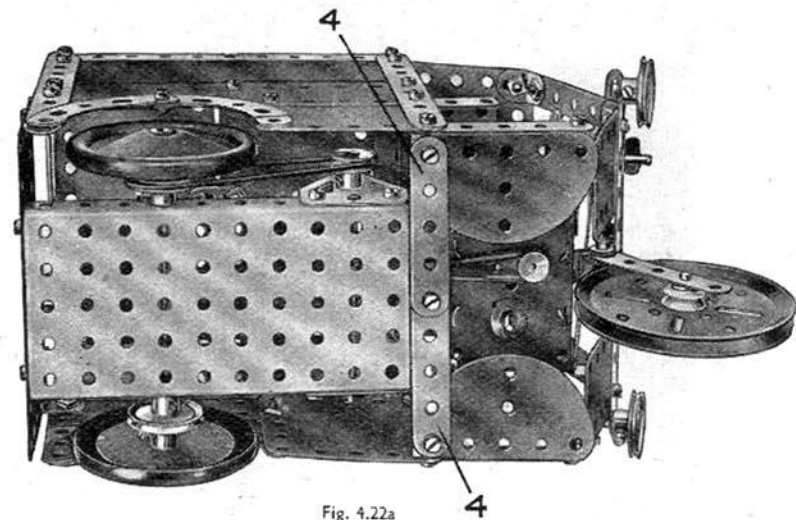
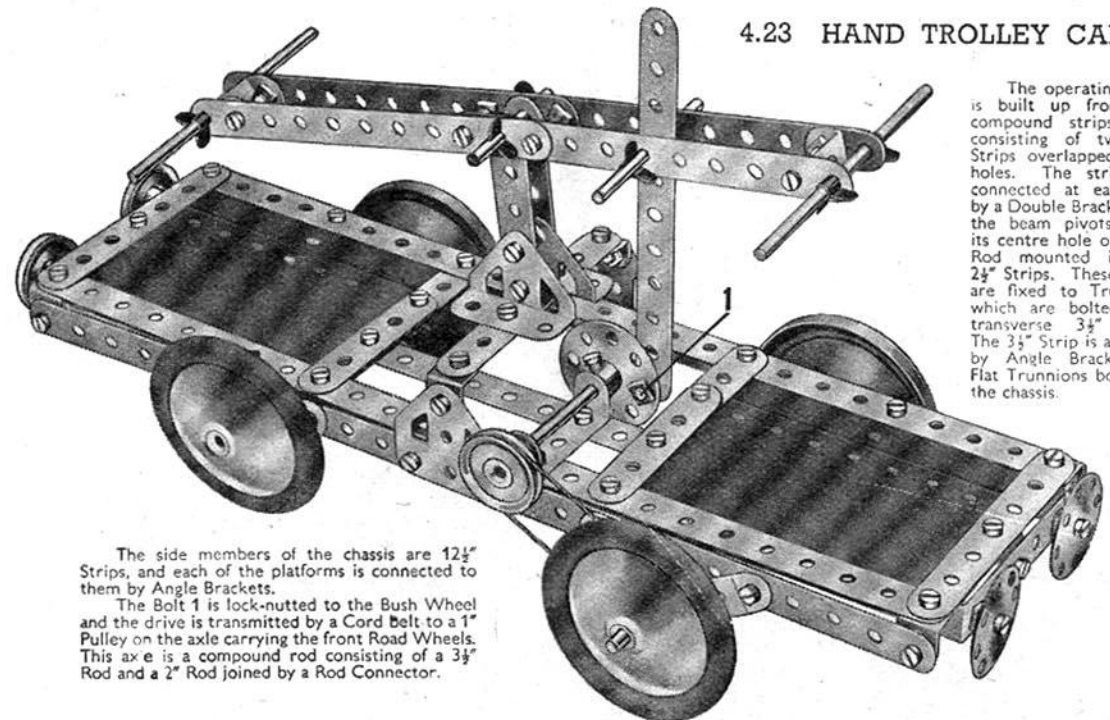

Fig. 4.22a

4.23 HAND TROLLEY CAR



The operating beam is built up from two compound strips, each consisting of two $5\frac{1}{2}''$ Strips overlapped three holes. The strips are connected at each end by a Double Bracket, and the beam pivots about its centre hole on a $1\frac{1}{2}''$ Rod mounted in two $2\frac{1}{2}''$ Strips. These Strips are fixed to Trunnions which are bolted to a transverse $3\frac{1}{2}''$ Strip. The $3\frac{1}{2}''$ Strip is attached by Angle Brackets to Flat Trunnions bolted to the chassis.

The side members of the chassis are $12\frac{1}{2}''$ Strips, and each of the platforms is connected to them by Angle Brackets.

The Bolt 1 is lock-nutted to the Bush Wheel and the drive is transmitted by a Cord Belt to a $1''$ Pulley on the axle carrying the front Road Wheels. This axle is a compound rod consisting of a $3\frac{1}{2}''$ Rod and a $2''$ Rod joined by a Rod Connector.

4.24 DUMPER TRUCK

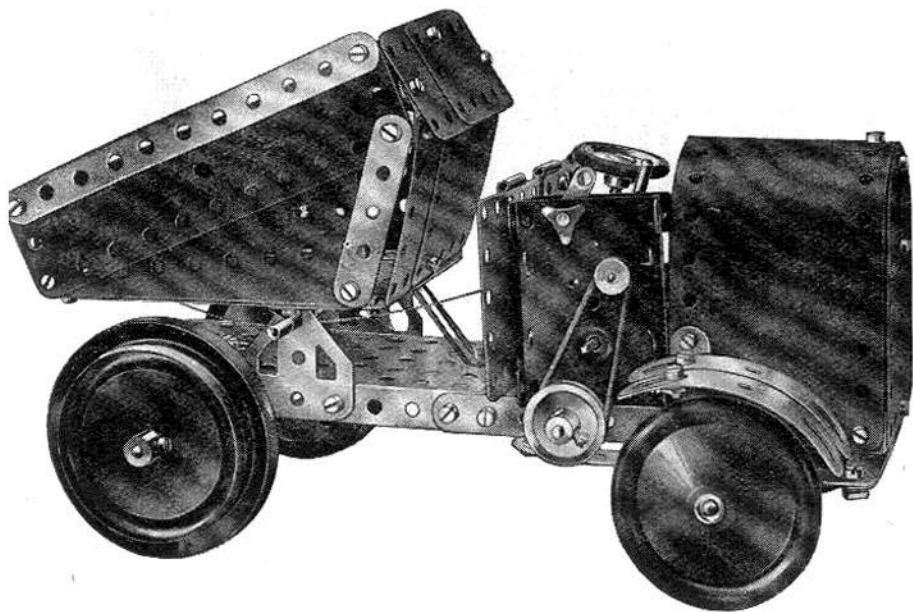

A $3\frac{1}{2}$ " Strip 3 (Fig. 4.24a) is bolted to a Double Angle Strip secured to the Strips 1. The $2\frac{1}{2}$ " Strips 4 and the Double Brackets 5 are free to turn on $\frac{1}{8}$ " Bolts fixed to the Strip 3 by two nuts. The Strips 4 are connected together by a $3\frac{1}{2}$ " Strip held by lock-nuts. Two Road Wheels are locked on $1\frac{1}{2}$ " Rods passed through the Double Brackets.

The steering column is a 4" Rod, which is passed through the Trunnion 6 and the $2\frac{1}{2}$ " x $1\frac{1}{2}$ " Flanged Plate. A Fishplate bolted to a Bush Wheel on this Rod is connected by a Curved Strip and lock-nuts to a $2\frac{1}{2}$ " Strip 7.

The driving axle is supported in Curved Strips bolted to the Flanged Plate, and consists of a $3\frac{1}{2}$ " and a 2" Rod joined by a Rod Connector.

Each side of the load carrier is formed by a Flanged Sector Plate and a $5\frac{1}{2}$ " x $1\frac{1}{2}$ " Flexible Plate. Its bottom consists of two $4\frac{1}{2}$ " x $2\frac{1}{2}$ " Flexible Plates overlapped three holes and bolted together. The back is made from two $1\frac{1}{2}$ " radius Curved Plates and two $2\frac{1}{2}$ " x $1\frac{1}{2}$ " Flexible Plates attached to the sides and bottom by Angle Brackets and Obtuse Angle Brackets. The load carrier pivots about a $3\frac{1}{2}$ " Rod, which is passed through Flat Trunnions bolted to the chassis and through an Angle Bracket fixed on each side of the carrier. One of the Angle Brackets is shown at 8.

The chassis consists of a $5\frac{1}{2}$ " x $2\frac{1}{2}$ " Flanged Plate extended by the $5\frac{1}{2}$ " Strips 1. These Strips are connected together by a $2\frac{1}{2}$ " x $\frac{1}{2}$ " Double Angle Strip 2 (Fig. 4.24b). The front of the driver's compartment is formed by half of a Hinged Flat Plate, which is attached to the end of the Flanged Plate by a Fishplate.

The engine housing is formed by two $5\frac{1}{2}$ " x $2\frac{1}{2}$ " Flexible Plates bolted to the Strips 1 and bent over and joined together at the top. The front and rear of the housing each consists of a Semi-Circular Plate and a $2\frac{1}{2}$ " x $2\frac{1}{2}$ " Flexible Plate. A $2\frac{1}{2}$ " x $1\frac{1}{2}$ " Flanged Plate forms the floor of the driver's compartment, and the seat is represented by a Trunnion bolted to a $1\frac{1}{2}$ " x $\frac{1}{2}$ " Double Angle Strip.

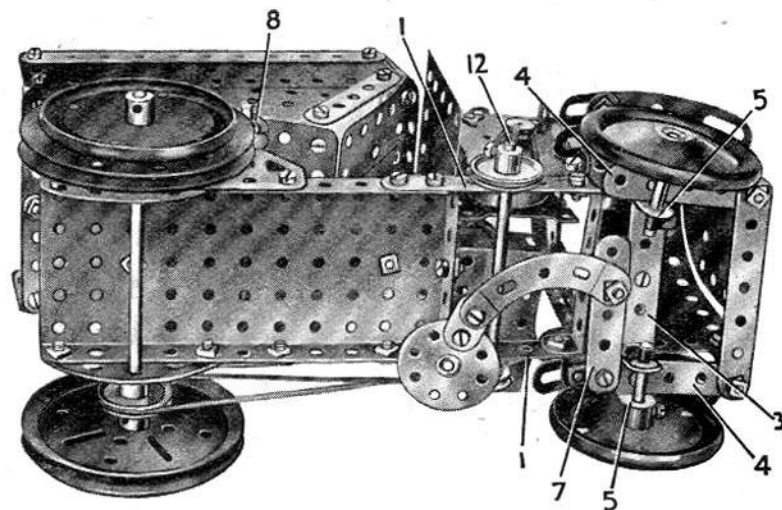

Fig. 4.24a

The mudguard over each of the rear wheels is represented by two Formed Slotted Strips. These are joined together by a Fishplate, and attached to the side of the engine housing by an Angle Bracket.

The carrier is tipped for unloading by a 2" Rod 9, held in a Rod and Strip Connector that is lock-nutted to the side of the $2\frac{1}{2}$ " x $1\frac{1}{2}$ " Flanged Plate. A length of Cord from this Rod passes through the Obtuse Angle Bracket 10, and is fastened to the front of the carrier. The carrier is returned to its normal position by the $2\frac{1}{2}$ " Driving Band 11.

The Magic Motor is bolted to a Fishplate attached to the chassis. The drive from the Motor is taken to a 1" Pulley on Rod 12, and a $\frac{1}{2}$ " Pulley on the same Rod drives a 1" Pulley on the driving axle through a crossed Driving Band 4.

Note: The Motor used in this model is not included in the Outfit.

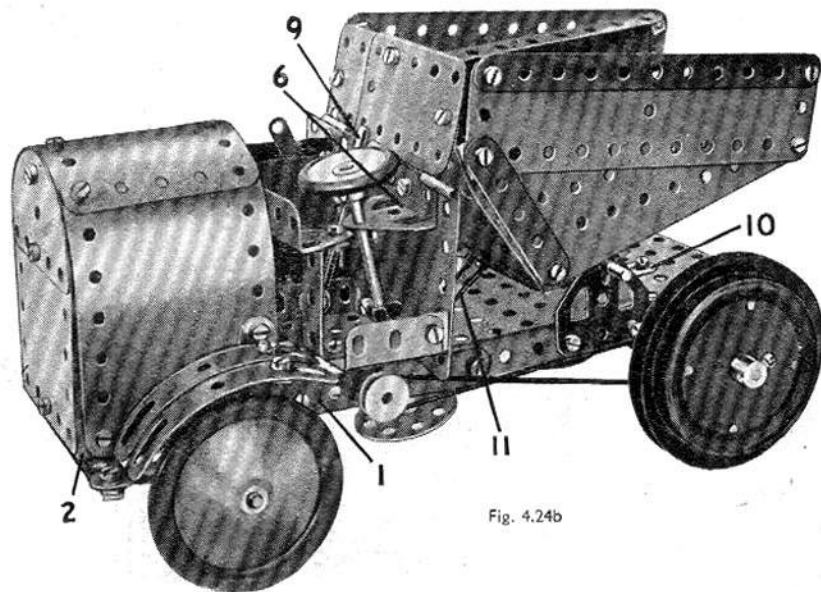

Fig. 4.24b

4.25 AUTOMATIC SHIP COALER

This fine model represents a type of high-speed coaler used for the automatic coaling of large ships. The coal is raised by a grab, which is then unloaded into a hopper truck. The truck travels along the elevated rails, and discharges its contents into a chute leading direct into the ship's coal bunkers.

The tower is built from four $12\frac{1}{2}$ " Strips bolted to a $5\frac{1}{2}$ " x $2\frac{1}{2}$ " Flanged Plate that forms the base. Two $5\frac{1}{2}$ " Strips 1 are bolted across the ends of the Flanged Plate to give stability. The plates 2 are obtained by removing the pin from a Hinged Flat Plate and using each half separately. The top of the tower is formed from two $5\frac{1}{2}$ " x $2\frac{1}{2}$ " Flexible Plates 3 attached to the $12\frac{1}{2}$ " Strips by Obtuse Angle Brackets. The rails on which the dumper truck travels are attached to the tower by $2\frac{1}{2}$ " x $\frac{1}{2}$ " Double Angle Strips, but they are spaced from the Double Angle Strips by a nut on each bolt. The rails are each made from two $5\frac{1}{2}$ " Strips overlapped five holes.

The Rod carrying the 3" Pulleys 4 is passed through the ends of $3\frac{1}{2}$ " Strips 5.

The dumper truck is made up from two $2\frac{1}{2}$ " x $2\frac{1}{2}$ " Curved Plates and two Semi-Circular Strips joined together by $2\frac{1}{2}$ " x $\frac{1}{2}$ " Double Angle Strips and pivoted by $\frac{3}{8}$ " Bolts on $2\frac{1}{2}$ " Strips 6 (Fig. 4.25a). The truck base is a $2\frac{1}{2}$ " x $1\frac{1}{2}$ " Flanged Plate, and a Double Bracket is bolted to the centre of each flange to provide bearings for $3\frac{1}{2}$ " Rods fitted with 1" Pulleys. Cord is tied to one axle, and is passed through the Angle Bracket 7, over Rod 8, and then wound around Rod 9, which carries a Bush Wheel. The other end of the Cord is passed over the Rod 8, threaded through the Angle Bracket 10, and then attached to the other axle of the truck.

A piece of Cord 11 is attached to one side of the body of the truck and then is passed through the Flanged Plate and tied to the side of the tower, as shown in Fig. 4.25b. The Cord is adjusted so that the body of the truck is tipped sideways when it reaches the chute.

The Cords that operate the grab are passed over the 3" Pulleys 4, then over the Rod 12, and finally are wound around the Crank Handle.

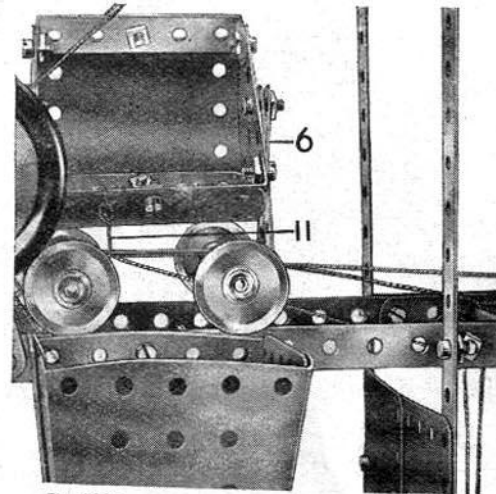
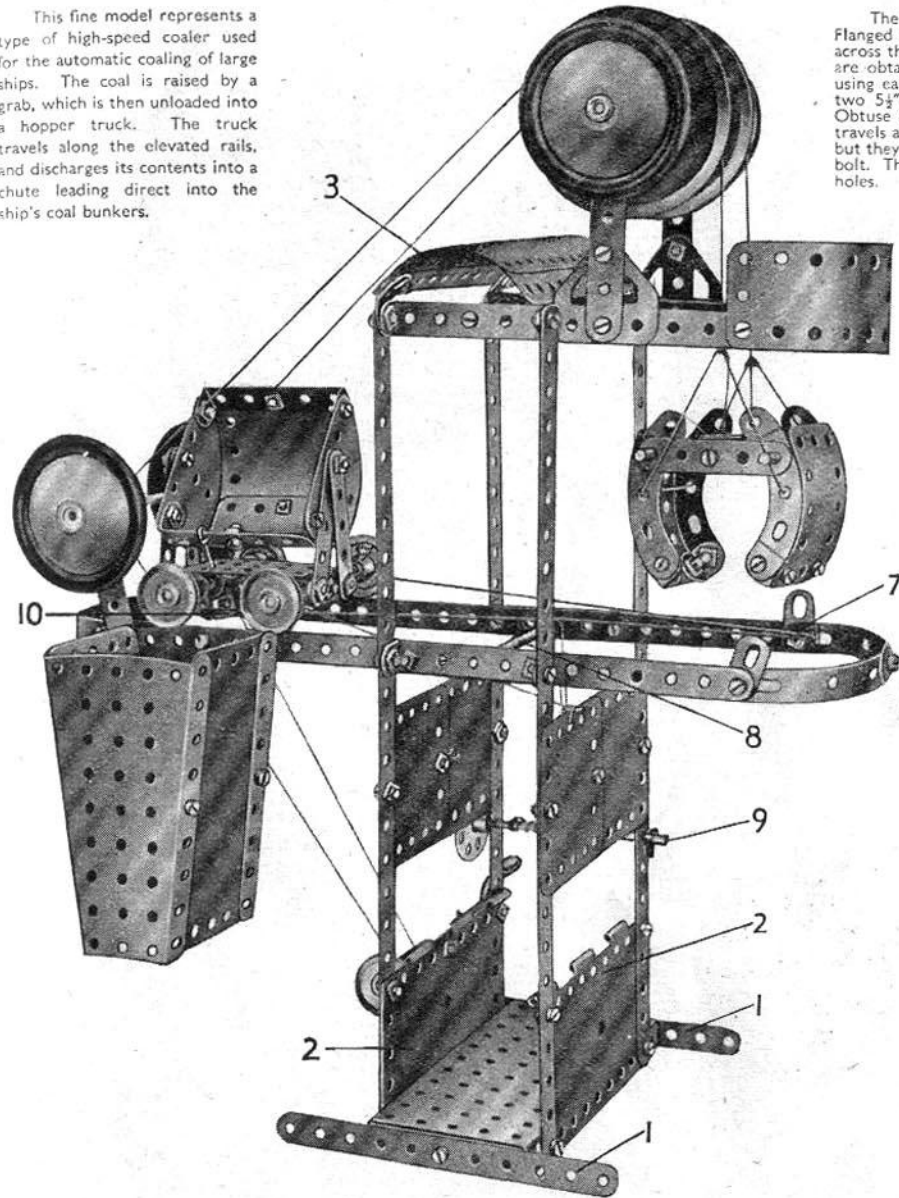

Fig. 4.25b

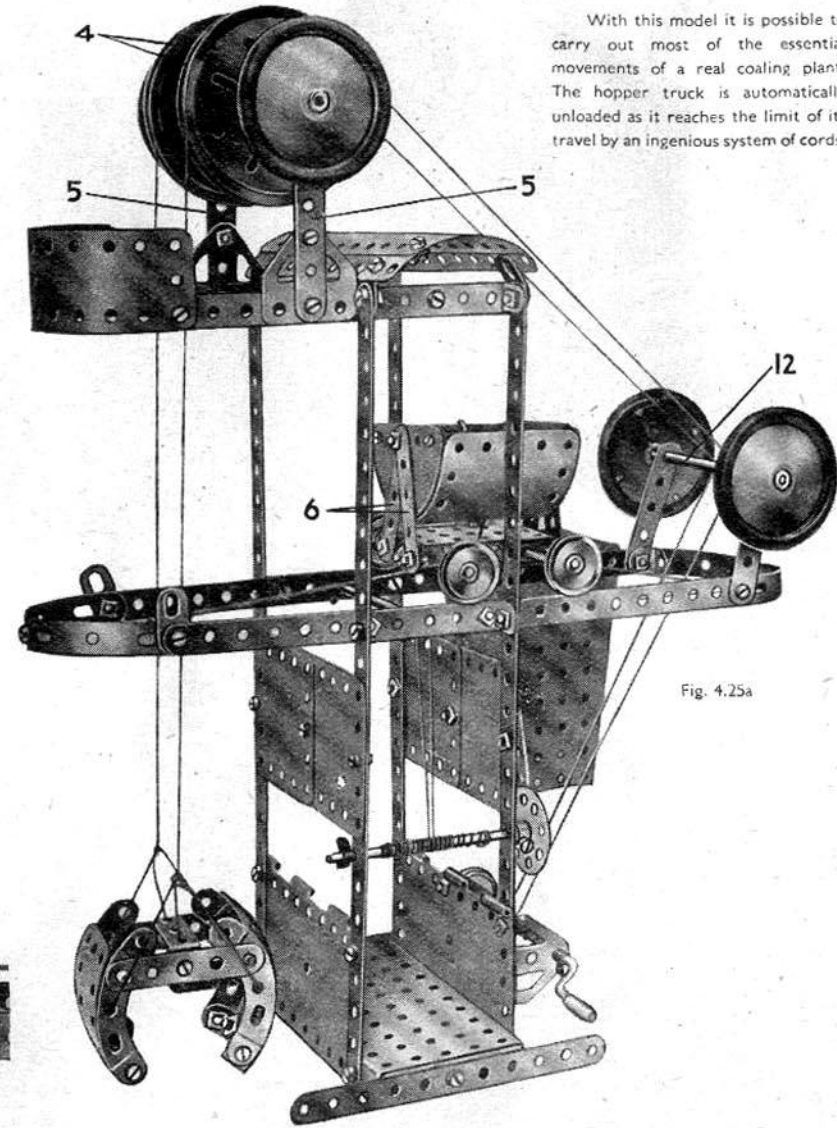

Fig. 4.25a

With this model it is possible to carry out most of the essential movements of a real coaling plant. The hopper truck is automatically unloaded as it reaches the limit of its travel by an ingenious system of cords.

BUILD BIGGER AND BETTER MODELS

When you have built all the models shown in this Book of Instructions, you will be keen to build bigger and more elaborate models. Your next step is to purchase a Meccano No. 4a Accessory Outfit containing all the parts required to convert your No. 4 into a No. 5 Outfit. You will then be able to build the full range of No. 5 Outfit models, a selection of which is illustrated on this page.

If you prefer to do so, you can build up and develop your Outfit quite easily by adding various parts to it from time to time. The model-building possibilities of the Meccano System are unlimited, and the more Meccano parts you have the bigger and better the models you will be able to build.

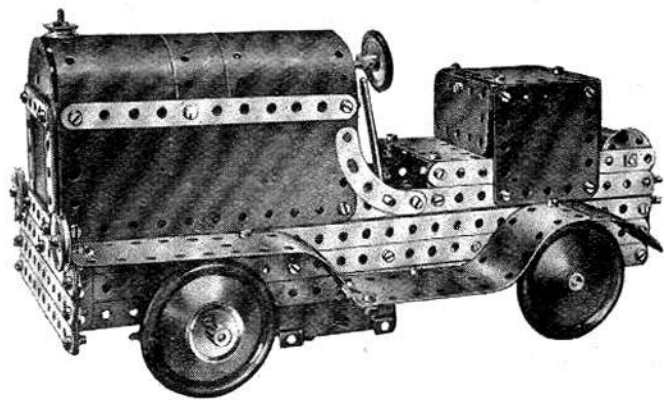
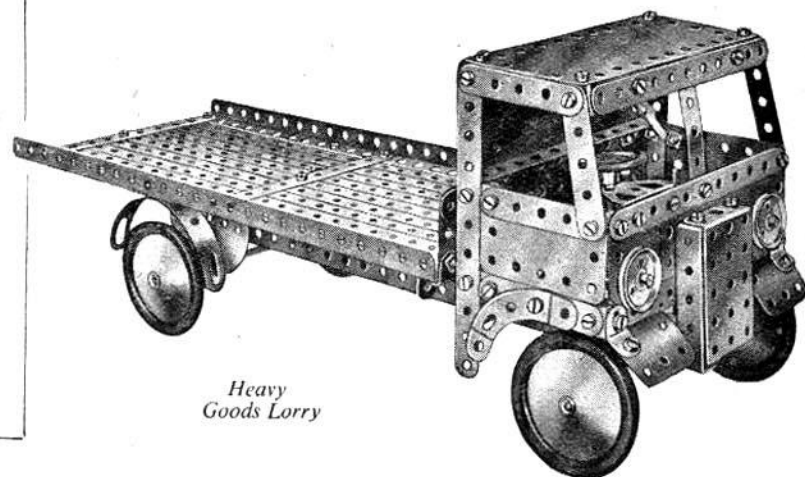
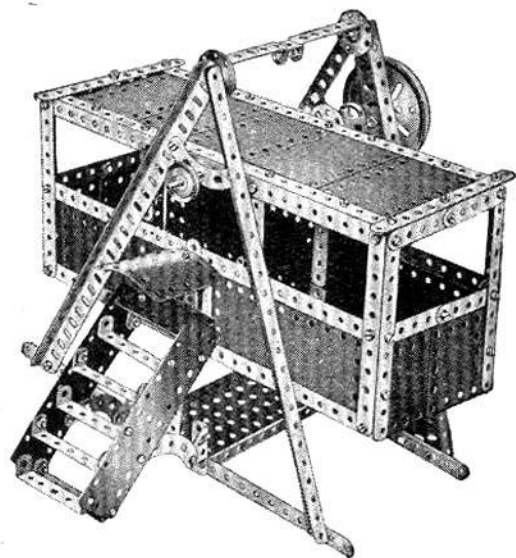
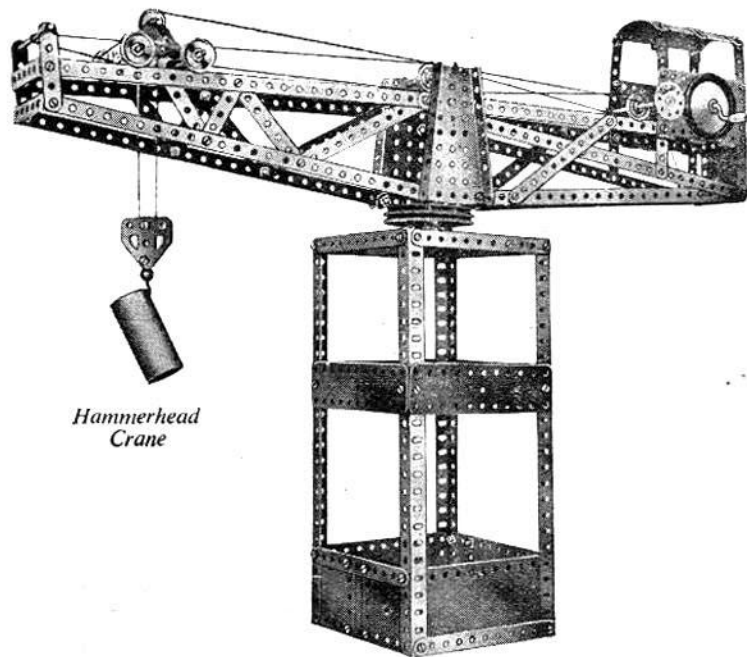
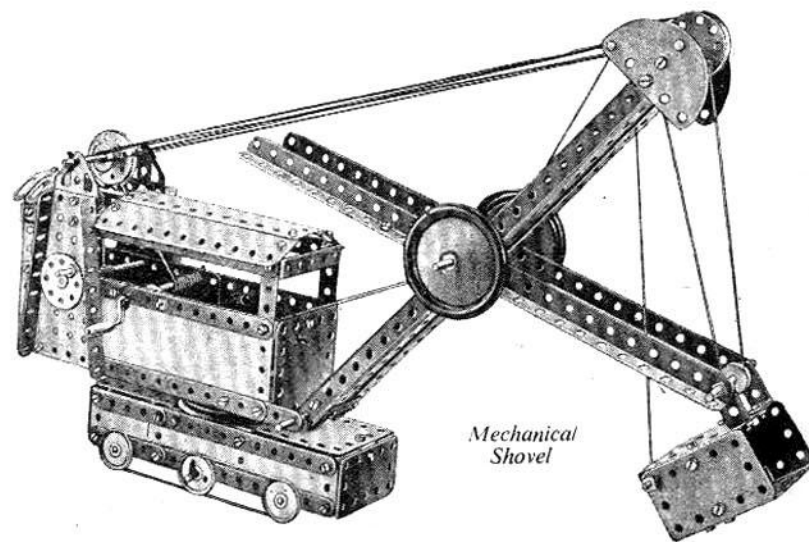
*Industrial Tractor**Heavy Goods Lorry**Giant Swing Boat**Hammerhead Crane**Mechanical Shovel*

Here are a few simple and interesting movements showing how easily real mechanisms can be reproduced with Meccano.

USEFUL BAND BRAKE

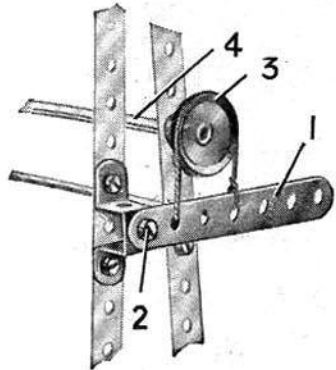

S.M.111. The brake lever consists of a $3\frac{1}{2}$ " Strip 1, pivotally attached at a suitable point on the frame of the model, to be fitted, by means of a lock-nutted $\frac{3}{8}$ " Bolt 2. The driven shaft 4 is fitted at one end with a 1" fast Pulley 3 round which a short length of cord is passed. The two ends of this Cord are secured to the brake lever at the points shown in the illustration.

If increased braking effect is desired a larger Pulley may be used in place of the 1" fast Pulley 3, the brake lever 1 being attached in a lower position if necessary. Alternatively a weight can be hung from the end of the brake lever.

BUILT UP ROLLER BEARING

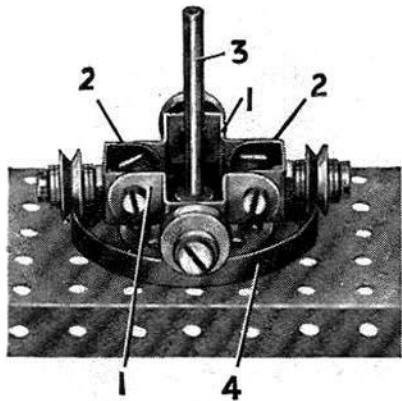

S.M.136. The spider frame is built up from Double Bent Strips 1 connected together by two Double Brackets 2. The four wheels used are represented by $\frac{1}{2}$ " loose Pulleys journalled on Pivot Bolts secured to the outer ends of the four arms of the frame. Four Washers, two on each side of the Pulleys are passed on to the shank of each of the Pivot Bolts that are attached to the Double Brackets 2. In the case of the other two Pivot Bolts, two Washers are placed against the external side only of the Pulley.

SIMPLE STEERING GEAR

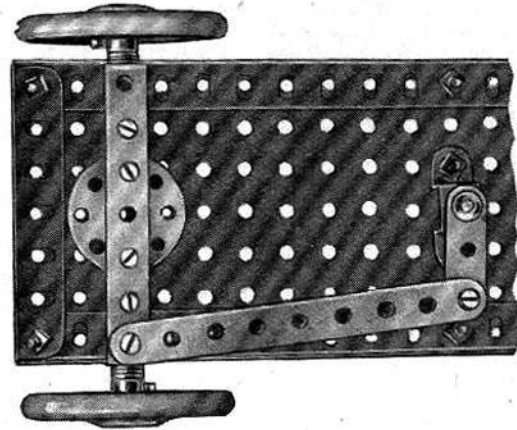

S.M.162. The simple steering gear will be found suitable for most small model vehicles.

In this example the two front wheels are mounted on separate stub axles that are secured to each end of a rigid front axle. The base of the chassis consists of two long Angle Girders connected together at the front end by a $3\frac{1}{2}$ " Angle Girder and filled in along their length by means of $5\frac{1}{2}$ " x $3\frac{1}{2}$ " Flat Plates.

The front axle, a $3\frac{1}{2}$ " x $\frac{1}{2}$ " Double Angle Strip, is pivotally mounted at its centre on a Bush Wheel and short Rod. It is fitted, $\frac{1}{2}$ " from each end, with a $\frac{1}{2}$ " x $\frac{1}{2}$ " Angle Bracket, this forming the inner bearing for its respective stub axle. The outer bearing for the axle consists of the upturned lug of the Double Angle Strip. One end of this latter part is fitted with a pivotally attached $4\frac{1}{2}$ " Strip, by means of which the front axle is linked up to a Crank fixed to the steering column.

SAFETY CATCH FOR CRANE WINDING GEAR

S.M.125. The Compression Spring 3 is mounted on the Crank Handle 1 between the Collar 4 and a Washer, and normally holds the Collar 2 against the inner side of the plate. The Collar 2 is fitted with a $\frac{3}{8}$ " Bolt, and if the Crank Handle commences to rotate, the head of this Bolt strikes against the stop 5 and prevents further movement.

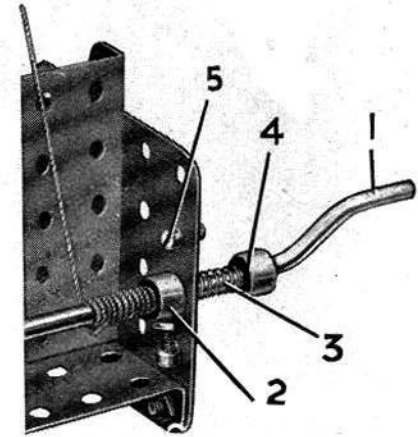

BRAKE LEVER and QUADRANT

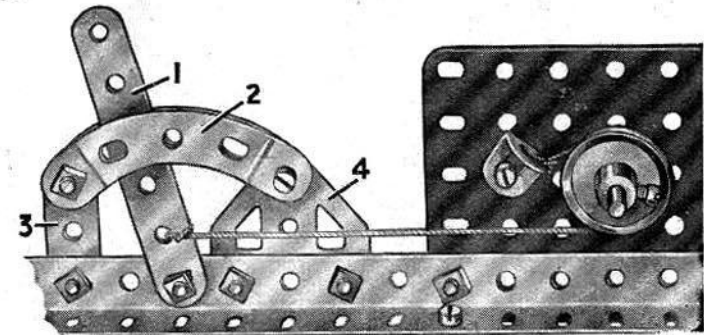

S.M.112. This mechanism is a form of band brake in which the lever 1 can be held in any position by means of the quadrant 2. In this way varying pressures can be applied to the Pulley forming the brake drum.

One end of the brake Cord is attached to a $\frac{1}{2}$ " x $\frac{1}{2}$ " Angle Bracket bolted in a suitable position on the model. After passing round the 1" fast Pulley forming the brake drum the Cord is secured at the next to bottom hole of a 3" Strip 1. This Strip forms the brake lever, and it is secured to the frame of the model by a lock-nutted Bolt.

More useful Mechanisms made with Meccano parts

SMOOTH MOVEMENT CAM

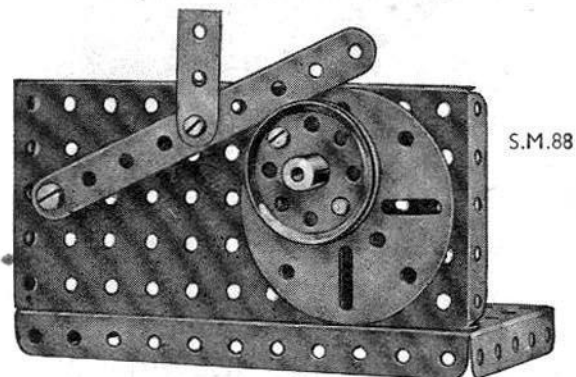

S.M.88

S.M.88. The cam disc consists of a $1\frac{1}{2}$ " Pulley attached by a nut and bolt to a Face Plate. The Rod on which this Face Plate is fixed is journaled in one of the holes of the vertical Plate, and also in the boss of a Double Arm Crank. The end of the Rod passes for a distance of about $\frac{1}{8}$ " through the boss of the Face Plate. This shaft extension also passes through the inner hole of the $1\frac{1}{2}$ " Pulley, and so prevents the part from twisting on its retaining bolt.

The tappet arm is represented by a $4\frac{1}{2}$ " Strip carrying at its fixed end a Crank. A Pivot Bolt passes through this Crank and is locked to the vertical Plate by two nuts. The edge of the tappet arm rests in the groove of the $1\frac{1}{2}$ " Pulley, the movement due to the rise and fall of the cam being transmitted to the desired point by a Strip pivotally attached to the tappet as shown.

USEFUL CAM MECHANISM

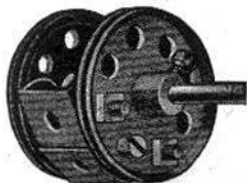

S.M.82

S.M.82. Cams are used for a large number of purposes in Meccano model-building and almost any design is possible. A typical example is shown in S.M.88 on this page. Tappet rods for use with the cam may consist simply of the edge of a Strip, or, for more

accurate work, a small roller carried at one end of a Rod or Strip. A small Flanged Wheel or Pulley can be used for this roller.

The illustration above shows a neat cam designed for use where very rapid action is not required. Each side consists of a $1\frac{1}{2}$ " Pulley or Bush Wheel and these are connected by three Double Brackets. In order to prevent the rims of the Pulleys from damage, a Washer is placed on the shank of each Bolt between the Pulleys and Double Brackets.

SLIDE CRANK MOVEMENT

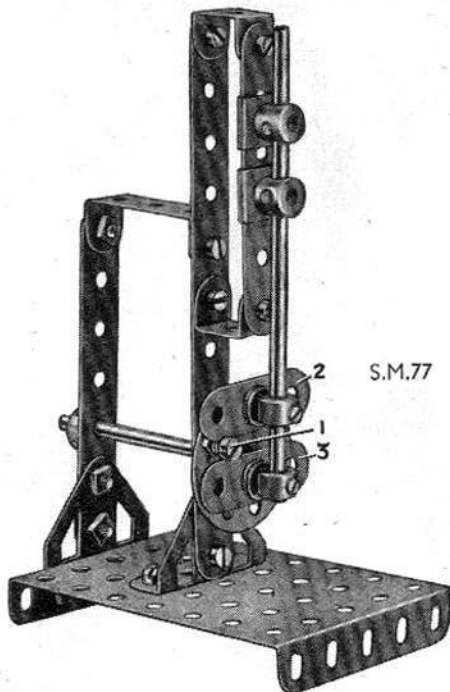

S.M.77

S.M.77. The mechanism shown above is an ingenious device for converting rotary to linear motion without the use of the usual type of crank and connecting rod.

The $5\frac{1}{2}$ " Strip carries at its upper end a Double Bracket and a second similar part at a point 3" from its lower end. The two outer flanges of these Brackets support a 3" Strip on which two Slide Pieces move.

The two Slide Pieces are arranged about $\frac{1}{2}$ " apart on a 5" Rod and are fixed in position by grub-screws. The lower end of the Rod carries two Collars fitted with Strips 2 and 3 respectively. Bolts fitted with two Washers each form the necessary connections. The inner edges of the two Strips are arranged so that the shank of a $\frac{3}{8}$ " Bolt 1 fits snugly between them without jamming. This Bolt is attached to a Bush Wheel by two nuts, the shaft on which the Bush Wheel is fitted forming the crankshaft.

FRONT AXLE TRACTOR MOUNTING

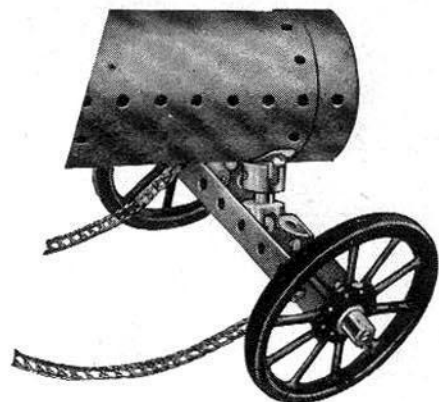

S.M.179

S.M.179. This front axle is built up from two $3\frac{1}{2}$ " Angle Girders bolted together to form a channel section, the Rods that carry the road wheels being journaled in Double Brackets. The central pivot is in two parts, a Handrail Support secured to the front axle and a Socket Coupling that is attached to the boss of a Double Arm Crank bolted to the underside of the boiler. The Handrail Support rests in the recess in the lower end of the Socket Coupling and is retained in place by two $\frac{1}{2}$ " x $\frac{1}{2}$ " Angle Brackets that are fixed to the front axle as shown.

CENTRIFUGAL GOVERNOR

S.M.102. This governor is designed primarily for use in slow running stationary engines.

The governor rod carries at its upper end a Bush Wheel, to the under side of which two Double Brackets are attached. Each of these Double Brackets is fitted with $1\frac{1}{2}$ " Strips pivotally attached, the lower holes of these being connected to further $1\frac{1}{2}$ " Strips.

The Rods linking these Strips, carry $1\frac{1}{8}$ " Flanged Wheels representing the governor weights. The lower ends of the second set of $1\frac{1}{2}$ " Strips are lock-nutted to Double Brackets bolted to the upper face of a pair of 2" Pulleys that are free to slide on the Rod. These Pulleys are fixed together by $\frac{1}{2}$ " Bolts, sufficient space being left between them to allow the shank of a Bolt to pass. This Bolt is secured to one end of the governor arm.

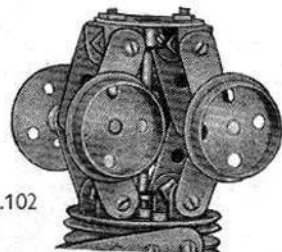

S.M.102

MECCANO PARTS

No. 120b. Compression Spring, $\frac{3}{8}$ " long



120^a



122

122. Miniature Loaded Sack



123

123. Cone Pulley, $1\frac{1}{2}$ ", 1" and $\frac{3}{4}$ " diam.



125

124. Reversed Angle Bracket, 1"

125. " " " $\frac{1}{2}$ "



126

126. Trunnion



126^a

126a. Flat Trunnion



127

127. Bell Crank



128

128. Bell Crank, with Boss



129

129. Toothed Segment, $1\frac{1}{2}$ " radius

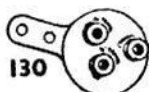

130

130. Eccentric, Triple Throw, $\frac{1}{4}$ ", $\frac{3}{8}$ " and $\frac{1}{2}$ "



130^a

130a. Eccentric, Single Throw, $\frac{1}{4}$ "



131

131. Dredger Bucket



132

132. Flywheel, $2\frac{1}{2}$ " diam.



133

133. Corner Bracket, $1\frac{1}{2}$ "



133^a

133a. " " 1"



134

No. 134. Crank Shaft, 1" stroke



136

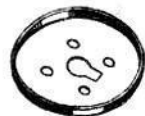

137

136. Handrail Support
136a. Handrail Coupling
137. Wheel Flange



136^a

138a. Ship Funnel



138^a

139. Flanged Bracket (right)

139a. " " (left)



139

140. Universal Coupling



142

142. Rubber Ring (to fit 3" diam. rim)



142^a

142a. Motor Tyre (to fit 2" diam. rim)

142b. " " " 3" "

142c. " " " 1" "

142d. " " " $1\frac{1}{2}$ " "



143

143. Circular Girder, $5\frac{1}{2}$ " diam.



144

No. 144. Dog Clutch

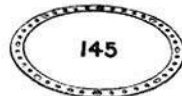

145

145. Circular Strip, $7\frac{1}{2}$ " diam. overall

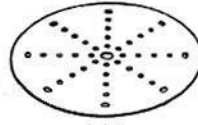

146

146. " Plate 6" "

146a. " " 4" "



147 & 148

147. Pawl, with Pivot Bolt and Nuts

147a. Pawl

147b. Pivot Bolts with 2 Nuts

147c. Pawl without boss

148. Ratchet Wheel



151

151. Pulley Block, Single Sheave

152. " " Two "

153. " " Three "



154^a & 154^b

154a. Corner Angle Bracket, $\frac{1}{4}$ " (right-hand)

154b. Corner Angle Bracket, $\frac{1}{4}$ " (left-hand)

155. Rubber Ring (for 1" Pulleys)



157

157. Fan, 2" diam.



160

160. Channel Bearing, $1\frac{1}{2}$ " x 1 " x $\frac{1}{2}$ "

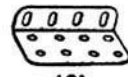

161

161. Girder Bracket, 2 " x 1 " x $\frac{1}{2}$ "

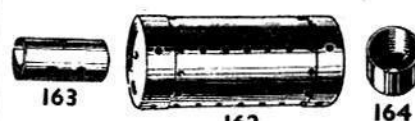

163

162

164

No. 162. Boiler, complete, 5" long x $2\frac{1}{4}$ " diam.
162a. " Ends, $2\frac{1}{4}$ " diam. x $\frac{1}{4}$ "
162b. " without ends, $4\frac{1}{2}$ " long x $2\frac{1}{4}$ " diam.
163. Sleeve Piece, $1\frac{1}{2}$ " long x $\frac{1}{4}$ " diam.
164. Chimney Adaptor, $\frac{3}{8}$ " diam. x $\frac{1}{4}$ " high



165

165. Swivel Bearing



166

166. End

167b. Flanged Ring, $9\frac{3}{8}$ " diam.

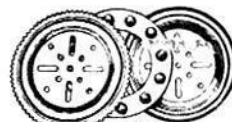

168

168. Ball Bearing, 4" diam.
168a. " Race, flanged disc, $3\frac{1}{2}$ " diam.
168b. " " toothed " 4" diam.
168c. " Cage, $3\frac{1}{2}$ " diam., complete with balls.



171

171. Socket Coupling



175

175. Flexible Coupling Unit



176

176. Anchoring Spring for Cord



179

179. Rod Socket
180. Gear Ring, $3\frac{1}{2}$ " diam. (133 ext. teeth, 95 int.)

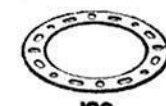

180



185

No. 185. Steering Wheel, $1\frac{1}{2}$ " diam.

186. Driving Band, $2\frac{1}{2}$ " (Light)

186a. " " 6" "

186b. " " 10" "

186c. " " 10" (Heavy)

186d. " " 15" "

186e. " " 20" "

187. Road Wheel, $2\frac{1}{2}$ " diam.

187a. Conical Disc, $1\frac{1}{2}$ " diam.



187

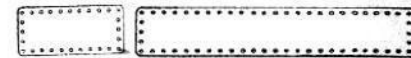

192

197

192. Flexible Plates. 190a. $3\frac{1}{2}$ " x $2\frac{1}{2}$ "

188. $2\frac{1}{2}$ " x $1\frac{1}{2}$ " 191. $4\frac{1}{2}$ " x $2\frac{1}{2}$ "

189. $5\frac{1}{2}$ " x $1\frac{1}{2}$ " 192. $5\frac{1}{2}$ " x $2\frac{1}{2}$ "

190. $2\frac{1}{2}$ " x $2\frac{1}{2}$ " Strip Plates. 197. $12\frac{1}{2}$ " x $2\frac{1}{2}$ "

196. $9\frac{3}{8}$ " x $2\frac{1}{2}$ "

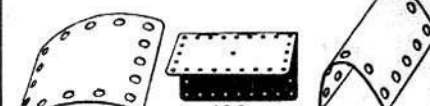

200

198

199

198. Hinged Flat Plate, $4\frac{1}{2}$ " x $2\frac{1}{2}$ "

199. Curved Plate, U-Section

$2\frac{1}{2}$ " x $2\frac{1}{2}$ " x $\frac{3}{8}$ " radius

200. " " $2\frac{1}{2}$ " x $2\frac{1}{2}$ " x $1\frac{1}{8}$ " radius



211^a & 211^b

211a. Helical Gear, $\frac{1}{2}$ " *Can only be used together*

211b. " " $1\frac{1}{2}$ "



212

212. Rod and Strip Connector



213

213. Rod Connector



214

214. Semi-Circular Plate, $2\frac{1}{2}$ "



215

215. Formed Slotted Strip, 3"



216

216. Cylinder, $2\frac{1}{2}$ " long, $1\frac{1}{4}$ " diam.