

MECCANO

INSTRUCTIONS FOR
No. 4a ACCESSORY OUTFIT



No.
52.4a



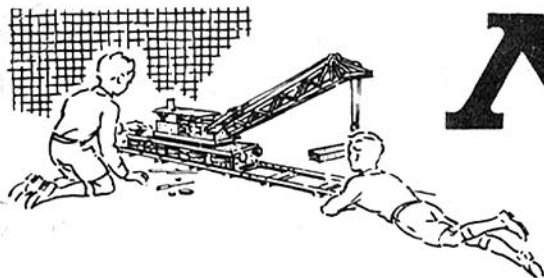

MECCANO

Registered Trade Mark

The World's Greatest Constructional Toy

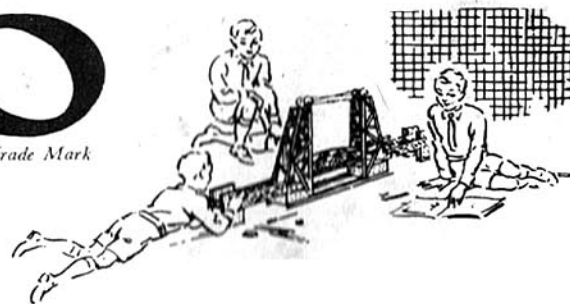

MODEL-BUILDING WITH MECCANO

There is no limit to the number of models that can be built with Meccano — Cranes, Clocks, Motor Cars, Aeroplanes, Machine Tools, Locomotives — in fact everything that interests boys. A screwdriver and a spanner, both of which are provided in each complete Outfit, are the only tools necessary.

When you have built all the models illustrated in the Books of Instructions the fun is not over, it is just beginning. Now comes the chance to make use of your own ideas. First of all, re-build some of the models with small changes in construction that may occur to you; then try building models entirely of your own design. In doing this you will enjoy the real thrill of the engineer and the inventor.

HOW TO BUILD UP YOUR OUTFIT

Meccano is sold in 12 different Outfits, ranging from No. OO to No. 10. Each Outfit can be converted into the next larger one by the purchase of an Accessory Outfit. Thus Meccano No. OO Outfit can be converted into No. O Outfit by adding to it a No. OOa Accessory Outfit. No. Oa Outfit would then convert it into a No. 1 and so on. In this way, no matter with which Outfit you begin, you can build it up by degrees until you have a complete No. 10 Outfit.

All Meccano parts are of the same high quality and finish, but the larger Outfits contain a greater quantity and variety, making possible the construction of more elaborate models.

THE 'MECCANO MAGAZINE'

The 'Meccano Magazine' is published specially for Meccano boys. Every month it describes and illustrates new Meccano models, and deals with suggestions from readers for new Meccano parts and for new methods of using the existing parts.

There are model-building competitions specially planned to give an equal chance to the owners of small and large Outfits. In addition, there are splendid articles on such subjects as Railways, Famous Engineers and Inventors, Electricity, Bridges, Cranes and Aeroplanes, and special sections dealing with the latest Engineering, Aviation, Motoring

and Shipping News. Other pages deal with Stamp Collecting, and Books of interest to boys; and a feature of outstanding popularity is the section devoted to short articles from readers.

Write to the Editor, The Meccano Magazine, Binns Road, Liverpool 13, for particulars and a specimen copy. You can order the Magazine from your Meccano dealer, or from any newsagent.

THE MECCANO GUILD

Every owner of a Meccano Outfit should join the Meccano Guild. This is a world-wide organisation, started at the request of Meccano boys. Its primary object is to bring boys together and to make them feel that they are all members of a great brotherhood, each trying to help others to get the very best out of life. Its members are in constant touch with Headquarters, giving news of their activities and being guided in their hobbies and interests. A leaflet containing full particulars of the Guild and an application form is included in this Book.

Clubs founded and established under the guidance of the Guild Secretary provide Meccano boys with opportunities of enjoying to the utmost the fun of model-building. Each has its Leader, Secretary, Treasurer and other officials. With the exception of the Leader, all the officials are boys, and as far as possible the proceedings of the clubs are conducted by boys.

MECCANO SERVICE

The service of Meccano does not end with selling an Outfit and a Book of Instructions. If ever you are in any difficulty with your models, or if you want advice on anything connected with this great hobby, write to us. We receive hundreds of interesting letters from boys in all parts of the world, and each of these is answered personally and promptly by one of our staff of experts.

Whatever your problem may be, write to us about it. We shall be delighted to help you in any way possible. Address your letters to *Information Service*.

5.1 ELEVATOR

Each side of the elevator is formed by two $2\frac{1}{2}'' \times 2\frac{1}{2}''$ Flexible Plates joined together and bolted to two $5\frac{1}{2}''$ Strips. A small radius Curved Strip is bolted across the upper ends of the $5\frac{1}{2}''$ Strips, and the sides are connected at the top by three $2\frac{1}{2}'' \times \frac{1}{2}''$ Double Angle Strips. At their lower ends the sides are joined by two $2\frac{1}{2}'' \times \frac{1}{2}''$ Double Angle Strips.

The two Flanged Sector Plates are connected to the $5\frac{1}{2}'' \times 2\frac{1}{2}''$ Flanged Plate by Angle Brackets, and the four $12\frac{1}{2}''$ Angle Girders are held in place by the same bolts. Guides for the elevator are provided by four Cords, three of which are shown at 1. These are tied to Washers underneath the Flanged Plate, and at the top of the shaft are fastened to Angle Brackets held by Bolts 2 on each side. Cord 3 is tied to a Washer, and passes through the centre hole of the $2\frac{1}{2}'' \times \frac{1}{2}''$ Double Angle Strip at the top of the elevator. It then passes over the $3''$ Pulley 4, and finally is fastened to a Cord Anchoring Spring on a Crank Handle journalled in the $5\frac{1}{2}''$ Strips that brace the elevator shaft.

A length of Cord passes around the rim of the $3''$ Pulley 5 and is tied to the brake lever, which is a $3\frac{1}{2}''$ Strip. This Strip is lock-nutted to a Trunnion fastened to a Flat Trunnion. The $\frac{1}{2}''$ loose Pulley bolted to the $3\frac{1}{2}''$ Strip maintains the brake band in tension.

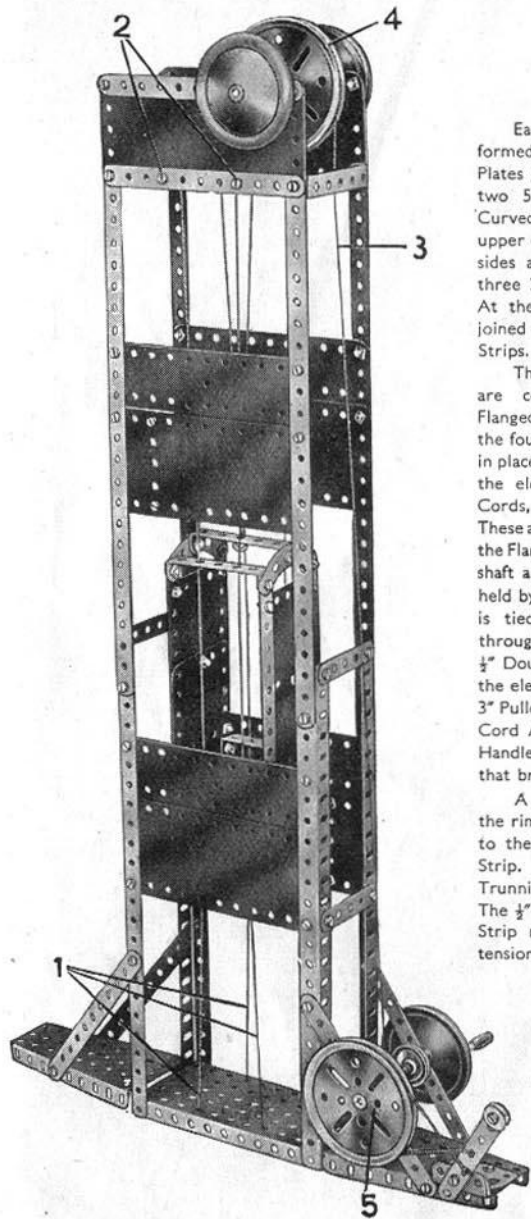

5.2 MOTOR LORRY

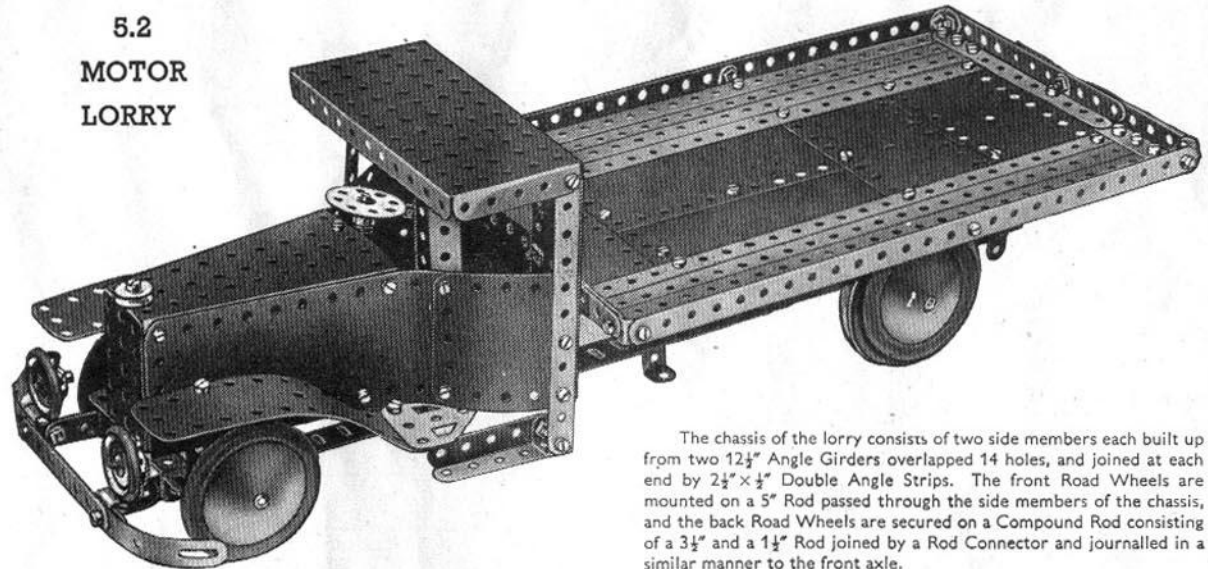

The chassis of the lorry consists of two side members each built up from two $12\frac{1}{2}''$ Angle Girders overlapped 14 holes, and joined at each end by $2\frac{1}{2}'' \times \frac{1}{2}''$ Double Angle Strips. The front Road Wheels are mounted on a $5''$ Rod passed through the side members of the chassis, and the back Road Wheels are secured on a Compound Rod consisting of a $3\frac{1}{2}''$ and a $1\frac{1}{2}''$ Rod joined by a Rod Connector and journalled in a similar manner to the front axle.

Flanged Sector Plates form the top and base for the bonnet and radiator. The narrow end of the bonnet is bolted to the centre hole of the $2\frac{1}{2}'' \times \frac{1}{2}''$ Double Angle Strip joining the forward ends of the chassis, and the wider end is attached to the centre of a $5\frac{1}{2}''$ Strip bolted across the chassis. The sides of the bonnet are $5\frac{1}{2}'' \times 2\frac{1}{2}''$ Flexible Plates, and are bolted to the flanges of the Flanged Sector Plates. The radiator is a $2\frac{1}{2}'' \times 1\frac{1}{2}''$ Flanged Plate, which is fastened by its flanges to the forward ends of the two Flanged Sector Plates. The radiator cap is represented by a $\frac{1}{2}''$ loose Pulley. The bumper consists of a $3\frac{1}{2}''$ Strip, to the end of which are bolted $3''$ Formed Slotted Strips, and it is fastened to the front end of the chassis by $1'' \times 1''$ Angle Brackets and $1\frac{1}{2}''$ Strips.

The headlamps are fitted to the bumper by means of Reversed Angle Brackets, and consist of $1''$ fast Pulleys held to the Brackets by bolts. The mudguards are $5\frac{1}{2}'' \times 1\frac{1}{2}''$ Flexible Plates, which are curved to the shape shown, and to their rear ends Flat Trunnions are attached, the pointed portions of these extending under the $1\frac{1}{4}''$ radius Curved Plates that are used to form the sides of the driver's compartment.

The cab is formed as follows. The short Strips are bolted vertically to the cab sides to form the front supports or the cab roof and the rear supports are $5\frac{1}{2}''$ Strips. The roof is a $5\frac{1}{2}'' \times 2\frac{1}{2}''$ Flanged Plate, which is bolted at each end to the $5\frac{1}{2}''$ Strips. At their lower ends each $5\frac{1}{2}''$ Strip carries a Double Bracket, to which are bolted at right angles two $2\frac{1}{2}''$ Strips that form the footsteps.

The platform of the lorry consists of $12\frac{1}{2}''$ Strips and Flexible Plates. The rear central portion of the platform is a Hinged Flat Plate, and the sides are $12\frac{1}{2}''$ Strips. Other Strips overlapped form the end. The end and sides are attached to the platform by means of Angle Brackets.

The platform is secured to the chassis at the front by $2\frac{1}{2}'' \times \frac{1}{2}''$ Double Angle Strips and at the rear by Trunnions and $2\frac{1}{2}''$ Strips.

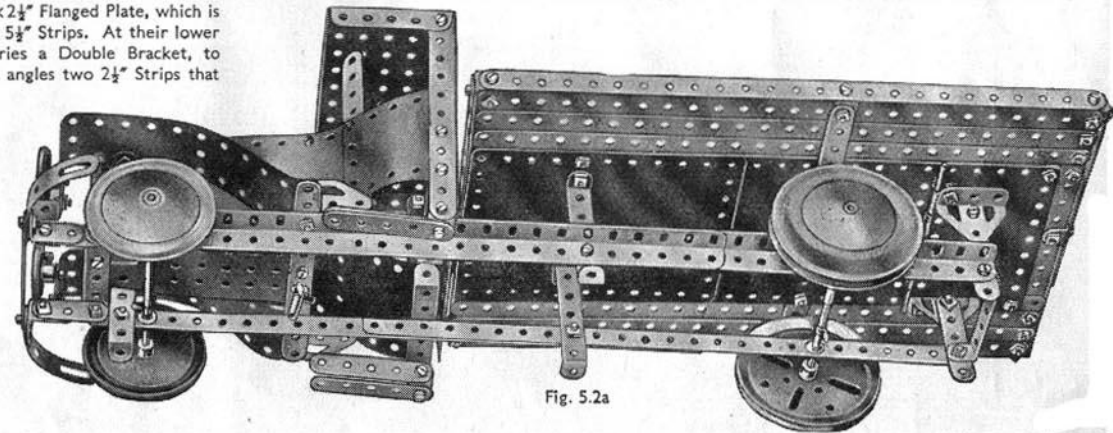

Fig. 5.2a

5.3 TRAVELLING GANTRY CRANE

The pin has been withdrawn from a Hinged Flat Plate and the halves are used as flat plates 1 in the construction of the supports for the gantry. Four Wheel Discs are fastened to the $12\frac{1}{2}$ " Strips by lock-nutted bolts, so that the gantry can travel along the ground.

Each of the rails along which the crane runs consists of two $12\frac{1}{2}$ " Angle Girders, overlapped three holes and joined across by $5\frac{1}{2}$ " Strips. Trunnions connect the rails to the supports.

The rails are braced by four compound strips, each consisting of a $5\frac{1}{2}$ " and a $2\frac{1}{2}$ " Strip overlapped three holes. These strips are bolted to the rails at their upper ends, and each carries an Angle Bracket at its lower end. These Angle Brackets are bolted to further Angle Brackets fixed to the vertical supports.

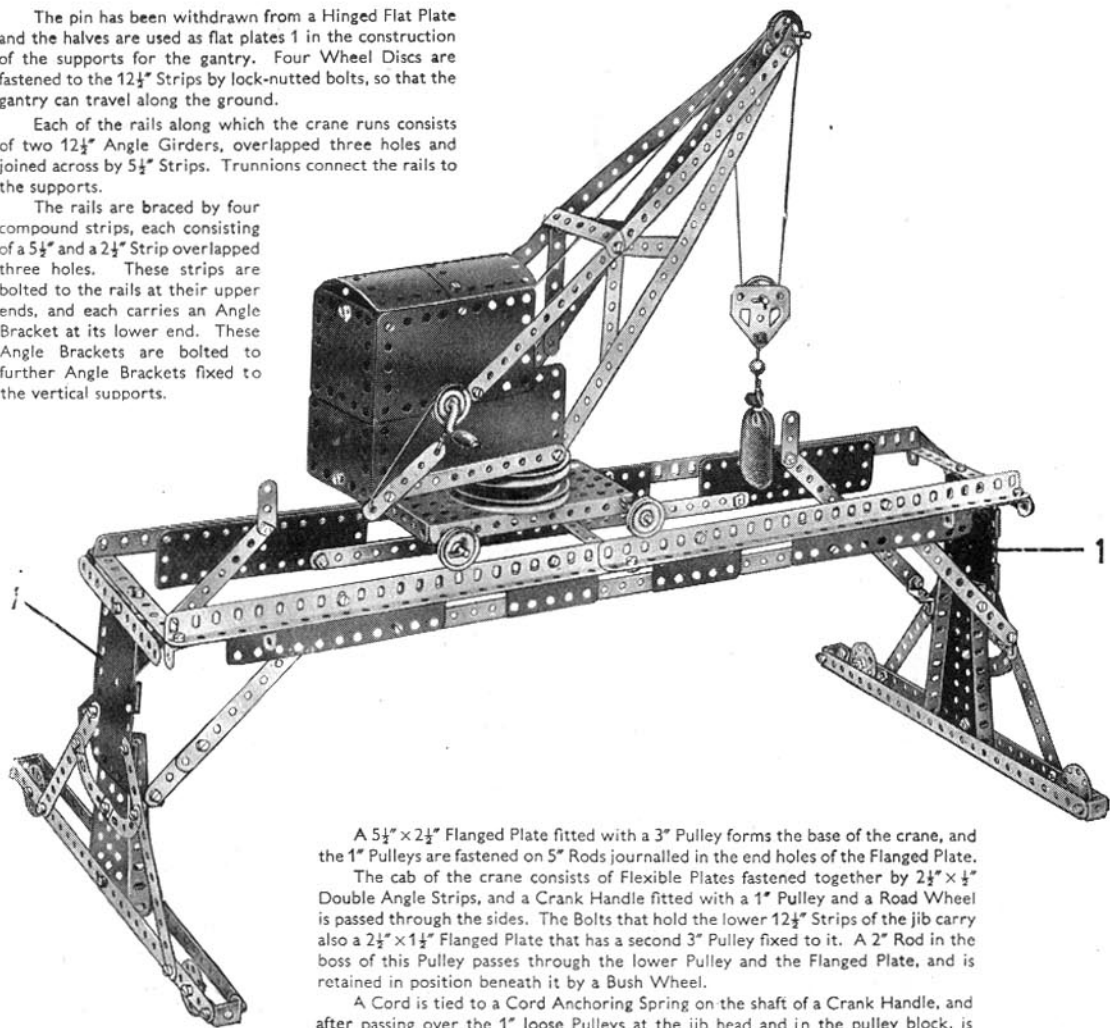

A $5\frac{1}{2}$ " x $2\frac{1}{2}$ " Flanged Plate fitted with a 3" Pulley forms the base of the crane, and the 1" Pulleys are fastened on 5" Rods journaled in the end holes of the Flanged Plate.

The cab of the crane consists of Flexible Plates fastened together by $2\frac{1}{2}$ " x $\frac{1}{2}$ " Double Angle Strips, and a Crank Handle fitted with a 1" Pulley and a Road Wheel is passed through the sides. The Bolts that hold the lower $12\frac{1}{2}$ " Strips of the jib carry also a $2\frac{1}{2}$ " x $1\frac{1}{2}$ " Flanged Plate that has a second 3" Pulley fixed to it. A 2" Rod in the boss of this Pulley passes through the lower Pulley and the Flanged Plate, and is retained in position beneath it by a Bush Wheel.

A Cord is tied to a Cord Anchoring Spring on the shaft of a Crank Handle, and after passing over the 1" loose Pulleys at the jib head and in the pulley block, is fastened to the jib as shown.

Stops to limit the travel of the crane along the rails are provided by $1\frac{1}{2}$ " Strips. These are bolted in a vertical position to the $12\frac{1}{2}$ " Angle Girders forming the rails as shown in the illustration. The rails are extended downwards by $5\frac{1}{2}$ " x $1\frac{1}{2}$ " and $2\frac{1}{2}$ " x $1\frac{1}{2}$ " Flexible Plates. These Plates are joined along their lower edges by $12\frac{1}{2}$ " Strips.

5.4 RAILWAY BREAKDOWN CRANE

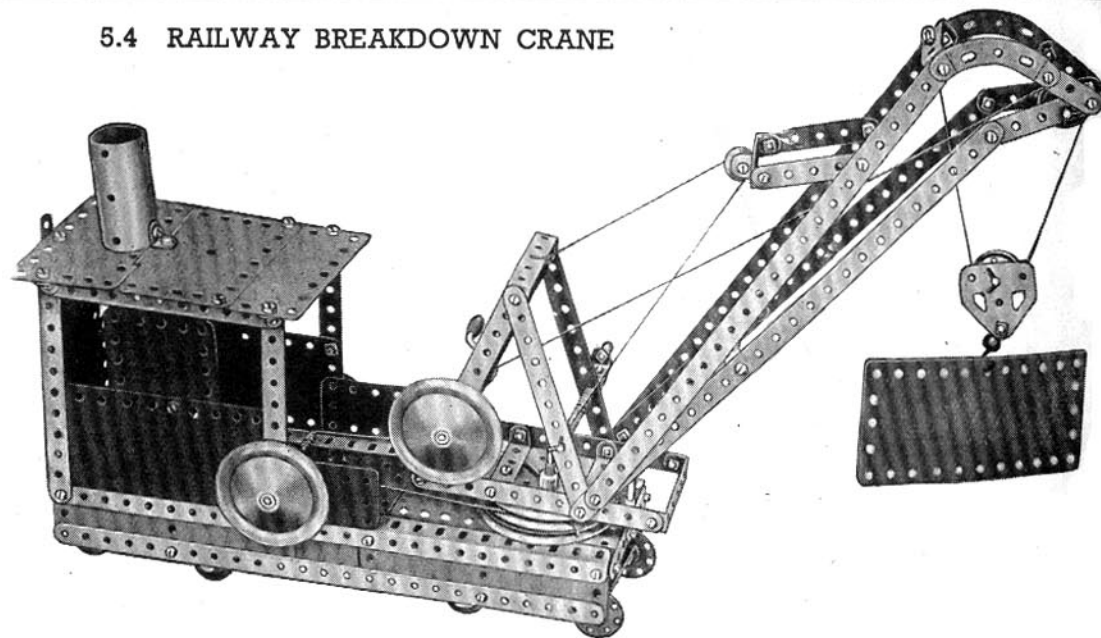

The chassis of the model consists of two U-Section girders built up from Angle Girders and joined at each end by $3\frac{1}{2}$ " Strips and Angle Brackets. A $5\frac{1}{2}$ " x $2\frac{1}{2}$ " Flanged Plate and a $5\frac{1}{2}$ " x $2\frac{1}{2}$ " Flexible Plate, overlapping one hole, are attached to the Angle Girders by Fishplates. The framework on which the jib is pivoted is fastened to a 3" Pulley by two $\frac{3}{8}$ " Bolts, which have two Washers on their shanks for spacing purposes. The $\frac{3}{8}$ " Bolts on which the jib luffs are lock-nutted.

The 3" Pulley on the jib swivels on a $3\frac{1}{2}$ " Rod passed through its boss and is held in place by a Cord Anchoring Spring.

The front bogie (Fig. 5.4a) pivots on the $3\frac{1}{2}$ " Rod and is held between a Road Wheel and a 1" Pulley as shown. The rear bogie is similarly pivoted on a 2" Rod, bearings for which are provided by the $5\frac{1}{2}$ " x $2\frac{1}{2}$ " Flexible Plate and two $2\frac{1}{2}$ " Strips overlapped three holes. The bogies are connected by a Driving Band, and the Bolts 1 are lock-nutted. Luffing of the jib is controlled by the built-up crank handle, consisting of a Double Bracket fitted with an Angle Bracket that carries a Pivot Bolt. The Bolt holding the Angle Bracket clamps the Double Bracket to the Rod.

Hoisting is controlled by the Crank Handle, and the slewing movement is carried out by a belt of Cord passed around the upper 3" Pulley at the base of the jib and then wound several times around the Rod journaled in the sides of the cab.

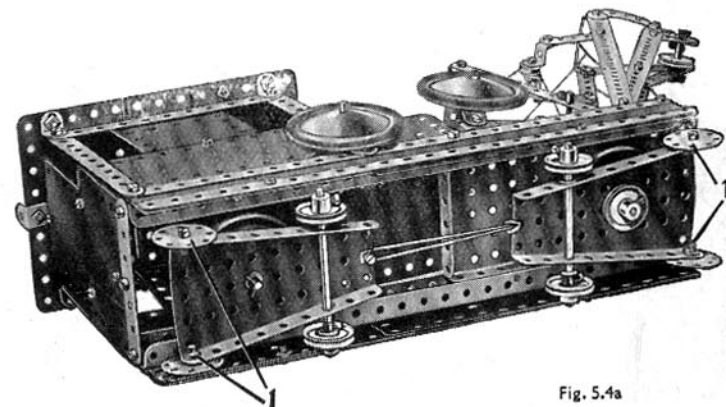
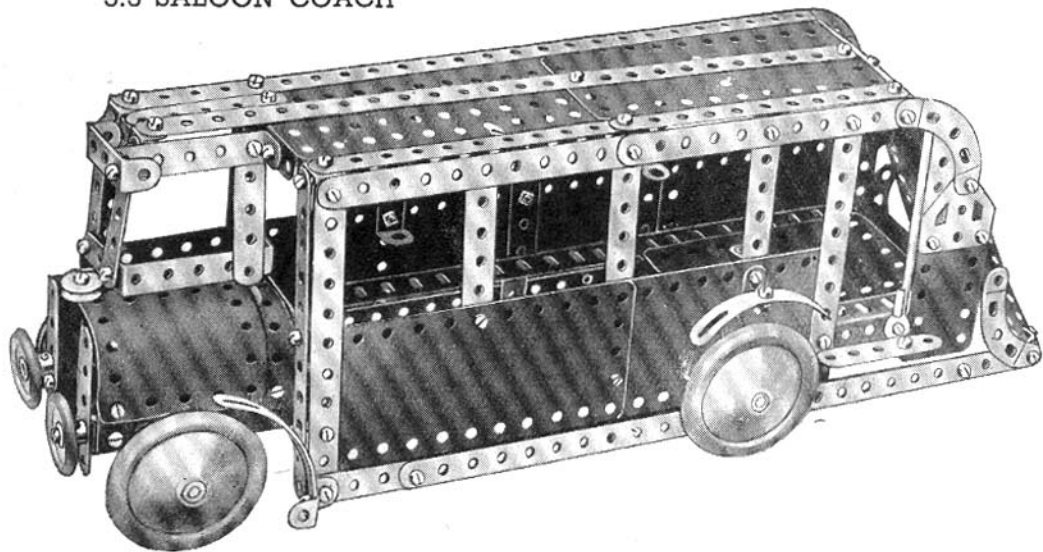

Fig. 5.4a

5.5 SALOON COACH



Two $12\frac{1}{2}$ " Angle Girders joined by $3\frac{1}{2}$ " Strips at each end comprise the chassis, and to this the Flexible Plates forming the sides are bolted. Supports for the roof are provided by $5\frac{1}{2}$ " Strips to which a $5\frac{1}{4}$ " \times $2\frac{1}{2}$ " Flanged Plate and two $5\frac{1}{2}$ " \times $1\frac{1}{2}$ " Flexible Plates are fastened by Angle Brackets. The curved back of the coach is formed by two $1\frac{1}{8}$ " radius Curved Plates, a $5\frac{1}{2}$ " \times $1\frac{1}{2}$ " Flexible Plate, and a $5\frac{1}{2}$ " \times $2\frac{1}{2}$ " Flexible Plate. The Flexible Plates are curved and bolted to the $1\frac{1}{8}$ " radius Curved Plates so that they overlap three holes.

The tail lamp is a 1" Pulley, which is secured to a Threaded Pin fastened to one of the Flexible Plates (Fig. 5.5a).

The bonnet is built up from two U-Section Curved Plates and a $2\frac{1}{2}$ " \times $1\frac{1}{2}$ " Flexible Plate. The radiator is a $2\frac{1}{2}$ " \times $1\frac{1}{2}$ " Flanged Plate.

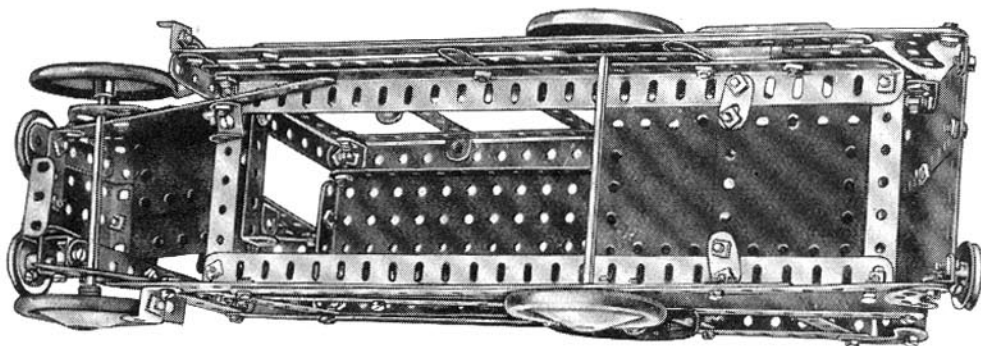

Fig. 5.5a

5.6 TRAVELLING CRANE

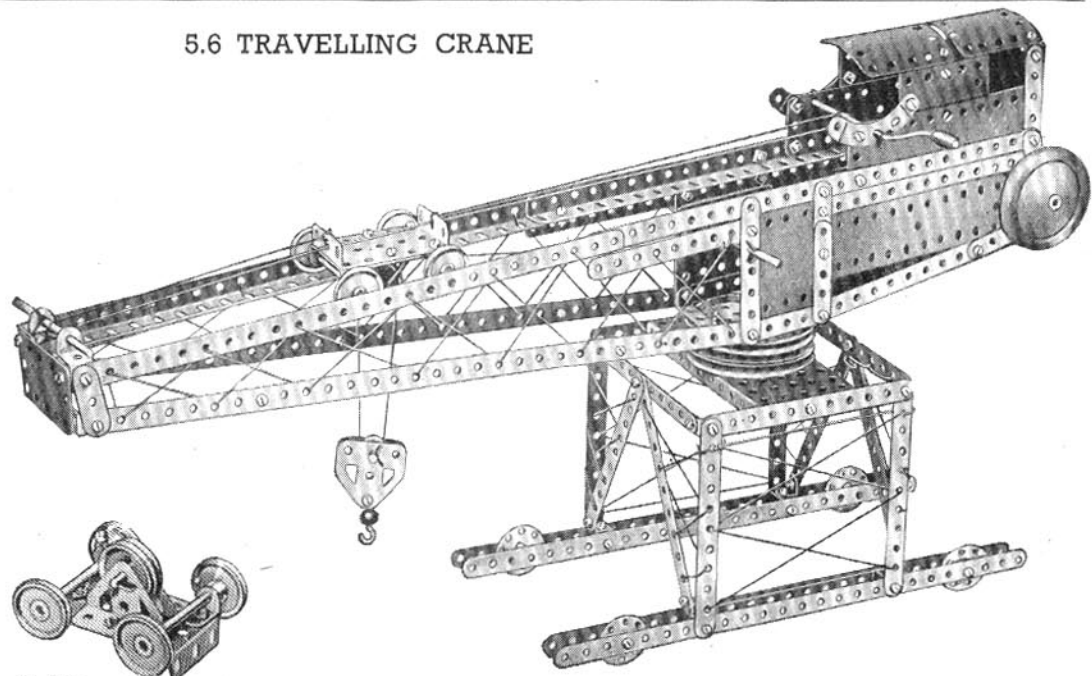

Fig. 5.6c

The construction of the superstructure and jib will be clear from the illustration. The Wheel Discs representing the wheels are held on lock-nutted bolts so that they are free to turn. In Fig. 5.6a the top of the cab has been removed to show the construction of the rear end of the jib.

A 3" Pulley is bolted to the jib by two $\frac{3}{8}$ " Bolts, which hold also a $2\frac{1}{2}$ " \times $\frac{1}{2}$ " Double Angle Strip fixed along the length of the jib on the underside of the 3" Pulley, so that its ends form a bearing between the two Pulleys. A $3\frac{1}{4}$ " Rod fastened in the boss of the upper 3" Pulley passes through the boss of the lower 3" Pulley, which is bolted to a $5\frac{1}{2}$ " \times $2\frac{1}{2}$ " Flanged Plate forming part of the superstructure. The Rod is retained in position below the Flanged Plate by a 1" Pulley as shown in Fig. 5.6b.

The hoisting carriage is shown in Fig. 5.6c; it runs on rails formed by Angle Girders at the top of the jib. A Cord is tied to the front end of the carriage, and is taken over a $3\frac{1}{2}$ " Rod at the jib head and wound six times around the Crank Handle. It is then tied to the rear of the carriage.

A second Cord is tied to a Cord Anchoring Spring on the $3\frac{1}{2}$ " Rod carrying the Bush Wheel and the Road Wheel. The Cord is then led around one of the 1" loose Pulleys in the carriage around the $\frac{1}{2}$ " loose Pulley in the Pulley block and back over the second 1" loose Pulley. Finally it is tied to the $2\frac{1}{2}$ " \times $1\frac{1}{2}$ " Flanged Plate at the jib head.

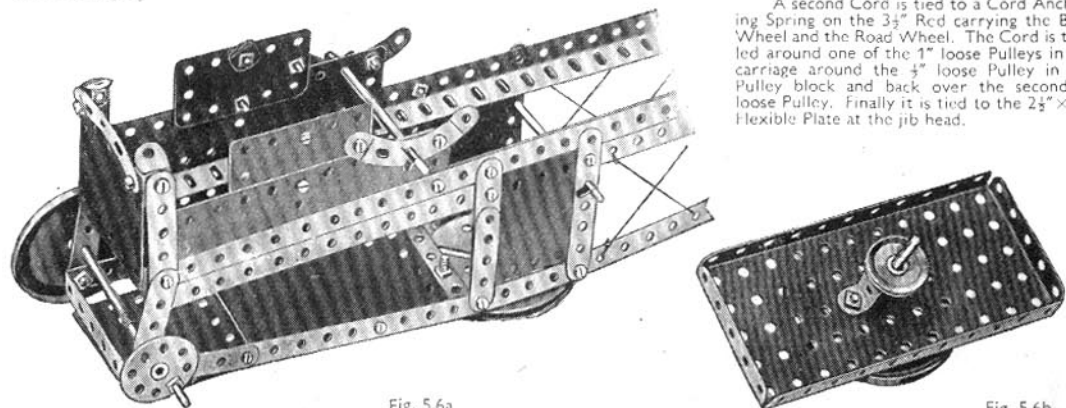
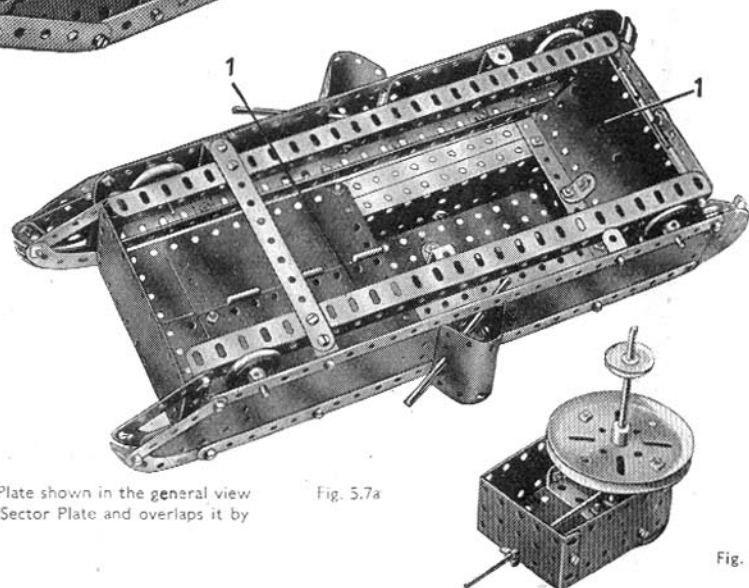
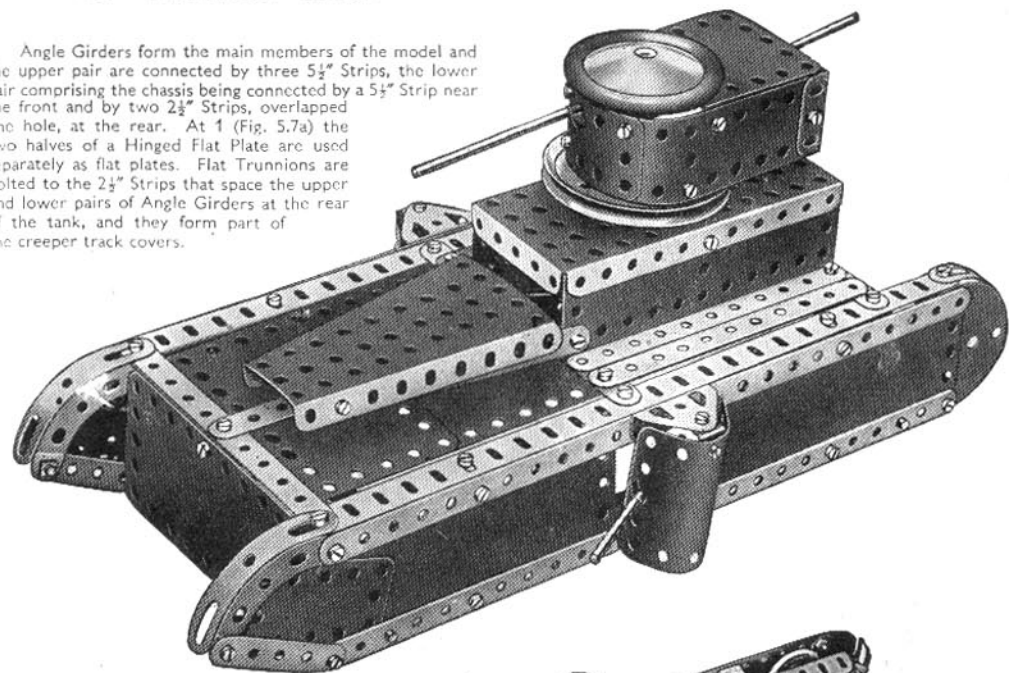

Fig. 5.6a

Fig. 5.6b

5.7 MILITARY TANK

Angle Girders form the main members of the model and the upper pair are connected by three $5\frac{1}{2}$ " Strips, the lower pair comprising the chassis being connected by a $5\frac{1}{2}$ " Strip near the front and by two $2\frac{1}{2}$ " Strips, overlapped one hole, at the rear. At 1 (Fig. 5.7a) the two halves of a Hinged Flat Plate are used separately as flat plates. Flat Trunnions are bolted to the $2\frac{1}{2}$ " Strips that space the upper and lower pairs of Angle Girders at the rear of the tank, and they form part of the creeper track covers.



The revolving gun turret is shown in Fig. 5.7b. The rear gun is a $3\frac{1}{2}$ " Rod, which is fitted with a Reversed Angle Bracket on the inside of the Flanged Plate, and is retained in position by Spring Clips. A 5 " Rod is fixed in the boss of the 3 " Pulley to which the turret is bolted, and a Road Wheel is secured to its top end. The lower end of the rod passes through the $5\frac{1}{2}$ " \times $2\frac{1}{2}$ " Flanged Plate and through a Double Bent Strip. A 1 " Pulley retains the complete unit in position. The Flanged Sector Plate shown in the general view is bolted to a second Flanged Sector Plate and overlaps it by eight holes.

Fig. 5.7a

Fig. 5.7b

5.8 PETROL TANK LORRY

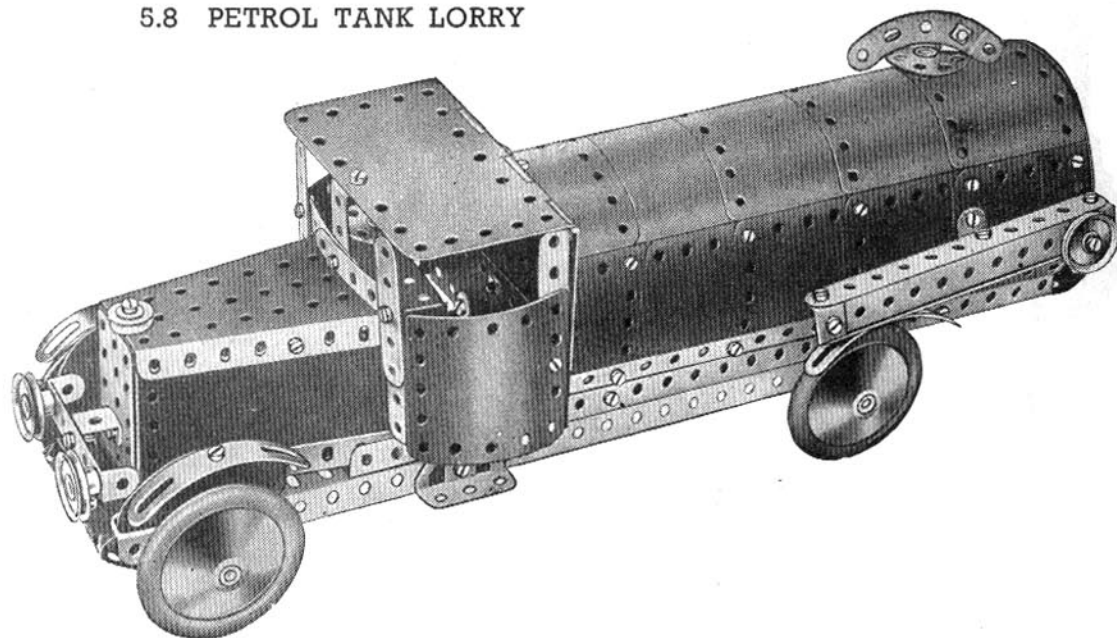

The chassis of the model is shown in Fig. 5.8a. Each side member consists of two $12\frac{1}{2}$ " Angle Girders overlapped 18 holes and bolted together. Flanged Sector Plates are used for the top and bottom of the bonnet, and $4\frac{1}{2}$ " \times $2\frac{1}{2}$ " Flexible Plates for the sides and are bolted on the inside of the flanges.

The Steering wheel is a Wheel Disc carried on a bolt lock-nutted to the Flanged Sector Plate.

The roof and back of the cab consist of a Hinged Flat Plate and two $2\frac{1}{2}$ " \times $1\frac{1}{2}$ " Flexible Plates overlapped one hole. The cab is fastened to the chassis by Angle Brackets, and to the bonnet by the $1\frac{1}{2}$ " \times $\frac{1}{2}$ " Double Angle Strip that forms the central division of the windscreen.

In Fig. 5.8a the tank is opened out to show its construction. The top of the tank consists of four $5\frac{1}{2}$ " \times $2\frac{1}{2}$ " Flexible Plates and a $5\frac{1}{2}$ " \times $1\frac{1}{2}$ " Flexible Plate. It is extended on the rear side by two $5\frac{1}{2}$ " \times $1\frac{1}{2}$ " Flexible Plates, and $12\frac{1}{2}$ " Strips are bolted to each longitudinal edge. The complete tank is attached to the Angle Girders by four Obtuse Angle Brackets. The tank filler cap is a Bush Wheel fitted with a $2\frac{1}{2}$ " small radius Curved Strip, and is fastened to the shank of the $\frac{1}{2}$ " Bolt at the top of the tank.

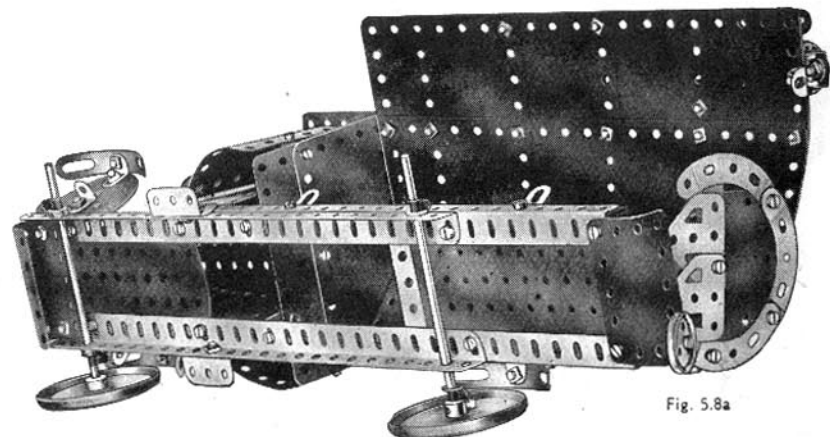
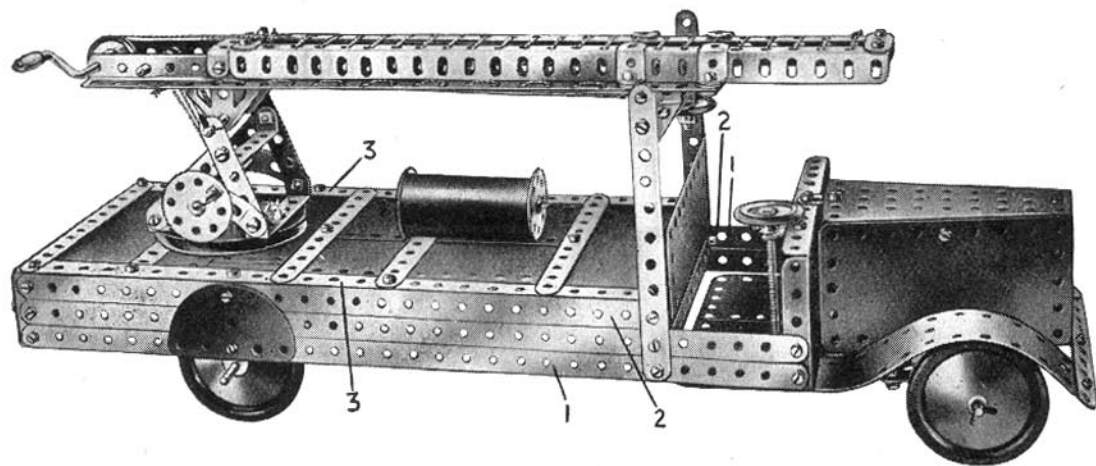

Fig. 5.8a

5.9 FIRE ENGINE



side of the model a second $2\frac{1}{2}$ " Strip 4, a Double Bracket and a third $2\frac{1}{2}$ " Strip 5, are assembled on a $\frac{3}{8}$ " Bolt and held tightly with a nut.

The free ends of the Strips 4 and 14 are now lock-nutted to the track rod 15.

The steering column is a 3" Screwed Rod journalled in Fishplates attached to the Flanged Plate. A $2\frac{1}{2}$ " Strip 6, bent upward slightly, is fastened to the Screwed Rod by two nuts and is connected to the Strip 5 by two $2\frac{1}{2}$ " Strips overlapped three holes. The front end of this compound strip is held between two nuts on a Bolt passed through the Strip 5. It should be noted that the Strip 5 is also bent upward slightly.

Details of the escape are shown in Fig. 5.9b. It is built up on a 3" Pulley locked on a 2" Rod. This Rod passes through the centre holes of a compound plate made by bolting the halves of a Hinged Flat Plate to the Strips 3. A 1" Pulley on the 2" Rod holds the escape in position. The Angle Girders 7 are joined at the top by a $2\frac{1}{2}$ " Strip, and at their lower ends by the $1\frac{1}{2}$ " x $\frac{1}{2}$ " Double Angle Strip 8.

The extending section of the escape is made by two Angle Girders joined at each end by $1\frac{1}{2}$ " Strips. These Girders pass over the Angle Girders 7 and slide under the Reversed Angle Brackets 9, each of which is spaced from the Girders 7 by two Washers. A length of Cord tied to the $1\frac{1}{2}$ " Strip 10 passes around a Pulley on the Crank Handle, and around a second Pulley 11 locked on a 1" Rod journalled in a Stepped Bent Strip. This Cord is then fastened to the Strip 10.

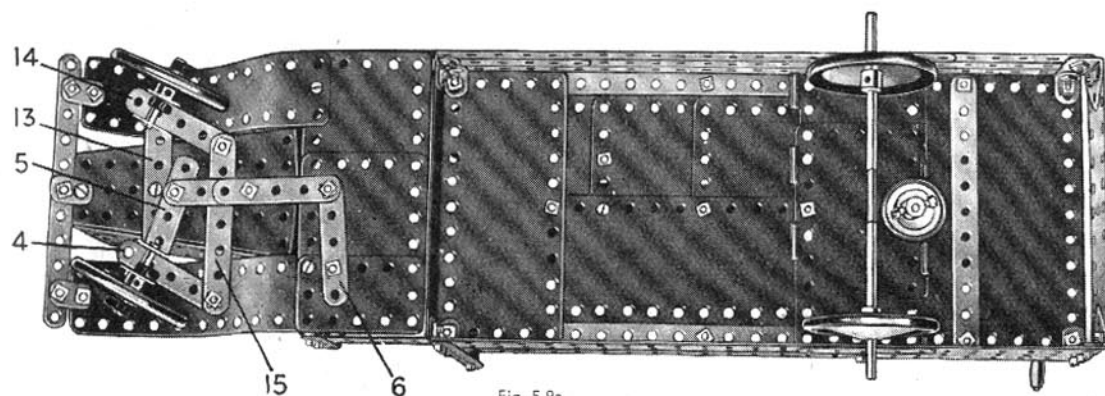

Fig. 5.9a

The body is built up on two compound Strips 1, each consisting of two $12\frac{1}{2}$ " Strips overlapped. These are joined at the front by a Flanged Plate that forms the back of the bonnet, and a Trunnion is bolted across the ends of the Strips at the rear. The Trunnions are joined by a $5\frac{1}{2}$ " x $1\frac{1}{2}$ " Flexible Plate strengthened by a $5\frac{1}{2}$ " Strip. The strips 2 are a $12\frac{1}{2}$ " and a $5\frac{1}{2}$ " Strip overlapped six holes. The $12\frac{1}{2}$ " Strips 3 are attached to the sides by Angle Brackets.

The bonnet is made from two Flanged Sector Plates joined by two $4\frac{1}{2}$ " x $2\frac{1}{2}$ " Flexible Plates, and is secured to the $5\frac{1}{2}$ " x $2\frac{1}{2}$ " Flanged Plates by Fishplates. The radiator is represented by a $2\frac{1}{2}$ " x $1\frac{1}{2}$ " Flanged Plate.

The rear axle is formed by two $3\frac{1}{2}$ " Rods joined together by a Rod Connector and journalled in Fishplates bolted to the chassis.

The front wheel mounting and steering arrangement is as follows. First, a $3\frac{1}{2}$ " Strip 13 (Fig. 5.9a) is bolted securely across the underside of the bonnet. A $2\frac{1}{2}$ " Strip 14 and a Double Bracket are then held freely by a nut on a $\frac{3}{8}$ " Bolt, and the remaining shank of the bolt is passed through one end of the $3\frac{1}{2}$ " Strip. A second nut is then placed on the Bolt so as to lock it firmly to the Strip, but at the same time leave the $2\frac{1}{2}$ " Strip free to pivot. One of the Road Wheels is then fixed to a 1" Rod held by a Spring Clip in the Double Bracket. At the other end of the $3\frac{1}{2}$ " Strip, the Bolt is then lock-nutted to the end of the $3\frac{1}{2}$ " Strip.

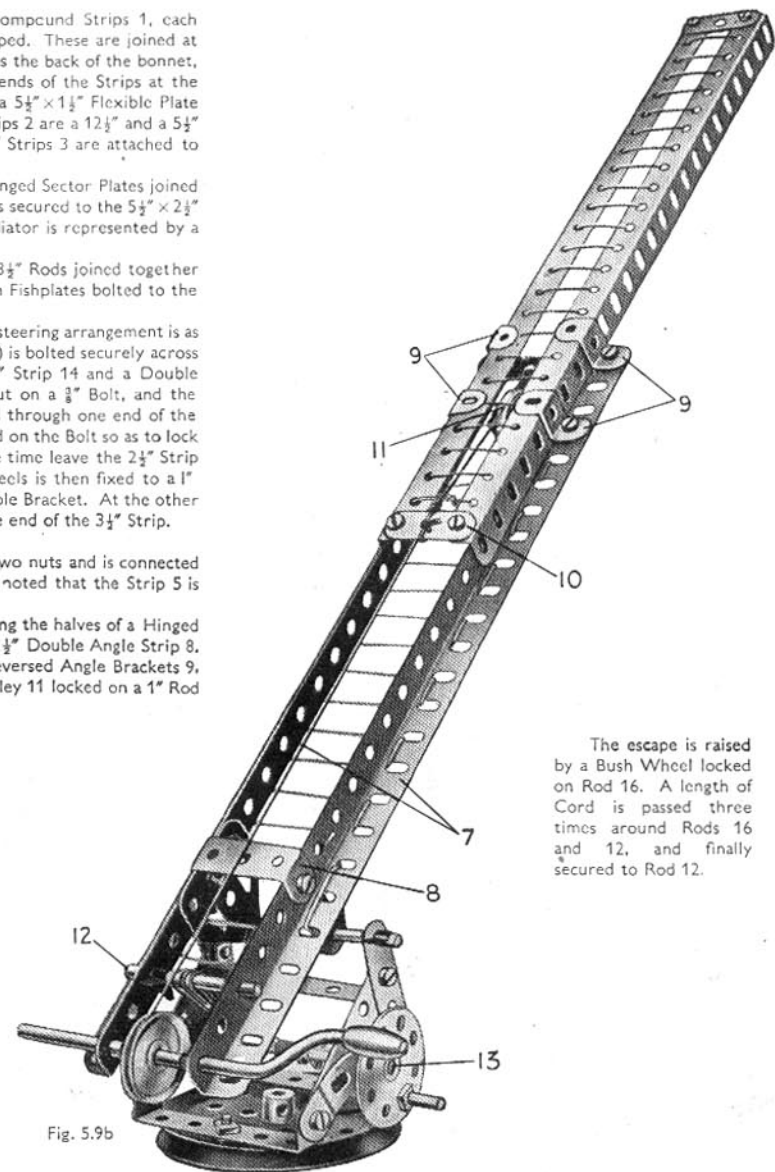
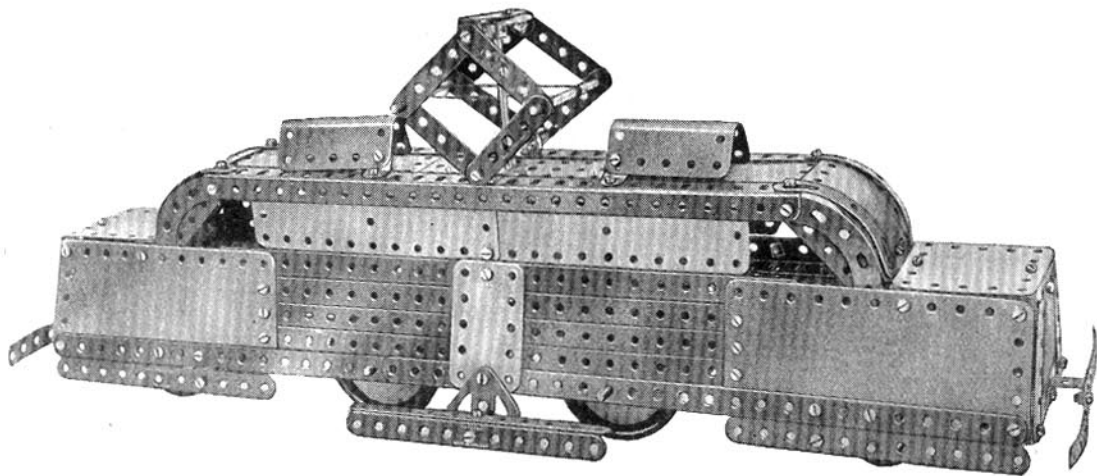

Fig. 5.9b

The escape is raised by a Bush Wheel locked on Rod 16. A length of Cord is passed three times around Rods 16 and 12, and finally secured to Rod 12.

5.10 ELECTRIC LOCOMOTIVE



Each side of the model consists of two $5\frac{1}{2}'' \times 2\frac{1}{2}''$ Flexible Plates that overlap the ends of three $12\frac{1}{4}''$ Strips and a $12\frac{1}{4}''$ Angle Girder by three holes. The Flexible Plates are joined at their lower edges by a compound Strip consisting of two $12\frac{1}{4}''$ Strips overlapped nine holes.

The upper edges of the sides are connected, at each end, by two $2\frac{1}{2}'' \times \frac{1}{2}''$ Double Angle Strips, and these Strips also support a $2\frac{1}{2}'' \times 2\frac{1}{2}''$ Flexible Plate. The lower edges are connected at each end, by a $3\frac{1}{2}''$ Strip attached to the sides by Angle Brackets. The front and rear of the locomotive are filled in by $2\frac{1}{2}'' \times 2\frac{1}{2}''$ Flexible Plates bolted to the $3\frac{1}{2}''$ Strips, and by $2\frac{1}{2}''$ Strips also attached to the $3\frac{1}{2}''$ Strips.

The centre of the roof consists of a $5\frac{1}{2}'' \times 2\frac{1}{2}''$ Flanged Plate fitted at each side with a $12\frac{1}{4}''$ Angle Girder. Two $5\frac{1}{2}'' \times 1\frac{1}{4}''$ Flexible Plates are held between the vertical flange of the Angle Girder and the Flanged Plate on each side of the model, and the Flexible Plates are attached by a Fishplate to the sides. The Flanged Plate of the roof is extended on each side by a $4\frac{1}{2}'' \times 2\frac{1}{2}''$ Flexible Plate and a $1\frac{1}{4}''$ radius Curved Plate.

Each side of the current collector consists of $2\frac{1}{2}''$ Strips, pairs of which are lock-nutted to an Angle Bracket and a $2\frac{1}{2}'' \times \frac{1}{2}''$ Double Angle Strip respectively. They are pivoted together on $3\frac{1}{2}''$ Rods, and a Driving Band is stretched between the Rods as shown. The Bush Wheel carries in its boss a $5''$ Rod that passes through a Double Bent Strip and the $5\frac{1}{2}'' \times 2\frac{1}{2}''$ Flanged Plate.

The two U-section Curved Plates are attached to the roof by Obtuse Angle Brackets.

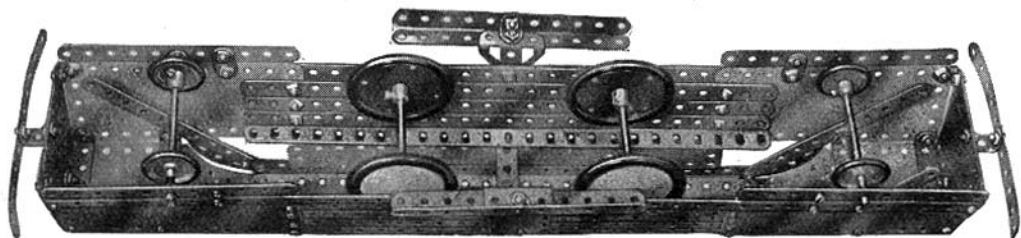

Fig. 5.10a

5.11 DERRICK CRANE

Reference to the illustrations will make clear the construction of the base and cabin.

Each side of the jib consists of three $12\frac{1}{4}''$ Strips, which are joined across the bottom by a $1\frac{1}{2}'' \times \frac{1}{2}''$ Double Angle Strip, in the centre by a $2\frac{1}{2}'' \times \frac{1}{2}''$ Double Angle Strip, and at the top by a Stepped Bent Strip. A $1\frac{1}{2}''$ Rod locked in the boss of the upper $3''$ Pulley passes through a second $3''$ Pulley bolted to the base and is held in position by a Spring Clip. The Double Bracket at the upper ends of the $12\frac{1}{4}''$ Strips is lock-nutted to the $2\frac{1}{2}'' \times 1\frac{1}{2}''$ Flanged Plate.

The $5''$ Rod 1, which controls the swivelling of the jib, has a belt of Cord wound round it several times. The Cord is taken round the $3''$ Pulley at the bottom of the jib. Crank Handle 2 controls the hoisting movement. Cord is wound a few turns around the shaft of the Crank Handle, then passed under a $2''$ Rod at the base of the jib, and over a $1''$ loose Pulley on a $1\frac{1}{2}''$ Rod at the top of the jib. The Cord is then led through the pulley block and tied to an Angle Bracket bolted to the jib. The $3\frac{1}{2}''$ Rod 3 carries a Bush Wheel, to which a Threaded Pin is fitted to form a handle for controlling the luffing movement of the jib.

Cord is tied to a Fishplate on the $2''$ Rod in the jib post and is taken around a $1''$ Pulley on the jib. It is then passed around a $\frac{1}{2}''$ loose Pulley on the $2''$ Rod and led over a second Pulley on the same Rod as the first $1''$ Pulley. Finally it is led back over the $2''$ Rod and wound around Rod 3.

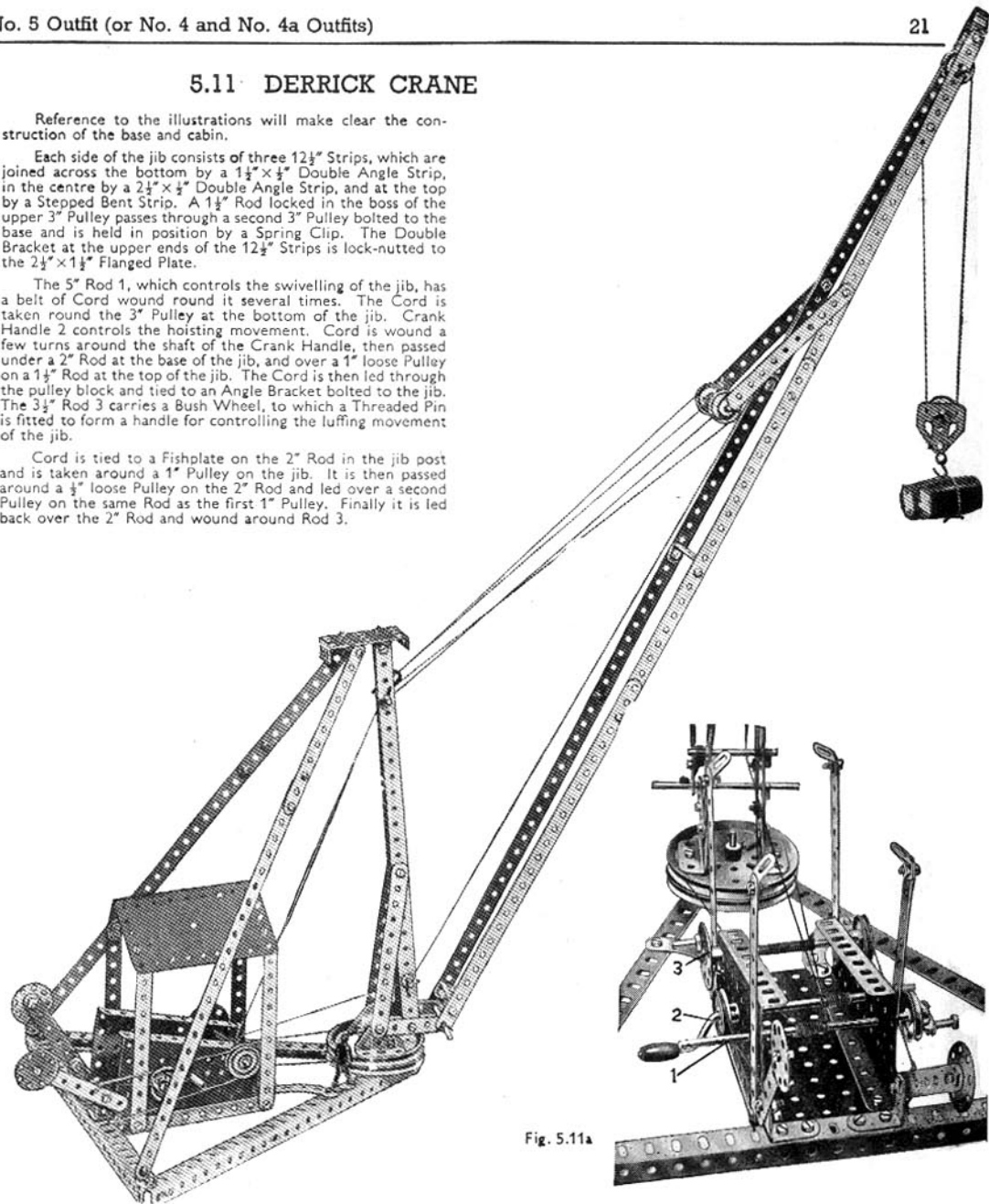
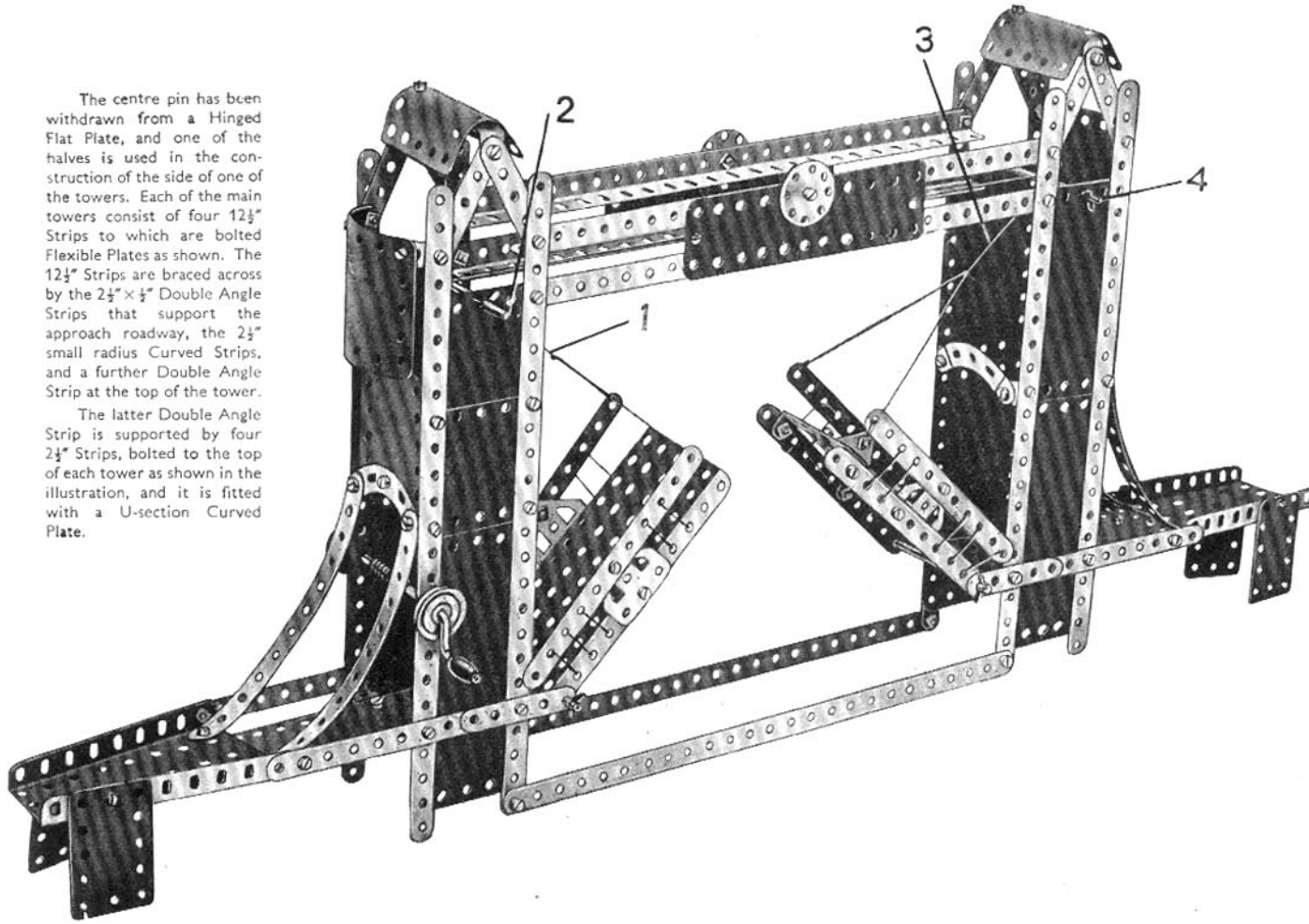

Fig. 5.11a

5.12 BASCULE BRIDGE

The centre pin has been withdrawn from a Hinged Flat Plate, and one of the halves is used in the construction of the side of one of the towers. Each of the main towers consist of four $12\frac{1}{2}$ " Strips to which are bolted Flexible Plates as shown. The $12\frac{1}{2}$ " Strips are braced across by the $2\frac{1}{2}$ " \times $\frac{1}{2}$ " Double Angle Strips that support the approach roadway, the $2\frac{1}{2}$ " small radius Curved Strips, and a further Double Angle Strip at the top of the tower.

The latter Double Angle Strip is supported by four $2\frac{1}{2}$ " Strips, bolted to the top of each tower as shown in the illustration, and it is fitted with a U-section Curved Plate.



The U-section Curved Plates are spaced from the $2\frac{1}{2}$ " \times $\frac{1}{2}$ " Double Angle Strips by three Washers. The two towers are joined across at the top by four Angle Girders, and at the bottom by two $12\frac{1}{2}$ " Strips.

Four $2\frac{1}{2}$ " Strips form bearings for the $3\frac{1}{2}$ " Rods on which the halves of the span are pivoted. The left hand half is a $5\frac{1}{2}$ " \times $2\frac{1}{2}$ " Flanged Plate fitted with Flat Trunnions and $5\frac{1}{2}$ " Strips as shown. The other half of the span is a part of the Hinged Flat Plate, and is connected to two $5\frac{1}{2}$ " Strips by a $2\frac{1}{2}$ " \times $\frac{1}{2}$ " Double Angle Strip and Angle Brackets.

The halves of the span are raised and lowered by turning a Crank Handle journalled in the sides of the left-hand tower. Cord 1 passes over Rod 2 and is fastened to a Cord Anchoring Spring on the Crank Handle. Cord 3 passes over Rod 4 and around Rod 2, and is then knotted to Cord 1 inside the tower.

5.13 MARINE ENGINE

Bearings for the Crankshaft are provided on the rear side by a Flat Trunnion and a Reversed Angle Bracket bolted to it, and on the other side by a second Flat Trunnion and a Wheel Disc. A $3\frac{1}{2}$ " Rod is held in the rear bearings by a $1"$ Pulley and a Spring Clip, and in the other bearings is a $2"$ Rod, which is retained in place by a Bush Wheel and a Spring Clip.

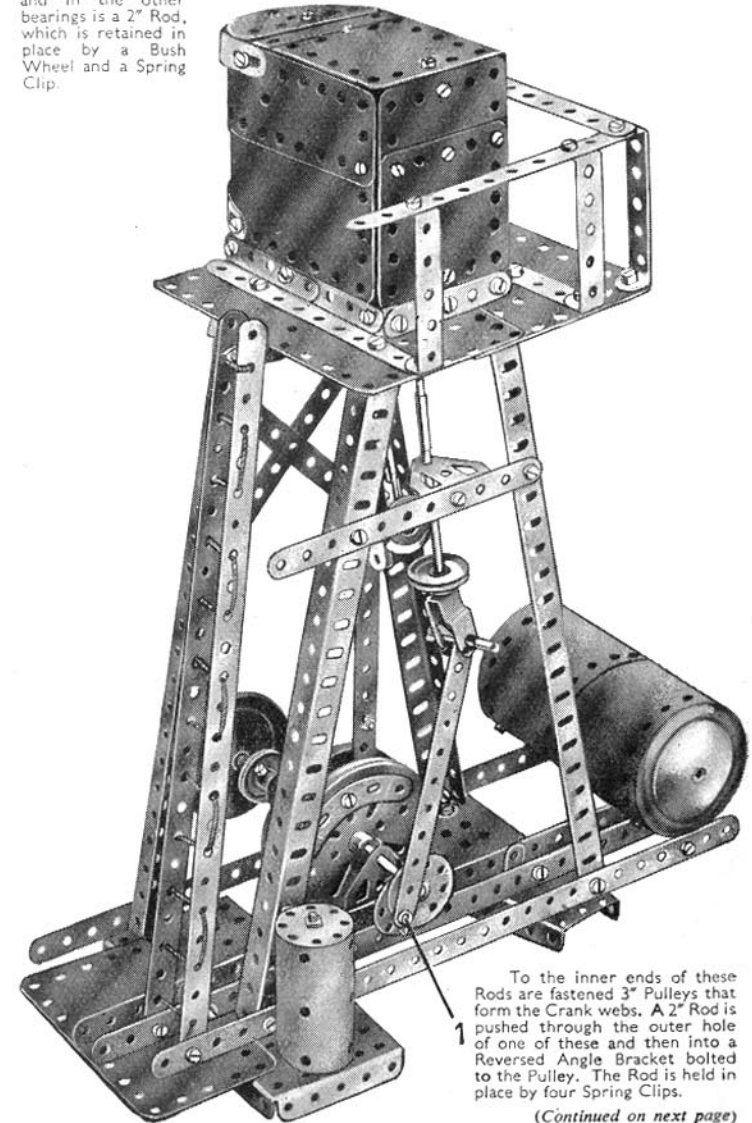

To the inner ends of these Rods are fastened $3"$ Pulleys that form the Crank webs. A $2"$ Rod is pushed through the outer hole of one of these and then into a Reversed Angle Bracket bolted to the Pulley. The Rod is held in place by four Spring Clips.

(Continued on next page)

5.13
MARINE
ENGINE—
continued

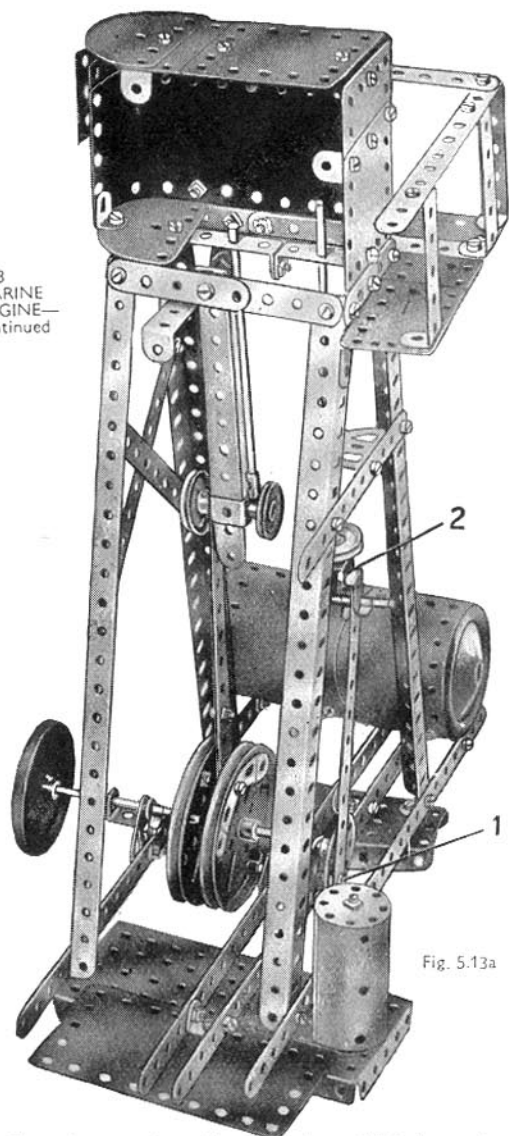

Fig. 5.13a

The main connecting rod consists of two $5\frac{1}{2}$ " Strips overlapped seven holes. Two $5\frac{1}{2}$ " Strips bolted together provide a guide for the piston rod and the crosshead is a Double Bracket pivoted to the connecting rod by a $1\frac{1}{2}$ " Rod. Two $3\frac{1}{2}$ " Rods joined by a Rod Connector form the slide valve, which is held in the Stepped Bent Strip 2 by a Cord Anchoring Spring and a 1" Pulley. The $5\frac{1}{2}$ " Strip forming the valve connecting rod is lock-nutted to the Bush Wheel at 1.

5.14 PITHEAD GEAR

This model is based on the usual type of headgear installed at the top of coal mine shafts, where it is used for supporting the huge wheels over which pass the wire ropes for raising and lowering the cage. From the pit-head wheels, hauling cables pass down to a powerful winding engine installed in a power house near the pit-head. The engine is often electrically driven but steam driven plants are used in many collieries and it is one of these that is represented in the Meccano model. The engine is fitted with powerful brakes and speed retarding devices, which automatically reduce the speed of the cage and bring it to rest smoothly at either the surface or the bottom of the shaft.

Construction of the model is commenced by bolting together two $12\frac{1}{2}$ " Angle Girders overlapped to make a compound angle girder $19\frac{1}{2}$ " long. Two such compound girders are required to form the long sides of the base.

The rear side of the engine house is a $5\frac{1}{2}$ " \times $2\frac{1}{2}$ " Flanged Plate bolted to one of the compound $19\frac{1}{2}$ " girders, and the rear side consists of a Flanged Sector Plate and a $2\frac{1}{2}$ " \times $1\frac{1}{2}$ " Flanged Plate, which are bolted to the rear $19\frac{1}{2}$ " compound angle girder.

The steam cylinder of the engine is represented by a $2\frac{1}{2}$ " Cylinder, which is lock-nutted so that it is free to pivot on the $5\frac{1}{2}$ " \times $2\frac{1}{2}$ " Flanged Plate. The Cylinder ends are Wheel Discs held in place by passing a 3" Screwed rod through holes in their circumference and screwing nuts on each end of it. The cylinder is fitted with a piston rod consisting of a 4" Rod, which carries at its outer end a Rod and Strip Connector. The Rod and Strip Connector pivots on a Threaded Pin, fixed in a hole of a Bush Wheel mounted on a 5" Rod journalled in the sides of the engine house, and is retained in position on the Pin by a Cord Anchoring Spring.

The roof of the engine house consists of a Hinged Flat Plate, which is attached by means of Obtuse Angle Brackets to the upper ends of four $5\frac{1}{2}$ " Strips bolted vertically to the $12\frac{1}{2}$ " Angle Girders of the base.

A 1" Pulley on the Crank Handle is connected by a belt of Cord to a similar Pulley on the 5" Rod of the winding gear. The Crank Handle is mounted in a $1\frac{1}{2}$ " \times $\frac{1}{2}$ " Double Angle Strip fixed to a Flat Trunnion, which is bolted to one of the Flanged Sector Plates.

The pulley-gear at the pit-head is arranged as follows. A 5" Rod is journalled in the holes of the two $2\frac{1}{2}$ " Strips at the top of the shaft tower, and it carries at its centre a 1" fast Pulley. On each side of this Pulley are a 3" Pulley and a Road Wheel. Just below the $2\frac{1}{2}$ " Strips are two $5\frac{1}{2}$ " Strips, and passed through these is a 4" Rod, which is held in place by Spring Clips. Directly beneath this Rod, at the bottom of the tower, is a $3\frac{1}{2}$ " Rod, which is supported in the holes of two Reversed Angle Brackets. This rod carries a $\frac{1}{2}$ " Loose Pulley held in place between two Spring Clips.

The Cords that form guides for the rising and falling cage are arranged as seen in the illustration.

The arrangement of the cage winding Cord is as follows. A length of Cord is tied through one of the holes in a 1" loose Pulley mounted on a Rod at the top of the cage, and then is passed over the 1" fast Pulley placed between the two 3" Pulleys at the top of the tower. It is then wound for about six turns around the 5" Rod in the engine house, and then led around the $\frac{1}{2}$ " loose Pulley at the bottom of the shaft. Finally the Cord is made fast in another hole of the 1" loose Pulley in the cage.

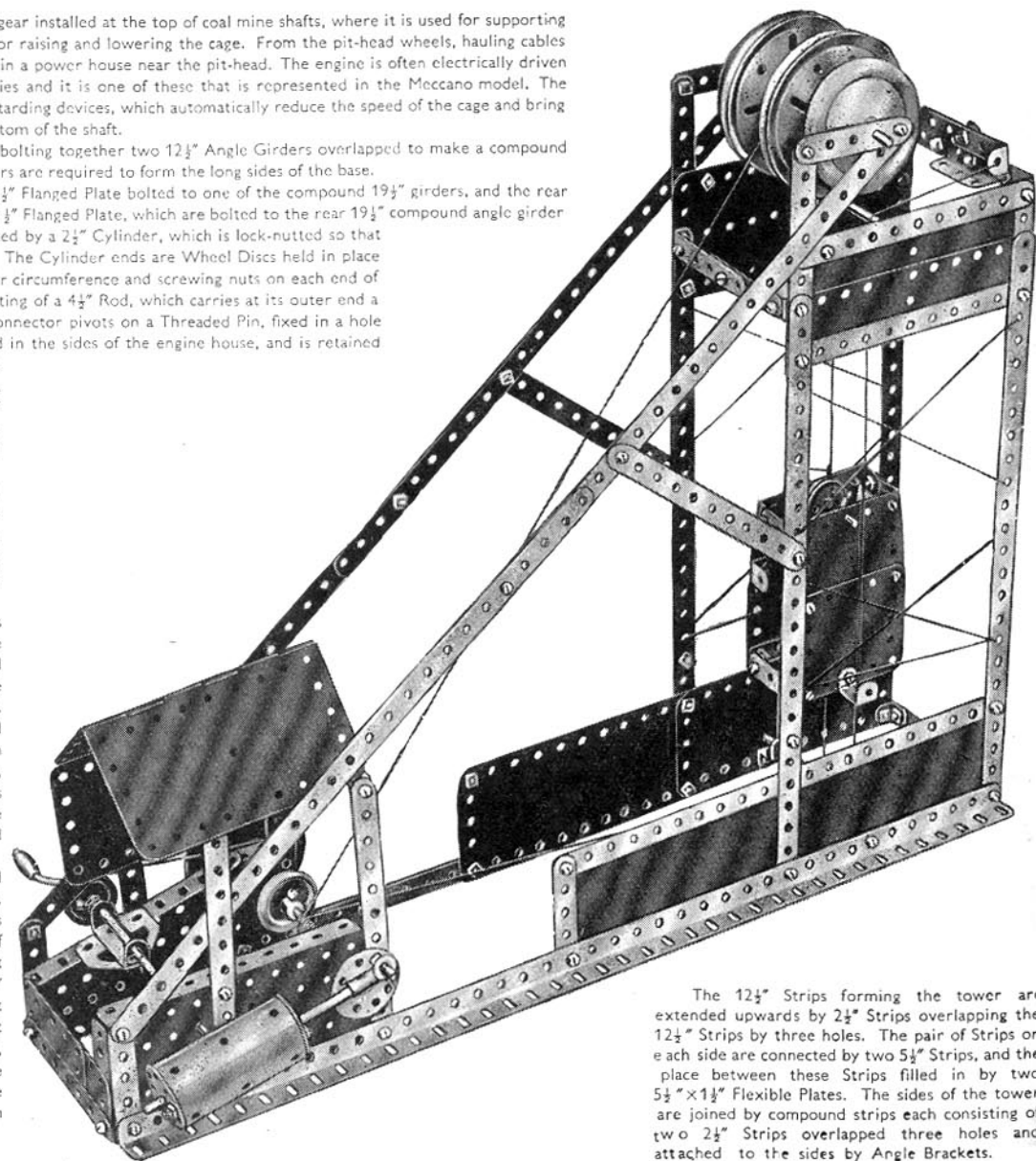

The $12\frac{1}{2}$ " Strips forming the tower are extended upwards by $2\frac{1}{2}$ " Strips overlapping the $12\frac{1}{2}$ " Strips by three holes. The pair of Strips on each side are connected by two $5\frac{1}{2}$ " Strips, and the place between these Strips filled in by two $5\frac{1}{2}$ " \times $1\frac{1}{2}$ " Flexible Plates. The sides of the tower are joined by compound strips each consisting of two $2\frac{1}{2}$ " Strips overlapped three holes and attached to the sides by Angle Brackets.

5.15 PADDLE STEAMER

Each side of the hull consists of a $5\frac{1}{2}'' \times 2\frac{1}{4}''$ Flexible Plate 1 at the bow, a $2\frac{1}{2}'' \times 2\frac{1}{2}''$ Plate 2, half of a Hinged Flat Plate 3, a second $5\frac{1}{2}'' \times 2\frac{1}{4}''$ Plate 4 and a $2\frac{1}{2}'' \times 2\frac{1}{4}''$ Plate 5. They are joined at the bow to a U-section Curved Plate and at the stern to two $1\frac{1}{4}''$ radius Curved Plates. A $5\frac{1}{2}'' \times 2\frac{1}{4}''$ Flanged Plate 6 (Fig. 5.15a) is bolted in position amidships and a Flanged Sector Plate 7 in the bows. A Flanged Sector Plate 8 extended by a Semi-Circular Plate fills in the stern. The $4\frac{1}{2}'' \times 2\frac{1}{4}''$ Flexible Plate 9 is attached by $2\frac{1}{4}'' \times \frac{1}{2}''$ Double Angle Strips to $5\frac{1}{2}''$ Strips. These Strips are secured to $2\frac{1}{2}'' \times \frac{1}{2}''$ Double Angle Strips bolted to the Flanged Plate.

The paddle wheels are represented by $3''$ Pulleys fixed on a $4''$ Rod journalled in the centre holes of the halves of the Hinged Flat Plate. The paddle casings are made by clamping a $2\frac{1}{2}'' \times 1\frac{1}{2}''$ Flexible plate between three $2\frac{1}{2}''$ Strips bridged by a $5\frac{1}{2}''$ Strip, and are attached to the upper part of the hull by Reversed Angle Brackets held to the casing by Bolt 13 on each side.

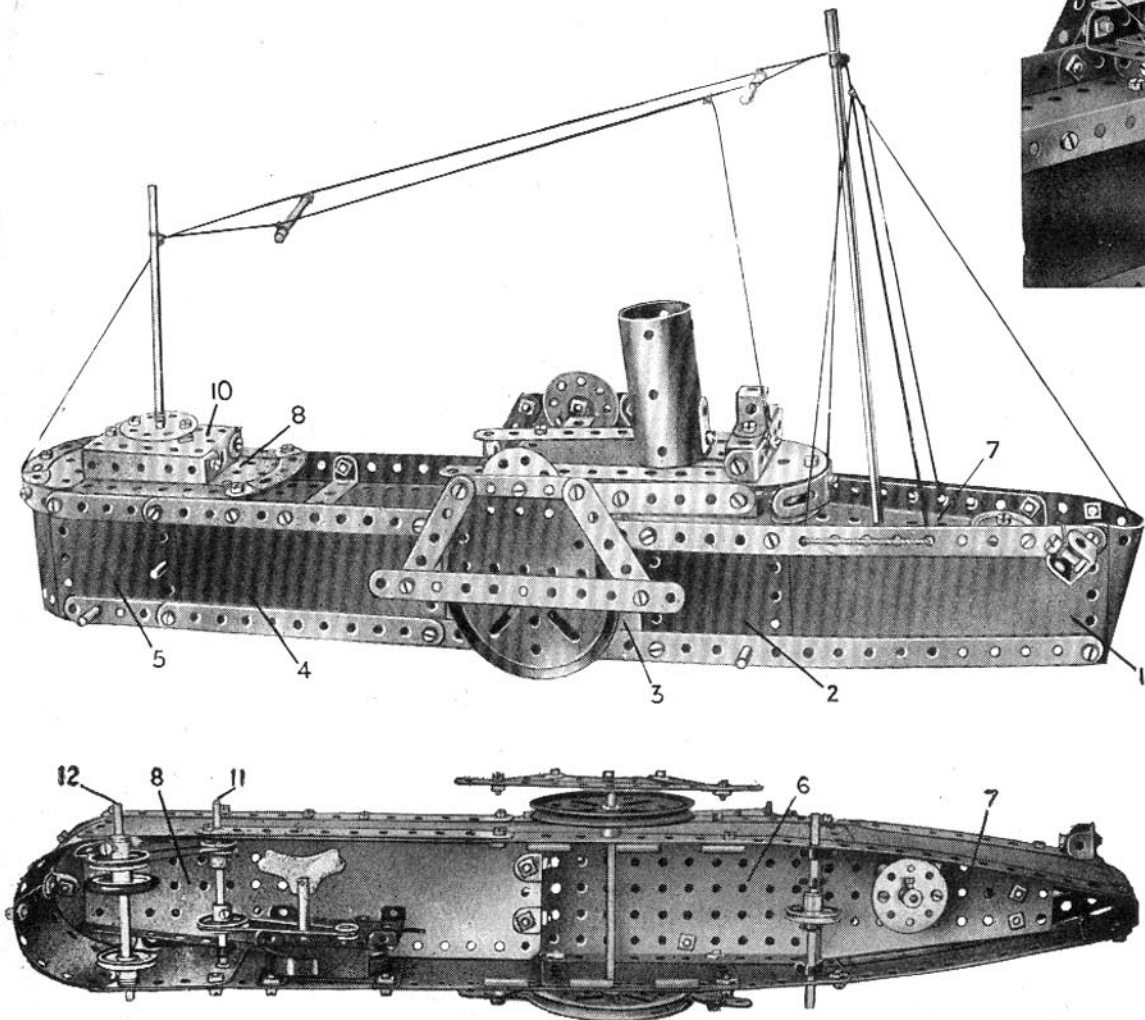

Fig. 5.15a

The forward mast is formed by a $5''$ and $4''$ Rod joined by a Rod Connector and it is "stepped" or mounted in a Bush Wheel bolted to the Sector Plate 7. The second mast is passed through a Wheel Disc bolted to the $2\frac{1}{2}'' \times 1\frac{1}{2}''$ Flanged Plate 10, and held by a Cord Anchoring Spring and a Spring Clip. The Wheel Disc is spaced from the Plate 10 by two nuts.

The method of mounting a *Magic* Motor to drive the model is shown in Fig. 5.15b. The drive from the Motor is taken to a $1''$ Pulley on Rod 11. A $\frac{1}{2}''$ Pulley on this Rod is connected by a Driving Band to a $1''$ Pulley on Rod 12, and a $1''$ Pulley fitted with a Rubber Ring on the same Rod contacts the ground and so drives the model along.

Note: The *Magic* Motor used in this model is not included in the Outfit.

Fig. 5.15b

5.16 PLATFORM WEIGHING MACHINE

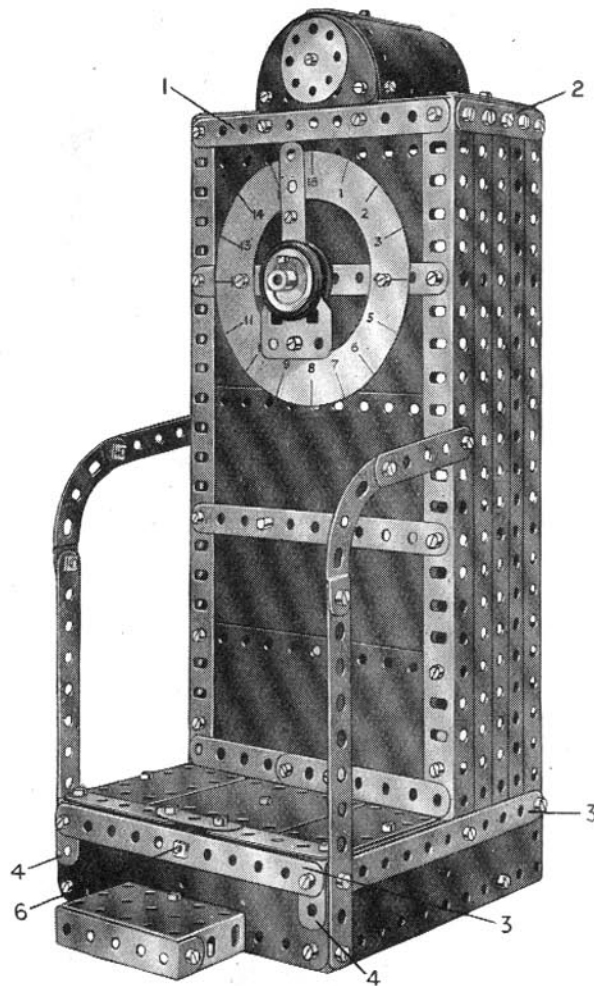

The upright column is formed by four $12\frac{1}{2}''$ Angle Girders joined by the $5\frac{1}{2}''$ Strips 1 and $2\frac{1}{4}''$ Strips 2. Each side is filled in by three $12\frac{1}{2}''$ Strips. The front is completed by four $4\frac{1}{2}'' \times 2\frac{1}{4}''$ Flexible Plates, and a $2\frac{1}{2}'' \times 2\frac{1}{2}''$ and a $4\frac{1}{2}'' \times 2\frac{1}{4}''$ Flexible Plate overlapped three holes.

The base is built up from the $5\frac{1}{2}''$ Strips 3 and $5\frac{1}{2}'' \times 1\frac{1}{2}''$ Flexible Plates. Two $2\frac{1}{2}'' \times 1\frac{1}{2}''$ Flexible Plates are attached to Double Angle Strips bolted to the $1'' \times 1''$ Angle Brackets 4. The weighing platform consists of half of a Hinged Flat Plate secured to the $5\frac{1}{2}''$ Strips 5 (Fig. 5.16a) by a Double Bracket. The Strips 5 are pivoted by a $1\frac{1}{2}''$ Rod to a second Double Bracket fastened to the base by Bolt 6.

(Continued on next page)

5.16 PLATFORM WEIGHING MACHINE—continued

A 3" Pulley is locked on the Rod 7. The 3½" Strips 8 are joined by a 1½" x ½" Double Angle Strip and attached to the 3" Pulley. The Strips 8 are connected by a 5½" Strip and an Angle Bracket to the levers 5 in the base. The balance weight consists of two Road Wheels locked on a 2" Rod mounted in the Strips 8.

The 3" Pulley is connected to a 1" Pulley on the Rod 9 by a belt of Cord.

The pointer, mounted on Rod 9, is made from two 2½" Strips overlapped three holes and a Flat Trunnion clamped between two 1" Pulleys fitted with Rubber Rings.

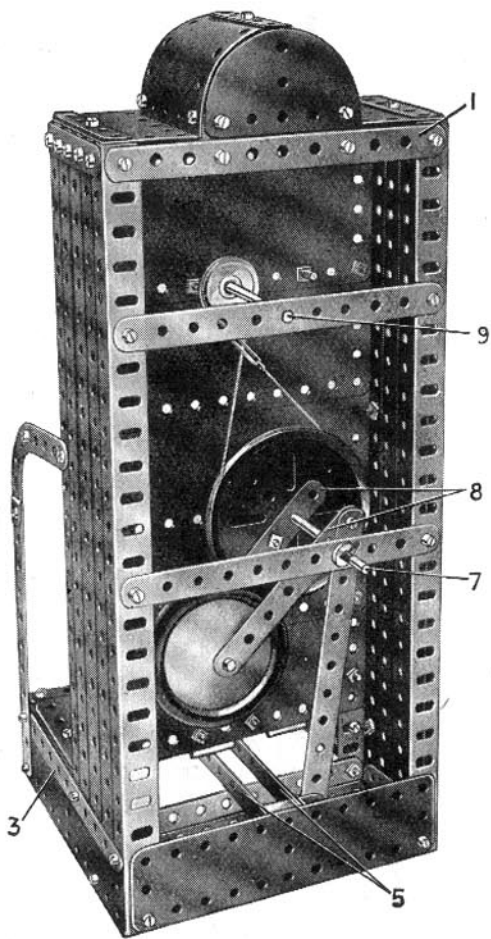

Fig. 5.16a

5.17
AUTOMATIC
SHIP-COALER

The construction of the cabin, hoisting carriage and truck are shown in Figs. 5.17a and 5.17c. The 2½" x 1½" Flanged Plate is lock-nutted to the 1½" radius Curved Plates (Fig. 5.17b) which are overlapped three holes. The built up pulley on the same 4" Rod as the Road Wheels consist of two ¾" Washers spaced by two Washers, and is retained in position by two Spring Clips.

The rails on which the grab hoist and truck run are Angle Girders. Those forming the rails for the grab hoist are bolted at their inner ends to the rear pair of 5½" Strips at the top of the tower, but are not connected to the second pair of Strips. This enables the hoist to travel the full length of the rails. The Wheel Discs that form the wheels of the grab hoist revolve on bolts lock-nutted to the 2½" x ½" Double Angle Strips.

The grab consists of 2½" small radius Curved Strips bolted to 3½" Strips, and the 5½" x 1½" Flexible Plate is attached to them by Angle Brackets.

The operating Cords are arranged as follows. Cord 1 is tied at 2 to the grab hoist, passed over a 3½" Rod in the tower, and then around a 1½" Rod held by Spring Clips in a Double Bracket. Finally it is tied to the rear of the truck at 3. Cord 4 is fastened to the truck at 5, led over a ¾" loose Pulley on the 3½" Rod halfway up the tower, and around the built-up pulley on the Rod that carries the Road Wheels. It is then wound around the Crank Handle.

Cord 6 is fastened to Fish-plate 7 on the grab, and is taken over one of the 1" loose Pulleys on the grab hoist. It then passes through the end holes of the 1" x 1" Angle Brackets at the end of the jib and is led over the second 1" loose Pulley and finally tied to the other Fishplate on the grab.

The length of the grab operating Cord should be adjusted so that the grab reaches the tower at the same time as the truck reaches the inner end of the rails.

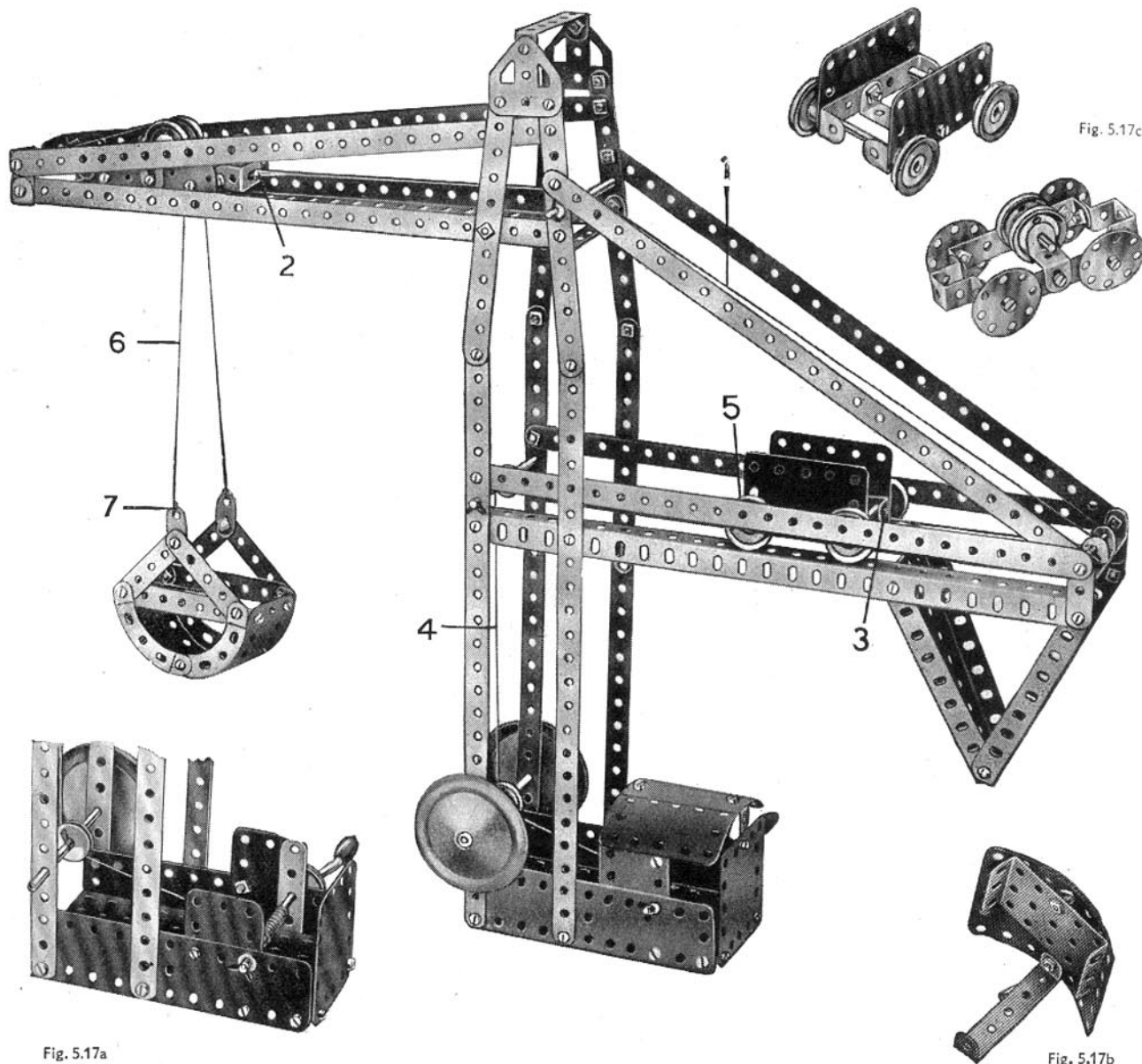
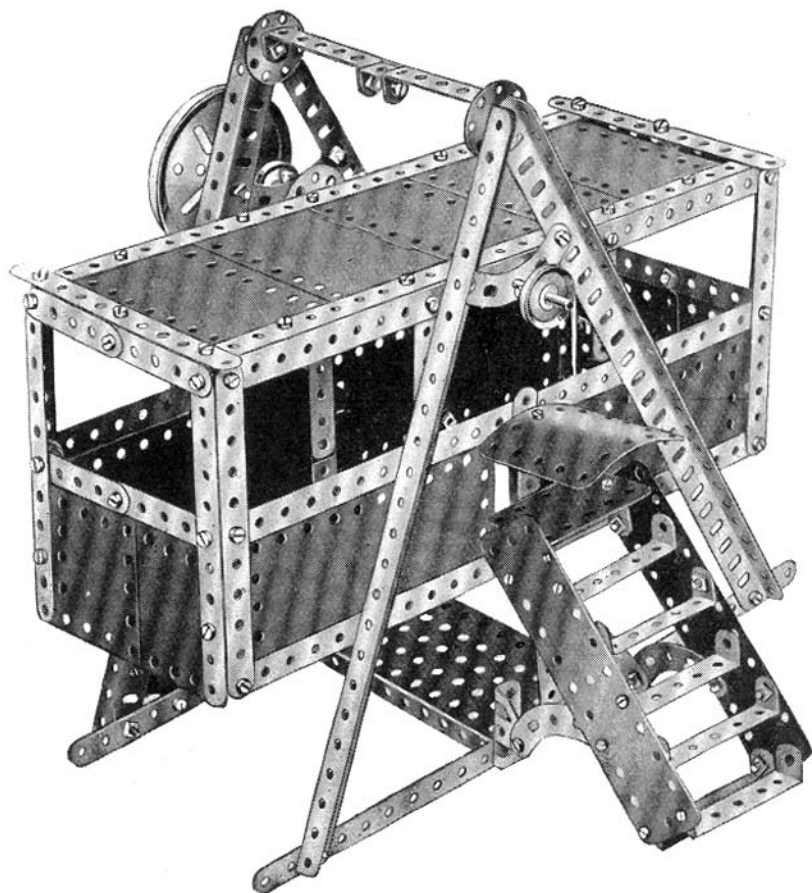

Fig. 5.17a

Fig. 5.17c

Fig. 5.17b

5.18 GIANT SWING BOAT



The main supports for the swing-boat are formed by $12\frac{1}{2}$ " Angle Girders, which are bolted to a base made by fastening two $12\frac{1}{2}$ " Strips to a $5\frac{1}{2}$ " \times $2\frac{1}{2}$ " Flanged Plate. The steps are supported by two $2\frac{1}{2}$ " small radius Curved Strips, bolted to the sides of the staircase and to two Trunnions fastened to the base. The platform at the top consists of a $2\frac{1}{2}$ " \times $1\frac{1}{2}$ " Flexible Plate held in position by two 1 " \times 1 " Angle Brackets.

The $1\frac{1}{4}$ " radius Curved Plate is fastened to a Double Bent Strip bolted to one end of a $5\frac{1}{2}$ " Strip, the other end of which is fastened to the base.

The swing-boat is pivoted on a compound rod consisting of 5 " Rod and a 4 " Rod joined by a Rod Connector. The compound Rod is held in the boss of a Bush Wheel bolted to the side of the swing-boat.

The model is driven by means of a Crank Handle journalled in holes in two Flanged Sector Plates as shown in Fig. 5.18a below. The Sector Plates are bolted at their lower ends to a $2\frac{1}{2}$ " \times $1\frac{1}{2}$ " Flanged Plate and to two Double Brackets. The Crank Handle carries a 1 " Pulley, which is connected by a Driving Band to a 3 " Pulley fixed on a 2 " Rod also journalled in the Flanged Sector Plates. A $5\frac{1}{2}$ " Strip is attached to a Pivot Bolt fixed in the 3 " Pulley, and its other end is pivoted on a bolt lock-nutted to another 3 " Pulley fixed on the pivot rod of the swing-boat.

If desired, a *Magic Motor* can be used to drive the model, and the method of fixing it in place is shown in Fig. 5.18a. The Motor should be bolted direct to the base, and the Pulley on its driving shaft then connected by a Driving Band to a second 1 " Pulley mounted on the Crank Handle.

Note: The Motor used in this model is not included in the Outfit.

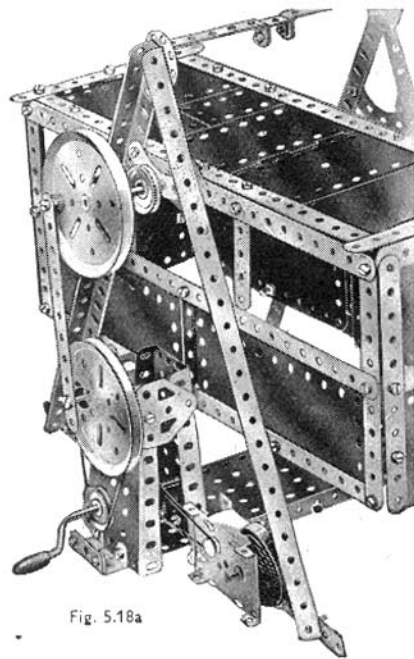
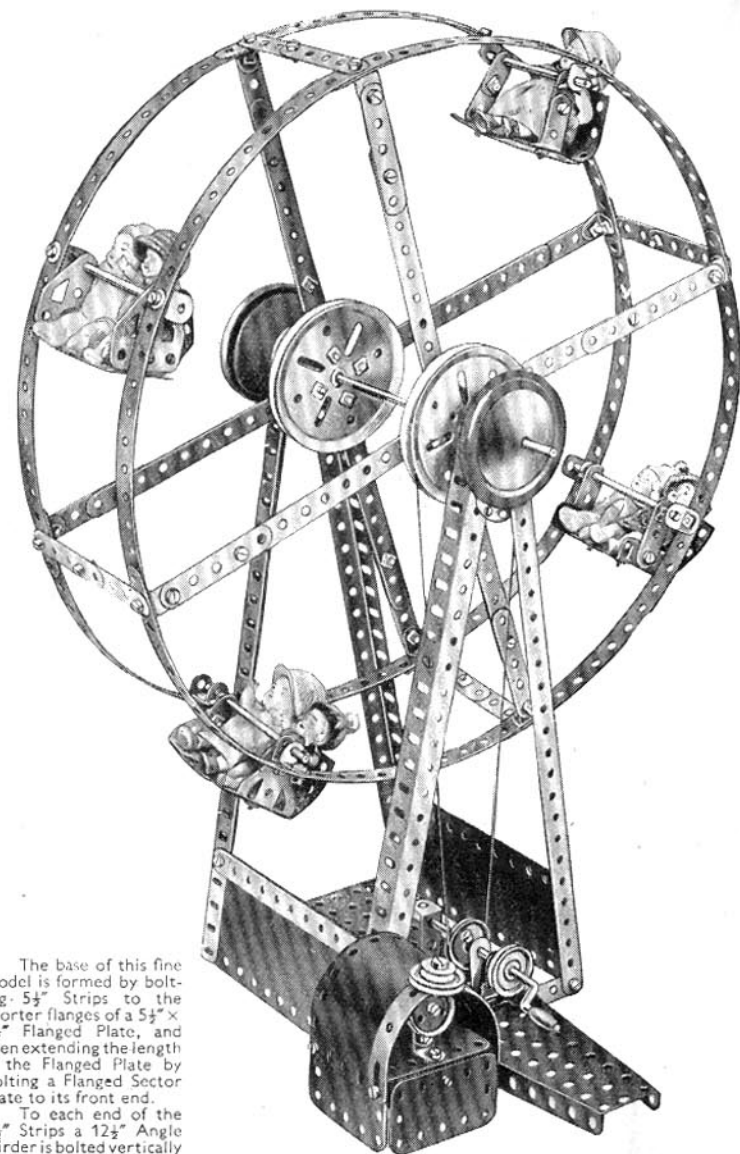

Fig. 5.18a

5.19 BIG WHEEL



The base of this fine model is formed by bolting $5\frac{1}{2}$ " Strips to the shorter flanges of a $5\frac{1}{2}$ " \times $2\frac{1}{2}$ " Flanged Plate, and then extending the length of the Flanged Plate by bolting a Flanged Sector Plate to its front end.

To each end of the $5\frac{1}{2}$ " Strips a $12\frac{1}{2}$ " Angle Girder is bolted vertically as shown and these form the pillars that support the axle of the wheel. A $5\frac{1}{2}$ " \times $2\frac{1}{2}$ " Flexible Plate is bolted across the Angle Girders at each side of the base in the positions shown.

(Continued on next page)

5.19 BIG WHEEL—continued

Each rim of the wheel consists of four $12\frac{1}{2}$ " Strips bolted so that they overlap three holes. The rims are connected by 4" compound strips consisting of $2\frac{1}{2}$ " Strips overlapped and bolted together, and are secured by $6\frac{1}{2}$ " compound strips to a Bush Wheel and the inner holes of a 3" Pulley on the supporting shaft. This shaft is a 5" Rod and a 4" Rod joined end to end by a Rod Connector, and is journalled in the centre holes of two Wheel Discs secured to the ends of the two $12\frac{1}{2}$ " Angle Girders bolted to the base.

The drive is taken by means of Cord belt from a 1" Pulley on the shaft of a Crank Handle to a 3" Pulley on the shaft of the wheel. The Crank Handle is journalled in the holes of a Stepped Bent Strip bolted to the Flanged Sector Plate and also in the upper hole of a $1\frac{1}{2}$ " x $\frac{1}{2}$ " Double Angle Strip fixed vertically to the $5\frac{1}{2}$ " x $2\frac{1}{2}$ " Flanged Plate.

The construction of the cars can be seen from the illustration and it will be noticed that their details vary from each other. In one of the cars the sides are formed from Flat Trunnions, while in the second Trunnions are used for this purpose. In a third car the sides are $1\frac{1}{2}$ " Strips, while in the fourth they are formed by 1 " x 1 " Angle Brackets to which Fishplates are bolted.

The pay-box is built up as follows. Three $2\frac{1}{2}$ " x $1\frac{1}{2}$ " Flexible Plates form the sides of the base. They are joined together and secured to the framework of the model by $2\frac{1}{2}$ " x $\frac{1}{2}$ " Double Angle Strips. The Plate forming the counter is held to the Front Plate by means of an Angle Bracket. The roof and upper portions of the sides of the box consist of a $5\frac{1}{2}$ " x $2\frac{1}{2}$ " Flexible Plate bent as shown and edged at the front with two 3" Formed Slotted Strips.

A decorative effect is provided by a 1" loose Pulley and a $\frac{1}{2}$ " loose Pulley fixed to the roof by means of a Pivot Bolt and Nut.

5.20 INDUSTRIAL TRACTOR

Each side of the chassis consists of two $12\frac{1}{2}$ " Angle Girders 1 (Fig. 5.20a), and two $12\frac{1}{2}$ " Strips 2 and 3. The chassis members are joined together at the rear by a $2\frac{1}{2}$ " x $1\frac{1}{2}$ " Flanged Plate, and at the front by two Double Angle Strips 4 (Fig. 5.20b). Three $5\frac{1}{2}$ " Strips are attached to Flat Trunnions and bolted to the Double Angle Strips.

The sides of the bonnet are formed by $5\frac{1}{2}$ " x $2\frac{1}{2}$ " Flexible Plates, and the radiator consists of a $2\frac{1}{2}$ " x $2\frac{1}{2}$ " Flexible Plate and a Semi-Circular Plate secured to a Double Angle Strip 5. The back of the bonnet is constructed in the same way as the radiator, and the top is made by bending a $4\frac{1}{2}$ " x $2\frac{1}{2}$ " and two $5\frac{1}{2}$ " x $2\frac{1}{2}$ " Flexible Plates and securing them to the sides.

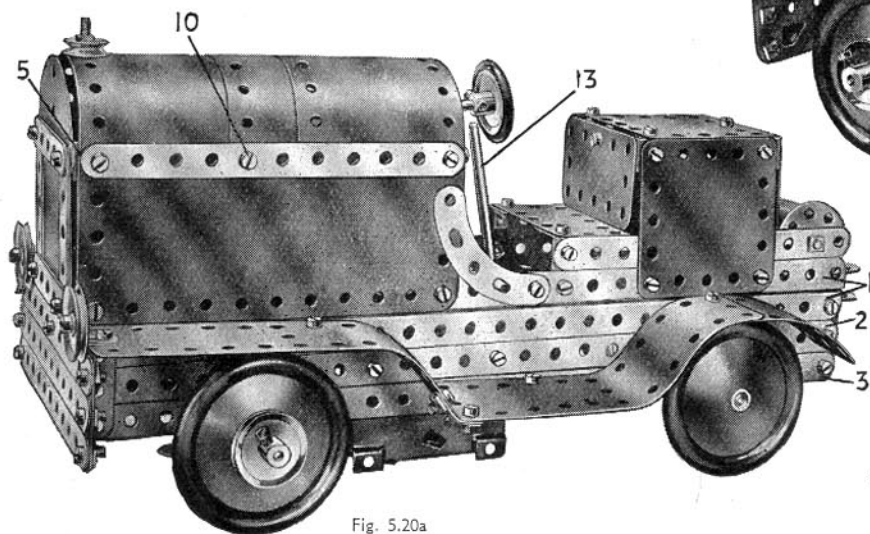
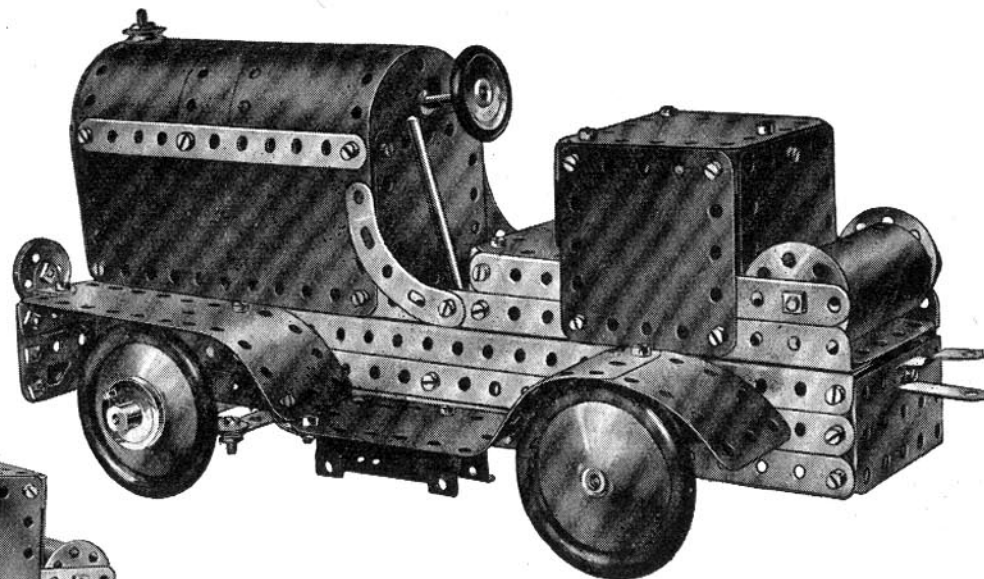

Fig. 5.20a

The mudguards on each side of the model consist of one $2\frac{1}{2}$ " x $1\frac{1}{2}$ " and two $5\frac{1}{2}$ " x $1\frac{1}{2}$ " Flexible Plates bolted together and attached to the chassis by four Angle Brackets, the Fishplates 6 and the Trunnions 7.

The front axle beam is made by overlapping a $2\frac{1}{2}$ " and a $3\frac{1}{2}$ " Strip three holes, and it is attached to the chassis by a $2\frac{1}{2}$ " x $\frac{1}{2}$ " Double Angle Strip. Each Road Wheel is free to turn on a $1\frac{1}{2}$ " Rod passed through a Double Bracket and held in position by a Spring Clip. The $\frac{3}{8}$ " Bolts 8 pass through the centre hole of a $2\frac{1}{2}$ " Strip and the Double Bracket, and are lock-nutted to the axle beam.

Steering is controlled by a Bush Wheel locked on a 5" Rod 9. The Rod is supported in the Semi-Circular Plate and a Double Angle Strip held by the Bolt 10. A compound Strip consisting of two $2\frac{1}{2}$ " Strips bolted together is secured to the Bush Wheel, and is connected to the track rod by a Threaded Pin passed through the slotted hole of an Angle Bracket 11.



A Magic Motor can be fitted as shown in Fig. 5.20b. The drive from the Motor is taken to a 1" Pulley on a $3\frac{1}{2}$ " Rod mounted in the chassis. A $\frac{1}{2}$ " Pulley on this Rod drives a 1" Pulley on the rear axle, which is formed by a $3\frac{1}{2}$ " and a 2" Rod joined by a Rod Connector. The Motor is controlled by a Rod 13, attached to the Motor brake lever by a Rod and Strip Connector.

Note: The Motor used in this model is not included in this Outfit.

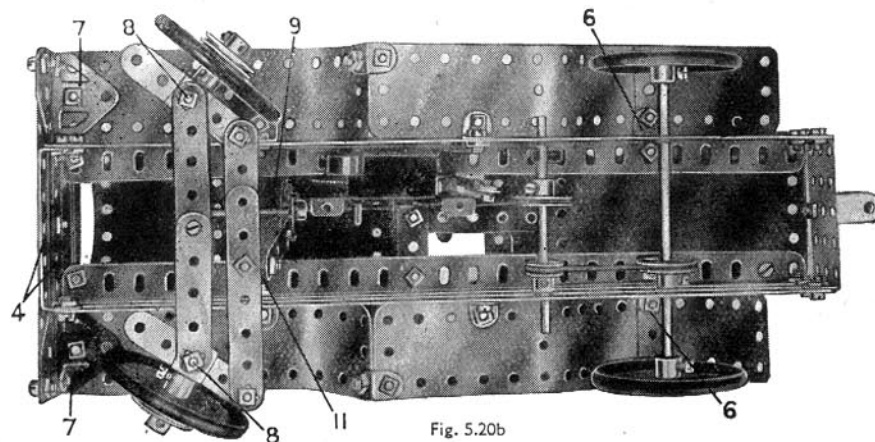

Fig. 5.20b

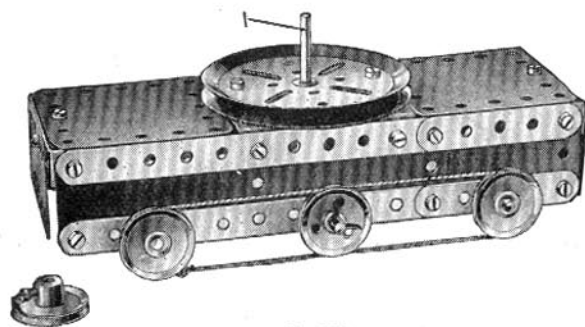
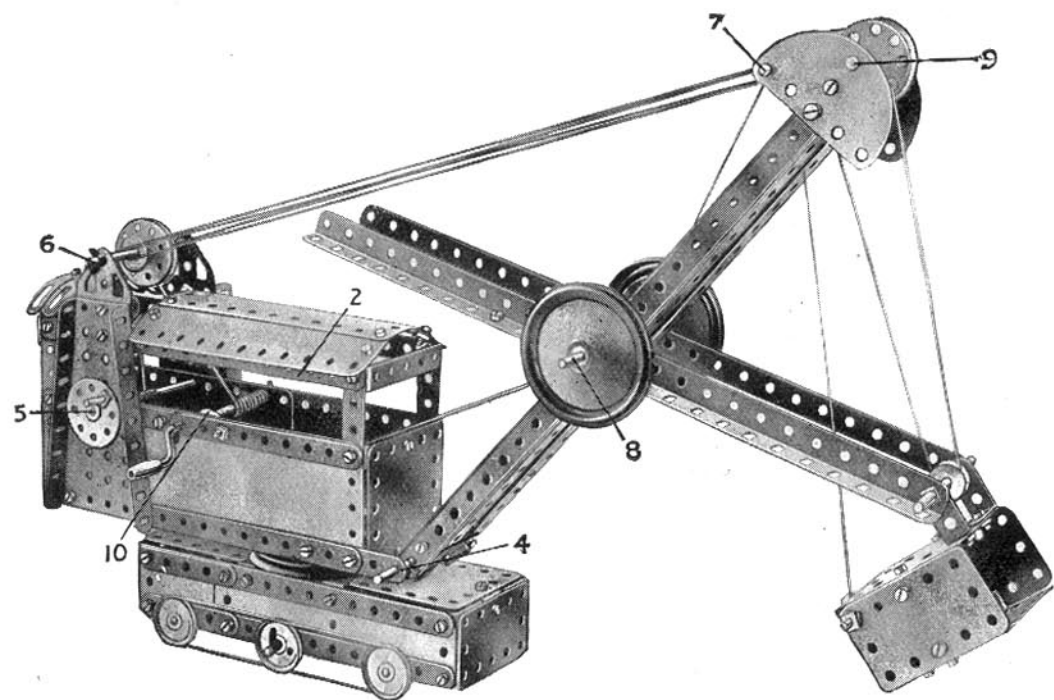

Fig. 5.21a

5.21 MECHANICAL SHOVEL

Each side of the tractor unit is formed by a $5\frac{1}{2}$ " Strip extended by a $2\frac{1}{2}$ " Strip, and by two $5\frac{1}{2}$ " \times $1\frac{1}{2}$ " Flexible Plates. The sides are joined by four Double Angle Strips, and a 3" Pulley is bolted to the inner pair of these. The 1" Pulleys are fastened to $3\frac{1}{2}$ " Rods, and a length of Cord represents the creeper tracks.

The sides of the cab consist of a $4\frac{1}{2}$ " \times $2\frac{1}{2}$ " and a $5\frac{1}{2}$ " \times $2\frac{1}{2}$ " Flexible Plate overlapped five holes and bolted to a $5\frac{1}{2}$ " \times $2\frac{1}{2}$ " Flanged Plate. A Trunnion secured to the front of the plate is passed over the Rod 1 (Fig. 5.21a) and a 1" Pulley is used to keep the cab in position. The sides are joined at the front by two Double Angle Strips and a $2\frac{1}{2}$ " \times $2\frac{1}{2}$ " Flexible Plate bolted in position. A similar Plate is attached at the rear.

The cab roof consists of two $5\frac{1}{2}$ " \times $2\frac{1}{2}$ " Flexible Plates and is secured to Obtuse Angle Brackets bolted to the Compound Strips 2. These Strips are formed by a $5\frac{1}{2}$ " Strip and a $3\frac{1}{2}$ " Strip overlapped two holes. The rear portion of the roof is made by securing three Formed Slotted Strips to a $1\frac{1}{2}$ " Double Angle Strip 3 (Fig. 5.21b), which is attached by a $\frac{1}{2}$ " Bolt to a Fishplate, six Washers being used for spacing purposes.

The jib consists of two U-section Girders joined at each end by a $1\frac{1}{2}$ " Strip, and it pivots about a $3\frac{1}{2}$ " Rod journalled in the $2\frac{1}{2}$ " Strips 4. Each girder is made from a $12\frac{1}{2}$ " Strip and an Angle Girder secured together by Angle Brackets. The jib is luffed by a length of Cord extending from the Rod 5. This is passed over Rod 6, around Rod 7 and again over Rods 6 and 7, and finally secured to Rod 6.

The shovel arm consists of two $12\frac{1}{2}$ " Angle Girders joined by a $2\frac{1}{2}$ " Strip and pivoted on Rod 8. The shovel is made from two $2\frac{1}{2}$ " \times $2\frac{1}{2}$ " and two $2\frac{3}{4}$ " \times $1\frac{1}{2}$ " Flexible Plates joined together by four Angle Brackets. The back is a $2\frac{1}{2}$ " \times $1\frac{1}{2}$ " Flanged Plate and is attached by lock-nuts. The shovel is pivoted on the arm by a 3" Screwed Rod. It is operated by a length of Cord from the Crank Handle. This Cord passes over two built-up Pulleys on Rods 6 and 9, around a $\frac{1}{2}$ " Pulley on the Screwed Rod and is then fastened in the jib head. Each of the built up Pulleys consist of two Wheel Discs separated by two Washers and fastened between Spring Clips.

The back of the shovel is released to discharge its contents by means of Cord from the $2\frac{1}{2}$ " Strip 10. This Cord passes over the jib and is tied to a Rod and Strip Connector fitted with a 1" Rod. The Rod passes through a Double Bracket on the back of the shovel and into a Fishplate bolted to the lower $2\frac{1}{2}$ " \times $2\frac{1}{2}$ " Flexible Plate.

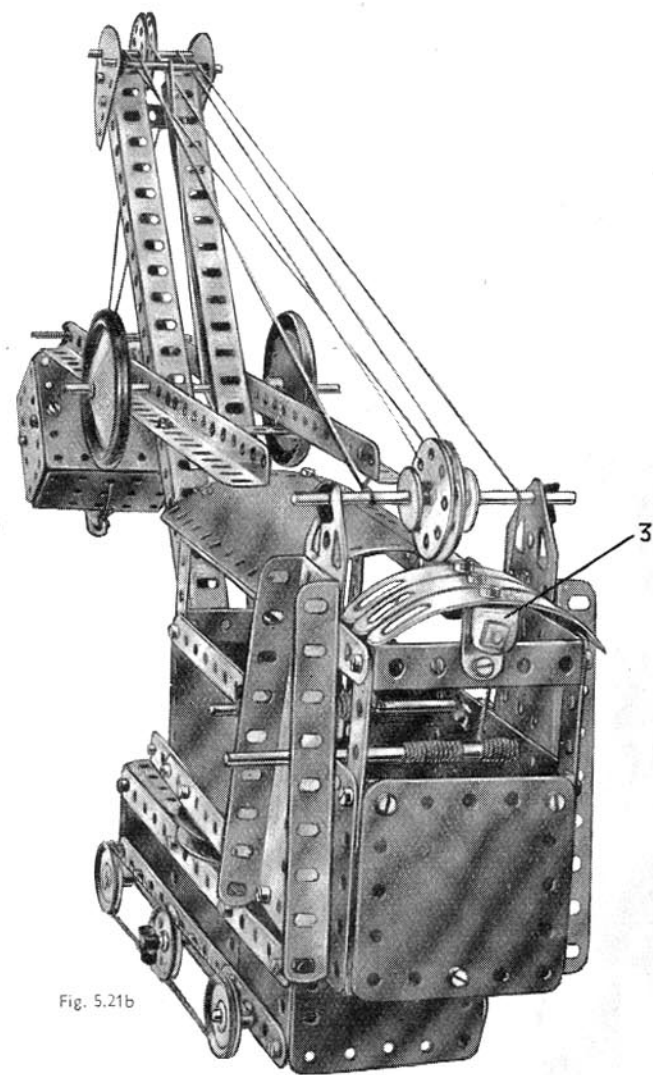

Fig. 5.21b

5.22 HAMMERHEAD CRANE

The upper girders of the jib are each made by bolting $12\frac{1}{2}$ " Strips to a $2\frac{1}{2}$ " Strip attached to a Flanged Sector Plate. The lower girders are also formed by two $12\frac{1}{2}$ " Strips, and these are joined to the Flanged Sector Plate at the centre and connected to the upper girders by $2\frac{1}{2}$ " Strips at each end as shown. The Flanged Sector Plates are attached to two $2\frac{1}{2}$ " x $\frac{1}{2}$ " Double Angle Strips bolted across a 3" Pulley and the free ends of the $12\frac{1}{2}$ " Strips are also connected by $2\frac{1}{2}$ " x $\frac{1}{2}$ " Double Angle Strips. The rear section of the jib is braced by a diagonal $12\frac{1}{2}$ " Strip at each side. This is bolted to the rear of the jib and attached to a Fishplate bolted to the Flanged Sector Plate. The forward section of the jib is braced by Strips of various sizes as shown.

The pin is removed from a Hinged Flat Plate, and the halves used separately to form the sides of the cab. The roof consists of two $1\frac{1}{8}$ " radius Curved Plates braced by Formed Slotted Strips. It is attached by Obtuse Angle Brackets to two $5\frac{1}{2}$ " and two $2\frac{1}{2}$ " Strips bolted to the sides of the cab.

The top of the tower consists of a $5\frac{1}{2}$ " x $2\frac{1}{2}$ " Flanged Plate bolted to the $5\frac{1}{2}$ " Strips 1. It is extended on each side by a $5\frac{1}{2}$ " x $2\frac{1}{2}$ " Flexible Plate. The 3" Pulley 2 is attached to the Flanged Plate by two Reversed Angle Brackets and two Double Brackets. A second 3" Pulley is secured to the jib by two Double Angle Strips and is free to turn about a 2" Rod locked in the Pulley 2. The jib is held in position by a Road Wheel.

The travelling carriage consists of a $2\frac{1}{2}$ " x $1\frac{1}{2}$ " Flanged Plate. The wheels are locked on $3\frac{1}{2}$ " Rods journalled in a $1\frac{1}{2}$ " x $\frac{1}{2}$ " Double Angle Strip and two Angle Brackets.

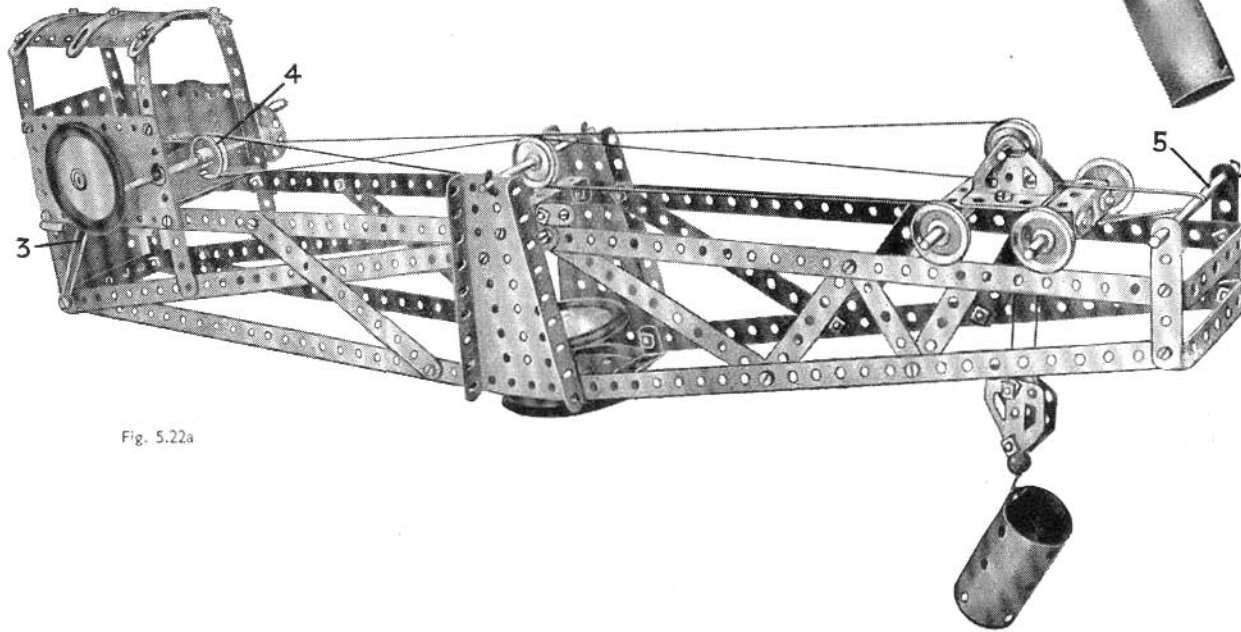
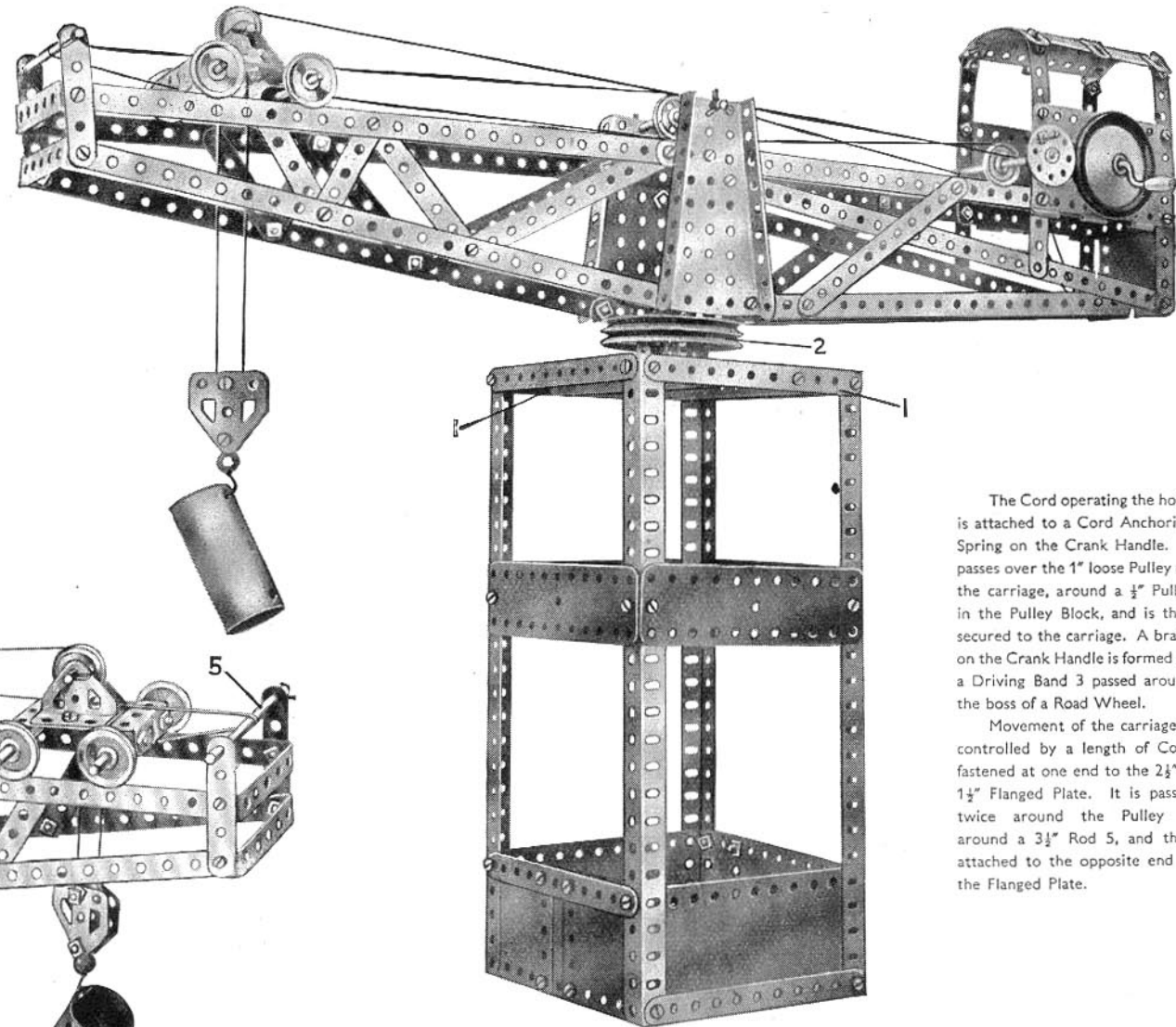

Fig. 5.22a



The Cord operating the hoist is attached to a Cord Anchoring Spring on the Crank Handle. It passes over the 1" loose Pulley on the carriage, around a $\frac{1}{2}$ " Pulley in the Pulley Block, and is then secured to the carriage. A brake on the Crank Handle is formed by a Driving Band 3 passed around the boss of a Road Wheel.

Movement of the carriage is controlled by a length of Cord fastened at one end to the $2\frac{1}{2}$ " x $1\frac{1}{2}$ " Flanged Plate. It is passed twice around the Pulley 4, around a $3\frac{1}{2}$ " Rod 5, and then attached to the opposite end of the Flanged Plate.

5.23 TRANSPORTER BRIDGE

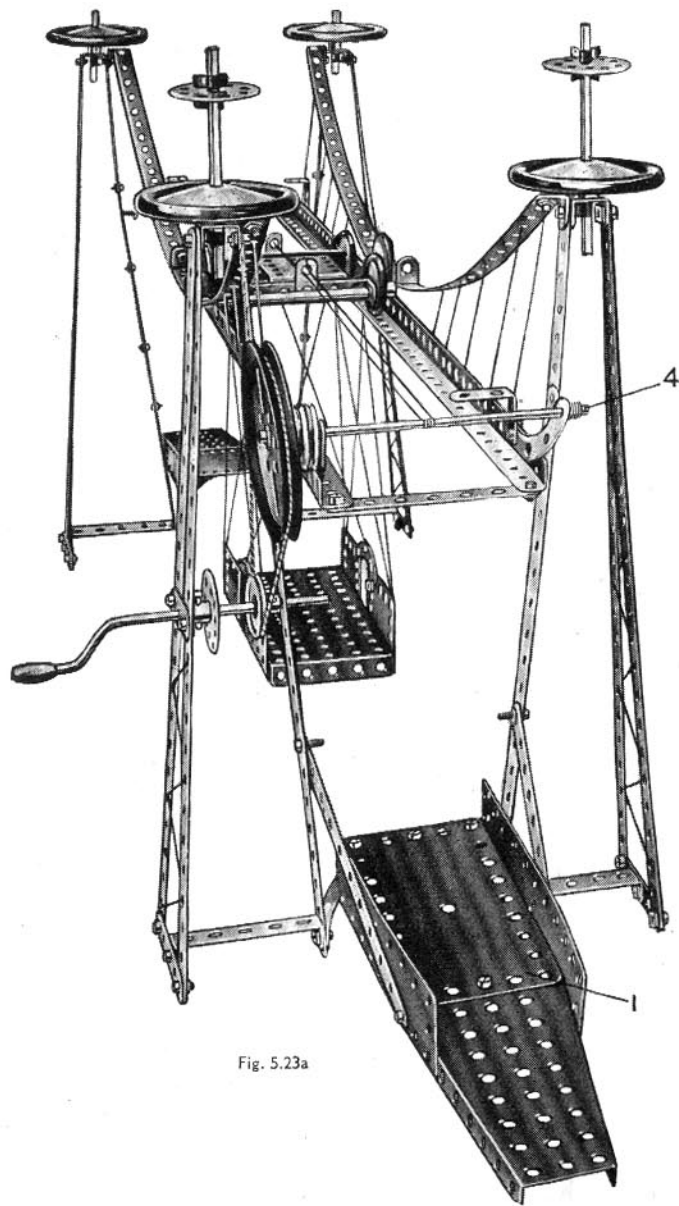
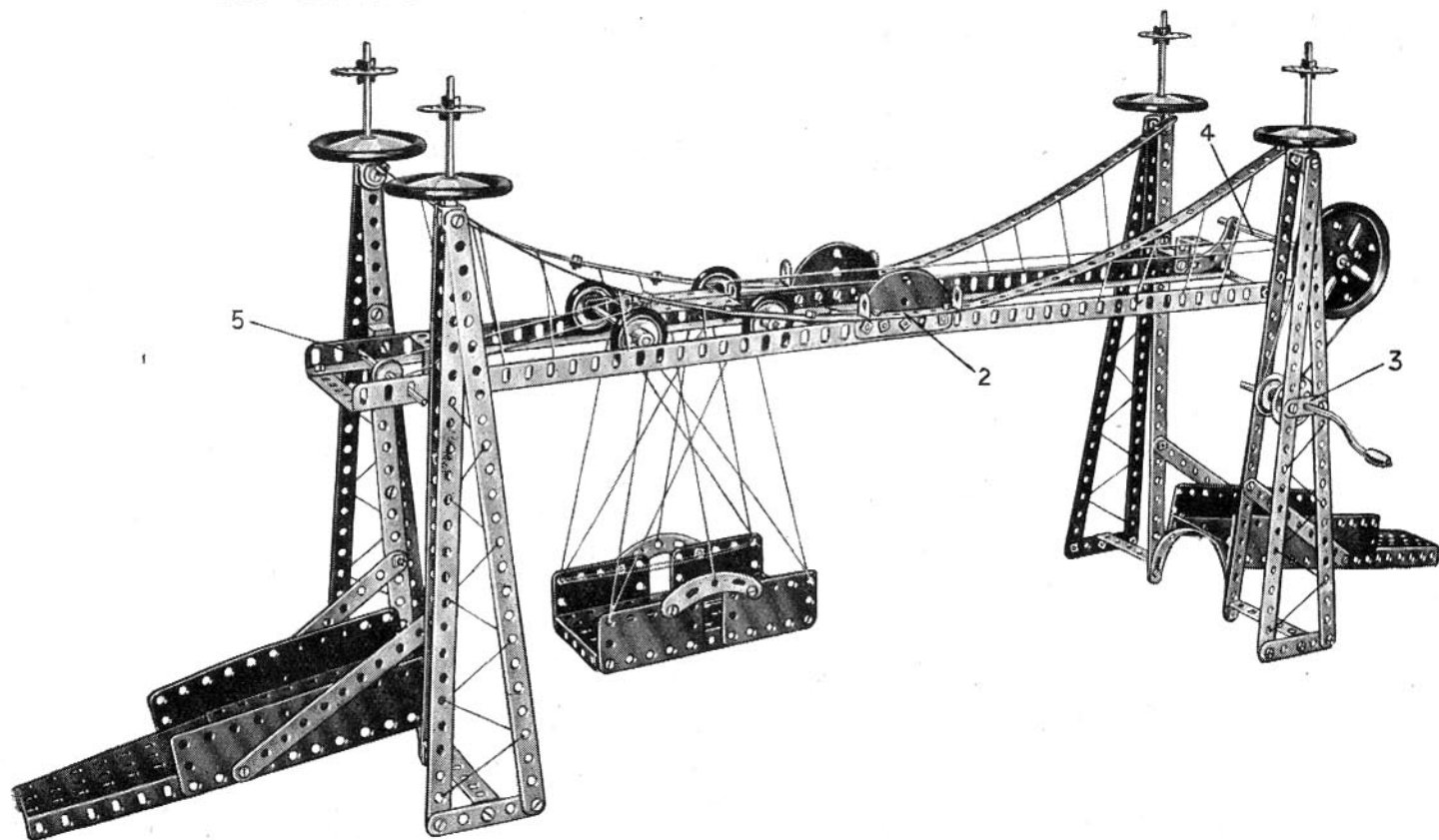

Fig. 5.23a



Two of the four supporting towers are built from three $12\frac{1}{2}$ " Strips joined at the top by a Double Bracket. The remaining towers are constructed similarly, but two of the strips used in them are made up from one $2\frac{1}{2}$ " and two $5\frac{1}{2}$ " Strips.

Each of the approach roadways consist of half of a Hinged Flat Plate 1 (Fig. 5.23a) and a Flanged Sector Plate. The sides are formed by $5\frac{1}{2}$ " x $1\frac{1}{2}$ " Flexible Plates. The approaches are attached to Formed Slotted Strips bolted to the bases of the tower.

Each side of the runway for the travelling carriage is formed by two $12\frac{1}{2}$ " Angle Girders, joined at the centre by a Semi-Circular Plate. The Girders are attached to a Reversed Angle Bracket bolted to each tower. The suspension links are each built up from three $5\frac{1}{2}$ " Strips, two $2\frac{1}{2}$ " Strips and a $2\frac{1}{2}$ " Double Angle Strip 2, and are attached to the towers and to the centre of the Angle Girders by Angle Brackets.

The travelling carriage consists of a $2\frac{1}{2}$ " x $1\frac{1}{2}$ " Flanged Plate, and runs on four 1 " Pulleys fitted with Rubber Rings. The Pulleys are locked on $3\frac{1}{2}$ " Rods journaled in Double Angle Strips bolted to each end of the Flanged Plate. The transporter carriage is made from four $2\frac{1}{2}$ " x $1\frac{1}{2}$ " Flexible Plates bolted to the sides of a $5\frac{1}{2}$ " x $2\frac{1}{2}$ " Flanged Plate, and is suspended from the travelling carriage by Cord.

The carriage is operated by a Crank Handle supported in a $12\frac{1}{2}$ " Strip of one of the towers and in a $1\frac{1}{2}$ " Strip 3. A 1 " Pulley on the Crank Handle is connected by a belt of Cord with a 3 " Pulley on the Rod 4, which is journaled in Curved Strips bolted to the Angle Girders. A length of Cord is tied to a Fishplate at one end of the carriage and taken around a $\frac{1}{2}$ " Pulley on Rod 5. It is then given several turns around Rod 4 and tied to a Fishplate at the other end of the travelling carriage.

5.24 RACING SEAPLANE

The fuselage is built up on two $12\frac{1}{2}$ " Strips, one of which can be seen at 1. These Strips are attached at the nose to a Bush Wheel by Angle Brackets and at the tail to a Double Bracket. The $5\frac{1}{2}$ " \times $2\frac{1}{2}$ " Flexible Plates 2 are then carefully bent and bolted to the Strips 1. A $2\frac{1}{2}$ " \times $1\frac{1}{2}$ " Flexible Plate 3 is held in position by a Fishplate 4 (Fig. 5.24a). A $5\frac{1}{2}$ " Strip 5 and a $2\frac{1}{2}$ " Strip 6, are bolted on each side to the lower ends of the Plates 2.

A $5\frac{1}{2}$ " \times $1\frac{1}{2}$ " Flexible Plate 7 and a $5\frac{1}{2}$ " Strip 8 are bolted to each side of the fuselage. The Strips 8 are joined by a Double Bracket, and are connected to the $12\frac{1}{2}$ " Strips 1 by Fishplates. Two U-section Curved Plates 9 are bolted together and held in position by a Bolt 10 on each side of the model.

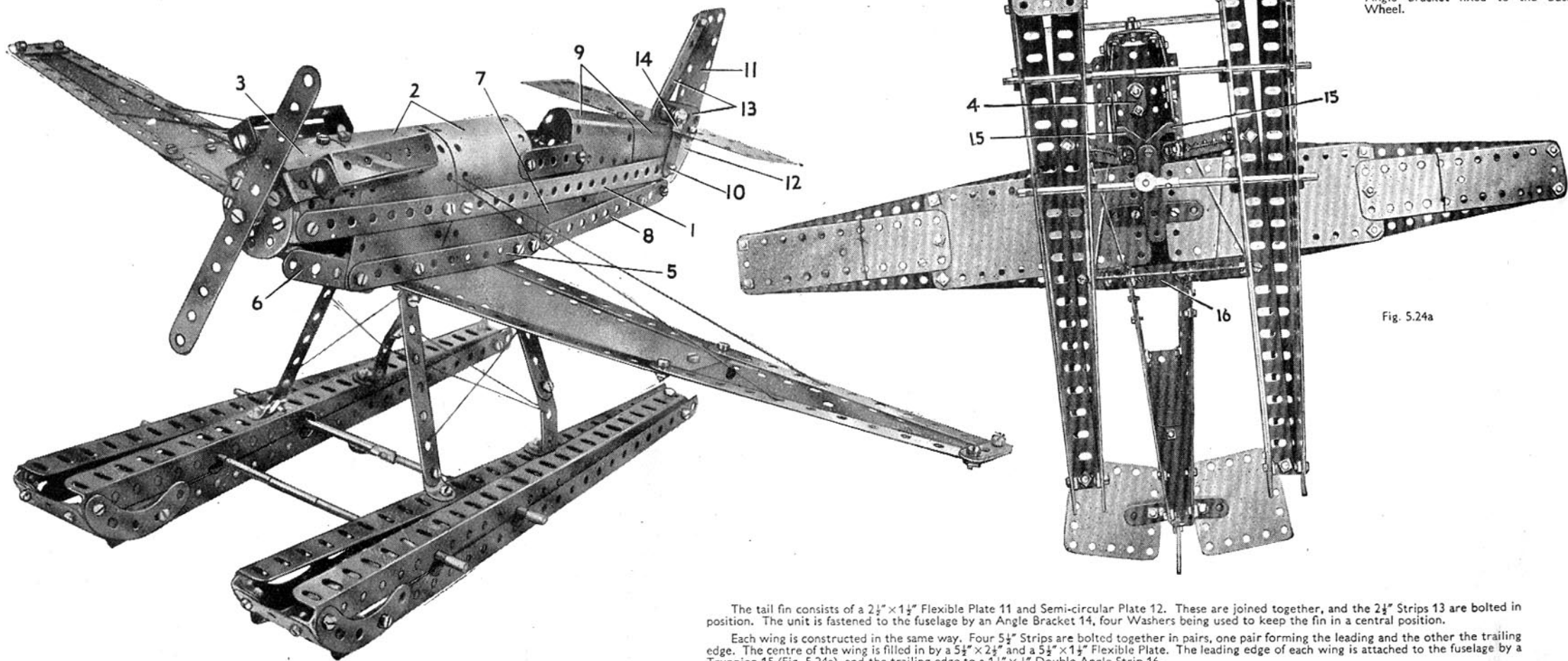

The propeller consists of a $5\frac{1}{2}$ " Strip pivoted on a $\frac{3}{8}$ " Bolt held in the Bush Wheel forming the nose of the fuselage. The exhaust manifolds on each side are represented by two $2\frac{1}{2}$ " \times $\frac{1}{2}$ " Double Angle Strips, bolted together and attached to a Reversed Angle Bracket fixed to the Bush Wheel.

Fig. 5.24a

The tail fin consists of a $2\frac{1}{2}$ " \times $1\frac{1}{2}$ " Flexible Plate 11 and Semi-circular Plate 12. These are joined together, and the $2\frac{1}{2}$ " Strips 13 are bolted in position. The unit is fastened to the fuselage by an Angle Bracket 14, four Washers being used to keep the fin in a central position.

Each wing is constructed in the same way. Four $5\frac{1}{2}$ " Strips are bolted together in pairs, one pair forming the leading and the other the trailing edge. The centre of the wing is filled in by a $5\frac{1}{2}$ " \times $2\frac{1}{2}$ " and a $5\frac{1}{2}$ " \times $1\frac{1}{2}$ " Flexible Plate. The leading edge of each wing is attached to the fuselage by a Trunnion 15 (Fig. 5.24a), and the trailing edge to a $1\frac{1}{2}$ " \times $\frac{1}{2}$ " Double Angle Strip 16.

Construction of the floats is clear from the illustrations. They are joined to the fuselage by four struts, the front pair consisting of $3\frac{1}{2}$ " Strips, and the rear pair of two $2\frac{1}{2}$ " \times $\frac{1}{2}$ " Double Angle Strips and two $2\frac{1}{2}$ " Strips bolted together. The float tie rods are formed by four $3\frac{1}{2}$ " Rods. Two of these are joined by a Rod Connector, and the remaining two by a Rod and Strip Connector.

5.25 HEAVY GOODS LORRY

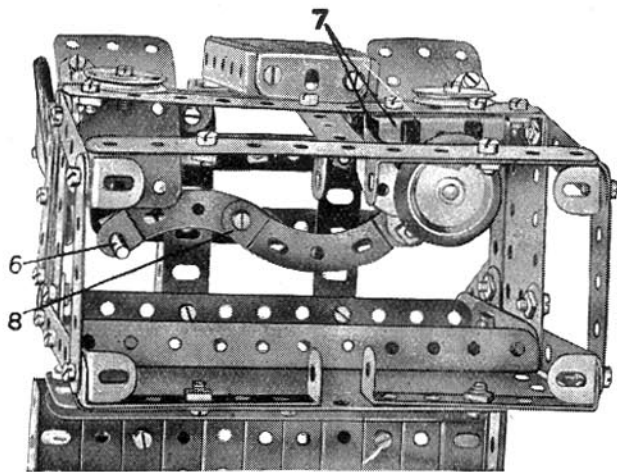
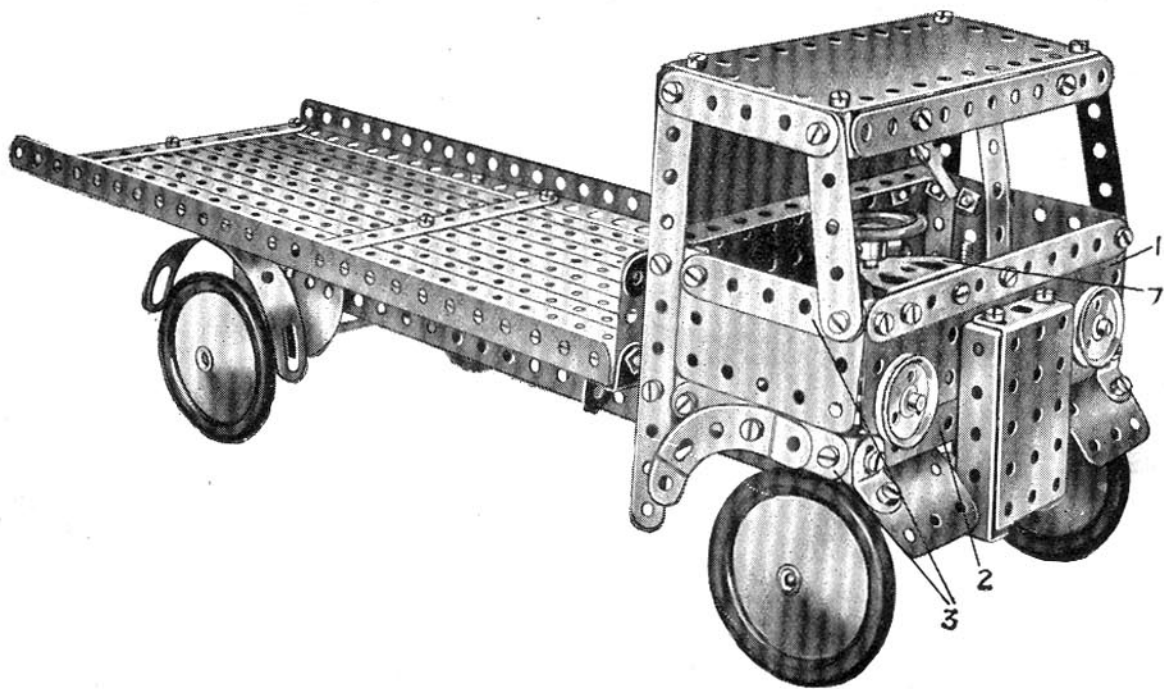

Fig. 5.25a

The 12½" Strips forming the loading platform are clamped securely between three pairs of 5½" Strips.

The platform is attached to the chassis by Reversed Angle Brackets 9 and 1"×1" Angle Brackets 10

The chassis consists of two 12½" Angle Girders joined at each end by a 2½" Double Angle Strip. The Flanged Plate forming the rear of the cab is bolted in position across the Girders. The rear axle is made from a 3½" and a 2" Rod joined by a Rod Connector, and is journaled in two Semi-Circular Plates.

The front of the cab consists of a 5½"×1½" Flexible Plate 1 and a 5½" Strip 2 attached to each side by Angle Brackets. The front mudguards are 2½"×1½" Flexible Plates, which are held in position by Obtuse Angle Brackets. The 2½" Strips 3 are extended at their rear ends by Fishplates. The radiator is a 2½"×1½" Flanged Plate and is attached to the front of the chassis by an Angle Bracket.

The front axle beam (see Fig. 5.25b) is made from a 3½" and a 2½" Strip overlapped three holes and attached to Double Brackets secured to the chassis. Each Road Wheel is locked on a 1½" Rod journaled in a Double Bracket, the Double Brackets being free to pivot on ¾" Bolts 4. These Bolts are passed through the 1½" Strips 5 and the Double Brackets, and are then locked to the axle beam by two nuts.

The Strips 5 are connected by a track Rod made from Strips in the same way as the axle beam. One end of it is lock-nutted to one of the 1½" Strips. The other end has a 3" Screwed Rod 6 (Fig. 5.25a) attached to it by two nuts. The Screwed Rod is passed through the other 1½" Strip and lock-nutted in position.

The steering column is a 2" Rod journaled in the Trunnions 7. This Rod is fitted with a Bush Wheel, and the two Curved Strips 8, which are bolted together, are attached by a Pivot Bolt at one end to a Fishplate secured to the Bush Wheel. The other end of the compound strip is passed over the Screwed Rod so that movement of the Bush Wheel is transmitted to the Road Wheels (see Fig. 5.25a).

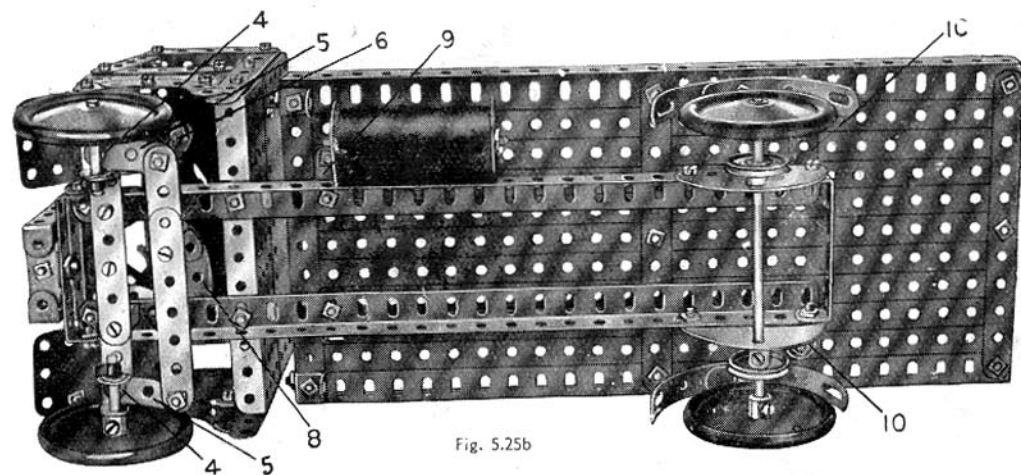
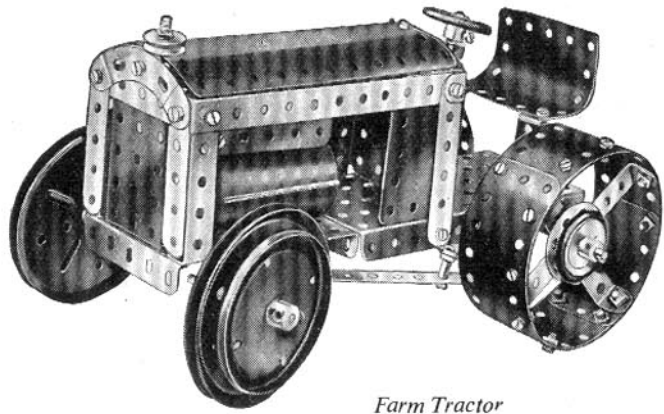

Fig. 5.25b



Farm Tractor

BUILD BIGGER AND BETTER MODELS

When you have built all the models shown in this Book of Instructions, you will be keen to build bigger and more elaborate models. Your next step is to purchase a Meccano No. 5a Accessory Outfit containing all the parts required to convert your No. 5 into a No. 6 Outfit. You will then be able to build the full range of No. 6 Outfit models, a selection of which is illustrated on this page.

If you prefer to do so, you can build up and develop your Outfit quite easily by adding various parts to it from time to time. The model-building possibilities of the Meccano System are unlimited, and the more Meccano parts you have the bigger and better the models you will be able to build.

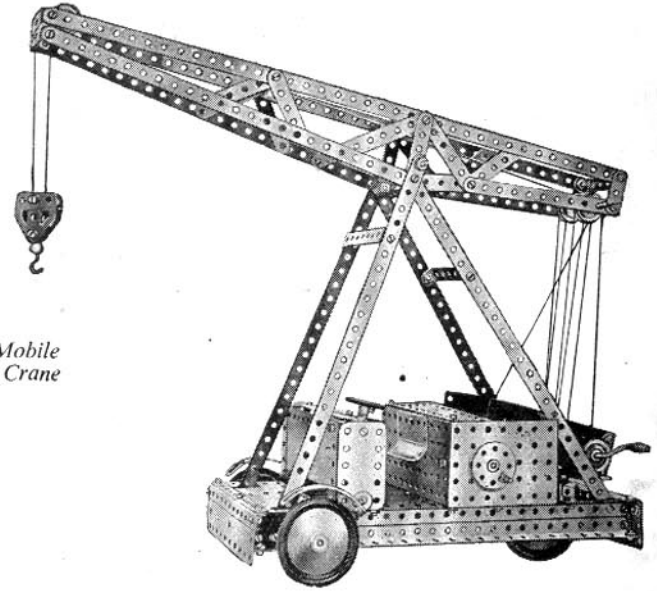

Mobile Crane

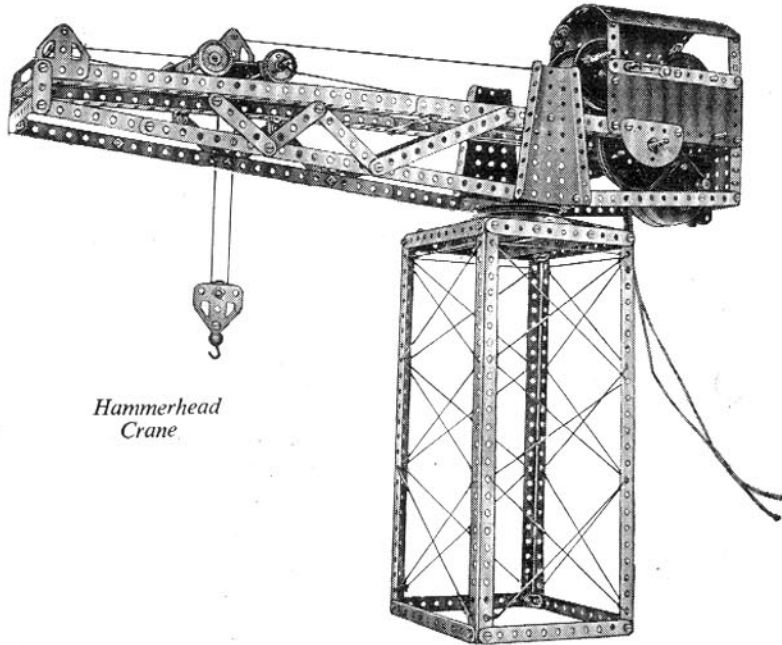

Hammerhead Crane

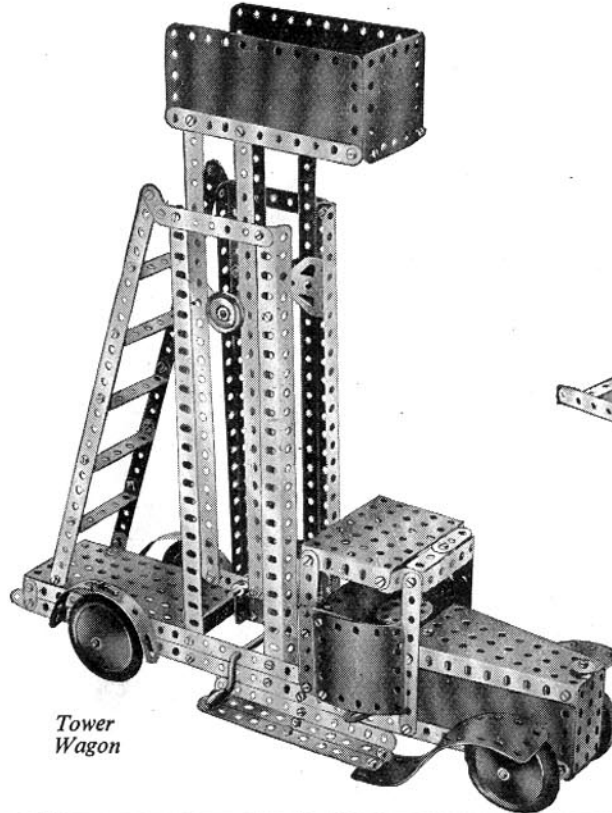

Tower Wagon

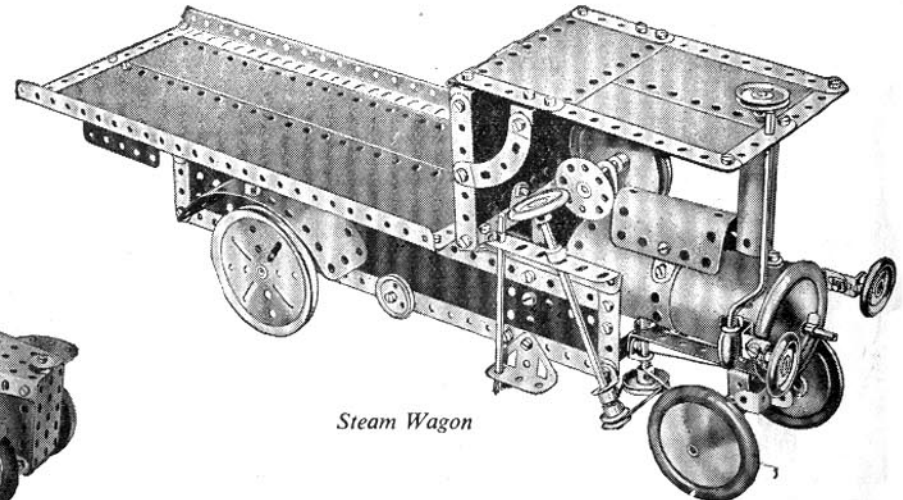

Steam Wagon

Here are a few simple and interesting movements showing how easily real mechanisms can be reproduced with Meccano.

USEFUL BAND BRAKE

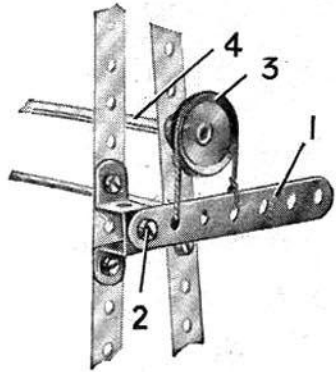

S.M.111. The brake lever consists of a $3\frac{1}{2}$ " Strip 1, pivotally attached at a suitable point on the frame of the model, to be fitted, by means of a lock-nutted $\frac{3}{8}$ " Bolt 2. The driven shaft 4 is fitted at one end with a 1" fast Pulley 3 round which a short length of cord is passed. The two ends of this Cord are secured to the brake lever at the points shown in the illustration.

If increased braking effect is desired a larger Pulley may be used in place of the 1" fast Pulley 3, the brake lever 1 being attached in a lower position if necessary. Alternatively a weight can be hung from the end of the brake lever.

BUILT UP ROLLER BEARING

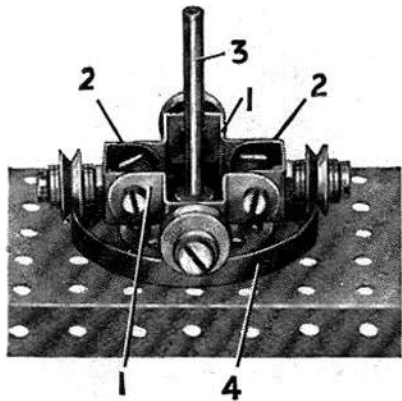

S.M.136. The spider frame is built up from Double Bent Strips 1 connected together by two Double Brackets 2. The four wheels used are represented by $\frac{1}{2}$ " loose Pulleys journalled on Pivot Bolts secured to the outer ends of the four arms of the frame. Four Washers, two on each side of the Pulleys are passed on to the shank of each of the Pivot Bolts that are attached to the Double Brackets 2. In the case of the other two Pivot Bolts, two Washers are placed against the external side only of the Pulley.

SIMPLE STEERING GEAR

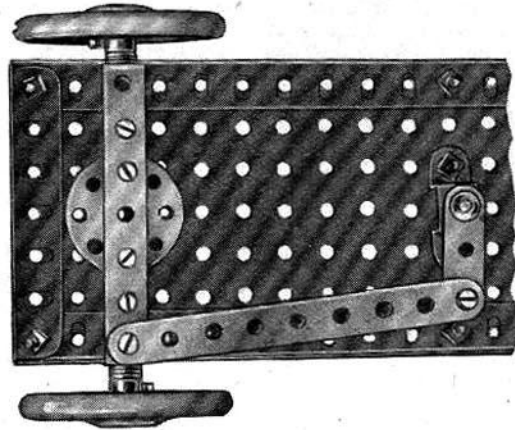

S.M.162. The simple steering gear will be found suitable for most small model vehicles.

In this example the two front wheels are mounted on separate stub axles that are secured to each end of a rigid front axle. The base of the chassis consists of two long Angle Girders connected together at the front end by a $3\frac{1}{2}$ " Angle Girder and filled in along their length by means of $5\frac{1}{2}$ " x $3\frac{1}{2}$ " Flat Plates.

The front axle, a $3\frac{1}{2}$ " x $\frac{1}{2}$ " Double Angle Strip, is pivotally mounted at its centre on a Bush Wheel and short Rod. It is fitted, $\frac{1}{2}$ " from each end, with a $\frac{1}{2}$ " x $\frac{1}{2}$ " Angle Bracket, this forming the inner bearing for its respective stub axle. The outer bearing for the axle consists of the upturned lug of the Double Angle Strip. One end of this latter part is fitted with a pivotally attached $4\frac{1}{2}$ " Strip, by means of which the front axle is linked up to a Crank fixed to the steering column.

SAFETY CATCH FOR CRANE WINDING GEAR

S.M.125. The Compression Spring 3 is mounted on the Crank Handle 1 between the Collar 4 and a Washer, and normally holds the Collar 2 against the inner side of the plate. The Collar 2 is fitted with a $\frac{3}{8}$ " Bolt, and if the Crank Handle commences to rotate, the head of this Bolt strikes against the stop 5 and prevents further movement.

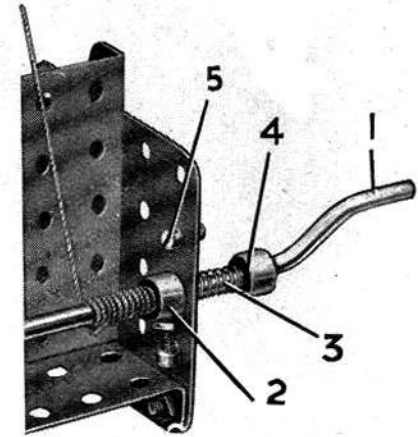

BRAKE LEVER and QUADRANT

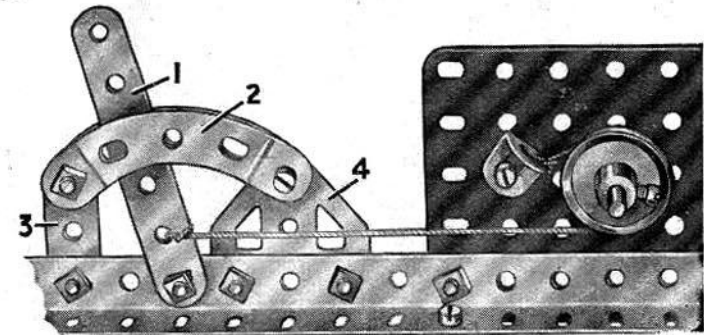

S.M.112. This mechanism is a form of band brake in which the lever 1 can be held in any position by means of the quadrant 2. In this way varying pressures can be applied to the Pulley forming the brake drum.

One end of the brake Cord is attached to a $\frac{1}{2}$ " x $\frac{1}{2}$ " Angle Bracket bolted in a suitable position on the model. After passing round the 1" fast Pulley forming the brake drum the Cord is secured at the next to bottom hole of a 3" Strip 1. This Strip forms the brake lever, and it is secured to the frame of the model by a lock-nutted Bolt.

More useful Mechanisms made with Meccano parts

SMOOTH MOVEMENT CAM

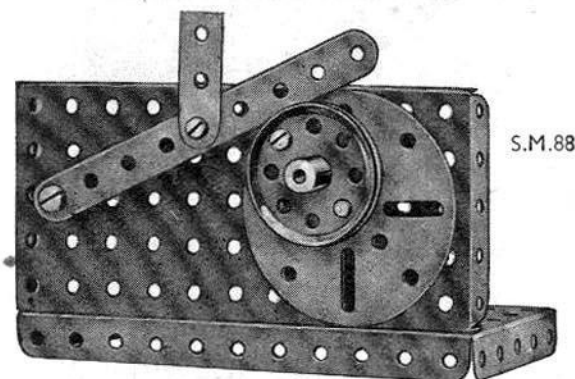

S.M.88

S.M.88. The cam disc consists of a $1\frac{1}{2}$ " Pulley attached by a nut and bolt to a Face Plate. The Rod on which this Face Plate is fixed is journaled in one of the holes of the vertical Plate, and also in the boss of a Double Arm Crank. The end of the Rod passes for a distance of about $\frac{1}{8}$ " through the boss of the Face Plate. This shaft extension also passes through the inner hole of the $1\frac{1}{2}$ " Pulley, and so prevents the part from twisting on its retaining bolt.

The tappet arm is represented by a $4\frac{1}{2}$ " Strip carrying at its fixed end a Crank. A Pivot Bolt passes through this Crank and is locked to the vertical Plate by two nuts. The edge of the tappet arm rests in the groove of the $1\frac{1}{2}$ " Pulley, the movement due to the rise and fall of the cam being transmitted to the desired point by a Strip pivotally attached to the tappet as shown.

USEFUL CAM MECHANISM

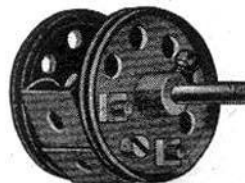

S.M.82

S.M.82. Cams are used for a large number of purposes in Meccano model-building and almost any design is possible. A typical example is shown in S.M.88 on this page. Tappet rods for use with the cam may consist simply of the edge of a Strip, or, for more

accurate work, a small roller carried at one end of a Rod or Strip. A small Flanged Wheel or Pulley can be used for this roller.

The illustration above shows a neat cam designed for use where very rapid action is not required. Each side consists of a $1\frac{1}{2}$ " Pulley or Bush Wheel and these are connected by three Double Brackets. In order to prevent the rims of the Pulleys from damage, a Washer is placed on the shank of each Bolt between the Pulleys and Double Brackets.

SLIDE CRANK MOVEMENT

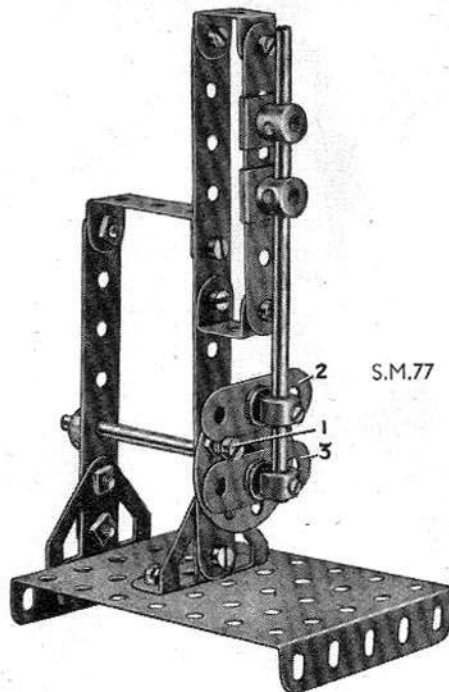

S.M.77

S.M.77. The mechanism shown above is an ingenious device for converting rotary to linear motion without the use of the usual type of crank and connecting rod.

The $5\frac{1}{2}$ " Strip carries at its upper end a Double Bracket and a second similar part at a point 3" from its lower end. The two outer flanges of these Brackets support a 3" Strip on which two Slide Pieces move.

The two Slide Pieces are arranged about $\frac{1}{2}$ " apart on a 5" Rod and are fixed in position by grub-screws. The lower end of the Rod carries two Collars fitted with Strips 2 and 3 respectively. Bolts fitted with two Washers each form the necessary connections. The inner edges of the two Strips are arranged so that the shank of a $\frac{3}{8}$ " Bolt 1 fits snugly between them without jamming. This Bolt is attached to a Bush Wheel by two nuts, the shaft on which the Bush Wheel is fitted forming the crankshaft.

FRONT AXLE TRACTOR MOUNTING

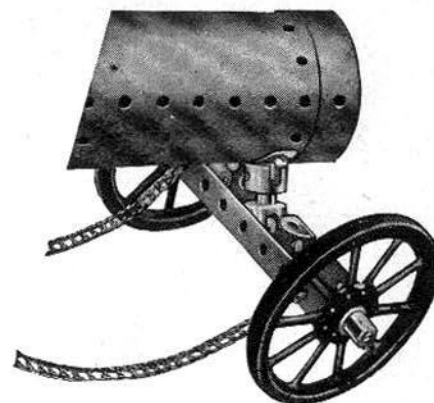

S.M.179

S.M.179. This front axle is built up from two $3\frac{1}{2}$ " Angle Girders bolted together to form a channel section, the Rods that carry the road wheels being journaled in Double Brackets. The central pivot is in two parts, a Handrail Support secured to the front axle and a Socket Coupling that is attached to the boss of a Double Arm Crank bolted to the underside of the boiler. The Handrail Support rests in the recess in the lower end of the Socket Coupling and is retained in place by two $\frac{1}{2}$ " x $\frac{1}{2}$ " Angle Brackets that are fixed to the front axle as shown.

CENTRIFUGAL GOVERNOR

S.M.102. This governor is designed primarily for use in slow running stationary engines.

The governor rod carries at its upper end a Bush Wheel, to the under side of which two Double Brackets are attached. Each of these Double Brackets is fitted with $1\frac{1}{2}$ " Strips pivotally attached, the lower holes of these being connected to further $1\frac{1}{2}$ " Strips.

The Rods linking these Strips, carry $1\frac{1}{8}$ " Flanged Wheels representing the governor weights. The lower ends of the second set of $1\frac{1}{2}$ " Strips are lock-nutted to Double Brackets bolted to the upper face of a pair of 2" Pulleys that are free to slide on the Rod. These Pulleys are fixed together by $\frac{1}{2}$ " Bolts, sufficient space being left between them to allow the shank of a Bolt to pass. This Bolt is secured to one end of the governor arm.

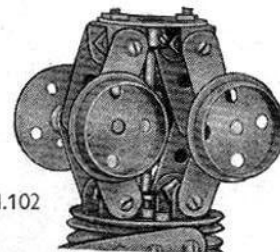

S.M.102

MECCANO PARTS

No. 120b. Compression Spring, $\frac{3}{8}$ " long



120^a



122

122. Miniature Loaded Sack



123

123. Cone Pulley, $1\frac{1}{2}$ ", 1" and $\frac{3}{4}$ " diam.



125

124. Reversed Angle Bracket, 1"
125. " " " $\frac{1}{2}$ "



126

126. Trunnion



126^a

126a. Flat Trunnion



127

127. Bell Crank



128

128. Bell Crank, with Boss



129

129. Toothed Segment, $1\frac{1}{2}$ " radius

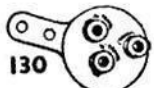

130

130. Eccentric, Triple Throw, $\frac{1}{4}$ ", $\frac{3}{8}$ " and $\frac{1}{2}$ "



130^a

130a. Eccentric, Single Throw, $\frac{1}{4}$ "



131

131. Dredger Bucket



132

132. Flywheel, $2\frac{1}{2}$ " diam.



133

133. Corner Bracket, $1\frac{1}{2}$ "



133^a

133a. " " 1"



134

No. 134. Crank Shaft, 1" stroke



136

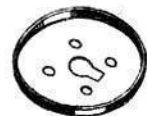

137

136. Handrail Support
136a. Handrail Coupling
137. Wheel Flange



136^a

138a. Ship Funnel



138^a

139. Flanged Bracket (right)



139

139a. " " (left)



140

140. Universal Coupling



142

142. Rubber Ring (to fit 3" diam. rim)



142^a

142a. Motor Tyre (to fit 2" diam. rim)
142b. " " " 3" "
142c. " " " 1" "
142d. " " " $1\frac{1}{2}$ " "



143

143. Circular Girder, $5\frac{1}{2}$ " diam.



144

No. 144. Dog Clutch

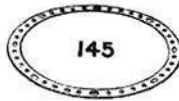

145

145. Circular Strip, $7\frac{1}{2}$ " diam. overall

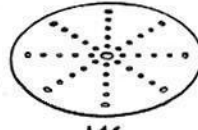

146

146. " Plate 6" "
146a. " " 4" "



147 & 148

147. Pawl, with Pivot Bolt and Nuts
147a. Pawl
147b. Pivot Bolts with 2 Nuts
147c. Pawl without boss
148. Ratchet Wheel



151

151. Pulley Block, Single Sheave
152. " " Two "
153. " " Three "



154^a & 154^b

154a. Corner Angle Bracket, $\frac{1}{4}$ " (right-hand)
154b. Corner Angle Bracket, $\frac{1}{4}$ " (left-hand)
155. Rubber Ring (for 1" Pulleys)



157

157. Fan, 2" diam.



160

160. Channel Bearing, $1\frac{1}{2}$ " x $1\frac{1}{2}$ " x $\frac{1}{2}$ "

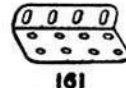

161

161. Girder Bracket, 2" x 1" x $\frac{1}{2}$ "



163



162



164

No. 162. Boiler, complete, 5" long x $2\frac{1}{4}$ " diam.
162a. " Ends, $2\frac{1}{4}$ " diam. x $\frac{1}{4}$ " "
162b. " without ends, $4\frac{1}{2}$ " long x $2\frac{1}{4}$ " diam.
163. Sleeve Piece, $1\frac{1}{2}$ " long x $\frac{1}{4}$ " diam.
164. Chimney Adaptor, $\frac{3}{8}$ " diam. x $\frac{1}{4}$ " high



165

165. Swivel Bearing



166

166. End
167b. Flanged Ring, $9\frac{3}{8}$ " diam.

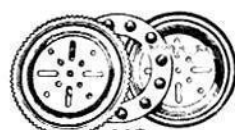

168

168. Ball Bearing, 4" diam.
168a. " Race, flanged disc, $3\frac{1}{2}$ " diam.
168b. " " toothed " 4" diam.
168c. " Cage, $3\frac{1}{2}$ " diam., complete with balls.



171

171. Socket Coupling



175

175. Flexible Coupling Unit



176

176. Anchoring Spring for Cord



179

179. Rod Socket
180. Gear Ring, $3\frac{1}{2}$ " diam. (133 ext. teeth, 95 int.)

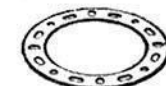

180



185

No. 185. Steering Wheel, $1\frac{1}{2}$ " diam.
186. Driving Band, $2\frac{1}{2}$ " (Light)
186a. " " 6" "
186b. " " 10" "
186c. " " 10" (Heavy)
186d. " " 15" "
186e. " " 20" "
187. Road Wheel, $2\frac{1}{2}$ " diam.
187a. Conical Disc, $1\frac{1}{2}$ " diam.



187

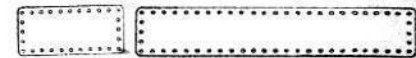

192

197

Flexible Plates.
188. $2\frac{1}{2}$ " x $1\frac{1}{2}$ " | 190a. $3\frac{1}{2}$ " x $2\frac{1}{2}$ "
189. $5\frac{3}{8}$ " x $1\frac{1}{2}$ " | 191. $4\frac{1}{2}$ " x $2\frac{1}{2}$ "
190. $2\frac{1}{2}$ " x $2\frac{1}{2}$ " | 192. $5\frac{3}{8}$ " x $2\frac{1}{2}$ "
Strip Plates.
196. $9\frac{3}{8}$ " x $2\frac{1}{2}$ " | 197. $12\frac{1}{2}$ " x $2\frac{1}{2}$ "

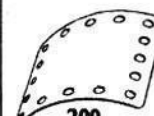

200



198

198. Hinged Flat Plate, $4\frac{1}{2}$ " x $2\frac{1}{2}$ "

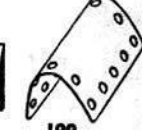

199

199. Curved Plate, U-Section
 $2\frac{1}{2}$ " x $2\frac{1}{2}$ " x $\frac{3}{8}$ " radius
200. " " $2\frac{1}{2}$ " x $2\frac{1}{2}$ " x $1\frac{1}{8}$ " radius



211^a & 211^b

211a. Helical Gear, $\frac{1}{2}$ " | Can only be used together
211b. " " 1"



212

212. Rod and Strip Connector



213

213. Rod Connector



214

214. Semi-Circular Plate, $2\frac{1}{2}$ "



215

215. Formed Slotted Strip, 3"



216

216. Cylinder, $2\frac{1}{2}$ " long, $1\frac{1}{4}$ " diam.