

MECCANO

REGD.
TRADE
MARK

INSTRUCTIONS FOR
ACCESSORY OUTFIT
No. 2A



COPYRIGHT BY MECCANO LTD LIVERPOOL

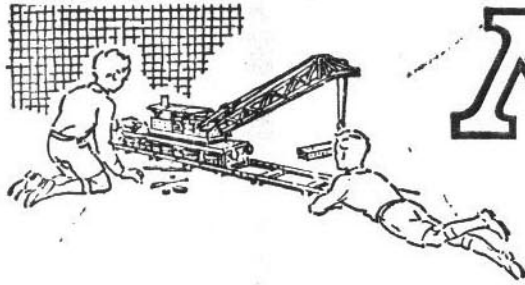

MECCANO

Registered Trade Mark

The World's Greatest Constructional Toy

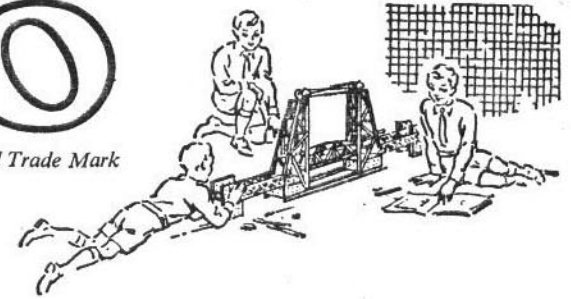

MODEL-BUILDING WITH MECCANO

There is no limit to the number of models that can be built with Meccano — Cranes, Clocks, Motor Cars, Aeroplanes, Machine Tools, Locomotives — in fact everything that interests boys. A screwdriver and a spanner, both of which are provided in each complete Outfit, are the only tools necessary.

When you have built all the models illustrated in the Books of Instructions the fun is not over, it is just beginning. Now comes the chance to make use of your own ideas. First of all, re-build some of the models with small changes in construction that may occur to you; then try building models entirely of your own design. In doing this you will enjoy the real thrill of the engineer and the inventor.

HOW TO BUILD UP YOUR OUTFIT

Meccano is sold in 12 different Outfits, ranging from No. 00 to No. 10. Each Outfit can be converted into the next larger one by the purchase of an Accessory Outfit. Thus Meccano No. 00 Outfit can be converted into No. 0 Outfit by adding to it a No. 00a Accessory Outfit. No. 0a Outfit would then convert it into a No. 1 and so on. In this way, no matter with which Outfit you begin, you can build it up by degrees until you have a complete No. 10 Outfit.

All Meccano parts are of the same high quality and finish, but the larger Outfits contain a greater quantity and variety, making possible the construction of more elaborate models.

THE 'MECCANO MAGAZINE'

The 'Meccano Magazine' is published specially for Meccano boys. Every month it describes and illustrates new Meccano models, and deals with suggestions from readers for new Meccano parts and for new methods of using the existing parts.

There are model-building competitions specially planned to give an equal chance to the owners of small and large Outfits. In addition, there are splendid articles on such subjects as Railways, Famous Engineers and Inventors, Electricity, Bridges, Cranes and

Aeroplanes, and special sections dealing with the latest Engineering, Aviation, Motoring and Shipping News. Other pages deal with Stamp Collecting, and a feature of outstanding popularity is the section devoted to short articles from readers.

Write to the Editor, the 'Meccano Magazine', Binns Road, Liverpool 13, for particulars and a specimen copy. You can order the Magazine from your Meccano dealer, or from any newsagent.

THE MECCANO GUILD

Every owner of a Meccano Outfit should join the Meccano Guild. This is a world-wide organisation, started at the request of Meccano boys. Its primary object is to bring boys together and to make them feel that they are all members of a great brotherhood, each trying to help others to get the very best out of life. Its members are in constant touch with Headquarters, giving news of their activities and being guided in their hobbies and interests. A leaflet containing full particulars of the Guild and an application form is included in this Book.

Clubs founded and established under the guidance of the Guild Secretary provide Meccano boys with opportunities of enjoying to the utmost the fun of model-building. Each has its Leader, Secretary, Treasurer and other officials. With the exception of the Leader, all the officials are boys, and as far as possible the proceedings of the clubs are conducted by boys.

MECCANO SERVICE

The service of Meccano does not end with selling an Outfit and a Book of Instructions. If ever you are in any difficulty with your models, or if you want advice on anything connected with this great hobby, write to us. We receive hundreds of interesting letters from boys in all parts of the world, and each of these is answered personally and promptly by one of our staff of experts.

Whatever your problem may be, write to us about it. We shall be delighted to help you in any way possible. Address your letters to *Information Service*.

3.1 STEAM TRACTOR AND TRAILER

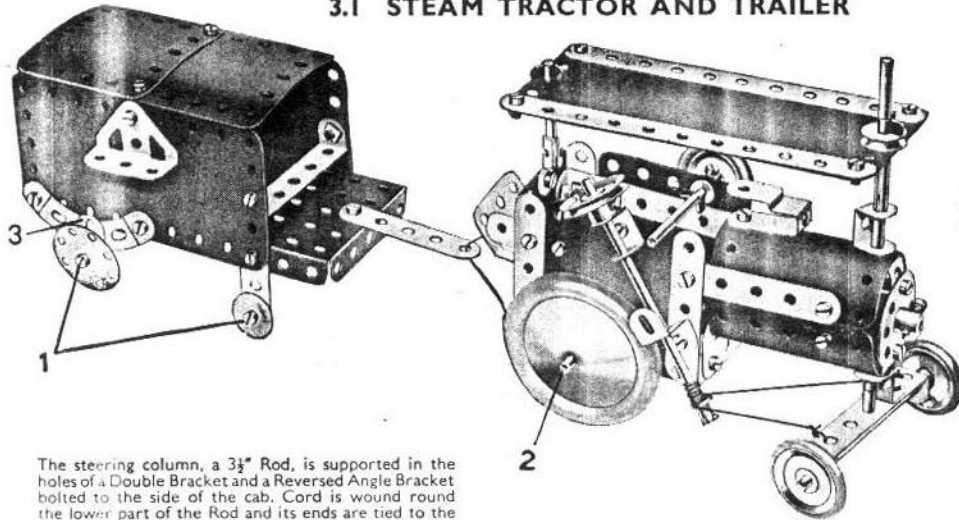

The steering column, a $3\frac{1}{2}$ " Rod, is supported in the holes of a Double Bracket and a Reversed Angle Bracket bolted to the side of the cab. Cord is wound round the lower part of the Rod and its ends are tied to the $2\frac{1}{2}$ " x $4\frac{1}{2}$ " Double Angle Strip that carries the front axle. Care must be taken that the Cord is wound tightly round the Rod or it will slip when the steering wheel is rotated. The Rod (2) is supported in holes in the Flexible Plates that form the sides of the cab.

The Bush Wheel that forms the front of the boiler has two Angle Brackets bolted to it, and a Rod passes through the free holes of these Brackets to hold the Bush Wheel in position. This Rod is joined by a Rod Connector to a 2" Rod that forms the chimney. The roof of the cab consists of a $5\frac{1}{2}$ " x $2\frac{1}{2}$ " Flexible Plate, and is held in position by Spring Clips on the two Rods that pass through it. The Fishplates (3) are bolted in the centre holes of the $2\frac{1}{2}$ " Curved Strips on each side of the model. The Bolts (1) are lock-nutted in position and the Wheel Discs and $\frac{1}{4}$ " Washers turn freely on them.

Parts Required

4 of No.	2	1 of No.	18a
7 " "	5	4 " "	22
2 " "	10	1 " "	23
2 " "	11	1 " "	24
8 " "	12	2 " "	24a
2 " "	15b	5 " "	35
3 " "	16	54 " "	37a
2 " "	17	46 " "	37b
		3 " "	38
		2 " "	38d
		1 " "	40
		1 " "	44
		2 " "	48a
		1 " "	52
		2 " "	90a
		4 " "	111c
		2 " "	125
		2 " "	126
		2 " "	126a
		3 " "	155
		1 " "	176
		2 " "	187
		1 " "	188
		2 " "	190
		2 " "	191
		1 " "	192
		2 " "	199
		2 " "	200
		1 " "	212
		1 " "	213
		2 " "	215

3.2 HORSE AND CART

The model is driven by a Magic Motor fastened underneath the $5\frac{1}{2}$ " x $2\frac{1}{2}$ " Flanged Plate that forms the bottom of the cart. The drive is taken by a Driving Band from the pulley of the Motor to a $\frac{1}{2}$ " fast Pulley on the cart axle. A $\frac{1}{2}$ " loose Pulley is fitted on a 2" Rod supported in the bottom holes of the Strips forming the hind legs of the horse, so that the model will travel smoothly along the ground.

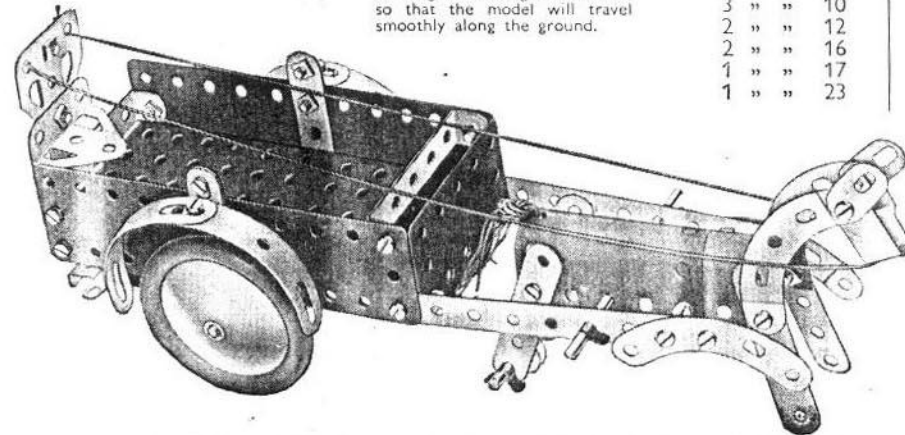

Parts Required

2 of No.	2	4 of No.	35
6 " "	5	32 " "	37a
3 " "	10	32 " "	37b
2 " "	12	4 " "	38
2 " "	16	1 " "	40
1 " "	17	1 " "	44
1 " "	23	2 " "	48a
		1 " "	52
		4 " "	90a
		1 " "	126
		1 " "	126a
		1 " "	186
		2 " "	187
		1 " "	188
		2 " "	189
		2 " "	199
		4 " "	215

Magic Motor
(not included in Outfit)

3.3 ELECTRIC CRANE TRUCK

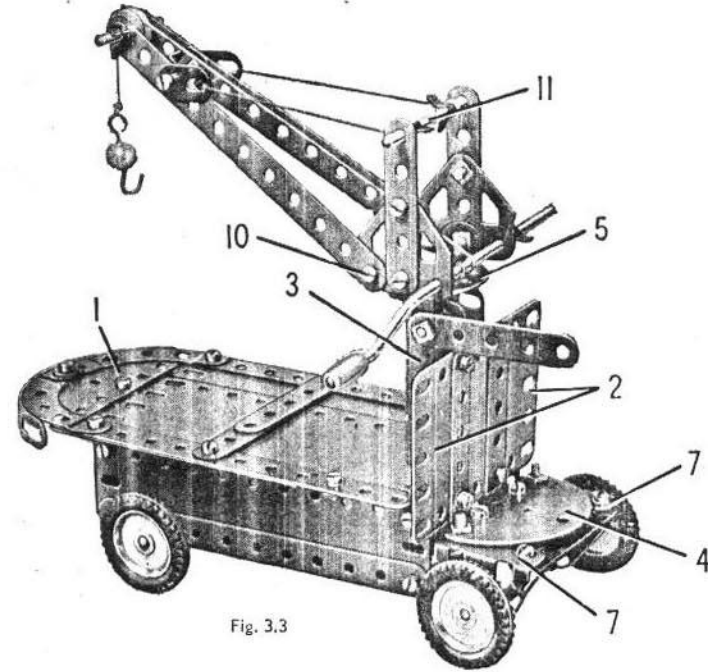

Fig. 3.3

The truck part of the model is built up first by bolting one $2\frac{1}{2}$ " x $1\frac{1}{2}$ " and two $5\frac{1}{2}$ " x $1\frac{1}{2}$ " Flexible Plates to the flanges of a Flanged Plate. At their lower edges the Flexible Plates are strengthened by $5\frac{1}{2}$ " Strips and two $2\frac{1}{2}$ " x $4\frac{1}{2}$ " Double Angle Strips. The platform consists of two $5\frac{1}{2}$ " x $2\frac{1}{2}$ " and two $4\frac{1}{2}$ " x $2\frac{1}{2}$ " Flexible Plates overlapped and extended by a Semi-Circular Plate (1).

Two $2\frac{1}{2}$ " x $2\frac{1}{2}$ " Flexible Plates (2), overlapped three holes, are bolted to the front end of the Flanged Plate, and a 'U'-section Curved Plate (3) is attached to these by a Double Bracket. A Semi-Circular Plate (4) is attached to the Flanged Plate by Angle Brackets.

The crane jib is supported by Flat Trunnions, which are attached to a Wheel Disc (5) by Angle Brackets. The Wheel Disc is lock-nutted through its centre hole to an Angle Bracket bolted to the top centre hole at the front of the 'U'-section Curved Plate (3).

The $5\frac{1}{2}$ " Strips forming the jib pivot on lock-nutted bolts (10) in the Flat Trunnions, and the jib is held at the required angle by a length of Cord. This Cord is tied to the Rod (11) and then passed through the Fishplates at the jib head, finally being tied again to the Rod (11).

The Trunnions (7), which form part of the steering device, are free to turn on $\frac{1}{2}$ " Bolts secured to the Semi-Circular Plate (4), and they carry $\frac{1}{2}$ " Bolts that form stub axles for the 1" Pulleys. The $2\frac{1}{2}$ " Strip (8), seen in the underneath view of the model, is bolted to each Trunnion by Cord as shown. The Bush Wheel is fixed to a $3\frac{1}{2}$ " Rod passed through the Flanged Plate and an Angle Bracket (9).

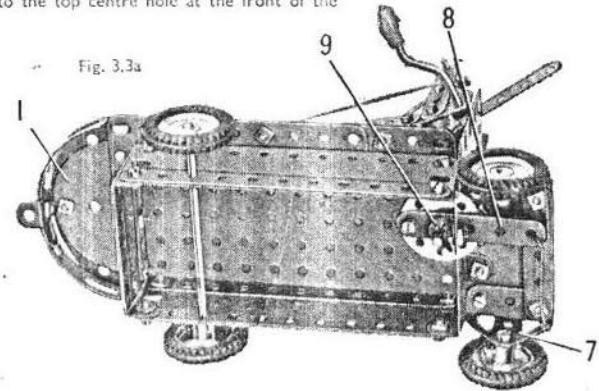

Fig. 3.3a

Parts Required

6 of No.	2
9 " "	5
2 " "	10
2 " "	11
6 " "	12
1 " "	15b
1 " "	16
1 " "	17
1 " "	18a
1 " "	19g
4 " "	22
1 " "	23
1 " "	24
1 " "	24a
6 " "	35
52 " "	37a
43 " "	37b
4 " "	38
1 " "	40
2 " "	48a
1 " "	52
1 " "	57c
2 " "	90a
5 " "	111c
1 " "	125
2 " "	126
2 " "	126a
4 " "	142c
1 " "	188
2 " "	189
2 " "	190
2 " "	192
1 " "	199
1 " "	212
2 " "	214
2 " "	215

3.4 RACING CAR

The chassis of the model is a $5\frac{1}{2}'' \times 2\frac{1}{2}''$ Flanged Plate (1), and a $5\frac{1}{2}'' \times 1\frac{1}{2}''$ Flexible Plate is bolted to each side so that two holes of the Flanged Plate are left clear at the front. The Flanged Plate is lengthened at the rear by a $5\frac{1}{2}''$ Strip (2) on each side, and a Flat Trunnion (3) is fixed to each $5\frac{1}{2}''$ Strip. A $2\frac{1}{2}'' \times 1\frac{1}{2}''$ Flexible Plate (4) is bolted to each of the Strips (2) and is connected to the $5\frac{1}{2}'' \times 1\frac{1}{2}''$ Flexible Plate by a Fishplate. Two $2\frac{1}{2}''$ Strips (5) are attached to the sides by Bolts (6).

The top of the bonnet is a $5\frac{1}{2}'' \times 2\frac{1}{2}''$ Flexible Plate, and it is attached to the sides by four Angle Brackets. Two Trunnions are connected by $\frac{3}{8}''$ Bolts (7) to a $1\frac{1}{4}''$ radius Curved Plate, which is then bolted between the $5\frac{1}{2}'' \times 2\frac{1}{2}''$ Flexible Plate and the front of the Flanged Plate.

Two 'U'-section Curved Plates (8) are fixed to the Flexible Plates (4) and the Flat Trunnions (3), and a Wheel Disc (9) is attached to one of them by an Angle Bracket. The tail assembly

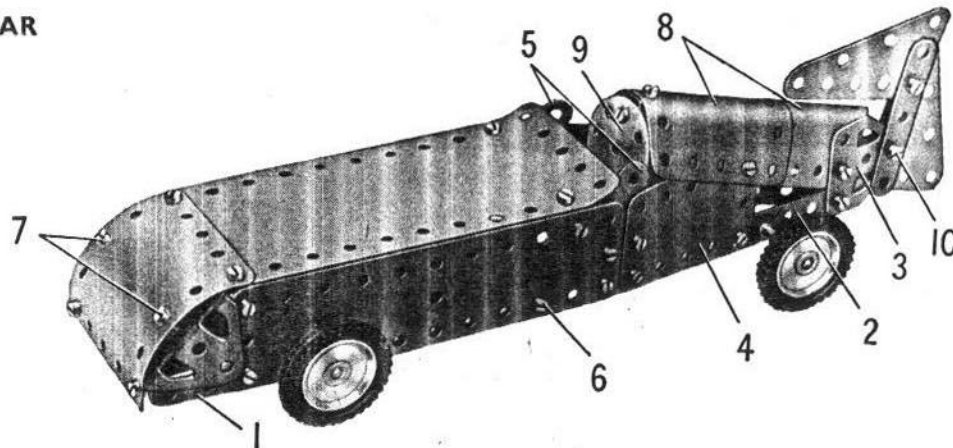

consists of two $2\frac{1}{2}'' \times 1\frac{1}{2}''$ Triangular Flexible Plates bolted between two $2\frac{1}{2}''$ Strips as shown, and it is fixed to the Flat Trunnions (3) by a $\frac{3}{8}''$ Bolt (10).

The wheels are mounted on $3\frac{1}{2}''$ Rods passed through the chassis as shown.

Parts Required

2 of No. 2	38 of No. 37a	2 of No. 189
4 " " 5	35 " " 37b	1 " " 192
2 " " 10	1 " " 52	2 " " 199
5 " " 12	3 " " 111c	1 " " 200
2 " " 16	2 " " 126	1 " " 214
4 " " 22	2 " " 126a	2 " " 221
1 " " 24a	4 " " 142c	
2 " " 35	2 " " 188	

3.5 TRAMCAR

Parts Required

4 of No. 2	2 of No. 48a	1 of No. 212
9 " " 5	1 " " 52	2 " " 214
4 " " 10	5 " " 111c	4 " " 215
1 " " 11	2 " " 126	
8 " " 12	2 " " 126a	
1 " " 15b	1 " " 176	
2 " " 16	2 " " 188	
4 " " 22	2 " " 189	
5 " " 35	2 " " 190	
54 " " 37a	2 " " 191	
49 " " 37b		
6 " " 38		
2 " " 38d		
1 " " 40		
1 " " 44		

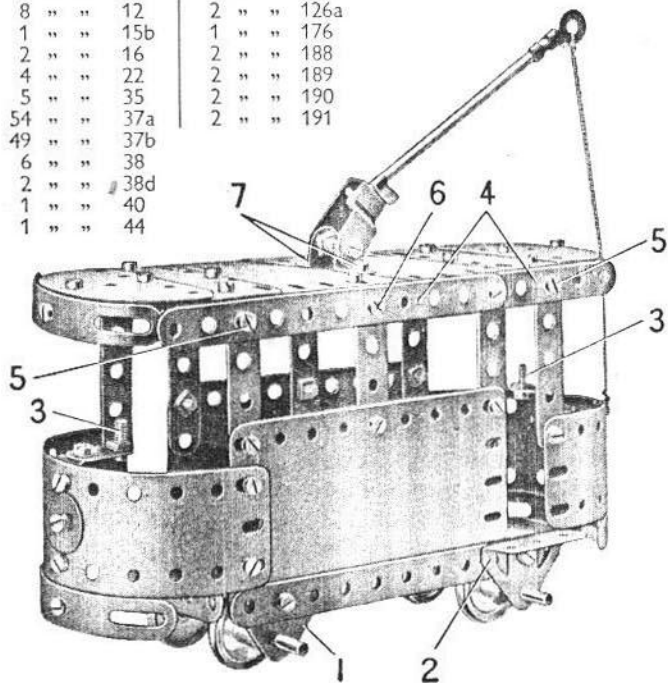

The chassis is a $5\frac{1}{2}'' \times 2\frac{1}{2}''$ Flanged Plate fitted at its sides with $4\frac{1}{2}'' \times 2\frac{1}{2}''$ Flexible Plates. The Flexible Plates are bolted to the flanges so that a space of two clear holes is left in each side flange, but at opposite ends. The lower edges of the Flexible Plates are edged by $5\frac{1}{2}''$ Strips, and a Flat Trunnion (1) and a Trunnion (2) are bolted to each side. The axles are supported in the Trunnions and Flat Trunnions.

The rounded ends consist of $5\frac{1}{2}'' \times 1\frac{1}{2}''$ Flexible Plates curved to shape and bolted to the sides. A Formed Slotted Strip is attached to each of the $5\frac{1}{2}'' \times 1\frac{1}{2}''$ Flexible Plates by a Fishplate. The control handles (3) are each made by bolting a Fishplate fitted with a $\frac{3}{8}''$ Bolt to an Angle Bracket fixed to the Flexible Plate.

The roof is supported on each side by four $2\frac{1}{2}''$ Strips. The tops of these Strips are connected by two $5\frac{1}{2}''$ Strips (4) overlapped seven holes, and these Strips are joined across by $2\frac{1}{2}'' \times \frac{1}{2}''$ Double Angle Strips held by the Bolts (5). An Angle Bracket on each side is fixed in place by a Bolt (6).

The roof consists of two $2\frac{1}{2}'' \times 2\frac{1}{2}''$ and two $2\frac{1}{2}'' \times 1\frac{1}{2}''$ Flexible Plates bolted end to end, and its rounded ends are Semi-Circular Plates. The roof is attached to the Double Angle Strips and the Angle Brackets held by Bolts (5) and (6). A Formed Slotted Strip is connected to each Semi-Circular Plate by an Angle Bracket.

The trolley pole is a $4''$ Rod fitted with a Rod and Strip Connector, and it is held in a Stepped Bent Strip by a Spring Clip and a Cord Anchoring Spring. The Stepped Bent Strip is bolted to two Angle Brackets (7) bolted to the centre of the roof.

3.6 TROTTING CAR

Parts Required

4 of No. 2	37 of No. 37a	2 of No. 126a
8 " " 5	37 " " 37b	4 " " 155
5 " " 10	6 " " 38	1 " " 176
1 " " 11	1 " " 40	2 " " 187
3 " " 12	1 " " 44	2 " " 188
1 " " 15b	2 " " 48a	2 " " 199
2 " " 16	3 " " 90a	1 " " 213
2 " " 17	3 " " 111c	4 " " 215
1 " " 18a	2 " " 125	
4 " " 22	2 " " 126	
1 " " 24		
1 " " 24a		
4 " " 35		

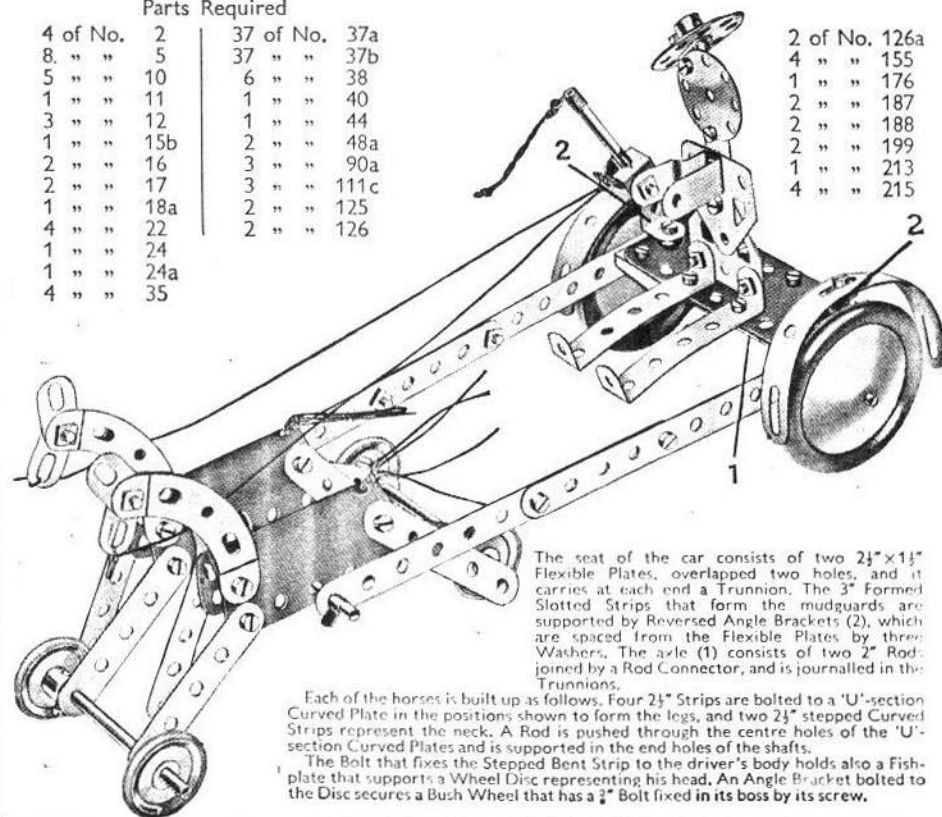

The seat of the car consists of two $2\frac{1}{2}'' \times 1\frac{1}{2}''$ Flexible Plates, overlapped two holes, and it carries at each end a Trunnion. The $3''$ Formed Slotted Strips that form the mudguards are supported by Reversed Angle Brackets (2), which are spaced from the Flexible Plates by three Washers. The axle (1) consists of two $2''$ Rods joined by a Rod Connector, and is journalled in the Trunnions.

Each of the horses is built up as follows. Four $2\frac{1}{2}''$ Strips are bolted to a 'U'-section Curved Plate in the positions shown to form the legs, and two $2\frac{1}{2}''$ stepped Curved Strips represent the neck. A Rod is pushed through the centre holes of the 'U'-section Curved Plates and is supported in the end holes of the shafts.

The Bolt that fixes the Stepped Bent Strip to the driver's body holds also a Fishplate that supports a Wheel Disc representing his head. An Angle Bracket bolted to the Disc secures a Bush Wheel that has a $\frac{3}{8}''$ Bolt fixed in its boss by its screw.

3.7 TRACTOR AND HARROW

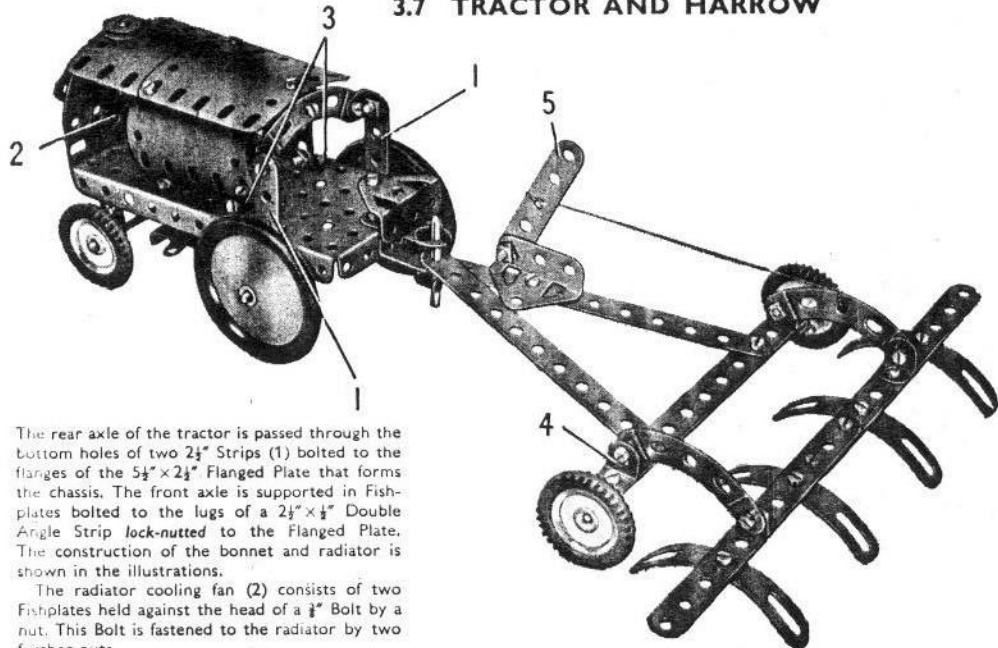

Fig. 3.7

The rear axle of the tractor is passed through the bottom holes of two 2½" Strips (1) bolted to the flanges of the 5½" x 2½" Flanged Plate that forms the chassis. The front axle is supported in Fishplates bolted to the lugs of a 2½" x ½" Double Angle Strip lock-nutted to the Flanged Plate. The construction of the bonnet and radiator is shown in the illustrations.

The radiator cooling fan (2) consists of two Fishplates held against the head of a ½" Bolt by a nut. This Bolt is fastened to the radiator by two further nuts.

The engine is represented by two 'U'-section Curved Plates, which are bolted together so that they overlap each other by two holes and are then attached to the Flanged Plate by two Angle Brackets (3).

The wheels of the harrow are held by ½" Bolts in Reversed Angle Brackets (4) at each end of a 5½" Strip. A 2½" Stepped Curved Strip is fastened to each Reversed Angle Bracket by a lock-nutted bolt, and Cord is attached to the centre hole of one of these Curved Strips and also to the operating lever (5), which is loosely held by a lock-nutted ½" Bolt to a Trunnion. By moving the lever forward the harrow may be raised from the ground when not in use.

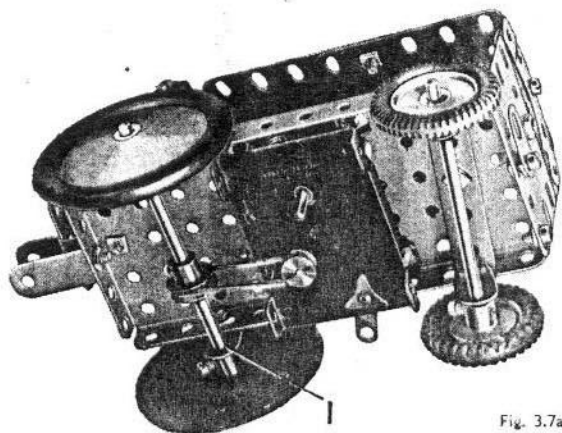

Fig. 3.7a

Parts Required

5 of No.	2	1 of No.	48a
3 " "	5	1 " "	52
5 " "	10	4 " "	90a
1 " "	11	4 " "	111c
8 " "	12	2 " "	125
1 " "	15b	2 " "	126
1 " "	16	4 " "	142c
1 " "	18a	2 " "	187
4 " "	22	1 " "	188
1 " "	23	2 " "	199
2 " "	35	2 " "	200
53 " "	37a	1 " "	214
42 " "	37b	4 " "	215
1 " "	40		
1 " "	44		

Magic Motor
(not included in
Outfit)

3.8 GIPSY CARAVAN

The base of the caravan is a 5½" x 2½" Flanged Plate, and the sides are 5½" x 2½" Flexible Plates strengthened along their upper edges by 5½" Strips. Three 2½" Strips are fixed to each side as shown, and these are connected by a 5½" Strip (1) lengthened at each end by 2½" Stepped Curved Strips attached to Angle Brackets.

The rear wheels are fixed on a 3½" Rod supported in Flat Trunnions bolted to the sides of the Flanged Plate. The front wheels are fastened on a 3½" Rod that is supported in two Trunnions (2). These Trunnions are bolted to a 2½" x 1½" Flexible Plate (3), fitted at each side with a 2½" Strip (4). A Bush Wheel (5) is fixed to the Plate (3), and a 2" Rod held in the Bush Wheel is passed through a ½" Reversed Angle Bracket (6) and the 5½" x 2½" Flanged Plate. A 'U'-section Curved Plate (7) and a ½" Pulley are slipped over the Rod, which is then held in position by a Spring Clip.

The shafts are 5½" Strips bolted to a 2½" x ½" Double Angle Strip (8). This is lock-nutted to a second Double Angle Strip bolted across the ends of Strips (4).

The roof consists of two 1½" radius Curved Plates (9) overlapped four holes, and two 5½" x 1½" Flexible Plates, one of which is seen at (10). The 5½" x 1½" Flexible Plates are placed side to side, and are bolted to Formed Slotted Strips as shown. The complete roof is attached to Angle Brackets bolted to the sides of the caravan. The Angle Brackets are bent out a little to allow a slight curve in the roof.

A step at the rear of the caravan consists of a 'U'-section Curved Plate bolted to the rear of the 5½" x 2½" Flanged Plate.

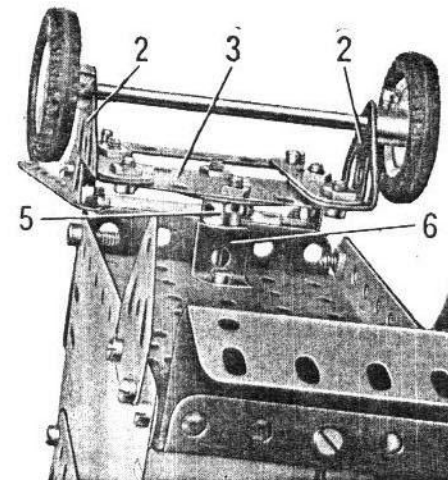

Fig. 3.8a

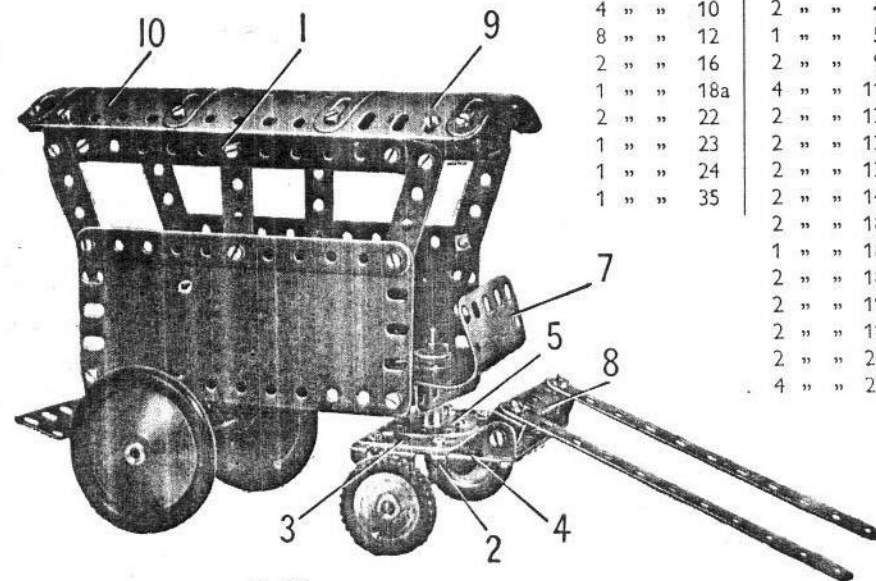

Fig. 3.8

Parts Required

6 of No.	2	56 of No.	37a
8 " "	5	50 " "	37b
4 " "	10	2 " "	48a
8 " "	12	1 " "	52
2 " "	16	2 " "	90a
1 " "	18a	4 " "	111c
2 " "	22	2 " "	125
1 " "	23	2 " "	126
1 " "	24	2 " "	126a
1 " "	35	2 " "	142c
		2 " "	187
		1 " "	188
		2 " "	189
		2 " "	192
		2 " "	199
		2 " "	200
		4 " "	215

3.9 FIRE ENGINE

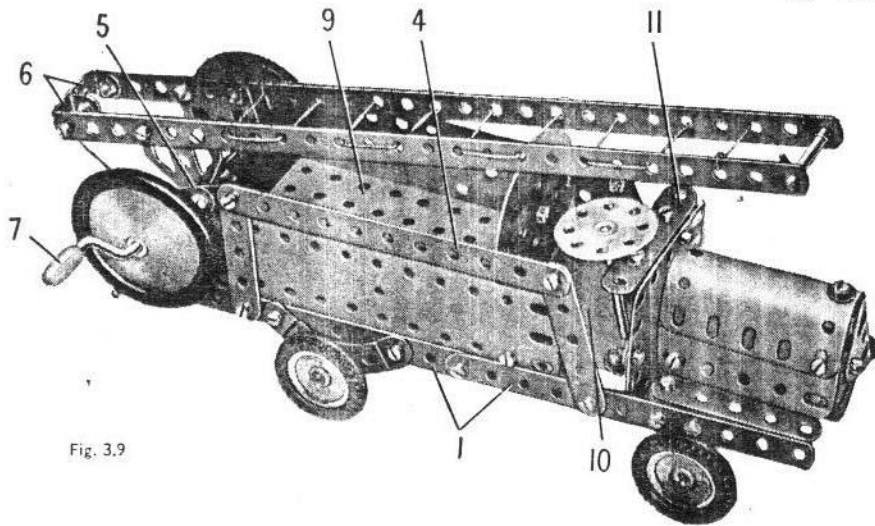

Fig. 3.9

Parts Required

2 of No.	1	1 of No.	48a
6 " "	2	1 " "	52
7 " "	5	4 " "	90a
5 " "	10	5 " "	111c
2 " "	11	2 " "	125
7 " "	12	2 " "	126
1 " "	15b	2 " "	126a
3 " "	16	4 " "	142c
1 " "	18a	2 " "	187
1 " "	19g	2 " "	188
4 " "	22	2 " "	189
1 " "	24	2 " "	190
4 " "	35	1 " "	192
55 " "	37a	1 " "	199
50 " "	37b	1 " "	212
6 " "	38	2 " "	214
1 " "	40	4 " "	215

Each side of the chassis of the model consists of two $5\frac{1}{2}$ " Strips (1) bolted end to end. These Strips are connected at the rear by a $5\frac{1}{2}$ " x $2\frac{1}{2}$ " Flexible Plate (2), which is attached to them by Angle Brackets. The bonnet is a 'U'-section Curved Plate fitted at each side with a $2\frac{1}{2}$ " x $1\frac{1}{2}$ " Flexible Plate, and it is connected by $\frac{1}{2}$ " Reversed Angle Brackets (3) to the Strips (1). The radiator consists of two Trunnions bolted to the Flexible Plate.

A $5\frac{1}{2}$ " Strip (4) on each side is attached to the Strips (1) by two $2\frac{1}{2}$ " Strips, and it is connected to a $2\frac{1}{2}$ " Stepped Curved Strip (5) by a Fishplate. The lower end of the Curved Strip is bolted to the rear of the Strips (1). The rear wheels are fixed on a $3\frac{1}{2}$ " Rod supported in $2\frac{1}{2}$ " Stepped Curved Strips bolted to the Strips (1), and the front wheels are fixed on a similar Rod passed through Fishplates also bolted to the Strips (1).

The ladder consists of two $12\frac{1}{2}$ " Strips joined together by two Double Brackets (6), and the rungs are represented by Cord. A Flat Trunnion is bolted to each Strip, and a Crank Handle (7) is passed through holes in the Curved Strips (5) and the holes at the pointed ends of the Flat Trunnions. A length of Cord tied to the Crank Handle is passed round a Rod (8) and is tied to the rear end of the ladder. Rod (8) is supported in a $2\frac{1}{2}$ " x $\frac{1}{2}$ " Double Angle Strip that is attached by Angle Brackets to the Flexible Plate (2).

The driving compartment and the body of the fire engine are assembled as a separate unit, which is fitted to the chassis when it is completed. A $5\frac{1}{2}$ " x $2\frac{1}{2}$ " Flanged Plate (9) is fitted at each side with a $5\frac{1}{2}$ " x $1\frac{1}{2}$ " Flexible Plate, and is extended towards the front by a $2\frac{1}{2}$ " x $2\frac{1}{2}$ " Flexible Plate (10). The back of the driving compartment consists of two Semi-Circular Plates bolted together and attached to the Flanged Plate by an Angle Bracket. The front of the compartment is a $2\frac{1}{2}$ " x $2\frac{1}{2}$ " Flexible Plate, which is bolted to Angle Brackets fixed to the Flexible Plate (10). The steering wheel is fixed on a Rod passed through a Fishplate bolted to a $2\frac{1}{2}$ " Strip (11), and through the Flexible Plate (10).

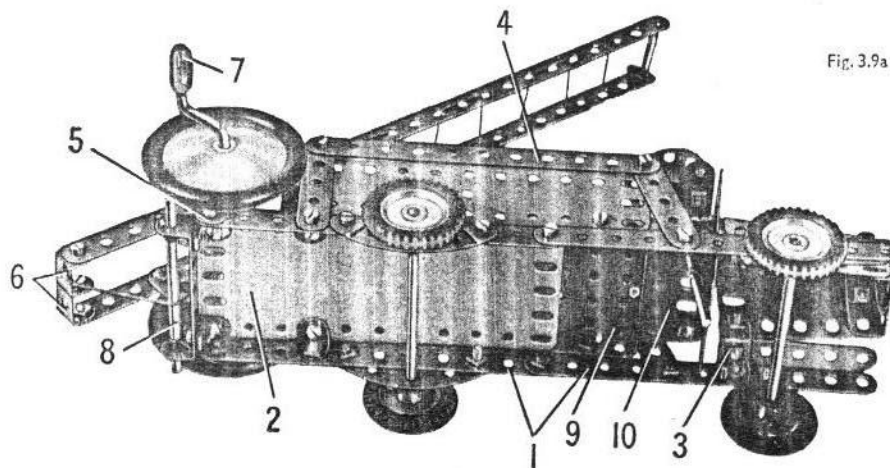

Fig. 3.9a

3.10 TANK

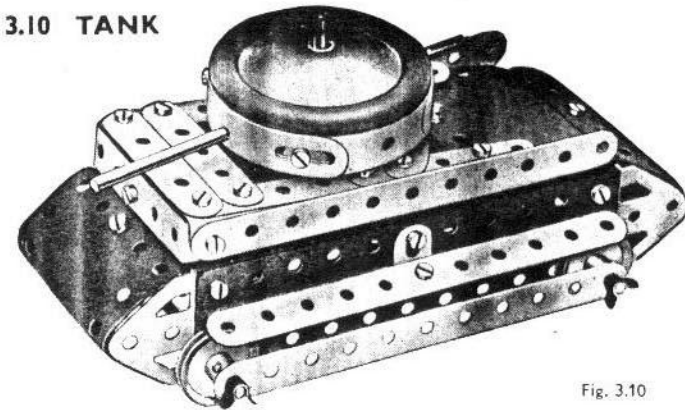

Fig. 3.10

Construction of the gun turret is commenced by bolting a $2\frac{1}{2}$ " Strip across a Bush Wheel. Four 3 " Formed Slotted Strips are bolted together to form a circle and fastened to the $2\frac{1}{2}$ " Strip by means of Angle Brackets. Next, two Angle Brackets are bolted to the Bush Wheel in the positions shown in Fig. 3.10a. Two Rods are pushed through holes in the Formed Slotted Strips and through the free holes of the Angle Brackets, and are fastened in position by means of Spring Clips. The turret is held in place by a $3\frac{1}{2}$ " Rod that is gripped in the boss of the Bush Wheel and then passed through the $5\frac{1}{2}$ " x $2\frac{1}{2}$ " Flanged Plate and through a hole in a Reversed Angle Bracket. A Cord Anchoring Spring is then screwed on to it to hold it in position. To complete the turret a Road Wheel is fastened on the upper end of the $3\frac{1}{2}$ " Rod. The Reversed Angle Bracket is bolted to the $5\frac{1}{2}$ " x $2\frac{1}{2}$ " Flanged Plate.

The Magic Motor is bolted to the Flanged Plate, and the drive is taken to the back axle by means of a Driving Band.

Parts Required

6 of No.	2	6 of No.	35	1 of No.	52	1 of No.	176
7 " "	5	37 " "	37a	1 " "	90a	1 " "	187
1 " "	10	37 " "	37b	1 " "	125	2 " "	189
7 " "	12	4 " "	38	2 " "	126	1 " "	190
2 " "	15b	2 " "	48a	2 " "	126a	2 " "	199
1 " "	16					4 " "	215
2 " "	17						
4 " "	22						
1 " "	24						

Magic Motor
(not included in
Outfit)

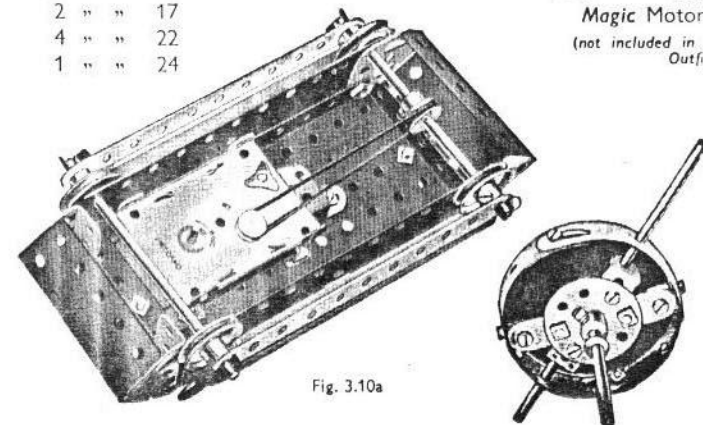

Fig. 3.10a

3.11 MOTOCART

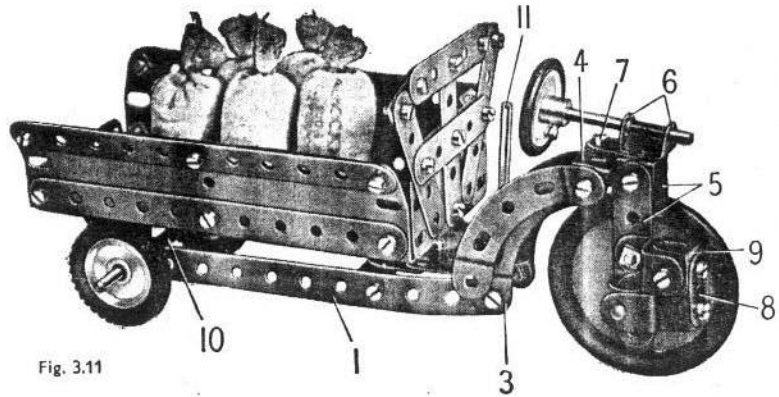

Fig. 3.11

The chassis of the model consists of two 5½" Strips (1). These are connected together at a point four holes from the front by a Flat Trunnion (2) attached to Angle Brackets. A second Flat Trunnion is bolted to the first to form the driver's platform, and the ends of Strips (1) are bent in slightly to correspond to the sloping sides of the Flat Trunnion. A 2½" Stepped Curved Strip (3) is attached to the end hole of each of the Strips (1), and the upper ends of the Curved Strips are connected

together by a Double Bracket (4). A second Curved Strip on each side is held in place by the same bolts that fix the Double Bracket.

The single castor, or steerable wheel at the front, is fixed on a 1¼" Rod supported in 2½" Strips (5). These Strips are bolted tightly to a Double Bracket, and a Fishplate and two Angle Brackets (6) are fixed to the centre hole of the Double Bracket. The Fishplate is pivoted on a ½" Bolt (7) held in the Double Bracket (4) by two nuts. Two Washers are used to space the Fishplate from the upper nut on the Bolt. The steering wheel is a 1" Pulley fixed on a 2" Rod that is held by Spring Clips in the Angle Brackets (6).

The engine unit is represented by a ¼" Reversed Angle Bracket bolted to one of the Strips (5). An Angle Bracket is bolted to the slotted hole of the Reversed Angle Bracket, and to the Angle Bracket a Fishplate (8) and a second Angle Bracket (9) are fixed. A Stepped Bent Strip is bolted to the Fishplate (8).

The rear wheels are held on a 3½" Rod passed through the end holes of the Strips (1). Two Trunnions (10) are pivoted on the Rod, and these are bolted to a 5½" x 2½" Flanged Plate that forms the floor of the load carrier. The sides are 5½" x 1¼" Flexible Plates edged by 5½" Strips, and the front is a 2½" x 1¼" Flexible Plate. The front is completed by five 2½" Strips and two Fishplates arranged as shown.

The load carrier or body can be raised for tipping the load by operating a lever (11). This is a 2" Rod held in a Rod and Strip Connector, and a 2¼" Strip (12) is bolted tightly to the Rod and Strip Connector by a ¾" Bolt. The Bolt is then **lock-nutted** to one of the Strips (1), and the end of Strip (12) is bent inward slightly so that it engages under the load carrier.

Parts Required

6 of No. 2	2 of No. 11	2 of No. 35
8 " " 5	7 " " 12	49 " " 37a
4 " " 10	1 " " 16	42 " " 37b
	2 " " 17	6 " " 38
	1 " " 18a	1 " " 44
	3 " " 22	1 " " 52
		4 " " 90a
		2 " " 111c
		2 " " 125
		2 " " 126
		2 " " 126a
		2 " " 142c
		1 " " 155
		1 " " 187
		1 " " 188
		2 " " 189
		1 " " 212

Fig. 3.11a

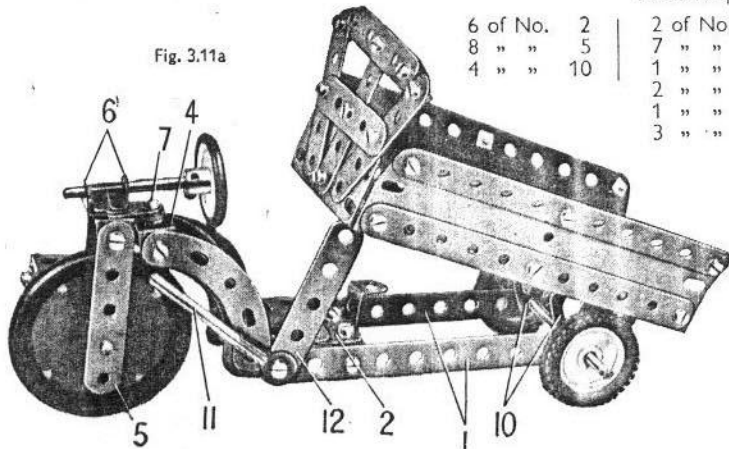

3.12 MECHANICAL HORSE AND TRAILER

Parts Required

6 of No. 2
9 " " 5
2 " " 10
2 " " 11
8 " " 12
2 " " 16
2 " " 17
1 " " 18a
4 " " 22
1 " " 23
1 " " 24
1 " " 24a
6 " " 35
56 " " 37a
50 " " 37b
6 " " 38
1 " " 38d
2 " " 48a
1 " " 52
4 " " 111c
1 " " 125
2 " " 126
2 " " 126a
4 " " 142c
2 " " 188
2 " " 189
2 " " 190
1 " " 199
1 " " 212
2 " " 214

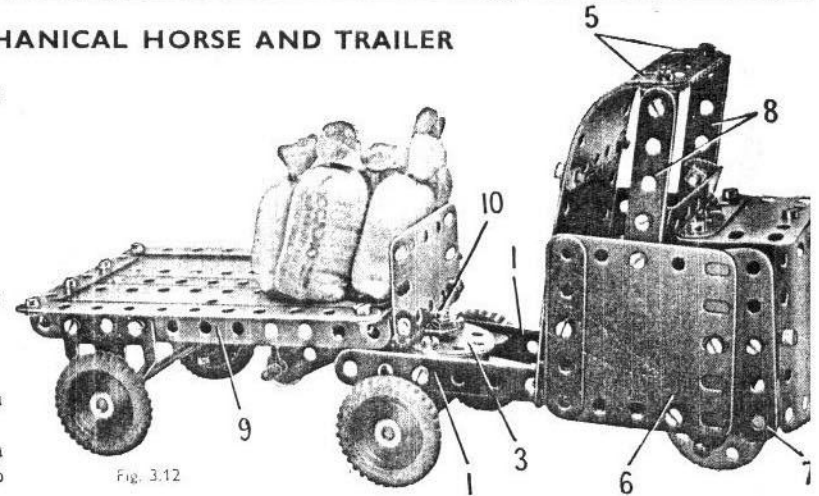

Fig. 3.12

The chassis of the Mechanical Horse consists of two 5½" Strips (1) fitted at one end with Trunnions (2). The Trunnions are connected together by a Wheel Disc (3). A Double Bracket (4) is bolted in the second hole from the front end of each 5½" Strip, and Angle Brackets are used to fix 5½" Strips (5) in position at each side. The upper ends of the 5½" Strips are curved as shown, and a straightened 1½" radius Curved Plate and an opened-out 'U'-section Curved Plate bolted to them, form the back and roof of the cab.

The cab sides each consist of a 2½" x 2½" Flexible Plate (6) and a Semi-Circular Plate (7). The sides are bolted to the Double Brackets (4), and they are attached to the Strips (5) by a 2½" x ¼" Double Angle Strip. The front of the bonnet is a 1½" radius Curved Plate that is connected to the sides by Angle Brackets, and the top is a 2½" x 1½" Flexible Plate fixed to an Angle Bracket bolted to the front. Two 2½" Strips (8) are bolted to the sides and are attached to Angle Brackets fastened to the roof.

The chassis of the Trailer is a 5½" x 2½" Flanged Plate (9), and its wheels are fixed on a 3½" Rod supported in Flat Trunnions that are bolted to the side flanges of the Plate. The load platform is made by bolting to each side a 5½" x 1¼" Flexible Plate so that it partly overlaps the Flanged Plate as shown. The edges of the Flexible Plates are strengthened by Strips.

The coupling between the Mechanical Horse and the Trailer is provided by a ¾" Bolt (10), which is fixed by nuts in a ¼" Reversed Angle Bracket bolted to the Flanged Plate (9). The shank of the Bolt engages in the centre hole of the Wheel Disc (3).

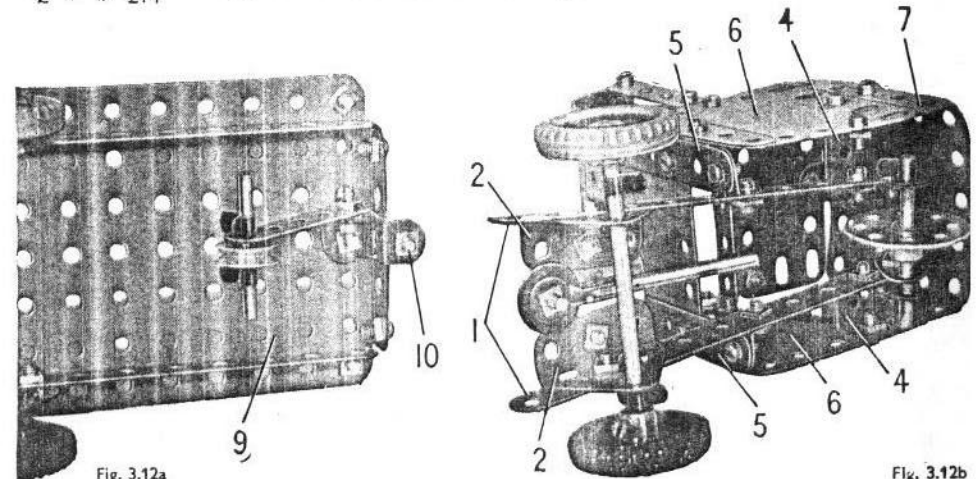

Fig. 3.12a

Fig. 3.12b

3.13 SWING BOAT

Parts Required

2 of No. 1	1 of No. 19g	2 of No. 48a	2 of No. 187
6 " " 2	4 " " 22	1 " " 52	2 " " 188
9 " " 5	1 " " 24	4 " " 90a	2 " " 189
4 " " 10	1 " " 24a	5 " " 111c	2 " " 200
1 " " 11	4 " " 35	2 " " 125	1 " " 212
8 " " 12	54 " " 37a	2 " " 126	1 " " 213
2 " " 15b	50 " " 37b	2 " " 126a	2 " " 214
1 " " 16	1 " " 44	4 " " 155	4 " " 215
1 " " 17			

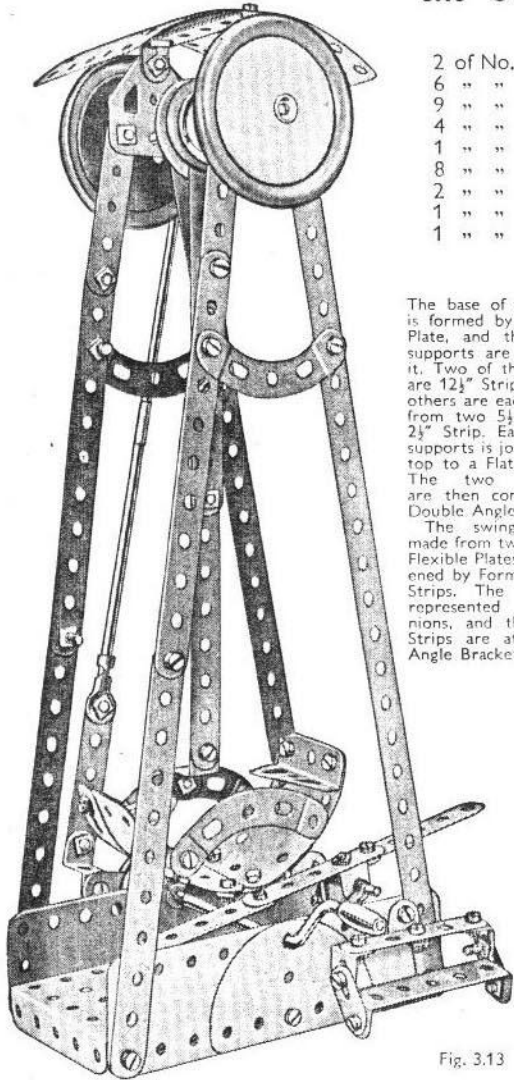

The base of the model is formed by a Flanged Plate, and the upright supports are bolted to it. Two of the uprights are 12½" Strips, and the others are each built up from two 5½" and one 2½" Strip. Each pair of supports is joined at the top to a Flat Trunnion. The two Trunnions are then connected by Double Angle Strip (1). The swing boat is made from two 2½" x 1½" Flexible Plates, strengthened by Formed Slotted Strips. The seats are represented by Trunnions, and the Curved Strips are attached by Angle Brackets.

Fig. 3.13

The swing is suspended from a compound strip consisting of two 5½" Strips overlapped four holes. The upper end of this strip is clamped firmly between two 1" Pulleys (2) fitted with Rubber Rings, and a Wheel Disc. The Pulleys are locked on a 4" Rod (3). A 2½" Strip is bolted to a Bush Wheel (4) also fixed on this Rod, and is connected to the Crank Handle by a lever made from a 3½" and a 4" Rod joined by a Rod Connector. The 2½" Strip (5) is clamped between two 1" Pulleys on the Crank Handle and is attached to the lever by a Reversed Angle Bracket. All Bolts numbered (6) are lock-nutted.

The brake for bringing the boat to rest is formed by three 2½" Strips joined together, and is bolted to a Double Bracket pivoted on a Rod (7).

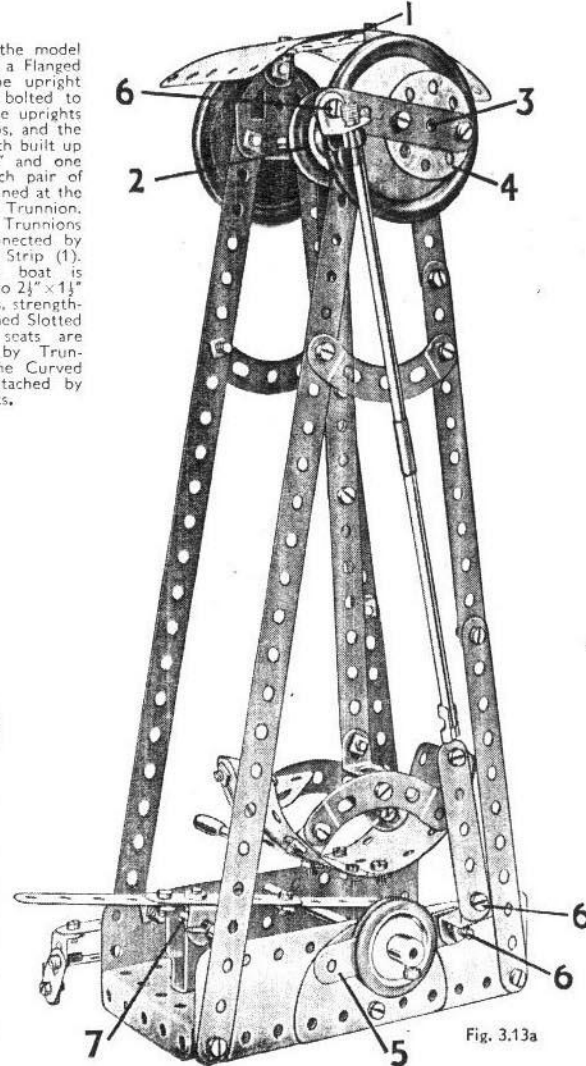

Fig. 3.13a

3.14 DUMPER TRUCK

Parts Required

6 of No. 2
9 " " 5
3 " " 10
1 " " 11
8 " " 12
2 " " 15b
2 " " 16
1 " " 17
3 " " 22
2 " " 24a
4 " " 35
53 " " 37a
41 " " 37b
5 " " 38
1 " " 38d
1 " " 40
2 " " 48a
1 " " 52
1 " " 90a
2 " " 111c
1 " " 125
2 " " 126
2 " " 126a
2 " " 142c
1 " " 186
2 " " 187
2 " " 188
1 " " 189
1 " " 190
1 " " 192
1 " " 212
2 " " 221

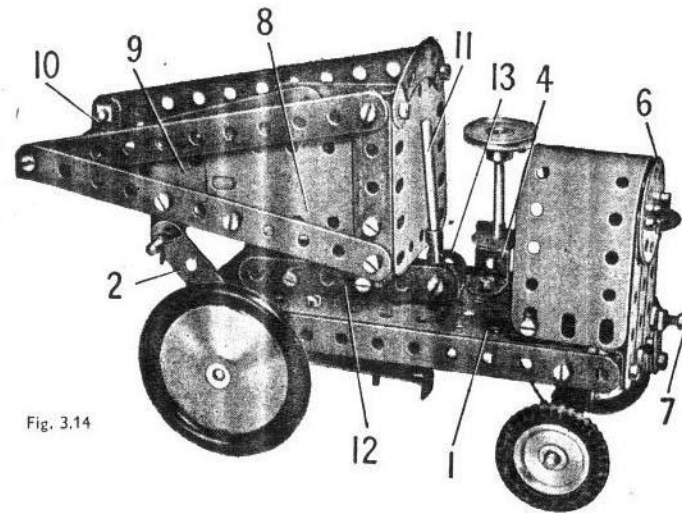

Fig. 3.14

A 5½" x 2½" Flanged Plate (1) is fitted at each side with a 5½" Strip. The front axle is supported in Flat Trunnions, and on each side one of the Bolts that hold the Flat Trunnions in place serves also to fix a 2½" Strip (2) in position.

The rear axle is supported in a 2½" x 1½" Double Angle Strip pivoted freely on a Bolt held by two nuts in a Trunnion (3). A 3½" Rod is passed through a ½" Reversed Angle Bracket (4), the Flanged Plate (1) and an Angle Bracket (5). The Angle Bracket and the Reversed Angle Bracket are bolted to the Flanged Plate and a length of Cord wound two or three times round the lower end of the Rod is tied at each end to the Double Angle Strip.

The engine housing is a 5½" x 1½" Flexible Plate curved to 'U'-shape and fixed to Angle Brackets bolted to the Flanged Plate (1). The radiator consists of three 2½" Strips bolted to the flange of a Trunnion, and a Wheel Disc (6) is fixed to their upper ends. The Trunnion is bolted to the Flanged Plate (1). The starting handle is a Fishplate fitted with a ½" Bolt (7).

The sides of the load carrier are 2½" x 1½" Flexible Plates (8) and 2½" x 1½" Triangular Plates (9) edged by Strips. The sides are connected together at the front by a 2½" x ½" Double Angle Strip (10), and at the rear by a 2½" x 2½" Flexible Plate and a Stepped Curved Strip attached to Angle Brackets. The floor is a 5½" x 2½" Flexible Plate supported at the rear by Angle Brackets.

The load carrier is pivoted on a 4" Rod passed through Fishplates bolted to its sides, and held by Spring Clips in the Strips (2). It can be tipped by operating a lever (11). This is a 2" Rod held in a Rod and Strip Connector, and two 2½" Strips (12), overlapped four holes, are fixed tightly to the Rod and Strip Connector by a nut on a ½" Bolt. The shank of the Bolt is then passed through a Double Bracket (13) and is fitted with lock-nuts, so that the lever and the Strips (12) pivot freely.

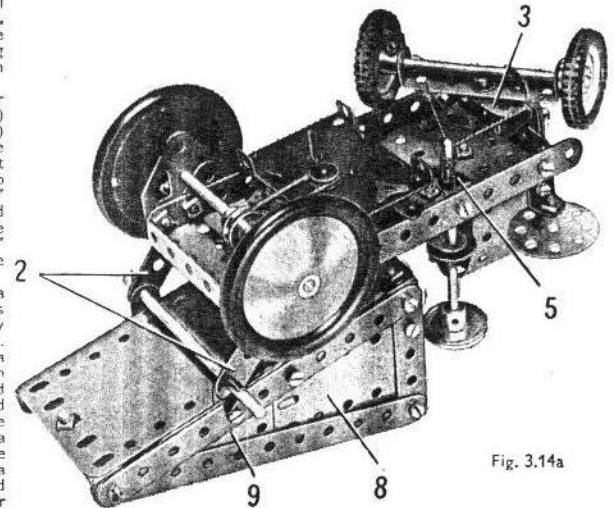

Fig. 3.14a

Magic Motor
(not included in
Outfit)

3.15 MILL ENGINE

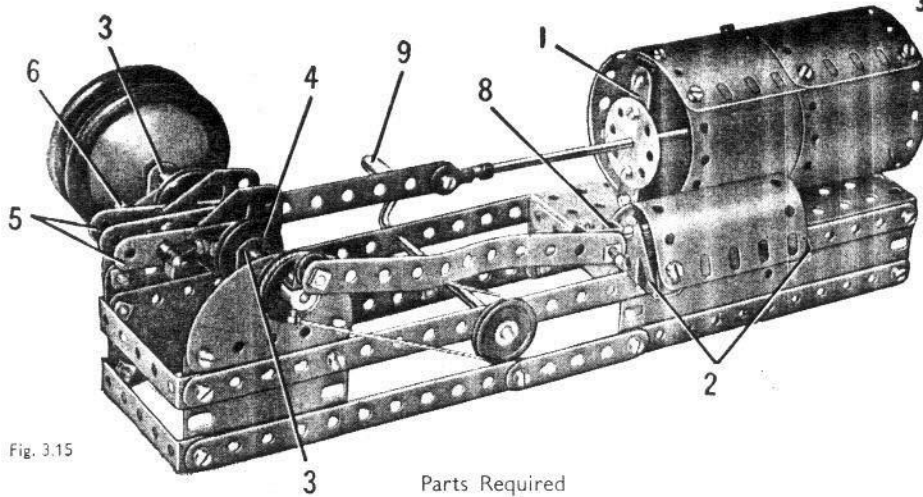

Fig. 3.15

Parts Required

2 of No.	1	2 of No.	15b	5 of No.	35	2 of No.	111c	2 of No.	189
6 " "	2	2 " "	16	53 " "	37a	2 " "	125	2 " "	191
6 " "	5	1 " "	17	48 " "	37b	2 " "	126	2 " "	192
5 " "	10	1 " "	19g	3 " "	38	2 " "	126a	1 " "	199
2 " "	11	4 " "	22	1 " "	40	1 " "	176	1 " "	212
8 " "	12	2 " "	24a	2 " "	48a	2 " "	187	1 " "	213
		1 " "		1 " "	52	2 " "	188	2 " "	214

The bed of the engine is built first. For this a start is made by bolting two 12½" Strips one to each side of a Flanged Plate. A 5½" × 1½" Flexible Plate also is attached to each side of the Flanged Plate, and to the lower edges of the Flexible Plates are bolted built-up strips, each consisting of two 5½" and one 2½" Strip. At the front end of the model the 12½" Strips are connected by a 2½" × ½" Double Angle Strip, and a similar part is used to connect the ends of the built-up strips. At the front end of the bed a 2½" × 1½" Flexible Plate is bolted to each side. A Semi-Circular Plate is attached to each Flexible Plate by Fishplates. The Semi-Circular Plates provide the bearings for the crankshaft.

The cylinder is made from two 5½" × 2½" and two 4½" × 2½" Flexible Plates curved and bolted together, and it is fixed to the Flanged Plate. A 2½" Strip (1) is attached by Angle Brackets to each end of the cylinder, and Wheel Discs are fixed to the Strips as shown.

The valve chamber at the side of the cylinder is represented by a 'U'-section Curved Plate and two Trunnions (2). The Curved Plate is attached to one of the Trunnions by an Angle Bracket.

The crankshaft is built up from a 4" and a 2" Rod, each of which is passed through a Semi-Circular Plate and through a ½" Reversed Angle Bracket (3) bolted to the Plate. A 1" Pulley (4) is fixed to the inner end of each Rod, and an Angle Bracket is held to the boss of each Pulley by a nut and Bolt. A Flat Trunnion and a 2½" Strip (5) are bolted to each Angle Bracket as shown.

The connecting-rod is a 5½" Strip, which is free to turn on a 1½" Rod (6) held by Spring Clips in the 2½" Strips (5). The free end of the 5½" Strip is lock-nutted to a Rod and Strip Connector fitted to the piston rod, which consists of two 3½" Rods joined by a Rod Connector.

The valve gear is operated by an Angle Bracket bolted to the boss of a 1" Pulley (7). A 5½" Strip is attached loosely by a lock-nutted bolt to this Angle Bracket, and also to a Double Bracket (8) on the valve rod. A Cord Anchoring Spring is placed on this Rod inside the Double Bracket.

The engine is set in motion by a belt of Cord running round a 1" Pulley on the Crank Handle (9) and the Pulley (7).

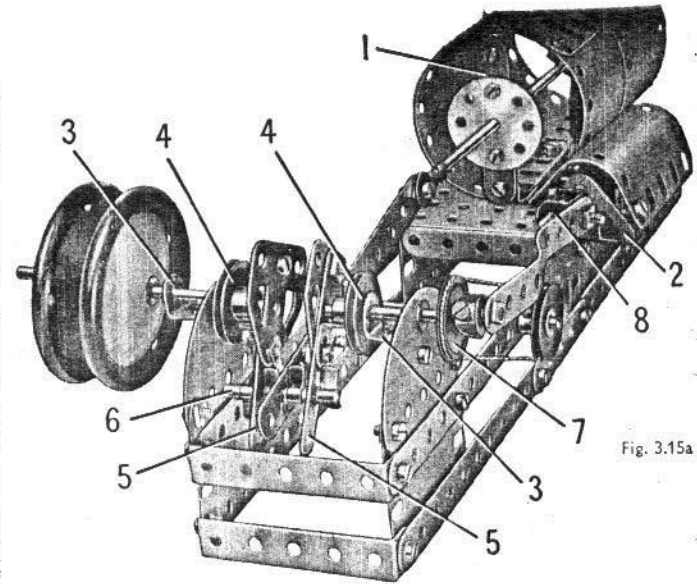

Fig. 3.15a

3.16 ROUNDABOUT

The two horses and the two cars are each fixed to 12½" Strips bolted at right angles to each other to a Bush Wheel that is fixed on a vertical 3½" Rod. The Rod is passed through a 2½" × ½" Double Angle Strip and through a hole in the Flanged Plate forming the base.

The model is driven by a belt of Cord passed round a 1" Pulley fixed on a Crank Handle supported in two Flat Trunnions bolted to the base and also round a further 1" Pulley fixed on the centre Rod of the roundabout.

Fig. 3.16a shows how the roundabout can be fitted with a Magic Motor if this is available. The Motor is bolted to one of the 5½" Strips of the base, and the drive is taken to a second 1" Pulley fastened on the Crank Handle and spaced from the Flat Trunnion by a Spring Clip and a Washer. This Pulley is removed from the end of the pivot rod of the roundabout underneath the 5½" × 2½" Flanged Plate.

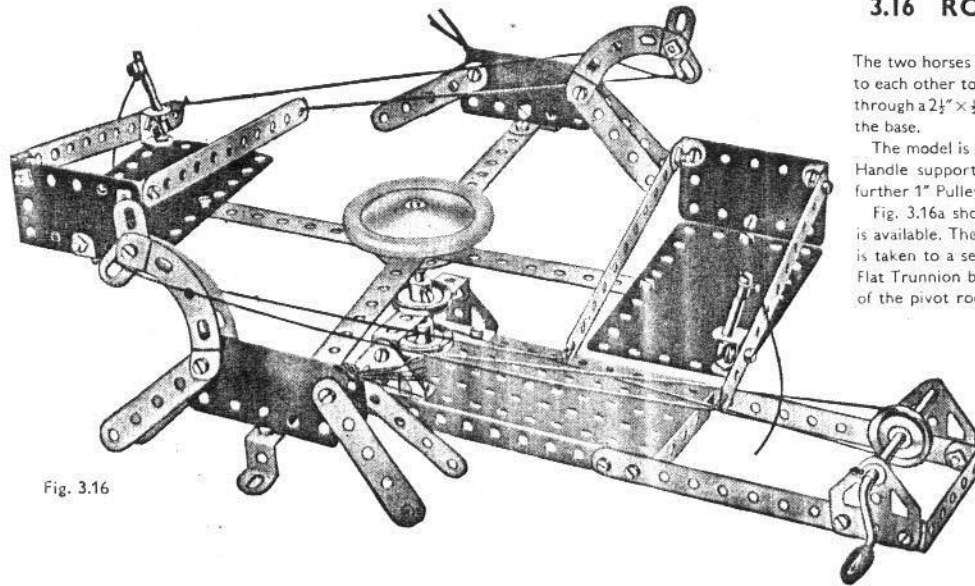

Fig. 3.16

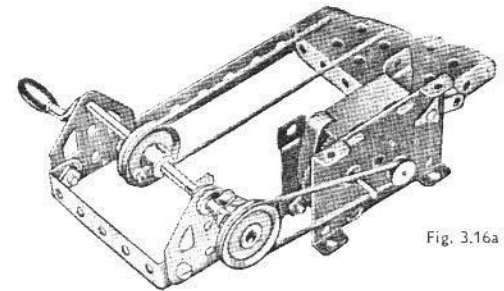

Fig. 3.16a

Parts Required

2 of No.	1	1 of No.	19g	2 of No.	48a	2 of No.	188
6 " "	2	4 " "	22	1 " "	52	2 " "	191
8 " "	5	1 " "	24	4 " "	90a	2 " "	199
4 " "	10	6 " "	35	2 " "	111c	Magic Motor (not included in Outfit)	
2 " "	11	52 " "	37a	2 " "	125		
8 " "	12	50 " "	37b	2 " "	126		
1 " "	16	2 " "	38	2 " "	126a		
2 " "	17	1 " "	40	1 " "	187		

3.17 TANK LOCOMOTIVE

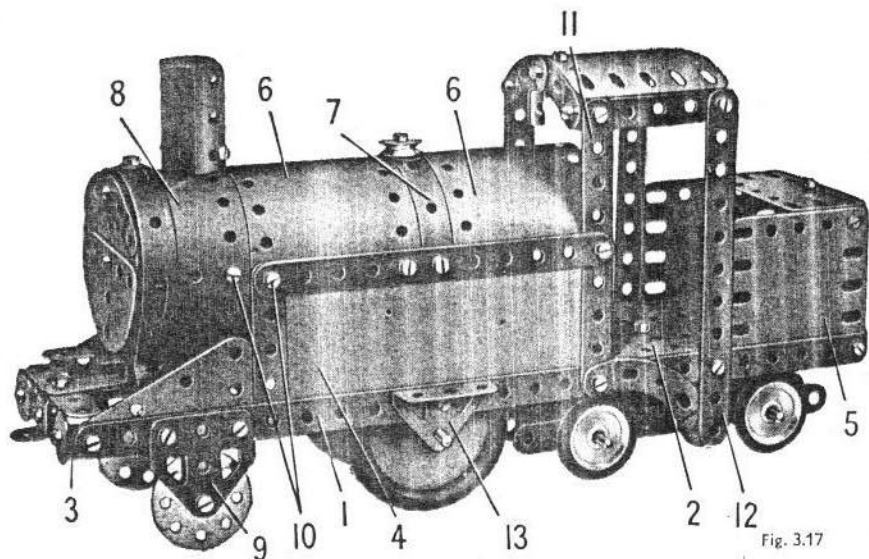

Fig. 3.17

A 12½" Strip (1) is bolted to each side of a 5½" x 2½" Flanged Plate (2) and to a 2½" x ½" Double Angle Strip (3). The water tanks are represented by 5½" x 2½" Flexible Plates (4) edged by 2½" and 5½" Strips, and the sides of the coal bunker are 2½" x 2½" Flexible Plates (5). The back of the bunker is a 1½" radius Curved Plate straightened out and bolted to the Flanged Plate (1) and to a 2½" x ½" Double Angle Strip placed between the Flexible Plates (5).

The boiler consists of two 4½" x 2½" Flexible Plates (6) and two Formed Slotted Strips (7). The smoke-box is made from two 5½" x 1½" Flexible Plates (8) curved as shown and bolted together at the top so that they overlap three holes. The lower ends of the Flexible Plates are attached to the Strips (1), and the Bolts holding them in place fix also a Flat Trunnion (9) and a 2½" x 1½" Triangular Flexible Plate on each side. The smoke-box is connected to the boiler by Fishplates held by the Bolts (10), and its front is attached by an Angle Bracket to the Flexible Plates (8). The smoke stack is a 2½" x 1½" Flexible Plate rolled to form a tube and bolted to an Angle Bracket.

The cab roof is supported by a 2½" Strip (11) and a 5½" Strip (12) on each side.

A Wheel Disc is lock-nutted to each Flat Trunnion (9), and two Road Wheels are fixed on a 3½" Rod supported in Trunnions (13). The bogie consists of two 5½" Strips connected by a Double Bracket (14). A 2½" x 1½" Triangular Flexible Plate (15) is bolted to each 5½" Strip, and the complete bogie is supported freely on a 1½" Rod (16) by a Cord Anchoring Spring and a Spring Clip.

Parts Required

2 of No.	1
6 "	2
9 "	5
3 "	10
1 "	11
8 "	12
1 "	15b
1 "	16
2 "	17
1 "	18a
4 "	22
1 "	23
1 "	24
2 "	24a
3 "	35
54 "	37a
48 "	37b
5 "	38
2 "	38d
1 "	44
2 "	48a
1 "	52
1 "	57c
4 "	90a

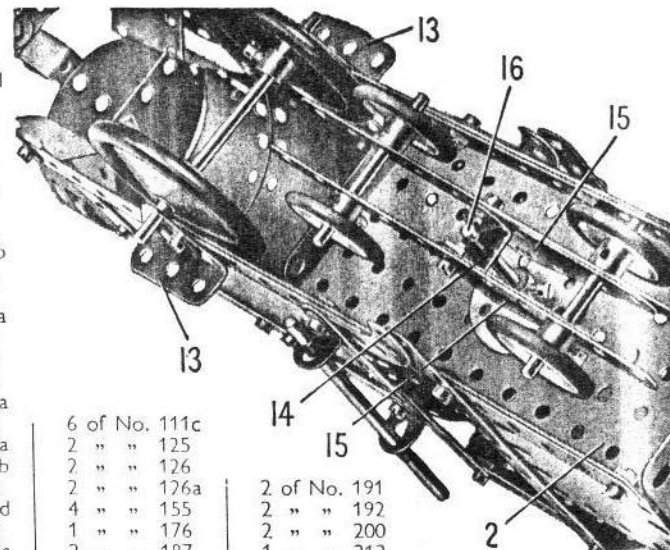

Fig. 3.17a

6 of No.	111c
2 "	125
2 "	126
2 "	126a
4 "	155
1 "	176
2 "	187
2 "	188
2 "	189
2 "	190

2 of No.	191
2 "	192
2 "	200
1 "	212
2 "	214
4 "	215
4 "	221

3.18 TRACTOR AND HAY WAGON

The chassis of the Tractor consists of a 5½" Strip (1) on each side. These are connected at the front by a Trunnion (2) attached to Angle Brackets fixed to the Strips, and by a 2½" Strip (3) that is also fixed to Angle Brackets. Two Flat Trunnions are bolted together and attached to the flange of the Trunnion (2), and a 2½" Strip (4) is fixed to each of the Strips (1). The upper ends of Strips (4) are connected to Angle Brackets attached to the radiator by 2½" Strips (5) lengthened by Fishplates. A Magic Motor is bolted direct to one of the Strips (see Fig. 3.18a).

The top of the bonnet consists of two 2½" x 1½" Flexible Plates attached to Angle Brackets bolted to Strips (4).

A 2½" Strip (6) and a 2½" x ½" Double Angle Strip (7) are bolted to the lower ends of Strips (4), and they support a 3½" Rod. This Rod is fitted with a 1" Pulley (8) that is connected by a Driving Band to the Motor pulley, and carries also a ½" Pulley (9) that drives a 1" Pulley on the rear axle. The ½" Pulley is supplied with the Magic Motor. The rear axle is a 4" Rod, and is supported in Semi-Circular Plates (10) attached to the end holes of Strip (3) by ½" Reversed Angle Brackets.

The front axle is a 3½" Rod supported in a 2½" x ½" Double Angle Strip (11) lock-nutted to the Trunnion (2). The steering column is a 3½" Rod passed through a Fishplate bolted to each of the rear flanged lugs of the Magic Motor. A length of Cord is wound round the lower end of the 3½" Rod and each end is then tied to Double Angle Strip (11). A Cord Anchoring Spring and a Washer are used to keep the Cord on the Rod.

The seat is a Trunnion bolted to a 2½" Strip (12) connected by an Angle Bracket to the Strip (3). The base of the Hay Wagon is a 5½" x 2½" Flanged Plate. The wheels turn on ½" Bolts, each fixed by two nuts in a 2½" Stepped Curved Strip.

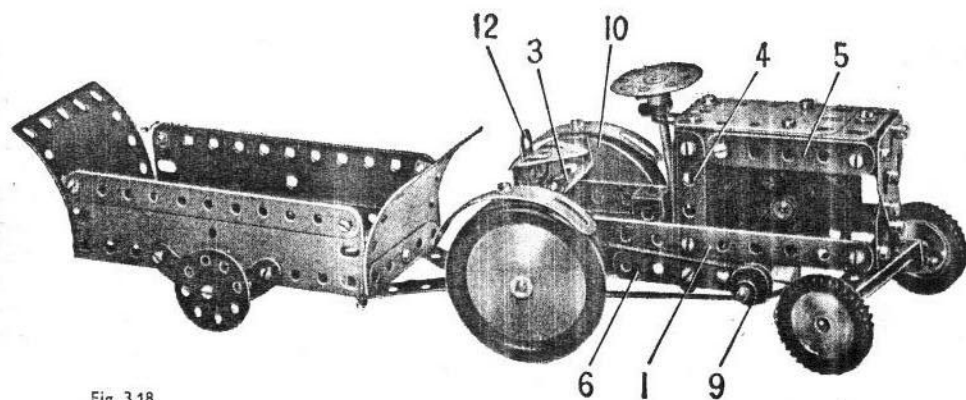

Fig. 3.18

Parts Required

4 of No.	2	1 of No.	52
9 "	5	2 "	90a
5 "	10	4 "	111c
2 "	11	2 "	125
8 "	12	2 "	126
1 "	15b	2 "	126a
3 "	16	2 "	142c
1 "	18a	1 "	176
4 "	22	2 "	187
1 "	24	2 "	188
2 "	24a	2 "	189
2 "	35	2 "	200
56 "	37a	2 "	214
47 "	37b	2 "	215
1 "	40		
1 "	44		
2 "	48a		

Magic Motor
(not included in
Outfit)

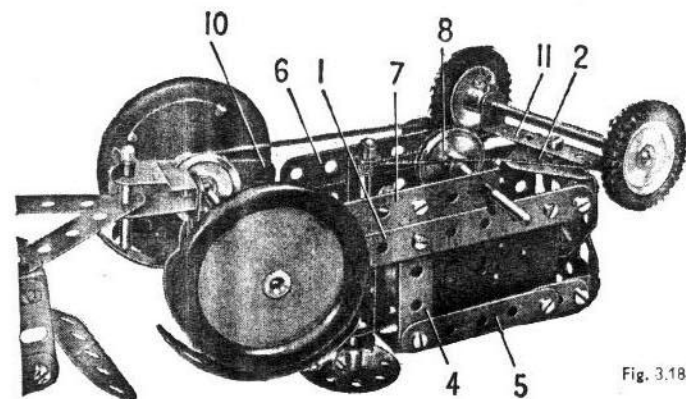

Fig. 3.18a

3.19 WINDMILL PUMP

The base of the model is a $5\frac{1}{2}" \times 2\frac{1}{4}"$ Flanged Plate, to the flanges of which $5\frac{1}{2}" \times 1\frac{1}{4}"$ and $2\frac{1}{2}" \times 1\frac{1}{4}"$ Flexible Plates are bolted. A $12\frac{1}{2}"$ Strip is fixed upright to each side, and two $2\frac{1}{2}" \times \frac{1}{4}"$ Double Angle Strips (1) are bolted between these Strips.

Two $2\frac{1}{2}" \times 1\frac{1}{4}"$ Triangular Flexible Plates (2) are attached to each $12\frac{1}{2}"$ Strip as shown, and they are connected to the top hole of the Strip by $2\frac{1}{4}"$ Stepped Curved Strips. The bolt that fixes the Curved Strips to the $12\frac{1}{2}"$ Strips is used also to secure a Semi-Circular Plate (3) and two Angle Brackets that support $2\frac{1}{2}" \times 2\frac{1}{2}"$ Flexible Plates (4).

The windmill blades are eight $2\frac{1}{2}"$ Strips, which are bolted to a Bush Wheel fixed on a 4" Rod fitted with a 1" Pulley (5). Pulley (5) is connected by a Cord belt to a 1" Pulley (6) fixed on a Crank Handle. A bolt passed through an Angle Bracket is fitted with two Washers, and is then screwed into one of the threaded holes of Pulley (6). The Bolt is tightened to hold the Angle Bracket firmly in place, and a $2\frac{1}{2}"$ Strip (7) is lock-nutted to the Angle Bracket and to a $5\frac{1}{2}"$ Strip (8).

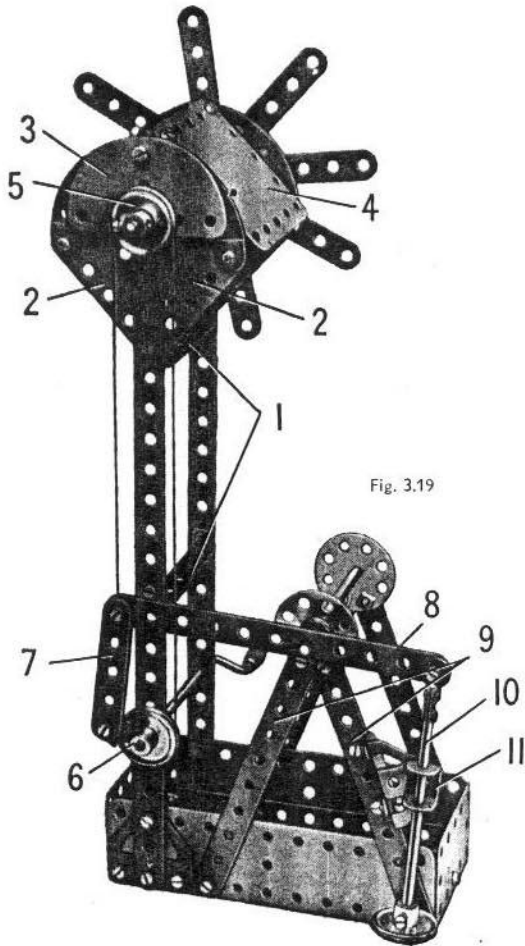

Fig. 3.19

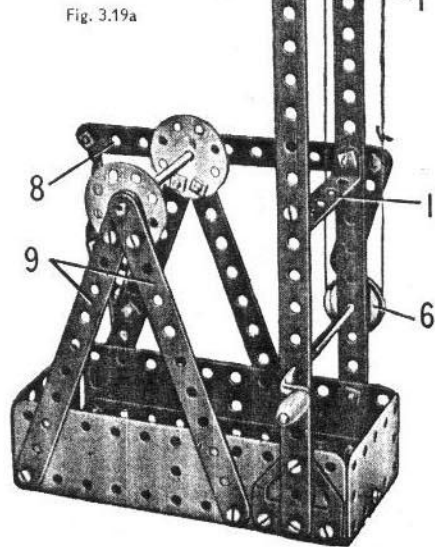

Fig. 3.19a

The Strip (8) is pivoted on a 4" Rod supported in a Wheel Disc and in the top holes of two $5\frac{1}{2}"$ Strips (9) on each side. The Strip is held on the 4" Rod by a Spring Clip, and it is connected by a lock-nutted Bolt to a Rod and Strip Connector fitted to a $3\frac{1}{4}"$ Rod (10). Rod (10) is free to slide in a Double Bracket (11) lock-nutted to a Trunion. The Trunion is attached by Angle Brackets to one of the Strips (9).

Parts Required		
2 of No. 1	1 of No. 24	2 of No. 111c
5 " " 2	2 " " 24a	1 " " 126
9 " " 5	2 " " 35	2 " " 126a
1 " " 11	53 " " 37a	2 " " 188
7 " " 12	47 " " 37b	2 " " 189
2 " " 15b	6 " " 38	2 " " 190
1 " " 16	1 " " 40	1 " " 212
1 " " 19g	2 " " 48a	2 " " 214
3 " " 22	1 " " 52	4 " " 221
	4 " " 90a	

3.20 BALANCE

One of the $12\frac{1}{2}"$ Strips that form the beam of the balance is bolted across a Bush Wheel (2). The $3\frac{1}{2}"$ Rod (3) that is gripped in the boss of the Bush Wheel rests on the two Curved Strips (4).

The Rod (1), by which the balance is adjusted, is pushed through the two holes of a Stepped Bent Strip fastened to the Bush Wheel (2) by a Reversed Angle Bracket. The $5\frac{1}{2}"$ Strips from which the weighing pans are suspended are pivoted at their upper ends on 2" Rods, which are passed through holes in the $12\frac{1}{2}"$ Strips of the beam.

Parts Required

2 of No. 1	2 of No. 16	3 of No. 38	2 of No. 126
6 " " 2	2 " " 17	1 " " 40	2 " " 126a
8 " " 5	4 " " 22	1 " " 44	2 " " 190
5 " " 10	1 " " 24	2 " " 48a	2 " " 191
2 " " 11	6 " " 35	1 " " 52	2 " " 192
3 " " 12	46 " " 37a	4 " " 90a	2 " " 200
2 " " 15b	46 " " 37b	1 " " 125	1 " " 212
			1 " " 213

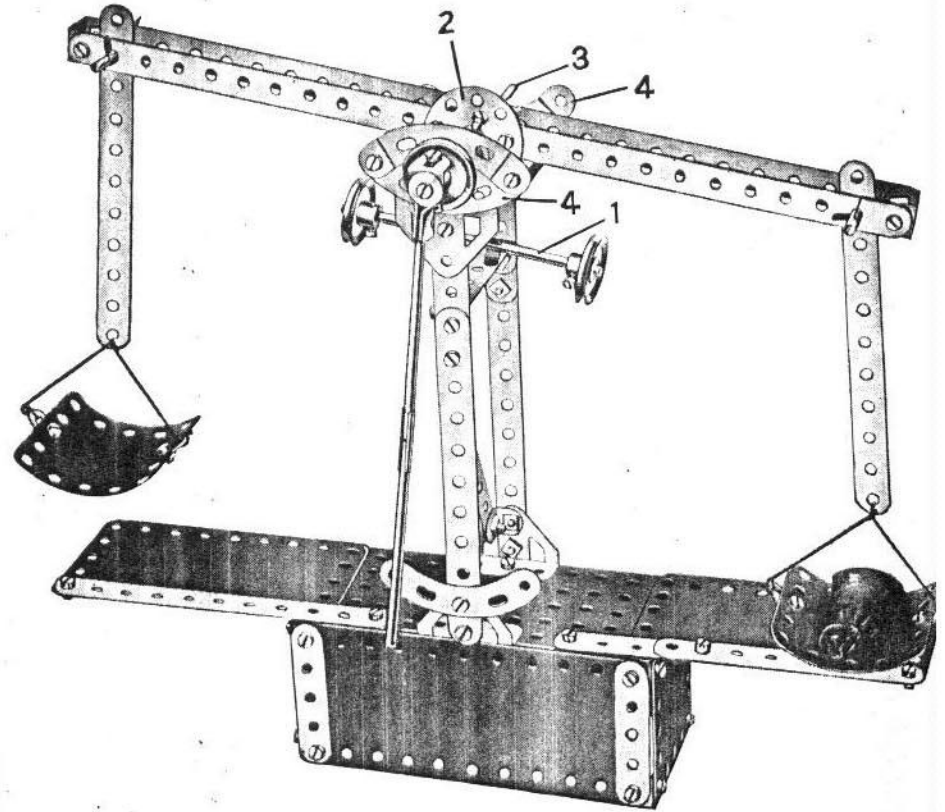

3.21 FORK LIFT TRUCK

The back of the model is a $5\frac{1}{2}'' \times 2\frac{1}{2}''$ Flanged Plate (1), and each side consists of a $5\frac{1}{2}'' \times 1\frac{1}{2}''$ Flexible Plate (2) placed vertically, a $5\frac{1}{2}'' \times 2\frac{1}{2}''$ Flexible Plate (3), a $4\frac{1}{2}'' \times 2\frac{1}{2}''$ Flexible Plate (4) and a $2\frac{1}{2}'' \times 2\frac{1}{2}''$ Flexible Plate (5). The upper edges of Plates (4) and (5), and the lower edges of Plates (3), are strengthened by $5\frac{1}{2}''$ Strips, and they are connected across by a $2\frac{1}{2}'' \times \frac{1}{2}''$ Double Angle Strip. Two $2\frac{1}{2}'' \times 1\frac{1}{2}''$ Triangular Plates (6), placed with their sloping edges overlapped, are bolted to the Double Angle Strip, and a $2\frac{1}{2}'' \times 1\frac{1}{2}''$ Flexible Plate (7) is attached to the sides by Angle Brackets. The driver's seat is also a $2\frac{1}{2}'' \times 1\frac{1}{2}''$ Flexible Plate, and the backrest is made from two Flat Trunnions.

A $2\frac{1}{2}'' \times \frac{1}{2}''$ Double Angle Strip (8) is bolted between the lower front corners of Plates (3), and two vertical $12\frac{1}{2}''$ Strips (9) are fixed to it. These Strips are connected three holes from their upper ends by a $2\frac{1}{2}''$ Strip, and they are attached to the Flexible Plates (5) by Double Brackets.

Two $5\frac{1}{2}''$ Strips (11) are joined together by four $2\frac{1}{2}''$ Strips arranged in pairs as indicated at (12). The Strips in each pair are arranged one on each side of the $5\frac{1}{2}''$ Strips, and they are further separated by a Washer on each of the bolts used to fix them in position. The $2\frac{1}{2}''$ Strips slide freely over the $12\frac{1}{2}''$ Strips (9). The fork platform consists of two $2\frac{1}{2}''$ Strips bolted to a further $2\frac{1}{2}''$ Strip (13), which is fixed to Strips (11) by Angle Brackets.

The fork platform can be raised or lowered by operating a handle formed by a $\frac{1}{2}''$ Bolt in a Bush Wheel. The Bush Wheel is fixed on a $2''$ Rod free to turn in two Angle Brackets (14). A length of Cord tied to a Cord Anchoring Spring on the $2''$ Rod is passed round a $3\frac{1}{2}''$ Rod (15) and over a $\frac{1}{2}''$ loose Pulley on a $3\frac{1}{2}''$ Rod held in Angle Brackets bolted to the upper ends of Strips (9). The Cord is then tied to the upper pair of $2\frac{1}{2}''$ Strips (12).

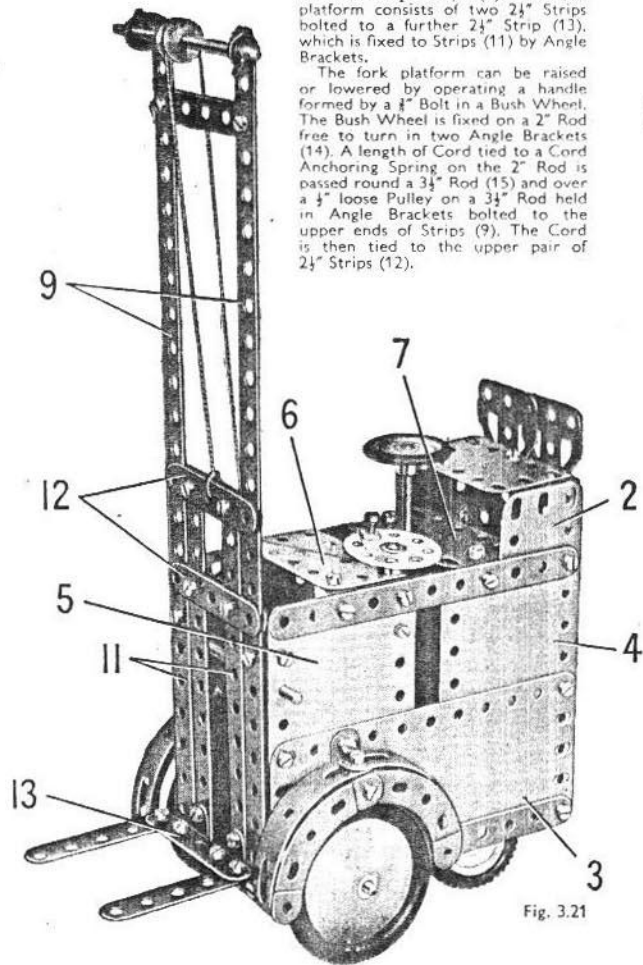

Fig. 3.21

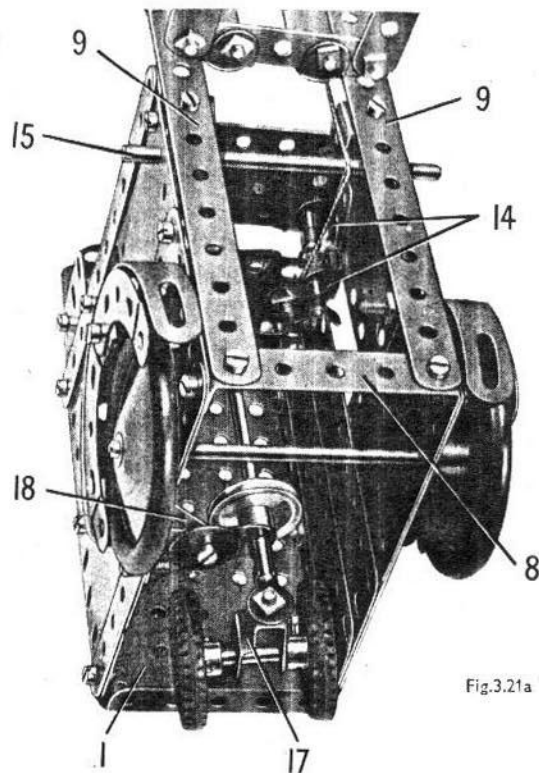

Fig. 3.21a

The front wheels are fixed on a $4''$ Rod supported in Plates (3) as shown, and each wheel is provided with a mudguard made from two Formed Slotted Strips and two Curved Strips bolted to a $\frac{1}{2}''$ Reversed Angle Bracket. The rear wheels are fixed on a $2''$ Rod passed through a Stepped Bent Strip (17). This is bolted tightly to a Rod and Strip Connector on a $4''$ Rod joined to a $2''$ Rod by a Rod Connector. The long rod thus formed is supported in the Flexible Plate (7) and in a Fishplate bolted to a Trunnion (18).

2 of No.		6 of No.		2 of No.	
1	1	35	142c	1	155
6	2	37a	1	176	1
9	5	37b	2	187	2
1	10	38	2	188	2
1	11	38d	2	189	2
8	12	40	2	190	2
2	15b	44	2	191	2
2	16	48a	2	192	2
2	17	52	1	212	1
1	18a	90a	1	213	1
4	22	111c	4	215	4
1	23	125	2	221	2
1	24	126	2		
		126a	2		

3.22 PORTABLE GARAGE CRANE

A $5\frac{1}{2}''$ Strip (1) is bolted to each side of a Flanged Plate (2) and $2\frac{1}{2}'' \times 1\frac{1}{2}''$ Triangular Flexible Plates (3) are then fixed in place as shown. The Road Wheels are fixed to a $3\frac{1}{2}''$ Rod supported in $2\frac{1}{2}''$ Curved Strips (4) on each side of the model. The front wheels are $1''$ Pulleys, which are fixed to $\frac{1}{2}''$ Bolts passed through Flat Trunnions.

The jib is built up from two $12\frac{1}{2}''$ Strips bolted to the sides of the Flanged Plate and extended at their upper ends by Curved Strips. It is held rigid by $5\frac{1}{2}''$ Strips fixed to the Flanged Plate and also to $2\frac{1}{2}'' \times 1\frac{1}{2}''$ Triangular Flexible Plates fastened to the $12\frac{1}{2}''$ Strips.

The handle used for hauling and manoeuvring the crane truck is represented by the $3\frac{1}{2}''$ Rod (5) fitted with a Bush Wheel, to which a $2\frac{1}{2}''$ Strip is bolted. The other end of the Rod carries a Rod and Strip Connector that pivots on a Bolt held in two Trunnions bolted to the Double Angle Strip (6).

The hoisting Cord is tied to a Cord Anchoring Spring on the Crank Handle and then is passed over a $1''$ Pulley at the jib head. Then the Cord passes round a $\frac{1}{2}''$ Pulley in the pulley block and is tied to one of the Curved Strips. The pulley block consists of a $\frac{1}{2}''$ Pulley placed between two Fishplates on a $\frac{1}{2}''$ Bolt fitted with lock-nuts.

A brake to prevent the load falling when the winding handle is released is formed by a belt of Cord, which is passed round a $1''$ Pulley (7) on the Crank Handle and then fastened to a weighted built-up strip (8). This strip is made up from two $2\frac{1}{2}''$ Strips bolted together, and to its outer end two Wheel Discs are attached. The other end of the Strip is pivoted on a $\frac{1}{2}''$ Bolt (9). The Bolt is fitted with two nuts tightened together.

Parts Required

2 of No.	1	1 of No.	40
6 "	2	1 "	44
9 "	5	2 "	48a
2 "	10	1 "	52
1 "	11	1 "	57c
2 "	16	4 "	90a
1 "	18a	6 "	111c
1 "	19g	2 "	126
4 "	22	2 "	126a
1 "	23	2 "	142c
1 "	24	1 "	176
2 "	24a	2 "	187
4 "	35	2 "	189
49 "	37a	1 "	212
48 "	37b	2 "	215
6 "	38	4 "	221

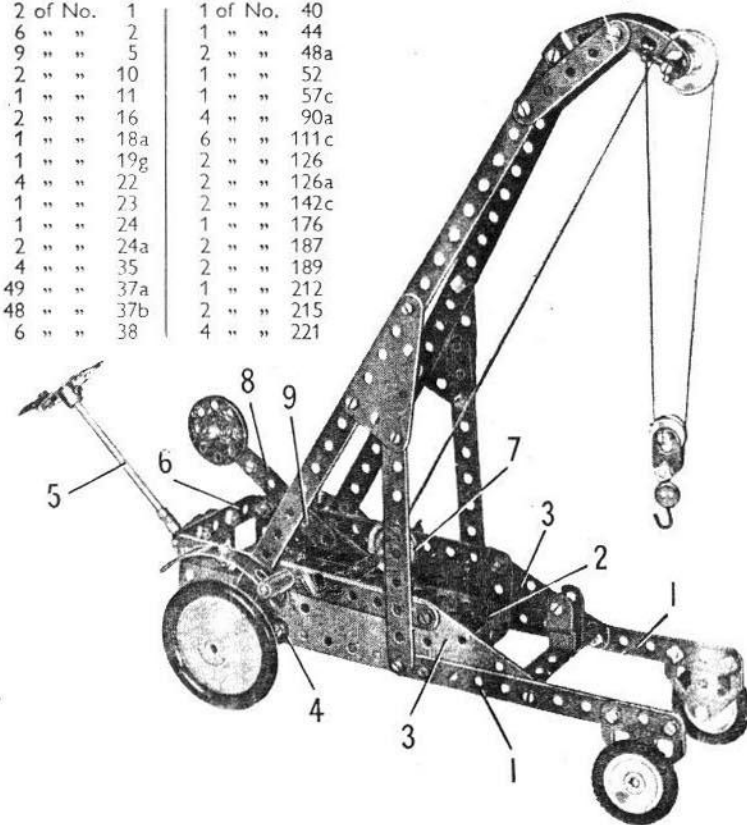

3.23 SIMPLE HAND LOOM

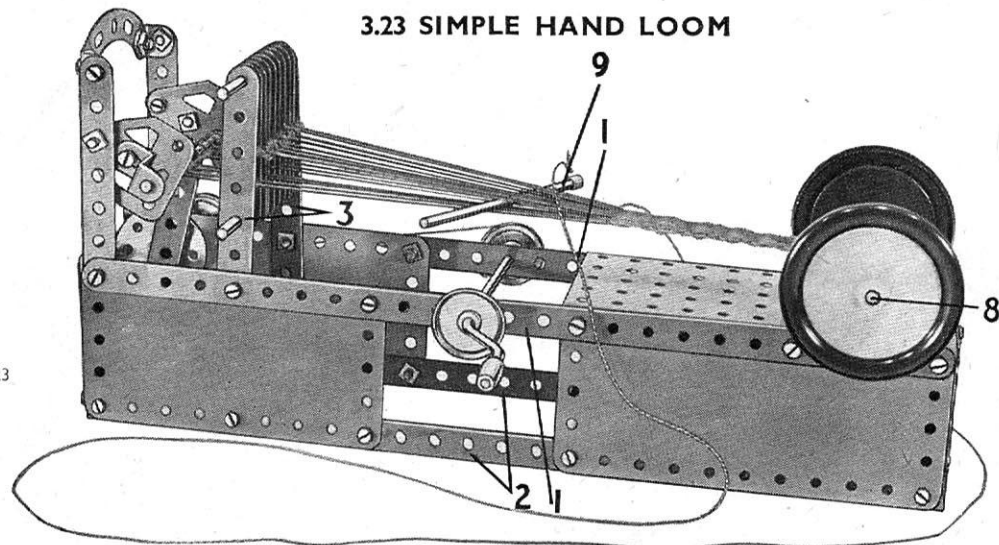

Fig. 3.23

Parts Required

2 of No. 1	3 of No. 16	2 of No. 24a	1 of No. 40	2 of No. 125	2 of No. 190
6 " " 2	2 " " 17	6 " " 35	2 " " 48a	1 " " 126	2 " " 191
9 " " 5	1 " " 19g	42 " " 37a	1 " " 52	2 " " 126a	2 " " 192
4 " " 12	3 " " 22	37 " " 37b	2 " " 90a	1 " " 176	2 " " 214
2 " " 15b	1 " " 24	6 " " 38	2 " " 111c	2 " " 187	4 " " 215

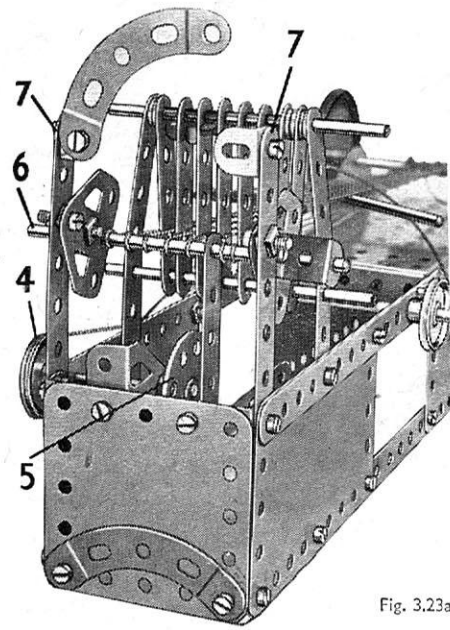

Fig. 3.23a

This interesting model is designed to demonstrate the principles of hand weaving. The base is formed by two 12½" Strips (1) bolted to a Flanged Plate at one end and joined by a 2½"×½" Double Angle Strip at the other. Two 5½"×2½" and two 4½"×2½" Flexible Plates are bolted to the Strips and joined at their lower edges by the 5½" Strips (2).

The 5½" Strips (3) form a support for the heald frame, which consists of eight 2½" Strips held by two 3½" Rods. The Strips are separated by Spring Clips and Washers as shown, these parts being placed between the Strips on the upper Rod.

The warp separating movement is operated from a Crank Handle. A 1" Pulley on this is connected by a belt of Cord to a similar Pulley (4), which is fixed on a 2" Rod that carries also the Bush Wheel (5). A 2½" Strip, lock-nutted to the Bush Wheel, links it with the Rod (6). This Rod is mounted in two Flat Trunnions, each fitted with a Reversed Angle Bracket. The Trunnions are free to turn on the shanks of ⅜" Bolts fastened in the Strips (7).

A 4" Rod (8) fitted with two Road Wheels passes through two Semi-Circular Plates bolted to the sides of the Flanged Plate.

A length of Cord taken from each of the 2½" Strips forming the healds, is tied to the Rod (8). A second set of similar Cords is taken from the Rod (8), passed between the healds and fastened to Rod (6).

To operate the model, the two sets of warp threads are separated by turning the Crank Handle slightly. A length of Cord is then passed between the layers by means of the 3½" Rod (9). The Crank Handle is then again turned slightly, thus changing the positions of the warp layers, and the Rod (9) is again passed through from the other side.

Cord is used in the illustrations to show the positions of the threads more clearly, but in actual operation it is better to use wool as this will give a closer and finer texture to the woven material.

3.24 SWIVELLING JIB CRANE

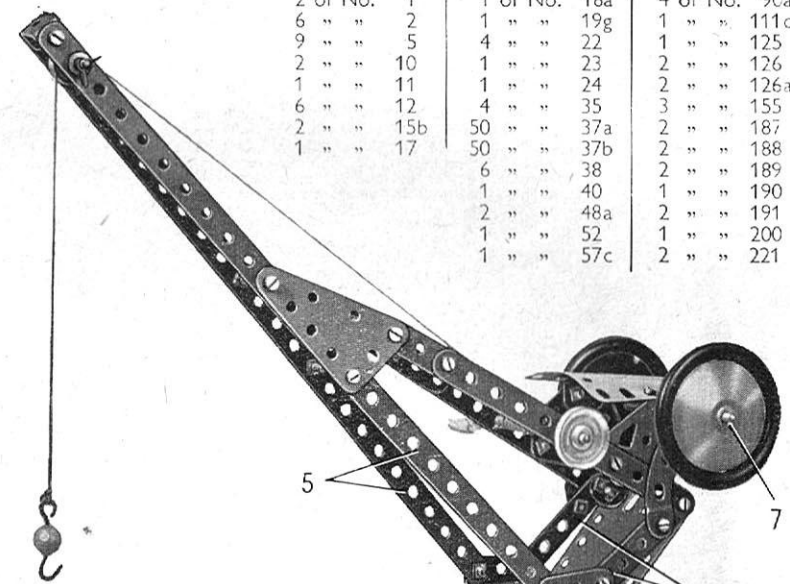

Parts Required

2 of No. 1	1 of No. 18a	4 of No. 90a
6 " " 2	1 " " 19g	1 " " 111c
9 " " 5	4 " " 22	1 " " 125
2 " " 10	1 " " 23	2 " " 126
1 " " 11	1 " " 24	2 " " 126a
2 " " 12	4 " " 35	3 " " 155
6 " " 15b	50 " " 37a	2 " " 187
1 " " 17	50 " " 37b	2 " " 188
	6 " " 38	2 " " 189
	1 " " 40	1 " " 190
	2 " " 48a	2 " " 191
	1 " " 52	1 " " 200
	1 " " 57c	2 " " 221

The base of the tower that supports the crane is a 5½"×2½" Flanged Plate, and two 5½" Strips are bolted to each side of it. The upper ends of these Strips are joined by two 2½" Stepped Curved Strips (1) at each side and by two 2½"×½" Double Angle Strips (2). A built-up strip (3), made from two 2½" Strips overlapped four holes, is bolted to each side, and two 2½"×1½" Flexible Plates, strengthened by a 2½" Strip where they overlap, are bolted to the Double Angle Strips (2).

Two Trunnions are bolted to a Bush Wheel (4), and two 12½" Strips (5) and two 2½" Strips (6) are fixed to the Trunnions as shown. The 12½" Strips form the main girders of the jib, and they are joined together at their upper ends by a Double Bracket. A 2½"×1½" Triangular Flexible Plate is bolted to the centre of each 12½" Strip, and is connected by a built-up strip to the Strip (6). The built-up strip is made from a 5½" and a 2½" Strip overlapped three holes. The cab roof is bolted to Angle Brackets fixed to Flat Trunnions as shown. A Rod (7) is supported in the top holes of 2½" Stepped Curved Strips bolted to the Strips (6).

A 2" Rod is fixed in the boss of the Bush Wheel (4), and this Rod is supported in a ½" Reversed Angle Bracket (8) and the top of the tower. The Rod carries at its lower end a 1" Pulley (9) fitted with a Rubber Ring, and this rests on a Rubber Ring carried by a 1" Pulley (10). Pulley (10) is fixed on a Rod mounted in Fishplates bolted to the Curved Strips (1). This arrangement provides a simple slewing or turning mechanism so that the cab and jib can be turned to raise or lower a load at any point round the base.

3.25 MOBILE CRANE

Parts Required

2 of No.	1
4 " "	2
9 " "	5
2 " "	10
1 " "	11
8 " "	12
2 " "	15b
3 " "	16
1 " "	18a
1 " "	19g
4 " "	22
1 " "	23
1 " "	24
2 " "	24a
6 " "	35
50 " "	37a
44 " "	37b
6 " "	38
2 " "	38d
1 " "	40
1 " "	44
2 " "	48a
1 " "	52
1 " "	57c
1 " "	90a
3 " "	111c
2 " "	126
2 " "	126a
2 " "	155

1 of No.	176
2 " "	187
2 " "	188
1 " "	190
2 " "	191
1 " "	192
1 " "	199
2 " "	214

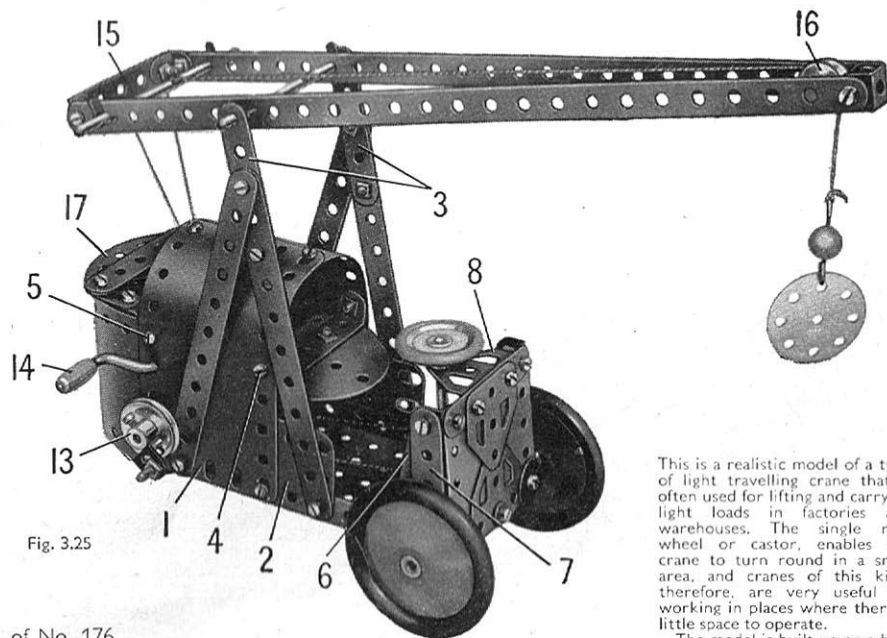

Fig. 3.25

This is a realistic model of a type of light travelling crane that is often used for lifting and carrying light loads in factories and warehouses. The single rear wheel or castor, enables the crane to turn round in a small area, and cranes of this kind, therefore, are very useful for working in places where there is little space to operate.

The model is built up on a base consisting of a $5\frac{1}{2}'' \times 2\frac{1}{2}''$ Flanged Plate, which is fitted at each side with a $4\frac{1}{2}'' \times 2\frac{1}{2}''$ Flexible Plate (1) and a $2\frac{1}{2}'' \times 1\frac{1}{2}''$ Flexible Plate (2). The Bolts fixing these Plates in position serve also to hold $5\frac{1}{2}''$ Strips that form the jib supports. These Strips are extended upward by $2\frac{1}{2}''$ Strips (3). The upper ends of the Plates (1) are curved and bolted together as shown, and two $2\frac{1}{2}'' \times \frac{1}{2}''$ Double Angle Strips, held by the Bolts (4) and (5), are placed between the Plates. The seat is a Semi-Circular Plate and is attached to the Double Angle Strip held by the Bolts (4). The curved end of the model is made from a $5\frac{1}{2}'' \times 2\frac{1}{2}''$ Flexible Plate bolted to the Flexible Plates (1).

A $2\frac{1}{2}'' \times 2\frac{1}{2}''$ Flexible Plate forms the front of the model, and it is connected by Angle Brackets to two $2\frac{1}{2}''$ Strips (6) and (7) on each side. Strip (6) is bolted to the Flanged Plate, and the front axle, which is a $4''$ Rod, is passed through Strips (7) and the Flanged Plate. A Trunnion (8) is fixed in position to the front.

The rear wheel or castor is fixed on a $1\frac{1}{2}''$ Rod supported in a Stepped Bent Strip (9). A $\frac{3}{4}''$ Bolt is held tightly in the Bent Strip by a nut, and the Bolt is then passed through a Trunnion (10) bolted to the rear of the Flanged Plate. A Wheel Disc (11) is fixed between two nuts on the upper end of the $\frac{3}{4}''$ Bolt.

The steering column is passed through Trunnion (8) and the base Flanged Plate, and a Bush Wheel on the Rod is connected at each side to the Wheel Disc (11) by a short length of Cord.

The jib consists of two $12\frac{1}{2}''$ Strips joined at the front by a Double Bracket, and connected at the rear by Angle Brackets to a $2\frac{1}{2}''$ Strip. It pivots on a $3\frac{1}{2}''$ Rod supported in the Strips (3). The jib is luffed, that is, raised and lowered, by a length of Cord tied to a Rod fitted with a Pulley (12). The Rod is fitted with a handle which is formed by a $\frac{3}{4}''$ Bolt in an Angle Bracket attached to a $1''$ Pulley (13). The Bolt is fitted with a nut and is passed through the Angle Bracket into one of the threaded holes in the boss of the Pulley. The nut is then tightened to hold the Angle Bracket in place.

A length of Cord is tied to a Crank Handle (14) and is taken over a Rod (15) in the jib. The Cord then passes round a $\frac{1}{2}''$ Pulley (16) and is fitted with a small Loaded Hook. The Pulley (16) is free to turn on a $\frac{3}{4}''$ Bolt attached to the jib by two nuts.

A $2\frac{1}{2}''$ Stepped Curved Strip (17) and a $2\frac{1}{2}''$ Strip are fitted at their ends with Fishplates, and these are connected by Angle Brackets to the Double Angle Strip held by the Bolts (5). A Semi-Circular Plate is attached to the Double Angle Strip to fill in the rounded end formed by the Flexible Plates (1).

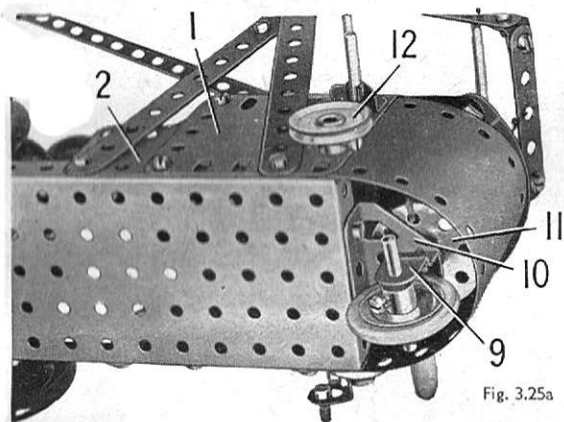

Fig. 3.25a

3.26 TOWER WAGON

Parts Required

6 of No.	2	1 of No.	17	2 of No.	38	2 of No.	125	2 of No.	190
9 " "	5	4 " "	22	1 " "	40	2 " "	126	2 " "	191
4 " "	10	1 " "	24	2 " "	48a	1 " "	126a	2 " "	192
2 " "	11	1 " "	35	1 " "	52	4 " "	142c	2 " "	200
8 " "	12	55 " "	37a	2 " "	90a	2 " "	188	1 " "	214
2 " "	16	49 " "	37b	6 " "	111c	2 " "	189	4 " "	221

The front of the chassis is a $5\frac{1}{2}'' \times 2\frac{1}{2}''$ Flanged Plate (1), and this is extended at each side at the rear by a $5\frac{1}{2}'' \times 2\frac{1}{2}''$ Flexible Plate that overlaps the Flanged Plate by two holes. A $2\frac{1}{2}''$ Stepped Curved Strip that supports the rear axle is attached to each side by the Bolts (2), and these Bolts also fix in place two $5\frac{1}{2}''$ Strips (3) and two Angle Brackets. A $4\frac{1}{2}'' \times 2\frac{1}{2}''$ Flexible Plate is bolted to the Angle Brackets to form the floor at the rear of the model.

The back of the cab is a $2\frac{1}{2}'' \times 2\frac{1}{2}''$ Flexible Plate bolted to a $2\frac{1}{2}'' \times \frac{1}{2}''$ Double Angle Strip held between the $5\frac{1}{2}'' \times 2\frac{1}{2}''$ Flexible Plates by a Bolt (4) on each side. The Bolts holding the Double Angle Strip in place fix also $2\frac{1}{2}'' \times 1\frac{1}{2}''$ Triangular Flexible Plates that form the cab sides. The roof is a $2\frac{1}{2}'' \times 2\frac{1}{2}''$ Flexible Plate fixed to a Double Bracket bolted to the back of the cab. A $2\frac{1}{2}'' \times 1\frac{1}{2}''$ Flexible Plate (5) is connected to the Flanged Plate (1) by an Angle Bracket.

The bonnet consists of two $1\frac{1}{2}''$ radius Curved Plates overlapped two holes and attached by Angle Brackets to the Flanged Plate (1). The radiator is a Flat Trunnion fixed to the front of the Flanged Plate

by a Fishplate. The $2''$ Rod to which the steering wheel is fixed is passed through the Flanged Plate and through a $\frac{1}{2}''$ Reversed Angle Bracket bolted to it. The front wheels are fixed on a $3\frac{1}{2}''$ Rod supported in Fishplates. The driver's seat is made by bolting two Trunnions together by their flanged ends, and it is fixed to the Flanged Plate (1).

The Strips (3) are lengthened by $2\frac{1}{2}''$ Strips, and a $5\frac{1}{2}'' \times 1\frac{1}{2}''$ Flexible Plate is bolted to the upper ends of these Strips on each side. A $2\frac{1}{2}'' \times 1\frac{1}{2}''$ Flexible Plate (6) is fixed to a Double Bracket and an Angle Bracket bolted to the $5\frac{1}{2}'' \times 1\frac{1}{2}''$ Flexible Plates, and a $\frac{1}{2}''$ Reversed Angle Bracket held by a Bolt (7) supports one end of a $4\frac{1}{2}'' \times 2\frac{1}{2}''$ Flexible Plate that forms the floor of the tower platform. The other end of this Plate is fixed to a $2\frac{1}{2}'' \times \frac{1}{2}''$ Double Angle Strip held by a Bolt (8) on each side, and a Semi-Circular Plate, indicated at (9), is fixed also to this Double Angle Strip.

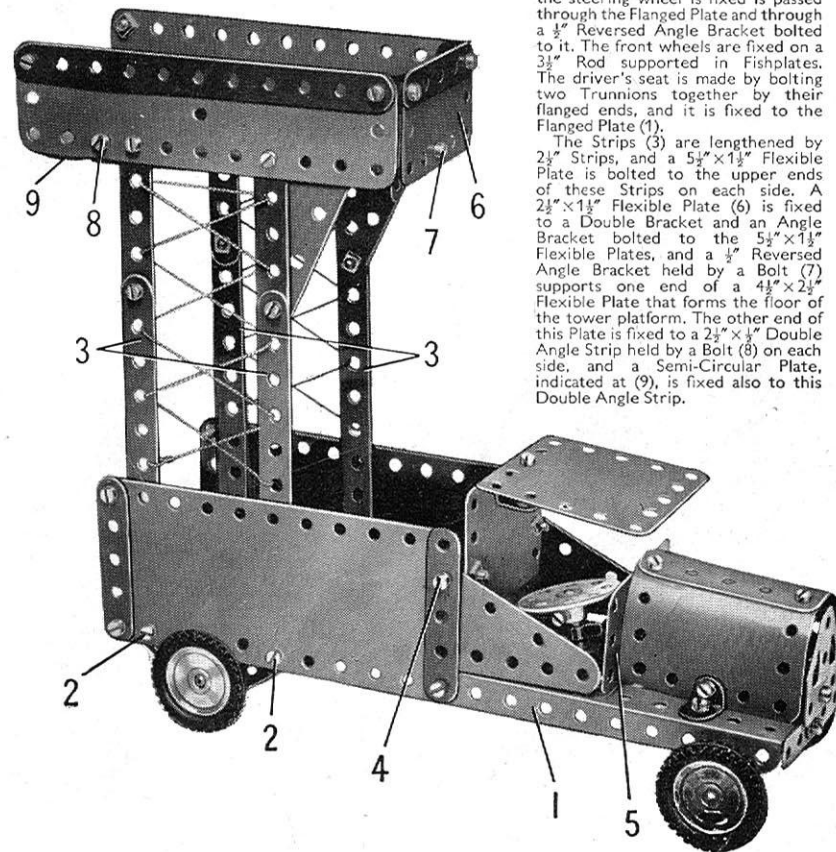

3.27 PITHEAD GEAR

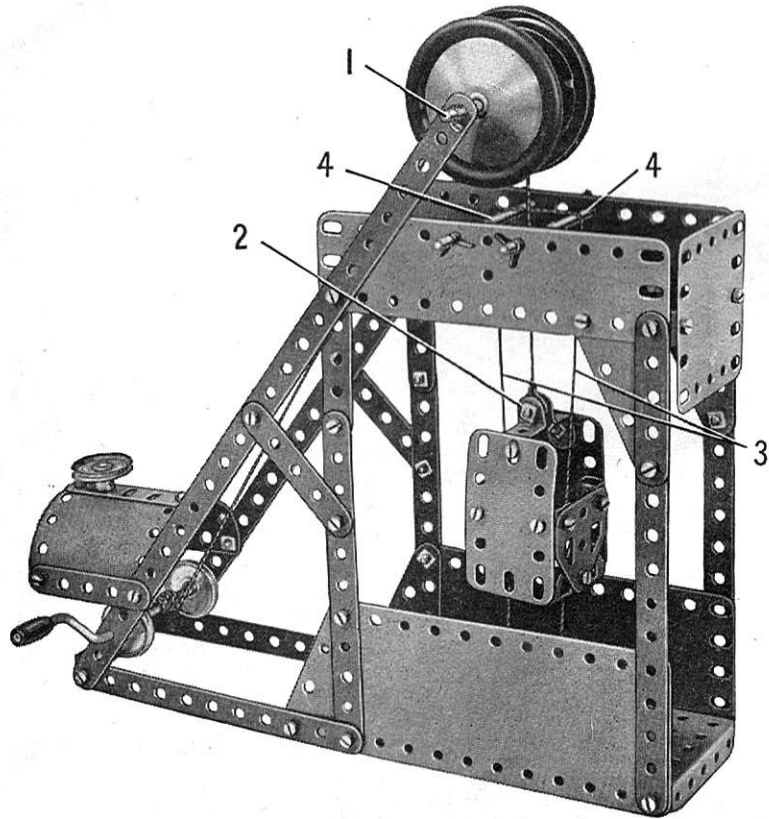

Parts Required

2 of No.	1
6 " "	2
9 " "	5
6 " "	12
3 " "	16
1 " "	19g
4 " "	22
1 " "	24
4 " "	35
47 " "	37a
46 " "	37b
6 " "	38
1 " "	40
2 " "	48a
1 " "	52
2 " "	111c
2 " "	125
2 " "	126
2 " "	126a
1 " "	176
2 " "	187
2 " "	188
2 " "	189
1 " "	190
2 " "	192
2 " "	200
4 " "	221

A $3\frac{1}{2}$ " Rod (1) is supported in the top holes of the $12\frac{1}{2}$ " Strips. Between two Road Wheels on this Rod is a 1" fast Pulley, over which passes a Cord from which the cage is suspended. A Cord Anchoring Spring is pushed on one end of the Rod (1) and a Bush Wheel is fixed to its other end.

The cage is built up from Trunnions and Flat Trunnions, and two $2\frac{1}{2}$ " x $1\frac{1}{2}$ " Flexible Plates, which form its sides, are fastened to the Flat Trunnions by Angle Brackets.

A $\frac{3}{8}$ " Bolt is passed through the holes of Reversed Angle Brackets (2) bolted to the top of the cage, and Washers are placed on its shank for spacing purposes.

The cage is guided while being raised or lowered by guides formed by a length of Cord (3). This is passed over two Rods (4) as shown, and its ends are then led downwards and pushed through two holes in the Flanged Plate that forms the base. Washers are tied to each end of the Cord, underneath the Plate, to hold it tightly in place.

The Cord used for raising and lowering the cage is tied to the Crank Handle and is passed over the Pulley on Rod (1) and tied to the Reversed Angle Brackets (2).

3.28 BLOCK-SETTING CRANE

The travelling bogie (1) consists of two Fishplates bolted together by their elongated holes, and at each end of it Double Brackets are fastened by $\frac{3}{8}$ " Bolts. Two 2" Rods are pushed through the Double Brackets and carry 1" fast Pulleys spaced so that their grooves fit on the two $12\frac{1}{2}$ " Strips that form the top of the jib. The Trunnions (2) at the base of the jib are secured to a Bush Wheel mounted on a Rod held in the bosses of two Road Wheels. The Road Wheels are placed one above and one below the $2\frac{1}{2}$ " x $1\frac{1}{2}$ " Flexible Plates that form the top of the tower.

Cord (3) is first fastened to the $\frac{3}{8}$ " Bolt at the rear end of the travelling bogie, and then wound three times round the Crank Handle, which is passed through the end holes of the $12\frac{1}{2}$ " Strips. It is then led round the Rod at the front of the jib and tied to the other $\frac{3}{8}$ " Bolt at the front of the bogie.

Cord (4) is first fastened to the Rod (5), and then led over the rear axle of the bogie. It is then passed round the $\frac{1}{2}$ " Pulley (6), led over the front axle of the bogie, round the Rod at the front end of the jib, and finally is tied to the bogie. The $\frac{1}{2}$ " loose Pulley (6) and its Rod are held in the Stepped Bent Strip by a Cord Anchoring Spring.

Parts Required

2 of No.	1	2 of No.	17	6 of No.	35	1 of No.	52	2 of No.	187
6 " "	2	1 " "	18a	56 " "	37a	4 " "	90a	2 " "	188
8 " "	5	1 " "	19g	50 " "	37b	6 " "	111c	1 " "	190
5 " "	10	4 " "	22	6 " "	38	2 " "	125	2 " "	199
2 " "	11	1 " "	23	1 " "	40	2 " "	126	2 " "	200
6 " "	12	1 " "	24	1 " "	44	2 " "	126a	4 " "	221
2 " "	16	1 " "	24a	2 " "	48a	1 " "	176		

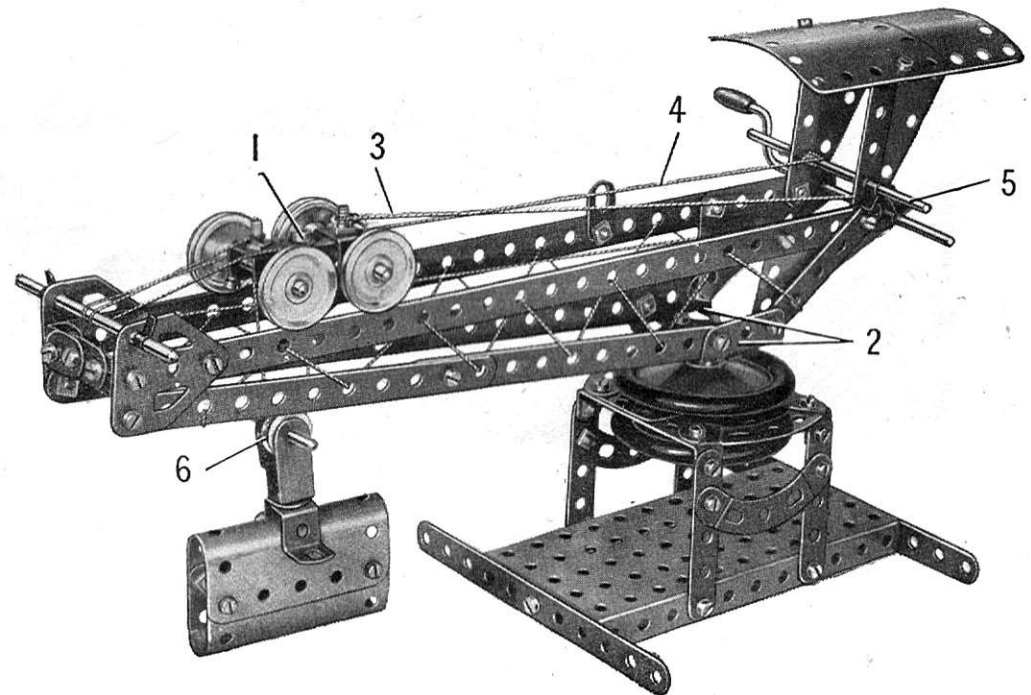

3.29 HIGH FLYER

Each side of the base consists of a $12\frac{1}{2}$ " Strip fitted with two upright $5\frac{1}{2}$ " Strips (1). A $2\frac{1}{2}$ " \times $1\frac{1}{2}$ " Triangular Flexible Plate is bolted between each of the Strips (1) and the $12\frac{1}{2}$ " Strip, and a $2\frac{1}{2}$ " \times $1\frac{1}{2}$ " Flexible Plate (2) and a $2\frac{1}{2}$ " Curved Strip (3) are fixed in position. The upper ends of Strips (1) are connected by a Semi-Circular Plate. The sides of the base are joined by two $2\frac{1}{2}$ " \times $\frac{1}{2}$ " Double Angle Strips (4), each of which is lengthened by a Double Bracket (5).

The floor of the high flyer is a $5\frac{1}{2}$ " \times $2\frac{1}{2}$ " Flanged Plate, and the sides are $5\frac{1}{2}$ " \times $2\frac{1}{2}$ " Flexible Plates. The ends are $2\frac{1}{2}$ " \times $2\frac{1}{2}$ " Flexible Plates. The roof is supported by four $2\frac{1}{2}$ " Strips, which are attached to the $5\frac{1}{2}$ " \times $2\frac{1}{2}$ " Flexible Plates so that they overlap the Plates by one clear hole. The upper ends of the $2\frac{1}{2}$ " Strips on each side are connected by a $5\frac{1}{2}$ " Strip (6), and they are joined to the Strips on the opposite side by Angle Brackets and by a $2\frac{1}{2}$ " Stepped Curved Strip (7). The roof consists of two $4\frac{1}{2}$ " \times $2\frac{1}{2}$ " Flexible Plates overlapped seven holes, and it is attached to Angle Brackets bolted to the Strip (6). The Angle Brackets are opened out so that the roof can be curved slightly.

The model is operated by a Crank Handle (8), supported in the $2\frac{1}{2}$ " \times $1\frac{1}{2}$ " Flexible Plates (2), and in a Flat Trunnion (9) attached to each side of the base. A Bush Wheel is fixed to the Crank Handle, and a $2\frac{1}{2}$ " Strip (10) is lock-nutted to the Bush Wheel. A second $2\frac{1}{2}$ " Strip is bolted tightly to Strip (10), and is lock-nutted to a further $2\frac{1}{2}$ " Strip (11), which is gripped on a 4 " Rod between two 1 " Pulleys (12) fitted with Rubber Rings. The Rod is supported in the Semi-Circular Plates, and is passed through the centre holes of Strips (6). A 1 " Pulley (13) fitted with a Rubber Ring is placed on the Rod at each side of the High Flyer, and is pressed tightly against the Strip (6) before it is fixed on the Rod.

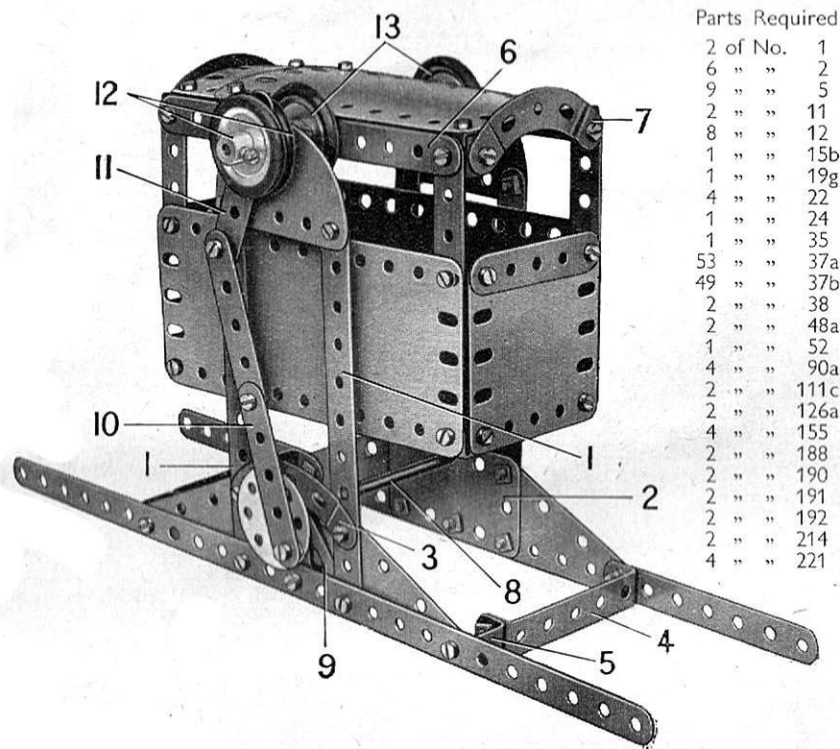

Parts Required

2 of No.	1
6 " "	2
9 " "	5
2 " "	11
8 " "	12
1 " "	15b
1 " "	19g
4 " "	22
1 " "	24
1 " "	35
53 " "	37a
49 " "	37b
2 " "	38
2 " "	48a
1 " "	52
4 " "	90a
2 " "	111c
2 " "	126a
4 " "	155
2 " "	188
2 " "	190
2 " "	191
2 " "	192
2 " "	214
4 " "	221

3.30 SHOVEL LOADER

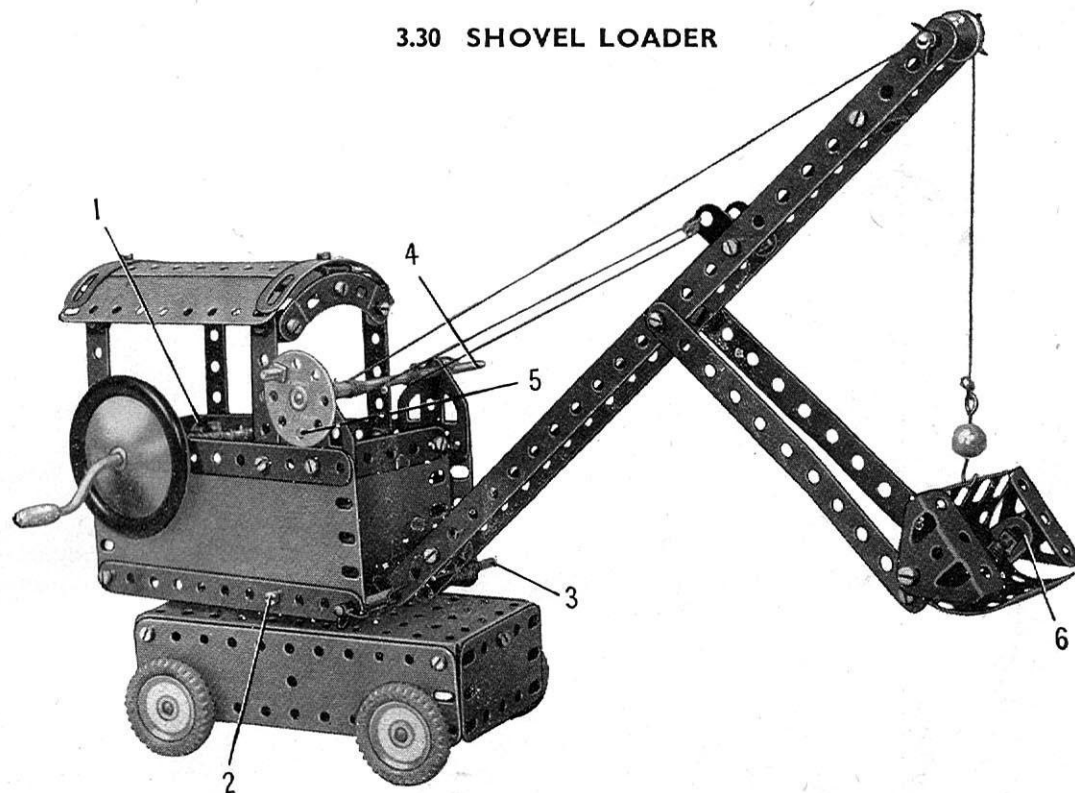

The tractor unit is made by bolting two $5\frac{1}{2}$ " \times $1\frac{1}{2}$ " and two $2\frac{1}{2}$ " \times $1\frac{1}{2}$ " Flexible Plates to the sides of a $5\frac{1}{2}$ " \times $2\frac{1}{2}$ " Flanged Plate. It is fitted with wheels formed by 1 " Pulleys with Tyres, which are fixed on $3\frac{1}{2}$ " Rods.

The cab sides are two $5\frac{1}{2}$ " \times $2\frac{1}{2}$ " Flexible Plates edged with $5\frac{1}{2}$ " Strips. These are joined by a Double Angle Strip (1) and a similar Double Angle Strip held by a Bolt (2) on each side of the cab. A $\frac{3}{8}$ " Bolt passed through this Double Angle Strip is used to attach the cab to the tractor unit. Two Wheel Discs are placed on the Bolt between the Double Angle Strip and the tractor unit, and the $\frac{3}{8}$ " Bolt is lock-nutted. The back of the cab is a $2\frac{1}{2}$ " \times $2\frac{1}{2}$ " Flexible Plate bolted to the Double Angle Strip (1).

The roof is made from two $4\frac{1}{2}$ " \times $2\frac{1}{2}$ " Flexible Plates, and is attached at each end to a Curved Strip by means of an Angle Bracket. The Curved Strips are connected by Angle Brackets to four $2\frac{1}{2}$ " Strips that support the roof.

The jib is made up from two $12\frac{1}{2}$ " Strips joined by Double Brackets. It pivots about a $3\frac{1}{2}$ " Rod (3), and is luffed by two Cords extending from a Rod (4) to the Fishplates bolted to the $12\frac{1}{2}$ " Strips. This Rod is fitted with a Bush Wheel, and can be prevented from turning round by pushing the Rod inwards so that a Bolt (5) fixed in the Flat Trunnion supporting the Rod engages in one of the holes in the Bush Wheel. By this means it is possible to maintain the jib in any position desired.

Two $5\frac{1}{2}$ " Strips lock-nutted to the jib form the arm that carries the shovel. The shovel is made from a 'U'-section Curved Plate, and the $5\frac{1}{2}$ " Strips are fixed to it by two Reversed Angle Brackets, one of which can be seen at (6). The sides of the shovel are formed by two Trunnions.

The shovel arm is raised or lowered by a length of Cord, which runs from the Loaded Hook attached to the shovel, over a $\frac{1}{2}$ " Pulley at the upper end of the jib and is then fastened to the Crank Handle.

Parts Required

2 of No.	1	3 of No.	16	6 of No.	35	2 of No.	90a	1 of No.	187
6 " "	2	1 " "	18a	48 " "	37a	2 " "	111c	2 " "	188
5 " "	5	1 " "	19g	45 " "	37b	2 " "	125	2 " "	189
2 " "	10	4 " "	22	1 " "	40	2 " "	126	2 " "	190
2 " "	11	1 " "	23	2 " "	48a	2 " "	126a	2 " "	191
8 " "	12	1 " "	24	1 " "	52	4 " "	142c	2 " "	192
1 " "	15b	2 " "	24a	1 " "	57c	1 " "	176	2 " "	199
								2 " "	215

3.31 CHANNEL STEAMER

Each side of the hull consists of a $5\frac{1}{2}'' \times 1\frac{1}{2}''$ Flexible Plate (1), a $5\frac{1}{2}'' \times 2\frac{1}{2}''$ Flexible Plate (2) and a $2\frac{1}{2}'' \times 2\frac{1}{2}''$ Flexible Plate (3), which are bolted to a $12\frac{1}{2}''$ Strip (4). The sides are joined together at the bow, and Strips (4) are lengthened towards the stern by a $2\frac{1}{2}''$ Strip (5) on each side. The rounded stern consists of two Formed Slotted Strips bolted to the Strips (5), and two further Formed Slotted Strips fixed to $2\frac{1}{2}''$ Strips that are attached to the Flexible Plates (3). A Flat Trunnion (6) is bolted to each of the $2\frac{1}{2}''$ Strips.

Two $5\frac{1}{2}''$ Strips overlapped seven holes are bolted along the upper edges of Plates (2) and (3) on each side, and a $5\frac{1}{2}'' \times 2\frac{1}{2}''$ Flanged Plate (7) is fixed between them. The Flanged Plate is lengthened towards the stern by a $4\frac{1}{2}'' \times 2\frac{1}{2}''$ Flexible Plate, and the rear end of the Flexible Plate is supported by a $2\frac{1}{2}'' \times \frac{1}{2}''$ Double Angle Strip bolted between the Plates (3). A Trunnion (8) is attached to the Double Angle Strip, and its flange downward, is bolted to the first. A $4\frac{1}{2}'' \times 2\frac{1}{2}''$ Flexible Plate (9), extended by a Semi-Circular Plate, is placed below the second Trunnion to form the stern deck.

A straightened $1\frac{1}{2}''$ radius Curved Plate is bolted to the front of the Flanged Plate (7), and a $2\frac{1}{2}'' \times \frac{1}{2}''$ Double Angle Strip (10) and a $2\frac{1}{2}''$ Strip are attached to a Double Bracket fixed to the Curved Plate. The funnel is made from two $2\frac{1}{2}'' \times 1\frac{1}{2}''$ Flexible Plates curved to shape, and it is attached to the Flanged Plate (7) by an Angle Bracket. The ventilators are two $1''$ Pulleys screwed by the threaded holes in their bosses to $\frac{3}{8}''$ Bolts fixed in the Flanged Plate by nuts.

The foredeck between the Flexible Plates (1) consists of two $2\frac{1}{2}''$ Strips on each side bolted to a Bush Wheel (11) and to a Semi-Circular Plate (12). This assembly is attached to the Strips (4) by Angle Brackets. The foremast, a $4''$ Rod joined to a $2''$ Rod by a Rod Connector, is fixed in the Bush Wheel.

The aftmast is a $4''$ Rod held by Spring Clips in the Flexible Plate (9) and in a $\frac{1}{2}''$ Reversed Angle Bracket bolted to the Semi-Circular Plate.

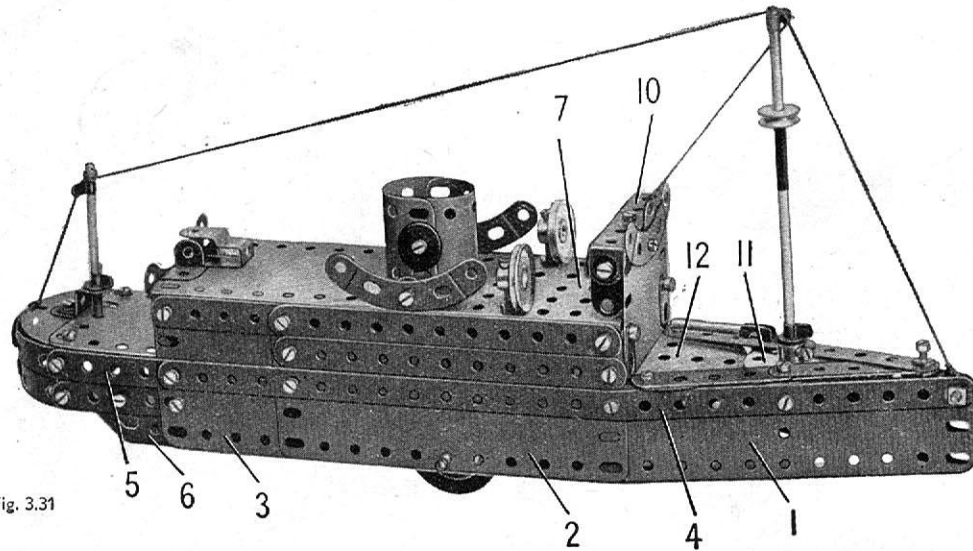

Fig. 3.31

Parts Required

2 of No. 1	1 of No. 17	6 of No. 38	1 of No. 125	2 of No. 191
6 " " 2	1 " " 18a	2 " " 38d	2 " " 126	2 " " 192
9 " " 5	4 " " 22	1 " " 40	2 " " 126a	1 " " 200
5 " " 10	1 " " 23	1 " " 44	2 " " 142c	1 " " 212
2 " " 11	1 " " 24	2 " " 48a	1 " " 176	1 " " 213
8 " " 12	4 " " 35	1 " " 52	2 " " 188	2 " " 214
1 " " 15b	55 " " 37a	4 " " 90a	2 " " 189	4 " " 215
2 " " 16	49 " " 37b	6 " " 111c	2 " " 190	

For more new models to build, see the
MECCANO MAGAZINE
which is published on the first of every month.

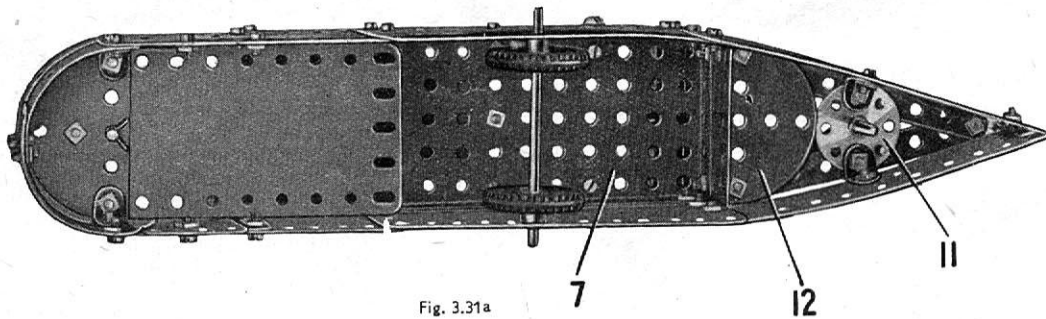

Fig. 3.31a

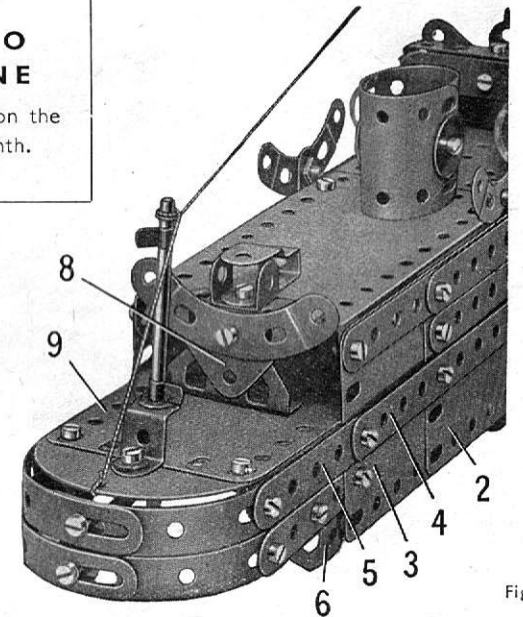
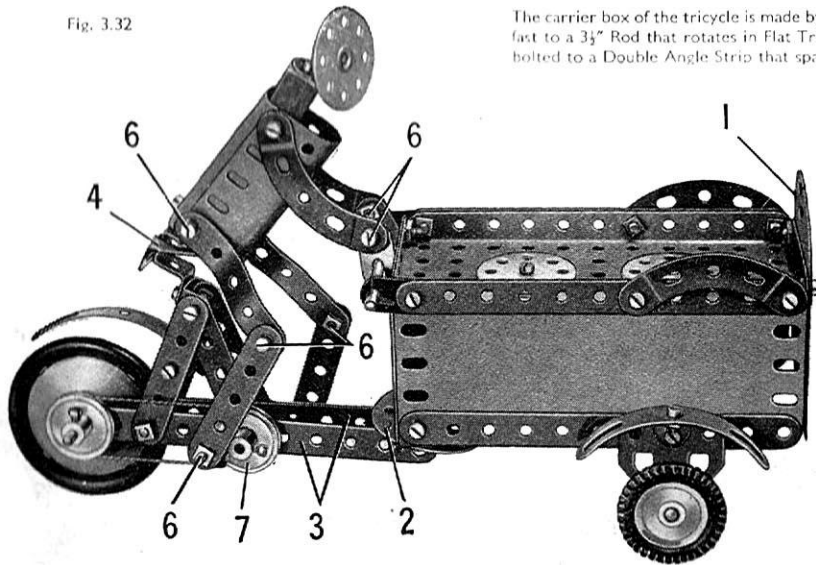

Fig. 3.31b

3.32 ICE CREAM VENDOR AND VAN

Fig. 3.32



The carrier box of the tricycle is made by bolting two $5\frac{1}{2}$ " \times $2\frac{1}{2}$ " and two $2\frac{1}{2}$ " \times $2\frac{1}{2}$ " Flexible Plates to a Flanged Plate. The wheels are made fast to a $3\frac{1}{2}$ " Rod that rotates in Flat Trunnions. A Semi-Circular Plate (1) is attached to the front of the carrier, and a similar part (2) is bolted to a Double Angle Strip that spans the sides of the carrier.

The $5\frac{1}{2}$ " Strips (3) are secured to a Double Bracket pivotally attached to the Semi-Circular Plate (2). The supports for the saddle consist of four $2\frac{1}{2}$ " Strips, and a Trunnion (4) is attached to these by a Reversed Angle Bracket and a Double Bracket (5).

The body of the rider is formed by two 'U'-section Curved Plates, and is attached to the Trunnion by an Angle Bracket. His legs are made from four $2\frac{1}{2}$ " Strips. It is important to note that all the Bolts numbered (6) are *lock-nutted* so that the parts they hold are free to pivot.

The rear wheel is fixed on a 2" Rod fitted with a 1" Pulley. This Pulley is connected by a belt of Cord to a second Pulley (7) on a $1\frac{1}{2}$ " Rod. An Angle Bracket is bolted to the boss of Pulley (7) and attached to one of the rider's legs, see Fig. 3.32a. The other leg is attached to a Reversed Angle Bracket. The slotted hole of the Bracket is fitted with a nut and bolt, and is then pushed on to the $1\frac{1}{2}$ " Rod. The effect of this is that the nut presses against the Rod and locks the Bracket firmly so that it rotates with the Rod.

Parts Required

6 of No. 2	4 of No. 22	1 of No. 52	2 of No. 190
8 " " 5	1 " " 24	4 " " 90a	2 " " 192
4 " " 10	2 " " 24a	3 " " 111c	2 " " 199
2 " " 11	3 " " 35	2 " " 125	2 " " 214
7 " " 12	53 " " 37a	1 " " 126	3 " " 215
2 " " 16	42 " " 37b	2 " " 126a	
1 " " 17	1 " " 44	2 " " 142c	
1 " " 18a	1 " " 48a	1 " " 187	

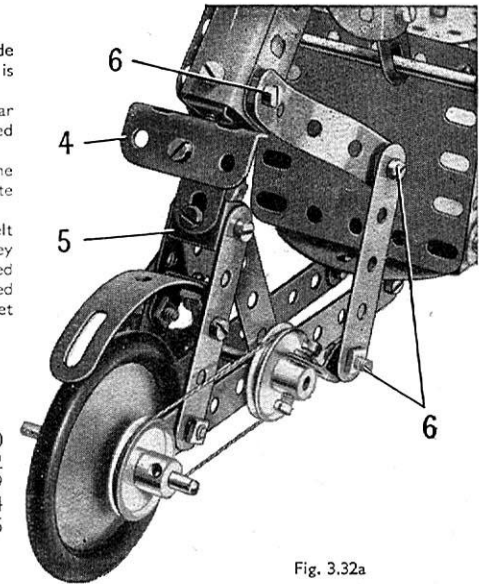

Fig. 3.32a

3.33 GIANT LORRY

The lorry is assembled on a $5\frac{1}{2}$ " \times $2\frac{1}{2}$ " Flanged Plate (1), and the wheels are fixed to $3\frac{1}{2}$ " Rods supported in Fishplates bolted to the side flanges. The bolts fixing the rear Fishplates serve also to attach a $2\frac{1}{2}$ " \times $1\frac{1}{2}$ " Triangular Flexible Plate to each side.

The bonnet is made from two 'U'-section Curved Plates connected to Angle Brackets bolted to the Flanged Plate, and the radiator consists of a Trunnion (2) fitted with a Wheel Disc. The mudguards are $5\frac{1}{2}$ " Strips, bent as shown, and they are attached to Double Brackets bolted to the Flanged Plate (1).

The back of the cab is a $2\frac{1}{2}$ " \times $2\frac{1}{2}$ " Flexible Plate. It is bolted to an Angle Bracket fixed to the Flanged Plate, and the cab roof, which is a $1\frac{1}{2}$ " radius Curved Plate, is attached to the back by an Angle Bracket. The front of the cab is a $2\frac{1}{2}$ " \times $1\frac{1}{2}$ " Flexible Plate (3), and this also is connected to the Flanged Plate by an Angle Bracket.

The trailer platform consists of a $2\frac{1}{2}$ " \times $2\frac{1}{2}$ " Flexible Plate and two $5\frac{1}{2}$ " \times $2\frac{1}{2}$ " Flexible Plates. These Plates are edged on each side by a $2\frac{1}{2}$ " and two $5\frac{1}{2}$ " Strips, and they are connected to $12\frac{1}{2}$ " Strips (4) by Angle Brackets.

Two $2\frac{1}{2}$ " Stepped Curved Strips (5) are bolted to each end of the trailer platform, and the rear pair of Curved Strips supports two Flat Trunnions (6). The trailer wheels are fixed to a 4" Rod supported in the holes at the pointed ends of the Flat Trunnions. A built-up strip (7), made from two $2\frac{1}{2}$ " Strips overlapped three holes, is attached to a $2\frac{1}{2}$ " \times $\frac{1}{2}$ " Double Angle Strip bolted to the Flat Trunnions and the Curved Strips.

The front pair of Curved Strips is connected by a $2\frac{1}{2}$ " \times $\frac{1}{2}$ " Double Angle Strip, to which a $1\frac{1}{2}$ " radius Curved Plate is bolted.

The coupling device between the lorry and trailer is a 2" Rod held in a Wheel Disc (8) by a Spring Clip and a Cord Anchoring Spring. The Rod is fitted with a $\frac{1}{2}$ " Pulley, and is passed through a $\frac{1}{2}$ " Reversed Angle Bracket (9).

Parts Required

2 of No. 1	8 of No. 5	4 of No. 22	1 of No. 52	2 of No. 126	1 of No. 188
6 " " 2	4 " " 10	1 " " 23	4 " " 90a	2 " " 126a	2 " " 190
	2 " " 11	2 " " 24a	6 " " 111c	4 " " 142c	2 " " 192
	7 " " 12	3 " " 35	2 " " 125	1 " " 176	2 " " 199
	1 " " 15b	56 " " 37a		2 " " 187	2 " " 200
	2 " " 16	50 " " 37b			4 " " 215
	1 " " 17	6 " " 38			2 " " 221
		2 " " 48a			

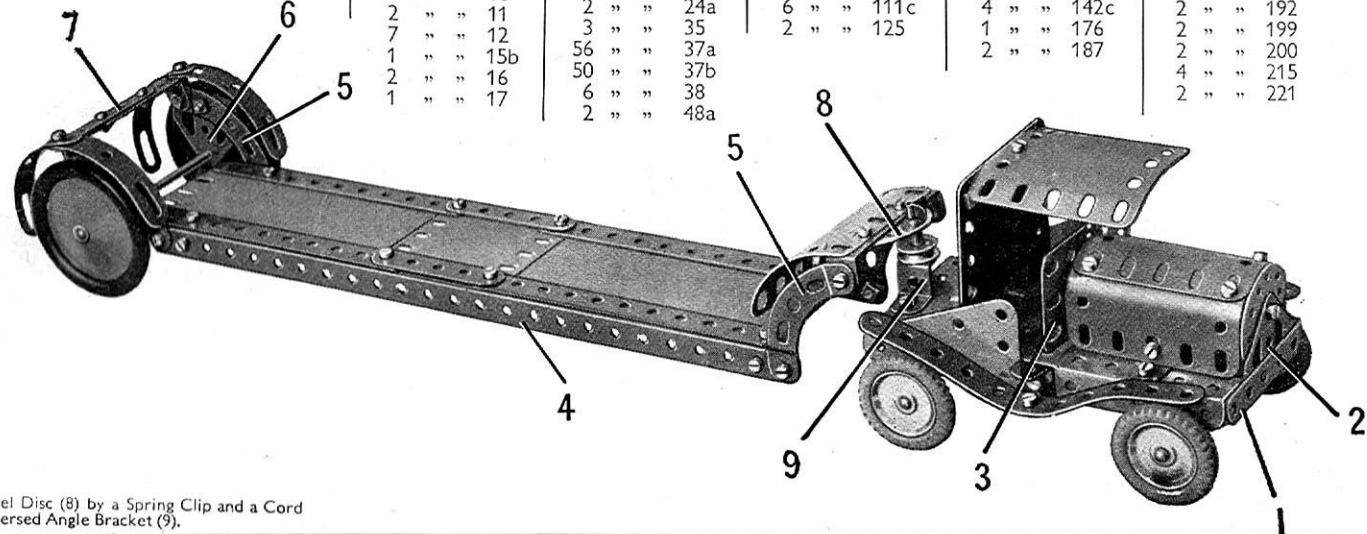

MECCANO PARTS

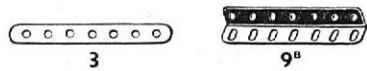

PERFORATED STRIPS

No.	1. 12 $\frac{1}{2}$ "	No.	2a. 4 $\frac{1}{2}$ "	No.	6. 2"
1a.	9 $\frac{1}{2}$ "	3.	3 $\frac{1}{2}$ "	6a.	1 $\frac{1}{2}$ "
1b.	7 $\frac{1}{2}$ "	4.	3"		
2.	5 $\frac{1}{2}$ "	5.	2 $\frac{1}{2}$ "		

ANGLE GIRDERS

7.	24 $\frac{1}{2}$ "	8b.	7 $\frac{1}{2}$ "	9c.	3"
7a.	18 $\frac{1}{2}$ "	9.	5 $\frac{1}{2}$ "	9d.	2 $\frac{1}{2}$ "
8.	12 $\frac{1}{2}$ "	9a.	4 $\frac{1}{2}$ "	9e.	2"
8a.	9 $\frac{1}{2}$ "	9b.	3 $\frac{1}{2}$ "	9f.	1 $\frac{1}{2}$ "



10. Fishplate | 11. Double Bracket

ANGLE BRACKETS

12.	1 $\frac{1}{2}$ " x 1 $\frac{1}{2}$ "	12b.	1" x 1 $\frac{1}{2}$ "	12c.	Obtuse, 1 $\frac{1}{2}$ " x 1"
12a.	1" x 1"				



AXLE RODS

13.	11 $\frac{1}{2}$ "	15a.	4 $\frac{1}{2}$ "	16b.	3"
13a.	8"	15b.	4"	17.	2"
14.	6 $\frac{1}{2}$ "	16.	3 $\frac{1}{2}$ "	18a.	1 $\frac{1}{2}$ "
15.	5"	16a.	2 $\frac{1}{2}$ "	18b.	1"

19g. Crank Handle, 3 $\frac{1}{2}$ " shaft, with grip
 19h. Crank Handle, 5" shaft, with grip
 19s. Crank Handle, 3 $\frac{1}{2}$ " shaft, without grip



19a. Spoked Wheel, 3" diam.
 20. Flanged Wheel, 1 $\frac{1}{2}$ " diam.
 20b. Flanged Wheel, 1" diam.

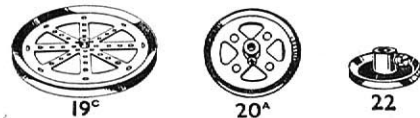

PULLEYS

19b.	3" diam., with boss and screw
19c.	6" diam., with boss and screw
20a.	2" diam., with boss and screw
21.	1 $\frac{1}{2}$ " diam., with boss and screw
22.	1" diam., with boss and screw



PULLEYS

22a.	1" diam., without boss
23.	1 $\frac{1}{2}$ " diam., without boss
23a.	1" diam., with boss and screw



No. 24. Bush Wheel, 1 $\frac{1}{2}$ " diam., eight holes
 24a. Wheel Disc, 1 $\frac{1}{2}$ " diam., without boss, eight holes
 24b. Bush Wheel, 1 $\frac{1}{2}$ " diam., six holes
 24c. Wheel Disc, 1 $\frac{1}{2}$ " diam., without boss, six holes

PINIONS

25.	1" diam., 1" face, 25 teeth
25a.	1" diam., 1" face, 25 teeth
25b.	1" diam., 1" face, 25 teeth
26.	1" diam., 1" face, 19 teeth
26a.	1" diam., 1" face, 19 teeth
26b.	1" diam., 1" face, 19 teeth
26c.	1" diam., 1" face, 15 teeth



GEAR WHEELS

27.	1 $\frac{1}{2}$ " diam., 50 teeth
27a.	1 $\frac{1}{2}$ " diam., 57 teeth
27b.	3" diam., 133 teeth
27c.	2 $\frac{1}{2}$ " diam., 95 teeth
27d.	1 $\frac{1}{2}$ " diam., 60 teeth



CONTRATE WHEELS

28.	1 $\frac{1}{2}$ " diam., 50 teeth
29.	1" diam., 25 teeth

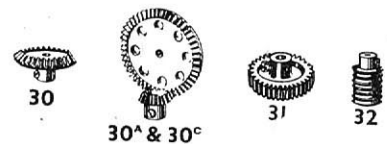

30° & 30°

30.	Bevel Gear, 1" diam., 26 teeth (for use in pairs)
30a.	Bevel Gear, 1" diam., 16 teeth Can only be used together
30c.	Bevel Gear, 1 $\frac{1}{2}$ " diam., 48 teeth used together
31.	Gear Wheel, 1" diam., 1" face, 38 teeth
32.	Worm, 1" diam.
34.	Spanner



34b.	Box Spanner
35.	Spring Clip
36.	Screwdriver
36a.	Screwdriver (longer)
36c.	Drift (for levering bolt holes into line)
37.	Nut and Bolt, 1/8"
37a.	Nut
37b.	Bolt, 1/8"
38.	Washer
38d.	Washer, 1/8"
40.	Hank of Cord



41. Propeller Blade | 43. Tension Spring, 2" long



No. 44. Bent Strip, stepped
 45. Double Bent Strip

DOUBLE ANGLE STRIPS

46.	2 $\frac{1}{2}$ " x 1"	48.	1 $\frac{1}{2}$ " x 1"	48c.	4 $\frac{1}{2}$ " x 1"
47.	2 $\frac{1}{2}$ " x 1 $\frac{1}{2}$ "	48a.	2 $\frac{1}{2}$ " x 1"	48d.	5 $\frac{1}{2}$ " x 1"
47a.	3" x 1 $\frac{1}{2}$ "	48b.	3 $\frac{1}{2}$ " x 1"		



50. Slide Piece
 51. Flanged Plate, 2 $\frac{1}{2}$ " x 1 $\frac{1}{2}$ "
 52. Flanged Plate, 5 $\frac{1}{2}$ " x 2 $\frac{1}{2}$ "
 52a. Flat Plate, 5 $\frac{1}{2}$ " x 3 $\frac{1}{2}$ "
 53. Flanged Plate, 3 $\frac{1}{2}$ " x 2 $\frac{1}{2}$ "
 53a. Flat Plate, 4 $\frac{1}{2}$ " x 2 $\frac{1}{2}$ "

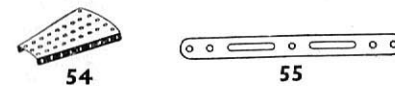

54. Flanged Sector Plate, 4 $\frac{1}{2}$ " long
 55. Perforated Strip, slotted, 5 $\frac{1}{2}$ " long
 55a. Perforated Strip, slotted, 2" long



57b. Hook, Loaded, large
 57c. Hook, Loaded, small
 58. Spring Cord, 40" length
 58a. Coupling Screw for Spring Cord
 58b. Hook for Spring Cord
 59. Collar, with screw

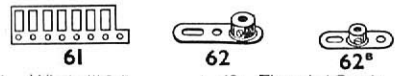

61. Windmill Sail Crank
 62. | 62a. Threaded Crank
 | 62b. Double Arm Crank



63. Coupling Strip Coupling
 63b. | 63c. Threaded Coupling
 | 63d. Short Coupling



64. Threaded Boss
 65. Centre Fork
 69. Set Screw, 1/8"

69a. Grub Screw, 1/8"
 69b. Grub Screw, 3/16"
 69c. Grub Screw, 1/4"

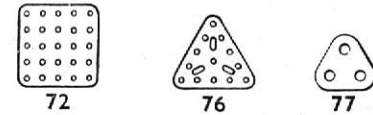

No. 70. Flat Plate, 5 $\frac{1}{2}$ " x 2 $\frac{1}{2}$ "
 71. Flat Plate, 2 $\frac{1}{2}$ " x 2 $\frac{1}{2}$ "
 72. Flat Plate, 3" x 1 $\frac{1}{2}$ "
 No. 76. Triangular Plate, 2 $\frac{1}{2}$ "
 77. Triangular Plate, 1"



80a. 5"
 80b. 4 $\frac{1}{2}$ "
 80c. 3"
 81. 2"
 82. 1"

89. 5 $\frac{1}{2}$ " (10" radius)
 89a. Stepped, 3" (1 $\frac{1}{2}$ " radius)
 89b. Stepped, 4" (4 $\frac{1}{2}$ " radius)
 90. 2 $\frac{1}{2}$ " (2 $\frac{1}{2}$ " radius)
 90a. Stepped, 2 $\frac{1}{2}$ " (1 $\frac{1}{2}$ " radius)

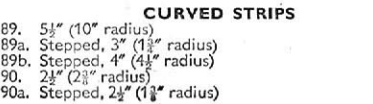

94. Sprocket Chain, 40" length

95. 2" diam., 36 teeth
 95a. 1 $\frac{1}{2}$ " diam., 28 teeth
 95b. 3" diam., 56 teeth
 96. 1" diam., 18 teeth
 96a. 1" diam., 14 teeth

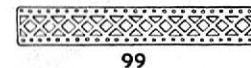

97. 3 $\frac{1}{2}$ " long
 97a. 3" long
 97b. 2 $\frac{1}{2}$ " long
 99. 12 $\frac{1}{2}$ " long
 99a. 9 $\frac{1}{2}$ " long
 99b. 7 $\frac{1}{2}$ " long
 100. 5 $\frac{1}{2}$ " long
 100a. 4 $\frac{1}{2}$ " long



101. Heald for Loom | 102. Single Bent Strip

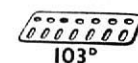

103. 5 $\frac{1}{2}$ " long
 103a. 9 $\frac{1}{2}$ " long
 103b. 12 $\frac{1}{2}$ " long
 103c. 4 $\frac{1}{2}$ " long
 103d. 3 $\frac{1}{2}$ " long
 103e. 3" long
 103f. 2 $\frac{1}{2}$ " long
 103g. 2" long
 103h. 1 $\frac{1}{2}$ " long
 103k. 7 $\frac{1}{2}$ " long

MECCANO PARTS

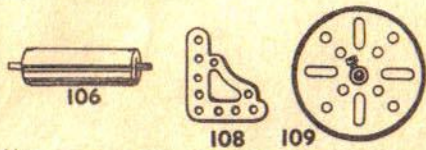

- No.
106. Wood Roller (complete with Rod and two Collars)
108. Corner Gusset
109. Face Plate, 2½" diam.

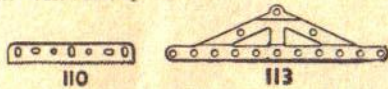

110. Rack Strip, 3½" long | 110a. Rack Strip, 6½" long

BOLTS

111. ½"
111a. ¾"
111c. ¾"
111d. 1¼"

113. Girder Frame

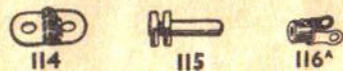

114. Hinge
115. Threaded Pin
116. Fork Piece, large
116a. Fork Piece, small



118. Hub Disc, 5½" diam.



- 120b. Compression Spring, ⅝" long
122. Loaded Sack



123. Cone Pulley, 1½", 1" and ¾" diam.
124. Reversed Angle Bracket, 1"
125. Reversed Angle Bracket, ½"



126. Trunnion
126a. Flat Trunnion
128. Bell Crank, with Boss



- No.
130. Eccentric, Triple Throw, ½", ¾" and 1"
130a. Eccentric, Single Throw, ½"

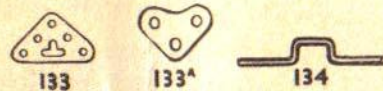

133. Corner Bracket, 1½"
133a. Corner Bracket, 1"
134. Crank Shaft, 1" stroke



136. Handrail Support | 136a. Handrail Coupling



137. Wheel Flange | 138. Ship's Funnel, Raked



139. Flanged Bracket (right)
139a. Flanged Bracket (left)
140. Universal Coupling



- 142a. Motor Tyre (to fit 2" diam. rim)
142b. Motor Tyre (to fit 3" diam. rim)
142c. Motor Tyre (to fit 1" diam. rim)
142d. Motor Tyre (to fit 1½" diam. rim)
143. Circular Girder, 5½" diam.
144. Dog Clutch



145. Circular Strip, 7½" diam. overall
146. Circular Plate, 6" diam. overall
146a. Circular Plate, 4" diam. overall

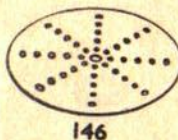

- No.
147. Pawl, with Pivot Bolt and Nuts
147a. Pawl
147b. Pivot Bolt, with two Nuts
147c. Pawl, without boss
148. Ratchet Wheel
151. Single Pulley Block
153. Triple Pulley Block
154a. Right Angle Bracket, ½" (right-hand)
154b. Corner Angle Bracket, ½" (left-hand)
155. Rubber Ring (for 1" Pulley)



157. Fan, 2" diam.



160. Channel Bearing, 1½" x 1" x ½"

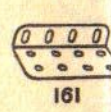

161. Girder Bracket, 2" x 1" x ½"

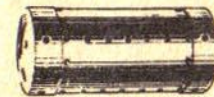

162. Boiler, complete, 5" long x 2½" diam.
162a. Boiler Ends, 2½" diam. x ½"
163. Sleeve Piece, 1½" long x ½" diam.
164. Chimney Adaptor, ½" diam. x ½" high



165. Swivel Bearing



166. End Bearing

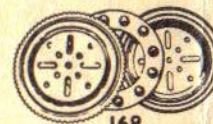

- 167b. Flanged Ring, 9½" diam.
168. Ball Thrust Bearing, 4" diam.
168a. Ball Thrust Race, flanged disc, 3½" diam.
168b. Ball Thrust Race, toothed disc, 4" diam.
168c. Ball Cage, 3½" diam., complete with balls
168d. Ball, ½" diam.



171. Socket Coupling
173a. Adaptor for Screwed Rod
175. Flexible Coupling Unit
176. Anchoring Spring for Cord

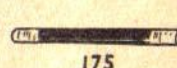

179. Rod Socket



180. Gear Ring, 3½" diam. (133 ext. teeth, 95 int.)



- No.
185. Steering Wheel, 1½" diam.

DRIVING BANDS

186. 2½" (light) | 186c. 10" (heavy)
186a. 6" (light) | 186d. 15" (heavy)
186b. 10" (light) | 186e. 20" (heavy)
187. Road Wheel, 2½" diam.
187a. Conical Disc, 1½" diam.

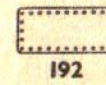

192. 2½" x 1½"

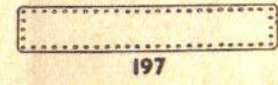

197. 2½" x 2½" | 191. 4½" x 2½"
198. 5½" x 1½" | 190a. 3½" x 2½" | 192. 5½" x 2½"

FLEXIBLE PLATES

STRIP PLATES

196. 9½" x 2½" | 197. 12½" x 2½"

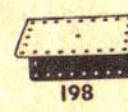

198. Hinged Flat Plate, 4½" x 2½"



199. Curved Plate, 1" U-section, 2½" x 2½" x ⅝" radius

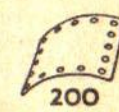

200. Curved Plate, 2½" x 2½" x 1½" radius



- 211a. Helical Gear, ½" } Can only be used
211b. Helical Gear, 1½" } together
212. Rod and Strip Connector
212a. Rod and Strip Connector, right-angle
213. Rod Connector
213a. Three-way Rod Coupling
213b. Three-way Rod Coupling with Pummel



- 212



- 213

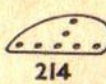

214. Semi-circular Plate, 2½"
215. Formed Slotted Strip, 3"

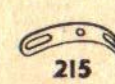

- 215



216. Cylinder, 2½" long, 1½" diam.

- 216

TRIANGULAR FLEXIBLE PLATES

221. 2½" x 1½" | 223. 2½" x 2½" | 225. 3½" x 2"
222. 2½" x 2" | 224. 3½" x 1½" | 226. 3½" x 2½"