

MECCANO

REGD.
TRADE
MARK

INSTRUCTIONS FOR
ACCESSORY OUTFIT
No. 4A



No. 54. 4A

COPYRIGHT BY MECCANO LTD LIVERPOOL

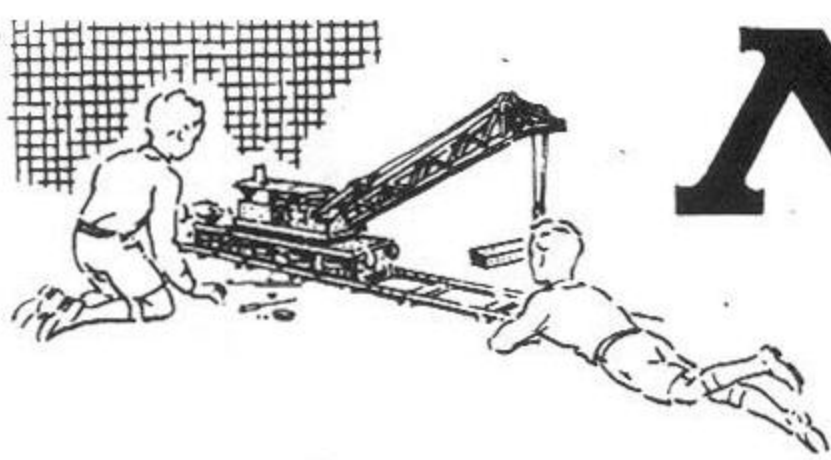

MECCANO

Registered Trade Mark

The World's Greatest Constructional Toy

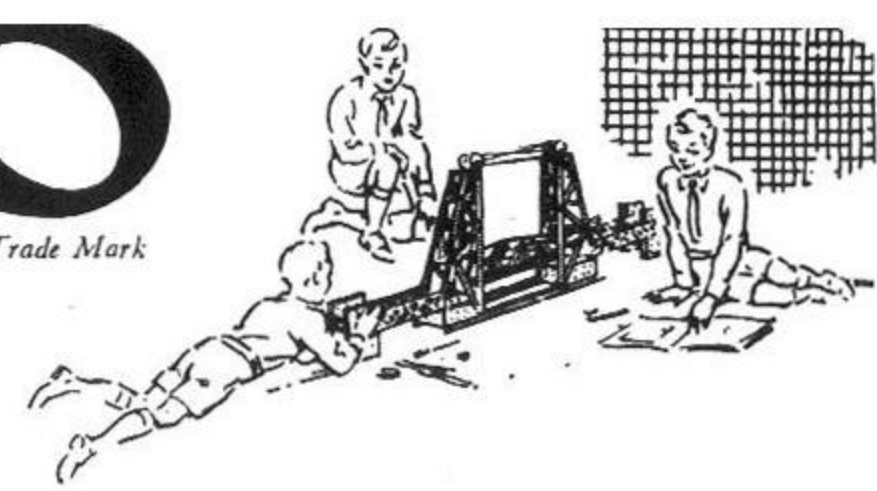

MODEL-BUILDING WITH MECCANO

SOME USEFUL HINTS

It will be noticed that with each model in this Book of Instructions is given a list of the parts required to build it. For the first few models it is a good plan to lay out on the table all the parts required for the one it is proposed to build, and put the remainder of the Outfit to one side. To help you pick out the correct parts for your model a complete list of Meccano parts is given at the back of this Book, and all the principal parts are illustrated. In the list the parts are all numbered, and in most cases, their measurements are given. There is no need, however, to measure the parts to find out which is which, as the size is easily found from the number of holes. All Meccano holes are spaced $\frac{1}{2}$ " apart, so that by counting two holes to the inch the size of a part can be found at once. For instance, Part No. 2 is listed as a $5\frac{1}{2}$ " Perforated Strip, so you look in your Outfit for a Strip with eleven holes. Similarly, No. 189 is a $5\frac{1}{2}$ " x $1\frac{1}{2}$ " Flexible Plate, so you look for a Flexible Plate eleven holes in length and three holes in width.

Beginners sometimes wonder which section of a model should be built first. There cannot be any definite rule for this, as it depends on the design of the model. In stationary models the base usually should be built first. In most of the small models a $5\frac{1}{2}$ " x $2\frac{1}{2}$ " Flanged Plate forms an important part of the structure, and often the best plan is to start building by bolting parts to this Plate. For other models a good general rule is that the sections that form supports for a number of other parts should be built first.

THE IMPORTANCE OF LOCK-NUTTING

In some models it is necessary to join certain parts together so that, although they cannot come apart, they are free to pivot or move in relation to one another. To do this the parts are bolted together as usual but the nut is not screwed up tightly, so that the parts are not gripped. Then, to prevent the nut from unscrewing, a second nut is screwed up tightly against it, the first nut being held with a spanner. This method of using a second nut is known as *Lock-nutting*.

A Rod is usually mounted in a support or bearing, such as a hole in a strip, so that it is free to revolve. The Rod is then said to be *Journalled* in the Strip.

DRIVING YOUR MODELS

Models can be driven by means of either clockwork or electric motors. Ask your dealer for details of these Meccano Motors. Small and light models can be driven direct from the driving pulley of the motor or through a belt running over two pulleys of the

same size giving what is known as a 1 : 1 (one-to-one) ratio. A better plan, however, is to take the drive from a small pulley on the motor shaft to a larger pulley on the driving shaft of the model. In most cases a 1" Pulley on the motor shaft and a 3" Pulley on the model shaft will be found satisfactory. This provides a reduction ratio of approximately 3 : 1.

Rubber bands are very convenient for driving belts. Sometimes, however, a rubber band of the right length is not available, and then Meccano Cord or thin string is used. To tie the Cord to form an endless belt you should use the familiar reef knot.

With the larger Outfits, belt drive can be replaced with advantage by gearing. To operate a slow-moving model demanding great power, such as a traction engine, gears that will provide a considerable reduction must be used. For example, a Worm meshed with a $\frac{1}{2}$ " Pinion will give a 19 : 1 reduction; a Worm meshed with a 57-tooth Gear will give a 57 : 1 reduction.

If the Motor is to operate successfully, however, you must make sure that there is no excessive friction in the mechanism of the model. This can be caused by shaft bearings being slightly out of line, or by a belt or Cord drive being too tight. Before condemning your motor, therefore, first make sure that every revolving shaft moves quite freely in its bearings, and that the bearings are in line with one another. The bearings can be brought into line by pushing through them a Drift (Part No. 36c) or a Rod, before the bolts holding the various parts are tightened up. Then apply a little light machine oil to every bearing or pivot on which moving parts are mounted.

Triangular Flexible Plates and Flexible Plates can be used for forming curved surfaces in models, but they should not be bent at a too sharp angle. With careful handling these Plates can be bent to the required curve and after use straightened again.

All Outfits from No. 2 upward include the Cord Anchoring Spring, Part No. 176. This part provides a neat and positive method of fastening a length of Cord to a Rod. The Spring is pushed on to a Rod or Crank Handle by turning it in such a way that its coils tend to unwind.

MECCANO SERVICE

If ever you are in any difficulty with your models, or if you want advice on anything connected with this great hobby, write to us. We shall be delighted to help you in any way possible. Address your letters to *Information Service*, Meccano Ltd, Binns Road, Liverpool 13.

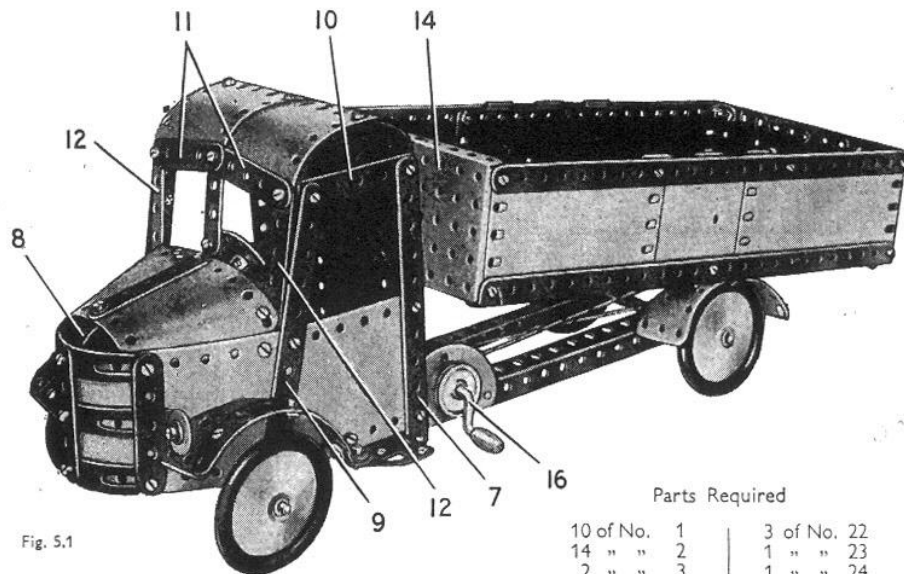

Fig. 5.1

Parts Required

10 of No.	1	3 of No.	22
14 " "	2	1 " "	23
2 " "	3	1 " "	24
12 " "	5	1 " "	24a
2 " "	6a	9 " "	35
4 " "	8	117 " "	37a
3 " "	10	107 " "	37b
2 " "	11	14 " "	38
8 " "	12	2 " "	38d
		1 " "	40
		1 " "	44
		1 " "	48
		6 " "	48a
		1 " "	51
		1 " "	52
		3 " "	90a
		2 " "	111a
		5 " "	111c
		1 " "	125
		2 " "	126
		2 " "	126a
		1 " "	147b
		2 " "	155
		1 " "	176
		4 " "	187
		4 " "	188
		4 " "	189
		4 " "	190
		2 " "	191
		4 " "	192
		1 " "	198
		2 " "	199
		1 " "	200
		1 " "	212
		2 " "	214
		1 " "	215
		4 " "	221
2 of No.	12a		
5 " "	12c		
1 " "	15		
1 " "	16		
1 " "	17		
2 " "	18a		
1 " "	18b		
1 " "	19g		

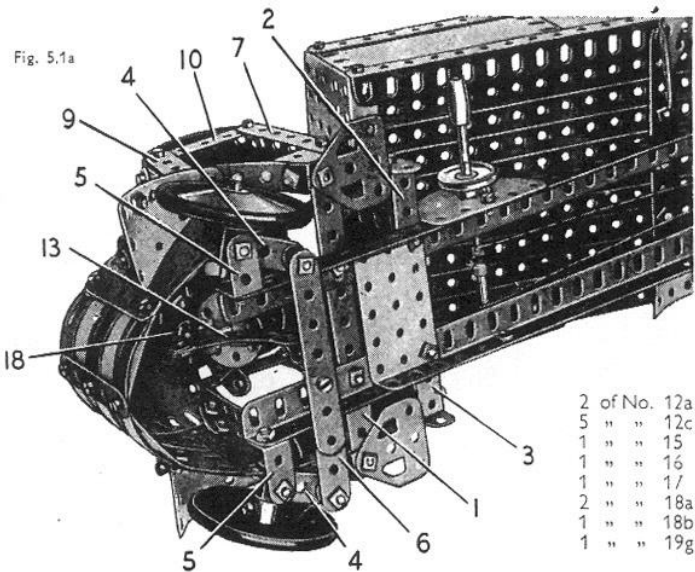

Fig. 5.1a

5.1 TIPPING LORRY

THE CHASSIS AND WHEELS

The chassis consists of two $12\frac{1}{2}$ " Angle Girders joined at the rear by a $2\frac{1}{2}$ " x $\frac{1}{2}$ " Double Angle Strip, and at the front by a $5\frac{1}{2}$ " Strip (1) and a $2\frac{1}{2}$ " x $1\frac{1}{2}$ " Flanged Plate. The Bolts holding the Flanged Plate to the Angle Girders serve also to fix a $2\frac{1}{2}$ " x $\frac{1}{2}$ " Double Angle Strip (2) and a $1\frac{1}{2}$ " x $\frac{1}{2}$ " Double Angle Strip (3).

The rear wheels are fixed as shown on a 5" Rod supported in the chassis. Each of the front wheels is mounted on a $1\frac{1}{2}$ " Rod held by a Spring Clip in a Double Bracket. A $\frac{3}{8}$ " Bolt is passed through a $1\frac{1}{2}$ " Strip (4) placed between the lugs of each Double Bracket, and the Bolt is then fixed by two nuts to a 1 " x 1 " Angle Bracket (5), so that the Double Bracket and the Strip pivot freely as a unit. The 1 " x 1 " Angle Brackets are bolted tightly to the chassis. The Strips (4) are connected by a built-up strip (6), made from two $3\frac{1}{4}$ " Strips overlapped five holes. A $\frac{1}{2}$ " Bolt is passed through each of the Strips (4), and is fitted with a Washer and a Spring Clip. The strip (6) is then held on the shank of the Bolt by two nuts.

CONSTRUCTION OF THE CAB

The sides of the cab consist of $5\frac{1}{2}$ " x $2\frac{1}{2}$ " Flexible Plates bolted together with $5\frac{1}{2}$ " Strips (7). (Fig. 5.1), to the Double Angle Strips (2) and (3). The Flexible Plates are connected by Angle Brackets to the ends of the Strip (1), and the front ends of the Plates are curved slightly to form the sides of the bonnet. The bonnet sides are connected by the radiator, which is made from two $5\frac{1}{2}$ " x $1\frac{1}{2}$ " Flexible Plates curved and bolted together by their longer sides. The radiator is edged as shown in Fig. 5.1 by three $2\frac{1}{2}$ " Strips and three Formed Slotted Strips.

The top of the bonnet is formed by two $2\frac{1}{2}$ " x $2\frac{1}{2}$ " Flexible Plates bolted together. The front ends of these Plates are bolted direct to the bonnet sides, so that the clear corner hole of each Plate projects below the side. The rear ends of the Plates are connected to the bonnet sides by Fishplates. The top of the bonnet is completed by a Formed Slotted Strip (8).

A $5\frac{1}{2}$ " Strip (9) is fixed at a slight angle to each side, and at its upper end it is connected by a $2\frac{1}{2}$ " x $\frac{1}{2}$ " Double Angle Strip (10) to the top of the Strip (7). The windscreen is made from two $2\frac{1}{2}$ " Strips (11) and two $2\frac{1}{2}$ " Strips (12) bolted to the lugs of the Double Angle Strips (10). The centre division is a $2\frac{1}{2}$ " Strip attached to the top of the bonnet by an Obtuse Angle Bracket.

The cab roof consists of two $1\frac{1}{2}$ " radius Curved Plates and two 'U'-section Curved Plates opened out slightly. It is attached to the lugs of the Double Angle Strips (10). The back of the cab is formed by a $5\frac{1}{2}$ " x $1\frac{1}{2}$ " Flexible Plate at each side, joined at the bottom by a $2\frac{1}{2}$ " x $2\frac{1}{2}$ " Flexible Plate. The complete back is bolted to the lugs of the Double Angle Strips (10) and to Angle Brackets fixed to the lower corners of the cab sides.

Each of the front mudguards is a $2\frac{1}{2}$ " x $1\frac{1}{2}$ " Triangular Flexible Plate edged by two $2\frac{1}{2}$ " Strips that overlap each other two holes. The mudguard is connected to the Strip (1) by an Obtuse Angle Bracket, and a Flat Trunnion representing the step is held by the same bolt.

THE STEERING MECHANISM

The steering wheel is a Bush Wheel fixed on a 2" Rod. The Rod is supported in the centre hole of a Wheel Disc and in a $\frac{1}{2}$ " Reversed Angle Bracket bolted to the Wheel Disc. A $2\frac{1}{2}$ " Stepped Curved Strip and an Angle Bracket (18) are held by the same Bolt, and the Angle Bracket is bolted to the rear edge of the top of the bonnet.

A Rod and Strip Connector is fitted to the end of the 2" Rod, and two $2\frac{1}{2}$ " Stepped Curved Strips (13) are bolted to the Rod and Strip Connector. The Curved Strips overlap each other three holes, and the end of the lower Curved Strip is attached to an Angle Bracket fixed to the centre of the strip (6).

THE TIPPING BODY AND ITS OPERATING MECHANISM

Each side of the body consists of a $5\frac{1}{2}$ " x $2\frac{1}{2}$ " and a $4\frac{1}{2}$ " x $2\frac{1}{2}$ " Flexible Plate and one half of a Hinged Flat Plate, bolted to a $12\frac{1}{2}$ " Angle Girder and a $12\frac{1}{2}$ " Strip. The sides are connected by a $5\frac{1}{2}$ " x $2\frac{1}{2}$ " Flanged Plate (14) and $5\frac{1}{2}$ " Strips (15). The bottom of the body is filled in by eight $12\frac{1}{2}$ " Strips and a built-up strip made from a $2\frac{1}{2}$ " and two $5\frac{1}{2}$ " Strips. The hinged tail-board is made from a $2\frac{1}{2}$ " x $2\frac{1}{2}$ " Flexible Plate and two $2\frac{1}{2}$ " x $1\frac{1}{2}$ " Flexible Plates bolted to two $5\frac{1}{2}$ " Strips. The tail-board is connected to the sides of the body by two Angle Brackets, which pivot on lock-nutted Bolts.

A $2\frac{1}{2}$ " x $\frac{1}{2}$ " Double Angle Strip is bolted underneath the body, and a $3\frac{1}{2}$ " Rod is passed through its lugs and through two Trunnions bolted to the rear ends of the chassis Girders. The Rod is held in place by Spring Clips.

A Crank Handle (16) is supported in Semi-Circular Plates bolted to the chassis, and a length of Cord is tied to a Cord Anchoring Spring on the Crank Handle. The Cord is taken round a $\frac{1}{2}$ " loose Pulley (17) and is tied to a Fishplate on the Crank Handle. The Pulley (17) is mounted on a 1" Rod supported in a stepped Bent Strip, which is bolted underneath the body as shown in Fig. 5.1b. The rear mudguards each consist of a $2\frac{1}{2}$ " x $1\frac{1}{2}$ " Flexible Plate and a $2\frac{1}{2}$ " x $1\frac{1}{2}$ " Triangular Flexible Plate.

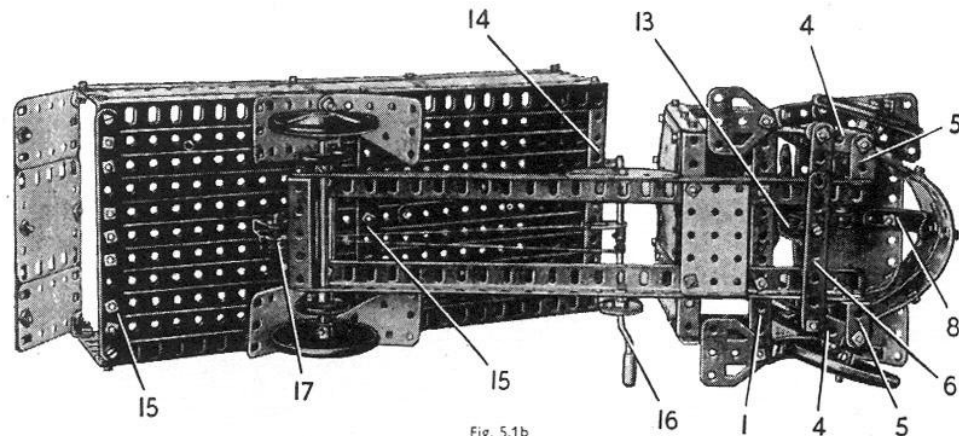

Fig. 5.1b

5.2 FERRY STEAMER

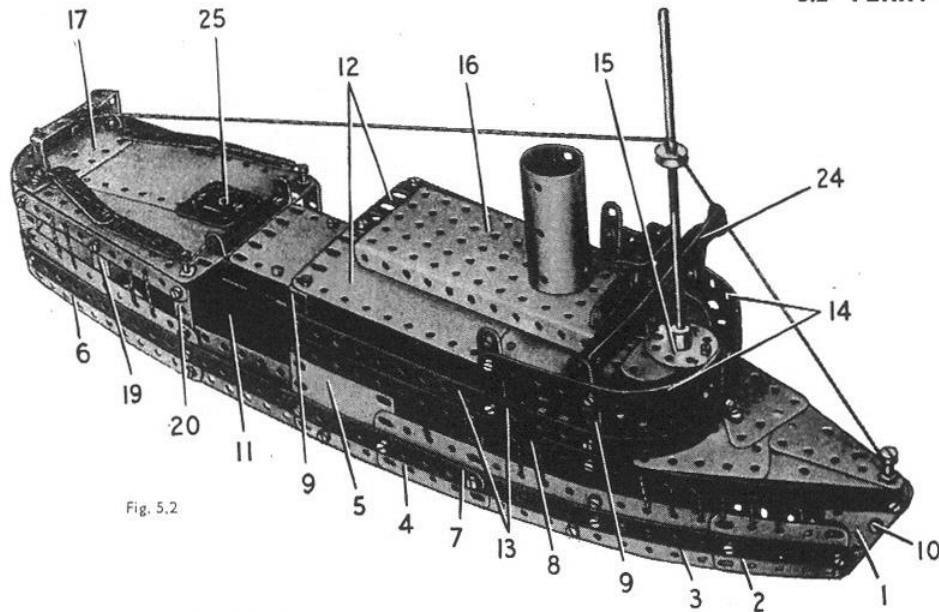

Fig. 5.2

CONSTRUCTION OF THE HULL

Each side of the hull of the Ferry Steamer consists of a $2\frac{1}{2} \times 1\frac{1}{2}$ " Triangular Flexible Plate (1), a $2\frac{1}{2} \times 1\frac{1}{2}$ " Flexible Plate (2), a $5\frac{1}{2} \times 1\frac{1}{2}$ " Flexible Plate (3), a $2\frac{1}{2} \times 1\frac{1}{2}$ " Flexible Plate (4), a $2\frac{1}{2} \times 2\frac{1}{2}$ " Flexible Plate (5) and a $5\frac{1}{2} \times 1\frac{1}{2}$ " Flexible Plate (6). These Plates are bolted to a built-up strip (7), made from two $12\frac{1}{2}$ " Strips overlapped eleven holes, and are also bolted to a $12\frac{1}{2}$ " Strip (8). Two $2\frac{1}{2} \times \frac{1}{4}$ " Double Angle Strips (9) are bolted to each side. On each side a Strip is bolted in the centre hole of the vertical $2\frac{1}{2}$ " Strip (20).

The sides are connected together at the bow by an Angle Bracket and by a $\frac{3}{8}$ " Bolt (10). A Hinged Flat Plate (11) is separated and the halves are bolted tightly together as shown in Fig. 5.2a. The Plate is fixed to the lower lugs of two of the Double Angle Strips (9) and at its rear end is attached to the sides of the hull by Angle Brackets.

The stern of the steamer consists of two $1\frac{1}{2}$ " radius Curved Plates. These are bolted to the rear edges of the Flexible Plates (6), and to a Formed Slotted Strip used to extend each of the strips (7).

ASSEMBLY OF THE DECKS

The upper deck is formed by two $5\frac{1}{2} \times 2\frac{1}{2}$ " Flexible Plates (12), (Fig. 5.2), and a $4\frac{1}{2} \times 2\frac{1}{2}$ " Flexible Plate bolted to the top lugs of the Double Angle Strips (9). Two $5\frac{1}{2}$ " Strips (13) at each side are fixed to the Double Angle Strips, and two of the Strips are curved to form the rounded front of the saloon deck. Two further curved $5\frac{1}{2}$ " Strips (14) are connected to the Strips (13) by a $1\frac{1}{2}$ " and two vertical $2\frac{1}{2}$ " Strips. Two $2\frac{1}{2}$ " Stepped Curved Strips and a Semi-Circular Plate are bolted to a Bush Wheel (15), and the complete assembly is connected to the Strips (14) by an Angle Bracket. A $5\frac{1}{2} \times 2\frac{1}{2}$ " Flanged Plate (16) is attached to the top deck by a Double Bracket and an Angle Bracket, and the funnel, a $2\frac{1}{2}$ " Cylinder, is connected to the Flanged Plate by an Angle Bracket.

The deck at the stern of the steamer consists of two $5\frac{1}{2} \times 2\frac{1}{2}$ " Flexible Plates fitted at the rear with two $2\frac{1}{2}$ " Stepped Curved Strips. A Semi-Circular Plate (17) is clamped between the ends of the Curved Strips and the Flexible Plates. The deck is attached at each side to a $\frac{1}{2}$ " Reversed Angle Bracket (18) and a $2\frac{1}{2} \times \frac{1}{4}$ " Double Angle Strip (19), and it is connected by an Angle Bracket to a $2\frac{1}{2}$ " Strip (20).

A $4\frac{1}{2} \times 2\frac{1}{2}$ " Flexible Plate (21) is fixed to Angle Brackets bolted between the sides of the hull, and a $2\frac{1}{2} \times 1\frac{1}{2}$ " Flanged Plate (22), (Fig. 5.2b), is attached to the Flexible Plate by an Angle Bracket. A $2\frac{1}{2} \times 2\frac{1}{2}$ " Flexible Plate (23) is fixed to two $5\frac{1}{2}$ " Strips bolted between the Plate (21) and the stern deck. A $12\frac{1}{2}$ " Strip is attached to the centre of Plate (21) and extends forward to the bows. The Strip is connected by an Angle Bracket to the curved ends of the Strips (13), and it supports the Triangular Flexible Plates used to form the deck over the bows. The Triangular Flexible Plates are arranged as shown in Fig. 5.2.

THE BRIDGE AND DECK FITTINGS

The bridge is made by bolting a $5\frac{1}{2}$ " Strip to two $\frac{1}{2}$ " Reversed Angle Brackets, which are connected by Fishplates to the Strips (14). A $5\frac{1}{2}$ " Strip (24), a $\frac{3}{8}$ " Strip and a Trunnion are fixed to a Double Bracket bolted to the centre of the first $5\frac{1}{2}$ " Strip. The mast consists of a $4\frac{1}{2}$ " and a $\frac{3}{8}$ " Rod joined by a Rod Connector, and it is fixed in the Bush Wheel (15).

A deck house (25) on the stern deck consists of two Flat Trunnions joined together. It is attached by a $\frac{3}{8}$ " Bolt, but is held up from the deck by a Spring Clip on the Bolt. The seats are represented by $2\frac{1}{2}$ " Strips also attached by $\frac{3}{8}$ " Bolts and separated from the deck by Spring Clips.

The lifeboat davits at the stern are $1\frac{1}{2} \times 1\frac{1}{2}$ " Angle Brackets bolted to the Reversed Angle Brackets (18). The lifeboat consists of two $2\frac{1}{2}$ " Strips separated at the centre by five Washers on a $\frac{3}{8}$ " Bolt, and it is suspended by Cord from the davits.

Two $12\frac{1}{2}$ " Angle Girders are bolted to the Hinged Flat Plate (11) (Fig. 5.2a), and to a Flanged Sector Plate (26). The wheels on which the model runs are fixed on $\frac{3}{8}$ " Rods supported in the Angle Girders.

The steamer is completed by adding Cord as shown to represent window divisions and the rigging.

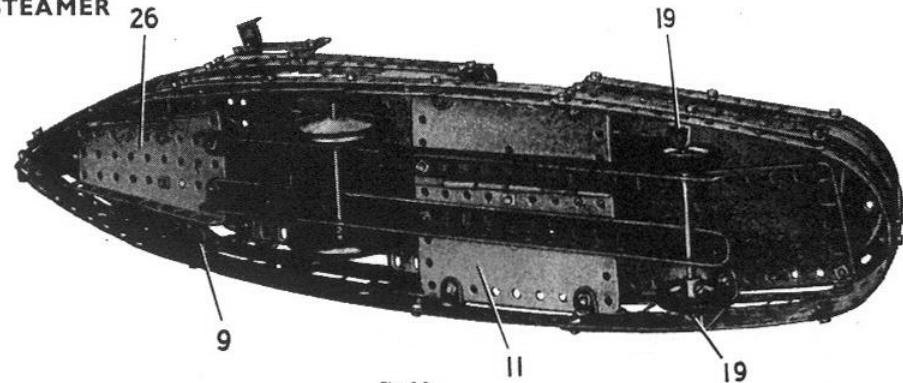

Fig. 5.2a

Parts Required

9 of No.	1
14 " "	2
2 " "	3
11 " "	5
1 " "	6a
2 " "	8
2 " "	10
2 " "	11
12 " "	12
2 " "	12a
1 " "	15a
3 " "	16
2 " "	22
1 " "	23
1 " "	24
13 " "	35
117 " "	37a
108 " "	37b
8 " "	38
1 " "	40
1 " "	48
8 " "	48a
1 " "	51
1 " "	52
1 " "	54
4 " "	90a
2 " "	111a
2 " "	191
6 " "	111c
4 " "	125
2 " "	126
2 " "	200
2 " "	126a
2 " "	142c
1 " "	147b
1 " "	176
2 " "	187
4 " "	188

4 of No.	189
3 " "	190
2 " "	191
4 " "	192
1 " "	198
1 " "	199
2 " "	200
1 " "	213
2 " "	214
4 " "	215
1 " "	216
4 " "	221
2 " "	222

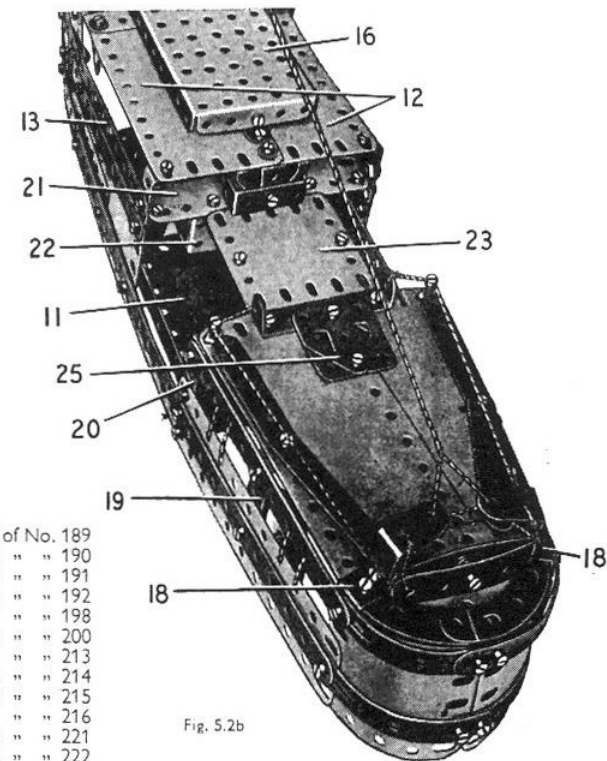

Fig. 5.2b

5.3 GAS TURBINE LOCOMOTIVE

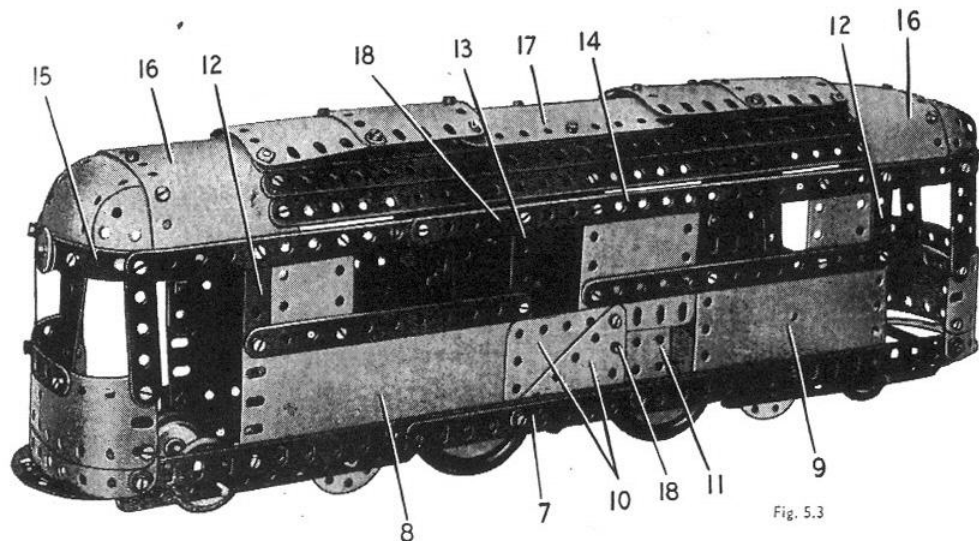

Fig. 5.3

THE POWER UNIT AND DRIVING WHEELS

A No. 1 Clockwork Motor is supported inside the body by two 4" Rods (18). These are passed through the sides of the body and the Motor side-plates, and are held in position by Spring Clips. Two 1½" Strips (19) are bolted to the girders (1) and (7) and to Angle Brackets fixed to the Motor. Two Road Wheels are fixed on a 3½" Rod (20) supported in the corner holes of the side-plates. A 57-tooth Gear also fixed on the Rod (20) is driven by a ½" Pinion on the Motor driving shaft.

A 2½" Strip (21) is attached to each side-plate of the Motor, and these support a second 3½" Rod that carries two Road Wheels.

THE BOGIE UNITS

Each unit consists of two 5½" Strips attached to the body by Angle Brackets. Two 1" Pulleys fitted with Rubber Rings are held on a 3½" Rod, and two Wheel Discs are attached to the 5½" Strips by lock-nutted bolts. At one end ordinary Wheel Discs are used, and at the other end Six-hole Wheel Discs.

Parts Required

9 of No. 1	1 of No. 17	15 of No. 38	1 of No. 147b	2 of No. 199
9 " " 2	4 " " 22	2 " " 38d	4 " " 155	1 " " 200
2 " " 3	2 " " 24a	8 " " 48a	4 " " 187	4 " " 215
11 " " 5	2 " " 24c	1 " " 51	4 " " 188	4 " " 221
2 " " 6a	1 " " 26	1 " " 52	4 " " 189	2 " " 222
4 " " 8	1 " " 27a	4 " " 90a	4 " " 190	
6 " " 12	9 " " 35	2 " " 111a	2 " " 191	
2 " " 15b	116 " " 37a	6 " " 111c	4 " " 192	
3 " " 16	103 " " 37b	1 " " 115	1 " " 198	

1 No. 1 Clockwork Motor
(not included in Outfit)

CONSTRUCTION OF THE SIDES

The side of the model seen in Fig. 5.3a is assembled on a built-up girder (1) made from two 12½" Angle Girders overlapped fifteen holes. The lower part of the side is filled in by a 5½" × 2½" Flanged Plate (2) at the centre, a 5½" × 2½" Flexible Plate (3) at one end and one half of a Hinged Flat Plate (4) at the other end. The top edges of these Plates are strengthened by a 12½" Strip extended by a 2½" Strip. The upper section of the side consists of a 4½" × 2½" Flexible Plate, two 2½" × 1½" Flexible Plates and two 2½" × ½" Double Angle Strips (5). A built-up strip (6), made from a 12½" and a 5½" Strip, is bolted to the top ends of the Double Angle Strips and the upper edges of the Plates.

The side seen in Fig. 5.3 is attached to a built-up Girder (7), also made from two 12½" Angle Girders overlapped fifteen holes. The lower part of this side is filled in by a 5½" × 2½" Flexible Plate (8) at one end and one half of a Hinged Flat Plate (9) at the other end. At the centre two 2½" × 2" Triangular Flexible Plates (10) and a 2½" × 1½" Flanged Plate (11) are bolted in the positions shown. The side is extended upward by two 2½" × ½" Double Angle Strips (12) and a 2½" Strip (13), and two 2½" × 1½" Flexible Plates and a 2½" × 2½" Flexible Plate are bolted in place. The top edges of the Plates are strengthened by a built-up strip (14), made from a 12½" and a 5½" Strip. The completed sides are connected at each end by a 3½" Strip bolted to the girders (1) and (7).

THE DRIVING CABS

The ends of the two cabs are similar in construction, and each consists of two 5½" × 1½" Flexible Plates overlapped two holes along their longer edges. The ends of the Plates are curved as shown and are fixed to the girders (1) and (7). The Flexible Plates are extended upward by two 2½" Strips and two 2½" × ½" Double Angle Strips. The upper ends of these parts are bolted to two Formed Slotted Strips (15), which are fixed to the ends of the strips (6) and (14). Two 2½" Stepped Curved Strips are bolted to each end as shown in Fig. 5.3a.

CONSTRUCTION OF THE ROOF

The roof is made by bending two 5½" × 2½" Flexible Plates (16) and bolting them between the strips (6) and (14) as shown. Three 12½" Strips are fixed between the Plates (16) on each side, and a 4½" × 2½" Flexible Plate (17) is bolted at the centre of the roof. The curved ends of the roof are made from an opened out 'U'-section Curved Plate and a 2½" × 2½" Flexible Plate, and each is attached to one of the Flexible Plates (16) and the Formed Slotted Strips (15). A 2½" × 1½" Triangular Flexible Plate is used to fill in the rounded corner on each side. The roof ventilators are made from two 2½" × 2½" Flexible Plates and two 1½" radius Curved Plates. They are attached to the roof by ½" Bolts, but a Spring Clip is placed on each Bolt to space the ventilators from the roof.

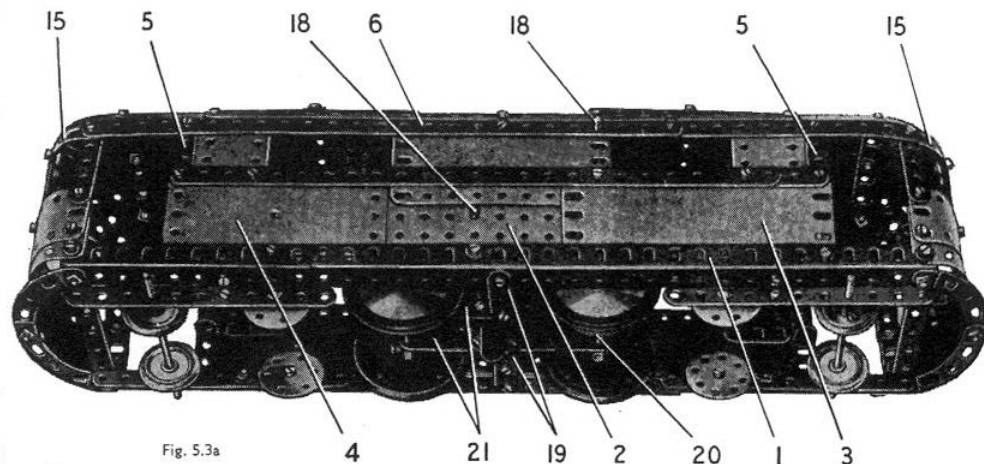

Fig. 5.3a

5.4 BULK LIQUID TRANSPORTER

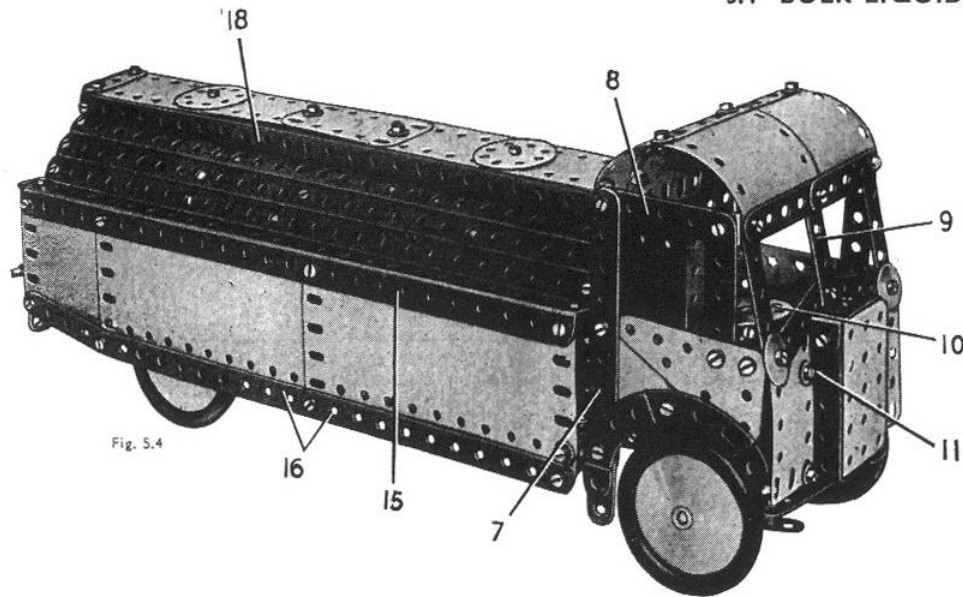

Fig. 5.4

THE CHASSIS AND WHEELS

The chassis is made by bolting two $12\frac{1}{2}$ " Angle Girders to a $5\frac{1}{2}$ " \times $2\frac{1}{2}$ " Flanged Plate (1), so that each Girder overlaps the Flanged Plate by five holes. The rear ends of the Girders are connected by a $2\frac{1}{2}$ " \times $\frac{1}{2}$ " Double Angle Strip (2). The rear wheels are fixed on a $4\frac{1}{2}$ " Rod supported in the Angle Girders.

A $3\frac{1}{2}$ " Strip (3) is bolted across the Flanged Plate (1). The front wheels are fixed on $1\frac{1}{2}$ " Rods supported in Double Brackets. One of the Rods is held in place by a Spring Clip and the other is retained by a Cord Anchoring Spring. At one side a $\frac{1}{2}$ " Bolt is passed through a $1\frac{1}{2}$ " Strip (4) and a Double Bracket and the Bolt is then gripped by two nuts in one end of Strip (3), leaving the Strip and the Double Bracket free to pivot as a unit on the Bolt. The construction at the other end of Strip (3) is similar, but a $2\frac{1}{2}$ " Strip (5) is used in place of the $1\frac{1}{2}$ " Strip (4). A $3\frac{1}{2}$ " Strip (6) is lock-nutted to the ends of the Strips (4) and (5).

CONSTRUCTION OF THE CAB

Each side of the cab is assembled on a $5\frac{1}{2}$ " Strip (7), which is attached by an Angle Bracket to a Trunnion bolted to the flange of the Flanged Plate (1). The side consists of two $2\frac{1}{2}$ " \times $1\frac{1}{2}$ " Triangular Flexible Plates arranged as shown in Fig. 5.4, and two $2\frac{1}{2}$ " Stepped Curved Strips are bolted together to form an arch over the front wheel. The window frame is made from a $2\frac{1}{2}$ " Strip, a $2\frac{1}{2}$ " \times $\frac{1}{2}$ " Double Angle Strip (8) and the top end of the Strip (7).

The front of the cab consists of a $2\frac{1}{2}$ " \times $1\frac{1}{2}$ " Flexible Plate on each side bolted to the front flange of the Flanged Plate (1), and connected to the sides of the cab by Angle Brackets. The windscreen frame is formed by six $2\frac{1}{2}$ " Strips arranged as shown, with a centre division provided by a $2\frac{1}{2}$ " \times $\frac{1}{2}$ " Double Angle Strip (9).

The radiator is a $2\frac{1}{2}$ " \times $1\frac{1}{2}$ " Flanged Plate edged by a $1\frac{1}{2}$ " \times $\frac{1}{2}$ " and two $2\frac{1}{2}$ " \times $\frac{1}{2}$ " Double Angle Strips. It is attached by an Angle Bracket to the lower end of the Double Angle Strip (9).

The back of the cab is partly filled by a $5\frac{1}{2}$ " \times $1\frac{1}{2}$ " Flexible Plate at each side. They are connected to the sides of the cab by Angle Brackets, and are bolted to the lugs of the Double Angle Strips (8). The top ends of the $5\frac{1}{2}$ " \times $1\frac{1}{2}$ " Flexible Plates are bent over and connected by a curved $2\frac{1}{2}$ " \times $2\frac{1}{2}$ " Flexible Plate to form part of the roof. The front section of the roof consists of two $1\frac{1}{2}$ " radius Curved Plates fixed to the front lugs of the Double Angle Strips (8).

THE STEERING MECHANISM

A Bush Wheel (10) is fixed on the end of a Screwed Rod, which is mounted in a hole of the Flanged Plate (1) and in a Stepped Bent Strip attached to the front of the cab by a Bolt (11). The Screwed Rod is held in place by two nuts locked together below the Flanged Plate, and a $2\frac{1}{2}$ " Strip (12) is held on the lower end of the Screwed Rod by two nuts. An Angle Bracket is pivoted on a Threaded Pin held in the end hole of Strip (12) by a Spring Clip, and the Angle Bracket is bolted to one lug of a $2\frac{1}{2}$ " \times $\frac{1}{2}$ " Double Angle Strip (13). The Double Angle Strip is connected to the Strip (5) by a Pivot Bolt (14) fitted with a Spring Clip.

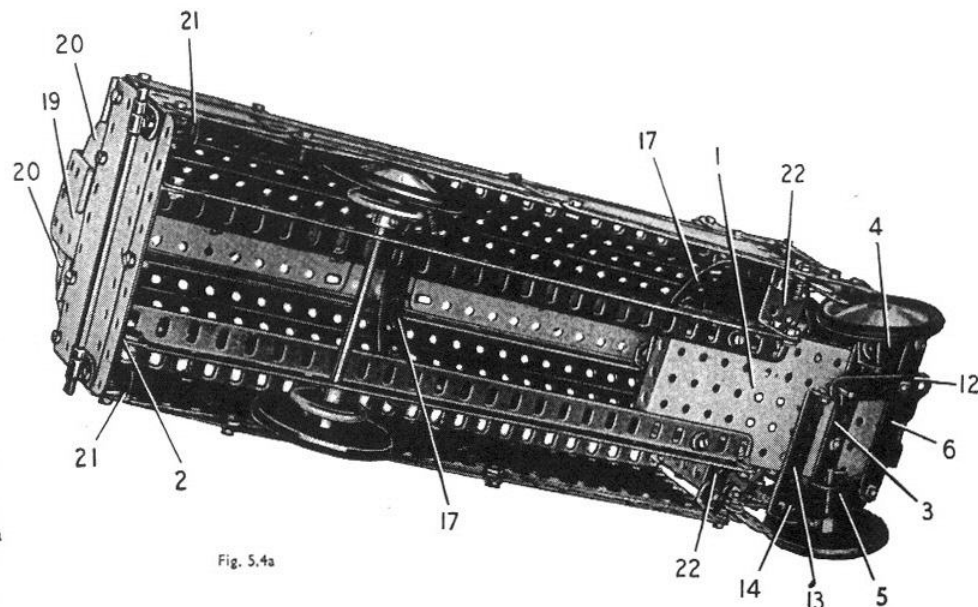

Fig. 5.4a

CONSTRUCTION OF THE TANK

Each side of the tank is formed by two $5\frac{1}{2}$ " \times $2\frac{1}{2}$ " and a $2\frac{1}{2}$ " \times $2\frac{1}{2}$ " Flexible Plate bolted to a $12\frac{1}{2}$ " Angle Girder (15). Two $5\frac{1}{2}$ " Strips (16) are attached to the $5\frac{1}{2}$ " \times $2\frac{1}{2}$ " Flexible Plate by a Fishplate, and are connected to the $2\frac{1}{2}$ " \times $2\frac{1}{2}$ " Flexible Plate by a $2\frac{1}{2}$ " Strip.

The rounded part of the tank consists of three $12\frac{1}{2}$ " Strips on each side. These are bolted to three $5\frac{1}{2}$ " Strips bent to form a half circle, and the two end Strips are connected to the sides of the tank by Obtuse Angle Brackets. The centre and the front $5\frac{1}{2}$ " Strips are seen at (17) in Fig. 5.4a.

Two $12\frac{1}{2}$ " Strips (18), one on each side, are fixed to the centre parts of four $\frac{1}{2}$ " Reversed Angle Brackets bolted to the front and rear curved $5\frac{1}{2}$ " Strips, and the top of the tank is attached to the lugs of the Reversed Angle Brackets. The top is made from a $2\frac{1}{2}$ " \times $1\frac{1}{2}$ " and two $5\frac{1}{2}$ " \times $1\frac{1}{2}$ " Flexible Plates bolted end to end.

The rear of the tank is made by separating and bolting together the halves of a Hinged Flat Plate. The halves overlap by four holes, and a $2\frac{1}{2}$ " \times $1\frac{1}{2}$ " Flexible Plate (19) and two Semi-Circular Plates (20) are fixed in position. A guard rail formed by a $5\frac{1}{2}$ " Rod held in Right-Angle Rod and Strip Connectors is bolted across the back. The back is connected to the sides by two Angle Brackets and two Double Brackets (21).

The completed tank is bolted at the back to the Double Angle Strip (2). The front end of the tank is supported on each side by an Angle Bracket bolted to a $1\frac{1}{2}$ " \times $1\frac{1}{2}$ " Angle Bracket (22). The Angle Brackets (22) are fixed to the chassis Girders and to the flanges of the Flanged Plate (1).

Parts Required

8 of No. 1	4 of No. 12c	20 of No. 38	5 of No. 111c	4 of No. 192
9 " " 2	1 " " 15	2 " " 38d	1 " " 115	1 " " 198
2 " " 3	1 " " 15a	1 " " 44	4 " " 125	1 " " 199
12 " " 5	2 " " 18a	1 " " 48	2 " " 126	2 " " 200
2 " " 6a	2 " " 22	7 " " 48a	1 " " 147b	2 " " 212a
4 " " 8	1 " " 24	1 " " 51	2 " " 155	2 " " 214
2 " " 10	2 " " 24a	1 " " 52	4 " " 187	2 " " 221
4 " " 11	3 " " 35	1 " " 80c	4 " " 188	2 " " 222
12 " " 12	118 " " 37a	4 " " 90a	4 " " 189	
2 " " 12a	105 " " 37b	2 " " 111a	2 " " 190	

5.5 ELEVATOR

THE ELEVATOR SHAFT

The shaft consists of four upright pieces, each made from a $12\frac{1}{2}$ " Angle Girder and a $12\frac{1}{2}$ " Strip overlapped three holes. The base of the shaft is a $5\frac{1}{2}$ " x $2\frac{3}{4}$ " Flanged Plate (1), and the $12\frac{1}{2}$ " Angle Girders are connected to the corners of the Flanged Plate by $\frac{1}{2}$ " Reversed Angle Brackets (2), (Fig. 5.5a). The $12\frac{1}{2}$ " Strips are joined at their upper ends by $5\frac{1}{2}$ " Strips (3), and by $3\frac{1}{2}$ " Strips (4) attached to Angle Brackets.

The base is extended at each side by a Flanged Sector Plate attached to a Semi-Circular Plate, and at one end by two $5\frac{1}{2}$ " Strips (5) bolted inside the flanges of the Flanged Plate. The outer ends of Strips (5) are connected by a $2\frac{1}{2}$ " x $\frac{1}{2}$ " Double Angle Strip, and they are braced by further $5\frac{1}{2}$ " Strips attached to the lift shaft by Angle Brackets.

The lift shaft is braced by $5\frac{1}{2}$ " Strips, $5\frac{1}{2}$ " x $2\frac{3}{4}$ " and $5\frac{1}{2}$ " x $1\frac{1}{2}$ " Flexible Plates arranged as shown, and by crossed $12\frac{1}{2}$ " and $5\frac{1}{2}$ " Strips and built-up strips (6). Each of the strips (6) consists of two $2\frac{1}{2}$ " Strips overlapped three holes. At the top of the shaft the joins between the $12\frac{1}{2}$ " Strips and the Strips (3) are strengthened by $2\frac{1}{2}$ " x $1\frac{1}{2}$ " Triangular Flexible Plates. At the lower end of the shaft $2\frac{1}{2}$ " x 2 " Triangular Flexible Plates (7) are fitted between two of the Angle Girders and the base.

THE CAGE AND ITS GUIDE CORDS

Each side of the cage is a $4\frac{1}{2}$ " x $2\frac{1}{2}$ " Flexible Plate strengthened by $2\frac{1}{2}$ " Strips and a $2\frac{1}{2}$ " x $\frac{1}{2}$ " Double Angle Strip (8) as shown in Fig. 5.5a. The sides are connected by a $2\frac{1}{2}$ " x $1\frac{1}{2}$ " Flanged Plate (9), and by two $2\frac{1}{2}$ " x $\frac{1}{2}$ " Double Angle Strips bolted to the lower edges of the sides. The floor of the cage is a $2\frac{1}{2}$ " x $2\frac{1}{2}$ " Flexible Plate bolted to these Double Angle Strips. The back is also a $2\frac{1}{2}$ " x $2\frac{1}{2}$ " Flexible Plate attached to a Double Angle Strip (10).

Two Trunnions are bolted to the Flanged Plate (9) and a $1\frac{1}{2}$ " loose Pulley (11) is freely mounted on a Pivot Bolt held by its nuts in one of the Trunnions.

The cage is guided by two Cords, arranged one on each side. Each Cord is fastened to a Washer and is passed through a hole in the Flanged Plate (1) and through the lugs of one of the Double Angle Strips (8). The Cord is then pulled tight and is tied to a $1\frac{1}{2}$ " x $1\frac{1}{2}$ " Angle Bracket bolted to half of a Hinged Flat Plate at the top of the shaft. Each half of the Hinged Flat Plate is fixed to one of the Strips (3).

THE OPERATING MECHANISM

A $3\frac{1}{2}$ " Pulley (12) fitted with a Threaded Pin is fixed on a Rod mounted as shown in Fig. 5.5a. A length of Cord is tied to a Cord Anchoring Spring on the Rod and is passed over a $3\frac{1}{2}$ " Pulley (13), round the Pulley (11) and is tied to the top of the lift shaft. Pulley (13) is fixed on a Rod held by Road Wheels in the halves of the Hinged Flat Plate.

The Pulley (12) is fitted with a brake formed by two $\frac{3}{4}$ " Washers bolted to a $2\frac{1}{2}$ " Stepped Curved Strip. The Curved Strip is lock-nutted to a Double Bracket (14), and the $\frac{3}{4}$ " Washers engage in the rim of Pulley (12). A length of Cord fastened to an Angle Bracket on the Curved Strip is tied to a Driving Band attached to the lift shaft. The Driving Band pulls the Washers against the Pulley. The Cord fastened to the Driving Band passes over a $\frac{1}{2}$ " loose Pulley (15) on the same Rod as the Pulley (12).

Parts Required

8 of No. 1	1 of No. 23	4 of No. 125
14 " " 2	116 " " 37a	2 " " 126
2 " " 3	110 " " 37b	1 " " 147b
12 " " 5	11 " " 38	1 " " 176
2 " " 6a	2 " " 38d	1 " " 186
4 " " 8	1 " " 40	2 " " 187
1 " " 11	6 " " 48a	4 " " 189
9 " " 12	1 " " 51	2 " " 190
2 " " 12a	1 " " 52	2 " " 191
1 " " 15a	2 " " 54	4 " " 192
1 " " 16	1 " " 90a	1 " " 198
2 " " 19b	1 " " 111a	2 " " 214
1 " " 22	2 " " 111c	4 " " 221
1 " " 22a	1 " " 115	2 " " 222

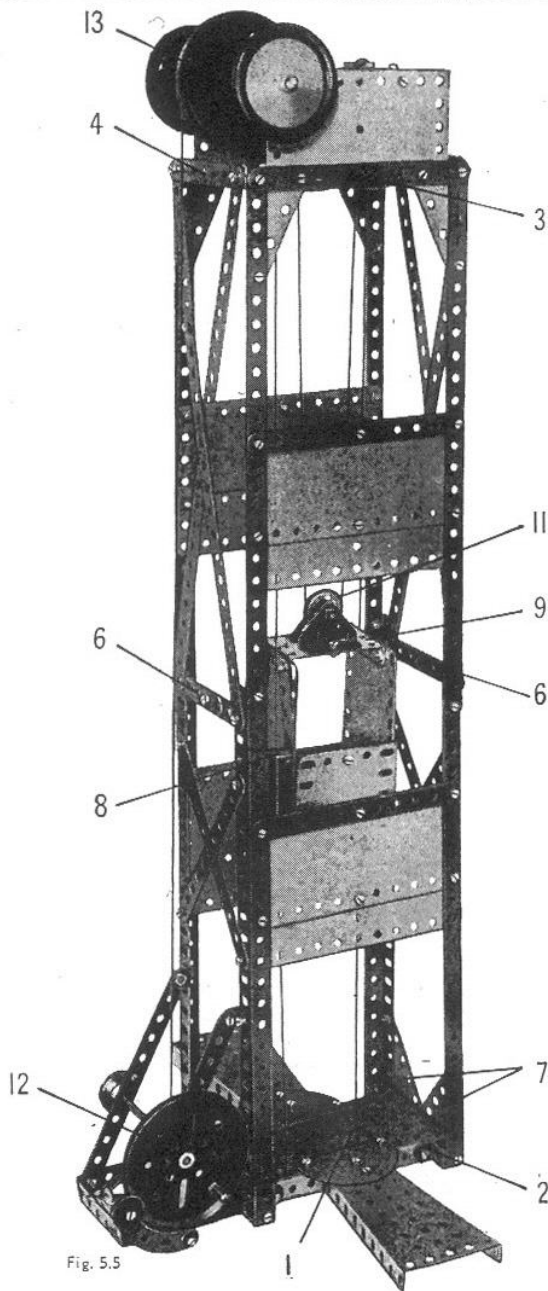

Fig. 5.5

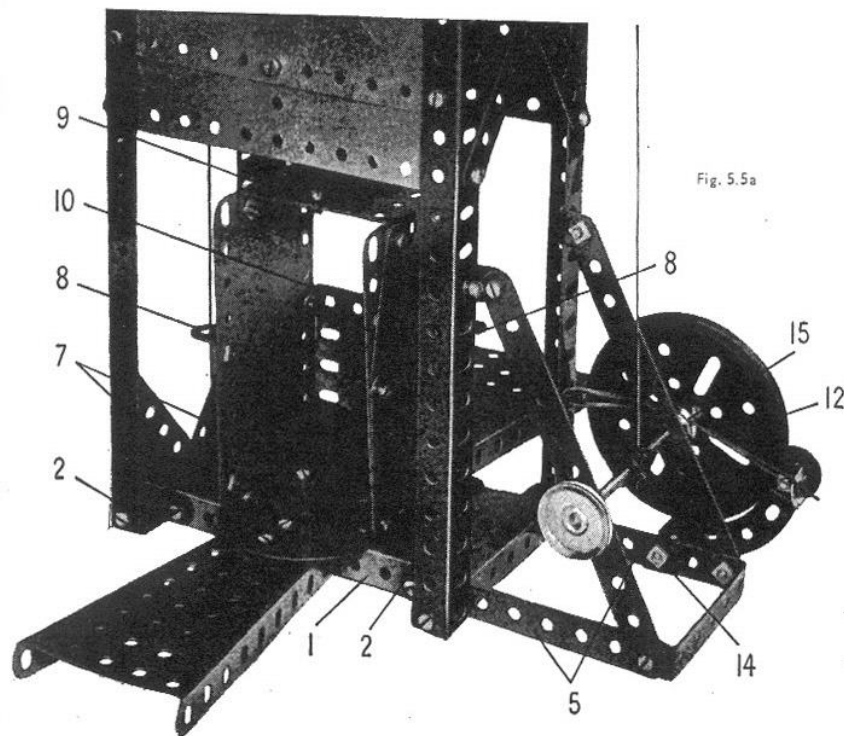

Fig. 5.5a

5.6 ESTATE CAR

THE CHASSIS AND WHEELS

The chassis consists of two 12½" Angle Girders bolted to a 5½" x 2½" Flanged Plate (1). The rear ends of the Girders are connected by a 2½" x ½" Double Angle Strip (2), and one half of a Hinged Flat Plate and a 2½" x 2½" Flexible Plate are fixed to the Girders as shown.

The front wheels are fixed on a 5" Rod passed through the Girders and the flanges of the Flanged Plate. The rear wheels are mounted on a built-up rod made from a 3½" and a 2" Rod joined by a Rod Connector.

CONSTRUCTION OF THE BODY

Each side of the body consists of a 5½" x 2½" Flexible Plate (3), a 2½" x 1½" Flexible Plate (4) and a 2½" x 2½" Flexible Plate (5). These Plates are bolted to a built-up strip (6), made from two 5½" Strips overlapped three holes. A built-up strip (7), consisting of two 5½" Strips overlapped four holes, is connected to strip (6) by 2½" x ½" Double Angle Strips (8) and a 5½" Strip (9). At one side a 2½" Strip is used in place of one of the Double Angle Strips (8).

The sides of the body are connected to the back by Angle Brackets. The back is the other half of the Hinged Flat Plate and it is bolted to the Double Angle Strip (2).

The roof consists of two 5½" x 2½" and two 4½" x 2½" Flexible Plates bolted to the tops of Double Angle Strips (8) and connected to the front ends of strips (7) by Angle Brackets. It is connected also to the back of the body by a 2½" x ½" Double Angle Strip.

The front end of the body is joined to the chassis by a 2½" x ½" Double Angle Strip (10) and a 1½" x ½" Double Angle Strip (11). A spare wheel cover at the back is represented by two Semi-Circular Plates held by a ½" Bolt. The rear bumper is a 5" Rod gripped in Right-Angle Rod and Strip Connectors.

ASSEMBLY OF THE BONNET

Each side of the bonnet is a 5½" x 1½" Flexible Plate (12), and a further 5½" x 1½" Flexible Plate (13) is bent as shown and arranged so that its ends overlap each of the Plates (12) by three holes. The top of the bonnet is made from two 1½" radius Curved Plates and two 'U'-section Curved Plates opened out slightly. These Plates are bolted to a 5½" Strip (14), which is bent as shown and bolted to the centre of Plate (13). The rear end of the top of the bonnet is attached to Obtuse Angle Brackets fixed to the sides, and the front end is bolted direct to the sides. The centre division of the wind-screen is a 1½" Strip fixed to Obtuse Angle Brackets.

The steering wheel is a Bush Wheel on a 1½" Rod held by a Spring Clip in a 2½" x 1½" Flanged Plate and a Double Bent Strip. The Flanged Plate is fixed at a slight angle to one side of the body. The driver's seat consists of two 2½" x 1½" Flexible Plates connected by an Angle Bracket and fixed to a Double Bracket bolted to the Flanged Plate (1).

THE WINGS AND THE RUNNING BOARDS

The side of each front wing is made from a 2½" x 1½" and a 2½" x 2" Triangular Flexible Plate, with a 2½" Strip attached to them by a Fishplate. The top of the wing is a 2½" x 1½" Triangular Flexible Plate and three 2½" Strips (15), two of which are joined to the Plate by Fishplates. It is connected to the side by Angle Brackets, and the assembly is bolted to a Double Bracket (16) fixed to the Plate (12). The rear edge of the wing is filled in by a Trunnion (17) and a ½" Reversed Angle Bracket (18).

At the front, each wing is joined by an Angle Bracket to a 5½" x 1½" Flexible Plate (19), which is bolted also to the Plate (13) and is fitted with two 3½" Strips. The front bumper is a 5½" Strip attached to the Plate (19) by ½" Bolts but spaced from it by Spring Clips on the Bolts.

Each running board is a 5½" Strip connected by an Angle Bracket to the Trunnion (17) and joined by a 1" x 1" Angle Bracket to the rear mudguard. The mudguard consists of two Formed Slotted Strips and two 2½" Stepped Curved Strips bolted to a ½" Reversed Angle Bracket, which is used also to connect the assembly to the side of the body.

Parts Required

14 of No. 2	2 of No. 15	2 of No. 38d	4 of No. 125	1 of No. 198
2 " " 3	1 " " 16	1 " " 45	2 " " 126	2 " " 199
12 " " 5	1 " " 17	1 " " 48	1 " " 147b	2 " " 200
2 " " 6a	1 " " 18a	8 " " 48a	4 " " 155	1 " " 212
2 " " 8	4 " " 22	1 " " 51	4 " " 187	2 " " 212a
7 " " 10	1 " " 24	1 " " 52	4 " " 188	1 " " 213
3 " " 11	3 " " 35	4 " " 90a	4 " " 189	2 " " 214
12 " " 12	116 " " 37a	2 " " 111a	3 " " 190	4 " " 215
2 " " 12a	110 " " 37b	4 " " 111c	2 " " 191	4 " " 221
4 " " 12c	18 " " 38	1 " " 115	4 " " 192	2 " " 222

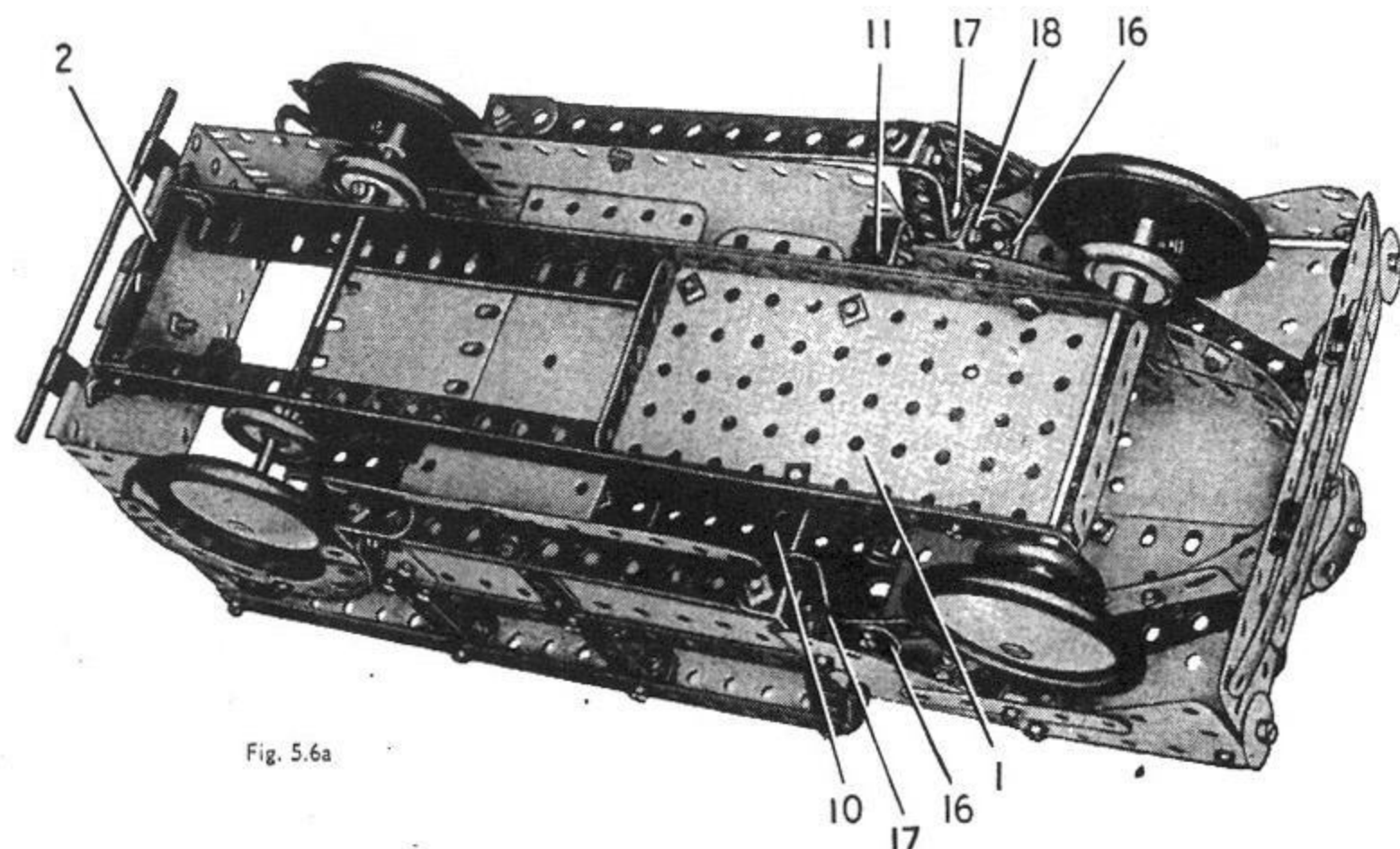

Fig. 5.6a

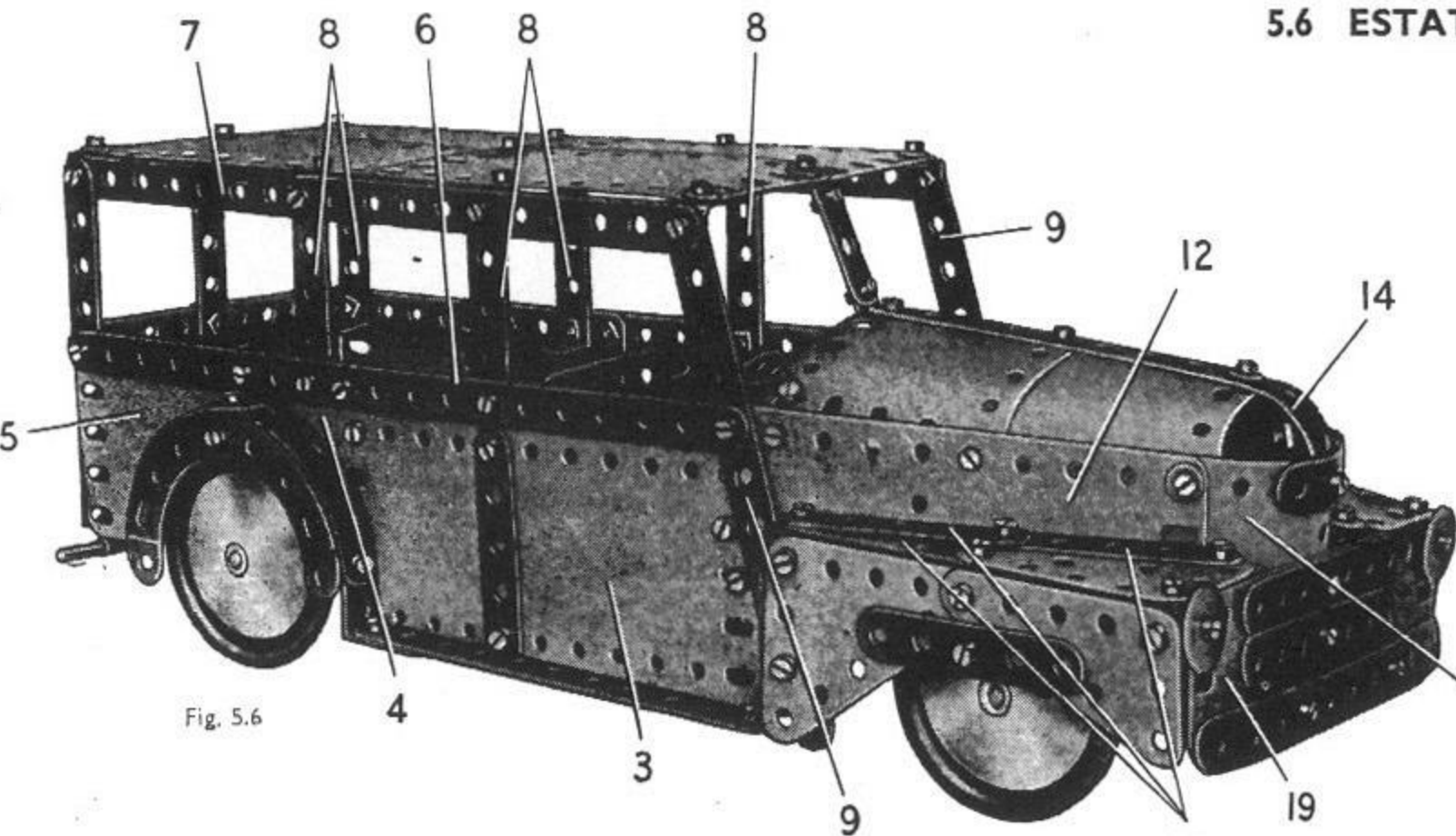

Fig. 5.6

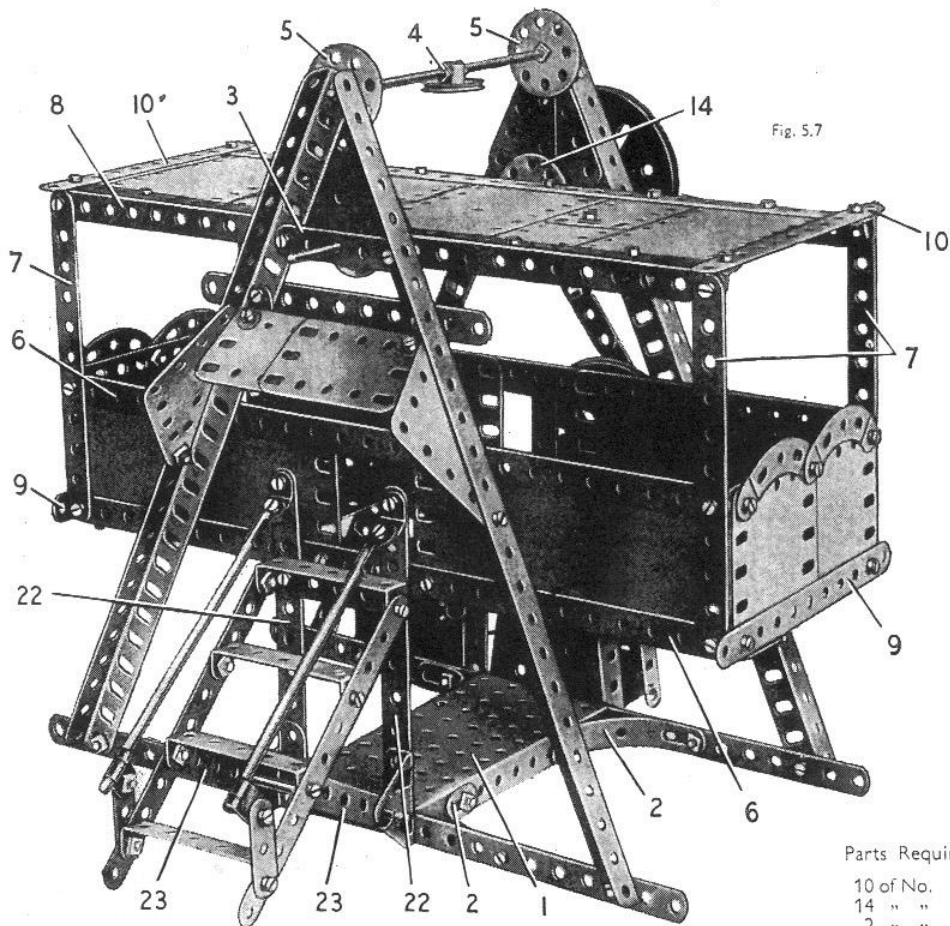

Fig. 5.7

5.7 GIANT SWING BOAT

ASSEMBLY OF THE BASE

Construction of the Giant Swing Boat is commenced by bolting 12 $\frac{1}{2}$ " Strips to the ends of a 5 $\frac{1}{2}$ " x 2 $\frac{1}{2}$ " Flanged Plate (1) (Fig. 5.7). The Strips are also held to the Flanged Plate by Formed Slotted Strips (2). Two 12 $\frac{1}{2}$ " Angle Girders are fixed to each 12 $\frac{1}{2}$ " Strip as shown, and the top ends of these Girders are connected by a 2 $\frac{1}{2}$ " Strip (3) and two 2 $\frac{1}{2}$ " x 1 $\frac{1}{2}$ " Triangular Flexible Plates arranged as shown. The upper ends of the supporting Girders on each side are joined by two Screwed Rods. These are screwed into the threaded holes in the boss of a 1" Pulley (4) and are locked in position by nuts. The outer ends of the Screwed Rods are then passed through the top holes of the 12 $\frac{1}{2}$ " Angle Girders and the centre holes of Wheel Discs (5), and are fixed in position by nuts.

CONSTRUCTION OF THE BOAT

Each side of the Swing Boat itself consists of two 5 $\frac{1}{2}$ " x 2 $\frac{1}{2}$ " Flexible Plates bolted to two 12 $\frac{1}{2}$ " Strips (6). A vertical 5 $\frac{1}{2}$ " Strip (7) is fixed at each end, and the tops of these Strips are connected by a 12 $\frac{1}{2}$ " Strip (8). The sides are joined at each end by two 5 $\frac{1}{2}$ " Strips (9) and (10) fixed to Angle Brackets, and the ends are partly filled in by 2 $\frac{1}{2}$ " x 2 $\frac{1}{2}$ " Flexible Plates connected to the sides by Angle Brackets and edged by 2 $\frac{1}{2}$ " Stepped Curved Strips.

The roof of the Swing Boat is formed by a Hinged Flat Plate: two 4 $\frac{1}{2}$ " x 2 $\frac{1}{2}$ " Flexible Plates and two 2 $\frac{1}{2}$ " x 1 $\frac{1}{2}$ " Flexible Plates bolted to two 12 $\frac{1}{2}$ " Strips. The ends of the 12 $\frac{1}{2}$ " Strips are fixed to the Strips (10). The floor is partly filled in by four 5 $\frac{1}{2}$ " x 1 $\frac{1}{2}$ " Flexible Plates (11), arranged two at each side. Two of the Plates are supported at their outer ends by 1" x 1" Angle Brackets fixed to the sides, and the other two are attached to Double Brackets. The inner ends of the four Flexible Plates are connected to the sides by $\frac{3}{4}$ " Reversed Angle Brackets. Two Semi-Circular Plates (12) are bolted together and are then attached to the inner corners of the 5 $\frac{1}{2}$ " x 1 $\frac{1}{2}$ " Flexible Plates. A straightened 1 $\frac{1}{4}$ " radius Curved Plate (13) is fixed between the two Flexible Plates at each end of the floor.

The Swing Boat swings on a built-up rod made from a 5" and a 3 $\frac{1}{2}$ " Rod joined by a Rod Connector. The rod is passed

2 of No.	24c
3 "	35
118 "	37a
109 "	37b
8 "	38
5 "	48a
1 "	51
1 "	52
2 "	54
2 "	80c
4 "	90a
4 "	111c
1 "	115
4 "	125
2 "	126
1 "	147b
1 "	176
1 "	186a
4 "	188
4 "	189
4 "	190
2 "	191
4 "	192
1 "	198
2 "	200
2 "	212
2 "	215a
1 "	215b
1 "	216
1 "	217
2 "	219b
1 "	219g
5 "	22
1 "	24
2 "	24a

1 Magic Clockwork Motor
(not included in Outfit)

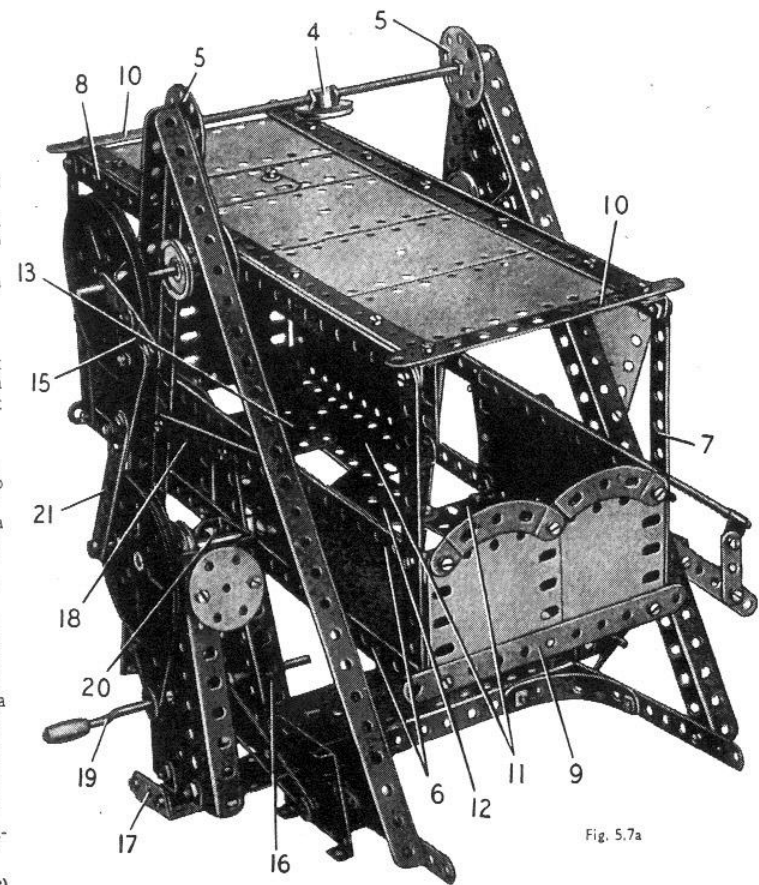

Fig. 5.7a

through the centre holes of the Strips (8) at the top of the Boat and is gripped in the boss of a Bush Wheel (14) bolted to one of these Strips. The rod is supported in the Strips (3) and it carries a 3" Pulley fitted with a 2 $\frac{1}{2}$ " Strip (15).

THE DRIVING MECHANISM

A Flanged Sector Plate (16) is bolted to the base at one side, and a second Flanged Sector Plate is attached by Double Brackets to a 2 $\frac{1}{2}$ " x 1 $\frac{1}{2}$ " Flanged Plate (17) also connected to the side of the base. The top ends of the Flanged Sector Plates are joined together by a Six-Hole Wheel Disc at each side. The Flanged Sector Plate (16) is connected by a 2 $\frac{1}{2}$ " Strip to a 5 $\frac{1}{2}$ " Strip (18) bolted across the Girders of the supporting columns.

A Magic Clockwork Motor is fixed to the base as shown, and its pulley is connected by a Driving Band to a 1" Pulley on the Crank Handle (19). A $\frac{1}{2}$ " fixed Pulley (supplied with the Motor) is fixed on the Crank Handle and is connected by a Driving Band to a 3" Pulley on a 2" Rod (20). A built-up strip (21), made from two 3 $\frac{1}{2}$ " Strips overlapped four holes, is mounted on a Pivot Bolt held by its nuts in a slotted hole of the 3" Pulley on Rod (20). The Pivot Bolt is placed centrally in the slotted hole, and the strip (21) is spaced from the Pulley by a Spring Clip on the Pivot Bolt. The top end of strip (21) is passed over a Threaded Pin attached to the end of Strip (15), and is held on the Pin by a Cord Anchoring Spring.

The steps leading to the Swing Boat consist of four 2 $\frac{1}{2}$ " x $\frac{1}{2}$ " Double Angle Strips bolted to two 5 $\frac{1}{2}$ " Strips. They are connected at the top to a 2 $\frac{1}{2}$ " x $\frac{1}{2}$ " Double Angle Strip bolted to two 5 $\frac{1}{2}$ " Strips (22) fixed to the base. Two 2 $\frac{1}{2}$ " Strips (23) attached to the steps are connected by a 3 $\frac{1}{2}$ " Rod to Trunnions also fixed to the base by the Bolts used to fix the Strips (22). The handrails are Rods gripped at the top of the steps in Rod and Strip Connectors attached to Obtuse Angle Brackets bolted to the Strips (22). The lower ends of the Rods are supported in Right-Angle Rod and Strip Connectors attached to 1 $\frac{1}{2}$ " Strips.

5.8 MOTOR COACH

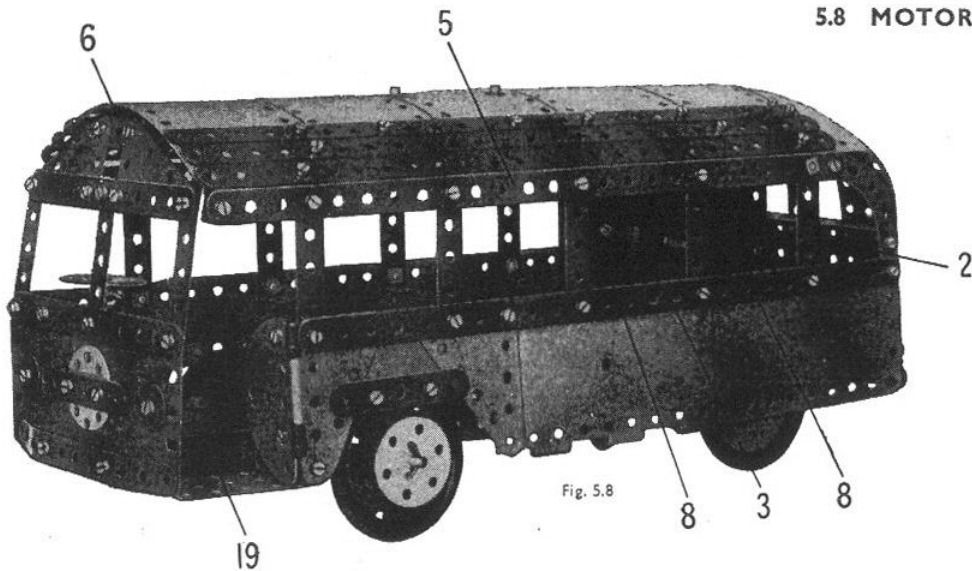

Fig. 5.8

The edges of the roof at each side are formed by three $1\frac{1}{2}$ " Strips. These are bolted to two $5\frac{1}{2}$ " x $2\frac{1}{2}$ " Flexible Plates, two $4\frac{1}{2}$ " x $2\frac{1}{2}$ " Flexible Plates and two $1\frac{1}{8}$ " radius Curved Plates. The roof is attached to Obtuse Angle Brackets bolted to the Strips (5). The rear panelling that connects the roof to the Flanged Plate is formed by a $5\frac{1}{2}$ " x $1\frac{1}{2}$ " Flexible Plate at each side, and two $2\frac{1}{2}$ " x $2\frac{1}{2}$ " Flexible Plates at the centre. The $2\frac{1}{2}$ " x $2\frac{1}{2}$ " Flexible Plates overlap each other by four holes, and they overlap the rear edge of the roof by three holes. A Formed Slotted Strip is fixed between these Plates and the Flanged Plate (2).

The windscreen is made by bolting three $2\frac{1}{2}$ " Strips to the front of the body. The upper ends of these Strips support a $5\frac{1}{2}$ " Strip, and this is connected to the Strips (5) by Angle Brackets. Two $2\frac{1}{2}$ " x $1\frac{1}{2}$ " Triangular Flexible Plates fixed to the $5\frac{1}{2}$ " Strip are connected by a $1\frac{1}{2}$ " x $\frac{1}{2}$ " Double Angle Strip (6). The bumper bar is a $5\frac{1}{2}$ " Strip attached to the front of the body by $\frac{3}{8}$ " Bolts, but separated from it by a Spring Clip on each Bolt. The front is completed by adding a Wheel Disc and $\frac{3}{8}$ " Washers as shown. The rear bumper is formed by two $5\frac{1}{2}$ " Strips (7) bolted to a Flat Trunnion fixed to the Flanged Plate (2).

THE MOTOR AND GEARING

A No. 1 Clockwork Motor is bolted to two $5\frac{1}{2}$ " Strips (8) fixed to one of the girders of the chassis. One of these Strips is bolted at an angle as shown in Fig. 5.8a. The top rear corner of the Motor is connected to one of the Strips (5) by a Screwed Rod (9). This is attached to the Strip and to the Motor by nuts. A $\frac{1}{2}$ " Pinion on the Motor driving shaft drives a 57-tooth Gear (10) on a 2" Rod supported in the Motor side-plates. This Rod is held in place by a Cord Anchoring Spring and it carries a 1" Pulley (11) that drives a similar Pulley (12) on the rear axle. The rear axle is a 5" Rod mounted in the chassis as shown.

STEERING MECHANISM

Each of the front wheels is free to turn on a $1\frac{1}{2}$ " Rod held by a Spring Clip in a Double Bracket (13). The wheel is retained on the Rod by a Six-Hole Wheel Disc and a Spring Clip. A $\frac{1}{2}$ " Bolt is passed through a $1\frac{1}{2}$ " Strip (14) and the Double Bracket (13), and is then clamped by two nuts in the hole at the pointed end of a Trunnion (15) bolted to the side girder of the chassis. The ends of the Strips (14) are connected by lock-nutted $\frac{1}{2}$ " Bolts to a built-up strip (16), made from two $3\frac{1}{2}$ " Strips overlapped five holes. The strip (16) is spaced from the Strips (14) by a Spring Clip on each Bolt, and a $5\frac{1}{2}$ " Strip (17) is pivoted on one of the Bolts. Strip (17) is connected by a lock-nutted Bolt to a Fishplate bolted tightly to a Wheel Disc (18), which is clamped by two nuts to the end of a Screwed Rod. The Screwed Rod is supported in a $\frac{1}{2}$ " Reversed Angle Bracket bolted to one of the chassis girders, and in a Stepped Bent Strip fixed to the front of the model. The steering wheel is a Bush Wheel secured at the top end of the Screwed Rod.

The entrance to the coach is formed by a $2\frac{1}{2}$ " x $2\frac{1}{2}$ " Flexible Plate (19) bolted to the chassis, and the step is a $2\frac{1}{2}$ " x $1\frac{1}{2}$ " Flanged Plate fixed to the front of the model and supported by a $\frac{1}{2}$ " Reversed Angle Bracket (20). A Semi-Circular Plate is attached to the side by a 1 " x 1 " Angle Bracket, and the hand-rail is formed by a 2" Rod gripped in Right-Angle Rod and Strip Connectors bolted to the Semi-Circular Plate.

THE CHASSIS AND BODY

The chassis of this model Motor Coach consists of two built-up girders, each made from two $1\frac{1}{2}$ " Angle Girders overlapped 21 holes. These are connected at the front by a $2\frac{1}{2}$ " x $\frac{1}{2}$ " Double Angle Strip (1), and at the rear they are bolted to a $5\frac{1}{2}$ " x $2\frac{1}{2}$ " Flanged Plate (2) that forms the end of the body. The front of the body consists of two $5\frac{1}{2}$ " x $1\frac{1}{2}$ " Flexible Plates bolted together and fixed to the Double Angle Strip (1).

The side of the model seen in Fig. 5.8 is bolted to a $12\frac{1}{2}$ " Strip (3). This side consists of a $5\frac{1}{2}$ " x $2\frac{1}{2}$ " Flexible Plate, one half of a Hinged Flat Plate, a $2\frac{1}{2}$ " x 2 " and a $2\frac{1}{2}$ " x $1\frac{1}{2}$ " Triangular Flexible Plate, and a $2\frac{1}{2}$ " x $1\frac{1}{2}$ " Flexible Plate. The side is bolted at the rear to the Flanged Plate (2), and is connected by an Angle Bracket to a $5\frac{1}{2}$ " Strip (4) fixed across the chassis. The other side of the model is similar but it is extended forward by two $2\frac{1}{2}$ " x $1\frac{1}{2}$ " Flexible Plates, which are connected to the front of the body by an Angle Bracket. A $12\frac{1}{2}$ " Strip and a $5\frac{1}{2}$ " Strip are used in place of the Strip (3) used on the near side.

A $12\frac{1}{2}$ " Strip (5) on each side is joined to the lower part of the body by a series of $2\frac{1}{2}$ " Strips and $2\frac{1}{2}$ " x $\frac{1}{2}$ " Double Angle Strips that represent the window divisions. The Strips (5) are connected to the Flanged Plate (2) by $2\frac{1}{2}$ " Stepped Curved Strips.

Parts Required

10 of No. 1	4 of No. 12c	8 of No. 35	2 of No. 80c	4 of No. 188
11 " " 2	1 " " 15	118 " " 37a	2 " " 90a	4 " " 189
2 " " 3	2 " " 17	104 " " 37b	2 " " 111a	3 " " 190
10 " " 5	2 " " 18a	18 " " 38	6 " " 111c	2 " " 191
2 " " 6a	3 " " 22	2 " " 38d	1 " " 115	4 " " 192
4 " " 8	1 " " 24	1 " " 44	2 " " 125	1 " " 198
3 " " 10	2 " " 24a	1 " " 48	2 " " 126	2 " " 200
2 " " 11	2 " " 24c	7 " " 48a	1 " " 126a	2 " " 212a
5 " " 12	1 " " 26	1 " " 51	1 " " 147b	1 " " 214
1 " " 12a	1 " " 27a	1 " " 52	1 " " 155	1 " " 215
			1 " " 176	4 " " 221
			1 " " 186	2 " " 222
			4 " " 187	

1 No. 1 Clockwork Motor
(Not included in Outfit)

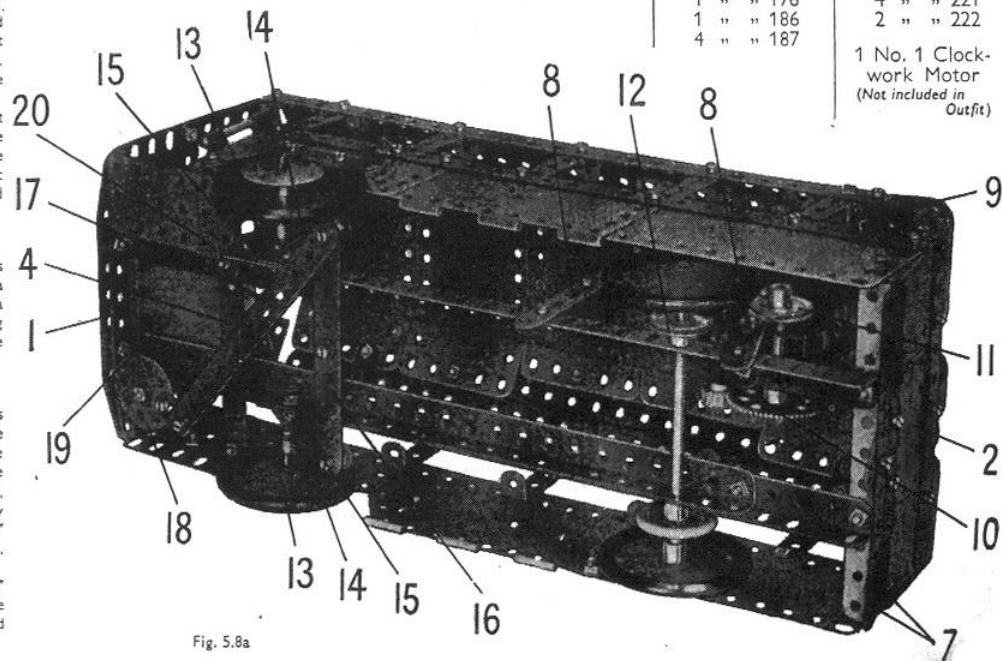

Fig. 5.8a

5.9 BIG WHEEL

CONSTRUCTION OF THE BASE

The base is made by bolting a $5\frac{1}{2}$ " Strip to each of the shorter flanges of a $5\frac{1}{2}$ " x $2\frac{1}{2}$ " Flanged Plate (1). A $12\frac{1}{2}$ " Angle Girder is attached to each of the ends of the $5\frac{1}{2}$ " Strips, and at the top the Angle Girders on each side are bolted to a Wheel Disc (2). The lower ends of the Angle Girders are braced by $5\frac{1}{2}$ " x $2\frac{1}{2}$ " Flexible Plates edged by $5\frac{1}{2}$ " Strips (3).

THE ENTRANCE AND PAY BOX

A Flanged Sector Plate is attached to each of the Angle Girders on one side, and a built-up strip (4) is connected to the base by three $2\frac{1}{2}$ " x $\frac{1}{2}$ " Double Angle Strips, arranged one at each end and one in the centre. The built-up strip is made from two $3\frac{1}{2}$ " Strips bolted together. The floor of the entrance consists of two $4\frac{1}{2}$ " x $2\frac{1}{2}$ " Flexible Plates bolted to the centre Double Angle Strip.

The sides of the entrance are formed by $2\frac{1}{2}$ " x $2\frac{1}{2}$ " Flexible Plates (5) fixed to the $2\frac{1}{2}$ " x $\frac{1}{2}$ " Double Angle Strips at the ends of the strip (4). The arch over the entrance consists of a $5\frac{1}{2}$ " x $1\frac{1}{2}$ " Flexible Plate and a $2\frac{1}{2}$ " x $1\frac{1}{2}$ " Triangular Flexible Plate (6) on each side bolted to the Plate (5). The $5\frac{1}{2}$ " x $1\frac{1}{2}$ " Flexible Plates are bent over and are bolted together at the centre, the same bolt fixing also a $1\frac{1}{2}$ " x $\frac{1}{2}$ " Double Angle Strip. A $2\frac{1}{2}$ " Strip is attached to each lug of the Double Angle Strip, and $2\frac{1}{2}$ " Stepped Curved Strips are bolted to the ends of the $2\frac{1}{2}$ " Strip.

The pay-box is represented by a $2\frac{1}{2}$ " x $1\frac{1}{2}$ " Flanged Plate fixed to a Flat Trunnion bolted to the strip (4). A $2\frac{1}{2}$ " x $\frac{1}{2}$ " Double Angle Strip is also bolted to the Flat Trunnion, and a 1" loose Pulley is attached to a 1" x 1" Angle Bracket connected to the Double Angle Strip.

ASSEMBLY OF THE WHEEL

The spokes of the wheel are formed by four built-up strips. Two of these are each made from a $12\frac{1}{2}$ " Strip and a $5\frac{1}{2}$ " Strip overlapped five holes. The other two each consist of three $5\frac{1}{2}$ " Strips and a $2\frac{1}{2}$ " Strip, bolted together so that they equal in length the built-up strips already mentioned. The spokes are fixed to 3" Pulleys (7) as shown, and they are connected at their outer ends by $2\frac{1}{2}$ " x $\frac{1}{2}$ " Double Angle Strips (8). The wheel rim is made up from $12\frac{1}{2}$ " Strips curved and attached to the Double Angle Strips (8).

The wheel is mounted on an axle, consisting of two Rods joined by a Rod Connector. The rod is supported in the Wheel Discs (2) and is held in position by 1" Pulleys. Each of the carriages consists of a $2\frac{1}{2}$ " x $1\frac{1}{2}$ " Flexible Plate curved and bolted to a Formed Slotted Strip. Two Angle Brackets are bolted to the centre holes in the longer sides of each Flexible Plate. Two of the carriages are pivoted on 2" Rods held by Spring Clips in Double Brackets bolted to the wheel. The other two carriages pivot on $3\frac{1}{2}$ " Rods mounted in Angle Brackets bolted to the wheel.

A Magic Clockwork Motor is bolted to the base as shown, and it drives a 1" Pulley on a Crank Handle (9). The Crank Handle is supported in $1\frac{1}{2}$ " Strips fixed to Trunnions (10) bolted to the Flanged Plate (1). A $\frac{1}{2}$ " fixed Pulley on the Crank Handle is connected by a Cord belt to one of the Pulleys (7). The $\frac{1}{2}$ " Pulley is supplied with the Magic Clockwork Motor, and is placed behind the second 1" Pulley seen on the Crank Handle in Fig. 5.9a.

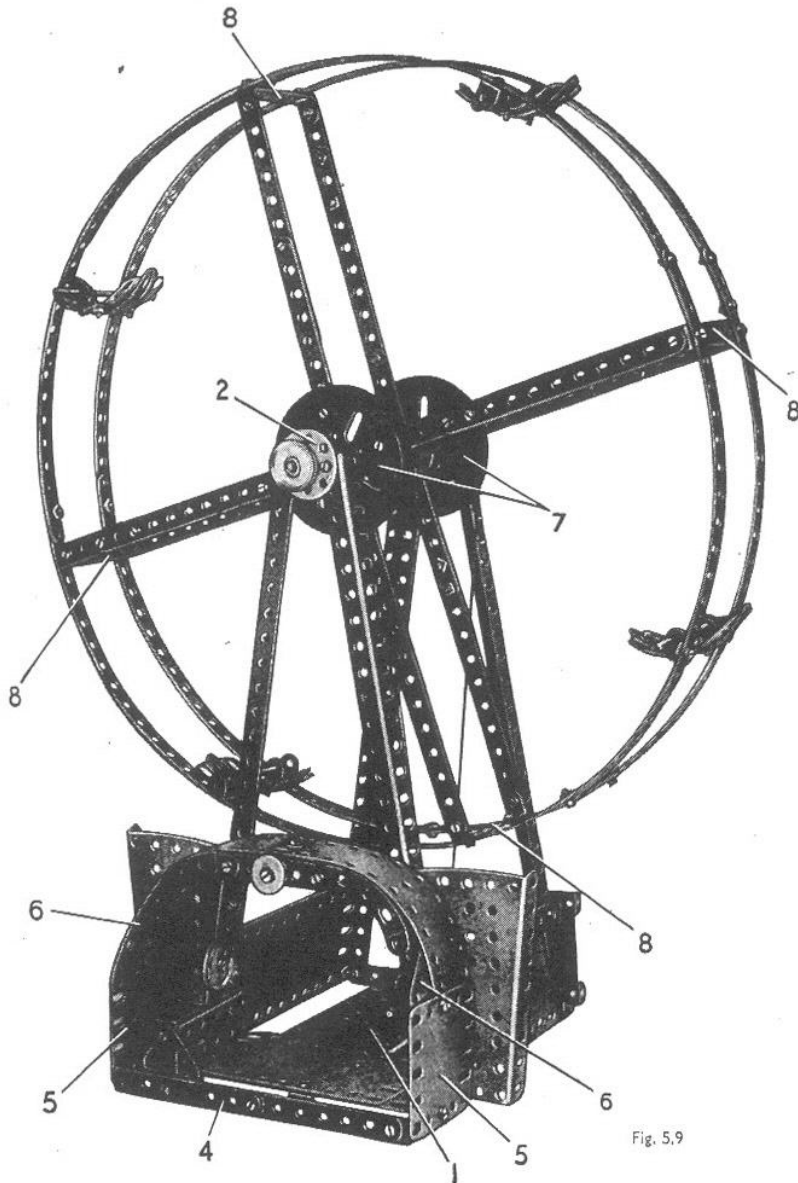

Fig. 5.9

Parts Required

10 of No. 1	1 of No. 24	2 of No. 126
14 " " 2	2 " " 24a	1 " " 126a
2 " " 3	9 " " 35	1 " " 186
4 " " 5	118 " " 37a	4 " " 188
2 " " 6a	110 " " 37b	2 " " 189
4 " " 8	18 " " 38	2 " " 190
4 " " 11	1 " " 38d	2 " " 191
12 " " 12	1 " " 40	2 " " 192
1 " " 12a	1 " " 48	1 " " 213
4 " " 16	8 " " 48a	4 " " 215
2 " " 17	1 " " 51	2 " " 221
2 " " 19b	1 " " 52	
1 " " 19g	2 " " 54	
4 " " 22	4 " " 90a	
1 " " 22a	1 " " 111a	
1 " " 23	6 " " 111c	

1 Magic Clockwork Motor
(Not included in Outfit)

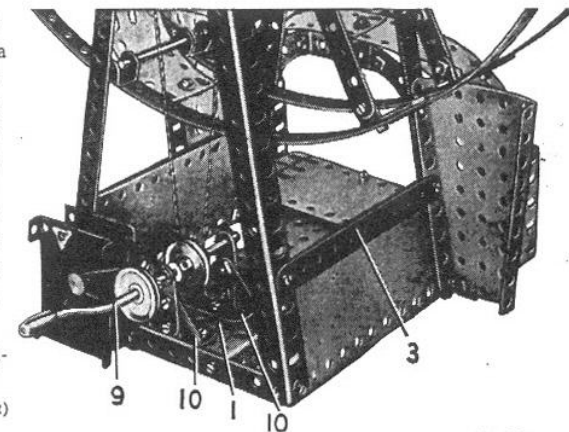

Fig. 5.9a

5.10 HAMMERHEAD CRANE

CONSTRUCTION OF THE TOWER

The lower section of the tower consists of four $1\frac{1}{2}$ " Angle Girders bolted to $5\frac{1}{2}$ " x $2\frac{1}{2}$ " Flexible Plates. Two of these Plates are strengthened by bolting half of a Hinged Flat Plate to each of them, and a $5\frac{1}{2}$ " x $2\frac{1}{2}$ " Flanged Plate is fixed across the base by the bolts holding the halves of the Hinged Flat Plate. A $2\frac{1}{2}$ " x $1\frac{1}{2}$ " Triangular Flexible Plate is attached to each corner of the base as shown. Two Formed Slotted Strips (1) and two similar parts on the opposite side are also bolted in position.

The upper ends of the $1\frac{1}{2}$ " Angle Girders are connected by $5\frac{1}{2}$ " x $1\frac{1}{2}$ " Flexible Plates and $5\frac{1}{2}$ " Strips (2), and the bolts holding them in place secure also further $5\frac{1}{2}$ " Strips (3), arranged in pairs to make built-up angle girders. The top ends of each pair of Strips are joined by an Angle Bracket, and each pair is connected to those on the opposite side by a $2\frac{1}{2}$ " x $\frac{1}{2}$ " Double Angle Strip. A 3" Pulley (4) is fixed to the two Double Angle Strips. The tower is strengthened by two diagonal $1\frac{1}{2}$ " Strips (5).

ASSEMBLY OF THE JIB

The lower jib members are built-up strips (6), each made from two $1\frac{1}{2}$ " Strips overlapped seven holes and bolted to a Flanged Sector Plate (7). The Flanged Sector Plates are attached to a 3" Pulley (8) by 1 " x 1 " Angle Brackets. A $1\frac{1}{2}$ " Rod fixed in the boss of the Pulley (8) is passed through the Pulley (4) and is held in place by a Road Wheel.

The strips (6) are connected at the front by a $1\frac{1}{2}$ " x $\frac{1}{2}$ " Double Angle Strip extended at each end by a Double Bracket (14), and at the rear by a $2\frac{1}{2}$ " x $1\frac{1}{2}$ " Flanged Plate. Each side of the cab is a $2\frac{1}{2}$ " x $2\frac{1}{2}$ " Flexible Plate, edged by a $3\frac{1}{2}$ " Strip (9) that is connected to the strips (6) by a $2\frac{1}{2}$ " Strip (10). The cab roof is formed by two $1\frac{1}{2}$ " radius Curved Plates and two $2\frac{1}{2}$ " x $1\frac{1}{2}$ " Flexible Plates bolted to the Strips (9). The roof is completed by a Semi-Circular Plate at the rear attached to a $2\frac{1}{2}$ " x $\frac{1}{2}$ " Double Angle Strip. The floor of the cab is a $4\frac{1}{2}$ " x $2\frac{1}{2}$ " Flexible Plate fixed to a $2\frac{1}{2}$ " x $\frac{1}{2}$ " Double Angle Strip at the front and attached to the Flanged Plate at the rear by an Angle Bracket.

The upper ends of the Flanged Sector Plates are connected by a $2\frac{1}{2}$ " x $\frac{1}{2}$ " Double Angle Strip and they are joined to the Strips (9) by $5\frac{1}{2}$ " Strips (11). Two $1\frac{1}{2}$ " Strips (12) are bolted to the Flanged Sector Plates and to $1\frac{1}{2}$ " Strips fixed to the front ends of the strips (6).

THE TRAVELLING CARRIAGE AND ITS RAILS

The rails are $1\frac{1}{2}$ " Strips, each of which is attached to one of the strips (6) by a Double Bracket (13), and is fixed at the front by the bolt connecting one of the Double Brackets (14) to the $1\frac{1}{2}$ " x $\frac{1}{2}$ " Double Angle Strip. These bolts fix also Fishplates and a $1\frac{1}{2}$ " Rod mounted in them is fitted with a $\frac{1}{2}$ " loose Pulley (15).

The travelling carriage consists of two $2\frac{1}{2}$ " x $\frac{1}{2}$ " Double Angle Strips connected at each end by a Fishplate. A $\frac{1}{2}$ " Reversed Angle Bracket is bolted to each Double Angle Strip, and these support a 1" loose Pulley (16) freely mounted on a $\frac{1}{2}$ " Bolt.

ARRANGEMENT OF THE CORDS

Cord is tied to an Angle Bracket fixed to one end of the travelling carriage, and is wound three or four times round a Crank Handle (17). The Cord is then passed round the Pulley (15) and is tied to an Angle Bracket bolted to the front of the travelling carriage. The Crank Handle is held in the Strips (10) by a 1" Pulley and a Spring Clip.

A length of Cord is fastened to a Cord Anchoring Spring on a $3\frac{1}{2}$ " Rod (18), that carries a Bush Wheel fitted with a Pivot Bolt. The Cord is passed over the Pulley (16), round a 1" loose Pulley in the pulley block, over the front axle of the travelling carriage and is tied finally to the front of the jib.

The pulley block consists of two Flat Trunnions spaced apart by nuts on $\frac{1}{2}$ " Bolts. The 1" loose Pulley is free to turn on one of the Bolts.

Parts Required

10 of No.	1	1 of No.	40
14 " "	2	1 " "	48
2 " "	3	8 " "	48a
12 " "	5	1 " "	51
2 " "	6a	1 " "	52
4 " "	8	2 " "	54
6 " "	10	1 " "	57c
4 " "	11	6 " "	111c
7 " "	12	2 " "	125
2 " "	12a	2 " "	126a
1 " "	16	1 " "	147b
2 " "	17	1 " "	176
2 " "	18a	1 " "	187
2 " "	19b	2 " "	188
1 " "	19g	4 " "	189
5 " "	22	2 " "	190
2 " "	22a	1 " "	191
1 " "	23	4 " "	192
1 " "	24	1 " "	198
4 " "	35	2 " "	200
113 " "	37a	1 " "	214
105 " "	37b	4 " "	215
20 " "	38	4 " "	221

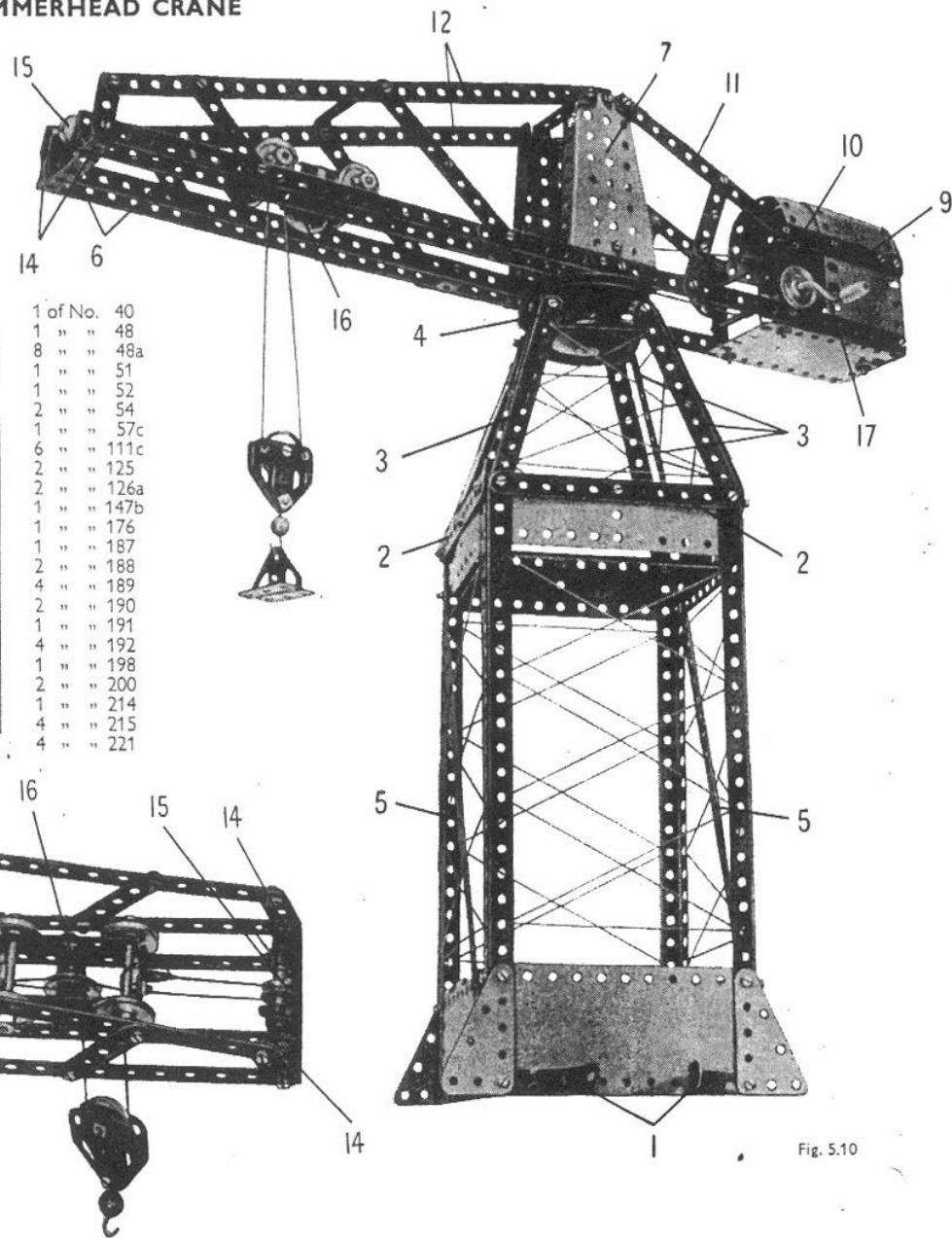

Fig. 5.10

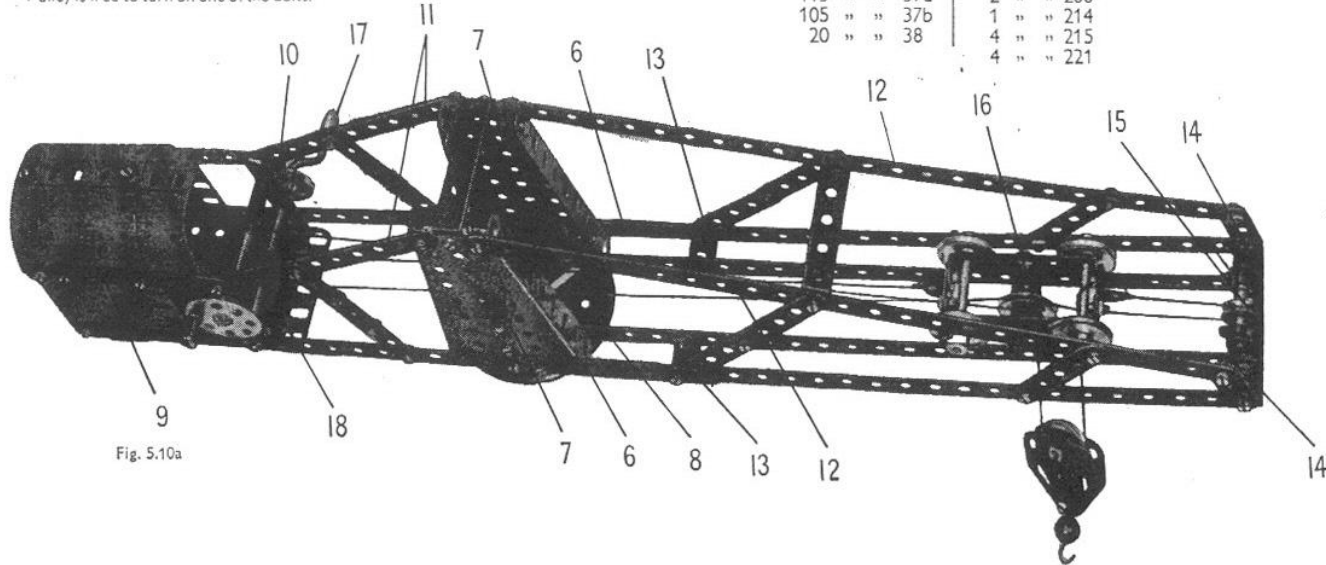

Fig. 5.10a

5.11 AUTOMATIC SHIP COALER

CONSTRUCTION OF THE TOWER

The base of the tower is a $5\frac{1}{2}'' \times 2\frac{1}{4}''$ Flanged Plate edged on each side by a $5\frac{1}{2}'' \times 1\frac{1}{2}''$ Flexible Plate, and a $5\frac{1}{2}''$ Strip that overhangs the Flanged Plate at one end by three clear holes. The lower section of the tower consists of four $12\frac{1}{2}''$ Strips bolted to the base. These are extended upward by $5\frac{1}{2}''$ Strips, and the upper ends of the Strips are attached to two Flat Trunnions connected by a $2\frac{1}{2}'' \times \frac{1}{2}''$ Double Angle Strip. The tower is braced by $5\frac{1}{2}''$ Strips arranged as shown, and by a $2\frac{1}{2}''$ Strip (1) fixed to Trunnions bolted to two of the $12\frac{1}{2}''$ Strips.

The engine house is made by bolting a $2\frac{1}{2}'' \times 1\frac{1}{4}''$ Flexible Plate (2) to each side of the base. The upper ends of the Flexible Plates are connected by a $2\frac{1}{2}'' \times 1\frac{1}{2}''$ Flanged Plate (3) (Fig. 5.11a). The roof is formed by two $1\frac{1}{2}''$ radius Curved Plates attached by a $\frac{1}{2}''$ Bolt to the Flanged Plate (3), and bolted to a $2\frac{1}{2}'' \times \frac{1}{2}''$ Double Angle Strip fixed to the Flanged Plate of the base. The back of the engine house is a $2\frac{1}{2}'' \times 2\frac{1}{2}''$ Flexible Plate.

THE GRAB AND ITS GANTRY

The gantry consists of two $12\frac{1}{2}''$ Angle Girders bolted to the top of the tower and braced by $12\frac{1}{2}''$ Strips (4). The Strips and Girders on each side are connected by Fishplates, and a $2\frac{1}{2}''$ Strip is bolted between the outer ends of the Angle Girders.

The grab truck is shown separately in Fig. 5.11c. It consists of two $2\frac{1}{2}'' \times \frac{1}{4}''$ Double Angle Strips connected at one end by a Double Bent Strip and at the other end by two $\frac{1}{2}''$ Reversed Angle Brackets. The truck wheels are Wheel Discs, each of which is free to turn on a $\frac{3}{4}''$ Bolt attached to the truck by two nuts. A $\frac{1}{2}''$ Reversed Angle Bracket (5) is bolted to each Double Angle Strip, and two $1''$ loose Pulleys (6) are mounted on a $1\frac{1}{2}''$ Rod held in the Reversed Angle Brackets by Spring Clips. The truck wheels run on the flanges of the Angle Girders forming the gantry.

The grab (Fig. 5.11d), consists of a $5\frac{1}{2}'' \times 1\frac{1}{4}''$ Flexible Plate curved as shown and bolted to Formed Slotted Strips. The Flexible Plate is connected by Angle Brackets to $3\frac{1}{2}''$ Strips (7), and two $2\frac{1}{2}''$ Stepped Curved Strips and two $2\frac{1}{2}''$ Strips (8) on each side are held by the same bolts. The upper ends of the Strips (8) are bolted to Fishplates. The grab is suspended from a length of Cord tied to one of the Fishplates and passed over one of the Pulleys (6) of the grab truck. The Cord is then looped through a $2\frac{1}{2}''$ Strip (9) (see Fig. 5.11), then taken over the second Pulley (6) and is tied to the other Fishplate of the grab. The Strip (9) is bolted to $1'' \times 1''$ Angle Brackets fixed to the end of the gantry.

THE HOPPER WAGON AND ITS GANTRY

The hopper wagon gantry consists of two $12\frac{1}{2}''$ Angle Girders bolted in the tower in the positions shown. Two $12\frac{1}{2}''$ Strips also bolted to the tower are connected to the ends of the Girders by $1\frac{1}{2}''$ Strips. The gantry is braced to the tower by two $12\frac{1}{2}''$ and two $5\frac{1}{2}''$ Strips. The unloading chute (10) is formed by two Flanged Sector Plates and four $2\frac{1}{2}'' \times 1\frac{1}{4}''$ Triangular Flexible Plates attached to the $12\frac{1}{2}''$ Angle Girders. A $2\frac{1}{2}''$ Strip (11) is bolted between the Girders inside the tower. (Continued on next page)

Fig. 5.11

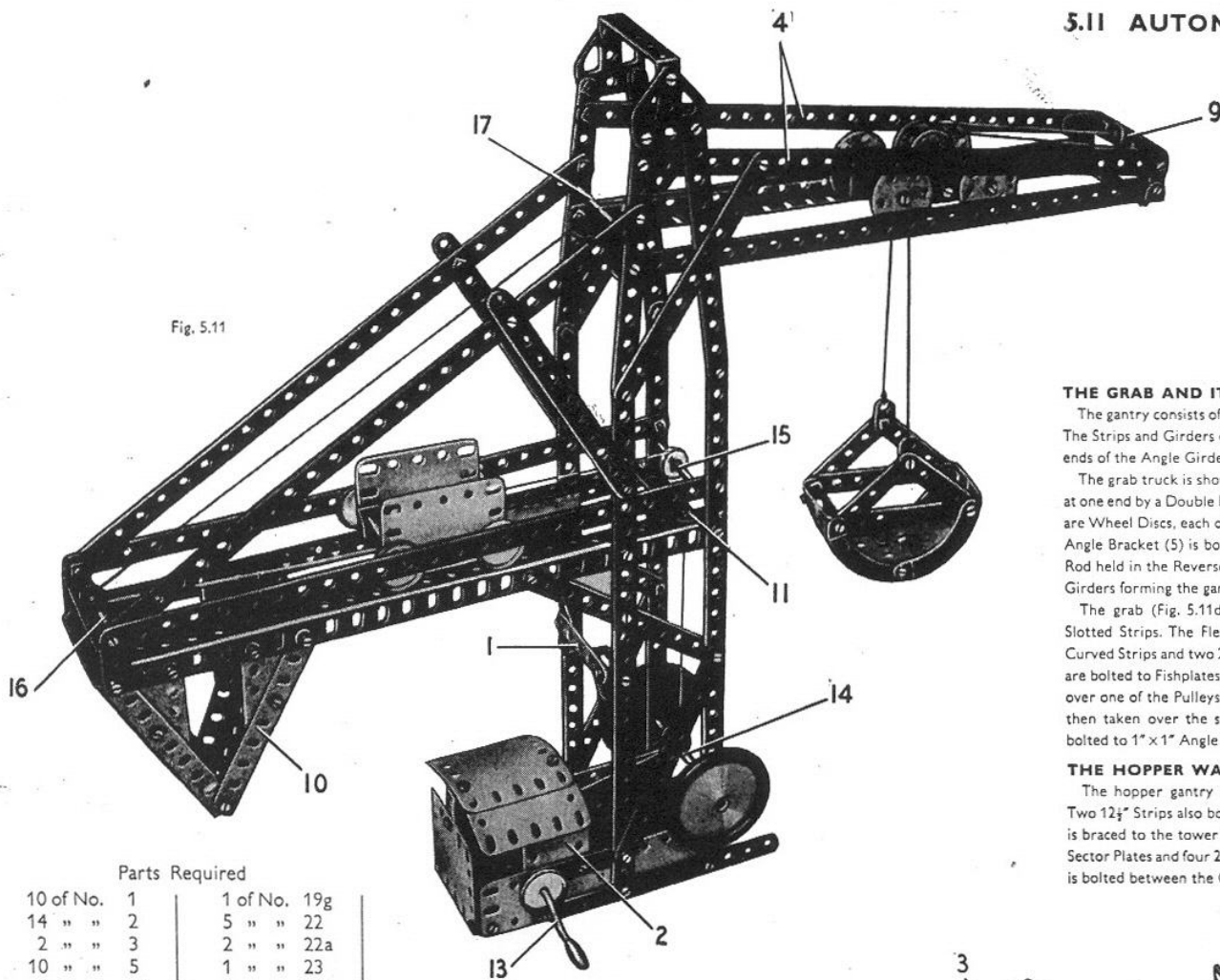

Parts Required	
10 of No. 1	1 of No. 19g
14 " " 2	5 " " 22
2 " " 3	2 " " 22a
10 " " 5	1 " " 23
2 " " 6a	2 " " 24a
4 " " 8	2 " " 24c
4 " " 10	12 " " 35
1 " " 11	118 " " 37a
6 " " 12	105 " " 37b
2 " " 12a	10 " " 38
1 " " 15b	2 " " 38d
2 " " 16	1 " " 40
2 " " 17	1 " " 45
2 " " 18a	1 " " 48

7 of No. 48a	2 of No. 126
1 " " 51	2 " " 126a
2 " " 51	2 " " 187
1 " " 52	4 " " 188
2 " " 54	3 " " 189
4 " " 90a	1 " " 190
1 " " 111a	2 " " 200
6 " " 111c	4 " " 215
4 " " 125	4 " " 221
	2 " " 222



Fig. 5.11a

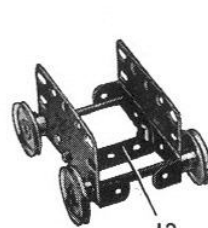

12

Fig. 5.11b

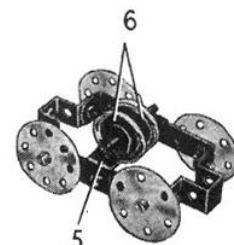
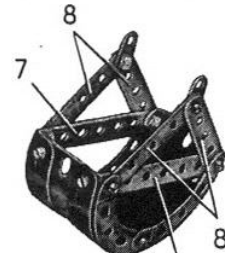

Fig. 5.11c



8

MODEL 5.11 AUTOMATIC SHIP COALER — Continued

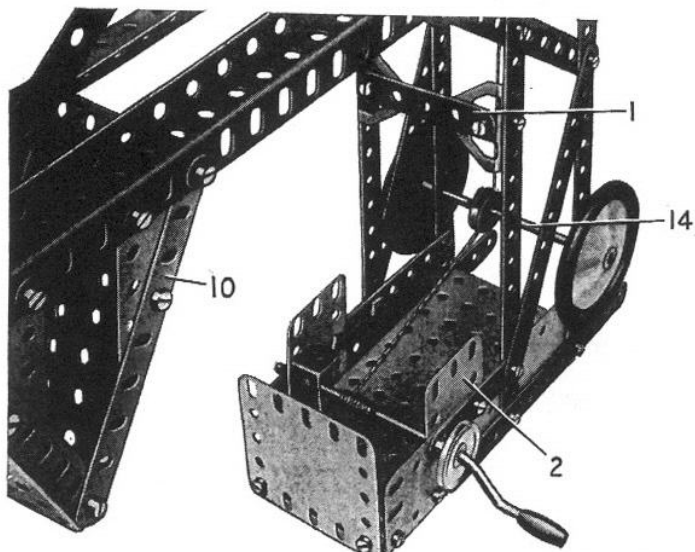

Fig. 5.11e

The hopper wagon is shown in Fig. 5.11b. It consists of two $2\frac{1}{2}'' \times 1\frac{1}{2}''$ Flexible Plates and two $2\frac{1}{2}'' \times \frac{1}{2}''$ Double Angle Strips bolted to a $1\frac{1}{2}'' \times \frac{1}{2}''$ Double Angle Strip (12). The wheels are 1" Pulleys on 2" Rods and they run on the $12\frac{1}{2}''$ Angle Girders of the gantry.

ARRANGEMENT OF THE CORD

A Crank Handle (13) is mounted in the sides of the engine house, and a length of Cord is tied to it. The Cord is taken between two $\frac{3}{8}''$ Washers placed between Spring Clips on a 4" Rod (14), and is passed round a $\frac{1}{2}''$ loose Pulley on a $3\frac{1}{2}''$ Rod (15). The Cord is then tied to the end of the hopper wagon nearest to Rod (15). A second length of Cord is fastened to the other end of the hopper wagon and is taken round a $1\frac{1}{2}''$ Rod (16) held by Spring Clips in a Double Bracket bolted to a $2\frac{1}{2}'' \times \frac{1}{2}''$ Double Angle Strip at the end of the hopper wagon gantry. The Cord passes over a $3\frac{1}{2}''$ Rod (17) mounted in the tower, and is tied to the end of the grab truck.

For more new models to build, see the
MECCANO MAGAZINE
 which is published on the first of every month.

5.12 LOADING SHOVEL

		Parts Required							
13 of No.	2	2 of No.	17	108 of No.	37b	1 of No.	90a	3 of No.	189
2 "	3	1 "	18b	20 "	38	6 "	111c	3 "	190
12 "	5	2 "	19b	2 "	38d	1 "	115	3 "	192
2 "	6a	1 "	19g	1 "	40	3 "	125	1 "	198
2 "	8	5 "	22	1 "	45	2 "	126	2 "	199
8 "	10	2 "	22a	1 "	48	2 "	126a	2 "	200
2 "	11	1 "	24	8 "	48a	1 "	147b	1 "	212
12 "	12	1 "	24a	1 "	51	4 "	155	1 "	213
4 "	12c	2 "	24c	1 "	52	1 "	176	2 "	214
2 "	15	13 "	35	1 "	54	4 "	187	4 "	221
3 "	16	117 "	37a	1 "	57c	4 "	188	2 "	222

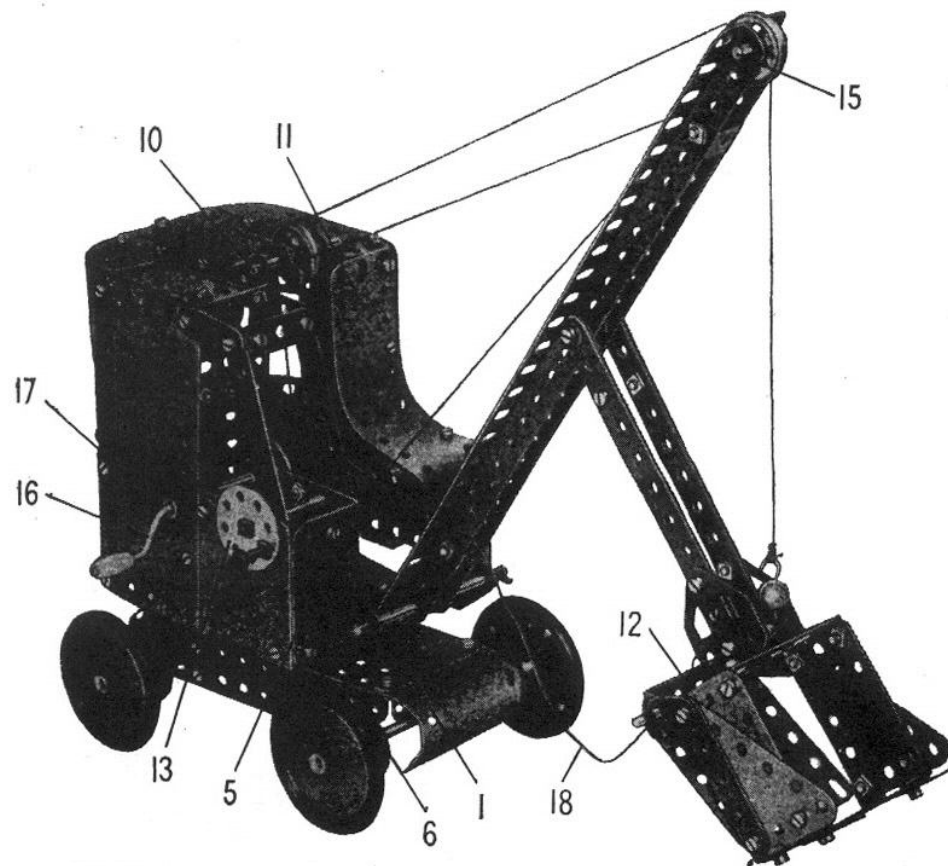
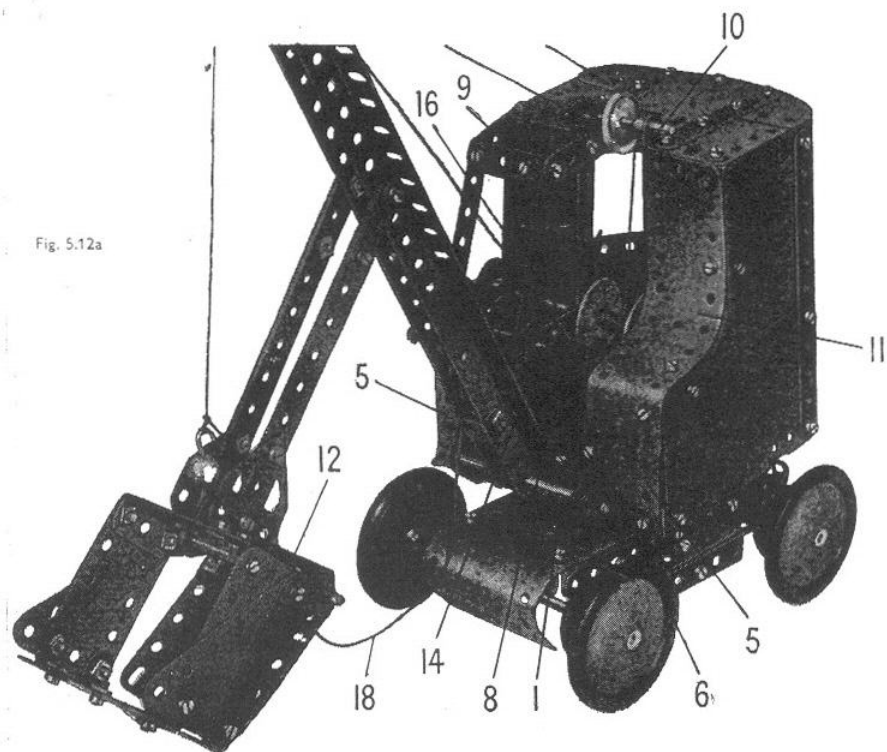

Fig. 5.12

(Continued on next page)

Fig. 5.12a



The sides of the shovel are each made from $2\frac{1}{2} \times 2$ " and $2\frac{1}{2} \times 1\frac{1}{2}$ " Triangular Flexible Plates, and the bottom consists of two $2\frac{1}{2} \times 1\frac{1}{2}$ " Triangular Flexible Plates bolted to $2\frac{1}{2} \times \frac{1}{2}$ " Double Angle Strips fixed between the sides. The back of the shovel is a $2\frac{1}{2} \times 2\frac{1}{2}$ " Flexible Plate attached by Obtuse Angle Brackets to a $2\frac{1}{2} \times \frac{1}{2}$ " Double Angle Strip (12). A $3\frac{1}{2}$ " Rod is passed through this Double Angle Strip and through the slotted holes of Fishplates bolted to the sides of the shovel. When the back is closed the lower edge of the Flexible Plate catches an Obtuse Angle Bracket bolted to the back edge of the bottom of the shovel.

THE OPERATING MECHANISM

A Wheel Disc (13) (Fig. 5.12) is fixed by a nut on a Threaded Pin, which is then passed through the side of the cab and is fitted in a Rod Connector. A $3\frac{1}{2}$ " Rod (14) (Fig. 5.12a) is passed through the Flexible Plate (8) into the Rod Connector, and a length of Cord is fastened to the Rod between $\frac{1}{2}$ " Washers as shown. The Cord is taken over a $1\frac{1}{2}$ " Rod (15) held in the top of the jib by Spring Clips, and is tied to a small Loaded Hook. The Hook is bolted to an Angle Bracket fixed to the top of the shovel.

A Crank Handle (16) is mounted in the side of the cab and in the Flexible Plate (8). A length of Cord is tied to a Cord Anchoring Spring placed between Six-hole Wheel Discs on the Crank Handle (see Fig. 5.12a), and is taken over the $1\frac{1}{2}$ " Pulley on Rod (10). The Cord passes round a $1\frac{1}{2}$ " loose Pulley on Rod (15), and is tied to an Obtuse Angle Bracket on Rod (10). The Crank Handle should be arranged so that it is free to move about $\frac{1}{4}$ " sideways in its bearings, so that when it is pushed inwards a bolt in the boss of a $1\frac{1}{2}$ " Pulley (17) can engage a $\frac{1}{2}$ " Bolt fixed in the side of the cab. This provides a simple brake to hold the jib in the required position.

The catch at the back of the shovel can be released to discharge the contents of the shovel by means of a Cord (18). This is tied to the cab and to the Double Angle Strip (12). When the Cord is pulled, the back of the shovel is raised to the upper ends of the slots in the Fishplates, and the lower edge of the Flexible Plate is lifted clear of the Obtuse Angle Bracket that forms the catch.

MODEL 5.12 LOADING SHOVEL — Continued

In building the Loading Shovel seen in Fig. 5.12 it is best to commence with the wheeled base. This is formed by a $5\frac{1}{2} \times 2\frac{1}{2}$ " Flanged Plate fitted at each of its longer sides with a $5\frac{1}{2}$ " Strip attached to Fishplates fixed to the Plate. A $2\frac{1}{2} \times \frac{1}{2}$ " Double Angle Strip and a $2\frac{1}{2}$ " Strip are attached to a $\frac{1}{2}$ " Reversed Angle Bracket on one side. The Road Wheels are fixed on $5\frac{1}{2}$ " Rods, which are held in position in the $5\frac{1}{2}$ " Strips by $1\frac{1}{2}$ " Pulleys. A 'U'-section Curved Plate is bolted to each end of the Flanged Plate, and a $3\frac{1}{2}$ " Pulley (1) is fixed to the centre of the Flanged Plate.

CONSTRUCTION OF THE CAB

The next section to be built is the cab. Each side of this is made from one half of a Hinged Flat Plate and a $5\frac{1}{2} \times 2\frac{1}{2}$ " Flexible Plate edged by a $5\frac{1}{2}$ " Strip. The back is formed by two $5\frac{1}{2} \times 1\frac{1}{2}$ " Flexible Plates (2) (Fig. 5.12b) and a $5\frac{1}{2} \times 2\frac{1}{2}$ " Flexible Plate (3) lengthened at each end by a $1\frac{1}{2}$ " radius Curved Plate. A $2\frac{1}{2} \times 2\frac{1}{2}$ " Flexible Plate is fixed at the centre between the Plates (2) and (3), and a $5\frac{1}{2}$ " Strip (4) is arranged at each side of the $2\frac{1}{2} \times 2\frac{1}{2}$ " Flexible Plate.

The front of the cab is formed by a $2\frac{1}{2} \times 1\frac{1}{2}$ " Flexible Plate (5) at each side, bolted to two $2\frac{1}{2}$ " Strips (6) (Fig. 5.12a) joined together and attached to the sides by Angle Brackets. A Flanged Sector Plate (7) is fixed by an Angle Bracket to the centre of the Strips (6), and is connected by two $2\frac{1}{2} \times \frac{1}{2}$ " Double Angle Strips to the back of the cab.

The operating cabin is placed at one side of the cab, and it is made by bolting a $2\frac{1}{2} \times 2\frac{1}{2}$ " Flexible Plate (8) (Fig. 5.12a) to a flange of the Flanged Sector Plate. The rear edge of Plate (8) is braced by a $5\frac{1}{2}$ " Strip (9), and the top edge is strengthened by a $2\frac{1}{2}$ " Strip. A $1\frac{1}{2} \times \frac{1}{2}$ " Double Angle Strip is fitted between the side of the cab and the Plates (5) and (8). The window frames are two $3\frac{1}{2}$ " Strips, two $1\frac{1}{2}$ " Strips and a $2\frac{1}{2}$ " Strip. These are arranged as shown and connected together by Angle Brackets, and the $2\frac{1}{2}$ " Strip is connected also to the Strip (9).

The top of the cab consists of two $2\frac{1}{2} \times 1\frac{1}{2}$ " Flexible Plates, two Semi-Circular Plates and a $2\frac{1}{2} \times 2\frac{1}{2}$ " Flexible Plate. It is attached to the sides and back by Angle Brackets. The Strip (9) is connected to the roof by an Angle Bracket. A $2\frac{1}{2}$ " Rod (10) carrying a $1\frac{1}{2}$ " loose Pulley held between Spring Clips is passed through $\frac{1}{2}$ " Reversed Angle Brackets.

The cab is completed by fixing in place a $5\frac{1}{2} \times 1\frac{1}{2}$ " Flexible Plate (11), which is curved as shown and bolted to one of the Flexible Plates (5) and to the lug of a $2\frac{1}{2} \times \frac{1}{2}$ " Double Angle Strip fixed to the top of the side. The Plate (11) is also connected to the side of the cab by two Angle Brackets.

A Bush Wheel is bolted to the Flanged Sector Plate (7) (see Fig. 5.12b), and a $2\frac{1}{2}$ " Rod is fixed in its boss. The Rod is passed through a $3\frac{1}{2}$ " Pulley and the Pulley (1) (Fig. 5.12b) and is held in place by a Rod and Strip Connector placed on the Rod below the $5\frac{1}{2} \times 2\frac{1}{2}$ " Flanged Plate of the base.

THE JIB AND SHOVEL ARM AND THE SHOVEL

The jib consists of two $12\frac{1}{2}$ " Angle Girders joined by two Double Brackets. It pivots on a $3\frac{1}{2}$ " Rod mounted in Trunnions bolted to the front of the cab.

The shovel arm is made from four $5\frac{1}{2}$ " Strips arranged in pairs, each pair being Jack-nutted to the jib by a $\frac{1}{2}$ " Bolt and fitted at its lower end with a Flat Trunnion. The two Flat Trunnions are then bolted to a Double Bent Strip fixed to a $2\frac{1}{2} \times 1\frac{1}{2}$ " Flanged Plate that forms the top of the shovel.

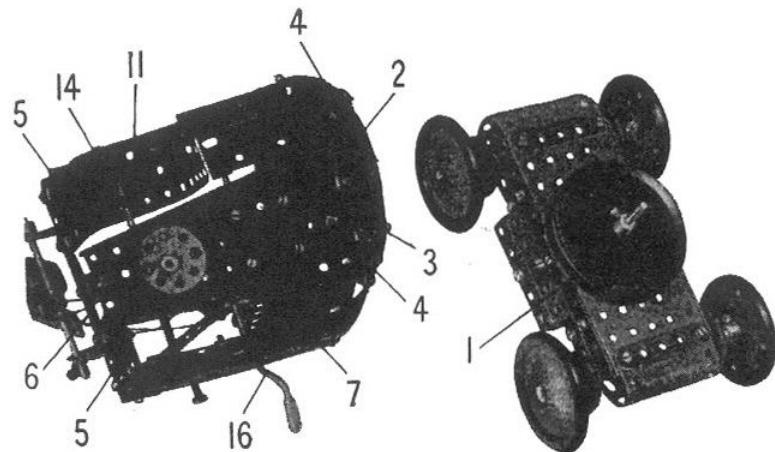

Fig. 5.12b

5.13 DELTA WING JET AEROPLANE

CONSTRUCTION OF THE WINGS

The wings of the model should be made first. Each wing consists of a series of plates bolted to a framework formed by two $12\frac{1}{2}$ " Strips (1) and (2) connected at their ends by a $1\frac{1}{2}$ " Strip (3) and a built-up strip (4). The built-up strip consists of two $5\frac{1}{2}$ " Strips overlapped four holes.

Each wing is filled in by two $5\frac{1}{2}$ " x $1\frac{1}{2}$ " Flexible Plates (5), a $2\frac{1}{2}$ " x $1\frac{1}{2}$ " Triangular Flexible Plate (6), a $2\frac{1}{2}$ " x $2\frac{1}{2}$ " Flexible Plate (7), two $5\frac{1}{2}$ " x $2\frac{1}{2}$ " Flexible Plates (8), one half of a Hinged Flat Plate (9) and a Semi-Circular Plate (10).

The wings are joined together by a $2\frac{1}{2}$ " Strip at the front. The $12\frac{1}{2}$ " Strips (2) are overlapped eight holes and are bolted together. A built-up strip (11), made from a $5\frac{1}{2}$ " and a $2\frac{1}{2}$ " Strip bolted together, is fixed across each wing as shown.

ASSEMBLY OF THE FUSELAGE

A $12\frac{1}{2}$ " Strip (12) is attached to each wing by Angle Brackets held by the Bolts (13) and (14). The rear ends of Strips (12) are connected by a $\frac{3}{4}$ " Bolt (15) that holds also a Fishplate, and a $5\frac{1}{2}$ " Strip (16) is attached to each side.

Fig. 5.13

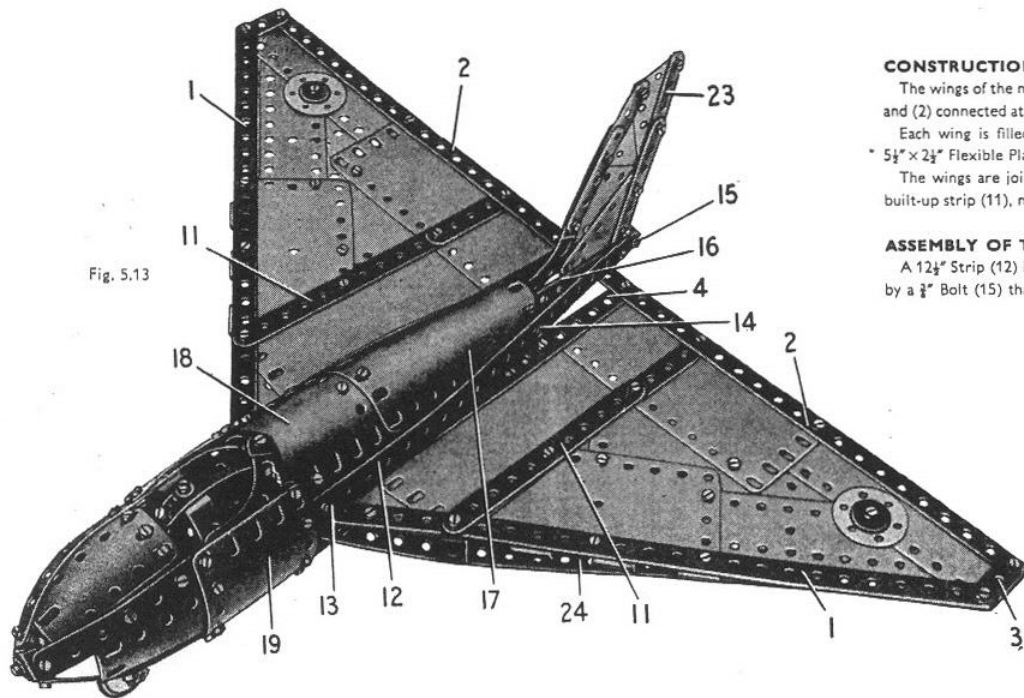

The top of the fuselage consists of a $4\frac{1}{2}$ " x $2\frac{1}{2}$ " Flexible Plate (17) bolted to the Strips (12) and (16) and connected by a Fishplate to a $1\frac{1}{2}$ " radius Curved Plate (18). The Curved Plate is fixed also to Fishplates bolted to the Strips (12).

A $2\frac{1}{2}$ " x $2\frac{1}{2}$ " Flexible Plate (19) on each side is curved slightly and is bolted to the front end of Strip (12) and to the Curved Plate (18). The lower edges of the Plates (19) are joined by a $1\frac{1}{2}$ " radius Curved Plate. The underside of the fuselage consists of a $4\frac{1}{2}$ " x $2\frac{1}{2}$ " Flexible Plate (20) bent to shape and bolted to the Curved Plate and connected at its rear ends to a $5\frac{1}{2}$ " Strip (21) on each side. The underside is completed by a 'U'-section Curved Plate (22), and the bolts holding it in place fix also Angle Brackets used to connect the fuselage to the underside of the wings.

The nose is made by extending the fuselage forward by four $5\frac{1}{2}$ " Strips curved to shape and arranged as shown. The front ends of these Strips are connected by four Obtuse Angle Brackets bolted together. The spaces between the Strips are filled by $2\frac{1}{2}$ " x $1\frac{1}{2}$ " Flexible Plates.

The cockpit cover consists of two $2\frac{1}{2}$ " Stepped Curved Strips and two Formed Slotted Strips. The Formed Slotted Strips are bolted together and connected to one of the Flexible Plates of the nose by an Angle Bracket.

THE TAIL AND THE LANDING WHEELS

The single wheel at the nose is a 1" loose Pulley with Rubber Ring mounted on a Pivot Bolt, which is held by its nuts in a Stepped Bent Strip. A Fishplate is fixed to the top of the Bent Strip, and a Threaded Pin is held tightly in the other hole of the Fishplate. The Threaded Pin is passed through a $\frac{3}{4}$ " Reversed Angle Bracket bolted inside the fuselage to the front of the Curved Plate. A Cord Anchoring Spring is used to hold the Threaded Pin in place. Two 1" fixed Pulleys with Rubber Rings are fixed on $\frac{3}{8}$ " Bolts passed through Flat Trunnions, which are bolted to Angle Brackets attached to the wings.

The tail consists of $2\frac{1}{2}$ " x $1\frac{1}{2}$ " and $2\frac{1}{2}$ " x 2" Triangular Flexible Plates bolted and clamped between two $3\frac{1}{2}$ " and two $2\frac{1}{2}$ " Strips (23) (overlapped two holes) on each side of the Plates. The front edges of the Plates are strengthened by $2\frac{1}{2}$ " Strips and $2\frac{1}{2}$ " Stepped Curved Strips. The tail is held by a $\frac{3}{8}$ " Bolt between the Strips (12) and is fixed to the Fishplate on Bolt (15).

The model is completed by a $12\frac{1}{2}$ " Strip (24) bolted to each wing. It is fixed direct to the wing tip and is connected to the wing by a Double Bracket. The free end of the Strip is placed between the Strip (12) and the Strip (21).

Fig. 5.13a

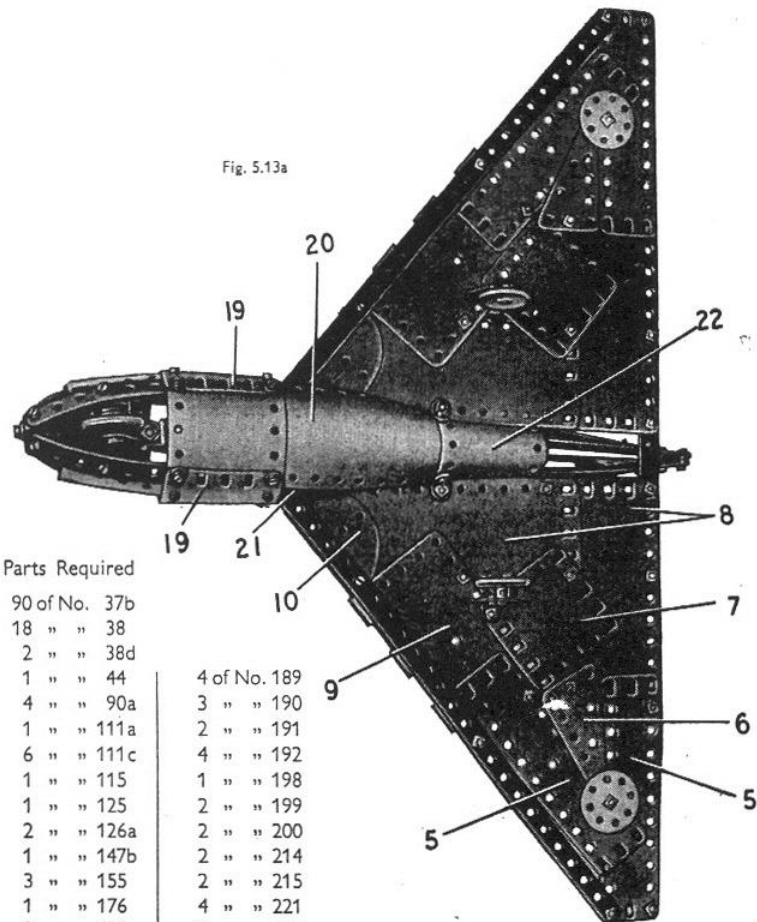

Parts Required

8 of No. 1	90 of No. 37b	
14 " " 2	18 " " 38	
2 " " 3	2 " " 38d	
11 " " 5	1 " " 44	
2 " " 6a	4 " " 90a	
4 " " 10	1 " " 111a	
2 " " 11	6 " " 111c	
9 " " 12	1 " " 115	
4 " " 12c	1 " " 125	
2 " " 22	2 " " 126a	
1 " " 22a	1 " " 147b	
2 " " 24a	3 " " 155	
2 " " 24c	1 " " 176	
95 " " 37a	3 " " 188	
	4 of No. 189	
	3 " " 190	
	2 " " 191	
	4 " " 192	
	1 " " 198	
	2 " " 199	
	2 " " 200	
	2 " " 214	
	2 " " 215	
	4 " " 221	
	2 " " 222	

5.14. HELICOPTER

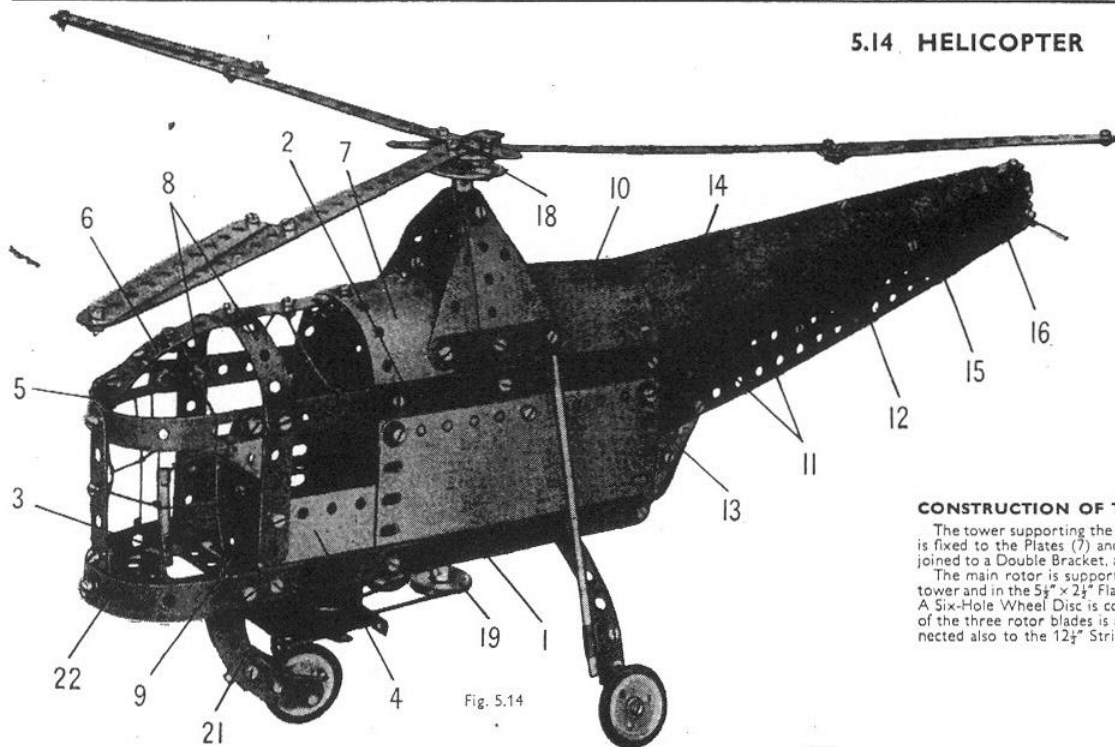

Fig. 5.14

The single wheel at the nose is a 1" fixed Pulley with Rubber Ring, held on a 1" Rod supported in two 2½" Stepped Curved Strips (21). The Curved Strips are connected by a Double Bracket and by a 'U'-shaped piece made from two Angle Brackets. A ½" Bolt is passed through the Double Bracket and is held in the Double Angle Strip (3) by two nuts. The nuts secure also a 1½" Strip that carries a Semi-Circular Plate (22). A Double Bracket attached to the Semi-Circular Plate supports a 1½" Rod that represents the control column. The Rod is held in place by two Spring Clips.

THE DRIVE TO THE ROTORS

A Magic Clockwork Motor is bolted underneath the 5½" x 2½" Flanged Plate, and is connected by a Driving Band to one of the Pulleys (19). The 1" Pulley inside the fuselage on the main rotor shaft is connected by a Cord belt to the ½" Pulley on the Rod (20).

Parts Required

9 of No. 1	5 of No. 22	2 of No. 90a	4 of No. 192
12 " " 2	2 " " 22a	2 " " 111a	1 " " 199
2 " " 3	1 " " 24	4 " " 111c	2 " " 212
10 " " 5	1 " " 24a	2 " " 125	2 " " 212a
1 " " 6a	1 " " 24c	1 " " 126	1 " " 213
8 " " 10	4 " " 35	2 " " 126a	1 " " 214
4 " " 11	105 " " 37a	3 " " 155	4 " " 215
4 " " 12	95 " " 37b	1 " " 176	4 " " 221
4 " " 12c	20 " " 38	1 " " 186a	2 " " 222
2 " " 15	1 " " 40	3 " " 188	
2 " " 16	2 " " 48a	3 " " 189	
2 " " 18a	1 " " 51	1 " " 190	
1 " " 18b	1 " " 52	1 " " 191	

1 Magic Clockwork Motor
(not included in Outfit)

CONSTRUCTION OF THE FUSELAGE

The centre section of the fuselage is made by bolting a 5½" x 2½" Flexible Plate to each side of a 5½" x 2½" Flanged Plate. The sides are extended upward by 5½" x 1½" Flexible Plates that overlap the 5½" x 2½" Flexible Plates by two holes. Each side is extended forward by two built-up strips (1) and (2). Strip (1) consists of a 5½" and a 3½" Strip overlapped two holes, and strip (2) is made from two 5½" Strips overlapped six holes. Strips (1) are connected at their front ends by a 2½" x ¼" Double Angle Strip (3). A 2½" x 1½" Flexible Plate (4) is attached to each side as shown.

The nose is made by bolting two pairs of Formed Slotted Strips to the ends of the strips (1) and (2). The Formed Slotted Strips are connected at the front by a 2½" Strip extended by a Fishplate, and an Obtuse Angle Bracket (5) is also fixed in position. A 5½" Strip (6) is curved slightly and then is bolted between the Obtuse Angle Bracket and a 5½" x 1½" Flexible Plate (7) bent to 'U'-shape and attached to the strips (2). Two curved 2½" Strips (8) are bolted to the Strip (6) and to 2½" Strips fixed vertically to the Flexible Plates (4). A 2½" x 1½" Flanged Plate (9) is bolted between the Plates (4), and a Trunnion and a Wheel Disc attached to the Plate (9) represent the pilot's seat.

A 4½" x 2½" Flexible Plate (10) is bent to 'U'-shape and is fixed between the rear ends of the strips (2).

ASSEMBLY OF THE TAIL

Two 12½" Strips (11) are fixed to each side at a slight angle, and are connected at their rear ends by a Fishplate. A third 12½" Strip (12) is attached to the lower of the Strips (11), and is fixed at its inner end to a 2½" x 2" Triangular Flexible Plate (13). The Strips (11) are bolted to a Double Bracket that connects the sides of the tail together. The tail is covered by two 5½" x 2½" Flexible Plates (14), a 'U'-section Curved Plate (15) and a 2½" x 1½" Flexible Plate (16). Two 5½" Strips (17) overlapped two holes are bolted to the Plates and to the Double Bracket at the end of the tail. A 2½" x 2½" Flexible Plate is attached by Angle Brackets to the Triangular Flexible Plates (13).

CONSTRUCTION OF THE ROTORS

The tower supporting the main rotor consists of two 2½" x 1½" Triangular Flexible Plates on each side bolted to a 2½" Strip. This assembly is fixed to the Plates (7) and (10), and is connected to the strip (2) by a Fishplate. The upper ends of the Triangular Flexible Plates are joined to a Double Bracket, and the front and rear faces of the tower are Flat Trunnions fixed to Obtuse Angle Brackets.

The main rotor is supported by an axle made from two 3½" Rods joined by a Rod Connector. The rod is supported in the top of the tower and in the 5½" x 2½" Flanged Plate, and it carries a Bush Wheel (18), two 1" Pulleys (19) and a third 1" Pulley placed inside the fuselage. A Six-Hole Wheel Disc is connected to the Bush Wheel by two ½" Bolts, and is spaced from the Bush Wheel by nuts on the Bolts. Each of the three rotor blades is a 12½" Strip fixed to the Six-Hole Wheel Disc. A 5½" Strip is bolted to each 12½" Strip at one end and is connected also to the 12½" Strip by a Fishplate.

The tail rotor is a 2½" Strip fixed to an Angle Bracket, which is passed over a 1½" Rod (20) mounted in the tail. The Angle Bracket is held between two Spring Clips, one of which is arranged with its lugs pressed against the face of the 2½" Strip so that it turns with the Rod. The Rod (20) carries a ½" fixed Pulley (supplied with the Magic Clockwork Motor) placed between the sides of the tail.

THE LANDING WHEELS

The main landing wheels are 1" loose Pulleys with Rubber Rings. Each of these is free to turn on a ½" Bolt, which is held by two nuts in a ½" Reversed Angle Bracket bolted to a 2½" Strip. The 2½" Strip is bolted to an Obtuse Angle Bracket fixed to the strip (1), and is braced by a 5" Rod held in a Rod and Strip Connector and a Right-Angle Rod and Strip Connector.

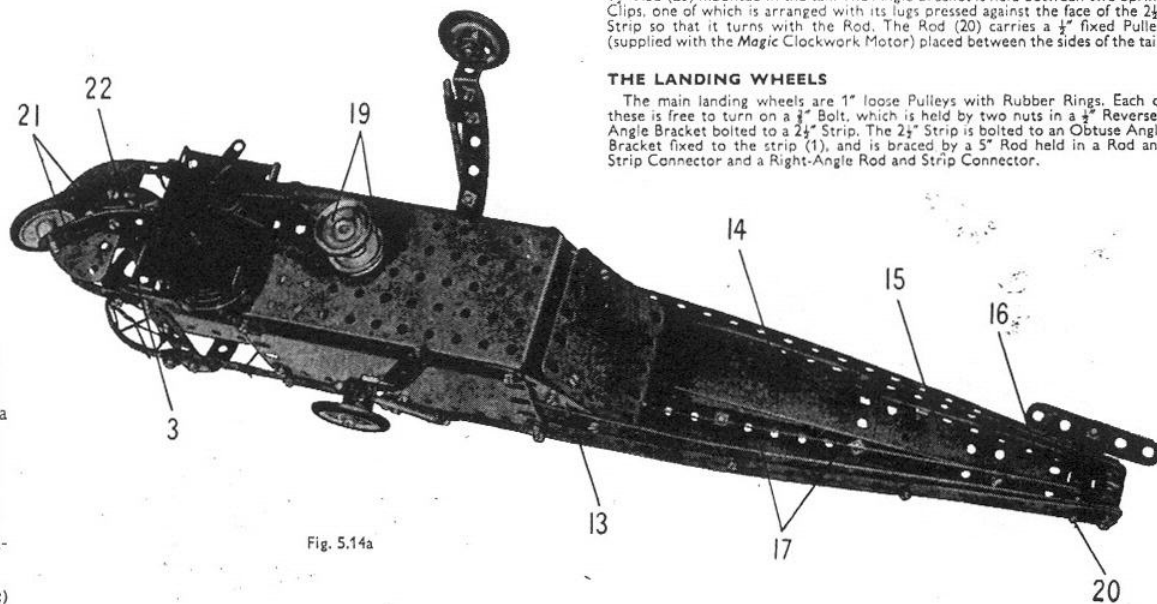

Fig. 5.14a

5.15 TRAVELLING CRANE

CONSTRUCTION OF THE TOWER

The top of the crane tower consists of four $5\frac{1}{2}$ " Strips connected at their ends by Angle Brackets. A $5\frac{1}{2}$ " x $2\frac{1}{2}$ " Flanged Plate (1) is bolted across the structure as shown, and $5\frac{1}{2}$ " Strips (2) are fixed to each corner to form the legs. Further $5\frac{1}{2}$ " Strips are bolted to the top of the tower and are attached to the legs by Angle Brackets.

The wheels on which the crane is mounted are supported by a $12\frac{1}{2}$ " Strip (3) on each side bolted to the lower ends of the legs. A further $12\frac{1}{2}$ " Strip is attached to the Strip (3) by a Double Bracket at each end and by $\frac{1}{2}$ " Reversed Angle Brackets held by the same bolts that fix Strip (3) to the legs. The wheels are Wheel Discs and they are free to turn on bolts, each of which is held in the Strip (3) by two nuts.

ASSEMBLY OF THE JIB

A 3" Pulley is bolted to two $2\frac{1}{2}$ " x $\frac{1}{2}$ " Double Angle Strips fixed between the side flanges of the Flanged Plate (1) and a 2" Rod is free to turn in the boss of the Pulley. The Rod is fixed in the boss of a 3" Pulley (4), and a Road Wheel on the Rod underneath the Flanged Plate holds the Pulleys together.

Two Flanged Sector Plates are attached to the Pulley (4) by Angle Brackets, and two $12\frac{1}{2}$ " Angle Girders overlapped five holes are fixed to the Flanged Sector Plates to form the upper girders of the jib. The lower girders consist of two built-up strips (5) at the front and two built-up strips (6) at the rear. The strips (5) are each made from two $12\frac{1}{2}$ " Strips overlapped 21 holes, and they are connected to a $2\frac{1}{2}$ " x $1\frac{1}{2}$ " Flanged Plate (7) bolted to the front ends of the $12\frac{1}{2}$ " Angle Girders. Strips (6) are each made from a $5\frac{1}{2}$ " and a $2\frac{1}{2}$ " Strip overlapped three holes, and their rear ends are connected by a $2\frac{1}{2}$ " x $\frac{1}{2}$ " Double Angle Strip (8) and are joined to the ends of the $12\frac{1}{2}$ " Angle Girders by $2\frac{1}{2}$ " Strips (9). The ends of the Angle Girders are connected also by a $2\frac{1}{2}$ " x $\frac{1}{2}$ " Double Angle Strip.

The rails on which the crab or trolley runs are $12\frac{1}{2}$ " Strips bolted at the front to a $1\frac{1}{2}$ " x $\frac{1}{2}$ " Double Angle Strip fixed to the Flanged Plate (7). The rear end of each Strip is supported by a 1 " x 1 " Angle Bracket (10) bolted to the $12\frac{1}{2}$ " Angle Girders. The bolts connecting the Strips to the $1\frac{1}{2}$ " x $\frac{1}{2}$ " Double Angle Strip secure also Fishplates, and in these a $\frac{1}{2}$ " Rod is mounted fitted with a $\frac{1}{2}$ " loose Pulley (11).

The rear end of the jib is braced by two 4" Rods, each of which is fixed in a Rod and Strip Connector and a Right-Angle Rod and Strip Connector.

THE CAB AND THE CRAB OR TROLLEY

Each side of the cab is a $5\frac{1}{2}$ " x $1\frac{1}{2}$ " Flexible Plate strengthened at the front by a $1\frac{1}{2}$ " Strip and at the rear by a $3\frac{1}{2}$ " Strip. A built-up strip (12), made from two $2\frac{1}{2}$ " Strips, is attached to the top of the $3\frac{1}{2}$ " Strip and is connected to the side by a $2\frac{1}{2}$ " Stepped Curved Strip. The rear ends of the strips (12) are joined by a $2\frac{1}{2}$ " x $\frac{1}{2}$ " Double Angle Strip, and a $2\frac{1}{2}$ " x $1\frac{1}{2}$ " Flexible Plate is fixed to each side as shown.

The cab roof is formed by two $1\frac{1}{2}$ " radius Curved Plates and two curved $2\frac{1}{2}$ " x $2\frac{1}{2}$ " Flexible Plates edged by Formed Slotted Strips. The back of the cab consists of a Semi-Circular Plate at the top, a $2\frac{1}{2}$ " x $1\frac{1}{2}$ " Flexible Plate (13) and a $2\frac{1}{2}$ " x $2\frac{1}{2}$ " Flexible Plate (14) bolted to the Double Angle Strips at the rear end of the jib.

A Crank Handle (15) is mounted in the $5\frac{1}{2}$ " x $1\frac{1}{2}$ " Flexible Plates and in $2\frac{1}{2}$ " Strips (16) bolted to the Plates. The Crank Handle carries a 1" Pulley fitted with a $\frac{1}{2}$ " Bolt that can be engaged with a Bolt in the side of the cab to form a simple brake. A $3\frac{1}{2}$ " Rod (17) is mounted also in the sides of the cab, and it carries a handle made from a Bush Wheel fitted with a Threaded Pin. The bottom of the cab is filled in by a $5\frac{1}{2}$ " x $2\frac{1}{2}$ " Flexible Plate supported by a Trunnion fixed to the back of the cab, and by a $2\frac{1}{2}$ " x $\frac{1}{2}$ " Double Angle Strip (18).

The crab consists of two $2\frac{1}{2}$ " x $\frac{1}{2}$ " Double Angle Strips connected at their ends by a Fishplate. The 1" Pulleys forming the wheels are fixed on 2" Rods. A Fishplate is attached to each Double Angle Strip by a $\frac{1}{2}$ " Bolt, but is spaced from it by a Spring Clip and a $\frac{3}{8}$ " Washer on the Bolt. A 1" Rod held in the lower ends of the Fishplates is fitted with a 1" loose Pulley (19).

ARRANGEMENT OF THE CORDS

A length of Cord is tied to an Angle Bracket at one end of the crab, is wound two or three times round the Rod (17) and is taken round the Pulley (11). The Cord is then tied to an Angle Bracket at the other end of the crab.

A length of Cord is fastened to a Cord Anchoring Spring on the Crank Handle (15) and is taken round the Pulley (19) on the crab. It is then taken round a 1" loose Pulley in the pulley block, over the front axle of the crab and is tied to the front of the jib.

The pulley block consists of two Flat Trunnions, spaced apart by nuts on $\frac{1}{2}$ " Bolts. The 1" loose Pulley is free to turn on one of the Bolts, and a small Loaded Hook is supported by the other Bolt.

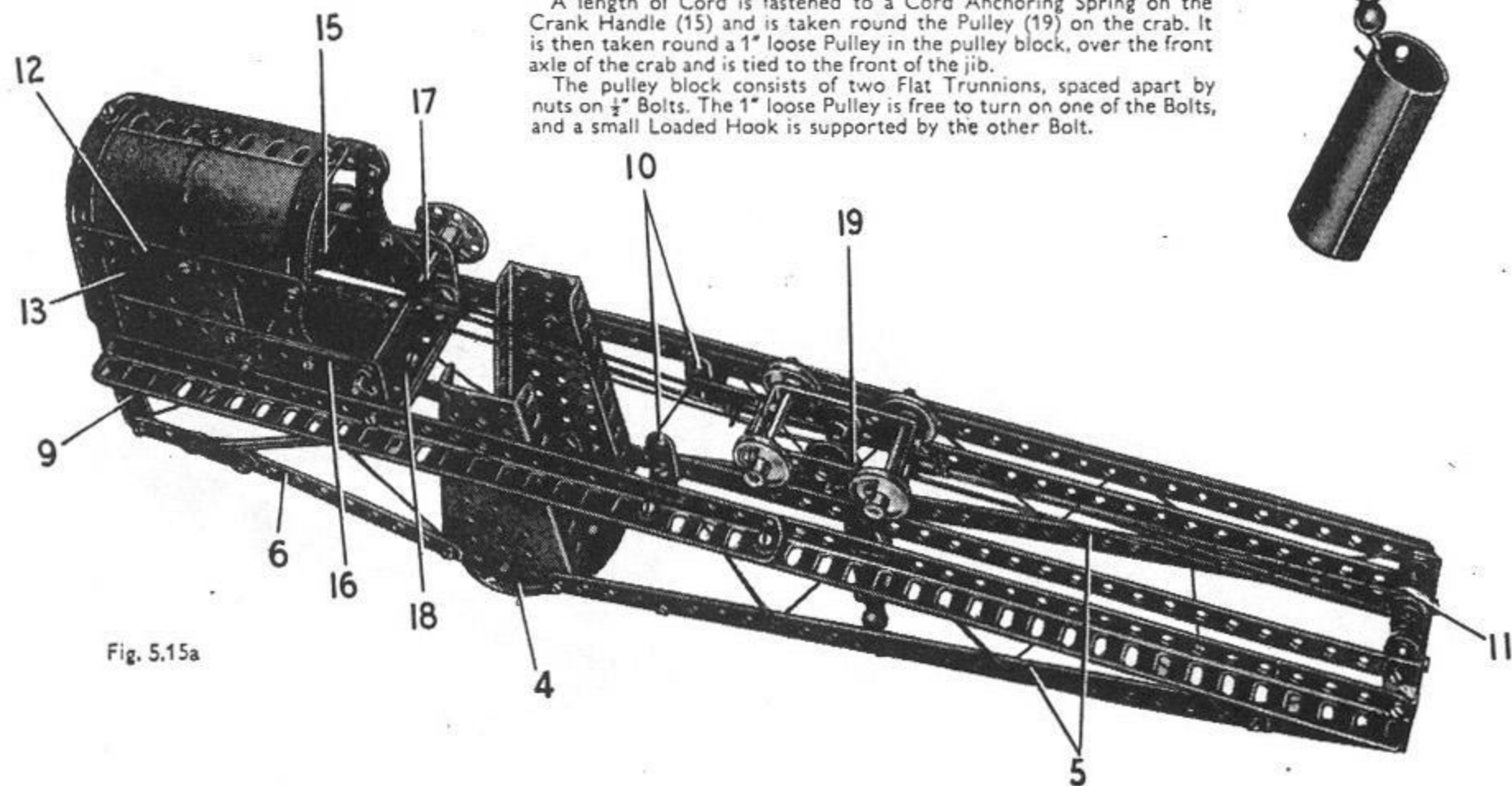

Fig. 5.15a

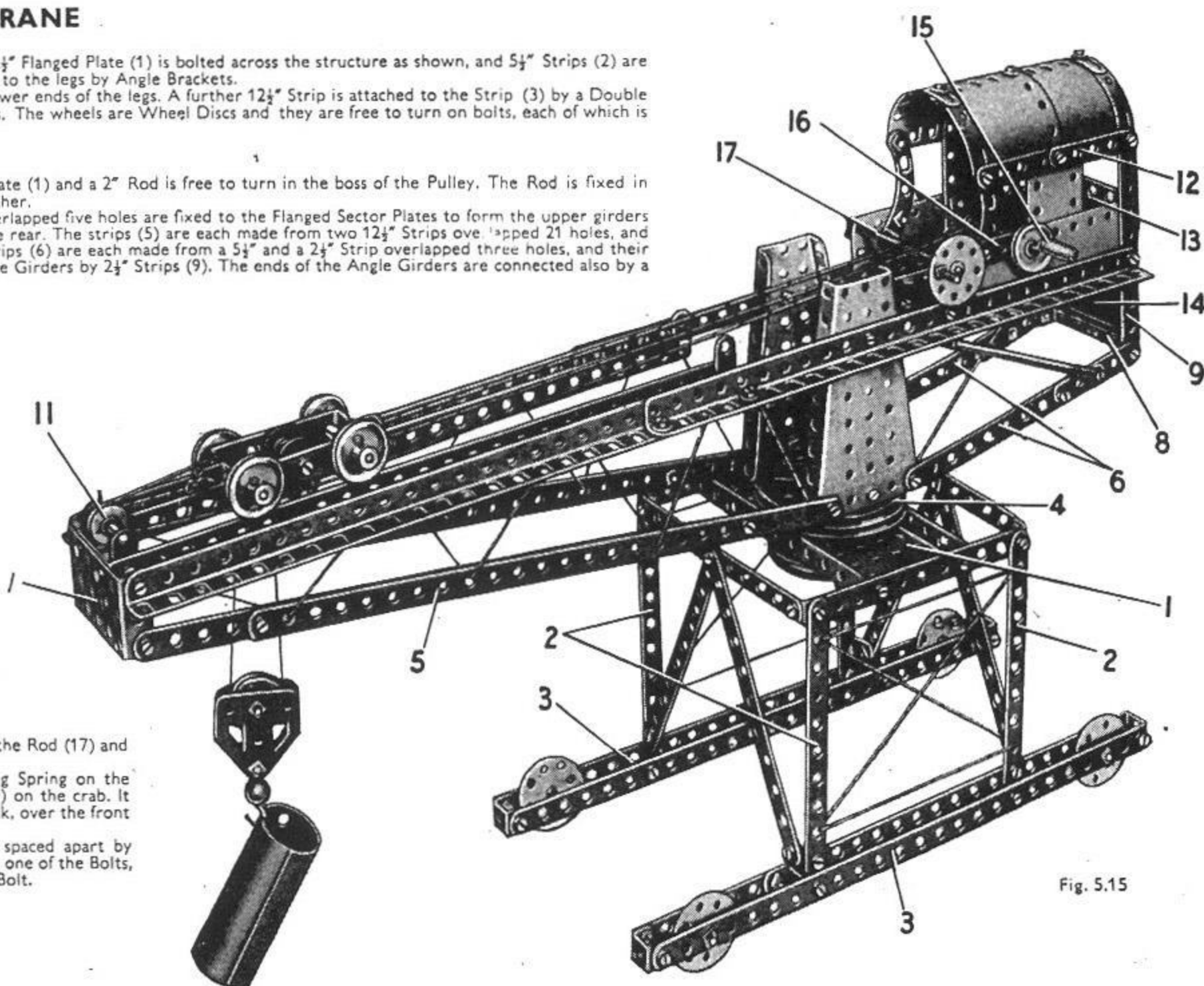

Fig. 5.15

Parts Required

10 of No. 1	1 of No. 16	2 of No. 24c	2 of No. 54	1 of No. 187
14 " " 2	2 " " 17	9 " " 35	1 " " 57c	3 " " 188
2 " " 3	2 " " 18a	118 " " 37a	2 " " 90a	2 " " 189
12 " " 5	1 " " 18b	107 " " 37b	2 " " 111a	3 " " 190
2 " " 6a	2 " " 19b	20 " " 38	6 " " 111c	1 " " 192
4 " " 8	1 " " 19g	2 " " 38d	1 " " 115	2 " " 200
6 " " 10	5 " " 22	1 " " 40	4 " " 125	2 " " 212
4 " " 11	2 " " 22a	1 " " 48	1 " " 126	2 " " 212a
12 " " 12	1 " " 23	8 " " 48a	2 " " 126a	1 " " 214
2 " " 12a	1 " " 24	1 " " 51	1 " " 147b	4 " " 215
2 " " 15b	2 " " 24a	1 " " 52	1 " " 176	

5.16 MILITARY TANK

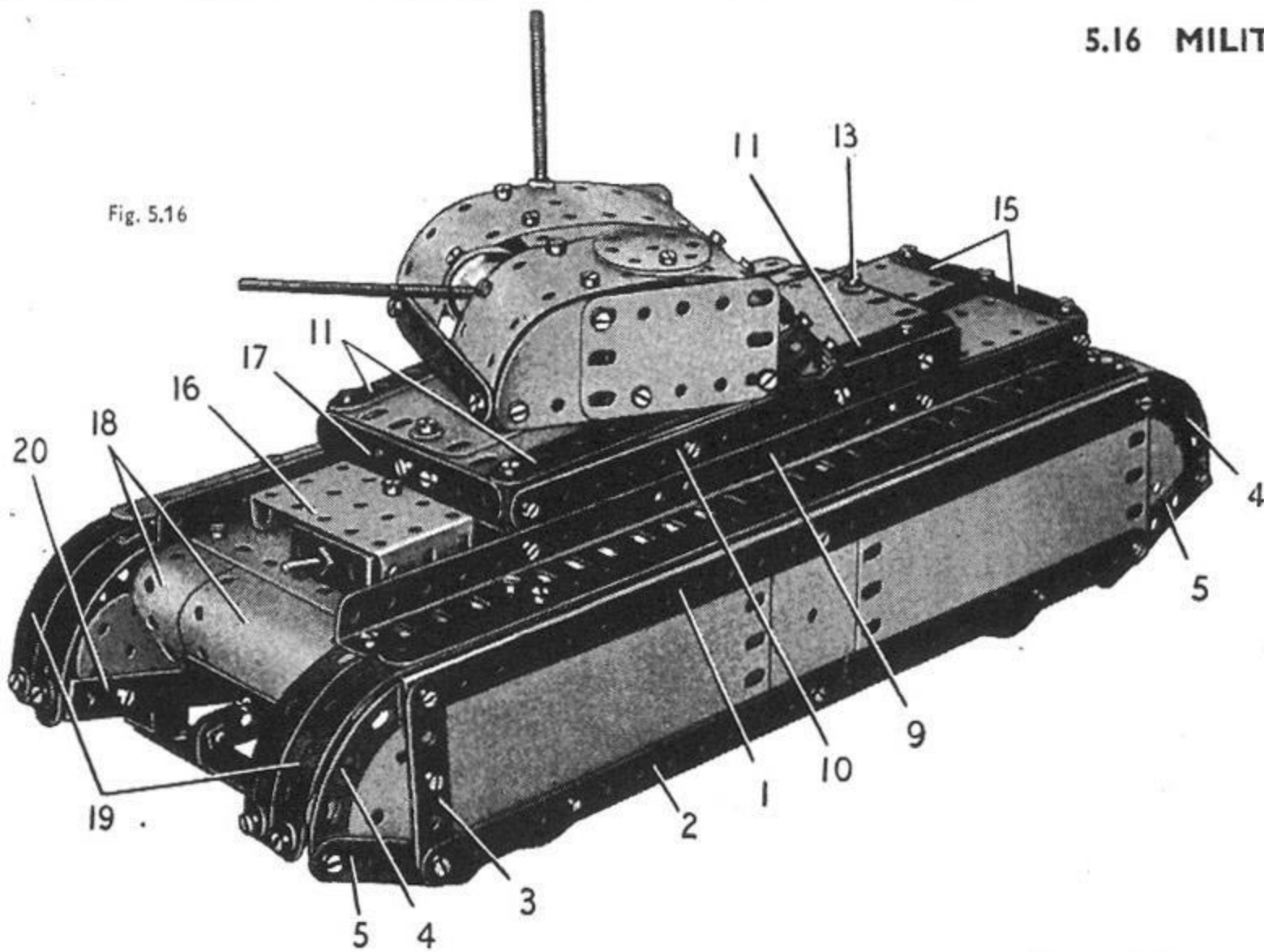

Fig. 5.16

Parts Required		
6 of No. 1	1 of No. 23	1 of No. 115
12 " " 2	1 " " 24	3 " " 125
2 " " 3	2 " " 24a	2 " " 126
12 " " 5	2 " " 24c	4 " " 142c
2 " " 6a	5 " " 35	1 " " 147b
4 " " 8	117 " " 37a	3 " " 188
8 " " 10	110 " " 37b	4 " " 189
4 " " 11	13 " " 38	3 " " 190
12 " " 12	1 " " 48	2 " " 191
2 " " 12a	8 " " 48a	4 " " 192
1 " " 12c	1 " " 51	1 " " 198
3 " " 16	1 " " 52	2 " " 199
2 " " 17	2 " " 80c	2 " " 214
1 " " 18a	4 " " 90a	4 " " 215
1 " " 19b	1 " " 111a	4 " " 221
5 " " 22	5 " " 111c	2 " " 222

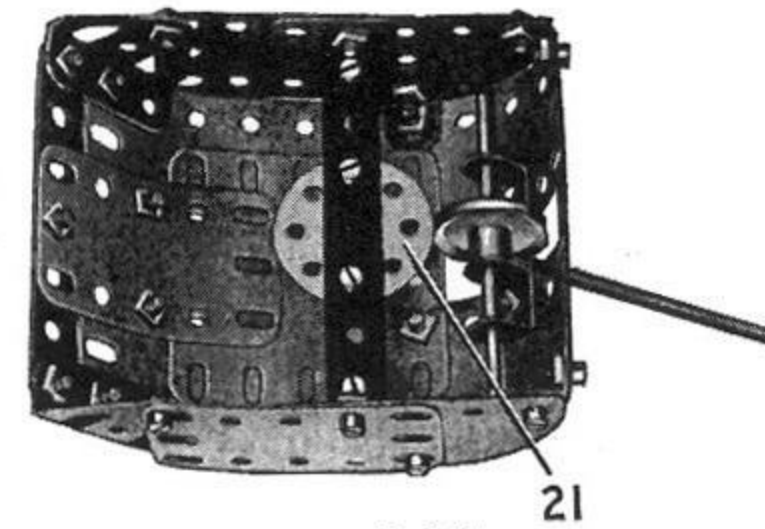

Fig. 5.16b

THE TANK BODY AND TRACK COVERS

Each side of the model tank seen in Fig. 5.16 is assembled on a framework formed by a $12\frac{1}{2}$ " Angle Girder (1), a $12\frac{1}{2}$ " Strip (2), a $2\frac{1}{2}$ " Strip (3), two $2\frac{1}{2}$ " Stepped Curved Strips (4) and two $2\frac{1}{2}$ " Strips (5), (see Figs. 5.16 and 5.16a). One side is filled in by two $5\frac{1}{2}$ " x $2\frac{1}{2}$ " Flexible Plates, one half of a Hinged Flat Plate and two $2\frac{1}{2}$ " x $1\frac{1}{2}$ " Triangular Flexible Plates. The other side is similar, but two $2\frac{1}{2}$ " x 2 " Triangular Flexible Plates are used in place of the half of a Hinged Flat Plate. The sides are joined together by a $5\frac{1}{2}$ " x $2\frac{1}{2}$ " Flanged Plate (6) and a $5\frac{1}{2}$ " Strip (7) bolted to Double Brackets. Two $12\frac{1}{2}$ " Strips are bolted to $2\frac{1}{2}$ " x $\frac{1}{2}$ " Double Angle Strips fixed to the Strip (7) and the Flanged Plate (6).

A $5\frac{1}{2}$ " Strip (8) is bolted across the Girders (1), and two $12\frac{1}{2}$ " Angle Girders (9) are bolted to this Strip and to the Flanged Plate (6). The other half of the Hinged Flat Plate is fixed to one end of the Girders (9). A $5\frac{1}{2}$ " Strip (10), extended by a $2\frac{1}{2}$ " x $\frac{1}{2}$ " Double Angle Strip, is attached by Fishplates to each of the Girders (9). Two $5\frac{1}{2}$ " Strips (11), overlapped seven holes, are connected by Angle Brackets to the Strips (10) on each side, and the space between the Strips (11) is filled by two $4\frac{1}{2}$ " x $2\frac{1}{2}$ " and two $2\frac{1}{2}$ " x $2\frac{1}{2}$ " Flexible Plates. A gap is left between the two pairs of Plates as shown in

Fig. 5.16a, and the boss of a 3" Pulley (12) is accommodated in the gap. The Pulley is bolted to the Plates and is connected to the Strips (10) by 1" x 1" Angle Brackets. A $2\frac{1}{2}$ " x $\frac{1}{2}$ " Double Angle Strip is connected to an Obtuse Angle Bracket held by a Bolt (13).

The rear end of the tank body is filled by two $5\frac{1}{2}$ " x $1\frac{1}{2}$ " Flexible Plates and a $2\frac{1}{2}$ " x $\frac{1}{2}$ " Double Angle Strip (14) connected to the Plates by a $1\frac{1}{2}$ " Strip. The assembly is edged by two $2\frac{1}{2}$ " Strips (15) and is attached to the Girders (9) by Angle Brackets.

A $2\frac{1}{2}$ " x $1\frac{1}{2}$ " Flanged Plate (16) is attached by a $\frac{1}{2}$ " Reversed Angle Bracket to the $2\frac{1}{2}$ " x $2\frac{1}{2}$ " Flexible Plates forming the top of the body. The Reversed Angle Bracket supports also a $2\frac{1}{2}$ " Strip (17) extended by a $1\frac{1}{2}$ " Strip, and further $\frac{1}{2}$ " Reversed Angle Brackets bolted to the Girders (9) fill in the gaps between the Flanged Plate (16) and the Girders. Two 'U'-section Curved Plates (18) are fixed to the front edge of the half of the Hinged Flat Plate between the Girders (9).

The rounded ends of the track covers are each made from a curved $5\frac{1}{2}$ " Strip (19) and a Formed Slotted Strip, which are connected at their outer ends by a Fishplate. A $12\frac{1}{2}$ " Strip is bolted along the top of each of the Girders (1) to cover the ends of the $5\frac{1}{2}$ " Strips (19). At one end the inner sides of the track covers are filled in by $2\frac{1}{2}$ " x $\frac{1}{2}$ " Double Angle Strips (20) and Six-Hole Wheel Discs.

THE GUN TURRET

Each side of the gun turret (Fig. 5.16b) is made from a Semi-Circular Plate, a $2\frac{1}{2}$ " x $1\frac{1}{2}$ " Flexible Plate and a Trunnion. The sides are connected at each end by a $3\frac{1}{2}$ " Strip, and the top is formed by two $5\frac{1}{2}$ " x $1\frac{1}{2}$ " Flexible Plates, a $2\frac{1}{2}$ " x $1\frac{1}{2}$ " Flexible Plate and a $2\frac{1}{2}$ " x $2\frac{1}{2}$ " Flexible Plate. The top is bolted to the Trunnions and to Angle Brackets fixed to the sides. A Bush Wheel (21) is fixed to two $2\frac{1}{2}$ " Strips attached to the sides by Angle Brackets. The gun is a Screwed Rod held in the threaded hole of a 1" Pulley. The Pulley is fixed on a $3\frac{1}{2}$ " Rod supported in two Double Brackets as shown. The radio mast is a Screwed Rod held by two nuts, and the turret door is represented by two Wheel Discs. A $1\frac{1}{2}$ " Rod gripped in the Bush Wheel (21) is passed through the Pulley (12) and is held in place by a Spring Clip. The turret is spaced from the tank body by a $\frac{1}{2}$ " loose Pulley and six Washers.

The tank runs on four 1" Pulleys fitted with Motor Tyres, which are mounted as shown in Fig. 5.16a.

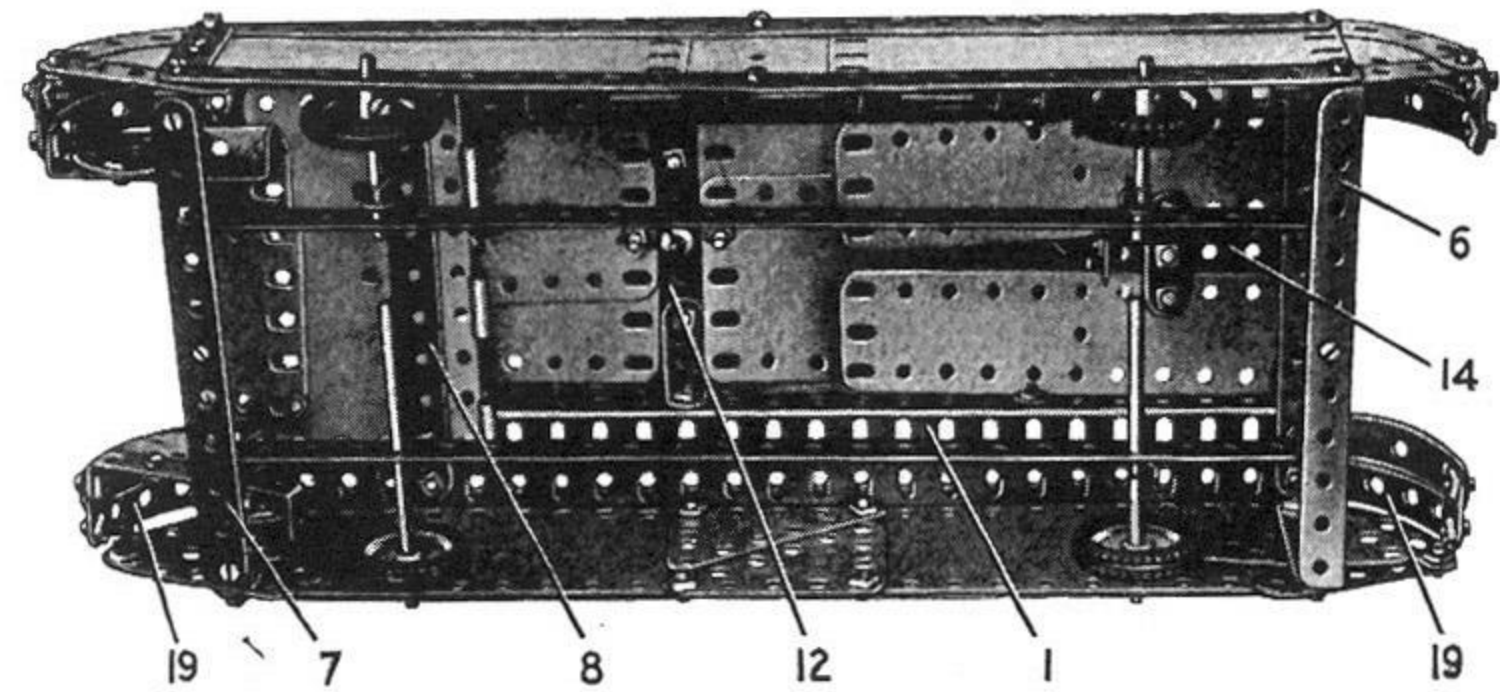

Fig. 5.16a

5.17 RAILWAY BREAKDOWN CRANE

DETAILS OF THE CRANE TRUCK AND BOGIES

The crane truck is shown separately in Fig. 5.17b. It is made by bolting two 12½" Angle Girders (1) to the flanges of a 5½" x 2½" Flanged Plate (2). The Girders (1) are connected also by two 2½" x ½" Double Angle Strips (3) and (4), and a 2½" x 1½" Flanged Plate (5) is fixed between the flanges of the Flanged Plate (2). A 3" Pulley (6) is bolted to a Semi-Circular Plate fixed to each of the Girders (1). The top of the crane truck is filled in by a 5½" x 2½" and a 2½" x 2½" Flexible Plate. These are attached to 5½" x 1½" and 2½" x 1½" Flexible Plates bolted between the Angle Girders (1) and a 12½" Strip (7) on each side.

A 5½" x 1½" Flexible Plate edged by a 5½" Strip is attached to each of the Girders (1) at one end of the truck, and the Flexible Plates are connected by a 2½" x ½" Double Angle Strip. Two Wheel Discs are lock-nutted on ½" Bolts attached to the Flexible Plates, and two 1" Pulleys with Rubber Rings are fixed on a 3½" Rod supported in the Flexible Plates. A 2½" x 1½" Flexible Plate and a 3½" Strip (8) are bolted to the end flange of the Flanged Plate (2).

The bogie unit consists of two 5½" Strips connected by three 2½" x ½" Double Angle Strips. It is pivoted on a Pivot Bolt passed through the centre Double Angle Strip, and held by a Spring Clip in a Double Bent Strip bolted to the Double Angle Strip (3).

The wheels are Wheel Discs free to turn on ½" Bolts, and 1" Pulleys fixed on a 3½" Rod. Each ½" Bolt is passed through a Wheel Disc and is fitted with a nut. A Spring Clip is slipped over the Bolt and it is then passed through the 5½" Strip and a second nut is tightened in place. A 2½" x 1½" Flexible Plate and a 3½" Strip are attached to the Double Angle Strip (4) by an Angle Bracket.

THE CAB

The cab is made by bolting a 5½" Strip (9) at each side to a Trunnion fixed to a 3" Pulley (10). A 2" Rod held in the boss of Pulley (10) is passed through the Pulley (6) and is held in position by a Rod and Strip Connector. The Strips (9) are extended by further 5½" Strips that overlap the Strips (9) by three holes, and each side of the cab is one half of a Hinged Flat Plate bolted to the 5½" Strips. The lower part of the rear of the cab consists of a 5½" x 2½" Flexible Plate curved and edged by two Formed Slotted Strips. A built-up strip, made from two 2½" Strips overlapped three holes, is fixed to Angle Brackets held by a Bolt (11) at each side, and two 4½" x 2½" Flexible Plates overlapped three holes are bolted between the built-up strip and the 3" Pulley (10). Two Flanged Sector Plates (12) connected together by their flanges are attached to the 4½" x 2½" Flexible Plates inside the cab.

Each side of the cab is extended upward by a 2½" x 2½" Flexible Plate and a 2½" Strip, and the top edge of the Flexible Plate is fitted with a 5½" Strip (13) that is connected to the lower part of the side by a 2½" Stepped Curved Strip. The cab roof consists of two 5½" x 2½" Flexible Plates and two 1½" radius Curved Plates bolted to the Strips (13). The top half of the rear of the cab is partly filled by a 2½" x 2½" Flexible Plate and two 2½" x 1½" Triangular Flexible Plates. These are curved to shape and are attached to two Formed Slotted Strips held by a Bolt (14) on each side.

THE JIB

The lower members of the jib are 12½" Strips extended four holes by 12½" Angle Girders (15). The upper members are 12½" Strips (16), connected to the lower members by 2½" x 1½" Triangular Flexible Plates, and joined together by a 2½" x ½" Double Angle Strip (17) and a 1½" x ½" Double Angle Strip (18). The Strips (16) are extended by 2½" Stepped Curved Strips, and these are joined to 2½" x 2" Triangular Flexible Plates bolted to the Angle Girders (15). The jib pivots on a 4" Rod held by Spring Clips in the end holes of the Strips (9).

Fig. 5.17

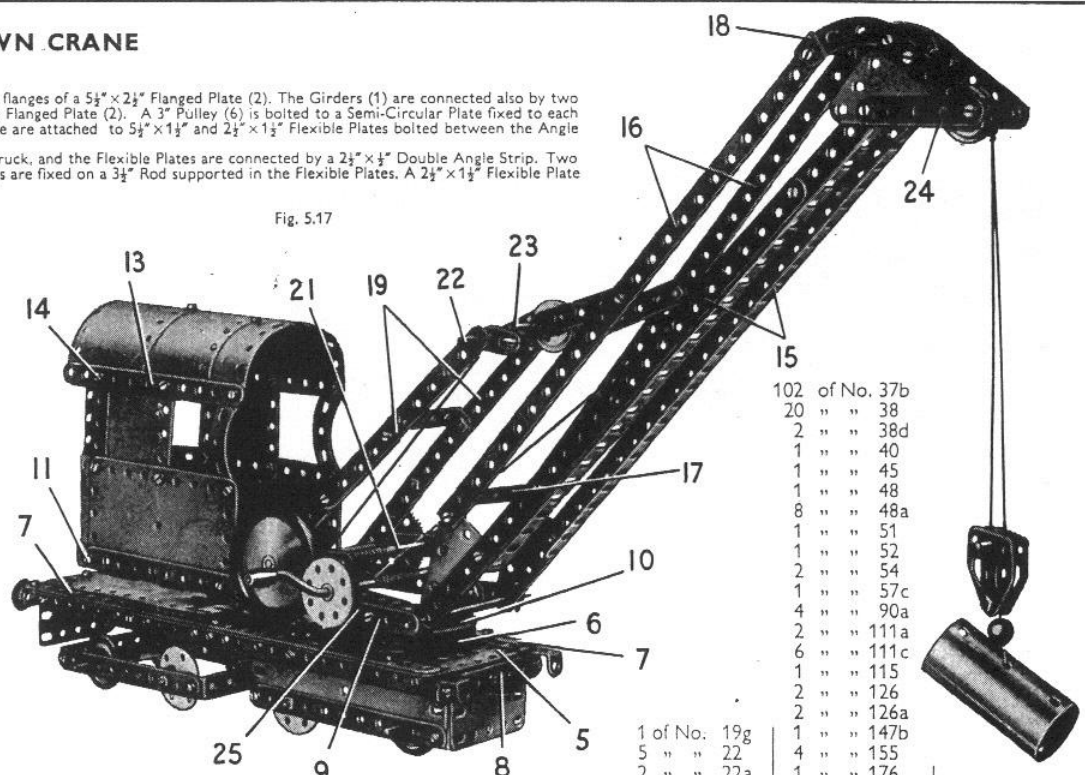

102	of No. 37b
20	" " 38
2	" " 38d
1	" " 40
1	" " 45
1	" " 48
8	" " 48a
1	" " 51
1	" " 52
2	" " 54
1	" " 57c
4	" " 90a
2	" " 111a
6	" " 111c
1	" " 115
2	" " 126
2	" " 126a
1	" " 147b
5	of No. 19g
2	" " 22
1	" " 22a
1	" " 23
1	" " 24
2	" " 24a
2	" " 24c
1	" " 26
1	" " 27a
14	" " 35
117	" " 37a
1	" " 155
4	" " 176
1	" " 187
4	" " 188
4	" " 189
3	" " 190
2	" " 214
4	" " 215
1	" " 216
4	" " 221
1	" " 199
2	" " 222

Parts Required

6	of No. 1	2	of No. 15b
14	" " 2	4	" " 16
2	" " 3	2	" " 17
12	" " 5	1	" " 18a
2	" " 6a	1	" " 18b
4	" " 8	2	" " 19b
5	" " 10		
2	" " 11		
7	" " 12		
1	" " 15a		

THE OPERATING MECHANISM

Two 5½" Strips (19) overlapped five holes are attached to the Strips (9) at each side, and a 2½" Strip (20) bolted to each Strip (19) is connected to Strip (9) by a 1½" Strip. The Strips (19) are joined by a 2½" x ½" Double Angle Strip.

A 57-tooth Gear fitted with a Threaded Pin is fixed on a 4½" Rod supported in the Strips (20), and it drives a ½" Pinion on a 4" Rod (21) also mounted in the Strips (20). A length of Cord is tied to a Cord Anchoring Spring on Rod (21), and is taken over a 3½" Rod (22) passed through the end holes of Strips (19). The Cord is taken round a 1" loose Pulley on a 3½" Rod (23), round Rod (22) and a second 1" loose Pulley on Rod (23), and is tied finally to a Fishplate on Rod (22). Rod (23) is held by Spring Clips in 2½" Strips lock-nutted to the jib.

A Crank Handle extended by a 1½" Rod joined by a Rod Connector is supported in the 1½" Strips as shown in Fig. 5.17a. A length of Cord tied to the Crank Handle is taken over a 1" Pulley on a 2" Rod (24), and is passed round a ½" Pulley in the pulley block. The Cord is then tied to an Angle Bracket bolted to the top of the jib. A Bush Wheel is fixed on the Crank Handle, and its set screw engages an Angle Bracket (25) to act as a simple brake when the Crank Handle is pushed in.

The pulley block consists of two Flat Trunnions joined by a ½" Bolt, and the ½" Pulley is mounted on a 1" Rod.

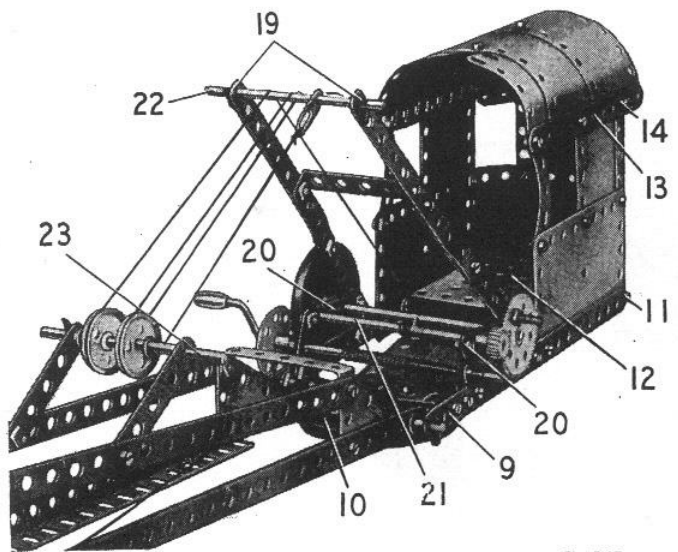

Fig. 5.17a

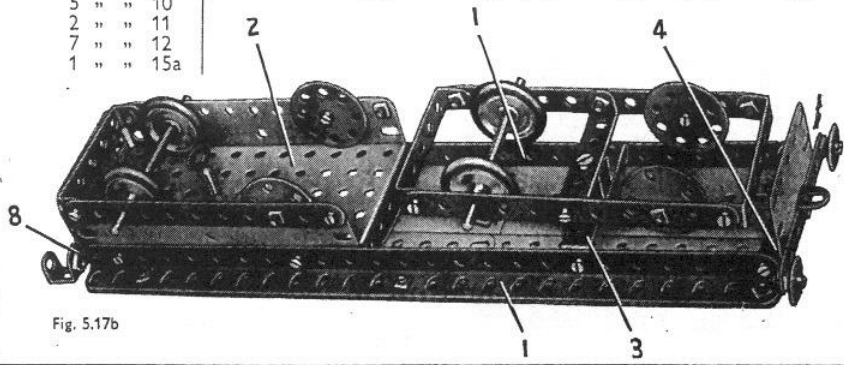

Fig. 5.17b

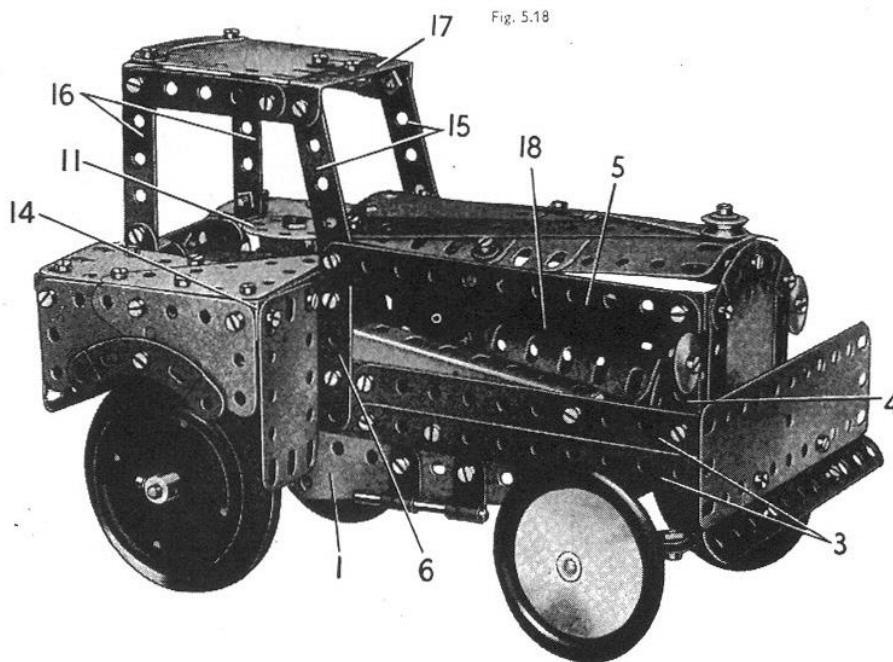

Fig. 5.18

5.18 SHUNTING TRACTOR

ASSEMBLY OF THE CHASSIS

Each side of the model is made by bolting a Flanged Sector Plate (1) to the edges of a $5\frac{1}{2}'' \times 2\frac{1}{2}''$ Flanged Plate (2). Two built-up strips (3), each made from two $5\frac{1}{2}''$ Strips overlapped three holes, are bolted to the side so that they overhang the Flanged Sector Plate at the front by four clear holes. The front ends of these Strips are connected together by Fishplates, and they are joined across by two $2\frac{1}{2}'' \times \frac{1}{2}''$ Double Angle Strips, and a $5\frac{1}{2}'' \times 1\frac{1}{2}''$ Flexible Plate is bolted in position. A $5\frac{1}{2}''$ Strip is attached to the lower Double Angle Strip by Obtuse Angle Brackets.

The radiator consists of a $2\frac{1}{2}'' \times 2\frac{1}{2}''$ Flexible Plate edged by two $2\frac{1}{2}''$ Strips and a $2\frac{1}{2}''$ Stepped Curved Strip. It is attached to Angle Brackets bolted to the strips (3), and a $2\frac{1}{2}''$ Strip (4) is fitted at each side. The upper ends of the Strips (4) are connected to a $2\frac{1}{2}'' \times \frac{1}{2}''$ Double Angle Strip fixed to the back of the radiator, and a $5\frac{1}{2}''$ Strip (5) on each side is held by the same bolt as the Strip (4). The Strips (5) are connected at their rear ends to the Flanged Sector Plates by $2\frac{1}{2}''$ Strips (6).

The top of the bonnet consists of two $1\frac{1}{2}''$ radius Curved Plates and a curved $2\frac{1}{2}'' \times 2\frac{1}{2}''$ Flexible Plate bolted together as shown, and strengthened by two $5\frac{1}{2}''$ Strips. The $5\frac{1}{2}''$ Strips are joined together at the front by a $\frac{1}{2}''$ Bolt, and a $\frac{1}{2}''$ loose Pulley and a Washer on the Bolt represent the radiator filler cap. The top of the bonnet is attached to the radiator by an Angle Bracket, and is connected to the Strips (6) by Obtuse Angle Brackets.

The rear wheels are fixed on a $3\frac{1}{2}''$ and a 2" Rod joined by a Rod Connector and supported in Flat Trunnions bolted to the sides of the Flanged Plate (2).

THE STEERING MECHANISM

The front axle beam is a $3\frac{1}{2}''$ Strip (7) attached to Fishplates bolted to the flanges of the Flanged Sector Plates. Each of the front wheels is fixed on a $1\frac{1}{2}''$ Rod supported in a Double Bracket. A $\frac{1}{2}''$ Bolt is passed through a $1\frac{1}{2}''$ Strip (8) and one of the Double Brackets and is fitted with three Washers. A nut is screwed loosely on the Bolt, which is then passed through an end hole of the Strip (7) and a second nut is screwed tightly in position. This arrangement leaves the Double Bracket and the Strip free to swivel as a unit on the Bolt. A similar system is used at the other side but the $1\frac{1}{2}''$ Strip is replaced by a $2\frac{1}{2}''$ Strip (9). A $3\frac{1}{2}''$ Strip (10) is lock-nutted to the ends of the Strips (8) and (9).

The steering column is a 3" Screwed Rod supported in the Flanged Plate (2) and in a Double Bent Strip bolted to it. The Screwed Rod is held in position by two 1" Pulleys, and a Wheel Disc (11) is attached tightly to its upper end by two nuts. A Fishplate is bolted to a Bush Wheel (12) fixed to the lower end of the Screwed Rod and a $5\frac{1}{2}''$ Strip is used to connect the Fishplate to a $2\frac{1}{2}''$ Strip bolted to the Strip (9). The $5\frac{1}{2}''$ Strip is lock-nutted to the $2\frac{1}{2}''$ Strip, and is connected to the Fishplate by a Threaded Pin. A Spring Clip on the Threaded Pin keeps the parts in position.

CONSTRUCTION OF THE CAB

The back of the cab is a $5\frac{1}{2}'' \times 1\frac{1}{2}''$ Flexible Plate (13) bolted to the end of the Flanged Plate (2). The top of each of the wheel guards consists of a $2\frac{1}{2}'' \times 1\frac{1}{2}''$ Flexible Plate and a $2\frac{1}{2}'' \times 2''$ Triangular Flexible Plate bolted together. It is attached by an Angle Bracket to a Semi-Circular Plate bolted to the upper strip (3) on each side, and is connected by a Trunnion to the Flexible Plate (13). The front of the wheel guard is a $2\frac{1}{2}'' \times 1\frac{1}{2}''$ Flexible Plate bolted to a $2\frac{1}{2}'' \times \frac{1}{2}''$ Double Angle Strip (14). The Double Angle Strip is connected by Angle Brackets to the Strip (6) and to the top of the wheel guard. The side of the wheel guard is made from two $2\frac{1}{2}'' \times 1\frac{1}{2}''$ Triangular Flexible Plates arranged as shown and attached to an Angle Bracket and to the lug of the Double Angle Strip (14). A $2\frac{1}{2}''$ Stepped Curved Strip is clamped to the Triangular Flexible Plates by a Washer and a nut on a bolt.

(Continued on next page)

Parts Required				
14 of No.	2	8 of No.	48a	
2	"	1	"	51
12	"	1	"	52
2	"	2	"	54
8	"	1	"	80c
3	"	4	"	90a
12	"	1	"	111a
2	"	4	"	111c
4	"	1	"	115
1	"	4	"	125
2	"	2	"	126
3	"	2	"	126a
2	"	1	"	147b
4	"	2	"	155
1	"	4	"	187
1	"	4	"	188
1	"	3	"	189
2	"	3	"	190
1	"	1	"	199
5	"	2	"	200
116	"	1	"	212
106	"	2	"	212a
20	"	1	"	213
2	"	2	"	214
1	"	4	"	221
1	"	2	"	222
1	"			48

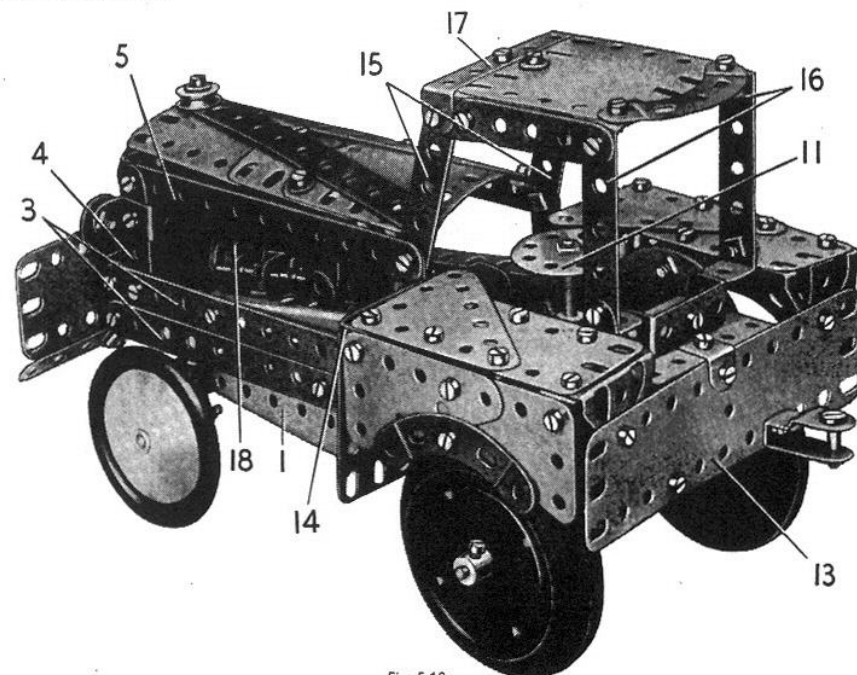

Fig. 5.18a

MODEL 5.18 SHUNTING TRACTOR — Continued

The driver's seat is a $2\frac{1}{2}'' \times 1\frac{1}{2}''$ Flanged Plate bolted to a $\frac{1}{2}''$ Reversed Angle Bracket fixed to the Flexible Plate (13). The back of the seat is a $1\frac{1}{2}'' \times \frac{1}{2}''$ Double Angle Strip and this also is attached to the Reversed Angle Bracket.

The cab roof is supported by two $2\frac{1}{2}''$ Strips (15), and two $2\frac{1}{2}'' \times \frac{1}{2}''$ Double Angle Strips (16) attached to the wheel guards by Angle Brackets. The Strips (15) are connected by a $2\frac{1}{2}'' \times \frac{1}{2}''$ Double Angle Strip (17), and they are joined to the Double Angle Strips (16) by $2\frac{1}{2}''$ Strips extended by Fishplates. The cab roof is a $2\frac{1}{2}'' \times 2\frac{1}{2}''$ Flexible Plate bolted to the lugs of the Double Angle Strips (16) and connected to the Double Angle Strip (17) by a Wheel Disc.

An engine unit is represented by a 'U'-section Curved Plate (18), which is fitted at the front with a 1" loose Pulley bolted to an Angle Bracket. The unit is connected to one of the Flanged Sector Plates by a $\frac{1}{2}''$ Reversed Angle Bracket.

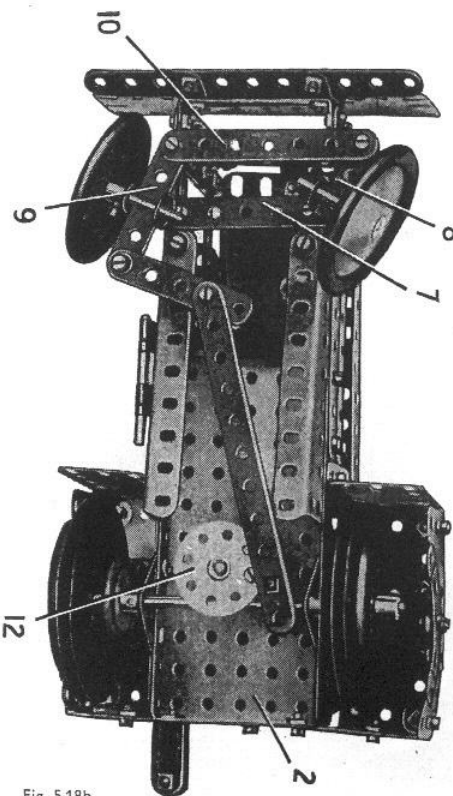

Fig. 5.18b

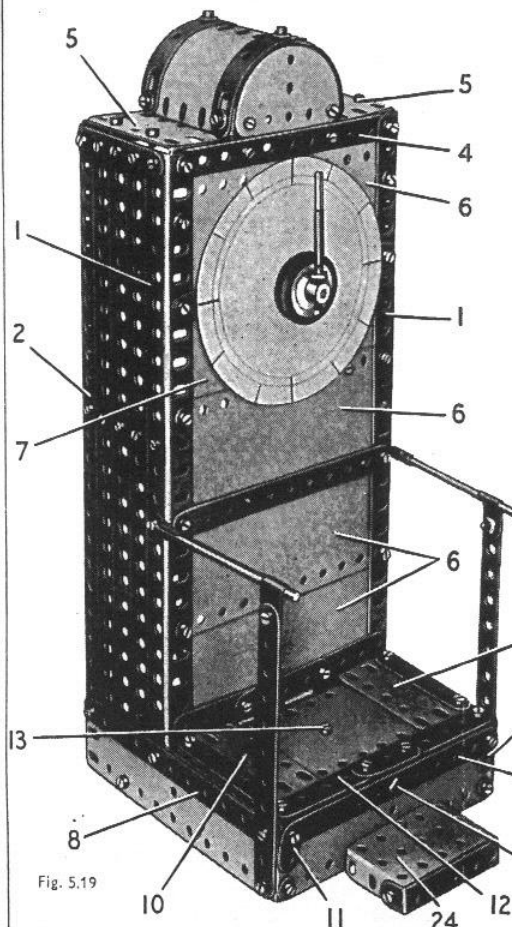

Fig. 5.19

The weighing platform is one half of a Hinged Flat Plate fixed by a Bolt (13) to a Double Bracket bolted to two $5\frac{1}{2}''$ Strips (14). These Strips form the operating lever, which pivots on a $1\frac{1}{2}''$ Rod held by Spring Clips in a Double Bracket (15). The Double Bracket is attached to the front of the base by a Bolt (16).

THE OPERATING MECHANISM

The Strips (14) are joined at their ends by a Double Bracket, and an Angle Bracket (17) is bolted also to the end of one of the Strips. A $5\frac{1}{2}''$ Strip (18) is lock-nutted to the Angle Bracket, and to one of two $3\frac{1}{2}''$ Strips (19) joined together by a $1\frac{1}{2}'' \times \frac{1}{2}''$ Double Angle Strip. The Strips (19) pivot on a $3\frac{1}{2}''$ Rod mounted in the front of the column and in a $5\frac{1}{2}''$ Strip (20). One of the Strips (19) is bolted to a 3" Pulley fixed on the $3\frac{1}{2}''$ Rod. The Strips (19) are weighted at one end by two Road Wheels on a 2" Rod.

A length of Cord is tied at one end to a 6" Driving Band and is passed round the 3" Pulley and one of two 1" Pulleys on a $3\frac{1}{2}''$ Rod (21). The Cord is then tied again to the Driving Band so that it is stretched slightly to make a tensioned driving belt. Rod (21) is mounted in the front of the column and in a $5\frac{1}{2}''$ Strip (22), and a 57-tooth Gear is fixed on the Rod. This Gear drives a 1" Pinion on the 4" Rod (23), which carries the pointer. Rod (23) is supported in the front of the column and in Strip (22). The pointer is a 1" Rod connected by a Rod Connector to a Threaded Pin that is screwed into the boss of a 1" Pulley. A second 1" Pulley is used to space the pointer from the front of the column. The dial is drawn on a sheet of cardboard and is passed over Rod (23).

The handrails are made from $5\frac{1}{2}''$ Strips, $3\frac{1}{2}''$ Rods, Rod and Strip Connectors and Right-Angle Rod and Strip Connectors arranged as shown. The step (24) is attached to the base by a $\frac{1}{2}''$ Reversed Angle Bracket.

5.19 PLATFORM WEIGHING MACHINE

CONSTRUCTION OF THE BODY

Each side of the column or body of the machine consists of two $12\frac{1}{2}''$ Angle Girders (1) and (2) and three $12\frac{1}{2}''$ Strips bolted to a $5\frac{1}{2}'' \times 2\frac{1}{2}''$ Flanged Plate (3). The upper ends of the Strips and Angle Girders on each side are bolted to a $2\frac{1}{2}''$ Strip, and the Angle Girders are connected to those of the opposite side by $5\frac{1}{2}''$ Strips (4).

The top of the column is formed by attaching a Semi-Circular Plate to Fishplates bolted to each of the Strips (4). Two $2\frac{1}{2}'' \times \frac{1}{2}''$ Double Angle Strips are bolted between the lower corners of the Semi-Circular Plates, and a $1\frac{1}{2}''$ radius Curved Plate edged by Formed Slotted Strips is fixed to each Double Angle Strip. A $2\frac{1}{2}'' \times 1\frac{1}{2}''$ Flexible Plate (5) is attached to a $2\frac{1}{2}'' \times \frac{1}{2}''$ Double Angle Strip bolted between the Girders (1) and (2) of each side.

The front of the column is filled by four $5\frac{1}{2}'' \times 2\frac{1}{2}''$ Flexible Plates (6), and a built-up plate (7) made from a $4\frac{1}{2}'' \times 2\frac{1}{2}''$ and a $2\frac{1}{2}'' \times 2\frac{1}{2}''$ Flexible Plate overlapped three holes.

THE BASE AND WEIGHING PLATFORM

A $5\frac{1}{2}'' \times 1\frac{1}{2}''$ Flexible Plate strengthened by a $5\frac{1}{2}''$ Strip (8) is bolted to each side of the main column, and the front edges of these parts are connected by Angle Brackets to a further $5\frac{1}{2}'' \times 1\frac{1}{2}''$ Flexible Plate fitted with a $5\frac{1}{2}''$ Strip (9). Two $2\frac{1}{2}'' \times 1\frac{1}{2}''$ Flexible Plates (10) are bolted to $2\frac{1}{2}'' \times \frac{1}{2}''$ Double Angle Strips attached by their lugs to the Angle Girders (1), and they are connected to the ends of the Strip (9) by $1'' \times 1''$ Angle Brackets seen at (11). The Plates (10) are edged by $2\frac{1}{2}''$ Strips. A built-up strip (12), made from a $1\frac{1}{2}''$ and two $2\frac{1}{2}''$ Strips, is bolted to the Angle Brackets (11).

Parts Required

6 of No. 1	1 of No. 40
14 " " 2	1 " " 48
2 " " 3	7 " " 48a
11 " " 5	1 " " 51
1 " " 6a	1 " " 52
4 " " 8	1 " " 111c
1 " " 10	1 " " 115
3 " " 11	1 " " 125
3 " " 12	2 " " 155
2 " " 12a	1 " " 186a
1 " " 15b	2 " " 187
4 " " 16	4 " " 188
1 " " 17	3 " " 189
1 " " 18a	1 " " 190
1 " " 18b	1 " " 191
1 " " 19b	4 " " 192
4 " " 22	1 " " 198
1 " " 26	2 " " 200
1 " " 27a	2 " " 212
6 " " 35	2 " " 212a
103 " " 37a	1 " " 213
101 " " 37b	2 " " 214
20 " " 38	4 " " 215
1 " " 38d	

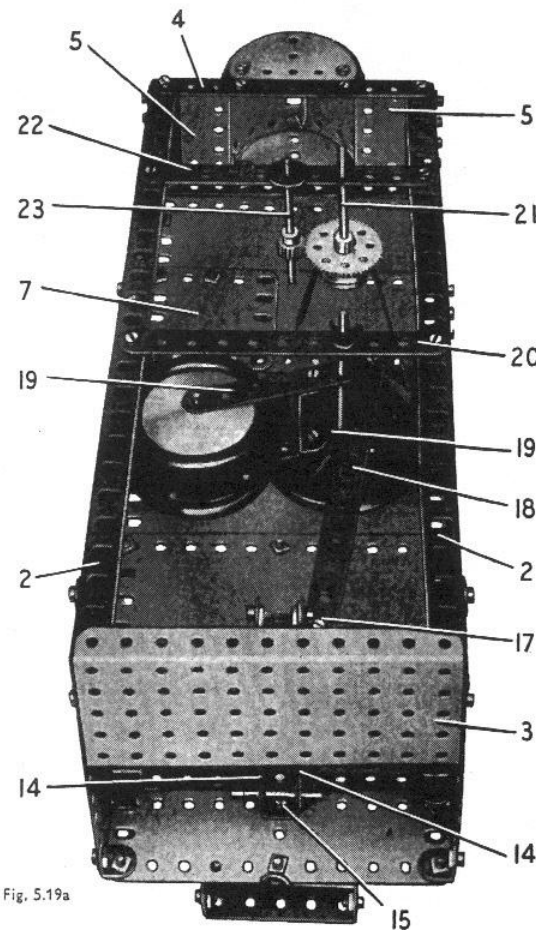

Fig. 5.19a

5.20 RACING SEAPLANE

THE FUSELAGE

Each side of the fuselage is formed by a $12\frac{1}{2}$ " Strip (1) and two $5\frac{1}{2}$ " Strips (2). The Strips are connected by a $2\frac{1}{2}$ " \times $1\frac{1}{4}$ " Triangular Flexible Plate at the nose, and by a $5\frac{1}{2}$ " \times $1\frac{1}{4}$ " Flexible Plate at the tail. At the centre two $5\frac{1}{2}$ " \times $2\frac{1}{4}$ " Flexible Plates (3) are bent as shown and fixed to the Strips (1) and (2) of each side. The nose is completed by two $2\frac{1}{2}$ " \times $1\frac{1}{4}$ " Flexible Plates (4) overlapped three holes and fixed to the front ends of the Strips (1), and by a Flat Trunnion (5) on each side attached by a Fishplate.

The fuselage sides are joined at the tail by a Double Bracket, and at the nose they are connected by a Bush Wheel (6) attached to Angle Brackets. Two 'U'-section Curved Plates (7) are bolted together and fixed to the rear ends of the sides, and at the front the Plates (7) are connected to one of the Plates (3) by a $2\frac{1}{2}$ " Strip at each side.

Two $2\frac{1}{2}$ " \times $\frac{1}{2}$ " Double Angle Strips (8) on each side are fixed to a $\frac{1}{2}$ " Reversed Angle Bracket, and the latter is bolted to the Bush Wheel (6). The propeller is made by bolting three $2\frac{1}{2}$ " Strips radially to a Six-Hole Wheel Disc, and this is free to turn on a $1\frac{1}{4}$ " Rod supported in the boss of the Bush Wheel. The Rod is held in position by a Spring Clip and a 1" Pulley fitted with a Rubber Ring.

CONSTRUCTION OF THE TAIL PLANE

A $2\frac{1}{2}$ " \times $1\frac{1}{2}$ " Flexible Plate (9) on each side is edged at the rear by a $2\frac{1}{2}$ " Strip, and is extended forward by a $2\frac{1}{2}$ " \times $1\frac{1}{4}$ " Triangular Flexible Plate. The two units are fixed to $1" \times 1"$ Angle Brackets (10) attached to the fuselage by the same bolts that hold the Double Bracket in position. The rudder consists of two $2\frac{1}{2}$ " \times $2"$ Triangular Flexible Plates placed one on each side of a Semi-Circular Plate. An Angle Bracket is attached to each side of the rudder, and these are bolted to Fishplates fixed to the Angle Brackets (10).

THE WINGS

Each wing consists of a $5\frac{1}{2}$ " \times $2\frac{1}{4}$ " and a $5\frac{1}{2}$ " \times $1\frac{1}{4}$ " Flexible Plate edged by $5\frac{1}{2}$ " Strips (11). The outer ends of the Strips are bolted to a Wheel Disc, and the inner ends of the $5\frac{1}{2}$ " \times $2\frac{1}{4}$ " Flexible Plates are connected to the Strips by Fishplates. The wings are bolted to a $1\frac{1}{2}$ " \times $\frac{1}{2}$ " Double Angle Strip (12) and two Trunnions (13) fixed between the sides of the fuselage.

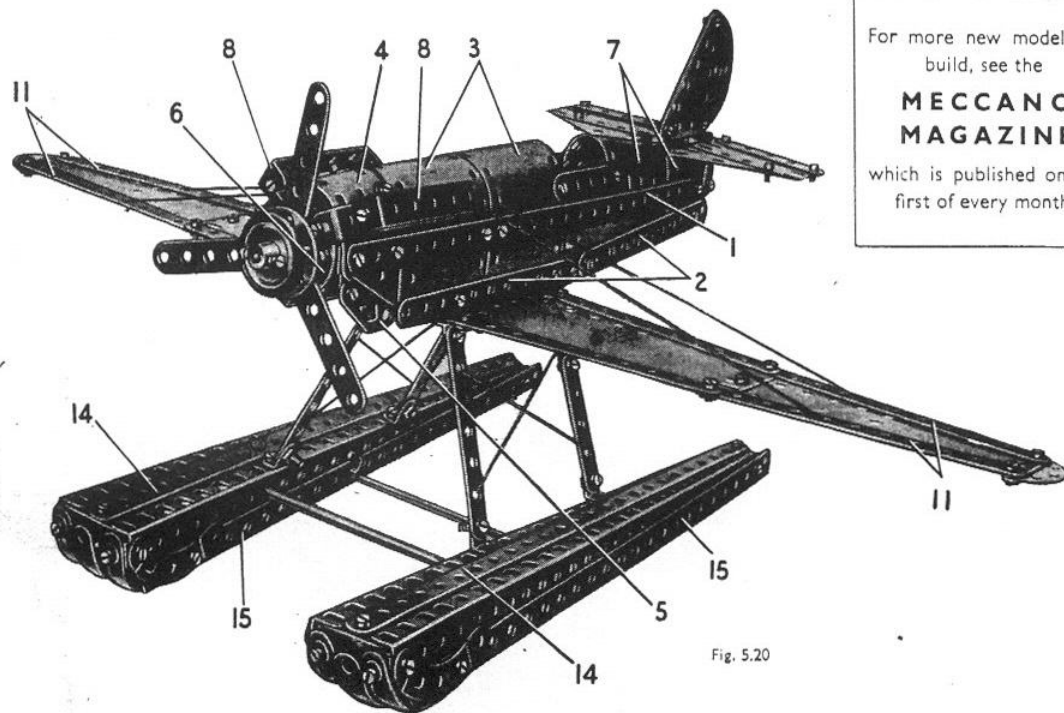

Fig. 5.20

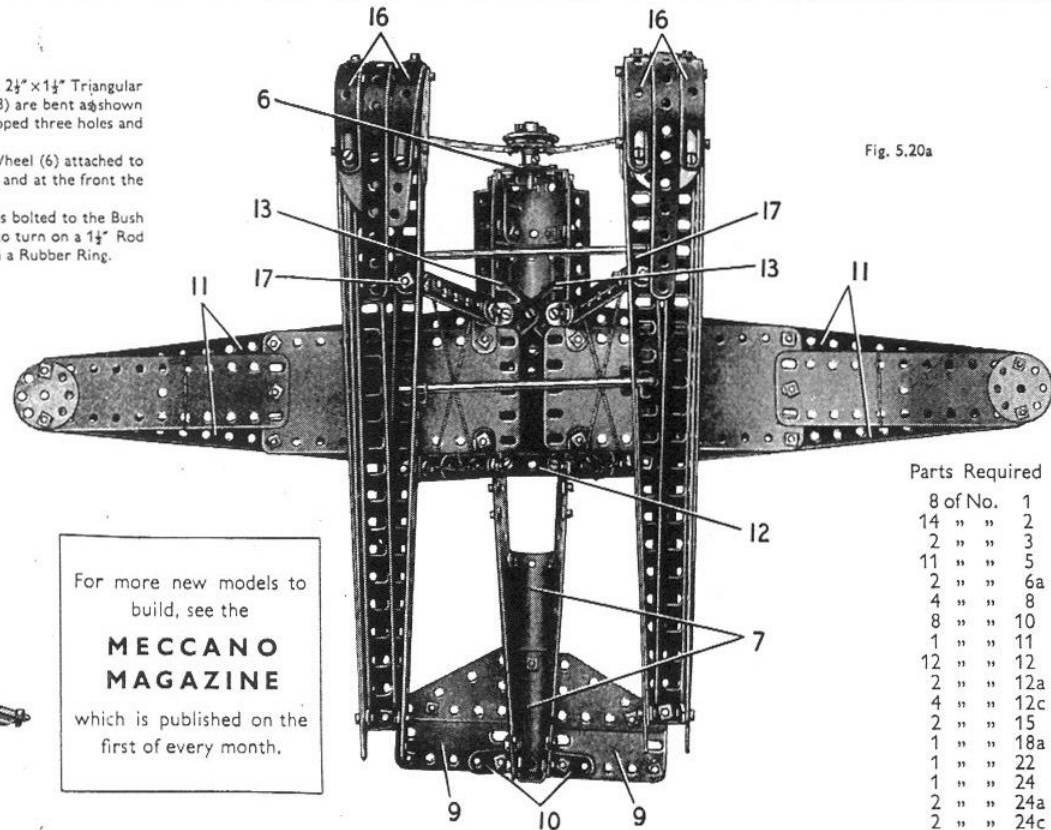

Fig. 5.20a

For more new models to build, see the
**MECCANO
MAGAZINE**
which is published on the first of every month.

Parts Required

8 of No.	1
14 "	2
2 "	3
11 "	5
2 "	6a
4 "	8
8 "	10
1 "	11
12 "	12
2 "	12a
4 "	12c
2 "	15
1 "	18a
1 "	22
1 "	24
2 "	24a
2 "	24c
5 "	35
116 "	37a
109 "	37b
14 "	38
1 "	40
1 "	48
4 "	48a
4 "	90a
6 "	111c
2 "	125
2 "	126
2 "	126a
1 "	155
4 "	188
4 "	189
4 "	192
2 "	199
2 "	212a
2 "	214
4 "	215
4 "	221
2 "	222

CONSTRUCTION OF THE FLOATS

The two floats are similar in general construction, but they vary in slight details. Each float consists of two $12\frac{1}{2}$ " Angle Girders bolted together at one end with a $12\frac{1}{2}$ " Strip (14) held by the same bolt. At the other end of the Strip a $1\frac{1}{2}$ " Strip is fixed, and the ends of the Angle Girders are clamped between the $1\frac{1}{2}$ " Strip and the Strip (14). A $12\frac{1}{2}$ " Strip (15) is fixed to each of the Angle Girders at the rear end of the float, and at the front it is attached to a $2\frac{1}{2}$ " Stepped Curved Strip bolted to the Angle Girder.

Two Formed Slotted Strips (16) are connected by Angle Brackets to the front of each float. In one of the floats the ends of the Formed Slotted Strips are bolted to a Semi-Circular Plate, but in the other float a Six-hole Wheel Disc is used in place of the Semi-Circular Plate. In each case a curved $5\frac{1}{2}$ " Strip is bolted between the Formed Slotted Strips.

The floats are connected by Obtuse Angle Brackets to two $3\frac{1}{2}$ " Strips and two built-up $3\frac{1}{2}$ " strips made from $2\frac{1}{2}$ " Strips overlapped. The Strips are fixed to Angle Brackets bolted to the Double Angle Strip (12) and the Trunnions (13). The two floats are connected by two 5" Rods. One of these is held in a Right-Angle Rod and Strip Connector (17) bolted to each float. The other Rod is passed through the $12\frac{1}{2}$ " Strips (15) and retained in position by Spring Clips.

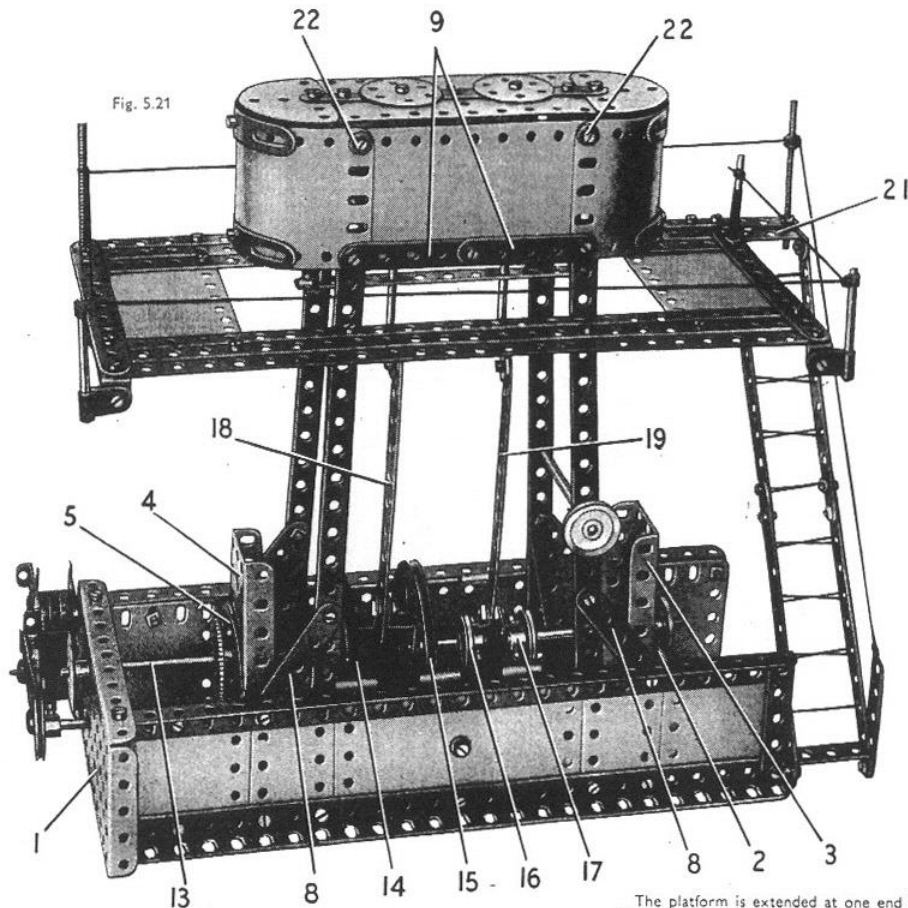

Fig. 5.21

The platform is extended at one end by a 2½" Strip and a 2½" × ½" Double Angle Strip (21), and a ladder is connected to the lug of this Double Angle Strip and to an Angle Bracket. The sides of the ladder are each made from two 5½" Strips overlapped two holes, and the lower ends of these Strips are bolted to a 1½" × ½" Double Angle Strip connected to the base by an Angle Bracket.

The handrail round the inspection platform is supported by two Screwed Rods, two 2" Rods held in Right-Angle Rod and Strip Connectors, and a 1" Rod joined to a Threaded Pin by a Rod Connector. The Right-Angle Rod and Strip Connectors are fixed to the lugs of 2½" × ½" Double Angle Strips bolted to the platform.

Parts Required

10 of No. 1	1 of No. 15b	1 of No. 26	1 of No. 51	1 of No. 147b	2 of No. 212
11 " " 2	3 " " 16	1 " " 27a	1 " " 52	1 " " 176	2 " " 212a
2 " " 3	2 " " 17	4 " " 35	2 " " 54	1 " " 186a	1 " " 213
12 " " 5	1 " " 18a	118 " " 37a	2 " " 80c	4 " " 188	2 " " 214
2 " " 5a	1 " " 18b	103 " " 37b	2 " " 90a	2 " " 189	4 " " 215
4 " " 8	2 " " 19b	11 " " 38	6 " " 111c	4 " " 190	4 " " 221
4 " " 11	5 " " 22	1 " " 40	1 " " 115	2 " " 191	1 Magic Clockwork Motor
12 " " 12	1 " " 24	1 " " 48	4 " " 125	4 " " 192	(Not included in Outfit)
2 " " 12a	2 " " 24c	7 " " 48a	1 " " 126a	1 " " 198	
1 " " 15					

5.21 TWIN CYLINDER MARINE ENGINE

THE BASE

Each side of the bed or base of the Ships Engine seen in Fig. 5.21 consists of two 12½" Angle Girders, connected by one half of a Hinged Flat Plate, two 2½" × 2½" and two 2½" × 1½" Flexible Plates. The sides are bolted at one end to a 5½" × 2½" Flanged Plate (1), and at the other end they are connected by a 3½" Strip (2) attached to Angle Brackets. A Flanged Sector Plate (3) is bolted to the 3½" Strip and is connected to the sides of the base by two Double Brackets. A Flanged Sector Plate (4) is similarly attached to the base by Double Brackets, and it is supported also by two 2½" Stepped Curved Strips (5) bolted to 1" × 1" Angle Brackets (6) fixed to the sides. A 3½" Strip (7) is connected to Angle Brackets bolted to the centre holes of the halves of the Hinged Flat Plate, and a Flat Trunnion is fixed to the centre of the 3½" Strip.

SUPPORTING COLUMNS FOR THE CYLINDER BLOCK

Each of the columns supporting the cylinder block consists of a 12½" Strip bolted to the base and braced by a 2½" × 1½" Triangular Flexible Plate and a 2½" Strip (8). The top ends of the columns on each side are connected by two 2½" Strips (9) and a 4½" × 2½" Flexible Plate, and they are joined to the columns on the other side by 2½" × ½" Double Angle Strips. A 5½" Strip (10) is fixed between the Double Angle Strips and a similar Strip (11) is connected to them by ½" Reversed Angle Brackets. A 2½" × 1½" Flanged Plate (12) is bolted between the Strips (9).

THE CYLINDER BLOCK

The rounded ends of the cylinder block are 5½" × 2½" Flexible Plates curved to shape and edged by Formed Slotted Strips. The top corners of the Plates are connected by 2½" × ½" Double Angle Strips held by Bolts (22), and the top of the block is attached to the Double Angle Strips. The top is formed by two 5½" × 1½" Flexible Plates and two Semi-Circular Plates bolted to a 5½" Strip. The covers of the cylinders are represented by Six-Hole Wheel Discs.

THE CRANKSHAFT, PISTON AND VALVE RODS

The crankshaft is in three sections. A 5" Rod (13) (Fig. 5.21) is supported in the Flanged Plate (1) and the Flanged Sector Plate (4), and is fitted with a 57-tooth Gear and a 3" Pulley (14). A 1½" Rod passed through a Flat Trunnion bolted to the Strip (7) (Fig. 5.21a), carries a 3" Pulley (15) and a 1" Pulley (16), and a 3½" Rod supported in the Flanged Sector Plate (3) has a 1" Pulley (17) fixed to it.

A ½" Reversed Angle Bracket is bolted tightly to each of the Pulleys (14) and (15), and the Brackets are connected by a ½" Bolt. The Bolt is held by a nut in one of the Reversed Angle Brackets, and on it is pivoted a 5½" Strip (18). The Bolt is then held by two nuts in the other Reversed Angle Bracket.

An Angle Bracket is fixed to the boss of each of the Pulleys (16) and (17). A bolt fitted with a nut is passed through the Angle Bracket and is screwed into a threaded hole in the boss of the Pulley. The nut is then tightened to hold the Angle Bracket firmly in place. The two Angle Brackets are connected by a ½" Bolt arranged in the same way as the Bolt in the Reversed Angle Brackets, and a 5½" Strip (19) is pivoted on the Bolt. The Strips (18) and (19) are lock-nutted to Rod and Strip Connectors, and Rods held in the Rod and Strip Connectors are free to slide through the Strips (10) and (11).

MOTOR AND GEARING

The model is driven by a Magic Clockwork Motor bolted to one end of the Flanged Plate (1). A Driving Band is passed round the Motor pulley and a 1" Pulley on a Rod (20), which is supported in the Flanged Plate (1) and the Flanged Sector Plate (4). The Rod is held in position by a ½" Pulley (supplied with the Motor), and a ½" Pinion fixed on it drives the 57-tooth Gear on Rod (13).

THE INSPECTION PLATFORM

The inspection platform round the cylinder block consists of three 12½" Strips on each side joined at their ends by 5½" Strips and 5½" × 2½" Flexible Plates. The platform is attached to the cylinder block supporting columns by Angle Brackets. The Angle Brackets are fixed to the columns by ½" Bolts, but are spaced from them by a Spring Clip on each Bolt.

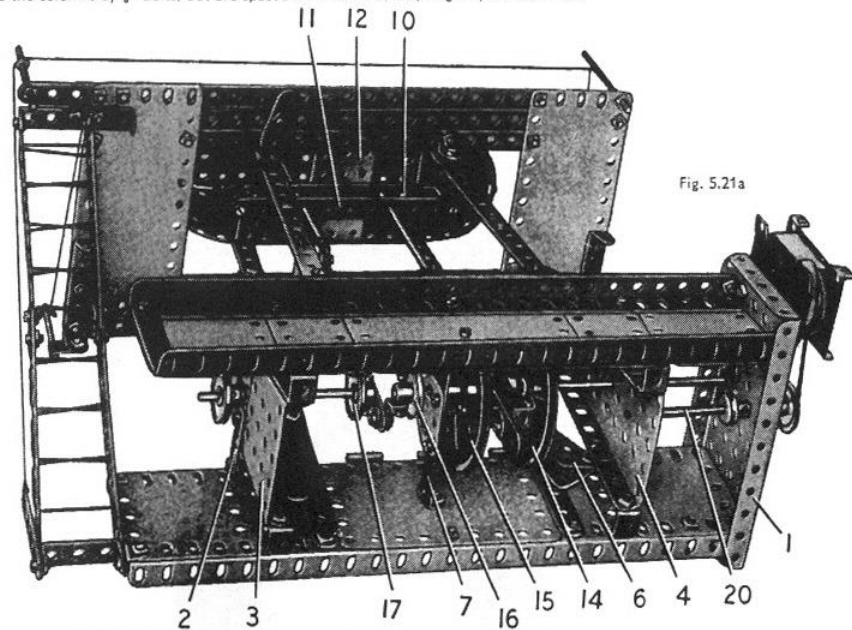

Fig. 5.21a

5.22 FIRE ENGINE

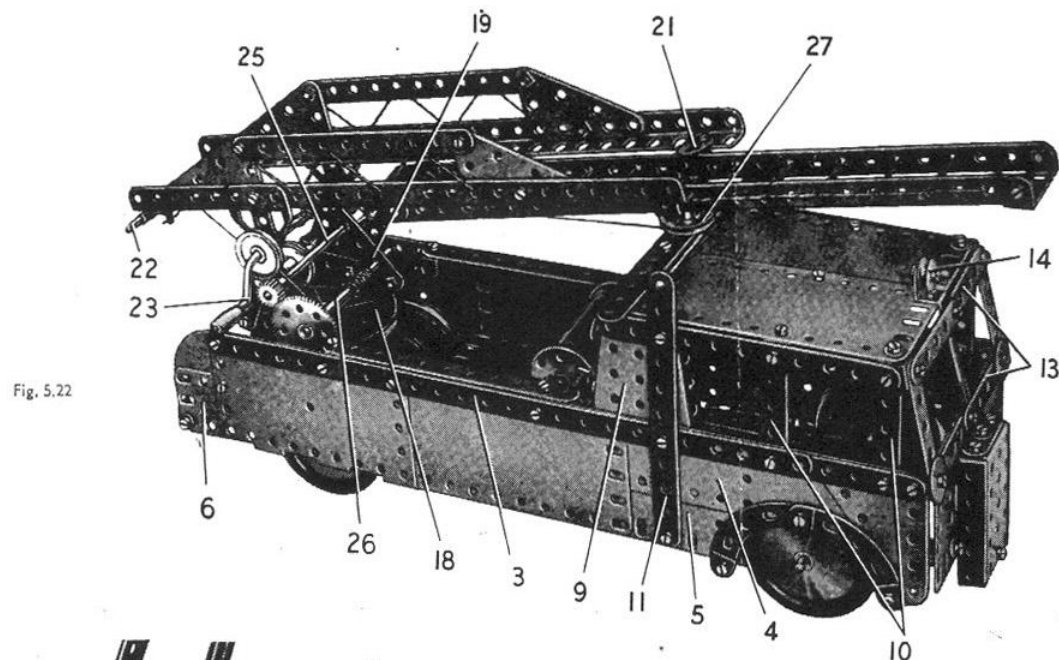
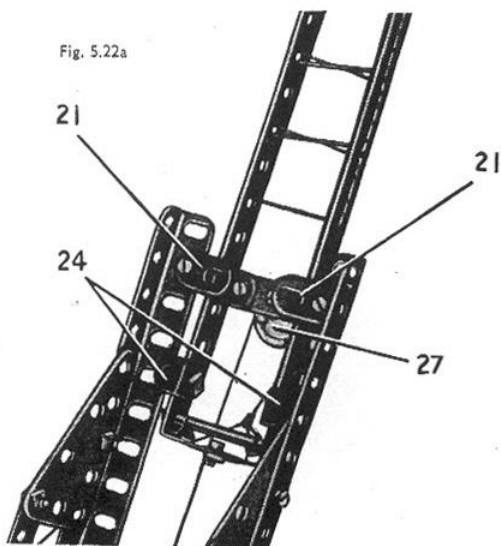

Fig. 5.22

Fig. 5.22a

**CONSTRUCTION OF THE CHASSIS**

The chassis consists of two 12½" Angle Girders, each extended by a 5½" Strip that overlaps the Girder by five holes. The 5½" Strips are connected by a 2½" x ½" Double Angle Strip (1), and the Angle Girders are bolted to a 5½" x 2½" Flanged Plate (2). The front wheels are fixed as shown on a 5" Rod, and the rear wheels are held on a 4½" Rod. Both Rods are supported directly in the chassis.

ASSEMBLING THE BODY

Each side of the body is identical in construction, and is made by bolting Plates to a built-up strip (3), made from a 12½" and a 5½" Strip overlapped seven holes. The side over the front wheels consists of a 2½" x 2" Triangular Flexible Plate, a 5½" x 1½" Flexible Plate (4), and a 2½" x 2½" Flexible Plate (5). The side is completed by a 5½" x 2½" Flexible Plate, one half of a Hinged Flat Plate, a 2½" x 1½" Flexible Plate (6) and a Semi-Circular Plate.

The completed sides are attached by Angle Brackets to two Trunnions (7), and to two 3½" Strips (8) overlapped five holes and bolted to the back of the Flanged Plate (2).

The driving cabin is made by bolting a Flanged Sector Plate (9) and two 2½" x ½" Double Angle Strips (10) to each side. A 5½" Strip (11) is fixed to the side and to the Flanged Sector Plate, and a further 5½" Strip is bolted across the upper ends of Double Angle Strips (10). The Flanged Sector Plates are joined across by a 5½" Strip (12).

The roof of the cab consists of two 5½" x 2½" Flexible Plates. These are bolted to the tops of the Double Angle Strips (10), and are connected to the Strip (12) by a Double Bracket. The front of the cab is made from two built-up strips (13), each made from two 2½" Strips and connected to the sides by Angle Brackets. A 2½" x 1½" Flexible Plate on each side is bolted to the lower of the strips (13) and to the Double Angle Strip (1). The centre division of the windscreen is a 2" Rod held in a Rod and Strip Connector. A ½" loose Pulley (14) representing a warning light is attached by a ½" Bolt to a ½" Reversed Angle Bracket.

The radiator is a 2½" x 1½" Flanged Plate fitted at each side with a 2½" x ½" Double Angle Strip. It is connected to the Double Angle Strip (1) by a ½" Reversed Angle Bracket, and is attached by an Angle Bracket to the lower of the strips (13).

A 4½" x 2½" Flexible Plate is bolted to the flanges of the Flanged Sector Plates, and a second 4½" x 2½" Flexible Plate (15) and two 5½" x 1½" Flexible Plates curved slightly at their front ends are bolted to the chassis.

(Continued on next page)

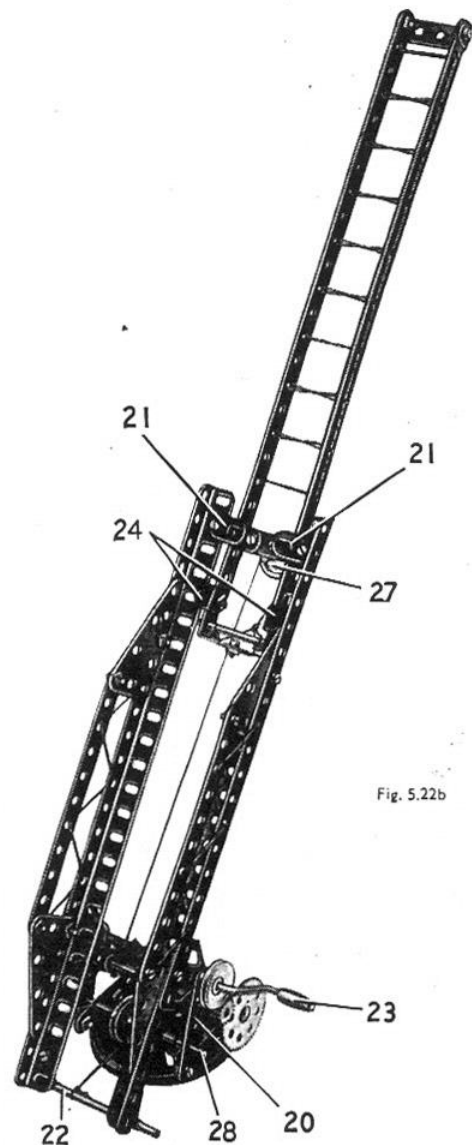

Fig. 5.22b

MODEL 5.22 FIRE ENGINE — Continued

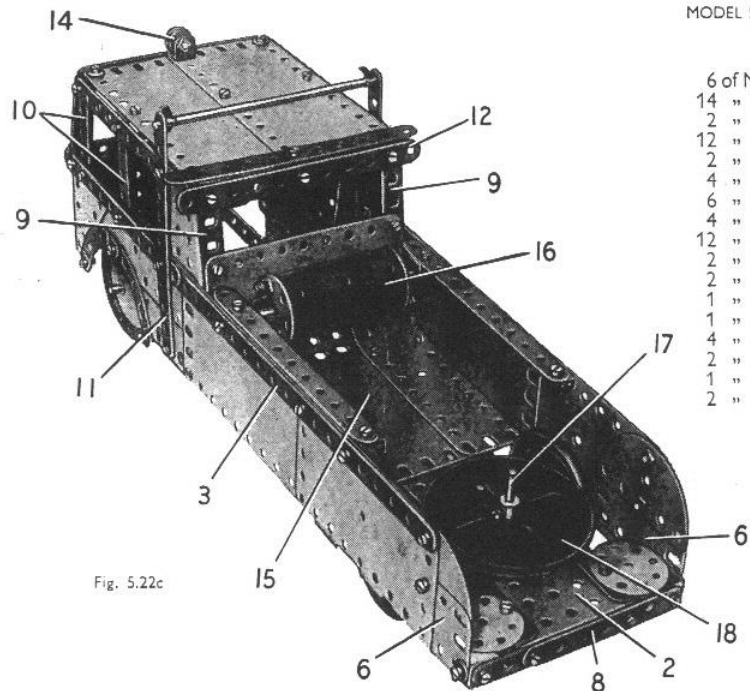

Fig. 5.22c

The hose reel (16) is made by fixing a Six-Hole Wheel Disc to each end of a $2\frac{1}{2}$ " Cylinder by means of 3" Screwed Rods. The reel is mounted on a 4" Rod supported in Double Brackets fixed to the sides of the body. A $5\frac{1}{2}$ " Strip on each side is bolted to the Double Bracket.

THE EXTENDING LADDER

A 2" Rod (17) is passed through the Flanged Plate (2) and through a Double Bent Strip bolted to the Flanged Plate. Two 3" Pulleys (18) are held on the Rod, and a $2\frac{1}{2}$ " x $\frac{1}{2}$ " Double Angle Strip is fixed across the centre of the upper Pulley. A $2\frac{1}{2}$ " Strip is bolted to each lug of the Double Angle Strip, and two further $2\frac{1}{2}$ " Strips (19) and (20) are attached to the ends of the $2\frac{1}{2}$ " Strip. The top ends of Strips (19) and (20) are bolted together so that one clear hole of Strip (20) remains above the bolt joining the Strips.

The fixed section of the ladder consists of two $12\frac{1}{2}$ " Angle Girders. These are connected together at their upper ends by a $1\frac{1}{2}$ " Strip bolted between two $\frac{1}{2}$ " Reversed Angle Brackets. The bolts fixing the Reversed Angle Brackets to the Girders also fix in position two Fishplates (21). At their lower ends the Girders are connected by a $3\frac{1}{2}$ " Rod (22) held in Right-Angle Rod and Strip Connectors. A Flat Trunnion is bolted to each Angle Girder, and a Crank Handle (23) is passed through them and through the top holes of the Strips (20). The side rails of the ladder are $5\frac{1}{2}$ " Strips attached to $2\frac{1}{2}$ " x $1\frac{1}{2}$ " Triangular Flexible Plates.

Each side of the extending section of the ladder consists of two $12\frac{1}{2}$ " Strips placed face to face. The sides are connected at their upper ends by a $1\frac{1}{2}$ " x $\frac{1}{2}$ " Double Angle Strip, and at the bottom they are joined by two 1 " x 1 " Angle Brackets bolted together to make a built-up $1\frac{1}{2}$ " x 1 " double angle strip. The extending section slides between the $\frac{1}{2}$ " Reversed Angle Brackets and the Fishplates (21). Two Angle Brackets (24) serve to locate the sliding ladder between the Angle Girders of the fixed section.

The ladder can be raised and lowered by turning a Bush Wheel fitted with a Threaded Pin and fixed on a $3\frac{1}{2}$ " Rod (25) mounted in the Strips (19). The Rod (25) carries a $\frac{1}{2}$ " Pinion that drives a 57-tooth Gear on a $3\frac{1}{2}$ " Rod (26). A length of Cord wound round Rod (26) is passed round a 1" Pulley on a Rod (28) and is tied to the Rod (22).

The ladder is extended by turning the Crank Handle (23). A length of Cord tied to the Crank Handle is passed round a 1" Pulley (27) and is fastened to the 1 " x 1 " Angle Brackets at the bottom of the extending section of the ladder. The Pulley (27) is fixed by its set screw on a $\frac{3}{8}$ " Bolt passed through the $1\frac{1}{2}$ " Strip attached to the Reversed Angle Brackets at the top of the fixed section of the ladder.

Parts Required

6 of No. 1	1 of No. 19g	8 of No. 48a	1 of No. 176
14 " " 2	5 " " 22	1 " " 51	4 " " 187
2 " " 3	2 " " 22a	1 " " 52	4 " " 188
12 " " 5	1 " " 23	2 " " 54	4 " " 189
2 " " 6a	1 " " 24	2 " " 80c	2 " " 190
4 " " 8	2 " " 24a	4 " " 90a	2 " " 191
6 " " 10	2 " " 24c	1 " " 111a	4 " " 192
4 " " 11	1 " " 26	5 " " 111c	1 " " 198
12 " " 12	1 " " 27a	1 " " 115	1 " " 212
2 " " 12a	14 " " 35	4 " " 125	2 " " 212a
2 " " 15	117 " " 37a	2 " " 126	2 " " 214
1 " " 15a	110 " " 37b	2 " " 126a	1 " " 216
1 " " 15b	17 " " 38	1 " " 147b	4 " " 221
4 " " 16	2 " " 38d	4 " " 155	2 " " 222
2 " " 17	1 " " 40		
1 " " 18a	1 " " 45		
2 " " 19b	1 " " 48		

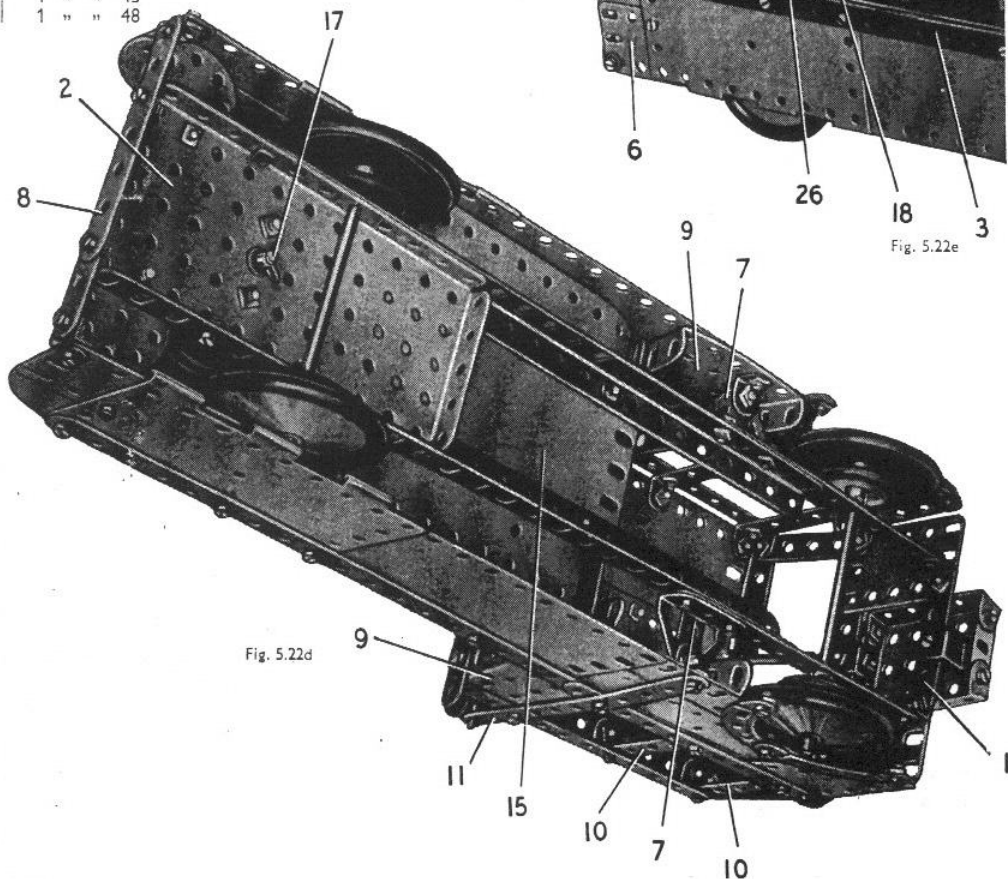

Fig. 5.22d

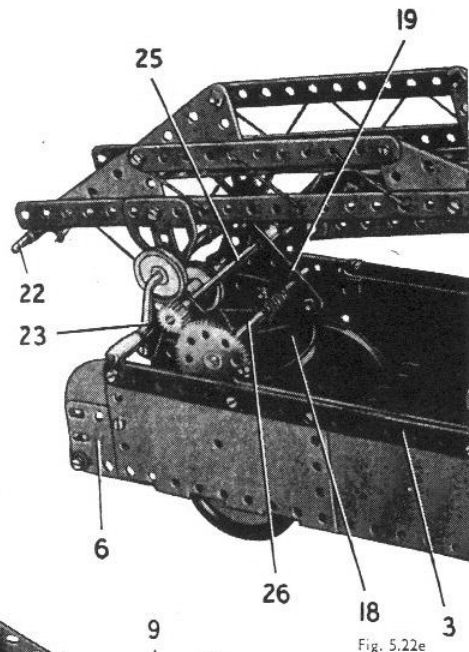

Fig. 5.22e

5.23 TRANSPORTER BRIDGE

CONSTRUCTION OF THE TOWERS

The four towers are similar in design and each of them is made from two $12\frac{1}{2}$ " Strips bolted at their lower ends to a $2\frac{1}{2}$ " Strip (1), and a built-up $12\frac{1}{2}$ " strip fixed to a $2\frac{1}{2} \times \frac{1}{2}$ " Double Angle Strip (2). The Strips are connected at the top by a Double Bracket (3) (Fig. 5.23a). The built-up strip is made from two $5\frac{1}{2}$ " and a $2\frac{1}{2}$ " Strip bolted together. Each tower is capped by a Road Wheel and a Wheel Disc on a Rod, which is held by a Spring Clip in the Double Bracket (3). The towers at each end of the bridge are connected by a $2\frac{1}{2} \times \frac{1}{2}$ " Double Angle Strip (4) and by two Formed Slotted Strips.

THE CONNECTING SPAN

The main girders of the span each consist of two $12\frac{1}{2}$ " Angle Girders overlapped three holes. The girders are connected at their ends by two $3\frac{1}{2}$ " Strips (5), and the complete span is attached to the towers by Angle Brackets in the position shown. Each of the suspension chains (6) is represented by built-up strips connected by a $\frac{1}{2}$ " Reversed Angle Bracket to the centre of the span, and attached to the towers by Angle Brackets. Lengths of Cord are threaded between the suspension links and the span.

THE BRIDGE APPROACHES

The roadway of each approach is a $5\frac{1}{2} \times 2\frac{1}{2}$ " Flexible Plate (7) extended by a Flanged Sector Plate. The Flexible Plate is bolted to a $2\frac{1}{2} \times \frac{1}{2}$ " Double Angle Strip fixed between the towers, and the Flanged Sector Plate is supported by a $4\frac{1}{2} \times 2\frac{1}{2}$ " Flexible Plate on one side and one half of a Hinged Flat Plate on the other side. The $5\frac{1}{2} \times 2\frac{1}{2}$ " Flexible Plate is edged by $5\frac{1}{2} \times 1\frac{1}{2}$ " Flexible Plates, which are bolted to the inner Strips of the towers. The bolts serve also to secure $2\frac{1}{2} \times 1\frac{1}{2}$ " Triangular Flexible Plates (8).

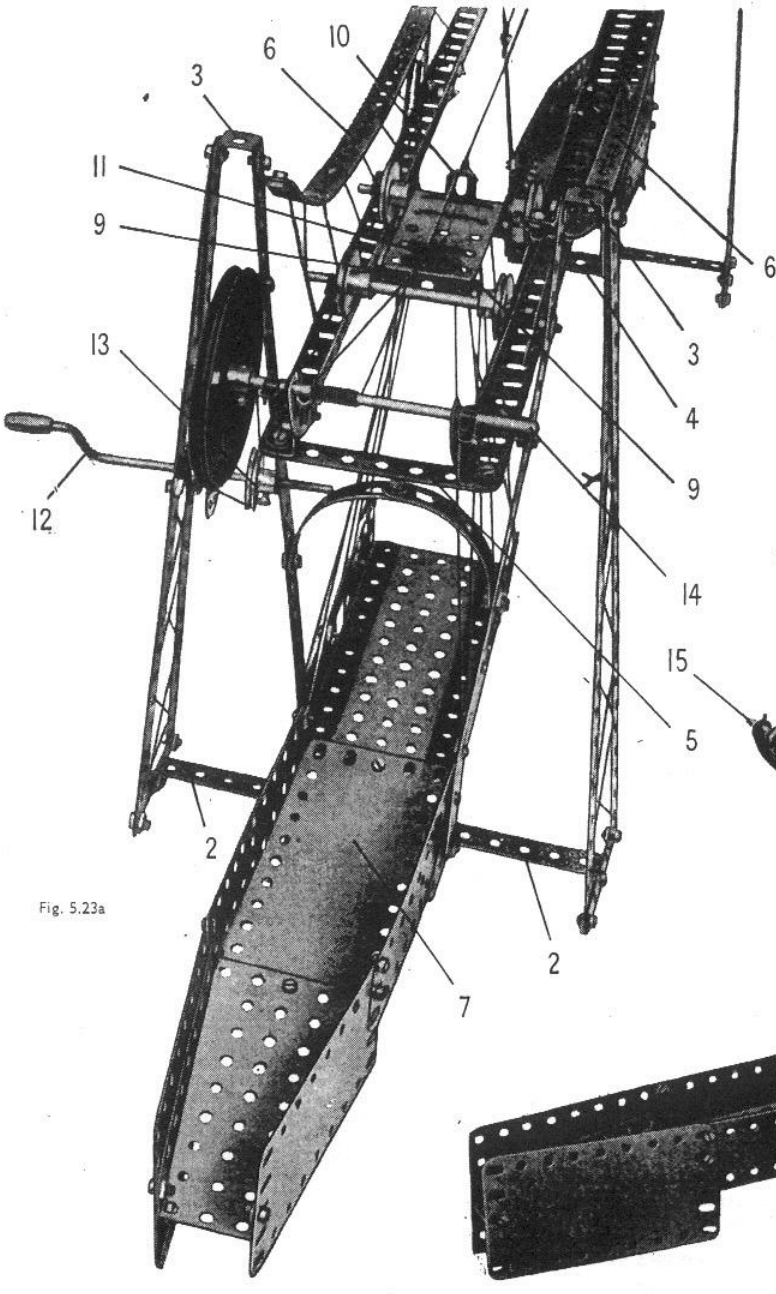

Fig. 5.23a

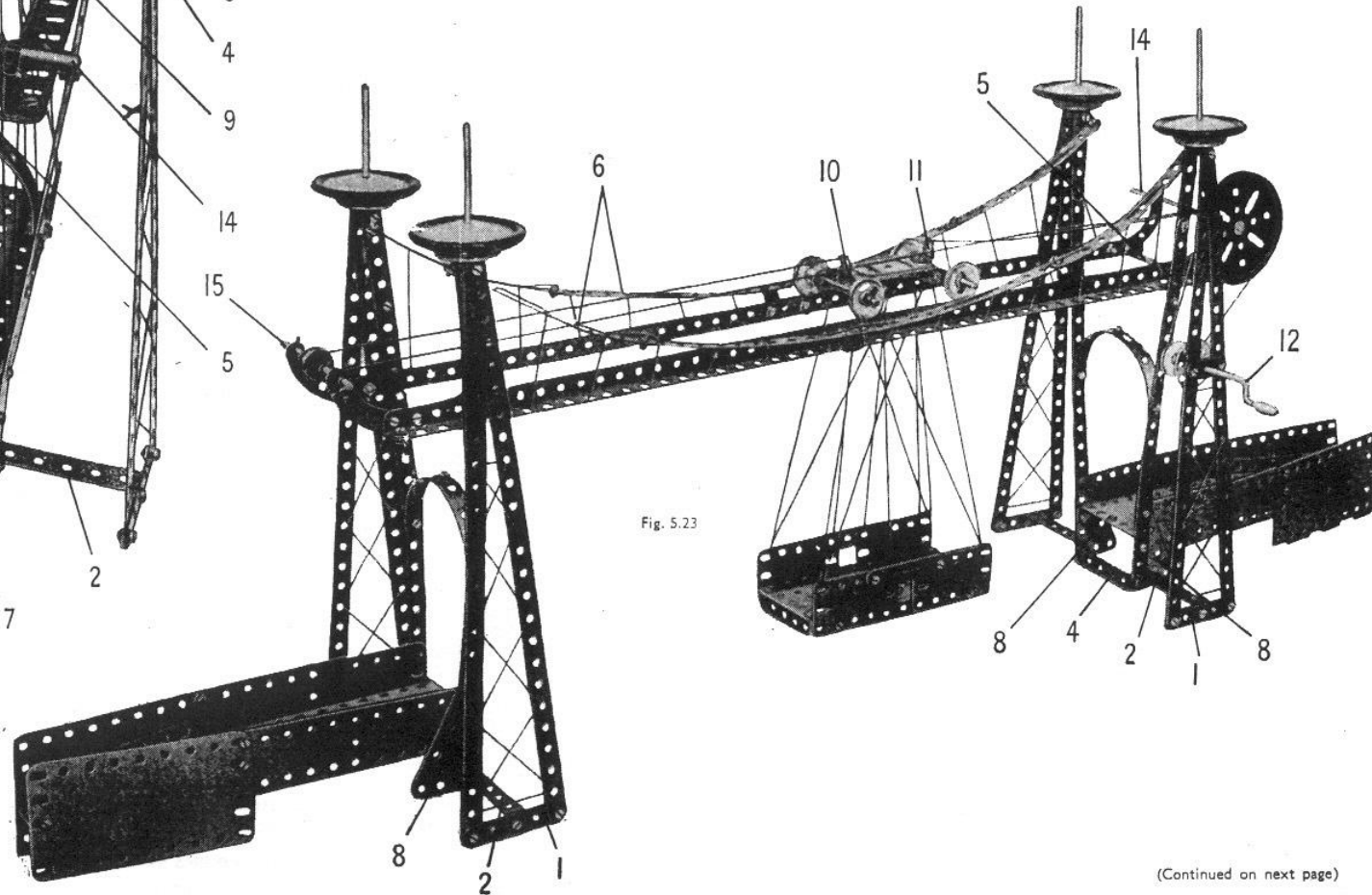

Fig. 5.23

(Continued on next page)

MODEL 5.23 TRANSPORTER BRIDGE — Continued

THE TROLLEY AND THE TRANSPORTER CARRIAGE

The trolley consists of a $2\frac{1}{2}'' \times 1\frac{1}{2}''$ Flanged Plate fitted with four 1" Pulleys spaced on $3\frac{1}{2}''$ Rods so that they run on the flanges of the girders of the span. The Pulleys are held in place on the Rods by Spring Clips. One of the Rods is supported in a $1\frac{1}{2}'' \times \frac{1}{2}''$ Double Angle Strip bolted to the flange at one end of the Flanged Plate. The second Rod is mounted in two Angle Brackets (9) bolted to the other flange of the Flanged Plate. A Fishplate (10) and an Angle Bracket (11) are fixed to the trolley.

The carriage is made by fixing two $2\frac{1}{2}'' \times 1\frac{1}{2}''$ Flexible Plates to each of the longer sides of a $5\frac{1}{2}'' \times 2\frac{1}{2}''$ Flanged Plate. The carriage is connected to the trolley by Cords arranged as shown in Fig. 5.23.

THE OPERATING MECHANISM

A Crank Handle (12) is supported in the inner Strip of one of the towers and in a $4\frac{1}{2}''$ Strip bolted across the two outer Strips. The Crank Handle is held in place by a Bush Wheel and a 1" Pulley (13), and the Pulley is connected by a Cord belt to a 3" Pulley on a 5" Rod (14). Rod (14) is held by Spring Clips in $2\frac{1}{2}''$ Stepped Curved Strips bolted to one end of the span. A Rod (15) is supported in $2\frac{1}{2}''$ Curved Strips bolted to the other end of the span, and a $\frac{1}{2}''$ loose Pulley is free to turn on the Rod.

A length of Cord is tied to the Angle Bracket (11) and is wound several times round the Rod (14). The Cord is passed round the Pulley on Rod (15) and is fastened to the Fishplate (10).

Parts Required

10 of No.	1	110 of No.	37a
14 " "	2	110 " "	37b
2 " "	3	20 " "	38
10 " "	5	2 " "	38d
1 " "	6a	1 " "	40
4 " "	8	1 " "	48
1 " "	10	8 " "	48a
4 " "	11	1 " "	51
11 " "	12	1 " "	52
1 " "	15	2 " "	54
1 " "	15a	4 " "	90a
2 " "	15b	2 " "	125
4 " "	16	4 " "	187
1 " "	19b	4 " "	188
1 " "	19g	4 " "	189
5 " "	22	2 " "	191
1 " "	23	2 " "	192
1 " "	24	1 " "	198
2 " "	24a	4 " "	215
2 " "	24c	4 " "	221
14 " "	35		

5.24 TRAVELLING GANTRY CRANE**CONSTRUCTION OF THE GANTRY**

The gantry that forms the rails supporting the crane consists of two built-up girders, each made from two $12\frac{1}{2}''$ Angle Girders connected together by a $2\frac{1}{2}''$ Strip (1). Each of the built-up girders is fitted with two $5\frac{1}{2}'' \times 1\frac{1}{2}''$ and two $2\frac{1}{2}'' \times 1\frac{1}{2}''$ Flexible Plates, and the lower edges of these Plates are connected by a $12\frac{1}{2}''$ Strip (2). The girders are bolted at their outer ends to $5\frac{1}{2}''$ Strips (3).

Two of the legs supporting the gantry are made with pairs of $5\frac{1}{2}''$ Strips, while the other two consist of $5\frac{1}{2}''$ and $2\frac{1}{2}''$ Strips. The legs are connected at the top by a $5\frac{1}{2}'' \times 2\frac{1}{2}''$ Flexible Plate and a $5\frac{1}{2}''$ Strip (5), and at their lower ends they are bolted to a $12\frac{1}{2}''$ Strip (6). The joints between the legs and the Strip (6) are braced by $2\frac{1}{2}'' \times 1\frac{1}{2}''$ Triangular Flexible Plates, and a Flanged Sector Plate is bolted between Strip (6) and the $5\frac{1}{2}'' \times 2\frac{1}{2}''$ Flexible Plate. A $12\frac{1}{2}''$ Strip (7) is attached to the Strips (6) by a Double Bracket at each end and by two $\frac{1}{2}''$ Reversed Angle Brackets (8). The wheels are Wheel Discs free to turn on bolts, each of which is held by two nuts in the Strip (6).

The completed towers are bolted to the lugs of $2\frac{1}{2}'' \times \frac{1}{2}''$ Double Angle Strips (9), which are fixed to the ends of the $12\frac{1}{2}''$ Angle Girders. The towers are braced by $5\frac{1}{2}''$ Strips attached to the gantry and the strips (4) by Angle Brackets.

THE TRAVELLING CRANE

The crane base is a $5\frac{1}{2}'' \times 2\frac{1}{2}''$ Flanged Plate (10) and its wheels are 1" Pulleys fixed on 5" Rods supported in the Flanged Plate. The Rods are held in place by Spring Clips and the Pulleys run on the edges of the $12\frac{1}{2}''$ Angle Girders.

The sides of the cab are the separated halves of a Hinged Flat Plate. They are connected by two $2\frac{1}{2}'' \times \frac{1}{2}''$ Double Angle Strips held by Bolts (11) on each side, and by a $2\frac{1}{2}'' \times 1\frac{1}{2}''$ Flanged Plate held by Bolts (12). A Bush Wheel is bolted to the Flanged Plate, and a 2" Rod held in its boss is passed through a 3" Pulley and the centre hole of the Flanged Plate (10). A Spring Clip is placed on the Rod underneath the Flanged Plate.

The cab roof consists of two $1\frac{1}{2}''$ radius Curved Plates and two curved $2\frac{1}{2}'' \times 2\frac{1}{2}''$ Flexible Plates bolted to a $3\frac{1}{2}''$ Strip (13) on each side. The Strips (13) are supported by $2\frac{1}{2}''$ Strips bolted to the sides of the cab. The back of the cab is filled in by a $2\frac{1}{2}'' \times 2\frac{1}{2}''$ Flexible Plate fixed to the Double Angle Strips held by the Bolts (11), and by a Semi-Circular Plate (14) also attached to a $2\frac{1}{2}'' \times \frac{1}{2}''$ Double Angle Strip.

The jib consists of four $12\frac{1}{2}''$ Strips bolted to the sides of the cab and connected at their upper ends by a 'U'-shaped piece made from two Angle Brackets. The jib is braced by two $2\frac{1}{2}'' \times 2''$ Triangular Flexible Plates, two $2\frac{1}{2}''$ Strips, two $1\frac{1}{2}''$ Strips, and a $1\frac{1}{2}'' \times \frac{1}{2}''$ Double Angle Strip (15).

A length of Cord is tied to a Cord Anchoring Spring on a Crank Handle (16), and is led over a 1" loose Pulley mounted on a 1" Rod at the top of the jib. The Cord passes round a 1" loose Pulley in the pulley block and is tied to the jib. The pulley block consists of two Flat Trunnions separated by nuts on $\frac{1}{2}''$ Bolts. The 1" loose Pulley is free to turn on one of the Bolts and the other Bolt supports a small Loaded Hook.

The Crank Handle (16) is permitted to slide slightly in its bearings, and when it is pushed in the set-screw in a 1" Pulley (17) engages a Rod and Strip Connector (18) to form a simple brake.

Parts Required

10 of No.	1	1 of No.	18b	1 of No.	51
14 " "	2	1 " "	19b	1 " "	52
2 " "	3	1 " "	19g	2 " "	54
12 " "	5	5 " "	22	1 " "	57c
2 " "	6a	2 " "	22a	2 " "	111a
4 " "	8	1 " "	23	6 " "	111c
4 " "	11	1 " "	24	4 " "	125
10 " "	12	2 " "	24a	2 " "	126a
2 " "	15	2 " "	24c	1 " "	147b
1 " "	18a	8 " "	35	1 " "	176
		117 " "	37a	4 " "	188
		108 " "	37b	4 " "	189
		17 " "	38	3 " "	190
		2 " "	38d	2 " "	192
		1 " "	40	1 " "	198
		1 " "	48	2 " "	199
		7 " "	48a	2 " "	200
				1 " "	212
				1 " "	214
				4 " "	221
				2 " "	222

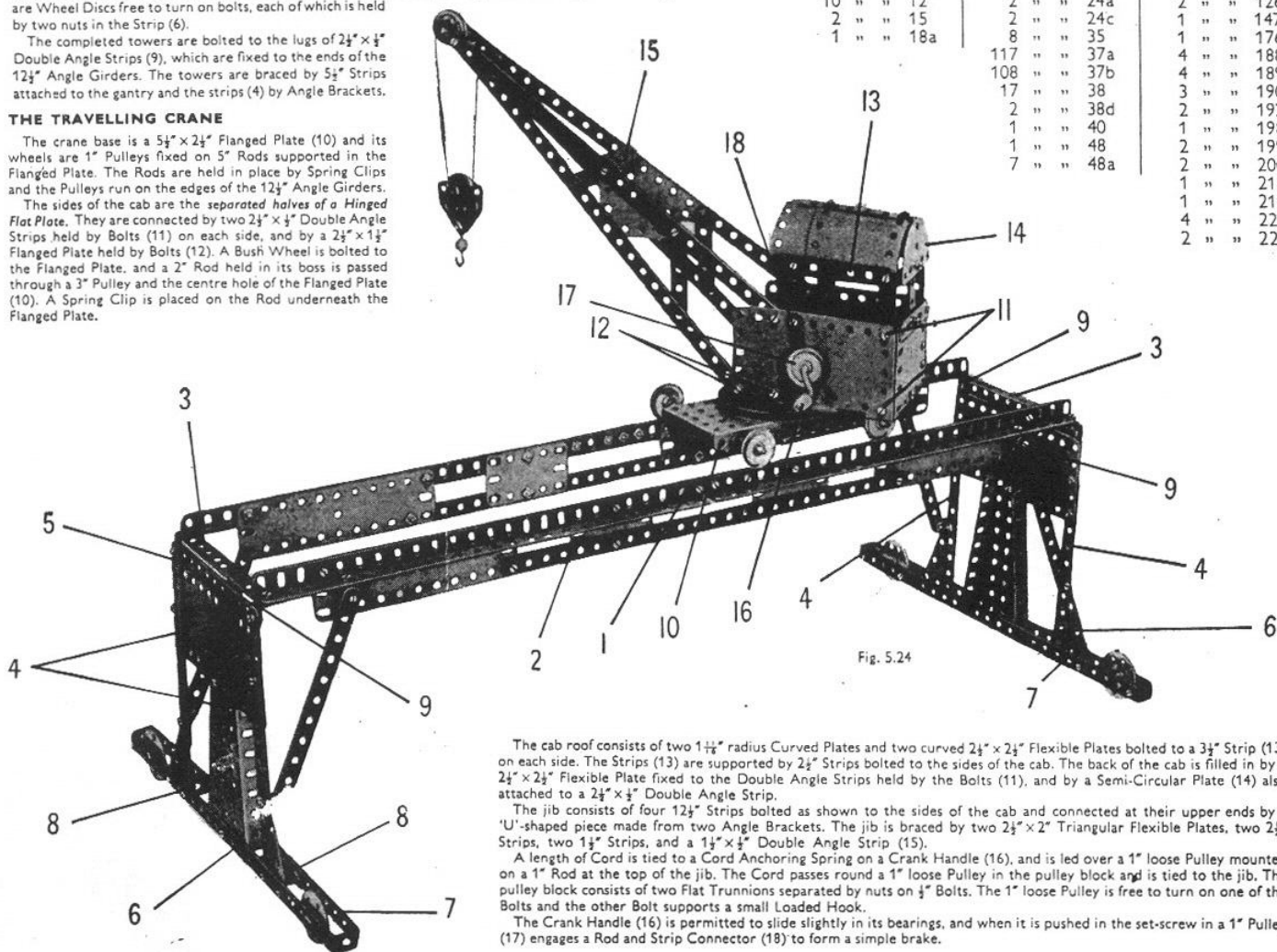

Fig. 5.24

The cab roof consists of two $1\frac{1}{2}''$ radius Curved Plates and two curved $2\frac{1}{2}'' \times 2\frac{1}{2}''$ Flexible Plates bolted to a $3\frac{1}{2}''$ Strip (13) on each side. The Strips (13) are supported by $2\frac{1}{2}''$ Strips bolted to the sides of the cab. The back of the cab is filled in by a $2\frac{1}{2}'' \times 2\frac{1}{2}''$ Flexible Plate fixed to the Double Angle Strips held by the Bolts (11), and by a Semi-Circular Plate (14) also attached to a $2\frac{1}{2}'' \times \frac{1}{2}''$ Double Angle Strip.

The jib consists of four $12\frac{1}{2}''$ Strips bolted to the sides of the cab and connected at their upper ends by a 'U'-shaped piece made from two Angle Brackets. The jib is braced by two $2\frac{1}{2}'' \times 2''$ Triangular Flexible Plates, two $2\frac{1}{2}''$ Strips, two $1\frac{1}{2}''$ Strips, and a $1\frac{1}{2}'' \times \frac{1}{2}''$ Double Angle Strip (15).

A length of Cord is tied to a Cord Anchoring Spring on a Crank Handle (16), and is led over a 1" loose Pulley mounted on a 1" Rod at the top of the jib. The Cord passes round a 1" loose Pulley in the pulley block and is tied to the jib. The pulley block consists of two Flat Trunnions separated by nuts on $\frac{1}{2}''$ Bolts. The 1" loose Pulley is free to turn on one of the Bolts and the other Bolt supports a small Loaded Hook.

The Crank Handle (16) is permitted to slide slightly in its bearings, and when it is pushed in the set-screw in a 1" Pulley (17) engages a Rod and Strip Connector (18) to form a simple brake.

5.25 MOUNTAIN RAILWAY

THE LOWER STATION

Each side of the station consists of one half of a Hinged Plate and two $5\frac{1}{2}$ " x $1\frac{1}{2}$ " Flexible Plates, edged at the front by a $5\frac{1}{2}$ " Strip (1) The sides are connected by a $5\frac{1}{2}$ " Strip (2) attached by Angle Brackets. The roof is formed by two $5\frac{1}{2}$ " x $2\frac{1}{2}$ " Flexible Plates, an opened out 'U'-section Curved Plate and a $1\frac{1}{2}$ " radius Curved Plate arranged as shown and edged by $3\frac{1}{2}$ " Strips and Formed Slotted Strips.

THE TOWER AND UPPER STATION

Each leg of the tower consists of a $12\frac{1}{2}$ " and a $5\frac{1}{2}$ " Strip overlapped three holes. The legs are bolted to a $5\frac{1}{2}$ " x $2\frac{1}{2}$ " Flanged Plate (3), and they are connected by three $5\frac{1}{2}$ " Strips (4), a $5\frac{1}{2}$ " Strip (5), two $2\frac{1}{2}$ " x $\frac{1}{2}$ " Double Angle Strips (6) and two $2\frac{1}{2}$ " x $\frac{1}{2}$ " Double Angle Strips (7). The top of the tower is formed by two Flanged Sector Plates, and $5\frac{1}{2}$ " x $2\frac{1}{2}$ " Flexible Plates are bolted to the upper and lower ends of the tower as shown.

THE RAILS

The two outer rails are each formed by two $12\frac{1}{2}$ " Angle Girders overlapped two holes. They are bolted to the sides of the lower station, and they are attached to the tower by Obtuse Angle Brackets held by the same bolts that fix the Strip (5) in position. The Angle Girders are connected at their lower ends and in the centre by $5\frac{1}{2}$ " Strips (8).

The inner rails are each made from two $12\frac{1}{2}$ " Strips. These are bolted to the lugs of a $1\frac{1}{2}$ " x $\frac{1}{2}$ " Double Angle Strip attached to the Strip (5), and they are connected by Angle Brackets to the Strips (8).

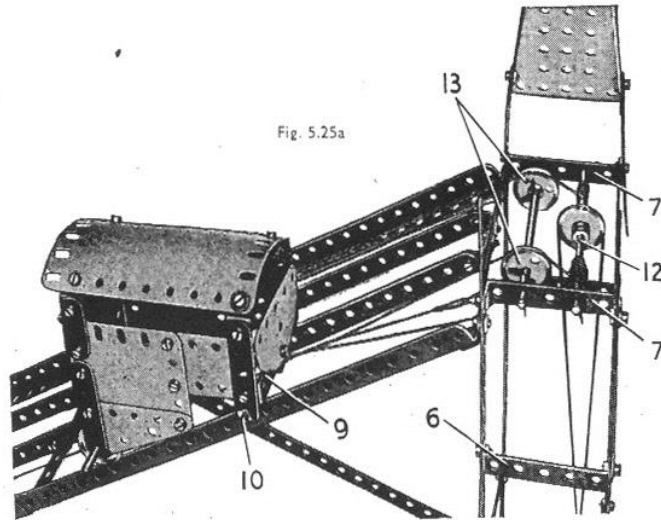

Fig. 5.25a

CONSTRUCTION OF THE CARRIAGES

The carriages are similar in design but they vary in some details. Each side is formed by a $2\frac{1}{2}$ " x $2\frac{1}{2}$ " Flexible Plate, a $2\frac{1}{2}$ " x $1\frac{1}{2}$ " Flexible Plate and a $2\frac{1}{2}$ " x $1\frac{1}{2}$ " Triangular Flexible Plate. Each side of one carriage is edged by two $2\frac{1}{2}$ " Strips and a $1\frac{1}{2}$ " Strip, but in the other carriage a further $2\frac{1}{2}$ " Strip replaces the $1\frac{1}{2}$ " Strip.

The sides of both carriages are connected by a $2\frac{1}{2}$ " x $\frac{1}{2}$ " Double Angle (9), and a Semi-Circular Plate is fixed to each Double Angle Strip. The back of one carriage is formed by two $2\frac{1}{2}$ " x $2\frac{1}{2}$ " Triangular Flexible Plates bolted to a $2\frac{1}{2}$ " x $1\frac{1}{2}$ " Flanged Plate fixed between the sides. The back of the other carriage is a straightened $1\frac{1}{2}$ " radius Curved Plate attached to the sides by Angle Brackets.

Each carriage is fitted with two 1" Pulleys arranged to run on the inclined rails. The Pulleys are free to turn on $3\frac{1}{2}$ " Rods supported as shown and held in place by Spring Clips. The front end of each carriage is fitted with a 3" Screwed Rod (10) held by nuts in the lower ends of the $2\frac{1}{2}$ " Strips. The Screwed Rods slide over the rails. Two lengths of Cord are fastened to the Strip (5) and are passed through Fishplates fixed to the Double Angle Strips (9). The Cords are then pulled taut and fastened to the lower of the Strips (8). These Cords serve as guides to keep the carriages on the rails.

The carriage roofs are $4\frac{1}{2}$ " x $2\frac{1}{2}$ " Flexible Plates curved and attached to Obtuse Angle Brackets.

THE OPERATING MECHANISM AND CORDS

A No. 1 Clockwork Motor is bolted to one of the legs of the tower, and a $\frac{1}{2}$ " Pinion on the Motor shaft drives a 57-tooth Gear on a 2" Rod (11). A $\frac{1}{2}$ " fixed Pulley (supplied with the Motor) on Rod (11) is connected by a Driving Band to a 1" Pulley on a 5" Rod (12), mounted as shown in the Double Angle Strips (7). Two lengths of Cord are tied to Rod (12) and are wound round the Rod in opposite directions. Each Cord is then taken over a 1" loose Pulley (13), round the Screwed Rod (10) of one of the carriages and is tied to the Strip (5). The Pulleys (13) are free to turn on a Rod supported in the Double Angle Strips (7). When the Clockwork Motor is set in motion one length of Cord on Rod (12) is wound in and the other is paid out, so that one carriage is raised as the other is lowered.

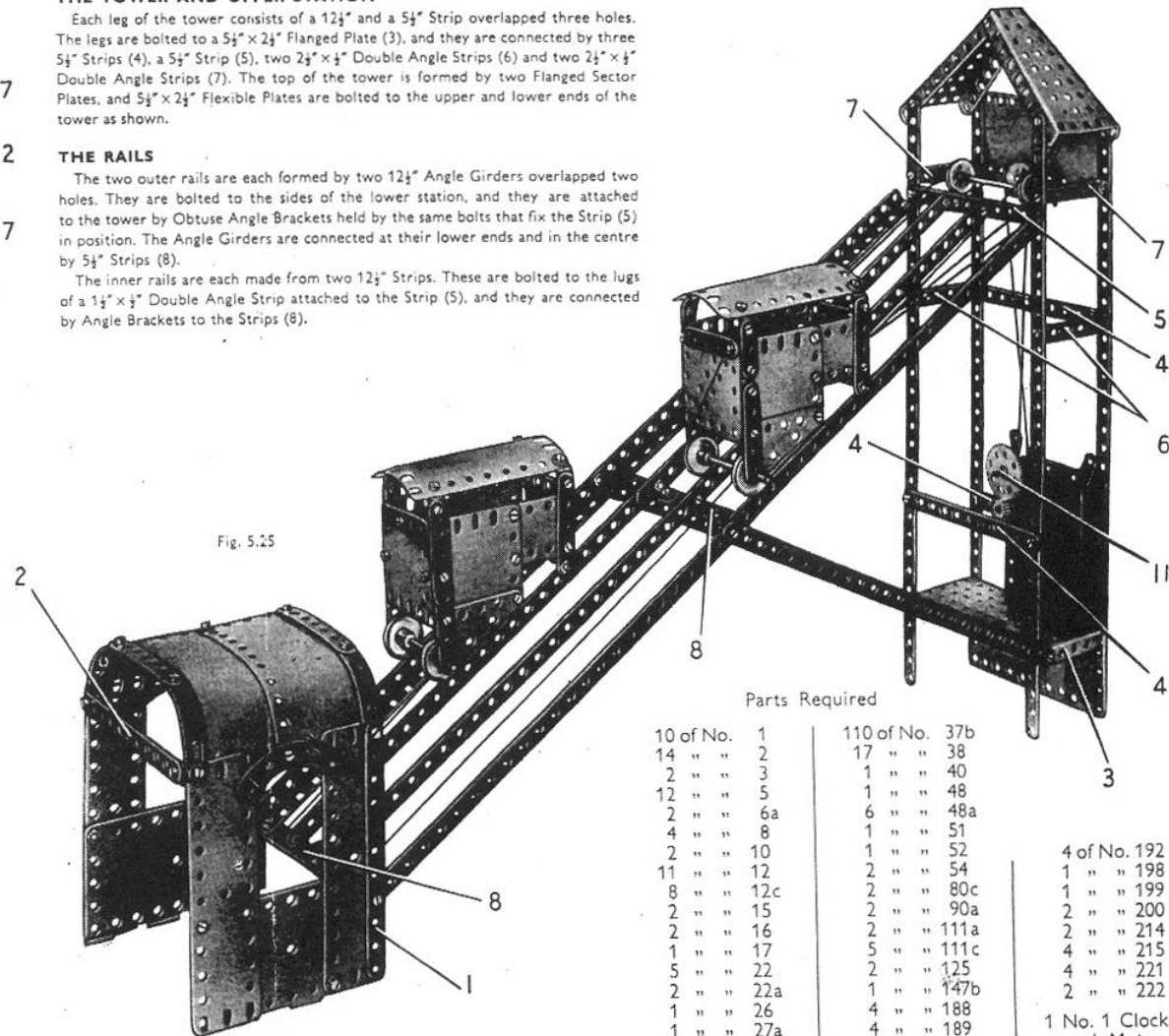

Fig. 5.25

Parts Required

10 of No. 1	1	110 of No. 37b	
14 " " 2	2	17 " " 38	
2 " " 3	1	1 " " 40	
12 " " 5	1	1 " " 48	
2 " " 6a	6	6 " " 48a	
4 " " 8	1	1 " " 51	
2 " " 10	1	1 " " 52	
11 " " 12	2	2 " " 54	
8 " " 12c	2	2 " " 80c	
2 " " 15	2	2 " " 90a	
2 " " 16	2	2 " " 111a	
1 " " 17	5	5 " " 111c	
5 " " 22	2	2 " " 125	
2 " " 22a	1	1 " " 147b	
1 " " 26	4	4 " " 188	
1 " " 27a	4	4 " " 189	
14 " " 35	4	4 " " 190	
118 " " 37a	2	2 " " 191	
		4 of No. 192	
		1 " " 198	
		1 " " 199	
		2 " " 200	
		2 " " 214	
		4 " " 215	
		4 " " 221	
		2 " " 222	
		1 No. 1 Clockwork Motor	
		(not included in Outfit)	

5.26 PITHEAD GEAR

Parts Required

10 of No.	1	2 of No.	38d
14 "	2	1 "	40
2 "	3	1 "	44
12 "	5	1 "	48
2 "	6a	8 "	48a
4 "	8	1 "	51
4 "	10	1 "	52
12 "	12	2 "	54
2 "	12a	4 "	90a
1 "	15	3 "	111c
1 "	15a	1 "	115
2 "	15b	4 "	125
1 "	16	2 "	126
2 "	19b	2 "	126a
4 "	22	1 "	147b
2 "	22a	1 "	176
1 "	24	2 "	187
1 "	26	4 "	188
1 "	27a	4 "	189
7 "	35	4 "	190
117 "	37a	2 "	191
110 "	37b	4 "	192
20 "	38	1 "	198
		1 "	199
		2 "	200
		2 "	212
		2 "	212a
		2 "	214
		4 "	215
		4 "	221
		2 "	222

THE BASE AND TOWER

The base of the model consists of two built-up angle girders, each made from two 12½" Angle Girders overlapped 11 holes. These are connected together at one end by a made-up strip (1), and at the other end by a 3¼" Strip (2), both of which are attached to the girders by Angle Brackets. The made-up strip consists of two 2½" Strips overlapped three holes.

The pithead tower is made by bolting two vertical 12½" Strips to each side of the base. Two 5½" x 2½" Flexible Plates (3) are fitted to each side of the tower, and the top edges of the Flexible Plates are strengthened by 5½" Strips. The upper ends of the 12½" Strips are extended by two 2½" Strips (4) and two 5½" Strips (5). These Strips are connected at the sides by two 5½" x 1½" Flexible Plates edged by 5½" Strips, and at the front by two 2½" x 2½" Flexible Plates overlapped three holes and attached to the Strips (4) by Angle Brackets. Two crossed 12½" Strips (6) are bolted between the 2½" x 2½" Flexible Plates and the strip (1). The Strips (5) are connected at their upper ends by a 2½" Stepped Curved Strip fixed to 1" x 1" Angle Brackets.

ENGINE HOUSE

The side of the engine house seen in Fig. 5.26a consists of one half of a Hinged Flat Plate and two 2½" x 1½" Flexible Plates. The opposite side is formed by bolting a No. 1 Clockwork Motor to the base as shown in the general view of the model. This side is completed by a straightened "U"-section Curved Plate bolted to the Motor and to two 2½" Strips joined together. One of these Strips is seen at (7). The rear of the engine house is formed by the other half of the Hinged Flat Plate and two 2½" x 1½" Triangular Flexible Plates (8). A 3¼" Strip (9) is attached to the sides of the house by Angle Brackets, and a Semi-Circular Plate (10) and two 2½" Stepped Curved Strips are fixed to the Strip (9). The roof of the engine house is formed by two 1½" radius Curved Plates, two curved 2½" x 2½" Flexible Plates, and two 2½" x 1½" Flexible Plates. These Plates are edged by four Formed Slotted Strips and two 1½" Strips, and they are bolted to the 2½" x 1½" Flexible Plates and to the 2½" Strip (7) of the sides. The roof is attached by a Fishplate to the top edge of the No. 1 Clockwork Motor.

The tower is braced to the engine house by two long strips, each made from two 12½" Strips overlapped eight holes. The top ends of these strips are bolted to 2½" x 2" Triangular Flexible Plates fixed to the Strips (5). A 4½" Rod (11) is held by Spring Clips in the Triangular Flexible Plates and carries two Road Wheels, two 3" Pulleys and a 1" Pulley placed between the two 3" Pulleys.

Plates fixed to the Strips (5). A 4½" Rod (11) is held by Spring Clips in the Triangular Flexible Plates and carries two Road Wheels, two 3" Pulleys and a 1" Pulley placed between the two 3" Pulleys.

THE CAGE AND GUIDE CORDS

The pit cage consists of two Flanged Sector Plates connected by a 4½" x 2½" Flexible Plate, a 2½" x 1½" Flanged Plate and a 2½" Strip (12). The floor of the cage is made from two 2½" x 1½" Triangular Flexible Plates and a Semi-Circular Plate bolted together, and it is attached to one of two ½" Reversed Angle Brackets (13) fixed to each of the Flanged Sector Plates. A 1" loose Pulley (14) is freely mounted on a Pivot Bolt held by its nuts in a Stepped Bent Strip bolted to the top of the cage. A safety bar covering the entrance of the cage consists of a 2½" Strip (15) lock-nutted to one of the Flanged Sector Plates. The free end of this Strip drops into a catch formed by a Fishplate bolted to the other Flanged Sector Plate but separated from it by two Washers on the Bolt. A Threaded Pin fixed to the Strip (15) forms a handle for raising the safety bar.

The pit cage is guided by two lengths of Cord. These are passed through the lugs of two 2½" x ½" Double Angle Strips (17) bolted to each side at the top of the tower, and are passed through the ½" Reversed Angle Brackets (13) fitted to the cage. The ends of each Cord are passed through 1" Pulleys (18), and holes spaced 1" apart in a 5½" x 2½" Flanged Plate. The Cord ends are tied together.

MOTOR AND HOISTING MECHANISM

The operating Cord for the cage is fastened between a Bush Wheel and a 57-tooth Gear (19) on a 3¼" Rod. The Rod is supported in the side-plates of the Motor, and is held in position by a Spring Clip. The 57-tooth Gear is driven by a ¼" Pinion on the Motor shaft. The Cord is taken over the 1" Pulley on Rod (11), round the 1" loose Pulley (14) and is tied between Spring Clips on a 4" Rod (20) supported at the top of the tower. The reversing lever of the Motor is extended by a 5" Rod held in a Rod and Strip Connector lock-nutted to the lever. The brake lever is similarly extended by a 3¼" Rod, and both Rods are fitted outside the engine-house with Right-Angle Rod and Strip Connectors.

A platform for unloading the cage is formed by two 5½" Strips (21) bolted to the lugs of three 2½" x ½" Double Angle Strips and one 1½" x ½" Double Angle Strip. A 4½" x 2½" Flexible Plate is attached at one end to Flat Trunnions bolted to the Strips (21), and its other end is supported by Fishplates also fixed to the Strips (21).

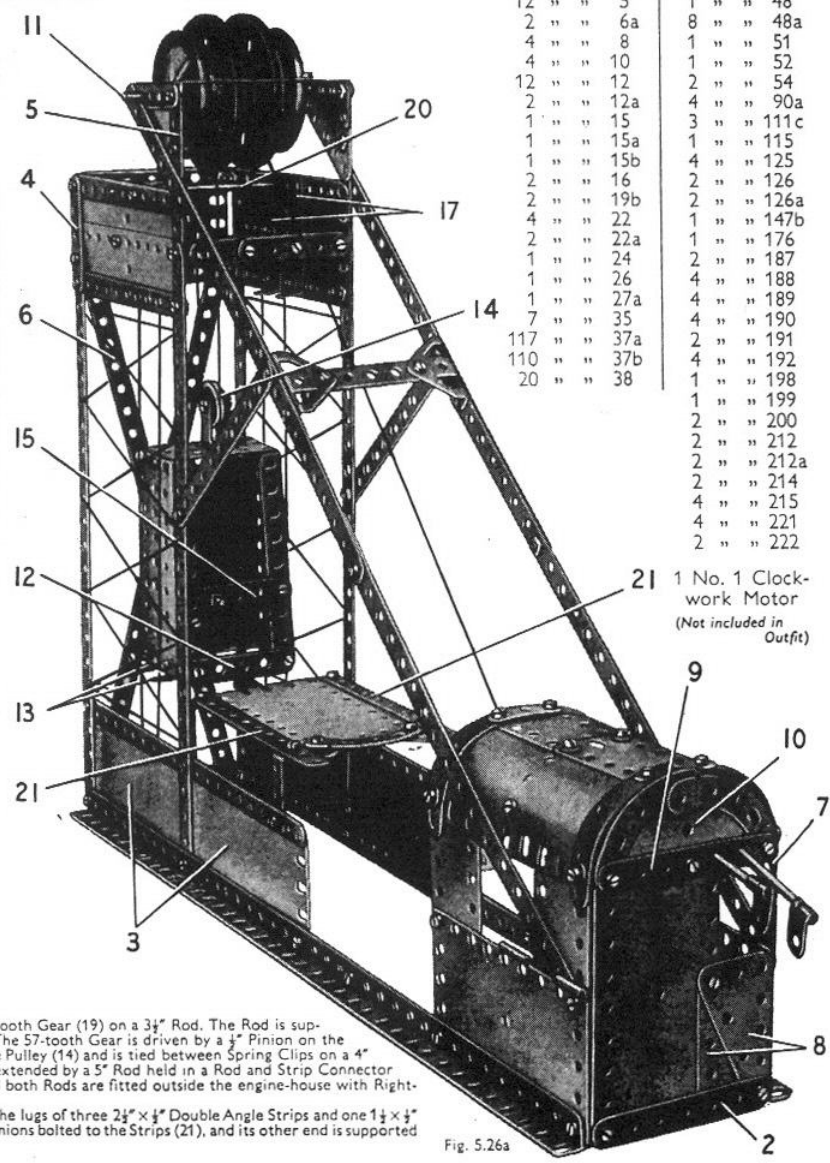

Fig. 5.26a

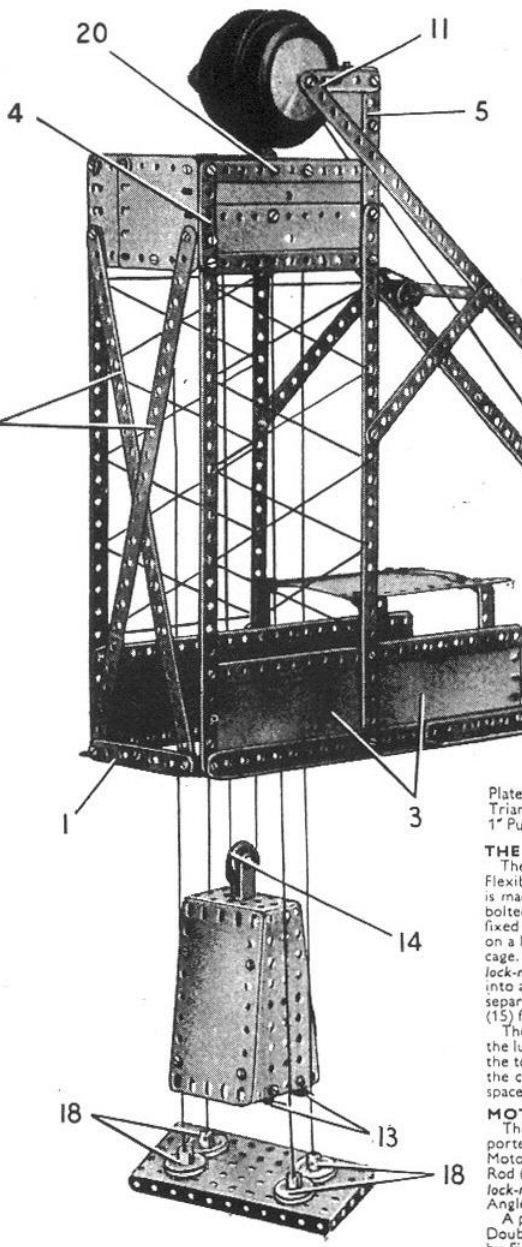

Fig. 5.26

MECCANO PARTS



PERFORATED STRIPS

No.	1.	2.	No.	3.	4.	No.	5.	6.
	12 1/2"	9 1/2"		4 1/2"	3 1/2"		2"	1 1/2"
	1a.	7 1/2"		3"	2 1/2"			
	1b.	7 1/2"		4"	3"			
	2.	5 1/2"		5.	2 1/2"			

ANGLE GIRDERS

	7.	24 1/2"		8b.	7 1/2"		9c.	3"
	7a.	18 1/2"		9.	5 1/2"		9d.	2 1/2"
	8.	12 1/2"		9a.	4 1/2"		9e.	2"
	8a.	9 1/2"		9b.	3 1/2"		9f.	1 1/2"



10. Fishplate | 11. Double Bracket

ANGLE BRACKETS

	12.	1/2" x 1/2"		12b.	1" x 1/2"
	12a.	1" x 1"		12c.	Obtuse, 1/2" x 1/2"



AXLE RODS

	13.	11 1/2"		15a.	4 1/2"		16b.	3"
	13a.	8 1/2"		15b.	4"		17.	2"
	14.	6 1/2"		16.	3 1/2"		18a.	1 1/2"
	15.	5"		16a.	2 1/2"		18b.	1"

19g. Crank Handle, 3 1/2" shaft, with grip
19h. Crank Handle, 5 1/2" shaft, with grip
19s. Crank Handle, 3 1/2" shaft, without grip



19a. Spoked Wheel, 3" diam.
20. Flanged Wheel, 1 1/2" diam.
20b. Flanged Wheel, 1/2" diam.



PULLEYS

19b. 3" diam., with boss and screw
19c. 6" diam., with boss and screw
20a. 2" diam., with boss and screw
21. 1 1/2" diam., with boss and screw
22. 1" diam., with boss and screw



PULLEYS

22a. 1" diam., without boss
23. 1/2" diam., without boss
23a. 1/2" diam., with boss and screw



No. 24. Bush Wheel, 1 1/2" diam., eight-hole
24a. Wheel Disc, 1 1/2" diam., without bush, eight-hole
24b. Bush Wheel, 1 1/2" diam., six-hole
24c. Wheel Disc, 1 1/2" diam., without bush, six-hole

PINIONS

25. 1/2" diam., 1/4" face, 25 teeth
25a. 3/8" diam., 1/4" face, 25 teeth
25b. 1/2" diam., 1/4" face, 25 teeth
26. 1/4" diam., 1/4" face, 19 teeth
26a. 1/2" diam., 1/4" face, 19 teeth
26b. 1/2" diam., 1/4" face, 19 teeth
26c. 1/2" diam., 1/4" face, 15 teeth



GEAR WHEELS

27. 1 1/2" diam., 50 teeth
27a. 1 1/2" diam., 57 teeth
27b. 3 1/2" diam., 133 teeth
27c. 2 1/2" diam., 95 teeth
27d. 1 1/2" diam., 60 teeth



CONTRATE WHEELS

28. 1 1/2" diam., 50 teeth
29. 1/2" diam., 25 teeth

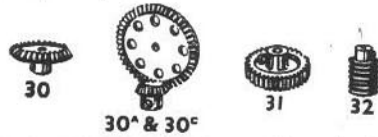

30. Bevel Gear, 7/8" diam., 26 teeth (for use in pairs)
30a. Bevel Gear, 1/2" diam., 16 teeth } Can only be used together
30c. Bevel Gear, 1 1/2" diam., 48 teeth }
31. Gear Wheel, 1" diam., 1/4" face, 38 teeth
32. Worm, 1/2" diam.
34. Spanner



34b. Box Spanner
35. Spring Clip
36. Screwdriver
36a. Screwdriver (longer)
36c. Drift (for levering bolt holes into line)
37. Nut and Bolt, 1/8"
37a. Nut
37b. Bolt, 1/8"
38. Washer
38d. Hank of Cord



41. Propeller Blade | 43. Tension Spring, 2" long



No. 44. Bent Strip, stepped
45. Double Bent Strip

DOUBLE ANGLE STRIPS

46. 2 1/2" x 1"
47. 2 1/2" x 1 1/2"
47a. 3" x 1 1/2"
48. 1 1/2" x 1/2"
48a. 2 1/2" x 1/2"
48b. 3 1/2" x 1/2"
48c. 4 1/2" x 1/2"
48d. 5 1/2" x 1/2"

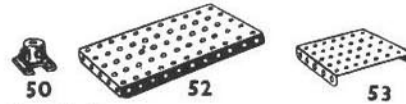

50. Slide Piece
51. Flanged Plate, 2 1/2" x 1 1/2"
52. Flanged Plate, 5 1/2" x 2 1/2"
52a. Flat Plate, 5 1/2" x 3 1/2"
53. Flanged Plate, 3 1/2" x 2 1/2"
53a. Flat Plate, 4 1/2" x 2 1/2"



54. Flanged Sector Plate, 4 1/2" long
55. Perforated Strip, slotted, 5 1/2" long
55a. Perforated Strip, slotted, 2" long



57b. Hook, Loaded, Large
57c. Hook, Loaded, Small
58. Spring Cord, 40" length
58a. Coupling Screw for Spring Cord
58b. Hook for Spring Cord
59. Collar, with screw



61. Windmill Sail
62. Crank
62a. Threaded Crank
62b. Double Arm Crank



63. Coupling
63b. Strip Coupling
63c. Threaded Coupling
63d. Short Coupling



64. Threaded Boss
65. Centre Fork
69. Set Screw, 1/8"
69a. Grub Screw, 1/8"
69b. Grub Screw, 1/4"
69c. Grub Screw, 3/8"

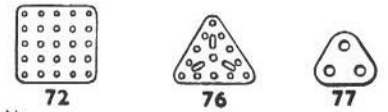

No. 70. Flat Plate, 5 1/2" x 2 1/2"
72. Flat Plate, 2 1/2" x 2 1/2"
73. Flat Plate, 3" x 1 1/2"
74. Triangular Plate, 2 1/2"
77. Triangular Plate, 1"



SCREWED RODS

78. 11 1/2"
79. 8"
79a. 6"
80. 5"
80a. 3 1/2"
80b. 4 1/2"
80c. 3"
81. 2"
82. 1"

CURVED STRIPS

89. 5 1/2" (10" radius)
89a. Stepped, 3" (1 1/2" radius)
89b. Stepped, 4" (4 1/2" radius)
90. 2 1/2" (2 1/2" radius)
90a. Stepped, 2 1/2" (1 1/2" radius)



94. Sprocket Chain, 40" length

SPROCKET WHEELS

95. 2" diam., 36 teeth
95a. 1 1/2" diam., 28 teeth
95b. 3" diam., 56 teeth
96. 1" diam., 18 teeth
96a. 1/2" diam., 14 teeth



BRACED GIRDERS

97. 3 1/2" long
97a. 3 1/2" long
98. 2 1/2" long
99. 12 1/2" long
99a. 9 1/2" long
99b. 7 1/2" long
100. 5 1/2" long
100a. 4 1/2" long



101. Heald for Loom | 102. Single Bent Strip

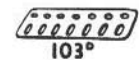

FLAT GIRDERS

103. 5 1/2" long
103a. 9 1/2" long
103b. 12 1/2" long
103c. 4 1/2" long
103d. 3 1/2" long
103e. 3" long
103f. 2 1/2" long
103g. 2" long
103h. 1 1/2" long
103k. 7/8" long

MECCANO PARTS

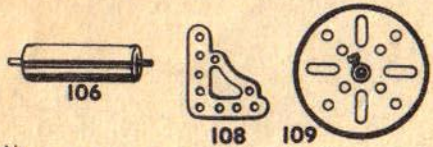

- No.
106. Wood Roller (complete with Rod and two Collars)
108. Corner Gusset
109. Face Plate, 2½" diam.

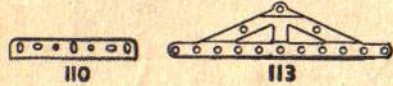

110. Rack Strip, 3½" long | 110a. Rack Strip, 6½" long

BOLTS

111. ¾" | 111c. ¾"
111a. ½" | 111d. ½"

113. Girder Frame



114. Hinge Pin | 116. Fork Piece, large
115. Threaded Pin | 116a. Fork Piece, small



118. Hub Disc, 5½" diam.



- 120b. Compression Spring, ⅝" long
122. Loaded Sack



123. Cone Pulley, 1½", 1" and ¾" diam.
124. Reversed Angle Bracket, 1"
125. Reversed Angle Bracket, ¾"



126. Trunnion
126a. Flat Trunnion
128. Bell Crank, with Boss



- No.
130. Eccentric, Triple Throw, ½", ¾" and 1"
130a. Eccentric, Single Throw, ½"



133. Corner Bracket, 1½"
133a. Corner Bracket, 1"
134. Crank Shaft, 1" stroke



136. Handrail Support | 136a. Handrail Coupling



137. Wheel Flange | 138. Ship's Funnel, Raked



139. Flanged Bracket (right)
139a. Flanged Bracket (left)
140. Universal Coupling



- 142a. Motor Tyre (to fit 2" diam. rim)
142b. Motor Tyre (to fit 3" diam. rim)
142c. Motor Tyre (to fit 1" diam. rim)
142d. Motor Tyre (to fit 1½" diam. rim)
143. Circular Girder, 5½" diam.
144. Dog Clutch

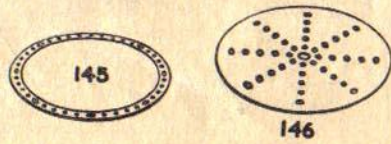

145. Circular Strip, 7½" diam. overall
146. Circular Plate, 6" diam. overall
146a. Circular Plate, 4" diam. overall



- No.
147. Pawl, with Pivot Bolt and Nuts
147a. Pawl
147b. Pivot Bolt, with two Nuts
147c. Pawl, without boss
148. Ratchet Wheel
151. Single Pulley Block
153. Triple Pulley Block
154a. Corner Angle Bracket, ½" (right-hand)
154b. Corner Angle Bracket, ½" (left-hand)
155. Rubber Ring (for 1" Pulley)



157. Fan, 2" diam.
160. Channel Bearing, 1½" x 1" x ½"
161. Girder Bracket, 2" x 1" x ½"

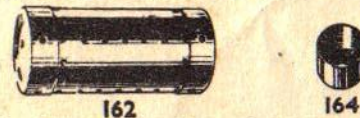

162. Boiler, complete, 5" long x 2½" diam.
162a. Boiler Ends, 2½" diam. x ¾"
163. Sleeve Piece, 1½" long x ½" diam.
164. Chimney Adaptor, ¾" diam. x ½" high



165. Swivel Bearing
166. End Bearing
167b. Flanged Ring, 9½" diam.
168. Ball Thrust Bearing, 4" diam.
168a. Ball Thrust Race, flanged disc, 3½" diam.
168b. Ball Thrust Race, toothed disc, 4" diam.
168c. Ball Cage, 3½" diam., complete with balls
168d. Ball, ¾" diam.

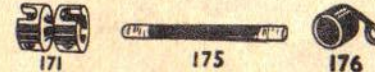

171. Socket Coupling
173a. Adaptor for Screwed Rod
175. Flexible Coupling Unit
176. Anchoring Spring for Col'd



179. Rod Socket
180. Gear Ring, 3½" diam. (133 ext. teeth, 95 int.)



- No.
185. Steering Wheel, 12" diam.

DRIVING BANDS

186. 2½" (light) | 186c. 10" (heavy)
186a. 6" (light) | 186d. 15" (heavy)
186b. 10" (light) | 186e. 20" (heavy)
187. Road Wheel, 2½" diam.
187a. Conical Disc, 1½" diam.

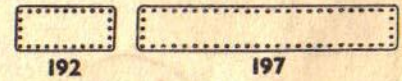

FLEXIBLE PLATES

188. 2½" x 1½" | 190. 2½" x 2½" | 191. 4½" x 2½"
189. 5½" x 1½" | 190a. 3½" x 2½" | 192. 5½" x 2½"

STRIP PLATES

196. 9½" x 2½" | 197. 12½" x 2½"



198. Hinged Flat Plate, 4½" x 2½"
199. Curved Plate, "U"-section, 2½" x 2½" x ⅝" radius
200. Curved Plate, 2½" x 2½" x 1½" radius



- 211a & 211b. Helical Gear, 1½" } Can only be used together
212. Rod and Strip Connector
212a. Rod and Strip Connector, right-angle
213. Rod Connector
213a. Three-way Rod Coupling
213b. Three-way Rod Coupling with Pummel



214. Semi-circular Plate, 2½"
215. Formed Slotted Strip, 3"
216. Cylinder, 2½" long, 1½" diam.

TRIANGULAR FLEXIBLE PLATES

221. 2½" x 1½" | 223. 2½" x 2½" | 225. 3½" x 2"
222. 2½" x 2" | 224. 3½" x 1½" | 226. 3½" x 2½"