

MECCANO

REGISTERED TRADE MARK



INSTRUCTIONS for OUTFIT No.7/8

COPYRIGHT BY MECCANO LIMITED
BINNS ROAD, LIVERPOOL 13, ENGLAND

54.7/8

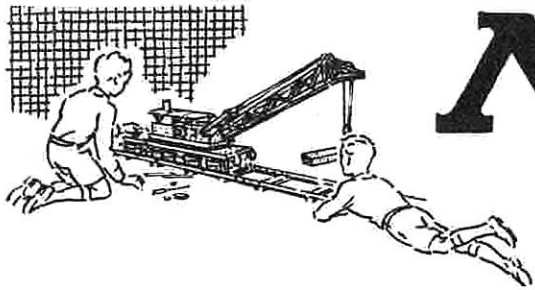

MECCANO

Registered Trade Mark

The World's Greatest Constructional Toy

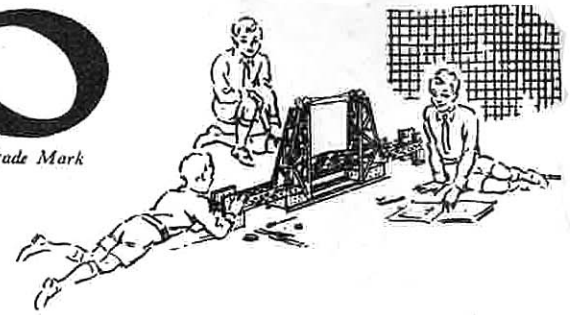

MODEL-BUILDING WITH MECCANO

There is no limit to the number of models that can be built with Meccano — Cranes, Clocks, Motor Cars, Aeroplanes, Machine Tools, Locomotives — in fact everything that interests boys. A screwdriver and a spanner, both of which are provided in each complete Outfit, are the only tools necessary.

When you have built all the models illustrated in the Books of Instructions the fun is not over, it is just beginning. Now comes the chance to make use of your own ideas. First of all, re-build some of the models with small changes in construction that may occur to you; then try building models entirely of your own design. In doing this you will enjoy the real thrill of the engineer and the inventor.

HOW TO BUILD UP YOUR OUTFIT

Meccano is sold in 12 different Outfits, ranging from No. OO to No. 10. Each Outfit can be converted into the next larger one by the purchase of an Accessory Outfit. Thus Meccano No. OO Outfit can be converted into No. O Outfit by adding to it a No. OOa Accessory Outfit. No. Oa Outfit would then convert it into a No. 1 and so on. In this way, no matter with which Outfit you begin, you can build it up by degrees until you have a complete No. 10 Outfit.

All Meccano parts are of the same high quality and finish, but the larger Outfits contain a greater quantity and variety, making possible the construction of more elaborate models.

THE 'MECCANO MAGAZINE'

The 'Meccano Magazine' is published specially for Meccano boys. Every month it describes and illustrates new Meccano models, and deals with suggestions from readers for new Meccano parts and for new methods of using the existing parts.

There are model-building competitions specially planned to give an equal chance to the owners of small and large Outfits. In addition, there are splendid articles on such subjects as Railways, Famous Engineers and Inventors, Electricity, Bridges, Cranes and Aeroplanes, and special sections dealing with the latest Engineering, Aviation, Motoring

and Shipping News. Other pages deal with Stamp Collecting, and Books of interest to boys; and a feature of outstanding popularity is the section devoted to short articles from readers.

Write to the Editor, The Meccano Magazine, Binns Road, Liverpool 13, for particulars and a specimen copy. You can order the Magazine from your Meccano dealer, or from any newsagent.

THE MECCANO GUILD

Every owner of a Meccano Outfit should join the Meccano Guild. This is a world-wide organisation, started at the request of Meccano boys. Its primary object is to bring boys together and to make them feel that they are all members of a great brotherhood, each trying to help others to get the very best out of life. Its members are in constant touch with Headquarters, giving news of their activities and being guided in their hobbies and interests. A leaflet containing full particulars of the Guild and an application form is included in this Book.

Clubs founded and established under the guidance of the Guild Secretary provide Meccano boys with opportunities of enjoying to the utmost the fun of model-building. Each has its Leader, Secretary, Treasurer and other officials. With the exception of the Leader, all the officials are boys, and as far as possible the proceedings of the clubs are conducted by boys.

MECCANO SERVICE

The service of Meccano does not end with selling an Outfit and a Book of Instructions. If ever you are in any difficulty with your models, or if you want advice on anything connected with this great hobby, write to us. We receive hundreds of interesting letters from boys in all parts of the world, and each of these is answered personally and promptly by one of our staff of experts.

Whatever your problem may be, write to us about it. We shall be delighted to help you in any way possible. Address your letters to **Information Service**.

Boys!

Read the

MECCANO MAGAZINE

THE IDEAL PAPER FOR BOYS

The happiest and most successful boys are those who take a keen interest in the world around them. The 'MECCANO MAGAZINE' is the ideal paper for these boys. Month by month its pages are filled with attractively-written articles, splendidly illustrated from actual photographs.

The subjects include Engineering in all its branches, Railways, Road Transport, Aeroplanes and Shipping. Inventions and Scientific Discoveries are described in simple language. Everything is dealt with in an attractive and straightforward style, and with an accuracy that has won for the Magazine the enthusiastic approval of the engineering, technical and scientific world. Special sections are devoted to Model-building with Meccano, fun with Dinky Toys, and the operation of realistic Miniature Railways; and Stamp Collecting forms still another important feature. Competitions of all kinds, and of a variety to suit every reader, are announced each month.



WHAT THE GUILD MEANS

The Meccano Guild is an organisation for boys, started at the request of boys, and as far as possible conducted by boys. In joining the Guild a Meccano boy becomes a member of a great brotherhood of world-wide extent. Wherever he happens to be, even in strange countries, he will know that he has met a friend whenever he sees the little triangular badge of membership. The Meccano Guild is bringing together Meccano boys all over the world, and helping them to get the best out of life. At its head — guiding and controlling and taking a personal interest in this great movement — is the President, Mr Roland G. Hornby, son of the inventor of Meccano.

HOW TO JOIN THE MECCANO GUILD

Any owner of a Meccano Outfit, no matter what its size, may become a member. All he has to do is to fill in the official application form on the back of this leaflet, have his signature witnessed, and send the form to Headquarters with a postal order (not stamps) for the necessary amount in payment for the official badge, which he will wear in his buttonhole.

The price of the badge for boys living in the British Isles is 1/-. For those living overseas it is 1/6 (30 cents in Canada).

Applicants living in Canada, Australia, New Zealand or South Africa should write to the Meccano agents in their countries. Their addresses are as follows:

CANADA: Meccano Ltd, 675 King Street West, Toronto.

AUSTRALIA: E. G. Page & Co. (Sales) Pty. Ltd (P.O. Box 1832), Dank's Building, 324 Pitt Street, Sydney, N.S.W.

NEW ZEALAND: Models Ltd (P.O. Box 129), 53 Fort Street, Auckland, C.I.

SOUTH AFRICA: Arthur E. Harris (Pty.) Ltd (P.O. Box 1199), 142 Market Street, Johannesburg.

Their Badges and Certificates are then forwarded without delay, while their application forms are sent to Headquarters in Liverpool.

Applicants living in any other country overseas should forward their forms, with a British postal order (not stamps) or a money order for 1/6, direct to the Secretary, the Meccano Guild, Binns Road, Liverpool, 13.

Guild members are eligible for the Correspondence Club, by which they are placed in touch with other members in various parts of the world. Full particulars and enrolment forms can be obtained from the Secretary.

The Secretary will send also, on request, full details of the Guild Recruiting Campaign, and of the Medallion awarded to members who are successful in obtaining recruits, together with particulars of the Meccano clubs founded and established by enthusiastic Meccano boys. A special booklet, 'How to run a Meccano Club' will be sent post free to any member on receipt of 2d. in stamps.

Join the

MECCANO GUILD

MECCANO MAGAZINE

for the really modern boy

The 'MECCANO MAGAZINE' is on sale at all bookstalls, newsagents and Meccano dealers, price 1/-. If you prefer to have each issue sent direct, the subscription rates are 14/- for twelve months or 7/- for six months, including postage, and an order form is attached.

The overseas prices of the 'M.M.' are 12c. in Canada, 1/3 in Australia, 15c. in the U.S.A. and 9d. elsewhere.

ORDER FORM

TO THE EDITOR,
MECCANO MAGAZINE,
BINNS ROAD, LIVERPOOL 13.

I enclose Postal Order for.....Please post the
'MECCANO MAGAZINE' for.....months, beginning with
the.....issue.

NAME (IN BLOCK LETTERS).....

ADDRESS.....

MECCANO GUILD

THE THREE GREAT OBJECTS OF THE GUILD

- To make every boy's life brighter and happier.
- To foster clean-mindedness, truthfulness, ambition and initiative in boys.
- To encourage boys in their hobbies, and especially in the development of their knowledge of mechanical and engineering principles.



Headquarters: BINNS ROAD LIVERPOOL 13

APPLICATION FOR MEMBERSHIP

I possess a Meccano Outfit, and I hereby make application for membership of the Meccano Guild, I approve of the objects of the Guild, and I promise on my honour

- (1) To conform to the rules and regulations of the Meccano Guild.
- (2) To promote its objects by my own example: to be helpful to others; to be clean in thought and habit; to be determined to learn and make progress.
- (3) To wear the Meccano Guild Badge on all possible occasions.
- (4) To recognise and acknowledge all other Members wearing the Guild Badge, and to render them help in case of need.

I enclose 1/- for the Guild Badge (Great Britain).

I enclose 1/6 for the Guild Badge (Overseas).

I enclose 30c. for the Guild Badge (Canada).

Strike out line not applicable (See other side of this form).

NAME OF APPLICANT.....
(BLOCK LETTERS PLEASE)

ADDRESS.....

DATE..... AGE.....

WITNESS

ADDRESS.....

The witness should be the Parent, Guardian, Employer, Schoolmaster or Church Minister and should state which when signing.

HOW TO BEGIN THE FUN

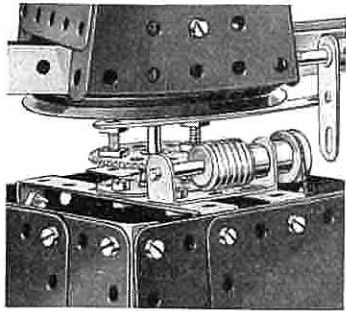

A Worm and a 57-tooth Gear give a useful drive ratio for many models

THE MOST FASCINATING OF ALL HOBBIES

Meccano model-building is the most fascinating of all hobbies, because it never becomes dull. There is always something new to be done. First of all there is the fun of building a new model, and watching it take shape as part after part is added. Then, when the model is complete, you can enjoy the thrill of setting it to work just like the real structure it represents, by means of a Meccano Motor.

SOME USEFUL HINTS

You may wonder which section of a model should be built first. There cannot be any definite rule for this, as it depends on the design of the model. In stationary models the base usually should be built first. In most of the smaller models a $5\frac{1}{2}'' \times 2\frac{1}{2}''$ Flanged Plate forms an important part of the structure, and often the best plan is to start building by bolting parts to this Plate. For other models a good general rule is that the sections that form supports for a number of other parts should be built first.

Triangular Flexible Plates and Flexible Plates can be used for forming curved surfaces in models, but they should not be bent at too sharp an angle. With careful handling these Plates can be bent to the required curve and after use straightened again.

A Rod is usually mounted in a support or bearing, such as a hole in a Strip, so that it is free to revolve. The Rod is then said to be *journalled* in the Strip.

During the construction of a model it is best to screw up the nuts with the fingers, followed by just a light turn with the screwdriver. The final tightening with spanner and screwdriver should be left until all the parts are connected up.

All Outfits from No. 2 upward include the Cord Anchoring Spring, Part No. 176. This part provides a neat and positive method of fastening a length of Cord to a Rod. When pushing the Spring on to a Rod or Crank Handle, turn clockwise so that its coils tend to unwind; turn it in the same direction when pulling it off the Rod.

THE IMPORTANCE OF LOCK-NUTTING

In some models it is necessary to join certain parts together so that, although they cannot come apart, they are free to pivot or move in relation to one another. To do this the parts are bolted together as usual but the nut is not screwed up tightly, so that the parts are not gripped. Then, to prevent the nut from unscrewing, a second nut is screwed up tightly against it, the first nut being held with a spanner. This method of using a second nut is known as *Lock-nutting*.

DRIVING YOUR MODELS

Models of suitable type can be driven by means of either Clockwork or Electric Motors.

Small and light models may be driven from a pulley on the Motor shaft through a belt running over a pulley of the same size on the driving shaft of the model, giving what is known as a 1 : 1 (one-to-one) ratio. For large models it is necessary to take the drive from a small pulley on the Motor shaft to a larger pulley on the driving shaft of the model. In most cases a 1" Pulley on the Motor shaft and a 3" Pulley on the model shaft will be found satisfactory. This provides a reduction ratio of approximately 3 : 1.

Rubber bands are very convenient for driving belts. Sometimes, however, a rubber band of the right length is not available, and then Meccano Cord or thin string is used. To tie the Cord to form an endless belt you should use the familiar reef knot.

With the larger Outfits, belt drive can be replaced with advantage by gearing. If you wish to operate a slow-moving model demanding great power, such as a traction engine, you will need to use gears that will provide a considerable reduction. For example, a Worm meshed with a $\frac{1}{2}''$ Pinion will give a 19 : 1 reduction; a Worm meshed with a 57-tooth Gear will give a 57 : 1 reduction.

All the models in this Book were built up and tested in our model-building department. Some are shown fitted with Motors, and provided that the models are properly constructed the Motors will drive them satisfactorily.

If the Motor is to operate successfully, however, there must be no excessive friction in the mechanism of the model. This can be caused by shaft bearings being slightly out of line, or by a belt or Cord drive being too tight. Before condemning your Motor, therefore, first make sure that every revolving shaft moves quite freely in its bearings, and that the bearings themselves are in line with one another. The bearings can be brought into line by pushing through them a Drift (Part No. 36c) or a Rod, before the Bolts holding the various parts are tightened up. To make the running perfectly smooth, apply a little light machine oil to every bearing or pivot on which moving parts are mounted.

The models included in this Book will give you a good idea of the various types of Meccano construction and serve as a guide to the building of a large number of other models with this Outfit. If any difficulty should arise in planning a new model, write to *Information Service, Meccano Ltd., Binns Road, Liverpool 13*, and all possible help will be given.

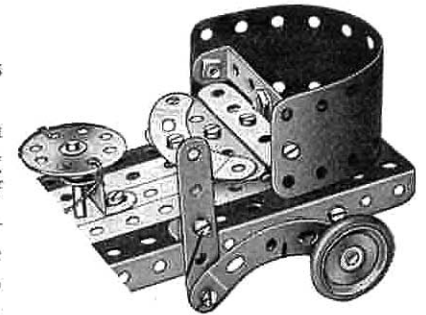

A Flexible Plate used to form a curved surface

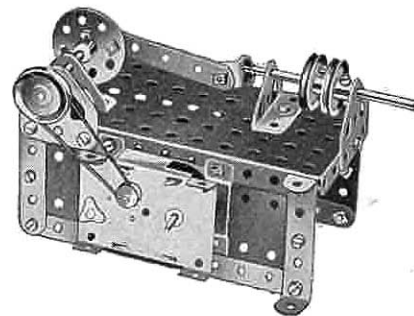

A Magic Motor fitted to drive a Steam Engine

7.1 LOCOMOTIVE AND TENDER

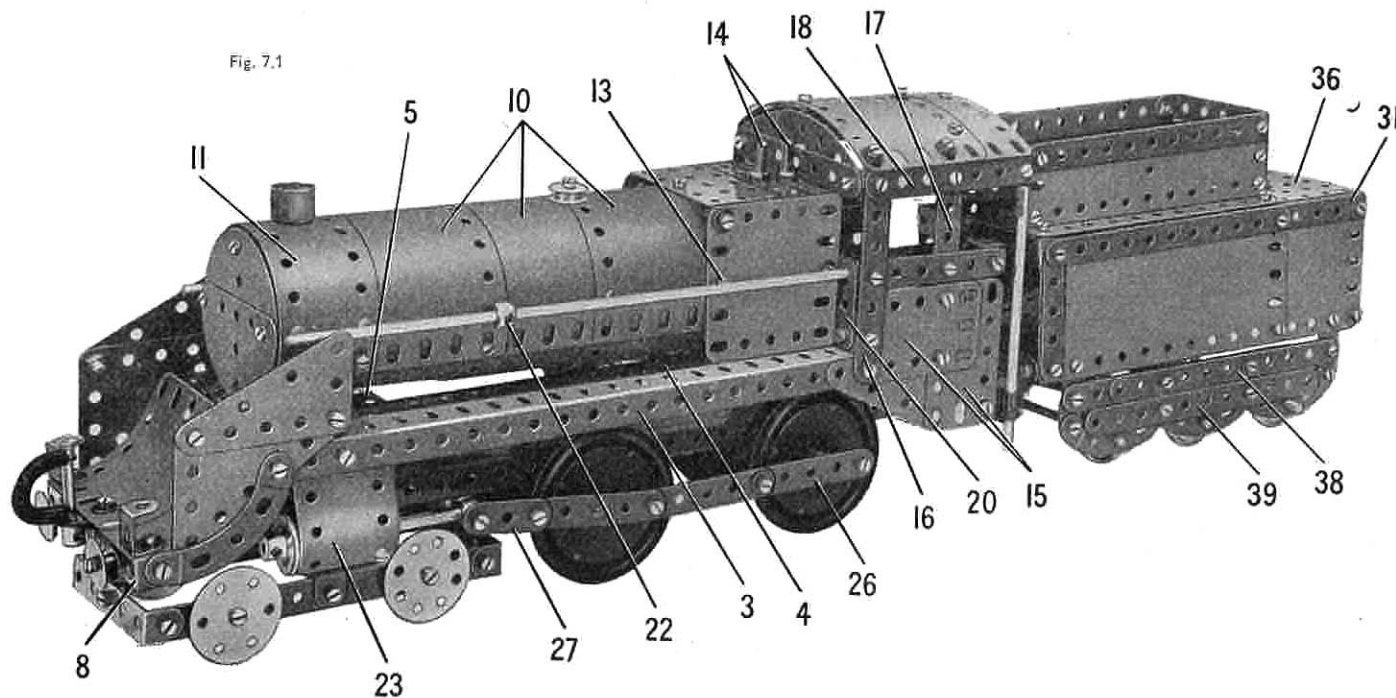

Parts Required

6 of No. 1	1 of No. 24	8 of No. 90a
18 " " 2	2 " " 24a	2 " " 111a
6 " " 3	2 " " 24c	6 " " 111c
2 " " 4	2 " " 26	2 " " 115
12 " " 5	9 " " 35	1 " " 116
4 " " 6a	200 " " 37a	4 " " 125
4 " " 8	184 " " 37b	2 " " 126
12 " " 10	32 " " 38	4 " " 126a
4 " " 11	2 " " 38d	1 " " 147b
18 " " 12	1 " " 43	2 " " 163
4 " " 12a	2 " " 45	1 " " 164
5 " " 12c	1 " " 46	1 " " 176
1 " " 13	2 " " 48	4 " " 187
1 " " 14	10 " " 48a	6 " " 188
3 " " 15a	2 " " 48b	6 " " 189
2 " " 15b	1 " " 51	8 " " 190
4 " " 16	2 " " 52	2 " " 191a
2 " " 17	3 " " 53	5 " " 192
2 " " 18a	2 " " 54	2 " " 200
1 " " 18b	6 " " 59	2 " " 212
2 " " 20b	2 " " 62	2 " " 212
5 " " 22	1 " " 63	1 " " 213
2 " " 22a	1 " " 80c	2 " " 214
1 " " 23	2 " " 90	4 " " 221
		2 " " 222

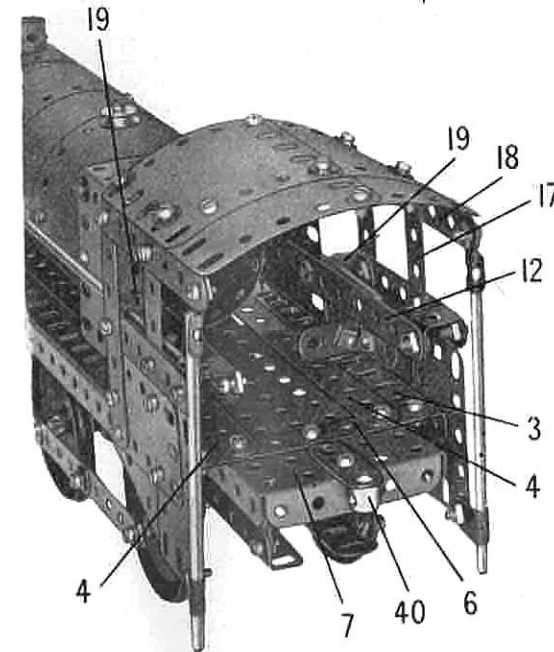
**CONSTRUCTION OF THE MAIN FRAME**

Each side of the main frame consists of a $12\frac{1}{2}$ " Angle Girder (1) and a $12\frac{1}{2}$ " Strip connected at their ends by Flat Trunnions placed with their wide ends pointing outward. The sides are joined together at each end by a $1\frac{1}{2}$ " \times $\frac{1}{2}$ " Double Angle Strip (2) bolted between the upper corners of the Flat Trunnions. The driving wheels are fixed on $3\frac{1}{2}$ " Rods. One of these is mounted in two $\frac{1}{2}$ " Reversed Angle Brackets, and the other is supported in Trunnions. The Reversed Angle Brackets and the Trunnions are fixed to the Girders (1) as shown in Fig. 7.1c.

ASSEMBLY OF THE RUNNING PLATES

The running plate on each side consists of a $12\frac{1}{2}$ " Angle Girder (3) and a $12\frac{1}{2}$ " Strip (4) (Fig. 7.1). These are bolted at the front to a $3\frac{1}{2}$ " \times $2\frac{1}{2}$ " Flanged Plate (5), and at the rear they are supported by a $3\frac{1}{2}$ " Strip (6) bolted across a $5\frac{1}{2}$ " \times $2\frac{1}{2}$ " Flanged Plate (7). The Plates (5) and (7) are fixed to the Double Angle Strips (2) of the main frame.

The dropped section of the running plates at the front is made by bolting a $2\frac{1}{2}$ " Stepped Curved Strip to each of the Girders (3). The Curved Strips are connected by a $3\frac{1}{2}$ " \times $\frac{1}{2}$ " Double Angle Strip (8), and two $1\frac{1}{4}$ " radius Curved Plates (9) are attached to the Double Angle Strip by two Angle Brackets and to the Flanged Plate (5) by an Obtuse Angle Bracket. The buffers are represented by $\frac{3}{8}$ " Washers spaced from the Double Angle Strip (8) by Spring Clips on $\frac{1}{2}$ " Bolts. The brake pipe is a Spring fitted as shown in Fig. 7.1 over a $1\frac{1}{2}$ " Rod and held in place by a Cord Anchoring Spring. The Rod is supported in a Crank bolted to the Plates (9).

The smoke deflectors are each made by bolting together a $2\frac{1}{2}$ " \times 2" and a $2\frac{1}{2}$ " \times $1\frac{1}{2}$ " Triangular Flexible Plate. They are attached to the ends of the Girders (3).

THE BOILER AND FIREBOX

The main section of the boiler is formed by three $5\frac{1}{2}$ " \times $2\frac{1}{2}$ " Flexible Plates (10) curved as shown in Fig. 7.1. The ends of two of these Plates are connected by two $4\frac{1}{2}$ " \times $2\frac{1}{2}$ " Flexible Plates that overlap the $5\frac{1}{2}$ " \times $2\frac{1}{2}$ " Flexible Plates by two holes at each end. The ends of the third $5\frac{1}{2}$ " \times $2\frac{1}{2}$ " Flexible Plate are connected by two 'U'-section Curved Plates opened out and bolted together. The smoke box (11) consists of two curved $5\frac{1}{2}$ " \times $1\frac{1}{2}$ " Flexible Plates overlapped three holes at their ends. The smoke box front is formed by two Semi-Circular Plates attached to Angle Brackets.

(Continued on next page)

Fig. 7.1a

MODEL 7.1 LOCOMOTIVE AND TENDER — Continued

The sections of the boiler are strengthened on the inside by two $2\frac{1}{2}$ " Strips (12), and a $2\frac{1}{2}$ " \times $\frac{1}{2}$ " Double Angle Strip is attached across the rear end of the boiler by a bolt (13) on each side (Fig. 7.1). These bolts fix also $2\frac{1}{2}$ " \times $2\frac{1}{2}$ " Flexible Plates that form the sides of the firebox. The top of the firebox consists of a $2\frac{1}{2}$ " \times $1\frac{1}{2}$ " Flanged Plate and two $2\frac{1}{2}$ " \times $\frac{1}{2}$ " Double Angle Strips. The Double Angle Strips are attached by Threaded Pins (14) to the end two holes of a $5\frac{1}{2}$ " Strip bolted to the Flanged Plate and to the inside of the boiler. The chimney is a Chimney Adaptor, and the dome is represented by a $\frac{1}{2}$ " loose Pulley on a $\frac{3}{8}$ " Bolt.

The boiler is bolted direct to the Flanged Plates (5) and (7).

CONSTRUCTION OF THE CAB

Each side of the cab is formed by two $2\frac{1}{2}$ " \times $1\frac{1}{2}$ " Flexible Plates (15) (Fig. 7.1) and a $2\frac{1}{2}$ " \times $1\frac{1}{2}$ " Triangular Flexible Plate bolted to one of the Girders (3). A $3\frac{1}{2}$ " Strip (16) and a $2\frac{1}{2}$ " Strip (17) are bolted to the Plates, and are connected by a 3" Strip and a $3\frac{3}{4}$ " Strip (18). One end of the 3" Strip is attached by a $\frac{3}{8}$ " Reversed Angle Bracket (19) to the side of the firebox, and the other end is joined by a Double Bracket to one of the Strips (12). A $1\frac{1}{2}$ " Strip (20) is connected to each side by an Angle Bracket.

The sides of the cab are connected by a $3\frac{1}{2}$ " Strip fitted at each end with a $2\frac{1}{2}$ " Curved Strip, and attached to Angle Brackets. The cab roof is formed by two $2\frac{1}{2}$ " \times $2\frac{1}{2}$ " and two $2\frac{1}{2}$ " \times $1\frac{1}{2}$ " Flexible Plates bolted together and secured to Obtuse Angle Brackets fixed to the Strips (18).

The cab handrails are $4\frac{1}{2}$ " Rods held in Rod and Strip Connectors and Right-Angle Rod and Strip Connectors. The handrails along the boiler are supported in the Reversed Angle Brackets (19) and in Collars (22). These Collars are screwed on to the ends of a Screwed Rod passed through the boiler. One of the handrails is an $11\frac{1}{2}$ " Rod and the other is made from a $6\frac{3}{4}$ " and a $4\frac{1}{2}$ " Rod joined by a Rod Connector.

THE CYLINDERS AND DRIVING MOTION

The cylinders are made by bolting a $5\frac{1}{2}$ " \times $1\frac{1}{2}$ " Flexible Plate (23), curved as shown, to each of the Girders (3). The Plates are overlapped seven holes and are bolted together and to the Girders (1) of the main frame. A Sleeve Piece, fitted at one end with a $\frac{3}{8}$ " Flanged Wheel, is bolted to each of the Plates (23). The piston rods are $3\frac{1}{2}$ " Rods, each of which is supported in one of the Flanged Wheels and in a Fishplate (24). The Fishplate is connected to one of the Girders (1) by an Angle Bracket, and a Collar (25) is fixed on each piston rod (Fig. 7.1c).

The coupling rods (26) are each made from two $2\frac{1}{2}$ " Strips bolted together and lock-nutted to Angle Brackets. Each Angle Bracket is bolted to the boss of one of the driving wheels. A bolt fitted with a nut is passed through the Angle Bracket and is screwed into a threaded hole in the boss. The nut is then tightened against the Angle Bracket to hold it firmly in place.

The connecting rods (27) are each made from a $2\frac{1}{2}$ " and a $1\frac{1}{2}$ " Strip (Fig. 7.1c). The connecting rod pivots at one end on the same bolt as the connecting rod, and at its other end it is pivotally connected by a bolt to the Collar (25).

ASSEMBLY OF THE BOGIE

The bogie frame is made by connecting two $5\frac{1}{2}$ " Strips at each end and at the centre by $2\frac{1}{2}$ " \times $\frac{1}{2}$ " Double Angle Strips. A $5\frac{1}{2}$ " Strip (28) (Fig. 7.1c), is fixed along the centre of the frame to an Angle Bracket and to a $2\frac{1}{2}$ " \times $\frac{1}{2}$ " Double Angle Strip (29). The bogie wheels are Wheel Discs, each of which is free to turn on a bolt attached to the frame by two nuts. The bogie pivots on a Pivot Bolt held in the boss of a Bush Wheel (30) bolted to the Girders (1).

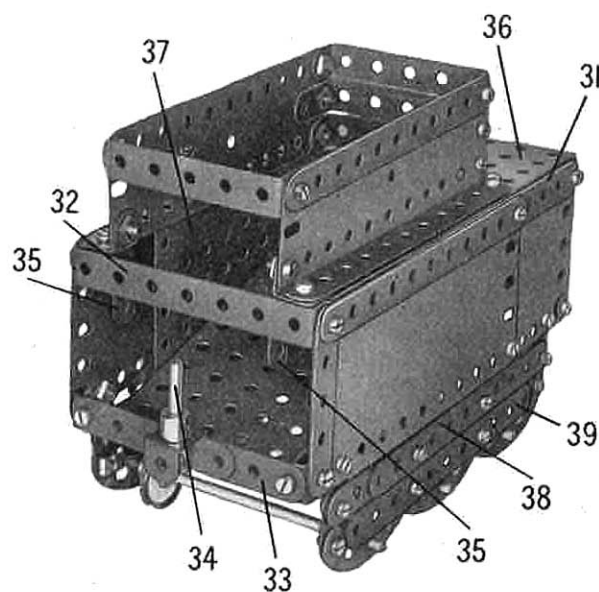

Fig. 7.1b

CONSTRUCTION OF THE TENDER

Each side of the tender consists of a $5\frac{1}{2}$ " \times $2\frac{1}{2}$ " and a $2\frac{1}{2}$ " \times $2\frac{1}{2}$ " Flexible Plate, edged by a $2\frac{1}{2}$ " Strip and a built-up strip (31) made from two $5\frac{1}{2}$ " Strips overlapped seven holes. The sides are connected at the rear by a $3\frac{1}{2}$ " \times $2\frac{1}{2}$ " Flanged Plate, and at the front by a $3\frac{1}{2}$ " \times $\frac{1}{2}$ " Double Angle Strip (32) and a built-up strip (33) attached to Angle Brackets. The strip (33) is made from two $2\frac{1}{2}$ " Strips overlapped three holes, and a large Fork Piece fitted with a 1" Rod (34) is bolted to its centre (Fig. 7.1b).

The bolts fixing the Double Angle Strip (32) secure also Double Bent Strips (35), and these support a $5\frac{1}{2}$ " Strip on each side. The rear ends of the $5\frac{1}{2}$ " Strips are bolted to a $3\frac{1}{2}$ " \times $2\frac{1}{2}$ " Flanged Plate (36). The sides of the coal bunker are Flanged Sector Plates (37) attached to the Flanged Plate (36). The sloping floor of the bunker is a $5\frac{1}{2}$ " \times $2\frac{1}{2}$ " Flanged Plate bolted between the Flanged Sector Plates.

The sides of the bunker are each extended by a $5\frac{1}{2}$ " \times $1\frac{1}{2}$ " Flexible Plate edged by a $5\frac{1}{2}$ " Strip and attached to the Double Bent Strips (35) and to Angle Brackets bolted to the Flanged Plate (36). The Flexible Plates are connected at the rear by a $2\frac{1}{2}$ " \times 1" and two $2\frac{1}{2}$ " \times $\frac{1}{2}$ " Double Angle Strips.

The tender underframe on each side consists of a built-up strip (38), made from two $5\frac{1}{2}$ " Strips overlapped nine holes, and connected to the side by a Fishplate at each end. A $5\frac{1}{2}$ " Strip (39) is joined to the strips (38) by a Fishplate and one lug of a 1" \times 1" Angle Bracket the bolts holding also three $2\frac{1}{2}$ " Stepped Curved Strips (Fig. 7.1b). The ends of the outer Curved Strips are connected to the strip (38) by Fishplates. Four of the tender wheels are 1" fixed Pulleys on 4" Rods mounted in the Curved Strips. The other two wheels are 1" loose Pulleys, held between Collars and Spring Clips on two 2" Rods joined by a Coupling.

The buffers at the rear of the tender are $\frac{3}{8}$ " Pinions, each held by its grub screw on a $\frac{3}{8}$ " Bolt passed through the $3\frac{1}{2}$ " \times $2\frac{1}{2}$ " Flanged Plate.

The tender is connected to the locomotive by passing the Rod (34) through the boss of a Crank (40).

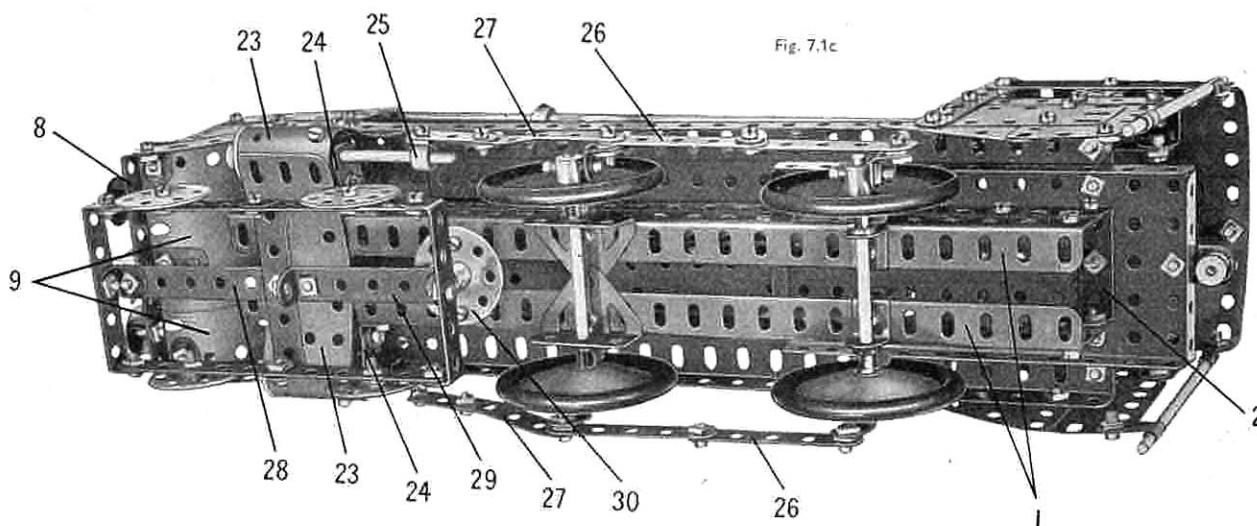

Fig. 7.1c

7.2 REFUSE WAGON

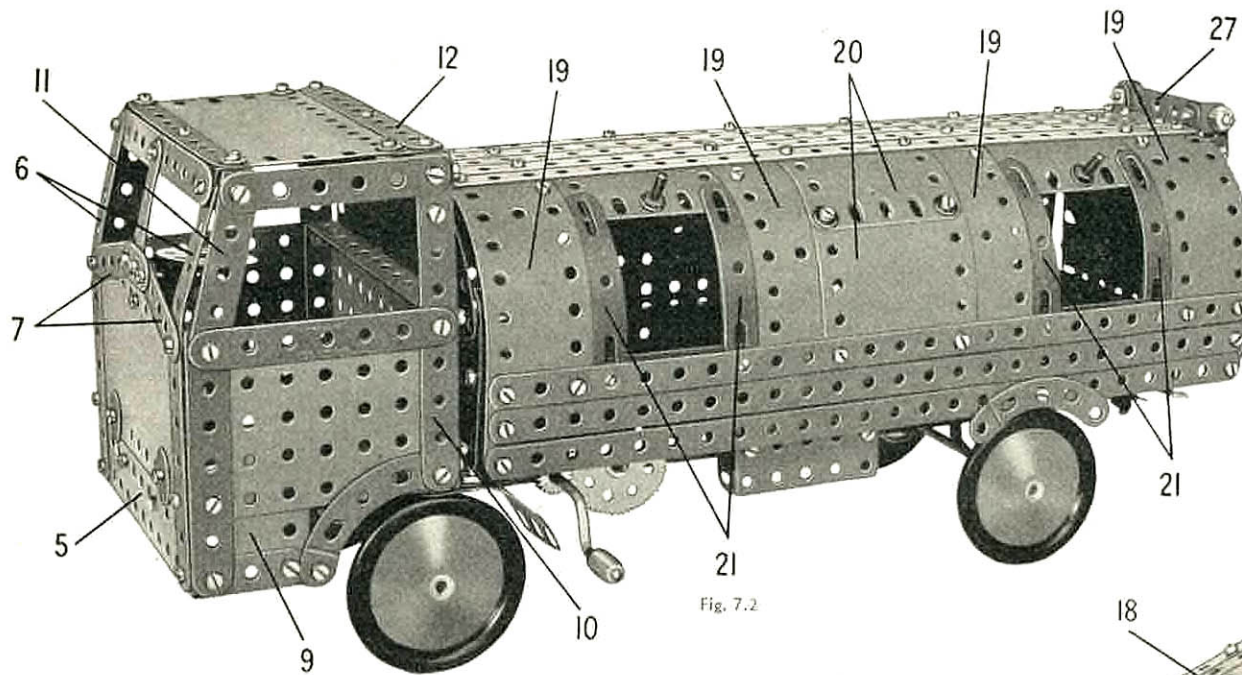

Fig. 7.2

Parts Required		
11 of No. 1	1 of No. 27a	3 of No. 111c
17 " " 2	8 " " 35	2 " " 115
6 " " 3	198 " " 37a	1 " " 125
2 " " 4	181 " " 37b	4 " " 126a
12 " " 5	32 " " 38	1 " " 147b
4 " " 6a	2 " " 38d	4 " " 155
6 " " 8	1 " " 40	1 " " 176
8 " " 10	1 " " 46	1 " " 186b
1 " " 11	2 " " 48	4 " " 187
14 " " 12	6 " " 48a	6 " " 188
4 " " 12a	1 " " 48b	6 " " 189
2 " " 15	1 " " 51	8 " " 190
4 " " 16	2 " " 52	2 " " 191
1 " " 18b	3 " " 53	6 " " 192
1 " " 19h	6 " " 59	2 " " 197
4 " " 22	2 " " 80c	2 " " 200
1 " " 23	2 " " 90	8 " " 215
1 " " 24	6 " " 90a	1 " " 216
2 " " 24c	2 " " 111	2 " " 221
1 " " 26	2 " " 111a	2 " " 222

CONSTRUCTION OF THE CHASSIS

The chassis consists of two $12\frac{1}{2}$ " Angle Girders connected by a $2\frac{1}{2}$ " \times $\frac{1}{2}$ " Double Angle Strip (1) and a $3\frac{1}{2}$ " \times $\frac{1}{2}$ " Double Angle Strip (2) (Fig. 7.2b). Each Girder is extended forward by a $5\frac{1}{2}$ " Strip (3) that overlaps the Girder by six holes, and the front ends of the Strips are joined by a $2\frac{1}{2}$ " \times 1 " Double Angle Strip (4). The front and rear wheels are fixed on 5 " Rods, which are held by 1 " Pulleys in Flat Trunnions bolted to the chassis.

At one side a Cylinder is attached by means of two $\frac{1}{2}$ " Bolts, but is spaced from the chassis by a Spring Clip on each Bolt. A Wheel Disc is clamped at each end of the Cylinder by nuts on two Screwed Rods. A $2\frac{1}{2}$ " \times $1\frac{1}{2}$ " Flanged Plate, fitted along its top edge with a $2\frac{1}{2}$ " \times $\frac{1}{2}$ " Double Angle Strip, is attached to the other side of the chassis by two $\frac{3}{8}$ " Bolts.

ASSEMBLY OF THE CAB

The front of the cab is made by bolting a $5\frac{1}{2}$ " \times $2\frac{1}{2}$ " Flanged Plate (5) to the Double Angle Strip (4) (Fig. 7.2b). A $5\frac{1}{2}$ " \times $2\frac{1}{2}$ " Flexible Plate overlaps the Flanged Plate by three holes, and is edged on each side by a $5\frac{1}{2}$ " Strip (6). A $2\frac{1}{2}$ " Strip (7) is attached to each top corner of the Flexible Plate and these Strips are connected as shown in Fig. 7.2 by a $1\frac{1}{2}$ " Strip. The top ends of the Strips (6) are joined by a $5\frac{1}{2}$ " Strip and a $2\frac{1}{2}$ " Strip is used for the centre division of the windscreen.

(Continued on next page)

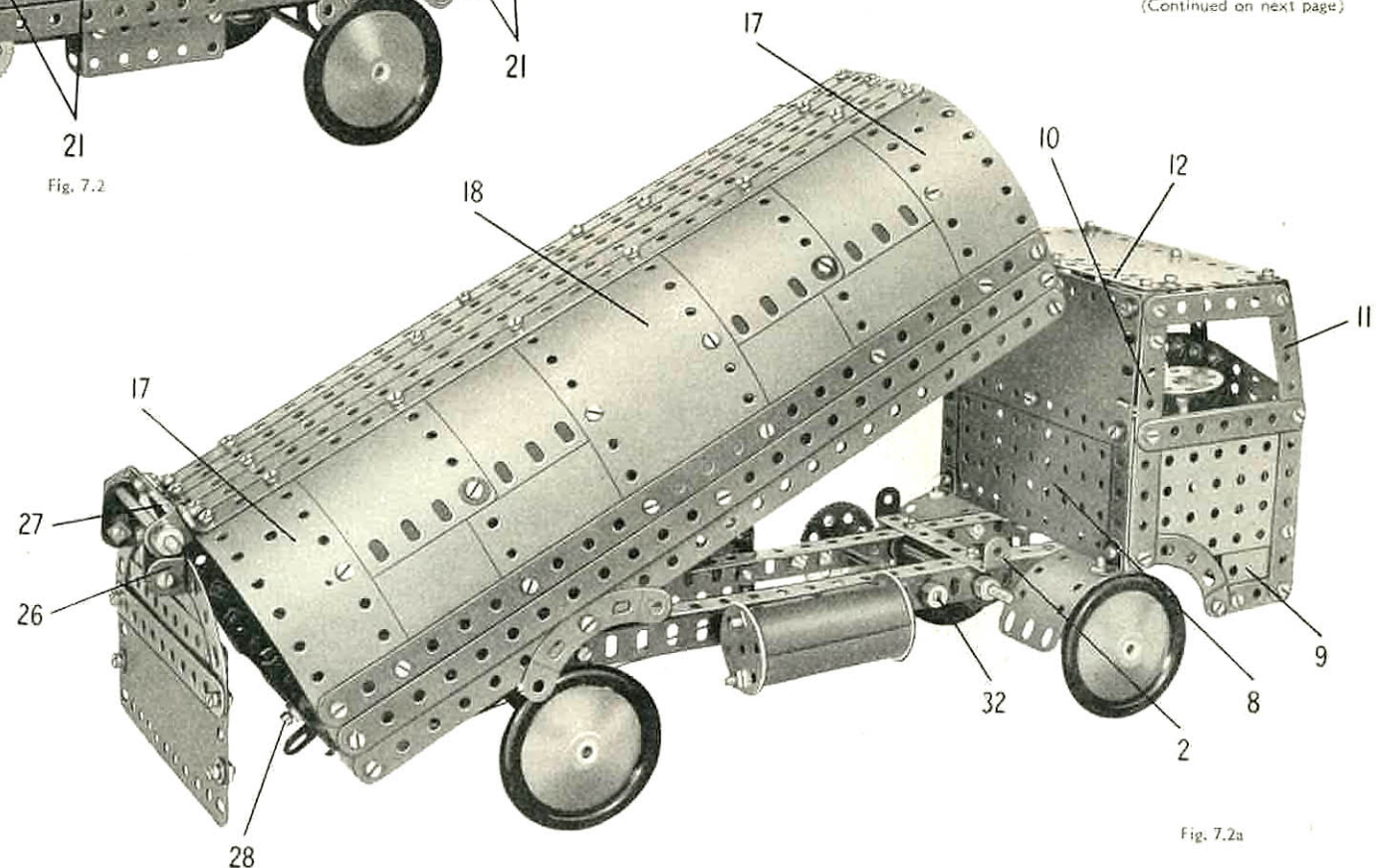

Fig. 7.2a

MODEL 7.2 REFUSE WAGON — Continued

The back of the cab is made by bolting a $5\frac{1}{2}'' \times 2\frac{1}{2}''$ Flanged Plate (8) across the chassis (Fig. 7.2a). The Flanged Plate is extended upward by a $5\frac{1}{2}'' \times 2\frac{1}{2}''$ Flexible Plate, which is joined by Angle Brackets at its upper corners to the cab sides.

Each side of the cab is a $3\frac{1}{2}'' \times 2\frac{1}{2}''$ Flanged Plate and a $2\frac{1}{2}'' \times 1\frac{1}{2}''$ Flexible Plate (9), edged by two $3\frac{1}{2}''$ Strips, a $1\frac{1}{2}''$ Strip, a $2\frac{1}{2}''$ Stepped Curved Strip and a built-up strip (10). The strip (10) is made from two $2\frac{1}{2}''$ Strips bolted together, and at its top end it is connected by a $3''$ Strip to a $2\frac{1}{2}''$ Strip (11).

A $1'' \times 1''$ Angle Bracket is attached to the top of each of the strips (10), and these support a $5\frac{1}{2}''$ Strip (12). The cab roof is a $5\frac{1}{2}'' \times 2\frac{1}{2}''$ Flexible Plate connected to the Strip (12) by three Fishplates, and to the windscreen by three Angle Brackets.

The steering column is a $3\frac{1}{2}''$ Rod, which is held by Spring Clips in a Double Bracket bolted to one of the Strips (3).

The mudflaps behind the front wheels are curved $2\frac{1}{2}'' \times 1\frac{1}{2}''$ Flexible Plates connected by Angle Brackets to the back of the cab.

REFUSE CONTAINER

The base of the container is made by connecting two $12\frac{1}{2}''$ Angle Girders (13) at each end and at the centre by means of $5\frac{1}{2}''$ Strips. A $12\frac{1}{2}''$ Angle Girder (14) is fixed to the ends of the Strips on each side, and the base is filled in by two $12\frac{1}{2}'' \times 2\frac{1}{2}''$ Strip Plates.

A $5\frac{1}{2}'' \times 2\frac{1}{2}''$ Flexible Plate is bolted across a $3\frac{1}{2}'' \times 2\frac{1}{2}''$ Flanged Plate (15), and is attached to the Angle Girders (14) by Angle Brackets. A $2\frac{1}{2}'' \times 2''$ Triangular Flexible Plate on each side is fixed between the top corner of the Flanged Plate (15) and the edge of the $5\frac{1}{2}'' \times 2\frac{1}{2}''$ Flexible Plate, and is edged by a $2\frac{1}{2}''$ Curved Strip bolted to the Flanged Plate.

The sides of the container are attached to $5\frac{1}{2}''$ Strips bolted to the ends of the Girders (14). One of these Strips is indicated at (16) (Fig. 7.2b), and they are curved as shown. The lower part of each side consists of three $12\frac{1}{2}''$ Strips. Two of these are bolted to the Strips (16) and the other is placed along the flange of the Girder (14).

The curved section of the side seen in Fig. 7.2a is filled in by two $5\frac{1}{2}'' \times 1\frac{1}{2}''$ Flexible Plates (17), a $4\frac{1}{2}'' \times 2\frac{1}{2}''$ Flexible Plate (18), and eight $2\frac{1}{2}'' \times 2\frac{1}{2}''$ Flexible Plates arranged as shown. The side fitted with the loading doors is shown in Figs. 7.2 and 7.2b. It consists of four $5\frac{1}{2}'' \times 1\frac{1}{2}''$ Flexible Plates (19) and two 'U'-section Curved Plates (20).

The top ends of the two Strips (16) at the front are bolted to the flange of the Flanged Plate (15), and the rear pair of $5\frac{1}{2}''$ Strips (16) is connected by a $2\frac{1}{2}''$ Strip. The top of the container is filled in by five $12\frac{1}{2}''$ Strips bolted to the $2\frac{1}{2}''$ Strip and to the flange of the Plate (15).

Each of the sliding doors in the side seen in Fig. 7.2 is a curved $5\frac{1}{2}'' \times 2\frac{1}{2}''$ Flexible Plate. It slides freely between two pairs of Formed Slotted Strips (21). At their lower ends the Formed Slotted Strips of each pair are attached one on each side of a built-up strip (22), Fig. 7.2b made from two $5\frac{1}{2}''$ Strips joined together. The heads of the bolts joining the Formed Slotted Strips to the strip (22) are placed behind the top $12\frac{1}{2}''$ Strip that forms part of the side of the container. The upper ends of the inner Formed Slotted Strips in each pair are clamped between the sides and a $3\frac{1}{2}''$ Strip (23) fitted to each door.

The hinged tailboard consists of a $5\frac{1}{2}'' \times 2\frac{1}{2}''$ Flexible Plate, two $2\frac{1}{2}'' \times 1\frac{1}{2}''$ Flexible Plates (24), and two $2\frac{1}{2}'' \times 1\frac{1}{2}''$ Triangular Flexible Plates (25). The Plates are strengthened by $5\frac{1}{2}''$ Strips and $2\frac{1}{2}''$ Stepped Curved Strips as shown, and a $2\frac{1}{2}'' \times \frac{1}{2}''$ Double Angle Strip (26) is fixed at the top of the tailboard. A Fishplate is bolted to each lug of the Double Angle Strip and these pivot on a $3\frac{1}{2}''$ Rod held by Collars in a further $2\frac{1}{2}'' \times \frac{1}{2}''$ Double Angle Strip (27). The latter is connected to the top of the container by two Angle Brackets. The tailboard is held in the closed position by placing the edge of the $5\frac{1}{2}'' \times 2\frac{1}{2}''$ Flexible Plate behind the head of a $\frac{1}{2}''$ Bolt (28) (Fig. 7.2b). This bolt is fixed by two nuts in the lugs of two $1\frac{1}{2}'' \times \frac{1}{2}''$ Double Angle Strips (29), bolted together by their lugs and fastened underneath the container.

THE TIPPING MECHANISM

A $2\frac{1}{2}'' \times \frac{1}{2}''$ Double Angle Strip (30) is bolted between the rear ends of the Girders (13), but is spaced from the Girders by a nut on each bolt (Fig. 7.2b). The Double Angle Strip (30) is fixed also to the lower of the Double Angle Strips (29), and it carries two $1'' \times 1''$ Angle Brackets. A $\frac{1}{2}''$ loose Pulley (31) is mounted on a $1''$ Rod held in the Angle Brackets by Spring Clips.

A $5''$ Crank Handle is mounted across the chassis and is held in place by a $\frac{1}{2}''$ Pinion and a Collar. The Pinion engages a 57-tooth Gear on a $3\frac{1}{2}''$ Rod (32), which is supported in $2\frac{1}{2}''$ Strips bolted to the inside of the chassis Girders. These Strips locate the Rod in the slotted holes of the Angle Girders.

A length of Cord is fastened at one end to a Cord Anchoring Spring on Rod (32), is passed round the Pulley (31) and is tied to a Fishplate that pivots between Spring Clips on Rod (32).

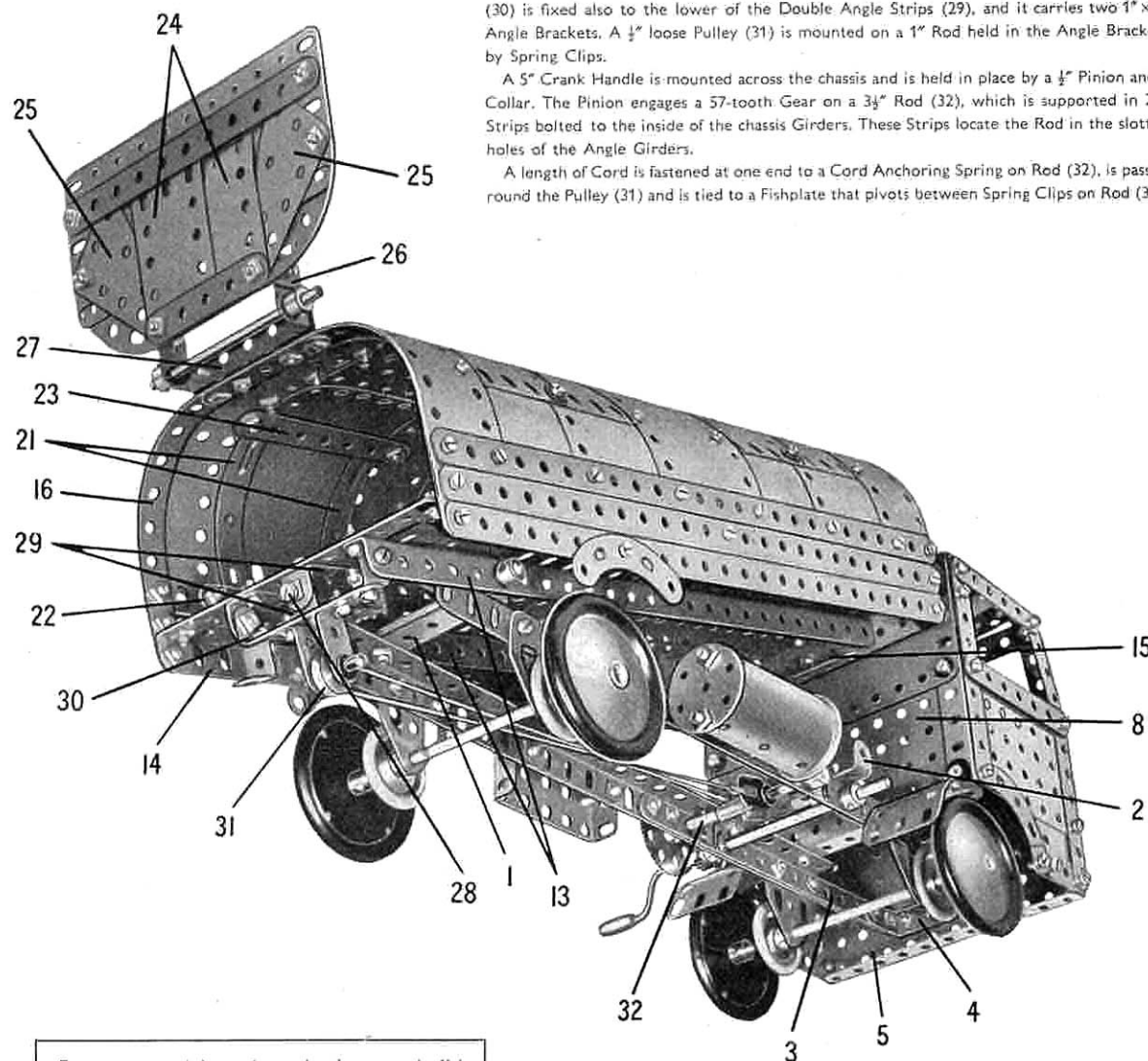

For new models and mechanisms to build
see the
MECCANO MAGAZINE
which is published monthly

Fig.7.2b

7.3 RAILWAY SERVICE CRANE

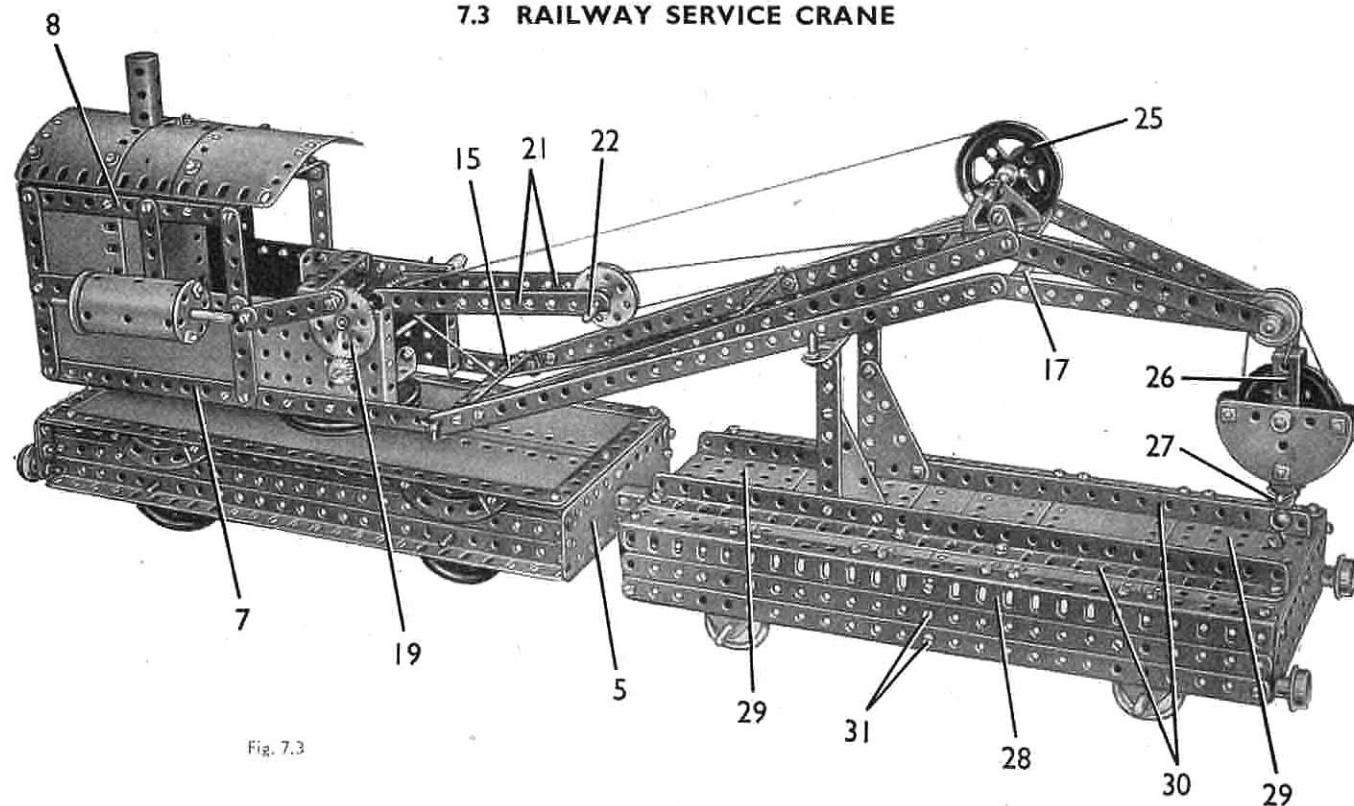

Fig. 7.3

CONSTRUCTION OF THE CRANE UNDERFRAME

Each side of the underframe consists of two $12\frac{1}{2}$ " Angle Girders (1) with a $12\frac{1}{2}$ " Strip between them, connected at their ends by $1\frac{1}{2}$ " Strips. The underframe top is filled in by a $12\frac{1}{2}$ " x $2\frac{1}{2}$ " Strip Plate on each side bolted to the upper pair of the Girders (1), and two $5\frac{1}{2}$ " x $2\frac{1}{2}$ " Flexible Plates (2) along the centre. The inner ends of the Plates (2) are strengthened by $5\frac{1}{2}$ " Strips (3), the ends of which are supported between the Girders (1) and the Strip Plates. A 3" Pulley (4) is attached by $\frac{1}{2}$ " Bolts to the Strips (3) (Fig. 7.3c).

The outer edges of the Strip Plates are covered by $12\frac{1}{2}$ " Strips, and a $5\frac{1}{2}$ " Strip is bolted along the edges of the Plates at each end of the underframe. A $5\frac{1}{2}$ " x $1\frac{1}{2}$ " Flexible Plate (5) is attached to each end by two 1 " x 1 " Angle Brackets bolted to the upper pair of the Girders (1). A coupling unit at one end is formed by a Stepped Bent Strip (6) (Fig. 7.3c), and the buffers at the other end are $\frac{5}{8}$ " Flanged Wheels held in the Plate (5) by $\frac{3}{4}$ " Bolts.

The underframe wheels are fixed on 5" Rods mounted as shown in Fig. 7.3c.

THE CRANE CAB

Each side of the cab is formed by a $5\frac{1}{2}$ " x $2\frac{1}{2}$ " Flexible Plate and a $3\frac{1}{2}$ " x $2\frac{1}{2}$ " Flanged Plate bolted to a built-up strip (7), made from two $5\frac{1}{2}$ " Strips overlapped two holes. The Flexible Plate is edged by one $5\frac{1}{2}$ " and two $2\frac{1}{2}$ " Strips, and is extended upward by three $2\frac{1}{2}$ " Strips, a $2\frac{1}{2}$ " x $2\frac{1}{2}$ " and a $2\frac{1}{2}$ " x $1\frac{1}{2}$ " Flexible Plate. The Strips and Flexible Plates support a $5\frac{1}{2}$ " Strip (8) (Fig. 7.3).

The sides are connected by a $3\frac{1}{2}$ " x $2\frac{1}{2}$ " Flanged Plate bolted between the rear ends of the $5\frac{1}{2}$ " x $2\frac{1}{2}$ " Flexible Plates. The Flanged Plate is extended upward by three $2\frac{1}{2}$ " x $1\frac{1}{2}$ " Flexible Plates bolted together and strengthened along their upper edges by a $3\frac{1}{2}$ " Strip. This Strip is connected to the Strips (8) by Angle Brackets. A $3\frac{1}{2}$ " Strip (9) is attached by Angle Brackets to the front ends of the Strips (8).

Two $3\frac{1}{2}$ " x $\frac{1}{2}$ " Double Angle Strips (10) are bolted between the strips (7) as shown in Fig. 7.3a, and a 3" Pulley is attached to them by $\frac{1}{2}$ " Bolts. A 2" Rod fixed in this Pulley is passed through the Pulley (4) and is held in place by a Bush Wheel.

The cab roof consists of two $4\frac{1}{2}$ " x $2\frac{1}{2}$ " Flexible Plates and two $1\frac{1}{2}$ " radius Curved Plates bolted together. It is attached by Obtuse Angle Brackets (11) on each side to four Fish-plates bolted to the Strips (8).

A Boiler is attached to the roof by a bolt passed through one of its Ends, and this bolt holds also a Chimney Adaptor that supports a Sleeve Piece representing the chimney. The other Boiler End is connected to the back of the cab by a $2\frac{1}{2}$ " x $\frac{1}{2}$ " Double Angle Strip (12) (Fig. 7.3a).

A $2\frac{1}{2}$ " x $\frac{1}{2}$ " Double Angle Strip (13) is bolted to one side of the cab and to a similar Double Angle Strip (14) fixed vertically to one of the Double Angle Strips (10).

(Continued on next page)

Parts Required

12 of No. 1	5 of No. 22	2 of No. 111a
18 " " 2	2 " " 22a	6 " " 111c
6 " " 3	1 " " 24	2 " " 115
2 " " 4	2 " " 24a	2 " " 126
11 " " 5	2 " " 24c	4 " " 126a
4 " " 6a	2 " " 26	1 " " 147b
8 " " 8	1 " " 27a	4 " " 155
6 " " 10	15 " " 35	1 " " 162
3 " " 11	201 " " 37a	1 " " 163
14 " " 12	184 " " 37b	1 " " 164
4 " " 12a	35 " " 38	2 " " 176
6 " " 12c	1 " " 40	4 " " 187
1 " " 14	1 " " 44	5 " " 188
2 " " 15	1 " " 46	6 " " 189
2 " " 15a	2 " " 48	2 " " 190
1 " " 15b	8 " " 48a	2 " " 191
3 " " 16	2 " " 48b	6 " " 192
1 " " 17	1 " " 51	2 " " 197
4 " " 18a	2 " " 52	2 " " 200
1 " " 18b	3 " " 53	1 " " 212
2 " " 19b	1 " " 57c	1 " " 213
1 " " 19g	6 " " 59	2 " " 214
1 " " 19h	2 " " 80c	1 " " 216
2 " " 20a	4 " " 90a	2 " " 221
4 " " 20b	2 " " 111	

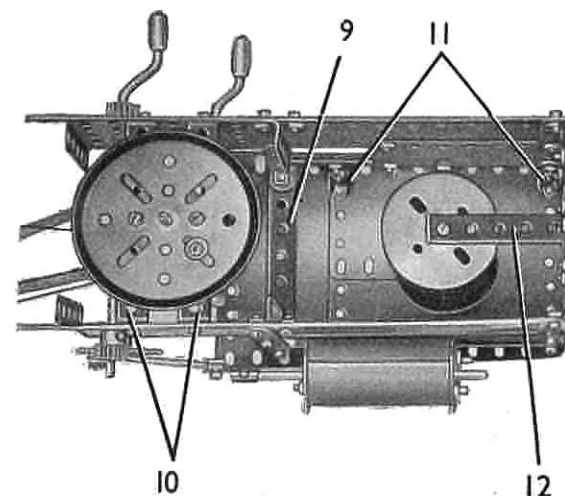

Fig. 7.3a

MODEL 7.3 RAILWAY SERVICE CRANE — Continued

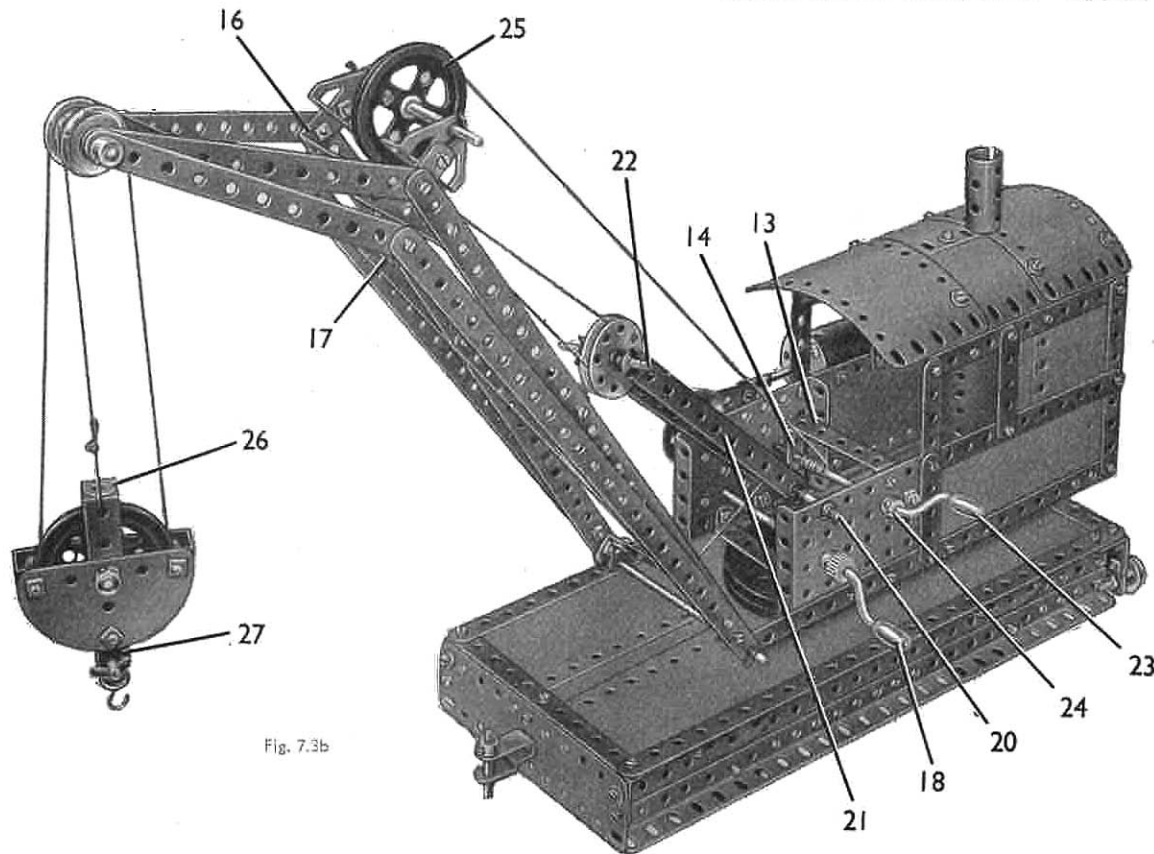

Fig. 7.3b

The pulley block consists of two Semi-Circular Plates joined by two Double Brackets. Two $2\frac{1}{2}$ " \times $\frac{1}{2}$ " Double Angle Strips (26) are bolted to the Semi-Circular Plates and a Double Bracket (27) is attached to them. A small Loaded Hook is passed over a 1" Rod held by Spring Clips in the Double Bracket. The 2" Pulley is mounted on a $1\frac{1}{2}$ " Rod kept in position by Collars.

THE MATCH TRUCK

The match truck is made by bolting two $12\frac{1}{2}$ " Angle Girders (28) to the ends of two $5\frac{1}{2}$ " \times $2\frac{1}{2}$ " Flanged Plates (29) (Fig. 7.3). The top of the truck is filled in by two $5\frac{1}{2}$ " \times $2\frac{1}{2}$ " and two $5\frac{1}{2}$ " \times $1\frac{1}{2}$ " Flexible Plates bolted to the Girders (28) and to two $12\frac{1}{2}$ " Angle Girders (30).

The sides of the truck are each formed by two $12\frac{1}{2}$ " Strips. These are fixed to a $1\frac{1}{2}$ " \times $\frac{1}{2}$ " Double Angle Strip on each side by the bolts (31). The ends of the truck are $5\frac{1}{2}$ " \times $1\frac{1}{2}$ " Flexible Plates bolted to the Flanged Plates (29) and attached to the $12\frac{1}{2}$ " Strips by Angle Brackets. The buffers at one end are $\frac{3}{4}$ " Flanged Wheels held by $\frac{1}{2}$ " Bolts.

The truck wheels are 1" Pulleys with Rubber Rings, and the axle bearings are Flat Trunnions bolted to one of the $12\frac{1}{2}$ " Strips of each side. Two of the wheels are fixed on a $6\frac{1}{2}$ " Rod, and the other two are mounted on two $3\frac{1}{2}$ " Rods joined by a Rod Connector.

The support for the jib is provided by two $3\frac{1}{2}$ " Strips and two $2\frac{1}{2}$ " \times $1\frac{1}{2}$ " Triangular Flexible Plates bolted to the Girders (30). The top ends of the Strips are connected by a $2\frac{1}{2}$ " \times $\frac{1}{2}$ " Double Angle Strip, and two $2\frac{1}{2}$ " Strips overlapped three holes are bolted to the Double Angle Strip. A Threaded Pin is fitted to the end of each $2\frac{1}{2}$ " Strip.

An Angle Bracket is bolted to one end of the match truck, and a $1\frac{1}{2}$ " Rod passed through this Angle Bracket and the Stepped Bent Strip (6) connects the truck to the crane. The $1\frac{1}{2}$ " Rod is fitted with a Collar.

ASSEMBLY OF THE JIB

Each side of the jib consists of two $12\frac{1}{2}$ " Strips bolted together at their lower ends so that one clear hole of the lower Strip overhangs the end of the upper Strip. At its upper end each Strip is extended by a $5\frac{1}{2}$ " Strip arranged as shown in Fig. 7.3b.

The sides of the jib are connected at their lower ends by a $3\frac{1}{2}$ " Strip (15) attached by Angle Brackets, at the centre by a 3" Strip also fixed to Angle Brackets, and at the joins between the $12\frac{1}{2}$ " and $5\frac{1}{2}$ " Strips they are connected by a $2\frac{1}{2}$ " \times 1" Double Angle Strip (16) and a $2\frac{1}{2}$ " \times $\frac{1}{2}$ " Double Angle Strip (17). At the top of the jib a 1" loose and a 1" fixed Pulley are freely mounted on a $1\frac{1}{2}$ " Rod held in place by Collars.

The jib pivots on a $4\frac{1}{2}$ " Rod, which is held by Spring Clips in the end holes of the strips (7).

THE OPERATING MECHANISM

A 5" Crank Handle (18) is held in the sides of the cab by a $\frac{1}{2}$ " Pinion at each end. One of these Pinions drives a 57-tooth Gear (19) on a 4" Rod (20). A $2\frac{1}{2}$ " Strip is lock-nutted to the Gear and to a Rod and Strip Connector on a $4\frac{1}{2}$ " Rod. This Rod is passed through the centre holes of two Wheel Discs, which are clamped to the ends of a Cylinder by means of nuts on Screwed Rods. The Cylinder is bolted to the side of the cab.

Two $5\frac{1}{2}$ " Strips (21) are held between Spring Clips on the Rod (20), and a 2" Rod (22) is supported in their top holes (Fig. 7.3). A 1" loose Pulley, with a Wheel Disc on each side, is mounted on the Rod between Spring Clips.

The jib is luffed, or raised and lowered, by turning a $3\frac{1}{2}$ " Crank Handle (23) fitted with a Collar (24) (Fig. 7.3b). The Crank Handle is allowed to slide about $\frac{1}{2}$ " in its bearings, and a bolt in the Collar (24) can be engaged with a bolt in the side of the cab to form a simple brake.

A length of Cord tied to Crank Handle (23) is taken round a 2" Pulley (25) on Rod (22) and is tied to one of two Trunnions bolted to the lugs of the Double Angle Strips (16). The Pulley (25) is fixed on a $3\frac{1}{2}$ " Rod held in the Trunnions by Spring Clips.

Load hoisting is operated by Cord tied to the Rod (20) between the Strips (21). The Cord is taken through holes in the Strip (15) and the Double Angle Strip (17), over the 1" fixed Pulley at the top of the jib, and round a 2" Pulley in the pulley block. The Cord is then taken round the 1" loose Pulley at the top of the jib and is tied finally to the pulley block.

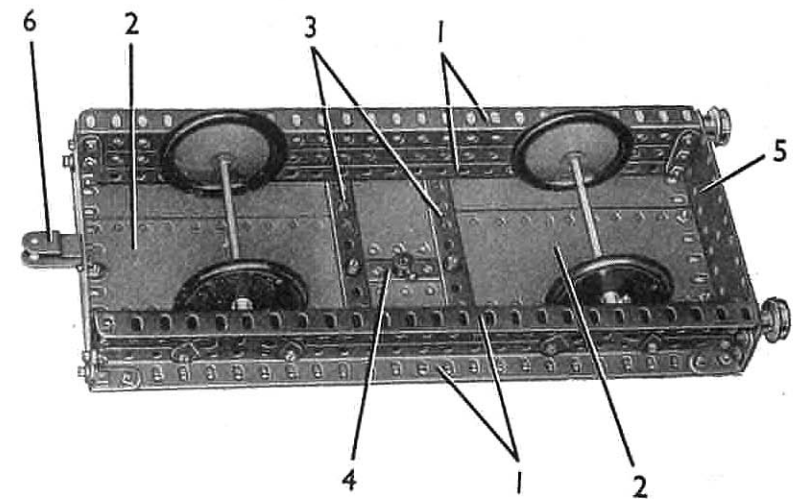

Fig. 7.3c

7.4 GIANT ARTICULATED LORRY

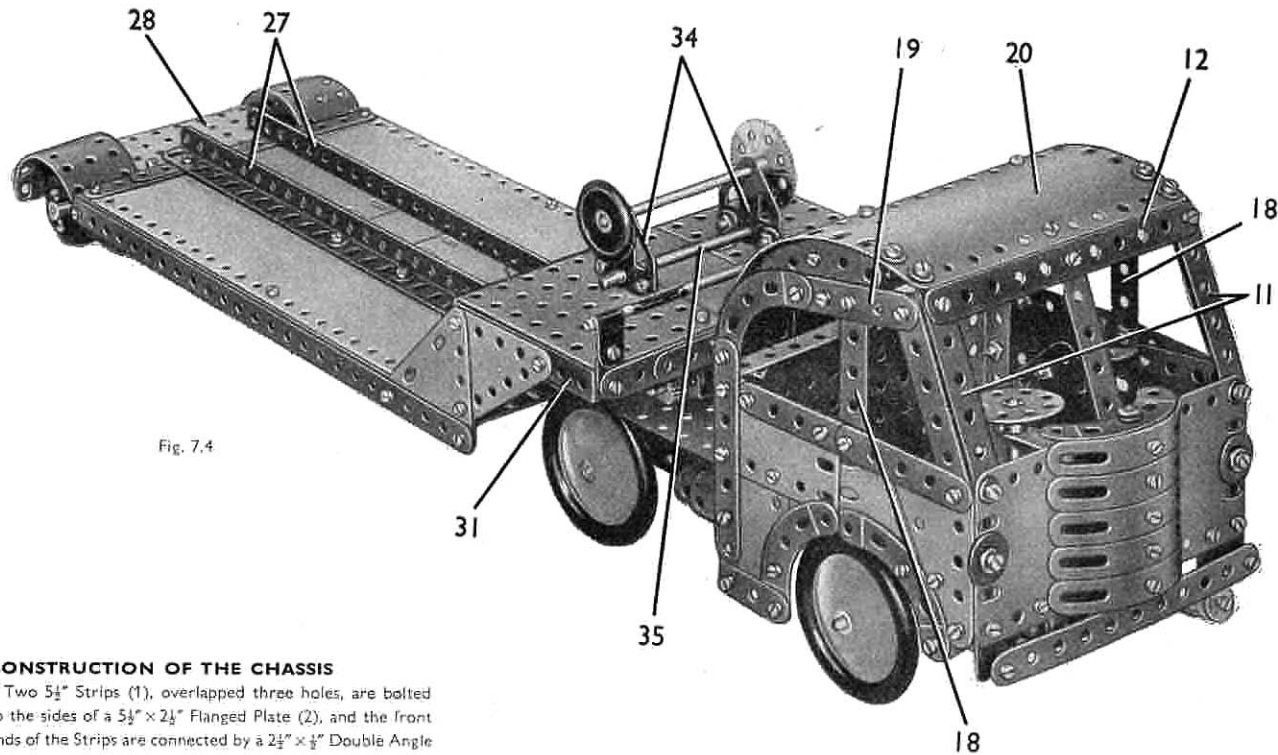

Fig. 7.4

CONSTRUCTION OF THE CHASSIS

Two $5\frac{1}{2}$ " Strips (1), overlapped three holes, are bolted to the sides of a $5\frac{1}{2}$ " \times $2\frac{1}{2}$ " Flanged Plate (2), and the front ends of the Strips are connected by a $2\frac{1}{2}$ " \times $\frac{1}{2}$ " Double Angle Strip (3) (Fig. 7.4a). The rear wheels are mounted on a 5" Rod held in the chassis by $\frac{3}{4}$ " Flanged Wheels.

Each of the front wheels is fixed on a $1\frac{1}{2}$ " Rod held in a Double Bracket by a Collar. A $1\frac{1}{4}$ " Strip (4) is placed between the lugs of each Double Bracket, and a $\frac{3}{8}$ " Bolt is passed through the two parts (Fig. 7.4a). One of the Bolts is fitted with a nut and two Washers, then passed through a $1" \times 1"$ Angle Bracket (5), and is held in place by a second nut. The other Bolt is similarly attached to a Trunnion bolted to the chassis opposite to the Angle Bracket (5). The Strips (4) and the Double Brackets *must be free to pivot on the Bolts*.

A Pivot Bolt is passed through a Rod and Strip Connector (6) and two Washers are placed on it before it is passed through a $3\frac{1}{2}$ " Strip (7). A Spring Clip is then fitted over the Pivot Bolt and it is held by its nuts in one of the Strips (4). A $\frac{1}{2}$ " Bolt is passed through a Rod and Strip Connector (8), fitted with a Spring Clip and then held by two nuts in the second of the Strips (4). The Rod and Strip Connectors are joined together by a $3\frac{1}{2}$ " Rod.

At one side of the chassis a Cylinder is attached to a Fishplate, and is fitted at each end with a Wheel Disc held in place by a nut on a Screwed Rod. At the other side is bolted a Sleeve Piece fitted with a Chimney Adaptor.

The coupling device on the chassis is made by pivoting a Large Fork Piece (9) on a $1\frac{1}{2}$ " Rod held in a Coupling. The Coupling is spaced from the Flanged Plate (2) by two Washers on the bolt that holds it in place.

ASSEMBLY OF THE CAB

The back of the cab is made by bolting a $5\frac{1}{2}$ " \times $2\frac{1}{2}$ " Flanged Plate (10) across the chassis (Fig. 7.4b), and the front consists of a $5\frac{1}{2}$ " \times $2\frac{1}{2}$ " Flexible Plate attached to the Double Angle Strip (3) by a Fishplate. The windscreen divisions are two $5\frac{1}{2}$ " Strips (11) and a central $3\frac{1}{2}$ " Strip, connected at their upper ends by a $5\frac{1}{2}$ " Strip (12). The bumper is a $5\frac{1}{2}$ " Strip connected to the lower ends of the Strips (11) by $\frac{3}{4}$ " Bolts, but separated from them by a Spring Clip on each Bolt. The radiator is made by bolting five Formed Slotted Strips and a $2\frac{1}{2}$ " Stepped Curved Strip to a $2\frac{1}{2}$ " \times $\frac{1}{2}$ " Double Angle Strip. It is connected to the front of the cab by Angle Brackets.

(Continued on next page)

Parts Required

2 of No. 1	5 of No. 22	2 of No. 52	1 of No. 164
16 " " 2	1 " " 23	3 " " 53	1 " " 176
6 " " 3	1 " " 23a	6 " " 59	4 " " 187
2 " " 4	1 " " 24	1 " " 62	6 " " 188
11 " " 5	2 " " 24c	1 " " 63	6 " " 189
4 " " 6a	2 " " 26	2 " " 80c	4 " " 190
6 " " 8	1 " " 27a	2 " " 90	1 " " 191
10 " " 10	4 " " 35	7 " " 90a	4 " " 192
2 " " 11	175 " " 37a	2 " " 111a	2 " " 197
14 " " 12	165 " " 37b	6 " " 111c	2 " " 212
3 " " 12a	33 " " 38	1 " " 115	2 " " 212a
3 " " 12c	2 " " 38d	1 " " 116	1 " " 213
1 " " 14	1 " " 43	2 " " 125	2 " " 214
2 " " 15	1 " " 44	2 " " 126	5 " " 215
1 " " 15b	1 " " 46	2 " " 126a	1 " " 216
4 " " 16	1 " " 48	4 " " 142c	4 " " 221
4 " " 18a	10 " " 48a	1 " " 147b	2 " " 222
4 " " 20b	2 " " 48b	1 " " 155	2 " " 223
	1 " " 51	1 " " 163	

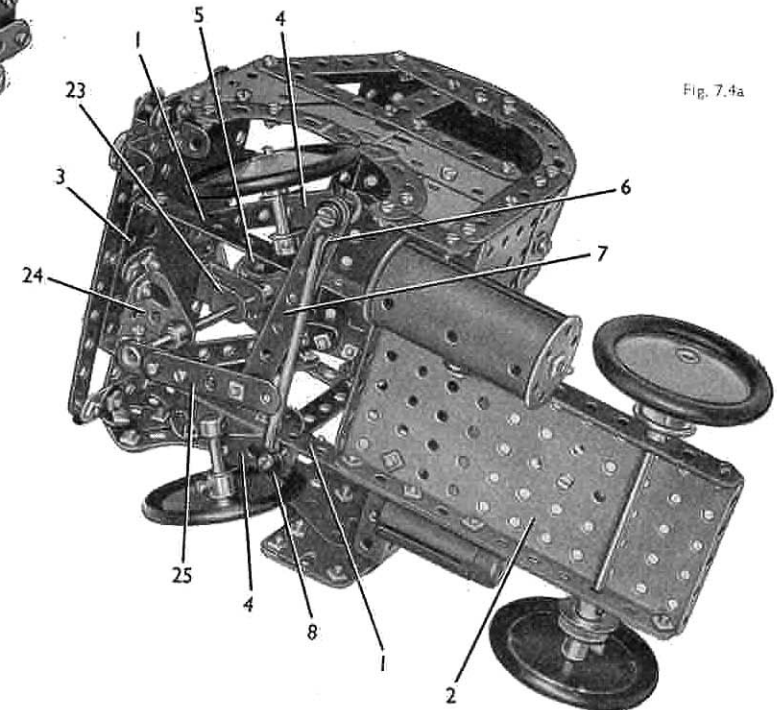

Fig. 7.4a

MODEL 7.4 GIANT ARTICULATED LORRY — Continued

Each side of the cab consists of three $2\frac{1}{2}'' \times 1\frac{1}{2}''$ Flexible Plates (13) and two $2\frac{1}{2}'' \times 1\frac{1}{2}''$ Triangular Flexible Plates (14), bolted together as shown and edged by a $3\frac{1}{2}''$ Strip (15), two $2\frac{1}{2}''$ Strips (16), two $2\frac{1}{2}''$ Stepped Curved Strips and a $1\frac{1}{2}''$ Strip (17) (Fig. 7.4b). The front Curved Strip on each side is attached to the Plates by Fishplates, and the side is bolted to the end of the Flanged Plate (10) and is connected to the front of the cab by two Angle Brackets.

Each side window frame is formed by a $3''$ Strip, a $2\frac{1}{2}'' \times \frac{1}{2}''$ Double Angle Strip (18) and a $2\frac{1}{2}''$ Stepped Curved Strip, connected at their upper ends by a $2\frac{1}{2}''$ Strip (19). A $2\frac{1}{2}''$ Curved Strip is attached to the Strip (19) by a Fishplate.

The roof is formed by a $5\frac{1}{2}'' \times 2\frac{1}{2}''$ Flexible Plate (20), two $1\frac{1}{2}''$ radius Curved Plates (21) and two $5\frac{1}{2}'' \times 1\frac{1}{2}''$ Flexible Plates (22). The Plate (20) is attached to three Obtuse Angle Brackets bolted to the Strip (12).

The steering column is a $3\frac{1}{2}''$ Rod supported in a Stepped Bent Strip (23) and a Trunnion (24), and held in place by a Collar. At its lower end the Rod carries a Crank extended by a Strip (25), which is lock-nutted to the Strip (7) but spaced from it by a Collar on the $\frac{1}{2}''$ Bolt (Fig. 7.4a).

A $2\frac{1}{2}'' \times 1\frac{1}{2}''$ Flanged Plate, fitted with a $2\frac{1}{2}'' \times \frac{1}{2}''$ Double Angle Strip, is attached to a $\frac{1}{2}''$ Reversed Angle Bracket bolted to the rear of the cab.

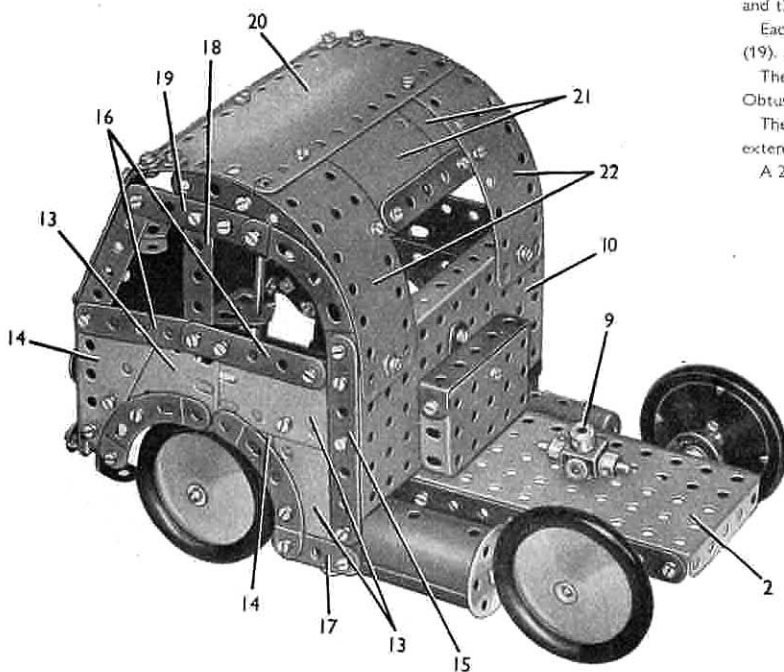

Fig. 7.4b

The trailer swan neck is made by bolting a $2\frac{1}{2}'' \times 2\frac{1}{2}''$ and a $2\frac{1}{2}'' \times 2''$ Triangular Flexible Plate to each of the outer Girders (26). The lower edge of the $2\frac{1}{2}'' \times 2\frac{1}{2}''$ Triangular Flexible Plate and the flange of the Angle Girder are covered by a $12\frac{1}{2}''$ Strip, and the join between the Triangular Flexible Plates is strengthened by a $2\frac{1}{2}''$ Strip on the inside. A $3\frac{1}{2}'' \times \frac{1}{2}''$ Double Angle Strip (31) (Fig. 7.4c) is bolted to each $2\frac{1}{2}'' \times 2''$ Triangular Flexible Plate, and each Double Angle Strip supports a $3\frac{1}{2}'' \times 2\frac{1}{2}''$ Flanged Plate (32). The front flanges of the Plates (32) are connected by two $5\frac{1}{2}''$ Strips overlapped nine holes, and to the rear flanges are attached two $5\frac{1}{2}'' \times 1\frac{1}{2}''$ Flexible Plates also overlapped nine holes and strengthened along their top edges by two $5\frac{1}{2}''$ Strips. Two $2\frac{1}{2}'' \times \frac{1}{2}''$ Double Angle Strips joined by a $2\frac{1}{2}''$ Strip (33) are bolted underneath the Flexible Plates to the $2\frac{1}{2}'' \times 2''$ Triangular Flexible Plates. Two $2\frac{1}{2}'' \times 2\frac{1}{2}''$ Flexible Plates are used to fill the gap between the Flanged Plates (32).

A winch fitted to the trailer is made by bolting two $2\frac{1}{2}'' \times \frac{1}{2}''$ Double Angle Strips to the Flanged Plates (32). These Double Angle Strips support two Flat Trunnions (34), and in them is mounted a $3\frac{1}{2}''$ Rod (35) fitted with a Cord Anchoring Spring at one end and a $\frac{1}{2}''$ Pinion at the other end. The Pinion engages a 57-tooth Gear on a second $3\frac{1}{2}''$ Rod, which carries also a $1''$ Pulley fitted with a Rubber Ring. A guard rail at the front of the trailer is formed by a $5''$ and a $1\frac{1}{2}''$ Rod joined by a Rod Connector. It is supported at each end in a Right-Angle Rod and Strip Connector that is bolted to a Fishplate fastened to the front of the trailer.

The trailer coupling unit is made by bolting a $2\frac{1}{2}'' \times 1''$ Double Angle Strip to the front corner hole of each of the Flanged Plates (32) (Fig. 7.4c). A $2\frac{1}{2}'' \times \frac{1}{2}''$ Double Angle Strip (36) is held by a $\frac{1}{2}''$ fixed Pulley and a $\frac{1}{2}''$ Pinion on a $4''$ Rod, which is supported in the lugs of the $2\frac{1}{2}'' \times 1''$ Double Angle Strip. A $\frac{3}{8}''$ Bolt (37) can be engaged in the boss of the Large Fork Piece (9) fitted to the motor unit.

DETAILS OF THE TRAILER

The trailer platform consists of a $12\frac{1}{2}'' \times 2\frac{1}{2}''$ Strip Plate on each side, and a $4\frac{1}{2}'' \times 2\frac{1}{2}''$ and two $5\frac{1}{2}'' \times 2\frac{1}{2}''$ Flexible Plates at the centre. The outer and inner edges of the Strip Plates are edged by $12\frac{1}{2}''$ Angle Girders (26) underneath the platform, and two similar Angle Girders (27) on the top. The rear edges of the Plates are strengthened by two $5\frac{1}{2}''$ Strips overlapped nine holes, and a $3\frac{1}{2}'' \times 2\frac{1}{2}''$ Flanged Plate (28) is bolted to them. A Semi-Circular Plate is attached through its centre hole in the second hole from the rear of each flange of the Flanged Plate, and is connected to the Flanged Plate by a $1'' \times 1''$ Angle Bracket bolted to the front corner hole of the Semi-Circular Plate.

The rear ends of the Semi-Circular Plates are connected by a built-up strip (29) (Fig. 7.4c) attached by Angle Brackets. This strip consists of two $5\frac{1}{2}''$ Strips overlapped nine holes. Two $3\frac{1}{2}''$ Strips (one of them is indicated at (30)) are bolted to a $\frac{1}{2}''$ Reversed Angle Bracket, and one of these Strips is connected to the rear corners of the Semi-Circular Plates by Angle Brackets. The trailer wheels are $1''$ Pulleys fitted with Motor Tyres, and they are fixed on a $6\frac{1}{2}''$ Rod that is held by $\frac{1}{2}''$ Flanged Wheels in the Semi-Circular Plates. The mudguards over the wheels are $5\frac{1}{2}'' \times 1\frac{1}{2}''$ Flexible Plates bent as shown. They are bolted to the ends of the strip (29) and are connected by Angle Brackets to the outer two of the Girders (26).

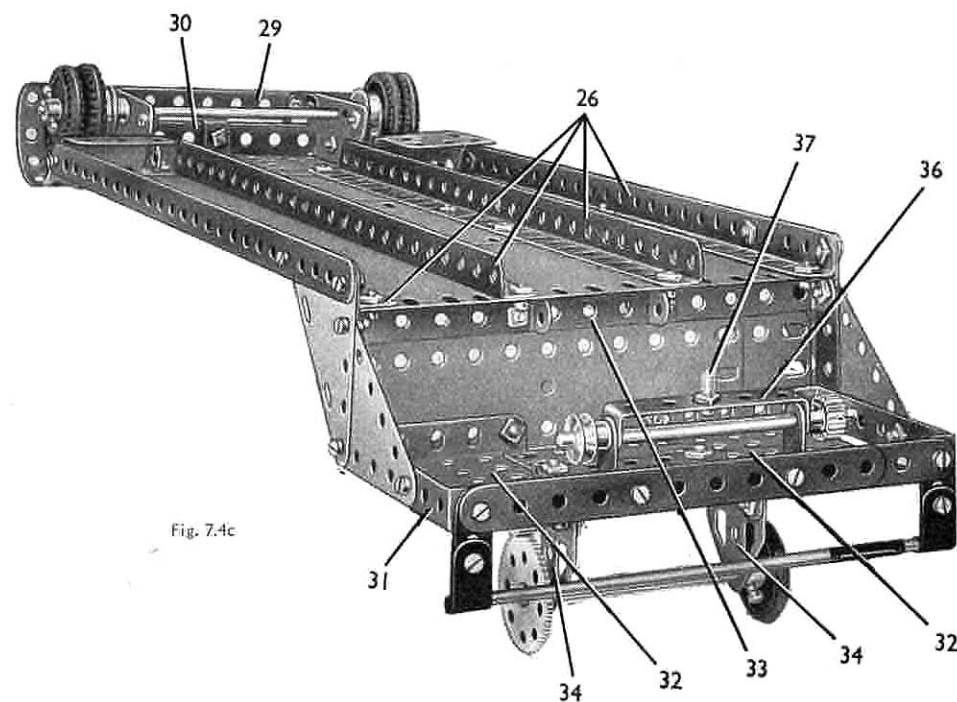

Fig. 7.4c

7.5 SHAPING MACHINE

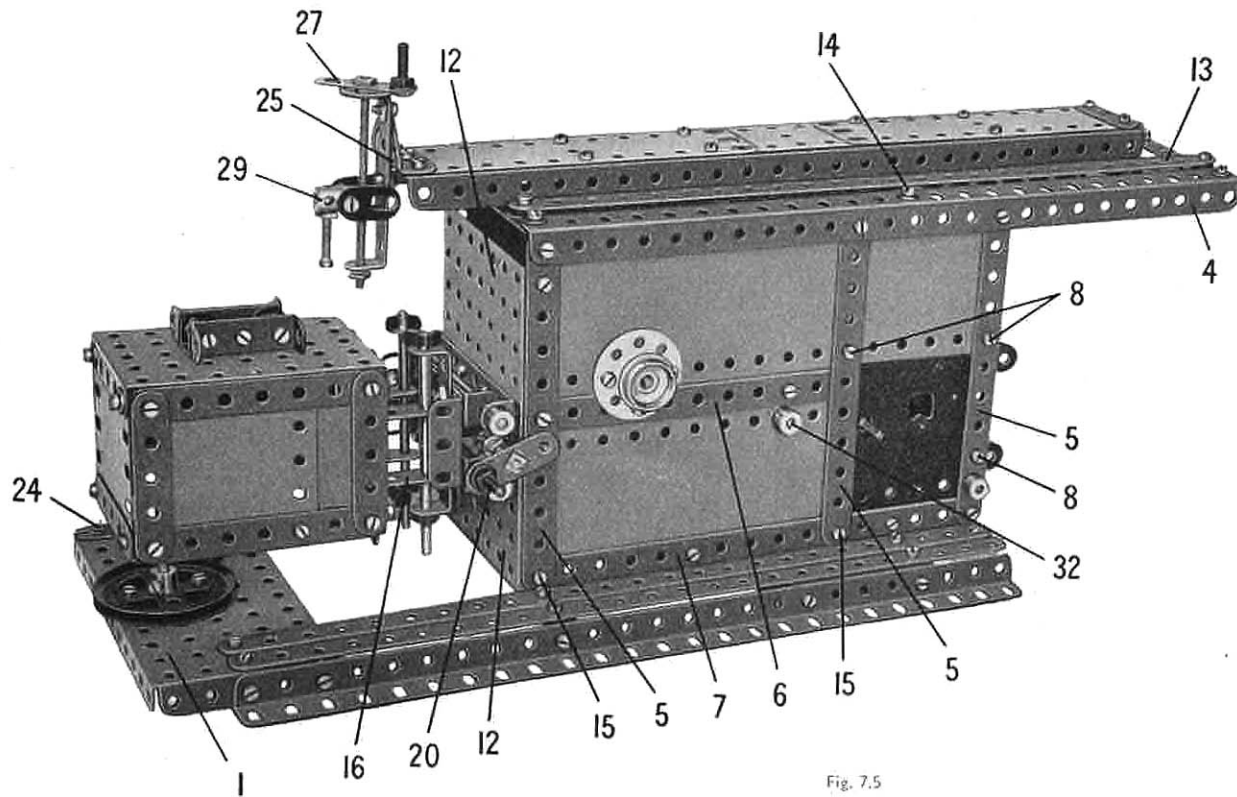

Fig. 7.5

DETAILS OF THE WORK-TABLE

The top of the work-table is a $3\frac{1}{2}'' \times 2\frac{1}{2}''$ Flanged Plate, and each end is a $2\frac{1}{2}'' \times 2\frac{1}{2}''$ Flexible Plate edged at the bottom by a $2\frac{1}{2}''$ Strip. Each side is formed by a $2\frac{1}{2}'' \times 2\frac{1}{2}''$ and a $2\frac{1}{2}'' \times 1\frac{1}{2}''$ Flexible Plate strengthened by two $3\frac{1}{2}''$ and two $2\frac{1}{2}''$ Strips. The sides are connected to the ends by Angle Brackets. Two $1\frac{1}{2}'' \times \frac{1}{2}''$ Double Angle Strips are bolted to the lugs of two Double Brackets, which are fixed to the top of the work-table. A $\frac{1}{2}''$ Bolt is passed through the centre holes of the Double Angle Strips.

Four $1'' \times 1''$ Angle Brackets (16) (Figs. 7.5a and 7.5c) are bolted to one end of the work-table. These Angle Brackets slide on two $3\frac{1}{2}''$ Rods, which are held by Spring Clips in two $2\frac{1}{2}'' \times \frac{1}{2}''$ Double Angle Strips (17) bolted to a $2\frac{1}{2}'' \times 1\frac{1}{2}''$ Flanged Plate. Two further $2\frac{1}{2}'' \times \frac{1}{2}''$ Double Angle Strips (18) are bolted to the other side of the Flanged Plate, and these slide freely over two $4''$ Rods held by Collars in $3\frac{1}{2}'' \times \frac{1}{2}''$ Double Angle Strips (19). The latter Double Angle Strips are bolted as shown to the Flanged Plates (12).

ADJUSTMENT OF THE WORK-TABLE

The sliding movement of the work-table is controlled by a handle (20) formed by a Threaded Pin in a $1\frac{1}{2}''$ Strip. The Strip is fixed by two nuts to one end of a Screwed Rod (21), which is mounted in a Collar (22) and is held in place by two nuts screwed tightly against each other at each side of the Collar. The Collar is screwed on to a bolt held by a nut in one of the Flanged Plates (12).

(Continued on next page)

CONSTRUCTION OF THE BASE

The base is made by bolting two $12\frac{1}{2}''$ Angle Girders to the end flanges of two $5\frac{1}{2}'' \times 2\frac{1}{2}''$ Flanged Plates (1) and (2) (Fig. 7.5c). A $5\frac{1}{2}''$ Strip (3) is attached to the Angle Girders by Angle Brackets, and two $12\frac{1}{2}''$ Strips on each side are bolted to the Plates (1) and (2) and the Strip (3).

ASSEMBLY OF THE BODY OF THE MACHINE

The side of the body seen in Fig. 7.5 is filled in by a $4\frac{1}{2}'' \times 2\frac{1}{2}''$ and two $5\frac{1}{2}'' \times 2\frac{1}{2}''$ Flexible Plates bolted to a framework formed by a $12\frac{1}{2}''$ Angle Girder (4), three $5\frac{1}{2}''$ Strips (5), a $5\frac{1}{2}''$ Strip (6) and a built-up strip (7). The built-up strip consists of two $5\frac{1}{2}''$ Strips overlapped six holes. A No. 1 Clockwork Motor is fixed to the side as shown in Fig. 7.5, but is spaced from it by a Washer on each of the bolts (8) that hold the Motor in place.

The side shown in Fig. 7.5c consists of a $4\frac{1}{2}'' \times 2\frac{1}{2}''$ and three $5\frac{1}{2}'' \times 2\frac{1}{2}''$ Flexible Plates bolted to a framework made from a $12\frac{1}{2}''$ Angle Girder (9), three $5\frac{1}{2}''$ Strips (10) and two built-up strips (11). Each of the strips (11) is formed by a $5\frac{1}{2}''$ and a $3''$ Strip bolted together. In Fig. 7.5c three of the Flexible Plates and part of one of the Strips (11) are removed to reveal details of the interior.

The sides are joined at the front by two $3\frac{1}{2}'' \times 2\frac{1}{2}''$ Flanged Plates (12), and at each end the Girders (4) and (9) are connected by a $3\frac{1}{2}''$ Strip. The $3\frac{1}{2}''$ Strips support a pair of $12\frac{1}{2}''$ Strips (13) on each side. The $12\frac{1}{2}''$ Strips in each pair are spaced apart by two Washers on each of the $\frac{3}{8}''$ Bolts that secure them to the $3\frac{1}{2}''$ Strips. At the centre the $12\frac{1}{2}''$ Strips are supported by Fishplates held by bolts (14) on each side.

The complete body is attached to the base by Angle Brackets held by bolts (15).

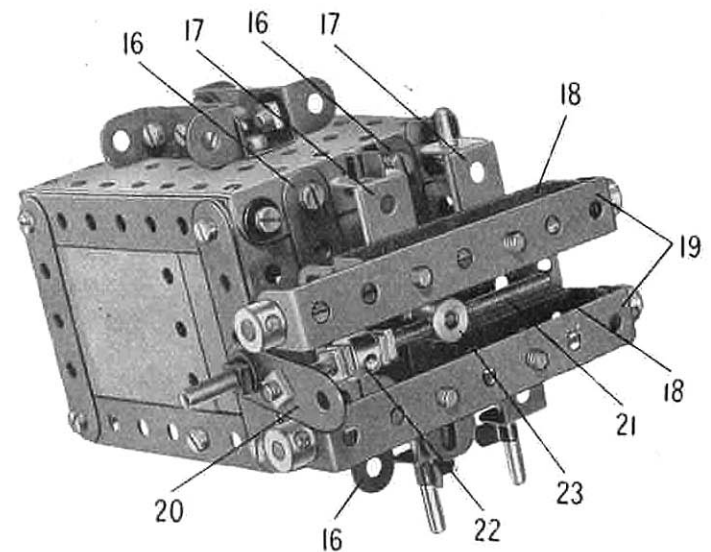

Fig. 7.5a

MODEL 7.5 SHAPING MACHINE — Continued

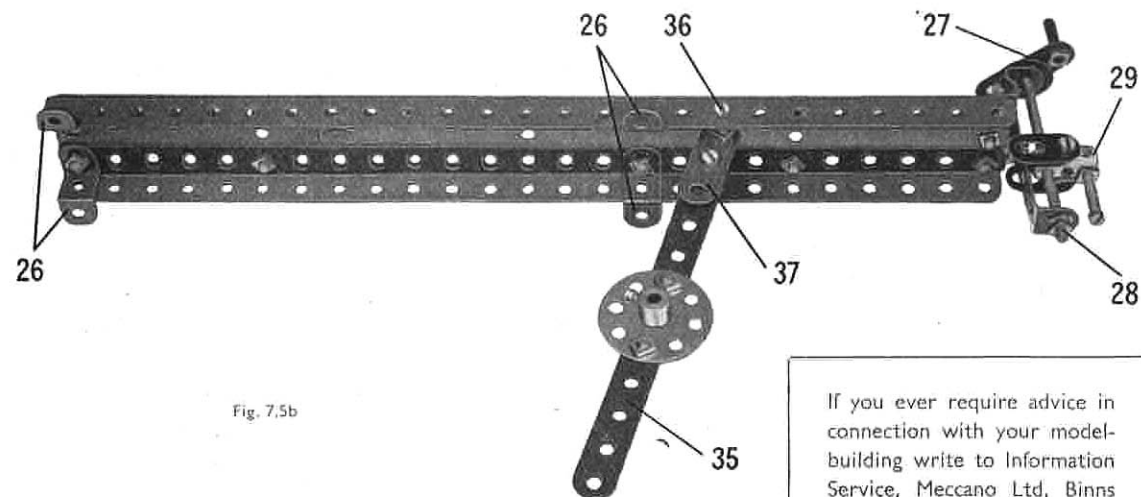

Fig. 7.5b

The Screwed Rod (21) is threaded through the screwed holes of a Crank (23), which is bolted to the $2\frac{1}{2}'' \times 1\frac{1}{2}''$ Flanged Plate but is separated from it by a Washer on the bolt.

The work-table is supported at the front by a Crank (24) fixed on a $1\frac{1}{2}''$ Rod. The Rod is held in a 2" Pulley bolted to the Flanged Plate (1).

THE SLIDING RAM

The sliding ram consists of two $12\frac{1}{2}''$ Angle Girders joined by three $5\frac{1}{2}'' \times 1\frac{1}{2}''$ Flexible Plates, and fitted at one end with a $1\frac{1}{2}''$ Strip and at the other end with a Trunnion (25) (Fig. 7.5c). Two $\frac{1}{2}''$ Reversed Angle Brackets (26) are bolted to each Angle Girder, and these slide freely between the pairs of $12\frac{1}{2}''$ Strips (13).

A $2\frac{1}{2}'' \times \frac{1}{2}''$ Double Angle Strip is bolted to the Trunnion (25), and in its lugs a 3" Screwed Rod is supported. A handle (27) formed by a Threaded Pin in a $1\frac{1}{2}''$ Strip is fixed by two nuts to one end of the Screwed Rod, and at the other end two nuts (28) are screwed tightly against each other, leaving the Screwed Rod free to turn.

TOOL HOLDER

A Coupling (29) is threaded on to the Screwed Rod, and in it is held a $\frac{3}{8}''$ Bolt that represents the cutting tool. The Coupling is prevented from turning by a Fishplate on each side, which is held by a nut on a bolt screwed into the Coupling.

OPERATING MECHANISM

A $\frac{1}{2}''$ Pinion on the Motor shaft drives a 57-tooth Gear (30) on a 2" Rod held by a Collar in the Motor side-plates. A 1" Pulley is fixed on this Rod, between the Gear and the side-plate, and is connected by a Driving Band to a 3" Pulley (31) on a $1\frac{1}{2}''$ Rod (32), also mounted in the Motor side-plates.

A Fishplate (33) is freely mounted on a $\frac{1}{2}''$ Bolt, which is *lock-nutted* to the Pulley (31). The Fishplate is spaced from the Pulley by a $\frac{1}{2}''$ loose Pulley and a Washer, and is bolted tightly to two $2\frac{1}{2}''$ Strips (34) placed face to face. These Strips are *lock-nutted* as shown in Fig. 7.5b, to a $5\frac{1}{2}''$ Strip (35) bolted across a Bush Wheel. The Bush Wheel is fixed on a $4\frac{1}{2}''$ Rod, which is mounted in Wheel Discs bolted to the sides of the body and is held in place by $\frac{3}{8}''$ Flanged Wheels.

A $\frac{1}{2}''$ Bolt (36) is passed through the sliding ram and is *lock-nutted* in position, so that it is free to swivel. A $1\frac{1}{2}''$ Strip (37) is then held by two nuts at the end of the Bolt, and is *lock-nutted* to the end of the Strip (35).

Parts Required

8 of No. 1	1	2 of No. 17	1 of No. 38d	4 of No. 125
13 " " 2	2	1 " " 18a	2 " " 48	1 " " 126
6 " " 3	3	1 " " 19b	5 " " 48a	1 " " 186b
2 " " 4	4	1 " " 20a	2 " " 48b	2 " " 188
8 " " 5	5	1 " " 22	1 " " 51	3 " " 189
4 " " 6a	6a	1 " " 23	3 " " 53	4 " " 190
6 " " 8	8	1 " " 24	6 " " 59	2 " " 191
5 " " 10	10	2 " " 24a	2 " " 62	5 " " 192
2 " " 11	11	1 " " 26	1 " " 63	
15 " " 12	12	1 " " 27a	2 " " 80c	
4 " " 12a	12a	5 " " 35	2 " " 111	
1 " " 15a	15a	146 " " 37a	2 " " 111a	
2 " " 15b	15b	121 " " 37b	6 " " 111c	
2 " " 16	16	28 " " 38	2 " " 115	

1 No. 1 Clock-work Motor
(not included in Outfit)

If you ever require advice in connection with your model-building write to Information Service, Meccano Ltd, Binns Road, Liverpool 13. Experts are waiting to help you

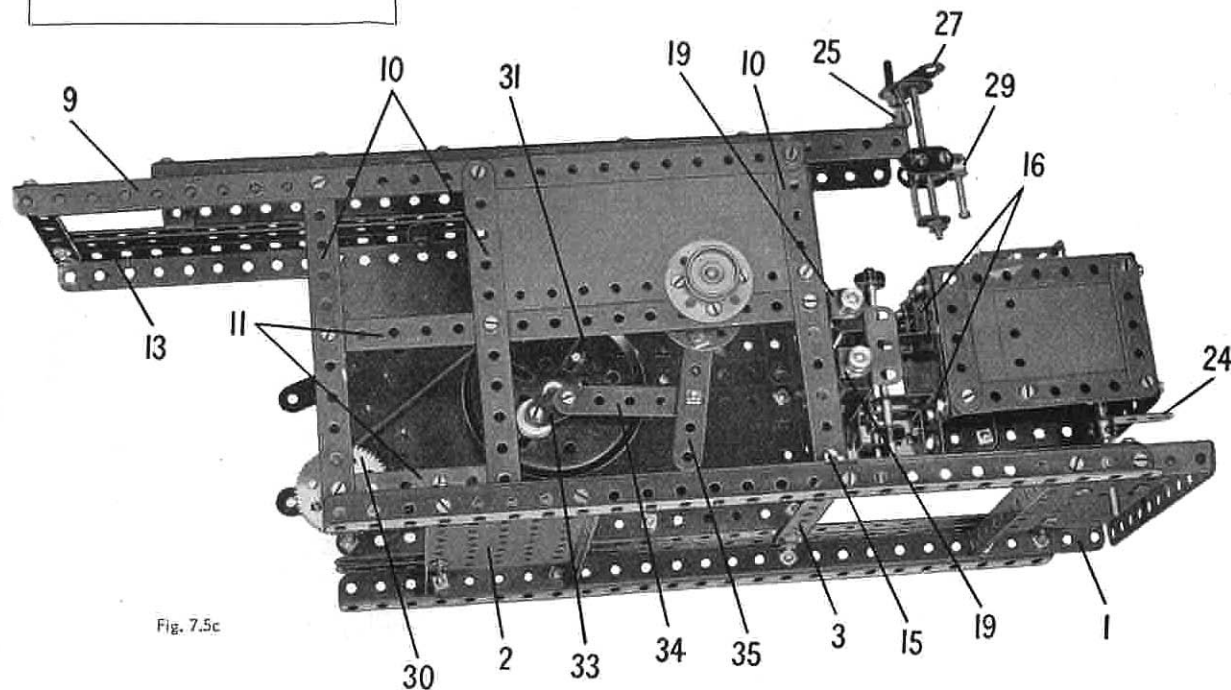

Fig. 7.5c

7.6 OCTOPUS ROUNDABOUT

Parts Required

12 of No. 1	4 of No. 12a	2 of No. 20a	202 of No. 37a	1 of No. 51	2 of No. 126	1 of No. 198
18 " " 2	2 " " 12c	3 " " 22	185 " " 37b	2 " " 52	1 " " 155	2 " " 212
6 " " 3	1 " " 14	1 " " 23	16 " " 38	3 " " 53	1 " " 186	1 " " 213
2 " " 4	1 " " 15	1 " " 23a	1 " " 40	4 " " 59	5 " " 188	2 " " 214
2 " " 5	2 " " 15a	1 " " 24	1 " " 45	1 " " 63	6 " " 189	
2 " " 6a	1 " " 15b	2 " " 24a	1 " " 46	1 " " 111	1 " " 190	1 EO20 Electric Motor (not included in Outfit)
7 " " 8	1 " " 16	1 " " 27a	2 " " 48	2 " " 111a	2 " " 191	
6 " " 10	2 " " 18a	1 " " 32	10 " " 48a	4 " " 111c	3 " " 192	
4 " " 11	1 " " 18b	4 " " 35	2 " " 48b	1 " " 125	2 " " 197	
18 " " 12	1 " " 19b					

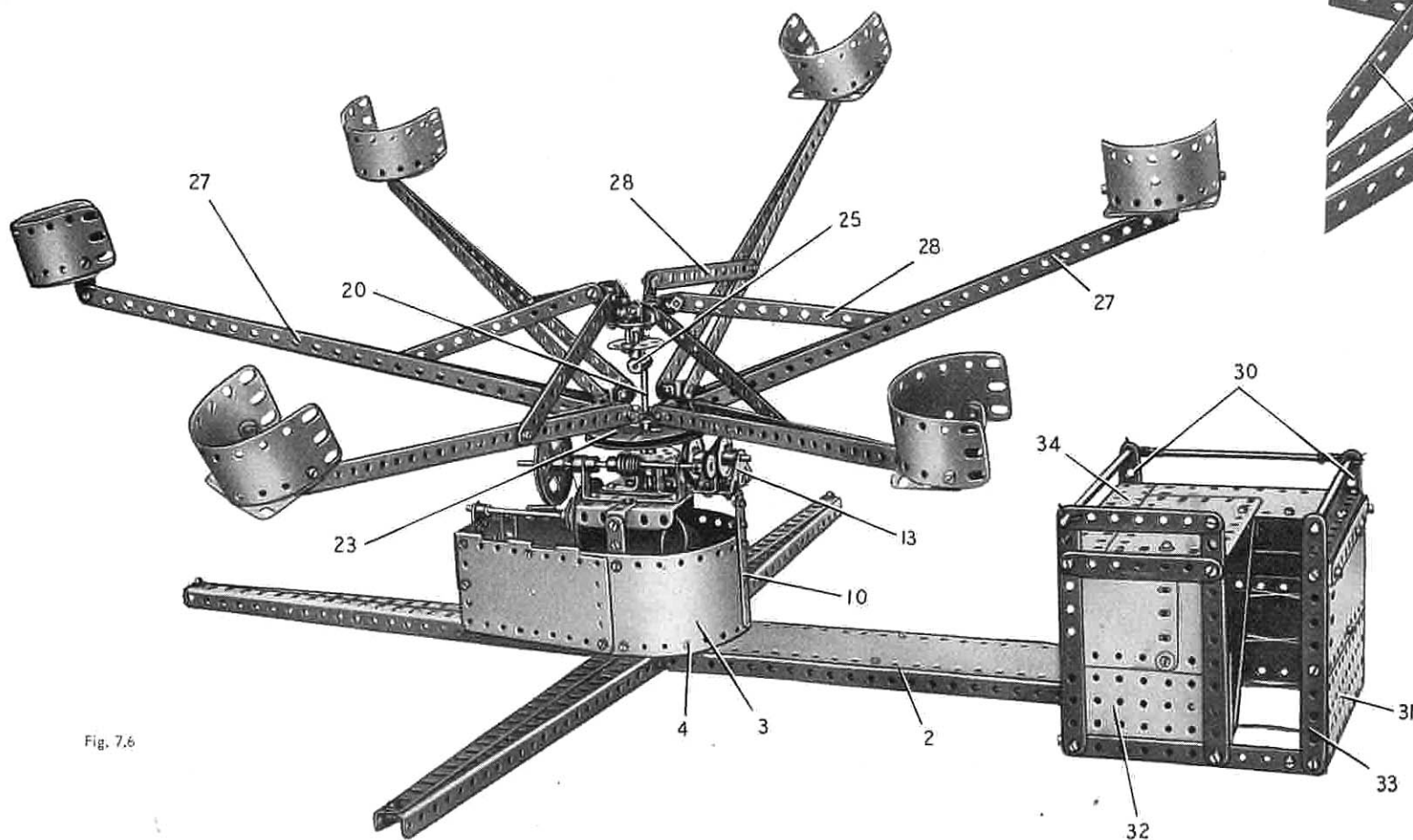

Fig. 7.6

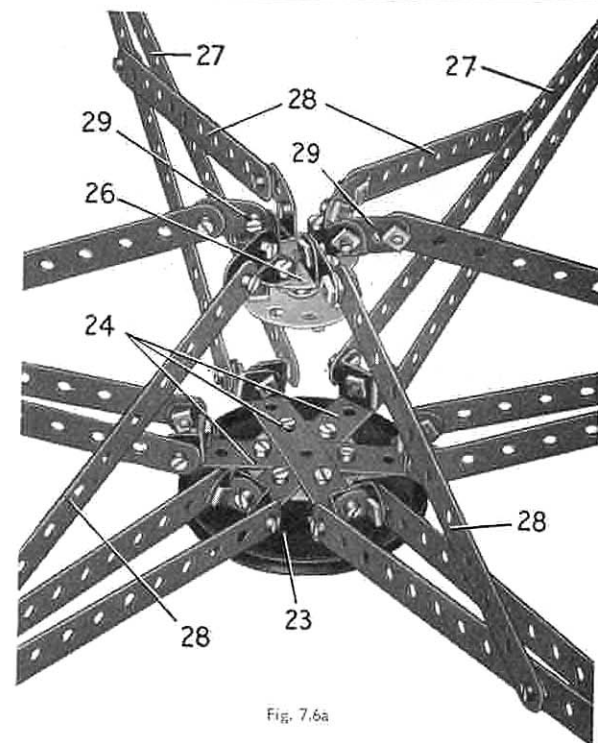

Fig. 7.6a

Most model-builders will be familiar with the 'Octopus', which is the name given to one of the more up-to-date joy-riding machines to be seen in fun fairs. It consists of a number of rotating arms, each of which carries at its outer end a small pivoted car provided with seats for the passengers. As the arms rotate they rise and fall, and this movement, coupled with the independent spinning action of the cars themselves, results in a very thrilling ride for the passengers.

The actual machine has eight arms, but as will be seen from Fig. 7.6, only six are fitted to the model, which is driven by an EO20 Electric Motor. The model carries out the movements of a real 'Octopus' machine, however, and it is a most interesting model to construct and watch in action.

CONSTRUCTION OF THE BASE

The centre of the base is a $3\frac{1}{2} \times 2\frac{1}{2}$ " Flanged Plate, one corner of which is seen at (1) (Fig. 7.6b). To this base are bolted four supporting legs. Three of the legs are each made from two $1\frac{1}{2}$ " Angle Girders, spaced three holes apart at the Flanged Plate and bolted together at their outer ends. The fourth leg is made by bolting two $1\frac{1}{2}$ " Angle Girders (2) to the edges of a $12\frac{1}{2} \times 2\frac{1}{2}$ " Strip Plate. Each of the Girders of the legs overlaps the Flanged Plate by two holes.

A $12\frac{1}{2} \times 2\frac{1}{2}$ " Strip Plate (3) is curved as shown, and is connected to a flange of the Plate (1) by an Obtuse Angle Bracket on each side, which is held by a bolt (4). The ends of the Strip Plate are extended by the separated halves of a Hinged Flat Plate as shown in Fig. 7.6b, and these halves are connected by a $2\frac{1}{4} \times 1\frac{1}{4}$ " Flanged Plate (5). A 3" Strip (6) is bolted to the Flanged Plate (5) and is supported by a Trunnion fixed to one of the legs of the base.

(Continued on next page)

MODEL 7.6 OCTOPUS ROUNDABOUT — Continued

A $3\frac{1}{2}'' \times 2\frac{1}{2}''$ Flanged Plate is fixed at the centre of the base to two $3\frac{1}{2}'' \times \frac{1}{2}''$ Double Angle Strips (8), and is connected by $1'' \times 1''$ Angle Brackets (9) to $3\frac{1}{2}''$ Strips secured to the Strip Plate (3). A further $3\frac{1}{2}''$ Strip (10) is bolted to the Strip Plate and is connected by a $1'' \times 1''$ Angle Bracket to a $3\frac{1}{2}''$ Strip (11) fixed to the Flanged Plate. A $1'' \times 1''$ Angle Bracket (12) and a Trunnion (13) are attached to the Strip (11), and a $2\frac{1}{2}'' \times 1''$ Double Angle Strip (14) is bolted across the Flanged Plate. Two $2\frac{1}{2}''$ Strips (15), placed face to face, are fixed as shown to the Double Angle Strips (8).

DRIVING MECHANISM

An EO20 Electric Motor (16) (Fig. 7.6c) is bolted to the Flanged Plate (1), and its pulley is connected by a Cord belt to a 2" Pulley on a 4" Rod (17). This Rod is mounted in the Strip (6) and the Strips (15), and it carries a 1" Pulley that drives, through a Cord belt, a 2" Pulley on a 5" Rod (18). Rod (18) is supported in the Double Angle Strip (14).

A Worm (19) on Rod (18) drives a 57-tooth Gear, which is fixed on a 4" Rod (20). The Rod (20) is mounted in the Flanged Plate and in a Double Bent Strip bolted to it, and is held in place by a Collar placed inside the Double Bent Strip. A $\frac{1}{2}''$ fixed Pulley on Rod (18) is connected by a $2\frac{1}{2}''$ Driving Band to a 1" Pulley (21) on a $1\frac{1}{2}''$ Rod supported in the Trunnion (13) and the Angle Bracket (12). This Rod is held in place by a Collar, and it carries a 1" Pulley (22) with Rubber Ring.

A 3" Pulley (23) has a six-hole Wheel Disc attached to it by two $\frac{1}{2}''$ Bolts. The Bolts are passed through the Wheel Disc and fixed in place by nuts; then they are held by two nuts on each Bolt, in holes in the Pulley (23). Three $2\frac{1}{2}'' \times \frac{1}{2}''$ Double Angle Strips (24) (Fig. 7.6a) are bolted centrally across the Wheel Disc. The Pulley (23) is free to turn on the Rod (20) and is driven by friction through the Rubber Ring on Pulley (22).

A Coupling (25) fitted with a 1" Rod is fixed to the top of the Rod (20). A Bush Wheel is free to turn on the 1" Rod, and has a six-hole Wheel Disc (25) attached to it by $\frac{1}{2}''$ Bolts, in the same way as the Wheel Disc attached to the Pulley (23).

THE CARRIAGES AND THEIR SUPPORTING ARMS

Each carriage is mounted at the end of an arm (27) made from two $1\frac{1}{2}''$ Strips. The two Strips of each arm are bolted together at their outer ends, the bolt holding also an Angle Bracket. The inner ends of the Strips are *lock-nutted* to brackets bolted to the lugs of the Double Angle Strips (24). Four of these brackets are Double Brackets, and the other two are each made from two Angle Brackets bolted together. A $5\frac{1}{2}''$ Strip (28) is *lock-nutted* as shown to each arm, and also to a Fishplate (29). These Fishplates are bolted tightly to Angle Brackets fixed to the Wheel Disc (26).

The back and sides of each carriage are made by curving a $5\frac{1}{2}'' \times 1\frac{1}{2}''$ Flexible Plate and bolting it to the lugs of a $2\frac{1}{2}'' \times \frac{1}{2}''$ Double Angle Strip. The floors of four of the carriages are $2\frac{1}{2}'' \times 1\frac{1}{2}''$ Flexible Plates, and those in the other two carriages are Semi-Circular Plates.

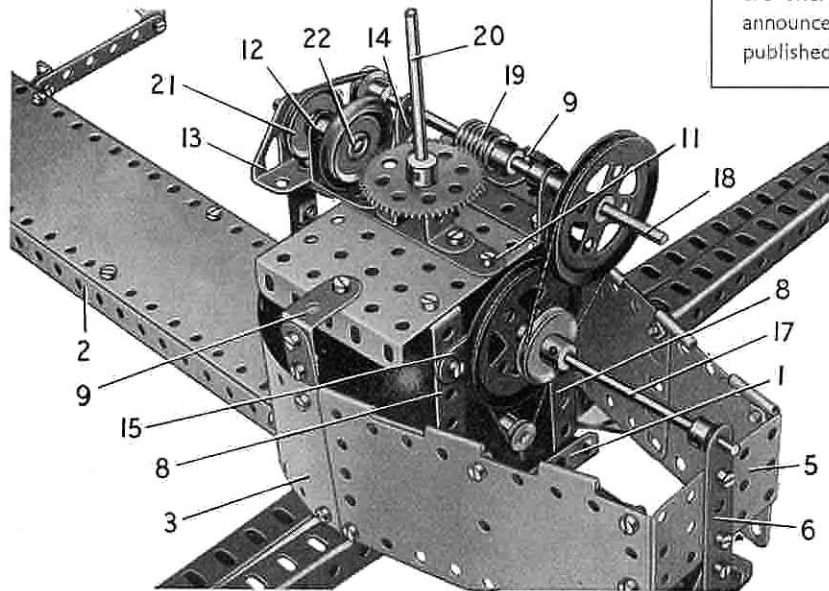

Fig. 7.6b

PRIZES FOR NEW MODELS

Model-Building Competitions, in which fine Cash Prizes are offered for new and original Meccano models, are announced in the "MECCANO MAGAZINE," which is published monthly.

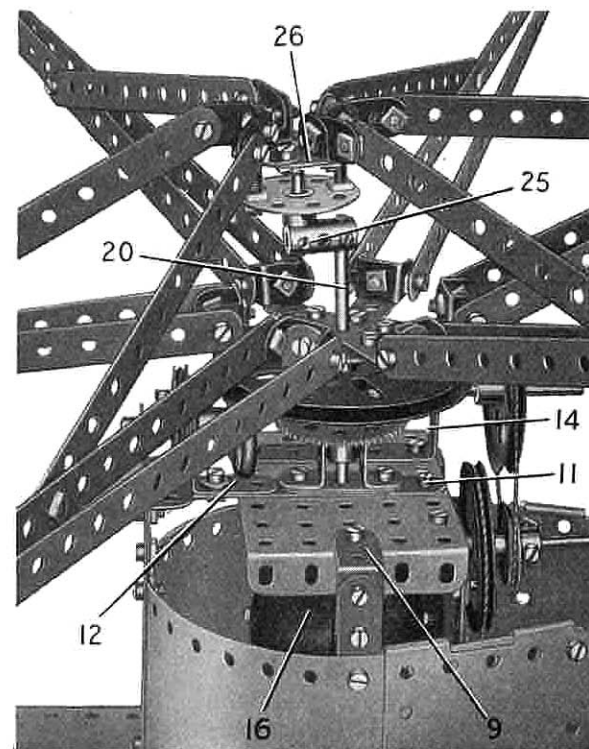

Fig. 7.6c

Each floor is attached to the Double Angle Strip by two nuts on a bolt, which passes also through the Angle Bracket at the end of one of the arms (27), leaving the carriage free to swivel.

THE LOADING PLATFORM

The far side of the loading platform (as seen in Fig. 7.6) is formed by two $5\frac{1}{2}'' \times 2\frac{1}{2}''$ Flexible Plates, edged vertically by two $5\frac{1}{2}''$ Strips (30) and horizontally by two similar Strips. The end consists of a $5\frac{1}{2}'' \times 2\frac{1}{2}''$ Flanged Plate (31), extended upward by a $5\frac{1}{2}'' \times 2\frac{1}{2}''$ Flexible Plate, which is strengthened along its upper edge by a $5\frac{1}{2}''$ Strip and connected to the far side by Angle Brackets. The side seen in Fig. 7.6 is made from a $3\frac{1}{2}'' \times 2\frac{1}{2}''$ Flanged Plate (32) and two $2\frac{1}{2}'' \times 2\frac{1}{2}''$ Flexible Plates edged by $5\frac{1}{2}''$ Strips and a $3\frac{1}{2}''$ Strip. This side is connected to the base by a 3" Strip fixed to a flange of the Flanged Plate (32) and to a $\frac{1}{2}''$ Reversed Angle Bracket bolted to one of the Girders (2). The side is completed by a $5\frac{1}{2}''$ Strip (33), which is bolted to a lug of a $2\frac{1}{2}'' \times \frac{1}{2}''$ Double Angle Strip secured to the top edge of the $5\frac{1}{2}'' \times 2\frac{1}{2}''$ Flexible Plate of the end.

The top of the platform is filled in by a $5\frac{1}{2}'' \times 2\frac{1}{2}''$ Flanged Plate (34) and two $4\frac{1}{2}'' \times 2\frac{1}{2}''$ Flexible Plates. The sides of the stairs are two $5\frac{1}{2}''$ Strips fixed at each end to a $1\frac{1}{2}'' \times \frac{1}{2}''$ Double Angle Strip, and the steps are represented by Cord.

The handrails along the edges of the platform are formed by a $6\frac{1}{2}''$ Rod, a $4\frac{1}{2}''$ Rod, and a built-up rod made from a $4\frac{1}{2}''$ and a $1\frac{1}{2}''$ Rod joined by a Rod Connector. The $4\frac{1}{2}''$ Rod is fitted at each end with a Rod and Strip Connector, and these are supported on the $6\frac{1}{2}''$ Rod and the built-up rod. The Rods are held in position by Spring Clips.

OPERATING HINTS

Before setting the model to work, the Worm reduction gear and the bearings for the driving shafts should be oiled, using a good quality light machine oil. The *lock-nutted* bolts used in the assembly of the arms and the cars should be adjusted so that the parts they connect can pivot freely.

Care must be taken, however, to prevent oil from reaching the driving belts, the face of the Pulley (23), and the Rubber Ring on the Pulley (22). The driving belts should be tight enough to drive without slipping, but they must not be too tight or they will add considerably to the load on the Motor.

7.7 MOBILE CRANE

Parts Required

6 of No. 1	1 of No. 32	4 of No. 90a	2 of No. 191
18 " " 2	6 " " 35	2 " " 111	2 " " 192
6 " " 3	166 " " 37a	2 " " 111a	1 " " 198
2 " " 4	155 " " 37b	5 " " 111c	2 " " 200
12 " " 5	22 " " 38	1 " " 115	2 " " 212
4 " " 6a	2 " " 38d	4 " " 125	2 " " 213
5 " " 10	1 " " 40	2 " " 126	2 " " 214
4 " " 11	2 " " 45	3 " " 126a	4 " " 221
16 " " 12	2 " " 48	1 " " 147b	1 " " 222
4 " " 12a	4 " " 48a	2 " " 155	
6 " " 12c	2 " " 48b	2 " " 176	
1 " " 15	1 " " 51	4 " " 187	
2 " " 15a	2 " " 52	6 " " 188	
2 " " 16	3 " " 53	6 " " 189	
2 " " 17	1 " " 54	8 " " 190	
4 " " 18	1 " " 57c		
1 " " 18b	6 " " 59		
2 " " 19	1 " " 63		
1 " " 19g	2 " " 90		
1 " " 19h			
3 " " 22			
1 " " 23			
1 " " 23a			
1 " " 24			
2 " " 24a			
2 " " 26			
1 " " 27a			

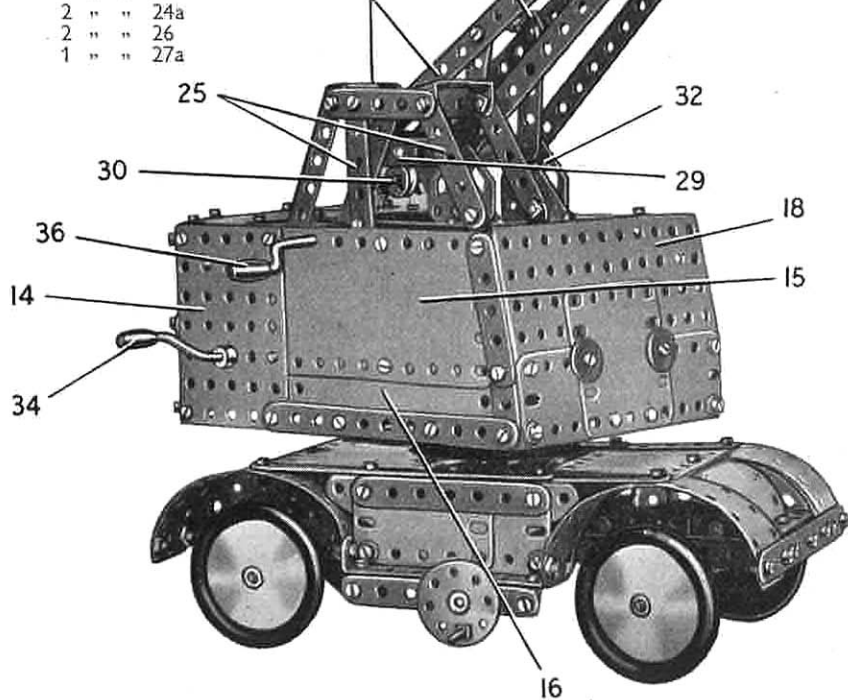

Fig. 7.7

THE WHEELED BASE

The chassis of the base consists of a built-up strip (1) on each side, made from two $5\frac{1}{2}$ " Strips bolted together. The join between the two Strips is strengthened by a third $5\frac{1}{2}$ " Strip (2). The strips (1) are connected at each end by a $2\frac{1}{2}$ " x $\frac{1}{2}$ " Double Angle Strip (3), and at the centre by a similar Double Angle Strip that supports a $5\frac{1}{2}$ " Strip (4) (Fig. 7.7b).

The top of the base is made by bolting two $4\frac{1}{2}$ " x $2\frac{1}{2}$ " Flexible Plates (5) and a Flanged Sector Plate (6) to a built-up strip on each side. These strips are each made from a $5\frac{1}{2}$ " and a $2\frac{1}{2}$ " Strip bolted together, and the Plates (5) are strengthened along their outer edges by $5\frac{1}{2}$ " Strips (7) (Fig. 7.7b). The mudguards are curved $5\frac{1}{2}$ " x $1\frac{1}{2}$ " Flexible Plates bolted to the Strips (7) and the Flexible Plates (5), and the outer edges of the mudguards at each end of the base are connected by $5\frac{1}{2}$ " Strips. These Strips are bolted to the Double Angle Strips (3).

One end of the base is filled in by a $2\frac{1}{2}$ " x $1\frac{1}{2}$ " Flanged Plate (8). This is connected to one of the Plates (5) by an Obtuse Angle Bracket, and is joined by a similar part to a $2\frac{1}{2}$ " x $\frac{1}{2}$ " Double Angle Strip that is attached by an Angle Bracket to one of the Double Angle Strips (3). The other end of the base is completed by a $1\frac{1}{2}$ " radius Curved Plate bolted to one of the Plates (5) and to a Double Bracket fixed to one of the Double Angle Strips (3). The Double Bracket supports also a $2\frac{1}{2}$ " Strip.

The inner ends of the mudguards on each side are attached to a $3\frac{1}{2}$ " x $\frac{1}{2}$ " Double Angle Strip (9), which is bolted to the end of the $5\frac{1}{2}$ " Strip (4) (Fig. 7.7b). A $3\frac{1}{2}$ " Strip (10) is connected to the Double Angle Strip by two $\frac{1}{2}$ " Reversed Angle Brackets, and these support also two $2\frac{1}{2}$ " x $1\frac{1}{2}$ " Flexible Plates overlapped three holes. Two $2\frac{1}{2}$ " x $1\frac{1}{2}$ " Triangular Flexible Plates (11) are attached to the $2\frac{1}{2}$ " x $1\frac{1}{2}$ " Flexible Plates, which are strengthened along their upper edges by a $3\frac{1}{2}$ " Strip and are connected to the Plates (5) by Angle Brackets.

The rear wheels are mounted on a $5\frac{1}{2}$ " Rod that is held by $1\frac{1}{2}$ " Pulleys in $1\frac{1}{2}$ " x $1\frac{1}{2}$ " Angle Brackets bolted to the strips (1). Each of the front wheels is fixed on a $1\frac{1}{2}$ " Rod supported in a Double Bracket. A $1\frac{1}{2}$ " Strip is placed between the lugs of the Double Bracket and a $\frac{1}{2}$ " Bolt is passed through the parts. The Bolt is then fixed by two nuts in a $1\frac{1}{2}$ " x $1\frac{1}{2}$ " Angle Bracket (12) bolted to one of the strips (1). The rear ends of the $1\frac{1}{2}$ " Strips are connected by lock-nutted bolts to Rod and Strip Connectors fitted to the ends of a $3\frac{1}{2}$ " Rod.

A $3\frac{1}{2}$ " Pulley (13) with its boss downward is connected by two $\frac{1}{2}$ " Bolts to the Flanged Sector Plate (6).

CONSTRUCTION OF THE CAB

Each side of the cab consists of a $3\frac{1}{2}$ " x $2\frac{1}{2}$ " Flanged Plate (14), a $5\frac{1}{2}$ " x $2\frac{1}{2}$ " Flexible Plate (15) and one half of a Hinged Flat Plate (16). These Plates are arranged as shown and are edged by a $5\frac{1}{2}$ " Strip and a $2\frac{1}{2}$ " Strip. The sides are connected by a $5\frac{1}{2}$ " x $2\frac{1}{2}$ " Flanged Plate (17), and a similar Flanged Plate (18) (Fig. 7.7). The Plate (18) is extended downward by two $2\frac{1}{2}$ " x $1\frac{1}{2}$ " Flexible Plates and a $2\frac{1}{2}$ " x $2\frac{1}{2}$ " Flexible Plate. The lower corners of the $2\frac{1}{2}$ " x $1\frac{1}{2}$ " Flexible Plates are connected to the sides by Angle Brackets.

The rounded end of the cab is formed by a $1\frac{1}{2}$ " radius Curved Plate and five curved $2\frac{1}{2}$ " x $2\frac{1}{2}$ " Flexible Plates bolted together as shown in Fig. 7.7a and attached to the sides by Obtuse Angle Brackets.

A $5\frac{1}{2}$ " Strip (19) is bolted to the upper flanges of the Flanged Plates (14), so as to leave one clear hole in the flanges towards the front of the model. Two $5\frac{1}{2}$ " Strips are bolted to the Strip (19) and to the top flange of the Flanged Plate (18). One of these Strips is seen at (20), and the other is placed above the flange of a $3\frac{1}{2}$ " x $2\frac{1}{2}$ " Flanged Plate (21), which is connected to one of the Flanged Plates (14) by two Double Bent Strips (Fig. 7.7a). A $5\frac{1}{2}$ " x $1\frac{1}{2}$ " Flexible Plate is fixed between the side of the cab and the Strip above the Flanged Plate (21). A $2\frac{1}{2}$ " x $2\frac{1}{2}$ " Flexible Plate (22) (Fig. 7.7a) is bolted to the Strip and to the top flange of the Plate (18).

The rear end of the top of the cab is filled in by a $5\frac{1}{2}$ " x $1\frac{1}{2}$ " Flexible Plate (23), placed immediately behind the Strip (19) and bolted to the flanges of the Plates (14). A $2\frac{1}{2}$ " x $2\frac{1}{2}$ " Flexible Plate is attached to the Plate (23) and is connected to the rear of the cab by two Angle Brackets. Each bolt connecting the Flexible Plate to the Angle Brackets secures also a Semi-Circular Plate and a $2\frac{1}{2}$ " Curved Strip. The Curved Strips are bolted in the end holes in the flanges of the Flanged Plates (14).

(Continued on next page)

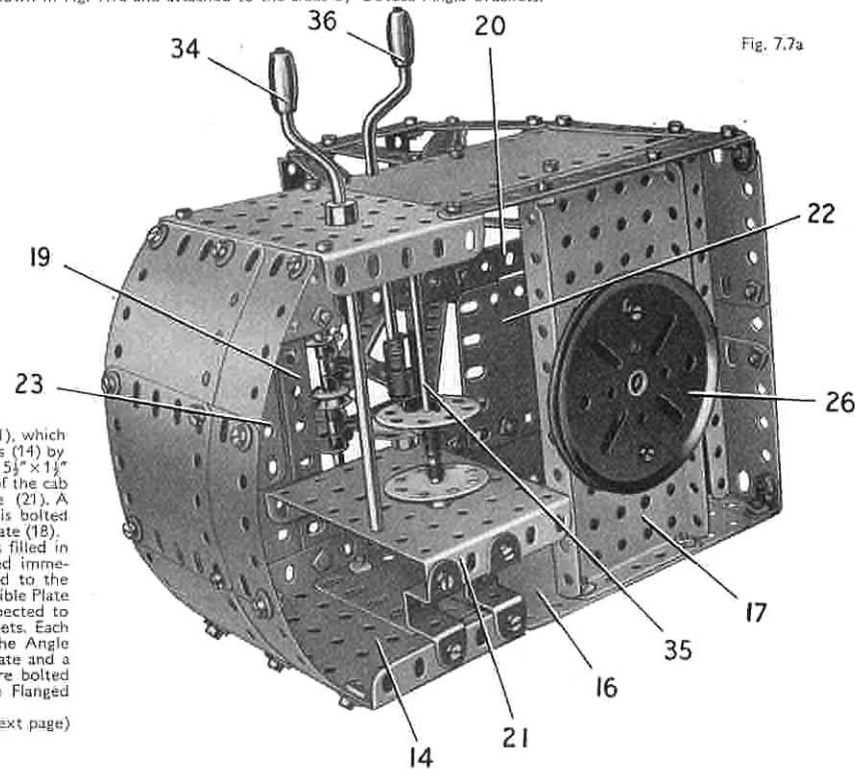

Fig. 7.7a

MODEL 7.7 MOBILE CRANE — Continued

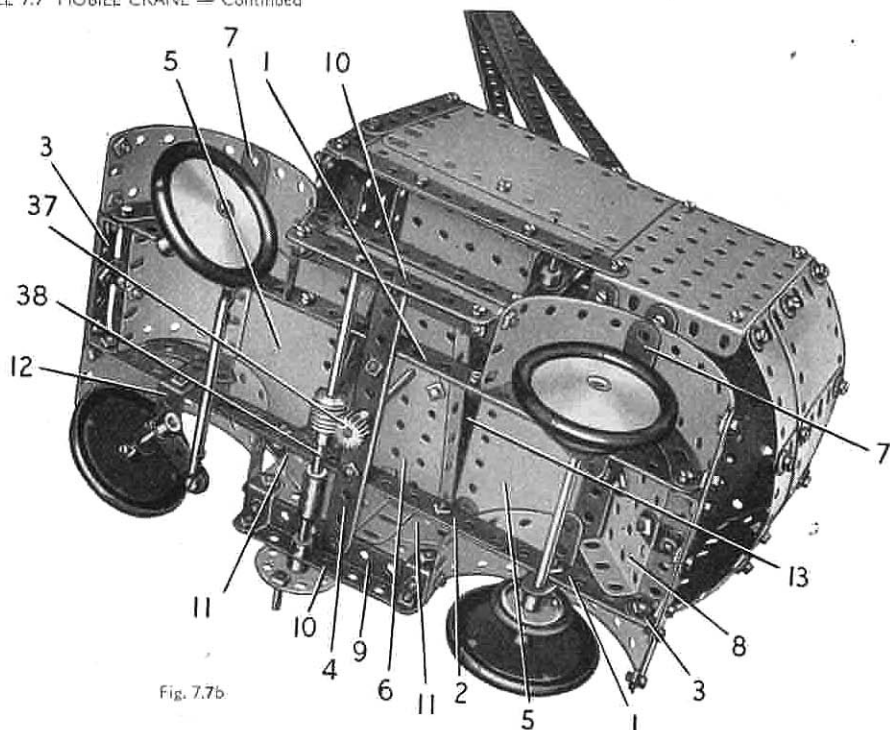

Fig. 7.7b

The inner frame of the windows of the operating cabin is made by bolting two $2\frac{1}{2}$ " Strips to Angle Brackets fixed to the Strip (20). The top ends of the Strips are connected by a $2\frac{1}{2}$ " Strip, and two $1\frac{1}{2}$ " x $\frac{1}{2}$ " Double Angle Strips (24) are held by the same bolts (Fig. 7.7). The outer frame of the window consists of a $3\frac{1}{2}$ " Strip and two $2\frac{1}{2}$ " Strips (25) connected to the cab side by Fishplates. The top ends of these Strips are joined to a $2\frac{1}{2}$ " Strip that is bolted to the Double Angle Strips (24).

A 3 " Pulley (26) is attached to the Flanged Plate (17) by two $\frac{3}{8}$ " Bolts.

ASSEMBLY OF THE JIB

Each side of the jib consists of a built-up strip (27) made from two $12\frac{1}{2}$ " Strips overlapped 19 holes, and a $12\frac{1}{2}$ " Strip (28). These are bolted together at their upper ends, and at its lower end the strip (27) is attached to a 3 " Strip (29). The sides of the jib are connected at the top by a Double Bracket and at their lower ends by a Flat Trunnion attached to Angle Brackets bolted to the strips (27) and the Strips (29). Each bolt securing one of the Angle Brackets holds also a Fishplate, and a 2 " Rod (30) is supported in the Fishplate. The Rod is fitted with a $\frac{1}{2}$ " loose Pulley and is held in place by Spring Clips. The sides of the jib are connected also by a bracket (31), made from two Angle Brackets and a Fishplate bolted together.

The jib supports are made by bolting Trunnions to the Strip (20) and the Strip placed above the Flanged Plate (21). A Flat Trunnion (32) is fixed to each Trunnion, and a built-up rod is passed through the Flat Trunnions and the Strips (28) and (29) of the jib. This rod consists of a $1\frac{1}{2}$ " and a 1 " Rod joined by a Rod Connector, and it is held in place by a Collar.

A $\frac{1}{2}$ " fixed Pulley (33) is fixed on a Pivot Bolt passed through the strips (27) of the jib.

THE OPERATING MECHANISM

The jib is luffed, or raised and lowered, by turning a 5 " Crank Handle (34), which is supported in the Flanged Plate (21) and one of the Flanged Plates (14) (Fig. 7.7a). The Crank Handle is fitted with a Collar and a $\frac{1}{2}$ " Pinion, placed one on each side of the Plate (14), and the Pinion drives a 57-tooth Gear on a $4\frac{1}{2}$ " Rod (35), which also is mounted in the Flanged Plates (14) and (21). A length of Cord is fastened to a Cord Anchoring Spring on the Rod, placed between two Wheel Discs held in place by Spring Clips. The Cord is passed over the $\frac{1}{2}$ " loose Pulley on the Rod (30) and is tied to the Strip (19).

A length of Cord is fastened to a Cord Anchoring Spring on a $3\frac{1}{2}$ " Crank Handle (36) (Fig. 7.7a), which is extended by a 2 " Rod held in a Rod Connector. The Crank Handle is passed through the side of the cab and the 2 " Rod is supported in the Flanged Plate (21). A Collar, fitted with a $\frac{3}{8}$ " Bolt, is fixed on the Crank Handle near to the side of the cab, and a 1 " Pulley is held on the 2 " Rod against the Flanged Plate (21). By pulling the Crank Handle outward the $\frac{3}{8}$ " Bolt in the Collar catches against a bolt in the side of the cab to form a simple brake. The Cord tied to the Crank Handle (36) is led over the $\frac{1}{2}$ " Pulley (33) and is fitted with a small Loaded Hook.

A $3\frac{1}{2}$ " Rod is fixed in the Pulley (26), then passed through the Pulley (13), the Flanged Sector Plate (6) and the Strip (4), and is fitted with a $\frac{1}{2}$ " Pinion (37). This Pinion engages a Worm on a built-up rod (38), which is made from a $4\frac{1}{2}$ " and a $1\frac{1}{2}$ " Rod joined by a Coupling. The rod is mounted in the Strips (10) and is fitted with a handle formed by a Threaded Pin in a Bush Wheel.

7.8 SIDE TIPPING WAGON

CONSTRUCTION OF THE CHASSIS

Each of the chassis side members consists of two $12\frac{1}{2}$ " Angle Girders connected at their ends by $2\frac{1}{2}$ " Strips (1) to form a channel section girder (Fig. 7.8a). The $2\frac{1}{2}$ " Strips are braced by Flat Trunnions bolted to the lower Girder of each side member. The side members are connected together at the front by a $3\frac{1}{2}$ " x $2\frac{1}{2}$ " Flanged Plate (2), and at the rear by two $2\frac{1}{2}$ " x $\frac{1}{2}$ " Double Angle Strips (3). The front and rear wheels are fixed on 5 " Rods, which are supported in the end holes of the Strips (1) and are held in position by 1 " Pulleys.

The fuel tank bolted to one side of the chassis is a Cylinder attached by $\frac{3}{8}$ " Bolts. A Cord Anchoring Spring on each Bolt is used to space the Cylinder from the chassis. A Wheel Disc is clamped at each end of the Cylinder by nuts on a 3 " Screwed Rod.

Each of the rear mudguards is a curved $5\frac{1}{2}$ " x $1\frac{1}{2}$ " Flexible Plate bolted to a $1\frac{1}{2}$ " x $\frac{1}{2}$ " Double Angle Strip (4) that is fixed to the chassis (Fig. 7.8b). Two $2\frac{1}{2}$ " Stepped Curved Strips are fixed to the outside lug of the Double Angle Strip, and are connected to the ends of the Flexible Plates by Angle Brackets. The mudguards on each side are connected together by two $5\frac{1}{2}$ " Strips (5).

ASSEMBLY OF THE CAB

The front of the cab is a $5\frac{1}{2}$ " x $2\frac{1}{2}$ " Flanged Plate (6) bolted lengthways by its centre row of holes to the flange of the Flanged Plate (2). The Flanged Plate (6) is extended upward by a $5\frac{1}{2}$ " x $1\frac{1}{2}$ " Flexible Plate. The back of the cab is made by bolting a $5\frac{1}{2}$ " x $2\frac{1}{2}$ " Flanged Plate (7) across the chassis as shown in Fig. 7.8a. The back is completed by fixing two $2\frac{1}{2}$ " x $1\frac{1}{2}$ " Flexible Plates (8) to each end of the Flanged Plate (7). A $5\frac{1}{2}$ " Strip is fixed across the upper pair of Flexible Plates (8).

Each side of the cab is a $3\frac{1}{2}$ " x $2\frac{1}{2}$ " Flanged Plate fixed between the Flanged Plates (6) and (7). A 3 " Strip is attached to the front edge of the side, and a $3\frac{1}{2}$ " Strip (9) is bolted to the rear edge. A $2\frac{1}{2}$ " Strip (10) is fixed to the top of the Strip (9), and is connected to the 3 " Strip at the front by a $2\frac{1}{2}$ " Curved Strip extended by a Fishplate. The arch over the front wheel is made from two $2\frac{1}{2}$ " Stepped Curved Strips bolted at the centre to a $2\frac{1}{2}$ " x $2\frac{1}{2}$ " Flexible Plate that overlaps the $3\frac{1}{2}$ " x $2\frac{1}{2}$ " Flanged Plate by four holes. The front Curved Strip is bolted also to the lower corner of the Flanged Plate (6), and the rear Curved Strip is supported by a $2\frac{1}{2}$ " Strip that overlaps the Strip (9) by three holes. The bolts securing the $2\frac{1}{2}$ " Strip to the Strip (9) secure also a $2\frac{1}{2}$ " x $2\frac{1}{2}$ " Triangular Flexible Plate that fills in the gap between the $3\frac{1}{2}$ " x $2\frac{1}{2}$ " Flanged Plate and the rear Curved Strip.

(Continued on next page)

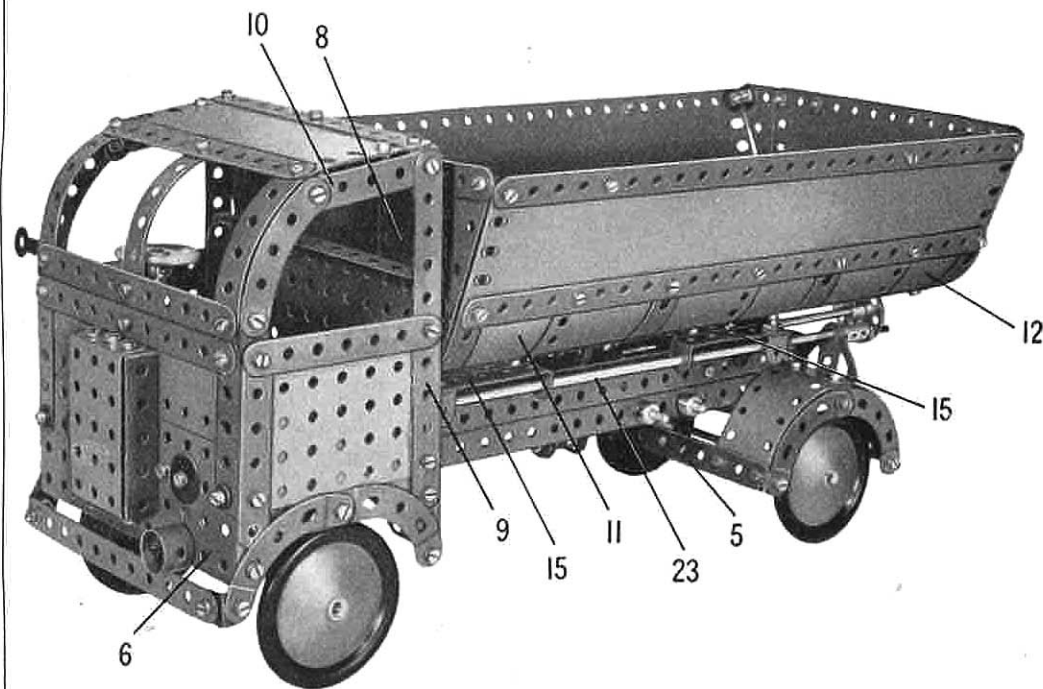

Fig. 7.8

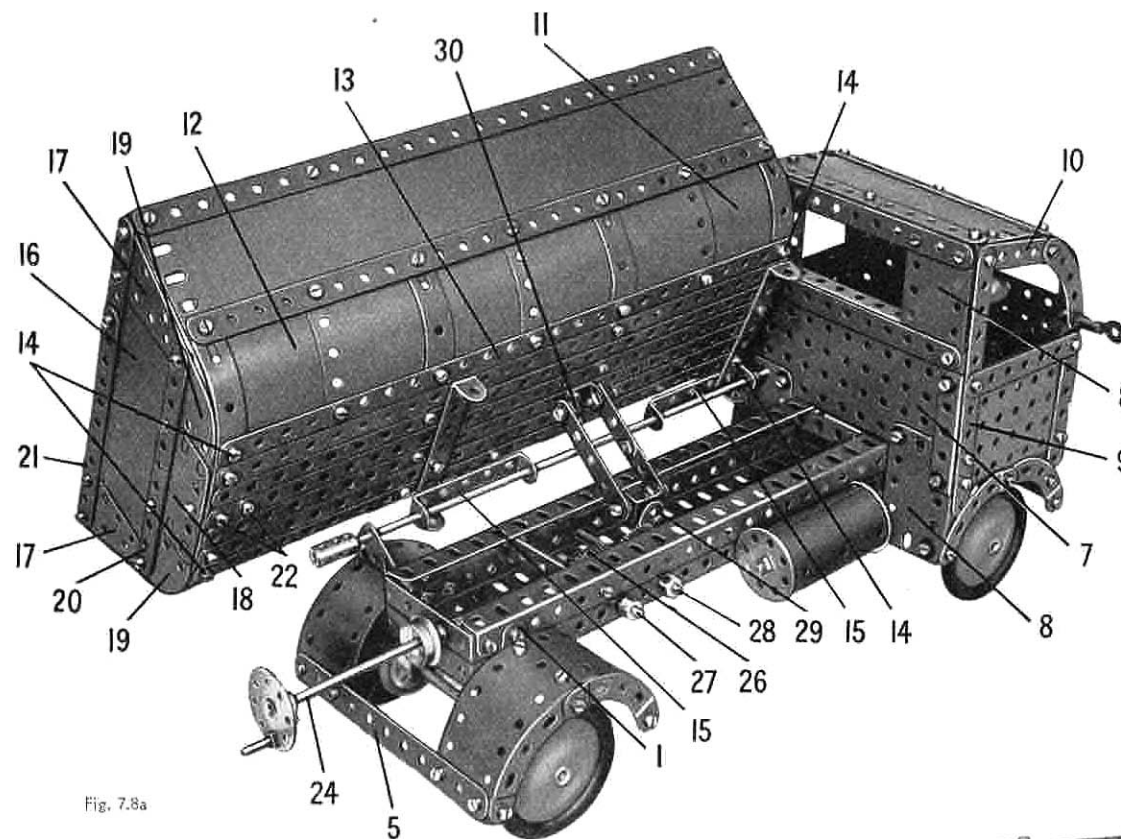

Fig. 7.8a

The Curved Plates are strengthened by Formed Slotted Strips as shown, and a $1\frac{1}{2}$ " Strip (13) is bolted along their lower edges (Fig. 7.8a). The two sides are connected by two $3\frac{1}{2}$ " Strips attached to the Strips (13) by the bolts marked (14), and by bolting together the ends of the Flexible Plates (12). The base of the body is filled in by five $1\frac{1}{2}$ " Strips bolted to the $3\frac{1}{2}$ " Strips and to the Plates (12). Two $3\frac{1}{2}$ " x $\frac{1}{2}$ " Double Angle Strips are fixed to the base as shown, and each of these supports a $2\frac{1}{2}$ " x $\frac{1}{2}$ " Double Angle Strip (15) (Fig. 7.8).

The rear end of the body is filled in by a $5\frac{1}{2}$ " x $2\frac{1}{2}$ " Flexible Plate (16), two $2\frac{1}{2}$ " x $1\frac{1}{2}$ " Triangular Flexible Plates (17), a $2\frac{1}{2}$ " x $1\frac{1}{2}$ " Flexible Plate (18) and two Semi-Circular Plates (19). The Plates are braced by a $5\frac{1}{2}$ " Strip (20) and a built-up strip (21) made from a $5\frac{1}{2}$ " Strip and a $2\frac{1}{2}$ " Strip. The end is attached to the sides of the body by $\frac{1}{2}$ " x $\frac{1}{2}$ " Angle Brackets, and to the base by a 1 " x 1 " Angle Bracket held by the bolts (22). The front end of the body is similar to the rear except that the Semi-Circular Plates (19) are replaced by $2\frac{1}{2}$ " x 2 " Triangular Flexible Plates.

The completed body pivots on an $11\frac{1}{2}$ " Rod (23) passed through the Double Angle Strips (15). The front end of the Rod is supported in the Flanged Plate (7) and the rear end in a Trunnion bolted to one of the rear mudguards. The Rod is held in place by a Coupling and a $\frac{1}{2}$ " fixed Pulley. The Pulley is placed inside the cab.

The body is tipped by turning a Bush Wheel on a $6\frac{1}{2}$ " Rod (24). This Rod is mounted in one of the Double Angle Strips (3) and in a similar Double Angle Strip (25), and it carries a Worm (26) (Fig. 7.8b). The Worm drives a $\frac{1}{2}$ " Pinion on a $3\frac{1}{2}$ " Rod (27), and the Pinion engages a 57-tooth Gear on a $3\frac{1}{2}$ " Rod (28). The Rods (27) and (28) are mounted in the chassis and are held in place by Collars.

A $1\frac{1}{2}$ " Strip (29) is bolted across the 57-tooth Gear and a Double Bracket is *lock-nutted* to the end of the Strip (Fig. 7.8a). A $2\frac{1}{2}$ " Strip and a built-up strip are *lock-nutted* as shown to the lugs of the Double Bracket, and also to a second Double Bracket (30) bolted underneath the body. The built-up strip is made from two $1\frac{1}{2}$ " Strips bolted together.

MODEL 7.8 SIDE TIPPING WAGON — Continued

The driving mirror at one side of the cab is a Rod and Strip Connector fitted over a Threaded Pin.

The cab roof is a $5\frac{1}{2}$ " x $2\frac{1}{2}$ " Flexible Plate edged by two $5\frac{1}{2}$ " Strips and attached to the sides by $\frac{1}{2}$ " x $\frac{1}{2}$ " and 1 " x 1 " Angle Brackets. The windscreen divisions are curved $5\frac{1}{2}$ " Strips bolted between the roof and the front of the cab.

The radiator is represented by a $2\frac{1}{2}$ " x $1\frac{1}{2}$ " Flanged Plate edged by two $2\frac{1}{2}$ " x $\frac{1}{2}$ " Double Angle Strips. It is attached to the front of the cab by Angle Brackets.

The steering column is a $3\frac{1}{2}$ " Rod supported by Collars in the Flanged Plate (2) and in a $\frac{1}{2}$ " Reversed Angle Bracket bolted to the top flange of the Flanged Plate (6).

THE BODY AND TIPPING MECHANISM

The sloping sides of the body each consist of a $12\frac{1}{2}$ " x $2\frac{1}{2}$ " Strip Plate edged by two $12\frac{1}{2}$ " Strips. The lower part of each side is rounded, and is made from a curved $5\frac{1}{2}$ " x $2\frac{1}{2}$ " Flexible Plate (11), a curved $4\frac{1}{2}$ " x $2\frac{1}{2}$ " Flexible Plate (12), three curved $2\frac{1}{2}$ " x $2\frac{1}{2}$ " Flexible Plates and a $1\frac{1}{2}$ " radius Curved Plate.

Parts Required

11 of No. 1	3 of No. 16	30 of No. 38	2 of No. 90	6 of No. 188
18 " " 2	1 " " 20b	2 " " 38d	8 " " 90a	3 " " 189
6 " " 3	5 " " 22	2 " " 48	2 " " 111	8 " " 190
2 " " 4	1 " " 23a	7 " " 48a	2 " " 111a	2 " " 191
12 " " 5	1 " " 24	2 " " 48b	6 " " 111c	5 " " 192
4 " " 6a	2 " " 24a	1 " " 51	2 " " 115	2 " " 197
4 " " 8	1 " " 26	2 " " 52	1 " " 125	2 " " 200
4 " " 10	1 " " 27a	3 " " 53	1 " " 126	1 " " 212
2 " " 11	1 " " 32	6 " " 59	4 " " 126a	2 " " 214
18 " " 12	199 " " 37a	1 " " 63	1 " " 147b	8 " " 215
4 " " 12a	183 " " 37b	1 " " 80c	3 " " 155	1 " " 216
1 " " 13			1 " " 164	4 " " 221
1 " " 14			2 " " 176	2 " " 222
2 " " 15			4 " " 187	2 " " 223

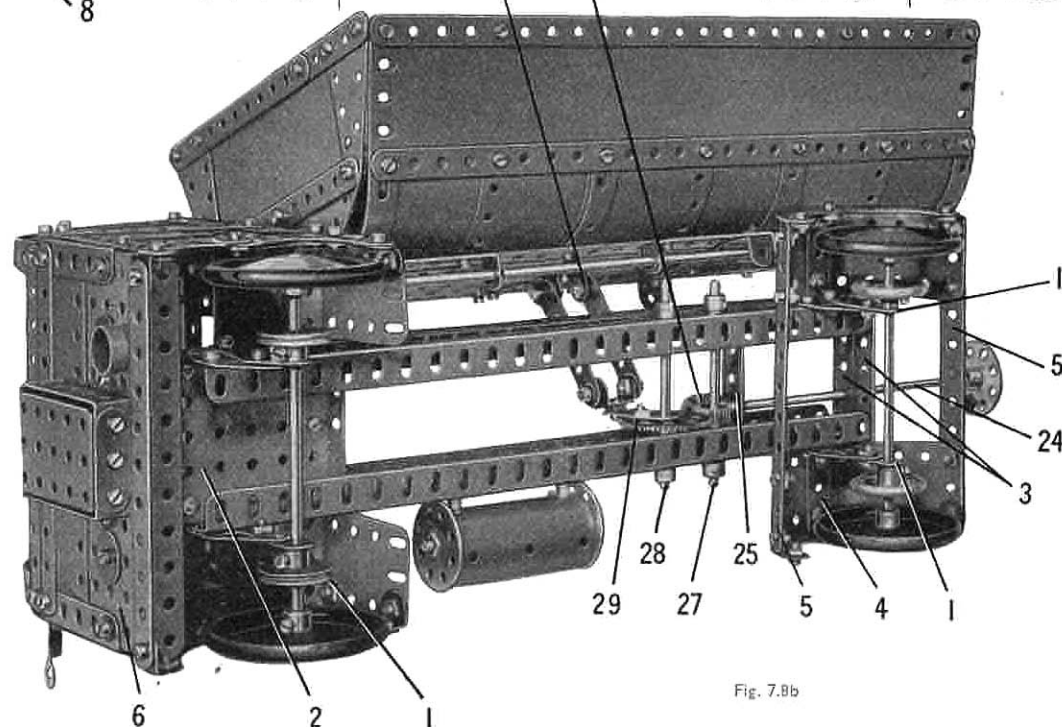

Fig. 7.8b

7.9 POWER PRESS

DETAILS OF THE BASE

The base is made by connecting together two built-up girders (1) at each end by a $5\frac{1}{2}$ " Strip (2) (Fig. 7.9). Each of the girders (1) consists of two $12\frac{1}{2}$ " Angle Girders bolted together by their flanges, and a further $5\frac{1}{2}$ " Strip (3) is attached to them at each end by means of Angle Brackets. A $12\frac{1}{2}$ " Strip (4) on each side is bolted to the Strips (2), and two $4\frac{1}{2}$ " x $2\frac{1}{2}$ " Flexible Plates and two built-up strips (5) are fixed to the Strips (4).

One of the strips (5) is made from a $3\frac{1}{2}$ " and a 3" Strip overlapped four holes; the other consists of a 3" and a $2\frac{1}{2}$ " Strip overlapped two holes.

ASSEMBLY OF THE PRESS COLUMN

Each side of the column is made by bolting two $12\frac{1}{2}$ " Angle Girders (6) to the ends of a $5\frac{1}{2}$ " x $2\frac{1}{2}$ " Flanged Plate (7) (Fig. 7.9). The bolts securing the Girders fix also a $5\frac{1}{2}$ " x $2\frac{1}{2}$ " Flexible Plate (8), which is strengthened along its edges by two $5\frac{1}{2}$ " Strips. The side of the left-hand column (Fig. 7.9), is filled in by a $3\frac{1}{2}$ " x $2\frac{1}{2}$ " Flanged Plate (9), a $2\frac{1}{2}$ " x $1\frac{1}{2}$ " and a $2\frac{1}{2}$ " x $2\frac{1}{2}$ " Flexible Plate. The other column is filled in by a similar set of Plates, but in addition a $2\frac{1}{2}$ " x $2\frac{1}{2}$ " Flexible Plate is bolted above the Flanged Plate. The top edge of this $2\frac{1}{2}$ " x $2\frac{1}{2}$ " Flexible Plate is strengthened by a $2\frac{1}{2}$ " Strip.

The sides of the column are connected at the base by two $5\frac{1}{2}$ " Strips, one of which is seen at (10), attached to the upper corners of the Flexible Plates (8) by Angle Brackets. Two $2\frac{1}{2}$ " x $1\frac{1}{2}$ " Flexible Plates (11) are bolted to each of the Strips (10), and the lower edges of these Plates are braced by $1\frac{1}{2}$ " Strips and are connected by Angle Brackets to the Plates (8). A $2\frac{1}{2}$ " x $\frac{1}{2}$ " Double Angle Strip is bolted vertically to the centre of each of the Plates (11) on the inside. The lower lugs of these Double Angle Strips are used to connect the column to the girders (1) of the base, and the upper lugs support two $5\frac{1}{2}$ " x $2\frac{1}{2}$ " Flexible Plates (12) edged as shown by $5\frac{1}{2}$ " Strips.

The sides of the column are connected by a $5\frac{1}{2}$ " x $1\frac{1}{2}$ " Flanged Plate (13), and at the front and the back of the model, by two $5\frac{1}{2}$ " Strips (14) (Fig. 7.9a). These Strips are bolted along the upper and lower edges of $5\frac{1}{2}$ " x $1\frac{1}{2}$ " Flexible Plates. The top of the column is covered by two $5\frac{1}{2}$ " x $1\frac{1}{2}$ " Flexible Plates bolted together and attached to three $2\frac{1}{2}$ " x $\frac{1}{2}$ " Double Angle Strips fixed between the upper pair of the Strips (14).

The Flanged Plate (13) represents the bed for the press tool, and the tool holder is made by bolting $1"$ x $1"$ Angle Brackets to each of the ends of two $2\frac{1}{2}$ " Strips. The $1"$ x $1"$ Angle Brackets are connected in pairs and are fixed to $\frac{1}{2}"$ x $\frac{1}{2}"$ Angle Brackets bolted to the Plate (13).

THE PRESS RAM

The sides of the ram are $5\frac{1}{2}$ " x $2\frac{1}{2}$ " Flexible Plates, each edged by two $2\frac{1}{2}$ " Strips and two $5\frac{1}{2}$ " Strips (15). The lower pair of Strips (15) are spaced from the Flexible Plates by a nut and two Washers on the bolts holding them in position, and these bolts secure also a $3\frac{1}{2}$ " x $\frac{1}{2}"$ Double Angle Strip on each side, which is placed inside the ram. A $3\frac{1}{2}$ " x $2\frac{1}{2}"$ Flanged Plate is bolted to the lugs of the Double Angle Strips, and this supports a $2\frac{1}{2}$ " x $1\frac{1}{2}"$ Flanged Plate (16) and a $1\frac{1}{2}"$ x $\frac{1}{2}"$ Double Angle Strip (17) (Fig. 7.9).

Two $2\frac{1}{2}"$ x $\frac{1}{2}"$ Double Angle Strips (18) are bolted across the top of the ram and a $3\frac{1}{2}"$ Strip (19) is fixed to them. The ends of the Strip (19) are connected by Angle Brackets to $2\frac{1}{2}"$ x $2\frac{1}{2}"$ Flexible Plates, which are fastened at their lower ends to the flanges of the $3\frac{1}{2}"$ x $2\frac{1}{2}"$ Flanged Plate. Two Trunnions (20) are bolted to the Double Angle Strips (18). The ram slides freely between the Girders (6), with the ends of the lower pair of Strips (15) outside the Girders.

THE OPERATING MECHANISM

A No. 1 Clockwork Motor is bolted to the upper end of one side of the column as shown, and a $\frac{1}{2}"$ Pinion on its driving shaft drives a 57-tooth Gear on a $3\frac{1}{2}"$ Rod (21). This Rod is held in the Motor side-plates by a $1"$ Pulley and a $\frac{1}{2}"$ fixed Pulley (22). The Pulley (22) is connected by a Cord belt to one of two 3" Pulleys on a $3\frac{1}{2}"$ Rod (23). This Rod is mounted in the side of the column and in a Double Bent Strip (24) and a $\frac{1}{2}"$ Reversed Angle Bracket (25) bolted to the side. The Rod is held in position by Collars and a 2" Pulley is bolted to its inner end. A Crank (26) is fastened across the face of the 2" Pulley (Fig. 7.9a).

A 2" Pulley, fitted with a Crank (27), is fixed on the end of a $3\frac{1}{2}"$ Rod (28). This Rod is mounted in the same way as the Rod (23), and is held in position by Collars.

A $3\frac{1}{2}"$ Rod (29) is fixed in the Cranks (26) and (27), and two $2\frac{1}{2}"$ Strips (30) are pivoted freely on the Rod between the Cranks and Spring Clips. The lower ends of the Strips (30) are passed over a 2" Rod (31), which is held by Collars in the Trunnions (20).

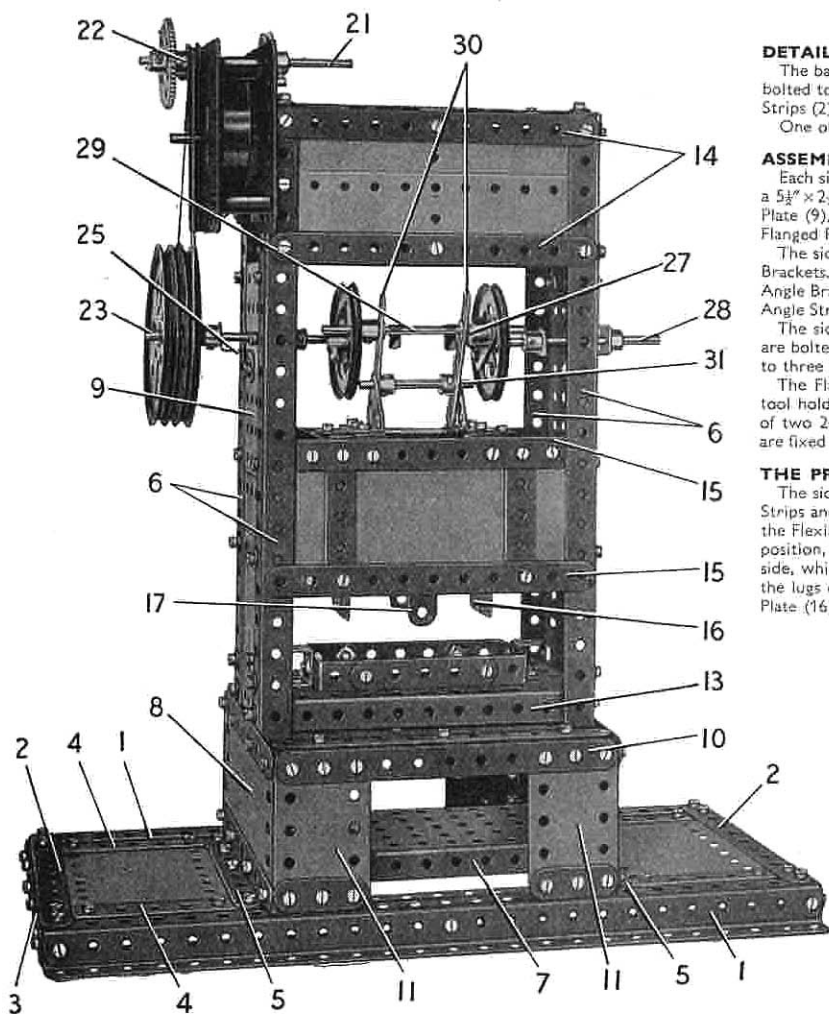

Fig. 7.9

Parts Required

2 of No. 1	8 of No. 8	2 of No. 19b	200 of No. 37a	1 of No. 48	3 of No. 53	2 of No. 126	6 of No. 192
18 " " 2	2 " " 11	2 " " 20a	186 " " 37b	9 " " 48a	6 " " 59	6 " " 188	1 No. 1 Clockwork Motor (not included in Outfit)
6 " " 3	18 " " 12	1 " " 22	34 " " 38	2 " " 48b	2 " " 62	6 " " 189	
2 " " 4	4 " " 12a	1 " " 26	1 " " 40	1 " " 51	6 " " 111c	5 " " 190	
10 " " 5	4 " " 16	1 " " 27a	2 " " 45	2 " " 52	2 " " 125	2 " " 191	
4 " " 6a	1 " " 17	2 " " 35					

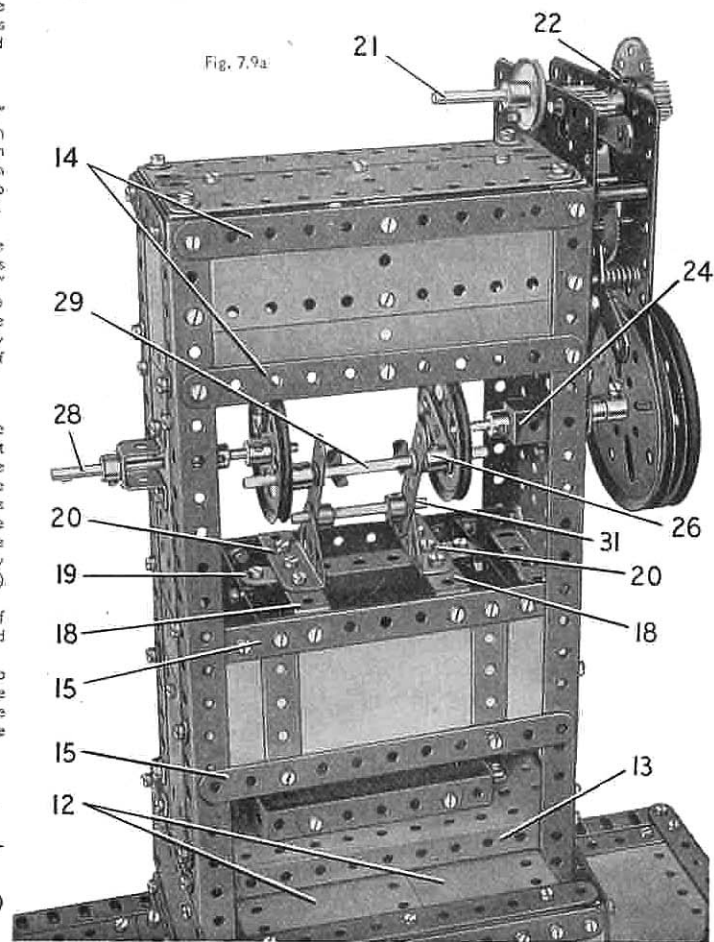

Fig. 7.9a

7.10 COALING TOWER

Parts Required

10 of No. 1	2 of No. 52
18 " " 2	3 " " 53
2 " " 4	2 " " 54
10 " " 5	6 " " 59
8 " " 8	2 " " 62
4 " " 10	1 " " 63
4 " " 11	2 " " 80c
15 " " 12	2 " " 90a
4 " " 12c	2 " " 111
1 " " 14	2 " " 111a
1 " " 15b	3 " " 111c
4 " " 16	1 " " 115
4 " " 18a	4 " " 125
3 " " 22	1 " " 147b
1 " " 23	2 " " 176
1 " " 23a	2 " " 186
1 " " 24	6 " " 188
1 " " 26	6 " " 189
1 " " 27a	8 " " 190
14 " " 35	2 " " 191
178 " " 37a	6 " " 192
156 " " 37b	2 " " 197
25 " " 38	1 " " 198
2 " " 38d	2 " " 200
1 " " 40	2 " " 212
1 " " 44	2 " " 212a
2 " " 45	2 " " 214
1 " " 46	4 " " 221
2 " " 48	2 " " 222
9 " " 48a	2 " " 223
1 " " 51	

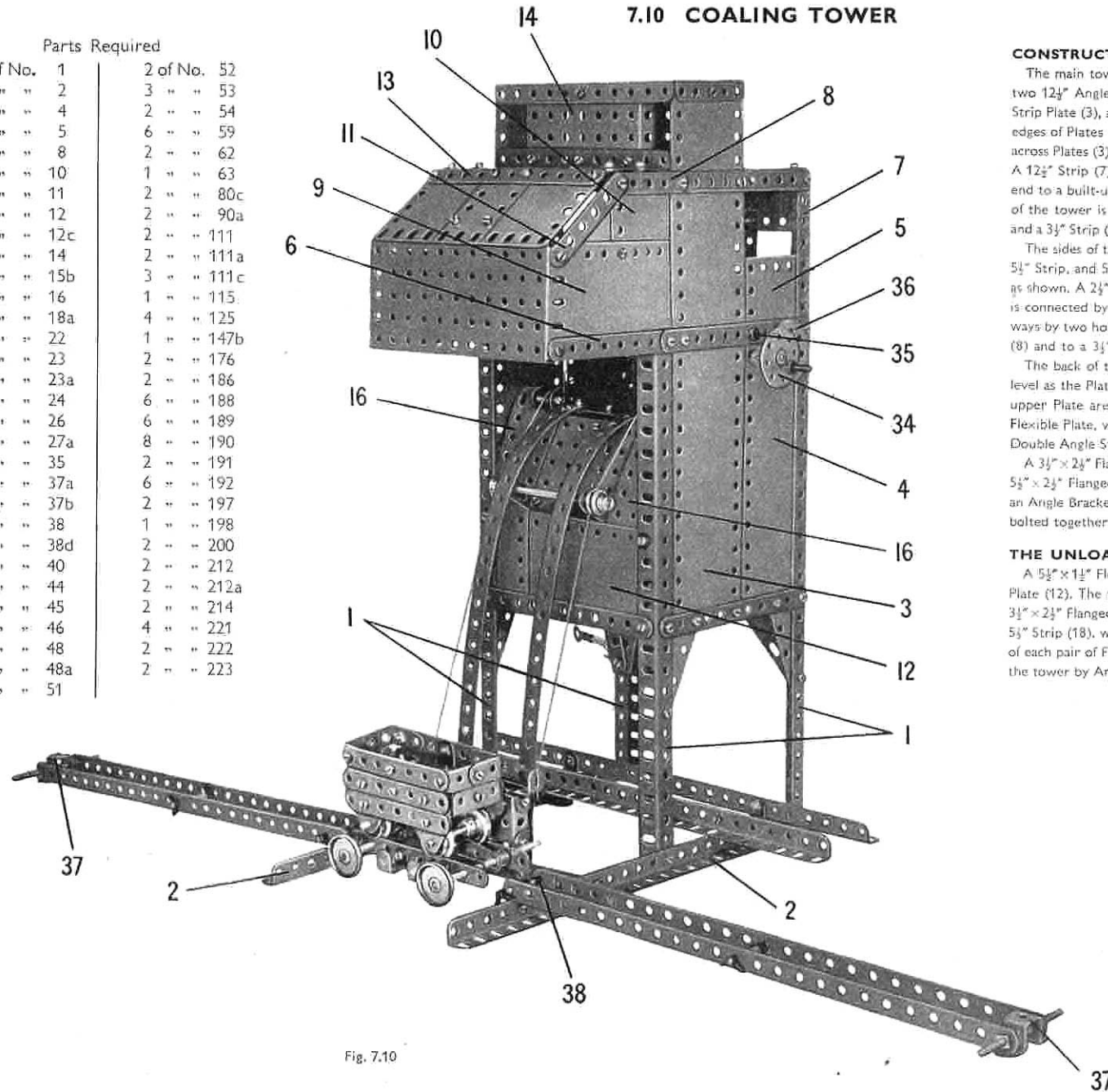

Fig. 7.10

CONSTRUCTION OF THE TOWER

The main tower supports are four $1\frac{1}{2}$ " Angle Girders (1), bolted at their lower ends to two $1\frac{1}{2}$ " Angle Girders (2) (Fig. 7.10). Each side of the tower is filled in by a $1\frac{1}{2}$ " \times $2\frac{1}{2}$ " Strip Plate (3), a $5\frac{1}{2}$ " \times $2\frac{1}{2}$ " Flexible Plate (4) and one half of a Hinged Flat Plate (5). The lower edges of Plates (3) and (4) are strengthened by a $5\frac{1}{2}$ " Strip, and a built-up strip (6) is bolted across Plates (3) and (5) as shown. This strip consists of two $5\frac{1}{2}$ " Strips overlapped four holes. A $12\frac{1}{2}$ " Strip (7) is bolted along the rear edge of the Plate (5) and is joined at its upper end to a built-up strip (8), made from a $5\frac{1}{2}$ " and a $2\frac{1}{2}$ " Strip overlapped two holes. Each side of the tower is completed by a $4\frac{1}{2}$ " \times $2\frac{1}{2}$ " Flexible Plate (9), a $2\frac{1}{2}$ " \times $2\frac{1}{2}$ " Flexible Plate (10) and a $3\frac{1}{2}$ " Strip (11) bolted along the edge of a $2\frac{1}{2}$ " \times $2\frac{1}{2}$ " Triangular Flexible Plate.

The sides of the tower are joined at the front by a $5\frac{1}{2}$ " \times $2\frac{1}{2}$ " Flexible Plate (12) edged by a $5\frac{1}{2}$ " Strip, and $5\frac{1}{2}$ " \times $2\frac{1}{2}$ " Flanged Plates are fixed between the ends of the Plates (3) and (9) as shown. A $2\frac{1}{2}$ " \times $1\frac{1}{2}$ " and two $2\frac{1}{2}$ " \times $2\frac{1}{2}$ " Flexible Plates are bolted to a $5\frac{1}{2}$ " Strip (13), which is connected by Obtuse Angle Brackets to two $5\frac{1}{2}$ " \times $1\frac{1}{2}$ " Flexible Plates overlapped lengthways by two holes. The $5\frac{1}{2}$ " \times $1\frac{1}{2}$ " Flexible Plates are attached by Angle Brackets to the strips (8) and to a $3\frac{1}{2}$ " \times $2\frac{1}{2}$ " Flanged Plate (14) (Fig. 7.10).

The back of the tower is filled in by three $5\frac{1}{2}$ " \times $2\frac{1}{2}$ " Flexible Plates, starting at the same level as the Plates (3) and (4). The bottom edge of the lowest Plate and the top edge of the upper Plate are strengthened by $5\frac{1}{2}$ " Strips. The back is extended upward by a $5\frac{1}{2}$ " \times $1\frac{1}{2}$ " Flexible Plate, which is connected to a similar Plate at the top of the tower by two $2\frac{1}{2}$ " \times $\frac{1}{2}$ " Double Angle Strips, and two $1\frac{1}{2}$ " Strips that overlap the rear pair of Girders (1).

A $3\frac{1}{2}$ " \times $2\frac{1}{2}$ " Flanged Plate, corresponding to the Plate (14), is bolted to the rear edge of the $5\frac{1}{2}$ " \times $2\frac{1}{2}$ " Flanged Plate at the top of the tower, and a built-up plate is connected to it by an Angle Bracket. This built-up plate consists of a $2\frac{1}{2}$ " \times $1\frac{1}{2}$ " and two $2\frac{1}{2}$ " \times $2\frac{1}{2}$ " Flexible Plates bolted together, and it is attached by Angle Brackets to the rear ends of the strips (8).

THE UNLOADING HOPPER

A $5\frac{1}{2}$ " \times $1\frac{1}{2}$ " Flexible Plate (16) (Fig. 7.10) is bolted vertically to each end of the Flexible Plate (12). The top ends of the Plates (16) are bent inward slightly and are connected by a $3\frac{1}{2}$ " \times $2\frac{1}{2}$ " Flanged Plate (17). The Flanged Plate is attached by an Obtuse Angle Bracket to a $5\frac{1}{2}$ " Strip (18), which supports two $2\frac{1}{2}$ " \times $1\frac{1}{2}$ " Flexible Plates (19) on each side. The rear edges of each pair of Flexible Plates are bolted to a $5\frac{1}{2}$ " Strip, and this is connected to the back of the tower by Angle Brackets.

(Continued on next page)

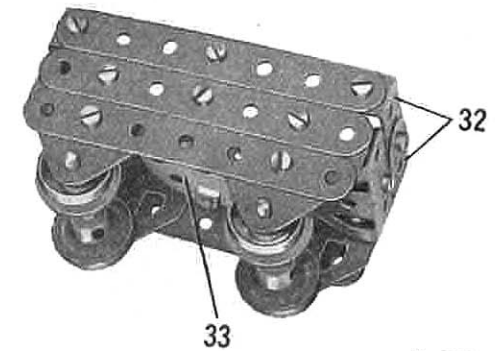

Fig. 7.10a

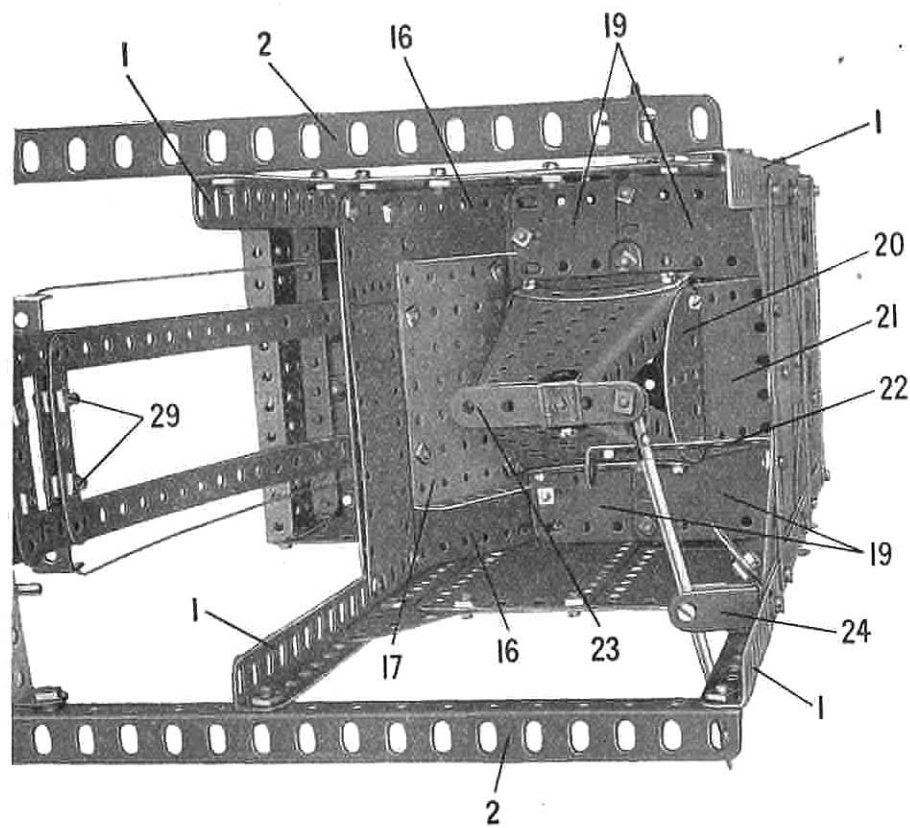

Fig. 7.10b

Each side of the truck is formed by three $3\frac{1}{2}$ " Strips. Two of these are connected by Fishplates, and the third is attached to Flat Trunnions that support the truck wheels. The sides are connected by two $1" \times 1"$ Angle Brackets (32) at each end, with a Trunnion joined to them by a Fishplate. The floor of the truck is filled in by two $3\frac{1}{2}$ " \times $\frac{1}{2}$ " Double Angle Strips bolted to a Wheel Disc (33) and connected to the sides by Angle Brackets. The $\frac{3}{4}$ " Flanged Wheels are fixed in pairs on 2" Rods.

THE OPERATING MECHANISM

A Bush Wheel (34) is fixed on a $\frac{3}{4}$ " Rod that carries also a $\frac{1}{2}$ " Pinion. The Rod is supported in the side of the tower, and in a Coupling held on the inside of one of the Plates (5) by a Pivot Bolt (35) (Fig. 7.10). The Rod is held in position by a Collar, and its Pinion drives a 57-tooth Gear (36) on a $6\frac{1}{4}$ " Rod passed through the centre holes of the Plates (5). The $6\frac{1}{4}$ " Rod is held in place by a 1" Pulley, and it carries, inside the tower, two Cord Anchoring Springs. A length of Cord is tied to one of these, is taken over the guides (26) and (27), and through $\frac{1}{2}$ " Reversed Angle Brackets bolted to the hoist platform. The Cord passes over the second pair of guides (26) and (27), and is tied to the other Cord Anchoring Spring.

THE RAILS AT THE BASE OF THE TOWER

The rails between the tower legs are $12\frac{1}{2}$ " Angle Girders connected by $1\frac{1}{2}$ " \times $\frac{1}{2}$ " Double Angle Strips, and attached by Angle Brackets to the Girders (2). The approach rails to the hoist platform are each formed by two $12\frac{1}{2}$ " Strips. These are spaced apart by nuts on a Screwed Rod that supports a Double Bent Strip (37). The Strips are spaced apart also by Spring Clips on $1\frac{1}{4}$ " Rods, the inner one of which carries between the Strips a Right-Angle Rod and Strip Connector (38), which is bolted to one of the Girders (2).

MODEL 7.10 COALING TOWER — Continued

The unloading chute is formed by two Flanged Sector Plates bolted together at their narrow ends and fixed by their wide ends to two Semi-Circular Plates, one of which is seen at (20). Two $2\frac{1}{2}$ " \times $2\frac{1}{2}$ " Flexible Plates and two $1\frac{1}{4}$ " radius Curved Plates (21) are attached to the wide end of the chute, and the $2\frac{1}{2}$ " \times $2\frac{1}{2}$ " Flexible Plates are connected to the Plates (19) by Angle Brackets. The lower end of the chute is supported by a $2\frac{1}{2}$ " \times $\frac{1}{2}$ " Double Angle Strip (22) bolted to the back of the tower.

The discharge from the chute is controlled by a trap formed by a $2\frac{1}{2}$ " Strip (23). This slides between a Double Bracket bolted to one of the Flanged Sector Plates, and one end is lock-nutted to a Rod and Strip Connector on a 4" Rod. A Collar on the Rod pivots on bolts passed through a Stepped Bent Strip (24) and screwed into the Collar. The Stepped Bent Strip is bolted to one of the Angle Girders (1).

THE HOIST RAILS AND GUIDES

Each of the hoist rails is a $12\frac{1}{2}$ " Strip, bent as shown and attached to the Strip (18). The lower ends of the $12\frac{1}{2}$ " Strips are bolted to two $2\frac{1}{2}$ " \times $\frac{1}{2}$ " Double Angle Strips (25), which are fixed to the Angle Girders (2) and are connected by a $2\frac{1}{2}$ " Strip.

The guides half-way up the rails are made from a $\frac{1}{2}$ " loose Pulley and a $\frac{1}{2}$ " fixed Pulley, indicated at (26), and are supported by a $3\frac{1}{2}$ " Rod mounted in a $2\frac{1}{2}$ " \times $1"$ Double Angle Strip. The Double Angle Strip is bolted to the Flanged Plate (17). The $\frac{1}{2}$ " loose Pulley is held on the Rod between Collars. The guides at the top of the rails are each formed by a $\frac{1}{2}$ " Bolt held by a nut in a Double Bracket (27) (Fig. 7.10c), which is bolted to one of the Plates (16).

THE HOIST PLATFORM AND TRUCK

The back of the platform is a $2\frac{1}{2}$ " \times $1\frac{1}{2}$ " Flanged Plate fitted with two $2\frac{1}{2}$ " \times $\frac{1}{2}$ " Double Angle Strips (28) (Fig. 7.10c). A $2\frac{1}{2}$ " Strip is attached to each Double Angle Strip by two $\frac{3}{8}$ " Bolts (29), but is spaced by a nut and $\frac{3}{8}$ " Washer on each Bolt. The hoist rails pass between the gaps at the ends of the Strips and Double Angle Strips.

The truck rails are supported by two $2\frac{1}{2}$ " \times $\frac{1}{2}$ " Double Angle Strips (30). Each rail is made from two $2\frac{1}{2}$ " Strips and is bolted to Angle Brackets. The clips that fit between the truck axles are formed by Fishplates bolted to Cranks. Each Crank is fixed on a $3\frac{1}{2}$ " Rod that is held in the rails by a Spring Clip. A $2\frac{1}{2}$ " Driving Band (31) is stretched between the Rods.

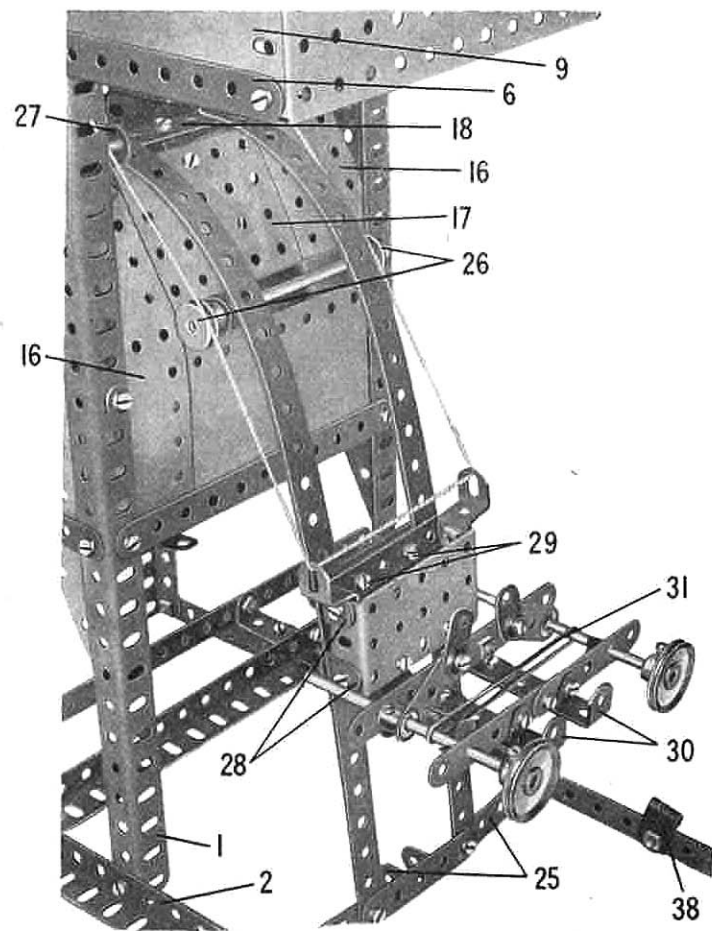

Fig. 7.10c

7.11 TAXI

Parts Required

1 of No. 1	4 of No. 12a	28 of No. 38	8 of No. 90a	3 of No. 192
8 " " 2	5 " " 12c	2 " " 48	6 " " 111c	1 " " 198
6 " " 3	2 " " 15	5 " " 48a	3 " " 125	2 " " 200
2 " " 4	1 " " 16	1 " " 51	2 " " 126	2 " " 212
12 " " 5	2 " " 18a	2 " " 52	2 " " 155	2 " " 214
4 " " 6a	2 " " 20b	3 " " 53	4 " " 187	8 " " 215
2 " " 8	2 " " 22	5 " " 59	6 " " 188	4 " " 221
11 " " 10	1 " " 24	1 " " 63	6 " " 189	2 " " 222
4 " " 11	160 " " 37a	1 " " 80c	8 " " 190	1 " " 223
17 " " 12	147 " " 37b	2 " " 90	2 " " 191	

BUILDING THE CHASSIS

The chassis is made by bolting two 12½" Angle Girders (1) to a 5½" × 2½" Flanged Plate, as seen in Fig. 7.11b. The rear wheels are fixed on a 5" Rod supported in the Girders (1).

Each of the front wheels is fixed on a 1½" Rod that is held by a Collar in a Double Bracket (2). A 1½" Strip (3) is placed between the lugs of the Double Bracket and a 1" Bolt is passed through the parts. The Bolt is held by two nuts in a 1" × 1" Angle Bracket (4) bolted to the chassis. The Double Bracket and the Strip pivot freely as a unit on the Bolt, and a Rod and Strip Connector is lock-nutted to the end of each of the Strips (3). The Rod and Strip Connectors are connected by a 3½" Rod, and a built-up strip (5) is pivoted on the same Bolt as one of them. This strip is made from two 2½" Strips overlapped two holes, and one end is lock-nutted to a Fishplate that is bolted to an Obtuse Angle Bracket (6).

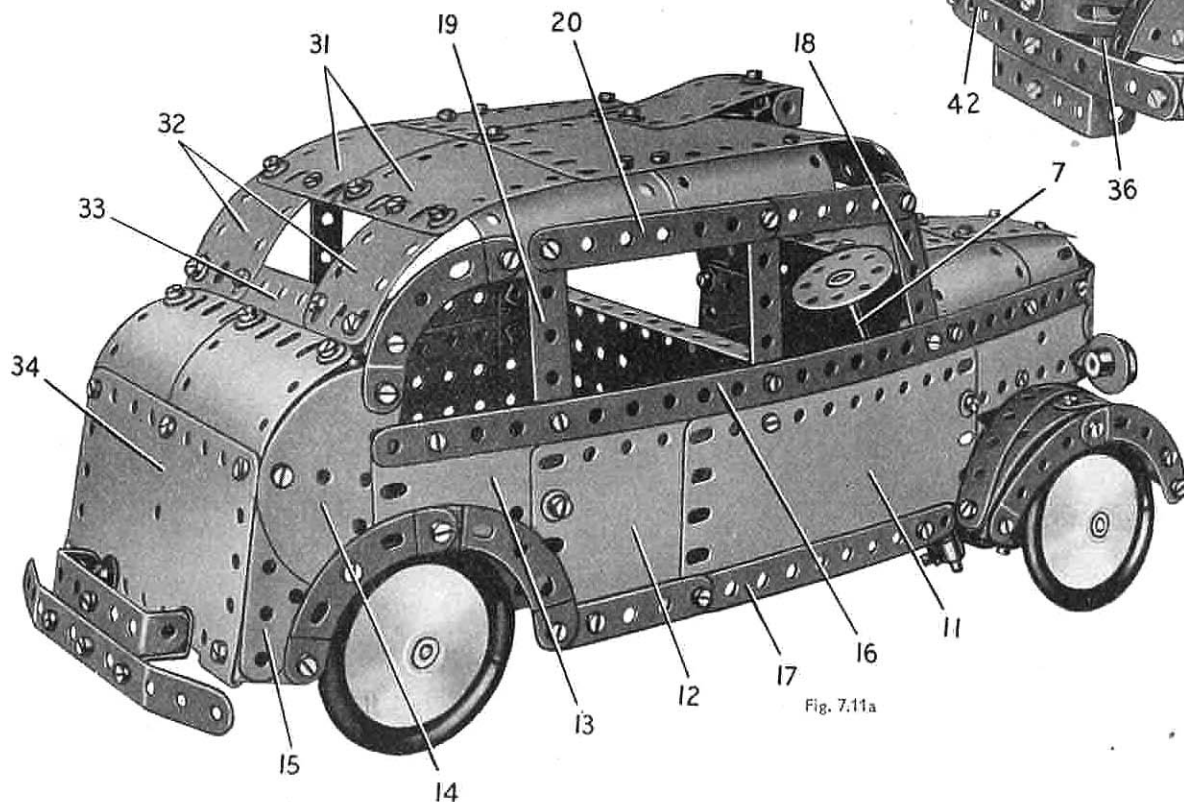

Fig. 7.11a

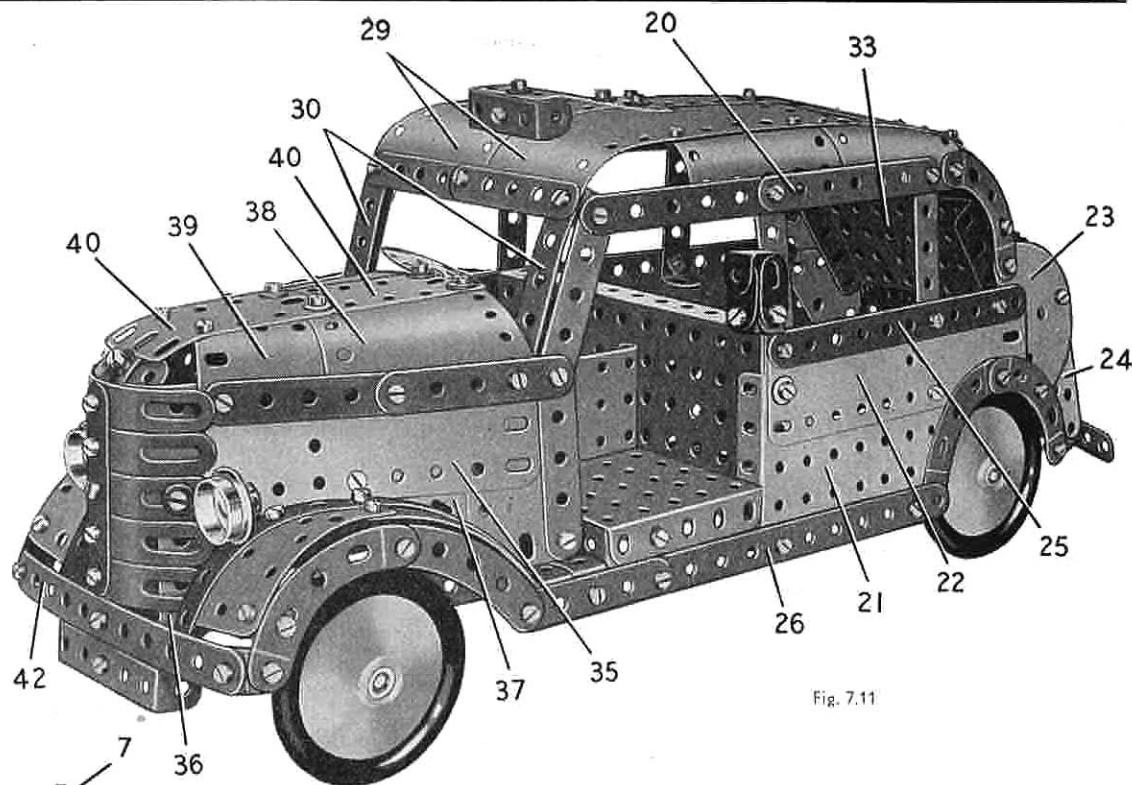

Fig. 7.11

A bolt is passed through the Obtuse Angle Bracket and is fitted with a nut. The bolt is then screwed tightly into a Collar on a 5" Rod (7), and the nut is tightened against the Bracket to fix it firmly on the bolt. Rod (7) is the steering column, and it is supported in a Coupling fixed to one of the Girders (1) by a Bolt (8). The Bolt carries two Washers for spacing so that it does not grip the Rod (7), which is held in position in the Coupling by two Collars.

THE SIDES OF THE BODY

The sides are supported by a 5½" × 2½" Flanged Plate (9) and a 5½" Strip (10) bolted across the chassis. The side seen in Fig. 7.11a consists of a 5½" × 2½" Flexible Plate (11), a 2½" × 2½" Flexible Plate (12), a 5½" × 1½" Flexible Plate (13), a Semi-Circular Plate (14) and a 2½" × 1½" Triangular Flexible Plate (15). These Plates are edged as shown by a 12½" Strip (16) and a built-up strip (17) made from a 5½" and a 2½" Strip overlapped two holes. The rear wheel arch is formed by two 2½" Stepped Curved Strips. The window divisions are provided by a 2½" Strip, a 3½" Strip (18) and a 2½" × 1½" Double Angle Strip (19). These parts are connected at their upper ends by a built-up strip (20), made from a 3½" and a 3" Strip.

The side shown in Fig. 7.11 consists of a 3½" × 2½" Flanged Plate (21), a 5½" × 1½" Flexible Plate (22), a Semi-Circular Plate (23) and a 2½" × 1½" Triangular Flexible Plate (24). These plates are edged by a 5½" Strip (25) and a built-up strip (26), made from a 5½" and a 2½" Strip. The window frames are made in the same way as those on the side already described.

The strip (17) is connected to the chassis by an Angle Bracket and a 1½" Strip (27), and the strip (26) is supported by a 1½" × ½" Double Angle Strip (28).

THE ROOF AND LUGGAGE BOOT

The strips (20) are connected at the front by Angle Brackets to two 5½" × 2½" Flexible Plates (29) (Fig. 7.11). The front edges of these Plates are edged by two 2½" Strips, and two 3½" Strips (30) are fixed to them. The Plates (29) are extended towards the rear by two 4½" × 2½" Flexible Plates (31) and two 5½" × 1½" Flexible Plates (32), which are bolted at their rear ends to a 3½" × 2½" Flanged Plate (33). The roof is connected to the strips (20) by a 'U'-section Curved Plate and a 1½" radius Curved Plate on each side.

The rear corners of the Plates (32) are connected to 2½" Stepped Curved Strips by Angle Brackets, and to two curved 2½" × 2½" Flexible Plates by Obtuse Angle Brackets. The latter Plates are bolted to one half of a Hinged Flat Plate (34), which is connected to the sides of the body by two ½" × ½" and two 1" × 1" Angle Brackets.

(Continued on next page)

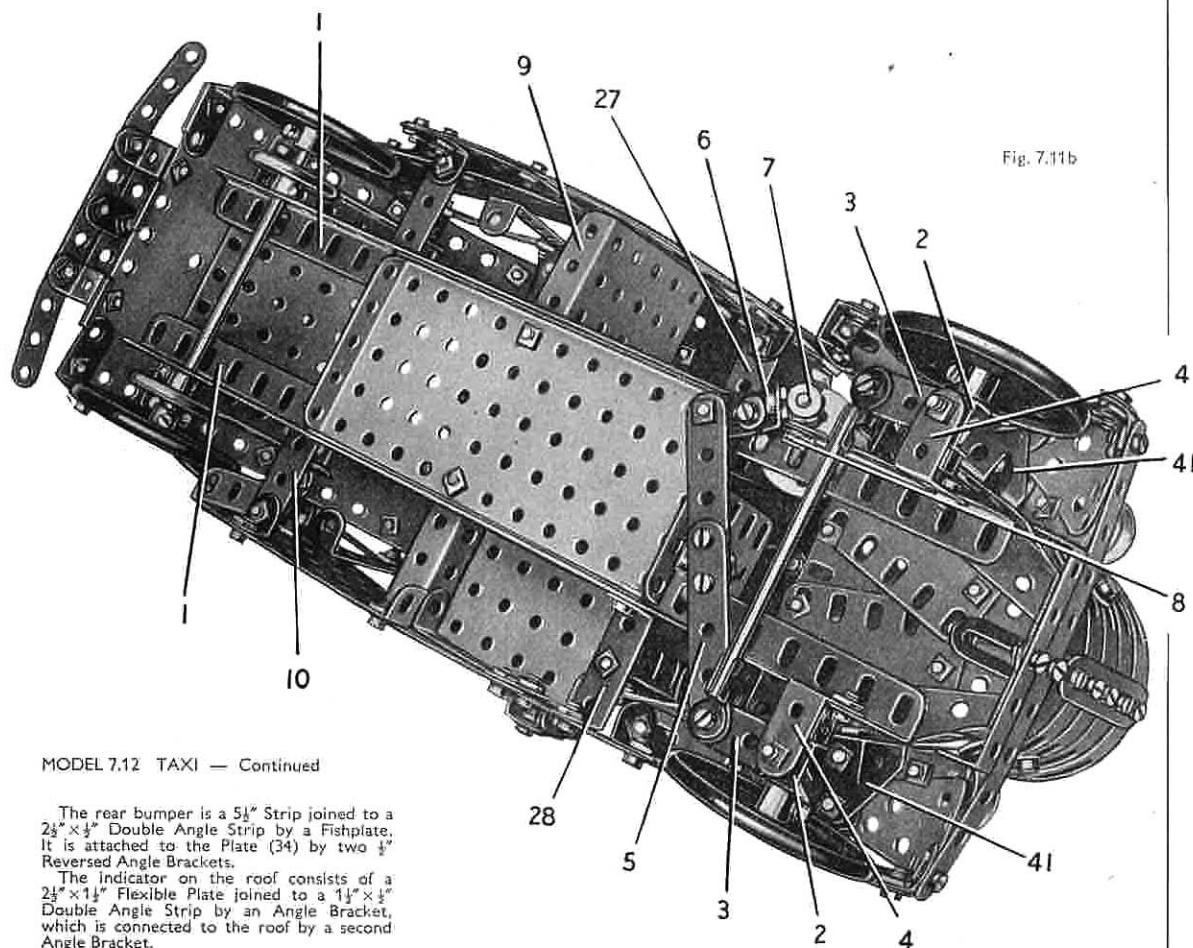

Fig. 7.11b

MODEL 7.12 TAXI — Continued

The rear bumper is a 5 1/2" Strip joined to a 2 1/2" x 1/2" Double Angle Strip by a Fishplate. It is attached to the Plate (34) by two 1/2" Reversed Angle Brackets.

The indicator on the roof consists of a 2 1/2" x 1 1/2" Flexible Plate joined to a 1 1/2" x 1/2" Double Angle Strip by an Angle Bracket, which is connected to the roof by a second Angle Bracket.

CONSTRUCTION OF THE BONNET

Each side of the bonnet is formed by a 5 1/2" x 1 1/2" Flexible Plate (35). One of these is bolted to the Strip (16), and the other is edged by two 2 1/2" Strips as shown in Fig. 7.11. The front ends of the Plates (35) are curved and bolted together. The radiator consists of five Formed Slotted Strips fastened to a 2 1/2" Strip that is attached to the Plates (35). A 2 1/2" x 2" Triangular Flexible Plate, one of which is indicated at (36), is secured to each side, and a 2 1/2" x 2 1/2" Triangular Flexible Plate (37), a 2 1/2" x 1 1/2" Flexible Plate and a 2 1/2" Strip, are attached to one side as shown in Fig. 7.11. The headlights are 1" Flanged Wheels screwed on to the ends of a 3" Screwed Rod passed through the sides of the bonnet and fixed in position by nuts on the Screwed Rod.

The top of the bonnet consists of a 2 1/2" x 2 1/2" Flexible Plate (38) and a 2 1/2" x 1 1/2" Flexible Plate (39) fastened to each side. These Plates are curved as shown and are bolted to two 2 1/2" x 1 1/2" Flexible Plates (40) joined together. The Plates (40) are connected to the radiator by a Formed Slotted Strip fitted with a 1 1/2" Strip.

THE FRONT MUDGUARDS AND THE LUGGAGE COMPARTMENT

The top of each mudguard is formed by a 2 1/2" x 1 1/2" Triangular Flexible Plate, a Formed Slotted Strip and a curved 5 1/2" Strip bolted to a Trunion (41) (Fig. 7.11b) that is fixed to the side of the bonnet. The mudguards are edged as shown by 2 1/2" Curved Strips and 2 1/2" Stepped Curved Strips. One of the mudguards is connected by an Angle Bracket to the strip (26), and the other is attached to a Double Bracket bolted to the Plate (11). The mudguards are joined by Obtuse Angle Brackets to a 5 1/2" Strip (42). This Strip is supported by a Fishplate bolted to the radiator, and a 2 1/2" x 1/2" Double Angle Strip is connected to it by a second Fishplate.

The floor of the luggage compartment is a 3 1/2" x 2 1/2" Flanged Plate, which is attached to the strip (26) by a Fishplate and has a 2 1/2" x 1/2" Double Angle Strip bolted to its outer flange. The division between the driving and luggage compartments is a 2 1/2" x 1 1/2" Flanged Plate bolted to the Flanged Plate (9).

The meter consists of three Fishplates, a Double Bracket, an Angle Bracket and a 1/2" Reversed Angle Bracket bolted together. One lug of the Reversed Angle Bracket is used to attach the meter to the body.

7.12 WINDMILL PUMP

Parts Required		1 of No. 198
11 of No. 1	1 of No. 198	1 of No. 198
17 " " 2	1 " " 212	1 " " 212
6 " " 3	2 " " 212a	2 " " 212a
12 " " 5	2 " " 213	2 " " 213
4 " " 6a	1 " " 215	1 " " 215
8 " " 8	4 " " 221	4 " " 221
5 " " 10	2 " " 222	2 " " 222
4 " " 11	2 " " 223	2 " " 223
18 " " 12		
4 " " 12a		
4 " " 12c		
1 " " 14		
2 " " 15		
2 " " 15a		
1 " " 15b		
4 " " 16		
1 " " 18a		
1 " " 18b		
1 " " 19b		
1 " " 19g		
1 " " 20a		
2 " " 20b		
5 " " 22		
1 " " 24		
1 " " 24c		
1 " " 26		
1 " " 27a		
8 " " 35		
201 " " 37a		
184 " " 37b		
30 " " 38		
1 " " 40		
1 " " 44		
2 " " 45		
2 " " 48		
8 " " 48a		
2 " " 48b		
2 " " 52		
3 " " 53		
2 " " 54		
6 " " 59		
1 " " 62		
1 " " 63		
2 " " 90		
8 " " 90a		
2 " " 111		
2 " " 111a		
6 " " 111c		
1 " " 116		
2 " " 126		
2 " " 126a		
1 " " 147b		
1 " " 162		
1 " " 163		
1 " " 164		
6 " " 188		
6 " " 189		
1 " " 190		
6 " " 192		

Fig. 7.12

(Continued on next page)

MODEL 7.12 WINDMILL PUMP — Continued

CONSTRUCTION OF THE BASE

The base is made by connecting two $5\frac{1}{2}'' \times 2\frac{1}{2}''$ Flanged Plates (1) by means of two $2\frac{1}{2}'' \times \frac{1}{2}''$ Double Angle Strips; one of which is seen at (2). Two $3\frac{1}{2}'' \times 2\frac{1}{2}''$ Flanged Plates (3) are bolted together and one of them is fixed to the Double Angle Strips (2) (Fig. 7.12a).

Each of the Flanged Plates (1) is extended on one side by a $2\frac{1}{2}''$ Strip that overlaps the Plate by two holes. A built-up plate (4), made from a $5\frac{1}{2}'' \times 1\frac{1}{2}''$ and a $2\frac{1}{2}'' \times 1\frac{1}{2}''$ Flexible Plate, is bolted across one of the Flanged Plates (3) and is connected to the Flanged Plates (1) by Angle Brackets. The base is edged on two sides by $5\frac{1}{2}'' \times 1\frac{1}{2}''$ and $2\frac{1}{2}'' \times 1\frac{1}{2}''$ Flexible Plates.

ASSEMBLY OF THE TOWER

Each of the main girders of the tower consists of two $12\frac{1}{2}''$ Angle Griders overlapped two holes. Two of these girders are bolted to the outer corners of the Flanged Plates (1), and the other two are fixed to the $2\frac{1}{2}''$ Strips used to extend the Flanged Plates. The latter girders are connected by a built-up strip (5) (Fig. 7.12b), made from a $5\frac{1}{2}''$ and a $2\frac{1}{2}''$ Strip.

The upper ends of the main girders are connected by four $3\frac{1}{2}''$ Strips, two of which are seen at (6). The main girders are connected at a point half-way up the tower by two $5\frac{1}{2}''$ Strips (7) and two similar Strips (8) (Fig. 7.12).

Two Flat Trunnions; one of which is seen at (9), are bolted to two of the Strips (6). A $5\frac{1}{2}''$ Strip (10) is supported by two $2\frac{1}{2}'' \times \frac{1}{2}''$ Double Angle Strips fixed to the Strips (8). The roof over the tower is a Hinged Flat Plate bolted to four Obtuse Angle Brackets.

A direction vane (11) fitted to the tower is formed by two Flanged Sector Plates bolted together. It is attached by a Formed Slotted Strip and two $2\frac{1}{2}''$ Stepped Curved Strips (12) to a Double Bracket bolted to a $3\frac{1}{2}''$ Strip (13). The Strip (13) is attached to Fishplates fixed to the tower (Fig. 7.12b).

The inspection platform half-way up the tower consists of three $5\frac{1}{2}'' \times 1\frac{1}{2}''$ and three $2\frac{1}{2}'' \times 1\frac{1}{2}''$ Flexible Plates. These Plates are strengthened by $5\frac{1}{2}''$ Strips placed underneath the platform as seen in Fig. 7.12a, and they are edged by a $5\frac{1}{2}''$ Strip (14) and two built-up strips (15) and (16). The strip (15) is made from a $5\frac{1}{2}''$ and a $2\frac{1}{2}''$ Strip overlapped two holes, and the strip (16) consists of a $5\frac{1}{2}''$ and a $3\frac{1}{2}''$ Strip. The Strip (14) and the strips (15) and (16) are connected together and to the platform by Angle Brackets. The platform is supported by four $1'' \times 1''$ Angle Brackets (17) and two $1\frac{1}{2}'' \times \frac{1}{2}''$ Double Angle Strips (18) bolted to the tower.

A $5''$ Rod (19) is fixed in a Collar screwed on to a bolt that is held by a nut in a $1\frac{1}{2}''$ Strip. The Strip is attached to the platform by an Angle Bracket. A Coupling connects the Rod (19) to a built-up rod (20), made from a $4\frac{1}{2}''$ and a $3\frac{1}{2}''$ Rod joined by a Rod Connector. This Rod is held in two Right-Angle Rod and Strip Connectors bolted to $1\frac{1}{2}''$ Strips fixed to the strip (16). A Rod and Strip Connector fitted to the end of rod (20) supports a built-up rod (21), which is made from two $3\frac{1}{2}''$ Rods joined by a Rod Connector. The rod (21) is fixed in a Crank extended by a Fishplate, and the latter is bolted to a $1\frac{1}{2}''$ Strip (22) attached to the end of the platform by Angle Brackets.

WINDMILL VANES

The spokes supporting the vanes are made by bolting three $12\frac{1}{2}''$ Strips across a Wheel Disc (six holes). One of the Strips is attached by two $\frac{1}{2}''$ Bolts, and these are used to connect the Wheel Disc to a $3''$ Pulley (23).

The Pulley (23) is fixed on a $5''$ Rod supported in the top holes of the Flat Trunnions (9). The Rod carries a $\frac{1}{2}''$ Pinion that is driven by a 57-tooth Gear on a $3\frac{1}{2}''$ Rod. This Rod is mounted in one of the Strips (6) and Flat Trunnions (9), and in a $3\frac{1}{2}'' \times \frac{1}{2}''$ Double Angle Strip (24) bolted inside the tower to two of the Strips (6). A Double Bent Strip is attached to the inside of the Strip (6) that supports the $3\frac{1}{2}''$ Rod, which is held in place by a Collar and is fitted with two $1''$ Pulleys (25).

PUMP MECHANISM

A $4''$ Rod (26) is mounted in one of the Strips (7) and in a Double Bent Strip bolted to the Strip, and also in a Double Bracket fixed to Strip (10). The Rod is fitted with a Bush Wheel (27) (Fig. 7.12b), two $1''$ Pulleys (28) and a $2''$ Pulley (29). A $5\frac{1}{2}''$ Strip is lock-nutted to the Bush Wheel and is pivoted on a $1\frac{1}{2}''$ Rod held by Spring Clips in one end of the pump beam (30). This beam consists of three $5\frac{1}{2}''$ Strips connected by two Double Brackets as shown, and it pivots between Spring Clips on a $6\frac{1}{2}''$ Rod (31) held by a $1''$ Rod held in place by a $1''$ Rod held in place by Spring Clips. A $4\frac{1}{2}''$ Rod fixed

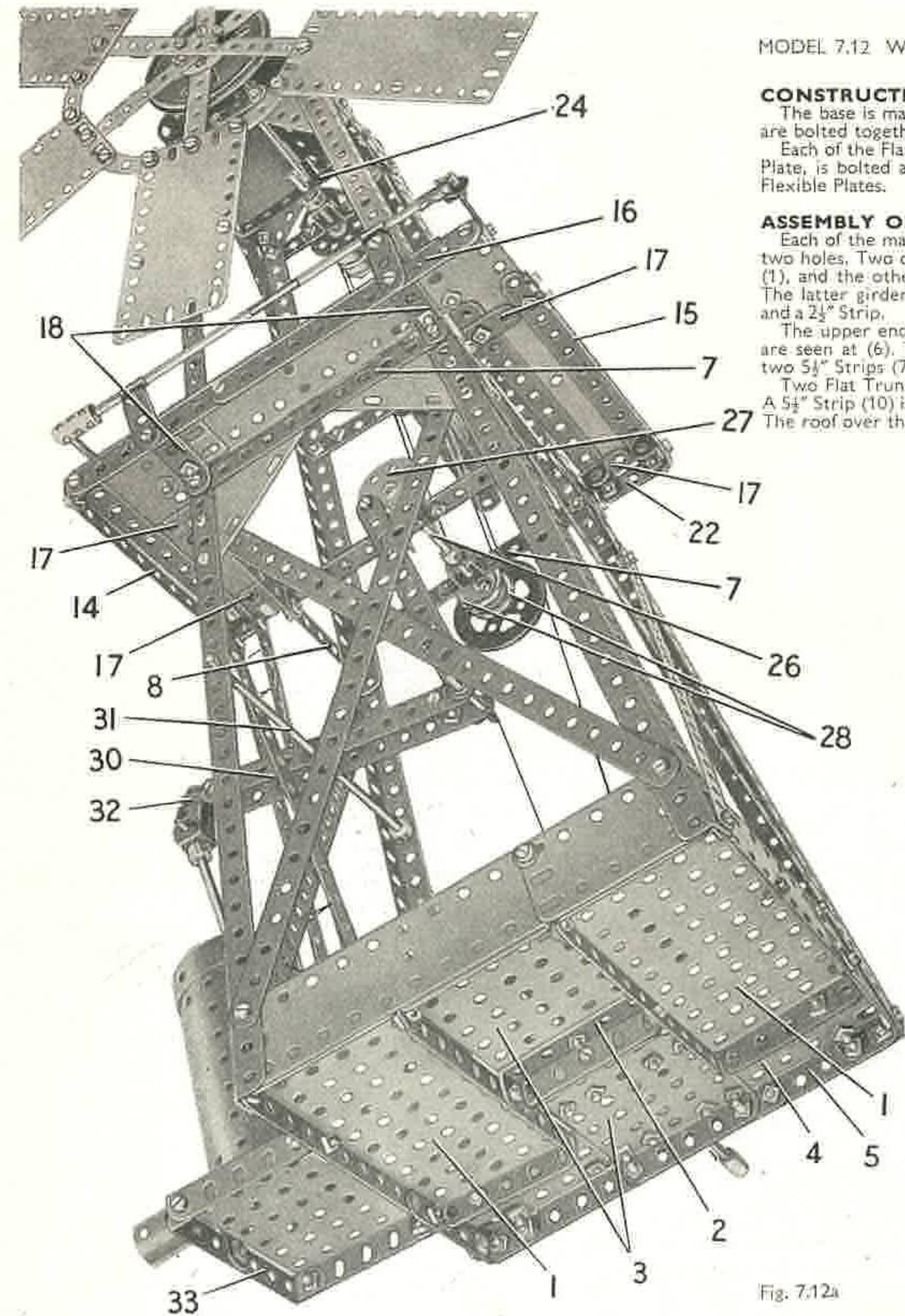

Fig. 7.12a

Collars in the tower. A Stepped Bent Strip (32) is bolted to the beam, and a large Fork Piece is connected to it by a $1''$ Rod held in place by Spring Clips. A $4\frac{1}{2}''$ Rod fixed in the Fork Piece is passed through the Boiler that represents the pump cylinder.

One end of the Boiler is removed, and it is then attached to a $3\frac{1}{2}'' \times 2\frac{1}{2}''$ Flanged Plate by an Angle Bracket. The Flanged Plate is connected to the base by Angle Brackets and is fitted along its outer edge with a $3\frac{1}{2}'' \times \frac{1}{2}''$ Double Angle Strip (33) (Fig. 7.12a). A Fishplate bolted to the Boiler is secured also to the Double Angle Strip. The pump outlet is represented by a Sleeve Piece fitted over a Chimney Adaptor bolted to the Boiler. A ladder from the $3\frac{1}{2}'' \times 2\frac{1}{2}''$ Flanged Plate to the inspection platform is formed by two $12\frac{1}{2}''$ Strips spaced apart by nuts on two $1''$ Bolts. It is attached at each end to Angle Brackets and the rungs are formed by Cord.

A $3\frac{1}{2}''$ Crank Handle is held by two $\frac{3}{4}''$ Flanged Wheels in two Trunnions bolted to the base. A $1''$ Pulley on the Crank Handle is connected by a Cord belt to the $2''$ Pulley (29). The Pulleys (28) and (25) are also connected by Cord belts.

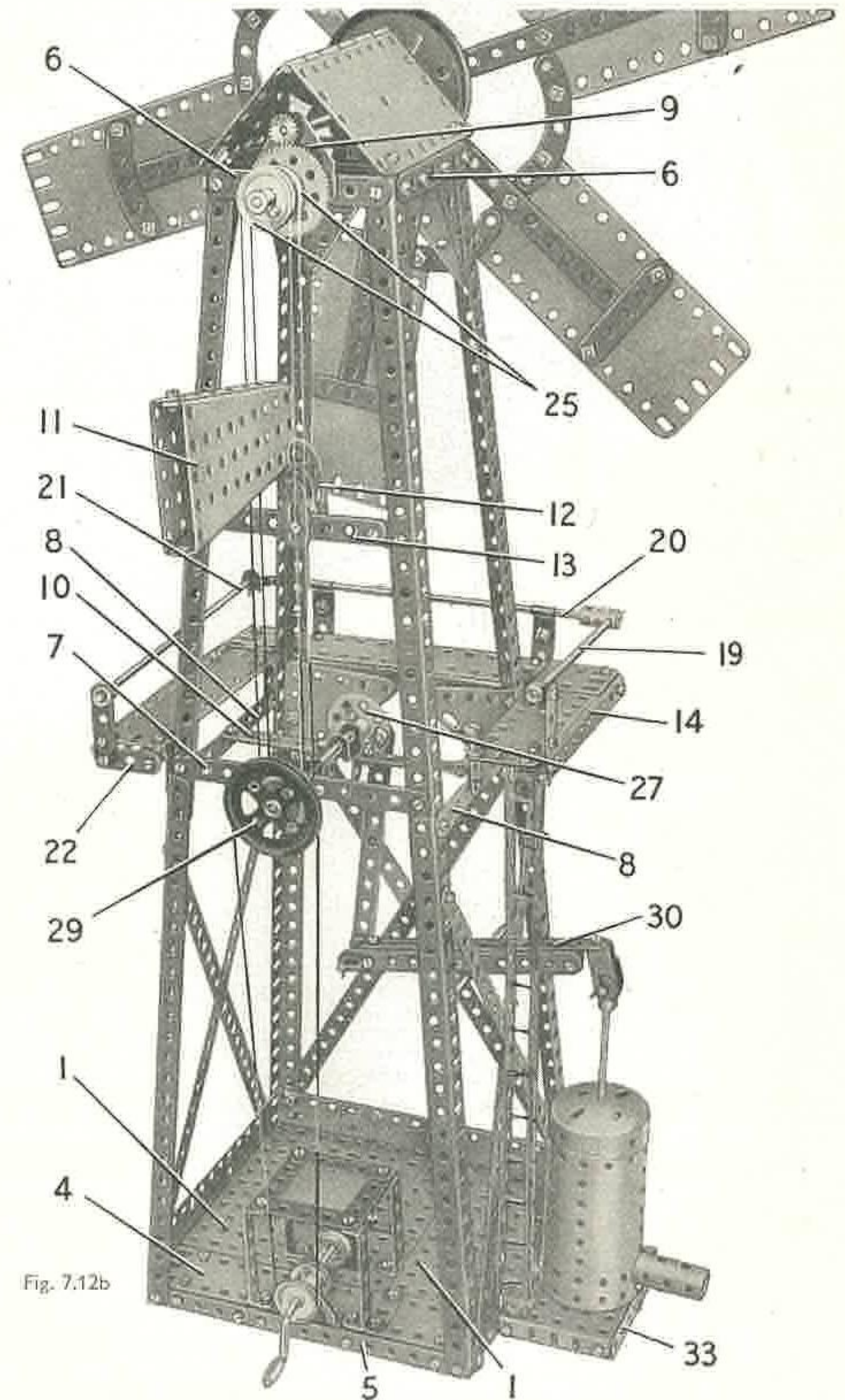
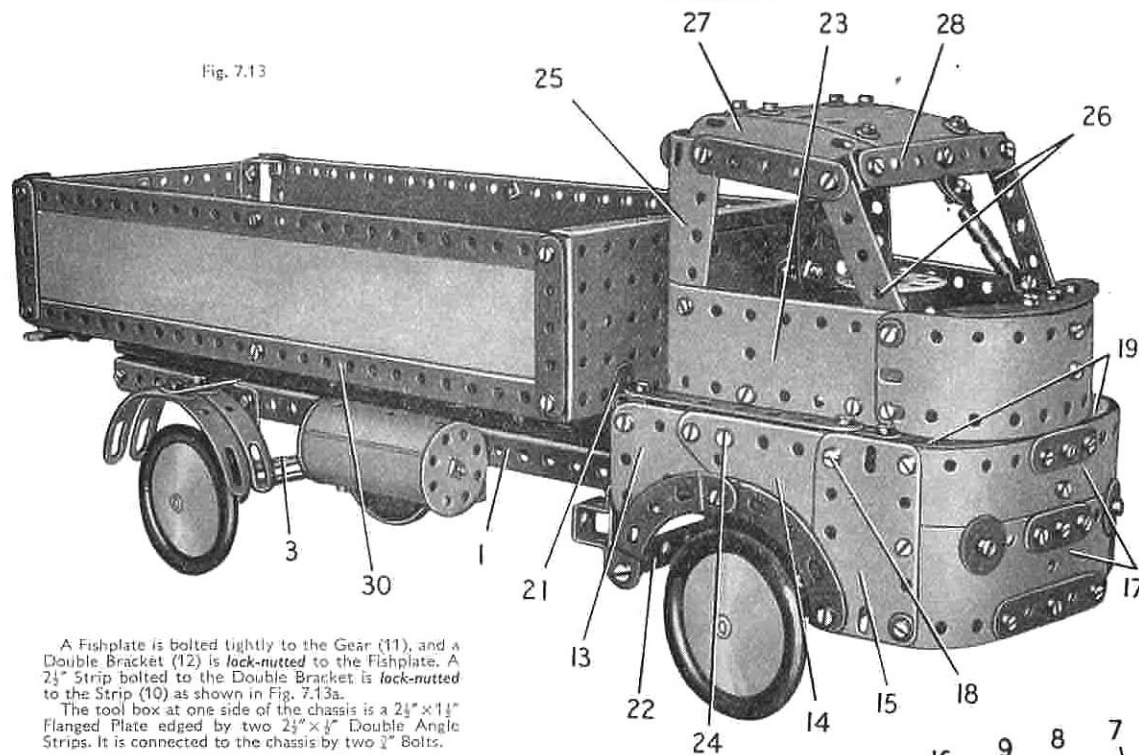

Fig. 7.12b

Fig. 7.13



A Fishplate is bolted tightly to the Gear (11), and a Double Bracket (12) is lock-nutted to the Fishplate. A $2\frac{1}{2}$ " Strip bolted to the Double Bracket is lock-nutted to the Strip (10) as shown in Fig. 7.13a. The tool box at one side of the chassis is a $2\frac{1}{2}$ " x $1\frac{1}{4}$ " Flanged Plate edged by two $2\frac{1}{2}$ " x $\frac{1}{2}$ " Double Angle Strips. It is connected to the chassis by two $\frac{1}{2}$ " Bolts.

ASSEMBLY OF THE CAB

The lower part of each side of the cab is made from a $2\frac{1}{2}$ " x $1\frac{1}{4}$ " Triangular Flexible Plate (13) (Fig. 7.13) a $2\frac{1}{2}$ " x $2\frac{1}{2}$ " Triangular Flexible Plate (14) and a $2\frac{1}{2}$ " x $1\frac{1}{4}$ " Flexible Plate (15). These Plates are bolted along their upper edges to a $3\frac{1}{2}$ " x $\frac{1}{2}$ " Double Angle Strip (16). The lower section of the front of the cab consists of two $5\frac{1}{2}$ " x $1\frac{1}{2}$ " Flexible Plates (17) curved as shown.

A $3\frac{1}{2}$ " Strip is attached by an Angle Bracket to the rear lug of each Double Angle Strip (16), and to a $\frac{1}{2}$ " Reversed Angle Bracket held by a bolt (18). A Semi-Circular Plate (19) is connected by a Fishplate to the $3\frac{1}{2}$ " Strip. A $5\frac{1}{2}$ " Strip (20) is bolted between the lugs of the Double Angle Strips (16), and the same bolts support a $3\frac{1}{2}$ " Strip (21) on each side. A further $5\frac{1}{2}$ " Strip (22) is fixed between the lower ends of these Strips.

The upper section of each side of the cab consists of a $5\frac{1}{2}$ " x $1\frac{1}{4}$ " Flexible Plate (23), attached to the Reversed Angle Bracket held by the bolt (18) and a similar part fixed by a bolt (24). A third $5\frac{1}{2}$ " x $1\frac{1}{4}$ " Flexible Plate is bent as shown and is joined to the front ends of the Plates (23). This Plate is connected to the centre of the Plates (17) by a $3\frac{1}{2}$ " Strip. The rear ends of the Plates (23) are curved inward and are bolted to a $2\frac{1}{2}$ " x $2\frac{1}{2}$ " Flexible Plate.

A $2\frac{1}{2}$ " x $1\frac{1}{4}$ " Flexible Plate (25) is curved and is bolted to each of the Plates (23). These Plates are connected at their top rear corners by a $3\frac{1}{2}$ " Strip, and are joined to $2\frac{1}{2}$ " Strips (26) by $2\frac{1}{2}$ " Strips and curved $2\frac{1}{2}$ " x $1\frac{1}{4}$ " Flexible Plates (27). A $3\frac{1}{2}$ " Strip (28) is connected by Angle Brackets to the Strips (26). The cab roof is completed by two $2\frac{1}{2}$ " x $2\frac{1}{2}$ " Flexible Plates, overlapped two holes and curved at their ends. These Plates are bolted to the $3\frac{1}{2}$ " Strip (28) and to the similar Strip at the rear of the cab, and also to the Plates (27).

The completed cab is bolted to the Double Angle Strip at the front of the chassis. The rear end of the cab is connected by Angle Brackets to the end holes of two $12\frac{1}{2}$ " Strips. Each of these is positioned over one of the chassis girders, and is bolted to three $2\frac{1}{2}$ " x $\frac{1}{2}$ " Double Angle Strips fixed between the girders. Two of these Double Angle Strips are indicated at (29); the third is positioned in the fourth holes behind the Strip (5).

DETAILS OF THE BODY

The floor of the body consists of six $5\frac{1}{2}$ " x $2\frac{1}{2}$ " Flexible Plates bolted between two $12\frac{1}{2}$ " Angle Girders (30) (Fig. 7.13a).

Two Angle Brackets, one of them is seen at (31), are bolted below the rear edge of the body, and each supports a Collar, which is spaced from the Angle Bracket by two Washers on a bolt. A $5\frac{1}{2}$ " Rod (32) is fixed in the Collars. The tailboard is made from a $5\frac{1}{2}$ " x $1\frac{1}{4}$ " and three $2\frac{1}{2}$ " x $2\frac{1}{2}$ " Flexible Plates, edged by two $5\frac{1}{2}$ " and two $2\frac{1}{2}$ " Strips. The tailboard pivots on two Right-Angle Rod and Strip Connectors (33), fitted over the Rod (32).

7.13 ARMY WAGON

Parts Required

6 of No. 1	2 of No. 15	25 of No. 38	1 of No. 80c	6 of No. 189
6 " " 2	1 " " 16	2 " " 38d	2 " " 90	4 " " 190
6 " " 3	2 " " 18a	1 " " 45	4 " " 90a	6 " " 192
2 " " 4	1 " " 18b	1 " " 46	2 " " 111	2 " " 197
12 " " 5	2 " " 20b	2 " " 48	2 " " 111a	2 " " 200
4 " " 6a	1 " " 22	10 " " 48a	6 " " 111c	2 " " 212
8 " " 8	1 " " 24	2 " " 48b	4 " " 125	2 " " 212a
3 " " 10	2 " " 24a	1 " " 51	2 " " 126	2 " " 214
3 " " 11	1 " " 26	1 " " 52	2 " " 126a	8 " " 215
13 " " 12	1 " " 27a	5 " " 59	2 " " 176	1 " " 216
4 " " 12a	1 " " 35	2 " " 62	4 " " 187	2 " " 221
3 " " 12c	202 " " 37a	1 " " 63	6 " " 188	2 " " 222
1 " " 14	182 " " 37b			

CONSTRUCTION OF THE CHASSIS

Each of the chassis girders consists of two $12\frac{1}{2}$ " Angle Girders overlapped 15 holes, with a third $12\frac{1}{2}$ " Angle Girder (1) (Fig. 7.13a) bolted to them. The chassis girders are connected at the front by a $2\frac{1}{2}$ " x $\frac{1}{2}$ " Double Angle Strip, and at the rear by two similar Double Angle Strips (2). The rear axle is supported in a $2\frac{1}{2}$ " x $\frac{1}{2}$ " Double Angle Strip (3). This is bolted to the lugs of two $1\frac{1}{2}$ " x $\frac{1}{2}$ " Double Angle Strips (4), which are fixed to the chassis girders and are braced by Flat Trunnions. The rear mudguards are fastened to a $5\frac{1}{2}$ " Strip (5).

A $2\frac{1}{2}$ " x $1\frac{1}{4}$ " Double Angle Strip (6) is attached to the chassis by two $\frac{1}{2}$ " Bolts, but is spaced from the girders by a Cord Anchoring Spring and a Washer on each Bolt. A $2\frac{1}{2}$ " x $\frac{1}{2}$ " Double Angle Strip is bolted between the lugs of the Double Angle Strip (6) and each lug supports a Trunnion (7).

Each of the front wheels is fixed on a $1\frac{1}{2}$ " Rod that is held by a Collar in a Double Bracket (8). A $1\frac{1}{2}$ " Strip (9) is placed between the lugs of each Double Bracket and a $\frac{1}{2}$ " Bolt is passed through the parts and is fitted with a nut. The Bolt is then inserted in a hole in one of the Trunnions (7) and is fitted with lock-nuts. The ends of the Strips (9) are connected by a $3\frac{1}{2}$ " Strip (10), which is pivoted on lock-nutted bolts.

The steering column is a $3\frac{1}{2}$ " Rod, which is held by a Collar and a 57-tooth Gear (11) in the boss of a Crank bolted to one of the chassis girders.

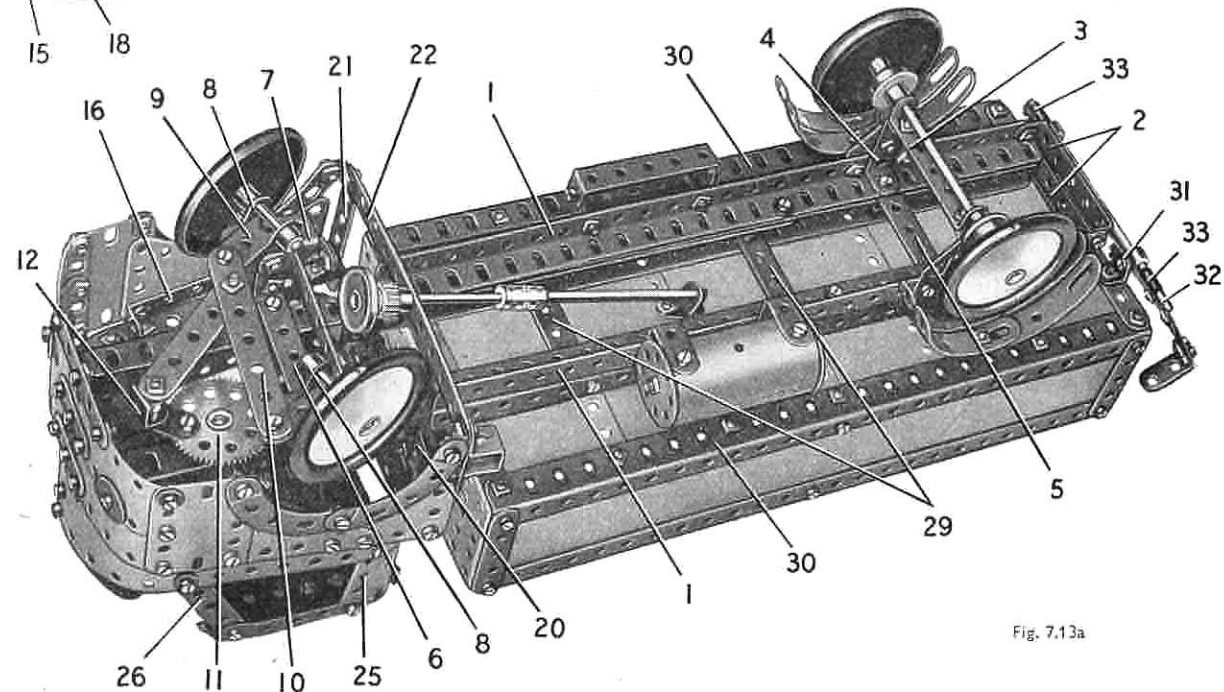

Fig. 7.13a

7.14 ENGINEERS' LATHE

CONSTRUCTION OF THE BASE OR BED

The side of the bed seen in Fig. 7.14 is made by bolting $5\frac{1}{2}$ " Strips between the ends of two built-up strips (1) and (2). The strip (1) consists of two $12\frac{1}{2}$ " Strips overlapped 17 holes, and the strip (2) is made from a $12\frac{1}{2}$ " and two $2\frac{1}{2}$ " Strips joined together. At one end the side is filled in by *half a Hinged Flat Plate* (3), a $4\frac{1}{2}$ " \times $2\frac{1}{2}$ " Flexible Plate and two $2\frac{1}{2}$ " \times $1\frac{1}{2}$ " Flexible Plates.

The side seen in Fig. 7.14d consists of a built-up strip (4) fitted at its ends with $5\frac{1}{2}$ " Strips (5) and (6). One end of the side is partly filled in by a $5\frac{1}{2}$ " \times $2\frac{1}{2}$ " and a $4\frac{1}{2}$ " \times $2\frac{1}{2}$ " Flexible Plate edged by a $5\frac{1}{2}$ " Strip, a $2\frac{1}{2}$ " Strip and a $3\frac{1}{2}$ " Strip (7).

The sides are connected together at one end by a $5\frac{1}{2}$ " \times $2\frac{1}{2}$ " Flanged Plate (8) (Fig. 7.14a), which is extended downward by two $3\frac{1}{2}$ " \times $2\frac{1}{2}$ " Flanged Plates connected at their lower ends by a $5\frac{1}{2}$ " Strip. A No. 1 Clockwork Motor, fitted with a 2" Pulley (9), is bolted to this end of the base.

The other end of the base consists of a $5\frac{1}{2}$ " \times $2\frac{1}{2}$ " Flanged Plate (10), a $5\frac{1}{2}$ " \times $2\frac{1}{2}$ " Flexible Plate and a $5\frac{1}{2}$ " \times $1\frac{1}{2}$ " Flexible Plate. These are edged as shown by three $5\frac{1}{2}$ " Strips, one of which is marked (11) (Fig. 7.14d).

A built-up angle girder (12), made from two $12\frac{1}{2}$ " Angle Girders overlapped 17 holes, is bolted along the top of the base on each side. At one end the girders are fixed to the Flanged Plate (8), and at the other end they are connected by a $5\frac{1}{2}$ " Strip; this is supported by an Angle Bracket bolted to the Strip (11).

The top of the base is filled in by two $12\frac{1}{2}$ " \times $2\frac{1}{2}$ " Strip Plates separated by a $12\frac{1}{2}$ " Strip (13), and a $5\frac{1}{2}$ " \times $2\frac{1}{2}$ " Flexible Plate (14) (Fig. 7.14a). A $5\frac{1}{2}$ " Strip (15) is connected to the girders (12) by Angle Brackets, and a similar Strip (16) is attached to Double Bent Strips.

SLIDES FOR THE TOOL CARRIAGE

A $3\frac{1}{2}$ " \times $2\frac{1}{2}$ " Flanged Plate, one flange of which is indicated at (17), is bolted to the top of the base at one end, and two $2\frac{1}{2}$ " \times $\frac{1}{2}$ " Double Angle Strips are fixed across the Flanged Plate. A third $2\frac{1}{2}$ " \times $\frac{1}{2}$ " Double Angle Strip (18) is bolted to the top of the base at the other end. A $12\frac{1}{2}$ " Strip (19) on each side is attached to the lugs of the Double Angle Strips (Fig. 7.14d).

A $12\frac{1}{2}$ " Angle Girder (20) on each side is supported by two $2\frac{1}{2}$ " Strips, a $2\frac{1}{2}$ " \times $2\frac{1}{2}$ " Flexible Plate and a $2\frac{1}{2}$ " \times $\frac{1}{2}$ " Double Angle Strip bolted to the Strip (19). The $12\frac{1}{2}$ " Angle Girders are connected by three $2\frac{1}{2}$ " \times $\frac{1}{2}$ " Double Angle Strips. One of these is seen at (21), another is held by the bolts (22) and the third is indicated at (23) (Fig. 7.14).

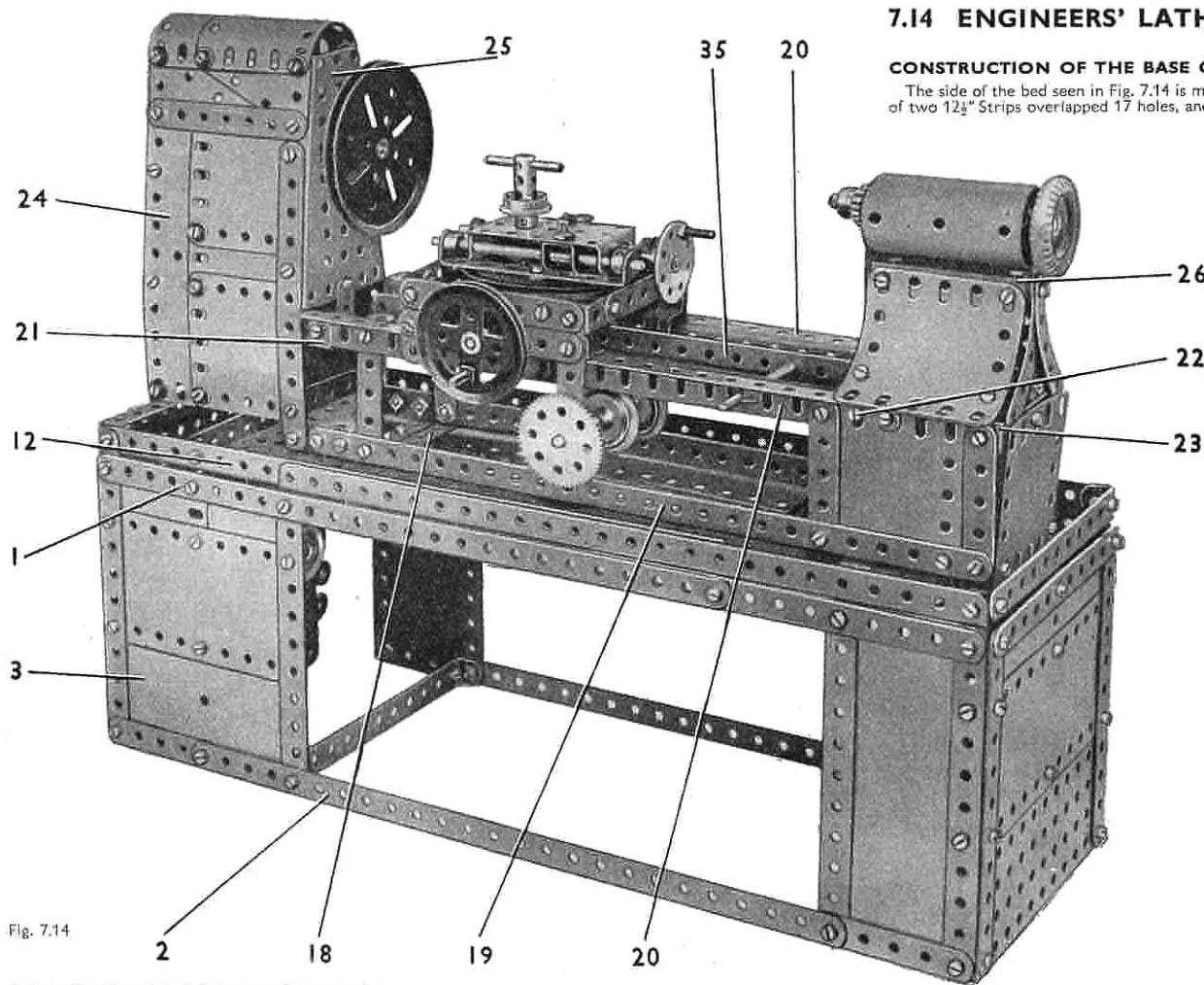

Fig. 7.14

CONSTRUCTION OF THE HEADSTOCK

The side of the headstock seen in Fig. 7.14 consists of a $5\frac{1}{2}$ " \times $1\frac{1}{2}$ " Flexible Plate (24), two $2\frac{1}{2}$ " \times $2\frac{1}{2}$ " Flexible Plates, a $2\frac{1}{2}$ " \times $1\frac{1}{2}$ " Flexible Plate and two $2\frac{1}{2}$ " \times $1\frac{1}{2}$ " Triangular Flexible Plates. These are strengthened by a $5\frac{1}{2}$ " and a $3\frac{1}{2}$ " Strip. The side seen in Fig. 7.14d is similar to the one already described, but the $2\frac{1}{2}$ " \times $1\frac{1}{2}$ " Triangular Flexible Plates and the $3\frac{1}{2}$ " Strip are omitted.

The sides are bolted at the front and the rear to Flanged Sector Plates (25). The rear Flanged Sector Plate is extended downward by two $2\frac{1}{2}$ " \times $2\frac{1}{2}$ " Triangular Flexible Plates, the lower corners of which are connected to the sides by Angle Brackets.

The headstock is connected by Fishplates to the ends of the Strips (19) and to the Flanged Plate (8), and also by a further Fishplate bolted to the front Flanged Sector Plate and to an Angle Bracket fixed to the Double Angle Strip (21). A 5" Rod is supported in the Flanged Sector Plates, and is held in place by a $\frac{1}{2}$ " Flanged Wheel and a Collar. The Rod carries inside the headstock a $\frac{1}{2}$ " fixed Pulley, which is connected by a Cord belt to the 2" Pulley (9).

THE TAILSTOCK

A Flat Trunnion, with its pointed end upward, is fixed to the centre of the Double Angle Strip (23), and a vertical 3" Strip is bolted to the top two holes of the Flat Trunnion. The 3" Strip is fitted with two $2\frac{1}{2}$ " Curved Strips as shown in Fig. 7.14d. A second Flat Trunnion is attached to a Trunnion bolted to the Double Angle Strip held by the bolts (22). This Flat Trunnion also supports a 3" Strip, and the two 3" Strips are connected at points two clear holes from their upper ends by two $2\frac{1}{2}$ " \times $\frac{1}{2}$ " Double Angle Strips (26). A $1\frac{1}{2}$ " radius Curved Plate on each side is secured to one of the Double Angle Strips (26) and to Obtuse Angle Brackets bolted to the Angle Girder (20).

The bolts fixing the Double Angle Strips (26) to the 3" Strips secure also Angle Brackets that support a $2\frac{1}{2}$ " Cylinder.

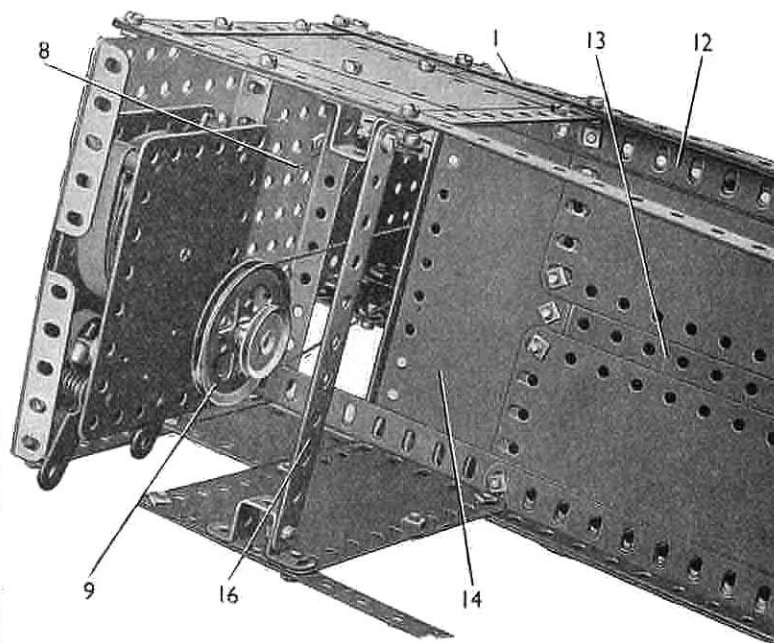

Fig. 7.14a

(Continued on next page)

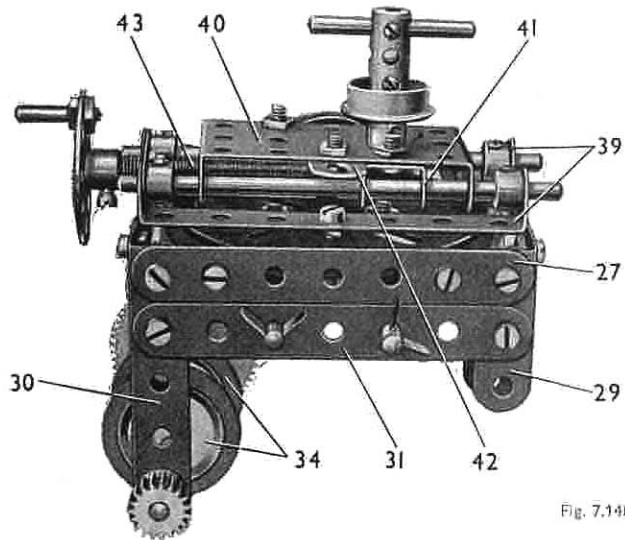
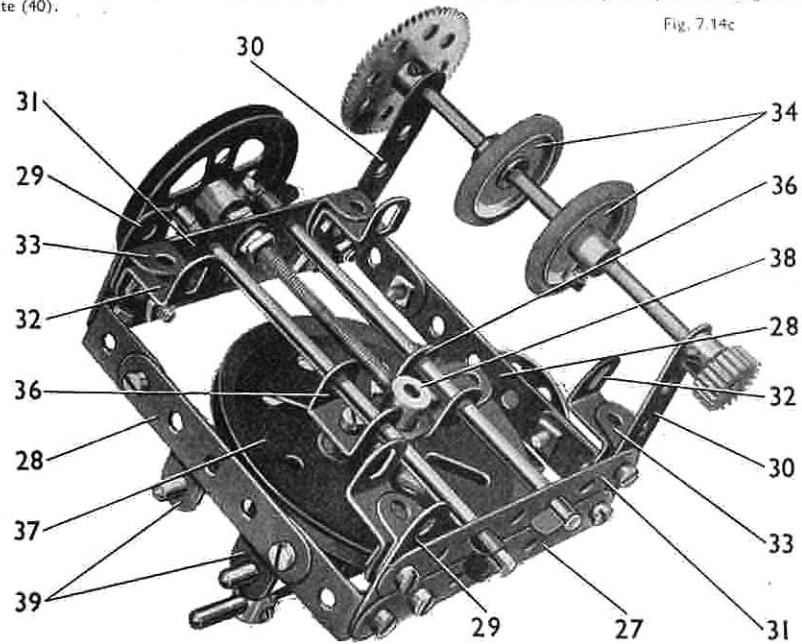

Fig. 7.14b

Two $3\frac{1}{2} \times \frac{1}{2}$ Double Angle Strips (39) are bolted tightly across the Pulley (37) and are spaced from it by a nut on each bolt. A 4" Rod is mounted in each Double Angle Strip, and a $2\frac{1}{2} \times 1\frac{1}{2}$ Flanged Plate (40), fitted with two Double Brackets, slides freely on the Rods. One of the Double Brackets is indicated at (41). A Crank (42) is bolted to the Flanged Plate, and a 3" Screwed Rod (43) is threaded into the boss of the Crank. The Screwed Rod passes through the centre hole of a $1\frac{1}{2}$ " Strip, which is supported by the 4" Rods and is held against the lugs of the Double Angle Strips (39) by Collars on the Rods. A Bush Wheel is fixed on the Screwed Rod and is spaced from the $1\frac{1}{2}$ " Strip by a Cord Anchoing Spring. Two nuts are screwed tightly against each other on the Screwed Rod at the opposite side of the $1\frac{1}{2}$ " Strip to the Cord Anchoing Spring. The tool holder is represented by a $\frac{3}{4}$ " Flanged Wheel and a Coupling fixed on a $\frac{3}{4}$ " Bolt passed through the Flanged Plate (40).

Fig. 7.14c



MODEL 7.14 ENGINEERS' LATHE — Continued

TOOL CARRIAGE AND THE TOOL REST

The carriage is shown separately in Figs. 7.14b and 7.14c. It is made by bolting 1×1 " Angle Brackets to the ends of two $3\frac{1}{2}$ " Strips (27). The Angle Brackets at each end are then connected by a $2\frac{1}{2}$ " Strip (28). At one end of the carriage two $1\frac{1}{2}$ " Strips (29) are bolted, and at the other end two $2\frac{1}{2}$ " Strips (30) are secured. A $3\frac{1}{2}$ " Strip (31) on each side is bolted between the Strips (29) and (30), and the bolts fix also $\frac{3}{4}$ " Reversed Angle Brackets (32) and Angle Brackets (33). The slotted holes in the Angle Brackets are used to leave gaps between these Brackets and the Reversed Angle Brackets, and the flanges of the Girders (20) are accommodated in the gaps.

A $4\frac{1}{2}$ " Rod is mounted in the end holes of the Strips (30) and is held in place by a $\frac{1}{2}$ " Pinion and a 57-tooth Gear. The Rod carries two 1" Pulleys (34), each fitted with a Rubber Ring that presses against the flange of one of two $12\frac{1}{2}$ " Angle Girders (35). The Girders (35) are bolted to the Double Angle Strip (21) and to the similar part held by the bolts (22). By turning the 57-tooth Gear the carriage can be moved up and down the Girders (20).

Two Double Brackets (36) are connected to a 3" Pulley (37) by $\frac{1}{2}$ " Bolts, but are spaced from the Pulley by a Spring Clip on each Bolt. One of the Bolts secures also a Crank (38). The Double Brackets slide freely on $4\frac{1}{2}$ " Rods held by Spring Clips in the Strips (31), and a 3" Screwed Rod is threaded into the Crank (38). The Screwed Rod is located in one of the Strips (31) by two nuts, which are screwed tightly against each other on the Rod at each side of the Strip. By turning a 2" Pulley on the Screwed Rod the 3" Pulley (37) can be moved across the carriage.

Fig. 7.14d

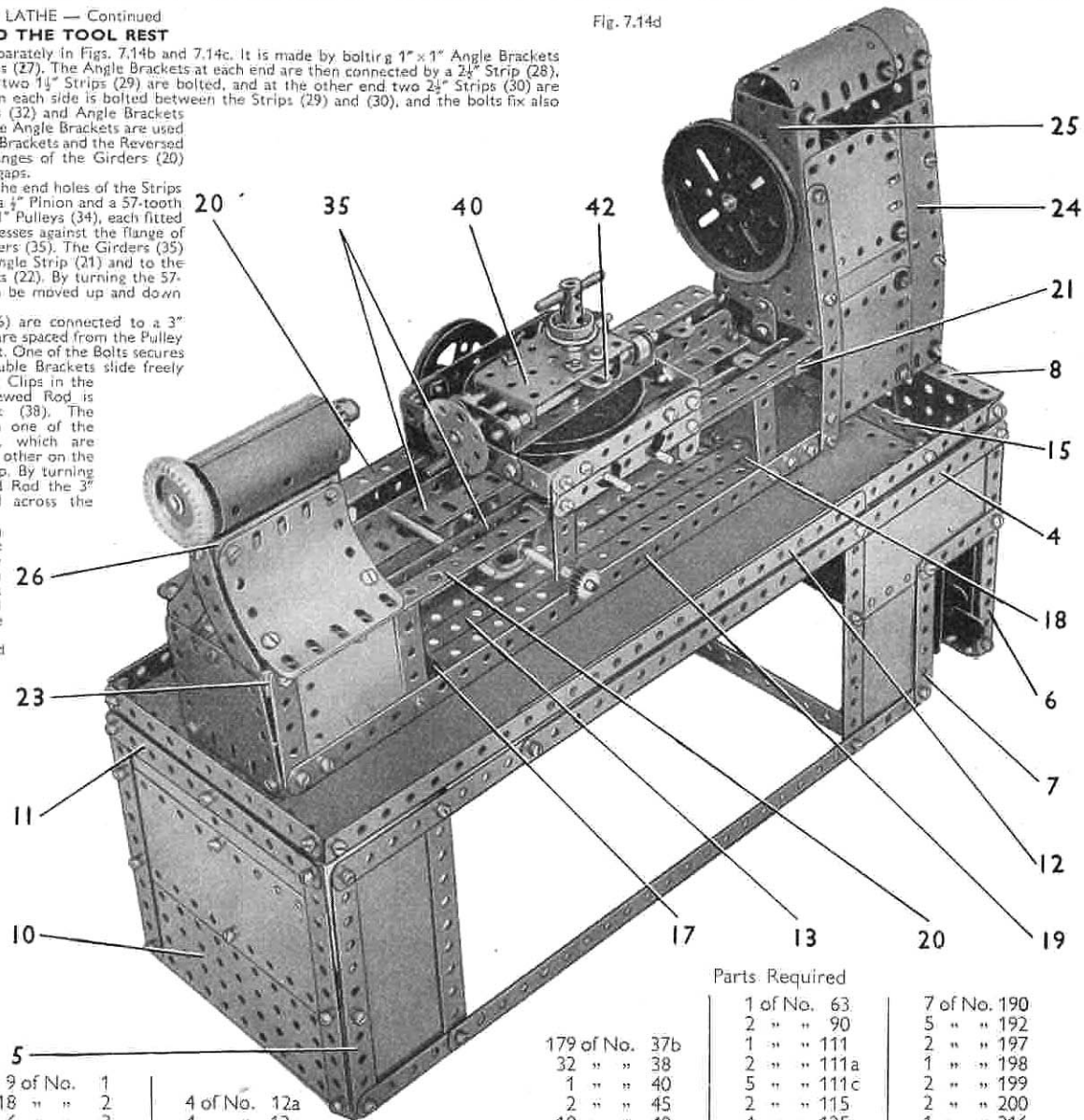

Parts Required			
9 of No. 1	4 of No. 12a	179 of No. 37b	1 of No. 63
18 " " 2	4 " " 12c	32 " " 38	2 " " 90
6 " " 3	1 " " 15	1 " " 40	1 " " 111
2 " " 4	3 " " 15a	2 " " 45	2 " " 111a
12 " " 5	2 " " 15b	10 " " 48a	5 " " 111c
3 " " 6a	2 " " 16	2 " " 48b	2 " " 115
8 " " 8	1 " " 18a	1 " " 51	4 " " 125
5 " " 10	2 " " 19b	2 " " 52	2 " " 126
4 " " 11	2 " " 20a	1 " " 54	2 " " 126a
18 " " 12		2 " " 54	1 " " 142c
		1 " " 57	2 " " 155
		6 " " 59	1 " " 176
		2 " " 62	4 " " 188
			3 " " 189
			7 of No. 190
			5 " " 192
			2 " " 197
			1 " " 198
			2 " " 199
			2 " " 200
			1 " " 216
			2 " " 221
			2 " " 223
			1 No. 1 Clock-work Motor (not included in Outfit)

Parts Required

12 of No. 1	1 of No. 17
18 " " 2	1 " " 19b
6 " " 3	1 " " 19h
2 " " 4	1 " " 20b
12 " " 5	1 " " 24
4 " " 6a	1 " " 27a
8 " " 8	
2 " " 10	
2 " " 11	
15 " " 12	
2 " " 12a	
1 " " 13	
1 " " 14	
2 " " 15	
1 " " 15a	
2 " " 15b	

1 of No. 32	
2 " " 35	
176 " " 37a	
185 " " 37b	
28 " " 38	2 of No. 115
2 " " 48	1 " " 116
8 " " 48a	4 " " 125
2 " " 48b	2 " " 126
2 " " 52	4 " " 126a
3 " " 53	1 " " 162
2 " " 54	2 " " 187
6 " " 59	6 " " 188
2 " " 62	6 " " 189
1 " " 63	8 " " 190
4 " " 90a	1 " " 191
2 " " 111	6 " " 192
2 " " 111a	2 " " 197
6 " " 111c	1 " " 198
	2 of No. 212
	2 " " 212a
	2 " " 213
	2 " " 214
	4 " " 221
	2 " " 223

7.15 LIFTING BEAM BRIDGE

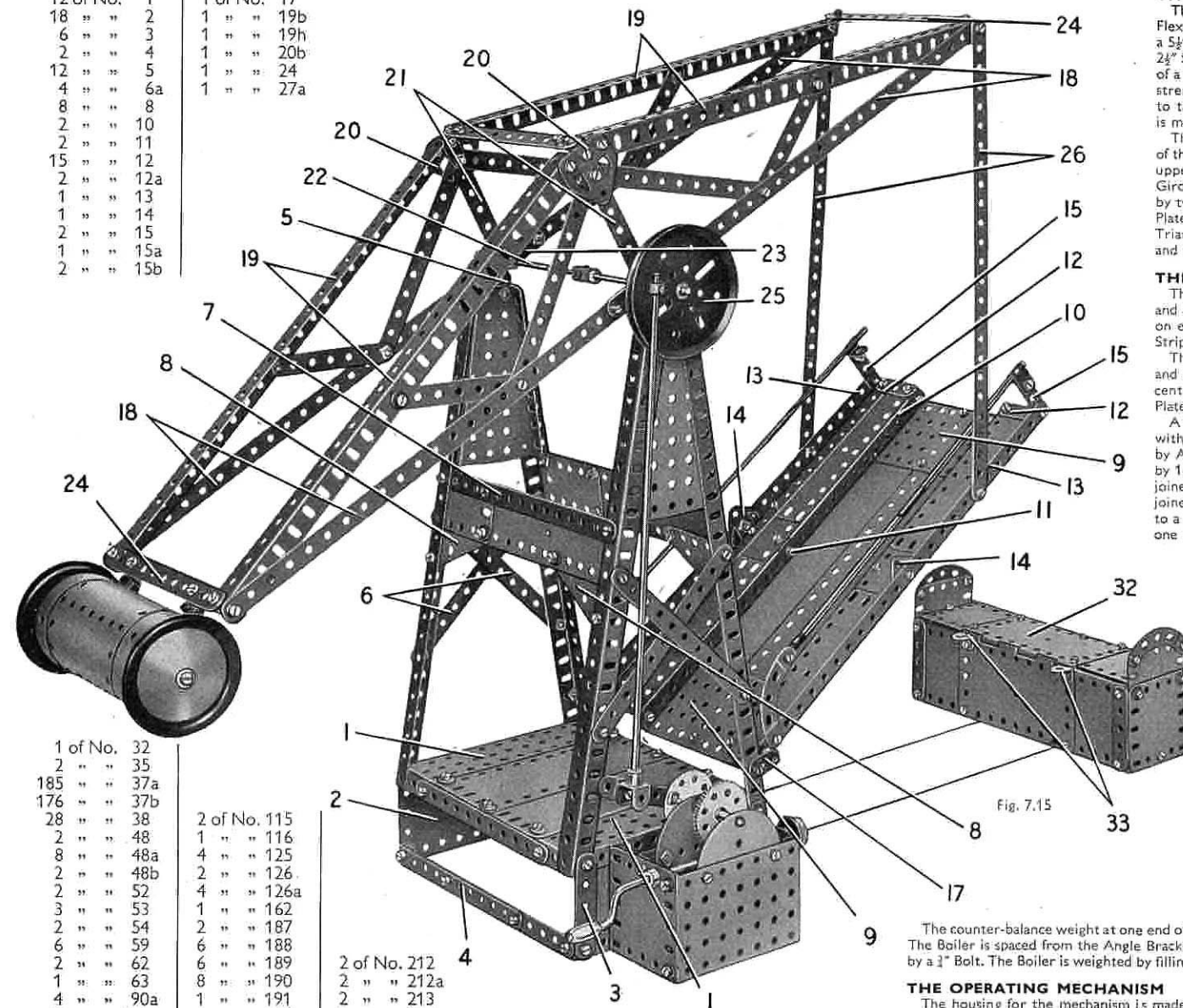

Fig. 7.15

THE TOWER AND ITS PIER

The top of the pier consists of two $5\frac{1}{2}'' \times 2\frac{1}{2}''$ Flanged Plates (1) and two $5\frac{1}{2}'' \times 2\frac{1}{2}''$ Flexible Plates bolted together as shown (Fig. 7.15). The front of the pier is made from a $5\frac{1}{2}'' \times 2\frac{1}{2}''$ and a $2\frac{1}{2}'' \times 2\frac{1}{2}''$ Flexible Plate joined together and edged by two $5\frac{1}{2}''$ and two $2\frac{1}{2}''$ Strips. The front is bolted to the flanges of the Flanged Plates (1). Each side consists of a $5\frac{1}{2}'' \times 2\frac{1}{2}''$ Flexible Plate (2) attached to a flange of one of the Flanged Plates (1) and strengthened by two $2\frac{1}{2}''$ Strips (3). The lower corners of the Plates (2) are connected to the front of the pier and to a built-up strip (4) by Angle Brackets. The strip (4) is made from two $5\frac{1}{2}''$ Strips overlapped seven holes.

The tower is made by bolting two $12\frac{1}{2}''$ Angle Girders to the outer corners of each of the Flanged Plates (1). A Flanged Sector Plate and a Flat Trunnion (5) are fixed to the upper ends of each pair of Girders, and bracing Strips (6) are arranged across the Girders as shown. Each pair of Girders is connected to the pair on the opposite side by two built-up strips (7), which are made from $5\frac{1}{2}''$ and $2\frac{1}{2}''$ Strips. A $5\frac{1}{2}'' \times 1\frac{1}{2}''$ Flexible Plate and a $2\frac{1}{2}'' \times 1\frac{1}{2}''$ Flexible Plate are bolted to each of the strips (7), and $2\frac{1}{2}'' \times 1\frac{1}{2}''$ Triangular Flexible Plates (8) are fitted in the corners between the Flexible Plates and the $12\frac{1}{2}''$ Angle Girders.

THE LIFTING SPAN

The central roadway of the span consists of two $12\frac{1}{2}'' \times 2\frac{1}{2}''$ Strip Plates bolted together and attached to a $3\frac{1}{2}'' \times 2\frac{1}{2}''$ Flanged Plate (9) at each end (Fig. 7.15). A $12\frac{1}{2}''$ Strip (10) on each side is bolted to the flanges of the Plates (9) and is connected to one of the Strip Plates by a Double Bracket held by a bolt (11).

The pavement at each side of the roadway is formed by two $5\frac{1}{2}'' \times 1\frac{1}{2}''$ Flexible Plates and a $2\frac{1}{2}'' \times 1\frac{1}{2}''$ Flexible Plate. These are bolted together as shown and are fixed at the centre to the Double Bracket held by the bolt (11). At each end the $5\frac{1}{2}'' \times 1\frac{1}{2}''$ Flexible Plates are supported by a $\frac{1}{2}''$ Reversed Angle Bracket fixed to the Strip (10).

A $12\frac{1}{2}''$ Strip is bolted along the outer edge of each pavement, and the ends are fitted with $1\frac{1}{2}''$ Strips (12). The $12\frac{1}{2}''$ Strips (13) are connected to the pivoted end of the span by Angle Brackets, to the centre by Trunnions (14) and to the outer end of the span by $1\frac{1}{2}'' \times \frac{1}{2}''$ Double Angle Strips (15). The handrail on one side consists of two 5" Rods joined by a Rod Connector, and that on the other side is formed by a 6" Rod and a 4" Rod joined by a Rod Connector. Each rail is supported by a Rod and Strip Connector bolted to a $2\frac{1}{2}''$ Stepped Curved Strip and by a Right-Angle Rod and Strip Connector fixed to one of the Double Angle Strips (15).

A Threaded Pin is held tightly by its nut in the end hole of each of the Strips (13). A Collar is fastened on the Threaded Pin, which is then passed through a Fishplate (17) bolted to the side of the tower (Fig. 7.15a).

CONSTRUCTION OF THE BEAM

Each side girder of the beam consists of two $12\frac{1}{2}''$ Strips (18) and two $12\frac{1}{2}''$ Angle Girders (19). The outer ends of the Girders and the Strips are bolted together as shown, and the inner ends of the Girders are connected by a Flat Trunnion (20). A $3\frac{1}{2}''$ Strip (21) is bolted to the Flat Trunnion. The lower end of this Strip and the inner end holes of the Strips (18) are passed over a built-up rod (22), made from a 4" and a $4\frac{1}{2}''$ Rod joined by a Coupling. A Crank (23) and a $2\frac{1}{2}''$ Strip are also passed over the rod (22) and the $2\frac{1}{2}''$ Strip is bolted by its end holes to the Strips (18) (Fig. 7.15). The Crank (23) is secured to one of the Strips (18) by the same bolt as the $2\frac{1}{2}''$ Strip. The side girders of the beam are completed by adding two diagonal $5\frac{1}{2}''$ Strips and two $3\frac{1}{2}''$ Strips as shown.

The two side girders are connected together by a $5\frac{1}{2}''$ Strip (24) at each end bolted to the Girders (19), and by a similar Strip at the centre secured to a $1'' \times 1''$ Angle Bracket fixed to each of the Flat Trunnions (20).

The Cranks (23) are fixed on the rod (22), which is supported in the top holes of the Flat Trunnions (5). The rod is held in place by a Collar at one end and by a 3" Pulley (25) at the other end. The beam is linked to the lifting span by two $12\frac{1}{2}''$ Strips (26), each of which is pivotally connected by lock-nutted bolts.

The counter-balance weight at one end of the beam is a Boiler secured by $\frac{1}{2}''$ Bolts to Angle Brackets bolted to the Strip (24). The Boiler is spaced from the Angle Brackets by Spring Clips on the Bolts, and a Road Wheel is attached to each Boiler End by a $\frac{1}{2}''$ Bolt. The Boiler is weighted by filling it with suitable small parts remaining in the Outfit when the model is completed.

THE OPERATING MECHANISM

The housing for the mechanism is made by connecting a $3\frac{1}{2}'' \times 2\frac{1}{2}''$ Flanged Plate to one side of the base by four $2\frac{1}{2}'' \times \frac{1}{2}''$ Double Angle Strips. One end of the housing is filled in by a $2\frac{1}{2}'' \times 2\frac{1}{2}''$ Flexible Plate, and the other end by two $2\frac{1}{2}'' \times 2\frac{1}{2}''$ Triangular Flexible Plates (27) (Fig. 7.15a). A Semi-Circular Plate is attached to the Flanged Plate, and a similar part is secured to a $3\frac{1}{2}'' \times \frac{1}{2}''$ Double Angle Strip (28) bolted across the housing.

(Continued on next page)

MODEL 7.15 LIFTING BEAM BRIDGE — Continued

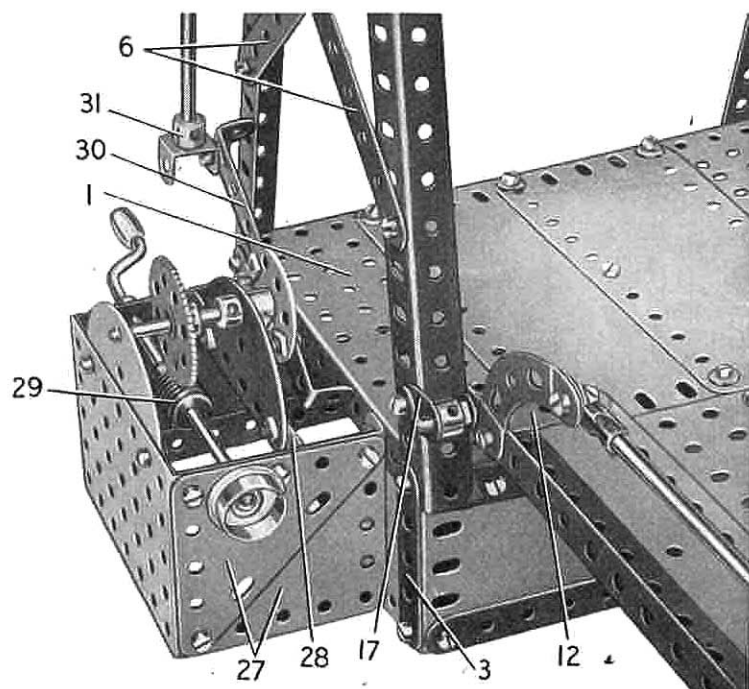

Fig. 7.15a

A 5" Crank Handle mounted as shown, is fitted with a Worm (29), and is held in place by a Collar and a $\frac{3}{8}$ " Flanged Wheel. The Worm drives a 57-tooth Gear on a 2" Rod supported in the Semi-Circular Plates. The 2" Rod is held in position by a Collar and a Bush Wheel. A $3\frac{1}{2}$ " \times $\frac{3}{8}$ " Double Angle Strip (30) is bolted across the Bush Wheel, and a large Fork Piece (31) is lock-nutted to one end of the Double Angle Strip. An 11 $\frac{1}{4}$ " Rod is held in the Fork Piece and is connected to the Pulley (25) by a Collar. The Collar is partly screwed on to a bolt that is held by a nut in the Pulley.

CONSTRUCTION OF THE SUPPORTING PIER

The top of this pier consists of one half of a Hinged Flat Plate (32), extended on each side by a $2\frac{1}{2}$ " \times $2\frac{1}{2}$ " Flexible Plate. The other half of the Hinged Flat Plate is swung down to form part of the front, and this also is extended at the sides by $2\frac{1}{2}$ " \times $2\frac{1}{2}$ " Flexible Plates. The latter Plates are strengthened by $2\frac{1}{4}$ " Strips. The back of the pier is formed by two $4\frac{1}{2}$ " \times $2\frac{1}{2}$ " Flexible Plates, and the outer edges of these are strengthened also by $2\frac{1}{2}$ " Strips. The front, top and back of the pier are connected by two $2\frac{1}{2}$ " \times $\frac{1}{2}$ " Double Angle Strips at each end. Two of these Double Angle Strips support the sides of the pier. Each side consists of a straightened $1\frac{1}{2}$ " radius Curved Plate, extended upward by a $2\frac{1}{2}$ " \times $1\frac{1}{2}$ " Flexible Plate and a $2\frac{1}{4}$ " Stepped Curved Strip. The sides are connected to the front and the back by Angle Brackets.

When the lifting span is down its end rests on two Angle Brackets (33) bolted to the Hinged Flat Plate (32). The supporting pier is connected to the base of the main part of the bridge by two lengths of Cord as shown.

7.16 HORIZONTAL STEAM ENGINE**CONSTRUCTION OF THE BASE**

Each side of the base consists of a $12\frac{1}{2}$ " \times $2\frac{1}{2}$ " Strip Plate and a $5\frac{1}{2}$ " \times $2\frac{1}{2}$ " Flexible Plate edged by built-up Angle Girders (1) and (2), each made from two $12\frac{1}{2}$ " Angle Girders overlapped 15 holes (Fig. 7.16). The ends of the base are each formed by a $5\frac{1}{2}$ " \times $2\frac{1}{2}$ " and a $2\frac{1}{2}$ " \times $2\frac{1}{2}$ " Flexible Plate, strengthened by built-up strips made from $5\frac{1}{2}$ " and $2\frac{1}{2}$ " Strips. The ends are connected to the sides by Angle Brackets.

At one side the top of the base is filled in by a $3\frac{1}{2}$ " \times $2\frac{1}{2}$ " Flanged Plate (3) and two $4\frac{1}{2}$ " \times $2\frac{1}{2}$ " Flexible Plates (4), strengthened by two $12\frac{1}{2}$ " Strips (5) (Fig. 7.16a). The inner ends of these Strips and one of the Flexible Plates, are supported by a built-up strip (6) fixed across the base. This strip consists of a $5\frac{1}{2}$ " and a $3\frac{1}{2}$ " Strip overlapped three holes. A $5\frac{1}{2}$ " \times $2\frac{1}{2}$ " Flanged Plate (7) is bolted to one end of the base and to a built-up strip (8) made from a $5\frac{1}{2}$ " and a $3\frac{1}{2}$ " Strip overlapped three holes. A $5\frac{1}{2}$ " \times $2\frac{1}{2}$ " Flexible Plate is attached to the strip (6) and to one of the girders (2). The other long edge of this Plate is strengthened by a $5\frac{1}{2}$ " Strip (9). A $2\frac{1}{2}$ " \times $1\frac{1}{4}$ " Flanged Plate (10) is bolted to one end of the base and to a built-up strip (11) made from a $5\frac{1}{2}$ " and a $3\frac{1}{2}$ " Strip.

ASSEMBLY OF THE BOILER

One side of the boiler consists of five $12\frac{1}{2}$ " Strips bolted to a $5\frac{1}{2}$ " \times $2\frac{1}{2}$ " Flanged Plate (12) and to a $2\frac{1}{2}$ " \times $\frac{1}{2}$ " Double Angle Strip (13) (Fig. 7.16). The Plate (12) forms one end of the boiler and the other end is a $3\frac{1}{2}$ " \times $2\frac{1}{2}$ " Flanged Plate (14). To each end are bolted two $2\frac{1}{2}$ " Stepped Curved Strips (15) and a $2\frac{1}{2}$ " \times $1\frac{1}{2}$ " Flexible Plate. At each side the rounded top is made from two curved $2\frac{1}{2}$ " \times $2\frac{1}{2}$ " Flexible Plates, a $1\frac{1}{2}$ " radius Curved Plate and a curved $2\frac{1}{2}$ " \times $1\frac{1}{2}$ " Flexible Plate. The Plates on each side are bolted at the centre to a $5\frac{1}{2}$ " \times $1\frac{1}{2}$ " Flexible Plate extended by a $2\frac{1}{2}$ " \times $1\frac{1}{2}$ " Flexible Plate. The joins in the Plates are strengthened by Formed Slotted Strips inside the top.

The curved Plates at one side of the boiler are connected by Fishplates to a $2\frac{1}{2}$ " \times $\frac{1}{2}$ " Double Angle Strip (16) and a $3\frac{1}{2}$ " \times $\frac{1}{2}$ " Double Angle Strip (17). A $1\frac{1}{2}$ " Strip is used to connect this side of the boiler to a flange of the Plate (14). Two $2\frac{1}{2}$ " \times $1\frac{1}{2}$ " Flexible Plates, overlapped two holes lengthways, fill in the gap between the Plate (14) and the cylinder. A Sleeve Piece is fitted over a Chimney Adaptor bolted to the top of the boiler.

(Continued on next page)

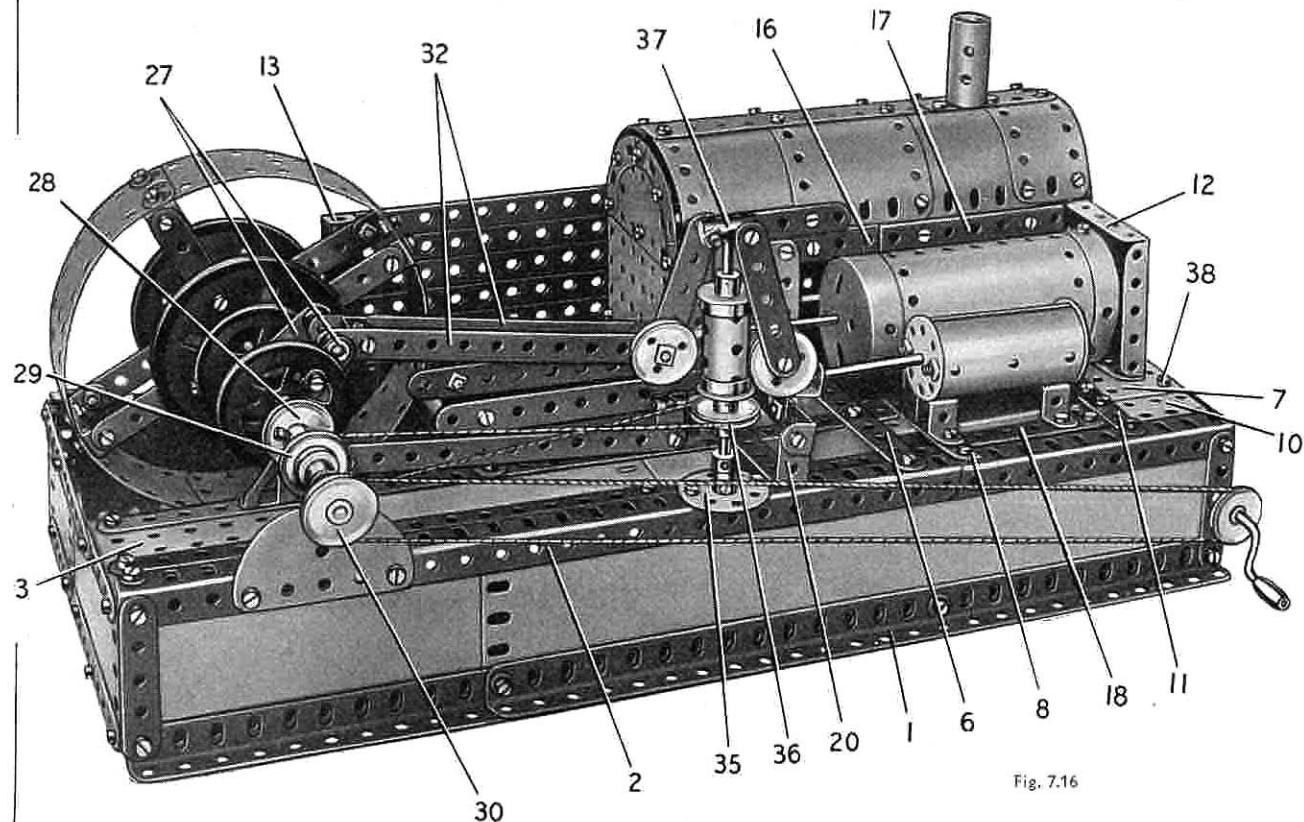

Fig. 7.16

MODEL 7.16 HORIZONTAL STEAM ENGINE — Continued

The Double Angle Strip (13) and the Plate (12) are bolted to the base, and the Plate (14) is connected to the Strip (9) by a 1" x 1" Angle Bracket.

CYLINDER, VALVE CHEST AND CROSSHEAD SLIDES

The cylinder is a Boiler fitted at each side with two Flat Trunnions. The wide ends of the Flat Trunnions on each side are connected by a 3½" Strip, and are attached to the strips (8) and (11) by Angle Brackets.

The valve chest is a Cylinder fitted with two Double Bent Strips. These are bolted to the Flanged Plate (7) and to a 3" Strip (18) (Fig. 7.16). A Wheel Disc is clamped at each end of the Cylinder by nuts on two Screwed Rods.

The crosshead slides are 5½" Strips attached at one end to 1" x 1" Angle Brackets bolted to a 5½" Strip (19). One of the slides is fixed also to the side of the boiler, and the other is supported by a 2½" x 1" Double Angle Strip (20).

ASSEMBLY OF THE CRANKSHAFT AND FLYWHEEL

The crankshaft is supported in four bearings. The bearing (21) consists of a Fishplate and a ½" Reversed Angle Bracket bolted to a Semi-Circular Plate. The bearings (22) and (23) are each formed by a 1½" Strip bolted to a Trunnion, and they are spaced from the base by a Washer on each bolt. The bearing (24) is a 3½" Strip extended by a Fishplate and bolted to a 3½" x ½" Double Angle Strip (25), which is connected by a 2½" Strip to a 3½" x 2½" Flanged Plate (26) (Fig. 7.16a).

The crankshaft webs are 2" Pulleys, each fitted with a Crank (27). One of the Pulleys is fixed on a 3½" Rod mounted in the bearings (23) and (24), and the other on a 1½" Rod supported in the bearing (22) and held in place by a Cord Anchoring Spring. The 1½" Rod carries a 1" Pulley (28). A 2" Rod is supported in the bearing (21) and is fitted with a ½" fixed Pulley and two 1" fixed Pulleys (29) and (30).

The flywheel rim consists of four 5½" x 1½" Flexible Plates curved and bolted together so that their ends overlap two holes at each join. The spokes are 5½" Strips bolted across 3" Pulleys. The rim is connected to the spokes by two 1½" x ½" Double Angle Strips and four Angle Brackets.

PISTON, CONNECTING ROD AND VALVE GEAR

The piston rod is a 5" Rod fitted with a large Fork Piece (31) which pivots on a 1½" Rod held by Spring Clips in two Angle Brackets. Two 5½" Strips (32) joined by a Double Bracket pivot also on the 1½" Rod, and the Angle Brackets are bolted to a 1½" Strip. This Strip is fitted at each end with a Double Bracket, and these slide freely over the crosshead slide bars as shown. The Strips (32) pivot on a 1½" Rod fixed in the Cranks (27).

An Angle Bracket is attached by a nut and bolt to the boss of each of the Pulleys (28) and (29). The bolt is fitted with a nut, passed through the Angle Bracket into a threaded hole of the Pulley, and the nut is then tightened against the Angle Bracket. The Angle Brackets are connected by nuts on a ½" Bolt, on which a 5½" Strip pivots freely. This Strip is lock-nutted to a Right-Angle Rod and Strip Connector (33), fitted to a 6½" Rod. The 6½" Rod is supported in the valve chest, and in a ½" Reversed Angle Bracket (34) bolted to a 2½" x ½" Double Angle Strip fixed to the lugs of the Double Angle Strip (20).

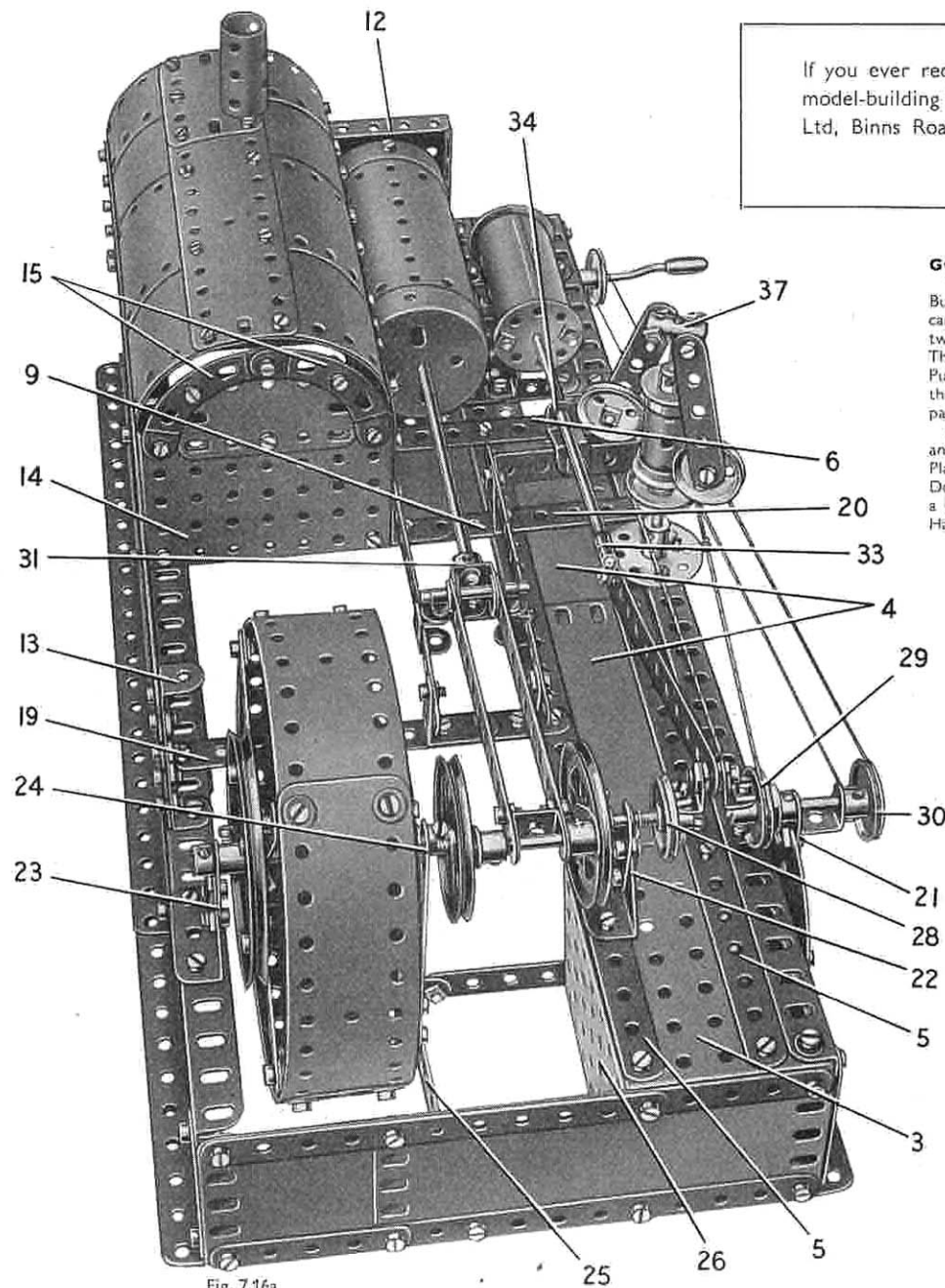

Fig. 7.16a

If you ever require advice in connection with your model-building write to Information Service, Meccano Ltd, Binns Road, Liverpool 13. Experts are waiting to help you

GOVERNOR AND DRIVING MECHANISM

The governor shaft is a 5" Rod that is free to turn in a Bush Wheel (35) and is held in place by Collars. The Rod carries a 1" Pulley (36), a Sleeve Piece clamped between two ½" Flanged Wheels, and a Coupling (37) (Fig. 7.16a). The governor arms are 2½" Strips weighted by 1" loose Pulleys, and each pivots on a ½" Bolt held by two nuts in the Coupling (37). The governor is driven by a belt of Cord passed round the Pulleys (29) and (36).

A 3½" Crank Handle is mounted on one side of the base and in a 2½" x ½" Double Angle Strip attached to the Flanged Plate (7) by a bolt (38) (Fig. 7.16). The lower end of the Double Angle Strip is connected to the end of the base by a ½" Reversed Angle Bracket. A 1" Pulley on the Crank Handle drives the Pulley (30) through a Cord belt.

Parts Required

7 of No.	1	7 of No.	48a	
18	" "	2	" "	48b
6	" "	3	" "	51
2	" "	4	" "	52
11	" "	5	" "	53
4	" "	6a	" "	59
8	" "	8	" "	62
5	" "	10	" "	63
4	" "	11	" "	80c
18	" "	12	" "	90a
3	" "	12a	" "	111
1	" "	14	" "	111a
2	" "	15	" "	111c
1	" "	16	" "	115
1	" "	17	" "	116
3	" "	18a	" "	125
2	" "	19b	" "	126
1	" "	19g	" "	126a
2	" "	20a	" "	162
2	" "	20b	" "	163
5	" "	22	" "	164
2	" "	22a	" "	176
1	" "	23a	" "	188
1	" "	24	" "	189
2	" "	24a	" "	190
2	" "	35	" "	191
199	" "	37a	" "	192
182	" "	37b	" "	197
32	" "	38	" "	200
1	" "	40	" "	212a
2	" "	45	" "	214
1	" "	46	" "	215
2	" "	48	" "	216

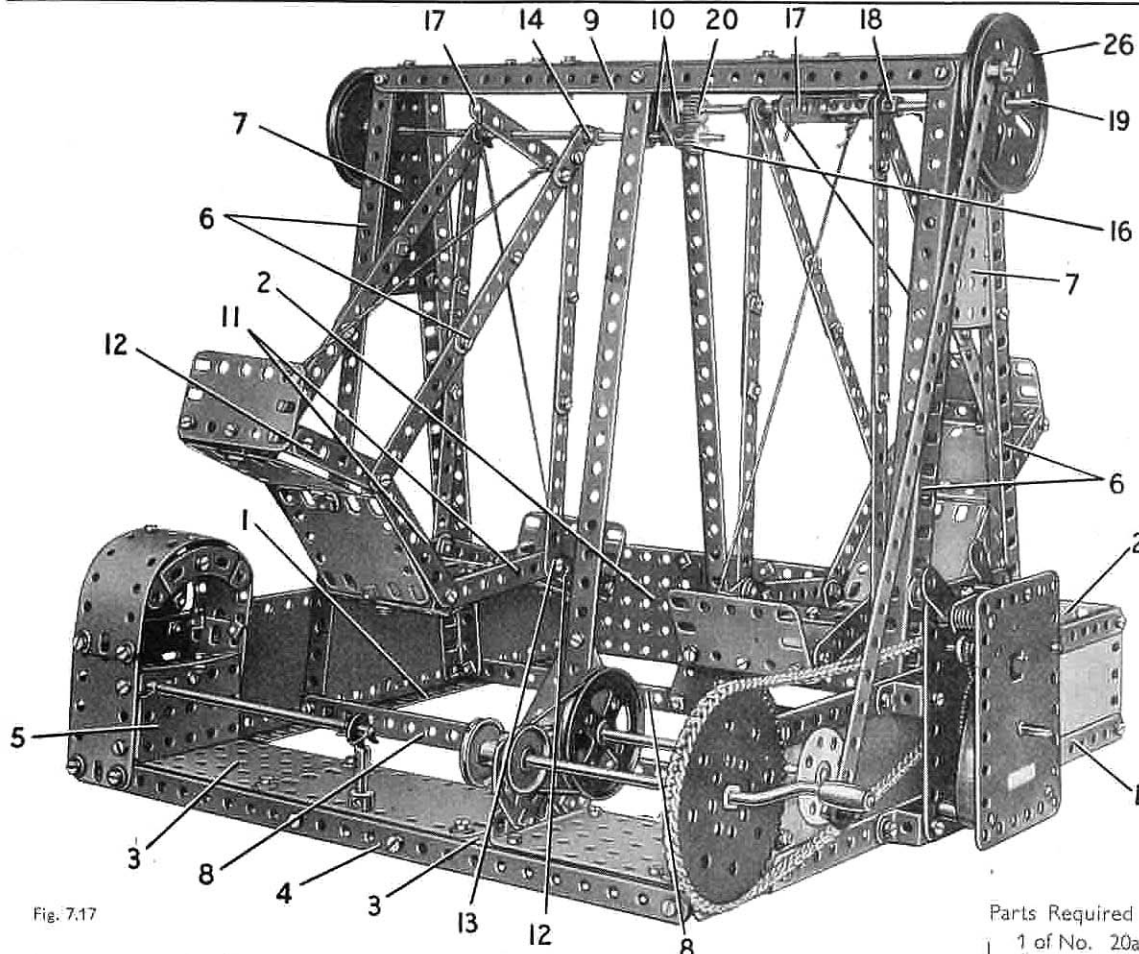

Fig. 7.17

The construction of the right-hand boat is similar to the one already described, but two of the 3½" Strips (11) are replaced by 3" Strips extended by Fishplates, and two straightened 1½" radius Curved Plates are used in place of two of the 2½" x 2½" Flexible Plates. The strips supporting this boat are each made from two 5½" Strips overlapped four holes, and one of them is fitted with a Crank (18). The Crank is fixed on a built-up rod (19) (Fig. 7.17), supported in the Flat Trunnions (10) and one of the Flanged Sector Plates (7). The rod (19) is made from a 4½" and a 3½" Rod joined by a Coupling, and it carries a ½" Pinion (20) that engages the Pinion (16). The rod is held in position by a Collar placed between the Flat Trunnions (10).

THE DRIVING MECHANISM

Fig. 7.17a shows the model arranged for hand-operation. A 3½" x 2½" Flanged Plate (21) is bolted to one side of the base, and two Flat Trunnions (22) are fixed to a flange of the Flanged Plate. A 5" Crank Handle is supported in one of the Flat Trunnions and in a 1½" x ½" Double Angle Strip (23) bolted to the other flange of the Plate (21). A 1" Pulley on the Crank Handle is connected by a Driving Band to a 2" Pulley on a 5" Rod (24). This Rod is supported in one of the Flat Trunnions (22) and in the side of the base. It is held in position by a Collar, and it carries a Bush Wheel (25). A 12½" Strip is mounted as shown on a Pivot Bolt fixed to the Bush Wheel. The upper end of the 12½" Strip is held by a Collar on a Threaded Pin attached to a 3" Pulley (26). This Pulley is fixed on the rod (19).

Fig. 7.17 shows the Swing Boats operated by a No. 1 Clockwork Motor. The Motor is attached to one side of the base by three ½" Reversed Angle Brackets, and to one of the columns by a fourth Reversed Angle Bracket. A 1" Sprocket is fixed on the Motor driving shaft, and is connected by Chain to a 3" Sprocket on the Crank Handle.

Note: The No. 1 Clockwork Motor, the Sprocket Wheels and the Chain used in the Motor-driven version of the model are not included in the Outfit.

Parts Required		1 of No. 20a		1 of No. 111	
12 of No.	1	2 "	22	2 "	111a
17 "	2	1 "	24	6 "	111c
6 "	3	2 "	26	1 "	115
2 "	4	9 "	35	4 "	125
10 "	5	185 "	37a	4 "	126a
6 "	8	176 "	37b	1 "	147b
3 "	10	34 "	38	1 "	186
3 "	11	1 "	40	1 "	187
7 "	12	2 "	48	6 "	188
8 "	12c	10 "	48a	4 "	189
1 "	14	1 "	51	8 "	190
2 "	15	2 "	52	1 "	191
1 "	15a	3 "	53	2 "	192
1 "	16	2 "	54	2 "	197
1 "	17	6 "	59	2 "	200
1 "	18a	2 "	62	1 "	212
1 "	19b	1 "	63	1 "	213
1 "	19h	1 "	90	1 "	214
		1 "	90a	4 "	221

7.17 SWING BOATS

CONSTRUCT THE BASE

Each side of the base is a 12½" x 2½" Strip Plate edged by a 12½" Angle Girder (1) (Fig. 7.17) and a 12½" Strip. The back of the base is formed by two 3½" x 2½" Flanged Plates (2) and two 5½" x 2½" Flexible Plates overlapped seven holes. These Plates are strengthened along their lower edges by a 12½" Strip. At the front the sides are connected by two 5½" x 2½" Flanged Plates (3), which are bolted to a 12½" Strip (4) at the front and at the rear are connected by a 5½" Strip. The space between the Flanged Plates is covered by a 4½" x 2½" Flexible Plate.

The back of the pay-box is formed by two 2½" x 2½" Flexible Plates, overlapped four holes and bolted to the end of one of the Flanged Plates (3). The back is extended upward by a Semi-Circular Plate fixed to one of the Flexible Plates. The sides are 2½" x 1½" Flexible Plates, and the roof is a curved 5½" x 1½" Flexible Plate attached to the sides. The roof is bolted at its centre to a 1½" x ½" Double Angle Strip fixed to the Semi-Circular Plate, and at the front of the pay-box the Double Angle Strip supports a 2½" Stepped Curved Strip. A 2½" x 1½" Flanged Plate (5) is bolted between the sides, and a 2½" Curved Strip is attached to it by an Angle Bracket.

THE SUPPORTING COLUMNS

The outer columns on each side are formed by two 12½" Angle Girders (6) (Fig. 7.17), bolted to the sides of the base. These Girders are attached at their upper ends to a Flanged Sector Plate (7). The outer columns are connected by two 12½" Strips (8) at the bottom, and by two similar Strips (9) at the top. The central column consists of two 12½" Strips, which are bolted between the Strips (8) and (9) and are braced at their lower ends by 2½" x 1½" Triangular Flexible Plates as shown in Fig. 7.17a. The bolts fixing the 12½" Strips to the Strips (9) secure also two Double Brackets, and these support two Flat Trunnions (10).

The Strips (9) are covered by three 5½" x 1½" Flexible Plates, which overlap each other by four holes and are supported by three Angle Brackets. Two of the Angle Brackets are attached to the Flanged Sector Plates (7), and the third is secured to one of the Flat Trunnions (10).

ASSEMBLY OF THE BOATS

Each side of the left-hand boat (Fig. 7.17) consists of two 3½" Strips (11) and two 2½" Strips (12) bolted together as shown. The sides are connected by five 2½" x ½" Double Angle Strips attached by the bolts marked (13). The gaps between the Double Angle Strips are filled by four 2½" x 2½" Flexible Plates, which are attached to the Double Angle Strips by Angle Brackets and Obtuse Angle Brackets. A 2½" x 1½" Flexible Plate is fixed to each end of the boat.

The boat is supported by four built-up strips, each made from two 5½" Strips overlapped five holes, and a Crank (14) is attached to the upper end of one of these strips. The boat is suspended from a built-up rod made from a 2" and a 6½" Rod joined by a Rod Connector. This rod is mounted in the Flat Trunnions (10) and in one of the Flanged Sector Plates (7), and it passes through the Crank (14) and the built-up strips that support the boat. The Crank is fixed by its grub screw on the rod. The rod is held in position by a Collar placed between the Flat Trunnions (10) and by a ½" Pinion (16).

A length of Cord is fastened to each end of the boat. These Cords are crossed as shown and are tied to a 2½" Strip (17).

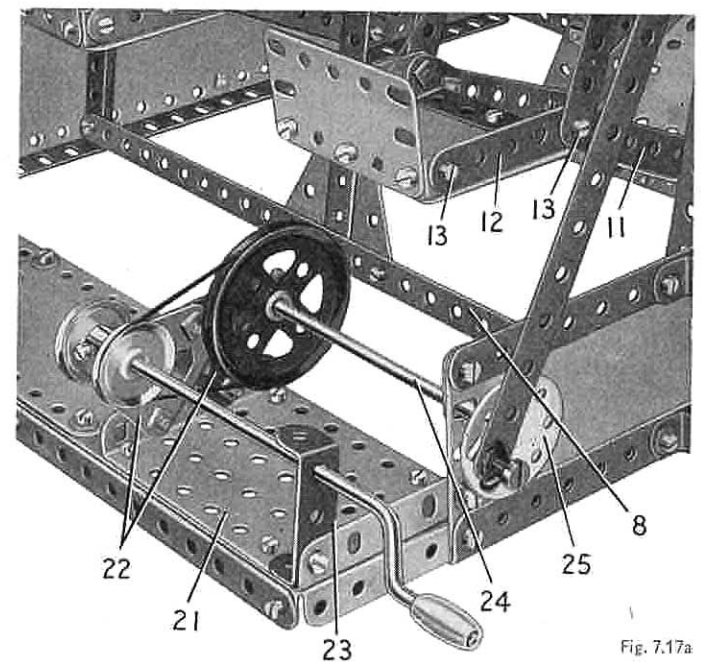

Fig. 7.17a

7.18 COUPE

DETAILS OF THE CHASSIS (Fig. 7.18b)

A $1\frac{1}{2}$ " Angle Girder is bolted to each side of a $5\frac{1}{2}$ " \times $2\frac{1}{2}$ " Flanged Plate (1) and a $3\frac{1}{2}$ " \times $2\frac{1}{2}$ " Flanged Plate (2). The front and rear wheels are fixed on 5" Rods, which are mounted in the Angle Girders and are held in place by 1" Pulleys.

THE SIDES OF THE BODY

Each side consists of a $5\frac{1}{2}$ " \times $2\frac{1}{2}$ " Flexible Plate (3) (Fig. 7.18), two $5\frac{1}{2}$ " \times $1\frac{1}{2}$ " Flexible Plates (4), a $2\frac{1}{2}$ " \times $1\frac{1}{2}$ " Flexible Plate (5) and a Semi-Circular Plate (6). These Plates are arranged between a framework formed by a $5\frac{1}{2}$ " Strip (7), a built-up strip (8) and a $2\frac{1}{2}$ " Strip (9). The strip (8) is made from two $5\frac{1}{2}$ " Strips overlapped six holes, and a $3\frac{1}{2}$ " Strip. The wheel arches are $2\frac{1}{2}$ " Stepped Curved Strips, and the strip (8) is extended forward by a $2\frac{1}{2}$ " Curved Strip and a $1\frac{1}{2}$ " Strip (10).

Two $5\frac{1}{2}$ " Strips (11) bolted together are attached to $\frac{1}{2}$ " Reversed Angle Brackets, which are fixed to the strip (8) by bolts (12). A $1\frac{1}{2}$ " Strip (13), extended two holes at the rear by a $2\frac{1}{2}$ " Strip, is also bolted to the Reversed Angle Brackets. The rear end of one of the Strips (11) is connected to the ends of the strips (8) and to the Strip (9) by an Angle Bracket.

The window frames at each side are represented by two $2\frac{1}{2}$ " Strips, a $2\frac{1}{2}$ " \times $\frac{1}{2}$ " Double Angle Strip and a $2\frac{1}{2}$ " \times $1\frac{1}{2}$ " Flexible Plate. These parts are connected at their upper ends by a built-up strip (14), made from two $3\frac{1}{2}$ " Strips. The rear end of each side is filled in by a $2\frac{1}{2}$ " Strip and a $2\frac{1}{2}$ " \times $\frac{1}{2}$ " Double Angle Strip bolted to a 1 " \times 1 " Angle Bracket.

Each of the front wings consists of a $2\frac{1}{2}$ " \times 2 " Triangular Flexible Plate (15) and a $2\frac{1}{2}$ " \times $1\frac{1}{2}$ " Triangular Flexible Plate (16) bolted to two $5\frac{1}{2}$ " Strips (17) curved as shown (Fig. 7.18). The inner corner of the Triangular Flexible Plate (15) is bolted to the front of the Flanged Plate (2) by a $\frac{1}{2}$ " Bolt. These Bolts on each side support

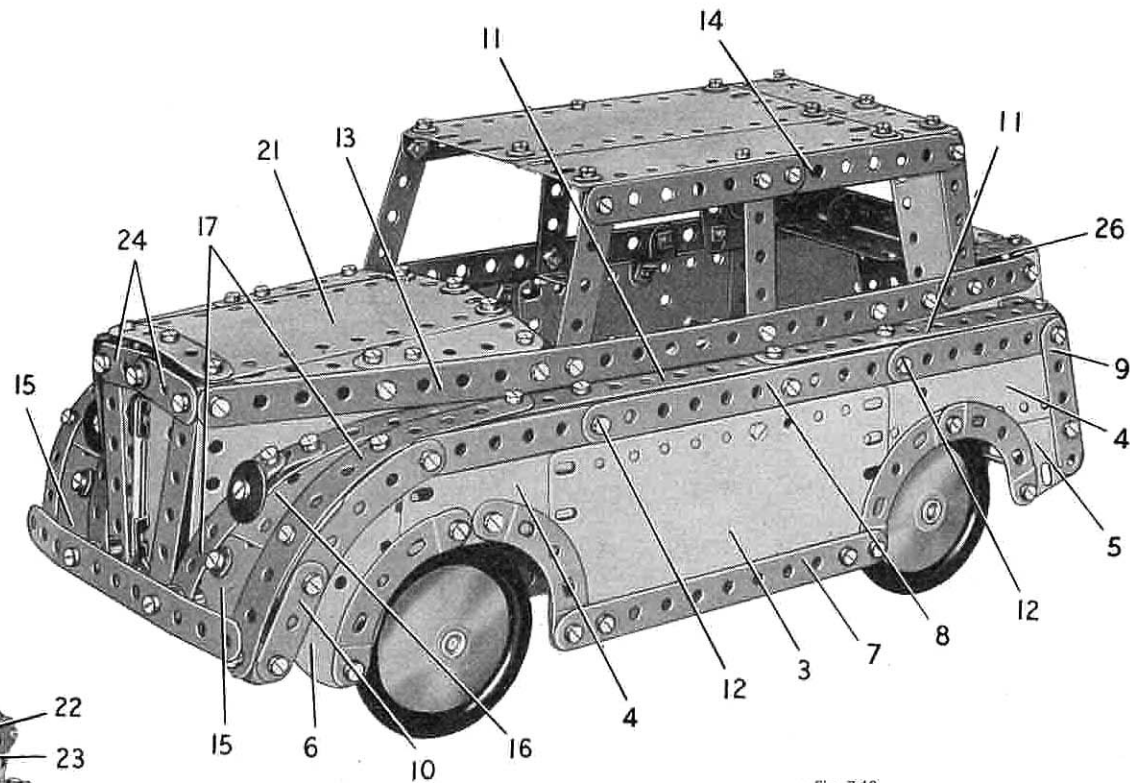

Fig. 7.18

also the front bumper, which is a $5\frac{1}{2}$ " Strip. It is spaced from the wings by Collars on the Bolts and a $3\frac{1}{2}$ " \times $\frac{1}{2}$ " Double Angle Strip (18). The outer corners of the Plates (15) are connected to the $1\frac{1}{2}$ " Strips (10) by Angle Brackets. The rear ends of the Strips (17) are bolted to the Strips (11).

Two $5\frac{1}{2}$ " Strips (19) are bolted across the Flanged Plate (1), and are connected to the sides of the body by Angle Brackets. The rear ends of the sides are supported by $1\frac{1}{2}$ " \times $\frac{1}{2}$ " Double Angle Strips (20) bolted to the chassis girders (Fig. 7.18b).

THE BONNET AND THE RADIATOR

The Strips (13) are curved inward slightly at their front ends and are connected by Angle Brackets to a $4\frac{1}{2}$ " \times $2\frac{1}{2}$ " Flexible Plate (21) that forms the centre of the top of the bonnet (Fig. 7.18). The Plate (21) is edged at the front by a $2\frac{1}{2}$ " Strip, and it is fitted at each side with a $2\frac{1}{2}$ " \times $2\frac{1}{2}$ " Flexible Plate (22) and a $2\frac{1}{2}$ " \times $2\frac{1}{2}$ " Triangular Flexible Plate (23). The Plates (23) are supported by Angle Brackets bolted to the Strips (13).

The radiator is a $2\frac{1}{2}$ " \times $1\frac{1}{2}$ " Flexible Plate edged by two $2\frac{1}{2}$ " Strips and two $1\frac{1}{2}$ " Strips (24). It is bolted to the front of the Flanged Plate (2) and is connected by an Angle Bracket to the Flexible Plate (21). A 2" Rod is fitted at each end with a Rod and Strip Connector, and is bolted vertically to the centre of the radiator.

THE LUGGAGE BOOT

The back of the luggage boot is a $3\frac{1}{2}$ " \times $2\frac{1}{2}$ " Flanged Plate bolted to the ends of the $2\frac{1}{2}$ " Strips that extend the Strips (13). A $2\frac{1}{2}$ " \times $2\frac{1}{2}$ " Flexible Plate (25) on each side (Fig. 7.18a) is attached by the same bolt that secures the Flanged Plate to the Strip, and the bolt fixes also a $3\frac{1}{2}$ " \times $\frac{1}{2}$ " Double Angle Strip (26) arranged across the top of the Flanged Plate. The top of the luggage boot is filled in by a $2\frac{1}{2}$ " \times $2\frac{1}{2}$ " Flexible Plate and two Flat Trunnions, and these parts are bolted to the Double Angle Strip (26).

(Continued on next page)

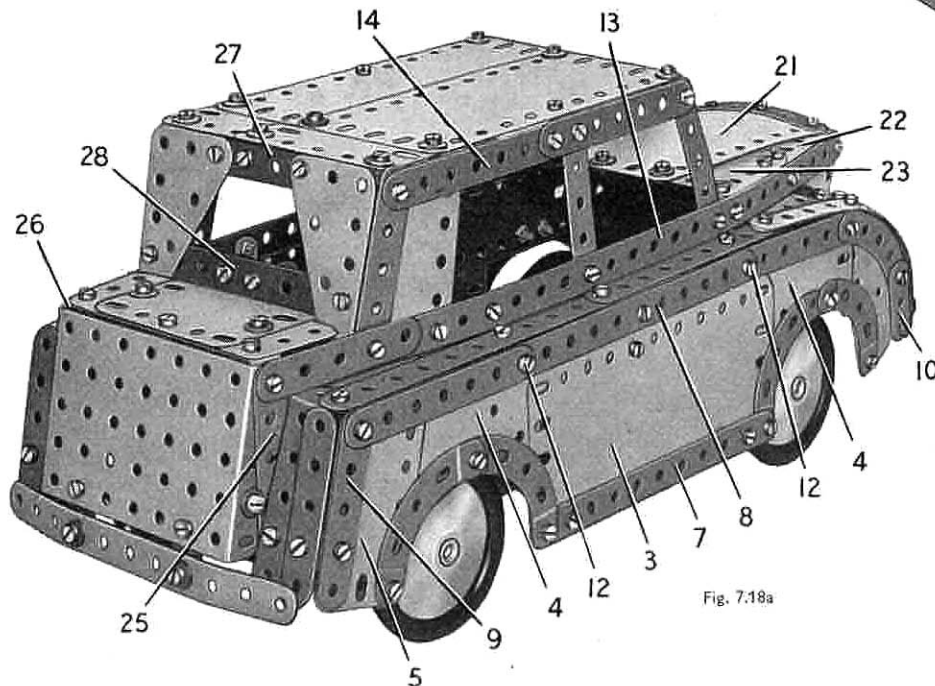

Fig. 7.18a

MODEL 7.18 COUPÉ — Continued

DETAILS OF THE ROOF

The roof consists of two $5\frac{1}{2}'' \times 2\frac{1}{2}''$, a $2\frac{1}{2}'' \times 2\frac{1}{2}''$ and a $2\frac{1}{2}'' \times 1\frac{1}{2}''$ Flexible Plate bolted together to make a built-up $6\frac{1}{2}'' \times 4''$ plate. The roof is attached to the strips (14) by Angle Brackets.

The rear window frame is formed by two $2\frac{1}{2}'' \times 1\frac{1}{2}''$ Triangular Flexible Plates bolted to a $2\frac{1}{2}'' \times \frac{1}{2}''$ Double Angle Strip (27) and a built-up strip (28). The strip (28) is made with a $2\frac{1}{2}'' \times \frac{1}{2}''$ Double Angle Strip and a $2\frac{1}{2}''$ Strip overlapped two holes. The lower corners of the Triangular Flexible Plates are connected to the ends of the Strips (13) by Double Brackets, and the Double Angle Strip (27) is attached to an Angle Bracket bolted to the roof.

Parts Required

2 of No. 1	18 of No. 12	2 of No. 38d	2 of No. 111a	8 of No. 190
18 " " 2	3 " " 12a	2 " " 48	3 " " 111c	1 " " 191
6 " " 3	2 " " 12c	6 " " 48a	4 " " 125	4 " " 192
2 " " 4	2 " " 15	2 " " 48b	2 " " 126a	2 " " 212
12 " " 5	1 " " 17	1 " " 52	4 " " 155	2 " " 214
4 " " 6a	4 " " 22	2 " " 53	4 " " 187	4 " " 221
2 " " 8	151 " " 37a	2 " " 59	6 " " 188	2 " " 222
4 " " 10	146 " " 37b	2 " " 90	4 " " 189	2 " " 223
2 " " 11	21 " " 38	8 " " 90a		

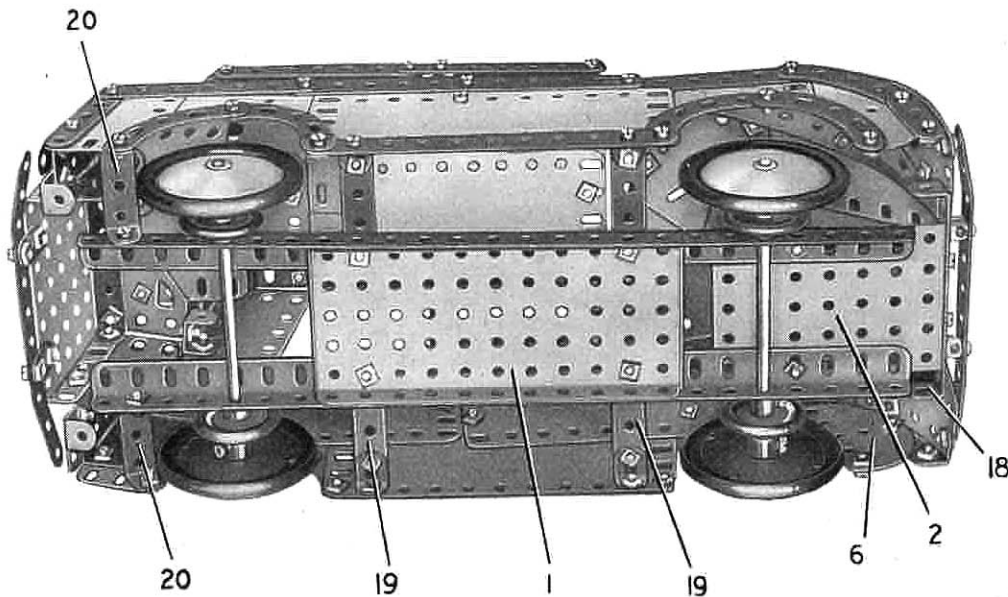

Fig. 7.18b

7.19 SLOTTING MACHINE

Parts Required

2 of No. 1	6 of No. 59	15
18 " " 2	2 " " 62	13
6 " " 3	1 " " 63	7
2 " " 4	2 " " 80c	12
12 " " 5	1 " " 111	8
4 " " 6a	2 " " 111a	5
6 " " 8	5 " " 111c	
2 " " 10	2 " " 115	
2 " " 11	3 " " 125	
16 " " 12	1 " " 126	
4 " " 12a	1 " " 147b	
1 " " 14	1 " " 155	
1 " " 15a	3 " " 188	
2 " " 15b	5 " " 189	
3 " " 16	3 " " 190	
1 " " 17	2 " " 191	
2 " " 18a	5 " " 192	
1 " " 18b	2 " " 197	
1 " " 19b	2 " " 212a	
3 " " 20b	1 " " 213	
2 " " 22	2 " " 223	
1 " " 23		
1 " " 24		
2 " " 24a		
2 " " 26		
1 " " 27a		
1 " " 32		
3 " " 35		
173 " " 37a		
147 " " 37b		
32 " " 38		
2 " " 48		
8 " " 48a		
1 " " 51		
2 " " 52		
3 " " 53		

1 No. 1 Clock-work Motor
(not included in Outfit)

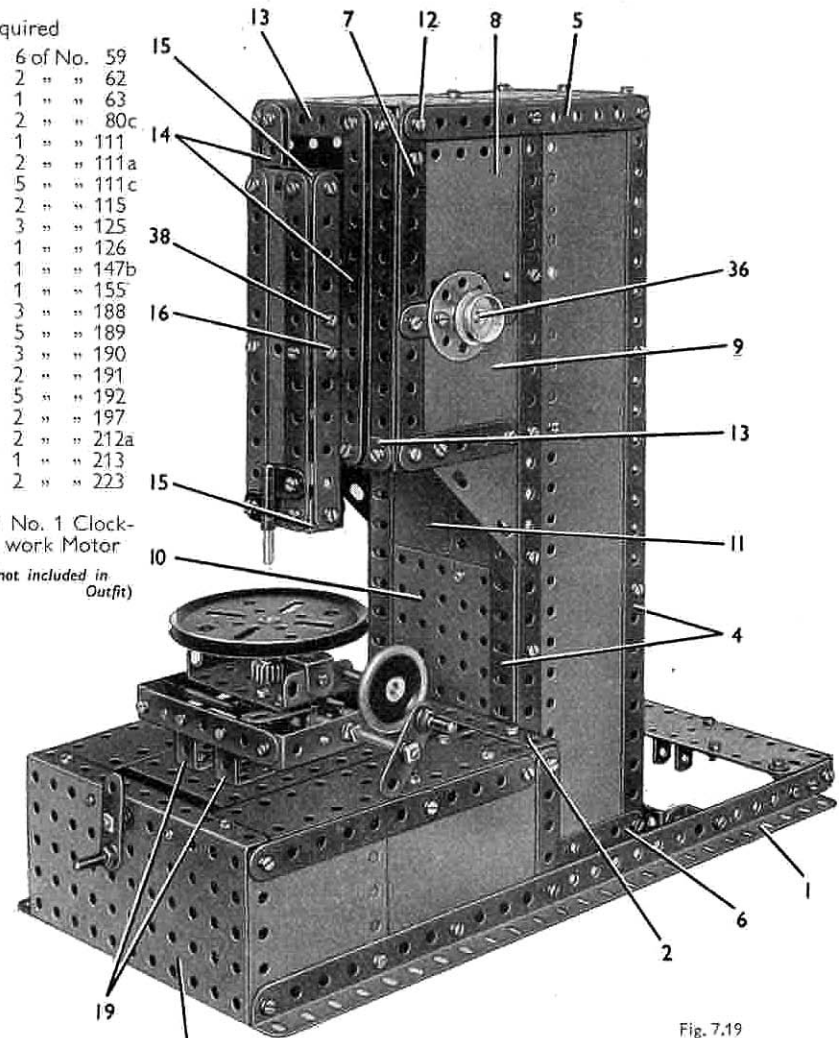

Fig. 7.19

CONSTRUCTION OF THE BASE

The base is made by bolting two $12\frac{3}{4}''$ Angle Girders (1) (Fig. 7.19c) to the end flanges of two $5\frac{1}{2}'' \times 2\frac{1}{2}''$ Flanged Plates (2). At their rear ends the Girders are extended one hole by $1\frac{1}{2}''$ Strips, and a $5\frac{1}{2}'' \times 1\frac{1}{4}''$ Flexible Plate is attached at each side to two $2\frac{1}{2}'' \times \frac{1}{2}''$ Double Angle Strips bolted to the $1\frac{1}{2}''$ Strips. The rear pair of Double Angle Strips is connected by a Trunnion (3).

At each side of the base a $5\frac{1}{2}'' \times 2\frac{1}{2}''$ and a $2\frac{1}{2}'' \times 2\frac{1}{2}''$ Flexible Plate overlapped four holes are bolted between the side flanges of the Flanged Plates (2). The top edges of the Plates on one side are strengthened by a $5\frac{1}{2}''$ Strip, and the other side is edged by a $3\frac{1}{2}''$ and a $2\frac{1}{2}''$ Strip. A $5\frac{1}{2}'' \times 1\frac{1}{2}''$ and a $2\frac{1}{2}'' \times 1\frac{1}{4}''$ Flexible Plate overlapped four holes are bolted to the top of the base on each side of the model, and are attached to the sides by Angle Brackets as shown in Fig. 7.19d.

THE VERTICAL COLUMN

The sides of the column are each formed by two $12\frac{1}{4}''$ Angle Girders (4) (Fig. 7.19) and a $12\frac{1}{4}'' \times 2\frac{1}{2}''$ Strip Plate. The Girders are connected at the top by a $5\frac{1}{2}''$ Strip (5) and at the bottom by a $3''$ Strip (6), and the edge of the front Girder on each side is covered by a $12\frac{1}{4}''$ Strip. A $5\frac{1}{2}''$ Strip (7) is bolted to the end of the Strip (5), and a $5\frac{1}{2}'' \times 2\frac{1}{2}''$ Flexible Plate (8) and a $4\frac{1}{2}'' \times 2\frac{1}{2}''$ Flexible Plate (9) are attached to this Strip and to the Girders (4). The edge of the Plate (9) is strengthened by a $2\frac{1}{2}''$ Strip, and a $2\frac{1}{2}'' \times 2\frac{1}{2}''$ Triangular Flexible Plate is bolted to this Plate and to one of the Girders (4).

(Continued on next page)

MODEL 7.19. SLOTTING MACHINE — Continued

The sides are connected at the front by a $3\frac{1}{2}'' \times 2\frac{1}{2}''$ Flanged Plate (10) and by a built-up plate (11) made from a $2\frac{1}{2}'' \times 2\frac{1}{2}''$ and a $2\frac{1}{2}'' \times 1\frac{1}{2}''$ Flexible Plate. At the top of the column the sides are joined by a $3\frac{1}{2}'' \times 2\frac{1}{2}''$ Flanged Plate held by bolts (12) on each side. A $5\frac{1}{2}'' \times 2\frac{1}{2}''$ and a $5\frac{1}{2}'' \times 1\frac{1}{2}''$ Flexible Plate are bolted together lengthways and are fixed to the Flanged Plate. The rear edges of the Flexible Plates are strengthened by a $3\frac{1}{2}''$ Strip and are connected to the sides by Angle Brackets.

The completed column is bolted to one of the Flanged Plates (2) of the base as shown.

THE TOOL CARRIAGE AND ITS SLIDES

Two $5\frac{1}{2}''$ Strips are connected at their ends by two $3\frac{1}{2}''$ Strips (13) (Fig. 7.19), and are fixed to Angle Brackets secured to the sides of the column. The slides for the tool carriage are formed by two pairs of $5\frac{1}{2}''$ Strips (14). The Strips in each pair are separated by two Washers at each end on a $\frac{1}{2}''$ Bolt, and the Bolts are used to attach the slides to the Strips (13).

The front of the tool carriage consists of a $5\frac{1}{2}'' \times 1\frac{1}{2}''$ Flexible Plate edged by $5\frac{1}{2}''$ Strips and fitted at each end with a $1\frac{1}{2}'' \times \frac{1}{2}''$ Double Angle Strip (15). The lugs of the Double Angle Strips support a $5\frac{1}{2}''$ Strip on each side, and the bolts holding these Strips in place also secure Angle Brackets. The lower pair of Angle Brackets are joined by a $1\frac{1}{2}''$ Strip, and the upper pair are connected by a $2\frac{1}{2}''$ Strip, which is spaced from the Angle Brackets by a Washer on each bolt. A second $2\frac{1}{2}''$ Strip is spaced by a Washer on each bolt from two further Angle Brackets secured to the centre of the carriage by bolts (16). The ends of the $2\frac{1}{2}''$ Strips slide freely between the slides (14).

The tool is represented by a $1\frac{1}{2}''$ Rod supported in two Right-Angle Rod and Strip Connectors bolted to the carriage.

CONSTRUCTION OF THE WORK TABLE

A $3\frac{1}{2}'' \times 2\frac{1}{2}''$ Flanged Plate, with a $2\frac{1}{2}''$ Strip bolted to each flange, slides freely on Rods (17) (Fig. 7.19d), which are held in the Flanged Plates (2) by Collars. One of the Rods (17) is a $6\frac{1}{2}''$ Rod and the other is made from two $3\frac{1}{2}''$ Rods joined by a Rod Connector. A Crank (18) is bolted underneath the Flanged Plate and has a Screwed Rod threaded through its boss. The Screwed Rod passes through one of the Flanged Plates (2), and is held in position by two nuts screwed tightly against each other at each side of the Flanged Plate. The Screwed Rod can be turned by a handle formed by a Threaded Pin in a $1\frac{1}{2}''$ Strip. The Strip is fixed tightly by two nuts at the end of the Screwed Rod.

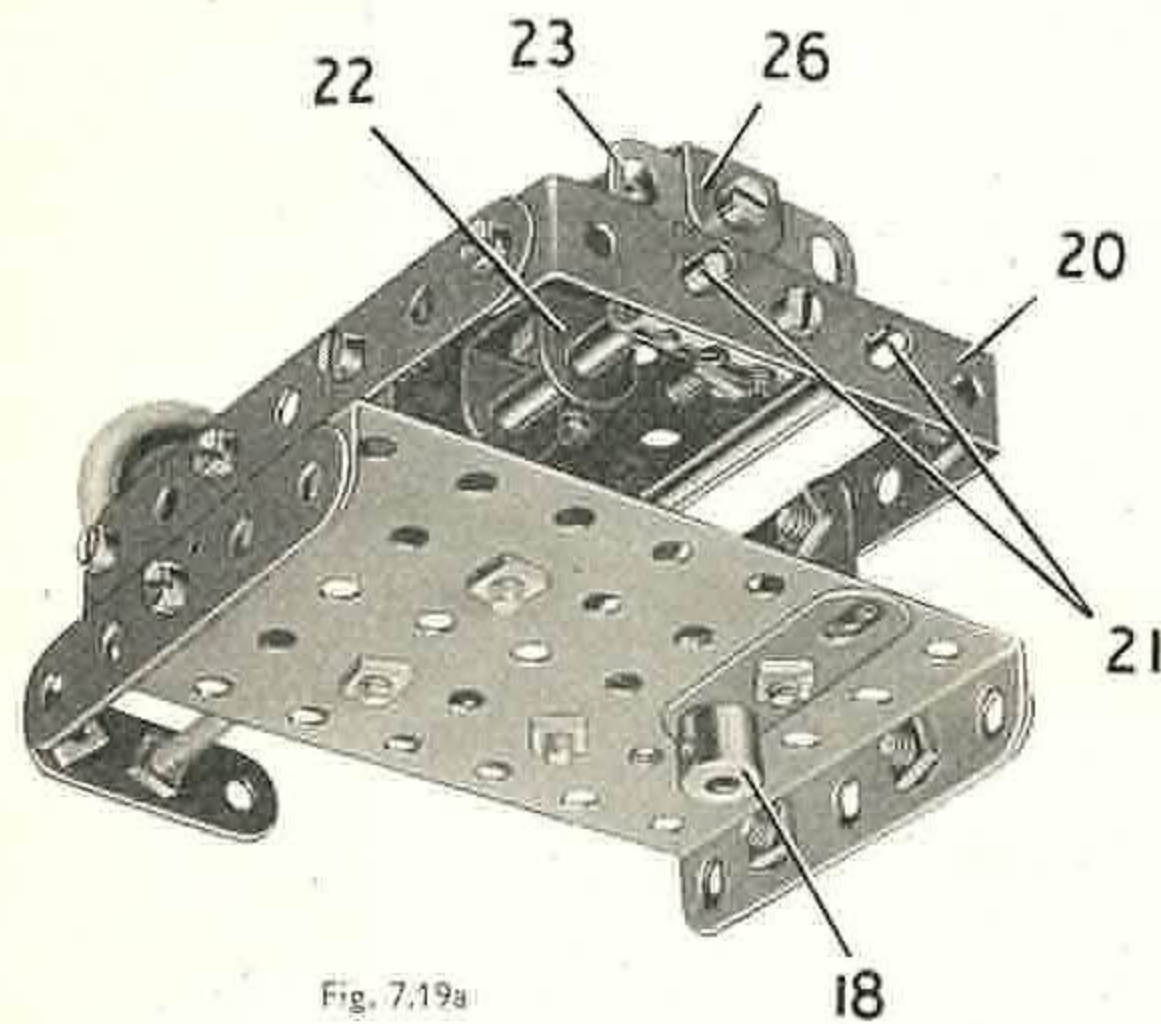

Fig. 7.19a

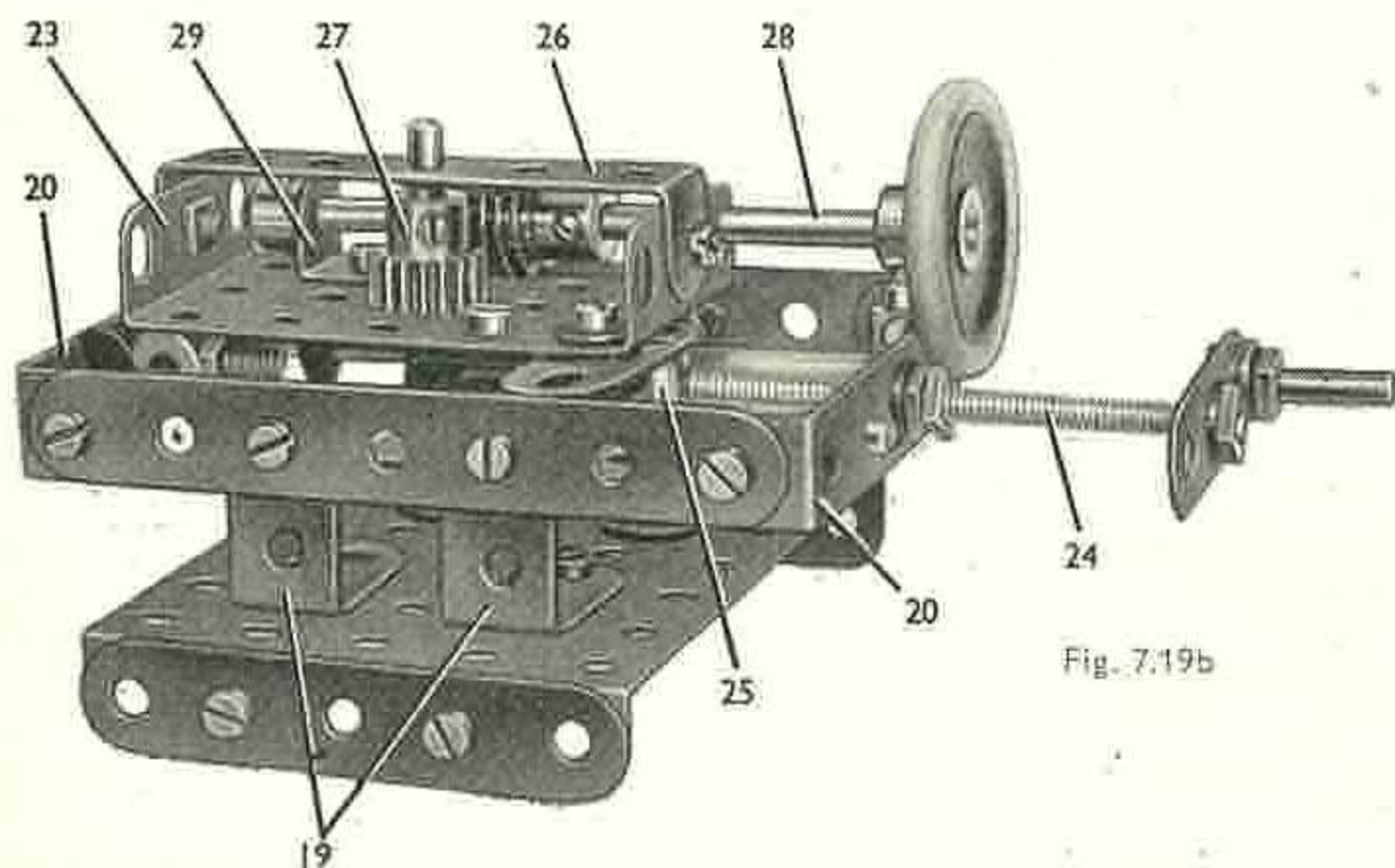

Fig. 7.19b

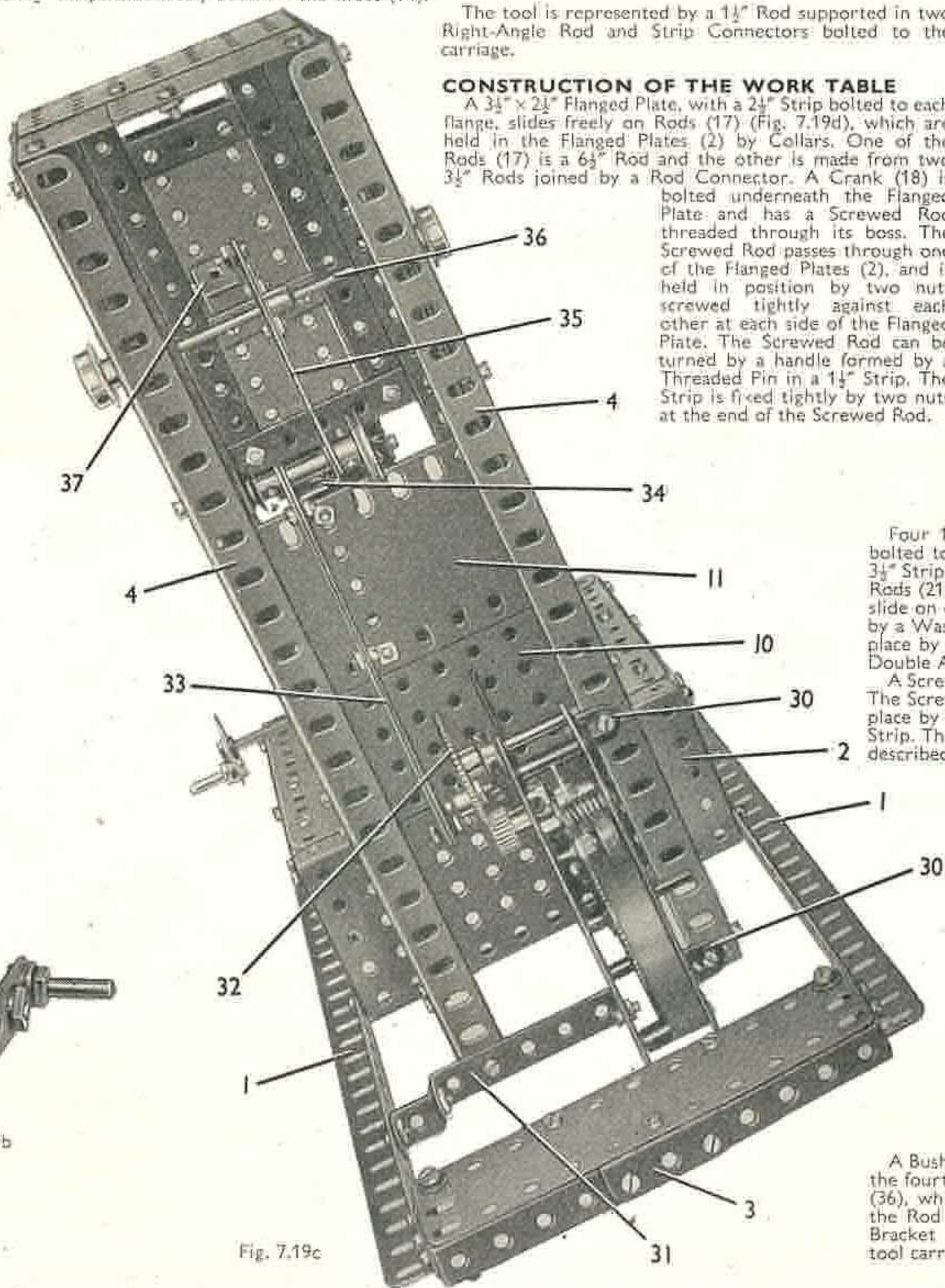

Fig. 7.19c

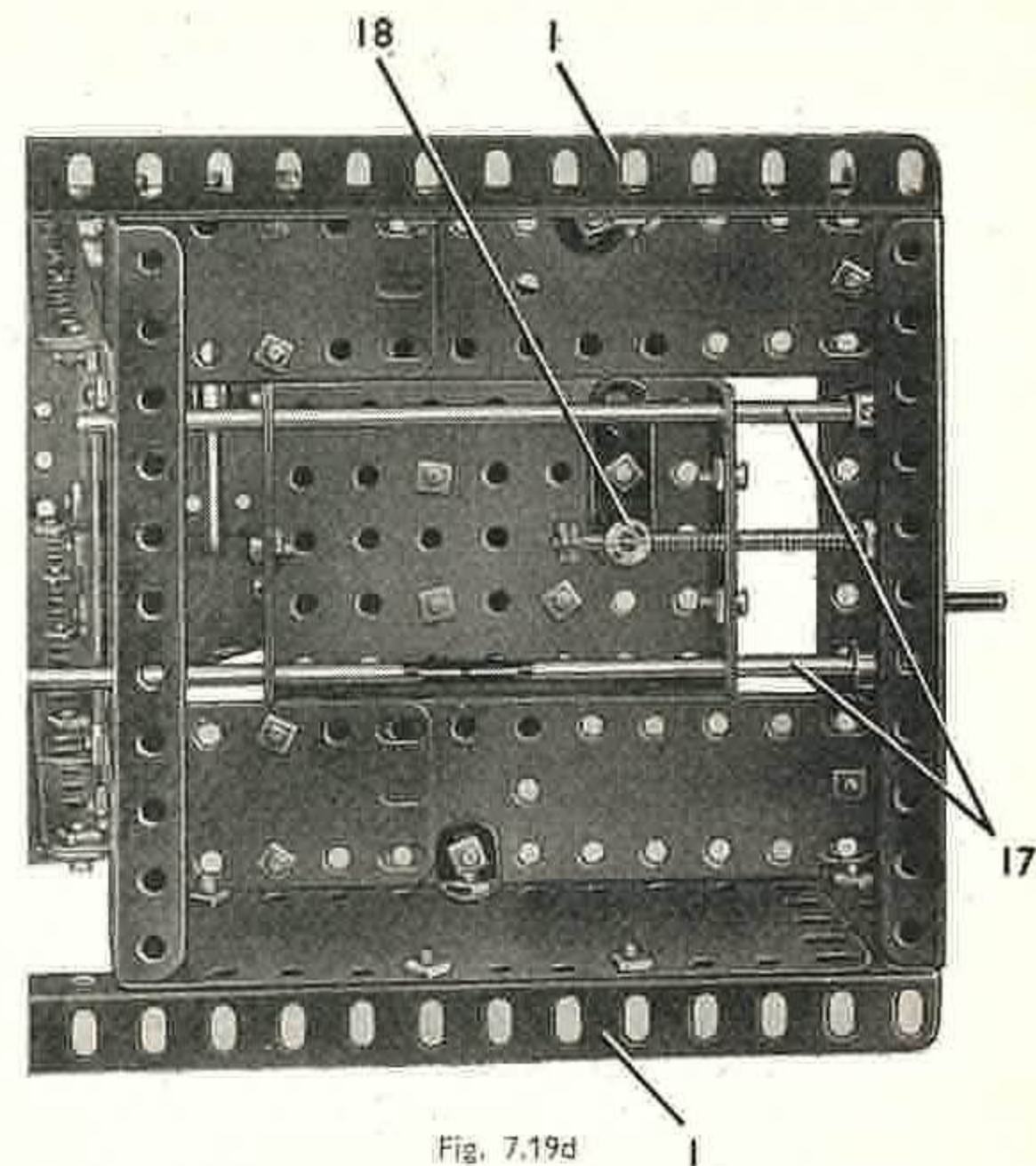

Fig. 7.19d

Four $1'' \times 1''$ Angle Brackets, two of which are indicated at (19) (Fig. 7.19b), are bolted to the Flanged Plate, and each pair of Angle Brackets supports a $3\frac{1}{2}''$ Strip. The $3\frac{1}{2}''$ Strips are connected at their ends by $2\frac{1}{2}'' \times \frac{1}{2}''$ Double Angle Strips (20). Two $4''$ Rods (21) are mounted in the Double Angle Strips, and a Double Bracket (22) is free to slide on each Rod. The Double Brackets are spaced from a $2\frac{1}{2}'' \times 1\frac{1}{2}''$ Flanged Plate (23) by a Washer on each of the bolts fixing them in place. One of the Rods (21) is held in place by two Spring Clips, and the other is gripped in a Coupling fitted to one of the Double Angle Strips (20) by a $\frac{3}{4}''$ Bolt.

A Screwed Rod (24) is threaded through a Crank (25) bolted to the Flanged Plate (23). The Screwed Rod is passed through one of the Double Angle Strips (20), and is held in place by pairs of nuts tightened against each other on either side of the Double Angle Strip. The Screwed Rod is fitted with a handle made in the same way as the one already described.

A $2\frac{1}{2}'' \times \frac{1}{2}''$ Double Angle Strip (26) (Fig. 7.19b) is bolted to the flanges of the Plate (23), and supports a $1''$ Rod fitted with a $\frac{1}{2}''$ Pinion (27). A $3''$ Pulley is fixed to the upper end of the Rod, and a Worm on a $3\frac{1}{2}''$ Rod (28) engages the Pinion (27). Rod (28) is passed through a flange of the Plate (23) and is held in a Double Bracket (29) by a Collar.

THE OPERATING MECHANISM

A No. 1 Clockwork Motor is attached to one of the Girders (4) by two Angle Brackets (30) and to a similar Girder by a $2\frac{1}{2}'' \times \frac{1}{2}''$ Double Angle Strip (31). The Double Angle Strip is connected to the base by a $\frac{1}{2}''$ Reversed Angle Bracket.

A $\frac{1}{2}''$ Pinion on the Motor driving shaft drives a 57-tooth Gear (32) on a $2''$ Rod, which is mounted in the Motor side-plates and is held in place by a $\frac{1}{2}''$ Flanged Wheel (Fig. 7.19c). The Gear (32) is spaced from the Motor by a $\frac{1}{2}''$ loose Pulley, and a Fishplate is bolted tightly to the Gear but is spaced from it by a Collar on a $\frac{1}{2}''$ Bolt. Two $5\frac{1}{2}''$ Strips (33) placed face to face are lock-nutted to the Fishplate by a second $\frac{1}{2}''$ Bolt, and the upper ends of these Strips support a $\frac{3}{4}''$ Reversed Angle Bracket (34). A $1\frac{1}{2}''$ Rod is held in the Strips and the Reversed Angle Brackets by a $\frac{1}{2}''$ and a $1''$ fixed Pulley, and one end of a $5\frac{1}{2}''$ Strip (35) is pivoted on the Rod.

A Bush Wheel is bolted to Strip (35) so that the boss of the Bush Wheel coincides with the fourth hole from the top end of the Strip. The Bush Wheel is fixed on a $\frac{1}{2}''$ Rod (36), which is held by $\frac{1}{2}''$ Flanged Wheels in the sides of the column. The bearings for the Rod are strengthened by Wheel Discs bolted to the sides. A $\frac{1}{2}''$ Reversed Angle Bracket (37) is lock-nutted to the end of the Strip (35), and is lock-nutted also to the tool carriage by a bolt (38) and nuts.

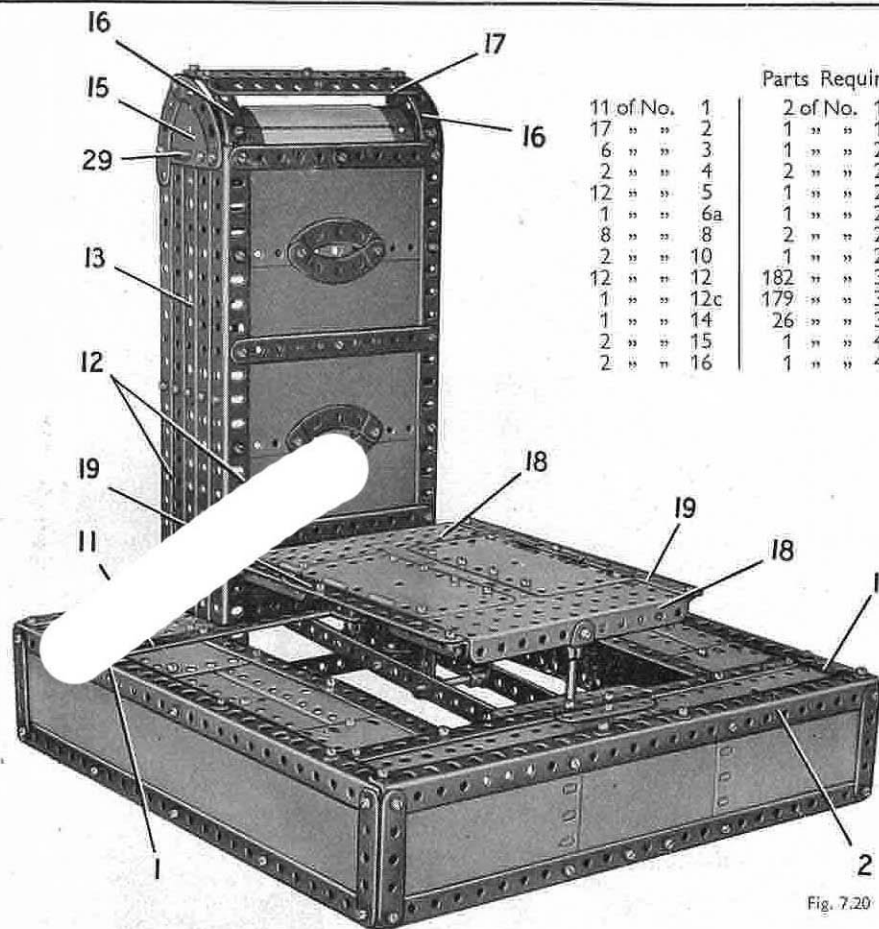

Fig. 7.20

Parts Required

11 of No. 1	2 of No. 17	2 of No. 48
17 " " 2	1 " " 18a	6 " " 48a
6 " " 3	1 " " 20a	2 " " 52
2 " " 4	2 " " 22	3 " " 53
12 " " 5	1 " " 23a	6 " " 59
1 " " 6a	1 " " 24	2 " " 62
8 " " 8	2 " " 26	1 " " 63
2 " " 10	1 " " 27a	2 " " 90
12 " " 12	182 " " 37a	6 " " 90a
1 " " 12c	179 " " 37b	1 " " 111a
1 " " 14	26 " " 38	1 " " 111c
2 " " 15	1 " " 40	1 " " 116
2 " " 16	1 " " 43	2 " " 126
		2 " " 126a
		1 " " 162
		1 " " 186a
		1 " " 188
		6 " " 189
		4 " " 190
		2 " " 191
		6 " " 192
		2 " " 197
		1 " " 198
		2 " " 214
		2 " " 215

A Semi-Circular Plate (15) is bolted to each side of the column, and these are edged by $2\frac{1}{2}$ " Stepped Curved Strips and $2\frac{1}{2}$ " Curved Strips. A Formed Slotted Strip (16) is attached to each of the Angle Girders at the front of the column and is connected by an Angle Bracket to the Curved Strips at the side. Two $5\frac{1}{2}$ " Strips, with a third Strip (17) attached to one of them by an Obtuse Angle Bracket, are bolted to the upper slotted holes in the Formed Slotted Strips.

7.20 AUTOMATIC SCALES

BUILDING THE BASE

Each side of the base is formed by a $12\frac{1}{2}$ " x $2\frac{1}{2}$ " Strip Plate edged by a $12\frac{1}{2}$ " Angle Girder (1) (Fig. 7.20), a $12\frac{1}{2}$ " Strip and two $2\frac{1}{2}$ " Strips. The front of the base consists of two $4\frac{1}{2}$ " x $2\frac{1}{2}$ " Flexible Plates and a $5\frac{1}{2}$ " x $2\frac{1}{2}$ " Flexible Plate bolted to a $12\frac{1}{2}$ " Angle Girder (2), a $12\frac{1}{2}$ " Strip and two $2\frac{1}{2}$ " Strips. The Angle Girders (1) and (2) are bolted together as shown, and the front and sides are connected at their lower corners by Angle Brackets. At the rear of the base a $12\frac{1}{2}$ " Angle Girder (3) is attached to Angle Brackets bolted to the sides.

The top of the base is partly filled in as shown in Fig. 7.20a. At the front two $5\frac{1}{2}$ " x $1\frac{1}{2}$ " Flexible Plates and a $3\frac{1}{2}$ " x $2\frac{1}{2}$ " Flanged Plate (4) are fixed to the Girder (2), and a $12\frac{1}{2}$ " Strip (5) is bolted between the Girders (1) along the edges of the Flexible Plates. To each side of the top are bolted two $2\frac{1}{2}$ " x $2\frac{1}{2}$ " Flexible Plates (6), two $5\frac{1}{2}$ " x $1\frac{1}{2}$ " Flexible Plates (7) and a $3\frac{1}{2}$ " x $2\frac{1}{2}$ " Flanged Plate (8). These Plates are supported by two built-up strips (9), two 3" Strips (10) and a $12\frac{1}{2}$ " Strip (11), arranged as shown. The Strips (9) are each made from two $5\frac{1}{2}$ " Strips.

THE COLUMN

Each side of the column is formed by two $12\frac{1}{2}$ " Angle Girders (12) (Fig. 7.20), two $12\frac{1}{2}$ " Strips and a built-up strip (13). These are connected at the centre by a $2\frac{1}{2}$ " Strip, and at their lower ends two of the Girders (12) are bolted to the Girder (3). The Strips and Girders of the sides are fixed to the flanges of the Flanged Plates (8) and a $5\frac{1}{2}$ " Strip (14) is bolted to the rear between two of the Girders (12). The front of the column is filled in by five $5\frac{1}{2}$ " x $2\frac{1}{2}$ " Flexible Plates, strengthened as shown by three $5\frac{1}{2}$ " Strips.

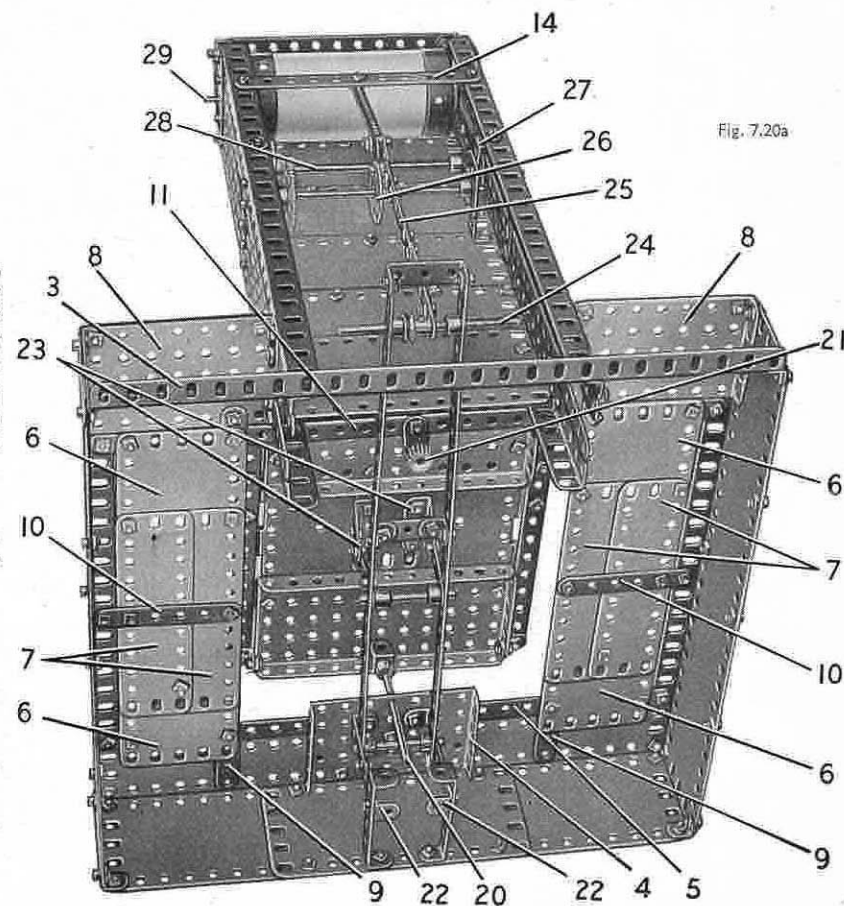

Fig. 7.20a

THE PLATFORM, OPERATING LEVER AND INDICATING MECHANISM

The platform consists of two $5\frac{1}{2}$ " x $2\frac{1}{2}$ " Flanged Plates (18) (Fig. 7.20), connected by two built-up strips (19), each of which consists of a $5\frac{1}{2}$ " and a $3\frac{1}{2}$ " Strip overlapped three holes. The strips are connected to the end flanges of the Plates (18) by Angle Brackets. The centre of the platform is filled in by the separated halves of a Hinged Flat Plate bolted one on each side of a $2\frac{1}{2}$ " x $1\frac{1}{2}$ " Flexible Plate.

A large Fork Piece is bolted to the side of one of the Flanged Plates (18), and a Coupling is secured to the other Flanged Plate by a bolt passed through the side flange into one of the threaded holes in the Coupling. A $3\frac{1}{2}$ " Rod (20) is fixed in the Fork Piece and a 2" Rod is held in the Coupling. The Rod (20) is passed through a hole in the Flanged Plate (4). The 2" Rod is passed through a Fishplate bolted to the centre of the Strip (11), and it carries at its lower end a $\frac{1}{2}$ " Pinion (21).

The bearings for the platform lever are provided by two $2\frac{1}{2}$ " x $\frac{1}{2}$ " Double Angle Strips (22) bolted below the Flanged Plate (4) and attached to two similar Double Angle Strips secured to the front of the base. The lever is made by connecting two $12\frac{1}{2}$ " Strips at each end by a $1\frac{1}{2}$ " x $\frac{1}{2}$ " Double Angle Strip. The lever pivots on a 2" Rod passed through the next-to-end holes of the Strips and the next-to-top holes of the Double Angle Strips (22). The Rod is held in place by Collars. Two Trunnions (23), each fitted with a $2\frac{1}{2}$ " Strip, are bolted underneath the platform. A Crank is attached to one of the $2\frac{1}{2}$ " Strips, and is fixed on a 2" Rod supported in the lever as shown in Fig. 7.20a. The Rod passes through the second $2\frac{1}{2}$ " Strip and a Collar is placed on the Rod against the Strip.

A $3\frac{1}{2}$ " Rod (24) is supported in the third holes from the end of the lever. This Rod is held in position by a Collar and a $\frac{1}{2}$ " fixed Pulley, and it carries a Crank bolted to a built-up strip (25). The strip consists of two $3\frac{1}{2}$ " Strips overlapped two holes, and a $2\frac{1}{2}$ " Strip that overlaps one of the $3\frac{1}{2}$ " Strips by three holes. At its upper end the strip (25) is lock-nutted by a $\frac{1}{2}$ " Bolt to a Fishplate bolted tightly to a Bush Wheel (26). A Spring is held by the same Bolt, and is bolted also to the centre of the Strip (14).

The Bush Wheel is fixed on a 5" Rod mounted in two $2\frac{1}{2}$ " x $\frac{1}{2}$ " Double Angle Strips, one of which is seen at (27), bolted between the Girders (12) at each side of the column. A Flat Trunnion is secured to each Double Angle Strip. The 5" Rod carries a 57-tooth Gear, and this drives a $\frac{1}{2}$ " Pinion on a second 5" Rod (28), which is supported in the holes at the pointed ends of the Flat Trunnions. Collars are used to hold the 5" Rods in place, and the Rod (28) is fitted with a 1" Pulley placed on the outside of one of the Flat Trunnions. This Pulley is connected by a Driving Band to a similar Pulley on a 6 $\frac{1}{2}$ " Rod (29). A Boiler is placed on this Rod between the 1" Pulley and a 2" Pulley that is bolted to one of the Boiler Ends.

A sheet of paper is wrapped round the Boiler, and can be calibrated to form the indicating dial. The markings on the dial are read off against a fixed Indicator, formed by a length of Cord attached by bolts to the Formed Slotted Strips (16).

7.21 SHIPYARD CRANE

Parts Required

12 of No.	1	4 of No.	18a	31 of No.	38	2 of No.	111a	6 of No.	188
18 "	2	1 "	18b	1 "	40	3 "	111c	6 "	189
6 "	3	2 "	19b	1 "	44	1 "	115	2 "	190
2 "	4	1 "	19g	1 "	45	4 "	125	5 "	192
12 "	5	1 "	19h	1 "	46	2 "	126	2 "	214
3 "	6a	1 "	20b	2 "	48	4 "	126a	4 "	221
8 "	8	5 "	22	10 "	48a	1 "	147b		
3 "	10	2 "	22a	2 "	48b	1 "	162		
2 "	11	1 "	23	1 "	51	2 "	176		
18 "	12	1 "	24	2 "	52				
4 "	12a	1 "	24c	3 "	53				
8 "	12c	1 "	27a	2 "	54				
1 "	13	1 "	32	1 "	57c				
1 "	14	3 "	35	1 "	63				
1 "	15a	195 "	37a	2 "	90				
1 "	15b	174 "	37b	2 "	111				

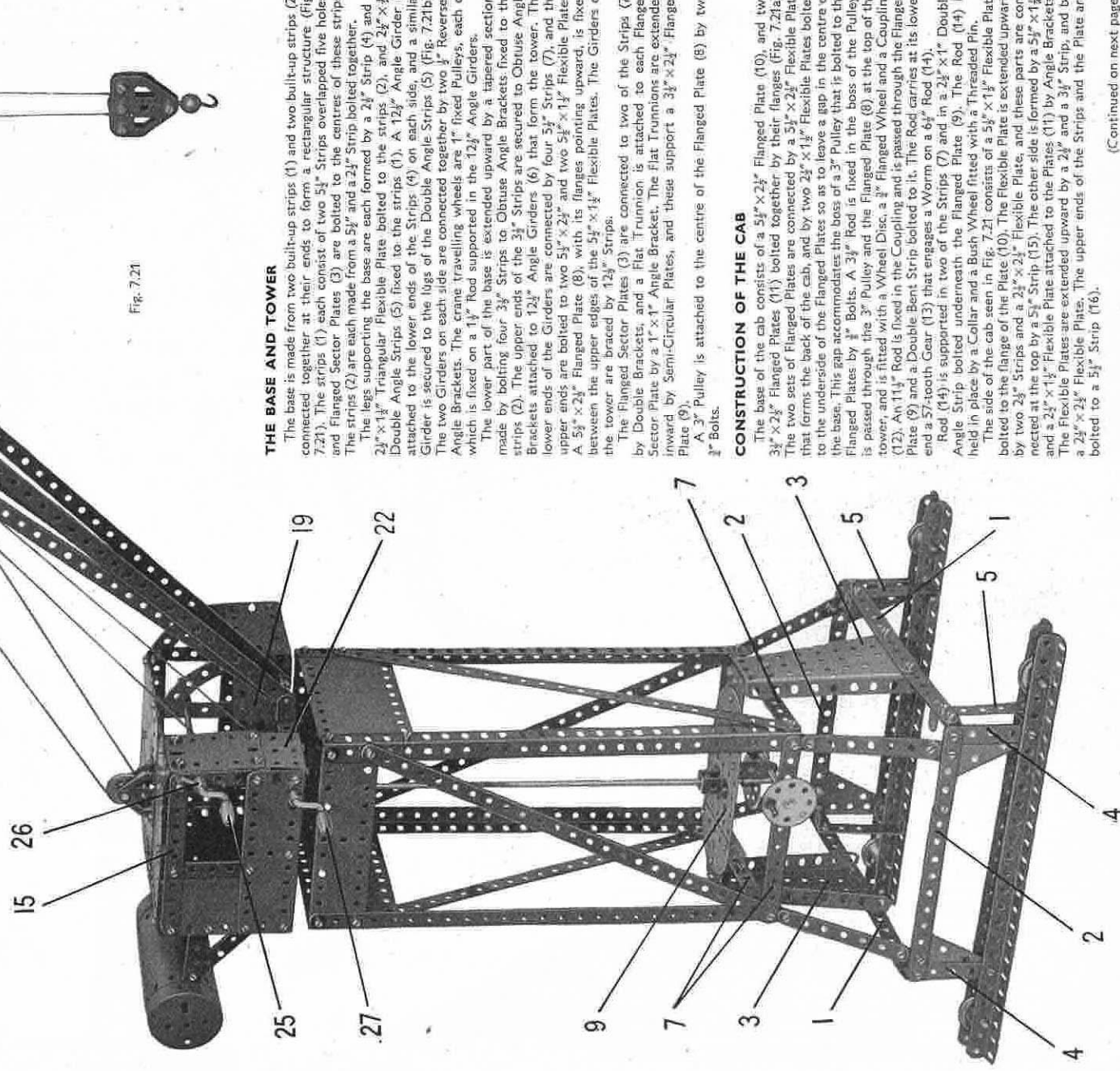

Fig. 7.21

THE BASE AND TOWER

The base is made from two built-up strips (1) and two built-up strips (2) connected together at their ends to form a rectangular structure (Fig. 7.21). The strips (1) each consist of two 5½" Strips overlapped five holes, and Flanged Sector Plates (3) are bolted to the centres of these strips. The strips (2) are each made from a 5½" and a 2½" Strip bolted together.

The legs supporting the base are each formed by a 2½" Strip (4) and a 2½" x 1½" Triangular Flexible Plate bolted to the strips (2), and 2½" x ½" Double Angle Strips (5) fixed to the strips (1). A 12½" Angle Girder is attached to the lower ends of the Strips (4) on each side, and a similar Girder is secured to the lugs of the Double Angle Strips (5) (Fig. 7.21b). The two Girders on each side are connected together by two ½" Reversed Angle Brackets. The crane travelling wheels are 1" fixed Pulleys, each of which is fixed on a 1½" Rod supported in the 12½" Angle Girders.

The lower part of the base is extended upward by a tapered section, made by bolting four 3½" Strips to Obtuse Angle Brackets fixed to the strips (2). The upper ends of the 3½" Strips are secured to Obtuse Angle Brackets attached to 12½" Angle Girders (6) that form the tower. The lower ends of the Girders are connected by four 5½" Strips (7), and the upper ends are bolted to two 5½" x 2½" and two 5½" x 1½" Flexible Plates. A 5½" x 2½" Flanged Plate (8), with its flanges pointing upward, is fixed between the upper edges of the 5½" x 1½" Flexible Plates. The Girders of the tower are braced by 12½" Strips.

The Flanged Sector Plates (3) are connected to two of the Strips (7) by Double Brackets, and a Flat Trunnion is attached to each Flanged Sector Plate by a 1" x 1" Angle Bracket. The Flat Trunnions are extended inward by Semi-Circular Plates, and these support a 3½" x 2½" Flanged Plate (9).

A 3" Pulley is attached to the centre of the Flanged Plate (8) by two 1" Bolts.

CONSTRUCTION OF THE CAB

The base of the cab consists of a 5½" x 2½" Flanged Plate (10), and two 3½" x 2½" Flanged Plates (11) bolted together by their flanges (Fig. 7.21a). The two sets of Flanged Plates are connected by a 5½" x 2½" Flexible Plate that forms the back of the cab, and by two 2½" x 1½" Flexible Plates bolted to the underside of the Flanged Plates so as to leave a gap in the centre of the base. This gap accommodates the boss of a 3" Pulley that is bolted to the Flanged Plates by ½" Bolts. A 3½" Rod is fixed in the boss of the Pulley, is passed through the 3" Pulley and the Flanged Plate (8) at the top of the tower, and is fitted with a Wheel Disc, a ½" Flanged Wheel and a Coupling (12). An 11½" Rod is fixed in Fig. 7.21 consists of a 5½" x 1½" Flexible Plate bolted to the strips of the Plate (10). The Flexible Plate is extended upward by two 2½" Strips and a 2½" x 2½" Flexible Plate, and these parts are connected at the top by a 5½" Strip (15). The other side is formed by a 5½" x 1½" and a 2½" x 1½" Flexible Plate attached to the Plates (11) by Angle Brackets. The Flexible Plates are extended upward by a 2½" and a 3½" Strip, and by a 2½" x 2½" Flexible Plate. The upper ends of the Strips and the Plate are bolted to a 5½" Strip (16).

Rod (14) is supported in two of the Strips (7) and in a 2½" x 1" Double Angle Strip bolted underneath the Flanged Plate (9). The Rod (14) is held in place by a Collar and a Bush Wheel fitted with a Threaded Pin.

(Continued on next page)

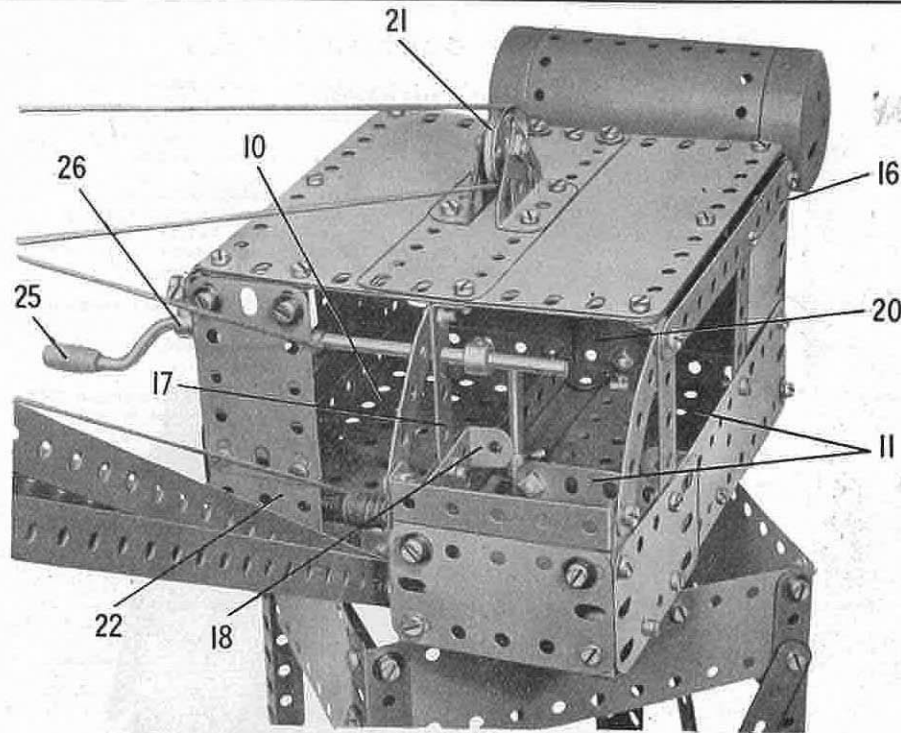

Fig. 7.21a

The front of the cab is completed by a $2\frac{1}{2}'' \times 1\frac{1}{2}''$ Flanged Plate (22) and a $2\frac{3}{4}'' \times 1\frac{1}{4}''$ Flexible Plate. These are fixed to the Flanged Plate (10) and to Angle Brackets bolted to the roof.

A balance weight at the rear of the cab is represented by a Boiler. This is bolted to a structure formed by three $2\frac{1}{2}'' \times \frac{1}{2}''$ Double Angle Strips and two built-up $3\frac{1}{2}''$ strips, each made from two $2\frac{1}{2}''$ Strips.

THE JIB

The jib is made from eight $12\frac{1}{2}''$ Strips, connected at the centre as shown by two $1\frac{1}{2}''$ Strips and two $1\frac{1}{2}'' \times \frac{1}{2}''$ Double Angle Strips. At its lower end the jib pivots on a $4''$ Rod, which is supported in two $1'' \times 1''$ Angle Brackets bolted to the front of the Flanged Plate (10). The Rod passes through the sides of the control cabin, and the Strips of the jib are held on the Rod between the two Angle Brackets. The pairs of Strips are spaced apart by two Collars, and are spaced from the Angle Bracket nearest to the control cabin by a Spring Clip.

At the upper end of the jib a $1''$ Pulley (23) is freely mounted on a $1''$ Rod, which is held in the $12\frac{1}{2}''$ Strips by Spring Clips. A $1''$ loose Pulley (24) is mounted on a Pivot Bolt held by its nuts in a Stepped Bent Strip. The Stepped Bent Strip is bolted to one of the Double Angle Strips at the centre of the jib.

THE OPERATING CORDS AND MECHANISM

The jib is luffed, or raised and lowered, by turning a $5''$ Crank Handle (25) supported in the side of the cab and the Double Angle Strip (17) (Fig. 7.21a). The Crank Handle is held in position by Collars, but it is allowed to slide lengthways about $\frac{1}{2}''$ in its bearings.

When the Crank Handle is pushed in a $\frac{1}{2}''$ Bolt in the Collar (26) engages a similar Bolt in the side of the cab and forms a simple brake. A length of Cord tied to the Crank Handle is taken round the Pulley (24) and the Pulley (21), and is fastened finally to the centre of the jib.

The load hook is operated by a length of Cord tied to a $3\frac{1}{2}''$ Crank Handle (27). This is mounted in the flanges of the Flanged Plate (10) and is held in place by Collars. The Cord is passed over the $1''$ Pulley (23), then through a Fishplate (28), round a $\frac{1}{2}''$ loose Pulley in the pulley block and is tied near its end to the Fishplate (28). The end of the Cord is then attached to the top of the jib. The purpose of the Fishplate is to reduce the tendency for the Cord to twist when the pulley block is fully lowered.

The pulley block consists of two Flat Trunnions spaced apart by nuts on $\frac{1}{2}''$ Bolts. One of these Bolts supports a small Loaded Hook, and the $\frac{1}{2}''$ loose Pulley is freely mounted on a $\frac{1}{2}''$ Bolt.

MODEL 7.21 SHIPYARD CRANE — Continued

The control cabin is made by fixing a $3\frac{1}{2}'' \times \frac{1}{2}''$ Double Angle Strip (17) to the base (Fig. 7.21a). A $2\frac{1}{2}'' \times \frac{1}{2}''$ Double Angle Strip (18) and a $2\frac{1}{2}'' \times 1\frac{1}{4}''$ Flexible Plate (19) are bolted to the Double Angle Strip (17) to form one side of the cabin. The cabin front is a further $2\frac{3}{4}'' \times 1\frac{1}{4}''$ Flexible Plate, which is fixed to the flange of one of the Plates (11), to a lug of the Double Angle Strip (18), and to an Angle Bracket secured to the side of the cabin. The window frames are represented by $2\frac{1}{2}''$ Curved Strips fixed to the Strip (16) and the Double Angle Strip (17), and attached at their lower ends to Fishplates bolted to the sides of the cabin.

The sides are connected to the back of the cab by Angle Brackets.

The $5\frac{1}{2}'' \times 2\frac{1}{2}''$ Flexible Plate forming the lower part of the back is extended upward by a $5\frac{1}{2}'' \times 1\frac{1}{2}''$ Flexible Plate, and the back is braced by a $3\frac{1}{2}'' \times \frac{1}{2}''$ Double Angle Strip (20). The cab roof consists of a $5\frac{1}{2}'' \times 1\frac{1}{2}''$ and two $5\frac{1}{2}'' \times 2\frac{1}{2}''$ Flexible Plates edged by $5\frac{1}{2}''$ Strips. The roof is connected to the sides by Angle Brackets, and is attached to the lugs of the Double Angle Strips (17) and (20). A $1''$ loose Pulley (21) is freely mounted on a $\frac{1}{2}''$ Bolt that is supported in two Trunnions bolted to the roof (Fig. 7.21a).

PRIZES FOR NEW MODELS

Model-Building Competitions, in which fine Cash Prizes are offered for new and original Meccano models, are announced in the "MECCANO MAGAZINE," which is published monthly.

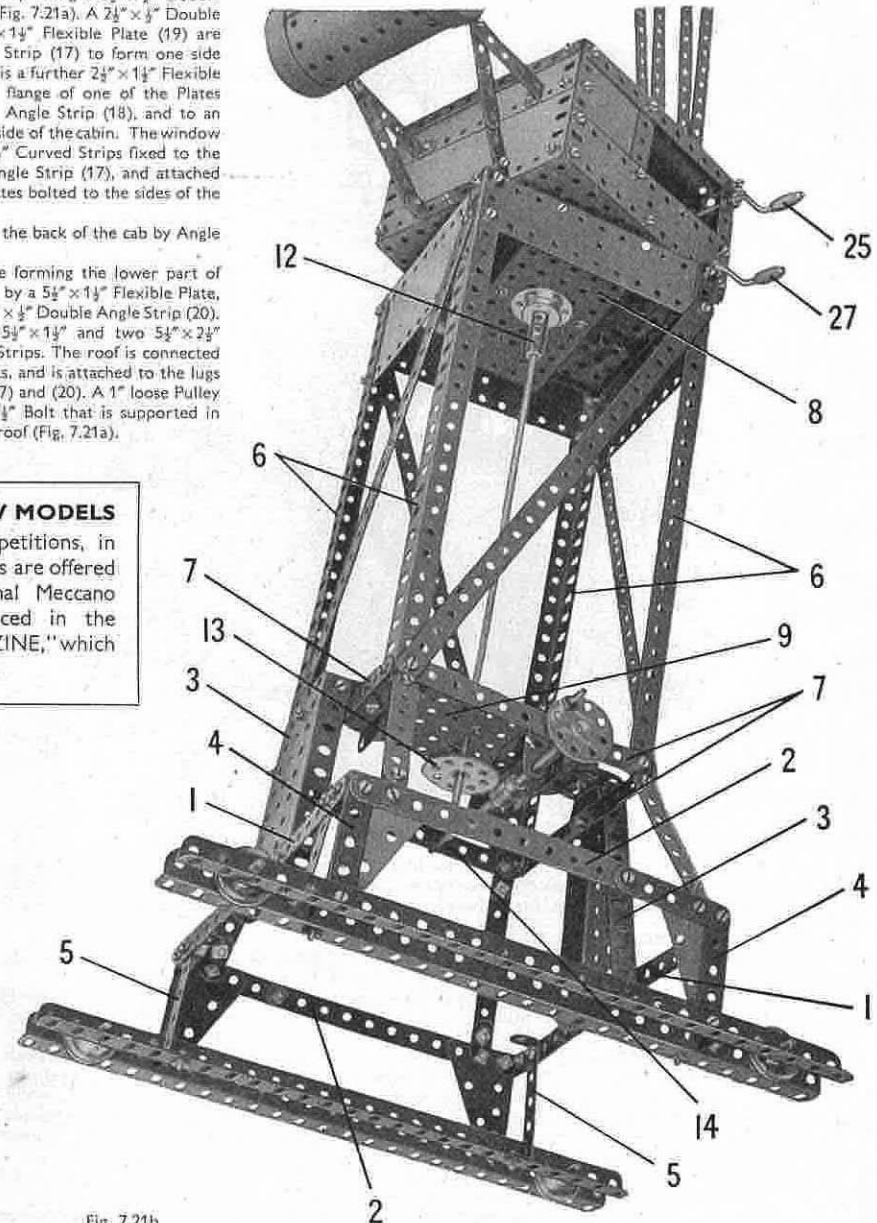

Fig. 7.21b

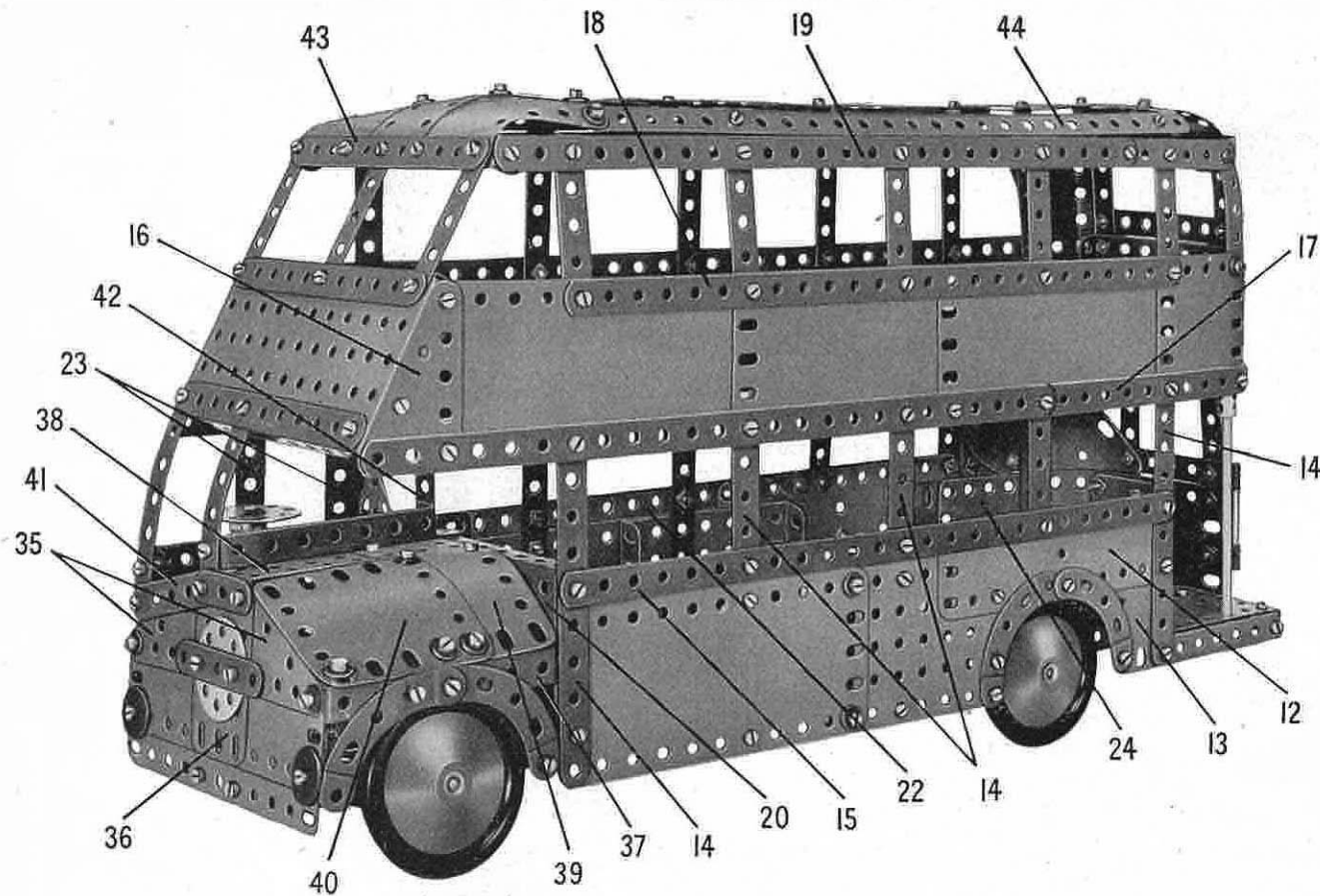

Fig. 7.22

The steering column is a 4" Rod freely mounted in the boss of a Crank (8) that is bolted to the chassis and to a Flat Trunnion (9). The Rod is held in position by a Collar and a Crank (10), which is spaced from the Crank (8) by four Washers. A Rod and Strip Connector fitted with a 3½" Rod is *lock-nutted* to Crank (10), and a second Rod and Strip Connector (11) is placed on the other end of the Rod. The Rod and Strip Connector (11) is *pivotaly* connected to one of the Collars (7) by a bolt.

THE SIDES OF THE BODY

The lower part of the side seen in Fig. 7.22 consists of a 5½" × 2½" Flexible Plate, a 3½" × 2½" Flanged Plate, a 5½" × 1½" Flexible Plate (12) and a 2½" × 1½" Flexible Plate (13). These Plates are attached to four 5½" Strips (14) bolted to a 12½" Strip (15).

The panelling of the upper deck consists of a 2½" × 1½" Triangular Flexible Plate (16), two 5½" × 2½" Flexible Plates, a 4½" × 2½" Flexible Plate and a 2½" × 2½" Flexible Plate. These Plates are attached to a built-up strip (17) made from a 12½" Strip and a 5½" Strip, which is fixed to the Strips (14). The upper edges of the Flexible Plates are strengthened by a 12½" Strip (18).

A built-up strip (19), made from a 12½" and a 5½" Strip overlapped six holes, is connected to the Strip (18) by a 5½" Strip and four 2½" × ½" Double Angle Strips. The side is bolted to a 5½" × 2½" Flanged Plate (20) and is connected by an Angle Bracket to a 5½" Strip (21) fixed across the chassis.

The other side of the bus is similar in general design to the one already described, but the panelling of the lower deck is extended at the front and the rear. The Strip (15) is replaced by a built-up strip (22), made from two 12½" Strips overlapped 14 holes, which overhangs the Flanged Plate (20) by seven clear holes at the front. Two 12½" Strips overlapped 20 holes are substituted for the strip (19). The strip (22) is connected to the strip corresponding to the strip (17) by two 2½" Strips (23). A 5½" × 1½" Flexible Plate is bolted to the front end of the strip (22) to form the side of the driver's cabin.

The arch over the wheel is made from two 2½" Stepped Curved Strips bolted together and to the Flexible Plate. The front end of the arch is connected to the Flexible Plate by a 1½" Strip, and the rear end is joined to the lower deck panelling by a Fishplate.

The panelling at the rear of the lower deck is extended by a 2½" × 2½" Flexible Plate (24) (Fig. 7.22c), and two Semi-Circular Plates bolted together are fixed to the strip (22) at its rear end.

7.22 DOUBLE-DECK BUS

CHASSIS AND STEERING MECHANISM

The chassis consists of two built-up girders, each made from two 12½" Angle Girders overlapped 12 holes. The girders are connected at the front and rear by two 2½" × ½" Double Angle Strips (1) and (2) (Fig. 7.22c). The rear wheels are fixed on a 5" Rod that is held in the chassis girders by 1" Pulleys.

Each of the front wheels is fixed on a 1½" Rod that is held by a Collar in a Double Bracket (3) (Fig. 7.22b). A 1½" Strip (4) is placed between the lugs of the Double Bracket and a ¾" Bolt is then passed through the two parts. The ¾" Bolt is fixed by two nuts to a 1" × 1" Angle Bracket (5), leaving the Double Bracket (3) and the Strip (4) free to swivel as a unit. The Angle Brackets (5) are bolted to the chassis girders, and they are strengthened by ½" × ½" Angle Brackets (6).

A bolt is passed through the end hole of each of the Strips (4) and is fitted with a Washer and a nut. A Collar (7) is then screwed on to the bolt and the nut is tightened against it to fix the Collar firmly on the bolt. A 4½" Rod is gripped in the Collars (7) and connects the Strips (4) together.

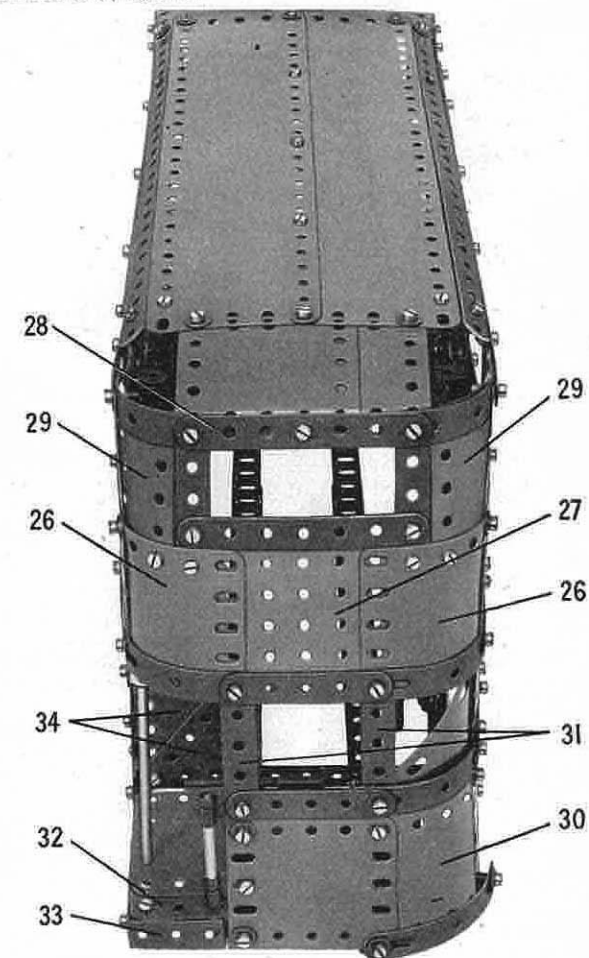

Fig. 7.22a

(Continued on next page)

MODEL 7.22 DOUBLE-DECK BUS — Continued

REAR PANNELLING AND THE ENTRANCE

The upper-deck panelling is extended on each side by a $1\frac{1}{2}$ " radius Curved Plate (26) fitted along its lower edge with a Formed Slotted Strip, and bolted to a $3\frac{1}{2}$ " x $2\frac{1}{2}$ " Flanged Plate (27) (Fig. 7.22a). The strips (19) are extended by Formed Slotted Strips connected by a $3\frac{1}{2}$ " Strip (28), and this is joined to the Flanged Plate (27) by two $2\frac{1}{2}$ " Strips. A $2\frac{1}{2}$ " x $1\frac{1}{2}$ " Flexible Plate (29) edged by a $2\frac{1}{2}$ " Curved Strip is fixed to each side as shown.

The lower-deck panelling on one side is extended by a curved $2\frac{1}{2}$ " x $2\frac{1}{2}$ " Flexible Plate (30), and a curved $2\frac{1}{2}$ " x $2\frac{1}{2}$ " Triangular Flexible Plate edged by a Formed Slotted Strip. The Plate (30) is bolted to a $2\frac{1}{2}$ " x $2\frac{1}{2}$ " Flexible Plate fixed to the Double Angle Strip (2), and the rear window consists of two $3\frac{1}{2}$ " Strips (31) and two $2\frac{1}{2}$ " Strips. A bumper at the lower edge of the Plate (30) is provided by a Formed Slotted Strip that is spaced from the Plate by Spring Clips on $\frac{1}{2}$ " Bolts.

The floor inside the entrance is formed by one half of a Hinged Flat Plate, and a $2\frac{1}{2}$ " x $2\frac{1}{2}$ " Triangular Flexible Plate (32) bolted across the chassis. These Plates are edged by a $3\frac{1}{2}$ " Strip and a $1\frac{1}{2}$ " x $\frac{1}{2}$ " Double Angle Strip (33) that is fixed to the end of one of the chassis girders. Two $2\frac{1}{2}$ " x $2\frac{1}{2}$ " Triangular Flexible Plates (34) are bolted together and are attached to one side of the body by a $1\frac{1}{2}$ " x $1\frac{1}{2}$ " Angle Bracket.

The centre handrail is a $4\frac{1}{2}$ " Rod gripped in a Coupling that is held by a bolt in the end hole of the strip (17). The handrail at the rear of the entrance is a 2" Rod held in Right-Angle Rod and Strip Connectors.

THE BONNET, RADIATOR, AND FRONT OF THE UPPER DECK

The radiator consists of two $5\frac{1}{2}$ " x $1\frac{1}{2}$ " Flexible Plates overlapped by two holes lengthways, two $2\frac{1}{2}$ " x $1\frac{1}{2}$ " Triangular Flexible Plates (35), and a $2\frac{1}{2}$ " x $1\frac{1}{2}$ " Flexible Plate (36) (Fig. 7.22). It is fixed to the Double Angle Strip (1) and is attached to one side of the model by an Angle Bracket. It is connected to the Flanged Plate (20) by a $3\frac{1}{2}$ " x $\frac{1}{2}$ " Double Angle Strip (37).

The top of the bonnet is formed by a $2\frac{1}{2}$ " x $1\frac{1}{2}$ " Flanged Plate (38), a $5\frac{1}{2}$ " x $1\frac{1}{2}$ " Flexible Plate (39) and a $2\frac{1}{2}$ " x $2\frac{1}{2}$ " Flexible Plate (40). The Flanged Plate is bolted to the top of the Flexible Plate (36), and the Flexible Plates are attached to the Flanged Plate (20) and the Double Angle Strip (37) by Angle Brackets and Obtuse Angle Brackets. The driver's seat is made from two Trunnions bolted to the inner end of the Flexible Plate (39).

The windscreen of the driver's cab consists of a $3\frac{1}{2}$ " and a 3" Strip bolted at their lower ends to a $2\frac{1}{2}$ " Strip (41). The $3\frac{1}{2}$ " Strip is connected by an Angle Bracket to the front end of the side, and a $3\frac{1}{2}$ " x $\frac{1}{2}$ " Double Angle Strip is bolted between the 3" Strip and a $1\frac{1}{2}$ " x $\frac{1}{2}$ " Double Angle Strip (42).

The upper ends of the $3\frac{1}{2}$ " and the 3" Strips are fixed to a $5\frac{1}{2}$ " x $2\frac{1}{2}$ " Flanged Plate bolted to the Triangular Flexible Plates (16). The front windows of the upper deck are formed by three $2\frac{1}{2}$ " Strips attached to the Flanged Plate and to a $5\frac{1}{2}$ " Strip (43) that is connected to the strips (19) by Angle Brackets (Fig. 7.22).

DETAILS OF THE ROOF

The front end of the roof is made by bolting two opened-out 'U'-section Curved Plates and a curved $2\frac{1}{2}$ " x $1\frac{1}{2}$ " Flexible Plate to the Strip (43). The rear end consists of two curved $2\frac{1}{2}$ " x $2\frac{1}{2}$ " Flexible Plates fixed to the Strip (28). Two $12\frac{1}{2}$ " x $2\frac{1}{2}$ " Strip Plates are bolted between the Plates at the front and the rear to fill in the centre of the roof. A $12\frac{1}{2}$ " Strip (44) (Fig. 7.22) is attached to each side of the body by Obtuse Angle Brackets, and is connected to one of the Strip Plates by a further Obtuse Angle Bracket.

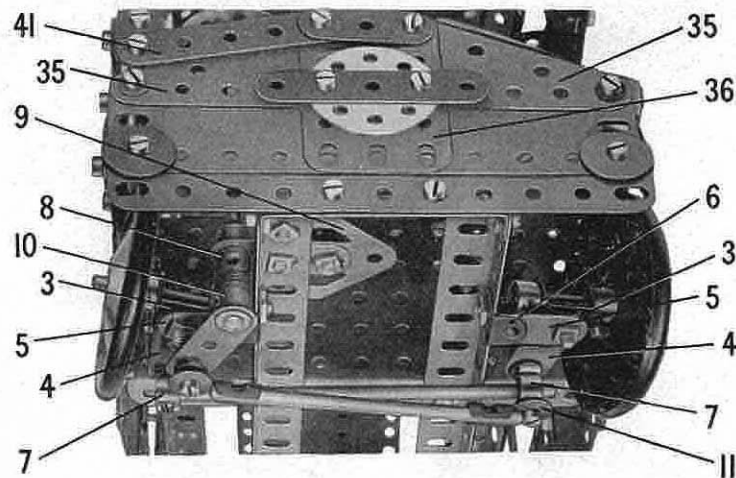

Fig. 7.22b

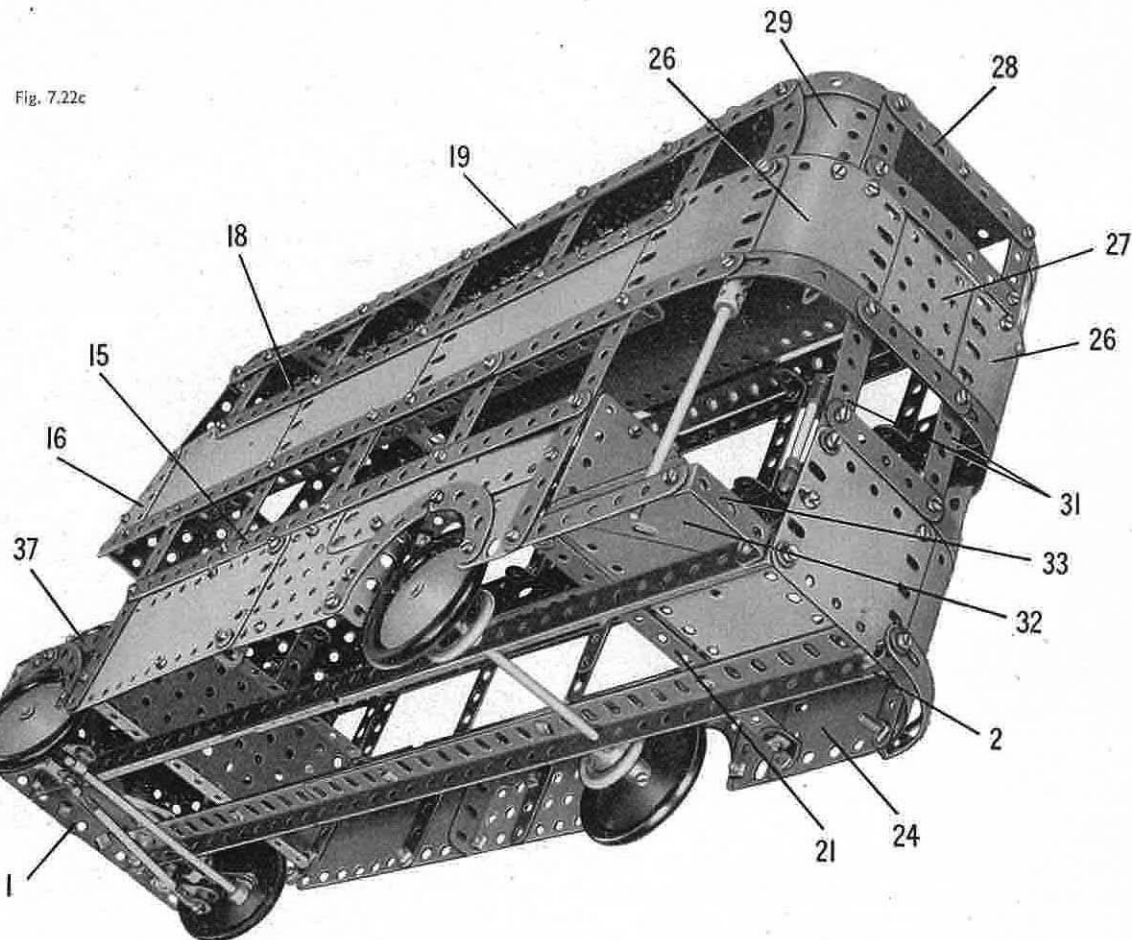

Fig. 7.22c

Parts Required

12 of No. 1	3 of No. 12a	1 of No. 24a	2 of No. 52	2 of No. 126	1 of No. 198
18 " " 2	7 " " 12c	2 " " 35	3 " " 53	1 " " 126a	2 " " 199
6 " " 3	1 " " 15	202 " " 37a	5 " " 59	2 " " 155	2 " " 200
2 " " 4	2 " " 15a	186 " " 37b	2 " " 62	4 " " 187	2 " " 212
12 " " 5	1 " " 15b	34 " " 38	1 " " 63	6 " " 188	2 " " 212a
4 " " 6a	1 " " 16	2 " " 38d	2 " " 90	6 " " 189	2 " " 214
6 " " 8	1 " " 17	2 " " 48	8 " " 90a	8 " " 190	6 " " 215
2 " " 10	2 " " 18a	10 " " 48a	2 " " 111	2 " " 191	4 " " 221
2 " " 11	2 " " 22	2 " " 48b	1 " " 111a	6 " " 192	2 " " 222
11 " " 12	1 " " 24	1 " " 51	5 " " 111c	2 " " 197	2 " " 223

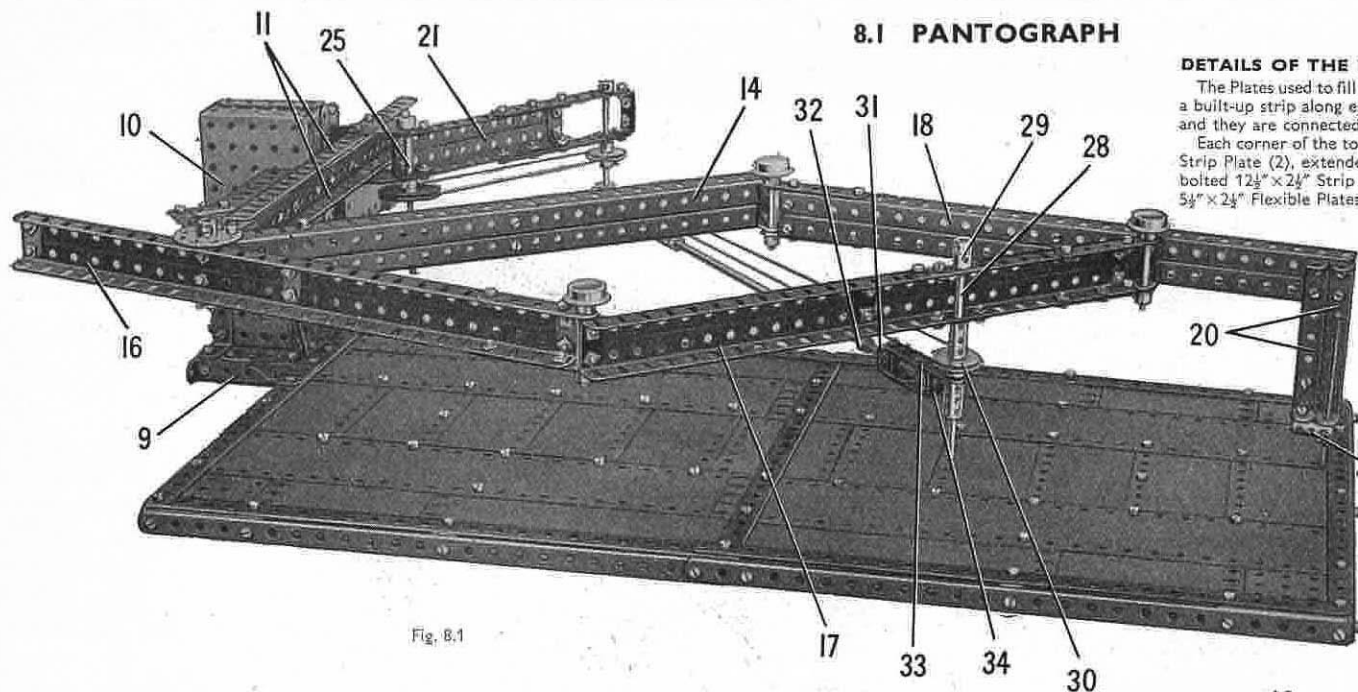

Fig. 8.1

8.1 PANTOGRAPH

The link (16) is extended one clear hole at one end by two $2\frac{1}{2}$ " Strips, and a 2" Rod is passed through these holes and through two Angle Brackets bolted to one end of the link (17). The Rod is held in place by a Collar and a $\frac{3}{8}$ " Flanged Wheel. At its other end the link (17) is fitted with two $2\frac{1}{2}$ " Strips that overhang the link by one hole. A 2" Rod is supported in the end holes of these Strips and is passed through Angle Brackets bolted to the ninth holes from one end of the link (18). This Rod also is held in position by a Collar and a $\frac{3}{8}$ " Flanged Wheel. At its inner end the link (18) is fitted with two $2\frac{1}{2}$ " Strips, each of which overhangs the link by one hole. A 2" Rod is held in the Strips by a $\frac{3}{8}$ " Flanged Wheel and a Collar, and is passed through two Angle Brackets bolted to the end of the link (14).

The tracing tool at the end of link (18) is a Screwed Rod held by a nut in a Coupling (19). This Coupling is attached by a Bolt to the lower lug of one of two $3\frac{1}{2}$ " x $\frac{1}{2}$ " Double Angle Strips (20), which are bolted to the link and connected by a Fishplate.

DRIVING MECHANISM

A pivoted arm (21) is made from two $5\frac{1}{2}$ " Angle Girders connected by Fishplates, and extended at one end by four $4\frac{1}{2}$ " Strips (22) placed face to face and bolted to the Girders. The outer ends of the Strips (22) are connected by two $1"$ x $1"$ Angle Brackets. A 4" Rod is mounted in the Strips (22) and is fitted with a $1"$ Pulley (23) and a $\frac{1}{2}"$ Pulley (24). The Rod is held in place by Collars.

The arm (21) is pivoted on a 4" Rod (25), which is located in the slotted holes of the $5\frac{1}{2}"$ Angle Girders by Fishplates. The Rod (25) is mounted in Flat Trunnions spaced from the Girders (11) by a Washer on each of the bolts. The Rod is held in place by a Collar and a $1\frac{1}{2}"$ Pulley (26), and it carries a second $1\frac{1}{2}"$ Pulley (27).

The cutting tool is represented by a 5" Rod (28), freely mounted in a Crank (29) and a $1\frac{1}{2}"$ Strip bolted to the Girders of the link (17). The Rod is held in place by a Collar and a Coupling, and it carries a $1"$ Pulley (30).

A tension link is provided between the arm (21) and the link (17). The tension link consists of an $11\frac{1}{2}"$ and a $3\frac{1}{2}"$ Rod joined by a Coupling, and at one end it is fitted with a Rod and Strip Connector, which pivots on the Rod carrying the Pulleys (23) and (24) and is held on the Rod by a Coupling.

At its other end the tension link is free to slide in the boss of a large Fork Piece (31). A Compression Spring is fitted between the Fork Piece and a Collar (32). A 3" Strip (33) and a 2" Strip are bolted to the arms of the Fork Piece and they are connected by a Double Bracket and a $\frac{1}{2}"$ Reversed Angle Bracket (34). The end hole of the Strip (33) is passed over the Rod (28) and is held in position by a Coupling.

A $1"$ Pulley on the lower end of the Motor armature shaft is connected by a Driving Band to the Pulley (27), and the Pulley (26) drives the Pulley (23) through a Cord driving belt. A Cord belt is fitted between the Pulleys (24) and (30). The length of this belt should be adjusted so that the Spring on the tension link is compressed tightly.

(Continued on next page)

DETAILS OF THE BASE

The Plates used to fill in the top of the base are bolted to a framework made from a $12\frac{1}{2}"$ Strip at each end and a built-up strip along each side. The built-up strips are each formed by two $12\frac{1}{2}"$ Strips overlapped three holes, and they are connected together at the centre by a $12\frac{1}{2}"$ Strip.

Each corner of the top of the base is filled in by a $3\frac{1}{2}"$ x $2\frac{1}{2}"$ Flanged Plate (1). To each side is bolted a $12\frac{1}{2}"$ x $2\frac{1}{2}"$ Strip Plate (2), extended at its ends by $4\frac{1}{2}"$ x $2\frac{1}{2}"$ Flexible Plates (3), and to the inner edges of these Plates are bolted $12\frac{1}{2}"$ x $2\frac{1}{2}"$ Strip Plates (4). The centre of the base is filled in by one half of a Hinged Flat Plate and ten $5\frac{1}{2}"$ x $2\frac{1}{2}"$ Flexible Plates, the arrangement of which can be seen clearly in Fig. 8.1b.

A built-up strip (5), made from two $12\frac{1}{2}"$ Strips, is attached to each of the sides of the base, and a $12\frac{1}{2}"$ Strip is connected to each end by Angle Brackets. The base is supported on the underside by Flanged Sector Plates, $2\frac{1}{2}"$ x $1\frac{1}{2}"$ Flanged Plates and Double Angle Strips of various sizes as shown.

MOTOR SUPPORT AND THE MOUNTINGS FOR THE LINKS

A $3\frac{1}{2}"$ x $2\frac{1}{2}"$ Flanged Plate (6) is connected to one corner of the base by two $5\frac{1}{2}"$ Strips (7) placed face to face, a Corner Gusset (8) and a $2\frac{1}{2}"$ x $\frac{1}{2}"$ Double Angle Strip (9). Two $5\frac{1}{2}"$ x $2\frac{1}{2}"$ Flanged Plates are connected by $1\frac{1}{2}"$ Strips and $5\frac{1}{2}"$ x $1\frac{1}{2}"$ Flexible Plates to form a supporting column (10), and this is attached to the Flanged Plate (6) by two $\frac{1}{2}"$ x $\frac{1}{2}"$ and two $1"$ x $1"$ Angle Brackets.

Two $12\frac{1}{2}"$ Angle Girders (11) are connected together at one end by a Fishplate and at the other end by the second half of the Hinged Flat Plate, and this assembly is bolted to the column (10) as shown in Fig. 8.1a. The Girders (11) are braced by two $4\frac{1}{2}"$ Strips (12) placed face to face and attached to the column by an Angle Bracket. Two $5\frac{1}{2}"$ Angle Girders are secured so that they overhang the ends of the Girders (11) by two clear holes, and to each $5\frac{1}{2}"$ Girder is bolted a $2\frac{1}{2}"$ Strip (13) braced by a $1\frac{1}{2}"$ Strip.

An E20R Electric Motor is bolted to the half of the Hinged Flat Plate as indicated.

BUILDING AND PIVOTING THE LINKS

Each link consists of two $12\frac{1}{2}"$ Angle Girders connected at the centre and at each end by Fishplates to form channel girders. Two $2\frac{1}{2}"$ Strips are bolted to the link (14) so that they overhang the end by one clear hole each, and two Bush Wheels (15) are fixed to the link so that their bosses coincide with the end holes in the $2\frac{1}{2}"$ Strips. Two Angle Brackets are fixed to the link (16) in the ninth holes from one end. A 2" Rod is passed through these Angle Brackets and through the Strips (13), and is fixed in the Bush Wheels (15).

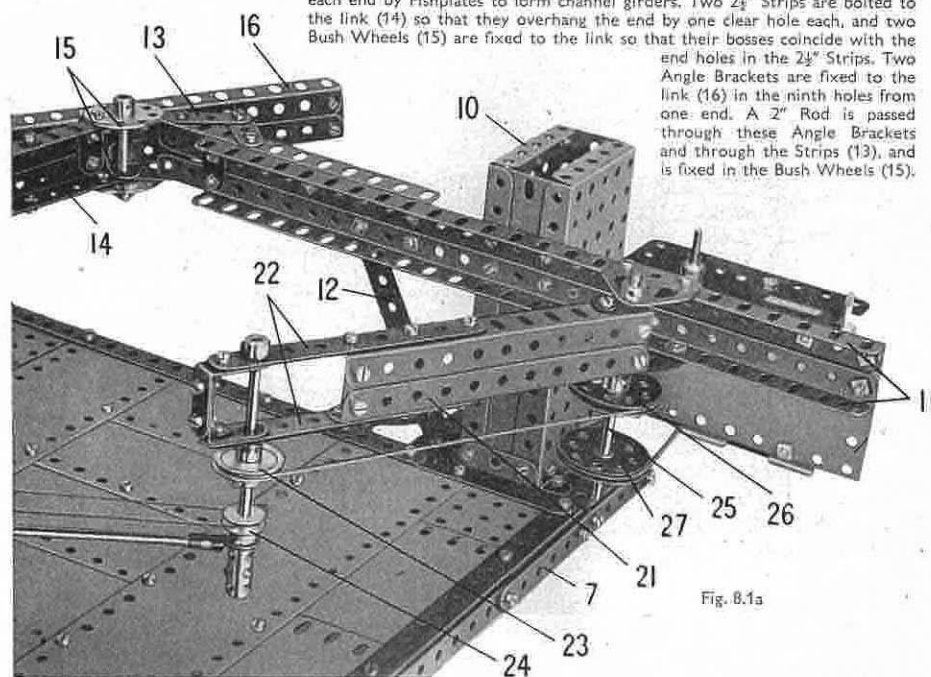

Fig. 8.1a

MODEL 8.1 PANTOGRAPH — Continued

		Parts Required			
13 of No. 1	18 of No. 12	2 of No. 24	8 of No. 59	6 of No. 197	
4 " " 2	4 " " 12a	199 " " 37a	1 " " 62	1 " " 198	
6 " " 2a	1 " " 12b	198 " " 37b	5 " " 63	1 " " 212	
1 " " 3	1 " " 13	22 " " 38	1 " " 80a		
1 " " 4	1 " " 15	1 " " 48a	1 " " 108		
10 " " 5	2 " " 15a	6 " " 48b	1 " " 111c		
1 " " 6	1 " " 15b	2 " " 48c	1 " " 120b		
6 " " 6a	4 " " 17	2 " " 48d	1 " " 125		
10 " " 8	3 " " 20b	2 " " 51	2 " " 126a		
4 " " 9	2 " " 21	2 " " 52	2 " " 189		
17 " " 10	3 " " 22	5 " " 53	4 " " 191		
1 " " 11	1 " " 23a	2 " " 54	10 " " 192		

1 E20R
Electric Motor
(not included
in Outfit)

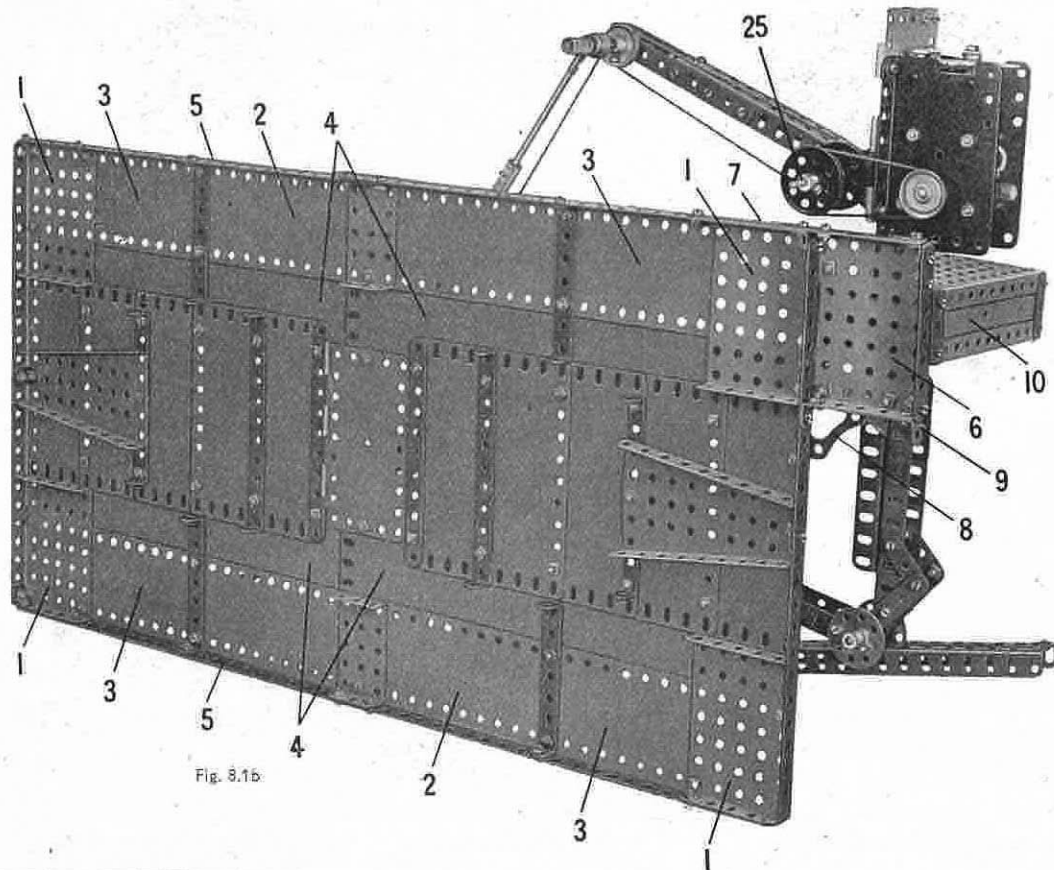

Fig. 8.1b

8.2 BORING MACHINE

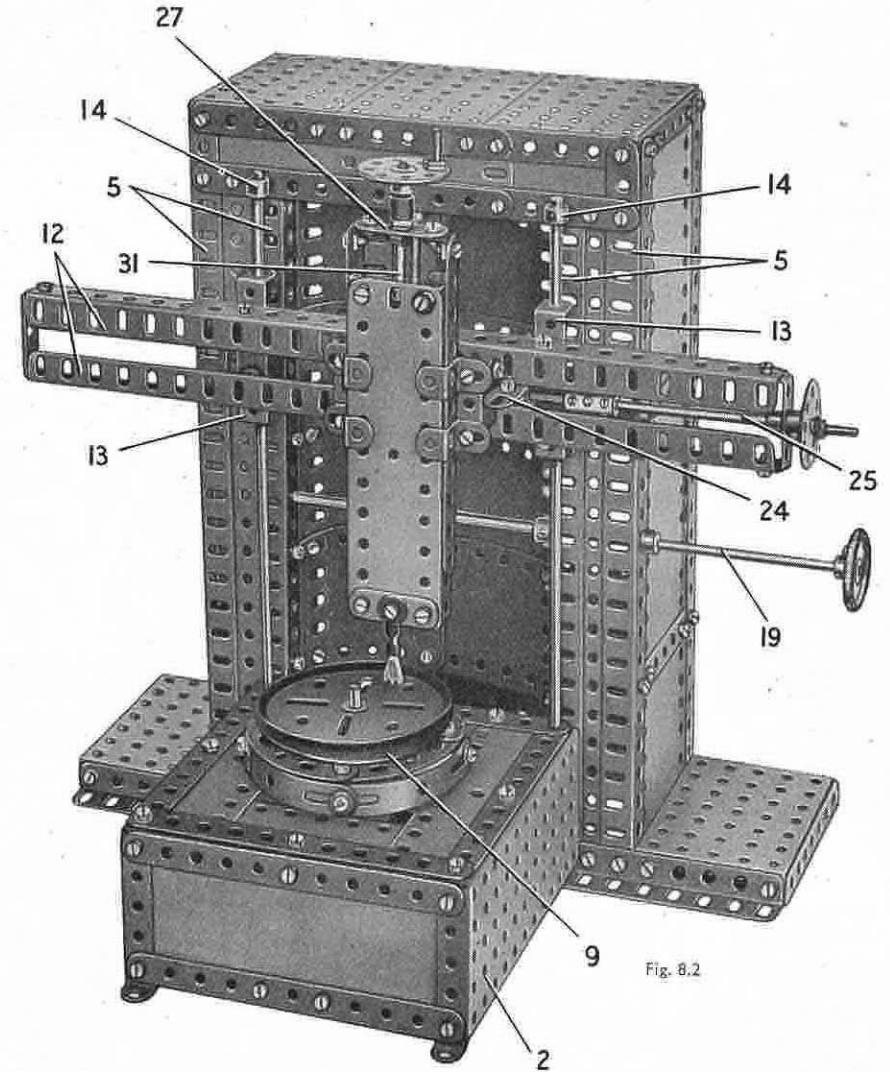

Fig. 8.2

Among the many machine tools used in modern engineering workshops is a kind of vertical lathe known as a boring machine. It is a machine of this kind that forms the subject of the line model shown in Fig. 8.2. For some kinds of turning and boring work a horizontal type lathe is preferable, but for certain jobs it is better to use a machine with a horizontal work-table such as is used in the model boring machine described here. In this model the cutting tool is carried in a movable ram head, which can be traversed to and fro across the worktable and can also be raised and lowered by turning handwheels provided for the purpose.

(Continued on next page)

MODEL 8.2 BORING MACHINE — Continued

CONSTRUCTION OF THE BASE

Two 12½" Angle Girders (1) (Fig. 8.2a) are connected at their ends by 3½" × 2½" Flanged Plates and 3½" × ½" Double Angle Strips, and to the Girders are bolted two 5½" × 2½" Flanged Plates (2). The front ends of the Plates (2) are connected by a 5½" × 2½" Flexible Plate edged by 5½" and 2½" Strips. Two 5½" × ½" Double Angle Strips (3) (Fig. 8.2a) are bolted between the Flexible Plate and one of the Girders (1), and a 5½" Strip (4) is fixed between the upper edges of the Plates (2).

Four 5½" × 1½" Flexible Plates are bolted to the upper edges of the Plates (2) and are strengthened by 5½" Strips, as shown in Fig. 8.2. This construction leaves a space 2½" square between the inner sides of the Flexible Plates.

THE SUPPORTING COLUMN

The front of the column is made by bolting two sets of 12½" Angle Girders (5) to one of the Girders (1), with a 12½" Strip between each pair of Angle Girders. The upper ends of the Girders (5) are connected by two 5½" × 1½" Flexible Plates, which are overlapped seven holes and edged as shown in Fig. 8.2 by 5½" and 1½" Strips. The front is completed by four curved 4½" × 2½" Flexible Plates, each of which overlaps a 1½" radius Curved Plate by four holes. The Plates are bolted together and are attached by Obtuse Angle Brackets to the inner one of each pair of Girders (5).

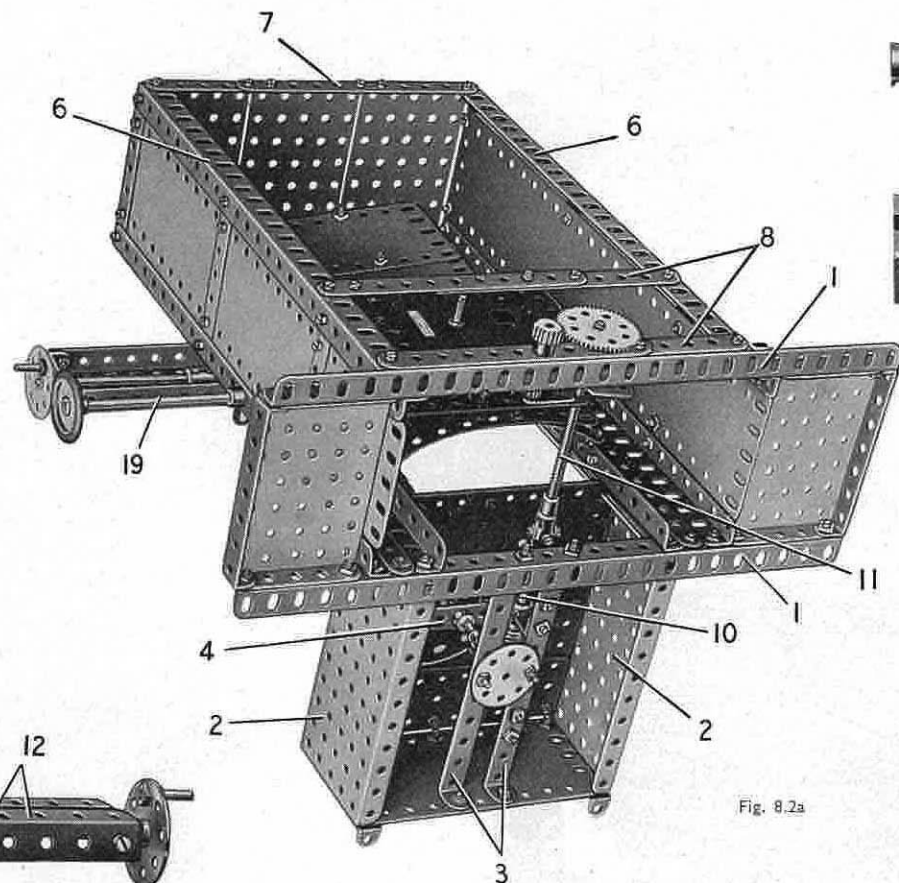

Fig. 8.2a

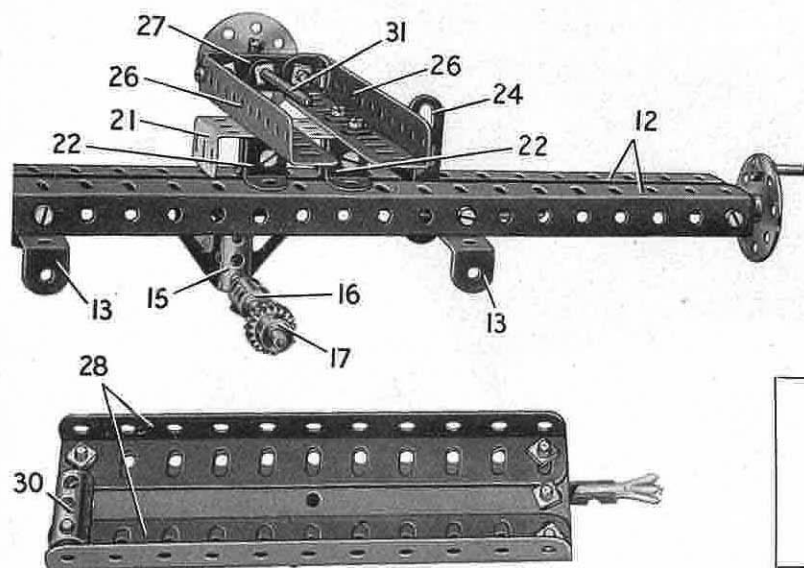

Fig. 8.2c

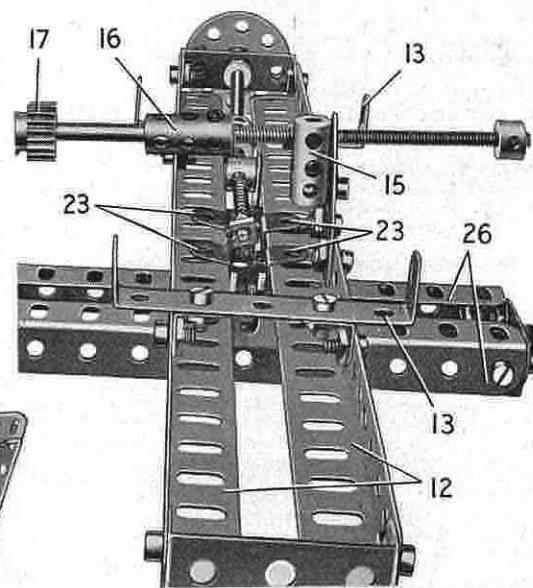

Fig. 8.2b

Two 12½" Angle Girders (6) are bolted to the rear Girder (1), and each of these is connected to the front of the column by three 3½" Strips. Each side is filled in by a 12½" × 2½" Strip Plate. The top of the column is formed by three 3½" × 2½" Flanged Plates.

Three built-up strips, numbered (7) and (8) (Fig. 8.2a) are bolted across the back of the column. Each strip consists of two 5½" Strips overlapped seven holes.

THE BORING TABLE AND ITS DRIVE

The table consists of a 3" Pulley and a Face Plate (9) edged by four 2½" Stepped Curved Strips, which are attached by Fishplates. Four Formed Slotted Strips are connected to the Curved Strips by Angle Brackets. The table is fixed to a 3½" Rod, which is mounted in the Strip (4) and in two Wheel Discs bolted to the Double Angle Strips (3) and in a Double Bent Strip fixed to the Wheel Discs. The Rod carries a ½" Pinion that engages a Worm on a 3½" Rod (10) (Fig. 8.2a). Rod (10) is supported in 1" × 1" Angle Brackets bolted to one of the Double Angle Strips (3). The 3½" Rods are held in place by Collars.

(Continued on next page)

If you ever require advice in connection with your model-building write to Information Service, Meccano Ltd, Binns Road, Liverpool 13. Experts are waiting to help you

MODEL 8.2 BORING MACHINE — Continued

A No. 1 Clockwork Motor is fixed to the strips (8) as shown in Fig. 8.2a, and a $\frac{1}{2}$ " Pinion on its driving shaft engages a 57-tooth Gear on a $\frac{1}{2}$ " Rod (11). This Rod is connected by a built-up universal coupling to the Rod (10). The universal coupling is made from a Swivel Bearing and a small Fork Piece connected by two bolts.

TOOL CARRIAGE

Two $1\frac{1}{2}$ " Angle Girders (12) are joined at their ends by $1\frac{1}{2}$ " \times $\frac{1}{2}$ " Double Angle Strips, and two $2\frac{1}{2}$ " \times $\frac{1}{2}$ " Double Angle Strips (13) are attached to the Girders by Angle Brackets. The Double Angle Strips (13) slide freely on $11\frac{1}{2}$ " Rods passed through the Flanged Plates (2) and fixed at their upper ends in Collars (14) (Fig. 8.2). These Collars are attached to the column by bolts screwed into their threaded holes. A Washer is placed on each bolt behind the Collar.

A Flat Trunnion is bolted to the upper one of the Girders (12), and a Coupling (15) (Fig. 8.2c) is fixed to it by a bolt. A Screwed Rod, fitted with a Coupling (16), is threaded through the Coupling (15). A 2" Rod is gripped in Coupling (16) and carries a $\frac{1}{2}$ " Pinion (17). The lower end of the 2" Rod is free to turn in a Coupling (18) (Fig. 8.2d), mounted on a built-up rod (19). This rod consists of an 8" and a 2" Rod joined by a Coupling, and it carries a $\frac{1}{4}$ " Contrate (20). The rod (19) is held in the Girders (5) by Collars, and the Pinion (17) engages the Contrate (20). By turning a 1" Pulley (fitted with Rubber Ring) on Rod (19), the tool carriage can be raised and lowered.

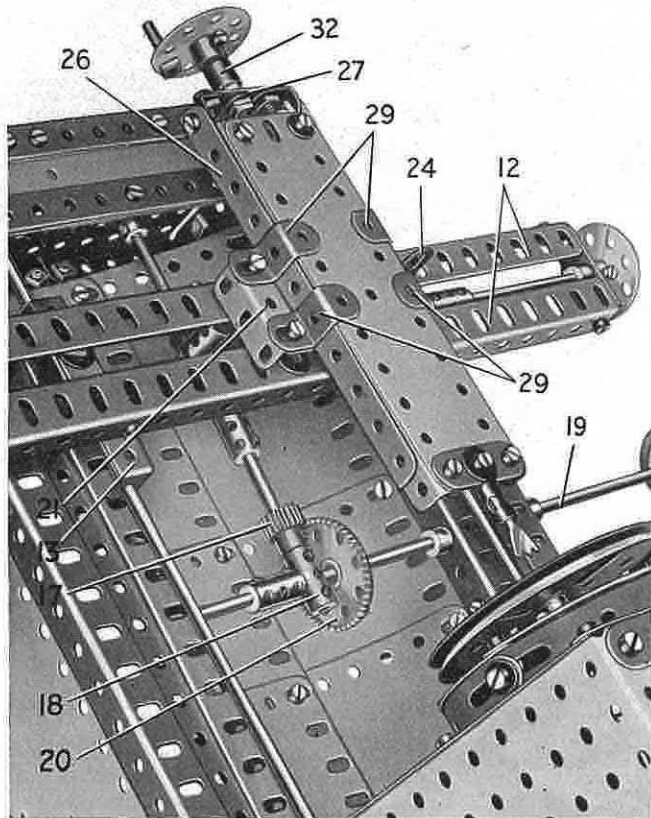

Fig. 8.2d

TOOL HOLDER

The tool holder is supported by a slide made from a $2\frac{1}{2}$ " \times $1\frac{1}{2}$ " Flanged Plate (21) (Fig. 8.2d). Four Double Brackets (22) (Fig. 8.2c) are bolted to the rear of the Flanged Plate, and their free lugs bear against the front edges of the Girders (12). Angle Brackets (23) are bolted by their slotted holes to the Double Brackets, with their free lugs *behind* the Girders (12). This arrangement allows the Plate (21) to slide freely on the Girders. A Crank (24) (Fig. 8.2e) is attached by an Angle Bracket to one flange of Plate (21), and a Screwed Rod is threaded through the Crank. The Screwed Rod is joined by a Coupling to a $\frac{3}{4}$ " Rod (25) (Fig. 8.2e), which is held by a Collar and a Bush Wheel in the Double Angle Strip at one end of the Girders (12). By turning the Bush Wheel the Plate (21) can be moved across the Girders.

Two $5\frac{1}{2}$ " Angle Girders (26) (Fig. 8.2c) are attached to the Plate (21) by the same bolts as the Double Brackets, and are connected at their upper ends by Angle Brackets and a $1\frac{1}{2}$ " Strip (27). The tool holder is a $5\frac{1}{2}$ " \times $1\frac{1}{2}$ " Flexible Plate edged by two $5\frac{1}{2}$ " Angle Girders (28). These Girders slide freely between the Girders (26), and are held in place by $\frac{1}{2}$ " Reversed Angle Brackets (29) (Fig. 8.2d). The tool is represented by a Centre Fork supported in a Rod and Strip Connector.

A Coupling (30) (Fig. 8.2c) is attached by a $\frac{3}{8}$ " Bolt to the upper end of the tool holder, and a Screwed Rod (31) (Fig. 8.2c) is threaded through the Coupling. At its upper end the Screwed Rod is connected to a Screwed Rod Adaptor (32) (Fig. 8.2e), and is held in the Strip (27) by *lock-nuts*. A Bush Wheel is fitted to the Screwed Rod Adaptor, and by turning this Bush Wheel the tool holder can be raised and lowered in its slides.

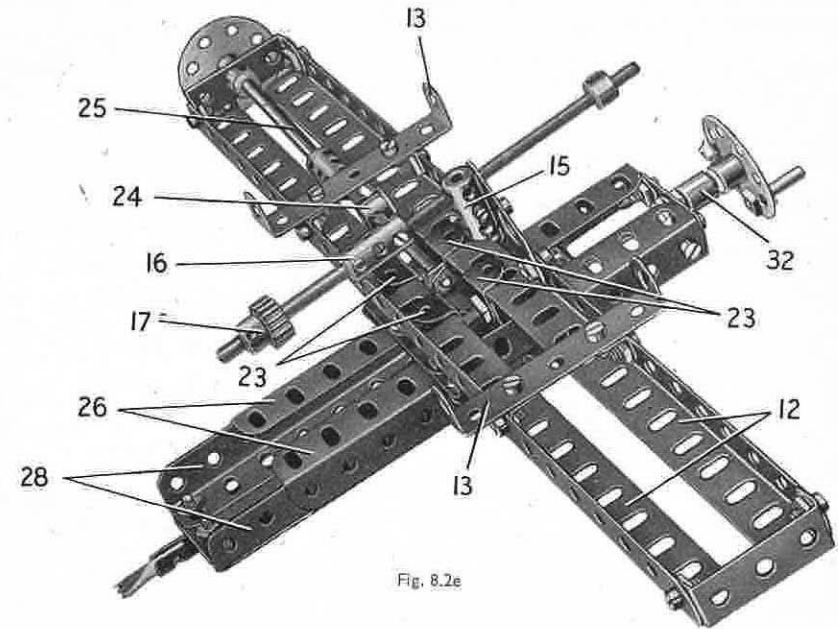

Fig. 8.2e

Parts Required

2 of No. 1	1 of No. 19b	1 of No. 51	1 of No. 126a
17 " " 2	1 " " 22	2 " " 52	1 " " 155
6 " " 3	2 " " 24	5 " " 53	1 " " 165
4 " " 6a	2 " " 24a	9 " " 59	1 " " 173a
10 " " 8	3 " " 26	1 " " 62	7 " " 189
4 " " 9	1 " " 27a	6 " " 63	4 " " 191
4 " " 10	1 " " 28	1 " " 65	1 " " 192
4 " " 11	1 " " 32	1 " " 80a	2 " " 197
17 " " 12	161 " " 37a	2 " " 80c	4 " " 200
2 " " 12a	155 " " 37b	4 " " 90a	1 " " 212
8 " " 12c	32 " " 38	1 " " 109	4 " " 215
2 " " 13	1 " " 45	1 " " 111a	
1 " " 13a	2 " " 48	5 " " 111c	
1 " " 15b	2 " " 48a	2 " " 115	
3 " " 16	2 " " 48b	1 " " 116a	
2 " " 17	2 " " 48d	4 " " 125	
			1 No. 1 Clockwork Motor (Not included in Outfit)

CONSTRUCTION OF THE MAIN PIER

Each side of this pier consists of two built-up girders (1), each made from a $1\frac{1}{2}$ " and a $5\frac{1}{2}$ " Angle Girder joined together. At one end the girders are connected by a $2\frac{1}{2}$ " Strip, and at the other end they are bolted to a $5\frac{1}{2}$ " x $2\frac{1}{2}$ " Flexible Plate, a $4\frac{1}{2}$ " Strip and a built-up strip (2). This strip consists of a 3 " and a $2\frac{1}{2}$ " Strip overlapped two holes; and a second $5\frac{1}{2}$ " x $2\frac{1}{2}$ " Flexible Plate is bolted to it and to the $4\frac{1}{2}$ " Strip.

The sides are connected at the front by a $12\frac{1}{2}$ " x $2\frac{1}{2}$ " Strip Plate edged at the bottom by a $12\frac{1}{2}$ " Angle Girder and at the top by a $12\frac{1}{2}$ " Strip. Two $12\frac{1}{2}$ " Strips (3) and (4) are bolted between the upper pair of girders (1).

A $12\frac{1}{2}$ " Strip (5) is fixed between the lower pair of girders (1), and a $12\frac{1}{2}$ " Angle Girder (6) is attached to the upper rear corners of the sides by 1 " x $\frac{1}{2}$ " Angle Brackets. The top of the raised approach road is filled in by three $5\frac{1}{2}$ " x $2\frac{1}{2}$ " Flexible Plates (7), a $5\frac{1}{2}$ " x $1\frac{1}{2}$ " Flexible Plate (8), a $4\frac{1}{2}$ " x $2\frac{1}{2}$ " Flexible Plate (9) and a $3\frac{1}{2}$ " x $2\frac{1}{2}$ " Flanged Plate (10). The Plates are bolted to a $12\frac{1}{2}$ " Strip (11) and are strengthened by $5\frac{1}{2}$ " and $3\frac{1}{2}$ " Strips as shown in Fig. 8.3b. The cut-away section at the span end of the approach is partly filled at the corners by a $2\frac{1}{2}$ " Stepped Curved Strip and a $3\frac{1}{2}$ " x $1\frac{1}{2}$ " Triangular Flexible Plate.

A $5\frac{1}{2}$ " x $2\frac{1}{2}$ " and two $4\frac{1}{2}$ " x $2\frac{1}{2}$ " Flexible Plates are bolted to the upper girder (1) on one side, and are edged on the inside by three $3\frac{1}{2}$ " x $\frac{1}{2}$ " Double Angle Strips. A $2\frac{1}{2}$ " x $2\frac{1}{2}$ " and two $5\frac{1}{2}$ " x $2\frac{1}{2}$ " Flexible Plates are fixed to the upper girder (1) on the other side, and are edged by a $12\frac{1}{2}$ " Strip. These Plates are extended inward by a $12\frac{1}{2}$ " x $2\frac{1}{2}$ " Strip Plate strengthened by a $12\frac{1}{2}$ " Strip (12).

THE MECHANISM AND TURNTABLE

A $3\frac{1}{2}$ " x $2\frac{1}{2}$ " Flanged Plate is bolted to the centre of Strip (3), and to its inner flange is bolted a $3\frac{1}{2}$ " x $2\frac{1}{2}$ " Flanged Plate (13). This is connected by $5\frac{1}{2}$ " Strips to a further $3\frac{1}{2}$ " x $2\frac{1}{2}$ " Flanged Plate (14), and another $3\frac{1}{2}$ " x $2\frac{1}{2}$ " Flanged Plate (15) is bolted between the $5\frac{1}{2}$ " Strips.

A $5\frac{1}{2}$ " x $2\frac{1}{2}$ " Flanged Plate is attached by Fishplates to the Flanged Plates (13) and (14), and is connected by a $2\frac{1}{2}$ " x $1\frac{1}{2}$ " Flanged Plate (16) to the Plate (15).

The span is opened and closed by turning a Bush Wheel on a $3\frac{1}{2}$ " Rod that carries a 17 " Contrate (17) at its lower end. The Rod is supported in Double Bent Strips bolted above and below the Flanged Plate (10), and in a Flat Trunnion fixed to the Strip (4). The Contrate drives a $1\frac{1}{2}$ " Pinion on a $6\frac{1}{2}$ " Rod (18), which is mounted in a Trunnion bolted to the Strip (4) and in a similar part fixed to a $3\frac{1}{2}$ " x $\frac{1}{2}$ " Double Angle Strip placed between the side of the approach and a $4\frac{1}{2}$ " x $\frac{1}{2}$ " Double Angle Strip (19). Rod (18) carries a $1\frac{1}{2}$ " Sprocket connected by Chain to a 2 " Sprocket on an $1\frac{1}{2}$ " Rod. The latter Rod is supported in the Flanged Plates (13) and (14) and in a Channel Bearing bolted to the Strip (4), and it carries a $1\frac{1}{2}$ " Pinion (20). This Pinion drives a 57-tooth Gear on a 4 " Rod that is mounted in the Flanged Plates (14) and (16) and is held in place by a Collar placed against the Plate (16). A $1\frac{1}{2}$ " Pinion (21) on the 4 " Rod engages a $1\frac{1}{2}$ " Contrate on a vertical $4\frac{1}{2}$ " Rod (22). This Rod is supported in the Flanged Plate (15), and it turns freely in a 2 " Pulley bolted below the $5\frac{1}{2}$ " x $2\frac{1}{2}$ " Flanged Plate. The Rod passes through a 3 " Pulley (23), which is connected to the $5\frac{1}{2}$ " x $2\frac{1}{2}$ " Flanged Plate by two $\frac{1}{2}$ " Bolts, but is spaced from the Plate by the flanges of a $2\frac{1}{2}$ " x $1\frac{1}{2}$ " Flanged Plate (24).

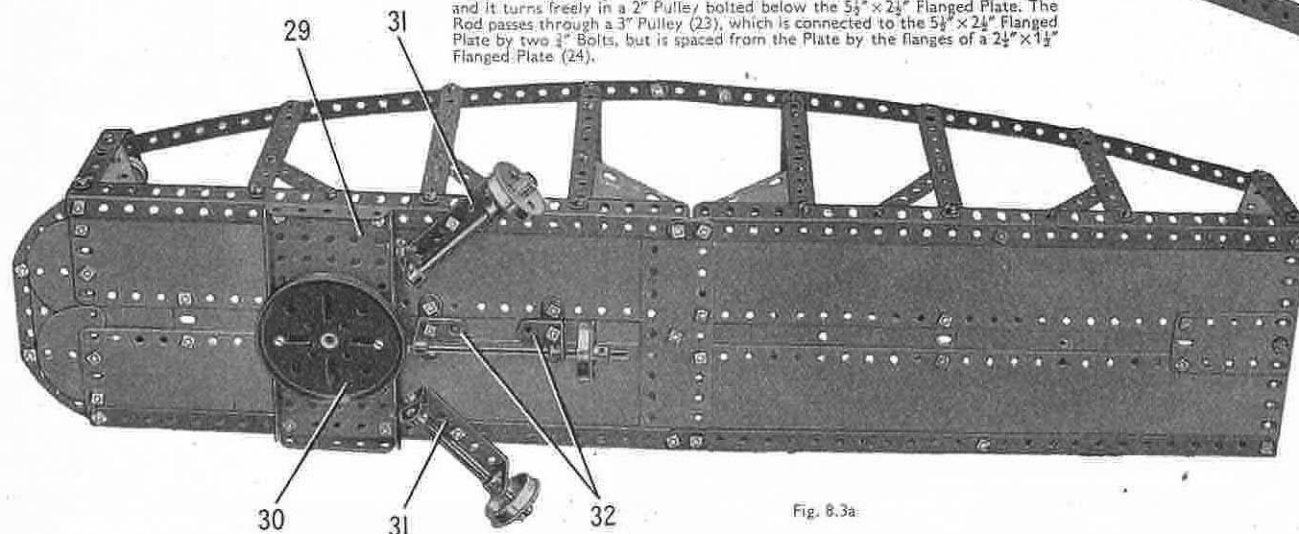

Fig. 8.3a:

8.3 SWING BRIDGE

Fig. 8.3

The track for the roller wheels of the span consists of a $12\frac{1}{2}$ " and a $5\frac{1}{2}$ " Strip overlapped two holes and curved as shown. It is attached to the top of the pier by three Angle Brackets, and at each end it is joined by a built-up strip (25) to an Obtuse Angle Bracket fixed to the $5\frac{1}{2}$ " x $2\frac{1}{2}$ " Flanged Plate. Each of the strips (25) consists of a $2\frac{1}{2}$ " x $\frac{1}{2}$ " Double Angle Strip extended one hole by a 1 " x 1 " Angle Bracket.

THE SUPPORTING PIER

Each side of this pier consists of a Flanged Sector Plate and a $4\frac{1}{2}$ " x $2\frac{1}{2}$ " Flexible Plate bolted together as shown in Fig. 8.3, and fitted with a Corner Gusset (26) bolted to a $2\frac{1}{2}$ " x $1\frac{1}{2}$ " Flexible Plate. The bolts connecting the Corner Gusset and the Flexible Plate support also a $2\frac{1}{2}$ " x $\frac{1}{2}$ " Double Angle Strip, and the lugs of these Double Angle Strips are bolted to $5\frac{1}{2}$ " Strips at the front and the rear. The top of the pier is a $5\frac{1}{2}$ " x $2\frac{1}{2}$ " Flexible Plate attached to two $2\frac{1}{2}$ " x $\frac{1}{2}$ " Double Angle Strips.

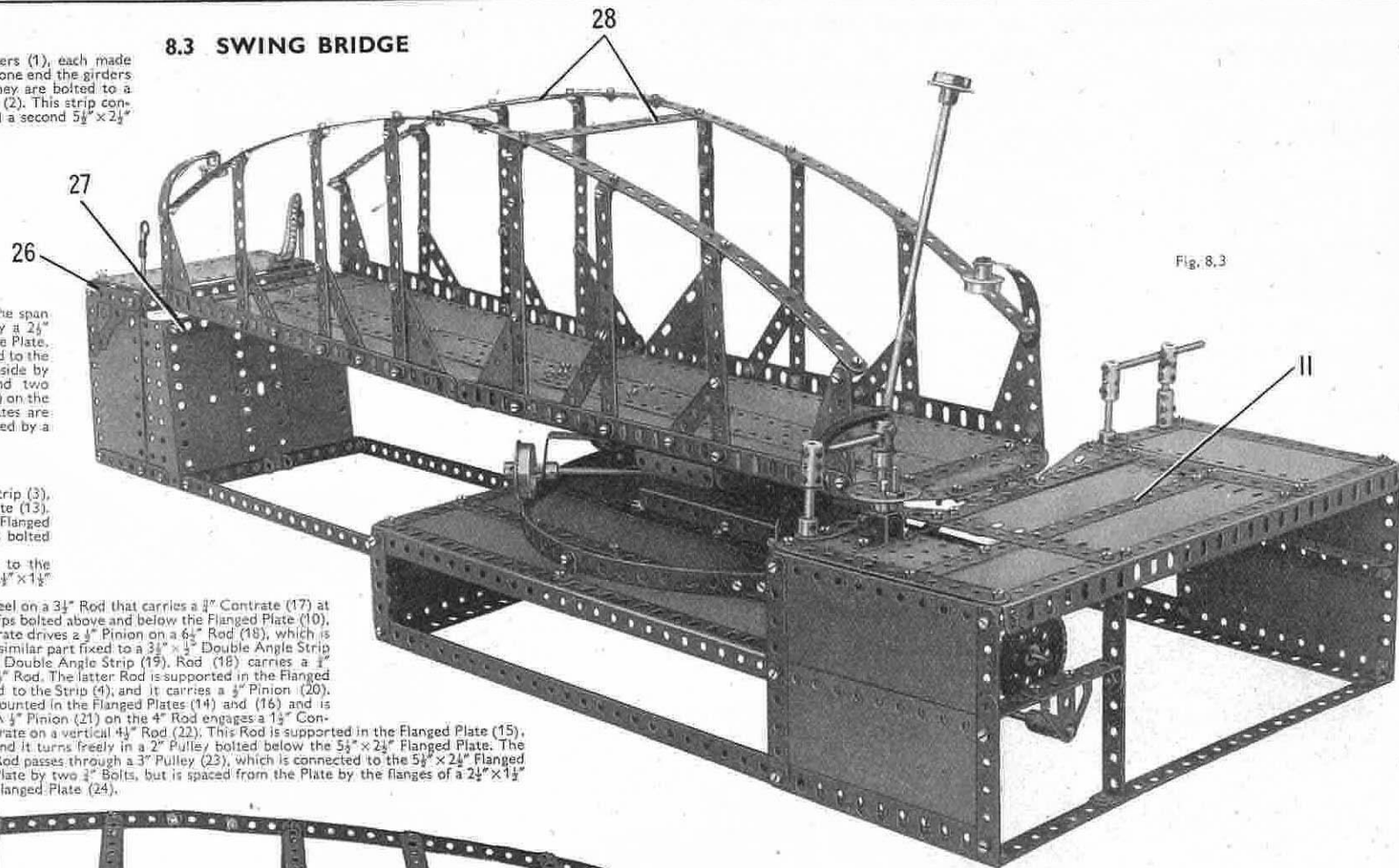
The lower rear corners of the sides are connected by two $2\frac{1}{2}$ " x $\frac{1}{2}$ " Double Angle Strips, spaced one hole apart at the centre by a Trunnion. The front of the pier is filled in by the separated halves of a Hinged Flat Plate and two $2\frac{1}{2}$ " x $1\frac{1}{2}$ " Flexible Plates, edged at the top by a $5\frac{1}{2}$ " Strip (27).

The supporting pier is connected to the main pier by two $12\frac{1}{2}$ " Strips, fixed to $2\frac{1}{2}$ " x $\frac{1}{2}$ " Double Angle Strips and to Angle Brackets attached to the main pier.

(Continued on next page)

MODEL 8.3 SWING BRIDGE — Continued

THE SWING SPAN

Each of the main side girders consists of two 12½" Angle Girders joined at the centre by a Fishplate. The roadway is filled in by two 12½" × 2½" Strip Plates on each side, with four 5½" × 1½" and two 2½" × 1½" Flexible Plates bolted along the centre. At each end the main girders are connected by a 5½" Strip, and at one end the roadway is extended by two Semi-Circular Plates and a 2½" × 1½" Flexible Plate. This end is edged by two 2½" Curved Strips and a 2½" Strip.

Each of the arch girders consists of two 12½" Strips joined at the centre to a 2" Strip. The arches are supported on each side by two 2½", two 4½", four 5½" and two built-up strips, and are connected across by two 5½" × ½" Double Angle Strips (28). The built-up strips are made from 5½" and 1½" Strips.

A 5½" × 2½" Flanged Plate (29), to which a 3" Pulley (30) is attached by Angle Brackets, is bolted underneath the roadway. Two 2½" × 1" Double Angle Strips (31) are connected by Obtuse Angle Brackets to the Flanged Plate (29), and are bolted to the main girders of the span. Two 1" × 1" Angle Brackets (32) are fixed to 1½" Strips bolted underneath the roadway. The Double Angle Strips and the 1" × 1" Angle Brackets support Rods carrying 1½" Flanged Wheels, which form the span rollers. The Pulley (30) is fixed to the Rod (22), and the Flanged Wheels rest on the roller track.

THE TRAFFIC BARRIERS

The barrier of the supporting pier is a length of Chain placed between two Rod and Strip Connectors. Each of these is supported on the upper end of a Screwed Rod.

The main approach barrier is a 6½" Rod fitted with a ¾" Flanged Wheel (33) and pivoted in a Swivel Bearing (34). The Swivel Bearing is fixed on a 1½" Rod supported in a Crank (35), and a 2" Rod (36) is held in a Coupling fixed on a 1½" Rod that is gripped in a Crank (37). A Tension Spring is placed over the 6½" Rod and the Rod (36), and is held in position by Cord Anchoring Springs mounted on the Rods.

The main barrier is held down by sliding a Rod (38) into the Flanged Wheel (33). Rod (38) is supported in two Couplings, one of which is fixed on a 2" Rod held in the top of the approach by a Collar and an End Bearing. The other Coupling is fixed on a 3½" Rod passed through the top of the approach and the Strip (4). This Rod is held in place by a Coupling and a large Fork Piece.

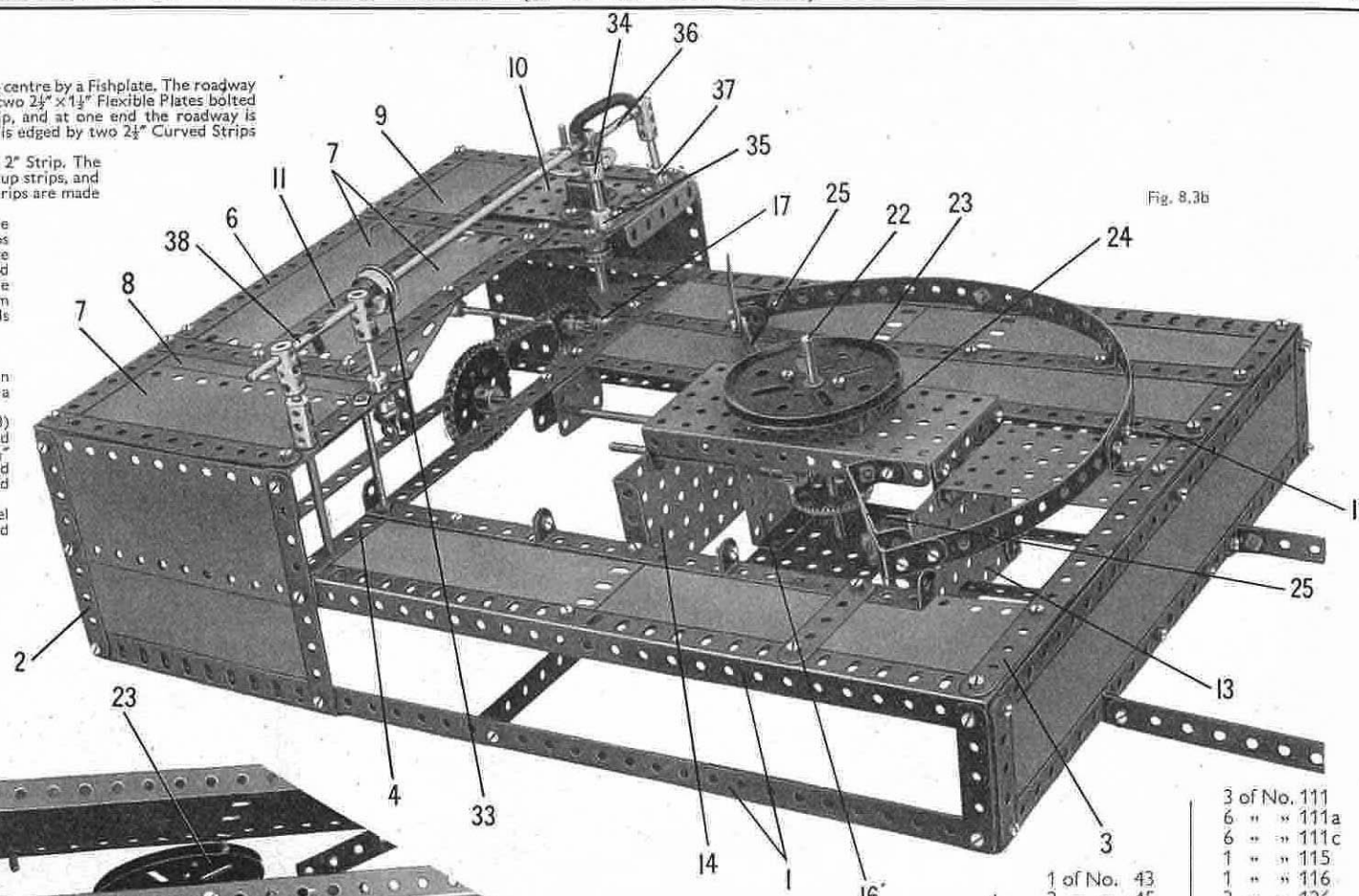

Fig. 8.3b

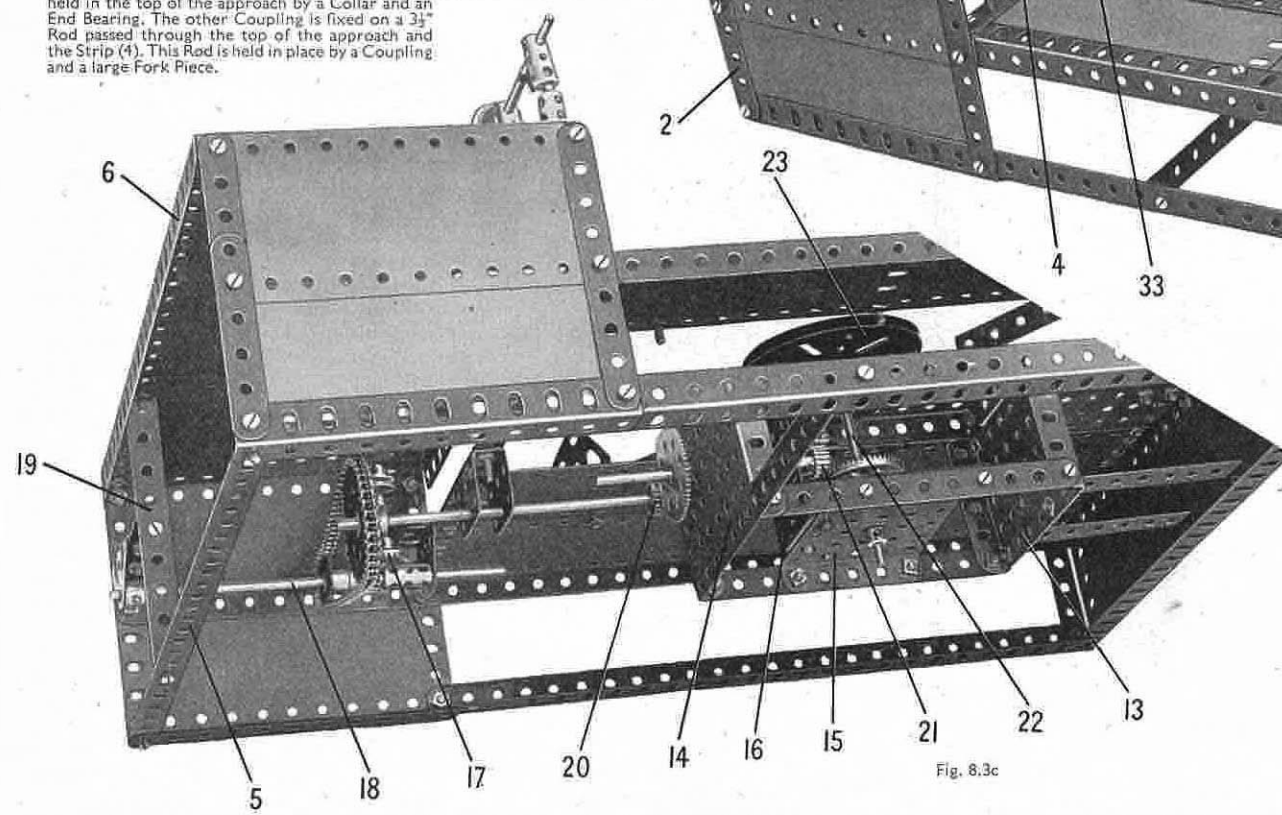

Fig. 8.3c

Parts Required		Parts Required		Parts Required	
14 of No.	1	1 of No.	15b	3 of No.	111
21 " "	2	5 " "	16	6 " "	111a
5 " "	2a	2 " "	17	6 " "	111c
6 " "	3	2 " "	18a	1 " "	115
6 " "	4	2 " "	19b	1 " "	116
18 " "	5	3 " "	20	3 " "	126
2 " "	6	1 " "	20a	3 " "	126a
6 " "	6a	3 " "	20b	2 " "	147b
10 " "	8	1 " "	23a	6 " "	160
4 " "	9	1 " "	24	1 " "	165
6 " "	10	3 " "	26	1 " "	166
23 " "	12	1 " "	27a	2 " "	176
6 " "	12a	1 " "	28	2 " "	188
2 " "	12b	1 " "	29	5 " "	189
4 " "	12c	1 " "	35	2 " "	190
1 " "	13	270 " "	37a	10 " "	191
2 " "	14	258 " "	37b	2 " "	192
2 " "	15a	35 " "	38	6 " "	197
				1 " "	198
				2 " "	212
				2 " "	214
				1 " "	215
				4 " "	221
				2 " "	222
				1 " "	223
				2 " "	224

8.4 CONTINENTAL SINGLE-DECK TRAM

ASSEMBLY OF THE SIDES

The side seen in Fig. 8.4 consists of two $12\frac{1}{2}'' \times 2\frac{1}{2}''$ Strip Plates overlapped seven holes and bolted to a built-up girder (1). This girder consists of three $12\frac{1}{2}''$ Angle Girders, the end two of which each overlap the centre Girder by nine holes. The top edges of the Strip Plates are strengthened by $12\frac{1}{2}''$ Strips, and a $5\frac{1}{2}''$ Strip (2) is bolted to the end of each Plate. The window divisions are made from two $3\frac{1}{2}''$ and two $5\frac{1}{2}''$ Strips, and a built-up strip (3) at the centre that is formed by a $5\frac{1}{2}''$ and a $2\frac{1}{2}''$ Strip overlapped two holes. The side is extended downward by two $5\frac{1}{2}'' \times 1\frac{1}{2}''$ and two $2\frac{1}{2}'' \times 1\frac{1}{2}''$ Flexible Plates, bolted to the strip (3) and supported by $2\frac{1}{2}''$ Stepped Curved Strips (4). A $12\frac{1}{2}''$ and two $5\frac{1}{2}''$ Strips forming a built-up strip (5), are fixed to the upper ends of the window divisions.

Fig. 8.4

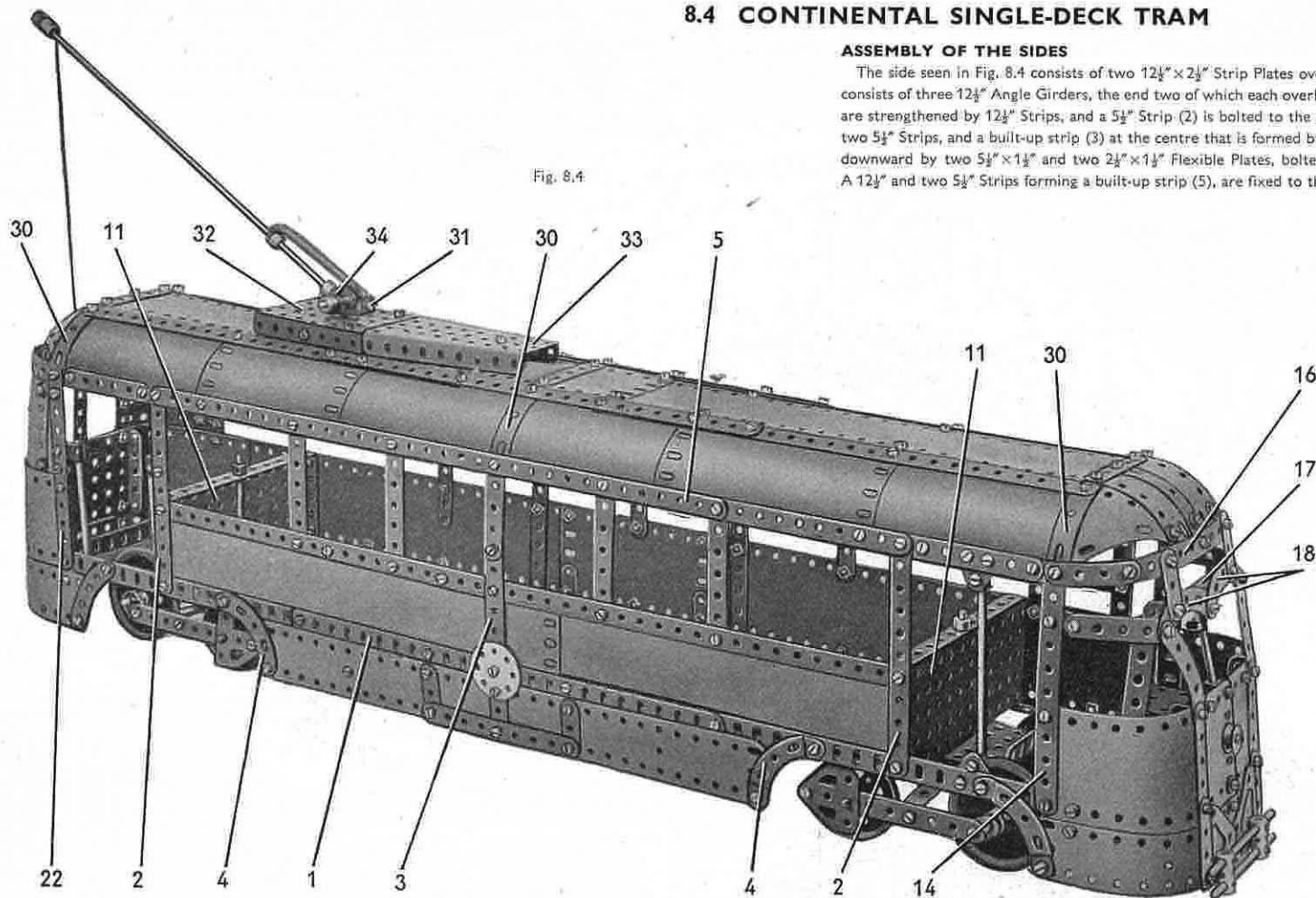

The side seen in Fig. 8.4b is formed by a $4\frac{1}{2}'' \times 2\frac{1}{2}''$ Flexible Plate and two $12\frac{1}{2}'' \times 2\frac{1}{2}''$ Strip Plates bolted to a girder (6), which is made in the same way as the girder (1). The upper edges of the Plates are fitted with three $12\frac{1}{2}''$ Strips, and to each end is bolted a $5\frac{1}{2}''$ Strip (7). At the centre a strip (8), made from a $5\frac{1}{2}''$ and a $2\frac{1}{2}''$ Strip overlapped two holes, is fixed. The side is extended downward by two $5\frac{1}{2}'' \times 1\frac{1}{2}''$ and two $2\frac{1}{2}'' \times 1\frac{1}{2}''$ Flexible Plates, arranged in the same way as the corresponding Plates of the other side. The window divisions are formed by a $3\frac{1}{2}''$, a $4\frac{1}{2}''$ and two $5\frac{1}{2}''$ Strips, and to their upper ends and to the ends of the Strips (7) and (8) is bolted a built-up strip (9). The latter consists of a $4\frac{1}{2}''$ and two $12\frac{1}{2}''$ Strips. At the front end of the model two $3\frac{1}{2}''$ Strips (10) are fixed, and they are connected by a $2\frac{1}{2}''$ Strip.

The sides are connected by two $5\frac{1}{2}'' \times 2\frac{1}{2}''$ Flanged Plates (11), two $5\frac{1}{2}''$ Angle Girders (12) and two $5\frac{1}{2}'' \times \frac{1}{2}''$ Double Angle Strips (13). At the centre the floor is filled in by a Hinged Flat Plate supported by $1'' \times 1''$ Angle Brackets bolted to the girders (1) and (6), and extended at each end by two $2\frac{1}{2}'' \times 2\frac{1}{2}''$ Flexible Plates.

THE DRIVING CAB AND ENTRANCE

The driving cab is shown in Fig. 8.4. The rounded front consists of two $5\frac{1}{2}'' \times 2\frac{1}{2}''$ Flexible Plates bolted to one of the Strips (7) and to a further $5\frac{1}{2}''$ Strip (14). The Plates are joined together by their front ends, and they overlap a $3\frac{1}{2}'' \times 2\frac{1}{2}''$ Flanged Plate (15) (Fig. 8.4b). Two $5\frac{1}{2}'' \times 1\frac{1}{2}''$ Flexible Plates are curved and attached to the $5\frac{1}{2}'' \times 2\frac{1}{2}''$ Plates by Fishplates and to the girders (1) and (6) by $2\frac{1}{2}''$ Stepped Curved Strips.

The strips (5) and (9) are extended by curved $2''$ Strips, bolted to a $5\frac{1}{2}''$ Strip (16). Strip (16) is connected by two $1\frac{1}{2}''$ Strips to a $3\frac{1}{2}'' \times \frac{1}{2}''$ Double Angle Strip (17), to which are bolted two $2\frac{1}{2}''$ Stepped Curved Strips (18). The ends of these Curved Strips are connected to the Plates of the front by $2\frac{1}{2}''$ Curved Strips, and to the Strips (7) and (14) by $2\frac{1}{2}''$ Strips extended by Fishplates. A $2''$ Rod forming the centre division of the windscreen is supported at each end in an Angle Bracket, and is held in place by Spring Clips.

The front is completed by two Corner Gussets, each extended upward by a $2\frac{1}{2}''$ Strip. The bumper is made from two $3\frac{1}{2}''$ Rods held in Couplings. The Couplings are fastened on $1\frac{1}{2}''$ Rods (19), each passed through the front of the cab and held in place by a Collar.

The driving seat is a Channel Bearing bolted in the fifth row of holes from the lower end of a Flanged Sector Plate (20), which is fixed to one of the Girders (12). The handrail is held by Spring Clips in Angle Brackets bolted to $1''$ Triangular Plates.

(Continued on next page)

Parts Required

14 of No. 1	19 of No. 10	1 of No. 17	26 of No. 38	5 of No. 53	6 of No. 111c	6 of No. 191
21 " " 2	1 " " 11	3 " " 18a	1 " " 38d	2 " " 54	1 " " 116	12 " " 192
6 " " 2a	4 " " 12	2 " " 19b	1 " " 40	9 " " 59	4 " " 126a	6 " " 197
6 " " 3	4 " " 12a	4 " " 20a	1 " " 43	2 " " 63	1 " " 147b	1 " " 198
4 " " 4	1 " " 12b	4 " " 20b	1 " " 48a	2 " " 77	1 " " 160	6 " " 200
18 " " 5	1 " " 13	3 " " 23	3 " " 48b	4 " " 90	1 " " 166	2 " " 212a
2 " " 6	4 " " 15	2 " " 24a	2 " " 48c	8 " " 90a	4 " " 187	8 " " 215
6 " " 6a	3 " " 15a	6 " " 35	2 " " 48d	2 " " 108	4 " " 188	2 " " 216
10 " " 8	2 " " 15b	280 " " 37a	2 " " 51	3 " " 111	8 " " 189	2 " " 222
4 " " 9	4 " " 16	240 " " 37b	2 " " 52	6 " " 111a	4 " " 190	2 " " 223

MODEL 8.4 CONTINENTAL SINGLE-DECK TRAM — Continued

THE EXIT AND REAR END OF THE TRAM

A $5\frac{1}{2}'' \times 2\frac{1}{2}''$ Flexible Plate is bolted to one of the Strips (7) so that it overlaps the side by three holes, and its other end is fixed to a $3\frac{1}{2}'' \times 2\frac{1}{2}''$ Flanged Plate (21). The Plate (21) is connected by a curved $4\frac{1}{2}'' \times 2\frac{1}{2}''$ Flexible Plate to a $5\frac{1}{2}''$ Strip (22). Three built-up strips (23) are fixed to the Plate (21) and are joined at their upper ends by a $3\frac{1}{2}''$ Strip. The latter is extended by two curved $3''$ Strips, bolted also to the Strips (7) and (22). The strips (23) are each made from a $5\frac{1}{2}''$ and a $2\frac{1}{2}''$ Strip overlapped two holes.

The end panelling is completed by two $1\frac{1}{8}''$ radius Curved Plates on each side. They are overlapped four holes and bolted to strips (23) and the Strips (7) and (22). Two $5\frac{1}{2}'' \times 1\frac{1}{2}''$ Flexible Plates are curved and bolted to the lower ends of Strips (23), and are attached by Fishplates and $2\frac{1}{2}''$ Curved Strips to the girders (1) and (6).

The handrails are $4''$ Rods supported in Right-Angle Rod and Strip Connectors.

DETAILS OF THE BOGIES

The two bogie units are identical in construction. Each is made by bolting a $4\frac{1}{2}'' \times \frac{1}{2}''$ Double Angle Strip (24) across a $2\frac{1}{2}'' \times 1\frac{1}{2}''$ Flanged Plate (25). A $4\frac{1}{2}''$ Strip is fixed to each lug of the Double Angle Strip, with a Flat Trunnion bolted to one end. The $4\frac{1}{2}''$ Strips and Fishplates bolted to the Strips provide bearings for the wheel axles, which are $5''$ Rods.

A $4\frac{1}{2}''$ Rod (26), fitted with a Collar, is passed through the bogie as shown and through a $3''$ Pulley and a $3\frac{1}{2}'' \times 2\frac{1}{2}''$ Flanged Plate (27) attached by $\frac{3}{8}''$ Bolts to the Plate (11). The Rod is held in position by a Collar placed above the Plate (11).

ASSEMBLY OF THE ROOF

The curved sides of the roof are each formed by five $5\frac{1}{2}'' \times 2\frac{1}{2}''$ Flexible Plates and a $4\frac{1}{2}'' \times 2\frac{1}{2}''$ Flexible Plate bolted to the strip (5) and the strip (9). Two $12\frac{1}{2}''$ Angle Girders (28) on each side are bolted inside the model along the lower edges of the Plates. These Girders are connected at the cab ends by $5\frac{1}{2}''$ Strips, and at the centre by $5\frac{1}{2}''$ Angle Girders (29). The upper edges of the Plates on each side are strengthened by three $12\frac{1}{2}''$ Strips and three Formed Slotted Strips (30) are fixed across the Plates as shown.

The centre of the roof is filled in by a $4\frac{1}{2}'' \times 2\frac{1}{2}''$ Flexible Plate and two $12\frac{1}{2}'' \times 2\frac{1}{2}''$ Strip Plates. These are attached to the curved sides by Obtuse Angle Brackets, and they are bolted also to the inner ends of the Formed Slotted Strips (30).

The roof over the driving cab consists of a $1\frac{1}{8}''$ radius Curved Plate and two $2\frac{1}{2}'' \times 2\frac{1}{2}''$ Triangular Flexible Plates. At the exit end the roof is formed by a $1\frac{1}{8}''$ radius Curved Plate and two $2\frac{1}{2}'' \times 2''$ Triangular Flexible Plates.

THE TROLLEY POLE

A $\frac{3}{8}''$ Bolt is passed through a $1'' \times \frac{1}{2}''$ Angle Bracket (31) placed between the lugs of a Double Bracket, and a $\frac{1}{4}''$ Washer is placed on the Bolt. The Bolt is then fixed by two nuts in a $3\frac{1}{2}'' \times 2\frac{1}{2}''$ Flanged Plate (32), which is fitted at each side with a $3\frac{1}{2}'' \times \frac{1}{2}''$ Double Angle Strip. The Flanged Plate is attached to the roof by two $\frac{3}{8}''$ Bolts, and a Flanged Sector Plate (33) is held in the same way by a further $\frac{3}{8}''$ Bolt.

A large Fork Piece (34) is pivoted on a $1\frac{1}{2}''$ Rod held by Collars in the Double Bracket. The trolley pole is an $11\frac{1}{2}''$ Rod fixed in the Fork Piece and fitted with an End Bearing. The pole is supported by a Spring passed over the $11\frac{1}{2}''$ Rod next to a Collar, and bolted by its other end to the lug of Angle Bracket (31).

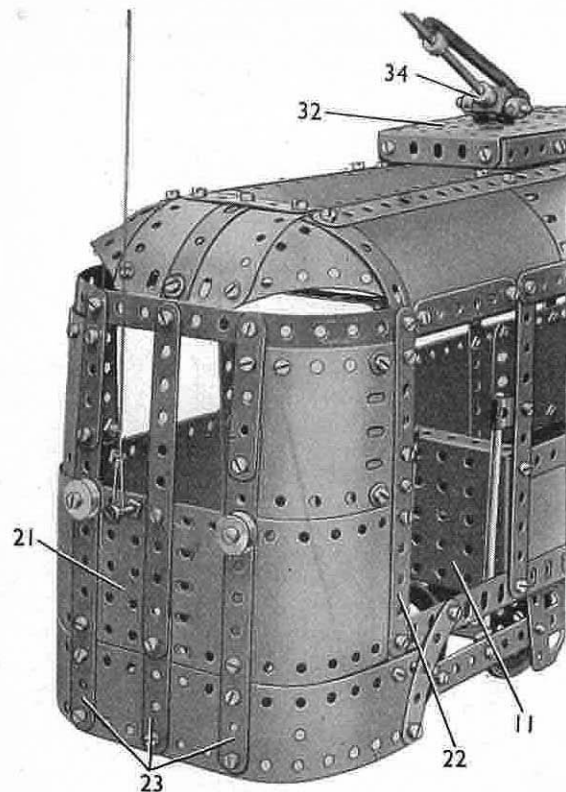

Fig. 8.4a

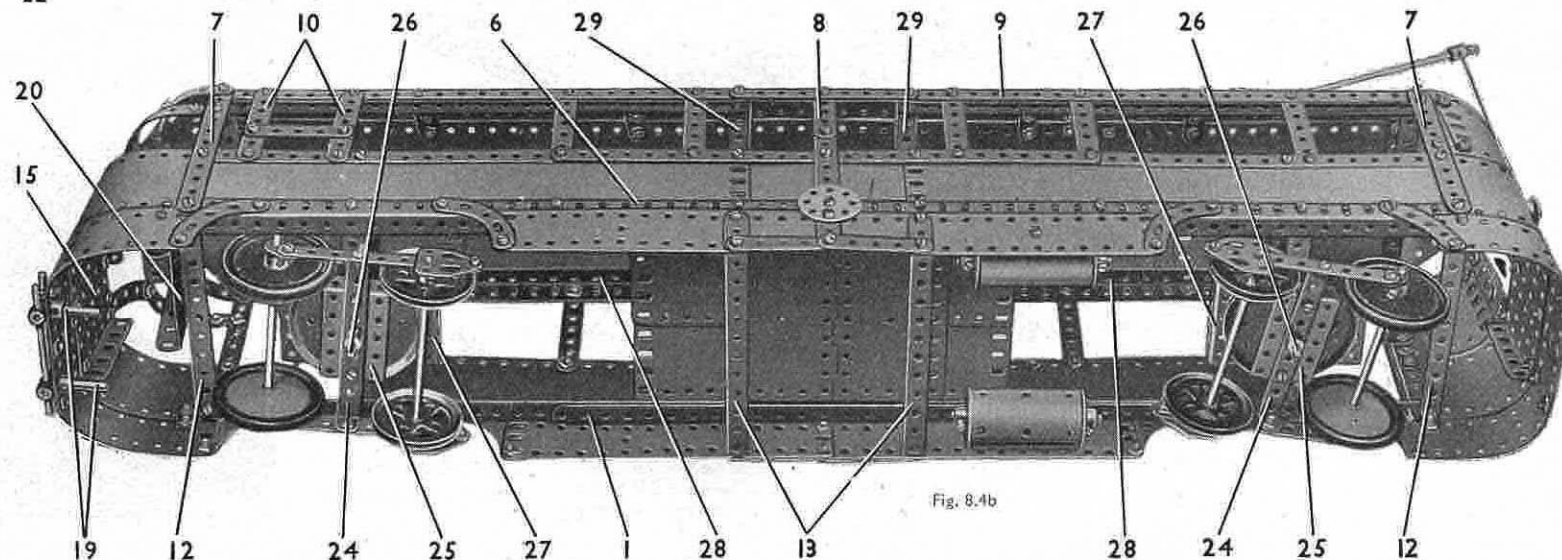

Fig. 8.4b

For new models
and mechanisms
to build see the
MECCANO
MAGAZINE
which is
published monthly

8.5 SKIMMER SCOOP

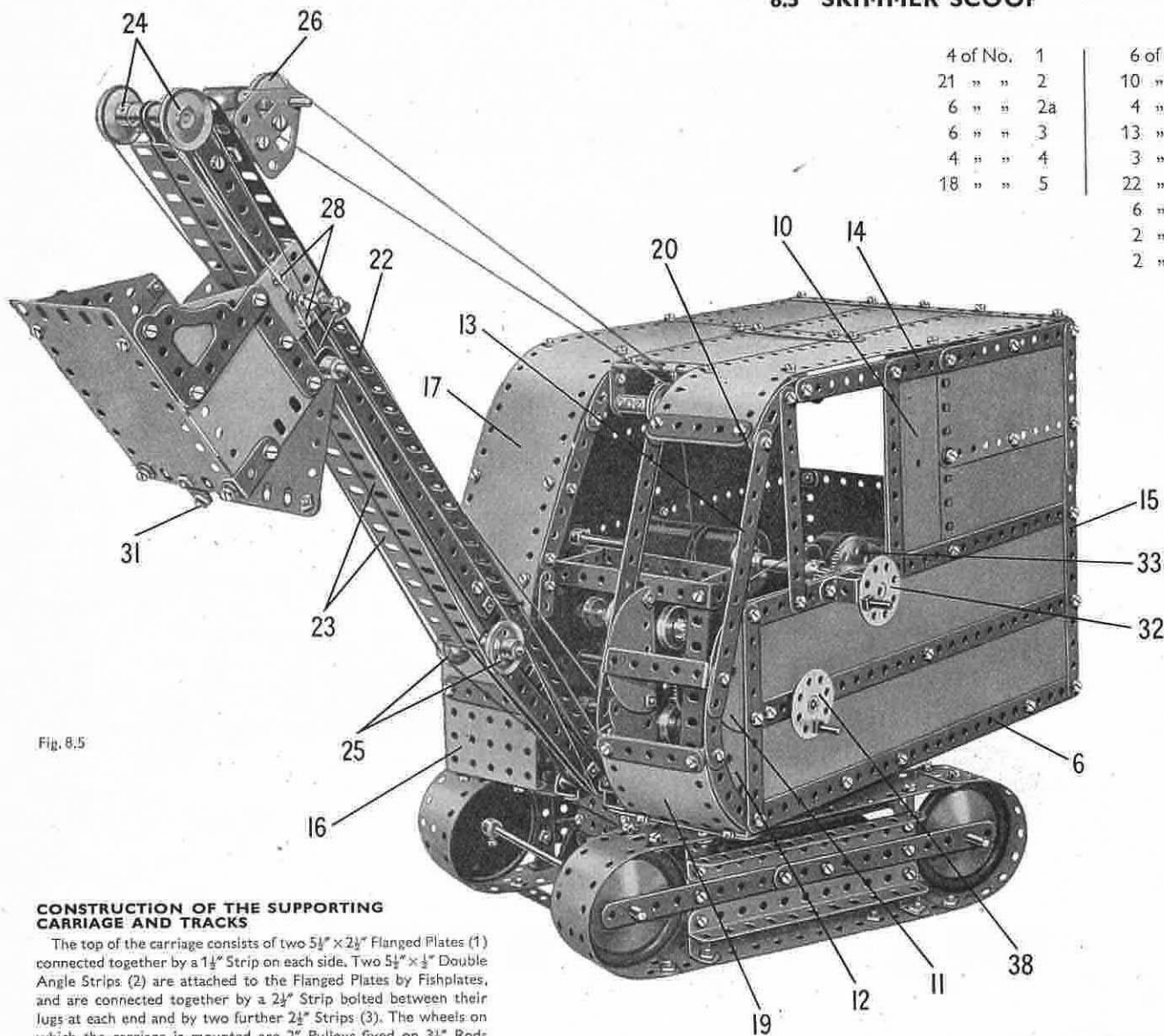

Fig. 8.5

CONSTRUCTION OF THE SUPPORTING CARRIAGE AND TRACKS

The top of the carriage consists of two $5\frac{1}{2}'' \times 2\frac{1}{2}''$ Flanged Plates (1) connected together by a $1\frac{1}{2}''$ Strip on each side. Two $5\frac{1}{2}'' \times \frac{1}{2}''$ Double Angle Strips (2) are attached to the Flanged Plates by Fishplates, and are connected together by a $2\frac{1}{2}''$ Strip bolted between their lugs at each end and by two further $2\frac{1}{2}''$ Strips (3). The wheels on which the carriage is mounted are 2" Pulleys fixed on $3\frac{1}{2}''$ Rods supported in Trunnions as shown in Fig. 8.5b.

Each of the dummy tracks consists of four $5\frac{1}{2}'' \times 1\frac{1}{2}''$ and two $2\frac{1}{2}'' \times 1\frac{1}{2}''$ Flexible Plates bolted together and fixed to the top of the base. Two $2\frac{1}{2}'' \times \frac{1}{2}''$ Double Angle Strips are placed between the upper and lower edges of each track, and they support two $5\frac{1}{2}''$ Angle Girders and a built-up strip (4). The built-up strip consists of two $5\frac{1}{2}''$ Strips overlapped three holes. The track wheels are Road Wheels, two of which are fixed on an 8" Rod and two on a $3\frac{1}{2}''$ and a 4" Rod joined by a Rod Connector.

A 3" Pulley (5) is bolted to the Flanged Plates (1).

		Parts Required							
4 of No.	1	6 of No.	6a	1 of No.	14	3 of No.	45	2 of No.	115
21 "	" 2	10 "	" 8	5 "	" 15a	2 "	" 46	4 "	" 126
6 "	" 2a	4 "	" 9	1 "	" 15b	1 "	" 48	2 "	" 126a
6 "	" 3	13 "	" 10	5 "	" 16	10 "	" 48a	2 "	" 147b
4 "	" 4	3 "	" 11	4 "	" 17	6 "	" 48b	1 "	" 160
18 "	" 5	22 "	" 12	1 "	" 18a	2 "	" 48c	1 "	" 162
		6 "	" 12a	2 "	" 19b	2 "	" 48d	2 "	" 163
		2 "	" 12b	2 "	" 20	2 "	" 51	1 "	" 186
		2 "	" 13a	4 "	" 20a	2 "	" 52	4 "	" 187
				4 "	" 20b	5 "	" 53	5 "	" 188
				5 "	" 22	2 "	" 54	8 "	" 189
				2 "	" 22a	10 "	" 59	5 "	" 190
				2 "	" 23	2 "	" 62	6 "	" 191
				1 "	" 23a	5 "	" 63	8 "	" 192
				2 "	" 24	4 "	" 90	6 "	" 197
				3 "	" 26	4 "	" 90a	1 "	" 198
				2 "	" 27a	1 "	" 95	2 "	" 200
				1 "	" 29	2 "	" 96	2 "	" 212a
				2 "	" 35	1 "	" 96a	2 "	" 213
				276 "	" 37a	2 "	" 108	2 "	" 214
				261 "	" 37b	1 "	" 109	1 "	" 216
				34 "	" 38	2 "	" 111	2 "	" 221
				2 "	" 38d	6 "	" 111a	2 "	" 222
				1 "	" 40	5 "	" 111c	1 "	" 225

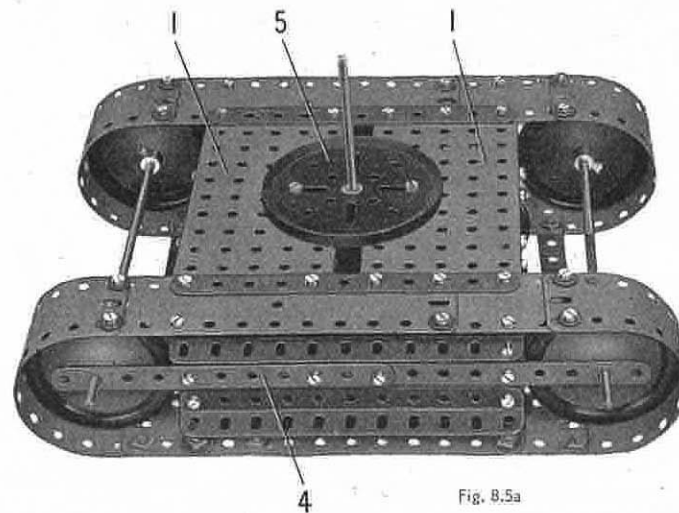

Fig. 8.5a

(Continued on next page)

MODEL 8.5 SKIMMER SCOOP — Continued

ASSEMBLY OF THE CAB

The cab base is made in two sections, each consisting of $12\frac{1}{2}$ " Angle Girders (6) and (7) connected by a $3\frac{1}{2}$ " x $2\frac{1}{2}$ " Flanged Plate (8) and by a similar Flanged Plate between the rear ends of the Girders. The sections are connected together by a 3" Pulley (9) and by a Double Bracket bolted between the rear ends of the Girders (7).

The side of the cab seen in Fig. 8.5 consists of two $12\frac{1}{2}$ " x $2\frac{1}{2}$ " Strip Plates, two $5\frac{1}{2}$ " x $2\frac{1}{2}$ " Flexible Plates, one half of a Hinged Flat Plate (10), a Semi-Circular Plate (11) and a $2\frac{1}{2}$ " x $1\frac{1}{2}$ " Triangular Flexible Plate (12).

The side is bolted to the Girder (6), and the Plates are edged by two $12\frac{1}{2}$ " Strips, three $4\frac{1}{2}$ " Strips, a $5\frac{1}{2}$ " Strip (13), Curved Strips and two built-up strips (14) and (15). Strip (14) consists of two $5\frac{1}{2}$ " Strips bolted together by their end holes, and strip (15) is made from a $5\frac{1}{2}$ " and a $3\frac{1}{2}$ " Strip.

The opposite side also makes use of two $12\frac{1}{2}$ " x $2\frac{1}{2}$ " Strip Plates and two $5\frac{1}{2}$ " x $2\frac{1}{2}$ " Flexible Plates, in the same way as the side already described. The Plates (11) and (12) are omitted, however, and the built-up strip (14) is replaced by two $5\frac{1}{2}$ " Strips overlapped three holes. The window space of the side already described is filled in on the second side by a $5\frac{1}{2}$ " x $2\frac{1}{2}$ ", a $2\frac{1}{2}$ " x $1\frac{1}{2}$ " and two $2\frac{1}{2}$ " x $2\frac{1}{2}$ " Flexible Plates, and a $3\frac{1}{2}$ " x 2 " Triangular-Flexible Plate at the front edge. A $4\frac{1}{2}$ " Strip is attached by a Fishplate to the top front corner of the upper $12\frac{1}{2}$ " x $2\frac{1}{2}$ " Strip Plate, and is joined by a $2\frac{1}{2}$ " Stepped Curved Strip to the front end of the strip corresponding to the strip (14).

One side of the front of the cab is made by bolting a $3\frac{1}{2}$ " x $2\frac{1}{2}$ " Flanged Plate (16) to one of the Girders (6), and connecting it to one of the Girders (7) by a $2\frac{1}{2}$ " Strip. A $12\frac{1}{2}$ " x $2\frac{1}{2}$ " Strip Plate (17) is bolted to the Plate (16) and is curved as shown to form part of the roof. The Strip Plate is connected to the side of the cab by an Angle Bracket and two $2\frac{1}{2}$ " x $\frac{1}{2}$ " Double Angle Strips, and is supported at its rear end by two $3\frac{1}{2}$ " x $\frac{1}{2}$ " Double Angle Strips (18) joined by a Double Bracket.

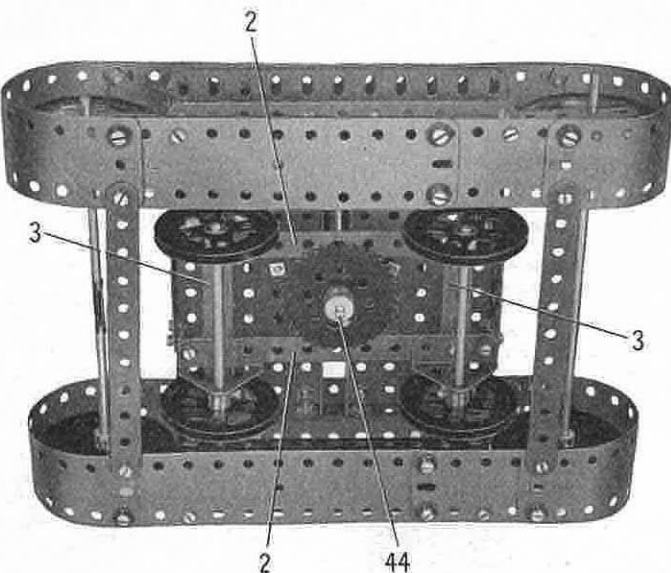

Fig. 8.5b

The front of the operating cabin is made by bolting two $1\frac{1}{8}$ " radius Curved Plates (19) overlapped four holes, to a 3" Strip and a 1 " x 1 " Angle Bracket bolted together and fitted between the front ends of the Girders (6) and (7). The vertical lug of the Angle Bracket supports a $4\frac{1}{2}$ " Strip, to which are bolted a Semi-Circular Plate and a $2\frac{1}{2}$ " x $1\frac{1}{2}$ " Triangular Flexible Plate corresponding to the Plates (11) and (12). The inner side of the cabin is completed by two $2\frac{1}{2}$ " Curved Strips and a $5\frac{1}{2}$ " Strip, in the same way as the outer side, and the Strips of each side are connected by three $2\frac{1}{2}$ " x $\frac{1}{2}$ " Double Angle Strips, one of which is indicated at (20).

The back of the cab is filled in as shown in Fig. 8.5c. It is attached to the sides by Angle Brackets and by the lugs of Double Angle Strips (21).

DETAILS OF THE JIB

The jib consists essentially of four girders joined together by Fishplates to form an 'H'-section girder. The upper two girders are each made from two $12\frac{1}{2}$ " Angle Girders (22) overlapped 15 holes, and the lower pair from two $12\frac{1}{2}$ " Angle Girders (23). Two $5\frac{1}{2}$ " Strips are bolted between the lower ends of the Girders (22) and (23).

A $1\frac{1}{2}$ " x $\frac{1}{2}$ " Double Angle Strip is attached centrally to the lower end of the jib by two Angle Brackets. A 2" Rod is passed through the lugs of the Double Angle Strip and is held in the Girders (7) by Spring Clips. A Crank is fixed to the upper end of each of the Girders (23), and a $1\frac{1}{2}$ " Rod freely mounted in the bosses of the Cranks is fitted with two 1" Pulleys (24). Two 1" loose Pulleys (25) are held by Collars on a 2" Rod passed through the jib and fixed in place by $\frac{1}{2}$ " Pulleys with bosses. Two Flat Trunnions are attached to the upper end of the jib by 1 " x 1 " Angle Brackets, and a 1" Pulley (26) is loosely mounted on a 2" Rod supported in the Flat Trunnions and held in place by Collars.

THE DIGGER BUCKET

The bucket is supported in the jib on a slide consisting of two $2\frac{1}{2}$ " x $1\frac{1}{2}$ " Flanged Plates (27) connected at their lower ends by two Fishplates. Two Angle Brackets on each side are held in place by bolts (28), and these Angle Brackets and the top flanges of the Plates (27) slide freely between the Girders (22) and (23) of the jib.

Each side of the bucket is a $2\frac{1}{2}$ " x $2\frac{1}{2}$ " Flexible Plate and a $2\frac{1}{2}$ " x 2 " Triangular Flexible Plate strengthened by a $2\frac{1}{2}$ " Strip and a Corner Gusset. The sides are attached to Double Bent Strips bolted to the Flanged Plates (27). The base of the bucket is a $4\frac{1}{2}$ " x $2\frac{1}{2}$ " Flexible Plate supported by two Angle Brackets and a $2\frac{1}{2}$ " x 1 " Double Angle Strip (29).

The hinged trap at the rear is a $2\frac{1}{2}$ " x $2\frac{1}{2}$ " Flexible Plate fitted along its lower edge with a $2\frac{1}{2}$ " Strip. The Plate is suspended from a $3\frac{1}{2}$ " Rod (30) by two Right-Angle Rod and Strip Connectors. Rod (30) is held by Collars in the slotted holes of Fishplates bolted to the sides of the bucket.

In its closed position the lower edge of the trap engages behind the head of a bolt (31) fixed by a nut in a Fishplate secured to the base of the bucket.

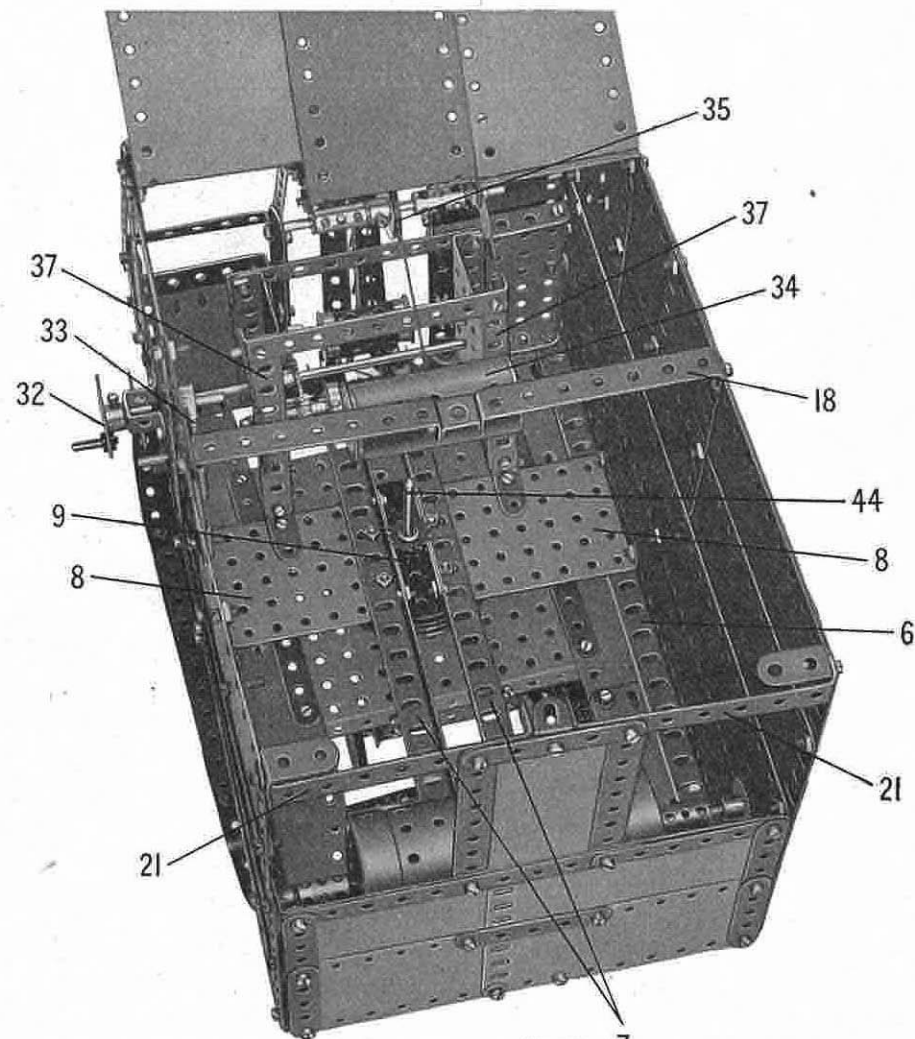

Fig. 8.5c

(Continued on next page)

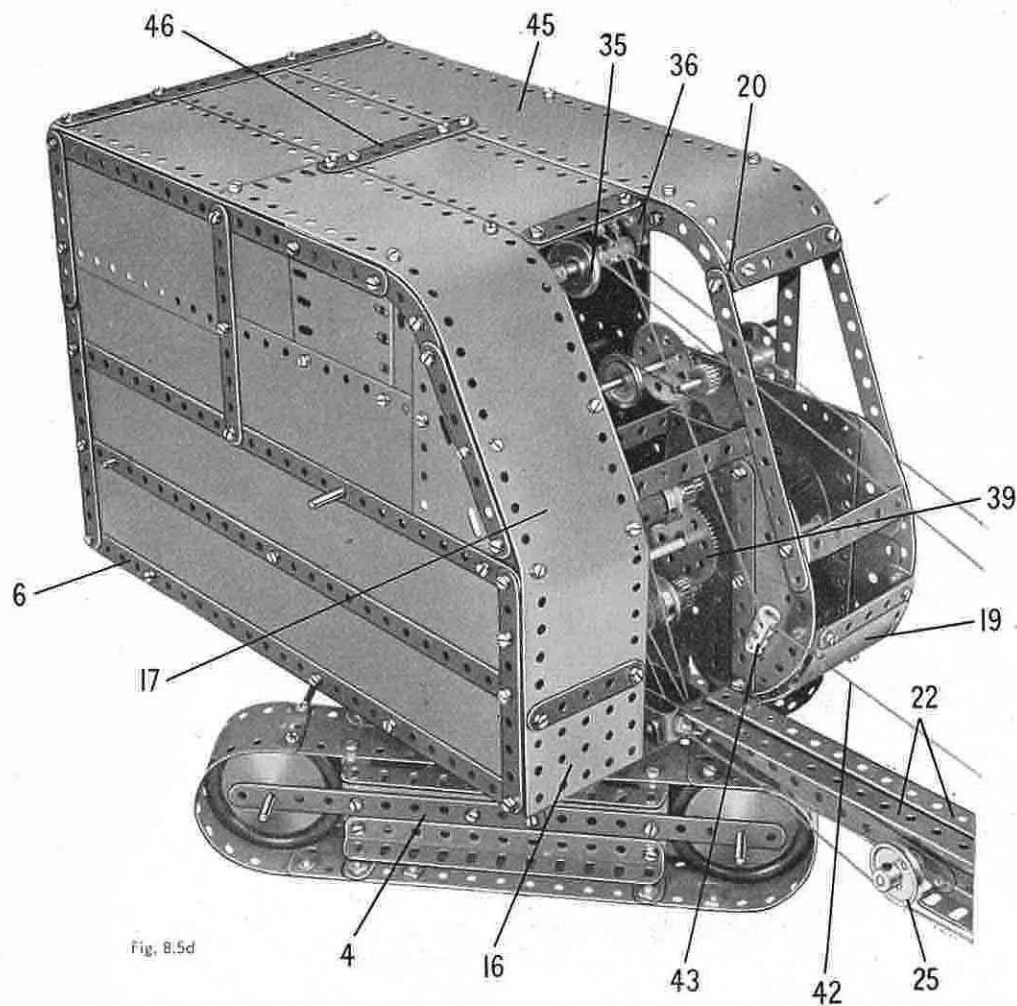

Fig. 8.5d

MOUNTING THE CAB ON THE CARRIAGE

A $4\frac{1}{2}$ " Rod (44) is passed through the Pulley (5) of the supporting carriage and the Pulley (9) of the cab. The Rod is held in place by a 2" Sprocket placed below the Pulley (5) and a $\frac{1}{2}$ " Sprocket fixed above the Pulley (9).

THE CAB ROOF

The Strip Plate (17) is extended towards the rear by a $5\frac{1}{2}$ " \times $2\frac{1}{2}$ " Flexible Plate, and a $12\frac{1}{2}$ " \times $2\frac{1}{2}$ " Strip Plate (45) is bolted between the rear of the cab and the Double Angle Strip (20). The centre of the roof is filled in by two $5\frac{1}{2}$ " \times $2\frac{1}{2}$ " Flexible Plates. The rear edge of the roof is strengthened by a $3\frac{1}{4}$ " and two $2\frac{1}{2}$ " Strips, and a further $3\frac{1}{2}$ " Strip (46) is bolted between the Strip Plates (17) and (45).

The roof is attached to the strip (18) and to $1"$ \times $1"$ Angle Brackets fixed to the upper rear corner of each side.

THE BALANCE WEIGHT

A balance weight is placed at the rear of the cab to give stability to the model. The weight consists of a Boiler filled with suitable parts in the Outfit that are not used in the construction of the model. An 8" Rod is passed through the Boiler which is positioned centrally on it by two Couplings, and the Rod itself is held in the sides of the cab by two 1" Sprockets.

MODEL 8.5 SKIMMER SCOOP — Continued

OPERATING MECHANISM

The jib is luffed by turning a Bush Wheel (32) fixed on a 2" Rod supported in the side of the cab and in a Double Bent Strip. The Rod carries a $\frac{1}{2}$ " Pinion that drives a 57-tooth Gear (33) on a built-up rod supported in the sides of the cab. This Rod consists of two $4\frac{1}{2}$ " Rods, each of which is gripped in a $1\frac{1}{4}$ " Flanged Wheel pressed into a Cylinder (34). A length of Cord tied to the Cylinder is passed over a 1" Pulley (35), round the Pulley (26) and is tied to the roof of the cab. The Pulley (35) is free to turn on a $3\frac{1}{2}$ " Rod, which is held by Couplings in a $2\frac{1}{2}$ " \times $1"$ Double Angle Strip (36) bolted to the Curved Strips that edge the operating cabin, and to the Strip Plate (17).

Two Flanged Sector Plates (37) are attached by $1"$ \times $1"$ Angle Brackets to the Flanged Plates (8), and to the front of the cab by $\frac{1}{2}"$ \times $\frac{1}{2}"$ Angle Brackets. The upper ends of the Flanged Sector Plates are connected by two $4\frac{1}{2}"$ \times $\frac{1}{2}"$ Double Angle Strips. A $6\frac{1}{2}"$ Rod, carrying a Bush Wheel (38), is mounted in a Face Plate bolted to one side of the cab and in the Flanged Sector Plates. The Rod is fitted with a 57-tooth Gear (39) that drives each of two $\frac{1}{2}"$ Pinions on $4\frac{1}{2}"$ Rods mounted in the Flanged Sector Plates, one above and one below the Gear (39). Each Rod carries a drum made from a Sleeve Piece and two $\frac{3}{4}"$ Flanged Wheels. Two separate lengths of Cord are tied to the lower drum, and are led under the jib pivot, then round the lower edge of the Pulleys (25) and are fastened to Pivot Bolts (40) fixed to the bucket slide. Two further lengths of Cord are tied to the upper drum and are led under the jib pivot, over the Pulleys (25) and round the Pulleys (24). These Cords also are tied to the Pivot Bolts (40). The Cords are arranged on the drums so that as those on the lower drum are wound in, those on the upper drum are paid out.

A length of Cord is tied to each end of the Rod (30) and is taken through an Angle Bracket (41) fastened to each of the Plates (27) by $\frac{1}{2}"$ Bolts. The ends of these Cords are tied together and to a single Cord (42), which is passed through a Coupling (43) and fastened to the cab roof. The Coupling weights the Cord and takes up the slack. When Cord (42) is pulled, the hinged trap of the bucket is raised clear of the bolt (31), and swings open to discharge the contents of the bucket. A light braking effect on the jib winding shaft is applied by a length of Cord passed round a 1" Pulley on the shaft. One end of the Cord is tied to one of the Flanged Sector Plates (37), and the other end is fastened to a Driving Band looped through the Flanged Sector Plate.

For new models and mechanisms to build see the
MECCANO MAGAZINE
which is published monthly

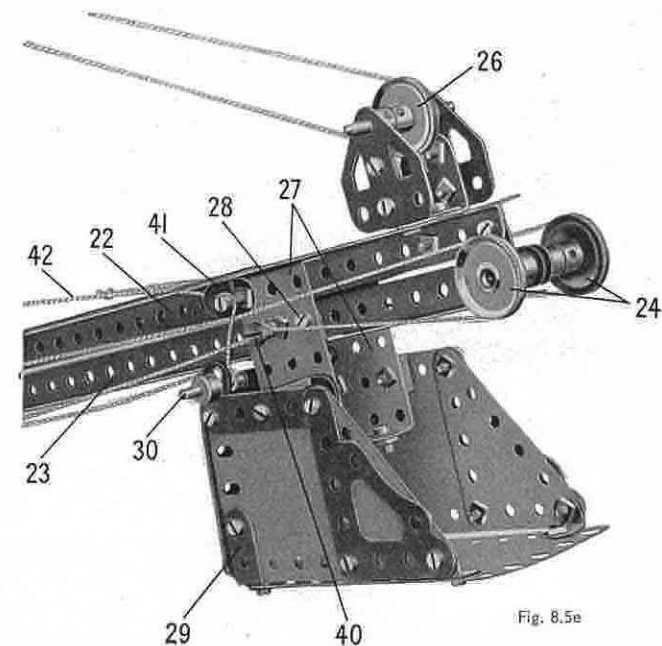

Fig. 8.5e

8.6 BREAKDOWN LORRY

CONSTRUCTION OF THE CHASSIS

Each side member of the chassis consists of two 12½" Angle Girders (1) and (2) joined together by Fish-plates so that they overlap 17 holes. A 4½" Strip (3) on each side is bolted between the rear ends of the Girders. The side members are connected by two 2½" × ½" Double Angle Strips (4) and (5). A 5½" × 2½" Flanged Plate (6) is bolted to the front ends of the Girders (2) so that it overlaps them by three holes, and to each side of this Plate is bolted a 5½" Strip overlapped five holes. Two 3½" Strips (7) are fixed to the Double Angle Strip (4) and to the Girders (1).

The rear wheels are fixed on an 8" Rod supported in the Strips (3), and each wheel is fitted with a Conical Disc held in place by a 1½" Flanged Wheel.

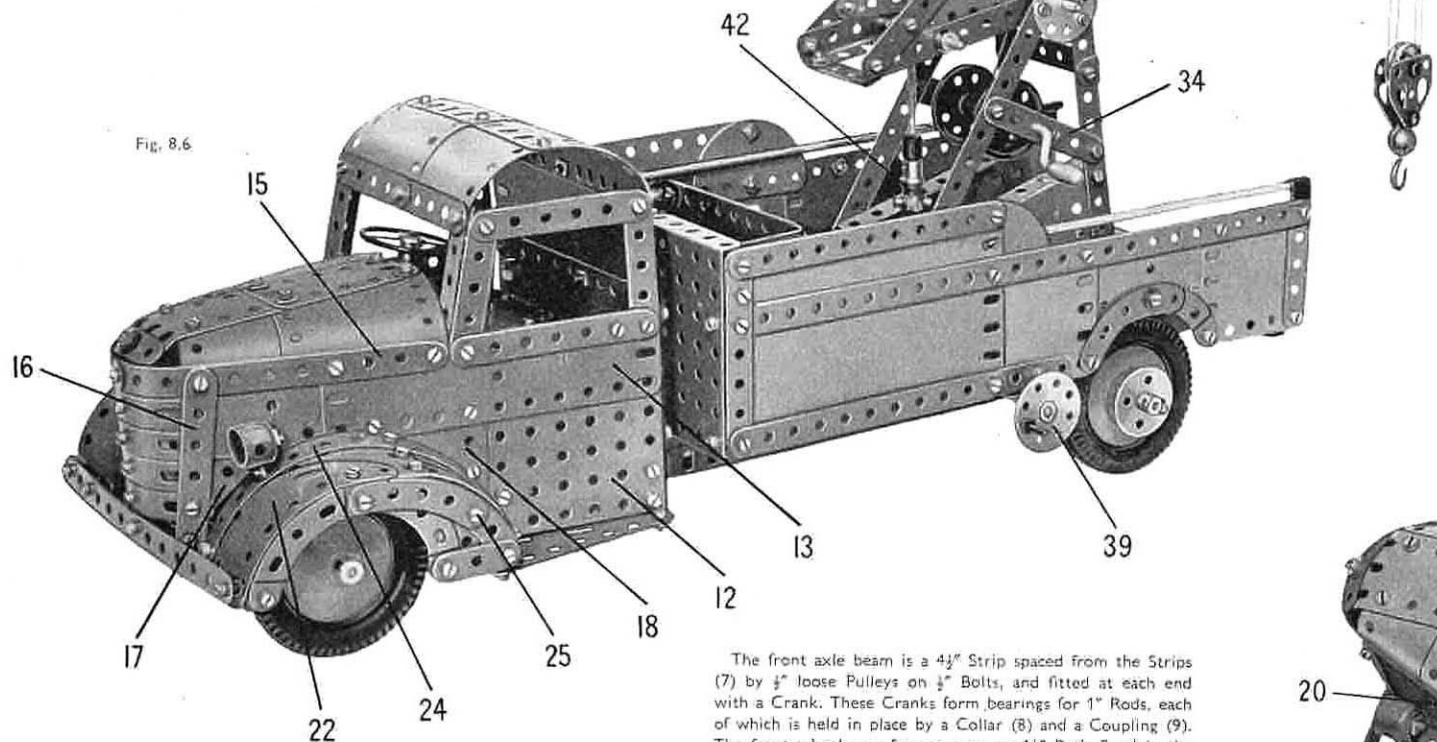

Fig. 8.6

The front axle beam is a 4½" Strip spaced from the Strips (7) by ½" loose Pulleys on ½" Bolts, and fitted at each end with a Crank. These Cranks form bearings for 1" Rods, each of which is held in place by a Collar (8) and a Coupling (9). The front wheels are free to turn on 1½" Rods fixed in the Couplings.

A ½" Bolt is locked by a nut in one of the threaded holes of each Coupling, and an Angle Bracket (10) is fixed against the head of each Bolt by a nut. The Angle Brackets are connected by a 4½" Strip that is attached by lock-nutted bolts.

ASSEMBLY OF THE CAB AND BONNET

The back of the cab consists of two 5½" × 2½" Flexible Plates (11) bolted together and fitted at each side with a 2½" × 1½" Flexible Plate (11). The back is fixed to 3½" × 2½" Flanged Plates (12) that form part of the cab sides. The panelling of each side is completed by a 5½" × 1½" Flexible Plate (13), and the window frame consists of a 3½", a 3" and two 2½" Strips. The top rear corners of the window frames are connected to the back of the cab by Angle Brackets. A 5½" Strip (14) is bolted across the Flanged Plate (6) and the cab sides are attached to this Strip by Angle Brackets.

The Plates (13) are extended forward by 5½" × 1½" Flexible Plates edged by 5½" Strips (15), and the front ends of these parts are curved as shown and bolted together. Each side of the bonnet is completed by a 3" Strip (16), a 2½" × 1½" Triangular Flexible Plate (17) and a 2½" × 2½" Triangular Flexible Plate (18). The radiator is formed by four Formed Slotted Strips bolted to a 3" Strip, and the latter part is connected to the Double Angle Strip (4) by a 1" × ½" Angle Bracket (19) as shown in Fig. 8.6b.

(Continued on next page)

Parts Required

5 of No. 1	2 of No. 22a	6 of No. 111c
21 " " 2	2 " " 23	2 " " 115
6 " " 2a	1 " " 23a	1 " " 116a
6 " " 3	2 " " 24	1 " " 120b
6 " " 4	2 " " 24a	2 " " 125
18 " " 5	3 " " 26	4 " " 126
2 " " 6	1 " " 27a	2 " " 126a
6 " " 6a	1 " " 29	4 " " 142a
8 " " 8	2 " " 35	2 " " 147b
4 " " 9	266 " " 37a	2 " " 164
7 " " 10	246 " " 37b	2 " " 165
32 " " 12	35 " " 38	1 " " 166
5 " " 12a	1 " " 38d	1 " " 173a
1 " " 12b	1 " " 40	1 " " 176
5 " " 12c	2 " " 45	1 " " 185
2 " " 13	3 " " 48a	4 " " 187a
1 " " 13a	2 " " 48c	8 " " 188
1 " " 14	1 " " 48d	8 " " 189
1 " " 15b	2 " " 52	10 " " 190
1 " " 16	5 " " 53	1 " " 191
4 " " 17	2 " " 54	8 " " 192
4 " " 18a	1 " " 57b	2 " " 197
2 " " 18b	10 " " 59	8 " " 200
1 " " 19g	2 " " 62	2 " " 212
2 " " 20	5 " " 63	2 " " 212a
4 " " 20a	2 " " 77	2 " " 214
3 " " 20b	1 " " 80c	8 " " 215
2 " " 21	4 " " 90	4 " " 221
2 " " 22	8 " " 90a	2 " " 222
	2 " " 108	2 " " 223
	3 " " 111	2 " " 224
	6 " " 111a	2 " " 225

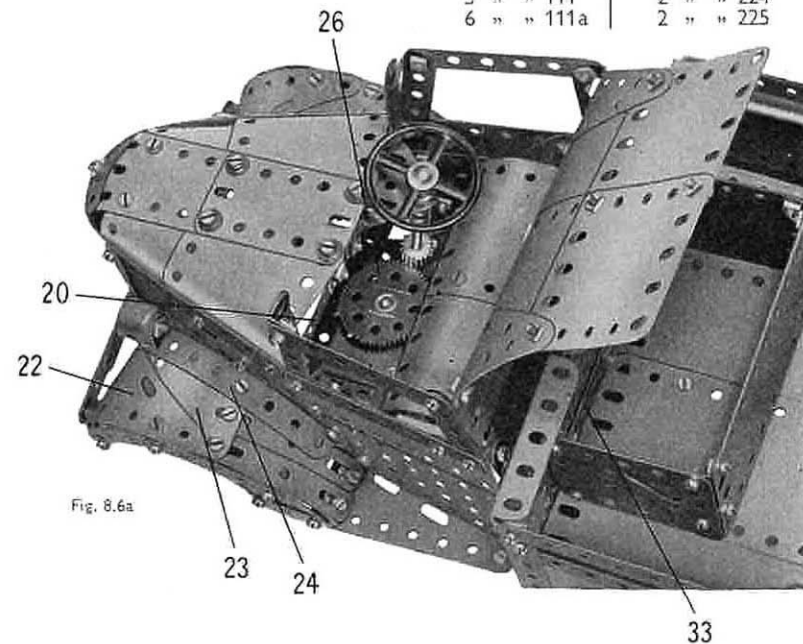

Fig. 8.6a

33

MODEL 8.6 BREAKDOWN LORRY — Continued

The top of the bonnet is filled in by two $2\frac{1}{2}'' \times 1\frac{1}{2}''$ Flexible Plates and four $1\frac{1}{4}''$ radius Curved Plates arranged as in Fig. 8.6a. At the front a $1\frac{1}{2}''$ Strip is bolted to an Obtuse Angle Bracket fixed to the radiator. Each side of the windscreen consists of a $2\frac{1}{2}''$ Strip connected to the top of the window frame by an Angle Bracket. At the top these Strips support a built-up strip made from two $2\frac{1}{4}''$ Strips, and to their lower ends is attached a similar strip (20) (Fig. 8.6a). The join at the centre of strip (20) is strengthened by a $1\frac{1}{2}''$ Strip.

The cab roof consists of four $2\frac{1}{2}'' \times 2\frac{1}{2}''$ Flexible Plates and two $2\frac{1}{2}'' \times 1\frac{1}{2}''$ Triangular Flexible Plates curved and arranged as shown in Fig. 8.6a. The driving seat is made from two $1\frac{1}{4}''$ radius Curved Plates, and it is attached to one side of the cab by a Trunnion and to the other side by a $1'' \times 1''$ Angle Bracket.

Each front mudguard is made from a $3\frac{1}{2}'' \times 2''$ Triangular Flexible Plate (22), a $2\frac{1}{2}'' \times 1\frac{1}{4}''$ Flexible Plate (23), two Formed Slotted Strips and a $5\frac{1}{2}''$ Strip (24). The Formed Slotted Strips are connected to the side of the cab by a $1'' \times 1''$ Angle Bracket at their rear ends, and at the front the mudguard is supported by an Obtuse Angle Bracket bolted to the Strip (16). The mudguard is edged by Curved Strips and a $1\frac{1}{2}''$ Strip as shown, with a $1''$ Triangular Plate attached by a Bolt (25). The step is a $3\frac{1}{2}'' \times 1\frac{1}{2}''$ Triangular Flexible Plate supported by Angle Brackets.

STEERING MECHANISM

The steering column is made from a $3\frac{1}{4}''$ Rod mounted in the Flanged Plate (6) and in a Trunnion bolted to the strip (20). The Rod is held in place by a Collar and a Coupling, and it carries a $\frac{1}{2}''$ Pinion that drives a 57-tooth Gear (26). This Gear is fixed on a $2''$ Rod supported in a Double Bent Strip bolted to the Plate (6), and is held in place by a $\frac{1}{2}''$ fixed Pulley. The Rod

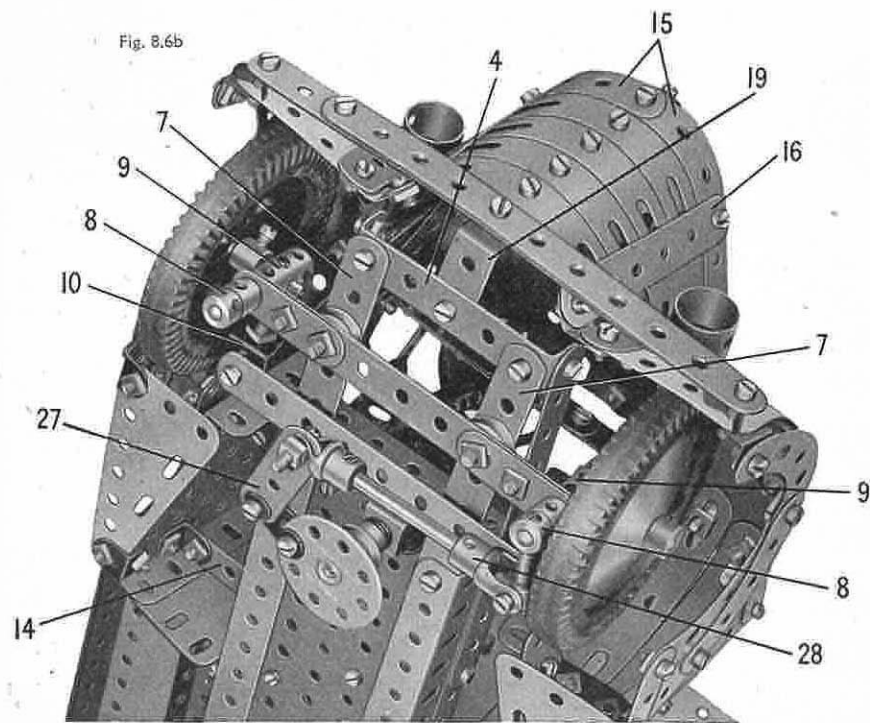

Fig. 8.6b

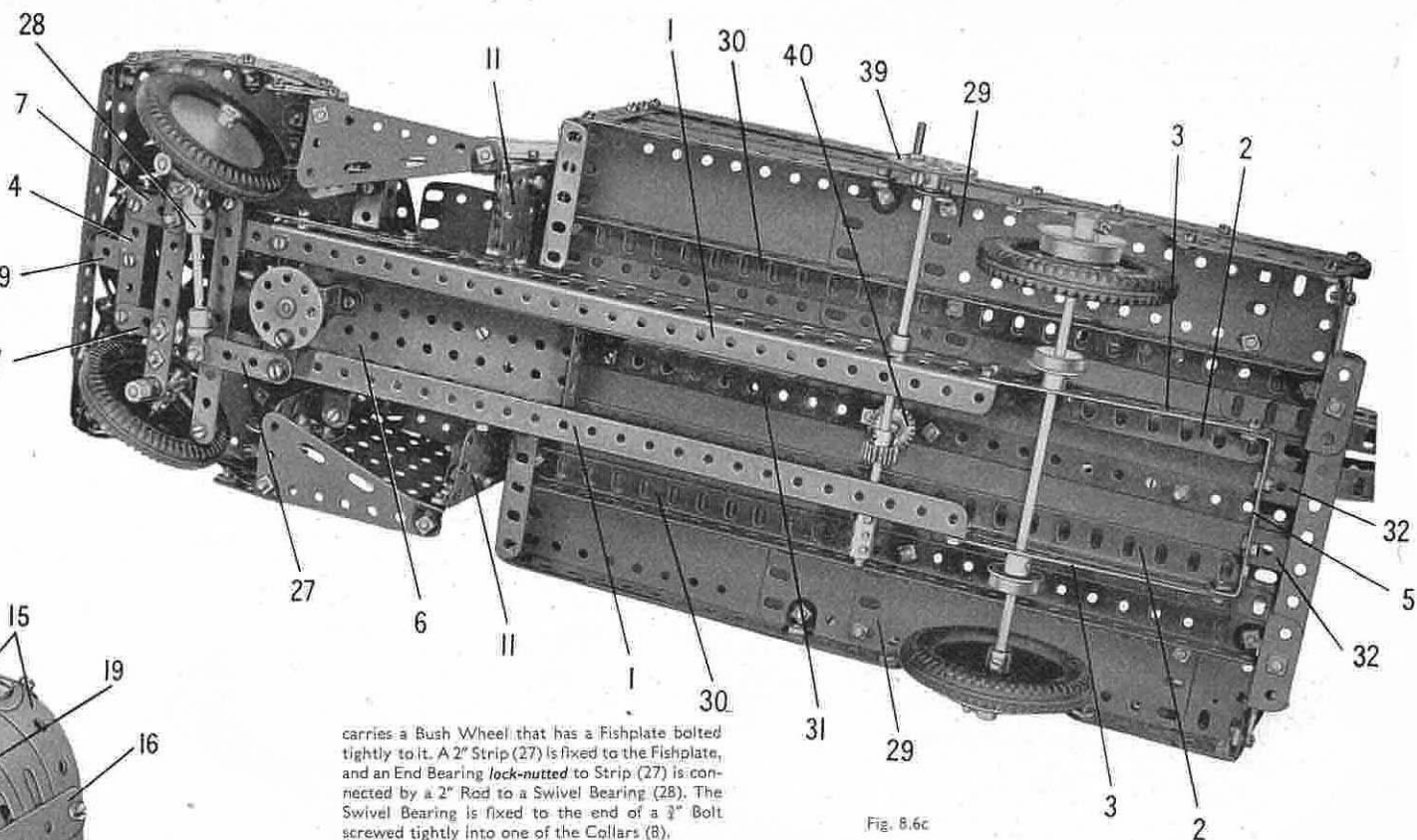

Fig. 8.6c

carries a Bush Wheel that has a Fishplate bolted tightly to it. A $2''$ Strip (27) is fixed to the Fishplate, and an End Bearing lock-nutted to Strip (27) is connected by a $2''$ Rod to a Swivel Bearing (28). The Swivel Bearing is fixed to the end of a $\frac{3}{4}''$ Bolt screwed tightly into one of the Collars (8).

DETAILS OF THE BODY

The floor of the body consists of two $12\frac{1}{2}'' \times 2\frac{1}{2}''$ Strip Plates at the centre, with a $5\frac{1}{2}'' \times 2\frac{1}{2}''$, a $2\frac{1}{2}'' \times 2\frac{1}{2}''$, a $2\frac{1}{2}'' \times 1\frac{1}{2}''$ and a $5\frac{1}{2}'' \times 1\frac{1}{2}''$ Flexible Plate (29) bolted to each side. The Plates (29) are curved slightly to clear the rear wheels. The floor is strengthened by two $12\frac{1}{2}''$ Angle Girders (30) and a $12\frac{1}{2}''$ Strip (31) on the underside. The sides are assembled from Strips, Curved Strips and Plates arranged as shown in Figs. 8.6 and 8.6d, and they are connected to the floor by Angle Brackets. At the rear the sides are attached by $1'' \times 1''$ Angle Brackets to a built-up strip, made from two $5\frac{1}{2}''$ Strips overlapped seven holes. This is connected to the Double Angle Strip (5) by $\frac{1}{2}''$ Reversed Angle Brackets (32). A $5\frac{1}{2}''$ Strip forming a step is attached to the built-up strip by two Trunnions.

The front of the body is made from three $3\frac{1}{2}'' \times 2\frac{1}{2}''$ Flanged Plates joined edge to edge by two $4\frac{1}{2}'' \times \frac{1}{2}''$ Double Angle Strips, one of which is seen at (33). The outer Flanged Plates are connected to the sides by Angle Brackets, and the central Flanged Plate is bolted to the chassis by its lower flange.

The sides of the tool box are $2\frac{1}{2}'' \times 2\frac{1}{2}''$ Flexible Plates fixed to the lugs of the Double Angle Strips (33) and strengthened by Corner Gussets. The rear of the tool box is a $4\frac{1}{2}'' \times 2\frac{1}{2}''$ Flexible Plate attached to Angle Brackets and edged at the top by a $4\frac{1}{2}''$ Strip.

The handrails are $1\frac{1}{2}''$ Rods supported in Rod and Strip Connectors and Right-Angle Rod and Strip Connectors.

THE BREAKDOWN CRANE

A $5\frac{1}{2}'' \times 2\frac{1}{2}''$ Flanged Plate is fixed to the floor of the lorry body, and to each of its longer flanges is bolted a Flanged Sector Plate. The Flanged Sector Plates support $5\frac{1}{2}''$ Strips, braced by $3''$ Strips (34) and connected at their upper ends by Wheel Discs (35).

The lower girders of the jib are $12\frac{1}{2}''$ Angle Girders (36), and the upper girders (37) are each made from two $5\frac{1}{2}''$ Angle Girders bolted together. The girders (36) and (37) on each side are joined at the rear by a $3\frac{1}{2}''$ and a $2\frac{1}{2}''$ Strip and a $2\frac{1}{2}'' \times 2''$ Triangular Flexible Plate. At the front the girders (37) are connected by a Fishplate, and at the centre and rear by $1\frac{1}{2}''$ Strips. The girders (36) are joined at the rear by a $2''$ Strip, and the jib is lengthened by two $2\frac{1}{2}''$ Strips. These Strips support a $2''$ Rod that carries two $1''$ Pulleys (38). The jib pivots on a $3\frac{1}{4}''$ Rod held in the Wheel Discs (35) by Collars.

(Continued on next page)

MODEL 8.6 BREAKDOWN LORRY — Continued

The jib is luffed by turning a Bush Wheel (39) fitted with a handle formed by a Threaded Pin. The Bush Wheel is fixed on a $6\frac{1}{2}$ " Rod held in the Girders (2) by a Collar and a Coupling, and it carries a $\frac{1}{2}$ " Pinion that drives a $\frac{1}{2}$ " Contrate (40). The Contrate is fixed on a 2" Rod supported by a Double Bent Strip (41). The Rod is fitted with a $\frac{1}{2}$ " Flanged Wheel and a universal coupling (42), which is made up from a Swivel Bearing and a small Fork Piece. An Adaptor for Screwed Rods is fixed in the universal coupling, and it carries a Screwed Rod locked tightly to it by a nut. This Screwed Rod is threaded through the centre screwed hole of a Coupling (43), which is fixed on two $1\frac{1}{2}$ " Rods held in the jib by Collars.

A $3\frac{1}{2}$ " Crank Handle is mounted in the Strips (34) and is fitted with a Compression Spring placed between one of the Strips and a $\frac{1}{2}$ " Pinion. Two $1\frac{1}{2}$ " Pulleys are fixed on the Crank Handle and a Threaded Pin is screwed into the boss of one of them. The Compression Spring normally pulls the Crank Handle to one side so that the Threaded Pin engages a bolt in one of the Strips (34) to form a simple brake.

Cord is tied to the Crank Handle between the $1\frac{1}{2}$ " Pulleys and is led over one of the Pulleys (38) and round a 1" loose Pulley in the pulley block. It is taken round the second Pulley (38) and a second 1" loose Pulley in the pulley block, and is tied finally to the top of the jib. The 1" loose Pulleys in the pulley block are mounted on a Pivot Bolt that connects the Flat Trunnions together, and a large Loaded Hook is supported by another Pivot Bolt.

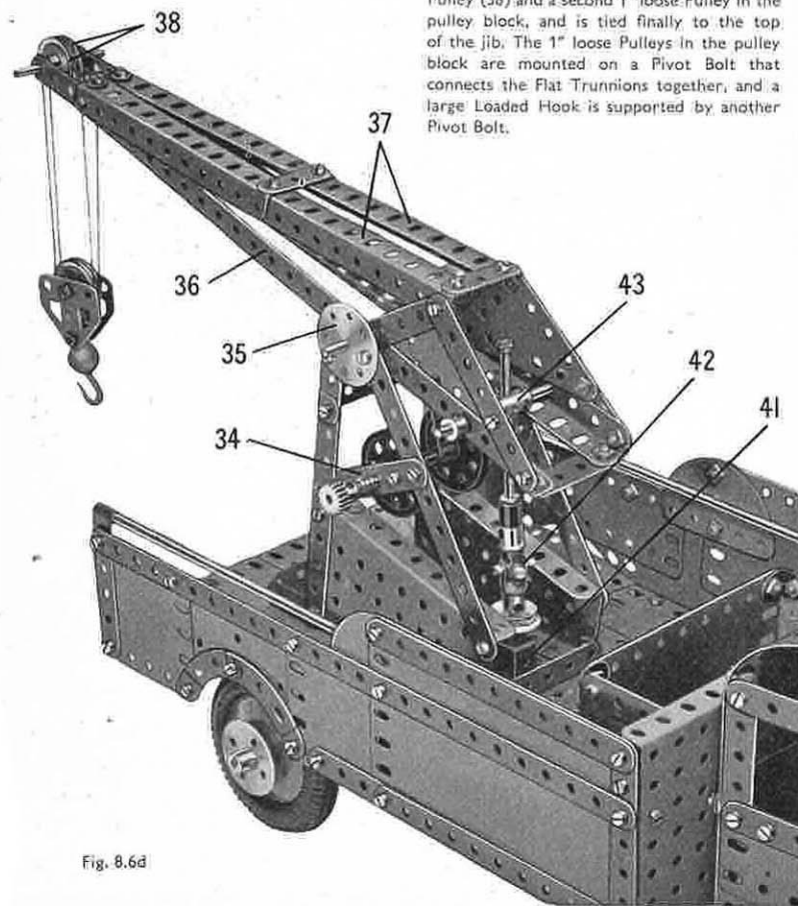

Fig. 8.6d

8.7 'JUMBO' MOBILE CRANE

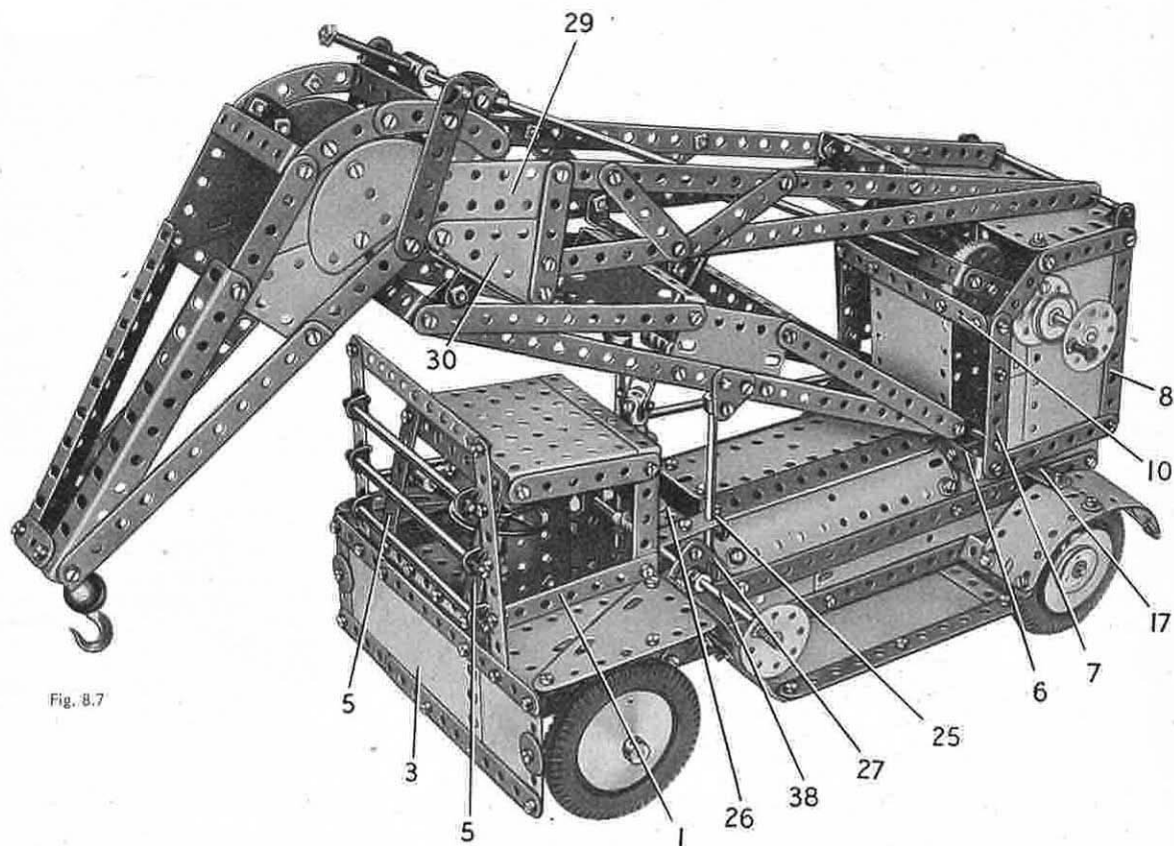

Fig. 8.7

BUILDING THE CHASSIS

Each side member of the chassis consists of a $12\frac{1}{2}$ " Angle Girder and a $12\frac{1}{2}$ " Strip connected by $3\frac{1}{2}$ " x $2\frac{1}{2}$ " Flanged Plates (1) and (2). The Plate (1) overhangs the $12\frac{1}{2}$ " Strip by three clear holes, and likewise, the Plate (2) overhangs the Angle Girder by three clear holes. The side member is filled in by two $5\frac{1}{2}$ " x $1\frac{1}{2}$ " Flexible Plates.

At the front the side members are bolted to a built-up plate (3), made from two $5\frac{1}{2}$ " x $2\frac{1}{2}$ " Flexible Plates overlapped seven holes and edged by $5\frac{1}{2}$ " and $2\frac{1}{2}$ " Strips. The rear flanges of the Plates (2) are bolted to a built-up plate (4), made from two $2\frac{1}{2}$ " x $2\frac{1}{2}$ " Flexible Plates overlapped three holes.

The front of the cab consists of two $4\frac{1}{2}$ " Strips (5), connected at the top by a $3\frac{1}{2}$ " x $\frac{1}{2}$ " Double Angle Strip that supports a $3\frac{1}{2}$ " x $2\frac{1}{2}$ " Flanged Plate forming the roof. The Flanged Plate is edged by two 3" Strips, and these support a further $3\frac{1}{2}$ " x $\frac{1}{2}$ " Double Angle Strip that is connected to the Plates (1) by a $2\frac{1}{2}$ " Strip on each side. The cab protection bars are a $4\frac{1}{2}$ " and two 5" Rods held by Spring Clips in Angle Brackets bolted to two $5\frac{1}{2}$ " Strips. These Strips are fixed to the plate (3) and are connected at their upper ends by a further $5\frac{1}{2}$ " Strip.

Two $4\frac{1}{2}$ " x $\frac{1}{2}$ " Double Angle Strips (6) are bolted across the Plates (2), and are connected at their ends by $3\frac{1}{2}$ " Strips. The Double Angle Strips support a $3\frac{1}{2}$ " Strip (7) and a $4\frac{1}{2}$ " Strip (8) on each side. The upper ends of these Strips are joined by a $2\frac{1}{2}$ " and a 2" Strip as shown in Fig. 8.7, and the space between the Strips on one side is filled in by a $4\frac{1}{2}$ " x $2\frac{1}{2}$ " and a $2\frac{1}{2}$ " x $2\frac{1}{2}$ " Flexible Plate and a $2\frac{1}{2}$ " x $1\frac{1}{2}$ " Triangular Flexible Plate. The other side is filled in by three $2\frac{1}{2}$ " x $2\frac{1}{2}$ " Flexible Plates and a $2\frac{1}{2}$ " x $1\frac{1}{2}$ " Flexible Plate, as shown in Fig. 8.7b.

Two $4\frac{1}{2}$ " x $2\frac{1}{2}$ " Flexible Plates are bolted to the plate (4) and to a $4\frac{1}{2}$ " Strip (9) attached to the Strips (8) by Angle Brackets. The Strips (7) are connected by Angle Brackets to a $4\frac{1}{2}$ " Strip (10) that supports a $4\frac{1}{2}$ " x $2\frac{1}{2}$ " Flexible Plate placed vertically. The structure is roofed by a $4\frac{1}{2}$ " x $2\frac{1}{2}$ " Flexible Plate attached to Angle Brackets.

A $5\frac{1}{2}$ " x $1\frac{1}{2}$ " Flexible Plate on each side is connected to the chassis side member by Obtuse Angle Brackets, and is edged at the top by a $5\frac{1}{2}$ " Strip. These Flexible Plates are joined by further Obtuse Angle Brackets to a $5\frac{1}{2}$ " x $1\frac{1}{2}$ " Flexible Plate (11). (Continued on next page)

MODEL 8.7 'JUMBO' MOBILE CRANE — Continued

THE WHEELS AND STEERING MECHANISM

The front wheels are fixed on an 8" Rod mounted in the chassis, and the Conical Discs are held in place by Collars. The rear axle is a 5½" Strip (12) attached to the chassis by ¾" Bolts but spaced from it by a ¼" loose Pulley on each Bolt.

The front mudguard on each side consists of a 3½" × 2" and a 3½" × 1½" Triangular Flexible Plate bolted at the front to a Corner Gusset (13) and attached to the Plate (1) and the plate (3) by Angle Brackets. The rear flap of each mudguard is made from a 2½" × 1½" Flexible Plate and a 2½" Strip connected by a Fishplate and a 1" × 1" Angle Bracket held by the bolts (14). The flap is attached to the top of the mudguard by an Obtuse Angle Bracket, and the 1" × 1" Angle Bracket is bolted to the lower edge of the chassis.

Each rear mudguard consists of two 2½" × 1½" Flexible Plates curved and edged by two Formed Slotted Strips. The assembly is attached to one of the Plates (2) by a 1" × ¼" and a 1" × 1" Angle Bracket. Between the front and rear mudguards on each side is fixed a 5½" × 2½" Flexible Plate, edged by 5½" Strips fixed across the chassis. A tool box (Fig. 8.7b) over one of these Plates is made from a 2½" × 1" and three 2½" × ½" Double Angle Strips, joined together by Fishplates and attached to the chassis by an Angle Bracket.

Two 1½" Strips (15) are fixed tightly by nuts to the ends of Threaded Pins, and each Pin is passed through one of the end holes of the Strip (12). A Coupling (16) is then locked on each Threaded Pin. A 1½" Rod is fixed in each Coupling and is supported in one of the rear mudguards and in a 1" × 1" Angle Bracket (17). The ends of the Strips (15) are connected by lock-nutted bolts to a 5½" Strip (18).

One of the 1½" Rods in the Couplings (16) is fitted with a Coupling (19) that carries also a 1" Rod. A Crank is fixed on the 1" Rod, and a Rod and Strip Connector lock-nutted to the Crank is fitted to one end of an 11½" Rod (20). The other end of Rod (20) is fixed in a Swivel Bearing mounted on a 1" Rod. This 1" Rod is held in a Rod and Strip Connector bolted tightly to a Crank on the steering column. The latter is a 3½" Rod and is held by a ¼" fixed Pulley in a Flat Trunnion bolted to a Channel Bearing (21). The Channel Bearing is fixed to a 3½" Strip attached to the Strips (5), and the lower end of the steering column is supported in a Trunnion (22) bolted to the plate (3).

Each of the rear wheels is free to turn on a ½" Bolt screwed into one of the Couplings (16). The wheel is spaced on the Bolt by a Washer, a 1" loose Pulley and a Conical Disc.

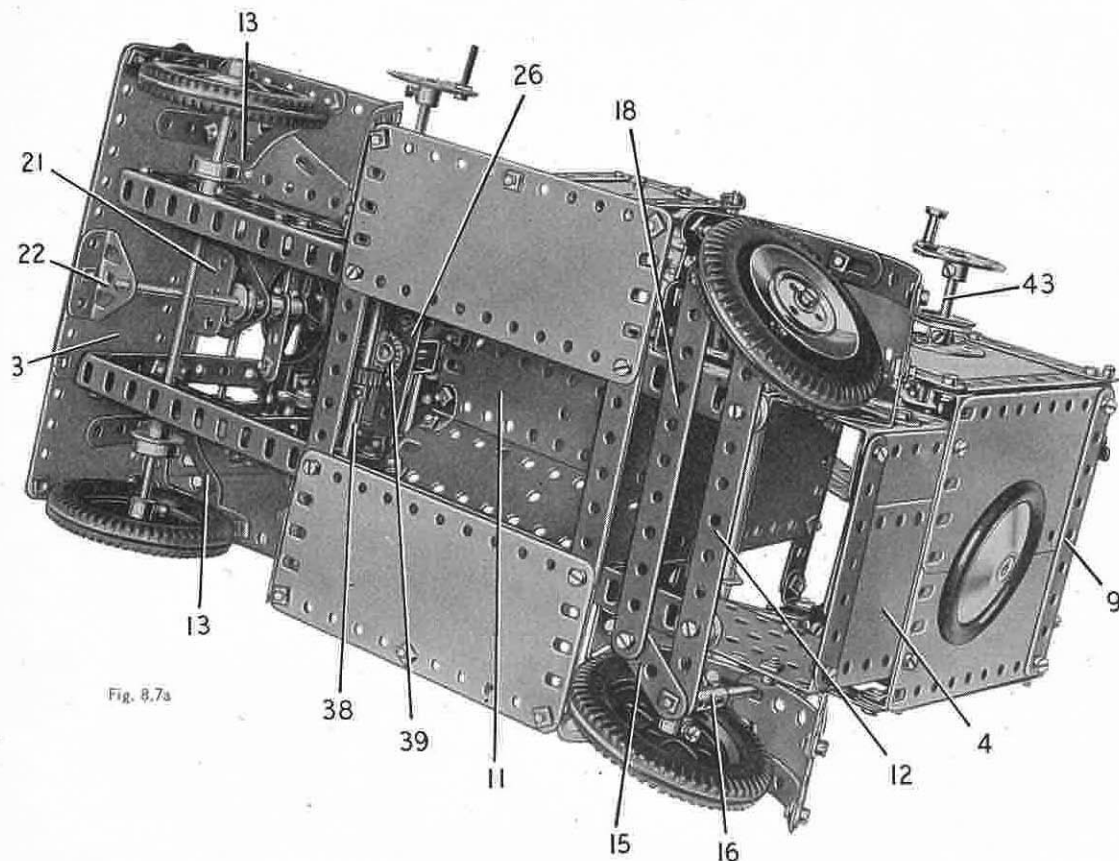

Fig. 8.7a

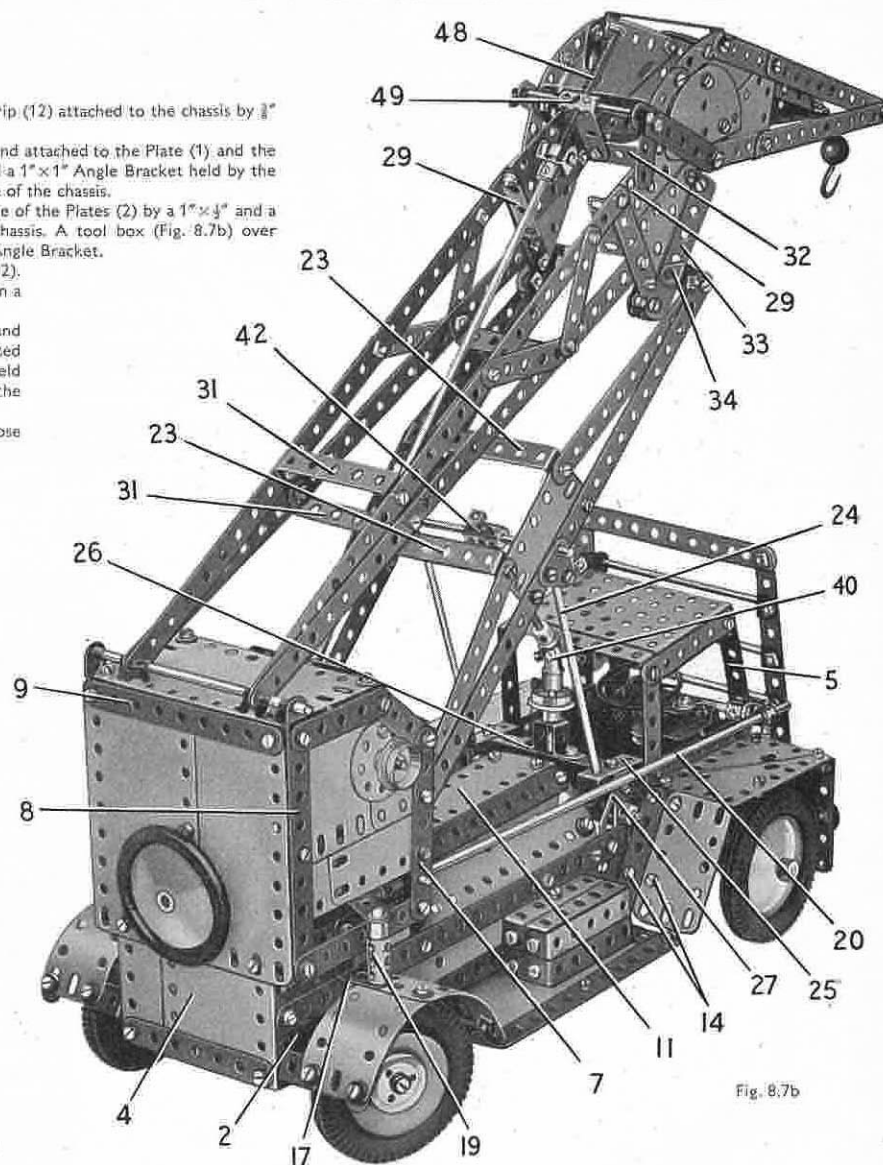

Fig. 8.7b

ASSEMBLY OF THE JIB

Each side of the lower limb of the jib consists of a 12½" Strip and two 5½" Strips, bolted together at their ends and fixed at the centre to a 2½" × 1½" Flexible Plate. The sides are connected by three 3½" × ½" Double Angle Strips (23), and each side is extended at its lower end by a Fishplate. The Fishplates pivot on a 5" Rod held by Spring Clips in the Strips (7). Two 1" Triangular Plates are fixed to the 12½" Strips, and 4½" Rods (24) are gripped in Collars pivoted on bolts passed through the Triangular Plates. These Rods slide freely in 1½" × ½" Double Angle Strips (25) bolted to the Plates (1) and to a 3½" × ½" Double Angle Strip (26), which is supported by Flat Trunnions (27) fixed to the chassis.

(Continued on next page)

MODEL 8.7 'JUMBO' MOBILE CRANE — Continued

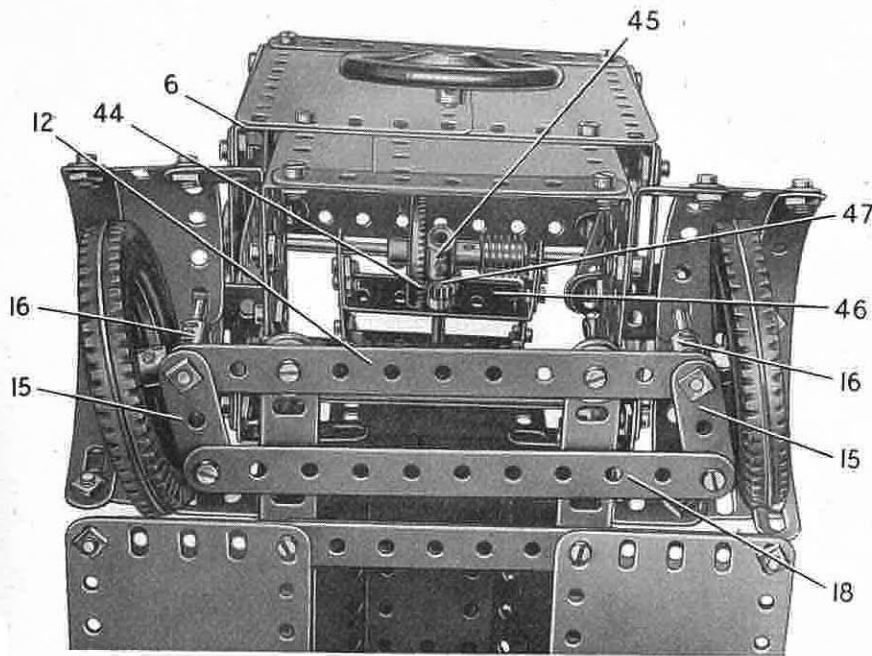

Fig. 8.7c

The upper limb consists of two 12½" Strips on each side bolted at their front ends to a 2½" Strip (28) (Fig. 8.7e), a 2½" × 1½" Flanged Plate (29), and a 2½" × 1½" Triangular Flexible Plate (30). The sides are braced by 2½" Strips, and are joined together by 2½" × ½" Double Angle Strips (31) and (32). The Double Angle Strip (32) is bolted to the front flanges of the Plates (29), but is spaced from them by a Washer on each bolt. The lower ends of the 12½" Strips pivot on a 5" Rod held by Spring Clips in Fishplates that extend the Strip (8).

A 3" Strip (33) on each side is attached by Angle Brackets to the front of the Flanged Plate (29) and to a Fishplate fixed to the lower end of the Strip (28). Strips (33) slide freely between two Angle Brackets (34) on each side, which are bolted together by their slotted holes. A ½" Bolt is used to connect each pair of Angle Brackets. This Bolt is passed through a Fishplate at each side of the upper end of the lower limb, and the Angle Brackets are fixed on it by two nuts.

The pivoted jib head (Fig. 8.7e) consists of two 5½" Angle Girders on each side. These are bolted together at the front and extended at the rear by 2½" Strips. A 3" Strip (35) is bolted to the lower 2½" Strip, and is connected to the upper Strip by two 2½" Curved Strips. The rear end of each side is plated by a 2½" × 2" and a 2½" × 2½" Triangular Flexible Plate and a Semi-Circular Plate. The sides are connected at the front by a 1½" Strip, and at the rear by two 2½" × ½" Double Angle Strips (36). A large Loaded Hook is mounted at the front on a ½" Bolt supported by two Angle Brackets. The jib head pivots on two lock-nutted ¾" Bolts (37) passed through the lugs of the Double Angle Strip (32).

THE OPERATING MECHANISM

The jib is raised and lowered by turning a Bush Wheel on a 6½" Rod (38). The Rod is held in place by Collars, and it carries a ½" Pinion that drives a ¾" Contrate (39) (Fig. 8.7a) on a 2" Rod. The 2" Rod is supported in the Double Angle Strip (26) and in a Double Bent Strip bolted to it, and at its upper end the Rod is fitted with a built-up universal coupling (40) (Fig. 8.7e). This is made from a Swivel Bearing and a small Fork Piece connected by two bolts, and is fixed to a Screwed Rod (41). The Screwed Rod is threaded through a Coupling (42), which is mounted on 2" Rods held in the sides of the lower limb by Collars.

The pivoted jib head can be raised and lowered by turning a Bush Wheel on a 6½" Rod (43), mounted as shown in Wheel Discs. The Rod carries a 1½" Contrate (44) (Fig. 8.7d), a Coupling (45) (Fig. 8.7c) held in place by a Worm, and two 1½" Strips bolted to the lugs of a 2½" × 1" Double Angle Strip (46). The Coupling is free to turn on the Rod.

An 11½" Rod is passed through the centre hole of Double Angle Strip (46) into the Coupling (45), and is fitted with a Collar and a ½" Pinion (47). The Pinion engages the Contrate (44). The upper end of the 11½" Rod carries a large Fork Piece, which is connected by two bolts to a Collar on the end of a Screwed Rod (48). The Screwed Rod is threaded through a Coupling (49), mounted on 1½" Rods held in the Strips (35) by Spring Clips.

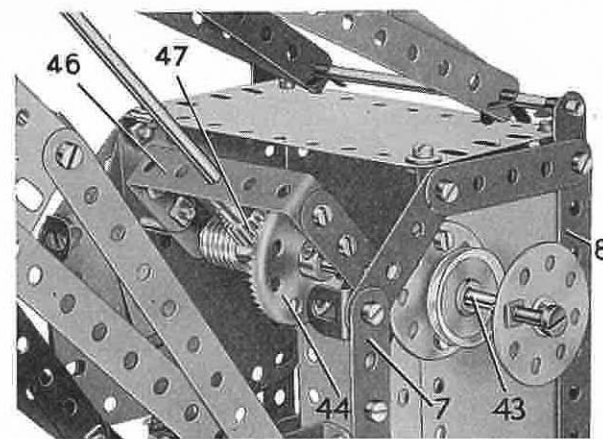

Fig. 8.7d

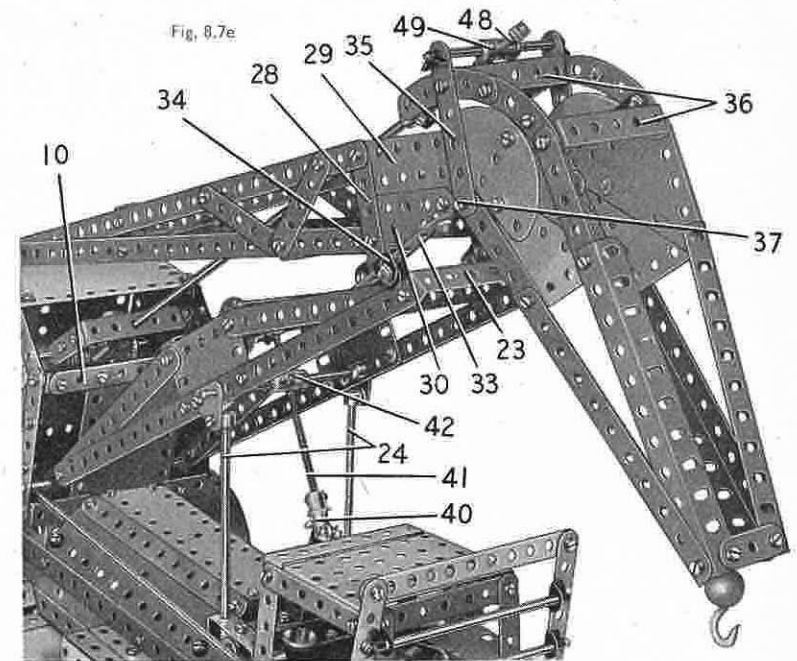

Fig. 8.7e

Parts Required	
8 of No. 1	4 of No. 20a
21 " " 2	4 " " 20b
6 " " 2a	1 " " 22
6 " " 3	2 " " 22a
6 " " 4	2 " " 23
18 " " 5	1 " " 23a
2 " " 6	2 " " 24
5 " " 6a	2 " " 24a
2 " " 8	2 " " 26
4 " " 9	1 " " 28
20 " " 10	1 " " 29
29 " " 12	1 " " 32
6 " " 12a	14 " " 35
2 " " 12b	254 " " 37a
8 " " 12c	234 " " 37b
2 " " 13	33 " " 38
1 " " 13a	2 " " 38d
2 " " 14	1 " " 45
4 " " 15	2 " " 46
2 " " 15a	2 " " 48
1 " " 16	9 " " 48a
2 " " 17	6 " " 48b
4 " " 18a	2 " " 48c
2 " " 18b	2 " " 51
5 of No. 53	
1 " " 57b	
9 " " 59	
2 " " 62	
6 " " 63	
2 " " 77	
1 " " 80a	
1 " " 80c	
4 " " 90	
2 " " 108	
3 " " 111	
3 " " 111a	
6 " " 111c	
2 " " 115	
1 " " 116	
1 " " 116a	
1 " " 126	
3 " " 126a	
4 " " 142a	
2 " " 147b	
1 " " 160	
2 " " 165	
1 " " 185	
1 " " 187	

4 of No. 187a	4 of No. 192	2 of No. 222
8 " " 188	2 " " 212	2 " " 223
7 " " 189	2 " " 214	2 " " 224
6 " " 190	4 " " 215	2 " " 225
5 " " 191	4 " " 221	

8.8 MILITARY TANK

CONSTRUCTION OF THE CHASSIS

Each side member of the chassis consists of two built-up girders (1) and (2). The girders (1) are each made from two $1\frac{1}{2}$ " Angle Girders overlapped 18 holes, and each of the girders (2) consists of two $1\frac{1}{2}$ " Angle Girders overlapped 15 holes. The girders (1) are connected by $5\frac{1}{2}$ " Angle Girders (3), and the girders (2) are joined by $5\frac{1}{2}$ " Angle Girders (4). The Girders (3) and (4) at the rear are connected by a $5\frac{1}{2}$ " x $2\frac{1}{2}$ " Flexible Plate edged by $2\frac{1}{2}$ " Strips, and at the front a $5\frac{1}{2}$ " x $2\frac{1}{2}$ " Flexible Plate is attached to Obtuse Angle Brackets bolted to the Girders (3) and (4). A $3\frac{1}{2}$ " Strip is bolted to the front ends of each pair of girders (1) and (2).

A $2\frac{1}{2}$ " Strip on each side, positioned at (5) (Fig. 8.8a), is bolted between the girders (1) and (2). A built-up strip (6) made from a $1\frac{1}{2}$ " Strip extended by a $4\frac{1}{2}$ " Strip, is bolted to each $2\frac{1}{2}$ " Strip, and is attached by an Angle Bracket to the Flexible Plate at the rear. A Corner Gusset is bolted to the girders (1) and (2) and the strip (6) of each side. The edge of one of the Corner Gussets can be seen at (7) (Fig. 8.8a).

The top of the chassis is filled in by two $5\frac{1}{2}$ " x $2\frac{1}{2}$ " Flanged Plates (8), two $5\frac{1}{2}$ " x $2\frac{1}{2}$ " Flexible Plates and a $5\frac{1}{2}$ " x $1\frac{1}{2}$ " Flexible Plate (9) on each side. A $3\frac{1}{2}$ " Pulley (10) is bolted to the Plates (8), and two Trunnions joined by a Double Bent Strip are fixed between the Plates on the underside.

Two built-up strips (11), each made from two $1\frac{1}{2}$ " Strips, are bolted to the top of the chassis as shown in Fig. 8.8b. A $5\frac{1}{2}$ " x $1\frac{1}{2}$ " and two $5\frac{1}{2}$ " x $2\frac{1}{2}$ " Flexible Plates are bolted together and are strengthened by three $5\frac{1}{2}$ " Strips, and then are attached by Angle Brackets to two $5\frac{1}{2}$ " x $1\frac{1}{2}$ " Double Angle Strips (12). These Double Angle Strips are connected by $5\frac{1}{2}$ " Strips, and the assembly is attached to the strips (11) by Angle Brackets.

The wheels on which the chassis is mounted are $2\frac{1}{2}$ " Pulleys with Motor Tyres, and they are fixed in pairs on $5\frac{1}{2}$ " Rods. These Rods are supported in $\frac{1}{2}$ " Reversed Angle Brackets bolted to the Girders (2).

THE TRACKS AND TRACK COVERS

The top of each track cover consists of a $1\frac{1}{2}$ " x $2\frac{1}{2}$ " Strip Plate and a $5\frac{1}{2}$ " x $2\frac{1}{2}$ " Flexible Plate, edged on the outside by a $1\frac{1}{2}$ " and a $5\frac{1}{2}$ " Strip. The Plates are connected to one of the Strips (6) by three $2\frac{1}{2}$ " x $1\frac{1}{2}$ " Double Angle Strips and an Angle Bracket. The side guards are each made from two $5\frac{1}{2}$ " x $2\frac{1}{2}$ " Flexible Plates, a $2\frac{1}{2}$ " x $2\frac{1}{2}$ " Triangular Flexible Plate, a $2\frac{1}{2}$ " x $1\frac{1}{2}$ " Flexible Plate (13), a $2\frac{1}{2}$ " x $1\frac{1}{2}$ " Triangular Flexible Plate and a $3\frac{1}{2}$ " x $2\frac{1}{2}$ " Triangular Flexible Plate (14). The guard is edged at the top by a $1\frac{1}{2}$ " and a $4\frac{1}{2}$ " Strip, and is bolted to the outer lugs of the Double Angle Strips that support the top of the track cover.

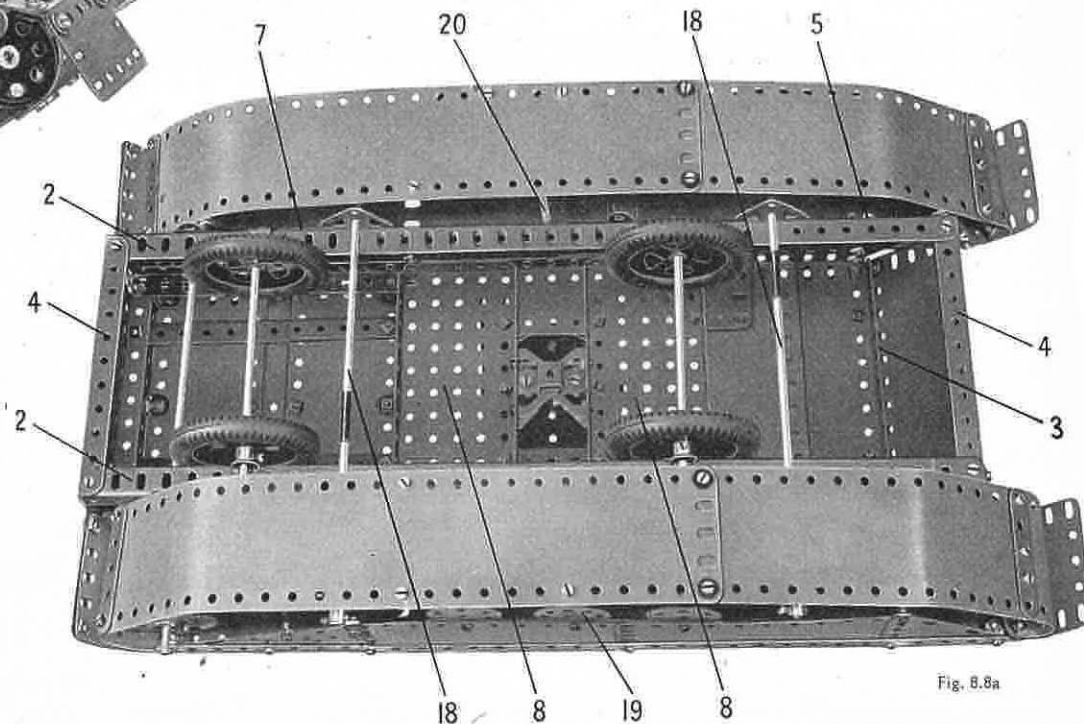
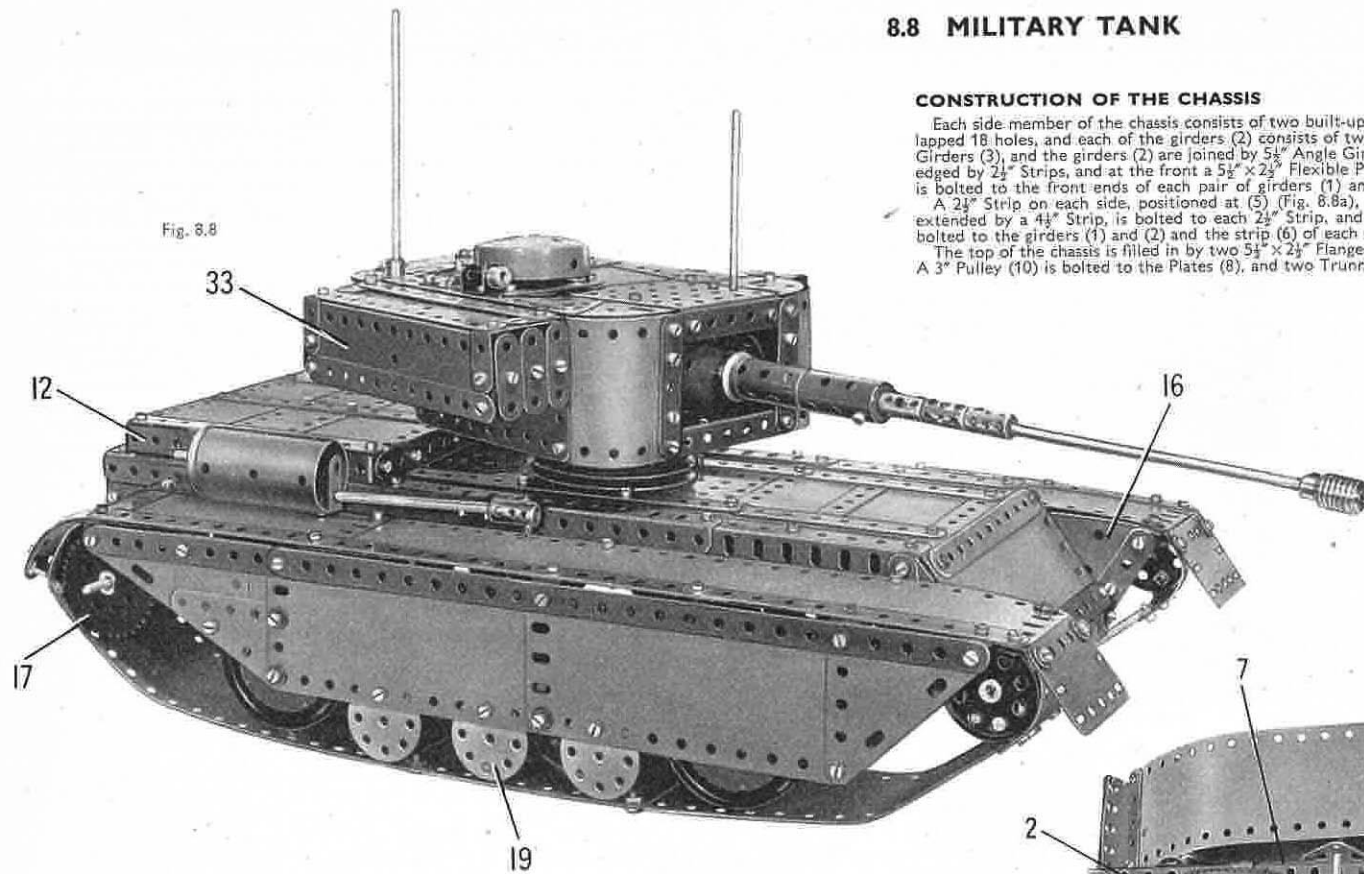

The track cover is extended at the rear by a $1\frac{1}{2}$ " radius Curved Plate edged by two Formed Slotted Strips, a $2\frac{1}{2}$ " Strip and a $3\frac{1}{2}$ " Strip (15). At the front of the cover a $2\frac{1}{2}$ " x $1\frac{1}{2}$ " Flexible Plate (16) is attached to Obtuse Angle Brackets. To the inside of each track cover at the front a $2\frac{1}{2}$ " x $1\frac{1}{2}$ " Triangular Flexible Plate (16) is attached by an Angle Bracket. Plate (16) is edged by a $2\frac{1}{2}$ " Strip that is bolted also to the front end of the girder (2).

Each of the dummy tracks consists of two $1\frac{1}{2}$ " x $2\frac{1}{2}$ " Strip Plates overlapped 12 holes and extended at each end by a $1\frac{1}{2}$ " radius Curved Plate. The track is shaped as shown in Figs. 8.8 and 8.8a and the ends of the Curved Plates are bolted to the track covers.

At the rear two $2\frac{1}{2}$ " Sprockets (17) are fixed on an $11\frac{1}{2}$ " Rod supported in $2\frac{1}{2}$ " Strips bolted to the girders (2) and the strips (6). A $1\frac{1}{2}$ " Pulley is attached to each track at the front by a $1\frac{1}{2}$ " x $1\frac{1}{2}$ " Angle Bracket. Two Road Wheels are fixed to each of the two built-up rods (18). These rods are made from $6\frac{1}{2}$ " and $4\frac{1}{2}$ " Rods joined by Rod Connectors, and they are supported in Flat Trunnions bolted to the girders (2). The rods are held in place by Collars.

A Bush Wheel (19) is fixed to the track guard on each side and to an Angle Bracket bolted to the track. Two Wheel Discs are bolted also to each track guard.

A Screwed Rod (20) is fixed to each track cover by two nuts, and a Coupling (21) is supported by the top end of each Screwed Rod. The Couplings carry $3\frac{1}{2}$ " Rods mounted also in $1\frac{1}{2}$ " x $1\frac{1}{2}$ " Angle Brackets bolted to Cylinders. These Cylinders are fixed to the Double Angle Strips (12), and each is fitted with a $1\frac{1}{2}$ " Rod.

ASSEMBLY OF THE TURRET

The base of the turret consists of two Flanged Sector Plates (22) connected by a $2\frac{1}{2}$ " x $1\frac{1}{2}$ " Flanged Plate, one flange of which is seen at (23) (Fig. 8.8d). A second $2\frac{1}{2}$ " x $1\frac{1}{2}$ " Flanged Plate is bolted at right angles to the first Plate, and is connected to a $3\frac{1}{2}$ " Pulley (24) by two $3\frac{1}{2}$ " Bolts.

(Continued on next page)

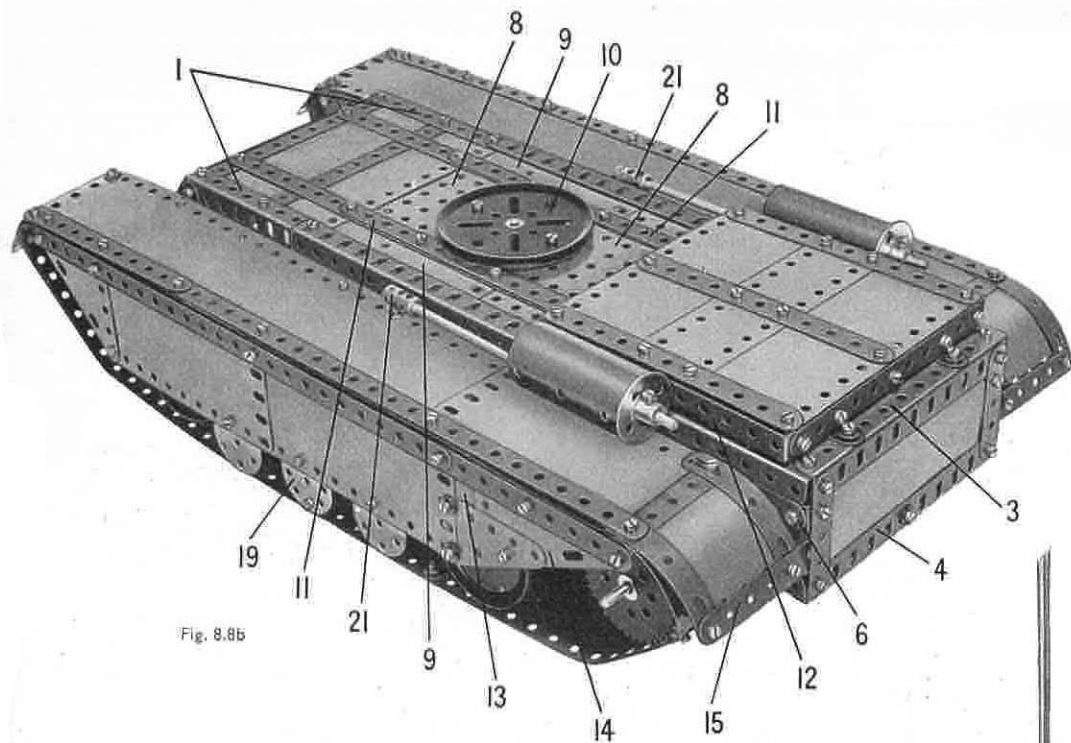

Fig. 8.8b

Parts Required

10 of No.	1
17 " "	2
5 " "	2a
4 " "	4
18 " "	5
2 " "	6
6 " "	6a
8 " "	8
4 " "	9
1 " "	11
29 " "	12
6 " "	12a
2 " "	12b
8 " "	12c
2 " "	13
2 " "	14
3 " "	15
1 " "	15a
2 " "	15b
3 " "	16
1 " "	17
2 " "	18a
1 " "	18b
2 " "	19b

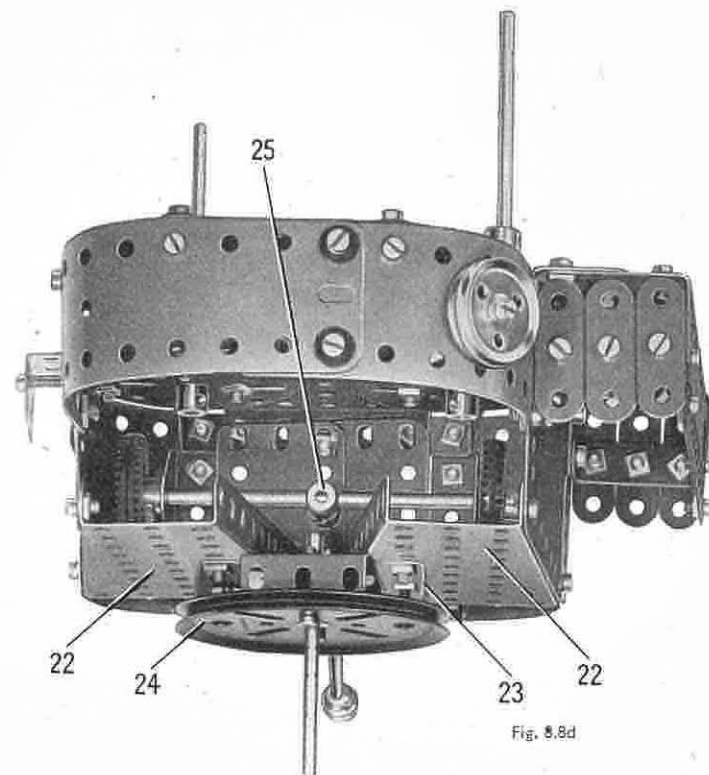

Fig. 8.8d

MODEL 8.8 MILITARY TANK — Continued

Each side of the turret is formed by a $4\frac{1}{2}'' \times 2\frac{1}{2}''$ Flexible Plate bolted to the outer flange of one of the Flanged Sector Plates. The back of the turret consists of two $5\frac{1}{2}'' \times 1\frac{1}{4}''$ Flexible Plates curved and joined together and then fixed to the sides. At the front a $1\frac{1}{4}''$ radius Curved Plate is bolted to each side. These are edged by $2\frac{1}{2}''$ Strips, and are connected by a $3\frac{1}{2}''$ Strip and a $3\frac{1}{2}'' \times \frac{1}{2}''$ Double Angle Strip to form a gap to accommodate the turret gun.

The gun consists of an $11\frac{1}{4}''$ Rod fitted with a $3''$ Flanged Wheel, two Sleeve Pieces joined by a Chimney Adaptor, a second Chimney Adaptor bolted to one of the Sleeve Pieces, and three Couplings. The inner end of the $11\frac{1}{4}''$ Rod is gripped in a Coupling (25) that is fixed on a $4\frac{1}{2}''$ Rod. This Rod is supported in Trunnions bolted to the front of the turret, and is held in place by 1" Pulleys fitted with Motor Tyres, which are pressed against the Trunnions. A gun shield (26) is formed by two curved $2\frac{1}{4}'' \times 1\frac{1}{4}''$ Flexible Plates bolted together and gripped between the Coupling (25) and the $3''$ Flanged Wheel.

The top of the turret is fitted in by a $3\frac{1}{2}'' \times 2\frac{1}{2}''$ Flanged Plate (27) fitted at each side with a Face Plate, a $2\frac{1}{2}'' \times 2\frac{1}{2}''$ Flexible Plate (28), a $4\frac{1}{2}'' \times 2\frac{1}{2}''$ Flexible Plate (29), two Semi-Circular Plates and a $2\frac{1}{2}'' \times 1\frac{1}{4}''$ Flexible Plate, a $2\frac{1}{2}'' \times 2''$ Triangular Flexible Plate (30) and a $3\frac{1}{2}'' \times 1\frac{1}{4}''$ Triangular Flexible Plate (31). These parts are bolted together as shown, and are attached to the sides by Angle Brackets.

The turret hatch is edged as shown in Fig. 8.8c with a $4\frac{1}{2}''$ Strip and three $2\frac{1}{4}''$ Stepped Curved Strips. The hatch cover is a Boiler End, to which a Right-Angle Rod and Strip Connector is attached by an Angle Bracket. A 1" Rod is pushed through the Right-Angle Rod and Strip Connector, and is held by Collars in a Double Bracket bolted to the top of the turret.

A $5\frac{1}{2}'' \times 1\frac{1}{4}''$ Flexible Plate (32) is edged by $5\frac{1}{2}''$ Strips and is attached to one side of the turret by $1'' \times 1''$ Angle Brackets. A second $5\frac{1}{2}'' \times 1\frac{1}{4}''$ Flexible Plate (33) is connected to Plate (32) by $1'' \times 1''$ Angle Brackets, and to each end of this assembly are bolted three $1\frac{1}{4}''$ Strips fixed to a $1\frac{1}{4}'' \times \frac{1}{4}''$ Double Angle Strip.

A Rod fixed in the Pulley (24) is passed through the Pulley (10) and is held in place by a 1" Pulley inside the chassis.

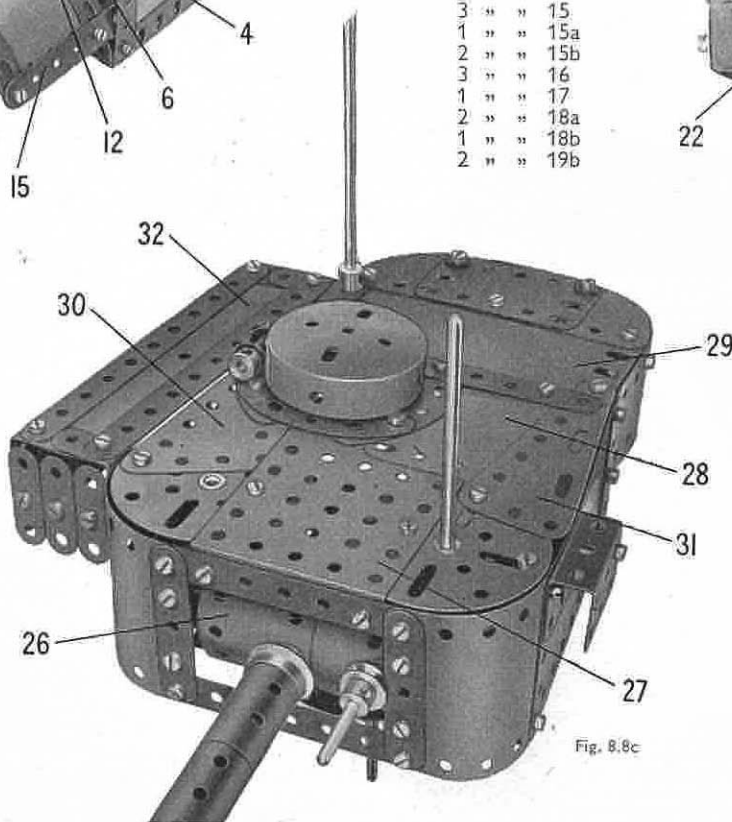
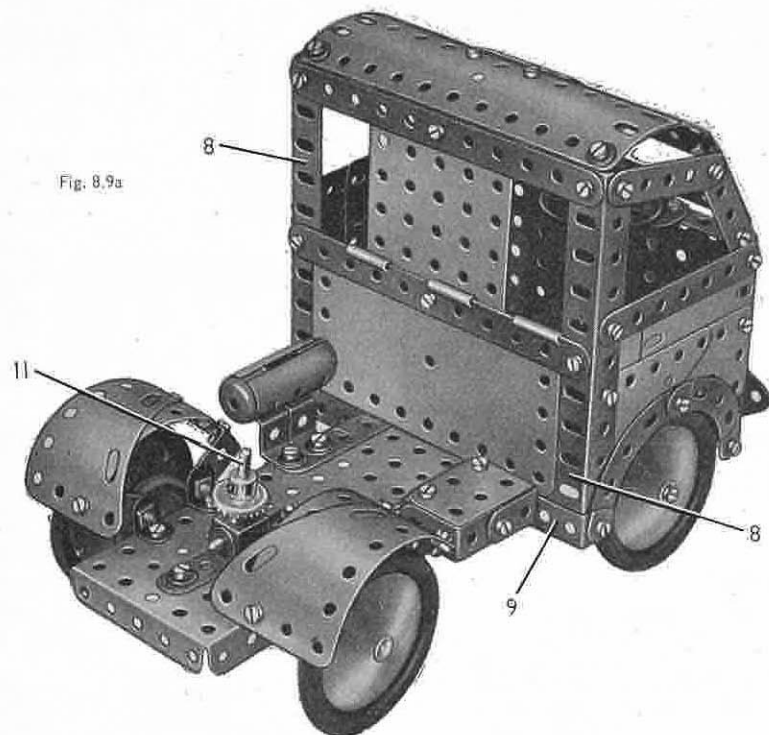

Fig. 8.8c

2 of No.	20	2 of No.	52	2 of No.	163
4 " "	20a	1 " "	53	2 " "	164
1 " "	20b	2 " "	54	4 " "	187
2 " "	21	7 " "	59	7 " "	188
4 " "	22	1 " "	62	7 " "	189
2 " "	22a	6 " "	63	2 " "	190
1 " "	23a	2 " "	80c	3 " "	191
2 " "	24	3 " "	90a	12 " "	192
2 " "	24a	2 " "	95	6 " "	197
2 " "	24c	2 " "	108	2 " "	199
1 " "	32	2 " "	109	5 " "	200
273 " "	37a	3 " "	111	1 " "	212a
256 " "	37b	6 " "	111a	2 " "	213
29 " "	38	5 " "	111c	2 " "	214
1 " "	45	4 " "	125	4 " "	215
1 " "	46	4 " "	126	2 " "	216
2 " "	48	4 " "	126a	4 " "	221
6 " "	48a	4 " "	142a	1 " "	222
2 " "	48b	2 " "	142c	2 " "	223
2 " "	48d	1 " "	160	1 " "	224
2 " "	51	1 " "	162	2 " "	225

8.9 ARTICULATED BOX LORRY



14 of No.	1
21 " "	2
6 " "	2a
6 " "	3
6 " "	4
18 " "	5
2 " "	6
4 " "	6a
10 " "	8
4 " "	9
9 " "	10
1 " "	11
16 " "	12
6 " "	12a

2 of No.	12b
2 " "	12c
1 " "	15
2 " "	15a
2 " "	15b
5 " "	16
3 " "	17
2 " "	18a
2 " "	18b
4 " "	20a
3 " "	20b
2 " "	22
3 " "	23
1 " "	23a

2 of No.	24
1 " "	29
6 " "	35
264 " "	37a
258 " "	37b
23 " "	38
2 " "	38d
2 " "	48
3 " "	48a
5 " "	48b
2 " "	48d
2 " "	51
2 " "	52
5 " "	53

Parts Required

10 of No.	59
2 " "	62
6 " "	63
2 " "	77
7 " "	90a
2 " "	111
3 " "	111a
5 " "	111c
1 " "	115
1 " "	116
4 " "	125
3 " "	126a
4 " "	142a
2 " "	147b

2 of No.	155
1 " "	160
1 " "	163
2 " "	164
2 " "	165
1 " "	166
1 " "	185
4 " "	187
4 " "	187a
7 " "	188
8 " "	189
5 " "	190
6 " "	191
12 " "	192

6 of No.	197
1 " "	198
6 " "	200
2 " "	212
2 " "	212a
2 " "	214
5 " "	215
4 " "	221
2 " "	224
2 " "	225

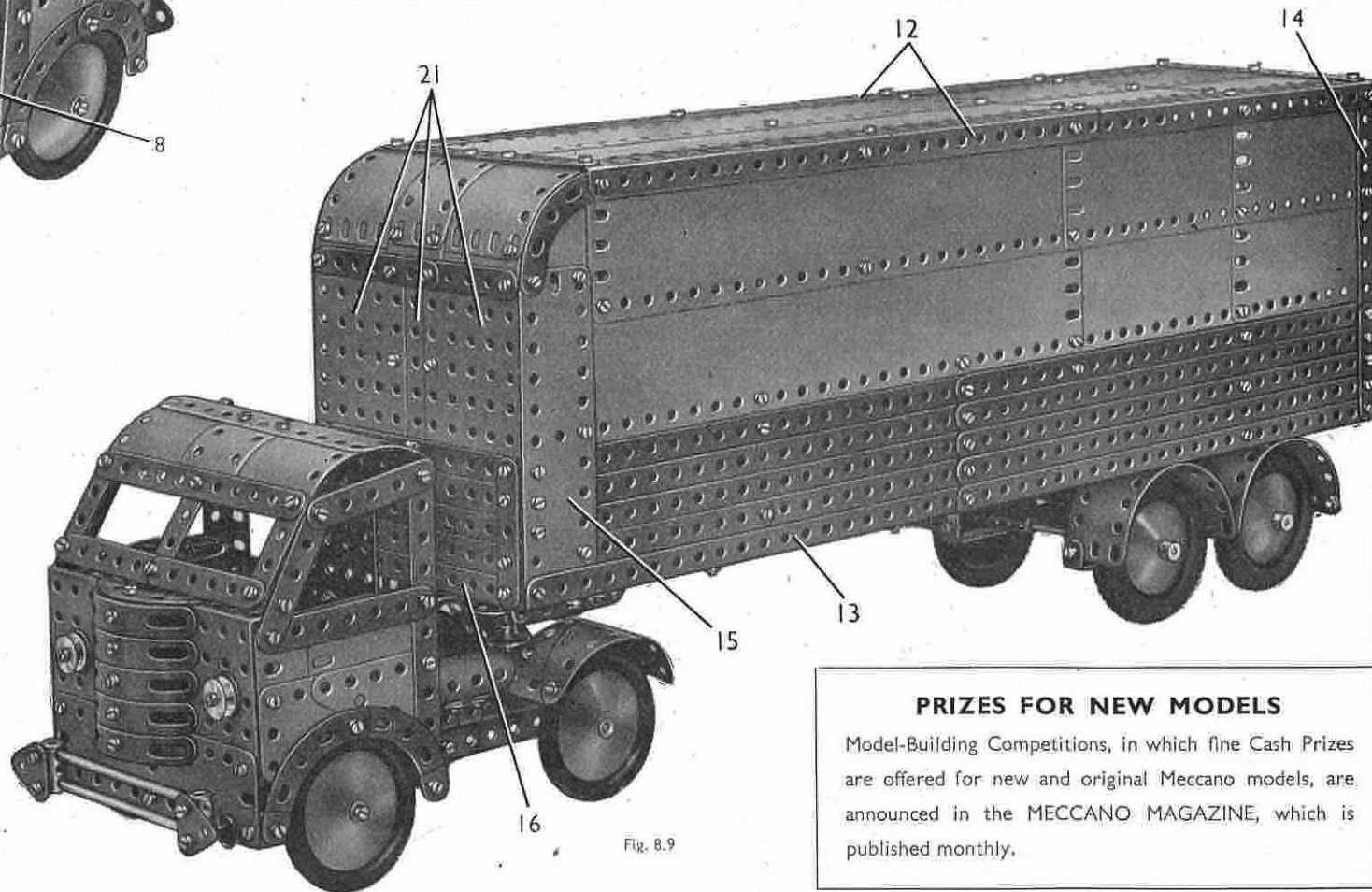

THE MOTOR UNIT CHASSIS

The chassis consists of a $5\frac{1}{2}'' \times 2\frac{1}{2}''$ Flanged Plate fitted with two $5\frac{1}{2}''$ Angle Girders (1) (Fig. 8.9b). These Girders are connected at the front by a $2\frac{1}{2}'' \times \frac{1}{2}''$ Double Angle Strip (2), and they overlap the Flanged Plate by four holes each.

The rear wheels are fixed on a $5''$ Rod mounted in the Flanged Plate. Each rear mudguard consists of a $3\frac{1}{2}'' \times 2''$ and a $3\frac{1}{2}'' \times 1\frac{1}{4}''$ Triangular Flexible Plate bolted together as shown in Fig. 8.9 and supported by two $1'' \times 1''$ Angle Brackets. The $1'' \times 1''$ Angle Brackets are attached to $\frac{1}{2}'' \times \frac{3}{4}''$ Angle Brackets bolted to the chassis.

Each of the front wheels is free to turn on a $\frac{1}{2}''$ Bolt screwed into a Coupling (3) (Fig. 8.9b) and fixed in place by a nut. The Couplings are locked on $1\frac{1}{4}''$ Rods, which are passed through the end holes of two $\frac{1}{2}''$ Strips (4) bolted face to face across the chassis, and through the bosses of Cranks attached to the Strips. Each Rod is held in position by a Collar placed above the Crank. A Pivot Bolt (5), fitted with a Collar, is screwed into each Coupling, and the Rod and Strip Connectors (6) are free to pivot on bolts fixed in the threaded holes of the Collars by nuts. A Threaded Pin is screwed tightly into one of the Collars placed above the Cranks, and a Swivel Bearing (7) is fixed on the shank of the Threaded Pin.

CONSTRUCTION OF THE CAB

The cab front is a $5\frac{1}{2}'' \times 2\frac{1}{2}''$ Flanged Plate extended downward by a $5\frac{1}{2}'' \times 1\frac{1}{4}''$ Flexible Plate that is bolted to the Double Angle Strip (2). Each side consists of a $3\frac{1}{2}''$ Strip, two $2\frac{1}{2}'' \times 1\frac{1}{4}''$ Flexible Plates, two $2\frac{1}{2}'' \times 1\frac{1}{4}''$ Triangular Flexible Plates and a $5\frac{1}{2}''$ Angle

(Continued on next page)

PRIZES FOR NEW MODELS

Model-Building Competitions, in which fine Cash Prizes are offered for new and original Meccano models, are announced in the MECCANO MAGAZINE, which is published monthly.

MODEL 8.9 ARTICULATED BOX LORRY — Continued

Girder (8). The Girders (8) are connected to the chassis by $1\frac{1}{2}'' \times \frac{1}{2}''$ Double Angle Strips (9) (Fig. 8.9b). The $2\frac{1}{2}''$ Stepped Curved Strips forming the wheel arches are attached to the front of the cab by Angle Brackets. The side window frames are made with $2\frac{1}{2}''$ Strips.

The back of the cab is filled in by one half of a Hinged Flat Plate and a $3\frac{1}{2}'' \times 2\frac{1}{2}''$ Flanged Plate bolted as shown in Fig. 8.9a to $5\frac{1}{2}''$ Strips fixed across the Girders (8). The windscreen consists of a $5\frac{1}{2}''$ Strip, two $2''$ Strips, two $3''$ Strips and a $2\frac{1}{2}''$ Strip. It is connected by Angle Brackets to the side window frames.

The roof is formed by a $5\frac{1}{2}'' \times 1\frac{1}{4}''$ Flexible Plate, a $2\frac{1}{2}'' \times 1\frac{1}{4}''$ Flexible Plate and two $2\frac{1}{2}'' \times 2\frac{1}{2}''$ Flexible Plates. It is bolted to the top of the windscreen and is attached by Obtuse Angle Brackets to the back of the cab.

The radiator consists of five Formed Slatted Strips bolted to a $2\frac{1}{2}''$ Strip and connected by Double Brackets to the front of the cab. A $2\frac{1}{2}''$ Stepped Curved Strip is bolted to the upper Double Bracket. The bumper is formed from two $4\frac{1}{2}''$ Rods fitted to Couplings, to each of which a $1''$ Triangular Plate is attached. The bumper is spaced from the front of the cab by a Washer and a Spring Clip on a $\frac{1}{4}''$ Bolt screwed into each Coupling.

STEERING MECHANISM AND TRAILER COUPLING DEVICE

The steering column is a $4''$ Rod supported in a Flat Trunnion bolted to the top flange of the Plate that forms the front of the cab, and in a Fishplate bolted to one of the Girders (1). The Rod is held in place by a Steering Wheel and a $\frac{1}{2}''$ fixed Pulley, and it carries a Bush Wheel to which is bolted a $1\frac{1}{2}''$ Strip (10). A $\frac{1}{4}''$ Bolt is fixed by a nut in this Strip, and an End Bearing is pivotally retained on the Bolt by two nuts screwed against each other. The End Bearing is linked to the Swivel Bearing (7) by a $2''$ Rod.

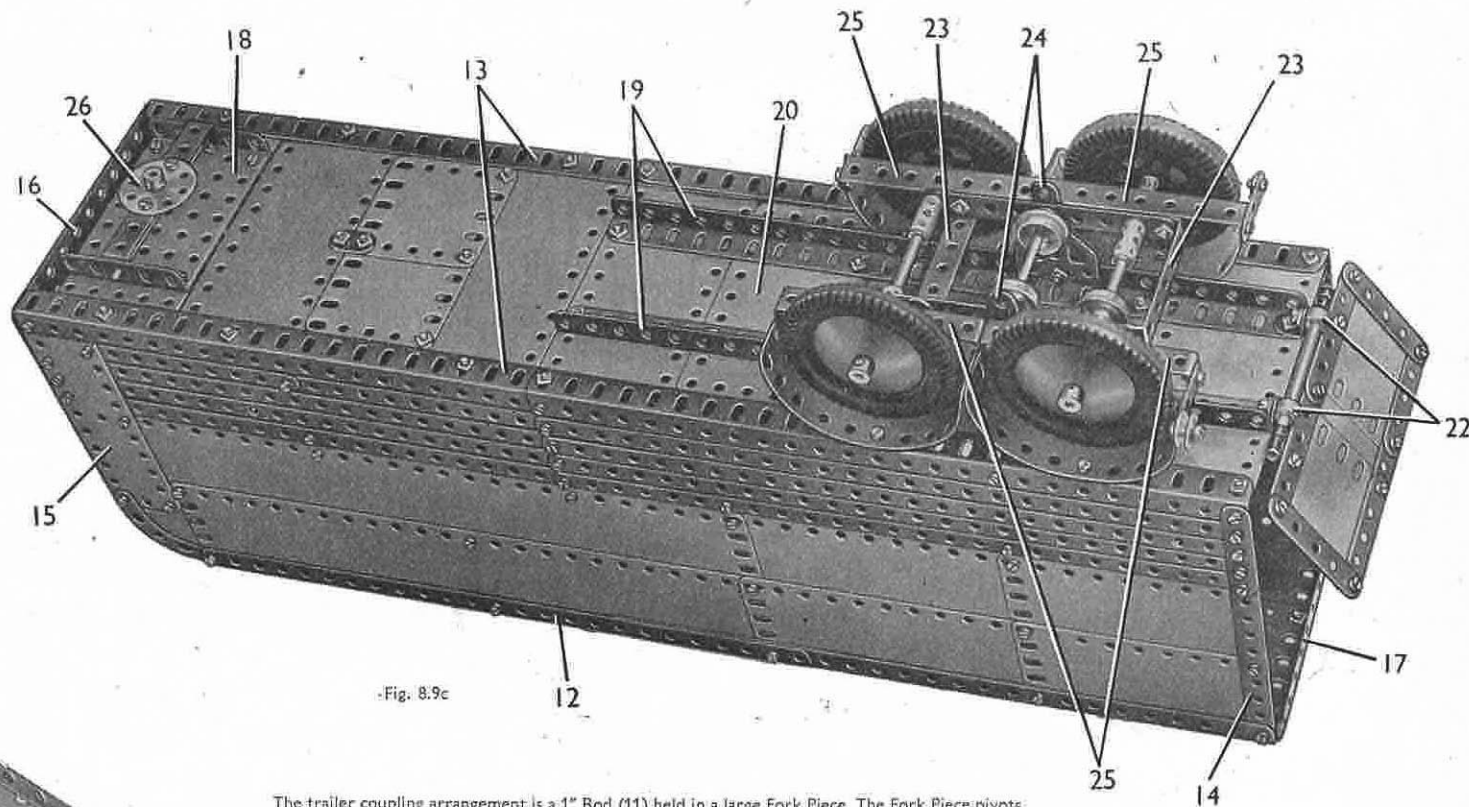

Fig. 8.9c

The trailer coupling arrangement is a $1''$ Rod (11) held in a large Fork Piece. The Fork Piece pivots on a second $1''$ Rod, which is mounted in $1'' \times \frac{1}{2}''$ Angle Brackets bolted to the chassis. The Rod is retained by two Spring Clips placed on it between the jaws of the Fork Piece.

THE VAN BODY

Each side of the body is attached to a framework formed by two built-up girders (12) and (13), a built-up strip (14) and a $5\frac{1}{2}'' \times 1\frac{1}{4}''$ Flexible Plate (15). The girder (12) consists of two $12\frac{1}{2}''$ Angle Girders overlapped eight holes, and the girder (13) is made from two $12\frac{1}{2}''$ Angle Girders overlapped five holes. The strip (14) is formed by a $5\frac{1}{2}''$ and a $2\frac{1}{2}''$ Strip overlapped two holes. The lower sections of the sides are filled in by Strips, and the upper sections by Strip and Flexible Plates, as shown in Figs. 8.9 and 8.9c. A Semi-Circular Plate and a $2\frac{1}{2}''$ Stepped Curved Strip are fixed at the upper front corner of each side. The Strips and Plates of the sides are connected on the inside by $5\frac{1}{2}''$ and $3''$ Strips, placed vertically.

The sides are connected at the front by a $5\frac{1}{2}'' \times \frac{1}{2}''$ Double Angle Strip (17). A $3\frac{1}{2}'' \times 2\frac{1}{2}''$ Flanged Plate (18) is bolted to two $2\frac{1}{2}'' \times 1\frac{1}{2}''$ Flanged Plates, each of which is secured to one of the girders (13). A $5\frac{1}{2}''$ Strip is attached between the rear ends of the girders (13), and a built-up strip, made from two $4\frac{1}{2}''$ Strips, is bolted across the centres of these girders. The floor is filled in by six $5\frac{1}{2}'' \times 2\frac{1}{2}''$ and two $2\frac{1}{2}'' \times 2\frac{1}{2}''$ Flexible Plates as shown in Fig. 8.9c. Two $12\frac{1}{2}''$ Angle Girders (19) are bolted along the underside of the floor, and to them is fixed the other half (20) of the Hinged Flat Plate.

The front of the body consists of four $5\frac{1}{2}''$ Strips bolted to $2\frac{1}{2}''$ Strips fixed to the Double Angle Strip (16), three $3\frac{1}{2}'' \times 2\frac{1}{2}''$ Flanged Plates (21), four $1\frac{1}{16}''$ radius Curved Plates, and two $2\frac{1}{2}'' \times 1\frac{1}{2}''$ Flexible Plates. The front is connected to the sides by Angle Brackets. The roof is filled in by two $12\frac{1}{2}'' \times 2\frac{1}{2}''$ Strip Plates, two $5\frac{1}{2}'' \times 2\frac{1}{2}''$ and two $4\frac{1}{2}'' \times 2\frac{1}{2}''$ Flexible Plates. These are bolted to $5\frac{1}{2}''$ Strips fixed between the girders (17).

The hinged tailboard is formed by three $2\frac{1}{2}'' \times 2\frac{1}{2}''$ Flexible Plates edged by Strips as shown in Fig. 8.9c. Two Right-Angle Rod and Strip Connectors are bolted to the lower edge of the tailboard, and these pivot on a $3\frac{1}{2}''$ Rod fixed in two Collars (22). Each Collar is attached by a nut and bolt to an Angle Bracket bolted to one of the Girders (19).

BOGIE UNIT, WHEELS AND COUPLING DEVICE

The rear wheels are held by Collars on built-up rods, each made from a $3\frac{1}{2}''$ and a $2''$ Rod joined by a Coupling. These rods are mounted in $4\frac{1}{2}''$ Strips connected by two $2\frac{1}{2}'' \times \frac{1}{2}''$ Double Angle Strips (23). The $4\frac{1}{2}''$ Strips pivot on a $3\frac{1}{2}''$ Rod, which is held by $2''$ Flanged Wheels in $2\frac{1}{2}''$ Strips (24). These Strips are bolted to the Girders (19) and are braced by Flat Trunnions at their lower ends.

The rear mudguards are curved $5\frac{1}{2}'' \times 1\frac{1}{2}''$ Flexible Plates bolted underneath the body and connected to $3\frac{1}{2}'' \times \frac{1}{2}''$ Double Angle Strips (25) on each side. A $3\frac{1}{2}'' \times \frac{1}{2}''$ Double Angle Strip fitted with a Bush Wheel (26) is pivoted on a $4''$ Rod held by Spring Clips in the flanges of the Plate (18). The boss of the Bush Wheel is passed over the Rod (11) to couple the trailer to the motor unit.

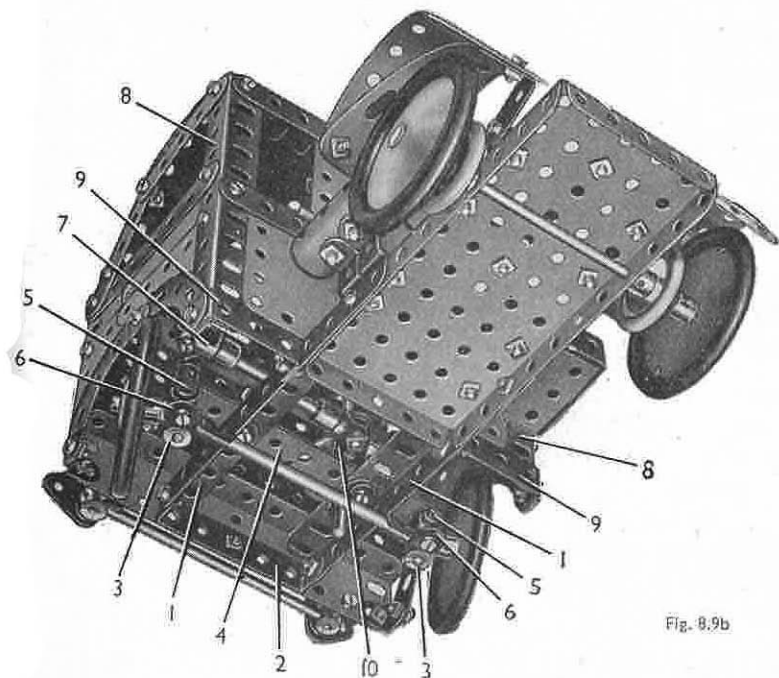

Fig. 8.9b

8.10 OIL TANKER

CONSTRUCTION OF THE HULL

Each side of the hull consists of a $4\frac{1}{2}'' \times 2\frac{1}{2}''$ Flexible Plate (1), a $5\frac{1}{2}'' \times 2\frac{1}{2}''$ Flexible Plate (2), a $2\frac{1}{2}'' \times 1\frac{1}{2}''$ Flexible Plate (3), a $5\frac{1}{2}'' \times 1\frac{1}{2}''$ Flexible Plate (4), a $2\frac{1}{2}'' \times 1\frac{1}{2}''$ Triangular Flexible Plate (5) and three $12\frac{1}{2}'' \times 2\frac{1}{2}''$ Strip Plates (6). These Plates are bolted together as shown, and are edged along the top of the hull by Strips and a $12\frac{1}{2}''$ Angle Girder (7). The lower edge of the hull amidships is strengthened by $12\frac{1}{2}''$ Angle Girders (8) extended at each end by $5\frac{1}{2}''$ Strips.

The sloping prow is formed by two 'U'-section Curved Plates opened out slightly and bolted at an angle to the Plates (1) and (3). A Flanged Sector Plate (9) is fixed between the top corners of the upper Curved Plate.

The sides of the hull are connected amidships by two $5\frac{1}{2}''$ Strips (10), each extended by two Fishplates bolted to the Angle Girders (7). The lower part of the rounded stern consists of three $1\frac{1}{2}''$ radius Curved Plates bolted together and fixed to the sides of the hull, as shown in Fig. 8.10a.

ASSEMBLY OF THE DECKS

The raised foredeck consists of three $5\frac{1}{2}'' \times 1\frac{1}{2}''$ Flexible Plates (11), a $2\frac{1}{2}'' \times 2\frac{1}{2}''$ Flexible Plate and two $2\frac{1}{2}'' \times 1\frac{1}{2}''$ Triangular Flexible Plates (12). These are bolted to the Flanged Sector Plate (9) and are supported at the rear by a $5\frac{1}{2}'' \times \frac{1}{2}''$ Double Angle Strip (13).

The deck between the foredeck and the bridge is plated by four $5\frac{1}{2}'' \times 2\frac{1}{2}''$ Flexible Plates bolted to two $12\frac{1}{2}''$ Strips (14). These Strips are supported by one of the Strips (10) and by a $5\frac{1}{2}'' \times \frac{1}{2}''$ Double Angle Strip (15). Two further $12\frac{1}{2}''$ Strips (16) are bolted between the Double Angle Strip (15) and the Girders (7). Three $1\frac{1}{2}''$ radius Curved Plates are connected at their upper ends by a $5\frac{1}{2}''$ Strip, and are bolted between the Double Angle Strip (15) and an Obtuse Angle Bracket attached to the Double Angle Strip (13).

The sides of the raised stern deck are each made from two $2\frac{1}{2}'' \times 2\frac{1}{2}''$ Flexible Plates and a $5\frac{1}{2}'' \times 2\frac{1}{2}''$ Flexible Plate (17), connected along their upper edges by a $5\frac{1}{2}''$ Strip. The ends of the Plates are curved and are bolted to a $1\frac{1}{2}''$ radius Curved Plate that completes the rounded stern.

The stern deck is plated by a $5\frac{1}{2}'' \times 2\frac{1}{2}''$ Flanged Plate (18), a Hinged Flat Plate, a Face Plate with a Semi-Circular Plate (19) on each side of it, two $3\frac{1}{2}'' \times 2''$ Triangular Flexible Plates (20) and two $2\frac{1}{2}'' \times 2''$ Triangular Flexible Plates (21). The deck is bolted to a $4\frac{1}{2}'' \times \frac{1}{2}''$ Double Angle Strip (22).

A $12\frac{1}{2}''$ Strip (23) (Fig. 8.10c), is bolted to each of the Girders (7) and is attached to the side of the hull by an Angle Bracket. A further $12\frac{1}{2}''$ Strip (24) on each side is fixed to one of the Strips (10), and these $12\frac{1}{2}''$ Strips support two $5\frac{1}{2}'' \times 2\frac{1}{2}''$ and three $4\frac{1}{2}'' \times 2\frac{1}{2}''$ Flexible Plates that fill in the deck between the bridge and the stern deck. The $4\frac{1}{2}'' \times 2\frac{1}{2}''$ Flexible Plates are attached to the Strips (24) by a $5\frac{1}{2}''$ Strip, two $2\frac{1}{2}''$ Strips and Fishplates, as shown in Fig. 8.10c, and a $12\frac{1}{2}''$ Strip (25) is bolted to them. This Strip is connected by an Angle Bracket to a $4\frac{1}{2}'' \times \frac{1}{2}''$ Double Angle Strip (26) and to the rear flange of the Flanged Plate (18) by a $1\frac{1}{2}''$ Strip and an Angle Bracket.

(Continued on next page)

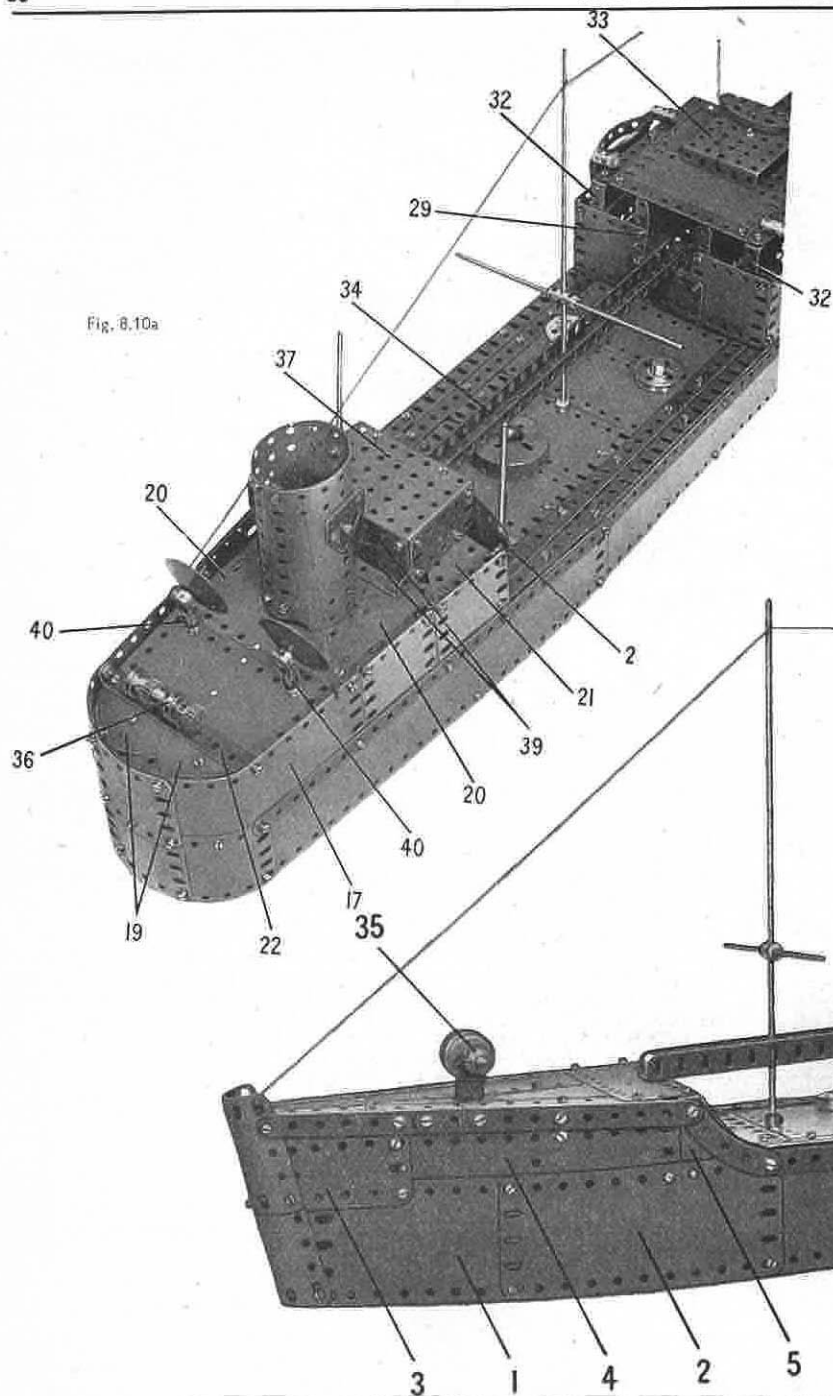

Fig. 8.10a

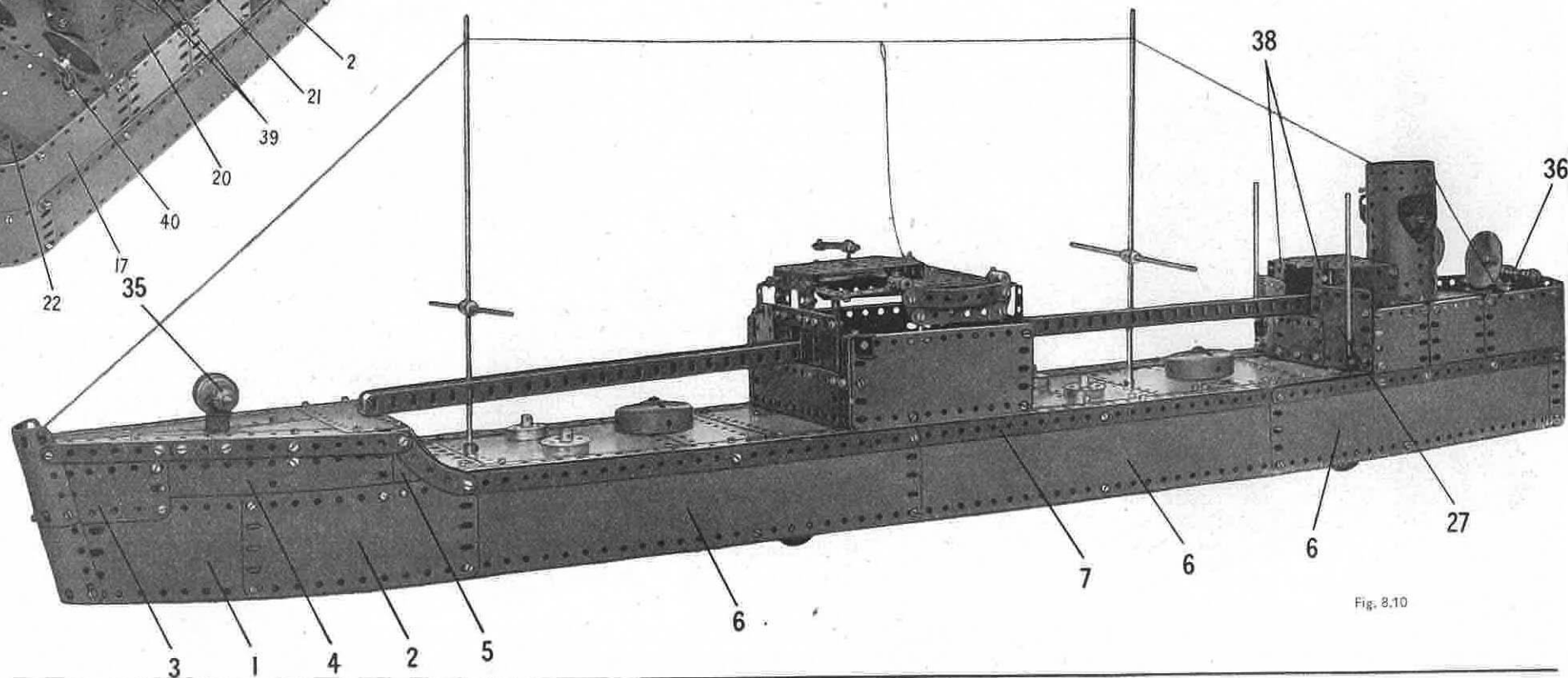

Fig. 8.10

MODEL 8.10 OIL TANKER — Continued

The front of the stern superstructure is filled in by a 2½" x 2½" Flexible Plate (27) on each side and a 2½" x 1½" Flexible Plate in the centre. These are connected to the deck sides by Angle Brackets, and are bolted to the front flange of the Flanged Plate (18).

DETAILS OF THE BRIDGE

Each side of the bridge is a 5½" x 2½" Flexible Plate connected to one of the Girders (7) by two Angle Brackets. The front is filled in by a 5½" x 1½" Flexible Plate edged at the top by a 5½" Strip, which is extended at each end by a Fishplate. The Fishplates support 2½" x ½" Double Angle Strips (28) and are connected to the sides by Angle Brackets.

The rear end is formed by two 2½" x 2½" Flexible Plates bolted to a 2½" x 1½" Flexible Plate at the centre. The end is attached to the sides by Angle Brackets, and a 5½" x 2½" Flanged Plate (29) is bolted between the Plates at the front and rear of the bridge. The front of the bridge is completed by two 2½" x 1½" Flexible Plates bolted to a 5½" Strip (30) two 2½" Strips and two 3½" Strips (31).

Four 2½" x ½" Double Angle Strips (32) (Fig. 8.10a and 8.10b), are bolted to the Strips (14) and (24) and these support the top of the bridge. The top consists of four ½" Strips arranged to form a square, and to these are bolted a 5½" x 1½" Flexible Plate on each side and a 4½" x 2½" Flexible Plate at the rear. A 3½" x 2½" Flanged Plate (33) is attached by Fishplates to the Strips at the front of the bridge, and to this Plate is fixed a ¾" Bolt that supports six 2½" Stepped Curved Strips.

The lifeboats are each made from two 3½" Strips curved as shown in Fig. 8.10b and bolted together, and connected by Fishplates to two 3" Strips that form the keel. The lifeboats are suspended by Cord from Couplings attached to the top of the bridge by ½" Bolts.

THE DECK FITTINGS

The catwalks (34) are each made from two 12½" Angle Girders supported as shown. The masts are 11½" Rods held in the decks by Collars, and each mast carries a Coupling that supports two 3½" Rods. The two Boiler Ends are fixed to the decks by nuts on Screwed Rods, and the four 1½" Flanged Wheels are locked on 2" Rods held in place by ¾" Flanged Wheels placed under the decks. The winch (35) in the bow is mounted in a Stepped Bent Strip bolted to the Flanged Sector Plate (9). The winch (36) is formed by a small Fork Piece fixed on a ¾" Bolt passed through the Double Angle Strip (22).

The funnel is a boiler with its ends connected by Obtuse Angle Brackets, and it is fixed to the deck by an Angle Bracket. The deck-house (37) is made by bolting a 3½" x 2½" Flanged Plate to the deck. The sides are 2½" x 1½" Flexible Plates, and the roof is a second 3½" x 2½" Flanged Plate fitted with two 1½" x ½" Double Angle Strips (38). The rear of the deck-house is filled in by two 3½" x 1½" Triangular Flexible Plates (39) attached to the sides and roof by Angle Brackets.

The ventilators are Conical Discs fixed to Swivel Bearings (40) by ½" Bolts. Each Swivel Bearing is spaced from the deck by a Collar, a nut and three Washers, on a 1" Bolt.

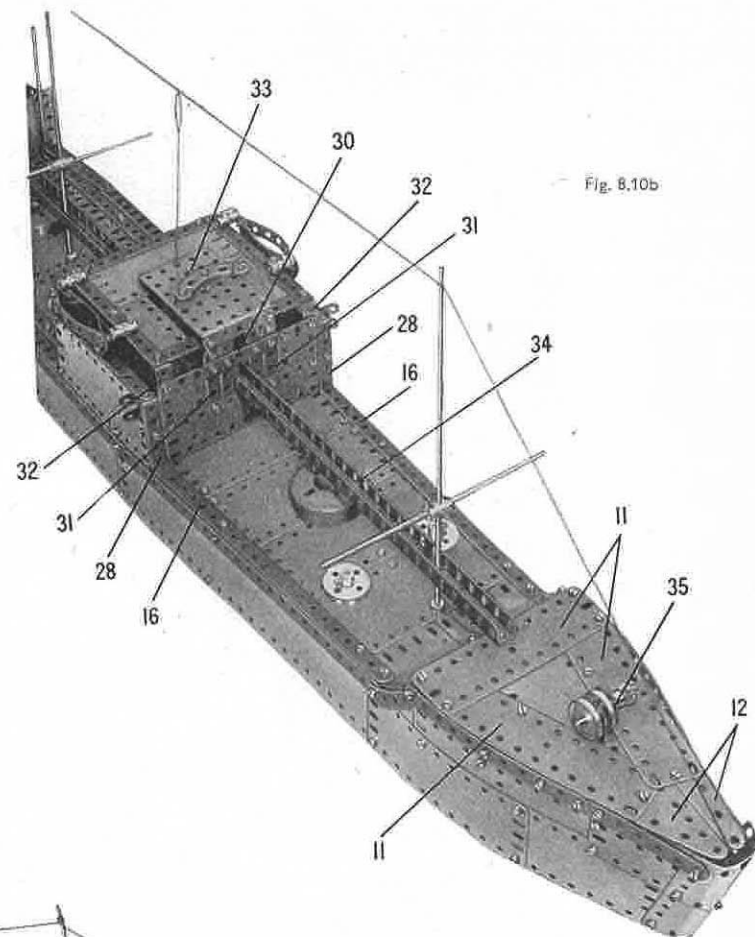

Fig. 8.10b

Parts Required

13 of No. 1	20 of No. 12	4 of No. 20b	1 of No. 40	1 of No. 54	2 of No. 126a	6 of No. 197
19 " " 2	1 " " 12a	3 " " 22	1 " " 44	8 " " 59	2 " " 155	1 " " 198
5 " " 2a	3 " " 12c	1 " " 22a	2 " " 48	6 " " 63	1 " " 162	2 " " 199
6 " " 3	2 " " 13	1 " " 23	2 " " 48a	2 " " 80c	2 " " 165	7 " " 200
4 " " 4	1 " " 14	1 " " 23a	4 " " 48b	2 " " 90	2 " " 187a	2 " " 212
4 " " 5	2 " " 15	3 " " 26	2 " " 48c	6 " " 90a	8 " " 188	2 " " 214
3 " " 6a	4 " " 16	271 " " 37a	2 " " 48d	1 " " 109	8 " " 189	4 " " 221
8 " " 8	5 " " 17	258 " " 37b	2 " " 52	3 " " 111	9 " " 190	2 " " 222
20 " " 10	1 " " 18a	6 " " 38	3 " " 53	6 " " 111a	6 " " 191	2 " " 224
2 " " 11	4 " " 20	2 " " 38d		1 " " 116a	12 " " 192	2 " " 225

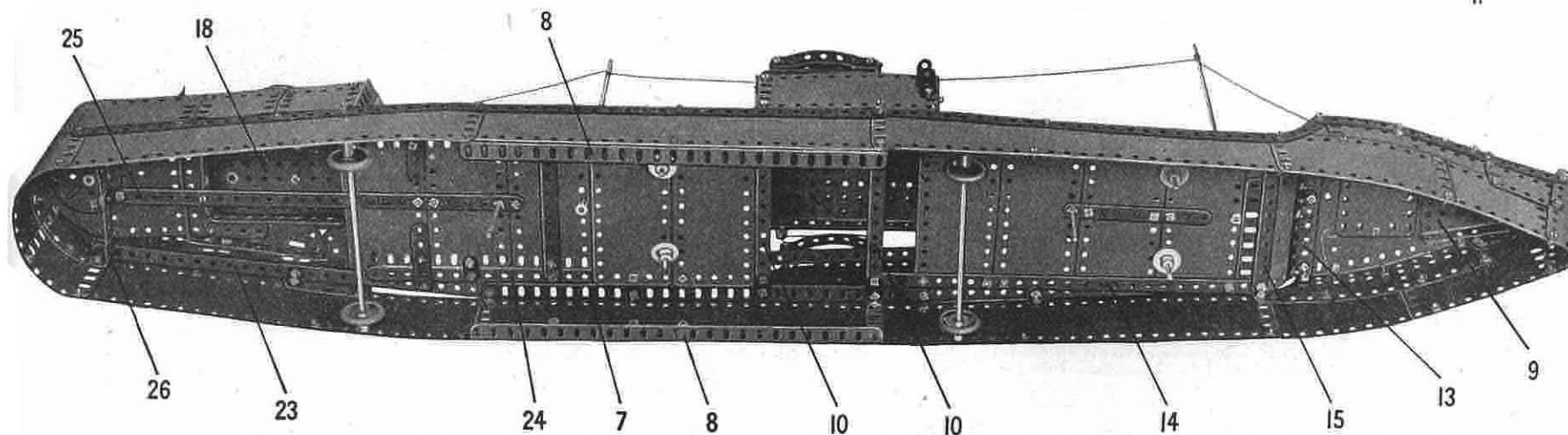

Fig. 8.10.

8.II MILLING MACHINE

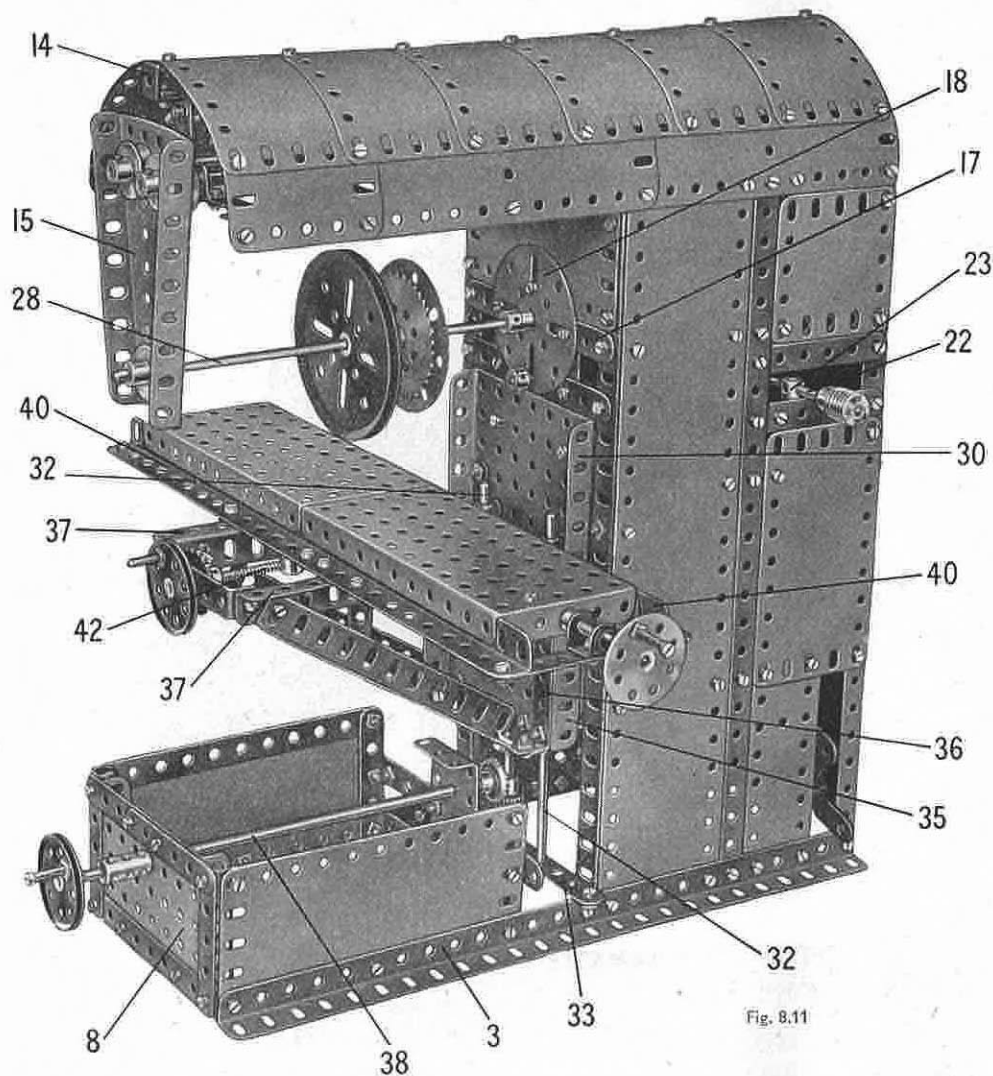

Fig. 8.11

The Rod (16) is fitted with two 1" Pulleys, a $\frac{1}{2}$ " Pinion (20) and a 57-tooth Gear (21). The Rod is free to slide about $\frac{1}{4}$ " in its bearings, and its movement is controlled by a lever (22) (Fig. 8.11). This lever is a 4" Rod that is held in a Coupling (23) and fitted with a Coupling (24) (Fig. 8.11c). The Coupling (23) pivots on a $\frac{3}{8}$ " Bolt passed through a Trunnion bolted to a $3\frac{1}{2}$ " Strip (25). The Coupling (24) carries a 1" Rod, and this and the end of the 4" Rod are located between the 1" Pulleys on Rod (16).

By moving the lever the Pinion (20) can be meshed with a 57-tooth Gear (26), or the Gear (21) can be engaged with a $\frac{1}{2}$ " Pinion (27). This arrangement provides a two-speed drive to the 11 $\frac{1}{2}$ " Rod (28) on which the Gear (26) and the Pinion (27) are fixed. Rod (28) is supported in a $4\frac{1}{2}$ " x $\frac{1}{2}$ " Double Angle Strip (29), the Face Plate (18) and the Flanged Sector Plate (15). Rod (28) is fitted with a Face Plate, a 2" Sprocket and a 3" Pulley.

The side seen in Fig. 8.11 can now be completed as shown. A $5\frac{1}{2}$ " Strip is bolted across the side to correspond to the Strip (4), and a $3\frac{1}{2}$ " Strip is bolted one clear hole above the Strip (25).

(Continued on next page)

THE SUPPORTING COLUMN

Two $12\frac{1}{2}$ " Angle Girders (1) on each side are connected at their upper and lower ends by $12\frac{1}{2}$ " Angle Girders (2) and (3). The side seen in Fig. 8.11b is filled in as shown by two $12\frac{1}{2}$ " Strip Plates and a $12\frac{1}{2}$ " Strip. These are strengthened on the inside by a $5\frac{1}{2}$ " Strip (4) (Fig. 8.11c) and are connected together by $1\frac{1}{2}$ " Strips held by the bolts (5).

The Girders (1) of each side are connected at the back by two $4\frac{1}{2}$ " Strips (6) (Fig. 8.11c), two $5\frac{1}{2}$ " x $2\frac{1}{2}$ " and two $2\frac{1}{2}$ " x $1\frac{1}{2}$ " Flexible Plates and a $4\frac{1}{2}$ " x $2\frac{1}{2}$ " Flexible Plate edged at the top by a built-up strip (7). This strip is made from a $3\frac{1}{2}$ " and a $2\frac{1}{2}$ " Strip overlapped three holes.

A $5\frac{1}{2}$ " x $2\frac{1}{2}$ " Flexible Plate is bolted to each of the Girders (3) and is edged on the inside by a $5\frac{1}{2}$ " and a $2\frac{1}{2}$ " Strip. At the front these Plates are connected by Angle Brackets to a $4\frac{1}{2}$ " Strip and a built-up $4\frac{1}{2}$ " strip, made from two 3" Strips overlapped. A $3\frac{1}{2}$ " x $2\frac{1}{2}$ " Flanged Plate (8) is bolted to the Strips. A $4\frac{1}{2}$ " x $\frac{1}{2}$ " Double Angle Strip (9) is fixed between the Girders (3), and a $5\frac{1}{2}$ " Strip (10) is attached to the rear ends of the Flexible Plates by Angle Brackets. A $2\frac{1}{2}$ " x $1\frac{1}{2}$ " Flanged Plate (11) is bolted to the Double Angle Strip and the Strip.

A $2\frac{1}{2}$ " x $1\frac{1}{2}$ " and two $5\frac{1}{2}$ " x $1\frac{1}{2}$ " Flexible Plates are bolted to each of the Girders (2). These Plates are connected by six $5\frac{1}{2}$ " x $2\frac{1}{2}$ " Flexible Plates curved as shown and strengthened along the centre by a $12\frac{1}{2}$ " Strip on the inside. A $2\frac{1}{2}$ " x $\frac{1}{2}$ " Double Angle Strip is bolted vertically to the strip (7), and to this Double Angle Strip are bolted a $2\frac{1}{2}$ " x $1\frac{1}{2}$ " Flexible Plate, two Semi-Circular Plates, and a $2\frac{1}{2}$ " Curved Strip, as shown in Fig. 8.11c.

Two built-up strips (12) are fixed to the Girders (2) (Fig. 8.11b), and to them are fastened two $2\frac{1}{2}$ " x $\frac{1}{2}$ " Double Angle Strips (13). Each of the strips (12) is made from a 3" and a $2\frac{1}{2}$ " Strip. The strip (12) at the front is fitted at its centre with a $1\frac{1}{2}$ " x $\frac{1}{2}$ " Double Angle Strip, which is connected by an Angle Bracket to a Double Bracket (14).

A Flanged Sector Plate (15) is held between $\frac{3}{4}$ " Flanged Wheels and 1" Pulleys on 5" Rods supported in the Double Angle Strips (13).

THE DRIVING MECHANISM

One side of the model is removed in Fig. 8.11c to show details of the drive and gear-box. A No. 1 Clockwork Motor is bolted to the Strips (6), and a $\frac{1}{2}$ " Sprocket on the Motor shaft is connected by Chain to a 2" Sprocket on a $6\frac{1}{2}$ " Rod (16). This Rod is supported in $4\frac{1}{2}$ " Strips bolted between the Girders (1) on each side. A further $4\frac{1}{2}$ " Strip (17) is fixed across the front, and to this and to a $4\frac{1}{2}$ " x $2\frac{1}{2}$ " Flexible Plate above it, is bolted a Face Plate (18). Two $2\frac{1}{2}$ " Strips (19) are fixed to the $4\frac{1}{2}$ " Strips at the front.

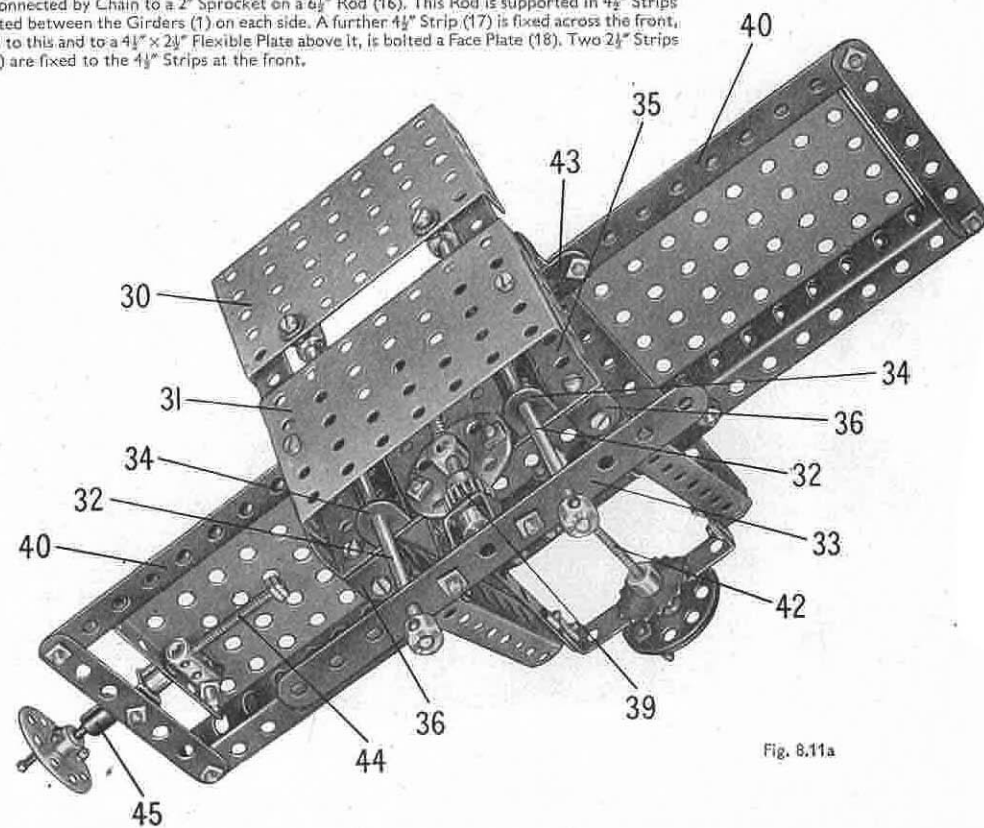

Fig. 8.11a

MODEL 8.11 MILLING MACHINE — Continued

ASSEMBLY OF THE TABLE CARRIAGE

A $3\frac{1}{2}'' \times 2\frac{1}{2}''$ Flanged Plate (30) is bolted to the Strip (19), and a further $3\frac{1}{2}'' \times 2\frac{1}{2}''$ Flanged Plate (31) is attached to $2\frac{1}{2}''$ Strips fixed to the Plate (30). Two $6\frac{1}{4}''$ Rods (32) are fixed in Collars spaced from the Plate (30) by two Washers on each of the bolts holding the Collars to the Plate, and the lower ends of these Rods are supported in a $5\frac{1}{2}''$ Strip (33) attached to the Girders (3) by Angle Brackets.

Two $2\frac{1}{2}'' \times 1\frac{1}{2}''$ Double Angle Strips (34) (Fig. 8.11a) are free to slide on Rods (32) and are bolted to a $3\frac{1}{2}'' \times 2\frac{1}{2}''$ Flanged Plate (35). Two $3\frac{1}{2}'' \times \frac{1}{2}''$ Double Angle Strips (36) are fixed to the Plate (35), with $5\frac{1}{2}''$ Angle Girders (37) bolted to their upper lugs. The Girders (37) are connected by further $5\frac{1}{2}''$ Angle Girders to Obtuse Angle Brackets fixed to the lower lugs of the Double Angle Strips (36).

The carriage can be raised or lowered by turning a $1\frac{1}{2}''$ Pulley on an 8" Rod (38), which is held in the Plates (8) and (11) by a Coupling and a $\frac{1}{2}''$ fixed Pulley. The Rod carries at its inner end a $\frac{3}{4}''$ Contrate that engages a $\frac{1}{2}''$ Pinion (39) on a Screwed Rod. The Screwed Rod is held by a Collar in a Double Bent Strip bolted to the Strip (33), and is threaded through the boss of a Bush Wheel attached to the Plate (35) (see Fig. 8.11a).

CONSTRUCTION OF THE TABLE

Two $12\frac{1}{2}''$ Angle Girders (40) are connected at their ends by $3\frac{1}{2}''$ Strips, and one of them is fitted with a Crank (41) (Fig. 8.11b). A Screwed Rod (42), threaded through the boss of the Crank, is held by a $1\frac{1}{2}''$ Pulley and a 1" Sprocket in a $2\frac{1}{2}'' \times \frac{1}{2}''$ Double Angle Strip bolted to the ends of Girders (37). The Girders (40) are located on the Girders (37) by Fishplates (43), which are spaced from the Girders (40) by a Washer on each bolt.

The table consists of two $5\frac{1}{2}'' \times 2\frac{1}{2}''$ Flanged Plates bolted end to end, and it slides on the Girders (40) as shown. A Coupling is attached to one end of the table by a Bolt, and a Screwed Rod (44) is threaded through this Coupling and is fixed by a nut in a Screwed Rod Adaptor (45) fitted with a Bush Wheel. The Screwed Rod passes through a Double Bracket bolted to one of the $3\frac{1}{2}''$ Strips connecting the Girders (40), and is held in place by a Collar.

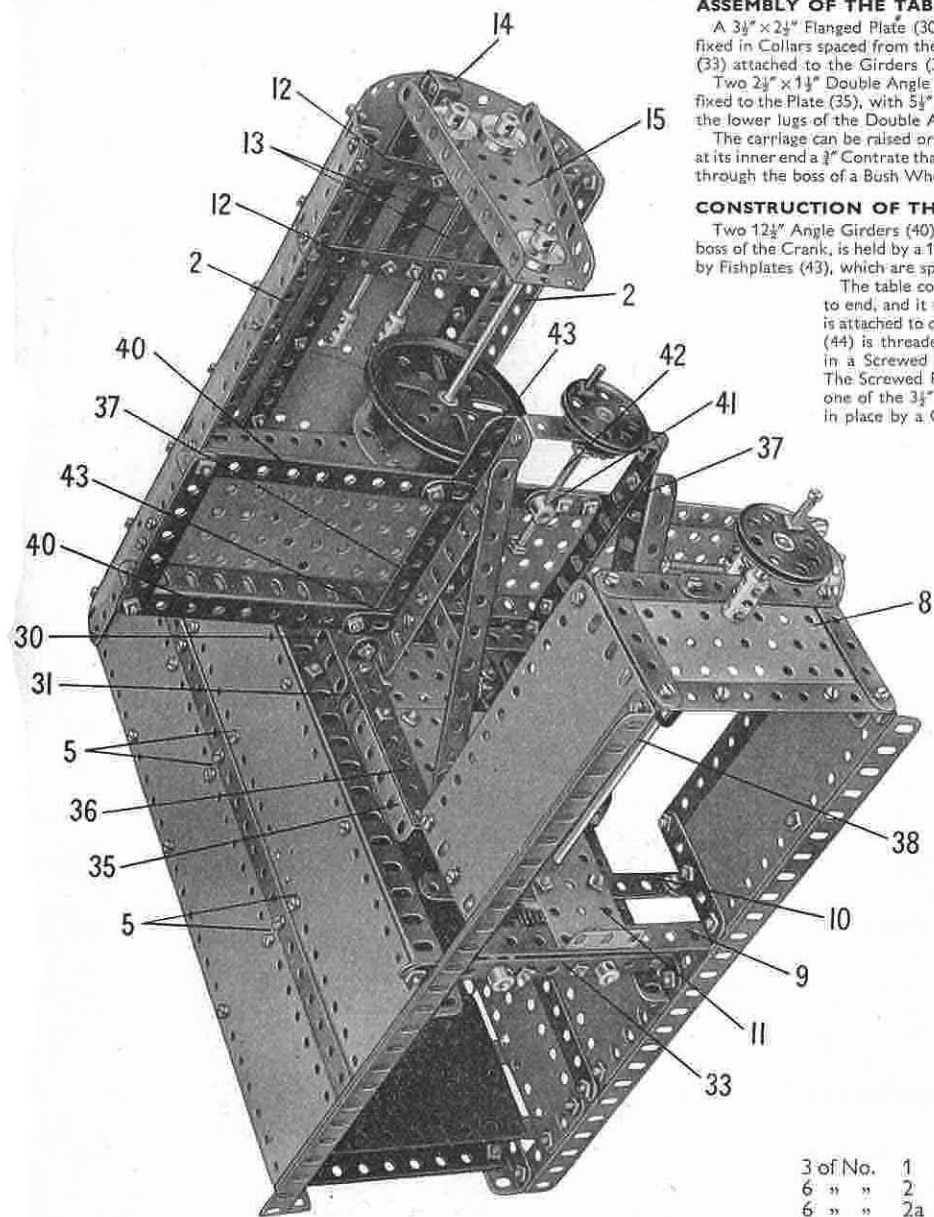

Fig. 8.11b

3 of No.	1
6 " "	2
6 " "	2a
5 " "	3
5 " "	4
14 " "	5

Parts Required

4 of No.	6a	1 of No.	51
10 " "	8	2 " "	52
4 " "	9	4 " "	53
4 " "	10	1 " "	54
2 " "	11	10 " "	59
9 " "	12	1 " "	62
2 " "	12b	6 " "	63
2 " "	12c	1 " "	80a
1 " "	13	2 " "	80c
1 " "	13a	1 " "	90
3 " "	14	1 " "	94
2 " "	15	2 " "	95
1 " "	15b	1 " "	96
1 " "	18a	1 " "	96a
1 " "	19b	2 " "	109
3 " "	20b	2 " "	111
2 " "	21	1 " "	111a
4 " "	22	2 " "	111c
1 " "	23a	1 " "	115
1 " "	24	1 " "	126
3 " "	26	1 " "	173a
2 " "	27a	5 " "	188
1 " "	29	5 " "	189
1 " "	32	1 " "	190
228 " "	37a	3 " "	191
217 " "	37b	10 " "	192
21 " "	38	3 " "	197
1 " "	45	2 " "	214
1 " "	46		
1 " "	48		
6 " "	48a		
2 " "	48b		
2 " "	48c		

1 No. 1 Clock-work Motor
(Not included in Outfit)

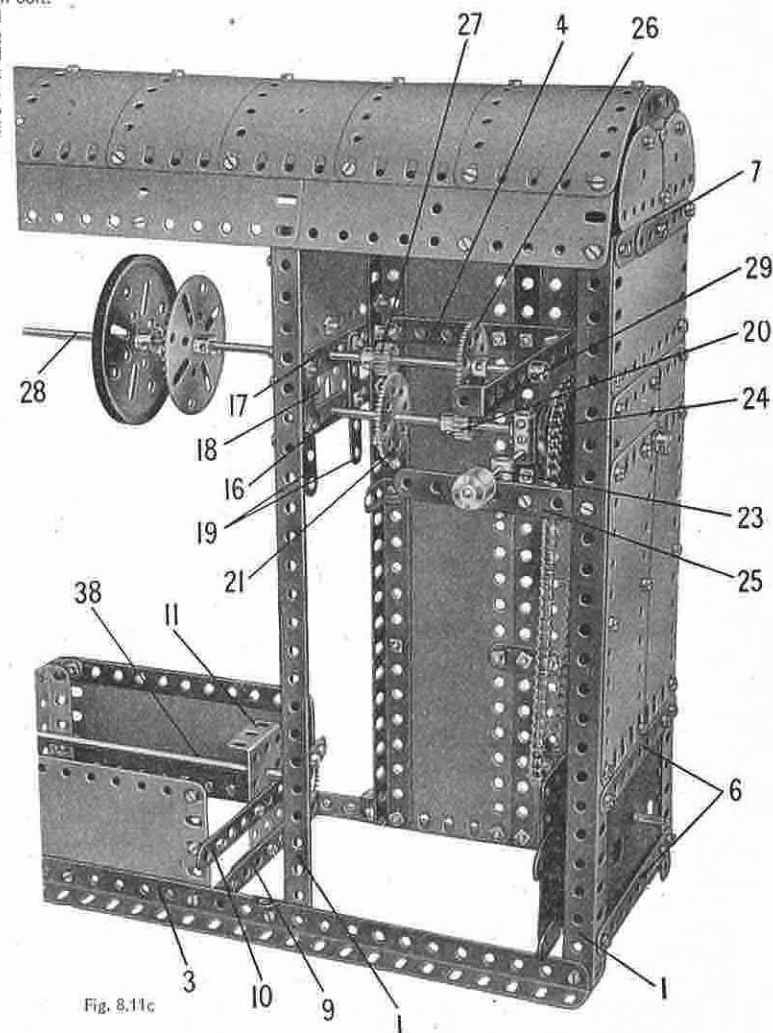

Fig. 8.11c

8.12 MECCANOGRAPH

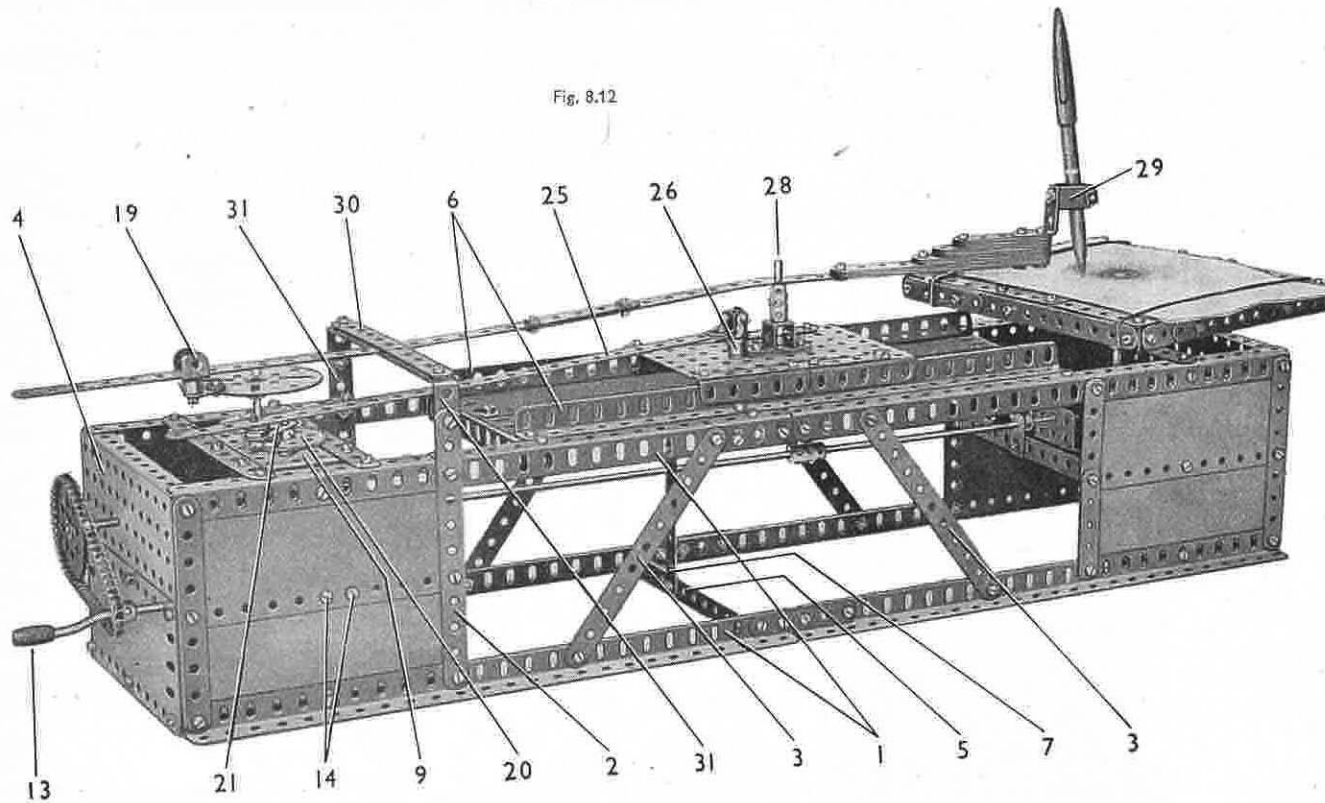

Fig. 8.12

Parts Required

3 of No. 1	1 of No. 19h	10 of No. 59
20 " " 2	3 " " 26	2 " " 62
6 " " 2a	2 " " 27a	4 " " 63
5 " " 3	1 " " 28	1 " " 94
6 " " 4	1 " " 29	1 " " 95
18 " " 5	1 " " 32	1 " " 96
4 " " 6a	182 " " 37a	1 " " 96a
10 " " 8	196 " " 37b	2 " " 109
4 " " 9	14 " " 38	3 " " 111
1 " " 10	1 " " 44	4 " " 111a
16 " " 12	1 " " 45	6 " " 111c
4 " " 12a	2 " " 48	1 " " 116
1 " " 13	2 " " 48a	1 " " 160
1 " " 13a	6 " " 48b	1 " " 165
1 " " 15a	2 " " 48d	2 " " 189
1 " " 15b	2 " " 51	4 " " 191
1 " " 16	2 " " 52	10 " " 192
1 " " 17	5 " " 53	2 " " 197
1 " " 18a	2 " " 54	

With this model many beautiful and interesting designs can be produced on a sheet of paper. The paper is fixed by means of rubber bands to a revolving table, and the designs are traced on it by a ball pen attached to a mechanically-operated moving arm.

The pattern obtained may be varied by altering the hole of the Strip through which the Rod (28) passes, and by altering the setting of the Fishplate holding the large Fork Piece (19). A few experiments will show the combinations that produce the most interesting and beautiful designs.

CONSTRUCTION OF THE FRAME

Each side of the frame consists of two built-up girders (1) made from $12\frac{1}{2}$ " Angle Girders connected at their inner ends by $2\frac{1}{2}$ " Strips. The girders are connected at each end by a $4\frac{1}{2}$ " Strip and two $5\frac{1}{2}$ " \times $2\frac{1}{2}$ " Flexible Plates arranged as shown in Fig. 8.12. The inner edges of one pair of Plates are strengthened by two $2\frac{1}{2}$ " Strips, and those of the other pair of Plates are edged by a $5\frac{1}{2}$ " Strip (2). The side is braced by two $5\frac{1}{2}$ " Strips (3).

The sides are connected at each end by a $5\frac{1}{2}$ " \times $2\frac{1}{2}$ " Flanged Plate (4), extended downward by a $5\frac{1}{2}$ " \times $2\frac{1}{2}$ " Flexible Plate. The lower edge of one Flexible Plate is strengthened by a $5\frac{1}{2}$ " Angle Strip and the other Plate is edged by a $5\frac{1}{2}$ " Strip. The lower corners of the Flexible Plates are attached to the sides by Angle Brackets. At the centre the sides are connected by a $5\frac{1}{2}$ " \times $\frac{1}{2}$ " Double Angle Strip (5).

Three $5\frac{1}{2}$ " Angle Girders are bolted across the top of the base and to them are fixed two $12\frac{1}{2}$ " \times $2\frac{1}{2}$ " Strip Plates and two $12\frac{1}{2}$ " Angle Girders (6). Two of the $5\frac{1}{2}$ " Angle Girders are placed at the ends of the Girders (6), and the third is positioned immediately above the Double Angle Strip (5). A built-up strip (7) is bolted between the Double Angle Strip and this Angle Girder. The strip (7) is made from a $3\frac{1}{2}$ " and a $1\frac{1}{2}$ " Strip.

A Flanged Sector Plate is bolted to each of the lower flanges of the Plates (4). Two $2\frac{1}{2}$ " \times $1\frac{1}{2}$ " Flanged Plates (8) are fixed to one of the Flanged Sector Plates and to a $3\frac{1}{2}$ " \times $2\frac{1}{2}$ " Flanged Plate (9) supported by two $5\frac{1}{2}$ " Strips fixed across the base. The other Flanged Sector Plate is connected by a 1 " \times 1 " Angle Bracket (10) to a $5\frac{1}{2}$ " \times $\frac{1}{2}$ " Double Angle Strip bolted between the sides of the base. A Channel Bearing (11) is secured to this Flanged Sector Plate.

A $5\frac{1}{2}$ " Strip (12) is bolted across the top of the base as shown in Fig. 8.12b.

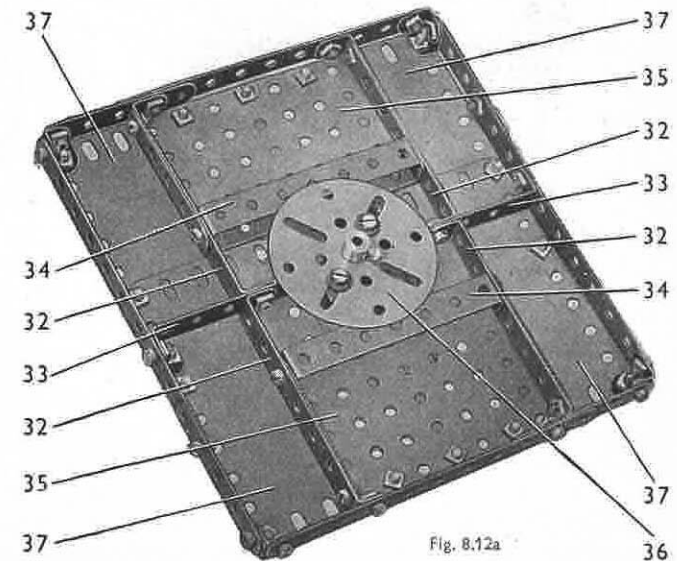

Fig. 8.12a

(Continued on next page)

MODEL 8.12 MECCANOGRAPH — Continued

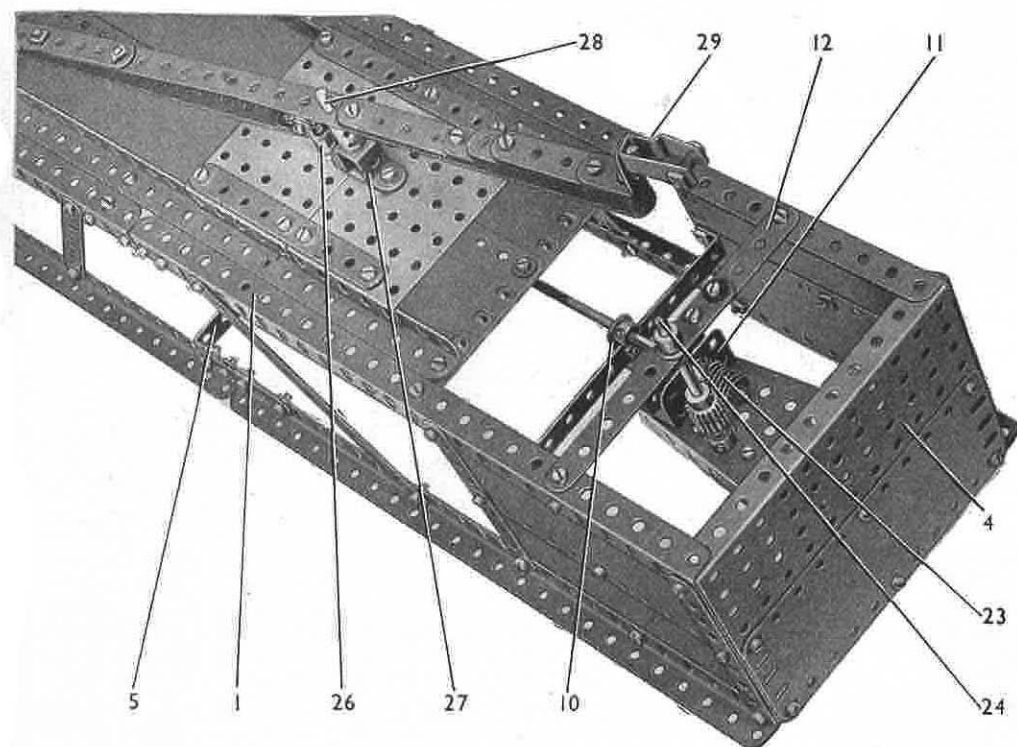

Fig. 8.12b

A Double Bent Strip (27) is bolted to the carriage but is spaced from it by two $1\frac{1}{2}$ " Strips. A 2" Rod (28) is supported in the carriage and the Double Bent Strip and is held in place by a Collar and a Coupling.

The pen arm consists of two $12\frac{1}{2}$ " Strips overlapped five holes and weighted at one end by $5\frac{1}{2}$ ", $3\frac{1}{2}$ ", 3" and $2\frac{1}{2}$ " Strips as shown. These Strips are attached by $\frac{1}{4}$ " and $\frac{3}{8}$ " Bolts. A $1" \times 1"$ Angle Bracket is bolted to the arm and it supports a Stepped Bent Strip (29). A ball-point pen or a pencil is fixed in the Stepped Bent Strip.

The pen arm slides between two $5\frac{1}{2}$ " Strips (30), spaced apart by two Washers at each end and attached by $\frac{3}{8}$ " Bolts to $1\frac{1}{2}" \times \frac{1}{2}"$ Double Angle Strips (31). The end of the arm is located between the jaws of the Fork Piece (19), and is passed over the Rod (28) in the sliding carriage.

THE TURNTABLE

The framework for the turntable is formed by four $3\frac{1}{2}" \times \frac{1}{2}"$ Double Angle Strips (32) (Fig. 8.12a) bolted on either side of two $2\frac{1}{2}" \times \frac{1}{2}"$ Double Angle Strips (33). Two $3\frac{1}{2}" \times \frac{1}{2}"$ Double Angle Strips (34) and two $3\frac{1}{2}" \times 2\frac{1}{2}"$ Flanged Plates (35) are fixed between the Double Angle Strips (32). A Face Plate (36) is attached by Angle Brackets to the lugs of the Double Angle Strips (33). Each edge of the turntable consists of a $5\frac{1}{2}"$ and a $2\frac{1}{2}"$ Strip, overlapped two holes for the longer side and three holes for the shorter side. The edges are bolted to the lugs of the Double Angle Strips (32) and (33) and are connected at the corners by Angle Brackets. The Face Plate is fixed to the end of Rod (24).

The top of the turntable consists of two $4\frac{1}{2}" \times 2\frac{1}{2}"$ Flexible Plates (37) along each of the longer sides and two $5\frac{1}{2}" \times 1\frac{1}{2}"$ Flexible Plates at the centre. The Plates are bolted to the Flanged Plates (35) and are connected to the corners of the table by Angle Brackets.

The sheet of paper is fastened to the turntable by two Driving Bands.

ASSEMBLY OF THE MECHANISM

A 5" Crank Handle (13) fitted with a $\frac{3}{4}"$ Sprocket, is mounted in one of the Flanged Plates (4) and in two $1" \times 1"$ Angle Brackets attached to the side of the base by Bolts (14). The Crank Handle is held in position by two Couplings, and its Sprocket is connected by Chain to a 2" Sprocket on a $3\frac{1}{2}"$ Rod (15). This Rod is held in place by Collars, and it carries at its inner end a $\frac{3}{8}"$ Contrate that drives a $\frac{1}{2}"$ Pinion (16). The Pinion is fixed on a vertical 4" Rod fitted with a 57-tooth Gear (17) and a Face Plate (18). The Rod is held in position by a Collar placed underneath the Flanged Sector Plate. A Fishplate is bolted tightly to the Face Plate, and a large Fork Piece (19) pivots freely on a $\frac{3}{8}"$ Bolt passed through the Fishplate.

The Gear (17) drives a similar Gear (20) fixed on a $1\frac{1}{2}"$ Rod that is held in position by a 1" Sprocket placed below the Flanged Plate (9). A $1\frac{1}{2}"$ Strip (21) is passed over the end of the $1\frac{1}{2}"$ Rod but is spaced from the Gear by a Collar on the Rod. The Strip is connected to the Gear by nuts on a $\frac{1}{2}"$ Bolt, which is passed through a hole in the Gear and is fixed in place by a nut.

The drive to the turntable is taken through a $1\frac{1}{2}"$ Contrate (22) that engages the Pinion (16). The Contrate is fixed on an $11\frac{1}{2}"$ Rod that is joined to an 8" Rod by a Coupling and is supported in one of the Flanged Plates (8), the Angle Bracket (10) and the Channel Bearing (11). The Rods are held in place by Collars, and a Worm (23) is fixed to the end of the 8" Rod. This Worm drives two $\frac{1}{2}"$ Pinions, placed next to each other on a 5" Rod (24). The Rod is mounted in one of the Flanged Sector Plates and in a Crank bolted to the Strip (12). The $\frac{1}{2}"$ Pinions are meshed with the Worm, and are then twisted as far as possible in opposite directions before their grub-screws are tightened. This reduces the amount of 'play' or backlash in the drive to the table.

THE SLIDING CARRIAGE AND THE PEN ARM

The sliding carriage consists of two $3\frac{1}{2}" \times 2\frac{1}{2}"$ Flanged Plates connected together by two $4\frac{1}{2}"$ Strips, and it slides freely over the Angle Girders (6). It is operated by a $12\frac{1}{2}"$ Strip (25) that pivots on a $\frac{1}{2}"$ Bolt fixed by a nut in the $1\frac{1}{2}"$ Strip (21). The Strip is spaced from the nut on the $\frac{1}{2}"$ Bolt by three Washers. The Strip (25) is fixed to an Angle Bracket, and a $\frac{3}{8}"$ Bolt passed through the Angle Bracket is locked in the 'spider' of a Swivel Bearing (26). This Swivel Bearing pivots on a $\frac{1}{2}"$ Bolt passed through a hole in the carriage.

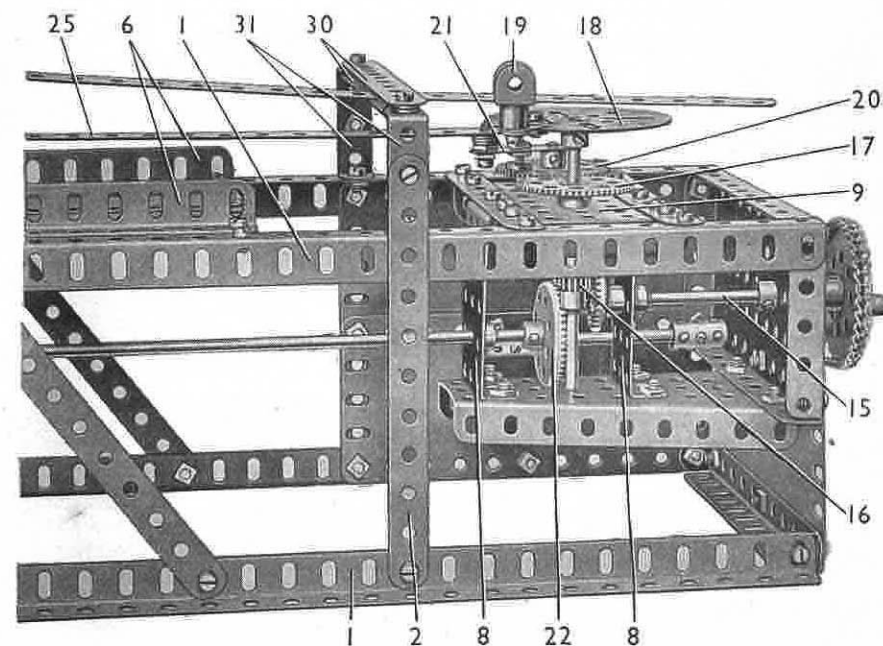

Fig. 8.12c

8.13 CARGO TRANSPORT PLANE

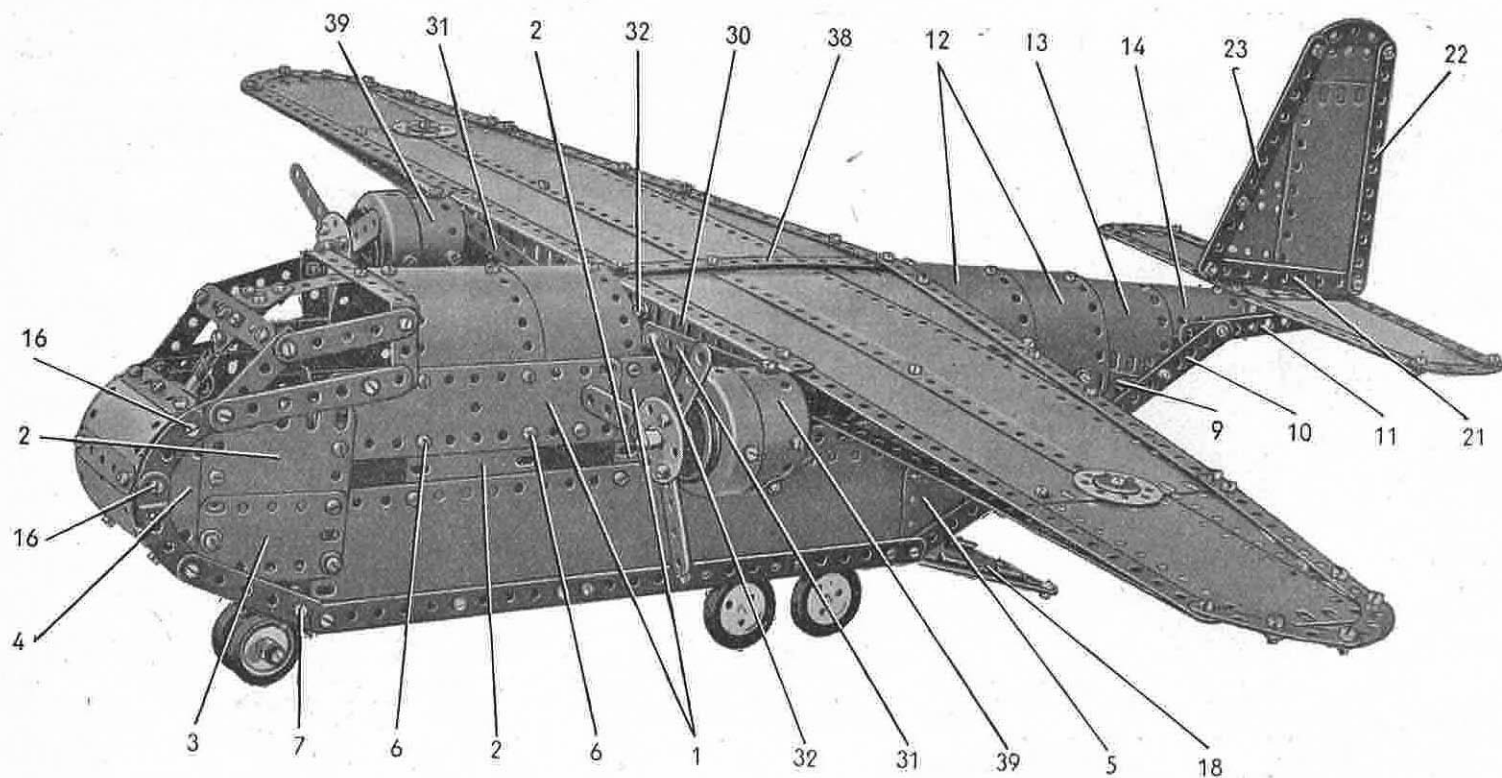

Fig. 8.13

ASSEMBLY OF THE FUSELAGE

Each side of the fuselage consists of a $12\frac{1}{2}'' \times 2\frac{1}{2}''$ Strip Plate, two $5\frac{1}{2}'' \times 1\frac{1}{2}''$ Flexible Plates (1), three $2\frac{1}{2}'' \times 2\frac{1}{2}''$ Flexible Plates (2), a $2\frac{1}{2}'' \times 1\frac{1}{2}''$ Flexible Plate (3), a Semi-Circular Plate (4) and a $3\frac{1}{2}'' \times 2''$ Triangular Flexible Plate (5). The lower edge of the Strip Plate is strengthened by a $12\frac{1}{2}''$ Strip, and a similar part is used to brace the lower edges of the Plates (1) on the inside. The rounded nose is edged by a $3''$ and a $3\frac{1}{2}''$ Strip, and two $2\frac{1}{2}''$ stepped Curved Strips.

The sides are connected by three $3\frac{1}{2}'' \times 2\frac{1}{2}''$ Flanged Plates as shown in Fig. 8.13a, by another $3\frac{1}{2}'' \times 2\frac{1}{2}''$ Flanged Plate held by bolts (6) on each side, and by a $3\frac{1}{2}'' \times \frac{1}{2}''$ Double Angle Strip held by bolts (7).

Each side is extended towards the tail by a $4\frac{1}{2}'' \times 2\frac{1}{2}''$ Flexible Plate (8) (Fig. 8.13b), and a $5\frac{1}{2}'' \times 1\frac{1}{2}''$ Flexible Plate, the rear end of which is indicated at (9) (Fig. 8.13). A built-up strip (10) on each side, made from a $4\frac{1}{2}''$ and a $5\frac{1}{2}''$ Strip, is bolted to the lower rear corner of the Strip Plate and to the lower rear corner of Plate (9). Each of these strips is extended at the tail by a $5\frac{1}{2}''$ Strip (11), and a Double Bracket is fixed between the rear ends of these Strips.

The rounded top of the fuselage between the cockpit and the front edges of the wings consists of two $5\frac{1}{2}'' \times 2\frac{1}{2}''$ Flexible Plates curved to shape. The fuselage top below the wings is formed by another curved $5\frac{1}{2}'' \times 2\frac{1}{2}''$ Flexible Plate and four $1\frac{1}{2}''$ radius Curved Plates. The rounded section between the rear edges of the wings and the tail is filled in by two curved $5\frac{1}{2}'' \times 2\frac{1}{2}''$ Flexible Plates (12) bolted to the Plates (8) and (9), a $4\frac{1}{2}'' \times 2\frac{1}{2}''$ Flexible Plate (13) fixed to the strips (10), and a 'U'-section Curved Plate (14). A $12\frac{1}{2}''$ Strip is bolted along the centre line of Plates (12), (13) and (14), and overhangs the Plate (14) by one clear hole.

The rounded nose is filled in by a $4\frac{1}{2}'' \times 2\frac{1}{2}''$ Flexible Plate extended by a $1\frac{1}{2}''$ radius Curved Plate, and two $3\frac{1}{2}''$ Strips (15) (Fig. 8.13a). These are bolted to the Double Angle Strip held by bolts (7), and to Angle Brackets fixed by bolts (16). A Flanged Sector Plate, edged by $5\frac{1}{2}''$ Strips (17) (Fig. 8.13a), is attached by the bolts that join the strips (10) and the Strips (11) together. The Strips (17) are supported at their front ends by Angle Brackets fixed to the strips (10), and are connected to the wide-end

of the Flanged Sector Plate by Fishplates.

The rear cargo loading door and ramp (18) is the overlapped separated halves of a Hinged Flat Plate bolted to $3\frac{1}{2}''$ Strips fixed to $4\frac{1}{2}''$ Strips (19). An Angle Bracket is bolted to each of these Strips, and pivots on a lock-nutted bolt that connects the strip (10) to the Strip/Plate. The Angle Bracket is fixed on the bolt by two nuts, leaving the bolt free to turn in the strips and the Strip Plate.

TAIL PLANE

Each half of the tail-plane is a $5\frac{1}{2}'' \times 2\frac{1}{2}''$ Flexible Plate bolted at its inner end to a $3\frac{1}{2}''$ Strip (20) (Fig. 8.13a) that is bolted to the Double Bracket between the Strips (11) and to the end hole of the $12\frac{1}{2}''$ Strip fixed to Plates (12), (13) and (14). Each Flexible Plate is edged by two $5\frac{1}{2}''$ Strips and a $2\frac{1}{2}''$ Stepped Curved Strip.

The tail fin is made by bolting a $4\frac{1}{2}''$ Strip (21), a $4\frac{1}{2}'' \times 2\frac{1}{2}''$ Flexible Plate and a $5\frac{1}{2}''$ Strip (22), to each lug of a Double Bracket. The Double Bracket is attached to the Strip (20) by the same $\frac{1}{2}''$ Bolt that fixes the Strip to the Double Bracket between the ends of Strips (11). An Angle Bracket bolted to one of the Strips (21) also is attached to Strip (20). Two $5\frac{1}{2}''$ Strips (23), with a $2\frac{1}{2}'' \times 1\frac{1}{2}''$ Flexible Plate and two $2\frac{1}{2}'' \times 2\frac{1}{2}''$ Triangular Flexible Plates bolted between them, are fixed to the front ends of the Strips (21). The upper ends of Strips (23) are connected to the Strips (22) by two $2\frac{1}{2}''$ Stepped Curved Strips, with two $2\frac{1}{2}'' \times 2\frac{1}{2}''$ Flexible Plates bolted between the Curved Strips.

DETAILS OF THE COCKPIT

The floor of the cockpit is a $3\frac{1}{2}'' \times 2\frac{1}{2}''$ Flanged Plate (24), (Fig. 8.13b) bolted to the Flanged Plate held by bolts (6). Each seat is a Trunnion connected to the Plate (24) by a $\frac{1}{2}''$ Reversed Angle Bracket.

Parts Required

12 of No.	1	1 of No.	63
19 "	2	2 "	77
6 "	2a	2 "	80c
6 "	3	4 "	90
5 "	4	8 "	90a
13 "	5	2 "	111
2 "	6	4 "	111a
2 "	6a	6 "	111c
1 "	8	2 "	125
2 "	9	2 "	126
6 "	10	4 "	142c
2 "	11	1 "	147b
10 "	12	2 "	155
2 "	12a	1 "	162
2 "	12b	5 "	188
6 "	12c	8 "	189
1 "	18b	10 "	190
2 "	21	6 "	191
2 "	22	12 "	192
4 "	22a	6 "	197
2 "	24a	1 "	198
2 "	24c	1 "	199
254 "	37a	5 "	200
223 "	37b	1 "	112
36 "	38	2 "	214
2 "	38d	4 "	221
5 "	48b	2 "	222
5 "	53	1 "	223
1 "	54	2 "	224
3 "	59	2 "	225

MODEL 8.13 CARGO TRANSPORT PLANE — Continued

The cockpit side windows are each formed by a $1\frac{1}{2}$ " and a $2\frac{1}{2}$ " Strip as shown in Fig. 8.13. The side windows are connected by a $3\frac{1}{2}$ " x $\frac{1}{2}$ " Double Angle Strip and a 3" Strip (25) attached to Angle Brackets. A $2\frac{1}{2}$ " Strip (26) is bolted to a 1" Triangular Plate, which is attached by Obtuse Angle Brackets to the Strip (25). A 1" Rod supported at its lower end in an Obtuse Angle Bracket bolted to the nose, is fitted in a Rod and Strip Connector attached to a second 1" Triangular Plate fixed to the Strip (25).

UNDERCARRIAGE

The main landing wheels are 1" loose Pulleys fitted with Motor Tyres. Two of them are mounted on lock-nutted $\frac{1}{2}$ " Bolts passed through $1" \times \frac{1}{2}"$ Angle Brackets. The other two are free to turn on $\frac{1}{2}"$ Bolts, each of which is held by two nuts in a $1" \times 1"$ Angle Bracket. The wheels are spaced from the Angle Brackets by Washers on the Bolts. The Angle Brackets are bolted to a $5\frac{1}{2}" \times 2\frac{1}{2}"$ Flexible Plate edged by a $2\frac{1}{2}"$ and two $5\frac{1}{2}"$ Strips. The rear end of the Plate is supported by a $3\frac{1}{2}" \times \frac{1}{2}"$ Double Angle Strip (27).

The pivoted nose-wheel assembly is formed by two 1" Pulleys with Rubber Rings, each of which is free to turn on a $\frac{1}{2}"$ Bolt screwed into a Coupling (28). The Bolts are fixed in the Coupling by nuts. A Pivot Bolt is passed through the front of the Flanged Plate forming the floor of the fuselage and is fixed in a Collar. A $\frac{1}{2}"$ Bolt (29), (Fig. 8.13b), is passed through the top hole of the Coupling (28) and is screwed tightly into a threaded hole of the Collar.

THE WINGS

The front edges of the wings are formed by a $12\frac{1}{2}"$ Angle Girder (30), two $5\frac{1}{2}"$ Angle Girders (31) and four $12\frac{1}{2}"$ Strips. The Girders (30) and (31) are bolted together at their outer ends and are connected towards the centre by Fishplates held by bolts (32). The $12\frac{1}{2}"$ Strips overlap the ends of the Girders by four holes each. The rear edges of the wings consist of two $12\frac{1}{2}"$ Strips, each extended by a $5\frac{1}{2}"$ Strip. The wing tips are $2\frac{1}{2}"$ Curved Strips.

The wing is plated by four $12\frac{1}{2}" \times 2\frac{1}{2}"$ Strip Plates (33), four $5\frac{1}{2}" \times 2\frac{1}{2}"$ Flexible Plates (34), two $2\frac{1}{2}" \times 2"$ Triangular Flexible Plates (35), two $3\frac{1}{2}" \times 1\frac{1}{2}"$ Triangular Flexible Plates (36), and two $2\frac{1}{2}" \times 2\frac{1}{2}"$ Flexible Plates (37). The wings are bolted to a $12\frac{1}{2}"$ Strip (38), (Fig. 8.13), fixed along the centres of the Curved Plates that form the rounded top of the fuselage.

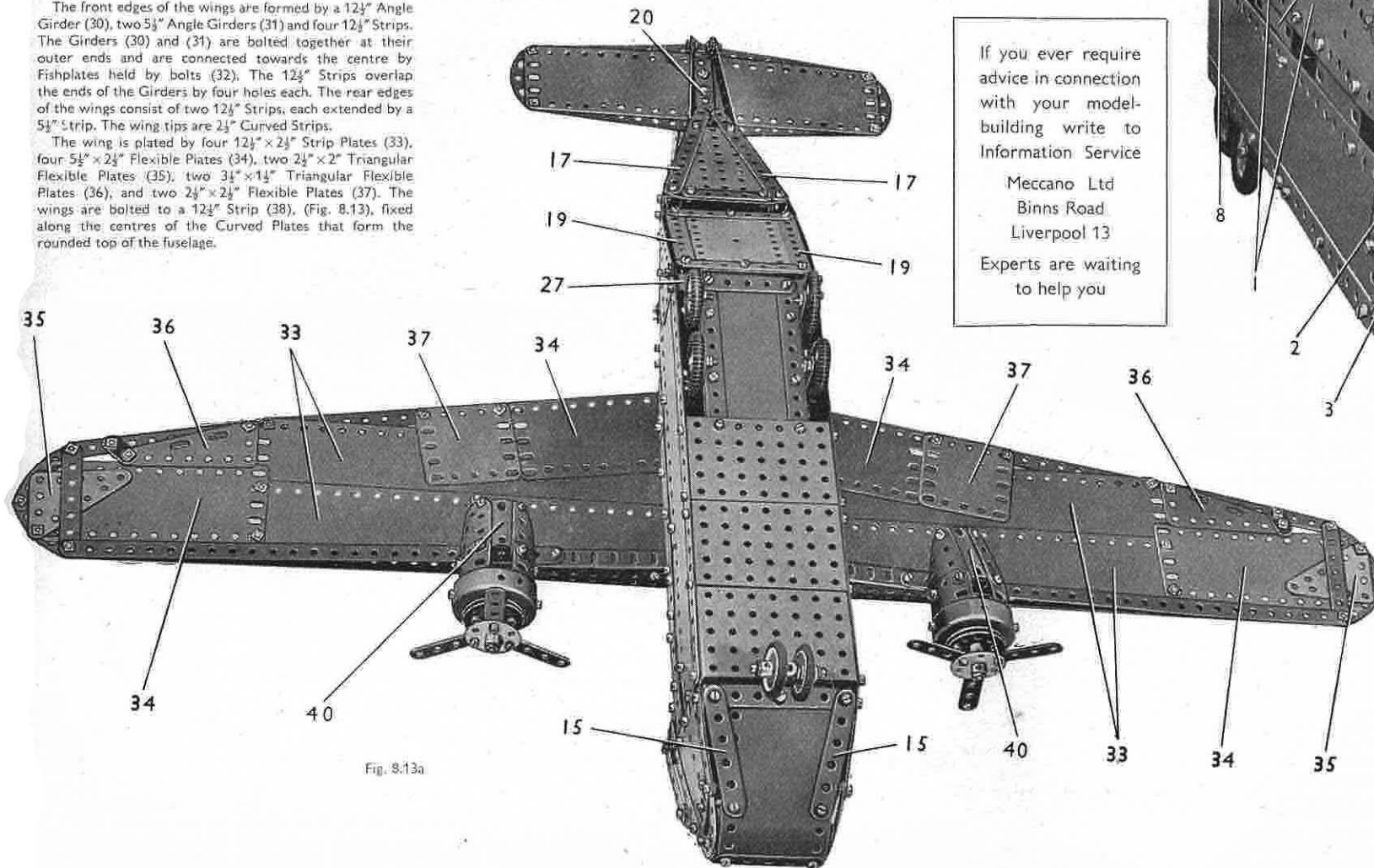

Fig. 8.13a

If you ever require advice in connection with your model-building write to Information Service

Meccano Ltd
Binns Road
Liverpool 13

Experts are waiting to help you

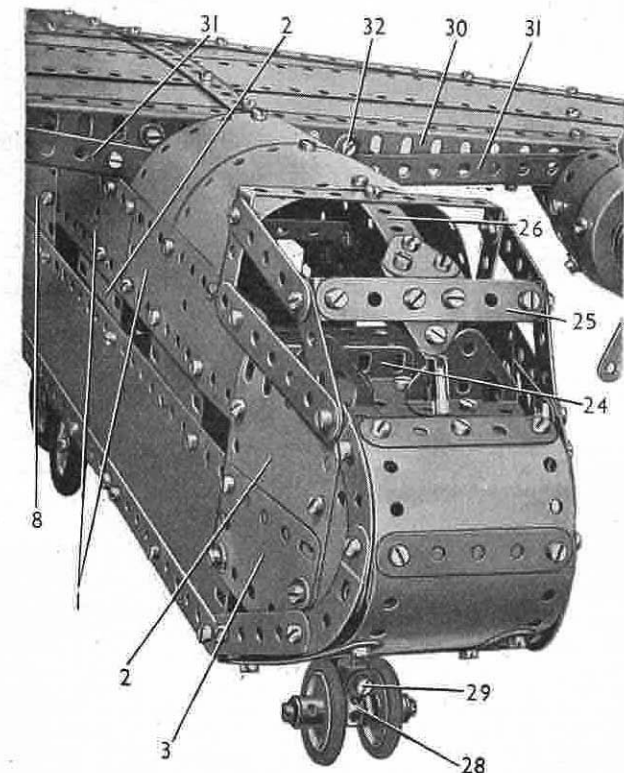

Fig. 8.13b

ENGINE UNITS

The two engine units are identical in construction. The propeller of each is made by bolting three $2\frac{1}{2}"$ Strips to a Six-hole Wheel Disc, which is held by a Collar and two nuts on a 3" Screwed Rod. The Screwed Rod is freely mounted in a $1\frac{1}{2}"$ Pulley bolted to the front of a Boiler End, and is retained in position by two nuts tightened against each other on the Screwed Rod, inside the Boiler End.

A $5\frac{1}{2}" \times 1\frac{1}{2}"$ Flexible Plate (39) is curved and is bolted inside the rim of the Boiler End. Two $2\frac{1}{2}" \times 1\frac{1}{2}"$ Triangular Flexible Plates and a $2\frac{1}{2}" \times 1\frac{1}{2}"$ Flexible Plate (40) are bolted to the Plate (39), as shown in Fig. 8.13a. The completed units are attached by Angle Brackets to the ends of the Girders (30) and (31).

8.14 STREAMLINED SPORTS CAR

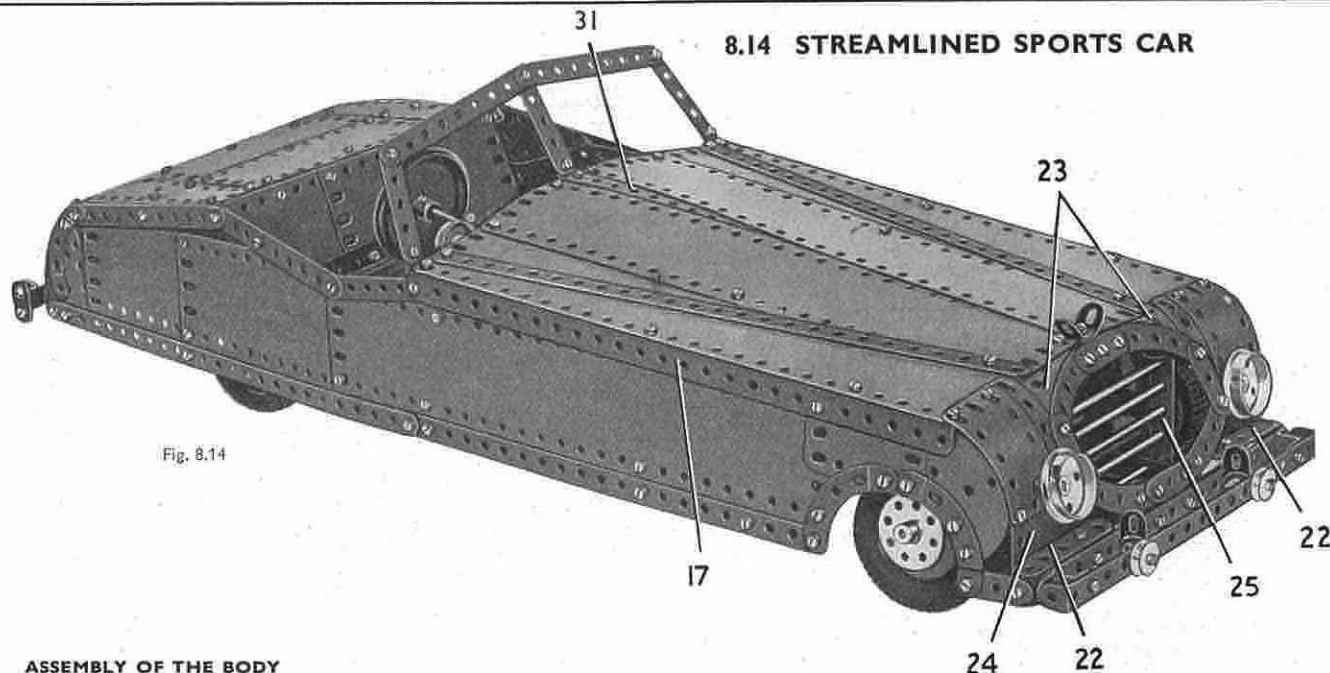

Fig. 8.14

ASSEMBLY OF THE BODY

Each side of the body consists of (from front to rear) a Semi-Circular Plate, a $2\frac{1}{2}'' \times 1\frac{1}{2}''$ Flexible Plate, a $12\frac{1}{2}'' \times 1\frac{1}{2}''$ Flexible Plate, a $5\frac{1}{2}'' \times 2\frac{1}{2}''$ and a $4\frac{1}{2}'' \times 2\frac{1}{2}''$ Flexible Plate, and a $2\frac{1}{2}'' \times 1\frac{1}{2}''$ Triangular Flexible Plate. The front wheel arch consists of two $2\frac{1}{2}''$ Stepped Curved Strips, and to the lower edges of the sides are attached two $12\frac{1}{2}''$ Strips overlapped five holes. These Strips are bolted to a vertical $3\frac{1}{2}''$ Strip placed behind the rear wheel, and to a $3''$ Strip (16) (Fig. 8.14a).

The top edges of the Plates at each side are edged by a $12\frac{1}{2}''$ Angle Girder (17), a $3\frac{1}{2}''$ and a $4\frac{1}{2}''$ Strip representing the top of the door, and by a $5\frac{1}{2}''$ Strip and a $2\frac{1}{2}''$ Stepped Curved Strip at the tail. The completed sides are bolted to the Double Brackets at the end of the strip (5) and to the lugs of Double Angle Strips (6) and (12) (Fig. 8.14c).

The top of the bonnet consists of four $12\frac{1}{2}'' \times 2\frac{1}{2}''$ Strip Plates, the inner pair being separated at their rear ends by a $12\frac{1}{2}''$ Strip (31). The rear edge of the bonnet is supported by a $3\frac{1}{2}'' \times 2\frac{1}{2}''$ Flanged Plate (18) (Fig. 8.14d) bolted to the strip (5). A $5\frac{1}{2}''$ Strip fixed to the end of Strip (13) (Fig. 8.14c), is connected to the Flanged Plate (18) by an Angle Bracket.

The curved tail consists of three $5\frac{1}{2}'' \times 2\frac{1}{2}''$ Flexible Plates extended downward by two $1\frac{1}{4}''$ radius Curved Plates and a curved $2\frac{1}{2}'' \times 1\frac{1}{2}''$ Flexible Plate, and widened on each side by two $5\frac{1}{2}'' \times 1\frac{1}{2}''$ Flexible Plates. The Plates are connected together by a built-up strip (19), made from two $5\frac{1}{2}''$ Strips overlapped five holes.

To the front edges of the Plates is bolted a $5\frac{1}{2}''$ Angle Girder (20), extended at each side by two $2\frac{1}{2}''$ Strips to make a built-up $8\frac{1}{2}''$ girder.

The Plates of the tail are attached to the sides by Angle Brackets, and at the rear they are edged by a $5\frac{1}{2}'' \times \frac{1}{2}''$ and two $1\frac{1}{2}'' \times \frac{1}{2}''$ Double Angle Strips bolted together by their lugs. The outer lugs of the $1\frac{1}{2}'' \times \frac{1}{2}''$ Double Angle Strips are fixed to the lower rear corners of the sides, and the $5\frac{1}{2}'' \times \frac{1}{2}''$ Double Angle Strip is bolted to the rear flange of Plate (3).

The rear bumper is made from a $4\frac{1}{2}'' \times \frac{1}{2}''$ and two $2\frac{1}{2}'' \times \frac{1}{2}''$ Double Angle Strips, and it is attached to the Plates of the tail by two Double Bent Strips. A dummy luggage boot handle (21) is fitted to the tail.

(Continued on next page)

CONSTRUCTION OF THE CHASSIS (Fig. 8.14a)

Each side member of the chassis consists of two $12\frac{1}{2}''$ Angle Girders overlapped eight holes. These are connected at the front by a $5\frac{1}{2}''$ Angle Girder (1) and at the rear by a similar Girder (2). The chassis is extended at the rear by a $5\frac{1}{2}'' \times 2\frac{1}{2}''$ Flanged Plate (3), and a further $5\frac{1}{2}'' \times 2\frac{1}{2}''$ Flanged Plate (4) is bolted between the side members. The Plate (4) is removed in Fig. 8.14c to show the steering mechanism clearly.

The rear axle is an $8''$ Rod mounted in the chassis and held in place by Collars. The Conical Discs covering the wheels are held on the Rod by Bush Wheels.

A built-up strip (5) is fixed across the chassis. This strip consists of four $5\frac{1}{2}''$ Strips arranged in pairs, the Strips of each pair being overlapped three holes. The pairs of Strips are connected at the centre by a Double Bent Strip, and at each end by a Double Bracket.

A $3\frac{1}{2}'' \times \frac{1}{2}''$ Double Angle Strip (6) is bolted to each side of the chassis.

STEERING MECHANISM (Figs. 8.14b and 8.14c)

The front axle consists of two $5\frac{1}{2}''$ Strips overlapped nine holes and bolted to the chassis. Each of the front wheels is fixed on a $2''$ Rod that is held in a Double Bracket by a Collar. A Conical Disc and a Wheel Disc are placed on the Rod and are retained by a Collar, and a $2\frac{1}{2}''$ Strip (7) is passed over each Rod and is held in place by the inner Collar. The Double Brackets are lock-nutted on $\frac{1}{2}''$ Bolts to the front axle.

Each of the Strips (7) is fixed to a Coupling (8) by a bolt screwed into the centre threaded hole of the Coupling. The Couplings are pivotally connected by two $5\frac{1}{2}''$ Strips, each of which is passed over bolts gripped in the Couplings by their grub screws. A Flat Trunnion is bolted to the upper $5\frac{1}{2}''$ Strip, and to it is lock-nutted a $3''$ Strip (9). This Strip is lock-nutted also to a Crank (10) that is bolted tightly by a $\frac{1}{2}''$ Bolt to a $1\frac{1}{2}''$ Contrate (11).

The Contrate (11) is fixed on a $3\frac{1}{2}''$ Rod. This Rod is supported in a $1''$ Triangular Plate bolted to a $3\frac{1}{2}'' \times \frac{1}{2}''$ Double Angle Strip (12), and also in a $5\frac{1}{2}''$ Strip (13) attached to a $2\frac{1}{2}'' \times 1\frac{1}{2}''$ Flanged Plate bolted to the Plate (4). The Flanged Plate is braced by $5\frac{1}{2}''$ Strips (14) to the Double Angle Strips (6), and a $2\frac{1}{2}'' \times \frac{1}{2}''$ Double Angle Strip (15) is bolted between the end of Strip (13) and the Double Angle Strip (12). The $3\frac{1}{2}''$ Rod carrying the Contrate (11) is held in place by Collars.

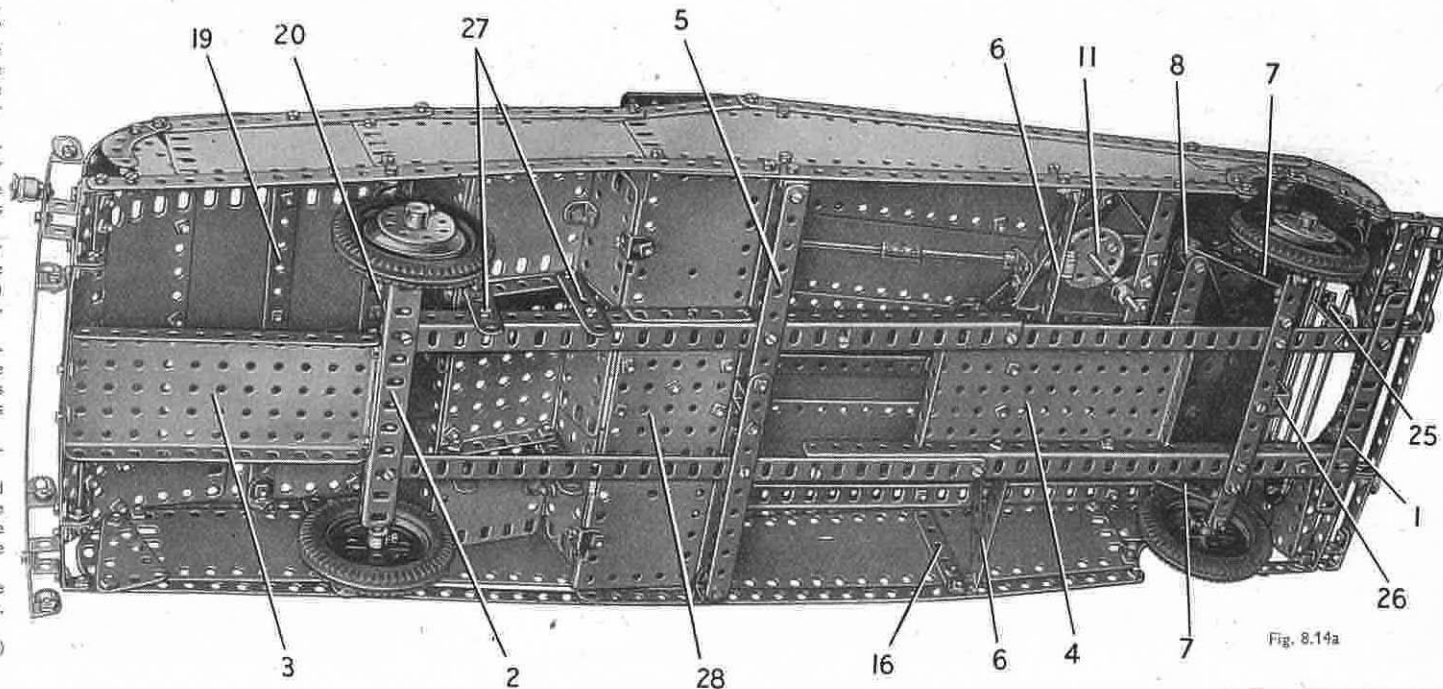

Fig. 8.14a

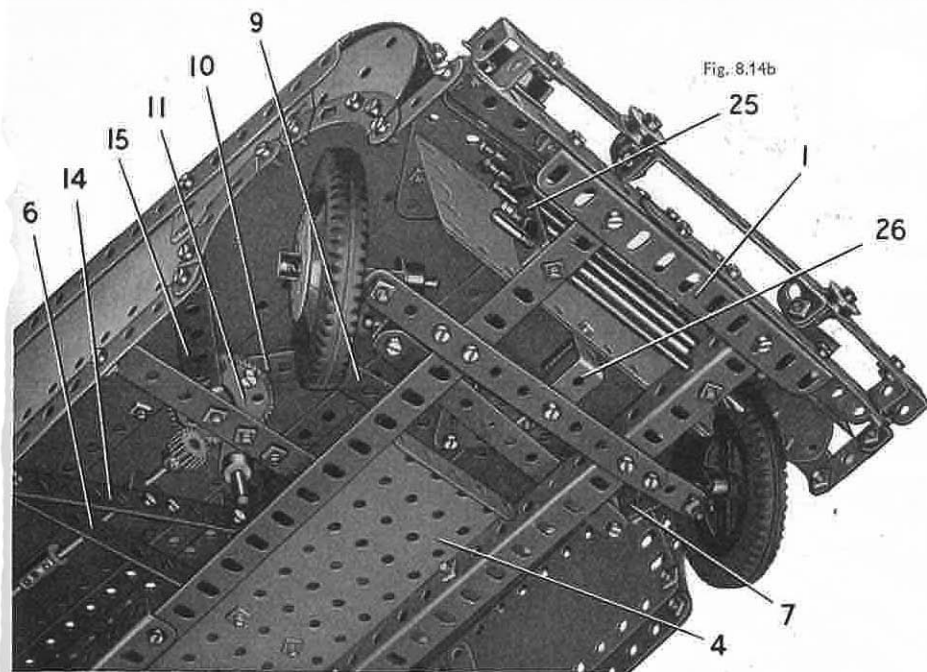

Fig. 8.14b

MODEL 8.14 STREAMLINED SPORTS CAR — Continued

RADIATOR GRILLE AND FRONT COWLING

A $1\frac{1}{2}$ " Strip is bolted to the front end of each front wheel arch, and a built-up strip is attached to the $1\frac{1}{2}$ " Strips by Angle Brackets. The built-up strip consists of two $5\frac{1}{2}$ " Strips overlapped five holes, and it is bolted to the Angle Girder (1). A $2\frac{1}{2}$ " Strip (22) on each side is joined to Girder (1) by an Angle Bracket (Fig. 8.14).

Each side of the front cowling consists of two $2\frac{1}{2}$ " \times $1\frac{1}{2}$ " Flexible Plates overlapped two holes lengthways, a $2\frac{1}{2}$ " \times 2 " Triangular Flexible Plate (23) at the top and a $3\frac{1}{2}$ " \times $1\frac{1}{2}$ " Triangular Flexible Plate (24) at the lower corner. The radiator grille is edged by four $1\frac{1}{2}$ " Strips and four $2\frac{1}{2}$ " Curved Strips arranged as shown, and is connected to the Girder (1) by Fishplates and to the top of the bonnet by an Obtuse Angle Bracket. Two $2\frac{1}{2}$ " \times $\frac{1}{2}$ " Double Angle Strips (25) are bolted to the chassis and support five Rods, which are held in place by Spring Clips. The radiator grille is backed by a $5\frac{1}{2}$ " \times $2\frac{1}{2}$ " Flexible Plate, which is attached to the front axle by a 1 " \times 1 " Angle Bracket (26) (Figs. 8.14a and 8.14c).

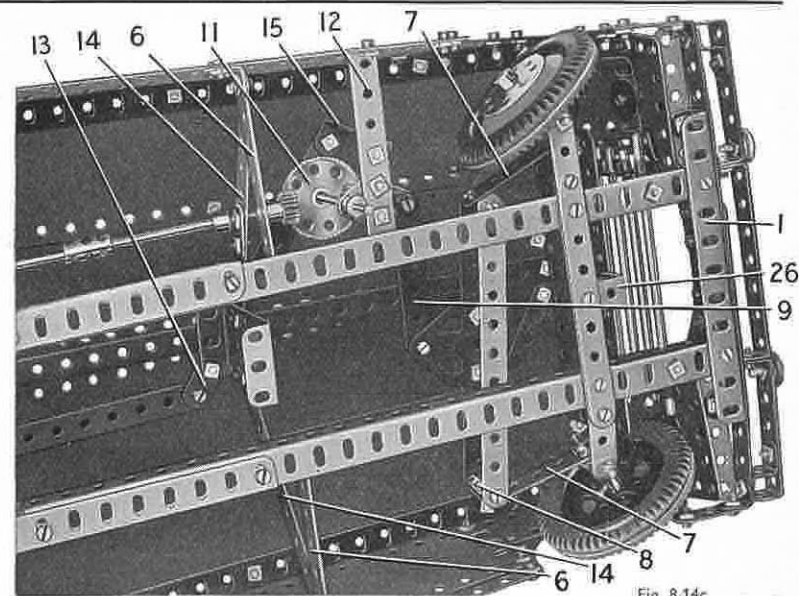

Fig. 8.14c

The front bumper is made from a $3\frac{1}{2}$ " \times $\frac{1}{2}$ " and two $2\frac{1}{2}$ " \times $\frac{1}{2}$ " Double Angle Strips, and is attached to two $\frac{1}{2}$ " Reversed Angle Brackets. The $1\frac{1}{4}$ " Flanged Wheels representing the headlamps are fixed on $\frac{1}{2}$ " Bolts.

DETAILS OF THE DRIVING COMPARTMENT

The back of the seat consists of a $5\frac{1}{2}$ " \times $2\frac{1}{2}$ " and a $4\frac{1}{2}$ " \times $2\frac{1}{2}$ " Flexible Plate overlapped three holes. It is bolted to the Girder (20) (Fig. 8.14a) and connected to the sides by Angle Brackets. To the lower edges of these Plates is bolted a $5\frac{1}{2}$ " Angle Girder, and this supports a $3\frac{1}{2}$ " \times $2\frac{1}{2}$ " Flanged Plate and two $2\frac{1}{2}$ " \times $2\frac{1}{2}$ " Flexible Plates that form the seat cushions. The Flanged Plate is connected to the chassis by 2" and $2\frac{1}{2}$ " Strips (27) (Fig. 8.14a). The front of the seat consists of two $5\frac{1}{2}$ " \times $1\frac{1}{2}$ " Flexible Plates, which are overlapped five holes and attached to the cushions and to the floor by Angle Brackets. The floor is made from a $3\frac{1}{2}$ " \times $2\frac{1}{2}$ " Flanged Plate (28) bolted to the chassis and extended on each side by one half of a Hinged Flat Plate.

The division between the bonnet and the driving compartment consists of two $4\frac{1}{2}$ " \times $2\frac{1}{2}$ " Flexible Plates (29), connected along their upper edges by two $5\frac{1}{2}$ " Strips overlapped three holes and attached to the sides by Angle Brackets at their upper corners (Fig. 8.14d).

A $4\frac{1}{2}$ " Strip (30) on each side is bolted to the Flanged Plate (18) and to an Angle Bracket fixed to the Girder (17). The steering column is made from a $6\frac{1}{2}$ " and a $3\frac{1}{2}$ " Rod joined by a Coupling. It is supported in a Trunion bolted to one of the Strips (30) and in a 1 " Triangular Plate fixed to one of the Strips (14), and carries at its lower end a $\frac{1}{2}$ " Pinion that engages the Contrate (11).

The windscreen consists of three $2\frac{1}{2}$ " and two $4\frac{1}{2}$ " Strips, and is attached to the top of the bonnet by a 1 " \times 1 " Angle Bracket and Obtuse Angle Brackets.

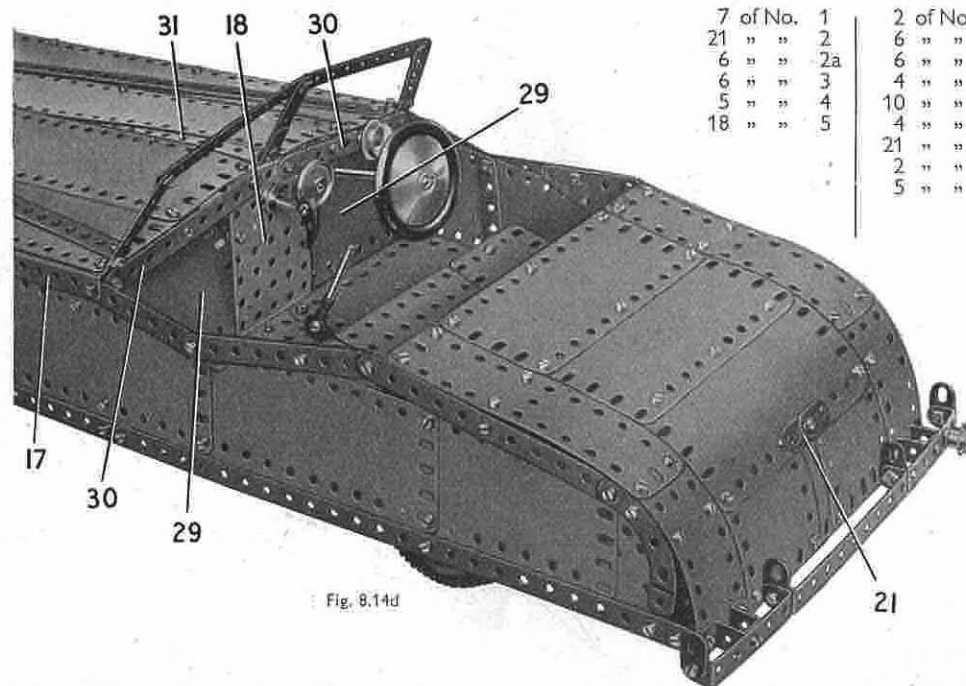
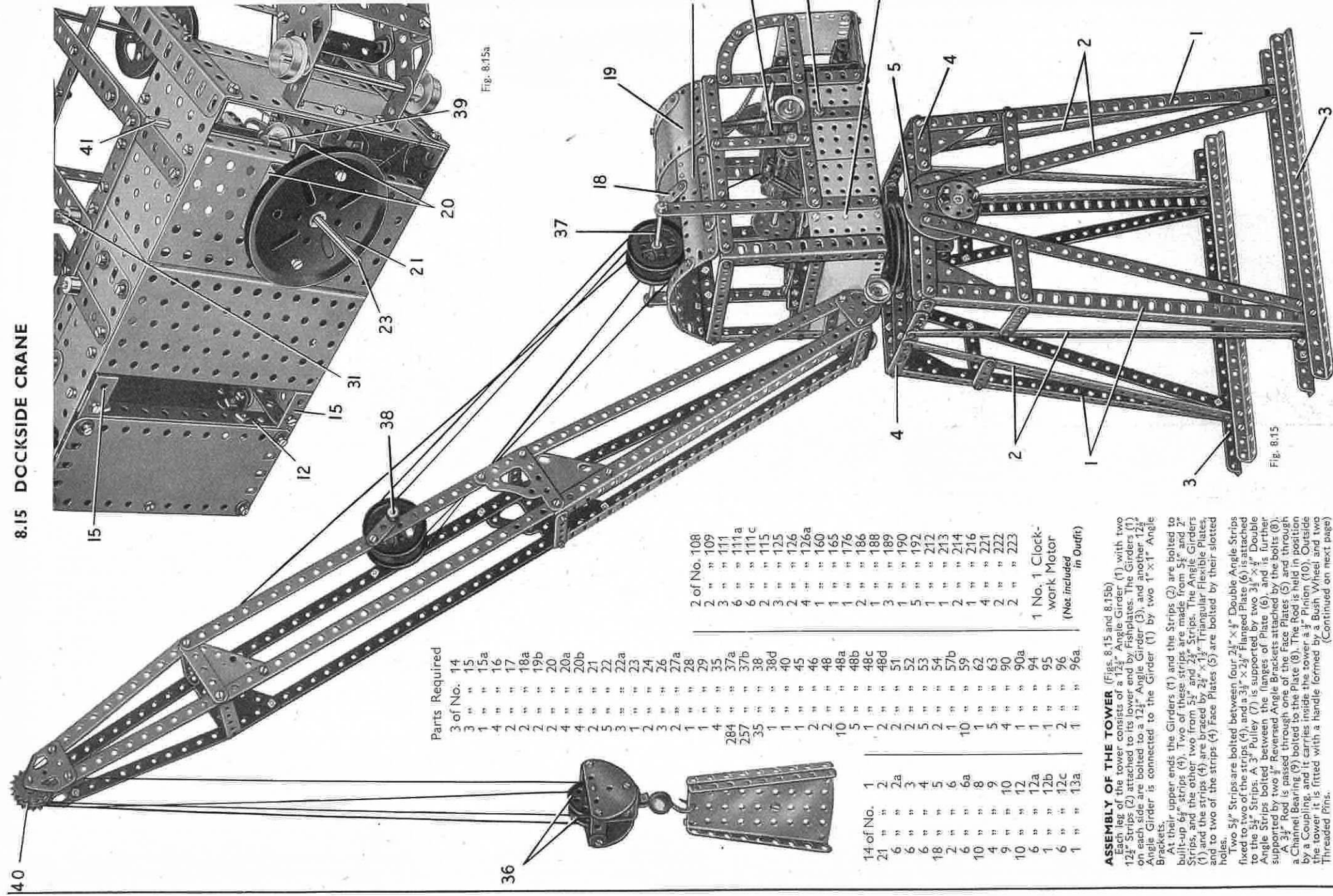

Fig. 8.14d

Parts Required

7 of No. 1	2 of No. 6	1 of No. 13a	3 of No. 53
21 " " 2	6 " " 6a	1 " " 14	10 " " 59
6 " " 2a	6 " " 8	1 " " 15	1 " " 62
6 " " 3	4 " " 9	4 " " 15a	4 " " 63
5 " " 4	10 " " 10	2 " " 16	2 " " 77
18 " " 5	4 " " 11	3 " " 17	4 " " 90
	21 " " 12	1 " " 18a	6 " " 90a
	2 " " 12a	2 " " 20	1 " " 111
	5 " " 12c	4 " " 20a	6 " " 111a
		2 " " 20b	6 " " 111c
		1 " " 22	1 " " 115
		3 " " 23	2 " " 125
		1 " " 23a	1 " " 126
		2 " " 24	1 " " 126a
		2 " " 24a	4 " " 142a
		1 " " 26	1 " " 147c
		1 " " 28	1 " " 187
		10 " " 35	4 " " 187a
		273 " " 37a	7 " " 188
		265 " " 37b	6 " " 189
		6 " " 38	4 " " 190
		2 " " 38d	5 " " 191
		3 " " 45	7 " " 192
		2 " " 48	6 " " 197
		7 " " 48a	1 " " 198
		4 " " 48b	2 " " 212
		1 " " 48c	2 " " 214
		1 " " 48d	4 " " 221
		1 " " 51	2 " " 222
		2 " " 52	2 " " 224

8.15 DOCKSIDE CRANE



Parts Required

3 of No.	14
3 "	15
1 "	15a
4 "	16
2 "	17
2 "	18a
2 "	19b
2 "	20
4 "	20a
4 "	20b
2 "	21
5 "	22
3 "	22a
1 "	23
2 "	24
3 "	26
2 "	27a
1 "	28
1 "	29
4 "	35
284 "	37a
257 "	37b
35 "	38
1 "	38d
1 "	40
1 "	45
2 "	46
1 "	165
10 "	176
5 "	186
1 "	188
2 "	189
2 "	190
2 "	192
5 "	53
2 "	54
2 "	57b
10 "	59
1 "	62
5 "	63
4 "	90
1 "	94
1 "	95
1 "	12a
6 "	12b
1 "	12c
6 "	13a

2 of No.	108
2 "	109
3 "	111
6 "	111a
2 "	111c
1 "	115
3 "	125
2 "	126
4 "	126a
1 "	160
1 "	165
1 "	176
2 "	186
1 "	188
3 "	189
1 "	190
5 "	192
1 "	212
1 "	213
2 "	214
1 "	216
4 "	221
2 "	222
2 "	223

1 No.	1 Clock-work Motor
(Not included in Outfit)	

ASSEMBLY OF THE TOWER (Figs. 8.15 and 8.15b)
 Each leg of the tower consists of a 1 1/2" Angle Girder (1) with two 1 1/2" Strips (2) attached to its lower end by Fishplates. The Girders (1) and Strips (2) are bolted to a 12 1/2" Angle Girder (3), and another 12 1/2" Angle Girder is connected to the Girder (1) by two 1" x 1" Angle Brackets.
 At their upper ends the Girders (1) and the Strips (2) are bolted to built-up 6 1/2" strips (4). Two of these strips are made from 5 1/2" and 3" Strips, and the other two from 5 1/2" and 2 1/2" Strips. The Angle Girders (1) and the strips (4) are braced by two 2 1/2" x 1 1/2" Triangular Fishplate Plates, and to two of the strips (4) Face Plates (5) are bolted by their slotted holes.
 Two 5 1/2" Strips are bolted between four 2 1/2" x 1 1/2" Double Angle Strips fixed to two of the strips (4), and a 3 1/2" x 2 1/2" Flanged Plate (6) is attached to the 5 1/2" Strip (4). A 3" Pulley (7) is supported by two 3 1/2" x 3" Double Angle Strips bolted between the flanges of Plate (6), and is further supported by two 1" Reversed Angle Brackets attached by the bolts (8). A 3 1/2" Rod is passed through one of the Face Plates (5) and through a Channel Bearing (9) bolted to the Plate (8). The Rod is held in position by a Coupling, and it carries inside the tower a 3" Pinion (10). Outside the tower it is fitted with a handle formed by a Bush Wheel and two Threaded Pins.
 (Continued on next page)

Fig. 8.15a

Fig. 8.15

MODEL 8.15 DOCKSIDE CRANE — Continued

CONSTRUCTION OF THE CAB

The base of the cab consists of two $5\frac{1}{2}'' \times 2\frac{1}{2}''$ Flanged Plates arranged as shown in Fig. 8.15a, and each side is fortified by two $3\frac{1}{2}'' \times 2\frac{1}{2}''$ Flanged Plates, bolted to the base. To the corners are bolted $5\frac{1}{2}''$ Angle Girders, and the Girders on each side are connected by built-up strips (11). Each of these strips consists of a $5\frac{1}{2}''$ and a $2\frac{1}{2}''$ Strip. The $5\frac{1}{2}''$ Angle Girders at the front are joined by a $5\frac{1}{2}'' \times 2\frac{1}{2}''$ Flexible Plate, edged by a $5\frac{1}{2}''$ Strip and a $5\frac{1}{2}'' \times 1''$ Double Angle Strip. The rear two $5\frac{1}{2}''$ Angle Girders are connected at their upper and lower ends and at the centre by $5\frac{1}{2}''$ Strips (12) (Figs. 8.15a and 8.15c). A $3\frac{1}{2}''$ Strip (13) and a $5\frac{1}{2}''$ Strip (14) are bolted to each side of the cab.

The cab is extended at the rear by two $3\frac{1}{2}'' \times 1\frac{1}{2}''$ Double Angle Strips (15) that support a $5\frac{1}{2}'' \times 2\frac{1}{2}''$ Flexible Plate. The rear lugs of the Double Angle Strips are connected by a $5\frac{1}{2}''$ Strip, and to this are bolted a $2\frac{1}{2}'' \times 1\frac{1}{2}''$ Flexible Plate, edged by two $1\frac{1}{2}''$ Strips, and a $2\frac{1}{2}'' \times 2\frac{1}{2}''$ Flexible Plate strengthened by a $2\frac{1}{2}''$ Strip. The upper edges of the Plates are connected by a $4\frac{1}{2}''$ Strip. A $5\frac{1}{2}'' \times 1\frac{1}{2}''$ Flexible Plate braced by a $3\frac{1}{2}''$ Strip is attached by Angle Brackets to one side of the cab extension (Fig. 8.15a) and on the other side a $3\frac{1}{2}''$ Strip (16) is placed in position. The upper rear corners of the extension are connected by Angle Brackets to two $2\frac{1}{2}''$ Curved Strips on each side, bolted to the $5\frac{1}{2}''$ Angle Girders. The cab roof consists of a $5\frac{1}{2}'' \times 1\frac{1}{2}''$ Flexible Plate (17) on each side, a $5\frac{1}{2}'' \times 2\frac{1}{2}''$ Flexible Plate (18) at the centre, and of two $5\frac{1}{2}'' \times 2\frac{1}{2}''$ Flexible Plates (19), overlapped nine holes, at the rear. Two curved $4\frac{1}{2}''$ Strips are attached to the roof, one at the front corners of the Plate (17) and the other along the front edge of Plate (18). The roof is attached to the sides of the cab by Obtuse Angle Brackets.

Two $2\frac{1}{2}'' \times 1\frac{1}{2}''$ Flanged Plates (20) are bolted at right angles to each other underneath the base, and one of them is attached to the front of the cab by a $\frac{1}{2}''$ Reversed Angle Bracket (see Fig. 8.15a). A $3''$ Pulley (21) is held below the Flanged Plates by two $\frac{1}{2}''$ Bolts. A built-up strip (22) (Fig. 8.15c), made from two $3''$ Strips (overlapping a $4\frac{1}{2}''$ Double Angle Strip, is supported by Trunnions bolted to the side of the cab. A $4\frac{1}{2}''$ Rod (23) (Fig. 8.15a) is passed through this strip and the base of the cab, and through a Bush Wheel bolted inside the cab base. The Rod is fixed in this Bush Wheel and in the Pulley (21). The Rod is passed through the Pulley (7) and the Flanged Plate (6) (Fig. 8.15b), a $\frac{1}{2}''$ loose Pulley is placed on the Rod and a $\frac{1}{2}''$ Contrate is fixed to its lower end. The Contrate engages the $\frac{1}{2}''$ Pinion (10).

THE JIB (Fig. 8.15b)

The lower section of the jib consists of two $12\frac{1}{2}''$ Angle Girders and two $12\frac{1}{2}''$ Strips connected at their lower ends by two Flat Trunnions, a $2\frac{1}{2}''$ Strip and a $2\frac{1}{2}'' \times 4''$ Double Angle Strip. At their upper ends the Girders and Strips are joined by a $2\frac{1}{2}''$ Strip, a $2\frac{1}{2}'' \times 4''$ Double Angle Strip, two $2\frac{1}{2}'' \times 2\frac{1}{2}''$ Triangular Flexible Plates and two Corner Gussets, and they are bolted four $12\frac{1}{2}''$ Strips that form the centre section of the jib. The $12\frac{1}{2}''$ Strips are connected at their upper ends by two $2\frac{1}{2}''$ Strips, two $2\frac{1}{2}'' \times 2''$ Triangular Flexible Plates and two $2\frac{1}{2}'' \times 1''$ Double Angle Strips, and each $12\frac{1}{2}''$ Strip is extended by a $5\frac{1}{2}''$ Strip. The $5\frac{1}{2}''$ Strips are connected by two Flat Trunnions and two $1\frac{1}{2}'' \times 1\frac{1}{2}''$ Double Angle Strips. The jib pivots on a $3\frac{1}{2}''$ Rod, which is held by $\frac{1}{2}''$ Flanged Wheels in a $2\frac{1}{2}'' \times 1''$ Double Angle Strip bolted to the front of the cab.

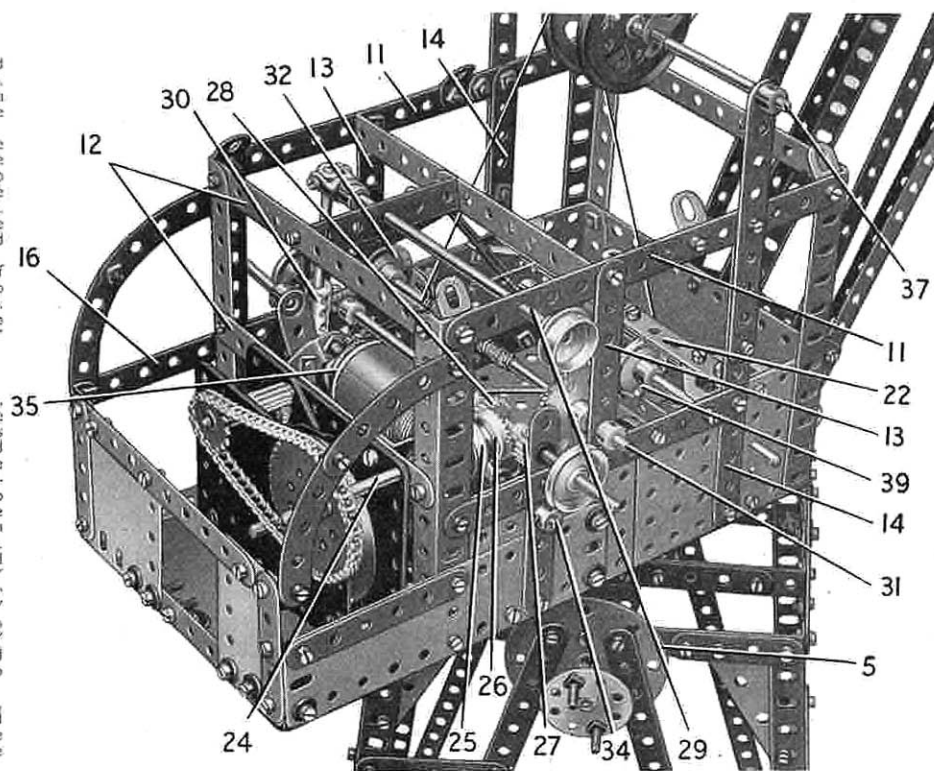

Fig. 8.15c

OPERATING MECHANISM

A No. 1 Clockwork Motor is bolted to two of the Strips (12) at the back of the cab, and a $\frac{1}{2}''$ Sprocket on the Motor shaft is connected by Chain to a $2''$ Sprocket on a $3\frac{1}{2}''$ Rod (24) (Fig. 8.15c) supported in the Motor side-plates and in a Double Bent Strip fixed to one of the Strips (12). The Rod is held in position by a $\frac{1}{2}''$ Flanged Wheel (25), and it carries at its inner end a $\frac{1}{2}''$ Contrate (26). The Contrate is positioned so that it can drive either of two $\frac{1}{2}''$ Pinions (27) and (28) on an $8''$ Rod mounted in $3\frac{1}{2}''$ Strips. This Rod is free to slide about $\frac{1}{4}''$ in the Strips and the Pinions are arranged so that either of them can be moved into mesh with the Contrate by sliding the Rod. The sliding movement is controlled by a Rod (29) mounted as shown in Fig. 8.15c. A Swivel Bearing on the end of this Rod is connected to a $5''$ Rod that carries a Coupling (30). A Rod and Strip Connector on the lower end of the $5''$ Rod is lock-nutted to a $1'' \times \frac{1}{2}''$ Angle Bracket bolted to the side of the cab. A $\frac{1}{2}''$ Bolt screwed into the Coupling (30) engages between two Collars on the sliding Rod.

When the lever is moved to the left (Fig. 8.15c), Pinion (27) engages the Contrate (26) and is engaged also with a 57-tooth Gear on a $6\frac{1}{2}''$ Rod (31) held in the Strips (13) by Collars. This Rod carries also a $1''$ Pulley (32). A $2\frac{1}{2}''$ Strip (33) (Fig. 8.15) is lock-nutted to one of the $3\frac{1}{2}''$ Strips supporting the sliding Rod, and rests in the groove of the Pulley (32). The Strip is held against the Pulley by a Driving Band, which is stretched slightly and is tied with Cord to the end of the Strip and to the base of the cab. A $\frac{1}{2}''$ Bolt fixed in the Strip by two nuts serves as a brake handle.

When the lever is moved to the right (Fig. 8.15c) the Pinion (28) engages the Contrate (26) and a 57-tooth Gear on a $6\frac{1}{2}''$ Rod (34). This Rod is fitted with a drum formed by a Cylinder and two $1\frac{1}{2}''$ Flanged Wheels, and it carries a $1''$ Pulley (35). A $2\frac{1}{2}''$ Stepped Curved Strip is lock-nutted to an Angle Bracket bolted to the Clockwork Motor, and the upper end of the Curved Strip rests in the groove of Pulley (34). A Driving Band is stretched slightly and is tied by Cord to the Curved Strip and to the strip (22). The brake lever is a $1\frac{1}{2}''$ Rod held in a Crank bolted to the Curved Strip.

THE PULLEY BLOCK

The sides of the pulley block are Semi-Circular Plates, one of which is fitted with a $2\frac{1}{2}'' \times 1''$ Double Angle Strip and the other with a $2\frac{1}{2}'' \times \frac{1}{2}''$ Double Angle Strip. The lugs of these Double Angle Strips are bolted together, and two $1\frac{1}{2}''$ Pulleys (36) are mounted on a $1\frac{1}{2}''$ Rod supported in the Semi-Circular Plates. A large Loaded Hook is lock-nutted to two $\frac{1}{2}'' \times \frac{1}{2}''$ Angle Brackets, which are attached to $1'' \times 1''$ Angle Brackets bolted to the Semi-Circular Plates.

ARRANGEMENT OF THE CORDS (Figs. 8.15 and 8.15c)

A length of Cord is tied to a Cord Anchoring Spring on Rod (31), passed over a $2''$ Pulley on a $6\frac{1}{2}''$ Rod (37), round a $2''$ Pulley on a $3\frac{1}{2}''$ Rod (38), and round a second $2''$ Pulley on Rod (37). The Cord is taken round a further $2''$ Pulley on Rod (38) and is then tied to a Fishplate on Rod (37). Rod (37) is held by Collars in $4\frac{1}{2}''$ Strips that overlap the Strips (14) by five holes each. Rod (38) is held by Collars in $1\frac{1}{2}''$ Strips lock-nutted to the jib.

A length of Cord fastened to the drum on Rod (34) is taken under a $1''$ Pulley (39), over a $1''$ Pulley placed between the $2''$ Pulleys on Rod (37), and round one of two $1''$ loose Pulleys (40) located between two $1''$ Sprockets on a $2''$ Rod at the jib head. The Cord is passed round one of the Pulleys (36), round the other Pulley (40) at the jib head and round the second Pulley (36). The Cord is tied finally to the jib head.

The Pulley (39) is fixed on a built-up rod (41), which is made from a $4\frac{1}{2}''$ and a $2''$ Rod joined by a Rod Connector and is held in the sides of the cab by Couplings.

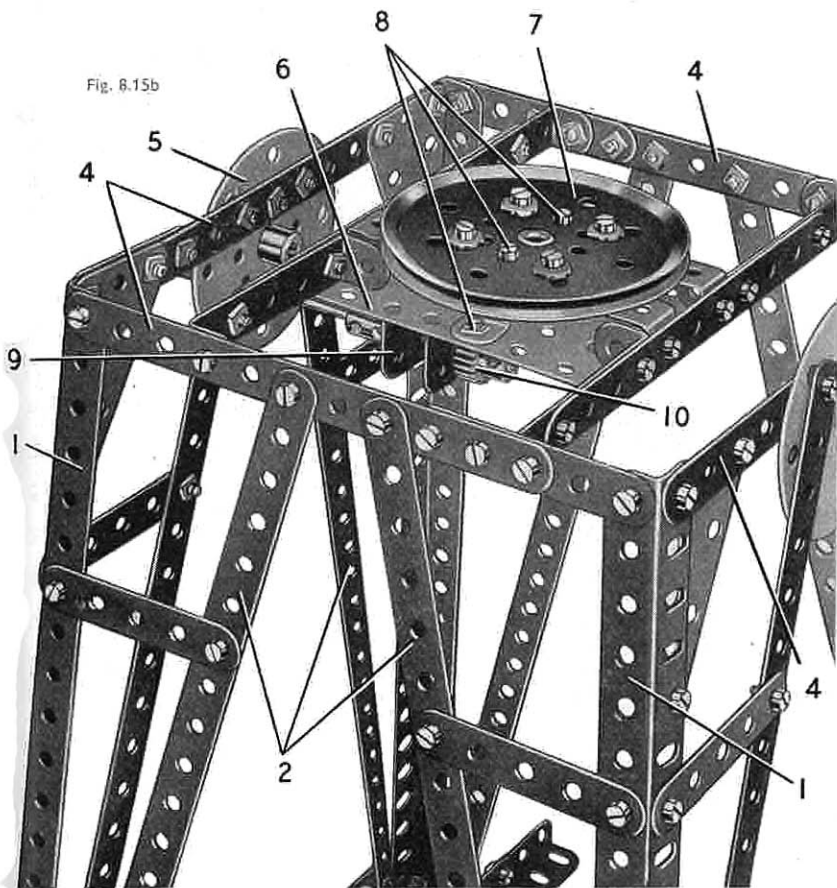

Fig. 8.15b

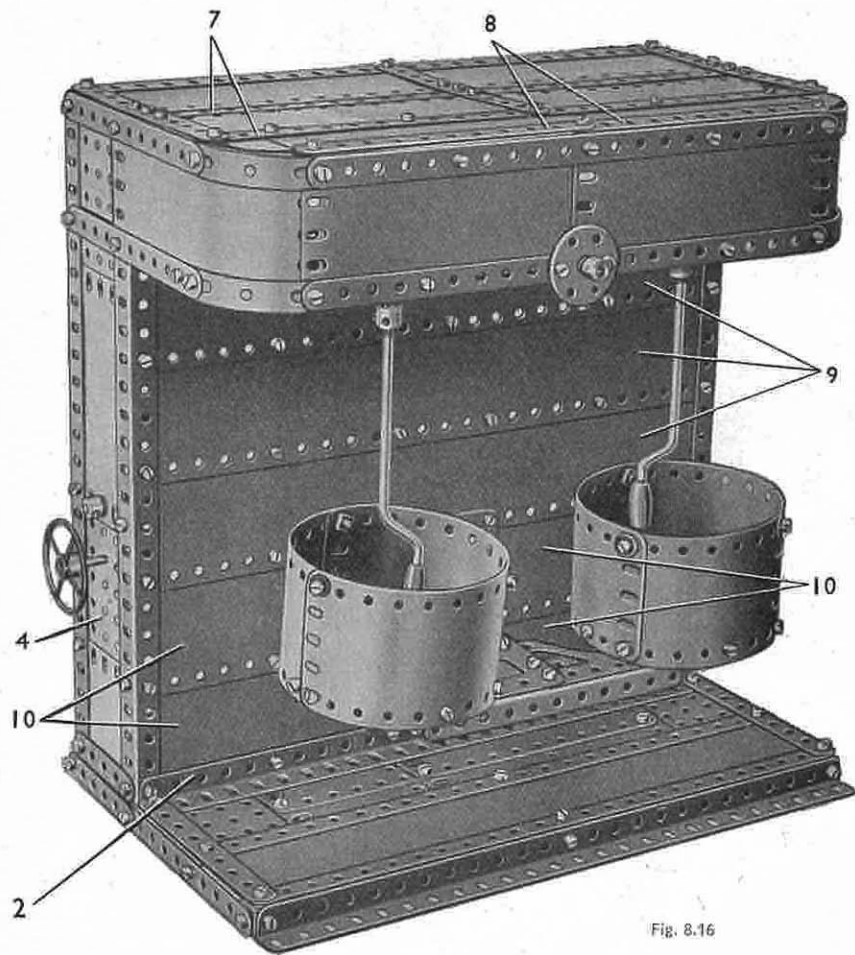

Fig. 8.16

Each side is extended forward by a $5\frac{1}{2}'' \times 2\frac{1}{2}''$ Flexible Plate, curved at the front as shown and edged by two $5\frac{1}{2}''$ Strips and two Formed Slotted Strips. The front ends of these Plates and Strips are connected by two $5\frac{1}{2}'' \times 2\frac{1}{2}''$ Flexible Plates and four $5\frac{1}{2}''$ Strips.

A $12\frac{1}{2}''$ Angle Girder (6) (Fig. 8.16a) and two $12\frac{1}{2}''$ Strips (7) (Fig. 8.16) are connected by $5\frac{1}{2}''$ Strips, and the spaces between them are filled by $12\frac{1}{2}'' \times 2\frac{1}{2}''$ Strip Plates. The Girder (6) is bolted to the sides of the column, and the Strips (7) are attached to the sides by Angle Brackets. The top of the column is completed by two $5\frac{1}{2}'' \times 1\frac{1}{2}''$ Flexible Plates and two Semi-Circular Plates bolted to the front Strip (7), and by two $5\frac{1}{2}''$ Strips (8) attached to the front by Angle Brackets.

The front of the column is filled in by three $12\frac{1}{2}'' \times 2\frac{1}{2}''$ Strip Plates (9) and four $5\frac{1}{2}'' \times 2\frac{1}{2}''$ Flexible Plates (10). The inner edges of the Flexible Plates are strengthened by vertical $4\frac{1}{2}''$ Strips, connected at their upper ends by a $2\frac{1}{2}''$ Strip. The Strip Plates are braced by a $12\frac{1}{2}''$ Strip (11) and another $12\frac{1}{2}''$ Strip fixed in front of a $3\frac{1}{2}'' \times 2\frac{1}{2}''$ Flanged Plate (13) (see Figs. 8.16a and 8.16b).

A built-up strip (14) is attached at each end to a $1''$ Triangular Plate that is supported by two Angle Brackets. This strip consists of three $5\frac{1}{2}''$ Strips overlapped on each other by five holes. Two $4\frac{1}{2}'' \times 2\frac{1}{2}''$ Double Angle Strips (15) are bolted by their lugs to the front of the column and are attached by Angle Brackets to the Strip (11).

THE MIXING BOWLS (Figs. 8.16b and 8.16a)

Each mixing bowl consists of a $5\frac{1}{2}'' \times 2\frac{1}{2}''$ and a $4\frac{1}{2}'' \times 2\frac{1}{2}''$ Flexible Plate bolted end to end, and curved so that they overlap by two holes the ends of another, $4\frac{1}{2}'' \times 2\frac{1}{2}''$ Flexible Plate. The base of each bowl is a Face Plate (16) and four $2\frac{1}{2}''$ Stepped Curved Strips. One of the bases is attached by four $1'' \times 1''$ Angle Brackets and the other by two $1'' \times 1''$ and two $1'' \times \frac{1}{2}''$ Angle Brackets. Each bowl is attached by a $\frac{3}{4}''$ Bolt passed through the boss of the Face Plate, to a Flat Trunnion bolted to a $5\frac{1}{2}''$ Angle Girder (17) and a $5\frac{1}{2}''$ Strip (18). The bowls are connected also to the Strip (18) by $\frac{1}{2}''$ Bolts (19), but are spaced from the Strip by a Collar and a Washer on each bolt.

8.16 MIXING MACHINE

Parts Required

6 of No. 1	2 of No. 12b	1 of No. 27a	2 of No. 52	2 of No. 111	6 of No. 197
19 " " 2	3 " " 14	1 " " 28	4 " " 53	2 " " 111a	2 " " 214
4 " " 2a	2 " " 15a	4 " " 35	1 " " 54	4 " " 111c	4 " " 215
2 " " 4	2 " " 17	196 " " 37a	9 " " 59	2 " " 126a	
3 " " 5	1 " " 19g	192 " " 37b	4 " " 63	1 " " 185	
1 " " 6a	1 " " 19h	32 " " 38	2 " " 77	2 " " 186a	
10 " " 8	4 " " 22	2 " " 45	1 " " 80a	6 " " 189	1 EO20
3 " " 9	1 " " 23a	1 " " 48a	8 " " 90a	1 " " 190	Electric Motor
17 " " 12	3 " " 24a	2 " " 48c	2 " " 108	6 " " 191	(not included in
6 " " 12a	2 " " 26	2 " " 51	2 " " 109	11 " " 192	Outfit)

CONSTRUCTION OF THE BASE

Each side of the base consists of a $5\frac{1}{2}'' \times 2\frac{1}{2}''$ Flanged Plate edged by a $3''$ Strip and extended forward four clear holes by a $5\frac{1}{2}''$ Strip (1). The Strips (1) are connected at the front by a $12\frac{1}{2}''$ Angle Girder attached by Angle Brackets, and at the rear the Flanged Plates are connected by a further $12\frac{1}{2}''$ Angle Girder.

Two $12\frac{1}{2}''$ Angle Girders (2) and (3) are bolted across the $5\frac{1}{2}'' \times 2\frac{1}{2}''$ Flanged Plates. The front of the base is filled in by a $12\frac{1}{2}'' \times 2\frac{1}{2}''$ Strip Plate edged by $12\frac{1}{2}''$ and $4\frac{1}{2}''$ Strips, and by four $5\frac{1}{2}'' \times 1\frac{1}{2}''$ Flexible Plates as shown in Fig. 8.16b. The $4\frac{1}{2}''$ Strips are bolted to the Flanged Plates, and the front corners of the Strip Plates are attached to the Strips (1) by Angle Brackets.

THE SUPPORTING COLUMN

Each side of the column consists of two $12\frac{1}{2}''$ Angle Girders, bolted at their lower ends to the Girders (2) and (3). The side seen in Fig. 8.16a is filled in by a $3\frac{1}{2}'' \times 2\frac{1}{2}''$ Flanged Plate, a $5\frac{1}{2}'' \times 2\frac{1}{2}''$ and a $4\frac{1}{2}'' \times 2\frac{1}{2}''$ Flexible Plate. The side shown in Fig. 8.16 is plated by a $3\frac{1}{2}'' \times 2\frac{1}{2}''$ Flanged Plate at the top, a $4\frac{1}{2}'' \times 2\frac{1}{2}''$ Flexible Plate, a $3\frac{1}{2}'' \times 2\frac{1}{2}''$ Flanged Plate (4), and a $2\frac{1}{2}'' \times 2\frac{1}{2}''$ Flexible Plate. The sides are connected by a $12\frac{1}{2}''$ Angle Girder (5) (Fig. 8.16a) at the back.

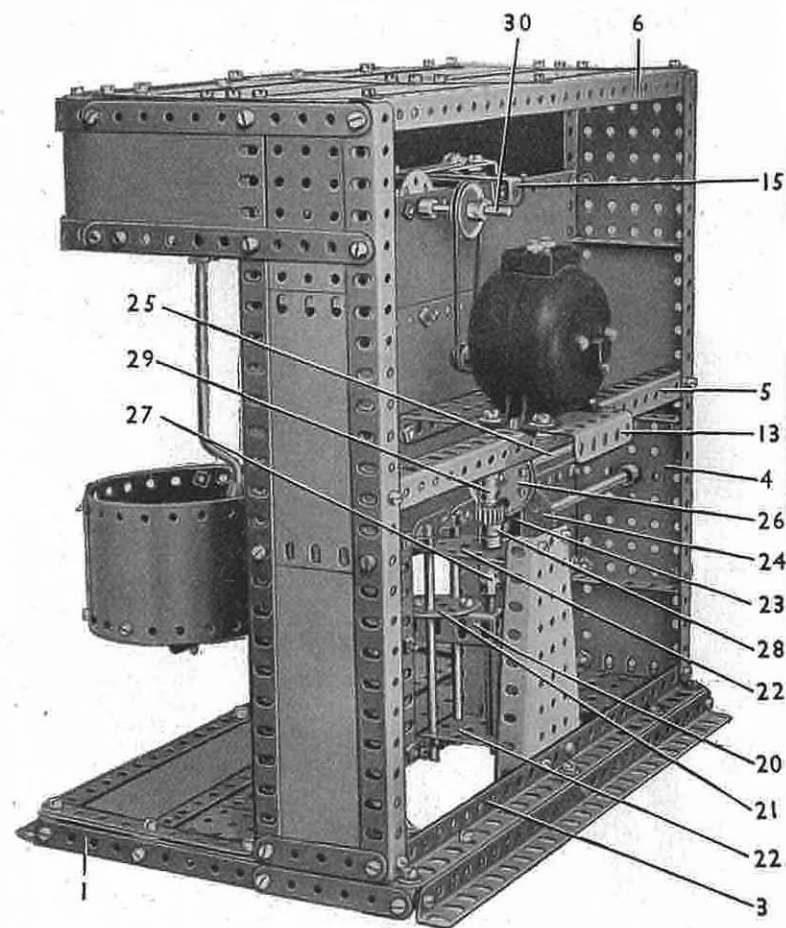

Fig. 8.16a

(Continued on next page)

MODEL 8.16 MIXING MACHINE — Continued

The Angle Girder (17) and the Strip (18) are fixed to a channel girder (20), with the connection between them strengthened by two Corner Gussets. The girder (20) consists of two 5½" Angle Girders bolted together, and it is fitted at its inner end with a Six-Hole Wheel Disc (21). The Wheel Disc slides freely on two ¼" Rods, which are held by Spring Clips in two 2½" x 1½" Flanged Plates (22) bolted to the front of the column. The rear ends of the Plates (22) are supported by a Flanged Sector Plate fixed to the Girder (3). A 2½" x ½" Double Angle Strip (23) is bolted between the upper Flanged Plate (22) and the Flanged Plate (13).

The bowls can be raised or lowered by turning a Steering Wheel on a 6½" Rod supported in the Flanged Plate (4) and the Double Angle Strip (23).

The Rod carries a 57-tooth Gear (24) that drives a ¼" Pinion on a second 6½" Rod (25) (Fig. 8.16b), also mounted in the Flanged Plate (4) and the Double Angle Strip (23). This Rod is fitted with a 1½" Contrate (26), spaced from the Double Angle Strip by three Washers. A 2" Rod, carrying a Coupling (27), a Collar and a ¼" Pinion (28), is free to turn in a Coupling (29) on the end of Rod (25). The 2" Rod is supported in the upper one of the Flanged Plates (22), and a Screwed Rod is gripped in the Coupling (27). The Screwed Rod passes through a threaded hole in a Coupling attached to the end of the girder (20) by a bolt.

THE MIXING MECHANISM

An E020 Electric Motor is bolted to the Flanged Plate (13), and its pulley is connected by a Driving Band to a 1" Pulley on a 6½" Rod (30). This Rod is supported in Wheel Discs bolted to the front of the column and to the Strip (11) (Fig. 8.16b), and is held in place by Collars. The Rod carries a ½" Pulley (31), and this drives through a Driving Band a 1" Pulley on a 5" Crank Handle. The Crank Handle is supported in one of the Double Angle Strips (15) and in a Double Bent Strip bolted to it. The Crank Handle carries another 1" Pulley (32), and is held in place by a Collar.

A 3¼" Crank Handle, fitted with a 1" Pulley (33), is extended by a Coupling and a 2" Rod, and the Rod is supported in the second Double Angle Strip (15) and in a Double Bent Strip. A Collar holds the Rod in place. The Pulleys (32) and (33) are connected by a Driving Band.

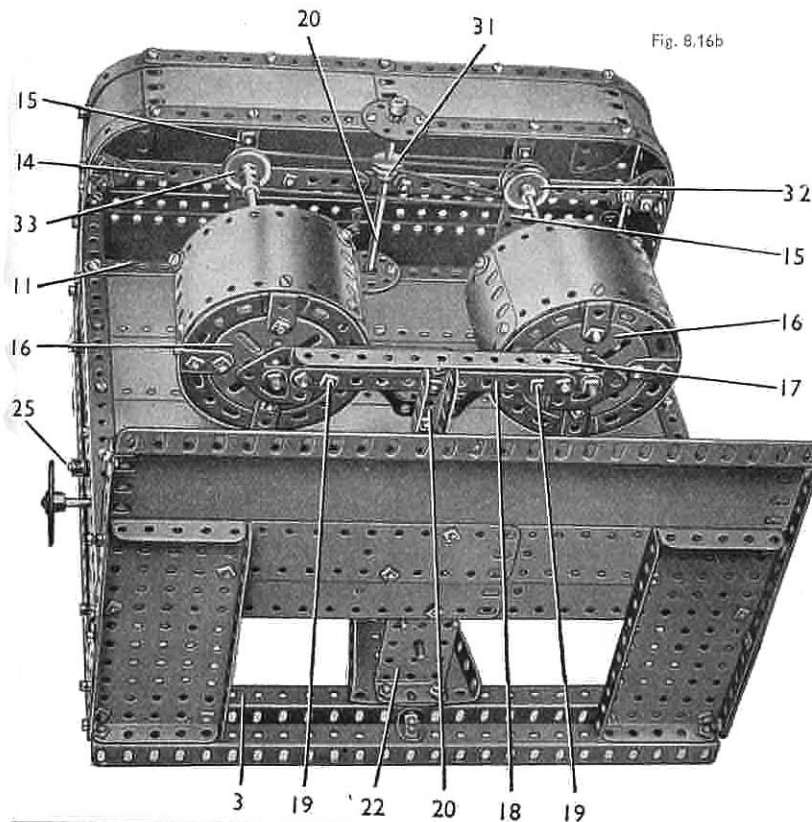

Fig. 8.16b

8.17 ROAD SWEEPER

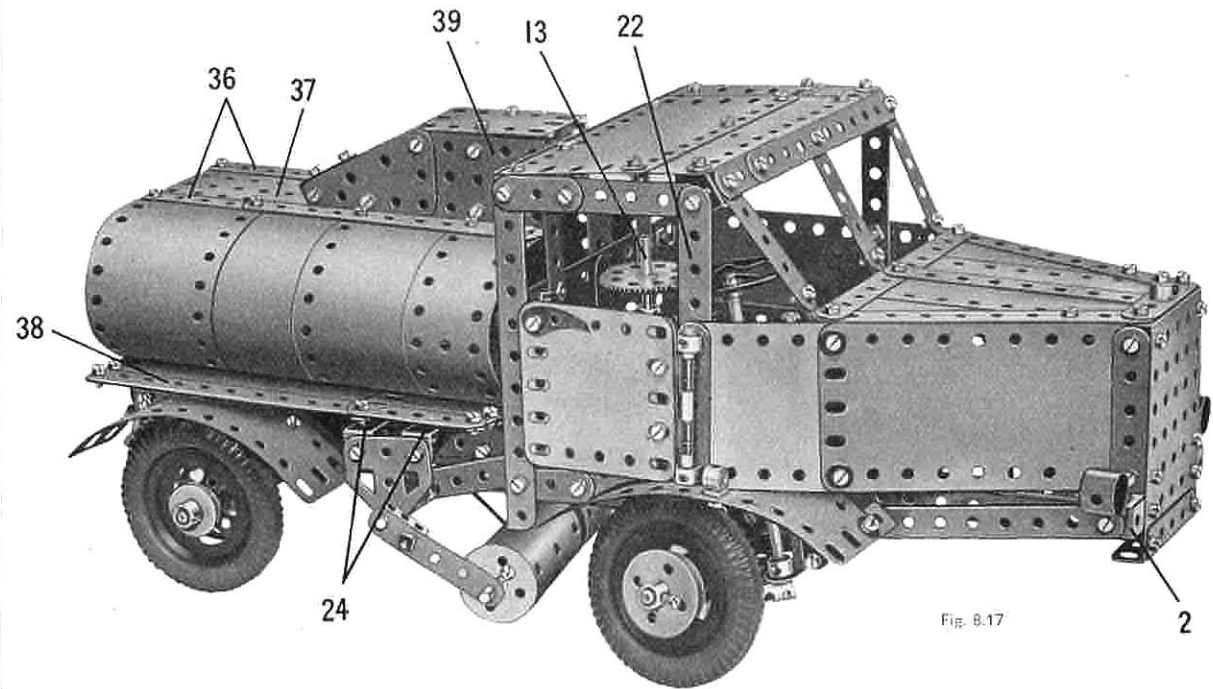

Fig. 8.17

Parts Required

20 of No. 2	2 of No. 14	2 of No. 24	2 of No. 48d	1 of No. 116	6 of No. 189
5 " " 2a	1 " " 15	2 " " 24a	2 " " 51	1 " " 116a	5 " " 190
6 " " 3	1 " " 15a	3 " " 26	1 " " 52	1 " " 120b	4 " " 191
4 " " 4	1 " " 15b	2 " " 27a	2 " " 53	3 " " 125	10 " " 192
18 " " 5	2 " " 16	1 " " 28	10 " " 59	2 " " 126	2 " " 212
1 " " 6	4 " " 17	1 " " 32	2 " " 62	4 " " 126a	2 " " 212a
6 " " 6a	4 " " 18a	2 " " 35	6 " " 63	4 " " 142a	2 " " 214
4 " " 8	2 " " 18b	245 " " 37a	1 " " 65	2 " " 147b	2 " " 216
4 " " 9	4 " " 20	220 " " 37b	1 " " 77	1 " " 147c	2 " " 221
10 " " 10	4 " " 20a	32 " " 38	2 " " 80c	1 " " 160	2 " " 225
5 " " 11	2 " " 20b	3 " " 45	2 " " 90	2 " " 164	
30 " " 12	2 " " 22	1 " " 48	3 " " 111	2 " " 165	
6 " " 12a	1 " " 22a	8 " " 48a	2 " " 111a	1 " " 185	1 E20R
1 " " 12b	3 " " 23	6 " " 48b	6 " " 111c	1 " " 186b	Electric Motor
5 " " 12c	1 " " 23a	2 " " 48c	2 " " 115	7 " " 188	(not included in
					Outfit)

(Continued on next page)

For new models and mechanisms to build see the

MECCANO MAGAZINE

which is published monthly

MODEL 8.17 ROAD SWEEPER — Continued

CONSTRUCTION OF THE CHASSIS

Each of the chassis side members is made by connecting together two 12½" Angle Girders by means of Fishplates. The upper Angle Girder is extended forward by a 5½" Angle Girder overlapped two holes, and a 5½" Strip (1) (Fig. 8.17c) is bolted between the lower 12½" Girder and the front end of the 5½" Girder. The side members are connected at the front by a 3½" × ½" Double Angle Strip (2), and at the rear by two similar Double Angle Strips.

The rear axle casing is in two sections, each consisting of a Bush Wheel (3) (Fig. 8.17d) and a Wheel Disc joined by 2½" × ½" Double Angle Strips. The sections are joined together at the centre by two Double Brackets, the front one of which supports a Fishplate and the other a ½" Reversed Angle Bracket. A 1½" Rod is mounted in the upper holes of the Fishplate and the Reversed Angle Bracket, and it carries a Worm between the two parts. The Worm drives a ¼" Pinion (4) fixed on a 4" Rod mounted freely in one side of the casing. A 3½" Rod is fixed in the Bush Wheel of the other section of the casing, and one of the rear wheels is free to rotate on this Rod and is held in place by a ½" Flanged Wheel.

Two Double Bent Strips (5) are bolted to the axle casing and serve to fix it to the rear springs. Each spring consists of a 4½", a 3½" and a 2½" Strip, and is attached at one end to an Angle Bracket *lock-nutted* to the chassis. The other end of the spring is located between a Double Bracket (6) and a ½" Bolt passed through the Double Bracket and held in the chassis by two nuts.

Each of the front springs is made from a 3½" and a 2½" Strip, and is bolted at one end to an Angle Bracket that is *lock-nutted* through its slotted hole to the chassis. The front ends of the springs are located between the lugs of a Double Bracket and two Angle Brackets bolted to the chassis.

The front axle consists of two 5½" Strips placed face to face and bolted to the Springs. Each end of the axle is fitted with a ½" Reversed Angle Bracket (7), and a 1½" and a 1" Rod are supported in the Reversed Angle Brackets and in the end holes of the axle. Each Rod is fitted with a Coupling (8) and a Crank (9).

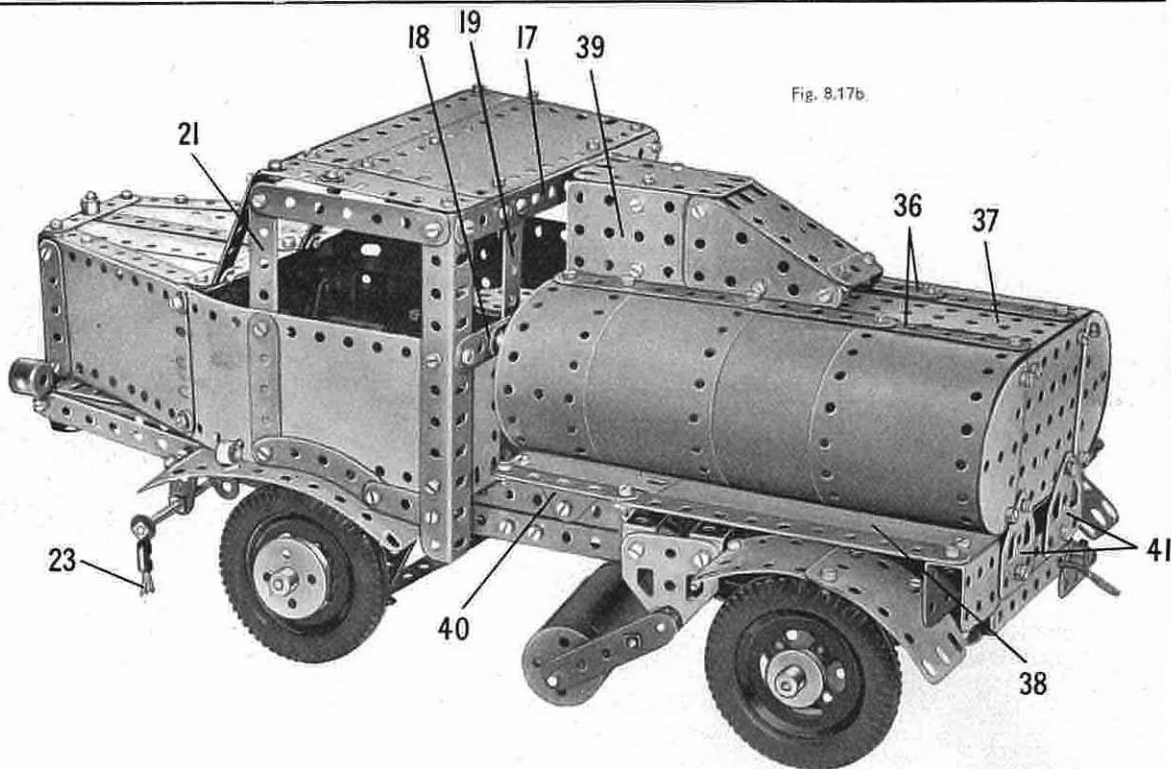

Fig. 8.17b.

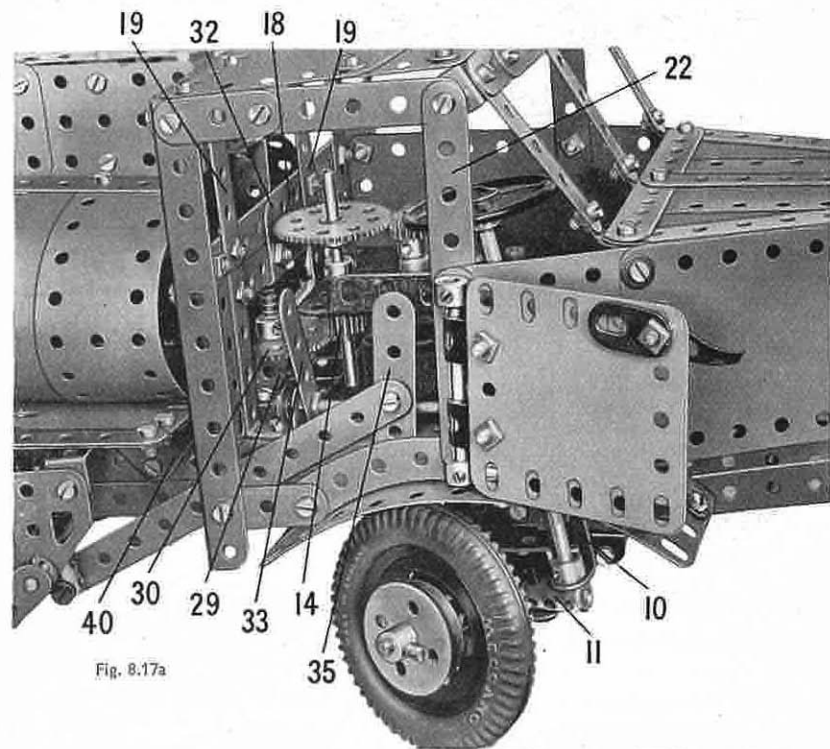

Fig. 8.17a.

The front wheels are mounted freely on 1½" Rods gripped in the Couplings (8) and are held in place by 1½" Flanged Wheels. The Cranks (9) are connected by a 5½" Strip attached by *lock-nutted* bolts.

The steering column is a 5" Rod supported in a 1½" × ½" Double Angle Strip (10) fixed to the chassis. The Rod is held in position by a Collar and a Coupling (11), and a 5½" Strip is pivoted on a Pivot Bolt fixed in the Coupling. The other end of this Strip is *lock-nutted* to one of the Cranks (9).

THE DRIVING MECHANISM

An E20R Electric Motor is attached to the chassis on one side by two Angle Brackets and by two Fishplates (12) on the other side. A ¼" Pinion on the Motor armature shaft drives a 57-tooth Gear on a 3½" Rod (13) mounted in the side-plates. The Rod carries two ¼" Pinions (14) and (15), (Figs. 8.17a and 8.17b), and is held in position by a Collar.

Two 3½" × ½" Double Angle Strips (16) are bolted across the chassis, and a 2" Rod is mounted in them. A 1½" Contrate at the front end of the Rod engages the Pinion (15), and a universal coupling at the rear end of the rod is connected by another 2" Rod to a second universal coupling, which is fixed to the 1½" Rod carrying the Worm that drives the rear axle. One of the universal couplings is made from a Swivel Bearing and a small Fork Piece, and the other is assembled from a Swivel Bearing and a large Fork Piece.

ASSEMBLY OF THE CAB AND BONNET

The back of the cab is made by bolting two 5½" Angle Girders to the ends of two strips (17) and (18) (Fig. 8.17b). Strip (17) consists of a 5½" and a 1½" Strip, and strip (18) is made from two 5½" Strips overlapped nine holes. Two 4½" × ½" Double Angle Strips (19) are bolted to the strips (17) and (18) and are fixed by their lugs to the chassis girders. A 2½" × ½" Double Angle Strip (20) (Fig. 8.17b) is bolted between one of the 5½" Angle Girders and the chassis. A 2½" × 1½" Flexible Plate on each side is attached to the strip (18).

The side of the cab and of the bonnet seen in Fig. 8.17b consists of a 5½" × 2½" and a 4½" × 2½" Flexible Plate, and the window frame is made from a 3½" Strip and a 3" Strip (21) as shown. The side seen in Fig. 8.17 is made from a 2½" × 2½" and a 4½" × 2½" Flexible Plate, attached to a built-up strip (22) made from a 3" and a 2½" Strip. This side is fitted with an opening door, made from two 2½" × 2½" Flexible Plates placed face to face with two Right-Angle Rod and Strip Connectors bolted between them. The door hinges on a 2" Rod gripped in two Collars. Each Collar is screwed on to a bolt held by a nut in the strip (22). The door handle is a Pawl without boss held by a nut on a ½" Bolt, which is passed through the door. A Fishplate is fixed on the Bolt, inside the door, by two nuts, to form a catch that engages behind one of the 5½" Angle Girders bolted to the back of the cab.

(Continued on next page)

MODEL 8.17 ROAD SWEEPER — Continued

The radiator is a $3\frac{1}{2}'' \times 2\frac{1}{2}''$ Flanged Plate bolted to the Double Angle Strip (2) (Fig. 8.17c) and connected to the sides of the bonnet by Angle Brackets.

The top of the bonnet consists of a $4\frac{1}{2}'' \times 2\frac{1}{2}''$ Flexible Plate at the centre with a $3\frac{1}{2}'' \times 2''$ Triangular Flexible Plate on each side. The Plates are strengthened by a $5\frac{1}{2}''$, a $2\frac{1}{2}''$ and three $4\frac{1}{2}''$ Strips, and they are bolted to the top of the radiator and to Angle Brackets fixed to the sides of the bonnet. The headlamps are Chimney Adaptors fixed to Fishplates.

The windscreen consists of three $2\frac{1}{2}''$ Strips and a built-up strip made from a $5\frac{1}{2}''$ and a $2\frac{1}{2}''$ Strip overlapped three holes. It is connected to the Strips (21) and (22) by Angle Brackets, and to the top of the bonnet by Obtuse Angle Brackets. The cab roof is made from a $5\frac{1}{2}'' \times 2\frac{1}{2}''$, a $4\frac{1}{2}'' \times 2\frac{1}{2}''$, a $5\frac{1}{2}'' \times 1\frac{1}{2}''$ and a $2\frac{1}{2}'' \times 1\frac{1}{2}''$ Flexible Plate, and is supported by Angle Brackets and Obtuse Angle Brackets. The water-sprinkler system is represented by a Centre Fork (23) held in a Rod and Strip Connector fitted to a Screwed Rod. This is fixed by nuts in a $1\frac{1}{2}''$ Strip bolted to the chassis.

THE BRUSH MECHANISM

Two $5\frac{1}{2}'' \times \frac{1}{2}''$ Double Angle Strips (24) (Fig. 8.17d) are bolted across the chassis, and a Flat Trunnion is fixed to the lugs at each end. A $6\frac{1}{2}''$ Rod is mounted in the Flat Trunnions, and is fitted with 1" loose and 1" fixed Pulleys (25) separated by four Washers and loosely held in place by Collars. It also carries two Couplings (26) and a Coupling (27). A $2\frac{1}{2}''$ Strip, curved slightly as shown in Fig. 8.17d, is attached to each of the Couplings (26) by a Threaded Pin, and a $6\frac{1}{2}''$ Rod is mounted in the end holes of the Strips. This Rod carries two $1\frac{1}{2}''$ Flanged Wheels, to each of which a Cylinder is fitted. A 1" fixed Pulley (28) is placed between the Cylinders.

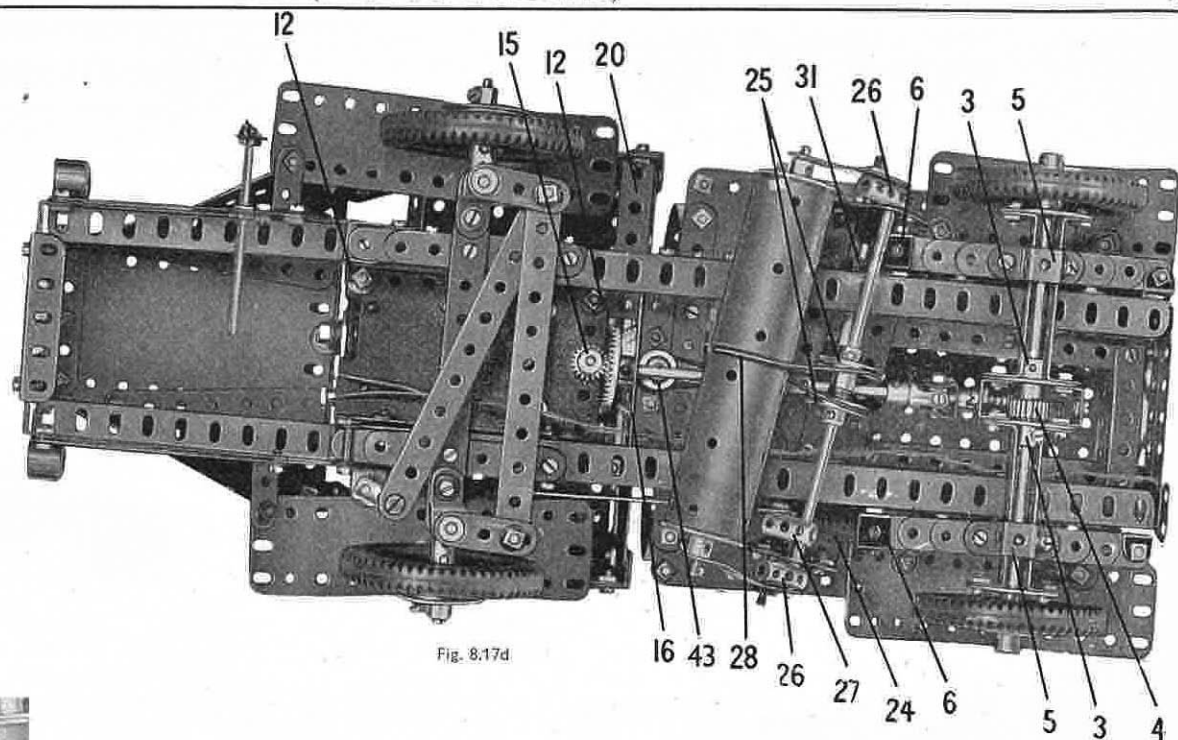

Fig. 8.17d

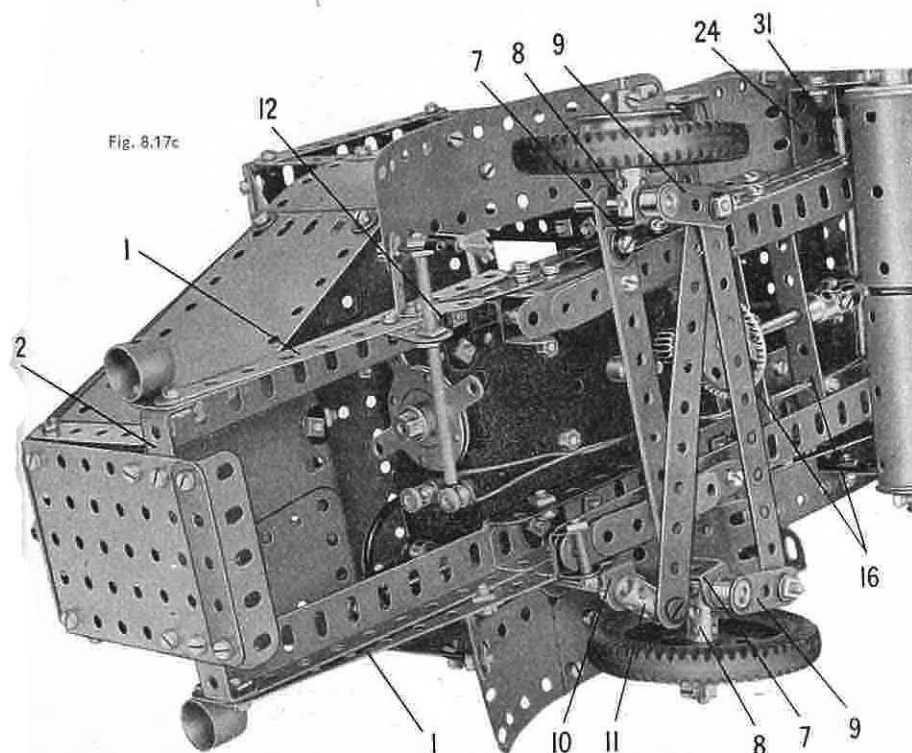

Fig. 8.17c

A 2" Rod is mounted vertically in a Double Bent Strip (29) bolted to a $3\frac{1}{2}''$ Strip fixed across the chassis. This Rod carries a 57-tooth Gear (30) (Fig. 8.17a) and a $\frac{1}{2}''$ fixed Pulley (43) (Fig. 8.17). A Compression Spring is placed over the Rod between the Gear (30) and a $1'' \times 1''$ Angle Bracket (32) bolted to a $3\frac{1}{2}'' \times \frac{1}{2}''$ Double Angle Strip fixed to the back of the cab. This Spring serves to hold the Gear (30) clear of the Pinion (14). The Gear can be moved into mesh with the Pinion by operating a lever (33), and for this purpose the 2" Rod should be allowed to slide about $\frac{1}{4}''$ in its bearings. The lever is a 2" Strip held by two nuts on a Screwed Rod that is mounted in a $2\frac{1}{2}'' \times \frac{1}{2}''$ Double Angle Strip bolted to the chassis. To one end of the Screwed Rod a Rod and Strip Connector is fixed tightly by two nuts. A 1" Rod in the Rod and Strip Connector engages underneath the Gear (30).

The brush is driven by a 10" Driving Band passed round the Pulley (31) (Fig. 8.17d) and over two $\frac{1}{2}''$ loose Pulleys on a 4" Rod (34) held at an angle by Spring Clips in the chassis. The Driving Band is passed round the Pulleys (25) and round the Pulley (28).

The brush can be raised clear of the ground by operating a lever (35), formed by a 3" Strip *lock-nutted* to the chassis. A $5\frac{1}{2}''$ Strip is *lock-nutted* to the lever and is connected by a Pivot Bolt to the Coupling (27).

CONSTRUCTION OF THE TANK

Each side of the tank consists of a $5\frac{1}{2}'' \times 1\frac{1}{2}''$ and three $5\frac{1}{2}'' \times 2\frac{1}{2}''$ Flexible Plates curved and bolted at their upper ends to a built-up strip (36) (Fig. 8.17b) made from two $5\frac{1}{2}''$ Strips overlapped seven holes. These strips are fixed along the edges of a $5\frac{1}{2}'' \times 2\frac{1}{2}''$ Flanged Plate (37). The lower edges of the Curved Plates of each side are attached to a built-up plate (38), made from a $5\frac{1}{2}'' \times 2\frac{1}{2}''$ and a $2\frac{1}{2}'' \times 2\frac{1}{2}''$ Flexible Plate bolted end to end and edged by a $5\frac{1}{2}''$ and a $2\frac{1}{2}''$ Strip.

The rear end of the tank is a $3\frac{1}{2}'' \times 2\frac{1}{2}''$ Flanged Plate bolted to the end of the Flanged Plate (37) and fitted at each side with a Semi-Circular Plate.

A $2\frac{1}{2}'' \times 1\frac{1}{2}''$ Flanged Plate (39) on each side is extended by a $2\frac{1}{2}'' \times 1\frac{1}{2}''$ Triangular Flexible Plate, and is attached to one of the strips (36) by two Angle Brackets. Two $2\frac{1}{2}'' \times 1\frac{1}{2}''$ Flexible Plates arranged as shown in Fig. 8.17b are supported by Angle Brackets fixed to the Flanged Plates (39) and the Triangular Flexible Plates.

The tank is attached to the chassis by a Trunnion (40) on each side and two Flat Trunnions (41) at the rear.

The front mudguards are $5\frac{1}{2}'' \times 1\frac{1}{2}''$ Flexible Plates, and each is attached to a side of the cab by a $\frac{1}{2}'' \times \frac{1}{2}''$ Angle Bracket. One of the Plates is connected to the chassis by a $1'' \times \frac{1}{2}''$ Angle Bracket, and the other by a $1'' \times 1''$ Angle Bracket. One of the rear mudguards is a $5\frac{1}{2}'' \times 1\frac{1}{2}''$ Flexible Plate, and the other consists of two $2\frac{1}{2}'' \times 1\frac{1}{2}''$ Flexible Plates. Both rear mudguards are supported by $1'' \times 1''$ Angle Brackets fixed to the chassis.

8.18 CAR FERRY

CONSTRUCTION OF THE HULL

Each side of the hull consists of four $5\frac{1}{2}'' \times 2\frac{1}{2}''$ Flexible Plates (1), two $5\frac{1}{2}'' \times 1\frac{1}{2}''$ Flexible Plates (2) and two $4\frac{1}{2}'' \times 2\frac{1}{2}''$ Flexible Plates (3). These Plates are strengthened on the outside by a built-up strip (4), made from three $1\frac{1}{2}''$ Strips overlapped three holes each. Two $1\frac{1}{2}''$ Angle Girders (5) and (6) (Fig. 8.18c) serve a similar purpose on the inside.

At the bow the sides are connected by two $1\frac{1}{2}''$ radius Curved Plates (7) overlapped two holes, and the strips (4) are joined by a Formed Slotted Strip. A $5\frac{1}{2}'' \times 1\frac{1}{2}''$ Flexible Plate (8) is bolted to the Plates (7) on each side, and is connected to one of the Plates (3) by a Fishplate. The Plate (8) is edged by a $5\frac{1}{2}''$ Strip, and is attached to one of the Plates (1) by a $2\frac{1}{2}''$ Stepped Curved Strip. The front ends of the $5\frac{1}{2}''$ Strips are connected by a Formed Slotted Strip.

The Plates (3) at the stern are bolted to a $1\frac{1}{2}''$ radius Curved Plate, and the rear ends of the strips (4) are connected by a Formed Slotted Strip.

Two built-up strips (9), each made from two $5\frac{1}{2}''$ Strips overlapped five holes, are bolted between the Girders (6) (Fig. 8.18c).

The front wheels of the model are fixed on a built-up rod, made from a $4\frac{1}{2}''$ and a $3\frac{1}{2}''$ Rod joined by a Rod Connector. This rod is mounted in the inner lugs of Double Angle Brackets bolted to the Girders (5). The rear wheels are fixed on a Rod supported in Corner Gussats bolted to the Girders (17).

ASSEMBLY OF THE FOREDECK AND THE MAIN DECK

The foredeck consists of one half of a Hinged Flat Plate (10) (Fig. 8.18b), extended forward by a $2\frac{1}{2}'' \times 2\frac{1}{2}''$ Flexible Plate, and fitted on each side with a $2\frac{1}{2}'' \times 1\frac{1}{2}''$ and a $2\frac{1}{2}'' \times 2''$ Triangular Flexible Plate. These Plates are edged by two $2\frac{1}{2}''$ Strips, two $2''$ Strips and two $2\frac{1}{2}''$ Curved Strips, and they are strengthened at the rear by two $5\frac{1}{2}''$ Strips (11) overlapped seven holes. The foredeck is attached to the Plates (7) and (8) by Angle Brackets. A $5\frac{1}{2}'' \times 2\frac{1}{2}''$ Flanged Plate is bolted centrally by one of its long flanges, underneath the Strips (11).

The main deck is seen from below in Fig. 8.18c. It consists of four $12\frac{1}{2}'' \times 2\frac{1}{2}''$ Strip Plates (12), seven $2\frac{1}{2}'' \times 2\frac{1}{2}''$ Flexible Plates (13), a $2\frac{1}{2}'' \times 1\frac{1}{2}''$ Flexible Plate, two Flanged Sector Plates (14), two $4\frac{1}{2}'' \times 2\frac{1}{2}''$ Flexible Plates (15), and two Semi-Circular Plates (16). These Plates are bolted together as shown, and are attached to the Girders (6), the strips (9), the Flanged Plate bolted underneath the Strips (11) and to two $1\frac{1}{2}''$ Angle Girders (17) (Fig. 8.18b).

SALOON AND UPPER DECK

Each side of the saloon (Fig. 8.18) is made by bolting a $2\frac{1}{2}'' \times 2\frac{1}{2}''$ Flexible Plate, two $2\frac{1}{2}'' \times 4\frac{1}{2}''$ Double Angle Strips, a $2\frac{1}{2}'' \times 1\frac{1}{2}''$ Flexible Plate and two $2\frac{1}{2}''$ Strips, to the Girder (17). The upper ends of the Strips and Plates support a $1\frac{1}{2}''$ Angle Girder (18), and the rear end of the saloon is a $3\frac{1}{2}'' \times 2\frac{1}{2}''$ Flanged Plate. A $3\frac{1}{2}'' \times \frac{1}{2}''$ Double Angle Strip, fitted on each side with a $2\frac{1}{2}''$ Strip, is bolted between the front ends of the Girders (18), and to this Double Angle Strip a $5\frac{1}{2}'' \times 2\frac{1}{2}''$ Flanged Plate (19) is attached by a $\frac{1}{2}''$ Bolt.

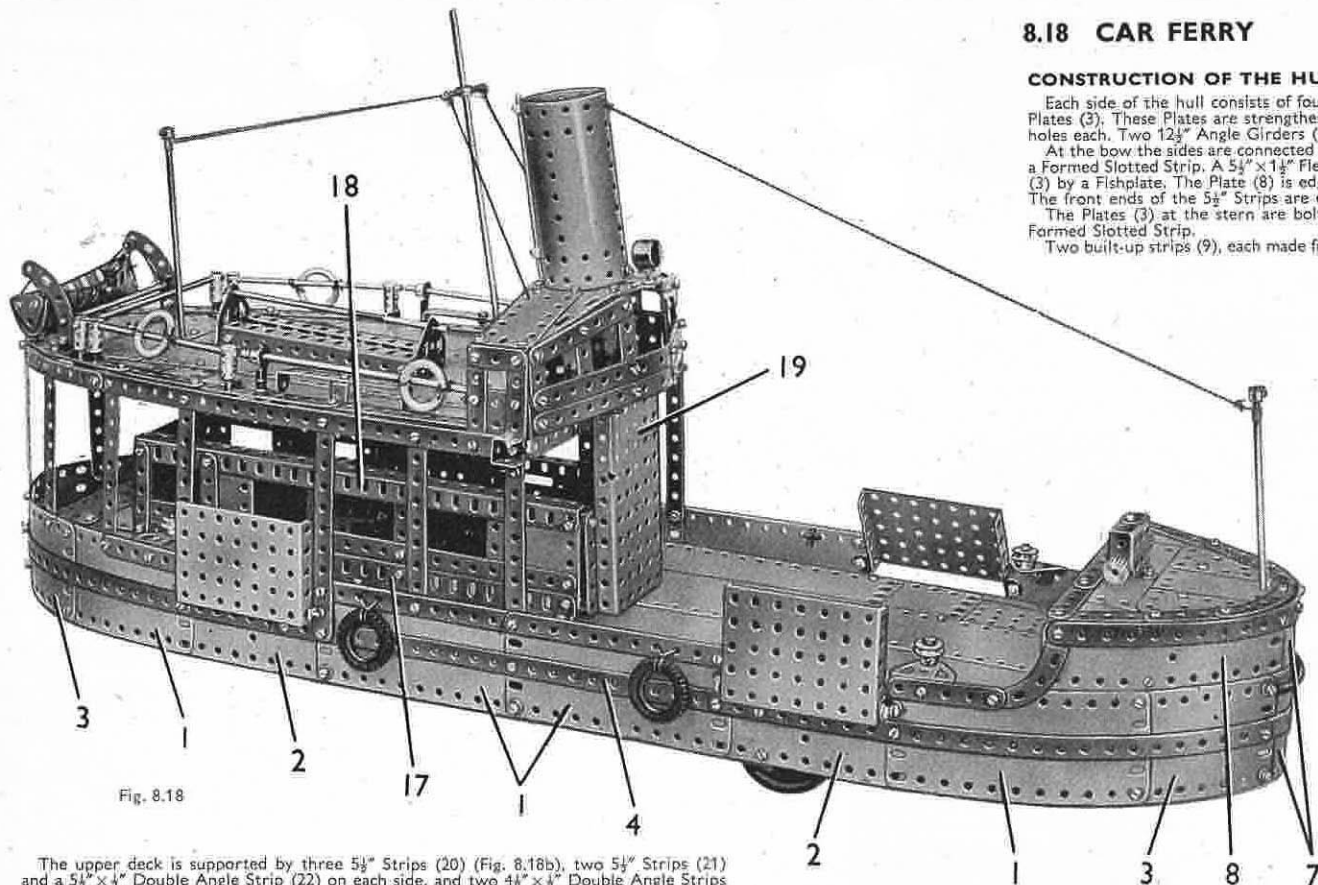

Fig. 8.18

The upper deck is supported by three $5\frac{1}{2}''$ Strips (20) (Fig. 8.18b), two $5\frac{1}{2}''$ Strips (21) and a $5\frac{1}{2}'' \times \frac{1}{2}''$ Double Angle Strip (22) on each side, and two $4\frac{1}{2}'' \times \frac{1}{2}''$ Double Angle Strips (23) at the stern. The upper ends of these Strips are connected by three $1\frac{1}{2}'' \times 2\frac{1}{2}''$ Strip Plates along the centre, and extended at the rear by the other half of the Hinged Flat Plate, a $3\frac{1}{2}'' \times 2\frac{1}{2}''$ Triangular Flexible Plate (24) (Fig. 8.18a) on each side and a $2\frac{1}{2}'' \times 1\frac{1}{2}''$ Flanged Plate (25). Each side of the deck is completed by two $5\frac{1}{2}'' \times 2\frac{1}{2}''$ Flexible Plates (26) overlapped two holes, a $2\frac{1}{2}'' \times 1\frac{1}{2}''$ Flexible Plate (27) and a $3\frac{1}{2}'' \times 2''$ Triangular Flexible Plate (28).

At the front the top deck is edged by two $5\frac{1}{2}''$ Angle Girders overlapped five holes. Each side of the deck is strengthened by a $5\frac{1}{2}''$, a $4\frac{1}{2}''$, two $3\frac{1}{2}''$ and a $2\frac{1}{2}''$ Strip. The rounded end is edged by two $2\frac{1}{2}''$ Curved Strips. The deck is attached to the lugs of Double Angle Strips (22) and to Angle Brackets, and also to a $\frac{1}{2}''$ Reversed Angle Bracket bolted to the Flanged Plate (19).

CONSTRUCTION OF THE BRIDGE

Each end of the bridge consists of two $2\frac{1}{2}''$ Strips connected by a Flat Trunnion and a $1\frac{1}{2}''$ Strip. The front is formed by three $3\frac{1}{2}''$ Strips at each side attached to Obtuse Angle Brackets bolted to the end. The lower pair of $3\frac{1}{2}''$ Strips is connected to those of the opposite side by Formed Slotted Strips. The window divisions are made from $1\frac{1}{2}''$ and $2\frac{1}{2}''$ Strips.

The top of the bridge consists of two $5\frac{1}{2}'' \times 1\frac{1}{2}''$ Flexible Plates (29) (Fig. 8.18b), overlapped five holes, a $3\frac{1}{2}'' \times 1\frac{1}{2}''$ Triangular Flexible Plate (30) on each side at the front and a $2\frac{1}{2}'' \times 1\frac{1}{2}''$ Flexible Plate at the centre. A $2\frac{1}{2}''$ Stepped Curved Strip is bolted to the centre of the front edge and a similar part to the rear edge. The top is attached to the ends by $\frac{1}{2}'' \times \frac{1}{2}''$ Angle Brackets, and to the front by $1'' \times \frac{1}{2}''$ Angle Brackets bolted to the $2\frac{1}{2}''$ Strips of the windows. A $1\frac{1}{2}''$ radius Curved Plate (31) is connected to the upper deck and to the top of the bridge by Angle Brackets, and a similar part is attached by an Angle Bracket bolted to the centre hole at the front edge of the overlapped Plates (29).

The funnel is a Boiler, with its edges joined by bolts screwed into two Collars. Two Washers are placed on each bolt inside the Boiler and the Collars support a $4\frac{1}{2}''$ Rod. The funnel is fixed to a $1'' \times 1''$ Angle Bracket bolted to the top of the bridge.

A Chimney Adaptor is fixed by a nut on a $\frac{1}{2}''$ Bolt, which is held by two nuts in the Stepped Curved Strip at the front of the bridge.

DECK FITTINGS

The winch on the foredeck consists of two $\frac{1}{2}''$ Pinions on a $2''$ Rod, which is supported in $1'' \times 1''$ Angle Brackets bolted to a Channel Bearing. The Channel Bearing is attached to a Double Bent Strip bolted to the deck. The $5''$ Rod (32) is held in a Crank fixed below the deck. The mainmast is an $11\frac{1}{2}''$ Rod, and the stern mast is an $8''$ Rod, both of which are supported in Bush Wheels bolted underneath the upper deck.

(Continued on next page)

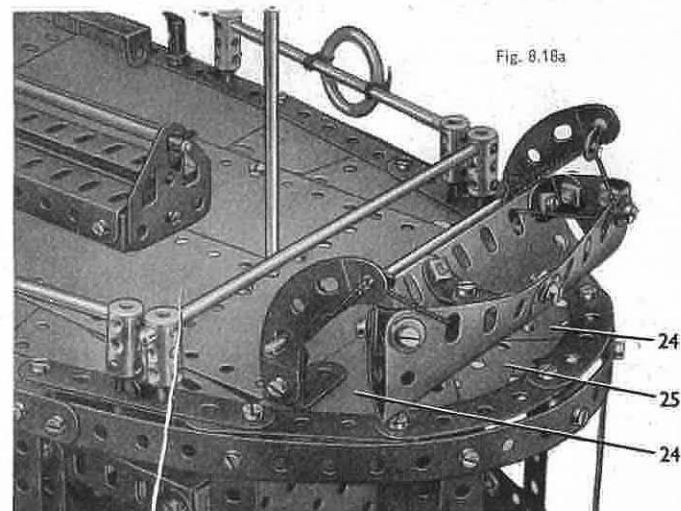

Fig. 8.18a

MODEL 8.18 CAR FERRY — Continued

The side seats on the upper deck are $3\frac{1}{2}'' \times \frac{1}{2}''$ Double Angle Strips attached to $\frac{1}{2}''$ Reversed Angle Brackets. The centre seat consists of two $5\frac{1}{2}''$ Angle Girders bolted to $1\frac{1}{2}'' \times \frac{1}{2}''$ Double Angle Strips, each of which carries a Flat Trunnion. A $4\frac{1}{2}''$ and a $2''$ Rod joined by a Rod Connector, are held in the Flat Trunnions by Spring Clips.

The handrails (33) are each formed by a $6\frac{1}{2}''$ Rod supported in an Angle Bracket bolted to the bridge and also in a Rod and Strip Connector fitted over a Threaded Pin, which is fixed by its nut to the deck. The remaining handrails are Rods gripped in Couplings, which are mounted on $1\frac{1}{2}''$ and $1''$ Rods held in the deck by Spring Clips and spaced from the deck by further $\frac{1}{2}''$ Spring Clips on the Rods. The fenders and lifebelts are $1''$ Motor Tyres and $1''$ Rubber Rings tied in place by Cord.

The lifeboat consists of two 'U'-section Curved Plates bolted together and shaped as shown in Fig. 8.18a. At the bows they are connected by an Angle Bracket, and at the stern by two Angle Brackets bolted to a $1''$ Triangular Plate. The seat is made from two Obtuse Angle Brackets and a Fishplate. The lifeboat is suspended by Cord tied to a $5''$ Rod supported in Stepped Curved Strips. The Curved Strips are fixed to $1'' \times 1''$ Angle Brackets bolted to the upper deck.

The gangways are $3\frac{1}{2}'' \times 2\frac{1}{2}''$ Flanged Plates, each of which pivots on bolts lock-nutted to Angle Brackets.

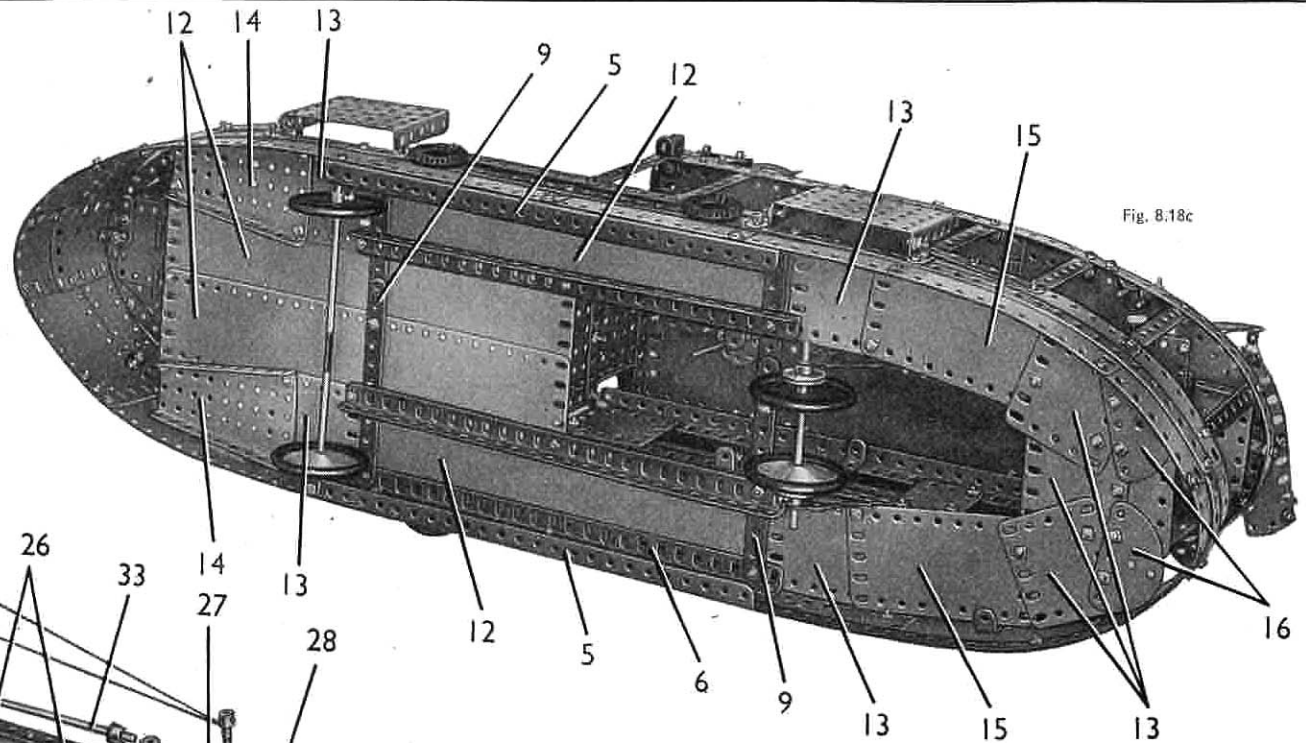

Fig. 8.18c

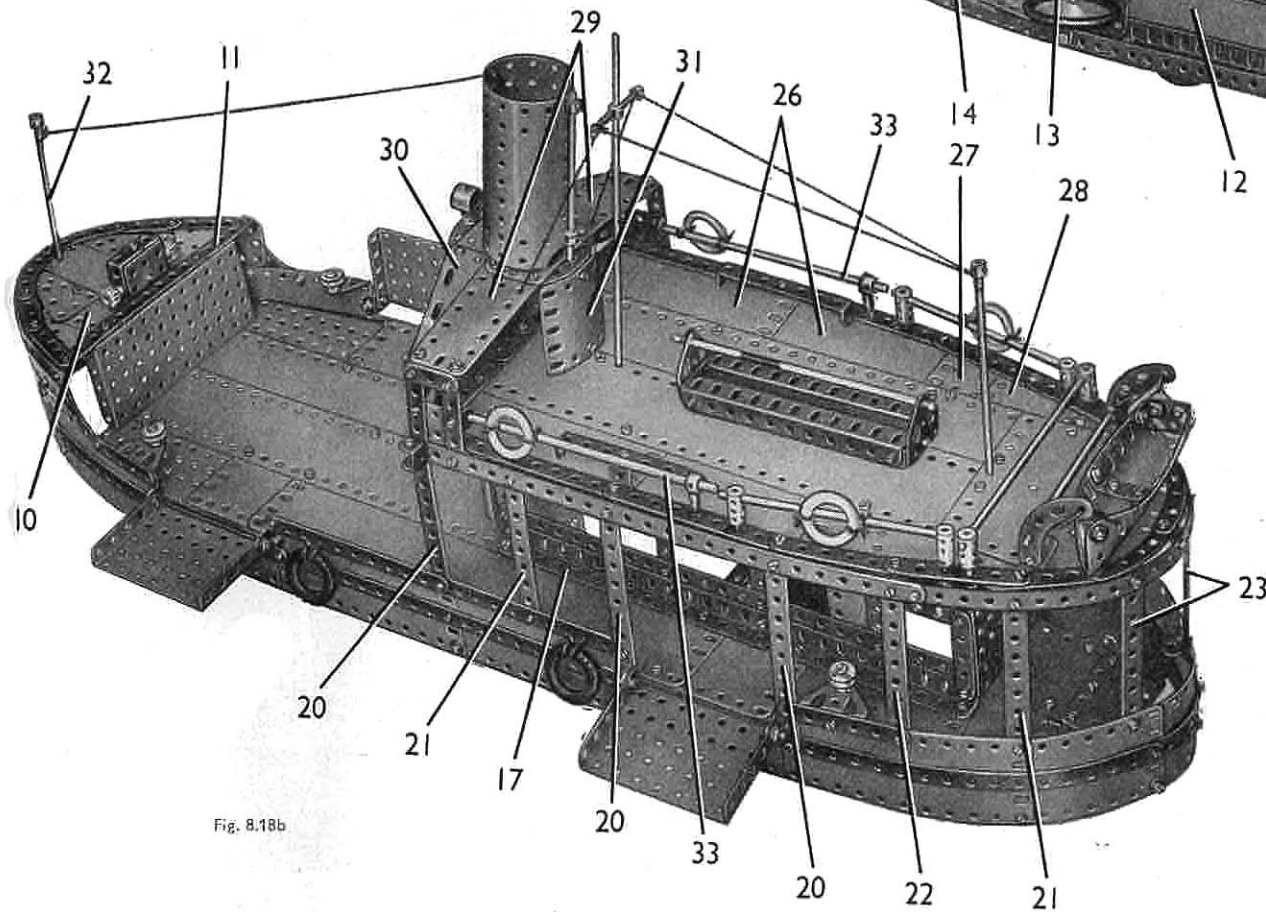

Fig. 8.18b

Parts Required

13 of No. 1	2 of No. 17	2 of No. 52	1 of No. 162
20 " " 2	4 " " 18a	5 " " 53	1 " " 164
6 " " 3	2 " " 18b	2 " " 54	2 " " 176
6 " " 4	2 " " 22	10 " " 59	4 " " 187
18 " " 5	3 " " 23	1 " " 62	7 " " 188
2 " " 6	1 " " 23a	6 " " 63	8 " " 189
6 " " 6a	2 " " 24	1 " " 77	10 " " 190
10 " " 8	2 " " 26	4 " " 90	6 " " 191
4 " " 9	17 " " 35	6 " " 90a	12 " " 192
10 " " 10	270 " " 37a	2 " " 108	6 " " 197
5 " " 11	253 " " 37b	3 " " 111	1 " " 198
32 " " 12	37 " " 38	5 " " 111a	2 " " 199
5 " " 12a	1 " " 40	6 " " 111c	5 " " 200
2 " " 12b	1 " " 43	2 " " 115	2 " " 212
6 " " 12c	1 " " 45	3 " " 125	2 " " 213
1 " " 13	2 " " 48	4 " " 126	2 " " 214
1 " " 13a	4 " " 48a	4 " " 126a	5 " " 215
3 " " 14	3 " " 48b	4 " " 142c	4 " " 221
4 " " 15	2 " " 48c	2 " " 147b	2 " " 222
4 " " 15a	2 " " 48d	4 " " 155	2 " " 223
1 " " 16	1 " " 51	1 " " 160	2 " " 224
			2 " " 225

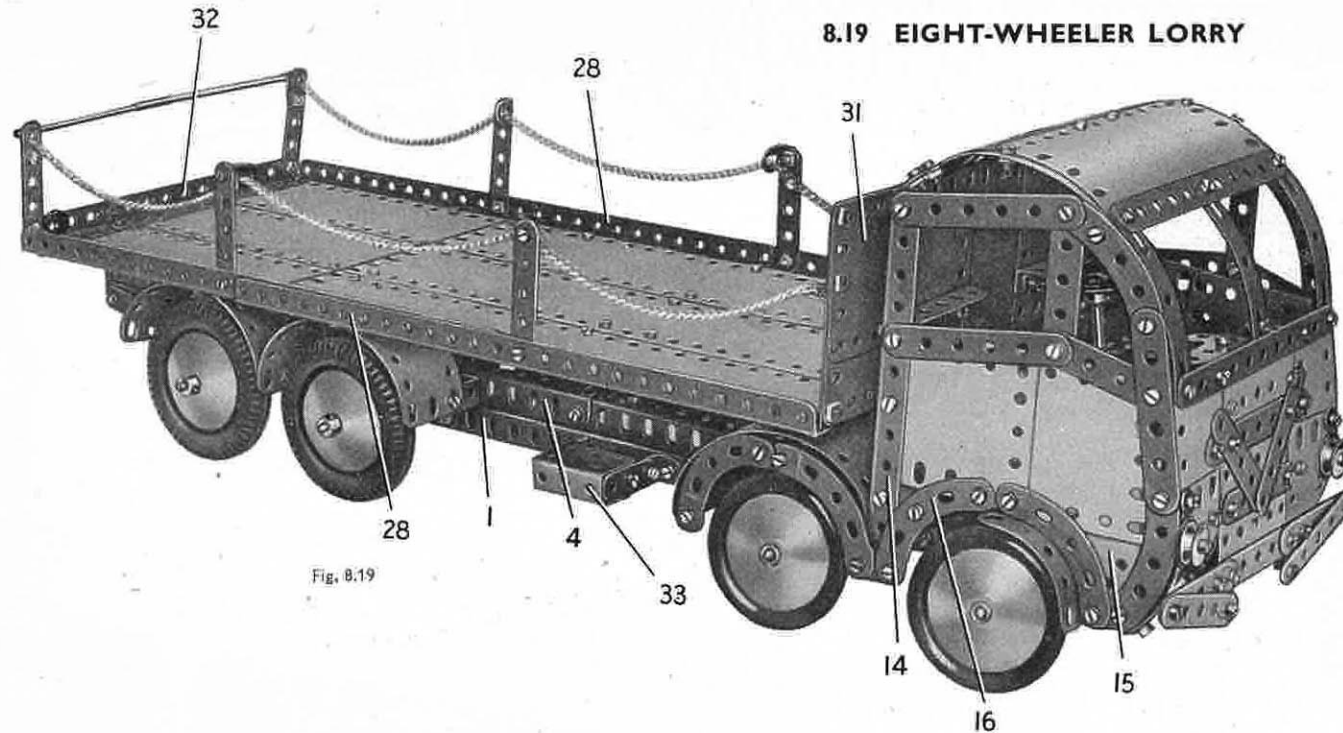

Fig. 8.19

8.19 EIGHT-WHEELER LORRY

CONSTRUCTION OF THE CHASSIS (Figs. 8.19a and 8.19b)

Each side member of the chassis consists of a 12½" Angle Girder (1) extended forward seven clear holes by a 12½" Strip, and at the rear by a 5½" Angle Girder that overlaps the 12½" Girder by five holes. Three 3½" × ½" Double Angle Strips (3) are bolted to the Girders (1), and to the lugs of these Double Angle Strips on each side a built-up girder (4) is bolted. Each of these girders consists of two 12½" Angle Girders (1) and (4) on each side, and a 3½" × 2½" Flanged Plate (5) is bolted to the girders (4). A 3½" × ½" Double Angle Strip (6) is attached to the Strips (2).

One pair of rear wheels is fixed on an 8" Rod supported in the chassis, and the other pair is mounted on a built-up rod made from a 4½" and a 3½" Rod joined by a Coupling.

The leading front axle is a 5½" Strip bolted to a 3½" × ½" Double Angle Strip, which is attached to 1" Triangular Plates fixed to the Strips (2). The second axle is also a 5½" Strip bolted to a 3½" × ½" Double Angle Strip, but this is attached to 1" × 1" Angle Brackets fixed to the Girders (1).

Each of the front wheels is free to turn on a 1½" Rod held by a Collar in the lugs of a Double Bracket. A 1½" Strip (7) is placed between the lugs of each Double Bracket and a ½" Bolt is passed through the parts. The Bolts are then each held by two nuts in the end holes of the 5½" Strips forming the axles, leaving the Double Brackets and Strips free to swivel as units on the Bolts. The Strips (7) are connected by lock-nutted bolts to 5½" Strips (8).

Two Cranks (9) are free to turn on Pivot Bolts lock-nutted to the front axles, and each Crank is lock-nutted also to one of the Strips (8). A ¾" Bolt, with an Angle Bracket (10) fixed tightly against its head by a nut, is screwed into the boss of each Crank and is held by a further nut tightened against the boss. A 2½" Strip (11) is extended at one end by a Fishplate, and at the other end by two Fishplates bolted together. The Fishplates at each end are lock-nutted to the Angle Brackets (10), a Rod and Strip Connector (12) being pivoted on the same ¾" Bolt as the Fishplate at the front.

ASSEMBLY OF THE CAB

The back of the cab is made by bolting a 3½" × 2½" Flanged Plate (13) (Fig. 8.19a) to each Girder (1). The Flanged Plates are connected at the centre by a 5½" × 2½" Flexible Plate placed vertically, and are extended upward on each side by a 2½" × 2½" Flexible Plate.

(Continued on next page)

Parts Required		
2 of No. 1	2 of No. 23	1 of No. 115
20 " " 2	1 " " 23a	4 " " 125
4 " " 2a	1 " " 24	4 " " 126
6 " " 3	1 " " 26	2 " " 126a
6 " " 4	1 " " 28	4 " " 142a
16 " " 5	281 " " 37a	2 " " 147b
2 " " 6	245 " " 37b	1 " " 160
6 " " 6a	29 " " 38	2 " " 163
10 " " 8	2 " " 38d	2 " " 164
4 " " 9	1 " " 46	1 " " 185
15 " " 10	2 " " 48	4 " " 187
4 " " 11	4 " " 48a	4 " " 187a
28 " " 12	6 " " 48b	7 " " 188
6 " " 12a	4 " " 53	6 " " 189
2 " " 12b	9 " " 59	8 " " 190
5 " " 12c	2 " " 62	5 " " 192
1 " " 13a	3 " " 63	6 " " 197
1 " " 15a	2 " " 77	1 " " 198
1 " " 15b	4 " " 90	2 " " 200
4 " " 16	8 " " 90a	2 " " 212
4 " " 18a	1 " " 94	1 " " 213
1 " " 18b	1 " " 108	3 " " 215
4 " " 20a	3 " " 111	3 " " 221
4 " " 20b	6 " " 111a	2 " " 224
	6 " " 111c	

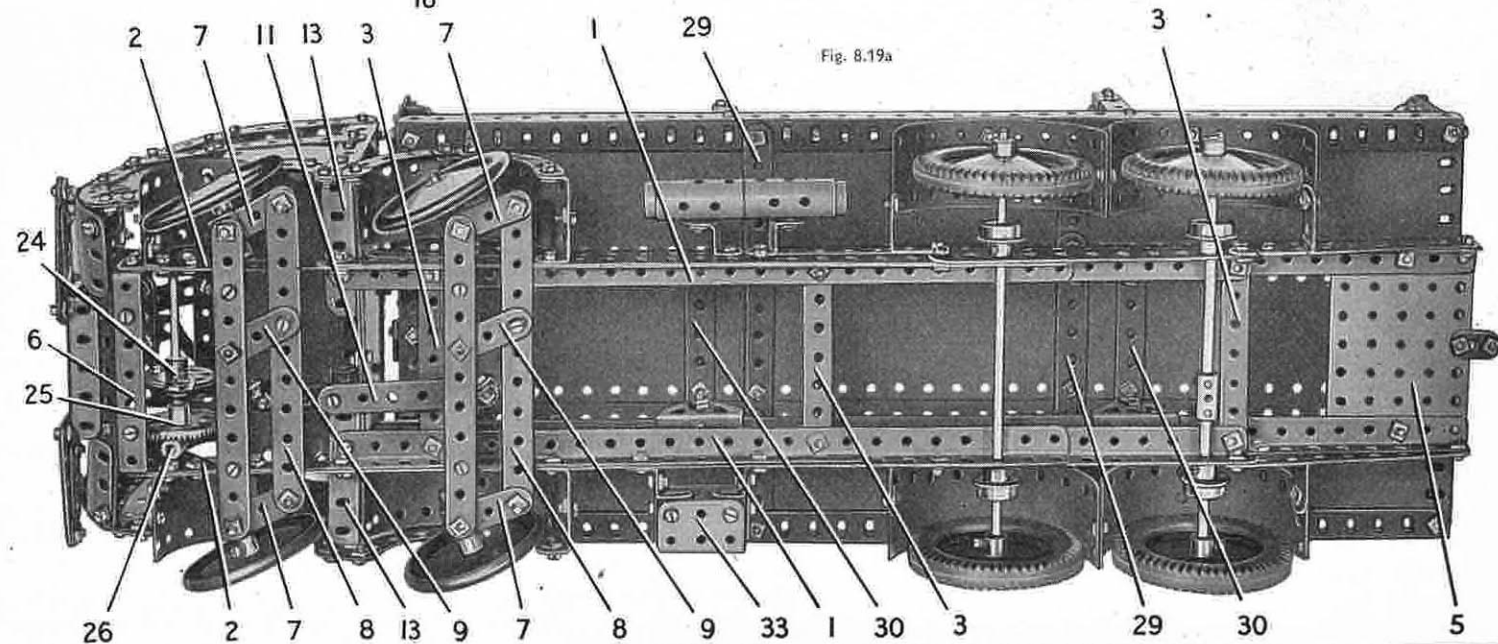
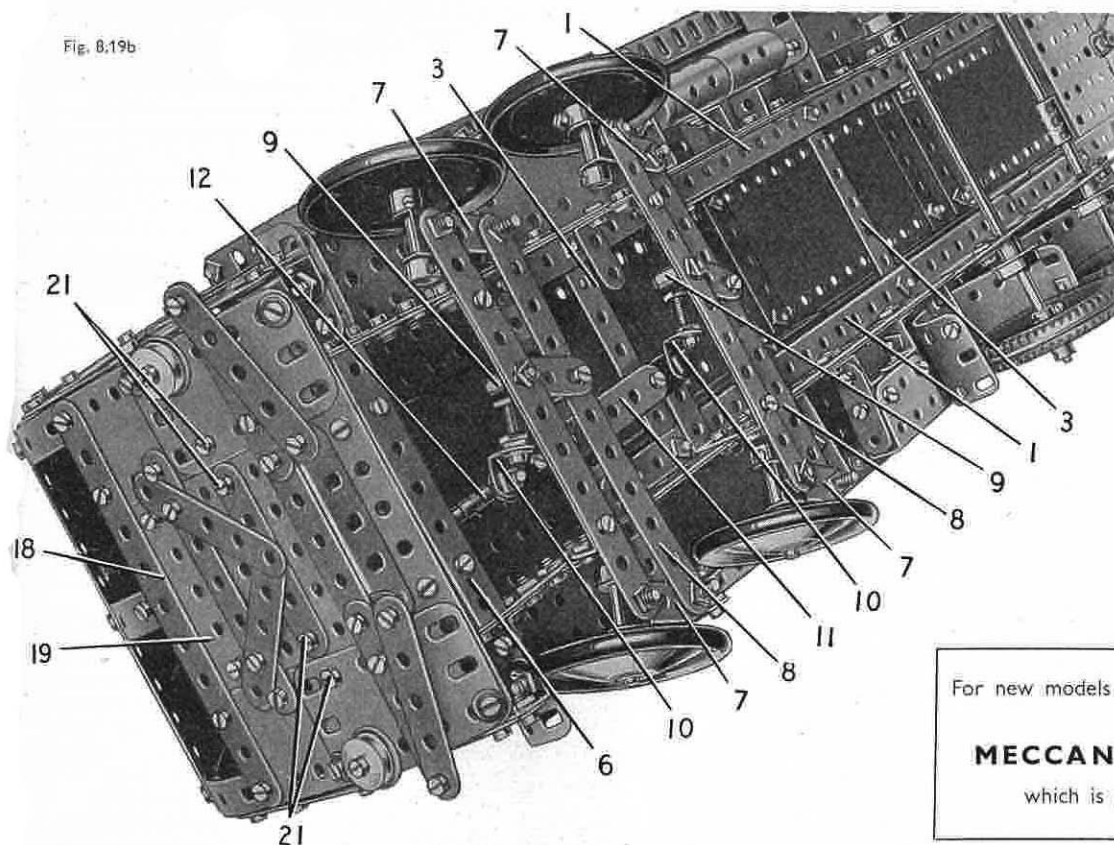

Fig. 8.19a

Fig. 8.19b



MODEL 8:19 EIGHT-WHEELER LORRY — Continued

The upper edges of the Flexible Plates are strengthened by two $3\frac{1}{2}$ " Strips, and a $5\frac{1}{2}$ " Angle Girder (14) (Fig. 8.19) is bolted to the Flanged Plate (13) and the $2\frac{1}{2}$ " \times $2\frac{1}{2}$ " Flexible Plate on each side.

Each side of the cab consists of two $2\frac{1}{2}$ " \times $2\frac{1}{2}$ " Flexible Plates and a $2\frac{1}{2}$ " \times $1\frac{1}{2}$ " Triangular Flexible Plate (15), edged as shown in Fig. 8.19 by Strips and Curved Strips. The rear Curved Strip (16) of the wheel arch is connected to the Girder (14) by a Fishplate. The window frames are arranged as shown.

The cab front is formed by two $2\frac{1}{2}$ " \times $1\frac{1}{2}$ " Flexible Plates (17) (Fig. 8.19c) on each side, overlapped two holes. These are connected to the cab by Angle Brackets at each end and at the centre. The upper edges of the Plates are strengthened by a $5\frac{1}{2}$ " Strip (18), and the lower edges by another $5\frac{1}{2}$ " Strip attached by Obtuse Angle Brackets to the Double Angle Strip (6). The radiator is a $3\frac{1}{2}$ " \times $2\frac{1}{2}$ " Flanged Plate (19), and it is fixed to a $3\frac{1}{2}$ " Strip (20) bolted between the Plates (17), and to a similar Strip on the inside held by bolts (21). The radiator grille and the front bumper are made from Strips as shown in Fig. 8.19c.

The windscreen pillars are Formed Slotted Strips connected at the top by a $5\frac{1}{2}$ " Strip (22) that is attached to the cab sides by Angle Brackets. The cab roof consists of a $5\frac{1}{2}$ " \times $2\frac{1}{2}$ " Flexible Plate at the front, and a $2\frac{1}{2}$ " \times $1\frac{1}{2}$ " Flexible Plate and two $1\frac{1}{2}$ " radius Curved Plates at the rear. A $3\frac{1}{2}$ " \times $1\frac{1}{2}$ " Triangular Flexible Plate (23) is bolted to each side of the roof. The roof is bolted at the front to Strip (22) and at the rear to Obtuse Angle Brackets fixed to the back of the cab.

The driving seat is a $5\frac{1}{2}$ " \times $2\frac{1}{2}$ " Flexible Plate, and it is supported by $2\frac{1}{2}$ " \times $\frac{1}{2}$ " Double Angle Strips fixed by their lugs to the sides of the cab.

STEERING MECHANISM

A Flat Trunnion is attached point upward to the front end of each of the Strips (2) (Fig. 8.19a), and a 4" Rod is held by a Collar and a $\frac{1}{2}$ " fixed Pulley in the holes at the pointed ends. This Rod carries a Bush Wheel (24) and a $1\frac{1}{2}$ " Contrate (25) fixed in place, and a Coupling (26) freely mounted by its centre cross hole. A Fishplate is bolted tightly to the Bush Wheel, and to the Fishplate is lock-nutted a Rod and Strip Connector. A 1" Rod in this Rod and Strip Connector is held also in the Rod and Strip Connector (12) (Fig. 8.19b).

For new models and mechanisms to build
see the
MECCANO MAGAZINE
which is published monthly

The steering column is a $3\frac{1}{2}$ " Rod supported in a Corner Gusset (27) (Fig. 8.19c) bolted to the top flange of Plate (19), and in the Coupling (26) (Fig. 8.19a). The Rod is held in place by a Coupling placed below the corner Gusset, and a $\frac{1}{2}$ " Pinion on the Rod engages the Contrate (25).

THE LOAD PLATFORM (Figs. 8.19 and 8.19a)

The platform side rails are built-up girders (28), each made from two $12\frac{1}{2}$ " Angle Girders overlapped 13 holes. These girders are connected at each end by a built-up strip, made from two $5\frac{1}{2}$ " Strips overlapped seven holes, and near the centre by two similar built-up strips (29). The platform is plated by six $12\frac{1}{2}$ " \times $2\frac{1}{2}$ " Strip Plates bolted to the built-up strips and girders.

Two $2\frac{1}{2}$ " \times $\frac{1}{2}$ " Double Angle Strips (30) are bolted underneath the platform and are attached to Trunnions fixed to the Girders (4). Beneath the front end of the platform a $2\frac{1}{2}$ " \times $1\frac{1}{2}$ " Double Angle Strip is attached, and the lugs of this part are supported by Angle Brackets fixed to the Girders (4).

The platform end (31) is made from two $5\frac{1}{2}$ " \times $2\frac{1}{2}$ " and two $2\frac{1}{2}$ " \times $2\frac{1}{2}$ " Flexible Plates and the separated half of a Hinged Flat Plate. These Plates are edged at the sides by $3\frac{1}{2}$ " Strips and along the top by two $4\frac{1}{2}$ " Strips overlapped three holes. The loading board is attached to the platform by Angle Brackets. At the rear of the platform two $2\frac{1}{2}$ " Strips are attached to a built-up strip (32), made from two $5\frac{1}{2}$ " Strips overlapped seven holes. This is connected to the platform by Angle Brackets. Right-Angle Rod and Strip Connectors bolted to the $2\frac{1}{2}$ " Strips support two $3\frac{1}{2}$ " Rods joined by a Rod Connector.

The platform chains are tied to Angle Brackets bolted to the loading board, and are passed through Angle Brackets bolted to $2\frac{1}{2}$ " Strips fixed to the girders (28).

THE MUDGUARDS AND CHASSIS FITTINGS

The mudguard over each of the leading front wheels is a $2\frac{1}{2}$ " \times $1\frac{1}{2}$ " Flexible Plate attached to the wheel arch and to the chassis by Angle Brackets. The mudguard over each trailing front wheel is a $5\frac{1}{2}$ " \times $1\frac{1}{2}$ " Flexible Plate connected at its rear end to a $1\frac{1}{2}$ " \times $\frac{1}{2}$ " Double Angle Strip bolted to the chassis. The front ends of the $5\frac{1}{2}$ " \times $1\frac{1}{2}$ " Flexible Plates are connected by two $5\frac{1}{2}$ " Strips overlapped nine holes.

Each rear mudguard is a $5\frac{1}{2}$ " \times $1\frac{1}{2}$ " Flexible Plate attached to the chassis by a $1\frac{1}{2}$ " \times $1\frac{1}{2}$ " Angle Bracket. The inner ends of each pair of mudguards are bolted together.

The tool box (33) is a Channel Bearing connected by Angle Brackets to a $1\frac{1}{2}$ " Strip on each side. These Strips are bolted to $\frac{1}{2}$ " Reversed Angle Brackets fixed to the chassis.

The fuel tank consists of two Sleeve Pieces supported by $\frac{1}{2}$ " Reversed Angle Brackets and fitted at their ends with Chimney Adaptors.

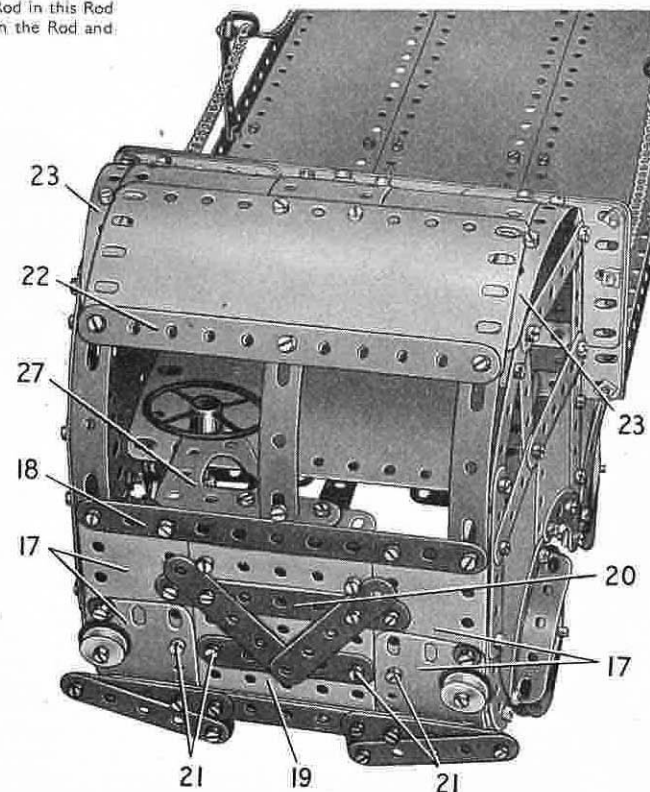

Fig. 8.19c

8.20 BULLDOZER

Parts Required

6 of No. 1	2 of No. 27a	4 of No. 111c	5 of No. 188	2 of No. 223
21 " " 2	248 " " 37a	2 " " 115	5 " " 189	
6 " " 2a	220 " " 37b	1 " " 116	4 " " 190	1 No. 1 Clockwork Motor
6 " " 3	30 " " 38	2 " " 126	6 " " 191	(Not included in outfit)
6 " " 4	2 " " 38d	2 " " 126a	11 " " 192	
18 " " 5	2 " " 48	2 " " 142a	2 " " 197	
2 " " 6	8 " " 48a	2 " " 142c	2 " " 212	
6 " " 6a	2 " " 48b	2 " " 147b	2 " " 214	
8 " " 8	2 " " 48c	1 " " 160	8 " " 215	
4 " " 9	1 " " 48d	2 " " 163	4 " " 221	
8 " " 10	5 " " 53	2 " " 164	2 " " 222	
1 " " 11	10 " " 59	4 " " 187		
15 " " 12	2 " " 62			
6 " " 12a	4 " " 63			
2 " " 12b	2 " " 77			
1 " " 15	1 " " 80a			
1 " " 16	1 " " 80c			
5 " " 17	4 " " 90			
3 " " 18a	7 " " 90a			
2 " " 20a	1 " " 95			
3 " " 20b	1 " " 96a			
4 " " 22	1 " " 108			
2 " " 23	1 " " 109			
1 " " 24	3 " " 111			
2 " " 26	6 " " 111a			

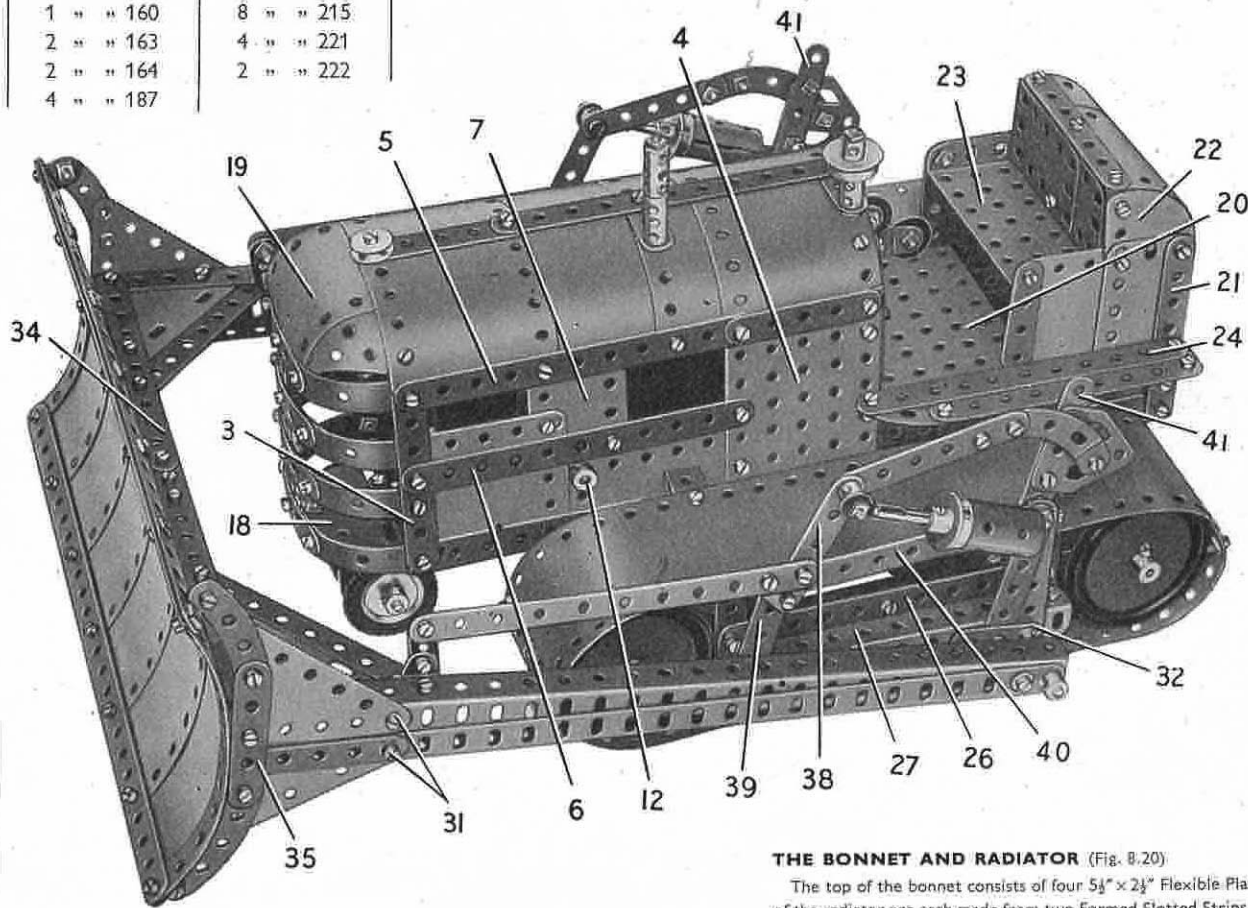

Fig. 8.20

CONSTRUCTION OF THE CHASSIS

Each side of the chassis consists of two $12\frac{1}{2}$ " Angle Girders (1) (Fig. 8.20a), spaced apart by a $12\frac{1}{2}$ " Strip and bolted at the rear to a $3\frac{1}{2}$ " x $2\frac{1}{2}$ " Flanged Plate (2). The front ends of the Strip and Girders on one side are connected by a $3\frac{1}{2}$ " Strip (3) and a $5\frac{1}{2}$ " x $2\frac{1}{2}$ " Flexible Plate, and those on the other side by a $3\frac{1}{2}$ " Strip (3) and a $2\frac{1}{2}$ " x $2\frac{1}{2}$ " Flexible Plate. A $3\frac{1}{2}$ " x $2\frac{1}{2}$ " Flanged Plate (4) is bolted to each side, and is connected by a built-up strip (5) to one of the Strips (3). The built-up strip is made from a $5\frac{1}{2}$ " and a $2\frac{1}{2}$ " Strip (see Fig. 8.20).

The side seen in Fig. 8.20 is completed by a $5\frac{1}{2}$ " x $1\frac{1}{2}$ " Flexible Plate edged by a $5\frac{1}{2}$ " Strip (6), and by a $2\frac{1}{2}$ " x $1\frac{1}{2}$ " Flexible Plate (7). The top edge of the $5\frac{1}{2}$ " x $2\frac{1}{2}$ " Flexible Plate on the other side is strengthened by a $5\frac{1}{2}$ " Strip, and is connected to the strip (5) by a $1\frac{1}{2}$ " Strip (8) (Fig. 8.20b).

A No. 1 Clockwork Motor is supported by a $1\frac{1}{2}$ " x $\frac{1}{2}$ " Double Angle Strip (9), bolted to one side-plate and to the Strip (8), and by a similar Double Angle Strip attached to one of the Plates (4) by a bolt (10). The Motor is further supported by a $3\frac{1}{2}$ " Rod (11), which is mounted in a Double Bracket bolted to one of the Girders (1) and is held in the side of the bonnet by a Collar (12) and a Coupling (13). The Motor brake lever is extended by a $1\frac{1}{2}$ " Strip and the reversing lever by a $2\frac{1}{2}$ " Stepped Curved Strip.

A Corner Gusset (14) and a $2\frac{1}{2}$ " Strip (15) are bolted to the Motor side-plates. A $\frac{1}{2}$ " Pinion on the driving shaft engages a 57-tooth Gear on a 2" Rod (16), and a $\frac{1}{2}$ " Pinion on this Rod drives a 57-tooth Gear on a 2" Rod (17). Rod (17) is held in the Corner Gusset (14) and in the Strip (15) by a Collar, and it carries a $\frac{1}{2}$ " Sprocket (13). This is connected by Chain to a 2" Sprocket on the rear axle, which is a $4\frac{1}{2}$ " Rod supported in Trunnions.

The front caster mounting is a Face Plate (18) bolted to a $3\frac{1}{2}$ " Strip. The caster wheels are 1" Pulleys with Tyres, held by Collars on a 2" Rod supported in a Channel Bearing. A Bush Wheel, with a $1\frac{1}{2}$ " Rod fixed in its boss, is bolted to the Channel Bearing. The Rod is fitted with a $\frac{1}{2}$ " loose Pulley, then passed through the boss of the Face Plate and held in place by a Collar.

THE BONNET AND RADIATOR (Fig. 8.20)

The top of the bonnet consists of four $5\frac{1}{2}$ " x $2\frac{1}{2}$ " Flexible Plates curved and bolted to the strips (5). The bars of the radiator are each made from two Formed Slotted Strips connected by a $2\frac{1}{2}$ " Strip, and fixed at the centre to a vertical $3\frac{1}{2}$ " x $\frac{1}{2}$ " Double Angle Strip. The lower lug of this Double Angle Strip is bolted to the Face Plate (18). A $1\frac{1}{2}$ " radius Curved Plate (19), with a $2\frac{1}{2}$ " x $1\frac{1}{2}$ " Triangular Flexible Plate on each side, is fixed between the radiator and the top of the bonnet.

(Continued on next page)

For new models and mechanisms to build see the

MECCANO MAGAZINE

which is published monthly

MODEL 8.20 BULLDOZER — Continued

A $5\frac{1}{2}$ " and a $2\frac{1}{2}$ " Strip are bolted along the top of the bonnet, and to the $5\frac{1}{2}$ " Strip are fixed two $1\frac{1}{2}$ " Strips. A Screwed Rod is passed through each of the $1\frac{1}{2}$ " Strips and a hole in the top of the bonnet, and these Screwed Rods support Couplings and a $\frac{1}{2}$ " Flanged Wheel representing the intake and exhaust pipes.

THE DRIVING PLATFORM AND SEAT (Fig. 8.20b)

A $3\frac{1}{2}$ " \times $2\frac{1}{2}$ " Flanged Plate (20) is fixed across the top of the chassis, and to each side is bolted a $2\frac{1}{2}$ " \times $2\frac{1}{2}$ " Flexible Plate and a $2\frac{1}{2}$ " \times $1\frac{1}{2}$ " Flexible Plate edged at the rear by a $3\frac{1}{2}$ " Strip (21). The Plates are extended upward by a Semi-Circular Plate (22).

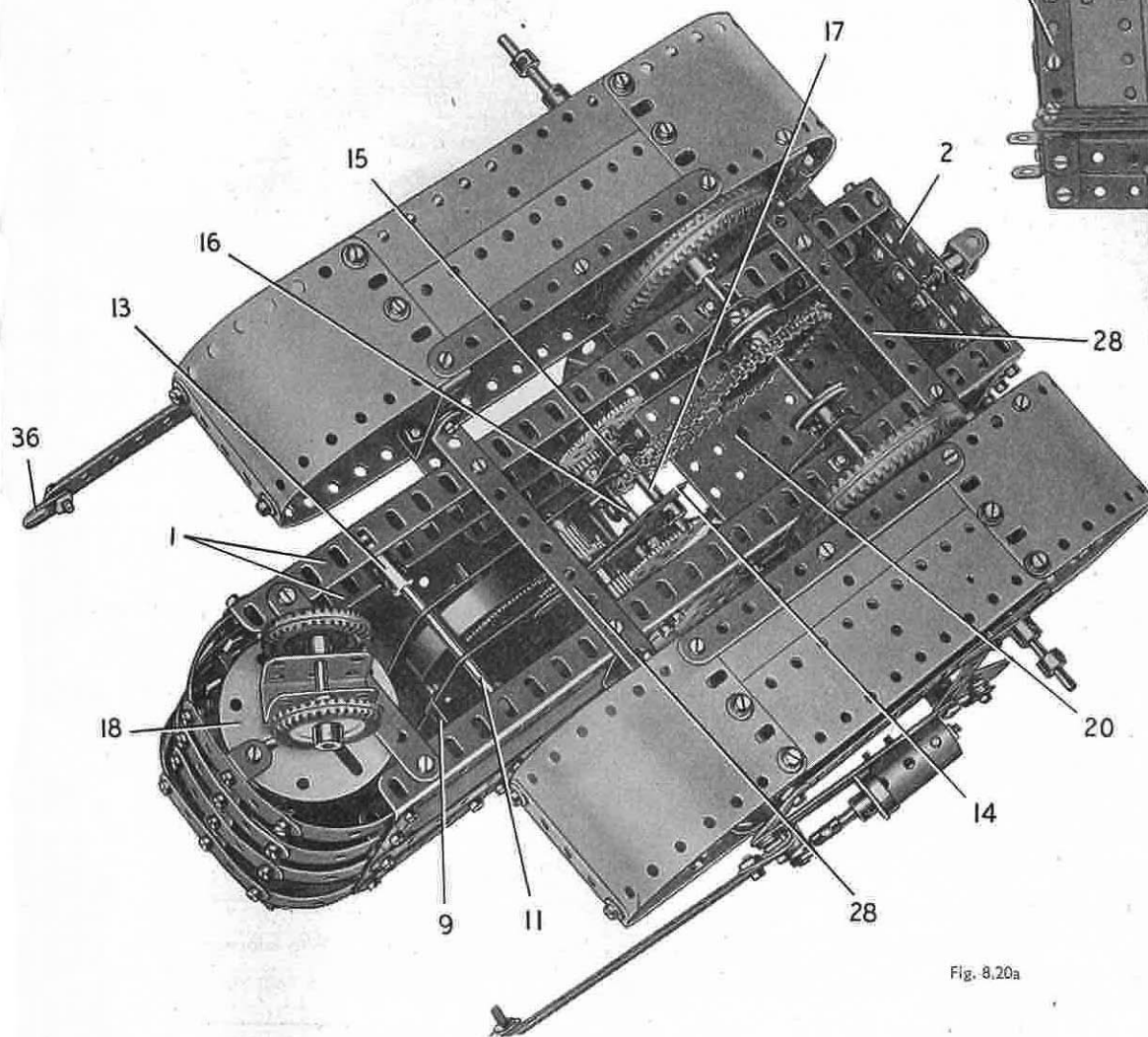

Fig. 8.20a

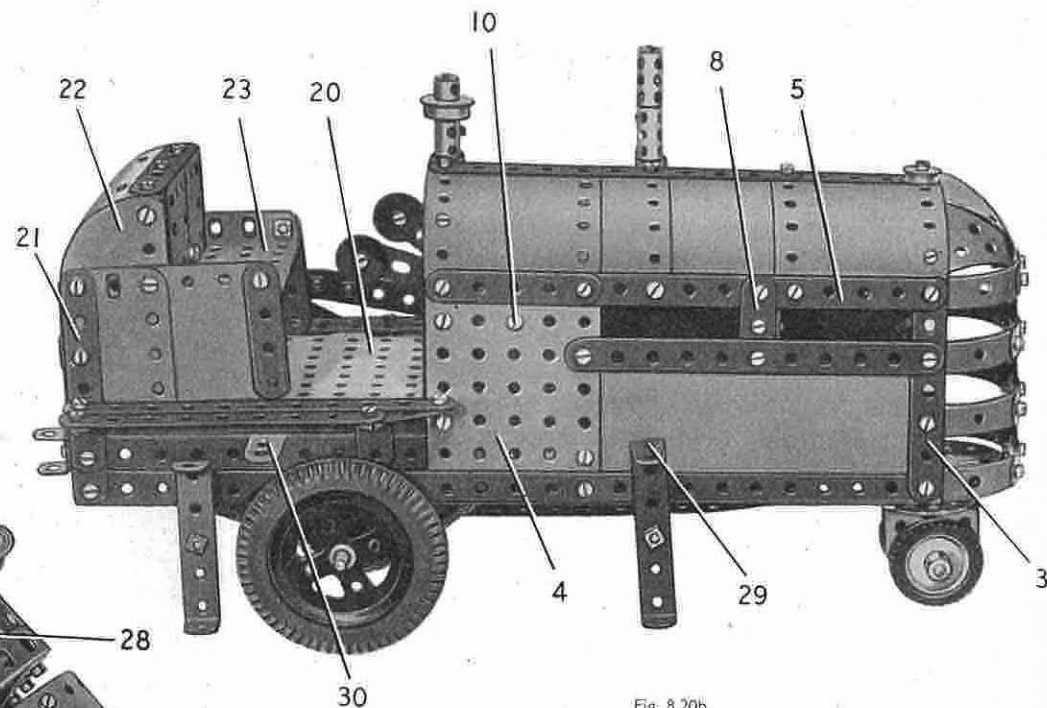

Fig. 8.20b

A $3\frac{1}{2}$ " \times $2\frac{1}{2}$ " Flanged Plate (23) forms the drivers seat, and the back consists of two $2\frac{1}{2}$ " \times $1\frac{1}{2}$ " Flexible Plates bolted to a $3\frac{1}{2}$ " \times $\frac{1}{2}$ " Double Angle Strip fixed between the flanges of Plate (23). The rear of the model is completed by two $4\frac{1}{2}$ " \times $2\frac{1}{2}$ " Flexible Plates bolted to the Flanged Plate (2) (Fig. 8.20d), curved, and attached by Angle Brackets to the Semi-Circular Plates (22).

The platform is extended on each side by a $5\frac{1}{2}$ " Strip (24), a $4\frac{1}{2}$ " Strip and a $2\frac{1}{2}$ " Stepped Curved Strip, bolted to 1 " \times 1 " Angle Brackets fixed to the chassis.

ASSEMBLY OF THE TRACKS

The top half of each track is a $12\frac{1}{2}$ " \times $2\frac{1}{2}$ " Strip Plate curved at its ends, and the lower half is formed by two curved $4\frac{1}{2}$ " \times $2\frac{1}{2}$ " Flexible Plates at the ends and two $5\frac{1}{2}$ " \times $1\frac{1}{2}$ " Flexible Plates at the centre. The $4\frac{1}{2}$ " \times $2\frac{1}{2}$ " Flexible Plates overlap the Strip Plate by two holes at each end. Two $2\frac{1}{2}$ " \times $\frac{1}{2}$ " Double Angle Strips (25) are bolted between the upper and lower edges of the track and to them is fixed a built-up strip made from two $5\frac{1}{2}$ " Strips overlapped five holes. A Road Wheel is attached to each end of this strip by a long Bolt. To each of the built-up strips is fixed a $5\frac{1}{2}$ " Angle Girder (26), and this supports a $5\frac{1}{2}$ " Angle Girder (27) (Fig. 8.20d).

Two $4\frac{1}{2}$ " \times $\frac{1}{2}$ " Double Angle Strips (28) are bolted across the chassis and are fixed to $2\frac{1}{2}$ " \times $\frac{1}{2}$ " Double Angle Strips bolted between the upper and lower edges of the tracks. Each track is further supported by a 1 " \times 1 " Angle Bracket (29), and a 1 " \times $\frac{1}{2}$ " Angle Bracket (30) (see Figs. 8.20a and 8.20b).

(Continued on next page)

MODEL 8.20 BULLDOZER — Continued

THE BLADE AND ITS LIFTING MECHANISM (Fig. 8.20d)

Each of the girders supporting the blade consists of two 12½" Angle Girders bolted together at one end and connected at the other end by a Fishplate held by the bolts (31). Each girder pivots between Collars on a 1½" Rod held in a Crank (32) bolted to the Girder (27). Two 3" Strips (33) are fixed between the Crank and the Girder.

At the front the main blade girders are connected by a built-up strip (34), made from two 5½" Strips that overlap a 5½" × ½" Double Angle Strip by five holes each. The joints between the girders and strip (34) are strengthened by 2½" × 2½" Triangular Flexible Plates and 4½" Strips.

The blade is attached by Angle Brackets to 2½" Curved Strips bolted to a 2½" Strip (35) on each side. The joints between Strips (35) and the blade girders are braced by 2½" × 2" and 2½" × 1½" Triangular Flexible Plates as shown. The blade is made from six 5½" × 2½" Flexible Plates edged by 5½" and 12½" Strips.

The mechanism for raising the blade is the same on each side. A Fishplate (36) is *lock-nutted* to an Angle Bracket bolted to the blade girder, and is *lock-nutted* also to two 5½" Strips (37) placed face to face. A 1" Triangular Plate and a 2½" Strip (38) are bolted tightly to Strips (37). The Triangular Plate is spaced by two Washers on a ½" Bolt from a 2½" Strip (39) and a 4½" Strip (40). The Bolt is held in these Strips by two nuts, leaving the Triangular Plate freely pivoted. Strip (39) is bolted to the Girder (27).

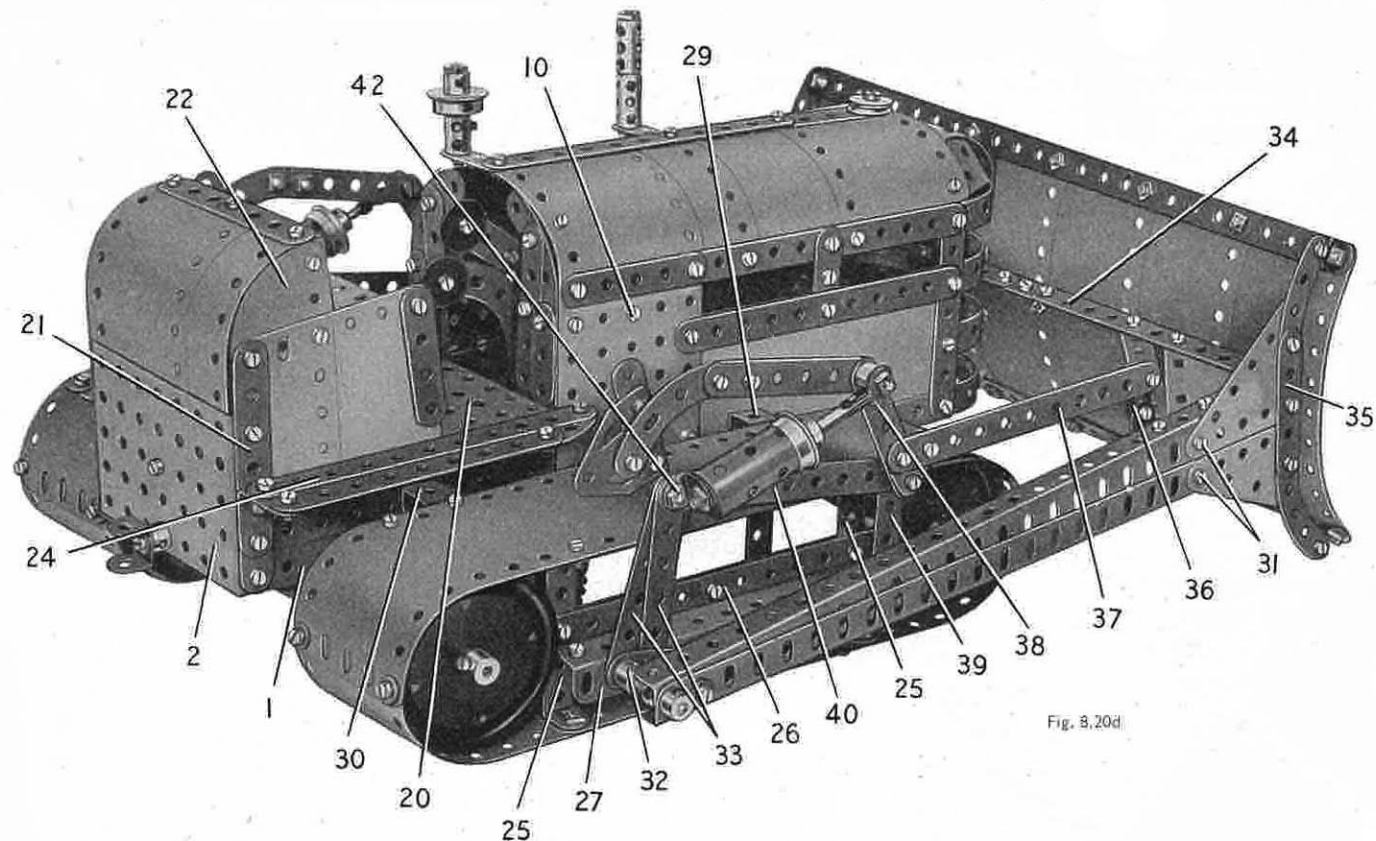

Fig. 8.20d

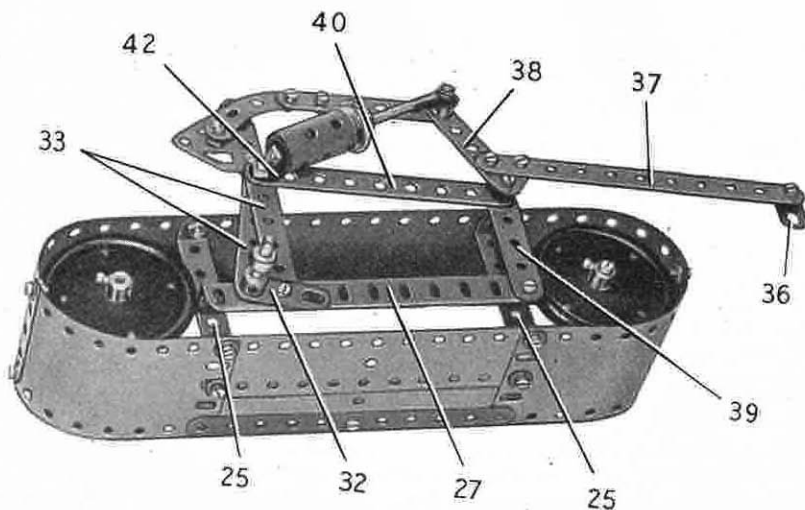

Fig. 8.20c

The operating lever is a 2½" Strip (41) (Fig. 8.20) fitted with a Flat Trunnion. A ½" Bolt is passed through the end of the Strip, and two nuts are screwed on the Bolt leaving the Strip free to pivot. The bolt is then passed through Strips (33) and (40) and an Angle Bracket (42), and these parts are fixed tightly in place by a bolt.

A 2½" Stepped Curved Strip extended by a 3" Strip is *lock-nutted* to the Flat Trunnion bolted to Strip (41), and a Pivot Bolt is passed through the 3" Strip and the end of Strip (38). A Collar and a Rod and Strip Connector are placed on the Pivot Bolt and are held in place by *lock-nuts*. A 2" Rod in the Rod and Strip Connector slides freely in a ¾" Flanged Wheel fitted to a Sleeve Piece. The Sleeve Piece is fitted over a Chimney Adaptor bolted to the Angle Bracket (42).

If you ever require advice in connection with your model-building write to Information Service, Meccano Ltd, Binns Road, Liverpool 13. Experts are waiting to help you

MECCANO PARTS



PERFORATED STRIPS		
No.	No.	No.
1. $1\frac{1}{2}''$	2a. $4\frac{1}{2}''$	6. $2''$
1a. $9\frac{1}{2}''$	3. $3\frac{1}{2}''$	6a. $1\frac{1}{2}''$
1b. $7\frac{1}{2}''$	4. $3''$	
2. $5\frac{1}{2}''$	5. $2\frac{1}{2}''$	

ANGLE GIRDERS		
7. $2\frac{1}{4}''$	8b. $7\frac{1}{4}''$	9c. $3''$
7a. $18\frac{1}{4}''$	9. $5\frac{1}{4}''$	9d. $2\frac{1}{4}''$
8. $12\frac{1}{4}''$	9a. $4\frac{1}{4}''$	9e. $2\frac{3}{4}''$
8a. $9\frac{1}{4}''$	9b. $3\frac{1}{4}''$	9f. $1\frac{1}{4}''$



ANGLE BRACKETS		
10. Fishplate	11. Double Bracket	
12. $\frac{1}{2}'' \times \frac{1}{2}''$	12b. $1'' \times \frac{1}{2}''$	
12a. $1'' \times 1''$	12c. Obtuse, $\frac{1}{2}'' \times \frac{1}{2}''$	



AXLE RODS		
13. $11\frac{1}{2}''$	15a. $4\frac{1}{2}''$	16b. $3''$
13a. $8\frac{1}{2}''$	15b. $4''$	17. $2''$
14. $6\frac{1}{2}''$	16. $3\frac{1}{2}''$	18a. $1\frac{1}{2}''$
15. $5\frac{1}{2}''$	16a. $2\frac{1}{2}''$	18b. $1''$
19g. Crank Handle, $3\frac{1}{2}''$ shaft, with grip		
19h. Crank Handle, $5''$ shaft, with grip		
19i. Crank Handle, $3\frac{1}{2}''$ shaft, without grip		



19a. Spoked Wheel, $3''$ diam.		
20. Flanged Wheel, $1\frac{1}{4}''$ diam.		
20b. Flanged Wheel, $\frac{1}{4}''$ diam.		



PULLEYS		
19c. $6''$ diam., with boss and screw		
20a. $2''$ diam., with boss and screw		
21. $1\frac{1}{4}''$ diam., with boss and screw		
22. $1''$ diam., with boss and screw		



PULLEYS		
22a. $1''$ diam., without boss		
23. $\frac{1}{2}''$ diam., without boss		
23a. $\frac{1}{2}''$ diam., with boss and screw		



PINIONS		
24. Bush Wheel, $1\frac{1}{2}''$ diam., eight-hole		
24a. Wheel Disc, $1\frac{1}{2}''$ diam., without bush, eight-hole		
24b. Bush Wheel, $1\frac{1}{2}''$ diam., six-hole		
24c. Wheel Disc, $1\frac{1}{2}''$ diam., without bush, six-hole		

GEAR WHEELS		
25. $\frac{1}{2}''$ diam., $\frac{1}{8}''$ face, 25 teeth		
25a. $\frac{1}{2}''$ diam., $\frac{1}{8}''$ face, 25 teeth		
25b. $\frac{1}{2}''$ diam., $\frac{1}{8}''$ face, 25 teeth		
26. $\frac{1}{2}''$ diam., $\frac{1}{8}''$ face, 19 teeth		
26a. $\frac{1}{2}''$ diam., $\frac{1}{8}''$ face, 19 teeth		
26b. $\frac{1}{2}''$ diam., $\frac{1}{8}''$ face, 19 teeth		
26c. $\frac{1}{2}''$ diam., $\frac{1}{8}''$ face, 15 teeth		



CONTRATE WHEELS		
27. $1\frac{1}{2}''$ diam., 50 teeth		
27a. $1\frac{1}{2}''$ diam., 57 teeth		
27b. $1\frac{1}{2}''$ diam., 133 teeth		
27c. $2\frac{1}{2}''$ diam., 95 teeth		
27d. $1\frac{1}{2}''$ diam., 60 teeth		



BEVEL GEARS		
28. $1\frac{1}{2}''$ diam., 50 teeth		
29. $\frac{3}{8}''$ diam., 25 teeth		



30. Bevel Gear, $\frac{1}{2}''$ diam., 26 teeth (for use in pairs)		
30a. Bevel Gear, $\frac{1}{2}''$ diam., 16 teeth	Can only be used together	
30b. Bevel Gear, $\frac{1}{2}''$ diam., 48 teeth		
30c. Bevel Gear, $1''$ diam., 48 teeth		
31. Gear Wheel, $1''$ diam., $\frac{1}{4}''$ face, 38 teeth		
32. Worm, $\frac{1}{2}''$ diam.		
34. Spanner		



34b. Box Spanner		
35. Spring Clip		
36. Screwdriver		
36a. Screwdriver (longer)		
36c. Drift (for levering bolt holes into line)		
37. Nut and Bolt, $\frac{1}{16}''$		
37a. Nut		
37b. Bolt, $\frac{1}{16}''$		
38. Washer		
38d. Washer, $\frac{1}{16}''$		
40. Hank of Cord		



41. Propeller Blade		43. Tension Spring, $2''$ long
---------------------	--	--------------------------------



DOUBLE ANGLE STRIPS		
44. Bent Strip, stepped		
45. Double Bent Strip		

46. $2\frac{1}{2}'' \times 1''$	48. $1\frac{1}{2}'' \times \frac{1}{2}''$	48c. $4\frac{1}{2}'' \times \frac{1}{2}''$
47. $2\frac{1}{2}'' \times 1\frac{1}{2}''$	48a. $2\frac{1}{2}'' \times \frac{1}{2}''$	48d. $5\frac{1}{2}'' \times \frac{1}{2}''$
47a. $3'' \times 1\frac{1}{2}''$	48b. $3\frac{1}{2}'' \times \frac{1}{2}''$	



50. Slide Piece		
51. Flanged Plate, $2\frac{1}{2}'' \times 1''$		
52. Flanged Plate, $5\frac{1}{2}'' \times 2\frac{1}{2}''$		
52a. Flat Plate, $5\frac{1}{2}'' \times 3\frac{1}{2}''$		
53. Flanged Plate, $3\frac{1}{2}'' \times 2\frac{1}{2}''$		
53a. Flat Plate, $4\frac{1}{2}'' \times 2\frac{1}{2}''$		



54. Flanged Sector Plate, $4\frac{1}{2}''$ long		
55. Perforated Strip, slotted, $5\frac{1}{2}''$ long		
55a. Perforated Strip, slotted, $2''$ long		



57b. Hook, Loaded, Large		
57c. Hook, Loaded, Small		
58. Spring Cord, $40''$ length		
58a. Coupling Screw for Spring Cord		
58b. Hook for Spring Cord		
59. Collar, with screw		



61. Windmill Sail	62a. Threaded Crank	
62. Crank	62b. Double Arm Crank	



63. Coupling Strip Coupling	63c. Threaded Coupling	
63b. Strip Coupling	63d. Short Coupling	



64. Threaded Boss	69a. Grub Screw, $\frac{1}{16}''$	
65. Centre Fork	69b. Grub Screw, $\frac{3}{32}''$	
69. Set Screw, $\frac{1}{16}''$	69c. Grub Screw, $\frac{1}{8}''$	



72. Flat Plate, $5\frac{1}{2}'' \times 2\frac{1}{2}''$	76. Triangular Plate, $2\frac{1}{2}''$
72. Flat Plate, $2\frac{1}{2}'' \times 2\frac{1}{2}''$	77. Triangular Plate, $1''$
73. Flat Plate, $3'' \times 1\frac{1}{2}''$	



SCREWED RODS		
80. $5''$	80c. $3''$	
80a. $3\frac{1}{2}''$	81. $2''$	
80b. $4\frac{1}{2}''$	82. $1''$	

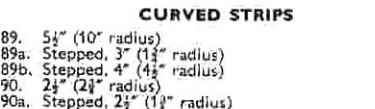

CURVED STRIPS		
89. $5\frac{1}{2}''$ ($10''$ radius)		
89a. Stepped, $3''$ ($1\frac{1}{2}''$ radius)		
89b. Stepped, $4''$ ($4\frac{1}{2}''$ radius)		
90. $2\frac{1}{2}''$ ($2\frac{1}{2}''$ radius)		
90a. Stepped, $2\frac{1}{2}''$ ($1\frac{1}{2}''$ radius)		

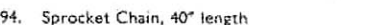

SPROCKET WHEELS		
95. $2''$ diam., 36 teeth	96. $1''$ diam., 18 teeth	
95a. $1\frac{1}{2}''$ diam., 28 teeth	96a. $\frac{3}{4}''$ diam., 14 teeth	
95b. $3''$ diam., 56 teeth		

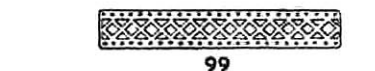

BRACED GIRDERS		
97. $3\frac{1}{2}''$ long	99. $12\frac{1}{2}''$ long	100. $5\frac{1}{2}''$ long
97a. $3''$ long	99a. $9\frac{1}{2}''$ long	100a. $4\frac{1}{2}''$ long
98. $2\frac{1}{2}''$ long	99b. $7\frac{1}{2}''$ long	



101. Heald for Loom	102. Single Bent Strip
---------------------	------------------------



FLAT GIRDERS		
103. $5\frac{1}{2}''$ long	103d. $3\frac{1}{2}''$ long	103h. $1\frac{1}{2}''$ long
103a. $9\frac{1}{2}''$ long	103e. $3''$ long	103k. $7\frac{1}{2}''$ long
103b. $12\frac{1}{2}''$ long	103f. $2\frac{1}{2}''$ long	
103c. $4\frac{1}{2}''$ long	103g. $2''$ long	

MECCANO PARTS

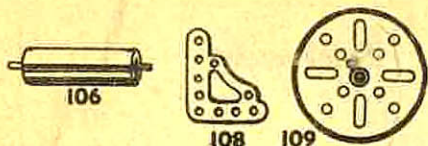

No. 106. Wood Roller (complete with Rod and two Collars)
108. Corner Gusset
109. Face Plate, 2½" diam.

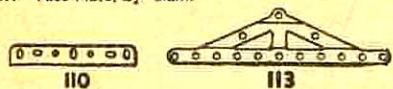

110. Rack Strip, 3½" long | 110a. Rack Strip, 6½" long

BOLTS

111. ⅜"
111a. ½"
111c. ⅞"
111d. 1"

113. Girder Frame



114. Hinge
115. Threaded Pin
116. Fork Piece, large
116a. Fork Piece, small

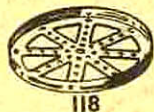

118. Hub Disc, 5½" diam.



120b. Compression Spring, ⅝" long
122. Loaded Sack



123. Cone Pulley, 1½", 1" and ¾" diam.
124. Reversed Angle Bracket, 1"
125. Reversed Angle Bracket, ½"

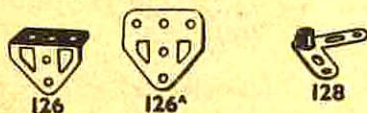

126. Trunnion
126a. Flat Trunnion
128. Bell Crank, with Boss



No. 130. Eccentric, Triple Throw, ½", ⅞" and 1"
130a. Eccentric, Single Throw, ½"

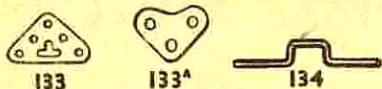

133. Corner Bracket, 1½"
133a. Corner Bracket, 1"
134. Crank Shaft, 1" stroke



136. Handrail Support



136a. Handrail Coupling



137. Wheel Flange



138. Ship's Funnel, Raked



139. Flanged Bracket (right)



139a. Flanged Bracket (left)
140. Universal Coupling



142a. Motor Tyre (to fit 2" diam. rim)
142b. Motor Tyre (to fit 3" diam. rim)
142c. Motor Tyre (to fit 1" diam. rim)
142d. Motor Tyre (to fit 1½" diam. rim)
143. Circular Girder, 5½" diam.
144. Dog Clutch

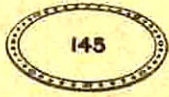

145. Circular Strip, 7½" diam. overall
146. Circular Plate, 6" diam. overall
146a. Circular Plate, 4" diam. overall

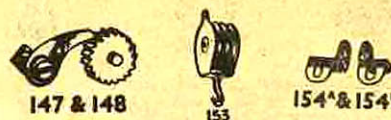
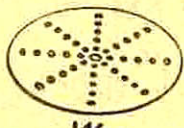

No. 147. Pawl, with Pivot Bolt and Nuts
147a. Pawl
147b. Pivot Bolt, with two Nuts
147c. Pawl, without boss
148. Ratchet Wheel
151. Single Pulley Block
153. Triple Pulley Block
154. Corner Angle Bracket, ½" (right-hand)
154b. Corner Angle Bracket, ½" (left-hand)
155. Rubber Ring (for 1" Pulley)



157. Fan, 2" diam.



160. Channel Bearing, 1½" × 1" × ½"

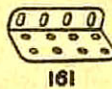

161. Girder Bracket, 2" × 1" × ½"

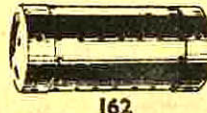

162. Boiler, complete, 5" long × 2½" diam.
162a. Boiler Ends, 2½" diam. × ½"
163. Sleeve Piece, 1½" long × ½" diam.
164. Chimney Adaptor, ¾" diam. × ½" high



165. Swivel Bearing
166. End Bearing
167b. Flanged Ring, 9½" diam.
168. Ball Thrust Bearing, 4" diam.
168a. Ball Thrust Race, flanged disc, 3½" diam.
168b. Ball Thrust Race, toothed disc, 4" diam.
168c. Ball Cage, 3½" diam., complete with balls
168d. Ball, ¾" diam.



171. Socket Coupling
173a. Adaptor for Screwed Rod
175. Flexible Coupling Unit
176. Anchoring Spring for Cord



179. Rod Socket

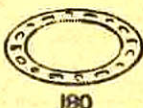

180. Gear Ring, 3½" diam. (133 ext. teeth, 95 int.)



No. 185. Steering Wheel, 1½" diam.



187. Road Wheel, 2½" diam.
187a. Conical Disc, 1½" diam.

DRIVING BANDS

186. 2½" (light) | 186c. 10" (heavy)
186a. 6" (light) | 186d. 15" (heavy)
186b. 10" (light) | 186e. 20" (heavy)



FLEXIBLE PLATES

188. 2½" × 1½" | 190. 2½" × 2½" | 191. 4½" × 2½"
189. 5½" × 1½" | 190a. 3½" × 2½" | 192. 5½" × 2½"

STRIP PLATES

196. 9½" × 2½" | 197. 12½" × 2½"

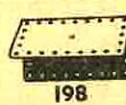

198. Hinged Flat Plate, 4½" × 2½"



199. Curved Plate, "U"-section, 2½" × 2½" × ⅜" radius



200. Curved Plate, 2½" × 2½" × 1½" radius



211a. Helical Gear, ½" } Can only be used
211b. Helical Gear, 1½" } together
212. Rod and Strip Connector
212a. Rod and Strip Connector, right-angle
213. Rod Connector
213a. Three-way Rod Coupling
213b. Three-way Rod Coupling with Pummel



211^a & 211^b



212

213

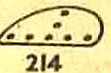

214. Semi-circular Plate, 2½"



215. Formed Slotted Strip, 3"

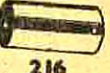

216. Cylinder, 2½" long, 1½" diam.

TRIANGULAR FLEXIBLE PLATES

221. 2½" × 1½" | 223. 2½" × 2½" | 225. 3½" × 2"
222. 2½" × 2" | 224. 3½" × 1½" | 226. 3½" × 2½"