

MECCANO

REGISTERED TRADE MARK



INSTRUCTIONS for OUTFIT No. 1

COPYRIGHT BY MECCANO LIMITED
BINNS ROAD, LIVERPOOL 13, ENGLAND

55.1

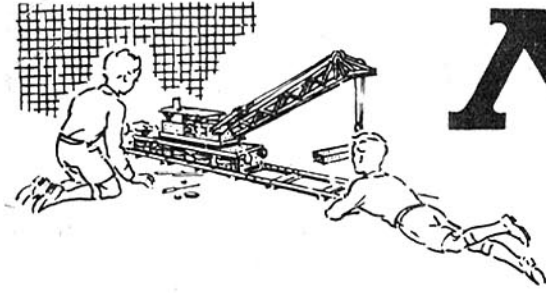

MECCANO

Registered Trade Mark

The World's Greatest Constructional Toy

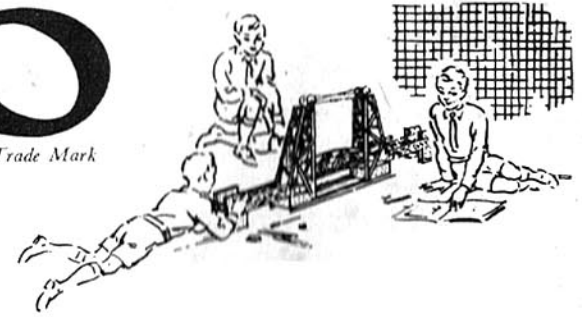

MODEL-BUILDING WITH MECCANO

There is no limit to the number of models that can be built with Meccano — Cranes, Clocks, Motor Cars, Aeroplanes, Machine Tools, Locomotives — in fact everything that interests boys. A screwdriver and a spanner, both of which are provided in each complete Outfit, are the only tools necessary.

When you have built all the models illustrated in the Books of Instructions the fun is not over, it is just beginning. Now comes the chance to make use of your own ideas. First of all, re-build some of the models with small changes in construction that may occur to you; then try building models entirely of your own design. In doing this you will enjoy the real thrill of the engineer and the inventor.

HOW TO BUILD UP YOUR OUTFIT

Meccano is sold in 12 different Outfits, ranging from No. OO to No. 10. Each Outfit can be converted into the next larger one by the purchase of an Accessory Outfit. Thus Meccano No. OO Outfit can be converted into No. O Outfit by adding to it a No. OOa Accessory Outfit. No. Oa Outfit would then convert it into a No. 1 and so on. In this way, no matter with which Outfit you begin, you can build it up by degrees until you have a complete No. 10 Outfit.

All Meccano parts are of the same high quality and finish, but the larger Outfits contain a greater quantity and variety, making possible the construction of more elaborate models.

THE 'MECCANO MAGAZINE'

The 'Meccano Magazine' is published specially for Meccano boys. Every month it describes and illustrates new Meccano models, and deals with suggestions from readers for new Meccano parts and for new methods of using the existing parts.

There are model-building competitions specially planned to give an equal chance to the owners of small and large Outfits. In addition, there are splendid articles on such subjects as Railways, Famous Engineers and Inventors, Electricity, Bridges, Cranes and Aeroplanes, and special sections dealing with the latest Engineering, Aviation, Motoring

and Shipping News. Other pages deal with Stamp Collecting, and Books of interest to boys; and a feature of outstanding popularity is the section devoted to short articles from readers.

Write to the Editor, The Meccano Magazine, Binns Road, Liverpool 13, for particulars and a specimen copy. You can order the Magazine from your Meccano dealer, or from any newsagent.

THE MECCANO GUILD

Every owner of a Meccano Outfit should join the Meccano Guild. This is a world-wide organisation, started at the request of Meccano boys. Its primary object is to bring boys together and to make them feel that they are all members of a great brotherhood, each trying to help others to get the very best out of life. Its members are in constant touch with Headquarters, giving news of their activities and being guided in their hobbies and interests. A leaflet containing full particulars of the Guild and an application form is included in this Book.

Clubs founded and established under the guidance of the Guild Secretary provide Meccano boys with opportunities of enjoying to the utmost the fun of model-building. Each has its Leader, Secretary, Treasurer and other officials. With the exception of the Leader, all the officials are boys, and as far as possible the proceedings of the clubs are conducted by boys.

MECCANO SERVICE

The service of Meccano does not end with selling an Outfit and a Book of Instructions. If ever you are in any difficulty with your models, or if you want advice on anything connected with this great hobby, write to us. We receive hundreds of interesting letters from boys in all parts of the world, and each of these is answered personally and promptly by one of our staff of experts.

Whatever your problem may be, write to us about it. We shall be delighted to help you in any way possible. Address your letters to **Information Service**.

Boys!

Read the

MECCANO MAGAZINE

THE IDEAL PAPER FOR BOYS

The happiest and most successful boys are those who take a keen interest in the world around them. The 'MECCANO MAGAZINE' is the ideal paper for these boys. Month by month its pages are filled with attractively-written articles, splendidly illustrated from actual photographs.

The subjects include Engineering in all its branches, Railways, Road Transport, Aeroplanes and Shipping. Inventions and Scientific Discoveries are described in simple language. Everything is dealt with in an attractive and straightforward style, and with an accuracy that has won for the Magazine the enthusiastic approval of the engineering, technical and scientific world. Special sections are devoted to Model-building with Meccano, fun with Dinky Toys, and the operation of realistic Miniature Railways; and Stamp Collecting forms still another important feature. Competitions of all kinds, and of a variety to suit every reader, are announced each month.



WHAT THE GUILD MEANS

The Meccano Guild is an organisation for boys, started at the request of boys, and as far as possible conducted by boys. In joining the Guild a Meccano boy becomes a member of a great brotherhood of world-wide extent. Wherever he happens to be, even in strange countries, he will know that he has met a friend whenever he sees the little triangular badge of membership. The Meccano Guild is bringing together Meccano boys all over the world, and helping them to get the best out of life. At its head — guiding and controlling and taking a personal interest in this great movement — is the President, Mr Roland G. Hornby, son of the inventor of Meccano.

HOW TO JOIN THE MECCANO GUILD

Any owner of a Meccano Outfit, no matter what its size, may become a member. All he has to do is to fill in the official application form on the back of this leaflet, have his signature witnessed, and send the form to Headquarters with a postal order (not stamps) for the necessary amount in payment for the official badge, which he will wear in his buttonhole.

The price of the badge for boys living in the British Isles is 1/-. For those living overseas it is 1/6 (30 cents in Canada).

Applicants living in Canada, Australia, New Zealand or South Africa should write to the Meccano agents in their countries. Their addresses are as follows:

CANADA: Meccano Ltd, 675 King Street West, Toronto.

AUSTRALIA: E. G. Page & Co. (Sales) Pty. Ltd (P.O. Box 1832), Dank's Building, 324 Pitt Street, Sydney, N.S.W.

NEW ZEALAND: Models Ltd (P.O. Box 129), 53 Fort Street, Auckland, C.I.

SOUTH AFRICA: Arthur E. Harris (Pty.) Ltd (P.O. Box 1199), 142 Market Street, Johannesburg.

Their Badges and Certificates are then forwarded without delay, while their application forms are sent to Headquarters in Liverpool.

Applicants living in any other country overseas should forward their forms, with a British postal order (not stamps) or a money order for 1/6, direct to the Secretary, the Meccano Guild, Binns Road, Liverpool, 13.

Guild members are eligible for the Correspondence Club, by which they are placed in touch with other members in various parts of the world. Full particulars and enrolment forms can be obtained from the Secretary.

The Secretary will send also, on request, full details of the Guild Recruiting Campaign, and of the Medallion awarded to members who are successful in obtaining recruits, together with particulars of the Meccano clubs founded and established by enthusiastic Meccano boys. A special booklet, 'How to run a Meccano Club' will be sent post free to any member on receipt of 2d. in stamps.

Join the

MECCANO GUILD

MECCANO MAGAZINE

for the really modern boy

The 'MECCANO MAGAZINE' is on sale at all bookstalls, newsagents and Meccano dealers, price 1/-. If you prefer to have each issue sent direct, the subscription rates are 14/- for twelve months or 7/- for six months, including postage, and an order form is attached.

The overseas prices of the 'M.M.' are 12c. in Canada, 1/3 in Australia, 15c. in the U.S.A. and 9d. elsewhere.

ORDER FORM

TO THE EDITOR,
MECCANO MAGAZINE,
BINNS ROAD, LIVERPOOL 13.

I enclose Postal Order for..... Please post the
'MECCANO MAGAZINE' for..... months, beginning with
the..... issue.

NAME (IN BLOCK LETTERS).....

ADDRESS.....
.....

MECCANO GUILD

THE THREE GREAT OBJECTS OF THE GUILD

- To make every boy's life brighter and happier.
- To foster clean-mindedness, truthfulness, ambition and initiative in boys.
- To encourage boys in their hobbies, and especially in the development of their knowledge of mechanical and engineering principles.



Headquarters: BINNS ROAD LIVERPOOL 13

APPLICATION FOR MEMBERSHIP

I possess a Meccano Outfit, and I hereby make application for membership of the Meccano Guild.
I approve of the objects of the Guild, and I promise on my honour

- (1) To conform to the rules and regulations of the Meccano Guild.
- (2) To promote its objects by my own example: to be helpful to others; to be clean in thought and habit; to be determined to learn and make progress.
- (3) To wear the Meccano Guild Badge on all possible occasions.
- (4) To recognise and acknowledge all other Members wearing the Guild Badge, and to render them help in case of need.

I enclose 1/- for the Guild Badge (Great Britain).

I enclose 1/6 for the Guild Badge (Overseas).

I enclose 30c. for the Guild Badge (Canada).

Strike out line not applicable (See other side of this form).

NAME OF APPLICANT.....
(BLOCK LETTERS PLEASE)

ADDRESS.....
.....

DATE..... AGE.....

WITNESS

ADDRESS.....

The witness should be the Parent, Guardian, Employer, Schoolmaster or Church Minister and should state which when signing.

HOW TO BEGIN THE FUN

THE MOST FASCINATING OF ALL HOBBIES

Meccano model-building is the most fascinating of all hobbies, because it never becomes dull. There is always something new to be done. First of all there is the fun of building a new model, and watching it take shape as part after part is added. Then, when the model is complete, comes the thrill of setting it to work just like the real structure it represents, by means of a Meccano Motor.

The following hints are given to show boys who are just starting the wonderful Meccano hobby how to get the greatest possible fun.

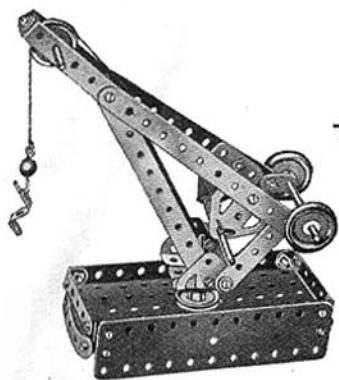

This Dockside Crane can be built with Outfit No. 1

A FEW USEFUL HINTS

It will be noticed that with each model in this Book of Instructions is given a list of the parts required to build it. For the first few models it is a good plan to lay out on the table all the parts required for the one it is proposed to build, and put the remainder of the Outfit to one side. To help you to pick out the correct parts for your model a complete list of Meccano parts is given at the back of this Book, and all the principal parts are illustrated. In the list the parts are all numbered, and in most cases their measurements are given. There is no need, however, to measure the parts to find out which is which, as the size is easily found from the number of holes. All Meccano holes are spaced $\frac{1}{2}$ " apart, so that by counting two holes to the inch the size of a part can be found at once. For instance, Part No. 2 is listed as a $5\frac{1}{2}$ " Perforated Strip, so you look in your Outfit for a Strip with eleven holes. Similarly No. 189 is a $5\frac{1}{2}$ " x $1\frac{1}{2}$ " Flexible Plate, so you look for a Flexible Plate eleven holes in length and three holes in width. By the time a few models have been built the names of the parts will have become familiar.

Beginners sometimes wonder which section of a model should be built first. There cannot be any definite rule for this, as it depends on the design of the model. In stationary models the base usually should be built first. In most of the small models a $5\frac{1}{2}$ " x $2\frac{1}{2}$ " Flanged Plate forms an important part of the structure, and often the best plan is to start building by bolting parts to this Plate. For other models a good general rule is that the sections that form supports for a number of other parts should be built first.

During the construction of a model it is best to screw up the nuts with the fingers, followed by a light turn with the screwdriver, leaving the final tightening until all the parts are connected up.

THE IMPORTANCE OF LOCK-NUTTING

In some models it is necessary to join certain parts together so that, although they cannot come apart, they are free to pivot or move in relation to one another. To do this the parts are bolted together as usual, but the nut is not screwed up tightly, so that the parts are not gripped. Then, to prevent the nut from unscrewing, a second nut is screwed up tightly against it, the first nut being held with a spanner. This method of using a second nut is known as *Lock-nutting*.

In building models in which Rods revolve in the holes of other parts it is important to make sure that such holes are exactly in line with one another. This can be done by pushing through the holes a Drift, Part No. 36c, or a Rod, before the Bolts holding the various parts are tightened up.

A Rod is usually mounted in a support or bearing so that it is free to revolve. The Rod is then said to be *Journalled* in the Strip.

DRIVING YOUR MODELS

Models can be driven by means of either clockwork or electric motors. Ask your Dealer for particulars of Meccano Clockwork and Electric Motors.

Small and light models may be driven direct from the driving pulley of the motor or through a belt running over two pulleys of the same size, giving what is known as a 1 : 1 (one-to-one) ratio. For large models it is necessary to take the drive from a small pulley on the motor shaft to a larger pulley on the driving shaft of the model. In most cases a 1" Pulley on the motor shaft and a 3" Pulley on the model shaft will be found satisfactory. This provides a reduction ratio of approximately 3 : 1.

Rubber bands are very convenient for driving belts. Sometimes, however, a rubber band of the right length is not available, and then Meccano Cord or thin string is used. To tie the Cord to form an endless belt, use the familiar reef knot.

All Outfits from No. 2 upward include a Cord Anchoring Spring, Part No. 176. This part provides a neat and positive method of fastening a length of Cord to a Rod. The Spring is placed on a Rod by pushing and turning it in such a way that its coils tend to unwind.

Flexible Plates are used for forming curved surfaces in models, but they are not intended to be bent at right angles. With careful handling a Plate can be bent to the required curve and after use straightened again.

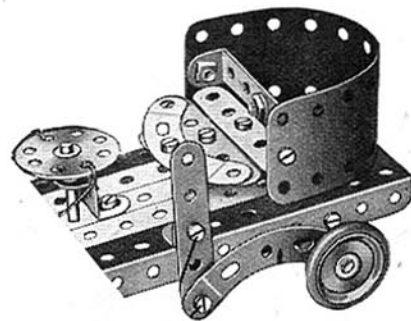

A Flexible Plate used to form a curved surface

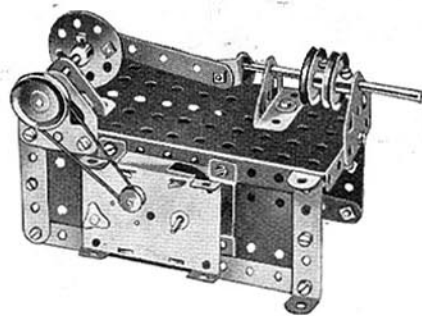

A 'Magic' Motor fitted to drive a Steam Engine

O.1 ELEVATOR

Parts Required

4 of No. 2	15 of No. 37b
2 " " 5	2 " " 48a
1 " " 16	1 " " 52
1 " " 19s	2 " " 126
1 " " 22	2 " " 126a
4 " " 35	
15 " " 37a	

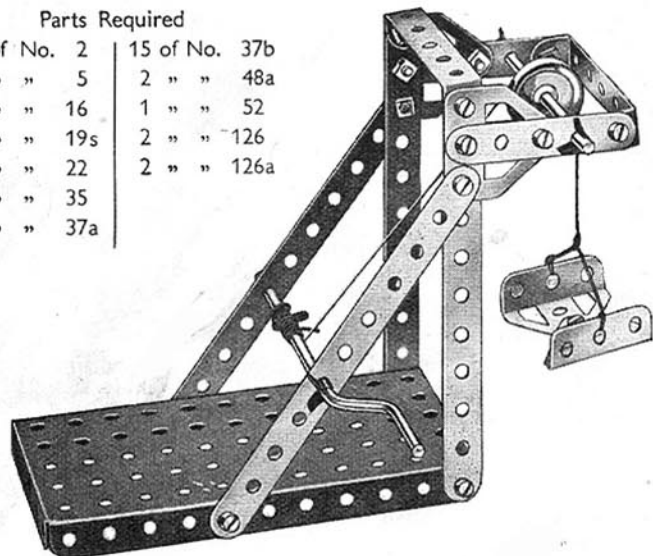
**O.2 BLACKSMITH**

Parts Required

2 of No. 5
2 " " 10
4 " " 12
1 " " 16
1 " " 17
1 " " 19s
2 " " 22

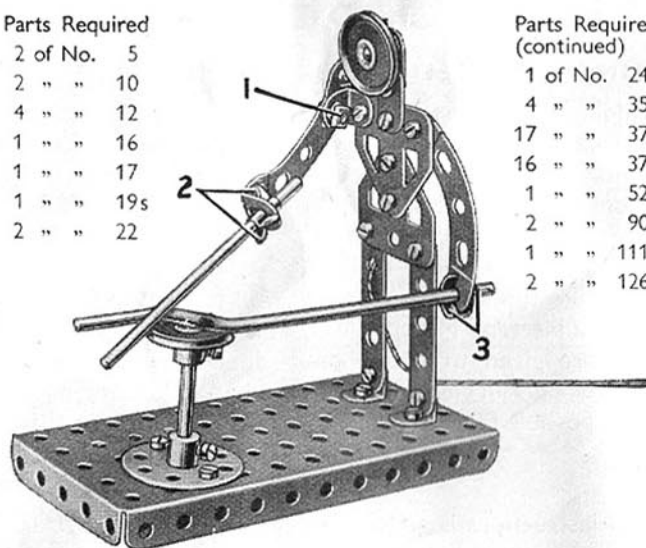
Parts Required
(continued)

1 of No. 24
4 " " 35
17 " " 37a
16 " " 37b
1 " " 52
2 " " 90a
1 " " 111c
2 " " 126a

The arm holding the hammer is a 2½" stepped Curved Strip, pivoted to an Angle Bracket by a lock-nutted Bolt (1). The hammer is a 3½" Rod held in an Angle Bracket at the end of the arm by two Spring Clips (2). The Crank Handle is fixed in the other arm by the Spring Clips (3).

O.3 GARDEN SEAT

Parts Required

4 of No. 2
2 " " 5
10 " " 37a
10 " " 37b
2 " " 48a
1 " " 52

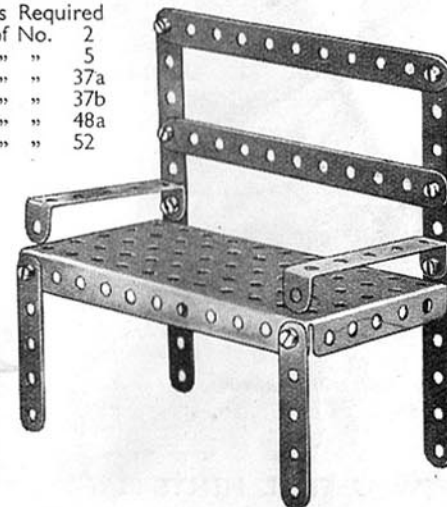
**O.4 STATION TRUCK**

The 5½" Strips forming the handle are placed one on each side of a Bush Wheel on the front axle, and they are held in place by Spring Clips (1) as shown in Fig. O.4a.

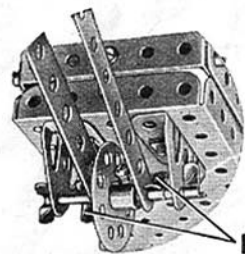

Fig. O.4a

Parts Required

4 of No. 2	2 of No. 22	2 of No. 48a
1 " " 5	1 " " 24	1 " " 52
2 " " 10	4 " " 35	2 " " 90a
2 " " 12	17 " " 37a	2 " " 126
1 " " 16	17 " " 37b	2 " " 126a
1 " " 17	1 " " 38	2 " " 142c

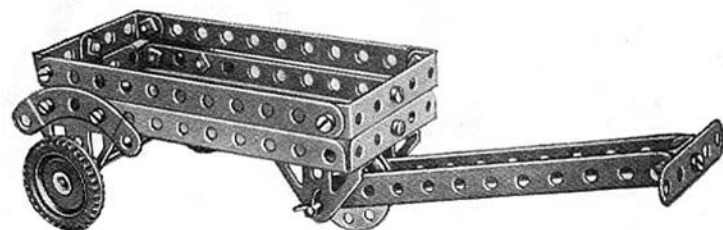
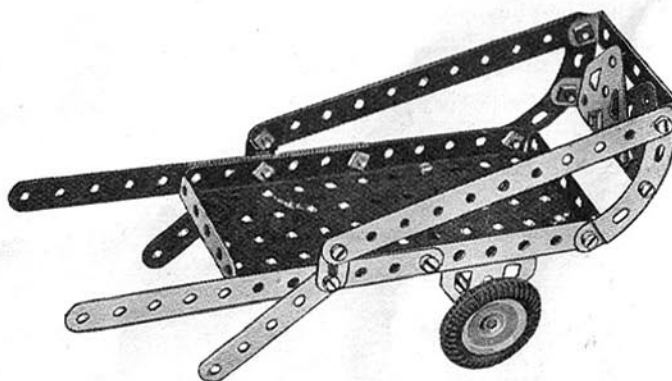

Fig. O.4

O.5 COSTER'S BARROW

Parts Required

4 of No. 2	2 of No. 22	2 of No. 90a
2 " " 5	16 " " 37a	2 " " 126
2 " " 10	16 " " 37b	2 " " 126a
1 " " 16	2 " " 48a	2 " " 142c
	1 " " 52	

O.6 BUCKING BRONCHO

The Bolts (1) are fitted with lock-nuts so that the parts they attach are free to pivot. Bearings for a 2" Rod, the end of which is seen at (2), are provided by a Fishplate (3), Fig. O.6a, bolted to an Angle Bracket (4), and a Trunnion (5).

Parts Required	20 of No. 37a
2 of No. 5	15 " " 37b
4 " " 10	1 " " 38
1 " " 12	1 " " 48a
1 " " 17	1 " " 52
1 " " 19s	2 " " 90a
2 " " 22	2 " " 111c
1 " " 24	2 " " 126
4 " " 35	2 " " 126a

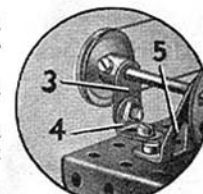

Fig. O.6a.

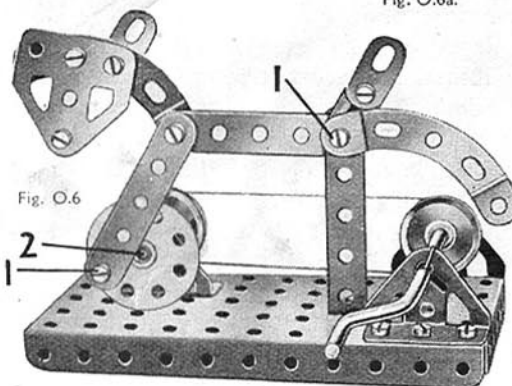
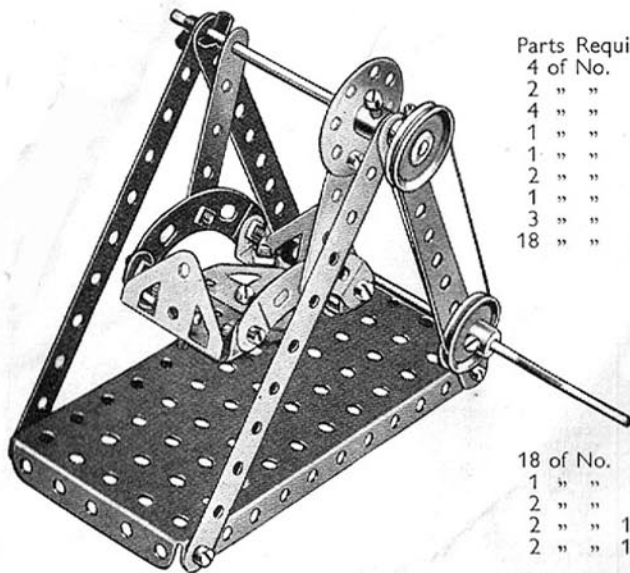

Fig. O.6

O.7 SWING BOAT



Parts Required	
4 of No.	2
2 " "	5
4 " "	12
1 " "	16
1 " "	19s
2 " "	22
1 " "	24
3 " "	35
18 " "	37a

18 of No.	37b
1 " "	52
2 " "	90a
2 " "	126
2 " "	126a

O.8 DROP HAMMER

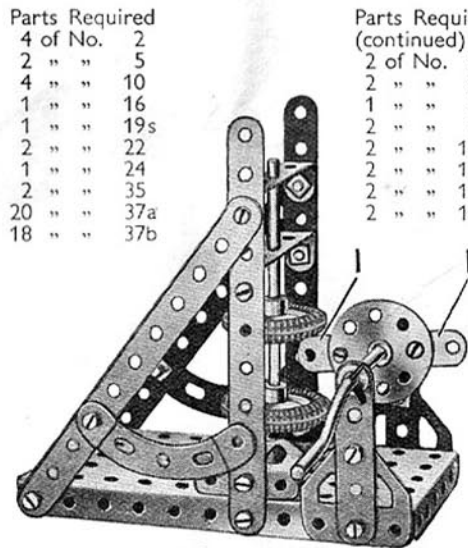

Parts Required	
4 of No.	2
2 " "	5
4 " "	10
1 " "	16
1 " "	19s
2 " "	22
1 " "	24
2 " "	35
20 " "	37a
18 " "	37b

Parts Required (continued)	
2 of No.	38
2 " "	48a
1 " "	52
2 " "	90a
2 " "	111c
2 " "	126
2 " "	126a
2 " "	142c

The hammer, which is formed by the two 1" Pulleys on a 3½" Rod, is lifted by the Fishplates (1) as they rotate when the Crank Handle is turned. The Fishplates are bolted to a Bush Wheel fixed on the Crank Handle.

O.9 ELECTRIC TRUCK

The two 5½" Strips (1) on each side of the model are fastened to the Flanged Plate by two Trunnions secured to the Plate on the underneath side. A Bush Wheel (2) is fixed on the 2" Rod (3), which passes through the end holes of the 5½" Strips that form the sides of the truck frame.

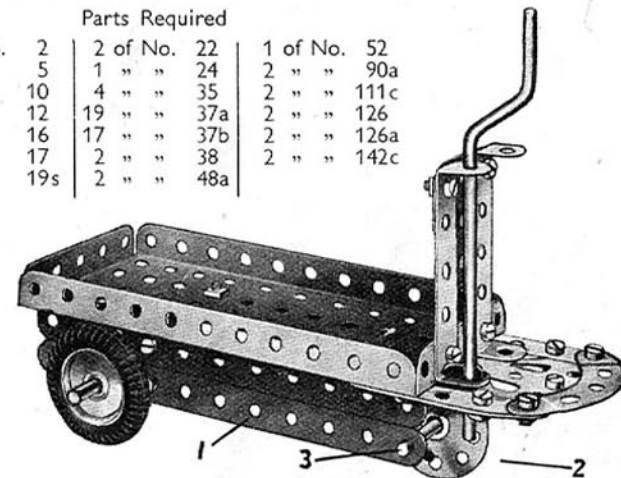

Parts Required			
4 of No.	2	1 of No.	52
2 " "	5	2 " "	90a
2 " "	10	2 " "	111c
2 " "	12	2 " "	126
1 " "	16	2 " "	126a
1 " "	17	2 " "	142c
1 " "	19s	2 of No.	22
		1 " "	24
		4 " "	35
		19 " "	37a
		17 " "	37b
		2 " "	38
		2 " "	48a

O.10 LAWN MOWER

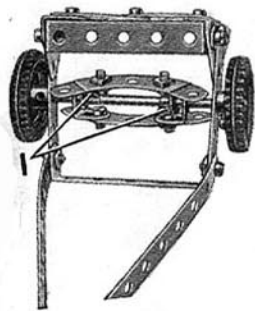

Fig. O.10a

Parts Required			
2 of No.	2	1 of No.	17
2 " "	5	2 " "	22
4 " "	12	4 " "	35
1 " "	16	13 " "	37a
		13 " "	37b
		2 " "	38
		2 " "	48a
		2 " "	90a
		2 " "	126
		2 " "	126a
		2 " "	142c

Fig. O.10

Two Angle Brackets are bolted to each of the Curved Strips forming the cutting blades. The wheel axle is then pushed through the four Angle Brackets and Spring Clips (1), shown in Fig. O.10a, are used to hold the blades in place.

O.11 COUNTER SCALES

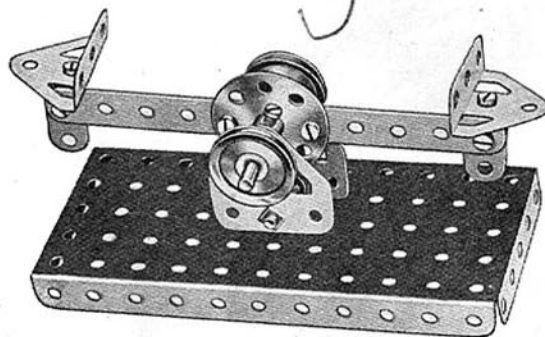

Parts Required

1 of No.	2	2 of No.	22	2 of No.	38
2 " "	10	1 " "	24	1 " "	52
4 " "	12	9 " "	37a	2 " "	126
1 " "	17	9 " "	37b	2 " "	126a

O.12 PUNCHING MACHINE

The Bolts (1) are lock-nutted. The lower bearing for the punch consists of two Fishplates (2), which are bolted together. One of them is then attached to an Angle Bracket that is fixed to one of the vertical 5½" Strips by the Bolt (3).

Parts Required

3 of No.	2
2 " "	10
4 " "	12
1 " "	16
1 " "	17
2 " "	22
1 " "	24
18 " "	37a
16 " "	37b
1 " "	48a
1 " "	52
2 " "	126
2 " "	126a
2 " "	142c

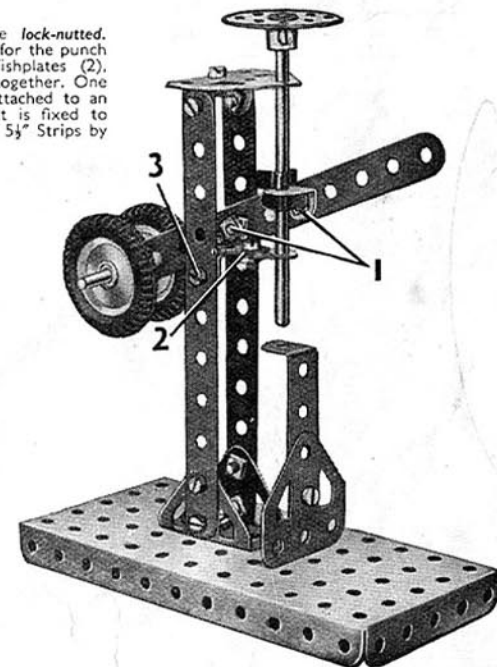

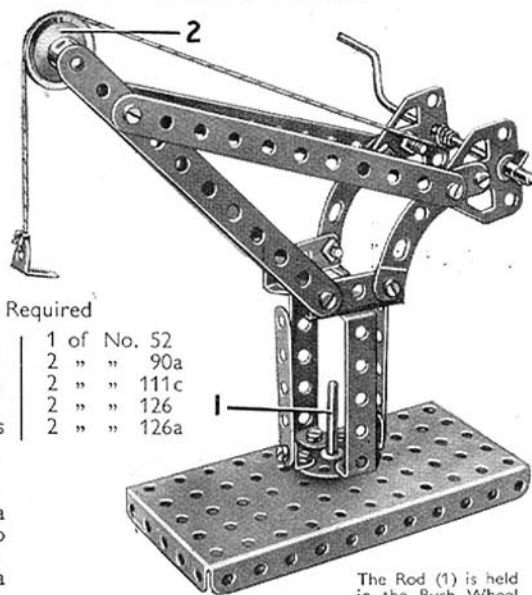
O.13 DOCKSIDE CRANE**Parts Required**

4 of No. 2	2	1 of No. 52
2 " " 5	2	" " 90a
4 " " 12	2	" " 111c
1 " " 17	2	" " 126
1 " " 19s	2	" " 126a
2 " " 22		
1 " " 24		
2 " " 35		
19 " " 37a		
18 " " 37b		
2 " " 38		
2 " " 48a		

The Rod (1) is held in the Bush Wheel and is passed through one of the holes of the Flanged Plate. A 1" Pulley fixed on the Rod underneath the Flanged Plate holds the crane in position on its base. The Pulley (2) is mounted on a $\frac{3}{8}$ " Bolt. The Bolt is passed through the top hole of one of the $5\frac{1}{2}$ " Strips, and is gripped by the set-screw in the boss of the Pulley.

O.16 MECHANICAL HAMMER**Parts Required**

3 of No. 2	2	1 of No. 19s	15 of No. 37b	2 of No. 126a
2 " " 5	2	" " 22	1 " " 38	1 " " 142c
1 " " 10	1	" " 24	1 " " 52	
4 " " 12	3	" " 35	1 " " 111c	
1 " " 17	15	" " 37a	2 " " 126	

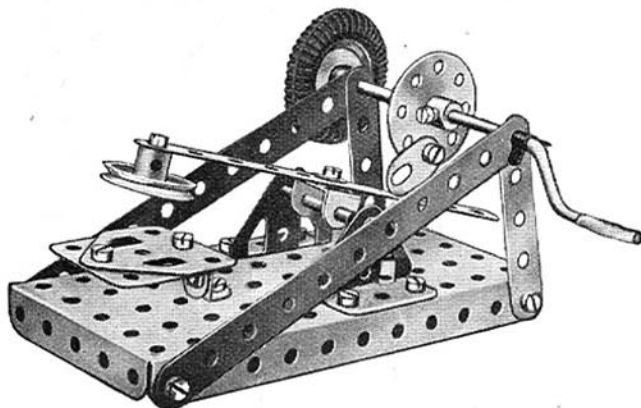
**O.14 PLOUGH**

A $\frac{3}{8}$ " Bolt (1) carries two nuts on its shank between the $5\frac{1}{2}$ " Strips. The nuts are screwed against the inner faces of the Strips and a third nut is then placed on the Bolt on the outside of the rear Strip.

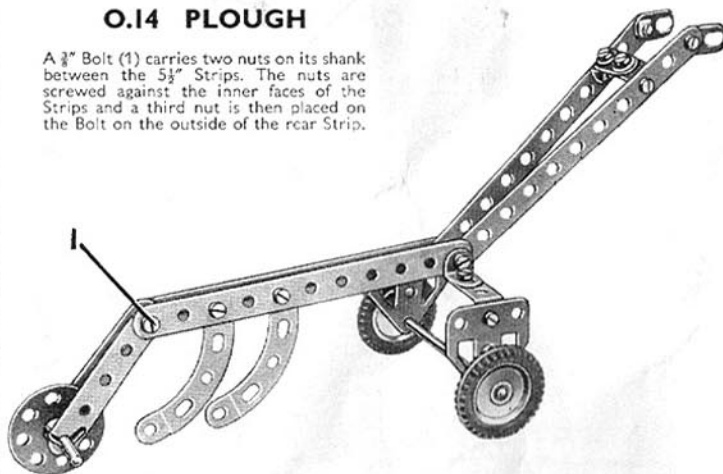
**Parts Required**

4 of No. 2	2	1 of No. 17	14 of No. 37b	2 of No. 126a
2 " " 5	2	" " 22	2 " " 38	2 " " 142c
3 " " 10	1	" " 24	1 " " 48a	
4 " " 12	2	" " 35	2 " " 90a	
1 " " 16	17	" " 37a	1 " " 111c	

O.17 LATHE

The inner support for the lathe spindle consists of a Fishplate (1) bolted to an Angle Bracket fixed to the $5\frac{1}{2}$ " Strip (2) that forms the lathe bed. The tool rest is a $2\frac{1}{2}$ " Strip that is supported by two Angle Brackets (3) bolted together to form a U-shaped piece.

Parts Required

2 of No. 2
2 " " 5
2 " " 10
4 " " 12
1 " " 17
1 " " 19s
2 " " 22
1 " " 24
3 " " 35

18 of No. 37a
18 " " 37b
2 " " 38
2 " " 48a
1 " " 52
1 " " 126
2 " " 126a

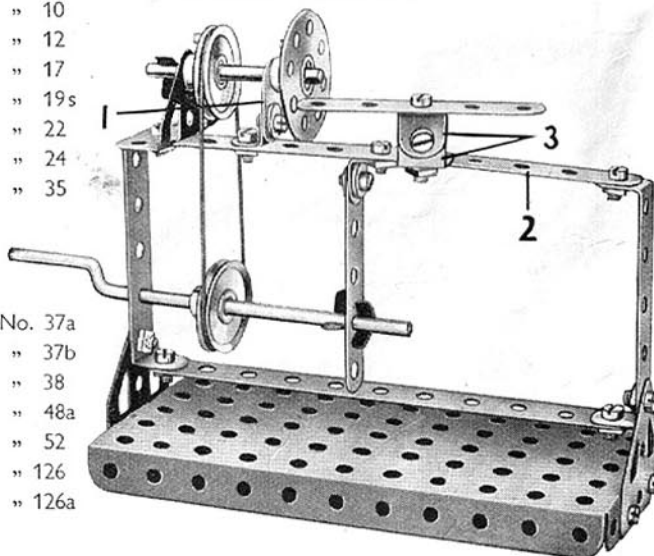
**O.15 WINDMILL****Parts Required**

4 of No. 2	2
2 " " 5	5
1 " " 16	16
1 " " 19s	19s
2 " " 22	22
1 " " 24	24
3 " " 35	35
18 " " 37a	37a
18 " " 37b	37b
2 " " 38	38
2 " " 48a	48a
1 " " 52	52
2 " " 90a	90a
2 " " 126	126
2 " " 126a	126a

Magic Motor
(not included in Outfit)

A Driving Band connects the pulley of the Magic Motor to a 1" Pulley fastened on the Crank Handle. The Crank Handle carries also a $\frac{3}{8}$ " Pulley, which is connected by a second Driving Band with a further 1" Pulley fixed to the $3\frac{1}{2}$ " Rod on which the sails are mounted. The $3\frac{1}{2}$ " Rod is held in place by Spring Clips, one behind the Bush Wheel, and one on its rear end. If a Motor is not used the $\frac{3}{8}$ " Pulley (which is supplied with the Motor) is replaced by a 1" Pulley.

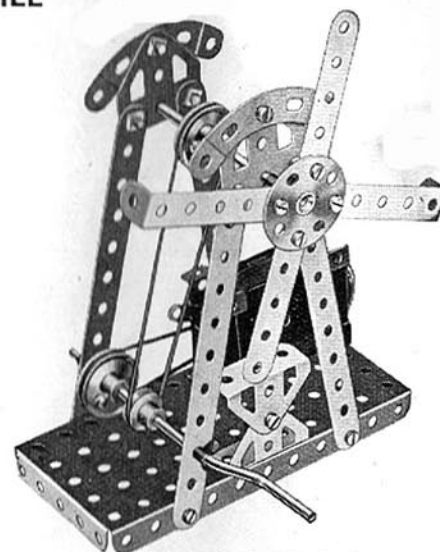
**O.18 WELL WINDLASS**

The end of the bucket hoisting cord is held under a Spring Clip (1) on the Crank Handle.

Parts Required

4 of No. 2
2 " " 5
4 " " 12
1 " " 19s
2 " " 22
1 " " 24
1 " " 35
18 " " 37a
18 " " 37b
2 " " 48a
1 " " 52
2 " " 90a
2 " " 126a

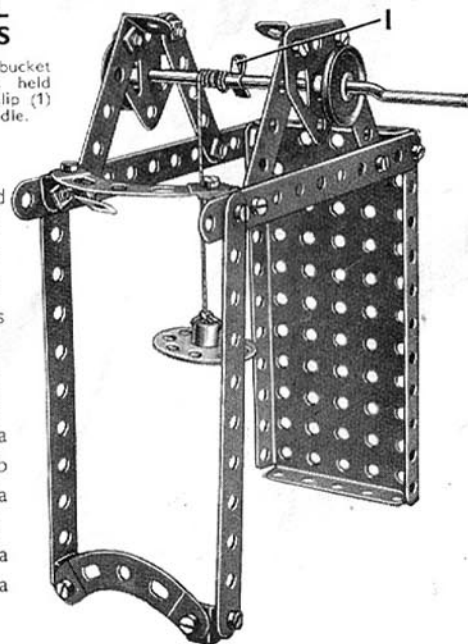

I.1 KIDDIE CAR

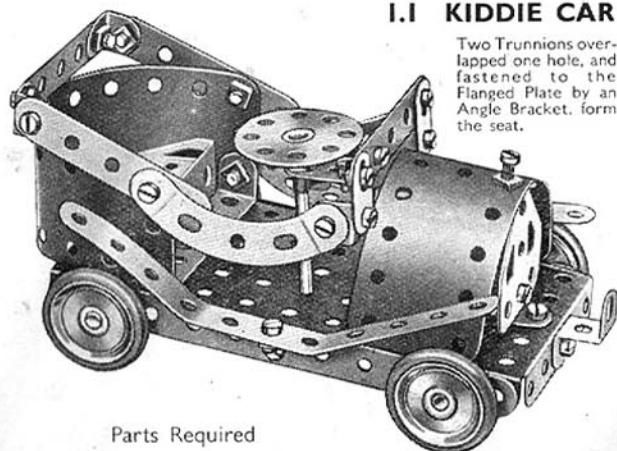

Two Trunnions overlapped one hole, and fastened to the Flanged Plate by an Angle Bracket, form the seat.

Parts Required

4 of No. 2	1 of No. 24	2 of No. 111c
4 " " 5	1 " " 35	1 " " 125
3 " " 10	27 " " 37a	2 " " 126
7 " " 12	24 " " 37b	1 " " 126a
2 " " 16	2 " " 48a	1 " " 155
1 " " 17	1 " " 52	4 " " 189
4 " " 22	2 " " 90a	

I.2 LETTER BALANCE

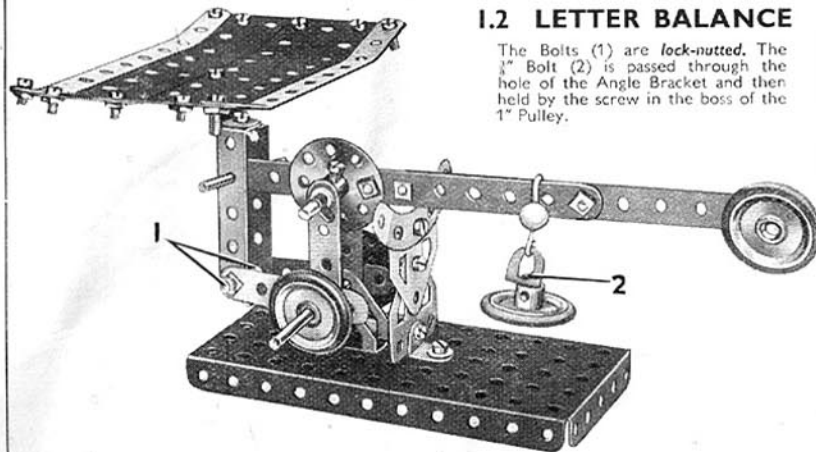

The Bolts (1) are lock-nutted. The 1" Bolt (2) is passed through the hole of the Angle Bracket and then held by the screw in the boss of the 1" Pulley.

Parts Required

4 of No. 2	4 of No. 22	4 of No. 38	4 of No. 111c
4 " " 5	1 " " 24	2 " " 48a	1 " " 125
4 " " 10	4 " " 35	1 " " 52	2 " " 126
2 " " 12	28 " " 37a	1 " " 57c	2 " " 126a
1 " " 16	24 " " 37b	1 " " 90a	4 " " 155
2 " " 17			2 " " 189

I.3 RACING SEAPLANE

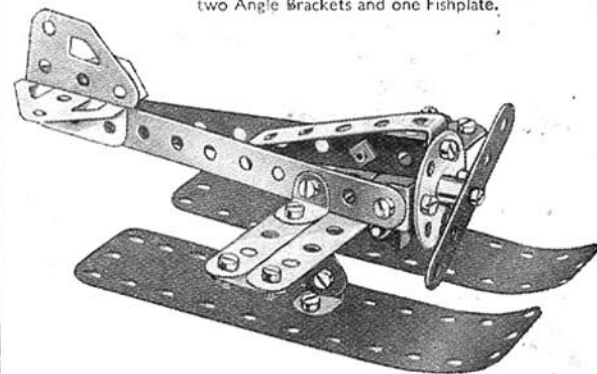

Each of the floats is secured to the wings by two Angle Brackets and one Fishplate.

Parts Required

3 of No. 2	1 of No. 24	2 of No. 111c
3 " " 5	20 " " 37a	2 " " 126
4 " " 10	19 " " 37b	1 " " 126a
8 " " 12	1 " " 48a	2 " " 189

I.4 RAILWAY BREAKDOWN CRANE

The hoisting Cord is secured to the Crank Handle and then led over the 3/8" Bolt (1). It is then passed through the pulley block and fastened to the jib at (2). The jib is attached to the Bush Wheel (3) by means of Angle Brackets, and the complete unit is pivoted as follows. A 1/2" Bolt is passed through the 5 1/2" x 2 1/2" Flanged Plate from the underside, and is secured in the boss of the Bush Wheel by its set screw.

Parts Required

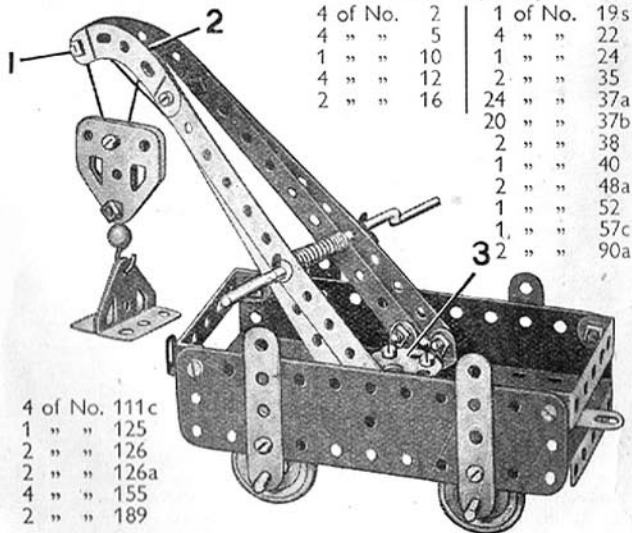

4 of No. 2	1 of No. 19s
4 " " 5	4 " " 22
1 " " 10	1 " " 24
4 " " 12	2 " " 35
2 " " 16	24 " " 37a
	20 " " 37b
	2 " " 38
	1 " " 40
	2 " " 48a
	1 " " 52
	1 " " 57c
	2 " " 90a

4 of No. 111c
1 " " 125
2 " " 126
2 " " 126a
4 " " 155
2 " " 189

I.5 TRICYCLE VAN

Parts Required

4 of No. 2	1 of No. 17	24 of No. 37b	2 of No. 111c
3 " " 5	3 " " 22	3 " " 38	2 " " 126
3 " " 10	1 " " 24	2 " " 48a	2 " " 126a
6 " " 12	4 " " 35	1 " " 52	2 " " 142c
2 " " 16	27 " " 37a	2 " " 90a	2 " " 189

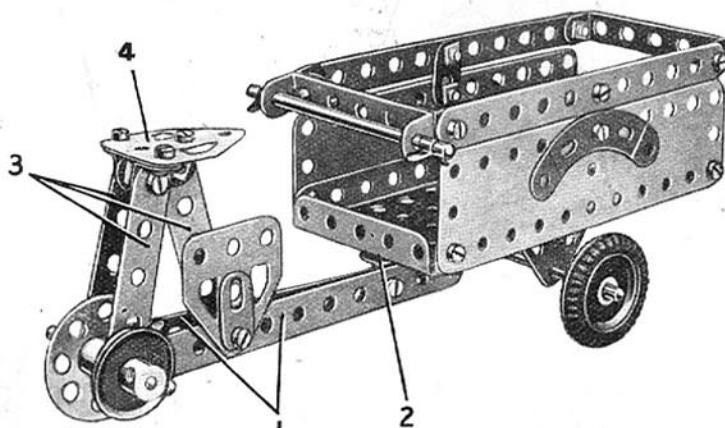

The frame of the cycle consists of two 5 1/2" Strips (1) connected at one end by a bolt that fixes them also to an Angle Bracket (2). The Angle Bracket pivots on a bolt lock-nutted to the Flanged Plate. The seat is carried by three 2 1/2" Strips (3), each of which is connected by an Angle Bracket to the Flat Trunnion (4). The front axle is carried in Trunnions bolted underneath the Flanged Plate.

I.6 STAMPING MILL

The anvil (1) is made up of two Trunnions bolted together. When the Crank Handle is rotated, the Fishplates bolted to the Bush Wheel strike the centre 1" Pulley on the hammer shaft and cause it to rise and fall.

Parts Required

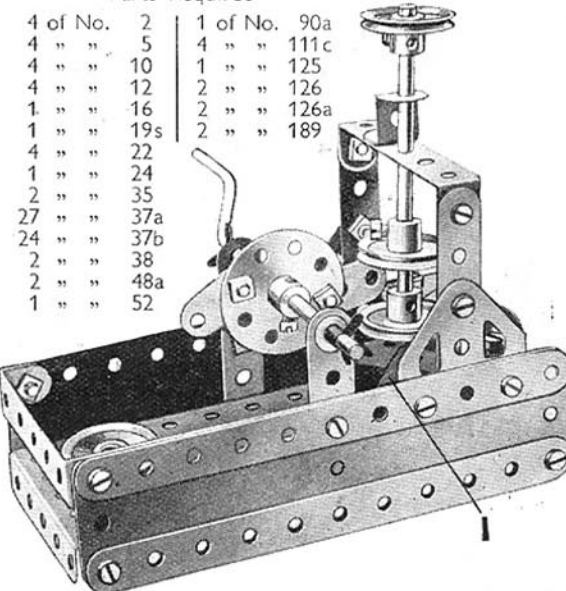

4 of No. 2	1 of No. 90a
4 " " 5	4 " " 111c
4 " " 10	1 " " 125
4 " " 12	2 " " 126
1 " " 16	2 " " 126a
1 " " 19s	2 " " 189
4 " " 22	
1 " " 24	
2 " " 35	
27 " " 37a	
24 " " 37b	
2 " " 38	
2 " " 48a	
1 " " 52	

I.7 MOTOR LORRY

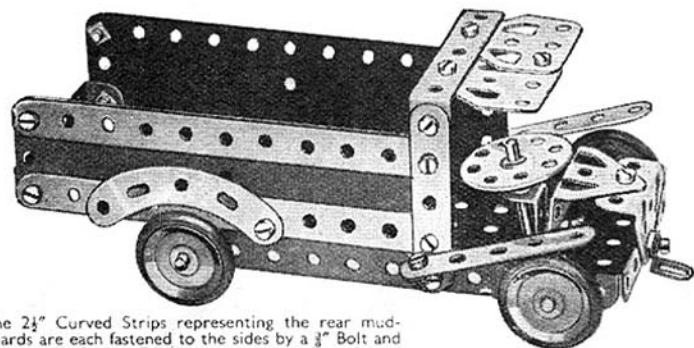

The $2\frac{1}{2}$ " Curved Strips representing the rear mudguards are each fastened to the sides by a $\frac{3}{8}$ " Bolt and nut, with a Spring Clip between the mudguards and the $5\frac{1}{4}$ " Strip to form a distance piece.

Parts Required			
4 of No. 2	4 of No. 22	2 of No. 48a	2 of No. 126
4 " " 5	1 " " 24	1 " " 52	2 " " 126a
3 " " 12	2 " " 35	2 " " 90a	4 " " 155
2 " " 16	23 " " 37a	3 " " 111c	2 " " 189
1 " " 17	19 " " 37b	1 " " 125	

I.8 MECHANICAL SHOVEL

The Bolts (1), on which the jib pivots, are *lock-nutted*. The shovel arm is pivoted on a 2" Rod and the shovel is supported by a Cord that passes over the $\frac{1}{2}$ " Bolt at the jib head and is fastened to a $2\frac{1}{2}$ " x $\frac{1}{2}$ " Double Angle Strip as shown. The Cord (2) is fastened to the jib and then passes over a $3\frac{1}{2}$ " Rod journalled in the holes above the $2\frac{1}{2}$ " Curved Strips, and is attached to a Fishplate fastened by the *lock-nutted* Bolt (3) to the Bush Wheel.

When the Crank Handle is rotated, the Bush Wheel imparts a digging motion to the jib and shovel arm.

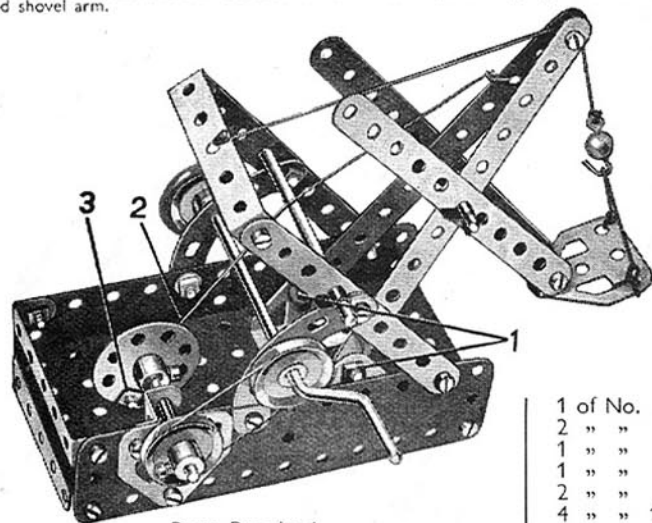

Parts Required		
4 of No. 2	1 of No. 16	1 of No. 24
4 " " 5	2 " " 17	28 " " 37a
1 " " 10	1 " " 19s	24 " " 37b
2 " " 12	3 " " 22	4 " " 38
		2 " " 40
		2 " " 48a
		1 " " 52
		1 " " 57c
		2 " " 90a
		4 " " 111c
		1 " " 125
		2 " " 126
		2 " " 126a
		1 " " 155
		2 " " 189

I.9 WINDMILL

The sails are gripped on the $3\frac{1}{2}$ " Rod by the 1" Pulley (with Rubber Ring) at the front and another 1" Pulley at the back of the sails. The Pulleys are pressed against the faces of the sails and locked on the Rod.

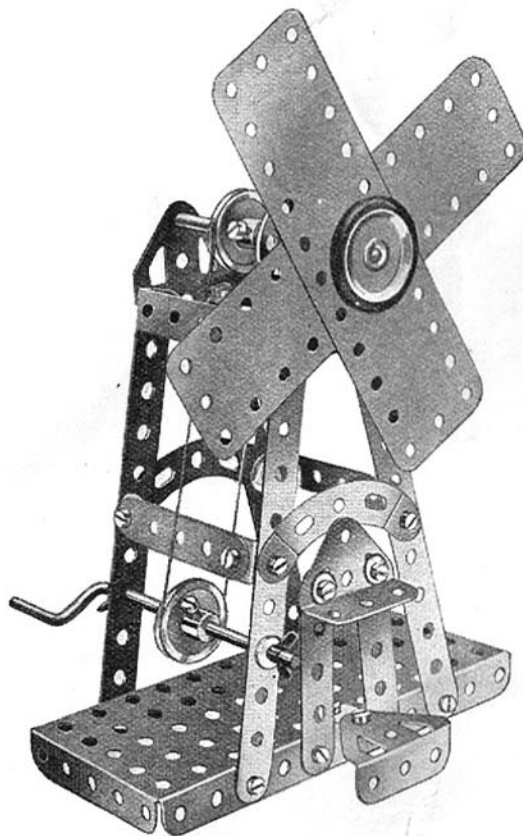

Parts Required		
4 of No. 2	1 of No. 24	1 of No. 52
4 " " 5	3 " " 35	2 " " 90a
1 " " 10	24 " " 37a	2 " " 126
4 " " 12	24 " " 37b	2 " " 126a
1 " " 16	4 " " 38	1 " " 155
1 " " 19s	1 " " 40	2 " " 189
4 " " 22	2 " " 48a	

I.10 COASTER

The Bolts (1) are *lock-nutted*. The rear axle Rod is pushed through the end hole of the Curved Strip (2) and through Fishplates bolted to the Flanged Plate.

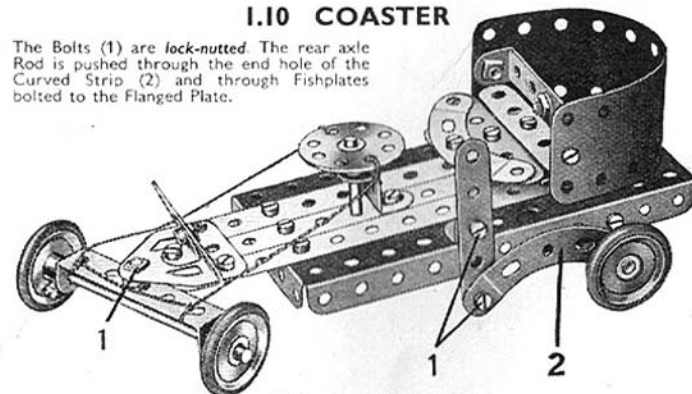

Parts Required			
3 of No. 2	4 of No. 22	1 of No. 40	2 of No. 126
4 " " 5	1 " " 24	2 " " 48a	2 " " 126a
2 " " 10	1 " " 35	1 " " 52	4 " " 155
5 " " 12	24 " " 37a	2 " " 90a	1 " " 189
2 " " 16	20 " " 37b	2 " " 111c	
1 " " 17	4 " " 38	1 " " 125	

I.11 STEAM WAGON

The front axle is supported in a $2\frac{1}{2}$ " x $\frac{1}{2}$ " Double Angle Strip (1) *lock-nutted* to a $\frac{1}{2}$ " Reversed Angle Bracket (2). The Reversed Angle Bracket is bolted to a $5\frac{1}{2}$ " Strip fixed to the centre of the Flanged Plate. The boiler is a $5\frac{1}{2}$ " x $1\frac{1}{2}$ " Flexible Plate rolled into a cylinder, and the Bush Wheel (3) is attached to an Angle Bracket. The roof is made from two Flat Trunnions bolted to a $2\frac{1}{2}$ " x $\frac{1}{2}$ " Double Angle Strip (4). The Curved Strips (5) are connected to the Flat Trunnions by Fishplates. A Trunnion (6) at each side is spaced from the Flanged Plate by two Washers.

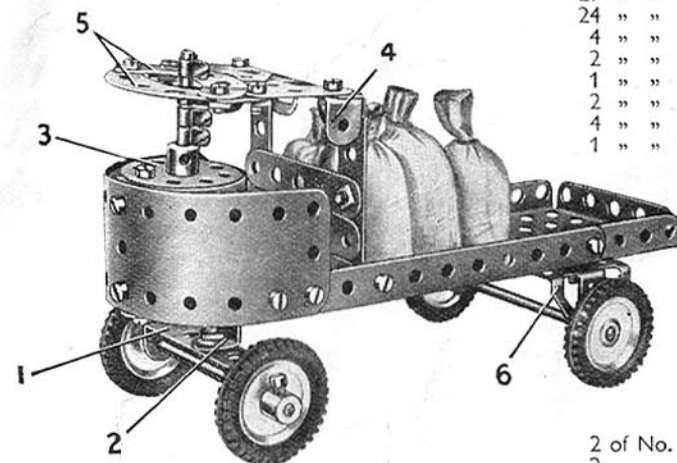

Note: The Loaded Sacks (Part No. 122) is not included in the Outfit

Parts Required	
3 of No. 2	2
4 " " 5	5
4 " " 10	10
4 " " 12	12
2 " " 16	16
1 " " 17	17
4 " " 22	22
1 " " 24	24
4 " " 35	35
29 " " 37a	37a
24 " " 37b	37b
4 " " 38	38
2 " " 48a	48a
1 " " 52	52
2 " " 90a	90a
4 " " 111c	111c
1 " " 125	125

2 of No. 126	126
2 " " 126a	126a
4 " " 142c	142c
2 " " 189	189

I.12 FLYING BOATS

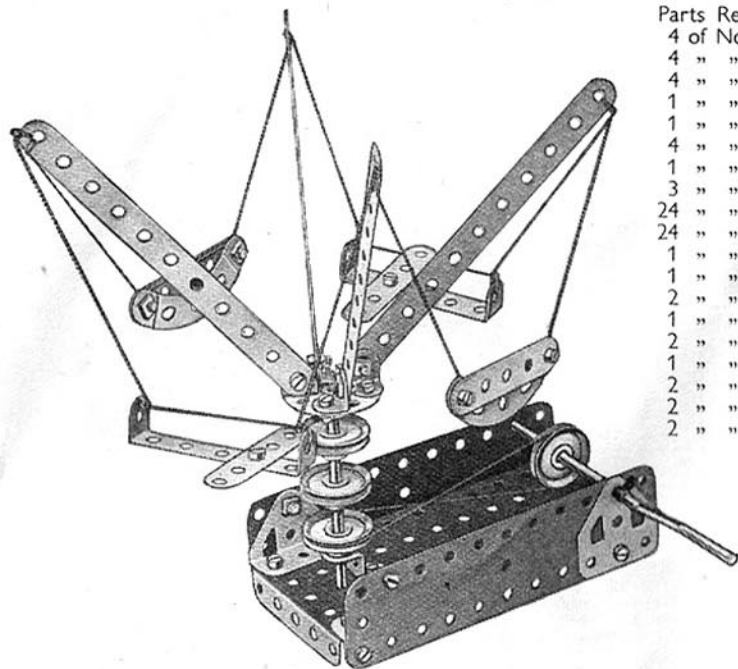

Parts Required

4 of No.	2
4 " "	5
4 " "	12
1 " "	16
1 " "	19s
4 " "	22
1 " "	24
3 " "	35
24 " "	37a
24 " "	37b
1 " "	38
1 " "	40
2 " "	48a
1 " "	52
2 " "	90a
1 " "	125
2 " "	126
2 " "	126a
2 " "	189

I.14 GYMNAST

The Bolts (1) are lock-nutted. The bearings for the Crank Handle in the Flexible Plates are reinforced by Trunnions bolted to the Flanged Plate.

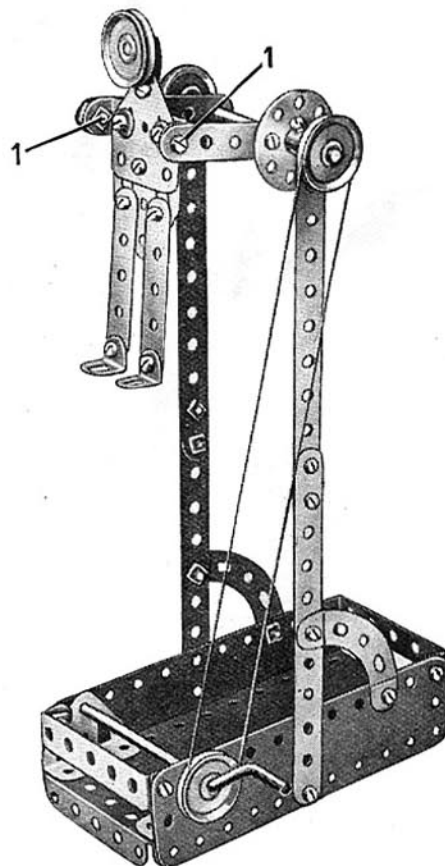

Parts Required

4 of No.	2
2 " "	5
2 " "	17
2 " "	22
1 " "	24
19 " "	37a
19 " "	37b
1 " "	38
1 " "	40
2 " "	48a
1 " "	52
2 " "	90a
1 " "	111c
2 " "	126
2 " "	126a
1 " "	155
2 " "	189

I.15 SCALES

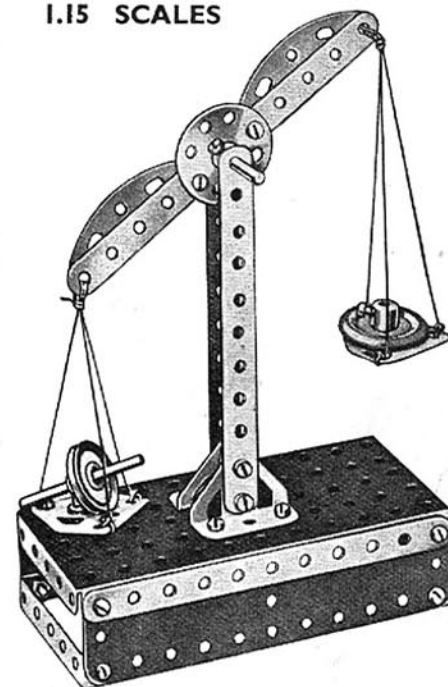

I.13 CIRCULAR SAW

The Bush Wheel (1) is fixed to a 3 1/4" Rod that is passed through two Trunnions bolted to the Flanged Plate.

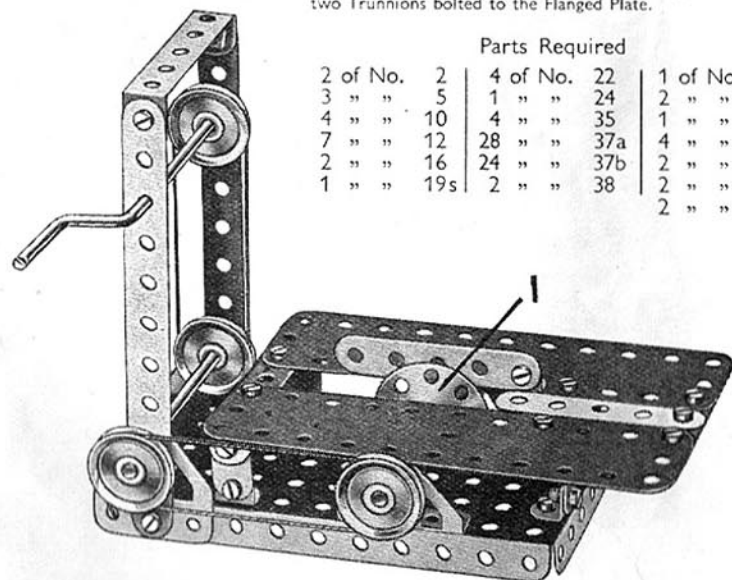

Parts Required

2 of No.	2	4 of No.	22	1 of No.	40
3 " "	5	1 " "	24	2 " "	48a
4 " "	10	4 " "	35	1 " "	52
7 " "	12	28 " "	37a	4 " "	111c
2 " "	16	24 " "	37b	2 " "	126
1 " "	19s	2 " "	38	2 " "	126a
		2 " "		2 " "	189

I.16 DRILLING MACHINE

Parts Required

4 of No.	2	4 of No.	38
3 " "	5	1 " "	40
8 " "	12	1 " "	52
1 " "	16	2 " "	126
1 " "	17	2 " "	126a
1 " "	19s		
4 " "	22		
4 " "	35		
20 " "	37a		
20 " "	37b		

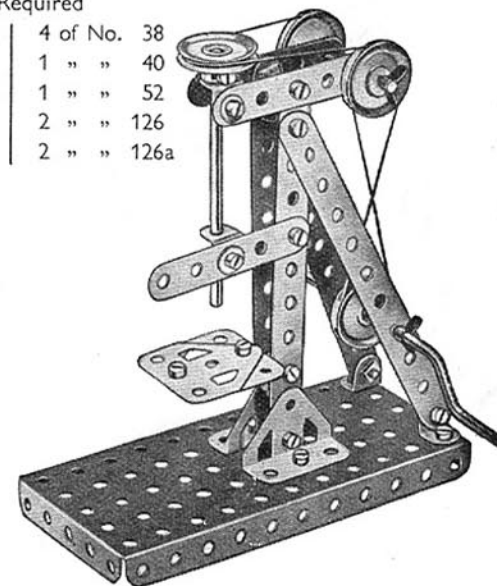

The drill table is made by bolting together two Flat Trunnions.

Parts Required

4 of No.	2	1 of No.	24	1 of No.	52
4 " "	5	2 " "	35	2 " "	90a
1 " "	10	29 " "	37a	4 " "	111c
4 " "	12	24 " "	37b	2 " "	126
1 " "	16	4 " "	38	2 " "	126a
1 " "	19s	1 " "	40	2 " "	189
4 " "	22	2 " "	48a		

I.17 COSTER AND BARROW

The man's body is made from two $2\frac{1}{2}'' \times \frac{1}{2}''$ Double Angle Strips, and a $\frac{1}{2}''$ Pulley (1) (supplied with the Magic Motor) is fixed on a 2" Rod that carries also a Bush Wheel (2). The leg (3) is lock-nutted to the Bush Wheel, and the foot, a $1''$ Pulley (4) with Rubber Ring, is attached by a Bolt passed through a Fishplate (5) and screwed into the boss of the Pulley. The head is a Flat Trunnion connected to an Angle Bracket.

To make the man walk successfully, the Pulley (4) and Fishplate (5) must be fixed as nearly as possible in the positions shown in the illustration.

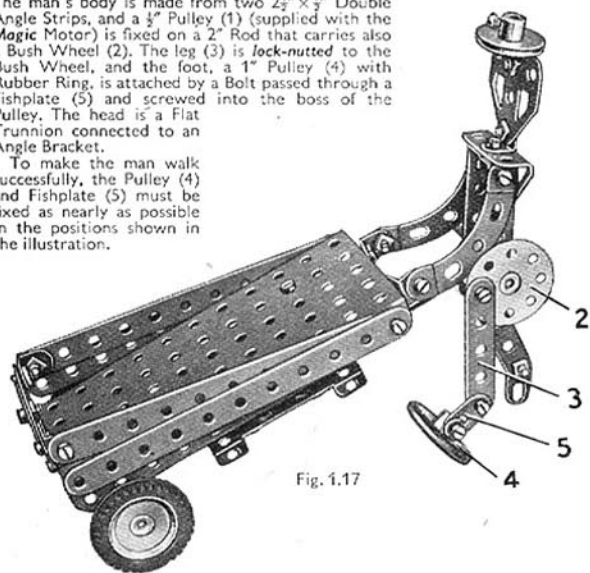

Fig. 1.17

Parts Required

4 of No. 2	27 of No. 37a	2 of No. 126a
3 " " 5	24 " " 37b	2 " " 142c
4 " " 10	4 " " 38	1 " " 155
6 " " 12	2 " " 48a	
1 " " 16	1 " " 52	1 Magic Clock-work Motor
1 " " 17	2 " " 90a	(not included in Outfit)
4 " " 22	3 " " 111c	
1 " " 24	1 " " 126	

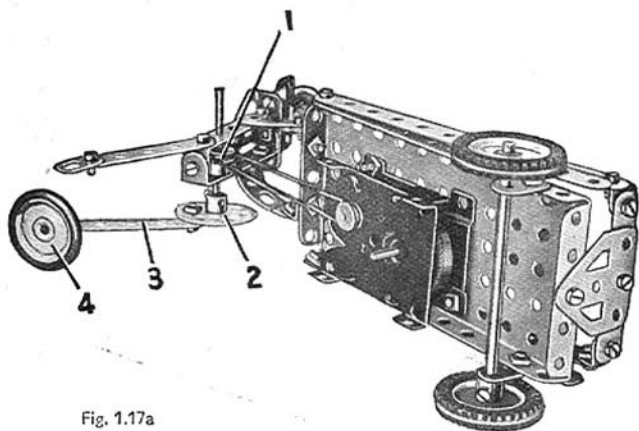
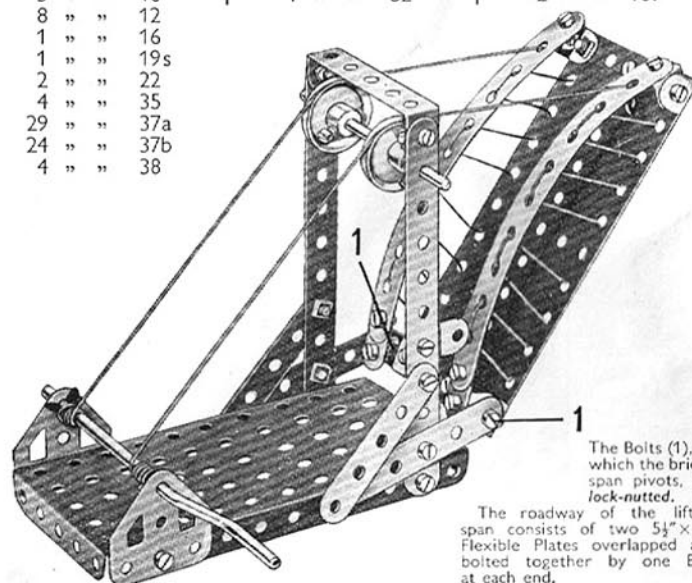

Fig. 1.17a

I.18 LIFTING BRIDGE

Parts Required

4 of No. 2	1 of No. 40	3 of No. 111c
4 " " 5	1 " " 48a	2 " " 126a
3 " " 10	1 " " 52	2 " " 189
8 " " 12		
1 " " 16		
1 " " 19s		
2 " " 22		
4 " " 35		
29 " " 37a		
24 " " 37b		
4 " " 38		



The Bolts (1), on which the bridge span pivots, are lock-nutted.

The roadway of the lifting span consists of two $5\frac{1}{2}'' \times 1\frac{1}{2}''$ Flexible Plates overlapped and bolted together by one Bolt at each end.

I.20 DERRICK CRANE

The jib is bolted to a Bush Wheel (1), which is fixed by its set-screw on a $\frac{3}{8}''$ Bolt passed through the Flanged Plate. The jib supporting Cord is passed round a $1''$ Pulley on a 2" Rod (2). This Rod is held in place by a Spring Clip placed underneath the Flat Trunnion.

The brake lever is lock-nutted to a $\frac{1}{2}''$ Reversed Angle Bracket (3). A brake is provided by a length of Cord passed over Pulley (4) and tied to the lever and to the Flanged Plate.

Parts Required

4 of No. 2	4 of No. 35	1 of No. 90a
4 " " 5	21 " " 37a	2 " " 111c
3 " " 12	20 " " 37b	1 " " 125
2 " " 17	1 " " 40	2 " " 126
1 " " 19s	2 " " 48a	1 " " 126a
4 " " 22	1 " " 52	
1 " " 24	1 " " 57c	

(Loaded Sack, Part No. 122, not included in Outfit)

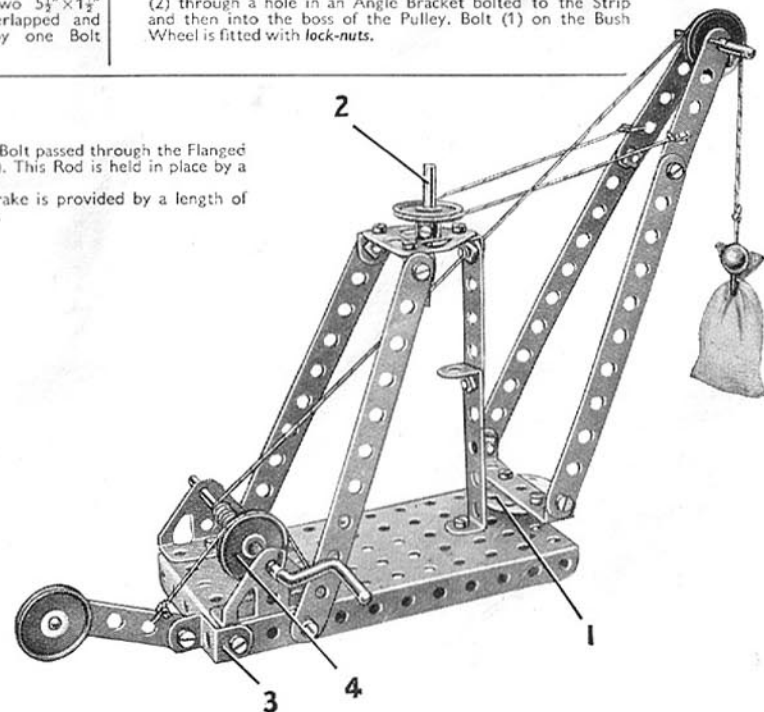

I.19 MECHANICAL SWING

Parts Required

4 of No. 2	2 of No. 5
2 " " 10	2 " " 12
3 " " 12	1 " " 16
1 " " 16	1 " " 19s
1 " " 19s	2 " " 22
2 " " 22	1 " " 24
4 " " 35	4 " " 37a
17 " " 37a	15 " " 37b
4 " " 38	4 " " 38
1 " " 40	1 " " 40
2 " " 48a	2 " " 48a
1 " " 52	1 " " 52
1 " " 111c	1 " " 111c
1 " " 125	1 " " 125
2 " " 126	2 " " 126
2 " " 189	2 " " 189

1 Magic Motor
(not included in Outfit)

The left-hand $2\frac{1}{2}''$ Strip that supports the swing is connected to the Crank Handle by passing the set screw of the $1''$ Pulley (2) through a hole in an Angle Bracket bolted to the Strip and then into the boss of the Pulley. Bolt (1) on the Bush Wheel is fitted with lock-nuts.

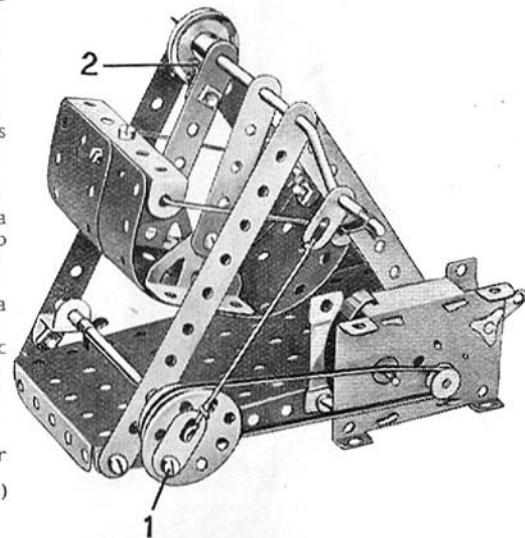

I.21 OPEN TRAMCAR

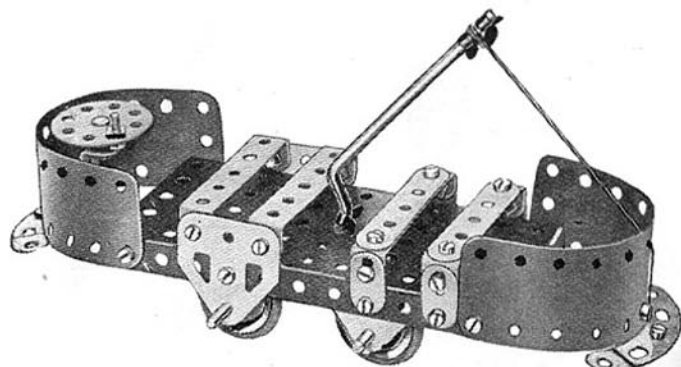

Parts Required		
2 of No. 5	1 of No. 19s	1 of No. 52
4 " " 10	4 " " 22	2 " " 90a
7 " " 12	1 " " 24	4 " " 111c
2 " " 16	4 " " 35	1 " " 125
	27 " " 37a	2 " " 126
	24 " " 37b	2 " " 126a
	1 " " 40	4 " " 155
	2 " " 48a	2 " " 189

I.22 FIRE ENGINE

Bolts (1) at each side are *lock-nutted*. The sides of the ladder are held together by two Angle Brackets (2), which are bolted together to form a 'U'-shaped bracket. The rear axle bearings (3) are Fishplates bolted inside the flange of the Flanged Plate. The Cord from the Crank Handle is tied in the fourth hole up the ladder so that when the Handle is turned it causes the ladder to lift.

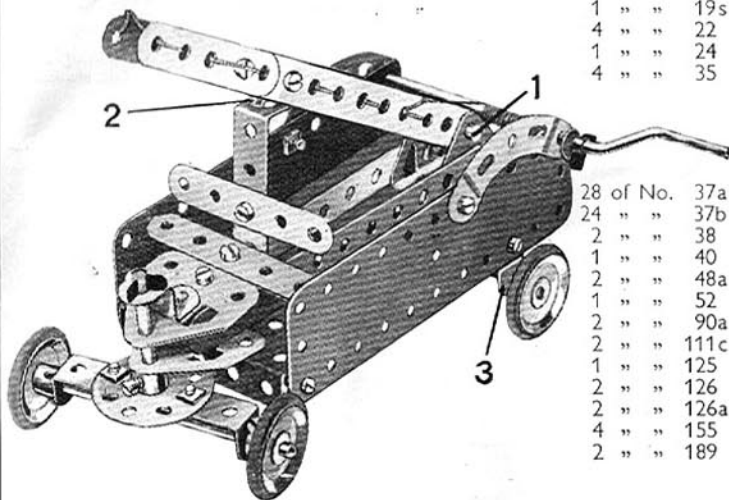

Parts Required	
4 of No. 2	28 of No. 37a
4 " " 5	24 " " 37b
3 " " 10	2 " " 38
5 " " 12	1 " " 40
2 " " 16	2 " " 48a
1 " " 17	1 " " 52
1 " " 19s	2 " " 90a
4 " " 22	2 " " 111c
1 " " 24	1 " " 125
4 " " 35	2 " " 126
	2 " " 126a
	4 " " 155
	2 " " 189

I.24 POWER PRESS

The Bolts (1) are *lock-nutted* and the Angle Bracket at the lower end of the 2 1/2" Strip has a 3/2" Rod in its elongated hole, where it is held by means of two Spring Clips. The Rod forming the press ram moves up and down in the circular holes of a Fishplate bolted to a 2 1/2" x 7" Double Angle Strip and also through the centre hole of another 2 1/2" x 1 1/2" Double Angle Strip.

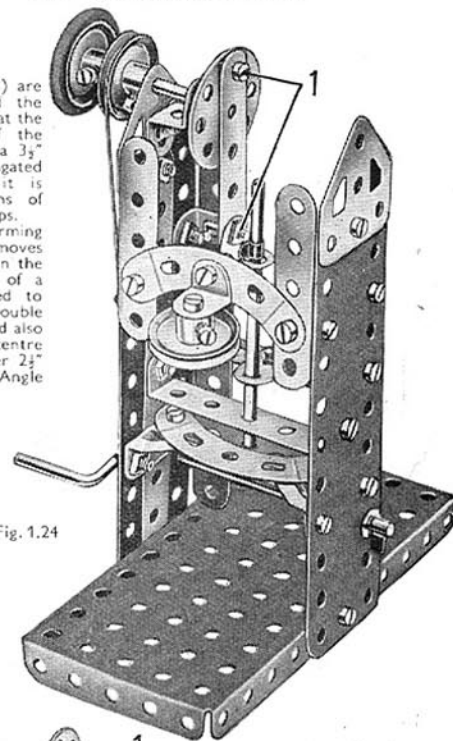
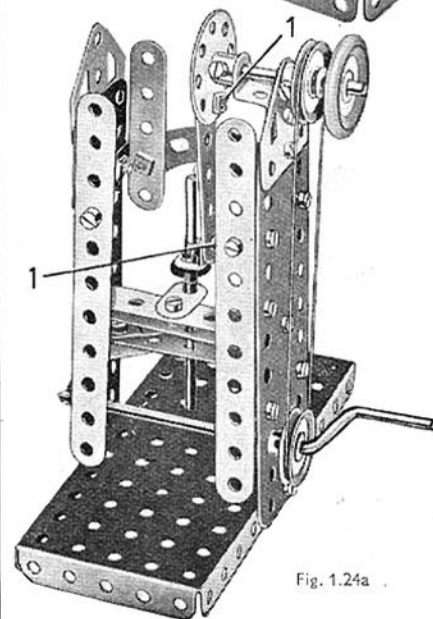

Fig. 1.24



Parts Required	
4 of No. 2	4 " " 5
1 " " 10	6 " " 12
1 " " 16	1 " " 17
1 " " 19s	4 " " 22
1 " " 24	1 " " 24
3 " " 35	29 " " 37a
24 " " 37b	1 " " 38
1 " " 40	2 " " 48a
1 " " 52	4 " " 111c
2 " " 90a	1 " " 125
1 " " 126	2 " " 126a
2 " " 155	1 " " 155
1 " " 189	2 " " 189

Fig. 1.24a

I.23 MOBILE CRANE

Parts Required		
4 of No. 2	4 of No. 35	3 of No. 111c
4 " " 5	29 " " 37a	1 " " 125
1 " " 10	23 " " 37b	2 " " 126
4 " " 12	2 " " 38	2 " " 126a
2 " " 16	1 " " 40	2 " " 142c
2 " " 17	2 " " 48a	2 " " 155
1 " " 19s	1 " " 52	2 " " 189
4 " " 22	1 " " 57c	
1 " " 24	2 " " 90a	

The rear wheels are fixed on a 2" Rod supported in two Trunnions (1) bolted tightly together by a 3/2" Bolt and nut. The Bolt is then passed through the Flanged Plate and is fitted with two nuts locked together, so that the wheels can pivot to steer the crane. The Bush Wheel (2) is on a 2" Rod passed through one of the jib supports and through a 1/2" Reversed Angle Bracket bolted to the support. A length of Cord tied to the Rod is attached to the rear end of the jib, and a Spring Clip and a Washer are used to prevent the Cord sliding off the Rod. The rear section of the jib is made from two 5 1/2" x 1 1/2" Flexible Plates joined by 'U'-shaped pieces, each made from two Angle Brackets bolted together. The 'U'-pieces are held by the Bolts (3) and (4).

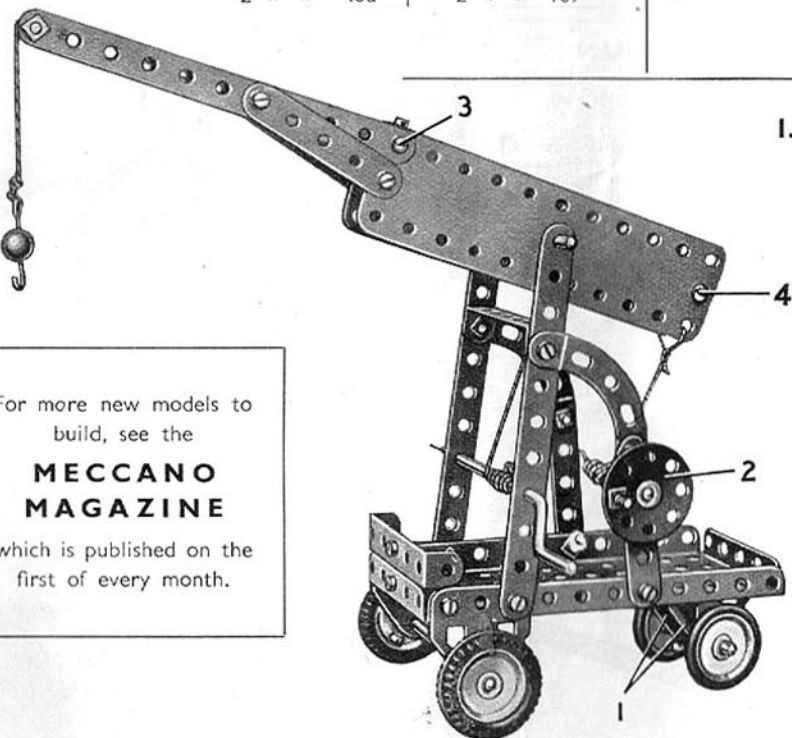

For more new models to build, see the **MECCANO MAGAZINE** which is published on the first of every month.

I.29 PITHEAD GEAR

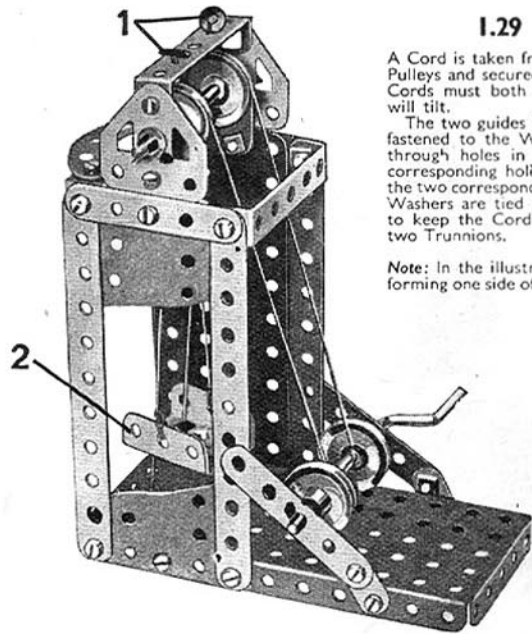

A Cord is taken from each side of the lift cage over the 1" Pulleys and secured to each end of the Crank Handle. The Cords must both be the same length, otherwise the lift will tilt.

The two guides for the lift consist of two pieces of Cord fastened to the Washers (1). The Cords are then passed through holes in the Double Angle Strip, through two corresponding holes in the lift cage (2), and then through the two corresponding holes in the Flanged Plate. Two more Washers are tied to the Cords beneath the Flanged Plate to keep the Cords tight. The lift cage (2) is made up of two Trunnions.

Note: In the illustration part of the 5 1/2" x 1 1/4" Flexible Plate forming one side of the tower is cut away to reveal the cage.

Parts Required

4 of No. 2	4 of No. 38
4 " " 5	1 " " 40
4 " " 10	2 " " 48a
2 " " 12	1 " " 52
1 " " 16	1 " " 90a
1 " " 19s	4 " " 111c
4 " " 22	2 " " 126
4 " " 35	2 " " 126a
24 " " 37a	2 " " 189
20 " " 37b	

I.30 HORIZONTAL ENGINE

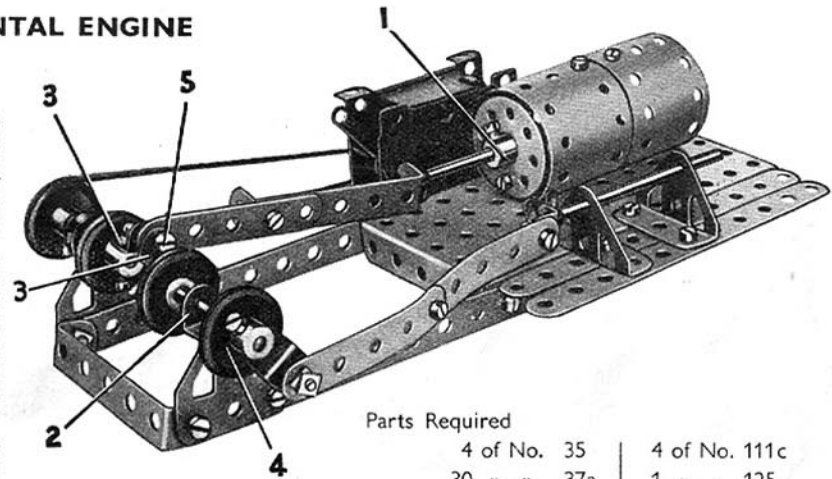

The cylinder is made from two 5 1/2" x 1 1/4" Flexible Plates rolled to shape and bolted to the base. The Bush Wheel (1) is fixed to an Angle Bracket. The crankshaft consists of two 2" Rods. One of them is passed through a Flat Trunnion, and the other is mounted in a Flat Trunnion and a 1/2" Reversed Angle Bracket (2). A 1" Pulley is fixed on the inner end of each 2" Rod, and an Angle Bracket (3) is fastened to the boss of each Pulley. A bolt fitted with a nut is passed through the hole of the Angle Bracket, and is screwed into the boss of the Pulley. The nut is then tightened against the Angle Bracket to hold it in position. A third Angle Bracket is similarly attached to a Pulley (4).

The connecting rod pivots on a 3/8" Bolt (5). This is passed through one of the Angle Brackets (3) and is held by a nut. The connecting rod is slipped over the Bolt, which is then fixed in the second Angle Bracket (3) by two nuts. The valve-operating rod is lock-nutted to the Angle Bracket fixed to Pulley (4).

Parts Required

4 of No. 2	2 of No. 16	4 of No. 35	4 of No. 111c
3 " " 5	2 " " 17	30 " " 37a	1 " " 125
1 " " 10	4 " " 22	22 " " 37b	2 " " 126
5 " " 12	1 " " 24	1 " " 38	2 " " 126a
		2 " " 48a	2 " " 189
		1 " " 52	1 Magic Motor
			(not included in Outfit)

I.31 TELPHER SPAN

The anchoring piece (1) consists of two Trunnions bolted together, and a hook, which is made of two Angle Brackets, fastened to them. A 2" Rod carrying a 1" fast Pulley is journaled in the Trunnions. The anchoring piece is hooked on a picture rail or other suitable support and the Cord (2), which can be of any length, is passed round the 1" Pulleys as shown. When the Crank Handle is rotated the car moves either backward or forward.

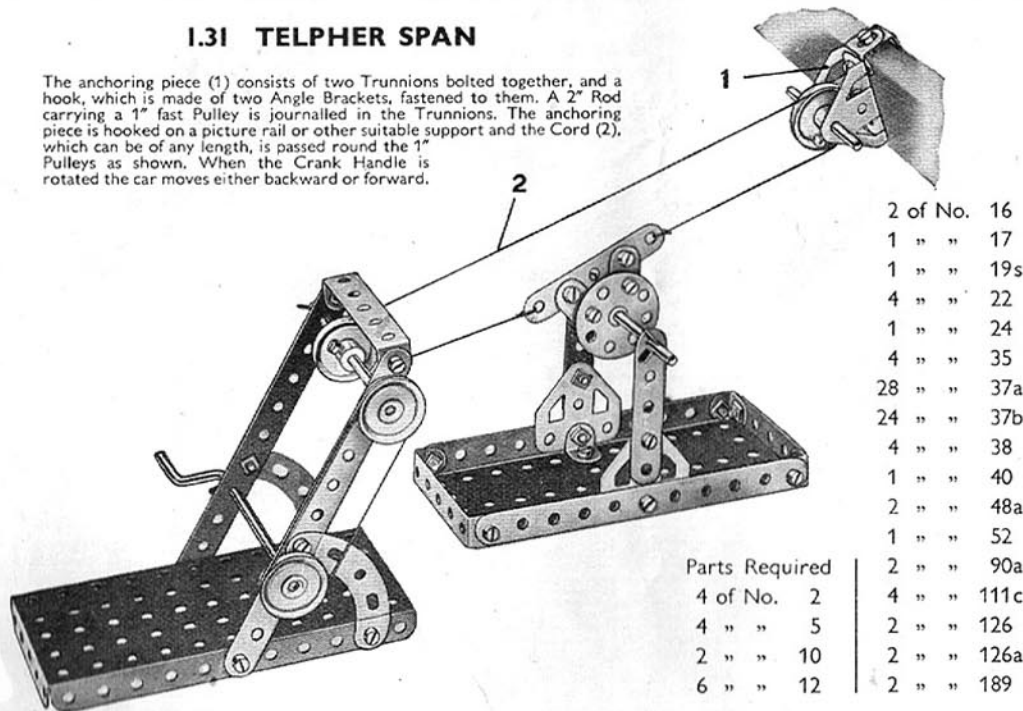

Parts Required

4 of No. 2	4 " " 111c
4 " " 5	2 " " 126
2 " " 10	2 " " 126a
6 " " 12	2 " " 189

2 of No. 16
1 " " 17
1 " " 19s
4 " " 22
1 " " 24
4 " " 35
28 " " 37a
24 " " 37b
4 " " 38
1 " " 40
2 " " 48a
1 " " 52
2 " " 90a
4 " " 111c
2 " " 126
2 " " 126a
2 " " 189

I.32 TRICYCLE ROUNDABOUT

The Curved Strips (1) are attached to Angle Brackets bolted to a 2 1/2" Strip (2). A Washer is placed on a Bolt (3) on each side before the nut is tightened, to locate it in the Flat Trunnion. The Flat Trunnion is fixed to an Angle Bracket, and the 1" Pulley (4) is held by its set-screw on a 3/8" Bolt passed through a 2 1/2" Strip (5). The model is set in motion by turning the Crank Handle.

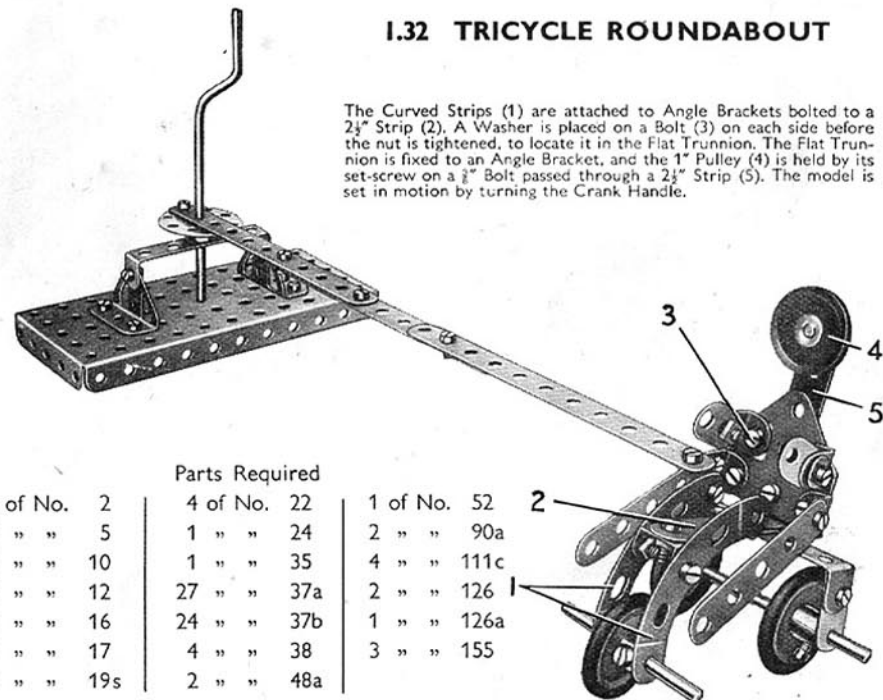

Parts Required

3 of No. 2	4 of No. 22	1 of No. 52
4 " " 5	1 " " 24	2 " " 90a
4 " " 10	1 " " 35	4 " " 111c
8 " " 12	27 " " 37a	2 " " 126
1 " " 16	24 " " 37b	1 " " 126a
1 " " 17	4 " " 38	3 " " 155
1 " " 19s	2 " " 48a	

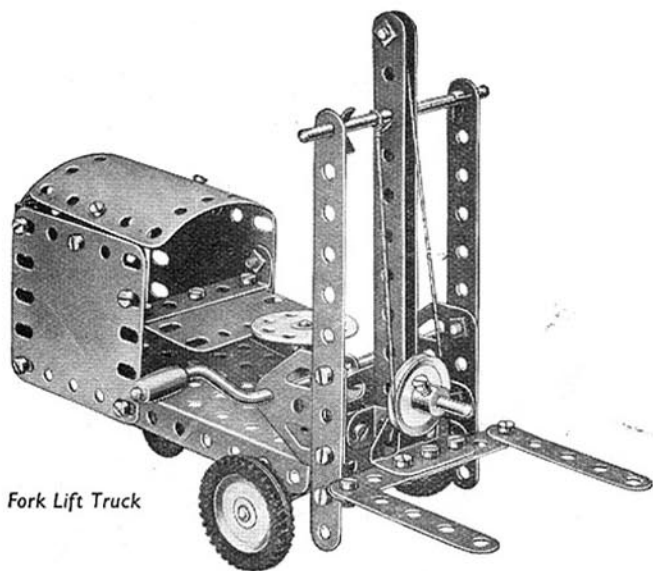

Fork Lift Truck

HOW TO CONTINUE

When you have built all the models shown in this Book of Instructions, you will be keen to build others bigger and more elaborate. Your next step is to purchase a Meccano No. 1a Accessory Outfit containing all the parts required to convert your No. 1 into a No. 2 Outfit. You will then be able to build the full range of No. 2 Outfit models, a few of which are illustrated on this page.

If you prefer to do so, you can build up and develop your Outfit quite easily by adding various parts to it from time to time. The variety of models you can make with Meccano is almost unlimited, and the more Meccano parts you have the bigger and better your models will be.

BUILD BIGGER AND BETTER MODELS

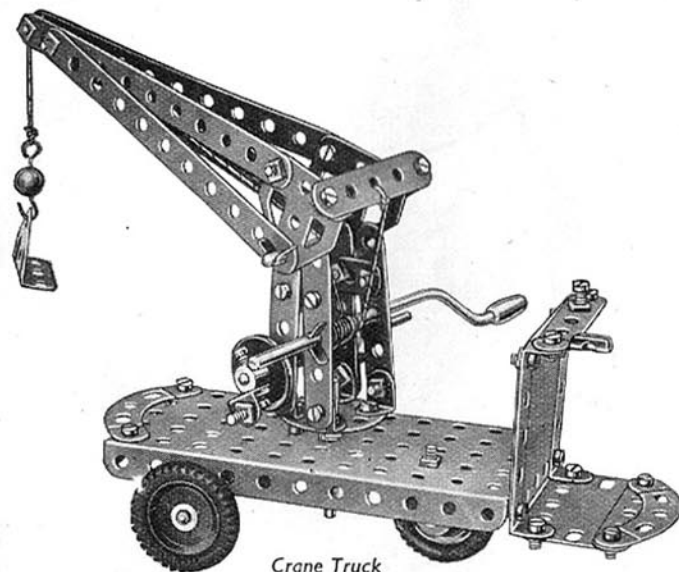

Crane Truck

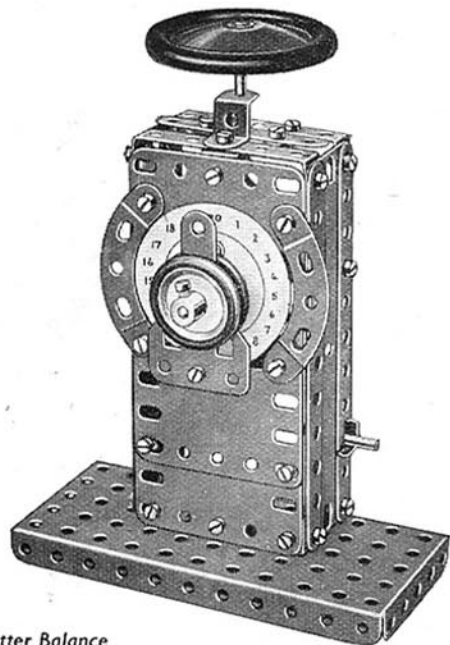

Letter Balance

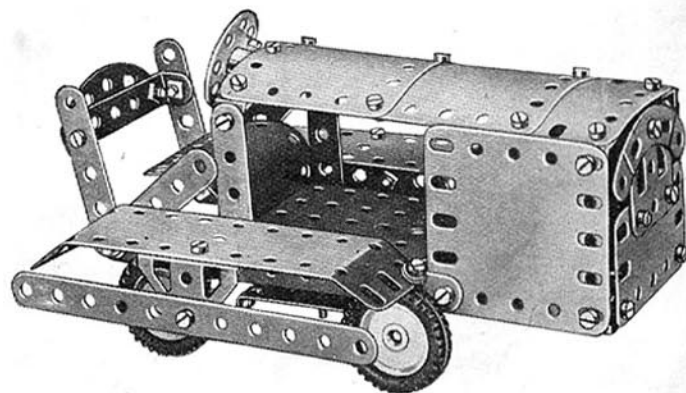

Tractor

Here is a selection of five models that are illustrated and described in the Instructions Book packed with Meccano Outfit No. 2.

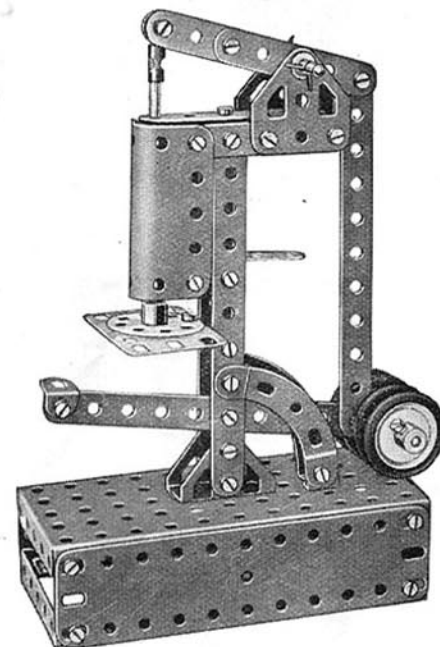

Punching Machine

MECCANO PARTS



PERFORATED STRIPS

No.	12 $\frac{1}{2}$ "	No.	2a.	4 $\frac{1}{2}$ "	No.	6.	2"
1.	9 $\frac{1}{2}$ "	2a.	3 $\frac{1}{2}$ "	3.	3 $\frac{1}{2}$ "	6a.	1 $\frac{1}{2}$ "
1b.	7 $\frac{1}{2}$ "	4.	3 $\frac{1}{2}$ "	5.	2 $\frac{1}{2}$ "		
2.	5 $\frac{1}{2}$ "						

ANGLE GIRDERS

7.	24 $\frac{1}{2}$ "	8b.	7 $\frac{1}{2}$ "	9c.	3"
7a.	18 $\frac{1}{2}$ "	9.	5 $\frac{1}{2}$ "	9d.	2 $\frac{1}{2}$ "
8.	12 $\frac{1}{2}$ "	9a.	4 $\frac{1}{2}$ "	9e.	2"
8a.	9 $\frac{1}{2}$ "	9b.	3 $\frac{1}{2}$ "	9f.	1 $\frac{1}{2}$ "



10. Fishplate | 11. Double Bracket

ANGLE BRACKETS

12.	$\frac{1}{2}$ " x $\frac{1}{2}$ "	12b.	1" x $\frac{1}{2}$ "
12a.	1" x 1"	12c.	Obtuse, $\frac{1}{2}$ " x $\frac{1}{2}$ "



AXLE RODS

13.	11 $\frac{1}{2}$ "	15a.	4 $\frac{1}{2}$ "	16b.	3"
13a.	8"	15b.	4"	17.	2"
14.	6 $\frac{1}{2}$ "	16.	3 $\frac{1}{2}$ "	18a.	1 $\frac{1}{2}$ "
15.	5"	16a.	2 $\frac{1}{2}$ "	18b.	1"
19g.	Crank Handle, 3 $\frac{1}{2}$ " shaft, with grip				
19h.	Crank Handle, 5" shaft, with grip				
19s.	Crank Handle, 3 $\frac{1}{2}$ " shaft, without grip				



19a. Spoked Wheel, 3" diam.
20. Flanged Wheel, 1 $\frac{1}{2}$ " diam.
20b. Flanged Wheel, $\frac{1}{4}$ " diam.

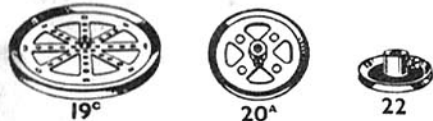

PULLEYS

19b.	3" diam., with boss and screw
19c.	6" diam., with boss and screw
20a.	2" diam., with boss and screw
21.	1 $\frac{1}{2}$ " diam., with boss and screw
22.	1" diam., with boss and screw

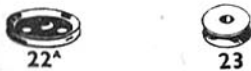

PULLEYS

22a.	1" diam., without boss
23.	$\frac{1}{2}$ " diam., without boss
23a.	$\frac{1}{2}$ " diam., with boss and screw



No. 24. Bush Wheel, 1 $\frac{1}{2}$ " diam., eight-hole
24a. Wheel Disc, 1 $\frac{1}{2}$ " diam., without bush, eight-hole
24b. Bush Wheel, 1 $\frac{1}{2}$ " diam., six-hole
24c. Wheel Disc, 1 $\frac{1}{2}$ " diam., without bush, six-hole
26. Wheel Disc, 1 $\frac{1}{2}$ " diam., without bush, six-hole

PINIONS

25.	$\frac{1}{2}$ " diam., $\frac{1}{4}$ " face, 25 teeth
25a.	$\frac{1}{2}$ " diam., $\frac{1}{4}$ " face, 25 teeth
25b.	$\frac{1}{2}$ " diam., $\frac{1}{4}$ " face, 25 teeth
26.	$\frac{1}{2}$ " diam., $\frac{1}{4}$ " face, 19 teeth
26a.	$\frac{1}{2}$ " diam., $\frac{1}{4}$ " face, 19 teeth
26b.	$\frac{1}{2}$ " diam., $\frac{1}{4}$ " face, 19 teeth
26c.	$\frac{1}{2}$ " diam., $\frac{1}{4}$ " face, 15 teeth



GEAR WHEELS

27.	1 $\frac{1}{2}$ " diam., 50 teeth
27a.	1 $\frac{1}{2}$ " diam., 57 teeth
27b.	3 $\frac{1}{2}$ " diam., 133 teeth
27c.	2 $\frac{1}{2}$ " diam., 95 teeth
27d.	1 $\frac{1}{2}$ " diam., 60 teeth



CONTRATE WHEELS

28.	1 $\frac{1}{2}$ " diam., 50 teeth
29.	$\frac{1}{2}$ " diam., 25 teeth

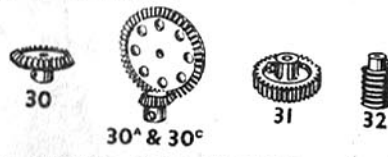

30. Bevel Gear, $\frac{1}{2}$ " diam., 26 teeth (for use in pairs)
30a. Bevel Gear, $\frac{1}{2}$ " diam., 16 teeth } Can only be used together
30b. Bevel Gear, 1 $\frac{1}{2}$ " diam., 48 teeth }
30c. Bevel Gear, 1 $\frac{1}{2}$ " diam., 48 teeth }
31. Gear Wheel, 1" diam., $\frac{1}{4}$ " face, 38 teeth
32. Worm, $\frac{1}{2}$ " diam.
34. Spanner



34b. Box Spanner
35. Spring Clip
36. Screwdriver
36a. Screwdriver (longer)
36c. Drift (for levering bolt holes into line)
37. Nut and Bolt, $\frac{1}{8}$ "
37a. Nut
37b. Bolt, $\frac{1}{8}$ "
38. Washer
38d. Washer, $\frac{1}{8}$ "
40. Hank of Cord



41. Propeller Blade | 43. Tension Spring, 2" long



No. 44. Bent Strip, stepped
45. Double Bent Strip

DOUBLE ANGLE STRIPS

46.	2 $\frac{1}{2}$ " x 1"	48.	1 $\frac{1}{2}$ " x $\frac{1}{2}$ "	48c.	4 $\frac{1}{2}$ " x $\frac{1}{2}$ "
47.	2 $\frac{1}{2}$ " x 1 $\frac{1}{2}$ "	48a.	2 $\frac{1}{2}$ " x $\frac{1}{2}$ "	48d.	5 $\frac{1}{2}$ " x $\frac{1}{2}$ "
47a.	3" x 1 $\frac{1}{2}$ "	48b.	3 $\frac{1}{2}$ " x $\frac{1}{2}$ "		

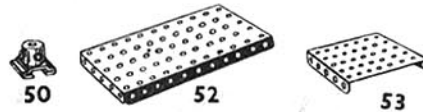

50. Slide Piece
51. Flanged Plate, 2 $\frac{1}{2}$ " x 1 $\frac{1}{2}$ "
52. Flanged Plate, 5 $\frac{1}{2}$ " x 2 $\frac{1}{2}$ "
52a. Flat Plate, 5 $\frac{1}{2}$ " x 3 $\frac{1}{2}$ "
53. Flanged Plate, 3 $\frac{1}{2}$ " x 2 $\frac{1}{2}$ "
53a. Flat Plate, 4 $\frac{1}{2}$ " x 2 $\frac{1}{2}$ "



54. Flanged Sector Plate, 4 $\frac{1}{2}$ " long
55. Perforated Strip, slotted, 5 $\frac{1}{2}$ " long
55a. Perforated Strip, slotted, 2" long



57b. Hook, Loaded, Large
57c. Hook, Loaded, Small
58. Spring Cord, 40" length
58a. Coupling Screw for Spring Cord
58b. Hook for Spring Cord
59. Collar, with screw



61. Windmill Sail
62. Crank
62a. Threaded Crank
62b. Double Arm Crank



63. Coupling
63b. Strip Coupling
63c. Threaded Coupling
63d. Short Coupling



64. Threaded Boss
65. Centre Fork
69. Set Screw, $\frac{1}{8}$ "
69a. Grub Screw, $\frac{1}{8}$ "
69b. Grub Screw, $\frac{3}{16}$ "
69c. Grub Screw, $\frac{1}{4}$ "

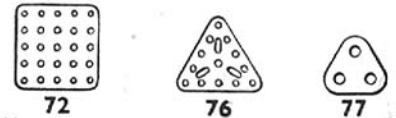

No. 72. Flat Plate, 5 $\frac{1}{2}$ " x 2 $\frac{1}{2}$ "
72. Flat Plate, 2 $\frac{1}{2}$ " x 2 $\frac{1}{2}$ "
73. Flat Plate, 3" x 1 $\frac{1}{2}$ "
76. Triangular Plate, 2 $\frac{1}{2}$ "
77. Triangular Plate, 1"



SCREWED RODS

78.	11 $\frac{1}{2}$ "	80.	5"	80c.	3"
79.	8"	80a.	3 $\frac{1}{2}$ "	81.	2"
79a.	6"	80b.	4 $\frac{1}{2}$ "	82.	1"

CURVED STRIPS

89.	5 $\frac{1}{2}$ " (10" radius)
89a.	Stepped, 3" (1 $\frac{1}{2}$ " radius)
89b.	Stepped, 4" (4 $\frac{1}{2}$ " radius)
90.	2 $\frac{1}{2}$ " (2 $\frac{3}{4}$ " radius)
90a.	Stepped, 2 $\frac{1}{2}$ " (1 $\frac{1}{2}$ " radius)

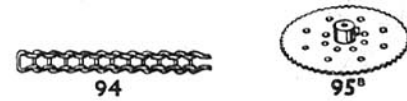

94. Sprocket Chain, 40" length

SPROCKET WHEELS

95.	2" diam., 36 teeth	96.	1" diam., 18 teeth
95a.	1 $\frac{1}{2}$ " diam., 28 teeth	96a.	$\frac{3}{4}$ " diam., 14 teeth
95b.	3" diam., 56 teeth		

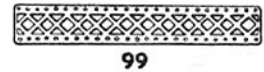

BRACED GIRDERS

97.	3 $\frac{1}{2}$ " long	99.	12 $\frac{1}{2}$ " long	100.	5 $\frac{1}{2}$ " long
97a.	3" long	99a.	9 $\frac{1}{2}$ " long	100a.	4 $\frac{1}{2}$ " long
98.	2 $\frac{1}{2}$ " long	99b.	7 $\frac{1}{2}$ " long		



101. Heald for Loom | 102. Single Bent Strip

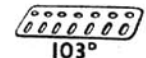

FLAT GIRDERS

103.	5 $\frac{1}{2}$ " long	103d.	3 $\frac{1}{2}$ " long	103h.	1 $\frac{1}{2}$ " long
103a.	9 $\frac{1}{2}$ " long	103e.	3" long	103k.	7 $\frac{1}{2}$ " long
103b.	12 $\frac{1}{2}$ " long	103f.	2 $\frac{1}{2}$ " long		
103c.	4 $\frac{1}{2}$ " long	103g.	2" long		

MECCANO PARTS

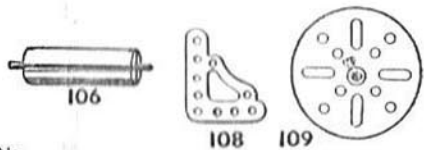

- No. 106. Wood Roller (complete with Rod and two Collars)
 108. Corner Gusset
 109. Face Plate, 2½" diam.

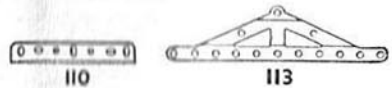

110. Rack Strip, ¾" long | 110a. Rack Strip, 6½" long

BOLTS

111. ¾" | 111c. ¾"
 111a. ½" | 111d. 1½"
 113. Girder Frame

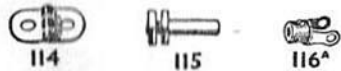

114. Hinge | 116. Fork Piece, large
 115. Threaded Pin | 116a. Fork Piece, small



118. Hub Disc, 5½" diam.



- 120b. Compression Spring, ¾" long
 122. Loaded Sack



123. Cone Pulley, 1½", 1" and ¾" diam.
 124. Reversed Angle Bracket, 1"
 125. Reversed Angle Bracket, ½"

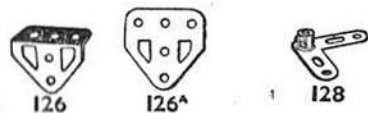

126. Trunnion
 126a. Flat Trunnion
 128. Bell Crank, with boss



- No. 130. Eccentric, Triple Throw, ¼", ¾" and 1"
 130a. Eccentric, Single Throw, ¼"

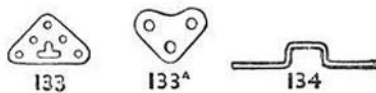

133. Corner Bracket, 1½"
 133a. Corner Bracket, 1"
 134. Crank Shaft, 1" stroke



136. Handrail Support | 136a. Handrail Coupling



137. Wheel Flange | 138. Ship's Funnel, Raked



139. Flanged Bracket (right)
 139a. Flanged Bracket (left)
 140. Universal Coupling

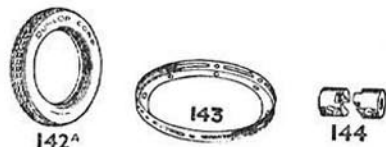

- 142a. Motor Tyre (to fit 2" diam. rim)
 142b. Motor Tyre (to fit 3" diam. rim)
 142c. Motor Tyre (to fit 1" diam. rim)
 142d. Motor Tyre (to fit 1½" diam. rim)
 143. Circular Girder, 5½" diam.
 144. Dog Clutch

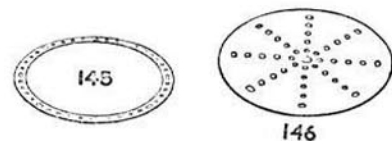

145. Circular Strip, 7½" diam. overall
 146. Circular Plate, 6" diam. overall
 146a. Circular Plate, 4" diam. overall

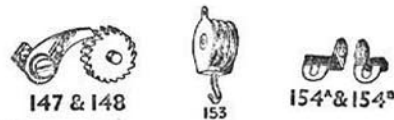

- No. 147. Pawl, with Pivot Bolt and nuts
 147a. Pawl
 147b. Pivot Bolt, with two nuts
 147c. Pawl, without boss
 148. Ratchet Wheel
 151. Single Pulley Block
 153. Triple Pulley Block
 154a. Corner Angle Bracket, ½" (right-hand)
 154b. Corner Angle Bracket, ½" (left-hand)
 155. Rubber Ring (for 1" Pulley)



157. Fan, 2" diam.
 160. Channel Bearing, 1½" x 1" x ½"
 161. Girder Bracket, 2" x 1" x ½"



162. Boiler, complete, 5" long x 2½" diam.
 162a. Boiler Ends, 2½" diam. x ½"
 163. Sleeve Piece, 1½" long x ½" diam.
 164. Chimney Adaptor, ¾" diam. x ½" high



165. Swivel Bearing
 165. End Bearing
 167b. Flanged Ring, 9½" diam.
 168. Ball Thrust Bearing, 4" diam.
 168a. Ball Thrust Race, flanged disc, 3½" diam.
 168b. Ball Thrust Race, toothed disc, 4" diam.
 168c. Ball Cage, 3½" diam., complete with balls
 168d. Ball, ¾" diam.

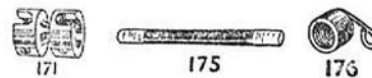

171. Socket Coupling
 173a. Adaptor for Screwed Rod
 175. Flexible Coupling Unit
 176. Anchoring Spring for Cord



179. Rod Socket
 180. Gear Ring, 3½" diam. (133 ext. teeth, 95 int.)



- No. 185. Steering Wheel, 13" diam.
 187. Conical Disc, 1½" diam.

DRIVING BANDS

186. 2½" (light) | 186c. 10" (heavy)
 186a. 6" (light) | 186d. 15" (heavy)
 186b. 10" (light) | 186e. 20" (heavy)
 187. Road Wheel, 2½" diam.
 187a. Conical Disc, 1½" diam.

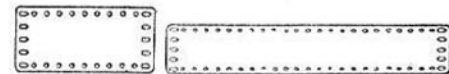

- 192 | 197

FLEXIBLE PLATES

188. 2½" x 1½" | 190. 2½" x 2½" | 191. 4½" x 2½"
 189. 5½" x 1½" | 190a. 3½" x 2½" | 192. 5½" x 2½"

STRIP PLATES

196. 9½" x 2½" | 197. 12½" x 2½"



198. Hinged Flat Plate, 4½" x 2½"
 199. Curved Plate, "U"-section, 2½" x 2½" x ½" radius
 200. Curved Plate, 2½" x 2½" x 1½" radius



- 211a. Helical Gear, ½" | Can only be used
 211b. Helical Gear, 1½" | together
 212. Rod and Strip Connector
 212a. Rod and Strip Connector, right-angle
 213. Rod Connector
 213a. Three-way Rod Connector
 213b. Three-way Rod Connector with boss



214. Semi-circular Plate, 2½"
 215. Formed Slotted Strip, 3"
 216. Cylinder, 2½" long, 1½" diam.

TRIANGULAR FLEXIBLE PLATES

221. 2½" x 1½" | 223. 2½" x 2½" | 225. 3½" x 2"
 222. 2½" x 2" | 224. 3½" x 1½" | 226. 3½" x 2½"
 230. 4" Rod with Keyway
 231. Key Bolt