

# MECCANO

REGISTERED TRADE MARK



**INSTRUCTIONS for OUTFIT No. 3**

COPYRIGHT BY MECCANO LIMITED  
BINNS ROAD, LIVERPOOL 13, ENGLAND

55.3



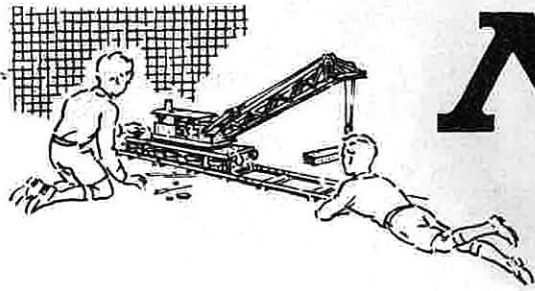

# MECCANO

Registered Trade Mark

The World's Greatest Constructional Toy

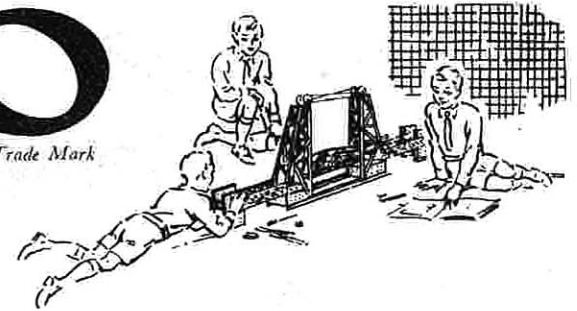

## MODEL-BUILDING WITH MECCANO

There is no limit to the number of models that can be built with Meccano — Cranes, Clocks, Motor Cars, Aeroplanes, Machine Tools, Locomotives — in fact everything that interests boys. A screwdriver and a spanner, both of which are provided in each complete Outfit, are the only tools necessary.

When you have built all the models illustrated in the Books of Instructions the fun is not over, it is just beginning. Now comes the chance to make use of your own ideas. First of all, re-build some of the models with small changes in construction that may occur to you; then try building models entirely of your own design. In doing this you will enjoy the real thrill of the engineer and the inventor.

## HOW TO BUILD UP YOUR OUTFIT

Meccano is sold in 12 different Outfits, ranging from No. 00 to No. 10. Each Outfit can be converted into the next larger one by the purchase of an Accessory Outfit. Thus Meccano No. 00 Outfit can be converted into No. 0 Outfit by adding to it a No. 00a Accessory Outfit. No. 0a Outfit would then convert it into a No. 1 and so on. In this way, no matter with which Outfit you begin, you can build it up by degrees until you have a complete No. 10 Outfit.

All Meccano parts are of the same high quality and finish, but the larger Outfits contain a greater quantity and variety, making possible the construction of more elaborate models.

## THE 'MECCANO MAGAZINE'

The 'Meccano Magazine' is published specially for Meccano boys. Every month it describes and illustrates new Meccano models, and deals with suggestions from readers for new Meccano parts and for new methods of using the existing parts.

There are model-building competitions specially planned to give an equal chance to the owners of small and large Outfits. In addition, there are splendid articles on such subjects as Railways, Famous Engineers and Inventors, Electricity, Bridges, Cranes and Aeroplanes, and special sections dealing with the latest Engineering, Aviation, Motoring

and Shipping News. Other pages deal with Stamp Collecting, and Books of interest to boys; and a feature of outstanding popularity is the section devoted to short articles from readers.

Write to the Editor, The Meccano Magazine, Binns Road, Liverpool 13, for particulars and a specimen copy. You can order the Magazine from your Meccano dealer, or from any newsagent.

## THE MECCANO GUILD

Every owner of a Meccano Outfit should join the Meccano Guild. This is a world-wide organisation, started at the request of Meccano boys. Its primary object is to bring boys together and to make them feel that they are all members of a great brotherhood, each trying to help others to get the very best out of life. Its members are in constant touch with Headquarters, giving news of their activities and being guided in their hobbies and interests. A leaflet containing full particulars of the Guild and an application form is included in this Book.

Clubs founded and established under the guidance of the Guild Secretary provide Meccano boys with opportunities of enjoying to the utmost the fun of model-building. Each has its Leader, Secretary, Treasurer and other officials. With the exception of the Leader, all the officials are boys, and as far as possible the proceedings of the clubs are conducted by boys.

## MECCANO SERVICE

The service of Meccano does not end with selling an Outfit and a Book of Instructions. If ever you are in any difficulty with your models, or if you want advice on anything connected with this great hobby, write to us. We receive hundreds of interesting letters from boys in all parts of the world, and each of these is answered personally and promptly by one of our staff of experts.

Whatever your problem may be, write to us about it. We shall be delighted to help you in any way possible. Address your letters to **Information Service**.

# Boys!

Read the

## MECCANO MAGAZINE

### THE IDEAL PAPER FOR BOYS

The happiest and most successful boys are those who take a keen interest in the world around them. The 'MECCANO MAGAZINE' is the ideal paper for these boys. Month by month its pages are filled with attractively-written articles, splendidly illustrated from actual photographs.

The subjects include Engineering in all its branches, Railways, Road Transport, Aeroplanes and Shipping. Inventions and Scientific Discoveries are described in simple language. Everything is dealt with in an attractive and straightforward style, and with an accuracy that has won for the Magazine the enthusiastic approval of the engineering, technical and scientific world. Special sections are devoted to Model-building with Meccano, fun with Dinky Toys, and the operation of realistic Miniature Railways; and Stamp Collecting forms still another important feature. Competitions of all kinds, and of a variety to suit every reader, are announced each month.



### WHAT THE GUILD MEANS

The Meccano Guild is an organisation for boys, started at the request of boys, and as far as possible conducted by boys. In joining the Guild a Meccano boy becomes a member of a great brotherhood of world-wide extent. Wherever he happens to be, even in strange countries, he will know that he has met a friend whenever he sees the little triangular badge of membership. The Meccano Guild is bringing together Meccano boys all over the world, and helping them to get the best out of life. At its head — guiding and controlling and taking a personal interest in this great movement — is the President, Mr Roland G. Hornby, son of the inventor of Meccano.

### HOW TO JOIN THE MECCANO GUILD

Any owner of a Meccano Outfit, no matter what its size, may become a member. All he has to do is to fill in the official application form on the back of this leaflet, have his signature witnessed, and send the form to Headquarters with a postal order (not stamps) for the necessary amount in payment for the official badge, which he will wear in his buttonhole.

The price of the badge for boys living in the British Isles is 1/-. For those living overseas it is 1/6 (30 cents in Canada).

Applicants living in Canada, Australia, New Zealand or South Africa should write to the Meccano agents in their countries. Their addresses are as follows:

CANADA: Meccano Ltd, 675 King Street West, Toronto.

AUSTRALIA: E. G. Page & Co. (Sales) Pty. Ltd (P.O. Box 1832), Dank's Building, 324 Pitt Street, Sydney, N.S.W.

NEW ZEALAND: Models Ltd (P.O. Box 129), 53 Fort Street, Auckland, C.I.

SOUTH AFRICA: Arthur E. Harris (Pty.) Ltd (P.O. Box 1199), 142 Market Street, Johannesburg.

Their Badges and Certificates are then forwarded without delay, while their application forms are sent to Headquarters in Liverpool.

Applicants living in any other country overseas should forward their forms, with a British postal order (not stamps) or a money order for 1/6, direct to the Secretary, the Meccano Guild, Binns Road, Liverpool, 13.

Guild members are eligible for the Correspondence Club, by which they are placed in touch with other members in various parts of the world. Full particulars and enrolment forms can be obtained from the Secretary.

The Secretary will send also, on request, full details of the Guild Recruiting Campaign, and of the Medallion awarded to members who are successful in obtaining recruits, together with particulars of the Meccano clubs founded and established by enthusiastic Meccano boys. A special booklet, 'How to run a Meccano Club' will be sent post free to any member on receipt of 2d. in stamps.

Join the

## MECCANO GUILD

# MECCANO MAGAZINE

*for the really modern boy*

The 'MECCANO MAGAZINE' is on sale at all bookstalls, newsagents and Meccano dealers, price 1/-. If you prefer to have each issue sent direct, the subscription rates are 14/- for twelve months or 7/- for six months, including postage, and an order form is attached.

The overseas prices of the 'M.M.' are 12c. in Canada, 1/3 in Australia, 15c. in the U.S.A. and 9d. elsewhere.

## ORDER FORM

TO THE EDITOR,  
MECCANO MAGAZINE,  
BINNS ROAD, LIVERPOOL 13.

I enclose Postal Order for..... Please post the  
'MECCANO MAGAZINE' for..... months, beginning with  
the..... issue.

NAME (IN BLOCK LETTERS).....

ADDRESS.....  
.....

# MECCANO GUILD

## THE THREE GREAT OBJECTS OF THE GUILD

- To make every boy's life brighter and happier.
- To foster clean-mindedness, truthfulness, ambition and initiative in boys.
- To encourage boys in their hobbies, and especially in the development of their knowledge of mechanical and engineering principles.



Headquarters: BINNS ROAD LIVERPOOL 13

## APPLICATION FOR MEMBERSHIP

I possess a Meccano Outfit, and I hereby make application for membership of the Meccano Guild.  
I approve of the objects of the Guild, and I promise on my honour

- (1) To conform to the rules and regulations of the Meccano Guild.
- (2) To promote its objects by my own example: to be helpful to others; to be clean in thought and habit; to be determined to learn and make progress.
- (3) To wear the Meccano Guild Badge on all possible occasions.
- (4) To recognise and acknowledge all other Members wearing the Guild Badge, and to render them help in case of need.

I enclose 1/- for the Guild Badge (Great Britain).

I enclose 1/6 for the Guild Badge (Overseas).

I enclose 30c. for the Guild Badge (Canada).

Strike out line not applicable (See other side of this form).

NAME OF APPLICANT.....  
(BLOCK LETTERS PLEASE)

ADDRESS.....  
.....

DATE..... AGE.....

WITNESS .....

ADDRESS.....

The witness should be the Parent, Guardian, Employer, Schoolmaster or Church Minister and should state which when signing.



# HOW TO BEGIN THE FUN

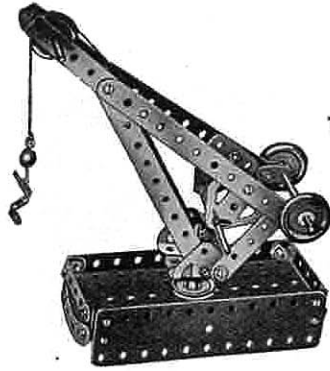

This Dockside Crane can be built with Outfit No. 1

## THE MOST FASCINATING OF ALL HOBBIES

Meccano model-building is the most fascinating of all hobbies, because it never becomes dull. There is always something new to be done. First of all there is the fun of building a new model, and watching it take shape as part after part is added. Then, when the model is complete, comes the thrill of setting it to work just like the real structure it represents, by means of a Meccano Motor.

The following hints are given to show boys who are just starting the wonderful Meccano hobby how to get the greatest possible fun.

## A FEW USEFUL HINTS

It will be noticed that with each model in this Book of Instructions is given a list of the parts required to build it. For the first few models it is a good plan to lay out on the table all the parts required for the one it is proposed to build, and put the remainder of the Outfit to one side. To help you to pick out the correct parts for your model a complete list of Meccano parts is given at the back of this Book, and all the principal parts are illustrated. In the list the parts are all numbered, and in most cases their measurements are given. There is no need, however, to measure the parts to find out which is which, as the size is easily found from the number of holes. All Meccano holes are spaced  $\frac{1}{2}$ " apart, so that by counting two holes to the inch the size of a part can be found at once. For instance, Part No. 2 is listed as a  $5\frac{1}{2}$ " Perforated Strip, so you look in your Outfit for a Strip with eleven holes. Similarly No. 189 is a  $5\frac{1}{2}$ "  $\times$   $1\frac{1}{2}$ " Flexible Plate, so you look for a Flexible Plate eleven holes in length and three holes in width. By the time a few models have been built the names of the parts will have become familiar.

Beginners sometimes wonder which section of a model should be built first. There cannot be any definite rule for this, as it depends on the design of the model. In stationary models the base usually should be built first. In most of the small models a  $5\frac{1}{2}$ "  $\times$   $2\frac{1}{2}$ " Flanged Plate forms an important part of the structure, and often the best plan is to start building by bolting parts to this Plate. For other models a good general rule is that the sections that form supports for a number of other parts should be built first.

During the construction of a model it is best to screw up the nuts with the fingers, followed by a light turn with the screwdriver, leaving the final tightening until all the parts are connected up.

## THE IMPORTANCE OF LOCK-NUTTING

In some models it is necessary to join certain parts together so that, although they cannot come apart, they are free to pivot or move in relation to one another. To do this the parts are bolted together as usual, but the nut is not screwed up tightly, so that the parts are not gripped. Then, to prevent the nut from unscrewing, a second nut is screwed up tightly against it, the first nut being held with a spanner. This method of using a second nut is known as *Lock-nutting*.

In building models in which Rods revolve in the holes of other parts it is important to make sure that such holes are exactly in line with one another. This can be done by pushing through the holes a Drift, Part No. 36c, or a Rod, before the Bolts holding the various parts are tightened up.

A Rod is usually mounted in a support or bearing so that it is free to revolve. The Rod is then said to be *Journalled* in the Strip.

## DRIVING YOUR MODELS

Models can be driven by means of either clockwork or electric motors. Ask your Dealer for particulars of Meccano Clockwork and Electric Motors.

Small and light models may be driven direct from the driving pulley of the motor or through a belt running over two pulleys of the same size, giving what is known as a 1 : 1 (one-to-one) ratio. For large models it is necessary to take the drive from a small pulley on the motor shaft to a larger pulley on the driving shaft of the model. In most cases a 1" Pulley on the motor shaft and a 3" Pulley on the model shaft will be found satisfactory. This provides a reduction ratio of approximately 3 : 1.

Rubber bands are very convenient for driving belts. Sometimes, however, a rubber band of the right length is not available, and then Meccano Cord or thin string is used. To tie the Cord to form an endless belt, use the familiar reef knot.

All Outfits from No. 2 upward include a Cord Anchoring Spring, Part No. 176. This part provides a neat and positive method of fastening a length of Cord to a Rod. The Spring is placed on a Rod by pushing and turning it in such a way that its coils tend to unwind.

Flexible Plates are used for forming curved surfaces in models, but they are not intended to be bent at right angles. With careful handling a Plate can be bent to the required curve and after use straightened again.

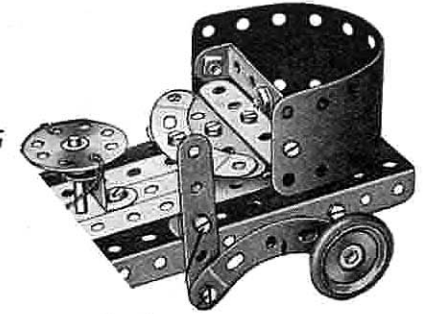

A Flexible Plate used to form a curved surface

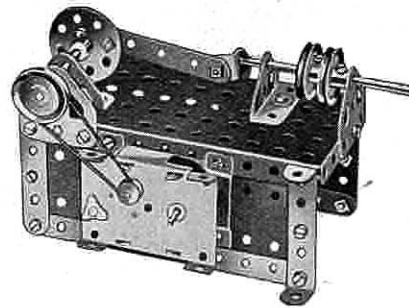

A 'Magic' Motor fitted to drive a Steam Engine

### O.1 ELEVATOR

Parts Required	
4 of No. 2	15 of No. 37b
2 " " 5	2 " " 48a
1 " " 16	1 " " 52
1 " " 19s	2 " " 126
1 " " 22	2 " " 126a
4 " " 35	
15 " " 37a	

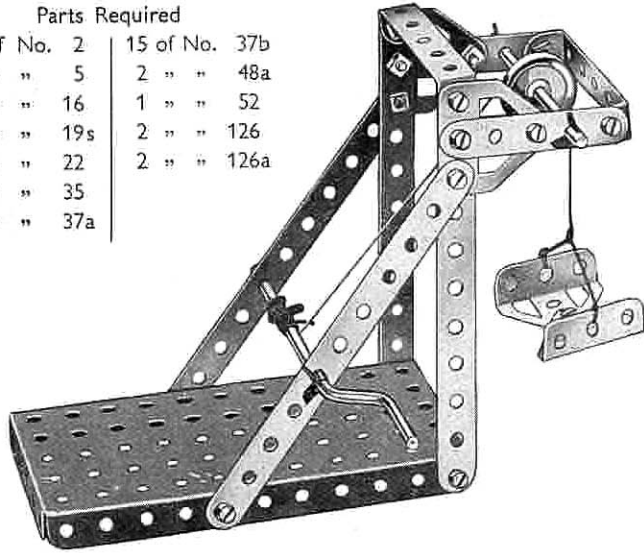

### O.2 BLACKSMITH

Parts Required	
2 of No. 5	
2 " " 10	
4 " " 12	
1 " " 16	
1 " " 17	
1 " " 19s	
2 " " 22	

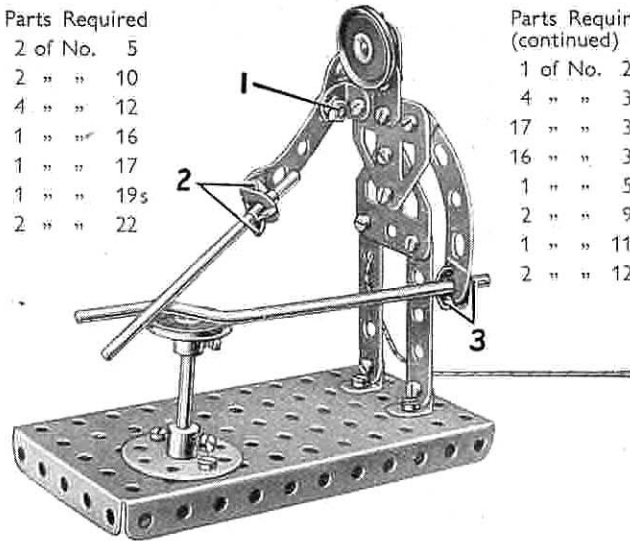

Parts Required (continued)	
1 of No. 24	
4 " " 35	
17 " " 37a	
16 " " 37b	
1 " " 52	
2 " " 90a	
1 " " 111c	
2 " " 126a	

The arm holding the hammer is a 2 1/2" stepped Curved Strip, pivoted to an Angle Bracket by a lock-nutted Bolt (1). The hammer is a 3/4" Rod held in an Angle Bracket at the end of the arm by two Spring Clips (2). The Crank Handle is fixed in the other arm by the Spring Clips (3).

### O.3 GARDEN SEAT

Parts Required	
4 of No. 2	
2 " " 5	
10 " " 37a	
10 " " 37b	
2 " " 48a	
1 " " 52	

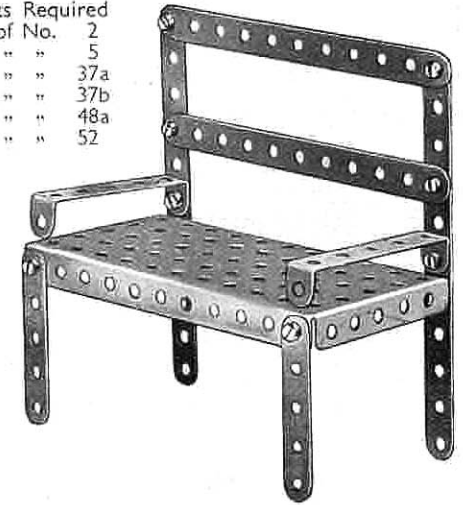

### O.4 STATION TRUCK

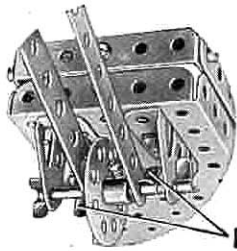

Fig. O.4a

The 5 1/2" Strips forming the handle are placed one on each side of a Bush Wheel on the front axle, and they are held in place by Spring Clips (1) as shown in Fig. O.4a.

Parts Required		
4 of No. 2	2 of No. 22	2 of No. 48a
1 " " 5	1 " " 24	1 " " 52
2 " " 10	4 " " 35	2 " " 90a
2 " " 12	17 " " 37a	2 " " 126
1 " " 16	17 " " 37b	2 " " 126a
1 " " 17	1 " " 38	2 " " 142c

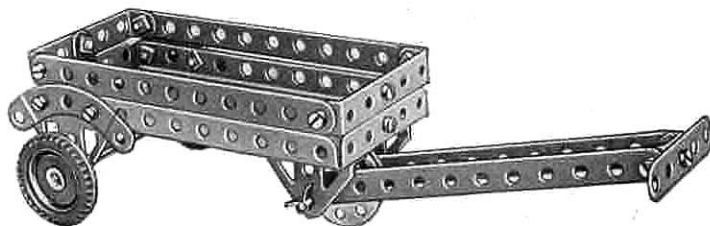
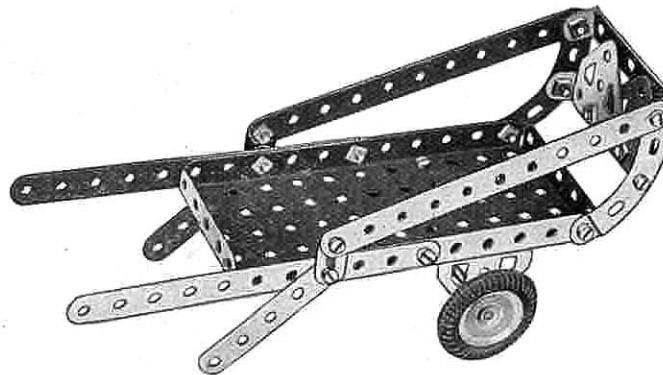

Fig. O.4

### O.5 COSTER'S BARROW



Parts Required		
4 of No. 2	2 of No. 22	2 of No. 90a
2 " " 5	16 " " 37a	2 " " 126
2 " " 10	16 " " 37b	2 " " 126a
1 " " 16	2 " " 48a	2 " " 142c
	1 " " 52	

### O.6 BUCKING BRONCHO

The Bolts (1) are fitted with lock-nuts so that the parts they attach are free to pivot. Bearings for a 2" Rod, the end of which is seen at (2), are provided by a Fishplate (3), Fig. O.6a, bolted to an Angle Bracket (4), and a Trunnion (5).

Parts Required	
2 of No. 5	20 of No. 37a
4 " " 10	15 " " 37b
1 " " 12	1 " " 38
1 " " 17	1 " " 48a
1 " " 19s	1 " " 52
2 " " 22	2 " " 90a
1 " " 24	2 " " 111c
4 " " 35	2 " " 126
	2 " " 126a

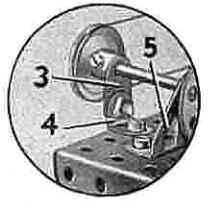

Fig. O.6a.

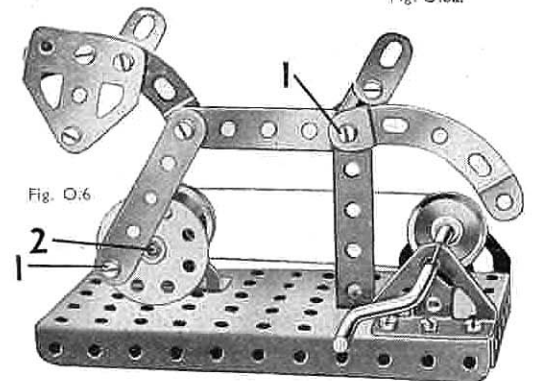
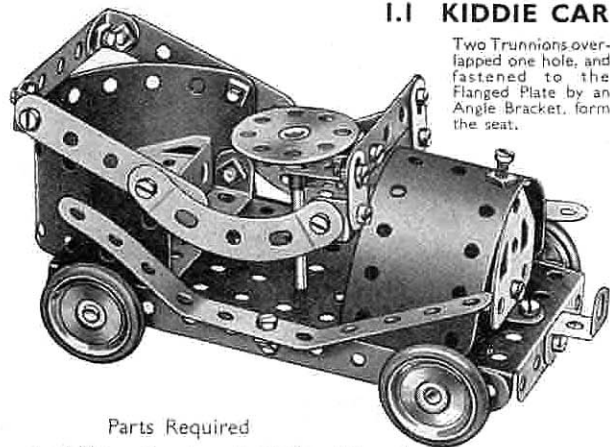

Fig. O.6



### I.1 KIDDIE CAR

Two Trunnions overlapped one hole, and fastened to the Flanged Plate by an Angle Bracket, form the seat.



Parts Required

4 of No. 2	1 of No. 24	2 of No. 111c
4 " " 5	1 " " 35	1 " " 125
3 " " 10	27 " " 37a	2 " " 126
7 " " 12	24 " " 37b	1 " " 126a
2 " " 16	2 " " 48a	4 " " 155
1 " " 17	1 " " 52	2 " " 189
4 " " 22	2 " " 90a	

### I.2 LETTER BALANCE

The Bolts (1) are lock-nutted. The  $\frac{3}{8}$ " Bolt (2) is passed through the hole of the Angle Bracket and then held by the screw in the boss of the 1" Pulley.

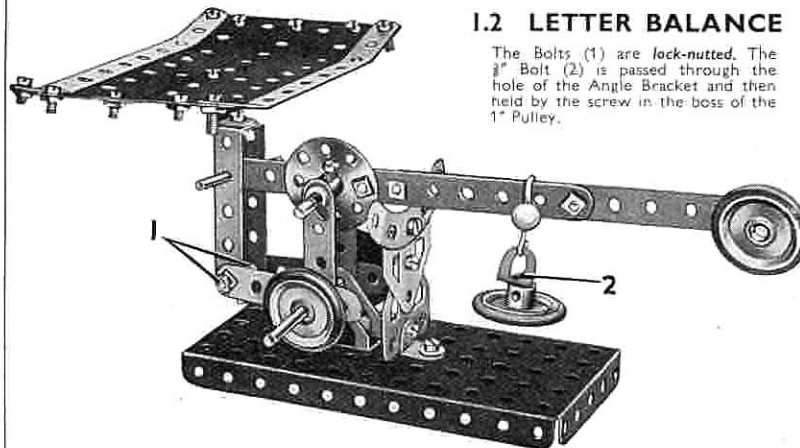

Parts Required

4 of No. 2	4 of No. 22	4 of No. 38	4 of No. 111c
4 " " 5	1 " " 24	2 " " 48a	1 " " 125
4 " " 10	4 " " 35	1 " " 52	2 " " 126
2 " " 12	28 " " 37a	1 " " 57c	2 " " 126a
1 " " 16	24 " " 37b	1 " " 90a	4 " " 155
2 " " 17			2 " " 189

### I.3 RACING SEAPLANE

Each of the floats is secured to the wings by two Angle Brackets and one Fishplate.

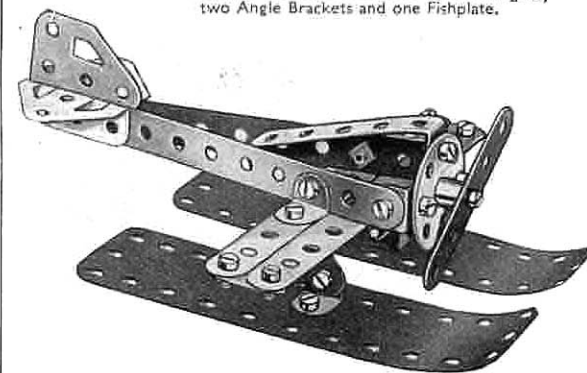

Parts Required

3 of No. 2	1 of No. 24	2 of No. 111c
3 " " 5	20 " " 37a	2 " " 126
4 " " 10	19 " " 37b	1 " " 126a
8 " " 12	1 " " 48a	2 " " 189

### I.4 RAILWAY BREAKDOWN CRANE

The hoisting Cord is secured to the Crank Handle and then led over the  $\frac{1}{2}$ " Bolt (1). It is then passed through the pulley block and fastened to the jib at (2). The jib is attached to the Bush Wheel (3) by means of Angle Brackets, and the complete unit is pivoted as follows. A  $\frac{3}{8}$ " Bolt is passed through the  $5\frac{1}{2}$ " x  $2\frac{1}{2}$ " Flanged Plate from the underside, and is secured in the boss of the Bush Wheel by its set screw.

Parts Required

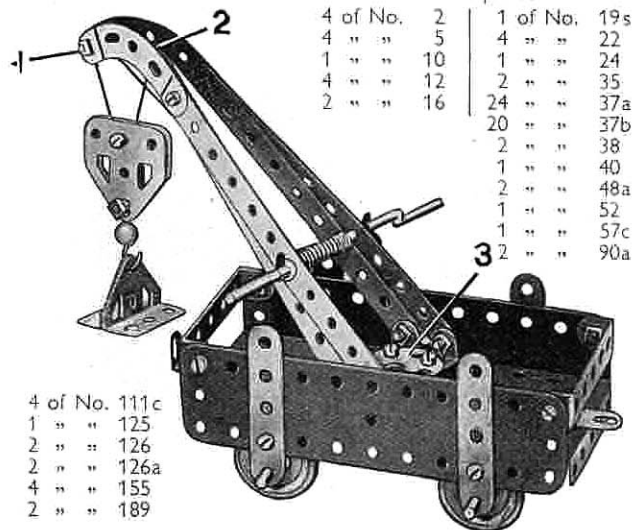

4 of No. 2	1 of No. 19s
4 " " 5	4 " " 22
1 " " 10	1 " " 24
4 " " 12	2 " " 35
2 " " 16	24 " " 37a
	20 " " 37b
	2 " " 38
	1 " " 40
	2 " " 48a
	1 " " 52
	1 " " 57c
	2 " " 90a

4 of No. 111c
1 " " 125
2 " " 126
2 " " 126a
4 " " 155
2 " " 189

### I.5 TRICYCLE VAN

Parts Required

4 of No. 2	1 of No. 17	24 of No. 37b	2 of No. 111c
3 " " 5	3 " " 22	3 " " 38	2 " " 126
3 " " 10	1 " " 24	2 " " 48a	2 " " 126a
6 " " 12	4 " " 35	1 " " 52	2 " " 142c
2 " " 16	27 " " 37a	2 " " 90a	2 " " 189

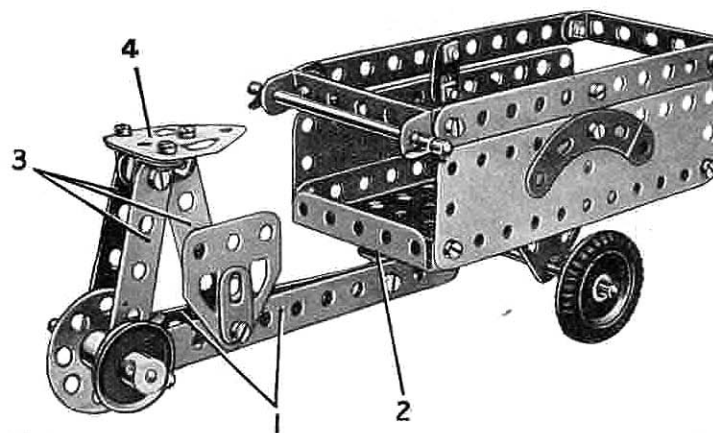

The frame of the cycle consists of two  $5\frac{1}{2}$ " Strips (1) connected at one end by a bolt that fixes them also to an Angle Bracket (2). The Angle Bracket pivots on a bolt lock-nutted to the Flanged Plate. The seat is carried by three  $2\frac{1}{2}$ " Strips (3), each of which is connected by an Angle Bracket to the Flat Trunnion (4). The front axle is carried in Trunnions bolted underneath the Flanged Plate.

### I.6 STAMPING MILL

The anvil (1) is made up of two Trunnions bolted together. When the Crank Handle is rotated, the Fishplates bolted to the Bush Wheel strike the centre 1" Pulley on the hammer shaft and cause it to rise and fall.

Parts Required

4 of No. 2	1 of No. 90a
4 " " 5	4 " " 111c
4 " " 10	1 " " 125
4 " " 12	2 " " 126
1 " " 16	2 " " 126a
1 " " 19s	2 " " 189
4 " " 22	
1 " " 24	
2 " " 35	
27 " " 37a	
24 " " 37b	
2 " " 38	
2 " " 48a	
1 " " 52	

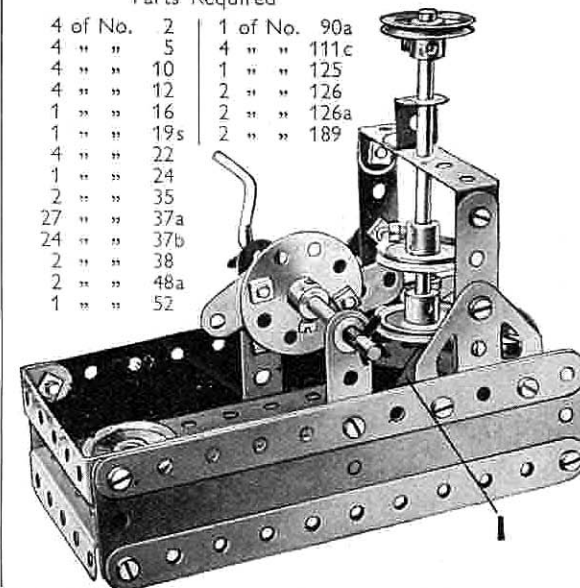

### 1.7 MOTOR LORRY

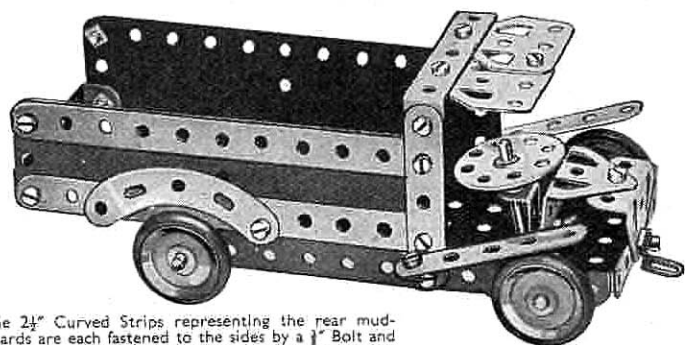

The  $2\frac{1}{2}$ " Curved Strips representing the rear mudguards are each fastened to the sides by a  $\frac{1}{2}$ " Bolt and nut, with a Spring Clip between the mudguards and the  $5\frac{1}{2}$ " Strip to form a distance piece.

Parts Required			
4 of No. 2	4 of No. 22	2 of No. 48a	2 of No. 126
4 " " 5	1 " " 24	1 " " 52	2 " " 126a
3 " " 12	2 " " 35	2 " " 90a	4 " " 155
2 " " 16	23 " " 37a	3 " " 111c	2 " " 189
1 " " 17	19 " " 37b	1 " " 125	

### 1.8 MECHANICAL SHOVEL

The Bolts (1), on which the jib pivots, are *lock-nutted*. The shovel arm is pivoted on a 2" Rod and the shovel is supported by a Cord that passes over the  $\frac{1}{2}$ " Bolt at the jib head and is fastened to a  $2\frac{1}{2}$ " x  $\frac{1}{2}$ " Double Angle Strip as shown. The Cord (2) is fastened to the jib and then passes over a  $3\frac{1}{2}$ " Rod journalled in the holes above the  $2\frac{1}{2}$ " Curved Strips, and is attached to a Fishplate fastened by the *lock-nutted* Bolt (3) to the Bush Wheel.

When the Crank Handle is rotated, the Bush Wheel imparts a digging motion to the jib and shovel arm.

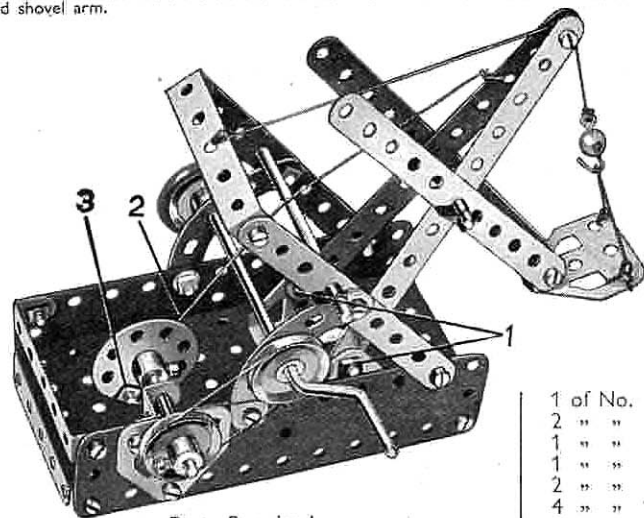

Parts Required			
4 of No. 2	1 of No. 16	1 of No. 24	1 of No. 40
4 " " 5	2 " " 17	28 " " 37a	2 " " 48a
1 " " 10	1 " " 19s	24 " " 37b	1 " " 52
2 " " 12	3 " " 22	4 " " 38	1 " " 57c
			2 " " 90a
			4 " " 111c
			1 " " 125
			2 " " 126
			2 " " 126a
			1 " " 155
			1 " " 19s
			4 " " 22

### 1.9 WINDMILL

The sails are gripped on the  $3\frac{1}{2}$ " Rod by the 1" Pulley (with Rubber Ring) at the front and another 1" Pulley at the back of the sails. The Pulleys are pressed against the faces of the sails and locked on the Rod.

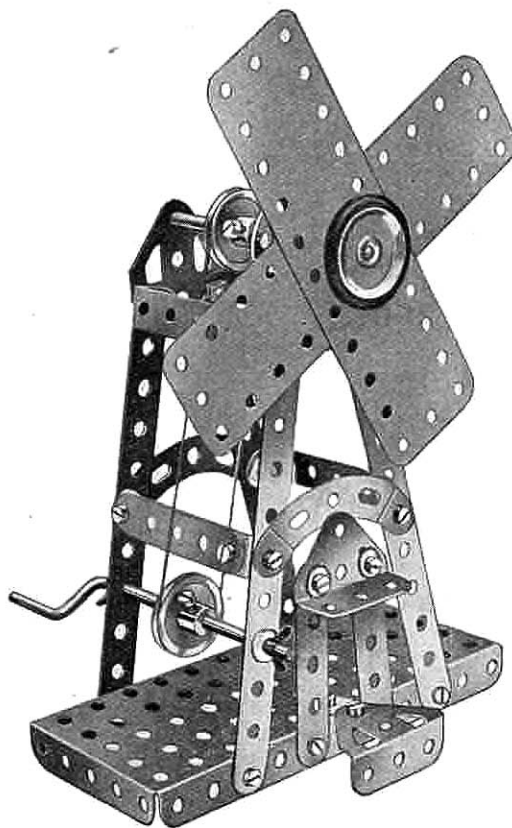

Parts Required		
4 of No. 2	1 of No. 24	1 of No. 52
4 " " 5	3 " " 35	2 " " 90a
1 " " 10	24 " " 37a	2 " " 126
4 " " 12	24 " " 37b	2 " " 126a
1 " " 16	4 " " 38	1 " " 155
1 " " 19s	1 " " 40	2 " " 189
4 " " 22	2 " " 48a	

### 1.10 COASTER

The Bolts (1) are *lock-nutted*. The rear axle Rod is pushed through the end hole of the Curved Strip (2) and through Fishplates bolted to the Flanged Plate.

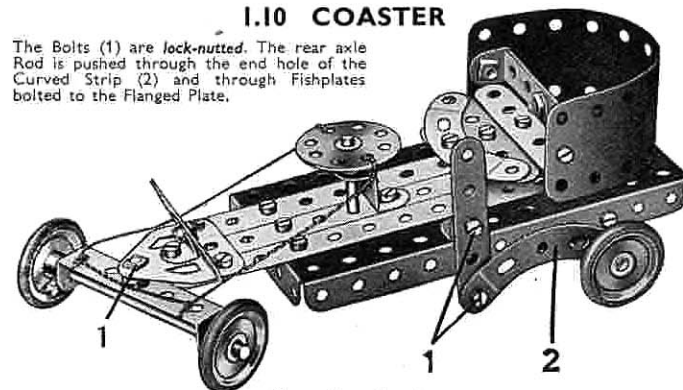

Parts Required			
3 of No. 2	4 of No. 22	1 of No. 40	2 of No. 126
4 " " 5	1 " " 24	2 " " 48a	2 " " 126a
2 " " 10	1 " " 35	1 " " 52	4 " " 155
5 " " 12	24 " " 37a	2 " " 90a	1 " " 189
2 " " 16	20 " " 37b	2 " " 111c	
1 " " 17	4 " " 38	1 " " 125	

### 1.11 STEAM WAGON

The front axle is supported in a  $2\frac{1}{2}$ " x  $\frac{1}{2}$ " Double Angle Strip (1) *lock-nutted* to a  $\frac{1}{2}$ " Reversed Angle Bracket (2). The Reversed Angle Bracket is bolted to a  $5\frac{1}{2}$ " Strip fixed to the centre of the Flanged Plate. The boiler is a  $5\frac{1}{2}$ " x  $1\frac{1}{2}$ " Flexible Plate rolled into a cylinder, and the Bush Wheel (3) is attached to an Angle Bracket. The roof is made from two Flat Trunnions bolted to a  $2\frac{1}{2}$ " x  $\frac{1}{2}$ " Double Angle Strip (4). The Curved Strips (5) are connected to the Flat Trunnions by Fishplates. A Trunnion (6) at each side is spaced from the Flanged Plate by two Washers.

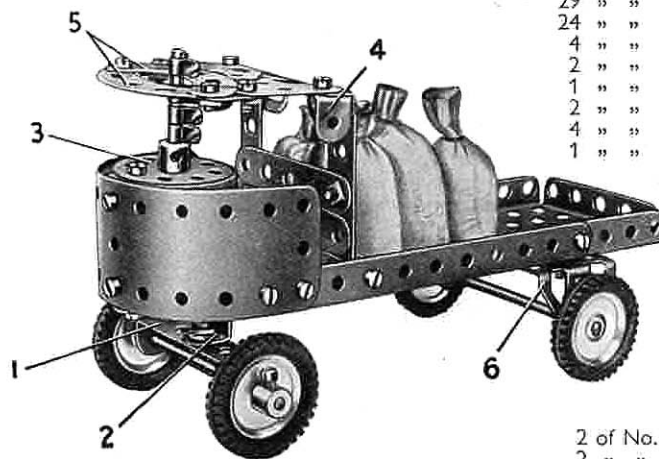

Parts Required	
3 of No. 2	2
4 " " 5	10
2 " " 10	12
4 " " 12	16
2 " " 16	17
1 " " 17	22
4 " " 22	24
1 " " 24	35
4 " " 35	37a
29 " " 37a	37b
24 " " 37b	38
4 " " 38	48a
2 " " 48a	52
1 " " 52	90a
2 " " 90a	111c
4 " " 111c	125
1 " " 125	

2 of No. 126
2 " " 126a
4 " " 142c
2 " " 189



### 2.1 CANAL BRIDGE

**Parts Required**

4 of No.	2
6 " "	5
4 " "	10
6 " "	12
1 " "	16
1 " "	19g
4 " "	22
1 " "	24

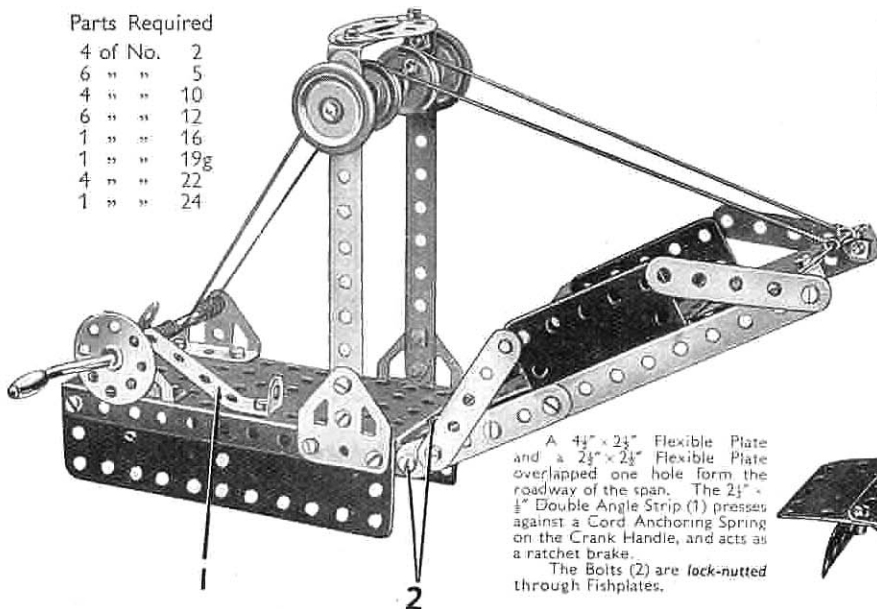

A  $4\frac{1}{2}'' \times 2\frac{1}{2}''$  Flexible Plate and a  $2\frac{1}{2}'' \times 2\frac{1}{2}''$  Flexible Plate overlapped one hole form the roadway of the span. The  $2\frac{1}{2}'' \times \frac{1}{2}''$  Double Angle Strip (1) presses against a Cord Anchoring Spring on the Crank Handle, and acts as a ratchet brake.  
The Bolts (2) are lock-nutted through Fishplates.

**Parts Required (continued)**

41 of No.	37a
39 " "	37b
2 " "	38
1 " "	40
2 " "	48a
1 " "	52
2 " "	90a
2 " "	126
2 " "	126a
2 " "	155
1 " "	176
2 " "	188
2 " "	189
2 " "	190
1 " "	191
1 " "	199
1 " "	200

### 2.2 DRILLING MACHINE

The horizontal  $2\frac{1}{2}''$  Strips at the top of the drill are joined together, and also to the vertical  $2\frac{1}{2}''$  Strips, by means of Angle Brackets. The lower bearings (1) are two Angle Brackets bolted to a  $2\frac{1}{2}''$  Strip, and the Rod forming the drill is journaled in these, and in a Fishplate at its upper end. A  $2\frac{1}{2}'' \times 2\frac{1}{2}''$  Flexible Plate is supported by a Double Angle Strip (2), and represents the table.

The drive is taken from the Motor to the 1" Pulley on the lower shaft. A second driving belt passes round the  $\frac{1}{2}''$  fixed Pulley supplied with the Motor, which is also fixed on the lower shaft, round the two Pulleys at (3), and finally round the 1" Pulley fastened on the vertical drill shaft.

**Parts Required**

2 of No.	2	1 of No.	24	1 of No.	111c
5 " "	5	4 " "	35	2 " "	126
1 " "	10	24 " "	37a	2 " "	126a
5 " "	12	22 " "	37b	1 " "	190
1 " "	16	1 " "	40	1 Magic Motor (not included in Outfit)	
2 " "	17	1 " "	48		
4 " "	22	1 " "	52		

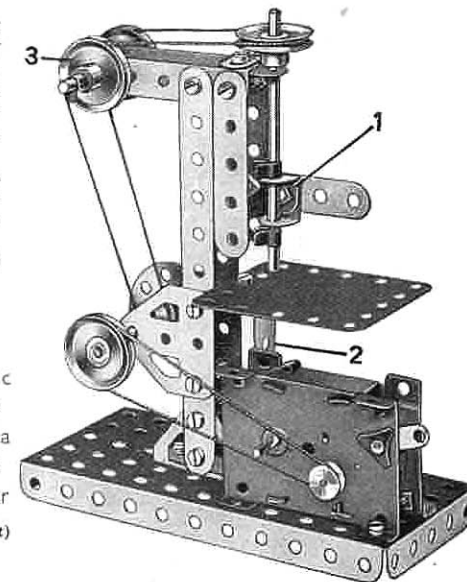

### 2.3 MILK DELIVERY WAGON

4 of No.	2
6 " "	5
2 " "	10
6 " "	12
2 " "	16

4 of No.	22
1 " "	24
37 " "	37a
37 " "	37b

**Parts Required**

4 of No.	38
2 " "	48a
1 " "	52
2 " "	90a

1 of No.	111c	2 of No.	188
1 " "	126	2 " "	189
2 " "	126a	2 " "	190
4 " "	155	1 " "	191
		1 " "	199

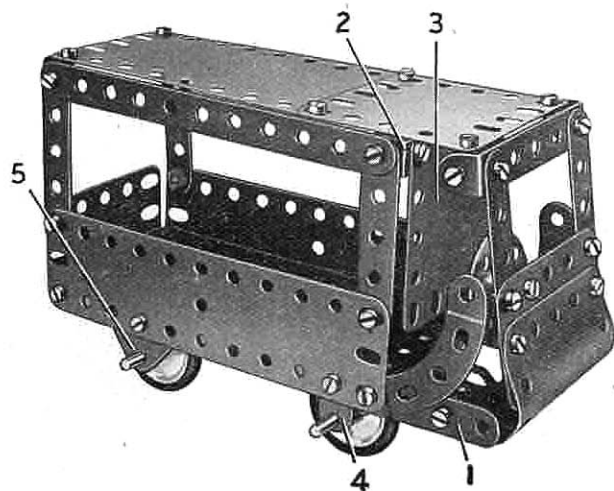

The floor of the wagon is a  $5\frac{1}{2}'' \times 2\frac{1}{2}''$  Flanged Plate placed with its flanges downward, and to each side a  $5\frac{1}{2}''$  Strip (1) is bolted, the Strips extending three holes beyond the Plate. The curved front consists of a "U"-section Curved Plate opened out slightly, and a  $2\frac{1}{2}'' \times 1\frac{1}{2}''$  Flexible Plate. The Curved Plate is connected to Angle Brackets bolted to the Strips (1).

The roof is attached to the side frames of the body and to the windscreen pillars by Angle Brackets, and the side frames are connected together by a  $2\frac{1}{2}'' \times \frac{1}{2}''$  Double Angle Strip (2). A  $2\frac{1}{2}'' \times 2\frac{1}{2}''$  Flexible Plate (3) is bolted to this Double Angle Strip.

The front wheels are fixed on a  $3\frac{1}{2}''$  Rod supported in a Fishplate (4) on each side of the model. The rear axle also is a  $3\frac{1}{2}''$  Rod and it is supported in the Flat Trunnions (5).

### 2.4 MECHANICAL HACKSAW

The base consists of Flexible Plates bolted to a Flanged Plate. One side is formed by a  $4\frac{1}{2}'' \times 2\frac{1}{2}''$  and a  $2\frac{1}{2}'' \times 1\frac{1}{2}''$  Flexible Plate, and the other by two  $5\frac{1}{2}'' \times 1\frac{1}{2}''$  Plates. A  $2\frac{1}{2}'' \times 2\frac{1}{2}''$  Flexible Plate is bolted to each end. The base is strengthened at each end by Double Angle Strips (1) and a  $5\frac{1}{2}''$  Strip on each side.

The saw is actuated by a crank formed from a Bush Wheel fixed to a  $3\frac{1}{2}''$  Rod. The Rod rotates in a Trunnion and a Flat Trunnion. The Trunnion is raised from the Flanged Plate by two Washers. The Rod carries a 1" Pulley (2) and a Road Wheel. The Pulley (2) is connected by a belt of Cord to a similar Pulley fixed on the Crank Handle.

The material to be sawn is clamped to the base by means of two  $2\frac{1}{2}''$  Strips, one of which is shown at (3).

**Parts Required**

3 of No.	2	2 of No.	48a
6 " "	5	1 " "	52
2 " "	12	4 " "	111c
2 " "	16	1 " "	126
1 " "	19g	1 " "	126a
3 " "	22	1 " "	187
1 " "	24	1 " "	188
38 " "	37a	2 " "	189
30 " "	37b	2 " "	190
4 " "	38	1 " "	191
1 " "	40		

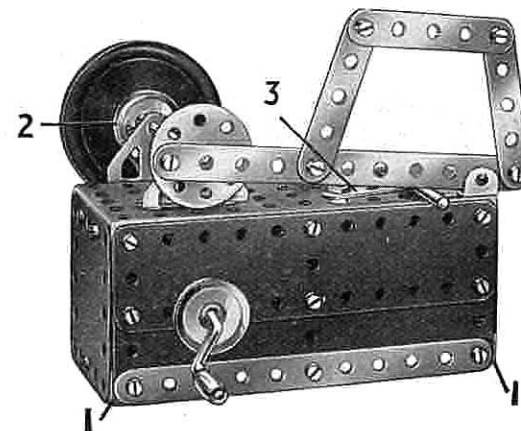

## 2.5 BEAM ENGINE

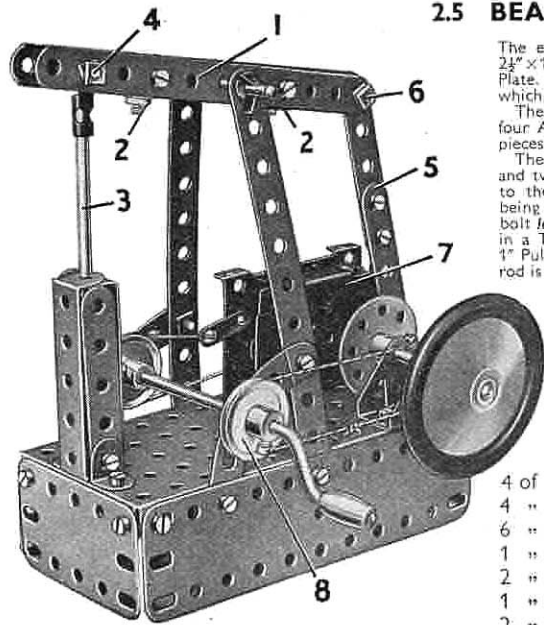

The engine bed or base consists of two  $5\frac{1}{2}'' \times 1\frac{1}{2}''$  and two  $2\frac{1}{2}'' \times 1\frac{1}{2}''$  Flexible Plates bolted to the sides of a Flanged Plate. Two  $5\frac{1}{2}''$  Strips form the supports for the beam (1), which pivots on a 2" Rod held in position by Spring Clips.

The beam is made from two  $5\frac{1}{2}''$  Strips held together by four Angle Brackets bolted in pairs to form two 'U'-shaped pieces. The positions of the pieces are marked (2).

The cylinder consists of two  $2\frac{1}{2}'' \times 1\frac{1}{2}''$  Double Angle Strips and two  $2\frac{1}{2}''$  Strips. The piston rod (3) is a  $3\frac{1}{2}''$  Rod attached to the beam by a Rod and Strip Connector, the Bolt (4) being lock-nutted. The connecting rod (5) is pivoted on a bolt lock-nutted to a Bush Wheel held on a 2" Rod journalled in a Trunnion and a Flat Trunnion. This Rod also carries a 1" Pulley and a Road Wheel. At its upper end the connecting rod is attached to the beam by the lock-nutted Bolt (6).

The Magic Motor (7) is bolted to the base by its flanges, and its pulley is connected by a Driving Band to a 1" Pulley on the Crank Handle. A further 1" Pulley (8) on the Crank Handle is connected by a belt of Cord to the Pulley on the 2" Rod.

### Parts Required

4 of No. 2	5	3 of No. 35	2 of No. 111c
4 " " 5	35 " " 37a	2 " " 126	
6 " " 12	30 " " 37b	1 " " 187	
1 " " 16	3 " " 38	2 " " 188	
2 " " 17	1 " " 40	2 " " 189	
1 " " 19g	2 " " 48a	1 " " 212	
2 " " 22	1 " " 52		
1 " " 24	2 " " 90a	1 Magic Motor	(not included in Outfit)

## 2.7 BACON SLICER

### Parts Required

3 of No. 2	1 of No. 17	40 of No. 37a	2 of No. 48a	1 of No. 125	2 of No. 188
6 " " 5	1 " " 19g	36 " " 37b	1 " " 52	2 " " 126a	2 " " 189
1 " " 10	4 " " 22	3 " " 38	2 " " 90a	1 " " 187	2 " " 190
8 " " 12	1 " " 24	1 " " 40			
1 " " 16	2 " " 35				

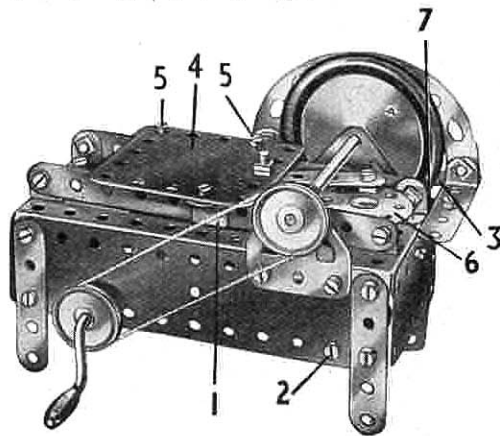

The base of the model consists of a Flanged Plate fitted with four  $2\frac{1}{2}''$  Strips for legs. Two  $5\frac{1}{2}'' \times 1\frac{1}{2}''$  and two  $2\frac{1}{2}'' \times 1\frac{1}{2}''$  Flexible Plates are bolted to the flanges of the Plate.

The guides for the sliding carriage (4) are formed by two  $5\frac{1}{2}''$  Strips attached to the Flanged Plate by Angle Brackets. The carriage consists of a  $2\frac{1}{2}'' \times 2\frac{1}{2}''$  Flexible Plate (4) and is guided along the Strips by the Reversed Angle Bracket (1) and two Angle Brackets on the opposite side. The Angle Brackets are held in place by Bolts (5).

The cutting blade is represented by a Road Wheel fixed on a  $3\frac{1}{2}''$  Rod journalled in two Flat Trunnions. A Pulley on this Rod is connected by a belt of Cord to a second Pulley on the Crank Handle.

The carriage is moved backwards and forwards by a crank consisting of a Bush Wheel (6) fixed on a 2" Rod. This Rod is journalled in the Flanged Plate and in the centre hole of a Double Angle Strip fixed across the interior of the base by the Bolt (2) and another in a similar position on the opposite side. A 1" Pulley on the 2" Rod is connected by a crossed belt of Cord to a further 1" Pulley secured to the Crank Handle between the  $5\frac{1}{2}'' \times 1\frac{1}{2}''$  Flexible Plates.

A guard for the rotating blade is provided by two Curved Strips attached to a  $5\frac{1}{2}''$  Strip (3). This Strip is fastened at one end to the Flanged Plate by a  $2\frac{1}{2}''$  Strip and a Fishplate (7), and at its other end it is attached to a  $2\frac{1}{2}'' \times 2\frac{1}{2}''$  Flexible Plate bolted horizontally to the Flanged Plate.

## 2.6 AUTOGIRO

### Parts Required

4 of No. 2	
6 " " 5	
4 " " 10	
6 " " 12	
1 " " 16	
1 " " 17	
4 " " 22	2 of No. 90a
1 " " 24	1 " " 111c
3 " " 35	1 " " 125
25 " " 37a	2 " " 126a
25 " " 37b	2 " " 155
2 " " 38	2 " " 188
2 " " 48a	1 " " 199

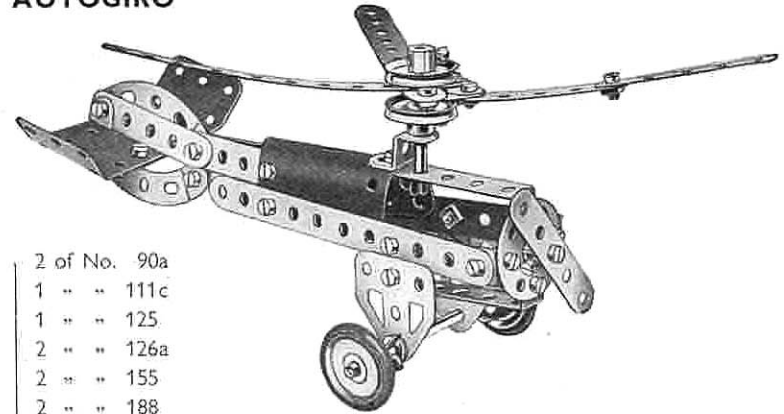

The rotor is made by passing a Rod through the next to end holes of two  $5\frac{1}{2}''$  Strips. Fishplates are bolted to the short ends of the Strips and the third blade of the rotor is fixed to them as shown.

## 2.8 CHARIOT AND DRIVER

The chariot is made by curving a  $5\frac{1}{2}'' \times 1\frac{1}{2}''$  Flexible Plate (1) to make a semi-circle with its ends bolted to the lugs of a  $2\frac{1}{2}'' \times \frac{1}{2}''$  Double Angle Strip. A second  $2\frac{1}{2}'' \times \frac{1}{2}''$  Double Angle Strip is bolted to the first with its lugs pointing downwards, the holes in the lugs forming supports for the chariot axle. A  $1\frac{1}{2}''$  radius Curved Plate is fixed to the front of the  $5\frac{1}{2}'' \times 1\frac{1}{2}''$  Flexible Plate. The shafts are  $5\frac{1}{2}''$  Strips and they are bolted to the  $5\frac{1}{2}'' \times 1\frac{1}{2}''$  Flexible Plate.

The driver's legs are  $2\frac{1}{2}''$  Strips. They are connected to Angle Brackets (2) fixed to a Flat Trunnion that is bolted by its pointed end to the centre holes of the Double Angle Strips. His body is made from two Trunnions joined by a Fishplate, and his arms are attached to the upper Trunnion by Angle Brackets (3). His head is a 1" Pulley held by its set-screw on a  $\frac{3}{8}''$  Bolt passed through a Fishplate (4). The body of the horse is a 'U'-section Curved Plate.

### Parts Required

2 of No. 2	
6 " " 5	
4 " " 10	
6 " " 12	
1 " " 16	
2 " " 17	
4 " " 22	
2 " " 35	
31 " " 37a	
31 " " 37b	
1 " " 40	
2 " " 48a	
2 " " 90a	
1 " " 111c	
2 " " 126	
2 " " 126a	
3 " " 142c	
1 " " 189	
1 " " 199	
1 " " 200	

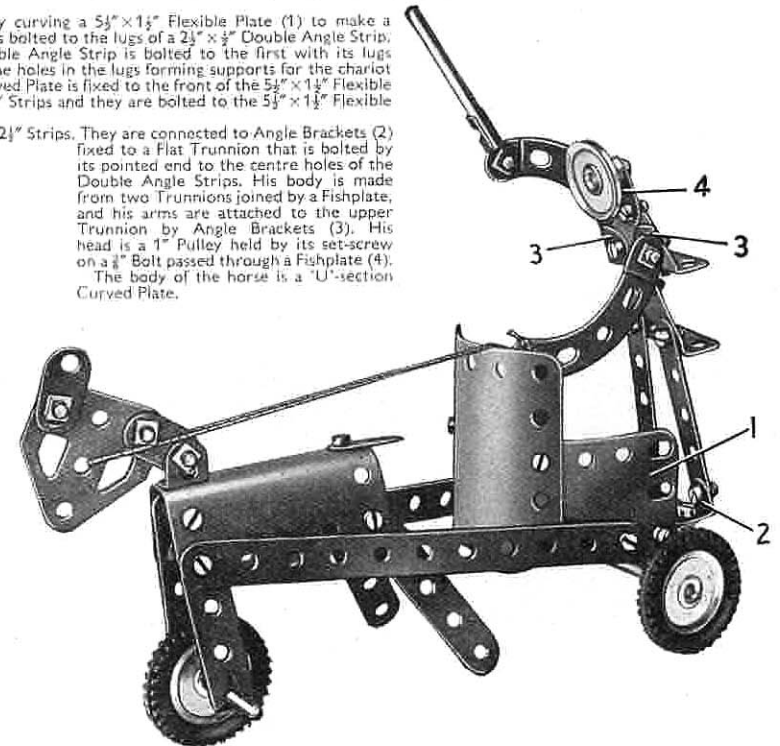



### 2.9 TRAMCAR

Parts Required

4 of No. 2	1 of No. 52	2 of No. 190
6 " " 5	2 " " 90a	1 " " 191
2 " " 10	4 " " 111c	2 " " 200
4 " " 12	2 " " 126	1 " " 212
2 " " 16	2 " " 126a	
1 " " 19g	4 " " 155	
4 " " 22	2 " " 188	
46 " " 37a	2 " " 189	
40 " " 37b		
4 " " 38		
1 " " 40		
2 " " 48a		

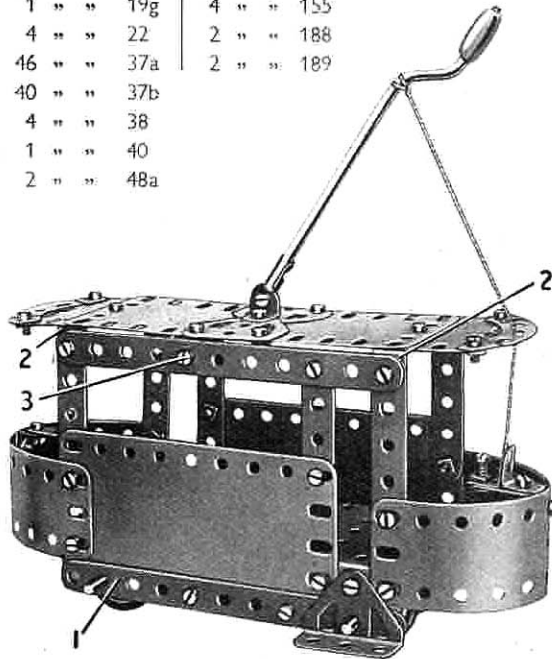

Two  $5\frac{1}{2} \times 1\frac{1}{4}$ " Flexible Plates are curved and bolted across the ends of a Flanged Plate to form the driving compartments at each end, and a  $4\frac{1}{2} \times 2\frac{1}{2}$ " Flexible Plate is used for one side of the model. This also is bolted to the Flanged Plate. The other side consists of two  $1\frac{1}{2}$ " radius Curved Plates, flattened and bolted in position. Both sides are strengthened by a  $5\frac{1}{2}$ " Strip, one of which is seen at (1).

The roof is supported on each side by three  $2\frac{1}{2}$ " Strips, connected at their upper ends by a  $5\frac{1}{2}$ " Strip. The roof is in halves, each half consisting of a  $2\frac{1}{2} \times 1\frac{1}{4}$ " and a  $2\frac{1}{2} \times 2\frac{1}{2}$ " Flexible Plate. The halves are joined at the centre by two Flat Trunnions, and the roof is secured to the Double Angle Strips (2) and Angle Brackets held by a Bolt (3) on each side. A Crank Handle is used to represent the trolley pole and it is held in a Rod and Strip Connector bolted to an Angle Bracket fixed to the Flat Trunnions.

The wheels are 1" Pulleys fixed on  $3\frac{1}{2}$ " Rods that run in holes in the sides of the model.

### 2.10 LUMBER TRUCK AND HORSE

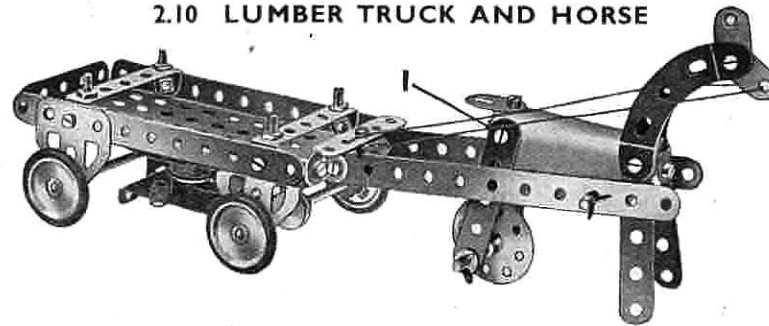

A Magic Motor is mounted beneath the cart, and the Driving Band is taken from the pulley on the Motor to a  $\frac{1}{2}$ " fixed Pulley (supplied with the Motor) fastened on the  $3\frac{1}{2}$ " Rod that forms the front axle.

The forelegs of the horse are held together by means of two Angle Brackets bolted in the positions shown. This construction is duplicated at (1) for the hind legs. The forelegs of the horse are held clear of the ground by the reins.

4 of No. 2	4 of No. 35	2 of No. 126
5 " " 5	27 " " 37a	2 " " 126a
3 " " 10	23 " " 37b	4 " " 155
6 " " 12	1 " " 40	1 " " 199
2 " " 16	2 " " 48a	1 Magic Motor
2 " " 17	1 " " 52	(not included in Outfit)
4 " " 22	2 " " 90a	
1 " " 24	4 " " 111c	

### 2.11 LAWN MOWER

Parts Required

4 of No. 2	2 of No. 48a
4 " " 5	2 " " 90a
4 " " 10	1 " " 125
5 " " 12	2 " " 126
1 " " 16	2 " " 142c
4 " " 22	2 " " 200
24 " " 37a	
24 " " 37b	
4 " " 38	

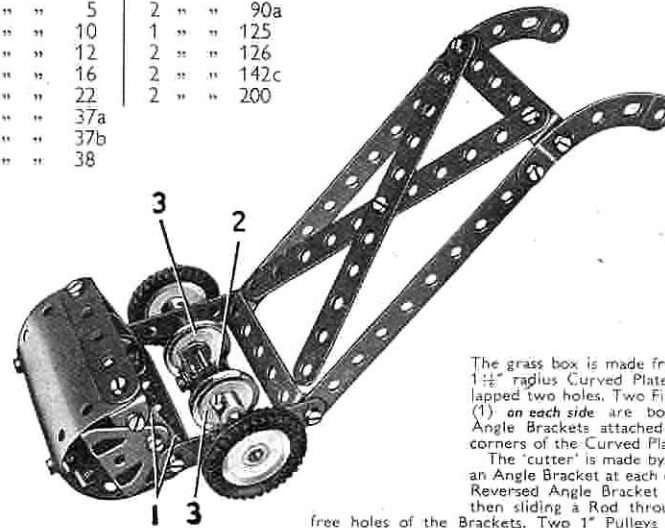

The grass box is made from two  $1\frac{1}{2}$ " radius Curved Plates overlapped two holes. Two Fishplates (1) on each side are bolted to Angle Brackets attached to the corners of the Curved Plates. The 'cutter' is made by bolting an Angle Bracket at each end of a Reversed Angle Bracket (2) and then sliding a Rod through the free holes of the Brackets. Two 1" Pulleys (3) are placed on the Rod and pushed tightly against the cutter so as to grip it and make it rotate with the Rod as the wheels revolve.

### 2.12 PUNCHING MACHINE

Parts Required

4 of No. 2	2 of No. 35	2 of No. 126
6 " " 5	46 " " 37a	2 " " 126a
3 " " 10	39 " " 37b	4 " " 155
7 " " 12	2 " " 38	2 " " 188
1 " " 16	2 " " 48a	2 " " 189
2 " " 17	1 " " 52	1 " " 212
4 " " 22	2 " " 90a	
1 " " 24	3 " " 111c	

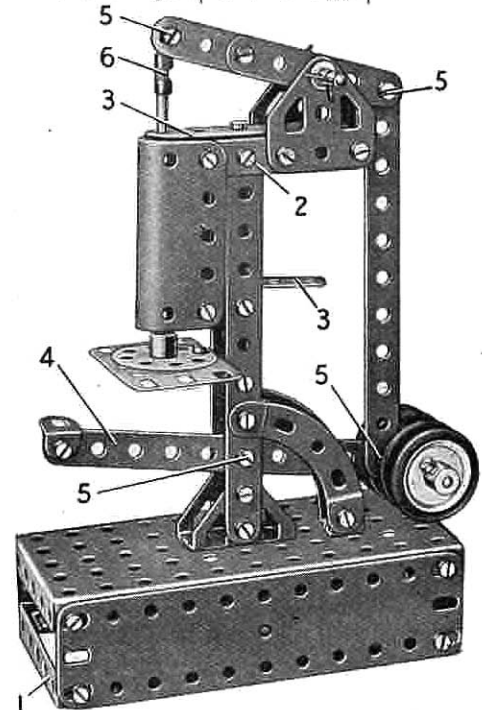

The base consists of a Flanged Plate, which is edged with two  $5\frac{1}{2} \times 1\frac{1}{4}$ " and one  $2\frac{1}{2} \times 1\frac{1}{4}$ " Flexible Plates. The  $5\frac{1}{2} \times 1\frac{1}{4}$ " Plates are braced together by the Double Angle Strips (1) at each end.

An upright column is formed from two  $5\frac{1}{2}$ " Strips fastened to two Trunnions attached to the base. They are joined at their upper ends by two Angle Brackets fixed together to form a 'U'-shaped piece. A 'U'-section Curved Plate is attached to the column at the top by a  $2\frac{1}{2}$ " Strip (2) and at its lower end by two Fishplates. The punch rod passes through holes in  $2\frac{1}{2}$ " guide Strips (3). One of these is bolted to the 'U'-shaped piece at the top of the column, and the other is fixed to an Angle Bracket bolted to the column.

Strips (2), one at each side of the machine, provide supports for two Flat Trunnions that carry a pivoted strip. The strip is formed from two  $2\frac{1}{2}$ " Strips overlapped three holes, and it is pivoted on a 2" Rod held in the Flat Trunnions. One end of this built-up strip is connected by a Rod and Strip Connector (6) to a  $3\frac{1}{2}$ " Rod representing the punching tool, and its rear end is connected to the foot-operated lever (4) by a  $5\frac{1}{2}$ " Strip. The lever is weighted by four 1" Pulleys fixed on a 2" Rod.

The Bolts (5) seen at different points of the model are each locked.

The punching table is a Bush Wheel bolted to a  $2\frac{1}{2} \times 1\frac{1}{4}$ " Flexible Plate attached to the column by a Fishplate and Angle Bracket.

## 3.1 STEAM TRACTOR AND TRAILER

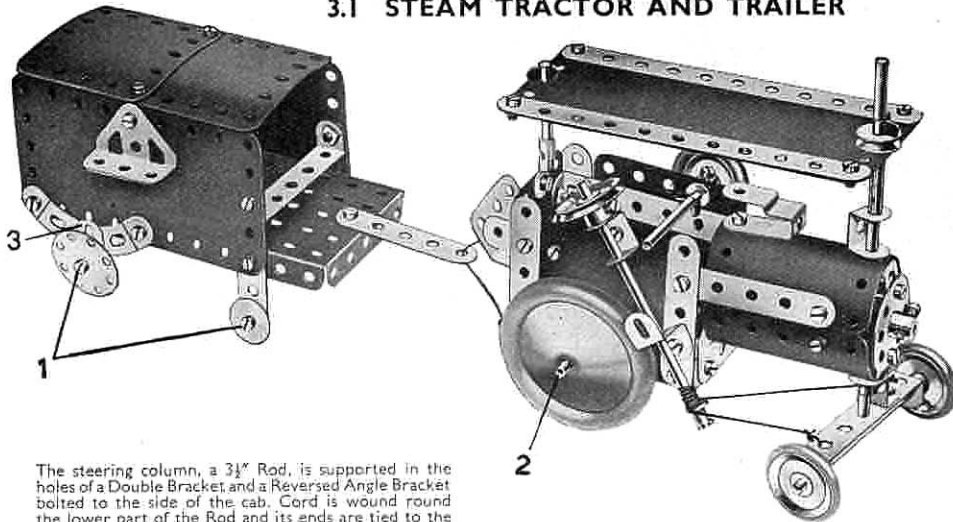

The steering column, a  $3\frac{1}{2}$ " Rod, is supported in the holes of a Double Bracket and a Reversed Angle Bracket bolted to the side of the cab. Cord is wound round the lower part of the Rod and its ends are tied to the  $2\frac{1}{2}$ " x  $\frac{1}{2}$ " Double Angle Strip that carries the front axle. Care must be taken that the Cord is wound tightly round the Rod or it will slip when the steering wheel is rotated. The Rod (2) is supported in holes in the Flexible Plates that form the sides of the cab.

The Bush Wheel that forms the front of the boiler has two Angle Brackets bolted to it, and a Rod passes through the free holes of these Brackets to hold the Bush Wheel in position. This Rod is joined by a Rod Connector to a 2" Rod that forms the chimney. The roof of the cab consists of a  $5\frac{1}{2}$ " x  $2\frac{1}{2}$ " Flexible Plate, and is held in position by Spring Clips placed on the two Rods that pass through it. The Fishplates (3) are bolted in the centre holes of the  $2\frac{1}{2}$ " Curved Strips on each side of the model. The Bolts (1) are lock-nutted in position and the Wheel Discs and  $\frac{1}{2}$ " Washers turn freely on them.

## Parts Required

4 of No.	2
7 " "	5
2 " "	10
2 " "	11
8 " "	12
2 " "	15b
3 " "	16
2 " "	17

1 of No.	18a
4 " "	22
1 " "	23
1 " "	24
2 " "	24a
5 " "	35
54 " "	37a
46 " "	37b
3 " "	38
2 " "	38d
1 " "	40
1 " "	44
2 " "	48a
1 " "	52
2 " "	90a
4 " "	111c
2 " "	125
2 " "	126
2 " "	126a
3 " "	155
1 " "	176
2 " "	187
1 " "	188
2 " "	190
2 " "	191
1 " "	192
2 " "	199
2 " "	200
1 " "	212
1 " "	213
2 " "	215

## 3.2 HORSE AND CART

The model is driven by a Magic Motor fastened underneath the  $5\frac{1}{2}$ " x  $2\frac{1}{2}$ " Flanged Plate that forms the bottom of the cart. The drive is taken by a Driving Band from the pulley of the Motor to a  $\frac{1}{2}$ " fast Pulley on the cart axle. A  $\frac{1}{2}$ " loose Pulley is fitted on a 2" Rod supported in the bottom holes of the Strips forming the hind legs of the horse, so that the model will travel smoothly along the ground.

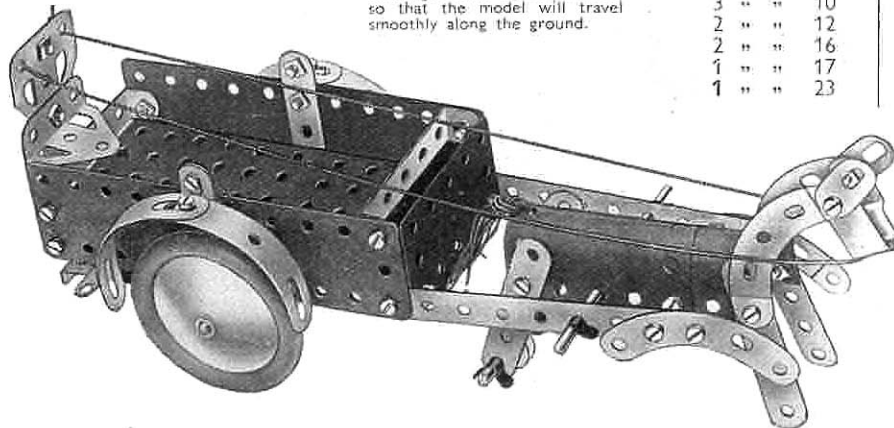

## Parts Required

2 of No.	2
6 " "	5
3 " "	10
2 " "	12
2 " "	16
1 " "	17
1 " "	23

4 of No.	35
32 " "	37a
32 " "	37b
4 " "	38
1 " "	40
1 " "	44
2 " "	48a
1 " "	52
4 " "	90a
1 " "	126
1 " "	126a
1 " "	186
2 " "	187
1 " "	188
2 " "	189
2 " "	199
4 " "	215

Magic Motor

(not included in Outfit)

## 3.3 ELECTRIC CRANE TRUCK

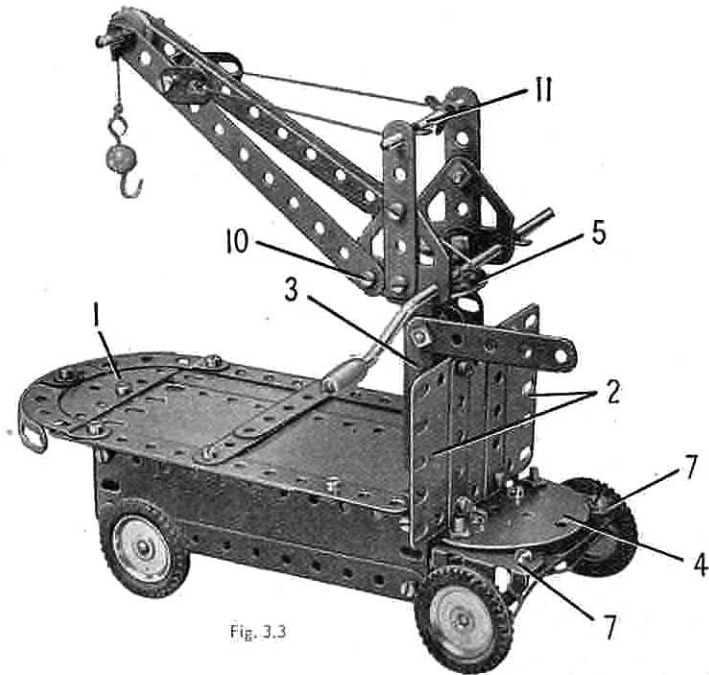

Fig. 3.3

The truck part of the model is built up first by bolting one  $2\frac{1}{2}$ " x  $1\frac{1}{2}$ " and two  $5\frac{1}{2}$ " x  $1\frac{1}{2}$ " Flexible Plates to the flanges of a Flanged Plate. At their lower edges the Flexible Plates are strengthened by  $5\frac{1}{2}$ " Strips and two  $2\frac{1}{2}$ " x  $\frac{1}{2}$ " Double Angle Strips. The platform consists of two  $5\frac{1}{2}$ " x  $2\frac{1}{2}$ " and two  $4\frac{1}{2}$ " x  $2\frac{1}{2}$ " Flexible Plates overlapped and extended by a Semi-Circular Plate (1).

Two  $2\frac{1}{2}$ " x  $2\frac{1}{2}$ " Flexible Plates (2), overlapped three holes, are bolted to the front end of the Flanged Plate, and a 'U'-section-Curved Plate (3) is attached to these by a Double Bracket. A Semi-Circular Plate (4) is attached to the Flanged Plate by Angle Brackets.

The crane jib is supported by Flat Trunnions, which are attached to a Wheel Disc (5) by Angle Brackets. The Wheel Disc is lock-nutted through its centre hole to an Angle Bracket bolted to the top centre hole at the front of the 'U'-section-Curved Plate (3).

The  $5\frac{1}{2}$ " Strips forming the jib pivot on lock-nutted bolts in the Flat Trunnions, and the jib is held at the required angle by a length of Cord. This Cord is tied to the Rod (11) and then passed through the Fishplates at the jib head, finally being tied again to the Rod (11).

The Trunnions (7), which form part of the steering device, are free to turn on  $\frac{1}{2}$ " Bolts secured to the Semi-Circular Plate (4), and they carry  $\frac{1}{2}$ " Bolts that form stub axles for the 1" Pulleys. The  $2\frac{1}{2}$ " Strip (8), seen in the underneath view of the model, is bolted to a Bush Wheel, and is connected to each Trunnion by Cord as shown. The Bush Wheel is fixed to a  $3\frac{1}{2}$ " Rod passed through the Flanged Plate and an Angle Bracket (9).

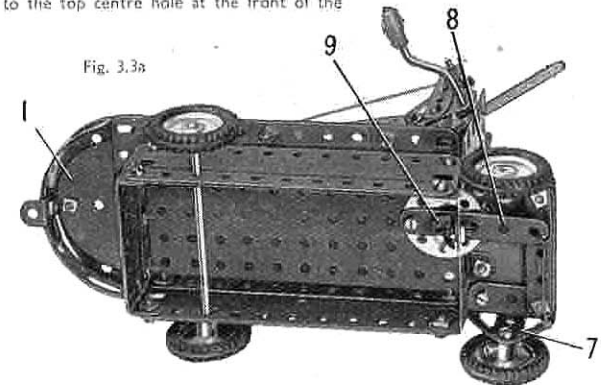

Fig. 3.3a

## Parts Required

6 of No.	2
9 " "	5
2 " "	10
2 " "	11
6 " "	12
1 " "	15b
1 " "	16
1 " "	17
1 " "	18a
1 " "	19g
4 " "	22
1 " "	23
1 " "	24
1 " "	24a
6 " "	35
52 " "	37a
43 " "	37b
4 " "	38
1 " "	40
2 " "	48a
1 " "	52
1 " "	57c
2 " "	90a
5 " "	111c
1 " "	125
2 " "	126
2 " "	126a
4 " "	142c
1 " "	188
2 " "	189
2 " "	190
2 " "	192
1 " "	199
1 " "	212
2 " "	214
2 " "	215



### 3.4 RACING CAR

The chassis of the model is a  $5\frac{1}{2}'' \times 2\frac{1}{2}''$  Flanged Plate (1), and a  $5\frac{1}{2}'' \times 1\frac{1}{2}''$  Flexible Plate is bolted to each side so that two holes of the Flanged Plate are left clear at the front. The Flanged Plate is lengthened at the rear by a  $5\frac{1}{2}''$  Strip (2) on each side, and a Flat Trunnion (3) is fixed to each  $5\frac{1}{2}''$  Strip. A  $2\frac{1}{2}'' \times 1\frac{1}{2}''$  Flexible Plate (4) is bolted to each of the Strips (2) and is connected to the  $5\frac{1}{2}'' \times 1\frac{1}{2}''$  Flexible Plate by a Fishplate. Two  $2\frac{1}{2}''$  Strips (5) are attached to the sides by Bolts (6).

The top of the bonnet is a  $5\frac{1}{2}'' \times 2\frac{1}{2}''$  Flexible Plate, and it is attached to the sides by four Angle Brackets. Two Trunnions are connected by  $\frac{3}{8}''$  Bolts (7) to a  $1\frac{1}{2}''$  radius Curved Plate, which is then bolted between the  $5\frac{1}{2}'' \times 2\frac{1}{2}''$  Flexible Plate and the front of the Flanged Plate.

Two 'U'-section Curved Plates (8) are fixed to the Flexible Plates (4) and the Flat Trunnions (3), and a Wheel Disc (9) is attached to one of them by an Angle Bracket. The tail assembly

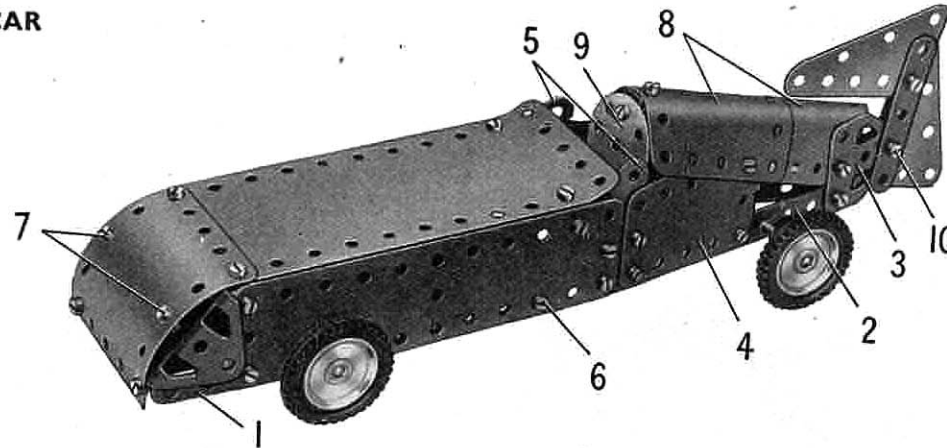

consists of two  $2\frac{1}{2}'' \times 1\frac{1}{2}''$  Triangular Flexible Plates bolted between two  $2\frac{1}{2}''$  Strips as shown, and it is fixed to the Flat Trunnions (3) by a  $\frac{3}{8}''$  Bolt (10).

The wheels are mounted on  $3\frac{1}{2}''$  Rods passed through the chassis as shown.

#### Parts Required

2 of No. 2	36 of No. 37a	2 of No. 189
4 " " 5	35 " " 37b	1 " " 192
2 " " 10	1 " " 52	2 " " 199
5 " " 12	1 " " 111c	1 " " 200
2 " " 16	2 " " 126	1 " " 214
4 " " 22	2 " " 126a	2 " " 221
1 " " 24a	4 " " 142c	
2 " " 35	2 " " 188	

### 3.5 TRAMCAR

#### Parts Required

4 of No. 2	2 of No. 48a	1 of No. 212
9 " " 5	1 " " 52	2 " " 214
4 " " 10	5 " " 111c	4 " " 215
1 " " 11	2 " " 126	
8 " " 12	2 " " 126a	
1 " " 15b	1 " " 176	
2 " " 16	2 " " 188	
4 " " 22	2 " " 189	
5 " " 35	2 " " 190	
54 " " 37a	2 " " 191	
49 " " 37b		
6 " " 38		
2 " " 38d		
1 " " 40		
1 " " 44		

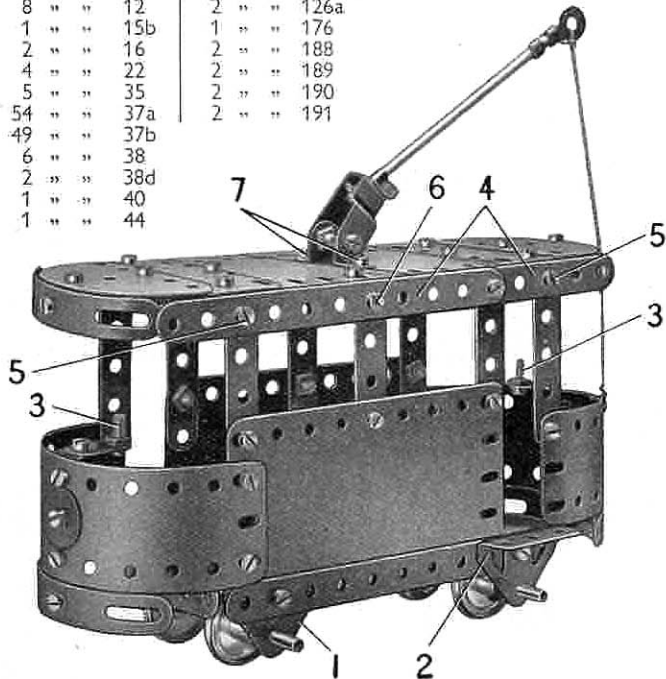

The chassis is a  $5\frac{1}{2}'' \times 2\frac{1}{2}''$  Flanged Plate fitted at its sides with  $4\frac{1}{2}'' \times 2\frac{1}{2}''$  Flexible Plates. The Flexible Plates are bolted to the flanges so that a space of two clear holes is left in each side flange, but at opposite ends. The lower edges of the Flexible Plates are edged by  $5\frac{1}{2}''$  Strips, and a Flat Trunnion (1) and a Trunnion (2) are bolted to each side. The axles are supported in the Trunnions and Flat Trunnions.

The rounded ends consist of  $5\frac{1}{2}'' \times 1\frac{1}{2}''$  Flexible Plates curved to shape and bolted to the sides. A Formed Slotted Strip is attached to each of the  $5\frac{1}{2}'' \times 1\frac{1}{2}''$  Flexible Plates by a Fishplate. The control handles (3) are each made by bolting a Fishplate fitted with a  $\frac{3}{8}''$  Bolt to an Angle Bracket fixed to the Flexible Plate.

The roof is supported on each side by four  $2\frac{1}{2}''$  Strips. The tops of these Strips are connected by two  $5\frac{1}{2}''$  Strips (4) overlapped seven holes, and these Strips are joined across by  $2\frac{1}{2}'' \times \frac{1}{2}''$  Double Angle Strips held by the Bolts (5). An Angle Bracket on each side is fixed in place by a Bolt (6).

The roof consists of two  $2\frac{1}{2}'' \times 2\frac{1}{2}''$  and two  $2\frac{1}{2}'' \times 1\frac{1}{2}''$  Flexible Plates bolted end to end, and its rounded ends are Semi-Circular Plates. The roof is attached to the Double Angle Strips and the Angle Brackets held by Bolts (5) and (6). A Formed Slotted Strip is connected to each Semi-Circular Plate by an Angle Bracket.

The trolley pole is a  $4''$  Rod fitted with a Rod and Strip Connector, and it is held in a Stepped Bent Strip by a Spring Clip and a Cord Anchoring Spring. The Stepped Bent Strip is bolted to two Angle Brackets (7) bolted to the centre of the roof.

### 3.6 TROTTING CAR

#### Parts Required

4 of No. 2	37 of No. 37a
8 " " 5	37 " " 37b
5 " " 10	6 " " 38
1 " " 11	1 " " 40
3 " " 12	1 " " 44
1 " " 15b	2 " " 48a
2 " " 16	3 " " 90a
2 " " 17	3 " " 111c
1 " " 18a	2 " " 125
4 " " 22	2 " " 126
1 " " 24	
1 " " 24a	
4 " " 35	

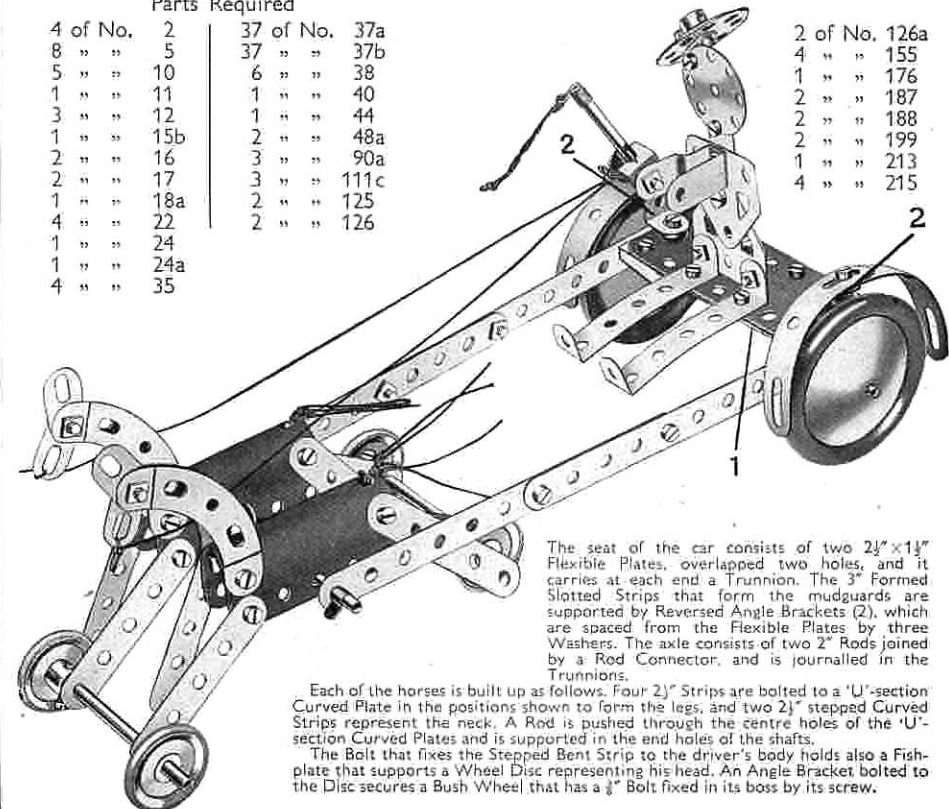

2 of No. 126a
4 " " 155
1 " " 176
2 " " 187
2 " " 188
2 " " 199
1 " " 213
4 " " 215

The seat of the car consists of two  $2\frac{1}{2}'' \times 1\frac{1}{2}''$  Flexible Plates, overlapped two holes, and it carries at each end a Trunnion. The  $3''$  Formed Slotted Strips that form the mudguards are supported by Reversed Angle Brackets (2), which are spaced from the Flexible Plates by three Washers. The axle consists of two  $2''$  Rods joined by a Rod Connector, and is journalled in the Trunnions.

Each of the horses is built up as follows. Four  $2\frac{1}{2}''$  Strips are bolted to a 'U'-section Curved Plate in the positions shown to form the legs, and two  $2\frac{1}{2}''$  stepped Curved Strips represent the neck. A Rod is pushed through the centre holes of the 'U'-section Curved Plates and is supported in the end holes of the shafts.

The Bolt that fixes the Stepped Bent Strip to the driver's body holds also a Fishplate that supports a Wheel Disc representing his head. An Angle Bracket bolted to the Disc secures a Bush Wheel that has a  $\frac{3}{8}''$  Bolt fixed in its boss by its screw.

## 3.7 TRACTOR AND HARROW

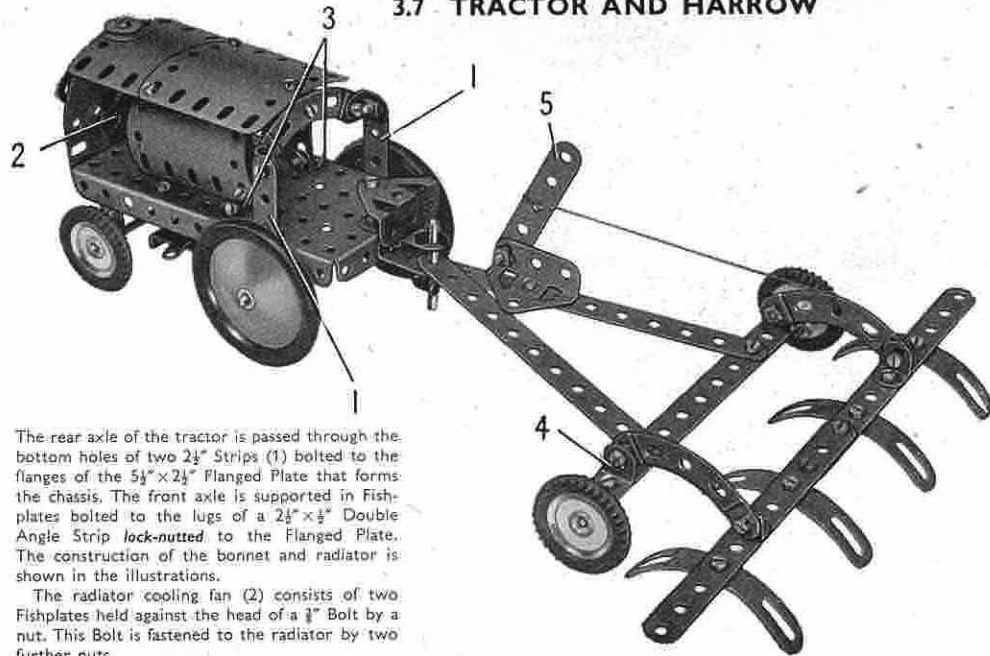

Fig. 3.7

The rear axle of the tractor is passed through the bottom holes of two  $2\frac{1}{2}$ " Strips (1) bolted to the flanges of the  $5\frac{1}{2}$ " x  $2\frac{1}{2}$ " Flanged Plate that forms the chassis. The front axle is supported in Fishplates bolted to the lugs of a  $2\frac{1}{2}$ " x  $\frac{1}{2}$ " Double Angle Strip *lock-nutted* to the Flanged Plate. The construction of the bonnet and radiator is shown in the illustrations.

The radiator cooling fan (2) consists of two Fishplates held against the head of a  $\frac{3}{8}$ " Bolt by a nut. This Bolt is fastened to the radiator by two further nuts.

The engine is represented by two 'U'-section Curved Plates, which are bolted together so that they overlap each other by two holes and are then attached to the Flanged Plate by two Angle Brackets (3).

The wheels of the harrow are held by  $\frac{3}{8}$ " Bolts in Reversed Angle Brackets (4) at each end of a  $5\frac{1}{2}$ " Strip. A  $2\frac{1}{2}$ " Stepped Curved Strip is fastened to each Reversed Angle Bracket by a *lock-nutted* bolt, and Cord is attached to the centre hole of one of these Curved Strips and also to the operating lever (5), which is loosely held by a *lock-nutted*  $\frac{3}{8}$ " Bolt to a Trunnion. By moving the lever forward the harrow may be raised from the ground when not in use.

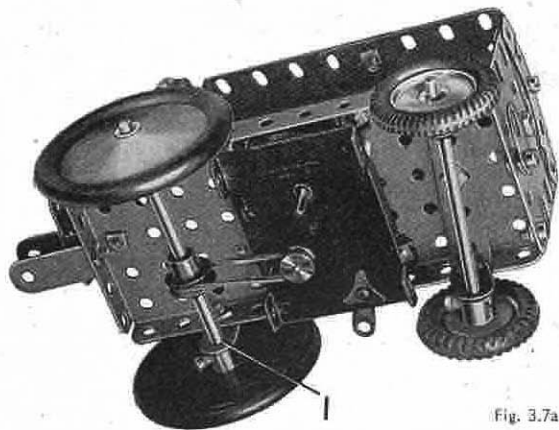

Fig. 3.7a

Parts Required		Parts Required	
5 of No.	2	1 of No.	48a
3 " "	5	1 " "	52
5 " "	10	4 " "	90a
1 " "	11	4 " "	111c
8 " "	12	2 " "	125
1 " "	15b	2 " "	126
1 " "	16	4 " "	142c
1 " "	18a	2 " "	187
4 " "	22	1 " "	188
1 " "	23	2 " "	199
2 " "	35	2 " "	200
53 " "	37a	1 " "	214
42 " "	37b	4 " "	215
1 " "	40		
1 " "	44		

Magic Motor  
(not included in  
Outfit)

## 3.8 GIPSY CARAVAN

The base of the caravan is a  $5\frac{1}{2}$ " x  $2\frac{1}{2}$ " Flanged Plate, and the sides are  $5\frac{1}{2}$ " x  $2\frac{1}{2}$ " Flexible Plates strengthened along their upper edges by  $5\frac{1}{2}$ " Strips. Three  $2\frac{1}{2}$ " Strips are fixed to each side as shown, and these are connected by a  $5\frac{1}{2}$ " Strip (1) lengthened at each end by a Fishplate. The  $5\frac{1}{2}$ " Strips are joined across at their ends by  $2\frac{1}{2}$ " Stepped Curved Strips attached to Angle Brackets.

The rear wheels are fixed on a  $3\frac{1}{2}$ " Rod supported in Flat Trunnions bolted to the sides of the Flanged Plate. The front wheels are fastened on a  $3\frac{1}{2}$ " Rod that is supported in two Trunnions (2). These Trunnions are bolted to a  $2\frac{1}{2}$ " x  $1\frac{1}{2}$ " Flexible Plate (3), fitted at each side with a  $2\frac{1}{2}$ " Strip (4). A Bush Wheel (5) is fixed to the Plate (3), and a  $2$ " Rod held in the Bush Wheel is passed through a  $\frac{1}{2}$ " Reversed Angle Bracket (6) and the  $5\frac{1}{2}$ " x  $2\frac{1}{2}$ " Flanged Plate. A 'U'-section Curved Plate (7) and a  $\frac{1}{2}$ " Pulley are slipped over the Rod, which is then held in position by a Spring Clip.

The shafts are  $5\frac{1}{2}$ " Strips bolted to a  $2\frac{1}{2}$ " x  $\frac{1}{2}$ " Double Angle Strip (8). This is *lock-nutted* to a second Double Angle Strip bolted across the ends of Strips (4).

The roof consists of two  $1\frac{1}{2}$ " radius Curved Plates (9) overlapped four holes, and two  $5\frac{1}{2}$ " x  $1\frac{1}{2}$ " Flexible Plates, one of which is seen at (10). The  $5\frac{1}{2}$ " x  $1\frac{1}{2}$ " Flexible Plates are placed side to side, and are bolted to Formed Slotted Strips as shown. The complete roof is attached to Angle Brackets bolted to the sides of the caravan. The Angle Brackets are bent out a little to allow a slight curve in the roof.

A step at the rear of the caravan consists of a 'U'-section Curved Plate bolted to the rear of the  $5\frac{1}{2}$ " x  $2\frac{1}{2}$ " Flanged Plate.

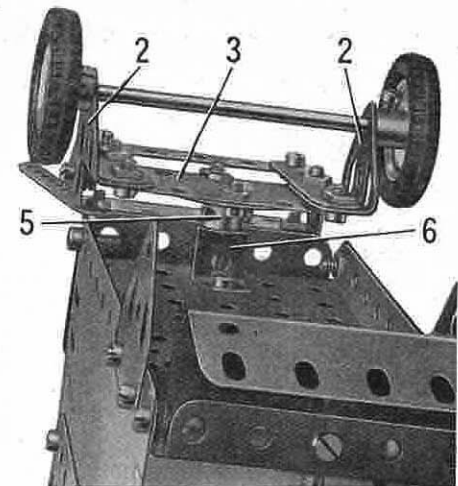

Fig. 3.8a

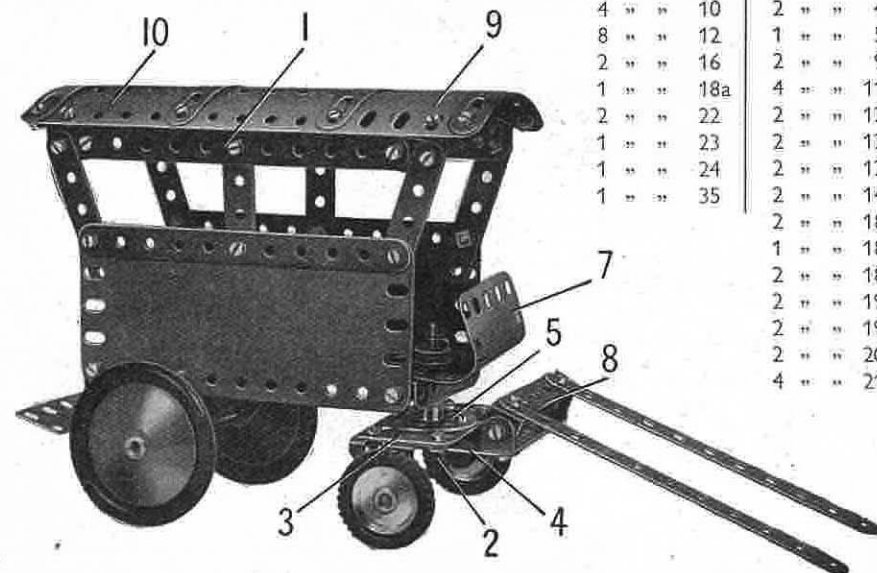

Fig. 3.8

## Parts Required

6 of No.	2	56 of No.	37a
8 " "	5	50 " "	37b
4 " "	10	2 " "	48a
8 " "	12	1 " "	52
2 " "	16	2 " "	90a
1 " "	18a	4 " "	111c
2 " "	22	2 " "	125
1 " "	23	2 " "	126
1 " "	24	2 " "	126a
1 " "	35	2 " "	142c
		2 " "	187
		1 " "	188
		2 " "	189
		2 " "	192
		2 " "	199
		2 " "	200
		4 " "	215

### 3.9 FIRE ENGINE

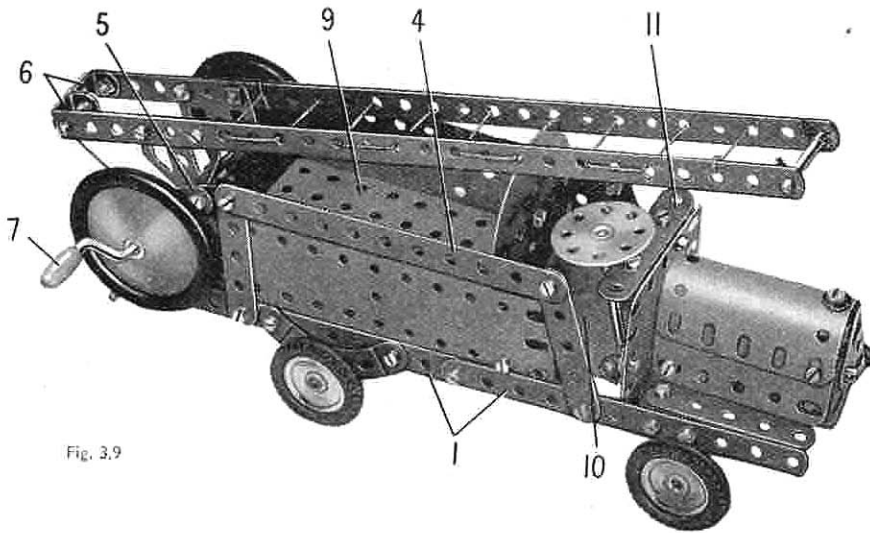

Fig. 3.9

Each side of the chassis of the model consists of two 5 1/2" Strips (1) bolted end to end. These Strips are connected at the rear by a 5 1/2" x 2 1/2" Flexible Plate (2), which is attached to them by Angle Brackets. The bonnet is a 'U'-section Curved Plate fitted at each side with a 2 1/2" x 1 1/2" Flexible Plate, and it is connected by 1/2" Reversed Angle Brackets (3) to the Strips (1). The radiator consists of two Trunnions bolted to the Flexible Plate.

A 5 1/2" Strip (4) on each side is attached to the Strips (1) by two 2 1/2" Strips, and it is connected to a 2 1/2" Stepped Curved Strip (5) by a Fishplate. The lower end of the Curved Strip is bolted to the rear of the Strips (1). The rear wheels are fixed on a 3/4" Rod supported in 2 1/2" Stepped Curved Strips bolted to the Strips (1), and the front wheels are fixed on a similar Rod passed through Fishplates also bolted to the Strips (1).

The ladder consists of two 12 1/2" Strips joined together by two Double Brackets (6), and the rungs are represented by Cord. A Flat Trunnion is bolted to each Strip, and a Crank Handle (7) is passed through holes in the Curved Strips (5) and the holes at the pointed ends of the Flat Trunnions. A length of Cord tied to the Crank Handle is passed round a Rod (8) and is tied to the rear end of the ladder. Rod (8) is supported in a 2 1/2" x 1/2" Double Angle Strip that is attached by Angle Brackets to the Flexible Plate (2).

The driving compartment and the body of the fire engine are assembled as a separate unit, which is fitted to the chassis when it is completed. A 5 1/2" x 2 1/2" Flanged Plate (9) is fitted at each side with a 5 1/2" x 1 1/2" Flexible Plate, and is extended towards the front by a 2 1/2" x 2 1/2" Flexible Plate (10). The back of the driving compartment consists of two Semi-Circular Plates bolted together and attached to the Flanged Plate by an Angle Bracket. The front of the compartment is a 2 1/2" x 2 1/2" Flexible Plate, which is bolted to Angle Brackets fixed to the Flexible Plate (10). The steering wheel is fixed on a Rod passed through a Fishplate bolted to a 2 1/2" Strip (11), and through the Flexible Plate (10).

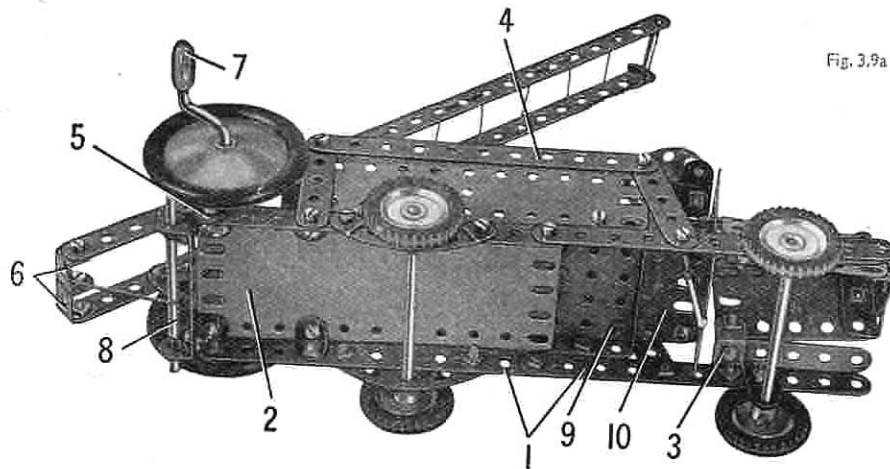

Fig. 3.9a

#### Parts Required

2 of No. 1	1 of No. 48a
6 " " 2	1 " " 52
7 " " 5	4 " " 90a
5 " " 10	5 " " 111c
2 " " 11	2 " " 125
7 " " 12	2 " " 126
1 " " 15b	2 " " 126a
3 " " 16	4 " " 142c
1 " " 18a	2 " " 187
1 " " 19g	2 " " 188
4 " " 22	2 " " 189
1 " " 24	2 " " 190
4 " " 35	1 " " 192
55 " " 37a	1 " " 199
50 " " 37b	1 " " 212
6 " " 38	2 " " 214
1 " " 40	4 " " 215

### 3.10 TANK

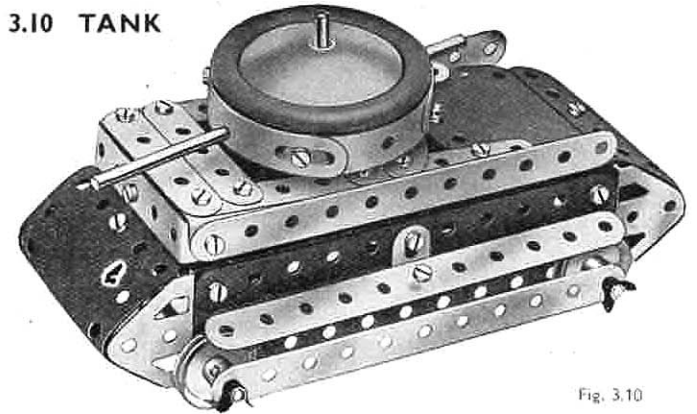

Fig. 3.10

Construction of the gun turret is commenced by bolting a 2 1/2" Strip across a Bush Wheel. Four 3" Formed Slotted Strips are bolted together to form a circle and fastened to the 2 1/2" Strip by means of Angle Brackets. Next, two Angle Brackets are bolted to the Bush Wheel in the positions shown in Fig. 3.10a. Two Rods are pushed through holes in the Formed Slotted Strips and through the free holes of the Angle Brackets, and are fastened in position by means of Spring Clips. The turret is held in place by a 3/4" Rod that is gripped in the boss of the Bush Wheel and then passed through the 5 1/2" x 2 1/2" Flanged Plate and through a hole in a Reversed Angle Bracket. A Cord Anchoring Spring is then screwed on to it to hold it in position. To complete the turret a Road Wheel is fastened on the upper end of the 3/4" Rod. The Reversed Angle Bracket is bolted to the 5 1/2" x 2 1/2" Flanged Plate.

The Magic Motor is bolted to the Flanged Plate, and the drive is taken to the back axle by means of a Driving Band.

#### Parts Required

6 of No. 2	6 of No. 35	1 of No. 52	1 of No. 176
7 " " 5	37 " " 37a	1 " " 90a	1 " " 187
1 " " 10	37 " " 37b	1 " " 125	2 " " 189
7 " " 12	4 " " 38	2 " " 126	1 " " 190
2 " " 15b	2 " " 48a	2 " " 126a	2 " " 199
1 " " 16			4 " " 215
2 " " 17			<b>Magic Motor</b>
4 " " 22			(not included in
1 " " 24			Outfit)

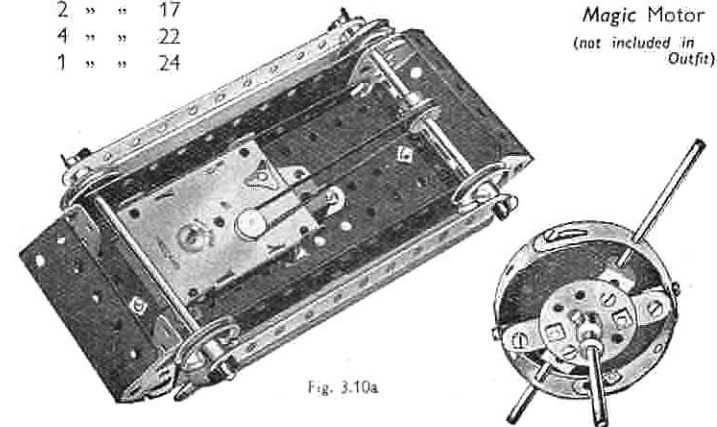

Fig. 3.10a



### 3.11 MOTOCART

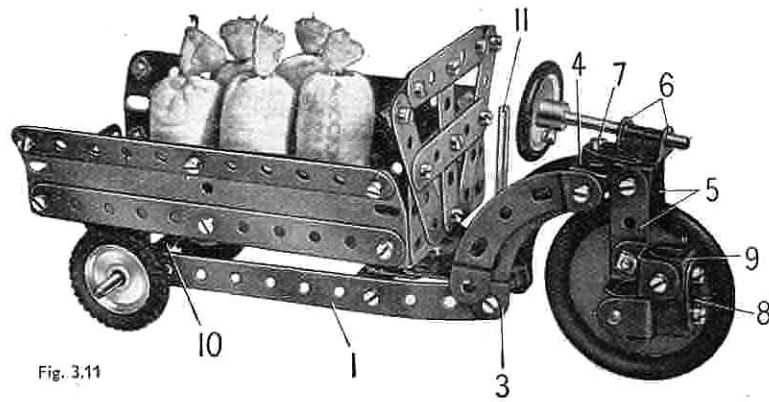

Fig. 3.11

The chassis of the model consists of two 5½" Strips (1). These are connected together at a point four holes from the front by a Flat Trunnion (2) attached to Angle Brackets. A second Flat Trunnion is bolted to the first to form the driver's platform, and the ends of Strips (1) are bent in slightly to correspond to the sloping sides of the Flat Trunnion. A 2½" Stepped Curved Strip (3) is attached to the end hole of each of the Strips (1), and the upper ends of the Curved Strips are connected together by a Double Bracket (4). A second Curved Strip on each side is held in place by the same bolts that fix the Double Bracket.

The single castor, or steerable wheel at the front, is fixed on a 1½" Rod supported in 2½" Strips (5). These Strips are bolted tightly to a Double Bracket, and a Fishplate and two Angle Brackets (6) are fixed to the centre hole of the Double Bracket. The Fishplate is pivoted on a ½" Bolt (7) held in the Double Bracket (4) by two nuts. Two Washers are used to space the Fishplate from the upper nut on the Bolt. The steering wheel is a 1" Pulley fixed on a 2" Rod that is held by Spring Clips in the Angle Brackets (6).

The engine unit is represented by a ½" Reversed Angle Bracket bolted to one of the Strips (5). An Angle Bracket is bolted to the slotted hole of the Reversed Angle Bracket, and to the Angle Bracket a Fishplate (8) and a second Angle Bracket (9) are fixed. A Stepped Bent Strip is bolted to the Fishplate (8).

The rear wheels are held on a 3½" Rod passed through the end holes of the Strips (1). Two Trunnions (10) are pivoted on the Rod, and these are bolted to a 5½" x 2½" Flanged Plate that forms the floor of the load carrier. The sides are 5½" x 1½" Flexible Plates edged by 5½" Strips, and the front is a 2½" x 1½" Flexible Plate. The front is completed by five 2½" Strips and two Fishplates arranged as shown.

The load carrier or body can be raised for tipping the load by operating a lever (11). This is a 2" Rod held in a Rod and Strip Connector, and a 2½" Strip (12) is bolted tightly to the Rod and Strip Connector by a ½" Bolt. The Bolt is then locked to one of the Strips (1), and the end of Strip (12) is bent inward slightly so that it engages under the load carrier.

#### Parts Required

6 of No. 2	2 of No. 11	2 of No. 35
8 " " 5	7 " " 12	49 " " 37a
4 " " 10	1 " " 16	42 " " 37b
	2 " " 17	6 " " 38
	1 " " 18a	1 " " 44
	3 " " 22	1 " " 52
		4 " " 90a
		2 " " 111c
		2 " " 125
		2 " " 126
		2 " " 126a
		2 " " 142c
		1 " " 155
		1 " " 187
		1 " " 188
		2 " " 189
		1 " " 212

Fig. 3.11a

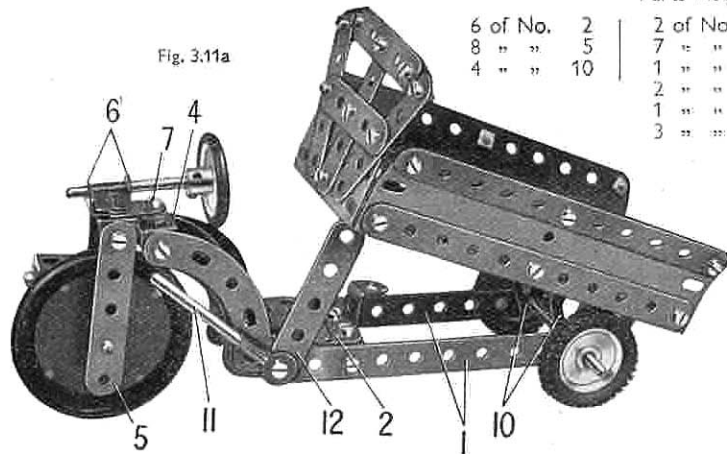

### 3.12 MECHANICAL HORSE AND TRAILER

#### Parts Required

6 of No. 2	2
9 " " 5	5
2 " " 10	10
2 " " 11	11
8 " " 12	12
2 " " 16	16
2 " " 17	17
1 " " 18a	18a
4 " " 22	22
1 " " 23	23
1 " " 24	24
1 " " 24a	24a
6 " " 35	35
56 " " 37a	37a
50 " " 37b	37b
6 " " 38	38
1 " " 38d	38d
2 " " 48a	48a
1 " " 52	52
4 " " 111c	111c
1 " " 125	125
2 " " 126	126
2 " " 126a	126a
4 " " 142c	142c
2 " " 188	188
2 " " 189	189
2 " " 190	190
1 " " 199	199
2 " " 200	200
1 " " 212	212
2 " " 214	214

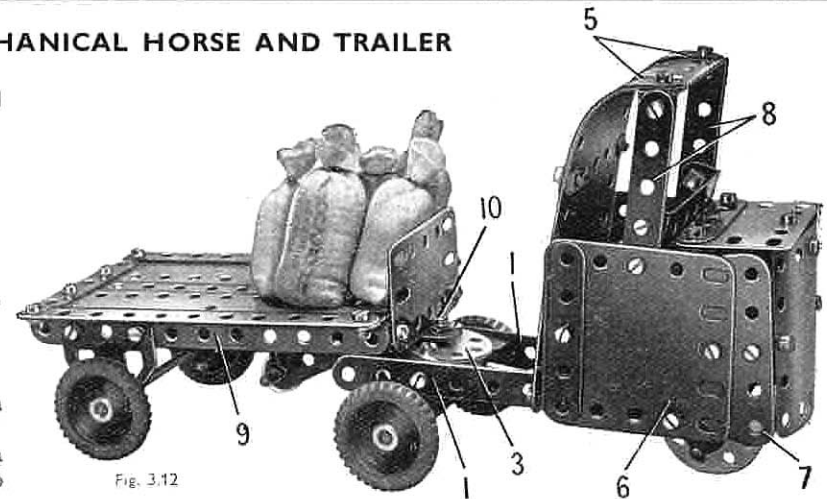

Fig. 3.12

The chassis of the Mechanical Horse consists of two 5½" Strips (1) fitted at one end with Trunnions (2). The Trunnions are connected together by a Wheel Disc (3). A Double Bracket (4) is bolted in the second hole from the front end of each 5½" Strip, and Angle Brackets are used to fix 5½" Strips (5) in position at each side. The upper ends of the 5½" Strips are curved as shown, and a straightened 1½" radius Curved Plate and an opened-out "U"-section Curved Plate bolted to them, form the back and roof of the cab.

The cab sides each consist of a 2½" x 2½" Flexible Plate (6) and a Semi-Circular Plate (7). The sides are bolted to the Double Brackets (4), and they are attached to the Strips (5) by a 2½" x ¼" Double Angle Strip. The front of the bonnet is a 1½" radius Curved Plate that is connected to the sides by Angle Brackets, and the top is a 2½" x 1½" Flexible Plate fixed to an Angle Bracket bolted to the front. Two 2½" Strips are bolted to the sides and are attached to Angle Brackets fastened to the roof.

The chassis of the Trailer is a 5½" x 2½" Flanged Plate (9), and its wheels are fixed on a 3½" Rod supported in Flat Trunnions that are bolted to the side flanges of the Plate. The load platform is made by bolting to each side a 5½" x 1½" Flexible Plate so that it partly overlaps the Flanged Plate as shown. The edges of the Flexible Plates are strengthened by Strips.

The coupling between the Mechanical Horse and the Trailer is provided by a ½" Bolt (10), which is fixed by nuts in a ½" Reversed Angle Bracket bolted to the Flanged Plate (9). The shank of the Bolt engages in the centre hole of the Wheel Disc (3).

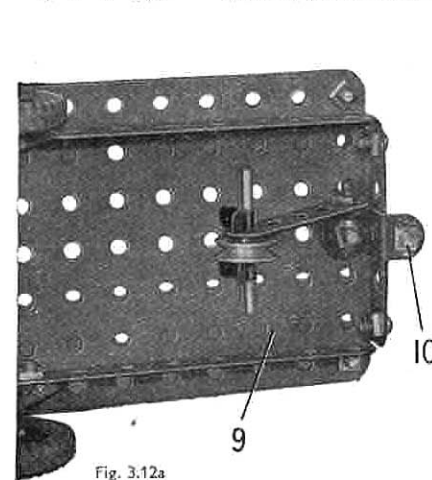

Fig. 3.12a

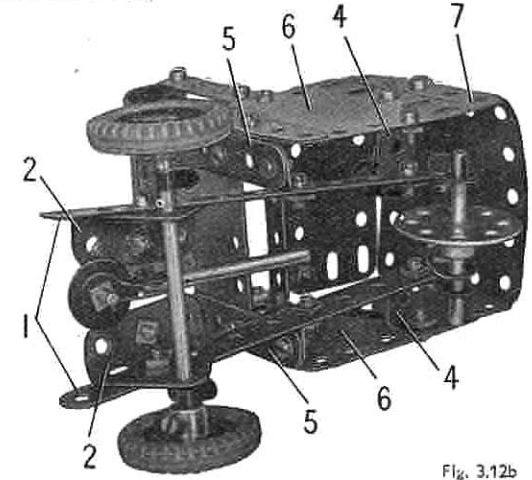
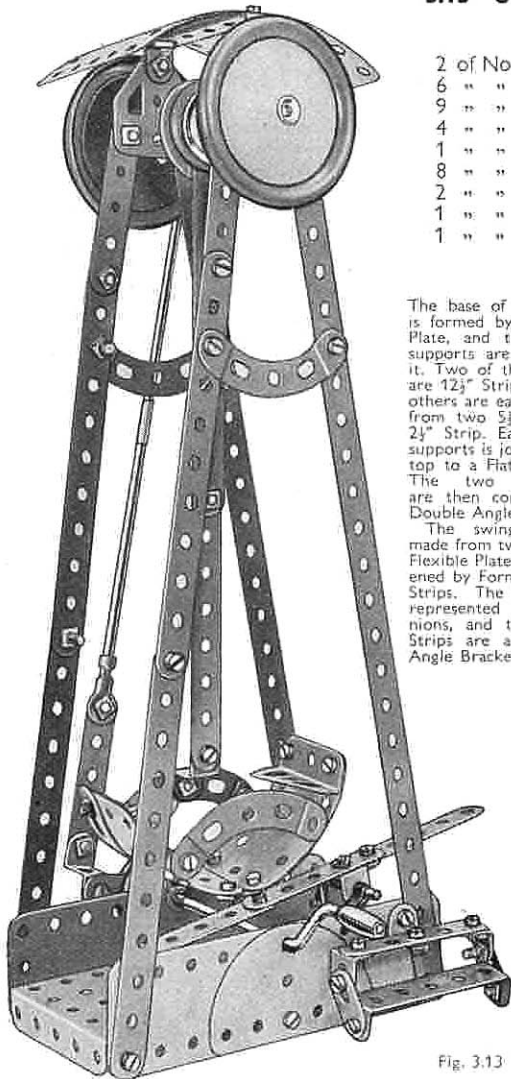

Fig. 3.12b

### 3.13 SWING BOAT

Parts Required

2 of No. 1	1 of No. 19g	2 of No. 48a	2 of No. 187
6 " " 2	4 " " 22	1 " " 52	2 " " 188
9 " " 5	1 " " 24	4 " " 90a	2 " " 189
4 " " 10	1 " " 24a	5 " " 111c	2 " " 200
1 " " 11	4 " " 35	2 " " 125	1 " " 212
8 " " 12	54 " " 37a	2 " " 126	1 " " 213
2 " " 15b	50 " " 37b	2 " " 126a	2 " " 214
1 " " 16	1 " " 44	4 " " 142c	4 " " 215
1 " " 17			



The base of the model is formed by a Flanged Plate, and the upright supports are bolted to it. Two of the uprights are 12½" Strips, and the others are each built up from two 5½" and one 2½" Strip. Each pair of supports is joined at the top to a Flat Trunnion. The two Trunnions are then connected by Double Angle Strip (1). The swing boat is made from two 2½" x 1½" Flexible Plates, strengthened by Formed Slotted Strips. The seats are represented by Trunnions, and the Curved Strips are attached by Angle Brackets.

Fig. 3.13

The swing is suspended from a compound strip consisting of two 5½" Strips overlapped four holes. The upper end of this strip is clamped firmly between two 1" Pulleys (2) fitted with Rubber Rings, and a Wheel Disc (6) is fixed to the 4" Rod (3). A 2½" Strip is bolted to a Bush Wheel (4) also fixed on this Rod, and is connected to the Crank Handle by a lever made from a 3½" and a 4" Rod joined by a Rod Connector. The 2½" Strip (5) is clamped between two 1" Pulleys on the Crank Handle and is attached to the lever by a Reversed Angle Bracket. All Bolts numbered (6) are lock-nutted. The brake for bringing the boat to rest is formed by three 2½" Strips joined together, and is bolted to a Double Bracket pivoted on a Rod (7).

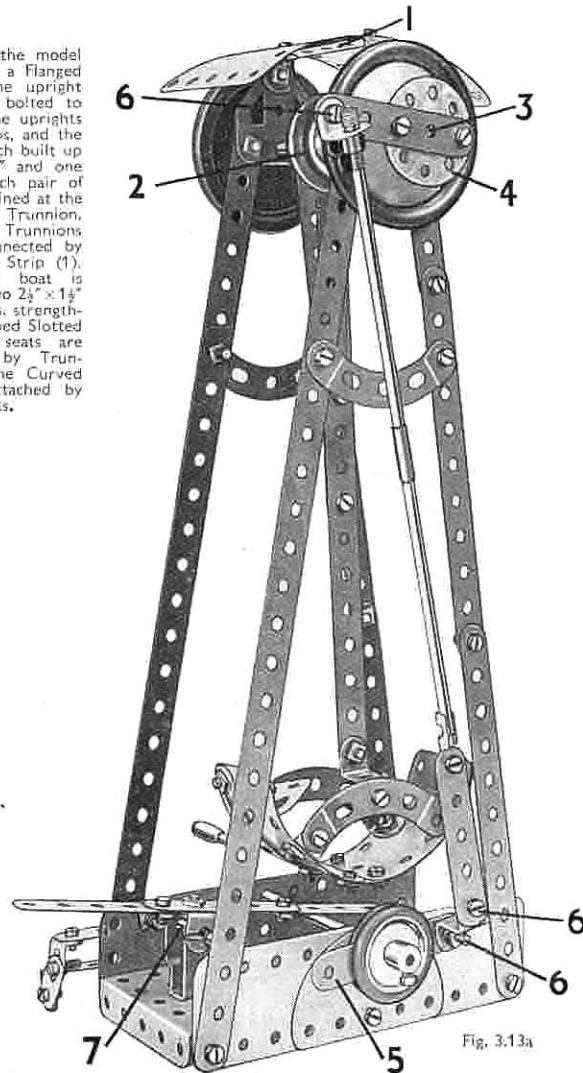

Fig. 3.13a

### 3.14 DUMPER TRUCK

Parts Required

6 of No. 2	
9 " " 5	
3 " " 10	
1 " " 11	
8 " " 12	
2 " " 15b	
2 " " 16	
1 " " 17	
3 " " 22	
2 " " 24a	
4 " " 35	
53 " " 37a	
41 " " 37b	
5 " " 38	
1 " " 38d	
1 " " 40	
2 " " 48a	
1 " " 52	
1 " " 90a	
2 " " 111c	
1 " " 125	
2 " " 126	
2 " " 126a	
2 " " 142c	
1 " " 186	
2 " " 187	
2 " " 188	
1 " " 189	
1 " " 190	
1 " " 192	
1 " " 212	
2 " " 221	

Magic Motor  
(not included in  
Outfit)

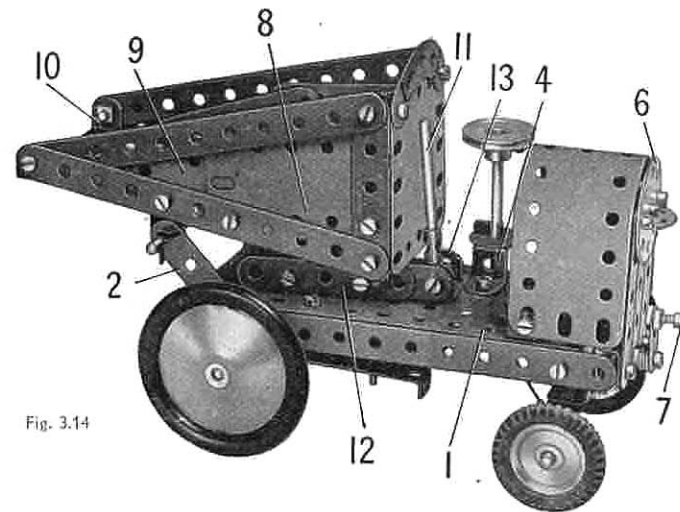

Fig. 3.14

A 5½" x 2½" Flanged Plate (1) is fitted at each side with a 5½" Strip. The front axle is supported in Flat Trunnions, and on each side one of the Bolts that hold the Flat Trunnions in place serves also to fix a 2½" Strip (2) in position.

The rear axle is supported in a 2½" x ½" Double Angle Strip pivoted freely on a Bolt held by two nuts in a Trunnion (3). A 3½" Rod is passed through a ½" Reversed Angle Bracket (4), the Flanged Plate (1) and an Angle Bracket (5). The Angle Bracket and the Reversed Angle Bracket are bolted to the Flanged Plate and a length of Cord wound two or three times round the lower end of the Rod is tied at each end to the Double Angle Strip.

The engine housing is a 5½" x 1½" Flexible Plate curved to 'U'-shape and fixed to Angle Brackets bolted to the Flanged Plate (1). The radiator consists of three 2½" Strips bolted to the flange of a Trunnion, and a Wheel Disc (6) is fixed to their upper ends. The Trunnion is bolted to the Flanged Plate (1). The starting handle is a Fishplate fitted with a ½" Bolt (7).

The sides of the load carrier are 2½" x 1½" Flexible Plates (8) and 2½" x 1½" Triangular Plates (9) edged by Strips. The sides are connected together at the front by a 2½" x ½" Double Angle Strip (10), and at the rear by a 2½" x 2½" Flexible Plate and a Stepped Curved Strip attached to Angle Brackets. The floor is a 5½" x 2½" Flexible Plate supported at the rear by Angle Brackets.

The load carrier is pivoted on a 4" Rod passed through Fishplates bolted to its sides, and held by Spring Clips in the Strips (2). It can be tipped by operating a lever (11). This is a 2" Rod held in a Rod and Strip Connector, and two 2½" Strips (12), overlapped four holes, are fixed tightly to the Rod and Strip Connector by a nut on a ½" Bolt. The shank of the Bolt is then passed through a Double Bracket (13) and is fitted with lock-nuts, so that the lever and the Strips (12) pivot freely.

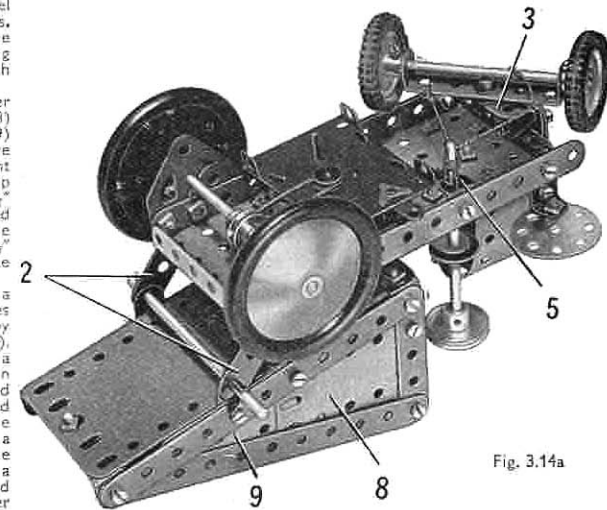

Fig. 3.14a

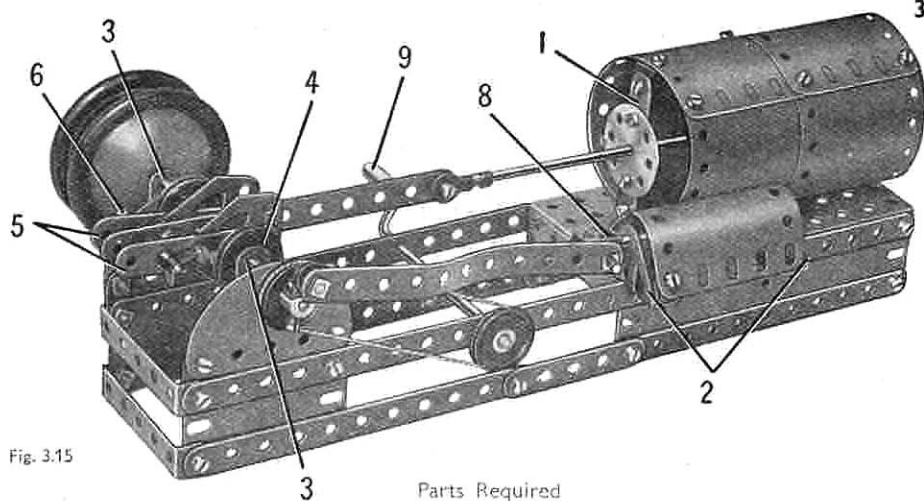

Fig. 3.15

## Parts Required

2 of No. 1	2 of No. 15b	5 of No. 35	2 of No. 111c	2 of No. 189
6 " " 2	2 " " 16	53 " " 37a	2 " " 125	2 " " 191
6 " " 5	1 " " 17	48 " " 37b	2 " " 126	2 " " 192
5 " " 10	1 " " 19g	3 " " 38	2 " " 126a	1 " " 199
2 " " 11	4 " " 22	1 " " 40	1 " " 176	1 " " 212
8 " " 12	2 " " 24a	2 " " 48a	2 " " 187	1 " " 213
		1 " " 52	2 " " 188	2 " " 214

## 3.15 MILL ENGINE

The bed of the engine is built first. For this a start is made by bolting two 12½" Strips one to each side of a Flanged Plate. A 5½" × 1½" Flexible Plate also is attached to each side of the Flanged Plate, and to the lower edges of the flexible Plates are bolted built-up strips, each consisting of two 5½" and one 2½" Strip. At the front end of the model the 12½" Strips are connected by a 2½" × ½" Double Angle Strip, and a similar part is used to connect the ends of the built-up strips. At the front end of the bed a 2½" × 1½" Flexible Plate is bolted to each side. A Semi-Circular Plate is attached to each Flexible Plate by Fishplates. The Semi-Circular Plates provide the bearings for the crankshaft.

The cylinder is made from two 5½" × 2½" and two 4½" × 2½" Flexible Plates curved and bolted together, and it is fixed to the Flanged Plate. A 2½" Strip (1) is attached by Angle Brackets to each end of the cylinder, and Wheel Discs are fixed to the Strips as shown.

The valve chamber at the side of the cylinder is represented by a "U"-section Curved Plate and two Trunnions (2). The Curved Plate is attached to one of the Trunnions by an Angle Bracket.

The crankshaft is built up from a 4" and a 2" Rod, each of which is passed through a Semi-Circular Plate and through a ½" Reversed Angle Bracket (3) bolted to the Plate. A 1" Pulley (4) is fixed to the inner end of each Rod, and an Angle Bracket is held to the boss of each Pulley by a nut and Bolt. A Flat Trunnion and a 2½" Strip (5) are bolted to each Angle Bracket as shown.

The connecting-rod is a 5½" Strip, which is free to turn on a 1½" Rod (6) held by Spring Clips in the 2½" Strips (5). The free end of the 5½" Strip is *lock-nutted* to a Rod and Strip Connector fitted to the piston rod, which consists of two 3½" Rods joined by a Rod Connector.

The valve gear is operated by an Angle Bracket bolted to the boss of a 1" Pulley (7). A 5½" Strip is attached loosely by a *lock-nutted* bolt to this Angle Bracket, and also to a Double Bracket (8) on the valve rod. A Cord Anchoring Spring is placed on this Rod inside the Double Bracket.

The engine is set in motion by a belt of Cord running round a 1" Pulley on the Crank Handle (9) and the Pulley (7).

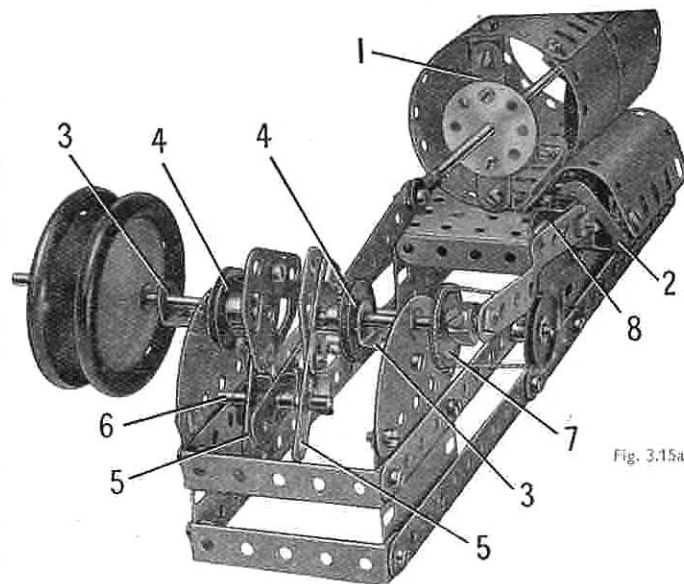

Fig. 3.15a

## 3.16 ROUNDABOUT

The two horses and the two cars are each fixed to 12½" Strips bolted at right angles to each other to a Bush Wheel that is fixed on a vertical 3½" Rod. The Rod is passed through a 2½" × ½" Double Angle Strip and through a hole in the Flanged Plate forming the base.

The model is driven by a belt of Cord passed round a 1" Pulley fixed on a Crank Handle supported in two Flat Trunnions bolted to the base and also round a further 1" Pulley fixed on the centre Rod of the roundabout.

Fig. 3.16a shows how the roundabout can be fitted with a *Magic Motor* if this is available. The Motor is bolted to one of the 5½" Strips of the base, and the drive is taken to a second 1" Pulley fastened on the Crank Handle and spaced from the Flat Trunnion by a Spring Clip and a Washer. This Pulley is removed from the end of the pivot rod of the roundabout underneath the 5½" × 2½" Flanged Plate.

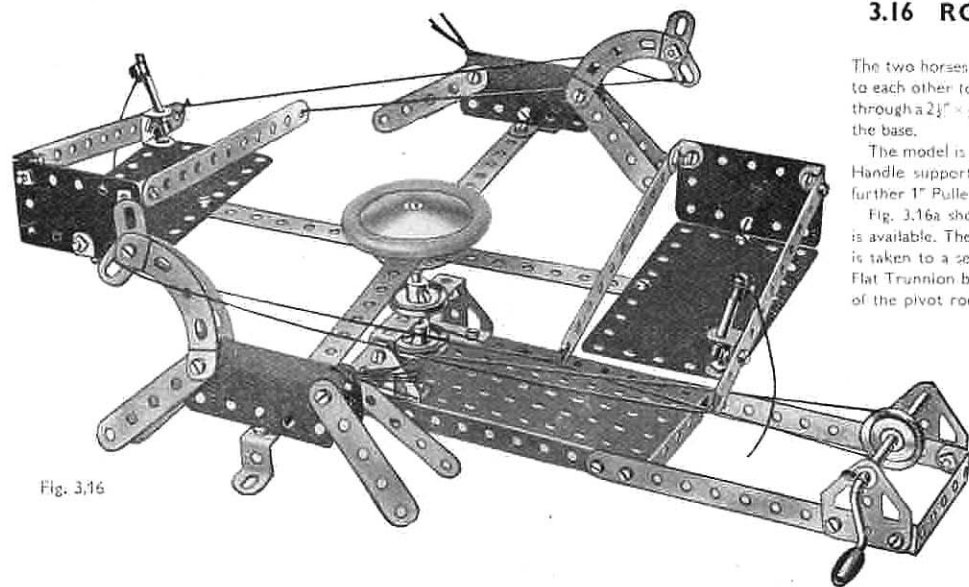

Fig. 3.16

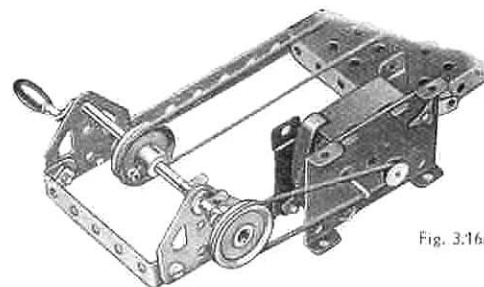

Fig. 3.16a

## Parts Required

2 of No. 1	1 of No. 19g	2 of No. 48a	2 of No. 188
6 " " 2	4 " " 22	1 " " 52	2 " " 191
8 " " 5	1 " " 24	4 " " 90a	2 " " 199
4 " " 10	6 " " 35	2 " " 111c	<i>Magic Motor</i>
2 " " 11	52 " " 37a	2 " " 125	(not included in
8 " " 12	50 " " 37b	2 " " 126	<i>Outfit</i> )
1 " " 16	2 " " 38	2 " " 126a	
2 " " 17	1 " " 40	1 " " 187	



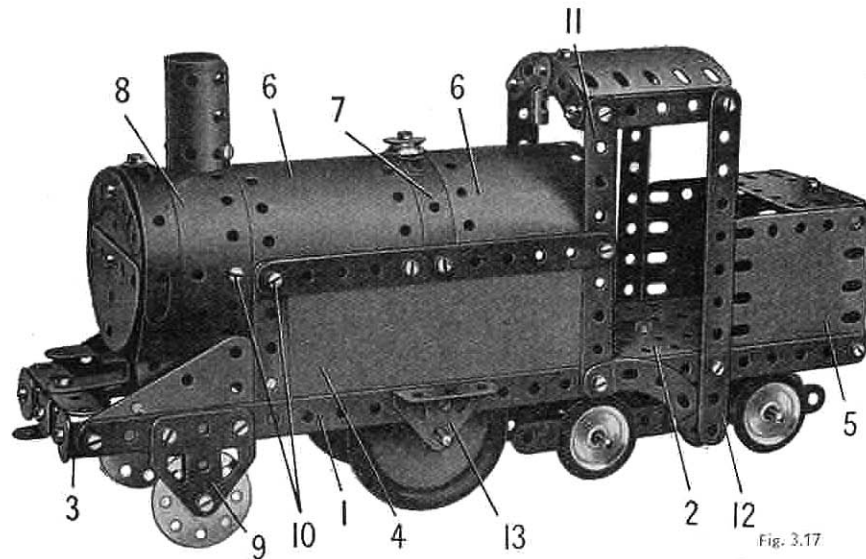

Fig. 3.17

### 3.17 TANK LOCOMOTIVE

A  $12\frac{1}{2}$ " Strip (1) is bolted to each side of a  $5\frac{1}{2}$ "  $\times$   $2\frac{1}{2}$ " Flanged Plate (2) and to a  $2\frac{1}{2}$ "  $\times$   $\frac{1}{2}$ " Double Angle Strip (3). The water tanks are represented by  $5\frac{1}{2}$ "  $\times$   $2\frac{1}{2}$ " Flexible Plates (4) edged by  $2\frac{1}{2}$ " and  $5\frac{1}{2}$ " Strips, and the sides of the coal bunker are  $2\frac{1}{2}$ "  $\times$   $2\frac{1}{2}$ " Flexible Plates (5). The back of the bunker is a  $1\frac{1}{2}$ " radius Curved Plate straightened out and bolted to the Flanged Plate (2) and to a  $2\frac{1}{2}$ "  $\times$   $\frac{1}{2}$ " Double Angle Strip placed between the Flexible Plates (5).

The boiler consists of two  $4\frac{1}{2}$ "  $\times$   $2\frac{1}{2}$ " Flexible Plates (6) and two Formed Slotted Strips (7). The smoke-box is made from two  $5\frac{1}{2}$ "  $\times$   $1\frac{1}{2}$ " Flexible Plates (8) curved as shown and bolted together at the top so that they overlap three holes. The lower ends of the Flexible Plates are attached to the Strips (1), and the Bolts holding them in place fix also a Flat Trunnion (9) and a  $2\frac{1}{2}$ "  $\times$   $1\frac{1}{2}$ " Triangular Flexible Plate on each side. The smoke-box is connected to the boiler by Fishplates held by the Bolts (10), and its front is attached by an Angle Bracket to the Flexible Plates (8). The smoke stack is a  $2\frac{1}{2}$ "  $\times$   $1\frac{1}{2}$ " Flexible Plate rolled to form a tube and bolted to an Angle Bracket.

The cab roof is supported by a  $2\frac{1}{2}$ " Strip (11) and a  $5\frac{1}{2}$ " Strip (12) on each side.

A Wheel Disc is lock-nutted to each Flat Trunnion (9), and two Road Wheels are fixed on a  $3\frac{1}{2}$ " Rod supported in Trunnions (13). The bogie consists of two  $5\frac{1}{2}$ " Strips connected by a Double Bracket (14). A  $2\frac{1}{2}$ "  $\times$   $1\frac{1}{2}$ " Triangular Flexible Plate (15) is bolted to each  $5\frac{1}{2}$ " Strip, and the complete bogie is supported freely on a  $1\frac{1}{2}$ " Rod (16) by a Cord Anchoring Spring and a Spring Clip.

#### Parts Required

2 of No.	1
6 "	2
9 "	5
3 "	10
1 "	11
8 "	12
1 "	15b
1 "	16
2 "	17
1 "	18a
4 "	22
1 "	23
1 "	24
2 "	24a
3 "	35
54 "	37a
48 "	37b
5 "	38
2 "	38d
1 "	44
2 "	48a
1 "	52
1 "	57c
4 "	90a

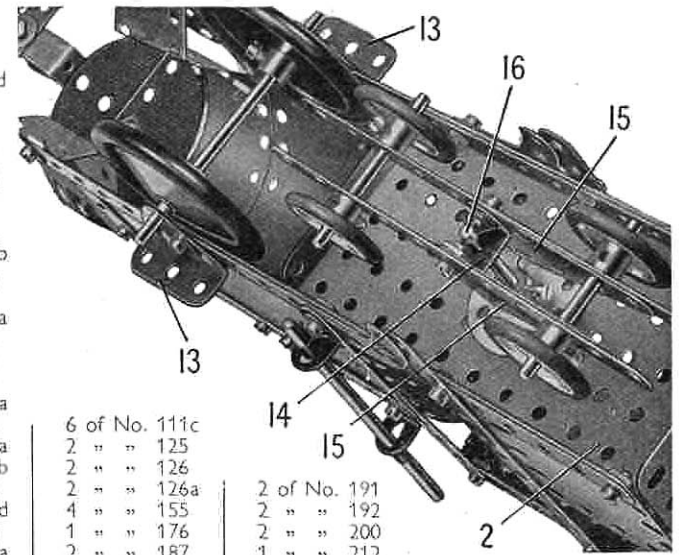

Fig. 3.17a

6 of No.	111c
2 "	125
2 "	126
2 "	126a
2 of No.	191
2 "	192
2 "	200
1 "	212
2 "	214
2 "	189
4 "	215
2 "	190
4 "	221

### 3.18 TRACTOR AND HAY WAGON

The chassis of the Tractor consists of a  $5\frac{1}{2}$ " Strip (1) on each side. These are connected at the front by a Trunnion (2) attached to Angle Brackets fixed to the Strips, and by a  $2\frac{1}{2}$ " Strip (3) that is also fixed to Angle Brackets. Two Flat Trunnions are bolted together and attached to the flange of the Trunnion (2), and a  $2\frac{1}{2}$ " Strip (4) is fixed to each of the Strips (1). The upper ends of Strips (4) are connected to Angle Brackets attached to the radiator by  $2\frac{1}{2}$ " Strips (5) lengthened by Fishplates. A Magic Motor is bolted direct to one of the Strips (see Fig. 3.18a).

The top of the bonnet consists of two  $2\frac{1}{2}$ "  $\times$   $1\frac{1}{2}$ " Flexible Plates attached to Angle Brackets bolted to Strips (4). A  $2\frac{1}{2}$ " Strip (6) and a  $2\frac{1}{2}$ "  $\times$   $\frac{1}{2}$ " Double Angle Strip (7) are bolted to the lower ends of Strips (4), and they support a  $3\frac{1}{2}$ " Rod. This Rod is fitted with a  $1\frac{1}{2}$ " Pulley (8) that is connected by a Driving Band to the Motor pulley, and carries also a  $\frac{1}{2}$ " Pulley (9) that drives a  $1\frac{1}{2}$ " Pulley on the rear axle. The  $\frac{1}{2}$ " Pulley is supplied with the Magic Motor. The rear axle is a 4" Rod, and is supported in Semi-Circular Plates (10) attached to the end holes of Strip (3) by  $\frac{1}{2}$ " Reversed Angle Brackets.

The front axle is a  $3\frac{1}{2}$ " Rod supported in a  $2\frac{1}{2}$ "  $\times$   $\frac{1}{2}$ " Double Angle Strip (11) lock-nutted to the Trunnion (2). The steering column is a  $3\frac{1}{2}$ " Rod passed through a Fishplate bolted to each of the rear flanged lugs of the Magic Motor. A length of Cord is wound round the lower end of the  $3\frac{1}{2}$ " Rod and each end is then tied to Double Angle Strip (11). A Cord Anchoring Spring and a Washer are used to keep the Cord on the Rod.

The seat is a Trunnion bolted to a  $2\frac{1}{2}$ " Strip (12) connected by an Angle Bracket to the Strip (3). The base of the Hay Wagon is a  $5\frac{1}{2}$ "  $\times$   $2\frac{1}{2}$ " Flanged Plate. The wheels turn on  $\frac{1}{2}$ " Bolts, each fixed by two nuts in a  $2\frac{1}{2}$ " Stepped Curved Strip.

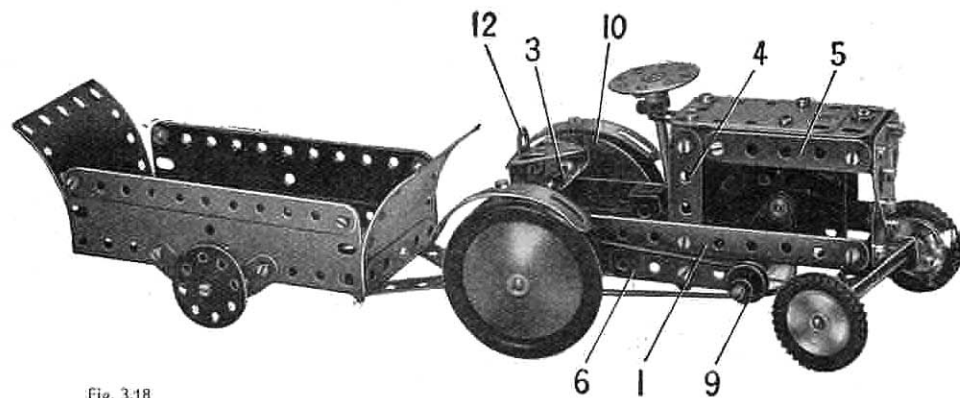

Fig. 3.18

#### Parts Required

4 of No.	2	1 of No.	52
9 "	5	2 "	90a
5 "	10	4 "	111c
2 "	11	2 "	125
8 "	12	2 "	126
1 "	15b	2 "	126a
3 "	16	2 "	142c
1 "	18a	1 "	176
4 "	22	2 "	187
1 "	24	2 "	188
2 "	24a	2 "	189
2 "	35	2 "	200
56 "	37a	2 "	214
47 "	37b	2 "	215
1 "	40		
1 "	44		
2 "	48a		

Magic Motor  
(not included in Outfit)

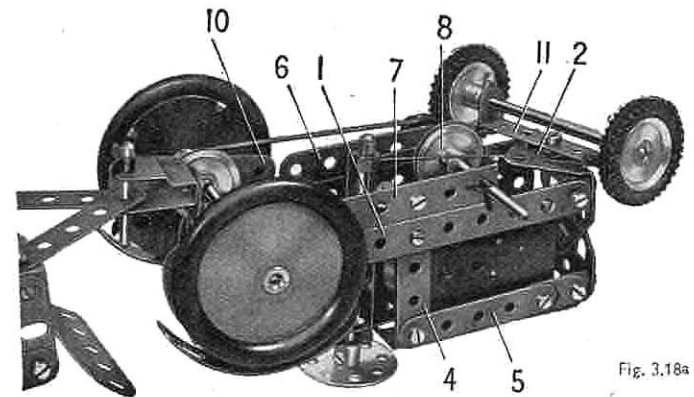

Fig. 3.18a

### 3.19 WINDMILL PUMP

The base of the model is a  $5\frac{1}{2}'' \times 2\frac{1}{2}''$  Flanged Plate, to the flanges of which  $5\frac{1}{2}'' \times 1\frac{1}{4}''$  and  $2\frac{1}{2}'' \times 1\frac{1}{4}''$  Flexible Plates are bolted. A  $12\frac{1}{2}''$  Strip is fixed upright to each side, and two  $2\frac{1}{2}'' \times 1\frac{1}{4}''$  Double Angle Strips (1) are bolted between these Strips.

Two  $2\frac{1}{2}'' \times 1\frac{1}{4}''$  Triangular Flexible Plates (2) are attached to each  $12\frac{1}{2}''$  Strip as shown, and they are connected to the top hole of the Strip by  $2\frac{1}{2}''$  Stepped Curved Strips. The bolt that fixes the Curved Strips to the  $12\frac{1}{2}''$  Strips is used also to secure a Semi-Circular Plate (3) and two Angle Brackets that support  $2\frac{1}{2}'' \times 2\frac{1}{2}''$  Flexible Plates (4).

The windmill blades are eight  $2\frac{1}{2}''$  Strips, which are bolted to a Bush Wheel fixed on a  $4''$  Rod fitted with a  $5\frac{1}{2}''$  Pulley (5). Pulley (5) is connected by a Cord belt to a  $1''$  Pulley (6) fixed on a Crank Handle. A bolt passed through an Angle Bracket is fitted with two Washers, and is then screwed into one of the threaded holes of Pulley (6). The Bolt is tightened to hold the Angle Bracket firmly in place, and a  $2\frac{1}{2}''$  Strip (7) is lock-nutted to the Angle Bracket and to a  $5\frac{1}{2}''$  Strip (8).

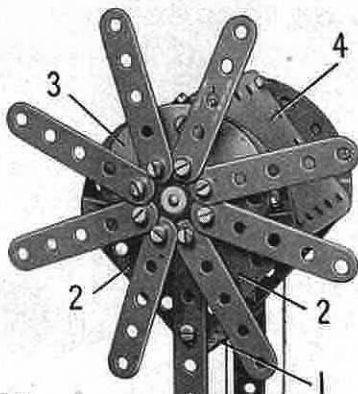

Fig. 3.19a

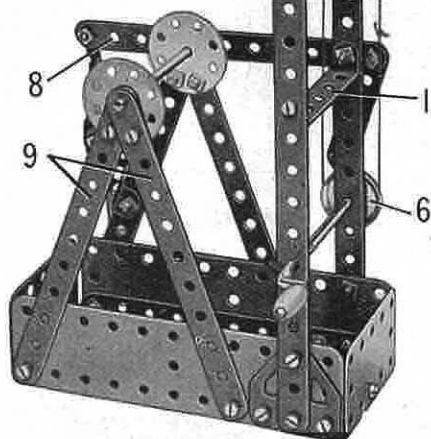
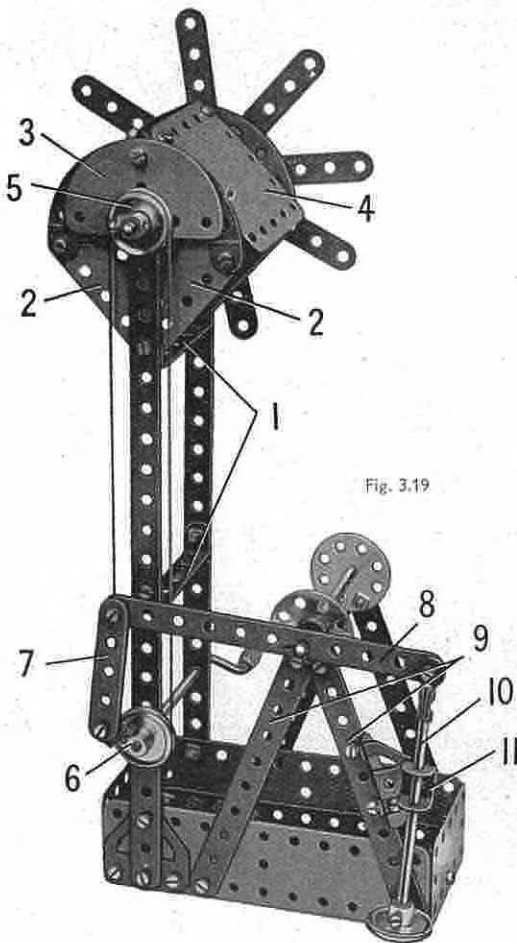

Fig. 3.19



The Strip (8) is pivoted on a  $4''$  Rod supported in a Wheel Disc and in the top holes of two  $5\frac{1}{2}''$  Strips (9) on each side. The Strip is held on the  $4''$  Rod by a Spring Clip, and it is connected by a lock-nutted Bolt to a Rod and Strip Connector fitted to a  $3\frac{1}{2}''$  Rod (10). Rod (10) is free to slide in a Double Bracket (11) lock-nutted to a Trunnion. The Trunnion is attached by Angle Brackets to one of the Strips (9).

Parts Required		
2 of No. 1	1 of No. 24	2 of No. 111c
5 " " 2	2 " " 24a	1 " " 126
9 " " 5	2 " " 35	2 " " 126a
1 " " 11	53 " " 37a	2 " " 188
7 " " 12	47 " " 37b	2 " " 189
2 " " 15b	6 " " 38	2 " " 190
1 " " 16	1 " " 40	1 " " 212
1 " " 19g	2 " " 48a	2 " " 214
3 " " 22	1 " " 52	4 " " 221
	4 " " 90a	

### 3.20 BALANCE

One of the  $12\frac{1}{2}''$  Strips that form the beam of the balance is bolted across a Bush Wheel (2). The  $3\frac{1}{2}''$  Rod (3) that is gripped in the boss of the Bush Wheel rests on the two Curved Strips (4).

The Rod (1), by which the balance is adjusted, is pushed through the two holes of a Stepped Bent Strip fastened to the Bush Wheel (2) by a Reversed Angle Bracket. The  $5\frac{1}{2}''$  Strips from which the weighing pans are suspended are pivoted at their upper ends on 2" Rods, which are passed through holes in the  $12\frac{1}{2}''$  Strips of the beam.

#### Parts Required

2 of No. 1	2 of No. 16	3 of No. 38	2 of No. 126
6 " " 2	2 " " 17	1 " " 40	2 " " 126a
8 " " 5	4 " " 22	1 " " 44	2 " " 190
5 " " 10	1 " " 24	2 " " 48a	2 " " 191
2 " " 11	6 " " 35	1 " " 52	2 " " 192
3 " " 12	46 " " 37a	4 " " 90a	2 " " 200
2 " " 15b	46 " " 37b	1 " " 125	1 " " 212
			1 " " 213

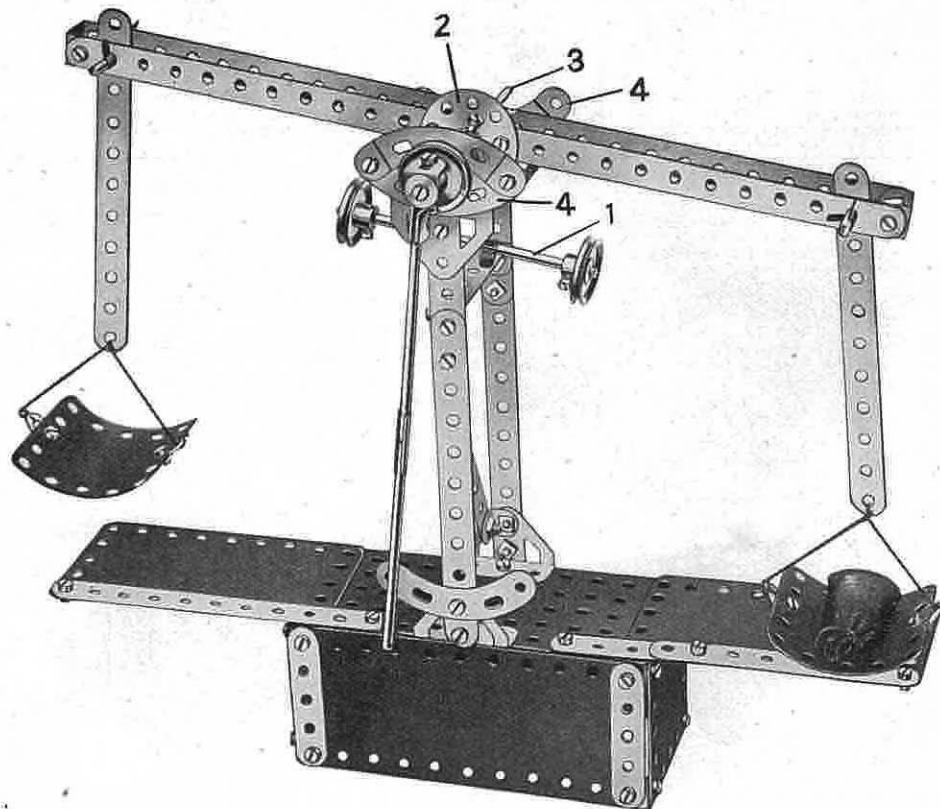

### 3.21 FORK LIFT TRUCK

The back of the model is a  $5\frac{1}{2}'' \times 2\frac{1}{2}''$  Flanged Plate (1), and each side consists of a  $5\frac{1}{2}'' \times 1\frac{1}{2}''$  Flexible Plate (2) placed vertically, a  $5\frac{1}{2}'' \times 2\frac{1}{2}''$  Flexible Plate (3), a  $4\frac{1}{2}'' \times 2\frac{1}{2}''$  Flexible Plate (4) and a  $2\frac{1}{2}'' \times 2\frac{1}{2}''$  Flexible Plate (5). The upper edges of Plates (4) and (5), and the lower edges of Plates (3), are strengthened by  $5\frac{1}{2}''$  Strips, and they are connected across by a  $2\frac{1}{2}'' \times \frac{1}{2}''$  Double Angle Strip. Two  $2\frac{1}{2}'' \times 1\frac{1}{2}''$  Triangular Plates (6), placed with their sloping edges overlapped, are bolted to the Double Angle Strip, and a  $2\frac{1}{2}'' \times 1\frac{1}{2}''$  Flexible Plate (7) is attached to the sides by Angle Brackets. The driver's seat is also a  $2\frac{1}{2}'' \times 1\frac{1}{2}''$  Flexible Plate, and the backrest is made from two Flat Trunnions.

A  $2\frac{1}{2}'' \times \frac{1}{2}''$  Double Angle Strip (8) is bolted between the lower front corners of Plates (3), and two vertical  $12\frac{1}{2}''$  Strips (9) are fixed to it. These Strips are connected three holes from their upper ends by a  $2\frac{1}{2}''$  Strip, and they are attached to the Flexible Plates (5) by Double Brackets.

Two  $5\frac{1}{2}''$  Strips (11) are joined together by four  $2\frac{1}{2}''$  Strips arranged in pairs as indicated at (12). The Strips in each pair are arranged one on each side of the  $5\frac{1}{2}''$  Strips, and they are further separated by a Washer on each of the bolts used to fix them in position. The  $2\frac{1}{2}''$  Strips slide freely over the  $12\frac{1}{2}''$  Strips (9). The fork platform consists of two  $2\frac{1}{2}''$  Strips bolted to a further  $2\frac{1}{2}''$  Strip (13), which is fixed to Strips (11) by Angle Brackets.

The fork platform can be raised or lowered by operating a handle formed by a  $\frac{3}{8}''$  Bolt in a Bush Wheel. The Bush Wheel is fixed on a  $2''$  Rod free to turn in two Angle Brackets (14). A length of Cord tied to a Cord Anchoring Spring on the  $2''$  Rod is passed round a  $3\frac{1}{2}''$  Rod (15) and over a  $\frac{1}{2}''$  loose Pulley on a  $3\frac{1}{2}''$  Rod held in Angle Brackets bolted to the upper ends of Strips (9). The Cord is then tied to the upper pair of  $2\frac{1}{2}''$  Strips (12).

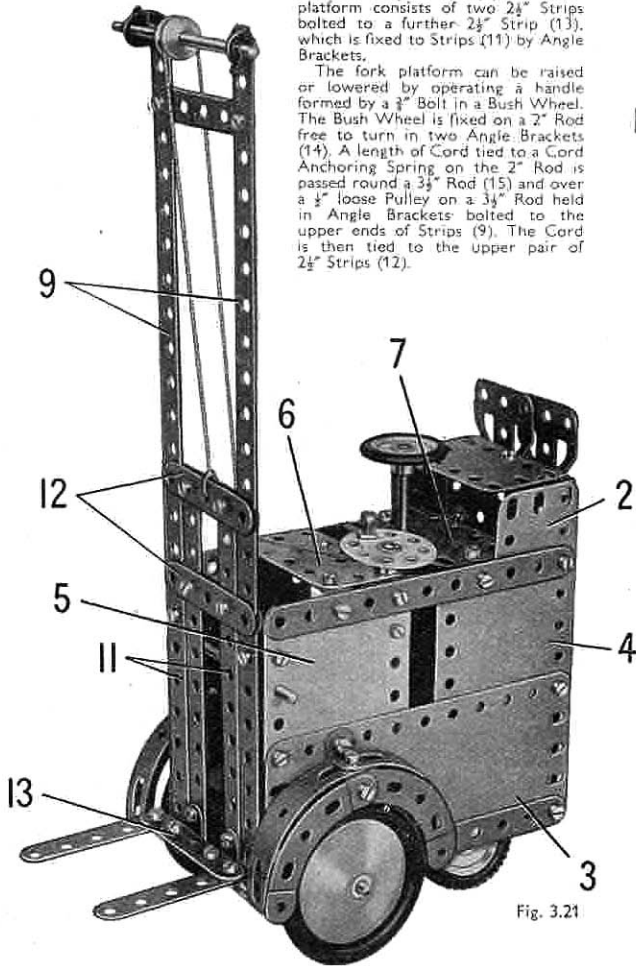

Fig. 3.21

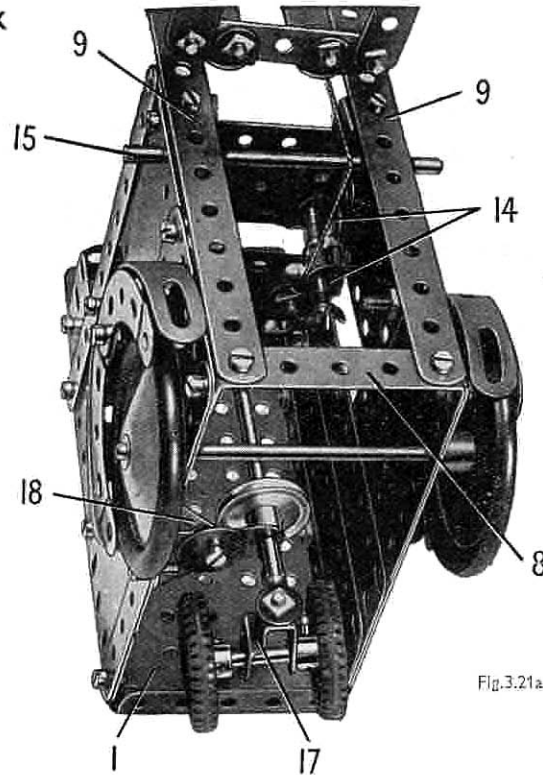

Fig. 3.21a

The front wheels are fixed on a  $4''$  Rod supported in Plates (3) as shown, and each wheel is provided with a mudguard made from two Farmed Slotted Strips and two Curved Strips bolted to a  $\frac{1}{2}''$  Reversed Angle Bracket. The rear wheels are fixed on a  $2''$  Rod passed through a Stepped Bent Strip (17). This is bolted tightly to a Rod and Strip Connector on a  $4''$  Rod joined to a  $2''$  Rod by a Rod Connector. The long rod thus formed is supported in the Flexible Plate (7) and in a Fishplate bolted to a Trunnion (18).

Parts Required		
2 of No. 1	6 of No. 35	2 of No. 142c
6 " " 2	54 " " 37a	1 " " 155
9 " " 5	50 " " 37b	1 " " 176
1 " " 10	2 " " 38	2 " " 187
1 " " 11	2 " " 38d	2 " " 188
8 " " 12	1 " " 40	2 " " 189
2 " " 15b	1 " " 44	2 " " 190
2 " " 16	2 " " 48a	2 " " 191
2 " " 17	1 " " 52	2 " " 192
1 " " 18a	4 " " 90a	1 " " 212
4 " " 22	4 " " 111c	1 " " 213
1 " " 23	2 " " 125	4 " " 215
1 " " 24	2 " " 126	2 " " 221
	2 " " 126a	

### 3.22 PORTABLE GARAGE CRANE

A  $5\frac{1}{2}''$  Strip (1) is bolted to each side of a Flanged Plate (2) and  $2\frac{1}{2}'' \times 1\frac{1}{2}''$  Triangular Flexible Plates (3) are then fixed in place as shown. The Road Wheels are fixed to a  $3\frac{1}{2}''$  Rod supported in  $2\frac{1}{2}''$  Curved Strips (4) on each side of the model. The front wheels are  $1''$  Pulleys, which are fixed to  $\frac{3}{8}''$  Bolts passed through Flat Trunnions.

The jib is built up from two  $12\frac{1}{2}''$  Strips bolted to the sides of the Flanged Plate and extended at their upper ends by Curved Strips. It is held rigid by  $5\frac{1}{2}''$  Strips fixed to the Flanged Plate and also to  $2\frac{1}{2}'' \times 1\frac{1}{2}''$  Triangular Flexible Plates fastened to the  $12\frac{1}{2}''$  Strips.

The handle used for hauling and manoeuvring the crane truck is represented by the  $3\frac{1}{2}''$  Rod (5) fitted with a Bush Wheel, to which a  $2\frac{1}{2}''$  Strip is bolted. The other end of the Rod carries a Rod and Strip Connector that pivots on a Bolt held in two Trunnions bolted to the Double Angle Strip (6).

The hoisting Cord is tied to a Cord Anchoring Spring on the Crank Handle and then is passed over a  $1''$  Pulley at the jib head. Then the Cord passes round a  $\frac{1}{2}''$  Pulley in the pulley block and is tied to one of the Curved Strips. The pulley block consists of a  $\frac{1}{2}''$  Pulley placed between two Fishplates on a  $\frac{3}{8}''$  Bolt fitted with lock-nuts.

A brake to prevent the load falling when the winding handle is released is formed by a belt of Cord, which is passed round a  $1''$  Pulley (7) on the Crank Handle and then fastened to a weighted built-up strip (8). This strip is made up from two  $2\frac{1}{2}''$  Strips bolted together, and to its outer end two Wheel Discs are attached. The other end of the Strip is pivoted on a  $\frac{3}{8}''$  Bolt (9). The Bolt is fitted with two nuts tightened together.

#### Parts Required

2 of No. 1	1 of No. 40
6 " " 2	1 " " 44
9 " " 5	2 " " 48a
2 " " 10	1 " " 52
1 " " 11	1 " " 57c
1 " " 16	4 " " 90a
1 " " 18a	6 " " 111c
1 " " 19g	2 " " 126
4 " " 22	2 " " 126a
1 " " 23	2 " " 142c
1 " " 24	1 " " 176
2 " " 24a	2 " " 187
4 " " 35	2 " " 189
49 " " 37a	1 " " 212
48 " " 37b	2 " " 215
6 " " 38	4 " " 221

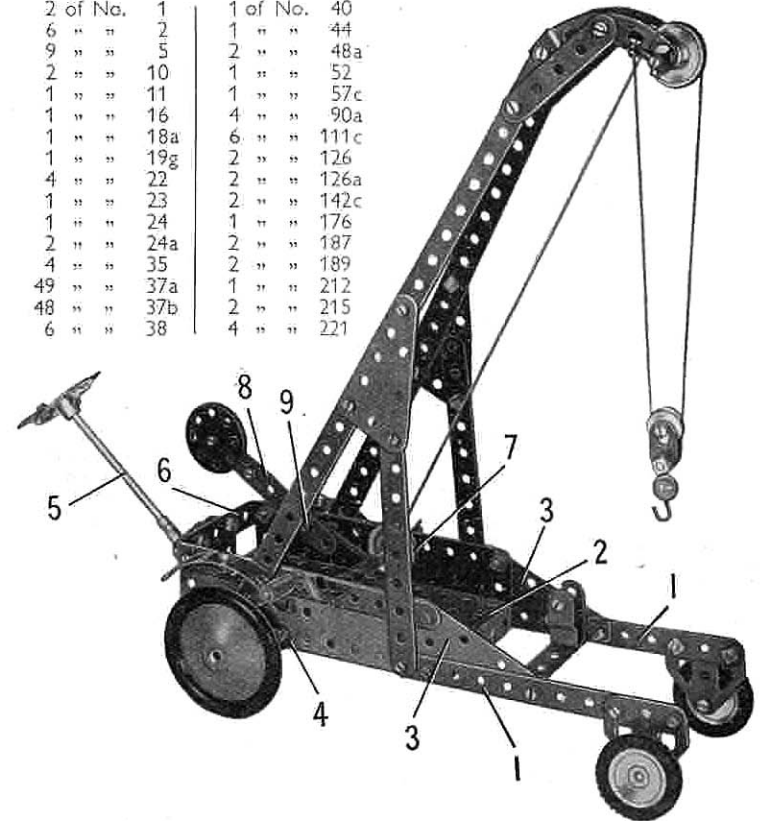



## 3.23 SIMPLE HAND LOOM

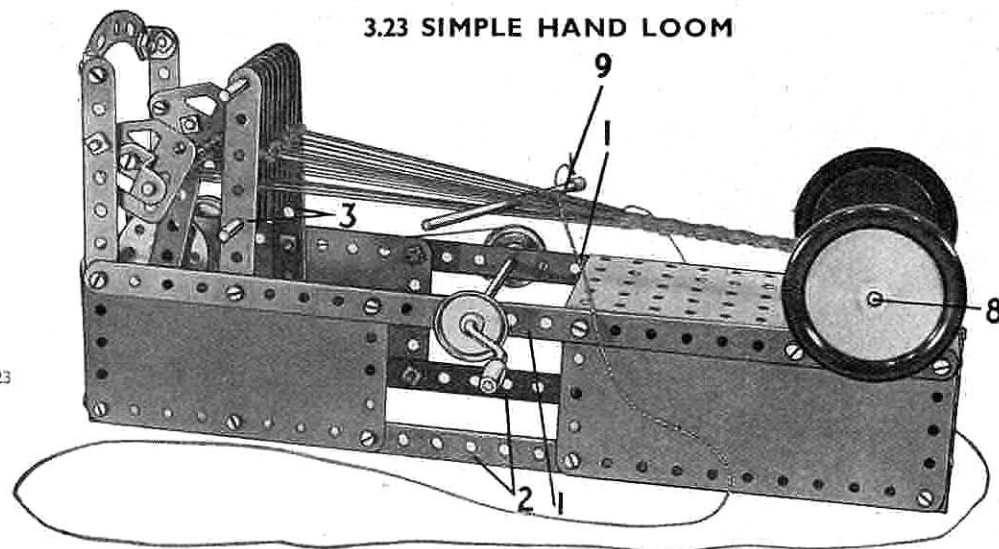

Fig. 3.23

## Parts Required

2 of No. 1	2 of No. 16	2 of No. 24a	1 of No. 40	2 of No. 125	2 of No. 190
6 " " 2	2 " " 17	6 " " 35	2 " " 48a	1 " " 126	2 " " 191
9 " " 5	1 " " 19g	42 " " 37a	1 " " 52	2 " " 126a	2 " " 192
4 " " 12	3 " " 22	37 " " 37b	2 " " 90a	1 " " 176	2 " " 214
2 " " 15b	1 " " 24	6 " " 38	2 " " 111c	2 " " 187	4 " " 215

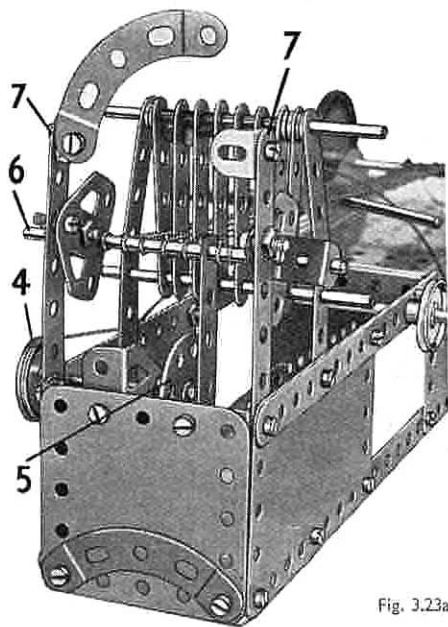

Fig. 3.23a

This interesting model is designed to demonstrate the principles of hand weaving. The base is formed by two 12½" Strips (1) bolted to a Flanged Plate at one end and joined by a 2½" × ½" Double Angle Strip at the other. Two 5½" × 2½" and two 4½" × 2½" Flexible Plates are bolted to the Strips and joined at their lower edges by the 5½" Strips (2).

The 5½" Strips (3) form a support for the heald frame, which consists of eight 2½" Strips held by two 3½" Rods. The Strips are separated by Spring Clips and Washers as shown, these parts being placed between the Strips on the upper Rod.

The warp separating movement is operated from a Crank Handle. A 1" Pulley on this is connected by a belt of Cord to a similar Pulley (4), which is fixed on a 2" Rod that carries also the Bush Wheel (5). A 2½" Strip, lock-nutted to the Bush Wheel, links it with the Rod (6). This Rod is mounted in two Flat Trunnions, each fitted with a Reversed Angle Bracket. The Trunnions are free to turn on the shanks of ½" Bolts fastened in the Strips (7).

A 4" Rod (8) fitted with two Rod Wheels passes through two Semi-Circular Plates bolted to the sides of the Flanged Plate.

A length of Cord taken from each of the 2½" Strips forming the healds, is tied to the Rod (8). A second set of similar Cords is taken from the Rod (8), passed between the healds and fastened to Rod (6).

To operate the model, the two sets of warp threads are separated by turning the Crank Handle slightly. A length of Cord is then passed between the layers by means of the 3½" Rod (9). The Crank Handle is then again turned slightly, thus changing the positions of the warp layers, and the Rod (9) is again passed through from the other side.

Cord is used in the illustrations to show the positions of the threads more clearly, but in actual operation it is better to use wool as this will give a closer and finer texture to the woven material.

## 3.24 SWIVELLING JIB CRANE

## Parts Required

2 of No. 1	1 of No. 18a	4 of No. 90a
6 " " 2	1 " " 19g	1 " " 111c
9 " " 5	4 " " 22	1 " " 125
2 " " 10	1 " " 23	2 " " 126
1 " " 11	1 " " 24	2 " " 126a
6 " " 12	4 " " 35	3 " " 155
2 " " 15b	50 " " 37a	2 " " 187
1 " " 17	50 " " 37b	2 " " 188
	6 " " 38	2 " " 189
	1 " " 40	1 " " 190
	2 " " 48a	2 " " 191
	1 " " 52	1 " " 200
	1 " " 57c	2 " " 221

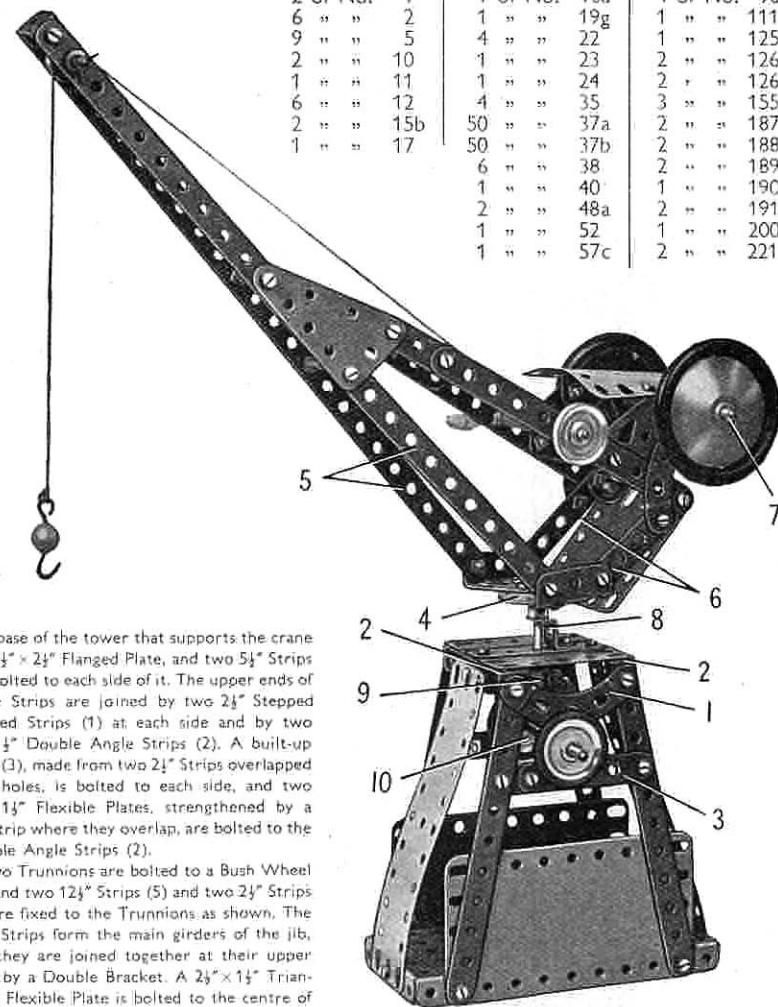

The base of the tower that supports the crane is a 5½" × 2½" Flanged Plate, and two 5½" Strips are bolted to each side of it. The upper ends of these Strips are joined by two 2½" Stepped Curved Strips (1) at each side and by two 2½" × ½" Double Angle Strips (2). A built-up strip (3), made from two 2½" Strips overlapped four holes, is bolted to each side, and two 2½" × 1½" Flexible Plates, strengthened by a 2½" Strip where they overlap, are bolted to the Double Angle Strips (2).

Two Trunnions are bolted to a Bush Wheel (4), and two 12½" Strips (5) and two 2½" Strips (6) are fixed to the Trunnions as shown. The 12½" Strips form the main girders of the jib, and they are joined together at their upper ends by a Double Bracket. A 2½" × 1½" Triangular Flexible Plate is bolted to the centre of each 12½" Strip, and is connected by a built-up strip to the Strip (6). The built-up strip is made from a 5½" and a 2½" Strip overlapped three holes. The cab roof is bolted to Angle Brackets fixed to Flat Trunnions as shown. A Rod (7) is supported in the top holes of 2½" Stepped Curved Strips bolted to the Strips (6).

A 2" Rod is fixed in the boss of the Bush Wheel (4), and this Rod is supported in a ½" Reversed Angle Bracket (8) and the top of the tower. The Rod carries at its lower end a 1" Pulley (9) fitted with a Rubber Ring, and this rests on a Rubber Ring carried by a 1" Pulley (10). Pulley (10) is fixed on a Rod mounted in Fishplates bolted to the Curved Strips (1). This arrangement provides a simple slewing or turning mechanism so that the cab and jib can be turned to raise or lower a load at any point round the base.

### 3.25 MOBILE CRANE

Parts Required

2 of No. 1	
4 " " 2	
9 " " 5	
2 " " 10	
1 " " 11	
8 " " 12	
1 " " 15b	
3 " " 16	
1 " " 18a	
1 " " 19g	
4 " " 22	
1 " " 23	
1 " " 24	
2 " " 24a	
6 " " 35	
50 " " 37a	
44 " " 37b	
6 " " 38	
2 " " 38d	
1 " " 40	
1 " " 44	
2 " " 48a	
1 " " 52	
1 " " 57c	
1 " " 90a	
3 " " 111c	
2 " " 126	
2 " " 126a	
2 " " 155	

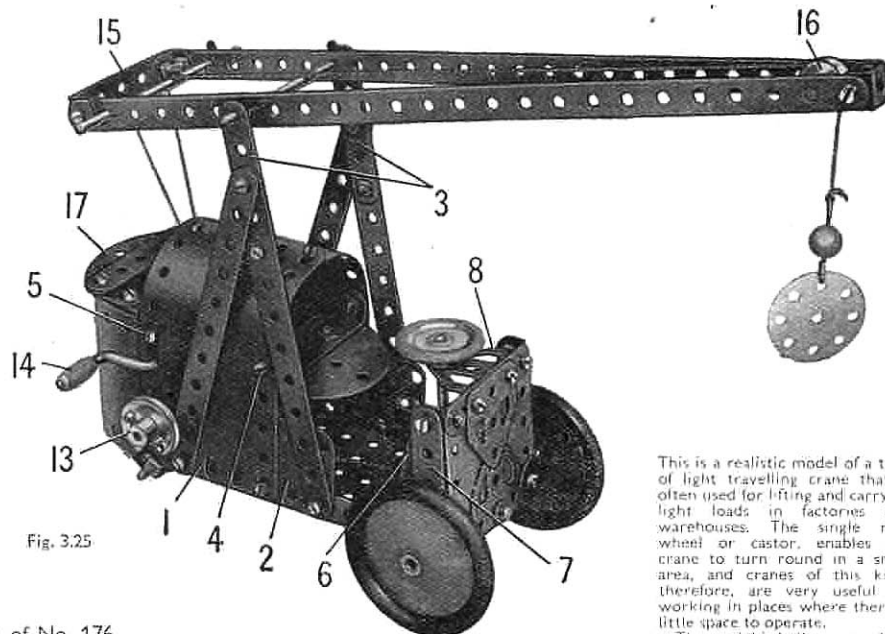

Fig. 3.25

This is a realistic model of a type of light travelling crane that is often used for lifting and carrying light loads in factories and warehouses. The single rear wheel or castor, enables the crane to turn round in a small area, and cranes of this kind, therefore, are very useful for working in places where there is little space to operate.

The model is built up on a base consisting of a  $5\frac{1}{2}'' \times 2\frac{1}{2}''$  Flanged Plate, which is fitted at each side with a  $4\frac{1}{2}'' \times 2\frac{1}{2}''$  Flexible Plate (1) and a  $2\frac{1}{2}'' \times 1\frac{1}{2}''$  Flexible Plate (2). The Bolts fixing these Plates in position serve also to hold  $5\frac{1}{2}''$  Strips that form the jib supports. These Strips are extended upward by  $2\frac{1}{2}''$  Strips (3). The upper ends of the Plates (1) are curved and bolted together as shown, and two  $2\frac{1}{2}'' \times \frac{1}{2}''$  Double Angle Strips, held by the Bolts (4) and (5), are placed between the Plates. The seat is a Semi-Circular Plate and is attached to the Double Angle Strip held by the Bolts (4). The curved end of the model is made from a  $5\frac{1}{2}'' \times 2\frac{1}{2}''$  Flexible Plate bolted to the Flexible Plate (1).

A  $2\frac{1}{2}'' \times 2\frac{1}{2}''$  Flexible Plate forms the front of the model, and it is connected by Angle Brackets to two  $2\frac{1}{2}''$  Strips (6) and (7) on each side. Strip (6) is bolted to the Flanged Plate, and the front axle, which is a  $4''$  Rod, is passed through Strips (7) and the Flanged Plate. A Trunnion (8) is fixed in position to the front.

The rear wheel or castor is fixed on a  $1\frac{1}{2}''$  Rod supported in a Stepped Bent Strip (9). A  $\frac{1}{8}''$  Bolt is held tightly in the Bent Strip by a nut, and the Bolt is then passed through a Trunnion (10) bolted to the rear of the Flanged Plate. A Wheel Disc (11) is fixed between two nuts on the upper end of the  $1\frac{1}{2}''$  Bolt.

The steering column is passed through Trunnion (8) and the base Flanged Plate, and a Bush Wheel on the Rod is connected at each side to the Wheel Disc (11) by a short length of Cord.

The jib consists of two  $12\frac{1}{2}''$  Strips joined at the front by a Double Bracket, and connected at the rear by Angle Brackets to a  $2\frac{1}{2}''$  Strip. It pivots on a  $3\frac{1}{2}''$  Rod supported in the Strips (3). The jib is luffed, that is, raised and lowered, by a length of Cord tied to a Rod fitted with a Pulley (12). The Rod is fitted with a handle which is formed by a  $\frac{1}{2}''$  Bolt in an Angle Bracket attached to a  $1''$  Pulley (13). The Bolt is fitted with a nut and is passed through the Angle Bracket into one of the threaded holes in the boss of the Pulley. The nut is then tightened to hold the Angle Bracket in place.

A length of Cord is tied to a Crank Handle (14) and is taken over a Rod (15) in the jib. The Cord then passes round a  $\frac{1}{2}''$  Pulley (16) and is fitted with a small Loaded Hook. The Pulley (16) is free to turn on a  $\frac{1}{4}''$  Bolt attached to the jib by two nuts.

A  $2\frac{1}{2}''$  Stepped Curved Strip (17) and a  $2\frac{1}{2}''$  Strip are fitted at their ends with Fishplates, and these are connected by Angle Brackets to the Double Angle Strip held by the Bolts (5). A Semi-Circular Plate is attached to the Double Angle Strip to fill in the rounded end formed by the Flexible Plates (1).

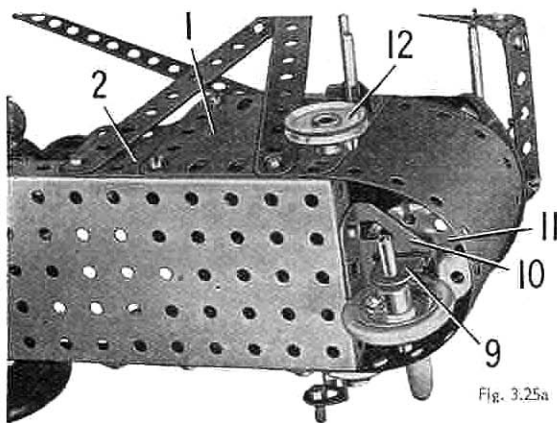

Fig. 3.25a

### 3.26 TOWER WAGON

Parts Required

6 of No. 2	1 of No. 17	2 of No. 38	2 of No. 126	2 of No. 191
9 " " 5	4 " " 22	1 " " 40	1 " " 126a	2 " " 192
4 " " 10	1 " " 24	2 " " 48a	4 " " 142c	2 " " 200
2 " " 11	1 " " 35	1 " " 52	2 " " 188	1 " " 214
8 " " 12	55 " " 37a	6 " " 111c	2 " " 189	4 " " 221
2 " " 16	49 " " 37b	2 " " 125	2 " " 190	

The front of the chassis is a  $5\frac{1}{2}'' \times 2\frac{1}{2}''$  Flanged Plate (1), and this is extended at each side at the rear by a  $5\frac{1}{2}'' \times 2\frac{1}{2}''$  Flexible Plate that overlaps the Flanged Plate by two holes. A  $2\frac{1}{2}''$  Stepped Curved Strip that supports the rear axle is attached to each side by the Bolts (2), and these Bolts also fix in place two  $5\frac{1}{2}''$  Strips (3) and two Angle Brackets. A  $4\frac{1}{2}'' \times 2\frac{1}{2}''$  Flexible Plate is bolted to the Angle Brackets to form the floor at the rear of the model.

The back of the cab is a  $2\frac{1}{2}'' \times 2\frac{1}{2}''$  Flexible Plate bolted to a  $2\frac{1}{2}'' \times \frac{1}{2}''$  Double Angle Strip held between the  $5\frac{1}{2}'' \times 2\frac{1}{2}''$  Flexible Plates by a Bolt (4) on each side. The Bolts holding the Double Angle Strip in place fix also  $2\frac{1}{2}'' \times 1\frac{1}{2}''$  Triangular Flexible Plates that form the cab sides. The roof is a  $2\frac{1}{2}'' \times 2\frac{1}{2}''$  Flexible Plate fixed to a Double Bracket bolted to the back of the cab. A  $2\frac{1}{2}'' \times 1\frac{1}{2}''$  Flexible Plate (5) is connected to the Flanged Plate (1) by an Angle Bracket.

The bonnet consists of two  $1\frac{1}{2}''$  radius Curved Plates overlapped two holes and attached by Angle Brackets to the Flanged Plate (1). The radiator is a Flat Trunnion fixed to the front of the Flanged Plate

by a Fishplate. The  $1\frac{1}{2}''$  Rod to which the steering wheel is fixed is passed through the Flanged Plate and through a  $\frac{1}{2}''$  Reversed Angle Bracket bolted to it. The front wheels are fixed on a  $3\frac{1}{2}''$  Rod supported in Fishplates. The driver's seat is made by bolting two Trunnions together by their flanged ends, and it is fixed to the Flanged Plate (1).

The Strips (3) are lengthened by  $2\frac{1}{2}''$  Strips, and a  $5\frac{1}{2}'' \times 1\frac{1}{2}''$  Flexible Plate is bolted to the upper ends of these Strips on each side. A  $2\frac{1}{2}'' \times 1\frac{1}{2}''$  Flexible Plate (6) is fixed to a  $2\frac{1}{2}'' \times \frac{1}{2}''$  Double Angle Strip bolted between the  $5\frac{1}{2}'' \times 2\frac{1}{2}''$  Flexible Plates, and a  $\frac{1}{2}''$  Reversed Angle Bracket held by a Bolt (7) supports one end of a  $4\frac{1}{2}'' \times 2\frac{1}{2}''$  Flexible Plate that forms the floor of the tower platform. The other end of this Plate is fixed to a  $2\frac{1}{2}'' \times \frac{1}{2}''$  Double Angle Strip held by a Bolt (8) on each side, and a Semi-Circular Plate, indicated at (9), is fixed also to this Double Angle Strip.

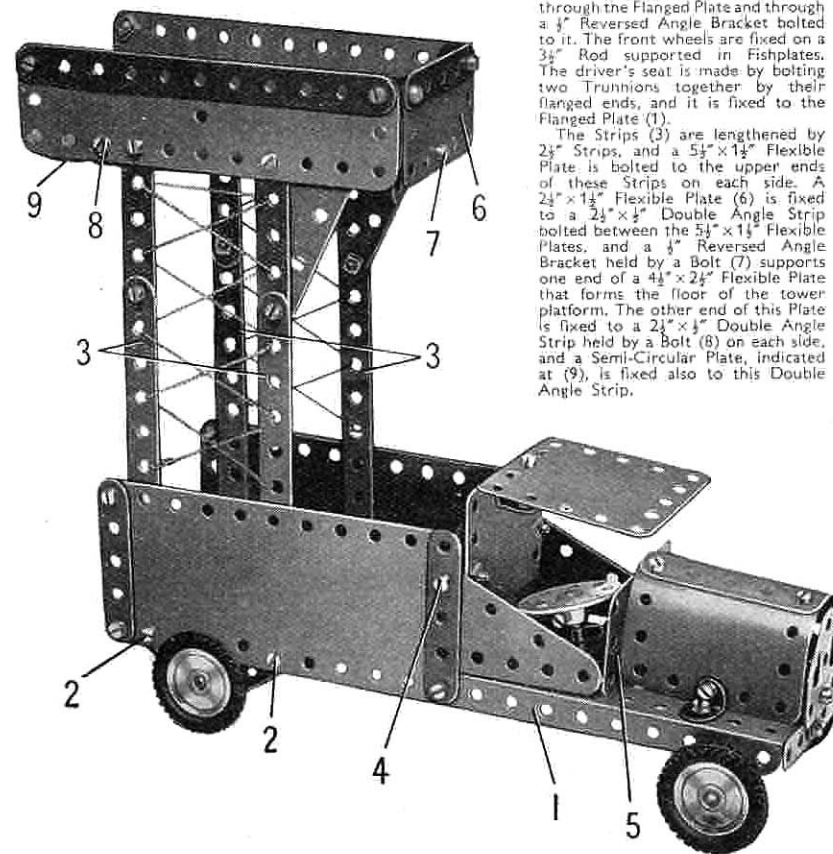

## 3.27 PITHEAD GEAR

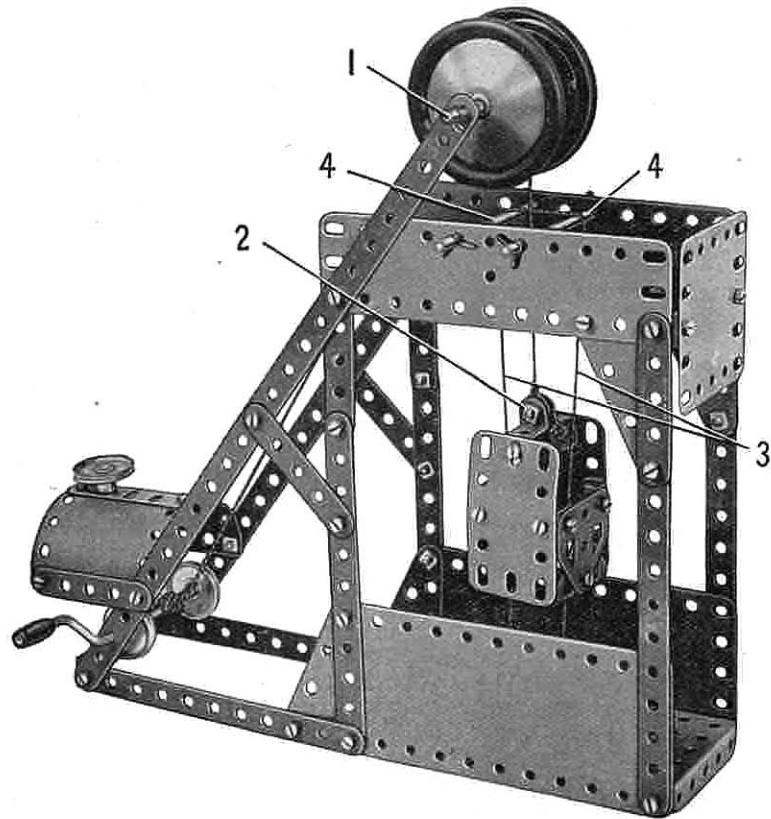

## Parts Required

2 of No.	1
6 " "	2
9 " "	5
6 " "	12
3 " "	16
1 " "	19g
4 " "	22
1 " "	24
4 " "	35
47 " "	37a
46 " "	37b
6 " "	38
1 " "	40
2 " "	48a
1 " "	52
2 " "	111c
2 " "	125
2 " "	126
2 " "	126a
1 " "	176
2 " "	187
2 " "	188
2 " "	189
1 " "	190
2 " "	192
2 " "	200
4 " "	221

A  $3\frac{1}{2}$ " Rod (1) is supported in the top holes of the  $12\frac{1}{2}$ " Strips. Between two Road Wheels on this Rod is a 1" fast Pulley, over which passes a Cord from which the cage is suspended. A Cord Anchoring Spring is pushed on one end of the Rod (1) and a Bush Wheel is fixed to its other end.

The cage is built up from Trunnions and Flat Trunnions, and two  $2\frac{1}{2}$ " x  $1\frac{1}{2}$ " Flexible Plates, which form its sides, are fastened to the Flat Trunnions by Angle Brackets.

A  $\frac{3}{8}$ " Bolt is passed through the holes of Reversed Angle Brackets (2) bolted to the top of the cage, and Washers are placed on its shank for spacing purposes.

The cage is guided while being raised or lowered by guides formed by a length of Cord (3). This is passed over two Rods (4) as shown, and its ends are then led downwards and pushed through two holes in the Flanged Plate that forms the base. Washers are tied to each end of the Cord, underneath the Plate, to hold it tightly in place.

The Cord used for raising and lowering the cage is tied to the Crank Handle and is passed over the Pulley on Rod (1) and tied to the Reversed Angle Brackets (2).

## 3.28 BLOCK-SETTING CRANE

The travelling bogie (1) consists of two Fishplates bolted together by their elongated holes, and at each end of it Double Brackets are fastened by  $\frac{7}{8}$ " Bolts. Two 2" Rods are pushed through the Double Brackets and carry 1" fast Pulleys spaced so that their grooves fit on the two  $12\frac{1}{2}$ " Strips that form the top of the jib. The Trunnions (2) at the base of the jib are secured to a Bush Wheel mounted on a Rod held in the bosses of two Road Wheels. The Road Wheels are placed one above and one below the  $2\frac{1}{2}$ " x  $1\frac{1}{2}$ " Flexible Plates that form the top of the tower.

Cord (3) is first fastened to the  $\frac{7}{8}$ " Bolt at the rear end of the travelling bogie, and then wound three times round the Crank Handle, which is passed through the end holes of the  $12\frac{1}{2}$ " Strips. It is then led round the Rod at the front of the jib and tied to the other  $\frac{7}{8}$ " Bolt at the front of the bogie.

Cord (4) is first fastened to the Rod (5), and then led over the rear axle of the bogie. It is then passed round the  $\frac{3}{4}$ " Pulley (6), led over the front axle of the bogie, round the Rod at the front end of the jib, and finally is tied to the bogie. The  $\frac{1}{2}$ " loose Pulley (6) and its Rod are held in the Stepped Bent Strip by a Cord Anchoring Spring.

## Parts Required

2 of No.	1	2 of No.	17	6 of No.	35	1 of No.	52	1 of No.	176
6 " "	2	1 " "	18a	56 " "	37a	4 " "	90a	2 " "	187
8 " "	5	1 " "	19g	50 " "	37b	6 " "	111c	2 " "	188
5 " "	10	4 " "	22	6 " "	38	2 " "	125	1 " "	190
2 " "	11	1 " "	23	1 " "	40	2 " "	126	2 " "	200
6 " "	12	1 " "	24	1 " "	44	2 " "	126a	4 " "	221
2 " "	16	1 " "	24a	2 " "	48a				

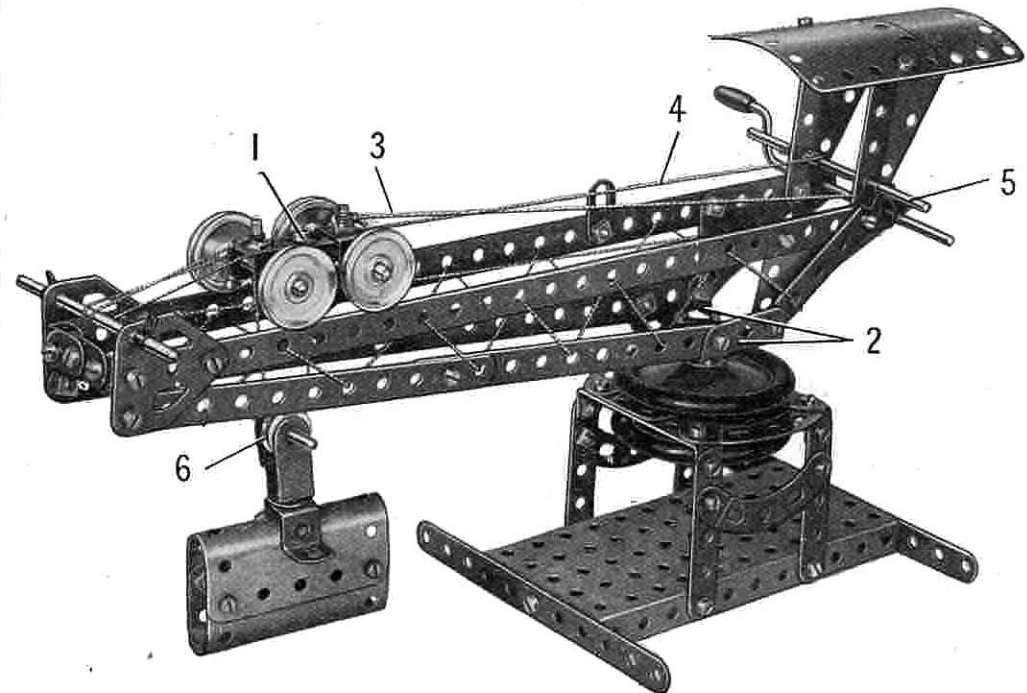



### 3.29 HIGH FLYER

Each side of the base consists of a 12½" Strip fitted with two upright 5½" Strips (1). A 2½" × 1½" Triangular Flexible Plate is bolted between each of the Strips (1) and the 12½" Strip, and a 2½" × 1½" Flexible Plate (2) and a 2½" Curved Strip (3) are fixed in position. The upper ends of Strips (1) are connected by a Semi-Circular Plate. The sides of the base are joined by two 2½" × ½" Double Angle Strips (4), each of which is lengthened by a Double Bracket (5).

The floor of the high flyer is a 5½" × 2½" Flanged Plate, and the sides are 5½" × 2½" Flexible Plates. The ends are 2½" × 2½" Flexible Plates. The roof is supported by four 2½" Strips, which are attached to the 5½" × 2½" Flexible Plates so that they overlap the Plates by one clear hole. The upper ends of the 2½" Strips on each side are connected by a 5½" Strip (6), and they are joined to the Strips on the opposite side by Angle Brackets and by a 2½" Stepped Curved Strip (7). The roof consists of two 4½" × 2½" Flexible Plates overlapped seven holes, and it is attached to Angle Brackets bolted to the Strip (6). The Angle Brackets are opened out so that the roof can be curved slightly.

The model is operated by a Crank Handle (8), supported in the 2½" × 1½" Flexible Plates (2), and in a Flat Trunnion (9) attached to each side of the base. A Bush Wheel is fixed to the Crank Handle, and a 2½" Strip (10) is lock-nutted to the Bush Wheel. A second 2½" Strip is bolted tightly to Strip (10), and is lock-nutted to a further 2½" Strip (11), which is gripped on a 4" Rod between two 1" Pulleys (12) fitted with Rubber Rings. The Rod is supported in the Semi-Circular Plates, and is passed through the centre holes of Strips (6). A 1" Pulley (13) fitted with a Rubber Ring is placed on the Rod at each side of the High Flyer, and is pressed tightly against the Strip (6) before it is fixed on the Rod.

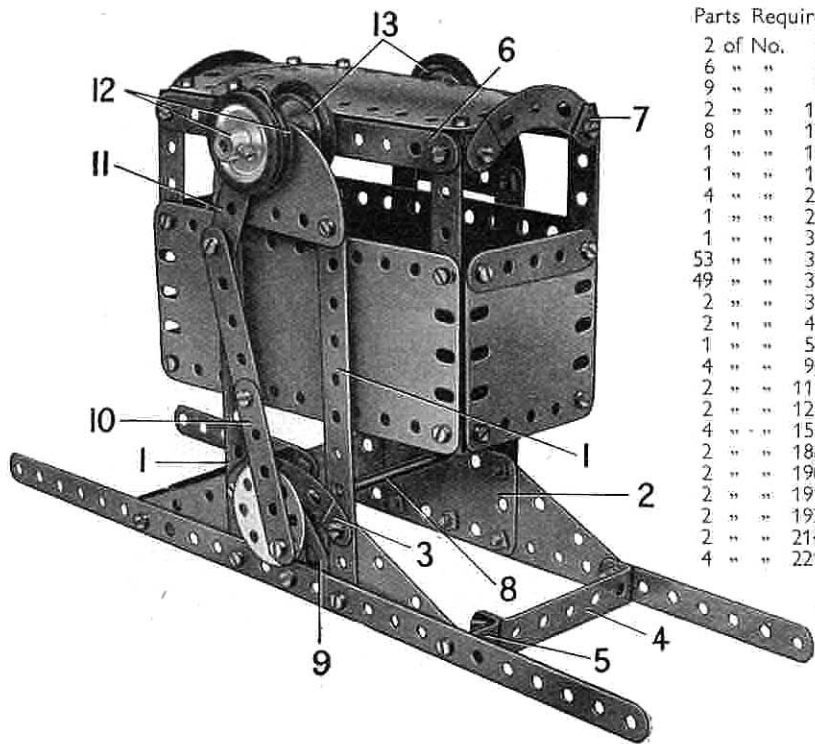

#### Parts Required

2 of No.	1
6 " "	2
9 " "	5
2 " "	11
8 " "	12
1 " "	15b
1 " "	19g
4 " "	22
1 " "	24
1 " "	35
53 " "	37a
49 " "	37b
2 " "	38
2 " "	48a
1 " "	52
4 " "	90a
2 " "	111c
2 " "	126a
4 " "	155
2 " "	188
2 " "	190
2 " "	191
2 " "	192
2 " "	214
4 " "	221

### 3.30 SHOVEL LOADER

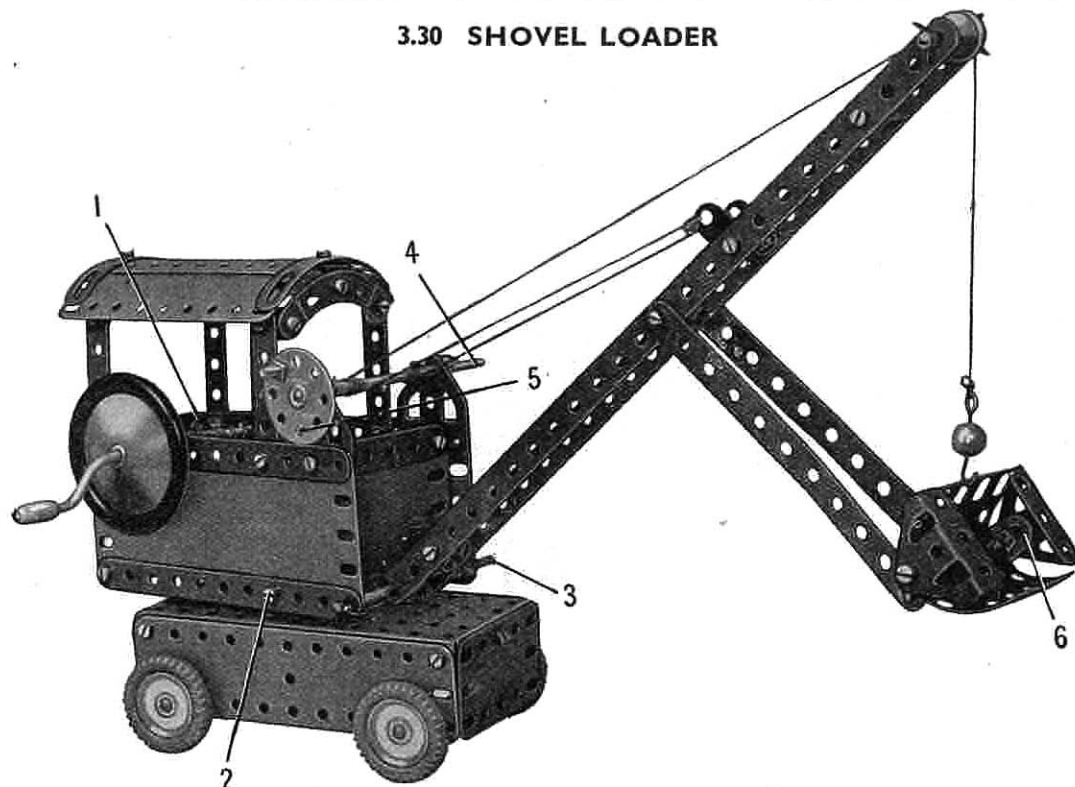

The tractor unit is made by bolting two 5½" × 1½" and two 2½" × 1½" Flexible Plates to the sides of a 5½" × 2½" Flanged Plate. It is fitted with wheels formed by 1" Pulleys with Tyres, which are fixed on 3½" Rods.

The cab sides are two 5½" × 2½" Flexible Plates edged with 5½" Strips. These are joined by a Double Angle Strip (1) and a similar Double Angle Strip held by a Bolt (2) on each side of the cab. A ½" Bolt passed through this Double Angle Strip is used to attach the cab to the tractor unit. Two Wheel Discs are placed on the Bolt between the Double Angle Strip and the tractor unit, and the ½" Bolt is lock-nutted. The back of the cab is a 2½" × 2½" Flexible Plate bolted to the Double Angle Strip (1).

The roof is made from two 4½" × 2½" Flexible Plates, and is attached at each end to a Curved Strip by means of an Angle Bracket. The Curved Strips are connected by Angle Brackets to four 2½" Strips that support the roof.

The jib is made up from two 12½" Strips joined by Double Brackets. It pivots about a 3½" Rod (3), and is luffed by two Cords extending from a Rod (4) to the Fishplates bolted to the 12½" Strips. This Rod is fitted with a Bush Wheel, and can be prevented from turning round by pushing the Rod inwards so that a Bolt (5) fixed in the Flat Trunnion supporting the Rod engages in one of the holes in the Bush Wheel. By this means it is possible to maintain the jib in any position desired.

Two 5½" Strips lock-nutted to the jib form the arm that carries the shovel. The shovel is made from a 'U'-section Curved Plate, and the 5½" Strips are fixed to it by two Reversed Angle Brackets, one of which can be seen at (6). The sides of the shovel are formed by two Trunnions.

The shovel arm is raised or lowered by a length of Cord, which runs from the Loaded Hook attached to the shovel, over a ½" Pulley at the upper end of the jib and is then fastened to the Crank Handle.

#### Parts Required

2 of No.	1	3 of No.	16	6 of No.	35	2 of No.	90a	1 of No.	187
6 " "	2	1 " "	18a	48 " "	37a	2 " "	111c	2 " "	188
5 " "	5	1 " "	19g	45 " "	37b	2 " "	125	2 " "	189
2 " "	10	4 " "	22	1 " "	40	2 " "	126	2 " "	190
2 " "	11	1 " "	23	2 " "	48a	2 " "	126a	2 " "	191
8 " "	12	1 " "	24	1 " "	52	4 " "	142c	2 " "	192
1 " "	15b	2 " "	24a	1 " "	57c	1 " "	176	2 " "	199
								2 " "	215



### 3.32 ICE CREAM VENDOR AND VAN

Fig. 3.32

The carrier box of the tricycle is made by bolting two  $5\frac{1}{2}'' \times 2\frac{1}{2}''$  and two  $2\frac{1}{2}'' \times 2\frac{1}{2}''$  Flexible Plates to a Flanged Plate. The wheels are made fast to a  $3\frac{1}{2}''$  Rod that rotates in Flat Trunnions. A Semi-Circular Plate (1) is attached to the front of the carrier, and a similar part (2) is bolted to a Double Angle Strip that spans the sides of the carrier.

The  $5\frac{1}{2}''$  Strips (3) are secured to a Double Bracket pivotally attached to the Semi-Circular Plate (2). The supports for the saddle consist of four  $2\frac{1}{2}''$  Strips, and a Trunnion (4) is attached to these by a Reversed Angle Bracket and a Double Bracket (5).

The body of the rider is formed by two 'U'-section Curved Plates, and is attached to the Trunnion by an Angle Bracket. His legs are made from four  $2\frac{1}{2}''$  Strips. It is important to note that all the Bolts numbered (6) are *lock-nutted* so that the parts they hold are free to pivot.

The rear wheel is fixed on a 2" Rod fitted with a 1" Pulley. This Pulley is connected by a belt of Cord to a second Pulley (7) on a  $1\frac{1}{2}''$  Rod. An Angle Bracket is bolted to the boss of Pulley (7) and attached to one of the rider's legs, see Fig. 3.32a. The other leg is attached to a Reversed Angle Bracket. The slotted hole of the Bracket is fitted with a nut and bolt, and is then pushed on to the  $1\frac{1}{2}''$  Rod. The effect of this is that the nut presses against the Rod and locks the Bracket firmly so that it rotates with the Rod.

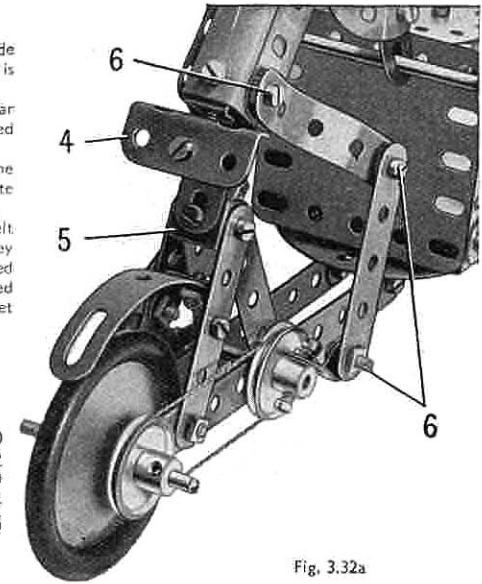
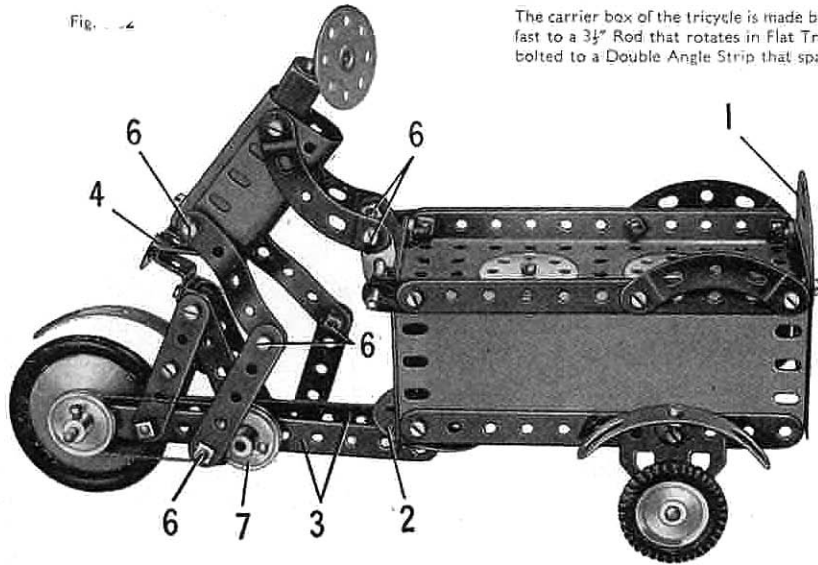

#### Parts Required

6 of No. 2	4 of No. 22	1 of No. 52	2 of No. 190
8 " " 5	1 " " 24	4 " " 90a	2 " " 192
4 " " 10	2 " " 24a	3 " " 111c	2 " " 199
2 " " 11	3 " " 35	2 " " 125	2 " " 214
7 " " 12	53 " " 37a	1 " " 126	3 " " 215
2 " " 16	42 " " 37b	2 " " 126a	
1 " " 17	1 " " 44	2 " " 142c	
1 " " 18a	1 " " 48a	1 " " 187	

Fig. 3.32a

### 3.33 GIANT LORRY

The lorry is assembled on a  $5\frac{1}{2}'' \times 2\frac{1}{2}''$  Flanged Plate (1), and the wheels are fixed to  $3\frac{1}{2}''$  Rods supported in Fishplates bolted to the side flanges. The bolts fixing the rear Fishplates serve also to attach a  $2\frac{1}{2}'' \times 1\frac{1}{2}''$  Triangular Flexible Plate to each side.

The bonnet is made from two 'U'-section Curved Plates connected to Angle Brackets bolted to the Flanged Plate, and the radiator consists of a Trunnion (2) fitted with a Wheel Disc. The mudguards are  $5\frac{1}{2}''$  Strips, bent as shown, and they are attached to Double Brackets bolted to the Flanged Plate (1).

The back of the cab is a  $2\frac{1}{2}'' \times 2\frac{1}{2}''$  Flexible Plate. It is bolted to an Angle Bracket fixed to the Flanged Plate, and the cab roof, which is a  $1\frac{1}{4}''$  radius Curved Plate, is attached to the back by an Angle Bracket. The front of the cab is a  $2\frac{1}{2}'' \times 1\frac{1}{2}''$  Flexible Plate (3), and this also is connected to the Flanged Plate by an Angle Bracket.

The trailer platform consists of a  $2\frac{1}{2}'' \times 2\frac{1}{2}''$  Flexible Plate and two  $5\frac{1}{2}'' \times 2\frac{1}{2}''$  Flexible Plates. These Plates are edged on each side by a  $2\frac{1}{2}''$  and two  $5\frac{1}{2}''$  Strips, and they are connected to  $12\frac{1}{2}''$  Strips (4) by Angle Brackets.

Two  $2\frac{1}{2}''$  Stepped Curved Strips (5) are bolted to each end of the trailer platform, and the rear pair of Curved Strips supports two Flat Trunnions (6). The trailer wheels are fixed to a 4" Rod supported in the holes at the pointed ends of the Flat Trunnions. A built-up strip (7), made from two  $2\frac{1}{2}''$  Strips overlapped three holes, is attached to a  $2\frac{1}{2}'' \times \frac{1}{2}''$  Double Angle Strip bolted to the Flat Trunnions and the Curved Strips.

The front pair of Curved Strips is connected by a  $2\frac{1}{2}'' \times \frac{1}{2}''$  Double Angle Strip, to which a  $1\frac{1}{4}''$  radius Curved Plate is bolted.

The coupling device between the lorry and trailer is a  $1\frac{1}{2}''$  Rod held in a Wheel Disc (8) by a Spring Clip and a Cord Anchoring Spring. The Rod is fitted with a  $\frac{1}{2}''$  Pulley, and is passed through a  $\frac{1}{2}''$  Reversed Angle Bracket (9).

#### Parts Required

2 of No. 1	8 of No. 5	4 of No. 22	1 of No. 52	2 of No. 126	1 of No. 188
6 " " 2	4 " " 10	1 " " 23	4 " " 90a	2 " " 126a	1 " " 190
	2 " " 11	2 " " 24a	6 " " 111c	4 " " 142c	2 " " 192
	7 " " 12	3 " " 35	2 " " 125	1 " " 176	2 " " 199
	3 " " 16	56 " " 37a		2 " " 187	2 " " 200
	1 " " 17	50 " " 37b			4 " " 215
		6 " " 38			2 " " 221
		2 " " 48a			

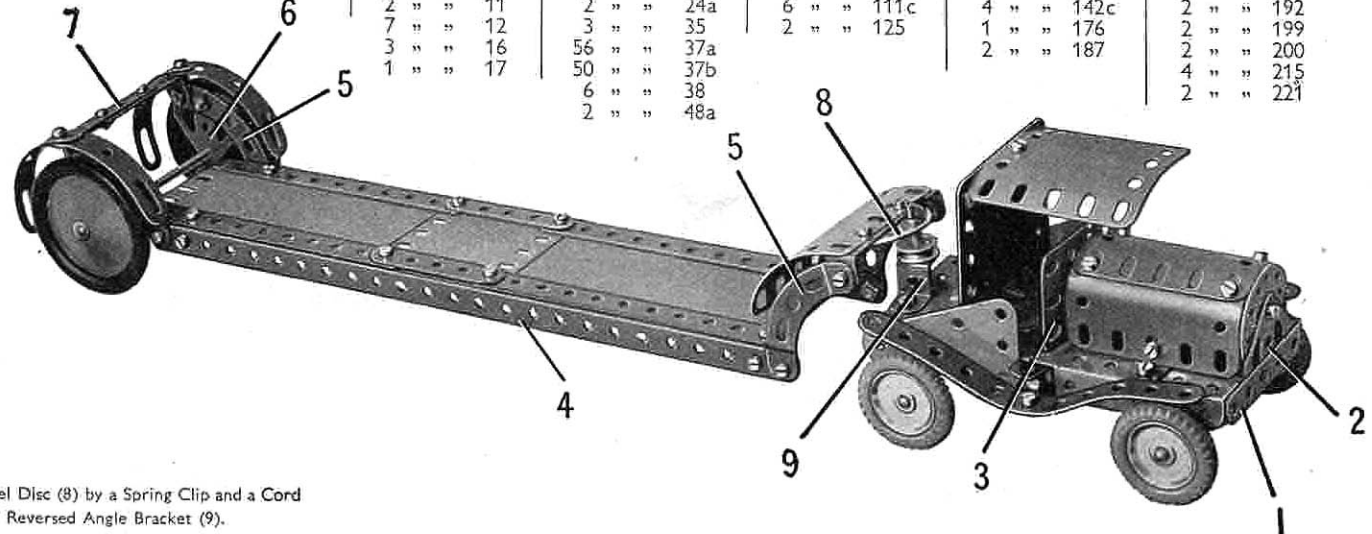



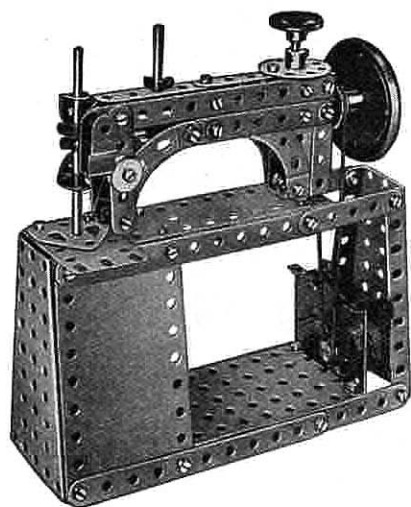

Sewing Machine

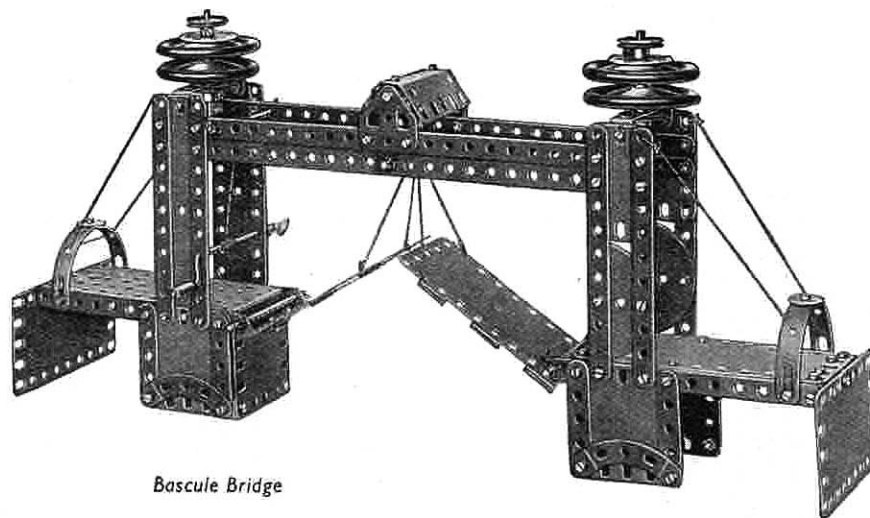

Bascule Bridge

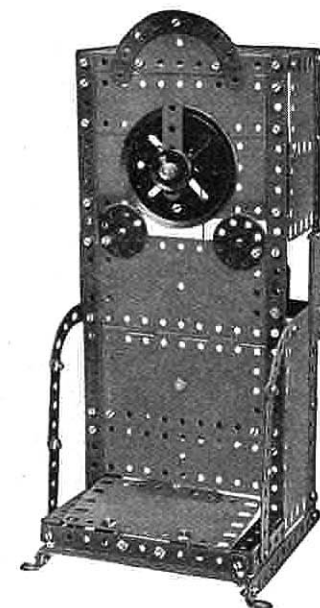
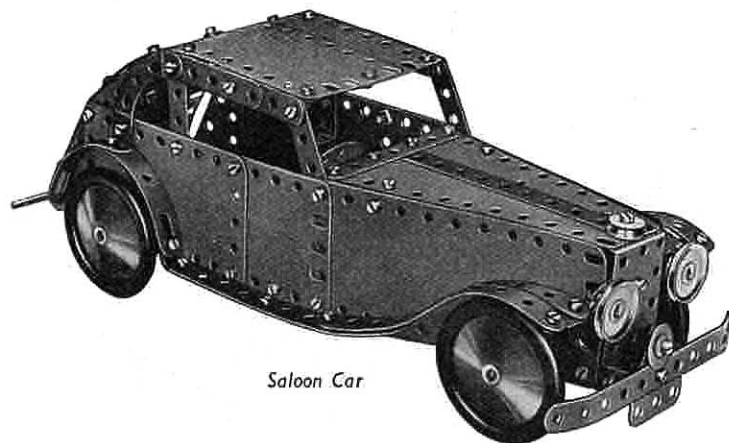
Penny-in-the-Slot  
Weighing Machine

Saloon Car

### HOW TO CONTINUE

When you have built all the models shown in this Book of Instructions, you will be keen to build others bigger and more elaborate. Your next step, therefore, is to purchase a Meccano No. 3a Accessory Outfit containing all the parts required to convert your No. 3 into a No. 4 Outfit. You will then be able to make the full range of No. 4 Outfit models, a selection of which is illustrated on this page.

If you prefer to do so, you can build up and develop your No. 3 Outfit quite easily by adding various parts to it from time to time. The model-building possibilities of the Meccano System are unlimited, and the more Meccano parts you have the bigger and better your models will be.

**BUILD BIGGER AND BETTER MODELS**

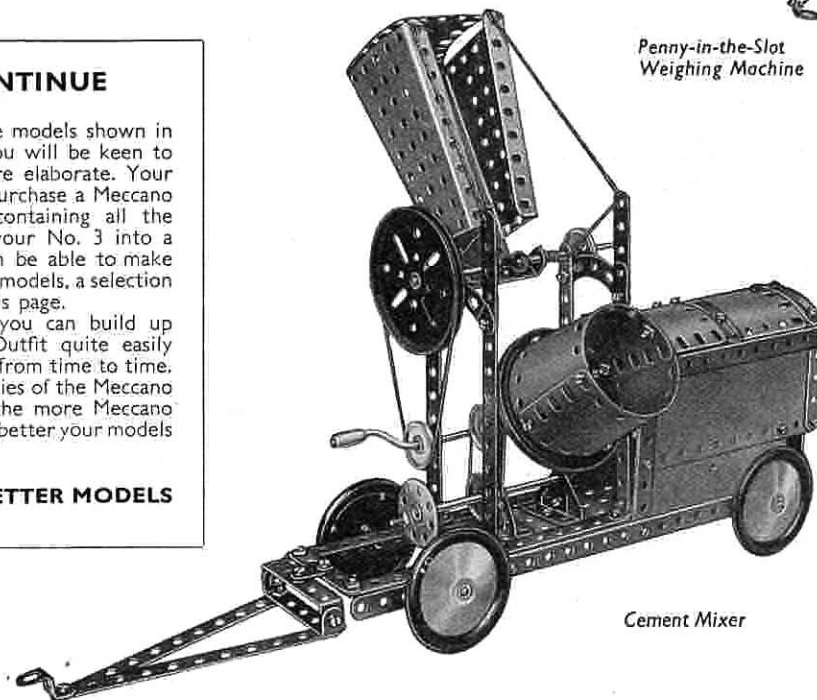

Cement Mixer







# MECCANO PARTS



## PERFORATED STRIPS

No.		No.		No.	
1.	12½"	2a.	4½"	6.	2"
1a.	9"	3.	3½"	6a.	1½"
1b.	7"	4.	3"		
2.	5½"	5.	2½"		

## ANGLE GIRDERS

7.	24½"	8b.	7½"	9c.	3"
7a.	18½"	9.	5½"	9d.	2½"
8.	12½"	9a.	4½"	9e.	2"
8a.	9½"	9b.	3½"	9f.	1½"



10. Fishplate | 11. Double Bracket

## ANGLE BRACKETS

12.	½" × ½"	12b.	1" × ½"
12a.	½" × 1"	12c.	Obtuse, ½" × ½"



## AXLE RODS

13.	11½"	15a.	4½"	16b.	3"
13a.	8"	15b.	4"	17.	2"
14.	6½"	16.	3½"	18a.	1½"
15.	5"	16a.	2½"	18b.	1"

19g. Crank Handle; 3½" shaft, with grip  
 19h. Crank Handle; 5" shaft, with grip  
 19s. Crank Handle; 3½" shaft, without grip



19a. Spoked Wheel, 3" diam.  
 20. Flanged Wheel, 1½" diam.  
 20b. Flanged Wheel, ½" diam.

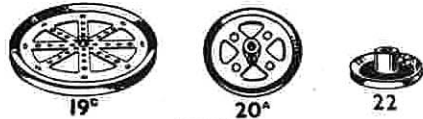

## PULLEYS

19b. 3" diam., with boss and screw  
 19c. 6" diam., with boss and screw  
 20a. 2" diam., with boss and screw  
 21. 1½" diam., with boss and screw  
 22. 1" diam., with boss and screw



## PULLEYS

22a. 1" diam., without boss  
 23. ½" diam., without boss  
 23a. ½" diam., with boss and screw



No. 24. Bush Wheel, 1½" diam., eight-hole  
 24a. Wheel Disc, 1½" diam., without bush, eight-hole  
 24b. Bush Wheel, 1½" diam., six-hole  
 24c. Wheel Disc, 1½" diam., without bush, six-hole

## PINIONS

25. ¾" diam., ½" face, 25 teeth  
 25a. ¾" diam., ½" face, 25 teeth  
 25b. ¾" diam., ½" face, 25 teeth  
 26. ½" diam., ½" face, 19 teeth  
 26a. ½" diam., ½" face, 19 teeth  
 26b. ½" diam., ½" face, 19 teeth  
 26c. ½" diam., ½" face, 15 teeth



## GEAR WHEELS

27. 1½" diam., 50 teeth  
 27a. 1½" diam., 57 teeth  
 27b. 3½" diam., 133 teeth  
 27c. 2½" diam., 95 teeth  
 27d. 1½" diam., 60 teeth



## CONTRATE WHEELS

28. 1½" diam., 50 teeth  
 29. ¾" diam., 25 teeth



30. Bevel Gear, ½" diam., 26 teeth (for use in pairs)  
 30a. Bevel Gear, ½" diam., 16 teeth } Can only be used together  
 30c. Bevel Gear, 1½" diam., 18 teeth }  
 31. Gear Wheel, 1" diam., ½" face, 36 teeth  
 32. Worm, ½" diam.  
 34. Spanner



34b. Box Spanner  
 35. Spring Clip  
 36. Screwdriver  
 36a. Screwdriver (longer)  
 36c. Drift (for levering bolt holes into line)  
 37. Nut and Bolt, ⅜"  
 37a. Nut  
 37b. Bolt, ⅜"  
 38. Washer  
 38d. Washer, ⅜"  
 40. Hank of Cord



41. Propeller Blade | 43. Tension Spring, 2" long



No. 44. Bent Strip, stepped  
 45. Double Bent Strip

## DOUBLE ANGLE STRIPS

46.	2½" × 1"	48.	1½" × ½"	48c.	4½" × ½"
47.	2½" × 1½"	48a.	2½" × ½"	48d.	5½" × ½"
47a.	3" × 1½"	48b.	3½" × ½"		

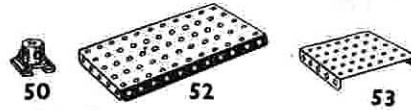

50. Slide Piece  
 51. Flanged Plate, 2½" × 1½"  
 52. Flanged Plate, 5½" × 2½"  
 52a. Flat Plate, 5½" × 3½"  
 53. Flanged Plate, 3½" × 2½"  
 53a. Flat Plate, 4½" × 2½"

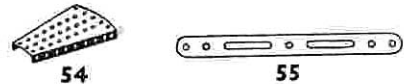

54. Flanged Sector Plate, 4½" long  
 55. Perforated Strip, slotted, 5½" long  
 55a. Perforated Strip, slotted, 2" long



57b. Hook, Loaded, Large  
 57c. Hook, Loaded, Small  
 58. Spring Cord, 40" length  
 58a. Coupling Screw for Spring Cord  
 58b. Hook for Spring Cord  
 59. Collar, with screw

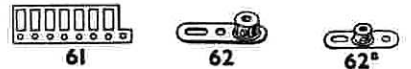

61. Windmill Sail  
 62. Crank | 62a. Threaded Crank  
 62b. Double Arm Crank



63. Coupling | 63c. Threaded Coupling  
 63b. Strip Coupling | 63d. Short Coupling



64. Threaded Boss  
 65. Centre Fork  
 69. Set Screw, ⅜"  
 69a. Grub Screw, ⅜"  
 69b. Grub Screw, ⅜"  
 69c. Grub Screw, ⅜"

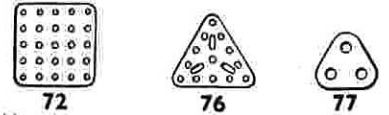

No. 72. Flat Plate, 5½" × 2½"  
 70. Flat Plate, 2½" × 2½"  
 73. Flat Plate, 3" × 1½"  
 76. Triangular Plate, 2½"  
 77. Triangular Plate, 1"



## SCREWED RODS

78.	11½"	80.	5"	80c.	3"
79.	8"	80a.	3½"	81.	2"
79a.	6"	80b.	4½"	82.	1"

## CURVED STRIPS

89. 5½" (10" radius)  
 89a. Stepped, 3" (1½" radius)  
 89b. Stepped, 4" (4½" radius)  
 90. 2½" (2½" radius)  
 90a. Stepped, 2½" (1½" radius)



94. Sprocket Chain, 40" length

## SPROCKET WHEELS

95. 2" diam., 36 teeth | 96. 1" diam., 18 teeth  
 95a. 1½" diam., 28 teeth | 96a. ¾" diam., 14 teeth  
 95b. 3" diam., 56 teeth



## BRACED GIRDERS

97.	3½" long	99.	12½" long	100.	5½" long
97a.	3" long	99a.	9½" long	100a.	4½" long
98.	2½" long	99b.	7½" long		



101. Heald for Loom | 102. Single Bent Strip

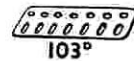

## FLAT GIRDERS

103.	5½" long	103d.	3½" long	103h.	1½" long
103a.	9½" long	103e.	3" long	103k.	7½" long
103b.	12½" long	103f.	2½" long		
103c.	4½" long	103g.	2" long		



# MECCANO PARTS

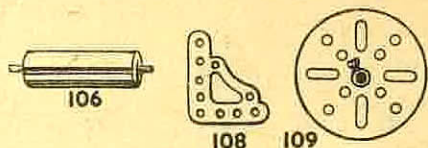

- No. 106. Wood Roller (complete with Rod and two Collars)  
 108. Corner Gusset  
 109. Face Plate, 2½" diam.

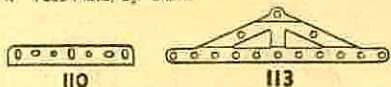

110. Rack Strip, 3½" long | 110a. Rack Strip, 6½" long

### BOLTS

111. ¾"  
 111a. ½"  
 111c. ¾"  
 111d. ½"

113. Girder Frame

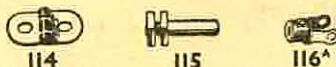

114. Hinge  
 115. Threaded Pin  
 116. Fork Piece, large  
 116a. Fork Piece, small

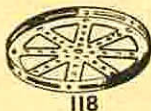

118. Hub Disc, 5½" diam.



- 120b. Compression Spring, ⅝" long



123. Cone Pulley, 1½", 1" and ¾" diam.  
 124. Reversed Angle Bracket, 1"  
 125. Reversed Angle Bracket, ½"

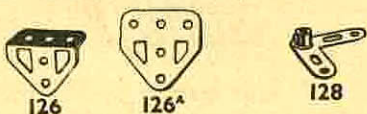

126. Trunnion  
 126a. Flat Trunnion  
 128. Bell Crank, with Boss



- No. 130. Eccentric, Triple Throw, ½", ¾" and 1"  
 130a. Eccentric, Single Throw, ½"

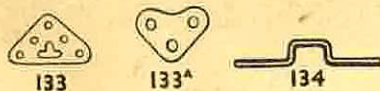

133. Corner Bracket, 1½"  
 133a. Corner Bracket, 1"  
 134. Crank Shaft, 1" stroke

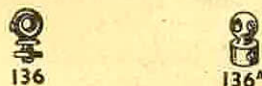

136. Handrail Support | 136a. Handrail Coupling



137. Wheel Flange | 138. Ship's Funnel, Raked



139. Flanged Bracket (right)  
 139a. Flanged Bracket (left)  
 140. Universal Coupling



- 142a. Motor Tyre (to fit 2" diam. rim)  
 142b. Motor Tyre (to fit 3" diam. rim)  
 142c. Motor Tyre (to fit 1" diam. rim)  
 142d. Motor Tyre (to fit 1½" diam. rim)  
 143. Circular Girder, 5½" diam.  
 144. Dog Clutch

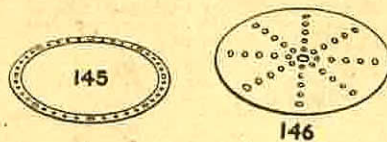

145. Circular Strip, 7½" diam, overall  
 146. Circular Plate, 6" diam, overall  
 146a. Circular Plate, 4" diam, overall

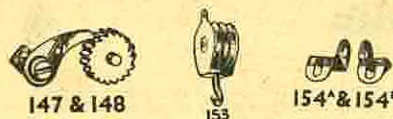

- No. 147. Pawl, with Pivot Bolt and Nuts  
 147a. Pawl  
 147b. Pivot Bolt, with two Nuts  
 147c. Pawl, without boss  
 148. Ratchet Wheel  
 151. Single Pulley Block  
 153. Triple Pulley Block  
 154a. Corner Angle Bracket, ½" (right-hand)  
 154b. Corner Angle Bracket, ½" (left-hand)  
 155. Rubber Ring (for 1" Pulley)



157. Fan, 2" diam.  
 160. Channel Bearing, 1½" x 1" x ½"  
 161. Girder Bracket, 2" x 1" x ½"



162. Boiler, complete, 5" long x 2½" diam.  
 162a. Boiler Ends, 2½" diam. x ½"  
 163. Sleeve Piece, 1½" long x ½" diam.  
 164. Chimney Adaptor, ½" diam. x ½" high



165. Swivel Bearing  
 166. End Bearing  
 167b. Flanged Ring, 9½" diam.  
 168. Ball Thrust Bearing, 4" diam.  
 168a. Ball Thrust Race, flanged disc, 3½" diam.  
 168b. Ball Thrust Race, toothed disc, 4" diam.  
 168c. Ball Cage, 3½" diam., complete with balls  
 168d. Ball, ¾" diam.



171. Socket Coupling  
 173a. Adaptor for Screwed Rod  
 175. Flexible Coupling Unit  
 176. Anchoring Spring for Cord



179. Rod Socket  
 180. Gear Ring, 3½" diam. (133 ext. teeth, 95 int.)

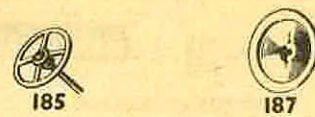

- No. 185. Steering Wheel, 13" diam.  
 187. Road Wheel, 2½" diam.

### DRIVING BANDS

186. 2½" (light) | 186c. 10" (heavy)  
 186a. 6" (light) | 186d. 15" (heavy)  
 186b. 10" (light) | 186e. 20" (heavy)  
 187. Road Wheel, 2½" diam.  
 187a. Conical Disc, 1½" diam.

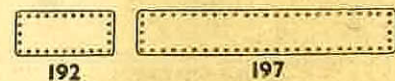

### FLEXIBLE PLATES

188. 2½" x 1½" | 190. 2½" x 2½" | 191. 4½" x 2½"  
 189. 5½" x 1½" | 190a. 3½" x 2½" | 192. 5½" x 2½"

### STRIP PLATES

196. 9½" x 2½" | 197. 12½" x 2½"

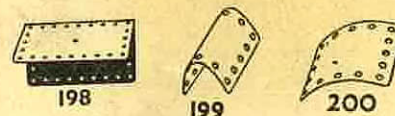

198. Hinged Flat Plate, 4½" x 2½"  
 199. Curved Plate, "U" section, 2½" x 2½" x ¼" radius  
 200. Curved Plate, 2½" x 2½" x 1½" radius



- 211a. Helical Gear, ½" } Can only be used  
 211b. Helical Gear, 1½" } together  
 212. Rod and Strip Connector  
 212a. Rod and Strip Connector, right-angle  
 213. Rod Connector  
 213a. Three-way Rod Coupling  
 213b. Three-way Rod Coupling with Pommel



214. Semi-circular Plate, 2½"  
 215. Formed Slatted Strip, 3"  
 216. Cylinder, 2½" long, 1½" diam.

### TRIANGULAR FLEXIBLE PLATES

221. 2½" x 1½" | 223. 2½" x 2½" | 225. 3½" x 2"  
 222. 2½" x 2" | 224. 3½" x 1½" | 226. 3½" x 2½"