

MECCANO



INSTRUCTIONS for OUTFIT No. 5

COPYRIGHT BY MECCANO LIMITED
BINNS ROAD, LIVERPOOL 13, ENGLAND

55.5

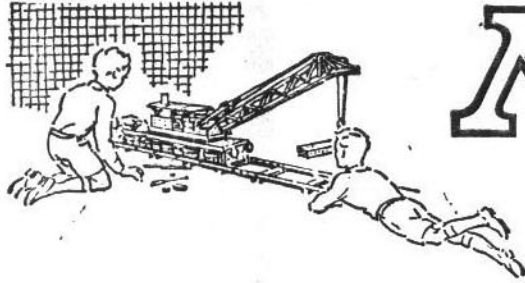

MECCANO

Registered Trade Mark

The World's Greatest Constructional Toy

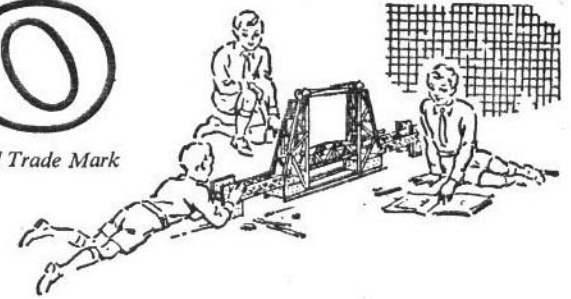

MODEL-BUILDING WITH MECCANO

There is no limit to the number of models that can be built with Meccano — Cranes, Clocks, Motor Cars, Aeroplanes, Machine Tools, Locomotives — in fact everything that interests boys. A screwdriver and a spanner, both of which are provided in each complete Outfit, are the only tools necessary.

When you have built all the models illustrated in the Books of Instructions the fun is not over, it is just beginning. Now comes the chance to make use of your own ideas. First of all, re-build some of the models with small changes in construction that may occur to you; then try building models entirely of your own design. In doing this you will enjoy the real thrill of the engineer and the inventor.

HOW TO BUILD UP YOUR OUTFIT

Meccano is sold in 12 different Outfits, ranging from No. 00 to No. 10. Each Outfit can be converted into the next larger one by the purchase of an Accessory Outfit. Thus Meccano No. 00 Outfit can be converted into No. 0 Outfit by adding to it a No. 00a Accessory Outfit. No. 0a Outfit would then convert it into a No. 1 and so on. In this way, no matter with which Outfit you begin, you can build it up by degrees until you have a complete No. 10 Outfit.

All Meccano parts are of the same high quality and finish, but the larger Outfits contain a greater quantity and variety, making possible the construction of more elaborate models.

THE 'MECCANO MAGAZINE'

The 'Meccano Magazine' is published specially for Meccano boys. Every month it describes and illustrates new Meccano models, and deals with suggestions from readers for new Meccano parts and for new methods of using the existing parts.

There are model-building competitions specially planned to give an equal chance to the owners of small and large Outfits. In addition, there are splendid articles on such subjects as Railways, Famous Engineers and Inventors, Electricity, Bridges, Cranes and

Aeroplanes, and special sections dealing with the latest Engineering, Aviation, Motoring and Shipping News. Other pages deal with Stamp Collecting, and a feature of outstanding popularity is the section devoted to short articles from readers.

Write to the Editor, the 'Meccano Magazine', Binns Road, Liverpool 13, for particulars and a specimen copy. You can order the Magazine from your Meccano dealer, or from any newsagent.

THE MECCANO GUILD

Every owner of a Meccano Outfit should join the Meccano Guild. This is a world-wide organisation, started at the request of Meccano boys. Its primary object is to bring boys together and to make them feel that they are all members of a great brotherhood, each trying to help others to get the very best out of life. Its members are in constant touch with Headquarters, giving news of their activities and being guided in their hobbies and interests. A leaflet containing full particulars of the Guild and an application form is included in this Book.

Clubs founded and established under the guidance of the Guild Secretary provide Meccano boys with opportunities of enjoying to the utmost the fun of model-building. Each has its Leader, Secretary, Treasurer and other officials. With the exception of the Leader, all the officials are boys, and as far as possible the proceedings of the clubs are conducted by boys.

MECCANO SERVICE

The service of Meccano does not end with selling an Outfit and a Book of Instructions. If ever you are in any difficulty with your models, or if you want advice on anything connected with this great hobby, write to us. We receive hundreds of interesting letters from boys in all parts of the world, and each of these is answered personally and promptly by one of our staff of experts.

Whatever your problem may be, write to us about it. We shall be delighted to help you in any way possible. Address your letters to *Information Service*.

Boys!

Read the

MECCANO MAGAZINE

THE IDEAL MAGAZINE FOR BOYS

The happiest and most successful boys are those who take a keen interest in the world around them. The 'MECCANO MAGAZINE' is ideal for these boys. Month by month its pages are filled with attractively-written articles, splendidly illustrated from actual photographs.

The subjects include Engineering in all its branches, Railways, Road Transport, Aeroplanes and Shipping. Inventions and Scientific Discoveries are described in simple language. Everything is dealt with in an attractive and straightforward style, and with an accuracy that has won for the Magazine the enthusiastic approval of the engineering, technical and scientific world. Special sections are devoted to Model-building with Meccano, fun with Dinky Toys and the operation of realistic Miniature Railways; and Stamp Collecting forms still another important feature. Model-building Competitions open to all owners of Meccano Outfits, are a special feature.



Join the

MECCANO GUILD

WHAT THE GUILD MEANS

The Meccano Guild is an organisation for boys, started at the request of boys, and as far as possible conducted by boys. In joining the Guild a Meccano boy becomes a member of a great brotherhood of world-wide extent. Wherever he happens to be, even in strange countries, he will know that he has met a friend whenever he sees the little triangular badge of membership. The Meccano Guild is bringing together Meccano boys all over the world, and helping them to get the best out of life. At its head — guiding and controlling and taking a personal interest in this great movement — is the President, Mr Roland G. Hornby, son of the inventor of Meccano.

HOW TO JOIN THE MECCANO GUILD

Any owner of a Meccano Outfit, no matter what its size, may become a member. All he has to do is to fill in the official application form on the back of this leaflet, have his signature witnessed, and send the form to Headquarters with a postal order (not stamps) for the necessary amount in payment for the official badge, which he will wear in his buttonhole.

The price of the badge for boys living in the British Isles is 1/- . For those living overseas it is 1/6 (30 cents in Canada).

Applicants living in Canada, Australia, New Zealand or South Africa should write to the Meccano agents in their countries. Their addresses are as follows:

AUSTRALIA:

New South Wales and A.C.T. — E. G. Page & Co. (Sales) (Pty.) Ltd, Box 1832, G.P.O., Sydney, N.S.W.
Queensland and Northern Territories — Thomas Brown & Sons Ltd, (P.O. Box 144C), Eagle Street, Brisbane, Queensland.
South Australia — Harris, Scarfe Ltd, Grenfell Street, Adelaide.
Victoria and Tasmania — Ponsford, Newman & Benson Ltd, 234 Flinders Lane, Melbourne, Victoria.
Western Australia — P. Falk & Co. Ltd, 317-9 Murray Street, Perth.

CANADA: Meccano Ltd, 675 King Street West, Toronto.

NEW ZEALAND: Models Ltd (P.O. Box 129), 53 Fort Street, Auckland, C.I.

RHODESIA: Woolley, Kinleyside & Co. (Pvt.) Ltd, P.O. Box 299, Bulawayo.

SOUTH AFRICA: Arthur E. Harris (Pty.) Ltd (P.O. Box 1199), 142 Market Street, Johannesburg.

Their Badges and Certificates are then forwarded without delay, while their application forms are sent to Headquarters in Liverpool.

Applicants living in any other country overseas should forward their forms, with a British postal order (not stamps) or a money order for 1/6, direct to the Secretary, the Meccano Guild, Binns Road, Liverpool, 13.

Guild members are eligible for the Correspondence Club, by which they are placed in touch with other members in various parts of the world. Full particulars and enrolment forms can be obtained from the Secretary.

The Secretary will send also, on request, full details of the Guild Recruiting Campaign, and of the Medallion awarded to members who are successful in obtaining recruits, together with particulars of the Meccano clubs founded and established by enthusiastic Meccano boys. A special booklet, 'How to run a Meccano Club' will be sent post free to any member on receipt of 2d. in stamps.

MECCANO MAGAZINE

for the really modern boy

The 'MECCANO MAGAZINE' is on sale at all bookstalls, newsagents and Meccano dealers, price 1/3. If you prefer to have each issue sent direct, the subscription rates are 18/- for twelve months or 9/- for six months, including postage, and an order form is attached.

The overseas prices of the 'M.M.' are 15c. in Canada, 1/6 in Australia, 18c. in the U.S.A. and 1/- elsewhere.

ORDER FORM

TO THE EDITOR,
MECCANO MAGAZINE,
BINNS ROAD, LIVERPOOL 13.

I enclose Postal Order for Please post the
'MECCANO MAGAZINE' for months, beginning with
the issue.

NAME (IN BLOCK LETTERS)

ADDRESS

MECCANO GUILD

THE THREE GREAT OBJECTS OF THE GUILD

- To make every boy's life brighter and happier.
- To foster clean-mindedness, truthfulness, ambition and initiative in boys.
- To encourage boys in their hobbies, and especially in the development of their knowledge of mechanical and engineering principles.



BADGE OF
MEMBERSHIP

Headquarters: BINNS ROAD LIVERPOOL 13

APPLICATION FOR MEMBERSHIP

I possess a Meccano Outfit, and I hereby make application for membership of the Meccano Guild.
I approve of the objects of the Guild, and I promise on my honour

- (1) To conform to the rules and regulations of the Meccano Guild.
- (2) To promote its objects by my own example: to be helpful to others; to be clean in thought and habit; to be determined to learn and make progress.
- (3) To wear the Meccano Guild Badge on all possible occasions.
- (4) To recognise and acknowledge all other Members wearing the Guild Badge, and to render them help in case of need.

I enclose 1/- for the Guild Badge (Great Britain).

I enclose 1/6 for the Guild Badge (Overseas).

I enclose 30c. for the Guild Badge (Canada).

Strike out line not applicable (See other side of this form).

NAME OF APPLICANT

(BLOCK LETTERS PLEASE)

ADDRESS

DATE

SIZE OF OUTFIT OWNED NO.

AGE

WITNESS

ADDRESS

The witness should be the Parent, Guardian, Employer, Schoolmaster or Church Minister
and should state which when signing.

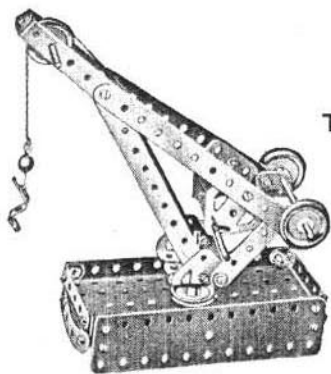

This Dockside Crane
can be built with Outfit No. 1

HOW TO BEGIN THE FUN

THE MOST FASCINATING OF ALL HOBBIES

Meccano model-building is the most fascinating of all hobbies, because it never becomes dull. There is always something new to be done. First of all there is the fun of building a new model, and watching it take shape as part after part is added. Then, when the model is complete, comes the thrill of setting it to work just like the real structure it represents, by means of a Meccano Motor.

The following hints are given to show boys who are just starting the wonderful Meccano hobby how to get the greatest possible fun.

A FEW USEFUL HINTS

It will be noticed that with each model in this Book of Instructions is given a list of the parts required to build it. For the first few models it is a good plan to lay out on the table all the parts required for the one it is proposed to build, and put the remainder of the Outfit to one side. To help you to pick out the correct parts for your model a complete list of Meccano parts is given at the back of this Book, and all the principal parts are illustrated. In the list the parts are all numbered, and in most cases their measurements are given. There is no need, however, to measure the parts to find out which is which, as the size is easily found from the number of holes. All Meccano holes are spaced $\frac{1}{2}$ " apart, so that by counting two holes to the inch the size of a part can be found at once. For instance, Part No. 2 is listed as a $5\frac{1}{2}$ " Perforated Strip, so you look in your Outfit for a Strip with eleven holes. Similarly No. 189 is a $5\frac{1}{2}$ " \times $1\frac{1}{2}$ " Flexible Plate, so you look for a Flexible Plate eleven holes in length and three holes in width. By the time a few models have been built the names of the parts will have become familiar.

Beginners sometimes wonder which section of a model should be built first. There cannot be any definite rule for this, as it depends on the design of the model. In stationary models the base usually should be built first. In most of the small models a $5\frac{1}{2}$ " \times $2\frac{1}{2}$ " Flanged Plate forms an important part of the structure, and often the best plan is to start building by bolting parts to this Plate. For other models a good general rule is that the sections that form supports for a number of other parts should be built first.

During the construction of a model it is best to screw up the nuts with the fingers, followed by a light turn with the screwdriver, leaving the final tightening until all the parts are connected up.

THE IMPORTANCE OF LOCK-NUTTING

In some models it is necessary to join certain parts together so that, although they cannot come apart, they are free to pivot or move in relation to one another. To do this the parts are bolted together as usual, but the nut is not screwed up tightly, so that the parts are not gripped. Then, to prevent the nut from unscrewing, a second nut is screwed up tightly against it, the first nut being held with a spanner. This method of using a second nut is known as *Lock-nutting*.

In building models in which Rods revolve in the holes of other parts it is important to make sure that such holes are exactly in line with one another. This can be done by pushing through the holes a Drift, Part No. 36c, or a Rod, before the Bolts holding the various parts are tightened up.

A Rod is usually mounted in a support or bearing so that it is free to revolve. The Rod is then said to be *Journalled* in the Strip.

DRIVING YOUR MODELS

Models can be driven by means of either clockwork or electric motors. Ask your Dealer for particulars of Meccano Clockwork and Electric Motors.

Small and light models may be driven direct from the driving pulley of the motor or through a belt running over two pulleys of the same size, giving what is known as a 1 : 1 (one-to-one) ratio. For large models it is necessary to take the drive from a small pulley on the motor shaft to a larger pulley on the driving shaft of the model. In most cases a 1" Pulley on the motor shaft and a 3" Pulley on the model shaft will be found satisfactory. This provides a reduction ratio of approximately 3 : 1.

Rubber bands are very convenient for driving belts. Sometimes, however, a rubber band of the right length is not available, and then Meccano Cord or thin string is used. To tie the Cord to form an endless belt, use the familiar reef knot.

All Outfits from No. 2 upward include a Cord Anchoring Spring, Part No. 176. This part provides a neat and positive method of fastening a length of Cord to a Rod. The Spring is placed on a Rod by pushing and turning it in such a way that its coils tend to unwind.

Flexible Plates are used for forming curved surfaces in models, but they are not intended to be bent at right angles. With careful handling a Plate can be bent to the required curve and after use straightened again.

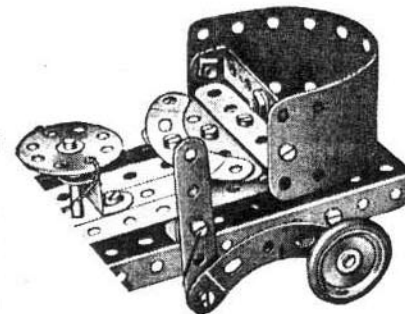

A Flexible Plate
used to form a curved surface

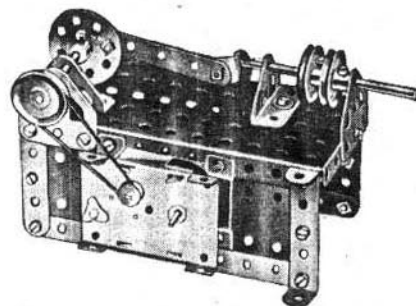

A 'Magic' Motor
fitted to drive a Steam Engine

I.1 KIDDIE CAR

Two Trunnions overlapped one hole, and fastened to the Flanged Plate by an Angle Bracket, form the seat.

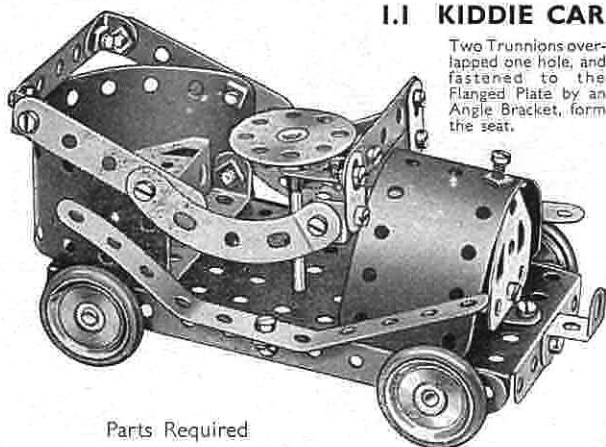
**Parts Required**

4 of No. 2	1 of No. 24	2 of No. 111c
4 " " 5	1 " " 35	1 " " 125
3 " " 10	27 " " 37a	2 " " 126
7 " " 12	24 " " 37b	1 " " 126a
2 " " 16	2 " " 48a	4 " " 155
1 " " 17	1 " " 52	2 " " 189
4 " " 22	2 " " 90a	

I.2 LETTER BALANCE

The Bolts (1) are lock-nutted. The $\frac{1}{2}$ " Bolt (2) is passed through the hole of the Angle Bracket and then held by the screw in the boss of the 1" Pulley.

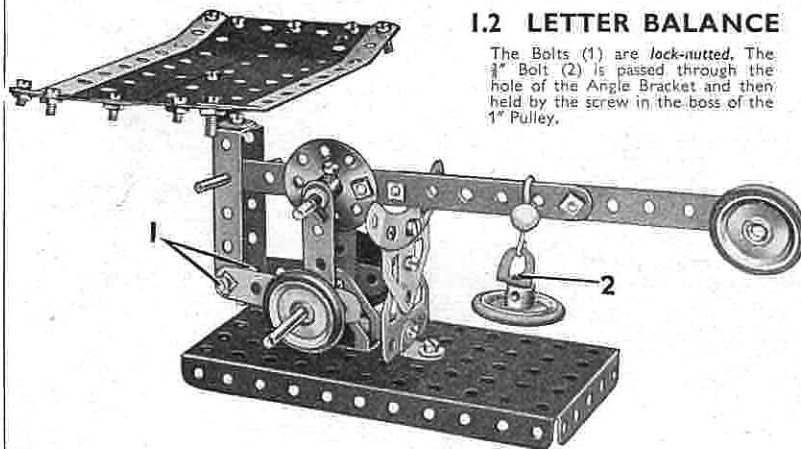
**Parts Required**

4 of No. 2	4 of No. 22	4 of No. 38	4 of No. 111c
4 " " 5	1 " " 24	2 " " 48a	1 " " 125
4 " " 10	4 " " 35	1 " " 52	2 " " 126
2 " " 12	28 " " 37a	1 " " 57c	2 " " 126a
1 " " 16	24 " " 37b	1 " " 90a	4 " " 155
2 " " 17			2 " " 189

I.3 RACING SEAPLANE

Each of the floats is secured to the wings by two Angle Brackets and one Fishplate.

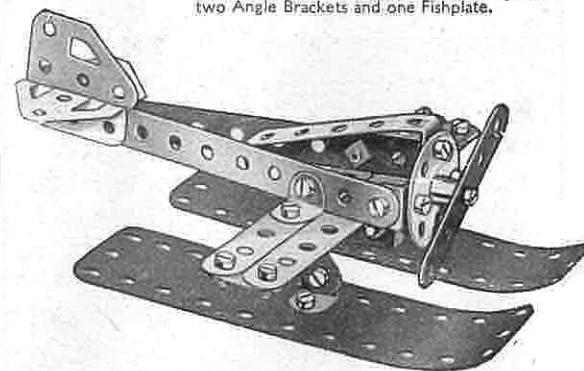
**Parts Required**

3 of No. 2	1 of No. 24	2 of No. 111c
3 " " 5	20 " " 37a	2 " " 126
4 " " 10	19 " " 37b	1 " " 126a
8 " " 12	1 " " 48a	2 " " 189

I.4 RAILWAY BREAKDOWN CRANE

The hoisting Cord is secured to the Crank Handle and then led over the $\frac{3}{8}$ " Bolt (1). It is then passed through the pulley block and fastened to the jib at (2). The jib is attached to the Bush Wheel (3) by means of Angle Brackets, and the complete unit is pivoted as follows. A $\frac{3}{8}$ " Bolt is passed through the $3\frac{1}{2}$ " x $2\frac{3}{8}$ " Flanged Plate from the underside, and is secured in the boss of the Bush Wheel by its set screw.

Parts Required

4 of No. 2	1 of No. 19s
4 " " 5	4 " " 22
1 " " 10	1 " " 24
4 " " 12	2 " " 35
2 " " 16	24 " " 37a
	20 " " 37b
	2 " " 38
	1 " " 40
	2 " " 48a
	1 " " 52
	1 " " 57c
	2 " " 90a

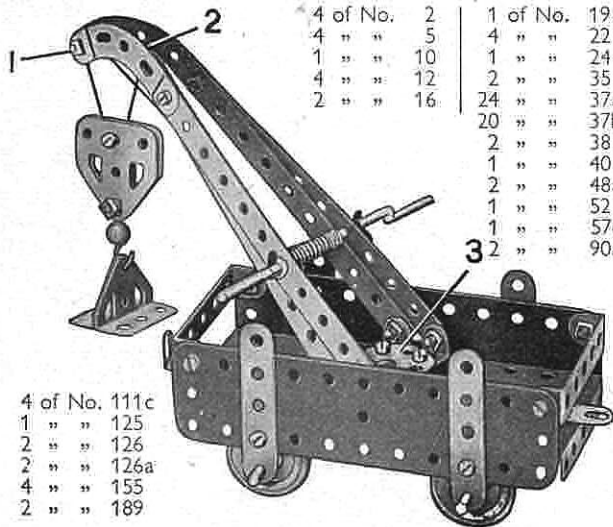

4 of No. 111c
1 " " 125
2 " " 126
2 " " 126a
4 " " 155
2 " " 189

I.5 TRICYCLE VAN**Parts Required**

4 of No. 2	1 of No. 17	24 of No. 37b	2 of No. 111c
3 " " 5	3 " " 22	3 " " 38	2 " " 126
3 " " 10	1 " " 24	2 " " 48a	2 " " 126a
6 " " 12	4 " " 35	1 " " 52	2 " " 142c
2 " " 16	27 " " 37a	2 " " 90a	2 " " 189

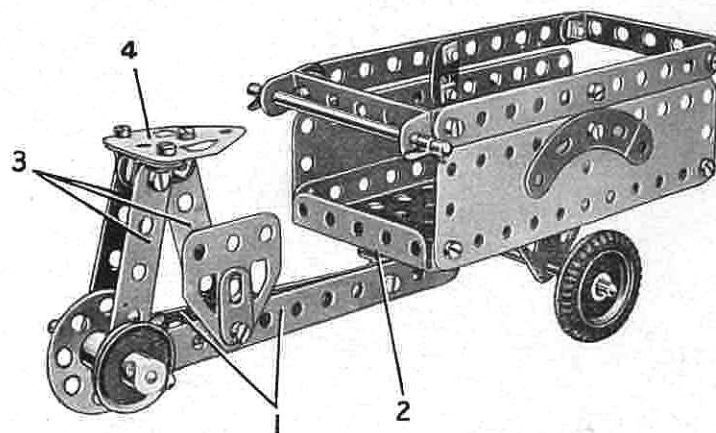

The frame of the cycle consists of two $5\frac{1}{2}$ " Strips (1) connected at one end by a bolt that fixes them also to an Angle Bracket (2). The Angle Bracket pivots on a bolt lock-nutted to the Flanged Plate. The seat is carried by three $2\frac{1}{2}$ " Strips (3), each of which is connected by an Angle Bracket to the Flat Trunnion (4). The front axle is carried in Trunnions bolted underneath the Flanged Plate.

I.6 STAMPING MILL

The anvil (1) is made up of two Trunnions bolted together. When the Crank Handle is rotated, the Fishplates bolted to the Bush Wheel strike the centre 1" Pulley on the hammer shaft and cause it to rise and fall.

Parts Required

4 of No. 2	1 of No. 90a
4 " " 5	4 " " 111c
4 " " 10	1 " " 125
4 " " 12	2 " " 126
1 " " 16	2 " " 126a
1 " " 19s	2 " " 189
4 " " 22	
1 " " 24	
2 " " 35	
27 " " 37a	
24 " " 37b	
2 " " 38	
2 " " 48a	
1 " " 52	

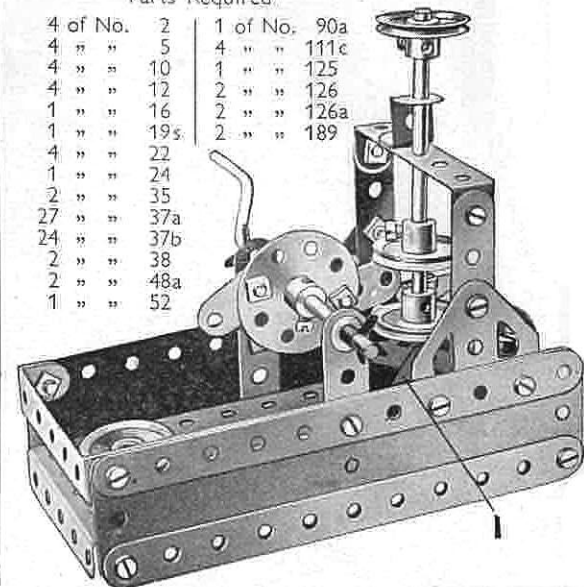

2.1 CANAL BRIDGE

Parts Required

4 of No.	2
6 " "	5
4 " "	10
6 " "	12
1 " "	16
1 " "	19g
4 " "	22
1 " "	24

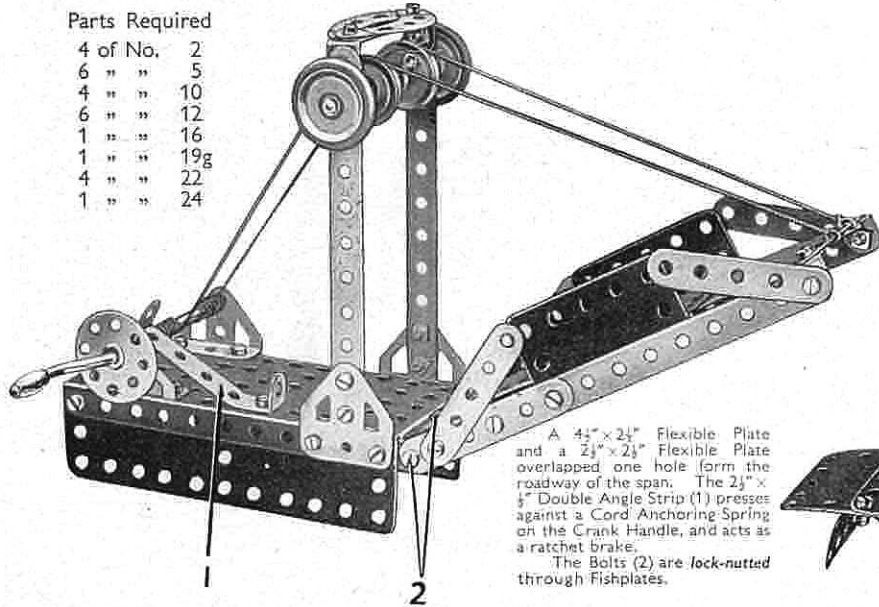

A $4\frac{1}{2}'' \times 2\frac{1}{2}''$ Flexible Plate and a $2\frac{1}{2}'' \times 2\frac{1}{2}''$ Flexible Plate overlapped one hole (form the roadway of the span). The $2\frac{1}{2}'' \times \frac{1}{2}''$ Double Angle Strip (1) presses against a Cord Anchoring Spring on the Crank Handle, and acts as a ratchet brake. The Bolts (2) are lock-nutted through Fishplates.

Parts Required (continued)

41 of No.	37a
39 " "	37b
2 " "	38
1 " "	40
2 " "	48a
1 " "	52
2 " "	90a
2 " "	126
2 " "	126a
2 " "	155
1 " "	176
2 " "	188
2 " "	189
2 " "	190
1 " "	191
1 " "	199
1 " "	200



2.2 DRILLING MACHINE

The horizontal $2\frac{1}{2}''$ Strips at the top of the drill are joined together, and also to the vertical $2\frac{1}{2}''$ Strips, by means of Angle Brackets. The lower bearings (1) are two Angle Brackets bolted to a $2\frac{1}{2}''$ Strip, and the Rod forming the drill is journaled in these, and in a Fishplate at its upper end. A $2\frac{1}{2}'' \times 2\frac{1}{2}''$ Flexible Plate is supported by a Double Angle Strip (2), and represents the table.

The drive is taken from the Motor to the 1" Pulley on the lower shaft. A second driving belt passes round the $\frac{1}{2}''$ fixed Pulley supplied with the Motor, which is also fixed on the lower shaft, round the two Pulleys at (3), and finally round the 1" Pulley fastened on the vertical drill shaft.

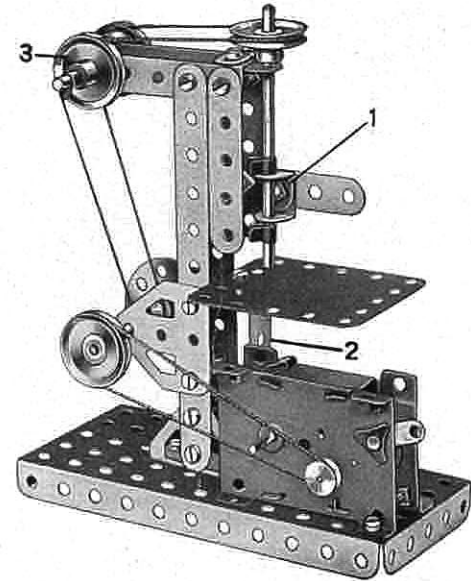

Parts Required

2 of No.	2	1 of No.	24	1 of No.	111c
5 " "	5	4 " "	35	2 " "	126
1 " "	10	24 " "	37a	2 " "	126a
5 " "	12	22 " "	37b	1 " "	190
1 " "	16	1 " "	40	1 Magic Motor	(not included in Outfit)
2 " "	17	1 " "	48a		
4 " "	22	1 " "	52		

2.3 MILK DELIVERY WAGON

4 of No.	2	4 of No.	22	4 of No.	38	1 of No.	111c	2 of No.	188
6 " "	5	1 " "	24	2 " "	48a	1 " "	126	2 " "	190
2 " "	10	37 " "	37a	1 " "	52	2 " "	126a	1 " "	191
6 " "	12	37 " "	37b	2 " "	90a	4 " "	155	1 " "	199
2 " "	16								

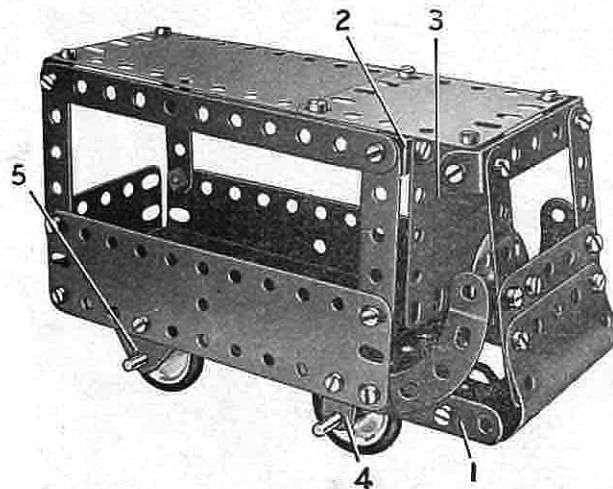

The floor of the wagon is a $5\frac{1}{2}'' \times 2\frac{1}{2}''$ Flanged Plate placed with its flanges downward, and to each side a $5\frac{1}{2}''$ Strip (1) is bolted, the Strips extending three holes beyond the Plate. The curved front consists of a 'U'-section Curved Plate opened out slightly, and a $2\frac{1}{2}'' \times 1\frac{1}{4}''$ Flexible Plate. The Curved Plate is connected to Angle Brackets bolted to the Strips (1).

The roof is attached to the side frames of the body and to the windscreen pillars by Angle Brackets, and the side frames are connected together by a $2\frac{1}{2}'' \times \frac{1}{2}''$ Double Angle Strip (2). A $2\frac{1}{2}'' \times 2\frac{1}{2}''$ Flexible Plate (3) is bolted to this Double Angle Strip.

The front wheels are fixed on a $3\frac{1}{2}''$ Rod supported in a Fishplate (4) on each side of the model. The rear axle also is a $3\frac{1}{2}''$ Rod and it is supported in the Flat Trunnions (5).

2.4 MECHANICAL HACKSAW

The base consists of Flexible Plates bolted to a Flanged Plate. One side is formed by a $4\frac{1}{2}'' \times 2\frac{1}{2}''$ and a $2\frac{1}{2}'' \times 1\frac{1}{4}''$ Flexible Plate, and the other by two $5\frac{1}{2}'' \times 1\frac{1}{4}''$ Plates. A $2\frac{1}{2}'' \times 2\frac{1}{2}''$ Flexible Plate is bolted to each end. The base is strengthened at each end by Double Angle Strips (1) and a $5\frac{1}{2}''$ Strip on each side.

The saw is actuated by a crank formed from a Bush Wheel fixed to a $3\frac{1}{2}''$ Rod. The Rod rotates in a Trunnion and a Flat Trunnion. The Trunnion is raised from the Flanged Plate by two Washers. The Rod carries a 1" Pulley (2) and a Road Wheel. The Pulley (2) is connected by a belt of Cord to a similar Pulley fixed on the Crank Handle.

The material to be sawn is clamped to the base by means of two $2\frac{1}{2}''$ Strips, one of which is shown at (3).

Parts Required

3 of No.	2	2 of No.	48a
6 " "	5	1 " "	52
2 " "	12	4 " "	111c
2 " "	16	1 " "	126
1 " "	19g	1 " "	126a
3 " "	22	1 " "	187
1 " "	24	1 " "	188
38 " "	37a	2 " "	189
30 " "	37b	2 " "	190
4 " "	38	1 " "	191
1 " "	40		

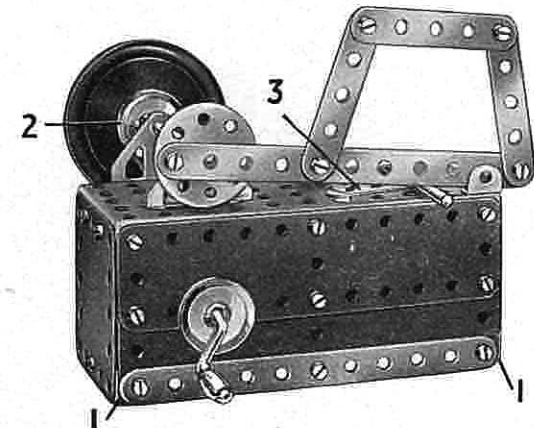

2.5 BEAM ENGINE

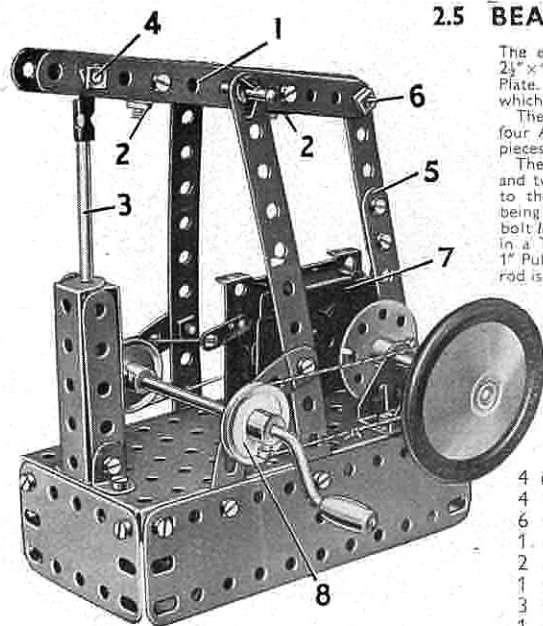

The engine bed or base consists of two $5\frac{1}{2} \times 1\frac{1}{2}$ and two $2\frac{1}{2} \times 1\frac{1}{2}$ Flexible Plates bolted to the sides of a Flanged Plate. Two $5\frac{1}{2}$ Strips form the supports for the beam (1), which pivots on a 2" Rod held in position by Spring Clips.

The beam is made from two $5\frac{1}{2}$ Strips held together by four Angle Brackets bolted in pairs to form two 'U'-shaped pieces. The positions of the pieces are marked (2).

The cylinder consists of two $2\frac{1}{2} \times 1\frac{1}{2}$ Double Angle Strips and two $2\frac{1}{2}$ Strips. The piston rod (3) is a $3\frac{1}{4}$ Rod attached to the beam by a Rod and Strip Connector; the Bolt (4) being lock-nutted. The connecting rod (5) is pivoted on a bolt lock-nutted to a Bush Wheel held on a 2" Rod journaled in a Trunnion and a Flat Trunnion. This Rod also carries a 1" Pulley and a Road Wheel. At its upper end the connecting rod is attached to the beam by the lock-nutted Bolt (6).

The Magic Motor (7) is bolted to the base by its flanges, and its pulley is connected by a Driving Band to a 1" Pulley on the Crank Handle. A further 1" Pulley (8) on the Crank Handle is connected by a belt of Cord to the Pulley on the 2" Rod.

Parts Required		Parts Required		Parts Required	
4 of No. 2	35 of No. 37a	1 of No. 126a	4 of No. 2	30 " " 37b	1 " " 187
4 " " 5	3 " " 38	2 " " 188	6 " " 12	1 " " 40	2 " " 189
1 " " 16	2 " " 48a	1 " " 212	2 " " 17	1 " " 52	
2 " " 19g	2 " " 90a		1 " " 19g	2 " " 111c	
3 " " 22	1 " " 126		3 " " 22	1 " " 126	
1 " " 24			1 " " 24		1 Magic Motor
3 " " 35			3 " " 35		(not included in Outfit)

2.7 BACON SLICER

Parts Required

3 of No. 2	1 of No. 17	40 of No. 37a	2 of No. 48a	1 of No. 125	2 of No. 188
6 " " 5	1 " " 19g	36 " " 37b	1 " " 52	2 " " 126a	2 " " 189
1 " " 10	4 " " 22	3 " " 38	2 " " 90a	1 " " 187	2 " " 190
8 " " 12	1 " " 24	1 " " 40			
1 " " 16	2 " " 35				

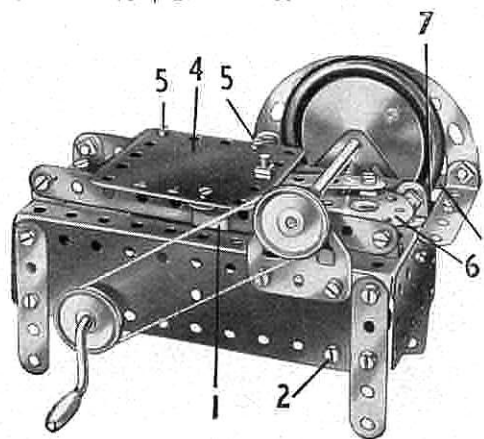

The base of the model consists of a Flanged Plate fitted with four $2\frac{1}{2}$ Strips for legs. Two $5\frac{1}{2} \times 1\frac{1}{2}$ and two $2\frac{1}{2} \times 1\frac{1}{2}$ Flexible Plates are bolted to the flanges of the Plate.

The guides for the sliding carriage (4) are formed by two $5\frac{1}{2}$ Strips attached to the Flanged Plate by Angle Brackets. The carriage consists of a $2\frac{1}{2} \times 2\frac{1}{2}$ Flexible Plate (4) and is guided along the Strips by the Reversed Angle Bracket (1) and two Angle Brackets on the opposite side. The Angle Brackets are held in place by Bolts (5).

The cutting blade is represented by a Road Wheel fixed on a $3\frac{1}{2}$ Rod journaled in two Flat Trunnions. A Pulley on this Rod is connected by a belt of Cord to a second Pulley on the Crank Handle.

The carriage is moved backwards and forwards by a crank consisting of a Bush Wheel (6) fixed on a 2" Rod. This Rod is journaled in the Flanged Plate and in the centre hole of a Double Angle Strip fixed across the interior of the base by the Bolt (2) and another in a similar position on the opposite side. A 1" Pulley on the 2" Rod is connected by a crossed belt of Cord to a further 1" Pulley secured to the Crank Handle between the $5\frac{1}{2} \times 1\frac{1}{2}$ Flexible Plates.

A guard for the rotating blade is provided by two Curved Strips attached to a $5\frac{1}{2}$ Strip (3). This Strip is fastened at one end to the Flanged Plate by a $2\frac{1}{2}$ Strip and a Fishplate (7), and at its other end it is attached to a $2\frac{1}{2} \times 2\frac{1}{2}$ Flexible Plate bolted horizontally to the Flanged Plate.

2.6 AUTOGIRO

Parts Required

4 of No. 2	2 of No. 90a
6 " " 5	1 " " 111c
4 " " 10	1 " " 125
6 " " 12	2 " " 126a
1 " " 16	2 " " 155
1 " " 17	2 " " 188
4 " " 22	1 " " 199
1 " " 24	
3 " " 35	
25 " " 37a	
25 " " 37b	
2 " " 38	
2 " " 48a	

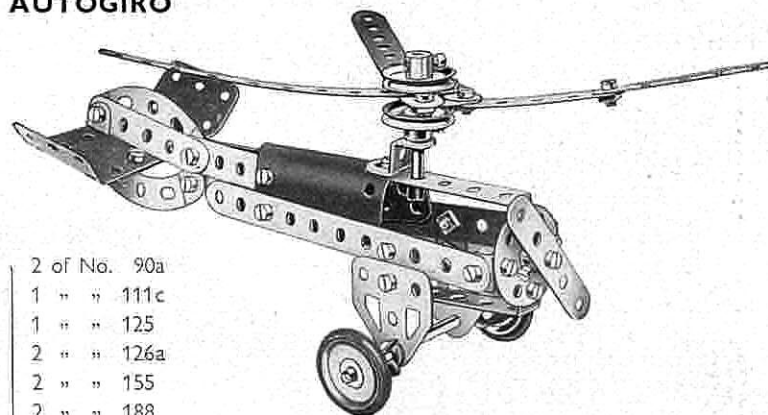

The rotor is made by passing a Rod through the next to end holes of two $5\frac{1}{2}$ Strips. Fishplates are bolted to the short ends of the Strips and the third blade of the rotor is fixed to them as shown.

2.8 CHARIOT AND DRIVER

The chariot is made by curving a $5\frac{1}{2} \times 1\frac{1}{2}$ Flexible Plate (1) to make a semi-circle with its ends bolted to the lugs of a $2\frac{1}{2} \times 1\frac{1}{2}$ Double Angle Strip. A second $2\frac{1}{2} \times 1\frac{1}{2}$ Double Angle Strip is bolted to the first with its lugs pointing downwards, the holes in the lugs forming supports for the chariot axle. A $1\frac{1}{2}$ radius Curved Plate is fixed to the front of the $5\frac{1}{2} \times 1\frac{1}{2}$ Flexible Plate. The shafts are $5\frac{1}{2}$ Strips and they are bolted to the $5\frac{1}{2} \times 1\frac{1}{2}$ Flexible Plate.

The driver's legs are $2\frac{1}{2}$ Strips. They are connected to Angle Brackets (2) fixed to a Flat Trunnion that is bolted by its pointed end to the centre holes of the Double Angle Strips. His body is made from two Trunnions joined by a Fishplate, and his arms are attached to the upper Trunnion by Angle Brackets (3). His head is a 1" Pulley held by its set-screw on a $\frac{1}{4}$ " Bolt passed through a Fishplate (4). The body of the horse is a 'U'-section Curved Plate.

Parts Required

2 of No. 2	2
6 " " 5	5
4 " " 10	10
6 " " 12	12
1 " " 16	16
2 " " 17	17
4 " " 22	22
2 " " 35	35
31 " " 37a	37a
31 " " 37b	37b
1 " " 40	40
2 " " 48a	48a
2 " " 90a	90a
1 " " 111c	111c
2 " " 126	126
2 " " 126a	126a
3 " " 142c	142c
1 " " 189	189
1 " " 199	199
1 " " 200	200

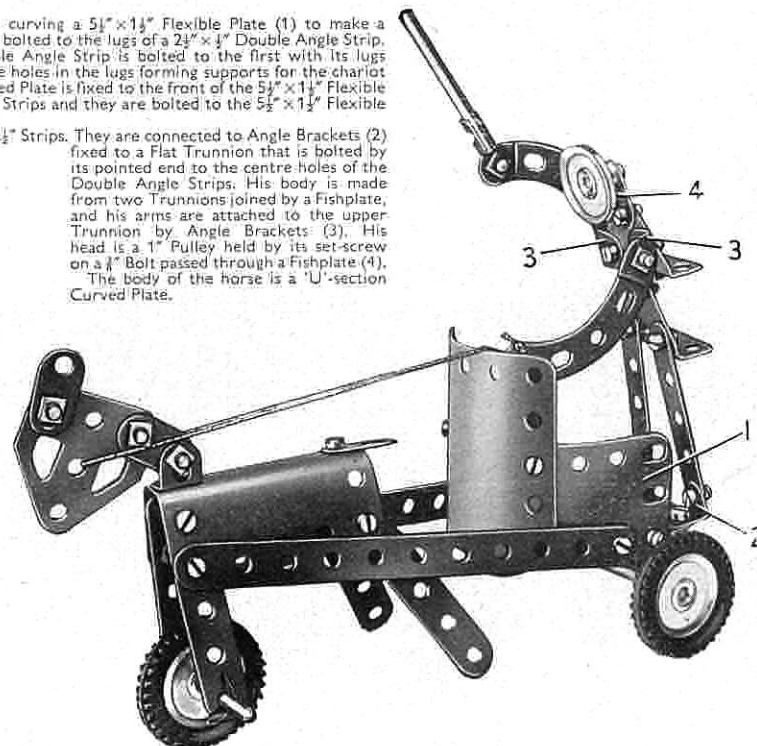

3.1 STEAM TRACTOR AND TRAILER

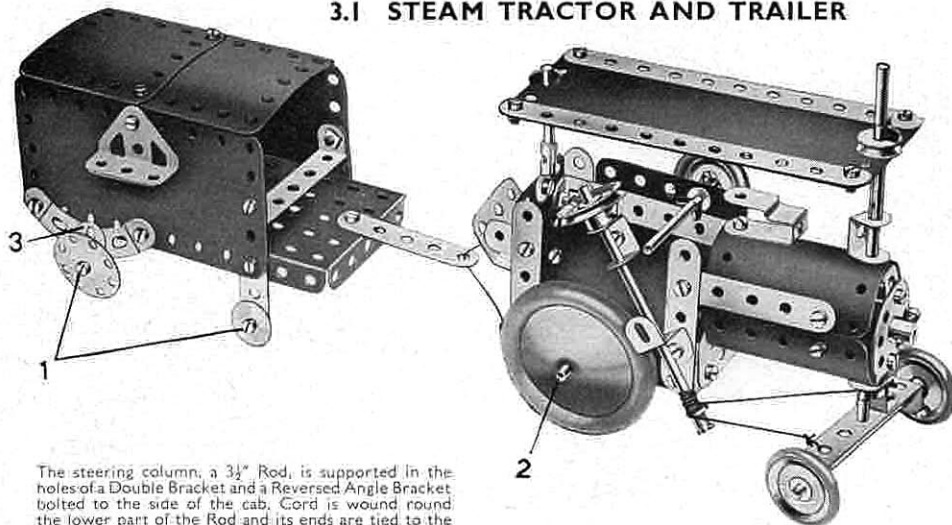

The steering column, a 3½" Rod, is supported in the holes of a Double Bracket and a Reversed Angle Bracket bolted to the side of the cab. Cord is wound round the lower part of the Rod and its ends are tied to the 2½" x ½" Double Angle Strip that carries the front axle. Care must be taken that the Cord is wound tightly round the Rod or it will slip when the steering wheel is rotated. The Rod (2) is supported in holes in the Flexible Plates that form the sides of the cab.

The Bush Wheel that forms the front of the boiler has two Angle Brackets bolted to it, and a Rod passes through the free holes of these Brackets to hold the Bush Wheel in position. This Rod is joined by a Rod Connector to a 2" Rod that forms the chimney. The roof of the cab consists of a 5½" x 2½" Flexible Plate, and is held in position by Spring Clips placed on the two Rods that pass through it. The Fishplates (3) are bolted in the centre holes of the 2½" Curved Strips on each side of the model. The Bolts (1) are lock-nutted in position and the Wheel Discs and 1" Washers turn freely on them.

1 of No.	18a
4 "	22
1 "	23
1 "	24
2 "	24a
5 "	35
54 "	37a
46 "	37b
3 "	38
2 "	38d
1 "	40
1 "	44
2 "	48a
1 "	52
2 "	90a
4 "	111c
2 "	125
2 "	126
2 "	126a
3 "	155
1 "	176
2 "	187
1 "	188
2 "	190
2 "	191
1 "	192
2 "	199
2 "	200
2 "	212
3 "	213
1 "	215

4 of No.	2
7 "	5
2 "	10
2 "	11
8 "	12
2 "	15b
3 "	16
2 "	17

3.2 HORSE AND CART

The model is driven by a Magic Motor fastened underneath the 5½" x 2½" Flanged Plate that forms the bottom of the cart. The drive is taken by a Driving Band from the pulley of the Motor to a ½" fast Pulley on the cart axle. A ½" loose Pulley is fitted on a 2" Rod supported in the bottom holes of the Strips forming the hind legs of the horse, so that the model will travel smoothly along the ground.

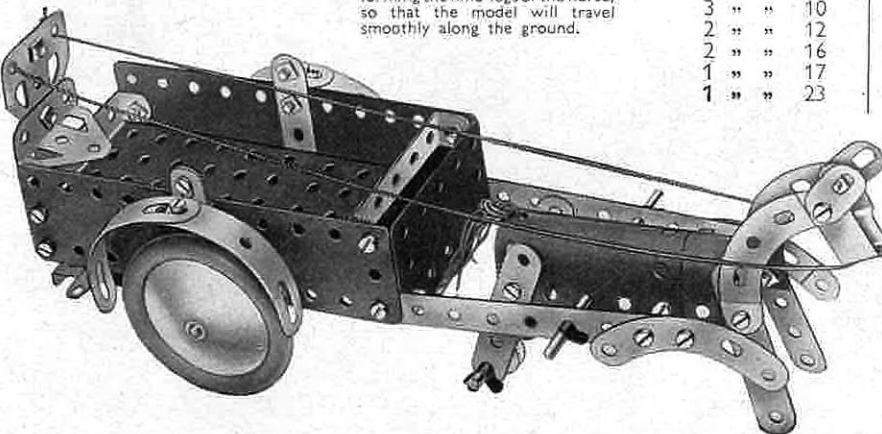

2 of No.	2	4 of No.	35
6 "	5	32 "	37a
3 "	10	32 "	37b
2 "	12	4 "	38
2 "	16	1 "	40
1 "	17	1 "	44
1 "	23	2 "	48a
		1 "	52
		4 "	90a
		1 "	126
		1 "	126a
		1 "	186
		2 "	187
		1 "	188
		2 "	189
		2 "	199
		4 "	215

Magic Motor
(not included in Outfit)

3.3 ELECTRIC CRANE TRUCK

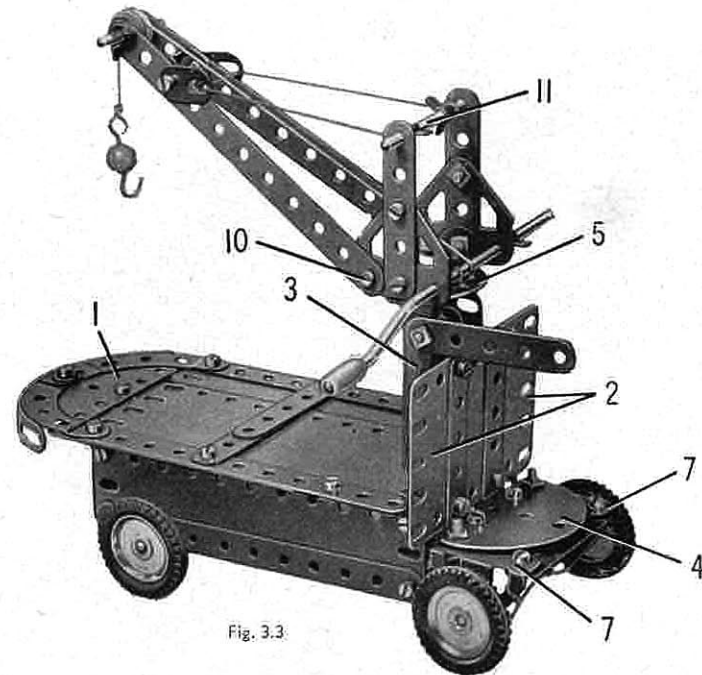

Fig. 3.3

The truck part of the model is built up first by bolting one 2½" x 1½" and two 5½" x 1½" Flexible Plates to the flanges of a Flanged Plate. At their lower edges the Flexible Plates are strengthened by 5½" Strips and two 2½" x ½" Double Angle Strips. The platform consists of two 5½" x 2½" and two 4½" x 2½" Flexible Plates overlapped and extended by a Semi-Circular Plate (1).

Two 2½" x 2½" Flexible Plates (2), overlapped three holes, are bolted to the front end of the Flanged Plate, and a 'U'-section Curved Plate (3) is attached to these by a Double Bracket. A Semi-Circular Plate (4) is attached to the Flanged Plate by Angle Brackets.

The crane jib is supported by Flat Trunnions, which are attached to a Wheel Disc (5) by Angle Brackets. The Wheel Disc is lock-nutted through its centre hole to an Angle Bracket bolted to the top centre hole at the front of the 'U'-section Curved Plate (3).

The 5½" Strips forming the jib pivot on lock-nutted bolts (10) in the Flat Trunnions, and the jib is held at the required angle by a length of Cord. This Cord is tied to the Rod (11) and then passed through the Fishplates at the jib head, finally being tied again to the Rod (11).

The Trunnions (7), which form part of the steering device, are free to turn on ½" Bolts secured to the Semi-Circular Plate (4), and they carry 1" Bolts that form stub axles for the 1" Pulleys. The 2½" Strip (8), seen in the underneath view of the model, is bolted to a Bush Wheel, and is connected to each Trunnion by Cord as shown. The Bush Wheel is fixed to a 3½" Rod passed through the Flanged Plate and an Angle Bracket (9).

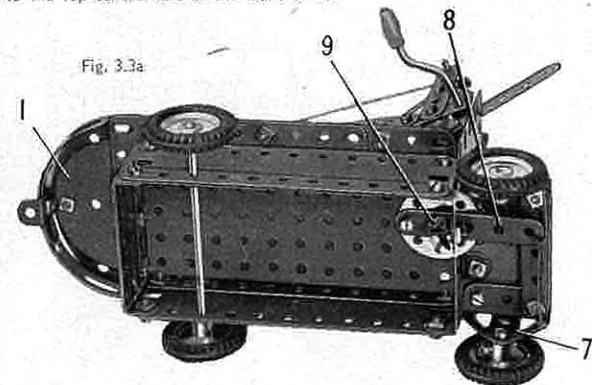

Fig. 3.3a

Parts Required	
6 of No.	2
9 "	5
2 "	10
2 "	11
6 "	12
1 "	15t
1 "	16
1 "	17
1 "	18a
1 "	19g
4 "	22
1 "	23
1 "	24
1 "	24a
6 "	35
52 "	37a
43 "	37b
4 "	38
1 "	40
2 "	48a
1 "	52
1 "	57c
2 "	90a
5 "	111c
1 "	125
2 "	126
2 "	126a
4 "	142c
1 "	188
2 "	189
2 "	190
2 "	192
1 "	199
1 "	212
2 "	214
2 "	215

3.4 RACING CAR

The chassis of the model is a $5\frac{1}{2}'' \times 2\frac{1}{2}''$ Flanged Plate (1), and a $5\frac{1}{2}'' \times 1\frac{1}{2}''$ Flexible Plate is bolted to each side so that two holes of the Flanged Plate are left clear at the front. The Flanged Plate is lengthened at the rear by a $5\frac{1}{2}''$ Strip (2) on each side, and a Flat Trunnion (3) is fixed to each $5\frac{1}{2}''$ Strip. A $2\frac{1}{2}'' \times 1\frac{1}{2}''$ Flexible Plate (4) is bolted to each of the Strips (2) and is connected to the $5\frac{1}{2}'' \times 1\frac{1}{2}''$ Flexible Plate by a Fishplate. Two $2\frac{1}{2}''$ Strips (5) are attached to the sides by Bolts (6).

The top of the bonnet is a $5\frac{1}{2}'' \times 2\frac{1}{2}''$ Flexible Plate, and it is attached to the sides by four Angle Brackets: Two Trunnions are connected by $\frac{3}{8}''$ Bolts (7) to a $1\frac{1}{2}''$ radius Curved Plate, which is then bolted between the $5\frac{1}{2}'' \times 2\frac{1}{2}''$ Flexible Plate and the front of the Flanged Plate.

Two 'U'-section Curved Plates (8) are fixed to the Flexible Plates (4) and the Flat Trunnions (3), and a Wheel Disc (9) is attached to one of them by an Angle Bracket. The tail assembly

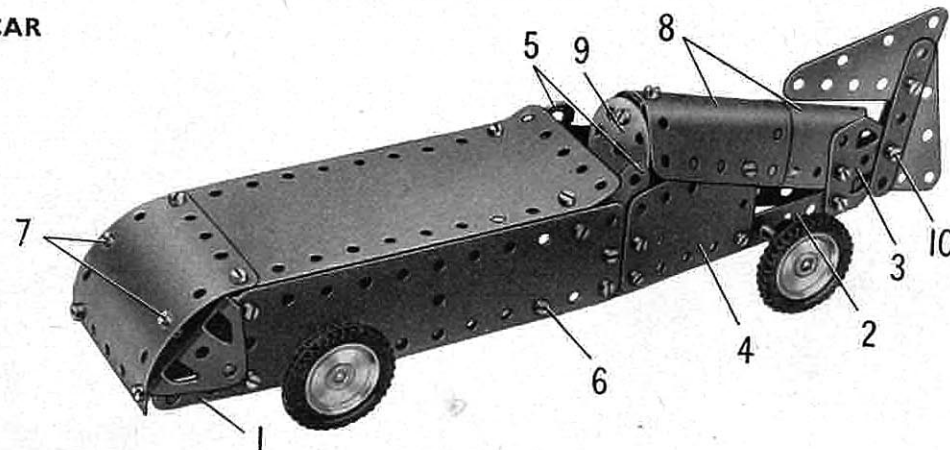

consists of two $2\frac{1}{2}'' \times 1\frac{1}{2}''$ Triangular Flexible Plates bolted between two $2\frac{1}{2}''$ Strips as shown, and it is fixed to the Flat Trunnions (3) by a $\frac{3}{8}''$ Bolt (10).

The wheels are mounted on $3\frac{1}{2}''$ Rods passed through the chassis as shown.

Parts Required		Parts Required		Parts Required	
2 of No. 2	38 of No. 37a	2 of No. 189			
4 " " 5	35 " " 37b	1 " " 192			
2 " " 10	1 " " 52	2 " " 199			
5 " " 12	3 " " 111c	1 " " 200			
2 " " 16	2 " " 126	1 " " 214			
4 " " 22	2 " " 126a	2 " " 221			
1 " " 24a	4 " " 142c				
2 " " 35	2 " " 188				

3.5 TRAMCAR

Parts Required		
4 of No. 2	2 of No. 48a	1 of No. 212
9 " " 5	1 " " 52	2 " " 214
4 " " 10	5 " " 111c	4 " " 215
1 " " 11	2 " " 126	
8 " " 12	2 " " 126a	
1 " " 15b	1 " " 176	
2 " " 16	2 " " 188	
4 " " 22	2 " " 189	
5 " " 35	2 " " 190	
54 " " 37a	2 " " 191	
49 " " 37b		
6 " " 38		
2 " " 38d		
1 " " 40		
1 " " 44		

The chassis is a $5\frac{1}{2}'' \times 2\frac{1}{2}''$ Flanged Plate fitted at its sides with $4\frac{1}{2}'' \times 2\frac{1}{2}''$ Flexible Plates. The Flexible Plates are bolted to the flanges so that a space of two clear holes is left in each side flange, but at opposite ends. The lower edges of the Flexible Plates are edged by $5\frac{1}{2}''$ Strips, and a Flat Trunnion (1) and a Trunnion (2) are bolted to each side. The axles are supported in the Trunnions and Flat Trunnions.

The rounded ends consist of $5\frac{1}{2}'' \times 1\frac{1}{2}''$ Flexible Plates curved to shape and bolted to the sides. A Formed Slotted Strip is attached to each of the $5\frac{1}{2}'' \times 1\frac{1}{2}''$ Flexible Plates by a Fishplate. The control handles (3) are each made by bolting a Fishplate fitted with a $\frac{3}{8}''$ Bolt to an Angle Bracket fixed to the Flexible Plate.

The roof is supported on each side by four $2\frac{1}{2}''$ Strips. The tops of these Strips are connected by two $5\frac{1}{2}''$ Strips (4) overlapped seven holes; and these Strips are joined across by $2\frac{1}{2}'' \times \frac{1}{2}''$ Double Angle Strips held by the Bolts (5). An Angle Bracket on each side is fixed in place by a Bolt (6).

The roof consists of two $2\frac{1}{2}'' \times 2\frac{1}{2}''$ and two $2\frac{1}{2}'' \times 1\frac{1}{2}''$ Flexible Plates bolted end to end, and its rounded ends are Semi-Circular Plates. The roof is attached to the Double Angle Strips and the Angle Brackets held by Bolts (5) and (6). A Formed Slotted Strip is connected to each Semi-Circular Plate by an Angle Bracket.

The trolley pole is a $4''$ Rod fitted with a Rod and Strip Connector, and it is held in a Stepped Bent Strip by a Spring Clip and a Cord Anchoring Spring. The Stepped Bent Strip is bolted to two Angle Brackets (7) bolted to the centre of the roof.

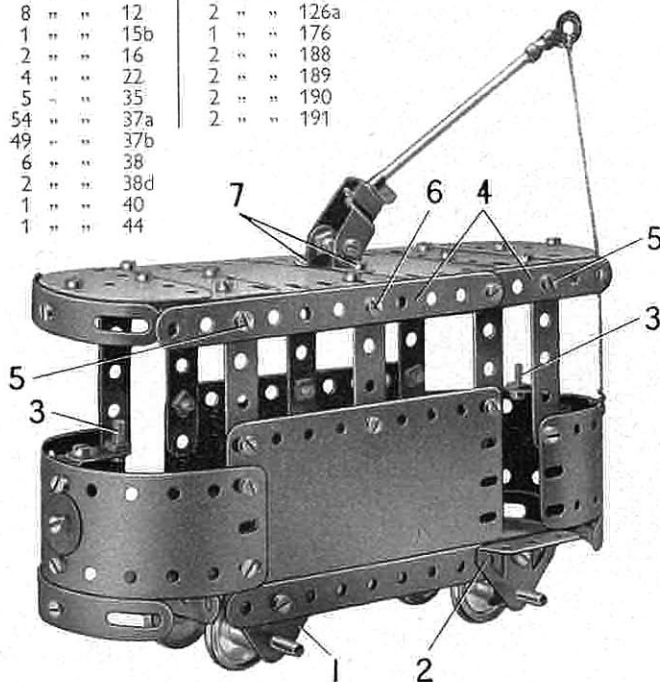

3.6 TROTTING CAR

Parts Required			Parts Required	
4 of No. 2	37 of No. 37a	2 of No. 126a		
8 " " 5	37 " " 37b	4 " " 155		
5 " " 10	6 " " 38	1 " " 176		
1 " " 11	1 " " 40	2 " " 187		
3 " " 12	1 " " 44	2 " " 188		
1 " " 15b	2 " " 48a	2 " " 199		
2 " " 16	3 " " 90a	1 " " 213		
2 " " 17	3 " " 111c	4 " " 215		
1 " " 18a	2 " " 125			
4 " " 22	2 " " 126			
1 " " 24				
1 " " 24a				
4 " " 35				

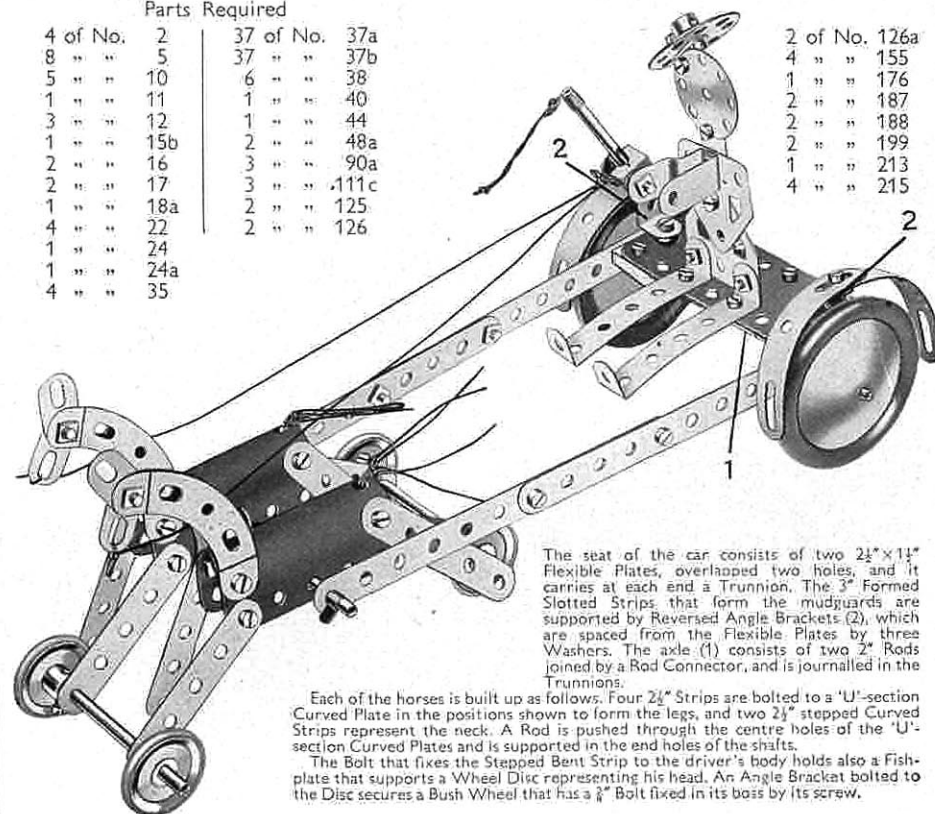

The seat of the car consists of two $2\frac{1}{2}'' \times 1\frac{1}{2}''$ Flexible Plates, overlapped two holes, and it carries at each end a Trunnion. The 3" Formed Slotted Strips that form the mudguards are supported by Reversed Angle Brackets (2), which are spaced from the Flexible Plates by three Washers. The axle (1) consists of two 2" Rods joined by a Rod Connector, and is journalled in the Trunnions.

Each of the horses is built up as follows. Four $2\frac{1}{2}''$ Strips are bolted to a 'U'-section Curved Plate in the positions shown to form the legs, and two $2\frac{1}{2}''$ stepped Curved Strips represent the neck. A Rod is pushed through the centre holes of the 'U'-section Curved Plates and is supported in the end holes of the shafts.

The Bolt that fixes the Stepped Bent Strip to the driver's body holds also a Fishplate that supports a Wheel Disc representing his head. An Angle Bracket bolted to the Disc secures a Bush Wheel that has a $\frac{3}{8}''$ Bolt fixed in its boss by its screw.

3.7 TRACTOR AND HARROW

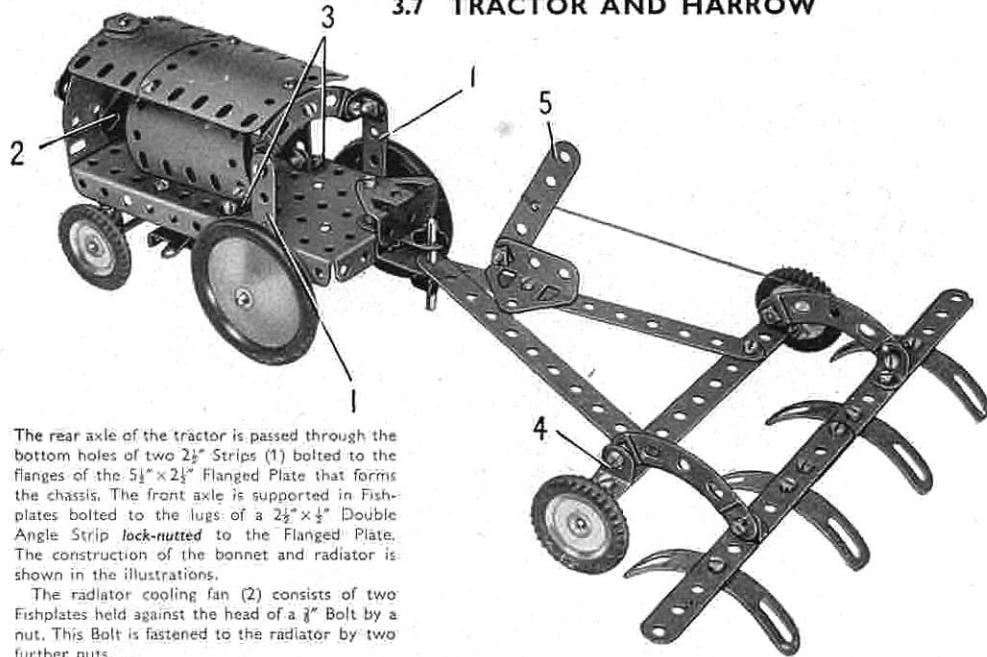

The rear axle of the tractor is passed through the bottom holes of two 2½" Strips (1) bolted to the flanges of the 5½" x 2½" Flanged Plate that forms the chassis. The front axle is supported in Fishplates bolted to the lugs of a 2½" x ½" Double Angle Strip lock-nutted to the Flanged Plate. The construction of the bonnet and radiator is shown in the illustrations.

The radiator cooling fan (2) consists of two Fishplates held against the head of a ½" Bolt by a nut. This Bolt is fastened to the radiator by two further nuts.

The engine is represented by two 'U'-section Curved Plates, which are bolted together so that they overlap each other by two holes and are then attached to the Flanged Plate by two Angle Brackets (3).

The wheels of the harrow are held by ½" Bolts in Reversed Angle Brackets (4) at each end of a 5¼" Strip. A 2½" Stepped Curved Strip is fastened to each Reversed Angle Bracket by a lock-nutted bolt, and Cord is attached to the centre hole of one of these Curved Strips and also to the operating lever (5), which is loosely held by a lock-nutted ½" Bolt to a Trunnion. By moving the lever forward the harrow may be raised from the ground when not in use.

Fig. 3.7

Parts Required

5 of No.	2	1 of No.	48a
3 " "	5	1 " "	52
5 " "	10	4 " "	90a
1 " "	11	4 " "	111c
8 " "	12	2 " "	125
1 " "	15b	2 " "	126
1 " "	16	4 " "	142c
1 " "	18a	2 " "	187
4 " "	22	1 " "	188
1 " "	23	2 " "	199
2 " "	35	2 " "	200
53 " "	37a	1 " "	214
42 " "	37b	4 " "	215
1 " "	40		
1 " "	44		

Magic Motor
(not included in
Outfit)

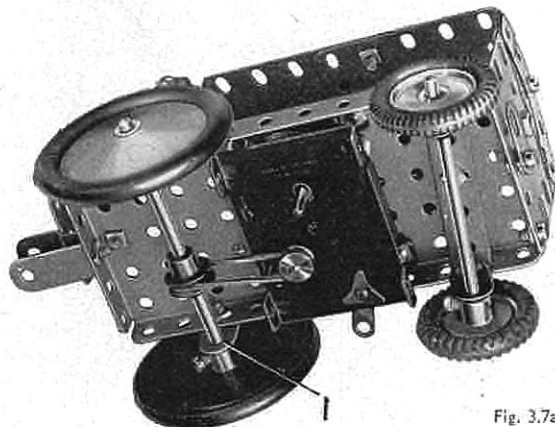

Fig. 3.7a

3.8 GIPSY CARAVAN

The base of the caravan is a 5½" x 2½" Flanged Plate, and the sides are 5½" x 2½" Flexible Plates strengthened along their upper edges by 5½" Strips. Three 2½" Strips are fixed to each side as shown, and these are connected by a 5½" Strip (1) lengthened at each end by a Fishplate. The 5½" Strips are joined across at their ends by 2½" Stepped Curved Strips attached to Angle Brackets.

The rear wheels are fixed on a 3½" Rod supported in Flat Trunnions bolted to the sides of the Flanged Plate. The front wheels are fastened on a 3½" Rod that is supported in two Trunnions (2). These Trunnions are bolted to a 2½" x 1½" Flexible Plate (3), fitted at each side with a 2½" Strip (4). A Bush Wheel (5) is fixed to the Plate (3), and a 2" Rod held in the Bush Wheel is passed through a ½" Reversed Angle Bracket (6) and the 5½" x 2½" Flanged Plate. A 'U'-section Curved Plate (7) and a ½" Pulley are slipped over the Rod, which is then held in position by a Spring Clip.

The shafts are 5½" Strips bolted to a 2½" x ½" Double Angle Strip (8). This is lock-nutted to a second Double Angle Strip bolted across the ends of Strips (4).

The roof consists of two 1½" radius Curved Plates (9) overlapped four holes, and two 5½" x 1½" Flexible Plates, one of which is seen at (10). The 5½" x 1½" Flexible Plates are placed side to side, and are bolted to Formed Slotted Strips as shown. The complete roof is attached to Angle Brackets bolted to the sides of the caravan. The Angle Brackets are bent out a little to allow a slight curve in the roof.

A step at the rear of the caravan consists of a 'U'-section Curved Plate bolted to the rear of the 5½" x 2½" Flanged Plate.

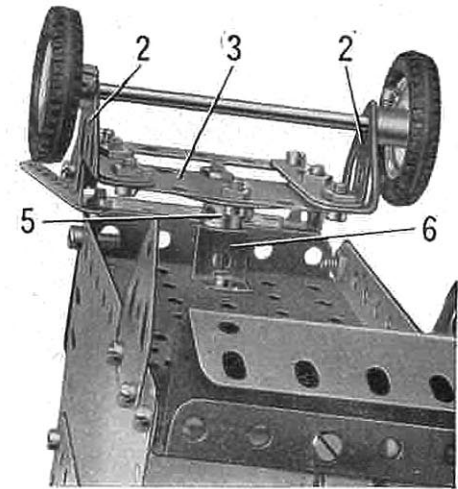

Fig. 3.8a

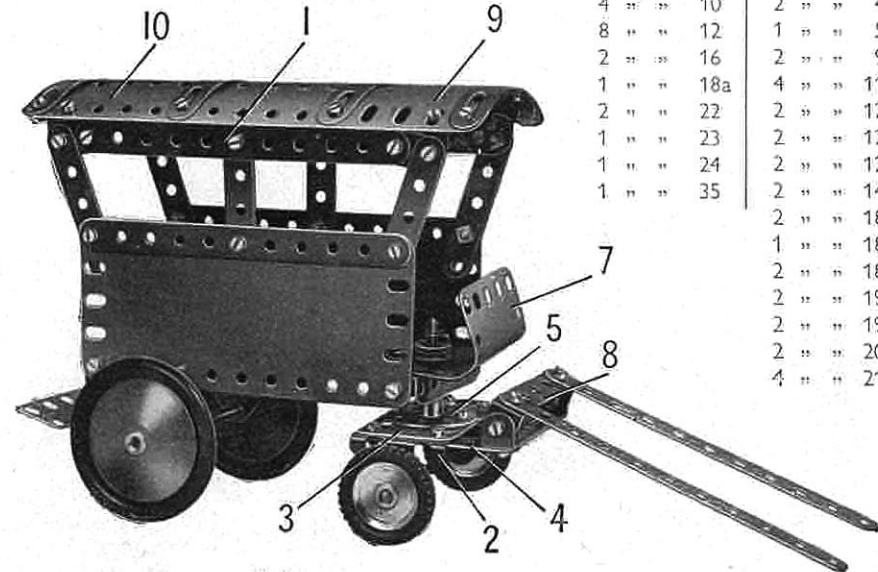

Fig. 3.8

Parts Required

6 of No.	2	56 of No.	37a
8 " "	5	50 " "	37b
4 " "	10	2 " "	48a
8 " "	12	1 " "	52
2 " "	16	2 " "	90a
1 " "	18a	4 " "	111c
2 " "	22	2 " "	125
1 " "	23	2 " "	126
1 " "	24	2 " "	126a
1 " "	35	2 " "	142c
		2 " "	187
		1 " "	188
		2 " "	189
		2 " "	192
		2 " "	199
		2 " "	200
		4 " "	215

4.1 CEMENT MIXER

The chassis of the model is built by bolting a 12½" Strip to each of the longer flanges of a 5½" × 2½" Flanged Plate. Two further 12½" Strips are fixed to the edges of the Plate, and the outer ends of these Strips are connected by a 2½" Strip (1).

A support for the mixing drum is made by bolting two 2½" Strips to Trunnions (2) fixed to the Flanged Plate as shown. A ½" Bolt is passed through one of the lugs of a 1½" × ½" Double Angle Strip (3), and a nut screwed loosely on to the Bolt. The shank is then passed through one of the vertical 2½" Strips and the centre hole of a 2½" Stepped Curved Strip (4), and a second nut is screwed firmly against the first. A ¾" Bolt is fixed tightly by a nut to the opposite lug of the Double Angle Strip, and passed through the second vertical 2½" Strip. A 1" Pulley is then fixed on the shank of the Bolt, and connected to a second 1" Pulley (5) by a Driving Band. The Pulley (5) is fixed on a 4" Rod mounted in the 2½" Strips. This Rod carries at its outer end a Bush Wheel fitted with a ½" Bolt, and it is used for tilting the mixing drum for unloading.

The mixing drum is made by bolting two 2½" × ½" Double Angle Strips at right-angles to each other across a 3" Pulley (6). Two 4½" × 2½" Flexible Plates are curved and fixed to the Double Angle Strips. The Pulley (6) is fixed on a 1½" Rod, which is passed through the Double Angle Strip (3) and through a Reversed Angle Bracket (7) and the Rod is held in position by a Spring Clip.

The supports for the loading hopper are four 5½" Strips attached to Angle Brackets fixed to the chassis and connected at the top by 2½" Stepped Curved Strips. Two of the 5½" Strips are extended by 2½" Strips (9). The sides of the hopper are Flanged Sector Plates, and these are bolted to 5½" × 1½" Flexible Plates arranged as shown. The back of the hopper is a 2½" × 2½" Flexible Plate attached by Angle Brackets.

The hopper is pivoted on a built-up rod made by a 3½" and a 2" Rod joined by a Rod and Strip Connector. This rod is passed through a 2½" × ½" Double Angle Strip (9) bolted to the hopper, and is fitted with a 3" Pulley. The 3" Pulley is connected by a Driving Band to a 1" Pulley fixed on a Crank Handle that is mounted in one of the hopper supports and in the 2½" Stepped Curved Strip (4). Two short lengths of Cord are tied to the built-up rod, and are passed through the end holes of the 2½" Strips (8). The Cords are then tied to the rear of the hopper.

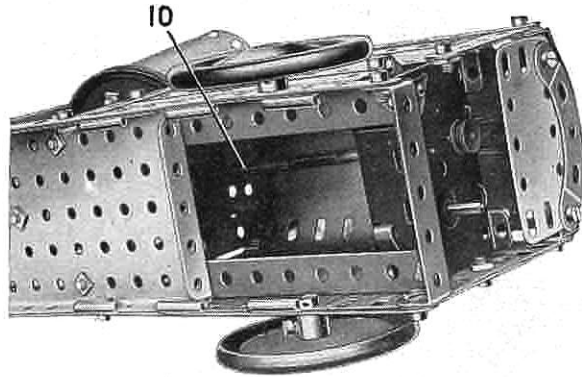

Fig. 4.1b

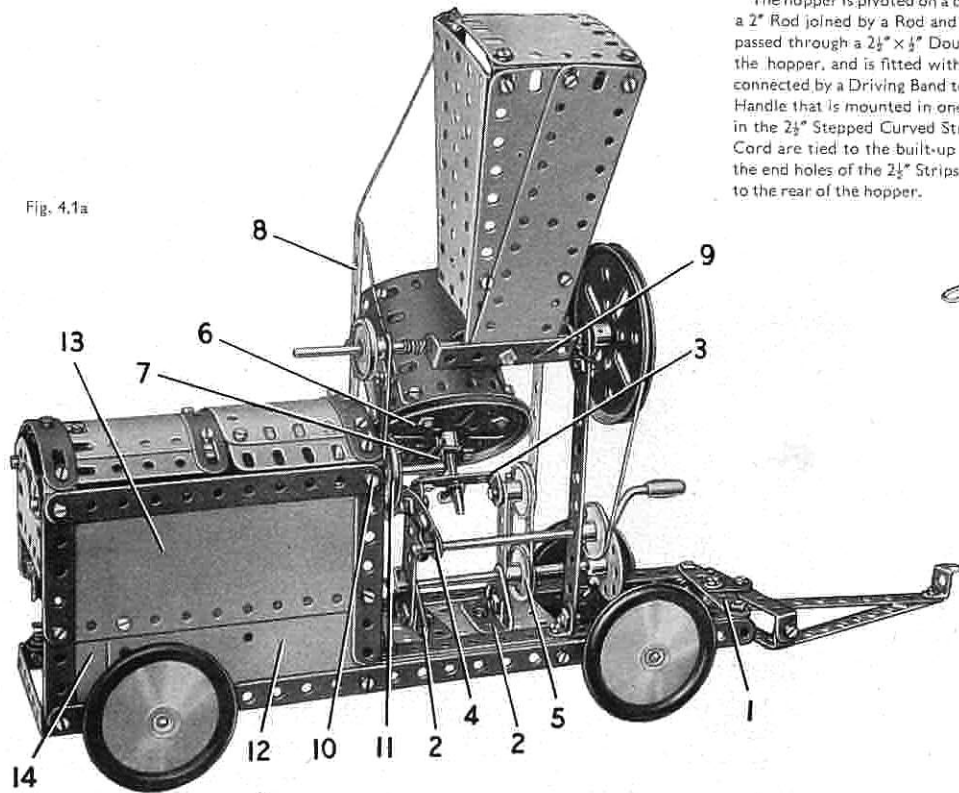

Fig. 4.1a

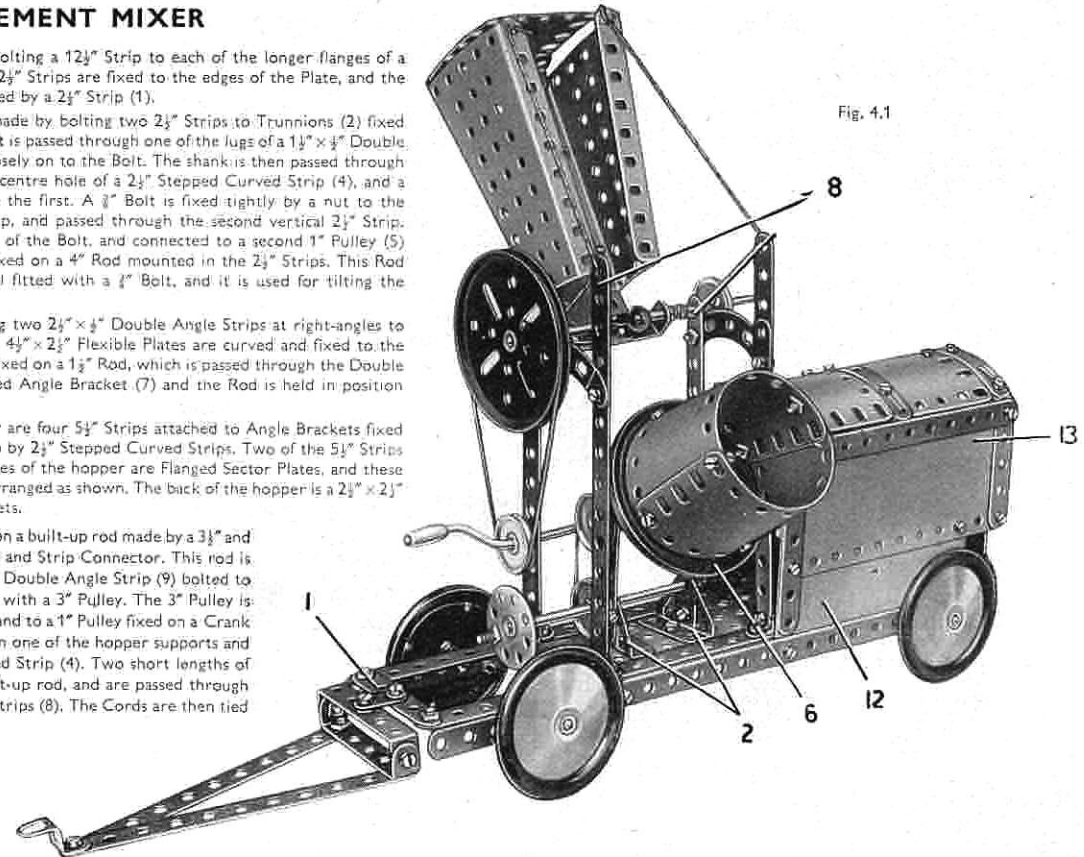

Fig. 4.1

The drum is rotated by a Magic Motor bolted to the 12½" Strips at one end of the chassis (see Fig. 4.1b). The drive from the Motor shaft is taken to a ½" Pulley on a built-up rod (10) made by joining two 3½" Rods by a Rod Connector. This rod is mounted at one end in a 2½" Strip bolted across two of the 5½" Strips used to support the hopper. The other end of the rod is supported in a Semi-Circular Plate bolted to the inner side-plate of the Magic Motor. The rod carries a 1" Pulley (11) fitted with a Rubber Ring, arranged so that it presses against the rim of the Pulley 6. The ½" Pulley is supplied with the Magic Motor.

The sides of the engine cover are made from the separated halves of a Hinged Flat Plate (12), 5½" × 2½" Flexible Plates (13) and a 2½" × 1½" Flexible Plate (14). The top is formed by two 1½" radius Curved Plates and two curved 2½" × 2½" Flexible Plates attached to Obtuse Angle Brackets fixed to the sides. The sides are edged by 5½", 2½" and 3½" Strips, and the top is strengthened by Formed Slotted Strips.

Parts Required

4 of No. 1	1 of No. 17	6 of No. 38	2 of No. 126	1 of No. 198
8 " " 2	1 " " 18a	1 " " 40	1 " " 155	2 " " 200
2 " " 3	2 " " 19b	1 " " 48	1 " " 186	1 " " 212
9 " " 5	1 " " 19g	6 " " 48a	4 " " 187	1 " " 213
3 " " 10	5 " " 22	1 " " 52	2 " " 188	1 " " 214
8 " " 12	1 " " 24	2 " " 54	2 " " 189	3 " " 215
4 " " 12c	4 " " 35	4 " " 90a	3 " " 190	
1 " " 15b	81 " " 37a	6 " " 111c	2 " " 191	
3 " " 16	77 " " 37b	2 " " 125	2 " " 192	

Magic Motor
 (not included in
 Outfit)

4.2 PLATFORM WEIGHING MACHINE

The base of the machine is made by bolting $5\frac{1}{2}'' \times 1\frac{1}{2}''$ Flexible Plates, edged by $5\frac{1}{2}''$ Strips, to the sides of a $5\frac{1}{2}'' \times 2\frac{1}{2}''$ Flanged Plate. The front is a $2\frac{1}{2}'' \times 1\frac{1}{2}''$ Flexible Plate, and the sides are connected by $2\frac{1}{2}'' \times \frac{1}{2}''$ Double Angle Strips (1) and (2). A lever (3) connected to the platform operates the recording mechanism, and it consists of two $5\frac{1}{2}''$ Strips joined by a Double Bracket (4). The lever is pivoted by *lock-nutted* bolts to a Double Bracket fixed by Bolt (5) to the Double Angle Strip (1). The platform is a $2\frac{1}{2}'' \times 2\frac{1}{2}''$ Flexible Plate edged by $2\frac{1}{2}''$ Strips, and is attached to the lever (3) by Angle Brackets.

Each side of the casing consists of two built-up strips, that at the rear being made from a $5\frac{1}{2}''$ and a $3\frac{1}{2}''$ Strip overlapped, while the front one is made from a $5\frac{1}{2}''$ and a $2\frac{1}{2}''$ Strip bolted together through their end holes. The side seen in Fig. 4.2 consists of two $5\frac{1}{2}'' \times 2\frac{1}{2}''$ Flexible Plates, the upper one being bent over and bolted to a $4\frac{1}{2}'' \times 2\frac{1}{2}''$ Flexible Plate that forms the upper part of the other side. The lower part of this side is formed by one half of a Hinged Flat Plate, the other half of which forms the rear door.

The front consists of a $2\frac{1}{2}'' \times 1\frac{1}{2}''$ Flanged Plate (6), and a $4\frac{1}{2}'' \times 2\frac{1}{2}''$ Flexible Plate (7) attached by Angle Brackets. The dial is a $3''$ Pulley. A Semi-Circular Plate (8) is attached to the Flanged Plate (6), and a similar part is fixed to a $2\frac{1}{2}'' \times \frac{1}{2}''$ Double Angle Strip at the rear. A $2\frac{1}{2}'' \times 1\frac{1}{2}''$ Flexible Plate is attached to a Double Angle Strip (9) fixed between the sides. The top of the casing is completed by Flat Trunnions and a 'U'-section Curved Plate attached to them by Angle Brackets.

A Rod (10) is passed through the $3''$ Pulley and the centre hole of Double Angle Strip (9). A Rod and Strip Connector on this Rod is separated from the Pulley by three Washers, and is held in place by a Spring Clip. A $1''$ Rod held in the Rod and Strip Connector engages between the lugs of the Spring Clip.

Cord is tied to $1\frac{1}{2}''$ Rod (11) held by Spring Clips in the lever (3), and is wound twice round Rod (10). Then it is tied to a $2\frac{1}{2}''$ Driving Band, which is stretched slightly and attached to the casing by bolt (12).

Fig. 4.2a

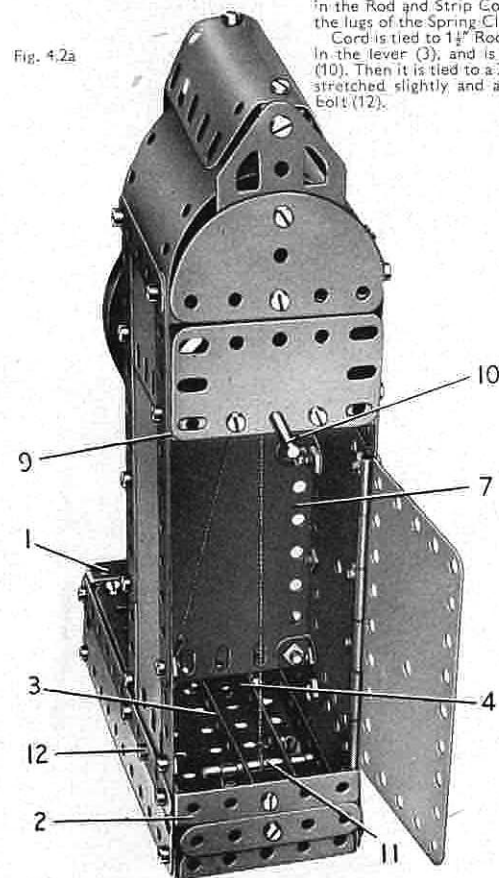
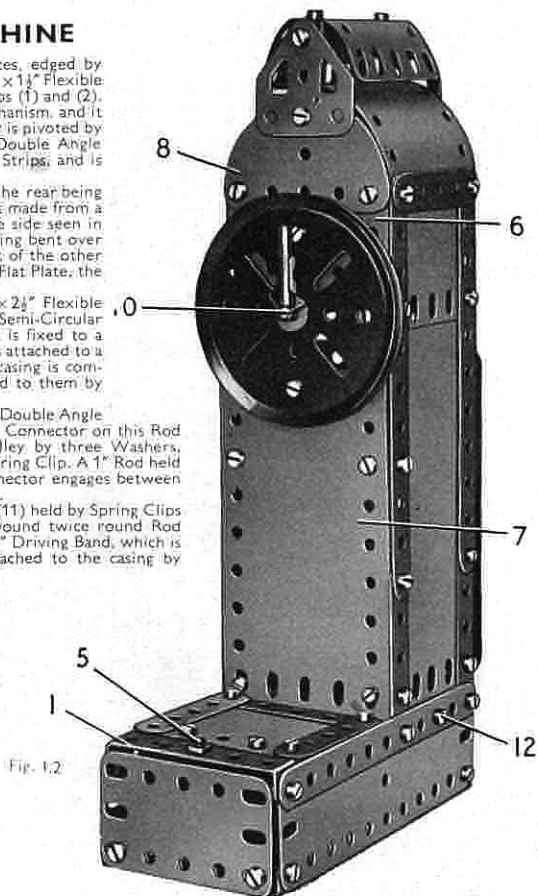

Fig. 4.2



Parts Required		Parts Required	
8 of No.	2	4 of No.	48a
2	3	1	51
9	5	1	52
1	10	2	126a
2	11	1	186
8	12	2	188
1	15b	2	189
1	18a	1	190
1	18b	2	191
1	19b	2	192
3	35	1	198
65	37a	1	199
65	37b	1	212
3	38	1	214
1	40	2	214

4.3 CARAVAN

Parts Required

8 of No.	2
2 " "	3
9 " "	5
5 " "	10
1 " "	11
7 " "	12
2 " "	15b
2 " "	17
1 " "	18b
4 " "	35
73 " "	37a
71 " "	37b
10 " "	38
1 " "	44
3 " "	48a
1 " "	51
1 " "	52
2 " "	54
4 " "	90a
1 " "	111c
2 " "	125
1 " "	126
2 " "	187
2 " "	188
4 " "	190
2 " "	191
1 " "	192
1 " "	198
2 " "	200
1 " "	212
2 " "	212a
2 " "	214
4 " "	215
4 " "	221

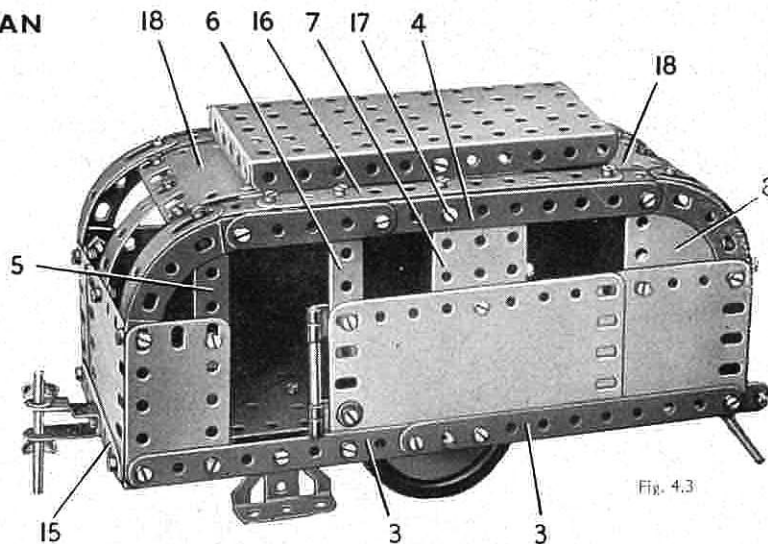

Fig. 4.3

The floor of the caravan is made by joining two Flanged Sector Plates to a $2\frac{1}{2}''$ Strip (1). Two $2\frac{1}{2}'' \times 1\frac{1}{2}''$ Triangular Flexible Plates (2) are bolted to each Flanged Sector Plate.

The side of the model seen in the general view consists of a $5\frac{1}{2}'' \times 2\frac{1}{2}''$ Flexible Plate overlapped seven holes, and a $2\frac{1}{2}'' \times 1\frac{1}{2}''$ Flexible Plate. The plates are bolted to two $5\frac{1}{2}''$ Strips (3) overlapped three holes. The top edge of the side consists of a $5\frac{1}{2}''$ Strip (4) lengthened by a $2\frac{1}{2}''$ Strip that overlaps it by three holes, and the made-up strip thus formed is connected to the Flexible Plates at each end by a $2\frac{1}{2}''$ Stepped Curved Strip. The window frames are provided by a $2\frac{1}{2}''$ Strip (5), a $2\frac{1}{2}'' \times \frac{1}{2}''$ Double Angle Strip (6), a $2\frac{1}{2}'' \times 1\frac{1}{2}''$ Flanged Plate (7) and a Semi-Circular Plate (8). A handrail is provided at one side of the door. It is made from a $2''$ Rod held in Right-Angle Rod and Strip Connectors.

The side seen in Fig. 4.3a consists of the separated halves (9) of a Hinged Flat Plate bolted to a $4\frac{1}{2}'' \times 2\frac{1}{2}''$ Flexible Plate and to two $5\frac{1}{2}''$ Strips (10) overlapped three holes. The window frames are provided by a Semi-Circular Plate (11), a $2\frac{1}{2}'' \times 2\frac{1}{2}''$ Flexible Plate (12) and a $2\frac{1}{2}'' \times \frac{1}{2}''$ Double Angle Strip (13). The top edge of the roof is made from a $5\frac{1}{2}''$ and a $2\frac{1}{2}''$ Strip overlapped three holes to make a built-up strip (14), and the curved ends are a $2\frac{1}{2}''$ Stepped Curved Strips.

The sides are connected at each end by a $3\frac{1}{2}''$ Strip (15) attached to Angle Brackets. One end consists of a $2\frac{1}{2}'' \times 2\frac{1}{2}''$ and a $2\frac{1}{2}'' \times 1\frac{1}{2}''$ Flexible Plate, and the other is made from two $2\frac{1}{2}'' \times 2\frac{1}{2}''$ Flexible Plates. The curved end windows consist of Formed Slotted Strips bolted to the Flexible Plates, and each Formed Slotted Strip is extended by a $2\frac{1}{2}''$ Strip that is bolted to a $5\frac{1}{2}''$ Strip (16). The Strips (16) are attached to the sides by $\frac{1}{2}''$ Reversed Angle Brackets held by bolts (17). The centre division of the curved window at one end is a $2\frac{1}{2}''$ Strip, and at the other end a $2\frac{1}{2}'' \times \frac{1}{2}''$ Double Angle Strip is used.

The roof consists of a $1\frac{1}{2}''$ radius Curved Plate (18) at each end that is attached to the Formed Slotted Strips by Fishplates. The centre section of the roof is a $5\frac{1}{2}'' \times 2\frac{1}{2}''$ Flanged Plate, and this is bolted to the lugs of the Reversed Angle Brackets held by the Bolts (17).

The body is attached to the Flanged Sector Plates by an Angle Bracket and a Double Bracket as shown in Fig. 4.3a. The towing attachment is a Stepped Bent Strip fitted with a $2''$ Rod that serves also as a support at one end of the caravan. At the other end the support is a $1''$ Rod in a Rod and Strip Connector that is *lock-nutted* to one of the Flanged Sector Plates.

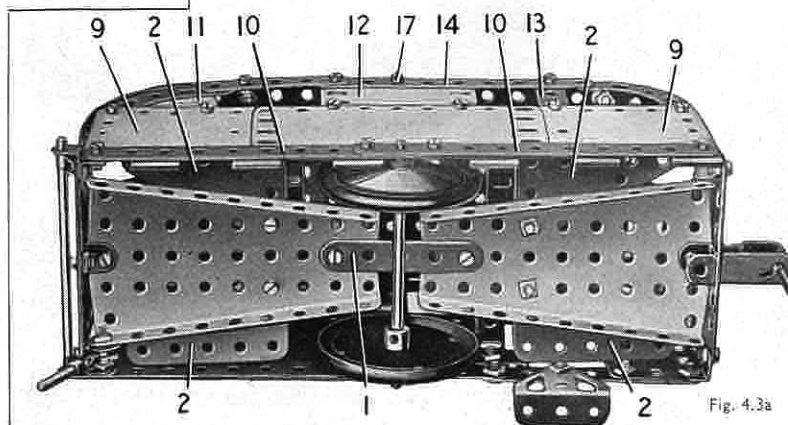

Fig. 4.3a

4.4 ELEVATED JIB CRANE

Parts Required

4 of No.	1	3 of No.	16
6 "	2	1 "	17
2 "	3	1 "	18b
7 "	5	1 "	19b
5 "	10	1 "	19g
1 "	11	5 "	22
4 "	12	1 "	23
4 "	12c	1 "	24
1 "	15b	8 "	35

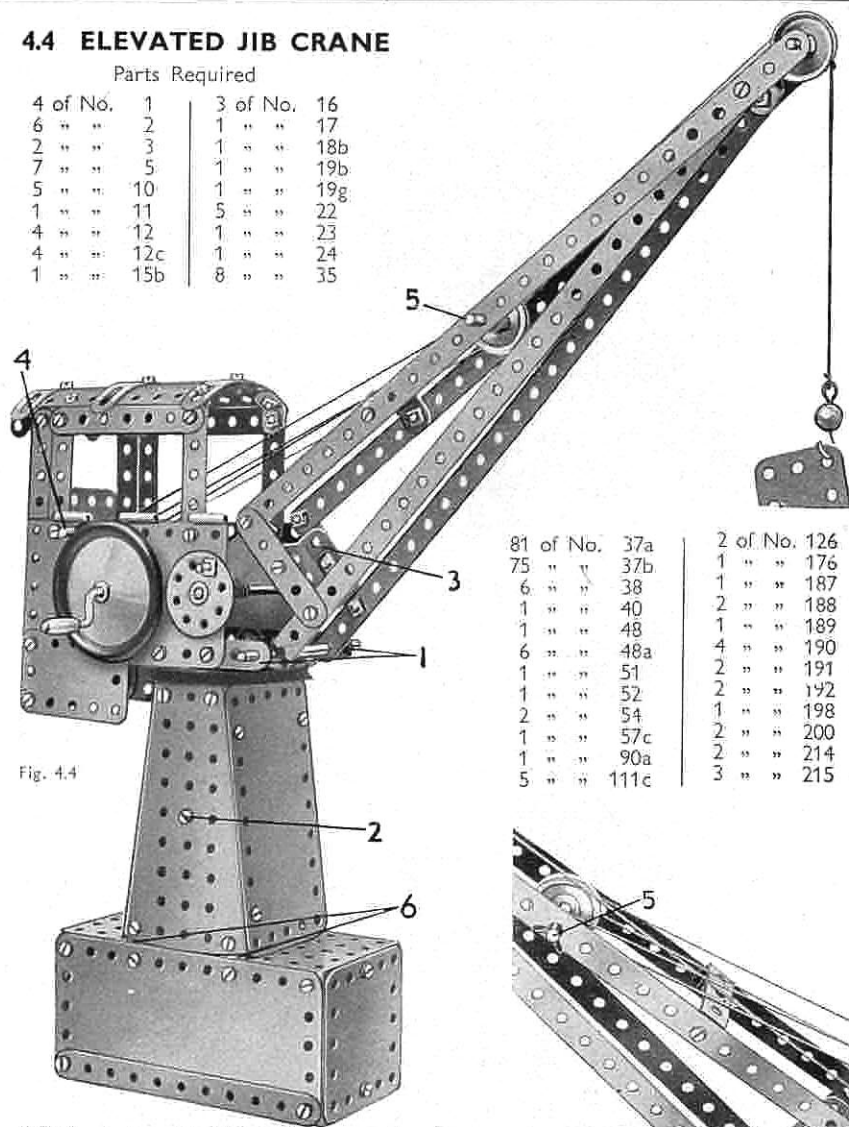

Fig. 4.4

A 3" Pulley is attached to 5½" Strips (1) by means of two Double Angle Strips. A 4" Rod fixed in this Pulley passes through a hole in a 2½" × 1½" Flanged Plate bolted to the Flanged Sector Plates and a Double Angle Strip held by a Bolt (2) on each side of the tower. The tower is attached to the base by Fishplates, two of which are seen marked (6).

The jib consists of four 12½" Strips joined at their outer ends by a Double Bracket and at their inner ends by two Trunnions (3) (Fig. 4.4a) bolted together.

Hoisting is carried out by a length of Cord attached to a Cord Anchoring Spring placed on the Crank Handle.

Luffing, or raising and lowering of the jib, is controlled by a Bush Wheel locked on a 3½" Rod. A length of Cord fastened to this Rod is passed round Rod (4) and then round the Rod (5) (Fig. 4.4a) in the jib. It passes again round Rods (5) and (4) and finally is tied to Rod (4).

81 of No.	37a	2 of No.	126
75 "	37b	1 "	176
6 "	38	1 "	187
1 "	40	2 "	188
1 "	48	1 "	189
6 "	48a	4 "	190
1 "	51	2 "	191
1 "	52	2 "	192
2 "	54	1 "	198
1 "	57c	2 "	200
1 "	90a	2 "	214
5 "	111c	3 "	215

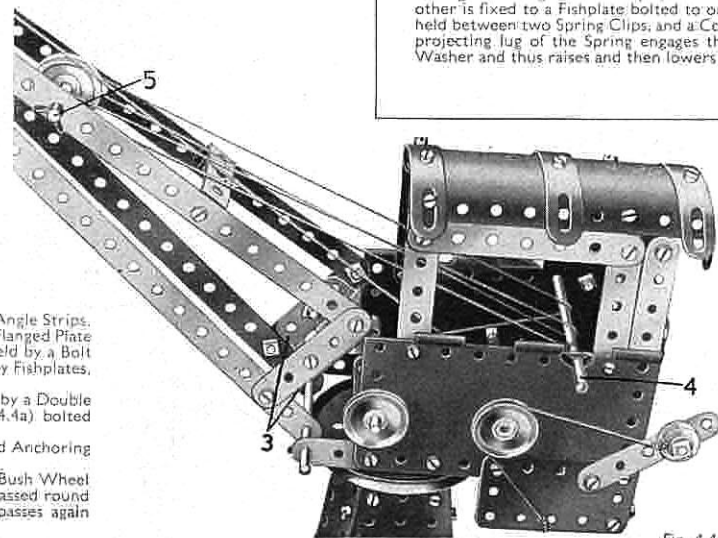

Fig. 4.4a

4.5 SEWING MACHINE

The base of the model is a 5½" × 2½" Flanged Plate, fitted at each side with two 5½" Strips. These Strips are arranged so that two clear holes overhang each end of the Flanged Plate. Flanged Sector Plates are bolted between the Strips as shown. A 4½" × 2½" Flexible Plate is bolted to each side, and the narrow ends of the Flanged Sector Plates are connected by made-up strips (1), consisting of 5½" and 2½" Strips bolted together.

A 5½" × 1½" Flexible Plate (2) is bolted to a 1½" × ¼" Double Angle Strip held by a Bolt (3) on each side, and to Angle Brackets attached by Bolts (4) on each side. The Flexible Plate is bolted also to a 2½" × 1½" Flanged Plate fixed to the strips (1) by Angle Brackets, which are secured by the Bolts (5).

Two 2½" × ¼" Double Angle Strips (6) are arranged so that their turned-up ends overlap, and they are fixed to the 2½" × 1½" Flanged Plate. A second pair of Double Angle Strips (7) is similarly arranged, and these also are bolted to the Flanged Plate. The two sets of Double Angle Strips are connected at the top by a 5½" Strip (8) and a 3½" Strip (9) on each side, and a Double Bracket is held between the Double Angle Strips (6) by the Bolts (10).

A 2½" Strip (11) on each side is bolted to the Strip (8), and is connected by a Stepped Curved Strip to the Strip (9). The Bolt (12) is fitted with a nut before it is passed through the Strips, and it serves to support a Double Bracket between the ends of Strips (9). Strips (8) are connected by a 'U'-shaped piece made from two Angle Brackets. This is attached by a Bolt (13) on each side, and two 2½" Strips (14) are fixed to the Angle Brackets. A 1½" Rod held by two Spring Clips in one of the Strips (14), and a 1" Rod fixed in a Bush Wheel (15), represent the bobbin spindles.

A Magic Clockwork Motor is bolted by its lugs to the 5½" × 2½" Flanged Plate of the base, and it is connected by a Driving Band to a 1" Pulley (16). The Pulley (16) is fixed on a 4" Rod supported in the Double Brackets held by Bolts (10) and (12), and this Rod is lengthened by a 1½" Rod (17) fitted in a Rod Connector.

The needle is represented by a 3½" Rod passed through two Angle Brackets (18). One of these is bolted to the end of one of the Strips (8), and the other is fixed to a Fishplate bolted to one of the 2½" Strips (11). The 3½" Rod carries a Washer (19) held between two Spring Clips, and a Cord Anchoring Spring (20) on Rod (17) is arranged so that the projecting lug of the Spring engages the Washer. As Rod (17) rotates the lug catches under the Washer and thus raises and then lowers the 3½" Rod.

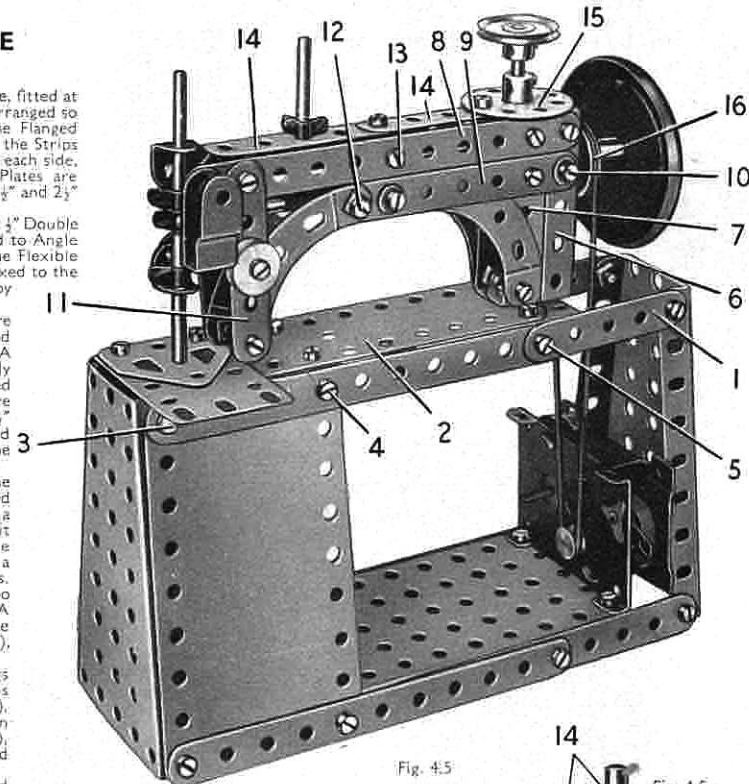
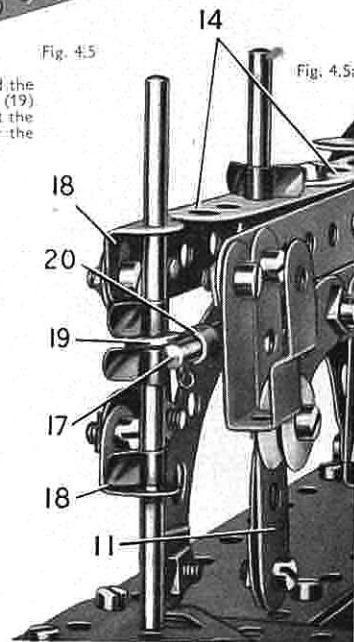

Fig. 4.5

Fig. 4.5a

Parts Required

8 of No.	2	1 of No.	44
2 "	3	1 "	48
6 "	5	4 "	48a
3 "	10	1 "	51
2 "	11	1 "	52
8 "	12	2 "	54
1 "	15b	4 "	90a
1 "	16	1 "	111c
1 "	17	1 "	126a
2 "	18a	1 "	176
2 "	22	1 "	187
1 "	23	1 "	188
1 "	24	1 "	189
5 "	35	2 "	191
55 "	37a	1 "	213
53 "	37b	1 Magic Motor	
8 "	38	(not included in	
		Outfit)	



4.6 DUMPER TRUCK

Parts Required

6 of No.	2	4 of No.	48a
2 " "	3	1 " "	51
9 " "	5	1 " "	52
4 " "	10	3 " "	90a
2 " "	11	3 " "	111c
8 " "	12	2 " "	125
4 " "	12c	2 " "	126
1 " "	15b	2 " "	126a
2 " "	16	1 " "	155
2 " "	17	1 " "	186
2 " "	18a	4 " "	187
2 " "	19b	2 " "	188
3 " "	22	2 " "	189
1 " "	24	4 " "	190
5 " "	35	2 " "	191
87 " "	37a	2 " "	192
81 " "	37b	1 " "	198
6 " "	38	1 " "	212
1 " "	38d	1 " "	213
1 " "	40	2 " "	214
1 " "	48	4 " "	215
		4 " "	221

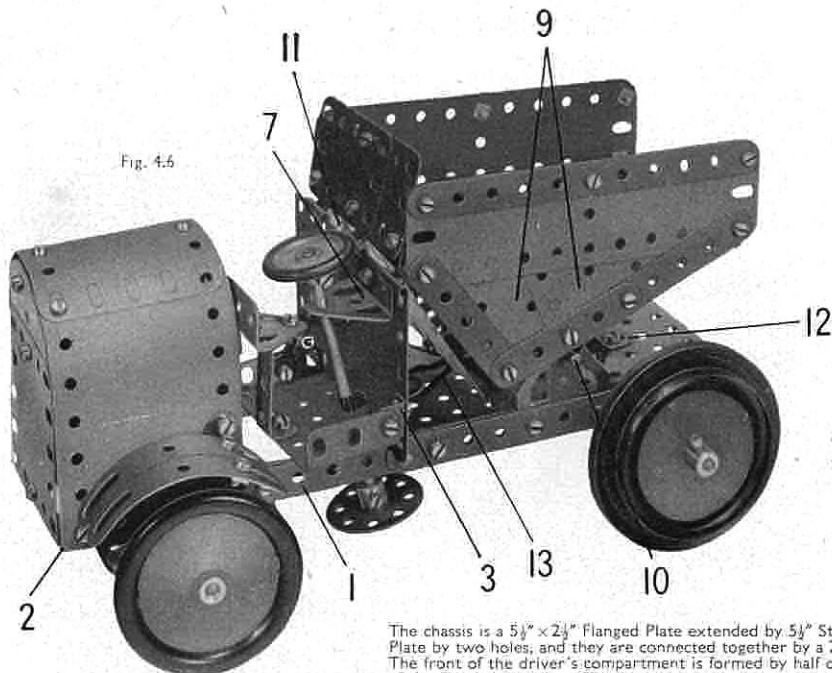

Fig. 4.6

The chassis is a $5\frac{1}{2}'' \times 2\frac{1}{2}''$ Flanged Plate extended by $5\frac{1}{2}''$ Strips (1). These Strips overlap the Flanged Plate by two holes, and they are connected together by a $2\frac{1}{2}'' \times 1''$ Double Angle Strip (2) (Fig. 4.6a). The front of the driver's compartment is formed by half of a Hinged Flat Plate attached to one end of the Flanged Plate by a Fishplate.

The engine housing is formed by two $5\frac{1}{2}'' \times 2\frac{1}{2}''$ Flexible Plates bolted to the Strips (1) and bent over and joined together at the top. The front and rear of the housing each consists of a Semi-Circular Plate and a $2\frac{1}{2}'' \times 2\frac{1}{2}''$ Flexible Plate. The rear is fixed to the Double Angle Strip (2), and the front is attached to a similar Double Angle Strip bolted between the Strips (1). A $2\frac{1}{2}'' \times 1\frac{1}{2}''$ Flanged Plate fixed to an Angle Bracket (3) forms the floor of the driver's compartment, and the seat is a Trunnion bolted to a $1\frac{1}{2}'' \times \frac{1}{2}''$ Double Angle Strip.

A $3\frac{1}{2}''$ Strip (4) (Fig. 4.6a) is bolted to a $2\frac{1}{2}'' \times 1''$ Double Angle Strip secured to the Strips (1). The $2\frac{1}{2}''$ Strips (5) and the Double Brackets (6) are free to turn on $\frac{1}{2}''$ Bolts fixed to the Strip (4) by two nuts. The Strips (5) are connected together by a $3\frac{1}{2}''$ Strip held by lock-nuts. Two Road Wheels are locked on $1\frac{1}{2}''$ Rods passed through the Double Brackets (6).

The steering column is a $4''$ Rod, which is passed through a Trunnion (7) and the $2\frac{1}{2}'' \times 1\frac{1}{2}''$ Flanged Plate. A Fishplate is bolted to a Bush Wheel on this Rod and a $2\frac{1}{2}''$ Stepped Curved Strip is fixed tightly to the Fishplate. The Curved Strip is connected by a $2\frac{1}{2}''$ Strip (8) to one of the Strips (5). The Bolts used to attach Strip (8) at each end are fitted with lock-nuts.

The driving axle is supported in $2\frac{1}{2}''$ Stepped Curved Strips bolted to the Flanged Plate, and it consists of a $3\frac{1}{2}''$ and a $2''$ Rod joined by a Rod Connector.

Each side of the load carrier is formed by two $2\frac{1}{2}'' \times 1\frac{1}{2}''$ Triangular Flexible Plates (9) and a $5\frac{1}{2}'' \times 1\frac{1}{2}''$ Flexible Plate edged by Strips as shown. The bottom consists of two $4\frac{1}{2}'' \times 2\frac{1}{2}''$ Flexible Plates, and the sides are connected to it by Angle Brackets. The back is made from two $2\frac{1}{2}'' \times 2\frac{1}{2}''$ Flexible Plates and two $2\frac{1}{2}'' \times 1\frac{1}{2}''$ Flexible Plates attached to the sides and bottom by Angle Brackets and Obtuse Angle Brackets. The load-carrier pivots about a $3\frac{1}{2}''$ Rod (10), which is passed through Flat Trunnions bolted to the chassis and through an Angle Bracket fixed on each side of the carrier.

The mudguard over each of the rear wheels is represented by two Formed Slotted Strips. These are joined together by a Fishplate, and attached to the side of the engine housing by an Angle Bracket.

The carrier is tipped for unloading by a $2''$ Rod (11), held in a Rod and Strip Connector that is lock-nutted to the side of the $2\frac{1}{2}'' \times 1\frac{1}{2}''$ Flanged Plate. A length of Cord from this Rod passes through an Obtuse Angle Bracket (12), and is fastened to the front of the carrier. The carrier is returned to its normal position by the $2\frac{1}{2}''$ Driving Band (13).

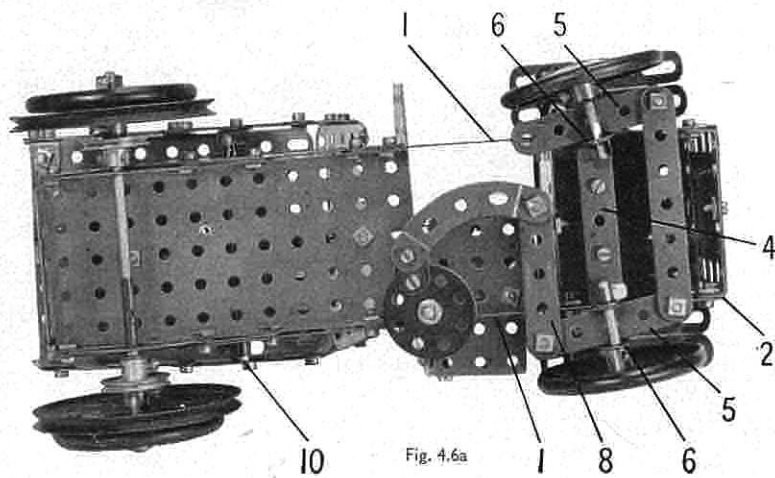

Fig. 4.6a

4.7 TELPHER SPAN

A $3''$ Pulley Wheel is fastened to the Crank Handle, and operates by means of a length of Cord another $3''$ Pulley on the driving shaft. A $1''$ Pulley also is secured on the driving shaft. The operating Cord is first tied to the top of the carriage as shown, then taken over the $2''$ Rod at the top of the tower, around the $1''$ Pulley on the driving shaft, then back again over the $2''$ Rod. From there it is led over the $\frac{1}{2}''$ loose Pulley in the anchorage, and finally is tied to the top of the carriage. One end of the guide Cord is tied to a $1\frac{1}{2}'' \times \frac{1}{2}''$ Double Angle Strip near the top of the tower, and the other end to the Double Bracket at the bottom of the anchorage.

The anchorage is formed by bolting two Trunnions to a $3\frac{1}{2}''$ Strip. A Double Bracket also is bolted to this Strip.

Two Flanged Sector Plates connected by four $2\frac{1}{2}''$ Strips and two $4\frac{1}{2}'' \times 2\frac{1}{2}''$ Flexible Plates form the carriage. The carriage superstructure consists of four $2\frac{1}{2}''$ Strips bolted to two Flat Trunnions, which are joined by a $2\frac{1}{2}'' \times \frac{1}{2}''$ Double Angle Strip. A $3\frac{1}{2}''$ Rod is passed through the flat Trunnions. It is held in place by a Spring Clip and a Bush Wheel.

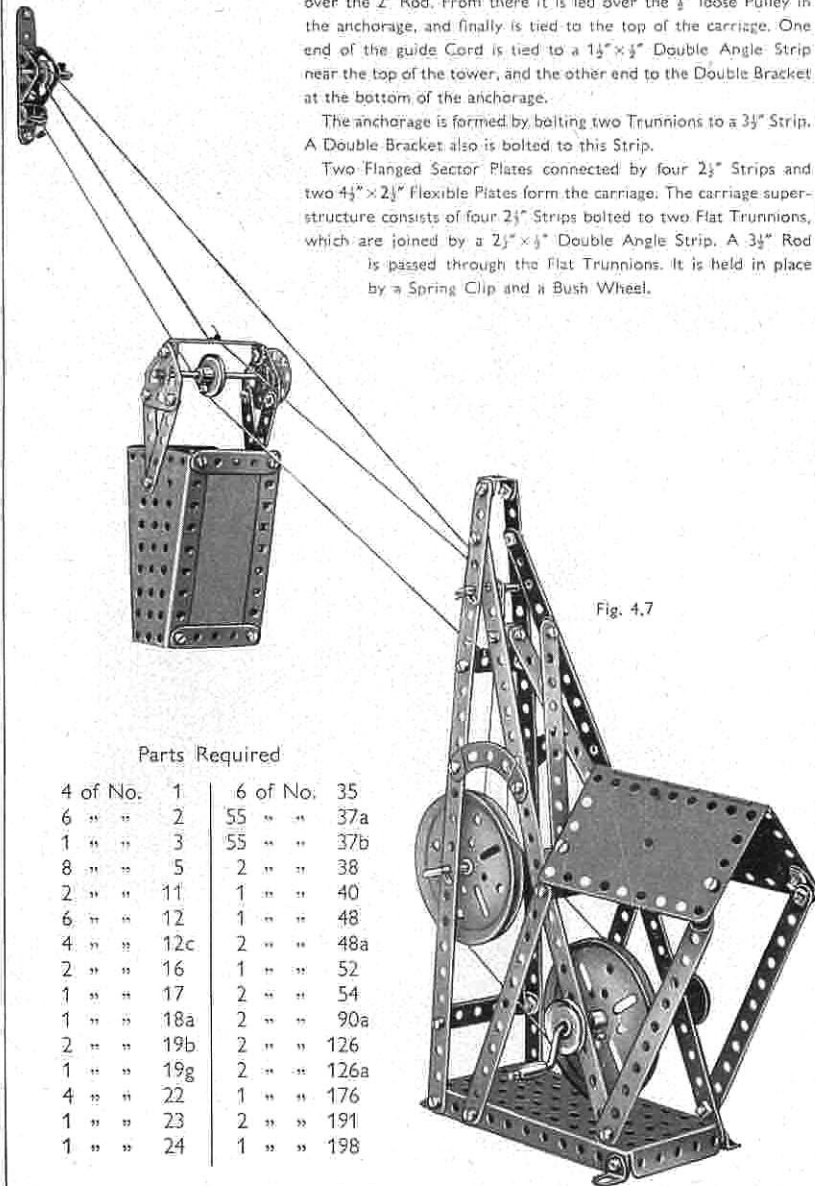

Fig. 4.7

Parts Required

4 of No.	1	6 of No.	35
6 " "	2	55 " "	37a
1 " "	3	55 " "	37b
8 " "	5	2 " "	38
2 " "	11	1 " "	40
6 " "	12	1 " "	48
4 " "	12c	2 " "	48a
2 " "	16	1 " "	52
1 " "	17	2 " "	54
1 " "	18a	2 " "	90a
2 " "	19b	2 " "	126
1 " "	19g	2 " "	126a
4 " "	22	1 " "	176
1 " "	23	2 " "	191
1 " "	24	1 " "	198

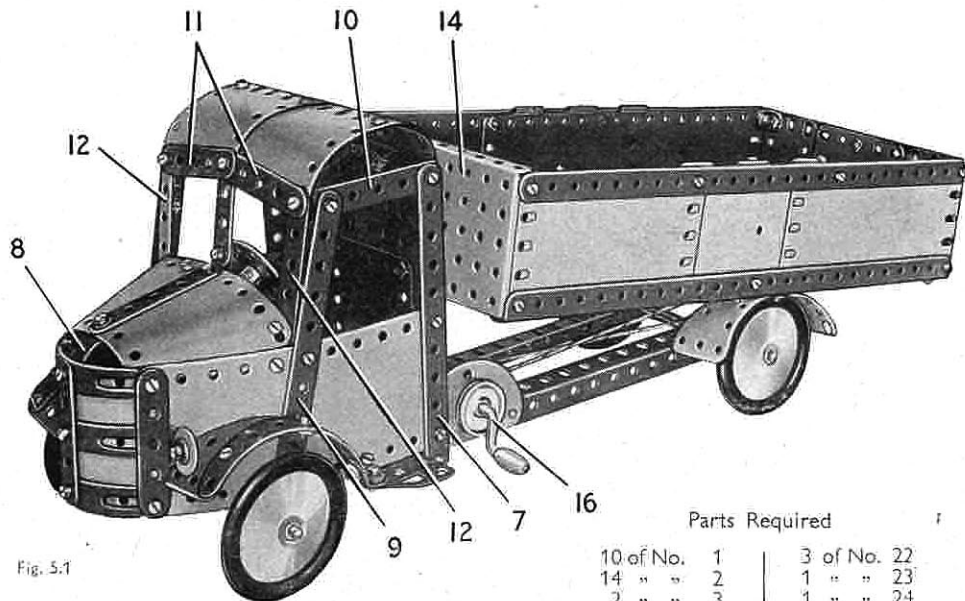

Fig. 5.1

Parts Required

10 of No. 1	3 of No. 22
14 " " 2	1 " " 23
2 " " 3	1 " " 24
12 " " 5	1 " " 24a
2 " " 6a	9 " " 35
4 " " 8	117 " " 37a
3 " " 10	107 " " 37b
2 " " 11	14 " " 38
8 " " 12	2 " " 38d
	1 " " 40
	1 " " 44
	1 " " 48
	6 " " 48a
	1 " " 51
	1 " " 52
	3 " " 90a
	2 " " 111a
	5 " " 111c
	1 " " 125
	2 " " 126
	2 " " 126a
	1 " " 147b
	4 " " 187
	4 " " 188
	4 " " 189
	4 " " 190
	2 " " 191
	4 " " 192
2 of No. 12a	1 " " 198
5 " " 12c	1 " " 199
1 " " 15	2 " " 200
1 " " 16	2 " " 212
1 " " 17	1 " " 214
2 " " 18a	2 " " 215
1 " " 18b	4 " " 221
1 " " 19g	

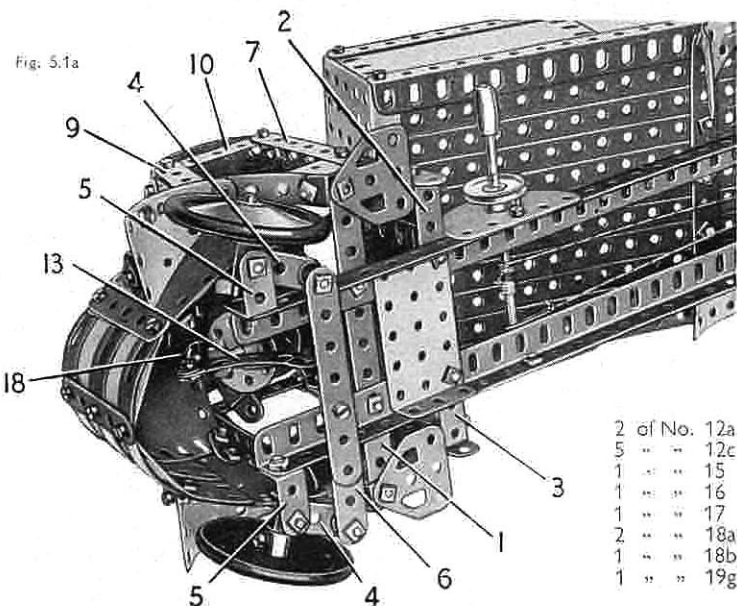

Fig. 5.1a

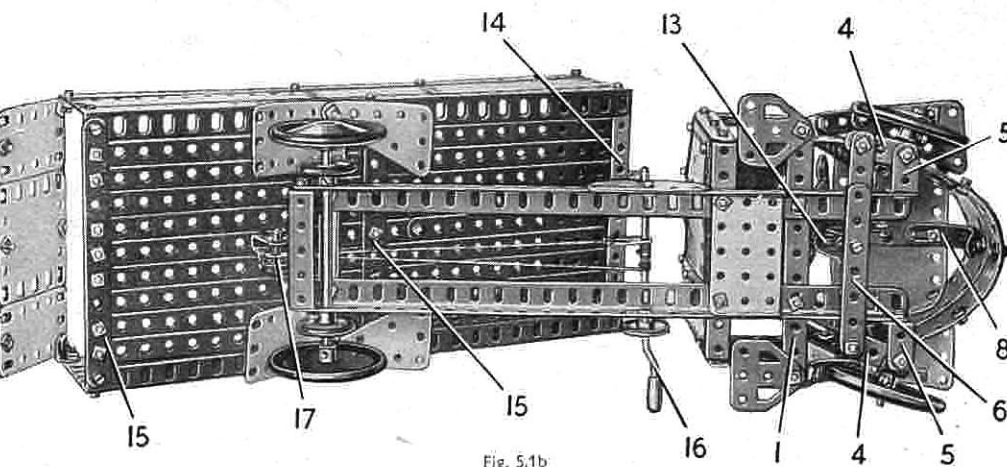

Fig. 5.1b

5.1 TIPPING LORRY

THE CHASSIS AND WHEELS

The chassis consists of two 12½" Angle Girders joined at the rear by a 2½" × ½" Double Angle Strip, and at the front by a 5½" Strip (1) and a 2½" × 1½" Flanged Plate. The Bolts holding the Flanged Plate to the Angle Girders serve also to fix a 2½" × ½" Double Angle Strip (2) and a 1½" × ½" Double Angle Strip (3).

The rear wheels are fixed as shown on a 5" Rod supported in the chassis. Each of the front wheels is mounted on a 1½" Rod held by a Spring Clip in a Double Bracket. A ¾" Bolt is passed through a 1½" Strip (4) placed between the lugs of each Double Bracket, and the Bolt is then fixed by two nuts to a 1" × 1" Angle Bracket (5) so that the Double Bracket and the Strip pivot freely as a unit. The 1" × 1" Angle Brackets are bolted tightly to the chassis. The Strips (4) are connected by a built-up strip (6), made from two 3½" Strips overlapped five holes. A ½" Bolt is passed through each of the Strips (4), and is fitted with a Washer and a Spring Clip. The strip (6) is then held on the shank of the Bolt by two nuts.

CONSTRUCTION OF THE CAB

The sides of the cab consist of 5½" × 2½" Flexible Plates bolted together with 5½" Strips (7), (Fig. 5.1), to the Double Angle Strips (2) and (3). The Flexible Plates are connected by Angle Brackets to the ends of the Strip (1), and the front ends of the Plates are curved slightly to form the sides of the bonnet. The bonnet sides are connected by the radiator, which is made from two 5½" × 1½" Flexible Plates curved and bolted together by their longer sides. The radiator is edged as shown in Fig. 5.1 by three 2½" Strips and three Formed Slotted Strips.

The top of the bonnet is formed by two 2½" × 2½" Flexible Plates bolted together. The front ends of these Plates are bolted direct to the bonnet sides, so that the clear corner hole of each Plate projects below the side. The rear ends of the Plates are connected to the bonnet sides by Fishplates. The top of the bonnet is completed by a Formed Slotted Strip (8).

A 5½" Strip (9) is fixed at a slight angle to each side, and at its upper end it is connected by a 2½" × ½" Double Angle Strip (10) to the top of the Strip (7). The windscreen is made from two 2½" Strips (11) and two 5½" Strips (12) bolted to the lugs of the Double Angle Strips (10). The centre division is a 2½" Strip attached to the top of the bonnet by an Obtuse Angle Bracket.

The cab roof consists of two 1½" radius Curved Plates and two 'U'-section Curved Plates opened out slightly. It is attached to the lugs of the Double Angle Strips (10). The back of the cab is formed by a 5½" × 1½" Flexible Plate at each side, joined at the bottom by a 2½" × 2½" Flexible Plate. The complete back is bolted to the lugs of the Double Angle Strips (10) and to Angle Brackets fixed to the lower corners of the cab sides.

Each of the front mudguards is a 2½" × 1½" Triangular Flexible Plate edged by two 2½" Strips that overlap each other two holes. The mudguard is connected to the Strip (1) by an Obtuse Angle Bracket, and a Flat Trunnion representing the step is held by the same bolt.

THE STEERING MECHANISM

The steering wheel is a Bush Wheel fixed on a 2" Rod. The Rod is supported in the centre hole of a Wheel Disc and in a ½" Reversed Angle Bracket bolted to the Wheel Disc. A 2½" Stepped Curved Strip and an Angle Bracket (18) are held by the same Bolt, and the Angle Bracket is bolted to the rear edge of the top of the bonnet.

A Rod and Strip Connector is fitted to the end of the 2" Rod, and two 2½" Stepped Curved Strips (13) are bolted to the Rod and Strip Connector. The Curved Strips overlap each other three holes, and the end of the lower Curved Strip is attached to an Angle Bracket fixed to the centre of the strip (6).

THE TIPPING BODY AND ITS OPERATING MECHANISM

Each side of the body consists of a 5½" × 2½" and a 4½" × 2½" Flexible Plate and one half of a Hinged Flat Plate, bolted to a 12½" Angle Girder and a 12½" Strip. The sides are connected by a 5½" × 2½" Flanged Plate (14) and 5½" Strips (15). The bottom of the body is filled in by eight 12½" Strips and a built-up strip made from a 2½" and two 5½" Strips. The hinged tail-board is made from a 2½" × 2½" Flexible Plate and two 2½" × 1½" Flexible Plates bolted to two 5½" Strips. The tail-board is connected to the sides of the body by two Angle Brackets, which pivot on lock-nutted Bolts.

A 2½" × ½" Double Angle Strip is bolted underneath the body, and a 3½" Rod is passed through its lugs and through two Trunnions bolted to the rear ends of the chassis Girders. The Rod is held in place by Spring Clips.

A Crank Handle (16) is supported in Semi-Circular Plates bolted to the chassis, and a length of Cord is tied to a Cord Anchoring Spring on the Crank Handle. The Cord is taken round a ½" loose Pulley (17) and is tied to a Fishplate on the Crank Handle. The Pulley (17) is mounted on a 1" Rod supported in a stepped Bent Strip, which is bolted underneath the body as shown in Fig. 5.1b. The rear mudguards each consist of a 2½" × 1½" Flexible Plate and a 2½" × 1½" Triangular Flexible Plate.

5.2 FERRY STEAMER

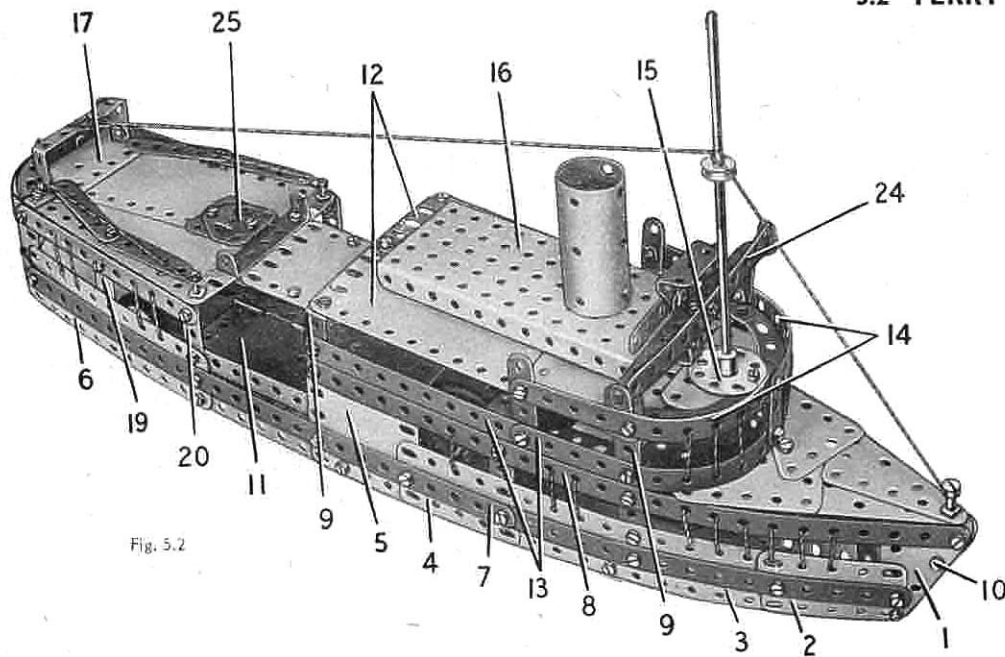

Fig. 5.2

CONSTRUCTION OF THE HULL

Each side of the hull of the Ferry Steamer consists of a $2\frac{1}{2}'' \times 1\frac{1}{2}''$ Triangular Flexible Plate (1), a $2\frac{3}{4}'' \times 1\frac{1}{2}''$ Flexible Plate (2), a $5\frac{1}{2}'' \times 1\frac{1}{2}''$ Flexible Plate (3), a $2\frac{1}{2}'' \times 1\frac{1}{2}''$ Flexible Plate (4), a $2\frac{1}{2}'' \times 2\frac{1}{2}''$ Flexible Plate (5) and a $5\frac{1}{2}'' \times 1\frac{1}{2}''$ Flexible Plate (6). These Plates are bolted to a built-up strip (7), made from two $12\frac{1}{2}''$ Strips overlapped eleven holes, and are also bolted to a $12\frac{1}{2}''$ Strip (8). Two $2\frac{1}{2}'' \times \frac{1}{2}''$ Double Angle Strips (9) are bolted to each side. On each side a Strip is bolted in the centre hole of the vertical $2\frac{1}{2}''$ Strip (20).

The sides are connected together at the bow by an Angle Bracket and by a $\frac{1}{2}''$ Bolt (10). A Hinged Flat Plate (11) is separated and the halves are bolted tightly together as shown in Fig. 5.2a. The Plate is fixed to the lower lugs of two of the Double Angle Strips (9) and at its rear end is attached to the sides of the hull by Angle Brackets.

The stern of the steamer consists of two $1\frac{1}{2}''$ radius Curved Plates. These are bolted to the rear edges of the Flexible Plates (6), and to a Formed Slotted Strip used to extend each of the strips (7).

ASSEMBLY OF THE DECKS

The upper deck is formed by two $5\frac{1}{2}'' \times 2\frac{1}{2}''$ Flexible Plates (12), (Fig. 5.2), and a $4\frac{1}{2}'' \times 2\frac{1}{2}''$ Flexible Plate bolted to the top lugs of the Double Angle Strips (9). Two $5\frac{1}{2}''$ Strips (13) at each side are fixed to the Double Angle Strips, and two of the Strips are curved to form the rounded front of the saloon deck. Two further curved $5\frac{1}{2}''$ Strips (14) are connected to the Strips (13) by a $\frac{1}{2}''$ and two vertical $2\frac{1}{2}''$ Strips. Two $2\frac{1}{2}''$ Stepped Curved Strips and a Semi-Circular Plate are bolted to a Bush Wheel (15), and the complete assembly is connected to the Strips (14) by an Angle Bracket. A $5\frac{1}{2}'' \times 2\frac{1}{2}''$ Flanged Plate (16) is attached to the top deck by a Double Bracket and an Angle Bracket, and the funnel, a $2\frac{1}{2}''$ Cylinder, is connected to the Flanged Plate by an Angle Bracket.

The deck at the stern of the steamer consists of two $5\frac{1}{2}'' \times 2\frac{1}{2}''$ Flexible Plates fitted at the rear with two $2\frac{1}{2}''$ Stepped Curved Strips. A Semi-Circular Plate (17) is clamped between the ends of the Curved Strips and the Flexible Plates. The deck is attached at each side to a $\frac{1}{2}''$ Reversed Angle Bracket (18) and a $2\frac{1}{2}'' \times \frac{1}{2}''$ Double Angle Strip (19), and it is connected by an Angle Bracket to a $2\frac{1}{2}''$ Strip (20).

A $4\frac{1}{2}'' \times 2\frac{1}{2}''$ Flexible Plate (21) is fixed to Angle Brackets bolted between the sides of the hull, and a $2\frac{1}{2}'' \times 1\frac{1}{2}''$ Flanged Plate (22), (Fig. 5.2b), is attached to the Flexible Plate by an Angle Bracket. A $2\frac{1}{2}'' \times 2\frac{1}{2}''$ Flexible Plate (23) is fixed to two $5\frac{1}{2}''$ Strips bolted between the Plate (21) and the stern deck. A $12\frac{1}{2}''$ Strip is attached to the centre of Plate (21) and extends forward to the bows. The Strip is connected by an Angle Bracket to the curved ends of the Strips (13), and it supports the Triangular Flexible Plates used to form the deck over the bows. The Triangular Flexible Plates are arranged as shown in Fig. 5.2.

THE BRIDGE AND DECK FITTINGS

The bridge is made by bolting a $5\frac{1}{2}''$ Strip to two $\frac{1}{2}''$ Reversed Angle Brackets, which are connected by Fishplates to the Strips (14). A $5\frac{1}{2}''$ Strip (24), a $3\frac{1}{2}''$ Strip and a Trunnion are fixed to a Double Bracket bolted to the centre of the first $5\frac{1}{2}''$ Strip. The mast consists of a $4\frac{1}{2}''$ and a $3\frac{1}{2}''$ Rod joined by a Rod Connector, and it is fixed in the Bush Wheel (15).

A deck house (25) on the stern deck consists of two Flat Trunnions joined together. It is attached by a $\frac{1}{2}''$ Bolt, but is held up from the deck by a Spring Clip on the Bolt. The seats are represented by $2\frac{1}{2}''$ Strips also attached by $\frac{1}{2}''$ Bolts and separated from the deck by Spring Clips.

The lifeboat davits at the stern are $1'' \times 1''$ Angle Brackets bolted to the Reversed Angle Brackets (18). The lifeboat consists of two $2\frac{1}{2}''$ Strips separated at the centre by five Washers on a $\frac{1}{2}''$ Bolt, and it is suspended by Cord from the davits.

Two $12\frac{1}{2}''$ Angle Girders are bolted to the Hinged Flat Plate (11) (Fig. 5.2a), and to a Flanged Sector Plate (26). The wheels on which the model runs are fixed on $3\frac{1}{2}''$ Rods supported in the Angle Girders.

The steamer is completed by adding Cord as shown to represent window divisions and the rigging.

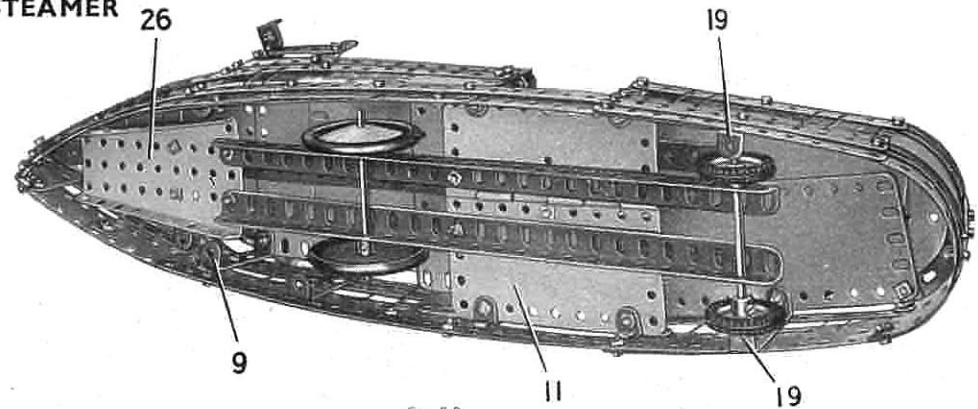

Fig. 5.2a

Parts Required

9 of No.	1
14 "	2
2 "	3
11 "	5
1 "	6a
2 "	8
2 "	10
2 "	11
12 "	12
2 "	12a
1 "	15a
3 "	16
2 "	22
1 "	23
1 "	24
13 "	35
117 "	37a
108 "	37b
8 "	38
1 "	40
1 "	48
8 "	48a
1 "	51
1 "	52
1 "	54
4 "	90a
2 "	111a
6 "	111c
4 "	125
2 "	126
2 "	126a
2 "	142c
1 "	147b
1 "	176
2 "	187
4 "	188
4 of No.	189
3 "	190
2 "	191
4 "	192
1 "	198
2 "	200
1 "	213
2 "	214
4 "	215
1 "	216
4 "	221
2 "	222

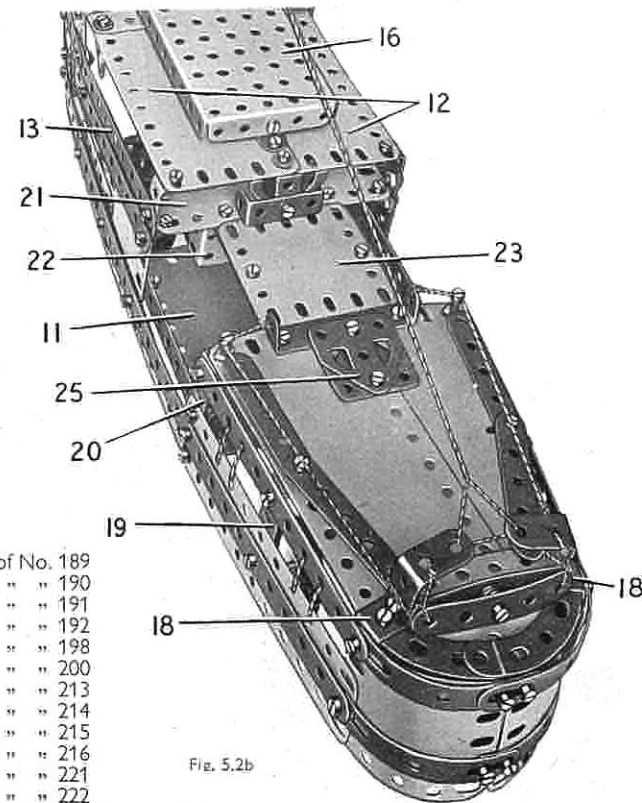

Fig. 5.2b

5.3 GAS TURBINE LOCOMOTIVE

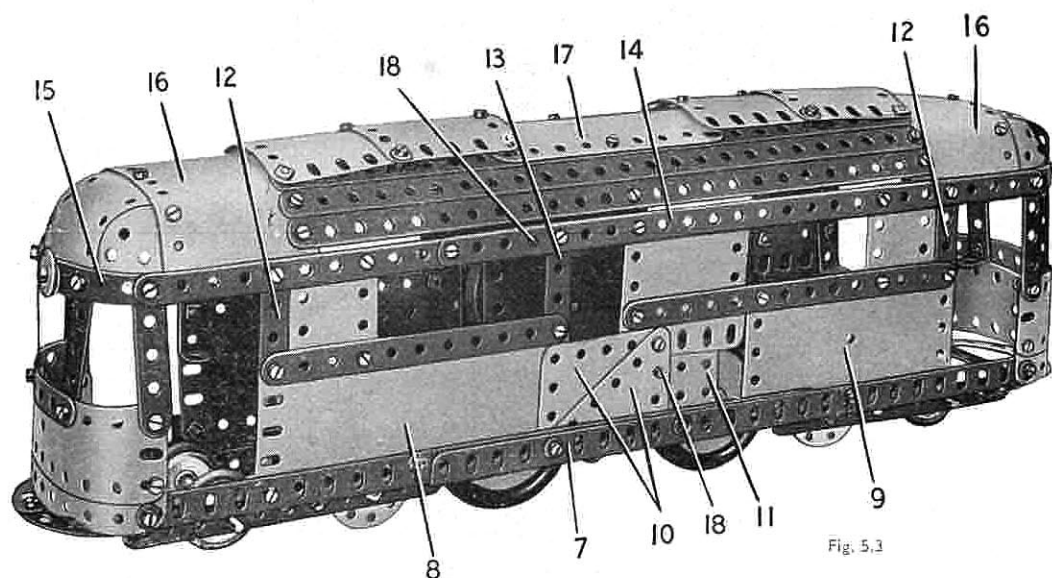

Fig. 5.3

THE POWER UNIT AND DRIVING WHEELS

A No. 1 Clockwork Motor is supported inside the body by two 4" Rods (18). These are passed through the sides of the body and the Motor side-plates, and are held in position by Spring Clips (19). Two 1½" Strips (19) are bolted to the girders (1) and (7) and to Angle Brackets fixed to the Motor. Two Road Wheels are fixed on a 3½" Rod (20) supported in the corner holes of the side-plates. A 57-tooth Gear also fixed on the Rod (20) is driven by a ½" Pinion on the Motor driving shaft.

A 2½" Strip (21) is attached to each side-plate of the Motor, and these support a second 3½" Rod that carries two Road Wheels.

THE BOGIE UNITS

Each unit consists of two 5½" Strips attached to the body by Angle Brackets. Two 1" Pulleys fitted with Rubber Rings are held on a 3½" Rod, and two Wheel Discs are attached to the 5½" Strips by lock-nutted bolts. At one end ordinary Wheel Discs are used, and at the other end Six-hole Wheel Discs.

Parts Required

9 of No. 1	1 of No. 17	15 of No. 38	1 of No. 147b	2 of No. 199
9 " " 2	4 " " 22	2 " " 38d	4 " " 155	1 " " 200
2 " " 3	2 " " 24a	8 " " 48a	4 " " 187	4 " " 215
11 " " 5	2 " " 24c	1 " " 51	4 " " 188	4 " " 221
2 " " 6a	1 " " 26	1 " " 52	4 " " 189	2 " " 222
4 " " 8	1 " " 27a	4 " " 90a	4 " " 190	
6 " " 12	9 " " 35	2 " " 111a	2 " " 191	
2 " " 15b	116 " " 37a	6 " " 111c	4 " " 192	
3 " " 16	103 " " 37b	1 " " 115	1 " " 198	

1 No. 1 Clockwork Motor (not included in Outfit)

CONSTRUCTION OF THE SIDES

The side of the model seen in Fig. 5.3a is assembled on a built-up girder (1) made from two 12½" Angle Girders overlapped fifteen holes. The lower part of the side is filled in by a 5½" × 2½" Flanged Plate (2) at the centre, a 5½" × 2½" Flexible Plate (3) at one end and *one half of a Hinged Flat Plate* (4) at the other end. The top edges of these Plates are strengthened by a 12½" Strip extended by a 2½" Strip. The upper section of the side consists of a 4½" × 2½" Flexible Plate, two 2½" × 1½" Flexible Plates and two 2½" × ½" Double Angle Strips (5). A built-up strip (6), made from a 12½" and a 5½" Strip, is bolted to the top ends of the Double Angle Strips and the upper edges of the Plates.

The side seen in Fig. 5.3 is attached to a built-up Girder (7), also made from two 12½" Angle Girders overlapped fifteen holes. The lower part of this side is filled in by a 5½" × 2½" Flexible Plate (8) at one end and *one half of a Hinged Flat Plate* (9) at the other end. At the centre two 2½" × 2" Triangular Flexible Plates (10) and a 2½" × 1½" Flanged Plate (11) are bolted in the positions shown. The side is extended upward by two 2½" × ½" Double Angle Strips (12) and a 2½" Strip (13), and two 2½" × 1½" Flexible Plates and a 2½" × 2½" Flexible Plate are bolted in place. The top edges of the Plates are strengthened by a built-up strip (14), made from a 12½" and a 5½" Strip. The completed sides are connected at each end by a 3½" Strip bolted to the girders (1) and (7).

THE DRIVING CABS

The ends of the two cabs are similar in construction, and each consists of two 5½" × 1½" Flexible Plates overlapped two holes along their longer edges. The ends of the Plates are curved as shown and are fixed to the girders (1) and (7). The Flexible Plates are extended upward by two 2½" Strips and two 2½" × ½" Double Angle Strips. The upper ends of these parts are bolted to two Formed Slotted Strips (15), which are fixed to the ends of the strips (6) and (14). Two 2½" Stepped Curved Strips are bolted to each end as shown in Fig. 5.3a.

CONSTRUCTION OF THE ROOF

The roof is made by bending two 5½" × 2½" Flexible Plates (16) and bolting them between the strips (6) and (14) as shown. Three 12½" Strips are fixed between the Plates (16) on each side, and a 4½" × 2½" Flexible Plate (17) is bolted at the centre of the roof. The curved ends of the roof are made from an opened out 'U'-section Curved Plate and a 2½" × 2½" Flexible Plate, and each is attached to one of the Flexible Plates (16) and the Formed Slotted Strips (15). A 2½" × 1½" Triangular Flexible Plate is used to fill in the rounded corner on each side. The roof ventilators are made from two 2½" × 2½" Flexible Plates and two 1½" radius Curved Plates. They are attached to the roof by ¼" Bolts, but a Spring Clip is placed on each Bolt to space the ventilators from the roof.

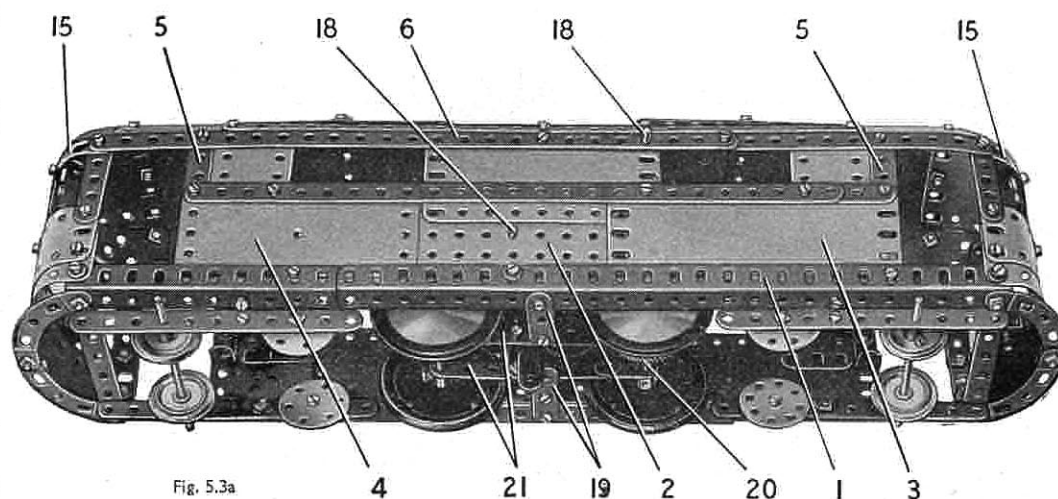

Fig. 5.3a

5.4 BULK LIQUID TRANSPORTER

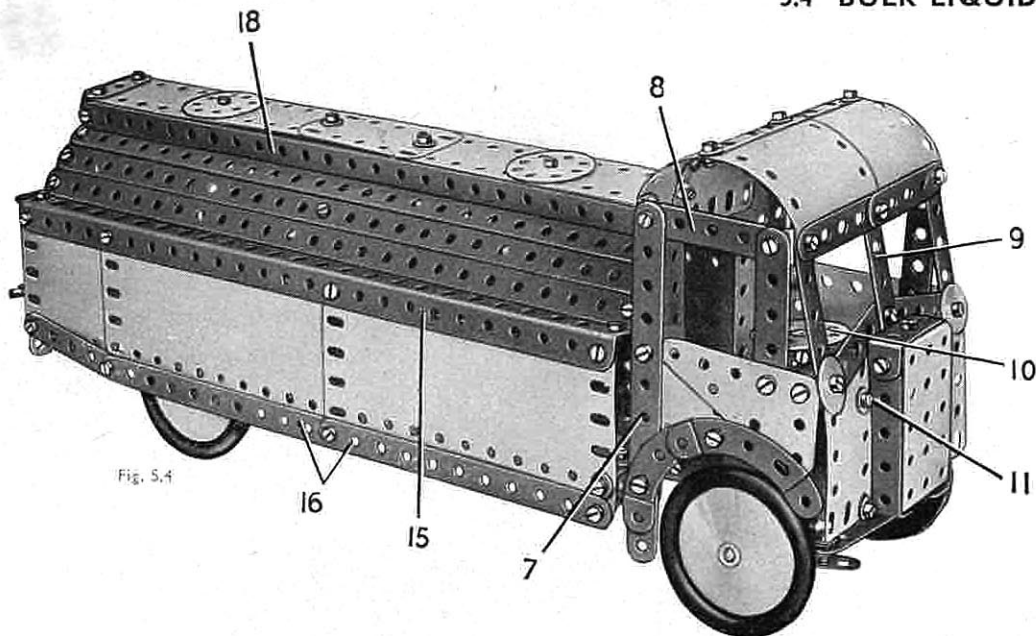

Fig. 5.4

CONSTRUCTION OF THE TANK

Each side of the tank is formed by two $5\frac{1}{2}'' \times 2\frac{1}{4}''$ and a $2\frac{1}{2}'' \times 2\frac{1}{4}''$ Flexible Plate bolted to a $12\frac{1}{2}''$ Angle Girder (15). Two $5\frac{1}{2}''$ Strips (16) are attached to the $5\frac{1}{2}'' \times 2\frac{1}{4}''$ Flexible Plate by a Fishplate, and are connected to the $2\frac{1}{2}'' \times 2\frac{1}{4}''$ Flexible Plate by a $2\frac{1}{2}''$ Strip.

The rounded part of the tank consists of three $12\frac{1}{2}''$ Strips on each side. These are bolted to three $5\frac{1}{2}''$ Strips bent to form a half circle, and the two end Strips are connected to the sides of the tank by Obtuse Angle Brackets. The centre and the front $5\frac{1}{2}''$ Strips are seen at (17) in Fig. 5.4a.

Two $12\frac{1}{2}''$ Strips (18), one on each side, are fixed to the centre parts of four $\frac{1}{4}''$ Reversed Angle Brackets bolted to the front and rear curved $5\frac{1}{2}''$ Strips; and the top of the tank is attached to the lugs of the Reversed Angle Brackets. The top is made from a $2\frac{1}{2}'' \times 1\frac{1}{2}''$ and two $5\frac{1}{2}'' \times 1\frac{1}{2}''$ Flexible Plates bolted end to end.

The rear of the tank is made by separating and bolting together the halves of a Hinged Flat Plate. The halves overlap by four holes, and a $2\frac{1}{2}'' \times 1\frac{1}{2}''$ Flexible Plate (19) and two Semi-Circular Plates (20) are fixed in position. A guard rail formed by a $5''$ Rod held in Right-Angle Rod and Strip Connectors is bolted across the back. The back is connected to the sides by two Angle Brackets and two Double Brackets (21).

The completed tank is bolted at the back to the Double Angle Strip (2). The front end of the tank is supported on each side by an Angle Bracket bolted to a $1'' \times 1''$ Angle Bracket (22). The Angle Brackets (22) are fixed to the chassis Girders and to the flanges of the Flanged Plate (1).

Parts Required

8 of No. 1	4 of No. 12c	20 of No. 38	5 of No. 111c	4 of No. 192
9 " " 2	1 " " 15	2 " " 38d	1 " " 115	1 " " 198
2 " " 3	1 " " 15a	1 " " 44	4 " " 125	1 " " 199
12 " " 5	2 " " 18a	1 " " 48	2 " " 126	2 " " 200
2 " " 6a	2 " " 22	7 " " 48a	1 " " 147b	2 " " 212a
4 " " 8	1 " " 24	1 " " 51	2 " " 155	2 " " 214
2 " " 10	2 " " 24a	1 " " 52	4 " " 187	2 " " 221
4 " " 11	3 " " 35	1 " " 80c	4 " " 188	2 " " 222
12 " " 12	118 " " 37a	4 " " 90a	4 " " 189	
2 " " 12a	105 " " 37b	2 " " 111a	2 " " 190	

THE CHASSIS AND WHEELS

The chassis is made by bolting two $12\frac{1}{2}''$ Angle Girders to a $5\frac{1}{2}'' \times 2\frac{1}{4}''$ Flanged Plate (1), so that each Girder overlaps the Flanged Plate by five holes. The rear ends of the Girders are connected by a $2\frac{1}{2}'' \times \frac{1}{2}''$ Double Angle Strip (2). The rear wheels are fixed on a $\frac{1}{4}''$ Rod supported in the Angle Girders.

A $3\frac{1}{2}''$ Strip (3) is bolted across the Flanged Plate (1). The front wheels are fixed on $1\frac{1}{2}''$ Rods supported in Double Brackets. One of the Rods is held in place by a Spring Clip and the other is retained by a Cord Anchoring Spring. At one side a $\frac{1}{4}''$ Bolt is passed through a $1\frac{1}{2}''$ Strip (4) and a Double Bracket and the Bolt is then gripped by two nuts in one end of Strip (3), leaving the Strip and the Double Bracket free to pivot as a unit on the Bolt. The construction at the other end of Strip (3) is similar, but a $2\frac{1}{2}''$ Strip (5) is used in place of the $1\frac{1}{2}''$ Strip (4). A $3\frac{1}{2}''$ Strip (6) is lock-nutted to the ends of the Strips (4) and (5).

CONSTRUCTION OF THE CAB

Each side of the cab is assembled on a $5\frac{1}{2}''$ Strip (7), which is attached by an Angle Bracket to a Trunnion bolted to the flange of the Flanged Plate (1). The side consists of two $2\frac{1}{2}'' \times 1\frac{1}{2}''$ Triangular Flexible Plates arranged as shown in Fig. 5.4, and two $2\frac{1}{2}''$ Stepped Curved Strips are bolted together to form an arch over the front wheel. The window frame is made from a $2\frac{1}{2}''$ Strip, a $2\frac{1}{2}'' \times \frac{1}{2}''$ Double Angle Strip (8) and the top end of the Strip (7).

The front of the cab consists of a $2\frac{1}{2}'' \times 1\frac{1}{2}''$ Flexible Plate on each side bolted to the front flange of the Flanged Plate (1), and connected to the sides of the cab by Angle Brackets. The windscreen frame is formed by six $2\frac{1}{2}''$ Strips arranged as shown, with a centre division provided by a $2\frac{1}{2}'' \times \frac{1}{2}''$ Double Angle Strip (9).

The radiator is a $2\frac{1}{2}'' \times 1\frac{1}{2}''$ Flanged Plate edged by a $1\frac{1}{2}'' \times \frac{1}{2}''$ and two $2\frac{1}{2}'' \times \frac{1}{2}''$ Double Angle Strips. It is attached by an Angle Bracket to the lower end of the Double Angle Strip (9).

The back of the cab is partly filled by a $5\frac{1}{2}'' \times 1\frac{1}{2}''$ Flexible Plate at each side. They are connected to the sides of the cab by Angle Brackets, and are bolted to the lugs of the Double Angle Strips (8). The top ends of the $5\frac{1}{2}'' \times 1\frac{1}{2}''$ Flexible Plates are bent over and connected by a curved $2\frac{1}{2}'' \times 2\frac{1}{2}''$ Flexible Plate to form part of the roof. The front section of the roof consists of two $1\frac{1}{4}''$ radius Curved Plates fixed to the front lugs of the Double Angle Strips (8).

THE STEERING MECHANISM

A Bush Wheel (10) is fixed on the end of a Screwed Rod, which is mounted in a hole of the Flanged Plate (1) and in a Stepped Bent Strip attached to the front of the cab by a Bolt (11). The Screwed Rod is held in place by two nuts locked together below the Flanged Plate, and a $2\frac{1}{2}''$ Strip (12) is held on the lower end of the Screwed Rod by two nuts. An Angle Bracket is pivoted on a Threaded Pin held in the end hole of Strip (12) by a Spring Clip, and the Angle Bracket is bolted to one lug of a $2\frac{1}{2}'' \times \frac{1}{2}''$ Double Angle Strip (13). The Double Angle Strip is connected to the Strip (5) by a Pivot Bolt (14) fitted with a Spring Clip.

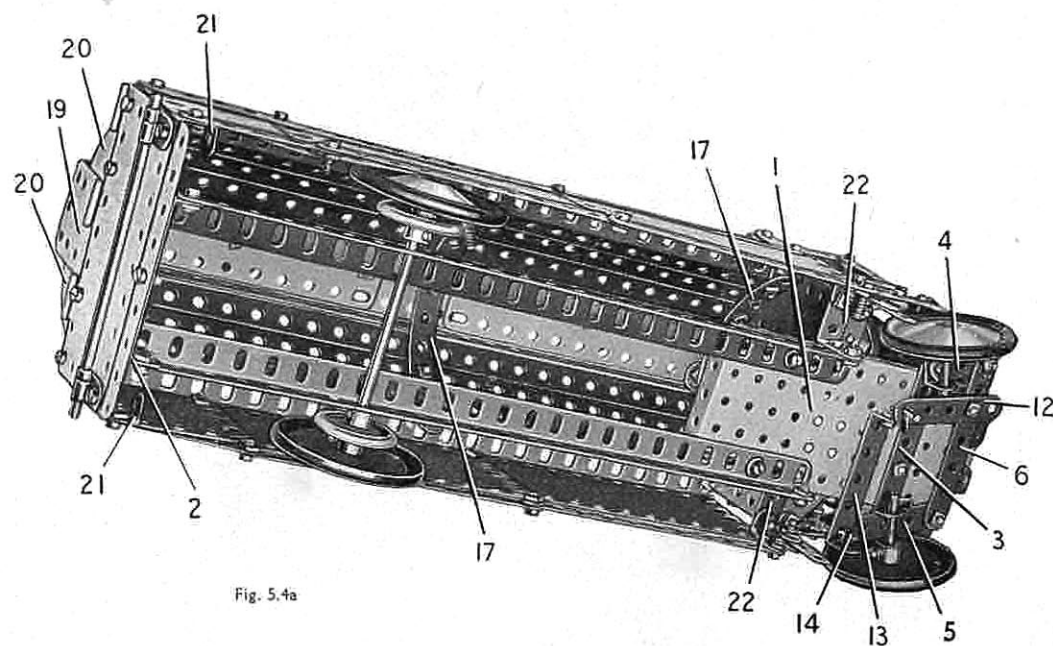

Fig. 5.4a

5.5 ELEVATOR

THE ELEVATOR SHAFT

The shaft consists of four upright pieces, each made from a $12\frac{1}{2}$ " Angle Girder and a $12\frac{1}{2}$ " Strip overlapped three holes. The base of the shaft is a $5\frac{1}{2}$ " x $2\frac{1}{2}$ " Flanged Plate (1), and the $12\frac{1}{2}$ " Angle Girders are connected to the corners of the Flanged Plate by $\frac{1}{2}$ " Reversed Angle Brackets (2), (Fig. 5.5a). The $12\frac{1}{2}$ " Strips are joined at their upper ends by $5\frac{1}{2}$ " Strips (3), and by $3\frac{1}{2}$ " Strips (4) attached to Angle Brackets.

The base is extended at each side by a Flanged Sector Plate attached to a Semi-Circular Plate, and at one end by two $5\frac{1}{2}$ " Strips (5) bolted inside the flanges of the Flanged Plate. The outer ends of Strips (5) are connected by a $2\frac{1}{2}$ " x $1\frac{1}{2}$ " Double Angle Strip, and they are braced by further $5\frac{1}{2}$ " Strips attached to the lift shaft by Angle Brackets.

The lift shaft is braced by $5\frac{1}{2}$ " Strips, $5\frac{1}{2}$ " x $2\frac{1}{2}$ " and $5\frac{1}{2}$ " x $1\frac{1}{2}$ " Flexible Plates arranged as shown, and by crossed $12\frac{1}{2}$ " and $5\frac{1}{2}$ " Strips and built-up strips (6). Each of the strips (6) consists of two $2\frac{1}{2}$ " Strips overlapped three holes. At the top of the shaft the joins between the $12\frac{1}{2}$ " Strips and the Strips (3) are strengthened by $2\frac{1}{2}$ " x $1\frac{1}{2}$ " Triangular Flexible Plates (7) are fitted between two of the Angle Girders and the base.

THE CAGE AND ITS GUIDE CORDS

Each side of the cage is a $4\frac{1}{2}$ " x $2\frac{1}{2}$ " Flexible Plate strengthened by $2\frac{1}{2}$ " Strips and a $2\frac{1}{2}$ " x $\frac{1}{2}$ " Double Angle Strip (9) as shown in Fig. 5.5a. The sides are connected by a $2\frac{1}{2}$ " x $1\frac{1}{2}$ " Flanged Plate (9), and by two $2\frac{1}{2}$ " x $\frac{1}{2}$ " Double Angle Strips bolted to the lower edges of the sides. The floor of the cage is a $2\frac{1}{2}$ " x $2\frac{1}{2}$ " Flexible Plate bolted to these Double Angle Strips. The back is also a $2\frac{1}{2}$ " x $2\frac{1}{2}$ " Flexible Plate attached to a Double Angle Strip (10).

Two Trunnions are bolted to the Flanged Plate (9) and a $1\frac{1}{2}$ " loose Pulley (11) is freely mounted on a Pivot Bolt held by its nuts in one of the Trunnions.

The cage is guided by two Cords, arranged one on each side. Each Cord is fastened to a Washer and is passed through a hole in the Flanged Plate (1) and through the lugs of one of the Double Angle Strips (8). The Cord is then pulled tight and is tied to a $1\frac{1}{2}$ " x $1\frac{1}{2}$ " Angle Bracket bolted to half of a Hinged Flat Plate at the top of the shaft. Each half of the Hinged Flat Plate is fixed to one of the Strips (3).

THE OPERATING MECHANISM

A $3\frac{1}{2}$ " Pulley (12) fitted with a Threaded Pin is fixed on a Rod mounted as shown in Fig. 5.5a. A length of Cord is tied to a Cord Anchoring Spring on the Rod and is passed over a $3\frac{1}{2}$ " Pulley (13), round the Pulley (11) and is tied to the top of the lift shaft. Pulley (13) is fixed on a Rod held by Rod Wheels in the halves of the Hinged Flat Plate.

The Pulley (12) is fitted with a brake formed by two $\frac{3}{4}$ " Washers bolted to a $2\frac{1}{2}$ " Stepped Curved Strip. The Curved Strip is lock-nutted to a Double Bracket (14), and the $\frac{3}{4}$ " Washers engage in the rim of Pulley (12). A length of Cord fastened to an Angle Bracket on the Curved Strip is tied to a Driving Band attached to the lift shaft. The Driving Band pulls the Washers against the Pulley. The Cord fastened to the Driving Band passes over a $\frac{1}{2}$ " loose Pulley (15) on the same Rod as the Pulley (12).

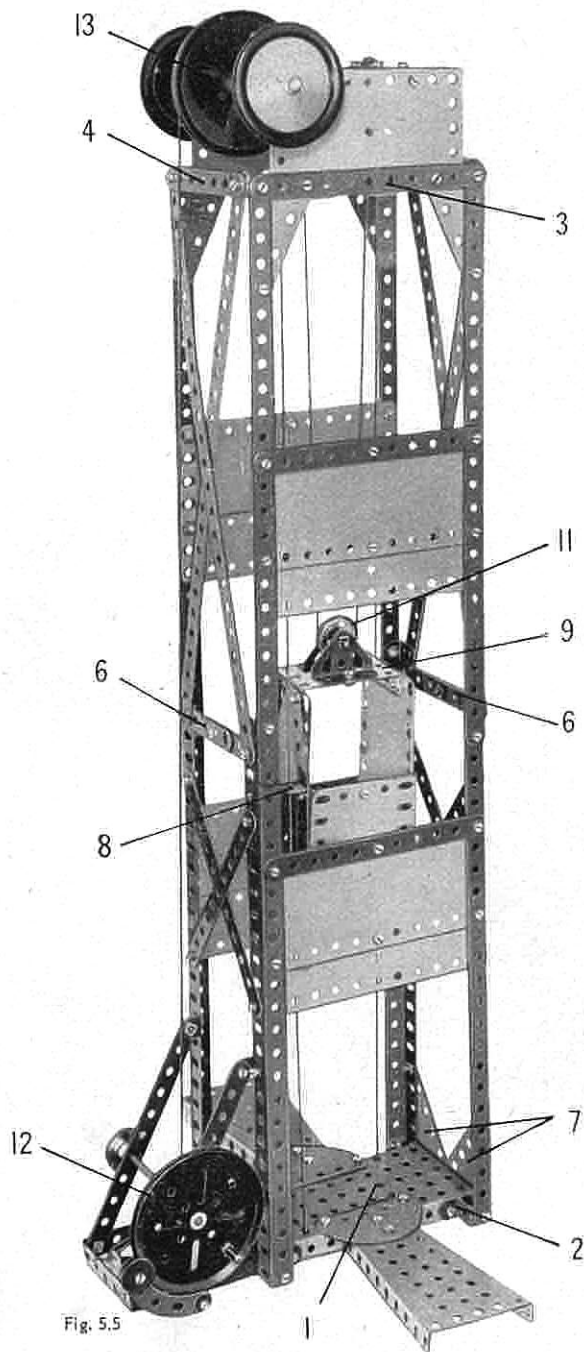

Fig. 5.5

Parts Required

8 of No. 1	1 of No. 23	4 of No. 125
14 " " 2	116 " " 37a	2 " " 126
2 " " 3	110 " " 37b	1 " " 147b
12 " " 5	11 " " 38	1 " " 176
2 " " 6a	2 " " 38d	1 " " 186
4 " " 8	1 " " 40	2 " " 187
1 " " 11	6 " " 48a	4 " " 189
9 " " 12	1 " " 51	2 " " 190
2 " " 12a	1 " " 52	2 " " 191
1 " " 15a	2 " " 54	4 " " 192
1 " " 16	1 " " 90a	1 " " 198
2 " " 19b	1 " " 111a	2 " " 214
1 " " 22	2 " " 111c	4 " " 221
1 " " 22a	1 " " 115	2 " " 222

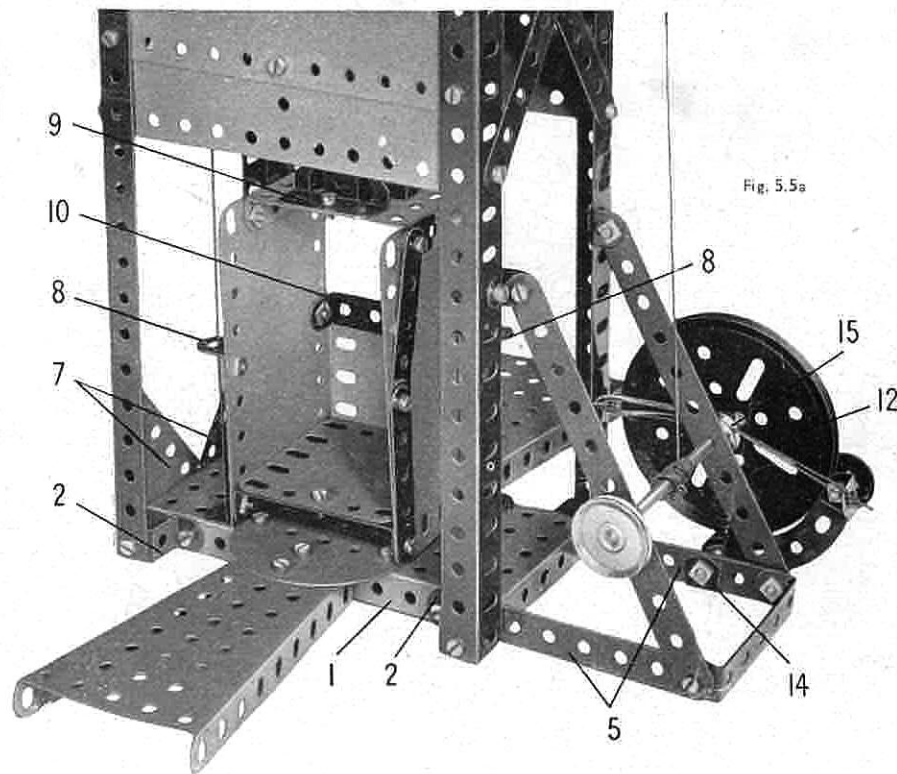

Fig. 5.5a

5.6 ESTATE CAR

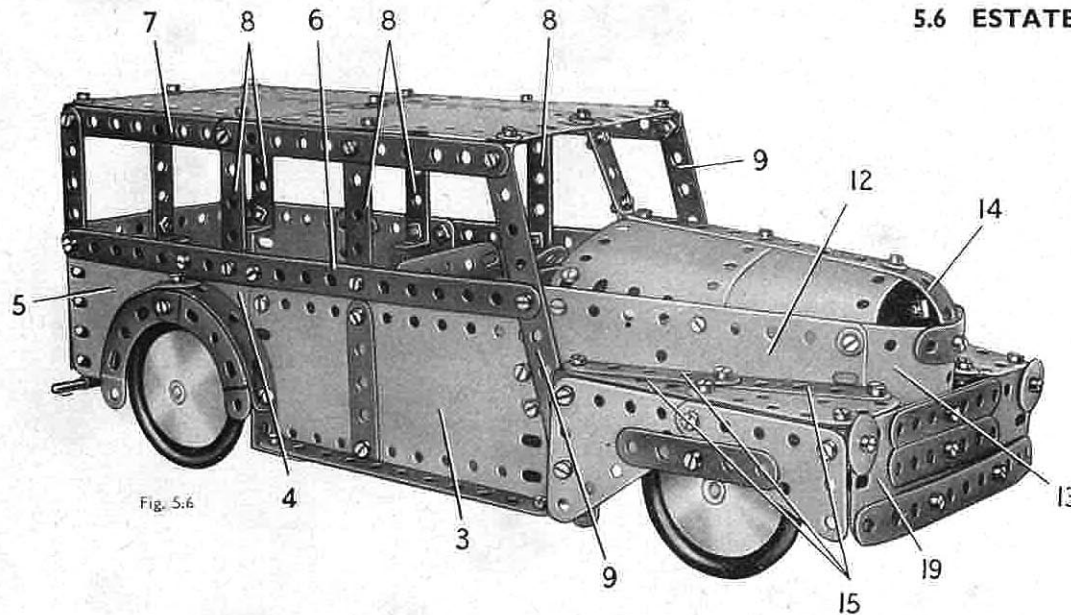

Fig. 5.6

THE WINGS AND THE RUNNING BOARDS

The side of each front wing is made from a $2\frac{1}{2}'' \times 1\frac{1}{2}''$ and a $2\frac{1}{2}'' \times 2''$ Triangular Flexible Plate, with a $2\frac{1}{2}''$ Strip attached to them by a Fishplate. The top of the wing is a $2\frac{1}{2}'' \times 1\frac{1}{2}''$ Triangular Flexible Plate and three $2\frac{1}{2}''$ Strips (15), two of which are joined to the Plate by Fishplates. It is connected to the side by Angle Brackets, and the assembly is bolted to a Double Bracket (16) fixed to the Plate (12). The rear edge of the wing is filled in by a Trunnion (17) and a $\frac{1}{2}''$ Reversed Angle Bracket (18).

At the front, each wing is joined by an Angle Bracket to a $5\frac{1}{2}'' \times 1\frac{1}{2}''$ Flexible Plate (19), which is bolted also to the Plate (13) and is fitted with two $3\frac{1}{2}''$ Strips. The front bumper is a $5\frac{1}{2}''$ Strip attached to the Plate (19) by 2" Bolts but spaced from it by Spring Clips on the Bolts.

Each running board is a $5\frac{1}{2}''$ Strip connected by an Angle Bracket to the Trunnion (17) and joined by a $1'' \times 1''$ Angle Bracket to the rear mudguard. The mudguard consists of two Formed Slotted Strips and two $2\frac{1}{2}''$ Stepped Curved Strips bolted to a $\frac{1}{2}''$ Reversed Angle Bracket, which is used also to connect the assembly to the side of the body.

Parts Required

14 of No. 2	2 of No. 15	2 of No. 38d	4 of No. 125	1 of No. 198
2 " " 3	1 " " 16	1 " " 45	2 " " 126	2 " " 199
12 " " 5	1 " " 17	1 " " 48	1 " " 147b	2 " " 200
2 " " 6a	1 " " 18a	8 " " 48a	4 " " 155	1 " " 212
2 " " 8	4 " " 22	1 " " 51	4 " " 187	2 " " 212a
7 " " 10	1 " " 24	1 " " 52	4 " " 188	1 " " 213
3 " " 11	3 " " 35	4 " " 90a	4 " " 189	2 " " 214
12 " " 12	116 " " 37a	2 " " 111a	3 " " 190	4 " " 215
2 " " 12a	110 " " 37b	4 " " 111c	2 " " 191	4 " " 221
4 " " 12c	18 " " 38	1 " " 115	4 " " 192	2 " " 222

THE CHASSIS AND WHEELS

The chassis consists of two $12\frac{1}{2}''$ Angle Girders bolted to a $5\frac{1}{2}'' \times 2\frac{1}{2}''$ Flanged Plate (1). The rear ends of the Girders are connected by a $2\frac{1}{2}'' \times \frac{1}{2}''$ Double Angle Strip (2), and one half of a Hinged Flat Plate and a $2\frac{1}{2}'' \times 2\frac{1}{2}''$ Flexible Plate are fixed to the Girders as shown.

The front wheels are fixed on a 5" Rod passed through the Girders and the flanges of the Flanged Plate. The rear wheels are mounted on a built-up rod made from a $3\frac{1}{2}''$ and a 2" Rod joined by a Rod Connector.

CONSTRUCTION OF THE BODY

Each side of the body consists of a $5\frac{1}{2}'' \times 2\frac{1}{2}''$ Flexible Plate (3), a $2\frac{1}{2}'' \times 1\frac{1}{2}''$ Flexible Plate (4) and a $2\frac{1}{2}'' \times 2\frac{1}{2}''$ Flexible Plate (5). These Plates are bolted to a built-up strip (6), made from two $5\frac{1}{2}''$ Strips overlapped three holes. A built-up strip (7), consisting of two $5\frac{1}{2}''$ Strips overlapped four holes, is connected to strip (6) by $2\frac{1}{2}'' \times \frac{1}{2}''$ Double Angle Strips (8) and a $5\frac{1}{2}''$ Strip (9). At one side a $2\frac{1}{2}''$ Strip is used in place of one of the Double Angle Strips (8).

The sides of the body are connected to the back by Angle Brackets. The back is the other half of the Hinged Flat Plate and it is bolted to the Double Angle Strip (2).

The roof consists of two $5\frac{1}{2}'' \times 2\frac{1}{2}''$ and two $4\frac{1}{2}'' \times 2\frac{1}{2}''$ Flexible Plates bolted to the tops of Double Angle Strips (8) and connected to the front ends of strips (7) by Angle Brackets. It is connected also to the back of the body by a $2\frac{1}{2}'' \times \frac{1}{2}''$ Double Angle Strip.

The front end of the body is joined to the chassis by a $2\frac{1}{2}'' \times \frac{1}{2}''$ Double Angle Strip (10) and a $1\frac{1}{2}'' \times \frac{1}{2}''$ Double Angle Strip (11). A spare wheel cover at the back is represented by two Semi-Circular Plates held by a $\frac{3}{8}''$ Bolt. The rear bumper is a 5" Rod gripped in Right-Angle Rod and Strip Connectors.

ASSEMBLY OF THE BONNET

Each side of the bonnet is a $5\frac{1}{2}'' \times 1\frac{1}{2}''$ Flexible Plate (12), and a further $5\frac{1}{2}'' \times 1\frac{1}{2}''$ Flexible Plate (13) is bent as shown and arranged so that its ends overlap each of the Plates (12) by three holes. The top of the bonnet is made from two $1\frac{1}{4}''$ radius Curved Plates and two "U"-section Curved Plates opened out slightly. These Plates are bolted to a $5\frac{1}{2}''$ Strip (14), which is bent as shown and bolted to the centre of Plate (13). The rear end of the top of the bonnet is attached to Obtuse Angle Brackets fixed to the sides, and the front end is bolted direct to the sides. The centre division of the windscreen is a $1\frac{1}{2}''$ Strip fixed to Obtuse Angle Brackets.

The steering wheel is a Bush Wheel on a $1\frac{1}{2}''$ Rod held by a Spring Clip in a $2\frac{1}{2}'' \times 1\frac{1}{2}''$ Flanged Plate and a Double Bent Strip. The Flanged Plate is fixed at a slight angle to one side of the body. The driver's seat consists of two $2\frac{1}{2}'' \times 1\frac{1}{2}''$ Flexible Plates connected by an Angle Bracket and fixed to a Double Bracket bolted to the Flanged Plate (1).

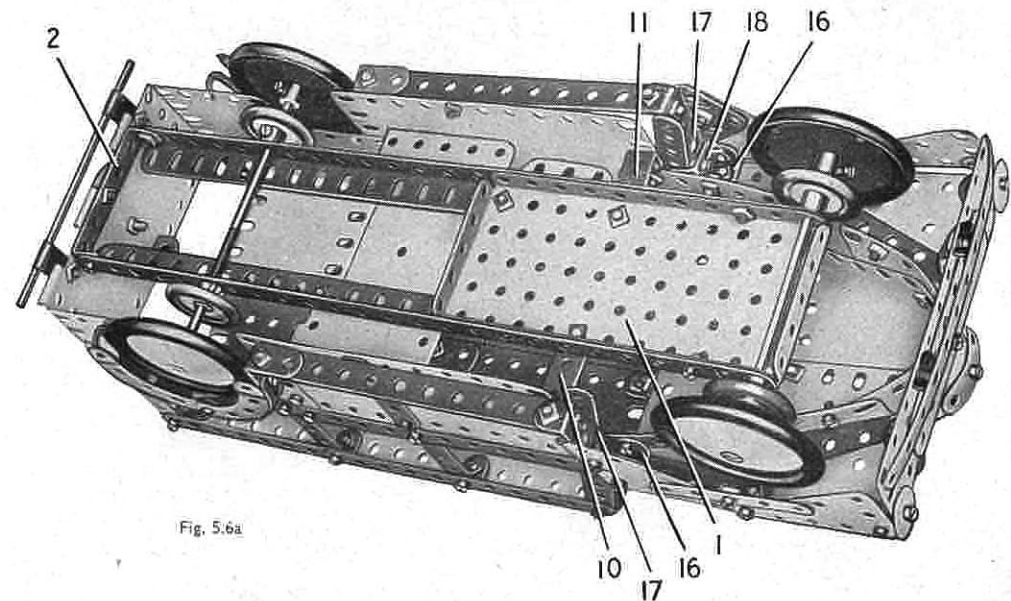

Fig. 5.6a

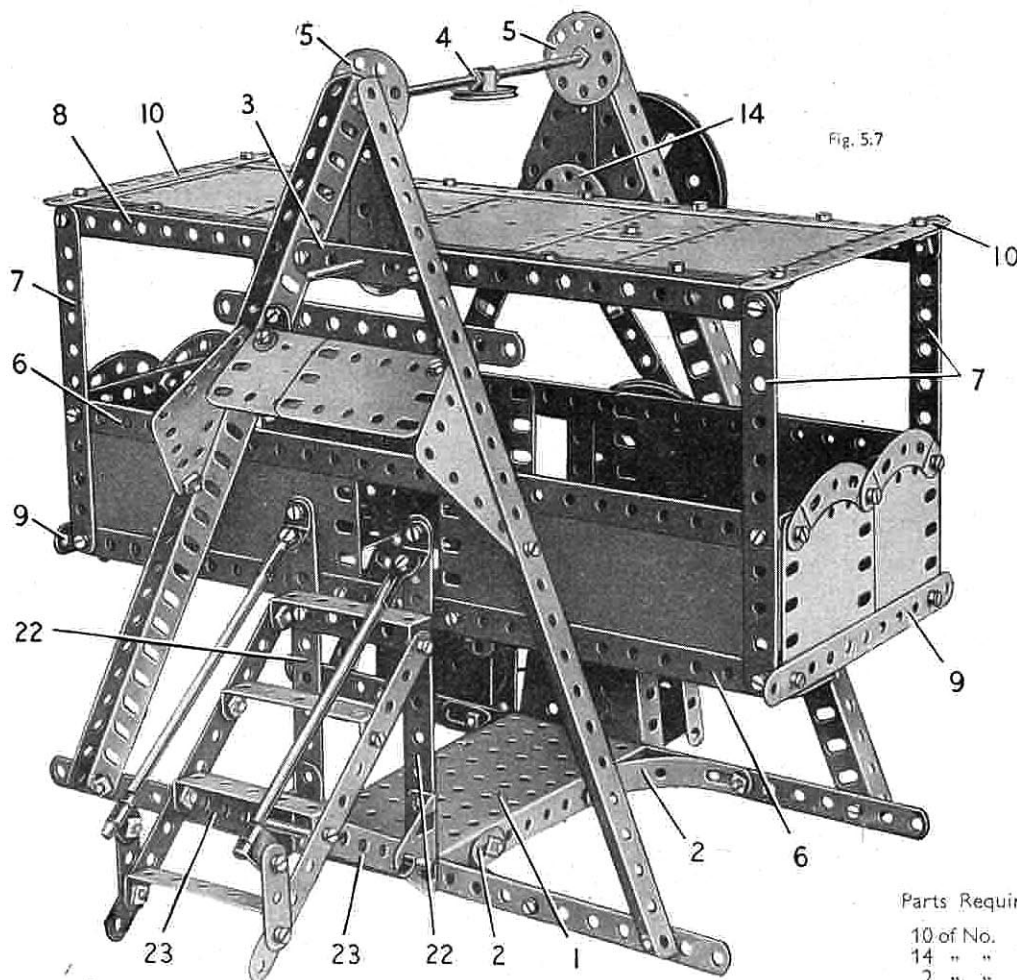

Fig. 5.7

through the centre holes of the Strips (8) at the top of the Boat and is gripped in the boss of a Bush Wheel (14) bolted to one of these Strips. The rod is supported in the Strips (3) and it carries a 3" Pulley fitted with a 2½" Strip (15).

THE DRIVING MECHANISM

A Flanged Sector Plate (16) is bolted to the base at one side, and a second Flanged Sector Plate is attached by Double Brackets to a 2½" × 1½" Flanged Plate (17) also connected to the side of the base. The top ends of the Flanged Sector Plates are joined together by a Six-Hole Wheel Disc at each side. The Flanged Sector Plate (16) is connected by a 2½" Strip to a 5½" Strip (18) bolted across the Girders of the supporting columns.

A Magic Clockwork Motor is fixed to the base as shown, and its pulley is connected by a Driving Band to a 1" Pulley on the Crank Handle (19). A ½" fixed Pulley (supplied with the Motor) is fixed on the Crank Handle and is connected by a Driving Band to a 3" Pulley on a 2" Rod (20). A built-up strip (21), made from two ¾" Strips overlapped four holes, is mounted on a Pivot Bolt held by its nuts in a slotted hole of the 3" Pulley on Rod (20). The Pivot Bolt is placed centrally in the slotted hole, and the strip (21) is spaced from the Pulley by a Spring Clip on the Pivot Bolt. The top end of strip (21) is passed over a Threaded Pin attached to the end of Strip (15), and is held on the Pin by a Cord Anchoring Spring.

The steps leading to the Swing Boat consist of four 2½" × ½" Double Angle Strips bolted to two 5½" Strips. They are connected at the top to a 2½" × 1½" Double Angle Strip bolted to two 5½" Strips (22) fixed to the base. Two 2½" Strips (23) attached to the steps are connected by a 4" Rod to Trunnions also fixed to the base by the Bolts used to fix the Strips (22). The handrails are Rods gripped at the top of the steps in Rod and Strip Connectors attached to Obtuse Angle Brackets bolted to the Strips (22). The lower ends of the Rods are supported in Right-Angle Rod and Strip Connectors attached to ½" Strips.

5.7 GIANT SWING BOAT

ASSEMBLY OF THE BASE

Construction of the Giant Swing Boat is commenced by bolting 12½" Strips to the ends of a 5½" × 2½" Flanged Plate (1) (Fig. 5.7). The Strips are also held to the Flanged Plate by Formed Slotted Strips (2). Two 12½" Angle Girders are fixed to each 12½" Strip as shown, and the top ends of these Girders are connected by a 2½" Strip (3) and two 2½" × 1½" Triangular Flexible Plates arranged as shown. The upper ends of the supporting Girders on each side are joined by two Screwed Rods. These are screwed into the threaded holes in the boss of a 1" Pulley (4) and are locked in position by nuts. The outer ends of the Screwed Rods are then passed through the top holes of the 12½" Angle Girders and the centre holes of Wheel Discs (5), and are fixed in position by nuts.

CONSTRUCTION OF THE BOAT

Each side of the Swing Boat itself consists of two 5½" × 2½" Flexible Plates bolted to two 12½" Strips (6). A vertical 5½" Strip (7) is fixed at each end, and the tops of these Strips are connected by a 12½" Strip (8). The sides are joined at each end by two 5½" Strips (9) and (10), fixed to Angle Brackets, and the ends are partly filled in by 2½" × 2½" Flexible Plates connected to the sides by Angle Brackets and edged by 2½" Stepped Curved Strips.

The roof of the Swing Boat is formed by a Hinged Flat Plate, two 4½" × 2½" Flexible Plates and two 2½" × 1½" Flexible Plates bolted to two 12½" Strips. The ends of the 12½" Strips are fixed to the Strips (10). The floor is partly filled in by four 5½" × 1½" Flexible Plates (11), arranged two at each side. Two of the Plates are supported at their outer ends by 1" × 1" Angle Brackets fixed to the sides, and the other two are attached to Double Brackets. The inner ends of the four Flexible Plates are connected to the sides by ½" Reversed Angle Brackets. Two Semi-Circular Plates (12) are bolted together and are then attached to the inner corners of the 5½" × 1½" Flexible Plates. A straightened 1½" radius Curved Plate (13) is fixed between the two Flexible Plates at each end of the floor.

The Swing Boat swings on a built-up rod made from a 5" and a 3½" Rod joined by a Rod Connector. The rod is passed

Parts Required

10 of No.	1
14 " "	2
2 " "	3
6 " "	5
2 " "	6a
4 " "	8
4 " "	11
12 " "	12
2 " "	12a
4 " "	12c
2 " "	15
2 " "	15a
1 " "	15b
1 " "	16
1 " "	17
2 " "	19b
1 " "	19g
5 " "	22
1 " "	24
2 " "	24a

2 of No.	24c
3 " "	35
118 " "	37a
109 " "	37b
8 " "	38
5 " "	48a
1 " "	51
1 " "	52
2 " "	54
2 " "	80c
4 " "	90a
4 " "	111c
1 " "	115
4 " "	125
2 " "	126
1 " "	147b
1 " "	176
1 " "	186a
4 " "	188
4 " "	189
4 " "	190
2 " "	191
4 " "	192
1 " "	198
2 " "	200
2 " "	212
2 " "	212a
1 " "	213
2 " "	214
4 " "	215
4 " "	221
2 " "	222
1 " "	24
1 " "	24a

1 Magic Clockwork Motor
(not included in Outfit)

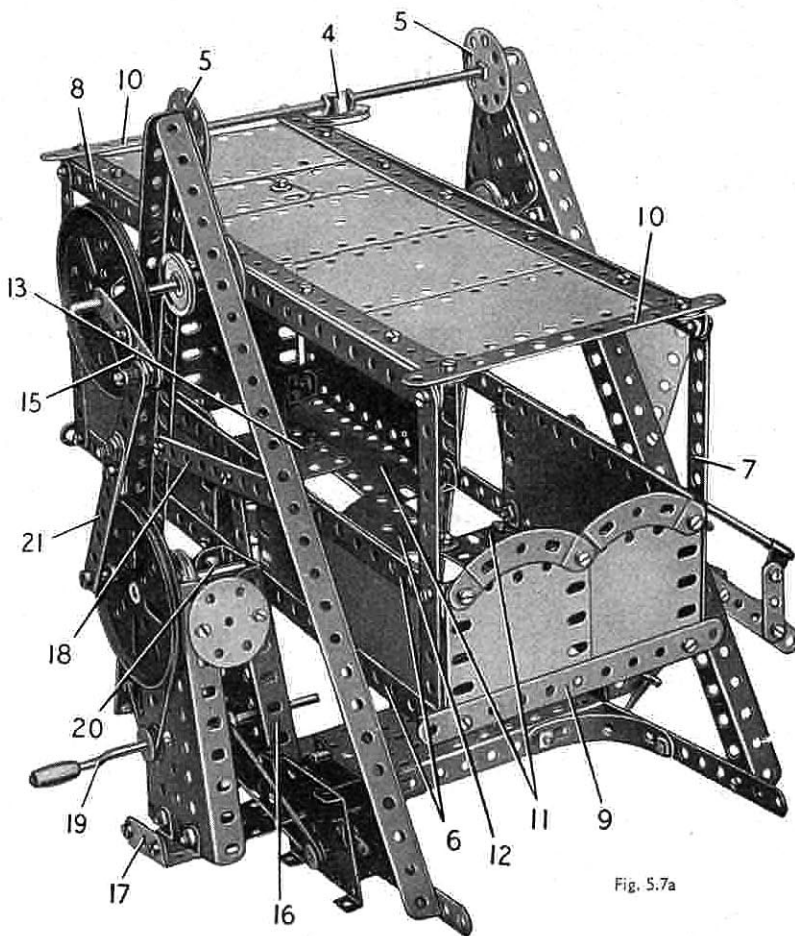

Fig. 5.7a

5.8 MOTOR COACH

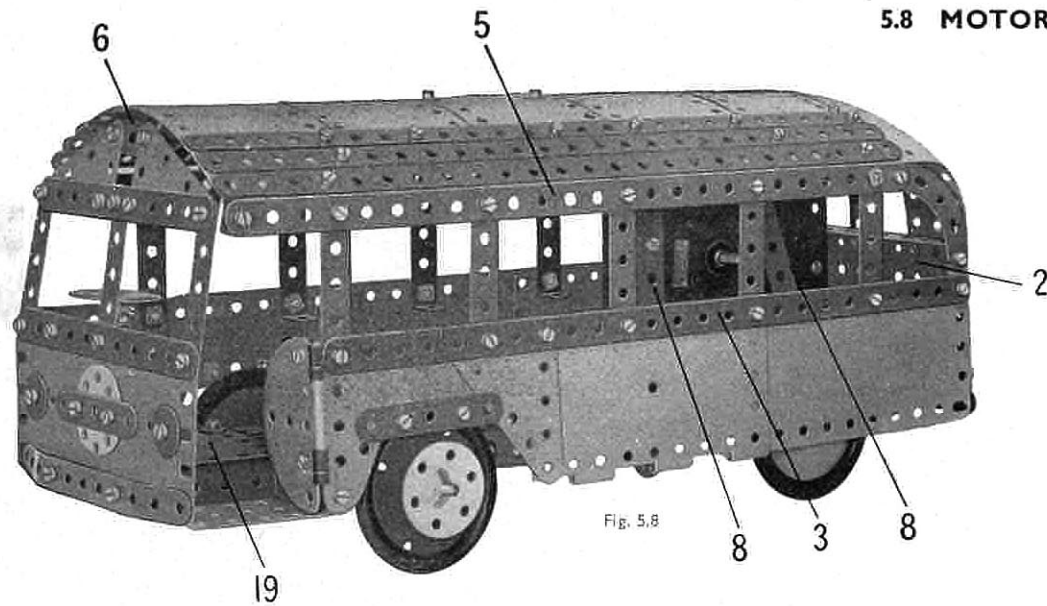

Fig. 5.8

The edges of the roof at each side are formed by three $12\frac{1}{2}$ " Strips. These are bolted to two $5\frac{1}{2}$ " x $2\frac{1}{2}$ " Flexible Plates, two $4\frac{1}{2}$ " x $2\frac{1}{2}$ " Flexible Plates and two $1\frac{1}{2}$ " radius Curved Plates. The roof is attached to Obtuse Angle Brackets bolted to the Strips (5). The rear panelling that connects the roof to the Flanged Plate is formed by a $5\frac{1}{2}$ " x $1\frac{1}{2}$ " Flexible Plate at each side, and two $2\frac{1}{2}$ " x $2\frac{1}{2}$ " Flexible Plates at the centre. The $2\frac{1}{2}$ " x $2\frac{1}{2}$ " Flexible Plates overlap each other by four holes, and they overlap the rear edge of the roof by three holes. A Formed Slotted Strip is fixed between these Plates and the Flanged Plate (2).

The windscreen is made by bolting three $2\frac{1}{2}$ " Strips to the front of the body. The upper ends of these Strips support a $5\frac{1}{2}$ " Strip, and this is connected to the Strips (5) by Angle Brackets. Two $2\frac{1}{2}$ " x $1\frac{1}{2}$ " Triangular Flexible Plates fixed to the $5\frac{1}{2}$ " Strip are connected by a $1\frac{1}{2}$ " x $\frac{1}{2}$ " Double Angle Strip (6). The bumper bar is a $5\frac{1}{2}$ " Strip attached to the front of the body by $\frac{3}{8}$ " Bolts, but separated from it by a Spring Clip on each Bolt. The front is completed by adding a Wheel Disc and $\frac{1}{2}$ " Washers as shown. The rear bumper is formed by two $5\frac{1}{2}$ " Strips (7) bolted to a Flat Trunnion fixed to the Flanged Plate (2).

THE MOTOR AND GEARING

A No. 1 Clockwork Motor is bolted to two $5\frac{1}{2}$ " Strips (8) fixed to one of the girders of the chassis. One of these Strips is bolted at an angle as shown in Fig. 5.8a. The top rear corner of the Motor is connected to one of the Strips (5) by a Screwed Rod (9). This is attached to the Strip and to the Motor by nuts. A Plinion on the Motor driving shaft drives a 57-tooth Gear (10) on a 2" Rod supported in the Motor side-plates. This Rod is held in place by a Cord Anchoring Spring and it carries a 1" Pulley (11) that drives a similar Pulley (12) on the rear axle. The rear axle is a 5" Rod mounted in the chassis as shown.

STEERING MECHANISM

Each of the front wheels is free to turn on a $1\frac{1}{2}$ " Rod held by a Spring Clip in a Double Bracket (13). The wheel is retained on the Rod by a Six-Hole Wheel Disc and a Spring Clip. A $\frac{3}{8}$ " Bolt is passed through a $1\frac{1}{2}$ " Strip (14) and the Double Bracket (13), and is then clamped by two nuts in the hole at the pointed end of a Trunnion (15) bolted to the side girder of the chassis. The ends of the Strips (14) are connected by lock-nutted $\frac{1}{4}$ " Bolts to a built-up strip (16), made from two $3\frac{1}{2}$ " Strips overlapped five holes. The strip (16) is spaced from the Strips (14) by a Spring Clip on each Bolt, and a $5\frac{1}{2}$ " Strip (17) is pivoted on one of the Bolts. Strip (17) is connected by a lock-nutted Bolt to a Fishplate bolted tightly to a Wheel Disc (18), which is clamped by two nuts to the end of a Screwed Rod. The Screwed Rod is supported in a $\frac{1}{2}$ " Reversed Angle Bracket bolted to one of the chassis girders, and in a Stepped Bent Strip fixed to the front of the model. The steering wheel is a Bush Wheel secured at the top end of the Screwed Rod.

The entrance to the coach is formed by a $2\frac{1}{2}$ " x $2\frac{1}{2}$ " Flexible Plate (19) bolted to the chassis, and the step is a $2\frac{1}{2}$ " x $1\frac{1}{2}$ " Flanged Plate fixed to the front of the model and supported by a $\frac{1}{2}$ " Reversed Angle Bracket (20). A Semi-Circular Plate is attached to the side by a $1\frac{1}{2}$ " x $1\frac{1}{2}$ " Angle Bracket, and the Hand-rail is formed by a 2" Rod gripped in Right-Angle Rod and Strip Connectors bolted to the Semi-Circular Plate.

THE CHASSIS AND BODY

The chassis of this model Motor Coach consists of two built-up girders, each made from two $12\frac{1}{2}$ " Angle Girders overlapped 21 holes. These are connected at the front by a $2\frac{1}{2}$ " x $\frac{1}{2}$ " Double Angle Strip (1), and at the rear they are bolted to a $5\frac{1}{2}$ " x $2\frac{1}{2}$ " Flanged Plate (2) that forms the end of the body. The front of the body consists of two $5\frac{1}{2}$ " x $1\frac{1}{2}$ " Flexible Plates bolted together and fixed to the Double Angle Strip (1).

The side of the model seen in Fig. 5.8 is bolted to a $12\frac{1}{2}$ " Strip (3). This side consists of a $5\frac{1}{2}$ " x $2\frac{1}{2}$ " Flexible Plate, one half of a Hinged Flat Plate, a $2\frac{1}{2}$ " x $2\frac{1}{2}$ " and a $2\frac{1}{2}$ " x $1\frac{1}{2}$ " Triangular Flexible Plate, and a $2\frac{1}{2}$ " x $1\frac{1}{2}$ " Flexible Plate. The side is bolted at the rear to the Flanged Plate (2), and is connected by an Angle Bracket to a $5\frac{1}{2}$ " Strip (4) fixed across the chassis. The other side of the model is similar but it is extended forward by two $2\frac{1}{2}$ " x $1\frac{1}{2}$ " Flexible Plates, which are connected to the front of the body by an Angle Bracket. A $12\frac{1}{2}$ " Strip and a $5\frac{1}{2}$ " Strip are used in place of the Strip (3) used on the rear side.

A $12\frac{1}{2}$ " Strip (5) on each side is joined to the lower part of the body by a series of $2\frac{1}{2}$ " Strips and $2\frac{1}{2}$ " x $\frac{1}{2}$ " Double Angle Strips that represent the window divisions. The Strips (5) are connected to the Flanged Plate (2) by $2\frac{1}{2}$ " Stepped Curved Strips.

Parts Required

10 of No. 1	4 of No. 12c	8 of No. 35	2 of No. 80c	4 of No. 188
11 " " 2	1 " " 15	118 " " 37a	2 " " 90a	4 " " 189
2 " " 3	2 " " 17	104 " " 37b	2 " " 111a	3 " " 190
10 " " 5	2 " " 18a	18 " " 38	6 " " 111c	2 " " 191
2 " " 6a	3 " " 22	2 " " 38d	1 " " 115	4 " " 192
4 " " 8	1 " " 24	1 " " 44	2 " " 125	1 " " 198
3 " " 10	2 " " 24a	1 " " 48	2 " " 126	2 " " 200
2 " " 11	2 " " 24c	7 " " 48a	1 " " 126a	2 " " 212a
5 " " 12	1 " " 26	1 " " 51	1 " " 147b	1 " " 214
1 " " 12a	1 " " 27a	1 " " 52	1 " " 155	1 " " 215
			1 " " 176	4 " " 221
			1 " " 186	2 " " 222
			4 " " 187	

1 No. 1 Clockwork Motor
(Not included in Outfit)

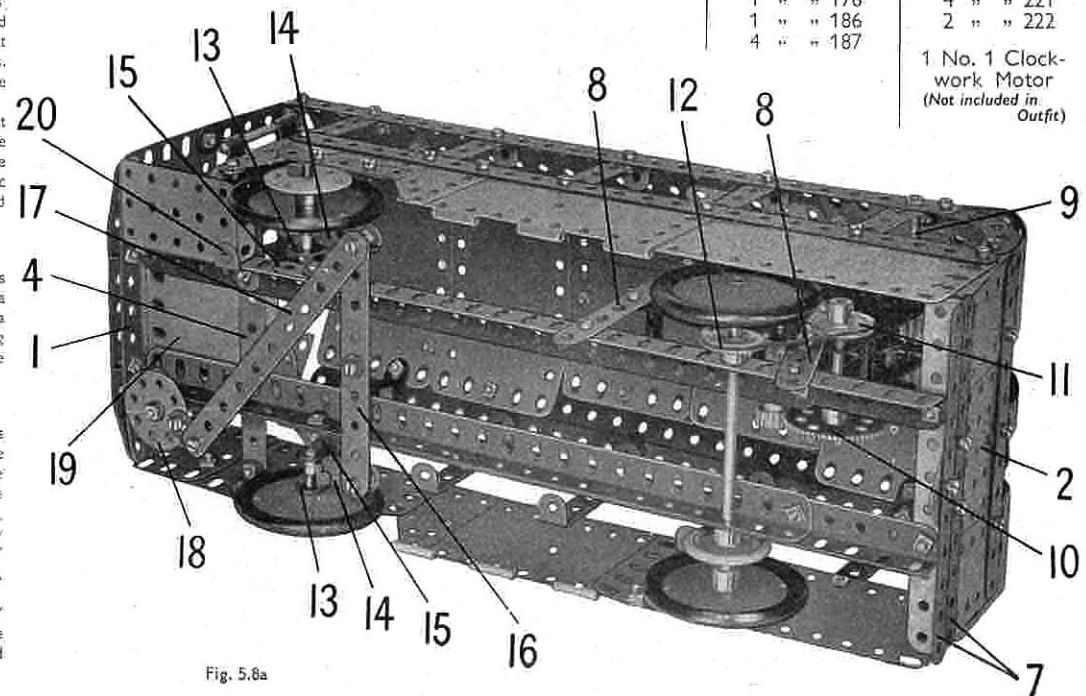

Fig. 5.8a

5.9 BIG WHEEL

CONSTRUCTION OF THE BASE

The base is made by bolting a $5\frac{1}{2}$ " Strip to each of the shorter flanges of a $5\frac{1}{2}$ " x $2\frac{1}{2}$ " Flanged Plate (1). A $12\frac{1}{2}$ " Angle Girder is attached to each of the ends of the $5\frac{1}{2}$ " Strips, and at the top the Angle Girders on each side are bolted to a Wheel Disc (2). The lower ends of the Angle Girders are braced by $5\frac{1}{2}$ " x $2\frac{1}{2}$ " Flexible Plates edged by $5\frac{1}{2}$ " Strips (3).

THE ENTRANCE AND PAY BOX

A Flanged Sector Plate is attached to each of the Angle Girders on one side, and a built-up strip (4) is connected to the base by three $2\frac{1}{2}$ " x $\frac{1}{2}$ " Double Angle Strips, arranged one at each end and one in the centre. The built-up strip is made from two $3\frac{1}{2}$ " Strips bolted together. The front of the entrance consists of two $4\frac{1}{2}$ " x $2\frac{1}{2}$ " Flexible Plates bolted to the centre Double Angle Strip.

The sides of the entrance are formed by $2\frac{1}{2}$ " x $2\frac{1}{2}$ " Flexible Plates (5) fixed to the $2\frac{1}{2}$ " x $\frac{1}{2}$ " Double Angle Strips at the ends of the strip. The arch over the entrance consists of a $5\frac{1}{2}$ " x $1\frac{1}{2}$ " Flexible Plate and a $2\frac{1}{2}$ " x $1\frac{1}{2}$ " Triangular Flexible Plate (6) on each side bolted to the Plate (5). The $5\frac{1}{2}$ " x $1\frac{1}{2}$ " Flexible Plates are bent over and are bolted together at the centre, the same bolt fixing also a $1\frac{1}{2}$ " x $\frac{1}{2}$ " Double Angle Strip. A $2\frac{1}{2}$ " Strip is attached to each lug of the Double Angle Strip, and $2\frac{1}{2}$ " Stepped Curved Strips are bolted to the ends of the $2\frac{1}{2}$ " Strip.

The pay-box is represented by a $2\frac{1}{2}$ " x $1\frac{1}{2}$ " Flanged Plate fixed to a Flat Trunnion bolted to the strip (4). A $2\frac{1}{2}$ " x $\frac{1}{2}$ " Double Angle Strip is also bolted to the Flat Trunnion, and a 1 " loose Pulley is attached to a 1 " x 1 " Angle Bracket connected to the Double Angle Strip.

ASSEMBLY OF THE WHEEL

The spokes of the wheel are formed by four built-up strips. Two of these are each made from a $12\frac{1}{2}$ " Strip and a $5\frac{1}{2}$ " Strip overlapped five holes. The other two each consist of three $5\frac{1}{2}$ " Strips and a $2\frac{1}{2}$ " Strip, bolted together so that they equal in length the built-up strips already mentioned. The spokes are fixed to 3 " Pulleys (7) as shown, and they are connected at their outer ends by $2\frac{1}{2}$ " x $\frac{1}{2}$ " Double Angle Strips (8). The wheel rim is made up from $12\frac{1}{2}$ " Strips curved and attached to the Double Angle Strips (8).

The wheel is mounted on an axle, consisting of two Rods joined by a Rod Connector. The rod is supported in the Wheel Discs (2) and is held in position by 1 " Pulleys. Each of the carriages consists of a $2\frac{1}{2}$ " x $1\frac{1}{2}$ " Flexible Plate curved and bolted to a Formed Slotted Strip. Two Angle Brackets are bolted to the centre holes in the longer sides of each Flexible Plate. Two of the carriages are pivoted on 2 " Rods held by Spring Clips in Double Brackets bolted to the wheel. The other two carriages pivot on $3\frac{1}{2}$ " Rods mounted in Angle Brackets bolted to the wheel.

A Magic Clockwork Motor is bolted to the base as shown, and it drives a 1 " Pulley on a Crank Handle (9). The Crank Handle is supported in $1\frac{1}{2}$ " Strips fixed to Trunnions (10) bolted to the Flanged Plate (1). A $\frac{1}{2}$ " fixed Pulley on the Crank Handle is connected by a Cord belt to one of the Pulleys (7). The $\frac{1}{2}$ " Pulley is supplied with the Magic Clockwork Motor, and is placed behind the second 1 " Pulley seen on the Crank Handle in Fig. 5.9a.

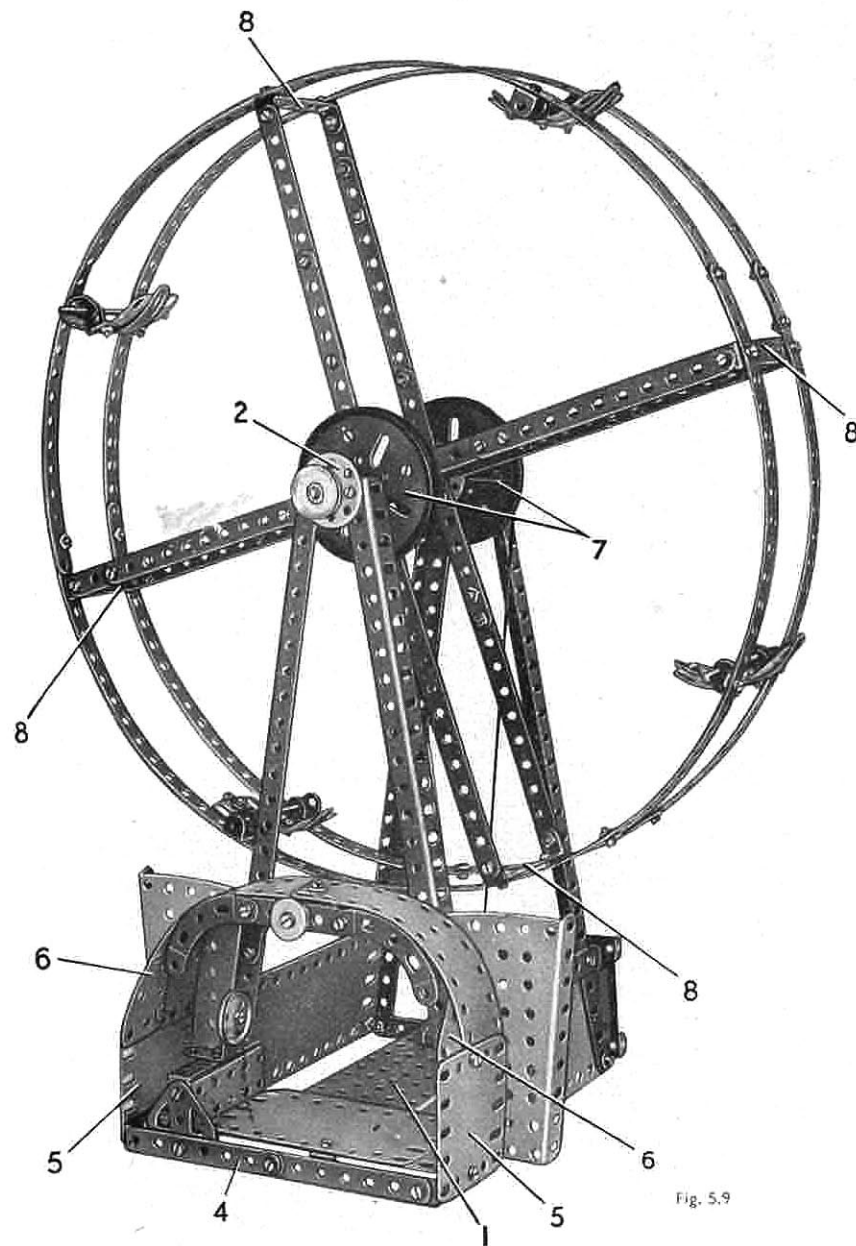

Fig. 5.9

Parts Required

10 of No. 1	1 of No. 24	2 of No. 126
14 " " 2	2 " " 24a	1 " " 126a
2 " " 3	9 " " 35	1 " " 186
4 " " 5	118 " " 37a	4 " " 188
2 " " 6a	110 " " 37b	2 " " 189
4 " " 8	18 " " 38	2 " " 190
4 " " 11	1 " " 38d	2 " " 191
12 " " 12	1 " " 40	2 " " 192
1 " " 12a	1 " " 48	1 " " 213
4 " " 16	8 " " 48a	4 " " 215
2 " " 17	1 " " 51	2 " " 221
2 " " 19b	1 " " 52	
1 " " 19g	2 " " 54	
4 " " 22	4 " " 90a	
1 " " 22a	1 " " 111a	
1 " " 23	6 " " 111c	

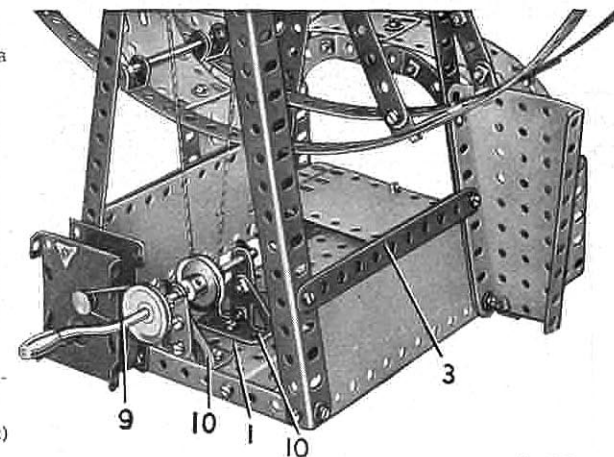

Fig. 5.9a

5.10 HAMMERHEAD CRANE

CONSTRUCTION OF THE TOWER

The lower section of the tower consists of four 12½" Angle Girders bolted to 5½" x 2½" Flexible Plates. Two of these Plates are strengthened by bolting half of a Hinged Flat Plate to each of them, and a 5½" x 2½" Flanged Plate is fixed across the base by the bolts holding the halves of the Hinged Flat Plate. A 2½" x 1½" Triangular Flexible Plate is attached to each corner of the base as shown. Two Formed Slotted Strips (1) and two similar parts on the opposite side are also bolted in position.

The upper ends of the 12½" Angle Girders are connected by 5½" x 1½" Flexible Plates and 5½" Strips (2), and the bolts holding them in place secure also further 5½" Strips (3), arranged in pairs to make built-up angle girders. The top ends of each pair of Strips are joined by an Angle Bracket, and each pair is connected to those on the opposite side by a 2½" x ½" Double Angle Strip. A 3" Pulley (4) is fixed to the two Double Angle Strips. The tower is strengthened by two diagonal 12½" Strips (5).

ASSEMBLY OF THE JIB

The lower jib members are built-up strips (6), each made from two 12½" Strips overlapped seven holes and bolted to a Flanged Sector Plate (7). The Flanged Sector Plates are attached to a 3" Pulley (8) by 1" x 1" Angle Brackets. A 1½" Rod fixed in the boss of the Pulley (8) is passed through the Pulley (4) and is held in place by a Road Wheel.

The strips (6) are connected at the front by a 1½" x ½" Double Angle Strip extended at each end by a Double Bracket (14), and at the rear by a 2½" x 1½" Flanged Plate. Each side of the cab is a 2½" x 2½" Flexible Plate, edged by a 3½" Strip (9) that is connected to the strips (6) by a 2½" Strip (10). The cab roof is formed by two 1½" radius Curved Plates and two 2½" x 1½" Flexible Plates bolted to the Strips (9). The roof is completed by a Semi-Circular Plate at the rear attached to a 2½" x ½" Double Angle Strip. The floor of the cab is a 4½" x 2½" Flexible Plate fixed to a 2½" x ½" Double Angle Strip at the front and attached to the Flanged Plate at the rear by an Angle Bracket.

The upper ends of the Flanged Sector Plates are connected by a 2½" x ½" Double Angle Strip and they are joined to the Strips (6) by 5½" Strips (11). Two 12½" Strips (12) are bolted to the Flanged Sector Plates and to 1½" Strips fixed to the front ends of the strips (6).

THE TRAVELLING CARRIAGE AND ITS RAILS

The rails are 12½" Strips, each of which is attached to one of the strips (6) by a Double Bracket (13), and is fixed at the front by the bolt connecting one of the Double Brackets (14) to the 1½" x ½" Double Angle Strip. These bolts fix also Fishplates and a 1½" Rod mounted in them is fitted with a 1" loose Pulley (15).

The travelling carriage consists of two 2½" x ½" Double Angle Strips connected at each end by a Fishplate. A ½" Reversed Angle Bracket is bolted to each Double Angle Strip, and these support a 1" loose Pulley (16) freely mounted on a ½" Bolt.

ARRANGEMENT OF THE CORDS

Cord is tied to an Angle Bracket fixed to one end of the travelling carriage, and is wound three or four times round a Crank Handle (17). The Cord is then passed round the Pulley (15) and is tied to an Angle Bracket bolted to the front of the travelling carriage. The Crank Handle is held in the Strips (10) by a 1" Pulley and a Spring Clip.

A length of Cord is fastened to a Cord Anchoring Spring on a 3½" Rod (18), that carries a Bush Wheel fitted with a Pivot Bolt. The Cord is passed over the Pulley (16), round a 1" loose Pulley in the pulley block, over the front axle of the travelling carriage and is tied finally to the front of the jib.

The pulley block consists of two Flat Trunnions spaced apart by nuts on ½" Bolts. The 1" loose Pulley is free to turn on one of the Bolts.

Parts Required

10 of No.	1	1 of No.	40
14 " "	2	1 " "	48
2 " "	3	8 " "	48a
12 " "	5	1 " "	51
2 " "	6a	1 " "	52
4 " "	8	2 " "	54
6 " "	10	1 " "	57c
4 " "	11	6 " "	111c
7 " "	12	2 " "	125
2 " "	12a	2 " "	126a
1 " "	16	1 " "	147b
2 " "	17	1 " "	176
2 " "	18a	1 " "	187
2 " "	19b	2 " "	188
1 " "	19g	4 " "	189
5 " "	22	2 " "	190
2 " "	22a	1 " "	191
1 " "	23	4 " "	192
1 " "	24	1 " "	198
4 " "	35	2 " "	200
113 " "	37a	1 " "	214
105 " "	37b	4 " "	215
20 " "	38	4 " "	221

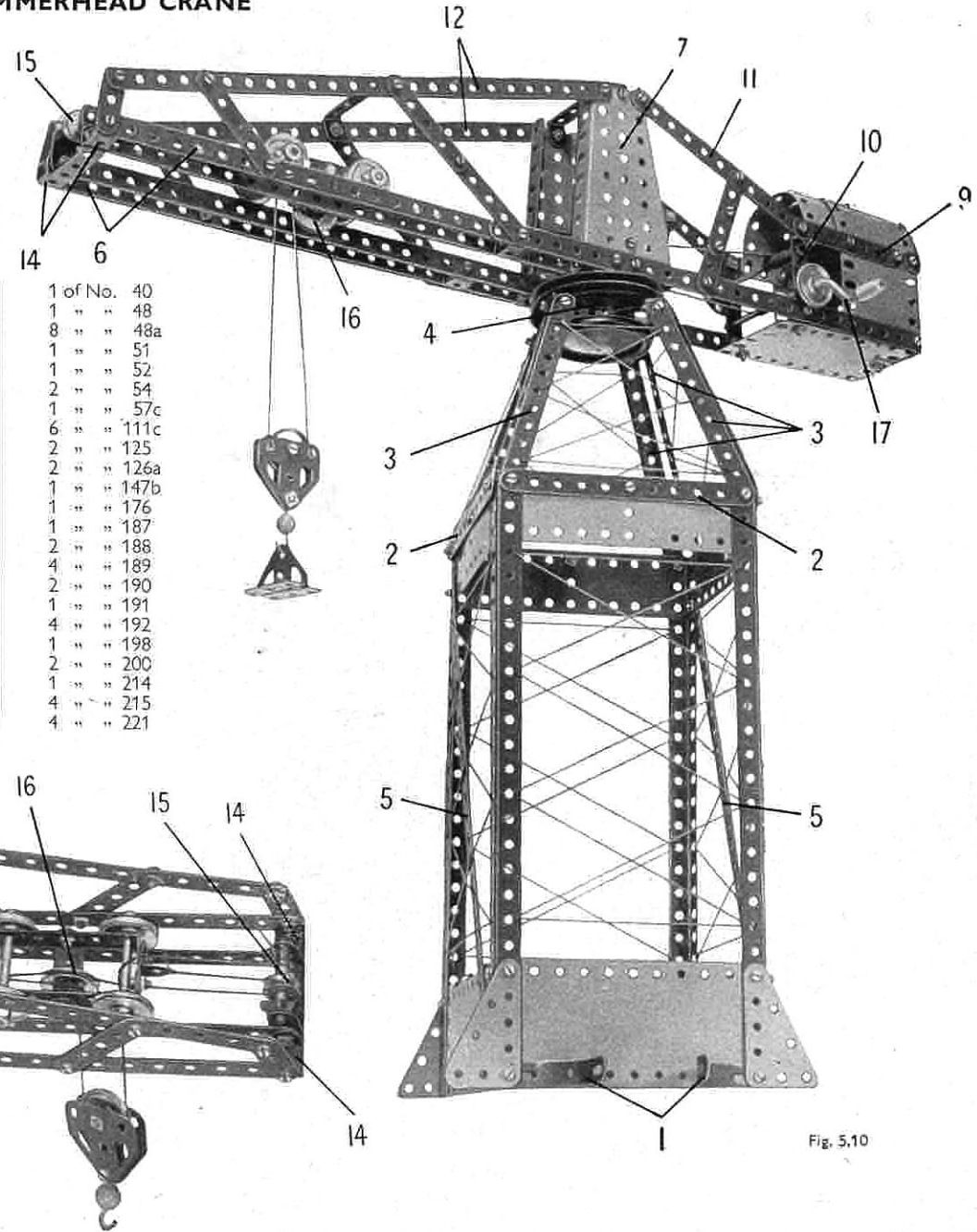

Fig. 5.10

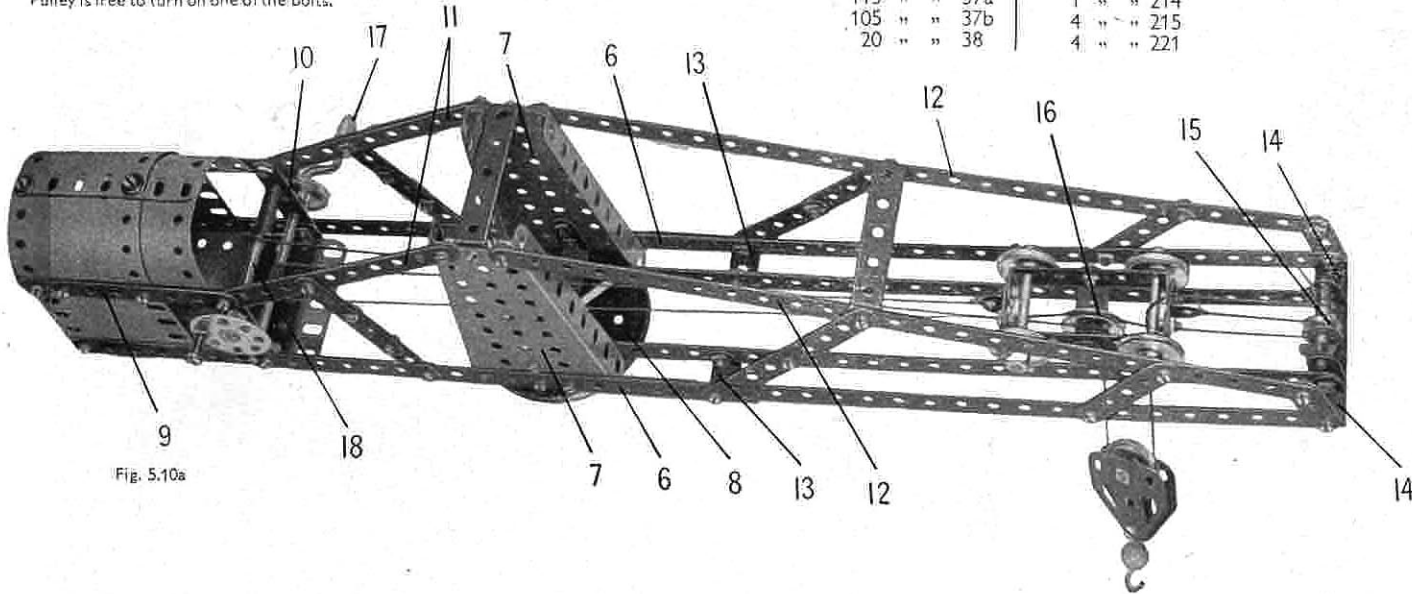

Fig. 5.10a

5.II AUTOMATIC SHIP COALER

CONSTRUCTION OF THE TOWER

The base of the tower is a $5\frac{1}{2}'' \times 2\frac{1}{2}''$ Flanged Plate edged on each side by a $5\frac{1}{2}'' \times 1\frac{1}{2}''$ Flexible Plate, and a $5\frac{1}{2}''$ Strip that overhangs the Flanged Plate at one end by three clear holes. The lower section of the tower consists of four $12\frac{1}{2}''$ Strips bolted to the base. These are extended upward by $5\frac{1}{2}''$ Strips, and the upper ends of the Strips are attached to two Flat Trunnions connected by a $2\frac{1}{2}'' \times \frac{1}{2}''$ Double Angle Strip. The tower is braced by $5\frac{1}{2}''$ Strips arranged as shown, and by a $2\frac{1}{2}''$ Strip (1) fixed to Trunnions bolted to two of the $12\frac{1}{2}''$ Strips.

The engine house is made by bolting a $2\frac{1}{2}'' \times 1\frac{1}{2}''$ Flexible Plate (2) to each side of the base. The upper ends of the Flexible Plates are connected by a $2\frac{1}{2}'' \times 1\frac{1}{2}''$ Flanged Plate (3) (Fig. 5.11a). The roof is formed by two $1\frac{1}{2}''$ radius Curved Plates attached by a $\frac{1}{2}''$ Bolt to the Flanged Plate (3), and bolted to a $2\frac{1}{2}'' \times \frac{1}{2}''$ Double Angle Strip fixed to the Flanged Plate of the base. The back of the engine house is a $2\frac{1}{2}'' \times 2\frac{1}{2}''$ Flexible Plate;

THE GRAB AND ITS GANTRY

The gantry consists of two $12\frac{1}{2}''$ Angle Girders bolted to the top of the tower and braced by $12\frac{1}{2}''$ Strips (4). The Strips and Girders on each side are connected by Fishplates, and a $2\frac{1}{2}''$ Strip is bolted between the outer ends of the Angle Girders.

The grab truck is shown separately in Fig. 5.11c. It consists of two $2\frac{1}{2}'' \times \frac{1}{2}''$ Double Angle Strips connected at one end by a Double Bent Strip and at the other end by two $\frac{1}{2}''$ Reversed Angle Brackets. The truck wheels are Wheel Discs, each of which is free to turn on a $\frac{1}{2}''$ Bolt attached to the truck by two nuts. A $\frac{1}{2}''$ Reversed Angle Bracket (5) is bolted to each Double Angle Strip, and two $1''$ loose Pulleys (6) are mounted on a $1\frac{1}{2}''$ Rod held in the Reversed Angle Brackets by Spring Clips. The truck wheels run on the flanges of the Angle Girders forming the gantry.

The grab (Fig. 5.11d), consists of a $5\frac{1}{2}'' \times 1\frac{1}{2}''$ Flexible Plate curved as shown and bolted to Formed Slotted Strips. The Flexible Plate is connected by Angle Brackets to $3\frac{1}{2}''$ Strips (7), and two $2\frac{1}{2}''$ Stepped Curved Strips and two $2\frac{1}{2}''$ Strips (8) on each side are held by the same bolts. The upper ends of the Strips (8) are bolted to Fishplates. The grab is suspended from a length of Cord tied to one of the Fishplates and passed over one of the Pulleys (6) of the grab truck. The Cord is then looped through a $2\frac{1}{2}''$ Strip (9) (see Fig. 5.11), then taken over the second Pulley (6) and is tied to the other Fishplate of the grab. The Strip (9) is bolted to $1'' \times 1''$ Angle Brackets fixed to the end of the gantry.

THE HOPPER WAGON AND ITS GANTRY

The hopper wagon consists of two $12\frac{1}{2}''$ Angle Girders bolted in the tower in the positions shown. Two $12\frac{1}{2}''$ Strips also bolted to the tower are connected to the ends of the Girders by $1\frac{1}{2}''$ Strips. The gantry is braced to the tower by two $12\frac{1}{2}''$ and two $5\frac{1}{2}''$ Strips. The unloading chute (10) is formed by two Flanged Sector Plates and four $2\frac{1}{2}'' \times 1\frac{1}{2}''$ Triangular Flexible Plates attached to the $12\frac{1}{2}''$ Angle Girders. A $2\frac{1}{2}''$ Strip (11) is bolted between the Girders inside the tower. (Continued on next page)

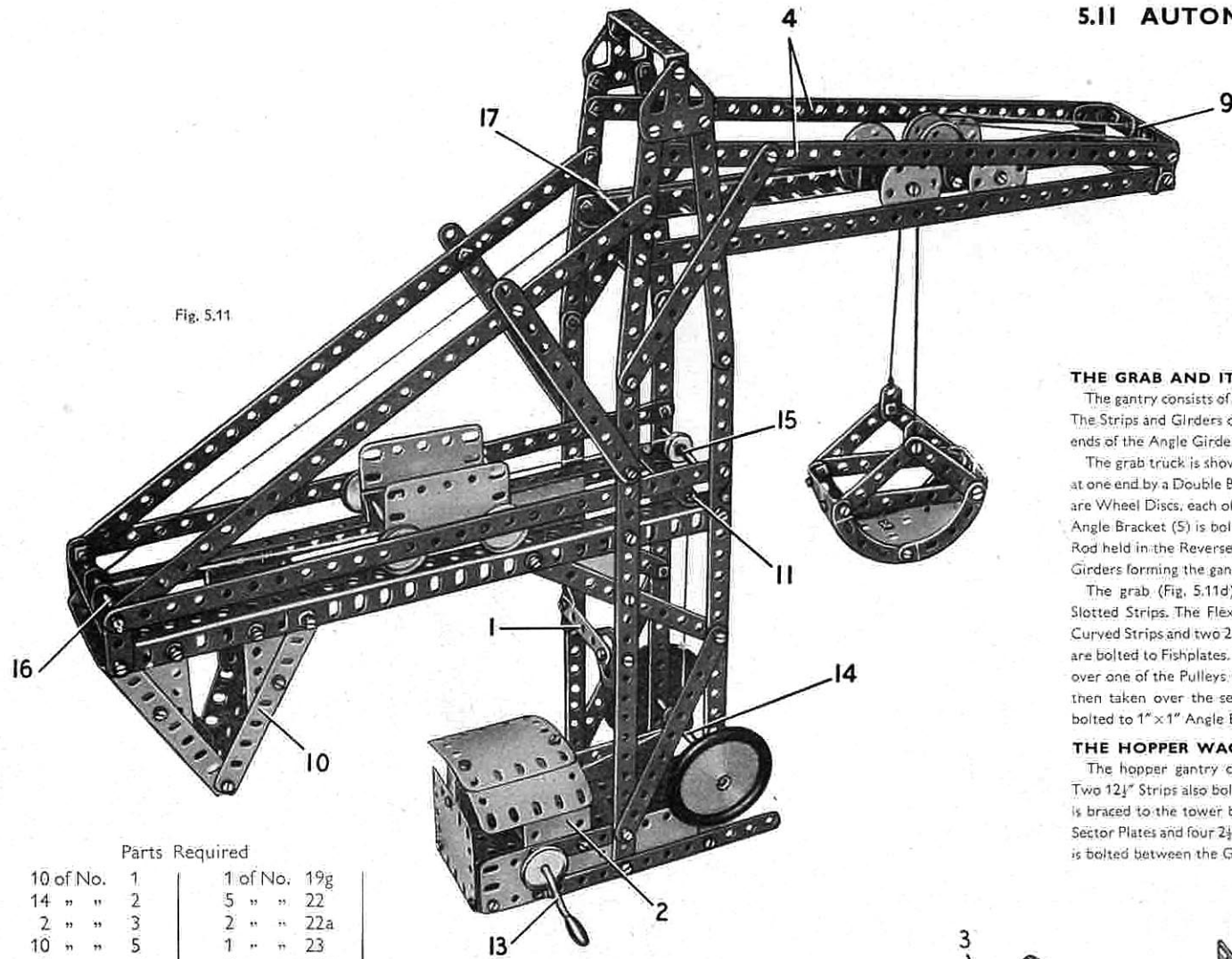

Fig. 5.11



Fig. 5.11a

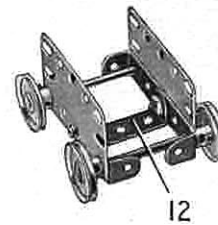

Fig. 5.11b

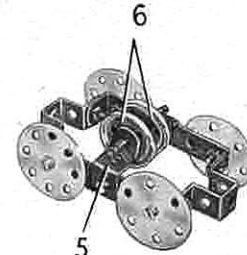

Fig. 5.11c

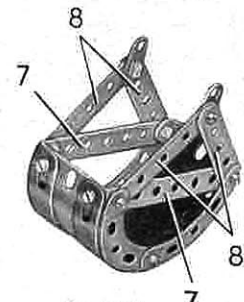

Fig. 5.11d

Parts Required

10 of No. 1	1 of No. 19g	7 of No. 48a	2 of No. 126
14 " " 2	5 " " 22	1 " " 51	2 " " 126a
2 " " 3	2 " " 22a	2 " " 52	2 " " 187
10 " " 5	1 " " 23	1 " " 54	4 " " 188
2 " " 6a	2 " " 24a	4 " " 90a	3 " " 189
4 " " 8	2 " " 24c	1 " " 111a	2 " " 190
4 " " 10	12 " " 35	1 " " 111c	2 " " 200
1 " " 11	118 " " 37a	6 " " 125	4 " " 215
6 " " 12	105 " " 37b		4 " " 221
2 " " 12a	10 " " 38		2 " " 222
1 " " 15b	2 " " 38d		
2 " " 16	1 " " 40		
2 " " 17	1 " " 45		
2 " " 18a	1 " " 48		

MODEL 5.11 AUTOMATIC SHIP COALER — Continued

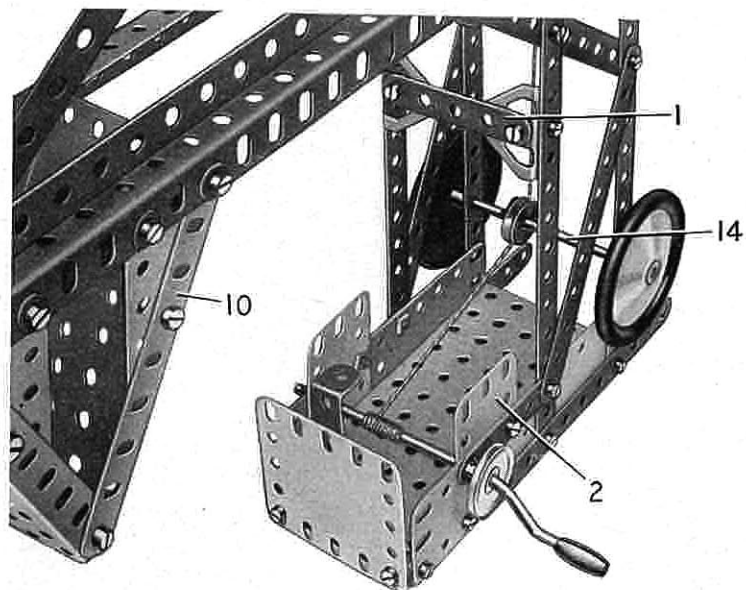

Fig. 5.11e

The hopper wagon is shown in Fig. 5.11b. It consists of two 2½" x 1½" Flexible Plates and two 2½" x ½" Double Angle Strips bolted to a 1½" x ½" Double Angle Strip (12). The wheels are 1" Pulleys on 2" Rods and they run on the 12½" Angle Girders of the gantry.

ARRANGEMENT OF THE CORD

A Crank-Handle (13) is mounted in the sides of the engine house, and a length of Cord is tied to it. The Cord is taken between two 2" Washers placed between Spring Clips on a 4" Rod (14), and is passed round a loose Pulley on a 3½" Rod (15). The Cord is then tied to the end of the hopper wagon nearest to Rod (15). A second length of Cord is fastened to the other end of the hopper wagon and is taken round a 1½" Rod (16) held by Spring Clips in a Double Bracket bolted to a 2½" x ½" Double Angle Strip at the end of the hopper wagon gantry. The Cord passes over a 3½" Rod (17) mounted in the tower, and is tied to the end of the grab truck.

For more new models to build, see the
MECCANO MAGAZINE
 which is published on the first of every month.

5.12 LOADING SHOVEL

		Parts Required							
13 of No.	2	2 of No.	17	108 of No.	37b	1 of No.	90a	3 of No.	189
2 "	3	1 "	18b	20 "	38	6 "	111c	3 "	190
12 "	5	2 "	19b	2 "	38d	1 "	115	3 "	192
2 "	6a	1 "	19g	1 "	40	3 "	125	1 "	198
2 "	8	5 "	22	1 "	45	2 "	126	2 "	199
8 "	10	2 "	22a	1 "	48	2 "	126a	2 "	200
2 "	11	1 "	24	8 "	48a	1 "	147b	1 "	212
12 "	12	1 "	24a	1 "	51	4 "	155	1 "	213
4 "	12c	2 "	24c	1 "	52	1 "	176	2 "	214
2 "	15	13 "	35	1 "	54	4 "	187	4 "	221
3 "	16	117 "	37a	1 "	57c	4 "	188	2 "	222

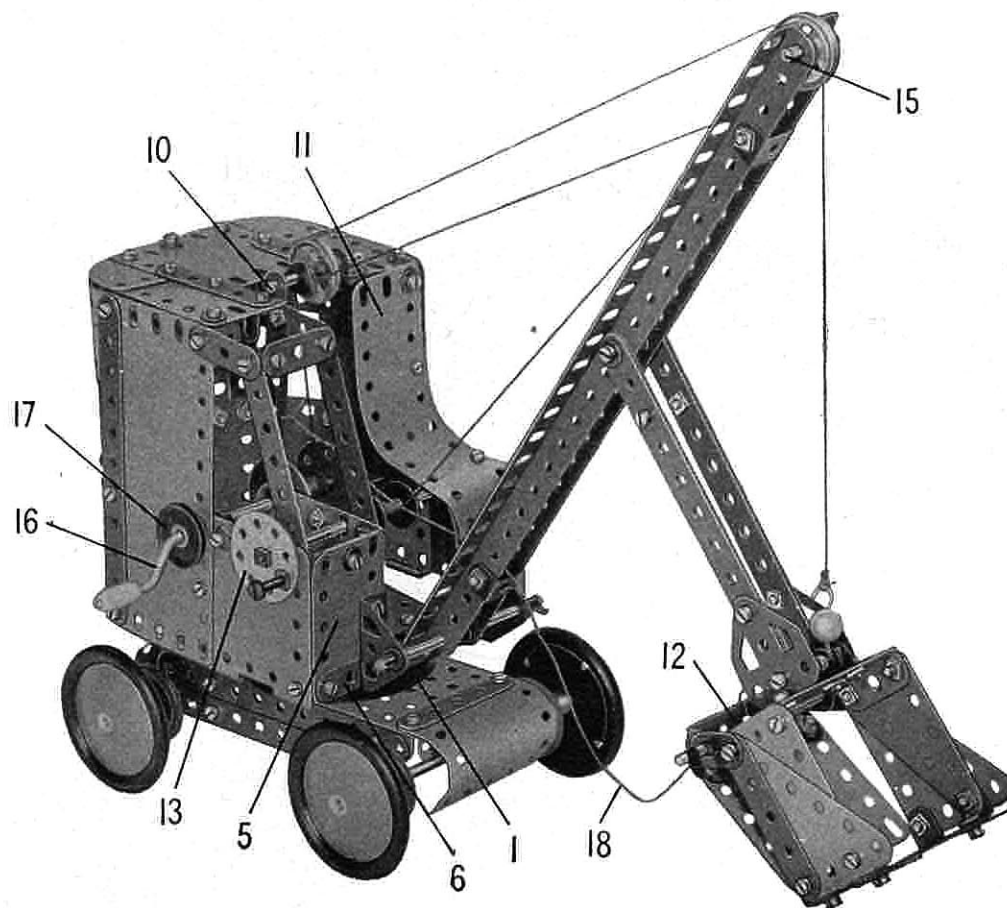

Fig. 5.12

(Continued on next page)

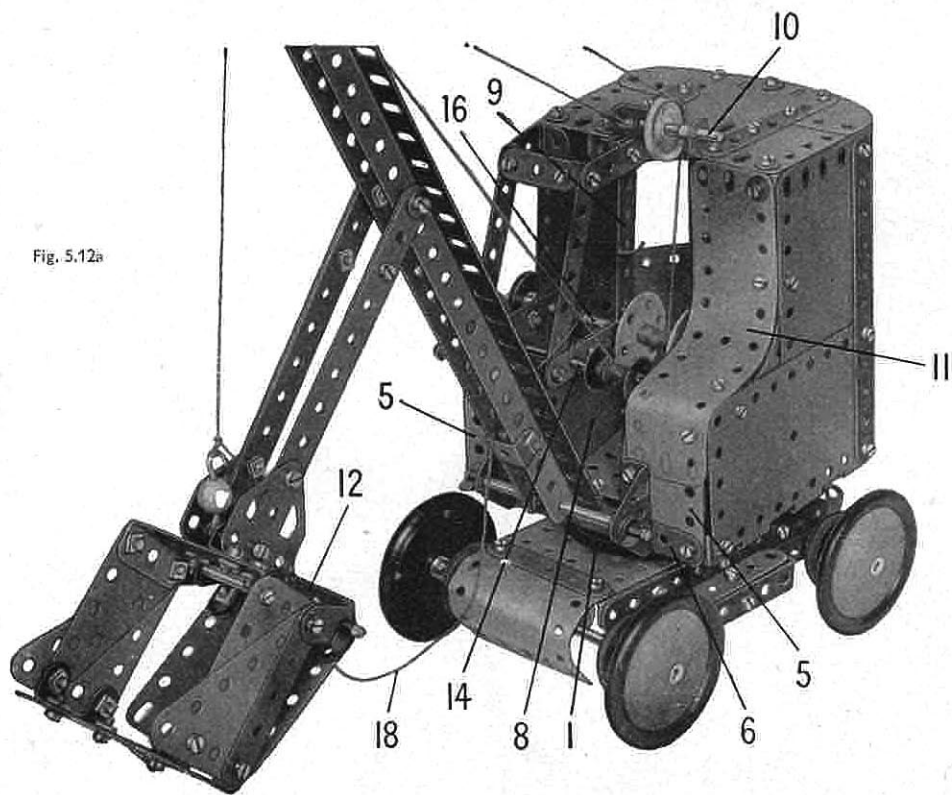

Fig. 5.12a

The sides of the shovel are each made from $2\frac{1}{2}'' \times 2''$ and $2\frac{1}{2}'' \times 1\frac{1}{2}''$ Triangular Flexible Plates, and the bottom consists of two $2\frac{1}{2}'' \times 1\frac{1}{2}''$ Triangular Flexible Plates bolted to $2\frac{1}{2}'' \times \frac{1}{2}''$ Double Angle Strips fixed between the sides. The back of the shovel is a $2\frac{1}{2}'' \times 2\frac{1}{2}''$ Flexible Plate attached by Obtuse Angle Brackets to a $2\frac{1}{2}'' \times \frac{1}{2}''$ Double Angle Strip (12). A $3\frac{1}{2}''$ Rod is passed through this Double Angle Strip and through the slotted holes of Fishplates bolted to the sides of the shovel. When the back is closed the lower edge of the Flexible Plate catches an Obtuse Angle Bracket bolted to the back edge of the bottom of the shovel.

THE OPERATING MECHANISM

A Wheel Disc (13) (Fig. 5.12) is fixed by a nut on a Threaded Pin, which is then passed through the side of the cab and is fitted in a Rod Connector. A $3\frac{1}{2}''$ Rod (14) (Fig. 5.12a) is passed through the Flexible Plate (8) into the Rod Connector, and a length of Cord is fastened to the Rod between 3" Washers, as shown. The Cord is taken over a 1" Rod (15) held in the top of the jib by Spring Clips, and is tied to a small Loaded Hook. The Hook is bolted to an Angle Bracket fixed to the top of the shovel.

A Crank Handle (16) is mounted in the side of the cab and in the Flexible Plate (8). A length of Cord is tied to a Cord Anchoring Spring placed between Six-hole Wheel Discs on the Crank Handle (see Fig. 5.12a), and is taken over the 1" Pulley on Rod (10). The Cord passes round a 1" loose Pulley on Rod (15), and is tied to an Obtuse Angle Bracket on Rod (10). The Crank Handle should be arranged so that it is free to move about $\frac{1}{4}''$ sideways in its bearings, so that when it is pushed inwards a bolt in the boss of a 1" Pulley (17) can engage a $\frac{3}{8}''$ Bolt fixed in the side of the cab. This provides a simple brake to hold the jib in the required position.

The catch at the back of the shovel can be released to discharge the contents of the shovel by means of a Cord (18). This is tied to the cab and to the Double Angle Strip (12). When the Cord is pulled, the back of the shovel is raised to the upper ends of the slots in the Fishplates, and the lower edge of the Flexible Plate is lifted clear of the Obtuse Angle Bracket that forms the catch.

MODEL 5.12. LOADING SHOVEL — Continued

In building the Loading Shovel seen in Fig. 5.12 it is best to commence with the wheeled base. This is formed by a $5\frac{1}{2}'' \times 2\frac{1}{2}''$ Flanged Plate fitted at each of its longer sides with a $5\frac{1}{2}''$ Strip attached to Fishplates fixed to the Plate. A $2\frac{1}{2}'' \times \frac{1}{2}''$ Double Angle Strip and a $2\frac{1}{2}''$ Strip are attached to a $\frac{1}{2}''$ Reversed Angle Bracket at one side. The Road Wheels are fixed on 5" Rods, which are held in position in the $5\frac{1}{2}''$ Strips by 1" Pulleys. A "U"-section Curved Plate is bolted to each end of the Flanged Plate, and a 3" Pulley (1) is fixed to the centre of the Flanged Plate.

CONSTRUCTION OF THE CAB

The next section to be built is the cab. Each side of this is made from *one half of a Hinged Flat Plate* and a $5\frac{1}{2}'' \times 2\frac{1}{2}''$ Flexible Plate edged by a $5\frac{1}{2}''$ Strip. The back is formed by two $5\frac{1}{2}'' \times 1\frac{1}{2}''$ Flexible Plates (2) (Fig. 5.12b) and a $5\frac{1}{2}'' \times 2\frac{1}{2}''$ Flexible Plate (3), lengthened at each end by a $1\frac{1}{8}''$ radius Curved Plate. A $2\frac{1}{2}'' \times 2\frac{1}{2}''$ Flexible Plate is fixed at the centre between the Plates (2) and (3), and a $5\frac{1}{2}''$ Strip (4) is arranged at each side of the $2\frac{1}{2}'' \times 2\frac{1}{2}''$ Flexible Plate.

The front of the cab is formed by a $2\frac{1}{2}'' \times 1\frac{1}{2}''$ Flexible Plate (5) at each side, bolted to two $2\frac{1}{2}''$ Strips (6) (Fig. 5.12a) joined together and attached to the sides by Angle Brackets. A Flanged Sector Plate (7) is fixed by an Angle Bracket to the centre of the Strips (6), and is connected by two $2\frac{1}{2}'' \times \frac{1}{2}''$ Double Angle Strips to the back of the cab.

The operating cabin is placed at one side of the cab, and it is made by bolting a $2\frac{1}{2}'' \times 7\frac{1}{2}''$ Flexible Plate (8) (Fig. 5.12a) to a flange of the Flanged Sector Plate. The rear edge of Plate (8) is braced by a $5\frac{1}{2}''$ Strip (9), and the top edge is strengthened by a $2\frac{1}{2}''$ Strip. A $1\frac{1}{2}'' \times \frac{1}{2}''$ Double Angle Strip is fitted between the side of the cab and the Plates (5) and (8). The window frames are two $3\frac{1}{2}''$ Strips, two $1\frac{1}{2}''$ Strips and a $2\frac{1}{2}''$ Strip. These are arranged as shown and connected together by Angle Brackets, and the $2\frac{1}{2}''$ Strip is connected also to the Strip (9).

The top of the cab consists of two $2\frac{1}{2}'' \times 1\frac{1}{2}''$ Flexible Plates, two Semi-Circular Plates and a $2\frac{1}{2}'' \times 2\frac{1}{2}''$ Flexible Plate. It is attached to the sides and back by Angle Brackets. The Strip (9) is connected to the roof by an Angle Bracket. A 2" Rod (10) carrying a 1" loose Pulley held between Spring Clips is passed through $\frac{1}{2}''$ Reversed Angle Brackets.

The cab is completed by fixing in place a $5\frac{1}{2}'' \times 1\frac{1}{2}''$ Flexible Plate (11), which is curved as shown and bolted to one of the Flexible Plates (5) and to the lug of a $2\frac{1}{2}'' \times \frac{1}{2}''$ Double Angle Strip fixed to the top of the side. The Plate (11) is also connected to the side of the cab by two Angle Brackets.

A Bush Wheel is bolted to the Flanged Sector Plate (7) (Fig. 5.12b), and a 2" Rod is fixed in its boss. The Rod is passed through a 3" Pulley and the Pulley (1) (Fig. 5.12b) and is held in place by a Rod and Strip Connector placed on the Rod below the $5\frac{1}{2}'' \times 2\frac{1}{2}''$ Flanged Plate of the base.

THE JIB AND SHOVEL ARM AND THE SHOVEL

The jib consists of two $12\frac{1}{2}''$ Angle Girders joined by two Double Brackets. It pivots on a $3\frac{1}{2}''$ Rod mounted in Trunnions bolted to the front of the cab.

The shovel arm is made from four $5\frac{1}{2}''$ Strips arranged in pairs, each pair being *lock-nutted* to the jib by a $\frac{1}{2}''$ Bolt and fitted at its lower end with a Flat Trunnion. The two Flat Trunnions are then bolted to a Double Bent Strip fixed to a $2\frac{1}{2}'' \times 1\frac{1}{2}''$ Flanged Plate that forms the top of the shovel.

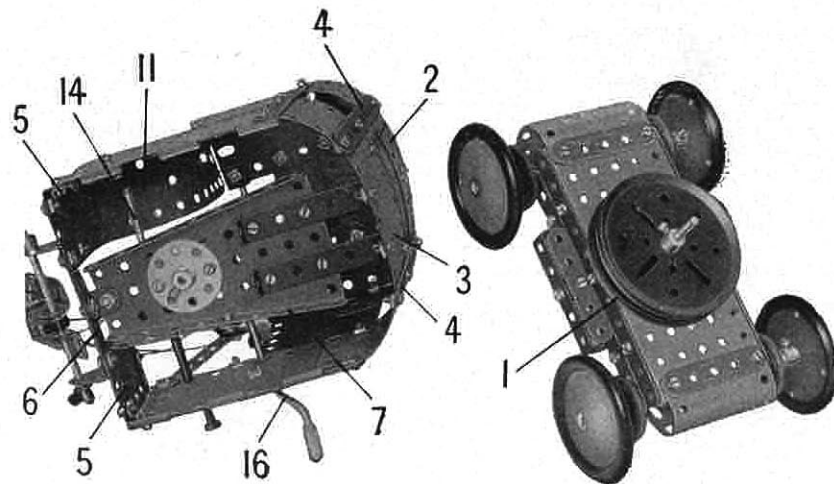

Fig. 5.12b

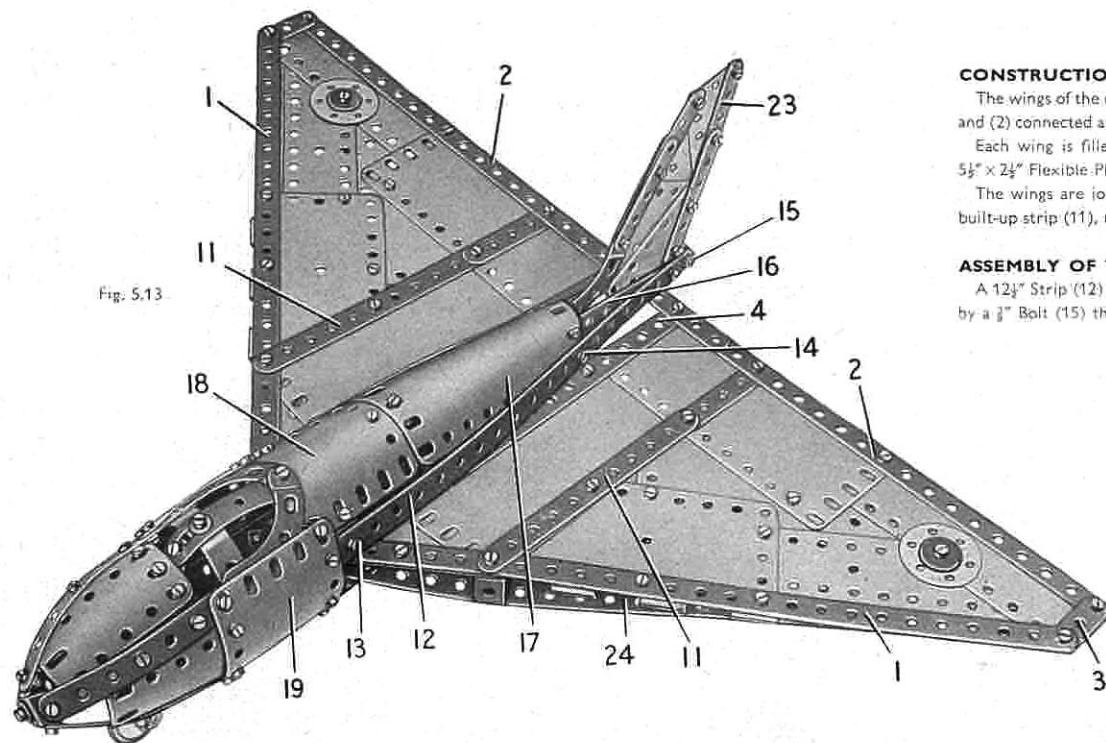

Fig. 5.13

The top of the fuselage consists of a $4\frac{1}{2}'' \times 2\frac{1}{2}''$ Flexible Plate (17) bolted to the Strips (12) and (16) and connected by a Fishplate to a $1\frac{1}{8}''$ radius Curved Plate (18). The Curved Plate is fixed also to Fishplates bolted to the Strips (12).

A $2\frac{1}{2}'' \times 2\frac{1}{2}''$ Flexible Plate (19) on each side is curved slightly and is bolted to the front end of Strip (12) and to the Curved Plate (18). The lower edges of the Plates (19) are joined by a $1\frac{1}{8}''$ radius Curved Plate. The underside of the fuselage consists of a $4\frac{1}{2}'' \times 2\frac{1}{2}''$ Flexible Plate (20) bent to shape and bolted to the Curved Plate and connected at its rear ends to a $5\frac{1}{2}''$ Strip (21) on each side. The underside is completed by a 'U'-section Curved Plate (22), and the bolts holding it in place fix also Angle Brackets used to connect the fuselage to the underside of the wings.

The nose is made by extending the fuselage forward by four $5\frac{1}{2}''$ Strips curved to shape and arranged as shown. The front ends of these Strips are connected by four Obtuse Angle Brackets bolted together. The spaces between the Strips are filled by $2\frac{1}{2}'' \times 1\frac{1}{4}''$ Flexible Plates.

The cockpit cover consists of two $2\frac{1}{2}''$ Stepped Curved Strips and two Formed Slotted Strips. The Formed Slotted Strips are bolted together and connected to one of the Flexible Plates of the nose by an Angle Bracket.

THE TAIL AND THE LANDING WHEELS

The single wheel at the nose is a 1" loose Pulley with Rubber Ring mounted on a Pivot Bolt, which is held by its nuts in a Stepped Bent Strip. A Fishplate is fixed to the top of the Bent Strip, and a Threaded Pin is held tightly in the other hole of the Fishplate. The Threaded Pin is passed through a $\frac{1}{2}''$ Reversed Angle Bracket bolted inside the fuselage to the front of the Curved Plate. A Cord Anchoring Spring is used to hold the Threaded Pin in place. Two 1" fixed Pulleys with Rubber Rings are fixed on $\frac{1}{4}''$ Bolts passed through Flat Trunnions, which are bolted to Angle Brackets attached to the wings.

The tail consists of $2\frac{1}{2}'' \times 1\frac{1}{2}''$ and $2\frac{1}{4}'' \times 2''$ Triangular Flexible Plates bolted and clamped between two $3\frac{1}{2}''$ and two $2\frac{1}{4}''$ Strips (23) (overlapped two holes) on each side of the Plates. The front edges of the Plates are strengthened by $2\frac{1}{2}''$ Strips and $2\frac{1}{2}''$ Stepped Curved Strips. The tail is held by a $\frac{3}{8}''$ Bolt between the Strips (12) and is fixed to the Fishplate on Bolt (15).

The model is completed by a $12\frac{1}{2}''$ Strip (24) bolted to each wing. It is fixed direct to the wing tip and is connected to the wing by a Double Bracket. The free end of the Strip is placed between the Strip (12) and the Strip (21).

5.13 DELTA WING JET AEROPLANE

CONSTRUCTION OF THE WINGS

The wings of the model should be made first. Each wing consists of a series of plates bolted to a framework formed by two $12\frac{1}{2}''$ Strips (1) and (2) connected at their ends by a $1\frac{1}{2}''$ Strip (3) and a built-up strip (4). The built-up strip consists of two $5\frac{1}{2}''$ Strips overlapped four holes.

Each wing is filled in by two $5\frac{1}{2}'' \times 1\frac{1}{2}''$ Flexible Plates (5), a $2\frac{1}{2}'' \times 1\frac{1}{2}''$ Triangular Flexible Plate (6), a $2\frac{1}{2}'' \times 2\frac{1}{2}''$ Flexible Plate (7), two $5\frac{1}{2}'' \times 2\frac{1}{2}''$ Flexible Plates (8), one half of a Hinged Flat Plate (9) and a Semi-Circular Plate (10).

The wings are joined together by a $2\frac{1}{2}''$ Strip at the front. The $12\frac{1}{2}''$ Strips (2) are overlapped eight holes and are bolted together. A built-up strip (11), made from a $5\frac{1}{2}''$ and a $2\frac{1}{2}''$ Strip bolted together, is fixed across each wing as shown.

ASSEMBLY OF THE FUSELAGE

A $12\frac{1}{2}''$ Strip (12) is attached to each wing by Angle Brackets held by the Bolts (13) and (14). The rear ends of Strips (12) are connected by a $\frac{3}{8}''$ Bolt (15) that holds also a Fishplate, and a $5\frac{1}{2}''$ Strip (16) is attached to each side.

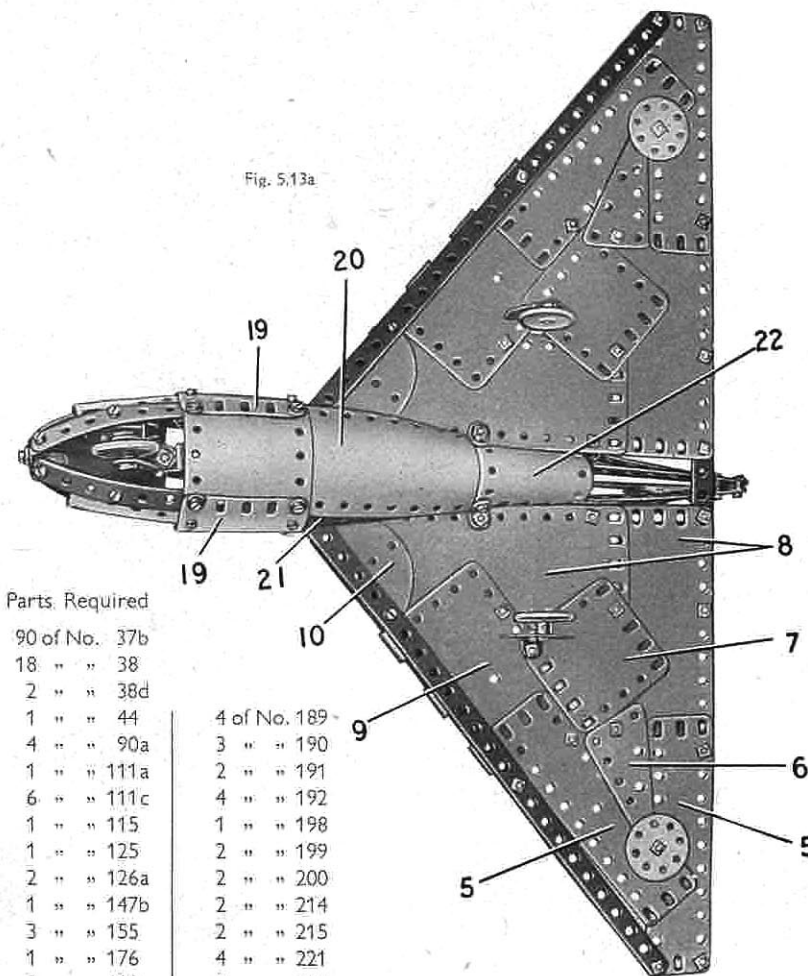

Fig. 5.13a

Parts Required

8 of No. 1	90 of No. 37b	
14 " " 2	18 " " 38	
2 " " 3	2 " " 38d	
11 " " 5	1 " " 44	
2 " " 6a	4 " " 90a	4 of No. 189
4 " " 10	1 " " 111a	3 " " 190
2 " " 11	6 " " 111c	2 " " 191
9 " " 12	1 " " 115	4 " " 192
4 " " 12c	1 " " 125	1 " " 198
2 " " 22	2 " " 126a	2 " " 199
1 " " 22a	1 " " 147b	2 " " 200
2 " " 24a	3 " " 155	2 " " 214
2 " " 24c	1 " " 176	2 " " 215
95 " " 37a	3 " " 188	4 " " 221
		2 " " 222

5.14 HELICOPTER

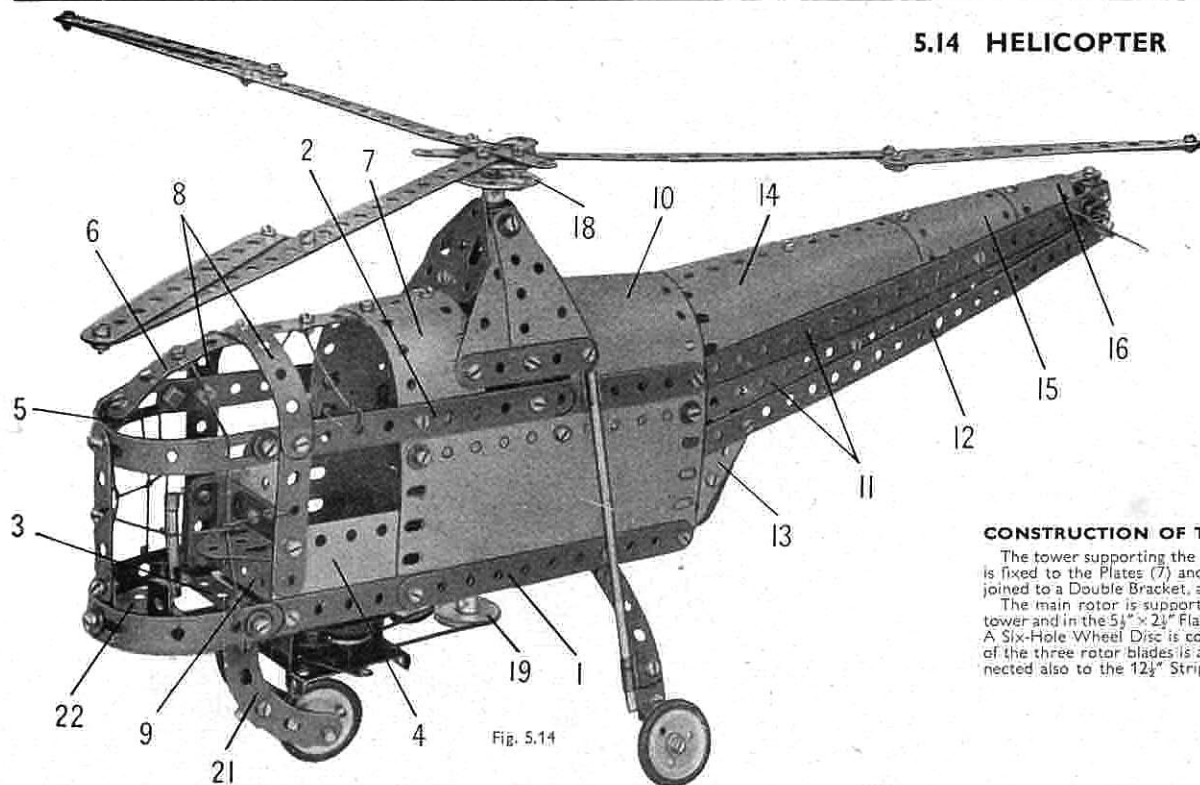

Fig. 5.14

The single wheel at the nose is a 1" fixed Pulley with Rubber Ring, held on a 1" Rod supported in two 2½" Stepped Curved Strips (21). The Curved Strips are connected by a Double Bracket and by a U-shaped piece made from two Angle Brackets. A ⅜" Bolt is passed through the Double Bracket and is held in the Double Angle Strip (3) by two nuts. The nuts secure also a 1½" Strip that carries a Semi-Circular Plate (22). A Double Bracket attached to the Semi-Circular Plate supports a 1½" Rod that represents the control column. The Rod is held in place by two Spring Clips.

THE DRIVE TO THE ROTORS

A Magic Clockwork Motor is bolted underneath the 5½" × 2½" Flanged Plate, and is connected by a Driving Band to one of the Pulleys (19). The 1" Pulley inside the fuselage on the main rotor shaft is connected by a Cord belt to the ⅜" Pulley on the Rod (20).

Parts Required

9 of No. 1	5 of No. 22	2 of No. 90a	4 of No. 192
12 " " 2	2 " " 22a	2 " " 111a	1 " " 199
2 " " 3	1 " " 24	4 " " 111c	2 " " 212
10 " " 5	1 " " 24a	2 " " 125	2 " " 212a
1 " " 6a	1 " " 24c	1 " " 126	1 " " 213
8 " " 10	4 " " 35	2 " " 126a	1 " " 214
4 " " 11	105 " " 37a	3 " " 155	4 " " 215
4 " " 12	95 " " 37b	1 " " 176	4 " " 221
4 " " 12c	20 " " 38	1 " " 186a	2 " " 222
2 " " 15	1 " " 40	3 " " 188	
2 " " 16	2 " " 48a	3 " " 189	
2 " " 18a	1 " " 51	1 " " 190	
1 " " 18b	1 " " 52	1 " " 191	

1 Magic Clockwork Motor
(not included in Outfit)

CONSTRUCTION OF THE FUSELAGE

The centre section of the fuselage is made by bolting a 5½" × 2½" Flexible Plate to each side of a 5½" × 2½" Flanged Plate. The sides are extended upward by 5½" × 1½" Flexible Plates that overlap the 5½" × 2½" Flexible Plates by two holes. Each side is extended forward by two built-up strips (1) and (2). Strip (1) consists of a 5½" and a 3½" Strip overlapped two holes, and strip (2) is made from two 5½" Strips overlapped six holes. Strips (1) are connected at their front-ends by a 2½" × ½" Double Angle Strip (3). A 2½" × 1½" Flexible Plate (4) is attached to each side as shown.

The nose is made by bolting two pairs of Formed Slotted Strips to the ends of the strips (1) and (2). The Formed Slotted Strips are connected at the front by a 2½" Strip extended by a Fishplate, and an Obtuse Angle Bracket (5) is also fixed in position. A 5½" Strip (6) is curved slightly and then is bolted between the Obtuse Angle Bracket and a 5½" × 1½" Flexible Plate (7) bent to U-shape and attached to the strips (2). Two curved 2½" Strips (8) are bolted to the Strip (6) and to 2½" Strips fixed vertically to the Flexible Plates (4). A 2½" × 1½" Flanged Plate (9) is bolted between the Plates (4), and a Trunnion and a Wheel Disc attached to the Plate (9) represent the pilot's seat.

A 4½" × 2½" Flexible Plate (10) is bent to U-shape and is fixed between the rear ends of the strips (2).

ASSEMBLY OF THE TAIL

Two 12½" Strips (11) are fixed to each side at a slight angle, and are connected at their rear ends by a Fishplate. A third 12½" Strip (12) is attached to the lower of the Strips (11), and is fixed at its inner end to a 2½" × 2" Triangular Flexible Plate (13). The Strips (11) are bolted to a Double Bracket that connects the sides of the tail together. The tail is covered by two 5½" × 2½" Flexible Plates (14), a U-section Curved Plate (15) and a 2½" × 1½" Flanged Plate (16). Two 5½" Strips (17) overlapped two holes are bolted to the Plates and to the Double Bracket at the end of the tail. A 2½" × 2½" Flexible Plate is attached by Angle Brackets to the Triangular Flexible Plates (13).

CONSTRUCTION OF THE ROTORS

The tower supporting the main rotor consists of two 2½" × 1½" Triangular Flexible Plates on each side bolted to a 2½" Strip. This assembly is fixed to the Plates (7) and (10), and is connected to the strip (2) by a Fishplate. The upper ends of the Triangular Flexible Plates are joined to a Double Bracket, and the front and rear faces of the tower are Flat Trunnions fixed to Obtuse Angle Brackets.

The main rotor is supported by an axle made from two 3½" Rods joined by a Rod Connector. The rod is supported in the top of the tower and in the 5½" × 2½" Flanged Plate, and it carries a Bush Wheel (18), two 1" Pulleys (19) and a third 1" Pulley placed inside the fuselage. A Six-Hole Wheel Disc is connected to the Bush Wheel by two ¼" Bolts, and is spaced from the Bush Wheel by nuts on the Bolts. Each of the three rotor blades is a 12½" Strip fixed to the Six-Hole Wheel Disc. A 5½" Strip is bolted to each 12½" Strip at one end and is connected also to the 12½" Strip by a Fishplate.

The tail rotor is a 2½" Strip fixed to an Angle Bracket, which is passed over a 1½" Rod (20) mounted in the tail. The Angle Bracket is held between two Spring Clips, one of which is arranged with its lugs pressed against the face of the 2½" Strip so that it turns with the Rod. The Rod (20) carries a ¼" fixed Pulley (supplied with the Magic Clockwork Motor) placed between the sides of the tail.

THE LANDING WHEELS

The main landing wheels are 1" loose Pulleys with Rubber Rings. Each of these is free to turn on a ⅜" Bolt, which is held by two nuts in a ⅜" Reversed Angle Bracket bolted to a 2½" Strip. The 2½" Strip is bolted to an Obtuse Angle Bracket fixed to the strip (1), and is braced by a 5" Rod held in a Rod and Strip Connector and a Right-Angle Rod and Strip Connector.

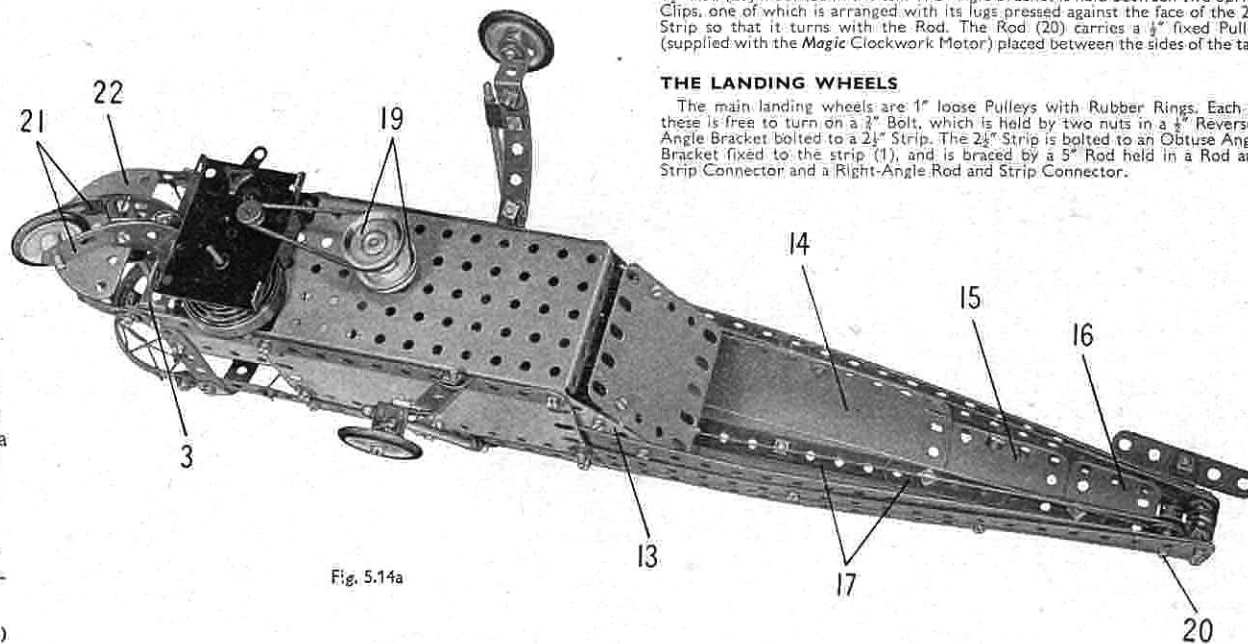

Fig. 5.14a

5.15 TRAVELLING CRANE

CONSTRUCTION OF THE TOWER

The top of the crane tower consists of four $5\frac{1}{2}$ " Strips connected at their ends by Angle Brackets. A $5\frac{1}{2}$ " x $2\frac{1}{2}$ " Flanged Plate (1) is bolted across the structure as shown, and $5\frac{1}{2}$ " Strips (2) are fixed to each corner to form the legs. Further $5\frac{1}{2}$ " Strips are bolted to the top of the tower and are attached to the legs by Angle Brackets.

The wheels on which the crane is mounted are supported by a $12\frac{1}{2}$ " Strip (3) on each side bolted, to the lower ends of the legs. A further $12\frac{1}{2}$ " Strip is attached to the Strip (3) by a Double Bracket at each end and by $1\frac{1}{2}$ " Reversed Angle Brackets held by the same bolts that fix Strip (3) to the legs. The wheels are Wheel Discs and they are free to turn on bolts, each of which is held in the Strip (3) by two nuts.

ASSEMBLY OF THE JIB

A 3" Pulley is bolted to two $2\frac{1}{2}$ " x $1\frac{1}{2}$ " Double Angle Strips fixed between the side flanges of the Flanged Plate (1) and a 2" Rod is free to turn in the boss of the Pulley. The Rod is fixed in the boss of a 3" Pulley (4), and a Road Wheel on the Rod underneath the Flanged Plate holds the Pulleys together.

Two Flanged Sector Plates are attached to the Pulley (4) by Angle Brackets, and two $12\frac{1}{2}$ " Angle Girders overlapped five holes are fixed to the Flanged Sector Plates to form the upper girders of the jib. The lower girders consist of two built-up strips (5) at the front and two built-up strips (6) at the rear. The strips (5) are each made from two $12\frac{1}{2}$ " Strips overlapped 21 holes, and they are connected to a $2\frac{1}{2}$ " x $1\frac{1}{2}$ " Flanged Plate (7) bolted to the front ends of the $12\frac{1}{2}$ " Angle Girders. Strips (6) are each made from a $5\frac{1}{2}$ " and a $2\frac{1}{2}$ " Strip overlapped three holes, and their rear ends are connected by a $2\frac{1}{2}$ " x $1\frac{1}{2}$ " Double Angle Strip (8) and are joined to the ends of the $12\frac{1}{2}$ " Angle Girders by $2\frac{1}{2}$ " Strips (9). The ends of the Angle Girders are connected also by a $2\frac{1}{2}$ " x $1\frac{1}{2}$ " Double Angle Strip.

The rails on which the crab or trolley runs are $12\frac{1}{2}$ " Strips bolted at the front to a $1\frac{1}{2}$ " x $1\frac{1}{2}$ " Double Angle Strip fixed to the Flanged Plate (7). The rear end of each Strip is supported by a $1\frac{1}{2}$ " x $1\frac{1}{2}$ " Angle Bracket (10) bolted to the $12\frac{1}{2}$ " Angle Girders. The bolts connecting the Strips to the $1\frac{1}{2}$ " x $1\frac{1}{2}$ " Double Angle Strip secure also Fishplates, and in these a $1\frac{1}{2}$ " Rod is mounted fitted with a $1\frac{1}{2}$ " loose Pulley (11).

The rear end of the jib is braced by two 4" Rods, each of which is fixed in a Rod and Strip Connector and a Right-Angle Rod and Strip Connector.

THE CAB AND THE CRAB OR TROLLEY

Each side of the cab is a $5\frac{1}{2}$ " x $1\frac{1}{2}$ " Flexible Plate strengthened at the front by a $1\frac{1}{2}$ " Strip and at the rear by a $3\frac{1}{2}$ " Strip. A built-up strip (12), made from two $2\frac{1}{2}$ " Strips, is attached to the top of the $3\frac{1}{2}$ " Strip and is connected to the side by a $2\frac{1}{2}$ " Stepped Curved Strip. The rear ends of the strips (12) are joined by a $2\frac{1}{2}$ " x $1\frac{1}{2}$ " Double Angle Strip, and a $2\frac{1}{2}$ " x $1\frac{1}{2}$ " Flexible Plate is fixed to each side as shown.

The cab roof is formed by two $1\frac{1}{2}$ " radius Curved Plates and two curved $2\frac{1}{2}$ " x $2\frac{1}{2}$ " Flexible Plates edged by Formed Slotted Strips. The back of the cab consists of a Semi-Circular Plate at the top, a $2\frac{1}{2}$ " x $1\frac{1}{2}$ " Flexible Plate (13) and a $2\frac{1}{2}$ " x $2\frac{1}{2}$ " Flexible Plate (14) bolted to the Double Angle Strips at the rear end of the jib.

A Crank Handle (15) is mounted in the $5\frac{1}{2}$ " x $1\frac{1}{2}$ " Flexible Plates and in $2\frac{1}{2}$ " Strips (16) bolted to the Plates. The Crank Handle carries a 1" Pulley fitted with a $\frac{1}{2}$ " Bolt that can be engaged with a Bolt in the side of the cab to form a simple brake. A $3\frac{1}{2}$ " Rod (17) is mounted also in the sides of the cab, and it carries a handle made from a Bush Wheel fitted with a Threaded Pin. The bottom of the cab is filled in by a $5\frac{1}{2}$ " x $2\frac{1}{2}$ " Flexible Plate supported by a Trunnion fixed to the back of the cab, and by a $2\frac{1}{2}$ " x $1\frac{1}{2}$ " Double Angle Strip (18).

The crab consists of two $2\frac{1}{2}$ " x $1\frac{1}{2}$ " Double Angle Strips connected at their ends by a Fishplate. The 1" Pulleys forming the wheels are fixed on 2" Rods. A Fishplate is attached to each Double Angle Strip by a 3" Bolt, but is spaced from it by a Spring Clip and a $\frac{1}{2}$ " Washer on the Bolt. A 1" Rod held in the lower ends of the Fishplates is fitted with a 1" loose Pulley (19).

ARRANGEMENT OF THE CORDS

A length of Cord is tied to an Angle Bracket at one end of the crab, is wound two or three times round the Rod (17) and is taken round the Pulley (11). The Cord is then tied to an Angle Bracket at the other end of the crab.

A length of Cord is fastened to a Cord Anchoring Spring on the Crank Handle (15) and is taken round the Pulley (19) on the crab. It is then taken round a 1" loose Pulley in the pulley block, over the front axle of the crab and is tied to the front of the jib.

The pulley block consists of two Flat Trunnions, spaced apart by nuts on $\frac{1}{2}$ " Bolts. The 1" loose Pulley is free to turn on one of the Bolts, and a small Loaded Hook is supported by the other Bolt.

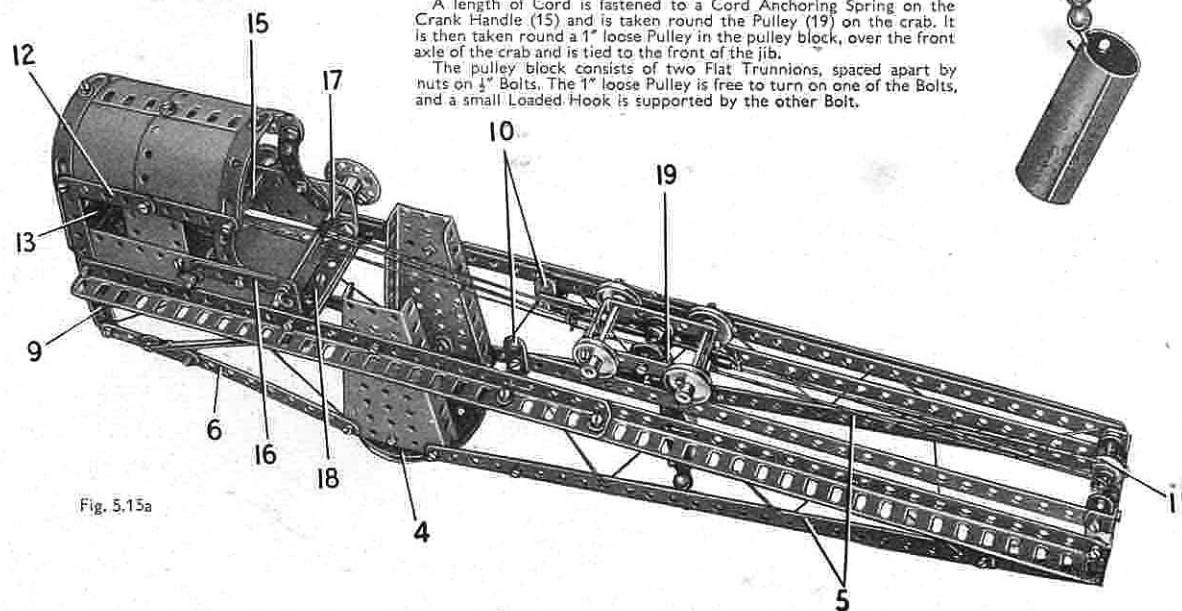

Fig. 5.15a

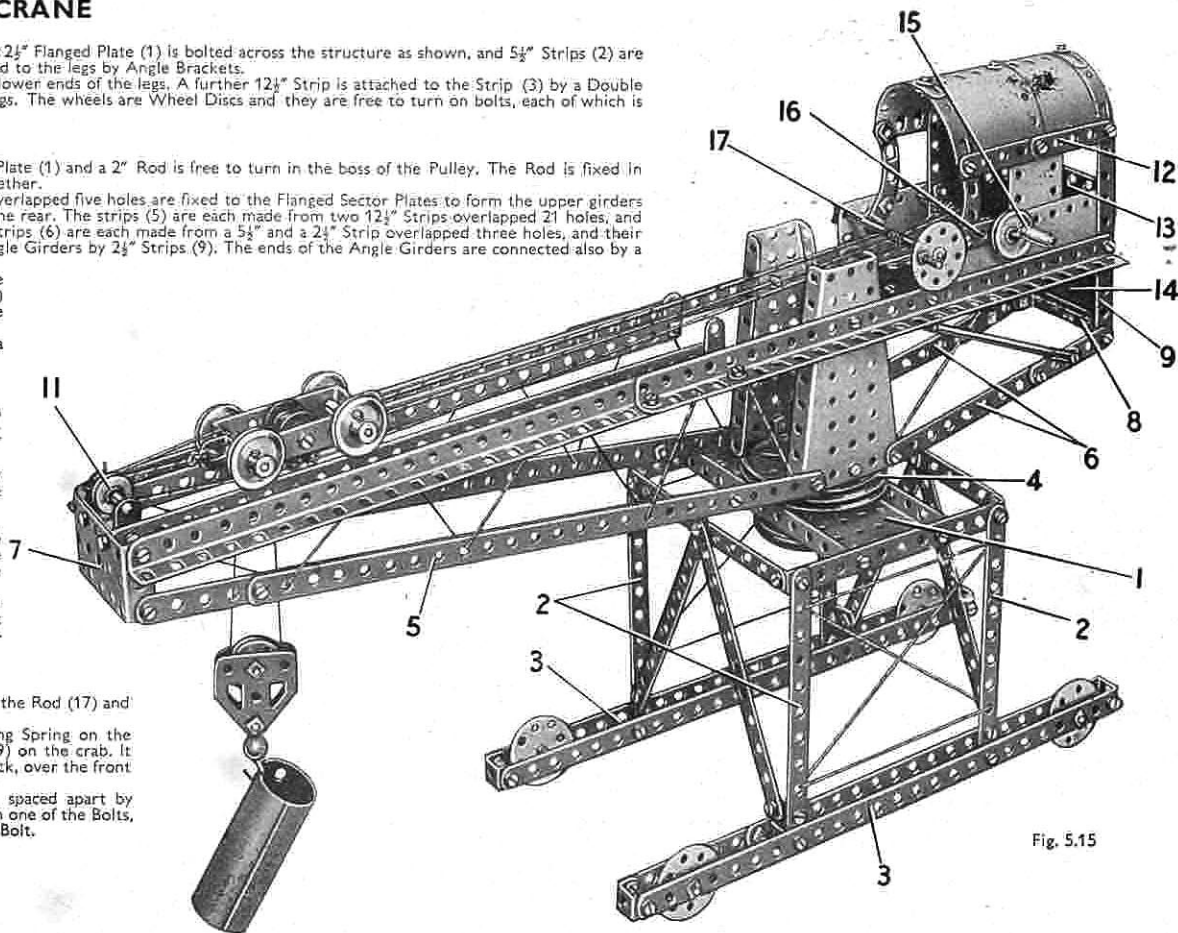

Fig. 5.15

Parts Required

10 of No. 1	1 of No. 16	2 of No. 24c	2 of No. 54	1 of No. 187
14 " " 2	2 " " 17	9 " " 35	1 " " 57c	3 " " 188
2 " " 3	2 " " 18a	118 " " 37a	2 " " 90a	2 " " 189
12 " " 5	1 " " 18b	107 " " 37b	2 " " 111a	3 " " 190
2 " " 6a	2 " " 19b	20 " " 38	6 " " 111c	1 " " 192
4 " " 8	1 " " 19g	2 " " 38d	1 " " 115	2 " " 200
6 " " 10	5 " " 22	1 " " 40	4 " " 125	2 " " 212
4 " " 11	2 " " 22a	1 " " 48	1 " " 126	2 " " 212a
12 " " 12	1 " " 23	8 " " 48a	2 " " 126a	1 " " 214
2 " " 12a	1 " " 24	1 " " 51	1 " " 147b	4 " " 215
2 " " 15b	2 " " 24a	1 " " 52	1 " " 176	1 " " 216

5.16 MILITARY TANK

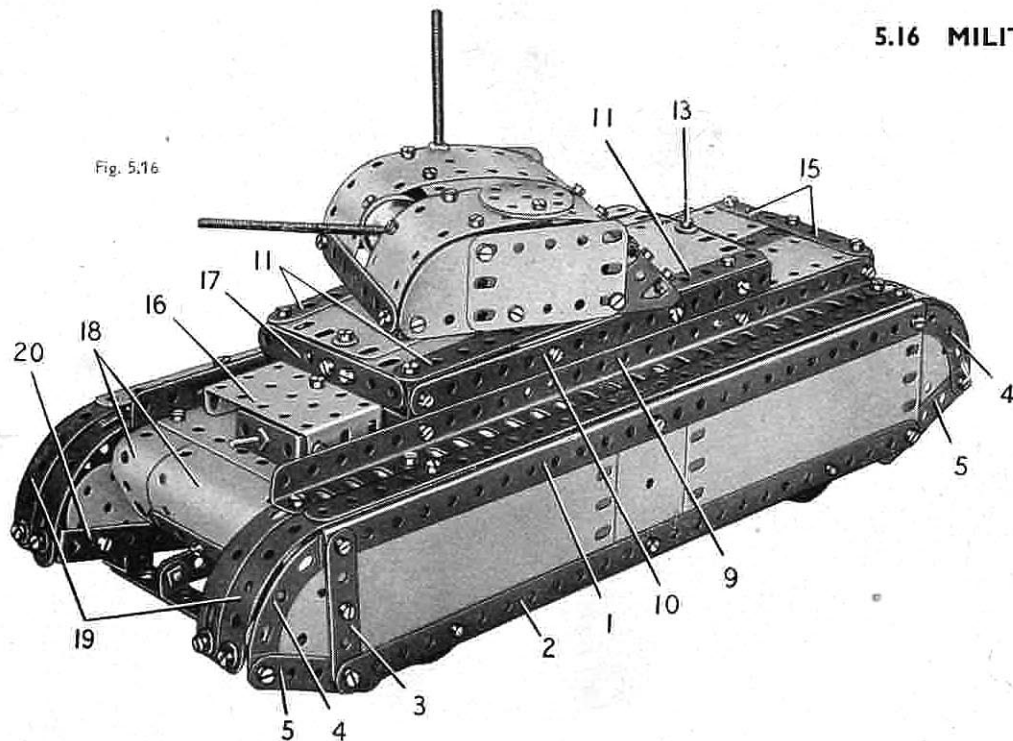

Fig. 5.16a

Fig. 5.16a, and the boss of a 3" Pulley (12) is accommodated in the gap. The Pulley is bolted to the Plates and is connected to the Strips (10) by 1" x 1" Angle Brackets. A 2½" x ½" Double-Angle Strip is connected to an Obtuse Angle Bracket held by a Bolt (13).

The rear end of the tank body is filled by two 5½" x 1½" Flexible Plates and a 2½" x ½" Double Angle Strip (14) connected to the Plates by a 1½" Strip. The assembly is edged by two 2½" Strips (15) and is attached to the Girders (9) by Angle Brackets.

A 2½" x 1½" Flanged Plate (16) is attached by a ½" Reversed Angle Bracket to the 2½" x 2½" Flexible Plates forming the top of the body. The Reversed Angle Bracket supports also a 2½" Strip (17) extended by a 1½" Strip, and further ½" Reversed Angle Brackets bolted to the Girders (9) fill in the gaps between the Flanged Plate (16) and the Girders (9). Two 'U'-section Curved Plates (18) are fixed to the front edge of the half of the Hinged Flat Plate between the Girders (9).

The rounded ends of the track covers are each made from a curved 5½" Strip (19) and a Formed Slotted Strip, which are connected at their outer ends by a Fishplate. A 12½" Strip is bolted along the top of each of the Girders (1) to cover the ends of the 5½" Strips (19). At one end the *inner sides* of the track covers are filled in by 2½" x ½" Double Angle Strips (20) and Six-Hole Wheel Discs.

THE GUN TURRET

Each side of the gun turret (Fig. 5.16b) is made from a Semi-Circular Plate, a 2½" x 1½" Flexible Plate and a Trunnion. The sides are connected at each end by a 3½" Strip, and the top is formed by two 5½" x 1½" Flexible Plates, a 2½" x 1½" Flexible Plate and a 2½" x 2½" Flexible Plate. The top is bolted to the Trunnions and to Angle Brackets fixed to the sides. A Bush Wheel (21) is fixed to two 2½" Strips attached to the sides by Angle Brackets. The gun is a Screwed Rod held in the threaded hole of a 1" Pulley. The Pulley is fixed on a 3½" Rod supported in two Double Brackets as shown. The radio mast is a Screwed Rod held by two nuts, and the turret door is represented by two Wheel Discs. A 1½" Rod gripped in the Bush Wheel (21) is passed through the Pulley (12) and is held in place by a Spring Clip. The turret is spaced from the tank body by a ½" loose Pulley and six Washers.

The tank runs on four 1" Pulleys fitted with Motor Tyres, which are mounted as shown in Fig. 5.16a.

Parts Required

6 of No. 1	1 of No. 23	1 of No. 115
12 " " 2	1 " " 24	3 " " 125
2 " " 3	2 " " 24a	2 " " 126
12 " " 5	2 " " 24c	4 " " 142c
2 " " 6a	5 " " 35	1 " " 147b
4 " " 8	117 " " 37a	3 " " 188
8 " " 10	110 " " 37b	4 " " 189
4 " " 11	13 " " 38	3 " " 190
12 " " 12	1 " " 48	2 " " 191
2 " " 12a	8 " " 48a	4 " " 192
1 " " 12c	1 " " 51	1 " " 198
3 " " 16	1 " " 52	2 " " 199
2 " " 17	2 " " 80c	2 " " 214
1 " " 18a	4 " " 90a	4 " " 215
1 " " 19b	1 " " 111a	4 " " 221
5 " " 22	5 " " 111c	2 " " 222

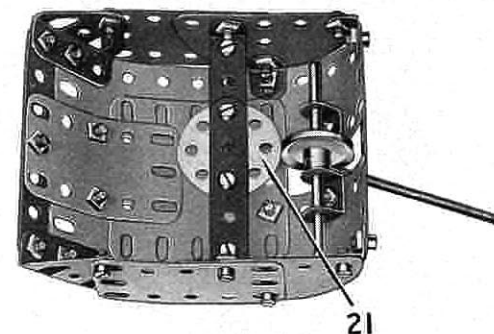

Fig. 5.16b

THE TANK BODY AND TRACK COVERS

Each side of the model tank seen in Fig. 5.16 is assembled on a framework formed by a 12½" Angle Girder (1), a 12½" Strip (2), a 2½" Strip (3), two 2½" Stepped Curved Strips (4) and two 2½" Strips (5), (see Figs. 5.16 and 5.16a). One side is filled in by two 5½" x 2½" Flexible Plates, *one half of a Hinged Flat Plate* and two 2½" x 1½" Triangular Flexible Plates. The other side is similar, but two 2½" x 2" Triangular Flexible Plates are used in place of the half of a Hinged Flat Plate. The sides are joined together by a 5½" x 2½" Flanged Plate (6) and a 5½" Strip (7) bolted to Double Brackets. Two 12½" Strips are bolted to 2½" x ½" Double Angle Strips fixed to the Strip (7) and the Flanged Plate (6).

A 5½" Strip (8) is bolted across the Girders (1), and two 12½" Angle Girders (9) are bolted to this Strip and to the Flanged Plate (6). The other half of the Hinged Flat Plate is fixed to one end of the Girders (9). A 5½" Strip (10), extended by a 2½" x ½" Double Angle Strip, is attached by Fishplates to each of the Girders (9). Two 5½" Strips (11), overlapped seven holes, are connected by Angle Brackets to the Strips (10) on each side, and the space between the Strips (11) is filled by two 4½" x 2½" and two 2½" x 2½" Flexible Plates. A gap is left between the two pairs of Plates as shown in

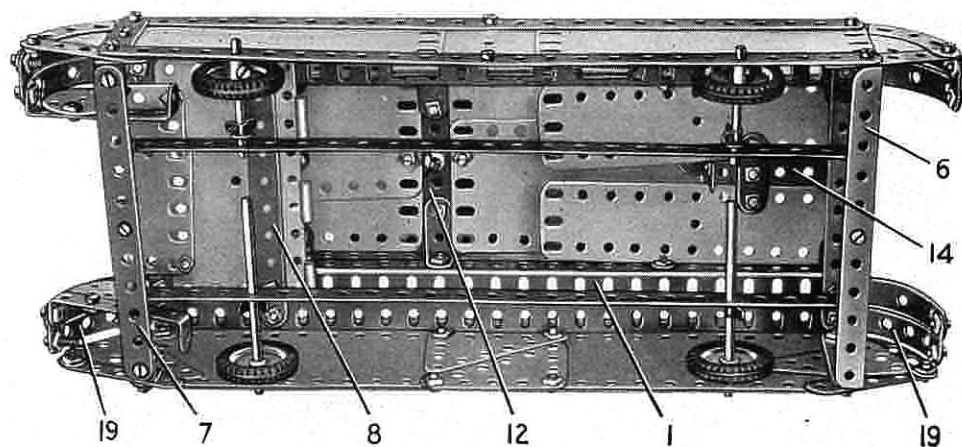

Fig. 5.16a

5.17 RAILWAY BREAKDOWN CRANE

DETAILS OF THE CRANE TRUCK AND BOGIES

The crane truck is shown separately in Fig. 5.17b. It is made by bolting two 12½" Angle Girders (1) to the flanges of a 5½" × 2½" Flanged Plate (2). The Girders (1) are connected also by two 2½" × ½" Double Angle Strips (3) and (4), and a 2½" × 1½" Flanged Plate (5) is fixed between the flanges of the Flanged Plate (2). A 3" Pulley (6) is bolted to a Semi-Circular Plate fixed to each of the Girders (1). The top of the crane truck is filled in by a 5½" × 2½" and a 2½" × 2½" Flexible Plate. These are attached to 5½" × 1½" and 2½" × 1½" Flexible Plates bolted between the Angle Girders (1) and a 12½" Strip (7) on each side.

A 5½" × 1½" Flexible Plate edged by a 5½" Strip is attached to each of the Girders (1) at one end of the truck, and the Flexible Plates are connected by a 2½" × ½" Double Angle Strip. Two Wheel Discs are **lock-nutted** on ½" Bolts attached to the Flexible Plates, and two 1" Pulleys with Rubber Rings are fixed on a 3½" Rod supported in the Flexible Plates. A 2½" × 1½" Flexible Plate and a 3½" Strip (8) are bolted to the end flange of the Flanged Plate (2).

The bogie unit consists of two 5½" Strips connected by three 2½" × ½" Double Angle Strips. It is pivoted on a Pivot Bolt passed through the centre Double Angle Strip, and held by a Spring Clip in a Double Bent Strip bolted to the Double Angle Strip (3).

The wheels are Wheel Discs free to turn on ½" Bolts, and 1" Pulleys fixed on a 3½" Rod. Each ½" Bolt is passed through a Wheel Disc and is fitted with a nut. A Spring Clip is slipped over the Bolt and it is then passed through the 5½" Strip and a second nut is tightened in place. A 2½" × 1½" Flexible Plate and a 3½" Strip are attached to the Double Angle Strip (4) by an Angle Bracket.

THE CAB

The cab is made by bolting a 5½" Strip (9) at each side to a Trunnion fixed to a 3" Pulley (10). A 2" Rod held in the boss of Pulley (10) is passed through the Pulley (6) and is held in position by a Rod and Strip Connector. The Strips (9) are extended by further 5½" Strips that overlap the Strips (9) by three holes, and each side of the cab is **one half of a Hinged Flat Plate** bolted to the 5½" Strips. The lower part of the rear of the cab consists of a 5½" × 2½" Flexible Plate curved and edged by two Formed Slotted Strips. A built-up strip, made from two 2½" Strips overlapped three holes, is fixed to Angle Brackets held by a Bolt (11) at each side, and two 4½" × 2½" Flexible Plates overlapped three holes are bolted between the built-up strip and the 3" Pulley (10). Two Flanged Sector Plates (12) connected together by their flanges are attached to the 4½" × 2½" Flexible Plates inside the cab.

Each side of the cab is extended upward by a 2½" × 2½" Flexible Plate and a 2½" Strip, and the top edge of the Flexible Plate is fitted with a 5½" Strip (13) that is connected to the lower part of the side by a 2½" Stepped Curved Strip. The cab roof consists of two 5½" × 2½" Flexible Plates and two 1½" radius Curved Plates bolted to the Strips (13). The top half of the rear of the cab is partly filled by a 2½" × 2½" Flexible Plate and two 2½" × 1½" Triangular Flexible Plates. These are curved to shape and are attached to two Formed Slotted Strips held by a Bolt (14) on each side.

THE JIB

The lower members of the jib are 12½" Strips extended four holes by 12½" Angle Girders (15). The upper members are 12½" Strips (16), connected to the lower members by 2½" × 1½" Triangular Flexible Plates, and joined together by a 2½" × ½" Double Angle Strip (17) and a 1½" × ½" Double Angle Strip (18). The Strips (16) are extended by 2½" Stepped Curved Strips, and these are joined to 2½" × 2" Triangular Flexible Plates bolted to the Angle Girders (15). The jib pivots on a 4" Rod held by Spring Clips in the end holes of the Strips (9).

Fig. 5.17

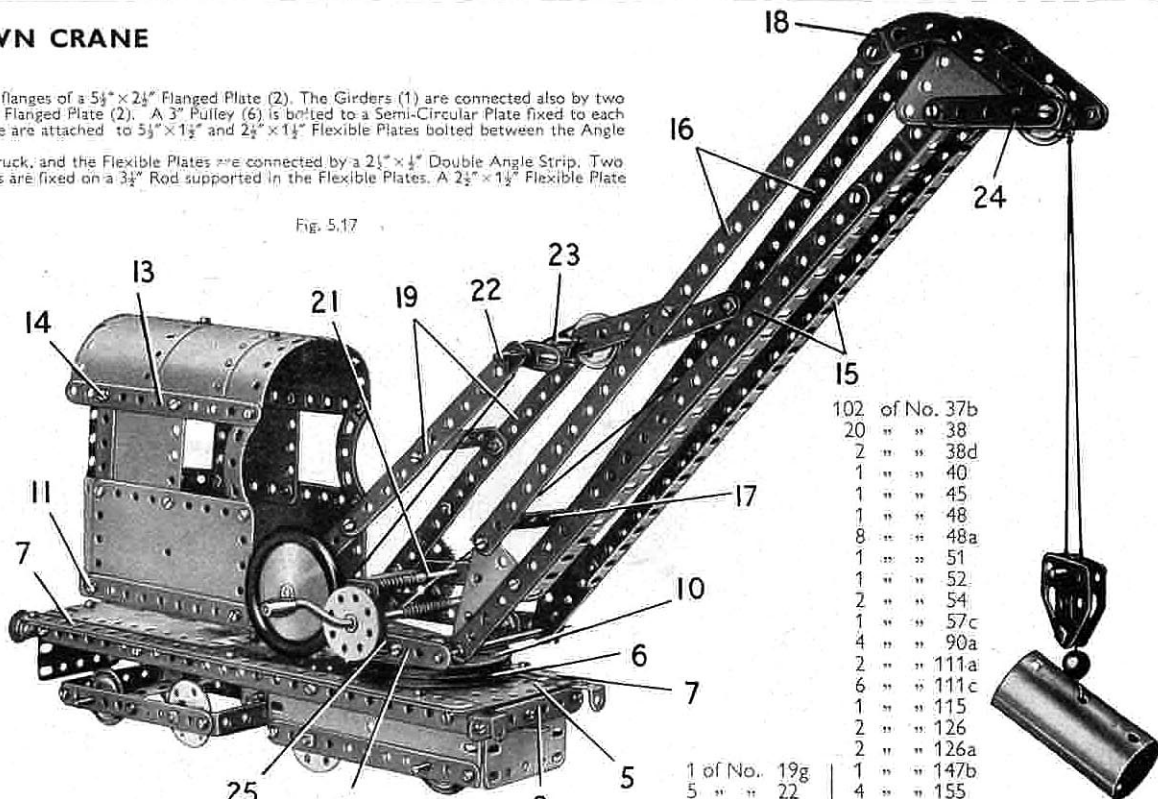

102	of No.	37b
20	" "	38
2	" "	38d
1	" "	40
1	" "	45
1	" "	48
8	" "	48a
1	" "	51
1	" "	52
2	" "	54
1	" "	57c
4	" "	90a
2	" "	111a
6	" "	111c
1	" "	115
2	" "	126
2	" "	126a
1	" "	147b
5	" "	155
2	" "	176
1	" "	187
1	" "	188
4	" "	189
2	" "	191
4	" "	192
1	" "	198
1	" "	199
1	" "	19g
5	" "	22
2	" "	22a
1	" "	23
1	" "	24
2	" "	24a
2	" "	24c
1	" "	26
1	" "	27a
14	" "	35
2	" "	18a
1	" "	18b
2	" "	19b
117	" "	37a
2	of No.	200
1	" "	212
1	" "	213
2	" "	214
4	" "	215
1	" "	216
4	" "	221
2	" "	222

THE OPERATING MECHANISM

Two 5½" Strips (19) overlapped five holes are attached to the Strips (9) at each side, and a 2½" Strip (20) bolted to each Strip (19) is connected to Strip (9) by a 1½" Strip. The Strips (19) are joined by a 2½" × ½" Double Angle Strip.

A 57-tooth Gear fitted with a Threaded Pin is fixed on a 4½" Rod supported in the Strips (20), and it drives a ½" Pinion on a 4" Rod (21) also mounted in the Strips (20). A length of Cord is tied to a Cord Anchoring Spring on Rod (21), and is taken over a 3½" Rod (22) passed through the end holes of Strips (19). The Cord is taken round a 1" loose Pulley on a 3½" Rod (23), round Rod (22) and a second 1" loose Pulley on Rod (23), and is tied finally to a Fishplate on Rod (22). Rod (23) is held by Spring Clips in 2½" Strips **lock-nutted** to the jib.

A Crank Handle extended by a 1½" Rod joined by a Rod Connector is supported in the 1½" Strips as shown in Fig. 5.17a. A length of Cord tied to the Crank Handle is taken over a 1" Pulley on a 2" Rod (24), and is passed round a ½" Pulley in the pulley block. The Cord is then tied to an Angle Bracket bolted to the top of the jib. A Bush Wheel is fixed on the Crank Handle, and its set screw engages an Angle Bracket (25) to act as a simple brake when the Crank Handle is pushed in.

The pulley block consists of two Flat Trunnions joined by a ½" Bolt, and the ½" Pulley is mounted on a 1" Rod.

Parts Required

6 of No.	1	2 of No.	15b
14 "	2	4 "	16
2 "	3	2 "	17
12 "	5	1 "	18a
2 "	6a	1 "	18b
4 "	8	2 "	19b
5 "	10	117 "	37a
2 "	11		
7 "	12		
1 "	15a		

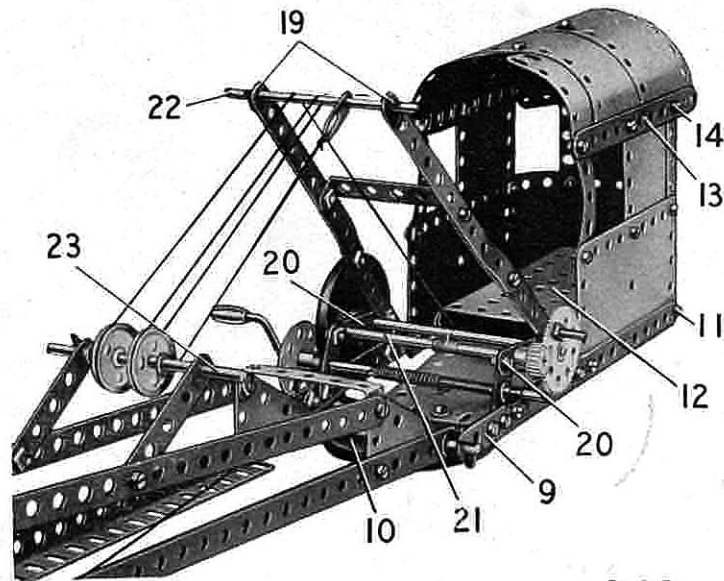

Fig. 5.17a

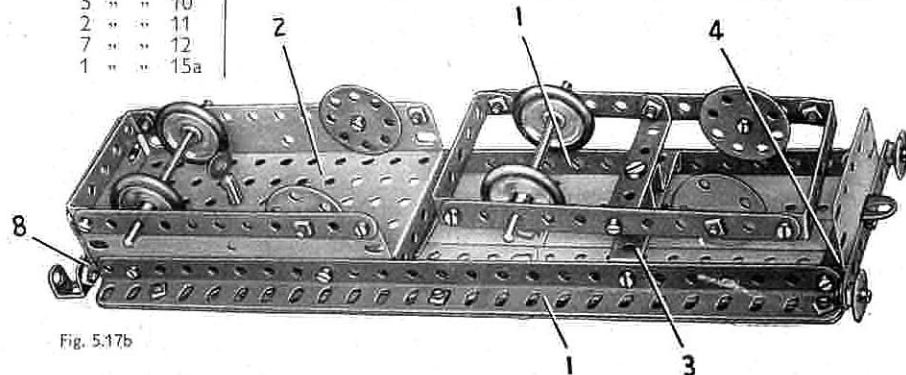

Fig. 5.17b

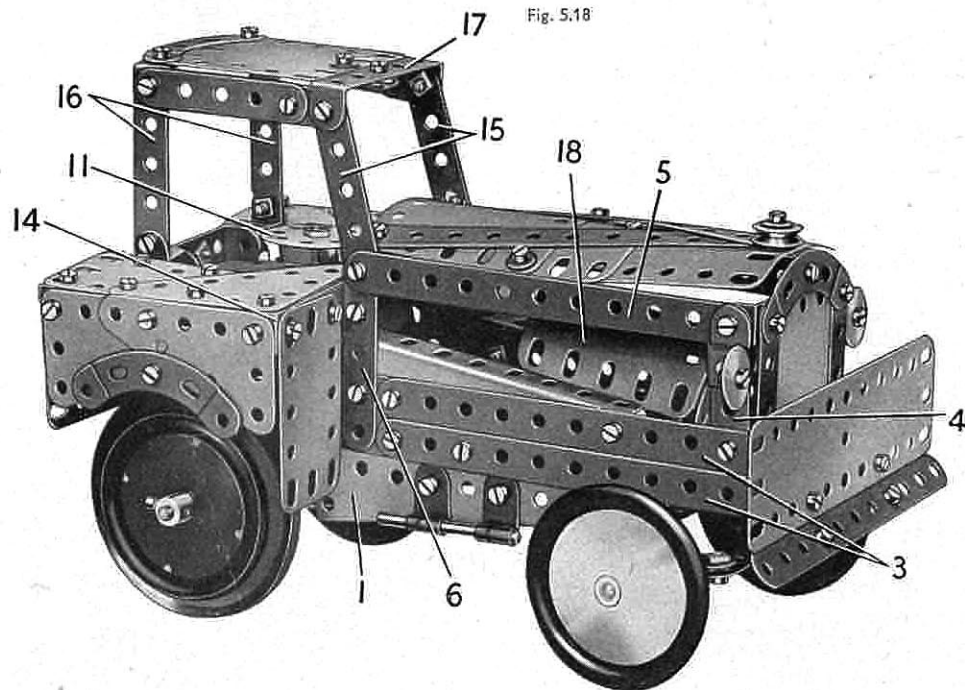

Fig. 5.18

5.18 SHUNTING TRACTOR

ASSEMBLY OF THE CHASSIS

Each side of the model is made by bolting a Flanged Sector Plate (1) to the edges of a $5\frac{1}{2}'' \times 2\frac{1}{4}''$ Flanged Plate (2). Two built-up strips (3), each made from two $5\frac{1}{2}''$ Strips overlapped three holes, are bolted to the side so that they overhang the Flanged Sector Plate at the front by four clear holes. The front ends of these Strips are connected together by Fishplates, and they are joined across by two $2\frac{1}{2}'' \times \frac{1}{2}''$ Double Angle Strips, and a $5\frac{1}{2}'' \times 1\frac{1}{2}''$ Flexible Plate is bolted in position. A $5\frac{1}{2}''$ Strip is attached to the lower Double Angle Strip by Obtuse Angle Brackets.

The radiator consists of a $2\frac{1}{2}'' \times 2\frac{1}{2}''$ Flexible Plate edged by two $2\frac{1}{2}''$ Strips and a $2\frac{1}{2}''$ Stepped Curved Strip. It is attached to Angle Brackets bolted to the strips (3), and a $2\frac{1}{2}''$ Strip (4) is fitted at each side. The upper ends of the Strips (4) are connected to a $2\frac{1}{2}'' \times \frac{1}{2}''$ Double Angle Strip fixed to the back of the radiator, and a $5\frac{1}{2}''$ Strip (5) on each side is held by the same bolt as the Strip (4). The Strips (5) are connected at their rear ends to the Flanged Sector Plates by $2\frac{1}{2}''$ Strips (6).

The top of the bonnet consists of two $1\frac{1}{2}''$ radius Curved Plates and a curved $2\frac{1}{2}'' \times 2\frac{1}{2}''$ Flexible Plate bolted together as shown, and strengthened by two $5\frac{1}{2}''$ Strips. The $5\frac{1}{2}''$ Strips are joined together at the front by a $\frac{1}{2}''$ Bolt, and a $\frac{1}{2}''$ loose Pulley and a Washer on the Bolt represent the radiator filler cap. The top of the bonnet is attached to the radiator by an Angle Bracket, and is connected to the Strips (6) by Obtuse Angle Brackets.

The rear wheels are fixed on a $3\frac{1}{2}''$ and a 2" Rod joined by a Rod Connector and supported in Flat Trunnions bolted to the sides of the Flanged Plate (2).

THE STEERING MECHANISM

The front axle beam is a $3\frac{1}{2}''$ Strip (7) attached to Fishplates bolted to the flanges of the Flanged Sector Plates. Each of the front wheels is fixed on a $1\frac{1}{2}''$ Rod supported in a Double Bracket. A $\frac{1}{2}''$ Bolt is passed through a $1\frac{1}{2}''$ Strip (8) and one of the Double Brackets and is fitted with three Washers. A nut is screwed loosely on the Bolt, which is then passed through an end hole of the Strip (7) and a second nut is screwed tightly in position. This arrangement leaves the Double Bracket and the Strip free to swivel as a unit on the Bolt. A similar system is used at the other side but the $1\frac{1}{2}''$ Strip is replaced by a $2\frac{1}{2}''$ Strip (9). A $3\frac{1}{2}''$ Strip (10) is lock-nutted to the ends of the Strips (8) and (9).

The steering column is a 3" Screwed Rod supported in the Flanged Plate (2) and in a Double Bent Strip bolted to it. The Screwed Rod is held in position by two 1" Pulleys, and a Wheel Disc (11) is attached tightly to its upper end by two nuts. A Fishplate is bolted to a Bush Wheel (12) fixed to the lower end of the Screwed Rod and a $5\frac{1}{2}''$ Strip is used to connect the Fishplate to a $2\frac{1}{2}''$ Strip bolted to the Strip (9). The $5\frac{1}{2}''$ Strip is lock-nutted to the $2\frac{1}{2}''$ Strip, and is connected to the Fishplate by a Threaded Pin. A Spring Clip on the Threaded Pin keeps the parts in position.

CONSTRUCTION OF THE CAB

The back of the cab is a $5\frac{1}{2}'' \times 1\frac{1}{2}''$ Flexible Plate (13) bolted to the end of the Flanged Plate (2). The top of each of the wheel guards consists of a $2\frac{1}{2}'' \times 1\frac{1}{2}''$ Flexible Plate and a $2\frac{1}{2}'' \times 2''$ Triangular Flexible Plate bolted together. It is attached by an Angle Bracket to a Semi-Circular Plate bolted to the upper strip (3) on each side, and is connected by a Trunnion to the Flexible Plate (13). The front of the wheel guard is a $2\frac{1}{2}'' \times 1\frac{1}{2}''$ Flexible Plate bolted to a $2\frac{1}{2}'' \times \frac{1}{2}''$ Double Angle Strip (14). The Double Angle Strip is connected by Angle Brackets to the Strip (6) and to the top of the wheel guard. The side of the wheel guard is made from two $2\frac{1}{2}'' \times 1\frac{1}{2}''$ Triangular Flexible Plates arranged as shown and attached to an Angle Bracket and to the lug of the Double Angle Strip (14). A $2\frac{1}{2}''$ Stepped Curved Strip is clamped to the Triangular Flexible Plates by a Washer and a nut on a bolt.

(Continued on next page)

Parts Required

14 of No.	2	8 of No.	48a
2 "	3	1 "	51
12 "	5	1 "	52
2 "	6a	2 "	54
8 "	10	1 "	80c
3 "	11	4 "	90a
12 "	12	1 "	111a
2 "	12a	4 "	111c
4 "	12c	1 "	115
1 "	16	4 "	125
2 "	17	2 "	126
3 "	18a	2 "	126a
2 "	19b	1 "	147b
4 "	22	2 "	155
1 "	22a	4 "	187
1 "	23	4 "	188
1 "	24	3 "	189
2 "	24a	3 "	190
1 "	24c	1 "	199
5 "	35	2 "	200
116 "	37a	1 "	212
106 "	37b	2 "	212a
20 "	38	1 "	213
2 "	38d	2 "	214
1 "	44	4 "	221
1 "	45	2 "	222
1 "	48		

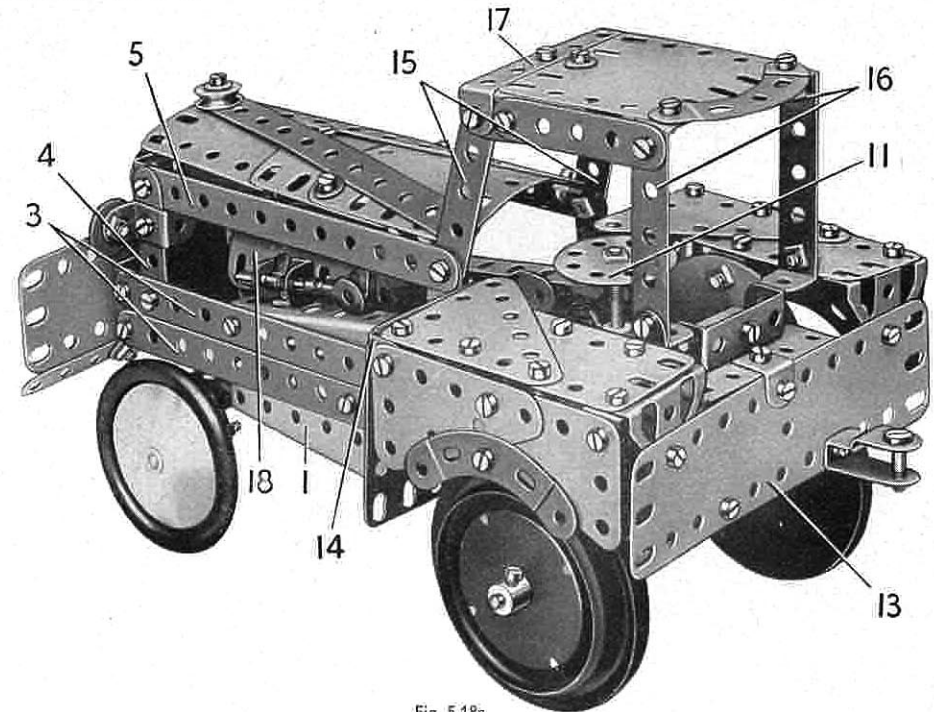

Fig. 5.18a

MODEL 5.18 SHUNTING TRACTOR — Continued

The driver's seat is a $2\frac{1}{2}'' \times 1\frac{1}{2}''$ Flanged Plate bolted to a $\frac{1}{2}''$ Reversed Angle Bracket fixed to the Flexible Plate (13). The back of the seat is a $1\frac{1}{2}'' \times \frac{1}{2}''$ Double Angle Strip and this also is attached to the Reversed Angle Bracket.

The cab roof is supported by two $2\frac{1}{2}''$ Strips (15), and two $2\frac{1}{2}'' \times \frac{1}{2}''$ Double Angle Strips (16) attached to the wheel guards by Angle Brackets. The Strips (15) are connected by a $2\frac{1}{2}'' \times \frac{1}{2}''$ Double Angle Strip (17), and they are joined to the Double Angle Strips (16) by $2\frac{1}{2}''$ Strips extended by Fishplates. The cab roof is a $2\frac{1}{2}'' \times 2\frac{1}{2}''$ Flexible Plate bolted to the lugs of the Double Angle Strips (16) and connected to the Double Angle Strip (17) by a Wheel Disc.

An engine unit is represented by a "U"-section Curve d Plate (18), which is fitted at the front with a 1" loose Pulley bolted to an Angle Bracket. The unit is connected to one of the Flanged Sector Plates by a $\frac{1}{2}''$ Reversed Angle Bracket.

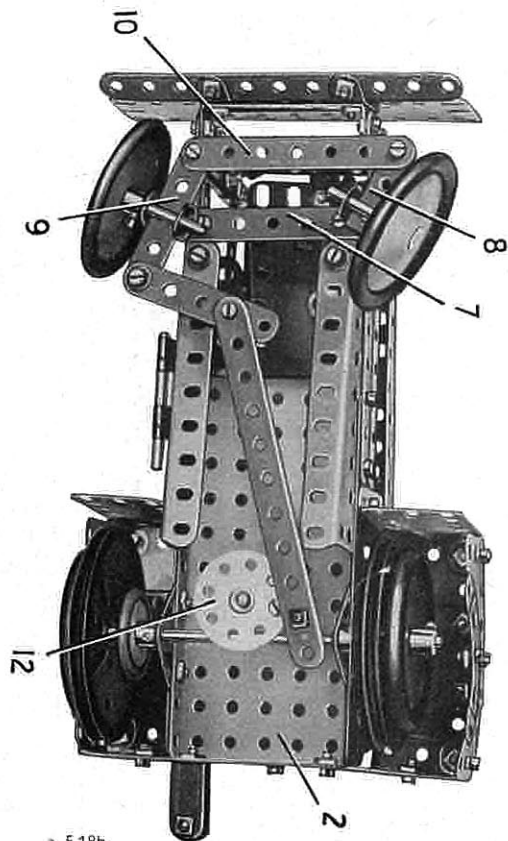

Fig. 5.18b

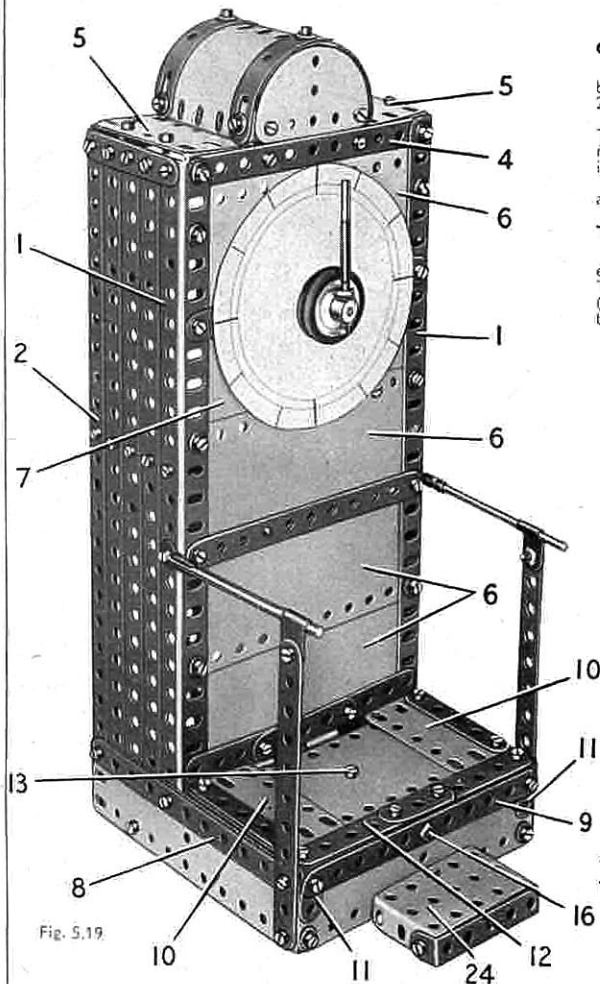

Fig. 5.19

The weighing platform is one half of a Hinged Flat Plate fixed by a Bolt (13) to a Double Bracket bolted to two $5\frac{1}{2}''$ Strips (14). These Strips form the operating lever, which pivots on a $1\frac{1}{2}''$ Rod held by Spring Clips in a Double Bracket (15). The Double Bracket is attached to the front of the base by a Bolt (16).

THE OPERATING MECHANISM

The Strips (14) are joined at their ends by a Double Bracket, and an Angle Bracket (17) is bolted also to the end of one of the Strips. A $5\frac{1}{2}''$ Strip (18) is lock-nutted to the Angle Bracket, and to one of two $3\frac{1}{2}''$ Strips (19) joined together by a $1\frac{1}{2}'' \times \frac{1}{2}''$ Double Angle Strip. The Strips (19) pivot on a $3\frac{1}{2}''$ Rod mounted in the front of the column and in a $5\frac{1}{2}''$ Strip (20). One of the Strips (19) is bolted to a 3" Pulley fixed on the $3\frac{1}{2}''$ Rod. The Strips (19) are weighted at one end by two Road Wheels on a 2" Rod.

A length of Cord is tied at one end to a 6" Driving Band and is passed round the 3" Pulley and one of two 1" Pulleys on a $3\frac{1}{2}''$ Rod (21). The Cord is then tied again to the Driving Band so that it is stretched slightly to make a tensioned driving belt. Rod (21) is mounted in the front of the column and in a $5\frac{1}{2}''$ Strip (22), and a 57-tooth Gear is fixed on the Rod. This Gear drives a $\frac{1}{2}''$ Pinion on the 4" Rod (23), which carries the pointer. Rod (23) is supported in the front of the column and in Strip (22). The pointer is a 1" Rod connected by a Rod Connector to a Threaded Pin that is screwed into the boss of a 1" Pulley. A second 1" Pulley is used to space the pointer from the front of the column. The dial is drawn on a sheet of cardboard and is passed over Rod (23).

The handrails are made from $5\frac{1}{2}''$ Strips, $3\frac{1}{2}''$ Rods, Rod and Strip Connectors and Right-Angle Rod and Strip Connectors arranged as shown. The step (24) is attached to the base by a $\frac{1}{2}''$ Reversed Angle Bracket.

5.19 PLATFORM WEIGHING MACHINE

CONSTRUCTION OF THE BODY

Each side of the column or body of the machine consists of two $12\frac{1}{2}''$ Angle Girders (1) and (2) and three $12\frac{1}{2}''$ Strips bolted to a $5\frac{1}{2}'' \times 2\frac{1}{2}''$ Flanged Plate (3). The upper ends of the Strips and Angle Girders on each side are bolted to a $2\frac{1}{2}''$ Strip, and the Angle Girders are connected to those of the opposite side by $5\frac{1}{2}''$ Strips (4).

The top of the column is formed by attaching a Semi-Circular Plate to Fishplates bolted to each of the Strips (4). Two $2\frac{1}{2}'' \times \frac{1}{2}''$ Double Angle Strips are bolted between the lower corners of the Semi-Circular Plates, and a $1\frac{1}{2}''$ radius Curved Plate edged by Formed Slotted Strips is fixed to each Double Angle Strip. A $2\frac{1}{2}'' \times 1\frac{1}{2}''$ Flexible Plate (5) is attached to a $2\frac{1}{2}'' \times \frac{1}{2}''$ Double Angle Strip bolted between the Girders (1) and (2) of each side. The front of the column is filled by four $5\frac{1}{2}'' \times 2\frac{1}{2}''$ Flexible Plates (6), and a built-up plate (7) made from a $4\frac{1}{2}'' \times 2\frac{1}{2}''$ and a $2\frac{1}{2}'' \times 2\frac{1}{2}''$ Flexible Plate overlapped three holes.

THE BASE AND WEIGHING PLATFORM

A $5\frac{1}{2}'' \times 1\frac{1}{2}''$ Flexible Plate strengthened by a $5\frac{1}{2}''$ Strip (8) is bolted to each side of the main column, and the front edges of these parts are connected by Angle Brackets to a further $5\frac{1}{2}'' \times 1\frac{1}{2}''$ Flexible Plate fitted with a $5\frac{1}{2}''$ Strip (9). Two $2\frac{1}{2}'' \times 1\frac{1}{2}''$ Flexible Plates (10) are bolted to $2\frac{1}{2}'' \times \frac{1}{2}''$ Double Angle Strips attached by their lugs to the Angle Girders (1), and they are connected to the ends of the Strip (9) by $1'' \times 1''$ Angle Brackets seen at (11). The Plates (10) are edged by $2\frac{1}{2}''$ Strips. A built-up strip (12), made from a $1\frac{1}{2}''$ and two $2\frac{1}{2}''$ Strips, is bolted to the Angle Brackets (11).

Parts Required

6 of No. 1	1 of No. 40
14 " " 2	1 " " 48
2 " " 3	7 " " 48a
11 " " 5	1 " " 51
1 " " 6a	1 " " 52
4 " " 8	1 " " 111c
4 " " 10	1 " " 115
3 " " 11	1 " " 125
3 " " 12	2 " " 155
2 " " 12a	1 " " 186a
1 " " 15b	2 " " 187
4 " " 16	4 " " 188
1 " " 17	3 " " 189
1 " " 18a	1 " " 190
1 " " 18b	1 " " 191
1 " " 19b	4 " " 192
4 " " 22	1 " " 198
1 " " 26	2 " " 200
1 " " 27a	2 " " 212
6 " " 35	2 " " 212a
103 " " 37a	1 " " 213
101 " " 37b	2 " " 214
20 " " 38	4 " " 215
1 " " 38d	

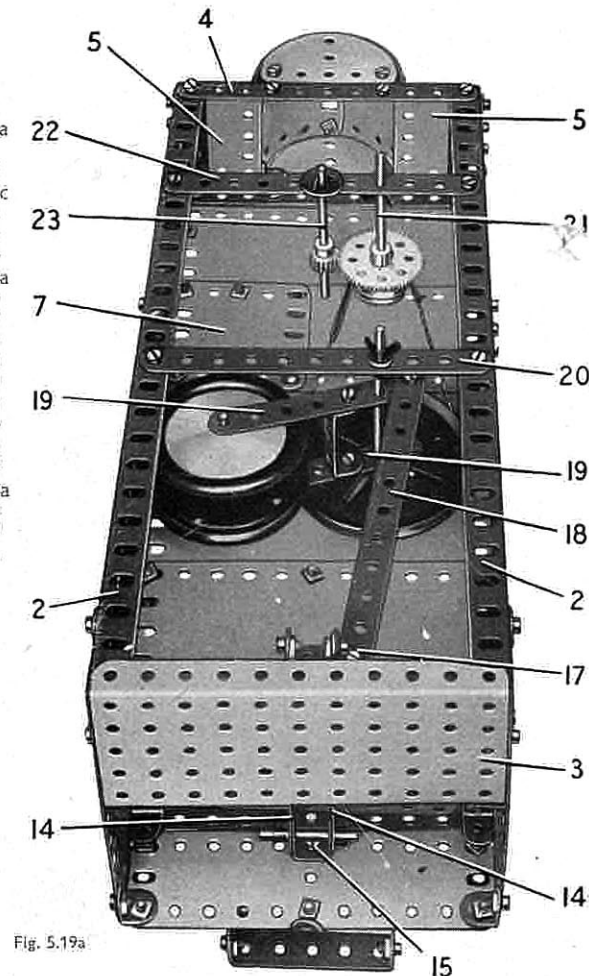

Fig. 5.19a

5.20 RACING SEAPLANE

THE FUSELAGE

Each side of the fuselage is formed by a $12\frac{1}{2}$ " Strip (1) and two $5\frac{1}{2}$ " Strips (2). The Strips are connected by a $2\frac{1}{2}$ " x $1\frac{1}{2}$ " Triangular Flexible Plate at the nose, and by a $5\frac{1}{2}$ " x $1\frac{1}{2}$ " Flexible Plate at the tail. At the centre two $5\frac{1}{2}$ " x $2\frac{1}{2}$ " Flexible Plates (3) are bent as shown and fixed to the Strips (1) and (2) of each side. The nose is completed by two $2\frac{1}{2}$ " x $1\frac{1}{2}$ " Flexible Plates (4) overlapped three holes and fixed to the front ends of the Strips (1), and by a Flat Trunnion (5) on each side attached by a Fishplate.

The fuselage sides are joined at the tail by a Double Bracket, and at the nose they are connected by a Bush Wheel (6) attached to Angle Brackets. Two 'U'-section Curved Plates (7) are bolted together and fixed to the rear ends of the sides, and at the front the Plates (7) are connected to one of the Plates (3) by a $2\frac{1}{2}$ " Strip at each side.

Two $2\frac{1}{2}$ " x $\frac{1}{2}$ " Double Angle Strips (8) on each side are fixed to a $\frac{1}{2}$ " Reversed Angle Bracket, and the latter is bolted to the Bush Wheel (6). The propeller is made by bolting three $2\frac{1}{2}$ " Strips radially to a Six-Hole Wheel Disc, and this is free to turn on a $1\frac{1}{2}$ " Rod supported in the boss of the Bush Wheel. The Rod is held in position by a Spring Clip and a 1" Pulley fitted with a Rubber Ring.

CONSTRUCTION OF THE TAIL PLANE

A $2\frac{1}{2}$ " x $1\frac{1}{2}$ " Flexible Plate (9) on each side is edged at the rear by a $2\frac{1}{2}$ " Strip, and is extended forward by a $2\frac{1}{2}$ " x $1\frac{1}{2}$ " Triangular Flexible Plate. The two units are fixed to 1" x 1" Angle Brackets (10) attached to the fuselage by the same bolts that hold the Double Bracket in position. The rudder consists of two $2\frac{1}{2}$ " x $2\frac{1}{2}$ " Triangular Flexible Plates placed one on each side of a Semi-Circular Plate. An Angle Bracket is attached to each side of the rudder, and these are bolted to Fishplates fixed to the Angle Brackets (10).

THE WINGS

Each wing consists of a $5\frac{1}{2}$ " x $2\frac{1}{2}$ " and a $5\frac{1}{2}$ " x $1\frac{1}{2}$ " Flexible Plate edged by $5\frac{1}{2}$ " Strips (11). The outer ends of the Strips are bolted to a Wheel Disc, and the inner ends of the $5\frac{1}{2}$ " x $2\frac{1}{2}$ " Flexible Plates are connected to the Strips by Fishplates. The wings are bolted to a $1\frac{1}{2}$ " x $\frac{1}{2}$ " Double Angle Strip (12) and two Trunnions (13) fixed between the sides of the fuselage.

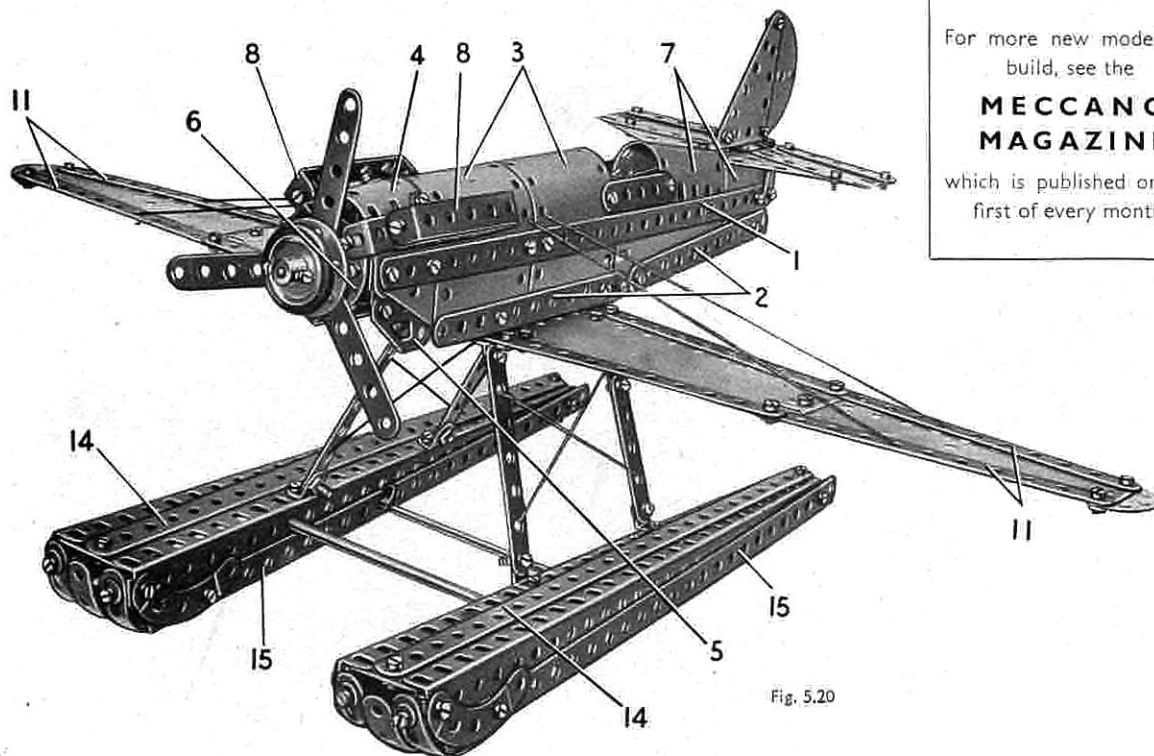

Fig. 5.20

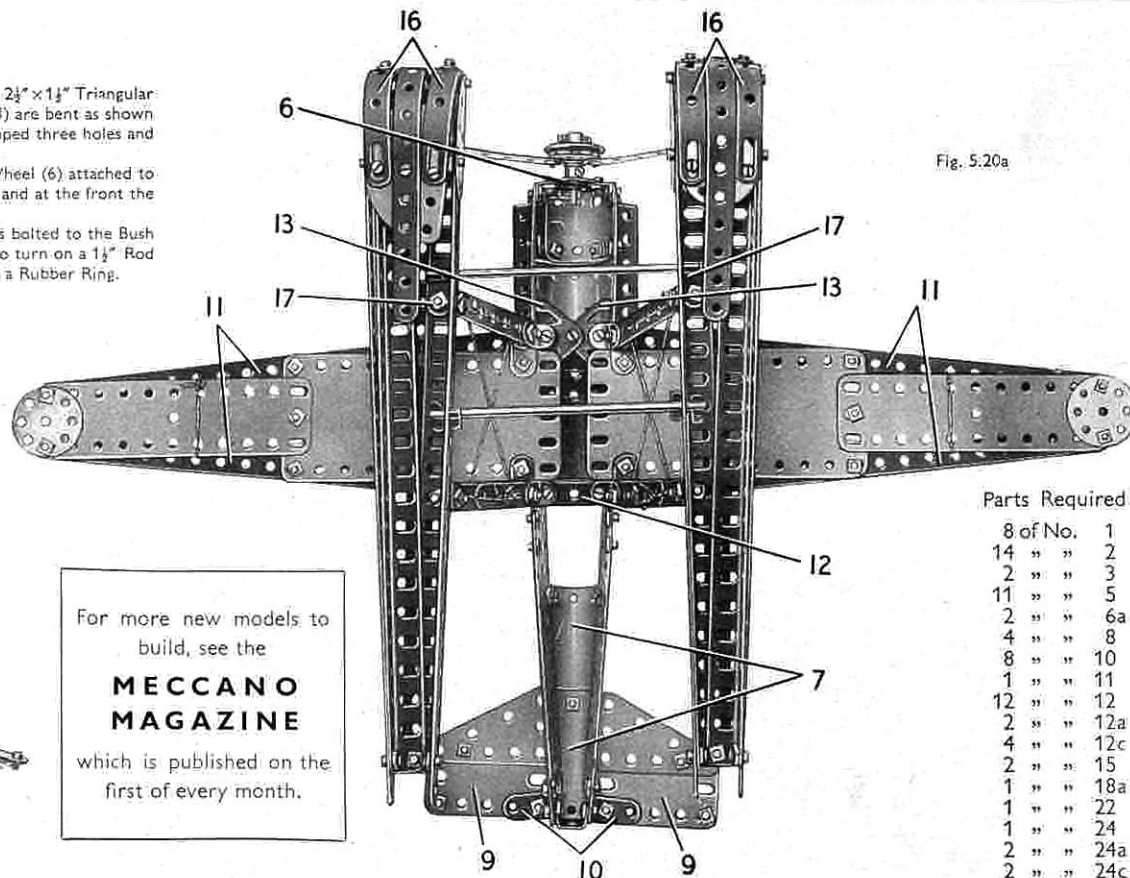

Fig. 5.20a

For more new models to build, see the
MECCANO MAGAZINE
which is published on the first of every month.

Parts Required

8 of No.	1
14	2
2	3
11	5
2	6a
4	8
8	10
1	11
12	12
2	12a
4	12c
2	15
1	18a
1	22
1	24
2	24a
2	24c
5	35
116	37a
109	37b
14	38
1	40
1	48
4	48a
4	90a
6	111c
2	125
2	126
2	126a
1	155
4	188
4	189
4	192
2	199
2	212a
2	214
4	215
4	221
2	222

CONSTRUCTION OF THE FLOATS

The two floats are similar in general construction, but they vary in slight details. Each float consists of two $12\frac{1}{2}$ " Angle Girders bolted together at one end with a $12\frac{1}{2}$ " Strip (14) held by the same bolt. At the other end of the Strip a $1\frac{1}{2}$ " Strip is fixed, and the ends of the Angle Girders are clamped between the $1\frac{1}{2}$ " Strip and the Strip (14). A $12\frac{1}{2}$ " Strip (15) is fixed to each of the Angle Girders at the rear end of the float, and at the front it is attached to a $2\frac{1}{2}$ " Stepped Curved Strip bolted to the Angle Girder.

Two Formed Slotted Strips (16) are connected by Angle Brackets to the front of each float. In one of the floats the ends of the Formed Slotted Strips are bolted to a Semi-Circular Plate, but in the other float a Six-hole Wheel Disc is used in place of the Semi-Circular Plate. In each case a curved $5\frac{1}{2}$ " Strip is bolted between the Formed Slotted Strips.

The floats are connected by Obtuse Angle Brackets to two $3\frac{1}{2}$ " Strips and two built-up $3\frac{1}{2}$ " strips made from $2\frac{1}{2}$ " Strips overlapped. The Strips are fixed to Angle Brackets bolted to the Double Angle Strip (12) and the Trunnions (13). The two floats are connected by two 5" Rods. One of these is held in a Right-Angle Rod and Strip Connector (17) bolted to each float. The other Rod is passed through the $12\frac{1}{2}$ " Strips (15) and retained in position by Spring Clips.

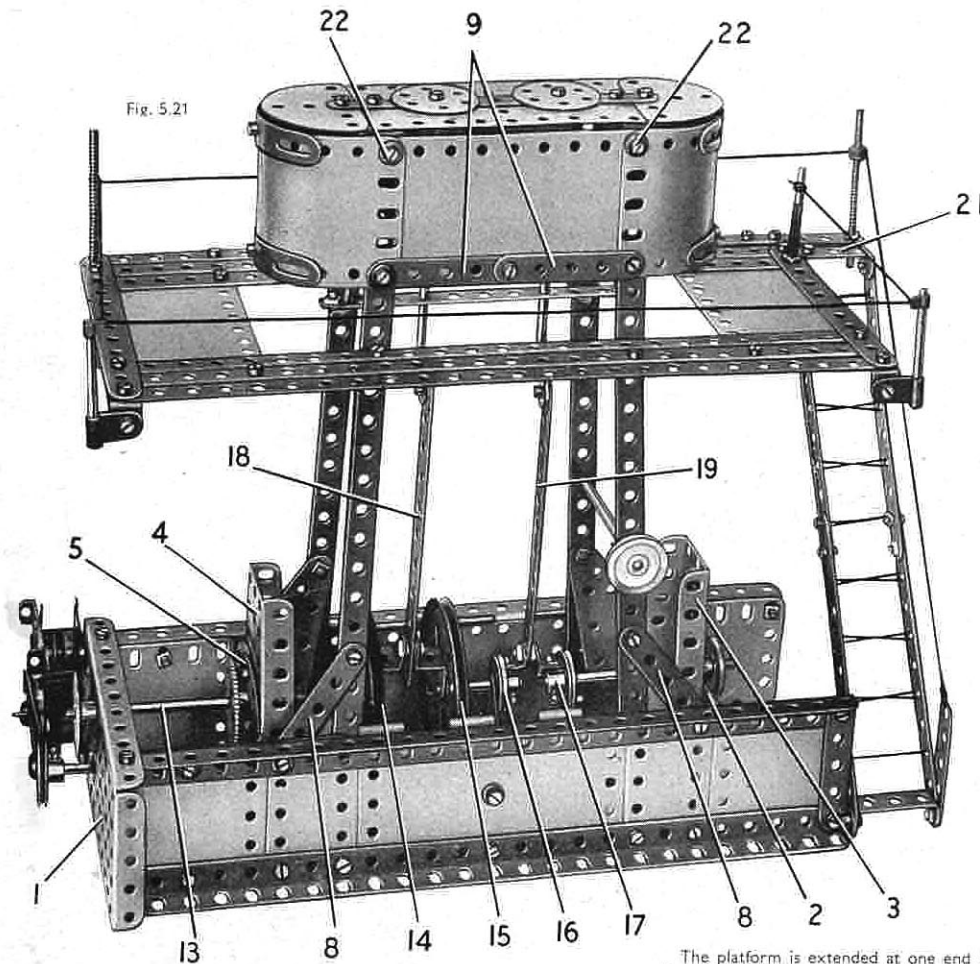

Fig. 5.21

THE BASE

Each side of the bed or base of the Ships Engine seen in Fig. 5.21 consists of two 12½" Angle Girders, connected by one half of a Hinged Flat Plate, two 2½" × 2½" and two 2½" × 1½" Flexible Plates. The sides are bolted at one end to a 5½" × 2½" Flanged Plate (1), and at the other end they are connected by a 3½" Strip (2) attached to Angle Brackets. A Flanged Sector Plate (3) is bolted to the 3½" Strip and is connected to the sides of the base by two Double Brackets. A Flanged Sector Plate (4) is similarly attached to the base by Double Brackets, and it is supported also by two 2½" Stepped Curved Strips (5) bolted to 1" × 1" Angle Brackets (6) fixed to the sides. A 3½" Strip (7) is connected to Angle Brackets bolted to the centre holes of the halves of the Hinged Flat Plate, and a Flat Trunnion is fixed to the centre of the 3½" Strip.

SUPPORTING COLUMNS FOR THE CYLINDER BLOCK

Each of the columns supporting the cylinder block consists of a 12½" Strip bolted to the base and braced by a 2½" × 1½" Triangular Flexible Plate and a 2½" Strip (8). The top ends of the columns on each side are connected by two 2½" Strips (9) and a 4½" × 2½" Flexible Plate, and they are joined to the columns on the other side by 2½" × ½" Double Angle Strips. A 5½" Strip (10) is fixed between the Double Angle Strips and a similar Strip (11) is connected to them by ½" Reversed Angle Brackets. A 2½" × 1½" Flanged Plate (12) is bolted between the Strips (9).

THE CYLINDER BLOCK

The rounded ends of the cylinder block are 5½" × 2½" Flexible Plates curved to shape and edged by Formed Slotted Strips. The top corners of the Plates are connected by 2½" × ½" Double Angle Strips held by Bolts (22), and the top of the block is attached to the Double Angle Strips. The top is formed by two 5½" × 1½" Flexible Plates and two Semi-Circular Plates bolted to a 5½" Strip. The covers of the cylinders are represented by Six-Hole Wheel Discs.

THE CRANKSHAFT, PISTON AND VALVE RODS

The crankshaft is in three sections. A 5" Rod (13) (Fig. 5.21) is supported in the Flanged Plate (1) and the Flanged Sector Plate (4), and is fitted with a 57-tooth Gear and a 3" Pulley (14). A 1½" Rod passed through a Flat Trunnion bolted to the Strip (7) (Fig. 5.21a), carries a 3" Pulley (15) and a 1" Pulley (16), and a 3½" Rod supported in the Flanged Sector Plate (3) has a 1" Pulley (17) fixed to it. A ½" Reversed Angle Bracket is bolted tightly to each of the Pulleys (14) and (15), and the Brackets are connected by a ½" Bolt. The Bolt is held by a nut in one of the Reversed Angle Brackets, and on it is pivoted a 5½" Strip (18). The Bolt is then held by two nuts in the other Reversed Angle Bracket.

An Angle Bracket is fixed to the boss of each of the Pulleys (16) and (17). A bolt fitted with a nut is passed through the Angle Bracket and is screwed into a threaded hole in the boss of the Pulley. The nut is then tightened to hold the Angle Bracket firmly in place. The two Angle Brackets are connected by a ½" Bolt arranged in the same way as the Bolt in the Reversed Angle Brackets, and a 5½" Strip (19) is pivoted on the Bolt. The Strips (18) and (19) are lock-nutted to Rod and Strip Connectors, and Rods held in the Rod and Strip Connectors are free to slide through the Strips (10) and (11).

MOTOR AND GEARING

The model is driven by a Magic Clockwork Motor bolted to one end of the Flanged Plate (1). A Driving Band is passed round the Motor pulley and a 1" Pulley on a Rod (20), which is supported in the Flanged Plate (1) and the Flanged Sector Plate (4). The Rod is held in position by a ½" Pulley (supplied with the Motor), and a ½" Pinion fixed on it drives the 57-tooth Gear on Rod (13).

THE INSPECTION PLATFORM

The inspection platform round the cylinder block consists of three 12½" Strips on each side joined at their ends by 5½" Strips and 5½" × 2½" Flexible Plates. The platform is attached to the cylinder block supporting columns by Angle Brackets. The Angle Brackets are fixed to the columns by ½" Bolts, but are spaced from them by a Spring Clip on each Bolt.

The platform is extended at one end by a 2½" Strip and a 2½" × ½" Double Angle Strip (21), and a ladder is connected to the lug of this Double Angle Strip and to an Angle Bracket. The sides of the ladder are each made from two 5½" Strips overlapped two holes, and the lower ends of these Strips are bolted to a 1½" × ½" Double Angle Strip connected to the base by an Angle Bracket.

The handrail round the inspection platform is supported by two Screwed Rods, two 2" Rods held in Right-Angle Rod and Strip Connectors, and a 1" Rod joined to a Threaded Pin by a Rod Connector. The Right-Angle Rod and Strip Connectors are fixed to the lugs of 2½" × ½" Double Angle Strips bolted to the platform.

Parts Required

10 of No. 1	1 of No. 15b	1 of No. 26	1 of No. 51	1 of No. 147b	2 of No. 212
11 " " 2	3 " " 16	1 " " 27a	1 " " 52	1 " " 176	2 " " 212a
2 " " 3	2 " " 17	4 " " 35	2 " " 54	1 " " 186a	1 " " 213
12 " " 5	1 " " 18a	118 " " 37a	2 " " 80c	4 " " 188	2 " " 214
2 " " 6a	1 " " 18b	103 " " 37b	2 " " 90a	2 " " 189	4 " " 215
4 " " 8	2 " " 19b	11 " " 38	6 " " 111c	4 " " 190	4 " " 221
4 " " 11	5 " " 22	1 " " 40	1 " " 115	2 " " 191	1 Magic Clockwork Motor
12 " " 12	1 " " 24	1 " " 48	4 " " 125	4 " " 192	(not included in Outfit)
2 " " 12a	2 " " 24c	7 " " 48a	1 " " 126a	1 " " 198	
1 " " 15					

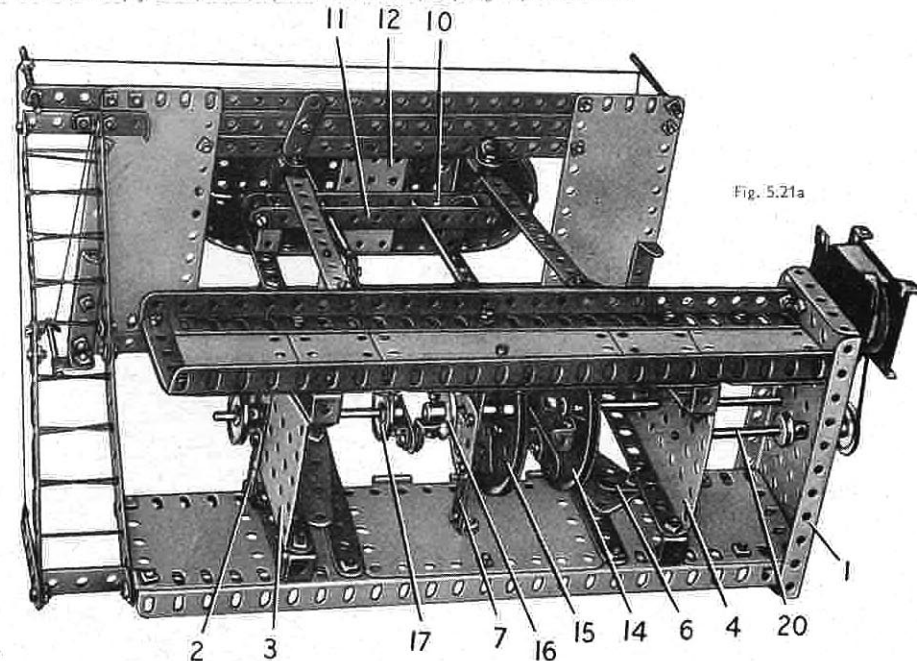

Fig. 5.21a

5.22 FIRE ENGINE

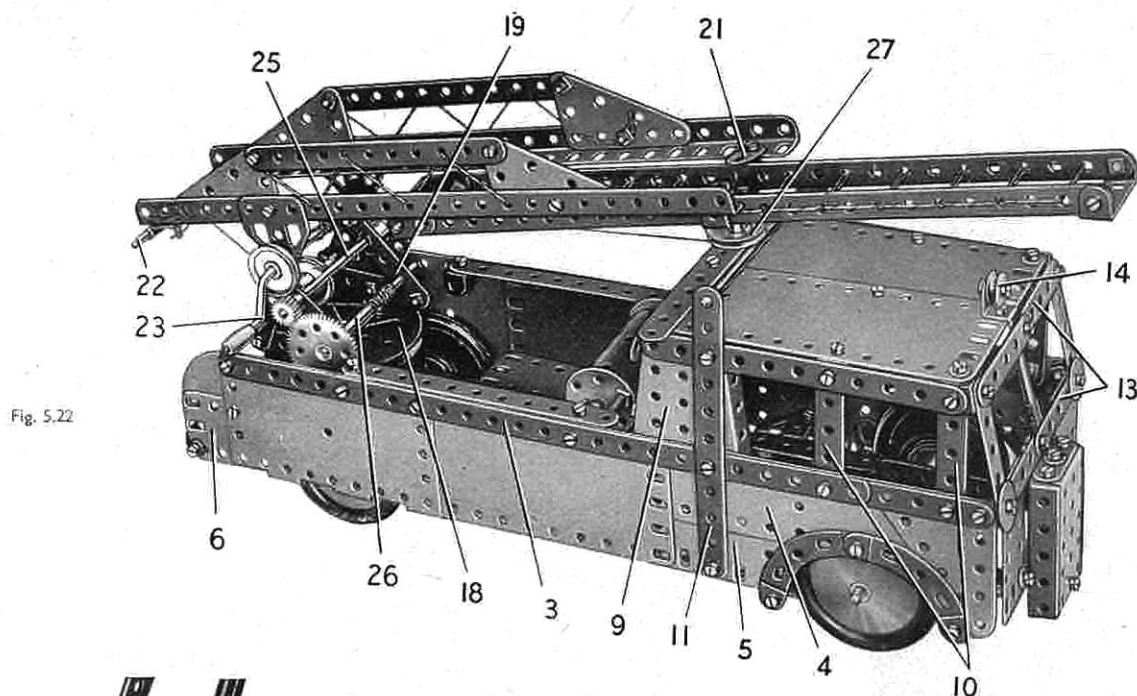

Fig. 5.22

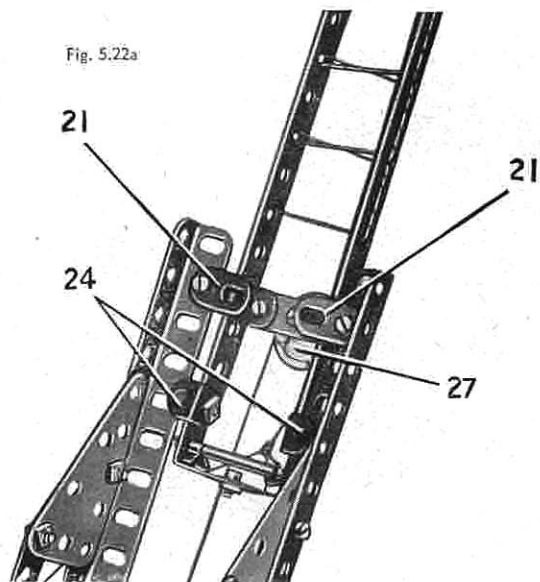

Fig. 5.22a

CONSTRUCTION OF THE CHASSIS

The chassis consists of two 12½" Angle Girders, each extended by a 5½" Strip that overlaps the Girder by five holes. The 5½" Strips are connected by a 2½" × ½" Double Angle Strip (1), and the Angle Girders are bolted to a 5½" × 2½" Flanged Plate (2). The front wheels are fixed as shown on a 5" Rod, and the rear wheels are held on a 4½" Rod. Both Rods are supported directly in the chassis.

ASSEMBLING THE BODY

Each side of the body is identical in construction, and is made by bolting Plates to a built-up strip (3), made from a 12½" and a 5½" Strip overlapped seven holes. The side over the front wheels consists of a 2½" × 2" Triangular Flexible Plate, a 5½" × 1½" Flexible Plate (4), and a 2½" × 2½" Flexible Plate (5). The side is completed by a 5½" × 2½" Flexible Plate, *one half of a Hinged Flat Plate*, a 2½" × 1½" Flexible Plate (6) and a Semi-Circular Plate.

The completed sides are attached by Angle Brackets to two Trunnions (7), and to two 3½" Strips (8) overlapped five holes and bolted to the back of the Flanged Plate (2).

The driving cabin is made by bolting a Flanged Sector Plate (9) and two 2½" × ½" Double Angle Strips (10) to each side. A 5½" Strip (11) is fixed to the side and to the Flanged Sector Plate, and a further 5½" Strip is bolted across the upper-ends of Double Angle Strips (10). The Flanged Sector Plates are joined across by a 5½" Strip (12).

The roof of the cab consists of two 5½" × 2½" Flexible Plates. These are bolted to the tops of the Double Angle Strips (10), and are connected to the Strip (12) by a Double Bracket. The front of the cab is made from two built-up strips (13), each made from two 2½" Strips and connected to the sides by Angle Brackets. A 2½" × 1½" Flexible Plate on each side is bolted to the lower of the strips (13) and to the Double Angle Strip (1). The centre division of the windscreen is a 2" Rod held in a Rod and Strip Connector. A ½" loose Pulley (14) representing a warning light is attached by a ½" Bolt to a ½" Reversed Angle Bracket.

The radiator is a 2½" × 1½" Flanged Plate fitted at each side with a 2½" × ½" Double Angle Strip. It is connected to the Double Angle Strip (1) by a ½" Reversed Angle Bracket, and is attached by an Angle Bracket to the lower of the strips (13).

A 4½" × 2½" Flexible Plate is bolted to the flanges of the Flanged Sector Plates, and a second 4½" × 2½" Flexible Plate (15) and two 5½" × 1½" Flexible Plates curved slightly at their front ends are bolted to the chassis.

(Continued on next page)

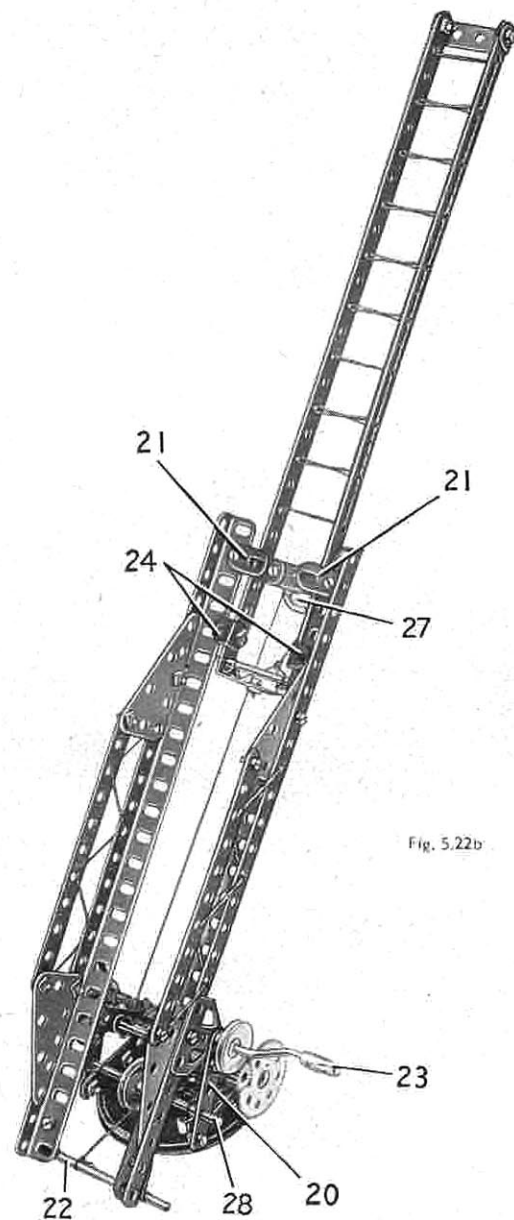

Fig. 5.22b

MODEL 5.22 FIRE ENGINE — Continued

Parts Required

6 of No. 1	1 of No. 19g	8 of No. 48a	1 of No. 176
14 " " 2	5 " " 22	1 " " 51	4 " " 187
2 " " 3	2 " " 22a	1 " " 52	4 " " 188
12 " " 5	1 " " 23	2 " " 54	4 " " 189
2 " " 6a	1 " " 24	2 " " 80c	2 " " 190
4 " " 8	2 " " 24a	4 " " 90a	2 " " 191
6 " " 10	2 " " 24c	1 " " 111a	4 " " 192
4 " " 11	1 " " 26	5 " " 111c	1 " " 198
12 " " 12	1 " " 27a	1 " " 115	1 " " 212
2 " " 12a	14 " " 35	4 " " 125	2 " " 212a
2 " " 15	117 " " 37a	2 " " 126	2 " " 214
1 " " 15a	110 " " 37b	2 " " 126a	1 " " 216
1 " " 15b	17 " " 38	1 " " 147b	4 " " 221
4 " " 16	2 " " 38d	4 " " 155	2 " " 222
2 " " 17	1 " " 40		
1 " " 18a	1 " " 45		
2 " " 19b	1 " " 48		

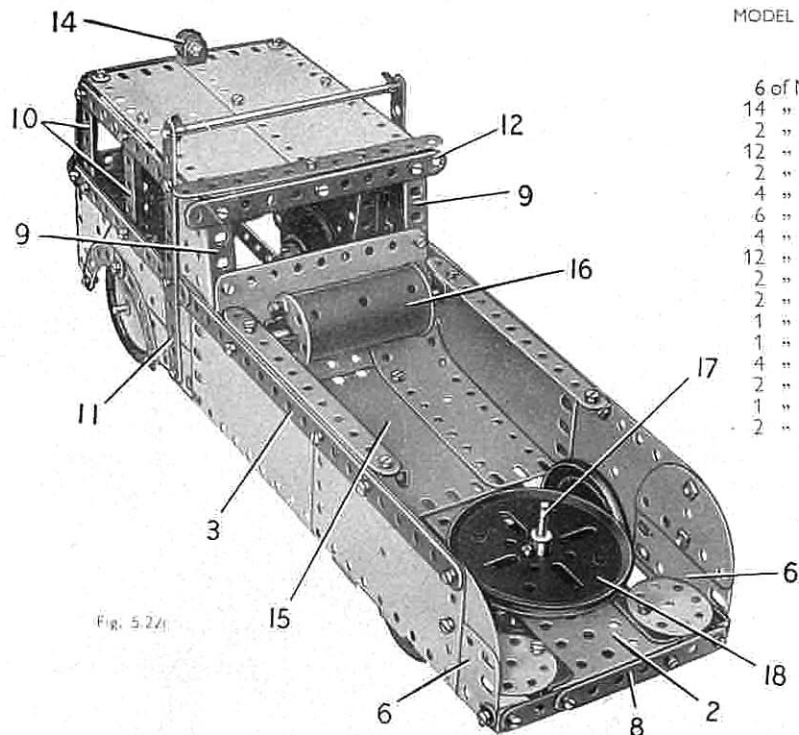

Fig. 5.22f

The hose reel (16) is made by fixing a Six-Hole Wheel Disc to each end of a 2½" Cylinder by means of 3" Screwed Rods. The reel is mounted on a 4" Rod supported in Double Brackets fixed to the sides of the body. A 5½" Strip on each side is bolted to the Double Bracket.

THE EXTENDING LADDER

A 2" Rod (17) is passed through the Flanged Plate (2) and through a Double Bent Strip bolted to the Flanged Plate. Two 3" Pulleys (18) are held on the Rod, and a 2½" x ½" Double Angle Strip is fixed across the centre of the upper Pulley. A 2½" Strip is bolted to each lug of the Double Angle Strip, and two further 2½" Strips (19) and (20) are attached to the ends of the 2½" Strip. The top ends of Strips (19) and (20) are bolted together so that one clear hole of Strip (20) remains above the bolt joining the Strips.

The fixed section of the ladder consists of two 12½" Angle Girders. These are connected together at their upper ends by a 1½" Strip bolted between two ½" Reversed Angle Brackets. The bolts fixing the Reversed Angle Brackets to the Girders also fix in position two Fishplates (21). At their lower ends the Girders are connected by a 3½" Rod (22) held in Right-Angle Rod and Strip Connectors. A Flat Trunnion is bolted to each Angle Girder, and a Crank Handle (23) is passed through them and through the top holes of the Strips (20). The side rails of the ladder are 5½" Strips attached to 2½" x 1½" Triangular Flexible Plates.

Each side of the extending section of the ladder consists of two 12½" Strips placed face to face. The sides are connected at their upper ends by a 1½" x ½" Double Angle Strip, and at the bottom they are joined by two 1" x 1" Angle Brackets bolted together to make a built-up 1½" x 1" double angle strip. The extending section slides between the ½" Reversed Angle Brackets and the Fishplates (21). Two Angle Brackets (24) serve to locate the sliding ladder between the Angle Girders of the fixed section.

The ladder can be raised and lowered by turning a Bush Wheel fitted with a Threaded Pin and fixed on a 3½" Rod (25) mounted in the Strips (19). The Rod (25) carries a ½" Pinion that drives a 57-tooth Gear on a 3¼" Rod (26). A length of Cord wound round Rod (26) is passed round a 1" Pulley on a Rod (28) and is tied to the Rod (22).

The ladder is extended by turning the Crank Handle (23). A length of Cord tied to the Crank Handle is passed round a 1" Pulley (27) and is fastened to the 1" x 1" Angle Brackets at the bottom of the extending section of the ladder. The Pulley (27) is fixed by its set screw on a ½" Bolt passed through the 1½" Strip attached to the Reversed Angle Brackets at the top of the fixed section of the ladder.

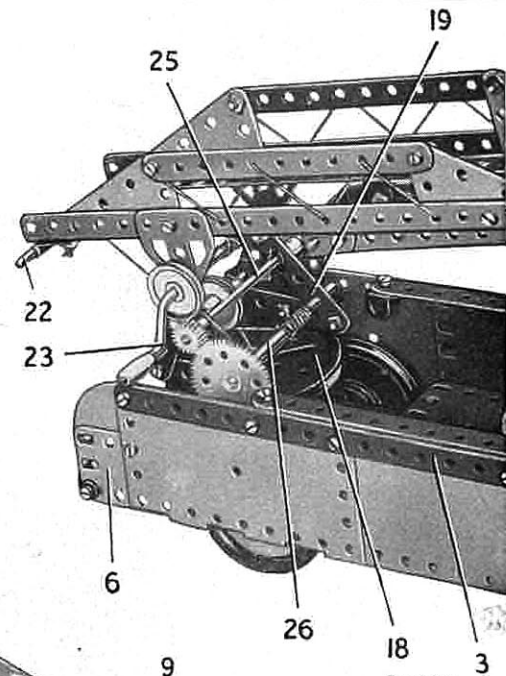

Fig. 5.22e

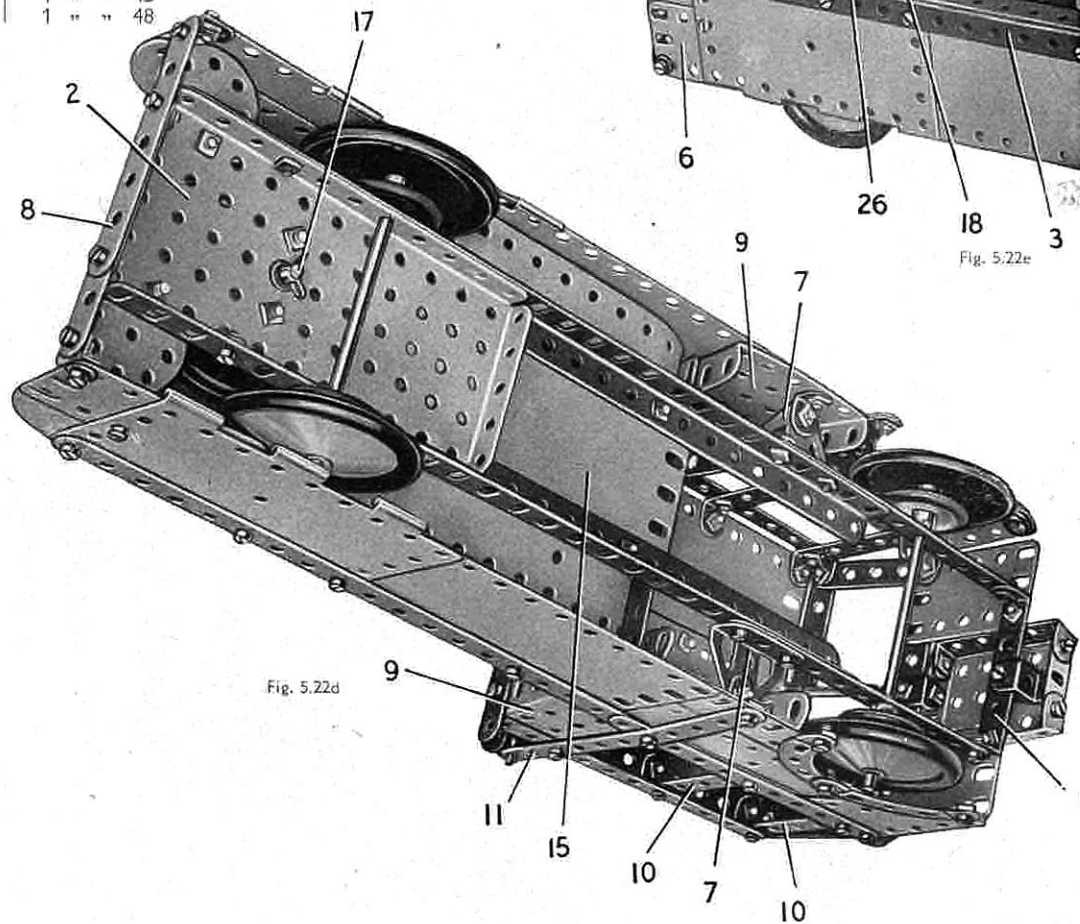

Fig. 5.22d

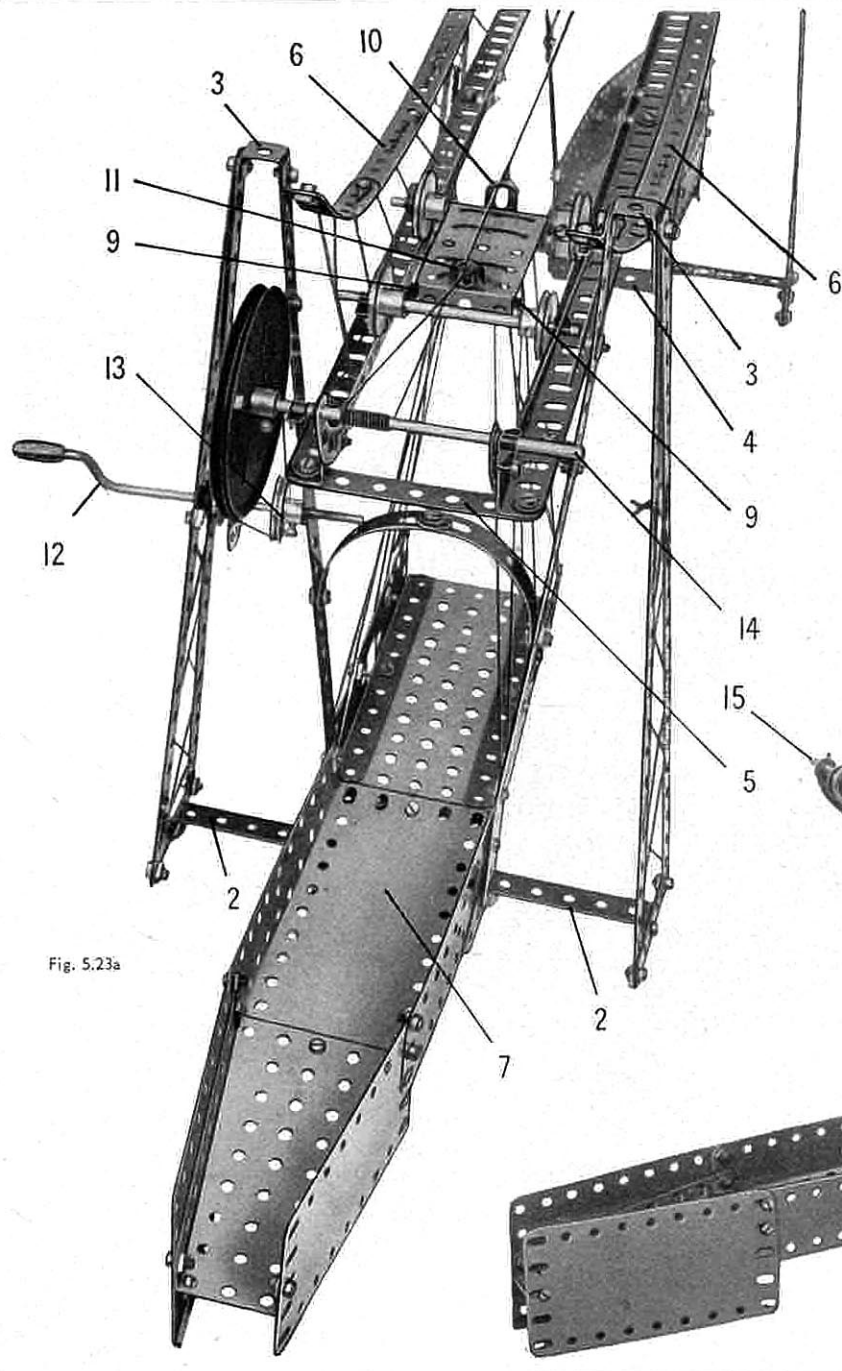

Fig. 5.23a

5.23 TRANSPORTER BRIDGE

CONSTRUCTION OF THE TOWERS

The four towers are similar in design and each of them is made from two $12\frac{1}{2}$ " Strips bolted at their lower ends to a $2\frac{1}{2}$ " Strip (1), and a built-up $12\frac{1}{2}$ " strip fixed to a $2\frac{1}{2}$ " x $\frac{1}{2}$ " Double Angle Strip (2). The Strips are connected at the top by a Double Bracket (3) (Fig. 5.23a). The built-up strip is made from two $5\frac{1}{2}$ " and a $2\frac{1}{2}$ " Strip bolted together. Each tower is capped by a Road Wheel and a Wheel Disc on a Rod, which is held by a Spring Clip in the Double Bracket (3). The towers at each end of the bridge are connected by a $2\frac{1}{2}$ " x $\frac{1}{2}$ " Double Angle Strip (4) and by two Formed Slotted Strips.

THE CONNECTING SPAN

The main girders of the span each consist of two $12\frac{1}{2}$ " Angle Girders overlapped three holes. The girders are connected at their ends by two $3\frac{1}{2}$ " Strips (5), and the complete span is attached to the towers by Angle Brackets in the position shown. Each of the suspension chains (6) is represented by built-up strips connected by a $\frac{1}{2}$ " Reversed Angle Bracket to the centre of the span, and attached to the towers by Angle Brackets. Lengths of Cord are threaded between the suspension links and the span.

THE BRIDGE APPROACHES

The roadway of each approach is a $5\frac{1}{2}$ " x $2\frac{1}{2}$ " Flexible Plate (7) extended by a Flanged Sector Plate. The Flexible Plate is bolted to a $2\frac{1}{2}$ " x $\frac{1}{2}$ " Double Angle Strip fixed between the towers, and the Flanged Sector Plate is supported by a $4\frac{1}{2}$ " x $2\frac{1}{2}$ " Flexible Plate on one side and one half of a Hinged Flat Plate on the other side. The $5\frac{1}{2}$ " x $2\frac{1}{2}$ " Flexible Plate is edged by $5\frac{1}{2}$ " x $1\frac{1}{2}$ " Flexible Plates, which are bolted to the inner Strips of the towers. The bolts serve also to secure $2\frac{1}{2}$ " x $1\frac{1}{2}$ " Triangular Flexible Plates (8).

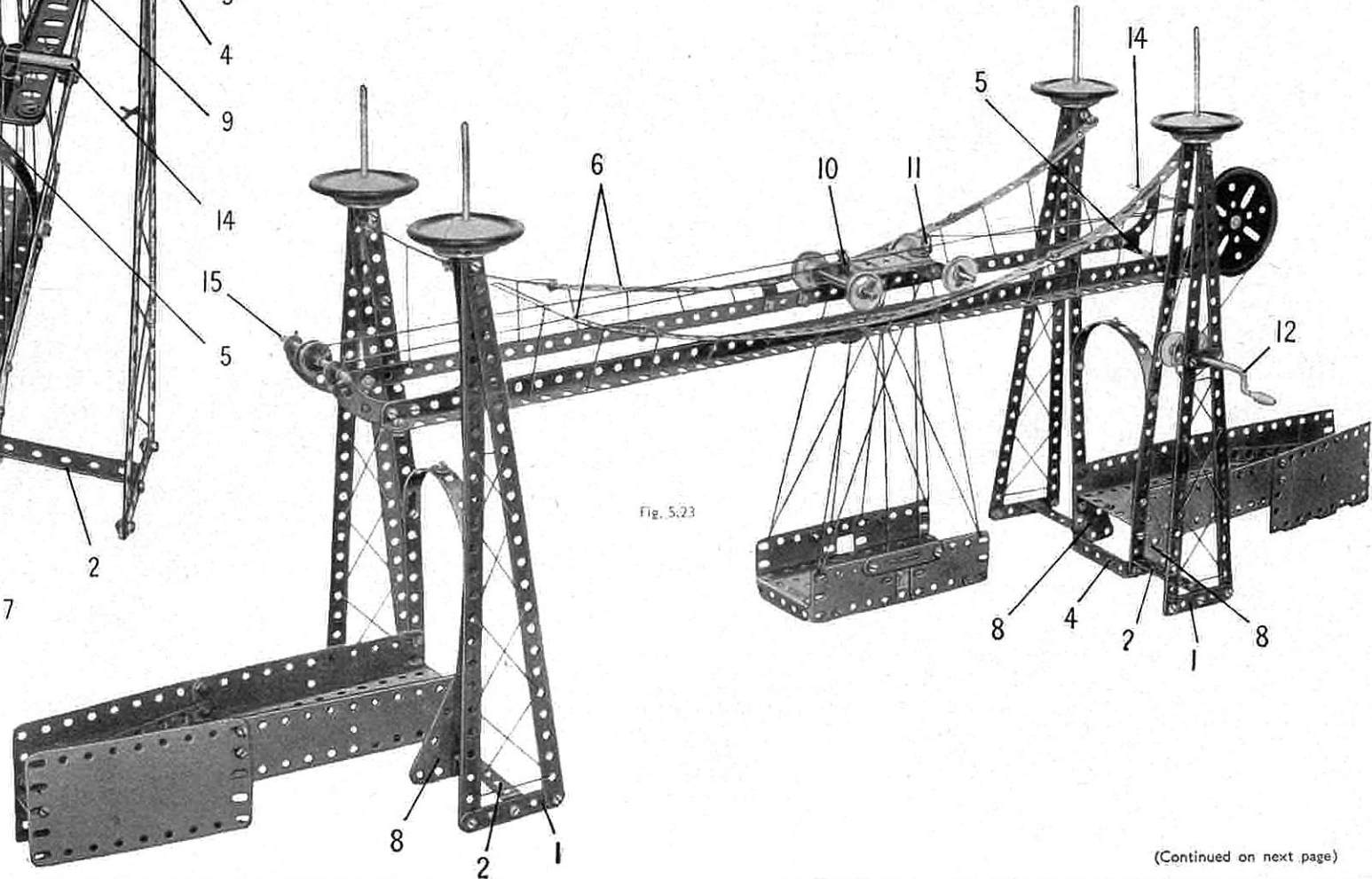

Fig. 5.23

(Continued on next page)

MODEL 5.23 TRANSPORTER BRIDGE — Continued

THE TROLLEY AND THE TRANSPORTER CARRIAGE

The trolley consists of a 2½" x 1½" Flanged Plate fitted with four 1" Pulleys spaced on ¾" Rods so that they run on the flanges of the girders of the span. The Pulleys are held in place on the Rods by Spring Clips. One of the Rods is supported in a 1½" x ½" Double Angle Strip bolted to the flange at one end of the Flanged Plate. The second Rod is mounted in two Angle Brackets (9) bolted to the other flange of the Flanged Plate. A Fishplate (10) and an Angle Bracket (11) are fixed to the trolley.

The carriage is made by fixing two 2½" x 1½" Flexible Plates to each of the longer sides of a 5½" x 2½" Flanged Plate. The carriage is connected to the trolley by Cords arranged as shown in Fig. 5.23.

THE OPERATING MECHANISM

A Crank Handle (12) is supported in the inner Strip of one of the towers and in a 1½" Strip bolted across the two outer Strips. The Crank Handle is held in place by a Bush Wheel and a 1" Pulley (13), and the Pulley is connected by a Cord belt to a 3" Pulley on a 5" Rod (14). Rod (14) is held by Spring Clips in 2½" Stepped Curved Strips bolted to one end of the span. A Rod (15) is supported in 2½" Curved Strips bolted to the other end of the span, and a ½" loose Pulley is free to turn on the Rod.

A length of Cord is tied to the Angle Bracket (11) and is wound several times round the Rod (14). The Cord is passed round the Pulley on Rod (15) and is fastened to the Fishplate (10).

Parts Required

10 of No. 1	110 of No. 37a
14 " " 2	110 " " 37b
2 " " 3	20 " " 38
10 " " 5	2 " " 38d
1 " " 6a	1 " " 40
4 " " 8	1 " " 48
1 " " 10	8 " " 48a
4 " " 11	1 " " 51
11 " " 12	1 " " 52
1 " " 15	2 " " 54
1 " " 15a	4 " " 90a
2 " " 15b	2 " " 125
4 " " 16	4 " " 187
1 " " 19b	4 " " 188
1 " " 19g	4 " " 189
5 " " 22	2 " " 191
1 " " 23	2 " " 192
1 " " 24	1 " " 198
2 " " 24a	4 " " 215
2 " " 24c	4 " " 221
14 " " 35	

5.24 TRAVELLING GANTRY CRANE

CONSTRUCTION OF THE GANTRY

The gantry that forms the rails supporting the crane consists of two built-up girders, each made from two 12½" Angle Girders connected together by a 2½" Strip (1). Each of the built-up girders is fitted with two 5½" x 1½" and two 2½" x 1½" Flexible Plates, and the lower edges of these Plates are connected by a 12½" Strip (2). The girders are bolted at their outer ends to 5½" Strips (3).

Two of the gantry legs (4) are made from 2½" and 5½" Strips and the other pair from two 5½" Strips each. The legs are connected at the top by a 5½" x 2½" Flexible Plate and a 5½" Strip (5), and at their lower ends they are bolted to a 12½" Strip (6). The joints between the legs and the Strip (6) are braced by 2½" x 1½" Triangular Flexible Plates, and a Flanged Sector Plate is bolted between the Strip (6) and the 5½" x 2½" Flexible Plate. A 12½" Strip (7) is attached to the Strips (6) by a Double Bracket at each end and by two ½" Reversed Angle Brackets (8). The wheels are Wheel Discs free to turn on bolts, each of which is held by two nuts in the Strip (6).

The completed towers are bolted to the lugs of 2½" x ½" Double Angle Strips (9), which are fixed to the ends of the 12½" Angle Girders. The towers are braced by 5½" Strips attached to the gantry and the strips (4) by Angle Brackets.

THE TRAVELLING CRANE

The crane base is a 5½" x 2½" Flanged Plate (10) and its wheels are 1" Pulleys fixed on 5" Rods supported in the Flanged Plate. The Rods are held in place by Spring Clips and the Pulleys run on the edges of the 12½" Angle Girders.

The sides of the cab are the separated halves of a Hinged Flat Plate. They are connected by two 2½" x ½" Double Angle Strips held by Bolts (11) on each side, and by a 2½" x 1½" Flanged Plate held by Bolts (12). A Bush Wheel is bolted to the Flanged Plate, and a 1½" Rod held in its boss is passed through a 3" Pulley and the centre hole of the Flanged Plate (10). A Spring Clip is placed on the Rod underneath the Flanged Plate.

Parts Required

10 of No. 1	1 of No. 18b	1 of No. 51
14 " " 2	1 " " 19b	1 " " 52
2 " " 3	1 " " 19g	2 " " 54
12 " " 5	5 " " 22	1 " " 57c
2 " " 6a	2 " " 22a	2 " " 111a
4 " " 8	1 " " 23	6 " " 111c
4 " " 11	1 " " 24	4 " " 125
10 " " 12	2 " " 24a	2 " " 126a
2 " " 15	2 " " 24c	1 " " 147b
1 " " 18a	8 " " 35	1 " " 176
	117 " " 37a	4 " " 188
	108 " " 37b	4 " " 189
	17 " " 38	3 " " 190
	2 " " 38d	2 " " 192
	1 " " 40	1 " " 198
	1 " " 48	2 " " 200
	7 " " 48a	1 " " 212
		1 " " 214
		4 " " 221
		2 " " 222

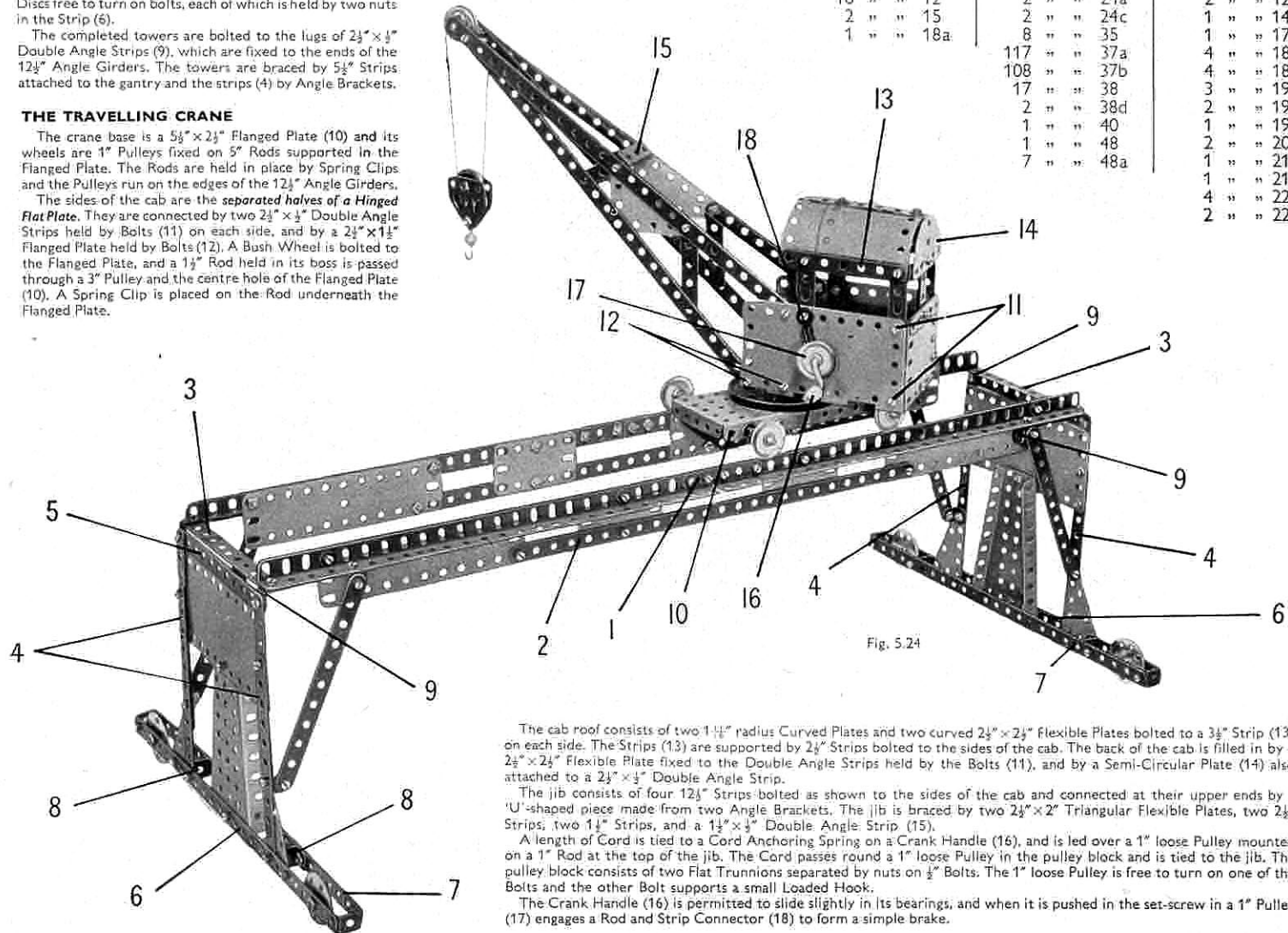

Fig. 5.24

The cab roof consists of two 1½" radius Curved Plates and two curved 2½" x 2½" Flexible Plates bolted to a 3½" Strip (13) on each side. The Strips (13) are supported by 2½" Strips bolted to the sides of the cab. The back of the cab is filled in by a 2½" x 2½" Flexible Plate fixed to the Double Angle Strips held by the Bolts (11), and by a Semi-Circular Plate (14) also attached to a 2½" x ½" Double Angle Strip.

The jib consists of four 12½" Strips bolted as shown to the sides of the cab and connected at their upper ends by a 'U'-shaped piece made from two Angle Brackets. The jib is braced by two 2½" x 2" Triangular Flexible Plates, two 2½" Strips, two 1½" Strips, and a 1½" x ½" Double Angle Strip (15).

A length of Cord is tied to a Cord Anchoring Spring on a Crank Handle (16), and is led over a 1" loose Pulley mounted on a 1" Rod at the top of the jib. The Cord passes round a 1" loose Pulley in the pulley block and is tied to the jib. The pulley block consists of two Flat Trunnions separated by nuts on ½" Bolts. The 1" loose Pulley is free to turn on one of the Bolts and the other Bolt supports a small Loaded Hook.

The Crank Handle (16) is permitted to slide slightly in its bearings, and when it is pushed in the set-screw in a 1" Pulley (17) engages a Rod and Strip Connector (18) to form a simple brake.

5.25 MOUNTAIN RAILWAY

THE LOWER STATION

Each side of the station consists of *one half of a Hinged Plate* and two $5\frac{1}{2}'' \times 1\frac{1}{2}''$ Flexible Plates, edged at the front by a $5\frac{1}{2}''$ Strip (1). The sides are connected by a $5\frac{1}{2}''$ Strip (2) attached by Angle Brackets. The roof is formed by two $5\frac{1}{2}'' \times 2\frac{1}{2}''$ Flexible Plates, an opened out 'U'-section Curved Plate and a $1\frac{1}{4}''$ radius Curved Plate arranged as shown and edged by $3\frac{1}{2}''$ Strips and Formed Slotted Strips.

THE TOWER AND UPPER STATION

Each leg of the tower consists of a $12\frac{1}{2}''$ and a $5\frac{1}{2}''$ Strip overlapped three holes. The legs are bolted to a $5\frac{1}{2}'' \times 2\frac{1}{2}''$ Flanged Plate (3), and they are connected by three $5\frac{1}{2}''$ Strips (4), a $5\frac{1}{2}''$ Strip (5), two $2\frac{1}{2}'' \times \frac{1}{2}''$ Double Angle Strips (6) and two $2\frac{1}{2}'' \times \frac{1}{2}''$ Double Angle Strips (7). The top of the tower is formed by two Flanged Sector Plates, and $5\frac{1}{2}'' \times 2\frac{1}{2}''$ Flexible Plates are bolted to the upper and lower ends of the tower as shown.

THE RAILS

The two outer rails are each formed by two $12\frac{1}{2}''$ Angle Girders overlapped two holes. They are bolted to the sides of the lower station, and they are attached to the tower by Angle Brackets held by the same Bolts that fix the Strip (5) in position. The Angle Girders are connected at their lower ends and in the centre by $5\frac{1}{2}''$ Strips (8).

The inner rails are each made from two $12\frac{1}{2}''$ Strips. These are bolted to the lugs of a $1\frac{1}{2}'' \times \frac{1}{2}''$ Double Angle Strip attached to the Strip (5), and they are connected by Angle Brackets to the Strips (8).

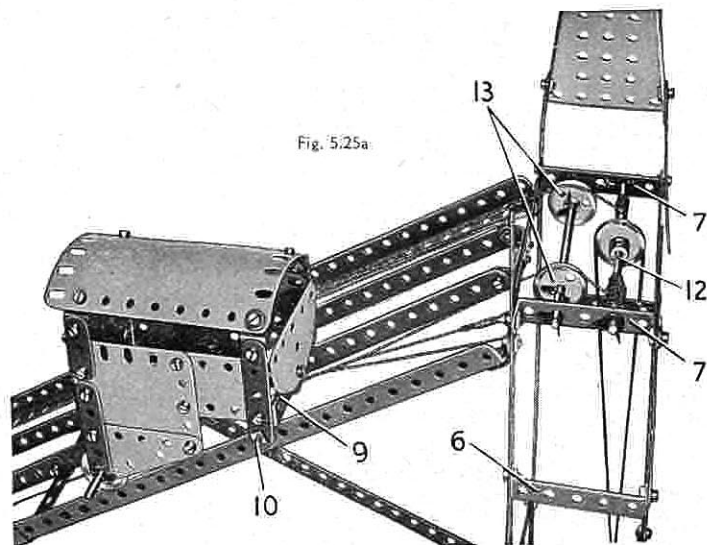

Fig. 5.25a

CONSTRUCTION OF THE CARRIAGES

The carriages are similar in design but they vary in some details. Each side is formed by a $2\frac{1}{2}'' \times 2\frac{1}{2}''$ Flexible Plate, a $2\frac{1}{2}'' \times 1\frac{1}{2}''$ Flexible Plate and a $2\frac{1}{2}'' \times 1\frac{1}{2}''$ Triangular Flexible Plate. Each side of one carriage is edged by two $2\frac{1}{2}''$ Strips and a $1\frac{1}{2}''$ Strip, but in the other carriage a further $2\frac{1}{2}''$ Strip replaces the $1\frac{1}{2}''$ Strip.

The sides of both carriages are connected by a $2\frac{1}{2}'' \times \frac{1}{2}''$ Double Angle (9), and a Semi-Circular Plate is fixed to each Double Angle Strip. The back of one carriage is formed by two $2\frac{1}{2}'' \times 2''$ Triangular Flexible Plates bolted to a $2\frac{1}{2}'' \times 1\frac{1}{2}''$ Flanged Plate fixed between the sides. The back of the other carriage is a straightened $1\frac{1}{4}''$ radius Curved Plate attached to the sides by Angle Brackets.

Each carriage is fitted with two $1''$ Pulleys arranged to run on the inclined rails. The Pulleys are free to turn on $3\frac{1}{2}''$ Rods supported as shown and held in place by Spring Clips. The front end of each carriage is fitted with a $3''$ Screwed Rod (10) held by nuts in the lower ends of the $2\frac{1}{2}''$ Strips. The Screwed Rods slide over the rails. Two lengths of Cord are fastened to the Strip (5) and are passed through Fishplates fixed to the Double Angle Strips (9). The Cords are then pulled taut and fastened to the lower of the Strips (8). These Cords serve as guides to keep the carriages on the rails.

The carriage roofs are $4\frac{1}{2}'' \times 2\frac{1}{2}''$ Flexible Plates curved and attached to Obtuse Angle Brackets.

THE OPERATING MECHANISM AND CORDS

A No. 1 Clockwork Motor is bolted to one of the legs of the tower, and a $\frac{1}{2}''$ Pinion on the Motor shaft drives a 57-tooth Gear on a $2''$ Rod (11). A $\frac{1}{2}''$ fixed Pulley (supplied with the Motor) on Rod (11) is connected by a Driving Band to a $1''$ Pulley on a $5''$ Rod (12), mounted as shown in the Double Angle Strips (7). Two lengths of Cord are tied to Rod (12) and are wound round the Rod in opposite directions. Each Cord is then taken over a $1''$ loose Pulley (13), round the Screwed Rod (10) of one of the carriages and is tied to the Strip (5). The Pulleys (13) are free to turn on a Rod supported in the Double Angle Strips (7). When the Clockwork Motor is set in motion one length of Cord on Rod (12) is wound in and the other is paid out, so that one carriage is raised as the other is lowered.

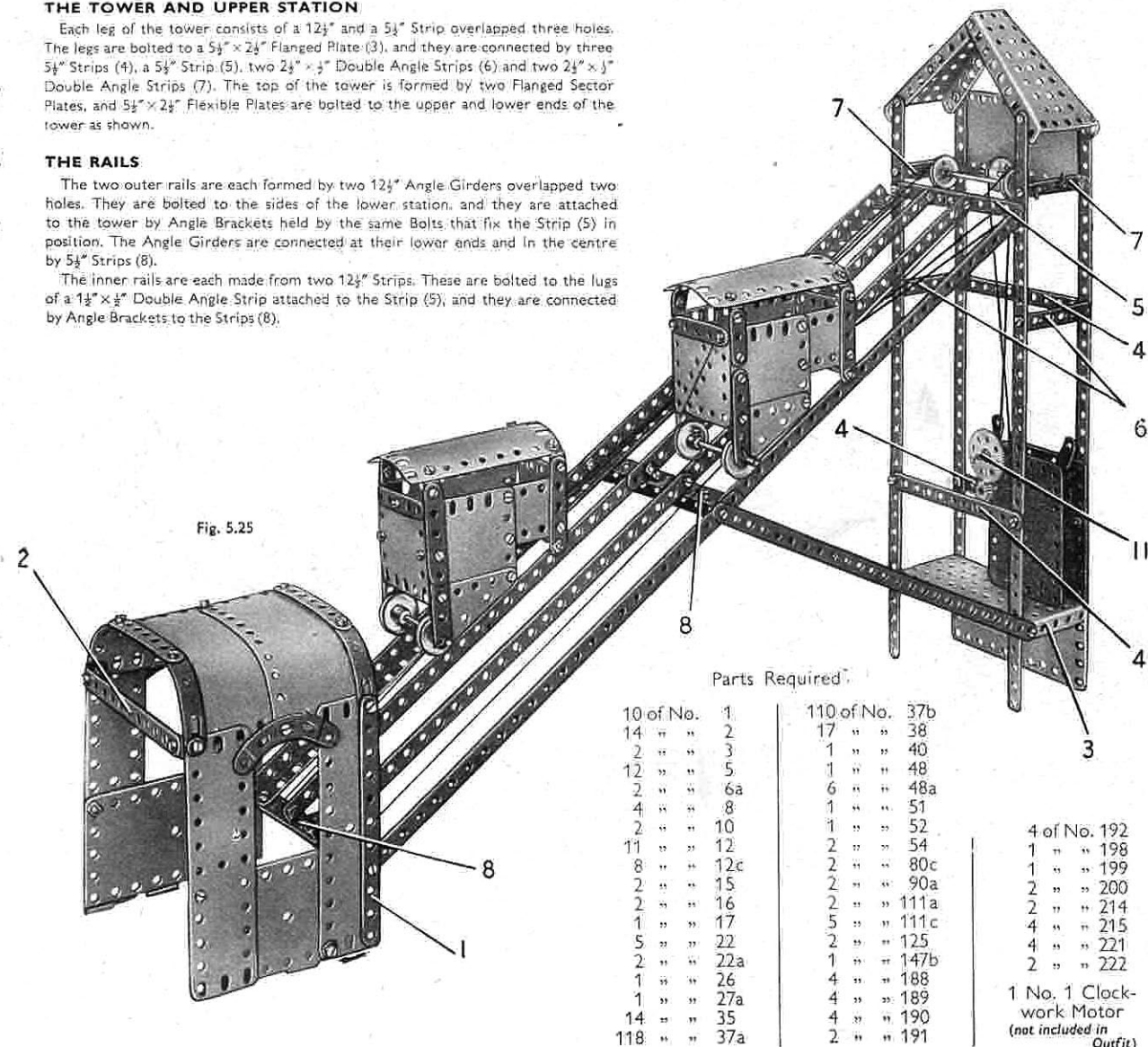
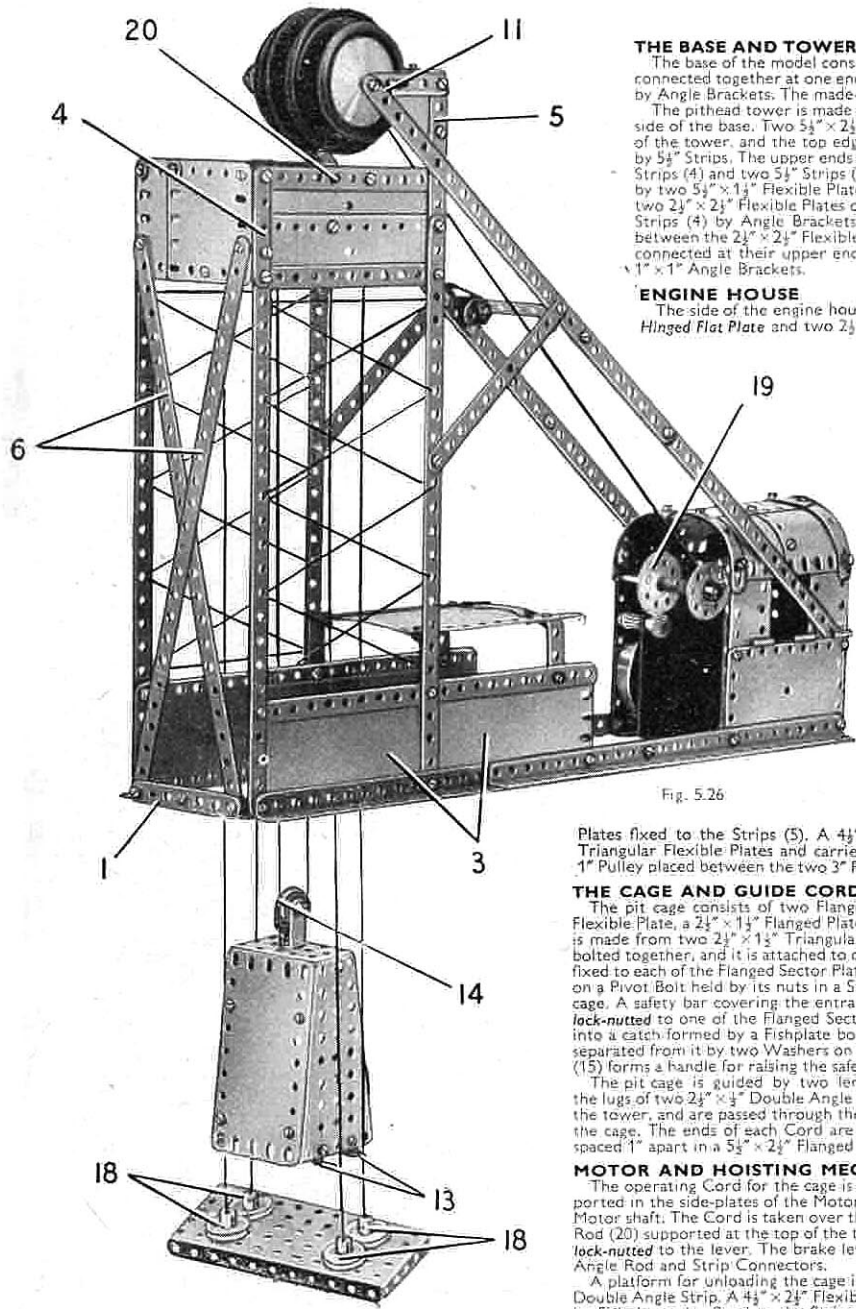

Fig. 5.25

Parts Required

10 of No. 1	1	110 of No. 37b	
14 " " 2	17	" " 38	
2 " " 3	1	" " 40	
12 " " 5	1	" " 48	
2 " " 6a	6	" " 48a	
4 " " 8	1	" " 51	
2 " " 10	1	" " 52	
11 " " 12	2	" " 54	
8 " " 12c	2	" " 80c	
2 " " 15	2	" " 90a	
2 " " 16	2	" " 111a	
1 " " 17	5	" " 111c	
5 " " 22	2	" " 125	
2 " " 22a	1	" " 147b	
1 " " 26	4	" " 188	
1 " " 27a	4	" " 189	
14 " " 35	4	" " 190	
118 " " 37a	2	" " 191	
		4 of No. 192	
		1 " " 198	
		1 " " 199	
		2 " " 200	
		2 " " 214	
		4 " " 215	
		4 " " 221	
		2 " " 222	
		1 No. 1 Clockwork Motor	
		(not included in Outfit)	

5.26 PITHEAD GEAR



THE BASE AND TOWER

The base of the model consists of two built-up angle girders, each made from two 12½" Angle Girders overlapped 11 holes. These are connected together at one end by a made-up strip (1), and at the other end by a 3½" Strip (2), both of which are attached to the girders by Angle Brackets. The made-up strip consists of two 2½" Strips overlapped three holes.

The pithead tower is made by bolting two vertical 12½" Strips to each side of the base. Two 5¼" x 2¼" Flexible Plates (3) are fitted to each side of the tower, and the top edges of the Flexible Plates are strengthened by 5½" Strips. The upper ends of the 12½" Strips are extended by two 2½" Strips (4) and two 5½" Strips (5). These Strips are connected at the sides by two 5¼" x 1¼" Flexible Plates edged by 5½" Strips, and at the front by two 2½" x 2½" Flexible Plates overlapped three holes and attached to the Strips (4) by Angle Brackets. Two crossed 12½" Strips (6) are bolted between the 2½" x 2½" Flexible Plates and the strip (1). The Strips (5) are connected at their upper ends by a 2½" Stepped Curved Strip fixed to 1" x 1" Angle Brackets.

ENGINE HOUSE

The side of the engine house seen in Fig. 5.26a consists of one half of a Hinged Flat Plate and two 2½" x 1¼" Flexible Plates. The opposite side is formed by bolting a No. 1 Clockwork Motor to the base as shown in the general view of the model. This side is completed by a straightened "U"-section Curved Plate bolted to the Motor and to two 2½" Strips joined together. One of these Strips is seen at (7). The rear of the engine house is formed by the other half of the Hinged Flat Plate and two 2½" x 1¼" Triangular Flexible Plates (8). A 3½" Strip (9) is attached to the sides of the house by Angle Brackets, and a Semi-Circular Plate (10) and two 2½" Stepped Curved Strips are fixed to the Strip (9). The roof of the engine house is formed by two 1½" radius Curved Plates, two curved 2¼" x 2½" Flexible Plates, and two 2¼" x 1¼" Flexible Plates. These Plates are edged by four Formed Slotted Strips and two 1½" Strips, and they are bolted to the 2½" x 1¼" Flexible Plates and to the 2½" Strip (7) of the sides. The roof is attached by a Fishplate to the top edge of the No. 1 Clockwork Motor.

The tower is braced to the engine house by two long strips, each made from two 12½" Strips overlapped eight holes. The top ends of these strips are bolted to 2½" x 2" Triangular Flexible Plates fixed to the Strips (5). A 4½" Rod (11) is held by Spring Clips in the Triangular Flexible Plates and carries two Road Wheels, two 3" Pulleys and a 1" Pulley placed between the two 3" Pulleys.

THE CAGE AND GUIDE CORDS

The pit cage consists of two Flanged Sector Plates connected by a 4½" x 2½" Flexible Plate, a 2¼" x 1¼" Flanged Plate and a 2½" Strip (12). The floor of the cage is made from two 2½" x 1¼" Triangular Flexible Plates and a Semi-Circular Plate bolted together, and it is attached to one of two ½" Reversed Angle Brackets (13) fixed to each of the Flanged Sector Plates. A 1" loose Pulley (14) is freely mounted on a Pivot Bolt held by its nuts in a Stepped Bent Strip bolted to the top of the cage. A safety bar covering the entrance of the cage consists of a 2½" Strip (15) lock-nutted to one of the Flanged Sector Plates. The free end of this Strip drops into a catch formed by a Fishplate bolted to the other Flanged Sector Plate but separated from it by two Washers on the Bolt. A Threaded Pin fixed to the Strip (15) forms a handle for raising the safety bar.

The pit cage is guided by two lengths of Cord. These are passed through the lugs of two 2½" x ½" Double Angle Strips (17) bolted to each side at the top of the tower, and are passed through the ½" Reversed Angle Brackets (13) fitted to the cage. The ends of each Cord are passed through 1" Pulleys (18), and holes spaced 1" apart in a 5½" x 2¼" Flanged Plate. The Cord ends are tied together.

MOTOR AND HOISTING MECHANISM

The operating Cord for the cage is fastened between a Bush Wheel and a 57-tooth Gear (19) on a 3½" Rod. The Rod is supported in the side-plates of the Motor, and is held in position by a Spring Clip. The 57-tooth Gear is driven by a ½" Pinion on the Motor shaft. The Cord is taken over the 1" loose Pulley (14), round the 1" loose Pulley (11), round the 1" loose Pulley (14) and is tied between Spring Clips on a 4" Rod (20) supported at the top of the tower. The reversing lever of the Motor is extended by a 5" Rod held in a Rod and Strip Connector lock-nutted to the lever. The brake lever is similarly extended by a 3½" Rod, and both Rods are fitted outside the engine-house with Right-Angle Rod and Strip Connectors.

A platform for unloading the cage is formed by two 5½" Strips (21) bolted to the lugs of three 2½" x ½" Double Angle Strips and one 1½" x ½" Double Angle Strip. A 4½" x 2¼" Flexible Plate is attached at one end to Flat Trunnions bolted to the Strips (21), and its other end is supported by Fishplates also fixed to the Strips (21).

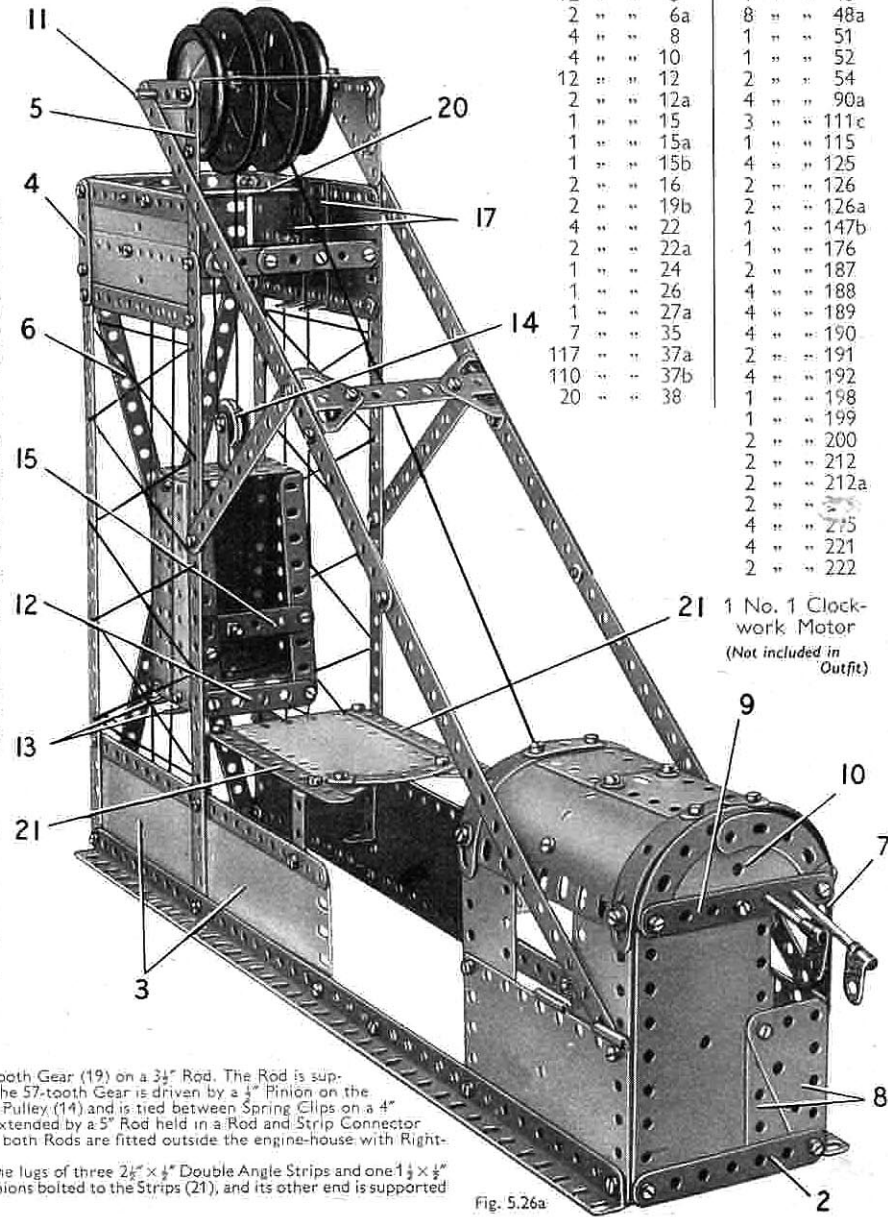

Parts Required

10 of No. 1	2 of No. 38d
14 " " 2	1 " " 40
2 " " 3	1 " " 44
12 " " 5	1 " " 48
2 " " 6a	8 " " 48a
4 " " 8	1 " " 51
4 " " 10	1 " " 52
12 " " 12	2 " " 54
2 " " 12a	4 " " 90a
1 " " 15	3 " " 111c
1 " " 15a	1 " " 115
1 " " 15b	4 " " 125
2 " " 16	2 " " 126
2 " " 19b	2 " " 126a
4 " " 22	1 " " 147b
2 " " 22a	1 " " 176
1 " " 24	2 " " 187
1 " " 26	4 " " 188
1 " " 27a	4 " " 189
7 " " 35	4 " " 190
117 " " 37a	2 " " 191
110 " " 37b	4 " " 192
20 " " 38	1 " " 198
	1 " " 199
	2 " " 200
	2 " " 212
	2 " " 212a
	2 " " 215
	4 " " 215
	4 " " 221
	2 " " 222

1 No. 1 Clockwork Motor
(Not included in Outfit)

Fig. 5.26a

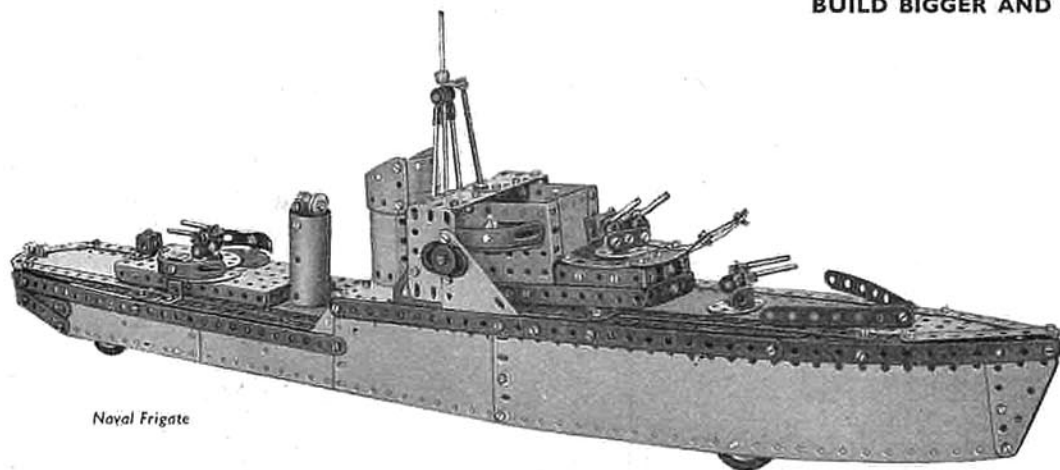
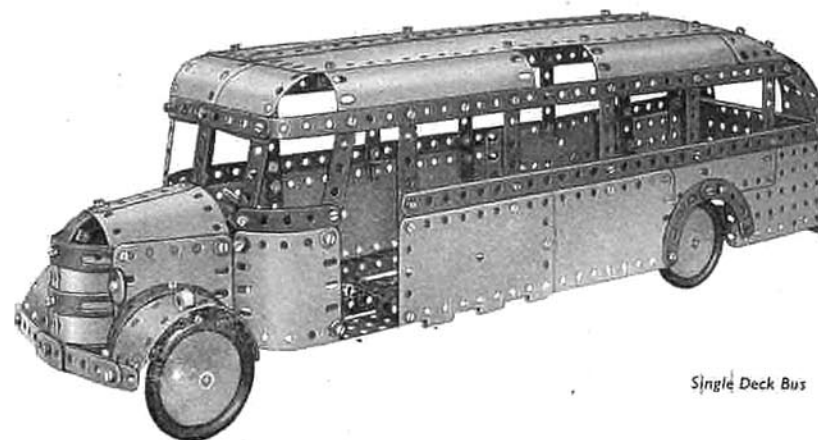
BUILD BIGGER AND BETTER MODELS*Naval Frigate**Single Deck Bus***HOW TO CONTINUE**

When you have built all the models shown in this Book of Instructions, you will be keen to build others bigger and more elaborate. Your next step therefore is to purchase a Meccano No. 5a Accessory Outfit containing all the parts required to convert your No. 5 into a No. 6 Outfit. You will then be able to build the full range of No. 6 Outfit models, a selection of which is illustrated on this page.

If you prefer to do so, you can build up and develop your No. 5 Outfit quite easily by adding various parts to it from time to time. The model-building possibilities of the Meccano System are unlimited, and the more Meccano parts you have the bigger and better the models you will be able to build.

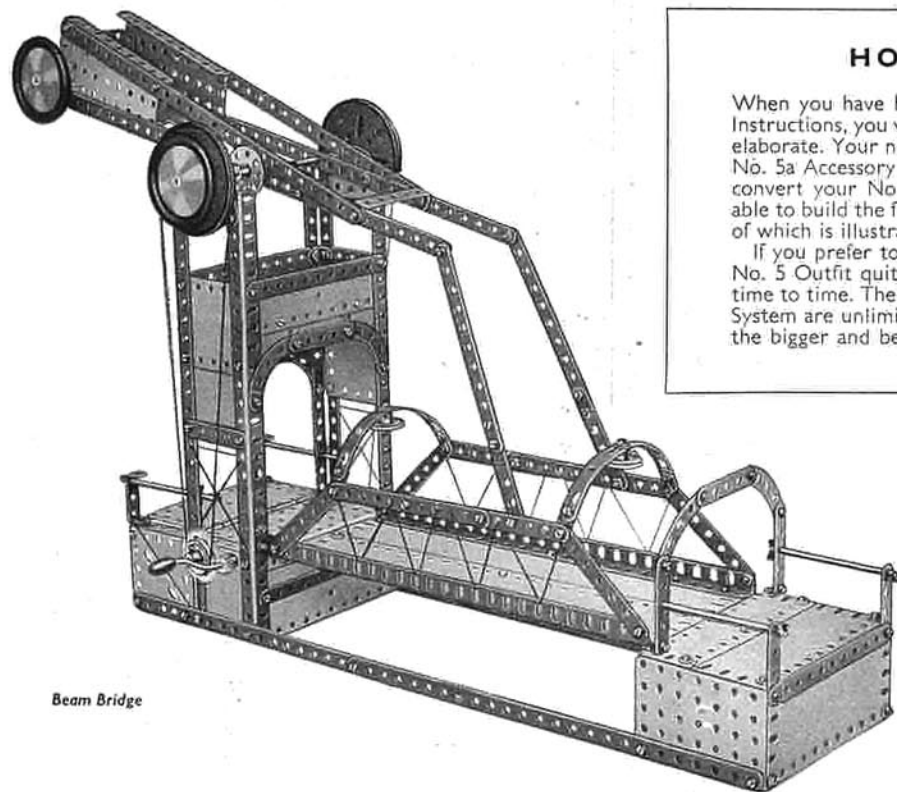
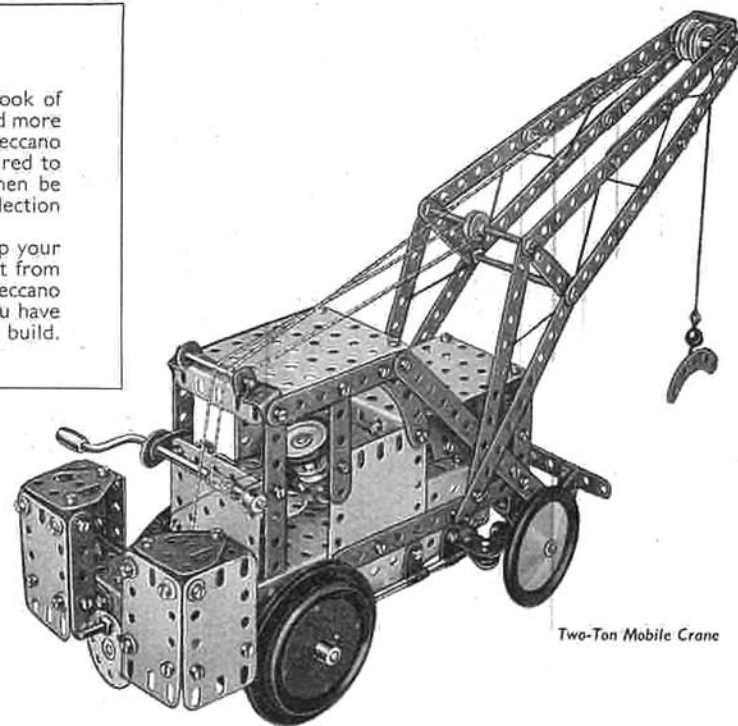
*Beam Bridge**Two-Ton Mobile Crane*

MECCANO PARTS



PERFORATED STRIPS

No.	1. 12 $\frac{1}{2}$ "	No.	2a. 4 $\frac{1}{2}$ "	No.	6. 2"
1a.	9 $\frac{1}{2}$ "	3.	3 $\frac{1}{2}$ "	6a.	1 $\frac{1}{2}$ "
1b.	7 $\frac{1}{2}$ "	4.	3"		
2.	5 $\frac{1}{2}$ "	5.	2 $\frac{1}{2}$ "		

ANGLE GIRDERS

7.	24 $\frac{1}{2}$ "	8b.	7 $\frac{1}{2}$ "	9c.	3"
7a.	18 $\frac{1}{2}$ "	9.	5 $\frac{1}{2}$ "	9d.	2 $\frac{1}{2}$ "
8.	12 $\frac{1}{2}$ "	9a.	4 $\frac{1}{2}$ "	9e.	2"
8a.	9 $\frac{1}{2}$ "	9b.	3 $\frac{1}{2}$ "	9f.	1 $\frac{1}{2}$ "



10. Fishplate | 11. Double Bracket

ANGLE BRACKETS

12.	1 $\frac{1}{2}$ " x 1 $\frac{1}{2}$ "	12b.	1" x 1 $\frac{1}{2}$ "	12c.	Obtuse, 1 $\frac{1}{2}$ " x 1"
12a.	1" x 1"				



AXLE RODS

13.	11 $\frac{1}{2}$ "	15a.	4 $\frac{1}{2}$ "	16b.	3"
13a.	8"	15b.	4"	17.	2"
14.	6 $\frac{1}{2}$ "	16.	3 $\frac{1}{2}$ "	18a.	1 $\frac{1}{2}$ "
15.	5"	16a.	2 $\frac{1}{2}$ "	18b.	1"

- 19g. Crank Handle, 3 $\frac{1}{2}$ " shaft, with grip
 19h. Crank Handle, 5" shaft, with grip
 19s. Crank Handle, 3 $\frac{1}{2}$ " shaft, without grip



19a. Spoked Wheel, 3" diam.
 20. Flanged Wheel, 1 $\frac{1}{2}$ " diam.
 20b. Flanged Wheel, 1" diam.

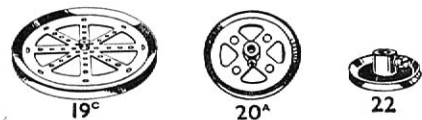

PULLEYS

- 19b. 3" diam., with boss and screw
 19c. 6" diam., with boss and screw
 20a. 2" diam., with boss and screw
 21. 1 $\frac{1}{2}$ " diam., with boss and screw
 22. 1" diam., with boss and screw



PULLEYS

- 22a. 1" diam., without boss
 23. 1 $\frac{1}{2}$ " diam., without boss
 23a. 1" diam., with boss and screw



- No. 24. Bush Wheel, 1 $\frac{1}{2}$ " diam., eight holes
 24a. Wheel Disc, 1 $\frac{1}{2}$ " diam., without boss, eight holes
 24b. Bush Wheel, 1 $\frac{1}{2}$ " diam., six holes
 24c. Wheel Disc, 1 $\frac{1}{2}$ " diam., without boss, six holes

PINIONS

25. 1 $\frac{1}{2}$ " diam., 1" face, 25 teeth
 25a. 1 $\frac{1}{2}$ " diam., 1" face, 25 teeth
 25b. 1 $\frac{1}{2}$ " diam., 1" face, 25 teeth
 26. 1 $\frac{1}{2}$ " diam., 1" face, 19 teeth
 26a. 1 $\frac{1}{2}$ " diam., 1" face, 19 teeth
 26b. 1 $\frac{1}{2}$ " diam., 1" face, 19 teeth
 26c. 1 $\frac{1}{2}$ " diam., 1" face, 15 teeth



GEAR WHEELS

27. 1 $\frac{1}{2}$ " diam., 50 teeth
 27a. 1 $\frac{1}{2}$ " diam., 57 teeth
 27b. 1 $\frac{1}{2}$ " diam., 133 teeth
 27c. 2 $\frac{1}{2}$ " diam., 95 teeth
 27d. 1 $\frac{1}{2}$ " diam., 60 teeth



CONTRATE WHEELS

28. 1 $\frac{1}{2}$ " diam., 50 teeth
 29. 1 $\frac{1}{2}$ " diam., 25 teeth

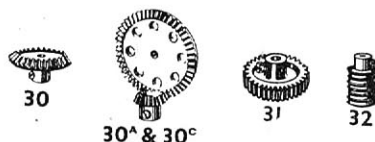

30. Bevel Gear, 1" diam., 26 teeth (for use in pairs)
 30a. Bevel Gear, 1" diam., 16 teeth | Can only be used together
 30c. Bevel Gear, 1 $\frac{1}{2}$ " diam., 48 teeth
 31. Gear Wheel, 1" diam., 1" face, 38 teeth
 32. Worm, 1" diam.
 34. Spanner



- 34b. Box Spanner
 35. Spring Clip
 36. Screwdriver
 36a. Screwdriver (longer)
 36c. Drift (for levering bolt holes into line)
 37. Nut and Bolt, 1/8"
 37a. Nut
 37b. Bolt, 1/8"
 38. Washer
 38d. Washer, 1/8"
 40. Hank of Cord



41. Propeller Blade | 43. Tension Spring, 2" long



- No. 44. Bent Strip, stepped
 45. Double Bent Strip

DOUBLE ANGLE STRIPS

46. 2 $\frac{1}{2}$ " x 1"
 47. 2 $\frac{1}{2}$ " x 1 $\frac{1}{2}$ " | 48. 1 $\frac{1}{2}$ " x 1"
 47a. 3" x 1 $\frac{1}{2}$ " | 48a. 2 $\frac{1}{2}$ " x 1"
 48b. 3 $\frac{1}{2}$ " x 1"
 48c. 4 $\frac{1}{2}$ " x 1"
 48d. 5 $\frac{1}{2}$ " x 1"

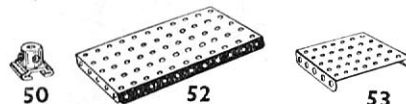

50. Slide Piece
 51. Flanged Plate, 2 $\frac{1}{2}$ " x 1 $\frac{1}{2}$ "
 52. Flanged Plate, 5 $\frac{1}{2}$ " x 2 $\frac{1}{2}$ "
 52a. Flat Plate, 5 $\frac{1}{2}$ " x 3 $\frac{1}{2}$ "
 53. Flanged Plate, 3 $\frac{1}{2}$ " x 2 $\frac{1}{2}$ "
 53a. Flat Plate, 4 $\frac{1}{2}$ " x 2 $\frac{1}{2}$ "



54. Flanged Sector Plate, 4 $\frac{1}{2}$ " long
 55. Perforated Strip, slotted, 5 $\frac{1}{2}$ " long
 55a. Perforated Strip, slotted, 2" long



- 57b. Hook, Loaded, large
 57c. Hook, Loaded, small
 58. Spring Cord, 40" length
 58a. Coupling Screw for Spring Cord
 58b. Hook for Spring Cord
 59. Collar, with screw

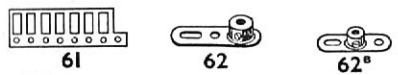

61. Windmill Sail Crank
 62. Threaded Crank
 62a. Threaded Crank
 62b. Double Arm Crank



63. Coupling Strip Coupling
 63b. Strip Coupling
 63c. Threaded Coupling
 63d. Short Coupling



64. Threaded Boss
 65. Centre Fork
 69. Set Screw, 1/8"
 69a. Grub Screw, 1/8"
 69b. Grub Screw, 3/16"
 69c. Grub Screw, 1/4"

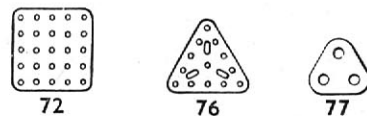

- No. 70. Flat Plate, 5 $\frac{1}{2}$ " x 2 $\frac{1}{2}$ "
 72. Flat Plate, 2 $\frac{1}{2}$ " x 2 $\frac{1}{2}$ "
 73. Flat Plate, 3" x 1 $\frac{1}{2}$ "
 No. 76. Triangular Plate, 2 $\frac{1}{2}$ "
 77. Triangular Plate, 1"



- 80a. 5"
 80b. 4 $\frac{1}{2}$ "
 80c. 3"
 81. 2"
 82. 1"
 90. Stepped, 2 $\frac{1}{2}$ " (1 $\frac{1}{8}$ " radius)

89. 5 $\frac{1}{2}$ " (10" radius)
 89a. Stepped, 3" (1 $\frac{1}{8}$ " radius)
 89b. Stepped, 4" (4 $\frac{1}{8}$ " radius)
 90. 2 $\frac{1}{2}$ " (2 $\frac{1}{8}$ " radius)
 90a. Stepped, 2 $\frac{1}{2}$ " (1 $\frac{1}{8}$ " radius)



94. Sprocket Chain, 40" length
 95. 2" diam., 36 teeth
 95a. 1 $\frac{1}{2}$ " diam., 28 teeth
 95b. 3" diam., 56 teeth
 96. 1" diam., 18 teeth
 96a. 1" diam., 14 teeth

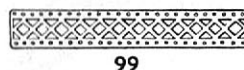

BRACED GIRDERS

97. 3 $\frac{1}{2}$ " long
 97a. 3" long
 97b. 2 $\frac{1}{2}$ " long
 99. 12 $\frac{1}{2}$ " long
 99a. 9 $\frac{1}{2}$ " long
 99b. 7 $\frac{1}{2}$ " long
 100. 5 $\frac{1}{2}$ " long
 100a. 4 $\frac{1}{2}$ " long



101. Heald for Loom | 102. Single Bent Strip

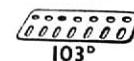

FLAT GIRDERS

103. 5 $\frac{1}{2}$ " long
 103a. 9 $\frac{1}{2}$ " long
 103b. 12 $\frac{1}{2}$ " long
 103c. 4 $\frac{1}{2}$ " long
 103d. 3 $\frac{1}{2}$ " long
 103e. 3" long
 103f. 2 $\frac{1}{2}$ " long
 103g. 2" long
 103h. 1 $\frac{1}{2}$ " long
 103k. 7 $\frac{1}{2}$ " long

MECCANO PARTS



- No. 106. Wood Roller (complete with Rod and two Collars)
 108. Corner Gusset
 109. Face Plate, 2½" diam.

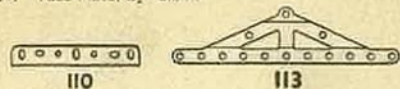

110. Rack Strip, 3½" long | 110a. Rack Strip, 6½" long

BOLTS

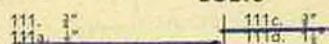

113. Girder Frame

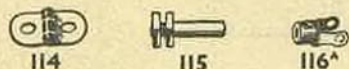

114. Hinge | 116. Fork Piece, large
 115. Threaded Pin | 116a. Fork Piece, small

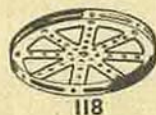

118. Hub Disc, 5½" diam.



- 120b. Compression Spring, ⅝" long
 122. Loaded Sack



123. Cone Pulley, 1½", 1" and ¾" diam.
 124. Reversed Angle Bracket, 1"
 125. Reversed Angle Bracket, ½"



126. Trunnion
 126a. Flat Trunnion
 128. Bell Crank, with Boss



- No. 130. Eccentric, Triple Throw, ½", ¾" and 1"
 130a. Eccentric, Single Throw, ½"

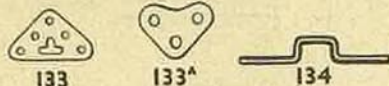

133. Corner Bracket, 1½"
 133a. Corner Bracket, 1"
 134. Crank Shaft, 1" stroke

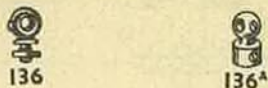

136. Handrail Support | 136a. Handrail Coupling



137. Wheel Flange | 138. Ship's Funnel, Raked



139. Flanged Bracket (right)
 139a. Flanged Bracket (left)
 140. Universal Coupling

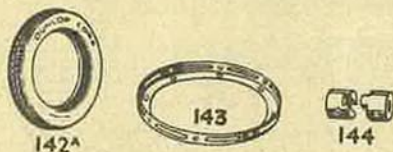

- 142a. Motor Tyre (to fit 2" diam. rim)
 142b. Motor Tyre (to fit 3" diam. rim)
 142c. Motor Tyre (to fit 1" diam. rim)
 142d. Motor Tyre (to fit 1½" diam. rim)
 143. Circular Girder, 5½" diam.
 144. Dog Clutch

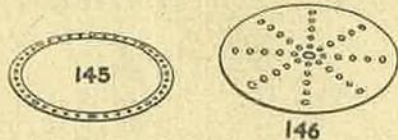

145. Circular Strip, 7½" diam. overall
 146. Circular Plate, 6" diam. overall
 146a. Circular Plate, 4" diam. overall



- No. 147. Pawl, with Pivot Bolt and Nuts
 147a. Pawl
 147b. Pivot Bolt, with two Nuts
 147c. Pawl, without boss
 148. Ratchet Wheel
 151. Single Pulley Block
 153. Triple Pulley Block
 154a. Corner Angle Bracket, ½" (right-hand)
 154b. Corner Angle Bracket, ½" (left-hand)
 155. Rubber Ring (for 1" Pulley)



157. Fan, 2" diam.
 160. Channel Bearing, 1½" x 1" x ½"
 161. Girder Bracket, 2" x 1" x ½"

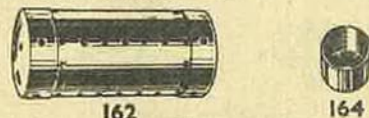

162. Boiler, complete, 5" long x 2 ⅞" diam.
 162a. Boiler Ends, 2 ⅞" diam. x ½"
 163. Sleeve Piece, 1½" long x ⅜" diam.
 164. Chimney Adaptor, ¾" diam. x ½" high



165. Swivel Bearing
 166. End Bearing
 167b. Flanged Ring, 9½" diam.
 168. Ball Thrust Bearing, 4" diam.
 168a. Ball Thrust Race, flanged disc, 3½" diam.
 168b. Ball Thrust Race, toothed disc, 4" diam.
 168c. Ball Cage, 3½" diam., complete with balls
 168d. Ball, ½" diam.

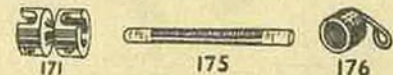

171. Socket Coupling
 173a. Adaptor for Screwed Rod
 175. Flexible Coupling Unit
 176. Anchoring Spring for Cord



179. Rod Socket
 180. Gear Ring, 3½" diam. (133 ext. teeth, 95 int.)



- No. 185. Steering Wheel, 1½" diam.
 187. Road Wheel, 2½" diam.

DRIVING BANDS

- | | |
|-------------------|-------------------|
| 186. 2½" (light) | 186c. 10" (heavy) |
| 186a. 6" (light) | 186d. 15" (heavy) |
| 186b. 10" (light) | 186e. 20" (heavy) |
187. Road Wheel, 2½" diam.
 187a. Conical Disc, 1½" diam.

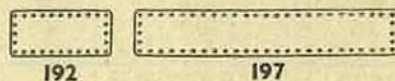

FLEXIBLE PLATES

- | | | |
|----------------|-----------------|----------------|
| 188. 2½" x 1½" | 190. 7½" x 2½" | 191. 4½" x 2½" |
| 189. 5½" x 1½" | 190a. 3½" x 2½" | 192. 5½" x 2½" |

STRIP PLATES

196. 9½" x 2½" | 197. 12½" x 2½"



198. Hinged Flat Plate, 4½" x 2½"
 199. Curved Plate, U-section, 2½" x 2½" x ¾" radius
 200. Curved Plate, 2½" x 2½" x 1½" radius



- 211a. Helical Gear, ½" } Can only be used
 211b. Helical Gear, 1½" } together
 212. Rod and Strip Connector
 213a. Rod and Strip Connector, right-angle
 213. Rod Connector
 213a. Three-way Rod Coupling
 213b. Three-way Rod Coupling with Pommel

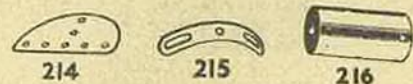

214. Semi-circular Plate, 2½"
 215. Formed Slotted Strip, 1"
 216. Cylinder, 2½" long, 1½" diam.

TRIANGULAR FLEXIBLE PLATES

- | | | |
|----------------|----------------|----------------|
| 221. 2½" x 1½" | 223. 2½" x 2½" | 225. 3½" x 2" |
| 222. 2½" x 2" | 224. 3½" x 1½" | 226. 3½" x 2½" |