

MECCANO

REGISTERED TRADE MARK



INSTRUCTIONS for OUTFIT No. 6

COPYRIGHT BY MECCANO LIMITED
BINNS ROAD, LIVERPOOL 13, ENGLAND

55.6

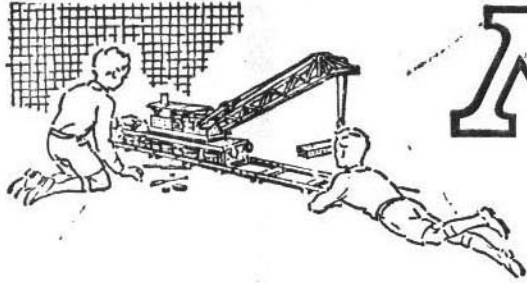

MECCANO

Registered Trade Mark

The World's Greatest Constructional Toy

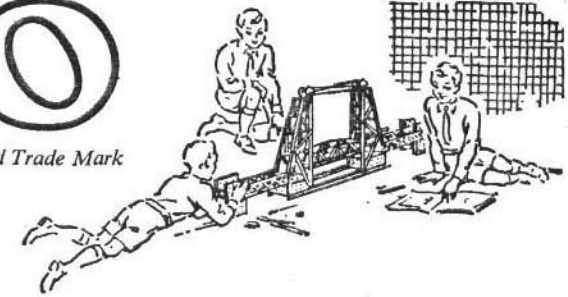

MODEL-BUILDING WITH MECCANO

There is no limit to the number of models that can be built with Meccano — Cranes, Clocks, Motor Cars, Aeroplanes, Machine Tools, Locomotives — in fact everything that interests boys. A screwdriver and a spanner, both of which are provided in each complete Outfit, are the only tools necessary.

When you have built all the models illustrated in the Books of Instructions the fun is not over, it is just beginning. Now comes the chance to make use of your own ideas. First of all, re-build some of the models with small changes in construction that may occur to you; then try building models entirely of your own design. In doing this you will enjoy the real thrill of the engineer and the inventor.

HOW TO BUILD UP YOUR OUTFIT

Meccano is sold in 12 different Outfits, ranging from No. 00 to No. 10. Each Outfit can be converted into the next larger one by the purchase of an Accessory Outfit. Thus Meccano No. 00 Outfit can be converted into No. 0 Outfit by adding to it a No. 00a Accessory Outfit. No. 0a Outfit would then convert it into a No. 1 and so on. In this way, no matter with which Outfit you begin, you can build it up by degrees until you have a complete No. 10 Outfit.

All Meccano parts are of the same high quality and finish, but the larger Outfits contain a greater quantity and variety, making possible the construction of more elaborate models.

THE 'MECCANO MAGAZINE'

The 'Meccano Magazine' is published specially for Meccano boys. Every month it describes and illustrates new Meccano models, and deals with suggestions from readers for new Meccano parts and for new methods of using the existing parts.

There are model-building competitions specially planned to give an equal chance to the owners of small and large Outfits. In addition, there are splendid articles on such subjects as Railways, Famous Engineers and Inventors, Electricity, Bridges, Cranes and

Aeroplanes, and special sections dealing with the latest Engineering, Aviation, Motoring and Shipping News. Other pages deal with Stamp Collecting, and a feature of outstanding popularity is the section devoted to short articles from readers.

Write to the Editor, the 'Meccano Magazine', Binns Road, Liverpool 13, for particulars and a specimen copy. You can order the Magazine from your Meccano dealer, or from any newsagent.

THE MECCANO GUILD

Every owner of a Meccano Outfit should join the Meccano Guild. This is a world-wide organisation, started at the request of Meccano boys. Its primary object is to bring boys together and to make them feel that they are all members of a great brotherhood, each trying to help others to get the very best out of life. Its members are in constant touch with Headquarters, giving news of their activities and being guided in their hobbies and interests. A leaflet containing full particulars of the Guild and an application form is included in this Book.

Clubs founded and established under the guidance of the Guild Secretary provide Meccano boys with opportunities of enjoying to the utmost the fun of model-building. Each has its Leader, Secretary, Treasurer and other officials. With the exception of the Leader, all the officials are boys, and as far as possible the proceedings of the clubs are conducted by boys.

MECCANO SERVICE

The service of Meccano does not end with selling an Outfit and a Book of Instructions. If ever you are in any difficulty with your models, or if you want advice on anything connected with this great hobby, write to us. We receive hundreds of interesting letters from boys in all parts of the world, and each of these is answered personally and promptly by one of our staff of experts.

Whatever your problem may be, write to us about it. We shall be delighted to help you in any way possible. Address your letters to *Information Service*.

Boys!

Read the

MECCANO MAGAZINE

THE IDEAL MAGAZINE FOR BOYS

The happiest and most successful boys are those who take a keen interest in the world around them. The 'MECCANO MAGAZINE' is ideal for these boys. Month by month its pages are filled with attractively-written articles, splendidly illustrated from actual photographs.

The subjects include Engineering in all its branches, Railways, Road Transport, Aeroplanes and Shipping, Inventions and Scientific Discoveries are described in simple language. Everything is dealt with in an attractive and straightforward style, and with an accuracy that has won for the Magazine the enthusiastic approval of the engineering, technical and scientific world. Special sections are devoted to Model-building with Meccano, fun with Dinky Toys and the operation of realistic Miniature Railways; and Stamp Collecting forms still another important feature. Model-building Competitions open to all owners of Meccano Outfits, are a special feature.



Join the

MECCANO GUILD

WHAT THE GUILD MEANS

The Meccano Guild is an organisation for boys, started at the request of boys, and as far as possible conducted by boys. In joining the Guild a Meccano boy becomes a member of a great brotherhood of world-wide extent. Wherever he happens to be, even in strange countries, he will know that he has met a friend whenever he sees the little triangular badge of membership. The Meccano Guild is bringing together Meccano boys all over the world, and helping them to get the best out of life. At its head — guiding and controlling and taking a personal interest in this great movement — is the President, Mr Roland G. Hornby, son of the inventor of Meccano.

HOW TO JOIN THE MECCANO GUILD

Any owner of a Meccano Outfit, no matter what its size, may become a member. All he has to do is to fill in the official application form on the back of this leaflet, have his signature witnessed, and send the form to Headquarters with a postal order (not stamps) for the necessary amount in payment for the official badge, which he will wear in his buttonhole.

The price of the badge for boys living in the British Isles is 1/- . For those living overseas it is 1/6 (30 cents in Canada).

Applicants living in Canada, Australia, New Zealand or South Africa should write to the Meccano agents in their countries. Their addresses are as follows:

AUSTRALIA:

New South Wales and A.C.T. — E. G. Page & Co. (Sales) (Pty.) Ltd, Box 1832, G.P.O., Sydney, N.S.W.

Queensland and Northern Territories — Thomas Brown & Sons Ltd, (P.O. Box 144C), Eagle Street, Brisbane, Queensland.

South Australia — Harris, Scarfe Ltd, Grenfell Street, Adelaide.

Victoria and Tasmania — Ponsford, Newman & Benson Ltd, 234 Flinders Lane, Melbourne, Victoria.

Western Australia — P. Falk & Co. Ltd, 317-9 Murray Street, Perth.

CANADA: Meccano Ltd, 675 King Street West, Toronto.

NEW ZEALAND: Models Ltd (P.O. Box 129), 53 Fort Street, Auckland, C.I.

RHODESIA: Woolley, Kinleyside & Co. (Pvt.) Ltd, P.O. Box 299, Bulawayo.

SOUTH AFRICA: Arthur E. Harris (Pty.) Ltd (P.O. Box 1199), 142 Market Street, Johannesburg.

Their Badges and Certificates are then forwarded without delay, while their application forms are sent to Headquarters in Liverpool.

Applicants living in any other country overseas should forward their forms, with a British postal order (not stamps) or a money order for 1/6, direct to the Secretary, the Meccano Guild, Binns Road, Liverpool, 13.

Guild members are eligible for the Correspondence Club, by which they are placed in touch with other members in various parts of the world. Full particulars and enrolment forms can be obtained from the Secretary.

The Secretary will send also, on request, full details of the Guild Recruiting Campaign, and of the Medallion awarded to members who are successful in obtaining recruits, together with particulars of the Meccano clubs founded and established by enthusiastic Meccano boys. A special booklet, 'How to run a Meccano Club' will be sent post free to any member on receipt of 2d. in stamps.

MECCANO MAGAZINE

for the really modern boy

The 'MECCANO MAGAZINE' is on sale at all bookstalls, newsagents and Meccano dealers, price 1/3. If you prefer to have each issue sent direct, the subscription rates are 18/- for twelve months or 9/- for six months, including postage, and an order form is attached.

The overseas prices of the 'M.M.' are 15c. in Canada, 1/6 in Australia, 18c. in the U.S.A. and 1/- elsewhere.

ORDER FORM

TO THE EDITOR,
MECCANO MAGAZINE,
BINNS ROAD, LIVERPOOL 13.

I enclose Postal Order for Please post the
'MECCANO MAGAZINE' for months, beginning with
the issue.

NAME (IN BLOCK LETTERS)

ADDRESS

MECCANO GUILD

THE THREE GREAT OBJECTS OF THE GUILD

- To make every boy's life brighter and happier.
- To foster clean-mindedness, truthfulness, ambition and initiative in boys.
- To encourage boys in their hobbies, and especially in the development of their knowledge of mechanical and engineering principles.



BADGE OF
MEMBERSHIP

Headquarters: BINNS ROAD LIVERPOOL 13

APPLICATION FOR MEMBERSHIP

I possess a Meccano Outfit, and I hereby make application for membership of the Meccano Guild.
I approve of the objects of the Guild, and I promise on my honour

- (1) To conform to the rules and regulations of the Meccano Guild.
- (2) To promote its objects by my own example: to be helpful to others; to be clean in thought and habit; to be determined to learn and make progress.
- (3) To wear the Meccano Guild Badge on all possible occasions.
- (4) To recognise and acknowledge all other Members wearing the Guild Badge, and to render them help in case of need.

I enclose 1/- for the Guild Badge (Great Britain).

I enclose 1/6 for the Guild Badge (Overseas).

I enclose 30c. for the Guild Badge (Canada).

Strike out line not applicable (See other side of this form).

NAME OF APPLICANT

(BLOCK LETTERS PLEASE)

ADDRESS

DATE

SIZE OF OUTFIT OWNED NO.

AGE

WITNESS

ADDRESS

The witness should be the Parent, Guardian, Employer, Schoolmaster or Church Minister
and should state which when signing.

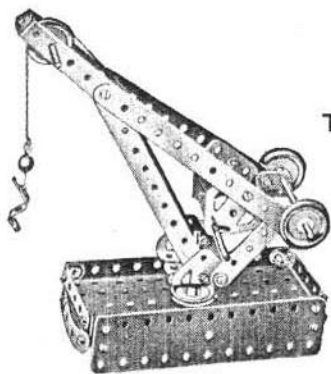

This Dockside Crane
can be built with Outfit No. 1

HOW TO BEGIN THE FUN

THE MOST FASCINATING OF ALL HOBBIES

Meccano model-building is the most fascinating of all hobbies, because it never becomes dull. There is always something new to be done. First of all there is the fun of building a new model, and watching it take shape as part after part is added. Then, when the model is complete, comes the thrill of setting it to work just like the real structure it represents, by means of a Meccano Motor.

The following hints are given to show boys who are just starting the wonderful Meccano hobby how to get the greatest possible fun.

A FEW USEFUL HINTS

It will be noticed that with each model in this Book of Instructions is given a list of the parts required to build it. For the first few models it is a good plan to lay out on the table all the parts required for the one it is proposed to build, and put the remainder of the Outfit to one side. To help you to pick out the correct parts for your model a complete list of Meccano parts is given at the back of this Book, and all the principal parts are illustrated. In the list the parts are all numbered, and in most cases their measurements are given. There is no need, however, to measure the parts to find out which is which, as the size is easily found from the number of holes. All Meccano holes are spaced $\frac{1}{2}$ " apart, so that by counting two holes to the inch the size of a part can be found at once. For instance, Part No. 2 is listed as a $5\frac{1}{2}$ " Perforated Strip, so you look in your Outfit for a Strip with eleven holes. Similarly No. 189 is a $5\frac{1}{2}$ " x $1\frac{1}{2}$ " Flexible Plate, so you look for a Flexible Plate eleven holes in length and three holes in width. By the time a few models have been built the names of the parts will have become familiar.

Beginners sometimes wonder which section of a model should be built first. There cannot be any definite rule for this, as it depends on the design of the model. In stationary models the base usually should be built first. In most of the small models a $5\frac{1}{2}$ " x $2\frac{1}{2}$ " Flanged Plate forms an important part of the structure, and often the best plan is to start building by bolting parts to this Plate. For other models a good general rule is that the sections that form supports for a number of other parts should be built first.

During the construction of a model it is best to screw up the nuts with the fingers, followed by a light turn with the screwdriver, leaving the final tightening until all the parts are connected up.

THE IMPORTANCE OF LOCK-NUTTING

In some models it is necessary to join certain parts together so that, although they cannot come apart, they are free to pivot or move in relation to one another. To do this the parts are bolted together as usual, but the nut is not screwed up tightly, so that the parts are not gripped. Then, to prevent the nut from unscrewing, a second nut is screwed up tightly against it, the first nut being held with a spanner. This method of using a second nut is known as *Lock-nutting*.

In building models in which Rods revolve in the holes of other parts it is important to make sure that such holes are exactly in line with one another. This can be done by pushing through the holes a Drift, Part No. 36c, or a Rod, before the Bolts holding the various parts are tightened up.

A Rod is usually mounted in a support or bearing so that it is free to revolve. The Rod is then said to be *Journalled* in the Strip.

DRIVING YOUR MODELS

Models can be driven by means of either clockwork or electric motors. Ask your Dealer for particulars of Meccano Clockwork and Electric Motors.

Small and light models may be driven direct from the driving pulley of the motor or through a belt running over two pulleys of the same size, giving what is known as a 1 : 1 (one-to-one) ratio. For large models it is necessary to take the drive from a small pulley on the motor shaft to a larger pulley on the driving shaft of the model. In most cases a 1" Pulley on the motor shaft and a 3" Pulley on the model shaft will be found satisfactory. This provides a reduction ratio of approximately 3 : 1.

Rubber bands are very convenient for driving belts. Sometimes, however, a rubber band of the right length is not available, and then Meccano Cord or thin string is used. To tie the Cord to form an endless belt, use the familiar reef knot.

All Outfits from No. 2 upward include a Cord Anchoring Spring, Part No. 176. This part provides a neat and positive method of fastening a length of Cord to a Rod. The Spring is placed on a Rod by pushing and turning it in such a way that its coils tend to unwind.

Flexible Plates are used for forming curved surfaces in models, but they are not intended to be bent at right angles. With careful handling a Plate can be bent to the required curve and after use straightened again.

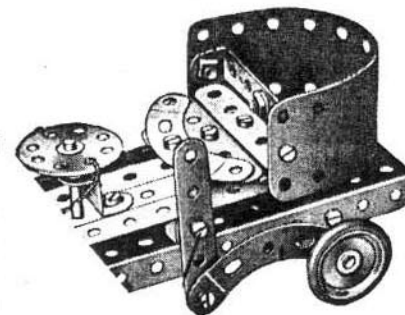

A Flexible Plate
used to form a curved surface

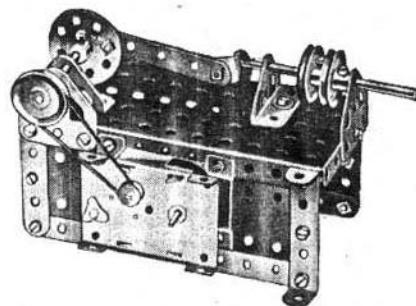

A 'Magic' Motor
fitted to drive a Steam Engine

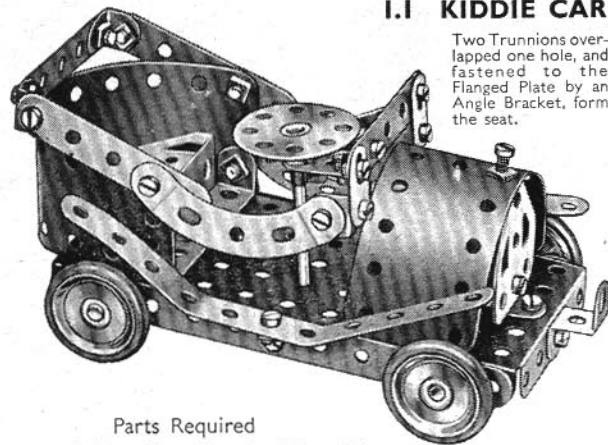
I.1 KIDDIE CAR

Two Trunnions overlapped one hole, and fastened to the Flanged Plate by an Angle Bracket, form the seat.

Parts Required

4 of No. 2	1 of No. 24	2 of No. 111c
4 " " 5	1 " " 35	1 " " 125
3 " " 10	27 " " 37a	1 " " 126
7 " " 12	2 " " 37b	1 " " 126a
2 " " 16	2 " " 48a	4 " " 155
1 " " 17	1 " " 52	2 " " 189
4 " " 22	2 " " 90a	

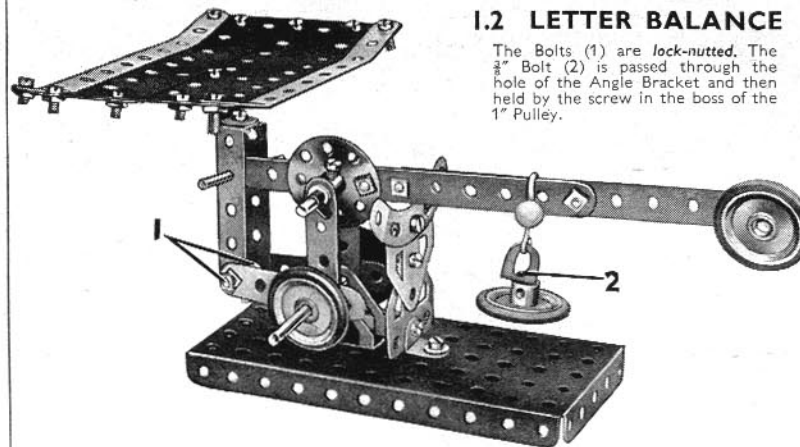
I.2 LETTER BALANCE

The Bolts (1) are *lock-nutted*. The $\frac{3}{8}$ " Bolt (2) is passed through the hole of the Angle Bracket and then held by the screw in the boss of the 1" Pulley.

Parts Required

4 of No. 2	4 of No. 22	4 of No. 38	4 of No. 111c
4 " " 5	1 " " 24	2 " " 48a	1 " " 125
4 " " 10	4 " " 35	1 " " 52	2 " " 126
2 " " 12	28 " " 37a	1 " " 57c	2 " " 126a
1 " " 16	24 " " 37b	1 " " 90a	4 " " 155
2 " " 17			2 " " 189

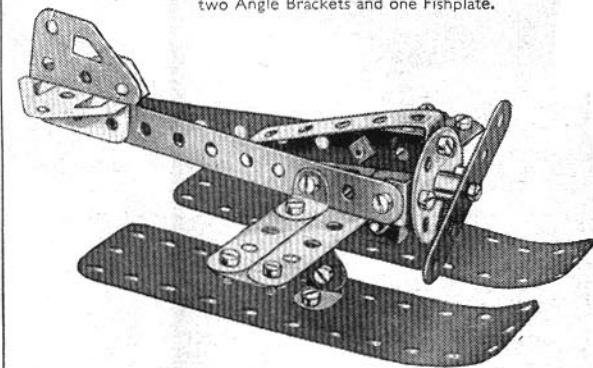
I.3 RACING SEAPLANE

Each of the floats is secured to the wings by two Angle Brackets and one Fishplate.

Parts Required

3 of No. 2	1 of No. 24	2 of No. 111c
3 " " 5	20 " " 37a	2 " " 126
4 " " 10	19 " " 37b	1 " " 126a
8 " " 12	1 " " 48a	2 " " 189

I.4 RAILWAY BREAKDOWN CRANE

The hoisting Cord is secured to the Crank Handle and then led over the $\frac{3}{8}$ " Bolt (1). It is then passed through the pulley block and fastened to the jib at (2). The jib is attached to the Bush Wheel (3) by means of Angle Brackets, and the complete unit is pivoted as follows. A $\frac{3}{8}$ " Bolt is passed through the $5\frac{1}{2}$ " x $2\frac{1}{2}$ " Flanged Plate from the underside, and is secured in the boss of the Bush Wheel by its set screw.

Parts Required

4 of No. 2	1 of No. 19s
4 " " 5	4 " " 22
1 " " 10	1 " " 24
4 " " 12	2 " " 35
2 " " 16	24 " " 37a
	20 " " 37b
	2 " " 38
	1 " " 40
	2 " " 48a
	1 " " 52
	1 " " 57c
	2 " " 90a

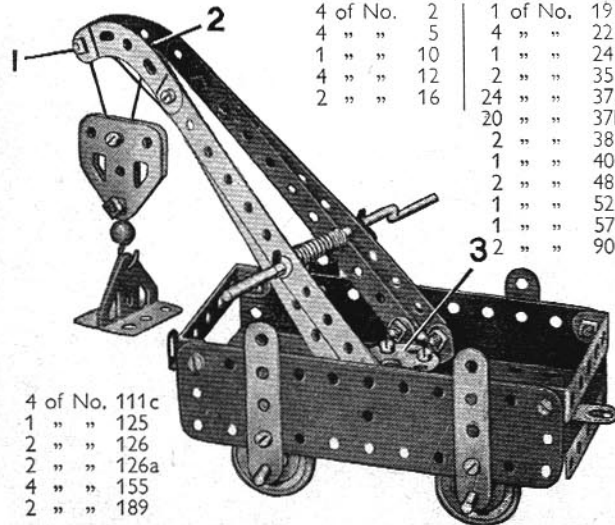

4 of No. 111c
1 " " 125
2 " " 126
2 " " 126a
4 " " 155
2 " " 189

I.5 TRICYCLE VAN**Parts Required**

4 of No. 2	1 of No. 17	24 of No. 37b	2 of No. 111c
3 " " 5	3 " " 22	3 " " 38	2 " " 126
3 " " 10	1 " " 24	2 " " 48a	2 " " 126a
6 " " 12	4 " " 35	1 " " 52	2 " " 142c
2 " " 16	27 " " 37a	2 " " 90a	2 " " 189

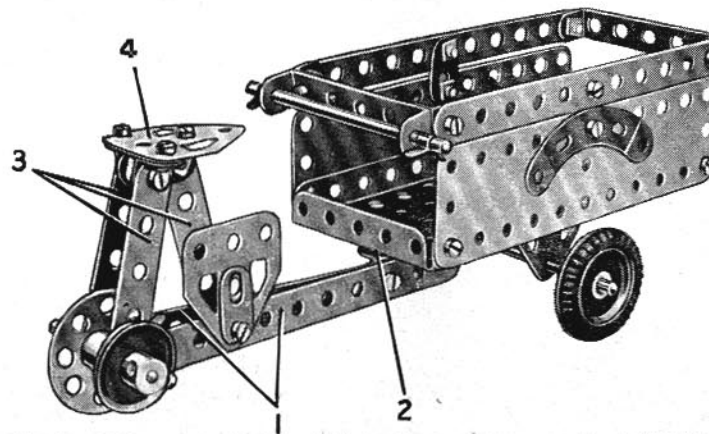

The frame of the cycle consists of two $5\frac{1}{2}$ " Strips (1) connected at one end by a bolt that fixes them also to an Angle Bracket (2). The Angle Bracket pivots on a bolt *lock-nutted* to the Flanged Plate. The seat is carried by three $2\frac{1}{2}$ " Strips (3), each of which is connected by an Angle Bracket to the Flat Trunnion (4). The front axle is carried in Trunnions bolted underneath the Flanged Plate.

I.6 STAMPING MILL

The anvil (1) is made up of two Trunnions bolted together. When the Crank Handle is rotated, the Fishplates bolted to the Bush Wheel strike the centre 1" Pulley on the hammer shaft and cause it to rise and fall.

Parts Required

4 of No. 2	1 of No. 90a
4 " " 5	4 " " 111c
4 " " 10	1 " " 125
4 " " 12	2 " " 126
1 " " 16	2 " " 126a
1 " " 19s	2 " " 189
4 " " 22	
1 " " 24	
2 " " 35	
27 " " 37a	
24 " " 37b	
2 " " 38	
2 " " 48a	
1 " " 52	

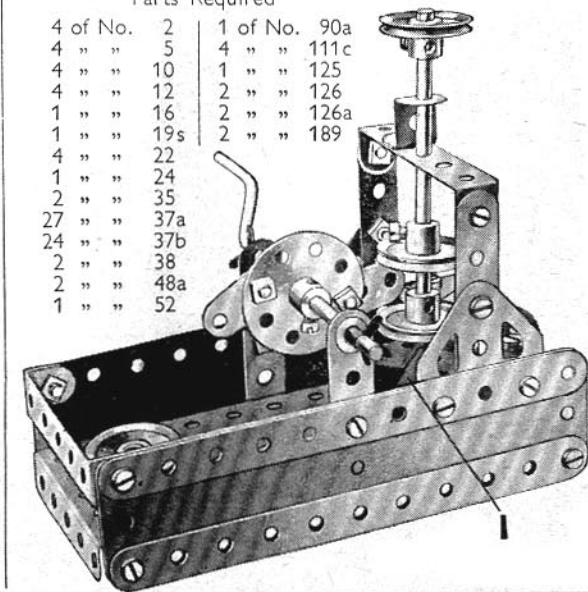

2.1 CANAL BRIDGE

Parts Required

4 of No.	2
6 " "	5
4 " "	10
6 " "	12
1 " "	16
1 " "	19g
4 " "	22
1 " "	24

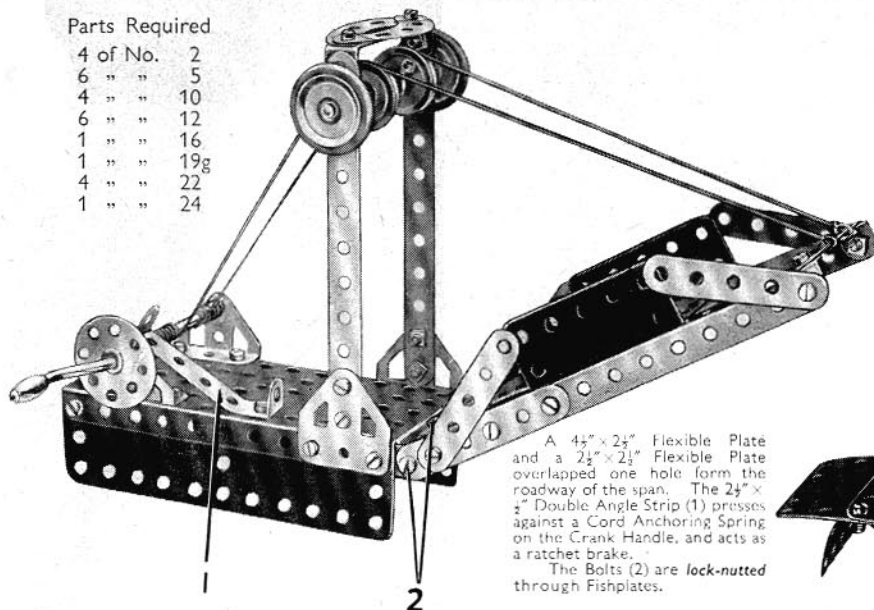

A $4\frac{1}{2}'' \times 2\frac{1}{2}''$ Flexible Plate and a $2\frac{1}{2}'' \times 2\frac{1}{2}''$ Flexible Plate overlapped one hole form the roadway of the span. The $2\frac{1}{2}'' \times \frac{1}{2}''$ Double Angle Strip (1) presses against a Cord Anchoring Spring on the Crank Handle, and acts as a ratchet brake.
The Bolts (2) are lock-nutted through Fishplates.

Parts Required (continued)

41 of No.	37a
39 " "	37b
2 " "	38
1 " "	40
2 " "	48a
1 " "	52
2 " "	90a
2 " "	126
2 " "	126a
2 " "	155
1 " "	176
2 " "	188
2 " "	189
2 " "	190
1 " "	191
1 " "	199
1 " "	200



2.2 DRILLING MACHINE

The horizontal $2\frac{1}{2}''$ Strips at the top of the drill are joined together, and also to the vertical $2\frac{1}{2}''$ Strips, by means of Angle Brackets. The lower bearings (1) are two Angle Brackets bolted to a $2\frac{1}{2}''$ Strip, and the Rod forming the drill is journaled in these, and in a Fishplate at its upper end. A $2\frac{1}{2}'' \times 2\frac{1}{2}''$ Flexible Plate is supported by a Double Angle Strip (2), and represents the table.

The drive is taken from the Motor to the 1" Pulley on the lower shaft. A second driving belt passes round the $\frac{1}{2}''$ fixed Pulley supplied with the Motor, which is also fixed on the lower shaft, round the two Pulleys at (3), and finally round the 1" Pulley fastened on the vertical drill shaft.

Parts Required

2 of No.	2	1 of No.	24	1 of No.	111c
5 " "	5	4 " "	35	2 " "	126
1 " "	10	24 " "	37a	2 " "	126a
5 " "	12	22 " "	37b	1 " "	190
1 " "	16	1 " "	40	1 Magic Motor	(not included in Outfit)
2 " "	17	1 " "	48a		
4 " "	22	1 " "	52		

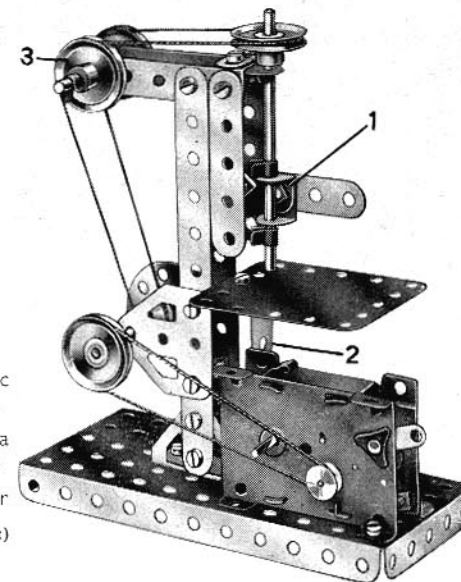

2.3 MILK DELIVERY WAGON

4 of No.	2
6 " "	5
2 " "	10
6 " "	12
2 " "	16

4 of No.	22
1 " "	24
37 " "	37a
37 " "	37b

Parts Required

4 of No.	38
2 " "	48a
1 " "	52
2 " "	90a

1 of No.	111c
1 " "	126
2 " "	126a
4 " "	155

2 of No.	188
2 " "	189
2 " "	190
1 " "	191
1 " "	199

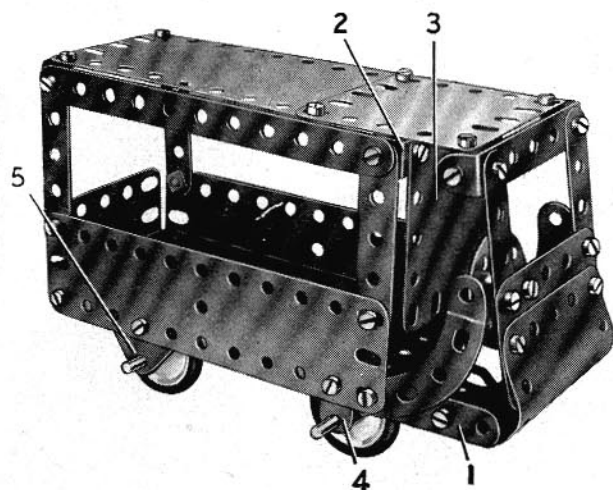

The floor of the wagon is a $5\frac{1}{2}'' \times 2\frac{1}{2}''$ Flanged Plate placed with its flanges downward, and to each side a $5\frac{1}{2}''$ Strip (1) is bolted, the Strips extending three-holes beyond the Plate. The curved front consists of a 'U'-section Curved Plate opened out slightly, and a $2\frac{1}{2}'' \times 1\frac{1}{2}''$ Flexible Plate. The Curved Plate is connected to Angle Brackets bolted to the Strips (1).

The roof is attached to the side frames of the body and to the windscreen pillars by Angle Brackets, and the side frames are connected together by a $2\frac{1}{2}'' \times \frac{1}{2}''$ Double Angle Strip (2). A $2\frac{1}{2}'' \times 2\frac{1}{2}''$ Flexible Plate (3) is bolted to this Double Angle Strip.

The front wheels are fixed on a $3\frac{1}{2}''$ Rod supported in a Fishplate (4) on each side of the model. The rear axle also is a $3\frac{1}{2}''$ Rod and it is supported in the Flat Trunnions (5).

2.4 MECHANICAL HACKSAW

The base consists of Flexible Plates bolted to a Flanged Plate. One side is formed by a $4\frac{1}{2}'' \times 2\frac{1}{2}''$ and a $2\frac{1}{2}'' \times 1\frac{1}{2}''$ Flexible Plate, and the other by two $5\frac{1}{2}'' \times 1\frac{1}{2}''$ Plates. A $2\frac{1}{2}'' \times 2\frac{1}{2}''$ Flexible Plate is bolted to each end. The base is strengthened at each end by Double Angle Strips (1) and a $5\frac{1}{2}''$ Strip on each side.

The saw is actuated by a crank formed from a Bush Wheel fixed to a $3\frac{1}{2}''$ Rod. The Rod rotates in a Trunnion and a Flat Trunnion. The Trunnion is raised from the Flanged Plate by two Washers. The Rod carries a 1" Pulley (2) and a Road Wheel. The Pulley (2) is connected by a belt of Cord to a similar Pulley fixed on the Crank Handle.

The material to be sawn is clamped to the base by means of two $2\frac{1}{2}''$ Strips, one of which is shown at (3).

Parts Required

3 of No.	2	2 of No.	48a
6 " "	5	1 " "	52
2 " "	12	4 " "	111c
2 " "	16	1 " "	126
1 " "	19g	1 " "	126a
3 " "	22	1 " "	187
1 " "	24	1 " "	188
38 " "	37a	2 " "	189
30 " "	37b	2 " "	190
4 " "	38	1 " "	191
1 " "	40		

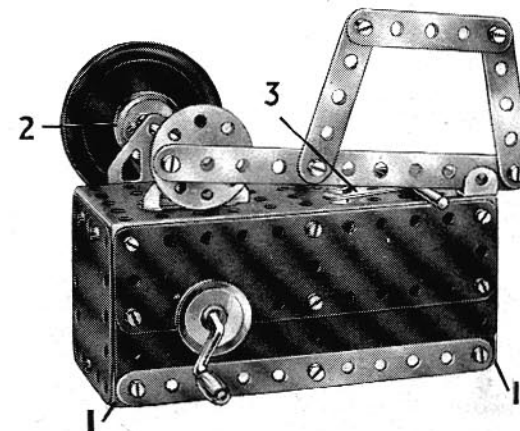

2.5 BEAM ENGINE

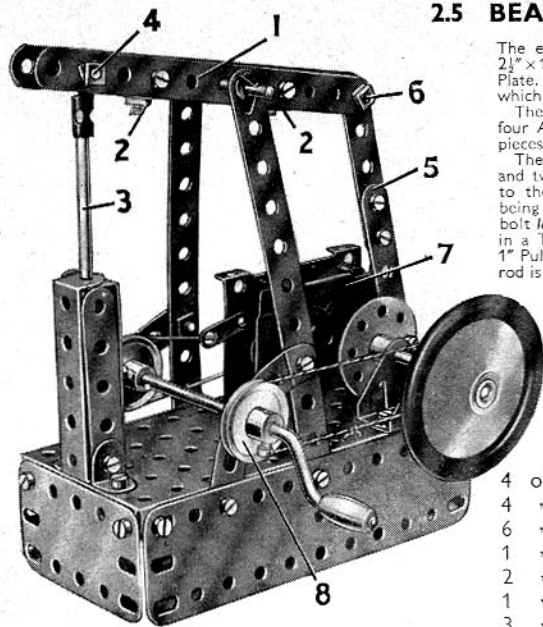

The engine bed or base consists of two $5\frac{1}{2}'' \times 1\frac{1}{2}''$ and two $2\frac{1}{2}'' \times 1\frac{1}{2}''$ Flexible Plates bolted to the sides of a Flanged Plate. Two $5\frac{1}{2}''$ Strips form the supports for the beam (1), which pivots on a 2" Rod held in position by Spring Clips.

The beam is made from two $5\frac{1}{2}''$ Strips held together by four Angle Brackets bolted in pairs to form two 'U'-shaped pieces. The positions of the pieces are marked (2).

The cylinder consists of two $2\frac{1}{2}'' \times \frac{3}{8}''$ Double Angle Strips and two $2\frac{1}{2}''$ Strips. The piston rod (3) is a $3\frac{1}{2}''$ Rod attached to the beam by a Rod and Strip Connector, the Bolt (4) being lock-nutted. The connecting rod (5) is pivoted on a bolt lock-nutted to a Bush Wheel held on a 2" Rod journalled in a Trunnion and a Flat Trunnion. This Rod also carries a 1" Pulley and a Road Wheel. At its upper end the connecting rod is attached to the beam by the lock-nutted Bolt (6).

The Magic Motor (7) is bolted to the base by its flanges, and its pulley is connected by a Driving Band to a 1" Pulley on the Crank Handle. A further 1" Pulley (8) on the Crank Handle is connected by a belt of Cord to the Pulley on the 2" Rod.

Parts Required

4 of No. 2	3 of No. 35	2 of No. 111c
4 " " 5	35 " " 37a	1 " " 126
6 " " 12	30 " " 37b	1 " " 126a
1 " " 16	3 " " 38	1 " " 187
2 " " 17	1 " " 40	2 " " 188
1 " " 19g	2 " " 48a	2 " " 189
3 " " 22	1 " " 52	1 " " 212
1 " " 24	2 " " 90a	1 Magic Motor
		(not included in Outfit)

2.7 BACON SLICER

Parts Required

3 of No. 2	1 of No. 17	40 of No. 37a	2 of No. 48a	1 of No. 125	2 of No. 188
6 " " 5	1 " " 19g	36 " " 37b	1 " " 52	2 " " 126a	2 " " 189
1 " " 10	4 " " 22	3 " " 38	2 " " 90a	1 " " 187	2 " " 190
8 " " 12	1 " " 24	1 " " 40			
1 " " 16	2 " " 35				

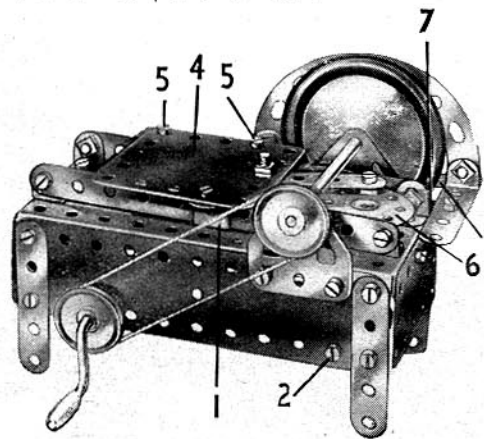

The base of the model consists of a Flanged Plate fitted with four $2\frac{1}{2}''$ Strips for legs. Two $5\frac{1}{2}'' \times 1\frac{1}{2}''$ and two $2\frac{1}{2}'' \times 1\frac{1}{2}''$ Flexible Plates are bolted to the flanges of the Plate.

The guides for the sliding carriage (4) are formed by two $5\frac{1}{2}''$ Strips attached to the Flanged Plate by Angle Brackets. The carriage consists of a $2\frac{1}{2}'' \times 2\frac{1}{2}''$ Flexible Plate (4) and is guided along the Strips by the Reversed Angle Bracket (1) and two Angle Brackets on the opposite side. The Angle Brackets are held in place by Bolts (5).

The cutting blade is represented by a Road Wheel fixed on a $3\frac{1}{2}''$ Rod journalled in two Flat Trunnions. A Pulley on this Rod is connected by a belt of Cord to a second Pulley on the Crank Handle.

The carriage is moved backwards and forwards by a crank consisting of a Bush Wheel (6) fixed on a 2" Rod. This Rod is journalled in the Flanged Plate and in the centre hole of a Double Angle Strip fixed across the interior of the base by the Bolt (2) and another in a similar position on the opposite side. A 1" Pulley on the 2" Rod is connected by a crossed belt of Cord to a further 1" Pulley secured to the Crank Handle between the $5\frac{1}{2}'' \times 1\frac{1}{2}''$ Flexible Plates.

A guard for the rotating blade is provided by two Curved Strips attached to a $5\frac{1}{2}''$ Strip (3). This Strip is fastened at one end to the Flanged Plate by a $2\frac{1}{2}''$ Strip and a Fishplate (7), and at its other end it is attached to a $2\frac{1}{2}'' \times 2\frac{1}{2}''$ Flexible Plate bolted horizontally to the Flanged Plate.

2.6 AUTOGIRO

Parts Required

4 of No. 2	2 of No. 90a
6 " " 5	1 " " 111c
4 " " 10	1 " " 125
6 " " 12	2 " " 126a
1 " " 16	2 " " 155
1 " " 17	2 " " 188
4 " " 22	1 " " 199
1 " " 24	
3 " " 35	
25 " " 37a	
25 " " 37b	
2 " " 38	
2 " " 48a	

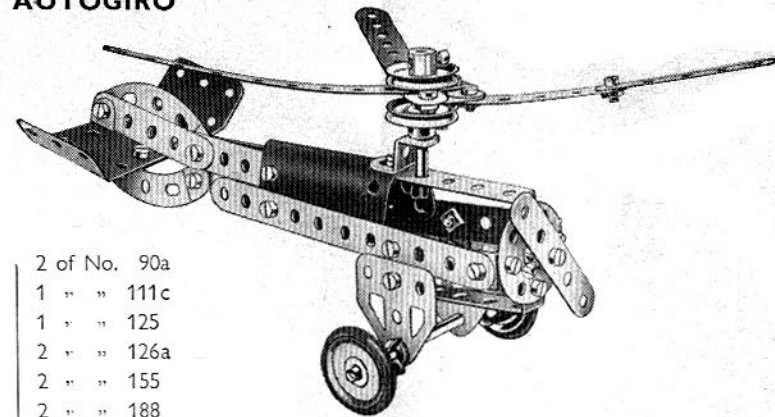

The rotor is made by passing a Rod through the next to end holes of two $5\frac{1}{2}''$ Strips. Fishplates are bolted to the short ends of the Strips and the third blade of the rotor is fixed to them as shown.

2.8 CHARIOT AND DRIVER

The chariot is made by curving a $5\frac{1}{2}'' \times 1\frac{1}{2}''$ Flexible Plate (1) to make a semi-circle with its ends bolted to the lugs of a $2\frac{1}{2}'' \times \frac{1}{2}''$ Double Angle Strip. A second $2\frac{1}{2}'' \times \frac{1}{2}''$ Double Angle Strip is bolted to the first with its lugs pointing downwards, the holes in the lugs forming supports for the chariot axle. A $1\frac{1}{4}''$ radius Curved Plate is fixed to the front of the $5\frac{1}{2}'' \times 1\frac{1}{2}''$ Flexible Plate. The shafts are $5\frac{1}{2}''$ Strips and they are bolted to the $5\frac{1}{2}'' \times 1\frac{1}{2}''$ Flexible Plate.

The driver's legs are $2\frac{1}{2}''$ Strips. They are connected to Angle Brackets (2) fixed to a Flat Trunnion that is bolted to the pointed end of the Double Angle Strips. His body is made from two Trunnions joined by a Fishplate, and his arms are attached to the upper Trunnion by Angle Brackets (3). His head is a 1" Pulley held by its set-screw on a $\frac{3}{8}''$ Bolt passed through a Fishplate (4). The body of the horse is a 'U'-section Curved Plate.

Parts Required

2 of No. 2
6 " " 5
4 " " 10
6 " " 12
1 " " 16
2 " " 17
4 " " 22
2 " " 35
31 " " 37a
31 " " 37b
1 " " 40
2 " " 48a
2 " " 90a
1 " " 111c
2 " " 126
2 " " 126a
3 " " 142c
1 " " 189
1 " " 199
1 " " 200

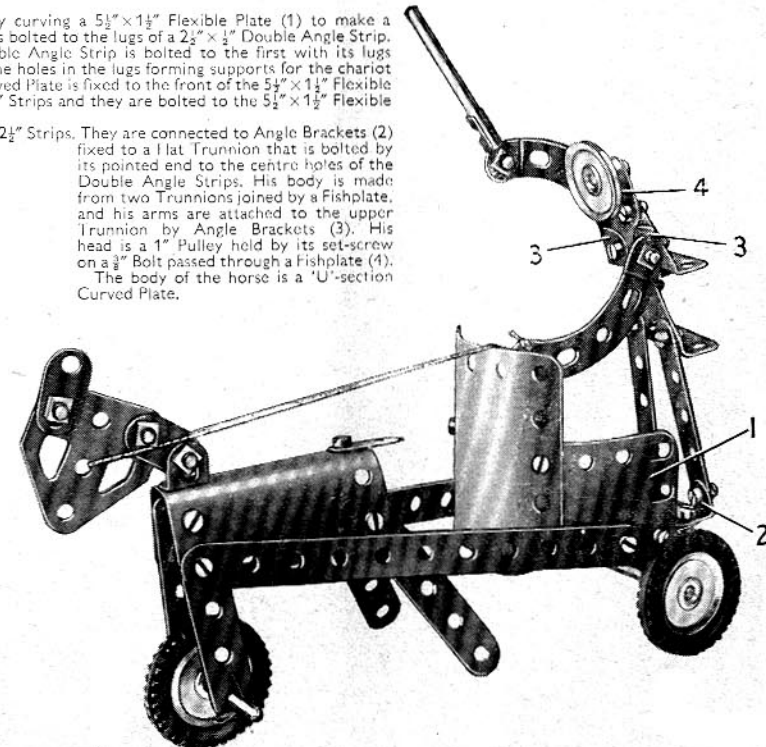

3.1 STEAM TRACTOR AND TRAILER

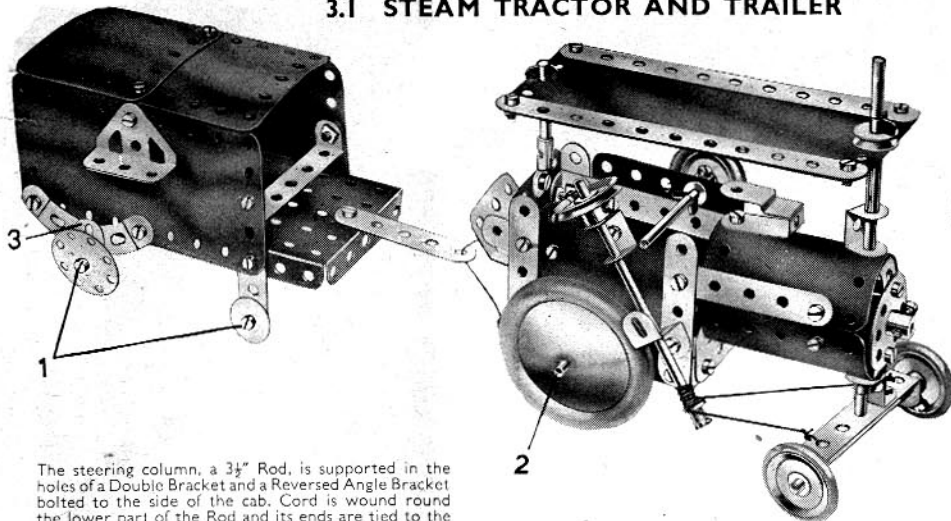

1	of No.	18a
4	" "	22
1	" "	23
1	" "	24
2	" "	24a
5	" "	35
54	" "	37a
46	" "	37b
3	" "	38
2	" "	38d
1	" "	40
1	" "	44
2	" "	48a
1	" "	52
2	" "	90a
4	" "	111c
2	" "	125
2	" "	126
2	" "	126a
3	" "	155
1	" "	176
2	" "	187
1	" "	188
2	" "	190
2	" "	191
1	" "	192
2	" "	199
8	" "	200
2	" "	212
3	" "	213
2	" "	215

Parts Required

4	of No.	2
7	" "	5
2	" "	10
2	" "	11
8	" "	12
2	" "	15b
3	" "	16
2	" "	17

The steering column, a 3/4" Rod, is supported in the holes of a Double Bracket and a Reversed Angle Bracket bolted to the side of the cab. Cord is wound round the lower part of the Rod and its ends are tied to the 2 1/2" x 1/2" Double Angle Strip that carries the front axle. Care must be taken that the Cord is wound tightly round the Rod or it will slip when the steering wheel is rotated. The Rod (2) is supported in holes in the Flexible Plates that form the sides of the cab.

The Bush Wheel that forms the front of the boiler has two Angle Brackets bolted to it, and a Rod passes through the free holes of these Brackets to hold the Bush Wheel in position. This Rod is joined by a Rod Connector to a 2" Rod that forms the chimney. The roof of the cab consists of a 5 1/2" x 2 1/2" Flexible Plate, and is held in position by Spring Clips placed on the two Rods that pass through it. The Fishplates (3) are bolted in the centre holes of the 2 1/2" Curved Strips on each side of the model. The Bolts (1) are lock-nutted in position and the Wheel Discs and 1/4" Washers turn freely on them.

3.2 HORSE AND CART

The model is driven by a Magic Motor fastened underneath the 5 1/2" x 2 1/2" Flanged Plate that forms the bottom of the cart. The drive is taken by a Driving Band from the pulley of the Motor to a 1/2" fast Pulley on the cart axle. A 1/2" loose Pulley is fitted on a 2" Rod supported in the bottom holes of the Strips forming the hind legs of the horse, so that the model will travel smoothly along the ground.

Parts Required

2	of No.	2	4	of No.	35
6	" "	5	32	" "	37a
3	" "	10	32	" "	37b
2	" "	12	4	" "	38
2	" "	16	1	" "	40
1	" "	17	1	" "	44
1	" "	23	2	" "	48a
			1	" "	52
			4	" "	90a
			1	" "	126
			1	" "	126a
			1	" "	186
			2	" "	187
			1	" "	188
			2	" "	189
			2	" "	199
			4	" "	215

Magic Motor
(not included in Outfit)

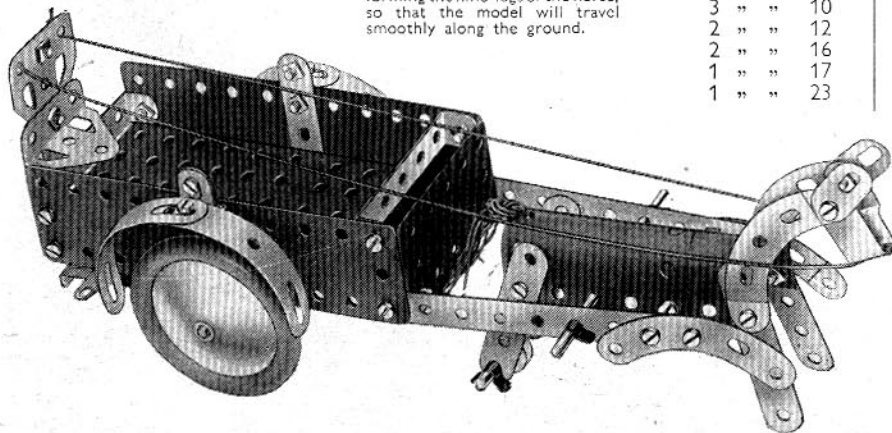

3.3 ELECTRIC CRANE TRUCK

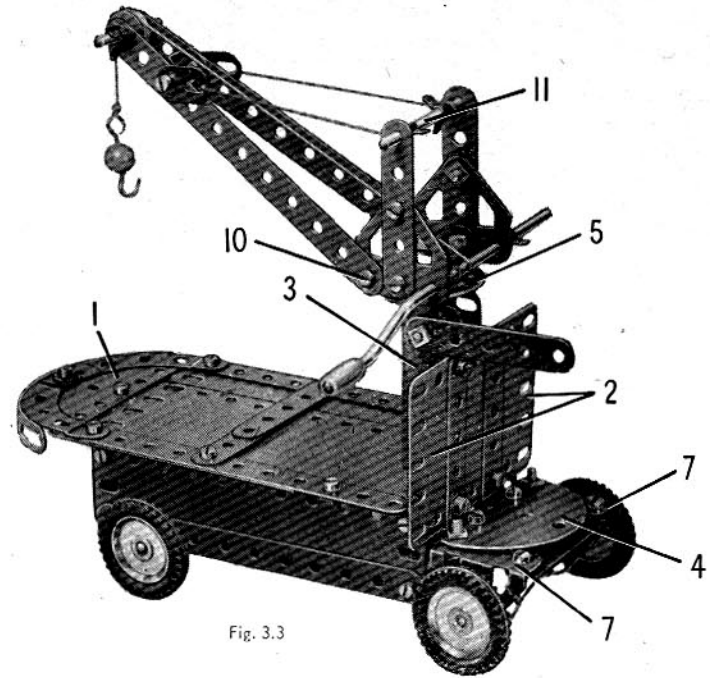

Fig. 3.3

Parts Required

6	of No.	2
9	" "	5
2	" "	10
2	" "	11
6	" "	12
1	" "	15b
1	" "	16
1	" "	17
1	" "	18a
1	" "	19g
4	" "	22
1	" "	23
1	" "	24
1	" "	24a
6	" "	35
52	" "	37a
43	" "	37b
4	" "	38
1	" "	40
2	" "	48a
1	" "	52
1	" "	57c
2	" "	90a
5	" "	111c
1	" "	125
2	" "	126
2	" "	126a
4	" "	142c
1	" "	188
2	" "	189
2	" "	190
2	" "	192
1	" "	199
1	" "	212
2	" "	214
2	" "	215

The truck part of the model is built up first by bolting one 2 1/2" x 1 1/2" and two 5 1/2" x 1 1/2" Flexible Plates to the flanges of a Flanged Plate. At their lower edges the Flexible Plates are strengthened by 5 1/2" Strips and two 2 1/2" x 1 1/2" Double Angle Strips. The platform consists of two 5 1/2" x 2 1/2" and two 4 1/2" x 2 1/2" Flexible Plates overlapped and extended by a Semi-Circular Plate (1).

Two 2 1/2" x 2 1/2" Flexible Plates (2), overlapped three holes, are bolted to the front end of the Flanged Plate, and a 'U'-section Curved Plate (3) is attached to these by a Double Bracket. A Semi-Circular Plate (4) is attached to the Flanged Plate by Angle Brackets.

The crane jib is supported by Flat Trunnions, which are attached to a Wheel Disc (5) by Angle Brackets. The Wheel Disc is lock-nutted through its centre hole to an Angle Bracket bolted to the top centre hole at the front of the 'U'-section Curved Plate (3).

The 5 1/2" Strips forming the jib pivot on lock-nutted bolts (10) in the Flat Trunnions, and the jib is held at the required angle by a length of Cord. This Cord is tied to the Rod (11) and then passed through the Fishplates at the jib head, finally being tied again to the Rod (11).

The Trunnions (7), which form part of the steering device, are free to turn on 3/8" Bolts secured to the Semi-Circular Plate (4), and they carry 3/8" Bolts that form stub axles for the 1" Pulleys. The 2 1/2" Strip (8), seen in the underneath view of the model, is bolted to a Bush Wheel, and is connected to each Trunnion by Cord as shown. The Bush Wheel is fixed to a 3/4" Rod passed through the Flanged Plate and an Angle Bracket (9).

Fig. 3.3a

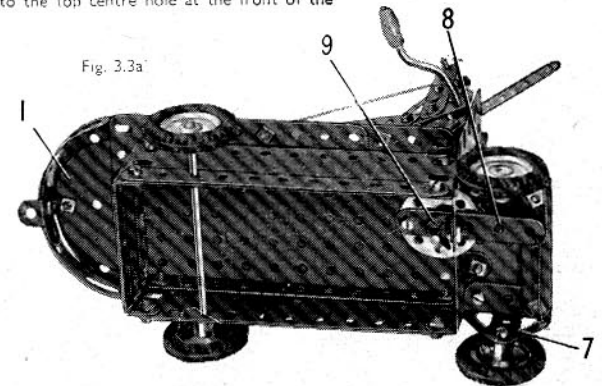

3.4 RACING CAR

The chassis of the model is a $5\frac{1}{2}'' \times 2\frac{1}{2}''$ Flanged Plate (1), and a $5\frac{1}{2}'' \times 1\frac{1}{2}''$ Flexible Plate is bolted to each side so that two holes of the Flexible Plate are left clear at the front. The Flanged Plate is lengthened at the rear by a $5\frac{1}{2}''$ Strip (2) on each side, and a Flat Trunnion (3) is fixed to each $5\frac{1}{2}''$ Strip. A $2\frac{1}{2}'' \times 1\frac{1}{2}''$ Flexible Plate (4) is bolted to each of the Strips (2) and is connected to the $5\frac{1}{2}'' \times 1\frac{1}{2}''$ Flexible Plate by a Fishplate. Two $2\frac{1}{2}''$ Strips (5) are attached to the sides by Bolts (6).

The top of the bonnet is a $5\frac{1}{2}'' \times 2\frac{1}{2}''$ Flexible Plate, and it is attached to the sides by four Angle Brackets. Two Trunnions are connected by $\frac{3}{8}''$ Bolts (7) to a $1\frac{1}{2}''$ radius Curved Plate, which is then bolted between the $5\frac{1}{2}'' \times 2\frac{1}{2}''$ Flexible Plate and the front of the Flanged Plate.

Two 'U'-section Curved Plates (8) are fixed to the Flexible Plates (4) and the Flat Trunnions (3), and a Wheel Disc (9) is attached to one of them by an Angle Bracket. The tail assembly

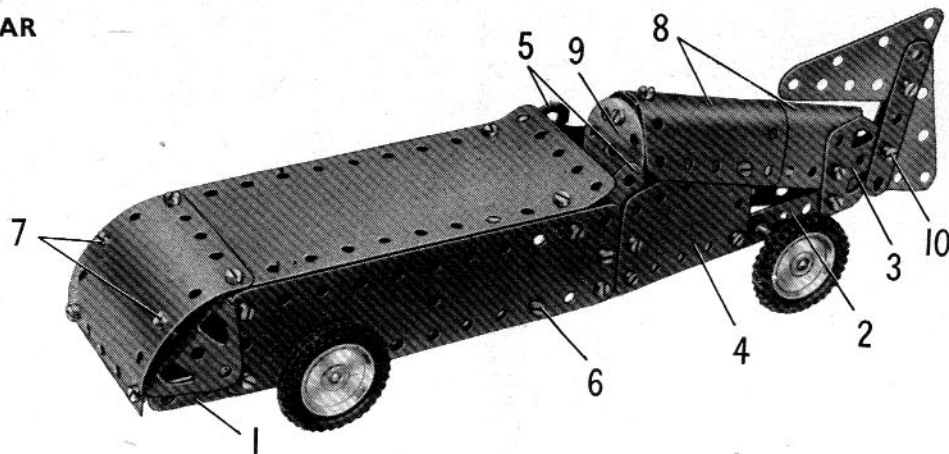

consists of two $2\frac{1}{2}'' \times 1\frac{1}{2}''$ Triangular Flexible Plates bolted between two $2\frac{1}{2}''$ Strips as shown, and it is fixed to the Flat Trunnions (3) by a $\frac{3}{8}''$ Bolt (10).

The wheels are mounted on $3\frac{1}{2}''$ Rods passed through the chassis as shown.

Parts Required

2 of No. 2	38 of No. 37a	2 of No. 189
4 " " 5	35 " " 37b	1 " " 192
2 " " 10	1 " " 52	2 " " 199
5 " " 12	3 " " 111c	1 " " 200
2 " " 16	2 " " 126	1 " " 214
4 " " 22	2 " " 126a	2 " " 221
1 " " 24a	4 " " 142c	
2 " " 35	2 " " 108	

3.5 TRAMCAR

Parts Required

4 of No. 2	2 of No. 48a	1 of No. 212
9 " " 5	1 " " 52	2 " " 214
4 " " 10	5 " " 111c	4 " " 215
1 " " 11	2 " " 126	
8 " " 12	2 " " 126a	
1 " " 15b	1 " " 176	
2 " " 16	2 " " 188	
4 " " 22	2 " " 189	
5 " " 35	2 " " 190	
54 " " 37a	2 " " 191	
49 " " 37b		
6 " " 38		
2 " " 38d		
1 " " 40		
1 " " 44		

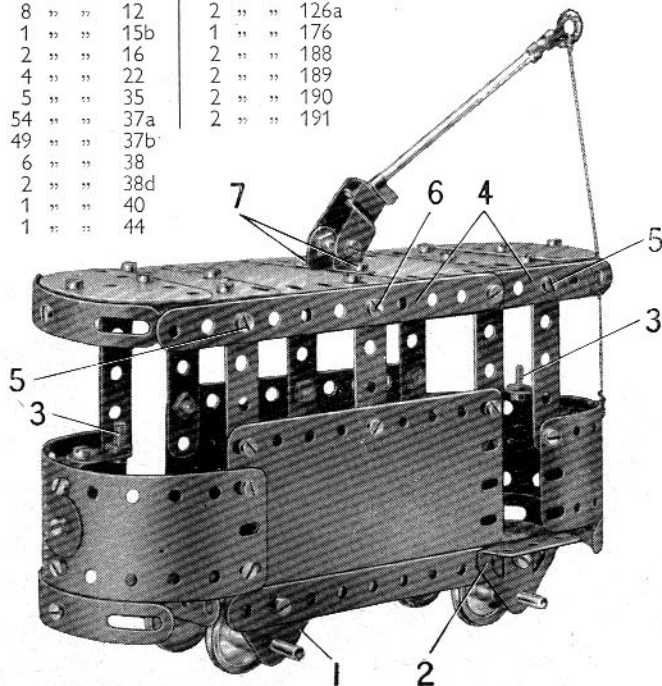

The chassis is a $5\frac{1}{2}'' \times 2\frac{1}{2}''$ Flanged Plate fitted at its sides with $4\frac{1}{2}'' \times 2\frac{1}{2}''$ Flexible Plates. The Flexible Plates are bolted to the flanges so that a space of two clear holes is left in each side flange, but at opposite ends. The lower edges of the Flexible Plates are edged by $5\frac{1}{2}''$ Strips, and a Flat Trunnion (1) and a Trunnion (2) are bolted to each side. The axles are supported in the Trunnions and Flat Trunnions.

The rounded ends consist of $5\frac{1}{2}'' \times 1\frac{1}{2}''$ Flexible Plates curved to shape and bolted to the sides. A Formed Slotted Strip is attached to each of the $5\frac{1}{2}'' \times 1\frac{1}{2}''$ Flexible Plates by a Fishplate. The control handles (3) are each made by bolting a fishplate fitted with a $\frac{3}{8}''$ Bolt to an Angle Bracket fixed to the Flexible Plate.

The roof is supported on each side by four $2\frac{1}{2}''$ Strips. The tops of these Strips are connected by two $5\frac{1}{2}''$ Strips (4) overlapped seven holes, and these Strips are joined across by $2\frac{1}{2}'' \times \frac{1}{4}''$ Double Angle Strips held by the Bolts (5). An Angle Bracket on each side is fixed in place by a Bolt (6).

The roof consists of two $2\frac{1}{2}'' \times 2\frac{1}{2}''$ and two $2\frac{1}{2}'' \times 1\frac{1}{2}''$ Flexible Plates bolted end to end, and its rounded ends are Semi-Circular Plates. The roof is attached to the Double Angle Strips and the Angle Brackets held by Bolts (5) and (6). A Formed Slotted Strip is connected to each Semi-Circular Plate by an Angle Bracket.

The trolley pole is a $4''$ Rod fitted with a Rod and Strip Connector, and it is held in a Stepped Bent Strip by a Spring Clip and a Cord Anchoring Spring. The Stepped Bent Strip is bolted to two Angle Brackets (7) bolted to the centre of the roof.

3.6 TROTTING CAR

Parts Required

4 of No. 2	37 of No. 37a
8 " " 5	37 " " 37b
5 " " 10	6 " " 38
1 " " 11	1 " " 40
3 " " 12	1 " " 44
1 " " 15b	2 " " 48a
2 " " 16	3 " " 90a
2 " " 17	3 " " 111c
1 " " 18a	2 " " 125
4 " " 22	2 " " 126
1 " " 24	
1 " " 24a	
4 " " 35	

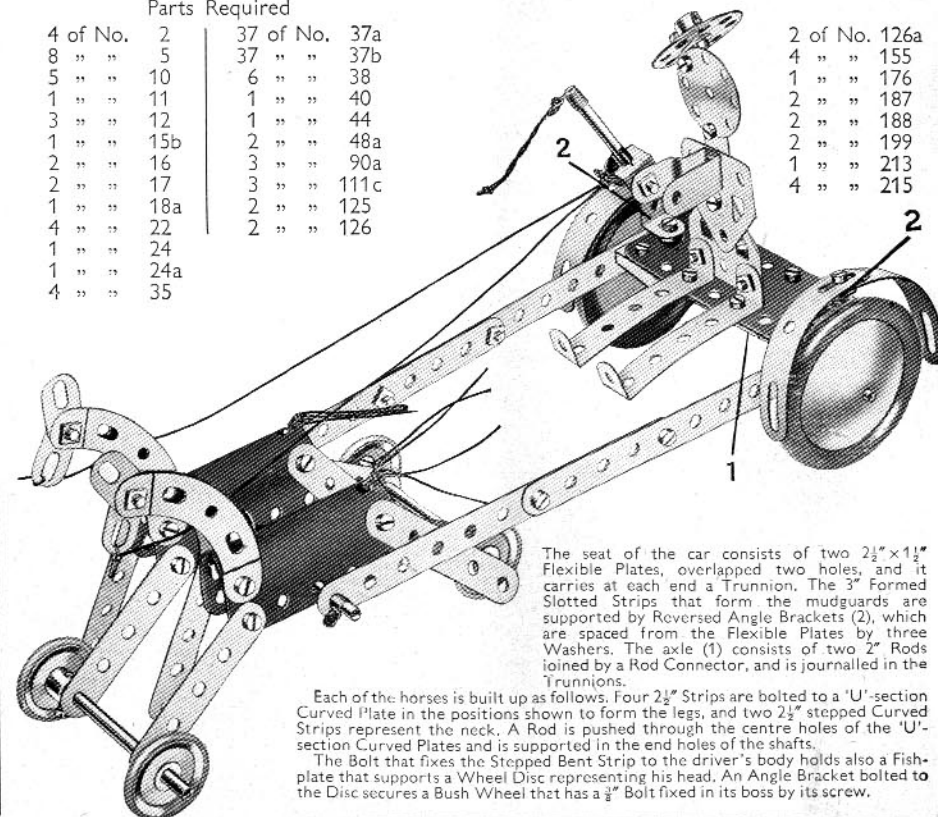

2 of No. 126a
4 " " 155
1 " " 176
2 " " 187
2 " " 188
2 " " 199
1 " " 213
4 " " 215

The seat of the car consists of two $2\frac{1}{2}'' \times 1\frac{1}{2}''$ Flexible Plates, overlapped two holes, and it carries at each end a Trunnion. The 3" Formed Slotted Strips that form the mudguards are supported by Reversed Angle Brackets (2), which are spaced from the Flexible Plates by three Washers. The axle (1) consists of two 2" Rods joined by a Rod Connector, and is journalled in the Trunnions.

Each of the horses is built up as follows. Four $2\frac{1}{2}''$ Strips are bolted to a 'U'-section Curved Plate in the positions shown to form the legs, and two $2\frac{1}{2}''$ stepped Curved Strips represent the neck. A Rod is pushed through the centre holes of the 'U'-section Curved Plates and is supported in the end holes of the shafts.

The Bolt that fixes the Stepped Bent Strip to the driver's body holds also a Fishplate that supports a Wheel Disc representing his head. An Angle Bracket bolted to the Disc secures a Bush Wheel that has a $\frac{3}{8}''$ Bolt fixed in its boss by its screw.

3.7 TRACTOR AND HARROW

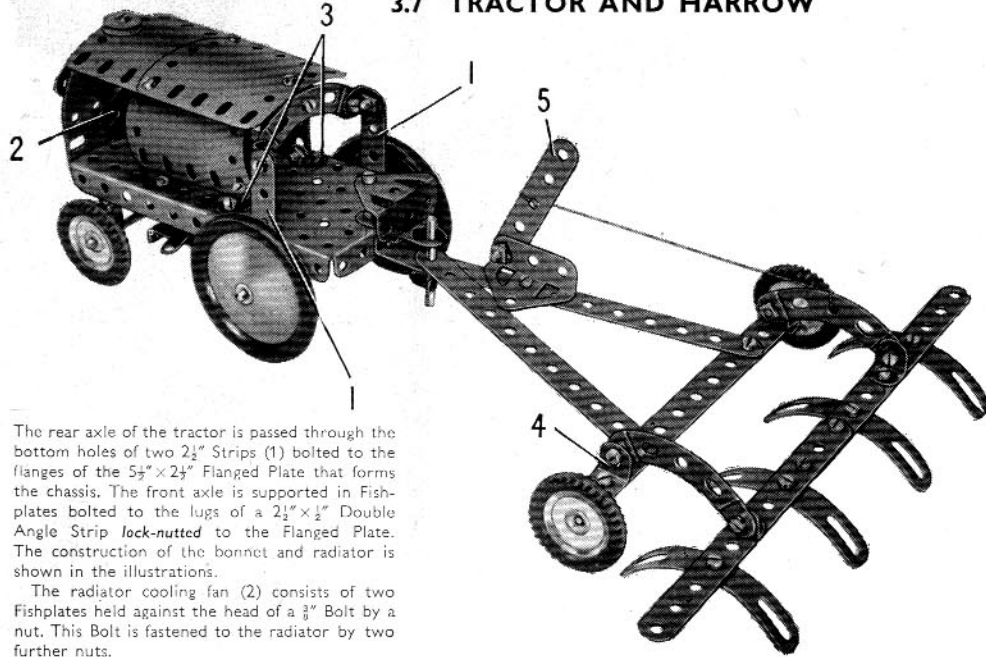

The rear axle of the tractor is passed through the bottom holes of two 2½" Strips (1) bolted to the flanges of the 5½" × 2½" Flanged Plate that forms the chassis. The front axle is supported in Fishplates bolted to the lugs of a 2½" × ½" Double Angle Strip *lock-nutted* to the Flanged Plate. The construction of the bonnet and radiator is shown in the illustrations.

The radiator cooling fan (2) consists of two Fishplates held against the head of a ¾" Bolt by a nut. This Bolt is fastened to the radiator by two further nuts.

The engine is represented by two 'U'-section Curved Plates, which are bolted together so that they overlap each other by two holes and are then attached to the Flanged Plate by two Angle Brackets (3).

The wheels of the harrow are held by ⅜" Bolts in Reversed Angle Brackets (4) at each end of a 5½" Strip. A 2½" Stepped Curved Strip is fastened to each Reversed Angle Bracket by a *lock-nutted* bolt, and Cord is attached to the centre hole of one of these Curved Strips and also to the operating lever (5), which is loosely held by a *lock-nutted* ⅜" Bolt to a Trunnion. By moving the lever forward the harrow may be raised from the ground when not in use.

Fig. 3.7

Parts Required

5 of No.	2	1 of No.	48a
3 " "	5	1 " "	52
5 " "	10	4 " "	90a
1 " "	11	4 " "	111c
8 " "	12	2 " "	125
1 " "	15b	2 " "	126
1 " "	16	4 " "	142c
1 " "	18a	2 " "	187
4 " "	22	1 " "	188
1 " "	23	2 " "	199
2 " "	35	2 " "	200
53 " "	37a	1 " "	214
42 " "	37b	4 " "	215
1 " "	40		
1 " "	44		

Magic Motor
(not included in
Outfit)

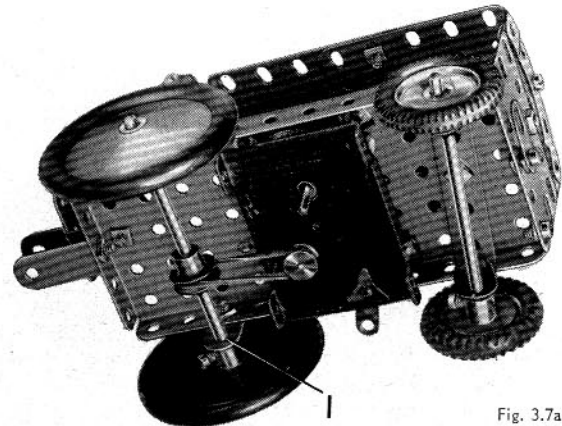

Fig. 3.7a

3.8 GIPSY CARAVAN

The base of the caravan is a 5½" × 2½" Flanged Plate, and the sides are 5½" × 2½" Flexible Plates strengthened along their upper edges by 5½" Strips. Three 2½" Strips are fixed to each side as shown, and these are connected by a 5½" Strip (1) lengthened at each end by a Fishplate. The 5½" Strips are joined across at their ends by 2½" Stepped Curved Strips attached to Angle Brackets.

The rear wheels are fixed on a 3½" Rod supported in Flat Trunnions bolted to the sides of the Flanged Plate. The front wheels are fastened on a 3½" Rod that is supported in two Trunnions (2). These Trunnions are bolted to a 2½" × 1½" Flexible Plate (3), fitted at each side with a 2½" Strip (4). A Bush Wheel (5) is fixed to the Plate (3), and a 2" Rod held in the Bush Wheel is passed through a ½" Reversed Angle Bracket (6) and the 5½" × 2½" Flanged Plate. A 'U'-section Curved Plate (7) and a ½" Pulley are slipped over the Rod, which is then held in position by a Spring Clip.

The shafts are 5½" Strips bolted to a 2½" × ½" Double Angle Strip (8). This is *lock-nutted* to a second Double Angle Strip bolted across the ends of Strips (4).

The roof consists of two 1½" radius Curved Plates (9) overlapped four holes, and two 5½" × 1½" Flexible Plates, one of which is seen at (10). The 5½" × 1½" Flexible Plates are placed side to side, and are bolted to Formed Slotted Strips as shown. The complete roof is attached to Angle Brackets bolted to the sides of the caravan. The Angle Brackets are bent out a little to allow a slight curve in the roof.

A step at the rear of the caravan consists of a 'U'-section Curved Plate bolted to the rear of the 5½" × 2½" Flanged Plate.

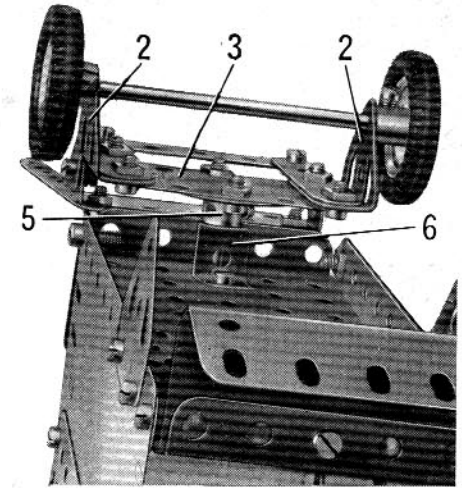

Fig. 3.8a

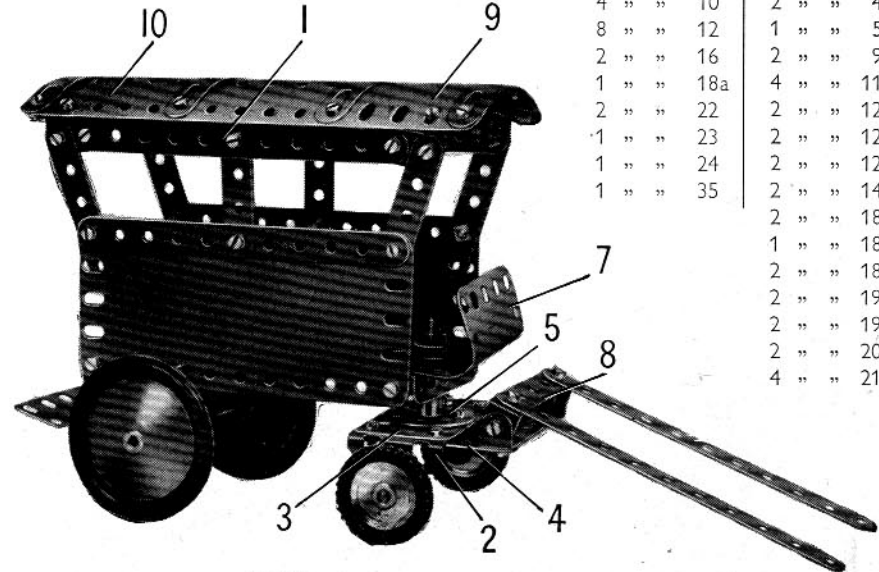

Fig. 3.8

Parts Required

6 of No.	2	56 of No.	37a
8 " "	5	50 " "	37b
4 " "	10	2 " "	48a
8 " "	12	1 " "	52
2 " "	16	2 " "	90a
1 " "	18a	4 " "	111c
2 " "	22	2 " "	125
1 " "	23	2 " "	126
1 " "	24	2 " "	126a
1 " "	35	2 " "	142c
		2 " "	187
		1 " "	188
		2 " "	189
		2 " "	192
		2 " "	199
		2 " "	200
		4 " "	215

4.1 CEMENT MIXER

The chassis of the model is built by bolting a 12½" Strip to each of the longer flanges of a 5½" × 2½" Flanged Plate. Two further 12½" Strips are fixed to the edges of the Plate, and the outer ends of these Strips are connected by a 2½" Strip (1).

A support for the mixing drum is made by bolting two 2½" Strips to Trunnions (2) fixed to the Flanged Plate as shown. A ½" Bolt is passed through one of the lugs of a 1½" × ½" Double Angle Strip (3), and a nut screwed loosely on the Bolt. The shank is then passed through one of the vertical 2½" Strips and the centre hole of a 2½" Stepped Curved Strip (4), and a second nut is screwed firmly against the first. A ¾" Bolt is fixed tightly by a nut to the opposite lug of the Double Angle Strip, and passed through the second vertical 2½" Strip. A 1" Pulley is then fixed on the shank of the Bolt, and connected to a second 1" Pulley (5) by a Driving Band. The Pulley (5) is fixed on a 4" Rod mounted in the 2½" Strips. This Rod carries at its outer end a Bush Wheel fitted with a ½" Bolt, and it is used for tilting the mixing drum for unloading.

The mixing drum is made by bolting two 2½" × ½" Double Angle Strips at right-angles to each other across a 3" Pulley (6). Two 4½" × 2½" Flexible Plates are curved and fixed to the Double Angle Strips. The Pulley (6) is fixed on a 1½" Rod, which is passed through the Double Angle Strip (3) and through a Reversed Angle Bracket (7) and the Rod is held in position by a Spring Clip.

The supports for the loading hopper are four 5½" Strips attached to Angle Brackets fixed to the chassis and connected at the top by 2½" Stepped Curved Strips. Two of the 5½" Strips are extended by 2½" Strips (9). The sides of the hopper are Flanged Sector Plates, and these are bolted to 5½" × 1½" Flexible Plates arranged as shown. The back of the hopper is a 2½" × 2½" Flexible Plate attached by Angle Brackets.

The hopper is pivoted on a built-up rod made by a 3½" and a 2" Rod joined by a Rod and Strip Connector. This rod is passed through a 2½" × ½" Double Angle Strip (9) bolted to the hopper, and is fitted with a 3" Pulley. The 3" Pulley is connected by a Driving Band to a 1" Pulley fixed on a Crank Handle that is mounted in one of the hopper supports and in the 2½" Stepped Curved Strip (4). Two short lengths of Cord are tied to the built-up rod, and are passed through the end holes of the 2½" Strips (8). The Cords are then tied to the rear of the hopper.

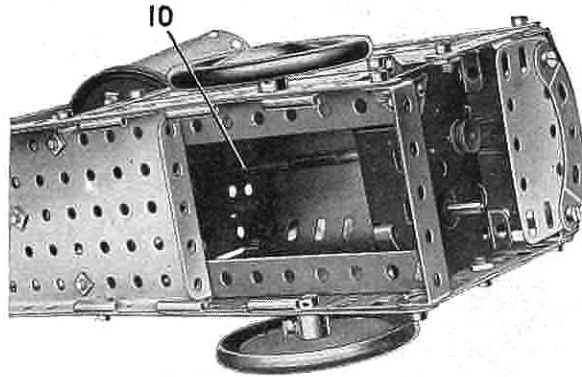

Fig. 4.1b

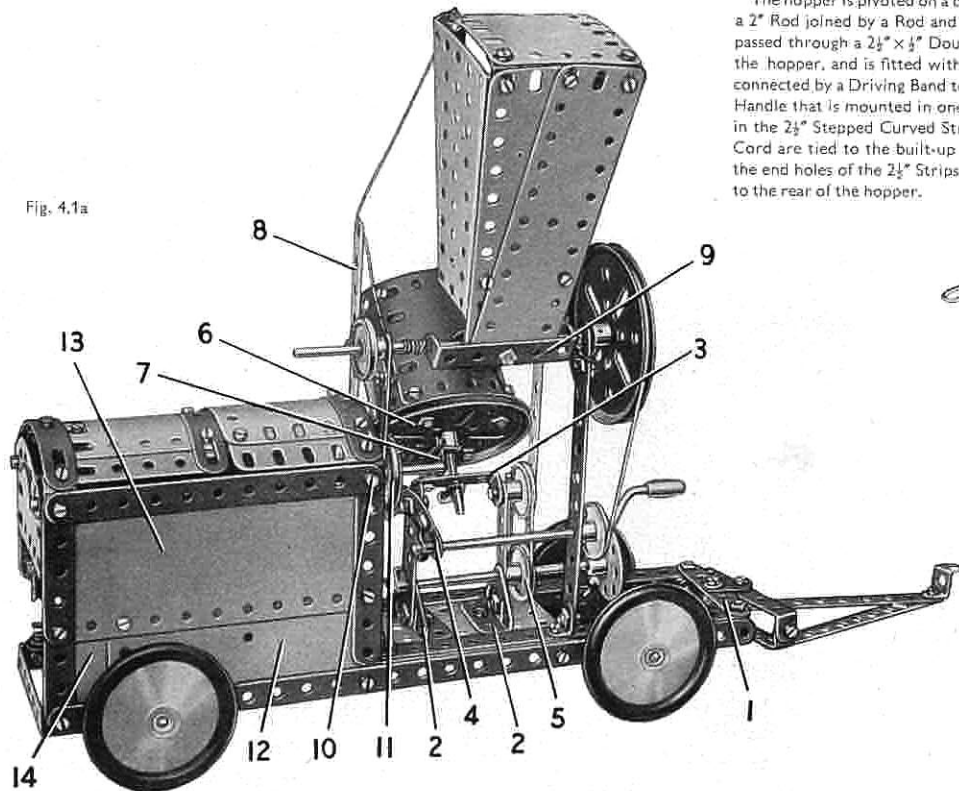

Fig. 4.1a

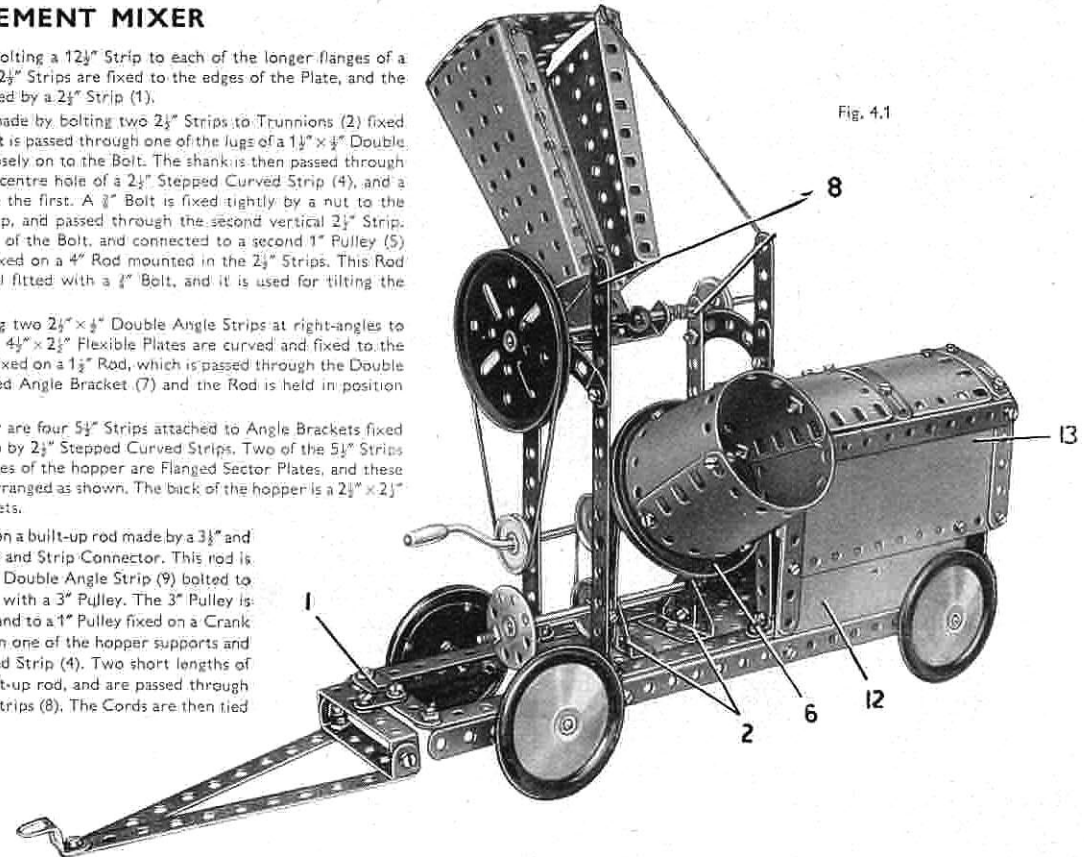

Fig. 4.1

The drum is rotated by a Magic Motor bolted to the 12½" Strips at one end of the chassis (see Fig. 4.1b). The drive from the Motor shaft is taken to a ½" Pulley on a built-up rod (10) made by joining two 3½" Rods by a Rod Connector. This rod is mounted at one end in a 2½" Strip bolted across two of the 5½" Strips used to support the hopper. The other end of the rod is supported in a Semi-Circular Plate bolted to the inner side-plate of the Magic Motor. The rod carries a 1" Pulley (11) fitted with a Rubber Ring, arranged so that it presses against the rim of the Pulley 6. The ½" Pulley is supplied with the Magic Motor.

The sides of the engine cover are made from the separated halves of a Hinged Flat Plate (12), 5½" × 2½" Flexible Plates (13) and a 2½" × 1½" Flexible Plate (14). The top is formed by two 1½" radius Curved Plates and two curved 2½" × 2½" Flexible Plates attached to Obtuse Angle Brackets fixed to the sides. The sides are edged by 5½", 2½" and 3½" Strips, and the top is strengthened by Formed Slotted Strips.

Parts Required

4 of No. 1	1 of No. 17	6 of No. 38	2 of No. 126	1 of No. 198
8 " " 2	1 " " 18a	1 " " 40	1 " " 155	2 " " 200
2 " " 3	2 " " 19b	1 " " 48	1 " " 186	1 " " 212
9 " " 5	1 " " 19g	6 " " 48a	4 " " 187	1 " " 213
3 " " 10	5 " " 22	1 " " 52	2 " " 188	1 " " 214
8 " " 12	1 " " 24	2 " " 54	2 " " 189	3 " " 215
4 " " 12c	4 " " 35	4 " " 90a	3 " " 190	
1 " " 15b	81 " " 37a	6 " " 111c	2 " " 191	
3 " " 16	77 " " 37b	2 " " 125	2 " " 192	

Magic Motor
 (not included in
 Outfit)

4.2 PLATFORM WEIGHING MACHINE

The base of the machine is made by bolting $5\frac{1}{2}'' \times 1\frac{1}{2}''$ Flexible Plates, edged by $5\frac{1}{2}''$ Strips, to the sides of a $5\frac{1}{2}'' \times 2\frac{1}{2}''$ Flanged Plate. The front is a $2\frac{1}{2}'' \times 1\frac{1}{2}''$ Flexible Plate, and the sides are connected by $2\frac{1}{2}'' \times \frac{1}{2}''$ Double Angle Strips (1) and (2). A lever (3) connected to the platform operates the recording mechanism, and it consists of two $5\frac{1}{2}''$ Strips joined by a Double Bracket (4). The lever is pivoted by lock-nutted bolts to a Double Bracket fixed by Bolt (5) to the Double Angle Strip (1). The platform is a $2\frac{1}{2}'' \times 2\frac{1}{2}''$ Flexible Plate edged by $2\frac{1}{2}''$ Strips, and is attached to the lever (3) by Angle Brackets.

Each side of the casing consists of two built-up strips, that at the rear being made from a $5\frac{1}{2}''$ and a $3\frac{1}{2}''$ Strip overlapped, while the front one is made from a $5\frac{1}{2}''$ and a $2\frac{1}{2}''$ Strip bolted together through their end holes. The side seen in Fig. 4.2 consists of two $5\frac{1}{2}'' \times 2\frac{1}{2}''$ Flexible Plates, the upper one being bent over and bolted to a $4\frac{1}{2}'' \times 2\frac{1}{2}''$ Flexible Plate that forms the upper part of the other side. The lower part of this side is formed by one half of a Hinged Flat Plate, the other half of which forms the rear door.

The front consists of a $2\frac{1}{2}'' \times 1\frac{1}{2}''$ Flanged Plate (6), and a $4\frac{1}{2}'' \times 2\frac{1}{2}''$ Flexible Plate (7) attached by Angle Brackets. The dial is a $3''$ Pulley. A Semi-Circular Plate (8) is attached to the Flanged Plate (6), and a similar part is fixed to a $2\frac{1}{2}'' \times \frac{1}{2}''$ Double Angle Strip at the rear. A $2\frac{1}{2}'' \times 1\frac{1}{2}''$ Flexible Plate is attached to a Double Angle Strip (9) fixed between the sides. The top of the casing is completed by Flat Trunnions and a U-section Curved Plate attached to them by Angle Brackets.

A Rod (10) is passed through the $3''$ Pulley and the centre hole of Double Angle Strip (9). A Rod and Strip Connector on this Rod is separated from the Pulley by three Washers, and is held in place by a Spring Clip. A $1''$ Rod held in the Rod and Strip Connector engages between the lugs of the Spring Clip.

Cord is tied to $1\frac{1}{2}''$ Rod (11) held by Spring Clips in the lever (3), and is wound twice round Rod (10). Then it is tied to a $2\frac{1}{2}''$ Driving Band, which is stretched slightly and attached to the casing by bolt (12).

Fig. 4.2a

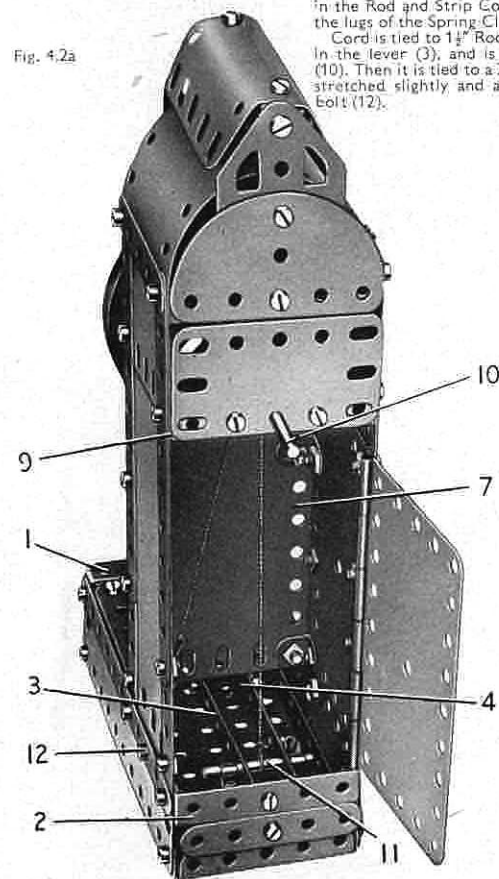
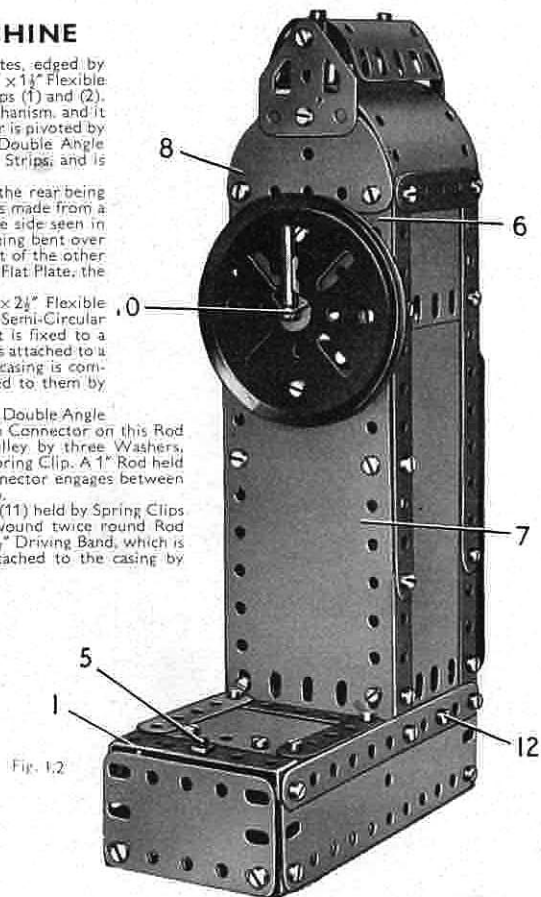

Fig. 4.2



Parts Required		Parts Required	
8 of No.	2	4 of No.	48a
2	3	1	51
9	5	1	52
1	10	2	126a
2	11	1	186
8	12	2	188
1	15b	2	189
1	18a	1	190
1	18b	2	191
1	19b	2	192
3	35	1	198
65	37a	1	199
65	37b	1	212
3	38	1	214
1	40	2	214

4.3 CARAVAN

Parts Required

8 of No.	2
2	3
9	5
5	10
1	11
7	12
2	15b
2	17
1	18b
4	35
73	37a
71	37b
10	38
1	44
3	48a
1	51
1	52
2	54
4	90a
1	111c
2	125
1	126
2	187
2	188
4	190
2	191
1	192
1	198
2	200
1	212
2	212a
2	214
4	215
4	221

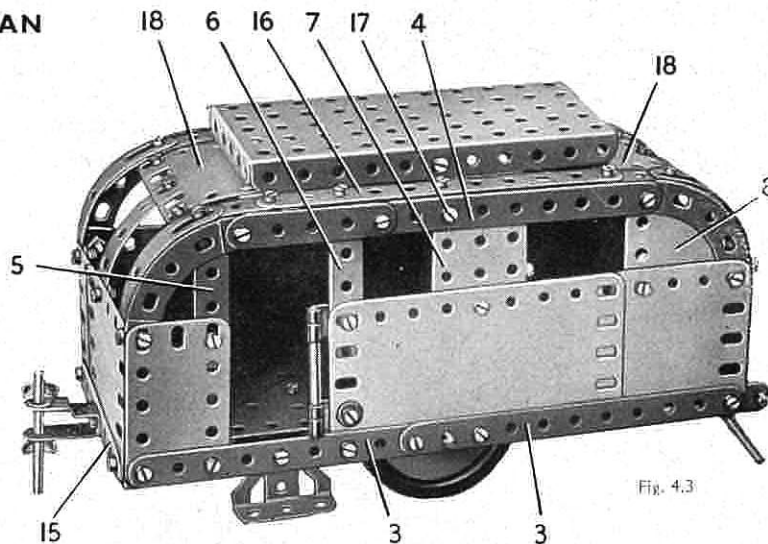

Fig. 4.3

The floor of the caravan is made by joining two Flanged Sector Plates to a $2\frac{1}{2}''$ Strip (1). Two $2\frac{1}{2}'' \times 1\frac{1}{2}''$ Triangular Flexible Plates (2) are bolted to each Flanged Sector Plate.

The side of the model seen in the general view consists of a $5\frac{1}{2}'' \times 2\frac{1}{2}''$ and a $4\frac{1}{2}'' \times 2\frac{1}{2}''$ Flexible Plate overlapped seven holes, and a $2\frac{1}{2}'' \times 1\frac{1}{2}''$ Flexible Plate. The plates are bolted to two $5\frac{1}{2}''$ Strips (3) overlapped three holes. The top edge of the side consists of a $5\frac{1}{2}''$ Strip (4) lengthened by a $2\frac{1}{2}''$ Strip that overlaps it by three holes, and the made-up strip thus formed is connected to the Flexible Plates at each end by a $2\frac{1}{2}''$ Stepped Curved Strip. The window frames are provided by a $2\frac{1}{2}''$ Strip (5), a $2\frac{1}{2}'' \times \frac{1}{2}''$ Double Angle Strip (6), a $2\frac{1}{2}'' \times 1\frac{1}{2}''$ Flanged Plate (7) and a Semi-Circular Plate (8). A handrail is provided at one side of the door. It is made from a $2''$ Rod held in Right-Angle Rod and Strip Connectors.

The side seen in Fig. 4.3a consists of the separated halves (9) of a Hinged Flat Plate bolted to a $4\frac{1}{2}'' \times 2\frac{1}{2}''$ Flexible Plate and to two $5\frac{1}{2}''$ Strips (10) overlapped three holes. The window frames are provided by a Semi-Circular Plate (11), a $2\frac{1}{2}'' \times 2\frac{1}{2}''$ Flexible Plate (12) and a $2\frac{1}{2}'' \times \frac{1}{2}''$ Double Angle Strip (13). The top edge of the roof is made from a $5\frac{1}{2}''$ and a $2\frac{1}{2}''$ Strip overlapped three holes to make a built-up strip (14), and the curved ends are a $2\frac{1}{2}''$ Stepped Curved Strips.

The sides are connected at each end by a $3\frac{1}{2}''$ Strip (15) attached to Angle Brackets. One end consists of a $2\frac{1}{2}'' \times 2\frac{1}{2}''$ and a $2\frac{1}{2}'' \times 1\frac{1}{2}''$ Flexible Plate, and the other is made from two $2\frac{1}{2}'' \times 2\frac{1}{2}''$ Flexible Plates. The curved end windows consist of Formed Slotted Strips bolted to the Flexible Plates, and each Formed Slotted Strip is extended by a $2\frac{1}{2}''$ Strip that is bolted to a $5\frac{1}{2}''$ Strip (16). The Strips (16) are attached to the sides by $\frac{1}{2}''$ Reversed Angle Brackets held by bolts (17). The centre division of the curved window at one end is a $2\frac{1}{2}''$ Strip, and at the other end a $2\frac{1}{2}'' \times \frac{1}{2}''$ Double Angle Strip is used.

The roof consists of a $1\frac{1}{2}''$ radius Curved Plate (18) at each end that is attached to the Formed Slotted Strips by Fishplates. The centre section of the roof is a $5\frac{1}{2}'' \times 2\frac{1}{2}''$ Flanged Plate, and this is bolted to the lugs of the Reversed Angle Brackets held by the Bolts (17).

The body is attached to the Flanged Sector Plates by an Angle Bracket and a Double Bracket as shown in Fig. 4.3a. The towing attachment is a Stepped Bent Strip fitted with a $2''$ Rod that serves also as a support at one end of the caravan. At the other end the support is a $1''$ Rod in a Rod and Strip Connector that is lock-nutted to one of the Flanged Sector Plates.

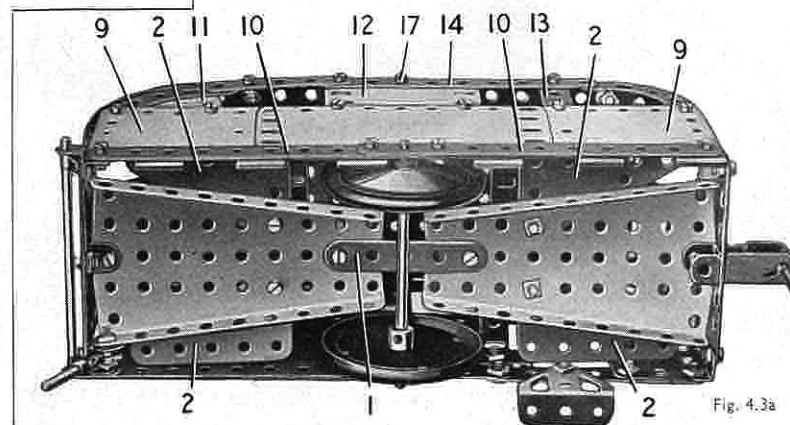

Fig. 4.3a

4.4 ELEVATED JIB CRANE

Parts Required

4 of No.	1	3 of No.	16
6 "	2	1 "	17
2 "	3	1 "	18b
7 "	5	1 "	19b
5 "	10	1 "	19g
1 "	11	5 "	22
4 "	12	1 "	23
4 "	12c	1 "	24
1 "	15b	8 "	35

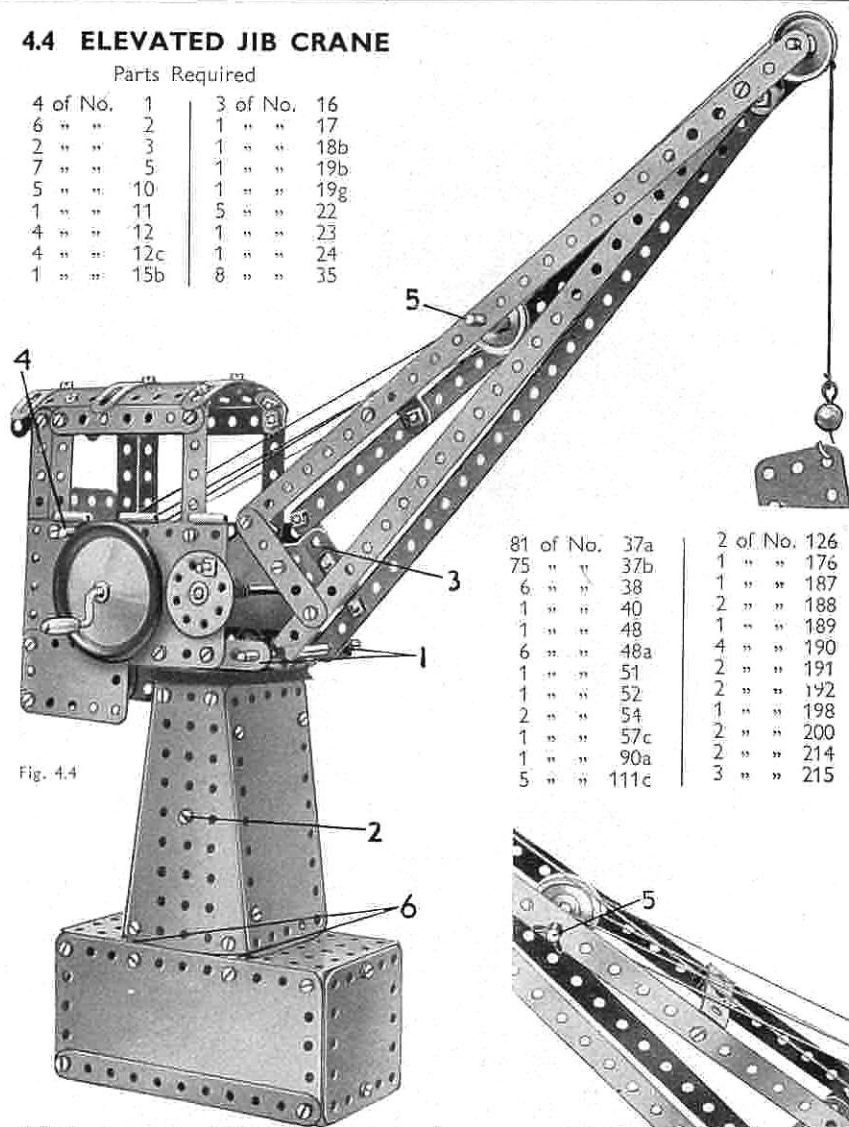

Fig. 4.4

A 3" Pulley is attached to 5½" Strips (1) by means of two Double Angle Strips. A 4" Rod fixed in this Pulley passes through a hole in a 2½" × 1½" Flanged Plate bolted to the Flanged Sector Plates and a Double Angle Strip held by a Bolt (2) on each side of the tower. The tower is attached to the base by Fishplates, two of which are seen marked (6).

The jib consists of four 12½" Strips joined at their outer ends by a Double Bracket and at their inner ends by two Trunnions (3) (Fig. 4.4a) bolted together.

Hoisting is carried out by a length of Cord attached to a Cord Anchoring Spring placed on the Crank Handle.

Luffing, or raising and lowering of the jib, is controlled by a Bush Wheel locked on a 3½" Rod. A length of Cord fastened to this Rod is passed round Rod (4) and then round the Rod (5) (Fig. 4.4a) in the jib. It passes again round Rods (5) and (4) and finally is tied to Rod (4).

81 of No.	37a	2 of No.	126
75 "	37b	1 "	176
6 "	38	1 "	187
1 "	40	2 "	188
1 "	48	1 "	189
6 "	48a	4 "	190
1 "	51	2 "	191
1 "	52	2 "	192
2 "	54	1 "	198
1 "	57c	2 "	200
1 "	90a	2 "	214
5 "	111c	3 "	215

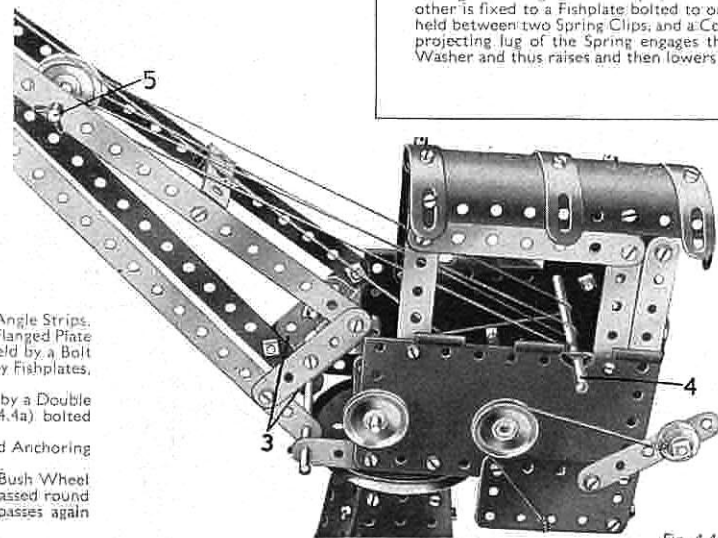

Fig. 4.4a

4.5 SEWING MACHINE

The base of the model is a 5½" × 2½" Flanged Plate, fitted at each side with two 5½" Strips. These Strips are arranged so that two clear holes overhang each end of the Flanged Plate. Flanged Sector Plates are bolted between the Strips as shown. A 4½" × 2½" Flexible Plate is bolted to each side, and the narrow ends of the Flanged Sector Plates are connected by made-up strips (1), consisting of 5½" and 2½" Strips bolted together.

A 5½" × 1½" Flexible Plate (2) is bolted to a 1½" × ¼" Double Angle Strip held by a Bolt (3) on each side, and to Angle Brackets attached by Bolts (4) on each side. The Flexible Plate is bolted also to a 2½" × 1½" Flanged Plate fixed to the strips (1) by Angle Brackets, which are secured by the Bolts (5).

Two 2½" × ¼" Double Angle Strips (6) are arranged so that their turned-up ends overlap, and they are fixed to the 2½" × 1½" Flanged Plate. A second pair of Double Angle Strips (7) is similarly arranged, and these also are bolted to the Flanged Plate. The two sets of Double Angle Strips are connected at the top by a 5½" Strip (8) and a 3½" Strip (9) on each side, and a Double Bracket is held between the Double Angle Strips (6) by the Bolts (10).

A 2½" Strip (11) on each side is bolted to the Strip (8), and is connected by a Stepped Curved Strip to the Strip (9). The Bolt (12) is fitted with a nut before it is passed through the Strips, and it serves to support a Double Bracket between the ends of Strips (9). Strips (8) are connected by a 'U'-shaped piece made from two Angle Brackets. This is attached by a Bolt (13) on each side, and two 2½" Strips (14) are fixed to the Angle Brackets. A 1½" Rod held by two Spring Clips in one of the Strips (14), and a 1" Rod fixed in a Bush Wheel (15), represent the bobbin spindles.

A Magic Clockwork Motor is bolted by its lugs to the 5½" × 2½" Flanged Plate of the base, and it is connected by a Driving Band to a 1" Pulley (16). The Pulley (16) is fixed on a 4" Rod supported in the Double Brackets held by Bolts (10) and (12), and this Rod is lengthened by a 1½" Rod (17) fitted in a Rod Connector.

The needle is represented by a 3½" Rod passed through two Angle Brackets (18). One of these is bolted to the end of one of the Strips (8), and the other is fixed to a Fishplate bolted to one of the 2½" Strips (11). The 3½" Rod carries a Washer (19) held between two Spring Clips, and a Cord Anchoring Spring (20) on Rod (17) is arranged so that the projecting lug of the Spring engages the Washer. As Rod (17) rotates the lug catches under the Washer and thus raises and then lowers the 3½" Rod.

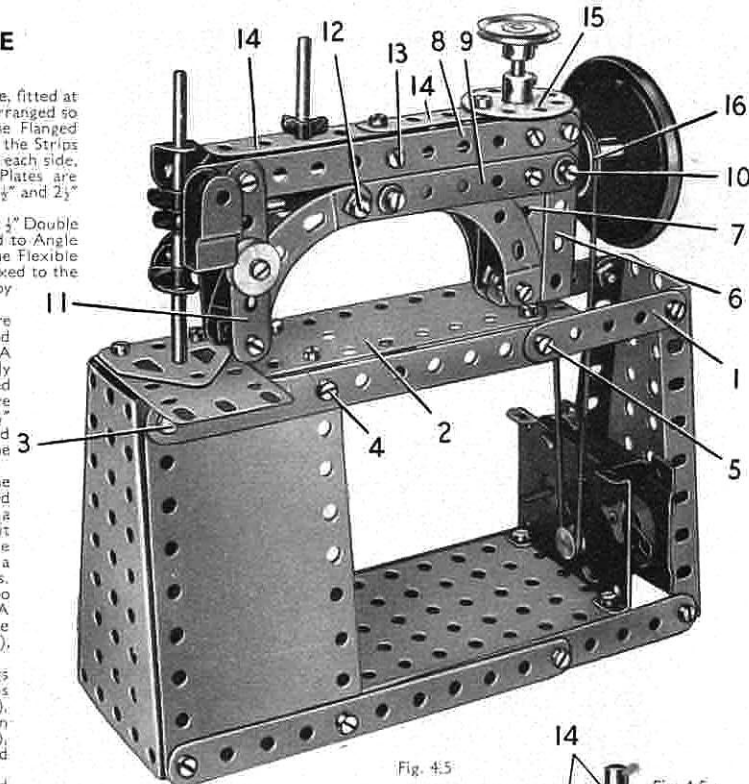

Fig. 4.5

Parts Required

8 of No.	2	1 of No.	44
2 "	3	1 "	48
6 "	5	4 "	48a
3 "	10	1 "	51
2 "	11	1 "	52
8 "	12	2 "	54
1 "	15b	4 "	90a
1 "	16	1 "	111c
1 "	17	1 "	126a
2 "	18a	1 "	176
2 "	22	1 "	187
1 "	23	1 "	188
1 "	24	1 "	189
5 "	35	2 "	191
55 "	37a	1 "	213
53 "	37b	1 Magic Motor	
8 "	38	(not included in	
		Outfit)	

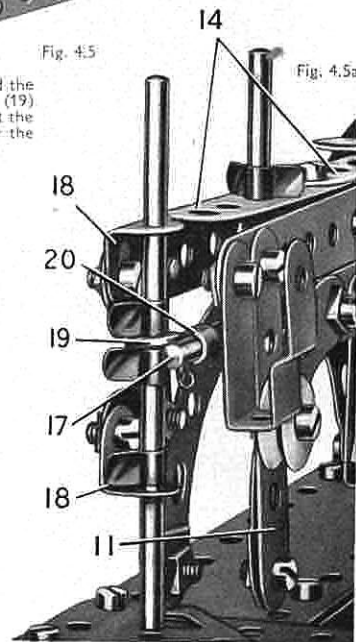

Fig. 4.5a

4.6 DUMPER TRUCK

Parts Required

6 of No.	2	4 of No.	48a
2 " "	3	1 " "	51
9 " "	5	1 " "	52
4 " "	10	3 " "	90a
2 " "	11	3 " "	111c
8 " "	12	2 " "	125
4 " "	12c	2 " "	126
1 " "	15b	2 " "	126a
2 " "	16	1 " "	155
2 " "	17	1 " "	186
2 " "	18a	4 " "	187
2 " "	19b	2 " "	188
3 " "	22	2 " "	189
1 " "	24	4 " "	190
5 " "	35	2 " "	191
87 " "	37a	2 " "	192
81 " "	37b	1 " "	198
6 " "	38	1 " "	212
1 " "	38d	1 " "	213
1 " "	40	2 " "	214
1 " "	48	4 " "	215
		4 " "	221

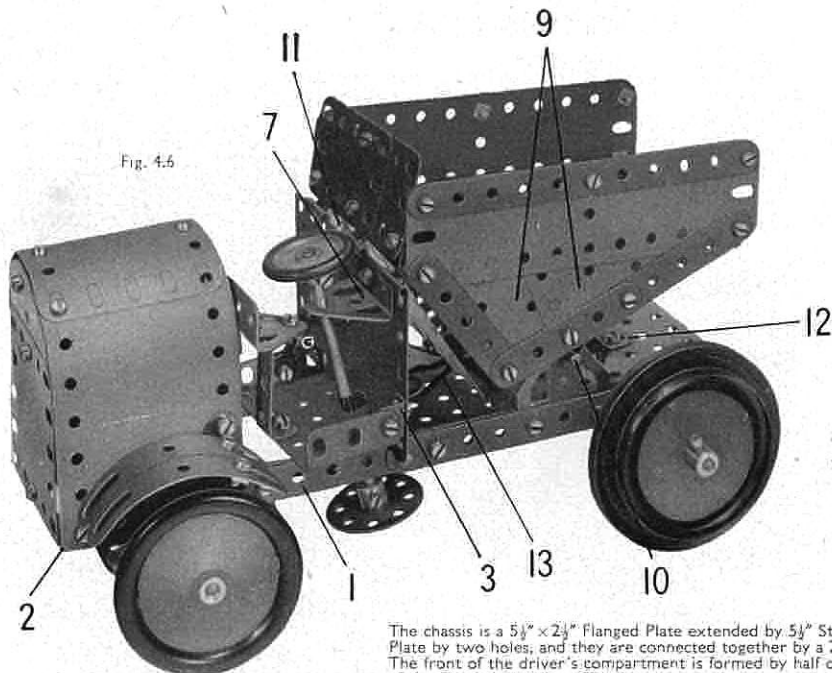

Fig. 4.6

The chassis is a $5\frac{1}{2}'' \times 2\frac{1}{2}''$ Flanged Plate extended by $5\frac{1}{2}''$ Strips (1). These Strips overlap the Flanged Plate by two holes, and they are connected together by a $2\frac{1}{2}'' \times 1''$ Double Angle Strip (2) (Fig. 4.6a). The front of the driver's compartment is formed by half of a Hinged Flat Plate attached to one end of the Flanged Plate by a Fishplate.

The engine housing is formed by two $5\frac{1}{2}'' \times 2\frac{1}{2}''$ Flexible Plates bolted to the Strips (1) and bent over and joined together at the top. The front and rear of the housing each consists of a Semi-Circular Plate and a $2\frac{1}{2}'' \times 2\frac{1}{2}''$ Flexible Plate. The rear is fixed to the Double Angle Strip (2), and the front is attached to a similar Double Angle Strip bolted between the Strips (1). A $2\frac{1}{2}'' \times 1\frac{1}{2}''$ Flanged Plate fixed to an Angle Bracket (3) forms the floor of the driver's compartment, and the seat is a Trunnion bolted to a $1\frac{1}{2}'' \times \frac{1}{2}''$ Double Angle Strip.

A $3\frac{1}{2}''$ Strip (4) (Fig. 4.6a) is bolted to a $2\frac{1}{2}'' \times 1''$ Double Angle Strip secured to the Strips (1). The $2\frac{1}{2}''$ Strips (5) and the Double Brackets (6) are free to turn on $\frac{1}{2}''$ Bolts fixed to the Strip (4) by two nuts. The Strips (5) are connected together by a $3\frac{1}{2}''$ Strip held by lock-nuts. Two Road Wheels are locked on $1\frac{1}{2}''$ Rods passed through the Double Brackets (6).

The steering column is a $4''$ Rod, which is passed through a Trunnion (7) and the $2\frac{1}{2}'' \times 1\frac{1}{2}''$ Flanged Plate. A Fishplate is bolted to a Bush Wheel on this Rod and a $2\frac{1}{2}''$ Stepped Curved Strip is fixed tightly to the Fishplate. The Curved Strip is connected by a $2\frac{1}{2}''$ Strip (8) to one of the Strips (5). The Bolts used to attach Strip (8) at each end are fitted with lock-nuts.

The driving axle is supported in $2\frac{1}{2}''$ Stepped Curved Strips bolted to the Flanged Plate, and it consists of a $3\frac{1}{2}''$ and a $2''$ Rod joined by a Rod Connector.

Each side of the load carrier is formed by two $2\frac{1}{2}'' \times 1\frac{1}{2}''$ Triangular Flexible Plates (9) and a $5\frac{1}{2}'' \times 1\frac{1}{2}''$ Flexible Plate edged by Strips as shown. The bottom consists of two $4\frac{1}{2}'' \times 2\frac{1}{2}''$ Flexible Plates, and the sides are connected to it by Angle Brackets. The back is made from two $2\frac{1}{2}'' \times 2\frac{1}{2}''$ Flexible Plates and two $2\frac{1}{2}'' \times 1\frac{1}{2}''$ Flexible Plates attached to the sides and bottom by Angle Brackets and Obtuse Angle Brackets. The load-carrier pivots about a $3\frac{1}{2}''$ Rod (10), which is passed through Flat Trunnions bolted to the chassis and through an Angle Bracket fixed on each side of the carrier.

The mudguard over each of the rear wheels is represented by two Formed Slotted Strips. These are joined together by a Fishplate, and attached to the side of the engine housing by an Angle Bracket.

The carrier is tipped for unloading by a $2''$ Rod (11), held in a Rod and Strip Connector that is lock-nutted to the side of the $2\frac{1}{2}'' \times 1\frac{1}{2}''$ Flanged Plate. A length of Cord from this Rod passes through an Obtuse Angle Bracket (12), and is fastened to the front of the carrier. The carrier is returned to its normal position by the $2\frac{1}{2}''$ Driving Band (13).

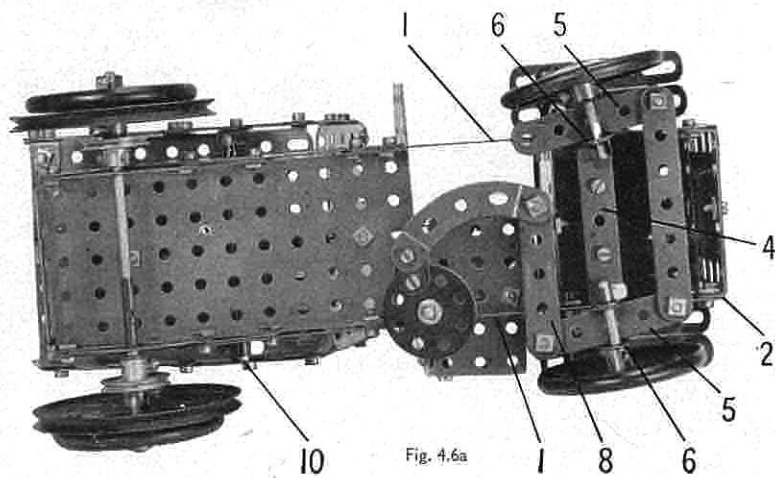

Fig. 4.6a

4.7 TELPHER SPAN

A $3''$ Pulley Wheel is fastened to the Crank Handle, and operates by means of a length of Cord another $3''$ Pulley on the driving shaft. A $1''$ Pulley also is secured on the driving shaft. The operating Cord is first tied to the top of the carriage as shown, then taken over the $2''$ Rod at the top of the tower, around the $1''$ Pulley on the driving shaft, then back again over the $2''$ Rod. From there it is led over the $\frac{1}{2}''$ loose Pulley in the anchorage, and finally is tied to the top of the carriage. One end of the guide Cord is tied to a $1\frac{1}{2}'' \times \frac{1}{2}''$ Double Angle Strip near the top of the tower, and the other end to the Double Bracket at the bottom of the anchorage.

The anchorage is formed by bolting two Trunnions to a $3\frac{1}{2}''$ Strip. A Double Bracket also is bolted to this Strip.

Two Flanged Sector Plates connected by four $2\frac{1}{2}''$ Strips and two $4\frac{1}{2}'' \times 2\frac{1}{2}''$ Flexible Plates form the carriage. The carriage superstructure consists of four $2\frac{1}{2}''$ Strips bolted to two Flat Trunnions, which are joined by a $2\frac{1}{2}'' \times \frac{1}{2}''$ Double Angle Strip. A $3\frac{1}{2}''$ Rod is passed through the flat Trunnions. It is held in place by a Spring Clip and a Bush Wheel.

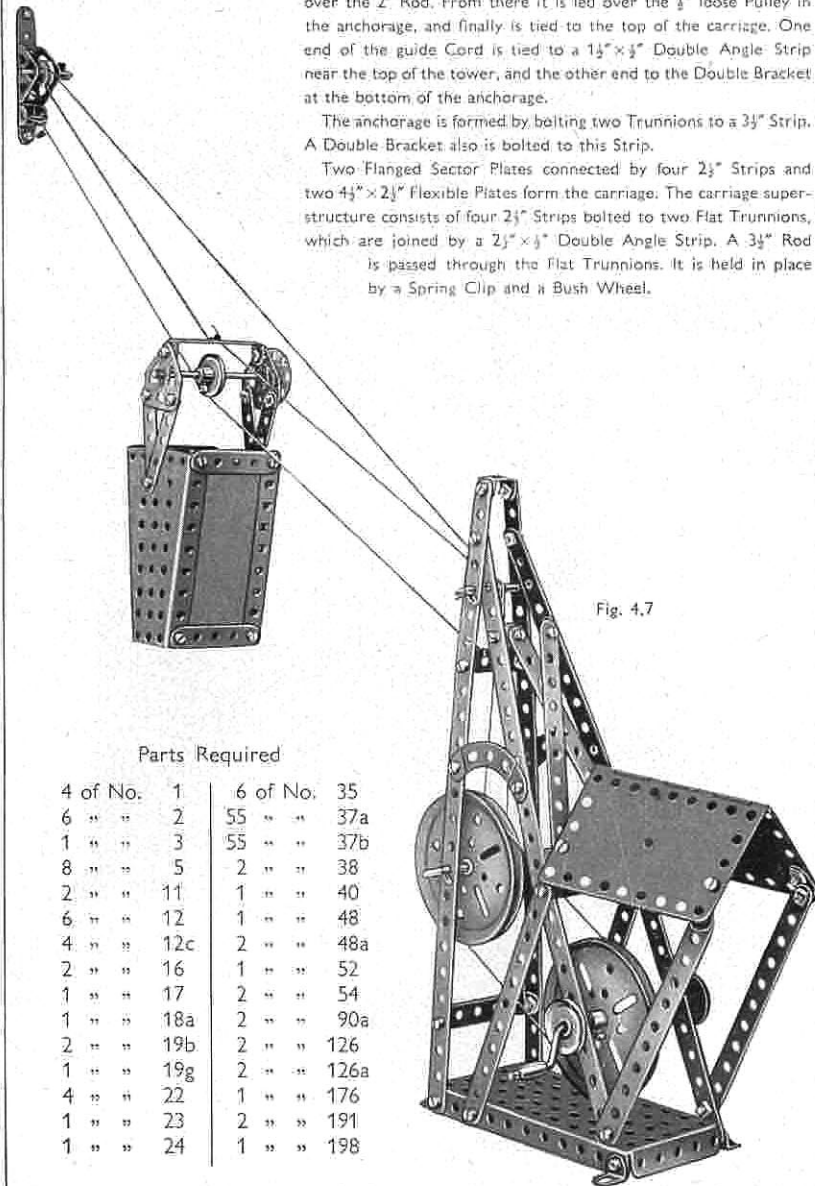

Fig. 4.7

Parts Required

4 of No.	1	6 of No.	35
6 " "	2	55 " "	37a
1 " "	3	55 " "	37b
8 " "	5	2 " "	38
2 " "	11	1 " "	40
6 " "	12	1 " "	48
4 " "	12c	2 " "	48a
2 " "	16	1 " "	52
1 " "	17	2 " "	54
1 " "	18a	2 " "	90a
2 " "	19b	2 " "	126
1 " "	19g	2 " "	126a
4 " "	22	1 " "	176
1 " "	23	2 " "	191
1 " "	24	1 " "	198

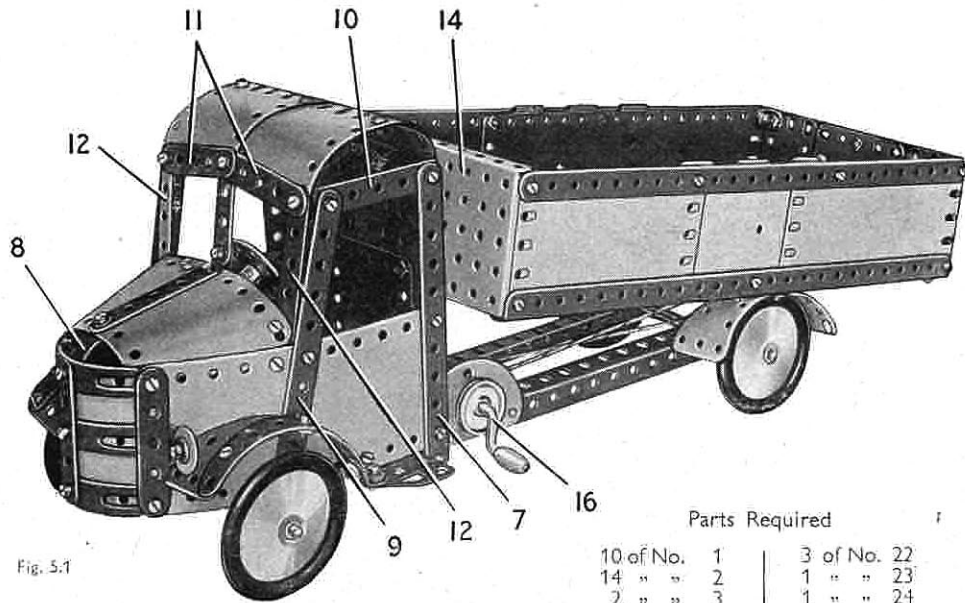

Fig. 5.1

Parts Required

10 of No. 1	3 of No. 22
14 " " 2	1 " " 23
2 " " 3	1 " " 24
12 " " 5	1 " " 24a
2 " " 6a	9 " " 35
4 " " 8	117 " " 37a
3 " " 10	107 " " 37b
2 " " 11	14 " " 38
8 " " 12	2 " " 38d

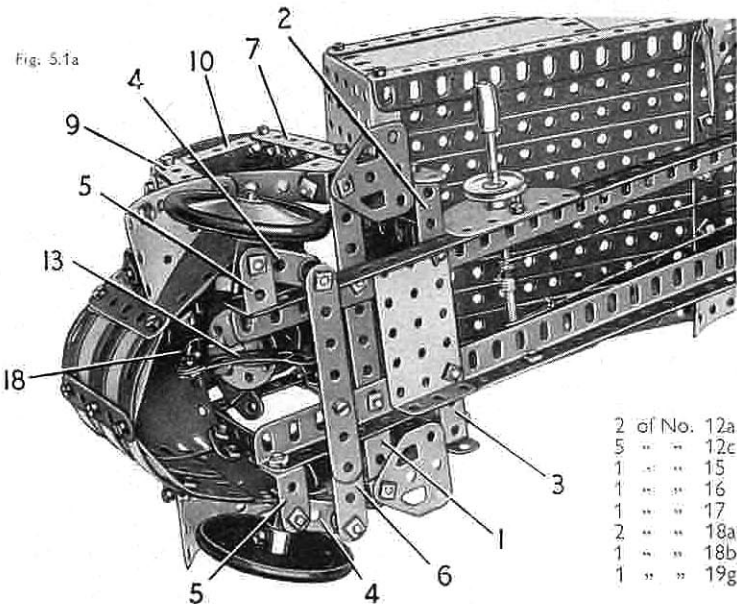

Fig. 5.1a

2 of No. 12a	1 of No. 198
5 " " 12c	1 " " 199
1 " " 15	2 " " 200
1 " " 16	2 " " 212
1 " " 17	1 " " 214
2 " " 18a	2 " " 215
1 " " 18b	4 " " 221
1 " " 19g	

5.1 TIPPING LORRY

THE CHASSIS AND WHEELS

The chassis consists of two 12½" Angle Girders joined at the rear by a 2½" × ½" Double Angle Strip, and at the front by a 5½" Strip (1) and a 2½" × 1½" Flanged Plate. The Bolts holding the Flanged Plate to the Angle Girders serve also to fix a 2½" × ½" Double Angle Strip (2) and a 1½" × ½" Double Angle Strip (3).

The rear wheels are fixed as shown on a 5" Rod supported in the chassis. Each of the front wheels is mounted on a 1½" Rod held by a Spring Clip in a Double Bracket. A ½" Bolt is passed through a 1½" Strip (4) placed between the lugs of each Double Bracket, and the Bolt is then fixed by two nuts to a 1" × 1" Angle Bracket (5) so that the Double Bracket and the Strip pivot freely as a unit. The 1" × 1" Angle Brackets are bolted tightly to the chassis. The Strips (4) are connected by a built-up strip (6), made from two 3½" Strips overlapped five holes. A ½" Bolt is passed through each of the Strips (4), and is fitted with a Washer and a Spring Clip. The strip (6) is then held on the shank of the Bolt by two nuts.

CONSTRUCTION OF THE CAB

The sides of the cab consist of 5½" × 2½" Flexible Plates bolted together with 5½" Strips (7), (Fig. 5.1), to the Double Angle Strips (2) and (3). The Flexible Plates are connected by Angle Brackets to the ends of the Strip (1), and the front ends of the Plates are curved slightly to form the sides of the bonnet. The bonnet sides are connected by the radiator, which is made from two 5½" × 1½" Flexible Plates curved and bolted together by their longer sides. The radiator is edged as shown in Fig. 5.1 by three 2½" Strips and three Formed Slotted Strips.

The top of the bonnet is formed by two 2½" × 2½" Flexible Plates bolted together. The front ends of these Plates are bolted direct to the bonnet sides, so that the clear corner hole of each Plate projects below the side. The rear ends of the Plates are connected to the bonnet sides by Fishplates. The top of the bonnet is completed by a Formed Slotted Strip (8).

A 5½" Strip (9) is fixed at a slight angle to each side, and at its upper end it is connected by a 2½" × ½" Double Angle Strip (10) to the top of the Strip (7). The windscreen is made from two 2½" Strips (11) and two 5½" Strips (12) bolted to the lugs of the Double Angle Strips (10). The centre division is a 2½" Strip attached to the top of the bonnet by an Obtuse Angle Bracket.

The cab roof consists of two 1½" radius Curved Plates and two 'U'-section Curved Plates opened out slightly. It is attached to the lugs of the Double Angle Strips (10). The back of the cab is formed by a 5½" × 1½" Flexible Plate at each side, joined at the bottom by a 2½" × 2½" Flexible Plate. The complete back is bolted to the lugs of the Double Angle Strips (10) and to Angle Brackets fixed to the lower corners of the cab sides.

Each of the front mudguards is a 2½" × 1½" Triangular Flexible Plate edged by two 2½" Strips that overlap each other two holes. The mudguard is connected to the Strip (1) by an Obtuse Angle Bracket, and a Flat Trunnion representing the step is held by the same bolt.

THE STEERING MECHANISM

The steering wheel is a Bush Wheel fixed on a 2" Rod. The Rod is supported in the centre hole of a Wheel Disc and in a ½" Reversed Angle Bracket bolted to the Wheel Disc. A 2½" Stepped Curved Strip and an Angle Bracket (18) are held by the same Bolt, and the Angle Bracket is bolted to the rear edge of the top of the bonnet.

A Rod and Strip Connector is fitted to the end of the 2" Rod, and two 2½" Stepped Curved Strips (13) are bolted to the Rod and Strip Connector. The Curved Strips overlap each other three holes, and the end of the lower Curved Strip is attached to an Angle Bracket fixed to the centre of the strip (6).

THE TIPPING BODY AND ITS OPERATING MECHANISM

Each side of the body consists of a 5½" × 2½" and a 4½" × 2½" Flexible Plate and one half of a Hinged Flat Plate, bolted to a 12½" Angle Girder and a 12½" Strip. The sides are connected by a 5½" × 2½" Flanged Plate (14) and 5½" Strips (15). The bottom of the body is filled in by eight 12½" Strips and a built-up strip made from a 2½" and two 5½" Strips. The hinged tail-board is made from a 2½" × 2½" Flexible Plate and two 2½" × 1½" Flexible Plates bolted to two 5½" Strips. The tail-board is connected to the sides of the body by two Angle Brackets, which pivot on lock-nutted Bolts.

A 2½" × ½" Double Angle Strip is bolted underneath the body, and a 3½" Rod is passed through its lugs and through two Trunnions bolted to the rear ends of the chassis Girders. The Rod is held in place by Spring Clips.

A Crank Handle (16) is supported in Semi-Circular Plates bolted to the chassis, and a length of Cord is tied to a Cord Anchoring Spring on the Crank Handle. The Cord is taken round a ½" loose Pulley (17) and is tied to a Fishplate on the Crank Handle. The Pulley (17) is mounted on a 1" Rod supported in a stepped Bent Strip, which is bolted underneath the body as shown in Fig. 5.1b. The rear mudguards each consist of a 2½" × 1½" Flexible Plate and a 2½" × 1½" Triangular Flexible Plate.

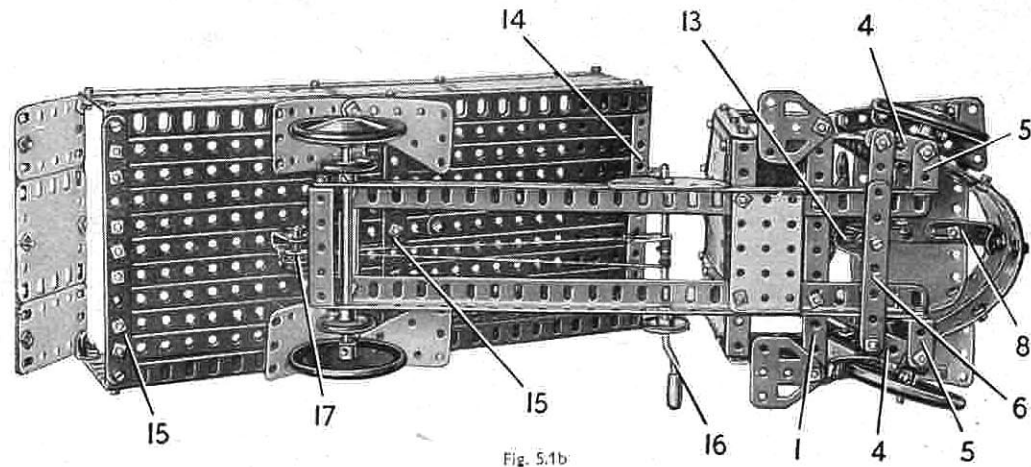

Fig. 5.1b

5.2 FERRY STEAMER

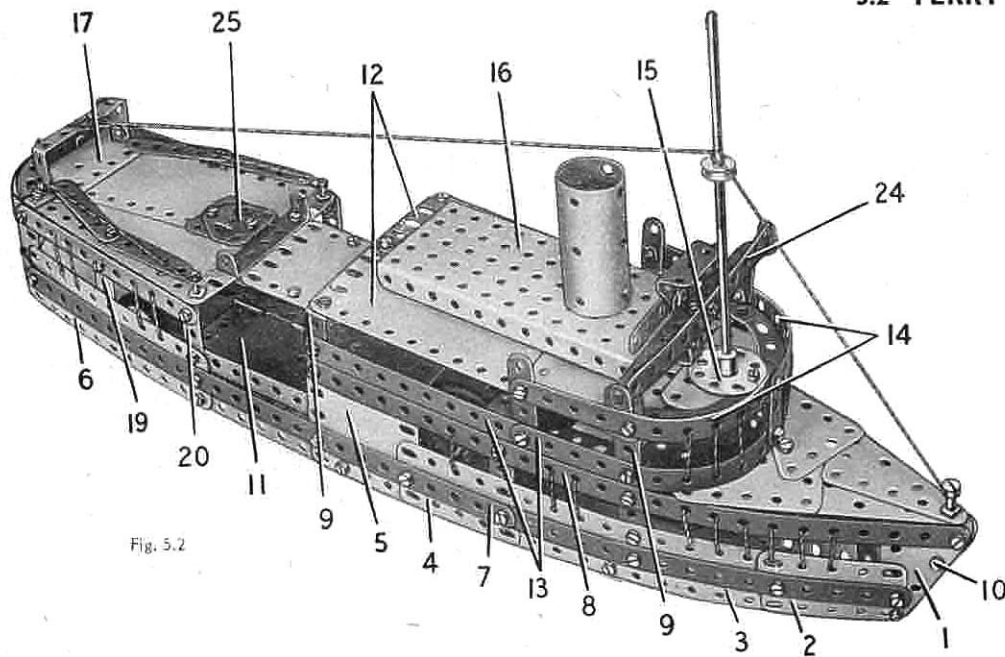

Fig. 5.2

CONSTRUCTION OF THE HULL

Each side of the hull of the Ferry Steamer consists of a $2\frac{1}{2}'' \times 1\frac{1}{2}''$ Triangular Flexible Plate (1), a $2\frac{3}{4}'' \times 1\frac{1}{2}''$ Flexible Plate (2), a $5\frac{1}{2}'' \times 1\frac{1}{2}''$ Flexible Plate (3), a $2\frac{1}{2}'' \times 1\frac{1}{2}''$ Flexible Plate (4), a $2\frac{1}{2}'' \times 2\frac{1}{2}''$ Flexible Plate (5) and a $5\frac{1}{2}'' \times 1\frac{1}{2}''$ Flexible Plate (6). These Plates are bolted to a built-up strip (7), made from two $12\frac{1}{2}''$ Strips overlapped eleven holes, and are also bolted to a $12\frac{1}{2}''$ Strip (8). Two $2\frac{1}{2}'' \times \frac{1}{2}''$ Double Angle Strips (9) are bolted to each side. On each side a Strip is bolted in the centre hole of the vertical $2\frac{1}{2}''$ Strip (20).

The sides are connected together at the bow by an Angle Bracket and by a $\frac{1}{2}''$ Bolt (10). A Hinged Flat Plate (11) is separated and the halves are bolted tightly together as shown in Fig. 5.2a. The Plate is fixed to the lower lugs of two of the Double Angle Strips (9) and at its rear end is attached to the sides of the hull by Angle Brackets.

The stern of the steamer consists of two $1\frac{1}{2}''$ radius Curved Plates. These are bolted to the rear edges of the Flexible Plates (6), and to a Formed Slotted Strip used to extend each of the strips (7).

ASSEMBLY OF THE DECKS

The upper deck is formed by two $5\frac{1}{2}'' \times 2\frac{1}{2}''$ Flexible Plates (12), (Fig. 5.2), and a $4\frac{1}{2}'' \times 2\frac{1}{2}''$ Flexible Plate bolted to the top lugs of the Double Angle Strips (9). Two $5\frac{1}{2}''$ Strips (13) at each side are fixed to the Double Angle Strips, and two of the Strips are curved to form the rounded front of the saloon deck. Two further curved $5\frac{1}{2}''$ Strips (14) are connected to the Strips (13) by a $\frac{1}{2}''$ and two vertical $2\frac{1}{2}''$ Strips. Two $2\frac{1}{2}''$ Stepped Curved Strips and a Semi-Circular Plate are bolted to a Bush Wheel (15), and the complete assembly is connected to the Strips (14) by an Angle Bracket. A $5\frac{1}{2}'' \times 2\frac{1}{2}''$ Flanged Plate (16) is attached to the top deck by a Double Bracket and an Angle Bracket, and the funnel, a $2\frac{1}{2}''$ Cylinder, is connected to the Flanged Plate by an Angle Bracket.

The deck at the stern of the steamer consists of two $5\frac{1}{2}'' \times 2\frac{1}{2}''$ Flexible Plates fitted at the rear with two $2\frac{1}{2}''$ Stepped Curved Strips. A Semi-Circular Plate (17) is clamped between the ends of the Curved Strips and the Flexible Plates. The deck is attached at each side to a $\frac{1}{2}''$ Reversed Angle Bracket (18) and a $2\frac{1}{2}'' \times \frac{1}{2}''$ Double Angle Strip (19), and it is connected by an Angle Bracket to a $2\frac{1}{2}''$ Strip (20).

A $4\frac{1}{2}'' \times 2\frac{1}{2}''$ Flexible Plate (21) is fixed to Angle Brackets bolted between the sides of the hull, and a $2\frac{1}{2}'' \times 1\frac{1}{2}''$ Flanged Plate (22), (Fig. 5.2b), is attached to the Flexible Plate by an Angle Bracket. A $2\frac{1}{2}'' \times 2\frac{1}{2}''$ Flexible Plate (23) is fixed to two $5\frac{1}{2}''$ Strips bolted between the Plate (21) and the stern deck. A $12\frac{1}{2}''$ Strip is attached to the centre of Plate (21) and extends forward to the bows. The Strip is connected by an Angle Bracket to the curved ends of the Strips (13), and it supports the Triangular Flexible Plates used to form the deck over the bows. The Triangular Flexible Plates are arranged as shown in Fig. 5.2.

THE BRIDGE AND DECK FITTINGS

The bridge is made by bolting a $5\frac{1}{2}''$ Strip to two $\frac{1}{2}''$ Reversed Angle Brackets, which are connected by Fishplates to the Strips (14). A $5\frac{1}{2}''$ Strip (24), a $3\frac{1}{2}''$ Strip and a Trunnion are fixed to a Double Bracket bolted to the centre of the first $5\frac{1}{2}''$ Strip. The mast consists of a $4\frac{1}{2}''$ and a $3\frac{1}{2}''$ Rod joined by a Rod Connector, and it is fixed in the Bush Wheel (15).

A deck house (25) on the stern deck consists of two Flat Trunnions joined together. It is attached by a $\frac{1}{2}''$ Bolt, but is held up from the deck by a Spring Clip on the Bolt. The seats are represented by $2\frac{1}{2}''$ Strips also attached by $\frac{1}{2}''$ Bolts and separated from the deck by Spring Clips.

The lifeboat davits at the stern are $1'' \times 1''$ Angle Brackets bolted to the Reversed Angle Brackets (18). The lifeboat consists of two $2\frac{1}{2}''$ Strips separated at the centre by five Washers on a $\frac{1}{2}''$ Bolt, and it is suspended by Cord from the davits.

Two $12\frac{1}{2}''$ Angle Girders are bolted to the Hinged Flat Plate (11) (Fig. 5.2a), and to a Flanged Sector Plate (26). The wheels on which the model runs are fixed on $3\frac{1}{2}''$ Rods supported in the Angle Girders.

The steamer is completed by adding Cord as shown to represent window divisions and the rigging.

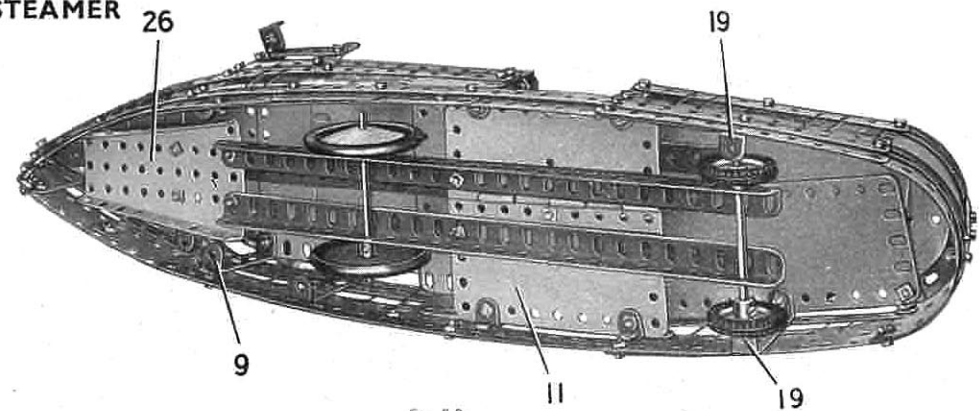

Fig. 5.2a

Parts Required

9 of No.	1
14 "	2
2 "	3
11 "	5
1 "	6a
2 "	8
2 "	10
2 "	11
12 "	12
2 "	12a
1 "	15a
3 "	16
2 "	22
1 "	23
1 "	24
13 "	35
117 "	37a
108 "	37b
8 "	38
1 "	40
1 "	48
8 "	48a
1 "	51
1 "	52
1 "	54
4 "	90a
2 "	111a
6 "	111c
4 "	125
2 "	126
2 "	126a
2 "	142c
1 "	147b
1 "	176
2 "	187
4 "	188
4 of No.	189
3 "	190
2 "	191
4 "	192
1 "	198
2 "	200
1 "	213
2 "	214
4 "	215
1 "	216
4 "	221
2 "	222

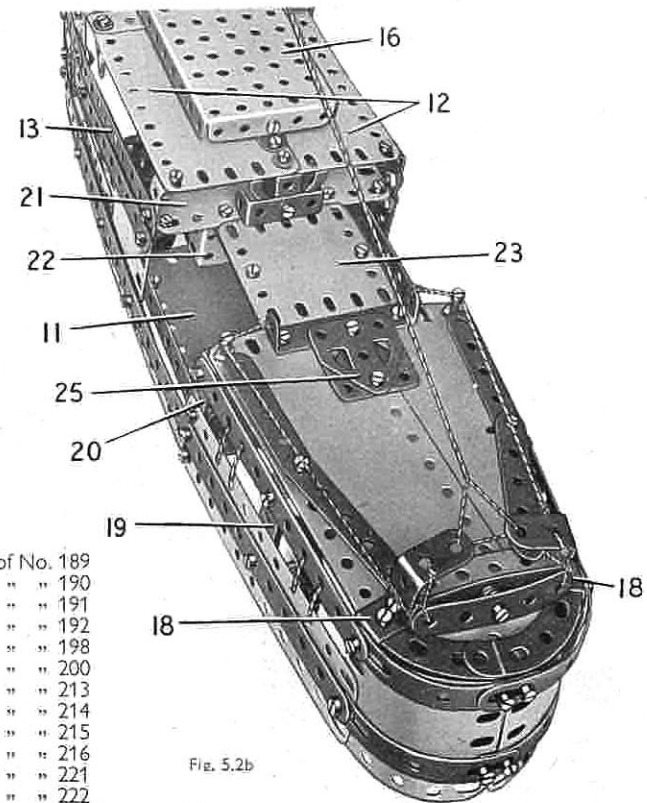

Fig. 5.2b

5.3 GAS TURBINE LOCOMOTIVE

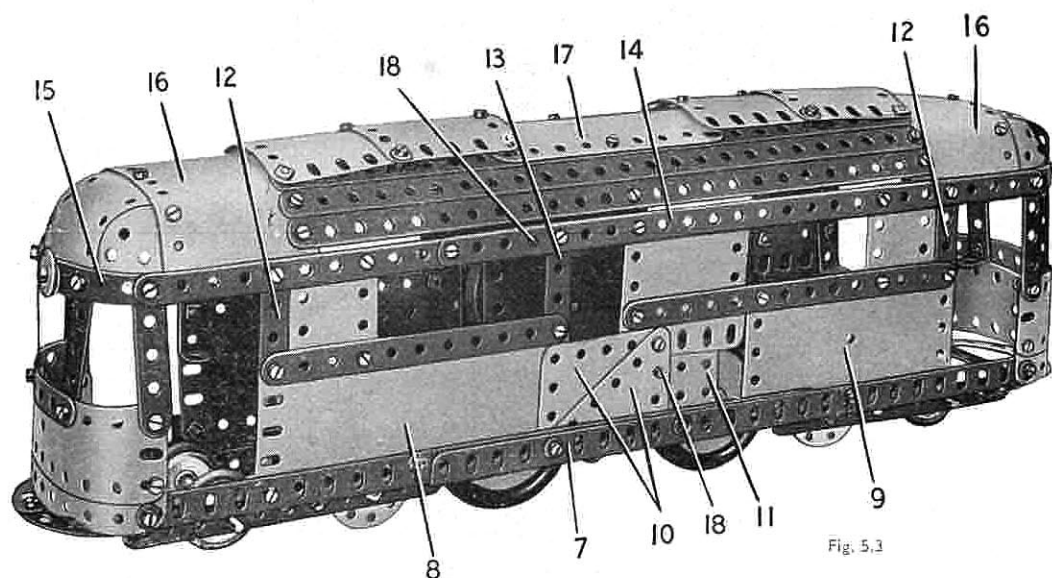

Fig. 5.3

THE POWER UNIT AND DRIVING WHEELS

A No. 1 Clockwork Motor is supported inside the body by two 4" Rods (18). These are passed through the sides of the body and the Motor side-plates, and are held in position by Spring Clips (19). Two 1½" Strips (19) are bolted to the girders (1) and (7) and to Angle Brackets fixed to the Motor. Two Road Wheels are fixed on a 3½" Rod (20) supported in the corner holes of the side-plates. A 57-tooth Gear also fixed on the Rod (20) is driven by a ½" Pinion on the Motor driving shaft.

A 2½" Strip (21) is attached to each side-plate of the Motor, and these support a second 3½" Rod that carries two Road Wheels.

THE BOGIE UNITS

Each unit consists of two 5½" Strips attached to the body by Angle Brackets. Two 1" Pulleys fitted with Rubber Rings are held on a 3½" Rod, and two Wheel Discs are attached to the 5½" Strips by lock-nutted bolts. At one end ordinary Wheel Discs are used, and at the other end Six-hole Wheel Discs.

Parts Required

9 of No. 1	1 of No. 17	15 of No. 38	1 of No. 147b	2 of No. 199
9 " " 2	4 " " 22	2 " " 38d	4 " " 155	1 " " 200
2 " " 3	2 " " 24a	8 " " 48a	4 " " 187	4 " " 215
11 " " 5	2 " " 24c	1 " " 51	4 " " 188	4 " " 221
2 " " 6a	1 " " 26	1 " " 52	4 " " 189	2 " " 222
4 " " 8	1 " " 27a	4 " " 90a	4 " " 190	
6 " " 12	9 " " 35	2 " " 111a	2 " " 191	1 No. 1 Clockwork Motor (not included in Outfit)
2 " " 15b	116 " " 37a	6 " " 111c	4 " " 192	
3 " " 16	103 " " 37b	1 " " 115	1 " " 198	

CONSTRUCTION OF THE SIDES

The side of the model seen in Fig. 5.3a is assembled on a built-up girder (1) made from two 12½" Angle Girders overlapped fifteen holes. The lower part of the side is filled in by a 5½" × 2½" Flanged Plate (2) at the centre, a 5½" × 2½" Flexible Plate (3) at one end and *one half of a Hinged Flat Plate* (4) at the other end. The top edges of these Plates are strengthened by a 12½" Strip extended by a 2½" Strip. The upper section of the side consists of a 4½" × 2½" Flexible Plate, two 2½" × 1½" Flexible Plates and two 2½" × ½" Double Angle Strips (5). A built-up strip (6), made from a 12½" and a 5½" Strip, is bolted to the top ends of the Double Angle Strips and the upper edges of the Plates.

The side seen in Fig. 5.3 is attached to a built-up Girder (7), also made from two 12½" Angle Girders overlapped fifteen holes. The lower part of this side is filled in by a 5½" × 2½" Flexible Plate (8) at one end and *one half of a Hinged Flat Plate* (9) at the other end. At the centre two 2½" × 2" Triangular Flexible Plates (10) and a 2½" × 1½" Flanged Plate (11) are bolted in the positions shown. The side is extended upward by two 2½" × ½" Double Angle Strips (12) and a 2½" Strip (13), and two 2½" × 1½" Flexible Plates and a 2½" × 2½" Flexible Plate are bolted in place. The top edges of the Plates are strengthened by a built-up strip (14), made from a 12½" and a 5½" Strip. The completed sides are connected at each end by a 3½" Strip bolted to the girders (1) and (7).

THE DRIVING CABS

The ends of the two cabs are similar in construction, and each consists of two 5½" × 1½" Flexible Plates overlapped two holes along their longer edges. The ends of the Plates are curved as shown and are fixed to the girders (1) and (7). The Flexible Plates are extended upward by two 2½" Strips and two 2½" × ½" Double Angle Strips. The upper ends of these parts are bolted to two Formed Slotted Strips (15), which are fixed to the ends of the strips (6) and (14). Two 2½" Stepped Curved Strips are bolted to each end as shown in Fig. 5.3a.

CONSTRUCTION OF THE ROOF

The roof is made by bending two 5½" × 2½" Flexible Plates (16) and bolting them between the strips (6) and (14) as shown. Three 12½" Strips are fixed between the Plates (16) on each side, and a 4½" × 2½" Flexible Plate (17) is bolted at the centre of the roof. The curved ends of the roof are made from an opened out 'U'-section Curved Plate and a 2½" × 2½" Flexible Plate, and each is attached to one of the Flexible Plates (16) and the Formed Slotted Strips (15). A 2½" × 1½" Triangular Flexible Plate is used to fill in the rounded corner on each side. The roof ventilators are made from two 2½" × 2½" Flexible Plates and two 1½" radius Curved Plates. They are attached to the roof by ¼" Bolts, but a Spring Clip is placed on each Bolt to space the ventilators from the roof.

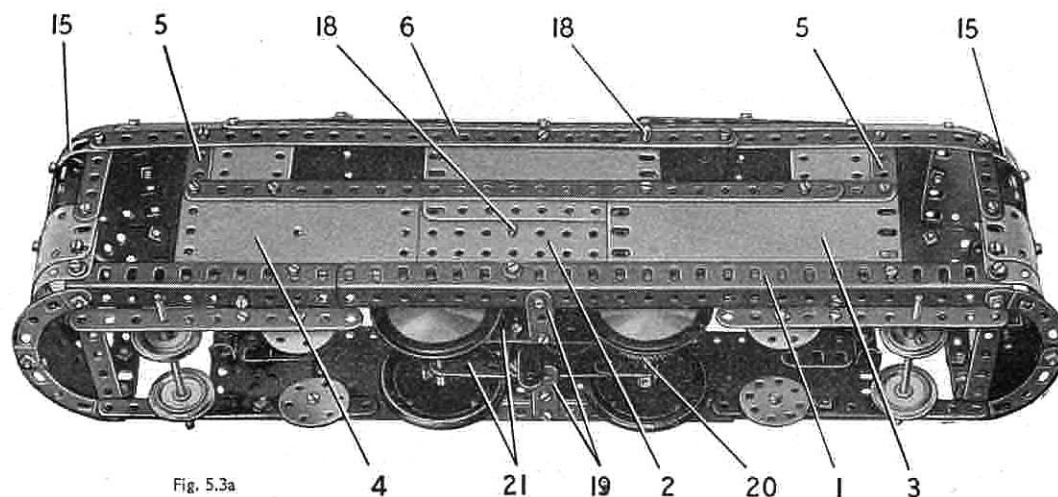

Fig. 5.3a

5.4 BULK LIQUID TRANSPORTER

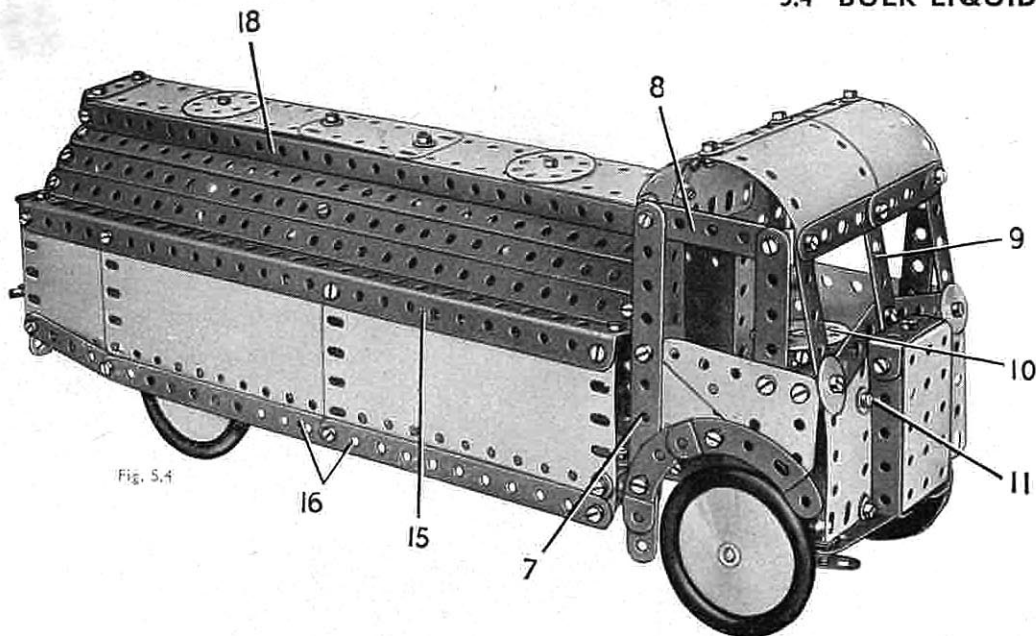

Fig. 5.4

CONSTRUCTION OF THE TANK

Each side of the tank is formed by two $5\frac{1}{2}'' \times 2\frac{1}{4}''$ and a $2\frac{1}{2}'' \times 2\frac{1}{4}''$ Flexible Plate bolted to a $12\frac{1}{2}''$ Angle Girder (15). Two $5\frac{1}{2}''$ Strips (16) are attached to the $5\frac{1}{2}'' \times 2\frac{1}{4}''$ Flexible Plate by a Fishplate, and are connected to the $2\frac{1}{2}'' \times 2\frac{1}{4}''$ Flexible Plate by a $2\frac{1}{2}''$ Strip.

The rounded part of the tank consists of three $12\frac{1}{2}''$ Strips on each side. These are bolted to three $5\frac{1}{2}''$ Strips bent to form a half circle, and the two end Strips are connected to the sides of the tank by Obtuse Angle Brackets. The centre and the front $5\frac{1}{2}''$ Strips are seen at (17) in Fig. 5.4a.

Two $12\frac{1}{2}''$ Strips (18), one on each side, are fixed to the centre parts of four $\frac{1}{4}''$ Reversed Angle Brackets bolted to the front and rear curved $5\frac{1}{2}''$ Strips; and the top of the tank is attached to the lugs of the Reversed Angle Brackets. The top is made from a $2\frac{1}{2}'' \times 1\frac{1}{2}''$ and two $5\frac{1}{2}'' \times 1\frac{1}{2}''$ Flexible Plates bolted end to end.

The rear of the tank is made by separating and bolting together the halves of a Hinged Flat Plate. The halves overlap by four holes, and a $2\frac{1}{2}'' \times 1\frac{1}{2}''$ Flexible Plate (19) and two Semi-Circular Plates (20) are fixed in position. A guard rail formed by a $5''$ Rod held in Right-Angle Rod and Strip Connectors is bolted across the back. The back is connected to the sides by two Angle Brackets and two Double Brackets (21).

The completed tank is bolted at the back to the Double Angle Strip (2). The front end of the tank is supported on each side by an Angle Bracket bolted to a $1'' \times 1''$ Angle Bracket (22). The Angle Brackets (22) are fixed to the chassis Girders and to the flanges of the Flanged Plate (1).

Parts Required

8 of No. 1	4 of No. 12c	20 of No. 38	5 of No. 111c	4 of No. 192
9 " " 2	1 " " 15	2 " " 38d	1 " " 115	1 " " 198
2 " " 3	1 " " 15a	1 " " 44	4 " " 125	1 " " 199
12 " " 5	2 " " 18a	1 " " 48	2 " " 126	2 " " 200
2 " " 6a	2 " " 22	7 " " 48a	1 " " 147b	2 " " 212a
4 " " 8	1 " " 24	1 " " 51	2 " " 155	2 " " 214
2 " " 10	2 " " 24a	1 " " 52	4 " " 187	2 " " 221
4 " " 11	3 " " 35	1 " " 80c	4 " " 188	2 " " 222
12 " " 12	118 " " 37a	4 " " 90a	4 " " 189	
2 " " 12a	105 " " 37b	2 " " 111a	2 " " 190	

THE CHASSIS AND WHEELS

The chassis is made by bolting two $12\frac{1}{2}''$ Angle Girders to a $5\frac{1}{2}'' \times 2\frac{1}{4}''$ Flanged Plate (1), so that each Girder overlaps the Flanged Plate by five holes. The rear ends of the Girders are connected by a $2\frac{1}{2}'' \times \frac{1}{2}''$ Double Angle Strip (2). The rear wheels are fixed on a $\frac{1}{4}''$ Rod supported in the Angle Girders.

A $3\frac{1}{2}''$ Strip (3) is bolted across the Flanged Plate (1). The front wheels are fixed on $1\frac{1}{2}''$ Rods supported in Double Brackets. One of the Rods is held in place by a Spring Clip and the other is retained by a Cord Anchoring Spring. At one side a $\frac{1}{4}''$ Bolt is passed through a $1\frac{1}{2}''$ Strip (4) and a Double Bracket and the Bolt is then gripped by two nuts in one end of Strip (3), leaving the Strip and the Double Bracket free to pivot as a unit on the Bolt. The construction at the other end of Strip (3) is similar, but a $2\frac{1}{2}''$ Strip (5) is used in place of the $1\frac{1}{2}''$ Strip (4). A $3\frac{1}{2}''$ Strip (6) is lock-nutted to the ends of the Strips (4) and (5).

CONSTRUCTION OF THE CAB

Each side of the cab is assembled on a $5\frac{1}{2}''$ Strip (7), which is attached by an Angle Bracket to a Trunnion bolted to the flange of the Flanged Plate (1). The side consists of two $2\frac{1}{2}'' \times 1\frac{1}{2}''$ Triangular Flexible Plates arranged as shown in Fig. 5.4, and two $2\frac{1}{2}''$ Stepped Curved Strips are bolted together to form an arch over the front wheel. The window frame is made from a $2\frac{1}{2}''$ Strip, a $2\frac{1}{2}'' \times \frac{1}{2}''$ Double Angle Strip (8) and the top end of the Strip (7).

The front of the cab consists of a $2\frac{1}{2}'' \times 1\frac{1}{2}''$ Flexible Plate on each side bolted to the front flange of the Flanged Plate (1), and connected to the sides of the cab by Angle Brackets. The windscreen frame is formed by six $2\frac{1}{2}''$ Strips arranged as shown, with a centre division provided by a $2\frac{1}{2}'' \times \frac{1}{2}''$ Double Angle Strip (9).

The radiator is a $2\frac{1}{2}'' \times 1\frac{1}{2}''$ Flanged Plate edged by a $1\frac{1}{2}'' \times \frac{1}{2}''$ and two $2\frac{1}{2}'' \times \frac{1}{2}''$ Double Angle Strips. It is attached by an Angle Bracket to the lower end of the Double Angle Strip (9).

The back of the cab is partly filled by a $5\frac{1}{2}'' \times 1\frac{1}{2}''$ Flexible Plate at each side. They are connected to the sides of the cab by Angle Brackets, and are bolted to the lugs of the Double Angle Strips (8). The top ends of the $5\frac{1}{2}'' \times 1\frac{1}{2}''$ Flexible Plates are bent over and connected by a curved $2\frac{1}{2}'' \times 2\frac{1}{2}''$ Flexible Plate to form part of the roof. The front section of the roof consists of two $1\frac{1}{4}''$ radius Curved Plates fixed to the front lugs of the Double Angle Strips (8).

THE STEERING MECHANISM

A Bush Wheel (10) is fixed on the end of a Screwed Rod, which is mounted in a hole of the Flanged Plate (1) and in a Stepped Bent Strip attached to the front of the cab by a Bolt (11). The Screwed Rod is held in place by two nuts locked together below the Flanged Plate, and a $2\frac{1}{2}''$ Strip (12) is held on the lower end of the Screwed Rod by two nuts. An Angle Bracket is pivoted on a Threaded Pin held in the end hole of Strip (12) by a Spring Clip, and the Angle Bracket is bolted to one lug of a $2\frac{1}{2}'' \times \frac{1}{2}''$ Double Angle Strip (13). The Double Angle Strip is connected to the Strip (5) by a Pivot Bolt (14) fitted with a Spring Clip.

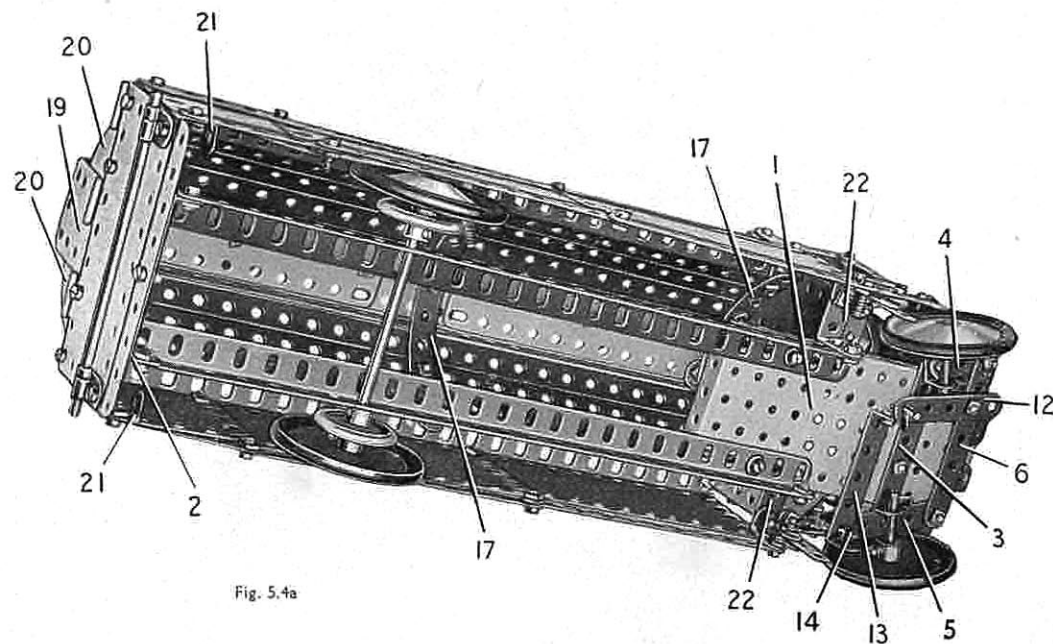

Fig. 5.4a

5.5 ELEVATOR

THE ELEVATOR SHAFT

The shaft consists of four upright pieces, each made from a $12\frac{1}{2}$ " Angle Girder and a $12\frac{1}{2}$ " Strip overlapped three holes. The base of the shaft is a $5\frac{1}{2}$ " x $2\frac{1}{2}$ " Flanged Plate (1), and the $12\frac{1}{2}$ " Angle Girders are connected to the corners of the Flanged Plate by $\frac{1}{2}$ " Reversed Angle Brackets (2), (Fig. 5.5a). The $12\frac{1}{2}$ " Strips are joined at their upper ends by $5\frac{1}{2}$ " Strips (3), and by $3\frac{1}{2}$ " Strips (4) attached to Angle Brackets.

The base is extended at each side by a Flanged Sector Plate attached to a Semi-Circular Plate, and at one end by two $5\frac{1}{2}$ " Strips (5) bolted inside the flanges of the Flanged Plate. The outer ends of Strips (5) are connected by a $2\frac{1}{2}$ " x $1\frac{1}{2}$ " Double Angle Strip, and they are braced by further $5\frac{1}{2}$ " Strips attached to the lift shaft by Angle Brackets.

The lift shaft is braced by $5\frac{1}{2}$ " Strips, $5\frac{1}{2}$ " x $2\frac{1}{2}$ " and $5\frac{1}{2}$ " x $1\frac{1}{2}$ " Flexible Plates arranged as shown, and by crossed $12\frac{1}{2}$ " and $5\frac{1}{2}$ " Strips and built-up strips (6). Each of the strips (6) consists of two $2\frac{1}{2}$ " Strips overlapped three holes. At the top of the shaft the joins between the $12\frac{1}{2}$ " Strips and the Strips (3) are strengthened by $2\frac{1}{2}$ " x $1\frac{1}{2}$ " Triangular Flexible Plates (7) are fitted between two of the Angle Girders and the base.

THE CAGE AND ITS GUIDE CORDS

Each side of the cage is a $4\frac{1}{2}$ " x $2\frac{1}{2}$ " Flexible Plate strengthened by $2\frac{1}{2}$ " Strips and a $2\frac{1}{2}$ " x $\frac{1}{2}$ " Double Angle Strip (9) as shown in Fig. 5.5a. The sides are connected by a $2\frac{1}{2}$ " x $1\frac{1}{2}$ " Flanged Plate (9), and by two $2\frac{1}{2}$ " x $\frac{1}{2}$ " Double Angle Strips bolted to the lower edges of the sides. The floor of the cage is a $2\frac{1}{2}$ " x $2\frac{1}{2}$ " Flexible Plate bolted to these Double Angle Strips. The back is also a $2\frac{1}{2}$ " x $2\frac{1}{2}$ " Flexible Plate attached to a Double Angle Strip (10).

Two Trunnions are bolted to the Flanged Plate (9) and a $1\frac{1}{2}$ " loose Pulley (11) is freely mounted on a Pivot Bolt held by its nuts in one of the Trunnions.

The cage is guided by two Cords, arranged one on each side. Each Cord is fastened to a Washer and is passed through a hole in the Flanged Plate (1) and through the lugs of one of the Double Angle Strips (8). The Cord is then pulled tight and is tied to a $1\frac{1}{2}$ " x $1\frac{1}{2}$ " Angle Bracket bolted to half of a Hinged Flat Plate at the top of the shaft. Each half of the Hinged Flat Plate is fixed to one of the Strips (3).

THE OPERATING MECHANISM

A $3\frac{1}{2}$ " Pulley (12) fitted with a Threaded Pin is fixed on a Rod mounted as shown in Fig. 5.5a. A length of Cord is tied to a Cord Anchoring Spring on the Rod and is passed over a $3\frac{1}{2}$ " Pulley (13), round the Pulley (11) and is tied to the top of the lift shaft. Pulley (13) is fixed on a Rod held by Rod Wheels in the halves of the Hinged Flat Plate.

The Pulley (12) is fitted with a brake formed by two $\frac{3}{4}$ " Washers bolted to a $2\frac{1}{2}$ " Stepped Curved Strip. The Curved Strip is lock-nutted to a Double Bracket (14), and the $\frac{3}{4}$ " Washers engage in the rim of Pulley (12). A length of Cord fastened to an Angle Bracket on the Curved Strip is tied to a Driving Band attached to the lift shaft. The Driving Band pulls the Washers against the Pulley. The Cord fastened to the Driving Band passes over a $\frac{1}{2}$ " loose Pulley (15) on the same Rod as the Pulley (12).

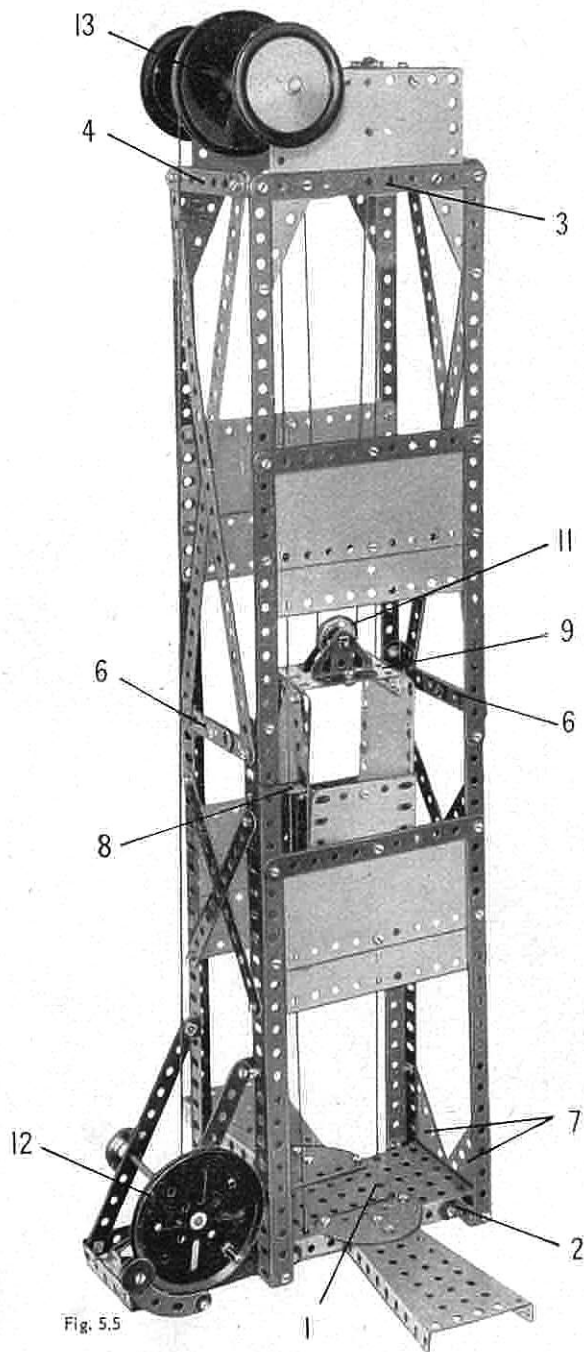

Fig. 5.5

Parts Required

8 of No. 1	1 of No. 23	4 of No. 125
14 " " 2	116 " " 37a	2 " " 126
2 " " 3	110 " " 37b	1 " " 147b
12 " " 5	11 " " 38	1 " " 176
2 " " 6a	2 " " 38d	1 " " 186
4 " " 8	1 " " 40	2 " " 187
1 " " 11	6 " " 48a	4 " " 189
9 " " 12	1 " " 51	2 " " 190
2 " " 12a	1 " " 52	2 " " 191
1 " " 15a	2 " " 54	4 " " 192
1 " " 16	1 " " 90a	1 " " 198
2 " " 19b	1 " " 111a	2 " " 214
1 " " 22	2 " " 111c	4 " " 221
1 " " 22a	1 " " 115	2 " " 222

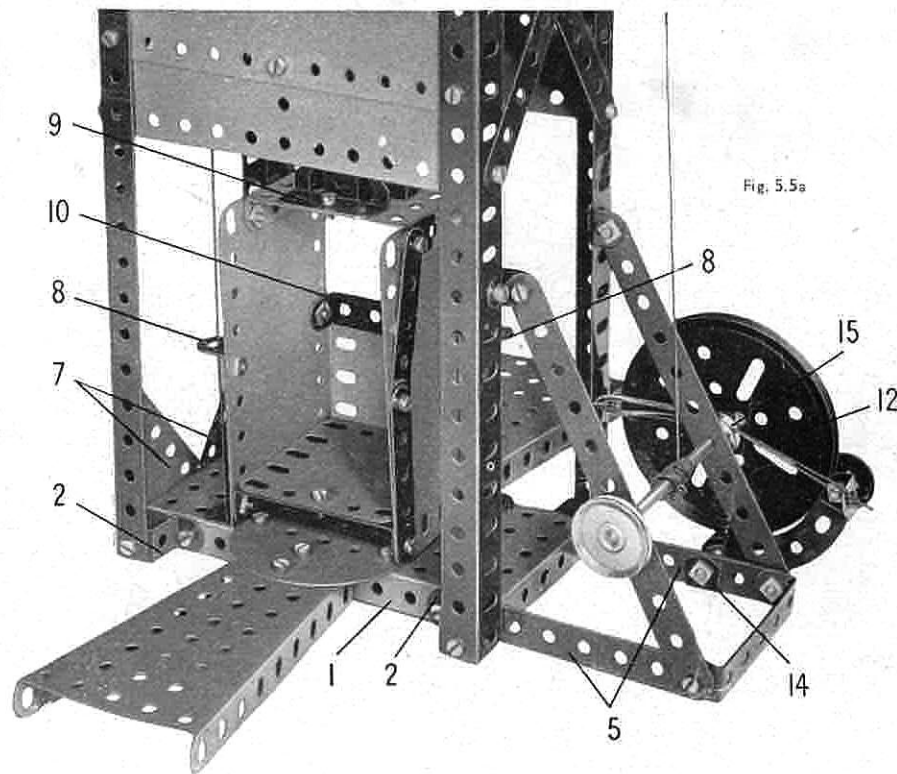

Fig. 5.5a

THE CENTRE PIER

Each side of the pier consists of two $5\frac{1}{2}'' \times 1\frac{1}{2}''$ and two $2\frac{1}{2}'' \times 1\frac{1}{2}''$ Flexible Plates bolted to two built-up strips (1) (Fig. 6.1). These strips are each made from a $12\frac{1}{2}''$ and a $5\frac{1}{2}''$ Strip overlapped seven holes. The sides are connected at the centre by a $5\frac{1}{2}'' \times 2\frac{1}{2}''$ Flanged Plate (2) and two $2\frac{1}{2}'' \times 1\frac{1}{2}''$ Double Angle Strips (3) (Fig. 6.1a), and at each end by a Flanged Sector Plate (4) and a $1\frac{1}{2}'' \times \frac{1}{2}''$ Double Angle Strip (5). A 3" Pulley (6) is bolted to a $2\frac{1}{2}'' \times 1\frac{1}{2}''$ Double Angle Strip fixed between the side flanges of the Flanged Plate (2). The Pulley is placed with its boss upwards.

Two $1'' \times 1''$ Angle Brackets are fixed to one of the Flanged Sector Plates by the Bolt (7) (Fig. 6.1), and two $\frac{1}{4}''$ Strips (8) are attached to the outer Angle Bracket by a $\frac{3}{4}''$ Bolt. The Strips are spaced apart by a Collar and a Washer on the Bolt. A Bush Wheel fitted with a Threaded Pin as a handle is fixed on a $\frac{1}{2}''$ Rod mounted in the top holes of the Strips (8). The Rod is held in place by a Collar, and it carries a $\frac{1}{2}''$ Pinion that drives a 57-tooth Gear on a $3\frac{1}{2}''$ Rod supported in the lower holes of the $1\frac{1}{2}'' \times 1\frac{1}{2}''$ Strips and in the $1'' \times 1''$ Angle Brackets. This Rod also is held in position by a Collar, and a 1" Pulley (9) (Fig. 6.1a), fitted with a Motor Tyre, is fixed on the inner end of the Rod. The Tyre on Pulley (9) presses against another Tyre on a 1" Pulley (10), which is held on a 2" Rod supported in the Flanged Sector Plate and in a Double Bent Strip bolted underneath the Plate. The Rod is held in position by a Collar and a 1" Pulley (11), which is spaced from the Flanged Sector Plate by four Washers.

THE BRIDGE APPROACHES

Each approach is made by bolting two $12\frac{1}{2}''$ Strips (12) (Fig. 6.1a) to Angle Brackets attached to the centre pier. The Strips are connected by a $3\frac{1}{2}'' \times \frac{1}{2}''$ and a $2\frac{1}{2}'' \times \frac{1}{2}''$ Double Angle Strip, and a $5\frac{1}{2}'' \times 2\frac{1}{2}''$ Flexible Plate is fitted to each side. A $3\frac{1}{2}'' \times 2\frac{1}{2}''$ Flanged Plate (13) is fixed between the Flexible Plates. The roadway is completed by a $1\frac{1}{2}'' \times 2\frac{1}{2}''$ Flexible Plate, a $2\frac{1}{2}'' \times 2''$ Triangular Flexible Plate and a $2\frac{1}{2}'' \times 2\frac{1}{2}''$ Triangular Flexible Plate attached to the Flanged Plate (13) and to a $2\frac{1}{2}'' \times \frac{1}{2}''$ Double Angle Strip (14). The side rails are $5\frac{1}{2}''$ Strips supported by $2\frac{1}{2}''$ Stepped Curved Strips and Flat Trunnions.

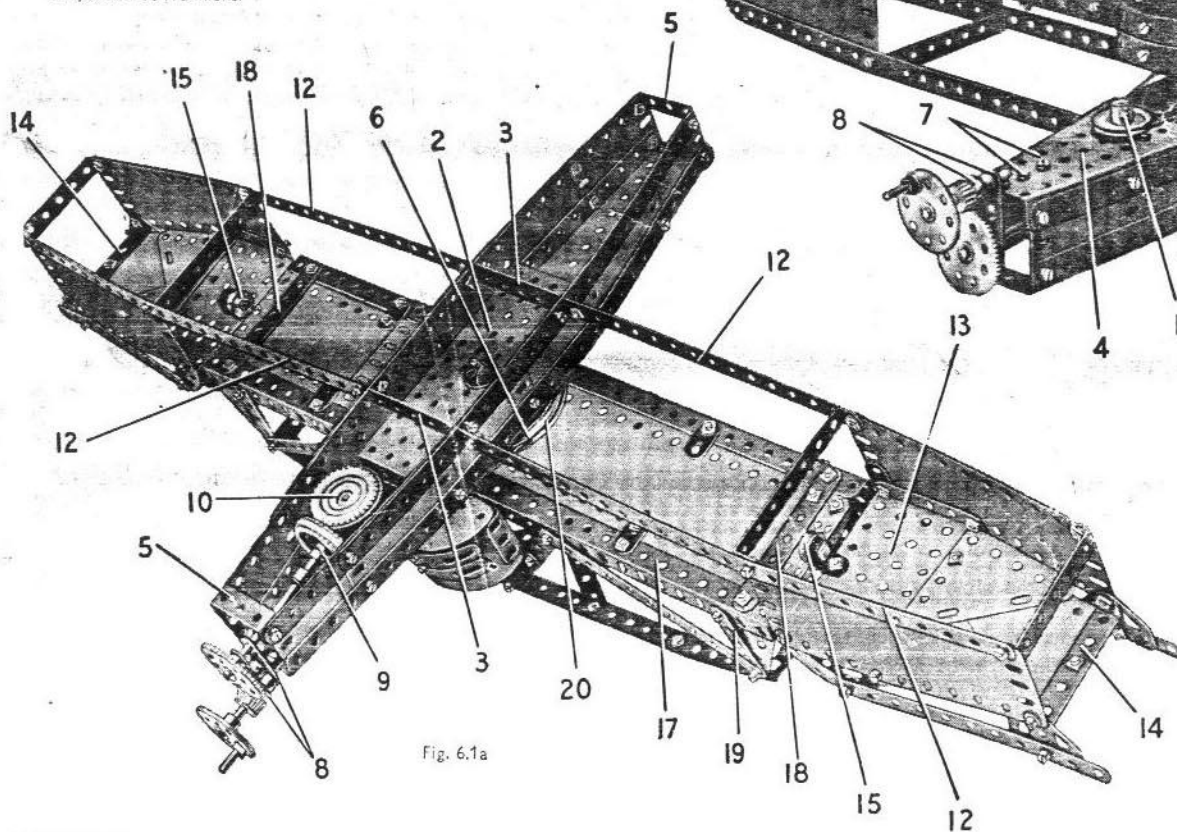

Fig. 6.1a

6.1 SWING BRIDGE**Parts Required**

12 of No. 1	1	4 of No. 8	8	2 of No. 19b	2	1 of No. 40	1	4 of No. 90a	4
14 " " 2	2	5 " " 10	5	3 " " 22	3	1 " " 45	1	2 " " 111	2
4 " " 3	3	3 " " 11	3	1 " " 22a	1	2 " " 48	2	1 " " 111a	1
12 " " 5	5	16 " " 12	16	1 " " 23	1	6 " " 48a	6	1 " " 111c	1
2 " " 6a	6a	2 " " 12a	2	1 " " 23a	1	2 " " 48b	2	1 " " 115	1
		1 " " 16	1	1 " " 24	1	1 " " 51	1	3 " " 125	3
		2 " " 17	2	1 " " 26	1	1 " " 52	1	2 " " 126	2
		3 " " 18a	3	1 " " 27a	1	2 " " 53	2	4 " " 126a	4
				2 " " 35	2	2 " " 54	2	2 " " 142c	2
				140 " " 37a	140	4 " " 59	4	1 " " 147b	1
				130 " " 37b	130	2 " " 80c	2	4 " " 188	4
				22 " " 38	22	2 " " 90	2	4 " " 189	4
								2 " " 191	2
								4 " " 192	4
								2 " " 197	2
								2 " " 212	2
								2 " " 214	2
								2 " " 215	2
								4 " " 221	4
								2 " " 222	2
								2 " " 223	2

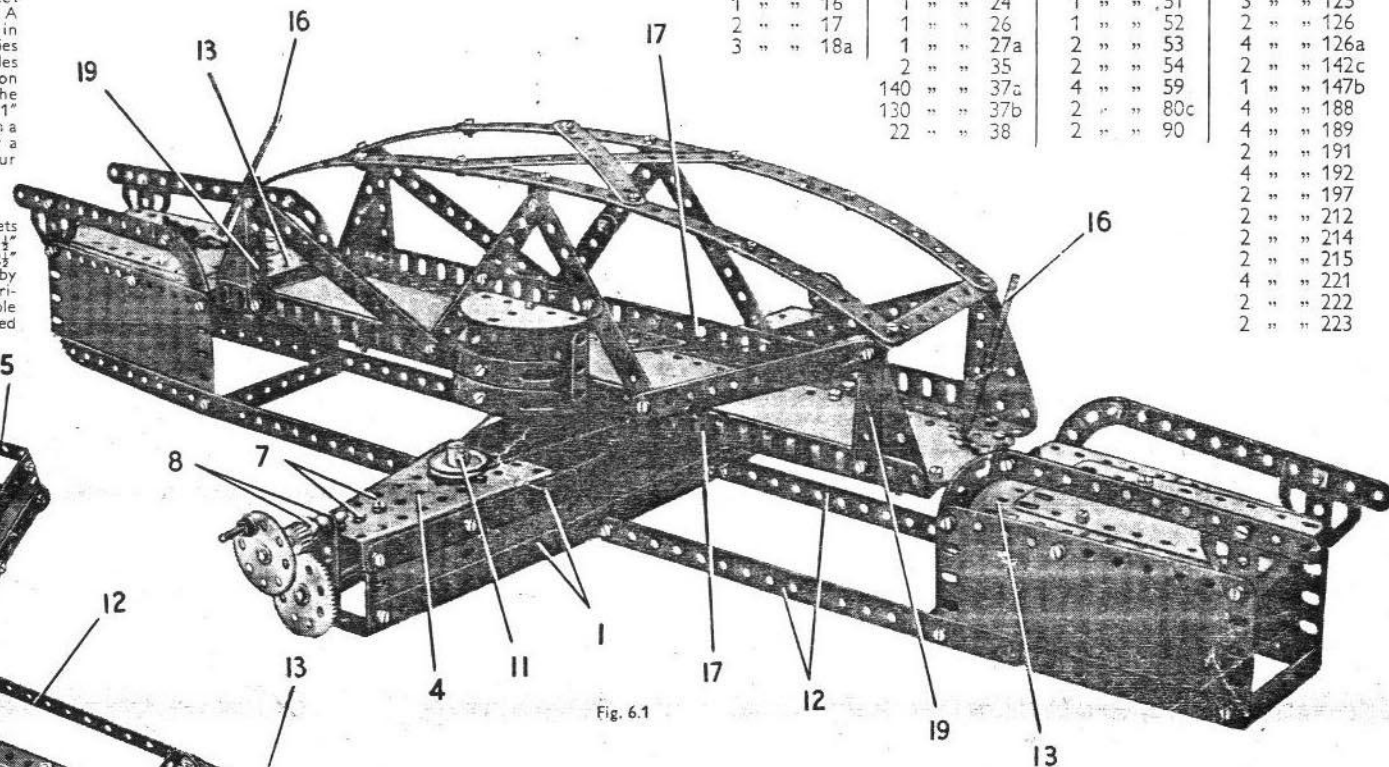

Fig. 6.1

When the bridge is open to road traffic the moving span is supported by rollers on the approaches. The rollers are $\frac{1}{2}''$ loose and $\frac{1}{2}''$ fixed Pulleys (15), each free to turn on a long Bolt held by two nuts in an Angle Bracket bolted to the approach. The traffic barriers are Screwed Rods (16), which are held by nuts in Rod and Strip Connectors fitted to $\frac{1}{4}''$ Rods. These Rods are held by Spring Clips in Double Brackets bolted to the side rails of the approaches.

THE MOVING SPAN

The roadway of the span consists of two built-up girders (17) (Fig. 6.1), joined at each end by a $3\frac{1}{2}''$ Strip (18). The girders are each made from two $12\frac{1}{2}''$ Angle Girders overlapped 17 holes. The roadway is filled in by two $12\frac{1}{2}'' \times 2\frac{1}{2}''$ Strip Plates bolted to the Strips (18) and supported at the centre of the span by Trunnions fixed to the girders (17). The Strip Plates are supported also by Fishplates attached to the girders (17).

The arch girders are each made from two $12\frac{1}{2}''$ Strips overlapped 19 holes, and connected at their ends by Angle Strips to $2\frac{1}{2}''$ Strips (19) and $2\frac{1}{2}'' \times 1\frac{1}{2}''$ Triangular Flexible Plates. The arch is braced by two $5\frac{1}{2}''$ Strips and two built-up $4\frac{1}{2}''$ strips, each made from two $2\frac{1}{2}''$ Strips. The built-up strips are connected to the centre of the arch by Angle Brackets.

The control cabin at the centre of the span is made by bolting a $2\frac{1}{2}'' \times 1\frac{1}{2}''$ Flanged Plate to one of the girders (17). The floor is a Semi-Circular Plate attached to a Double Bracket, and the front consists of two formed Slotted Strips connected by a Fishplate and bolted to an Angle Bracket fixed to the floor. The roof also is a Semi-Circular Plate, and it is connected to the Flanged Plate by a $\frac{1}{2}''$ Reversed Angle Bracket.

A 3" Pulley (20) is attached to the centre of the span by two $\frac{1}{2}''$ Reversed Angle Brackets. The Pulley is arranged with its boss upwards, and a 2" Rod is held in the boss. The Rod is passed through the Pulley (6) and the Flanged Plate (2), and is held in position by a Spring Clip. A belt of Cord is passed round the 3" Pulley (20) and the 1" Pulley (11).

6.2 BEAM BRIDGE

CONSTRUCTION OF THE TOWER

The tower consists of two 12½" Angle Girders (1) (Fig. 6.2), and two 12½" built-up girders (2) bolted to a 5½" x 2½" Flanged Plate (3). The Girders (1) are connected by two 5½" x 1½" Flexible Plates and a 5½" Strip (4), and by a 5½" x 1½" Flexible Plate (5) and a further 5½" Strip. The girders (2) are connected by a 5½" Strip and a 5½" x 2½" Flexible Plate (6) (Fig. 6.2a). A Semi-Circular Plate (7) on each side is fixed in the second hole from the top of each Girder.

THE BRIDGE APPROACHES

Two 2½" x 2½" Triangular Flexible Plates (8) (Fig. 6.2) are used in making one side of the approach at the tower end of the bridge. Two 2½" x 5" Double Angle Strips (9) (Fig. 6.2a) are fixed to the Plate (3) and support further 2½" x 1" Double Angle Strips (10). One half of a Hinged Flat Plate forming the road is bolted to a 5½" Strip fixed to Double Angle Strips (9). The other half of the Hinged Flat Plate is swung downward and is attached to the side of Plate (3).

The roadway of the other approach is connected to the sides by Angle Brackets. The arch is supported by two 2½" Strips (11). The approaches are connected by two built-up strips (12).

THE LIFTING SPAN

The roadway is attached to two 12½" Angle Girders (13) (Figs. 6.2 and 6.2a). The strips (14) are each made from two 5½" Strips. A Fishplate (15) fixed to each of the Girders (13) is lock-nutted to an Angle Bracket bolted to one of the Girders (1).

CONSTRUCTION OF THE BEAM

Each side consists of a 12½" Strip (17) and a strip (16) made from a 12½" and a 5½" Strip overlapped five holes. The sides are connected by a Double Angle Strip (18) and a 2½" x 1½" Flanged Plate (19). A Bush Wheel (21) bolted to the beam is fixed on a rod (20) mounted in the Semi-Circular Plates (7).

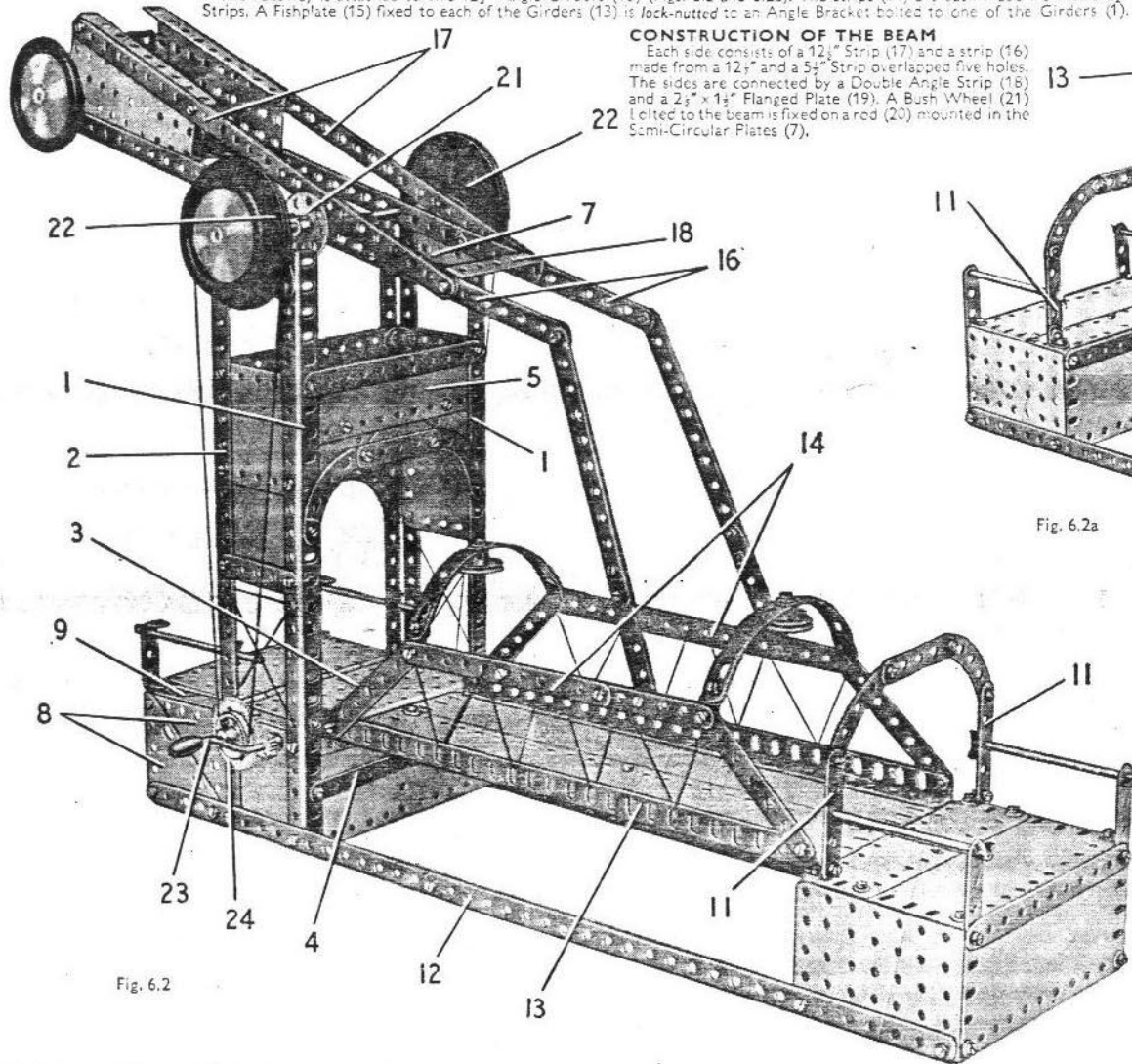

Fig. 6.2

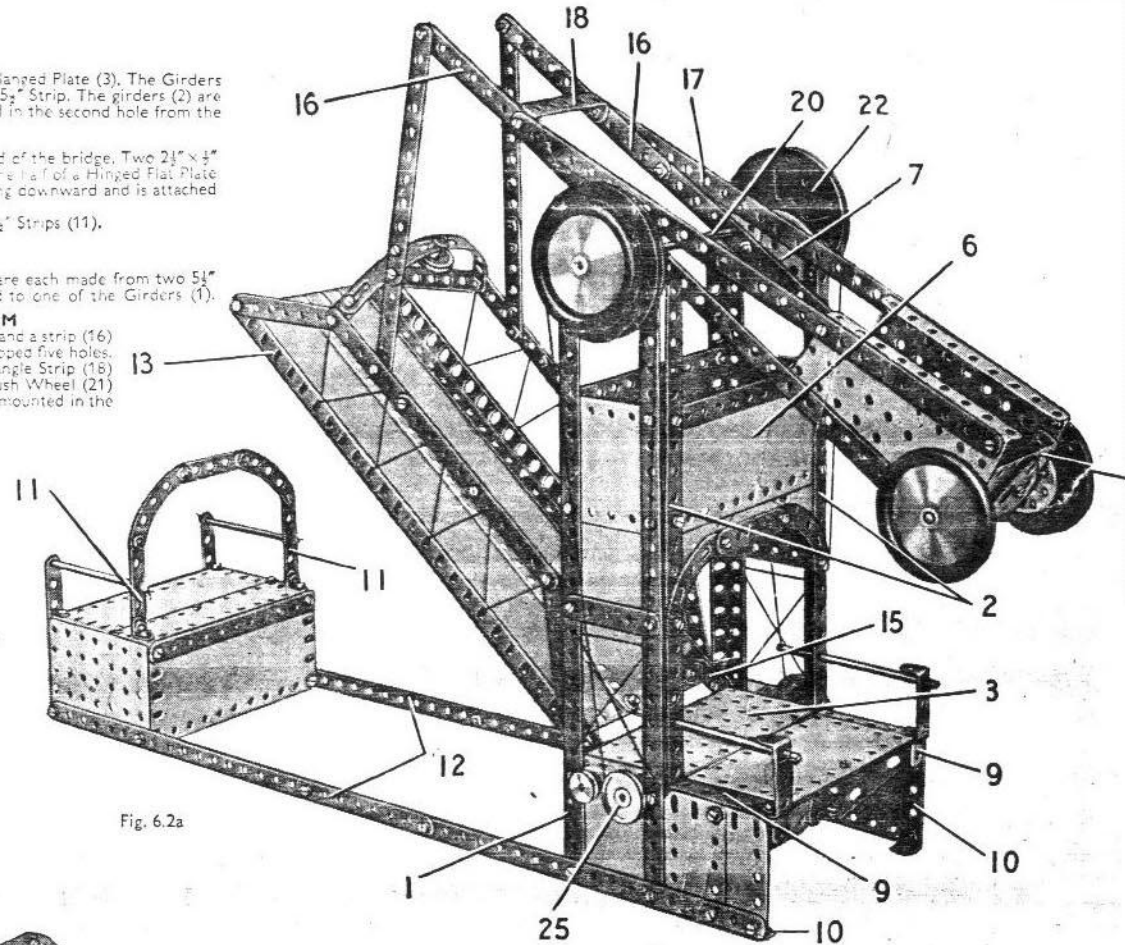

Fig. 6.2a

Rod (20) is made from two 4" Rods joined by a Rod Connector, and carries two 3" Pulleys (22).

THE OPERATING MECHANISM

A Crank Handle (23), joined to a 2" Rod by a Rod Connector, carries a ½" Pinion that drives a Gear (24) on a 6½" Rod. A Pulley (25) on each side is connected by Cord to one of the Pulleys (22).

Parts Required				
12 of No. 1	2 of No. 15b	1 of No. 26	2 of No. 53	4 of No. 188
14 " " 2	4 " " 16	1 " " 27a	2 " " 54	4 " " 189
4 " " 3	1 " " 17	8 " " 35	2 " " 90	6 " " 190
2 " " 4	2 " " 19b	139 " " 37a	4 " " 90a	1 " " 191
9 " " 5	1 " " 19h	127 " " 37b	2 " " 111	4 " " 192
4 " " 8	4 " " 22	19 " " 38	1 " " 111a	2 " " 197
2 " " 10	2 " " 22a	1 " " 40	6 " " 111c	1 " " 198
12 " " 12	1 " " 23a	2 " " 48	1 " " 115	2 " " 213
4 " " 12c	1 " " 24	5 " " 48a	4 " " 126a	2 " " 214
1 " " 14	2 " " 24a	1 " " 51	1 " " 147b	4 " " 215
1 " " 15a	2 " " 24c	1 " " 52	4 " " 187	4 " " 221
				2 " " 223

6.3 WINDMILL

Fig. 6.3

THE CIRCULAR BASE

The circular base is made from two $12\frac{1}{2}'' \times 2\frac{1}{2}''$ Strip Plates. These are curved and are bolted together so that their ends overlap each other by seven holes. The lower edges of the Plates are fitted with four curved $5\frac{1}{2}''$ Strips. A $5\frac{1}{2}'' \times 2\frac{1}{2}''$ Flanged Plate (1) is attached to the top of the base by two Fishplates.

THE WINDMILL BODY

The body is hexagonal or six-sided, but only five of the sides are actually filled in. The sixth side is left open at the rear of the windmill to give access to the *Magic Clockwork Motor* that drives the sails.

Three of the sides are each formed by a $5\frac{1}{2}'' \times 2\frac{1}{2}''$ Flexible Plate extended at its lower end by a $2\frac{1}{2}'' \times 2\frac{1}{2}''$ Flexible Plate. Two built-up strips (2), made from $5\frac{1}{2}''$ and $2\frac{1}{2}''$ Strips, are bolted to the top corners of the $5\frac{1}{2}'' \times 2\frac{1}{2}''$ Flexible Plate. The fourth side consists of two $2\frac{1}{2}'' \times 2\frac{1}{2}''$ Flexible Plates overlapped three holes, and these also are edged by built-up strips (2) as previously described. The lower ends of the strips (2) of two of the sides are bolted to $3\frac{1}{2}'' \times \frac{1}{2}''$ Double Angle Strips (3) fixed to the $2\frac{1}{2}'' \times 2\frac{1}{2}''$ Flexible Plates. In one of the other sides the strips (2) are attached to a $3\frac{1}{2}''$ Strip, and in the fourth side they are connected by a built-up strip (4), made from two $2\frac{1}{2}''$ Strips overlapped three holes. The four sides described above are connected together in pairs by the lugs of the Double Angle Strips (3), and the pairs are attached to the base by Fishplates. The pairs of sides are opposite to each other, alongside the longer edges of the Flanged Plate (1).

The fifth side is a $5\frac{1}{2}'' \times 2\frac{1}{2}''$ Flexible Plate and this also is edged by two built-up strips (2). The lower ends of these strips are bolted to a $3\frac{1}{2}''$ Strip (20) fixed to the front of the Flanged Plate (1). The doorway is formed by two $2\frac{1}{2}'' \times \frac{1}{2}''$ Double Angle Strips (5) bolted to the Strip (20) and connected by a $2\frac{1}{2}''$ Strip attached to their top lugs.

The upper corners of the five sides are connected to each other by Obtuse Angle Brackets, and a $2\frac{1}{2}''$ Strip is bolted at the top of the open side to Obtuse Angle Brackets. One of the Bolts holding the $2\frac{1}{2}''$ Strip to the Obtuse Angle Brackets is indicated at (6) (Fig. 6.3a).

CONSTRUCTION OF THE ROOF

The front and rear gable ends of the roof are similar in construction. Each consists of a $2\frac{1}{2}'' \times 2\frac{1}{2}''$ and two $2\frac{1}{2}'' \times 1\frac{1}{2}''$ Triangular Flexible Plates arranged as shown in Fig. 6.3a, and supported by two $2\frac{1}{2}''$ Stepped Curved Strips (7). A Flat Trunnion (8) is bolted to the front side of the model, and a similar part (9) is attached to the $2\frac{1}{2}''$ Strip held by the Bolts (6).

The roof is a Hinged Flat Plate extended on each side by a $2\frac{1}{2}'' \times 1\frac{1}{2}''$ Flexible Plate, and a $2\frac{1}{2}'' \times 2\frac{1}{2}''$ Flexible Plate. It is attached to Angle Brackets bolted to the gable ends, but it should not be fixed in place until the mechanism is assembled.

THE OPERATING MECHANISM

A *Magic Clockwork Motor* (10) is bolted by its lugs to the Flanged Plate (1), and the Motor Pulley is connected by a Driving Band to a $1''$ Pulley on a $6\frac{1}{2}''$ Rod (11). The Rod is held in position by a Collar at one end and a $\frac{1}{2}''$ Pinion at the other end. The Pinion drives a 57-tooth Gear (12) on a built-up rod (13), made from two $3\frac{1}{2}''$ Rods joined by a Rod Connector. The rod (13) is supported in the top holes of the Flat Trunnions (8) and (9) and is held in position by two Collars.

The Rod (11) is extended at the rear by a $1''$ Rod joined by a Rod Connector. A $\frac{1}{2}''$ Pulley is fixed on the $1''$ Rod, and a $2\frac{1}{2}''$ Driving Band is passed round this Pulley and round a built-up pulley (14). The pulley (14) consists of two $\frac{3}{4}''$ Washers separated by three ordinary Washers. The Washers are held tightly by nuts on a $3''$ Screwed Rod (15), which is supported in $2\frac{1}{2}'' \times \frac{1}{2}''$ Double Angle Strips (16). Each Double Angle Strip is braced by a $2\frac{1}{2}''$ Curved Strip, which is attached to an Angle Bracket fixed to the Strip held by the Bolts (6). The direction vanes are two $3\frac{1}{2}''$ Strips held at right angles on the end of the Screwed Rod (15) by two nuts. A Collar is fitted to the other end of the Screwed Rod.

THE SAILS AND ENTRANCE STEPS

The sails are made by fixing $5\frac{1}{2}'' \times 1\frac{1}{2}''$ Flexible Plates to arms made from two $12\frac{1}{2}''$ Strips bolted at right angles across a Bush Wheel (17). The Bush Wheel is fixed on the rod (13) and a $1''$ Pulley with Rubber Ring is held on the rod in front of the Bush Wheel.

The steps are attached to two $2\frac{1}{2}'' \times 2''$ Triangular Flexible Plates edged by $2\frac{1}{2}'' \times \frac{1}{2}''$ Double Angle Strips (18). The lower corners of the Triangular Flexible Plates are connected to the base by Angle Brackets, and the upper corners are joined by Angle Brackets to a Trunnion (19) bolted to the base. Two of the steps are $1\frac{1}{2}'' \times \frac{1}{2}''$ Double Angle Strips, and two are made from $1\frac{1}{2}''$ Strips attached to Angle Brackets bolted to the Triangular Flexible Plates. The fifth step consists of two $1'' \times 1''$ Angle Brackets joined together to make a built-up $1\frac{1}{2}'' \times 1''$ double angle strip.

Each of the handrails is a $3\frac{1}{2}''$ Rod fitted with a Rod and Strip Connector and a Right-Angle Rod and Strip Connector. The Rod and Strip Connector is fixed to an Angle Bracket bolted to one of the Double Angle Strips (5). The Right-Angle Rod and Strip Connector is attached to a Fishplate that is secured to the Triangular Flexible Plate.

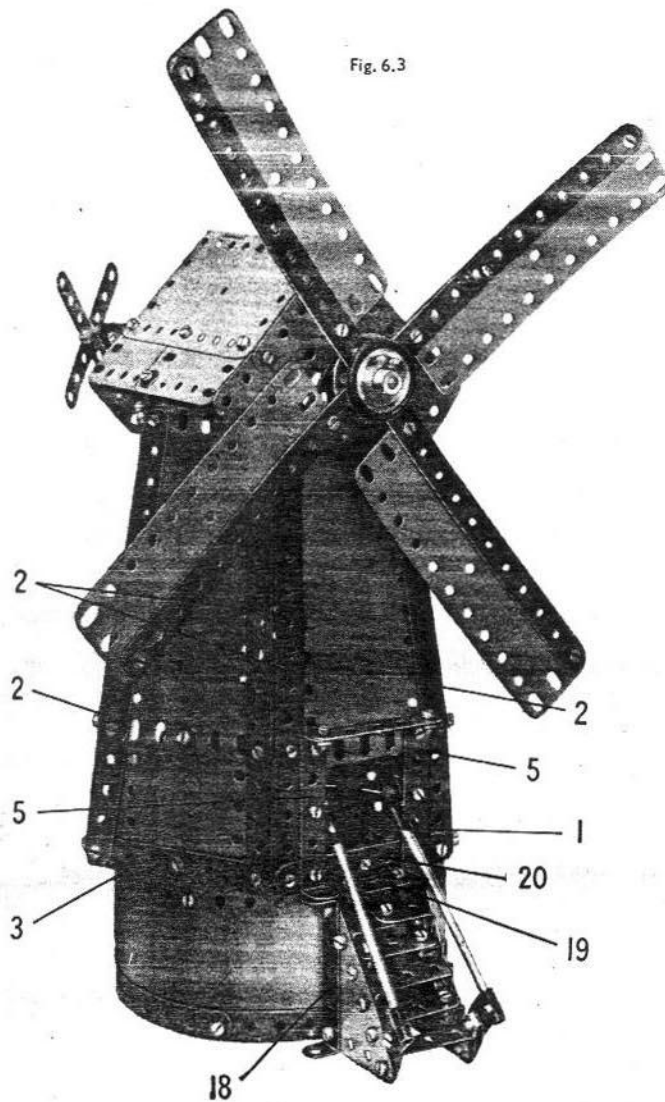
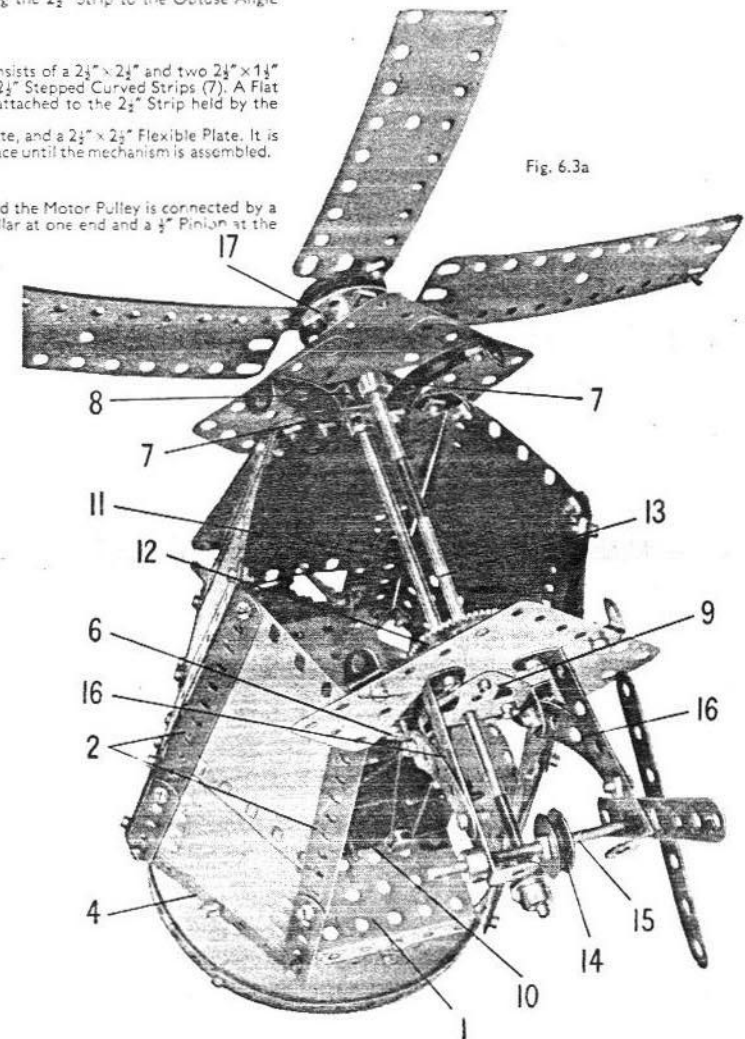

Fig. 6.3a



Parts Required

2 of No. 1	6 of No. 12c	127 of No. 37a	1 of No. 80c	2 of No. 188	2 of No. 213
14 " " 2	1 " " 14	119 " " 37b	2 " " 90	4 " " 189	4 " " 221
4 " " 3	4 " " 16	13 " " 38	4 " " 90a	5 " " 190	2 " " 222
2 " " 4	1 " " 18b	2 " " 38d	3 " " 111c	2 " " 191	2 " " 223
12 " " 5	2 " " 22	2 " " 48	1 " " 126	4 " " 192	
2 " " 6a	1 " " 23a	6 " " 48a	2 " " 126a	2 " " 197	
8 " " 10	1 " " 24	2 " " 48b	1 " " 155	1 " " 198	
16 " " 12	1 " " 26	1 " " 52	1 " " 186	2 " " 212	1 Magic Motor
2 " " 12a	1 " " 27a	4 " " 59	1 " " 186b	2 " " 212a	(Not included in Outfit)

6.4 HIGH FLYER

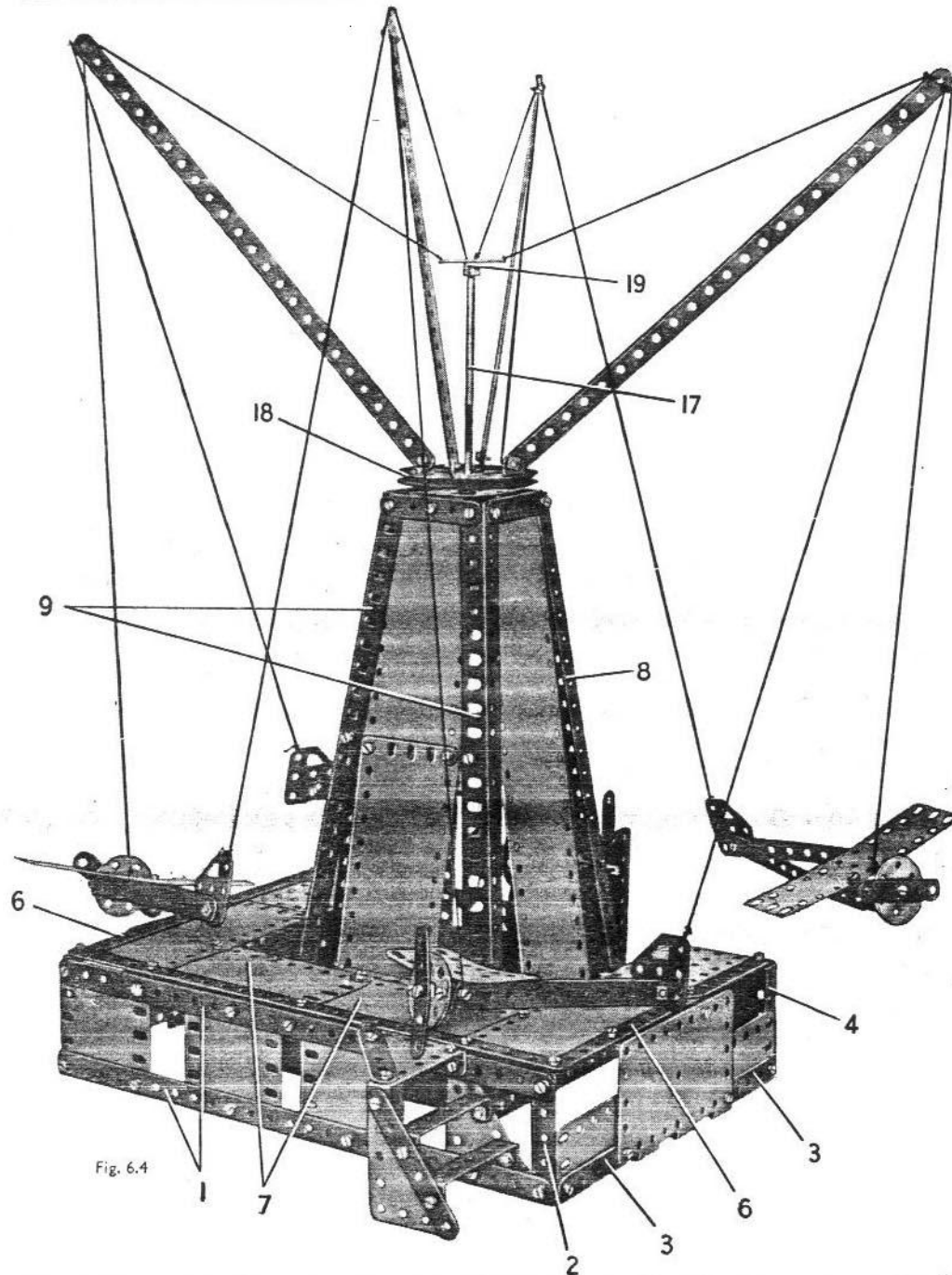

Fig. 6.4

Parts Required

9 of No. 1	1 of No. 26	1 of No. 186a
13 " " 2	1 " " 27a	1 " " 187
4 " " 3	137 " " 37a	4 " " 188
2 " " 4	130 " " 37b	4 " " 189
12 " " 5	25 " " 38	6 " " 190
1 " " 6a	1 " " 40	2 " " 191
4 " " 8	2 " " 48	4 " " 192
2 " " 10	8 " " 48a	2 " " 197
4 " " 11	2 " " 48b	1 " " 198
16 " " 12	1 " " 51	1 " " 213
2 " " 12a	1 " " 52	1 " " 214
1 " " 13	2 " " 53	2 " " 222
3 " " 16	4 " " 59	1 " " 223
2 " " 19b	6 " " 111c	1 No. 1 Clockwork Motor (Not included in Outfit)
2 " " 22	1 " " 125	
1 " " 24	2 " " 126	
2 " " 24a	4 " " 126a	
2 " " 24c	1 " " 155	

ASSEMBLY OF THE BASE

The front of the base consists of two $12\frac{1}{2}$ " Strips (1) bolted to three $2\frac{1}{2}$ " x $2\frac{1}{2}$ " Flexible Plates, and connected at each end by a $2\frac{1}{2}$ " x $\frac{1}{2}$ " Double Angle Strip (2). Each side is made by bolting two $2\frac{1}{2}$ " Strips (3) to one half of a Hinged Flat Plate. One of the Strips (3) is attached to the front of the base by an Angle Bracket, and the other is fixed to a lug of a $3\frac{1}{2}$ " x $\frac{1}{2}$ " Double Angle Strip. The Bolt holding the Double Angle Strip to the Strip secures also a $2\frac{1}{2}$ " x $\frac{1}{2}$ " Double Angle Strip (4), and the $3\frac{1}{2}$ " x $\frac{1}{2}$ " Double Angle Strips are connected by a $12\frac{1}{2}$ " Strip (5) (Fig. 6.4a).

The top of the base is filled in at each side by a $5\frac{1}{2}$ " x $2\frac{1}{2}$ " Flexible Plate and a $3\frac{1}{2}$ " x $2\frac{1}{2}$ " Flanged Plate. These parts are bolted to the lugs of the Double Angle Strips (2) and (4), and they are connected to the half of the Hinged Flat Plate by a Double Bracket. The Plates are edged by a built-up strip (6) made from a $5\frac{1}{2}$ " and a $3\frac{1}{2}$ " Strip.

The top of the base is filled in at the front by two $4\frac{1}{2}$ " x $2\frac{1}{2}$ " Flexible Plates (7), which are strengthened along their edges by $12\frac{1}{2}$ " Strips. The steps are $2\frac{1}{2}$ " x $\frac{1}{2}$ " Double Angle Strips bolted between $2\frac{1}{2}$ " x $2\frac{1}{2}$ " Triangular Flexible Plates, one of which is fixed to the Strips (1). A $2\frac{1}{2}$ " x $2\frac{1}{2}$ " Triangular Flexible Plate at the top of the steps makes a loading platform.

CONSTRUCTION OF THE TOWER

The tower consists of four $12\frac{1}{2}$ " Angle Girders (8) and (9). The Girders (8) are fixed to the lugs of the $3\frac{1}{2}$ " x $\frac{1}{2}$ " Double Angle Strips bolted to the $12\frac{1}{2}$ " Strip (5). The Girders (9) are attached to $5\frac{1}{2}$ " Strips bolted to the Girders (8), and they are connected together by a further $5\frac{1}{2}$ " Strip. The upper ends of the Girders (8) and (9) are connected by $2\frac{1}{2}$ " Strips, and a $2\frac{1}{2}$ " x $1\frac{1}{2}$ " Flanged Plate is bolted to two of these Strips. A $5\frac{1}{2}$ " x $2\frac{1}{2}$ " Flanged Plate (10) is fixed to the lower end of the tower. The sides of the tower are $12\frac{1}{2}$ " x $2\frac{1}{2}$ " Strip Plates, and the front is filled in by a $2\frac{1}{2}$ " x $2\frac{1}{2}$ " and two $5\frac{1}{2}$ " x $2\frac{1}{2}$ " Flexible Plates. The front is connected to the Plates (7) of the base by a Semi-Circular Plate, which is attached to the $2\frac{1}{2}$ " x $2\frac{1}{2}$ " Flexible Plate by Double Brackets.

THE OPERATING MECHANISM

A No. 1 Clockwork Motor is attached to the base by a 1 " x 1 " Angle Bracket (11) and a $\frac{1}{2}$ " x $\frac{1}{2}$ " Angle Bracket. A second 1 " x 1 " Angle Bracket connects the Motor to a $1\frac{1}{2}$ " Strip fixed to one of the Angle Girders (8). A $\frac{1}{2}$ " Pinion on the Motor driving shaft is meshed with a 57-tooth Gear on a Rod (12) mounted in the Motor side-plates. A 1 " Pulley on the Rod (12) drives a 3 " Pulley (13) through a Driving Band.

The Pulley (13) is fixed on a $3\frac{1}{2}$ " Rod supported in two $3\frac{1}{2}$ " Strips, one of which is seen at (14). These Strips are bolted to Trunnions fixed to the Flanged Plate (10), and they are connected at their upper ends by a $2\frac{1}{2}$ " x $\frac{1}{2}$ " Double Angle Strip. A 1 " Pulley fitted with a Rubber Ring (15) is fixed on the $3\frac{1}{2}$ " Rod, and the Rubber Ring presses against the rim of a Road Wheel (16) on the main driving shaft (17). This shaft consists of an $11\frac{1}{2}$ " and a $3\frac{1}{2}$ " Rod joined by a Rod Connector, and it is mounted in the Flanged Plate at the top of the tower and in the Double Angle Strip bolted to the Strips (14). A 3 " Pulley (18) is fixed on the shaft (17) and four $12\frac{1}{2}$ " Strips are attached to the Pulley by Angle Brackets. The Strips are connected by Cord to a Bush Wheel (19) at the top of the shaft (17).

DETAILS OF THE AEROPLANES

The fuselage of each aeroplane consists of two $5\frac{1}{2}$ " Strips, bolted one on each side of a Flat Trunnion that forms the tail. In two of the aeroplanes the $5\frac{1}{2}$ " Strips are connected by Angle Brackets to Wheel Discs, but in the other two the Strips are bolted to $1\frac{1}{2}$ " x $\frac{1}{2}$ " Double Angle Strips, to each of which a Wheel Disc is attached. The propellers are $2\frac{1}{2}$ " Strips free to turn on $\frac{1}{8}$ " Bolts, which are held by nuts in the Wheel Discs. The aeroplanes are suspended by Cord as shown.

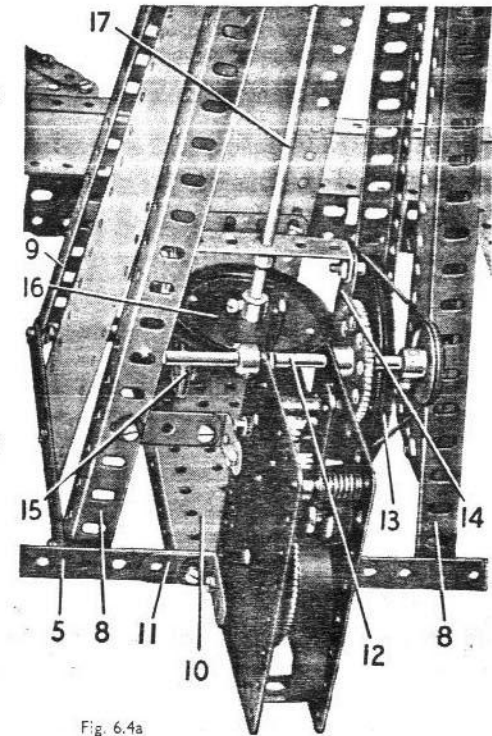

Fig. 6.4a

6.5 POWER PRESS

THE PRESS BED

The top of the bed is a $5\frac{1}{2}'' \times 2\frac{1}{2}''$ Flanged Plate (1) (Figs. 6.5 and 6.5a); the front is a $5\frac{1}{2}'' \times 2\frac{1}{2}''$ Flexible Plate. Each side is a $2\frac{1}{2}'' \times 2\frac{1}{2}''$ Flexible Plate bolted to the Flanged Plate and fixed to a $2\frac{1}{2}'' \times \frac{1}{2}''$ Double Angle Strip attached to the front by Bolt (2). The rear lugs of these Double Angle Strips are connected by a $5\frac{1}{2}''$ Strip, and a $3\frac{1}{2}'' \times 2\frac{1}{2}''$ Flanged Plate is fixed to the centre of this Strip and to the Flanged Plate (1). A No. 1 Clockwork Motor is bolted to a $5\frac{1}{2}''$ Strip (3) as shown (Fig. 6.5).

CONSTRUCTION OF THE COLUMN

The side of the column seen in Fig. 6.5a consists of two $5\frac{1}{2}'' \times 1\frac{1}{2}''$ Flexible Plates (4) overlapped nine holes and edged by two $5\frac{1}{2}''$ Strips (5). The upper part is made from two $2\frac{1}{2}'' \times 2\frac{1}{2}''$ Flexible Plates (6) bolted to a $5\frac{1}{2}''$ Strip (7), a $2\frac{1}{2}''$ Strip, a $5\frac{1}{2}''$ Strip (8), a $2\frac{1}{2}''$ Curved Strip (9) and a Fishplate. A $3''$ Strip (10) is bolted across the side, and a Flat Trunnion (11) is bolted at the lower end of the side.

The side seen in Fig. 6.5 is similar to the other except that one of the Strips (5) is omitted. The two sides are bolted to the flanges of the $3\frac{1}{2}'' \times 2\frac{1}{2}''$ Flanged Plate at the back of the press bed. The Clockwork Motor is connected to one side by a $\frac{3}{8}''$ Bolt (12) but is spaced by a Spring Clip on the Bolt.

The lower part of the back of the column is filled in by a $3\frac{1}{2}'' \times 2\frac{1}{2}''$ Flanged Plate with two $4\frac{1}{2}'' \times 2\frac{1}{2}''$ Flexible Plates (13) overlapped lengthways fixed to it. The Flexible Plates are secured to Angle Brackets (14). The Bolts connecting the $4\frac{1}{2}'' \times 2\frac{1}{2}''$ Flexible Plates to the Angle Brackets fix also two $5\frac{1}{2}'' \times 2\frac{1}{2}''$ Flexible Plates. These pass over a $3\frac{1}{2}'' \times \frac{1}{2}''$ Double Angle Strip held by the Bolts (15), and are connected to the sides by Angle Brackets held by Bolts (16) (Fig. 6.5a).

Two $1\frac{1}{2}''$ radius Curved Plates and two $2\frac{1}{2}'' \times 1\frac{1}{2}''$ Flexible Plates complete the column. These are secured to the Angle Brackets held by the Bolts (16) and to a $3\frac{1}{2}'' \times \frac{1}{2}''$ Double Angle Strip fixed between the Strips (7).

THE RAM AND OPERATING MECHANISM

The ram is seen separately in Fig. 6.5b. Its front is a $2\frac{1}{2}'' \times 1\frac{1}{2}''$ Flanged Plate fitted with two Trunnions (17) and a Bush Wheel (18). The sides are $2\frac{1}{2}'' \times 1\frac{1}{2}''$ Flexible Plates bolted to two $1\frac{1}{2}'' \times \frac{1}{2}''$ Double Angle Strips. A $1'' \times 1''$ Angle Bracket (19) is attached to each side and a $2\frac{1}{2}''$ Strip is bolted to this Angle Bracket and also to a $\frac{3}{8}'' \times \frac{1}{2}''$ Angle Bracket. A Fishplate (20) is secured to each $2\frac{1}{2}''$ Strip. The punch tool is a Rod (21).

Angle Brackets (19) and Fishplates (20) slide between two $5\frac{1}{2}''$ Strips (22) on each side (Figs. 6.5 and 6.5a). These Strips are spaced apart by Washers on $\frac{3}{8}''$ Bolts fixed in Angle Brackets secured to the column.

The crank that operates the ram consists of two $1''$ Pulleys (23), each fitted with an Angle Bracket held tightly by a nut on a Bolt screwed into the boss of the Pulley. A Bolt (24) is passed through each Angle Bracket and is fitted with a nut. The Bolt is then screwed into a Collar (25) until it grips a $1\frac{1}{2}''$ Rod. The nut is then tightened against the Collar. The $1\frac{1}{2}''$ Rod is held in a Collar (26) (Fig. 6.5) that pivots on bolts passed through the Trunnions (17).

One of the Pulleys (23) is fixed on a $2''$ Rod supported in one of the Strips (7), in a $\frac{1}{2}''$ Reversed Angle Bracket bolted to the Strip inside the column, and in a Double Bent Strip (27). The other Pulley (23) is fixed on a $3\frac{1}{2}''$ Rod supported in one of the Strips (7), in a Wheel Disc (28) bolted to the Strip and in a $\frac{1}{2}''$ Reversed Angle Bracket (29). The Rod carries two $3''$ Pulleys, one of which is connected by Cord to a $1''$ Pulley (30) on a $2''$ Rod. A 57-tooth Gear on this Rod is driven by a $\frac{1}{2}''$ Pinion.

Two $2\frac{1}{2}'' \times \frac{1}{2}''$ Double Angle Strips (31) are fixed to the ends of two $1\frac{1}{2}''$ Strips. A Wheel Disc is attached to this Rod by $\frac{1}{2}''$ Bolts between two of the Double Angle Strips (31) and a further $2\frac{1}{2}'' \times \frac{1}{2}''$ Double Angle Strip (32) is supported by Fishplates. The $\frac{1}{2}''$ Bolts are held by nuts in the Flanged Plate (1).

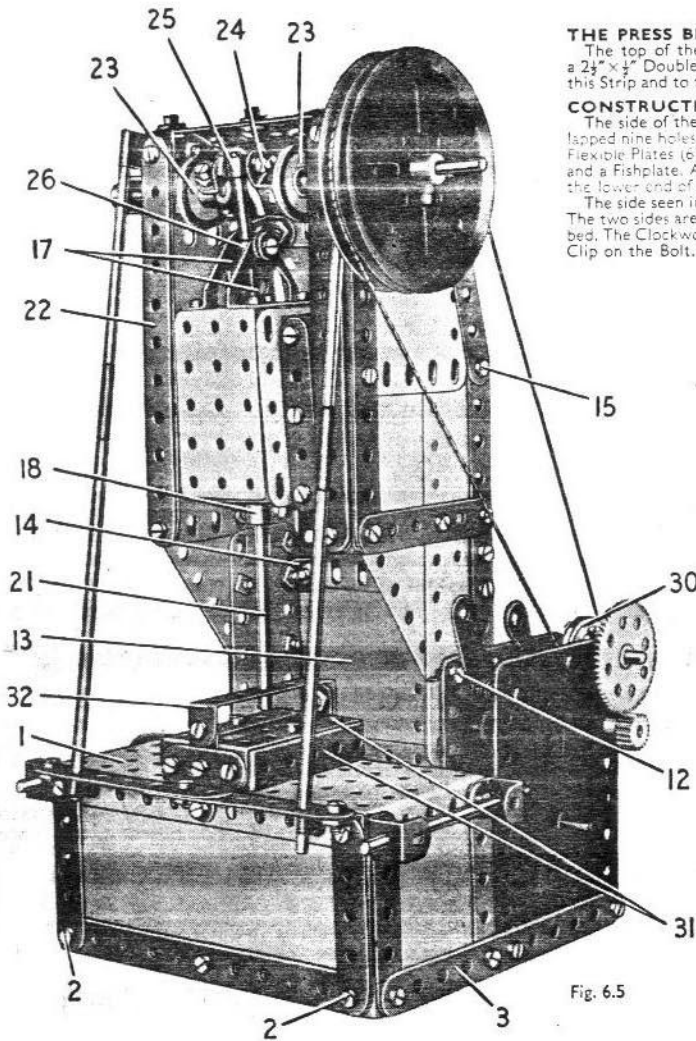

Fig. 6.5

Parts Required

14 of No. 2	4 of No. 16	104 of No. 37b	2 of No. 90	2 of No. 200
4 " " 3	2 " " 17	24 " " 38	2 " " 111	2 " " 212a
2 " " 4	1 " " 18a	1 " " 40	5 " " 111c	2 " " 213
11 " " 5	2 " " 19b	1 " " 45	2 " " 125	2 " " 222
2 " " 6a	3 " " 22	2 " " 48	2 " " 126	
6 " " 10	1 " " 24	7 " " 48a	1 " " 126a	
4 " " 11	2 " " 24a	2 " " 48b	4 " " 158	
15 " " 12	1 " " 26	1 " " 51	4 " " 189	
2 " " 12a	1 " " 27a	1 " " 52	6 " " 190	
2 " " 15	5 " " 35	2 " " 53	2 " " 191	
2 " " 15b	111 " " 37a	4 " " 59	3 " " 192	

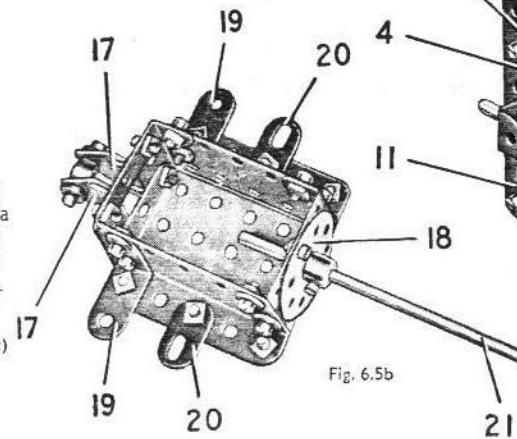

Fig. 6.5b

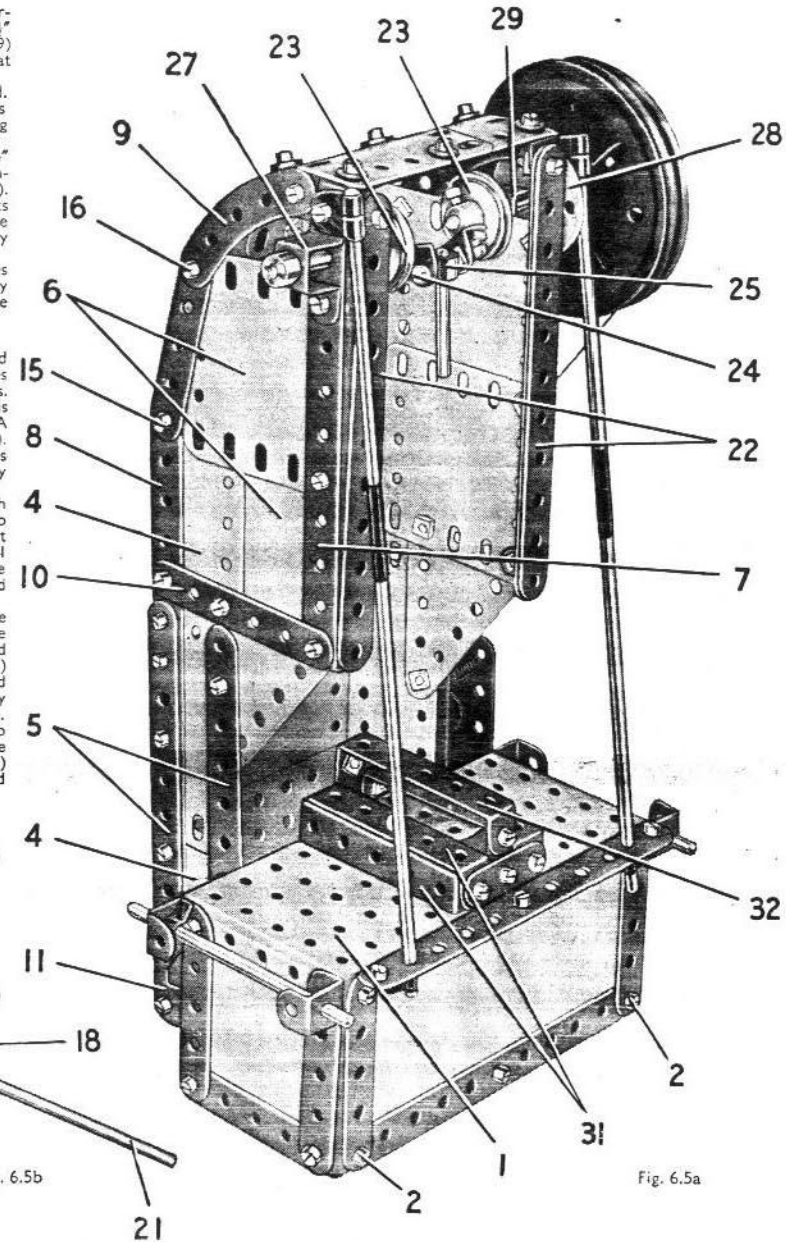

Fig. 6.5a

6.6 NAVAL FRIGATE

CONSTRUCTION OF THE HULL

Each side of the hull consists of a $2\frac{1}{2}'' \times 1\frac{1}{4}''$ Triangular Flexible Plate (1), a $12\frac{1}{2}'' \times 2\frac{1}{4}''$ Strip Plate (2), a $5\frac{1}{2}'' \times 2\frac{1}{4}''$ Flexible Plate (3) and two $5\frac{1}{2}'' \times 1\frac{1}{4}''$ Flexible Plates (4). The Plates (1), (2) and (3) are edged by two $12\frac{1}{2}''$ Strips (5) overlapped 13 holes. The built-up strip thus formed is bolted direct to the rear corners of the Plate (3), and is clamped to the top edge of the Plate (2) by a Flat Trunnion (6) (Fig. 6.6a) bolted to the strip. This construction is used to give a sloping edge to the side of the hull. The Plates (4) are edged by a $12\frac{1}{2}''$ Strip (7), and a $2\frac{1}{2}'' \times 2''$ Triangular Flexible Plate (8) is placed at the join between the Plates (4) and (3). The sides are strengthened by $12\frac{1}{2}''$ Angle Girders (9) (Fig. 6.6a) bolted along the upper and lower edges of the Plates (4).

The sides are connected at the bow by Angle Brackets attached to the Strips (5) and the Plates (1), and at the centre by one half of a Hinged Flat Plate (10) (Fig. 6.6a) fixed to the upper pair of the Angle Girders (9). The stern is made by bending a $5\frac{1}{2}''$ Strip (11) and bolting it to the ends of the Strips (7). A second curved $5\frac{1}{2}''$ Strip is connected to the strip (11) by Fishplates, and two $2\frac{1}{2}''$ Strips (12) are arranged as shown on each side.

ASSEMBLY OF THE FOREDECK

The foredeck is plated by a Flanged Sector Plate (13) (Fig. 6.6a), a $4\frac{1}{2}'' \times 2\frac{1}{4}''$ Flexible Plate (14) and a $2\frac{1}{2}'' \times 2\frac{1}{4}''$ Flexible Plate (15). These parts are bolted to a central $12\frac{1}{2}''$ Strip (16), which is fixed to two $2\frac{1}{2}''$ Strips (17) attached to the strips (5) by Angle Brackets. The edges of the deck are filled in at each side by two $5\frac{1}{2}''$ Strips (18) held by the same Bolt that holds the Strip (17), and by a $12\frac{1}{2}''$ Strip (19). The Strips (19) are supported at the front by Angle Brackets bolted to the Strips (5), and their rear ends are fixed to the other half of the Hinged Flat Plate, indicated at (20), which is attached to the Plates (3) by Angle Brackets. Each of the Strips (19) is extended towards the bow by a $3''$ Strip (21), and a $3\frac{1}{2}''$ Strip (22). The front ends of the Strips (22) are bolted together. A storm shield is formed in the bows by two $3\frac{1}{2}''$ Strips bolted to a $1'' \times 1''$ Angle Bracket, which is fixed to the Flanged Sector Plate (13) by a $\frac{1}{2}'' \times \frac{1}{2}''$ Angle Bracket.

THE AFT DECK

The edges of the deck at the stern are provided by a $5\frac{1}{2}''$ Strip (23) and a $12\frac{1}{2}''$ Strip (24) on each side. These Strips are attached to the ends of the Strips (7) by Angle Brackets, the bolts securing also two $2\frac{1}{2}''$ Stepped Curved Strips (25). The Strips (23) are bolted to the upper pair of the Angle Girders (9), and Strips (24) are supported by the half of the Hinged Flat Plate marked (10). A $12\frac{1}{2}''$ Strip is arranged between the Curved Strips (25) and the Plate (10), and this supports a $5\frac{1}{2}'' \times 2\frac{1}{4}''$ Flexible Plate (26). A $5\frac{1}{2}'' \times 2\frac{1}{4}''$ Flanged Plate is fitted with a Semi-Circular Plate (27) on each side, and the latter are fixed to $\frac{1}{2}''$ Reversed Angle Brackets bolted to the Girders (9). The Semi-Circular Plates are edged by Formed Slotted Strips attached to Double Brackets. A Cylinder is bolted to the flange at one end of the Flanged Plate, and two $2\frac{1}{2}''$ Strips are arranged

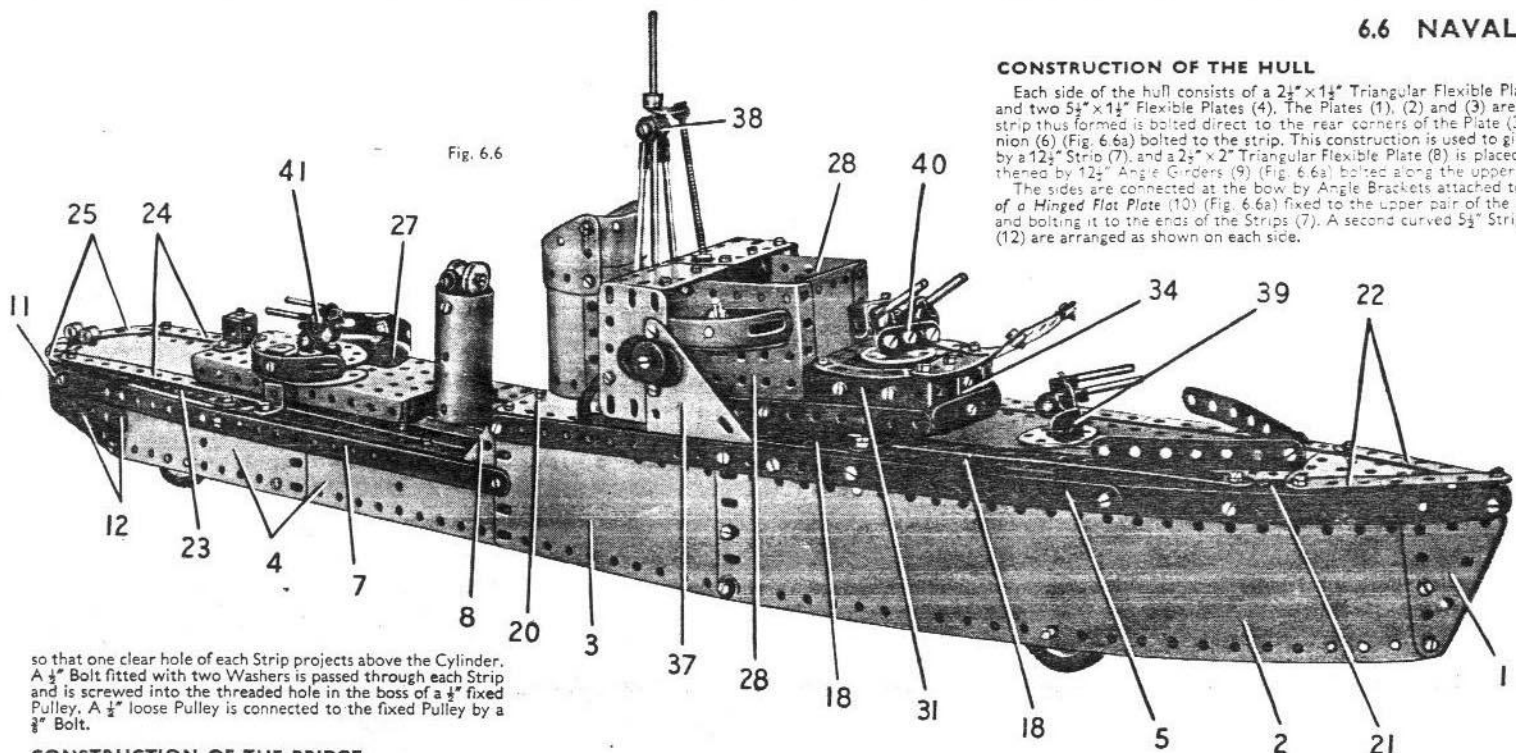

so that one clear hole of each Strip projects above the Cylinder. A $\frac{1}{2}''$ Bolt fitted with two Washers is passed through each Strip and is screwed into the threaded hole in the boss of a $\frac{1}{2}''$ fixed Pulley. A $\frac{1}{2}''$ loose Pulley is connected to the fixed Pulley by a $\frac{1}{2}''$ Bolt.

CONSTRUCTION OF THE BRIDGE

The bridge and the forward gun platform are assembled as one unit, which is bolted in position when complete. Two $3\frac{1}{2}'' \times 2\frac{1}{2}''$ Flanged Plates (28) (Figs. 6.6 and 6.6b) are connected by a $4\frac{1}{2}'' \times 2\frac{1}{4}''$ Flexible Plate (29) and a $2\frac{1}{2}'' \times 2\frac{1}{2}''$ Flexible Plate (30). A $5\frac{1}{2}''$ Strip is bolted to the lower edge of each Flanged Plate, and extends forward to form part of the gun platform. The upper part of the platform consists of a $2\frac{1}{2}'' \times \frac{1}{2}''$ Double Angle Strip (31) on each side bolted to the Flanged Plates. The Double Angle Strips are connected by a $2\frac{1}{2}'' \times 1\frac{1}{4}''$ Flanged Plate (32) and a $2\frac{1}{2}'' \times \frac{1}{2}''$ Double Angle Strip. A $2\frac{1}{2}''$ Strip (33) is supported by two $2\frac{1}{2}''$ Stepped Curved Strips, and the blast shield at the front of the platform is a $1\frac{1}{2}''$ radius Curved Plate edged by two curved $2\frac{1}{2}''$ Strips. The Bolt holding the Curved Plate to the Flanged Plate (32) secures also a $\frac{1}{2}'' \times \frac{1}{2}''$ Angle Bracket, with a $1'' \times 1''$ Angle Bracket (34) bolted to it.

A $2\frac{1}{2}'' \times \frac{1}{2}''$ Double Angle Strip is bolted between the Flanged Plates (28), and two $2\frac{1}{2}'' \times 1\frac{1}{4}''$ Flexible Plates (35) are fixed to the Double Angle Strip. The Plates (35) are connected to a $2\frac{1}{2}'' \times 1\frac{1}{4}''$ Flexible Plate on each side by a $2\frac{1}{2}'' \times \frac{1}{2}''$ Double Angle Strip (36). A $2\frac{1}{2}'' \times 2\frac{1}{4}''$ Triangular Flexible Plate (37) is attached also to the Double Angle Strip (36), and a Flat Trunnion is bolted to each of the $2\frac{1}{2}'' \times 1\frac{1}{4}''$ Flexible Plates at the sides.

The gun platform at each side of the bridge is formed by a Trunnion bolted to the Flanged Plate (28). The bolts holding the Trunnions in place secure also a $2\frac{1}{2}'' \times \frac{1}{2}''$ Double Angle Strip, and to this a $2\frac{1}{2}'' \times 2\frac{1}{4}''$ Flexible Plate is attached. A $\frac{1}{2}''$ Bolt representing the gun is fixed in an Obtuse Angle Bracket, which pivots on a Bolt held by two nuts at the pointed end of the Trunnion. The same Bolt holds in position a $2\frac{1}{2}''$ Curved Strip. The gun platform is edged as shown by a Formed Slotted Strip.

The complete structure is attached to the hull by bolting the Triangular Flexible Plates (37) to the strips (5), and by fixing the Angle Bracket (34) to the Strips (17).

(Continued on next page)

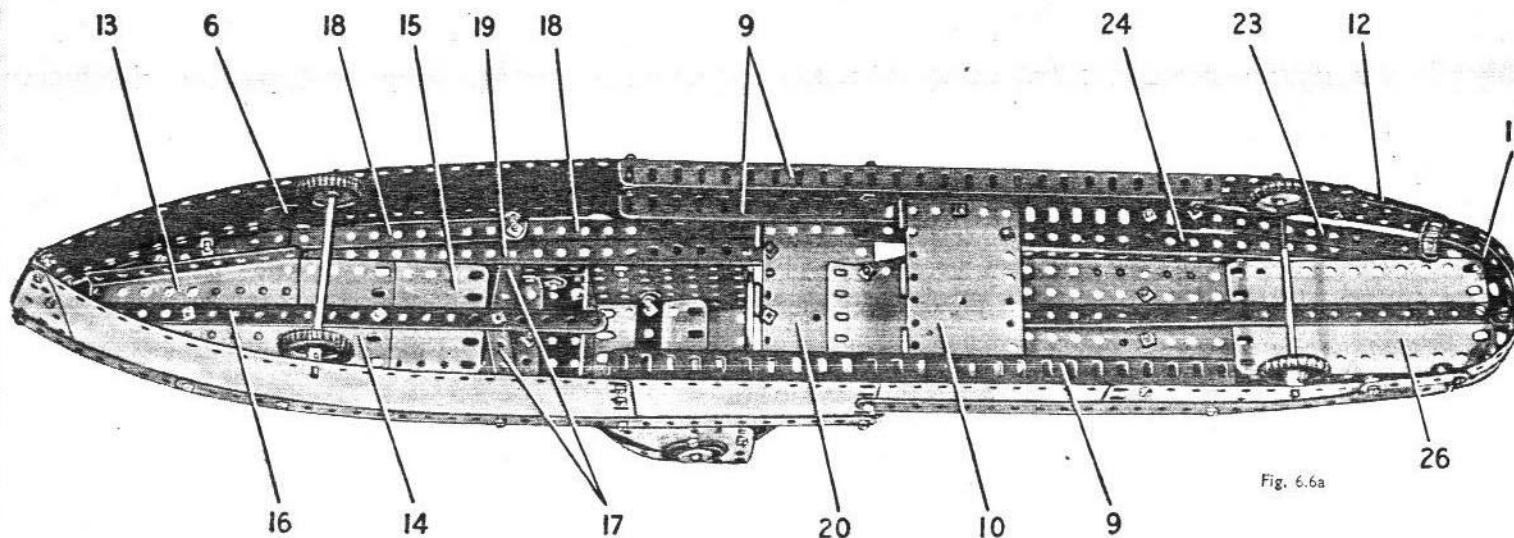

Fig. 6.6a

MODEL 6.6 NAVAL FRIGATE—Continued

THE MAST, FUNNEL AND GUN TURRETS

The centre pole of the mast is a 6½" Rod fitted in a Rod Connector that is supported by a Threaded Pin attached to the Plate (20). The 6½" Rod is fitted with a Collar (38) from which the Grub Screw is removed. A Rod and Strip Connector is attached to each side of the Collar by a Bolt screwed into one of its threaded holes, and a 5" Rod in each Rod and Strip Connector is pressed against the Plate (20). A Fishplate is passed over the 6½" Rod and is held in place on it by a Collar. One end of a 3" Screwed Rod is held by two nuts in the Fishplate and its other end is held similarly in the Plates (35).

The funnel consists of two U-section Curved Plates opened out slightly, two curved 2½" x 2½" Flexible Plates and two 2½" x 1½" Triangular Flexible Plates. The funnel is fitted at its lower end with an Angle Bracket, and this is attached to the Plate (20) by the Threaded Pin that supports the mast.

The gun turret (39) is made by bolting two Fishplates to a 1½" x ½" Double Angle Strip. A 1½" Rod is held by Spring Clips in each Fishplate and an Angle Bracket bolted to the Double Angle Strip pivots on a ½" Bolt lock-nutted in place at the join between the Plates (14) and (15). A Wheel Disc is placed between the turret and the Plates.

The turret (40) consists of a 1½" Strip fitted with an Angle Bracket that is lock-nutted to the Flanged Plate (32) in the same way as the turret (39) already described. The guns are 2" Rods held by Spring Clips in Obtuse Angle Brackets bolted to the 1½" Strip. A 1½" x ½" Double Angle Strip is attached to the 1½" Strip by two Obtuse Angle Brackets bolted together.

The guns in the turret (41) are 1½" Rods held by Spring Clips in Fishplates bolted to a 1½" Strip. An Angle Bracket fixed to the 1½" Strip is lock-nutted to the 5½" x 2½" Flanged Plate.

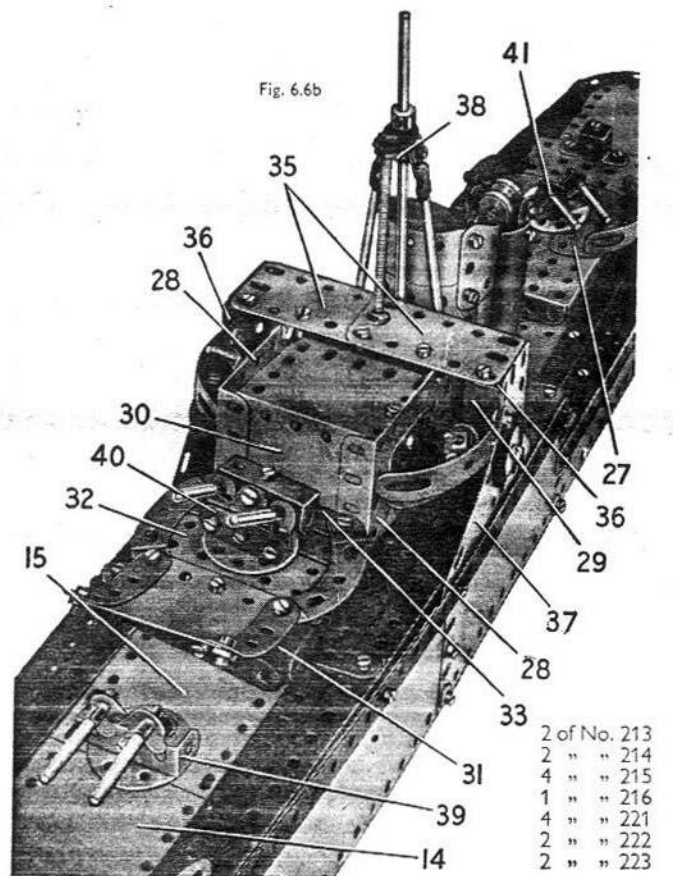

Parts Required

12 of No.	1
10 " "	2
4 " "	3
2 " "	4
12 " "	5
2 " "	6a
4 " "	8
7 " "	10
3 " "	11
16 " "	12
2 " "	12a
6 " "	12c
1 " "	14
2 " "	15
1 " "	15a
1 " "	16
2 " "	17
4 " "	18a
1 " "	18b
4 " "	22
1 " "	23
1 " "	23a
2 " "	24a
1 " "	24c
12 " "	35
140 " "	37a
131 " "	37b
14 " "	38
2 " "	38d
1 " "	45
2 " "	48
7 " "	48a
1 " "	51
1 " "	52
2 " "	53
1 " "	54
4 " "	59
1 " "	80c
2 " "	90
4 " "	90a
2 " "	111
2 " "	111a
6 " "	111c
1 " "	115
2 " "	125
2 " "	126
4 " "	126a
4 " "	142c
1 " "	147b
2 " "	155
4 " "	188
4 " "	189
6 " "	190
2 " "	191
3 " "	192
2 " "	197
1 " "	198
1 " "	199
2 " "	200
2 " "	222
2 " "	212
2 of No.	213
2 " "	214
4 " "	215
1 " "	216
4 " "	221
2 " "	222
2 " "	223

6.7 ARMOURED CAR

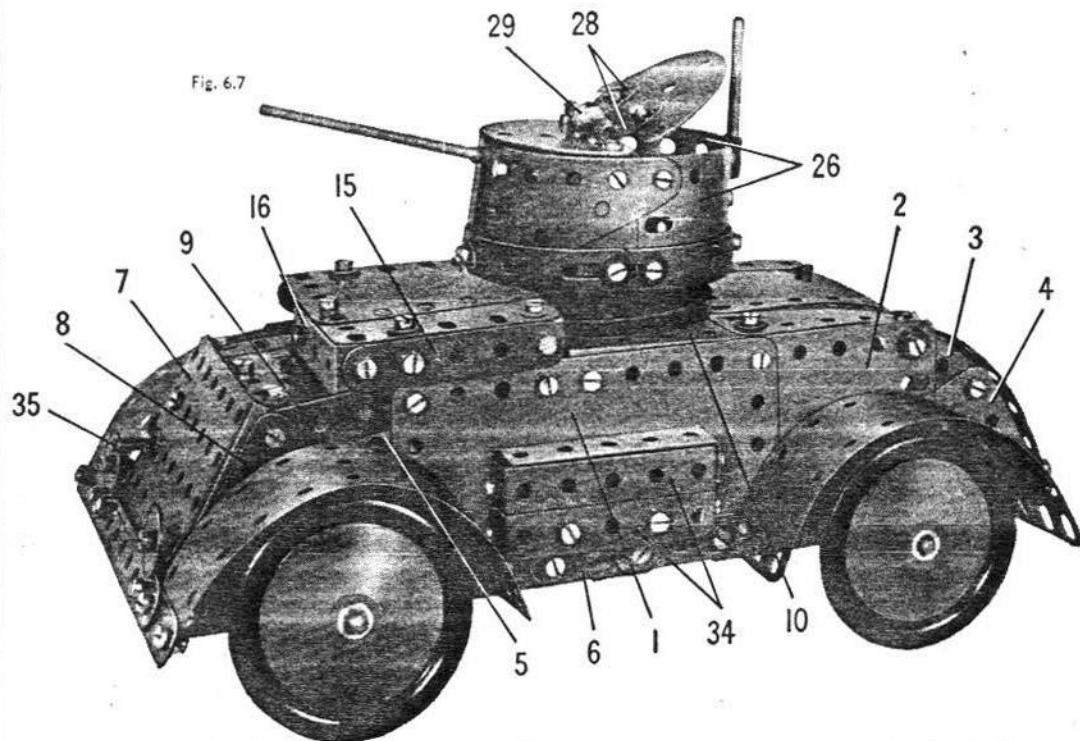

Parts Required

8 of No.	2	1 of No.	14	2 of No.	24a	5 of No.	48a	1 of No.	126	1 of No.	212
2 " "	3	1 " "	16	1 " "	26	2 " "	48b	2 " "	126a	2 " "	212a
6 " "	5	2 " "	17	1 " "	27a	2 " "	53	2 " "	155	2 " "	214
2 " "	6a	4 " "	18a	4 " "	35	4 " "	59	4 " "	187	4 " "	215
6 " "	10	2 " "	19b	115 " "	37a	2 " "	80c	4 " "	188	1 " "	216
4 " "	11	3 " "	22	96 " "	37b	2 " "	111	4 " "	189	4 " "	221
16 " "	12	1 " "	23	25 " "	38	2 " "	111a	4 " "	190	2 " "	222
2 " "	12a	1 " "	23a	2 " "	38d	6 " "	111c	2 " "	192	2 " "	223
3 " "	12c	1 " "	24	1 " "	45	2 " "	125	1 " "	198		

CONSTRUCTION OF THE BODY

Each side of the body consists of one half of a Hinged Flat Plate (1) (Fig. 6.7), a 2½" x 2½" Flexible Plate (2), a Flat Trunnion (3), a 2½" x 2" Triangular Flexible Plate (4) and a 2½" x 2½" Triangular Flexible Plate (5). The 2½" x 2½" Flexible Plate is bolted to the half of the Hinged Flat Plate, and the lower edges of these Plates are strengthened by a built-up strip (6). The strip (6) overhangs the end of the Flexible Plate by three clear holes, and the end of the Plate (1) by five clear holes.

The Triangular Flexible Plate (4) is fixed to one end of the strip (6) and is joined to the Plate (1) by the Flat Trunnion (3). The Triangular Flexible Plate (5) is bolted to the Plate (1), the bolt passing through one of the slotted holes in the Plate (5). This Plate is arranged so that its longest edge is parallel to, and immediately above, the overhanging part of the strip (6).

(Continued on next page)

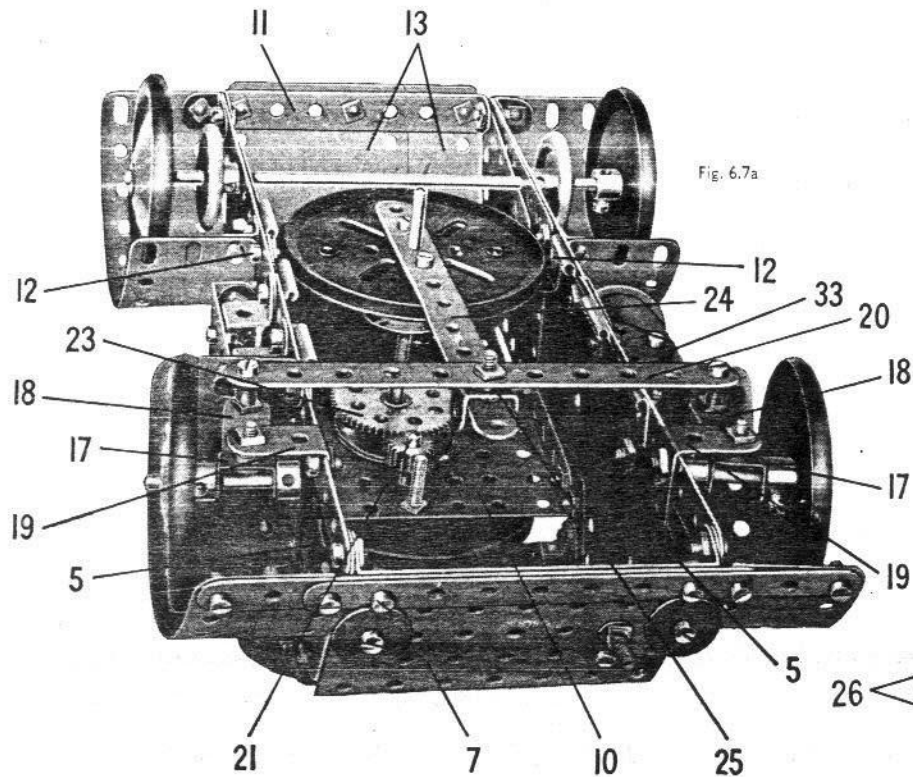

Fig. 6.7a

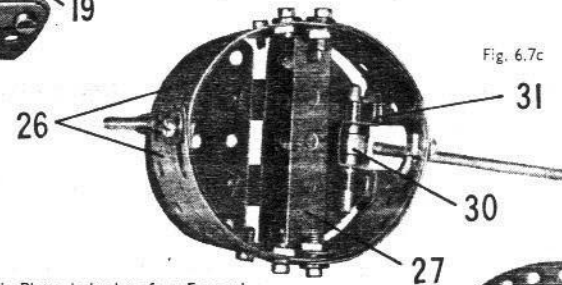

Fig. 6.7c

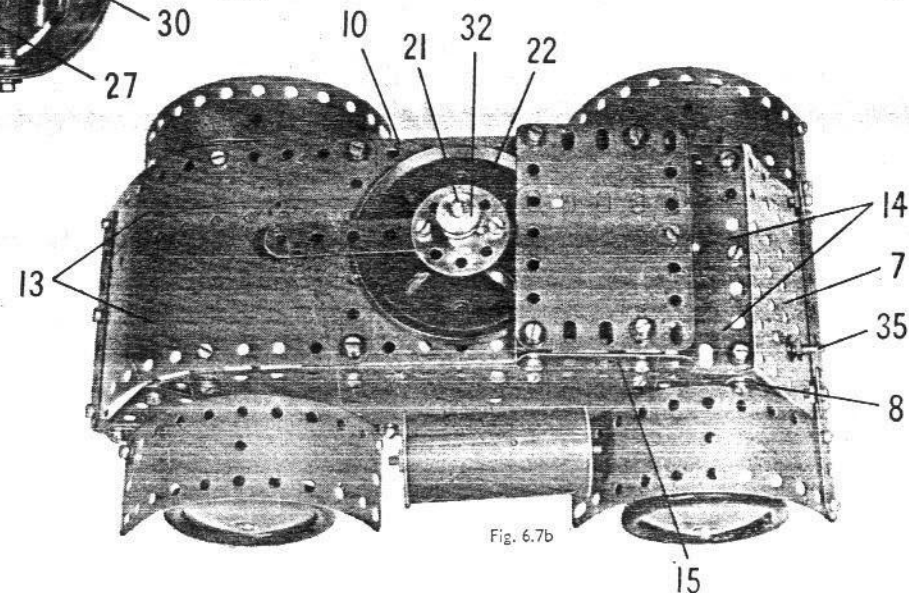

Fig. 6.7b

ASSEMBLY OF THE TURRET

The oval turret consists of two $2\frac{1}{2}'' \times 1\frac{1}{2}''$ Flexible Plates (26) and four $2\frac{1}{2}'' \times 1\frac{1}{2}''$ Triangular Flexible Plates bolted to four Formed Slotted Strips. The Triangular Flexible Plates are arranged as shown in Fig. 6.7 to leave a gap at the front, and a $2\frac{1}{2}'' \times \frac{1}{2}''$ Double Angle Strip (27) is bolted across the turret. The fixed part of the top is a Semi-Circular Plate attached to the turret walls by Angle Brackets. The hinged section of the top is also a Semi-Circular Plate, and to it are bolted two Right-Angle Rod and Strip Connectors (21) (Fig. 6.7). Each of these is spaced from the Semi-Circular Plate by a Washer on the bolt. A Collar (29) is connected to the fixed part of the top by a Bolt fitted with a nut and passed through the Semi-Circular Plate. The Bolt is then screwed into one of the threaded holes of the Collar (29). A $1\frac{1}{2}''$ Rod is pushed through the Right-Angle Rod and Strip Connectors and is gripped in the Collar (29) by its Grub Screw.

The gun is represented by a 3" Screwed Rod fixed by a nut in one of the threaded holes of a Collar (30). The Collar is fixed on a $1\frac{1}{2}''$ Rod that is held by Spring Clips in a Double Bent Strip (31) bolted to the turret. The radio mast is a 2" Rod supported in a Rod and Strip Connector.

The Double Angle Strip (27) is passed over the Rod (21), but is spaced from the Bush Wheel on the Rod by a $\frac{1}{2}''$ loose Pulley (32). The turret is held on Rod (21) by a $\frac{1}{2}''$ fixed Pulley.

CONSTRUCTION OF THE MUDGUARDS AND THE BODY FITTINGS

The rear mudguards are $5\frac{1}{2}'' \times 1\frac{1}{2}''$ Flexible Plates curved and attached to the strips (6) by Angle Brackets. The front mudguards are also curved $5\frac{1}{2}'' \times 1\frac{1}{2}''$ Flexible Plates, and they are connected by Angle Brackets at their rear ends to the strips (6). At the front they are supported by two $5\frac{1}{2}''$ Strips overlapped nine holes and bolted to the Flanged Plate (7).

At one side of the body a Cylinder is bolted to a Trunnion (33) fixed to the strip (6). A Wheel Disc is placed at each end of the Cylinder, and they are held in place by nuts on a 3" Screwed Rod passed through the Cylinder and the Wheel Discs. At the other side of the body two $2\frac{1}{2}'' \times \frac{1}{2}''$ Double Angle Strips (34) are connected together by Fishplates, and a third Double Angle Strip is bolted to them. This assembly is connected to the body by two $\frac{3}{4}''$ Reversed Angle Brackets.

Two $\frac{3}{4}''$ Washers are attached to Obtuse Angle Brackets bolted to the Flanged Plate (7), and a $\frac{3}{4}''$ Bolt (35) (Fig. 6.7) is supported in the Flanged Plate and in an Obtuse Angle Bracket fixed to the Plate inside the body.

MODEL 6.7 ARMoured CAR — Continued

The sides are connected at one end by a $3\frac{1}{2}'' \times 2\frac{1}{2}''$ Flanged Plate (7). A $2\frac{1}{2}''$ Strip (8) is used to edge each flange of the Flanged Plate, and the ends of the Triangular Flexible Plates (5) are clamped between the flanges and the Strips (8). A $2\frac{1}{2}''$ Strip (9) on each side is bolted between the Plate (1) and the Flanged Plate (7).

A second $3\frac{1}{2}'' \times 2\frac{1}{2}''$ Flanged Plate (10) is fixed between the top edges of the Plates (1) as shown in Fig. 6.7a, and the sides of the body are connected also by a $3\frac{1}{2}'' \times \frac{1}{2}''$ Double Angle Strip (11) and a similar Double Angle Strip held by the Bolts (12).

The rear end of the body is filled in by two $5\frac{1}{2}'' \times 2\frac{1}{2}''$ Flexible Plates (13) bolted to the Flanged Plate (10) and to the Double Angle Strip (11). Each Flexible Plate is connected by an Angle Bracket to a corner of one of the Plates (2). At the front two $2\frac{1}{2}'' \times 1\frac{1}{2}''$ Flexible Plates (14) are overlapped three holes and are fixed to Angle Brackets bolted to the ends of the Strips (8) and (9). A $2\frac{1}{2}''$ Strip (15) is attached to each side by Fishplates and two $2\frac{1}{2}'' \times 2\frac{1}{2}''$ Flexible Plates overlapped three holes are fixed to Angle Brackets bolted to the Strips. A $2\frac{1}{2}'' \times \frac{1}{2}''$ Double Angle Strip (16) is fixed to one of the Strips (15) and is connected to the Flexible Plates by an Angle Bracket.

THE WHEELS AND THE STEERING MECHANISM

The rear wheels are fixed on a $6\frac{1}{2}''$ Rod supported in the strips (6) and held in place by 1" Pulleys. Each of the front wheels is fixed on a $1\frac{1}{2}''$ Rod mounted in a Double Bracket (17). Collars are used to hold the Rods in position. A $1\frac{1}{2}''$ Strip (18) (Fig. 6.7a) is placed between the lugs of each Double Bracket and a $\frac{3}{8}''$ Bolt is passed through the two parts. The Bolt is fitted with a Washer and a nut, then is inserted in the end hole of a $1'' \times 1''$ Angle Bracket (19) and a second nut is screwed into place. The two nuts are tightened against the Angle Bracket, leaving the Strip (18) and the Double Bracket free to swivel as a unit on the Bolt. The Strips (18) are connected by a $5\frac{1}{2}''$ Strip (20) attached by $\frac{1}{2}''$ Bolts. Each of these Bolts is passed through the Strip and is fitted with a Spring Clip. The Bolt is then held tightly in one of the Strips (18) by two nuts.

The steering control is a $3\frac{1}{2}''$ Strip bolted to a Bush Wheel fixed to a 2" Rod (21) (Figs. 6.7a and 6.7b). This Rod is supported in the Flanged Plate (10) and in the boss of a 3" Pulley (22) fixed to the Flanged Plate. The Rod carries at its lower end a $\frac{1}{2}''$ Pinion that engages a 57-tooth Gear (23). The Gear is fixed on a $3\frac{1}{2}''$ Rod mounted in the Flanged Plate (10) and in the Double Angle Strip held by the Bolts (12). The bearing for the Rod in the Flanged Plate is strengthened by two Wheel Discs bolted to the Plate, and the Rod carries at its lower end a 3" Pulley fitted with a $5\frac{1}{2}''$ Strip (24) (Fig. 6.7a). The end of the Strip engages between the lugs of a Double Bracket (25) lock-nutted to the Strip (20).

6.8 LEYLAND LORRY

CONSTRUCTION OF THE CHASSIS

The chassis is made by bolting two 12½" Angle Girders to the sides of a 5½" × 2½" Flanged Plate (1) (Fig. 6.8a), so that seven clear holes of the Girders overhang the ends of the Flanged Plate. A 2½" × ½" Double Angle Strip (2) is fixed between the front ends of the Angle Girders, and each Girder is extended by a 12½" Strip (3) overlapped 13 holes. A 2½" × 1½" Flanged Plate is bolted between the ends of the Strips (3). A 12½" Angle Girder (4) at each side is connected to one of the Strips (3) by a Fishplate and a Flat Trunnion (5), and a 2½" × ½" Double Angle Strip (6) is bolted to the Girders (4).

The rear wheels are fixed on a 5" Rod held in the end holes of the Flat Trunnions (5) by 1" Pulleys. The front wheels are mounted on a 5" Rod supported in the centre holes of Flat Trunnions bolted to the front end of the chassis. This Rod also is held in position by 1" Pulleys, which are spaced from the Flat Trunnions by Washers.

A petrol tank at one side of the chassis is represented by two 3½" × ½" Double Angle Strips attached to a ½" Reversed Angle Bracket.

THE DRIVER'S CAB

The floor of the cab is one half of a Hinged Flat Plate connected to the Flanged Plate by a Threaded Pin (7) (Fig. 6.8a). Each side consists of a 2½" × 2½" Flexible Plate (8), a 2½" × 1½" Flexible Plate (9) (Fig. 6.8), and a 2½" × 2" Triangular Flexible Plate, the lower corner of which is indicated at (10). The sides are connected to the floor by Angle Brackets, and each window frame is made from a 3½" Strip (11), a 3" Strip (12), a 2½" Strip and a 2½" × 3" Double Angle Strip (13).

The lower part of the back of the cab is a 4½" × 2½" Flexible Plate connected to the sides by Angle Brackets at its top corners. A 5½" × 1½" Flexible Plate (14) is placed vertically at each side of the 4½" × 2½" Flexible Plate, and the top ends of the Plates (14) are curved slightly into the shape of the roof. The roof consists of two 1½" radius Curved Plates and two opened-out "U"-section Curved Plates bolted together and fixed to the lugs of the Double Angle Strips (13). The centre division of the windscreen is a 1½" Rod gripped in a Rod and Strip Connector.

THE BONNET AND FRONT WINGS

The front of the bonnet is made by joining together two 5½" × 1½" Flexible Plates (15) (Fig. 6.8) so that they overlap two holes at their longer sides. These Plates are fixed to the Double Angle Strip (2) by ½" Bolts. A 5½" Strip representing the bumper is attached also by the ½" Bolts, but is spaced from the Plates (15) by a Spring Clip on each of them.

The top of the bonnet consists of a curved 2½" × 2½" Flexible Plate (16) bolted to the Plates (15) and extended by a further 2½" × 2½" Flexible Plate (17). The Plate (16) is fitted with a 2½" Curved Strip at each side and a Formed Slotted Strip at the centre. A 2½" × 1½" Triangular Flexible Plate (18) edged by a 2½" Strip is attached to each side of the plate (17). The radiator grille is formed by a 2½" and two 3½" Strips arranged as shown.

Each side of the bonnet consists of a 2½" × 1½" Flexible Plate (19) and a Semi-Circular Plate (20). The Plate (19) is bolted to the front end of the Strip (12) and the side is connected to the top of the bonnet by two Obtuse Angle Brackets.

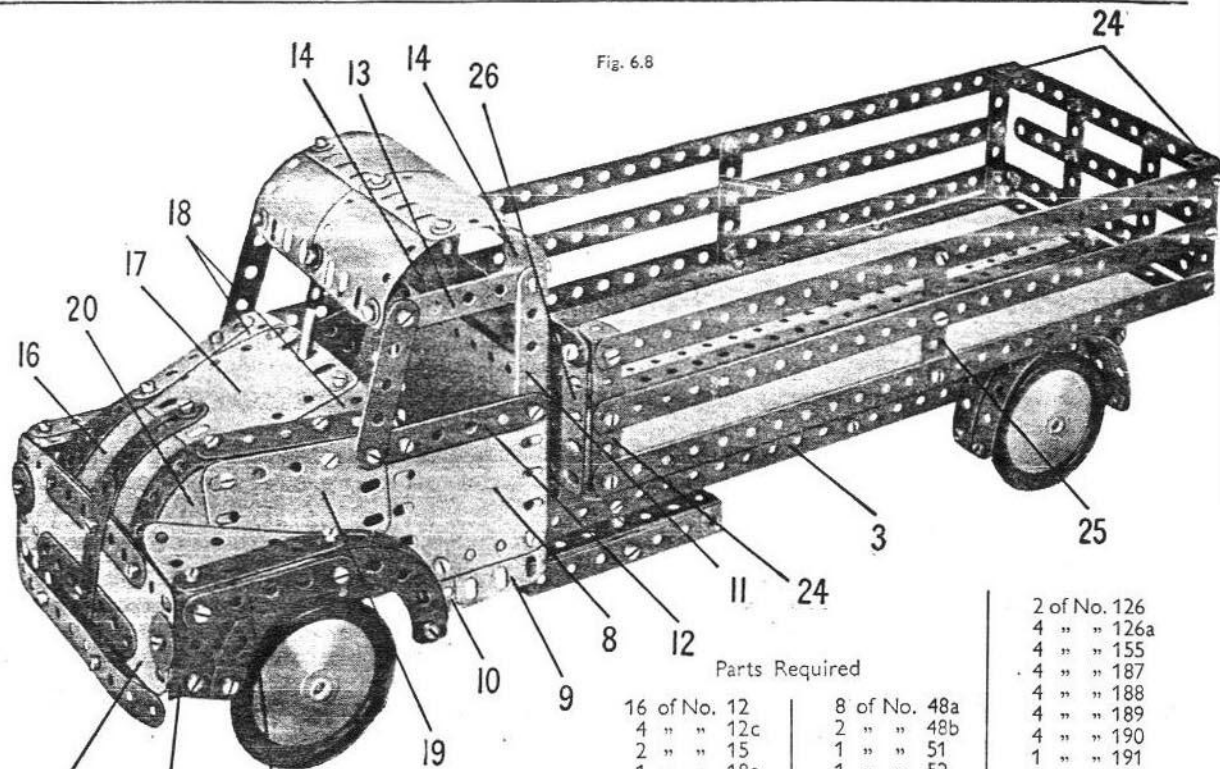

Fig. 6.8

Parts Required

16 of No. 12	8 of No. 48a	2 of No. 126
4 " " 12c	2 " " 48b	4 " " 126a
2 " " 15	1 " " 51	4 " " 155
1 " " 18a	1 " " 52	4 " " 187
4 " " 22	4 " " 59	4 " " 188
1 " " 24a	2 " " 90	4 " " 189
2 " " 35	4 " " 90a	4 " " 190
2 " " 4	2 " " 111	1 " " 191
12 " " 5	2 " " 111a	1 " " 192
2 " " 6a	6 " " 111c	2 " " 197
4 " " 8	1 " " 115	1 " " 198
8 " " 10	2 " " 125	2 " " 199
		2 " " 200
		1 " " 212
		2 " " 214
		3 " " 215
		4 " " 221
		2 " " 222

Each of the front wings is made by bolting a Trunnion (21) to the Flexible Plates (15). A 2½" Strip (22) is attached to the Trunnion, and is fitted with two 2½" Stepped Curved Strips. The lower end of one of the Curved Strips is connected to the Trunnion by a Fishplate, and the other Curved Strip is supported by a 1½" × ½" Double Angle Strip (23) bolted to the chassis. The top of each wing is covered by a 2½" × 1½" Triangular Flexible Plate edged by a 2½" Strip, and connected to the Strip (22) by two Angle Brackets. A Formed Slotted Strip is bolted between the Double Angle Strip (23) and the rear end of the Triangular Flexible Plate.

ASSEMBLY OF THE LOAD PLATFORM

The floor of the platform is made from two 12½" × 2½" Strip Plates and a 12½" Strip bolted at each end and at the centre to 5½" Strips. The outer edges of the Strip Plates are strengthened by 12½" Strips. The rails at the sides of the platform are each made from three 12½" Strips attached to 2½" × ½" Double Angle Strips (24) and a 2½" Strip (25). The Strips (25) are connected to the platform by Angle Brackets. The front ends of the side rails are joined by Angle Brackets to a 5½" × 2½" Flexible Plate (26), which is connected also to the platform by a ½" Reversed Angle Bracket. The end rail is made from three 5½" and two 2½" Strips bolted together and fixed to Angle Brackets bolted to the Double Angle Strips (24).

The completed platform is attached to the chassis by two ½" and two ¾" Bolts, but is spaced from it by a Collar on each Bolt. The ½" Bolts are passed through the 5½" Strip and the Strip Plates at the front of the platform, and are held by nuts in the Angle Girders (4). The ¾" Bolts are passed through the platform and through a Wheel Disc (27) before the Collars are placed on them. The Bolts are then fixed in the Double Angle Strip (6).

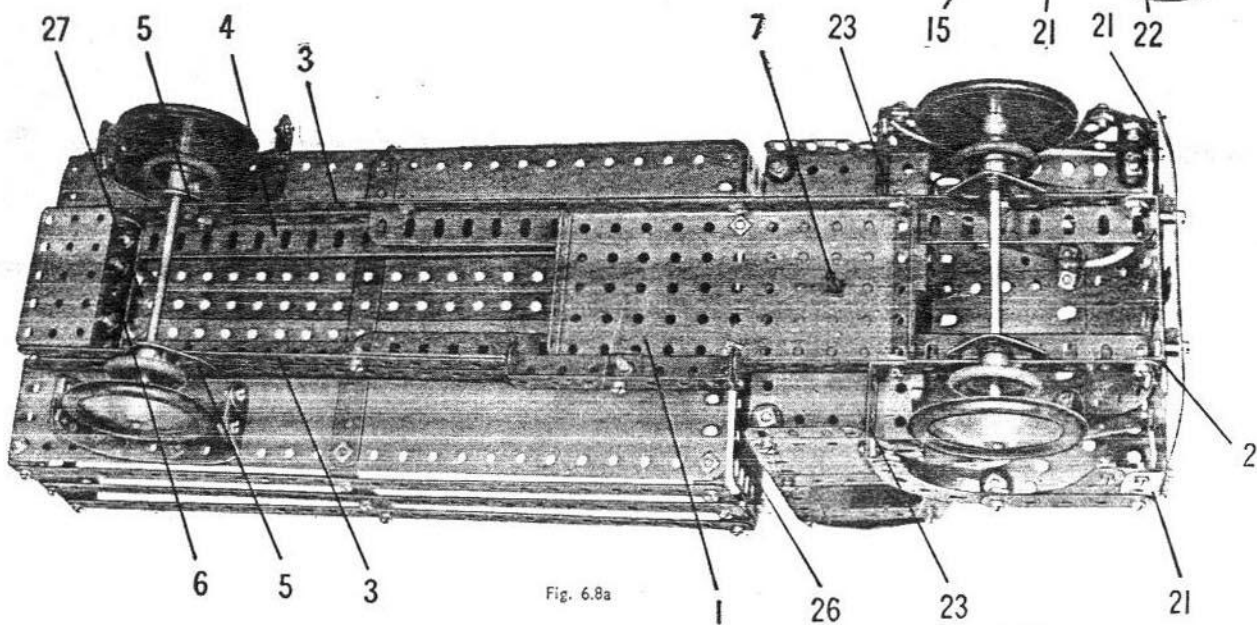

Fig. 6.8a

6.9 SINGLE-DECK TRAMCAR

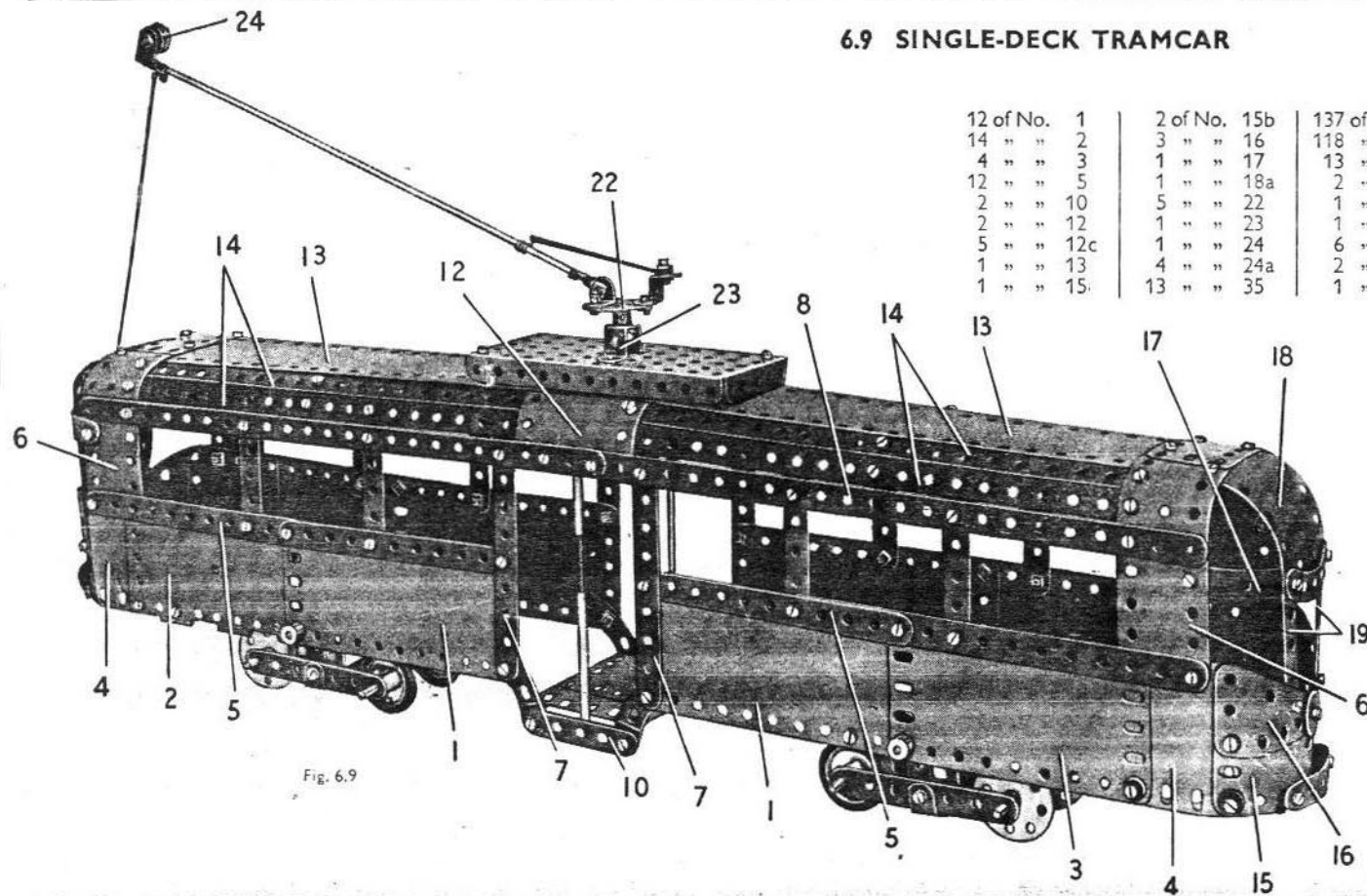

Fig. 6.9

Two $2\frac{1}{2}$ " Strips (19) are fixed between the Formed Slotted Strip and the Triangular Flexible Plates, and the end of the Curved Plate (18) is bolted to the Flexible Plates (6).

The bumper is a curved $2\frac{1}{2}$ " Strip, which is attached to the front of the cab by $\frac{3}{8}$ " Bolts, but is spaced from the cab by a Spring Clip on each Bolt.

CONSTRUCTION OF THE WHEEL BOGIES

Each bogie consists of two $3\frac{1}{2}$ " Strips and two Flat Trunnions bolted to the lugs of a $2\frac{1}{2}$ " x $\frac{1}{2}$ " Double Angle Strip (20). Two of the wheels are 1" Pulleys fitted with Rubber Rings and fixed on a $3\frac{1}{2}$ " Rod supported in the $3\frac{1}{2}$ " Strips. The other wheels are Wheel Discs, each of which is held by two nuts on a 3" Screwed Rod also mounted in the $3\frac{1}{2}$ " Strips. A Spring Clip is placed between the Wheel Disc and the $3\frac{1}{2}$ " Strips on each side.

The bogies rock on 4" Rods (21), which are passed through the holes at the pointed ends of the Flat Trunnions and also through the sides of the tram, where they are held in place by a Spring Clip and Collar as shown.

THE TROLLEY POLE

The trolley pole is an $11\frac{1}{2}$ " Rod held in a Rod and Strip Connector that is lock-nutted to an Angle Bracket bolted to a Bush Wheel (22). A $2\frac{1}{2}$ " Driving Band is looped between a Cord Anchoring Spring on the $11\frac{1}{2}$ " Rod and a $\frac{3}{8}$ " Reversed Angle Bracket fixed to the Bush Wheel. The Bush Wheel is held on a $1\frac{1}{2}$ " Rod supported in a $5\frac{1}{2}$ " x $2\frac{1}{2}$ " Flanged Plate and a Double Bent Strip (23). The Rod is held in position by a 1" Pulley underneath the Flanged Plate, and after this is fitted the Flanged Plate is attached to the roof of the model by $\frac{3}{8}$ " Bolts.

A $\frac{1}{2}$ " loose Pulley (24) is free to turn on a $\frac{1}{2}$ " Bolt held by two nuts in a Right-Angle Rod and Strip Connector at the upper end of the $11\frac{1}{2}$ " Rod. A length of Cord is tied between the Rod and a Threaded Pin (25) fixed to one end of the model.

Parts Required

12 of No. 1	2 of No. 15b	137 of No. 37a	2 of No. 53	4 of No. 126a	4 of No. 192
14 " " 2	3 " " 16	118 " " 37b	4 " " 59	1 " " 147b	2 " " 197
4 " " 3	1 " " 17	13 " " 38	2 " " 80c	4 " " 155	1 " " 198
12 " " 5	1 " " 18a	2 " " 38d	2 " " 90	1 " " 176	2 " " 199
2 " " 10	5 " " 22	1 " " 40	4 " " 90a	1 " " 186	2 " " 200
2 " " 12	1 " " 23	1 " " 45	2 " " 111	4 " " 188	2 " " 212
5 " " 12c	1 " " 24	6 " " 48a	1 " " 111a	4 " " 189	1 " " 213
1 " " 13	4 " " 24a	2 " " 48b	6 " " 111c	6 " " 190	4 " " 215
1 " " 15	13 " " 35	1 " " 52	1 " " 125	2 " " 191	4 " " 221

CONSTRUCTION OF THE SIDES

The two sides of the model are identical in arrangement, and each consists of two $5\frac{1}{2}$ " x $2\frac{1}{2}$ " Flexible Plates (1), one half of a Hinged Flat Plate (2), a $4\frac{1}{2}$ " x $2\frac{1}{2}$ " Flexible Plate (3) and two $2\frac{1}{2}$ " x $2\frac{1}{2}$ " Flexible Plates (4). The Plates are bolted to two built-up strips (5), each made from two $5\frac{1}{2}$ " Strips bolted together. A $5\frac{1}{2}$ " x $1\frac{1}{2}$ " Flexible Plate (6) is bolted to the side at each end, and two $5\frac{1}{2}$ " Strips (7) are placed as shown at the centre. A built-up strip (8), made from two $12\frac{1}{2}$ " Strips overlapped three holes, is fixed to the Flexible Plates (6) and the Strips (7), and the ends of these Plates and Strips above the strips (8) are bent over. The window divisions are made from $2\frac{1}{2}$ " Strips and $2\frac{1}{4}$ " x $\frac{1}{4}$ " Double Angle Strips.

The sides are connected at each end by a $3\frac{1}{2}$ " x $2\frac{1}{2}$ " Flanged Plate (9) (Fig. 6.9a). Two $2\frac{1}{2}$ " Stepped Curved Strips joined by a $2\frac{1}{2}$ " Strip (10) are fixed to each side and $3\frac{1}{2}$ " x $\frac{1}{2}$ " Double Angle Strips (11) are bolted between the lower ends of the Curved Strips. Two $2\frac{1}{2}$ " x $2\frac{1}{2}$ " Flexible Plates fixed to the Double Angle Strips (11) form the floor of the entrance lobby. The handrail in the entrance at one side is a 5" Rod held in a Rod and Strip Connector, and that on the other side of the tram consists of a $3\frac{1}{2}$ " and a 2" Rod joined by a Rod Connector and gripped in a Right-Angle Rod and Strip Connector.

ARRANGEMENT OF THE ROOF

A 'U'-section Curved Plate (12) is opened out slightly and is bolted to the strip (8) at each side of the model. The top ends of the Flexible Plates (6) at each end are overlapped three holes and are bolted together, the bolt securing also a $12\frac{1}{2}$ " x $2\frac{1}{2}$ " Strip Plate (13). The other ends of the Strip Plates are bolted to the Curved Plates (12), and four $12\frac{1}{2}$ " Strips (14) on each side are fixed between the Flexible Plates (6) and the Curved Plate (12). The Strips (14) are connected in pairs by Obtuse Angle Brackets.

THE DRIVING CABS

The rounded driving cab at each end is made by bolting a $2\frac{1}{2}$ " x $1\frac{1}{2}$ " Flexible Plate (15) and a $2\frac{1}{2}$ " x $1\frac{1}{2}$ " Triangular Flexible Plate (16) to each of the Plates (4). The Plates (15) and (16) are curved as shown and are bolted together. A Formed Slotted Strip (17) is fixed to each of the Flexible Plates (6) and their other ends are attached to a $2\frac{1}{2}$ " Curved Strip and a $1\frac{1}{8}$ " radius Curved Plate (18).

Fig. 6.9a

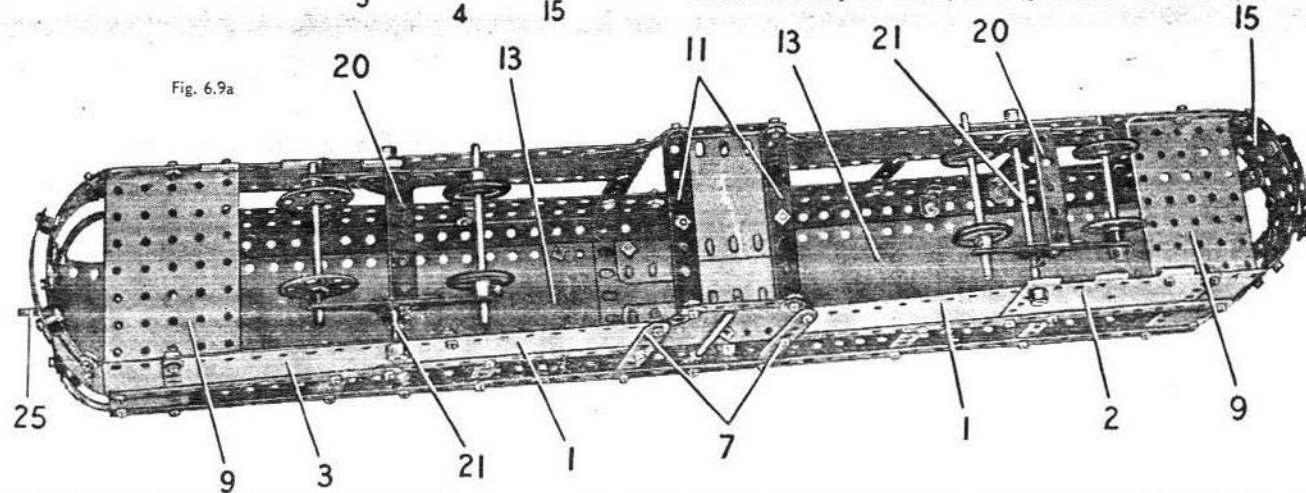

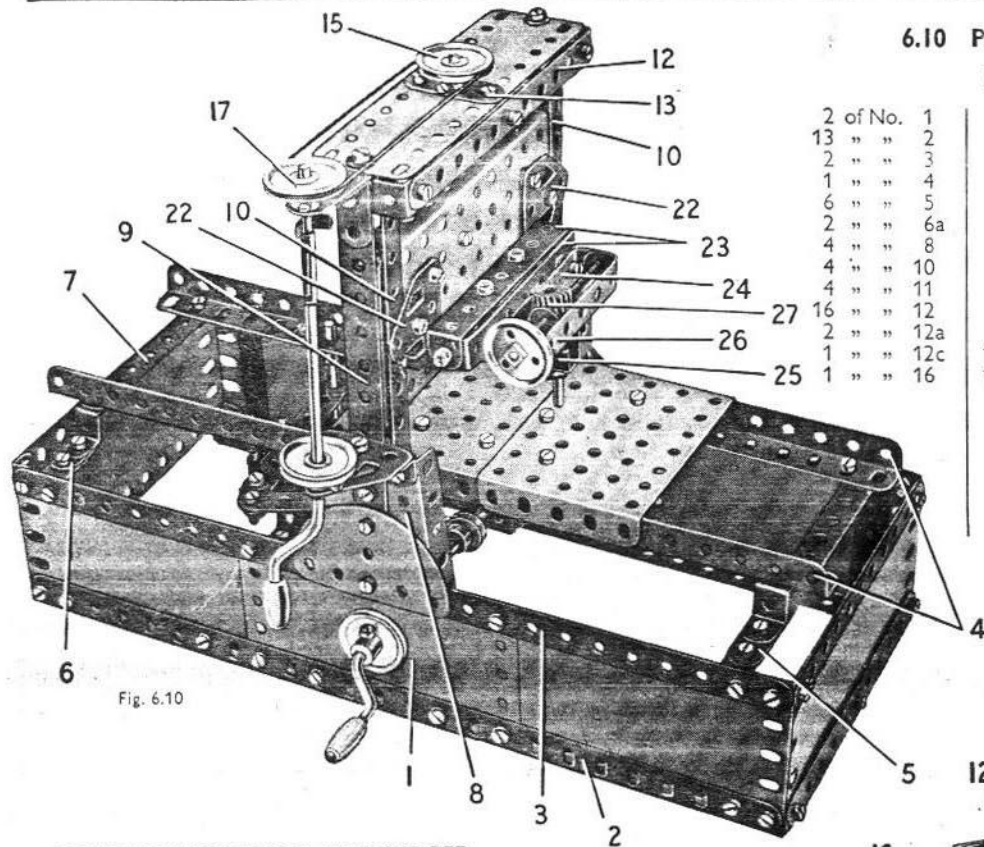

Fig. 6.10

6.10 PLANING MACHINE

Parts Required

2 of No. 1	1 of No. 17	1 of No. 51
13 " " 2	1 " " 18a	1 " " 52
2 " " 3	1 " " 19g	2 " " 53
1 " " 4	1 " " 19h	2 " " 54
6 " " 5	5 " " 22	4 " " 59
2 " " 6a	1 " " 22a	2 " " 80c
4 " " 8	1 " " 23a	1 " " 111a
4 " " 10	1 " " 24	6 " " 111c
4 " " 11	1 " " 26	1 " " 115
16 " " 12	1 " " 27a	4 " " 125
2 " " 12a	2 " " 35	2 " " 126
1 " " 12c	138 " " 37a	3 " " 126a
1 " " 16	115 " " 37b	1 " " 147b
	18 " " 38	1 " " 186a
	1 " " 40	1 " " 189
	1 " " 44	2 " " 191
	1 " " 45	4 " " 192
	2 " " 48	1 " " 198
	8 " " 48a	1 " " 213
	2 " " 48b	2 " " 214

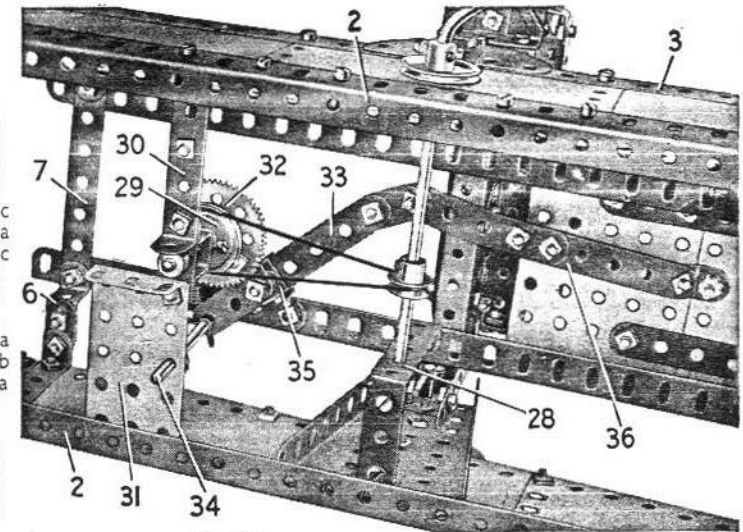

Fig. 6.10b

CROSS-SLIDE AND TOOL HOLDER

The cross-slide (23) is made by bolting together two $3\frac{1}{2} \times 4$ " Double Angle Strips (23), and the assembly is then fixed to a Trunnion attached to the Flanged Plate (11) by Bolts (37). A $2\frac{1}{2} \times 4$ " Double Angle Strip (24) is bolted to one of the Double Angle Strips (23) but is spaced from it by five Washers on each of the $\frac{1}{2}$ " Bolts used to hold the parts together.

The tool holder is a Stepped Bent Strip (25) fitted with a Threaded Pin. A 1" Loose Pulley is held by two nuts on a 3" Screwed Rod, which is supported in the lugs of the Double Angle Strip (24) and a similar Double Angle Strip (26). The Stepped Bent Strip (25) is mounted on the Screwed Rod, and when the Rod is turned the Stepped Bent Strip is made to move from side to side by a $\frac{1}{2}$ " Pinion (27). This Pinion is placed between the jaws of the Stepped Bent Strip, and the Screwed Rod is threaded through the holes in its body. The Screwed Rod is held in the Double Angle Strips by two nuts locked together at the opposite end to that carrying the 1" Loose Pulley.

THE WORK TABLE AND THE QUICK-RETURN MECHANISM

The work table consists of two $3\frac{1}{2} \times 2\frac{1}{2}$ " Flanged Plates joined together by two 2 $\frac{1}{2}$ " Strips.

The table is moved to and fro by a special mechanism, that causes the return or non-cutting stroke to be made at a faster speed than the cutting stroke. The mechanism is operated by a 5" Crank Handle mounted in the centre hole of one half of the Hinged Flat Plate (1), and in a $2\frac{1}{2} \times 4$ " Double Angle Strip (28) bolted at its upper end to one of the Girders (4). The lower end of the Double Angle Strip is supported by a $1\frac{1}{2}$ " Strip attached to the side of the machine by a 1" \times 1" Angle Bracket.

The Crank Handle carries a $\frac{1}{2}$ " fixed Pulley connected to a 1" Pulley (29) by a Cord driving belt. The Pulley (29) is fixed on a 2" Rod, which is mounted in a Double Bent Strip and a 2 $\frac{1}{2}$ " Strip bolted to a $2\frac{1}{2} \times 4$ " Double Angle Strip (30) and a 2 $\frac{1}{2} \times 1\frac{1}{2}$ " Flanged Plate (31). The 2" Rod is held in place by a Collar, and it is fitted at its upper end with a 57-tooth Gear (32). A 2 $\frac{1}{2}$ " Strip (33) is pivoted on a $3\frac{1}{2}$ " Rod (34), mounted in the Flanged Plate (31) and in a 2 $\frac{1}{2}$ " Strip bolted to one of the Girders (4). The Strip (33) is supported on the Rod by a Spring Clip.

Strip (33) is free to slide in a special slide bracket (35), which is pivoted to a Fishplate bolted tightly to the Gear (32). The bracket consists of two Angle Brackets fixed by a nut on a $\frac{1}{2}$ " Bolt to form a "U"-shaped piece. The Strip is held loosely in the bracket by a further Angle Bracket bolted to one of the lugs of the "U"-shaped piece. The $\frac{1}{2}$ " Bolt is fitted with two Washers and another nut, and is passed through the Fishplate on the Gear (32) and is then retained in place by lock-nuts, but the bracket must be free to pivot.

The Strip (33) is extended by a Fishplate, and a built-up strip (36) is lock-nutted to it and to an Obtuse Angle Bracket lock-nutted by a $\frac{1}{2}$ " Bolt to the underside of the work table.

CONSTRUCTION OF THE MACHINE BED

Each side of the bed consists of a $4\frac{1}{2} \times 2\frac{1}{2}$ " Flexible Plate, a $5\frac{1}{2} \times 2\frac{1}{2}$ " Flexible Plate and one half of a Hinged Flat Plate (1), which are bolted to a $12\frac{1}{2}$ " Angle Girder (2) and a $12\frac{1}{2}$ " Strip (3). The ends of the bed are connected to the sides by Angle Brackets.

Two $12\frac{1}{2}$ " Angle Girders (4) are attached at one end to $\frac{1}{2}$ " Reversed Angle Brackets bolted to a $5\frac{1}{2}$ " Strip (5). The Strip is fixed to the lugs of two $2\frac{1}{2} \times 4$ " Double Angle Strips bolted to the sides. The other ends of the Girders (4) are supported by $\frac{1}{2}$ " Reversed Angle Brackets bolted to Fishplates (6). Each Fishplate is fixed to the lug of a $2\frac{1}{2} \times 4$ " Double Angle Strip attached to the side, and a $3\frac{1}{2}$ " Strip (7) connects the Angle Girders (4) at this end.

THE TOOL CARRIAGE AND ITS COLUMNS

The tool carriage (11) (Fig. 6.10a) is supported by two columns, each made by bolting a Flanged Sector Plate (8) to the side. A $5\frac{1}{2}$ " Strip (9) and a Semi-Circular Plate are fixed to the Flanged Sector Plate, and two further $5\frac{1}{2}$ " Strips (10) are attached at their ends to the lugs of Double Brackets bolted to the Strip (9).

The carriage is a $5\frac{1}{2} \times 2\frac{1}{2}$ " Flanged Plate (11) and it slides in the channels formed by the Strips (9) and (10) at each side. The tops of the columns are joined by two $5\frac{1}{2}$ " Strips (12), bolted to the lugs of $1\frac{1}{2} \times 4$ " Double Angle Strips fixed to the upper ends of the Strips (9). A $5\frac{1}{2} \times 1\frac{1}{2}$ " Flexible Plate is attached to each of the Strips (9) by an Angle Bracket, and at its centre to Angle Brackets bolted to each of the Strips (12). A $1\frac{1}{2}$ " Strip (13) is fixed also at the centre of the $5\frac{1}{2} \times 1\frac{1}{2}$ " Flexible Plate.

The Flanged Plate can be raised or lowered by means of a 3" Screwed Rod (14). This carries a 1" Pulley (15), and is passed through the Strip (13) and the side of the Flanged Plate (11) into the boss of a Bush Wheel (16). The Pulley (15) is connected by a Driving Band to a 1" Pulley (17) which is fixed on a $1\frac{1}{2}$ " Rod joined to a $3\frac{1}{2}$ " Crank Handle by a Rod Connector. The Crank Handle is supported in a Flat Trunnion (18) bolted to a Trunnion fixed to the side of the column. The $1\frac{1}{2}$ " Rod is mounted in a 2 $\frac{1}{2}$ " Strip (19) attached to the top of the column by a 1" \times 1" Angle Bracket. The carriage is prevented from descending too far by an Angle Bracket (20) and a Pivot Bolt (21).

The Flanged Plate is guided in the columns by Flat Trunnions (22) (Fig. 6.10), spaced from the Flanged Plate by two Washers on each Bolt.

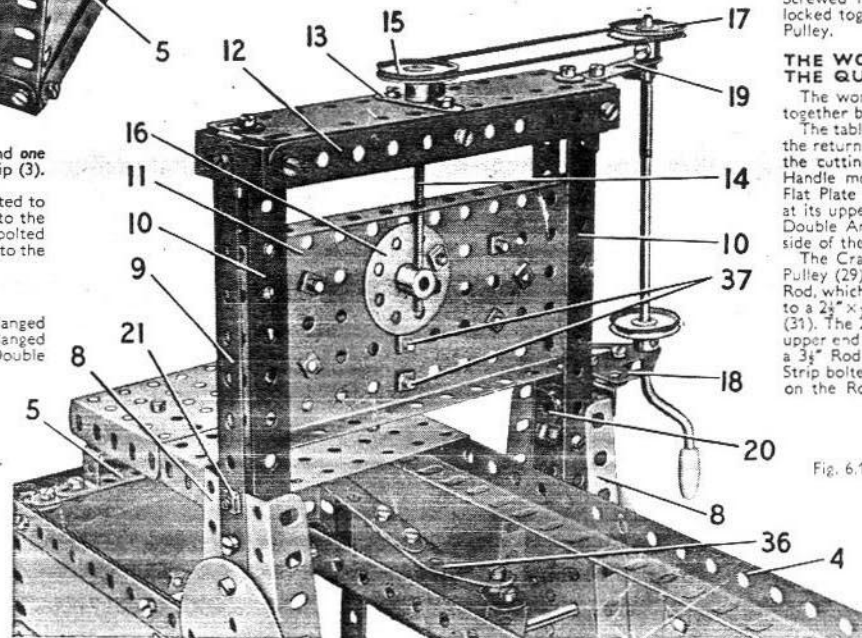

Fig. 6.10a

6.II TWO-TON MOBILE CRANE

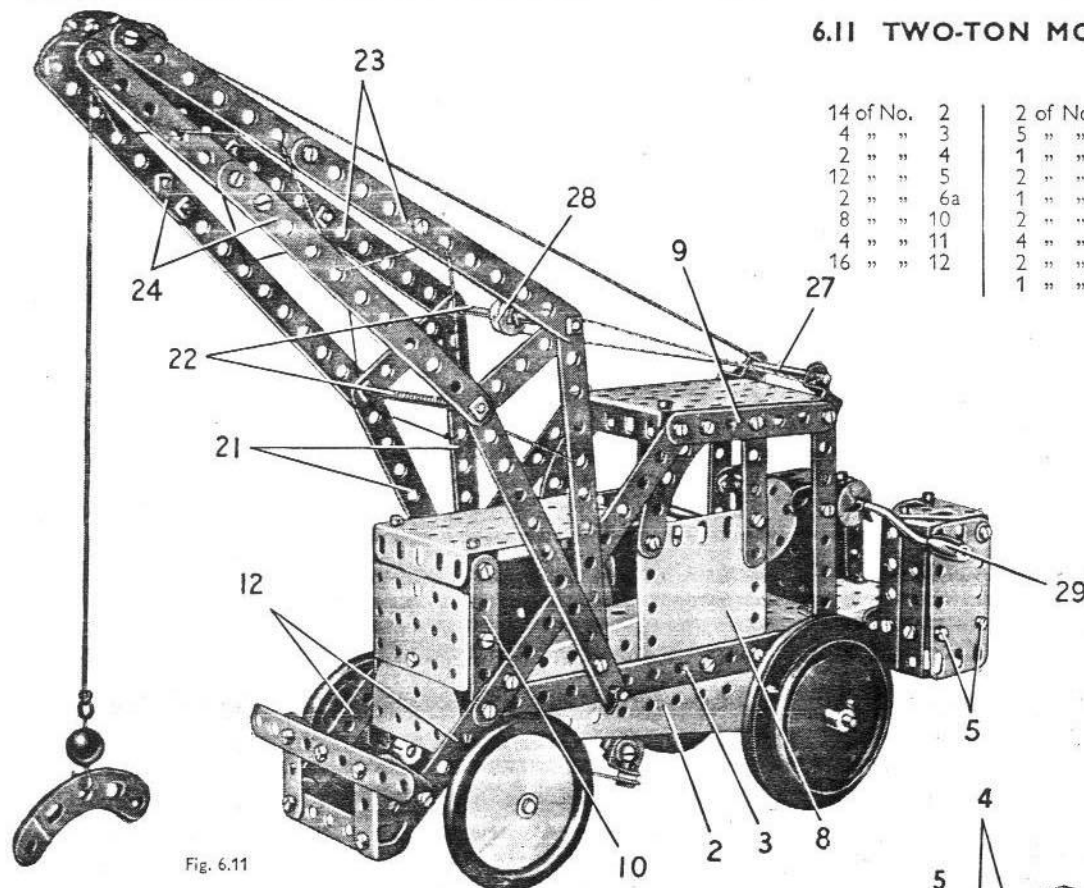

Fig. 6.11

The top of the bonnet is a $3\frac{1}{2}'' \times 2\frac{1}{2}''$ Flanged Plate supported at the rear by Angle Brackets bolted to the corners of the Flexible Plates (8). The front end of the Flanged Plate is connected by Angle Brackets to a built-up strip (10) (Figs. 6.11 and 6.11b) on each side. These strips are each made from a $2\frac{1}{2}''$ Strip and a $2\frac{1}{2}'' \times \frac{1}{2}''$ Double Angle Strip overlapped four holes, and they are bolted to the front ends of the Strips (3). A $2\frac{1}{2}'' \times \frac{1}{2}''$ Flanged Plate, extended downwards by a Semi-Circular Plate, is bolted between the strips (10) to form the radiator. A Semi-Circular Plate (11) is connected by Obtuse Angle Brackets to the rear end of the bonnet.

A built-up strip (12) (Fig. 6.11), made from a $5\frac{1}{2}''$ and a $3''$ Strip overlapped two holes, is bolted to each side between the ends of the Strips (3) and (9), and the bumper is attached to Trunnions bolted to the lower ends of the strips (12). The bumper consists of a $2\frac{1}{2}'' \times \frac{1}{2}''$ Double Angle Strip and two $2\frac{1}{2}''$ Strips bolted together.

The engine unit is represented by a 'U'-section Curved Plate attached to Obtuse Angle Brackets bolted to the Flanged Sector Plates (2). A Wheel Disc is bolted to a $2\frac{1}{2}'' \times \frac{1}{2}''$ Double Angle Strip fixed to the front end of the 'U'-section Curved Plate.

THE ROAD WHEELS AND STEERING MECHANISM

Each of the rear wheels consists of a Road Wheel and a $3''$ Pulley fixed on a $5''$ Rod supported in Flat Trunnions. The Flat Trunnions are bolted to the flanges of the Flanged Plate (1), and the wheels are spaced from them by a $1''$ loose Pulley and two Washers on each side.

The front wheels are Road Wheels, each of which is fixed on a $1\frac{1}{2}''$ Rod held by a Collar in a Double Bracket (13) (Fig. 6.11a). A $1\frac{1}{2}''$ Strip (14) is placed between the lugs of each Double Bracket, and a $3''$ Bolt is passed through the parts. A Washer is placed on the Bolt, which is then gripped tightly by two nuts in a Fishplate. The Fishplate is fastened to the lower lug of the Double Angle Strip forming part of the strip (10) on each side of the model.

A $3''$ Bolt is passed through one of the Strips (14), fitted with a Washer, and then is fixed by two nuts in a Rod and Strip Connector (15). A $2\frac{1}{2}''$ Strip (16) is gripped tightly by a nut on a $3''$ Bolt, which is then passed through the second of the Strips (14). A Washer is placed on the Bolt, and a second nut is used to fix the Strips (14) and (16) tightly together. A Rod and Strip Connector (17) is then passed over the Bolt and is retained on it by two nuts screwed against each other. The Rod and Strip Connectors are fitted over the ends of a $2''$ Rod, and they must be able to swivel freely on their respective Bolts.

(Continued on next page)

Parts Required

14 of No. 2	2 of No. 12a	5 of No. 22	114 of No. 37b	1 of No. 52	1 of No. 111a	4 of No. 187
4 " " 3	5 " " 12c	2 " " 22a	23 " " 38	2 " " 53	5 " " 111c	4 " " 188
2 " " 4	1 " " 15	1 " " 23	2 " " 38d	2 " " 54	1 " " 115	2 " " 190
12 " " 5	2 " " 15b	1 " " 23a	1 " " 40	1 " " 57c	4 " " 125	1 " " 199
2 " " 6a	1 " " 16	1 " " 24	1 " " 44	4 " " 59	2 " " 126	2 " " 212
8 " " 10	2 " " 17	2 " " 24a	2 " " 48	2 " " 80c	4 " " 126a	2 " " 212a
4 " " 11	4 " " 18a	2 " " 24c	8 " " 48a	2 " " 90	1 " " 147b	1 " " 213
16 " " 12	2 " " 19b	7 " " 35	2 " " 48b	3 " " 90a	3 " " 155	2 " " 214
	1 " " 19g	140 " " 37a	1 " " 51	1 " " 111	1 " " 176	2 " " 222

CONSTRUCTION OF THE CHASSIS

The chassis consists of a $5\frac{1}{2}'' \times 2\frac{1}{2}''$ Flanged Plate (1) (Fig. 6.11a), fitted at each side with a Flanged Sector Plate (2). The Flanged Sector Plates overlap the Plate (1) by four holes, and a $5\frac{1}{2}''$ Strip (3) is bolted to the centre of each Flanged Sector Plate and overhangs it at the front by two clear holes.

The two counter-balance weight boxes at the rear of the chassis each consists of two $2\frac{1}{2}'' \times 1\frac{1}{2}''$ Flexible Plates (4) connected by an Angle Bracket and a $1\frac{1}{2}'' \times \frac{1}{2}''$ Double Angle Strip held by the Bolts (5). A $2\frac{1}{2}''$ Strip (6) is bolted to a $\frac{1}{2}''$ Reversed Angle Bracket fixed to one of the Plates (4), and the lug of the Reversed Angle Bracket is used to attach the assembly to the Flanged Plate (1). The front of each box consists of two $2\frac{1}{2}'' \times \frac{1}{2}''$ Double Angle Strips joined together by a Fishplate and bolted to a lug of the Double Angle Strip attached by the Bolts (5). The front of the box is connected to the side of the Flanged Plate (1) by an Angle Bracket. The top of the box is a Flat Trunnion bolted to the top lug of one of the $2\frac{1}{2}'' \times \frac{1}{2}''$ Double Angle Strips and connected to the Strip (6) by an Angle Bracket.

ASSEMBLY OF THE CAB AND THE BONNET

Each side of the cab is made by bolting a $3\frac{1}{2}'' \times \frac{1}{2}''$ Double Angle Strip (7) (Fig. 6.11b) and a $2\frac{1}{2}'' \times 2\frac{1}{2}''$ Flexible Plate (8) to the Flanged Plate (1). A $2\frac{1}{2}''$ Curved Strip and a $2\frac{1}{2}''$ Strip are fixed to the Plate (7), and a $3\frac{1}{2}''$ Strip (9) is bolted to the top ends of these parts and to the Double Angle Strip (7). The cab roof is a $3\frac{1}{2}'' \times 2\frac{1}{2}''$ Flanged Plate attached to the Strips (9) by Angle Brackets. The back of the cab consists of two $2\frac{1}{2}'' \times 2''$ Triangular Flexible Plates bolted together to form a $2\frac{1}{2}'' \times 2''$ plate. The back is connected to the Double Angle Strips (7) by a Double Bracket and an Angle Bracket.

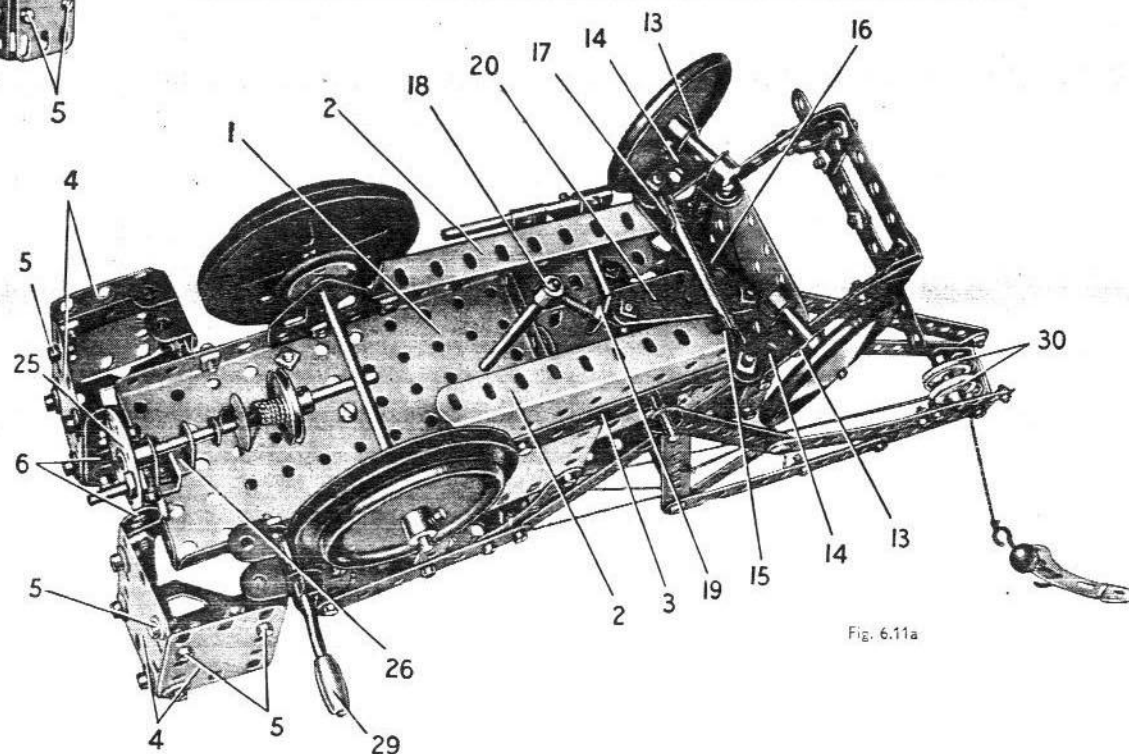

Fig. 6.11a

MODEL 6.11 TWO-TON MOBILE CRANE—Continued

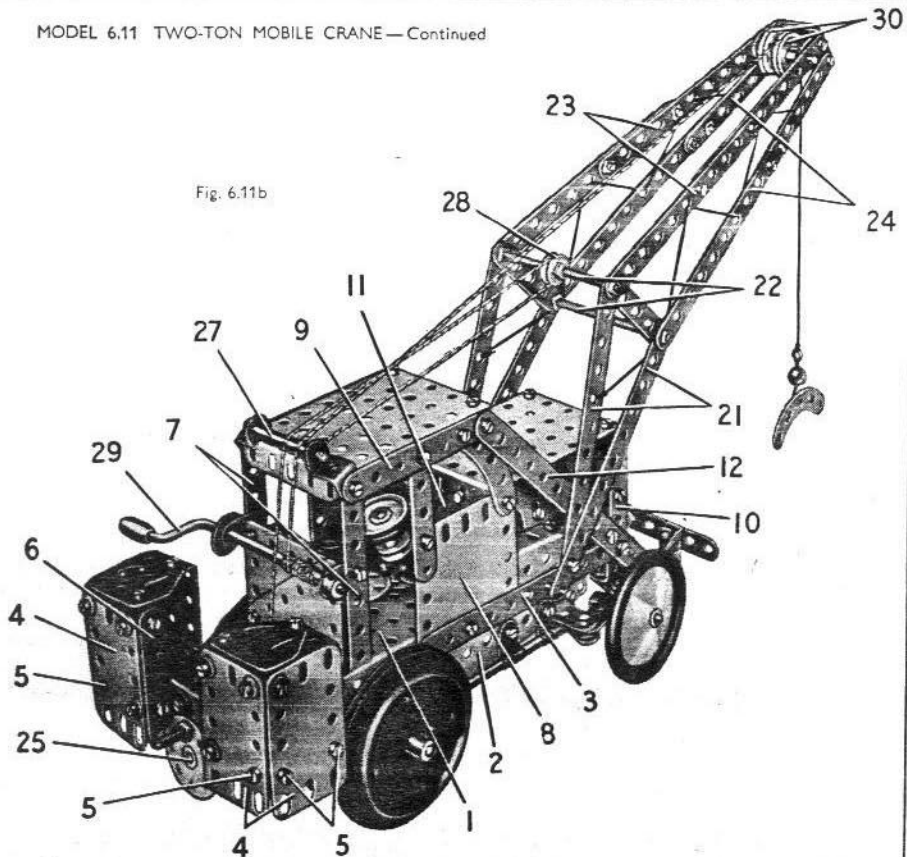

Fig. 6.11b

The steering column is a 4" Rod supported in the Flanged Plate (1) and in the Semi-Circular Plate (11) (Fig. 6.11b). It is held in position by a 1/2" fixed Pulley and a 1" fixed Pulley placed one on each side of the Semi-Circular Plate. The Rod carries at its lower end a Collar (18) (Fig. 6.11a). A 3/8" Bolt is fixed by a nut in an Angle Bracket (19), and the bolt is screwed tightly into a threaded hole in the Collar (18). A 2 1/2" Strip (20) is lock-nutted to the Angle Bracket, and also to the end of the 2 1/2" Strip (16).

The driving-seat consists of two Six-Hole Wheel Discs connected by an Obtuse Angle Bracket. It is fixed to a Double Bracket bolted to the Flanged Plate (1).

CONSTRUCTION OF THE JIB

The two side members of the jib are identical in construction, and the lower section of each consists of two 5 1/2" Strips (21) (Figs. 6.11 and 6.11b) bolted together at the bottom and joined at the top to a 2 1/2" Strip. The 2 1/2" and the 5 1/2" Strips are connected by nuts on two 3" Screwed Rods (22), and these nuts secure also two built-up strips (23) and (24) that form the upper section of the jib side-members. The Screwed Rods serve also to connect the two side members together at the centre of the jib. Each of the strips (23) consists of two 5 1/2" Strips overlapped five holes, and the strips (24) are each made from a 5 1/2" and a 3 1/2" Strip overlapped two holes. The strips (23) and (24) are connected at their upper ends by Fishplates, and they are joined to the corresponding strips on the other side of the jib by two 1" x 1" Angle Brackets bolted together. The jib pivots on a 4" Rod supported in the Flanged Sector Plates (2).

The jib is luffed, or raised and lowered, by turning a Bush Wheel (25) (Figs. 6.11a and 6.11b) fitted with a Threaded Pin. The Bush Wheel is fixed on a 3 1/2" Rod supported in a Stepped Bent Strip (26). A Cord Anchoring Spring is placed on the Rod between a 3" Washer and a 1" Pulley, and a length of Cord tied to the Spring is passed through a hole in the Flanged Plate (1). The Cord is led over a 2" Rod (27), round a 3/4" loose Pulley (28) and is tied to the Rod (27). The 3/4" loose Pulley is freely mounted on one of the Screwed Rods (22) between two sets of two nuts locked together, and Rod (27) is held by Spring Clips in 3/4" Reversed Angle Brackets bolted to the Strips (9). A 3/8" Bolt in the boss of the Bush Wheel (25) engages the Flanged Plate (1) when the Bush Wheel is pushed in fully, and acts as a simple brake. The brake is released by pulling the Bush Wheel slightly outwards.

A Crank Handle (29) is supported in Fishplates bolted to the Double Angle Strips (7). A length of Cord from the Crank Handle passes over Rod (27), round one of two 1" Pulleys (30) and is fitted with a small Loaded Hook. The Pulleys (30) are separated by a Spring Clip on a 1 1/2" Rod mounted at the top of the jib.

6.12 ELECTRIC ARTICULATED LORRY

Parts Required

8 of No. 1	1 of No. 12a	2 of No. 24a	4 of No. 48a	5 of No. 111c	2 of No. 191
11 " " 2	1 " " 12c	2 " " 24c	1 " " 48b	1 " " 115	2 " " 192
4 " " 3	1 " " 15	6 " " 35	1 " " 52	4 " " 126a	2 " " 197
2 " " 4	1 " " 15a	140 " " 37a	2 " " 53	1 " " 147b	1 " " 198
12 " " 5	2 " " 15b	124 " " 37b	4 " " 59	4 " " 155	2 " " 199
2 " " 6a	1 " " 17	26 " " 38	1 " " 80c	1 " " 186	2 " " 200
4 " " 8	3 " " 18a	2 " " 38d	2 " " 90	4 " " 187	2 " " 212
8 " " 10	2 " " 19b	1 " " 44	4 " " 90a	4 " " 188	1 " " 212a
4 " " 11	4 " " 22	1 " " 45	2 " " 111	4 " " 189	4 " " 221
16 " " 12	1 " " 24	1 " " 48	2 " " 111a	3 " " 190	2 " " 222

DETAILS OF THE LORRY CHASSIS

The chassis consists of a 5 1/2" x 2 1/2" Flanged Plate (1) (Figs. 6.12b and 6.12c), and a 3 1/2" x 2 1/2" Flanged Plate (2) bolted together by their flanges. The rear wheels are fixed on a 4 1/2" Rod that is held by 1" Pulleys in the Flanged Plate (1). Each of the front wheels is secured on a 1 1/2" Rod mounted freely in the lugs of a Double Bracket (3) and held in place by a Spring Clip. A 2 1/2" Strip (4) is placed between the lugs of one of the Double Brackets and a 3/8" Bolt is passed through the two parts. The Bolt is then fitted with three Washers and a nut, and is inserted in one of the end holes of a 3 1/2" Strip (5) bolted across the chassis. A second nut is screwed tightly on the Bolt to fix it in the Strip (5), leaving the Double Bracket and the Strip (4) free to swivel as a unit. A similar arrangement is used for the other front wheel, but the Strip (4) is replaced by a 1 1/2" Strip (6). The ends of the Strips (4) and (6) are connected by a 3 1/2" Strip attached by lock-nutted bolts.

The trailer coupling unit is provided by bolting a 2 1/2" x 1 1/2" Triangular Flexible Plate to each side of a Double Bent Strip (7) (Fig. 6.12b). A Double Bracket (8) is fixed between the Triangular Flexible Plates. The uncoupling lever is pivoted to a 1 1/2" x 1/4" Double Angle Strip (9) bolted to the chassis. A 3/8" Bolt is passed through the Double Angle Strip and is fitted with a nut. A 1 1/2" Strip (10) and a Right-Angle Rod and Strip Connector are then held tightly on the Bolt by a second nut. The lever is a 2" Rod gripped in the Right-Angle Rod and Strip Connector, and the Strip (10) is extended by an Obtuse Angle Bracket. A 2 1/2" Driving Band is looped through the Obtuse Angle Bracket and is gripped between a Washer and a nut on a 1/2" Bolt that is itself attached to the chassis by two nuts.

The battery boxes at each side of the chassis are represented by 'U'-section Curved Plates fitted with 2 1/2" x 1/4" Double Angle Strips.

(Continued on next page)

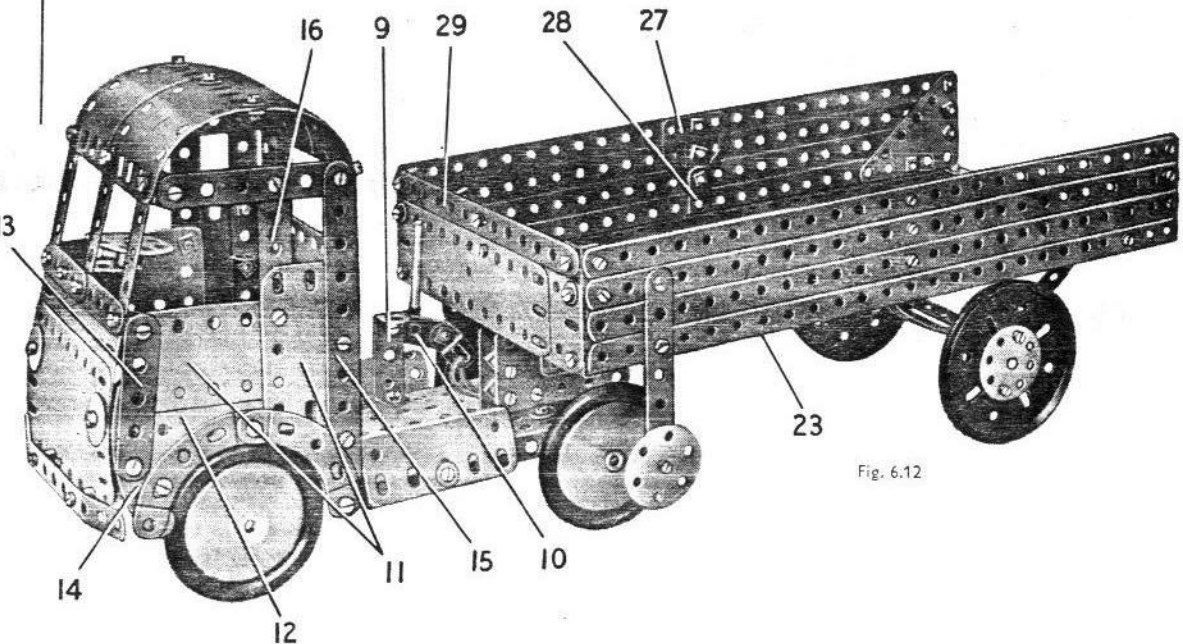

Fig. 6.12

MODEL 6.12 ELECTRIC ARTICULATED LORRY — Continued

ASSEMBLY OF THE CAB

The front of the cab consists of two $4\frac{1}{2}'' \times 2\frac{1}{2}''$ Flexible Plates overlapped lengthways by three holes. These Plates are curved slightly and are attached to the Flanged Plate (2) by two $\frac{3}{8}''$ Bolts. The Bolts support the front bumper, which is a $5\frac{1}{2}''$ Strip spaced from the front of the cab by a Spring Clip on each $\frac{3}{8}''$ Bolt. The top edge of the upper Flexible Plate is strengthened by two $2\frac{1}{2}''$ Strips, and the windscreen consists of three $2\frac{1}{2}''$ Strips arranged vertically.

Each side is formed by two $2\frac{1}{2}'' \times 1\frac{1}{2}''$ Flexible Plates (11) (Fig. 6.12) and a $2\frac{1}{2}'' \times 1\frac{1}{2}''$ Triangular Flexible Plate (12). The Triangular Flexible Plate is clamped between a $2\frac{1}{2}''$ Strip (13) and a $2\frac{1}{2}''$ Curved Strip (14), bolted together and fixed to the top corner of one of the Plates (11). The bolt securing the Strip (13) to the Plate (11) is used also to attach the side to an Angle Bracket fixed to the front of the cab. The side is edged by a $5\frac{1}{2}''$ Strip (15), which is connected at its upper end to a $3''$ Strip. The $3''$ Strip is attached to one of the $2\frac{1}{2}''$ Strips of the windscreen by an Angle Bracket, and it is joined to the Plates (11) by a $2\frac{1}{2}''$ Strip (16). The wheel arch is formed by two $2\frac{1}{2}''$ Stepped Curved Strips bolted together. One of the Curved Strips is attached to the Strip (15) and the other is connected to the Strip (13) by a Fishplate. The sides are supported at the rear by a $2\frac{1}{2}'' \times \frac{1}{2}''$ Double Angle Strip bolted vertically inside the cab to each of the Strips (15). The lugs of the Double Angle Strips are attached to two $2\frac{1}{2}''$ Strips (17) bolted across the Flanged Plate (1).

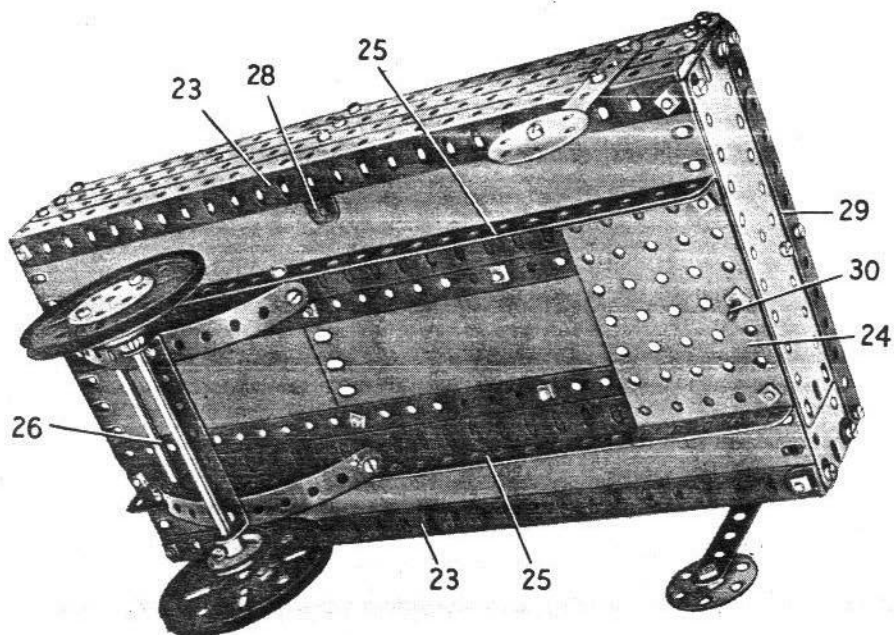

Fig. 6.12a

The back of the cab consists of one half of a Hinged Flat Plate (18) fitted at each side with a vertical $5\frac{1}{2}'' \times 1\frac{1}{2}''$ Flexible Plate, and at the centre with a $2\frac{1}{2}'' \times 2\frac{1}{2}''$ Flexible Plate (19). The back is attached to the sides by Angle Brackets. The roof is made from two $1\frac{1}{2}''$ radius Curved Plates and two $2\frac{1}{2}'' \times 2\frac{1}{2}''$ Flexible Plates. It is bolted to the back of the cab and to the $2\frac{1}{2}''$ Strips of the windscreen.

THE STEERING MECHANISM

The steering wheel is a Bush Wheel fixed to a $4''$ Rod (20) (Fig. 6.12c). This Rod is supported in the Flanged Plate (2) and in a Stepped Bent Strip bolted to the front of the cab. The Rod is held in place by a Collar, and at its lower end carries a second Collar fitted with a $\frac{3}{8}''$ Bolt (21). A Collar is fixed against the head of this Bolt, and a $3''$ Screwed Rod is locked in one of the threaded holes of the Collar by a nut. A Collar (22) is fixed on the Screwed Rod and is pivotally connected to a Rod and Strip Connector by a bolt fitted with two Washers and screwed into a threaded hole of the Collar. The Rod and Strip Connector is linked by a $1\frac{1}{2}''$ Rod to a second Rod and Strip Connector lock-nutted to the Strip (4).

CONSTRUCTION OF THE TRAILER

Each side of the trailer floor is a $12\frac{1}{2}'' \times 2\frac{1}{2}''$ Strip Plate fitted with a $12\frac{1}{2}''$ Angle Girder (23) (Fig. 6.12a). The centre of the floor is filled in by two $5\frac{1}{2}'' \times 2\frac{1}{2}''$ Flexible Plates and a $3\frac{1}{2}'' \times 2\frac{1}{2}''$ Flanged Plate (24). The joins between the Strip and the Flexible Plates are covered by $12\frac{1}{2}''$ Strips, and the floor is strengthened at each end by a built-up strip made from two $5\frac{1}{2}''$ Strips overlapped nine holes.

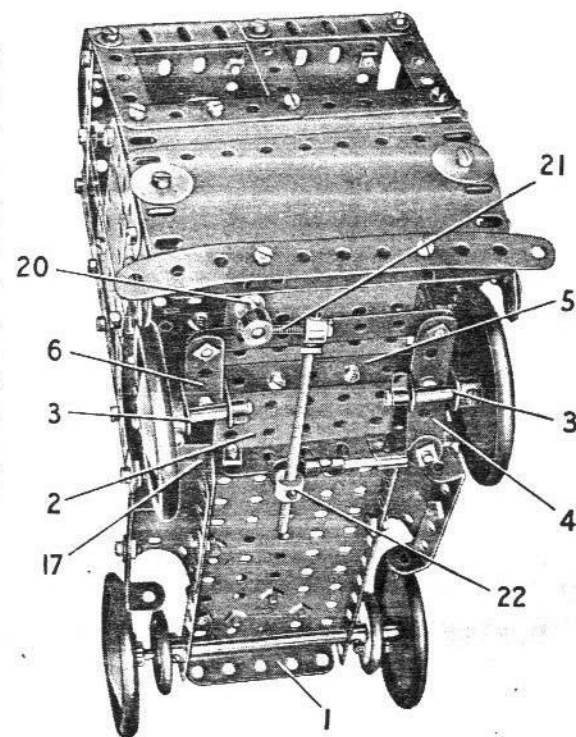

Fig. 6.12c

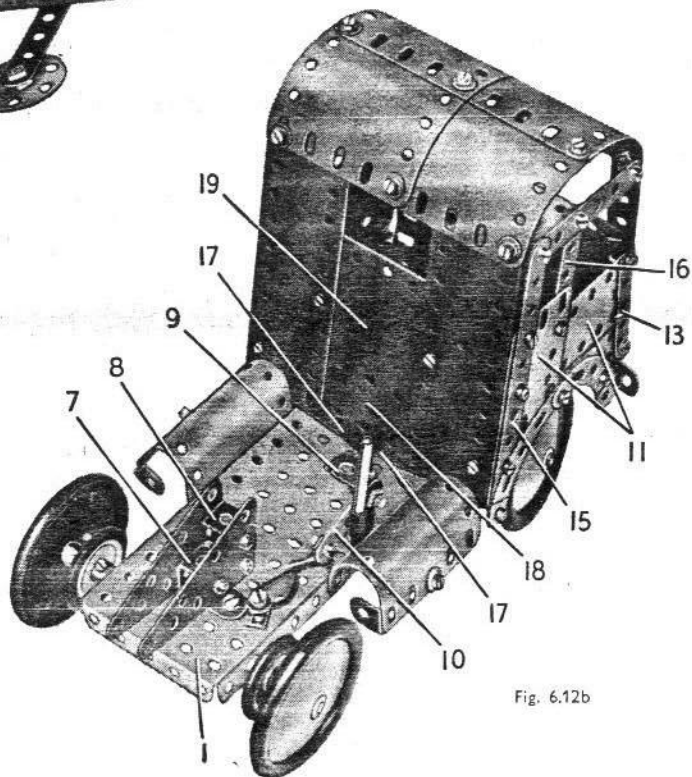

Fig. 6.12b

Two $12\frac{1}{2}''$ Angle Girders (25) are bolted underneath the floor as shown in Fig. 6.12a. The trailer springs are represented by two curved $5\frac{1}{2}''$ Strips, each fitted with two Angle Brackets. One of the Angle Brackets of each spring is bolted to the Girder (25) and the other is pivoted on a $4''$ Rod (26) held in the Girders (25) by Spring Clips. The trailer wheels are $3''$ Pulleys, and they are fixed on a $5''$ Rod supported in a $3\frac{1}{2}'' \times \frac{1}{2}''$ Double Angle Strip bolted to the springs.

Each side of the trailer is formed by three $12\frac{1}{2}''$ Strips bolted at the rear to a $2\frac{1}{2}'' \times 2''$ Triangular Flexible Plate fixed to one of the Girders (23). At the centre the Strips are connected by a Flat Trunnion (27) (Fig. 6.12). At one side the Flat Trunnion is extended downward by a $1'' \times 1''$ Angle Bracket, seen at (28), but at the other side a Fishplate is used in place of the Angle Bracket. The front of the trailer is made from two $5\frac{1}{2}'' \times 1\frac{1}{2}''$ Flexible Plates overlapped nine holes and connected to a built-up strip (29) by three Fishplates. This strip is made from two $5\frac{1}{2}''$ Strips overlapped nine holes and it is attached to the trailer sides by Angle Brackets. Each $5\frac{1}{2}'' \times 1\frac{1}{2}''$ Flexible Plate is connected to the floor by an Angle Bracket.

The wheels that support the trailer when it is disconnected from the lorry are Wheel Discs lock-nutted to $3\frac{1}{2}''$ Strips bolted to the trailer sides. The connection between the trailer and the lorry is made by a $\frac{3}{8}''$ Bolt (30) that engages in the Double Bracket (8).

6.13 BEDFORD TYPE LORRY

THE CHASSIS

Construction of the chassis is begun by bolting two 12½" Strips (1) (Fig. 6.13a) to the sides of a 5½" × 2½" Flanged Plate (2). The Strips overlap the Flanged Plate by three holes, and a 12½" Angle Girder (3) is attached to each Strip by Fishplates. A Cylinder is attached to one side by two 3" Bolts, but is spaced from the Strip by three Washers on each Bolt. The Bolts secure also 1" × 1" Angle Brackets, and a Six-Hole Wheel Disc at each end of the Cylinder is held by a nut on a 3" Screwed Rod passed through the Angle Brackets.

CONSTRUCTION OF THE CAB

The back of the cab is one of the *separated halves of a Hinged Flat Plate* attached to the Girders (3) by Angle Brackets. A 5½" × 1½" Flexible Plate (4) (Fig. 6.13b), is bolted to each side of the back, and these are connected at their upper ends by two 2½" × 2" Triangular Flexible Plates (5).

Each side of the cab consists of a 2½" × 2½" Flexible Plate (6) extended upwards by a 2½" × 1½" Flexible Plate that overlaps the Plate (6) by two holes. The sides are connected to the back of the cab by Angle Brackets, and each window frame is formed by a 3" Strip (7), two upright 2½" Strips, and a 2½" × ½" Double Angle Strip (8). A 2½" Stepped Curved Strip (9) is bolted to one end of the Double Angle Strip, and it is connected to the other end by a Fishplate.

The Flexible Plates (4) are bolted to the rear lugs of the Double Angle Strips (8), and the projecting ends of the Plates are curved to form part of the cab roof. The centre windscreen division is a 1½" Rod gripped in a Rod and Strip Connector.

ASSEMBLY OF THE BONNET

Each side of the bonnet is made by bolting a 5½" × 1½" Flexible Plate (20) (Fig. 6.13) so that it overlaps the Plate (6) by five holes. The side is completed by a 2½" × 2½" Triangular Flexible Plate (21) and by a 3½" Strip (10). The front of the bonnet consists of a 2½" × 1½" Flexible Plate (11) on each side, bolted to the front flange of the Flanged Plate (2). The Plates (11) are connected at their upper ends by a 2½" Strip, and five 2½" Strips representing the radiator are bolted between this Strip and the Flanged Plate (2). The sides and front of the bonnet are connected by Angle Brackets and by ½" Reversed Angle Brackets (12).

The top of the bonnet consists of a 4½" × 2½" Flexible Plate and the other half of the Hinged Flat Plate, bolted together. It is connected to the front and the sides of the bonnet by Angle Brackets.

The steering wheel is a Bush Wheel on a 1½" Rod that is held by a ½" fixed Pulley in a Stepped Bent Strip, which is supported by an Obtuse Angle Bracket.

THE LOAD PLATFORM

The floor of the platform consists of a 12½" × 2½" Strip Plate on each side, and two 5½" × 2½" Flexible Plates and a 3½" × 2½" Flanged Plate (13) at the centre. The Strip Plates are edged by 12½" Angle Girders (14), and at each end they are bolted to a built-up strip (15), made from two 5½" Strips overlapped nine holes.

At the centre each side is strengthened by two Flat Trunnions (16) (Fig. 6.13). The end of the platform is made from a 5½" × 2½" and a 2½" × 2½" Flexible Plate edged by two built-up strips (17). These strips each consist of two 5½" Strips overlapped nine holes, and the completed end is bolted to two 2½" × ½" Double Angle Strips fixed to the floor of the platform. The hinged tailboard is made in a similar way to the end already described, and it is fitted with two Right-Angle Rod and Strip Connectors (18). A 5" Rod is pushed through them and is gripped in two Collars (19). Each of these Collars is screwed on to a bolt passed through an Angle Bracket bolted to the platform. Two Washers are placed on each bolt before it is inserted in the Angle Bracket.

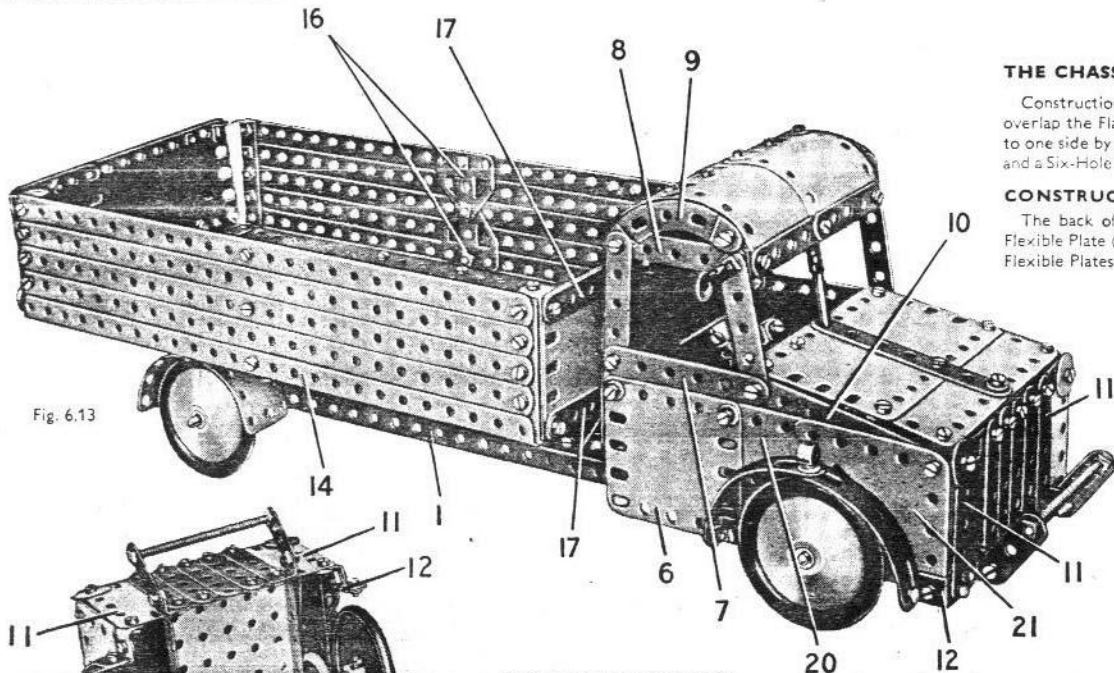

Fig. 6.13

Fig. 6.13a

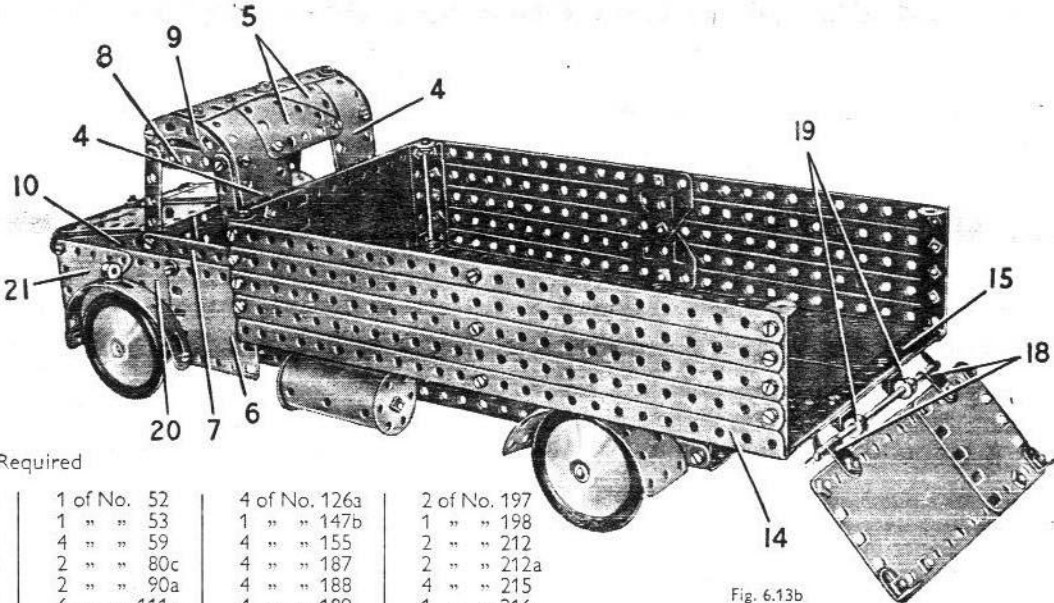
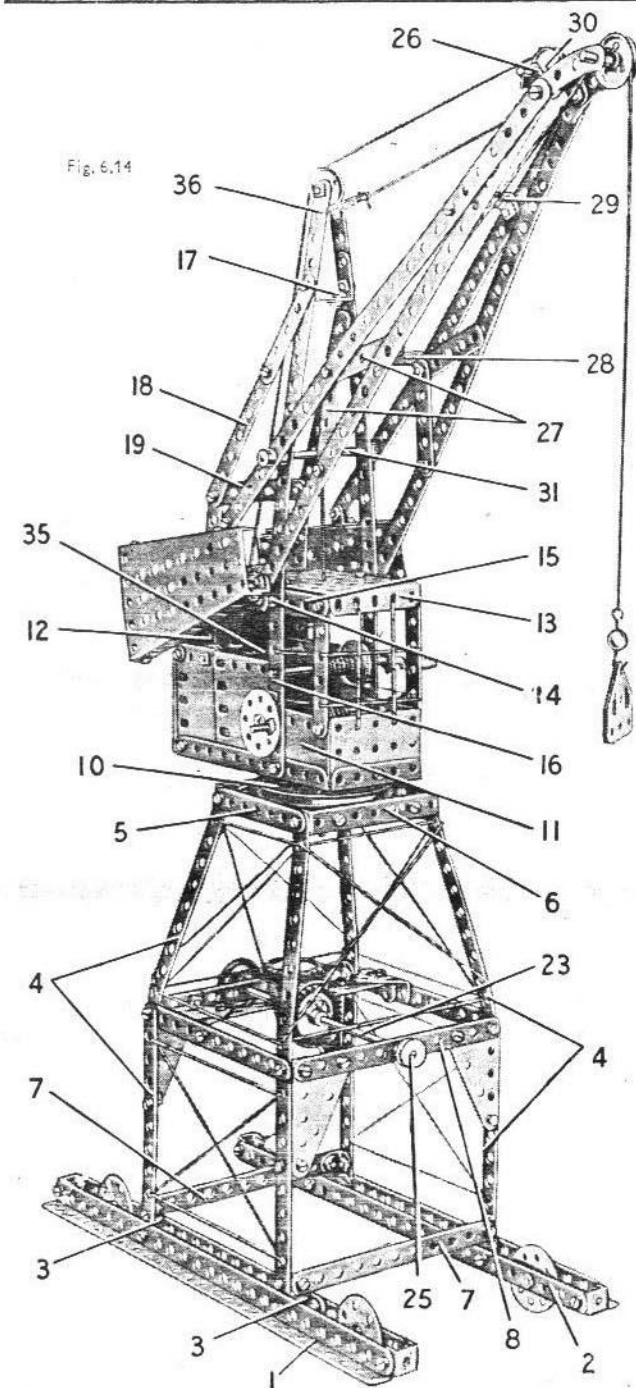

Fig. 6.13b

Parts Required

10 of No. 1	2 of No. 12a	2 of No. 24c	1 of No. 52	4 of No. 126a	2 of No. 197
12 " " 2	3 " " 12c	2 " " 35	1 " " 53	1 " " 147b	1 " " 198
3 " " 3	1 " " 14	139 " " 37a	4 " " 59	4 " " 155	2 " " 212
2 " " 4	2 " " 15	134 " " 37b	2 " " 80c	4 " " 187	2 " " 212a
12 " " 5	2 " " 18a	27 " " 38	2 " " 90a	4 " " 188	4 " " 215
2 " " 6a	4 " " 22	2 " " 38d	6 " " 111c	4 " " 189	1 " " 216
4 " " 8	1 " " 23	1 " " 44	1 " " 115	6 " " 190	4 " " 221
7 " " 10	1 " " 23a	8 " " 48a	4 " " 125	1 " " 191	2 " " 222
16 " " 12	1 " " 24	1 " " 51	2 " " 126	4 " " 192	2 " " 223

6.14 DOCKSIDE CRANE



Parts Required

10 of No. 1	16 of No. 12	5 of No. 22	6 of No. 35	1 of No. 51	2 of No. 111a	1 of No. 176
14 " " 2	2 " " 12a	2 " " 22a	130 " " 37a	1 " " 52	4 " " 111c	4 " " 188
4 " " 3	1 " " 14	1 " " 23	114 " " 37b	2 " " 53	1 " " 115	6 " " 190
2 " " 4	1 " " 15a	1 " " 23a	20 " " 38	2 " " 54	4 " " 125	2 " " 200
12 " " 5	1 " " 15b	1 " " 24	1 " " 40	1 " " 57c	2 " " 126	1 " " 214
1 " " 6a	1 " " 16	2 " " 24a	1 " " 45	4 " " 59	3 " " 126a	4 " " 221
2 " " 8	3 " " 18a	2 " " 24c	1 " " 48	1 " " 80c	2 " " 142c	
2 " " 10	2 " " 19b	1 " " 26	8 " " 48a	2 " " 90	1 " " 147b	
4 " " 11	1 " " 19g	1 " " 27a	2 " " 48b	2 " " 111	1 " " 155	

CONSTRUCTION OF THE TOWER AND CABIN

Each side of the base of the tower consists of a $12\frac{1}{2}$ " Angle Girder (1) and a $12\frac{1}{2}$ " Strip (2) (Fig. 6.14). The Angle Girder is joined to the Strip at each end by means of a Double Bracket and by two Reversed Angle Brackets (3). Two Wheel Discs are supported on bolts lock-nutted in the $12\frac{1}{2}$ " Strip. Each leg consists of two $5\frac{1}{2}$ " Strips (4). The upper ends of these Strips are joined by $3\frac{1}{2}$ " Strips (5) and $3\frac{1}{2}$ " x $\frac{1}{2}$ " Double Angle Strips (6). Two further $5\frac{1}{2}$ " Strips (7) brace the legs as shown, and the tower is braced at the centre by further $5\frac{1}{2}$ " Strips, one of which is shown at (8). A $3\frac{1}{2}$ " x $2\frac{1}{2}$ " Flanged Plate is bolted by its flanges to the Double Angle Strip (6) at the top of the tower and to it is fixed a 3" Pulley. A Trunnion is bolted to each of two of the Strips (8) and these support $2\frac{1}{2}$ " x $\frac{1}{2}$ " Double Angle Strips. The inner ends of the Double Angle Strips are joined by a $1\frac{1}{2}$ " Strip and by a Double Bent Strip (9) (Fig. 6.14a). The Double Angle Strips are spaced from the Trunnions by two Washers on their Bolts.

The base of the cabin is a $5\frac{1}{2}$ " x $2\frac{1}{2}$ " Flanged Plate fitted with a 3" Pulley (10) held by two $\frac{1}{2}$ " Bolts. The boss of the Pulley is placed upwards. Each side consists of two $2\frac{1}{2}$ " x $2\frac{1}{2}$ " Flexible Plates, a $2\frac{1}{2}$ " x $1\frac{1}{2}$ " Flexible Plate (11) and a similar Plate (12). The rounded back is formed from two $2\frac{1}{2}$ " x $2\frac{1}{2}$ " Flexible Plates and two $1\frac{1}{2}$ " radius Curved Plates. The roof of the cab at the rear is a Semi-Circular Plate fixed to a $2\frac{1}{2}$ " x $\frac{1}{2}$ " Double Angle Strip while the front portion is a $3\frac{1}{2}$ " x $2\frac{1}{2}$ " Flanged Plate (13) fixed to a $2\frac{1}{2}$ " x $\frac{1}{2}$ " Double Angle Strip held by bolts (14). The upper edge of the cabin on each side consists of two $2\frac{1}{2}$ " Strips (15) joined end to end.

To each side of the cabin a $12\frac{1}{2}$ " Strip (16) is bolted. These are linked together by two 1 " x 4 " Angle Brackets (17), and they support a 1" loose Pulley mounted on a Pivot Bolt. The $12\frac{1}{2}$ " Strips are braced by built-up strips (18), each consisting of two $2\frac{1}{2}$ " Strips and one $3\frac{1}{2}$ " Strip. These built-up strips are joined across by a $2\frac{1}{2}$ " x $\frac{1}{2}$ " Double Angle Strip (19).

The cabin swivels on a $1\frac{1}{2}$ " Rod held in the boss of the 3" Pulley (10) and passed through the lower 3" Pulley. A 57-tooth Gear is fixed on the Rod below the Flanged Plate, and this engages a $\frac{1}{2}$ " Pinion on a Rod (20) (Fig. 6.14a). The upper end of this Rod is mounted in a hole in the Flanged Plate, and the lower end is supported in the Double Bent Strip (9). It carries a 1" Pulley (21) fitted with a Motor Tyre. The Tyre is in contact with a second tyred Pulley (22) on a $6\frac{1}{2}$ " Rod (23). The Rod is fitted with a 1" Pulley (24) and is held in place by a $\frac{1}{2}$ " fast Pulley (25).

THE BALANCED JIB

Each side of the jib is formed from two $12\frac{1}{2}$ " Strips, bolted together at the jib head and extended by a $2\frac{1}{2}$ " Curved Strip. The bolt that holds the Strips together secures also a Fishplate (26). At their rear ends the pairs of $12\frac{1}{2}$ " Strips are connected by Angle Brackets to Flanged Sector Plates. Bracing is provided by two $2\frac{1}{2}$ " Strips (27) on each side, and the two sides are joined together by $2\frac{1}{2}$ " x $\frac{1}{2}$ " and $1\frac{1}{2}$ " x $\frac{1}{2}$ " Double Angle Strips (28) and (29).

The Fishplates (26) support a $1\frac{1}{2}$ " Rod, which carries a 1" Pulley (30). Another $1\frac{1}{2}$ " Rod mounted at the jib head carries a 1" loose Pulley. The jib is pivoted on a $3\frac{1}{2}$ " Rod (31) mounted in the $12\frac{1}{2}$ " Strips (16).

JIB LUFFING AND HOISTING CORDS

The jib is raised and lowered by turning a Bush Wheel (32) mounted on a 4" Rod (33) journaled in the sides of the cabin. A brake is provided by a $\frac{1}{2}$ " Bolt screwed into the boss of the Bush Wheel and the Rod is arranged to slide endways so that when it is pushed inwards this Bolt can be brought into contact with a second $\frac{1}{2}$ " Bolt (34).

A length of Cord is tied to the Rod (33) and is then taken over a $\frac{1}{2}$ " loose Pulley mounted on a 3" Screwed Rod (35), which is passed through the cab and is fixed in the cabin by means of two nuts at each end. The Cord is then taken over the 1" Pulley at the upper ends of the Strips (16) and round the 1" Pulley (30) and then is led back and tied at (36).

The load hook is raised and lowered by turning the Crank Handle (37). A 1" fixed Pulley (38) mounted on the Crank Handle has in its boss a $\frac{1}{2}$ " Bolt, to serve as a catch brake. By sliding the Crank Handle this Bolt can be brought into contact with a further $\frac{1}{2}$ " Bolt (39) fixed in the side of the cabin.

A length of Cord is tied to the Crank Handle, taken through a hole in the Flanged Plate (13) and over the Rod (31) on which the jib is pivoted. This Cord is then led over the 1" Pulley at the jib head and is tied to a small Loaded Hook.

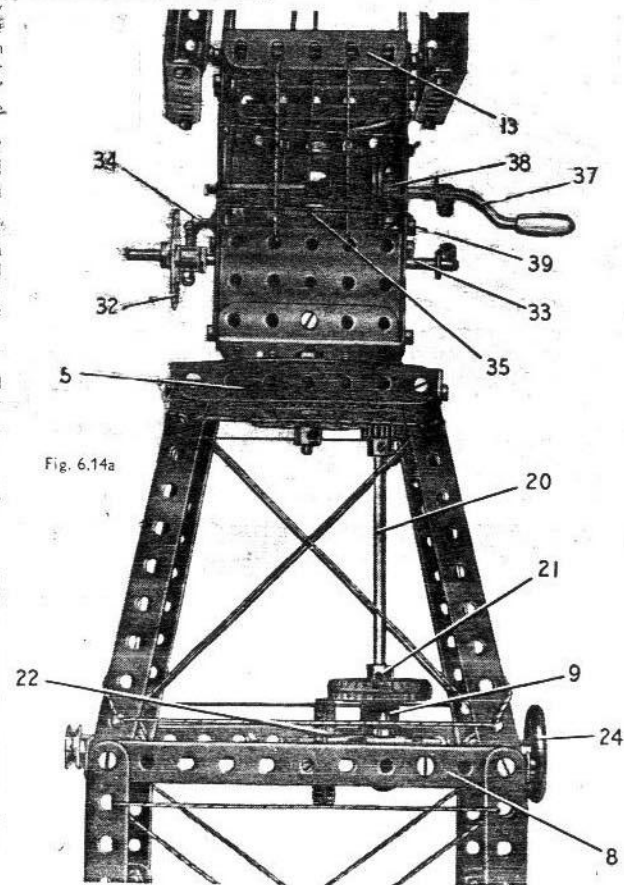

6.15 PITHEAD GEAR

Parts Required

12 of No. 1	4 of No. 11	1 of No. 24a	2 of No. 48	4 of No. 90a	4 of No. 188	2 of No. 222 1 No. 1 Clockwork Motor (Not included in Outfit)
14 " " 2	16 " " 12	1 " " 26	8 " " 48a	1 " " 111	4 " " 189	
4 " " 3	2 " " 12a	1 " " 27a	2 " " 48b	6 " " 111a	6 " " 190	
2 " " 4	1 " " 14	137 " " 37a	1 " " 52	6 " " 111c	2 " " 191	
10 " " 5	1 " " 15	128 " " 37b	1 " " 53	1 " " 115	4 " " 192	
4 " " 8	2 " " 19b	26 " " 38	2 " " 54	2 " " 126	1 " " 198	
2 " " 10	1 " " 24	1 " " 40	3 " " 59	2 " " 126a	4 " " 221	

THE LIFT SHAFT

The base of the shaft consists of two Flanged Sector Plates joined together by two $2\frac{1}{2}'' \times 2\frac{1}{2}''$ Flexible Plates and a $2\frac{1}{2}''$ Strip (1) (Fig. 6.15). The lower section of the shaft is made from four corner strips, each of which consists of two $12\frac{1}{2}''$ Strips placed face to face. Two of the corner strips are attached to the base by $1'' \times 1''$ Angle Brackets, and the other two are fixed to Trunnions.

Each corner of the shaft is extended upward by a $12\frac{1}{2}''$ Angle Girder, and the upper ends of the Angle Girders on each side are bolted to a $5\frac{1}{2}''$ Strip (2). The Strips (2) are connected at each end by a $5\frac{1}{2}''$ Strip (3) attached to Angle Brackets. The top of the shaft is filled in by two $5\frac{1}{2}'' \times 2\frac{1}{2}''$ Flexible Plates, a $5\frac{1}{2}'' \times 1\frac{1}{2}''$ Flexible Plate, a $3\frac{1}{2}'' \times 2\frac{1}{2}''$ Flanged Plate and two $2\frac{1}{2}'' \times 2''$ Triangular Flexible Plates. These Plates are fixed to Angle Brackets bolted to the ends of the $12\frac{1}{2}''$ Angle Girders.

A $5\frac{1}{2}''$ Strip (4) and two built-up strips (5) are bolted to the centre of the lift shaft. Each of the strips (5) consists of two $12\frac{1}{2}''$ Strips overlapped 16 holes. Two $5\frac{1}{2}''$ Strips (6) and a similar Strip (7) are fixed to the upper end of the shaft. The Strips (6) are connected to the Strips (2) by $3\frac{1}{2}''$ Strips, and two $3\frac{1}{2}'' \times \frac{1}{2}''$ Double Angle Strips (8) are bolted between Strip (7) and the Plates at the top of the shaft.

The shed (17) at the pithead consists of a $5\frac{1}{2}'' \times 1\frac{1}{2}''$ and a $2\frac{1}{2}'' \times 2\frac{1}{2}''$ Flexible Plate on each side, edged by a $5\frac{1}{2}''$ and a $3''$ Strip as shown. The roof of the shed is formed by two $5\frac{1}{2}'' \times 2\frac{1}{2}''$ Flexible Plates and a $5\frac{1}{2}'' \times 1\frac{1}{2}''$ Flexible Plate attached to the sides by Angle Brackets. The shed is braced to the ends of the Strips (6) by two built-up strips, each made from two $5\frac{1}{2}''$ Strips overlapped five holes.

CONSTRUCTION OF THE ENGINE HOUSE

The ends of the strips (5) are bolted to a $5\frac{1}{2}'' \times 2\frac{1}{2}''$ Flanged Plate that forms the back of the engine house. The side of the house seen in Fig. 6.15 is made from a $4\frac{1}{2}'' \times 2\frac{1}{2}''$ Flexible Plate and a $2\frac{1}{2}'' \times 2\frac{1}{2}''$ Flexible Plate. The other side is formed by a No. 1 Clockwork Motor bolted to one of the strips (5).

The roof of the house consists of a $4\frac{1}{2}'' \times 2\frac{1}{2}''$ Flexible Plate extended on each side by one half of a Hinged Flat Plate. The roof is attached by Angle Brackets to built-up strips (9), which are supported by $2\frac{1}{2}''$ Strips bolted to the sides. Each of the Strips (9) is made from two $2\frac{1}{2}''$ Strips. The back of the engine house is completed by a $2\frac{1}{2}'' \times 2\frac{1}{2}''$ Flexible Plate, which is connected to the roof by Double Brackets.

THE CAGES

Each cage consists of two $2\frac{1}{2}'' \times 1\frac{1}{2}''$ Flexible Plates connected by four $2\frac{1}{2}'' \times \frac{1}{2}''$ Double Angle Strips. The Double Angle Strips are joined together by two $2\frac{1}{2}''$ Stepped Curved Strips and a $1\frac{1}{2}'' \times \frac{1}{2}''$ Double Angle Strip (10). A Fishplate (11) is bolted to the bottom of the cage.

Each cage is guided by a length of Cord (12). This is fastened to a Washer underneath the base of the shaft and is passed through a hole in the base and the Fishplate (11) of the cage. The Cord is then tied to a Flat Trunnion bolted to the lower lug of one of the Double Angle Strips (8).

THE OPERATING MECHANISM

A $\frac{1}{2}''$ Pinion on the shaft of the No. 1 Clockwork Motor drives a 57-tooth Gear on a 6" Rod (13). A Bush Wheel (14) is fixed on the Rod, and a Wheel Disc is attached to the Bush Wheel by $\frac{1}{2}''$ Bolts. This arrangement divides the Rod into two sections, and a length of Cord is fastened tightly to each section. The Cords are wound round the Rod in opposite directions, so that when the Rod is driven by the Motor one Cord is wound in and the other is unwound. Each Cord is passed over a 3" Pulley (15) and is tied to the top of one of the cages. The Pulleys (15) are freely mounted on a 5" Rod, which is supported in Double Brackets fixed to the $12\frac{1}{2}''$ Angle Girders by the Bolts (16). The Rod is held in position by Collars.

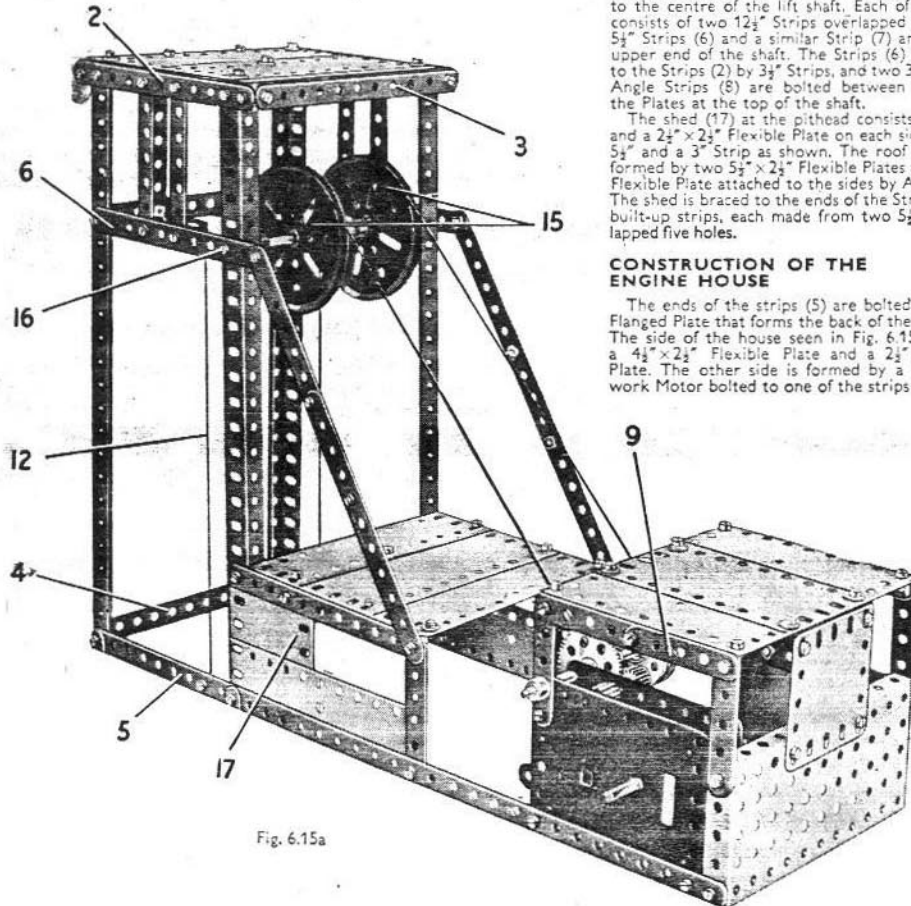

Fig. 6.15a

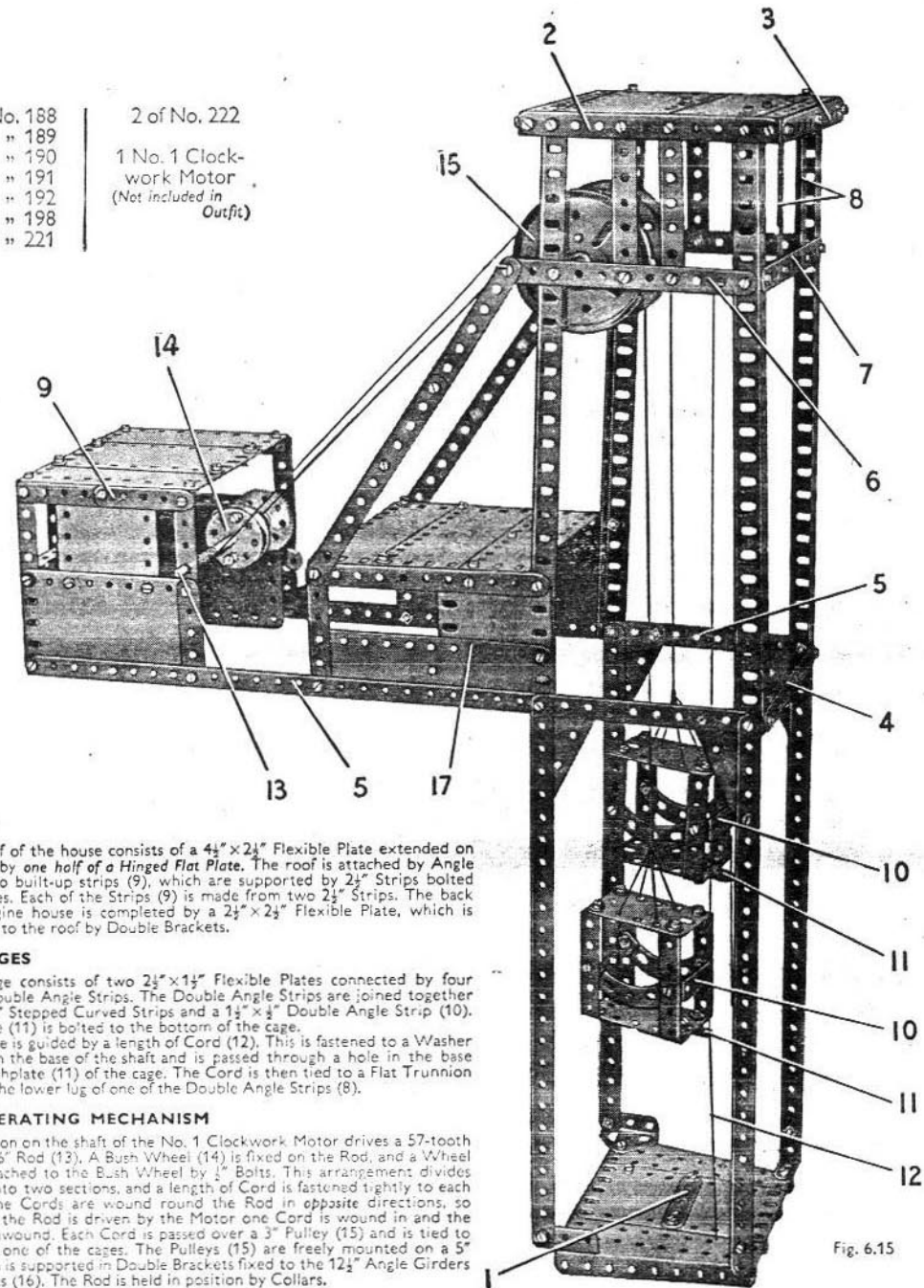

Fig. 6.15

6.16 FORGE CRANE

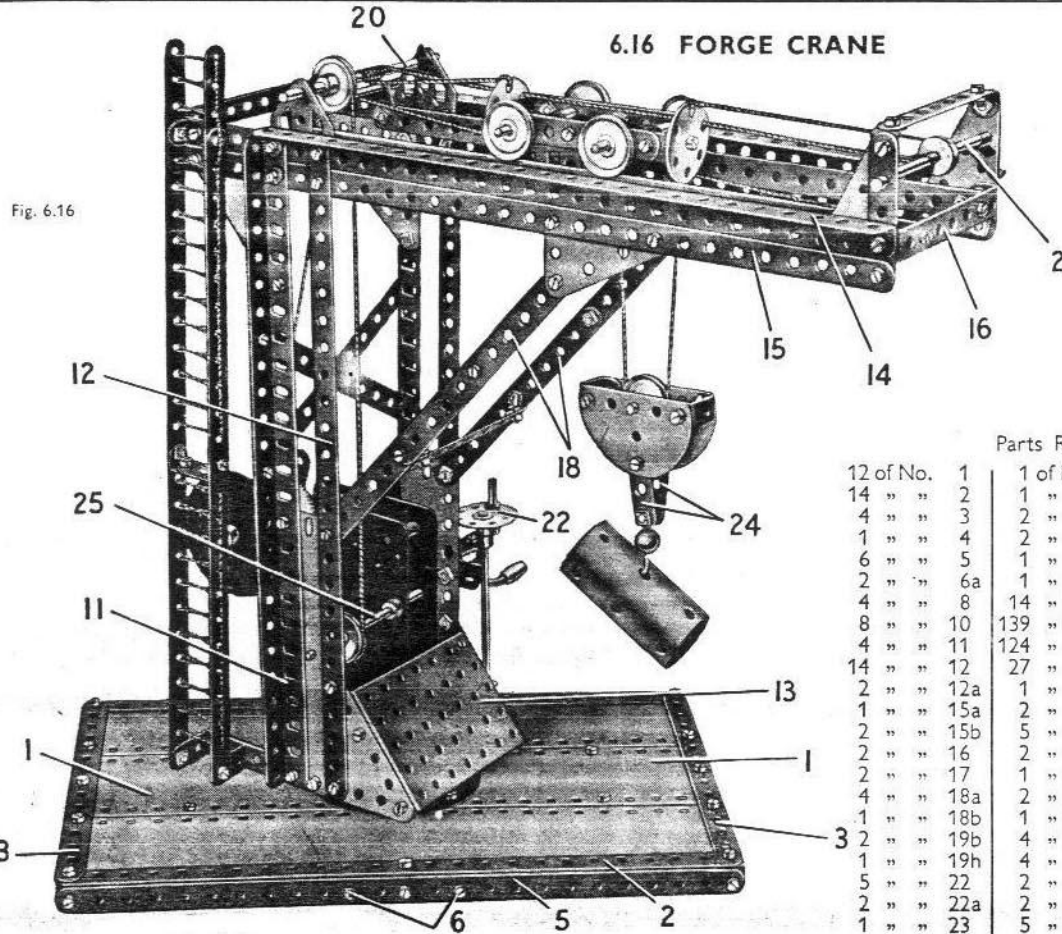

Fig. 6.16

Parts Required		
12 of No. 1	1 of No. 23a	1 of No. 115
14 " " 2	1 " " 24	2 " " 126
4 " " 3	2 " " 24a	4 " " 126a
1 " " 4	2 " " 24c	1 " " 147b
6 " " 5	1 " " 26	1 " " 176
2 " " 6a	1 " " 27a	1 " " 186a
4 " " 8	14 " " 35	1 " " 187
8 " " 10	139 " " 37a	2 " " 189
4 " " 11	124 " " 37b	2 " " 192
14 " " 12	27 " " 38	2 " " 197
2 " " 12a	1 " " 40	1 " " 198
1 " " 15a	2 " " 48	2 " " 213
2 " " 15b	5 " " 48a	2 " " 214
2 " " 16	2 " " 48b	1 " " 216
2 " " 17	1 " " 52	4 " " 221
4 " " 18a	2 " " 53	2 " " 222
1 " " 18b	1 " " 57c	2 " " 223
2 " " 19b	4 " " 59	
1 " " 19h	4 " " 90a	
5 " " 22	2 " " 111	1 No. 1 Clockwork Motor (Not included in Outfit)
2 " " 22a	2 " " 111a	
1 " " 23	5 " " 111c	

A $12\frac{1}{2}$ " Angle Girder (11) and a $12\frac{1}{2}$ " Strip (12) are bolted to each flange of the Plate (9). The $12\frac{1}{2}$ " Strips are braced by $2\frac{1}{2}$ " x $2\frac{1}{2}$ " Triangular Plates connected by a $3\frac{1}{2}$ " x $2\frac{1}{2}$ " Flanged Plate (13). At their upper ends the Girder (11) and the Strip (12) on each side are bolted to a $12\frac{1}{2}$ " Angle Girder (14) and to a built-up strip (15) made from a $12\frac{1}{2}$ " and a $5\frac{1}{2}$ " Strip overlapped six holes. The Girders (14) are connected at one end by a $3\frac{1}{2}$ " x $3\frac{1}{2}$ " Double Angle Strip (16).

The Angle Girders (14) are each extended by a $5\frac{1}{2}$ " Strip, which is connected by a Fishplate to one of the strips (15). A $3\frac{1}{2}$ " x $3\frac{1}{2}$ " Double Angle Strip (17) is bolted between the ends of the $5\frac{1}{2}$ " Strips. The jib is braced by two built-up strips (18), each made from two $5\frac{1}{2}$ " Strips overlapped six holes.

THE CRAB OR TRAVELLING CARRIAGE AND ITS RAILS

The rails are formed by two $12\frac{1}{2}$ " Strips connected by Double Brackets to the Girders (14) and bolted to the lugs of a $2\frac{1}{2}$ " x $4\frac{1}{2}$ " Double Angle Strip fixed to the Double Angle Strip (16). The bolts securing the Strips to the Double Brackets fix also Fishplates, which support a $3\frac{1}{2}$ " Rod (19). A $4\frac{1}{2}$ " Rod (20), fitted with a $1\frac{1}{2}$ " Pulley, is mounted in Flat Trunnions bolted to the Girders (14), and a $4\frac{1}{2}$ " Rod (20), fitted with a $1\frac{1}{2}$ " Pulley, is mounted in Flat Trunnions bolted to the Girders (14).

The crab consists of two $3\frac{1}{2}$ " Strips connected at their ends by $1\frac{1}{2}$ " x $4\frac{1}{2}$ " Double Angle Strips. The wheels are $1\frac{1}{2}$ " Pulleys fixed on built-up rods, each made from two $1\frac{1}{2}$ " Rods joined by a Rod Connector. A Six-Hole Wheel Disc is fixed to each end of the crab, and a Flat Trunnion is attached to each $3\frac{1}{2}$ " Strip. A $2\frac{1}{2}$ " Rod is supported in the lower ends of the Flat Trunnions, and a $1\frac{1}{2}$ " loose Pulley is free to turn between Spring Clips on the Rod.

OPERATING MECHANISM

The jib can be swivelled by turning a Bush Wheel (22). This is fixed on a $4\frac{1}{2}$ " Rod supported in two brackets, each of which is made from a $1\frac{1}{2}$ " Strip bolted to a Trunnion attached to one of the Strips (12). The Rod carries at its lower end a $1\frac{1}{2}$ " fixed Pulley (supplied with the Clockwork Motor) and a belt of Cord is passed round this Pulley and the $3\frac{1}{2}$ " Pulley (8).

A No. 1 Clockwork Motor is bolted to one of the Angle Girders (11) as shown. A $3\frac{1}{2}$ " Pinion on its driving shaft engages a 57-tooth Gear on a $3\frac{1}{2}$ " Rod (23). A length of Cord fastened to a Cord Anchoring Spring on Rod (23) is taken over Rod (19) and round the $1\frac{1}{2}$ " loose Pulley in the crab. The Cord is passed round a $1\frac{1}{2}$ " loose Pulley in the pulley block, over the front axle of the crab and through a hole in one of the Wheel Discs. Finally the Cord is tied to the Double Angle Strip (16).

A small Loaded Hook is attached to the pulley block by a $3\frac{1}{2}$ " Bolt held in two $2\frac{1}{2}$ " Strips (24). The crab can be moved along its rails by turning a Crank Handle (25) held in position by Collars. The handle carries a $1\frac{1}{2}$ " Pulley that is connected by a Driving Band to the $1\frac{1}{2}$ " Pulley on Rod (20). A length of Cord is tied to the front end of the crab, then passed round a $1\frac{1}{2}$ " loose Pulley on Rod (21) and is wound three or four times round Rod (20). The Cord is then tied to the rear of the crab.

CONSTRUCTION OF THE BASE

Two $12\frac{1}{2}$ " x $2\frac{1}{2}$ " Strip Plates and two $5\frac{1}{2}$ " x $2\frac{1}{2}$ " Flexible Plates (1) fill in the top of the base. The Plates are bolted to a $12\frac{1}{2}$ " Strip (2) along each side and built-up strips (3) at the ends. One half of a Hinged Flat Plate is fixed underneath each end of the base and is held by the bolts (4) (Fig. 6.16a).

At their inner ends the $5\frac{1}{2}$ " x $2\frac{1}{2}$ " Flexible Plates are bolted to a $5\frac{1}{2}$ " x $2\frac{1}{2}$ " Flanged Plate placed lengthways across the base. Two $2\frac{1}{2}$ " x $4\frac{1}{2}$ " Double Angle Strips are fixed to each end of the Flanged Plate and are attached to $12\frac{1}{2}$ " Strips (5) by the bolts (6). The Double Angle Strips overlap the Flanged Plate by three holes each, and they are placed inside the flanges of the Plate. A ring (7), made from four $2\frac{1}{2}$ " Stepped Curved Strips, is bolted to the centre of the base, and a $3\frac{1}{2}$ " Pulley (8) with its boss downward is attached by a Pivot Bolt and a $3\frac{1}{2}$ " Bolt to the Flanged Plate of the base, in the centre of the ring.

ASSEMBLY OF THE JIB

The jib is assembled on a $3\frac{1}{2}$ " x $2\frac{1}{2}$ " Flanged Plate (9) (Fig. 6.16a), which is attached by two $4\frac{1}{2}$ " Bolts to a $3\frac{1}{2}$ " Pulley (10). Each Bolt is passed through a hole in the Pulley and is held in place by a nut. It is then fitted with another nut and is passed through the Flanged Plate and two Wheel Discs, and a third nut is used to fix these parts on the Bolt. A $2\frac{1}{2}$ " Rod gripped in the boss of Pulley (10) is passed through the Pulley (8) and the base, and is held in position by a $4\frac{1}{2}$ " fixed Pulley below the base.

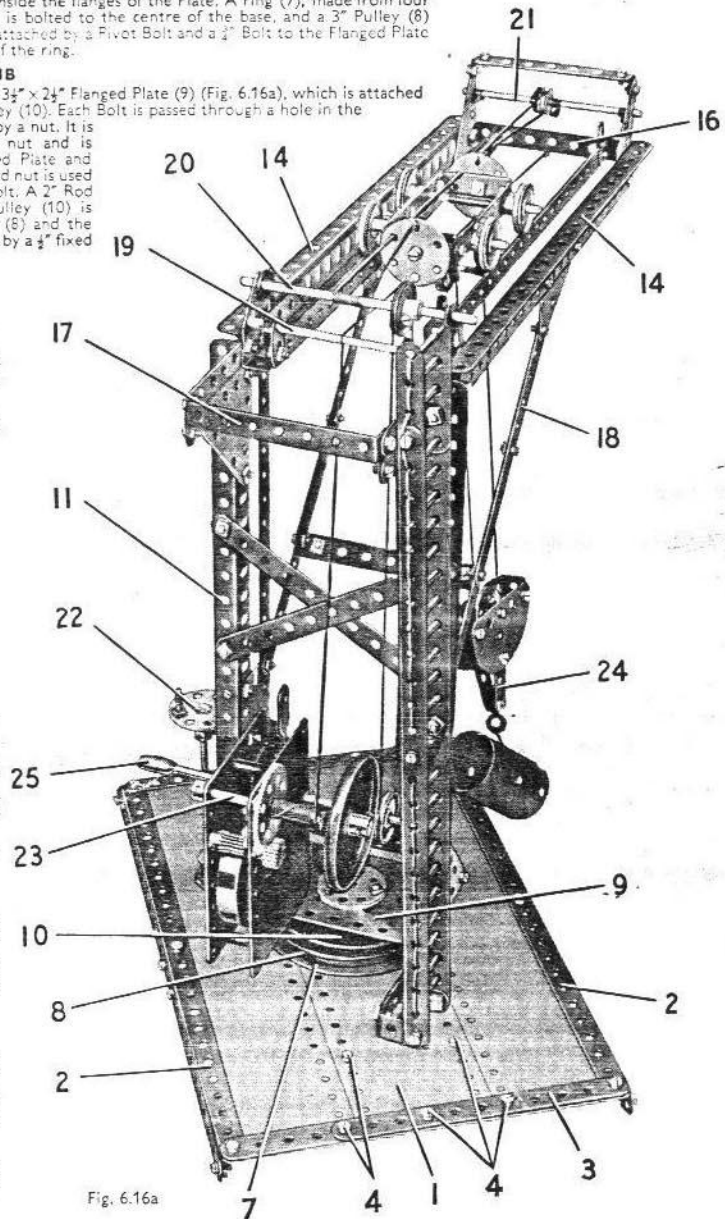

Fig. 6.16a

6.17 DIESEL SHUNTING LOCOMOTIVE

Parts Required

8 of No. 1	2 of No. 12a	1 of No. 23	22 of No. 38	2 of No. 111a	1 of No. 191
14 " " 2	8 " " 12c	1 " " 23a	2 " " 38d	6 " " 111c	4 " " 192
4 " " 3	1 " " 14	1 " " 24	2 " " 48	1 " " 115	2 " " 212
2 " " 4	2 " " 15	2 " " 24a	6 " " 48a	4 " " 126a	2 " " 212a
12 " " 5	1 " " 15a	2 " " 24c	2 " " 48b	1 " " 176	2 " " 213
2 " " 6a	3 " " 16	1 " " 26	1 " " 52	1 " " 186b	1 " " 221
4 " " 8	2 " " 17	1 " " 27a	2 " " 53	4 " " 187	2 " " 222
7 " " 10	1 " " 18a	4 " " 35	1 " " 57c	4 " " 188	1 No. 1 Clockwork Motor
4 " " 11	1 " " 19b	139 " " 37a	4 " " 59	4 " " 189	(not included in Outfit)
16 " " 12	5 " " 22	127 " " 37b	2 " " 111	4 " " 190	

THE LOCOMOTIVE CHASSIS AND WHEELS

Each side of the chassis consists of a 12½" Angle Girder (1) (Fig. 6.17a) and three 12½" Strips. These are connected together at the front by a Flat Trunnion (2) extended downward by a Fishplate, and at the rear they are bolted to a 2½" Strip (3).

The sides are connected by a 5½" Strip (4) and two 3½" × ½" Double Angle Strips (5) and (6), and by a 5½" × 2½" Flanged Plate (7). The running plates on each side are formed by a 12½" Angle Girder (8) and a 12½" Strip bolted to the Strip (4) and to the Flanged Plate (7). The front end of the chassis is filled in by two 5½" × 1½" Flexible Plates and a 5½" Strip bolted to two 2½" Strips (9) (Fig. 6.17). One of the Flexible Plates is attached to the Double Angle Strip (6) (Fig. 6.17a), and the 5½" Strip is connected to the Girders (1) by Angle Brackets. The Strip is fixed to the Angle Brackets by ½" Bolts, and 1" Pulleys on these Bolts represent the buffers.

The rear end of the chassis is filled by a 5½" × 1½" Flexible Plate and a 5½" Strip bolted to two 2½" Strips (10). The top ends of the Strips (10) are fixed to the Flanged Plate (7). A Cord Anchoring Spring is screwed into the centre hole of the 5½" Strip and supports in its lug a small Loaded Hook.

The front driving wheels are fixed on a 5" Rod supported in the chassis. The rear driving wheels are mounted on a built-up rod made from a 3½" and a 1½" Rod joined by a Rod Connector. Each Road Wheel has an Angle Bracket fixed to its boss by a nut and a bolt. The bolt is passed through the round hole of the Angle Bracket and is screwed into a threaded hole in the boss of the Road Wheel. The nut is then tightened against the Angle Bracket to fix it securely to the boss.

The Angle Brackets of the Road Wheels on each side are connected by coupling rods consisting of 5½" Strips. Each Strip is lock-nutted to the rear Angle Bracket by an ordinary bolt, but at the front a ¾" Bolt is used, and this serves also to connect a built-up strip (11) (Fig. 6.17). The built-up strips on each side are made from 5½" and 3" Strips bolted together. Each of the strips (11) is connected to a crank on the end of a 5" Rod (12) (Fig. 6.17a) mounted in the chassis. The crank (13) consists of a Flat Trunnion bolted to a Bush Wheel fixed on the Rod (12) but spaced from the chassis by a Collar. The strip (11) pivots on a ¾" Bolt held in the Flat Trunnion and the Bush Wheel by two nuts, and the strip is spaced from the Flat Trunnion by a ½" fixed Pulley on the Bolt.

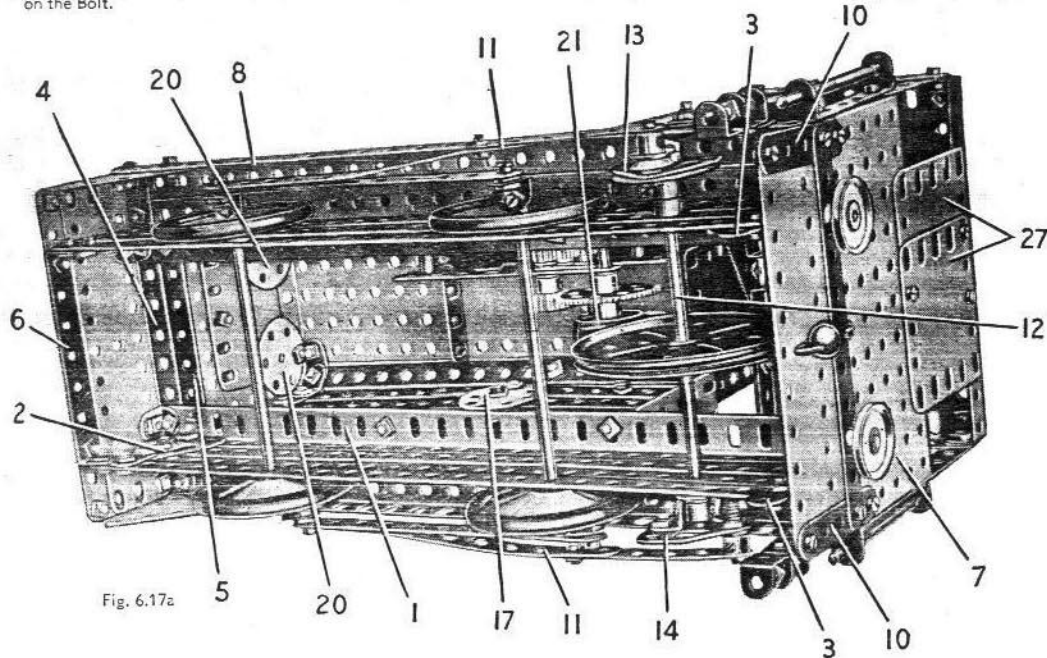

Fig. 6.17a

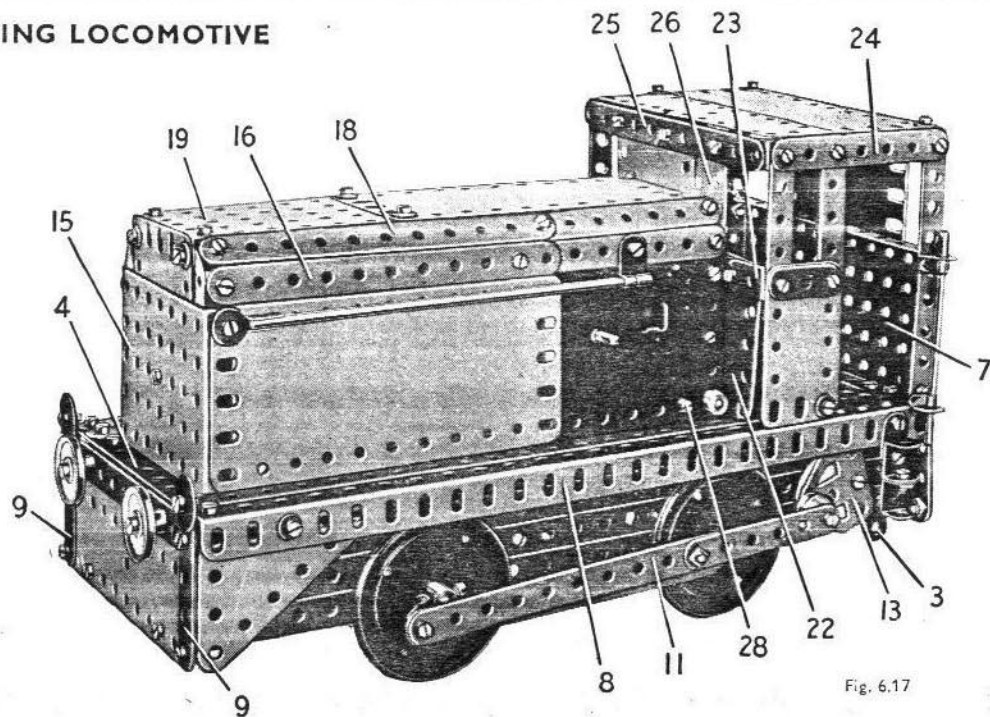

Fig. 6.17

The crank (14) is made by fixing a Collar to the end of Rod (12). A ½" loose Pulley is used to space the Collar from the chassis, and an Angle Bracket is fixed to the Collar in the same way as the Angle Brackets attached to the Road Wheels. A Flat Trunnion is bolted to the Angle Bracket as shown, and one of the strips (11) pivots on a ¾" Bolt held in the Flat Trunnion by two nuts. A Collar on the Bolt is used to space the strip from the Flat Trunnion.

THE ENGINE HOUSING AND DRIVING MECHANISM

A No. 1 Reversing Clockwork Motor is attached to one of the Girders (1) by an Angle Bracket fixed to the Motor by Bolt (28), and the Motor side-plate is extended forward by a 5½" × 2½" Flexible Plate. The opposite side of the engine housing consists of a 4½" × 2½" and a 5½" × 2½" Flexible Plate overlapped three holes. The lower corners of the 4½" × 2½" Flexible Plate are attached to one of the Girders (1) by Angle Brackets, and the front ends of the 5½" × 2½" Flexible Plates are bolted to a 3½" × 2½" Flanged Plate (15).

Each side of the housing is extended upward by a built-up strip (16) made from two 5½" Strips overlapped five holes. These are attached to the sides by Fishplates at the ends of the strips and by Wheel Discs (17) (Fig. 6.17a) at the centre. A further built-up strip (18) (Fig. 6.17), made from a 5½" and a 3½" Strip, is connected to each of the strips (16) by Obtuse Angle Brackets. The top of the engine housing consists of a 5½" × 2½" Flexible Plate and a 3½" × 2½" Flanged Plate (19), and it is bolted to Obtuse Angle Brackets fixed to the strips (18).

The front of the housing is completed by a 2½" × 2½" Flexible Plate bolted to the flange of the Plate (19) and to the Flanged Plate (15). A Wheel Disc (20) is attached to each upper corner of the Flexible Plate. The hand rails along the sides of the housing consist of a 6½" Rod and a built-up rod made from a 4½" and a 2" Rod joined by a Rod Connector.

A ½" Pinion on the Motor driving shaft engages a 57-tooth Gear on a 2" Rod that is held by a Collar in the Motor side-plates. The Rod is fitted also with a 1" Pulley (21) (Fig. 6.17a) and this is connected by a Driving Band to a 3" Pulley on the Rod (12).

CONSTRUCTION OF THE CAB

The front of the cab is made by fitting a 2½" × 1½" Flexible Plate (22) (Fig. 6.17) to each side of the engine housing. One of these Plates is attached to the Clockwork Motor by a ½" × ½" Angle Bracket, and the other is connected to the opposite side of the housing by a 1" × 1" Angle Bracket.

The side of the cab seen in Fig. 6.17 consists of a 2½" × 1½" Flexible Plate attached to one of the Plates (22) by a 1" × 1" Angle Bracket (23), and to one of the Girders (8) by a 1½" × ½" Double Angle Strip placed vertically. The opposite side is also a 2½" × 1½" Flexible Plate. This is fixed to a 1½" × ½" Double Angle Strip bolted to one of the Plates (22) and is connected to one of the Girders (8) by an Angle Bracket.

The roof is supported by three 2½" Strips on each side arranged as shown and connected at their upper ends by 3½" Strips (24). A 2½" × ½" Double Angle Strip is bolted to the front end of each of the Strips (24), and a 5½" Strip (25) is fixed to the Double Angle Strips. A 2½" × 2½" Flexible Plate and a 2½" × 1½" Triangular Flexible Plate (26) are attached to the Strip (25). The rear ends of the Strips (24) are also bolted to 2½" × ½" Double Angle Strips. Two 2½" × 2½" Flexible Plates (27) (Fig. 6.17a) are fixed to these Double Angle Strips and to the Flanged Plate (7).

The roof consists of a 5½" × 2½" and a 5½" × 1½" Flexible Plate attached to the Strips (24) (Fig. 6.17) by Angle Brackets.

6.18 FORK LIFT TRUCK

Parts Required

14 of No. 2	2	16 of No. 12	1 of No. 19h	6 of No. 35	8 of No. 48a	2 of No. 111	1 of No. 186a	2 of No. 199
4 " " 3		2 " " 12a	5 " " 22	137 " " 37a	2 " " 48b	2 " " 111a	4 " " 187	2 " " 200
2 " " 4		3 " " 12c	1 " " 23	125 " " 37b	1 " " 51	1 " " 115	4 " " 188	1 " " 212
12 " " 5		1 " " 14	1 " " 23a	27 " " 38	1 " " 52	2 " " 125	2 " " 189	1 " " 213
2 " " 6a		2 " " 15	1 " " 24	2 " " 38d	2 " " 53	2 " " 126	6 " " 190	2 " " 214
4 " " 8		1 " " 15a	2 " " 24a	1 " " 40	4 " " 59	1 " " 147b	2 " " 191	4 " " 221
2 " " 10		2 " " 16	1 " " 26	1 " " 44	2 " " 90	2 " " 155	1 " " 192	2 " " 222
4 " " 11		1 " " 18b	1 " " 27a	2 " " 48	4 " " 90a	1 " " 176	1 " " 198	2 " " 223

Fig. 6.18a

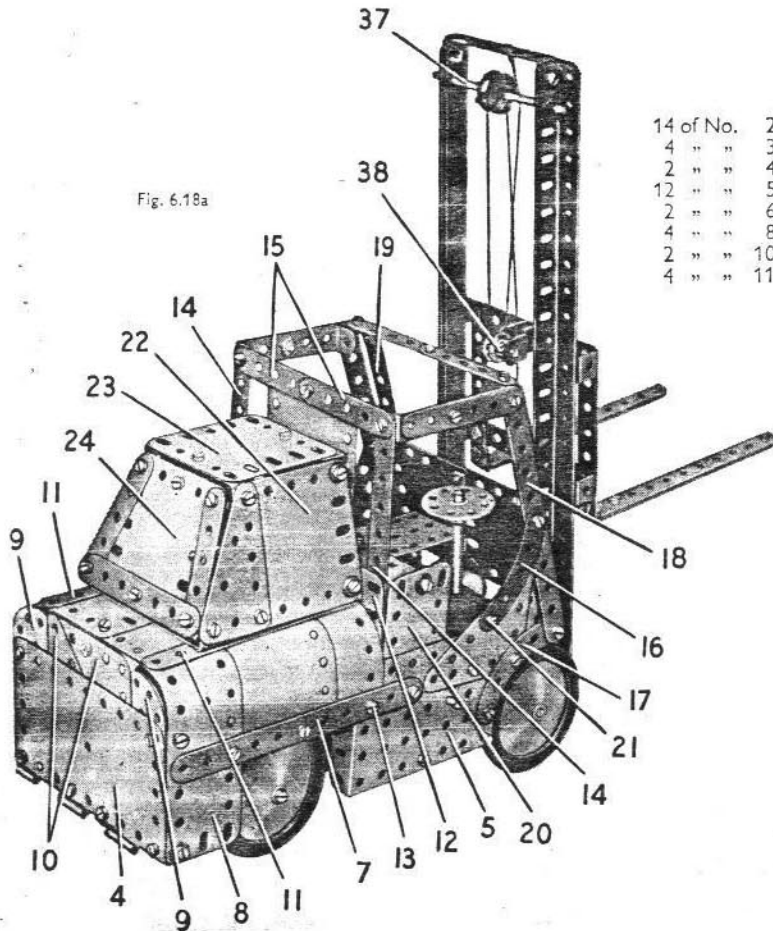

CONSTRUCTION OF THE TRUCK BODY

The base of the body is a $5\frac{1}{2}'' \times 2\frac{1}{4}''$ Flanged Plate (1) (Fig. 6.18b) with one half of a Hinged Flat Plate (2) bolted across it. Two $5\frac{1}{2}''$ Strips (3) are also fixed to the Flanged Plate, and each of these is connected by a $1\frac{1}{2}'' \times \frac{1}{2}''$ Double Angle Strip to the other half of the Hinged Flat Plate (4), which forms the back of the body.

Each side consists of a $3\frac{1}{2}'' \times 2\frac{1}{4}''$ Flanged Plate (5) (Figs. 6.18 and 6.18a), attached to the half of the Hinged Flat Plate (2) by an Angle Bracket. A $5''$ Rod (6) is passed through the Flanged Plates (5) and (1) and is held in place by Spring Clips.

A $5\frac{1}{2}''$ Strip (7) is fixed to each of the Flanged Plates (5) and to these Strips are bolted two opened-out 'U'-section Curved Plates on one side and two $1\frac{1}{4}''$ radius Curved Plates on the other side. Two $5\frac{1}{2}'' \times 1\frac{1}{4}''$ Flexible Plates (8) are also fixed to the Strips (7) and the ends of these Plates are curved over and are bolted together. The Plates (8) are connected to the half of the Hinged Flat Plate (4) by Angle Brackets, and the same bolts also fix in position two Wheel Discs (9). The back of the body is completed by two $2\frac{1}{2}'' \times 2\frac{1}{4}''$ Triangular Flexible Plates (10), which are connected to the Plates (8) by a $2\frac{1}{2}'' \times \frac{1}{2}''$ Double Angle Strip. The curved sides of the body are strengthened by two built-up strips (11), each made from two $2\frac{1}{2}''$ Strips.

The back of the driving compartment is a $4\frac{1}{2}'' \times 2\frac{1}{4}''$ Flexible Plate (12) (Fig. 6.18a) attached to the sides by $\frac{1}{2}''$ Reversed Angle Brackets held by the bolts (13). The ends of the Plate are edged by $5\frac{1}{2}''$ Strips (14), which are bridged at their upper ends by two $2\frac{1}{2}''$ Strips (15). A $5\frac{1}{2}'' \times 2\frac{1}{4}''$ Flexible Plate is bolted between the Strips (15) and the Plate (12).

Each side of the driving compartment is formed by a $2\frac{1}{2}'' \times 2''$ Triangular Flexible Plate, a $2\frac{1}{2}'' \times 1\frac{1}{4}''$ Triangular Flexible Plate, a $2\frac{1}{2}''$ Curved Strip (16) and a $2\frac{1}{2}''$ Stepped Curved Strip (17). A $5\frac{1}{2}''$ Strip (18) is bolted to each side and is connected to one of the Strips (14) by a $3''$ Strip and a $2\frac{1}{2}'' \times \frac{1}{2}''$ Double Angle Strip.

The front of the driving compartment consists of two $2\frac{1}{2}'' \times 2\frac{1}{4}''$ Flexible Plates bolted to two $5\frac{1}{2}''$ Strips (19), which are connected to the Strips (18) by Angle Brackets. The upper ends of the Strips (18) are bridged by two $2\frac{1}{2}''$ Strips bolted to Angle Brackets.

The driving seat is made from two $2\frac{1}{2}'' \times 1\frac{1}{4}''$ Flexible Plates bolted end to end and connected by Trunnions to a $2\frac{1}{2}'' \times 1\frac{1}{4}''$ Flexible Plate (20) on each side. The floor is a $4\frac{1}{2}'' \times 2\frac{1}{4}''$ Flexible Plate fixed to Angle Brackets held by the bolts (21).

A $2\frac{1}{2}'' \times 2\frac{1}{4}''$ Flexible Plate (22) and a $2\frac{1}{2}'' \times 1\frac{1}{4}''$ Triangular Flexible Plate on each side are fixed to the lugs of two $3\frac{1}{2}'' \times 1\frac{1}{4}''$ Triangular Flexible Plates bolted across the strips (11). The upper edges of the Flexible Plates are connected by two $2\frac{1}{2}'' \times \frac{1}{2}''$ Double Angle Strips and a $2\frac{1}{2}'' \times 2\frac{1}{4}''$ Flexible Plate (23) is fixed to the Double Angle Strips. A further $2\frac{1}{2}'' \times 2\frac{1}{4}''$ Flexible Plate (24) edged by a $3\frac{1}{2}''$ and two $2\frac{1}{2}''$ Strips as shown in Fig. 6.18a is attached to the Plate (23) by an Obtuse Angle Bracket.

THE WHEELS AND THE STEERING MECHANISM

The front wheels are fixed on a $4\frac{1}{2}''$ Rod supported in the Flanged Plate (1) and held in position by $1''$ Pulleys. Each of the rear wheels is free to turn on a $\frac{3}{8}''$ Bolt held by two nuts in one lug of an Angle Bracket. A $\frac{1}{2}''$ Bolt (25) is gripped tightly by a nut in a $1\frac{1}{2}''$ Strip (26) and a second nut is screwed against the first.

The Bolt is passed through a hole in a Semi-Circular Plate bolted to the Strips (3), and the Angle Bracket to which the front wheel is fixed is gripped tightly on the Bolt by two nuts. The ends of the Strips (26) are connected by a Semi-Circular Plate (27) attached by Lock-nutted bolts.

The steering column is a $5''$ Rod that carries at its lower end a $\frac{1}{2}''$ Pinion (28) (Fig. 6.18b). The Rod is supported in the Flexible Plate forming the floor of the cab and in the Flanged Plate (1). The Pinion engages a 57-tooth Gear (29), which is fixed on a Threaded Pin passed through the Flanged Plate. A $6\frac{1}{2}''$ Rod is attached to the Gear (29) by a Rod and Strip Connector fixed by a $\frac{3}{8}''$ Bolt, and a Collar held by a bolt fitted with a nut and screwed into a threaded hole of the Collar. The Rod and Strip Connector is spaced from the Gear by two nuts on the $\frac{3}{8}''$ Bolt. The end of the $6\frac{1}{2}''$ Rod slides in a Collar (30), which is pivoted by its threaded hole on a bolt held by a nut in the Semi-Circular Plate (27).

THE FORK LIFT MECHANISM

Each of the slides for the lifting forks consists of two $12\frac{1}{2}''$ Angle Girders bolted together by their slotted holes as shown, so that a gap sufficient to accommodate the lug of a Double Bracket is left between the narrower flanges of the Angle Girders. The pairs of Angle Girders are fixed at their lower ends to the front of the Flanged Plate (1), and they are connected at the top by a $2\frac{1}{2}'' \times \frac{1}{2}''$ Double Angle Strip. The Girders are braced to the Flanged Plate by a $2\frac{1}{2}''$ Stepped Curved Strip (31).

The back-plate for the lifting forks is made from two $5\frac{1}{2}''$ Strips (32) joined together by a further $3\frac{1}{2}''$ Strip and a built-up strip made from two $2\frac{1}{2}''$ Strips overlapped three holes. Two Double Brackets are attached to each side of the back-plate, and their lugs slide freely in the gaps between the $12\frac{1}{2}''$ Angle Girders. The lifting forks are each made from two $5\frac{1}{2}''$ Strips connected to the back-plate by $1'' \times 1''$ Angle Brackets.

(Continued on next page)

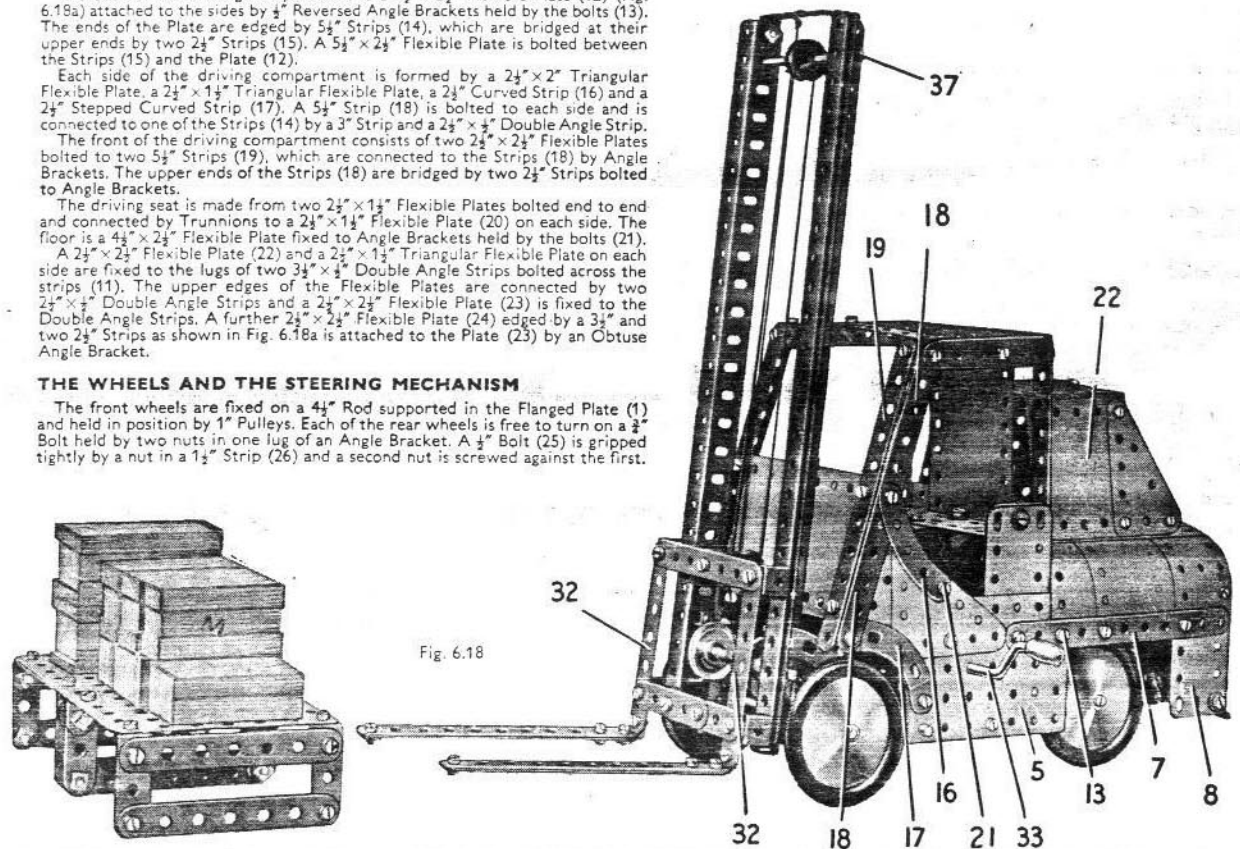

MODEL 6.18 FORK LIFT TRUCK — Continued

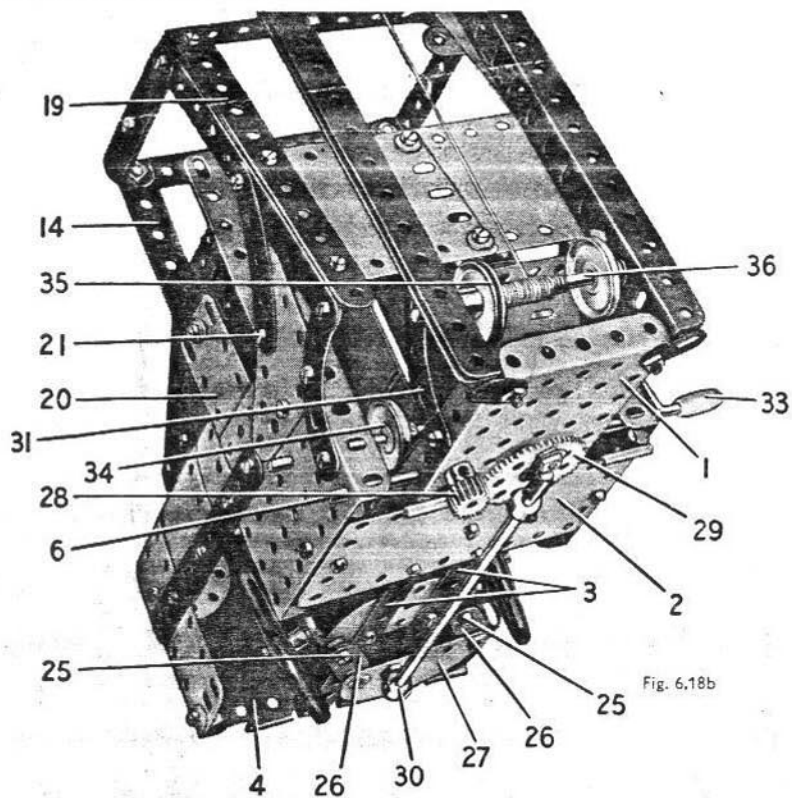

Fig. 6.18b

A 5" Crank Handle (33) is joined to a 1½" Rod by a Rod Connector and is mounted in the Flanged Plates (5). The Crank Handle is held in place by a Collar, and it carries a 1" Pulley (34) that is connected to a similar Pulley (35) by a Driving Band. The Pulley (35) and another 1" Pulley are fixed on a 3½" Rod (36) that is fitted with a Cord Anchoring Spring. A length of Cord fastened to the Cord Anchoring Spring is taken over a ½" loose Pulley on a 3½" Rod (37) (Figs. 6.18 and 6.18a), round a ½" fixed Pulley (38) and is tied to the top of the fork lift slides. The Pulley (38) is held on a Pivot Bolt supported in a Stepped Bent Strip.

CONSTRUCTION OF THE PALLET

A load-carrying pallet for use with the Fork Lift Truck can be made as shown in Fig. 6.18c. The load platform is a 2½" Flat Plate, and each of the legs is made from two 3½" and two 1½" Strips. The legs are arranged in pairs bolted to the lugs of 2½" x ½" Double Angle Strips, which are fixed to the Flat Plate.

Note: The parts used in the construction of the pallet are not included in a No. 6 Outfit.

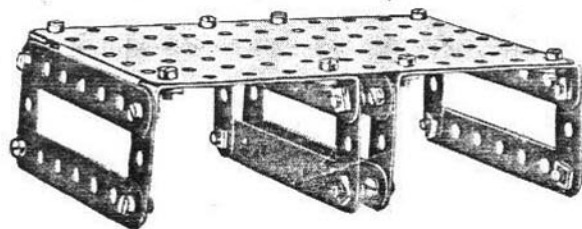

Fig. 6.18c

6.19 SINGLE-DECK BUS

CONSTRUCTION OF THE CHASSIS (See Figs. 6.19a and 6.19b)

The chassis consists of two built-up girders, each made from two 12½" Angle Girders overlapped 13 holes. The rear ends of the girders are bolted to a 5½" x 2½" Flanged Plate (1), and the front ends are connected by a 2½" x ½" Double Angle Strip (2) and a 5½" Strip (3). Each of the chassis girders is extended forward by a 5½" Strip (4) that overlaps the girder by seven holes.

ASSEMBLY OF THE BODY

The side of the body seen in Fig. 6.19 is attached to two built-up strips (5) and (6). The strip (5) consists of a 12½" and a 5½" Strip overlapped three holes, the 5½" Strip being curved at the front as shown. The strip (6) is made from a 12½" and a 5½" Strip overlapped seven holes. Strips (5) and (6) are connected by two 5½" Strips (7), a 3½" x ½" Double Angle Strip (8), and two 2½" x ½" Double Curved Angle Strips (9). A curved 2½" Strip (10) is connected to the strip (5) by a 3½" and a 3" Strip. The side is plated by a 1½" radius Curved Plate (11), one half of a hinged Flat Plate (12), a 4½" x 2½" Flexible Plate (13), a 5½" x 1½" Flexible Plate (14) and a 3½" x 2½" Flanged Plate (15). The Curved Plate (11) is bolted to the ends of the 3½" and the 3" Strip, and the Flanged Plate (15) is fixed to the Flanged Plate (1). The other Plates of the side are secured to the Strips (7) and the Double Angle Strip (8). The wheel arch is formed by two 2½" Stepped Curved Strips.

The other side of the bus is similar to the side already described, but the strip (6) is replaced by a built-up strip made from a 12½" and a 5½" Strip overlapped three holes, which is bolted at its front end to a 2½" Strip corresponding to the Strip (10). The gap left for the entrance in the side shown in Fig. 6.19 is filled in on the opposite side by two 2½" x 2½" Triangular Flexible Plates bolted together to make a 2½" x 2½" plate.

(Continued on next page)

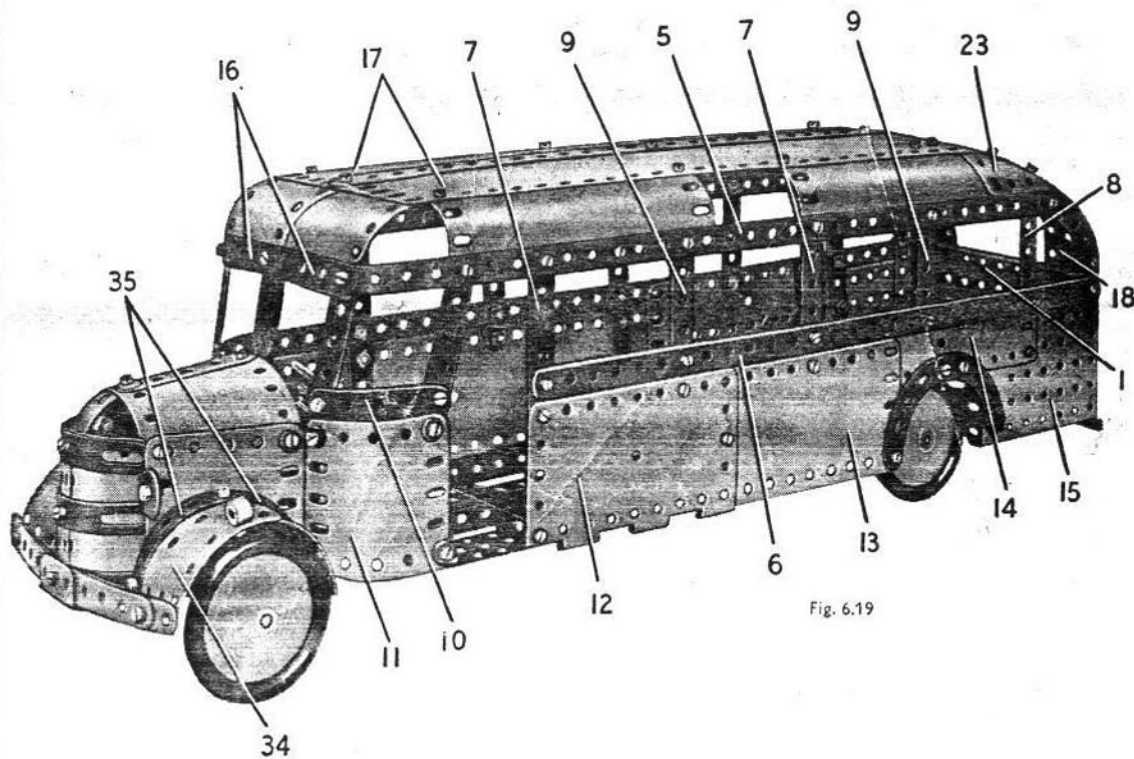

Fig. 6.19

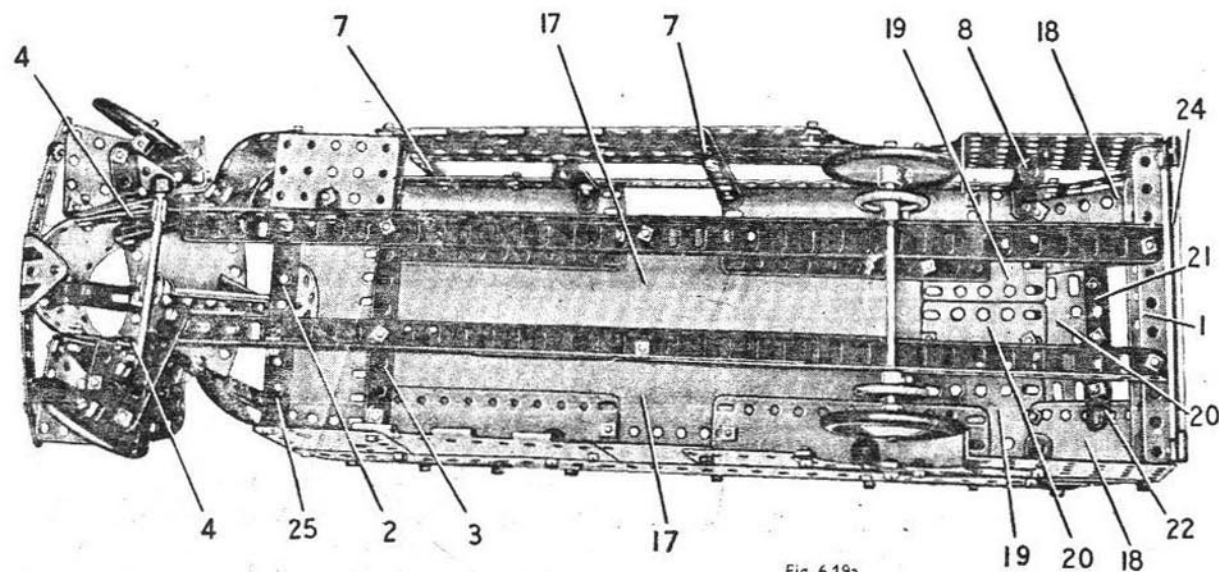

Fig. 6.19a

The top of the bonnet consists of two curved $2\frac{1}{2}'' \times 2\frac{1}{2}''$ Flexible Plates bolted together and attached to the sides as shown. A Formed Slotted Strip is fixed between the top and the radiator. The front bumper is a $5\frac{1}{2}''$ Strip extended on each side by a $2\frac{1}{2}''$ Strip. It is fixed to the lower end of the radiator, and a Trunnion is secured by the same bolt.

Each of the front wheels is fixed on a $1\frac{1}{2}''$ Rod that is held in a Double Bracket (26) (Fig. 6.19b) by a Collar. A $1\frac{1}{2}''$ Strip (27) is placed between the lugs of each Double Bracket and a $\frac{3}{8}''$ Bolt is passed through the two parts. A Washer and a nut are placed on the Bolt, which is then passed through an arm of a $1'' \times 1''$ Angle Bracket (28) and is fitted with a second nut. The two nuts are screwed tightly together to fix the Bolt in the Angle Bracket, leaving the Double Bracket and the $1\frac{1}{2}''$ Strip free to swivel as a unit on the Bolt. The Angle Brackets (28) are bolted tightly to the sides of the bonnet.

A Rod and Strip Connector is lock-nutted to each of the Strips (27). One of them is attached by a $\frac{1}{2}''$ Bolt, on which is pivoted a $2\frac{1}{2}''$ Strip (29). The Strip is spaced from the Rod and Strip Connector by four Washers. A $4''$ Rod is held at each end in one of the Rod and Strip Connectors.

The steering column is a $3\frac{1}{2}''$ Rod supported in a $2\frac{1}{2}'' \times \frac{1}{2}''$ Double Angle Strip seen at (30). The Double Angle Strip is bolted at a slight angle to a Trunnion (31) attached to the chassis. The $3\frac{1}{2}''$ Rod carries at its upper end a Bush Wheel and a $\frac{1}{2}''$ loose Pulley, and at its lower end a $\frac{1}{2}''$ fixed Pulley (32) is fixed. An Angle Bracket (33) is gripped by a nut on a $\frac{3}{8}''$ Bolt, which is then screwed tightly into a threaded hole in the Pulley (32). The Angle Bracket is lock-nutted to the end of the Strip (29).

Each of the front mudguards consists of a $2\frac{1}{2}'' \times 2''$ Triangular Flexible Plate (34) (Fig. 6.19c) and a $2\frac{1}{2}'' \times 1\frac{1}{2}''$ Triangular Flexible Plate. These Plates are fixed to two curved $2\frac{1}{2}''$ Strips (35) bolted together and connected by Angle Brackets at their lower ends to the side of the bonnet.

Parts Required

6 of No. 1	2 of No. 12a	1 of No. 24	1 of No. 52	2 of No. 155	2 of No. 199
14 " " 2	4 " " 12c	140 " " 37a	2 " " 53	4 " " 187	2 " " 200
4 " " 3	2 " " 15	129 " " 37b	4 " " 59	4 " " 188	2 " " 212
2 " " 4	1 " " 15b	24 " " 38	2 " " 90	4 " " 189	2 " " 212a
12 " " 5	1 " " 16	2 " " 38d	4 " " 90a	6 " " 190	2 " " 214
2 " " 6a	2 " " 18a	2 " " 48	1 " " 111	2 " " 191	4 " " 215
4 " " 8	2 " " 22	6 " " 48a	2 " " 111a	4 " " 192	4 " " 221
6 " " 10	1 " " 23	2 " " 48b	6 " " 111c	2 " " 197	2 " " 222
2 " " 11	1 " " 23a	1 " " 51	2 " " 126	1 " " 198	2 " " 223
11 " " 12					

MODEL 6.19 SINGLE-DECK BUS — Continued

CONSTRUCTION OF THE ROOF

The strip (5) (Fig. 6.19) and the corresponding strip on the opposite side are connected at the front by two $2\frac{1}{2}''$ Strips (16), and the centre division of the windscreen is a $3\frac{1}{2}''$ Strip. Two opened out 'U'-section Curved Plates are bolted to the Strips (16), and are joined to two $12\frac{1}{2}'' \times 2\frac{1}{2}''$ Strip Plates (17). The Strip Plates are connected to the sides of the bus by two curved $5\frac{1}{2}'' \times 2\frac{1}{2}''$ Flexible Plates on each side.

The rear end of the roof and the curved panelling at the rear are formed by two $5\frac{1}{2}'' \times 1\frac{1}{2}''$ Flexible Plates (18) that overlap the Flanged Plate (1) (Figs. 6.19 and 6.19a) by four holes. The top ends of these Flexible Plates are connected to the Strip Plates (17) by two $2\frac{1}{2}'' \times 1\frac{1}{2}''$ Flexible Plates (19). The gap between the Plates (19) is filled by two further $2\frac{1}{2}'' \times 1\frac{1}{2}''$ Flexible Plates (20). Two $12\frac{1}{2}''$ Strips overlapped 18 holes are bolted along the centre of the roof, and the end of one of these Strips is secured to a $3\frac{1}{2}''$ Strip (21). The Strip (21) is clamped to the Flexible Plates (18) on each side by a Fishplate (22) bolted to the Strip. A $2\frac{1}{2}'' \times 1\frac{1}{2}''$ Triangular Flexible Plate (23) (Fig. 6.19) is fixed to each side as shown.

The body is completed by bolting a $5\frac{1}{2}''$ Strip to the lower rear corners of the Flanged Plates (15). The bolts securing the Strip hold also Right-Angle Rod and Strip Connectors that support a $5''$ Rod (24) (Fig. 6.19a).

The body is attached to the chassis at the front by Angle Brackets bolted to the ends of the Strip (3), and by a $1\frac{1}{2}'' \times \frac{1}{2}''$ Double Angle Strip (25) on each side. The step inside the doorway is a $2\frac{1}{2}'' \times 1\frac{1}{2}''$ Flanged Plate that is connected to the chassis by an Angle Bracket.

The rear wheels are fixed on a $5''$ Rod supported in the chassis and held in place by $1''$ Pulleys.

THE BONNET AND STEERING MECHANISM

Each side of the bonnet is a $2\frac{1}{2}'' \times 2\frac{1}{2}''$ Flexible Plate attached to the Curved Plate (11) by Obtuse Angle Brackets and bolted to the end of one of the Strips (4) (Fig. 6.19b). The radiator is formed by two curved $2\frac{1}{2}'' \times 2\frac{1}{2}''$ Flexible Plates bolted together and edged by three Formed Slotted Strips. These Plates overlap the sides of the bonnet by two holes on each side.

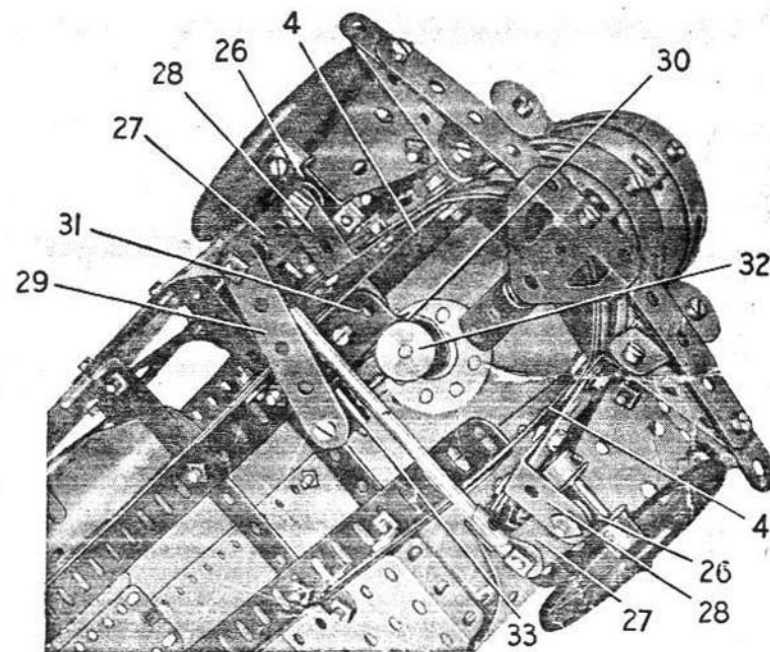

Fig. 6.19b

6.20 TOWER WAGON

Parts Required	
8 of No. 1	2 of No. 15b
14 " " 2	2 " " 17
4 " " 3	3 " " 18a
2 " " 4	1 " " 19h
12 " " 5	5 " " 22
2 " " 6a	1 " " 23
4 " " 8	1 " " 23a
8 " " 10	1 " " 24
2 " " 11	1 " " 26
16 " " 12	1 " " 27a
2 " " 12a	3 " " 35
2 " " 15	141 " " 37a
1 " " 15a	
131 of No. 37b	4 of No. 59
20 " " 38	2 " " 90
2 " " 38d	4 " " 90a
1 " " 40	2 " " 111
1 " " 44	2 " " 111a
2 " " 48	6 " " 111c
8 " " 48a	2 " " 125
2 " " 48b	2 " " 126
1 " " 51	4 " " 155
1 " " 52	1 " " 176
2 " " 53	4 " " 187
2 " " 54	4 " " 188
	4 of No. 189
	2 " " 190
	2 " " 191
	4 " " 192
	2 " " 197
	2 " " 199
	2 " " 200
	2 " " 212
	2 " " 212a
	2 " " 213
	2 " " 214
	3 " " 215
	4 " " 221
	2 " " 222

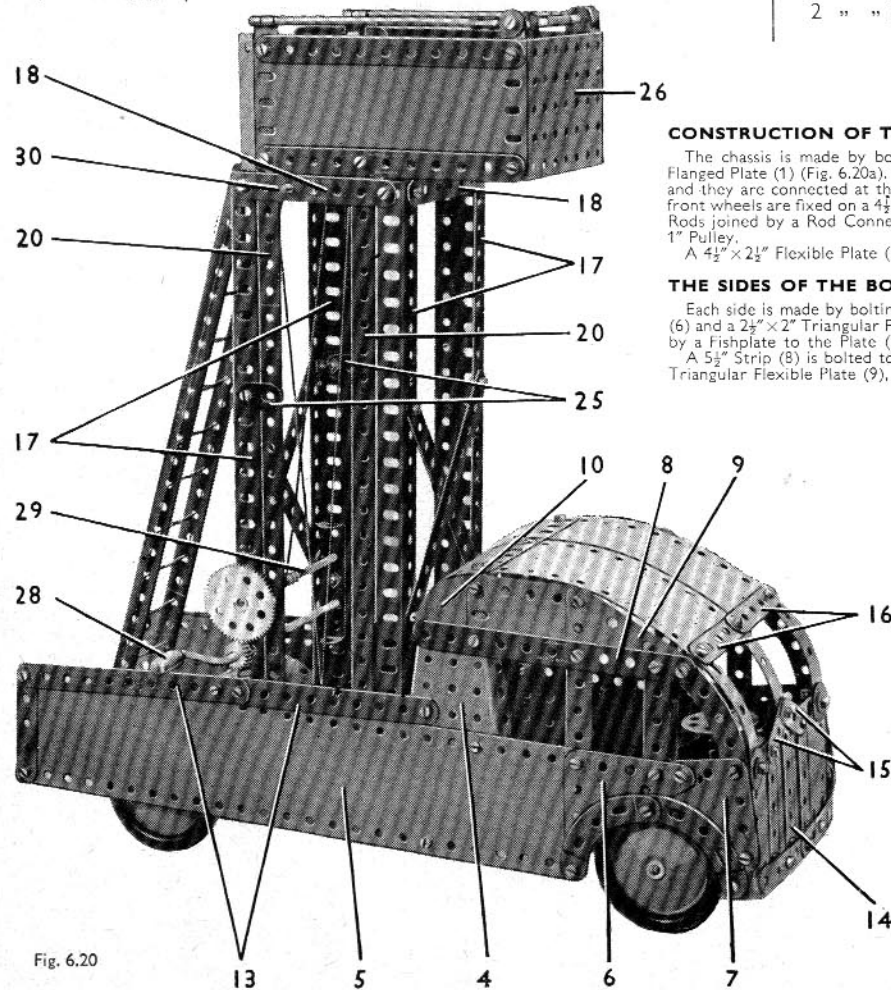

Fig. 6.20

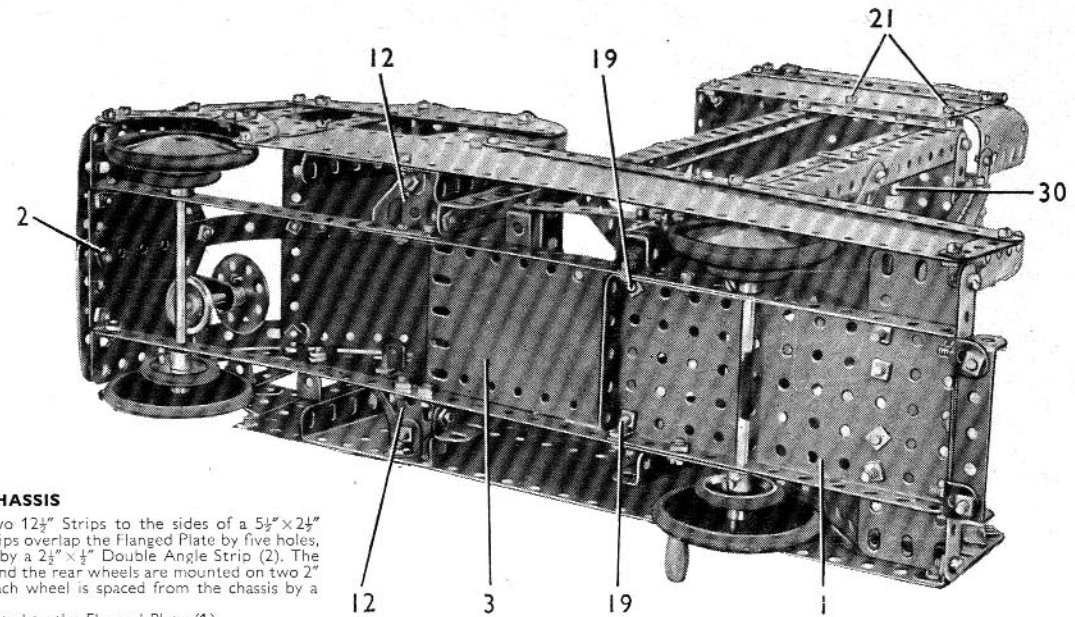

Fig. 6.20a

CONSTRUCTION OF THE CHASSIS

The chassis is made by bolting two 12 1/2" Strips to the sides of a 5 1/2" x 2 1/2" Flanged Plate (1) (Fig. 6.20a). The Strips overlap the Flanged Plate by five holes, and they are connected at the front by a 2 1/2" x 1/2" Double Angle Strip (2). The front wheels are fixed on a 4 1/2" Rod, and the rear wheels are mounted on two 2" Rods joined by a Rod Connector. Each wheel is spaced from the chassis by a 1" Pulley.

A 4 1/2" x 2 1/2" Flexible Plate (3) is bolted to the Flanged Plate (1).

THE SIDES OF THE BODY

Each side is made by bolting a Flanged Sector Plate (4) to a 12 1/2" x 2 1/2" Strip Plate (5) (Fig. 6.20). The Strip Plate is extended forward by a 2 1/2" x 1 1/2" Triangular Flexible Plate (6) and a 2 1/2" x 2" Triangular Flexible Plate (7). The wheel arch consists of two 2 1/2" Stepped Curved Strips. One of these is bolted to the Strip Plate (5) and the other is attached by a Fishplate to the Plate (7).

A 5 1/2" Strip (8) is bolted to the Flanged Sector Plate (4), and is connected to the Plates (6) and (7) by two 2 1/2" x 1/2" Double Angle Strips and a 2 1/2" Curved Strip. A 2 1/2" x 1 1/2" Triangular Flexible Plate (9), a 2 1/2" x 1 1/2" Flexible Plate and a Semi-Circular Plate (10) are fixed to the Strip (8) as shown.

Each side is connected to the chassis by Angle Brackets bolted to a built-up strip (11) (Fig. 6.20b), and Trunnions (12) (Fig. 6.20a). The built-up strip consists of a 3" and a 2 1/2" Strip overlapped two holes. A step at the rear is made from a 2 1/2" x 1 1/2" Double Angle Strip attached to the strip (11) by Angle Brackets. A sloping edge to each side is provided by two 5 1/2" Strips (13) fixed to the Flanged Sector Plate (4) and the Strip Plate (5).

THE FRONT OF THE CAB AND THE ROOF

The front consists of two 2 1/2" x 2 1/2" Flexible Plates attached by a 3" and two 1/2" Bolts to the Double Angle Strip (2) (Fig. 6.20a). These Bolts support also the front bumper, which consists of two 2 1/2" Strips spaced from the cab by a Spring Clip on each Bolt. The 3" Bolt secures also a 3" Strip (14) (Fig. 6.20), and each 1/2" Bolt holds in place a 2 1/2" Strip. The top ends of the Strips are joined as shown by two 1 1/2" Strips (15). The 2 1/2" x 2 1/2" Flexible Plates are attached to the sides of the body by Angle Brackets.

The windscreen pillars are three Formed Slotted Strips, connected at their upper ends by two 2 1/2" Strips (16) and two 5 1/2" x 2 1/2" Flexible Plates. The Flexible Plates are extended to the rear by two 1 1/2" radius Curved Plates, which are bolted to the Flanged Sector Plates (4) and are connected by Angle Brackets to the Semi-Circular Plates (10).

The steering wheel is a Bush Wheel on a 1 1/2" Rod that is held in a Stepped Bent Strip by a 1" Pulley. The Stepped Bent Strip is bolted to the front of the cab.

DETAILS OF THE TOWER

The fixed part of the tower consists of four 12 1/2" Angle Girders (17) (Figs. 6.20 and 6.20b) connected at their upper ends by four 3 1/2" Strips (18). The front pair of Girders is attached to the 12 1/2" Strips of the chassis by 1/2" x 1/2" Angle Brackets. The rear Girders are connected to the Flanged Plate (1) by 1" x 1" Angle Brackets held by the bolts (19). The Girders are braced as shown by crossed 5 1/2" Strips.

The lifting section of the tower consists of four 12 1/2" Strips (20) bolted at their upper ends to a 3 1/2" x 2 1/2" Flanged Plate that forms part of the tower platform. The Strips are connected to the Plate by two bolts (21) on each side. The lower ends of the Strips (20) are joined by a 2 1/2" Strip (22) on each side, and by a 3 1/2" x 1/2" Double Angle Strip (23) and a similar part held by bolts (24). The Strips (20) slide between the Girders (17), and they are guided by pairs of Fishplates (25) bolted to two of the Girders. The Fishplates in each pair are spaced apart by the flange of the Girder and by a Washer on the bolt holding the Fishplates in position.

The sides of the platform are 5 1/2" x 2 1/2" Flexible Plates edged by 5 1/2" Strips, and they are attached by the bolts (21) to the Flanged Plate previously mentioned. The Flexible Plates are bolted at their front ends to a 3 1/2" x 2 1/2" Flanged Plate (26). The platform floor is filled in by two 5 1/2" x 1 1/2" Flexible Plates and a 4 1/2" x 2 1/2" Flexible Plate. These are fixed to the Flanged Plate held by the bolts (21), and the front ends of the 5 1/2" x 1 1/2" Flexible Plates are attached by Angle Brackets to the Flanged Plate (26).

Two "U"-section Curved Plates (27) are opened out slightly and are fixed to the sides of the platform. The Plates (27) are connected by a 2 1/2" Strip, and this is bolted to the flange of a 2 1/2" x 1 1/2" Flanged Plate fixed to the platform floor. The platform side rails are 5" Rods supported in Right-Angle Rod and Strip Connectors and in Rod and Strip Connectors bolted to the sides. The front rail is made from two 1 1/2" Rods joined by a Rod Connector, and it is supported in 1/2" Reversed Angle Brackets bolted to the platform sides.

The rear wheel covers are 5 1/2" x 1 1/2" Flexible Plates curved as shown and secured at the front to two of the Girders (17). The rear ends of the Flexible Plates are bolted to the Flanged Plate (1).

(Continued on next page)

MODEL 6.20 TOWER WAGON — Continued

The ladder to the tower consists of two $12\frac{1}{2}$ " Strips bolted to two $1\frac{1}{2}$ " x $\frac{1}{2}$ " Double Angle Strips. The rungs are represented by Cord.

THE PLATFORM OPERATING MECHANISM

A $2\frac{1}{2}$ " x $\frac{1}{2}$ " Double Angle Strip is bolted to each of the rear Angle Girders (17), and a Crank Handle (28) and a 4" Rod (29) are supported in the Double Angle Strips. A $\frac{1}{2}$ " Pinion on the Crank Handle drives a 57-tooth Gear on the Rod (29). The Crank Handle and the Rod are held in position by Collars.

A length of Cord is fastened to a Cord Anchoring Spring on the Rod (29), and the Cord is led over a $\frac{1}{2}$ " fixed Pulley on a 4" Rod (30). This Rod is held by Collars in two of the Strips (18). The Cord is passed round a $\frac{1}{2}$ " loose Pulley (31), and finally is tied to one of the Strips (18) at a point (32). The Pulley (31) is freely mounted on a $\frac{1}{4}$ " Bolt that is held by two nuts in the Double Angle Strip (23).

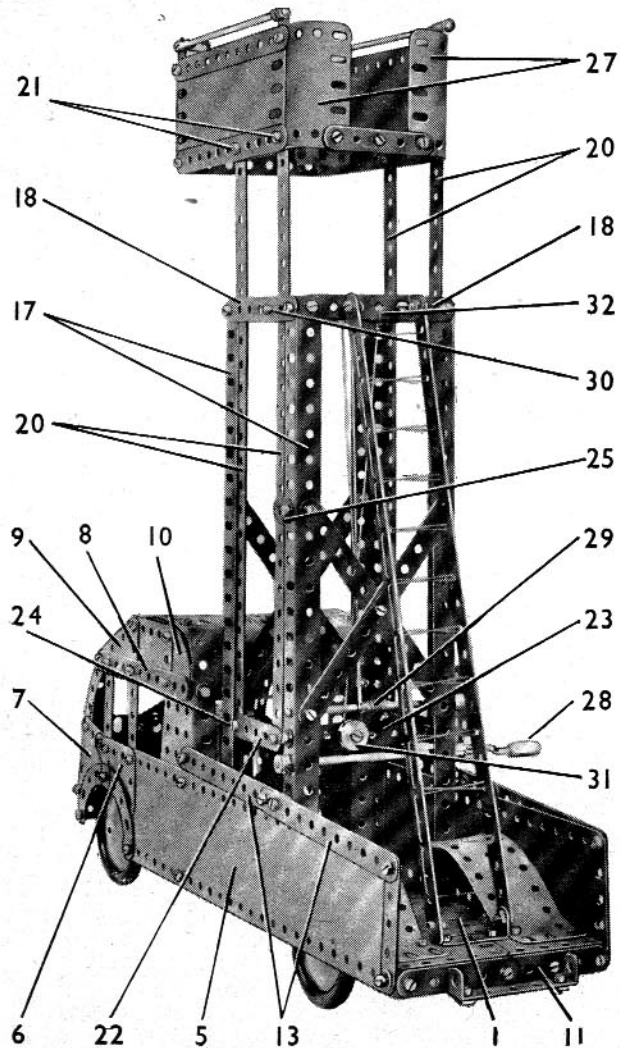

Fig. 6.20b

6.21 REAR DUMPING TRUCK

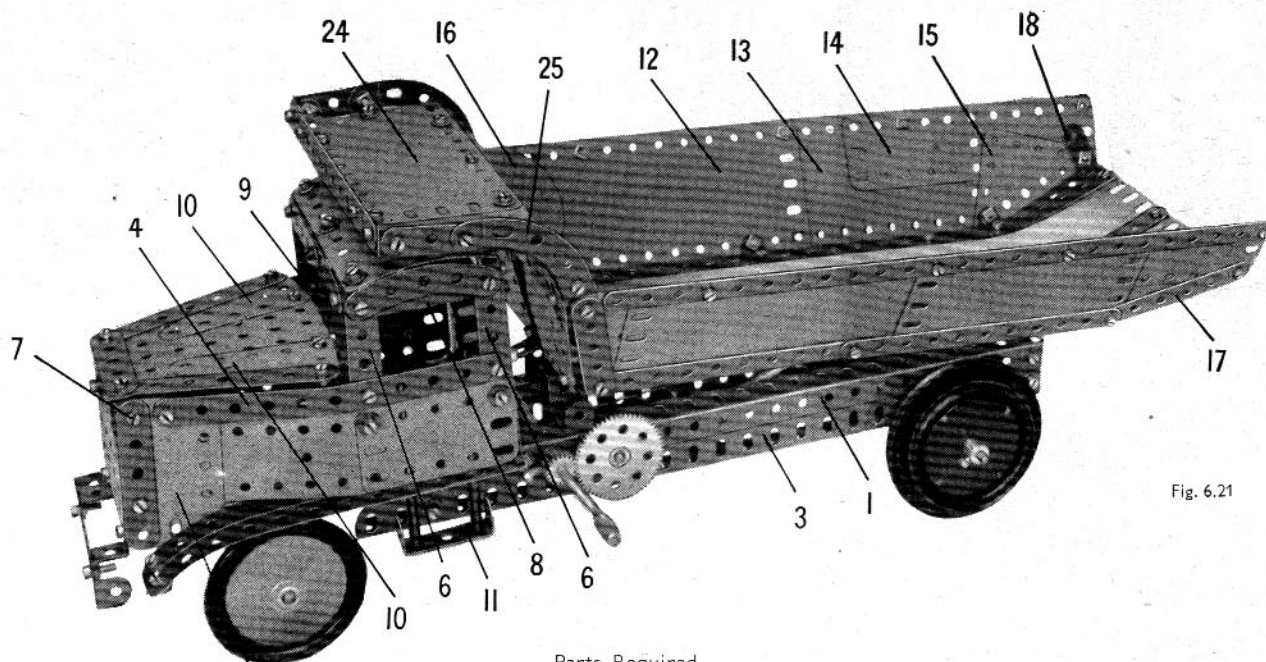

Fig. 6.21

Parts Required

5 of No. 1	3 of No. 11	1 of No. 19g	1 of No. 45	2 of No. 111a	2 of No. 191
14 " " 2	16 " " 12	2 " " 22	2 " " 48	6 " " 111c	4 " " 192
4 " " 3	2 " " 12a	1 " " 26	8 " " 48a	4 " " 125	2 " " 197
2 " " 4	8 " " 12c	1 " " 27a	2 " " 48b	2 " " 126	1 " " 198
12 " " 5	1 " " 15	1 " " 35	1 " " 51	4 " " 126a	2 " " 200
2 " " 6a	1 " " 15a	140 " " 37a	1 " " 52	1 " " 147b	1 " " 212
4 " " 8	3 " " 16	130 " " 37b	1 " " 53	2 " " 155	2 " " 213
8 " " 10	2 " " 19b	26 " " 38	4 " " 59	1 " " 176	2 " " 214
		1 " " 40	2 " " 80c	4 " " 187	2 " " 215
			2 " " 90	4 " " 188	4 " " 221
			3 " " 90a	4 " " 189	2 " " 222
			1 " " 111	4 " " 190	2 " " 223

CONSTRUCTION OF THE CHASSIS

The chassis is made by bolting a $12\frac{1}{2}$ " Angle Girder (1) to each side of a $5\frac{1}{2}$ " x $2\frac{1}{2}$ " Flanged Plate (2), Fig. 6.21b so that the Girders overlap the Flanged Plate by four holes. A $12\frac{1}{2}$ " Angle Girder (3) is connected to each of the Girders (1) by Fishplates. The front wheels are fixed on a $4\frac{1}{2}$ " Rod supported in Flat Trunnions bolted to the sides of the Flanged Plate (2). The rear wheels are 3" Pulleys and Road Wheels, and they are held on a 5" Rod mounted in Double Brackets bolted to the Girders (3). The front bumper is a $3\frac{1}{2}$ " x $\frac{1}{2}$ " Double Angle Strip attached to $\frac{1}{2}$ " Reversed Angle Brackets bolted to the Flanged Plate (2). The rear ends of the Girders (1) are connected by a $2\frac{1}{2}$ " x $\frac{1}{2}$ " Double Angle Strip.

ASSEMBLY OF THE DRIVER'S CAB

The floor and part of the back of the cab consist of a Hinged Flat Plate, one half of which is bolted to the Flanged Plate (2) (Fig. 6.21b), so that it overhangs the Flanged Plate at the rear by one row of holes. The other half of the Hinged Flat Plate is turned at right angles to the floor to form the lower section of the back of the cab. The upper part of the back is made by bolting two $2\frac{1}{2}$ " x $2\frac{1}{2}$ " Triangular Flexible Plates to the half of the Hinged Flat Plate. The Triangular Flexible Plates overlap the Hinged Flat Plate by three holes, and they are placed so that their right-angled corners form the top corners of the back of the cab.

Each side of the cab and bonnet is formed by a $5\frac{1}{2}$ " x $1\frac{1}{2}$ " and a $2\frac{1}{2}$ " x $1\frac{1}{2}$ " Flexible Plate overlapped four holes. These parts are connected to a $5\frac{1}{2}$ " Strip (4) (Fig. 6.21) by a $2\frac{1}{2}$ " x $1\frac{1}{2}$ " Flexible Plate (5) and two $2\frac{1}{2}$ " Strips (6). The rear ends of the Strips (4) are attached to the back of the cab by Angle Brackets, and the front edges of the Flexible Plates (5) are strengthened by $2\frac{1}{2}$ " Strips and are connected by a $2\frac{1}{2}$ " x $1\frac{1}{2}$ " Flanged Plate, and a $2\frac{1}{2}$ " x $\frac{1}{2}$ " Double Angle Strip held by a bolt (7) on each side.

(Continued on next page)

MODEL 6.21 REAR DUMPING TRUCK — Continued

The top ends of the Strips (6) on each side are connected by a $2\frac{1}{2}$ " \times $\frac{1}{2}$ " Double Angle Strip (8) and a $2\frac{1}{2}$ " Curved Strip. The rear lugs of the Double Angle Strips (8) are bolted to the back of the cab, and their front lugs support two $2\frac{1}{2}$ " Strips bolted together. A $2\frac{1}{2}$ " \times $\frac{1}{2}$ " Double Angle Strip (9) is fixed to the centre of the $2\frac{1}{2}$ " Strips.

The top of the bonnet consists of a $3\frac{1}{2}$ " \times $2\frac{1}{2}$ " Flanged Plate and two $2\frac{1}{2}$ " \times $1\frac{1}{2}$ " Triangular Flexible Plates (10). The Plates are edged by a $2\frac{1}{2}$ " and two $3\frac{1}{2}$ " Strips, and the Flanged Plate is attached by its flanges to the Double Angle Strip (9) and to the Double Angle Strip held by the bolts (7).

The cab roof is made from two $1\frac{1}{2}$ " radius Curved Plates. It is fixed to Angle Brackets attached to the lugs of the Double Angle Strips (8). The Angle Brackets are opened out slightly, so that the roof can be curved as shown.

The front mudguards are each made from two $5\frac{1}{2}$ " Strips connected at the front by a Fishplate and fixed at their rear ends to the floor of the cab. The mudguard seen in Fig. 6.21 is attached to the floor by nuts on two 3" Screwed Rods. The Screwed Rods project below the floor and each is fitted with a Rod Connector. A $1\frac{1}{2}$ " \times $\frac{1}{2}$ " Double Angle Strip (11) is held tightly against the Rod Connectors by nuts on the lower ends of the Screwed Rods.

THE TIPPING BODY

The floor of the body is made from two $12\frac{1}{2}$ " \times $2\frac{1}{2}$ " Strip Plates bolted together lengthways and strengthened at the centre and at each side by a $12\frac{1}{2}$ " Strip. The sides of the body are each made from a $5\frac{1}{2}$ " \times $2\frac{1}{2}$ " Flexible Plate (12) (Fig. 6.21), a $4\frac{1}{2}$ " \times $2\frac{1}{2}$ " Flexible Plate (13), a $5\frac{1}{2}$ " \times $1\frac{1}{2}$ " Flexible Plate (14), a $2\frac{1}{2}$ " \times 2 " Triangular Flexible Plate (15) and a Semi-Circular Plate (16). The upper edges of these Plates are bolted to a $12\frac{1}{2}$ " Strip, and the lower edges are strengthened by two $5\frac{1}{2}$ " Strips joined together and a 3" Strip (17). Each side is connected to the floor by three Obtuse Angle Brackets, and the rear end of the floor is curved upward slightly and is fixed to 1 " \times 1 " Angle Brackets (18) bolted to the sides.

The front of the body is filled in by four $2\frac{1}{2}$ " \times $2\frac{1}{2}$ " Flexible Plates (19) (Fig. 6.21b) and two $2\frac{1}{2}$ " \times $1\frac{1}{2}$ " Triangular Flexible Plates (20). These Plates are arranged on each side of a $3\frac{1}{2}$ " \times $\frac{1}{2}$ " Double Angle Strip (21), which is connected to the floor by an Angle Bracket, and a strip (22) is bolted across the Plates. This strip is made from two $5\frac{1}{2}$ " Strips overlapped nine holes, and it is attached at each end to Angle Brackets bolted to the sides. Two Flat Trunnions (23) are used to fill in the top corners at the front of the body.

The protection plate (24) over the driver's cab consists of two $5\frac{1}{2}$ " \times $2\frac{1}{2}$ " Flexible Plates overlapped nine holes. It is bolted to the top lug of the Double Angle Strip (21), and is edged on each side by a $2\frac{1}{2}$ " Stepped Curved Strip (25) extended forward by a $1\frac{1}{2}$ " Strip. The Curved Strips are attached to the sides by Fishplates, and the $1\frac{1}{2}$ " Strips are connected by Angle Brackets to two $5\frac{1}{2}$ " Strips overlapped nine holes. The plate (24) is supported at the front by Angle Brackets attached to the ends of the $5\frac{1}{2}$ " Strips, and it is braced on each side by a Formed Slotted Strip (26).

A Trunnion (27) is bolted to each side of the tipping body and a $3\frac{1}{2}$ " Rod is passed through the Trunnions and through the lugs of a $2\frac{1}{2}$ " \times $\frac{1}{2}$ " Double Angle Strip (28) fixed across the ends of the Girders (1). The Rod is held in position by Collars.

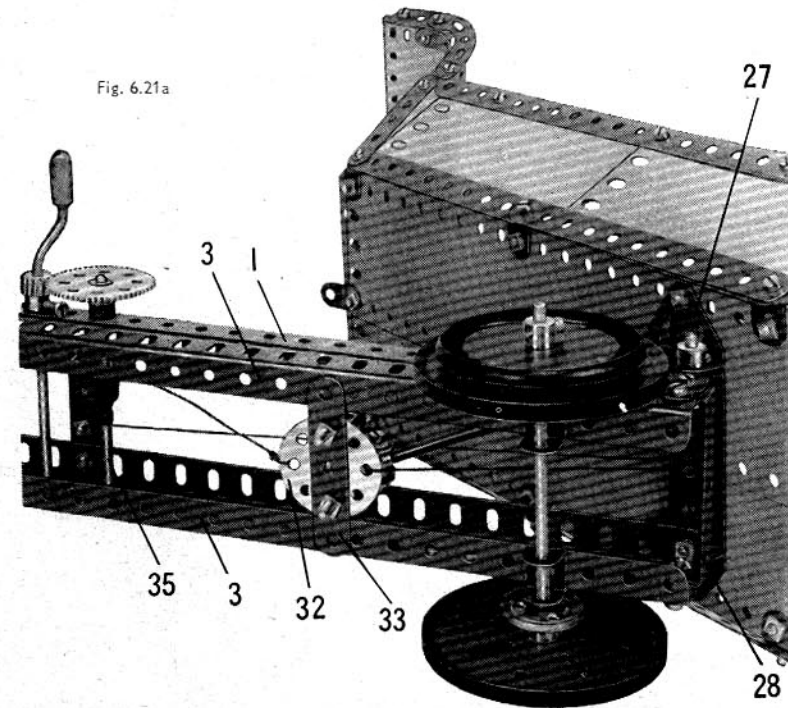

Fig. 6.21a

If you ever require advice in connection with your model-building write to
Information Service,
Meccanno Ltd, Binns Road,
Liverpool 13
Experts are waiting to help you

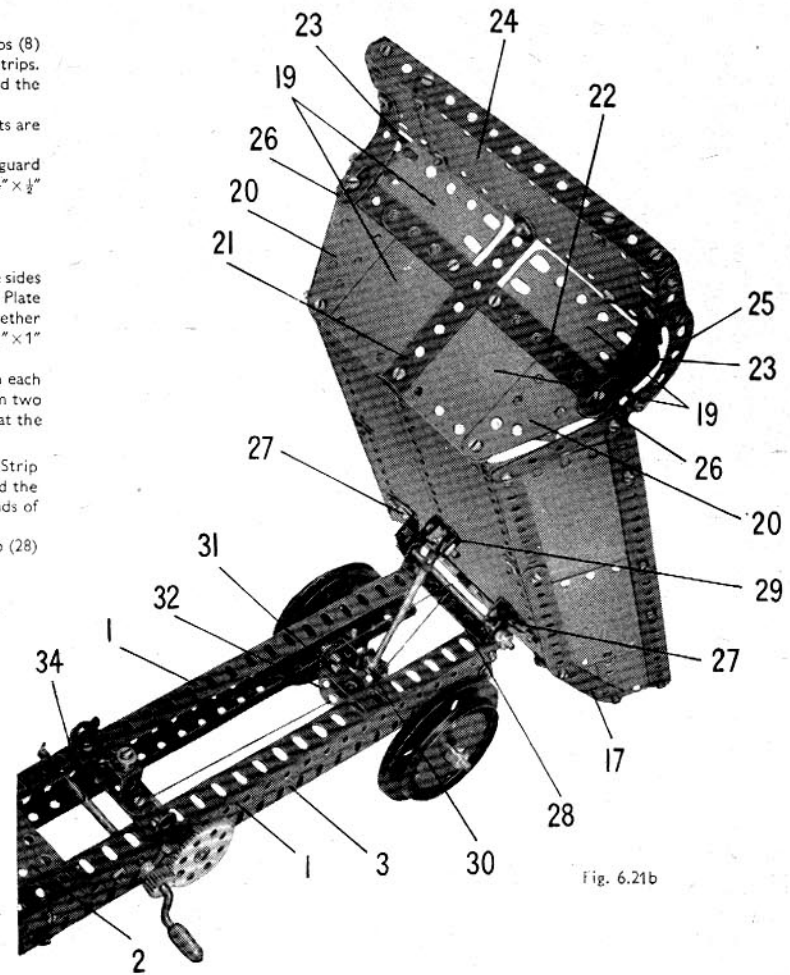

Fig. 6.21b

THE TIPPING MECHANISM

A Double Bracket (29) (Fig. 6.21b) is bolted underneath the body, and to one of its lugs a Rod and Strip Connector is attached by a lock-nutted bolt. The Rod and Strip Connector is fitted on a $3\frac{1}{2}$ " Rod that carries at its lower end a Collar (30). The Collar pivots on two bolts, each of which is passed through a $\frac{1}{2}$ " Reversed Angle Bracket and is screwed into a threaded hole in the Collar. The $\frac{1}{2}$ " Reversed Angle Brackets are fixed to the lugs of a $1\frac{1}{2}$ " \times $\frac{1}{2}$ " Double Angle Strip (31), which is connected by two $\frac{1}{2}$ " Bolts to a slide assembly fitted to the flanges of the Girders (3). Each Bolt is passed through a hole in the Double Angle Strip and one of the slotted holes of a $2\frac{1}{2}$ " Stepped Curved Strip. The Bolts then pass through a Wheel Disc (32) and a $2\frac{1}{2}$ " Strip (33) (Fig. 6.21a) and are fitted with nuts to hold the parts tightly together. The Stepped Curved Strip is placed above the flanges of the Girders (3) and the $2\frac{1}{2}$ " Strip (33) lies below the flanges, so that the complete assembly is free to slide up and down the Girders.

A $\frac{1}{2}$ " Pinion on a Crank Handle (34) drives a 57-tooth Gear on a $3\frac{1}{2}$ " Rod (35). The Crank Handle is held in place by a Cord Anchoring Spring, and the Rod is retained in position by a Spring Clip. The 57-tooth Gear is spaced from the chassis by four Washers. The Crank Handle is permitted to slide about $\frac{1}{4}$ " across the chassis, so that a $\frac{3}{8}$ " Bolt in the $\frac{1}{2}$ " Pinion can engage a bolt in one of the Girders (1) to provide a simple brake.

A length of Cord is tied at one end to the Wheel Disc (32) and is wound several times round the Rod (35). The Cord is then taken over the $3\frac{1}{2}$ " Rod supported in the Trunnions (27), and is fastened again to the Wheel Disc (32). When the Crank Handle is turned the Cord winds round the Rod (35), and in doing so pulls the slide assembly along the flanges of the Girders (3), thus tipping the body.

6.22 MOBILE SWIVELLING CRANE

Parts Required

4 of No. 1	1 of No. 16	11 of No. 35	1 of No. 57c	3 of No. 189
11 " " 2	1 " " 17	140 " " 37a	4 " " 59	2 " " 190
4 " " 3	2 " " 18a	130 " " 37b	2 " " 111	2 " " 191
2 " " 4	1 " " 18b	12 " " 38	2 " " 111a	2 " " 192
10 " " 5	2 " " 19b	1 " " 40	6 " " 111c	1 " " 198
2 " " 6a	1 " " 19g	2 " " 48	4 " " 125	2 " " 199
3 " " 10	1 " " 19h	8 " " 48a	2 " " 126	2 " " 214
4 " " 11	4 " " 22	2 " " 48b	4 " " 126a	4 " " 221
14 " " 12	2 " " 22a	1 " " 51	4 " " 155	1 " " 222
2 " " 12a	1 " " 23	1 " " 52	1 " " 176	2 " " 223
1 " " 12c	1 " " 23a	1 " " 53	4 " " 187	
2 " " 15	1 " " 24	1 " " 54	4 " " 188	

THE WHEELED BASE

The base consists of a $5\frac{1}{2}'' \times 2\frac{1}{2}''$ Flanged Plate (1) (Fig. 6.22a), fitted at each end with a $3\frac{1}{2}'' \times \frac{1}{2}''$ Double Angle Strip. A $5\frac{1}{2}'' \times 1\frac{1}{2}''$ Flexible Plate (2), strengthened along its top edge by a $5\frac{1}{2}''$ Strip, is attached to the lugs of the Double Angle Strips on each side. To the ends of the Flexible Plates are bolted Flat Trunnions (3), and a 5" Rod is supported in the Flat Trunnions at each end of the base. The Rods are held in place by 1" Pulleys and they carry the Road Wheels on which the base is mounted. A "U"-section Curved Plate (4) is connected to one end of the Flanged Plate (1) by a $2\frac{1}{2}'' \times \frac{1}{2}''$ Double Angle Strip, and a similar Plate is attached to the other end by two Double Brackets.

A 3" Pulley (5), with its boss downward, is connected to the Flanged Plate (1) by two $\frac{1}{2}''$ Bolts. A $2\frac{1}{2}'' \times 1\frac{1}{2}''$ Flanged Plate (6) is attached to one of the Plates (2) by a Double Bracket and a $\frac{1}{2}''$ Reversed Angle Bracket.

CONSTRUCTION OF THE CAB

The cab is assembled on a Flanged Sector Plate (7) extended at the rear by a $3\frac{1}{2}'' \times 2\frac{1}{2}''$ Flanged Plate (8) that overlaps the Sector Plate by three holes. A 3" Strip (9) is connected to the Flanged Sector Plate by a $\frac{1}{2}''$ Reversed Angle Bracket, and to the ends of this strip are bolted a $2\frac{1}{2}'' \times 1\frac{1}{2}''$ Flexible Plate (10) and two $2\frac{1}{2}'' \times 1\frac{1}{2}''$ Triangular Flexible Plates (11). Two $5\frac{1}{2}''$ Strips (12), connected by a $1\frac{1}{2}''$ Strip and a $1\frac{1}{2}'' \times \frac{1}{2}''$ Double Angle Strip (13), are fixed to the Plate (10).

The side of the cab seen in Fig. 6.22a consists of a $5\frac{1}{2}'' \times 2\frac{1}{2}''$ Flexible Plate (14), a $4\frac{1}{2}'' \times 2\frac{1}{2}''$ Flexible Plate (15) and a $2\frac{1}{2}'' \times 1\frac{1}{2}''$ Flexible Plate (16). These Plates are strengthened by two vertical $5\frac{1}{2}''$ Strips placed as shown and bolted at their upper ends to a $3\frac{1}{2}''$ Strip (17). The window frame on this side is completed by two further $3\frac{1}{2}''$ Strips, one of which is used to edge the Plate (16). The side is connected to the Plate (10) by an Angle Bracket and to the Flanged Plate (8) by a $\frac{1}{2}''$ Reversed Angle Bracket supported by a Bolt (18).

The side seen in Fig. 6.22 consists of a $5\frac{1}{2}'' \times 2\frac{1}{2}''$ Flexible Plate (19) edged by a $5\frac{1}{2}''$ Strip, a $4\frac{1}{2}'' \times 2\frac{1}{2}''$ Flexible Plate (20) and a $2\frac{1}{2}'' \times 2''$ Triangular Flexible Plate (21). The Plate (21) is attached to each of the Plates (19) and (20) by a Fishplate. This side is connected to the Plates (11) by two Angle Brackets and to the Flanged Plate (8) by a $\frac{1}{2}''$ Reversed Angle Bracket held by a Bolt (22).

The back of the cab is formed by the separated halves of a Hinged Flat Plate bolted together. It is attached to the sides and to the Flanged Plate (8) by Angle Brackets.

The cab roof consists of a $5\frac{1}{2}'' \times 1\frac{1}{2}''$ Flexible Plate connected to the Plates (11) by an Obtuse Angle Bracket, two $2\frac{1}{2}'' \times 2\frac{1}{2}''$ Flexible Plates (23) and two $2\frac{1}{2}'' \times 1\frac{1}{2}''$ Triangular Flexible Plates (24). The Plates (23) are fixed to Angle Brackets bolted to one side and to the back, and the Plates (24) are attached to the other side by Angle Brackets and are connected to the Plates (23) by a $2\frac{1}{2}''$ Strip.

The window frame is completed by bolting a $3\frac{1}{2}''$ Strip (25) to the Double Angle Strip (13) and to a similar part attached to the rear end of the Strip (17). A built-up strip (26), made from two $2\frac{1}{2}''$ Strips, is connected to the Strip (25) by two $2\frac{1}{2}''$ Strips and a 3" Strip (27). The Strip (27) is attached to one of the Plates (23) by an Angle Bracket.

ASSEMBLY OF THE JIB

Each side of the jib is formed by two $12\frac{1}{2}''$ Strips joined together at their lower ends and connected at their upper ends by a $2\frac{1}{2}''$ Strip and a $2\frac{1}{2}'' \times 2\frac{1}{2}''$ Triangular Flexible Plate (28). A $5\frac{1}{2}''$ Strip (29) is used to extend one of the $12\frac{1}{2}''$ Strips, and a further $5\frac{1}{2}''$ Strip connects the Strip (29) to the Plate (28). The sides of the jib are connected by four $2\frac{1}{2}'' \times \frac{1}{2}''$ Double Angle Strips. Two of these are indicated at (30) and a third is held by a bolt (31) on each side. The fourth Double Angle Strip is seen at (32), and two $1'' \times 1''$ Angle Brackets are bolted to it. A 1" loose Pulley (33) is mounted on a $1\frac{1}{2}''$ Rod held in the Angle Brackets by Spring Clips.

The ends of the Strips (29) are connected by a $1\frac{1}{2}''$ Rod held in place by Spring Clips. A 1" loose Pulley (34) is mounted on the Rod. The jib is attached to the cab by a $3\frac{1}{2}''$ Rod, which is held by Spring Clips in Trunnions bolted to the Plates (10) and (11).

ARRANGEMENT OF THE CORDS

The jib is luffed, or raised and lowered, by operating a $3\frac{1}{2}''$ Crank Handle (35). This is supported in the side of the cab and in the end hole of the Strip (27), and in a $2\frac{1}{2}'' \times \frac{1}{2}''$ Double Angle Strip bolted to the centre hole in the front row of holes in the Flanged Plate (8). A length of Cord is fastened to the Crank Handle between the Strip (27) and the Double Angle Strip. The Cord is passed round the 1" Pulley (33) and is tied to a Fishplate bolted to the Plate (28).

A 5" Crank Handle (36) is supported in the side of the cab and in a $2\frac{1}{2}'' \times \frac{1}{2}''$ Double Angle Strip (37) bolted to the Flanged Sector Plate (7). A length of Cord tied to a Cord Anchoring Spring on the Crank Handle is passed over the Pulley (34) round a $\frac{1}{2}''$ loose Pulley in the pulley block and tied to the top of the jib.

The pulley block consists of two Semi-Circular Plates spaced apart by five Washers on each of two $\frac{1}{2}''$ Bolts. The $\frac{1}{2}''$ loose Pulley is mounted on a 1" Rod that is held in place by Spring Clips. A small Loaded Hook is pivoted on a $\frac{3}{8}''$ Bolt passed through the Semi-Circular Plates.

A Collar (38) is fixed on each Crank Handle. One of these is fitted with a $\frac{3}{8}''$ Bolt and the other with a $\frac{1}{2}''$ Bolt. The Crank Handles are permitted to slide about $\frac{1}{2}''$ in their bearings, so that the Bolts in the Collars can be engaged with Bolts held by two nuts in the side of the cab.

A Bush Wheel (39) is bolted to the Flanged Sector Plate (7). A 2" Rod fixed in the Bush Wheel is passed through a 3" Pulley (40), the 3" Pulley (5) and the Flanged Plate (1). The Rod is held in place by a Collar placed underneath the Flanged Plate (1).

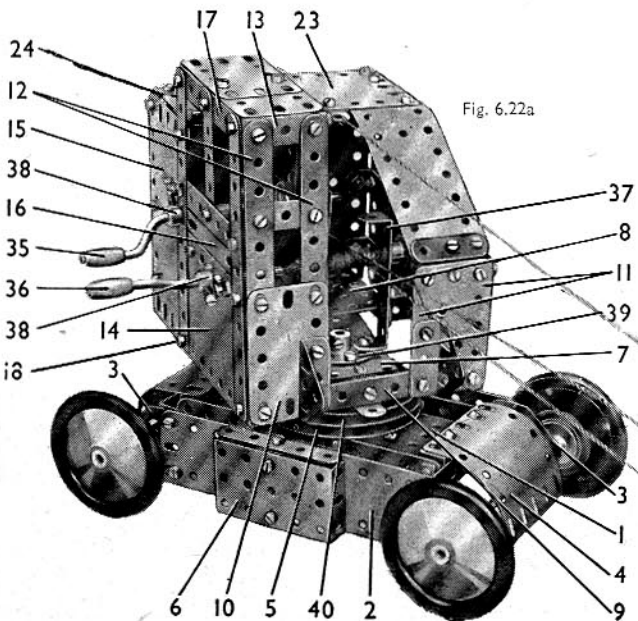

Fig. 6.22a

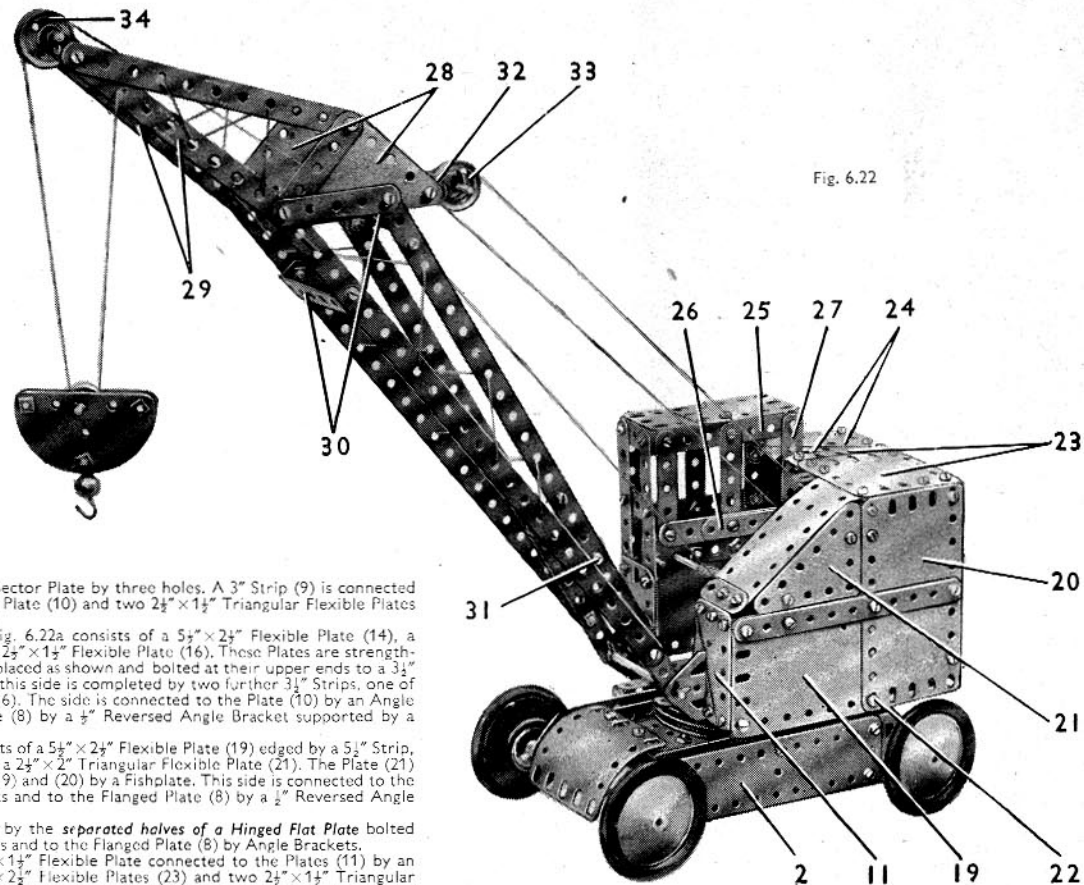
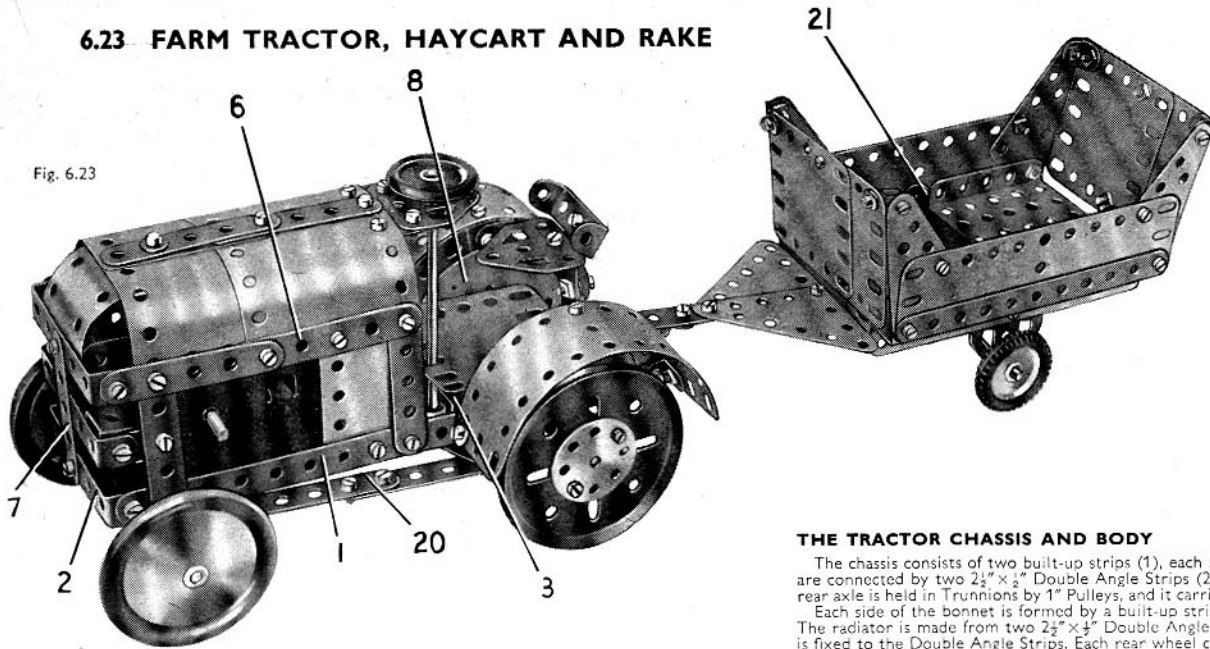

Fig. 6.22

6.23 FARM TRACTOR, HAYCART AND RAKE

Fig. 6.23



THE MOTOR AND DRIVING GEARS

Two $\frac{1}{2}$ " Reversed Angle Brackets (9) fixed to the strips (1), support a $1\frac{1}{2}$ " x $\frac{1}{2}$ " Double Angle Strip (10). The bolt (11) passes through a hole in the side-plate of a No. 1 Clockwork Motor. A $3\frac{1}{2}$ " Strip (12) is attached to the Double Angle Strip by two $\frac{1}{2}$ " Bolts (13), one of which projects inside the side-plate of the Motor and prevents it from slipping off the shank of the bolt (11). The rear end of the Motor is supported by a Double Bracket (14).

A $\frac{1}{2}$ " Pinion on the Motor driving shaft engages a 57-tooth Gear on a 2" Rod (15), and a $\frac{1}{2}$ " Pulley on this Rod is connected to the Pulley (5).

STEERING ARRANGEMENT

A $\frac{3}{8}$ " Bolt is passed through a $1\frac{1}{2}$ " Strip (16) (Fig. 6.23a) and a Double Bracket (17) on each side of the model, and the Bolt is held by two nuts in an end hole of the Strip (12). A $3\frac{1}{2}$ " Strip (18) is lock-nutted to one of the Strips (16) and is attached to the other Strip (16) by a $\frac{3}{8}$ " Bolt. The Bolt is first fixed tightly in a 2" Curved Strip (19) by means of a nut and a Spring Clip is placed on the Bolt, which is then fixed in the Strip (18), by two nuts.

The Curved Strip (19) is lock-nutted to two $2\frac{1}{2}$ " Strips (20), one of which is lock-nutted to a Fishplate bolted to a Bush Wheel at the lower end of the steering column. The 1" Pulley used as the steering wheel is supplied with the No. 1 Clockwork Motor.

CONSTRUCTION OF THE HAY CART

The chassis is a $5\frac{1}{2}$ " x $2\frac{1}{2}$ " Flanged Plate to the sides of which Flat Trunnions are bolted. The floor consists of two $3\frac{1}{2}$ " x $2\frac{1}{2}$ " Flanged Plates and a $3\frac{1}{2}$ " x $\frac{1}{2}$ " Double Angle Strip (21). At the front a $2\frac{1}{2}$ " x $1\frac{1}{2}$ " Flexible Plate is bolted to the flange of the $5\frac{1}{2}$ " x $2\frac{1}{2}$ " Flanged Plate. A $3\frac{1}{2}$ " x $\frac{1}{2}$ " Angle Strip also is attached to the front of the Flanged Plate.

The towing attachment consists of two Rod and Strip Connectors fitted on a 1" Rod passed through the lug of the Double Angle Strip. A $\frac{1}{2}$ " Bolt fixed in one of the Rod and Strip Connectors enables the cart to be coupled to a $\frac{1}{2}$ " Reversed Angle Bracket (22).

THE HAY RAKE

The frame consists of two $2\frac{1}{2}$ " x $\frac{1}{2}$ " Double Angle Strips (23) (Fig. 6.23b) on each side connected by two built-up strips, each made from two $5\frac{1}{2}$ " Strips overlapped nine holes. One of these strips is marked (24). The other is fixed to the front lugs of the Double Angle Strips. An Angle Bracket (25) is fixed to each side of the frame. The axle is a $6\frac{1}{2}$ " and a $1\frac{1}{2}$ " Rod joined by a Rod Connector. The wheel (26) is spaced from the frame by a Cord Anchoring Spring.

The tines are bolted to two $5\frac{1}{2}$ " Strips overlapped nine holes. An Angle Bracket (27) is fixed to the outer end of each $5\frac{1}{2}$ " Strip and one of them is lock-nutted to one of the Angle Brackets (25). A $\frac{1}{2}$ " Bolt (28) is fixed by a nut in the other Angle Bracket (27), and the Bolt is passed through the second Angle Bracket (25). A Fishplate fitted with a Collar (29) is gripped tightly on the Bolt (28) between two nuts. The set screw in the wheel (26) engages the Collar as the wheel rotates.

A $2\frac{1}{2}$ " Strip (30) is lock-nutted to an Angle Bracket and carries a Collar screwed on to a bolt held by a nut. A 2" Rod is gripped in the Collar, and a Right-Angle Rod and Strip Connector on the Rod is fitted with a Fishplate (31). The Fishplate is connected to the tines by a Pivot Bolt (32). The towing attachment is a Threaded Pin (33).

THE TRACTOR CHASSIS AND BODY

The chassis consists of two built-up strips (1), each made from two $5\frac{1}{2}$ " Strips overlapped five holes. The strips (1) are connected by two $2\frac{1}{2}$ " x $\frac{1}{2}$ " Double Angle Strips (2) and (3) (Fig. 6.23a) and by a $2\frac{1}{2}$ " x $1\frac{1}{2}$ " Flanged Plate (4). The rear axle is held in Trunnions by 1" Pulleys, and it carries a further 1" Pulley (5).

Each side of the bonnet is formed by a built-up strip (6), made from a $3\frac{1}{2}$ " and a $2\frac{1}{2}$ " Strip overlapped three holes. The radiator is made from two $2\frac{1}{2}$ " x $\frac{1}{2}$ " Double Angle Strips, one of which is attached by Fishplates. A $2\frac{1}{2}$ " Strip (7) is fixed to the Double Angle Strips. Each rear wheel cover consists of a Semi-Circular Plate (8) and two $2\frac{1}{2}$ " Stepped Curved Strips. The driver's seat is fixed to two 1" x 1" Angle Brackets bolted together and attached to the Plate (4).

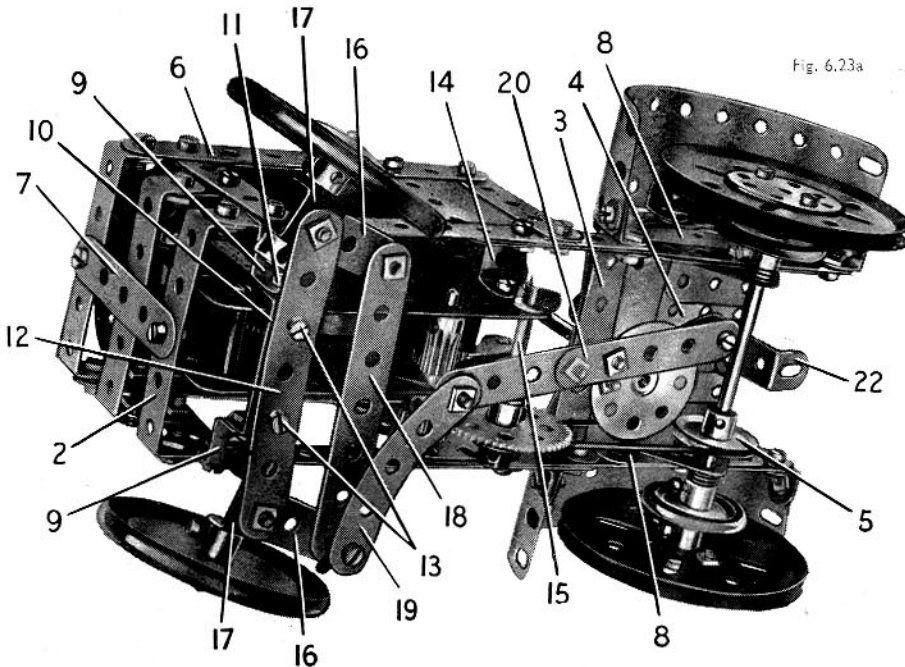

Fig. 6.23a

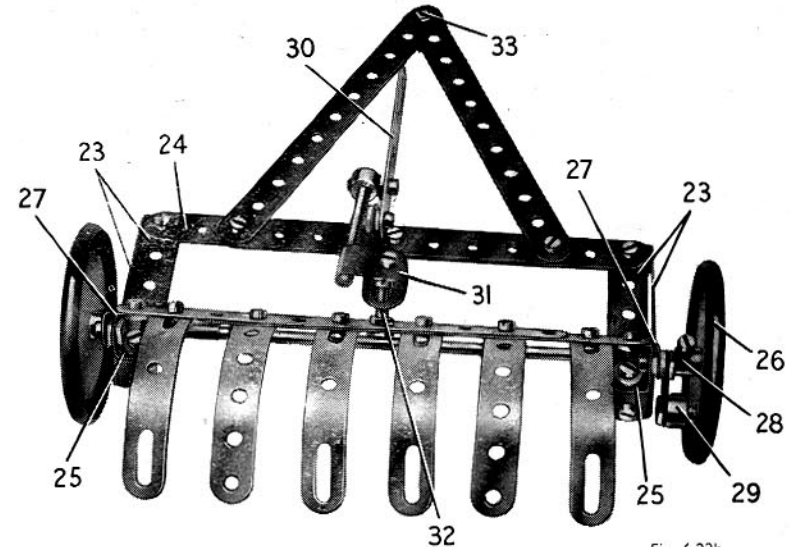

Fig. 6.23b

Parts Required

14 of No.	2	1 of No.	52
4 " "	3	2 " "	53
2 " "	4	4 " "	59
12 " "	5	1 " "	90
2 " "	6a	4 " "	90a
6 " "	10	1 " "	111
3 " "	11	2 " "	111a
16 " "	12	6 " "	111c
2 " "	12a	1 " "	115
1 " "	12c	3 " "	125
1 " "	14	2 " "	126
1 " "	15a	3 " "	126a
1 " "	15b	2 " "	142c
1 " "	16	1 " "	147b
2 " "	17	3 " "	155
3 " "	18a	1 " "	176
1 " "	18b	4 " "	187
2 " "	19b	4 " "	188
5 " "	22	4 " "	189
1 " "	24	6 " "	190
2 " "	24a	1 " "	199
1 " "	26	2 " "	200
1 " "	27a	2 " "	212
3 " "	35	1 " "	212a
138 " "	37a	1 " "	213
117 " "	37b	2 " "	214
25 " "	38	4 " "	215
1 " "	40	4 " "	221
1 " "	45	2 " "	222
2 " "	48		
8 " "	48a	1 No. 1 Clockwork Motor	
2 " "	48b	(Not included in Outfit)	
1 " "	51		

6.24 LIFTING BRIDGE

For more new models to
build, see the

**MECCANO
MAGAZINE**

which is published on the
first of every month

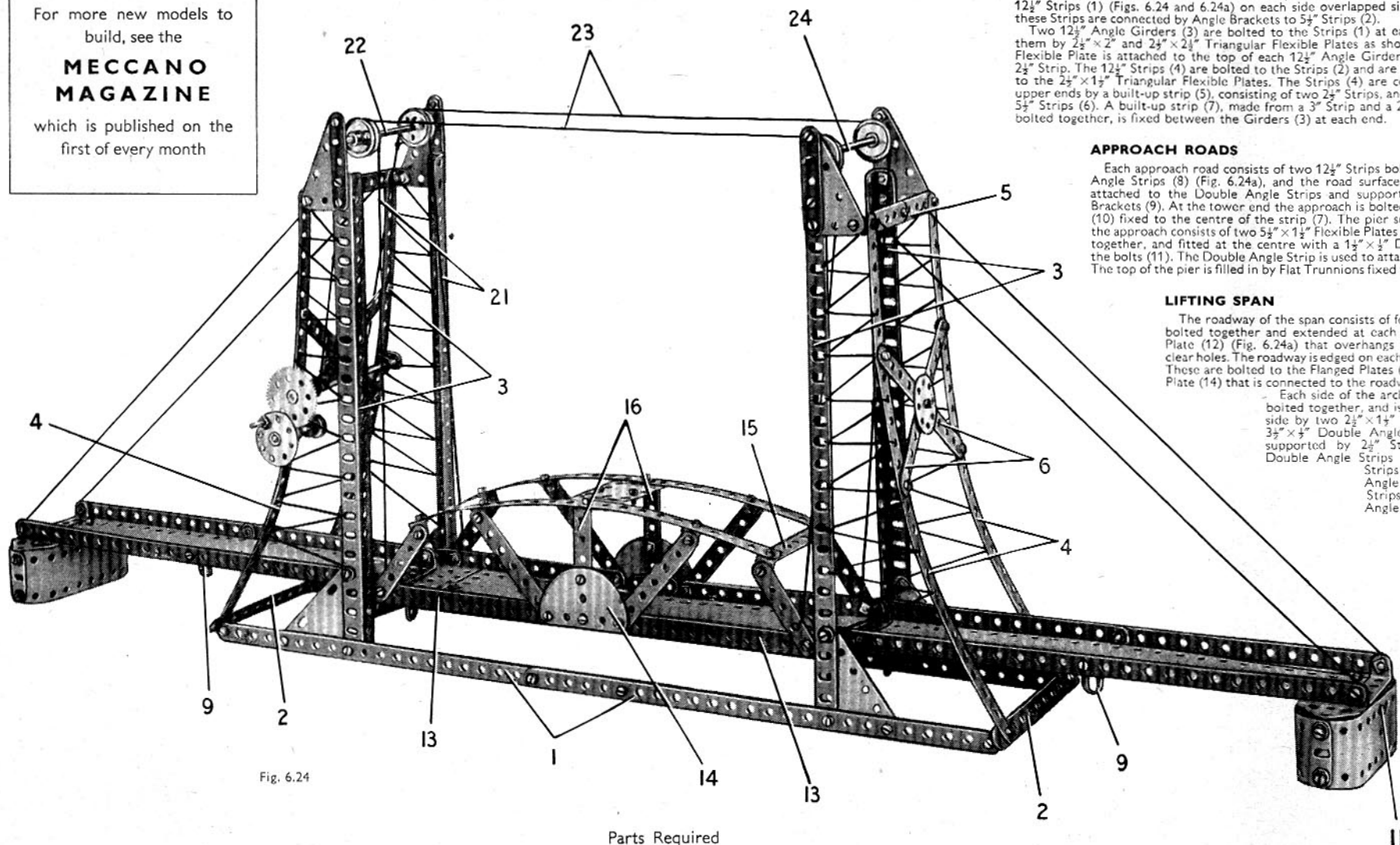

Fig. 6.24

Parts Required

12 of No. 1	4 of No. 10	2 of No. 17	1 of No. 26	1 of No. 38d	3 of No. 59	4 of No. 126a	
14 " " 2	3 " " 11	4 " " 22	1 " " 27a	1 " " 40	2 " " 111a	2 " " 188	
4 " " 3	12 " " 12	2 " " 22a	7 " " 35	2 " " 48	5 " " 111c	4 " " 189	2 of No. 214
2 " " 4	2 " " 12a	1 " " 23a	140 " " 37a	8 " " 48a	1 " " 115	4 " " 192	4 " " 221
12 " " 5	2 " " 15	1 " " 24	129 " " 37b	2 " " 48b	4 " " 125	2 " " 197	2 " " 222
4 " " 8	1 " " 16	2 " " 24a	22 " " 38	2 " " 53	2 " " 126	1 " " 213	2 " " 223

CONSTRUCTION OF THE TOWERS

The two towers are similar in construction, and the base for each of them consists of two $12\frac{1}{2}$ " Strips (1) (Figs. 6.24 and 6.24a) on each side overlapped six holes. The outer ends of these Strips are connected by Angle Brackets to $5\frac{1}{2}$ " Strips (2).

Two $12\frac{1}{2}$ " Angle Girders (3) are bolted to the Strips (1) at each end, and are braced to them by $2\frac{1}{2}$ " \times "2" and $2\frac{1}{2}$ " \times " $2\frac{1}{2}$ " Triangular Flexible Plates as shown. A $2\frac{1}{2}$ " \times " $1\frac{1}{2}$ " Triangular Flexible Plate is attached to the top of each $12\frac{1}{2}$ " Angle Girder, and is strengthened by a $2\frac{1}{2}$ " Strip. The $12\frac{1}{2}$ " Strips (4) are bolted to the Strips (2) and are attached by Angle Brackets to the $2\frac{1}{2}$ " \times " $1\frac{1}{2}$ " Triangular Flexible Plates. The Strips (4) are connected together at their upper ends by a built-up strip (5), consisting of two $2\frac{1}{2}$ " Strips, and are made rigid by crossed $5\frac{1}{2}$ " Strips (6). A built-up strip (7), made from a 3" Strip and a $2\frac{1}{2}$ " \times " $\frac{1}{2}$ " Double Angle Strip bolted together, is fixed between the Girders (3) at each end.

APPROACH ROADS

Each approach road consists of two $12\frac{1}{2}$ " Strips bolted to two $2\frac{1}{2}$ " \times " $\frac{1}{2}$ " Double Angle Strips (8) (Fig. 6.24a), and the road surface is a $12\frac{1}{2}$ " \times " $2\frac{1}{2}$ " Strip Plate attached to the Double Angle Strips and supported by $\frac{1}{2}$ " Reversed Angle Brackets (9). At the tower end the approach is bolted to a $1"$ \times " $1"$ Angle Bracket (10) fixed to the centre of the strip (7). The pier supporting the other end of the approach consists of two $5\frac{1}{2}$ " \times " $1\frac{1}{2}$ " Flexible Plates curved as shown and bolted together, and fitted at the centre with a $1\frac{1}{2}$ " \times " $\frac{1}{2}$ " Double Angle Strip held by the bolts (11). The Double Angle Strip is used to attach the pier to the approach. The top of the pier is filled in by Flat Trunnions fixed to the approach.

LIFTING SPAN

The roadway of the span consists of four $5\frac{1}{2}$ " \times " $2\frac{1}{2}$ " Flexible Plates bolted together and extended at each end by a $3\frac{1}{2}$ " \times " $2\frac{1}{2}$ " Flanged Plate (12) (Fig. 6.24a) that overhangs the Flexible Plates by two clear holes. The roadway is edged on each side by two $5\frac{1}{2}$ " Strips (13). These are bolted to the Flanged Plates (12), and to a Semi-Circular Plate (14) that is connected to the roadway by a Trunnion.

Each side of the arch consists of two $5\frac{1}{2}$ " Strips bolted together, and is connected to the opposite side by two $2\frac{1}{2}$ " \times " $1\frac{1}{2}$ " Flexible Plates and by two $3\frac{1}{2}$ " \times " $\frac{1}{2}$ " Double Angle Strips (15). The arch is supported by $2\frac{1}{2}$ " Strips bolted between the Double Angle Strips (15) and the ends of the Strips (13), by $2\frac{1}{2}$ " \times " $\frac{1}{2}$ " Double Angle Strips (16), and by $3\frac{1}{2}$ " Strips attached to the arch by Angle Brackets.

(Continued on next page)

MODEL 6.24 LIFTING BRIDGE — Continued

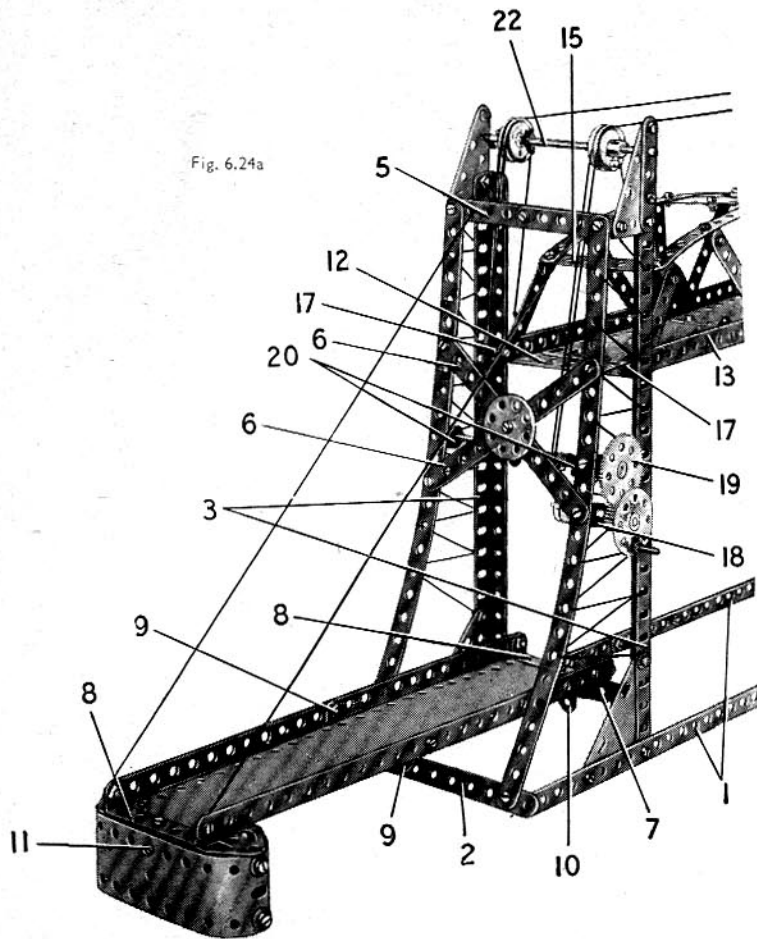

Fig. 6.24a

The lifting span is guided by four rollers (17), which engage the inner faces of the Angle Girders (3). Each roller consists of a Collar fixed on a $\frac{1}{8}$ " Bolt that is free to turn in a hole in a Fishplate. The Fishplates are bolted to the Flanged Plates (12).

OPERATING MECHANISM AND THE CORDS

A Bush Wheel fitted with a Threaded Pin as a handle is fixed on a 2" Rod mounted on a Double Bracket (18) (Fig. 6.24a). The Rod is held in place by a $\frac{1}{2}$ " fixed Pulley, and it carries a $\frac{1}{2}$ " Pinion that drives a 57-tooth Gear (19). This Gear is fixed on a 5" Rod supported in Double Brackets (20).

Two separate lengths of Cord (21) are tied to the 5" Rod and are taken over 1" loose Pulleys on a 5" Rod (22). The Cords are fastened to the nearest end of the lifting span. Two further lengths of Cord (23) are tied to the Cords (21) at a point near to the winding shaft, and are led over 1" fixed Pulleys free to turn on Rod (22), over similar Pulleys on a rod (24) and are then tied to the opposite end of the lifting span. Rod (24) consists of a $3\frac{1}{2}$ " and a 2" Rod joined together by a Rod Connector.

6.25 HAMMERHEAD CRANE

Parts Required

12 of No. 1	6 of No. 12	2 of No. 22a	1 of No. 38d	1 of No. 57c	1 of No. 186	1 of No. 198
14 " " 2	2 " " 12a	1 " " 23	1 " " 40	4 " " 59	1 " " 186a	2 " " 200
4 " " 3	2 " " 15	1 " " 23a	1 " " 45	1 " " 111a	1 " " 186b	2 " " 212
2 " " 4	1 " " 15a	1 " " 24	2 " " 48	1 " " 111c	4 " " 187	2 " " 214
12 " " 5	3 " " 16	2 " " 24a	4 " " 48a	4 " " 125	4 " " 188	
2 " " 6a	1 " " 17	10 " " 35	2 " " 48b	2 " " 126	1 " " 189	
4 " " 8	3 " " 18a	131 " " 37a	1 " " 51	2 " " 126a	4 " " 190	
2 " " 10	2 " " 19b	121 " " 37b	2 " " 53	2 " " 155	2 " " 191	
2 " " 11	5 " " 22	24 " " 38	2 " " 54	1 " " 176	2 " " 192	

1 EO20
Electric Motor
(Not included in
Outfit)

THE CRANE TOWER

Each leg of the tower consists of a $12\frac{1}{2}$ " Angle Girder and two $12\frac{1}{2}$ " Strips. These parts are bolted together at their lower ends as shown, and at their upper ends they are fixed to built-up strips (1) (Fig. 6.25). Two of the built-up strips are each made from two $5\frac{1}{2}$ " Strips overlapped nine holes. The other two built-up strips are each formed by a $5\frac{1}{2}$ " and a $3\frac{1}{2}$ " Strip overlapped five holes.

The top of the tower is filled in by two $4\frac{1}{2}$ " x $2\frac{1}{2}$ " Flexible Plates and the separated halves of a Hinged Flat Plate. Each half of the Hinged Flat Plate is attached to one of the strips (1) by a Trunnion held by the bolts (2). A 3" Strip pointing towards the centre of the top of the tower is fixed to the Trunnion by the same bolt that secures the half of the Hinged Flat Plate. Each $4\frac{1}{2}$ " x $2\frac{1}{2}$ " Flexible Plate is bolted to a $2\frac{1}{2}$ " x $\frac{1}{2}$ " Double Angle Strip fixed to one of the strips (1) by a bolt (3). A 3" Pulley (4) is connected to the Plates at the exact centre of the tower.

CONSTRUCTION OF THE BOOM

Each side of the boom consists of two $5\frac{1}{2}$ " Strips (5), a $12\frac{1}{2}$ " Strip (6) and a built-up Strip (7) (Fig. 6.25). The strip (7) is made from two $5\frac{1}{2}$ " Strips bolted together, and a $3\frac{1}{2}$ " Strip that overlaps one of the $5\frac{1}{2}$ " Strips by three holes. The Strips (5), (6) and (7) are bolted at their inner ends to a Flanged Sector Plate, and the Flanged Sector Plates on each side are connected by two $3\frac{1}{2}$ " x $\frac{1}{2}$ " Double Angle Strips (8). The outer ends of the Strips (5) are bolted to a $3\frac{1}{2}$ " x $2\frac{1}{2}$ " Flanged Plate (9). The Strips (6) and (7) are connected by a $1\frac{1}{2}$ " Strip, and are joined to the similar Strips at the opposite side of the boom by two $2\frac{1}{2}$ " x $1\frac{1}{2}$ " Flexible Plates and two $2\frac{1}{2}$ " Strips (10) overlapped three holes. The Flexible Plates and the Strips are attached to Angle Brackets.

The rails on which the crab or travelling carriage is mounted are $12\frac{1}{2}$ " Strips supported by $\frac{1}{2}$ " Reversed Angle Brackets (11). The rear ends of the $12\frac{1}{2}$ " Strips are connected by a $2\frac{1}{2}$ " x $\frac{1}{2}$ " Double Angle Strip, and a $3\frac{1}{2}$ " Rod (12) is held by Spring Clips in Fishplates bolted to the front ends of the Strips.

(Continued on next page)

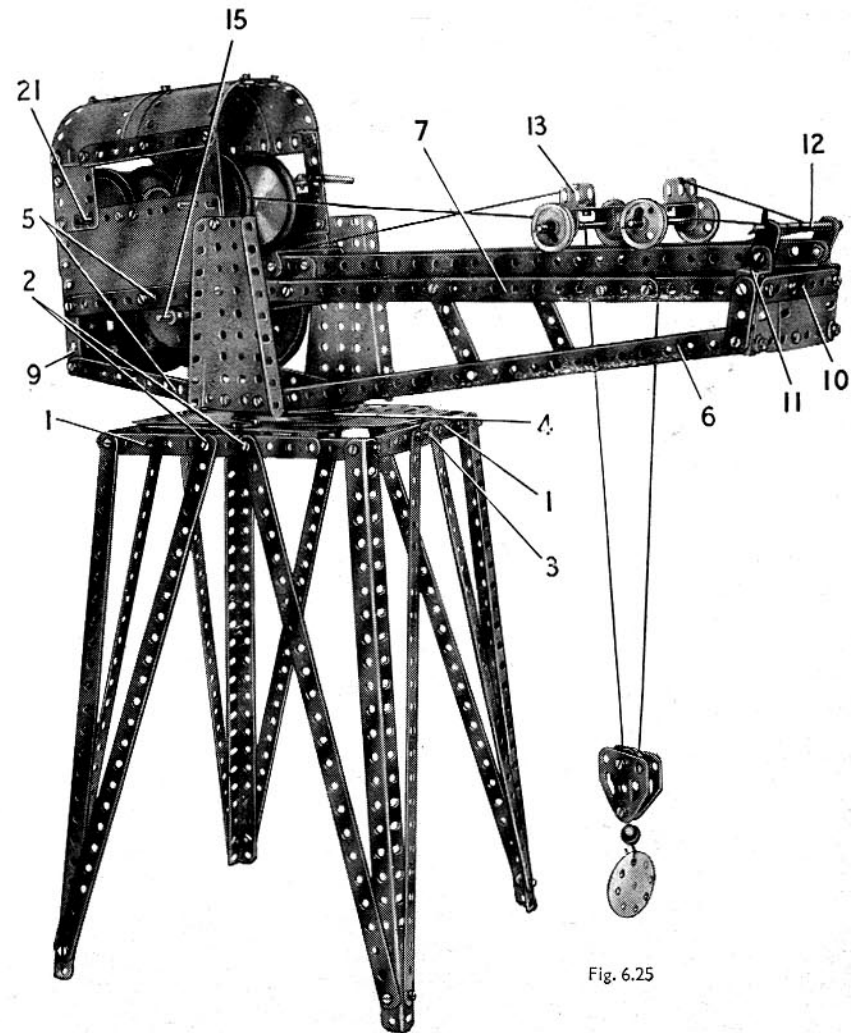

Fig. 6.25

MODEL 6.25 HAMMERHEAD CRANE — Continued

The travelling carriage is made by bolting a $1\frac{1}{2}'' \times \frac{1}{2}''$ Double Angle Strip to each end of a $2\frac{1}{2}'' \times 1\frac{1}{2}''$ Flanged Plate (13). The Double Angle Strips support two $3\frac{1}{2}''$ Rods, and the wheels, which are two 1" loose and two 1" fixed Pulleys, are held on these Rods by Spring Clips.

A Bush Wheel (14) is fixed to the Double Angle Strips (8) and a $1\frac{1}{2}''$ Rod held in the Bush Wheel is passed through the Pulley (4).

ASSEMBLY OF THE CAB AND THE OPERATING MECHANISM

Each side of the cab is a $5\frac{1}{2}'' \times 2\frac{1}{2}''$ Flexible Plate bolted to one of the Strips (5) (Fig. 6.25b) and to one of the Flanged Sector Plates. The back of the cab is a $3\frac{1}{2}'' \times 2\frac{1}{2}''$ Flanged Plate.

The cab roof consists of a $1\frac{1}{8}''$ radius Curved Plate and two curved $2\frac{1}{2}'' \times 2\frac{1}{2}''$ Flexible Plates on each side, connected by a $5\frac{1}{2}'' \times 1\frac{1}{2}''$ Flexible Plate that forms the centre of the roof. The roof is supported by a $2\frac{1}{2}'' \times 1\frac{1}{2}''$ Flexible Plate and a $2\frac{1}{2}''$ Strip on one side, and a $2\frac{1}{2}'' \times 1\frac{1}{2}''$ Flexible Plate and a $2\frac{1}{2}'' \times \frac{1}{2}''$ Double Angle Strip on the other side. In Figs. 6.25a and 6.25b the roof is bent back to reveal the cab mechanism.

An EO20 Electric Motor is bolted by its lugs to the Flanged Plate (9), and the Motor pulley is connected by a Driving Band to a 3" Pulley on a 5" Rod (15). Rod (15) is held by Collars in Semi-Circular Plates attached to the upper pair of the Strips (5). A $\frac{1}{2}''$ Pulley (16) on Rod (15) drives a 1" Pulley (17) on a 2" Rod. The 2" Rod is supported in a Double Bent Strip and in a $2\frac{1}{2}''$ Strip bolted to 1" \times 1" Angle Brackets fixed to the sides of the cab. The Rod carries 1" Pulleys (18) and (19) fitted with Rubber Rings. The Pulley (19) is spaced from the $2\frac{1}{2}''$ Strip by three Washers.

The crane winding shafts are a 5" Rod (20) and a 4" Rod (21), each fitted with two Road Wheels spaced apart slightly wider than the diameter of the Rubber Rings on the Pulleys (18) and (19). The drive to each winding shaft is engaged by pressing one or other of its Road Wheels against the Rubber Ring on the 1" Pulley. The direction of the drive depends on which of the Road Wheels is in contact with the Rubber Ring, and a neutral position is obtained when neither Road Wheel is pressed against the Rubber Ring.

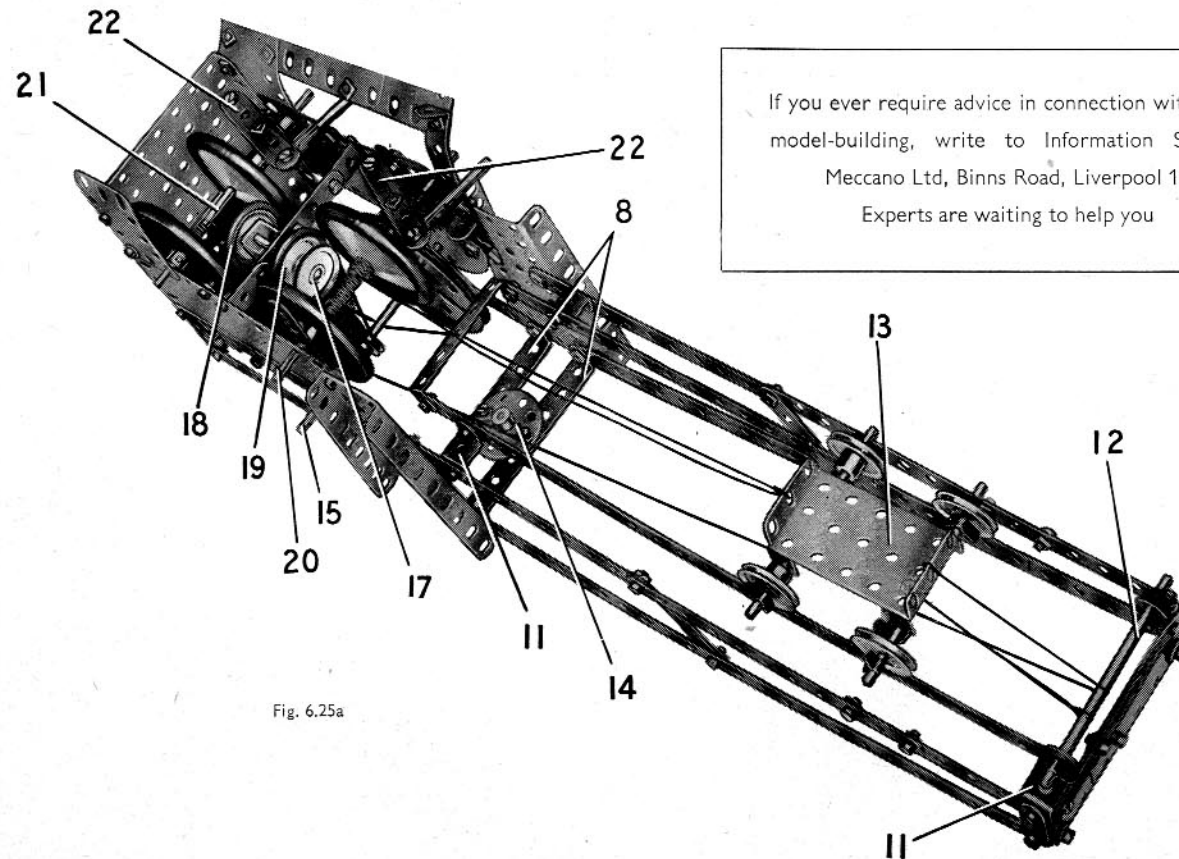

Fig. 6.25a

If you ever require advice in connection with your model-building, write to Information Service, Meccano Ltd, Binns Road, Liverpool 13
Experts are waiting to help you

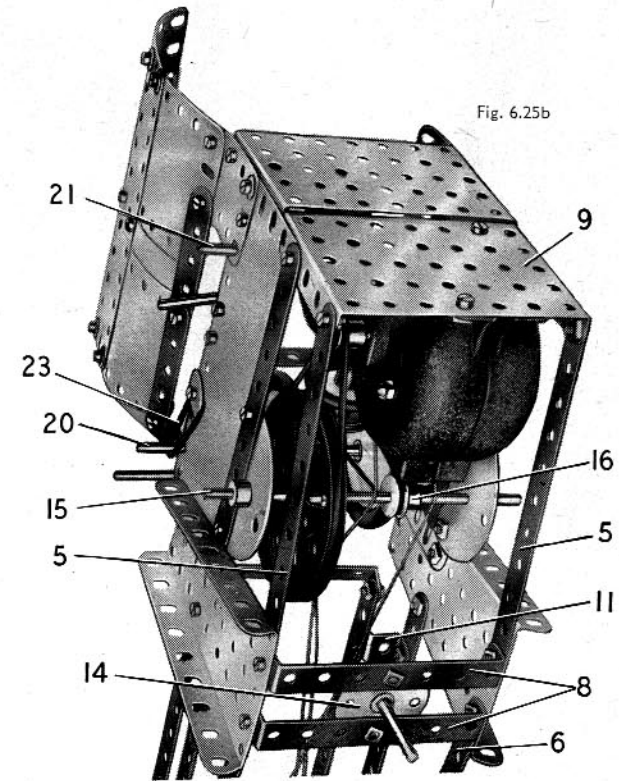

Fig. 6.25b

The sliding movement of Rods (20) and (21) necessary to engage the Road Wheels is controlled in each case by a $2\frac{1}{2}''$ Strip (22). These are *lock-nutted* to Angle Brackets bolted to the side of the cab, and they are *lock-nutted* also to Double Brackets slipped over the winding shafts. Spring Clips are placed on the winding shafts on either side of the Double Brackets. The operating handles are $1\frac{1}{2}''$ Rods held in Rod and Strip Connectors that are bolted to the Strips (22). A light braking effect is applied to Rod (20) by a $2\frac{1}{2}''$ Driving Band (23) looped over the Rod and held behind a $\frac{3}{8}''$ Washer on a bolt fixed to the side of the cab.

ARRANGEMENT OF THE WINDING CORDS

A length of Cord is tied to the front end of the Flanged Plate (13) (Fig. 6.25a) then taken round Rod (12) and under Rod (15). The Cord is then wound two or three times round Rod (21) between the Road Wheels, is taken again under Rod (15) and is tied finally to the end, nearest the cab, of the Flanged Plate (13).

A second length of Cord is fastened to a Cord Anchoring Spring on the Rod (20), is led over the rear axle of the travelling carriage and is passed round a $\frac{1}{2}''$ loose Pulley in the pulley block. The Cord then is led over the front axle of the carriage and is tied to the Rod (12). The $\frac{1}{2}''$ loose Pulley is freely mounted on a $\frac{1}{2}''$ Bolt held by nuts in two Flat Trunnions. A small Loaded Hook is pivoted between Washers on a $\frac{3}{8}''$ Bolt supported in the Flat Trunnions.

6.26 HORSE BOX

Parts Required

10 of No. 1	1 of No. 15a	2 of No. 90	4 of No. 192
14 " " 2	1 " " 15b	4 " " 90a	2 " " 197
4 " " 3	1 " " 23	2 " " 111	1 " " 198
2 " " 4	3 " " 35	2 " " 111a	2 " " 199
10 " " 5	137 " " 37a	6 " " 111c	2 " " 200
2 " " 6a	123 " " 37b	2 " " 126	2 " " 212
4 " " 8	19 " " 38	2 " " 126a	2 " " 214
7 " " 10	2 " " 38d	1 " " 147b	3 " " 215
4 " " 11	2 " " 48	4 " " 187	4 " " 221
16 " " 12	3 " " 48a	4 " " 188	2 " " 222
2 " " 12a	2 " " 48b	4 " " 189	2 " " 223
4 " " 12c	2 " " 53	6 " " 190	
1 " " 15	4 " " 59	2 " " 191	

CONSTRUCTION OF THE CHASSIS

The chassis consists of two built-up girders, each made from two 12½" Angle Girders overlapped 16 holes. The girders are connected at the front by a 3½" × ½" Double Angle Strip (1) (Fig. 6.26a) and at the rear by a similar Double Angle Strip (2).

ASSEMBLY OF THE SIDES OF THE BODY

The side seen in Fig. 6.26 is bolted to a built-up strip (3) fitted at its ends with 5½" Strips (4) and (5). Strip (3) consists of two 12½" Strips overlapped 21 holes. The side is plated by a 5½" × 2½" Flexible Plate (6), a 2½" × 1½" Flexible Plate (7), two 5½" × 1½" Flexible Plates (8), a 4½" × 2½" Flexible Plate (9), a Semi-Circular Plate (10) and a 3½" × 2½" Flanged Plate (11). The Plate (9) is connected to the lower end of the Strip (5) by a 5½" Strip (12), and a further 5½" Strip (13) (Fig. 6.26a) is used to brace one edge of the gap left for the ramp. Two Angle Brackets (14) are bolted to the ramp, and are connected by lock-nutted bolts to further Angle Brackets fixed to the Strips (5) and (13). The catch to hold the ramp in the closed position is made by fixing a ¼" Bolt in a Rod and Strip Connector by means of a nut. The Bolt is then passed through a hole in the ramp and a Fishplate (15) is held tightly on it by two nuts.

This side of the body is attached to the chassis by a 1½" × ½" Double Angle Strip (16), a 1" × 1" Angle Bracket (17), and a Trunnion (18). The side seen in Fig. 6.26a is assembled on a framework made from a built-up strip (19) fitted at its ends with 5½" Strips (20) and (21). This side is filled in by three 5½" × 2½" Flexible Plates (22), two 5½" × 1½" Flexible Plates (23), a 2½" × 1½" Flexible Plate (24), two 2½" × 2½" Flexible Plates (25), a Semi-Circular Plate (26) and a 3½" × 2½" Flanged Plate (27). The side is connected to the chassis by a 1½" × ½" Double Angle Strip (28), a 2½" × 1½" Double Angle Strip (29) and a Trunnion (30). The side is strengthened by 5½" Strips placed vertically on the inside. Two of these Strips can be seen through the open ramp in Fig. 6.26.

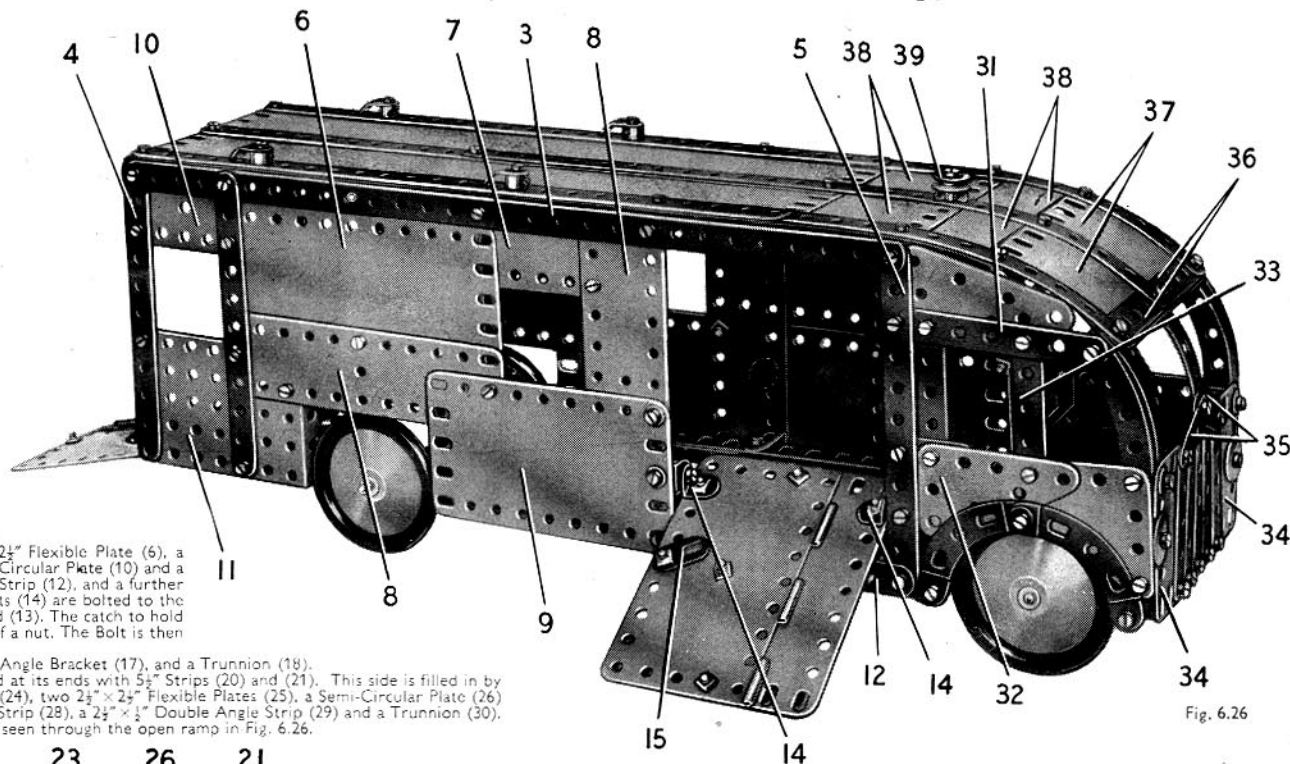

Fig. 6.26

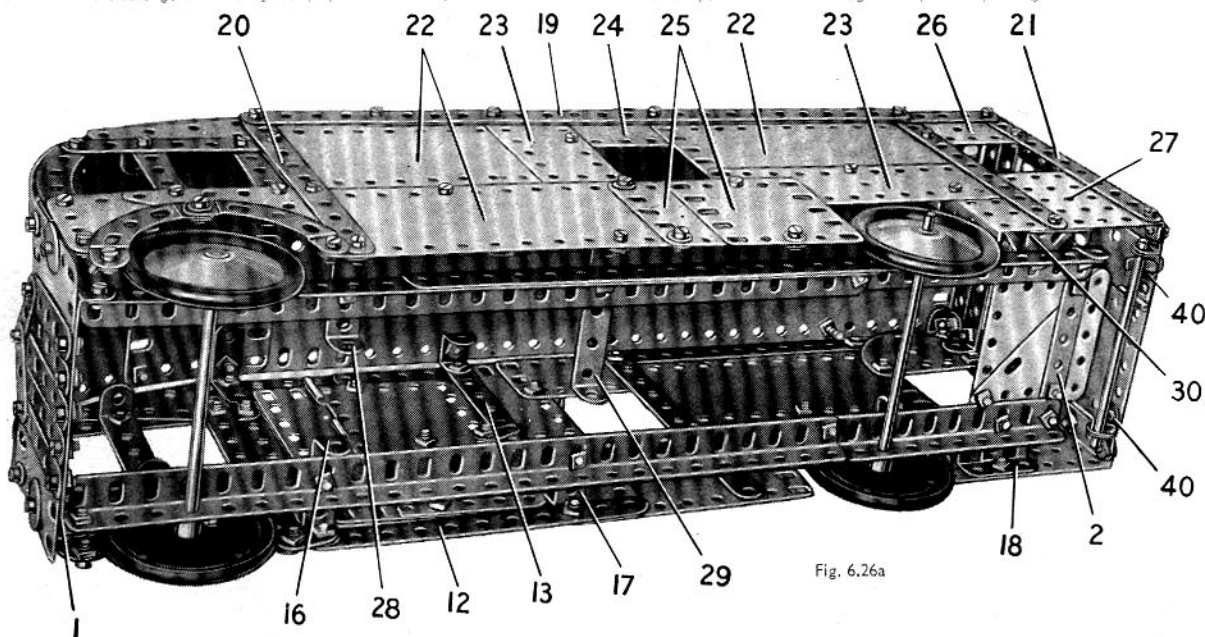

Fig. 6.26a

THE DRIVER'S CAB

Each side of the cab is made by bolting a 3½" Strip (31) to the side of the van body, and by fixing a 2½" × 1½" Triangular Flexible Plate (32) to a Flat Trunnion bolted to one of the Strips (5) or (20). The Plate (32) is extended forward by a 2½" × 2" Triangular Flexible Plate, and this is connected to the Strip (31) by a 2½" Curved Strip and by a 2½" × ½" Double Angle Strip (33). A 2½" × 1½" Triangular Flexible Plate is fixed to the Strip (31) as shown. The wheel arch consists of two 2½" Stepped Curved Strips bolted together and attached to the side of the cab by Fishplates.

The cab front consists of two 2½" × 1½" Flexible Plates (34) connected to the sides by Angle Brackets and bolted to the Double Angle Strip (1). The Plates (34) are joined together by two 1½" Strips (35). The radiator is made by bolting five 2½" Strips to the Double Angle Strip (1), the outer Strips on each side being held at the top by the same bolts that secure the Strips (35). The windscreen frame is made from three Formed Slotted Strips connected at the top by two 2½" Strips (36). The outer Formed Slotted Strips are attached to the Strips (31) by Angle Brackets.

CONSTRUCTION OF THE ROOF

The roof is made from two opened-out 'U'-section Curved Plates (37), four 2½" × 2½" Flexible Plates (38) and two 12½" × 2½" Strip Plates. These Plates are bolted to 12½" Strips arranged along the join in the centre and along each outer edge. The Curved Plates are fixed at the front to the Strips (36), and the other Plates are attached to the sides of the body by four ½" × ½" Angle Brackets, a 1" × 1" Angle Bracket and two Double Brackets.

The roof ventilators consist of Obtuse Angle Brackets and Collars held by ¼" and ⅜" Bolts. A ¼" loose Pulley (39) is spaced from the roof by a Spring Clip on a Pivot Bolt.

THE REAR RAMP

A 5½" Strip is bolted to the rear flange of each of the Flanged Plates (11) and (27), and the top ends of these Strips are connected to the sides of the body by Angle Brackets. Two built-up 4½" strips are bolted to the tops of the 5½" Strips on each side, in the next-to-end and the end holes of the 5½" Strips. One of the built-up strips consists of two 2½" Strips, and the other is made from a 3" Strip and a 2½" × ½" Double Angle Strip.

The ramp is formed by the other half of the Hinged Flat Plate and two straightened 1½" radius Curved Plates bolted together to make a 4½" × 3½" built-up plate. Two Angle Brackets (40) are fixed to the lower corners of the ramp, and a 4" Rod is mounted in them and in Angle Brackets attached to the flanges of the Flanged Plates (11) and (27). The Rod is held in place by Spring Clips. The catch for this ramp is made in the same way as the one previously described for the side ramp.

6.27 LOADING GRAB

Parts Required

12 of No. 2	3 of No. 16	1 of No. 24c	1 of No. 54	4 of No. 187
4 " " 3	2 " " 17	7 " " 35	4 " " 59	3 " " 188
2 " " 4	1 " " 18a	111 " " 37a	2 " " 90	4 " " 189
10 " " 5	1 " " 18b	103 " " 37b	2 " " 90a	4 " " 190
2 " " 6a	2 " " 19b	26 " " 38	2 " " 111	1 " " 191
4 " " 8	1 " " 19g	1 " " 38d	1 " " 111a	3 " " 192
8 " " 10	1 " " 19h	1 " " 40	6 " " 111c	1 " " 198
1 " " 11	5 " " 22	1 " " 48	1 " " 115	2 " " 200
16 " " 12	2 " " 22a	7 " " 48a	3 " " 125	1 " " 212
2 " " 12a	1 " " 23a	2 " " 48b	1 " " 147b	2 " " 213
1 " " 14	1 " " 24	1 " " 51	4 " " 155	2 " " 214
1 " " 15a	2 " " 24a	2 " " 53	1 " " 176	4 " " 221

CONSTRUCTION OF THE BASE

The top of the wheeled base consists of two $3\frac{1}{2}'' \times 2\frac{1}{4}''$ Flanged Plates bolted to a $5\frac{1}{2}''$ Strip (1) (Fig. 6.27) on each side. Further $5\frac{1}{2}''$ Strips (2) are connected to the Strips (1) by Fishplates, and a $3\frac{1}{2}'' \times \frac{1}{2}''$ Double Angle Strip (3) is attached to each end of the base. The wheels on which the base is mounted are fixed on a $6\frac{1}{2}''$ Rod and a built-up rod made from a $4\frac{1}{2}''$ and a $2''$ Rod joined by a Rod Connector.

A $3''$ Pulley (4) is bolted to the top of the base, with its boss accommodated in the gap between the two $3\frac{1}{2}'' \times 2\frac{1}{4}''$ Flanged Plates.

ASSEMBLY OF THE CAB

The cab is assembled on a Flanged Sector Plate (5) (Fig. 6.27b), fitted at its wide end with two $2\frac{1}{2}'' \times \frac{1}{2}''$ Double Angle Strips (6) that overlap it by three holes lengthways. A $3''$ Strip (7) is connected to the narrow end of the Sector Plate by an Angle Bracket and a $\frac{1}{2}''$ Reversed Angle Bracket, and the same bolts secure also two $1'' \times 1''$ Angle Brackets (8). A $3''$ Pulley (9) is bolted to the Flanged Sector Plate by two $\frac{1}{2}''$ Bolts. A $1\frac{1}{2}''$ Rod is fixed in this Pulley (4) and is held in place by a Spring Clip.

The back of the cab consists of a vertical $5\frac{1}{2}'' \times 2\frac{1}{4}''$ Flexible Plate and a $2\frac{1}{2}'' \times 2\frac{3}{8}''$ Flexible Plate arranged to leave a gap for a window in the top right-hand corner (Fig. 6.27). The back is edged on each side by a $5\frac{1}{2}''$ Strip and at the top and bottom by built-up $4\frac{1}{2}''$ strips, each made with two $2\frac{1}{2}''$ Strips. The back is bolted to the lugs of the Double Angle Strips (6).

The side seen in Fig. 6.27 consists of a $5\frac{1}{2}'' \times 2\frac{1}{4}''$ Flexible Plate (10), a $5\frac{1}{2}'' \times 1\frac{1}{2}''$ Flexible Plate (11) and one half of a Hinged Flat Plate (12) arranged as shown. The Plates are strengthened by Strips as indicated, and the side is extended forward by a Semi-Circular Plate (13) bolted to a $2\frac{1}{2}''$ Stopped Curved Strip (14). The Curved Strip is connected to a $1\frac{1}{2}''$ Strip at the top of the side by a $3\frac{1}{2}''$ Strip (15). A $1\frac{1}{2}'' \times \frac{1}{2}''$ Double Angle Strip (16) (Fig. 6.27b) is bolted between the Curved Strip (15) and a similar part fixed at its lower end to the Flanged Sector Plate (5). A $5\frac{1}{2}''$ Strip (17) is connected to the Flanged Sector Plate by the same Bolt as the Curved Strip and a $3\frac{1}{2}''$ Strip is then bolted to the next-to-top hole of the Strip (17) so that it projects by two clear holes in front of the $5\frac{1}{2}''$ Strip. The front end of the $3\frac{1}{2}''$ Strip is joined by a $3\frac{1}{2}''$ Strip (18) to the inner lug of Double Angle Strip (16). A curved $2\frac{1}{2}'' \times 1\frac{1}{4}''$ Flexible Plate is bolted to the Double Angle Strip (16). The completed side is connected to the back of the cab by two Angle Brackets.

The opposite side of the cab is made from a $5\frac{1}{2}'' \times 2\frac{1}{4}''$ Flexible Plate, a $5\frac{1}{2}'' \times 1\frac{1}{2}''$ Flexible Plate and one half of a Hinged Flat Plate arranged in the same way as the Plates (10), (11) and (12) already described. In this side, however, the front edge of the Hinged Flat Plate forms the end of the side, and the Semi-Circular Plate (13) and the Curved Strip (14) are omitted. The top front corner of the Hinged Flat Plate is connected to the upper front corner of the $5\frac{1}{2}'' \times 2\frac{1}{4}''$ Flexible Plate by two $2\frac{1}{2}''$ Curved Strips. The gap between the Curved Strips and the Plates is filled by a Semi-Circular Plate and a $2\frac{1}{2}'' \times 2\frac{1}{2}''$ Flexible Plate. This side is connected to the back of the cab and to the Strip (7) (Fig. 6.27b) by Angle Brackets. A $2\frac{1}{2}'' \times 1\frac{1}{2}''$ Flexible Plate (19) is bolted to the Strip (7) and is attached to the top corner of the Hinged Flat Plate by an Angle Bracket.

The cab roof consists of a $4\frac{1}{2}'' \times 2\frac{1}{4}''$ Flexible Plate and two $2\frac{1}{2}'' \times 2\frac{1}{2}''$ Flexible Plates. The roof is extended forward by two $5\frac{1}{2}'' \times 1\frac{1}{2}''$ Flexible Plates (20) and (21) (Fig. 6.27). The Plate (20) is connected to the Strips (15) and (18) by Angle Brackets, and the Plate (21) is bolted to the top edge of the Plate (19).

DETAILS OF THE JIB AND THE GRAB

The jib consists of two built-up girders, each made from two $12\frac{1}{2}''$ Angle Girders overlapped 15 holes. The Girders are bolted together at their upper ends and are connected at their lower ends by a Wheel Disc (22) (Fig. 6.27b). One of the girders is extended by a $3\frac{1}{2}''$ Strip (23) (Fig. 6.27), and the other by a $3''$ Strip (24). A $1''$ Rod is supported in the top holes of Strips (23) and (24) and it carries a $1''$ fixed pulley and two $1''$ loose Pulleys.

The sides of each half of the grab are $2\frac{1}{2}'' \times 1\frac{1}{4}''$ Triangular Flexible Plates, edged by $2\frac{1}{2}''$ Strips and connected by a $2\frac{1}{2}'' \times \frac{1}{2}''$ Double Angle Strip (25). A $1\frac{1}{2}''$ radius Curved Plate is bolted to each Double Angle Strip. The back of one half of the grab is filled in by a $2\frac{1}{2}'' \times 1\frac{1}{2}''$ Flanged Plate. The other half uses a $2\frac{1}{2}'' \times 1\frac{1}{2}''$ Flexible Plate attached by Angle Brackets. A $2\frac{1}{2}'' \times \frac{1}{2}''$ Double Angle Strip (26) has two Fishplates (27) bolted tightly to each of its lugs. The jaws of the grab pivot on $3\frac{1}{2}''$ Rods held by Spring Clips in the Fishplates.

(Continued on next page)

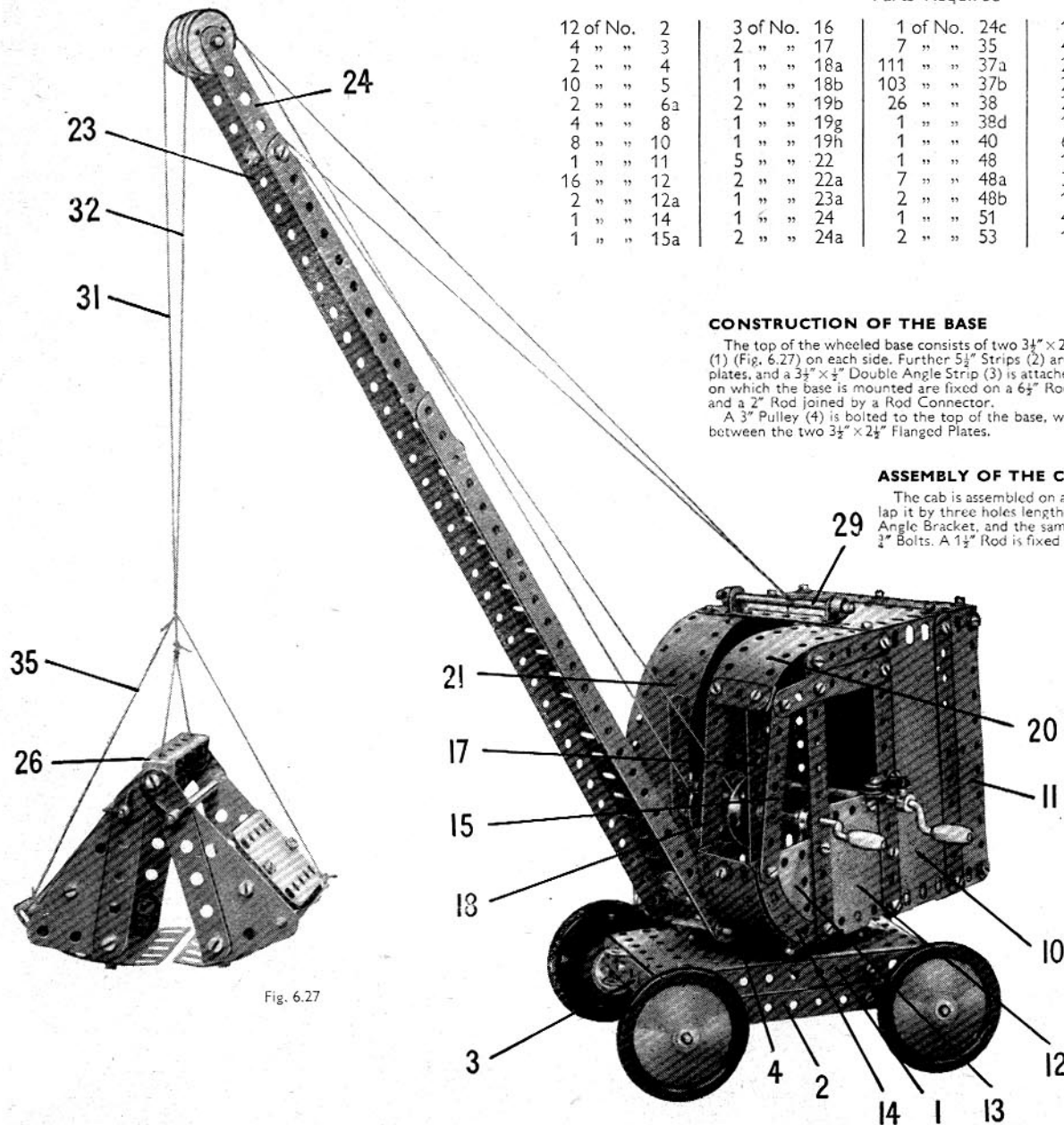

Fig. 6.27

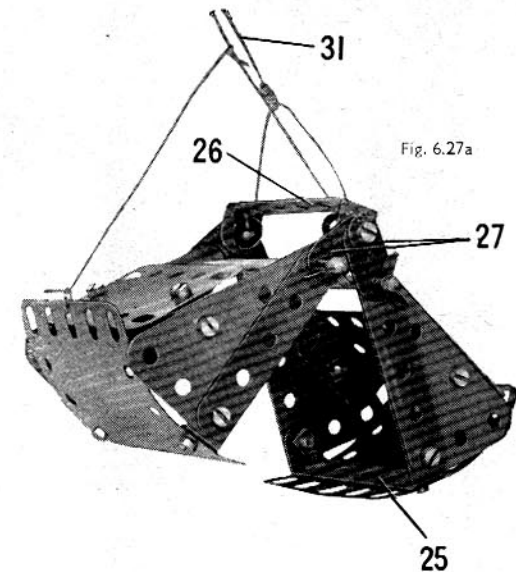

Fig. 6.27a

MODEL 6.27 LOADING GRAB — Continued

ARRANGEMENT OF THE CORDS AND OPERATING MECHANISM

The jib is luffed by a length of Cord fastened to a Cord Anchoring Spring on a 5" Crank Handle (28) (Fig. 6.27b). The Crank Handle is passed through one side of the cab, and is joined by a Rod Connector to a Threaded Pin passed through the opposite side of the cab. The Cord is passed over a 3 1/2" Rod (29) (Fig. 6.27), round the 1" fixed Pulley at the top of the jib, and is tied to Rod (29).

A Collar fitted with a 3/8" Bolt is fixed on the Crank Handle (28), and a Rod and Strip Connector (30) is lock-nutted to a 3/8" Reversed Angle Bracket bolted to the side of the cab. The Rod and Strip Connector can be swung round so that it engages the 3/8" Bolt in the Collar to form a simple brake.

The grab is suspended from two lengths of Cord (31) and (32) (Fig. 6.27), fastened to a 3 1/2" Crank Handle (33). The Cord (32) is tied between a Bush Wheel (34) and a Wheel Disc, and the Cord (31) is fastened between the Wheel Disc and another similar part. Each Cord is led over one of the 1" loose Pulleys at the top of the jib. The Cord (32) is attached as shown to the Double Angle Strip (26) of the grab. The Cord (32) is fastened to the centre of a length of Cord (35) (Fig. 6.27), which is tied to the jaws of the grab. The Cord (32) passes under a Pivot Bolt (36) (Fig. 6.27b), which is fixed in a 2 1/2" Strip lock-nutted to an Angle Bracket. The Angle Bracket is bolted to the Flexible Plate (19). When the 2 1/2" Strip is pressed down, the movement of the Pivot Bolt (19) depresses the Cord (32). This has the effect of shortening the effective length of the Cord in comparison with that of the Cord (31), and thus the jaws of the grab are pulled open.

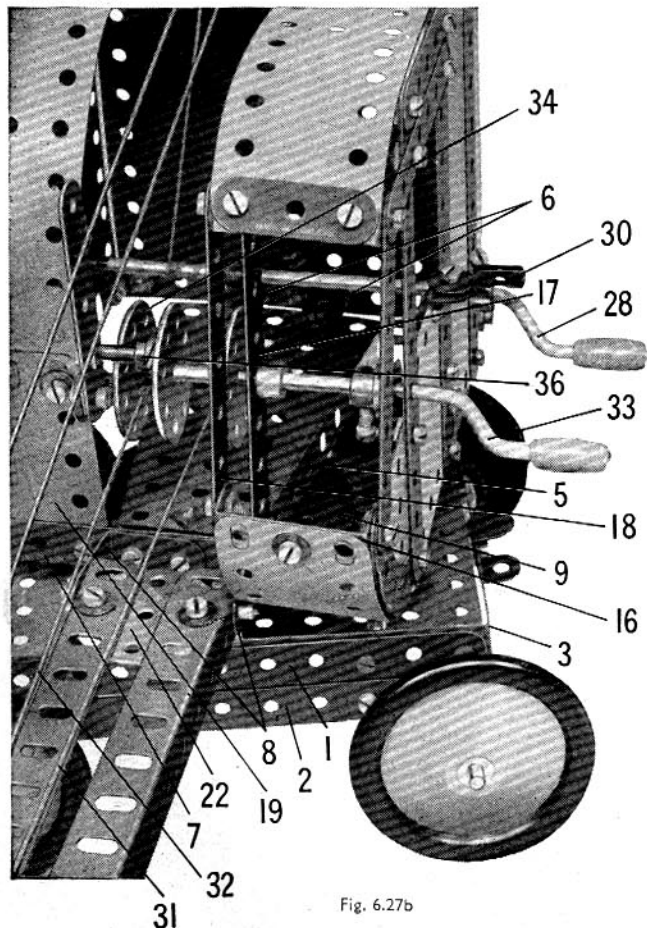

Fig. 6.27b

CONSTRUCTION OF THE BASE

Each side of the base is a 12 1/2" x 2 1/2" Strip Plate edged by two 12 1/4" Strips and two 5 1/2" Strips (1) and (2). The sides are extended upward at one end by 2 1/2" x 2 1/2" Flexible Plates (3). One end of the base consists of a 5 1/2" x 2 1/2" Flexible Plate (4), a 2 1/2" x 2 1/2" Flexible Plate (5), one half of a Hinged Flat Plate (6) and a 5 1/2" x 1 1/2" Flexible Plate. This end is connected to the sides by 1" x 1" Angle Brackets at the lower corners of the base.

The other half of the Hinged Flat Plate is arranged horizontally to form part of the top of a platform at one end of the base. The top is completed by a 2 1/2" x 2 1/2" Flexible Plate bolted to the Hinged Flat Plate, and the assembly is connected to each side of the base by a 1 1/2" x 1 1/2" Double Angle Strip held by a bolt (7). A 5 1/2" x 1 1/2" Flexible Plate is connected to the front of the platform by 2 1/2" x 1 1/2" Double Angle Strips, which are held also by the bolts (7).

The opposite end of the base is filled in by two 5 1/2" x 2 1/2" Flexible Plates edged by a 5 1/2" Strip, and attached to the sides by Angle Brackets. The loading platform is a 5 1/2" x 2 1/2" Flanged Plate bolted to the end of the base and to the Strips (2). The inner end of the platform is supported by a 3 1/2" Strip (8) on each side, and the platform is edged by a 5 1/2" x 1 1/2" Flexible Plate. The entrance consists of a 2 1/2" Curved Strip bolted to one of the Strips (2) and to a 2 1/2" Strip that extends one of the Strips (8).

The steps to the loading platform are made by bolting two 2 1/2" x 1 1/2" Double Angle Strips and a 2 1/2" Strip fitted at each end with an Angle Bracket, between two 2 1/2" x 2" Triangular Flexible Plates edged by 3" Strips.

The steps are connected to the base by a Fishplate and an Angle Bracket.

ASSEMBLY OF THE TOWER AND THE FLYBOAT ARMS

The tower consists of four 12 1/2" Angle Girders bolted as shown to the base. The Girders are connected across by two 5 1/2" Strips (9) and they are braced to the Strips (1) and (2) by further 5 1/2" Strips. The top ends of the Girders on each side are connected by a 3 1/2" Strip, and the flyboat shaft (10) is supported in Semi-Circular Plates bolted to the 3 1/2" Strips. The shaft is a 6 1/2" Rod.

The arms supporting the flyboats are each made from two 12 1/2" Strips overlapped 19 holes. The arms are connected together in pairs as shown, and they are bolted at right angles to a 3" Pulley (11). Two of the arms are connected by 3 1/2" x 1 1/2" Double Angle Strips, and the other two are joined by built-up double angle strips, each made from a 2 1/2" and a 1 1/2" Strip and two Angle Brackets. The Rod (10) is held in position by two Road Wheels, placed one on each side of one of the Semi-Circular Plates.

A Crank Handle (12) is supported in the side of the base and in a Double Bracket fixed to one of the Strips (9). The Crank Handle carries a 1/2" Pinion that drives a 57-tooth Gear on a 1 1/2" Rod. This Rod is mounted in the side of the base and in a Double Bent Strip bolted to the side, and a 1" Pulley on the Rod is connected by a Cord belt to a 3" Pulley on the Rod (10). The Crank Handle and the 1 1/2" Rod are held in position by Collars.

THE FLYBOAT CHAIRS

Two of the chairs are each made from a 3 1/2" x 2 1/2" Flanged Plate, fitted with two 2 1/2" Stopped Curved Strips and two 2 1/2" x 1 1/2" Triangular Flexible Plates attached to a 2 1/2" x 1 1/2" Double Angle Strip. The Double Angle Strip is fixed to one flange of the Flanged Plate, and a 2 1/2" x 1 1/2" Flexible Plate is bolted to the other flange. Each of these chairs pivots on a built-up rod held by Spring Clips in the end holes of the flyboat arms. The rods are made from 2" and 1 1/4" Rods joined by Rod Connectors.

The other two chairs are each formed by a Flanged Sector Plate with a 2 1/2" x 1 1/2" Double Angle Strip bolted across its wide end. A 1 1/4" radius Curved Plate edged by Formed Slotted Strips is fixed to the Double Angle Strip, and is connected to the Flanged Plate on each side by a 2 1/2" Strip (13) and an Angle Bracket. Each of these chairs pivots on a 4" Rod.

Parts Required

12 of No. 1	1 of No. 22	2 of No. 111a
12 " " 2	1 " " 26	5 " " 111c
4 " " 3	1 " " 27a	2 " " 126
2 " " 4	12 " " 35	2 " " 187
12 " " 5	137 " " 37a	2 " " 188
2 " " 6a	130 " " 37b	3 " " 189
4 " " 8	1 " " 40	4 " " 190
1 " " 10	1 " " 45	3 " " 192
1 " " 11	2 " " 48	2 " " 197
16 " " 12	8 " " 48a	1 " " 198
2 " " 12a	2 " " 48b	2 " " 200
1 " " 14	1 " " 52	2 " " 213
2 " " 15b	2 " " 53	2 " " 214
2 " " 17	2 " " 54	4 " " 215
3 " " 18a	2 " " 59	4 " " 221
2 " " 19b	1 " " 90	2 " " 222
1 " " 19h	4 " " 90a	

6.28 FLYBOATS

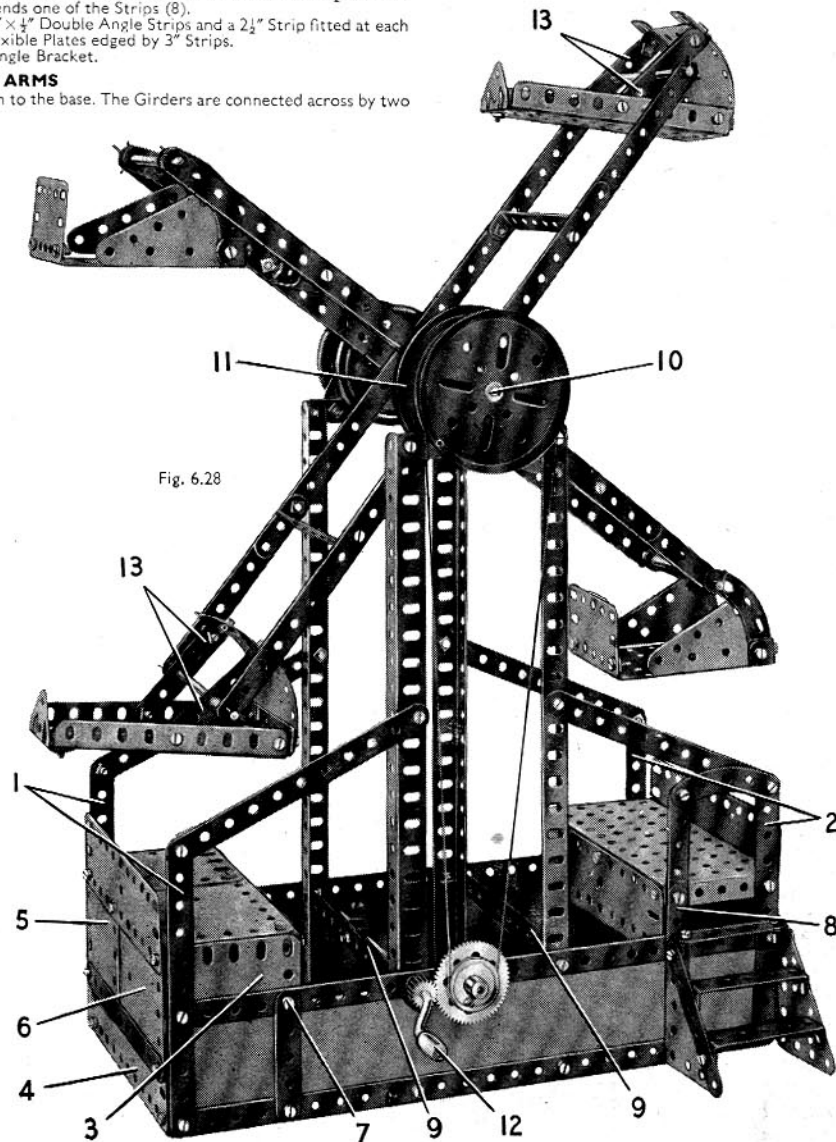

Fig. 6.28

6.29 GANTRY CRANE

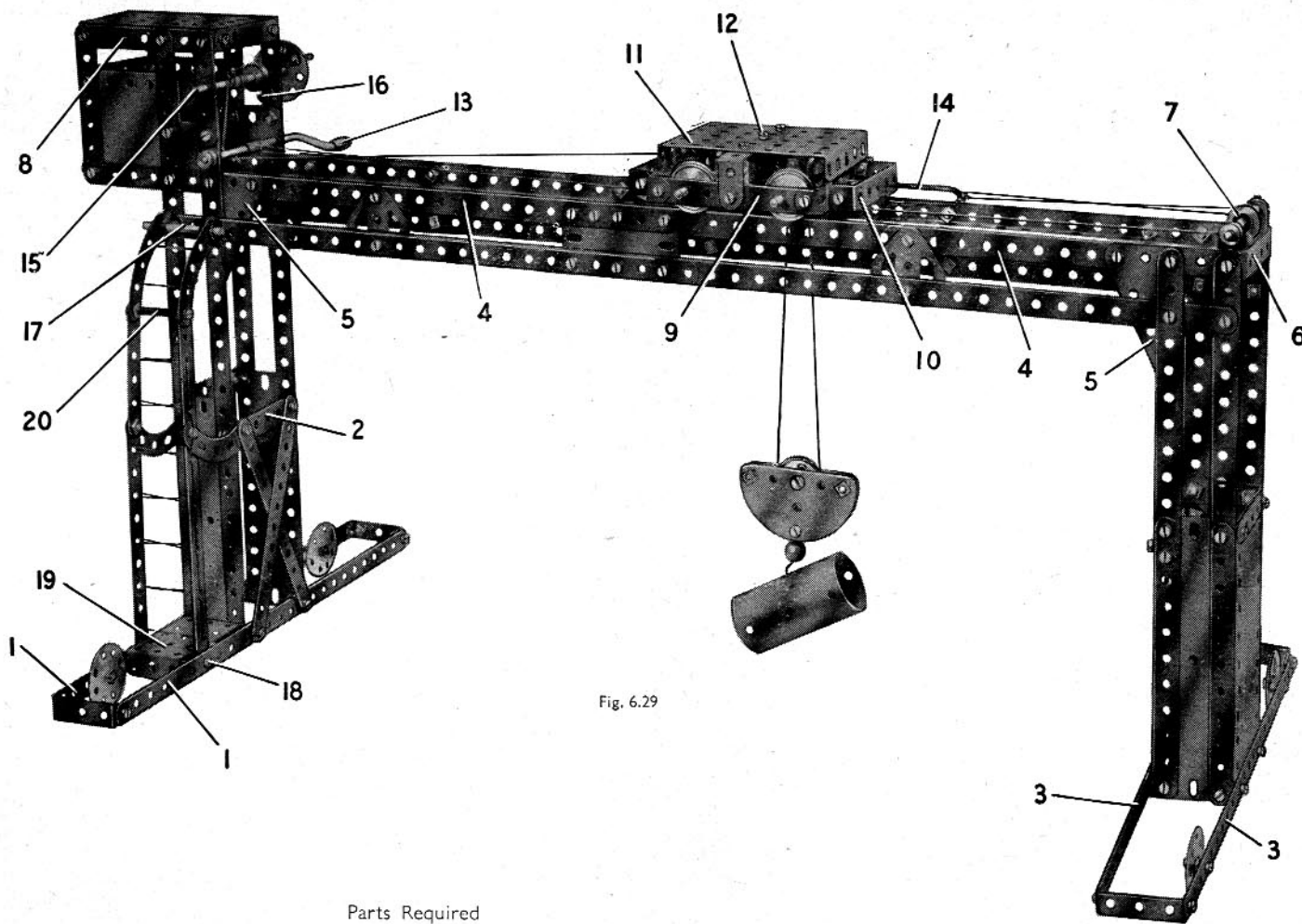

Fig. 6.29

Parts Required

12 of No. 1	2 of No. 15b	2 of No. 24c	2 of No. 53	1 of No. 147b
14 " " 2	2 " " 16	12 " " 35	1 " " 57c	1 " " 176
4 " " 3	2 " " 17	139 " " 37a	4 " " 59	1 " " 186
2 " " 4	1 " " 18b	128 " " 37b	2 " " 90	4 " " 188
11 " " 5	1 " " 19g	23 " " 38	2 " " 90a	4 " " 189
2 " " 6a	5 " " 22	1 " " 40	1 " " 111	3 " " 190
4 " " 8	1 " " 22a	1 " " 44	2 " " 111a	2 " " 192
2 " " 10	1 " " 23	2 " " 48	6 " " 111c	1 " " 213
2 " " 11	1 " " 23a	8 " " 48a	1 " " 115	2 " " 214
16 " " 12	1 " " 24	2 " " 48b	4 " " 125	1 " " 216
2 " " 12a	2 " " 24a	1 " " 51	4 " " 126a	4 " " 221

CONSTRUCTION OF THE TOWERS

The main supports of the left-hand tower are four $12\frac{1}{2}$ " Strips attached by $2\frac{1}{2}$ " \times $\frac{1}{2}$ " Double Angle Strips at their lower ends to two $12\frac{1}{2}$ " Strips (1). The sides of the tower are partly plated by two $5\frac{1}{2}$ " \times $1\frac{1}{2}$ " Flexible Plates, and a $5\frac{1}{2}$ " \times $2\frac{1}{2}$ " Flexible Plate at the back is fixed to one of the Strips (1) and is connected to the tower by two Angle Brackets. A $2\frac{1}{2}$ " Strip (2) is also attached by Angle Brackets, and the front of the tower is braced by two crossed $5\frac{1}{2}$ " Strips. The Strips (1) are connected at one end by a $1\frac{1}{2}$ " \times $\frac{1}{2}$ " Double Angle Strip, and at the other end by a $1\frac{1}{2}$ " Strip attached to Angle Brackets.

The right-hand tower consists of four built-up strips, each made from two $5\frac{1}{2}$ " Strips. These are attached at their lower ends to two $2\frac{1}{2}$ " \times $\frac{1}{2}$ " Double Angle Strips bolted to two $12\frac{1}{2}$ " Strips (3), and the tower is braced by Flexible Plates and Strips in the same way as the left-hand tower already described.

The wheels on which the crane travels are Wheel Discs, each of which is free to turn on a bolt attached by two nuts to the base of the tower.

GANTRY AND THE CONTROL CAB

The gantry consists of two built-up girders, each made from two $12\frac{1}{2}$ " Angle Girders (4) placed end to end and connected by a $2\frac{1}{2}$ " Strip, and two $12\frac{1}{2}$ " Strips overlapped four holes. The Girders and the Strips are connected by a $2\frac{1}{2}$ " \times $1\frac{1}{2}$ " Flexible Plate and two Flat Trunnions. Each built-up girder is bolted to the tops of the towers as shown, and the joints are braced by $2\frac{1}{2}$ " \times $1\frac{1}{2}$ " Triangular Flexible Plates (5). At one end the Girders (4) are connected by a $2\frac{1}{2}$ " \times $\frac{1}{2}$ " Double Angle Strip (6), and the bolts holding this part secure also Fishplates that support a $3\frac{1}{2}$ " Rod fitted with a $\frac{1}{2}$ " loose Pulley (7). The Rod is held in place by Collars.

Each side of the control cab is a $2\frac{1}{2}$ " \times $2\frac{1}{2}$ " and a $2\frac{1}{2}$ " \times $1\frac{1}{2}$ " Flexible Plate bolted to the Angle Girder (4). The rear edge of the cab is strengthened by a $3\frac{1}{2}$ " Strip, and the $12\frac{1}{2}$ " Strips of the tower are each lengthened by a $2\frac{1}{2}$ " Strip that overlaps the $12\frac{1}{2}$ " Strip by three holes. The $3\frac{1}{2}$ " and the $2\frac{1}{2}$ " Strips are connected at their upper ends by $3\frac{1}{2}$ " \times $\frac{1}{2}$ " Double Angle Strips (8), and the roof, a $3\frac{1}{2}$ " \times $2\frac{1}{2}$ " Flanged Plate, is bolted to the lugs of these Double Angle Strips. The back of the cab is a $2\frac{1}{2}$ " \times $2\frac{1}{2}$ " Flexible Plate attached to two $2\frac{1}{2}$ " \times $\frac{1}{2}$ " Double Angle Strips.

THE CRAB OR TRAVELLING CARRIAGE

The crab consists of a $3\frac{1}{2}$ " Strip (9) at each side, connected at each end to a $2\frac{1}{2}$ " \times $\frac{1}{2}$ " Double Angle Strip (10) by a $\frac{1}{2}$ " Reversed Angle Bracket. The wheels are 1" Pulleys fixed on 4" Rods supported in the Strips (9). A $3\frac{1}{2}$ " \times $2\frac{1}{2}$ " Flanged Plate (11) is attached to 1" \times 1" Angle Brackets bolted to the Strips (9), and a Stepped Bent Strip is fixed underneath the Flanged Plate by a bolt (12). A 1" Pulley is held on a 1" Rod supported in the Stepped Bent Strip.

ARRANGEMENT OF THE CORDS

A Crank Handle (13) is mounted as shown in the front of the cab and is held in place by Collars. A length of Cord fastened to one end of the crab is wound three or four times round the Crank Handle and is taken round the $\frac{1}{2}$ " Pulley (7). The Cord is then tied to a Driving Band (14), which is attached to the other end of the crab. The Driving Band is stretched slightly to tension the Cord.

A Bush Wheel, fitted with a Threaded Pin as a handle, is fixed on a $3\frac{1}{2}$ " Rod (15) supported in the front of the cab. The Rod is held in position by a $\frac{1}{2}$ " fixed Pulley, but it is allowed to slide about $\frac{1}{4}$ " in its bearings. A $\frac{1}{2}$ " Bolt in the boss of the Bush Wheel engages a $\frac{1}{2}$ " Bolt (16) held in place by two nuts. This forms a simple brake, which is released by sliding the Rod to disengage the Bolts. A length of Cord is tied to a Cord Anchoring Spring on Rod (15), is passed under the Crank Handle, through a hole in the end of the Flanged Plate (11) and round the 1" Pulley supported in the Stepped Bent Strip. The Cord is taken round a 1" loose Pulley in the pulley block, over one axle of the crab and through the centre hole of Double Angle Strip (10). The Cord is tied finally to the Rod carrying the Pulley (7).

The pulley block consists of two Semi-Circular Plates spaced apart by nuts on $\frac{1}{2}$ " Bolts. The 1" loose Pulley is free to turn on a Pivot Bolt, which is held by its nuts in one of the Semi-Circular Plates.

ASSEMBLY OF THE LADDER

Each side of the ladder consists of a $5\frac{1}{2}$ " Strip, a 3" Strip and a $2\frac{1}{2}$ " Curved Strip held by a Spring Clip on a 2" Rod (17) supported in Angle Brackets bolted to the tower. The lower end of the ladder is held on a 2" Rod (18) passed through the Strips (1). Two Double Brackets are placed on the Rod between the Strips (1), and a $2\frac{1}{2}$ " \times $1\frac{1}{2}$ " Flanged Plate (19) rests on these Double Brackets and is bolted by one of its flanges to the tower. A Rod Connector (20) is slipped over the shanks of two bolts, and the rungs of the ladder are represented by Cord.

BUILD BIGGER AND BETTER MODELS

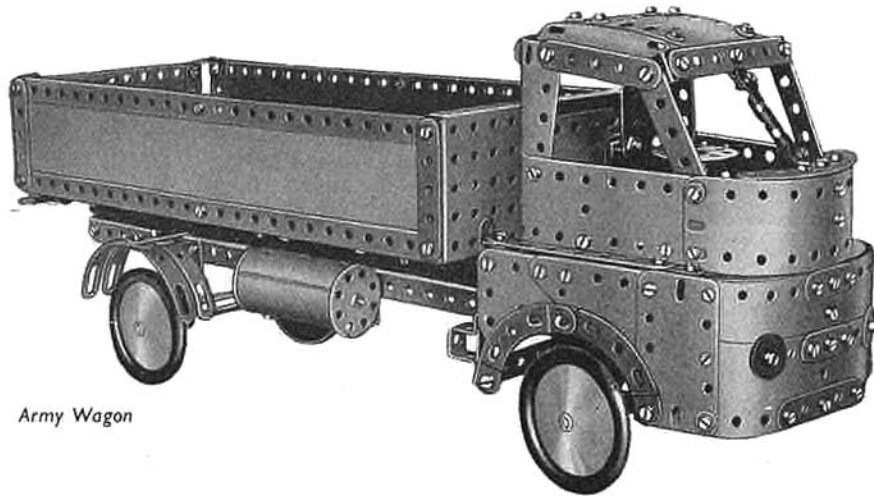

Army Wagon

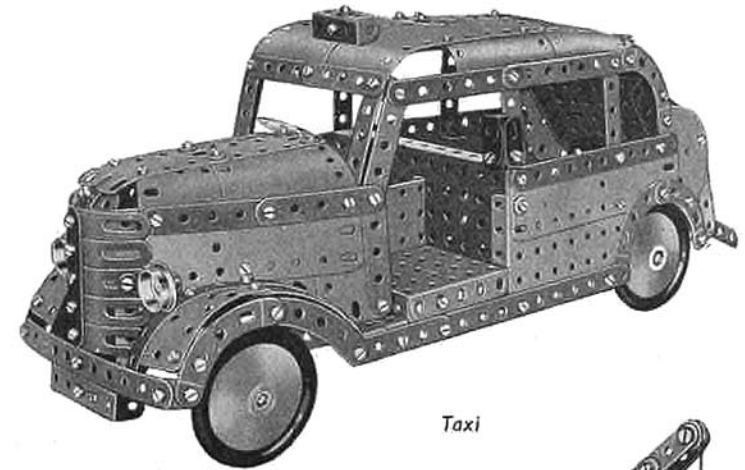

Taxi

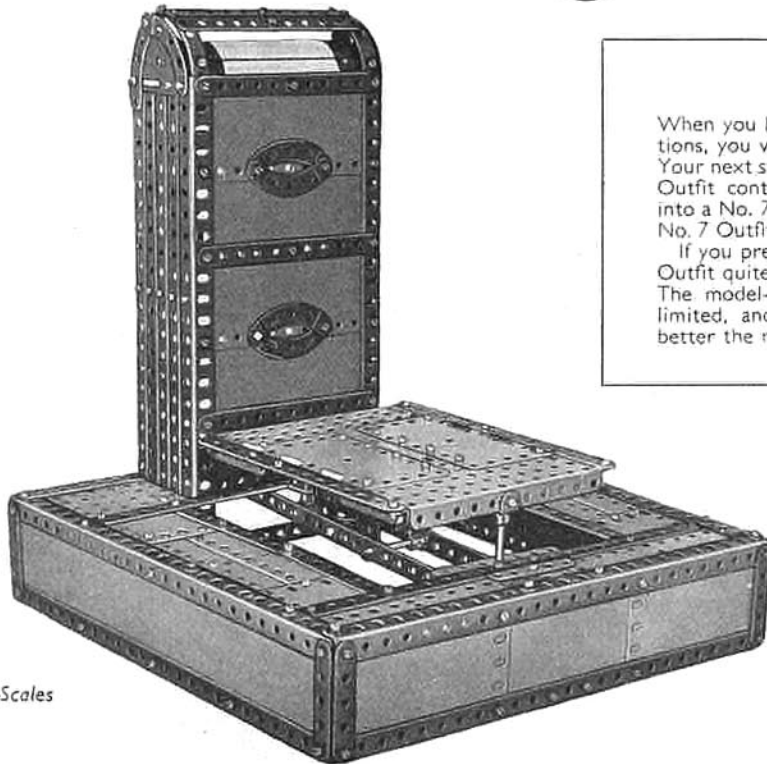

Auto-Scales

HOW TO CONTINUE

When you have built all the models shown in this Book of Instructions, you will be keen to build others bigger and more elaborate. Your next step therefore is to purchase a Meccano No. 6a Accessory Outfit containing all the parts required to convert your No. 6 into a No. 7 Outfit. You will then be able to build the full range of No. 7 Outfit models, a selection of which is illustrated on this page.

If you prefer to do so, you can build up and develop your No. 6 Outfit quite easily by adding various parts to it from time to time. The model-building possibilities of the Meccano System are unlimited, and the more Meccano parts you have the bigger and better the models you will be able to build.

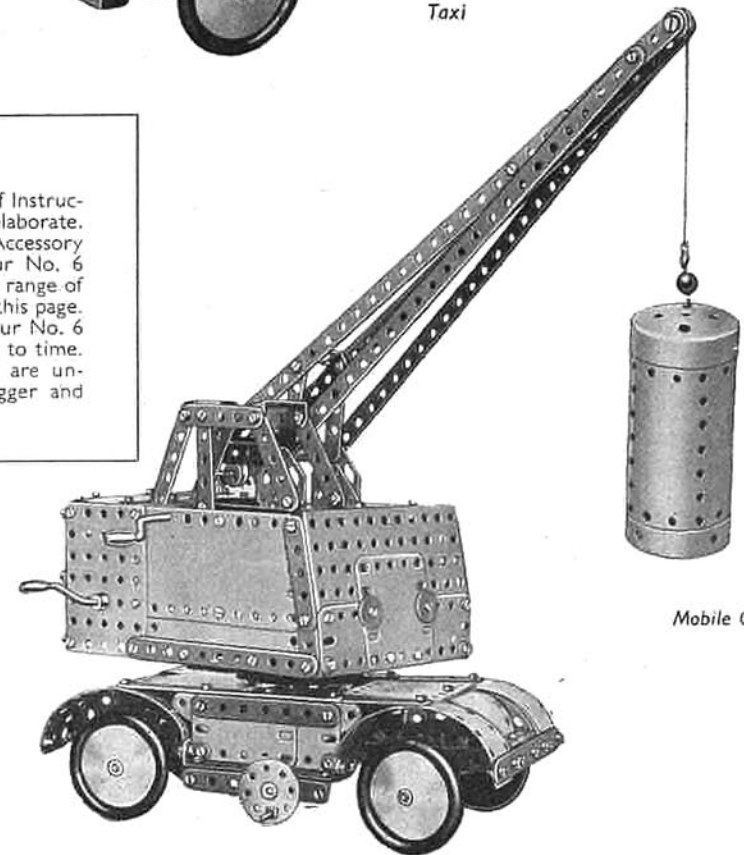

Mobile Crane

Here are a few simple and interesting movements showing how easily real mechanisms can be reproduced with Meccano

USEFUL BAND BRAKE

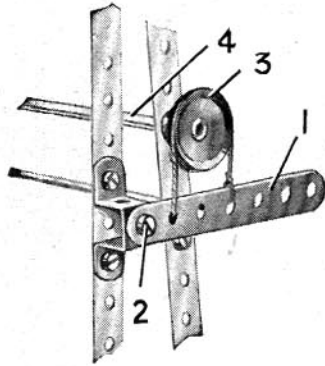

The brake lever consists of a $3\frac{1}{2}$ " Strip (1), pivotally attached at a suitable point on the frame of the model by means of a lock-nutted $\frac{3}{8}$ " Bolt (2). The driven shaft (4) is fitted at one end with a 1" fast Pulley (3) round which a short length of Cord is passed. The two ends of this Cord are secured to the brake lever at the points shown in the illustration.

If increased braking effect is desired, a larger Pulley may be used in place of the 1" fast Pulley (3), the brake lever (1) being attached in a lower position if necessary. Alternatively, a weight can be hung from the end of the brake lever.

SIMPLE REVERSING MECHANISM

When a *Magic Motor*, which is non-reversing, is used for driving a small model such as a crane, a simple reversing mechanism that does not require any gears can be built up on the lines shown below.

The drive from the Motor is taken to a Rod (1) on which are fixed two 1" Pulleys each fitted with a Rubber Ring. This Rod is arranged to that it can be moved endways in its bearings, so as to bring either of the 1" Pulleys into Contact with a third 1" Pulley fixed on a Rod (2) placed at right angles to Rod (1). The direction of the drive can be changed by sliding Rod (1) as required.

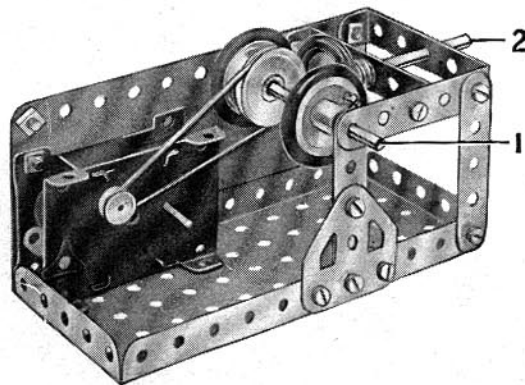

SIMPLE STEERING GEAR

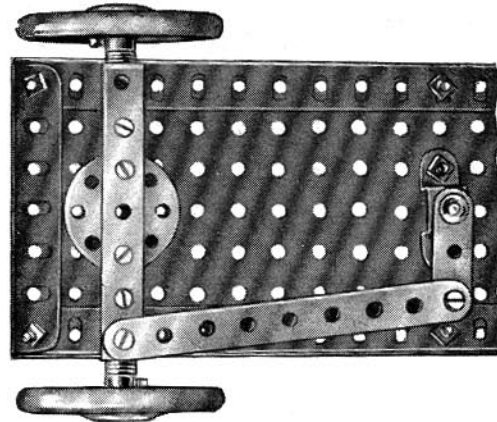

This simple steering gear will be found suitable for most small model vehicles.

In this example the two front wheels are mounted on separate stub axles that are secured to each end of a rigid front axle. The base of the chassis consists of two long Angle Girders connected together at the front end by a $3\frac{1}{2}$ " Angle Girder and filled in along their length by means of $5\frac{1}{2}$ " \times $3\frac{1}{2}$ " Flat Plates.

The front axle, a $3\frac{1}{2}$ " \times $\frac{1}{2}$ " Double Angle Strip, is pivotally mounted at its centre on a Bush Wheel and short Rod. It is fitted, $\frac{1}{2}$ " from each end, with a $\frac{1}{2}$ " \times $\frac{1}{2}$ " Angle Bracket, this forming the inner bearing for its respective stub axle. The outer bearing for the axle consists of the upturned lug of the Double Angle Strip. One end of this latter part is fitted with a pivotally attached $4\frac{1}{2}$ " Strip, by means of which the front axle is linked to a Crank fixed to the steering column.

SAFETY CATCH FOR CRANE WINDING GEAR

The Compression Spring (3) is mounted on the Crank Handle (1) between the Collar (4) and a Washer, and normally holds the Collar (2) against the inner side of the Plate. The Collar (2) is fitted with a $\frac{3}{8}$ " Bolt, and if the Crank Handle commences to rotate, the head of this Bolt strikes against the stop (5) and prevents further movement.

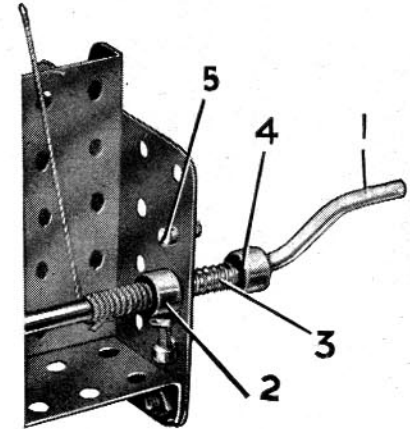

USEFUL ROLLER BEARING

The simple roller bearing shown below is suitable for use in model cranes and others having a swivelling superstructure.

The lower Pulley (1) should be firmly attached to the top of the crane tower or support. A 2" Rod is fixed in the Pulley, and on it is freely mounted a 'spider' that carries the roller wheels. The 'spider' is made by bolting two $2\frac{1}{2}$ " \times $\frac{1}{2}$ " Double Angle Strips at right angles to each other across the face of a Wheel Disc. The roller wheels consist of two 1" loose and two 1" fixed Pulleys. The fixed Pulleys are free to turn on $\frac{3}{8}$ " Bolts, and the loose Pulleys are mounted on $\frac{1}{2}$ " Bolts. Each Bolt is then fixed by two nuts to one of the lugs of the Double Angle Strips.

The 1" Pulleys rest on the edge of the rim of the Pulley (1), and a further 3" Pulley (2) is passed over the 2" Rod and is held in place by a Collar.

The Pulley (2) is attached to the cab or superstructure of the model.

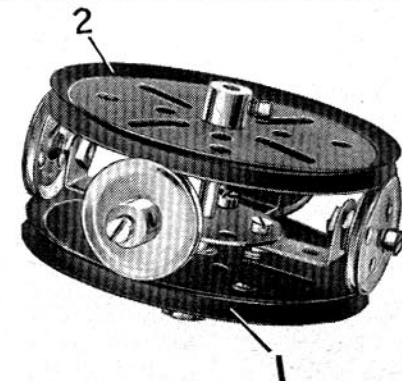

MECCANO PARTS

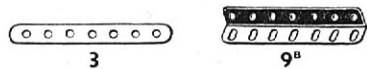

PERFORATED STRIPS

No.	1. 12 $\frac{1}{2}$ "	No.	2a. 4 $\frac{1}{2}$ "	No.	6. 2"
1a.	9 $\frac{1}{2}$ "	3.	3 $\frac{1}{2}$ "	6a.	1 $\frac{1}{2}$ "
1b.	7 $\frac{1}{2}$ "	4.	3"		
2.	5 $\frac{1}{2}$ "	5.	2 $\frac{1}{2}$ "		

ANGLE GIRDERS

7.	24 $\frac{1}{2}$ "	8b.	7 $\frac{1}{2}$ "	9c.	3"
7a.	18 $\frac{1}{2}$ "	9.	5 $\frac{1}{2}$ "	9d.	2 $\frac{1}{2}$ "
8.	12 $\frac{1}{2}$ "	9a.	4 $\frac{1}{2}$ "	9e.	2"
8a.	9 $\frac{1}{2}$ "	9b.	3 $\frac{1}{2}$ "	9f.	1 $\frac{1}{2}$ "



10. Fishplate | 11. Double Bracket

ANGLE BRACKETS

12.	1 $\frac{1}{2}$ " x 1 $\frac{1}{2}$ "	12b.	1" x 1 $\frac{1}{2}$ "	12c.	Obtuse, 1 $\frac{1}{2}$ " x 1"
12a.	1" x 1"				



AXLE RODS

13.	11 $\frac{1}{2}$ "	15a.	4 $\frac{1}{2}$ "	16b.	3"
13a.	8"	15b.	4"	17.	2"
14.	6 $\frac{1}{2}$ "	16.	3 $\frac{1}{2}$ "	18a.	1 $\frac{1}{2}$ "
15.	5"	16a.	2 $\frac{1}{2}$ "	18b.	1"

19g. Crank Handle, 3 $\frac{1}{2}$ " shaft, with grip
19h. Crank Handle, 5" shaft, with grip
19s. Crank Handle, 3 $\frac{1}{2}$ " shaft, without grip



19a. Spoked Wheel, 3" diam.
20. Flanged Wheel, 1 $\frac{1}{2}$ " diam.
20b. Flanged Wheel, 1" diam.

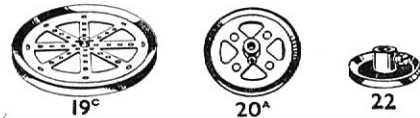

PULLEYS

19b. 3" diam., with boss and screw
19c. 6" diam., with boss and screw
20a. 2" diam., with boss and screw
21. 1 $\frac{1}{2}$ " diam., with boss and screw
22. 1" diam., with boss and screw



PULLEYS

22a. 1" diam., without boss
23. 1 $\frac{1}{2}$ " diam., without boss
23a. 1" diam., with boss and screw



No. 24. Bush Wheel, 1 $\frac{1}{2}$ " diam., eight holes
24a. Wheel Disc, 1 $\frac{1}{2}$ " diam., without boss, eight holes
24b. Bush Wheel, 1 $\frac{1}{2}$ " diam., six holes
24c. Wheel Disc, 1 $\frac{1}{2}$ " diam., without boss, six holes

PINIONS

25. 1 $\frac{1}{2}$ " diam., 1 $\frac{1}{2}$ " face, 25 teeth
25a. 1 $\frac{1}{2}$ " diam., 1 $\frac{1}{2}$ " face, 25 teeth
25b. 1 $\frac{1}{2}$ " diam., 1 $\frac{1}{2}$ " face, 25 teeth
26. 1 $\frac{1}{2}$ " diam., 1 $\frac{1}{2}$ " face, 19 teeth
26a. 1 $\frac{1}{2}$ " diam., 1 $\frac{1}{2}$ " face, 19 teeth
26b. 1 $\frac{1}{2}$ " diam., 1 $\frac{1}{2}$ " face, 19 teeth
26c. 1 $\frac{1}{2}$ " diam., 1 $\frac{1}{2}$ " face, 15 teeth



GEAR WHEELS

27. 1 $\frac{1}{2}$ " diam., 50 teeth
27a. 1 $\frac{1}{2}$ " diam., 57 teeth
27b. 3 $\frac{1}{2}$ " diam., 133 teeth
27c. 2 $\frac{1}{2}$ " diam., 95 teeth
27d. 1 $\frac{1}{2}$ " diam., 60 teeth



CONTRATE WHEELS

28. 1 $\frac{1}{2}$ " diam., 50 teeth
29. 1 $\frac{1}{2}$ " diam., 25 teeth

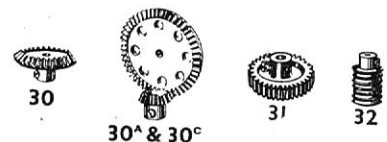

30° & 30°

30. Bevel Gear, 1 $\frac{1}{2}$ " diam., 26 teeth (for use in pairs)
30a. Bevel Gear, 1 $\frac{1}{2}$ " diam., 16 teeth | Can only be used together
30c. Bevel Gear, 1 $\frac{1}{2}$ " diam., 48 teeth
31. Gear Wheel, 1 $\frac{1}{2}$ " diam., 1 $\frac{1}{2}$ " face, 38 teeth
32. Worm, 1 $\frac{1}{2}$ " diam.
34. Spanner



34b. Box Spanner
35. Spring Clip
36. Screwdriver
36a. Screwdriver (longer)
36c. Drift (for levering bolt holes into line)
37. Nut and Bolt, 3 $\frac{1}{2}$ "
37a. Nut
37b. Bolt, 3 $\frac{1}{2}$ "
38. Washer
38d. Washer, 3 $\frac{1}{2}$ "
40. Hank of Cord



41. Propeller Blade | 43. Tension Spring, 2" long



No. 44. Bent Strip, stepped
45. Double Bent Strip

DOUBLE ANGLE STRIPS

46. 2 $\frac{1}{2}$ " x 1"
47. 2 $\frac{1}{2}$ " x 1 $\frac{1}{2}$ "
47a. 3" x 1 $\frac{1}{2}$ "
48. 1 $\frac{1}{2}$ " x 1"
48a. 2 $\frac{1}{2}$ " x 1"
48b. 3 $\frac{1}{2}$ " x 1"
48c. 4 $\frac{1}{2}$ " x 1"
48d. 5 $\frac{1}{2}$ " x 1"

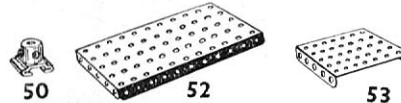

50. Slide Piece
51. Flanged Plate, 2 $\frac{1}{2}$ " x 1 $\frac{1}{2}$ "
52. Flanged Plate, 5 $\frac{1}{2}$ " x 2 $\frac{1}{2}$ "
52a. Flat Plate, 5 $\frac{1}{2}$ " x 3 $\frac{1}{2}$ "
53. Flanged Plate, 3 $\frac{1}{2}$ " x 2 $\frac{1}{2}$ "
53a. Flat Plate, 4 $\frac{1}{2}$ " x 2 $\frac{1}{2}$ "



54. Flanged Sector Plate, 4 $\frac{1}{2}$ " long
55. Perforated Strip, slotted, 5 $\frac{1}{2}$ " long
55a. Perforated Strip, slotted, 2" long



57b. Hook, Loaded, large
57c. Hook, Loaded, small
58. Spring Cord, 40" length
58a. Coupling Screw for Spring Cord
58b. Hook for Spring Cord
59. Collar, with screw

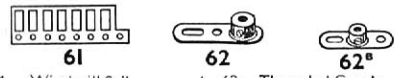

61. Windmill Sail Crank
62. Threaded Crank
62a. Threaded Crank
62b. Double Arm Crank



63. Coupling Strip Coupling
63b. Strip Coupling
63c. Threaded Coupling
63d. Short Coupling



64. Threaded Boss
65. Centre Fork
69. Set Screw, 3 $\frac{1}{2}$ "
69a. Grub Screw, 3 $\frac{1}{2}$ "
69b. Grub Screw, 3 $\frac{1}{2}$ "
69c. Grub Screw, 3 $\frac{1}{2}$ "

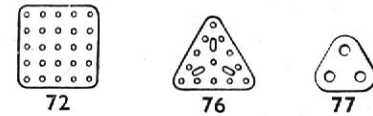

No. 70. Flat Plate, 5 $\frac{1}{2}$ " x 2 $\frac{1}{2}$ "
72. Flat Plate, 2 $\frac{1}{2}$ " x 2 $\frac{1}{2}$ "
73. Flat Plate, 3" x 1 $\frac{1}{2}$ "
76. Triangular Plate, 2 $\frac{1}{2}$ "
77. Triangular Plate, 1"



80a. 5"
80b. 4 $\frac{1}{2}$ "
80c. 3"
81. 2"
82. 1"
89. 5 $\frac{1}{2}$ " (10" radius)
89a. Stepped, 3" (1 $\frac{1}{2}$ " radius)
89b. Stepped, 4" (4 $\frac{1}{2}$ " radius)
90. 2 $\frac{1}{2}$ " (2 $\frac{1}{2}$ " radius)
90a. Stepped, 2 $\frac{1}{2}$ " (1 $\frac{1}{2}$ " radius)

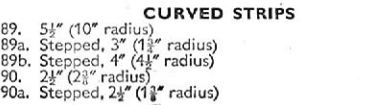

94. Sprocket Chain, 40" length
95a. 2" diam., 36 teeth
95a. 1 $\frac{1}{2}$ " diam., 28 teeth
95b. 3" diam., 56 teeth
96. 1" diam., 18 teeth
96a. 1" diam., 14 teeth

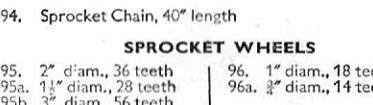

97. 3 $\frac{1}{2}$ " long
97a. 3" long
97b. 2 $\frac{1}{2}$ " long
99. 12 $\frac{1}{2}$ " long
99a. 9 $\frac{1}{2}$ " long
99b. 7 $\frac{1}{2}$ " long
100. 5 $\frac{1}{2}$ " long
100a. 4 $\frac{1}{2}$ " long

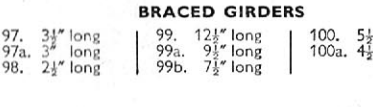

101. Heald for Loom | 102. Single Bent Strip

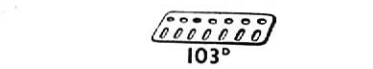

103. 5 $\frac{1}{2}$ " long
103a. 9 $\frac{1}{2}$ " long
103b. 12 $\frac{1}{2}$ " long
103c. 4 $\frac{1}{2}$ " long
103d. 3 $\frac{1}{2}$ " long
103e. 3" long
103f. 2 $\frac{1}{2}$ " long
103g. 2" long
103h. 1 $\frac{1}{2}$ " long
103k. 7 $\frac{1}{2}$ " long

MECCANO PARTS

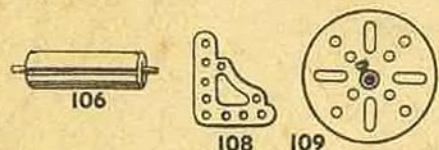

- No. 106. Wood Roller (complete with Rod and two Collars)
 108. Corner Gusset
 109. Face Plate, 2½" diam.



110. Rack Strip, 3½" long | 110a. Rack Strip, 6½" long

BOLTS

111. ½" | 111c. ½"
 111a. ½" | 111d. ½"

113. Girder Frame

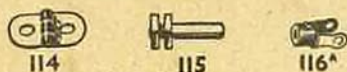

114. Hinge | 116. Fork Piece, large
 115. Threaded Pin | 116a. Fork Piece, small



118. Hub Disc, 5½" diam.



- 120b. Compression Spring, ⅞" long
 122. Loaded Sack



123. Cone Pulley, 1½", 1" and ¾" diam.
 124. Reversed Angle Bracket, 1"
 125. Reversed Angle Bracket, ½"



126. Trunnion
 126a. Flat Trunnion
 128. Bell Crank, with Boss



- No. 130. Eccentric, Triple Throw, ¼", ⅜" and ½"
 130a. Eccentric, Single Throw, ½"

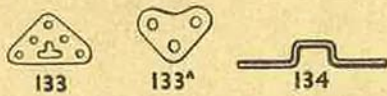

133. Corner Bracket, 1½"
 133a. Corner Bracket, 1"
 134. Crank Shaft, 1" stroke



136. Handrail Support | 136a. Handrail Coupling



137. Wheel Flange



138. Ship's Funnel, Raked



139. Flanged Bracket (right)
 139a. Flanged Bracket (left)
 140. Universal Coupling



- 142a. Motor Tyre (to fit 2" diam. rim)
 142b. Motor Tyre (to fit 3" diam. rim)
 142c. Motor Tyre (to fit 1" diam. rim)
 142d. Motor Tyre (to fit 1½" diam. rim)
 143. Circular Girder, 5½" diam.
 144. Dog Clutch



145. Circular Strip, 7½" diam. overall
 146. Circular Plate, 6" diam. overall
 146a. Circular Plate, 4" diam. overall

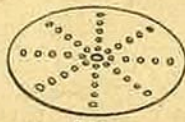

- No. 147. Pawl, with Pivot Bolt and Nuts
 147a. Pawl
 147b. Pivot Bolt, with two Nuts
 147c. Pawl, without boss
 148. Ratchet Wheel
 151. Single Pulley Block
 153. Triple Pulley Block
 154a. Corner Angle Bracket, ½" (right-hand)
 154b. Corner Angle Bracket, ½" (left-hand)
 155. Rubber Ring (for 1" Pulley)



157. Fan, 2" diam.
 160. Channel Bearing, 1½" x 1" x ½"
 161. Girder Bracket, 2" x 1" x ½"



162. Boiler, complete, 5" long x 2½" diam.
 162a. Boiler Ends, 2½" diam. x 3"
 163. Sleeve Piece, 1½" long x 1½" diam.
 164. Chimney Adaptor, 1" diam. x ½" high



165. Swivel Bearing
 166. End Bearing
 167b. Flanged Ring, 9½" diam.
 168. Ball Thrust Bearing, 4" diam.
 168a. Ball Thrust Race, flanged disc, 3½" diam.
 168b. Ball Thrust Race, toothed disc, 4" diam.
 168c. Ball Cage, 3½" diam., complete with balls
 168d. Ball, 1" diam.



171. Socket Coupling
 173a. Adaptor for Screwed Rod
 175. Flexible Coupling Unit
 176. Anchoring Spring for Cord



179. Rod Socket
 180. Gear Ring, 3½" diam. (133 ext. teeth, 95 int.)

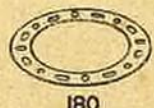

- No. 185. Steering Wheel, 1½" diam.
 187. Road Wheel, 2½" diam.

DRIVING BANDS

186. 2½" (light) | 186c. 10" (heavy)
 186a. 6" (light) | 186d. 15" (heavy)
 186b. 10" (light) | 186e. 20" (heavy)
 187a. Conical Disc, 1½" diam.

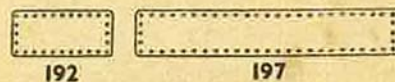

192. 2½" x 14" | 190. 2½" x 2½" | 191. 4½" x 2½"
 189. 5½" x 1½" | 190a. 3½" x 2½" | 192. 5½" x 2½"

STRIP PLATES

196. 9½" x 2½" | 197. 12½" x 2½"



198. Hinged Flat Plate, 4½" x 2½"
 199. Curved Plate, 'U'-section, 2½" x 2½" x ⅜" radius
 200. Curved Plate, 2½" x 2½" x 1½" radius



- 211a. Helical Gear, ½" } Can only be used
 211b. Helical Gear, 1½" } together
 212. Rod and Strip Connector
 212a. Rod and Strip Connector, right-angle
 213. Rod Connector
 213a. Three-way Rod Coupling
 213b. Three-way Rod Coupling with Pummel



214. Semi-circular Plate, 2½"
 215. Formed Slotted Strip, 3"
 216. Cylinder, 2½" long, 1½" diam.

TRIANGULAR FLEXIBLE PLATES

221. 2½" x 1½" | 223. 2½" x 2½" | 225. 3½" x 2"
 222. 2½" x 2½" | 224. 3½" x 1½" | 226. 3½" x 2½"