

MECCANO

REGISTERED TRADE MARK



INSTRUCTIONS for OUTFIT No. 9

COPYRIGHT BY MECCANO LIMITED
BINNS ROAD, LIVERPOOL 13, ENGLAND

56.9

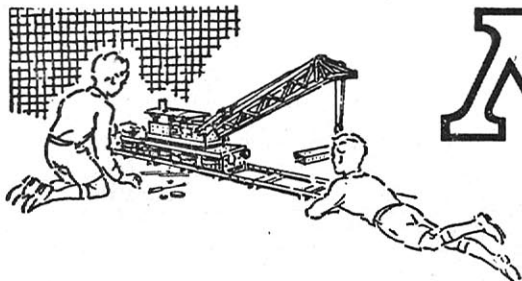

MECCANO

Registered Trade Mark

The World's Greatest Constructional Toy

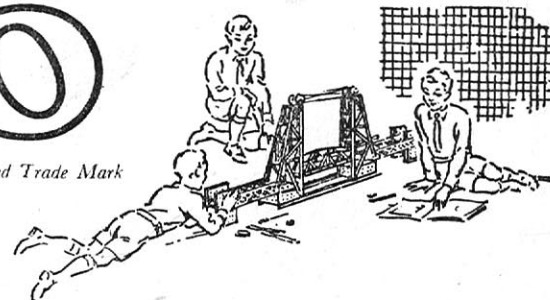

MODEL BUILDING WITH MECCANO

There is no limit to the number of models that can be built with Meccano — Cranes, Clocks, Motor Cars, Aeroplanes, Machine Tools, Locomotives — in fact everything that interests boys. A screwdriver and a spanner, both of which are provided in each complete Outfit, are the only tools necessary.

When you have built all the models illustrated in the Books of Instructions the fun is not over, it is just beginning. Now comes the chance to make use of your own ideas. First of all, re-build some of the models with small changes in construction that may occur to you. Then try building models entirely of your own design; in doing this, you will enjoy the real thrill of the engineer and the inventor.

HOW TO BUILD UP YOUR OUTFIT

Meccano is sold in 12 different Outfits, ranging from No. 00 to No. 10. Each Outfit can be converted into the next larger one by the purchase of an Accessory Outfit. Thus Meccano No. 00 Outfit can be converted into No. 0 Outfit by adding to it a No. 00a Accessory Outfit. No. 0a Outfit would then convert it into a No. 1 and so on. In this way, no matter with which Outfit you begin, you can build it up by degrees until you have a complete No. 10 Outfit.

SOME USEFUL HINTS

Triangular Flexible Plates and Flexible Plates can be used for forming curved surfaces in models, but they should not be bent at too sharp an angle. With careful handling these Plates can be bent to the required curve and afterwards straightened again for use in further models.

A Rod is usually mounted in a support or bearing, such as a hole in a Strip, so that it is free to revolve. The Rod is then said to be *journalled* in the Strip.

All Outfits from No. 2 upward include the Cord Anchoring Spring, Part No. 176. This part provides a neat and positive method of fastening a length of Cord to a Rod. When pushing the Spring on to a Rod or Crank Handle, turn it clockwise so that its coils tend to unwind; turn it in the same direction when pulling it off the Rod.

THE IMPORTANCE OF LOCK-NUTTING

In some models it is necessary to join certain parts together so that, although they cannot come apart, they are free to pivot or move in relation to one another. To do this the parts are bolted together as usual, but the nut is not screwed up tightly, so that the parts are not gripped.

Then, to prevent the nut from unscrewing, a second nut is screwed up tightly against it, the first nut being held with a spanner. This method of using a second nut is known as *lock-nutting*.

DRIVING YOUR MODELS

Models of suitable type can be driven by means of either Clockwork or Electric Motors.

Small and light models may be driven from a pulley on the Motor shaft through a belt running over a pulley of the same size on the driving shaft of the model, giving what is known as a 1 : 1 (one-to-one) ratio. For large models it may be necessary to take the drive from a small pulley on the Motor shaft to a larger pulley on the driving shaft of the model.

Rubber bands make very convenient driving belts. If a rubber band of the right length is not available, however, Meccano Cord or thin string can be used. To tie the Cord to form an endless belt you should use the familiar reef knot.

With the larger Outfits, belt drive can be replaced with advantage by gearing. If you wish to operate a slow-moving model demanding great power, such as a traction engine, you will need to use gears that will provide a considerable reduction. For example, a Worm meshed with a $\frac{1}{2}$ " Pinion will give a 19 : 1 reduction; a Worm meshed with a 57-tooth Gear will give a 57 : 1 reduction.

All the models in this Book were built up and tested in our model-building department. Some are shown fitted with Motors, and provided that the models are properly constructed the Motors will drive them satisfactorily.

If the Motor is to operate successfully, there must be no excessive friction in the mechanism of the model. This can be caused by shaft bearings being slightly out of line, or by a belt or Cord drive being too tight. To get the best from your Motor, therefore, first make sure that every revolving shaft moves quite freely in its bearings, and that the bearings themselves are in line with one another. The bearings can be brought into line by pushing through them a Drift (Part No. 36c) or a Rod, before the Bolts holding the various parts are tightened up. To make the running perfectly smooth, apply a little light machine oil to every bearing or pivot on which moving parts are mounted.

MECCANO SERVICE

The service of Meccano does not end with selling an Outfit and a Book of Instructions. If ever you are in any difficulty with your models, or if you want advice on anything connected with this great hobby, no matter what your problem may be, write to us about it. We shall be delighted to help you in any way possible. Address your letters to *Information Service, Meccano Ltd, Binns Road, Liverpool 13.*

Boys!

Read the

MECCANO MAGAZINE

THE IDEAL PAPER FOR BOYS

The happiest and most successful boys are those who take a keen interest in the world around them. The 'MECCANO MAGAZINE' is the ideal paper for these boys. Month by month its pages are filled with attractively-written articles, splendidly illustrated from actual photographs.

The subjects include Engineering in all its branches, Railways, Road Transport, Aeroplanes and Shipping. Inventions and Scientific Discoveries are described in simple language. Everything is dealt with in an attractive and straightforward style, and with an accuracy that has won for the Magazine the enthusiastic approval of the engineering, technical and scientific world. Special sections are devoted to Model-building with Meccano, fun with Dinky Toys and the operation of realistic Miniature Railways; and Stamp Collecting forms still another important feature. Competitions of all kinds, and of a variety to suit every reader, are announced each month.



WHAT THE GUILD MEANS

The Meccano Guild is an organisation for boys, started at the request of boys, and as far as possible conducted by boys. In joining the Guild a Meccano boy becomes a member of a great brotherhood of world-wide extent. Wherever he happens to be, even in strange countries, he will know that he has met a friend whenever he sees the little triangular badge of membership. The Meccano Guild is bringing together Meccano boys all over the world, and helping them to get the best out of life. At its head — guiding and controlling and taking a personal interest in this great movement — is the President, Mr Roland G. Hornby, son of the inventor of Meccano.

HOW TO JOIN THE MECCANO GUILD

Any owner of a Meccano Outfit, no matter what its size, may become a member. All he has to do is to fill in the official application form on the back of this leaflet, have his signature witnessed, and send the form to Headquarters with a postal order (not stamps) for the necessary amount in payment for the official badge, which he will wear in his buttonhole.

The price of the badge for boys living in the British Isles is 1/-. For those living overseas it is 1/6 (30 cents in Canada).

Applicants living in Canada, Australia, New Zealand or South Africa should write to the Meccano agents in their countries. Their addresses are as follows:

AUSTRALIA:

New South Wales and A.C.T. — E. G. Page & Co. (Sales) (Pty.) Ltd, Danks Building, 324 Pitt Street, N.S.W.

Queensland and Northern Territories — Thomas, Brown & Sons Ltd, (P.O. Box 144C), Eagle Street, Brisbane, Queensland.

South Australia — Harris, Scarfe Ltd, Grenfell Street, Adelaide.

Victoria and Tasmania — Ponsford Newman & Benson Ltd, 234 Flinders Lane, Melbourne, Victoria.

Western Australia — P. Falk & Co. Ltd, 317-9 Murray Street, Perth.

CANADA: Meccano Ltd, 675 King Street West, Toronto.

NEW ZEALAND: Models Ltd (P.O. Box 129), 53 Fort Street, Auckland, C.I.

RHODESIA: Woolley, Kinleyside & Co. (Pvt.) Ltd, P.O. Box 299, Bulawayo.

SOUTH AFRICA: Arthur E. Harris (Pty.) Ltd (P.O. Box 1199), 142 Market Street, Johannesburg.

Their Badges and Certificates are then forwarded without delay, while their application forms are sent to Headquarters in Liverpool.

Applicants living in any other country overseas should forward their forms, with a British postal order (not stamps) or a money order for 1/6, direct to the Secretary, the Meccano Guild, Binns Road, Liverpool, 13.

Guild members are eligible for the Correspondence Club, by which they are placed in touch with other members in various parts of the world. Full particulars and enrolment forms can be obtained from the Secretary.

The Secretary will send also, on request, full details of the Guild Recruiting Campaign, and of the Medallion awarded to members who are successful in obtaining recruits, together with particulars of the Meccano clubs founded and established by enthusiastic Meccano boys. A special booklet, 'How to run a Meccano Club' will be sent post free to any member on receipt of 2d. in stamps.

Join the

MECCANO GUILD

MECCANO MAGAZINE

for the really modern boy

The 'MECCANO MAGAZINE' is on sale at all bookstalls, newsagents and Meccano dealers, price 1/3. If you prefer to have each issue sent direct, the subscription rates are 18/- for twelve months or 9/- for six months, including postage, and an order form is attached.

The overseas prices of the 'M.M.' are 15c. in Canada, 1/6 in Australia, 18c. in the U.S.A. and 1/- elsewhere.

ORDER FORM

TO THE EDITOR,
MECCANO MAGAZINE,
BINNS ROAD, LIVERPOOL 13.

I enclose Postal Order for Please post the
'MECCANO MAGAZINE' for months, beginning with
the issue.

NAME (IN BLOCK LETTERS)

ADDRESS

MECCANO GUILD

THE THREE GREAT OBJECTS OF THE GUILD

- To make every boy's life brighter and happier.
- To foster clean-mindedness, truthfulness, ambition and initiative in boys.
- To encourage boys in their hobbies, and especially in the development of their knowledge of mechanical and engineering principles.



BADGE OF
MEMBERSHIP

Headquarters: BINNS ROAD LIVERPOOL 13

APPLICATION FOR MEMBERSHIP

I possess a Meccano Outfit, and I hereby make application for membership of the Meccano Guild.
I approve of the objects of the Guild, and I promise on my honour

- (1) To conform to the rules and regulations of the Meccano Guild.
- (2) To promote its objects by my own example: to be helpful to others; to be clean in thought and habit; to be determined to learn and make progress.
- (3) To wear the Meccano Guild Badge on all possible occasions.
- (4) To recognise and acknowledge all other Members wearing the Guild Badge, and to render them help in case of need.

I enclose 1/- for the Guild Badge (Great Britain).

I enclose 1/6 for the Guild Badge (Overseas).

I enclose 30c. for the Guild Badge (Canada).

Strike out line not applicable (See other side of this form).

NAME OF APPLICANT
(BLOCK LETTERS PLEASE)

ADDRESS

DATE SIZE OF OUTFIT OWNED NO. AGE

WITNESS

ADDRESS

The witness should be the Parent, Guardian, Employer, Schoolmaster or Church Minister
and should state which when signing.

HOW TO BEGIN THE FUN

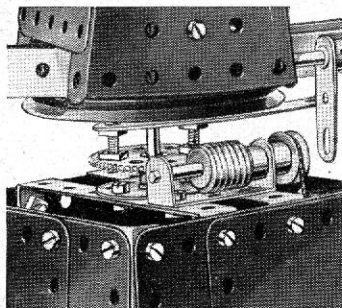

A Worm and a 57-tooth Gear give a useful drive ratio for many models

THE MOST FASCINATING OF ALL HOBBIES

Meccano model-building is the most fascinating of all hobbies, because it never becomes dull. There is always something new to be done. First of all there is the fun of building a new model, and watching it take shape as part after part is added. Then, when the model is complete, you can enjoy the thrill of setting it to work just like the real structure it represents, by means of a Meccano Motor.

SOME USEFUL HINTS

You may wonder which section of a model should be built first. There cannot be any definite rule for this, as it depends on the design of the model. In stationary models the base usually should be built first. In most of the smaller models a $5\frac{1}{2}'' \times 2\frac{1}{2}''$ Flanged Plate forms an important part of the structure, and often the best plan is to start building by bolting parts to this Plate. For other models a good general rule is that the sections that form supports for a number of other parts should be built first.

Triangular Flexible Plates and Flexible Plates can be used for forming curved surfaces in models, but they should not be bent at too sharp an angle. With careful handling these Plates can be bent to the required curve and after use straightened again.

A Rod is usually mounted in a support or bearing, such as a hole in a Strip, so that it is free to revolve. The Rod is then said to be *journalled* in the Strip.

During the construction of a model it is best to screw up the nuts with the fingers, followed by just a light turn with the screwdriver. The final tightening with spanner and screwdriver should be left until all the parts are connected up.

All Outfits from No. 2 upward include the Cord Anchoring Spring, Part No. 176. This part provides a neat and positive method of fastening a length of Cord to a Rod. When pushing the Spring on to a Rod or Crank Handle, turn clockwise so that its coils tend to unwind; turn it in the same direction when pulling it off the Rod.

THE IMPORTANCE OF LOCK-NUTTING

In some models it is necessary to join certain parts together so that, although they cannot come apart, they are free to pivot or move in relation to one another. To do this the parts are bolted together as usual but the nut is not screwed up tightly, so that the parts are not gripped. Then, to prevent the nut from unscrewing, a second nut is screwed up tightly against it, the first nut being held with a spanner. This method of using a second nut is known as *Lock-nutting*.

DRIVING YOUR MODELS

Models of suitable type can be driven by means of either Clockwork or Electric Motors.

Small and light models may be driven from a pulley on the Motor shaft through a belt running over a pulley of the same size on the driving shaft of the model, giving what is known as a 1 : 1 (one-to-one) ratio. For large models it is necessary to take the drive from a small pulley on the Motor shaft to a larger pulley on the driving shaft of the model. In most cases a 1" Pulley on the Motor shaft and a 3" Pulley on the model shaft will be found satisfactory. This provides a reduction ratio of approximately 3 : 1.

Rubber bands are very convenient for driving belts. Sometimes, however, a rubber band of the right length is not available, and then Meccano Cord or thin string is used. To tie the Cord to form an endless belt you should use the familiar reef knot.

With the larger Outfits, belt drive can be replaced with advantage by gearing. If you wish to operate a slow-moving model demanding great power, such as a traction engine, you will need to use gears that will provide a considerable reduction. For example, a Worm meshed with a $\frac{1}{2}''$ Pinion will give a 19 : 1 reduction; a Worm meshed with a 57-tooth Gear will give a 57 : 1 reduction.

All the models in this Book were built up and tested in our model-building department. Some are shown fitted with Motors, and provided that the models are properly constructed the Motors will drive them satisfactorily.

If the Motor is to operate successfully, however, there must be no excessive friction in the mechanism of the model. This can be caused by shaft bearings being slightly out of line, or by a belt or Cord drive being too tight. Before condemning your Motor, therefore, first make sure that every revolving shaft moves quite freely in its bearings, and that the bearings themselves are in line with one another. The bearings can be brought into line by pushing through them a Drift (Part No. 36c) or a Rod, before the Bolts holding the various parts are tightened up. To make the running perfectly smooth, apply a little light machine oil to every bearing or pivot on which moving parts are mounted.

The models included in this Book will give you a good idea of the various types of Meccano construction and serve as a guide to the building of a large number of other models with this Outfit. If any difficulty should arise in planning a new model, write to *Information Service, Meccano Ltd., Binns Road, Liverpool 13*, and all possible help will be given.

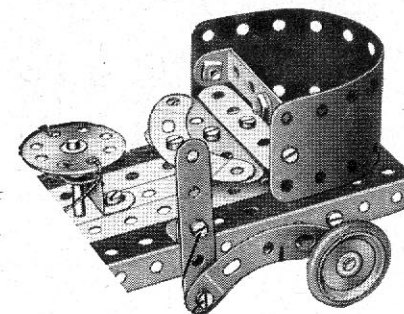

A Flexible Plate used to form a curved surface

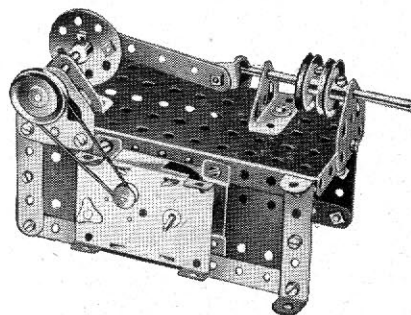

A Magic Motor fitted to drive a Steam Engine

9.1 MECHANICAL HORSE AND TRAILER

Parts Required

4 of No. 1	2 of No. 24	2 of No. 46	1 of No. 62b	2 of No. 108	2 of No. 161	13 of No. 192	1 No. 1 Clockwork Motor
2 " " 1b	2 " " 24c	2 " " 48	4 " " 63	3 " " 111	2 " " 164	6 " " 197	(Not included in Outfit)
22 " " 2	1 " " 25	1 " " 48a	2 " " 70	6 " " 111a	1 " " 165	1 " " 212	
5 " " 2a	1 " " 26	5 " " 48b	2 " " 76	12 " " 111c	1 " " 179	2 " " 212a	
5 " " 3	1 " " 27	3 " " 48d	2 " " 77	2 " " 115	1 " " 185	2 " " 214	
8 " " 4	1 " " 28	2 " " 51	1 " " 80a	2 " " 124	1 " " 186a	8 " " 215	
18 " " 5	2 " " 35	2 " " 52	2 " " 80c	4 " " 125	2 " " 187a	1 " " 216	
4 " " 6	354 " " 37a	4 " " 52a	2 " " 89	2 " " 126	9 " " 188	2 " " 221	
5 " " 6a	324 " " 37b	5 " " 53	4 " " 90	5 " " 126a	10 " " 189	2 " " 224	
2 " " 7a	43 " " 38	2 " " 53a	4 " " 90a	1 " " 128	1 " " 190	2 " " 225	
7 " " 8	1 " " 40	1 " " 55a	1 " " 94	1 " " 133a	2 " " 191	2 " " 226	
2 " " 8a	1 " " 43	10 " " 59	1 " " 96	6 " " 142a			
1 " " 8b	3 " " 45	2 " " 62	1 " " 96a	1 " " 147c			
4 " " 9							
2 " " 9d							
2 " " 9f							
12 " " 10							
6 " " 11							
26 " " 12							
4 " " 12a							
2 " " 12b							
5 " " 12c							
1 " " 13a							
2 " " 14							
2 " " 15							
2 " " 15b							
5 " " 16							
1 " " 16a							
1 " " 17							
1 " " 18a							
1 " " 18b							
2 " " 20							
6 " " 20a							
4 " " 20b							
2 " " 21							
3 " " 22							
1 " " 22a							
1 " " 23a							

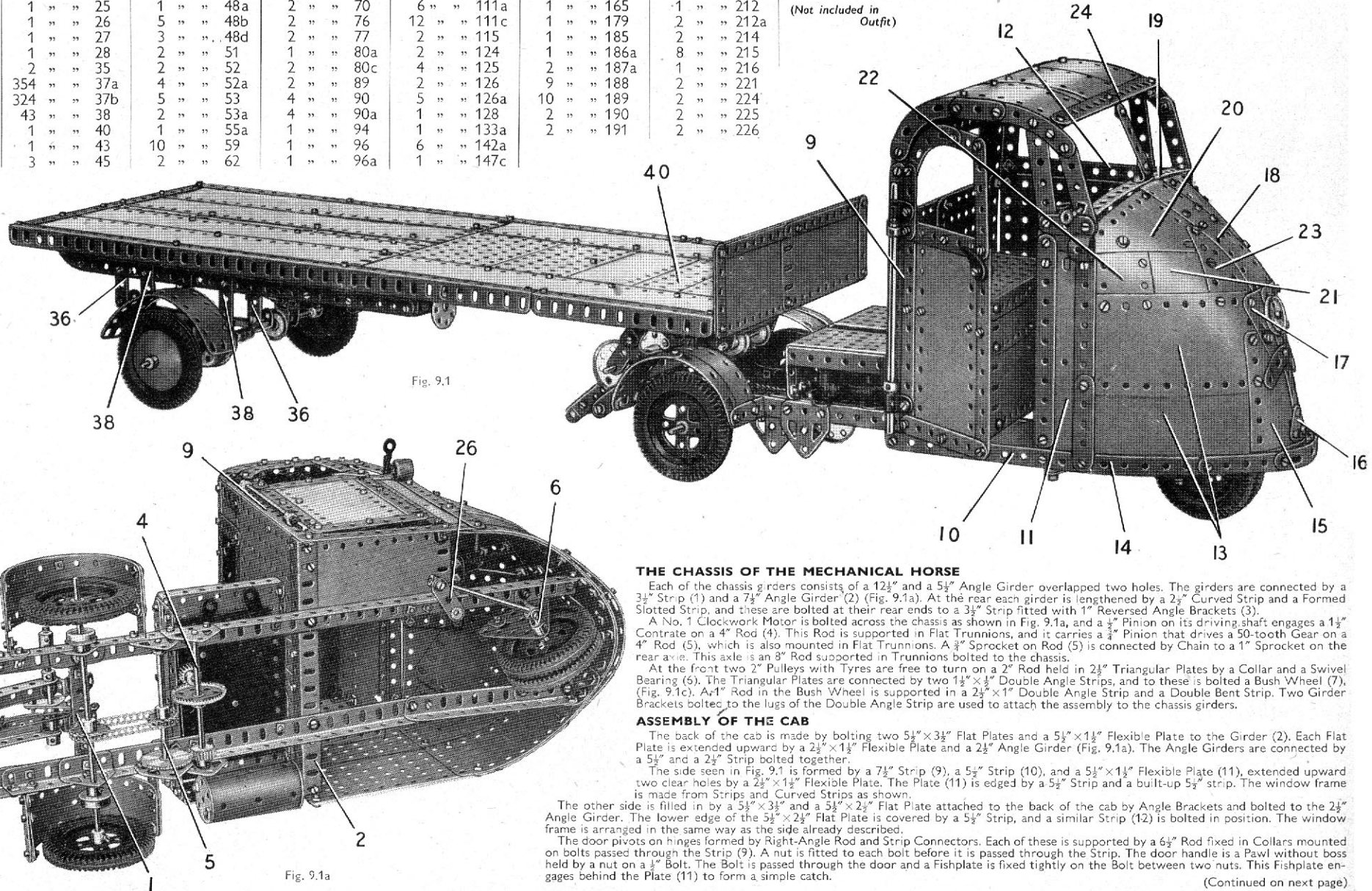

Fig. 9.1

Fig. 9.1a

THE CHASSIS OF THE MECHANICAL HORSE

Each of the chassis girders consists of a $12\frac{1}{2}$ " and a $5\frac{1}{2}$ " Angle Girder overlapped two holes. The girders are connected by a $3\frac{1}{2}$ " Strip (1) and a $7\frac{1}{2}$ " Angle Girder (2) (Fig. 9.1a). At the rear each girder is lengthened by a $2\frac{1}{2}$ " Curved Strip and a Formed Slotted Strip, and these are bolted at their rear ends to a $3\frac{1}{2}$ " Strip fitted with 1" Reversed Angle Brackets (3).

A No. 1 Clockwork Motor is bolted across the chassis as shown in Fig. 9.1a, and a $\frac{1}{2}$ " Pinion on its driving shaft engages a $1\frac{1}{2}$ " Contrate on a 4" Rod (4). This Rod is supported in Flat Trunnions, and it carries a $\frac{1}{2}$ " Pinion that drives a 50-tooth Gear on a 4" Rod (5), which is also mounted in Flat Trunnions. A $\frac{3}{4}$ " Sprocket on Rod (5) is connected by Chain to a 1" Sprocket on the rear axle. This axle is an 8" Rod supported in Trunnions bolted to the chassis.

At the front two 2" Pulleys with Tyres are free to turn on a 2" Rod held in $2\frac{1}{2}$ " Triangular Plates by a Collar and a Swivel Bearing (6). The Triangular Plates are connected by two $1\frac{1}{2}$ " x $\frac{1}{2}$ " Double Angle Strips, and to these is bolted a Bush Wheel (7). (Fig. 9.1c). A 1" Rod in the Bush Wheel is supported in a $2\frac{1}{2}$ " x 1" Double Angle Strip and a Double Bent Strip. Two Girder Brackets bolted to the lugs of the Double Angle Strip are used to attach the assembly to the chassis girders.

ASSEMBLY OF THE CAB

The back of the cab is made by bolting two $5\frac{1}{2}$ " x $3\frac{1}{2}$ " Flat Plates and a $5\frac{1}{2}$ " x $1\frac{1}{2}$ " Flexible Plate to the Girder (2). Each Flat Plate is extended upward by a $2\frac{1}{2}$ " x $1\frac{1}{2}$ " Flexible Plate and a $2\frac{1}{2}$ " Angle Girder (Fig. 9.1a). The Angle Girders are connected by a $5\frac{1}{2}$ " and a $2\frac{1}{2}$ " Strip bolted together.

The side seen in Fig. 9.1 is formed by a $7\frac{1}{2}$ " Strip (9), a $5\frac{1}{2}$ " Strip (10), and a $5\frac{1}{2}$ " x $1\frac{1}{2}$ " Flexible Plate (11), extended upward two clear holes by a $2\frac{1}{2}$ " x $1\frac{1}{2}$ " Flexible Plate. The Plate (11) is edged by a $5\frac{1}{2}$ " Strip and a built-up $5\frac{1}{2}$ " strip. The window frame is made from Strips and Curved Strips as shown.

The other side is filled in by a $5\frac{1}{2}$ " x $3\frac{1}{2}$ " and a $5\frac{1}{2}$ " x $2\frac{1}{2}$ " Flat Plate attached to the back of the cab by Angle Brackets and bolted to the $2\frac{1}{2}$ " Angle Girder. The lower edge of the $5\frac{1}{2}$ " x $2\frac{1}{2}$ " Flat Plate is covered by a $5\frac{1}{2}$ " Strip, and a similar Strip (12) is bolted in position. The window frame is arranged in the same way as the side already described.

The door pivots on hinges formed by Right-Angle Rod and Strip Connectors. Each of these is supported by a $6\frac{1}{2}$ " Rod fixed in Collars mounted on bolts passed through the Strip (9). A nut is fitted to each bolt before it is passed through the Strip. The door handle is a Pawl without boss held by a nut on a $\frac{1}{2}$ " Bolt. The Bolt is passed through the door and a Fishplate is fixed tightly on the Bolt between two nuts. This Fishplate engages behind the Plate (11) to form a simple catch.

(Continued on next page)

MODEL 9.1 MECHANICAL HORSE AND TRAILER — Continued

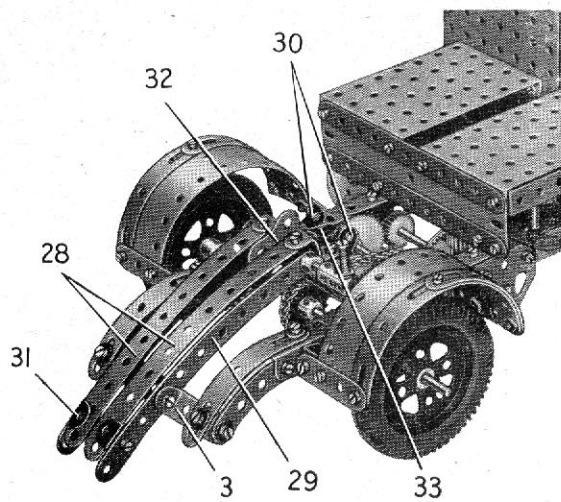

Fig. 9.1b

The driving seat consists of a $5\frac{1}{2}'' \times 2\frac{1}{2}''$ Flanged Plate (Fig. 9.1), fitted at each end with a $3\frac{1}{2}'' \times 2\frac{1}{2}''$ Flanged Plate. The front is filled in by a $5\frac{1}{2}'' \times 2\frac{1}{2}''$ and a $5\frac{1}{2}'' \times 1\frac{1}{2}''$ Flexible Plate. These are fixed to the $5\frac{1}{2}'' \times 2\frac{1}{2}''$ Flanged Plate and to a $5\frac{1}{2}'' \times \frac{1}{2}''$ Double Angle Strip bolted between the $3\frac{1}{2}'' \times 2\frac{1}{2}''$ Flanged Plates.

The front bumper is a Formed Slotted Strip supported by $2\frac{1}{2}''$ Strips fixed to the Strips (14).

THE COUPLING DEVICE, REAR MUDGUARDS AND THE ENGINE COVER

An Angle Bracket and a $\frac{1}{2}''$ Reversed Angle Bracket are bolted to each of two $5\frac{1}{2}''$ Strips (28) (Fig. 9.1b), and a $2\frac{1}{2}''$ Rod is passed through the Angle Brackets and through $5\frac{1}{2}''$ Curved Strips (29). The Curved Strips are bolted to the $1''$ Reversed Angle Brackets (3), and the $\frac{1}{2}''$ Reversed Angle Brackets are secured, together with two Obtuse Angle Brackets (30), to further $\frac{1}{2}''$ Reversed Angle Brackets bolted to the Strip (1). Each of the Strips (28) is clamped between the free lugs of two Angle Brackets (31), which are fixed to one of the Curved Strips by a bolt passed through their slotted holes.

A $1''$ Corner Bracket (32) and a Fishplate (33) are bolted to a Double Arm Crank on the $2\frac{1}{2}''$ Rod. A stretched Driving Band is connected between the Fishplate and a short piece of Cord fastened to the $3\frac{1}{2}''$ Strip (see Fig. 9.1a). The operating lever is a $2''$ Bolt screwed into a Coupling on the $2\frac{1}{2}''$ Rod.

The rear mudguards are $5\frac{1}{2}'' \times 1\frac{1}{2}''$ Flexible Plates, and each is supported at the front by a $1'' \times \frac{1}{2}''$ Angle Bracket and at the rear by a $\frac{1}{2}'' \times \frac{1}{2}''$ Angle Bracket and a $2''$ Strip.

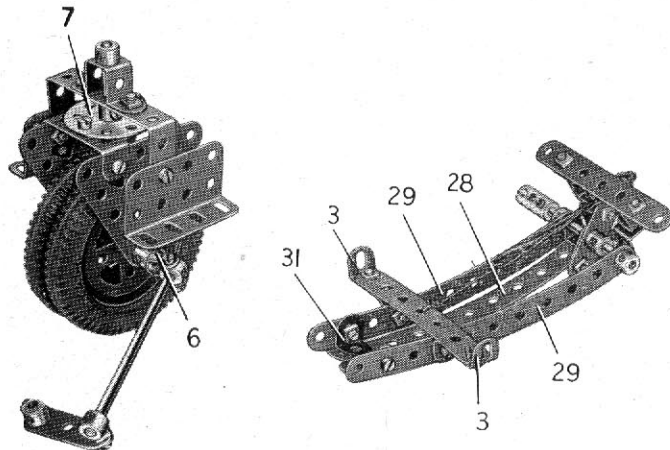

Fig. 9.1c

The rounded front consists of two $5\frac{1}{2}'' \times 2\frac{1}{2}''$ Flexible Plates (13) on each side that overlap the cab sides by two holes each. The lower Plates are edged by $5\frac{1}{2}''$ Strips (14), and these Strips are connected at their front ends by a Formed Slotted Strip and a $3\frac{1}{2}'' \times 2''$ Triangular Flexible Plate (15) on each side. A $1''$ Triangular Plate (16) is fixed to the Plates (15), and a $3\frac{1}{2}'' \times 1\frac{1}{2}''$ Triangular Flexible Plate (17) on each side is bolted to the top hole of the Triangular Plate (16).

A $5\frac{1}{2}'' \times 1\frac{1}{2}''$ Flexible Plate (18) is bolted between the upper ends of the Plates (17) and a built-up strip (19), which is made from two $4\frac{1}{2}''$ Strips overlapped three holes. The space on each side of the Plate (18) is filled by a $3\frac{1}{2}'' \times 2\frac{1}{2}''$ Triangular Flexible Plate (20), $2\frac{1}{2}'' \times 2\frac{1}{2}''$ and $2\frac{1}{2}'' \times 1\frac{1}{2}''$ Flexible Plates (21) and (22), and a $2\frac{1}{2}'' \times 1\frac{1}{2}''$ Triangular Flexible Plate (23). The Plates (20) are supported by a $2\frac{1}{2}'' \times 1\frac{1}{2}''$ Flexible Plate bolted across the upper end of the Plate (18).

The roof consists of a $5\frac{1}{2}'' \times 1\frac{1}{2}''$ and three $5\frac{1}{2}'' \times 2\frac{1}{2}''$ Flexible Plates fixed to the back of the cab and to a $7\frac{1}{2}''$ Strip (24), which is supported by Angle Brackets.

The steering column is a $6\frac{3}{4}''$ Rod, which is mounted in a Crank bolted to the chassis and in a $2\frac{1}{2}'' \times 1\frac{1}{2}''$ Flanged Plate, one end of which is fixed to the side of the cab. The Rod is held in place by a Coupling fixed above the Crank, and it carries at its lower end a Crank (26) (Fig. 9.1a). A Collar is pivoted on a bolt held by a nut in Crank (26), and is connected by a $3\frac{1}{2}''$ Rod to the Swivel Bearing (6).

A cover over the Clockwork Motor is provided by two $3\frac{1}{2}'' \times 2\frac{1}{2}''$ Flanged Plates bolted to the back of the cab. The Flanged Plates are edged by $3\frac{1}{2}'' \times \frac{1}{2}''$ Double Angle Strips, and at the rear they are connected by a $5\frac{1}{2}'' \times 1\frac{1}{2}''$ Flexible Plate and two $5\frac{1}{2}''$ Strips. One side of the cover is filled in by two $2\frac{1}{2}'' \times 1\frac{1}{2}''$ Flexible Plates bolted to the $3\frac{1}{2}'' \times \frac{1}{2}''$ Double Angle Strip. The cover is attached at the rear to $1'' \times 1''$ Angle Brackets fixed to the chassis.

CONSTRUCTION OF THE TRAILER CHASSIS

The chassis consists of two girders, each of which is made from two $12\frac{1}{2}''$ Angle Girders overlapped two holes, and they are connected at their ends by $9\frac{1}{2}''$ Angle Girders. At the rear the depth of the chassis is increased on each side by two $12\frac{1}{2}''$ Strips bolted to Semi-Circular Plates and $1\frac{1}{2}''$ Angle Girders (34) (Fig. 9.1d).

The rear axle is formed by two $5''$ Rods joined by a Coupling, and is supported in Double Brackets bolted to Double Bent Strips (35), (Fig. 9.1d). The Double Bent Strips are fastened to springs, each made from three $5\frac{1}{2}''$, a $4\frac{1}{2}''$, a $3\frac{1}{2}''$ and two $2\frac{1}{2}''$ Strips. Double Brackets are bolted to the ends of the springs and are attached to $2\frac{1}{2}''$ Strips (36) fixed to the chassis. Two $1\frac{1}{2}''$ Flanged Wheels (37) are secured to the rear axle. The rear mudguards are $5\frac{1}{2}'' \times 1\frac{1}{2}''$ Flexible Plates fixed to $1'' \times 1''$ Angle Brackets bolted to the chassis and to $\frac{1}{2}'' \times \frac{1}{2}''$ Angle Brackets attached to $3''$ Strips (38).

THE TRAILER PLATFORM

The platform consists of six $12\frac{1}{2}'' \times 2\frac{1}{2}''$ Strip Plates and Flat and Flexible Plates bolted to the chassis as shown in Fig. 9.1d. A $12\frac{1}{2}''$ Angle Girder (39) is attached underneath the platform, and a $5\frac{1}{2}'' \times 2\frac{1}{2}''$ Flanged Plate (40) is bolted between the chassis girders. The platform is edged on each side by an $18\frac{1}{2}''$ and a $5\frac{1}{2}''$ Angle Girder.

DETAILS OF THE COUPLING UNIT AND SUPPORTING WHEELS

A $2\frac{1}{2}'' \times 1\frac{1}{2}''$ Flanged Plate is bolted between the side flanges of Plate (40), and a $3\frac{1}{2}'' \times 2\frac{1}{2}''$ Flanged Plate (41) is pivoted on a $1''$ Rod held in place by two $1''$ Pulleys. A $3\frac{1}{2}'' \times \frac{1}{2}''$ Double Angle Strip is bolted to each side of the Plate (41), and two $2\frac{1}{2}''$ Flanged Wheels (42) are fixed on a $3\frac{1}{2}''$ Rod that is held by Spring Clips in Fishplates fixed to the Double Angle Strips. The Flanged Wheels are spaced so that they rest on the Obtuse Angle Brackets (30) when the Mechanical Horse and the Trailer are coupled together. The $3\frac{1}{2}''$ Rod engages behind the $1''$ Corner Bracket (32). When the operating lever is moved the Fishplate (33) lifts the Rod clear of the Corner Bracket.

The supporting wheels are $1\frac{1}{2}''$ Pulleys on a $3\frac{1}{2}''$ Rod supported in Corner Gussets. The Corner Gussets are connected by a $2\frac{1}{2}'' \times \frac{1}{2}''$ Double Angle Strip, and a Ball Crank with boss is bolted to one of them. The Ball Crank is fixed on a $3\frac{1}{2}''$ Rod passed through the Corner Gussets and the Double Angle Strips bolted to the Plate (41). A Spring (43) is arranged between one of the Double Angle Strips and a Corner Gusset, so that the wheels are returned to the supporting position automatically as the Trailer is uncoupled.

THE TRAILER BRAKE

A Screwed Rod fitted with a Rod Socket (44) is held by lock-nuts in the lugs of a $2\frac{1}{2}'' \times 1''$ Double Angle Strip bolted to one side of the chassis. A length of Sprocket Chain is tied to a $5\frac{1}{2}'' \times \frac{1}{2}''$ Double Angle Strip between the lower pair of $12\frac{1}{2}''$ Strips forming the rear end of the chassis. The Chain is passed around the Flanged Wheels (37), over a Rod (45), and is fastened to the shank of the Rod Socket (44). Rod (45) is held by a Coupling and a $\frac{1}{2}''$ fixed Pulley in the chassis and in the Girder (39).

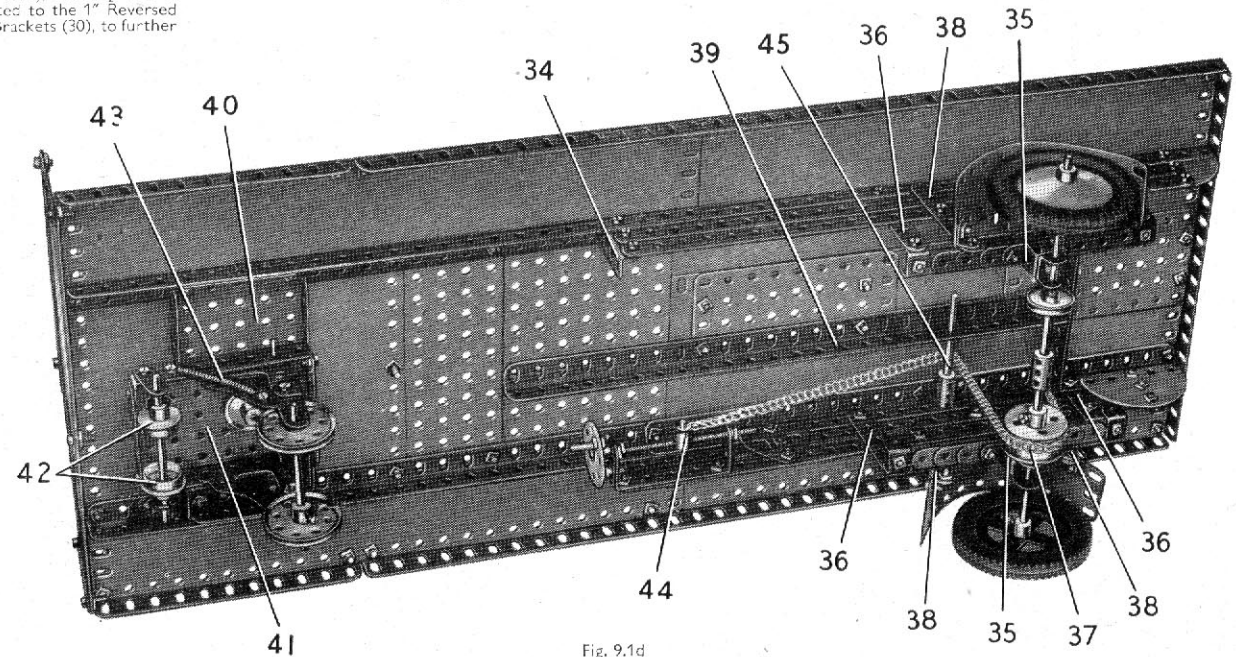

Fig. 9.1d

9.2 FLOATING CRANE

CONSTRUCTION OF THE HULL

Each side of the hull, from bow to stern, consists of four $5\frac{1}{2}'' \times 2\frac{3}{8}''$ Flexible Plates, two $5\frac{1}{2}'' \times 1\frac{1}{8}''$ Flexible Plates, and two further $5\frac{1}{2}'' \times 2\frac{3}{8}''$ Flexible Plates. These are strengthened by two $5\frac{1}{2}''$ Strips (1) at the bow, a $12\frac{1}{2}''$ Strip, an $18\frac{1}{2}''$ Angle Girder (2) and a second $12\frac{1}{2}''$ Strip at the stern. On the inside the Plates are strengthened along their lower edges by two $12\frac{1}{2}''$ Strips and a $12\frac{1}{2}''$ Angle Girder (3) (Fig. 9.2a).

The $5\frac{1}{2}'' \times 2\frac{3}{8}''$ Flexible Plates at the bows on each side are bolted together, and the $5\frac{1}{2}'' \times 2\frac{3}{8}''$ Flexible Plates at the stern are connected by another $5\frac{1}{2}'' \times 2\frac{3}{8}''$ Flexible Plate, which is strengthened by a curved $5\frac{1}{2}''$ Strip. The front ends of the Girders (2) are joined by a $9\frac{1}{2}''$ Angle Girder (4), and the stern ends are connected by two $5\frac{1}{2}''$ Strips overlapped three holes. The deck between the Girders (2) is filled in by six $12\frac{1}{2}'' \times 2\frac{3}{8}''$ Strip Plates, as shown in Fig. 9.2a.

The deck at the stern is plated by two $5\frac{1}{2}'' \times 3\frac{1}{2}''$ Flat Plates, placed one on each side of a $5\frac{1}{2}'' \times 2\frac{3}{8}''$ Flanged Plate (5) (Fig. 9.2a). These Plates are supported by a $9\frac{1}{2}''$ Angle Girder (6) attached to the sides of the hull by Angle Brackets. The centre of the rounded stern is filled in by two $4\frac{1}{2}'' \times 2\frac{3}{8}''$ Flexible Plates, two Semi-Circular Plates (7), and two $3\frac{1}{2}'' \times 2\frac{3}{8}''$ Triangular Flexible Plates (8). The stern deck is edged on each side by two $5\frac{1}{2}''$ Strips, two $5\frac{1}{2}''$ Curved Strips, and two $2\frac{1}{2}''$ Curved Strips, the latter parts being connected by a Fishplate at the centre of the stern. The deck is attached to the sides of the hull by Angle Brackets, and is supported by a built-up strip (9), made from two $5\frac{1}{2}''$ Strips overlapped five holes, and by two Wheel Discs arranged as shown in Fig. 9.2a. A $5\frac{1}{2}'' \times 2\frac{3}{8}''$ Flanged Plate (10) is connected to the Flanged Plate (5) by two $2\frac{3}{8}''$ Strips and two Corner Gussets.

The sides of the hull at the bows are extended upward by three $5\frac{1}{2}'' \times 1\frac{1}{8}''$ Flexible Plates and two $2\frac{1}{2}'' \times 1\frac{1}{8}''$ Triangular Flexible Plates. These Plates support a built-up strip made from two $5\frac{1}{2}''$ Strips and a $3\frac{1}{2}''$ Strip, bolted to the top corners of the Triangular Flexible Plates and attached at the front to two Fishplates. The deck is filled in by two Flanged Sector Plates, two $4\frac{1}{2}'' \times 2\frac{3}{8}''$ Flexible Plates, a $2\frac{1}{2}'' \times 2\frac{3}{8}''$ Flexible Plate (11) and a $2\frac{1}{2}'' \times 2''$ Triangular Flexible Plate (12) on each side. The Plates are bolted to a strip (13) (Fig. 9.2), made from a $7\frac{1}{2}''$ and a $2\frac{1}{2}''$ Strip, and are edged by two $2\frac{1}{2}''$ Strips and a $4''$ Stepped Curved Strip on each side. The front ends of the $4''$ Stepped Curved Strips are connected by a $2\frac{1}{2}''$ Curved Strip. The deck is attached to the sides of the hull by Angle Brackets, and three $1\frac{1}{8}''$ radius Curved Plates, one of them indicated at (14) (Fig. 9.2c), are fixed to the strip (13). The winch is made by bolting a Channel Bearing to a Double Bent Strip fixed to the deck. A $1\frac{1}{2}'' \times \frac{1}{2}''$ Double Angle Strip bolted to the centre section of the Double Bent Strip supports a $2\frac{1}{2}''$ Rod that carries two $\frac{1}{2}''$ Pin ones.

ASSEMBLY OF THE BRIDGE

A strip (15) on each side, made from a $5\frac{1}{2}''$ and a $3\frac{1}{2}''$ Strip, is supported by five $2\frac{1}{2}''$ Strips. A $\frac{1}{2}''$ Reversed Angle Bracket is fixed to each end of the strip (15), and these support a strip (16), a $5\frac{1}{2}'' \times 2\frac{3}{8}''$ Flat Plate and a $3\frac{1}{2}'' \times 2\frac{3}{8}''$ Flanged Plate (17). The strip (16) on one side consists of a $7\frac{1}{2}''$ and a $2\frac{1}{2}''$ Strip, and on the other side it is made from a $5\frac{1}{2}''$ and a $3\frac{1}{2}''$ Strip.

The front of the bridge (Fig. 9.2), consists of a $5\frac{1}{2}'' \times 3\frac{1}{2}''$ Flat Plate (18), two $2\frac{1}{2}'' \times 1\frac{1}{8}''$ Flexible Plates (19) and a $2\frac{1}{2}'' \times 2\frac{3}{8}''$ Flexible Plate (20) on each side. The windows are formed by a $5\frac{1}{2}''$ Curved Strip, two $1\frac{1}{2}''$ Strips, and a central $2\frac{1}{2}''$ Strip. The front is bolted to the flanges of the Plates (17). The rear end of the bridge consists of a $5\frac{1}{2}'' \times 3\frac{1}{2}''$ Flat Plate and two $4\frac{1}{2}'' \times 2\frac{3}{8}''$ Flat Plates (Fig. 9.2c), and is attached to the sides by Angle Brackets.

(Continued on next page)

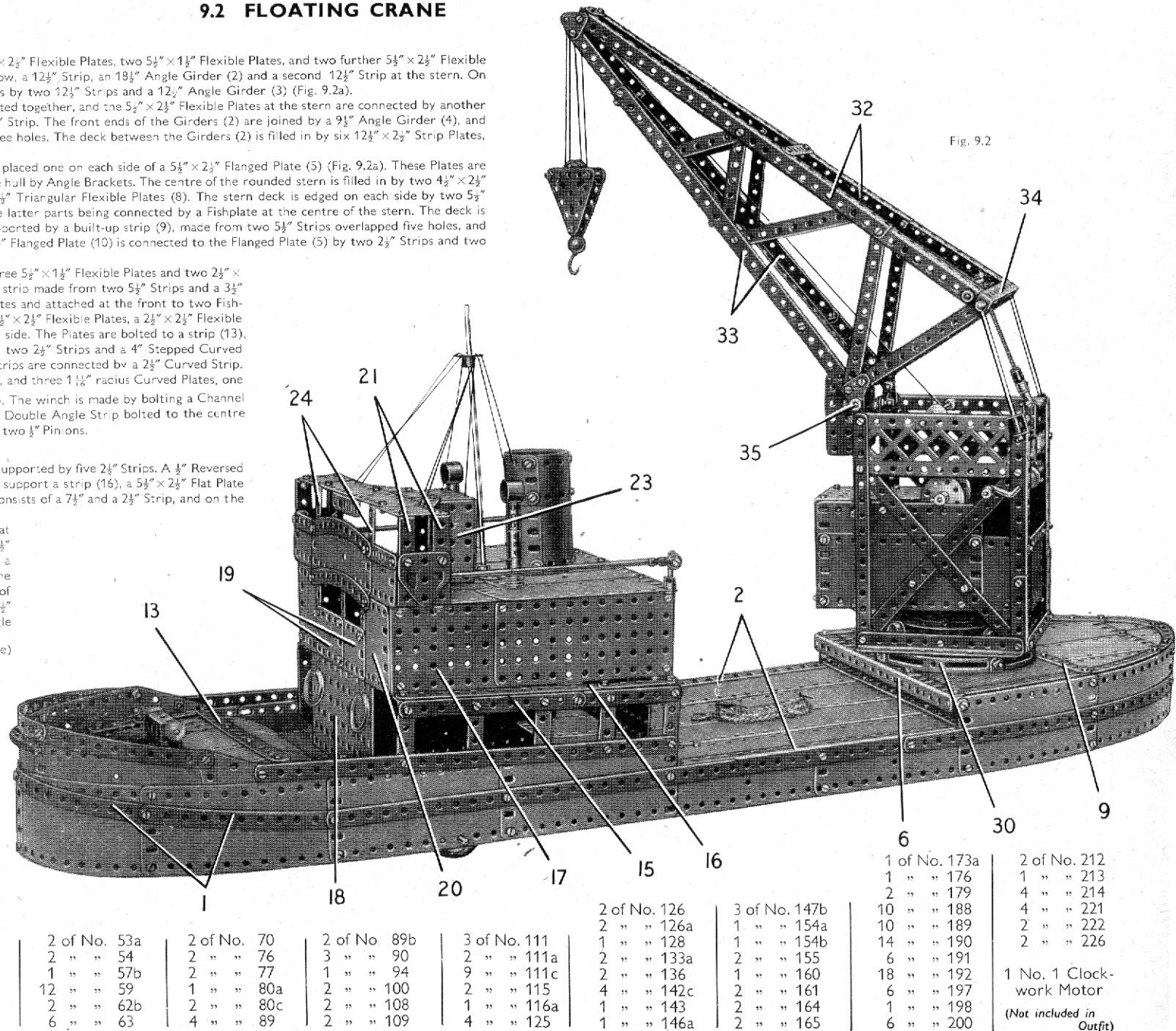

Parts Required		
14 of No. 1	2 of No. 12b	1 of No. 27a
2 " " 1b	2 " " 12c	1 " " 29
24 " " 2	1 " " 13a	2 " " 32
6 " " 2a	3 " " 14	5 " " 35
6 " " 3	2 " " 15	351 " " 37a
8 " " 4	3 " " 15a	322 " " 37b
22 " " 5	1 " " 15b	39 " " 38
1 " " 6	3 " " 16a	1 " " 40
3 " " 6a	2 " " 17	1 " " 43
2 " " 7a	1 " " 18a	1 " " 45
8 " " 8	2 " " 18b	3 " " 46
2 " " 8a	1 " " 19h	1 " " 48
2 " " 8b	4 " " 20b	9 " " 48a
4 " " 9	5 " " 22	3 " " 48b
2 " " 9d	2 " " 22a	2 " " 48c
2 " " 9f	3 " " 23	4 " " 48d
7 " " 10	1 " " 23a	2 " " 51
3 " " 11	2 " " 24	2 " " 52
35 " " 12	2 " " 24a	4 " " 52a
4 " " 12a	4 " " 26	5 " " 53

2 of No. 53a	2 of No. 70	2 of No. 89b
2 " " 54	2 " " 76	3 " " 90
1 " " 57b	2 " " 77	1 " " 94
12 " " 59	1 " " 80a	2 " " 100
2 " " 62b	2 " " 80c	2 " " 108
6 " " 63	4 " " 89	2 " " 109

2 of No. 126	3 of No. 147b
2 " " 126a	1 " " 154a
1 " " 128	1 " " 154b
2 " " 133a	2 " " 155
2 " " 136	1 " " 160
4 " " 142c	2 " " 161
1 " " 143	2 " " 164
1 " " 146a	2 " " 165

1 of No. 173a	2 of No. 212
1 " " 176	1 " " 213
2 " " 179	4 " " 214
10 " " 188	4 " " 221
10 " " 189	2 " " 222
14 " " 190	2 " " 226
6 " " 191	
18 " " 192	1 No. 1 Clock-work Motor
6 " " 197	(Not included in Outfit)
1 " " 198	
6 " " 200	

MODEL 9.2 FLOATING CRANE — continued

The top deck is filled in by a $5\frac{1}{2}'' \times 2\frac{1}{2}''$ and a $4\frac{1}{2}'' \times 2\frac{1}{2}''$ Flexible Plate on each side. These are extended inward by *one half of a Hinged Flat Plate* and two $2\frac{1}{2}'' \times 2\frac{1}{2}''$ Flexible Plates on each side, and the centre section of the deck is a $5\frac{1}{2}'' \times 1\frac{1}{2}''$ Flexible Plate bolted to the halves of the Hinged Flat Plate. The deck is attached to the sides and front and back of the bridge by Angle Brackets.

Two $2\frac{1}{2}'' \times \frac{1}{2}''$ Double Angle Strips (21) on each side support a $5\frac{1}{2}'' \times 1\frac{1}{2}''$ Flexible Plate extended at each end by a $2\frac{1}{2}'' \times 1\frac{1}{2}''$ Flexible Plate. A $3\frac{1}{2}'' \times 2\frac{1}{2}''$ Flanged Plate (22) (Fig. 9.2c) is bolted to the centre of this structure and is connected to it by two $2\frac{1}{2}'' \times 1\frac{1}{2}''$ Triangular Flexible Plates. A $2\frac{1}{2}'' \times 1\frac{1}{2}''$ Flanged Plate (23) on each side and a $2\frac{1}{2}'' \times 2\frac{1}{2}''$ Flexible Plate at the rear, are bolted to the Flanged Plate (22).

At the front a $5\frac{1}{2}'' \times 1\frac{1}{2}''$ Flexible Plate is fixed to two $2\frac{1}{2}'' \times \frac{1}{2}''$ Double Angle Strips (24), and $2\frac{1}{2}'' \times 1\frac{1}{2}''$ Flexible Plates are bolted to these Double Angle Strips and to Angle Brackets fixed to two of the Double Angle Strips (21). The Flexible Plates are edged by a $5\frac{1}{2}''$ Curved Strip and two $2\frac{1}{2}''$ Strips.

The funnel is formed by three $2\frac{1}{2}'' \times 2\frac{1}{2}''$ and three $2\frac{1}{2}'' \times 1\frac{1}{2}''$ Flexible Plates rolled to make a cylinder, and is attached to the top deck by two Angle Brackets. The mast is an 8" Rod fixed in a Double Arm Crank, and the rigging Cords are tied to a second Double Arm Crank held on the Rod.

Each of the two ventilators consists of a Worm, two Couplings and a Chimney Adaptor held by nuts on a 3" Screwed Rod. The handrails are $6\frac{1}{2}''$ Rods supported at the front in Corner Angle Brackets bolted to two of the Double Angle Strips (21). At the rear each Rod is fitted with a Rod and Strip Connector, and this is fixed by a nut on a bolt screwed into a Collar. The Collars are held on 1" Rods supported in Rod Sockets.

THE CRANE TOWER AND BEARING

Each side of the tower consists of a $7\frac{1}{2}''$ Angle Girder and a $5\frac{1}{2}''$ Angle Girder joined to a $2\frac{1}{2}''$ Angle Girder. These are connected at their lower ends by a $5\frac{1}{2}''$ Angle Girder and at their upper ends by a $5\frac{1}{2}''$ Braced Girder. The side is braced by two $5\frac{1}{2}''$ Strips, each extended by a $2\frac{1}{2}''$ Strip. The sides are connected to each other by two $4\frac{1}{2}''$ Strips (25) (Fig. 9.2d), a $4\frac{1}{2}'' \times \frac{1}{2}''$ Double Angle Strip (26) and further $4\frac{1}{2}''$ Strips (27) and (28) (Fig. 9.2b).

A 4" Circular Plate, fitted with two $3\frac{1}{2}'' \times \frac{1}{2}''$ Double Angle Strips (29) (Fig. 9.2d), is bolted to a $5\frac{1}{2}'' \times \frac{1}{2}''$ Double Angle Strip fixed between the Strips (25). The Circular Plate is further supported by a Trunnion on each side. Four $\frac{3}{4}''$ Flanged Wheels are attached to the lugs of Double Angle Strips (29). Two of these Flanged Wheels are free to turn on Pivot Bolts, and the other two are freely mounted on $\frac{3}{4}''$ Bolts. The Pivot Bolts and $\frac{3}{4}''$ Bolts are fixed to the lugs of the Double Angle Strips by two nuts each.

The Flanged Wheels run on the edge of a Circular Girder (30), (Fig. 9.2c), which is attached to the stern deck by four Angle Brackets. A $4\frac{1}{2}''$ Rod is fixed in a Face Plate bolted to the 4" Circular Plate. The Rod is passed through the Flanged Plates (5) and (10), and is held in place by a second Face Plate (see Fig. 9.2a).

The control cabin at the front of the tower is made by bolting a $2\frac{1}{2}'' \times 2\frac{1}{2}''$ Flexible Plate and two Girder Brackets (31) to the Strip (28). The roof consists of two $2\frac{1}{2}'' \times 1''$ Double Angle Strips connected by a Fishplate, and the front is formed by two Semi-Circular Plates bolted together and attached to $1\frac{1}{2}''$ Angle Girders. The centre window division is a $2\frac{1}{2}'' \times \frac{1}{2}''$ Double Angle Strip.

CONSTRUCTION OF THE JIB

Each side consists of built-up girders (32) and (33) connected at the tower end by a $5\frac{1}{2}''$ Strip and at the jib head by a 1" Triangular Plate, and braced by Strips as shown. The girder (32) consists of two $12\frac{1}{2}''$ Angle Girders overlapped 17 holes, and girder (33) is made from a $12\frac{1}{2}''$ Angle Girder and a $12\frac{1}{2}''$ Strip overlapped 20 holes. The sides are connected by a $4\frac{1}{2}'' \times \frac{1}{2}''$ Double Angle Strip (34), and by a $2\frac{1}{2}''$, a $1\frac{1}{2}''$ and two 3" Strips. At the jib head two $\frac{1}{2}''$ loose Pulleys are mounted between a Spring Clip and a Cord Anchoring Spring on a 2" Rod, which is held by Collars in the 1" Triangular Plates.

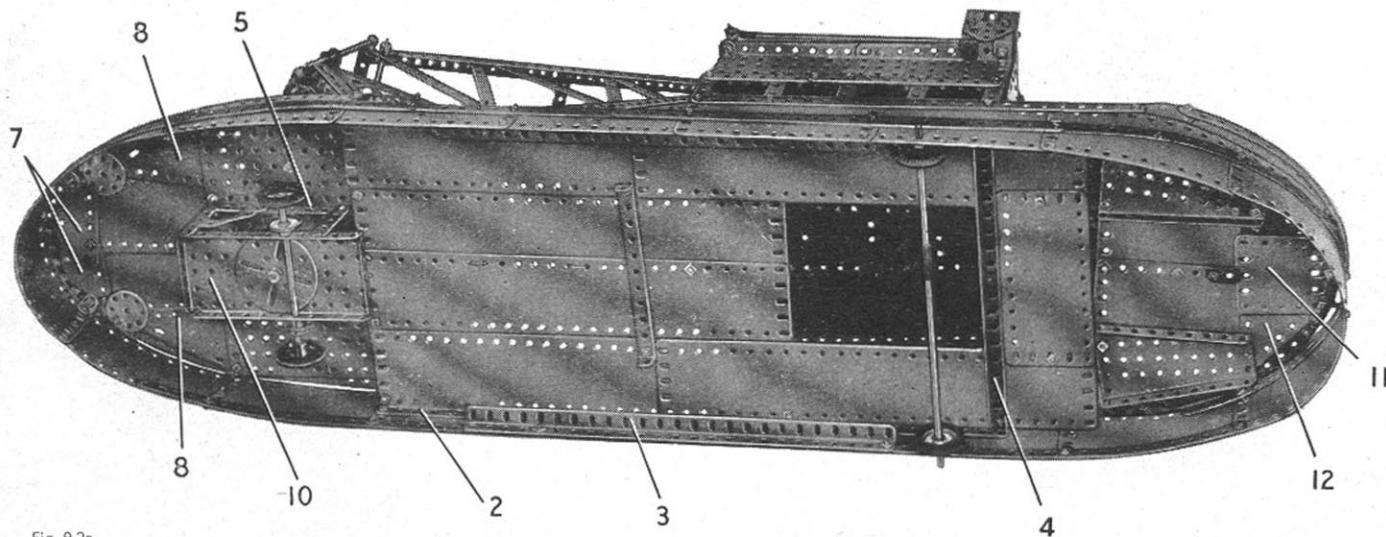

Fig. 9.2a

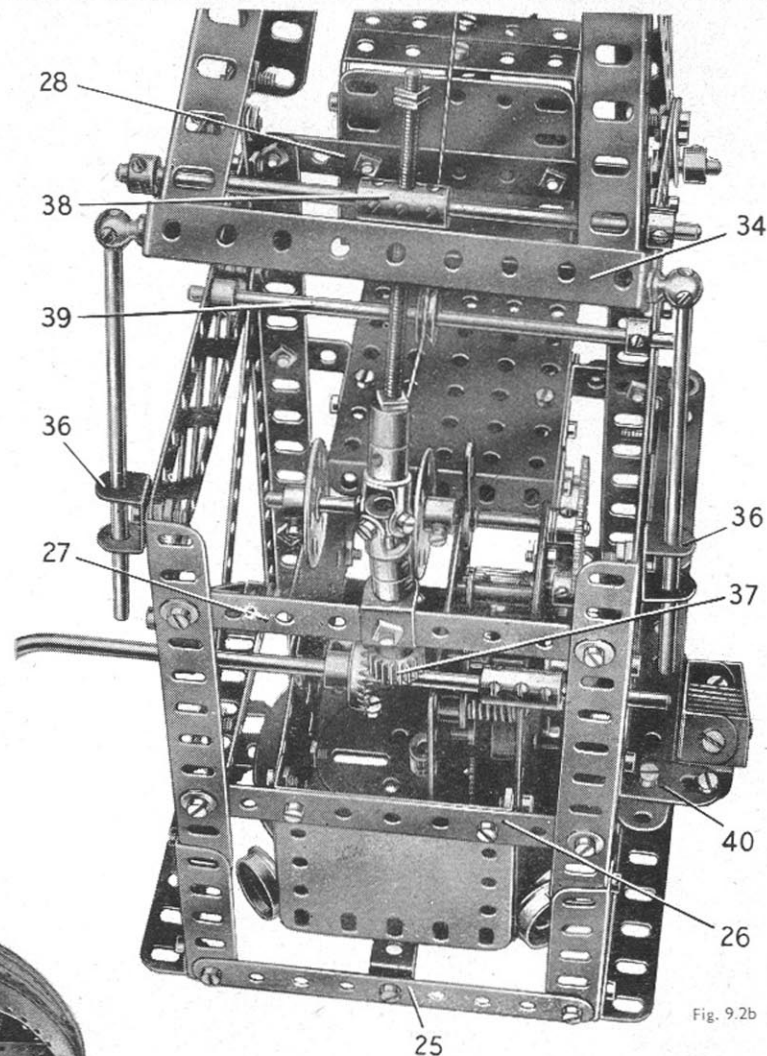

Fig. 9.2b

Two 1" Corner Brackets are bolted to the lower end of the jib, and these are pivoted on Threaded Pins (35) that are held by their nuts in Fishplates bolted to the tower. A $4\frac{1}{2}''$ Rod on each side is fixed in a Handrail Support lock-nutted to the jib, and is free to slide in a Double Bracket (36) (Fig. 9.2d) lock-nutted to the tower.

The jib is luffed by turning a 5" Crank Handle joined to a $1\frac{1}{2}''$ Rod by a Coupling. The Crank Handle is held in place by Collars, and it carries a $\frac{3}{4}''$ Contrate that drives a $\frac{1}{2}''$ Pinion (37) on a 2" Rod. This Rod is mounted in a Double Bracket bolted to Strip (27) and is fitted with a Collar and a built-up universal coupling, made from a Swivel Bearing and a small Fork Piece. A Screwed Rod Adaptor held in the universal coupling has a $3\frac{1}{2}''$ Screwed Rod fixed in it by a nut. The Screwed Rod is threaded through a Coupling (38), which is supported by two $2\frac{1}{2}''$ Rods held in the jib by Collars. (Continued on next page)

MODEL 9.2 FLOATING CRANE — Continued

THE ENGINE HOUSE AND HOISTING MECHANISM

The side of the engine house seen in Fig. 9.2 consists of two $5\frac{1}{2}'' \times 2\frac{1}{2}''$ Flexible Plates overlapped lengthways three holes, with a $2\frac{1}{2}'' \times 2\frac{1}{2}''$ Flexible Plate overlapping them at the rear by two holes. The side is bolted to the lug of a $2\frac{1}{2}'' \times \frac{1}{2}''$ Double Angle Strip fixed to the Double Angle Strip (26), and is supported at the front by two $1'' \times 1''$ Angle Brackets bolted to the tower. The side seen in Fig. 9.2c is made by bolting a No. 1 Clockwork Motor to the other lug of the $2\frac{1}{2}'' \times \frac{1}{2}''$ Double Angle Strip. This side is completed by a $4\frac{1}{2}'' \times 3\frac{1}{2}''$ built-up plate bolted to the Motor and supported at the front by two $1'' \times 1''$ Angle Brackets. The Plate consists of a $2\frac{1}{2}'' \times 1\frac{1}{2}''$ and three $2\frac{1}{2}'' \times 2\frac{1}{2}''$ Flexible Plates. The front and roof of the housing are $3\frac{1}{2}'' \times 2\frac{1}{2}''$ Flanged Plates, which are attached to the sides by two Angle Brackets, a $2\frac{1}{2}'' \times 1''$ and a $2\frac{1}{2}'' \times \frac{1}{2}''$ Double Angle Strip.

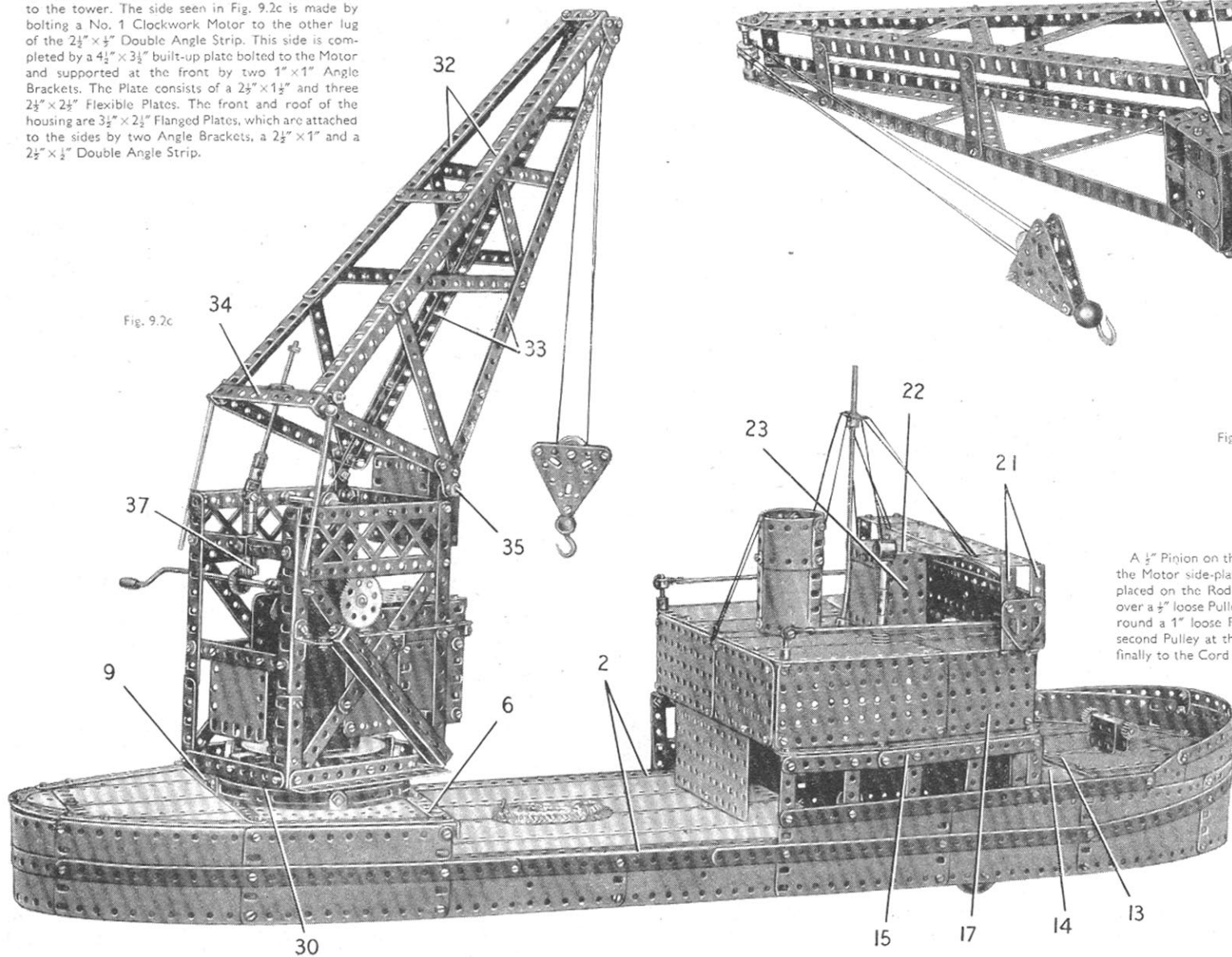

Fig. 9.2d

A $\frac{1}{2}''$ Pinion on the Motor shaft drives a 57-tooth Gear on a $3\frac{1}{2}''$ Rod supported in the Motor side-plates. The hoisting Cord is fastened to a Cord Anchoring Spring placed on the Rod between two Bush Wheels (see Fig. 9.2b). The Cord is taken over a $\frac{1}{2}''$ loose Pulley on a 5" Rod (39), over one of the $\frac{1}{2}''$ Pulleys at the jib head, and round a 1" loose Pulley in the pulley block. The Cord is then passed round the second Pulley at the jib head and the other Pulley in the pulley block, and is tied finally to the Cord Anchoring Spring at the jib head.

The pulley block consists of two $2\frac{1}{2}''$ Triangular Plates, separated by two Spring Clips on each of two $\frac{3}{8}''$ Bolts. The 1" loose Pulleys are mounted on the shank of a $\frac{3}{8}''$ Bolt that is held in one of the Triangular Plates by a nut, and the large Loaded Hook is supported by a second $\frac{1}{2}''$ Bolt.

THE INSPECTION PLATFORM AND LADDER

The inspection platform is formed by a Bell Crank, a $2\frac{1}{2}''$ Strip and a $3\frac{1}{2}'' \times \frac{1}{2}''$ Double Angle Strip. It is attached to the tower by a $\frac{3}{8}'' \times \frac{1}{2}''$ Angle Bracket and a $1'' \times \frac{1}{2}''$ Angle Bracket (40). The ladder is made by bolting together two $5\frac{1}{2}'' \times \frac{1}{2}''$ Double Angle Strips, and the rungs are represented by Cord. The ladder is bolted at its lower end to a $1'' \times \frac{1}{2}''$ Angle Bracket, and at its upper end it is supported by an Obtuse Angle Bracket fixed to the Angle Bracket (40).

9.3 SALOON CAR AND CARAVAN

Parts Required

14 of No. 1	24 of No. 12	1 of No. 25	2 of No. 52a	2 of No. 108	1 of No. 165	5 of No. 191	2 of No. 212	2 of No. 222	1 No. 1 Clockwork Motor (Not included in Outfit)
2 " " 1b	2 " " 12b	5 " " 26	5 " " 53	3 " " 111	1 " " 166	18 " " 192	2 " " 212a	2 " " 224	
24 " " 2	8 " " 12c	1 " " 27a	2 " " 53a	6 " " 111a	2 " " 179	6 " " 197	8 " " 215	2 " " 225	
5 " " 2a	1 " " 13a	2 " " 28	12 " " 59	9 " " 111c	1 " " 185	1 " " 198	4 " " 221	2 " " 226	
6 " " 3	2 " " 14	2 " " 29	2 " " 62	1 " " 115	6 " " 187a	6 " " 200			
1 " " 4	3 " " 15	6 " " 35	2 " " 62b	1 " " 116	8 " " 188				
32 " " 5	5 " " 15a	309 " " 37a	6 " " 63	2 " " 124	10 " " 189				
2 " " 6	1 " " 16a	292 " " 37b	2 " " 70	2 " " 133a	13 " " 190				
3 " " 6a	5 " " 17	38 " " 38	1 " " 77	1 " " 134					
2 " " 7a	1 " " 18a	2 " " 38d	3 " " 89	2 " " 136					
6 " " 8	2 " " 18b	1 " " 45	2 " " 89b	6 " " 142a					
1 " " 8a	6 " " 20a	2 " " 48	4 " " 90	2 " " 147b					
2 " " 8b	4 " " 20b	2 " " 48a	8 " " 90a	1 " " 147c					
4 " " 9	2 " " 23	6 " " 48b	2 " " 100	1 " " 164					
2 " " 9d	1 " " 23a	1 " " 50							
2 " " 9f	2 " " 24	2 " " 52							
13 " " 10									
7 " " 11									

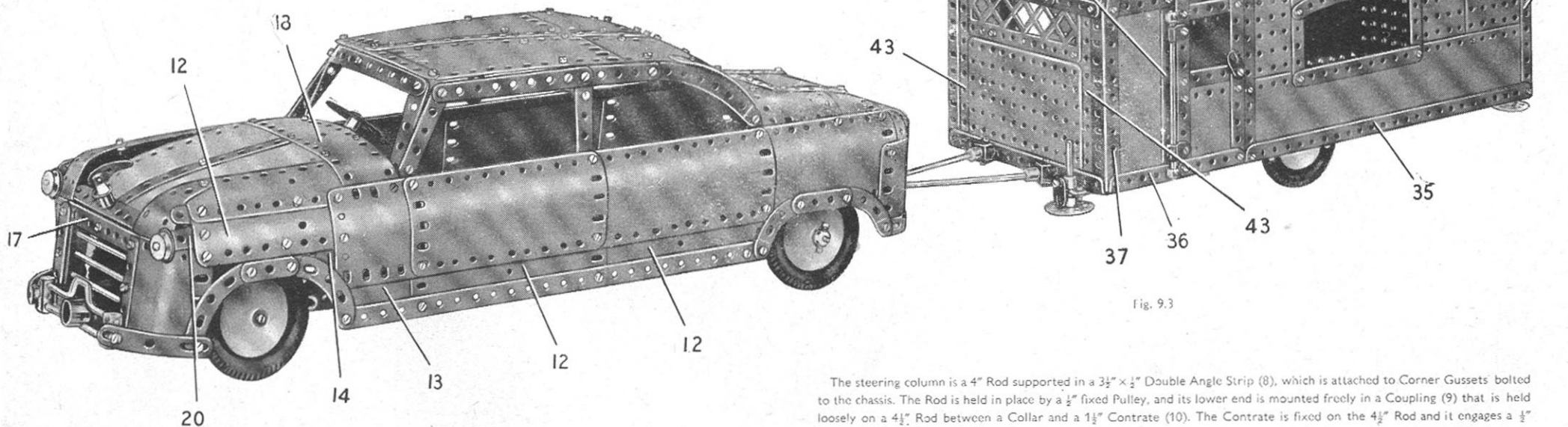

Fig. 9.3

THE CAR: CONSTRUCTION OF THE CHASSIS (Fig. 9.3b)

The chassis consists of two $1\frac{1}{2}$ " Angle Girders connected by two $7\frac{1}{2}$ " Strips (1), two $3\frac{1}{2}$ " \times $\frac{1}{2}$ " Double Angle Strips (2) and (3) and a $4\frac{1}{2}$ " Strip (4). The Strip (4) is extended at each end by a Crank, placed with its boss overhanging the end of the Strip. A $1\frac{1}{2}$ " Rod is freely mounted in each Crank and carries a Coupling (5). One of the Rods is held in place by a Collar and the other is retained in position by a Coupling (6). Each of the front wheels is free to turn on a $\frac{3}{8}$ " Bolt screwed into the uppermost threaded hole of one of the Couplings (5).

A Pivot Bolt, with a Collar fixed on its plain shank, is screwed into the centre threaded hole of each Coupling (5) and is held by a nut tightened against the Coupling. A $5\frac{1}{2}$ " Strip (7) is pivotally attached by bolts screwed into the Collars.

The steering column is a 4" Rod supported in a $3\frac{1}{2}$ " \times $\frac{1}{2}$ " Double Angle Strip (8), which is attached to Corner Gussets bolted to the chassis. The Rod is held in place by a $\frac{1}{2}$ " fixed Pulley, and its lower end is mounted freely in a Coupling (9) that is held loosely on a $4\frac{1}{2}$ " Rod between a Collar and a $1\frac{1}{2}$ " Contrate (10). The Contrate is fixed on the $4\frac{1}{2}$ " Rod and it engages a $\frac{1}{2}$ " Pinion on the steering column.

A $2\frac{1}{2}$ " Rod in the Coupling (6) is fitted at its inner end with a Collar, and a Rod and Strip Connector pivots on a bolt held in the Collar by a nut. The Rod and Strip Connector is joined to a similar part by a $1\frac{1}{2}$ " Rod. The second Rod and Strip Connector is lock-nutted to a Fishplate bolted tightly to the Contrate (10).

A No. 1 Clockwork Motor is bolted direct to one side of the chassis and attached to the other side by an Angle Bracket. A $\frac{1}{2}$ " Pinion on the Motor shaft drives a 57-tooth Gear on a 2" Rod supported in Double Angle Strip (2) and in a Double Bent Strip bolted to the Double Angle Strip. The Rod is held in place by a Collar and a $\frac{3}{8}$ " Contrate, and it carries at its lower end a $\frac{3}{8}$ " Pinion (11). This Pinion drives a $\frac{3}{8}$ " Contrate on a $6\frac{1}{2}$ " Rod held by $\frac{1}{2}$ " Pinions in the Double Angle Strip (3) and in a Double Bracket bolted to one of the Strips (1). A $\frac{1}{2}$ " Pinion on the rear end of the $6\frac{1}{2}$ " Rod engages a $1\frac{1}{2}$ " Contrate on the rear axle. This axle is an 8" Rod held in the chassis by $\frac{3}{8}$ " Flanged Wheels.

(Continued on next page)

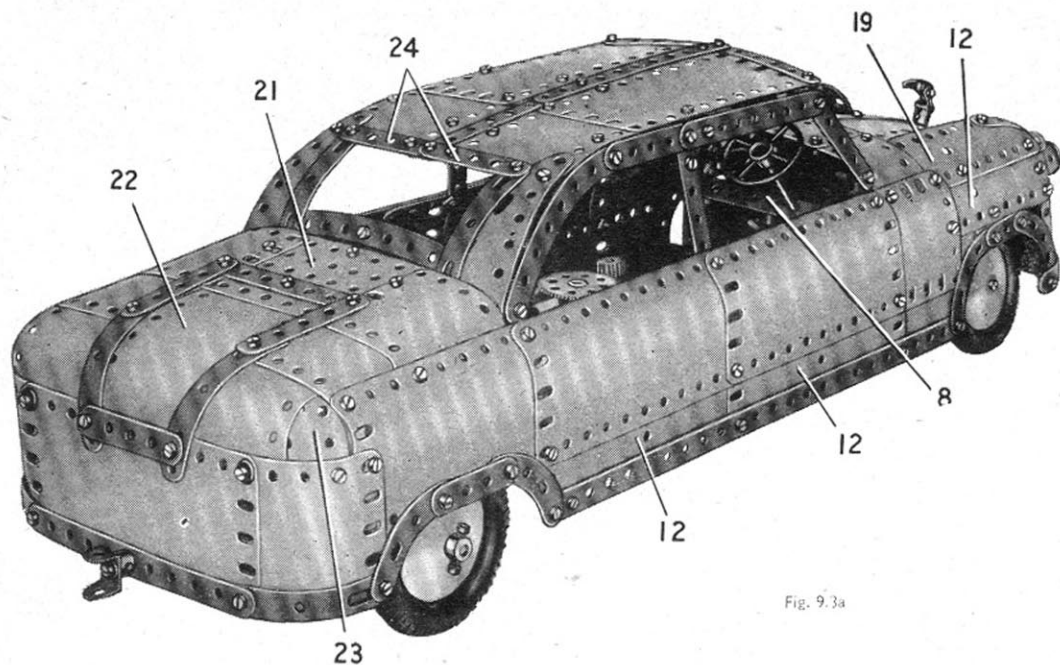

Fig. 9.3a

ASSEMBLY OF THE TAIL (Fig. 9.3a)

A $1\frac{1}{2}$ " radius Curved Plate is bolted to each side and the two are joined at their inner ends by a $5\frac{1}{2}$ " \times $2\frac{1}{2}$ " Flexible Plate. Two other $1\frac{1}{2}$ " radius Curved Plates are also fixed to each side and these are bolted at their inner ends to a $4\frac{1}{2}$ " \times $2\frac{1}{2}$ " Flat Plate (21) and a $4\frac{1}{2}$ " \times $2\frac{1}{2}$ " Flexible Plate (22). The rear corners are filled in by curved $2\frac{1}{2}$ " \times $2\frac{1}{2}$ " Flexible Plates and $2\frac{1}{2}$ " \times $2\frac{1}{2}$ " Triangular Flexible Plates (23). The towing attachment is a large Fork Piece held by a $\frac{1}{2}$ " Bolt.

CONSTRUCTION OF THE ROOF

Each side of the roof consists of a $5\frac{1}{2}$ " \times $2\frac{1}{2}$ " and a $4\frac{1}{2}$ " \times $2\frac{1}{2}$ " Flexible Plate overlapped four holes. At the centre two $5\frac{1}{2}$ " Strips are overlapped five holes, and one of these Strips and the $5\frac{1}{2}$ " \times $2\frac{1}{2}$ " Flexible Plates are bolted to a $5\frac{1}{2}$ " Curved Strip at the front. The rear ends of the Strips and Plates are bolted to two $2\frac{1}{2}$ " Strips (24) that form the top edge of the window. The window is completed by two Formed Slotted Strips and a $5\frac{1}{2}$ " Curved Strip. The latter is attached to the Plate (21) by an Angle Bracket. A $3\frac{1}{2}$ " \times $1\frac{1}{2}$ " Triangular Flexible Plate is bolted at each side of the window.

The roof is attached to the side window frames and to the top of the windscreen by Angle Brackets.

THE CARAVAN: DETAILS OF THE SIDES

The side seen in Fig. 9.3c consists of Plates bolted to a framework formed by a built-up girder (25), two $5\frac{1}{2}$ " Angle Girders (26) and built-up strips (27) and (28). The girder (25) is made from a $12\frac{1}{2}$ " and a $9\frac{1}{2}$ " Angle Girder overlapped nine holes; strip (27) consists of two $12\frac{1}{2}$ " Strips overlapped 15 holes, and strip (28) is formed by two $2\frac{1}{2}$ " Strips, a $4\frac{1}{2}$ " Strip, a $3\frac{1}{2}$ " Strip, a $5\frac{1}{2}$ " Strip and two $2\frac{1}{2}$ " Curved Strips.

(Continued on next page)

THE SIDES OF THE BODY

Each side consists of two $5\frac{1}{2}$ " \times $2\frac{1}{2}$ " Flexible Plates, three $5\frac{1}{2}$ " \times $1\frac{1}{2}$ " Flexible Plates (12), a $2\frac{1}{2}$ " \times $2\frac{1}{2}$ " Flexible Plate, a $4\frac{1}{2}$ " \times $2\frac{1}{2}$ " Flexible Plate, a $2\frac{1}{2}$ " \times $1\frac{1}{2}$ " Flexible Plate (13) and a $2\frac{1}{2}$ " \times $1\frac{1}{2}$ " Triangular Flexible Plate (14) (Fig. 9.3) The Plates are edged on the outside by a $12\frac{1}{2}$ " Strip, and are strengthened on the inside by a $12\frac{1}{2}$ " Strip (15) and a built-up strip (16) (Fig. 9.3b). Strip (16) consists of two $12\frac{1}{2}$ " Strips overlapped ten holes. The sides are connected to the ends of the Strips (1) by Angle Brackets.

The window frames are formed by a $2\frac{1}{2}$ ", a $3\frac{1}{2}$ " and a $4\frac{1}{2}$ " Strip, and one $4\frac{1}{2}$ " Stepped Curved Strip. The Curved Strip and the $2\frac{1}{2}$ " Strip are attached to the sides by Obtuse Angle Brackets. The centre division on each side is a $2\frac{1}{2}$ " Strip, braced at its upper end by a $1\frac{1}{2}$ " Corner Bracket.

THE FRONT GRILLE AND THE BONNET

A $1\frac{1}{2}$ " radius Curved Plate is bolted to each side, and the inner edges of these Plates are strengthened by $2\frac{1}{2}$ " Strips, and are connected by $4\frac{1}{2}$ " Strips (17). The lower $4\frac{1}{2}$ " Strip is connected to the chassis by two $1\frac{1}{2}$ " \times $\frac{1}{2}$ " Angle Brackets (Fig. 9.3b). Three $4\frac{1}{2}$ " Rods are held by Spring Clips in $1\frac{1}{2}$ " Angle Girders bolted to the inner edges of the Curved Plates.

The front bumper consists of two Formed Slotted Strips attached to the Curved Plates by Double Brackets, and two $2\frac{1}{2}$ " Rods and a Crankshaft supported by Couplings. Each of these Couplings is fixed by a $\frac{1}{2}$ " Bolt to the front of the car.

The top of the bonnet consists of two $5\frac{1}{2}$ " \times $2\frac{1}{2}$ " Flexible Plates, with the joint covered by a $5\frac{1}{2}$ " Strip. These Plates are bolted at the rear to two $5\frac{1}{2}$ " \times $1\frac{1}{2}$ " Flexible Plates (18) overlapped ten holes, and at the front they are connected by an Obtuse Angle Bracket to the upper $4\frac{1}{2}$ " Strip (17). The Plates are attached to the Bracket by a Threaded Pin, and an End Bearing fitted with a Pawl without boss, is fixed on the Pin to represent the mascot.

A $5\frac{1}{2}$ " \times $1\frac{1}{2}$ " Flexible Plate (19) on each side is connected to the Curved Plate at the front by a $2\frac{1}{2}$ " \times $1\frac{1}{2}$ " Triangular Flexible Plate. The headlamps are $\frac{1}{2}$ " loose Pulleys and $\frac{1}{2}$ " Washers bolted to the lugs of $1\frac{1}{2}$ " \times $\frac{1}{2}$ " Double Angle Strips (20).

The windscreen is formed by a $5\frac{1}{2}$ " and two $2\frac{1}{2}$ " Strips, and is attached to Obtuse Angle Brackets bolted to the side window frames.

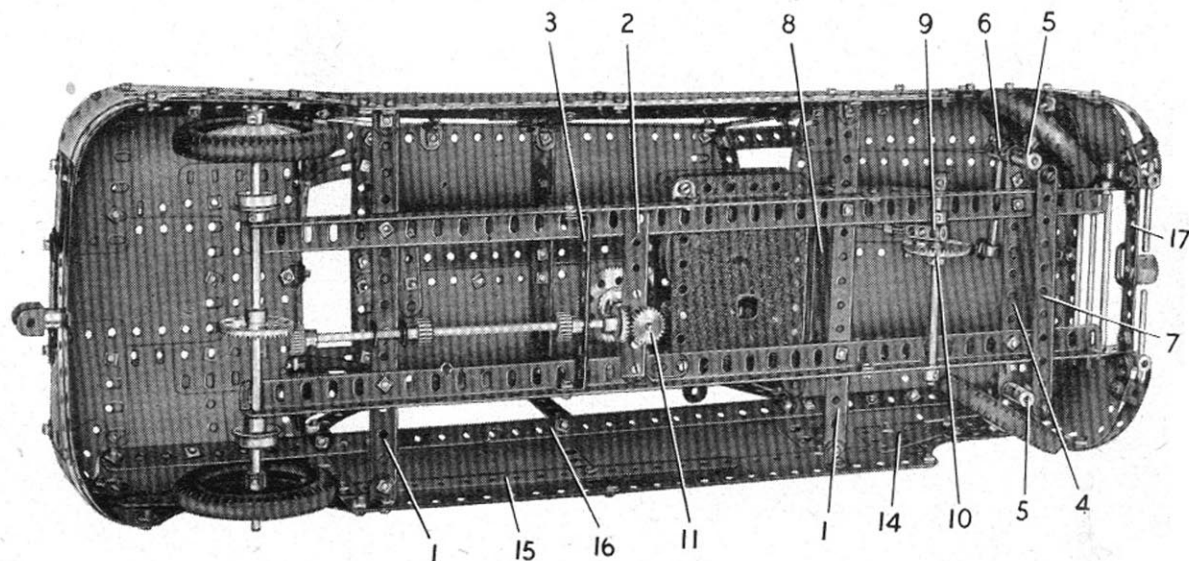

Fig. 9.3b

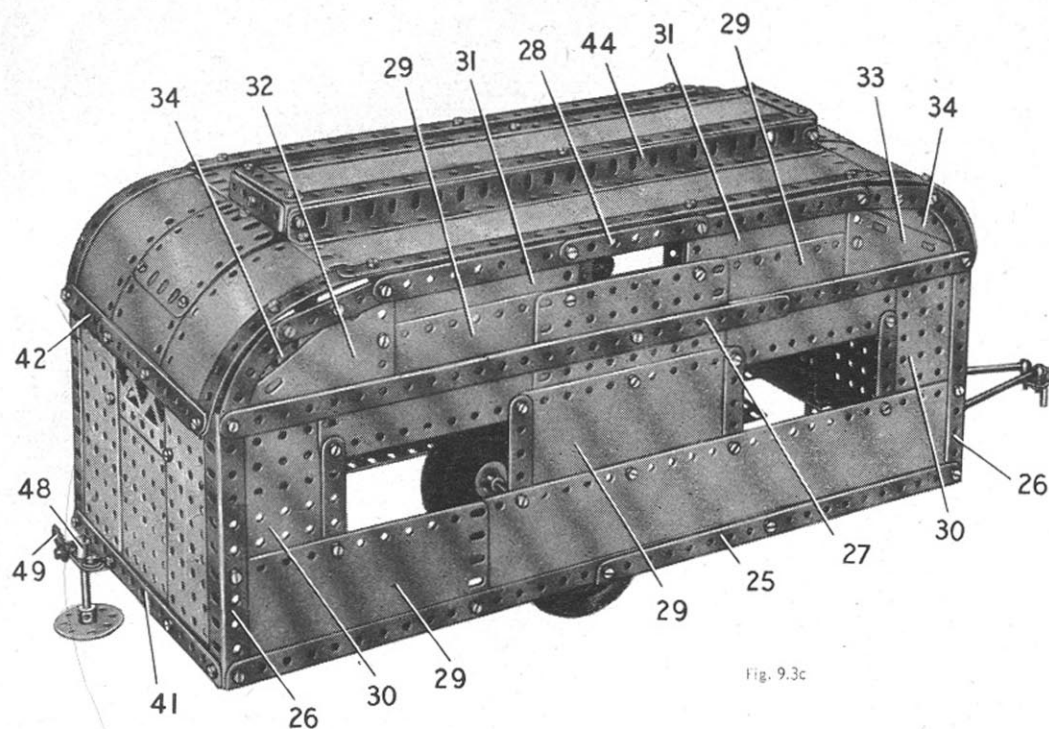

Fig. 9.3c

THE WHEELS, TOWING BAR AND JACKS

The wheels are freely mounted between Collars and $\frac{3}{8}$ " Flanged Wheels on a $6\frac{1}{2}$ " Rod, which is supported in 1" Reversed Angle Brackets (46) (Fig. 9.3d).

The towing bar consists of two 5" Rods fitted with Handrail Supports and Rod Sockets. The Handrail Supports are fixed to a 1" Triangular Plate, and the Rod Sockets are attached to Double Brackets (47). The Double Brackets are bolted to further Double Brackets fixed to one of the Girders (41).

The supporting jacks at each end of the caravan are made by bolting Double Arm Cranks (48) to Fishplates fixed to the Girders (41). A 2" Rod fitted with a Bush Wheel is passed through the boss of each Double Arm Crank, and can be fixed in place by turning a Fishplate (49). The Fishplates are held by nuts on $\frac{3}{8}$ " Bolts screwed into the threaded holes of the Double Arm Cranks.

Model-building Competitions, in which fine Cash Prizes are offered for new and original Meccano models, are announced in the MECCANO MAGAZINE, which is published monthly.

MODEL 9.3 SALOON CAR AND CARAVAN — Continued

^E The side is plated by a $12\frac{1}{2}$ " \times $2\frac{1}{2}$ " Strip plate, four $5\frac{1}{2}$ " \times $2\frac{1}{2}$ " Flexible Plates (29), two $3\frac{1}{2}$ " \times $2\frac{1}{2}$ " Flanged Plates (30), a $4\frac{1}{2}$ " \times $2\frac{1}{2}$ " Flat Plate, the Separated halves (31) of a Hinged Flat Plate, a $3\frac{1}{2}$ " \times $2\frac{1}{2}$ " Triangular Flexible Plate (32), a $3\frac{1}{2}$ " \times 2" Triangular Flexible Plate (33), and two $2\frac{1}{2}$ " \times $1\frac{1}{2}$ " Flexible Plates (34).

The side seen in Fig. 9.3 consists of Plates bolted to a $12\frac{1}{2}$ " Angle Girder (35), a $2\frac{1}{2}$ " Angle Girder (36), two $5\frac{1}{2}$ " Angle Girders (37) and built-up strips (38) and (39). Strip (38) is formed by a $12\frac{1}{2}$ " and a $2\frac{1}{2}$ " Strip, and strip (39) consists of a $12\frac{1}{2}$ " Strip, two $2\frac{1}{2}$ " Strips and two $2\frac{1}{2}$ " Curved Strips. This side is filled in by two $12\frac{1}{2}$ " \times $2\frac{1}{2}$ " Strip Plates, three $3\frac{1}{2}$ " \times $2\frac{1}{2}$ " Flanged Plates, two $2\frac{1}{2}$ " \times $1\frac{1}{2}$ " Flexible Plates above the window, and a $5\frac{1}{2}$ " \times $2\frac{1}{2}$ " Flexible Plate edged by a $5\frac{1}{2}$ " Strip (40). The upper corners are filled in by Triangular Flexible Plates and $2\frac{1}{2}$ " \times $1\frac{1}{2}$ " Flexible Plates, as described for the other side.

The door is formed by two $5\frac{1}{2}$ " and three $2\frac{1}{2}$ " Strips and a $2\frac{1}{2}$ " \times $2\frac{1}{2}$ " Flexible Plate. Its hinges are Right-Angle Rod and Strip Connectors mounted on a 5" Rod. This Rod is fixed in Collars held by bolts passed through the Strip (40). Each bolt is fitted with two Washers. The handle is a Fishplate fixed by a nut on a $\frac{3}{8}$ " Bolt. The Bolt is passed through the door and is fitted with a catch consisting of a second Fishplate gripped on the Bolt by two nuts.

CONSTRUCTION OF THE ENDS

The sides are connected by $7\frac{1}{2}$ " Angle Girders (11) and built-up strips (42) at each end. The strips (42) are made from $5\frac{1}{2}$ " Strips overlapped. The end seen in Fig. 9.3 is plated by two $5\frac{1}{2}$ " \times $2\frac{1}{2}$ " Flanged Plates (43), a $5\frac{1}{2}$ " \times $3\frac{1}{2}$ " Flat Plate and a $5\frac{1}{2}$ " Braced Girder. The other end is similar, but the Flanged Plates (43) are replaced by $5\frac{1}{2}$ " \times $2\frac{1}{2}$ " Flat Plates.

ASSEMBLY OF THE ROOF

Each side of the roof is formed by a $12\frac{1}{2}$ " \times $2\frac{1}{2}$ " Strip Plate and two $5\frac{1}{2}$ " \times $2\frac{1}{2}$ " Flexible Plates edged by a $12\frac{1}{2}$ " Strip and two curved $5\frac{1}{2}$ " Strips. The centre section consists of two $2\frac{1}{2}$ " \times $2\frac{1}{2}$ " Flexible Plates at each end overlapped two holes, and with the join strengthened on the inside by a $3\frac{1}{2}$ " \times $\frac{1}{2}$ " Double Angle Strip. The raised centre section is a $12\frac{1}{2}$ " \times $2\frac{1}{2}$ " Strip Plate edged by $12\frac{1}{2}$ " Angle Girders. These Girders are bolted to further $12\frac{1}{2}$ " Angle Girders (44), and $2\frac{1}{2}$ " \times $\frac{1}{2}$ " Double Angle Strips at the ends are attached to the $2\frac{1}{2}$ " \times $2\frac{1}{2}$ " Flexible Plates by Angle Brackets.

The roof is attached to the sides of the caravan by Angle Brackets and by a $2\frac{1}{2}$ " Angle Girder (45) (Fig. 9.3)

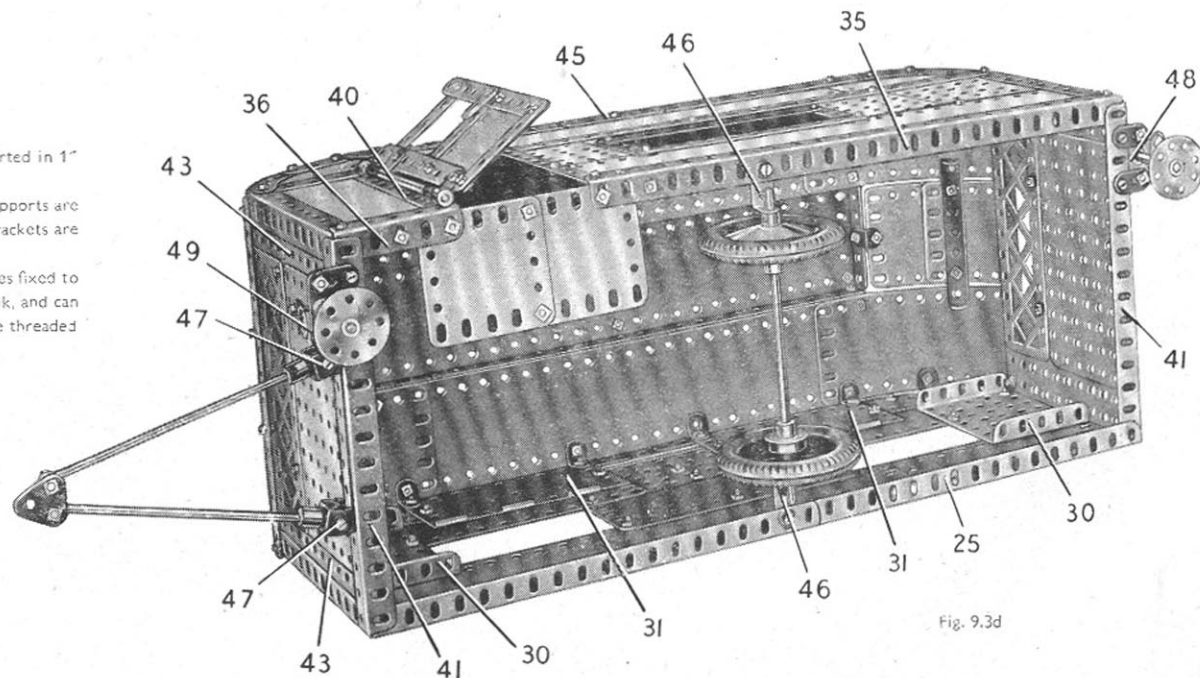

Fig. 9.3d

9.4 TRAIN FERRY

Parts Required

14 of No. 1	1 of No. 28	6 of No. 111a
1 " " 1b	351 " " 37a	12 " " 111c
23 " " 2	320 " " 37b	2 " " 115
6 " " 2a	24 " " 38	2 " " 133a
6 " " 3	1 " " 38d	1 " " 136
8 " " 4	1 " " 40	3 " " 147b
29 " " 5	2 " " 48	4 " " 155
2 " " 6	2 " " 48a	2 " " 161
6 " " 6a	3 " " 48b	1 " " 162b
2 " " 7a	2 " " 48c	1 " " 164
8 " " 8	1 " " 48d	10 " " 188
2 " " 8a	2 " " 51	10 " " 189
1 " " 8b	1 " " 52	5 " " 190
2 " " 9	3 " " 52a	6 " " 191
2 " " 9f	5 " " 53	9 " " 192
19 " " 10	2 " " 53a	6 " " 197
5 " " 11	2 " " 54	1 " " 198
28 " " 12	12 " " 59	2 " " 200
1 " " 12a	4 " " 63	2 " " 212a
4 " " 12c	2 " " 76	4 " " 214
1 " " 13a	2 " " 77	1 " " 215
3 " " 14	1 " " 80a	4 " " 221
3 " " 15a	2 " " 80c	2 " " 222
1 " " 15b	4 " " 90	2 " " 223
2 " " 17	4 " " 90a	2 " " 224
1 " " 18a	1 " " 94	2 " " 226
1 " " 18b	1 " " 96	
4 " " 22	1 " " 96a	
1 " " 23a	1 " " 100	
3 " " 26	1 " " 109	
1 " " 27a	3 " " 111	

1 No. 1 Clock-work Motor
(Not included in Outfit)

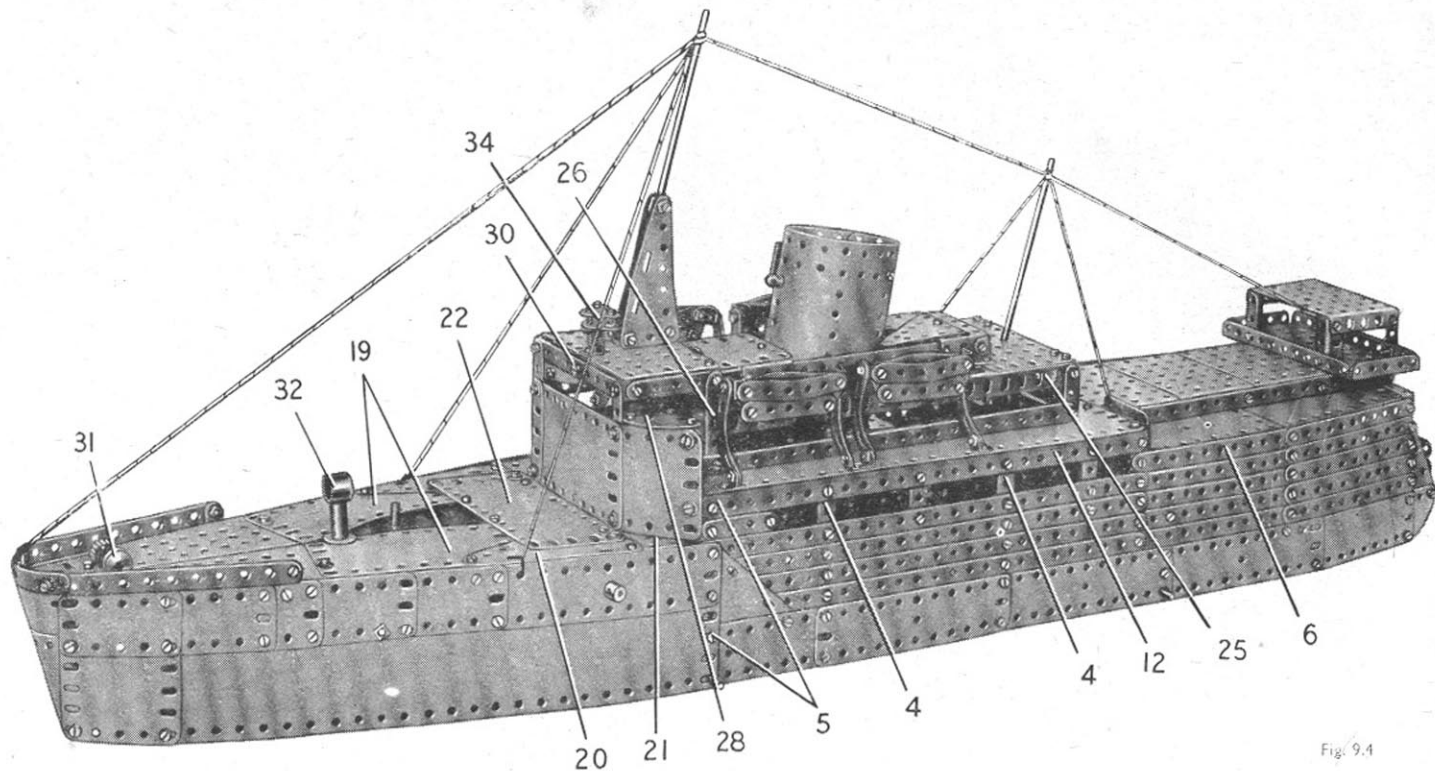

Fig. 9.4

THE SIDES OF THE HULL

The fore part of each side is made from five $2\frac{1}{2}'' \times 1\frac{1}{2}''$ Flexible Plates, a $5\frac{1}{2}'' \times 1\frac{1}{2}''$ Flexible Plate, a $2\frac{1}{2}'' \times 2\frac{1}{2}''$ Flexible Plate and a $12\frac{1}{2}'' \times 2\frac{1}{2}''$ Strip Plate. The top edges of the $2\frac{1}{2}'' \times 1\frac{1}{2}''$ and the $5\frac{1}{2}'' \times 1\frac{1}{2}''$ Flexible Plates, and the top edge of the Strip Plate, are strengthened towards the ends of the $12\frac{1}{2}''$ Strips. The centre section of each side is formed by four $5\frac{1}{2}'' \times 1\frac{1}{2}''$ Flexible Plates, and the stern consists of a $5\frac{1}{2}'' \times 2\frac{1}{2}''$ Flexible Plate (1) and a Semi-Circular Plate (2) (Fig. 9.4c). An $18\frac{1}{2}''$ Angle Girder (3) is bolted along the top edges of the $5\frac{1}{2}'' \times 1\frac{1}{2}''$ Flexible Plates as shown in Fig. 9.4a.

Three vertical $4\frac{1}{2}''$ Strips are bolted to each side. Two of these are indicated at (4) (Fig. 9.4), and the other is held by bolts (5). Four $12\frac{1}{2}''$ Strips are attached to the $4\frac{1}{2}''$ Strips, and each is extended towards the stern by two $5\frac{1}{2}''$ Strips. A $2\frac{1}{2}'' \times 1\frac{1}{2}''$ Triangular Flexible Plate is bolted between the ends of the $5\frac{1}{2}''$ Strips and the Semi-Circular Plate (2). The Strips on each side are connected by five $2\frac{1}{2}''$ Strips, placed as indicated by the rows of bolts seen in Fig. 9.4. A built-up strip (6), made from two $5\frac{1}{2}''$ Strips, is attached at the stern to one of the $2\frac{1}{2}''$ Strips mentioned above, at its centre to a Fishplate, and at its front end to a $1\frac{1}{2}''$ Strip.

The sides are connected at the bows by two 'U'-section Curved Plates, by two $7\frac{1}{2}''$ Strips bolted to the Girders (3) and by a $7\frac{1}{2}''$ Angle Girder (7) also bolted to the Girders (3). One of the Strips is indicated at (8) and the other is held by bolts (9) (Fig. 9.4a). At the stern the sides are connected by a $5\frac{1}{2}''$ Angle Girder (10) attached to Angle Brackets, and by a $5\frac{1}{2}'' \times \frac{1}{2}''$ Double Angle Strip (11) (Fig. 9.4b). A $3\frac{1}{2}''$ Strip, extended by a $2\frac{1}{2}''$ Strip, is bolted to Fishplates fixed to the Girder (10).

A $12\frac{1}{2}''$ Angle Girder (12) is bolted to the upper ends of the Strips (4) on each side and $12\frac{1}{2}'' \times 2\frac{1}{2}''$ Strip Plates are attached to these Girders. The rear ends of the Strip Plates are connected by a $3\frac{1}{2}'' \times 2\frac{1}{2}''$ Flanged Plate (13) (Fig. 9.4c); and a $5\frac{1}{2}'' \times 3\frac{1}{2}''$ Flat Plate (14) (Fig. 9.4a), is bolted between them.

THE TRAIN DECK

Each side of this deck consists of a $12\frac{1}{2}'' \times 2\frac{1}{2}''$ Strip Plate, a $4\frac{1}{2}'' \times 2\frac{1}{2}''$ Flexible Plate and a $5\frac{1}{2}'' \times 2\frac{1}{2}''$ Flexible Plate. These are bolted to the Girders (3), (7) and (10), and to the $7\frac{1}{2}''$ Strips between the Girders (3). The centre of the deck is filled in by a $5\frac{1}{2}''$ Braced Girder, two $5\frac{1}{2}'' \times 3\frac{1}{2}''$ Flat Plates (15) (Fig. 9.4a), and two $5\frac{1}{2}'' \times 2\frac{1}{2}''$ Flexible Plates. A $5\frac{1}{2}''$ Angle Girder is attached to the Strip held by bolts (9).

(Continued on next page)

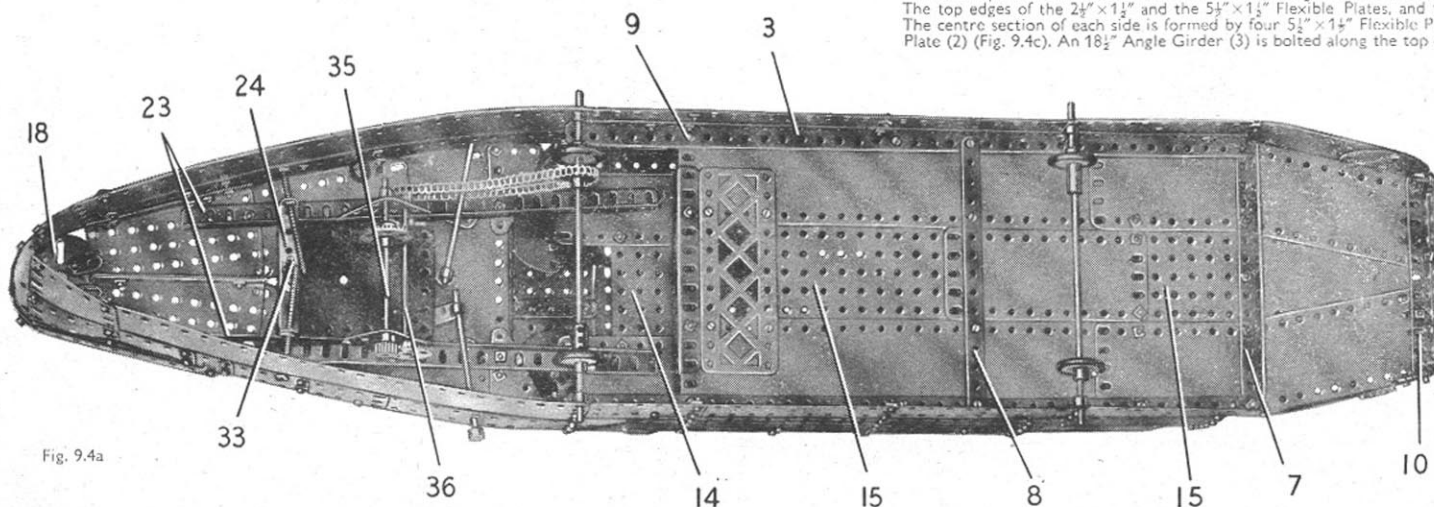

Fig. 9.4a

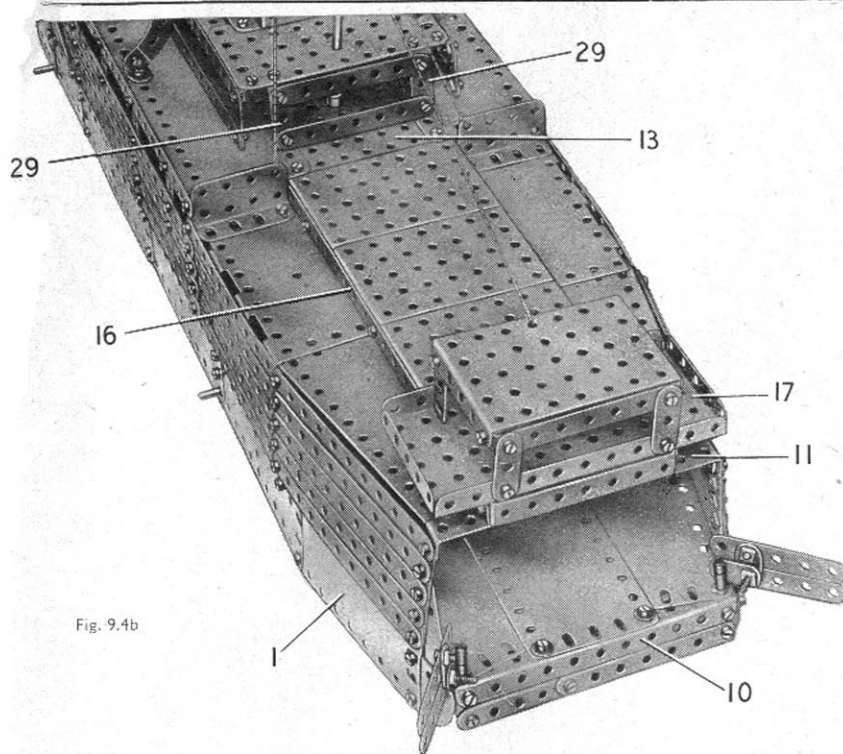

Fig. 9.4b

THE BRIDGE

The front of the bridge is a $4\frac{1}{2}'' \times 2\frac{1}{2}''$ Flexible Plate, and the curved sides are $1\frac{1}{4}''$ radius Curved Plates. A $4\frac{1}{2}'' \times \frac{1}{2}''$ Double Angle Strip (30) is supported by two $3\frac{1}{2}''$ Strips, and to each lug of this Double Angle Strip a $2\frac{1}{2}''$ Strip is bolted. The $2\frac{1}{2}''$ Strips are attached to the upper ends of the Strips (26). The bridge is connected by Angle Brackets to the front ends of the Girders (25) and to the Semi-Circular Plates (28), and by Obtuse Angle Brackets to the Girders (12).

The top of the bridge is a $4\frac{1}{2}'' \times 2\frac{1}{2}''$ Flat Plate. It is attached to a $2\frac{1}{2}'' \times \frac{1}{2}''$ Double Angle Strip bolted to the Double Angle Strip (30) and to Angle Brackets fixed to the Strips (26).

THE LIFEBOATS, MASTS AND DECK FITTINGS

Each lifeboat consists of two $3''$ Strips curved as shown in Fig. 9.4c and connected by Fishplates to a $2\frac{1}{2}''$ Strip that forms the keel. The lifeboats are attached by Angle Brackets to $2\frac{1}{2}''$ Stepped Curved Strips, which are bolted to Angle Brackets and Double Brackets fixed to the Girders (12).

The foremast is an $8''$ Rod held in a Coupling and a Collar placed between two $3\frac{1}{2}'' \times 1\frac{1}{2}''$ Triangular Flexible Plates. The Coupling and the Collar are held by bolts fitted with nuts, which are passed through the Plates into the threaded holes in the Coupling and the Collar. A Double Bracket bolted between the Plates is secured to the top of the bridge.

The aft-mast is a $6\frac{1}{2}''$ Rod, and it is held by Collars in holes in the boat deck and the Plate (13). The winch (31) consists of a $\frac{1}{2}''$ Pulley and a $\frac{1}{2}''$ Pinion on a $1\frac{1}{2}''$ Rod, which is supported in a Double Bracket bolted to the deck.

A Chimney Adaptor (32) is held by nuts on a Screwed Rod (33) (Fig. 9.4a), and is spaced from the deck by a Coupling.

The radar mast (34) is made from two $1''$ Corner Brackets spaced by nuts on $\frac{1}{2}''$ Bolts. It is attached to a Double Bracket bolted to the bridge.

THE DRIVING MECHANISM

A $\frac{1}{2}''$ Pinion on the driving shaft of the No. 1 Clockwork Motor engages a $1\frac{1}{2}''$ Contrate on a $4\frac{1}{2}''$ Rod (35). This Rod is mounted in $2\frac{1}{2}''$ Triangular Plates bolted to the Girders (23). A $\frac{1}{2}''$ Pinion on Rod (35) drives a 57-tooth Gear on a $4\frac{1}{2}''$ Rod (36), which is also mounted in the $2\frac{1}{2}''$ Triangular Plates. A $\frac{3}{4}''$ Sprocket on Rod (36) is connected by Chain to a $1''$ Sprocket on the front axle. Bolts are passed through the holes in the Motor brake and reversing levers and are screwed into Collars. Rods fixed in the Collars are passed through holes in the sides of the hull as shown in Fig. 9.4a.

Each of the axles consists of a $6\frac{1}{2}''$ and a $2''$ Rod joined by a Coupling, and the wheels are $1''$ Pulleys fitted with Rubber Rings.

MODEL 9.4 TRAIN FERRY — Continued

Each of the hinged doors at the stern is formed by two $2\frac{1}{2}''$ Strips connected by a Fishplate. A Right-Angle Rod and Strip Connector is bolted to the lower Strip and is pivoted on a Threaded Pin that is held by its nut at the end of the Girder (10).

THE STERN DECK

Two $12\frac{1}{2}''$ Angle Girders (16) (Fig. 9.4c) are bolted to the flanges of Plate (13) and to the Double Angle Strip (11). Three $3\frac{1}{2}'' \times 2\frac{1}{2}''$ Flanged Plates are bolted between these Girders, and a $5\frac{1}{2}'' \times 2\frac{1}{2}''$ Flanged Plate (17) is attached to Double Angle Strip (11) by two $\frac{3}{4}''$ Bolts. A $3\frac{1}{2}'' \times 2\frac{1}{2}''$ Flanged Plate is connected to Plate (17) by two $1\frac{1}{2}''$ Angle Girders and two $1\frac{1}{2}''$ Strips. The upper ends of the Strips are bolted to a $3\frac{1}{2}'' \times \frac{1}{2}''$ Double Angle Strip fixed to the flanges of the $3\frac{1}{2}'' \times 2\frac{1}{2}''$ Flanged Plate.

The stern deck is completed by one half of a Hinged Flat Plate and a $5\frac{1}{2}'' \times 2\frac{1}{2}''$ Flexible Plate bolted to each of the Girders (16). A Girder Bracket is fixed to each half of the Hinged Flat Plate.

THE FORE DECK

This deck consists of a Face Plate (18) at the bows and two Flanged Sector Plates bolted together. A $4\frac{1}{2}'' \times 2\frac{1}{2}''$ Flexible Plate (19), a $3\frac{1}{2}'' \times 2\frac{1}{2}''$ Triangular Flexible Plate (20) and a $2\frac{1}{2}'' \times 1\frac{1}{2}''$ Triangular Flexible Plate (21) are fitted at each side and are connected by a $5\frac{1}{2}'' \times 2\frac{1}{2}''$ Flexible Plate (22).

Two $12\frac{1}{2}''$ Angle Girders (23) (Fig. 9.4a) are bolted underneath the Plates, which are attached to the sides of the hull by Angle Brackets. The Face Plate also is connected to the bow by Angle Brackets.

A No. 1 Clockwork Motor is bolted to the fore deck so that its winding spindle projects through the gap between the Plates. A $3\frac{1}{2}'' \times \frac{1}{2}''$ Double Angle Strip (24) is bolted to the Motor, and a Screwed Rod is fixed by two nuts in each lug of the Double Angle Strip. The ends of the Screwed Rods pass through holes in the sides of the hull and are fixed in place by further nuts.

THE BOAT DECK

Two $12\frac{1}{2}''$ Angle Girders (25) are connected to $12\frac{1}{2}''$ Strips by $1\frac{1}{2}''$ Strips and by $2\frac{1}{2}''$ Strips (26) (Fig. 9.4). A $4\frac{1}{2}'' \times 2\frac{1}{2}''$ Flat Plate is bolted between the rear ends of the Girders, and this supports a $9\frac{1}{2}''$ Angle Girder (27) on each side. The front ends of the Girders (27) are bolted to Semi-Circular Plates (28) fixed to the Girders (25). Two $2\frac{1}{2}'' \times 1\frac{1}{2}''$ Flanged Plates are attached to the Girders (27) and they support a $2\frac{1}{2}'' \times 2\frac{1}{2}''$ Flexible Plate and two $2\frac{1}{2}'' \times 2''$ Triangular Flexible Plates.

Before the boat deck is bolted in place the funnel should be attached. This consists of a Boiler pressed to an oval shape, with a $4\frac{1}{2}'' \times 2\frac{1}{2}''$ Flexible Plate bolted to its ends. A $1'' \times 1''$ Angle Bracket is fixed to the front of the funnel and a $\frac{1}{2}'' \times \frac{1}{2}''$ Angle Bracket to its rear, at the lower end. The Angle Brackets are bolted to the Flat Plate (14).

The boat deck is attached to two $1\frac{1}{2}'' \times \frac{1}{2}''$ Double Angle Strips (29) (Fig. 9.4b), which are connected by two $3\frac{1}{2}''$ Strips.

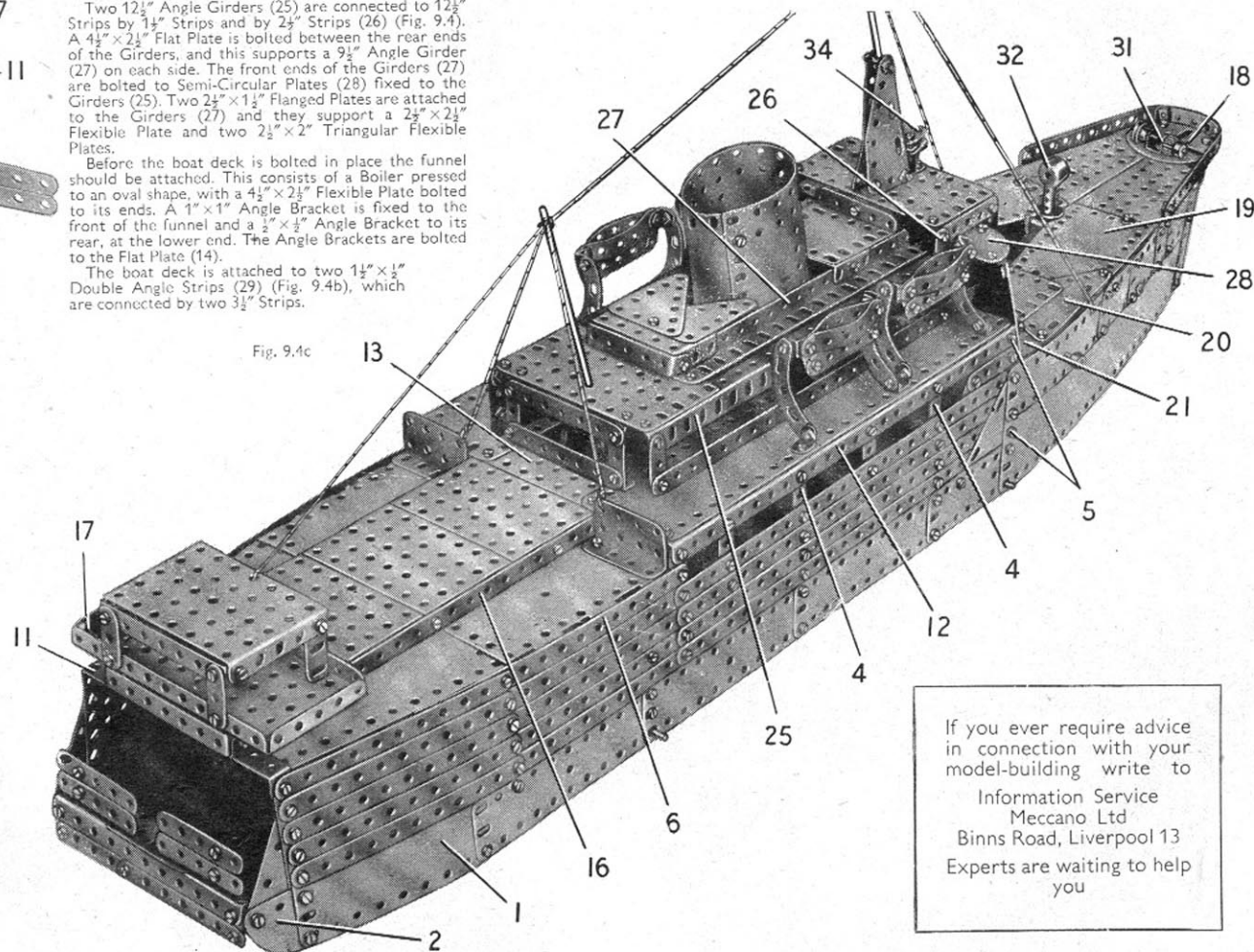

Fig. 9.4c

If you ever require advice in connection with your model-building write to
Information Service
Meccano Ltd
Binns Road, Liverpool 13
Experts are waiting to help you

9.5 COAL ELEVATOR

BASE FRAME AND TOWER

The base consists of two $12\frac{1}{2}$ " Angle Girders (1) connected by a $9\frac{1}{2}$ " Angle Girder (2) and a $12\frac{1}{2}$ " Angle Girder (3). The Girder (3) is attached by Angle Brackets, and two further $12\frac{1}{2}$ " Angle Girders are fixed at the centre of the base to Angle Brackets bolted to the Girders (1).

The main tower supports are two $12\frac{1}{2}$ " Angle Girders (4) at the front, and two $18\frac{1}{2}$ " Angle Girders (5) at the back. Each of the Girders (5) is extended upward by two $4\frac{1}{2}$ " Strips, which overlap the Girder by three holes. The Girders (4) are extended by $5\frac{1}{2}$ " Strips (6) (Fig. 9.5), and a $12\frac{1}{2}$ " Strip (7) is bolted between the top end of the Strip (6) and the Girder (5) on each side.

Each side of the tower is plated by three $12\frac{1}{2}$ " x $2\frac{1}{2}$ " Strip Plates, a $2\frac{1}{2}$ " x $2\frac{1}{2}$ " and two $5\frac{1}{2}$ " x $2\frac{1}{2}$ " Flexible Plates, as shown in Fig. 9.5g. The lower ends of the Plates are edged by a $5\frac{1}{2}$ " and a $3\frac{1}{2}$ " Strip, and a $12\frac{1}{2}$ " Strip is bolted to each corner between the Plates and the Girders (1). The corners between the legs and the tower are braced by $2\frac{1}{2}$ " x $2\frac{1}{2}$ " and $2\frac{1}{2}$ " x $2\frac{1}{2}$ " Triangular Flexible Plates.

Each side is extended at the front by a $5\frac{1}{2}$ " x $2\frac{1}{2}$ " Flexible Plate, a $2\frac{1}{2}$ " x $1\frac{1}{2}$ " Flexible Plate, a $3\frac{1}{2}$ " x $2\frac{1}{2}$ " Triangular Flexible Plate (8) and a $3\frac{1}{2}$ " x $2\frac{1}{2}$ " Flanged Plate (9). The front flanges of the Flanged Plates (9) are connected by two $5\frac{1}{2}$ " x $2\frac{1}{2}$ " Flexible Plates overlapped three holes and edged as shown in Fig. 9.5 by $2\frac{1}{2}$ " and $5\frac{1}{2}$ " Strips.

The top ends of the Girders (5) are connected by a $9\frac{1}{2}$ " Angle Girder (10). The back of the tower is filled in by two $5\frac{1}{2}$ " x $3\frac{1}{2}$ " Flat Plates (11) (Fig. 9.5), which are bolted to the Girders (4) and edged by two $5\frac{1}{2}$ " Strips.

Each side is extended upward by two $2\frac{1}{2}$ " x $1\frac{1}{2}$ " Flexible Plates edged by two $2\frac{1}{2}$ " Strips and a $2\frac{1}{2}$ " Angle Girder (12). These Girders are connected by two built-up strips, one of which consists of two $5\frac{1}{2}$ " Strips overlapped three holes, while the other is made from a $7\frac{1}{2}$ " and a $2\frac{1}{2}$ " Strip. The space between the built-up strips is filled by five $2\frac{1}{2}$ " x $2\frac{1}{2}$ " Flexible Plates. At the back two $5\frac{1}{2}$ " Braced Girders are attached to one of the built-up strips by two Angle Brackets, and are fixed also to the lugs of two $2\frac{1}{2}$ " x $1\frac{1}{2}$ " Double Angle Strips bolted across the built-up strips. A built-up strip (13) is supported by the front lugs of these Double Angle Strips and is connected by two $2\frac{1}{2}$ " Strips to another built-up strip (14). Each of the strips (13) and (14) consist of two $5\frac{1}{2}$ " Strips overlapped three holes.

Four $5\frac{1}{2}$ " x $2\frac{1}{2}$ " Flexible Plates and a $5\frac{1}{2}$ " x $1\frac{1}{2}$ " Flexible Plate are bolted together by their long sides and are supported by $5\frac{1}{2}$ " Angle Girders (15) (Fig. 9.5g). The front edges of the Plates are strengthened by two $5\frac{1}{2}$ " Strips. A cover plate (60) is made from two $5\frac{1}{2}$ " x $2\frac{1}{2}$ " Flexible Plates, four $2\frac{1}{2}$ " x $2\frac{1}{2}$ " Flexible Plates and a $2\frac{1}{2}$ " x $1\frac{1}{2}$ " Flexible Plate. These are edged by Strips as shown in Fig. 9.5, and the cover plate is attached to the top of the tower and to the Flexible Plates at the front by Obtuse Angle Brackets.

The rear part of the roof of the tower is filled in by a $2\frac{1}{2}$ " x $1\frac{1}{2}$ " and two $4\frac{1}{2}$ " x $2\frac{1}{2}$ " Flexible Plates. These are bolted to the Angle Girder (10) and to $4\frac{1}{2}$ " Strips fixed between the Girder (10) and the Girders (15).

THE COAL HOPPER

Two $5\frac{1}{2}$ " x $2\frac{1}{2}$ " Flat Plates (16) (Fig. 9.5b) are overlapped three holes and are attached to the Plates (11) by Obtuse Angle Brackets. The Plates (16) are extended by two $1\frac{1}{2}$ " radius Curved Plates, each of which is fitted with a Girder Bracket (17) (Fig. 9.5e). One of the Girder Brackets is bolted to a $3\frac{1}{2}$ " x $2\frac{1}{2}$ " Flanged Plate, which is connected to one side of the tower by an Angle Bracket and is supported also by a $5\frac{1}{2}$ " x $2\frac{1}{2}$ " Flanged Plate (18). A $5\frac{1}{2}$ " x $1\frac{1}{2}$ " Flexible Plate (19) (Fig. 9.5b), is bolted to the front flange of the Plate (18).

The loading chute is made by bolting the separated halves of a Hinged Flat Plate (20) and $5\frac{1}{2}$ " x $1\frac{1}{2}$ " Flexible Plates (21) (Fig. 9.5e), to the flanges of two Flanged Sector Plates. The gaps between the Flanged Sector Plates and the lower sections of the Flexible Plates (21) are filled in by two $3\frac{1}{2}$ " x $2\frac{1}{2}$ " and two $3\frac{1}{2}$ " x $1\frac{1}{2}$ " Triangular Flexible Plates. One of the halves of the Hinged Flat Plate is bolted to the Flexible Plate (19), and the other half is connected by Angle Brackets to the Plates (16).

The unloading trap is made by bolting together two Flat Trunnions (22) (Fig. 9.5e). An Angle Bracket is fixed to one end of the trap, and a bolt fitted with a nut is passed through the Angle Bracket and is screwed into a Coupling (23). This Coupling is fixed on a $6\frac{1}{2}$ " Rod supported in a Corner Gusset bolted to one side of the tower, and in a Double Bracket bolted to one of the Flanged Sector Plates of the chute. The Rod carries a Bell Crank (24) and a lever (25). The lever consists of a $2\frac{1}{2}$ " Rod held in a Coupling, and a Tension Spring is stretched between a bolt in one arm of the Bell Crank and another in the side of the tower (see Fig. 9.5e).

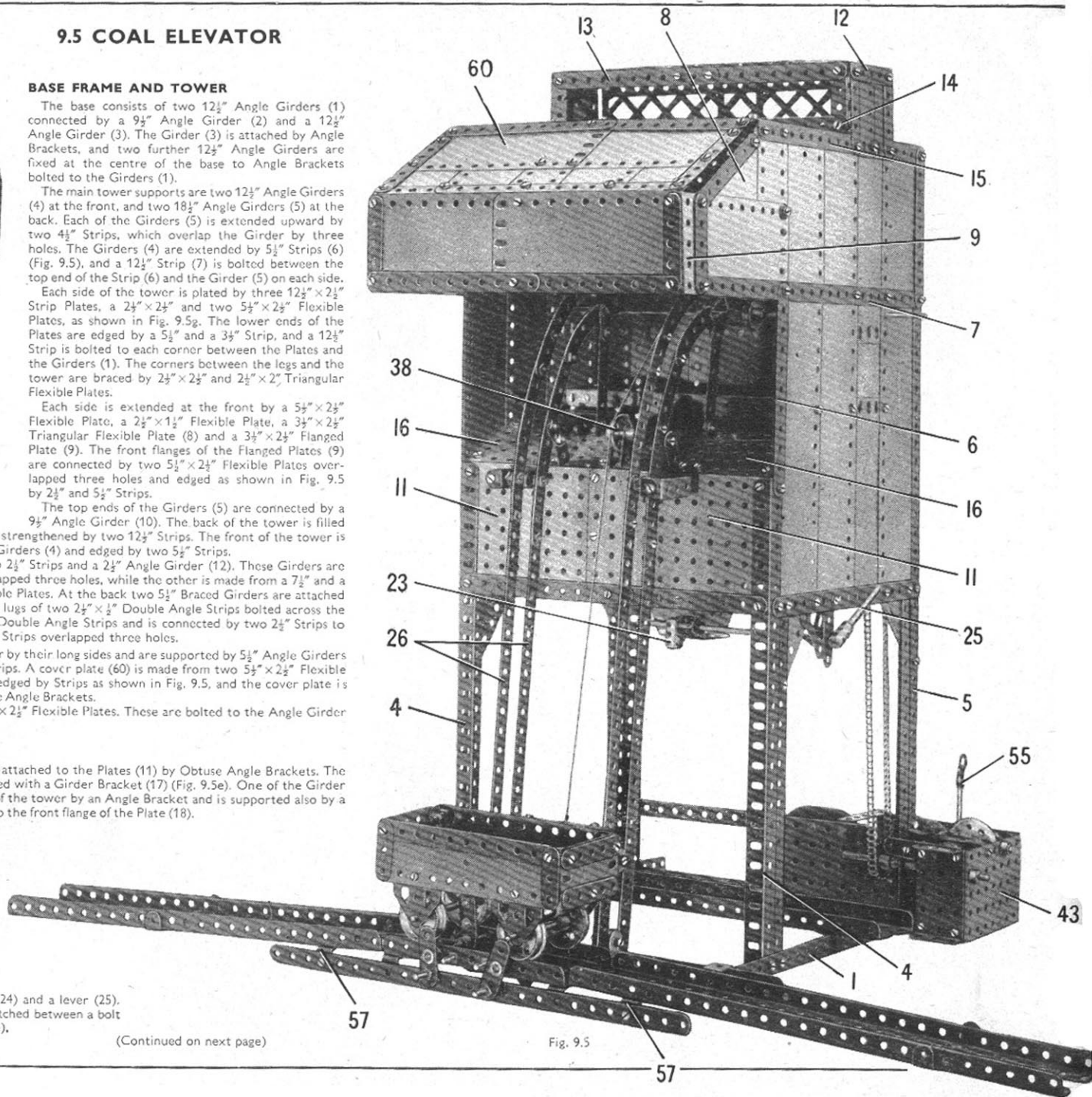

(Continued on next page)

Fig. 9.5

MODEL 9.5 COAL ELEVATOR — Continued

ELEVATOR RAILS

The rails on each side are formed by two $1\frac{1}{2}$ " Strips (26), two $5\frac{1}{2}$ " Curved Strips (27) (Fig. 9.5), a $2\frac{1}{2}$ " Curved Strip (28) and a 4" Stepped Curved Strip (29). The lower ends of the rails are spaced by a Washer on each of the bolts that fixes them to $1\frac{1}{2}$ " Angle Girders. The $1\frac{1}{2}$ " Angle Girders are bolted to the lugs of a $3\frac{1}{2}$ " x $\frac{1}{2}$ " Double Angle Strip fastened to the Girder (3). The upper ends of the rails are supported by 3" Strips (30) (Fig. 9.5b), which are attached to Angle Brackets bolted to the Flat Plates (16). The Strips (30) are connected to the Curved Strips (28) by Fishplates, the bolts holding also Double Bent Strips that are bolted to the Stepped Curved Strips (29). A $3\frac{1}{2}$ " x $\frac{1}{2}$ " Double Angle Strip (31) is fixed to $1\frac{1}{2}$ " Strips fastened to the ends of the Strips (30).

The rails on each side are connected by $1\frac{1}{2}$ " x $\frac{1}{2}$ " Double Angle Strips (32) (Fig. 9.5b), each of which is fitted with two Angle Brackets. A $\frac{1}{2}$ " Bolt is fixed in each Angle Bracket by a nut, and is then passed through a hole in the rail and held in place by two nuts.

The rails are supported also by Fishplates bolted to $1\frac{1}{2}$ " x $1\frac{1}{2}$ " Angle Brackets (33) (Fig. 9.5b).

ELEVATOR PLATFORM AND HOISTING MECHANISM

The platform rails are $5\frac{1}{2}$ " Angle Girders bolted to $2\frac{1}{2}$ " x $\frac{1}{2}$ " Double Angle Strips. Two $5\frac{1}{2}$ " Strips, placed face to face, are bolted to the rear lugs of the Double Angle Strips, and to these Strips are bolted two $\frac{1}{2}$ " Reversed Angle Brackets (34) (Fig. 9.5c), each of which is spaced by three Washers on the $\frac{3}{8}$ " Bolt that holds it in position. A $2\frac{1}{2}$ " Strip (35) is fixed to the Reversed Angle Brackets, and is connected by Angle Brackets to two $3\frac{1}{2}$ " x $\frac{1}{2}$ " Double Angle Strips joined at their upper ends by a $2\frac{1}{2}$ " Strip (36). The platform wheels are formed by a $\frac{1}{2}$ " fixed Pulley and three $\frac{1}{2}$ " loose Pulleys. Two of these Pulleys are free to turn on Pivot Bolts, and the other two are mounted on 2" Bolts. The Bolts and Pivot Bolts are each fixed by two nuts in one of the $3\frac{1}{2}$ " x $\frac{1}{2}$ " Double Angle Strips, and the Pulleys are mounted between the rails as shown in Fig. 9.5c.

The clips for securing the truck to the platform are each formed by a Fishplate fastened to a 2" Strip that is bolted to a Crank. The Crank is fixed on a $3\frac{1}{2}$ " Rod supported in the platform rails, and the control handle is a Double Arm Crank fitted with a Threaded Pin. A $2\frac{1}{2}$ " Driving Band (37) is bolted between the lower ends of the 2" Strips. When a truck is carried on the platform, the Fishplates clip over the truck axles as shown in Fig. 9.5a, and hold the truck in place.

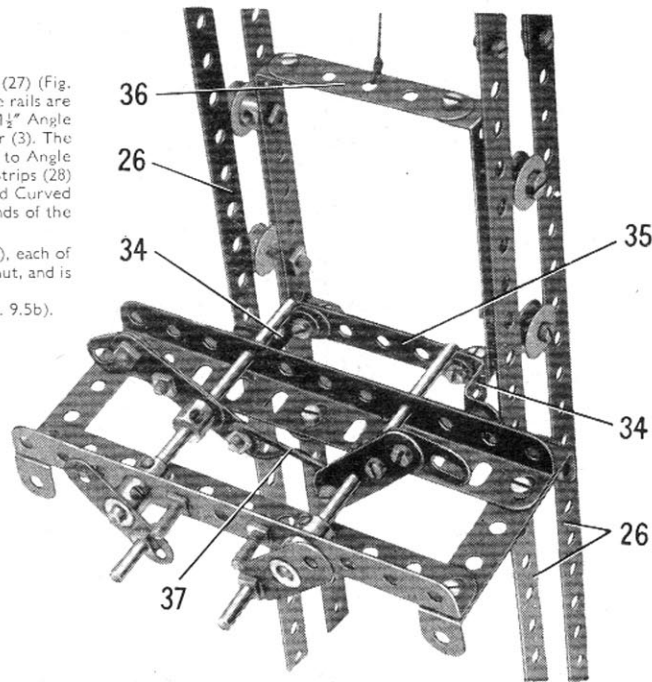

Fig. 9.5c

is attached to the Plate (43) by an Angle Bracket. The Flanged Plate (45) is connected to one of the Girders (1) by a $1\frac{1}{2}$ " x $1\frac{1}{2}$ " Angle Bracket. A $2\frac{1}{2}$ " Strip is bolted to the edge of the inner $4\frac{1}{2}$ " x $2\frac{1}{2}$ " Flat Plate, to cover the slotted holes in this part and in the Angle Girder (5).

An EO20 Electric Motor is bolted in position as shown in Fig. 9.5d, and a $\frac{1}{2}$ " Pinion on its armature shaft drives a $1\frac{1}{2}$ " Contrate on a $3\frac{1}{2}$ " Rod (46), which is held in place by a Coupling and a $\frac{1}{2}$ " Pinion. This Pinion drives a 57-tooth Gear on a $3\frac{1}{2}$ " Rod (47), and a $\frac{3}{8}$ " Pinion (48) on the same Rod engages a 50-tooth Gear on a 4" Rod (49). Rod (49) carries two $\frac{3}{8}$ " Contrates, spaced apart slightly wider than the diameter of a $\frac{1}{2}$ " Pinion (50). This Pinion is fixed on a 2" Rod that carries another $\frac{1}{2}$ " Pinion (51), and the latter drives a $1\frac{1}{2}$ " Contrate on a 2" Rod fitted with a Worm (52). The Worm is in constant mesh with a $\frac{1}{2}$ " Pinion (53) on a $4\frac{1}{2}$ " Rod (54), and a 1" Sprocket on this Rod is connected by Chain to the Sprocket (40).

By moving a lever (55) either of the $\frac{3}{8}$ " Contrates can be moved into mesh with the Pinion (50), the direction of the drive depending on which of the Contrates is engaged. The lever is a $3\frac{1}{2}$ " Rod held in an End Bearing that is lock-nutted to a Double Bent Strip (56). The $3\frac{1}{2}$ " Rod engages between two Collars on Rod (49).

THE COAL TRUCK AND THE APPROACH RAILS

The base of the truck is a $5\frac{1}{2}$ " x $2\frac{1}{2}$ " Flanged Plate, and the wheels are fixed on axles each made from two $1\frac{1}{2}$ " Rods joined by a Rod Connector. The axles are mounted in Flat Trunnions (Fig. 9.5f).

The truck ends are $2\frac{1}{2}$ " x $1\frac{1}{2}$ " Flexible Plates, and the sides are $5\frac{1}{2}$ " x $1\frac{1}{2}$ " Flexible Plates attached to the ends by Angle Brackets. The Angle Brackets of one side are lock-nutted, so that this side is pivotally attached, (see Fig. 9.5f).

Two $4\frac{1}{2}$ " x $\frac{1}{2}$ " Double Angle Strips (57) are bolted to the Angle Girder (3) and are connected by a $12\frac{1}{2}$ " Strip. The approach rails on each side are bolted to the Double Angle Strips (57) and are connected towards the ends of the rails by $2\frac{1}{2}$ " x $\frac{1}{2}$ " Double Angle Strips. Three of the rails are $12\frac{1}{2}$ " Angle Girders and the fourth consists of two 7" Angle Girders.

(Continued on next page)

Fig. 9.5b

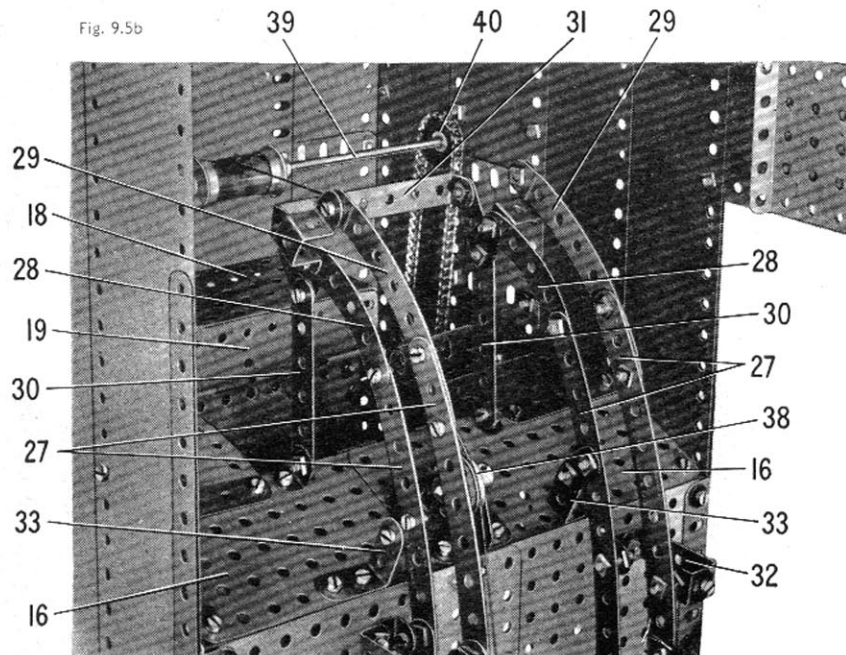

A length of Cord tied to the Strip (36) is passed over a 1" loose Pulley (38) (Fig. 9.5b), through a hole in the Double Angle Strip (31), and is fastened to a drum on an 11" Rod (39). The drum consists of a Sleeve Piece and two $\frac{3}{8}$ " Flanged Wheels, and the Pulley (38) is supported on a 1" Rod held by two Collars in Trunnions bolted to the Flat Plates (16). A 1" Sprocket (40) is fixed on Rod (39).

MOTOR AND GEARING

A $4\frac{1}{2}$ " x $2\frac{1}{2}$ " Flat Plate is bolted to the Angle Girder (2) and to one of the Angle Girders (5), and is connected to the other Girder (5) by a $5\frac{1}{2}$ " Strip. A second $4\frac{1}{2}$ " x $2\frac{1}{2}$ " Flat Plate is attached to the one already mentioned by two $2\frac{1}{2}$ " x $\frac{1}{2}$ " Double Angle Strips (41) (Fig. 9.5d), and is connected to the end of one of the Girders (1) by an Angle Bracket. A $2\frac{1}{2}$ " x $\frac{1}{2}$ " Double Angle Strip (42) is bolted to the outer Flat Plate and is connected to the leg of the tower by a Corner Angle Bracket.

A $3\frac{1}{2}$ " x $2\frac{1}{2}$ " Flanged Plate (43) is bolted to the outer Flat Plate as shown, and is connected to the leg of the tower by a $2\frac{1}{2}$ " Strip (44) and a $1\frac{1}{2}$ " x $\frac{1}{2}$ " Angle Bracket. A $2\frac{1}{2}$ " x $1\frac{1}{2}$ " Flanged Plate is bolted to the flange of Plate (43), and another $2\frac{1}{2}$ " x $1\frac{1}{2}$ " Flanged Plate (45)

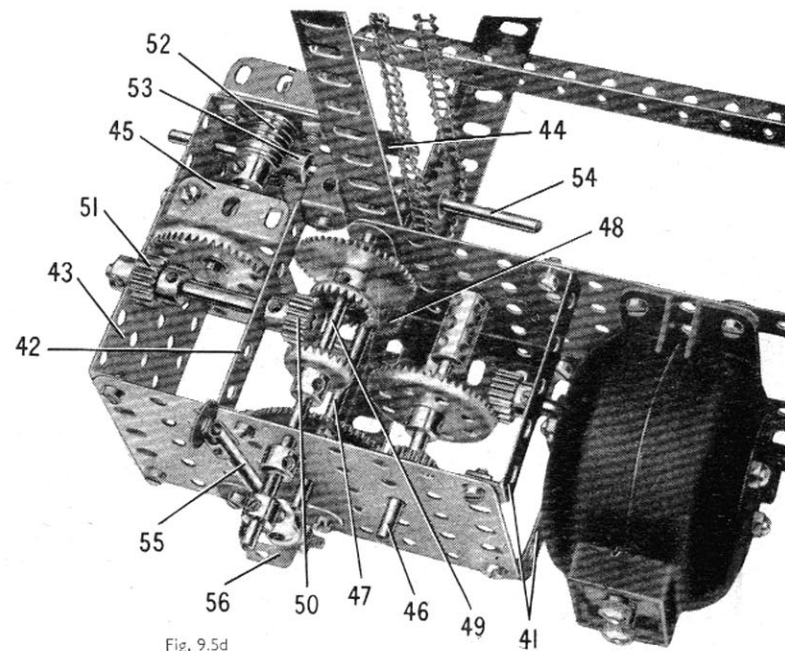

Fig. 9.5d

MODEL 9.5 COAL ELEVATOR — Continued

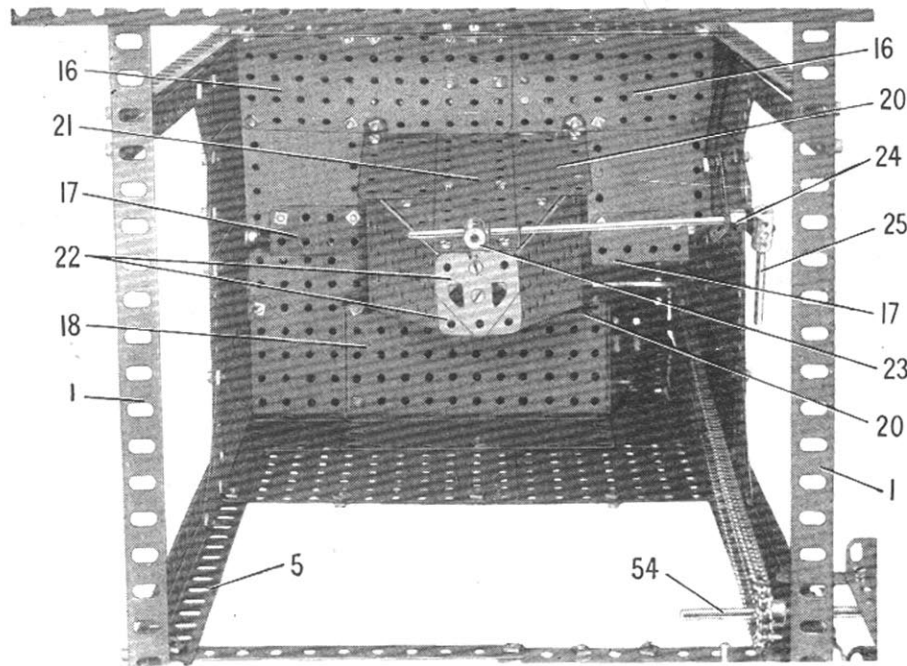

Fig. 9.5e

Parts Required

13 of No. 1	4 of No. 6a	6 of No. 10	1 of No. 15a	2 of No. 48
2 " " 1b	2 " " 7a	1 " " 11	2 " " 15b	9 " " 48a
24 " " 2	10 " " 8	35 " " 12	4 " " 16	4 " " 48b
6 " " 2a	2 " " 8a	3 " " 12a	3 " " 16a	2 " " 48c
6 " " 3	2 " " 8b	2 " " 12b	4 " " 18a	2 " " 51
2 " " 4	4 " " 9	8 " " 12c	1 " " 18b	2 " " 52
23 " " 5	2 " " 9d	1 " " 13	4 " " 20	4 " " 52a
4 " " 6	2 " " 9f	1 " " 14	2 " " 20b	4 " " 53
			1 " " 22a	2 " " 53a
			3 " " 23	2 " " 54
			1 " " 23a	10 " " 59
			1 " " 25	2 " " 62
			5 " " 26	2 " " 62b
			1 " " 27	3 " " 63
			1 " " 27a	2 " " 70
			2 " " 28	4 " " 89
			2 " " 29	2 " " 89b
			1 " " 32	2 " " 90
			349 " " 37a	1 " " 94
			318 " " 37b	2 " " 96
			39 " " 38	2 " " 100
			1 " " 40	1 " " 108
			1 " " 43	2 " " 111
			3 " " 45	6 " " 111a

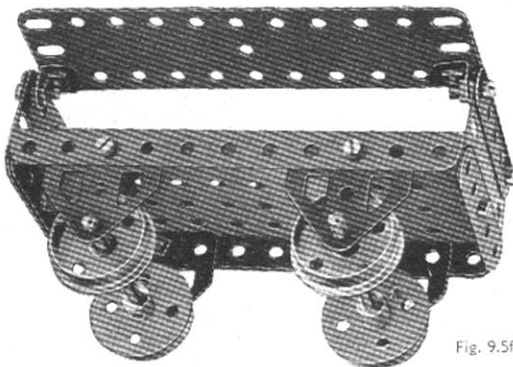

Fig. 9.5f

Parts Required — Continued

9 of No. 111c
2 " " 115
2 " " 125
2 " " 126
6 " " 126a
1 " " 128
3 " " 147b
1 " " 154a
2 " " 161
1 " " 163
1 " " 166
1 " " 176
1 " " 186
10 " " 188
7 " " 189
13 " " 190
6 " " 191
18 " " 192
6 " " 197
1 " " 198
1 " " 212
2 " " 213
2 " " 222
2 " " 223
2 " " 224
2 " " 225
2 " " 226

1 EO20
Electric Motor
(Not included in
Outfit)

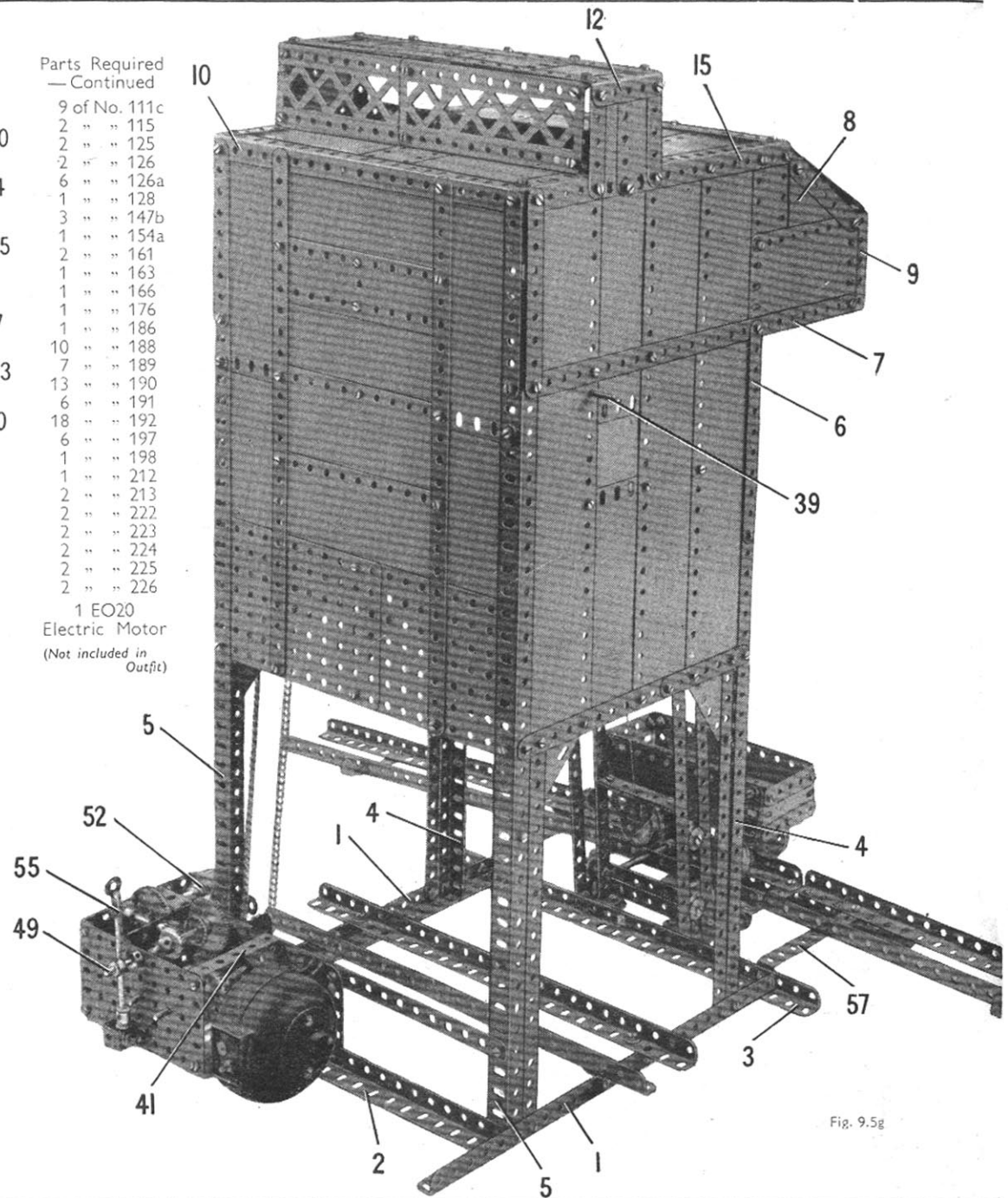

Fig. 9.5g

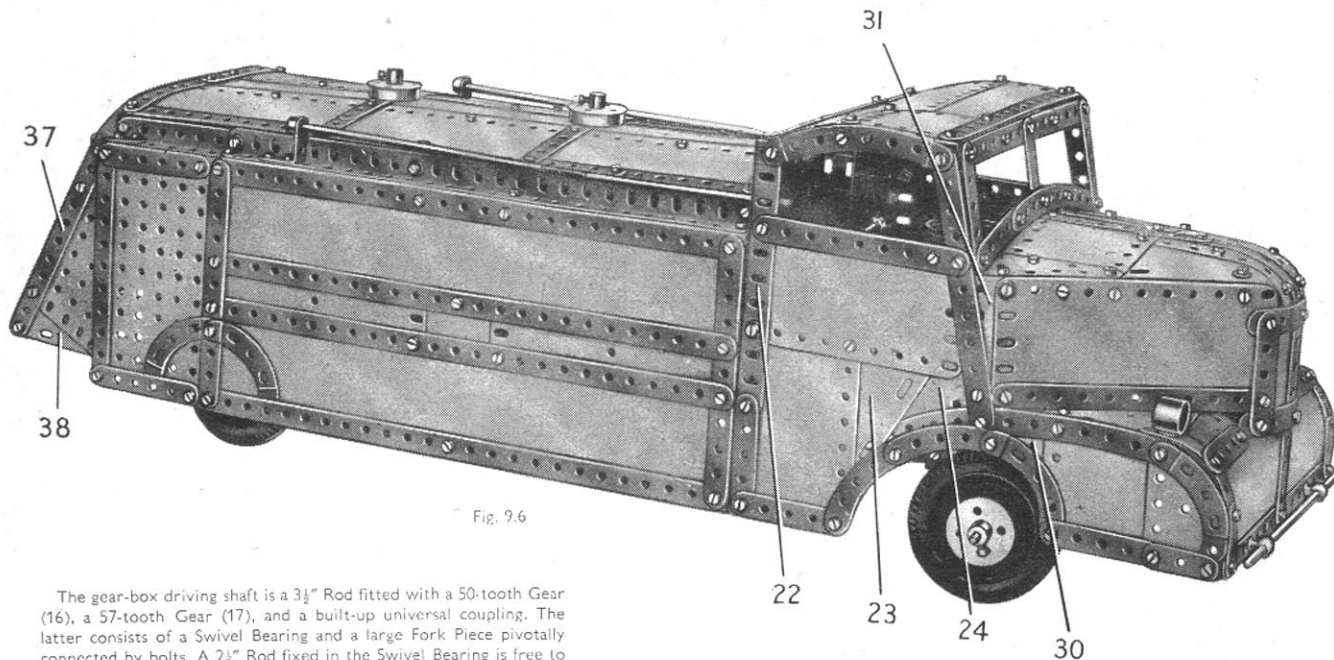

Fig. 9.6

The gear-box driving shaft is a $3\frac{1}{2}$ " Rod fitted with a 50-tooth Gear (16), a 57-tooth Gear (17), and a built-up universal coupling. The latter consists of a Swivel Bearing and a large Fork Piece pivotally connected by bolts. A $2\frac{1}{2}$ " Rod fixed in the Swivel Bearing is free to turn in the Coupling (4). A $\frac{5}{8}$ " Pinion on the $2\frac{1}{2}$ " Rod engages the Concrate on the rear axle.

A $2\frac{1}{2}$ " Rod mounted across the gear-box is fitted with a Crank (18), a Coupling (19) and a 1" Pulley. A $\frac{1}{2}$ " Bolt in the Coupling engages between the bosses of the Pinions (14) and (15). The gear-change lever is a $4\frac{1}{2}$ " Strip (20) (Fig. 9.6b), that pivots on one of two $\frac{3}{8}$ " Bolts used to connect a Channel Bearing (21) to the chassis. An Angle Bracket is *lock-nutted* to the lower end of Strip (20), and a Right-Angle Rod and Strip Connector is bolted to the Angle Bracket. An $11\frac{1}{2}$ " Rod is held in the Right-Angle Rod and Strip Connector and in an End Bearing *lock-nutted* to the Crank (18).

CONSTRUCTION OF THE CAB

A $5\frac{1}{2}$ " Angle Girder (22), extended downward by a $2\frac{1}{2}$ " Strip, is bolted to each of the plates (9). These plates are connected at their upper ends by a $5\frac{1}{2}$ " Strip. Each side of the cab consists of two $4\frac{1}{2}$ " x $2\frac{1}{2}$ " Flexible Plates, a $3\frac{1}{2}$ " x 2" Triangular Flexible Plate (23) and a $3\frac{1}{2}$ " x $1\frac{1}{2}$ " Triangular Flexible Plate (24) (Fig. 9.6). These Plates are edged by Strips and Curved Strips as shown in Figs. 9.6 and 9.6d. The roof is formed by two $5\frac{1}{2}$ " x $2\frac{1}{2}$ " and two $2\frac{1}{2}$ " x $2\frac{1}{2}$ " Flexible Plates, edged at the front by a $7\frac{1}{2}$ " Strip and at the back by a $5\frac{1}{2}$ " and a $3\frac{1}{2}$ " Strip overlapped. The roof is attached to Angle Brackets and to $2\frac{1}{2}$ " x $\frac{1}{2}$ " Double Angle Strips bolted by their lugs to the upper ends of the Girders (22).

The windscreen is made from Strips and Curved Strips as shown in Fig. 9.6e, and is attached to the sides of the cab by Angle Brackets.

A $7\frac{1}{2}$ " Angle Girder (25) (Fig. 9.6b), is connected to the sides of the cab by 1" x 1" Angle Brackets. The steering column is a $6\frac{1}{2}$ " Rod supported in the Girder (25) and in one of the chassis girders by two $\frac{3}{4}$ " Flanged Wheels. A Crank fixed to the lower end of the steering column is connected by a *lock-nutted* bolt to a $4\frac{1}{2}$ " Strip (26), which is pivoted on one of the bolts in the Fork Piece (8).

(Continued on next page)

9.6 TANK LORRY

CHASSIS AND STEERING MECHANISM

Each girder of the chassis consists of an $18\frac{1}{2}$ " and a $9\frac{1}{2}$ " Angle Girder overlapped four holes. The girders are connected by $3\frac{3}{8}$ " x $\frac{1}{2}$ " Double Angle Strips (1) and (2) (Fig. 9.6a), and a $3\frac{1}{2}$ " x $2\frac{1}{2}$ " Flanged Plate (3) is bolted to each Girder. These Flanged Plates are joined across by a further $3\frac{1}{2}$ " x $2\frac{1}{2}$ " Flanged Plate.

The rear axle is an 8" Rod supported in the Flanged Plates (3). A $1\frac{1}{2}$ " Concrate and a Coupling are fixed on the axle, with a second Coupling (4) mounted freely between them.

The front axle beam is a $4\frac{1}{2}$ " x $\frac{1}{2}$ " Double Angle Strip (5) (Fig. 9.6a), bolted to 1" x 1" Angle Brackets, which are supported by $2\frac{1}{2}$ " Triangular Plates fixed to the chassis. A 1" Rod on each side, fitted with a Coupling (6), is supported in the Double Angle Strip and in a $\frac{1}{2}$ " Reversed Angle Bracket. Two $1\frac{1}{2}$ " Rods are fixed in the Couplings (6), and one of them carries a Swivel Bearing (7) and the other a small Fork Piece (8). A 5" Rod is held in a Collar pivoted between the jaws of the Fork Piece, and in the 'spider' of the Swivel Bearing. The front wheels are mounted freely between $1\frac{1}{4}$ " Flanged Wheels and 1" Pulleys on 2" Rods, each of which is gripped in one of the Couplings (6).

DRIVING MECHANISM

The centre pin is withdrawn from a Hinged Flat Plate, and each half of the Plate is attached to the chassis by an Angle Bracket, as indicated at (9) (Fig. 9.6a). An F20R Electric Motor is supported by an Angle Bracket fixed to one of the chassis girders and by a Corner Angle Bracket bolted to one of the plates (9). A $2\frac{1}{2}$ " Rod (10) (Fig. 9.6b), is gripped in a Collar that pivots on a bolt passed through one arm of the Motor switch.

A $\frac{1}{2}$ " Pinion on the Motor shaft drives a $1\frac{1}{2}$ " Concrate on a 2" Rod (Fig. 9.6b). This Rod is supported in a $2\frac{1}{2}$ " Angle Girder bolted to the Double Angle Strip (1), and in a Double Bent Strip fixed to the Angle Girder. The Rod carries a Bush Wheel (12) (Fig. 9.6a), fitted with two Threaded Pins.

The gear-box housing (Fig. 9.6c), consists of two $2\frac{1}{2}$ " x $1\frac{1}{2}$ " Flanged Plates joined together by two $1\frac{1}{2}$ " Strips and two $1\frac{1}{2}$ " Angle Girders. The $1\frac{1}{2}$ " Angle Girders are bolted to the Double Angle Strips (2). The input shaft is a 5" Rod fitted with a Bush Wheel (13), a $\frac{3}{4}$ " Pinion (14) and a $\frac{1}{2}$ " Pinion (15). The Rod is free to slide about $\frac{1}{2}$ ", but its movement is limited by Collars. The Threaded Pins in the Bush Wheel (12) engage in holes in the Bush Wheel (13). This arrangement allows the drive to be transmitted irrespective of the sliding movement of the 5" Rod.

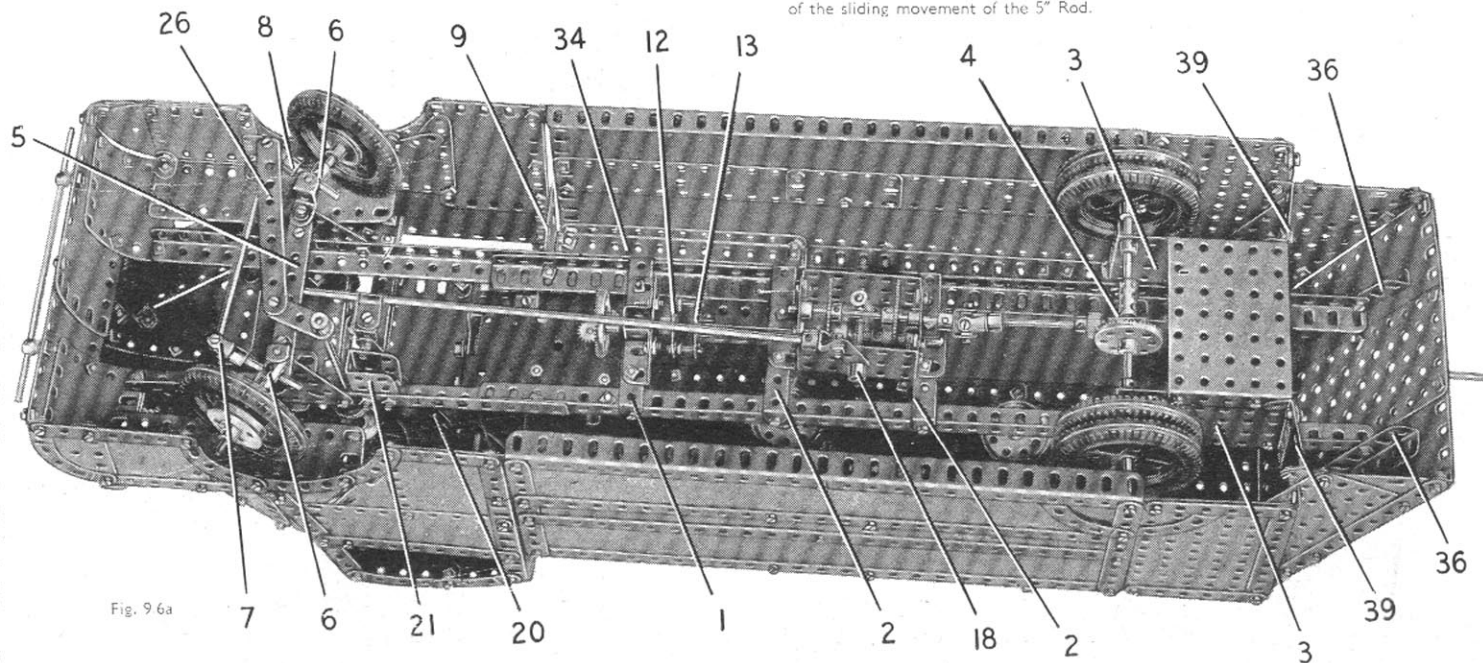

Fig. 9.6a

MODEL 9.6 TANK LORRY — Continued

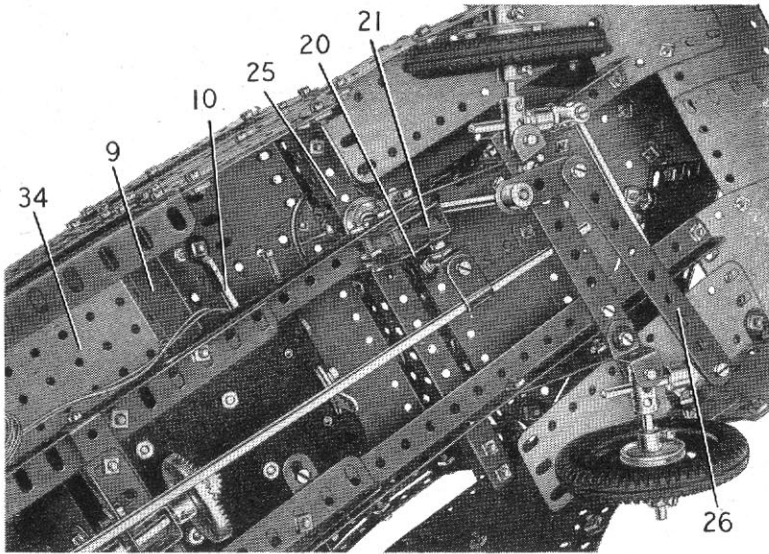

Fig. 9.6b

Parts Required

8 of No. 1	3 of No. 15
2 " " 1b	1 " " 16
24 " " 2	3 " " 16a
6 " " 2a	4 " " 17
6 " " 3	3 " " 18a
4 " " 4	2 " " 18b
23 " " 5	4 " " 20
1 " " 6	6 " " 20a
6 " " 6a	2 " " 20b
2 " " 7a	2 " " 21
6 " " 8	3 " " 22
2 " " 8a	2 " " 24
1 " " 8b	1 " " 25
4 " " 9	3 " " 26
1 " " 9d	1 " " 27
2 " " 9f	1 " " 27a
2 " " 10	2 " " 28
35 " " 12	313 " " 37a
6 " " 12a	296 " " 37b
2 " " 12b	29 " " 38
8 " " 12c	1 " " 45
2 " " 13	2 " " 48
1 " " 13a	2 " " 48a
3 " " 14	4 " " 48b

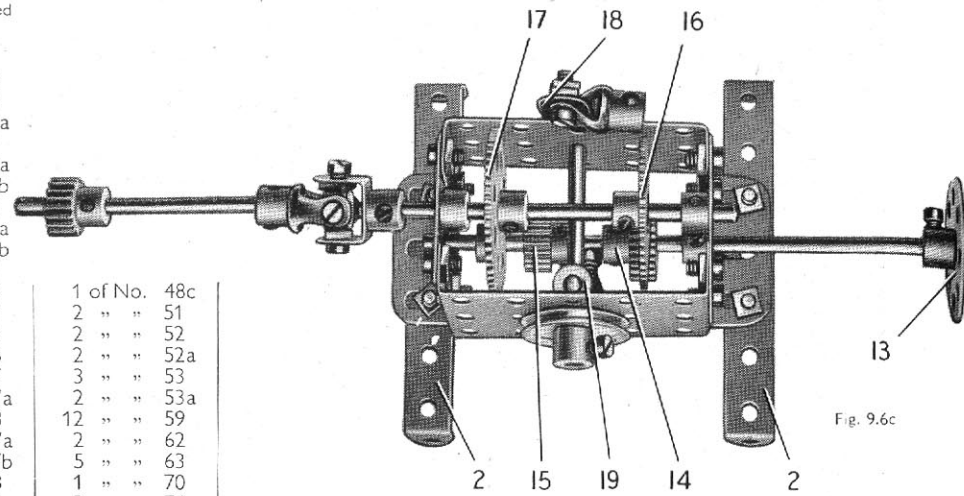

Fig. 9.6c

1 of No. 48c
2 " " 51
2 " " 52
2 " " 52a
3 " " 53
2 " " 53a
12 " " 59
2 " " 62
5 " " 63
1 " " 70
2 " " 76
4 " " 89
2 " " 89b
4 " " 90

8 of No. 90a	6 of No. 142a
3 " " 111	1 " " 154b
3 " " 111a	1 " " 160
8 " " 111c	2 " " 164
2 " " 115	2 " " 165
1 " " 116	1 " " 166
1 " " 116a	1 " " 185
2 " " 125	4 " " 188
2 " " 136	7 " " 189

2 of No. 190	4 of No. 221
6 " " 191	2 " " 222
12 " " 192	2 " " 223
6 " " 197	2 " " 224
1 " " 198	2 " " 225
1 " " 200	2 " " 226
1 " " 212	
1 " " 212a	
1 " " 213	
4 " " 214	
7 " " 215	

1 E20R
Electric Motor
(Not included in
Outfit)

THE BONNET AND FRONT WINGS

The front of the bonnet consists of two 4 1/2" x 2 1/2" Flexible Plates bolted to a 7 1/2" Strip (27) (Fig. 9.6e), and extended on each side by a 1 1/8" radius Curved Plate (28). The Curved Plates are bolted to the front ends of the chassis girders and each supports a 5 1/2" x 1 1/2" Flexible Plate (29). The side of each wing is filled in by a Semi-Circular Plate, a 2 1/2" x 2 1/2" Flexible Plate and a 2 1/2" x 1 1/2" Triangular Flexible Plate (30). These Plates are edged as shown in Figs. 9.6 and 9.6d by Strips and Curved Strips, and are supported by Angle Brackets fixed to the Flexible Plates (29) and the ends of the Strip (27).

Each side of the bonnet is a 5 1/2" x 2 3/4" Flexible Plate edged by a 5 1/2" Strip. The lower rear corner of each Plate is attached to an Obtuse Angle Bracket bolted to the side of the cab, and the top rear corner is fixed to a 2 1/2" x 2" Triangular Flexible Plate (31) (Fig. 9.6). The front ends of the Plates are connected by a 1 1/8" radius Curved Plate, and this is joined to the Strip (27) by a 4 1/2" Strip. The Curved Plate is edged by 2 1/2" Strips and Formed Slotted Strips (Fig. 9.6e).

The top of the bonnet is filled in by a 5 1/2" x 2 3/4" Flexible Plate (32), with a 2 7/8" x 1 1/2" Triangular Flexible Plate on each side, and a 5 1/2" x 1 1/2" Flexible Plate (33), with a 3 1/2" x 2 1/2" Triangular Flexible Plate on each side. The top is attached to the sides of the bonnet and to the windscreen by Angle Brackets.

CONSTRUCTION OF THE TANK

Each side consists of two 12 1/2" x 2 1/2" Strip Plates, two 5 1/2" x 1 1/2" Flexible Plates, a 2 1/2" x 1 1/2" Flexible Plate and a 5 1/2" x 3 1/2" Flat Plate. The sides are edged and strengthened by Strips and Angle Girders, as indicated in Figs. 9.6 and 9.6a. The lower front corner of each side is connected to the cab by a Fishplate, and the top front corner is bolted to one of the long flanges of a 5 1/2" x 2 1/2" Flanged Plate (34). Each of these Flanged Plates is fixed to one of the plates (9).

On each side a built-up girder (35) made from two 12 1/2" Angle Girders overlapped 19 holes, is bolted to the Flanged Plate (34), and is attached to the side at the rear by an Angle Bracket. The top of the tank is filled in along each side by a 12 1/2" x 2 1/2" Strip Plate and a 5 1/2" x 2 1/2" Flexible Plate overlapped five holes, and at the centre by three 5 1/2" x 2 1/2" Flexible Plates. The top is edged along the sides by Strips, and at each end by two 3 1/2" Strips bolted together. The bracing strips towards the centre are made from 5 1/2" and 2 1/2" Strips, and above each of them is fixed a 1 1/4" Flanged Wheel. The Rods on which the Flanged Wheels are fastened are held in place by 1 1/2" Pulleys. The top of the tank is attached to the girders (35) by Angle Brackets.

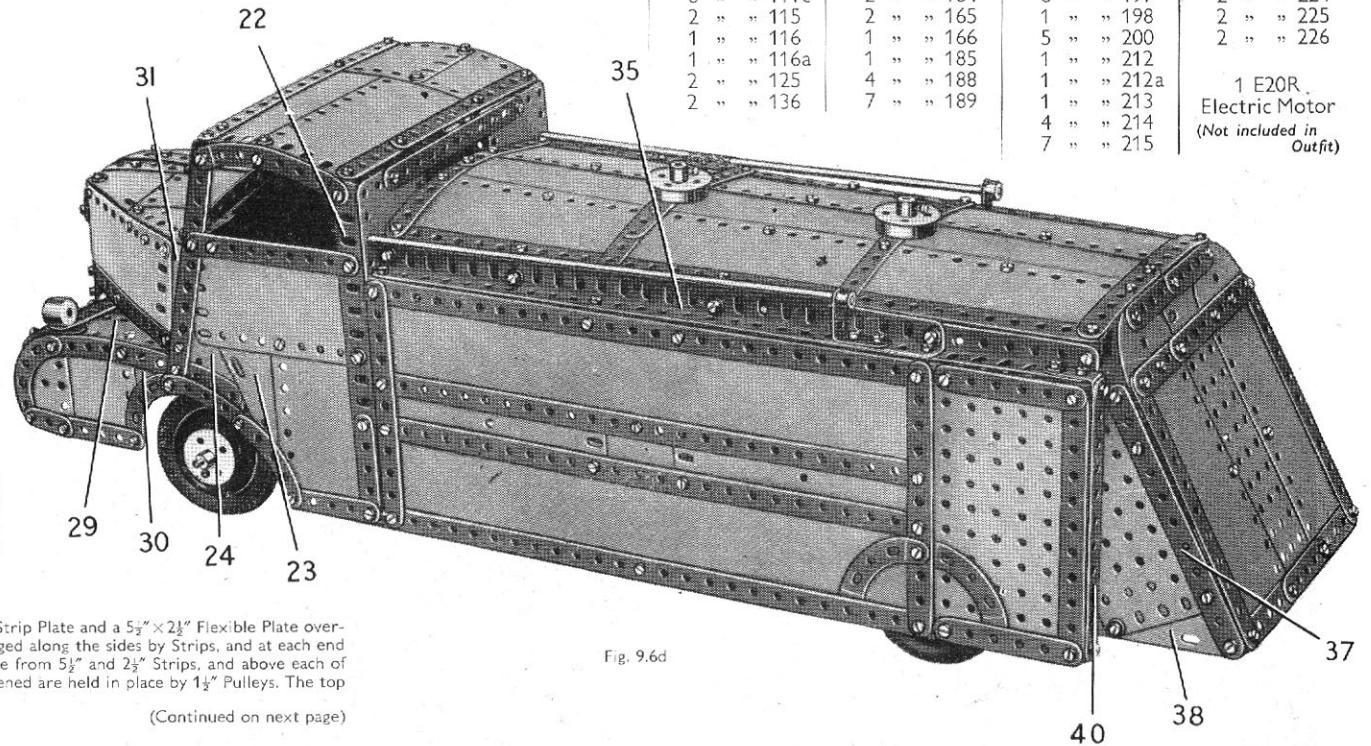

Fig. 9.6d

(Continued on next page)

MODEL 9.6 TANK LORRY — Continued

The sloping end of the tank (Fig. 9.6d) consists of a $5\frac{1}{2}'' \times 2\frac{1}{2}''$ Flat Plate in the middle and a $5\frac{1}{2}'' \times 2\frac{1}{2}''$ Flexible Plate on each side. These Plates are extended upward by two $2\frac{1}{2}'' \times 1\frac{1}{2}''$ Flexible Plates and two Semi-Circular Plates. The back is fitted on the inside with two $5\frac{1}{2}''$ Angle Girders (36), which are bolted at their upper ends to the lugs of a $3\frac{1}{2}'' \times \frac{1}{2}''$ Double Angle Strip fastened to the rear edge of the top of the tank. The Girders (36) are bolted also to the rear ends of the chassis girders (Fig. 9.6a).

A $5\frac{1}{2}''$ Strip (37) extended upward by a Formed Slotted Strip, is connected by Angle Brackets to each side of the back of the tank. A $4\frac{1}{2}'' \times 2\frac{1}{2}''$ Flat Plate and a $2\frac{1}{2}'' \times 2\frac{1}{2}''$ Triangular Flexible Plate (38), are fixed to each of the Strips (37). The front corners of the Plates (38) are bolted to the lugs of $1\frac{1}{2}'' \times \frac{1}{2}''$ Double Angle Strips (39), which are fixed to the chassis. A $5\frac{1}{2}''$ Strip (40) on each side is secured to a $1'' \times \frac{1}{2}''$ and a $\frac{1}{2}'' \times \frac{1}{2}''$ Angle Bracket.

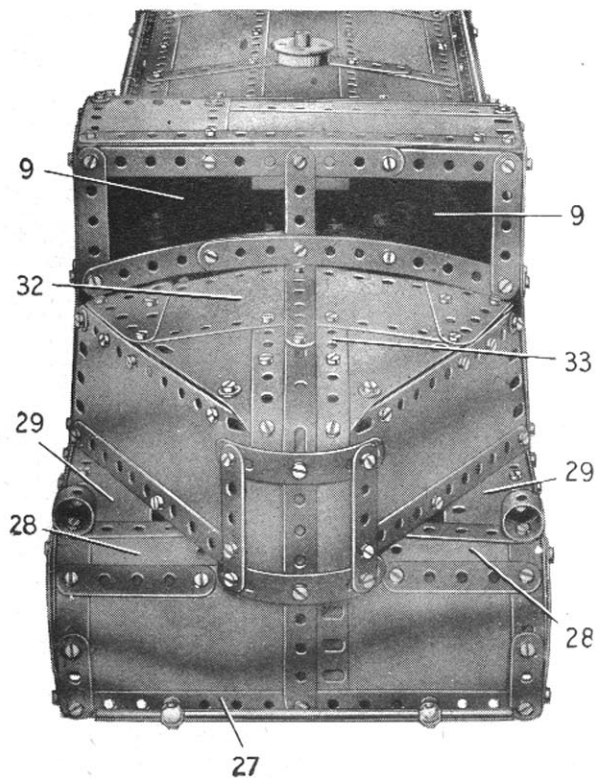

Fig. 9.6e

9.7 OBSERVATION COACH

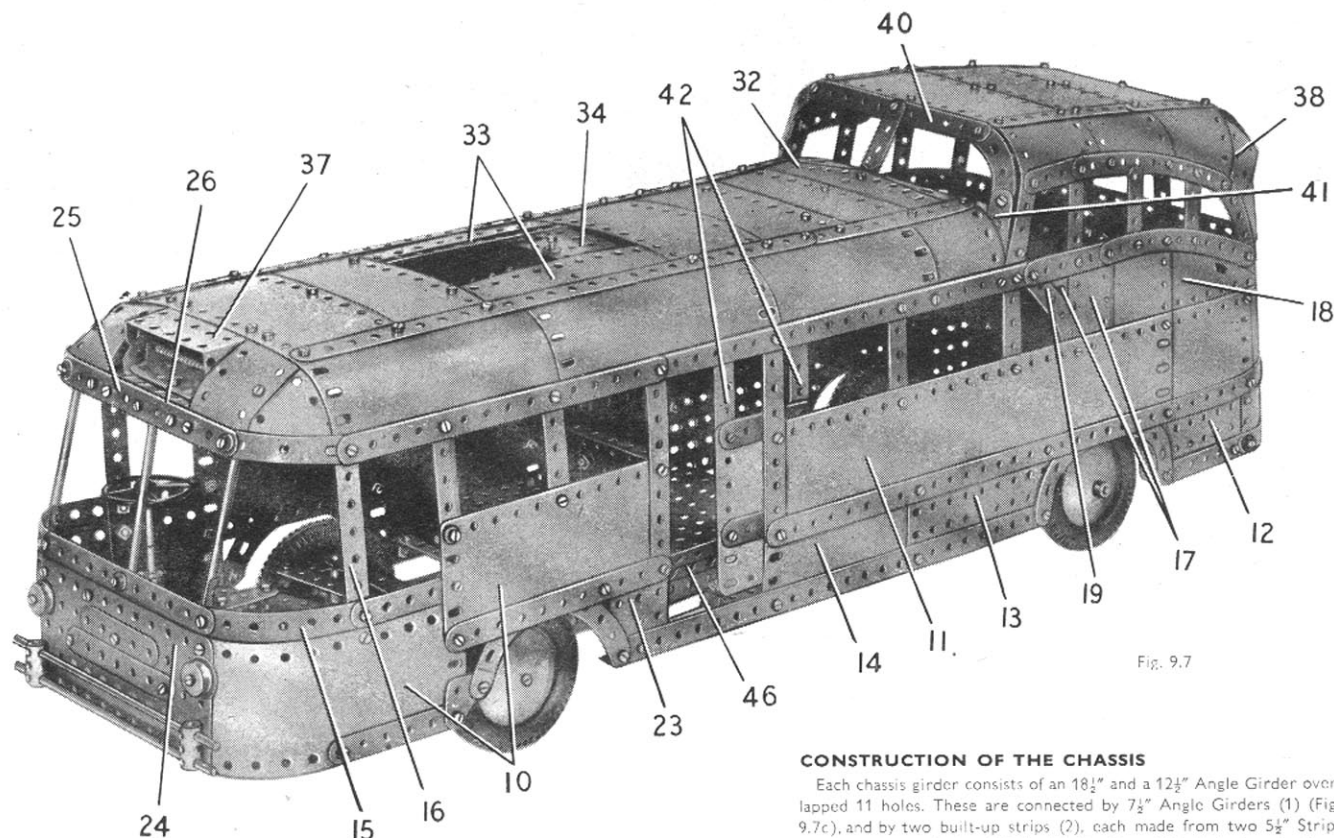

Fig. 9.7

CONSTRUCTION OF THE CHASSIS

Each chassis girder consists of an $18\frac{1}{2}''$ and a $12\frac{1}{2}''$ Angle Girder overlapped 11 holes. These are connected by $7\frac{1}{2}''$ Angle Girders (1) (Fig. 9.7c), and by two built-up strips (2), each made from two $5\frac{1}{2}''$ Strips overlapped seven holes. A $5\frac{1}{2}'' \times 2\frac{1}{2}''$ Flat Plate (3) is bolted to the front of the chassis, and a $5\frac{1}{2}'' \times 3\frac{1}{2}''$ Flat Plate (4) is fixed at the rear end.

The rear wheels are fixed on an 8" Rod that is held in position by two $1\frac{1}{8}''$ Flanged Wheels. The front axle beam is formed by two $5\frac{1}{2}''$ Strips (5) (Fig. 9.7b), bolted to the lugs of two $1''$ Reversed Angle Brackets, which are fixed to the chassis girders. The lower one of the Strips (5) is spaced from the Reversed Angle Brackets by three Washers on each bolt.

A Coupling (6) and a Crank (7) on each side are fixed on a $1\frac{1}{2}''$ Rod supported at the ends of the Strips (5). The front wheels are free to turn on $\frac{3}{4}''$ Bolts screwed into the Couplings. The Cranks (7) are connected by a $5\frac{1}{2}''$ Strip attached by *lock-nutted* bolts, and a further $5\frac{1}{2}''$ Strip (8) also is pivoted on one of these bolts. The other end of this Strip is *lock-nutted* to a $2\frac{1}{2}''$ Strip bolted across a 57-tooth Gear (9). This Gear is fixed on a $1\frac{1}{2}''$ Rod supported in the Flat Plate (3) and in an Angle Bracket bolted to one of the chassis girders, see Fig. 9.7c. The Gear is spaced from the Flat Plate by two Washers, and the Rod is held in position by a Collar placed below the Angle Bracket.

SIDES OF THE COACH

The lower part of the side seen in Fig. 9.7 consists of two $5\frac{1}{2}'' \times 2\frac{1}{2}''$ Flexible Plates (10) at the front, a $12\frac{1}{2}'' \times 2\frac{1}{2}''$ Strip Plate (11) extended six holes by a $4\frac{1}{2}'' \times 2\frac{1}{2}''$ Flexible Plate, a $3\frac{1}{2}'' \times 2\frac{1}{2}''$ Flanged Plate (12), a $4\frac{1}{2}'' \times 2\frac{1}{2}''$ Flat Plate (13), a $4\frac{1}{2}'' \times 2\frac{1}{2}''$ Flexible Plate (14) and a $2\frac{1}{2}'' \times 1\frac{1}{2}''$ Flanged Plate (23). A built-up strip (15), made from a $3\frac{1}{2}''$ and a $2\frac{1}{2}''$ Strip, is connected to one of the Plates (10) by a Fishplate and a $5\frac{1}{2}''$ Strip (16). The other Plates of the side are strengthened by Strips as shown, and the wheel arches are made from Curved Strips.

The plating of the raised section of the side consists of two $2\frac{1}{2}'' \times 1\frac{1}{2}''$ Flexible Plates (17), a $2\frac{1}{2}'' \times 2\frac{1}{2}''$ Flexible Plate and a $3\frac{1}{2}'' \times 2''$ Triangular Flexible Plate (18). These are edged at the front by a 4" Stepped Curved Strip (19), and at their upper ends by a $5\frac{1}{2}''$ Curved Strip extended by a $3\frac{1}{2}''$ Strip.

The window frames are formed by $2\frac{1}{2}''$ Strips, 3" Strips and $2\frac{1}{2}'' \times \frac{1}{2}''$ Double Angle Strips.

(Continued on next page)

MODEL 9.7 OBSERVATION COACH — Continued

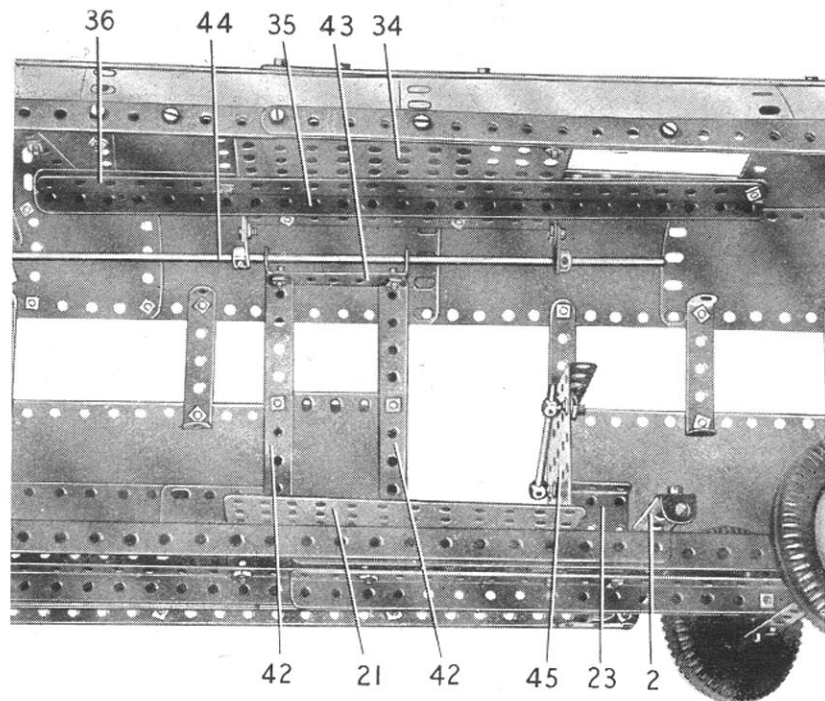

Fig. 9.7a

THE REAR PANNELLING AND LUGGAGE BOOT

Each side is extended by three $1\frac{1}{8}$ " radius Curved Plates (28), a curved $2\frac{1}{2}" \times 1\frac{1}{2}"$ Flexible Plate (29) and two Formed Slotted Strips (Fig. 9.7d). These parts are connected by four $5\frac{1}{2}"$ Strips and a $5\frac{1}{2}" \times 1\frac{1}{2}"$ Flexible Plate (30), and the rear window is completed by three $2\frac{1}{2}"$ Strips. A $5\frac{1}{2}" \times 2\frac{1}{2}"$ Flanged Plate is fixed vertically by one of its long flanges to the inner side of the Flat Plate (4) and a $5\frac{1}{2}"$ Strip (31) (Fig. 9.7c), is attached to an Angle Bracket bolted to the rear panelling. The door of the luggage boot is one half of a Hinged Flat Plate. The other half of the Hinged Flat Plate is fitted with two Angle Brackets on the hinge side, and these are bolted to the panelling. A catch on the door is provided by a $\frac{1}{2}"$ Bolt screwed into a Collar, which is fixed on another $\frac{1}{2}"$ Bolt. This Bolt is then passed through a hole in the lower edge of the door, and a fishplate is fixed tightly on the Bolt by two nuts.

ASSEMBLY OF THE ROOF

Each side of the main section of the roof consists of three curved $5\frac{1}{2}" \times 2\frac{1}{2}"$ Flexible Plates and a $1\frac{1}{8}"$ radius Curved Plate bolted to the side of the body. These are joined across as shown in Figs. 9.7 and 9.7d by five $5\frac{1}{2}" \times 2\frac{1}{2}"$ Flexible Plates and a $5\frac{1}{2}" \times 1\frac{1}{2}"$ Flexible Plate (32), arranged to leave a gap for the sliding section of the roof. The sides of this gap are edged by $5\frac{1}{2}" \times 1\frac{1}{2}"$ Flexible Plates (33). Two $3\frac{1}{2}" \times 1\frac{1}{2}"$ Triangular Flexible Plates are bolted to the rear edge of Plate (32). Each corner at the front of the roof is filled in by a $2\frac{1}{2}" \times 1\frac{1}{2}"$ Flexible Plate and a $2\frac{1}{2}" \times 2"$ Triangular Flexible Plate.

The opening section of the roof is a $5\frac{1}{2}" \times 3\frac{1}{2}"$ Flat Plate (34) that slides freely between a $12\frac{1}{2}"$ Angle Girder (35) and a $12\frac{1}{2}"$ Strip (36) on each side. The Strip and the Angle Girder are separated by a Washer on each of the bolts that attaches them to the roof.

The destination indicator at the front is made by bolting a $2\frac{1}{2}" \times 1\frac{1}{2}"$ Flanged Plate (37) to the front of the roof. A Trunnion is attached to each flange of the Flanged Plate by nuts on a $3"$ Screwed Rod, which is passed through the flanges. A second Screwed Rod is held in the Trunnions by nuts, and a $2\frac{1}{2}" \times 1\frac{1}{2}"$ Flexible Plate is bolted to the flanges of the Trunnions to form the base of the indicator. Two $2\frac{1}{2}"$ Strips are attached to a lug of a $1" \times 1"$ Angle Bracket bolted to the Flexible Plate, and these Strips fill in the back of the indicator.

The raised section of the roof at the rear of the coach consists of three curved $2\frac{1}{2}" \times 2\frac{1}{2}"$ Flexible Plates and a curved $2\frac{1}{2}" \times 1\frac{1}{2}"$ Triangular Flexible Plate (38) on each side. These Plates are joined across by four $5\frac{1}{2}" \times 2\frac{1}{2}"$ Flexible Plates, which are connected together by a $5\frac{1}{2}"$ Strip (39) (Fig. 9.7c). The rear $5\frac{1}{2}" \times 2\frac{1}{2}"$ Flexible Plate is curved as shown in Fig. 9.7d, and bolted to the rear panelling. The joints between the side and centre Plates of the roof are covered by Strips and Formed Slotted Strips as indicated in Figs. 9.7 and 9.7d.

The side seen in Fig. 9.7d is generally similar to the side already described, except that the Strip Plate (11) extended by a $4\frac{1}{2}" \times 2\frac{1}{2}"$ Flexible Plate, and one of the Flexible Plates (10), are replaced by two $12\frac{1}{2}" \times 2\frac{1}{2}"$ Strip Plates that cover the complete length of the side. A $4\frac{1}{2}" \times 2\frac{1}{2}"$ Flexible Plate (20) is bolted to this side in addition to a similar Flexible Plate that corresponds to the Plate (13) of the other side.

The sides are connected by Angle Brackets to the ends of the Girders (1) and the strips (2) (Fig. 9.7c). Two $5\frac{1}{2}" \times 3\frac{1}{2}"$ Flat Plates (21) are bolted together and are attached to Double Brackets fixed to one of the chassis girders. A Girder Bracket (22) connects the Plates to one side of the body.

DETAILS OF THE FRONT OF THE COACH

The front $5\frac{1}{2}" \times 2\frac{1}{2}"$ Flexible Plates of the sides are curved and are bolted to the ends of a $5\frac{1}{2}" \times 2\frac{1}{2}"$ Flat Plate (24), and the strips (15) are connected by a $5\frac{1}{2}"$ Strip. At the top a Formed Slotted Strip is bolted to each side, and these are joined by a $5\frac{1}{2}"$ Strip (25). A $2\frac{1}{2}"$ Angle Girder (26) is bolted to the Strip (25).

The side windscreen divisions are $3\frac{1}{2}"$ Rods held at their lower ends in Rod and Strip Connectors, and fixed at the top in Collars screwed on to bolts passed through the Strip (25). The centre division is a $3\frac{1}{2}"$ Rod fixed at each end in a Collar.

The steering column is a $3\frac{1}{2}"$ Rod supported in the front Angle Girder (1) and in a $2"$ Strip (27) bolted to a Girder Bracket that is fixed to the front of the coach (Fig. 9.7c). A $\frac{1}{2}"$ Pinion on the steering column engages the Gear (9).

The Couplings that support the front bumper are screwed on to bolts, each of which is fitted with two Washers before it is passed through the Plate 24.

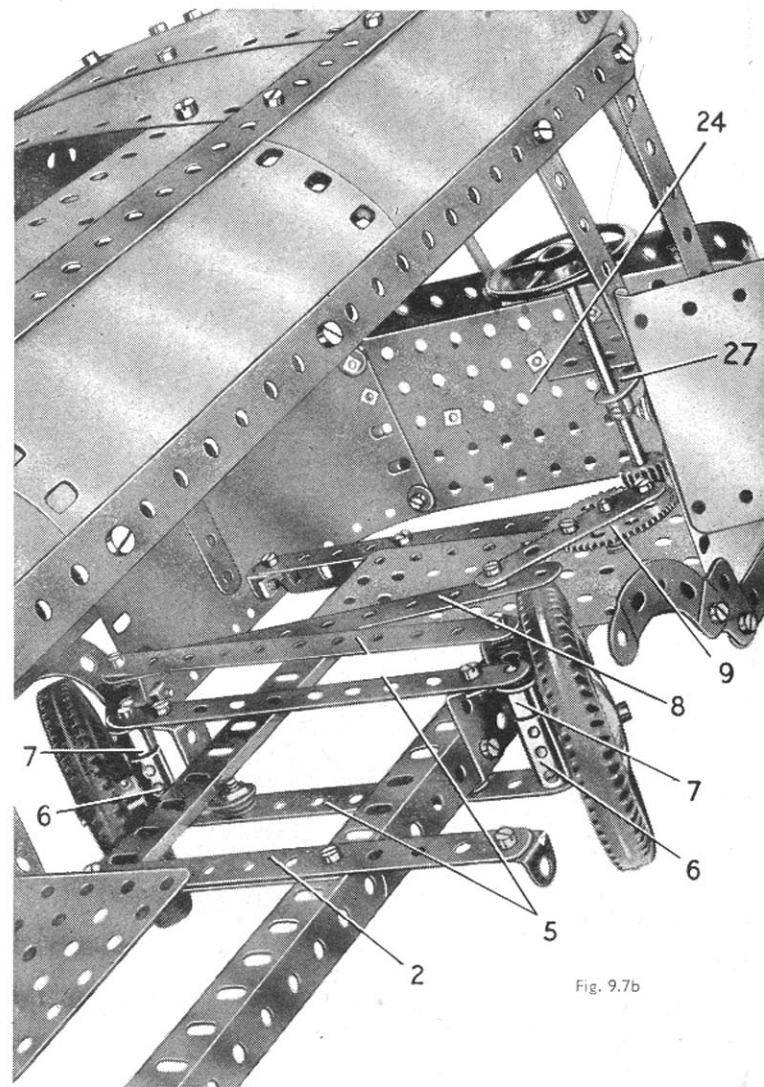

Fig. 9.7b

(Continued on next page)

MODEL 9.7 OBSERVATION COACH — Continued

The window frame at the front of the raised section of the roof consists of a $5\frac{1}{2}$ " Strip and two Stepped Curved Strips. A $1\frac{1}{2}$ " Strip (41) is bolted to each Curved Strip. The frame is attached to the upper and lower sections of the roof by Obtuse Angle Brackets and the Strips (41) are connected to the side window frames by further Obtuse Angle Brackets.

THE SLIDING DOOR

The door consists of two $2\frac{1}{2}$ " x $2\frac{1}{2}$ " Flexible Plates overlapped three holes and bolted to $5\frac{1}{2}$ " x $\frac{1}{2}$ " Double Angle Strips (42) (Fig. 9.7a). These Double Angle Strips are connected at each end by $2\frac{1}{2}$ " x $\frac{1}{2}$ " Double Angle Strips, one of which is indicated at (43). A $2\frac{1}{2}$ " Strip is attached to the lower of the Double Angle Strips (43) by a Fishplate. The lugs of the Double Angle Strips (43) slide freely on $11\frac{1}{2}$ " Rods (44) (Figs. 9.7a and 9.7c). The upper one of these Rods is held by Collars in two Fishplates, which are bolted to the lugs of a $5\frac{1}{2}$ " x $\frac{1}{2}$ " Double Angle Strip fixed underneath the roof. The lower Rod (44) is supported in Corner Angle Brackets bolted to the Strips (2). A $3\frac{1}{2}$ " x $2\frac{1}{2}$ " Flanged Plate (45) is attached to the side of the body by two Angle Brackets, and is connected to one of the Strips (2) by a Fishplate. A $2\frac{1}{2}$ " Rod is gripped in two Handrail Supports fixed to the Flanged Plate (45).

A folding step is made by connecting a $2\frac{1}{2}$ " Strip to a $2\frac{1}{2}$ " Angle Girder (46) by means of two Fishplates (Fig. 9.7c). An Angle Bracket is bolted to each end of the Angle Girder (46), and one of them is *lock-nutted* to the Flanged Plate (45). The other Angle Bracket is *lock-nutted* to the short lug of a $1\frac{1}{2}$ " x $\frac{1}{2}$ " Angle Bracket (47), which is spaced from one of the Plates (21) by two Washers on a $\frac{3}{8}$ " Bolt.

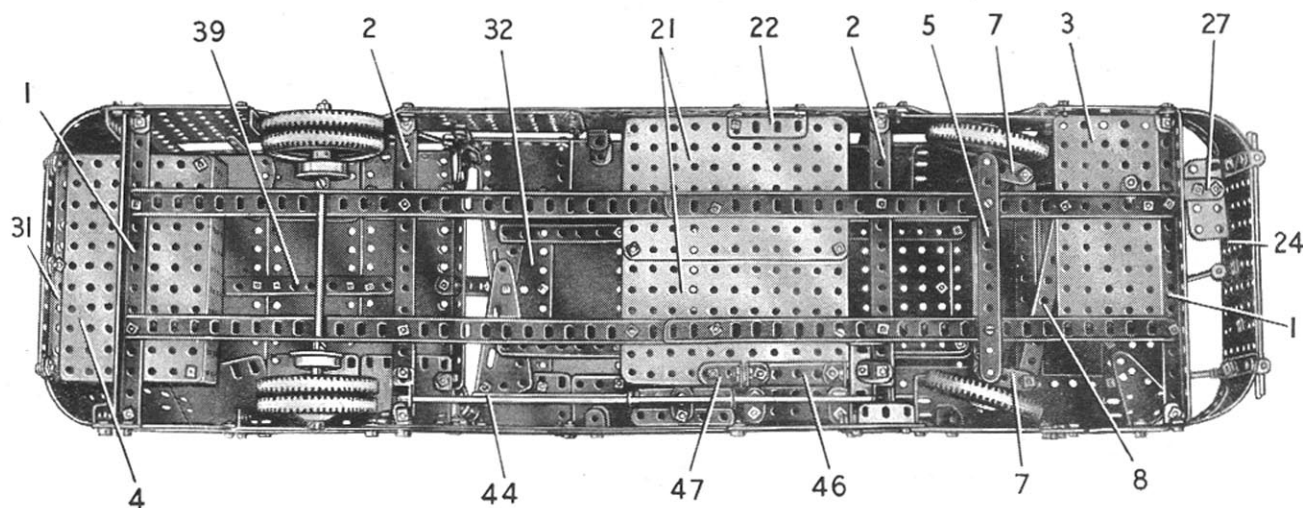

Fig. 9.7c

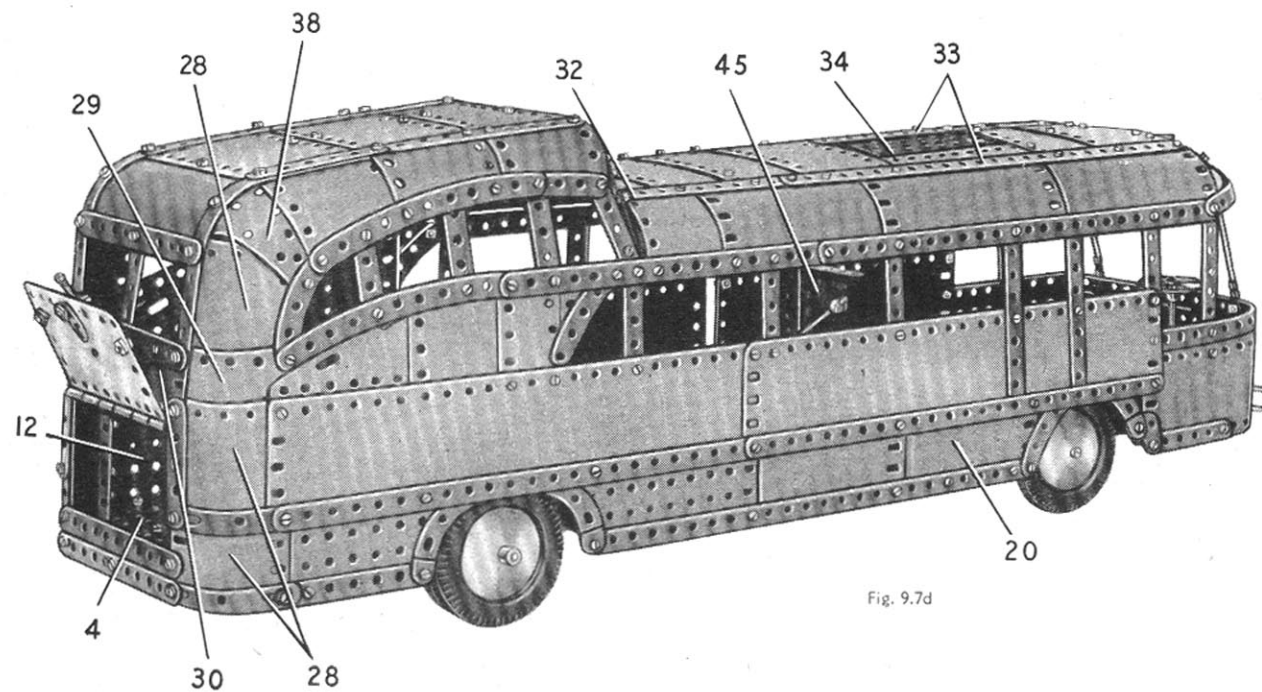

Fig. 9.7d

Parts Required

12 of No. 1	6 of No. 20a	3 of No. 111a
1 " " 1b	1 " " 23	11 " " 111c
24 " " 2	1 " " 26	2 " " 124
6 " " 2a	1 " " 27a	2 " " 126
5 " " 3	2 " " 35	2 " " 133a
6 " " 4	294 " " 37a	2 " " 136
28 " " 5	271 " " 37b	6 " " 142a
3 " " 6	39 " " 38	1 " " 154a
3 " " 6a	2 " " 38d	1 " " 154b
2 " " 7a	5 " " 48a	2 " " 161
4 " " 8	3 " " 48d	1 " " 185
2 " " 8b	2 " " 51	4 " " 187a
2 " " 9d	1 " " 52	9 " " 188
9 " " 10	4 " " 52a	4 " " 189
2 " " 11	3 " " 53	10 " " 190
15 " " 12	2 " " 53a	4 " " 191
1 " " 12a	1 " " 55a	18 " " 192
1 " " 12b	11 " " 59	3 " " 197
6 " " 12c	2 " " 62	1 " " 198
2 " " 13	4 " " 63	8 " " 200
1 " " 13a	2 " " 70	2 " " 212
2 " " 14	2 " " 80c	8 " " 215
4 " " 16	4 " " 89	2 " " 221
1 " " 16a	2 " " 89b	2 " " 222
3 " " 18a	4 " " 90	2 " " 224
2 " " 20	8 " " 90a	2 " " 225
	2 " " 111	

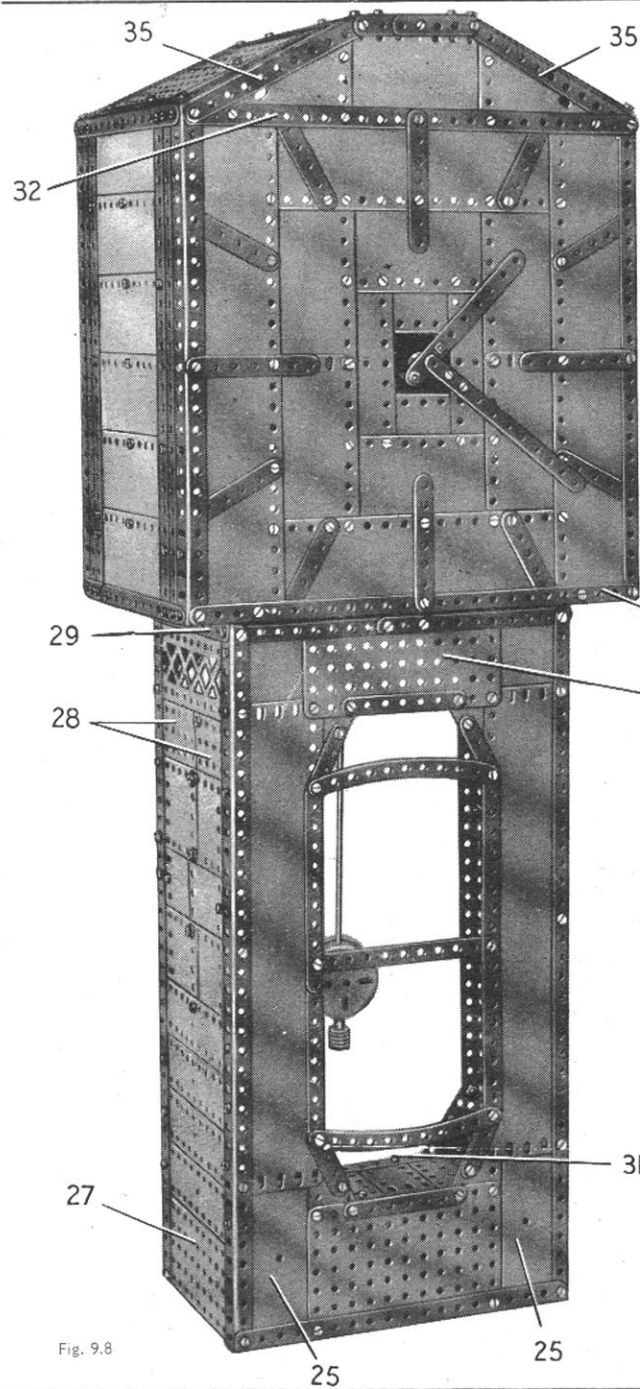

Fig. 9.8

9.8 CLOCK

Parts Required

14 of No. 1	2 of No. 8a	1 of No. 16a	3 of No. 48a	2 of No. 63	3 of No. 111	4 of No. 221
2 " " 1b	2 " " 8b	1 " " 17	3 " " 48b	2 " " 70	6 " " 111a	2 " " 222
24 " " 2	4 " " 9	1 " " 25	2 " " 48c	2 " " 89	12 " " 111c	2 " " 223
6 " " 2a	2 " " 9d	5 " " 26	2 " " 48d	1 " " 90	1 " " 137	2 " " 225
6 " " 3	12 " " 10	1 " " 27	2 " " 51	1 " " 94	1 " " 162	2 " " 226
5 " " 4	7 " " 12	2 " " 27a	2 " " 52	2 " " 95	9 " " 188	
23 " " 5	8 " " 12c	2 " " 28	4 " " 52a	1 " " 95b	10 " " 189	1 No. 1 Clockwork Motor
4 " " 6	2 " " 13	2 " " 32	5 " " 53	2 " " 96	14 " " 190	(Not included in Outfit)
1 " " 6a	3 " " 15	344 " " 37a	2 " " 53a	1 " " 96a	6 " " 191	
2 " " 7a	2 " " 15a	320 " " 37b	2 " " 54	2 " " 100	14 " " 192	
10 " " 8	2 " " 15b	36 " " 38	9 " " 59	2 " " 108	6 " " 197	
		2 " " 45	2 " " 62	1 " " 109	1 " " 198	

THE MECHANISM FRAME

Two 12½" Angle Girders (1) and (2) (Figs. 9.8a and 9.8b), are bolted to one side-plate of a No. 1 Clockwork Motor as shown, and a 5½" Angle Girder is fixed to the Girder (2). A 5½" × 2½" Flat Plate (3) is attached to the 5½" Angle Girder, and is connected to a 5½" × 3½" Flat Plate (4) by two 3½" × 1½" Double Angle Strips (5) and (6) (Fig. 9.8a). A 5½" Angle Girder bolted along the lower edge of the Plate (4) is connected to the Clockwork Motor by a 2½" × ½" Double Angle Strip (7) (Fig. 9.8b).

A 4½" Strip (8) overlaps the Plate (3) by two holes, and a 5½" Strip (9) overlaps Plate (4) by three holes. These Strips are connected by a 3½" × ½" Double Angle Strip as shown in Fig. 9.8a. A 12½" Angle Girder (10) is supported by two 5½" Strips, each of which overlaps the Plate (4) by five holes.

THE GEAR TRAINS

A ½" Pinion on the Motor shaft drives a 1½" Contrate (11) on a vertical 4½" Rod, which is held by a Collar and a ½" Pinion (12) in the Double Angle Strips (7) and (6). The Pinion (12) engages a 57-tooth Gear on a 2½" Rod supported in the Double Angle Strips (5) and (6). This Rod carries a Worm (13) and a 1½" Contrate (14), which is spaced from Double Angle Strip (5) by a Washer.

The Worm (13) drives a 57-tooth Gear on a 5" Rod (15), which is held in Plates (3) and (4) by a Collar and a ¾" Pinion (16). Pinion (16) engages a 50-tooth Gear on a 4" Rod that carries also a 1" Sprocket (17), and this is connected by Chain to a 2" Sprocket (18) on a 4½" Rod. A ½" Pinion on the same Rod drives another ½" Pinion on a 2" Rod (19) (Fig. 9.8a). Rod (19) is supported in the Flat Plate (3) and in a Double Bent Strip bolted to the Plate, and it carries outside the Plate a 1" Sprocket (20). The 1" Sprocket is connected by Chain to a 3" Sprocket, which is free to turn on Rod (15) but is spaced from the Plate (3) by a Collar. The hour hand is a 4½" Strip and is fixed by two nuts on each of two ¾" Bolts. These Bolts are passed through holes in the 3" Sprocket and are held in place by nuts. The minute hand is a 5½" Strip, which is bolted to a Crank fixed on the end of Rod (15). It is important to make sure that the shafts carrying the gears is able to turn freely in their bearings.

A 4" Rod is supported in the Plate (4) and in a 2½" Strip (21) bolted to Plate (3). The Rod is held in place by a Collar and a 2" Sprocket (22), and a ½" Pinion on the Rod is driven by the Contrate (14). The Sprocket (22) is connected by Chain to a ¾" Sprocket on a 5" Rod (23) (Fig. 9.8b).

CRUTCH, PALLET AND PENDULUM

The crutch (Fig. 9.8c), is a 2½" Curved Strip, to each end of which an Angle Bracket is bolted. The Curved Strip is attached to a Crank (24), which is fixed on a 5" Rod supported in the Strips (8) and (9).

A Face Plate is used as the pallet wheel and to it eight Fishplates are bolted firmly at a slight angle, as shown in Fig. 9.8c.

The pendulum consists of two 11½" Rods joined by a Coupling. The bob weight is made from a Boiler End and a Wheel Flange. One of the 11½" Rods is passed through holes in the rim of the Boiler End and is fixed in a Collar. This Collar is screwed on to a bolt passed through the centre portion of a Double Bent Strip, which is bolted to the Wheel Flange. A Worm is fixed to the lower end of the 11½" Rod. The pendulum is gripped in a Coupling fixed on the same Rod as the Crank (24).

ADJUSTMENT OF THE MECHANISM

After the clock is completed it will be necessary to adjust the angles of the Angle Brackets on the crutch, and the positions of the Fishplates of the pallet wheel, until the clock ticks evenly. It may take some little time to adjust the relative positions correctly, but once these have been set the clock will be found to work quite satisfactorily, and by careful adjustment of the position of the bob weight on the pendulum rod, the accuracy of its time-keeping can be regulated very closely.

(Continued on next page)

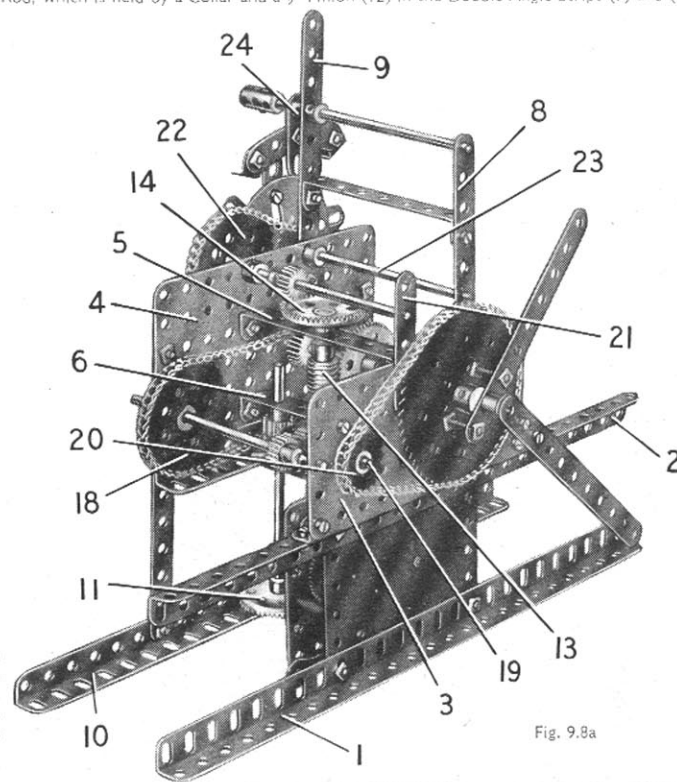

Fig. 9.8a

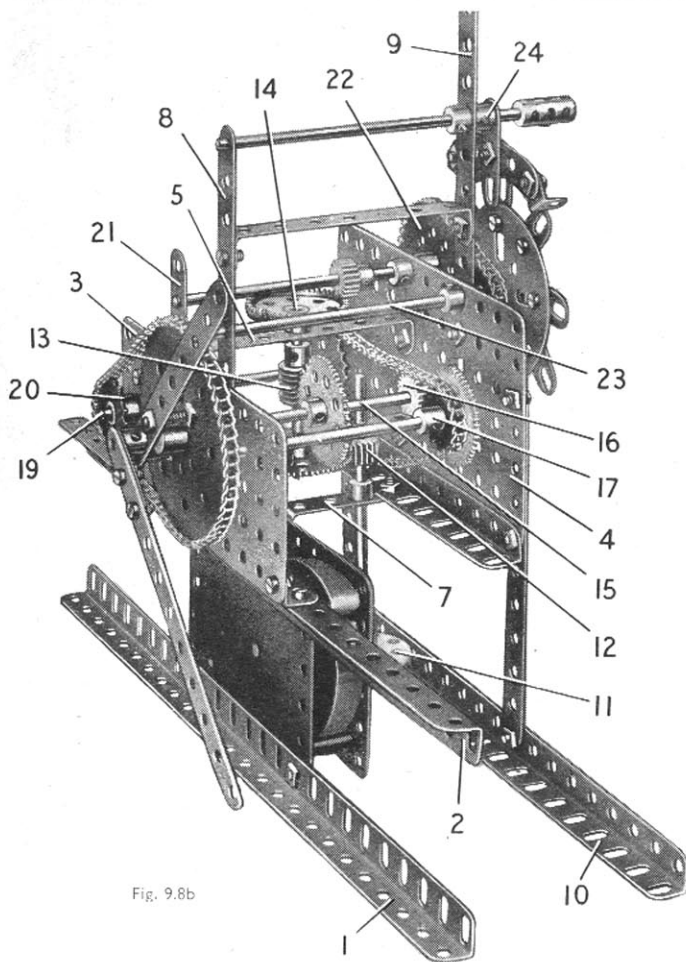

Fig. 9.8b

The outer edges of the clock face are filled in by four $12\frac{1}{2} \times 2\frac{1}{2}$ Strip Plates. To these are bolted four $4\frac{1}{2} \times 2\frac{1}{2}$ and two $5\frac{1}{2} \times 2\frac{1}{2}$ Flexible Plates, and the centre of the face is completed by two $5\frac{1}{2} \times 1\frac{1}{2}$ and two $2\frac{1}{2} \times 1\frac{1}{2}$ Flexible Plates. The hour markings are Strips arranged as shown.

Each side of the top is filled in by a $5\frac{1}{2} \times 3\frac{1}{2}$ Flat Plate and two $5\frac{1}{2} \times 2\frac{1}{2}$ Flexible Plates edged by four $5\frac{1}{2}$ and two $2\frac{1}{2}$ Strips. This assembly is attached to the side by two Obtuse Angle Brackets, and is connected by Angle Brackets to $5\frac{1}{2}$ Strips (35) at the front and rear. The inner ends of each pair of Strips (35) are connected by two $2\frac{1}{2}$ Strips overlapped three holes. At the front the space between these Strips and the clock face is filled in by a $3\frac{1}{2} \times 2\frac{1}{2}$ Triangular Flexible Plate on each side and a $4\frac{1}{2} \times 2\frac{1}{2}$ Flexible Plate at the centre. The central part of the top is completed by two $4\frac{1}{2} \times 2\frac{1}{2}$ Flat Plates overlapped three holes. These are attached to the sides of the top by Fishplates.

The completed housing is bolted to the lugs of a $4\frac{1}{2} \times \frac{1}{2}$ Double Angle Strip (36) and a $2\frac{1}{2} \times \frac{1}{2}$ Double Angle Strip (37) on each side. These parts are fixed to the Angle Girders (29).

The clock mechanism is located in the casing by bolting the ends of the Angle Girders (1) and (10) to the $7\frac{1}{2}$ Angle Girders (34).

MODEL 9.8 CLOCK — Continued

THE BASE OF THE CASING

The front of the lower part of the case consists of two $18\frac{1}{2}$ Angle Girders connected at their lower ends by a $9\frac{1}{2}$ Angle Girder and at their upper ends by a $1\frac{1}{2}$ and two $4\frac{1}{2}$ Strips. The front is plated by two $12\frac{1}{2} \times 2\frac{1}{2}$ Strip Plates, two $2\frac{1}{2} \times 2\frac{1}{2}$ Flexible Plates, the separated halves of a Hinged Flat Plate (25), a $5\frac{1}{2} \times 3\frac{1}{2}$ Flat Plate and a $5\frac{1}{2} \times 2\frac{1}{2}$ Flat Plate (26). The corners of the centre window are filled in by $2\frac{1}{2} \times 1\frac{1}{2}$ Triangular Flexible Plates. The window is edged by Strips and Curved Strips as shown.

Each side of the lower part of the case is filled in by a $5\frac{1}{2} \times 2\frac{1}{2}$ Flanged Plate (27), four $5\frac{1}{2} \times 1\frac{1}{2}$ Flexible Plates, six $2\frac{1}{2} \times 2\frac{1}{2}$ Flexible Plates, two $3\frac{1}{2} \times 2\frac{1}{2}$ Flanged Plates (28), and a $5\frac{1}{2}$ Braced Girder. At the top of the side a $5\frac{1}{2}$ Angle Girder (29) is fixed in position. The rear edge of one side is formed by two $12\frac{1}{2}$ Angle Girders overlapped 13 holes, but on the opposite side a $12\frac{1}{2}$ Angle Girder extended by two $12\frac{1}{2}$ Strips is used. The lower rear corners of the sides are connected by a $9\frac{1}{2}$ Angle Girder (30), which is braced by a $3\frac{1}{2} \times 2$ Triangular Flexible Plate at each end.

A platform is attached to two built-up strips (31), each made from a $5\frac{1}{2}$ and a $4\frac{1}{2}$ Strip bolted to the Flanged Plates (27). The platform is formed by a $4\frac{1}{2} \times 2\frac{1}{2}$ Flexible Plate, a $3\frac{1}{2} \times 2\frac{1}{2}$ Flanged Plate, three $2\frac{1}{2} \times 1\frac{1}{2}$ Flexible Plates, two Flanged Sector Plates and two $2\frac{1}{2} \times 1\frac{1}{2}$ Flanged Plates. It is extended downward at the back by four $2\frac{1}{2} \times 1\frac{1}{2}$ Flexible Plates edged as shown in Fig. 9.8d by Strips, and with a $2\frac{1}{2} \times 2$ Triangular Flexible Plate at each end.

The upper corners of the sides are fitted with $2\frac{1}{2} \times 2\frac{1}{2}$ Triangular Flexible Plates, each of which is edged at the top by a $2\frac{1}{2}$ Angle Girder. The two Girders are connected by a $5\frac{1}{2} \times \frac{1}{2}$ Double Angle Strip.

THE MECHANISM HOUSING AND THE CLOCK FACE

Each side of the housing consists of two $12\frac{1}{2}$ Angle Girders, four $12\frac{1}{2}$ Strips, and six $5\frac{1}{2} \times 2\frac{1}{2}$ Flexible Plates. These are connected at the top by a $7\frac{1}{2}$ Strip, and at their lower ends by a $5\frac{1}{2}$ and a $2\frac{1}{2}$ Strip.

The sides are joined together at the front by two $12\frac{1}{2}$ Strips (32), and at the back by two similar Strips (33). The lower one of the last mentioned Strips is braced by Corner Gussets as shown in Fig. 9.8d. A $7\frac{1}{2}$ Angle Girder (34) is fitted inside the housing on each side.

Note: With the parts in this Outfit it is not possible to provide the exact 12 : 1 ratio that is required between the hour and the minute hands. It will be necessary therefore to adjust the relative positions of the clock hands periodically.

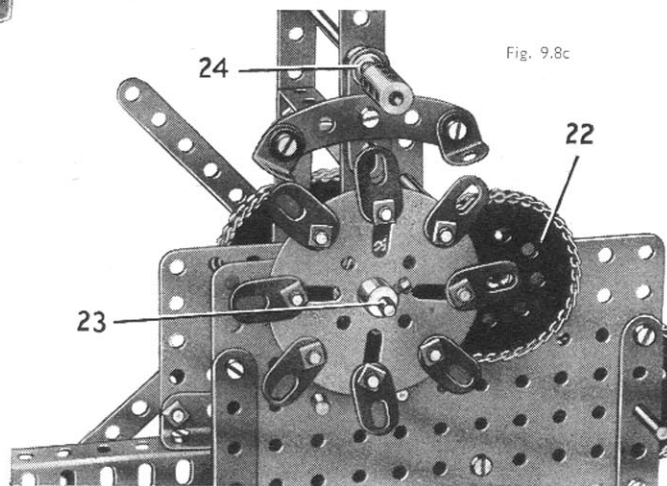

Fig. 9.8c

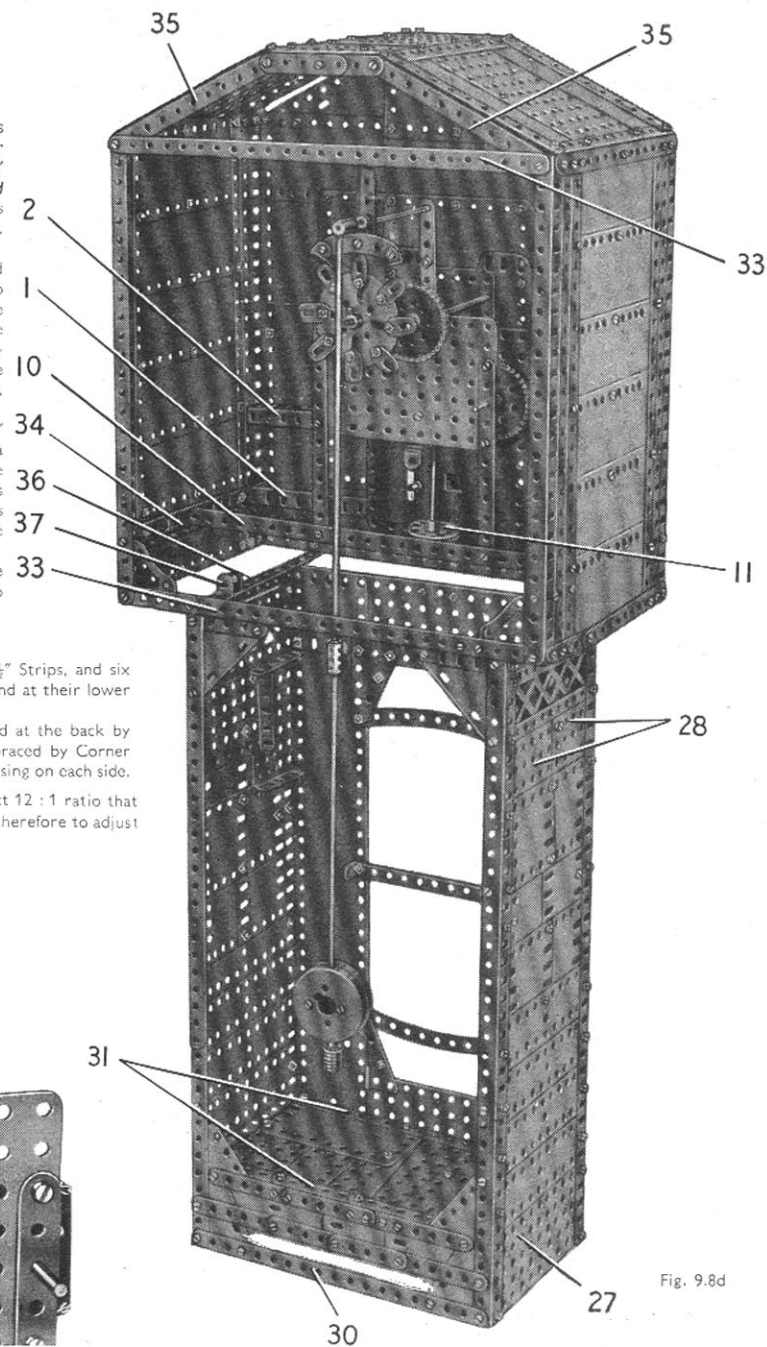

Fig. 9.8d

9.9 LIFTING BRIDGE

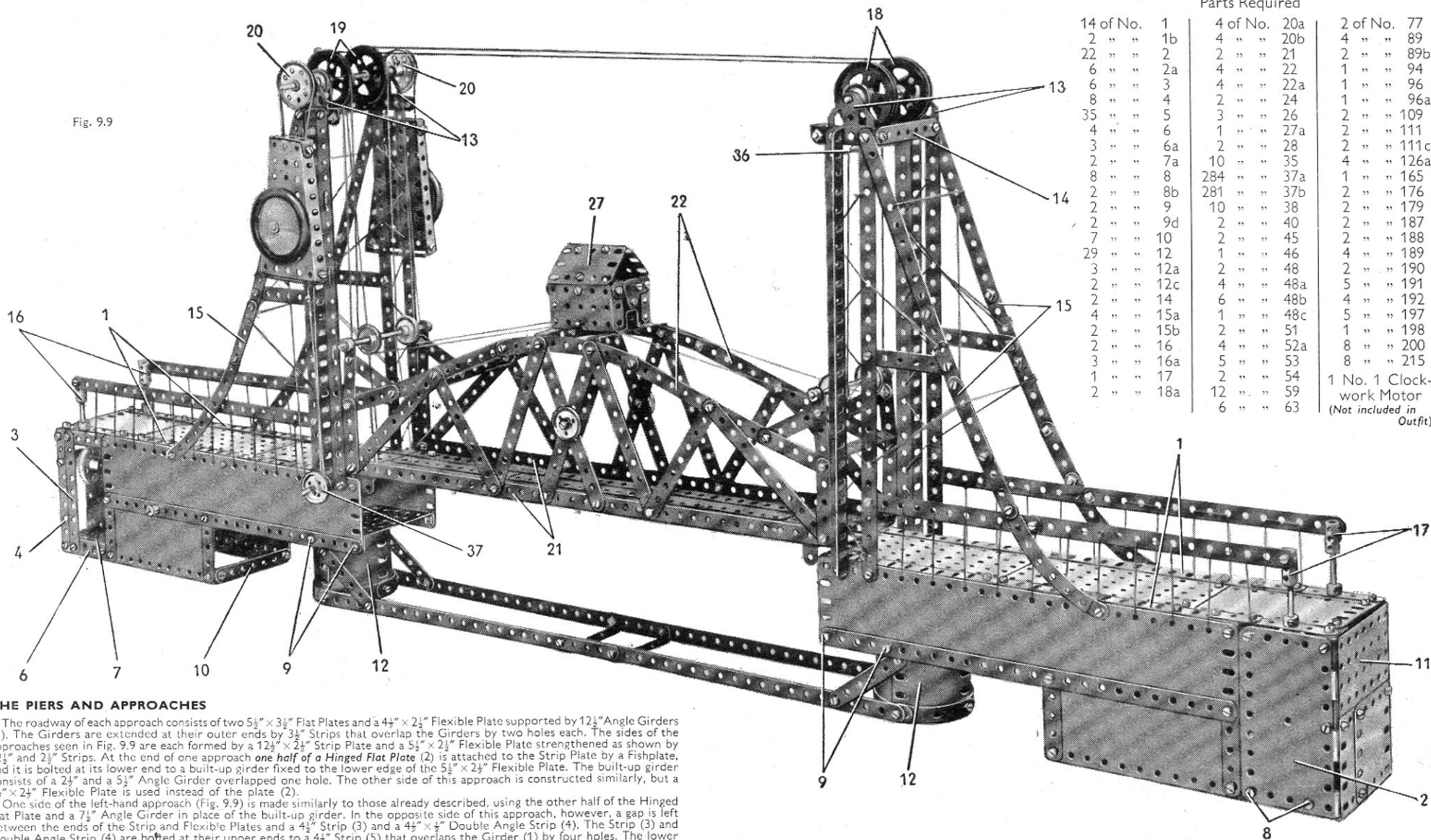

Fig. 9.9

Parts Required

14 of No. 1	4 of No. 20a	2 of No. 77
2 " " 1b	4 " " 20b	4 " " 89
22 " " 2	2 " " 21	2 " " 89b
6 " " 2a	4 " " 22	1 " " 94
6 " " 3	4 " " 22a	1 " " 96
8 " " 4	2 " " 24	1 " " 96a
35 " " 5	3 " " 26	2 " " 109
4 " " 6	1 " " 27a	2 " " 111
3 " " 6a	2 " " 28	2 " " 111c
2 " " 7a	10 " " 35	4 " " 126a
8 " " 8	284 " " 37a	1 " " 165
2 " " 8b	281 " " 37b	2 " " 176
2 " " 9	10 " " 38	2 " " 179
2 " " 9d	2 " " 40	2 " " 187
7 " " 10	2 " " 45	2 " " 188
29 " " 12	1 " " 46	4 " " 189
3 " " 12a	2 " " 48	2 " " 190
2 " " 12c	4 " " 48a	5 " " 191
2 " " 14	6 " " 48b	4 " " 192
4 " " 15a	1 " " 48c	5 " " 197
2 " " 15b	2 " " 51	1 " " 198
2 " " 16	4 " " 52a	8 " " 200
3 " " 16a	5 " " 53	8 " " 215
1 " " 17	2 " " 54	
2 " " 18a	12 " " 59	1 No. 1 Clockwork Motor
	6 " " 63	(Not included in Outfit)

THE PIERS AND APPROACHES

The roadway of each approach consists of two $5\frac{1}{2}'' \times 3\frac{1}{2}''$ Flat Plates and a $4\frac{1}{2}'' \times 2\frac{1}{2}''$ Flexible Plate supported by $12\frac{1}{2}''$ Angle Girders (1). The Girders are extended at their outer ends by $3\frac{1}{2}''$ Strips that overlap the Girders by two holes each. The sides of the approaches seen in Fig. 9.9 are each formed by a $12\frac{1}{2}'' \times 2\frac{1}{2}''$ Strip Plate and a $5\frac{1}{2}'' \times 2\frac{1}{2}''$ Flexible Plate strengthened as shown by $12\frac{1}{2}''$ and $2\frac{1}{2}''$ Strips. At the end of one approach one half of a Hinged Flat Plate (2) is attached to the Strip Plate by a Fishplate, and it is bolted at its lower end to a built-up girder fixed to the lower edge of the $5\frac{1}{2}'' \times 2\frac{1}{2}''$ Flexible Plate. The built-up girder consists of a $2\frac{1}{2}''$ and a $5\frac{1}{2}''$ Angle Girder overlapped one hole. The other side of this approach is constructed similarly, but a $4\frac{1}{2}'' \times 2\frac{1}{2}''$ Flexible Plate is used instead of the plate (2).

One side of the left-hand approach (Fig. 9.9) is made similarly to those already described, using the other half of the Hinged Flat Plate and a $7\frac{1}{2}''$ Angle Girder in place of the built-up girder. In the opposite side of this approach, however, a gap is left between the ends of the Strip and Flexible Plates and a $4\frac{1}{2}''$ Strip (3) and a $4\frac{1}{2}'' \times \frac{1}{2}''$ Double Angle Strip (4). The Strip (3) and Double Angle Strip (4) are bolted at their upper ends to a $4\frac{1}{2}''$ Strip (5) that overlaps the Girder (1) by four holes. The lower end of Strip (3) is bolted to a $7\frac{1}{2}''$ Angle Girder (6) (Fig. 9.9).

The sides of the approaches are connected by $3\frac{1}{2}'' \times 2\frac{1}{2}''$ Flanged Plates. One of these is indicated at (7) (Fig. 9.9) and the other is held by bolts (8) on each side. Further $3\frac{1}{2}'' \times 2\frac{1}{2}''$ Flanged Plates are secured by bolts (9) on each side. A $3\frac{1}{2}''$ Strip (10) is connected to one approach by Angle Brackets, and in the other approach a $2\frac{1}{2}''$ and a $1\frac{1}{2}''$ Strip bolted together are used in place of the Strip (10). The end of the $4\frac{1}{2}'' \times 2\frac{1}{2}''$ Flexible Plate forming part of the roadway of one approach is supported by $1'' \times 1''$ Angle Brackets bolted to the sides. The end of this approach is filled in by a $3\frac{1}{2}'' \times 2\frac{1}{2}''$ Flanged Plate (11) and two $2\frac{1}{2}'' \times 2\frac{1}{2}''$ Flexible Plates (Fig. 9.9). The $4\frac{1}{2}'' \times 2\frac{1}{2}''$ Flexible Plate of the roadway of the other approach is supported by a $3\frac{1}{2}''$ Strip. The Strip is connected to one side by an Angle Bracket, and is bolted at the other side to the top lug of Double Angle Strip (4).

The circular supporting piers (12) are each formed by four $1\frac{1}{2}''$ radius Curved Plates strengthened along their lower edges by four Formed Slotted Strips. Each pier is connected to a Face Plate by three Angle Brackets, and the bolts that connect the Angle Brackets to the Face Plate also attach the pier to the Flanged Plate held by the bolts (9).

The piers (12) are connected by two built-up strips each, made from two $12\frac{1}{2}''$ Strips overlapped five holes. These strips are connected at the centre by two $2\frac{1}{2}'' \times \frac{1}{2}''$ Double Angle Strips, and are braced to the piers (12) by $3''$ Strips.

(Continued on next page)

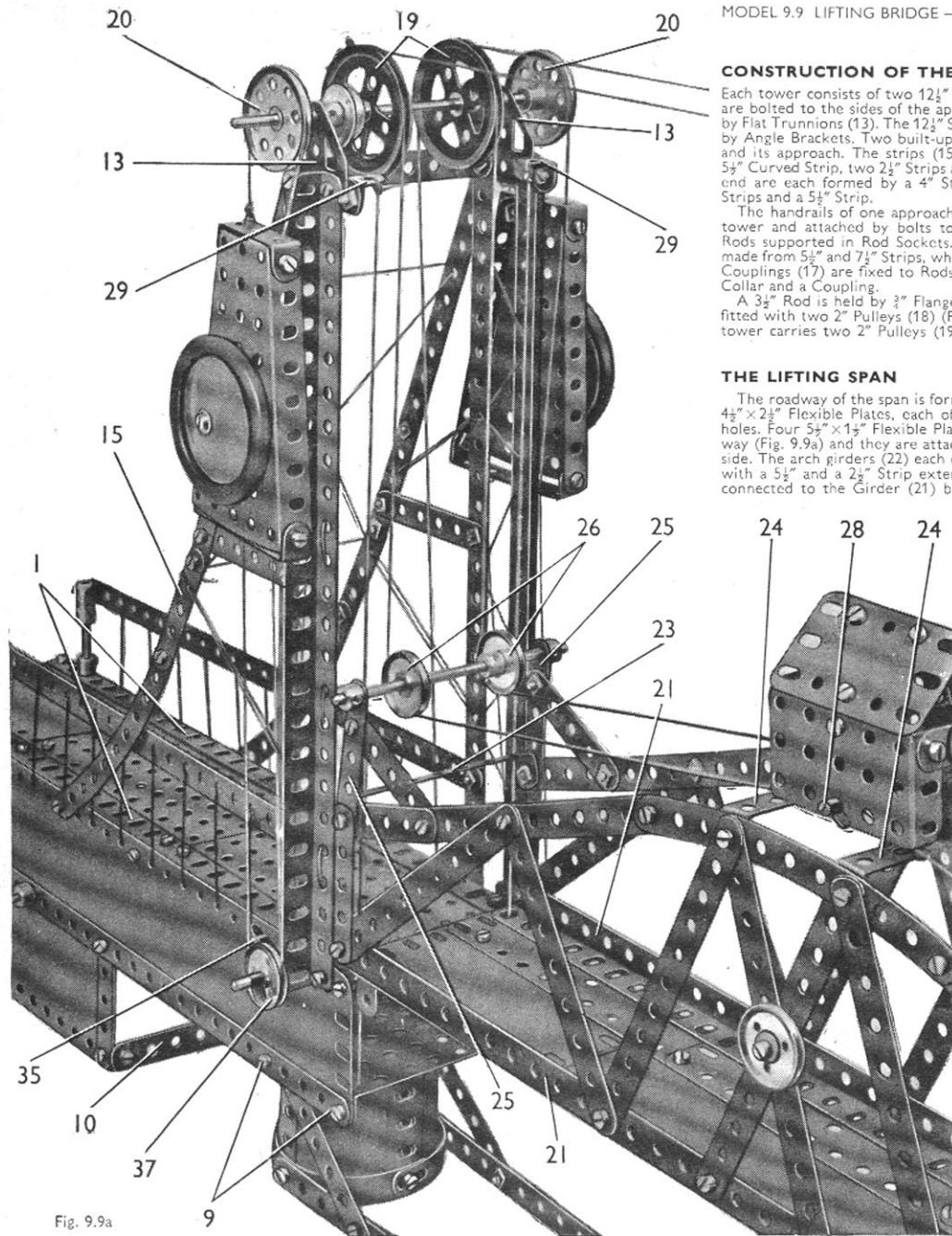

Fig. 9.9a

MODEL 9.9 LIFTING BRIDGE — Continued

CONSTRUCTION OF THE TOWERS

Each tower consists of two $12\frac{1}{2}$ " Angle Girders and two $12\frac{1}{2}$ " Strips, which are bolted to the sides of the approach and connected at their upper ends by Flat Trunnions (13). The $12\frac{1}{2}$ " Strips are joined by a $3\frac{1}{2}$ " Strip (14) attached by Angle Brackets. Two built-up strips (15) are fixed between each tower and its approach. The strips (15) of one approach are each made from a $5\frac{1}{2}$ " Curved Strip, two $2\frac{1}{2}$ " Strips and a $5\frac{1}{2}$ " Strip. The strips (15) at the other end are each formed by a 4" Stepped Curved Strip, a 2" Strip, two $2\frac{1}{2}$ " Strips and a $5\frac{1}{2}$ " Strip.

The handrails of one approach are $12\frac{1}{2}$ " Strips. These are bolted to the tower and attached by bolts to Couplings (16), which are fixed on $1\frac{1}{2}$ " Rods supported in Rod Sockets. The handrails of the other approach are made from $5\frac{1}{2}$ " and $7\frac{1}{2}$ " Strips, which are attached by bolts to Couplings (17). Couplings (17) are fixed to Rods, each held in a hole in the approach by a Collar and a Coupling.

A $3\frac{1}{2}$ " Rod is held by $\frac{3}{8}$ " Flanged Wheels at the top of one tower and is fitted with two 2" Pulleys (18) (Fig. 9.9). A $6\frac{1}{2}$ " Rod at the top of the other tower carries two 2" Pulleys (19) and two $1\frac{1}{2}$ " Pulleys (20).

THE LIFTING SPAN

The roadway of the span is formed by a $12\frac{1}{2}$ " Strip Plate extended by two $4\frac{1}{2}$ " x $2\frac{1}{2}$ " Flexible Plates, each of which overlaps the Strip Plate by three holes. Four $5\frac{1}{2}$ " x $1\frac{1}{2}$ " Flexible Plates are bolted along one side of the roadway (Fig. 9.9a) and they are attached to an $18\frac{1}{2}$ " Angle Girder (21) on each side. The arch girders (22) each consist of a $5\frac{1}{2}$ " Curved Strip at the centre with a $5\frac{1}{2}$ " and a $2\frac{1}{2}$ " Strip extending each of its ends. The arch girder is connected to the Girder (21) by two crossed $5\frac{1}{2}$ " Strips at the centre, a

$2\frac{1}{2}$ " Strip at each end and $5\frac{1}{2}$ " and $4\frac{1}{2}$ " bracing Strips as shown in Fig. 9.9. The arch girders are connected at each end by a $3\frac{1}{2}$ " x $\frac{3}{8}$ " Double Angle Strip (23) and by two similar Double Angle Strips (24) at the centre.

To each end of the span two $2\frac{1}{2}$ " Strips (25) are attached. They are braced by further $2\frac{1}{2}$ " Strips. A $4\frac{1}{2}$ " Rod is held by Collars in each pair of Strips (25) and is fitted with two 1" Pulleys (26).

The sides of the control cabin (27) are $2\frac{1}{2}$ " x $1\frac{1}{2}$ " Flanged Plates joined at each end by a 2" Strip. Two 1" Triangular Plates bolted to the 2" Strips are connected by Angle Brackets to Double Bent Strips fixed to the Double Angle Strips (24). The roof consists of two $2\frac{1}{2}$ " x $1\frac{1}{2}$ " Flexible Plates connected by Angle Brackets and attached to the sides by Obtuse Angle Brackets. A $2\frac{1}{2}$ " Rod (28) is held in the sides of the cabin by Spring Clips.

The lifting span is guided by Cord fastened to each tower. The ends of each length of Cord are passed through holes in the Flanged Plates held by bolts (9), through the roadway of the span and through holes in the Double Angle Strips (23). Each end of each Cord is then tied to an Angle Bracket (29), which is bolted to a Fishplate fixed to the top of the tower (Fig. 9.9a).

THE OPERATING MECHANISM

A No. 1 Clockwork Motor is attached to the Flanged Plate (7) by three Angle Brackets, and a $3\frac{1}{2}$ " Rod (30) is held by Collars in a $2\frac{1}{2}$ " x $1\frac{1}{2}$ " Double Angle Strip bolted to the Motor side-plate (Fig. 9.9b). One lug of the Double Angle Strip is braced to the Double Angle Strip (4) by a $1\frac{1}{2}$ " x $1\frac{1}{2}$ " Angle Bracket.

A $\frac{1}{2}$ " Pinion on the Motor driving shaft engages a $1\frac{1}{2}$ " Contrate on the Rod (30), and a $\frac{1}{2}$ " Pinion on Rod (30) engages a further $1\frac{1}{2}$ " Contrate (31). The Contrate (31) is fixed on a 2" Rod supported in the upper end holes of the Motor side-plates, and a $\frac{1}{2}$ " Pinion (32) also fixed on the Rod drives a 57-tooth Gear (33). The Gear (33) is carried by a $2\frac{1}{2}$ " Rod, which is held in the Motor side-plates by a Collar. A $\frac{1}{2}$ " Sprocket on the $2\frac{1}{2}$ " Rod drives a 1" Sprocket on a $4\frac{1}{2}$ " Rod (34) supported in the sides of the approach (Fig. 9.9b). Two Bush Wheels are fixed on the Rod as shown.

Two separate lengths of Cord are tied to Cord Anchoring Springs on Rod (34). These Cords are passed round a $4\frac{1}{2}$ " Rod (35), which is held by Spring Clips in the sides of the approach, and are taken through holes in the roadway. The Cords are then passed round Pulleys (19) and (18), over a 4" Rod (36), and round two of the Pulleys (26). The Cords pass over the Rod (28) in the control cabin, round the second pair of Pulleys (26), and are taken again over the Pulleys (19). The free end of each Cord is then tied to the section of the same Cord just below one of the Pulleys (19).

THE BALANCE WEIGHTS

Each balance weight is a Flanged Sector Plate. A Road Wheel is attached to it by a $\frac{3}{8}$ " Bolt, and it is fitted with a $1\frac{1}{2}$ " x $\frac{1}{2}$ " and a $2\frac{1}{2}$ " x $\frac{1}{2}$ " Double Angle Strip at its narrow and broad ends, respectively. A length of Cord tied to the $1\frac{1}{2}$ " x $\frac{1}{2}$ " Double Angle Strip is taken round one of the Pulleys (20), is passed through holes in the Double Angle Strips and is taken round a 1" loose Pulley (37). The Cord is then pulled tight and is tied to the $2\frac{1}{2}$ " x $\frac{1}{2}$ " Double Angle Strip. The Pulley (37) on each side is mounted between a Collar and a Spring Clip on a $6\frac{1}{2}$ " Rod, which is held by Spring Clips in the sides of the approach.

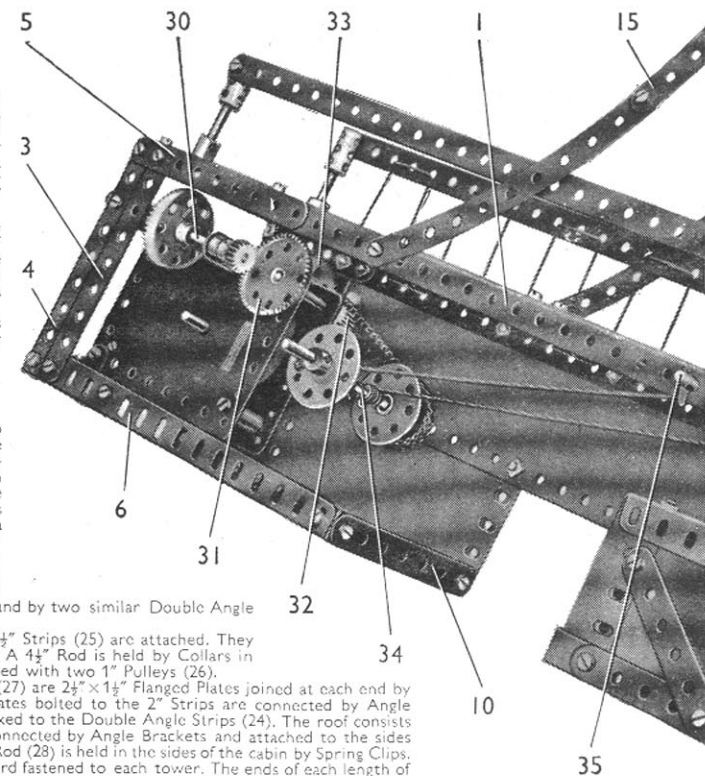

Fig. 9.9b

9.10 GIANT WALKING DRAGLINE

BASE OF THE CAB

The base is made by joining two $18\frac{1}{2}$ " Angle Girders (1) (Fig. 9.10a), by two $7\frac{1}{2}$ " Angle Girders (2). Two $5\frac{1}{2}$ " \times $3\frac{1}{2}$ " Flat Plates and a $5\frac{1}{2}$ " \times $2\frac{1}{2}$ " Flat Plate are connected by $2\frac{1}{2}$ " Strips as shown and are attached to the Girders (1) by Angle Brackets. A $4\frac{1}{2}$ " \times $2\frac{1}{2}$ " Flat Plate is bolted to the front ends of the Girders (1).

Two $4\frac{1}{2}$ " \times $\frac{1}{2}$ " Double Angle Strips are fixed at right angles to each other across a 4" Circular Plate, which is bolted together with a Face Plate (3), underneath the Girders (1). The bolts that fasten the Face Plate secure also Angle Brackets. Four $1\frac{1}{2}$ " Rods are mounted in the Angle Brackets and in the lugs of the Double Angle Strips, and each Rod is fitted with a $\frac{3}{4}$ " Flanged Wheel and is held in position by a Collar.

The circular base on which the dragline rests consists of a Circular Girder, with two $5\frac{1}{2}$ " Strips bolted across it. A Face Plate is bolted to the Strips and a $2\frac{1}{2}$ " Rod is fixed in its boss. This Rod is passed freely through the Face Plate (3) and is held in place by a 2" Pulley placed above the 4" Circular Plate.

A girder (4) on each side, made from a $12\frac{1}{2}$ " Angle Girder and a $5\frac{1}{2}$ " Angle Girder overlapped three holes, is bolted to the ends of the Girders (2).

ASSEMBLY OF THE CAB

The side seen in Fig. 9.10 is made by bolting a $5\frac{1}{2}$ " Angle Girder (5) and two $5\frac{1}{2}$ " Strips (6) to the girder (4). The Girder and the Strips support two $12\frac{1}{2}$ " Strips, one of which is indicated at (7), and the side is completed by two $5\frac{1}{2}$ " \times $2\frac{1}{2}$ " Flexible Plates and *one half of a Hinged Flat Plate*. The side of the control cabin is made by bolting a $3\frac{1}{2}$ " Strip (8) to the end of the girder (4). The top of this Strip is connected to the Angle Girder (5) by a 4" Stepped Curved Strip extended by a Fishplate. The side of the cabin is filled in by a $2\frac{1}{2}$ " \times $1\frac{1}{2}$ " Flexible Plate, and these are edged by two $2\frac{1}{2}$ " Strips.

The side seen in Fig. 9.10b is made by bolting a $5\frac{1}{2}$ " Angle Girder (9) and a $5\frac{1}{2}$ " Strip (10) to the girder (4). A $12\frac{1}{2}$ " Strip (11) and two $12\frac{1}{2}$ " \times $2\frac{1}{2}$ " Strip Plates are fixed to the Girder (9) and the Strip (10), and to another $5\frac{1}{2}$ " Strip bolted vertically at the centre of the side inside the Strip Plates. The side of the control cabin is made in the same way as the one already described.

The back of the cab is made by bolting a curved $5\frac{1}{2}$ " \times $2\frac{1}{2}$ " Flexible Plate (12) to each side. The Plates (12) are connected by two $5\frac{1}{2}$ " Braced Girders (Fig. 9.10b), fourteen $5\frac{1}{2}$ " \times $2\frac{1}{2}$ " Flexible Plates, nine $5\frac{1}{2}$ " \times $1\frac{1}{2}$ " Flexible Plates and four $5\frac{1}{2}$ " Strips. The Flexible Plates and the Strips are placed face to face, with their lower edges together, and they act as a balance weight at the rear of the cab.

(Continued on next page)

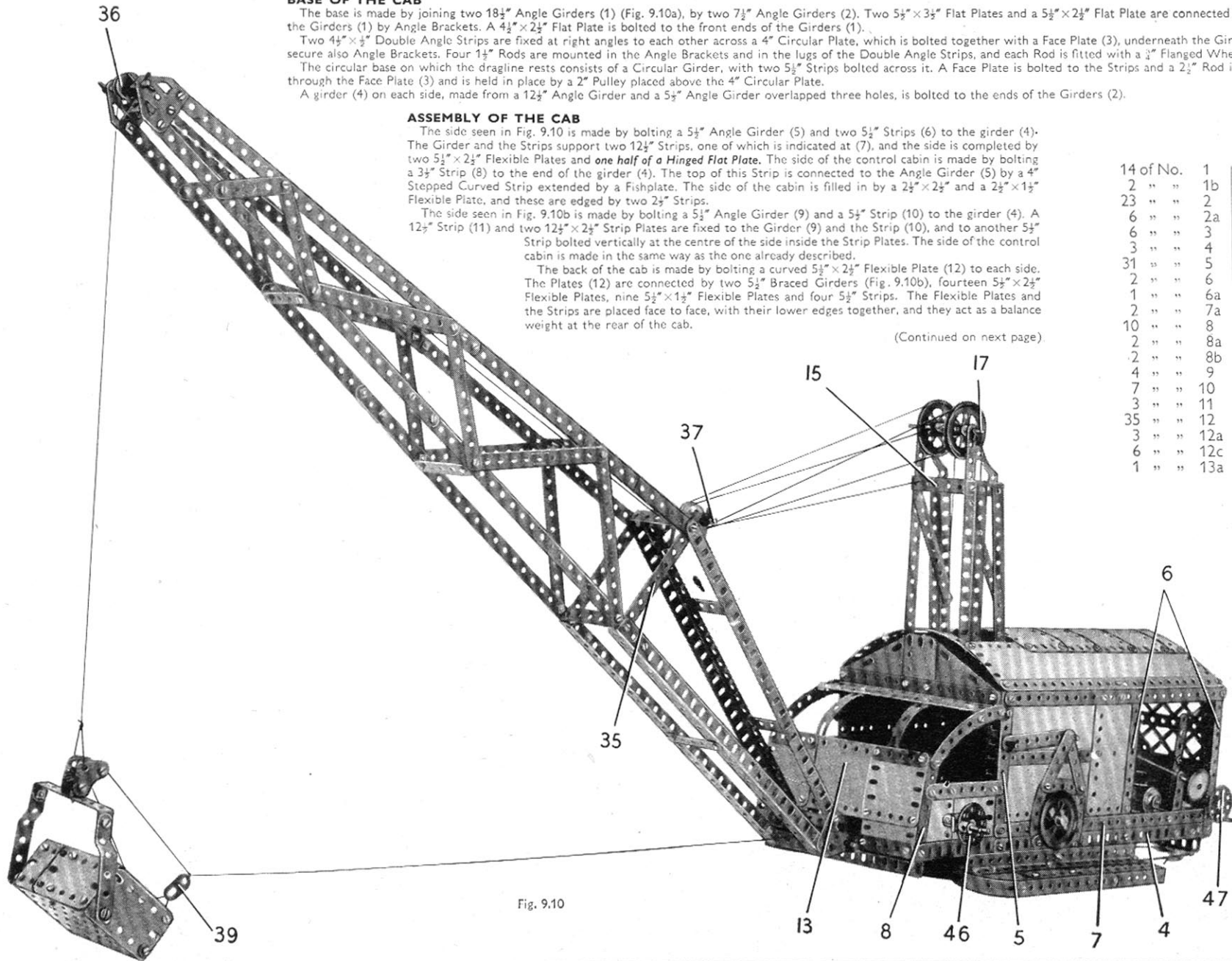

Fig. 9.10

Parts Required

14 of No.	1	3 of No.	14	4 of No.	90
2 "	1b	3 "	15	2 "	90a
23 "	2	3 "	15a	1 "	94
6 "	2a	2 "	15b	1 "	95
6 "	3	5 "	16	2 "	96
3 "	4	2 "	16a	1 "	96c
31 "	5	5 "	17	2 "	100
2 "	6	4 "	18a	2 "	108
1 "	6a	2 "	18b	2 "	109
2 "	7a	4 "	20	2 "	111
10 "	8	5 "	20a	5 "	111c
2 "	8a	4 "	20b	11 "	111c
2 "	8b	2 "	21	2 "	115
4 "	9	5 "	22	1 "	125
7 "	10	3 "	22a	3 "	126
3 "	11	3 "	23	4 "	126c
35 "	12	1 "	23a	1 "	128
3 "	12a	2 "	24	2 "	133a
6 "	12c	1 "	25	2 "	136
1 "	13a	5 "	26	1 "	143
		1 "	27	1 "	146a
		2 "	27a	3 "	147b
		1 "	28	1 "	154a
		2 "	29	1 "	155
		1 "	32	2 "	165
		16 "	35	1 "	166
		333 "	37a	1 "	186
		300 "	37b	1 "	186a
		41 "	38	10 "	188
		2 "	38d	10 "	189
		2 "	40	8 "	190
		1 "	45	6 "	191
		1 "	48	18 "	192
		9 "	48a	4 "	197
		2 "	48b	1 "	198
		2 "	48c	1 "	200
		1 "	50	2 "	212
		2 "	51	1 "	212a
		2 "	52	2 "	214
		2 "	52a	6 "	215
		5 "	53	2 "	216
		1 "	53a	2 "	222
		12 "	59	2 "	223
		2 "	62	2 "	225
		1 "	62b		
		6 "	63		
		2 "	70		
		2 "	89b		

1 E20R
Electric Motor
(Not included in
Outfit)

MODEL 9.10 GIANT WALKING DRAGLINE — Continued

At the front a $4\frac{1}{2}'' \times 2\frac{3}{4}''$ Flexible Plate (13) is extended on each side by a $2\frac{3}{4}'' \times 2\frac{1}{2}''$ Flexible Plate, and to each of the latter Plates is bolted a $2\frac{1}{2}'' \times 1\frac{1}{2}''$ Flexible Plate. These Plates form the front of the control cabin and they are attached to the Strips (8) by Angle Brackets. The roof of the cabin consists of a $5\frac{1}{2}'' \times 1\frac{1}{2}''$ and a $2\frac{1}{2}'' \times 1\frac{1}{2}''$ Flexible Plate bolted to a $7\frac{1}{2}''$ Strip, and this is connected to the $4''$ Curved Strips by Angle Brackets. A further $7\frac{1}{2}''$ Strip is bolted to the top ends of the Girders (5) and (9), and to this Strip are fixed a $2\frac{1}{2}'' \times 1\frac{1}{2}''$ Flexible Plate and two $3\frac{1}{4}'' \times 2''$ Triangular Flexible Plates. Two $12\frac{1}{2}''$ Angle Girders are fixed to each of the Girders (1), and are connected at their upper ends by two Corner Gussets (14) and two $2\frac{3}{4}'' \times \frac{3}{4}''$ Double Angle Strips (15). The tower thus formed is braced by two $4\frac{1}{2}''$ Strips. Two $5\frac{1}{2}''$ Strips (16) (Fig. 9.10c) are bolted to the tower and are attached to the front of the control cabin by Angle Brackets. A $3\frac{1}{2}''$ Rod (17) held in the Corner Gussets by Spring Clips, carries freely two $2''$ Pulleys placed between them. A $3\frac{1}{2}''$ Rod (18) is held by Spring Clips in the end holes of the Strips (16) (Fig. 9.10c).

POWER UNIT AND GEAR BOX

An E20R Electric Motor is bolted to the base in the position shown in Fig. 9.10d. A $\frac{1}{2}''$ Pinion on the Motor shaft drives a 57-tooth Gear on a $5''$ Rod (19) mounted in the Motor side-plates. A Double Arm Crank is bolted to the inner side-plate to strengthen the bearing for the Rod, which is retained in position by a $1''$ Pulley. A further Bearing for the Rod is provided by a $1\frac{1}{2}''$ Strip (20) bolted to a Trunnion fixed to the base of the cab.

Two $3\frac{1}{2}'' \times 2\frac{1}{2}''$ Flanged Plates (21) are bolted to the base of the cab and are connected at their upper ends by two $2\frac{1}{2}''$ Strips. Two further $2\frac{3}{4}''$ Strips, each bolted to a $1'' \times 1''$ Angle Bracket, brace the structure to the side of the cab.

A Worm on Rod (19) is in constant mesh with a $\frac{1}{2}''$ Pinion on a $4''$ Rod mounted in the second holes from the rear of the next to bottom rows of holes in the Flanged Plates (21). The Rod is held in place by Collars, and it carries a $\frac{1}{2}''$ Pinion (22) (Fig. 9.10d).

A $6\frac{1}{2}''$ Rod (23) is supported in the holes immediately behind the $4''$ Rod, and is free to slide about $\frac{1}{4}''$ in its bearings, but is prevented from moving further by Collars. When the Rod is moved to the left (Fig. 9.10d), a $\frac{1}{2}''$ Pinion (24) on the Rod engages the Pinion (22). The sliding movement is controlled by a $2''$ Rod (25) that is held in a Rod and Strip Connector *lock-nutted* to a Double Bracket bolted to the base. The $2''$ Rod fits between a Collar and a Coupling on the Rod (23). A $1''$ Sprocket (26) and a $1''$ Pulley are fixed on Rod (23), and a belt of Cord passed round the Pulley is tied to a strip (27), which is made from a $3''$ and a $2\frac{1}{2}''$ Strip overlapped two holes. This strip is *lock-nutted* to a Double Bent Strip bolted to one of the girders (4). A Driving Band tied to strip (27) and to the back of the cab tightens the Cord round the Pulley to form a simple brake.

A $5''$ Rod (28) fitted with a $\frac{1}{2}''$ Pinion and a $\frac{1}{2}''$ Pulley (29) (Fig. 9.10c), is mounted in the holes in front of the Rod that carries the Pinion (22).

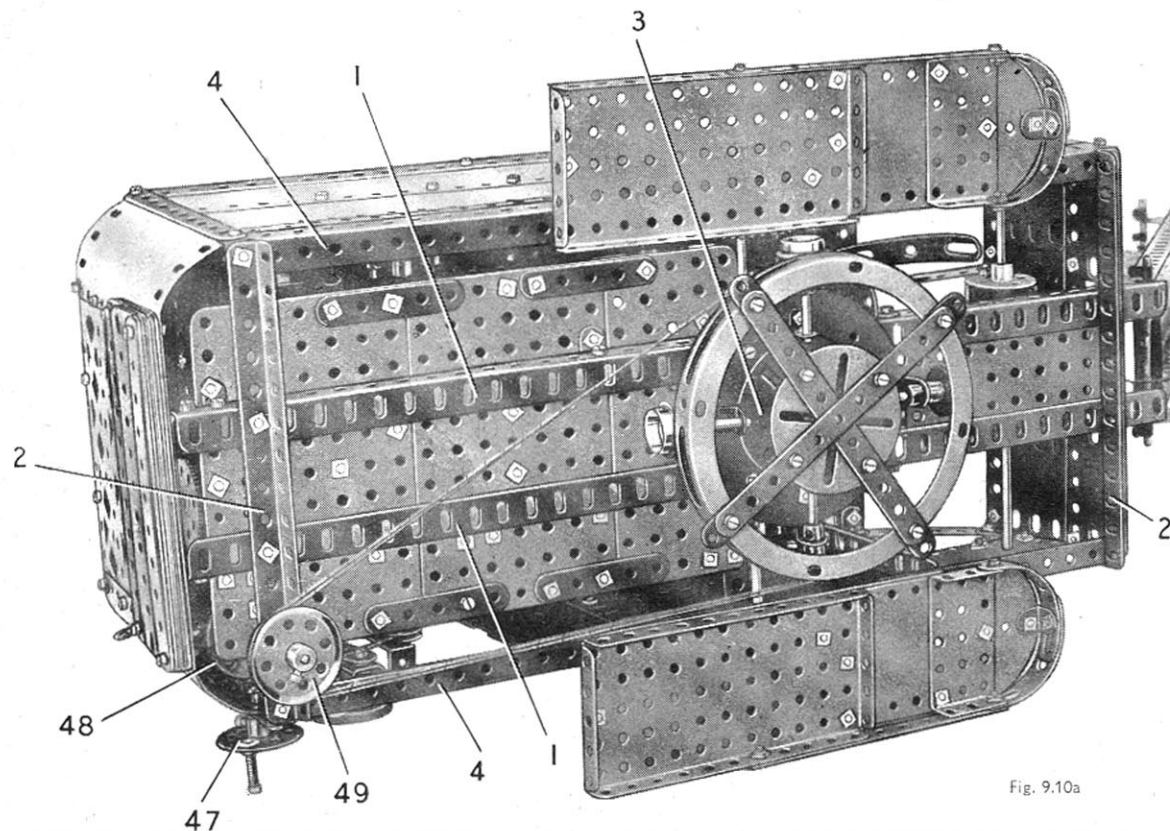

Fig. 9.10a

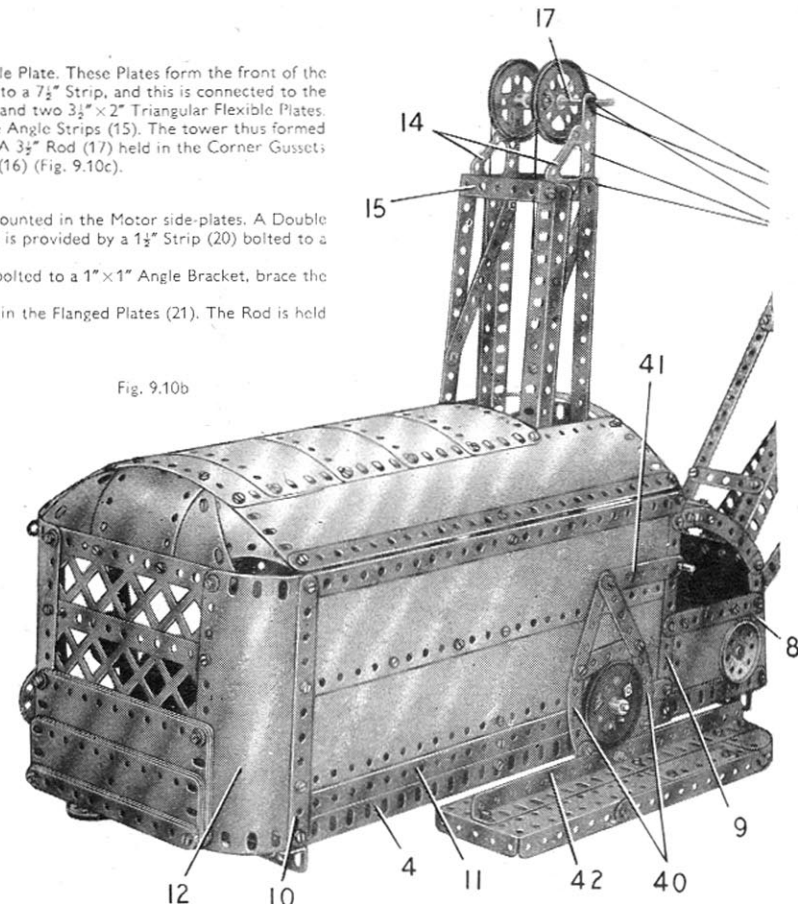

Fig. 9.10b

Rod (28) is free to slide in its bearings in the same way as Rod (23), so that its Pinion can be engaged with the Pinion (22). The lever that controls the movement of Rod (28) is made in the same way as that fitted to Rod (23).

A $6\frac{1}{2}''$ Rod (30), mounted two holes above the Rod carrying the Pinion (22), is fitted with a $\frac{3}{4}''$ Pinion (31) and a 57-tooth Gear (32). Rod (30) is free to slide about $\frac{1}{4}''$ in its bearings, so that the Gear (32) can be moved into mesh with Pinion (22). The Pinion (31) drives a 50-tooth Gear on a $4''$ Rod that carries also a $\frac{1}{2}''$ Sprocket (33). The sliding movement of Rod (30) is controlled by a $3\frac{1}{2}''$ Rod held in a Right-Angle Rod and Strip Connector that is *lock-nutted* to a Corner Angle Bracket bolted to the base. The $3\frac{1}{2}''$ Rod engages between a Collar and a Coupling on Rod (30).

An $8''$ Rod is passed through a $2\frac{1}{2}''$ Strip bolted to the girder (4), and is fitted with a Handrail Support that is *lock-nutted* to an arm of a Bell Crank (34). To the other arm of the Bell Crank (34) is connected by a $1''$ Rod to a Handrail Support. The Handrail Support in turn is *lock-nutted* to the Motor switch, and the Bell Crank pivots on a $\frac{1}{2}''$ Bolt *lock-nutted* to the Motor side-plate.

CONSTRUCTION OF THE JIB AND BUCKET

The lower member of each side of the jib consists of a $12\frac{1}{2}''$ Angle Girder and two $12\frac{1}{2}''$ Strips, overlapped by three holes each. The upper member is formed by a $12\frac{1}{2}''$ Angle Girder, and two $12\frac{1}{2}''$ Strips overlapped four holes. The upper and lower members are connected by a $4\frac{1}{2}''$ Strip (35), and by a Flat Trunnion at each end. The sides of the jib are joined at their lower ends by two $2\frac{1}{2}'' \times \frac{1}{2}''$ Double Angle Strips, and at the jib head by a $1\frac{1}{2}'' \times \frac{1}{2}''$ Double Angle Strip. Two further $2\frac{3}{4}'' \times \frac{3}{4}''$ Double Angle Strips are bolted between the ends of Strips (35), and three $2\frac{1}{2}''$ Strips are bolted across the $12\frac{1}{2}''$ Angle Girders. Two $2\frac{3}{4}''$ Strips and two $2''$ Strips are fixed to Angle Brackets bolted to the $12\frac{1}{2}''$ Strips.

(Continued on next page)

MODEL 9.10 GIANT WALKING DRAGLINE — Continued

The jib pivots on a $3\frac{1}{2}$ " Rod supported in the end holes of the Girders (1). A 2" Rod at the jib head carries a $\frac{1}{2}$ " loose Pulley (36), with a $\frac{3}{4}$ " Washer on each side of it held in place by a Spring Clip. A $2\frac{1}{2}$ " Rod (37) is fitted with three 1" loose Pulleys and is held by Spring Clips in Trunnions bolted to the jib.

The sides of the bucket are made by bolting $2\frac{1}{2}$ " x $1\frac{1}{2}$ " Flexible Plates to a $3\frac{1}{2}$ " x $2\frac{1}{2}$ " Flanged Plate. The top consists of two $2\frac{1}{2}$ " x $2\frac{1}{2}$ " Flexible Plates overlapped three holes and bolted to a $2\frac{1}{2}$ " x $\frac{1}{2}$ " Double Angle Strip at each side. At the front edge the top is connected to the sides by Angle Brackets, and at the rear two $2\frac{1}{2}$ " x $1\frac{1}{2}$ " Flexible Plates are bolted to the lugs of the Double Angle Strips. The lower corners of these Plates are fixed to Angle Brackets, which are attached to the sides of the bucket by Pivot Bolts. A 3" Strip is mounted on each Pivot Bolt, and these Strips are connected by a $3\frac{1}{2}$ " x $\frac{1}{2}$ " Double Angle Strip. Two 1" Corner Brackets are fixed to a Double Bracket that is bolted to the Double Angle Strip. A $\frac{1}{2}$ " loose Pulley (38) is free to turn on a $\frac{3}{4}$ " Bolt, which is supported in the Corner Brackets and fitted with lock-nuts. A Fishplate (39) is passed over a length of Cord that is tied at each end to the front of the bucket.

WALKING MOTION, ECCENTRICS AND SHOES

The main walking shaft is made from a $6\frac{1}{2}$ " and a $2\frac{1}{2}$ " Rod joined by a Coupling. This shaft is mounted in the Strips (7) and (11), and it carries a 2" Sprocket that is connected by Chain to the $\frac{1}{2}$ " Sprocket (33).

Each eccentric is made by bolting a Crank across the face of a 2" Pulley, so that the boss of the Crank coincides with a hole in the Pulley. The Crank is fixed on the end of the walking shaft. The eccentric strap consists of two $2\frac{1}{2}$ " Curved Strips (40), connected at their upper ends by a $2\frac{1}{2}$ " Strip and at their lower ends by a $2\frac{1}{2}$ " Stepped Curved Strip. The strap slides freely in the groove of the 2" Pulley. Two $2\frac{1}{2}$ " Strips bolted to the top of the strap are lock-nutted to a $3\frac{1}{2}$ " Strip (41), which is held by a Spring Clip on a Threaded Pin that is fixed by its nut to the side of the cab.

Each shoe consists of a Semi-Circular Plate, a $2\frac{1}{2}$ " x $1\frac{1}{2}$ " Flanged Plate, a $2\frac{1}{2}$ " x $2\frac{1}{2}$ " Flexible Plate and a $5\frac{1}{2}$ " x $2\frac{1}{2}$ " Flanged Plate (Fig. 9.10b), bolted to a $9\frac{1}{2}$ " Angle Girder (42). The front edge of the shoe is completed by two Formed Slotted Strips, which are connected to the Semi-Circular Plate by an Angle Bracket. The outer Formed Slotted Strip is joined to the $5\frac{1}{2}$ " x $2\frac{1}{2}$ " Flanged Plate by a $5\frac{1}{2}$ " Strip.

The shoes are lock-nutted to the $2\frac{1}{2}$ " Stepped Curved Strips of the eccentric straps.

LUFFING, HOISTING, DIGGING AND SLEWING MOTIONS

The Sprocket (26) is connected by Chain to a 1" Sprocket (43) (Fig. 9.10d) on a $4\frac{1}{2}$ " Rod. This Rod is mounted in two $3\frac{1}{2}$ " x $2\frac{1}{2}$ " Flanged Plates (44) bolted to the base of the cab, and it carries a winding drum formed by two $1\frac{1}{2}$ " Flanged Wheels pressed into the ends of a Cylinder. Cord tied to

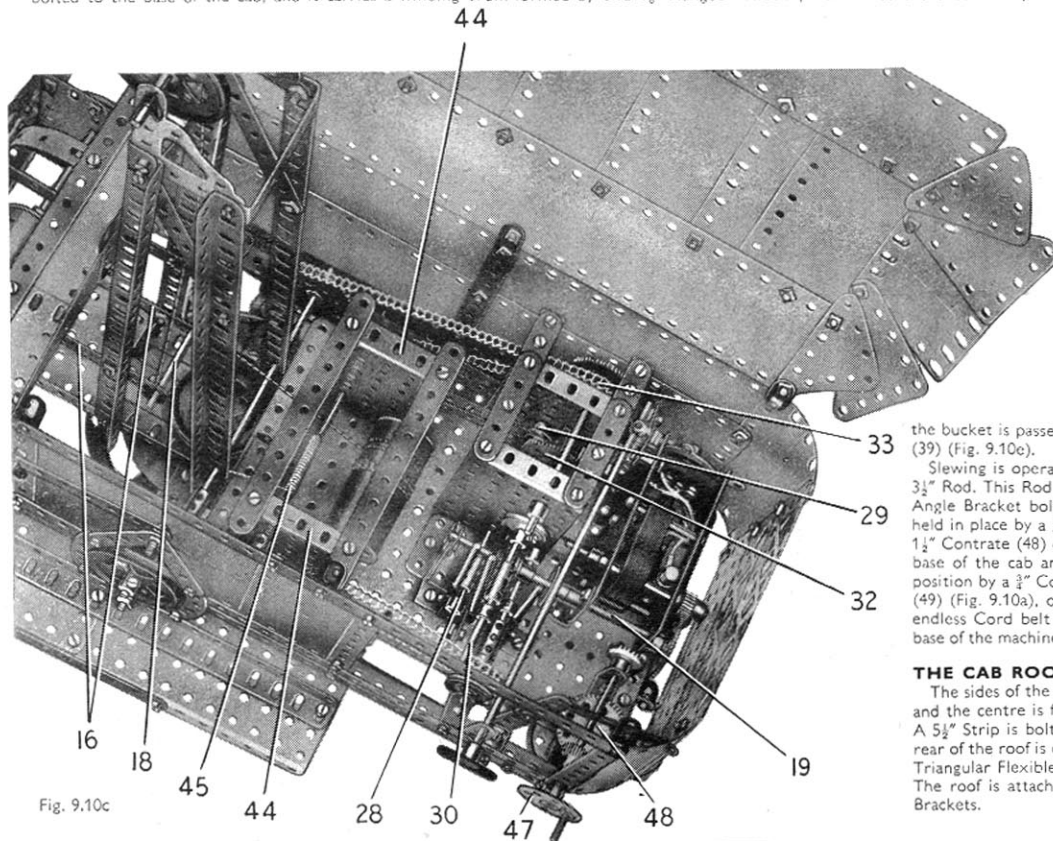

Fig. 9.10c

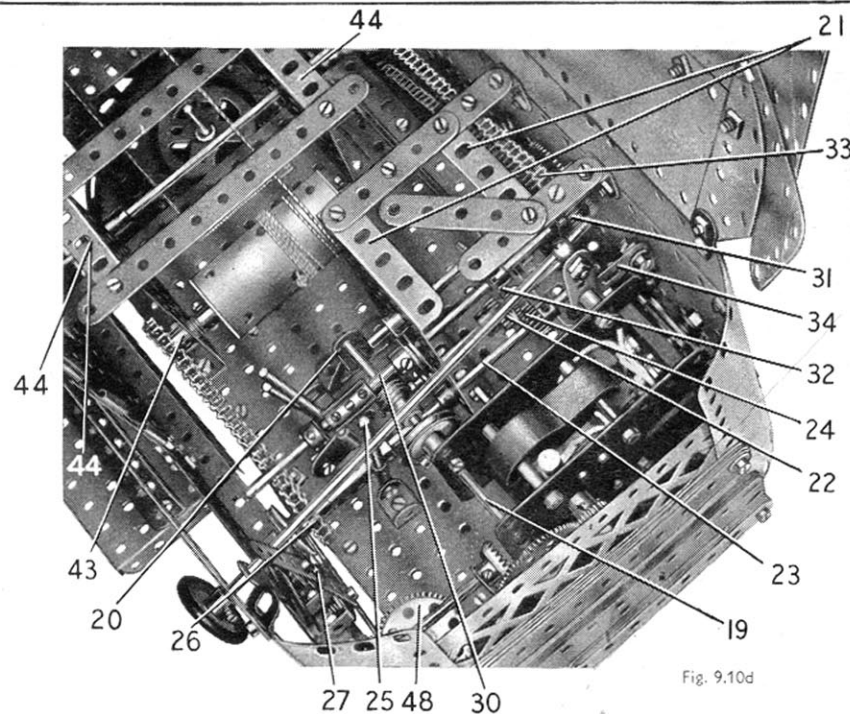

Fig. 9.10d

the Cylinder is passed under Rod (18), over one of the 2" Pulleys on Rod (17) and round a 1" loose Pulley on Rod (37). The Cord is taken round the second 2" Pulley on Rod (17), round another 1" Pulley on Rod (37) and is tied finally to one of the Double Angle Strips (15).

The Pulley (27) is connected by a Driving Band to a 1" Pulley on a 5" Rod (45), which is held by a Collar and a Coupling in the Flanged Plates (44). Cord tied to the Rod is passed under the main walking shaft, round the $\frac{1}{2}$ " Pulley on Rod (17) and under the centre 1" loose Pulley on Rod (37). The Cord is then taken through the centre hole of the Double Angle Strip bolted to the top ends of the Strips (35), round the Pulley (36) at the jib head and is tied finally to the Corner Brackets of the bucket.

The digging motion is hand-controlled through a handle formed by a 1" Rod fixed in a Rod Socket bolted to a Bush Wheel (46). The Bush Wheel is fixed on an axle formed by two $4\frac{1}{2}$ " Rods joined by a Coupling. This axle is held in the sides of the control cabin by a Slide Piece and a $1\frac{1}{2}$ " Pulley, and it carries a winding drum formed by a Cylinder and two $1\frac{1}{2}$ " Flanged Wheels. The drum fits over the Coupling that connects the $4\frac{1}{2}$ " Rods. Cord tied to the drum is passed under the Rod on which the jib pivots and is tied to the Fishplate (39). A short piece of Cord fastened to the top of

the bucket is passed round the Pulley (38), and is tied to the Fishplate (39) (Fig. 9.10e).

Slewing is operated by turning a Bush Wheel (47) (Fig. 9.10a) on a $3\frac{1}{2}$ " Rod. This Rod is mounted in one of the Strips (6) and in a $1\frac{1}{2}$ " x $1\frac{1}{2}$ " Angle Bracket bolted to the base of the cab (Fig. 9.10c). The Rod is held in place by a $\frac{3}{4}$ " Contrate, and it carries a $\frac{1}{2}$ " Pinion that engages a $1\frac{1}{2}$ " Contrate (48) on a vertical 2" Rod. The 2" Rod is supported in the base of the cab and in one of the Angle Girders (2), and is held in position by a $\frac{3}{4}$ " Contrate placed underneath the cab base. A $1\frac{1}{2}$ " Pulley (49) (Fig. 9.10a), on the lower end of the 2" Rod, is connected by an endless Cord belt to the $5\frac{1}{2}$ " Circular Girder that forms the circular base of the machine.

THE CAB ROOF

The sides of the roof are $12\frac{1}{2}$ " x $2\frac{1}{2}$ " Strip Plates edged by $12\frac{1}{2}$ " Strips, and the centre is filled in by five $4\frac{1}{2}$ " x $2\frac{1}{2}$ " Flexible Plates (Fig. 9.10b). A $5\frac{1}{2}$ " Strip is bolted between the front ends of the Strip Plates. The rear of the roof is completed by a $2\frac{1}{2}$ " x $2\frac{1}{2}$ " Flexible Plate, two $2\frac{1}{2}$ " x $2\frac{1}{2}$ " Triangular Flexible Plates and two $2\frac{1}{2}$ " x 2" Triangular Flexible Plates. The roof is attached to each side of the cab by three Obtuse Angle Brackets.

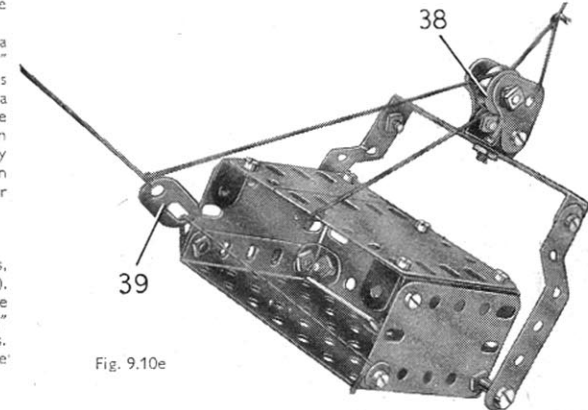

Fig. 9.10e

9.II TROLLEY BUS

Parts Required

14 of No. 1	4 of No. 18a	1 of No. 55a	2 of No. 147b
2 " " 1b	1 " " 18b	12 " " 59	1 " " 154a
24 " " 2	6 " " 20a	2 " " 62	1 " " 160
6 " " 2a	3 " " 20b	2 " " 62b	2 " " 161
6 " " 3	2 " " 22	6 " " 63	2 " " 165
8 " " 4	3 " " 23	2 " " 70	2 " " 176
30 " " 5	1 " " 23a	2 " " 89	2 " " 179
2 " " 6	1 " " 24a	2 " " 89b	1 " " 185
3 " " 6a	1 " " 25	4 " " 90	6 " " 187a
2 " " 7a	5 " " 26	8 " " 90a	8 " " 188
2 " " 8	1 " " 27	1 " " 94	4 " " 189
2 " " 8a	1 " " 27a	1 " " 96	4 " " 190
2 " " 8b	2 " " 29	1 " " 96a	5 " " 191
3 " " 9	3 " " 35	1 " " 102	18 " " 192
2 " " 9d	318 " " 37a	1 " " 109	4 " " 197
9 " " 10	289 " " 37b	3 " " 111	1 " " 198
24 " " 12	26 " " 38	6 " " 111a	2 " " 212
2 " " 12b	2 " " 38d	12 " " 111c	2 " " 212a
2 " " 13	1 " " 43	1 " " 115	2 " " 213
1 " " 13a	2 " " 48	1 " " 116	5 " " 215
4 " " 15	10 " " 48a	2 " " 124	4 " " 221
5 " " 15a	4 " " 48b	1 " " 125	2 " " 222
2 " " 15b	1 " " 50	1 " " 126a	2 " " 223
2 " " 16	4 " " 52a	2 " " 133a	2 " " 224
2 " " 16a	3 " " 53	2 " " 136	2 " " 226
2 " " 17	2 " " 53a	6 " " 142a	

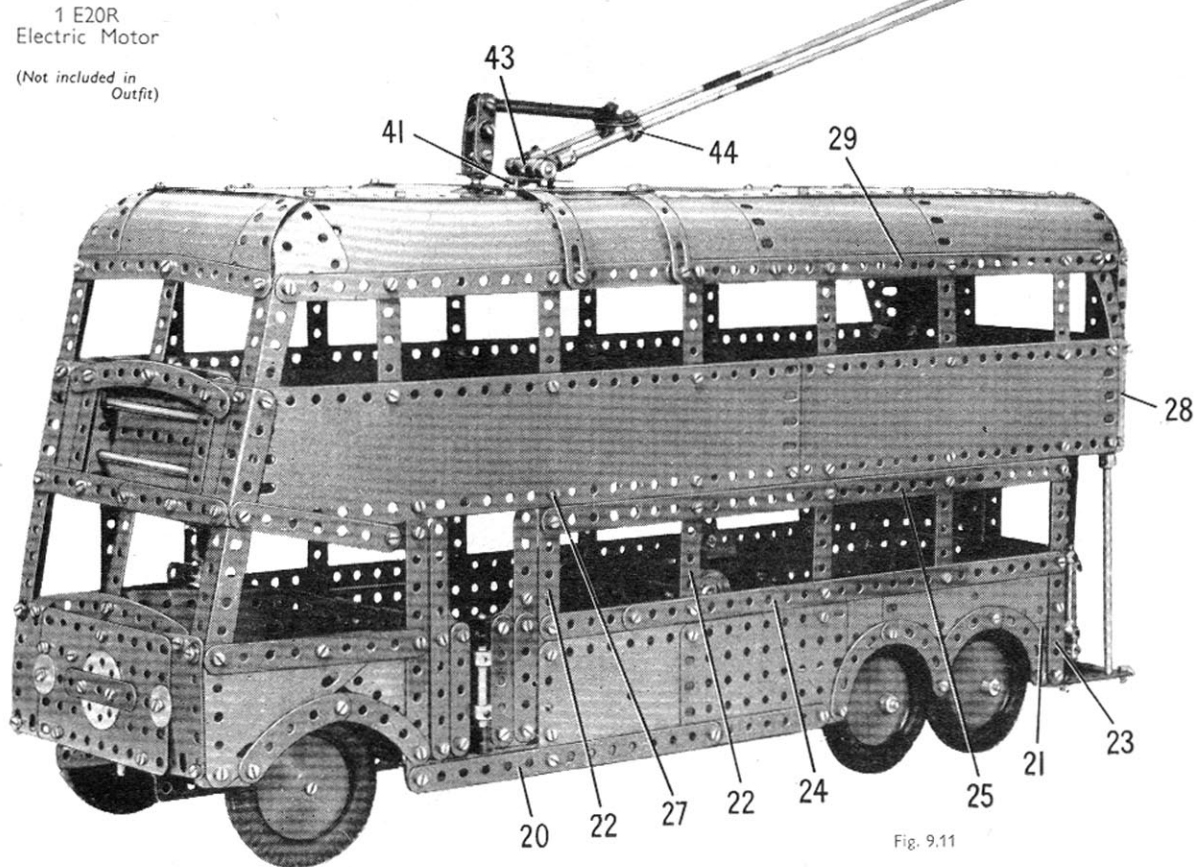

Fig. 9.11

CONSTRUCTION OF THE CHASSIS

Each of the chassis girders consists of an $18\frac{1}{2}$ " and a $9\frac{3}{4}$ " Angle Girder overlapped eight holes. The girders are connected by a $7\frac{1}{2}$ " Angle Girder (1); two $5\frac{1}{2}$ " Strips (2) overlapped seven holes and a $7\frac{1}{2}$ " Angle Girder (3). A $5\frac{1}{2}$ " x $3\frac{1}{2}$ " Flat Plate is bolted to the rear of the chassis and a similar Plate is fitted behind the Girder (1).

Two $5\frac{1}{2}$ " Strips (4) (Fig. 9.11a) are fixed to the lugs of 1" Reversed Angle Brackets bolted to the chassis, but the lower Strip is spaced from the Reversed Angle Brackets by three Washers on each Bolt. Each of the front wheels is free to turn on a $\frac{1}{4}$ " Bolt screwed into a Coupling (5). These Couplings are fixed, together with Cranks (6), on $1\frac{1}{2}$ " Rods supported in the ends holes of the Strips (4). The Cranks (6) are connected by a $5\frac{1}{2}$ " Strip (7) held by lock-nutted bolts.

An E20R Electric Motor is fixed to the Strips (2) and to a $5\frac{1}{2}$ " Strip bolted across the chassis. A $\frac{1}{2}$ " Pinion on the Motor shaft drives a 57-tooth Gear on a $3\frac{1}{2}$ " Rod mounted in the Motor side-plates. This Rod is held in place by a $\frac{1}{2}$ " Pinion on one side and by a $\frac{3}{4}$ " Flanged Wheel (8) on the other side, and it carries a $\frac{3}{4}$ " Sprocket. The Sprocket is connected by Chain to a 1" Sprocket on a $\frac{1}{2}$ " Rod (9) (Fig. 9.11c). A $\frac{3}{4}$ " Pinion on Rod (9) drives a 50-tooth Gear on the leading rear axle, which is an 8" Rod. The trailing axle is made from two 4" Rods joined by a Coupling. Two 1" Pulleys are fixed to the ends of a 5" Rod, which is supported in the Motor side-plates. A Pivot Bolt is passed through the top arm of the Motor switch and is screwed into a Collar on the 5" Rod.

THE SIDES OF THE DRIVING CAB AND THE LOWER SALOON

The side seen in Fig. 9.11b consists of two $5\frac{1}{2}$ " x $2\frac{1}{2}$ " Flat Plates, two $5\frac{1}{2}$ " x $1\frac{1}{2}$ " Flexible Plates overlapped six holes, two $5\frac{1}{2}$ " x $2\frac{1}{2}$ " Flexible Plates (10), a $3\frac{3}{4}$ " x $1\frac{1}{2}$ " Triangular Flexible Plate (11), a $2\frac{1}{2}$ " x $2\frac{1}{2}$ " Triangular Flexible Plate (12) and a $3\frac{3}{4}$ " x $2\frac{1}{2}$ " Triangular Flexible Plate (13). The wheel arches are made from Curved Strips and two $5\frac{1}{2}$ " Strips are bolted to the lower edges of the Flat Plates. A $5\frac{1}{2}$ " Angle Girder (14), two $5\frac{1}{2}$ " Strips (15) and a further $5\frac{1}{2}$ " Strip held by bolts (16), are fixed to the Plates. The built-up strips (17) and (18) are attached to the Strips and the Angle Girders. Strip (17) consists of two $12\frac{1}{4}$ " Strips overlapped four holes, and strip (18) is made from two $12\frac{1}{4}$ " Strips overlapped 11 holes. The strip (18) is extended forward by a $3\frac{1}{2}$ " Strip (19), which is supported at its front end by a 3" Strip. The window divisions are completed by bolting Strips in position as shown.

(Continued on next page)

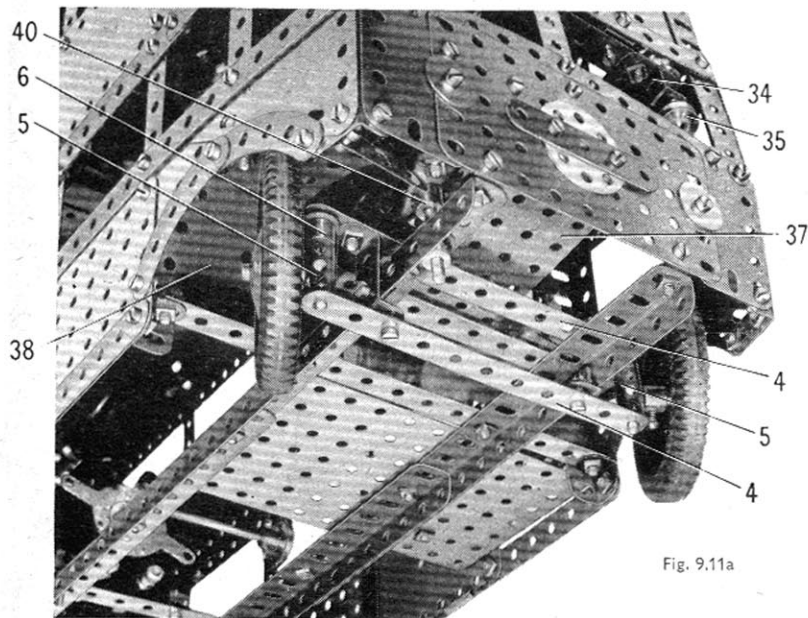

Fig. 9.11a

MODEL 9.11 TROLLEY BUS — Continued

The side of the cab seen in Fig. 9.11 is made in the same way as the side already described, except that Strip (19) is connected to the Girder (14) by a Fishplate and the Triangular Flexible Plates are edged by a $4\frac{1}{2}$ " Strip. A built-up strip (20), made from a $7\frac{1}{2}$ " and a $5\frac{1}{2}$ " Strip overlapped five holes, is bolted to the lower end of the Girder (14) and to the lower edges of one half of a Hinged Flat Plate and a $4\frac{1}{2}$ " \times $2\frac{1}{2}$ " Flat Plate. The plating of this side is completed by a $5\frac{1}{2}$ " \times $1\frac{1}{2}$ " and a $2\frac{1}{2}$ " \times $1\frac{1}{2}$ " Flexible Plate, and by a $3\frac{1}{2}$ " \times $1\frac{1}{2}$ " Triangular Flexible Plate (21). Two $5\frac{1}{2}$ " Strips (22) and a $5\frac{1}{2}$ " Angle Girder (23), are fixed to the Plates and are connected by built-up strips (24) and (25). The strip (24) consists of a $12\frac{1}{2}$ " and a $2\frac{1}{2}$ " Strip, and strip (25) is made from a $12\frac{1}{2}$ " and a $7\frac{1}{2}$ " Strip overlapped 11 holes.

The sides are attached to the ends of the Girders (1) and (3) and to the Strips (2) by Angle Brackets. The door is in two sections, one of which consists of a $2\frac{1}{2}$ " \times $1\frac{1}{2}$ " Flexible Plate to which are bolted three $2\frac{1}{2}$ " Strips. A further $2\frac{1}{2}$ " Strip is attached to a 1" Corner Bracket bolted to the top edge of the Plate. The other section is formed by a $4\frac{1}{2}$ " and a $2\frac{1}{2}$ " Strip joined by a 1" Corner Bracket and a Fishplate (Fig. 9.11d). Two Right-Angle Rod and Strip Connectors are bolted to this section, and are fitted over a $2\frac{1}{2}$ " Rod held in Collars bolted to the other section. Each Collar is screwed on to the shank of a bolt, which is fitted with a nut and is passed through the door.

The main door hinge is made by passing a $2\frac{1}{2}$ " Rod through Angle Brackets bolted to the side of the saloon. The Rod is held in place by Spring Clips, and on it are pivoted two Fishplates. Each Fishplate is bolted tightly to an Angle Bracket fixed to the door.

THE SIDES OF THE UPPER SALOON

Each side consists of two $12\frac{1}{2}$ " \times $2\frac{1}{2}$ " Strip Plates overlapped six holes and bolted to the ends of the $5\frac{1}{2}$ " Strips and Angle Girders of the lower saloon. The side is bolted at the front to a $2\frac{1}{2}$ " Angle Girder (26), and is strengthened inside the body by a $12\frac{1}{2}$ " Angle Girder, whose front end is fixed by a bolt (27). At each end the $12\frac{1}{2}$ " Girders are joined across by two $5\frac{1}{2}$ " Strips overlapped seven holes.

The window frames on each side are formed by two $2\frac{1}{2}$ " Strips, five $2\frac{1}{2}$ " \times $\frac{1}{2}$ " Double Angle Strips, and a 4" Stepped Curved Strip. At the rear the sides are extended by $4\frac{1}{2}$ " \times $2\frac{1}{2}$ " Flexible Plates (28). A built-up strip (29) on each side, made from two $12\frac{1}{2}$ " Strips overlapped eight holes, is bolted in position.

THE BACK OF THE BODY AND THE PLATFORM

The Plates (10) are curved and the lower Plate is fixed to a $3\frac{1}{2}$ " \times $2\frac{1}{2}$ " Flanged Plate bolted to the ends of the chassis girders. The upper plate is attached to a $5\frac{1}{2}$ " Strip fixed vertically to the Flanged Plate, and a second $5\frac{1}{2}$ " Strip (30) is connected to the top corner of the upper Plate (10) by a $3\frac{1}{2}$ " \times $\frac{1}{2}$ " Double Angle Strip.

The Plates (28) are curved and their ends are connected by a $4\frac{1}{2}$ " \times $2\frac{1}{2}$ " Flexible Plate (31) (Fig. 9.11b), but this is spaced from the Plates (28) by a nut on each bolt. The upper rear window consists of two $4\frac{1}{2}$ " and two $2\frac{1}{2}$ " Strips, and to each side of it is bolted a $1\frac{1}{2}$ " radius Curved Plate.

The rear platform is a $2\frac{1}{2}$ " \times $2\frac{1}{2}$ " Flexible Plate edged by a $2\frac{1}{2}$ " and a 2" Strip. It is attached to one of the chassis girders by a $\frac{1}{2}$ " \times $\frac{1}{2}$ " Angle Bracket, and to Girder (23) by a $\frac{1}{2}$ " Corner Angle Bracket. The division (32) (Fig. 9.11b), between the platform and the saloon, is a $2\frac{1}{2}$ " \times $2\frac{1}{2}$ " Flexible Plate, which is fitted with a $4\frac{1}{2}$ " Strip at its inner edge and is bolted to the Girders (3) and (23).

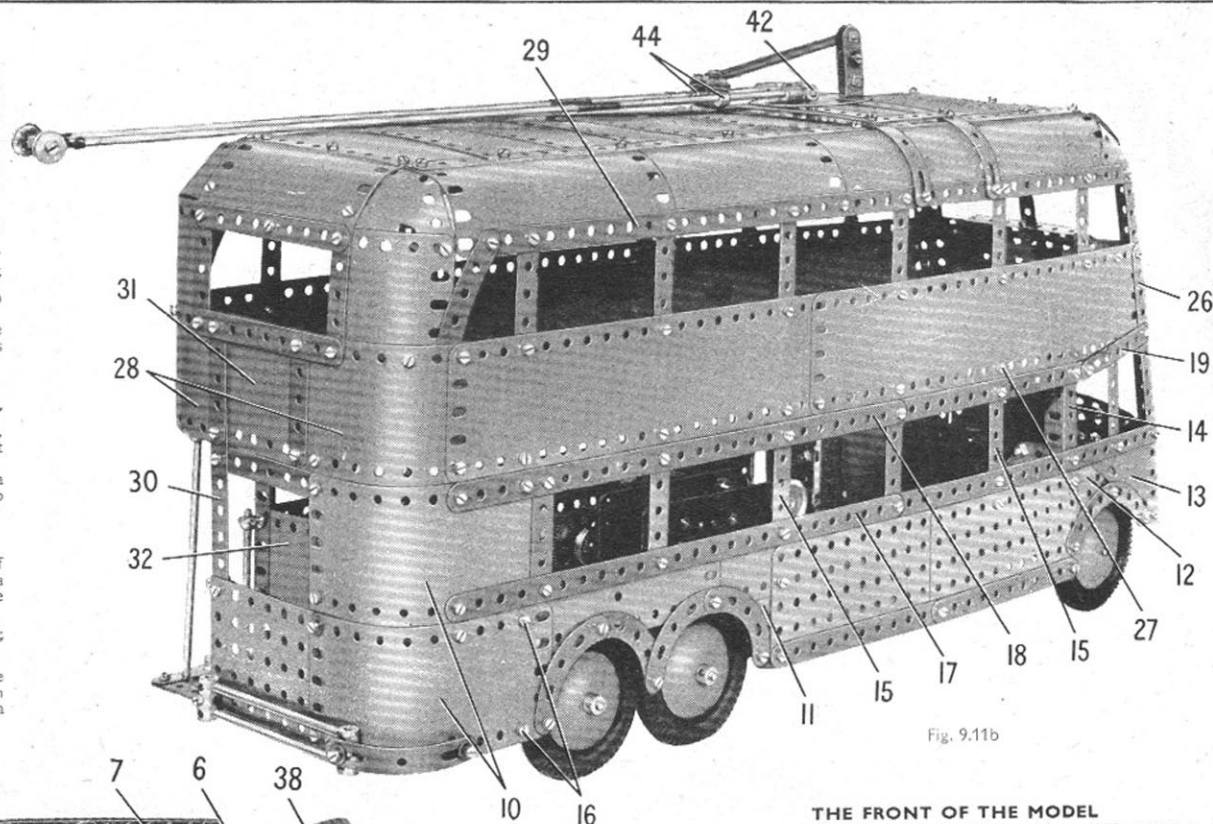

Fig. 9.11b

THE FRONT OF THE MODEL

The front of the driving cab is a $4\frac{1}{2}$ " \times $2\frac{1}{2}$ " Flat Plate extended at each side by a $2\frac{1}{2}$ " \times $1\frac{1}{2}$ " Flexible Plate. It is attached to the top corners of the sides of the cab by $1\frac{1}{2}$ " \times $\frac{1}{2}$ " Angle Brackets, and to the lower corners of the sides of the cab by $5\frac{1}{2}$ " Curved Strips.

The front of the upper saloon is made by bolting a $2\frac{1}{2}$ " \times $1\frac{1}{2}$ " Flexible Plate to each of the Angle Girders (26). The lower edges of these Plates are connected by two $3\frac{1}{2}$ " Strips, and the top edges are joined by a $5\frac{1}{2}$ " Curved Strip. A $3\frac{1}{2}$ " \times $2\frac{1}{2}$ " Flanged Plate (33), fitted with two $3\frac{1}{2}$ " \times $\frac{1}{2}$ " Double Angle Strips, is attached to the Strips and the Curved Strip by Angle Brackets. A $2\frac{1}{2}$ " Strip is bolted to each flange of the Flanged Plate, and a $5\frac{1}{2}$ " Strip is supported by the lower $3\frac{1}{2}$ " \times $\frac{1}{2}$ " Double Angle Strip. To one end of this Strip is bolted a $\frac{1}{2}$ " Reversed Angle Bracket (34).

The rollers for the destination blind are $4\frac{1}{2}$ " Rods mounted in the Flanged Plate (33) as shown in Fig. 9.11d. Each Rod carries a $\frac{1}{2}$ " Pinion and is held in position by a Cord Anchoring Spring. A third $\frac{1}{2}$ " Pinion is fixed on the shank of a Pivot Bolt, which is passed through the flange of the Plate (33). The Pinion is placed between the two Pinions on the $4\frac{1}{2}$ " Rods so that it engages both of them. A $\frac{1}{2}$ " fixed Pulley (35) is held on a $1\frac{1}{2}$ " Rod supported in the Reversed Angle Bracket (34) and the end of the $5\frac{1}{2}$ " Strip. A $\frac{1}{2}$ " loose Pulley is fitted over the Rod, and then a $\frac{1}{2}$ " Contrate is fixed in place so that it engages the lower one of the three $\frac{1}{2}$ " Pinions.

THE DRIVING CABIN

The division between the cabin and lower saloon is formed by the remaining half of the Hinged Flat Plate and a $4\frac{1}{2}$ " \times $2\frac{1}{2}$ " Flexible Plate bolted to Girder (1). A plate (36), made from two $2\frac{1}{2}$ " \times $1\frac{1}{2}$ " Flexible Plates overlapped two holes and edged at the top by two $2\frac{1}{2}$ " Strips, is connected to the front of the cabin by an Angle Bracket. A $3\frac{1}{2}$ " \times $2\frac{1}{2}$ " Flanged Plate (37) (Fig. 9.11a), is also bolted to the front of the cabin, and a $5\frac{1}{2}$ " \times $1\frac{1}{2}$ " Flexible Plate (38) is curved over one of the front wheels and is attached to the side of the cabin by Angle Brackets. The driver's seat is formed from two Girder Brackets bolted together and fixed to two $1\frac{1}{2}$ " \times $\frac{1}{2}$ " Double Angle Strips that are fastened to the division at the back of the cabin.

(Continued on next page)

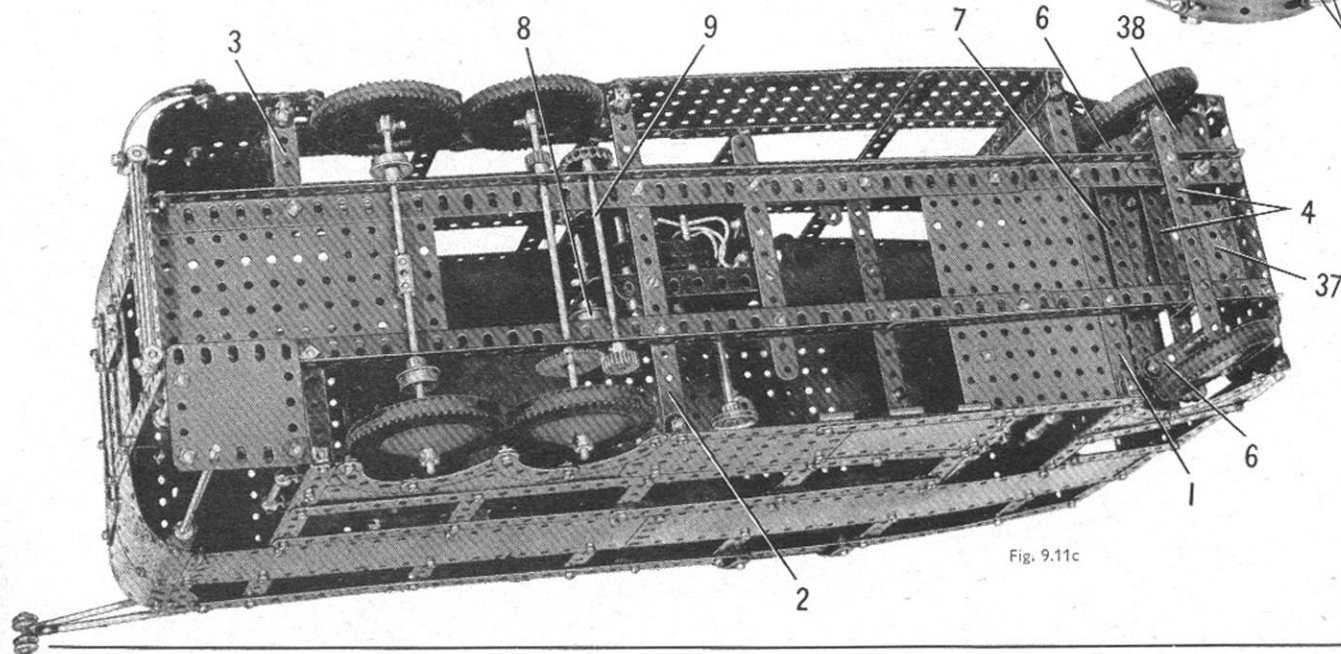

Fig. 9.11c

MODEL 9.11 TROLLEY BUS — Continued

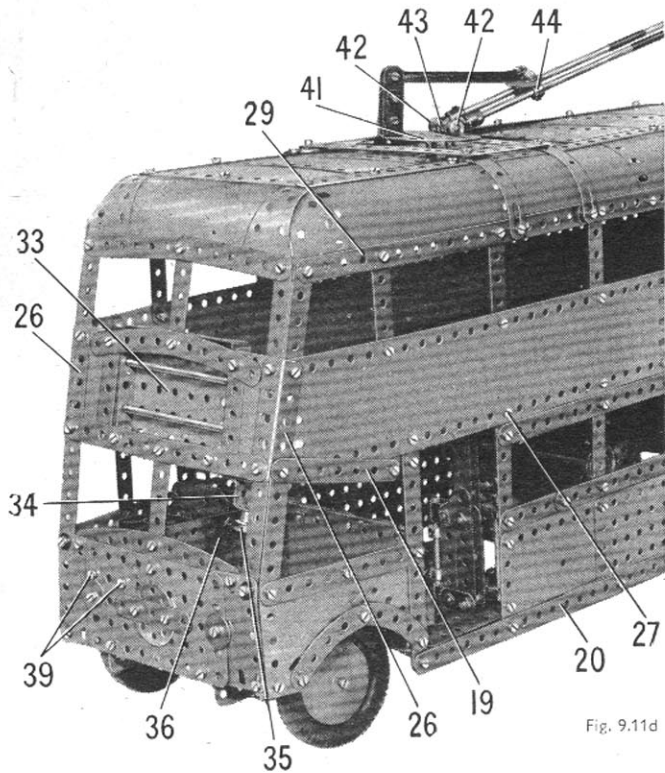

Fig. 9.11d

The steering column is a $3\frac{1}{2}$ " Rod, and it is supported in the hole at the pointed end of a Flat Trunnion and in a round hole in a 2" Slotted Strip fixed to one of the chassis girders. The Flat Trunnion is bolted to a Channel Bearing attached to the front of the cabin by the bolts (39) (Fig. 9.11d). The steering column is held in place by a Slide Piece placed below the steering wheel and by a Collar, and it carries a Double Arm Crank (40) (Fig. 9.11a), to which is bolted a $2\frac{1}{2}$ " Strip. A $4\frac{1}{2}$ " Strip is lock-nutted to the end of the $2\frac{1}{2}$ " Strip and to one of the Cranks (6).

CONSTRUCTION OF THE ROOF

Each of the rounded sides of the roof consists of four Curved $5\frac{1}{2}$ " x $2\frac{1}{2}$ " Flexible Plates edged at their inner ends by overlapped 12 $\frac{1}{2}$ " Strips. The centre of the roof is filled in by seven $5\frac{1}{2}$ " x $2\frac{1}{2}$ " Flexible Plates, a $5\frac{1}{2}$ " x $3\frac{1}{2}$ " and a $5\frac{1}{2}$ " x $2\frac{1}{2}$ " Flat Plate. At the front a $5\frac{1}{2}$ " x $2\frac{1}{2}$ " Flexible Plate is fitted as shown in Fig. 9.11, and each corner is filled in by two $2\frac{1}{2}$ " x $1\frac{1}{2}$ " Triangular Flexible Plates. The rear end of the roof is completed by a $4\frac{1}{2}$ " x $2\frac{1}{2}$ " Flexible Plate and two $2\frac{1}{2}$ " x $2\frac{1}{2}$ " Triangular Flexible Plates, as shown in Fig. 9.11b.

THE TROLLEY BOOMS

The straps that attach the booms to the roof are represented by two Formed Slotted Strips at each side and two $5\frac{1}{2}$ " and two 3" Strips at the centre. The $5\frac{1}{2}$ " and 3" Strips are spaced from the roof by a nut on each of the $\frac{3}{8}$ " Bolts that hold them in place, and the Formed Slotted Strips are spaced from the sides by two Washers on each Bolt.

A Face Plate (41) is fixed on a 1" Rod that is supported in a hole in the roof and in a Double Arm Crank bolted underneath it. The Rod is held in place by a $\frac{3}{4}$ " Contrate placed below the Double Arm Crank.

The trolley booms each consist of an $11\frac{1}{2}$ " and a 5" Rod joined by a Rod Connector. A $\frac{1}{2}$ " loose Pulley is free to turn on a $\frac{3}{8}$ " Bolt gripped by nuts in a Rod and Strip Connector at the upper end of each boom. The lower ends of the booms are fixed in Rod Sockets, each of which is screwed into a Collar (42) and is held in place by a nut. The Collars are fixed on a $1\frac{1}{2}$ " Rod that is free to turn in a Coupling (43). A Bolt is passed through the Face Plate (41), fitted with a nut, and then screwed into a threaded centre hole of the Coupling (43). The nut is then tightened against the Face Plate. The booms are connected by bolts passed through a $1\frac{1}{2}$ " Strip and screwed into Collars (44). Two Washers are placed on each of these bolts. A Spring is bolted to the centre of the $1\frac{1}{2}$ " Strip and is passed over a $\frac{1}{2}$ " Bolt supported in two $1\frac{1}{2}$ " Strips. These Strips are fixed to a Single Bent Strip bolted to the Face Plate (41).

9.12 FORK LIFT TRUCK

Parts Required

8 of No.	1
2 " "	1b
22 " "	2
6 " "	2a
6 " "	3
1 " "	4
28 " "	5
4 " "	6
6 " "	6a
2 " "	7a
4 " "	8
2 " "	8a
2 " "	8b
3 " "	9
2 " "	9d
2 " "	9f
12 " "	10
4 " "	11
35 " "	12
6 " "	12a
2 " "	12b
2 " "	12c
2 " "	13
1 " "	13a
3 " "	14
3 " "	15
4 " "	15a
1 " "	15b
3 " "	16
2 " "	16a
3 " "	18a
1 " "	18b
6 " "	20a
1 " "	20b
1 " "	21
1 " "	23a
2 " "	24
5 " "	26
2 " "	27a

2 of No.	28
1 " "	32
1 " "	35
333 " "	37a
314 " "	37b
35 " "	38
2 " "	38d

2 of No.	45
1 " "	46
1 " "	48a
6 " "	48b
2 " "	48d

1 of No.	50
4 " "	52a
3 " "	53
2 " "	53a
1 " "	55a
12 " "	59
2 " "	62
1 " "	62b
6 " "	63
2 " "	70
1 " "	80c
4 " "	90
4 " "	90a
1 " "	94

2 of No.	96
2 " "	100
2 " "	111
2 " "	111a
4 " "	111c
2 " "	115
1 " "	116
1 " "	116a
2 " "	124
4 " "	125
4 " "	126
3 " "	126a
2 " "	133a
1 " "	136
6 " "	142a
2 " "	147b
1 " "	154a
1 " "	154b
2 " "	161
2 " "	165
2 " "	179
1 " "	185
3 " "	188
4 " "	189
2 " "	190
2 " "	191
4 " "	200
2 " "	212
2 " "	212a
1 " "	213
4 " "	214
8 " "	215
4 " "	221
2 " "	224
2 " "	225

1 E20R Electric Motor

(Not included in Outfit)

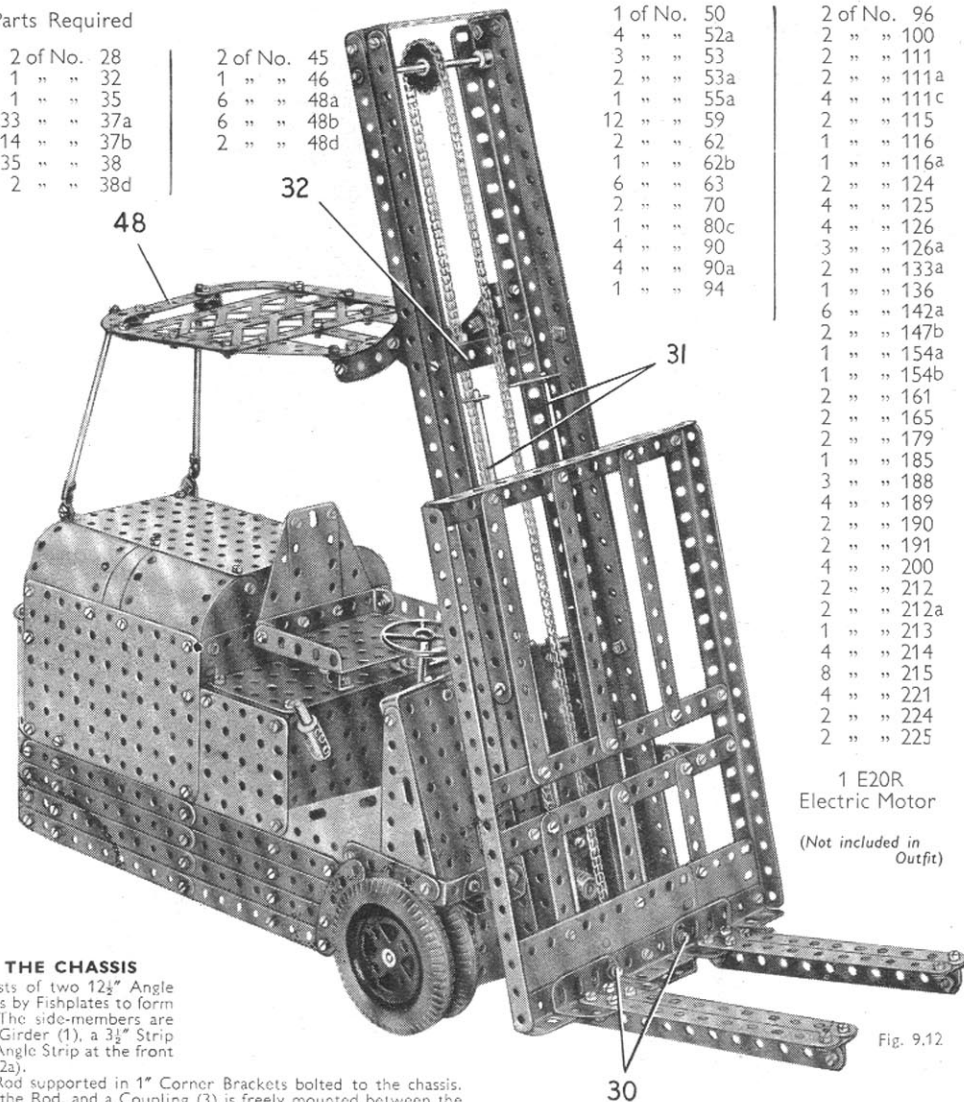

Fig. 9.12

CONSTRUCTION OF THE CHASSIS

Each side-member consists of two 12 $\frac{1}{2}$ " Angle Girders joined at their ends by Fishplates to form a channel section girder. The side-members are connected by a 5 $\frac{1}{2}$ " Angle Girder (1), a 3 $\frac{1}{2}$ " Strip (2), and a 3 $\frac{1}{2}$ " x $\frac{3}{8}$ " Double Angle Strip at the front of the chassis (see Fig. 9.12a).

The front axle is a 6 $\frac{1}{2}$ " Rod supported in 1" Corner Brackets bolted to the chassis. A 1 $\frac{1}{2}$ " Contrate is fixed to the Rod, and a Coupling (3) is freely mounted between the Contrate and a Collar.

The rear wheels are free to turn on a 2 $\frac{1}{2}$ " Rod supported in the end holes of two 2 $\frac{1}{2}$ " Strips on each side. The upper ends of these Strips are bolted to 1 $\frac{1}{2}$ " Angle Girders, which are fixed to a 1 $\frac{1}{2}$ " Pulley (4) (Fig. 9.12b). A 1 $\frac{1}{2}$ " Rod is fixed in the Pulley and is mounted in a 2 $\frac{1}{2}$ " x 1" Double Angle Strip (5) and a Double Bent Strip. The Double Angle Strip is bolted to two 1" x $\frac{3}{4}$ " Angle Brackets fixed to the chassis. The 1 $\frac{1}{2}$ " Rod is held in place by a Slide Piece, and a Swivel Bearing (6) is fixed to one end of the rear axle (Fig. 9.12a).

THE POWER UNIT AND GEAR BOX

An E20R Electric Motor is supported by 1 $\frac{1}{2}$ " Strips and Angle Brackets attached to the Girder (1) and the chassis, as shown in Fig. 9.12b. A $\frac{1}{2}$ " Pinion on the Motor shaft drives a 1 $\frac{1}{2}$ " Contrate on a 5" Rod (7). This Rod is the main shaft of the gear box.

(Continued on next page)

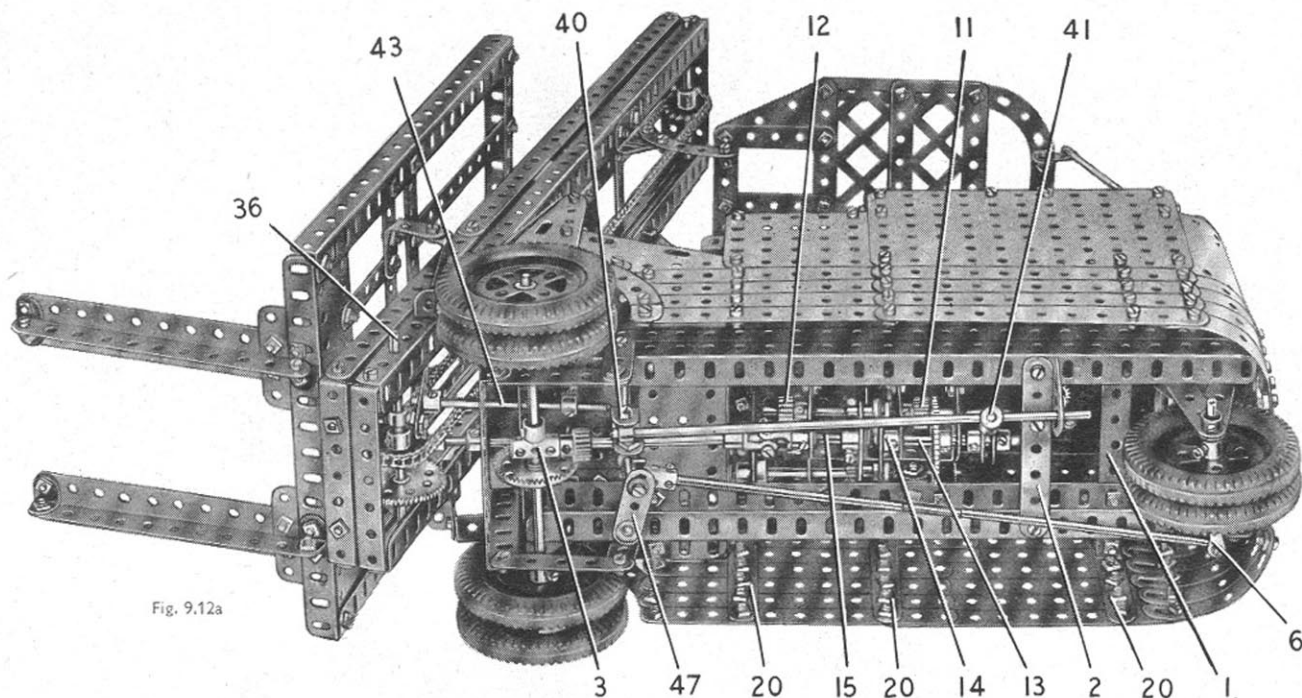

Fig. 9.12a

MODEL 9.12 FORK LIFT TRUCK — Continued

The gear-box frame consists of a $2\frac{1}{2}'' \times \frac{1}{2}''$ Double Angle Strip (8) on each side bolted to two $3\frac{1}{2}''$ Strips (9). A Flat Trunnion, with its pointed end downward, is fixed to each of the Strips (9), and another Flat Trunnion is attached to Angle Brackets held by a bolt (10) on each side (Fig. 9.12b). The ends of the Strips (9) are connected by Angle Brackets to the chassis.

The Rod (7) is supported in the Strips (9) and the Flat Trunnions, and it carries two $\frac{1}{2}''$ Pinions seen at (11) and (12) (Figs. 9.12a and 9.12b). The Pinion (11) is positioned on the Rod so that a 57-tooth Gear on a $2\frac{1}{2}''$ Rod (13) can be moved into mesh with the Pinion by sliding the Rod. The Rod (13) is mounted in the holes at the pointed ends of two of the Flat Trunnions, and it carries a Bush Wheel (14) fitted with two Threaded Pins. The Threaded Pins pass freely through holes in a second Bush Wheel on a $1\frac{1}{2}''$ Rod (15), which is supported in the third Flat Trunnion. Rod (15) is fitted with a built-up universal coupling, made from a Swivel Bearing and a small Fork Piece. A $3\frac{1}{2}''$ Rod fixed in this Coupling is mounted freely in the Coupling (3), and a $\frac{1}{2}''$ Pinion on the Rod engages the Contrate on the front axle.

ASSEMBLY OF THE BODY

A $3\frac{1}{2}'' \times 2\frac{1}{2}''$ Flanged Plate (16) is attached to the Double Angle Strip at the front by two $\frac{1}{2}''$ Reversed Angle Brackets, and is connected at its lower end to the chassis by $1\frac{1}{2}''$ and $2\frac{1}{2}''$ Strips as shown in Fig. 9.12a. A $5\frac{1}{2}'' \times \frac{1}{2}''$ Double Angle Strip (17) is bolted to the top of Plate (16), and a $5\frac{1}{2}'' \times 3\frac{1}{2}''$ Flat Plate is attached to the Double Angle Strip by Obtuse Angle Brackets. A further $5\frac{1}{2}'' \times \frac{1}{2}''$ Double Angle Strip is connected to the top of the Flat Plate by Angle Brackets, and $3\frac{1}{2}'' \times 2''$ and $3\frac{1}{2}'' \times 1\frac{1}{2}''$ Triangular Flexible Plates on each side are fixed in place as shown.

Two $5\frac{1}{2}''$ Angle Girders (18) (Figs. 9.12b and 9.12c), are fixed across the chassis above a $5\frac{1}{2}'' \times 1\frac{1}{2}''$ Flexible Plate, and to one of the Angle Girders a $5\frac{1}{2}'' \times 2\frac{1}{2}''$ Flat Plate (19) is bolted.

The lower part of each side of the body consists of eight $5\frac{1}{2}''$ Strips and four Formed Slotted Strips bolted to $2\frac{1}{2}''$ Strips (20). This section of the side is connected by Angle Brackets to the Girders (1) and (18) and to the rear of the chassis.

The upper part of each side is formed by a $5\frac{1}{2}'' \times 3\frac{1}{2}''$ and a $4\frac{1}{2}'' \times 2\frac{1}{2}''$ Flat Plate, extended upward by a curved $2\frac{1}{2}'' \times 1\frac{1}{2}''$ Flexible Plate and two $1\frac{1}{2}''$ radius Curved Plates. The Curved Plates are connected at the top by a $5\frac{1}{2}'' \times 3\frac{1}{2}''$ Flat Plate. The back is filled in by two $4\frac{1}{2}'' \times 2\frac{1}{2}''$ Flexible Plates bolted to the sides. These Plates are curved and their ends are overlapped two holes. A $3\frac{1}{2}''$ Strip (21), with a $5\frac{1}{2}''$ Strip attached to it by two $2\frac{1}{2}''$ Stepped Curved Strips, is connected to the Flexible Plates by Angle Brackets. Above these Strips the back is filled in by a $3\frac{1}{2}'' \times 2\frac{1}{2}''$ Flanged Plate and two Semi-Circular Plates bolted to Angle Brackets.

A $5\frac{1}{2}'' \times 2\frac{1}{2}''$ Flat Plate (22) is bolted to $2\frac{1}{2}''$ Angle Girders fixed to the sides. The driving seat is a $3\frac{1}{2}'' \times 2\frac{1}{2}''$ Flanged Plate supported by two $\frac{1}{2}''$ Reversed Angle Brackets. The back of the seat is made from a $2\frac{1}{2}'' \times 1\frac{1}{2}''$ Flexible Plate and two $2\frac{1}{2}'' \times 1\frac{1}{2}''$ Triangular Flexible Plates bolted to a $3\frac{1}{2}'' \times \frac{1}{2}''$ Double Angle Strip.

Behind the seat the body is filled in by a $5\frac{1}{2}'' \times 1\frac{1}{2}''$ and two $2\frac{1}{2}'' \times 2\frac{1}{2}''$ Flexible Plates, and two Semi-Circular Plates fixed to Angle Brackets.

The upper section of the body is made as a unit, and is bolted to the Strips (20) when the mechanism is completely assembled.

THE SLIDES AND THE LIFTING FORKS

Each girder of the slide (Fig. 9.12c) consists of an $18\frac{1}{2}''$ Angle Girder (23) and a built-up strip (24) connected by Fishplates, but a gap, obtained by making use of the slotted holes in the Fishplates, is left between them. The strip (24) is made from four $12\frac{1}{2}''$ Strips arranged in pairs face to face, with the pairs overlapped 13 holes. The slide girders are connected at each end by two $3\frac{1}{2}'' \times \frac{1}{2}''$ Double Angle Strips.

A Corner Angle Bracket (25) and a $1'' \times 1''$ Angle Bracket (26) are attached to each girder. The Corner Angle Brackets are bolted to Double Brackets (27) (Fig. 9.12d), and the Angle Brackets are attached to Fishplates (28).

The frame of the lifting forks consists of two $9\frac{1}{2}''$ and two $7\frac{1}{2}''$ Angle Girders bolted together and fitted with Strips as shown in Figs. 9.12 and 9.12c. Each of the forks consists of three $5\frac{1}{2}''$ Strips connected by Fishplates and Angle Brackets to make a 'T'-section girder, which is attached to Girder Brackets bolted to the frame.

A Coupling (29) on each side is attached to the back of the frame by a $\frac{1}{2}''$ Bolt (30) (Fig. 9.12), but is spaced from the frame by a Washer and three nuts on the Bolt. These Couplings slide freely on $11\frac{1}{2}''$ Rods (31), each of which is fixed at its lower end in a Rod Socket and is supported at the top in a $1'' \times 1''$ Angle Bracket bolted to a $3\frac{1}{2}''$ Strip (32). A $1''$ Reversed Angle Bracket (33) on each side is bolted to a $1'' \times 1''$ Angle Bracket fixed to the frame. The free lug of the Reversed Angle Bracket slides between the Girder (23) and the strip (24).

(Continued on next page)

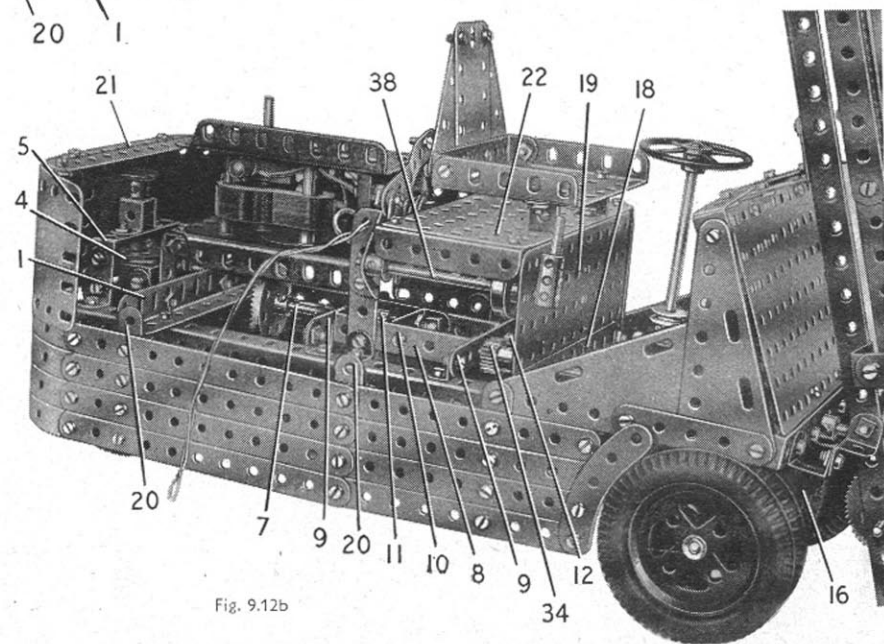

Fig. 9.12b

9.12 FORK LIFT TRUCK — Continued

THE HOISTING MECHANISM

A $6\frac{1}{2}$ " Rod, fitted with a $\frac{1}{2}$ " Pinion (34) and a Worm (35) (Figs. 9.12b and 9.12d), is mounted in the Girders (18) and the Plate (16). The Pinion (34) is in constant mesh with the Pinion (12). A 57-tooth Gear is positioned on a $4\frac{1}{2}$ " Rod (36) (Fig. 9.12c), so that by sliding the Rod the Gear is moved into mesh with the Worm (35). A 1" Sprocket on Rod (36) is connected by Chain to a similar Sprocket on a 4" Rod supported at the top of the fork slides. The Chain is fastened by a short piece of Cord to a Double Bracket (37).

ARRANGEMENT OF THE CONTROLS

A 3" Strip is *lock-nutted* to the Motor switch and to a Crank on a $3\frac{1}{2}$ " Rod (38) (Fig. 9.12b). This Rod is supported in the Plate (19) and in a Trunnion bolted to a flange of the Motor. A 1" Rod in a Coupling on Rod (38) forms the control lever.

The drive to the wheels is engaged by moving a lever (39), formed by a $4\frac{1}{2}$ " Rod held in a Handrail Support that is *lock-nutted* to an Angle Bracket bolted to the chassis. A large Fork Piece (40) (Fig. 9.12a), is fixed to the lower end of the lever, and an 8" Rod is held in a Collar pivoted on bolts passed through the lugs of the Fork Piece. The other end of this Rod is supported in a Trunnion bolted to Strip (2), and it carries a Coupling (41) fitted with a 2" Rod. The 2" Rod is located between two $\frac{1}{2}$ " Washers placed between Collars on the end of Rod (13).

The hoist to the forks is engaged by moving a lever (42), formed by a Screwed Rod fixed by a nut in the threaded hole of a Collar. This Collar is fixed on a $3\frac{1}{2}$ " Rod (43) (Fig. 9.12a), supported in the Plate (16) and in the Double Angle Strip at the front of the chassis. A Double Arm Crank, which is fitted with a $\frac{1}{2}$ " Bolt (44), (Fig. 9.12d), is fixed to the front end of Rod (43). This Bolt engages between a Collar and the 1" Sprocket on Rod (36).

A cover plate (45) (Fig. 9.12e), is made from Strips of various sizes arranged to leave gaps to accommodate the levers. The Strips are bolted to $2\frac{1}{2}$ " x $\frac{1}{2}$ " Double Angle Strips attached by bolts (46) to one of the Girders (18).

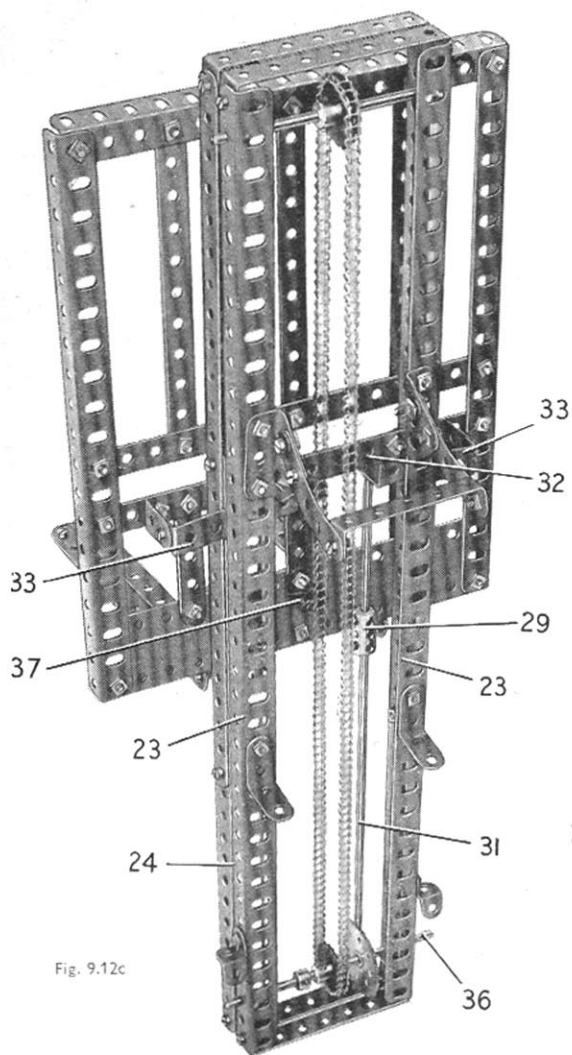

Fig. 9.12c

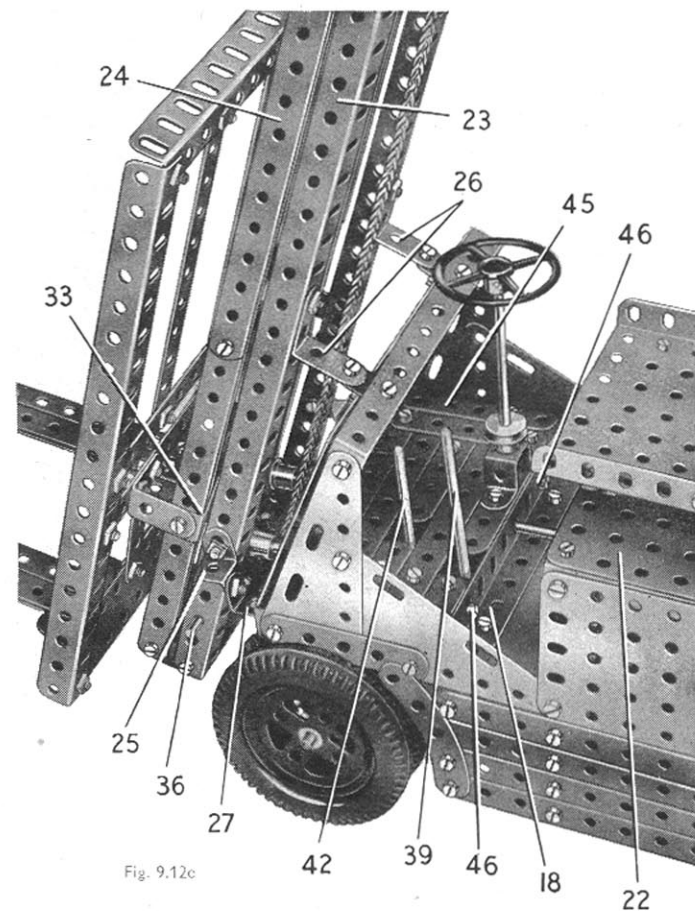

Fig. 9.12c

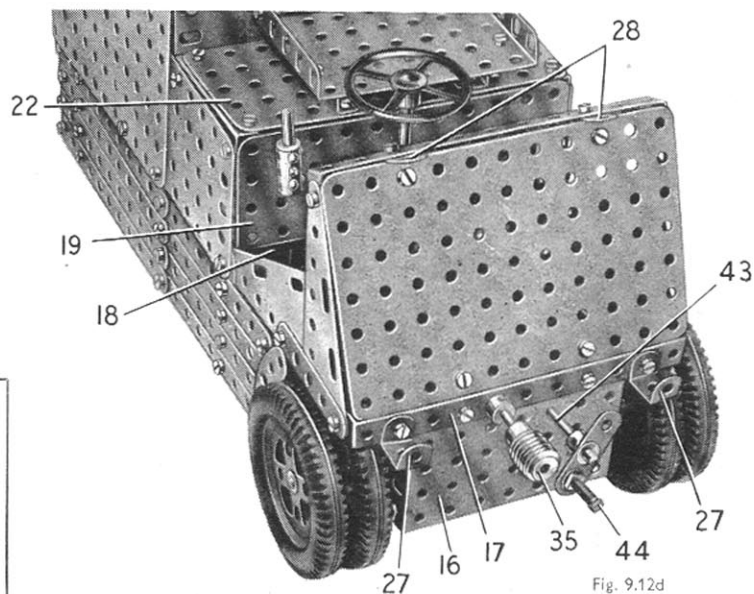

Fig. 9.12d

THE STEERING MECHANISM

The steering column is a $6\frac{1}{2}$ " Rod supported in the cover plate (45) and in a Double Bent Strip, and is held in place by a $\frac{1}{2}$ " fixed Pulley and a Collar. A Crank (47) is fixed to the lower end of the Rod and a Coupling is pivoted to it by a *lock-nutted* $\frac{3}{8}$ " Bolt. A $4\frac{1}{2}$ " Rod in the Coupling is joined by a Rod Connector to a 5" Rod held in the Swivel Bearing (6).

When the body is bolted in position, a guard is fitted over the driver's seat as shown in Fig. 9.12. Two $2\frac{1}{2}$ " Curved Strips are attached to Trunnions bolted to the slides, and are joined at their other ends by a $2\frac{1}{2}$ " x $\frac{1}{2}$ " Double Angle Strip. A $2\frac{1}{2}$ " and a 2" Strip, overlapped two holes, are bolted to this Double Angle Strip, and are connected by three $2\frac{1}{2}$ " Strips and two $2\frac{1}{2}$ " x $1\frac{1}{2}$ " Triangular Flexible Plates, to two $5\frac{1}{2}$ " Braced Girders bolted together. Two $2\frac{1}{2}$ " Stepped Curved Strips bolted to the rear one of the two Braced Girders are joined by a $2\frac{1}{2}$ " x $\frac{1}{2}$ " Double Angle Strip (48). Two $4\frac{1}{2}$ " Rods, fitted with Rod and Strip Connectors and Right-Angle Rod and Strip Connectors, are attached to the Double Angle Strip and to Angle Brackets bolted to the body.

For new models and mechanisms to build

see the

'MECCANO MAGAZINE'

which is published monthly

9.13 GANTRY CRANE

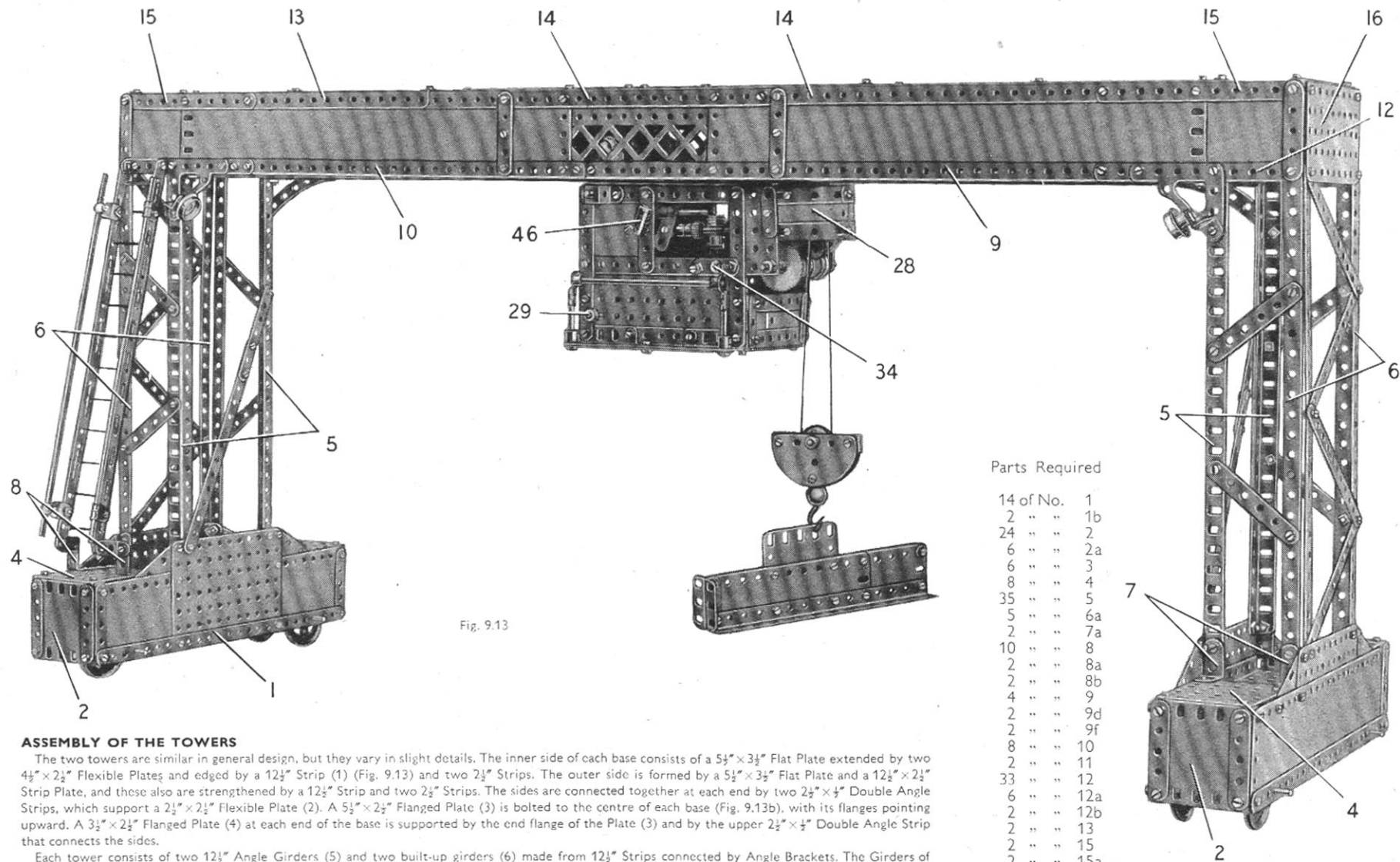

Fig. 9.13

ASSEMBLY OF THE TOWERS

The two towers are similar in general design, but they vary in slight details. The inner side of each base consists of a $5\frac{1}{2}'' \times 3\frac{1}{2}''$ Flat Plate extended by two $4\frac{1}{2}'' \times 2\frac{1}{2}''$ Flexible Plates and edged by a $12\frac{1}{2}''$ Strip (1) (Fig. 9.13) and two $2\frac{1}{2}''$ Strips. The outer side is formed by a $5\frac{1}{2}'' \times 3\frac{1}{2}''$ Flat Plate and a $12\frac{1}{2}'' \times 2\frac{1}{2}''$ Strip Plate, and these also are strengthened by a $12\frac{1}{2}''$ Strip and two $2\frac{1}{2}''$ Strips. The sides are connected together at each end by two $2\frac{1}{2}'' \times \frac{1}{2}''$ Double Angle Strips, which support a $2\frac{1}{2}'' \times 2\frac{1}{2}''$ Flexible Plate (2). A $5\frac{1}{2}'' \times 2\frac{1}{2}''$ Flanged Plate (3) is bolted to the centre of each base (Fig. 9.13b), with its flanges pointing upward. A $3\frac{1}{2}'' \times 2\frac{1}{2}''$ Flanged Plate (4) at each end of the base is supported by the end flange of the Plate (3) and by the upper $2\frac{1}{2}'' \times \frac{1}{2}''$ Double Angle Strip that connects the sides.

Each tower consists of two $12\frac{1}{2}''$ Angle Girders (5) and two built-up girders (6) made from $12\frac{1}{2}''$ Strips connected by Angle Brackets. The Girders of one base are bolted to the $5\frac{1}{2}'' \times 3\frac{1}{2}''$ Flat Plates and are connected to the Flanged Plates (4) by $1'' \times 1''$ Angle Brackets (7) (Fig. 9.13). The Girders of the other base are supported similarly, except that two of the $1'' \times 1''$ Angle Brackets are replaced by $2\frac{1}{2}'' \times 1''$ Double Angle Strips (8).

DETAILS OF THE GANTRY

Each side girder of the gantry consists of two $5\frac{1}{2}'' \times 2\frac{1}{2}''$ Flexible Plates, two $12\frac{1}{2}'' \times 2\frac{1}{2}''$ Strip Plates, two $2\frac{1}{2}'' \times 2\frac{1}{2}''$ Flexible Plates and a $5\frac{1}{2}''$ Braced Girder. The $5\frac{1}{2}'' \times 2\frac{1}{2}''$ Flexible Plates overlap the Strip Plates by six holes each. The lower edges of the Plates are strengthened by an $18\frac{1}{2}''$ Angle Girder (9), a $12\frac{1}{2}''$ (Continued on next page)

Parts Required

14 of No.	1		
2 "	1b		
24 "	2		
6 "	2a		
6 "	3		
8 "	4		
35 "	5		
5 "	6a		
2 "	7a		
10 "	8		
2 "	8a		
2 "	8b		
4 "	9		
2 "	9d		
2 "	9f		
8 "	10		
2 "	11		
33 "	12		
6 "	12a		
2 "	12b		
2 "	13		
2 "	15		
2 "	15a		
2 "	15b		
5 "	16		
3 "	16a	4 of No.	20b
4 "	17	1 "	22
2 "	18a	1 "	22a
4 "	20	2 "	23
6 "	20a	1 "	25
		5 of No.	26
		1 "	27
		2 "	27a
		2 "	28
		1 "	32
349 of No.	37a		
319 "	37b		
31 "	38		
1 "	40		
1 "	45		
2 "	46		
2 "	48		
10 "	48a		
6 "	48b		
2 "	51		
2 "	52		
4 "	52a		
5 "	53		
2 "	53a		
2 "	54		
1 "	57b		
12 "	59		
2 "	62		
1 "	62b		
6 "	63		
2 "	70		
2 "	89b		
2 "	90a		
2 "	100		
2 "	108		
3 "	111		
6 "	111a		
12 "	111c		
1 "	120b		
1 "	125		
2 "	136		
1 "	147b		
1 "	154a		
1 "	154b		
1 "	160		
2 "	161		
1 "	163		
1 "	166		
2 "	179		
1 "	186		
10 "	188		
10 "	189		
14 "	190		
6 "	191		
18 "	192		
6 "	197		
1 "	198		
2 "	212a		
2 "	213		
2 "	214		
4 "	215		
4 "	221		
2 "	223		
2 "	225		
		1 E20R	
		Electric Motor	
		(Not included in	
		Outfit)	

MODEL 9.13 GANTRY CRANE — Continued

Angle Girder (10) and a $2\frac{1}{2}$ " Angle Girder (11) (Fig. 9.13b). The lower sides of the $5\frac{1}{2}$ " \times $2\frac{1}{2}$ " Flexible Plates are edged by $5\frac{1}{2}$ " Strips (12). The top edge of each side of the gantry is strengthened by a $9\frac{1}{2}$ " Angle Girder (13) that overlaps one of two $12\frac{1}{2}$ " Angle Girders (14) by two holes. A $5\frac{1}{2}$ " Strip (15) at each end overlaps one of the Girders by six holes.

The sides of the gantry are connected at each end by a $4\frac{1}{2}$ " \times $2\frac{1}{2}$ " Flat Plate (16), attached by Angle Brackets.

The top of the gantry is filled in by a Hinged Flat Plate (17) at the centre. Six $5\frac{1}{2}$ " \times $2\frac{1}{2}$ " Flexible Plates, a Flanged Sector Plate (18), and a $4\frac{1}{2}$ " \times $2\frac{1}{2}$ " Flexible Plate (19) (Fig. 9.13b), are bolted on either side of the Hinged Flat Plate. The Flexible Plates (19) are attached to the Flat Plates (16) by Angle Brackets. Two $4\frac{1}{2}$ " Strips, one of them seen at (20) (Fig. 9.13b), are bolted to the Angle Brackets fixed to the centre holes at the inner ends of the Strip Plates.

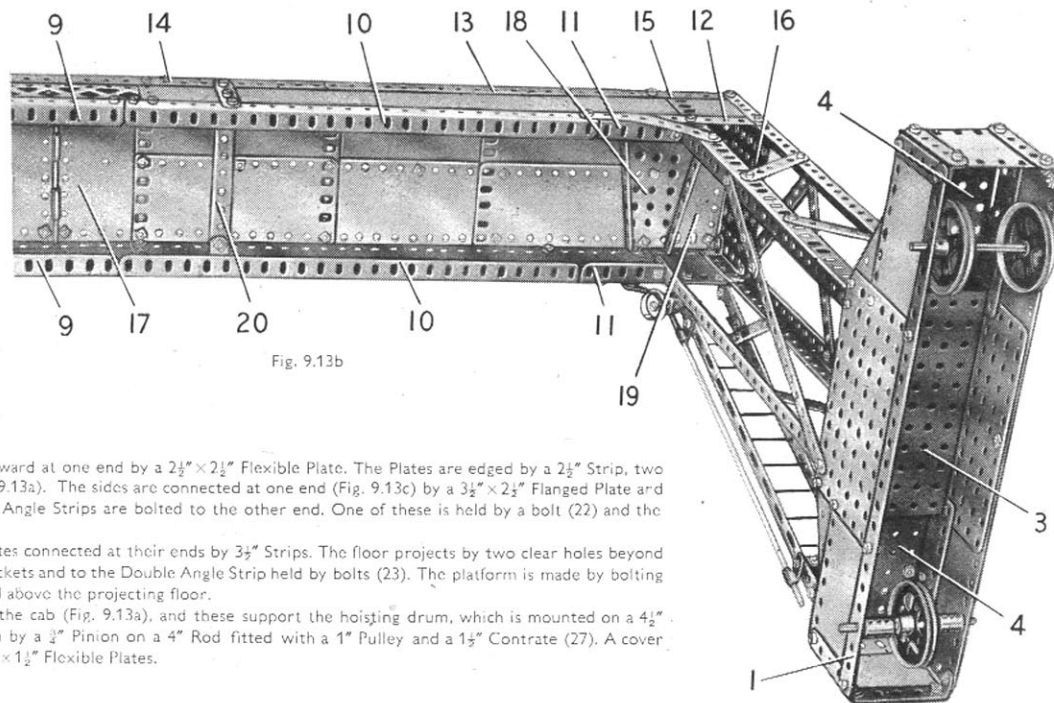

Fig. 9.13b

CAB AND HOIST

Each side of the cab is a $5\frac{1}{2}$ " \times $2\frac{1}{2}$ " Flat Plate extended upward at one end by a $2\frac{1}{2}$ " \times $2\frac{1}{2}$ " Flexible Plate. The Plates are edged by a $2\frac{1}{2}$ " Strip, two $4\frac{1}{2}$ " Strips, two $5\frac{1}{2}$ " Strips and a $5\frac{1}{2}$ " Angle Girder (21) (Fig. 9.13a). The sides are connected at one end (Fig. 9.13c) by a $3\frac{1}{2}$ " \times $2\frac{1}{2}$ " Flanged Plate and two $3\frac{1}{2}$ " \times $\frac{1}{2}$ " Double Angle Strips, and two $3\frac{1}{2}$ " \times $\frac{1}{2}$ " Double Angle Strips are bolted to the other end. One of these is held by a bolt (22) and the other by a bolt (23) on each side.

The floor of the cab consists of two $5\frac{1}{2}$ " \times $2\frac{1}{2}$ " Flexible Plates connected at their ends by $3\frac{1}{2}$ " Strips. The floor projects by two clear holes beyond one side of the cab, and is attached to the sides by Angle Brackets and to the Double Angle Strip held by bolts (23). The platform is made by bolting two Girder Brackets to the side so that they are positioned above the projecting floor.

A $2\frac{1}{2}$ " \times $1\frac{1}{2}$ " Flanged Plate (24) is bolted to each side of the cab (Fig. 9.13a), and these support the hoisting drum, which is mounted on a $4\frac{1}{2}$ " Rod that carries also a 50-tooth Gear. This Gear is driven by a $\frac{1}{2}$ " Pinion on a 4" Rod fitted with a 1" Pulley and a $1\frac{1}{2}$ " Contrate (27). A cover plate (28) for the hoisting mechanism is made from two $2\frac{1}{2}$ " \times $1\frac{1}{2}$ " Flexible Plates.

POWER UNIT AND HOIST MECHANISM

An E20R Electric Motor is bolted by its flanges to one side of the cab, and a $2\frac{1}{2}$ " Rod (29) is fixed in an End Bearing that is *lock-nutted* to the lower arm of the Motor switch. A Worm (30) (Fig. 9.13c) is fixed on the Motor armature shaft.

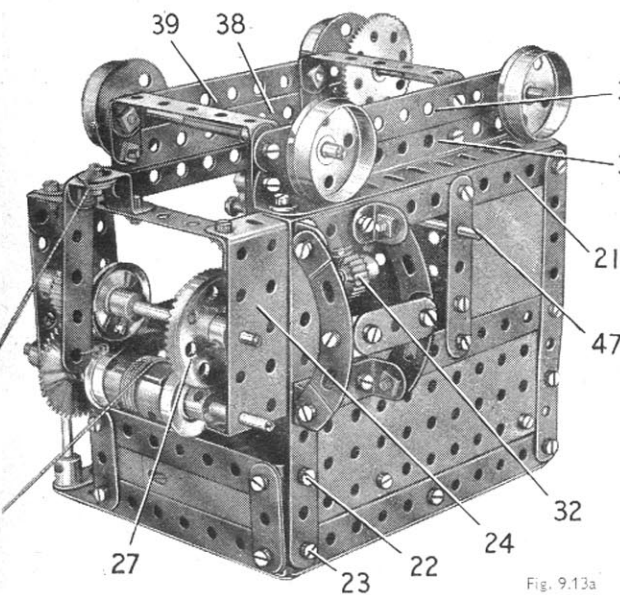

Fig. 9.13a

The driving shaft to the hoist is a $2\frac{1}{2}$ " Rod supported in a Channel Bearing (31) bolted to the Motor. The Rod carries a $\frac{1}{2}$ " Pinion (32) (Fig. 9.13a), a Collar and a second $\frac{1}{2}$ " Pinion (33). A Compression Spring is placed on the Rod between Pinion (32) and the Channel Bearing, and the Rod is free to slide about $\frac{1}{4}$ " in its bearings. The Compression Spring tends to move the Rod so that Pinion (32) engages the Worm (30), but by turning a Double Arm Crank (34) the Rod can be moved to disengage the Worm and the Pinion. The Double Arm Crank is fixed on a 4" Rod which is mounted in the sides of the cab and carries a Crank fitted with a $\frac{3}{8}$ " Bolt (35). This Bolt engages between the Pinion (33) and the Collar. A $\frac{1}{2}$ " Bolt (36) held by two nuts in the Double Arm Crank, is adjusted so that it can be pushed into a hole in the side of the cab. When the Bolt (36) is pushed into the hole the Pinion is held clear of the Worm.

The $\frac{1}{2}$ " Pinion (33) is in constant mesh with the $1\frac{1}{2}$ " Contrate. A brake for the hoist drum is provided by a $2\frac{1}{2}$ " Strip, which is *lock-nutted* to an Angle Bracket. The Angle Bracket is bolted to a $\frac{1}{2}$ " Reversed Angle Bracket supported by a $3\frac{1}{2}$ " \times $\frac{1}{2}$ " Double Angle Strip fixed between the top flanges of the Flanged Plates (24). The Strip is held against the groove of the 1" Pulley by a Driving Band looped through the Strip and tied by Cord to the Motor side-plate.

The pulley block consists of two Semi-Circular Plates connected by two Double Brackets, with a large Loaded Hook attached to the Plates by a $\frac{1}{2}$ " Bolt. A 1" loose Pulley is placed between two $\frac{1}{2}$ " loose Pulleys on a $1\frac{1}{2}$ " Rod that is held in

position by Collars. A length of Cord tied to the hoisting drum is passed round the 1" loose Pulley, and is tied to the $\frac{1}{2}$ " Reversed Angle Bracket that supports the brake lever.

CAB DRIVING MECHANISM

A $5\frac{1}{2}$ " Angle Girder (38) is bolted to each of the Girders (21), and a $5\frac{1}{2}$ " Strip (39) is connected to each Girder (38) by two Fishplates. These Strips are joined across by two $2\frac{1}{2}$ " \times $\frac{1}{2}$ " Double Angle Strips, which are spaced from the Strips by a Washer on each bolt.

The $1\frac{1}{2}$ " Flanged Wheels on which the cab travels are fixed on axles each made from two 2" Rods joined by a Rod Connector. One of the axles carries a 57-tooth Gear, and this engages a $\frac{1}{2}$ " Pinion (40) on a $2\frac{1}{2}$ " Rod that is supported in one side of the cab and in a Double Bent Strip bolted to it. A $1\frac{1}{2}$ " Contrate (41) is also fixed on this Rod, and it is driven by a $\frac{1}{2}$ " Pinion on a $3\frac{1}{2}$ " Rod. The $3\frac{1}{2}$ " Rod is mounted in the $3\frac{1}{2}$ " \times $2\frac{1}{2}$ " Flanged Plate at one end of the cab and in a $3\frac{1}{2}$ " \times $\frac{1}{2}$ " Double Angle Strip (42). A 57-tooth Gear (43) on the $3\frac{1}{2}$ " Rod engages a $\frac{1}{2}$ " Pinion on a 5" Rod (44), which is supported in the $3\frac{1}{2}$ " \times $2\frac{1}{2}$ " Flanged Plate and in the Channel Bearing (31). Rod (44) is free to slide about $\frac{1}{4}$ " in its bearings, and it carries a $\frac{1}{2}$ " Pinion (45) that can be moved into mesh with the Worm (30) by sliding the Rod.

The sliding movement of Rod (44) is controlled by turning a Coupling (46) on a $4\frac{1}{2}$ " Rod (47) (Fig. 9.13a), which is supported in the sides of the cab and is held in place by a Coupling. A Crank fixed on Rod (47) is fitted in its centre hole with a $\frac{3}{8}$ " Bolt held in place by a nut. The shank of this Bolt engages between a Collar on Rod (44) and the boss of the Pinion that engages the Gear (43).

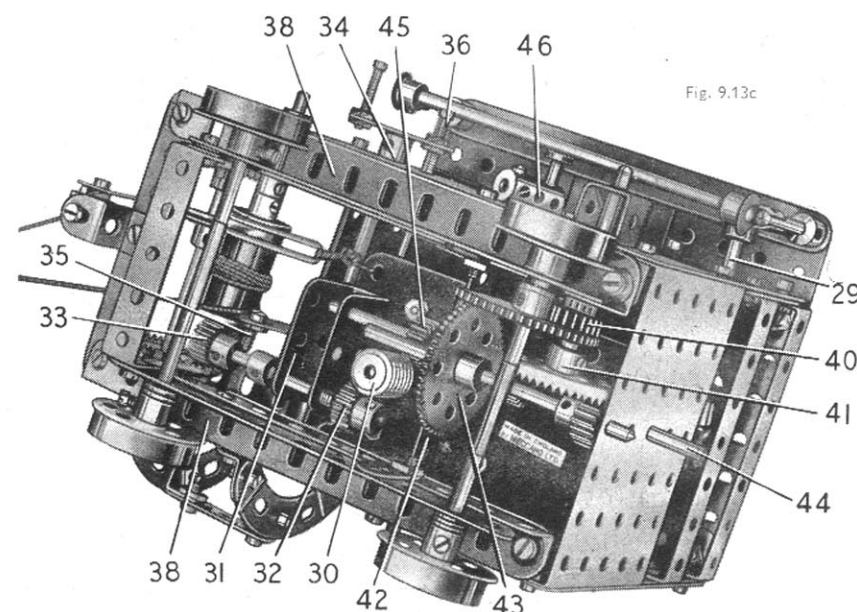

Fig. 9.13c

9.14 VERTICAL MILLING MACHINE

CONSTRUCTION OF THE BASE

The frame for the base consists of two $12\frac{1}{2}$ " Angle Girders (1) connected at the front by a built-up girder (2) made from two $12\frac{1}{2}$ " Strips. One of these Strips is connected to the Girders (1) by Angle Brackets. At the rear a $12\frac{1}{2}$ " Angle Girder (3) is attached to the Girders (1) by Angle Brackets, and a $12\frac{1}{2}$ " Strip (4) (Fig. 9.14a), is also fixed to Angle Brackets bolted to the Girders (1). Two $18\frac{1}{2}$ " Angle Girders (5) are bolted vertically to the Girder (3), and two $7\frac{1}{2}$ " Angle Girders (6) are fixed to the Girders (5) and to the flanges of a $3\frac{1}{2}$ " x $2\frac{1}{2}$ " Flanged Plate (11) bolted to the Strip (4).

The base is filled in as shown in Figs. 9.14 and 9.14a by Plates of various sizes supported by $12\frac{1}{2}$ " and $5\frac{1}{2}$ " Strips.

THE VERTICAL COLUMN

Two $5\frac{1}{2}$ " x $2\frac{1}{2}$ " Flexible Plates, extended upward by $2\frac{1}{2}$ " x $1\frac{1}{2}$ " Flexible Plates, are bolted to each end of the Girder (3) (Fig. 9.14c). The edge of the outer $5\frac{1}{2}$ " x $2\frac{1}{2}$ " Flexible Plate is strengthened by a $5\frac{1}{2}$ " Strip on the inside, and a $4\frac{1}{2}$ " x $\frac{1}{2}$ " Double Angle Strip is bolted along the top edges of the $2\frac{1}{2}$ " x $1\frac{1}{2}$ " Flexible Plates. The inner lugs of these Double Angle Strips are attached to the Girders (5). A $4\frac{1}{2}$ " x $2\frac{1}{2}$ " Flexible Plate (7) on each side is connected to the Plates at the rear by two Angle Brackets, and is edged at the front by a $12\frac{1}{2}$ " Angle Girder (8). A $5\frac{1}{2}$ " x $2\frac{1}{2}$ " Flat Plate at each end is attached to the base by an Angle Bracket, and is bolted at the top to the outer lug of the $4\frac{1}{2}$ " x $\frac{1}{2}$ " Double Angle Strip.

Two $12\frac{1}{2}$ " Angle Girders (9) are bolted vertically to the flange of a $3\frac{1}{2}$ " x $2\frac{1}{2}$ " Flanged Plate (10) (Fig. 9.14), which is fixed to the Girders (5) and to the centre of the Girder (8). The sides of the column are filled in by $12\frac{1}{2}$ " x $2\frac{1}{2}$ " Strip Plates, and the top is formed by a $3\frac{1}{2}$ " x $2\frac{1}{2}$ " Flanged Plate. The back is completed by two $5\frac{1}{2}$ " x $3\frac{1}{2}$ " Flat Plates and a $12\frac{1}{2}$ " x $2\frac{1}{2}$ " Strip Plate bolted between the Girders (5). At the upper end of the front of the column a $2\frac{1}{2}$ " x $2\frac{1}{2}$ " Flexible Plate is edged by two $3\frac{1}{2}$ " Strips and it is attached by an Angle Bracket to the $3\frac{1}{2}$ " x $2\frac{1}{2}$ " Flanged Plate that fills in the top.

(Continued on next page)

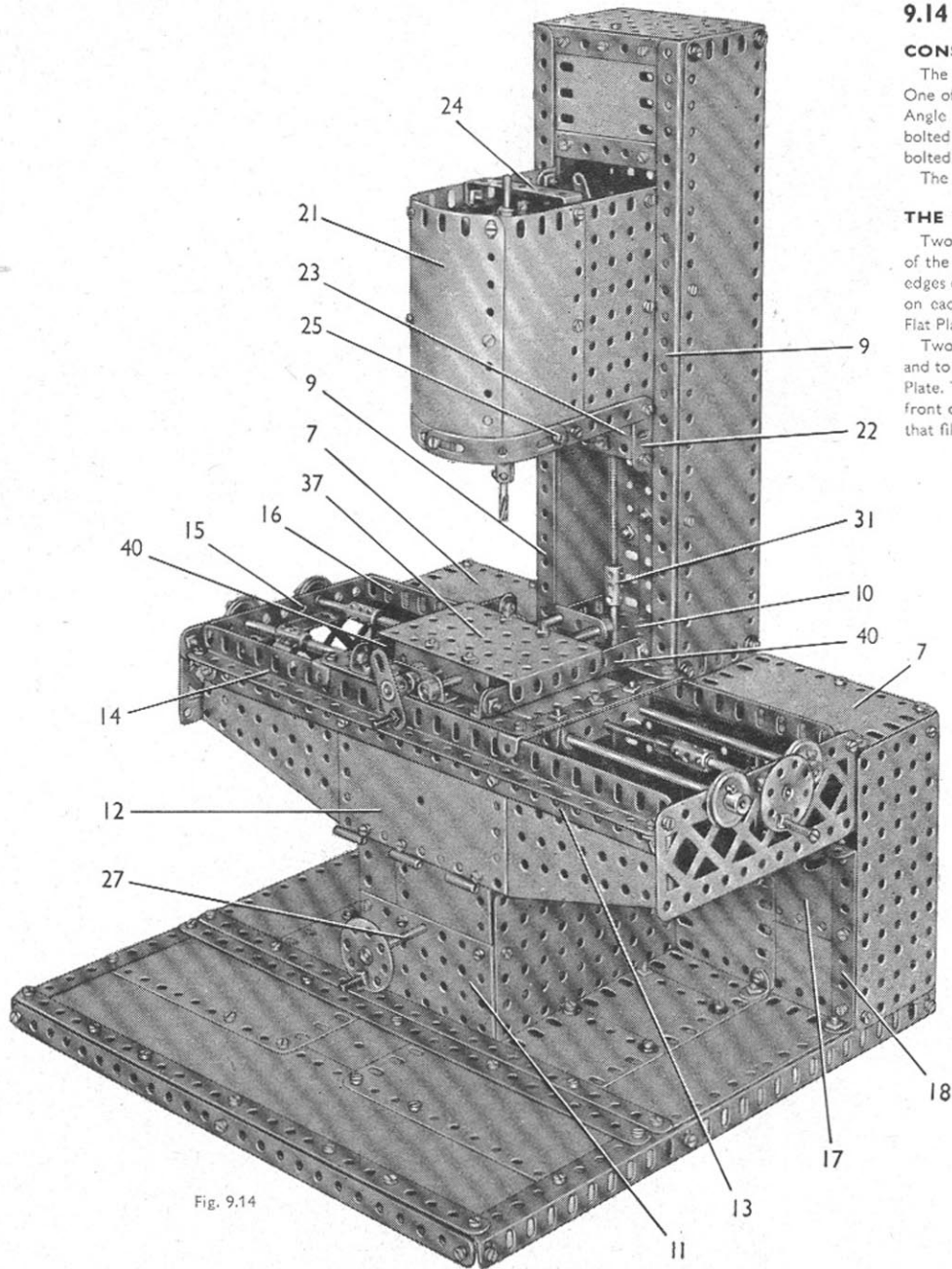

Fig. 9.14

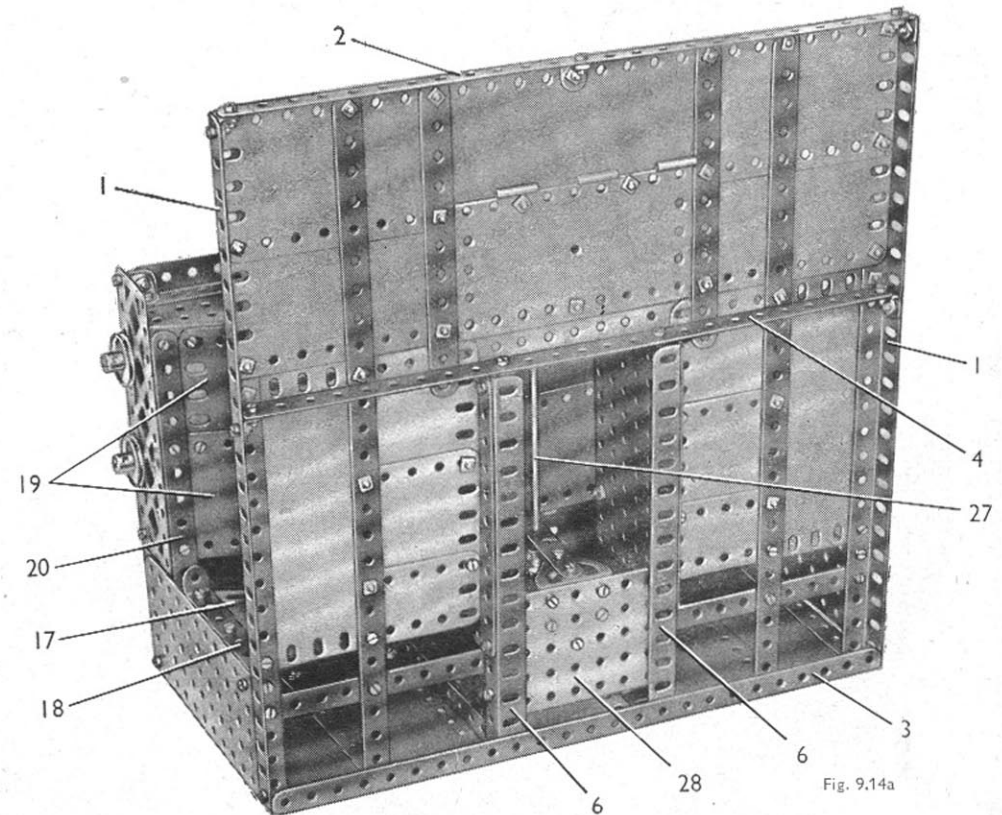

Fig. 9.14a

MODEL 9.14 VERTICAL MILLING MACHINE — Continued

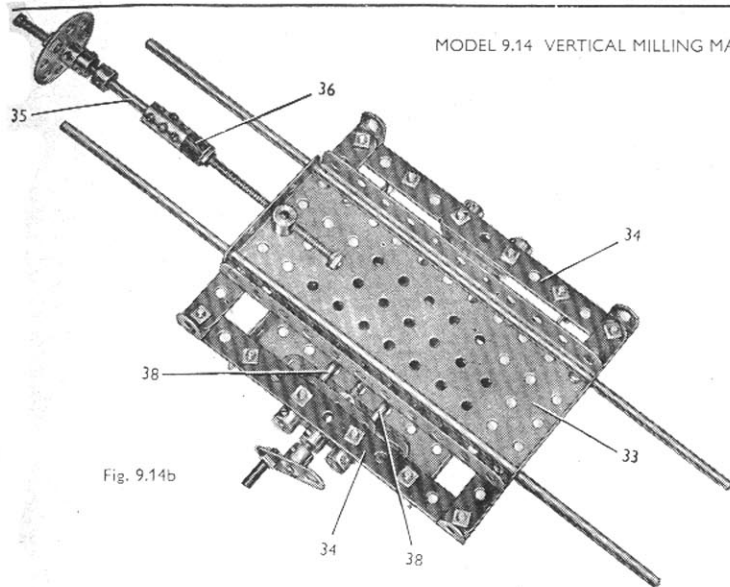

Fig. 9.14b

ASSEMBLY OF THE WORK TABLE BED

The bed is made by fixing a $5\frac{1}{2}'' \times 3\frac{1}{2}''$ Flat Plate to each of the Girders (6), and to a $3\frac{1}{2}'' \times 2\frac{1}{2}''$ Flanged Plate (11). The Flanged Plate (11) is extended upward by a $2\frac{1}{2}'' \times 2\frac{1}{2}''$ and a $2\frac{1}{2}'' \times 1\frac{1}{2}''$ Flexible Plate and by one half of a Hinged Flat Plate (12). These Plates are strengthened on the inside by two $5\frac{1}{2}''$ Strips placed vertically, and a $12\frac{1}{2}''$ Angle Girder (13) is fixed to the top edge of the plate (12). A Flanged Sector Plate is bolted between each end of the plate (12) and the end of the Girder (13), and a further $12\frac{1}{2}''$ Angle Girder (14) is attached to the Girder (13) by Angle Brackets.

A $5\frac{1}{2}''$ Angle Girder (15) is bolted to each end of the Girder (14), and the other ends of the $5\frac{1}{2}''$ Angle Girders are supported by a $12\frac{1}{2}''$ Angle Girder fixed to the Girder (8). This $12\frac{1}{2}''$ Angle Girder supports also a further $12\frac{1}{2}''$ Angle Girder (16) (Fig. 9.14), and a $5\frac{1}{2}''$ Braced Girder is bolted to each of the Girders (15).

Two $2\frac{1}{2}'' \times 2\frac{1}{2}''$ Flexible Plates and a $3\frac{1}{2}'' \times 2''$ Triangular Flexible Plate (17) on each side, are bolted together and are connected to the base by an Angle Bracket and a $3\frac{1}{2}'' \times \frac{1}{2}''$ Double Angle Strip (18).

Two $12\frac{1}{2}'' \times 2\frac{1}{2}''$ Strip Plates (19) (Fig. 9.14a) are bolted together by their long edges, but are staggered slightly so that a clear row of holes in one of the Plates overhangs the end of the other Plate. The Strip Plates are then fastened to the lower flanges of the Flanged Sector Plates and to a $7\frac{1}{2}''$ Strip (20) at each side (Fig. 9.14a). The Strips (20) are connected by Angle Brackets to the back of the column.

THE TOOL HEAD

The tool head (21) is made by bolting a $5\frac{1}{2}''$ Angle Girder (22) and a $4\frac{1}{2}'' \times 2\frac{1}{2}''$ Flat Plate to the flanges of an E20R Electric Motor. At the other side a similar Angle Girder and a second Flat Plate are attached to the Motor side-plates by Angle Brackets. The rounded front is formed by three $4\frac{1}{2}'' \times 2\frac{1}{2}''$ Flexible Plates, and the lower edges of the head are covered by $3\frac{1}{2}''$ Strips and Formed Slotted Strips as shown in Fig. 9.14. A $2\frac{1}{2}'' \times 1\frac{1}{2}''$ Flanged Plate (23) is bolted between the lower ends of the $5\frac{1}{2}''$ Angle Girders, and a $2\frac{1}{2}'' \times \frac{1}{2}''$ Double Angle Strip (24) is fixed between the top edges of the $4\frac{1}{2}'' \times 2\frac{1}{2}''$ Flat Plates.

A Coupling, holding a 2" Rod, is fastened to the Motor armature shaft, and the lower end of the Rod is mounted in a $2\frac{1}{2}'' \times 1''$ Double Angle Strip held by a bolt (25) on each side. A second Coupling fitted to the 2" Rod carries the milling tool. The tool can be represented by a Centre Fork, or, if it is available, a short length of a twist drill can be used with better effect, as shown in the illustrations.

The head is free to slide up and down the column and is located by fitting the flanges of the $5\frac{1}{2}''$ Angle Girders (22) between the Girders (9) and a $9\frac{1}{2}''$ Angle Girder (26) (Fig. 9.14c), on each side. The Girders (26) are bolted to the sides of the column, but by making use of the slotted holes in the Girders (9), gaps are left between the Girders to accommodate the flanges of the Angle Girders (22). The movement of the tool head is controlled by turning a Bush Wheel on a $6\frac{1}{2}''$ Rod

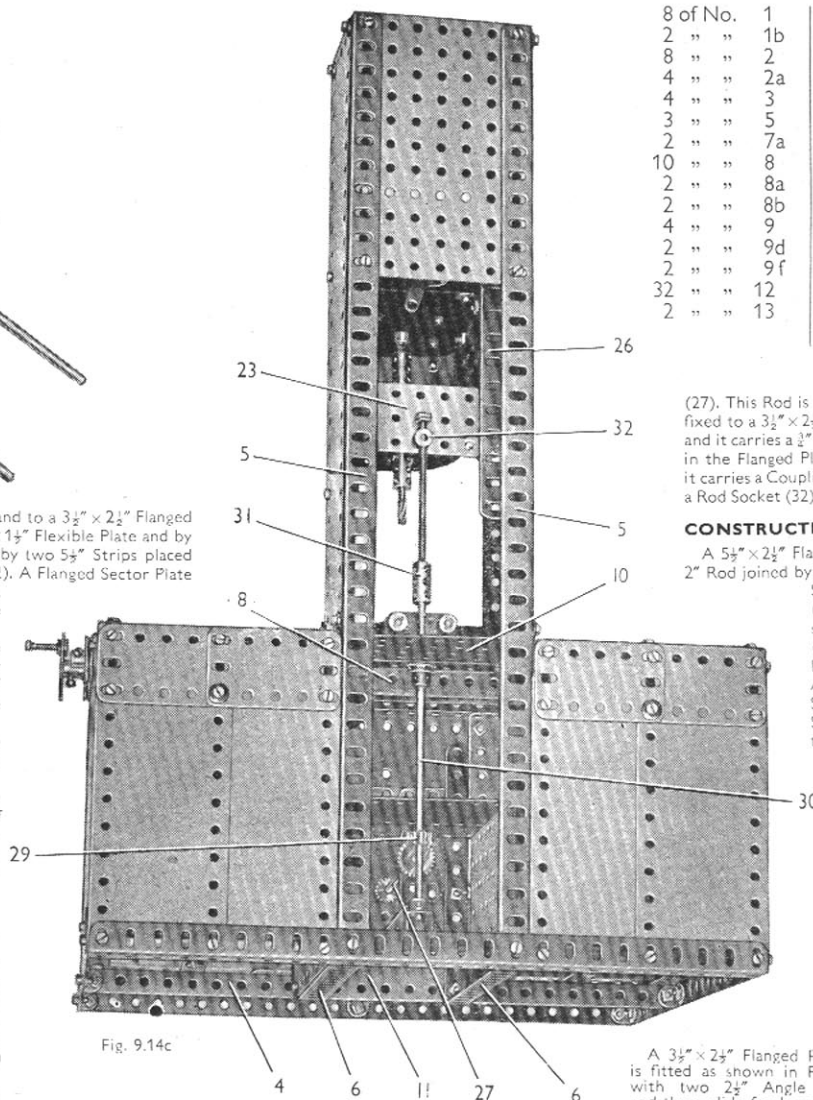

Fig. 9.14c

		Parts Required					
8 of No.	1	2 of No.	14	1 of No.	51	1 of No.	126
2 "	1b	2 "	15	1 "	52	1 "	173a
8 "	2	4 "	17	4 "	52a	2 "	179
4 "	2a	4 "	22	5 "	53	7 "	188
4 "	3	1 "	23a	2 "	53a	10 "	190
3 "	5	2 "	24	2 "	54	5 "	191
2 "	7a	2 "	26	9 "	59	8 "	192
10 "	8	1 "	29	1 "	62	6 "	197
2 "	8a	240 "	37a	1 "	62b	1 "	198
2 "	8b	229 "	37b	6 "	63	2 "	215
4 "	9	20 "	38	2 "	70	2 "	225
2 "	9d	1 "	45	1 "	80a		
2 "	9f	1 "	46	2 "	80c		
32 "	12	1 "	48a	2 "	100		
2 "	13	2 "	48b	1 "	111		
		2 "	48c	2 "	115		

1 E20R
Electric Motor
(Not included in
Outfit)

(27). This Rod is supported in the Flanged Plate (11) and in a $2\frac{1}{2}''$ Strip bolted to a Trunnion fixed to a $3\frac{1}{2}'' \times 2\frac{1}{2}''$ Flanged Plate (28) (Fig. 9.14a). The Rod is held in position by a $\frac{1}{2}''$ Pinion, and it carries a $\frac{1}{2}''$ Contrace that drives a $\frac{1}{2}''$ Pinion (29) on a $6\frac{1}{2}''$ Rod (30). This Rod is mounted in the Flanged Plate (10) and in a Double Bent Strip bolted to the Flanged Plate (28), and it carries a Coupling (31). A $3\frac{1}{2}''$ Screwed Rod is fixed in the Coupling and is threaded through a Rod Socket (32) fixed to the Flanged Plate (23).

CONSTRUCTION OF THE WORK TABLE (Figs. 9.14b and 9.14d)

A $5\frac{1}{2}'' \times 2\frac{1}{2}''$ Flanged Plate (33) is passed over two guides, each made from an $11\frac{1}{2}''$ and a 2" Rod joined by a Coupling. The guides are held in the girders (15) by 1" Pulleys. Two $4\frac{1}{2}''$ Strips are bolted across the Flanged Plate and are connected by $5\frac{1}{2}''$ Strips (34). Angle Brackets bolted to the ends of the $4\frac{1}{2}''$ and $5\frac{1}{2}''$ Strips are arranged so that they slide freely over the upturned flanges of the Girders (14) and (16). The Flanged Plate (33) can be moved along its guides by turning a Bush Wheel on a 2" Rod (35) (Fig. 9.14b). This Rod is held in one of the Angle Girders (15) by two Collars, and it carries a Coupling fitted with a Screwed Rod Adaptor (36). A 3" Screwed Rod is fixed by a nut in the Screwed Rod Adaptor as shown in Fig. 9.14b. The Screwed Rod is threaded through a Rod Socket fixed to one end of the Flanged Plate (33).

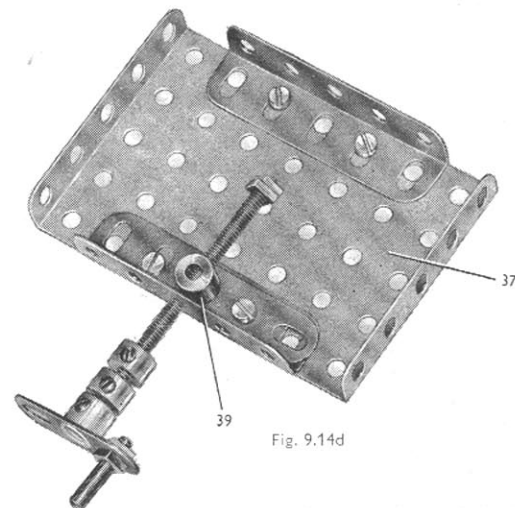

Fig. 9.14d

A $3\frac{1}{2}'' \times 2\frac{1}{2}''$ Flanged Plate (37) is fitted as shown in Fig. 9.14d with two $2\frac{1}{2}''$ Angle Girders, and these slide freely on 5" Rods (38). The Rods (38) are held by Collars in $1\frac{1}{2}''$ Angle Girders, which are bolted to the $5\frac{1}{2}''$ Strips (34). A Double Arm Crank is fixed on a 3" Screwed Rod passed through the centre hole of one of the $1\frac{1}{2}''$ Angle Girders and held in place by two Collars. The Screwed Rod is threaded through the boss of a Crank (39) bolted underneath the Flanged Plate (37). The flanges of this Plate slide freely on $4\frac{1}{2}''$ Strips (40), which are connected by Angle Brackets to the Strips (34).

9.15 LOCOMOTIVE, TENDER AND WAGON

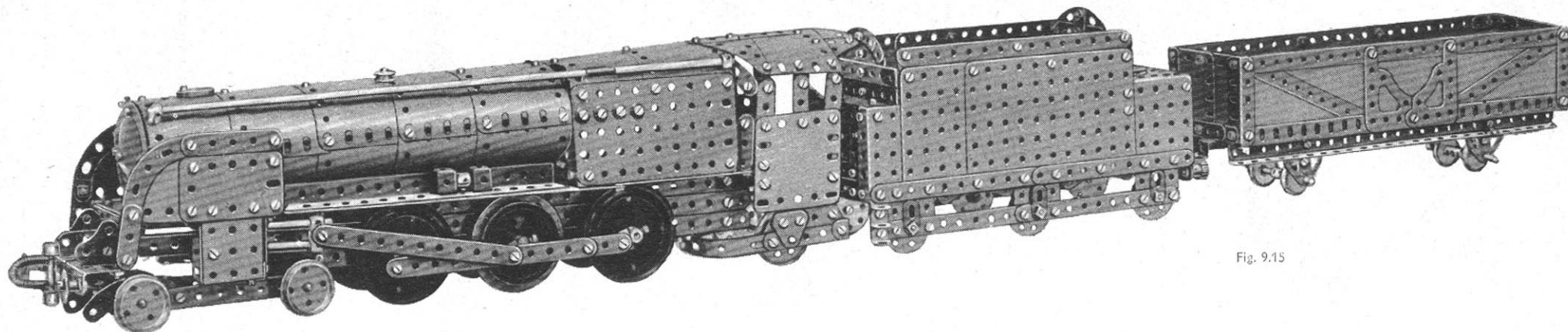

Fig. 9.15

Parts Required

9 of No. 1	8 of No. 4	8 of No. 8	22 of No. 10	2 of No. 15a	1 of No. 23	6 of No. 48b	2 of No. 80c	4 of No. 126	1 of No. 187a
2 " " 1b	36 " " 5	2 " " 8b	6 " " 11	1 " " 15b	2 " " 24	2 " " 51	4 " " 90	6 " " 126a	10 " " 188
22 " " 2	4 " " 6	2 " " 9	35 " " 12	5 " " 16	2 " " 24a	4 " " 52a	8 " " 90a	2 " " 133a	3 " " 189
2 " " 2a	6 " " 6a	2 " " 9d	4 " " 12a	3 " " 16a	2 " " 24c	5 " " 53	1 " " 102	2 " " 136	14 " " 190
6 " " 3	2 " " 7a	2 " " 9f	2 " " 12b	2 " " 17	2 " " 26	2 " " 53a	2 " " 108	2 " " 147b	6 " " 191
			8 " " 12c	4 " " 18a	350 " " 37a	1 " " 55a	2 " " 109	2 " " 161	2 " " 192
			2 " " 13	2 " " 18b	319 " " 37b	12 " " 59	2 " " 111	2 " " 164	3 " " 197
				4 " " 20	41 " " 38	2 " " 62	6 " " 111a	2 " " 165	8 " " 200
				2 " " 20a	2 " " 38d	1 " " 62b	10 " " 111c	2 " " 176	2 " " 213
				2 " " 21	1 " " 43	6 " " 63	2 " " 115	2 " " 179	4 " " 214
				4 " " 22	2 " " 48	2 " " 70	2 " " 124	1 " " 186	2 " " 215
				1 " " 22a	2 " " 48a	2 " " 77	1 " " 125	4 " " 187	4 " " 221

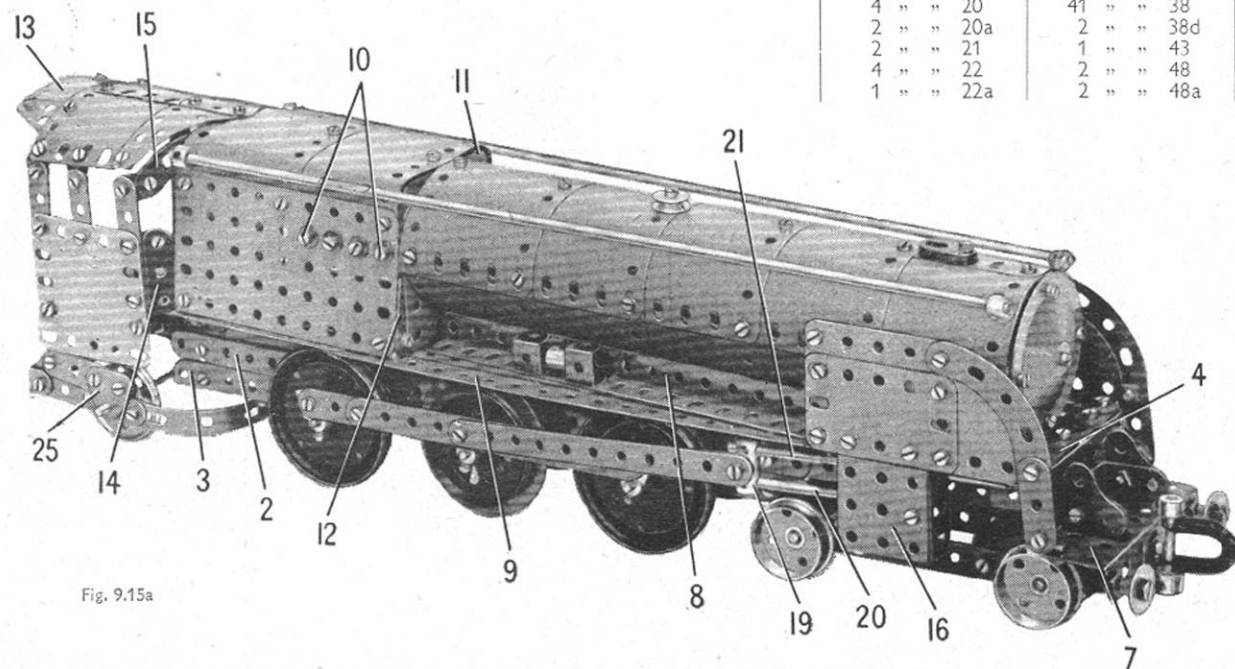

Fig. 9.15a

THE LOCOMOTIVE MAIN FRAMES

Each side consists of an $18\frac{1}{2}$ " Angle Girder (1) (Fig. 9.15b), a built-up strip (2), and a $12\frac{1}{2}$ " Angle Girder (3) (Fig. 9.15c). The built-up strip is formed by a $12\frac{1}{2}$ " and a $5\frac{1}{2}$ " Strip overlapped three holes. The Girders and the strip are connected by two Flat Trunnions, placed one at each end of the Girder (3). The Girder (1) overhangs the strip and the Girder (3) by four clear holes at the rear.

The Girders (1) are connected at the front by a $3\frac{1}{2}$ " Strip (4), and at the rear by a $3\frac{1}{2}$ " x $2\frac{1}{2}$ " Flanged Plate (5). The Girders (3) are joined by two $1\frac{1}{2}$ " Strips (6) (Fig. 9.15b). The dropped section at the front of the frames is made by bolting two $3\frac{1}{2}$ " Strips to the centre portions of two 1" Reversed Angle Brackets fixed to the ends of the Strip (4). Two Girder Brackets (7) are attached to the lower lugs of the Reversed Angle Brackets, and two 1" Corner Brackets are supported by 1" x 1" Angle Brackets bolted to the lower one of the two $3\frac{1}{2}$ " Strips. The buffers are $\frac{3}{8}$ " Washers spaced by Cord Anchoring Springs on Pivot Bolts fitted to the Girder Brackets. The vacuum pipe is a Spring looped over and held by a Collar on a $1\frac{1}{2}$ " Rod, which is fixed to a Crank. The Crank is attached to a 1" x $\frac{1}{2}$ " Angle Bracket fixed to the Girder Brackets.

BOILER AND FIREBOX

The upper half of the boiler consists of four curved $4\frac{1}{2}$ " x $2\frac{1}{2}$ " Flexible Plates, and the lower half is formed by $2\frac{1}{2}$ " x $2\frac{1}{2}$ " Flexible Plates curved and arranged in pairs, each pair corresponding to a $4\frac{1}{2}$ " x $2\frac{1}{2}$ " Flexible Plate. The smoke-box consists of four $1\frac{1}{4}$ " radius Curved Plates bolted together, and the front is made with two Semi-Circular Plates, to which a Conical Disc is attached by a $\frac{1}{2}$ " Bolt. The front is connected to the $1\frac{1}{4}$ " radius Curved Plates by Angle Brackets. At each side of the boiler a $7\frac{1}{2}$ " Angle Girder (8) is bolted to one of the Girders (1). Two Double Brackets are attached to the Girder (8) and a Rod Socket is held by its nut in a further Double Bracket.

(Continued on next page)

MODEL 9.15 LOCOMOTIVE, TENDER AND WAGON — Continued

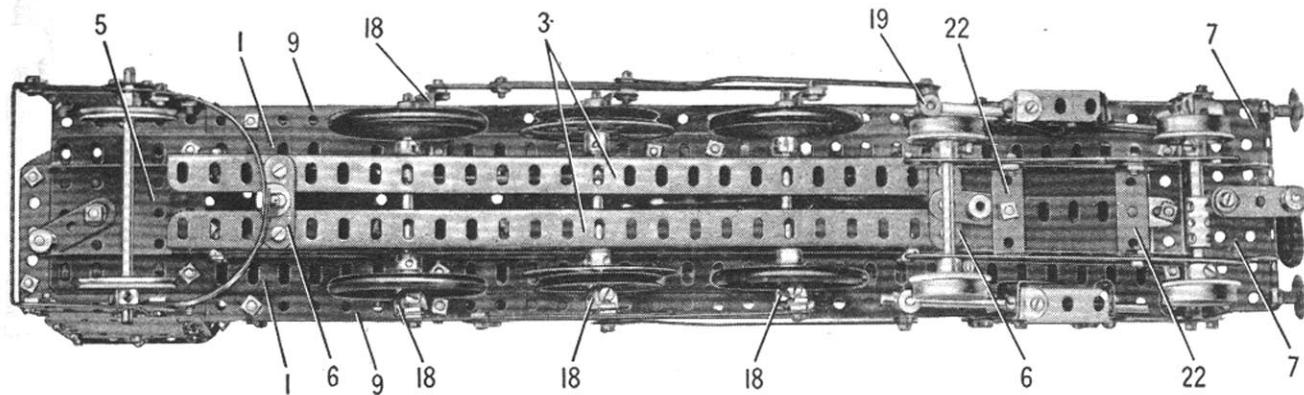

Fig. 9.15b

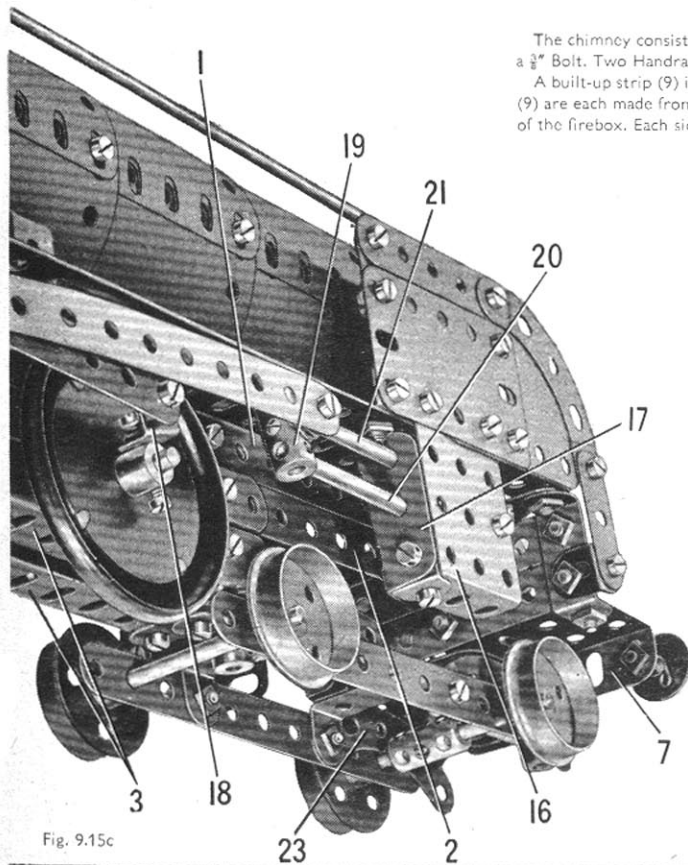

Fig. 9.15c

The chimney consists of six Fishplates held by a $\frac{3}{8}$ " Bolt, and the dome is a $\frac{1}{2}$ " loose Pulley, also fastened by a $\frac{3}{8}$ " Bolt. Two Handrail Supports are fitted to the smoke-box as shown.

A built-up strip (9) is bolted on each side of the model to the Flanged Plate (5) and the Strip (4). The strips (9) are each made from a $1\frac{1}{2}$ " and a $5\frac{1}{2}$ " Strip, and to them are bolted Angle Brackets that support the sides of the firebox. Each side is a $4\frac{1}{2}$ " x $2\frac{1}{2}$ " Flat Plate, and the top consists of two $4\frac{1}{2}$ " x $2\frac{1}{2}$ " Flexible Plates curved as shown in Fig. 9.15a, and bolted to the sides. The boiler is connected to the firebox by a $2\frac{1}{2}$ " Strip at the top, and by a similar Strip on each side held by bolts (10).

A $2\frac{1}{2}$ " Strip (11) (Fig. 9.15a) is attached to the top of the firebox by an Angle Bracket, and a similar Strip (12) is supported by an Angle Bracket on each side. A $2\frac{1}{2}$ " x $2\frac{1}{2}$ " Flexible Plate that fills in the front of the firebox is bolted to the top ends of the Strips (12).

Each handrail is made from an $11\frac{1}{2}$ " and a $3\frac{1}{2}$ " Rod joined by a Rod Connector. It is fixed at the front in one of the Handrail Supports, and at the rear in a Collar screwed on to a bolt passed through the firebox.

ASSEMBLY OF THE CAB

Each side of the cab is a $2\frac{1}{2}$ " x $2\frac{1}{2}$ " Flexible Plate fitted with three $2\frac{1}{2}$ " Strips and bolted to a flange of the Plate (5). The centre of the roof is formed by two $1\frac{1}{8}$ " radius Curved Plates with a $2\frac{1}{2}$ " x $1\frac{1}{2}$ " Flexible Plate fixed underneath the join in the middle. At the front two $2\frac{1}{2}$ " x $1\frac{1}{2}$ " Triangular Flexible Plates are bolted between the Curved Plates and the end of the firebox. At the rear the roof is extended by a $2\frac{1}{2}$ " x $1\frac{1}{2}$ " Flexible Plate (13), fitted at each side with a $2\frac{1}{2}$ " x $1\frac{1}{2}$ " Triangular Flexible Plate. The roof is attached to the sides of the cab by Obtuse Angle Brackets.

A $1\frac{1}{2}$ " Strip (14) and a $2\frac{1}{2}$ " Stepped Curved Strip (15) on each side are fixed to Obtuse Angle Brackets bolted to the cab.

THE SMOKE DEFLECTORS AND CYLINDERS

Each smoke deflector consists of a $2\frac{1}{2}$ " x $1\frac{1}{2}$ " Flexible Plate and a Semi-Circular Plate attached to one of the strips (9) by Angle Brackets. The Plates are edged by a $2\frac{1}{2}$ " Strip supported by Fishplates, and by a $2\frac{1}{2}$ " Stepped Curved Strip extended by a $1\frac{1}{2}$ " Strip. The lower end of the $1\frac{1}{2}$ " Strip is connected to the locomotive frame by an Angle Bracket.

Each cylinder is made by fixing a $2\frac{1}{2}$ " x $1\frac{1}{2}$ " Flanged Plate (16) to the smoke deflector (Fig. 9.15c). At the front a $1\frac{1}{2}$ " Angle Girder is bolted to the Flanged Plate, and at the rear a Trunnion (17) is attached to an Angle Bracket.

THE DRIVING WHEELS AND MOTION

The front and rear pairs of driving wheels are Road Wheels fixed on $3\frac{1}{2}$ " Rods and spaced from the main frames by Collars. The centre pair of wheels is formed by Face Plates and 2" Pulleys also fixed on a $3\frac{1}{2}$ " Rod. An Angle Bracket (18) (Fig. 9.15c) is bolted to the boss of each wheel. A bolt, fitted with a nut, is passed through the round hole of each Angle Bracket, and is screwed into the boss of the wheel. The nut is then tightened against the Angle Bracket to fix it in place.

The coupling rod on each side consists of a $5\frac{1}{2}$ " and a $4\frac{1}{2}$ " Strip overlapped seven holes. It is *lock-nutted* to the Angle Brackets (18). The connecting rods are $5\frac{1}{2}$ " Strips bent slightly and *lock-nutted* to the Angle Brackets on the centre wheels. The front end of each Strip is spaced from a Coupling (19) by four Washers on a $\frac{1}{2}$ " Bolt. The Bolt is held in the Coupling by a grub-screw. The piston rod is a $2\frac{1}{2}$ " Rod (20) and the valve rod is a $4\frac{1}{2}$ " Rod (21).

(Continued on next page)

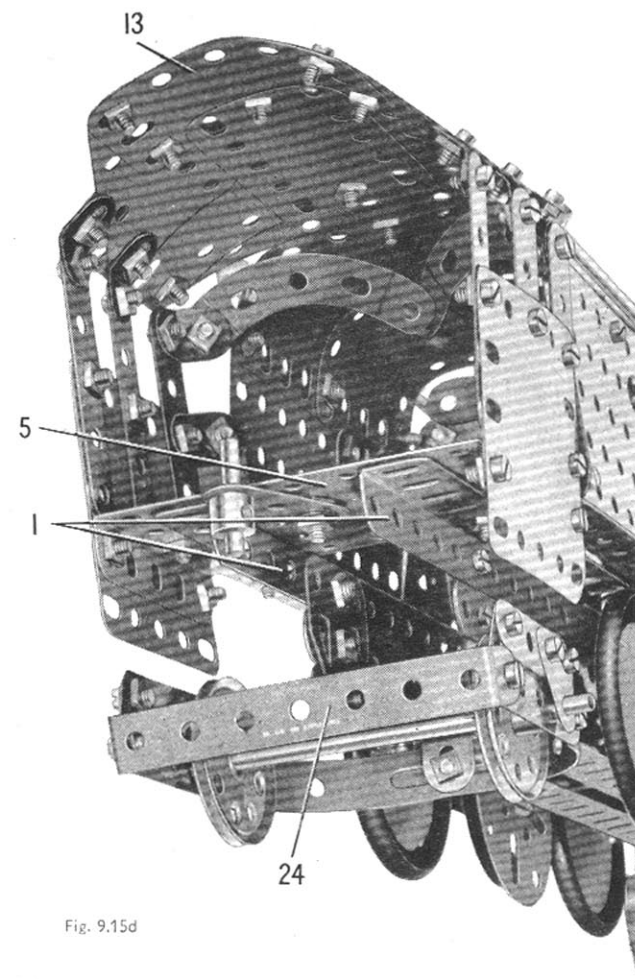

Fig. 9.15d

MODEL 9.15 LOCOMOTIVE, TENDER AND WAGON — Continued

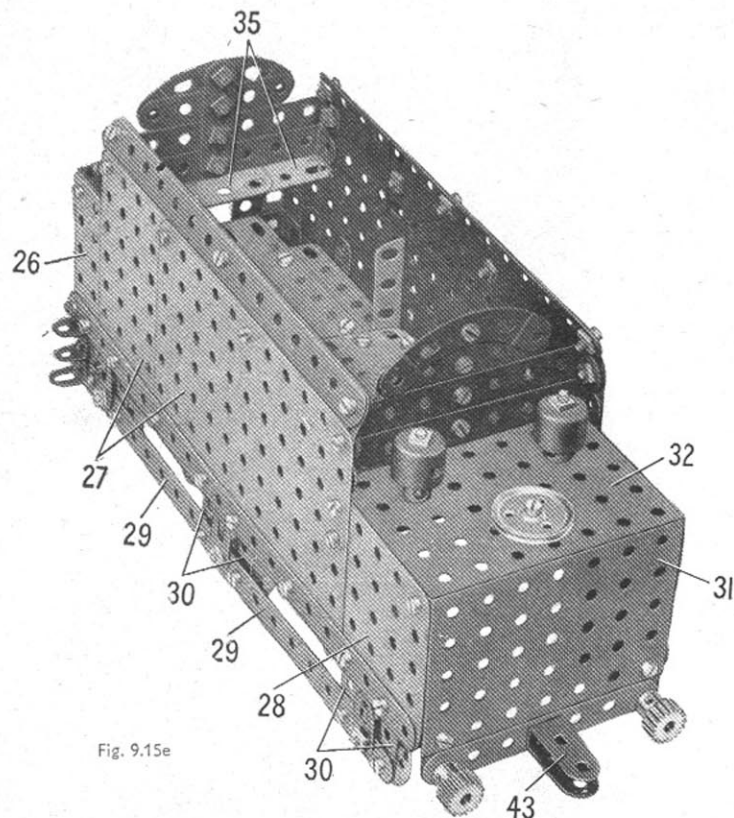

Fig. 9.15e

Two Chimney Adaptors (Fig. 9.15e) are fitted over Couplings and are held in place by nuts on Screwed Rods passed through the Flanged Plate (32). The buffers are $\frac{1}{2}$ " Pinions, each of which is fixed on a Threaded Pin that is used to attach a $3\frac{1}{2}$ " Strip to a $2\frac{1}{2}$ " Strip bolted to the Flanged Plate (31).

The centre wheels of the tender are Bush Wheels free to turn on $\frac{3}{8}$ " Bolts, each of which is fitted with two Washers and is attached to the Strips (29) by two nuts. The other wheels are Wheel Discs free to turn on $\frac{1}{2}$ " Bolts also fixed in the Strips (29) by two nuts each. The Wheel Discs are spaced on the Bolts by Collars, and each of the $\frac{1}{2}$ " and $\frac{3}{8}$ " Bolts carries a Fishplate placed outside the Strips (29).

The coupling between the locomotive and the tender is formed by a 1" Rod held in a Crank that is *lock-nutted* to the Flanged Plate (5). This Rod engages in a hole in a $1" \times \frac{1}{2}"$ Angle Bracket bolted to the Double Angle Strip (34).

ASSEMBLY OF THE WAGON

Each side is a $12\frac{1}{2}" \times 2\frac{1}{2}"$ Strip Plate edged by Strips and a $12\frac{1}{2}"$ Angle Girder (39) (Fig. 9.15f). The ends are each formed by two $2\frac{1}{2}" \times 2\frac{1}{2}"$ Flexible Plates overlapped three holes. One end is strengthened by two $2\frac{1}{2}"$ Angle Girders and two 3" Strips overlapped five holes, and the other end by two $2\frac{1}{2}"$ Strips and two 3" Strips. The $2\frac{1}{2}"$ Angle Girders of one end are bolted to the sides, and the other end is attached to the sides by two $1" \times 1"$ and two $\frac{1}{2}" \times \frac{1}{2}"$ Angle Brackets. The floor of the wagon is a $12\frac{1}{2}" \times 2\frac{1}{2}"$ Strip Plate, supported at each end by two 3" Strips overlapped five holes and bolted to the Girders (39).

A $12\frac{1}{2}"$ Angle Girder (40) is fixed to each of the Girders (39) and these support further $12\frac{1}{2}"$ Angle Girders (41). The wagon axles are mounted in Trunnions and Flat Trunnions bolted to these Girders. Each axle consists of a 2" and a $1\frac{1}{2}"$ Rod joined by a Coupling.

The coupling between the wagon and the tender is provided by a Rod passed through a $\frac{1}{2}"$ Reversed Angle Bracket (42) and a Single Bent Strip (43).

THE FRONT AND REAR BOGIES

The front bogie consists of two $5\frac{1}{2}"$ Strips connected by $1\frac{1}{2}" \times \frac{1}{2}"$ Double Angle Strips (22) (Fig. 9.15b). The bolts holding the front Double Angle Strip secure also a $2\frac{1}{2}"$ Stepped Curved Strip (23) on each side. Two of the wheels are fixed on a $2\frac{1}{2}"$ Rod, and the other two are held on a $1\frac{1}{2}"$ and a 1" Rod joined by a Coupling. A Double Arm Crank is bolted to the rear Double Angle Strip (22) and is *lock-nutted* to one of the Strips (6).

The rear bogie is formed by two Formed Slotted Strips bolted together, the bolt securing also an Angle Bracket that is *lock-nutted* to one of the Strips (6). Each Formed Slotted Strip is extended by a $2\frac{1}{2}"$ Strip, and these are connected at the rear by a $3\frac{1}{2}" \times \frac{1}{2}"$ Double Angle Strip (24) (Fig. 9.15d). A 2" Strip, fitted with a 1" Triangular Plate (25), is attached to a Fishplate on each side. The wheels are $1\frac{1}{2}"$ Pulleys on a 4" Rod.

CONSTRUCTION OF THE TENDER

Each side of the tender consists of a $3\frac{1}{2}" \times 2\frac{1}{2}"$ Flanged Plate (26), two $5\frac{1}{2}" \times 3\frac{1}{2}"$ Flat Plates (27), and a $5\frac{1}{2}" \times 2\frac{1}{2}"$ Flat Plate (28) (Fig. 9.15e). The side is extended upward by a $7\frac{1}{2}"$ Strip bolted to the upper edges of a $5\frac{1}{2}" \times 1\frac{1}{2}"$ and a $2\frac{1}{2}" \times 1\frac{1}{2}"$ Flexible Plate fixed to the side and bent inwards as shown. The lower edge of the side is fitted with two $5\frac{1}{2}"$ Strips, and two further $5\frac{1}{2}"$ Strips (29), overlapped three holes, are attached to $2\frac{1}{2}"$ Strips (30) (Fig. 9.15g). The step at the front is formed by three Angle Brackets bolted to a $2\frac{1}{2}"$ Strip.

The sides are connected by two $3\frac{1}{2}" \times 2\frac{1}{2}"$ Flanged Plates (31) and (32) (Fig. 9.15e), by two $3\frac{1}{2}"$ Strips (33) and a $3\frac{1}{2}" \times \frac{1}{2}"$ Double Angle Strip (34) (Fig. 9.15g). Two vertical $2\frac{1}{2}" \times \frac{1}{2}"$ Double Angle Strips are fixed to one of the Strips (33) and the Double Angle Strip (34). At each end of the tender a $2\frac{1}{2}"$ Stepped Curved Strip, a $2\frac{1}{2}"$ Strip and two $3\frac{1}{2}" \times \frac{1}{2}"$ Double Angle Strips are bolted to a vertical 2" Strip, and are fixed between the sides. At the front two $2\frac{1}{2}" \times 1\frac{1}{2}"$ Flexible Plates (35) are supported by Angle Brackets.

The sloping floor of the coal bunker consists of a $5\frac{1}{2}" \times 2\frac{1}{2}"$ and a $5\frac{1}{2}" \times 1\frac{1}{2}"$ Flexible Plate, a further $5\frac{1}{2}" \times 2\frac{1}{2}"$ Flexible Plate (36) and two $2\frac{1}{2}" \times 1\frac{1}{2}"$ Flexible Plates (37). These are supported by a $5\frac{1}{2}"$ Angle Girder (38) on each side (Fig. 9.15g).

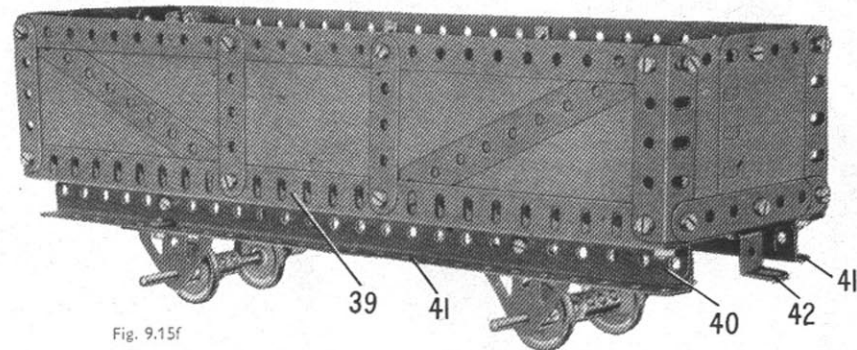

Fig. 9.15f

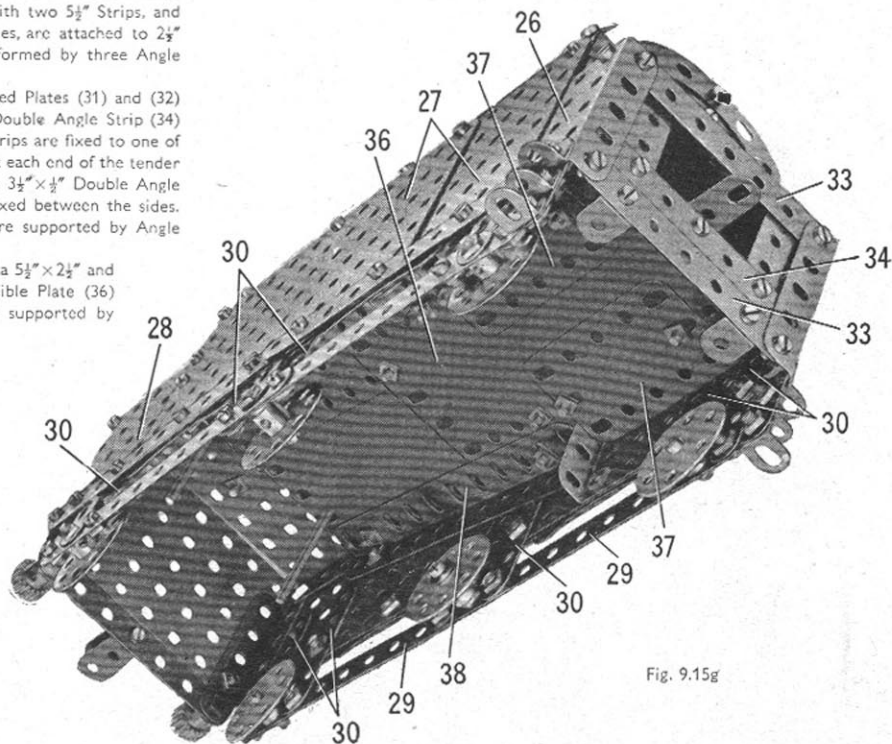

Fig. 9.15g

9.16 HIGH-SPEED PRESS

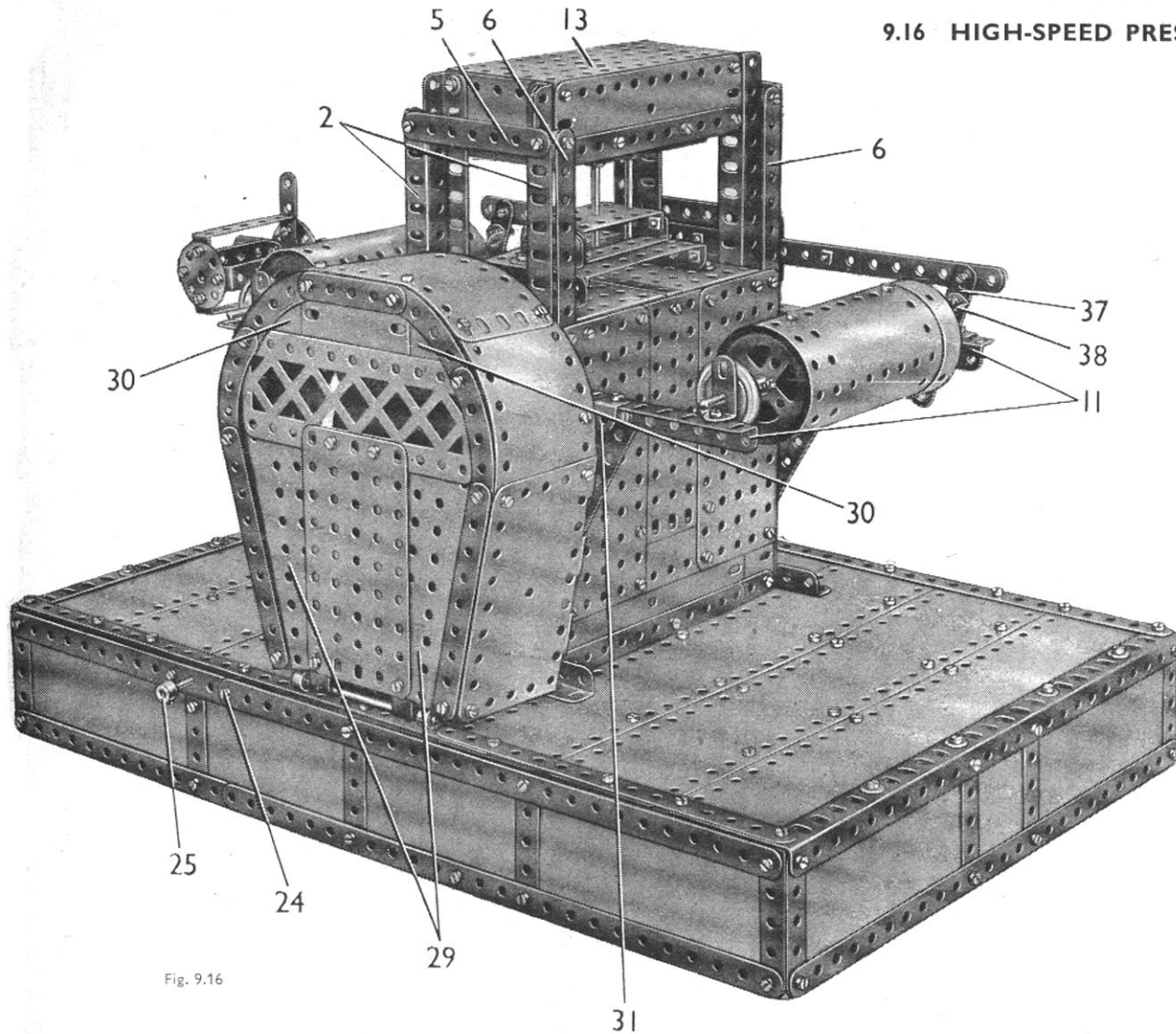

Fig. 9.16

A built-up girder (11), made from a $9\frac{1}{2}$ " and a $5\frac{1}{2}$ " Angle Girder overlapped five holes, is bolted across each side of the column. The girders (11) are braced to the column by two $4\frac{1}{2}$ " Strips on each side. On one side the spaces between the Strips and the column are filled by $3\frac{1}{2}$ " x $2\frac{1}{2}$ " Triangular Flexible Plates, and on the other side $2\frac{1}{2}$ " x $2\frac{1}{2}$ " Triangular Flexible Plates are used.

THE PRESS RAM

The ram is made by bolting two $12\frac{1}{2}$ " Angle Girders (12) to each end of $5\frac{1}{2}$ " x $2\frac{1}{2}$ " Flanged Plates (13) and (14) (Figs. 9.16 and 9.16e). The Girders are adjusted by their slotted holes so that they slide freely outside the flanges of the Girders (2) of the press column. Two $5\frac{1}{2}$ " x $1\frac{1}{2}$ " and two $2\frac{1}{2}$ " x $1\frac{1}{2}$ " Flexible Plates are bolted to the flanges of the Flanged Plate (13), and are connected together at their lower corners by Angle Brackets. A $3\frac{1}{2}$ " x $2\frac{1}{2}$ " Flanged Plate is bolted to two $2\frac{1}{2}$ " x $\frac{1}{2}$ " Double Angle Strips fixed between the $5\frac{1}{2}$ " x $1\frac{1}{2}$ " Flexible Plates. This Flanged Plate supports the punches, which are three 2" Rods (15) (Fig. 9.16c). Two of these Rods are fixed in Double Arm Cranks, and the centre Rod is supported by a Rod Socket. The Rods are arranged so that they pass freely through holes in the Flanged Plates (8) and (9) as the ram descends.

CONSTRUCTION OF THE BASE

Each side of the base consists of two $5\frac{1}{2}$ " x $2\frac{1}{2}$ " and two $4\frac{1}{2}$ " x $2\frac{1}{2}$ " Flexible Plates bolted together and strengthened as shown in Fig. 9.16 by $12\frac{1}{2}$ " and $2\frac{1}{2}$ " Strips. Each end is formed by a $2\frac{1}{2}$ " x $2\frac{1}{2}$ " Flexible Plate and two $5\frac{1}{2}$ " x $2\frac{1}{2}$ " Flexible Plates, and these are edged by a $12\frac{1}{2}$ " Strip, $2\frac{1}{2}$ " Strips and a $12\frac{1}{2}$ " Angle Girder. The sides and ends are connected by Angle Brackets (Fig. 9.16b).

The top of the base is filled in by six $12\frac{1}{2}$ " x $2\frac{1}{2}$ " Strip Plates and a $5\frac{1}{2}$ " x $1\frac{1}{2}$ " Flexible Plate. The Strip Plates are bolted to two $18\frac{1}{2}$ " Angle Girders (1) and are edged at each side by a $12\frac{1}{2}$ " Strip and a $7\frac{1}{2}$ " Strip overlapped three holes. The top is connected to the sides by Angle Brackets and is bolted to the $12\frac{1}{2}$ " Angle Girders of the ends of the base.

DETAILS OF THE PRESS COLUMN

Two $12\frac{1}{2}$ " Angle Girders (2) on each side are fixed to a $5\frac{1}{2}$ " Angle Girder (3) that is bolted above the Girder (1). The Girders (2) are connected by a $5\frac{1}{2}$ " x $3\frac{1}{2}$ " Flat Plate (4) and a $3\frac{1}{2}$ " Strip (5) (Fig. 9.16d). To each of the Girders (2) a $5\frac{1}{2}$ " Strip (6) is attached by Angle Brackets.

The front of the press column is filled in by two $5\frac{1}{2}$ " x $3\frac{1}{2}$ " Flat Plates extended downward by two $5\frac{1}{2}$ " x $1\frac{1}{2}$ " Flexible Plates overlapped nine holes. The lower edges of the Flexible Plates are strengthened by two $5\frac{1}{2}$ " Strips (Fig. 9.16d), and the Plates are attached to the sides and base of the column by Angle Brackets. The back of the column is filled in by two $5\frac{1}{2}$ " x $2\frac{1}{2}$ " Flat Plates, a $4\frac{1}{2}$ " x $2\frac{1}{2}$ " Flat Plate, a $2\frac{1}{2}$ " x $1\frac{1}{2}$ " Flexible Plate, and two $5\frac{1}{2}$ " x $1\frac{1}{2}$ " Flexible Plates overlapped nine holes (Fig. 9.16). These Plates also are attached to the sides of the column by Angle Brackets.

Two $3\frac{1}{2}$ " x $2\frac{1}{2}$ " Flanged Plates (7) (Fig. 9.16c) are bolted in position as shown, with a $3\frac{1}{2}$ " x $\frac{1}{2}$ " Double Angle Strip between them. A further $3\frac{1}{2}$ " x $2\frac{1}{2}$ " Flanged Plate (8) is attached to the Plates (7) by $2\frac{1}{2}$ " Angle Girders, and a $2\frac{1}{2}$ " x $1\frac{1}{2}$ " Flanged Plate (9) and two $2\frac{1}{2}$ " x $\frac{1}{2}$ " Double Angle Strips are bolted to $1\frac{1}{2}$ " Angle Girders fixed to the Plate (8). One of the Double Angle Strips is indicated at (10), and use is made of the slotted holes in the $1\frac{1}{2}$ " Angle Girders to raise the Double Angle Strips just clear of the Plate (8).

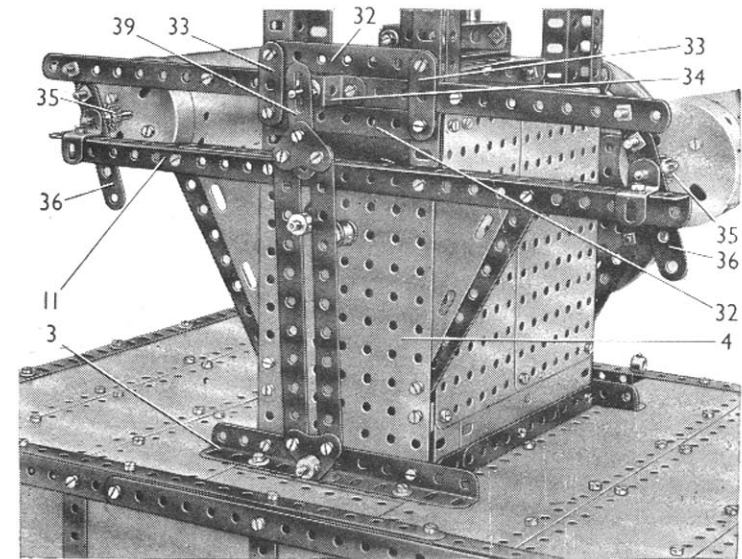

Fig. 9.16a

(Continued on next page)

MODEL 9.16 HIGH-SPEED PRESS — Continued

THE RAM ECCENTRICS

The ram is operated by two eccentrics, each of which is made by bolting a Crank (16) across the face of a $1\frac{1}{2}$ " Pulley (Fig. 9.16e). Two $2\frac{1}{2}$ " Stepped Curved Strips are connected at their ends by $1\frac{1}{2}$ " Strips, and this assembly is arranged to rotate freely in the groove of the $1\frac{1}{2}$ " Pulley. Two 2" Strips (17) are bolted to the lower ends of the Stepped Curved Strips, and are held by a Collar on a $4\frac{1}{2}$ " Rod supported in a $3\frac{1}{2}$ " x $\frac{1}{2}$ " Double Angle Strip that is bolted to the Flanged Plate (14) (Fig. 9.16c).

The eccentrics are fixed by the grub screws in the bosses of the Cranks (16) to an axle (18), made from two $4\frac{1}{2}$ " Rods joined by a Coupling. This axle is mounted in the Flat Plates (4) and is held in position by a Collar and a Rod Socket (19) (Fig. 9.16d).

ARRANGEMENT OF THE DRIVE

A Corner Gusset is bolted to each side-plate of an E20R Electric Motor, and a $2\frac{1}{2}$ " Strip (20) is fixed to each side plate and to a $2\frac{1}{2}$ " Strip (21) (Fig. 9.16b). The Strips and the Corner Gussets are connected as shown by two $1\frac{1}{2}$ " x $\frac{1}{2}$ " Double Angle Strips. This assembly is attached by two Double Brackets (22) to one of the Girders (1), and by two 1" Reversed Angle Brackets to the side of the base. One of the Reversed Angle Brackets is seen at (23), and the other is fixed to the base by a bolt (24) (Fig. 9.16). A $2\frac{1}{2}$ " Rod is gripped in a Handrail Support that is lock-nutted to the top arm of the Motor switch. The Rod is passed through a hole in the side of the base and is fitted with a Collar (25).

A $\frac{1}{2}$ " Pinion on the Motor shaft drives a 57-tooth Gear on a $3\frac{1}{2}$ " Rod (26). This Rod carries also a $\frac{3}{4}$ " Pinion that engages a 50-tooth Gear on a $2\frac{1}{2}$ " Rod fitted with a $\frac{1}{2}$ " Pinion (27). The 57-tooth Gear is spaced on the Rod (26) so that it clears the Pinion (27), and Rod (26) is held in position by a Collar.

Pinion (27) drives a 57-tooth Gear on a $2\frac{1}{2}$ " Rod (28), which is held in the Corner Gussets by a Collar. A $\frac{3}{4}$ " Sprocket on Rod (28) is connected by Chain to a 3" Sprocket on the axle (18). The flywheel consists of a Circular Girder bolted to two $5\frac{1}{2}$ " Strips crossed at right angles. A Face Plate, a 4" Circular Plate, and a 3" Pulley are bolted to the Strips, and the Pulley is fixed to the end of the axle (18).

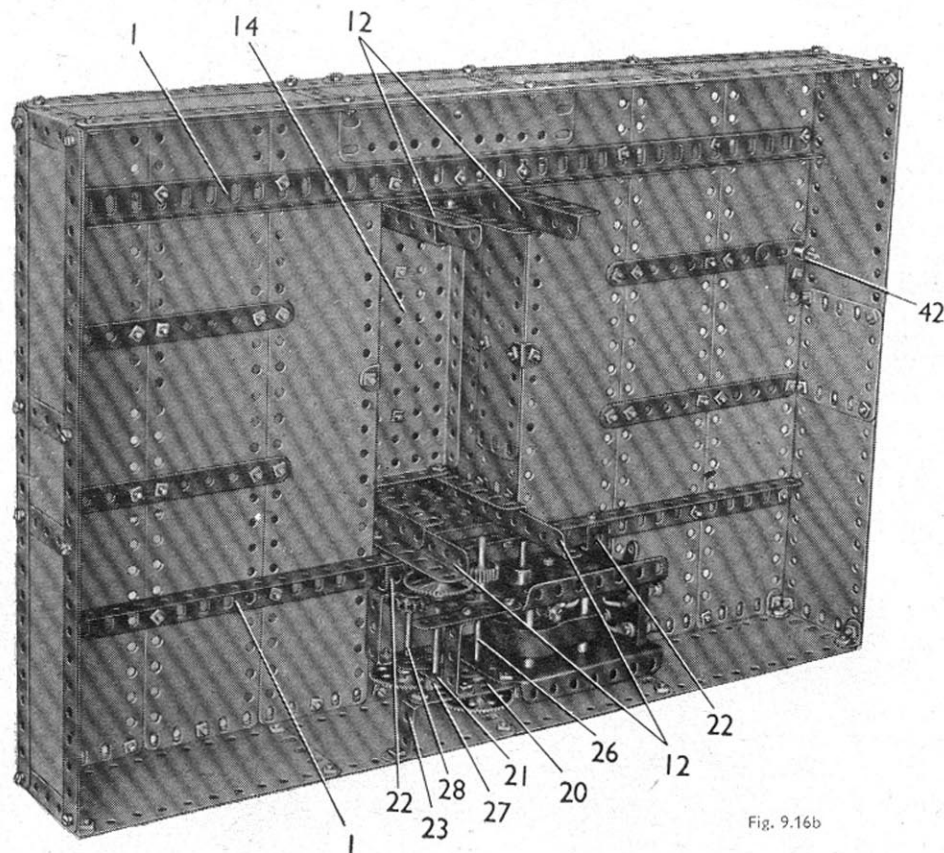

Fig. 9.16b

PRIZES FOR NEW MODELS

Model-Building Competitions in which fine Cash Prizes are offered for new and original Meccano Models are announced in the 'MECCANO MAGAZINE' which is published monthly

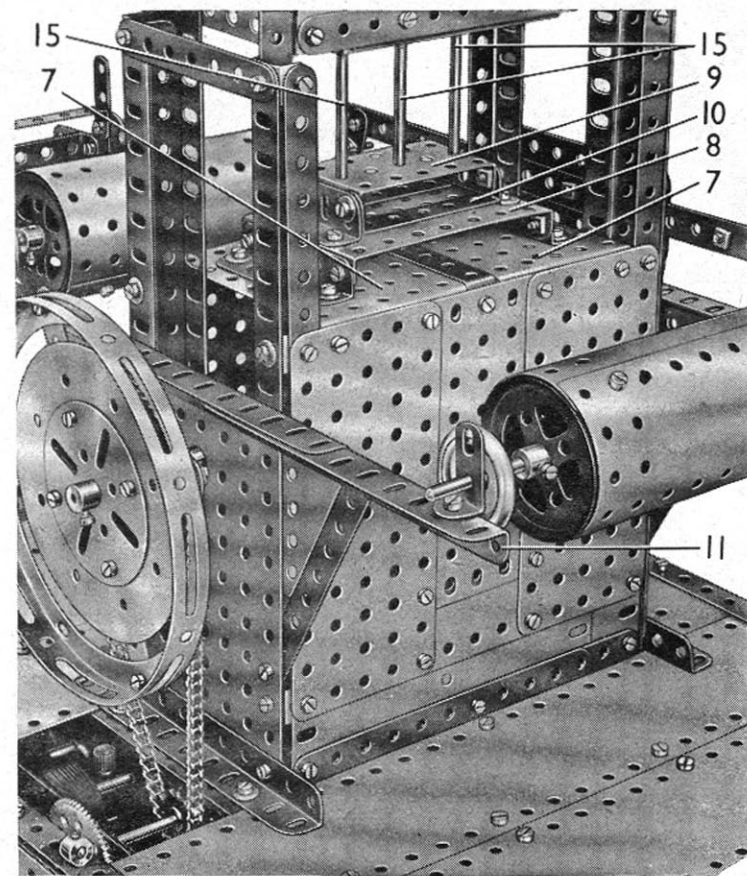

Fig. 9.16c

The chain guard consists of the separated halves of a Hinged Flat Plate, two $4\frac{1}{2}$ " x $2\frac{1}{2}$ " Flexible Plates, and a $5\frac{1}{2}$ " x $2\frac{1}{2}$ " Flexible Plate, attached by Angle Brackets to a frame made from Strips and Curved Strips as shown in Fig. 9.16. The frame is filled in by two Flanged Sector Plates (29), a $4\frac{1}{2}$ " x $2\frac{1}{2}$ " Flat Plate, a $5\frac{1}{2}$ " Braced Girder, a $2\frac{1}{2}$ " x $1\frac{1}{2}$ " Flexible Plate, and two Semi-Circular Plates (30). Two Right-Angle Rod and Strip Connectors are bolted to the lower edge of the guard, and a $3\frac{1}{2}$ " Rod passed through them is fixed in two Collars. Each of these Collars is screwed on to a bolt that is fitted with a nut and is passed through a hole in the top of the base. The guard is held in place by Corner Angle Brackets one of which can be seen at (31) (Fig. 9.16).

RATCHET FEED MECHANISM

Four $3\frac{1}{2}$ " Strips (32) (Fig. 9.16a) are arranged face to face in pairs and each pair is bolted between two of the Girders (2) as shown. Two $1\frac{1}{2}$ " Strips (33) are held by the same bolts but are spaced from the Strips (32) by a Washer on each bolt. Two $12\frac{1}{2}$ " Strips placed face to face are fitted with a Double Bent Strip (34) and are free to slide between the Girders (2) and the Strips (33).

Each feed drum consists of a Boiler End placed round two 2" Pulleys, with a Boiler End fitted at one end of the assembly. The drums are fixed on 8" Rods, which are supported in $\frac{3}{4}$ " Reversed Angle Brackets and $1\frac{1}{2}$ " x $\frac{1}{2}$ " Angle Brackets bolted to the girders (11). Each Rod carries a 1" Pulley with Rubber Ring and a $\frac{1}{2}$ " Pinion (35). The Pulley is arranged so that its Rubber Ring presses lightly against the $1\frac{1}{2}$ " x $\frac{1}{2}$ " Angle Bracket to prevent the drum from spinning freely.

A $2\frac{1}{2}$ " Strip (36) (Fig. 9.16d) is freely mounted between the Pinion (35) and the $\frac{1}{2}$ " Reversed Angle Bracket. This Strip is extended upward by a Fishplate (37) (Fig. 9.16), which is fixed by two nuts on a $\frac{1}{2}$ " Bolt. An Angle Bracket (38) is freely pivoted on the $\frac{1}{2}$ " Bolt, so that it engages the teeth of the Pinion (35) to act as a ratchet pawl. A $\frac{1}{2}$ " Bolt is passed through the slotted hole of the Fishplate (37), and is held by two nuts in the $12\frac{1}{2}$ " Strips of the feed mechanism. The Fishplate must pivot freely on the Bolt.

(Continued on next page)

MODEL 9.16 HIGH-SPEED PRESS — Continued

Two 5½" Strips are connected at each end by a 1" Corner Bracket, and are extended by a 2" Slotted Strip (39) (Fig. 9.16a). The lower Corner Bracket is held by a Collar on a Threaded Pin fixed to one of the Girders (3). A Threaded Pin in Double Bent Strip (34) passes through the slotted hole of the Slotted Strip. A Fishplate is bolted tightly to the shank of the Rod Socket (19) and an Adaptor for Screwed Rods is screwed firmly on to a bolt passed through the slotted hole of the Fishplate. The shank of the Adaptor is passed between the 5½" Strips, and is then fitted with a Collar.

The raw material reel (40) (Fig. 9.16d) is supported by a 6½" Rod held in a large Fork Piece (41) and in a Bell Crank (42) (Fig. 9.16b).

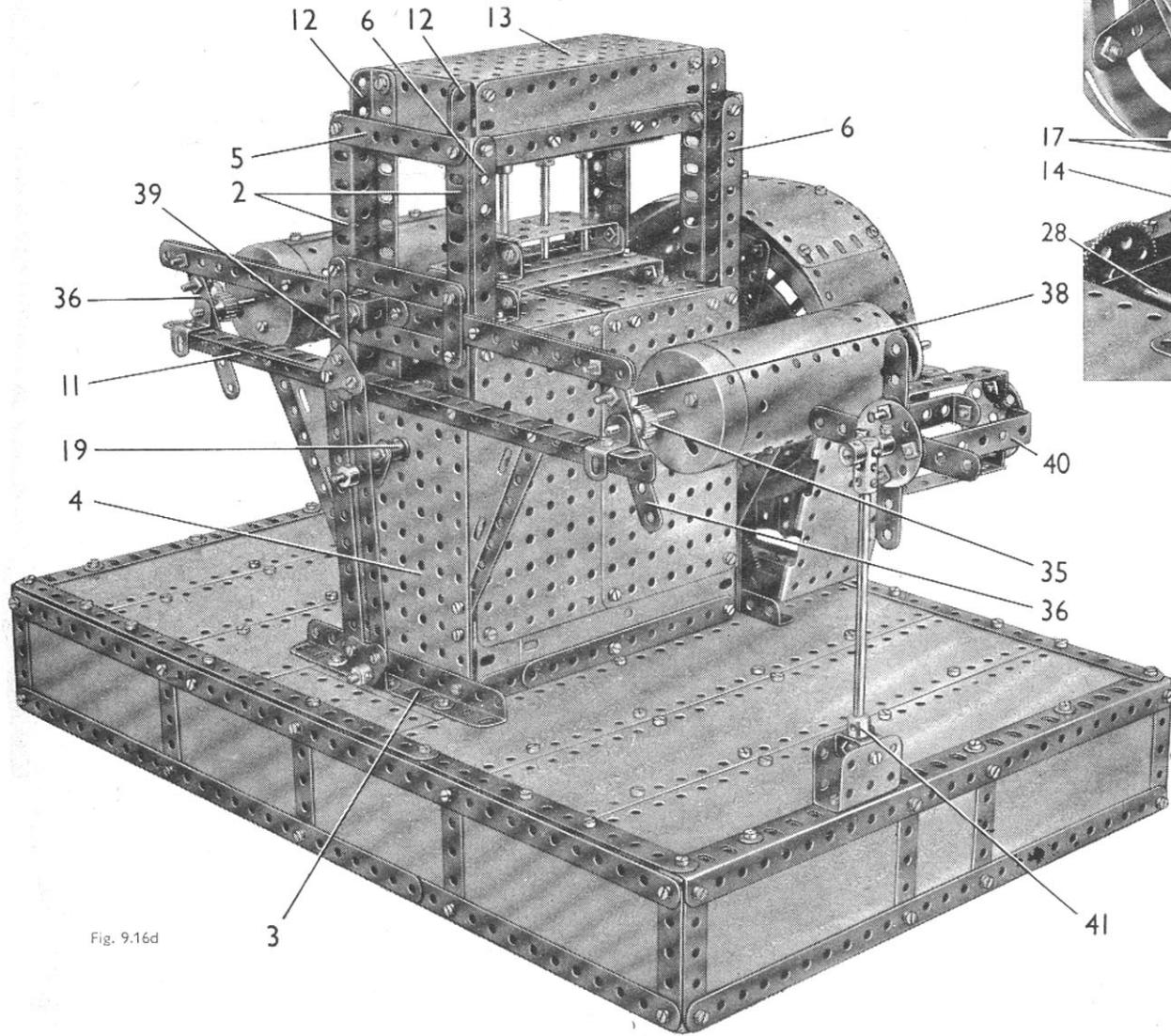

Fig. 9.16d

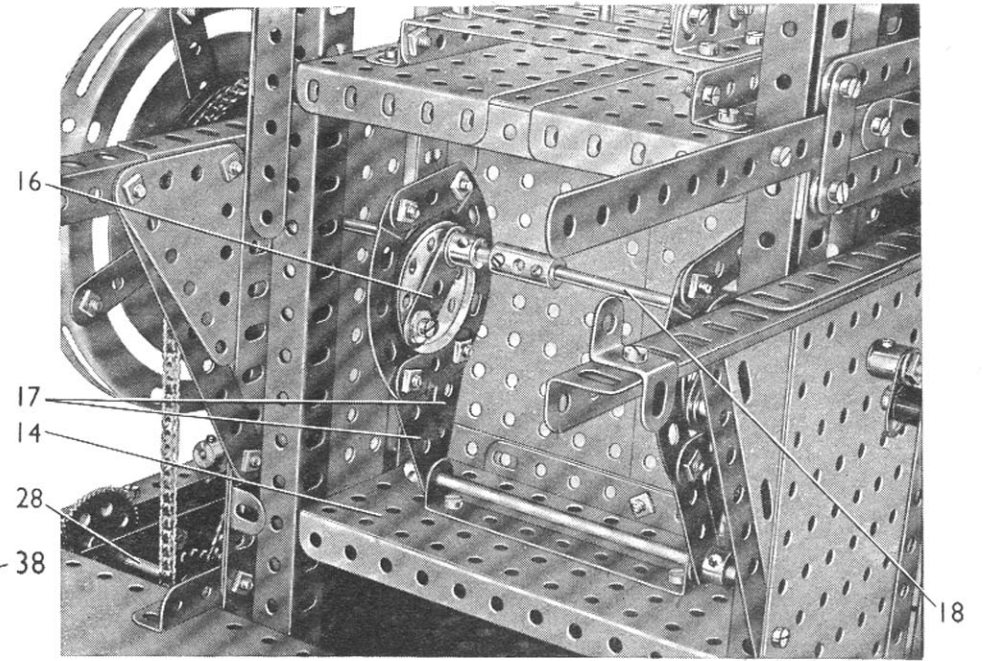

Fig. 9.16e

Parts Required

14 of No. 1	1 of No. 19b	2 of No. 62	2 of No. 155
2 " " 1b	4 " " 20a	2 " " 62b	1 " " 160
19 " " 2	2 " " 21	3 " " 63	1 " " 162
6 " " 2a	2 " " 22	2 " " 70	1 " " 162b
6 " " 3	1 " " 24	4 " " 90	1 " " 173a
29 " " 5	1 " " 24a	4 " " 90a	2 " " 179
4 " " 6	1 " " 25	1 " " 94	4 " " 188
6 " " 6a	4 " " 26	1 " " 95b	7 " " 189
2 " " 7a	1 " " 27	1 " " 96a	2 " " 190
10 " " 8	2 " " 27a	1 " " 100	6 " " 191
2 " " 8a	315 " " 37a	2 " " 108	9 " " 192
4 " " 9	288 " " 37b	1 " " 109	6 " " 197
2 " " 9d	44 " " 38	6 " " 111a	1 " " 198
2 " " 9f	1 " " 45	12 " " 111c	2 " " 212a
3 " " 10	2 " " 48	2 " " 115	2 " " 214
3 " " 11	8 " " 48a	1 " " 116	2 " " 222
35 " " 12	2 " " 48b	2 " " 124	2 " " 225
2 " " 12b	1 " " 51	2 " " 125	
1 " " 13a	2 " " 52	1 " " 128	
1 " " 14	4 " " 52a	2 " " 133a	
4 " " 15a	4 " " 53	1 " " 136	
5 " " 16	2 " " 53a	1 " " 143	
3 " " 16a	2 " " 54	1 " " 146a	
1 " " 17	1 " " 55a	1 " " 154a	
1 " " 18b	11 " " 59	1 " " 154b	

1 E20R
Electric Motor
(not included in
Outfit)

9.17 ARTICULATED LORRY

ASSEMBLY OF THE MOTOR CHASSIS

Each girder of the chassis (see Figs. 9.17a and 9.17c), consists of two $1\frac{1}{2}$ " Angle Girders joined together to make a $12\frac{1}{2}$ " channel girder. These girders are connected at the front and the rear by $3\frac{1}{2}$ " x $\frac{1}{2}$ " Double Angle Strips. A No. 1 Clockwork Motor is bolted to one of the channel girders, and is connected to the other by two Angle Brackets. A $\frac{1}{2}$ " Pinion on the Motor shaft drives a $1\frac{1}{2}$ " Contrace on a $4\frac{1}{2}$ " Rod (1). This Rod is supported in $1\frac{1}{2}$ " Angle Girders bolted to the chassis, and it carries a $\frac{1}{2}$ " Pinion that drives a 50-tooth Gear on another $4\frac{1}{2}$ " Rod (2). Rod (2) also is supported in the $1\frac{1}{2}$ " Angle Girders. A $\frac{3}{8}$ " Sprocket on Rod (2) is connected by Chain to a 2" Sprocket on the rear axle, which is an 8" Rod held by Collars in Double Brackets bolted to the chassis girders.

The front axle beam is a $3\frac{1}{2}$ " x $\frac{1}{2}$ " Double Angle Strip (3) fitted at each end with a $\frac{1}{2}$ " Reversed Angle Bracket (4). A Coupling (5) is mounted on a 1" Rod supported in each of the Reversed Angle Brackets and in the end hole of the Double Angle Strip. A $1\frac{1}{2}$ " Rod fitted with a Swivel Bearing (6) is fixed in each Coupling, and the Swivel Bearings are connected by a rod (7) made from a 4" and a 2" Rod joined by a Rod Connector. A $5\frac{1}{2}$ " Strip is pivoted at one end on a bolt in one of the Swivel Bearings. The other end of this Strip is lock-nutted to a Crank (8) on the steering column, which is a $6\frac{1}{2}$ " Rod held in one of the chassis girders by two Collars.

A 3" Pulley (9) is attached to two $\frac{1}{2}$ " Reversed Angle Brackets bolted to a $4\frac{1}{2}$ " x $\frac{1}{2}$ " Double Angle Strip, which is fixed to the back of the chassis and to the lower side-plate of the No. 1 Clockwork Motor.

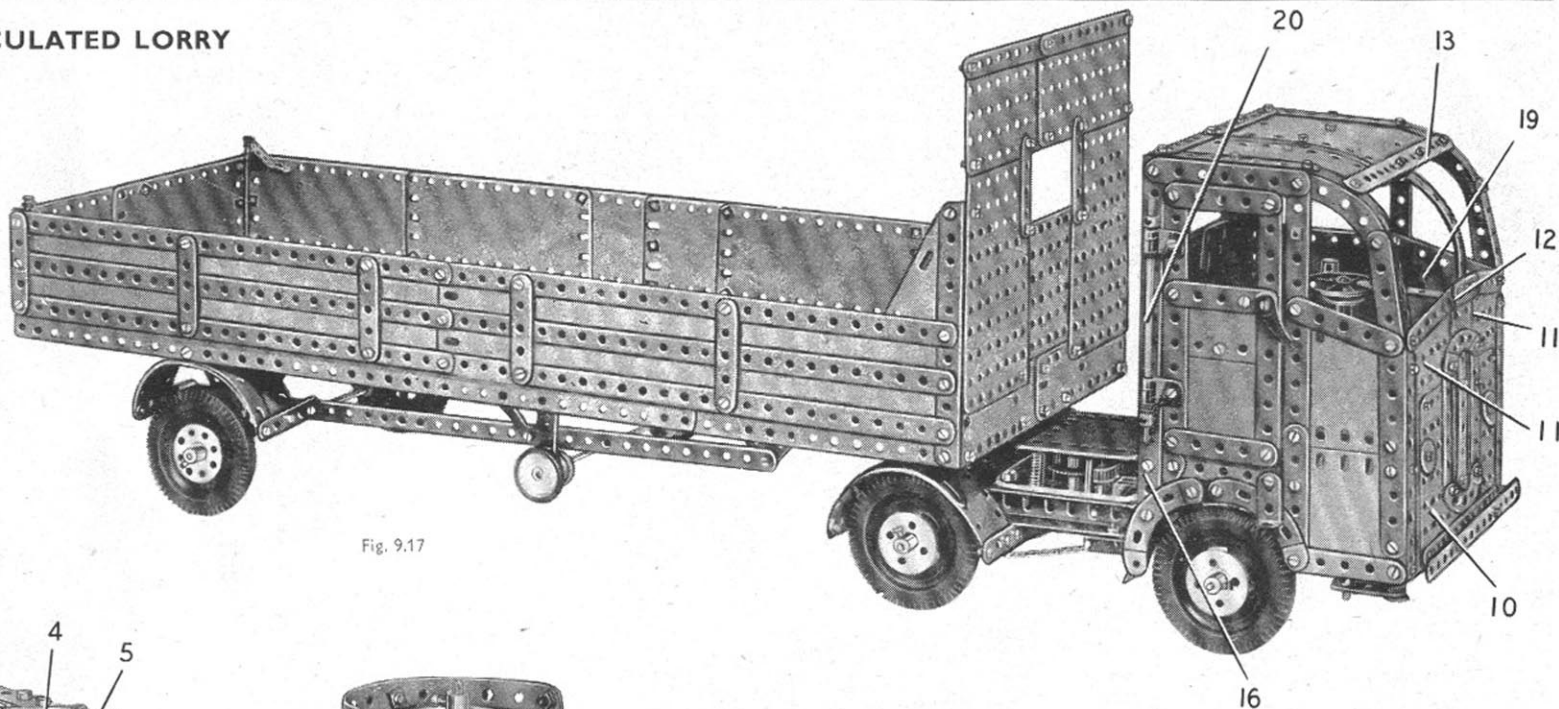

Fig. 9.17

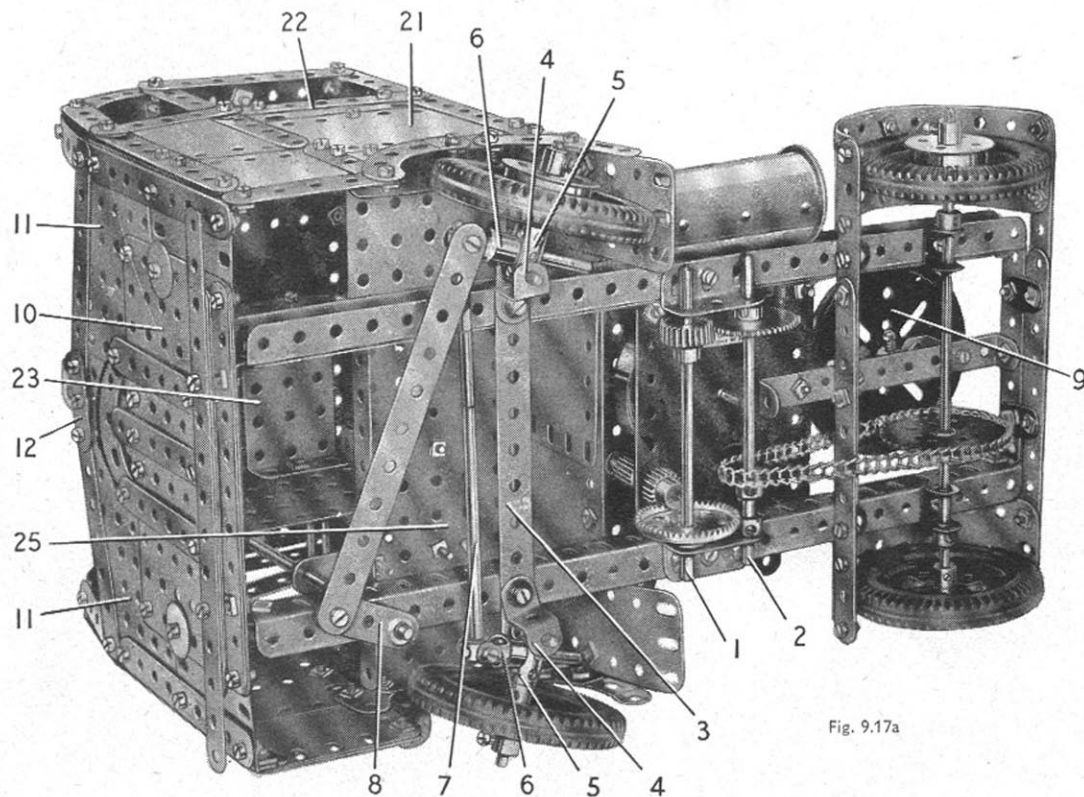

Fig. 9.17a

CONSTRUCTION OF THE CAB

The front of the cab is made by bolting a $5\frac{1}{2}$ " x $3\frac{1}{2}$ " Flat Plate (10) (Fig. 9.17) to the Double Angle Strip at the front of the chassis. A $2\frac{1}{2}$ " x $1\frac{1}{2}$ " Flexible Plate is fixed to each side of the Flat Plate, and a $3\frac{1}{2}$ " x $2\frac{1}{2}$ " Flanged Plate (11) is placed above each of the Flexible Plates. The Flanged Plates are connected at the centre by a $2\frac{1}{2}$ " x $1\frac{1}{2}$ " Flexible Plate. The top edge of the front is formed by two $3\frac{1}{2}$ " Strips joined by a $1\frac{1}{2}$ " Strip (12), and a $4\frac{1}{2}$ " Strip is bolted to each side. The radiator is represented by three 3" Strips and two $2\frac{1}{2}$ " Stepped Curved Strips.

The windscreen frame is made from two $2\frac{1}{2}$ " Strips extended by Formed Slotted Strips with a curved $5\frac{1}{2}$ " Strip at the centre. These are connected at the top by a $7\frac{1}{2}$ " Strip (13). The front bumper is a $7\frac{1}{2}$ " Strip with two $5\frac{1}{2}$ " Strips placed centrally behind it. These are spaced from the front of the cab by nuts on two $\frac{1}{2}$ " Bolts.

The back of the cab consists of Plates bolted to built-up strips (14) and (15) (Fig. 9.17c), and to $7\frac{1}{2}$ " Angle Girders (16). Strip (14) is made from a $5\frac{1}{2}$ " and a $2\frac{1}{2}$ " Strip, and strip (15) is formed by two $5\frac{1}{2}$ " Strips overlapped seven holes. The back is plated by two $4\frac{1}{2}$ " x $2\frac{1}{2}$ " Flexible Plates bolted to the Strip (14), with a vertical $5\frac{1}{2}$ " x $2\frac{1}{2}$ " Flexible Plate (17) fixed to each of the Girders (16). The separated halves of a Hinged Flat Plate overlapped three holes are bolted between the Plate (17). The rear window is edged by a $3\frac{1}{2}$ " and two $2\frac{1}{2}$ " Strips. The back of the cab is attached to each of the chassis girders by an Angle Bracket.

The cab side seen in Fig. 9.17c consists of two $2\frac{1}{2}$ " x $2\frac{1}{2}$ " Flexible Plates (18), with a $2\frac{1}{2}$ " x $1\frac{1}{2}$ " Flexible Plate overlapping the join on the inside. These are bolted to the flange of the Plate (11) and connected to the lower corner of the front by an Angle Bracket. The Plates are edged by Strips, and the window frame is formed by Curved Strips and Strips as shown. A $2\frac{1}{2}$ " x $1\frac{1}{2}$ " Triangular Flexible Plate (19) is placed above the upper $2\frac{1}{2}$ " x $2\frac{1}{2}$ " Flexible Plate (18). The wheel arch consists of two $2\frac{1}{2}$ " Stepped Curved Strips connected by a Fishplate. The door is formed by a $2\frac{1}{2}$ " x $2\frac{1}{2}$ " and a $2\frac{1}{2}$ " x $1\frac{1}{2}$ " Flexible Plate bolted to two $5\frac{1}{2}$ " Strips, which are connected by three $2\frac{1}{2}$ " Strips. Two Right-Angle Rod and Strip Connectors bolted to the door pivot on a 5" Rod (20) fixed in two Collars. Each of these Collars is screwed on a bolt which is fitted with a nut and then passed through the Girder (16). The handle is a Pawl without boss fixed by a nut on a $\frac{1}{2}$ " Bolt. This Bolt is passed through the door, and a Fishplate is then held tightly on it by two nuts.

The side seen in Fig. 9.17a is similar to the side described above, but the door is omitted and is replaced by a $4\frac{1}{2}$ " x $2\frac{1}{2}$ " Flexible Plate (21), extended upward by a $2\frac{1}{2}$ " x $1\frac{1}{2}$ " Flexible Plate. A $3\frac{1}{2}$ " Strip (22) is bolted to the top edge of the $2\frac{1}{2}$ " x $1\frac{1}{2}$ " Flexible Plate.

THE CAB FITTINGS AND ROOF

The engine cover is made by fixing two $3\frac{1}{2}$ " x $2\frac{1}{2}$ " Flanged Plates by their flanges over the front of the cab. These are joined by a $2\frac{1}{2}$ " x $1\frac{1}{2}$ " Flanged Plate (23) and by two $1\frac{1}{16}$ " radius Curved Plates, which are bolted at the centre to a 3" Strip (24) (Fig. 9.17c).

The cab floor is a $5\frac{1}{2}$ " x $2\frac{1}{2}$ " Flanged Plate (25) (Fig. 9.17a) attached to the Girder (16) by a 1" Triangular Plate and to the lower one of the Plates (18) by a 1" Corner Bracket. The Flanged Plate is lengthened by a $4\frac{1}{2}$ " x $2\frac{1}{2}$ " Flat Plate fitted at its outer end with a $2\frac{1}{2}$ " Angle Girder. This Angle Girder is connected to the side of the cab by a 1" Triangular Plate and a 1" Corner Bracket, in the same way as the Flanged Plate. A $2\frac{1}{2}$ " Strip (26) bolted to the Flanged Plate (25), provides an additional bearing for the steering column. A $3\frac{1}{2}$ " Rod held in a Crank that is fixed by the same bolt as that holding Strip (26), represents the gear lever.

(Continued on next page)

MODEL 9.17 ARTICULATED LORRY — Continued

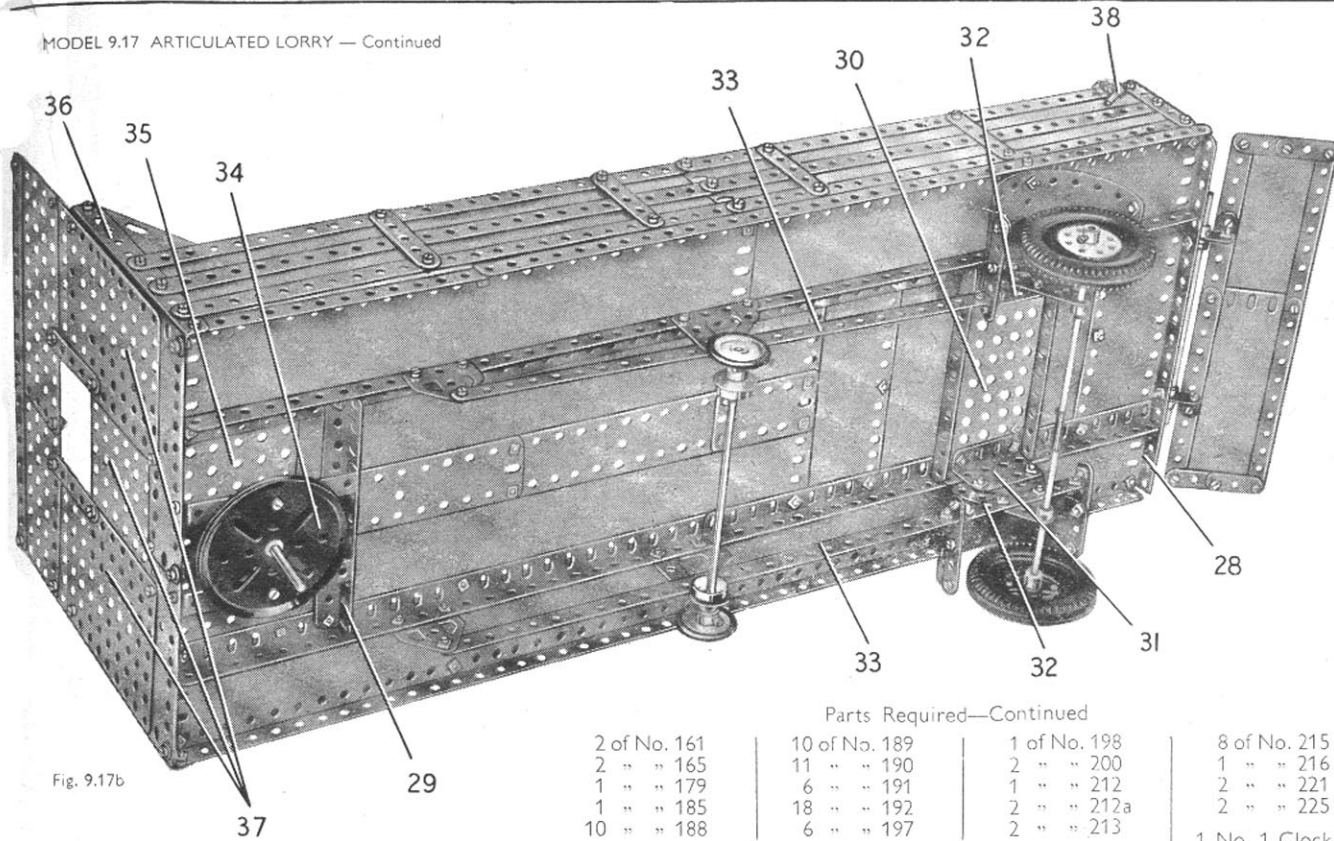

Fig. 9.17b

Parts Required—Continued

2 of No. 161	10 of No. 189	1 of No. 198	8 of No. 215
2 " " 165	11 " " 190	2 " " 200	1 " " 216
1 " " 179	6 " " 191	1 " " 212	2 " " 221
1 " " 185	18 " " 192	2 " " 212a	2 " " 225
10 " " 188	6 " " 197	2 " " 213	

The seat is formed by a Channel Bearing bolted to a 2½" × 1½" Flanged Plate that is fixed to the Flanged Plate (25). The back of the seat consists of a Flat Trunnion bolted to a Trunnion fixed to the top flange of the 2½" × 1½" Flanged Plate.

The cab roof consists of three 4½" × 2½" Flexible Plates and two 2½" × 2½" Flexible Plates, arranged as shown in Fig. 9.17c. These are edged at the back by two 4½" Strips overlapped three holes, and on each side by two 2" Strips. The roof is bolted to the Strip (13) and to the Formed Slotted Strips of the windscreen, and it is connected to the sides and back of the cab by Angle Brackets.

THE TRAILER CHASSIS

Each girder of the trailer chassis consists of two 12½" Angle Girders overlapped one hole (see Fig. 9.17b). These girders are connected by 9½" Angle Girders at each end, a 5½" Angle Girder (29), and a 5½" × 2½" Flanged Plate (30). The rear axle is made from a 5" and a 4" Rod joined by a Rod Connector, and is held by Collars in 2½" Triangular Plates bolted to Girder Brackets (31).

Each of the mudguards is formed by a curved 5½" × 1½" Flexible Plate strengthened by two Formed Slotted Strips and two 2½" Strips. The 2½" Strips are connected by Angle Brackets to built-up strips (32), each made from two 2½" Strips overlapped three holes. A 12½" Strip (33) is connected by an Angle Bracket to the front of each mudguard, and is supported at its front end by a Flat Trunnion bolted to the chassis. A Corner Gusset on each side is fixed between the chassis girder and the Strip (33).

A 3" Pulley (34) is attached to two 3½" × ½" Double Angle Strips bolted between the 9½" Angle Girder and the Girder (29). A 2" Rod held in the boss of Pulley (34) is passed through the boss of Pulley (9) and is held in place by a Collar.

ASSEMBLY OF THE TRAILER PLATFORM

The floor of the platform is filled in by Strip Plates and Flexible Plates arranged as shown in Fig. 9.17b, and at one end a 5½" × 2½" Flat Plate (35) is bolted in position. The edges are strengthened by 18½" and 12½" Angle Girders overlapped. One side consists of two 12½" × 2½" Strip Plates, strengthened by 12½" and 2½" Strips (see Fig. 9.17). The other side is formed by four 5½" × 2½" and two 2½" × 2½" Flexible Plates, and these also are braced by Strips.

A 5½" Angle Girder (36) and a 3½" × 2" Triangular Flexible Plate are bolted to the front of each side. The load board at the front consists of two 5½" × 1½" Flexible Plates bolted to the 9½" Angle Girder, three 5½" × 3½" Flat Plates (37) (Fig. 9.17b), and a 5½" × 2½" and a 4½" × 2½" Flat Plate at the top.

The hinged tailboard consists of two 5½" × 2½" Flexible Plates overlapped three holes. A Fishplate is bolted tightly to each of two Angle Brackets fixed to the lower edge of the tailboard. The Fishplates pivot on a 6½" Rod that is held in two Handrail Supports attached to the Girder (28). The tailboard is supported in the closed position by Threaded Pins (38) (Fig. 9.17b).

Parts Required

14 of No. 1	1 of No. 13a	354 of No. 37a	4 of No. 90
2 " " 1b	3 " " 14	322 " " 37b	4 " " 90a
23 " " 2	2 " " 15	34 " " 38	1 " " 94
6 " " 2a	3 " " 15a	2 " " 38d	1 " " 95
6 " " 3	1 " " 15b	4 " " 48b	1 " " 96a
5 " " 4	1 " " 16	1 " " 48c	2 " " 108
36 " " 5	2 " " 17	1 " " 48d	3 " " 111
4 " " 6	4 " " 18a	2 " " 51	6 " " 111a
6 " " 6a	2 " " 18b	2 " " 52	12 " " 111c
2 " " 7a	2 " " 19b	4 " " 52a	2 " " 115
10 " " 8	4 " " 20	4 " " 53	4 " " 125
2 " " 8a	6 " " 20a	2 " " 53a	1 " " 126
2 " " 8b	3 " " 20b	1 " " 55a	3 " " 126a
3 " " 9	2 " " 22	12 " " 59	2 " " 133a
1 " " 9d	1 " " 24	2 " " 62	2 " " 136
2 " " 9f	2 " " 24a	2 " " 63	6 " " 142a
9 " " 10	1 " " 25	2 " " 70	2 " " 147b
2 " " 11	1 " " 26	2 " " 76	1 " " 147c
30 " " 12	1 " " 27	2 " " 77	2 " " 155
1 " " 12b	1 " " 28	2 " " 80c	1 " " 160

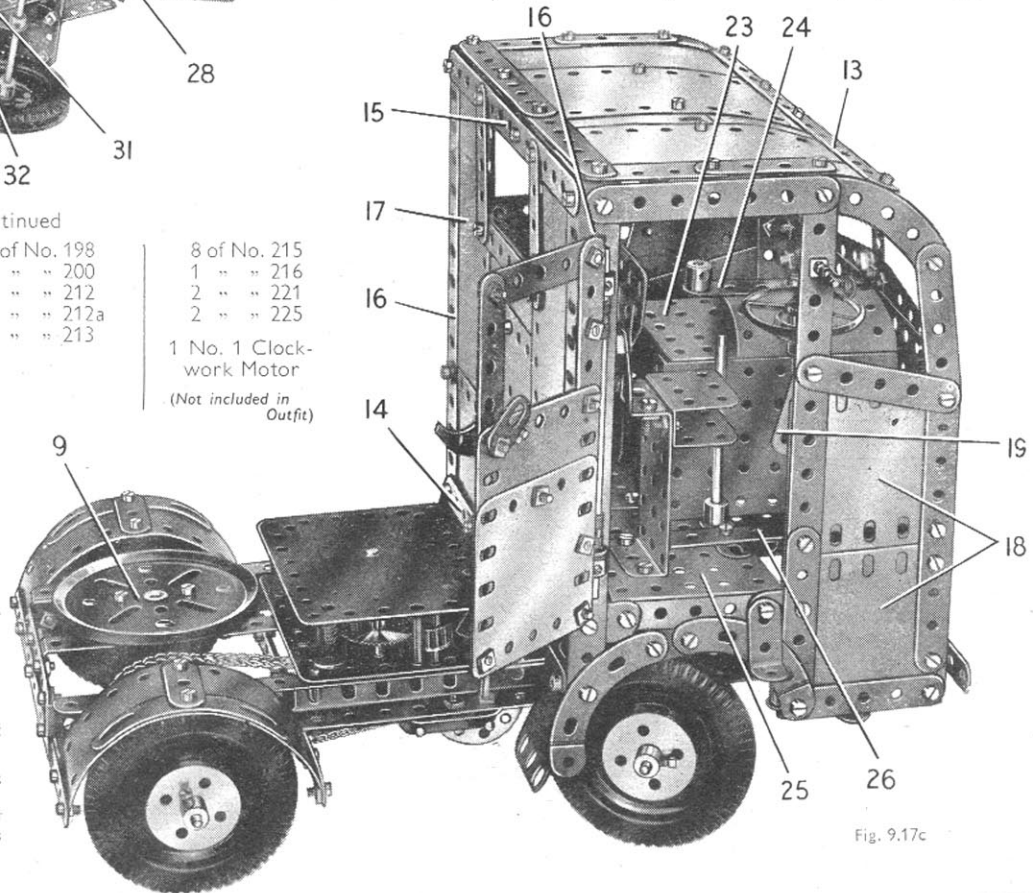

Fig. 9.17c

1 No. 1 Clock-work Motor
(Not included in Outfit)

9.18 MARINE ENGINE

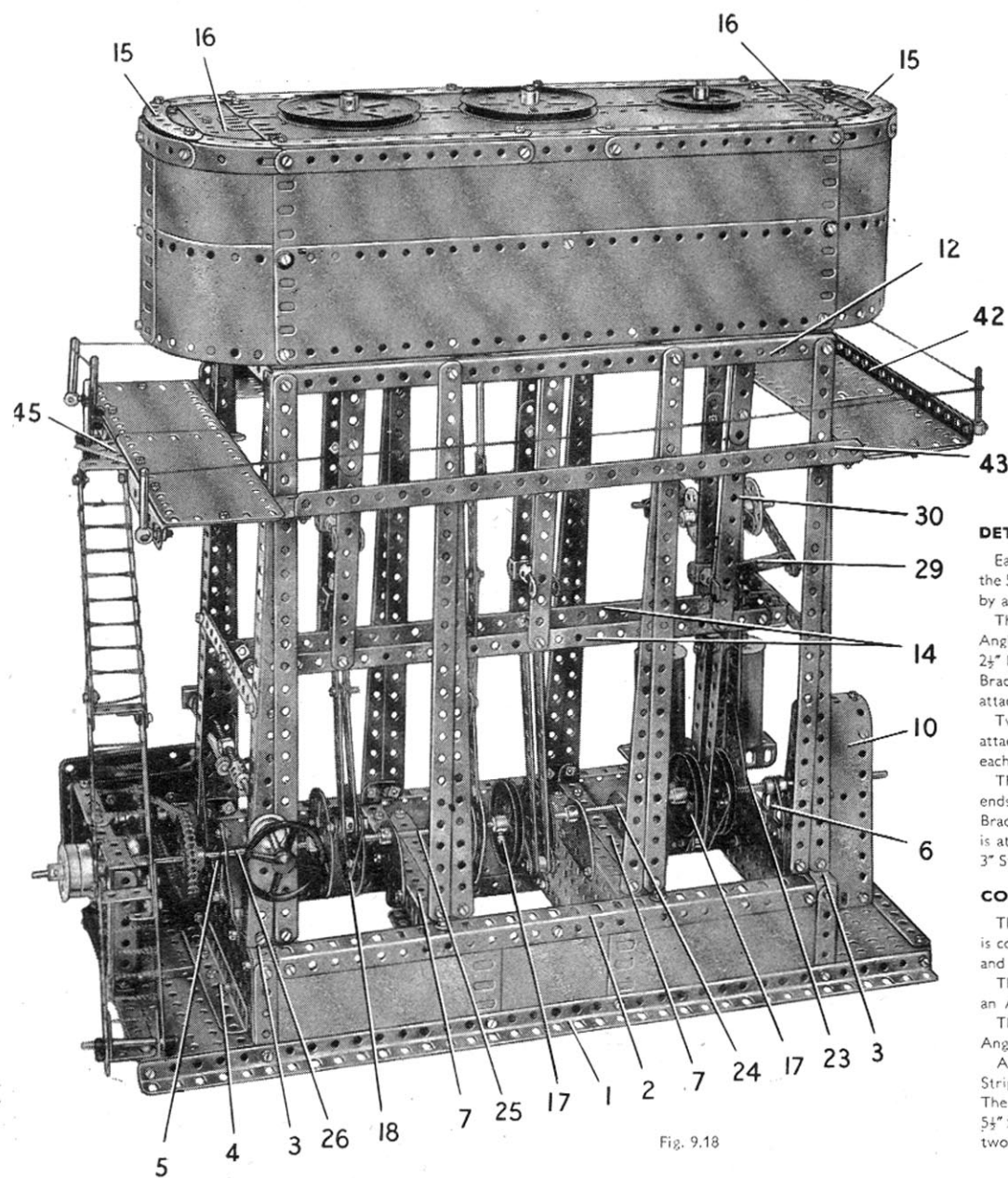

Fig. 9.18

Parts Required

14 of No. 1	3 of No. 15	3 of No. 45	7 of No. 90a	2 of No. 176
2 " " 1b	5 " " 15a	2 " " 48	1 " " 94	2 " " 179
24 " " 2	2 " " 15b	5 " " 48a	1 " " 95	1 " " 185
6 " " 2a	1 " " 16	2 " " 48b	1 " " 96a	4 " " 188
6 " " 3	2 " " 16a	1 " " 48c	2 " " 108	10 " " 189
8 " " 4	5 " " 17	2 " " 48d	2 " " 109	2 " " 191
32 " " 5	4 " " 18a	1 " " 50	3 " " 111	16 " " 192
3 " " 6	2 " " 18b	2 " " 51	5 " " 111a	6 " " 197
5 " " 6a	2 " " 19b	2 " " 52	12 " " 111c	1 " " 198
2 " " 7a	4 " " 20	4 " " 52a	1 " " 115	2 " " 212
10 " " 8	6 " " 20a	5 " " 53	1 " " 116	2 " " 213
2 " " 8a	2 " " 20b	2 " " 53a	2 " " 124	4 " " 214
2 " " 8b	2 " " 21	2 " " 54	4 " " 125	4 " " 215
4 " " 9	1 " " 23a	12 " " 59	1 " " 126a	2 " " 216
2 " " 9d	2 " " 24	2 " " 62	1 " " 128	4 " " 221
2 " " 9f	2 " " 24a	1 " " 62b	1 " " 133a	1 " " 225
19 " " 10	1 " " 27a	6 " " 63	2 " " 136	
8 " " 11	1 " " 32	2 " " 70	3 " " 147b	
3 " " 12	7 " " 35	1 " " 80a	1 " " 160	
4 " " 12a	349 " " 37a	2 " " 80c	2 " " 161	
2 " " 12b	318 " " 37b	4 " " 89	2 " " 165	
1 " " 13a	42 " " 38	2 " " 89b	1 " " 166	
3 " " 14	1 " " 40	4 " " 90	1 " " 173a	

1 E20R
Electric Motor
(Not included in
Outfit)

DETAILS OF THE ENGINE BED OR BASE

Each side of the bed is made by bolting a $4\frac{1}{2}'' \times 2\frac{1}{2}''$ and two $5\frac{1}{2}'' \times 2\frac{1}{2}''$ Flexible Plates to an $18\frac{1}{2}''$ Angle Girder (1). Each of the $5\frac{1}{2}'' \times 2\frac{1}{2}''$ Flexible Plates overlaps the $4\frac{1}{2}'' \times 2\frac{1}{2}''$ Flexible Plates by two holes, and the top edges of the Plates are strengthened by a $12\frac{1}{2}''$ Angle Girder (2). A $\frac{1}{2}''$ Reversed Angle Bracket (3) and a $2\frac{1}{2}''$ Strip are bolted to each end.

The $18\frac{1}{2}''$ Angle Girders are connected at each end by a $7\frac{1}{2}''$ Strip, to which two $3\frac{1}{2}'' \times 2\frac{1}{2}''$ Flanged Plates are bolted. A $5\frac{1}{2}'' \times 2\frac{1}{2}''$ Angle Girder (4) is fixed to each pair of Flanged Plates (Figs. 9.18 and 9.18c), and to each of these Girders are bolted a $5\frac{1}{2}'' \times 2\frac{1}{2}''$ Flat Plate and a $4\frac{1}{2}'' \times 2\frac{1}{2}''$ Flat Plate, overlapped five holes. The Flat Plates are connected to the sides of the base by Angle Brackets. Two Corner Gussets (5) are fixed to the Flat Plates at one end of the base (Fig. 9.18), and a Flat Trunnion (6) is attached to the other end (Fig. 9.18b).

Two $7\frac{1}{2}''$ Angle Girders (7) (Fig. 9.18) are fixed across the Girders (2), and to each of them a $5\frac{1}{2}'' \times 2\frac{1}{2}''$ Flanged Plate (8) is attached by Fishplates. The Flanged Plates are connected at their lower corners by two $3\frac{1}{2}'' \times \frac{1}{2}''$ Double Angle Strips, and to each Angle Girder (7) and Flanged Plate (8) a Semi-Circular Plate (9) is attached.

The thrust block (10) (Fig. 9.18c) consists of two Flanged Sector Plates connected by two $5\frac{1}{2}'' \times 1\frac{1}{2}''$ Flexible Plates. The top ends of these Plates are curved and bolted together, and two Wheel Discs are attached to them by Angle Brackets. Four Angle Brackets are used to fix the thrust block to the base. At the end of the base opposite to the thrust block a bearing block (11) is attached. This consists of four $3''$ Strips bolted in pairs to two $1\frac{1}{2}''$ Angle Girders fixed to the base. The top ends of the $3''$ Strips support a Channel Bearing, and a $2\frac{1}{2}''$ Angle Girder is bolted on each side to one of the $3''$ Strips.

COLUMNS SUPPORTING THE CYLINDER BLOCK

The four end columns are each made by bolting a $12\frac{1}{2}''$ Angle Girder to one of the Reversed Angle Brackets (3). A $12\frac{1}{2}''$ Strip is connected by a Fishplate to the lower end of the Girder, and a $2\frac{1}{2}'' \times 1\frac{1}{2}''$ Triangular Flexible Plate is bolted to the column and to the end of the engine bed.

The centre columns each consist of two $12\frac{1}{2}''$ Strips connected at their lower ends by a Fishplate and they are attached by an Angle Bracket to one of the Girders (2).

The four columns on each side support a $12\frac{1}{2}''$ Angle Girder (12), and these Girders are connected at their ends by $5\frac{1}{2}''$ Angle Girders. A $5\frac{1}{2}'' \times 3\frac{1}{2}''$ Flat Plate at each end and a similar Plate at the centre are fixed between the Girders (12).

A strip (13), made from a $5\frac{1}{2}''$ and a $3\frac{1}{2}''$ Strip overlapped six holes, is fixed across each pair of end columns, and two $12\frac{1}{2}''$ Strips (14), (Fig. 9.18), are bolted to two $1'' \times \frac{1}{2}''$ Angle Brackets and to two $\frac{3}{4}'' \times \frac{1}{2}''$ Angle Brackets attached to strips (13). The Strips (14) support the lower ends of the crosshead guides whose upper ends are fixed to Angle Brackets bolted to the $5\frac{1}{2}'' \times 3\frac{1}{2}''$ Flat Plates. Four of these guides are each formed by a $5\frac{1}{2}''$ Strip and a $3\frac{1}{2}''$ Strip overlapped three holes. The other two guides each consist of a $5\frac{1}{2}''$ and a $3''$ Strip overlapped two holes.

(Continued on next page)

MODEL 9.18 MARINE ENGINE — Continued

THE CYLINDER BLOCK

Each side consists of two $12\frac{1}{2}'' \times 2\frac{1}{2}''$ Strip Plates, edged at the top by two $5\frac{1}{2}''$ Strips and a $2\frac{1}{2}''$ Strip. The rounded ends are each made from four $5\frac{1}{2}'' \times 2\frac{1}{2}''$ Flexible Plates, as shown in Fig. 9.18b, and these are strengthened by a curved $4\frac{1}{2}''$ Strip and two Formed Slotted Strips.

The top of the block consists of a $12\frac{1}{2}'' \times 2\frac{1}{2}''$ Strip Plate on each side. These are connected at the centre by a $5\frac{1}{2}'' \times 3\frac{1}{2}''$ Flat Plate placed lengthways across the top, and the gaps between the Strip Plates are filled in by $5\frac{1}{2}'' \times 1\frac{1}{2}''$ Flexible Plates. The outer edge of each Strip Plate is strengthened by a $2\frac{1}{2}''$ Strip and two $5\frac{1}{2}''$ Strips. These Strips at each end are extended forward by $2\frac{1}{2}''$ Curved Strips, which are connected together by a $4''$ Stepped Curved Strip (15) (Fig. 9.18). The gap at each end between the Curved Strips and the Strip Plates is filled in by the *separated half of a Hinged Flat Plate* (16), and two $2\frac{1}{2}'' \times 1\frac{1}{2}''$ Flexible Plates.

The top is attached to the sides of the block by Angle Brackets. The cylinder caps are represented by two $3''$ Pulleys held by Pivot Bolts and a $2''$ Pulley fixed by a $\frac{1}{2}''$ Bolt.

The completed cylinder block is bolted to the lugs of two $5\frac{1}{2}'' \times \frac{1}{2}''$ Double Angle Strips fixed across the ends of the Girders (12).

If you ever require advice in connection with your model-building, write to
Information Service
Meccano Ltd
Binns Road
Liverpool 13
Experts are waiting to help you

DETAILS OF THE CRANKS AND ECCENTRICS

The cranks (17) (Fig. 9.18) are each made by bolting two $2\frac{1}{2}''$ Strips across the face of each of two $2''$ Pulleys. The bolts pass through the next-to-end holes of the Strips. The other ends of the Strips of each Pulley are brought together so that their end holes overlap. A $\frac{3}{4}''$ Bolt is fixed by a nut in the overlapped holes of two of the Strips, and two $5\frac{1}{2}''$ Strips separated by a Collar are pivoted on the bolt. The bolt is then fixed by two nuts in the end holes of the second pair of $2\frac{1}{2}''$ Strips. The third crank (18) (Fig. 9.18), is made in the same way as each of the two cranks described above, but the $2''$ Pulleys are replaced by Face Plates.

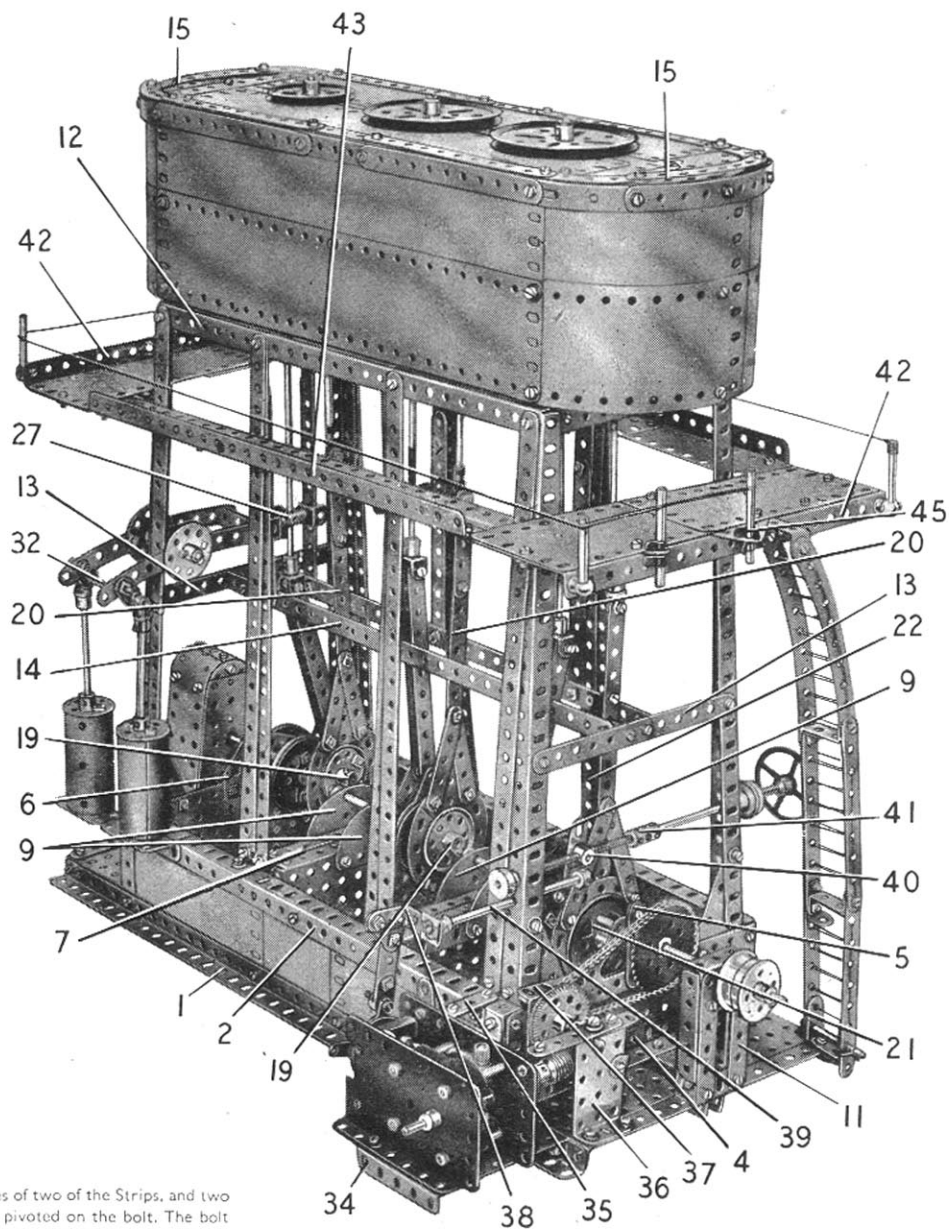

Fig. 9.18b

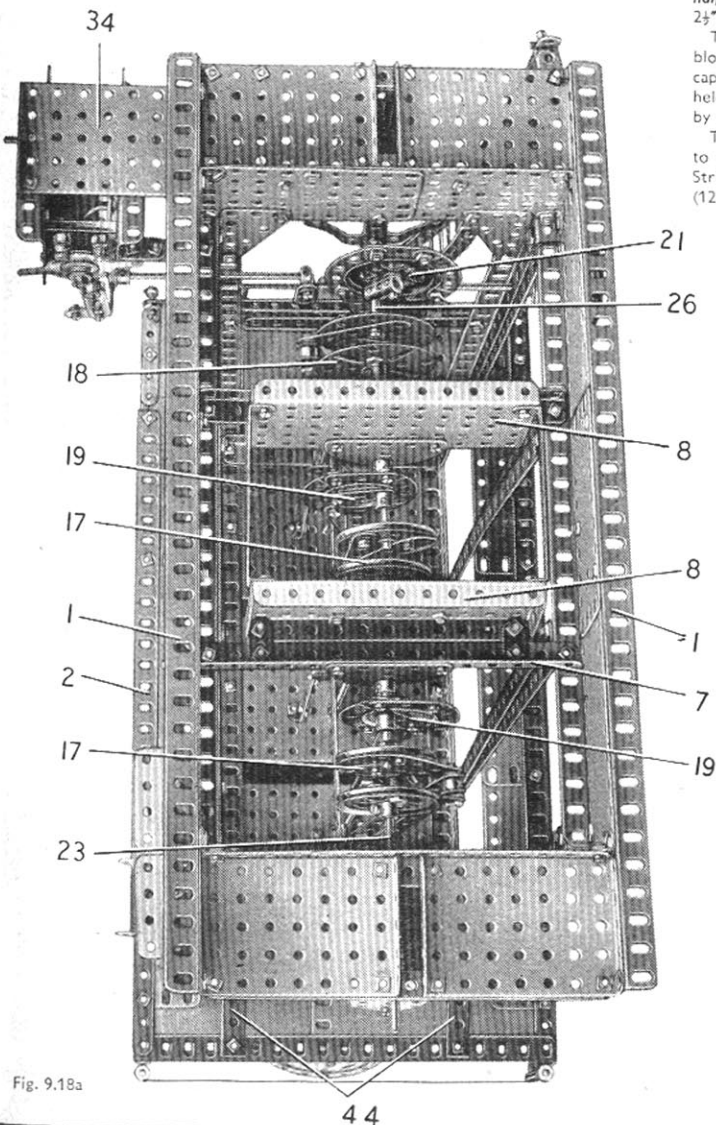

Fig. 9.18a

(Continued on next page)

MODEL 9.18 MARINE ENGINE — Continued

The eccentrics (19) (Fig. 9.18b) each consist of a $1\frac{1}{2}$ " Pulley with a Crank bolted across it so that the boss of the Crank coincides with a hole in the edge of the Pulley. The Rod on which the eccentric is mounted is passed through the boss of the Crank and the hole in the Pulley. The eccentric strap is formed by two $2\frac{1}{2}$ " Stepped Curved Strips joined at their ends by $1\frac{1}{2}$ " Strips, and arranged so that the inner edges of the Strips and Curved Strips slide freely in the groove of the Pulley. Two $2\frac{1}{2}$ " Strips are bolted to the top of the strap, and to them is fixed a built-up strip (20) (Fig. 9.18b), made from a $5\frac{1}{2}$ " and a $2\frac{1}{2}$ " Strip bolted together.

The third eccentric (21) (Fig. 9.18a) is made by fixing a Coupling on a 1" Rod gripped in the boss of a 2" Pulley. The Coupling is arranged so that its outer hole coincides with a hole at the edge of the Pulley, and the Rod on which the eccentric is mounted is passed through this hole and is fixed in the Coupling. The strap of this eccentric consists of three $2\frac{1}{2}$ " Stepped Curved Strips bolted together and connected by a $1\frac{1}{2}$ " Strip, and these parts are arranged so that they slide freely in the groove of the 2" Pulley. Two 3" Strips bolted to the strap are fixed at their upper ends to a built-up strip (22), made from a $4\frac{1}{2}$ " and a $2\frac{1}{2}$ " Strip bolted together.

A 2" Pulley of one of the cranks (17) is fixed on a $4\frac{1}{2}$ " Rod (23) supported in the thrust block (10) and the Flat Trunnion (6). The second Pulley of the Crank is fixed on a 4" Rod (24), mounted in two of the Semi-Circular Plates (9), and one of the eccentrics (19) is fixed also on this Rod. A 2" Pulley of the second crank (17) is locked on the inner end of Rod (24), and the other Pulley of this crank is fixed on a 4" Rod (25). This Rod is supported in the second pair of Semi-Circular Plates (9), and it carries the second eccentric (19). One Face Plate of the Crank (18) is fixed to the end of Rod (25), and the other Face Plate is fastened to a $6\frac{1}{2}$ " Rod (26) that carries also the eccentric (21). Rod (26) is supported in the Corner Gussets (5) and in the bearing block (11). Rods (23), (24) and (25) are held in place by Collars, and Rod (26) is retained in position by two $1\frac{1}{2}$ " Flanged Wheels.

PISTON AND VALVE RODS

Two of the piston rods are 8" Rods, and the third consists of a $6\frac{1}{2}$ " and a 2" Rod joined by a Rod Connector. A Coupling (27) (Fig. 9.18b) is fixed on each piston rod, and two Double Brackets (28) (Fig. 9.18c) are attached to its ends by $\frac{3}{8}$ " Bolts passed through the centre holes of the Double Brackets and gripped in the Couplings by their grub screws. The Double Brackets slide freely over the crosshead guides.

A Rod Socket is fixed to the lower end of each of two of the piston rods, and a Double Bracket is held by a nut on the Threaded shank of the Rod Socket. The $5\frac{1}{2}$ " Strips that form the connecting rods of the cranks (17) are lock-nutted to the Double Brackets. A large Fork Piece is fixed to the lower end of the third piston rod, and to it are lock-nutted the connecting rod Strips of the Crank (18).

The valve rods are 5" Rods, which slide freely in the $5\frac{1}{2}$ " x $3\frac{1}{2}$ " Flat Plates bolted to the Girders (12) and in Double Bent Strips fixed to the Flat Plates. The strips (20) of the eccentrics (19) are lock-nutted to Rod and Strip Connectors fitted to two of the valve rods. The strip (22) of the eccentric (21) is lock-nutted to an End Bearing on the third valve rod.

ASSEMBLY OF THE FEED PUMP

Two $5\frac{1}{2}$ " Curved Strips are connected by a $1\frac{1}{2}$ " x $\frac{1}{2}$ " Double Angle Strip (29) (Fig. 9.18c) and are pivoted on a $2\frac{1}{2}$ " Rod mounted in one of the cylinder-block supporting columns and in the boss of a Bell Crank bolted to the column. One of the Curved Strips is bolted to a Bush Wheel (30), and the other is pivoted on the Rod between a $\frac{3}{4}$ " Flanged Wheel and a Bush Wheel. The inner Curved Strip has a Fishplate bolted tightly to one end, and another Fishplate

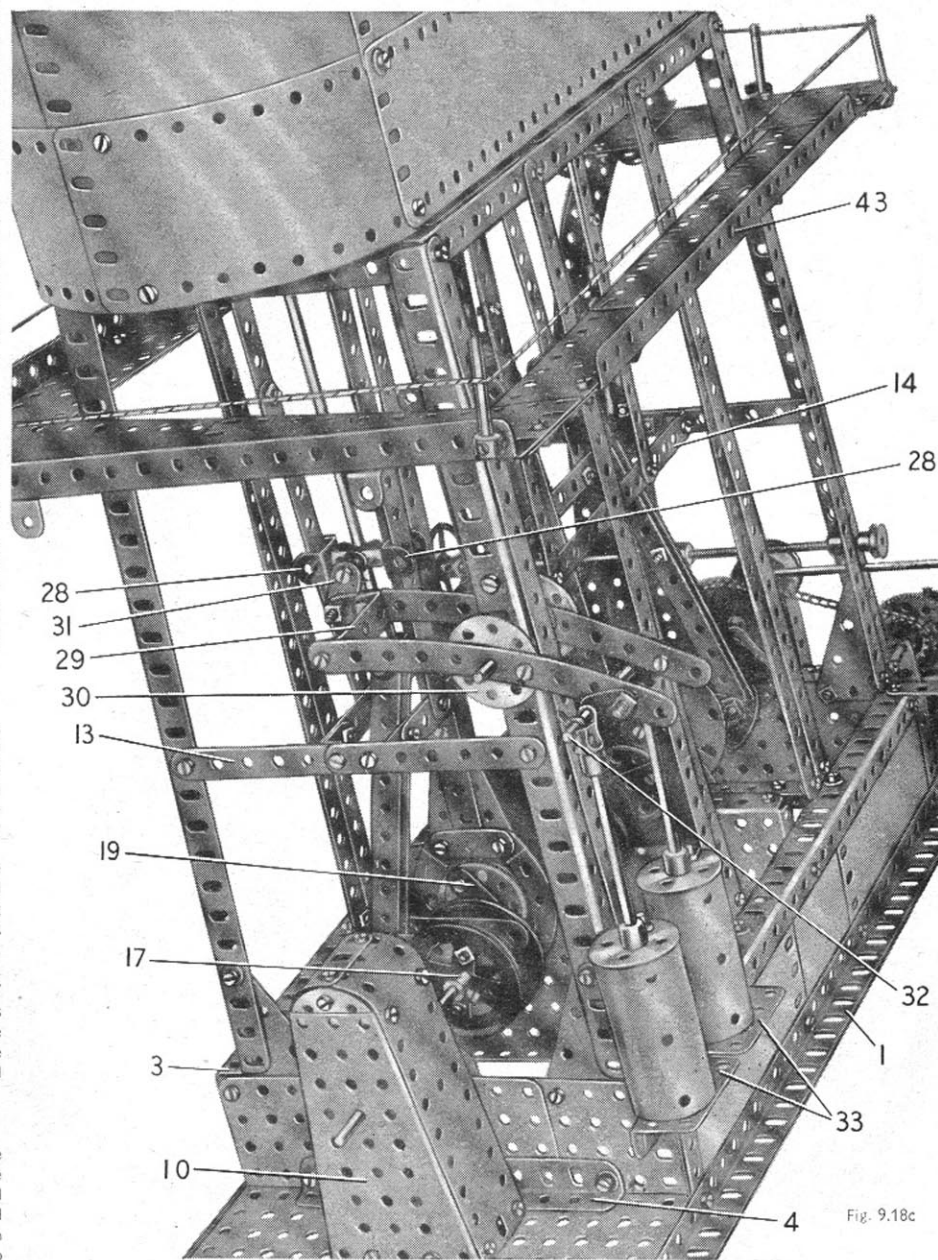

Fig. 9.18c

(31) (Fig. 9.18c) is lock-nutted to the first Fishplate. Fishplate (31) pivots on a $\frac{1}{2}$ " Bolt screwed into the centre threaded hole of one of the Couplings (27).

A Fishplate is lock-nutted in the next-to-end hole at the outer end of each Curved Strip, and these support a $3\frac{1}{2}$ " Rod (32).

The lugs of two small Fork Pieces are passed over the Rod and are held in place by Spring Clips. Each Fork Piece is fitted with a Rod that slides freely in the boss of a $1\frac{1}{8}$ " Flanged Wheel fitted to a Cylinder. Each Cylinder is attached to a Girder Bracket (33) by a 3" Screwed Rod. The Screwed Rod is passed through holes in the Flanged Wheel and the Girder Bracket and is fixed in position by nuts at each end.

THE DRIVING MECHANISM

An E20R Electric Motor is bolted by its flanges to a $3\frac{1}{2}$ " x $2\frac{1}{2}$ " Flanged Plate (34) (Fig. 9.18a). The Motor is connected to one of the Girders (2) by a $1\frac{1}{2}$ " x $1\frac{1}{2}$ " Angle Bracket and a 2" Strip (35), and is joined to a $2\frac{1}{2}$ " x $1\frac{1}{2}$ " Flanged Plate (36) by a $\frac{1}{2}$ " x $\frac{1}{2}$ " Angle Bracket and a $2\frac{1}{2}$ " Strip. A second $2\frac{1}{2}$ " x $1\frac{1}{2}$ " Flanged Plate (37) is bolted to the base, and is connected to the Flanged Plate (36) by a $1\frac{1}{2}$ " x $\frac{1}{2}$ " Double Angle Strip.

A Coupling is fixed to one end of the Motor armature shaft, and in it is fixed a 1" Rod. A Worm on this Rod drives a 57-tooth Gear on a $2\frac{1}{2}$ " Rod that is held by a Collar and a 2" Sprocket in the Flanged Plates (36) and (37). The $\frac{3}{4}$ " Sprocket is connected by Chain to a 2" Sprocket on the Rod (26).

A Fishplate is held by a Collar on a Pivot Bolt that is passed through the top arm of the Motor switch. The Fishplate is bolted tightly to a 2" Strip fitted with a 1" Corner Bracket and a $1\frac{1}{2}$ " x $1\frac{1}{2}$ " Angle Bracket (38) (Fig. 9.18b). A Slide Piece fitted over an arm of the Angle Bracket (38) is fixed on a $4\frac{1}{2}$ " Rod (39), which projects slightly through the end hole of the Angle Bracket. The Rod (39) carries at its inner end a 'spider' from a Swivel Bearing, and this is screwed on to a bolt that is held by a nut in a Double Arm Crank (40). A $3\frac{1}{2}$ " Screwed Rod is threaded through the boss of the Double Arm Crank, and carries at one end a Screwed Rod Adaptor and at the other end a Coupling (41). The plain shank of the Screwed Rod Adaptor is supported in one of the cylinder block columns, and the Coupling is fitted with a $4\frac{1}{2}$ " Rod mounted in the opposite column. By turning a Steering Wheel on the $4\frac{1}{2}$ " Rod the Double Arm Crank (40) is moved up or down the Screwed Rod, and thus operates the Motor switch.

INSPECTION PLATFORM AND LADDER

Each end of the platform is made by bolting two $5\frac{1}{2}$ " x $2\frac{1}{2}$ " Flexible Plates to a $9\frac{1}{2}$ " Angle Girder (42), and each side consists of three $5\frac{1}{2}$ " x $1\frac{1}{2}$ " Flexible Plates attached to a $12\frac{1}{2}$ " Angle Girder (43). The platform is supported at each end by two $2\frac{1}{2}$ " x $\frac{1}{2}$ " Double Angle Strips (44) (Fig. 9.18a) bolted to the end cylinder block columns.

The sides of the ladder consist of $4\frac{1}{2}$ " Strips, a $4\frac{1}{2}$ " x $\frac{1}{2}$ " Double Angle Strip and $5\frac{1}{2}$ " Curved Strips. The sides are joined together by two 1" Reversed Angle Brackets, and the rungs are represented by Cord. One of the $5\frac{1}{2}$ " Curved Strips is bolted to one of the Angle Girders (42), and the other Curved Strip is fixed to a lug of a $2\frac{1}{2}$ " x $\frac{1}{2}$ " Double Angle Strip attached to the Girder. The lower end of the ladder is held by Spring Clips on a 2" Rod, which is passed through the arms of two $1\frac{1}{2}$ " x $1\frac{1}{2}$ " Angle Brackets bolted to the base.

The handrail round the inspection platform consists of Cord. This is supported by two $1\frac{1}{2}$ " Rods fixed in Handrail Supports, two $1\frac{1}{2}$ " Rods gripped in Collars screwed on to bolts held in one of the Girders (42) by nuts, and by two 2" Rods. One of the 2" Rods is held by Spring Clips in a Fishplate bolted to the platform, and the other is supported by Spring Clips in a $3\frac{1}{4}$ " x 2" Triangular Flexible Plate 45.

9.19 POWER PRESS

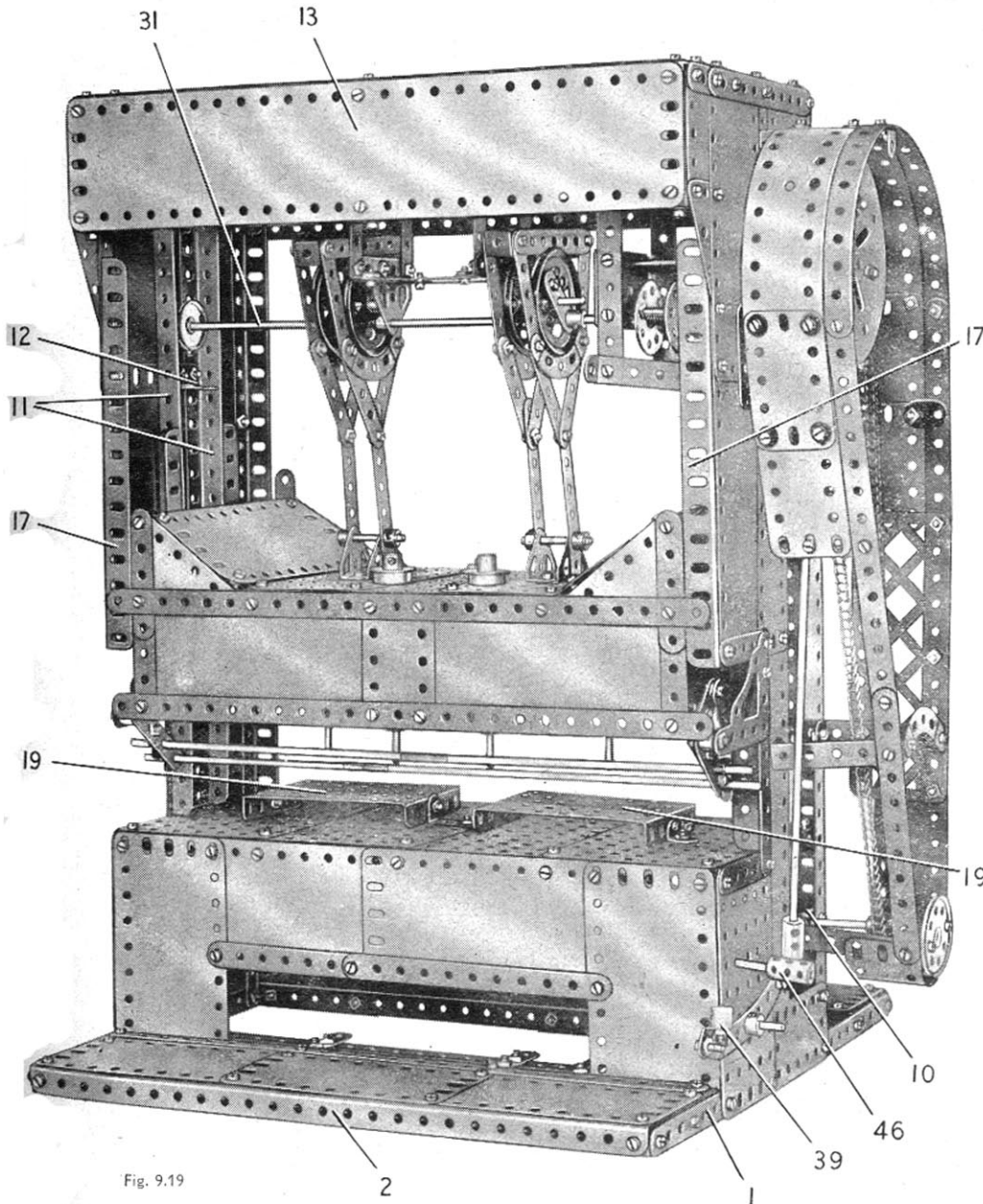

Fig. 9.19

Parts Required

14 of No.	1	2 of No.	52
2 " "	1b	4 " "	52a
19 " "	2	5 " "	53
6 " "	2a	2 " "	53a
6 " "	3	1 " "	55a
7 " "	4	12 " "	59
36 " "	5	2 " "	62
4 " "	6	1 " "	62b
6 " "	6a	3 " "	63
2 " "	7a	2 " "	70
10 " "	8	1 " "	89b
2 " "	8a	5 " "	90a
2 " "	8b	1 " "	94
4 " "	9	1 " "	95b
2 " "	9d	1 " "	96a
2 " "	9f	1 " "	100
5 " "	10	2 " "	108
8 " "	11	3 " "	111
34 " "	12	6 " "	111a
5 " "	12a	11 " "	111c
2 " "	12b	2 " "	115
4 " "	12c	1 " "	120b
2 " "	13	4 " "	126
1 " "	13a	2 " "	126a
2 " "	14	1 " "	128
1 " "	15	1 " "	133a
2 " "	15a	1 " "	136
2 " "	15b	1 " "	146a
1 " "	16	3 " "	147b
1 " "	16a	2 " "	161
3 " "	17	1 " "	165
4 " "	18a	2 " "	179
1 " "	18b	10 " "	188
4 " "	20a	9 " "	189
4 " "	20b	5 " "	190
1 " "	21	6 " "	191
5 " "	22	17 " "	192
2 " "	24	6 " "	197
1 " "	25	1 " "	198
2 " "	26	1 " "	212
1 " "	27	1 " "	212a
2 " "	27a	2 " "	213
4 " "	35	2 " "	221
349 " "	37a	2 " "	222
323 " "	37b	2 " "	225
40 " "	38		
1 " "	48		
8 " "	48a		
4 " "	48b		
1 " "	51		

1 E20R
Electric Motor
(Not included in
Outfit)

DETAILS OF THE PRESS BED OR BASE

The base is made by bolting two 12½" Strips (1) to Angle Brackets and Double Brackets fixed to Girders (2) (Fig. 9.19b). One of these is a 12½" Angle Girder and the other consists of two 9½" Angle Girders. A 12½" Angle Girder (3) is supported by Angle Brackets bolted to the Strips (1), and a 12½" Strip (4) is attached to two 18½" Angle Girders (5) secured vertically to the Strips (1) as shown (Fig. 9.19b). At the front of the base three 4½"×2½" Flexible Plates are bolted to the Girder (2) and are supported by 2½" Angle Girders attached to the Strips (1) and by 4½" Strips fixed to the Girders (2) and (3). Two 12½" Strips are bolted also to the 4½" Strips. At the rear of the base a 4½"×2½" and four 2½"×2½" Flexible Plates are fixed to the Girder (2), and also to a made-up 12½" strip that is supported by Double Brackets bolted to the Strips (1).

THE PRESS COLUMN

The side seen in Fig. 9.19b consists of a 4½"×2½" Flat Plate (6), and Strip and Flexible Plates bolted together and supported by the Girder (5). A 5½" Strip (7) is fixed between two of the Flexible Plates at the top of the side, and the top is edged by a built-up strip made from a 5½" and a 1½" Strip. The recessed section of the side is edged by a 4½" Strip and two 2½" Strips, and to it is bolted a Corner Gusset (8).

The opposite side is made in the same way, except that a gap is left corresponding to the 5½"×2½" Flexible Plate (9) (Fig. 9.19b). A 3" Strip, indicated at (10) (Fig. 9.19), is bolted across this gap.

(Continued on next page)

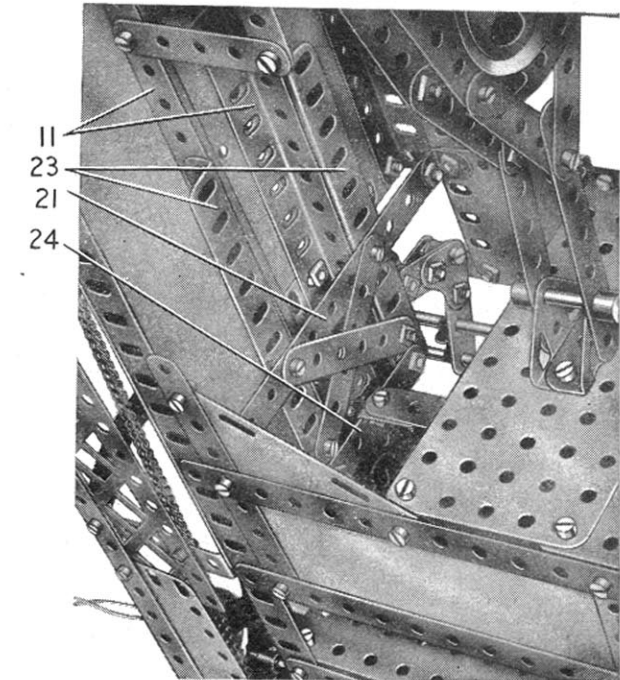

Fig. 9.19a

MODEL 9.19 POWER PRESS — Continued

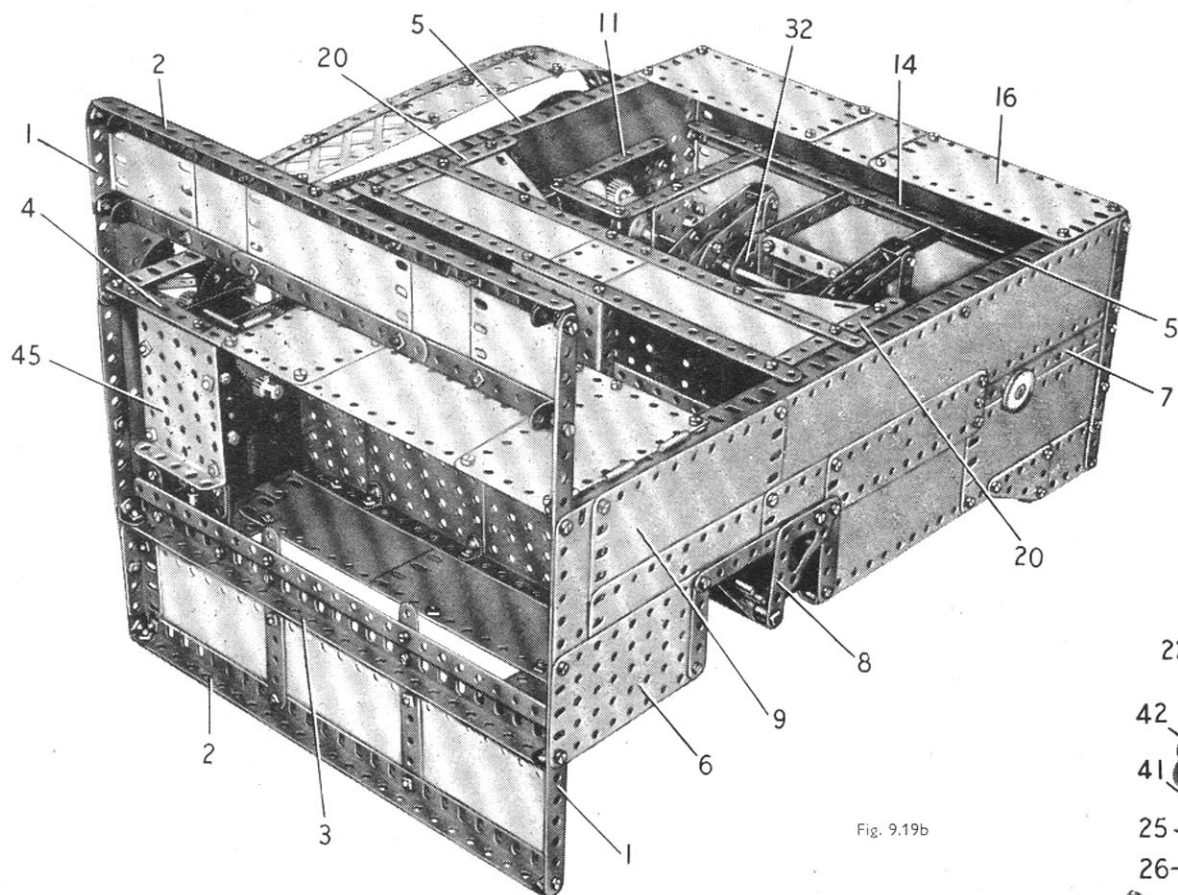

Fig. 9.19b

The sides are connected at each end by a $5\frac{1}{2}$ " Strip (21) attached to Angle Brackets (Fig. 9.19a), and also at the centre by two $5\frac{1}{2}$ " \times $2\frac{1}{2}$ " Flanged Plates (22) (Fig. 9.19c and 9.19e). Two vertical $5\frac{1}{2}$ " Angle Girders (23) are bolted to each of the Strips (21) and are braced by a $2\frac{1}{2}$ " Strip (24) and crossed 3" Strips as shown in Fig. 9.19a. A $3\frac{1}{2}$ " \times $2\frac{1}{2}$ " Flanged Plate (25) is bolted to each side of the lower Flanged Plate (22), and is connected to the Strip (24) by a 2" Strip and a $1"$ \times $1"$ Angle Bracket. The Girders (23) are arranged so that they slide freely against the outer flanges of the Girders (11).

A $5\frac{1}{2}$ " \times $2\frac{1}{2}$ " Flat Plate is bolted to each side of the upper Flanged Plate (22) and is connected to the side of the ram by two Angle Brackets. A $5\frac{1}{2}$ " \times $2\frac{1}{2}$ " Flexible Plate, strengthened by two $2\frac{1}{2}$ " Strips, is bolted to two Obtuse Angle Brackets fixed to each of the Flat Plates.

Two 4" Rods are held in the Flanged Plates (25) by Collars and $\frac{3}{8}$ " Flanged Wheels, and a $1\frac{1}{2}$ " Rod (26) is fixed in each of the Flanged Plates (25) by a 1" Pulley and a $\frac{3}{4}$ " Flanged Wheel. These Rods are arranged so that they pass freely through holes in the Flanged Plates (19) when the ram descends.

THE RAM ECCENTRICS

The sheave of each eccentric consists of two 2" Pulleys, and the straps are arranged so that they slide freely round the grooves of the Pulleys. Each half of the strap consists of a $2\frac{1}{2}$ " Stepped Curved Strip fitted at its ends with $2\frac{1}{2}$ " Strips. The upper ends of the $2\frac{1}{2}$ " Strips are bolted to a $3\frac{1}{2}$ " Strip (27) (Fig. 9.19d), and the same bolts support Double Brackets that join the halves of the strap together. Two $2\frac{1}{2}$ " Strips are bolted to the lower end of each half of the strap. Two of these Strips are fixed to a $3\frac{1}{2}$ " Strip (28), and the other two are bolted to a 3" Strip (29).

(Continued on next page)

Two vertical $12\frac{1}{2}$ " Angle Girders (11) and a horizontal $1\frac{1}{2}$ " Angle Girder (12) (Fig. 9.19) are bolted to each side. The sides are connected at their upper ends by a $12\frac{1}{2}$ " \times $2\frac{1}{2}$ " Strip Plate (13) at the front. This is attached to the sides by Angle Brackets, and is fitted at each end and at the centre with a vertical $2\frac{1}{2}$ " \times $\frac{1}{2}$ " Double Angle Strip. A $12\frac{1}{2}$ " Strip is supported by the lower lugs of these Double Angle Strips, and to their upper lugs the top of the column is attached. The top consists of three $12\frac{1}{2}$ " \times $2\frac{1}{2}$ " Strip Plates, and these are connected to the sides of the column by two $1"$ \times $1"$ and two $1"$ \times $\frac{1}{2}"$ Angle Brackets. Two $12\frac{1}{2}"$ Angle Girders, one of which is seen at (14) (Fig. 9.19d), are bolted underneath the joins in the Strip Plates, and another $12\frac{1}{2}"$ Angle Girder (15) is fixed below the top of the column.

At the rear of the column a plate (16) (Fig. 9.19b), is bolted to the Girders (5). This plate consists of a $2\frac{1}{2}"$ \times $2\frac{1}{2}"$ and two $5\frac{1}{2}"$ \times $2\frac{1}{2}"$ Flexible Plates, edged at the top by a $12\frac{1}{2}"$ Angle Girder and along their lower edges by a $12\frac{1}{2}"$ Strip. A $7\frac{1}{2}"$ Angle Girder (17) is bolted to each side at the front.

The lower part of the front of the column is made by bolting a $4\frac{1}{2}"$ \times $2\frac{1}{2}"$ Flexible Plate to each end of the Girder (3). Two $5\frac{1}{2}"$ \times $2\frac{1}{2}"$ Flexible Plates are fixed between the $4\frac{1}{2}"$ \times $2\frac{1}{2}"$ Flexible Plates (Fig. 9.19), and are edged at the top by a $12\frac{1}{2}"$ Strip and at the bottom by two $5\frac{1}{2}"$ Strips. The ends of the $12\frac{1}{2}"$ Strip are connected to the Plates (6) by Angle Brackets. The lower part of the back of the column is filled by the separated halves of a Hinged Flat Plate and two $5\frac{1}{2}"$ \times $2\frac{1}{2}"$ Flexible Plates. These are bolted to the $12\frac{1}{2}"$ Strip (4) and to a similar Strip (18) (Fig. 9.19e).

The press table consists of four $5\frac{1}{2}"$ \times $3\frac{1}{2}"$ Flat Plates bolted together and attached by Angle Brackets to the Strip (18) and the corresponding Strip at the front. Two $3\frac{1}{2}"$ \times $2\frac{1}{2}"$ Flanged Plates (19) are joined by a $1\frac{1}{2}"$ \times $\frac{1}{2}"$ Double Angle Strip, and are connected to the table by Angle Brackets.

ASSEMBLY OF THE SLIDING RAM AND ITS GUIDES

One side of the ram (Fig. 9.19b) consists of a $2\frac{1}{2}"$ \times $1\frac{1}{2}"$ and two $5\frac{1}{2}"$ \times $2\frac{1}{2}"$ Flexible Plates edged by two $12\frac{1}{2}"$ Strips and two $4\frac{1}{2}"$ Strips (20). Two $3\frac{1}{2}"$ \times $2"$ Triangular Flexible Plates are bolted between the ends of the upper $12\frac{1}{2}"$ Strip and the Strips (20). The other side is similar, but two $2\frac{1}{2}"$ Strips overlapped two holes are used in place of each of the Strips (20), and the $3\frac{1}{2}"$ \times $2"$ Triangular Flexible Plates are replaced by $2\frac{1}{2}"$ \times $2"$ Triangular Flexible Plates.

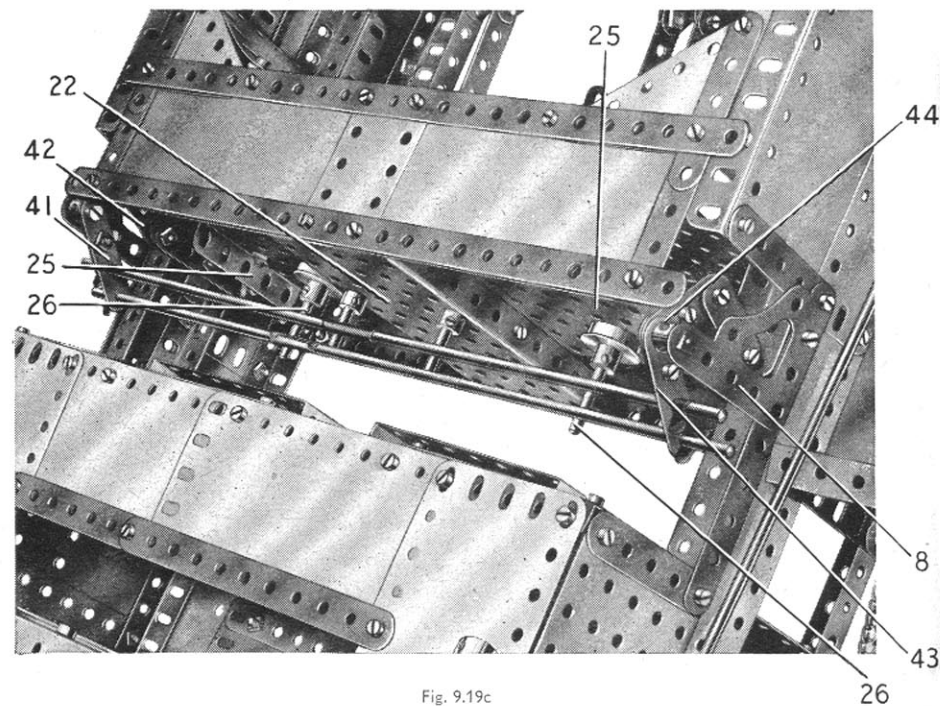

Fig. 9.19c

MODEL 9.19 POWER PRESS — Continued

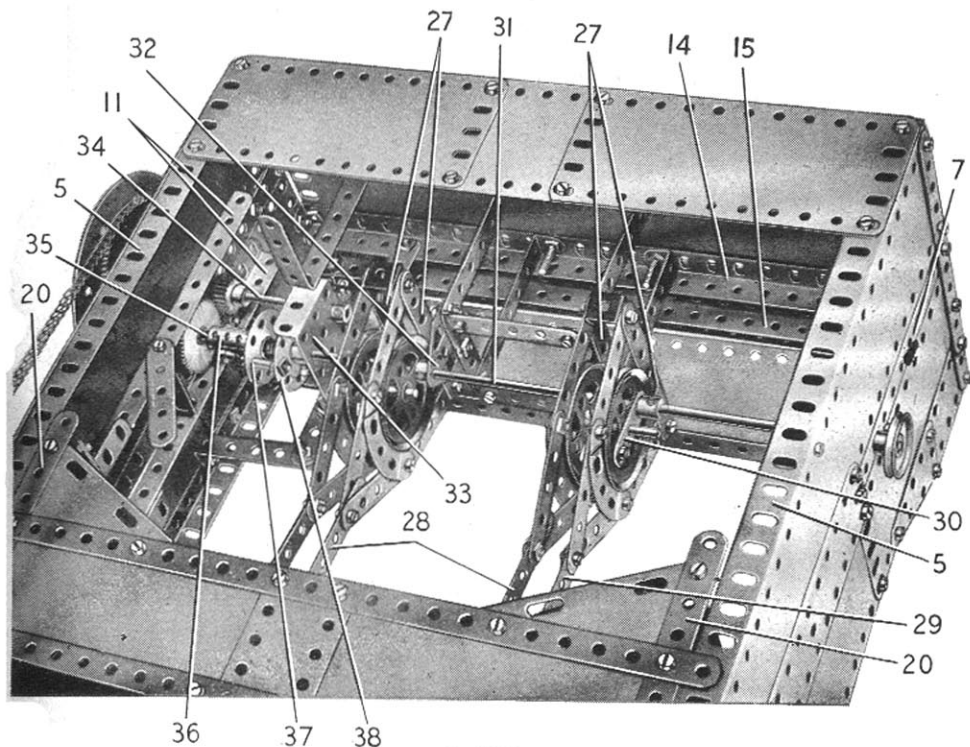

Fig. 9.19d

The sliding movement of Rod (35) is controlled by a foot pedal (39), which is formed by a Rod Socket fixed to an Angle Bracket bolted to a 4" Stepped Curved Strip. The Curved Strip is held by a Collar on a 1" Rod fixed in a Rod Socket, which is then attached to the side of the column. A Right-Angle Rod and Strip Connector is *lock-nutted* to the Curved Strip and is fitted over the lower end of an 11½" Rod. The upper end of this Rod carries a Rod and Strip Connector that is *lock-nutted* to a Double Arm Crank (40), in which a ¾" Bolt is held by two nuts. This Bolt bears against the face of a 1" Pulley on the end of Rod (35). The Double Arm Crank is free to turn on a Pivot Bolt, which is *lock-nutted* to a Girder Bracket bolted to the side of the column. A Coupling is fixed on the 11½" Rod above the Right-Angle Rod and Strip Connector.

AUTOMATIC GUARD MECHANISM

The guard consists of two bars, one made from two 6½" Rods joined by a Rod Connector and the other from a 5" and an 8" Rod joined by a Rod Connector. At one end the bars are held by Spring Clips in a 2" Strip (41) (Fig. 9.19c) that is used to extend one arm of a Bell Crank. The Bell Crank is mounted on a Pivot Bolt that is fixed by its nuts to the end of one of the Corner Gussets (8). A 1½" Strip (42) is *lock-nutted* to the other arm of the Bell Crank and is *lock-nutted* also in the lower end hole of one of the 5½" Angle Girders (23) of the sliding ram.

The other ends of the guard bars are held by Spring Clips in holes in a 2" Strip (43) (Fig. 9.19c). This Strip is connected to a 1½" Strip (44) by a 1" Corner Bracket, to make a built-up bell crank. A Pivot Bolt is passed through the overlapped holes of the Strips and the Corner Bracket, and on it is placed the 'spider' from a Swivel Bearing. The Pivot Bolt is then fixed by its nuts in the second Corner Gusset (8). A 1½" Strip is *lock-nutted* to the Strip (44) and to the lower end hole of another of the Angle Girders (23).

DETAILS OF THE DRIVING MECHANISM

A 3½" x 2½" Flanged Plate (45) is bolted to the Strip (4) (Fig. 9.19b), and an E20R Electric Motor is attached to the Flanged Plate. A 2½" and a 1½" Strip are bolted between the Motor flanges and the Angle Girder (3). A Handrail Support *lock-nutted* to the top lug of the Motor switch is fitted with a 3½" Rod that projects through a hole in the side of the column. The outer end of this Rod carries a handle formed by a Coupling (46).

A ½" Pinion on the inner end of the Motor shaft drives a 57-tooth Gear on a 2½" Rod (47). This Rod is supported in the centre holes of the Motor side-plates, and it carries a ½" Pinion that drives a 57-tooth Gear on a 4½" Rod (48), which is mounted in the top holes of the side-plates and in the Strip (10). A ¾" Sprocket on Rod (48) is connected by Chain to a 3" Sprocket on Rod (34). A 4" Circular Plate is attached to the 3" Sprocket by ¾" Bolts, but is spaced by Washers on each Bolt so as to clear the Chain.

A guard is fitted over the Chain drive as shown in Fig. 9.19.

A Crank (30) (Fig. 9.19d) is bolted across the face of the outer 2" Pulley in each eccentric, and a 1½" Rod fixed in the bosses of the two Pulleys is passed through the centre hole of the Crank. The Strips (28) and (29) are pivoted on 1½" Rods held by Collars in Trunnions bolted to the top of the ram (see Fig. 9.19).

The eccentrics are fixed by the grub screws in the bosses of the Cranks (30) to an 11½" Rod (31). This Rod is mounted in one of the Strips (7), in two Flat Trunnions (32) (Fig. 9.19d) and in a 2½" x 1½" Flanged Plate (33). The Flat Trunnions (32) are bolted to 2½" Strips supported by 3½" x ½" Double Angle Strips, which are fixed to the Girders (14) by their top lugs and are connected by 2½" Strips bolted to the lower lugs of the Double Angle Strips. The Flanged Plate (33) is bolted between two 5½" Strips fixed to the Girders (14). The lower end of one 5½" Strip is connected to one of the Girders (11) by a 2½" Strip, and the other 5½" Strip is joined to the side of the column by a 2½" x ½" Double Angle Strip. One of the 5½" Strips and the 2½" Strip are twisted in Fig. 9.19d to reveal the clutch mechanism clearly.

CLUTCH MECHANISM

The drive to the eccentrics is engaged through a simple built-up dog clutch. A 4½" Rod (34) (Fig. 9.19d) is supported in the side of the column and in the Flanged Plate (33), and a 2" Pinion on the Rod drives a 50-tooth Gear on a 2" Rod (35). Rod (35) is passed through the side of the column and it carries one half of the clutch assembly, consisting of a Coupling (36) and a Bush Wheel (37) connected by two Fishplates. Bolts, each fitted with a nut, are passed through the Fishplates and are screwed into threaded holes in the Coupling and the Bush Wheel. The Rod (35) occupies about half the long bore of the Coupling, which is fixed on the Rod. The eccentric Rod (31) passes into the boss of the Bush Wheel (37), but it must not touch the end of the Rod (35).

A Bush Wheel (38) fitted with two Threaded Pins, is fixed on the Rod (31), and a Compression Spring is slipped over the Rod between the Bush Wheels (37) and (38). This Spring normally keeps the Bush Wheels apart, so that there is no connection between Rods (31) and (35). When Rod (35) is pushed inwards, however, the Threaded Pins in Bush Wheel (38) engage holes in the Bush Wheel (37) to provide a coupling between the two Rods.

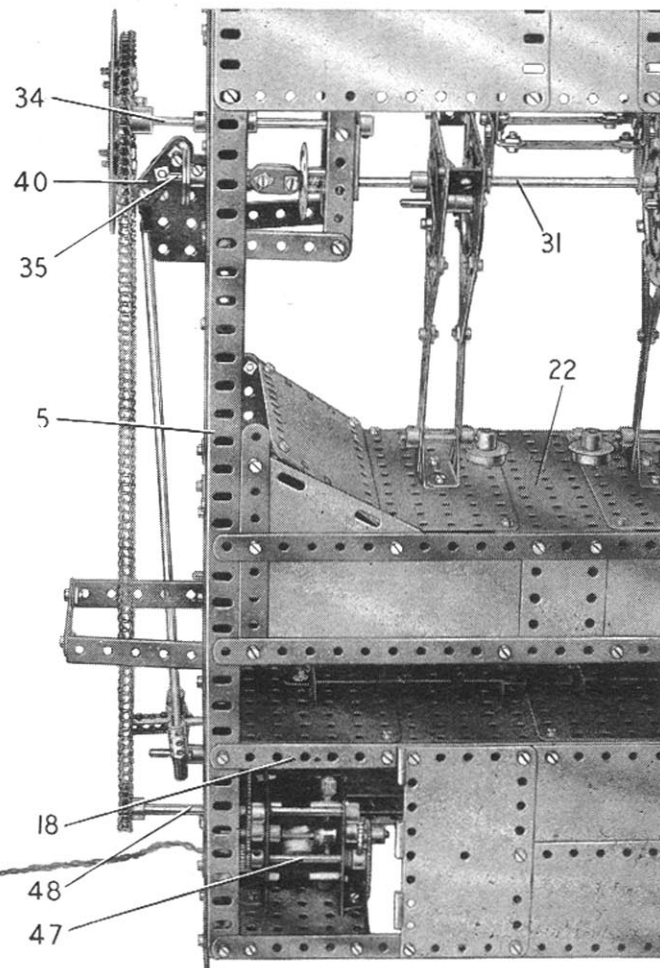

Fig. 9.19e

9.20 TOWER BRIDGE

DETAILS OF THE MAIN PIERS AND TOWERS

The main piers and towers on each side are identical in general construction. The sides of each pier are $5\frac{1}{2}'' \times 2\frac{1}{2}''$ Flexible Plates edged along their upper sides by $5\frac{1}{2}''$ Strips, and the ends are formed by $1\frac{1}{2}''$ radius Curved Plates and curved $2\frac{1}{2}'' \times 2\frac{1}{2}''$ Flexible Plates, as shown in Fig. 9.20. Two $3\frac{1}{2}'' \times \frac{1}{2}''$ Double Angle Strips are fixed across the top of the pier by bolts (1) on each side (Fig. 9.20c).

A Semi-Circular Plate (2) is attached by Angle Brackets to each of the Double Angle Strips held by the bolts (1). Two $2\frac{1}{2}''$ Stepped Curved Strips at each end are supported by Fishplates bolted to the Semi-Circular Plate.

Each side of the tower consists of two $12\frac{1}{2}''$ Angle Girders bolted to a $12\frac{1}{2}'' \times 2\frac{1}{2}''$ Strip Plate. The Strip Plate overhangs the lower ends of the Girders by four clear holes. The Angle Girders are fixed to the Double Angle Strips held by the bolts (1), and the lower ends of the Strip Plates are attached to $2\frac{1}{2}'' \times \frac{1}{2}''$ Double Angle Strips (3) (Fig. 9.20b). The sides of the tower are strengthened by $2\frac{1}{2}''$ Strips bolted between the Angle Girders as shown in Fig. 9.20.

The front of each tower is filled in by two $2\frac{1}{2}'' \times 1\frac{1}{2}''$ Triangular Flexible Plates (4), with a $4''$ Stepped Curved Strip attached to them at the centre by means of a $1''$ Triangular Plate. Above the Triangular Flexible Plates are bolted two $2\frac{1}{2}'' \times 1\frac{1}{2}''$ Flexible Plates, and above these is placed a horizontal $4\frac{1}{2}'' \times 2\frac{1}{2}''$ Flexible Plate. At the top of the tower two $4\frac{1}{2}'' \times 2\frac{1}{2}''$ Flexible Plates are fixed in position vertically. A $4\frac{1}{2}''$ Strip and three built-up $4\frac{1}{2}''$ strips are fixed across the front as shown in Fig. 9.20c, corresponding to the $2\frac{1}{2}''$ Strips of the sides of the tower.

The back of each tower is filled in by two $2\frac{1}{2}'' \times 2\frac{1}{2}''$ and two $5\frac{1}{2}'' \times 2\frac{1}{2}''$ Flexible Plates, with two $4\frac{1}{2}''$ Strips and two built-up $4\frac{1}{2}''$ strips bolted across them (Fig. 9.20c). Two $2\frac{1}{2}''$ Curved Strips form an arch over the roadway.

A Collar is screwed on to a bolt passed through the top of each $12\frac{1}{2}''$ Angle Girder. A nut and a Washer are fitted to each bolt before it is passed through the Girder, and $2''$ and $1\frac{1}{2}''$ Rods are fixed in the Collars.

Each tower is capped by an assembly formed from two $2\frac{1}{2}'' \times 2\frac{1}{2}''$ Flexible Plates (5) (Fig. 9.20c), edged as shown by $2\frac{1}{2}''$ and $3\frac{1}{2}''$ Strips. These Plates are connected by Obtuse Angle Brackets to a $2\frac{1}{2}'' \times \frac{1}{2}''$ Double Angle Strip (6), which carries two Trunnions arranged as shown. Flat Trunnions are bolted to $2''$ Strips that are fixed to the lugs of the Double Angle Strips (6). The caps are attached to the tops of the towers by Obtuse Angle Brackets held by bolts (7). Two of the bolts (7) secure also Flat Trunnions to the outer faces of the towers.

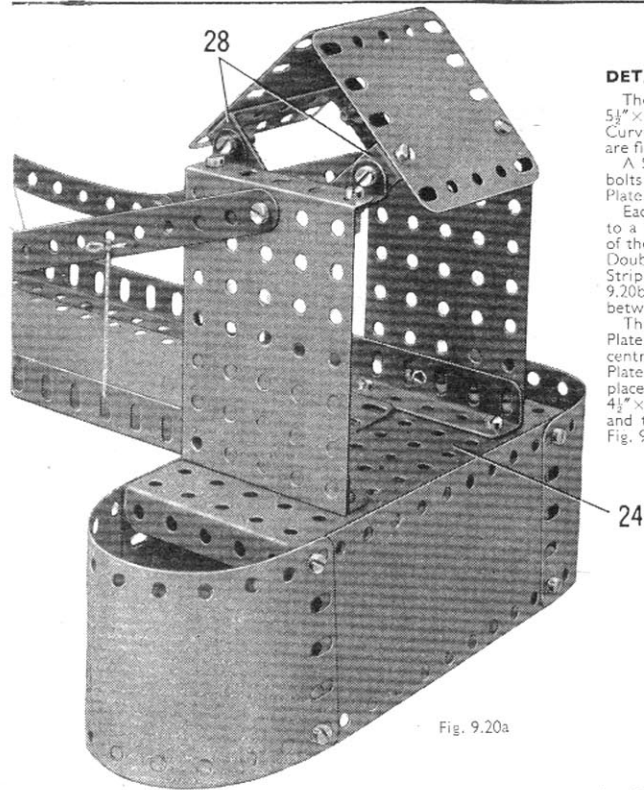

Fig. 9.20a

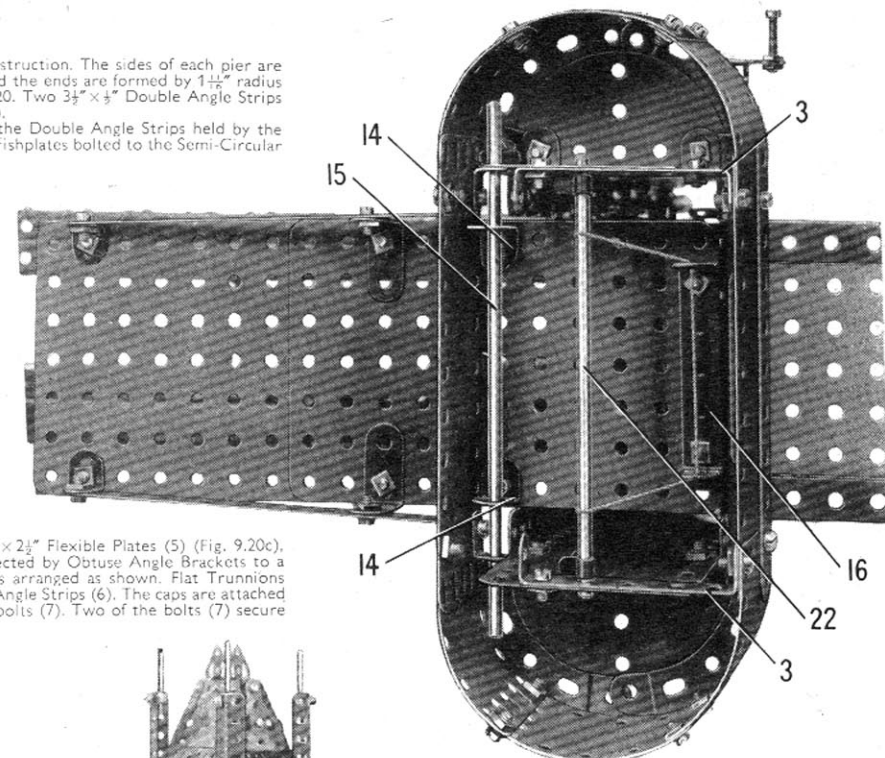

Fig. 9.20b

The towers are connected by made-up girders (8) and made-up strips (9) on each side (Fig. 9.20c), attached to the towers by Angle Brackets. The girders (8) are each made from a $12\frac{1}{2}''$ and a $1\frac{1}{2}''$ Angle Girder overlapped two holes, and each of the strips (9) consists of a $12\frac{1}{2}''$ and a $1\frac{1}{2}''$ Strip overlapped two holes. A $12\frac{1}{2}''$ Strip (10), extended by a Fishplate at one end, is attached to each of the girders (8) by a $1'' \times 1''$ Angle Bracket at one end and a $1'' \times \frac{1}{2}''$ Angle Bracket and a Fishplate at the other end. A further $12\frac{1}{2}''$ Strip on each side is bolted to the lower lugs of the Angle Brackets, and this, together with a flange of the girder (8), forms a foot walk between the towers. The two $12\frac{1}{2}''$ Strips on each side are connected at the centre by $1''$ Reversed Angle Brackets (11).

(Continued on next page)

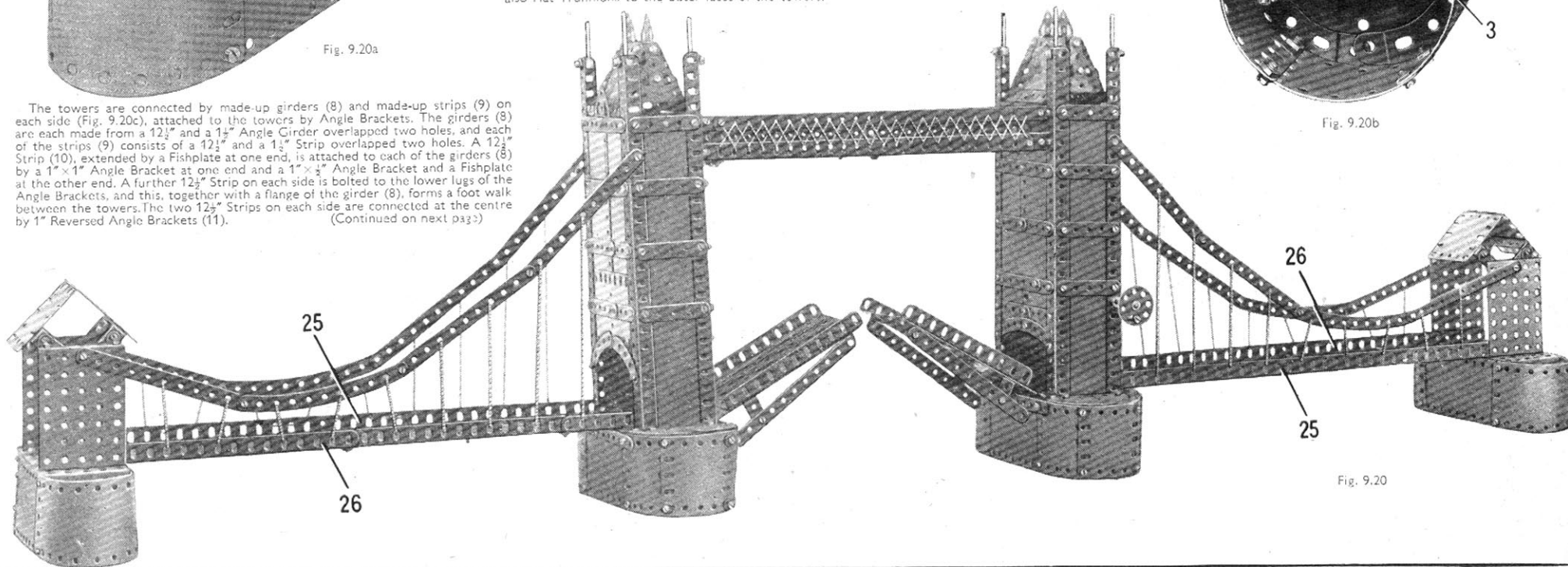

Fig. 9.20

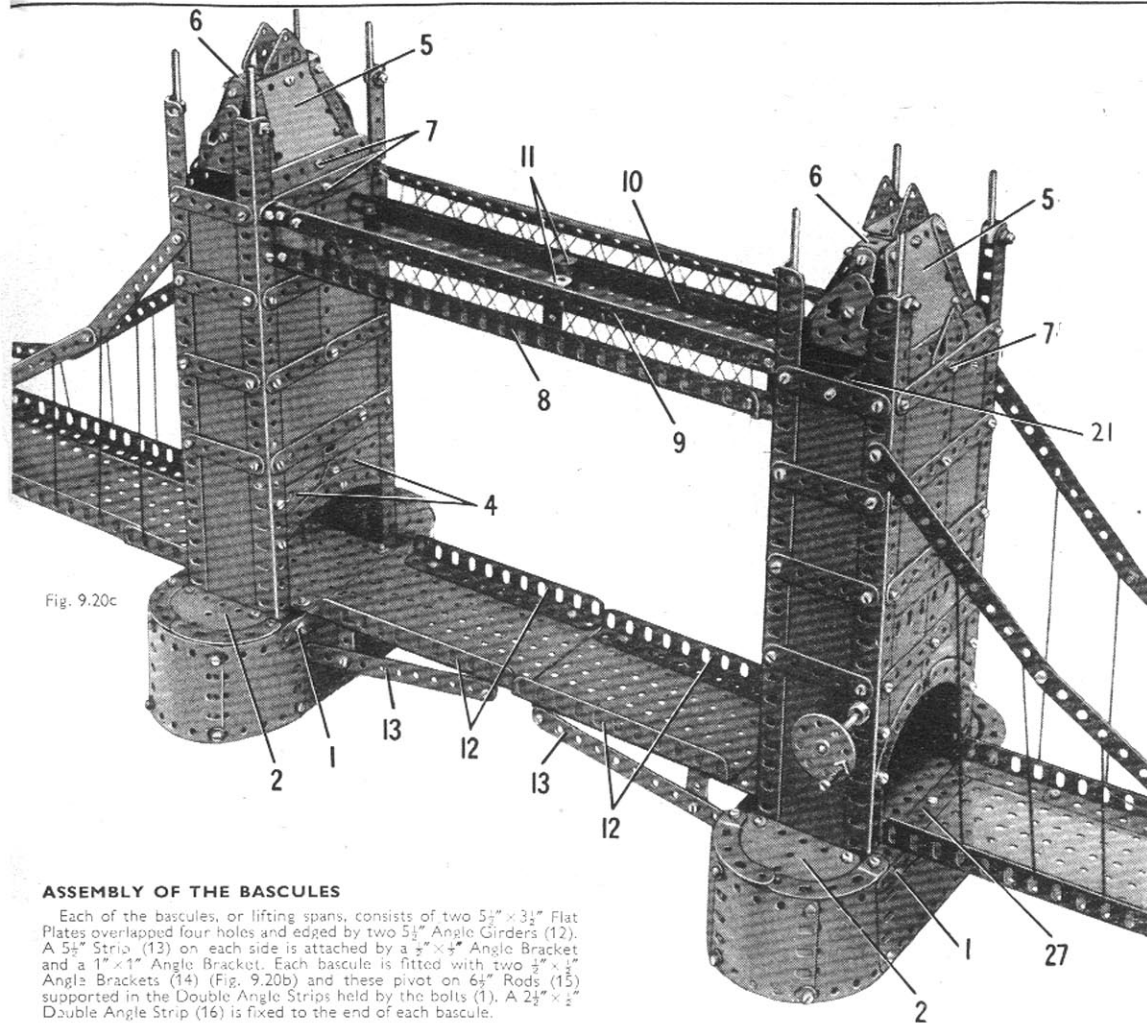

Fig. 9.20c

ASSEMBLY OF THE BASCULES

Each of the bascules, or lifting spans, consists of two $5\frac{1}{2}'' \times 3\frac{1}{2}''$ Flat Plates overlapped four holes and edged by two $5\frac{1}{2}''$ Angle Girders (12). A $5\frac{1}{2}''$ Strip (13) on each side is attached by a $\frac{3}{4}'' \times \frac{3}{4}''$ Angle Bracket and a $1'' \times 1''$ Angle Bracket. Each bascule is fitted with two $\frac{3}{4}'' \times \frac{1}{2}''$ Angle Brackets (14) (Fig. 9.20b) and these pivot on $6\frac{1}{2}''$ Rods (15) supported in the Double Angle Strips held by the bolts (1). A $2\frac{1}{2}'' \times \frac{1}{2}''$ Double Angle Strip (16) is fixed to the end of each bascule.

ARRANGEMENT OF THE MECHANISM AND CORDS

A Girder Bracket (17) (Fig. 9.20d) on each side of one of the towers is bolted to a $2\frac{1}{2}'' \times \frac{1}{2}''$ Double Angle Strip seen at (18). A $6\frac{1}{2}''$ Rod is supported in the sides of the tower and in the Girder Brackets, and is fitted with a Bush Wheel and a $\frac{1}{2}''$ Pinion (19). A $\frac{1}{2}''$ Bolt fixed in the Bush Wheel by two nuts, forms a winding handle, and the $6\frac{1}{2}''$ Rod is held in place by Collars.

The Pinion (19) drives a 57-tooth Gear on a $4''$ Rod (20), which is mounted in the Girder Brackets and is held in place by a Collar. Two Cord Anchoring Springs are fitted to this Rod, and to each of them is attached a length of Cord. One of these Cords is taken round a $5''$ Rod (21) at the top of the tower, round a $5''$ Rod (22) (Fig. 9.20b), in the base of the same tower, and through the lugs of the Double Angle Strip (16) bolted to the bascule of this tower. The Cord is then passed again round the Rods (22) and (21), and is tied finally to the other Cord Anchoring Spring.

The second length of Cord is passed over the Rod (21) and over a similar Rod at the top of the other tower. This Cord is taken round a $5''$ Rod at the base of the second tower, through the lugs of the Double Angle Strip (16) of the bascule and again round the two $5''$ Rods of the same tower. It then passes over Rod (21) and is tied to the other Cord Anchoring Spring. The lengths of the two Cords must be adjusted so that the bascules are level when the Cords are fully unwound.

THE SUPPORTING PIERS AND APPROACHES

Each of the supporting piers is made by curving two $5\frac{1}{2}'' \times 2\frac{1}{2}''$ Flexible Plates and bolting them to the ends of a $5\frac{1}{2}'' \times 2\frac{1}{2}''$ Flanged Plate (24). The sides of each approach road are formed by an $18\frac{1}{2}''$ Angle Girder (25) (Fig. 9.20), and a built-up girder (26) made from a $9\frac{1}{2}''$, a $7\frac{1}{2}''$, and a $2\frac{1}{2}''$ Angle Girder. The outer ends of the Girders are bolted to the Flanged Plate, and the inner ends are fixed to a $5\frac{1}{2}''$ Strip (27) (Fig. 9.20c), which is attached to two of the $2\frac{1}{2}''$ Stepped Curved Strips of the main pier. At the centre the Girders are connected by a $3\frac{1}{2}'' \times \frac{1}{2}''$ Double Angle Strip. The roadway is filled in by a $12\frac{1}{2}'' \times 2\frac{1}{2}''$ Strip Plate and a $5\frac{1}{2}'' \times 2\frac{1}{2}''$ Flat Plate.

The arch over each supporting pier is made by bolting two $3\frac{1}{2}'' \times 2\frac{1}{2}''$ Flanged Plates to the Flanged Plate (24). Two $2\frac{1}{2}'' \times 2\frac{1}{2}''$ Flexible Plates are bolted to $2\frac{1}{2}'' \times 1''$ Double Angle Strips (28), which are connected to the $3\frac{1}{2}'' \times 2\frac{1}{2}''$ Flanged Plates by Angle Brackets.

The links between the arches and the towers are each formed by three $5\frac{1}{2}''$ Strips and a $5\frac{1}{2}''$ Curved Strip.

MODEL 9.20 TOWER BRIDGE — Continued

Parts Required

6 of No. 1	1 of No. 24	2 of No. 89b	2 of No. 176
22 " " 2	1 " " 26	4 " " 90	4 " " 188
6 " " 2a	1 " " 27a	8 " " 90a	14 " " 190
6 " " 3	12 " " 35	3 " " 111	6 " " 191
4 " " 4	342 " " 37a	5 " " 111a	16 " " 192
36 " " 5	323 " " 37b	12 " " 111c	6 " " 197
4 " " 6	24 " " 38	2 " " 124	2 " " 199
6 " " 6a	2 " " 40	4 " " 126	8 " " 200
2 " " 7a	4 " " 46	6 " " 126a	4 " " 214
10 " " 8	10 " " 48a	2 " " 161	4 " " 221
2 " " 8a	6 " " 48b		
2 " " 8b	2 " " 52		
4 " " 9	4 " " 52a		
2 " " 9d	4 " " 53		
2 " " 9f	12 " " 59		
12 " " 10	2 " " 70		
32 " " 12	2 " " 77		
6 " " 12a	4 " " 89		
2 " " 12b			
8 " " 12c			
3 " " 14			
4 " " 15			
1 " " 15b			
4 " " 17			
4 " " 18a			

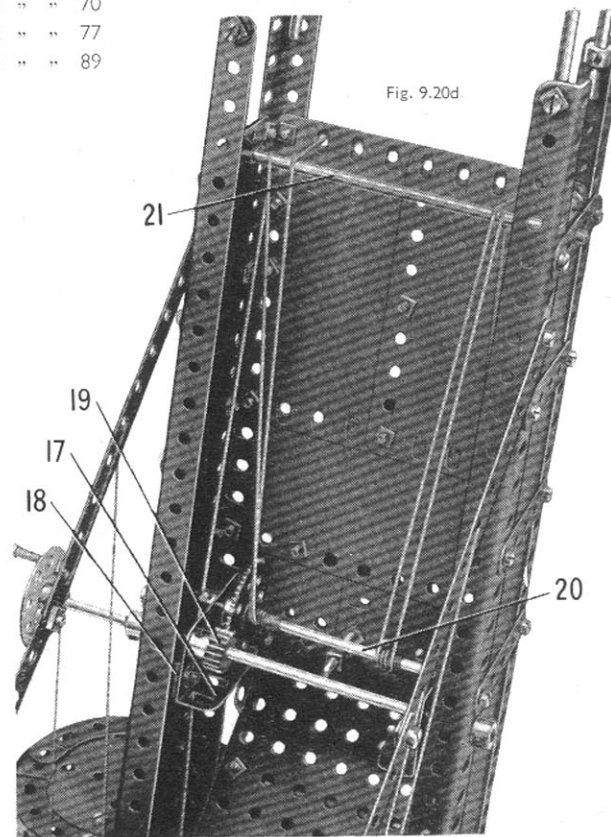

Fig. 9.20d

MECCANO PARTS



PERFORATED STRIPS

No.	12 $\frac{1}{2}$ "	No.	2a.	4 $\frac{1}{2}$ "	No.	6.	2"
1a.	9"	3.	3 $\frac{1}{2}$ "	3.	3 $\frac{1}{2}$ "	6a.	1 $\frac{1}{2}$ "
1b.	7 $\frac{1}{2}$ "	4.	3"	5.	2 $\frac{1}{2}$ "		
2.	5 $\frac{1}{2}$ "						

ANGLE GIRDERS

7.	24 $\frac{1}{2}$ "	8b.	7 $\frac{1}{2}$ "	9c.	3"
7a.	18 $\frac{1}{2}$ "	9.	5 $\frac{1}{2}$ "	9d.	2 $\frac{1}{2}$ "
8.	12 $\frac{1}{2}$ "	9a.	4 $\frac{1}{2}$ "	9e.	2"
8a.	9 $\frac{1}{2}$ "	9b.	3 $\frac{1}{2}$ "	9f.	1 $\frac{1}{2}$ "



10. Fishplate | 11. Double Bracket

ANGLE BRACKETS

12.	$\frac{1}{2}$ " x $\frac{1}{2}$ "	12b.	1" x $\frac{1}{2}$ "
12a.	$\frac{1}{2}$ " x 1"	12c.	Obtuse, $\frac{1}{2}$ " x $\frac{1}{2}$ "



AXLE RODS

13.	11 $\frac{1}{2}$ "	15a.	4 $\frac{1}{2}$ "	16b.	3"
13a.	8"	15b.	4"	17.	2"
14.	6 $\frac{1}{2}$ "	16.	3 $\frac{1}{2}$ "	18a.	1 $\frac{1}{2}$ "
15.	5"	16a.	2 $\frac{1}{2}$ "	18b.	1"
19g.	Crank Handle, 3 $\frac{1}{2}$ " shaft, with grip				
19h.	Crank Handle, 5" shaft, with grip				
19s.	Crank Handle, 3 $\frac{1}{2}$ " shaft, without grip				



19a. Spoked Wheel, 3" diam.
20. Flanged Wheel, 1 $\frac{1}{2}$ " diam.
20b. Flanged Wheel, $\frac{1}{2}$ " diam.

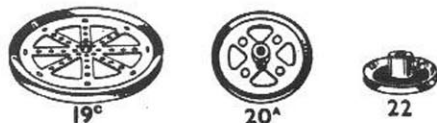

PULLEYS

19b.	3" diam., with boss and screw
19c.	6" diam., with boss and screw
20a.	2" diam., with boss and screw
21.	1 $\frac{1}{2}$ " diam., with boss and screw
22.	1" diam., with boss and screw



PULLEYS

22a.	1" diam., without boss
23.	$\frac{1}{2}$ " diam., without boss
23a.	$\frac{1}{2}$ " diam., with boss and screw



No. 24. Bush Wheel, 1 $\frac{1}{2}$ " diam., eight-hole
24a. Wheel Disc, 1 $\frac{1}{2}$ " diam., without bush, eight-hole
24b. Bush Wheel, 1 $\frac{1}{2}$ " diam., six-hole
24c. Wheel Disc, 1 $\frac{1}{2}$ " diam., without bush, six-hole

PINIONS

25.	$\frac{1}{2}$ " diam., $\frac{1}{4}$ " face, 25 teeth
25a.	$\frac{1}{2}$ " diam., $\frac{1}{4}$ " face, 25 teeth
25b.	$\frac{1}{2}$ " diam., $\frac{1}{4}$ " face, 25 teeth
26.	$\frac{1}{2}$ " diam., $\frac{1}{4}$ " face, 19 teeth
26a.	$\frac{1}{2}$ " diam., $\frac{1}{4}$ " face, 19 teeth
26b.	$\frac{1}{2}$ " diam., $\frac{1}{4}$ " face, 19 teeth
26c.	$\frac{1}{2}$ " diam., $\frac{1}{4}$ " face, 15 teeth



27. 1 $\frac{1}{2}$ " diam., 50 teeth
27a. 1 $\frac{1}{2}$ " diam., 57 teeth
27b. 3 $\frac{1}{2}$ " diam., 133 teeth
27c. 2 $\frac{1}{2}$ " diam., 95 teeth
27d. 1 $\frac{1}{2}$ " diam., 60 teeth

GEAR WHEELS



28. 1 $\frac{1}{2}$ " diam., 50 teeth
29. $\frac{1}{2}$ " diam., 25 teeth

CONTRATE WHEELS



30. Bevel Gear, $\frac{1}{2}$ " diam., 26 teeth (for use in pairs)
30a. Bevel Gear, $\frac{1}{2}$ " diam., 16 teeth } Can only be
30c. Bevel Gear, 1 $\frac{1}{2}$ " diam., 48 teeth } used together
31. Gear Wheel, $\frac{1}{2}$ " diam., $\frac{1}{4}$ " face, 38 teeth
32. Worm, $\frac{1}{2}$ " diam.
34. Spanner



34b. Box Spanner
35. Spring Clip
36. Screwdriver
36a. Screwdriver (longer)
36c. Drift (for levering bolt holes into line)
37. Nut and Bolt, $\frac{1}{8}$ "
37a. Nut
37b. Bolt, $\frac{1}{8}$ "
38. Washer
38d. Washer, $\frac{1}{8}$ "
40. Hank of Cord



41. Propeller Blade | 43. Tension Spring, 2" long



No. 44. Bent Strip, stepped
45. Double Bent Strip

DOUBLE ANGLE STRIPS

46.	2 $\frac{1}{2}$ " x 1"	48.	1 $\frac{1}{2}$ " x $\frac{1}{2}$ "	48c.	4 $\frac{1}{2}$ " x $\frac{1}{2}$ "
47.	2 $\frac{1}{2}$ " x 1 $\frac{1}{2}$ "	48a.	2 $\frac{1}{2}$ " x $\frac{1}{2}$ "	48d.	5 $\frac{1}{2}$ " x $\frac{1}{2}$ "
47a.	3" x 1 $\frac{1}{2}$ "	48b.	3 $\frac{1}{2}$ " x $\frac{1}{2}$ "		

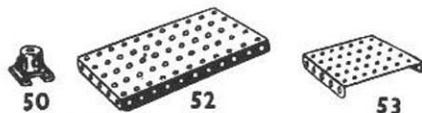

50. Slide Piece
51. Flanged Plate, 2 $\frac{1}{2}$ " x 1 $\frac{1}{2}$ "
52. Flanged Plate, 5 $\frac{1}{2}$ " x 2 $\frac{1}{2}$ "
52a. Flat Plate, 5 $\frac{1}{2}$ " x 3 $\frac{1}{2}$ "
53. Flanged Plate, 3 $\frac{1}{2}$ " x 2 $\frac{1}{2}$ "
53a. Flat Plate, 4 $\frac{1}{2}$ " x 2 $\frac{1}{2}$ "



54. Flanged Sector Plate, 4 $\frac{1}{2}$ " long
55. Perforated Strip, slotted, 5 $\frac{1}{2}$ " long
55a. Perforated Strip, slotted, 2" long



57b. Hook, Loaded, Large
57c. Hook, Loaded, Small
58. Spring Cord, 40" length
58a. Coupling Screw for Spring Cord
58b. Hook for Spring Cord
59. Collar, with screw



61. Windmill Sail | 62a. Threaded Crank
62. Crank | 62b. Double Arm Crank



63. Coupling | 63c. Threaded Coupling
63b. Strip Coupling | 63d. Short Coupling



64. Threaded Boss | 69a. Grub Screw, $\frac{1}{8}$ "
65. Centre Fork | 69b. Grub Screw, $\frac{1}{16}$ "
69. Set Screw, $\frac{1}{8}$ " | 69c. Grub Screw, $\frac{1}{16}$ "

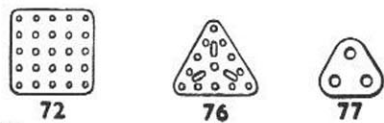

No. 72. Flat Plate, 5 $\frac{1}{2}$ " x 2 $\frac{1}{2}$ " | 76. Triangular Plate, 2 $\frac{1}{2}$ "
72. Flat Plate, 2 $\frac{1}{2}$ " x 2 $\frac{1}{2}$ " | 77. Triangular Plate, 1 $\frac{1}{2}$ "
73. Flat Plate, 3" x 1 $\frac{1}{2}$ "



78. 11 $\frac{1}{2}$ " | 80. 5" | 80c. 3"
79. 8" | 80a. 3 $\frac{1}{2}$ " | 81. 2"
79a. 6" | 80b. 4 $\frac{1}{2}$ " | 82. 1"

CURVED STRIPS

89. 5 $\frac{1}{2}$ " (10" radius)
89a. Stepped, 3" (1 $\frac{1}{2}$ " radius)
89b. Stepped, 4" (4 $\frac{1}{2}$ " radius)
90. 2 $\frac{1}{2}$ " (2 $\frac{1}{2}$ " radius)
90a. Stepped, 2 $\frac{1}{2}$ " (1 $\frac{1}{2}$ " radius)



94. Sprocket Chain, 40" length

SPROCKET WHEELS

95. 2" diam., 36 teeth | 96. 1" diam., 18 teeth
95a. 1 $\frac{1}{2}$ " diam., 28 teeth | 96a. $\frac{1}{2}$ " diam., 14 teeth
95b. 3" diam., 56 teeth



BRACED GIRDERS

97. 3 $\frac{1}{2}$ " long | 99. 12 $\frac{1}{2}$ " long | 100. 5 $\frac{1}{2}$ " long
97a. 3" long | 99a. 9 $\frac{1}{2}$ " long | 100a. 4 $\frac{1}{2}$ " long
98. 2 $\frac{1}{2}$ " long | 99b. 7 $\frac{1}{2}$ " long



101. Heald for Loom | 102. Single Bent Strip

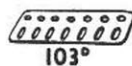

FLAT GIRDERS

103. 5 $\frac{1}{2}$ " long | 103d. 3 $\frac{1}{2}$ " long | 103h. 1 $\frac{1}{2}$ " long
103a. 9 $\frac{1}{2}$ " long | 103e. 3" long | 103k. 7 $\frac{1}{2}$ " long
103b. 12 $\frac{1}{2}$ " long | 103f. 2 $\frac{1}{2}$ " long
103c. 4 $\frac{1}{2}$ " long | 103g. 2" long

MECCANO PARTS

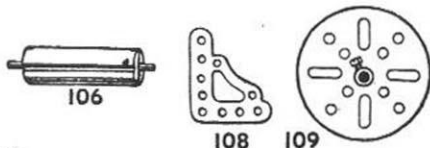

- No. 106. Wood Roller (complete with Rod and two Collars)
108. Corner Gusset
109. Face Plate, 2½" diam.

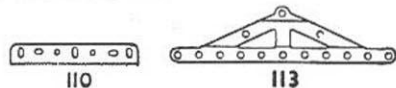

110. Rack Strip, 3½" long | 110a. Rack Strip, 6½" long

BOLTS

111. ½" | 111c. ¾"
111a. ½" | 111d. 1½"

113. Girder Frame



114. Hinge | 116. Fork Piece, large
115. Threaded Pin | 116a. Fork Piece, small



118. Hub Disc, 5½" diam.



- 120b. Compression Spring, ¾" long
122. Loaded Sack



123. Cone Pulley, 1½", 1" and ¾" diam.
124. Reversed Angle Bracket, 1"
125. Reversed Angle Bracket, ½"



126. Trunnion
126a. Flat Trunnion
128. Bell Crank, with boss



- No. 130. Eccentric, Triple Throw, ½", ¾" and 1"
130a. Eccentric, Single Throw, ½"

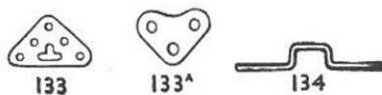

133. Corner Bracket, 1½"
133a. Corner Bracket, 1"
134. Crank Shaft, 1" stroke



136. Handrail Support | 136a. Handrail Coupling



137. Wheel Flange | 138. Ship's Funnel, Raked



139. Flanged Bracket (right)
139a. Flanged Bracket (left)
140. Universal Coupling

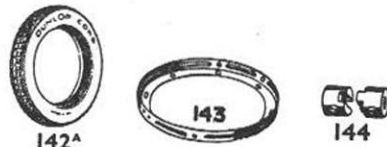

- 142a. Motor Tyre (to fit 2" diam. rim)
142b. Motor Tyre (to fit 3" diam. rim)
142c. Motor Tyre (to fit 1" diam. rim)
142d. Motor Tyre (to fit 1½" diam. rim)
143. Circular Girder, 5½" diam.
144. Dog Clutch

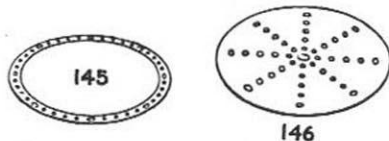

145. Circular Strip, 7½" diam. overall
146. Circular Plate, 6" diam. overall
146a. Circular Plate, 4" diam. overall

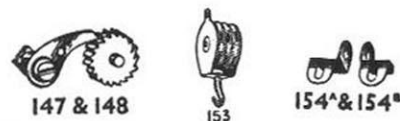

- No. 147. Pawl, with Pivot Bolt and nuts
147a. Pawl
147b. Pivot Bolt, with two nuts
147c. Pawl, without boss
148. Ratchet Wheel
151. Single Pulley Block
153. Triple Pulley Block
154a. Corner Angle Bracket, ½" (right-hand)
154b. Corner Angle Bracket, ½" (left-hand)
155. Rubber Ring (for 1" Pulley)



157. Fan, 2" diam.
160. Channel Bearing, 1½" x 1" x ½"
161. Girder Bracket, 2" x 1" x ½"



162. Boiler, complete, 5" long x 2½" diam.
162a. Boiler Ends, 2½" diam. x ½"
163. Sleeve Piece, 1½" long x ½" diam.
164. Chimney Adaptor, ½" diam. x ½" high



165. Swivel Bearing
166. End Bearing
167b. Flanged Ring, 9½" diam.
168. Ball Thrust Bearing, 4" diam.
168a. Ball Thrust Race, flanged disc, 3½" diam.
168b. Ball Thrust Race, toothed disc, 4" diam.
168c. Ball Cage, 3½" diam., complete with balls
168d. Ball, ¾" diam.



171. Socket Coupling
173a. Adaptor for Screwed Rod
175. Flexible Coupling Unit
176. Anchoring Spring for Cord



179. Rod Socket
180. Gear Ring, 3½" diam. (133 ext. teeth, 95 int.)



- No. 185. Steering Wheel, 1½" diam.
187a. Conical Disc, 1½" diam.

DRIVING BANDS

186. 2½" (light) | 186c. 10" (heavy)
186a. 6" (light) | 186d. 15" (heavy)
186b. 10" (light) | 186e. 20" (heavy)

187. Road Wheel, 2½" diam.
187a. Conical Disc, 1½" diam.

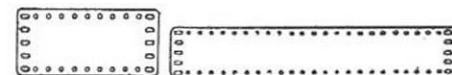

- 192 | 197

FLEXIBLE PLATES

188. 2½" x 1½" | 190. 2½" x 2½" | 191. 4½" x 2½"
189. 5½" x 1½" | 190a. 3½" x 2½" | 192. 5½" x 2½"

STRIP PLATES

196. 9½" x 2½" | 197. 12½" x 2½"



198. Hinged Flat Plate, 4½" x 2½"
199. Curved Plate, 'U'-section, 2½" x 2½" x ¼" radius
200. Curved Plate, 2½" x 2½" x 1½" radius



- 211a. Helical Gear, ½" } Can only be used
211b. Helical Gear, 1½" } together
212. Rod and Strip Connector
212a. Rod and Strip Connector, right-angle
213. Rod Connector
213a. Three-way Rod Coupling
213b. Three-way Rod Coupling with Pummel



214. Semi-Circular Plate, 2½"
215. Formed Slotted Strip, 3"
216. Cylinder, 2½" long, 1½" diam.

TRIANGULAR FLEXIBLE PLATES

221. 2½" x 1½" | 223. 2½" x 2½" | 225. 3½" x 2"
222. 2½" x 2" | 224. 3½" x 1½" | 226. 3½" x 2½"

A SELECTION OF FASCINATING MODELS FROM THE MECCANO INSTRUCTIONS BOOKS

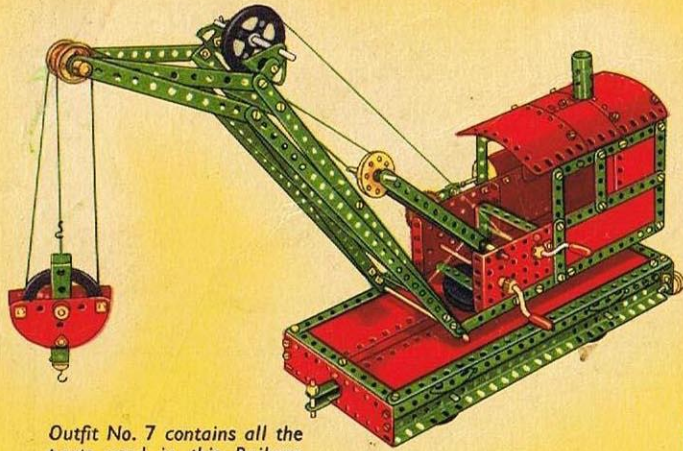

Outfit No. 7 contains all the parts used in this Railway Service Crane

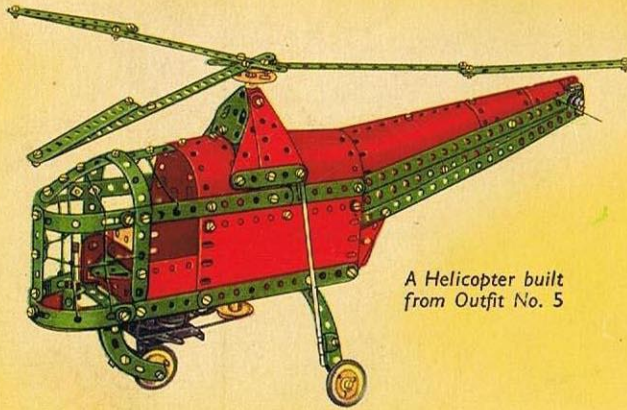

A Helicopter built from Outfit No. 5

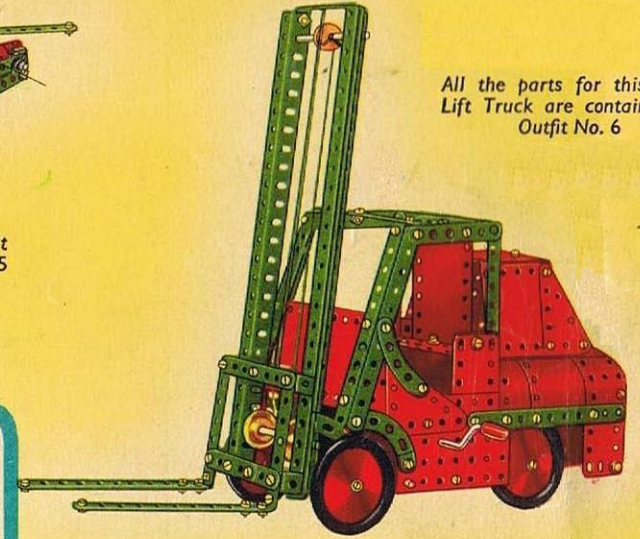

All the parts for this Fork Lift Truck are contained in Outfit No. 6

HOW TO CONTINUE

When you have built all the models shown in this Book of Instructions, you will be keen to build others bigger and more elaborate. Your next step, therefore, is to purchase the appropriate Accessory Outfit containing all the parts required to convert your present Outfit into the next larger complete Outfit, as explained on page 2 of cover. You will then be able to build a new range of fascinating models.

If you prefer to do so, you can build up and develop your present Outfit quite easily by adding various parts to it from time to time. The model-building possibilities of the Meccano System are unlimited, and the more Meccano parts you have, the finer and more varied the models you will be able to build.

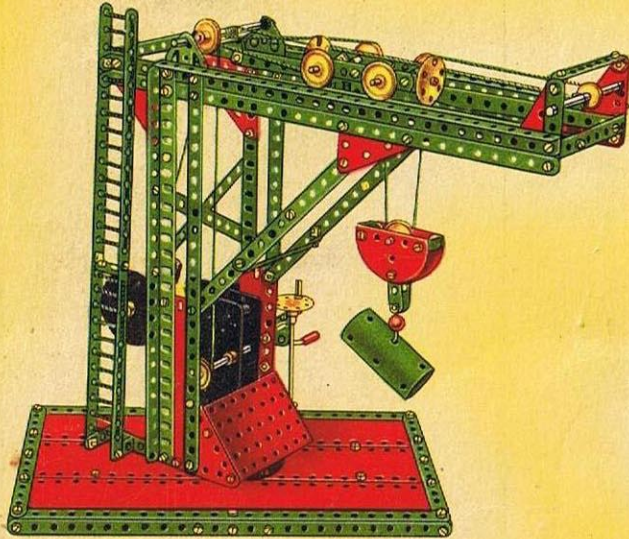

This Forge Crane is another of the fine working models built with Outfit No. 6

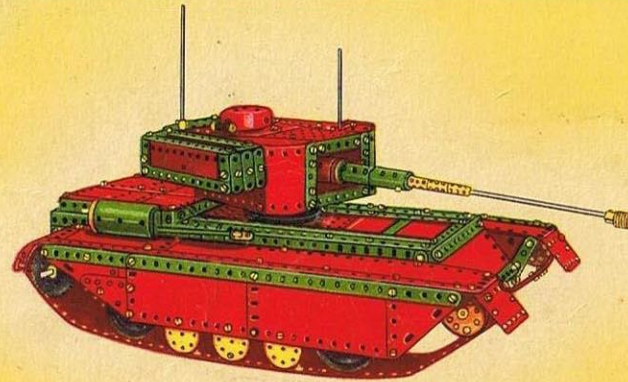

This Military Tank is one of the attractive models that can be built with Outfit No. 8

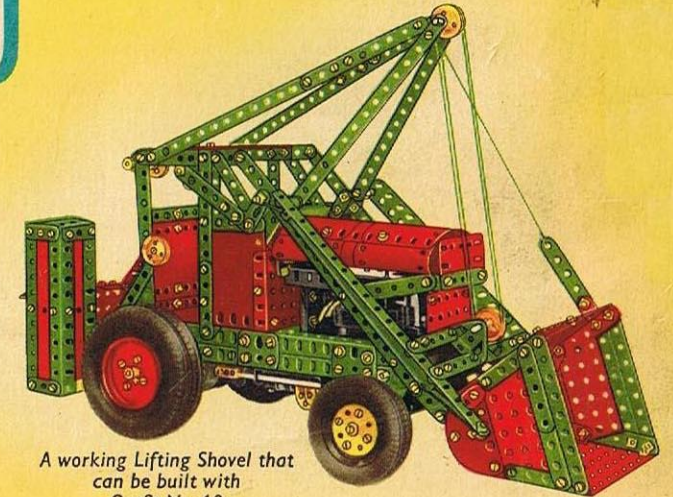

A working Lifting Shovel that can be built with Outfit No. 10