

# MECCANO

REGISTERED TRADE MARK

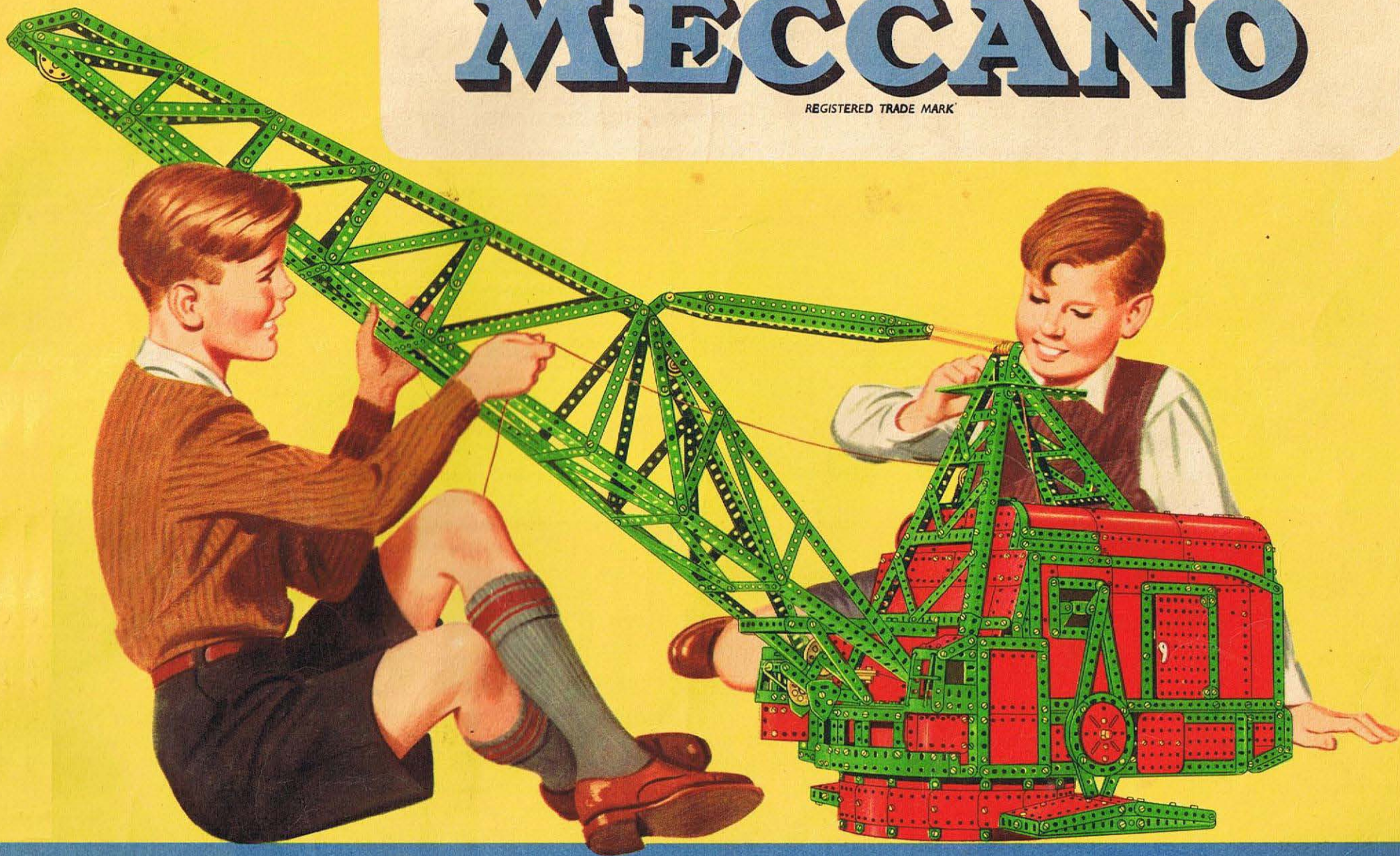

**OUTFIT No. 2**

COPYRIGHT BY MECCANO LIMITED BINNS ROAD LIVERPOOL 13 ENGLAND

58.2

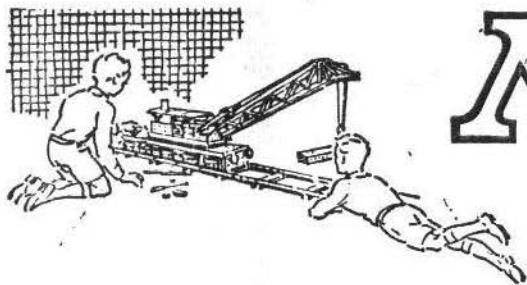

# MECCANO

Registered Trade Mark

The World's Greatest Constructional Toy

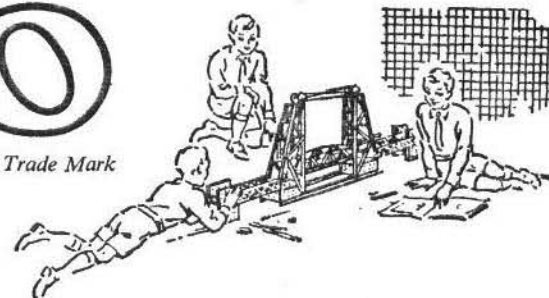

## MODEL-BUILDING WITH MECCANO

There is no limit to the number of models that can be built with Meccano — Cranes, Clocks, Motor Cars, Aeroplanes, Machine Tools, Locomotives — in fact everything that interests boys. A screwdriver and a spanner, both of which are provided in each complete Outfit, are the only tools necessary.

When you have built all the models illustrated in the Books of Instructions the fun is not over, it is just beginning. Now comes the chance to make use of your own ideas. First of all, re-build some of the models with small changes in construction that may occur to you; then try building models entirely of your own design. In doing this you will enjoy the real thrill of the engineer and the inventor.

## HOW TO BUILD UP YOUR OUTFIT

Meccano is sold in 12 different Outfits, ranging from No. 00 to No. 10. Each Outfit can be converted into the next larger one by the purchase of an Accessory Outfit. Thus Meccano No. 00 Outfit can be converted into No. 0 Outfit by adding to it a No. 00a Accessory Outfit. No. 0a Outfit would then convert it into a No. 1 and so on. In this way, no matter with which Outfit you begin, you can build it up by degrees until you have a complete No. 10 Outfit.

All Meccano parts are of the same high quality and finish, but the larger Outfits contain a greater quantity and variety, making possible the construction of more elaborate models.

## THE 'MECCANO MAGAZINE'

The 'Meccano Magazine' is published specially for Meccano boys. Every month it describes and illustrates new Meccano models, and deals with suggestions from readers for new Meccano parts and for new methods of using the existing parts.

There are model-building competitions specially planned to give an equal chance to the owners of small and large Outfits. In addition, there are splendid articles on such subjects as Railways, Famous Engineers and Inventors, Electricity, Bridges, Cranes and

Aeroplanes, and special sections dealing with the latest Engineering, Aviation, Motoring and Shipping News. Other pages deal with Stamp Collecting, and a feature of outstanding popularity is the section devoted to short articles from readers.

Write to the Editor, the 'Meccano Magazine', Binns Road, Liverpool 13, for particulars and a specimen copy. You can order the Magazine from your Meccano dealer, or from any newsagent.

## THE MECCANO GUILD

Every owner of a Meccano Outfit should join the Meccano Guild. This is a world-wide organisation, started at the request of Meccano boys. Its primary object is to bring boys together and to make them feel that they are all members of a great brotherhood, each trying to help others to get the very best out of life. Its members are in constant touch with Headquarters, giving news of their activities and being guided in their hobbies and interests. A leaflet containing full particulars of the Guild and an application form is included in this Book.

Clubs founded and established under the guidance of the Guild Secretary provide Meccano boys with opportunities of enjoying to the utmost the fun of model-building. Each has its Leader, Secretary, Treasurer and other officials. With the exception of the Leader, all the officials are boys, and as far as possible the proceedings of the clubs are conducted by boys.

## MECCANO SERVICE

The service of Meccano does not end with selling an Outfit and a Book of Instructions. If ever you are in any difficulty with your models, or if you want advice on anything connected with this great hobby, write to us. We receive hundreds of interesting letters from boys in all parts of the world, and each of these is answered personally and promptly by one of our staff of experts.

Whatever your problem may be, write to us about it. We shall be delighted to help you in any way possible. Address your letters to *Information Service*.

# Boys!

Read the

# MECCANO MAGAZINE

## THE IDEAL MAGAZINE FOR BOYS

The happiest and most successful boys are those who take a keen interest in the world around them. The 'MECCANO MAGAZINE' is ideal for these boys. Month by month its pages are filled with attractively-written articles, splendidly illustrated from actual photographs.

The subjects include Engineering in all its branches, Railways, Road Transport, Aeroplanes and Shipping, Inventions and Scientific Discoveries are described in simple language. Everything is dealt with in an attractive and straightforward style, and with an accuracy that has won for the Magazine the enthusiastic approval of the engineering, technical and scientific world. Special sections are devoted to Model-building with Meccano, fun with Dinky Toys and the operation of realistic Miniature Railways; and Stamp Collecting forms still another important feature. Model-building Competitions open to all owners of Meccano Outfits, are a special feature.



Join the

# MECCANO GUILD

## WHAT THE GUILD MEANS

The Meccano Guild is an organisation for boys, started at the request of boys, and as far as possible conducted by boys. In joining the Guild a Meccano boy becomes a member of a great brotherhood of world-wide extent. Wherever he happens to be, even in strange countries, he will know that he has met a friend whenever he sees the little triangular badge of membership. The Meccano Guild is bringing together Meccano boys all over the world, and helping them to get the best out of life. At its head — guiding and controlling and taking a personal interest in this great movement — is the President, Mr Roland G. Hornby, son of the inventor of Meccano.

## HOW TO JOIN THE MECCANO GUILD

Any owner of a Meccano Outfit, no matter what its size, may become a member. All he has to do is to fill in the official application form on the back of this leaflet, have his signature witnessed, and send the form to Headquarters with a postal order (not stamps) for the necessary amount in payment for the official badge, which he will wear in his buttonhole.

The price of the badge for boys living in the British Isles is 1/- . For those living overseas it is 1/6 (30 cents in Canada).

Applicants living in Canada, Australia, New Zealand or South Africa should write to the Meccano agents in their countries. Their addresses are as follows:

### AUSTRALIA:

New South Wales and A.C.T. — E. G. Page & Co. (Sales) (Pty.) Ltd, Box 1832, G.P.O., Sydney, N.S.W.  
Queensland and Northern Territories — Thomas Brown & Sons Ltd, (P.O. Box 144C), Eagle Street, Brisbane, Queensland.  
South Australia — Harris, Scarfe Ltd, Grenfell Street, Adelaide.  
Victoria and Tasmania — Ponsford, Newman & Benson Ltd, 234 Flinders Lane, Melbourne, Victoria.  
Western Australia — P. Falk & Co. Ltd, 317-9 Murray Street, Perth.

CANADA: Meccano Ltd, 675 King Street West, Toronto.

NEW ZEALAND: Models Ltd (P.O. Box 129), 53 Fort Street, Auckland, C.I.

RHODESIA: Woolley, Kinleyside & Co. (Pvt.) Ltd, P.O. Box 299, Bulawayo.

SOUTH AFRICA: Arthur E. Harris (Pty.) Ltd (P.O. Box 1199), 142 Market Street, Johannesburg.

Their Badges and Certificates are then forwarded without delay, while their application forms are sent to Headquarters in Liverpool.

Applicants living in any other country overseas should forward their forms, with a British postal order (not stamps) or a money order for 1/6, direct to the Secretary, the Meccano Guild, Binns Road, Liverpool, 13.

Guild members are eligible for the Correspondence Club, by which they are placed in touch with other members in various parts of the world. Full particulars and enrolment forms can be obtained from the Secretary.

The Secretary will send also, on request, full details of the Guild Recruiting Campaign, and of the Medallion awarded to members who are successful in obtaining recruits, together with particulars of the Meccano clubs founded and established by enthusiastic Meccano boys. A special booklet, 'How to run a Meccano Club' will be sent post free to any member on receipt of 2d. in stamps.

# MECCANO MAGAZINE

*for the really modern boy*

The 'MECCANO MAGAZINE' is on sale at all bookstalls, newsagents and Meccano dealers, price 1/3. If you prefer to have each issue sent direct, the subscription rates are 18/- for twelve months or 9/- for six months, including postage, and an order form is attached.

The overseas prices of the 'M.M.' are 15c. in Canada, 1/6 in Australia, 18c. in the U.S.A. and 1/- elsewhere.

## ORDER FORM

TO THE EDITOR,  
MECCANO MAGAZINE,  
BINNS ROAD, LIVERPOOL 13.

I enclose Postal Order for ..... Please post the  
'MECCANO MAGAZINE' for ..... months, beginning with  
the ..... issue.

NAME (IN BLOCK LETTERS) .....

ADDRESS .....

# MECCANO GUILD

## THE THREE GREAT OBJECTS OF THE GUILD

- To make every boy's life brighter and happier.
- To foster clean-mindedness, truthfulness, ambition and initiative in boys.
- To encourage boys in their hobbies, and especially in the development of their knowledge of mechanical and engineering principles.



BADGE OF  
MEMBERSHIP

Headquarters: BINNS ROAD LIVERPOOL 13

## APPLICATION FOR MEMBERSHIP

I possess a Meccano Outfit, and I hereby make application for membership of the Meccano Guild.  
I approve of the objects of the Guild, and I promise on my honour

- (1) To conform to the rules and regulations of the Meccano Guild.
- (2) To promote its objects by my own example: to be helpful to others; to be clean in thought and habit; to be determined to learn and make progress.
- (3) To wear the Meccano Guild Badge on all possible occasions.
- (4) To recognise and acknowledge all other Members wearing the Guild Badge, and to render them help in case of need.

I enclose 1/- for the Guild Badge (Great Britain).

I enclose 1/6 for the Guild Badge (Overseas).

I enclose 30c. for the Guild Badge (Canada).

Strike out line not applicable (See other side of this form).

NAME OF APPLICANT .....

(BLOCK LETTERS PLEASE)

ADDRESS .....

DATE .....

SIZE OF OUTFIT OWNED NO. ....

AGE .....

WITNESS .....

ADDRESS .....

The witness should be the Parent, Guardian, Employer, Schoolmaster or Church Minister  
and should state which when signing.

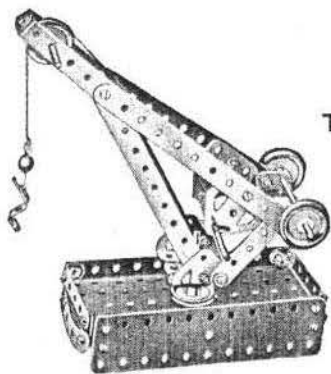

This Dockside Crane  
can be built with Outfit No. 1

# HOW TO BEGIN THE FUN

## THE MOST FASCINATING OF ALL HOBBIES

Meccano model-building is the most fascinating of all hobbies, because it never becomes dull. There is always something new to be done. First of all there is the fun of building a new model, and watching it take shape as part after part is added. Then, when the model is complete, comes the thrill of setting it to work just like the real structure it represents, by means of a Meccano Motor.

The following hints are given to show boys who are just starting the wonderful Meccano hobby how to get the greatest possible fun.

## A FEW USEFUL HINTS

It will be noticed that with each model in this Book of Instructions is given a list of the parts required to build it. For the first few models it is a good plan to lay out on the table all the parts required for the one it is proposed to build, and put the remainder of the Outfit to one side. To help you to pick out the correct parts for your model a complete list of Meccano parts is given at the back of this Book, and all the principal parts are illustrated. In the list the parts are all numbered, and in most cases their measurements are given. There is no need, however, to measure the parts to find out which is which, as the size is easily found from the number of holes. All Meccano holes are spaced  $\frac{1}{2}$ " apart, so that by counting two holes to the inch the size of a part can be found at once. For instance, Part No. 2 is listed as a  $5\frac{1}{2}$ " Perforated Strip, so you look in your Outfit for a Strip with eleven holes. Similarly No. 189 is a  $5\frac{1}{2}$ "  $\times$   $1\frac{1}{2}$ " Flexible Plate, so you look for a Flexible Plate eleven holes in length and three holes in width. By the time a few models have been built the names of the parts will have become familiar.

Beginners sometimes wonder which section of a model should be built first. There cannot be any definite rule for this, as it depends on the design of the model. In stationary models the base usually should be built first. In most of the small models a  $5\frac{1}{2}$ "  $\times$   $2\frac{1}{2}$ " Flanged Plate forms an important part of the structure, and often the best plan is to start building by bolting parts to this Plate. For other models a good general rule is that the sections that form supports for a number of other parts should be built first.

During the construction of a model it is best to screw up the nuts with the fingers, followed by a light turn with the screwdriver, leaving the final tightening until all the parts are connected up.

## THE IMPORTANCE OF LOCK-NUTTING

In some models it is necessary to join certain parts together so that, although they cannot come apart, they are free to pivot or move in relation to one another. To do this the parts are bolted together as usual, but the nut is not screwed up tightly, so that the parts are not gripped. Then, to prevent the nut from unscrewing, a second nut is screwed up tightly against it, the first nut being held with a spanner. This method of using a second nut is known as *Lock-nutting*.

In building models in which Rods revolve in the holes of other parts it is important to make sure that such holes are exactly in line with one another. This can be done by pushing through the holes a Drift, Part No. 36c, or a Rod, before the Bolts holding the various parts are tightened up.

A Rod is usually mounted in a support or bearing so that it is free to revolve. The Rod is then said to be *Journalled* in the Strip.

## DRIVING YOUR MODELS

Models can be driven by means of either clockwork or electric motors. Ask your Dealer for particulars of Meccano Clockwork and Electric Motors.

Small and light models may be driven direct from the driving pulley of the motor or through a belt running over two pulleys of the same size, giving what is known as a 1 : 1 (one-to-one) ratio. For large models it is necessary to take the drive from a small pulley on the motor shaft to a larger pulley on the driving shaft of the model. In most cases a 1" Pulley on the motor shaft and a 3" Pulley on the model shaft will be found satisfactory. This provides a reduction ratio of approximately 3 : 1.

Rubber bands are very convenient for driving belts. Sometimes, however, a rubber band of the right length is not available, and then Meccano Cord or thin string is used. To tie the Cord to form an endless belt, use the familiar reef knot.

All Outfits from No. 2 upward include a Cord Anchoring Spring, Part No. 176. This part provides a neat and positive method of fastening a length of Cord to a Rod. The Spring is placed on a Rod by pushing and turning it in such a way that its coils tend to unwind.

Flexible Plates are used for forming curved surfaces in models, but they are not intended to be bent at right angles. With careful handling a Plate can be bent to the required curve and after use straightened again.

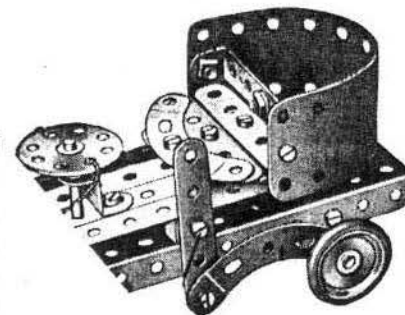

A Flexible Plate  
used to form a curved surface

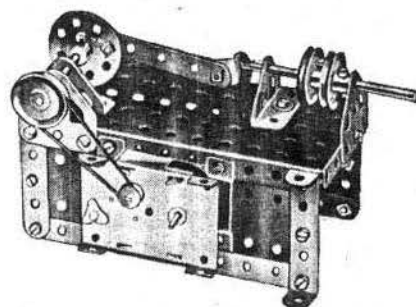

A 'Magic' Motor  
fitted to drive a Steam Engine

### O.1 ELEVATOR

Parts Required

4 of No. 2	15 of No. 37b
2 " " 5	2 " " 48a
1 " " 16	1 " " 52
1 " " 19s	2 " " 126
1 " " 22	2 " " 126a
4 " " 35	
15 " " 37a	

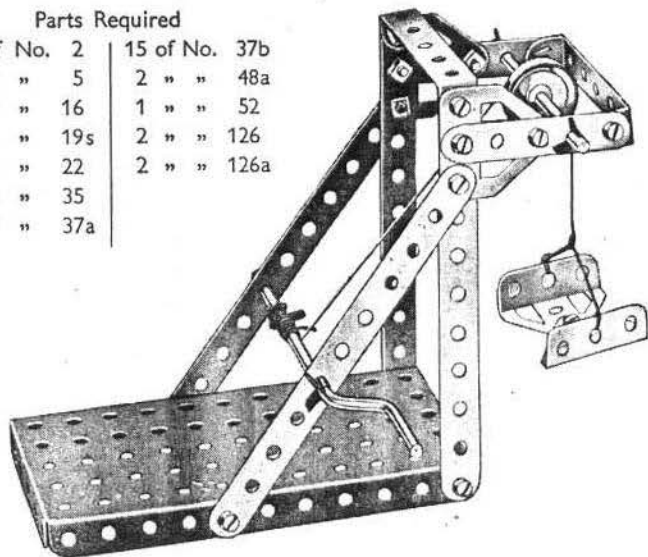

### O.2 BLACKSMITH

Parts Required

2 of No. 5
2 " " 10
4 " " 12
1 " " 16
1 " " 17
1 " " 19s
2 " " 22

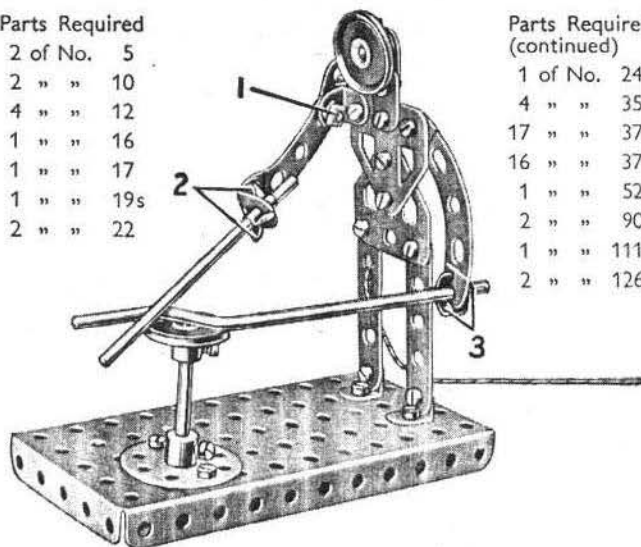

Parts Required (continued)

1 of No. 24
4 " " 35
17 " " 37a
16 " " 37b
1 " " 52
2 " " 90a
1 " " 111c
2 " " 126a

The arm holding the hammer is a 2½" stepped Curved Strip, pivoted to an Angle Bracket by a lock-nutted bolt (1). The hammer is a 3½" Rod held in an Angle Bracket at the end of the arm by two Spring Clips (2). The Crank Handle is fixed in the other arm by the Spring Clip (3). The hammer arm is operated by a Cord attached to the end of the Curved Strip forming the arm.

### O.3 GARDEN SEAT

Parts Required

4 of No. 2
2 " " 5
10 " " 37a
10 " " 37b
2 " " 48a
1 " " 52

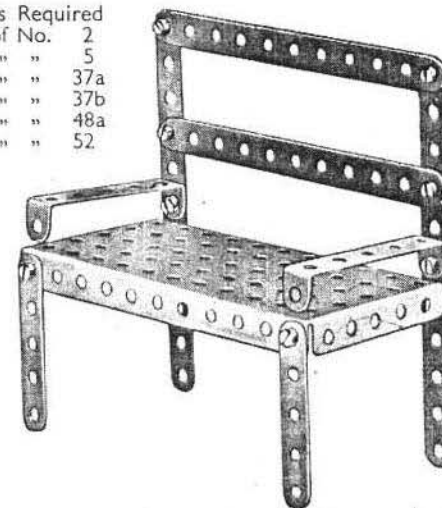

### O.4 STATION TRUCK

The 5½" Strips forming the handle are placed one on each side of a Bush Wheel on the front axle, and they are held in place by Spring Clips (1) as shown in Fig. O.4a.

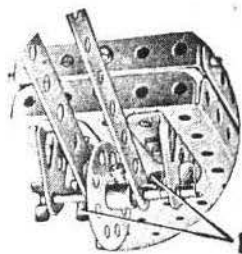

Fig. O.4a

Parts Required

4 of No. 2	2 of No. 22	2 of No. 48a
1 " " 5	1 " " 24	1 " " 52
2 " " 10	4 " " 35	2 " " 90a
2 " " 12	17 " " 37a	2 " " 126
1 " " 16	17 " " 37b	2 " " 126a
1 " " 17	1 " " 38	2 " " 142c

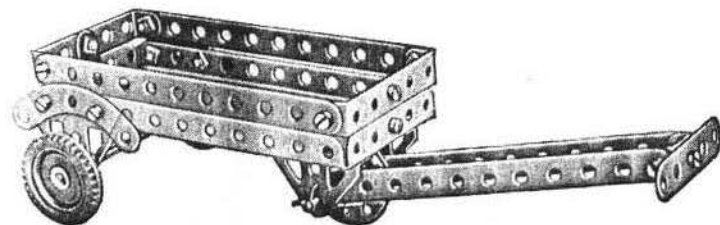
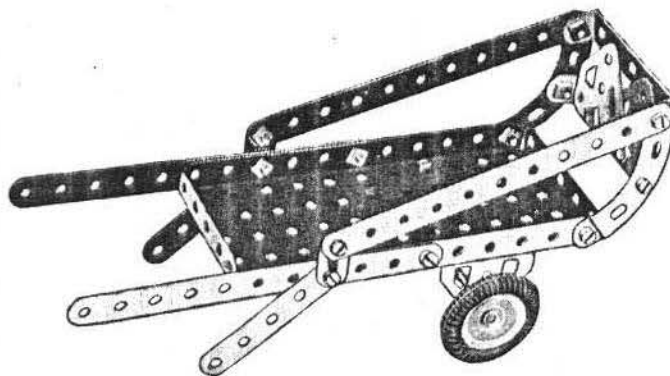

Fig. O.4

### O.5 COSTER'S BARROW



Parts Required

4 of No. 2	2 of No. 22	2 of No. 90a
2 " " 5	16 " " 37a	2 " " 126
2 " " 10	16 " " 37b	2 " " 126a
1 " " 16	2 " " 48a	2 " " 142c
	1 " " 52	

### O.6 BUCKING BRONCHO

The Bolts (1) are fitted with lock-nuts so that the parts they attach are free to pivot. Bearings for a 2" Rod, the end of which is seen at (2), are provided by a Fishplate (3), Fig. O.6a, bolted to an Angle Bracket (4), and a Trunnion (5).

Parts Required

20 of No. 37a
2 of No. 5
15 " " 37b
4 " " 10
1 " " 12
1 " " 17
1 " " 19s
2 " " 22
1 " " 24
4 " " 35
1 " " 38
1 " " 48a
1 " " 52
2 " " 90a
2 " " 111c
2 " " 126
2 " " 126a

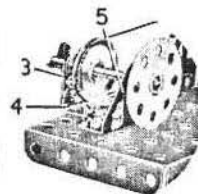

Fig. O.6a.

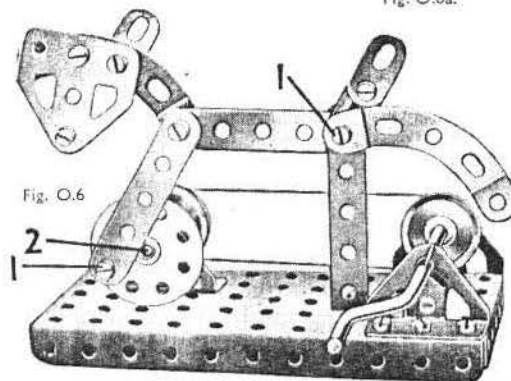
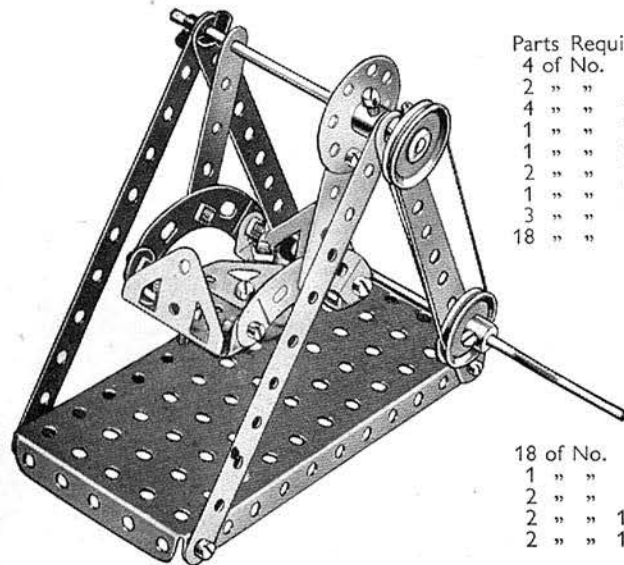

Fig. O.6

### O.7 SWING BOAT



Parts Required

4 of No.	2
2 " "	5
4 " "	12
1 " "	16
1 " "	19s
2 " "	22
1 " "	24
3 " "	35
18 " "	37a

18 of No.	37b
1 " "	52
2 " "	90a
2 " "	126
2 " "	126a

### O.8 DROP HAMMER

Parts Required

4 of No.	2
2 " "	5
4 " "	10
1 " "	16
1 " "	19s
2 " "	22
1 " "	24
2 " "	35
20 " "	37a
18 " "	37b

Parts Required (continued)

2 of No.	38
2 " "	48a
1 " "	52
2 " "	90a
2 " "	111c
2 " "	126
2 " "	126a
2 " "	142c

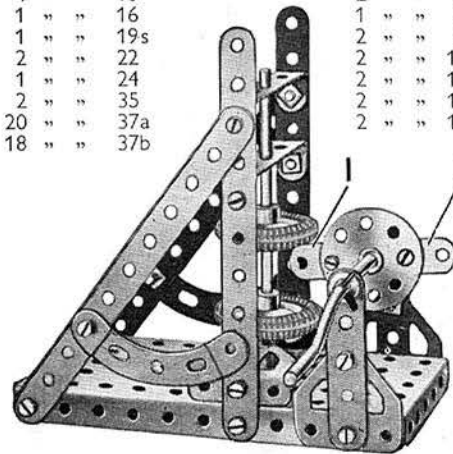

The hammer, which is formed by the two 1" Pulleys on a 3 1/2" Rod, is lifted by the Fishplates (1) as they rotate when the Crank Handle is turned. The Fishplates are bolted to a Bush Wheel fixed on the Crank Handle.

### O.9 ELECTRIC TRUCK

The two 5 1/2" Strips (1) on each side of the model are fastened to the Flanged Plate by two Trunnions secured to the Plate on the underneath side. A Bush Wheel (2) is fixed on the 2" Rod (3), which passes through the end holes of the 5 1/2" Strips that form the sides of the truck frame.

Parts Required

4 of No.	2	2 of No.	22	1 of No.	52
2 " "	5	1 " "	24	2 " "	90a
2 " "	10	4 " "	35	2 " "	111c
2 " "	12	19 " "	37a	2 " "	126
1 " "	16	17 " "	37b	2 " "	126a
1 " "	17	2 " "	38	2 " "	142c
1 " "	19s	2 " "	48a		

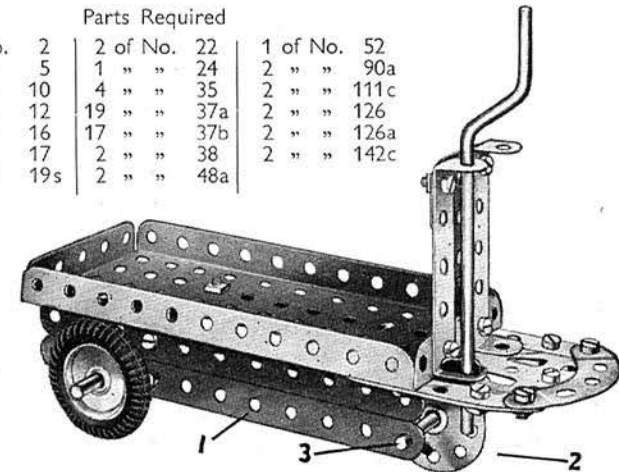

### O.10 LAWN MOWER

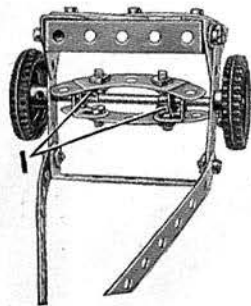
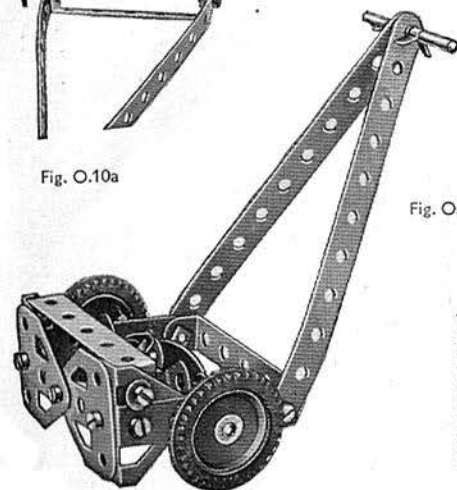

Fig. O.10a

Parts Required

2 of No.	2	1 of No.	17
2 " "	5	2 " "	22
4 " "	12	4 " "	35
1 " "	16	13 " "	37a
		13 " "	37b
		2 " "	38
		2 " "	48a
		2 " "	90a
		2 " "	126
		2 " "	126a
		2 " "	142c

Fig. O.10



Two Angle Brackets are bolted to each of the Curved Strips forming the cutting blades. The wheel axle is then pushed through the four Angle Brackets and Spring Clips (1), shown in Fig. O.10a, are used to hold the blades in place.

### O.11 COUNTER SCALES

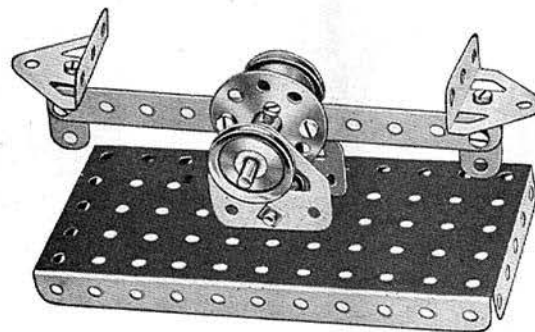

Parts Required

1 of No.	2	2 of No.	22	2 of No.	38
2 " "	10	1 " "	24	1 " "	52
4 " "	12	9 " "	37a	2 " "	126
1 " "	17	9 " "	37b	2 " "	126a

### O.12 PUNCHING MACHINE

The Bolts (1) are *lock-nutted*. The lower bearing for the punch consists of two Fishplates (2), which are bolted together. One of them is then attached to an Angle Bracket that is fixed to one of the vertical 5 1/2" Strips by the Bolt (3).

Parts Required

3 of No.	2
2 " "	10
4 " "	12
1 " "	16
1 " "	17
2 " "	22
1 " "	24
18 " "	37a
16 " "	37b
1 " "	48a
1 " "	52
2 " "	126
2 " "	126a
2 " "	142c

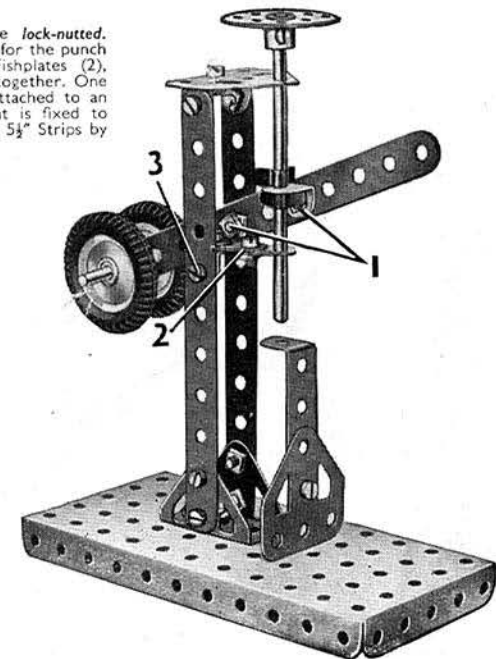

**I.1 KIDDIE CAR**

Two Trunnions overlapped one hole, and fastened to the Flanged Plate by an Angle Bracket, form the seat.

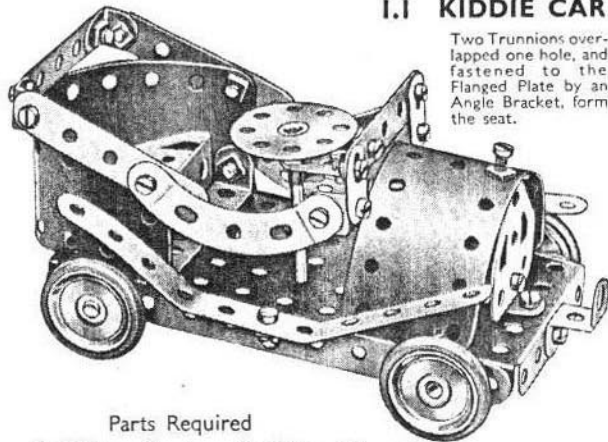
**Parts Required**

4 of No. 2	1 of No. 24	2 of No. 111c
4 " " 5	1 " " 35	1 " " 125
3 " " 10	27 " " 37a	2 " " 126
7 " " 12	24 " " 37b	1 " " 126a
2 " " 16	2 " " 48a	4 " " 155
1 " " 17	1 " " 52	2 " " 189
4 " " 22	2 " " 90a	

**I.2 LETTER BALANCE**

The Bolts (1) are lock-nutted. The  $\frac{3}{4}$ " Bolt (2) is passed through the hole of the Angle Bracket and then held by the screw in the boss of the 1" Pulley.

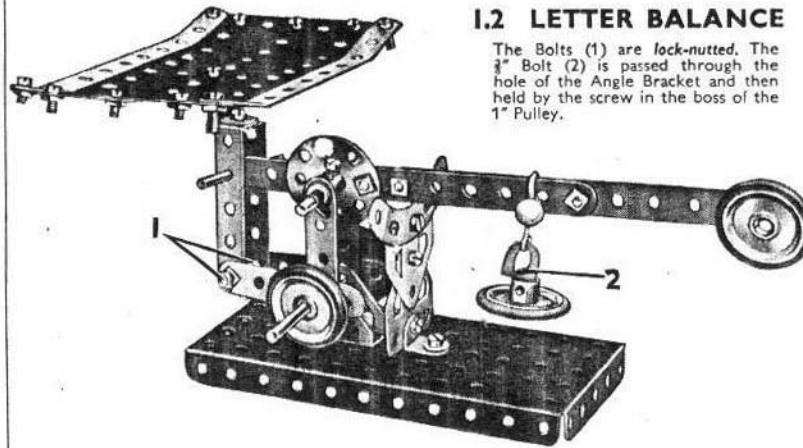
**Parts Required**

4 of No. 2	4 of No. 22	4 of No. 38	4 of No. 111c
4 " " 5	1 " " 24	2 " " 48a	1 " " 125
4 " " 10	1 " " 35	1 " " 52	2 " " 126
2 " " 12	28 " " 37a	1 " " 57c	4 " " 126a
1 " " 16	24 " " 37b	1 " " 90a	2 " " 155
2 " " 17			2 " " 189

**I.3 RACING SEAPLANE**

Each of the floats is secured to the wings by two Angle Brackets and one Fishplate.

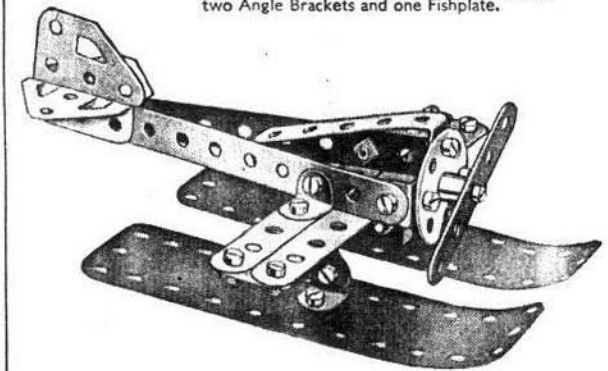
**Parts Required**

3 of No. 2	1 of No. 24	2 of No. 111c
3 " " 5	20 " " 37a	2 " " 126
4 " " 10	19 " " 37b	1 " " 126a
8 " " 12	1 " " 48a	2 " " 189

**I.4 RAILWAY BREAKDOWN CRANE**

The hoisting Cord is secured to the Crank Handle and then led over the 1" Bolt (1). It is then passed through the pulley block and fastened to the jib at (2). The jib is attached to the Bush Wheel (3) by means of Angle Brackets, and the complete unit is pivoted as follows. A  $\frac{3}{4}$ " Bolt is passed through the  $5\frac{1}{2}$ "x $2\frac{1}{2}$ " Flanged Plate from the underside, and is secured in the boss of the Bush Wheel by its set screw.

**Parts Required**

4 of No. 2	1 of No. 19s
4 " " 5	4 " " 22
1 " " 10	1 " " 24
4 " " 12	2 " " 35
2 " " 16	24 " " 37a
	20 " " 37b
	2 " " 38
	1 " " 40
	2 " " 48a
	1 " " 52
	1 " " 57c
	2 " " 90a

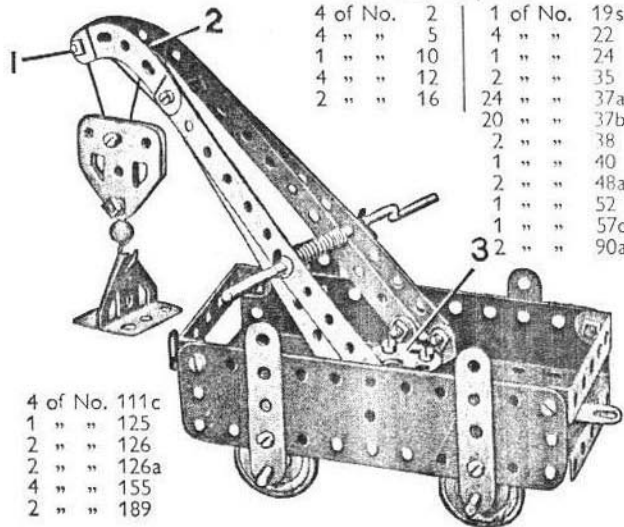

4 of No. 111c
1 " " 125
2 " " 126
2 " " 126a
4 " " 155
2 " " 189

**I.5 TRICYCLE VAN****Parts Required**

4 of No. 2	1 of No. 17	24 of No. 37b	2 of No. 111c
3 " " 5	3 " " 22	3 " " 38	2 " " 126
3 " " 10	1 " " 24	2 " " 48a	2 " " 126a
6 " " 12	4 " " 35	1 " " 52	2 " " 142c
2 " " 16	27 " " 37a	2 " " 90a	2 " " 189

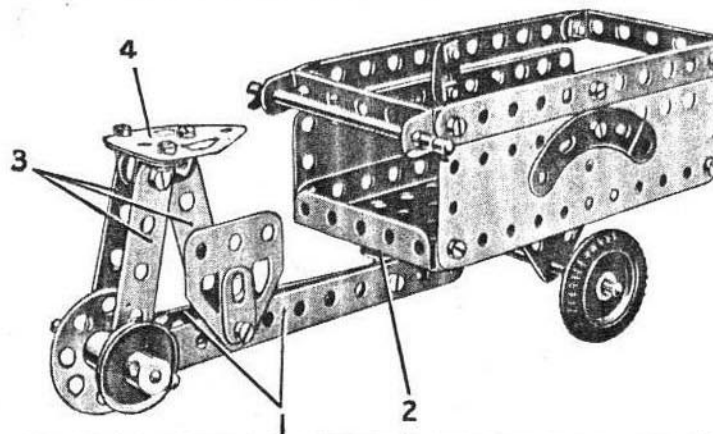

The frame of the cycle consists of two  $5\frac{1}{2}$ " Strips (1) connected at one end by a bolt that fixes them also to an Angle Bracket (2). The Angle Bracket pivots on a bolt lock-nutted to the Flanged Plate. The seat is carried by three  $2\frac{1}{2}$ " Strips (3), each of which is connected by an Angle Bracket to the Flat Trunnion (4). The front axle is carried in Trunnions bolted underneath the Flanged Plate.

**I.6 STAMPING MILL**

The anvil (1) is made up of two Trunnions bolted together. When the Crank Handle is rotated, the Fishplates bolted to the Bush Wheel strike the centre 1" Pulley on the hammer shaft and cause it to rise and fall.

**Parts Required**

4 of No. 2	1 of No. 90a
4 " " 5	4 " " 111c
4 " " 10	1 " " 125
4 " " 12	2 " " 126
1 " " 16	2 " " 126a
1 " " 19s	2 " " 189
4 " " 22	
1 " " 24	
2 " " 35	
27 " " 37a	
24 " " 37b	
2 " " 38	
2 " " 48a	
1 " " 52	

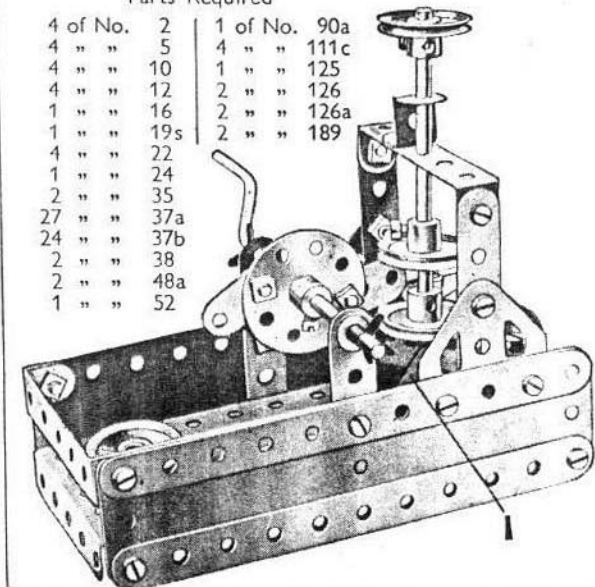



### I.7 MOTOR LORRY

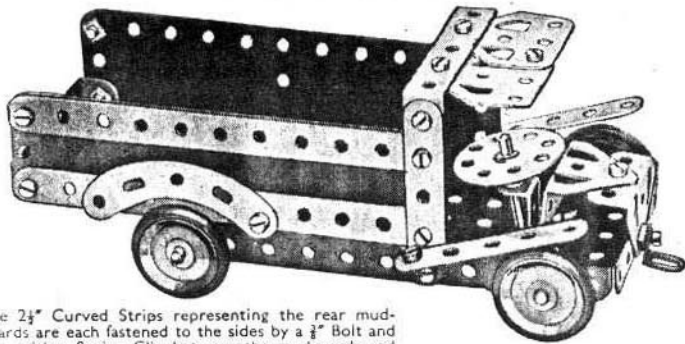

The 2½" Curved Strips representing the rear mudguards are each fastened to the sides by a ½" Bolt and nut, with a Spring Clip between the mudguards and the 5½" Strip to form a distance piece.

Parts Required			
4 of No. 2	4 of No. 22	2 of No. 48a	2 of No. 126
4 " " 5	1 " " 24	1 " " 52	2 " " 126a
3 " " 12	2 " " 35	2 " " 90a	4 " " 155
2 " " 16	23 " " 37a	3 " " 111c	2 " " 189
1 " " 17	19 " " 37b	1 " " 125	

### I.8 MECHANICAL SHOVEL

The Bolts (1), on which the jib pivots, are lock-nutted. The shovel arm is pivoted on a 2" Rod and the shovel is supported by a Cord that passes over the ½" Bolt at the jib head and is fastened to a 2½" x ½" Double Angle Strip as shown. The Cord (2) is fastened to the jib and then passes over a 3½" Rod journalled in the holes above the 2½" Curved Strips, and is attached to a Fishplate fastened by the lock-nutted Bolt (3) to the Bush Wheel.

When the Crank Handle is rotated, the Bush Wheel imparts a digging motion to the jib and shovel arm.

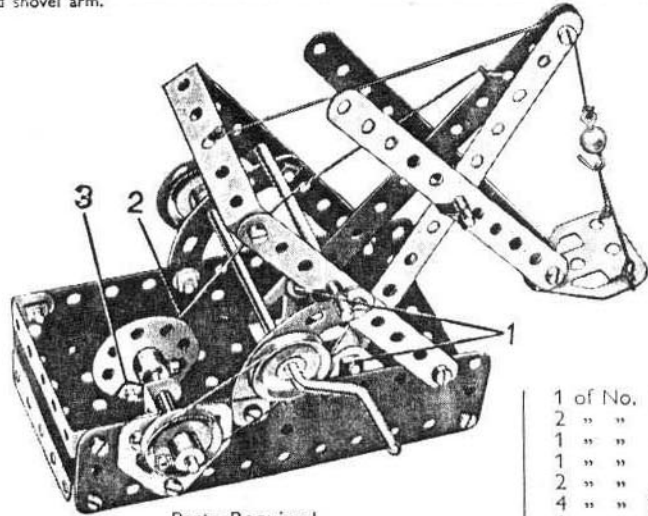

Parts Required			
4 of No. 2	1 of No. 16	1 of No. 24	1 of No. 40
4 " " 5	2 " " 17	28 " " 37a	2 " " 48a
1 " " 10	1 " " 19s	24 " " 37b	1 " " 52
2 " " 12	3 " " 22	4 " " 38	1 " " 57c
			2 " " 90a
			4 " " 111c
			1 " " 125
			2 " " 126
			2 " " 126a
			1 " " 155
			2 " " 189

### I.9 WINDMILL

The sails are gripped on the 3½" Rod by the 1" Pulley (with Rubber Ring) at the front and another 1" Pulley at the back of the sails. The Pulleys are pressed against the faces of the sails and locked on the Rod.

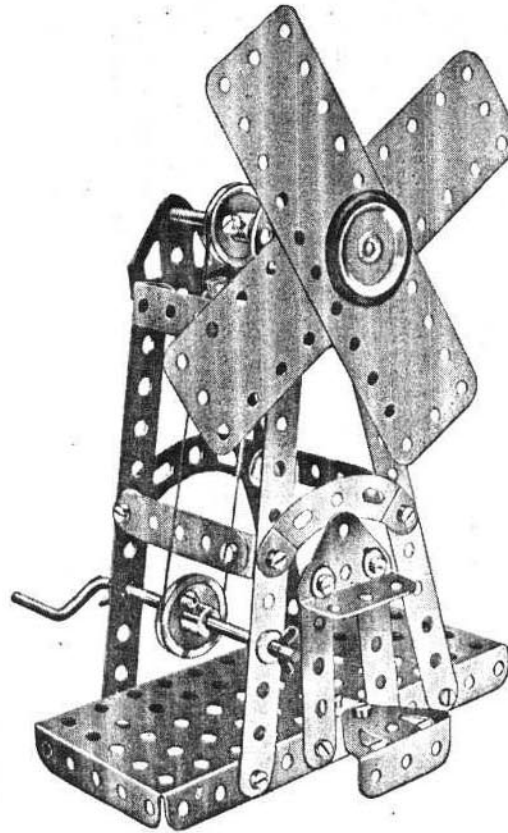

Parts Required		
4 of No. 2	1 of No. 24	1 of No. 52
4 " " 5	3 " " 35	2 " " 90a
1 " " 10	24 " " 37a	2 " " 126
4 " " 12	24 " " 37b	2 " " 126a
1 " " 16	4 " " 38	1 " " 155
1 " " 19s	1 " " 40	2 " " 189
4 " " 22	2 " " 48a	

### I.10 COASTER

The Bolts (1) are lock-nutted. The rear axle Rod is pushed through the end hole of the Curved Strip (2) and through Fishplates bolted to the Flanged Plate.

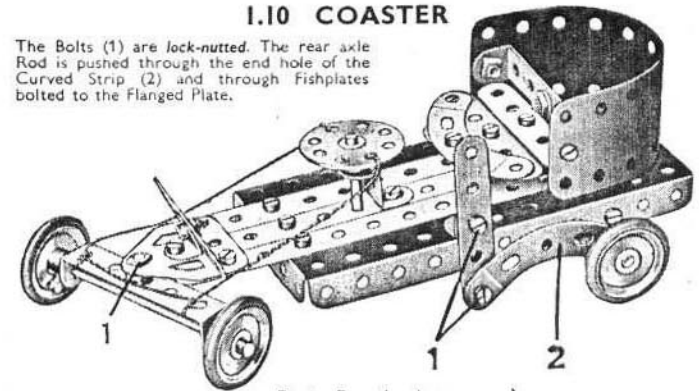

Parts Required			
3 of No. 2	4 of No. 22	1 of No. 40	2 of No. 126
4 " " 5	1 " " 24	2 " " 48a	2 " " 126a
2 " " 10	1 " " 35	1 " " 52	4 " " 155
5 " " 12	24 " " 37a	2 " " 90a	1 " " 189
2 " " 16	20 " " 37b	2 " " 111c	
1 " " 17	4 " " 38	1 " " 125	

### I.11 STEAM WAGON

The front axle is supported in a 2½" x ½" Double Angle Strip (1) lock-nutted to a ½" Reversed Angle Bracket (2). The Reversed Angle Bracket is bolted to a 5½" Strip fixed to the centre of the Flanged Plate. The boiler is a 5½" x 1½" Flexible Plate rolled into a cylinder, and the Bush Wheel (3) is attached to an Angle Bracket. The roof is made from two Flat Trunnions bolted to a 2½" x ½" Double Angle Strip (4). The Curved Strips (5) are connected to the Flat Trunnions by Fishplates. A Trunnion (6) at each side is spaced from the Flanged Plate by two Washers.

Parts Required	
3 of No. 2	2
4 " " 5	5
2 " " 10	10
4 " " 12	12
2 " " 16	16
1 " " 17	17
4 " " 22	22
1 " " 24	24
4 " " 35	35
29 " " 37a	37a
24 " " 37b	37b
4 " " 38	38
2 " " 48a	48a
1 " " 52	52
2 " " 90a	90a
4 " " 111c	111c
1 " " 125	125

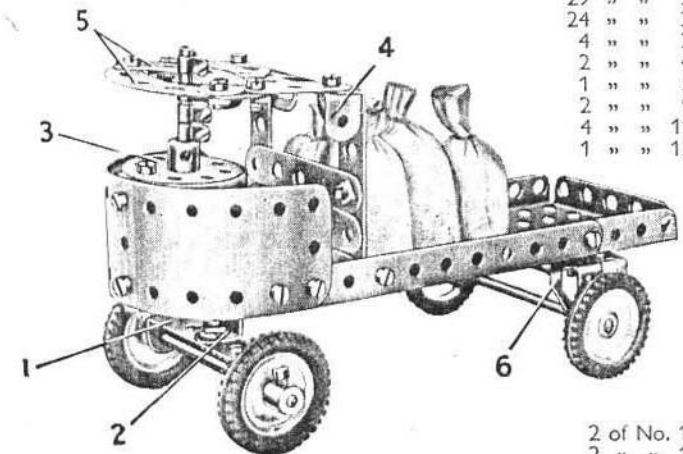

Note: The Loaded Sacks (Part No. 122) are not included in the Outfit

2 of No. 126
2 " " 126a
4 " " 142c
2 " " 189

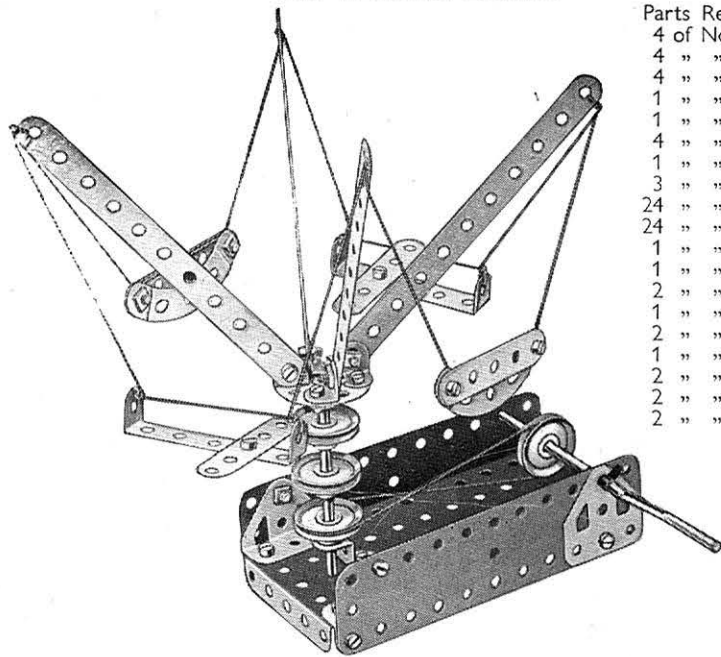
**I.12 FLYING BOATS****Parts Required**

4 of No.	2
4 " "	5
4 " "	12
1 " "	16
1 " "	19s
4 " "	22
1 " "	24
3 " "	35
24 " "	37a
24 " "	37b
1 " "	38
1 " "	40
2 " "	48a
1 " "	52
2 " "	90a
1 " "	125
2 " "	126
2 " "	126a
2 " "	189

**I.14 GYMNAST**

The Bolts (1) are *lock-nutted*. The bearings for the Crank Handle in the Flexible Plates are reinforced by Trunnions bolted to the Flanged Plate.

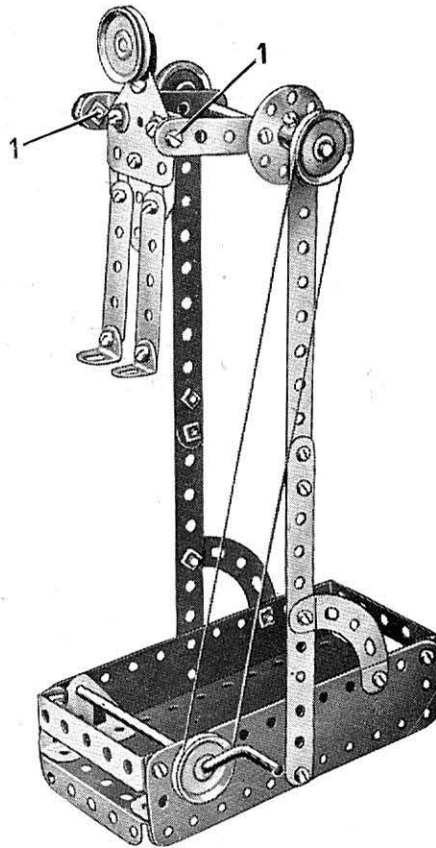

1

**Parts Required**

4 of No.	2	1 of No.	24	1 of No.	52
4 " "	5	2 " "	35	2 " "	90a
1 " "	10	29 " "	37a	4 " "	111c
4 " "	12	24 " "	37b	2 " "	126
1 " "	16	4 " "	38	2 " "	126a
1 " "	19s	1 " "	40	2 " "	189
4 " "	22	2 " "	48a		

**I.15 SCALES****Parts Required**

4 of No.	2
2 " "	5
2 " "	17
2 " "	22
1 " "	24
19 " "	37a
19 " "	37b
1 " "	38
1 " "	40
2 " "	48a
1 " "	52
2 " "	90a
1 " "	111c
2 " "	126
2 " "	126a
1 " "	155
2 " "	189

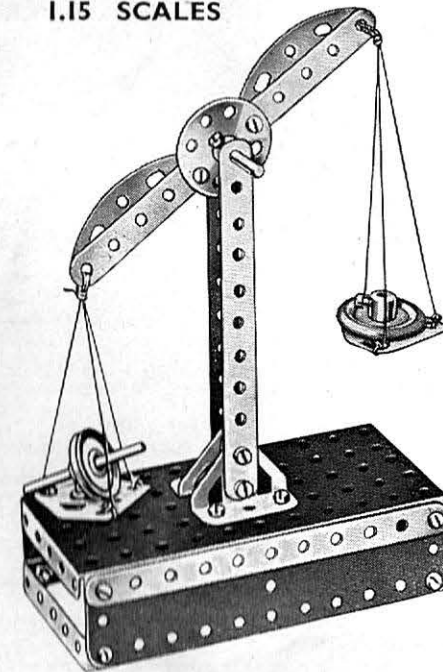
**I.13 CIRCULAR SAW**

The Bush Wheel (1) is fixed to a  $3\frac{1}{2}$ " Rod that is passed through two Trunnions bolted to the Flanged Plate.

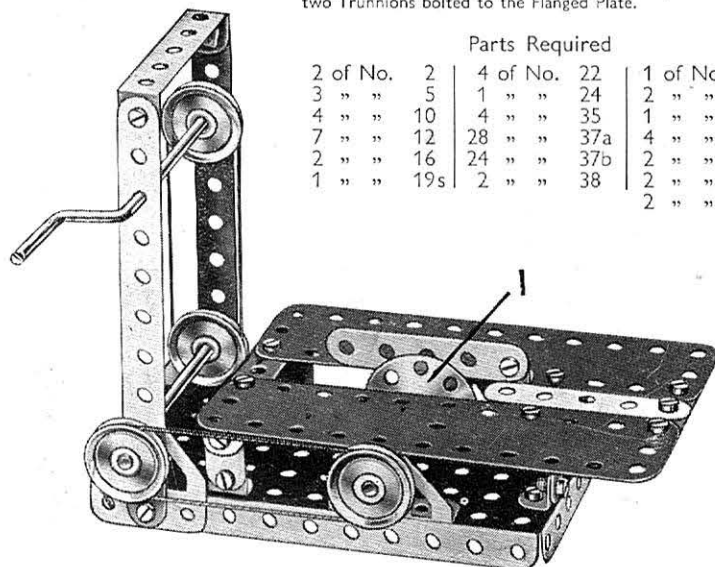
**Parts Required**

2 of No.	2	4 of No.	22	1 of No.	40
3 " "	5	1 " "	24	2 " "	48a
4 " "	10	4 " "	35	1 " "	52
7 " "	12	28 " "	37a	4 " "	111c
2 " "	16	24 " "	37b	2 " "	126
1 " "	19s	2 " "	38	2 " "	126a
		2 " "		2 " "	189

**I.16 DRILLING MACHINE****Parts Required**

4 of No.	2	4 of No.	38
3 " "	5	1 " "	40
8 " "	12	1 " "	52
1 " "	16	2 " "	126
1 " "	17	2 " "	126a
1 " "	19s		
4 " "	22		
4 " "	35		
20 " "	37a		
20 " "	37b		

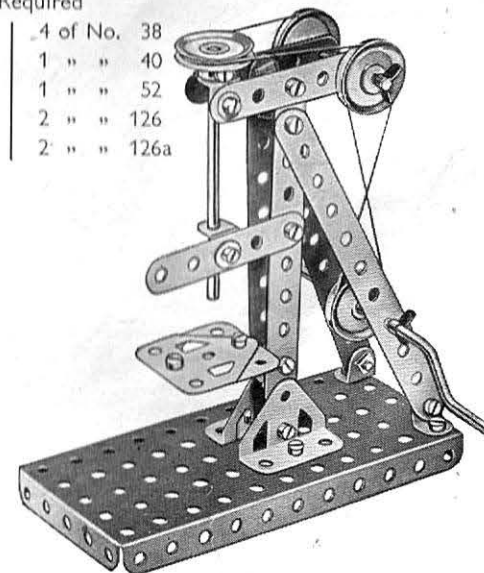

The drill table is made by bolting together two Flat Trunnions.

### I.17 COSTER AND BARROW

The man's body is made from two 2½" x ½" Double Angle Strips, and a ½" Pulley (1) (supplied with the Magic Motor) is fixed on a 2" Rod that carries also a Bush Wheel (2). The leg (3) is lock-nutted to the Bush Wheel, and the foot, a 1" Pulley (4) with Rubber Ring, is attached by a Bolt passed through a Fishplate (5) and screwed into the boss of the Pulley. The head is a Flat Trunnion connected to an Angle Bracket.

To make the man walk successfully, the Pulley (4) and Fishplate (5) must be fixed as nearly as possible in the positions shown in the illustration.

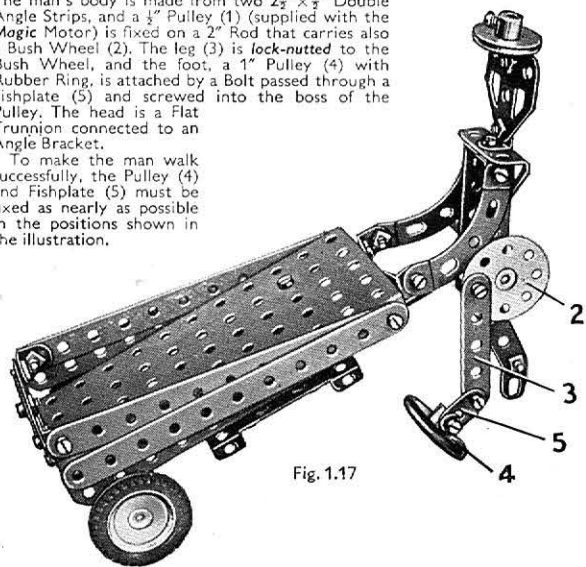

Fig. 1.17

#### Parts Required

4 of No. 2	27 of No. 37a	2 of No. 126a
3 " " 5	24 " " 37b	2 " " 142c
4 " " 10	4 " " 38	1 " " 155
6 " " 12	2 " " 48a	
1 " " 16	1 " " 52	
1 " " 17	2 " " 90a	
4 " " 22	3 " " 111c	1 Magic Clockwork Motor (not included in Outfit)
1 " " 24	1 " " 126	

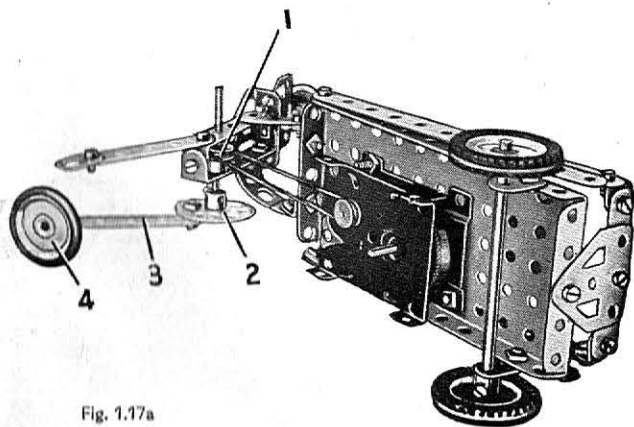
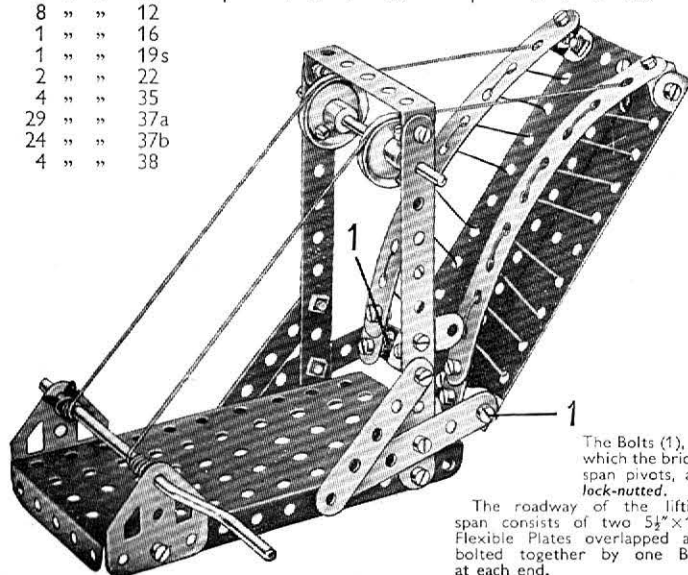

Fig. 1.17a

### I.18 LIFTING BRIDGE

#### Parts Required

4 of No. 2	1 of No. 40	3 of No. 111c
4 " " 5	1 " " 48a	2 " " 126a
3 " " 10	1 " " 52	2 " " 189
8 " " 12		
1 " " 16		
1 " " 19s		
2 " " 22		
4 " " 35		
29 " " 37a		
24 " " 37b		
4 " " 38		



The Bolts (1), on which the bridge span pivots, are lock-nutted.

The roadway of the lifting span consists of two 5½" x 1½" Flexible Plates overlapped and bolted together by one Bolt at each end.

### I.20 DERRICK CRANE

The jib is bolted to a Bush Wheel (1), which is fixed by its set-screw on a ¾" Bolt passed through the Flanged Plate. The jib supporting Cord is passed round a 1" Pulley on a 2" Rod (2). This Rod is held in place by a Spring Clip placed underneath the Flat Trunnion.

The brake lever is lock-nutted to a ½" Reversed Angle Bracket (3). A brake is provided by a length of Cord passed over Pulley (4) and tied to the lever and to the Flanged Plate.

#### Parts Required

4 of No. 2	4 of No. 35	1 of No. 90a
4 " " 5	21 " " 37a	2 " " 111c
3 " " 12	20 " " 37b	1 " " 125
2 " " 17	1 " " 40	2 " " 126
1 " " 19s	2 " " 48a	1 " " 126a
4 " " 22	1 " " 52	
1 " " 24	1 " " 57c	

(Loaded Sack, Part No. 122, not included in Outfit)

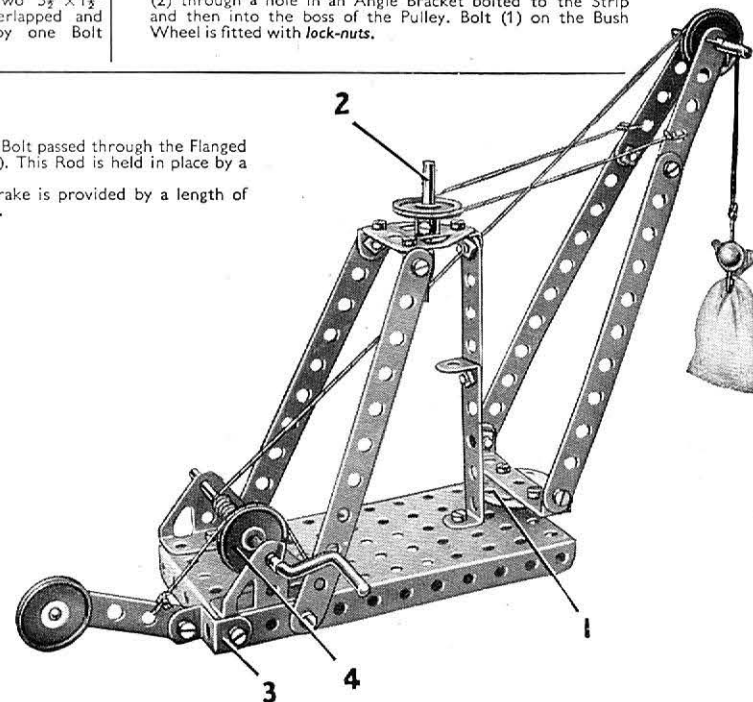

### I.19 MECHANICAL SWING

#### Parts Required

4 of No. 2	2 of No. 5
2 " " 10	3 " " 12
1 " " 16	1 " " 19s
2 " " 22	1 " " 24
4 " " 35	17 " " 37a
15 " " 37b	4 " " 38
1 " " 40	2 " " 48a
1 " " 52	1 " " 111c
1 " " 125	1 " " 126
2 " " 189	

1 Magic Motor (not included in Outfit)

The left-hand 2½" Strip that supports the swing is connected to the Crank Handle by passing the set screw of the 1" Pulley (2) through a hole in an Angle Bracket bolted to the Strip and then into the boss of the Pulley. Bolt (1) on the Bush Wheel is fitted with lock-nuts.

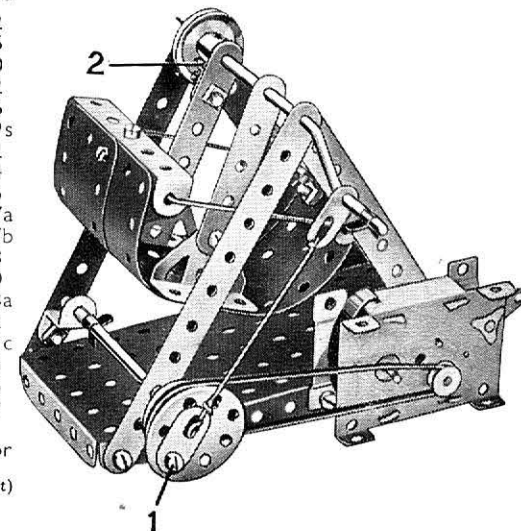

## 2.1 CANAL BRIDGE

## Parts Required

4 of No.	2
6 " "	5
4 " "	10
6 " "	12
1 " "	16
1 " "	19g
4 " "	22
1 " "	24

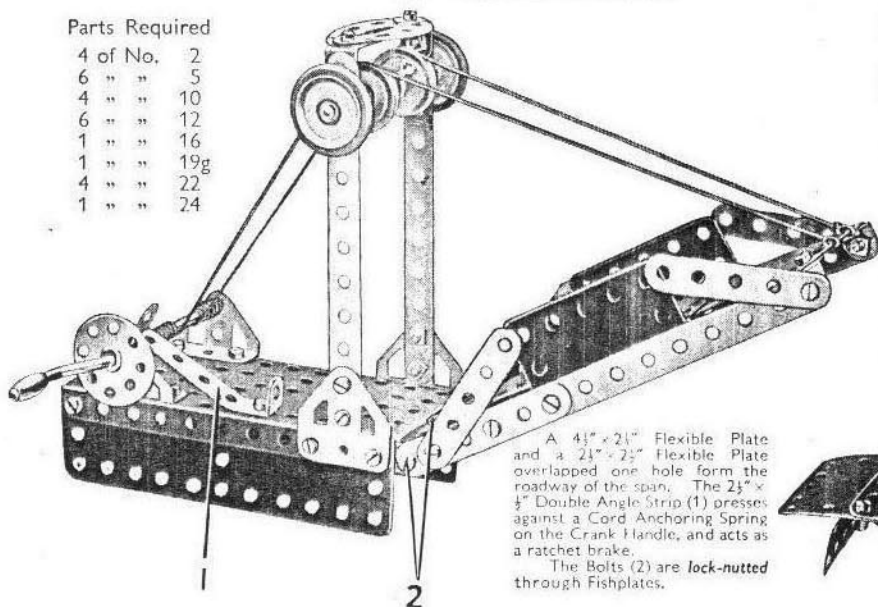

A  $4\frac{1}{2}'' \times 2\frac{1}{2}''$  Flexible Plate and a  $2\frac{1}{2}'' \times 2\frac{1}{2}''$  Flexible Plate overlapped one hole form the roadway of the span. The  $2\frac{1}{2}'' \times \frac{1}{2}''$  Double Angle Strip (1) presses against a Cord Anchoring Spring on the Crank Handle, and acts as a ratchet brake.

The Bolts (2) are lock-nutted through Fishplates.

## Parts Required (continued)

41 of No.	37a
39 " "	37b
2 " "	38
1 " "	40
2 " "	48a
1 " "	52
2 " "	90a
2 " "	126
2 " "	126a
2 " "	155
1 " "	176
2 " "	188
2 " "	189
2 " "	190
1 " "	191
1 " "	199
1 " "	200

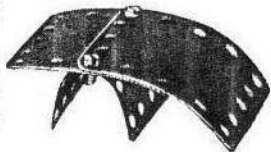

## 2.2 DRILLING MACHINE

The horizontal  $2\frac{1}{2}''$  Strips at the top of the drill are joined together, and also to the vertical  $2\frac{1}{2}''$  Strips, by means of Angle Brackets. The lower bearings (1) are two Angle Brackets bolted to a  $2\frac{1}{2}''$  Strip, and the Rod forming the drill is journaled in these, and in a Fishplate at its upper end. A  $2\frac{1}{2}'' \times 2\frac{1}{2}''$  Flexible Plate is supported by a Double Angle Strip (2), and represents the table.

The drive is taken from the Motor to the 1" Pulley on the lower shaft. A second driving belt passes round the  $\frac{1}{2}''$  fixed Pulley supplied with the Motor, which is also fixed on the lower shaft, round the two Pulleys at (3), and finally round the 1" Pulley fastened on the vertical drill shaft.

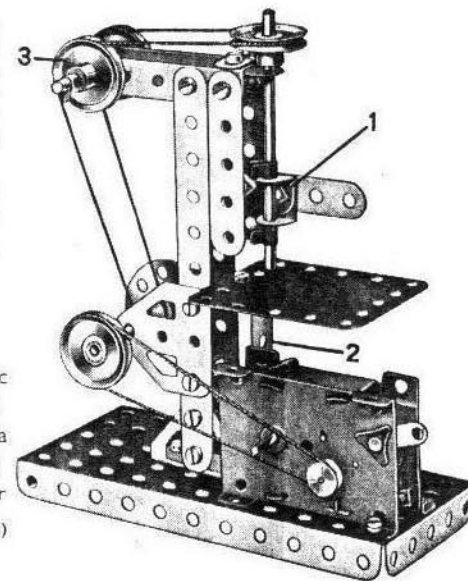

## Parts Required

2 of No.	2	1 of No.	24	1 of No.	111c
5 " "	5	4 " "	35	2 " "	126
1 " "	10	24 " "	37a	2 " "	126a
5 " "	12	22 " "	37b	1 " "	190
1 " "	16	1 " "	40	1 Magic Motor	
2 " "	17	1 " "	48a	(not included in	
4 " "	22	1 " "	52	Outfit)	

## 2.3 MILK DELIVERY WAGON

4 of No.	2
6 " "	5
2 " "	10
6 " "	12
2 " "	16

4 of No.	22
1 " "	24
37 " "	37a
37 " "	37b

## Parts Required

4 of No.	38
2 " "	48a
1 " "	52
2 " "	90a

1 of No.	111c
1 " "	126
2 " "	126a
4 " "	155

2 of No.	188
2 " "	189
2 " "	190
1 " "	191
1 " "	199

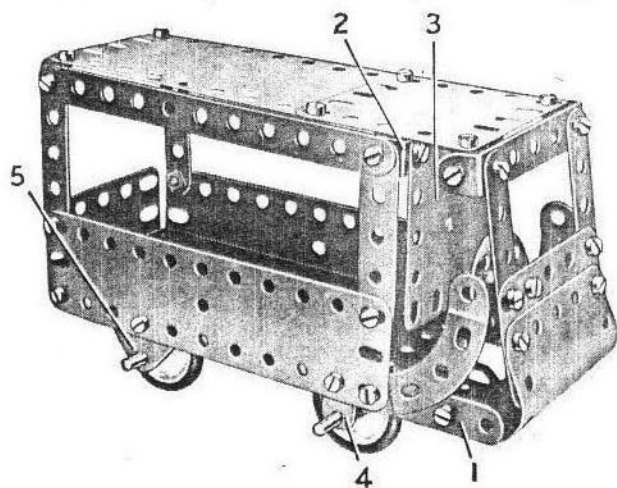

The floor of the wagon is a  $5\frac{1}{2}'' \times 2\frac{1}{2}''$  Flanged Plate placed with its flanges downward, and to each side a  $5\frac{1}{2}''$  Strip (1) is bolted, the Strips extending three holes beyond the Plate. The curved front consists of a 'U'-section Curved Plate opened out slightly, and a  $2\frac{1}{2}'' \times 1\frac{1}{2}''$  Flexible Plate. The Curved Plate is connected to Angle Brackets bolted to the Strips (1).

The roof is attached to the side frames of the body and to the windscreen pillars by Angle Brackets, and the side frames are connected together by a  $2\frac{1}{2}'' \times \frac{1}{2}''$  Double Angle Strip (2). A  $2\frac{1}{2}'' \times 2\frac{1}{2}''$  Flexible Plate (3) is bolted to this Double Angle Strip.

The front wheels are fixed on a  $3\frac{1}{2}''$  Rod supported in a Fishplate (4) on each side of the model. The rear axle also is a  $3\frac{1}{2}''$  Rod and it is supported in the Flat Trunnions (5).

## 2.4 MECHANICAL HACKSAW

The base consists of Flexible Plates bolted to a Flanged Plate. One side is formed by a  $4\frac{1}{2}'' \times 2\frac{1}{2}''$  and a  $2\frac{1}{2}'' \times 1\frac{1}{2}''$  Flexible Plate, and the other by two  $5\frac{1}{2}'' \times 1\frac{1}{2}''$  Plates. A  $2\frac{1}{2}'' \times 2\frac{1}{2}''$  Flexible Plate is bolted to each end. The base is strengthened at each end by Double Angle Strips (1) and a  $5\frac{1}{2}''$  Strip on each side.

The saw is actuated by a crank formed from a Bush Wheel fixed to a  $3\frac{1}{2}''$  Rod. The Rod rotates in a Trunnion and a Flat Trunnion. The Trunnion is raised from the Flanged Plate by two Washers. The Rod carries a 1" Pulley (2) and a Road Wheel. The Pulley (2) is connected by a belt of Cord to a similar Pulley fixed on the Crank Handle.

The material to be sawn is clamped to the base by means of two  $2\frac{1}{2}''$  Strips, one of which is shown at (3).

## Parts Required

3 of No.	2	2 of No.	48a
6 " "	5	1 " "	52
2 " "	12	4 " "	111c
2 " "	16	1 " "	126
1 " "	19g	1 " "	126a
3 " "	22	1 " "	187
1 " "	24	1 " "	188
38 " "	37a	2 " "	189
30 " "	37b	2 " "	190
4 " "	38	1 " "	191
1 " "	40		

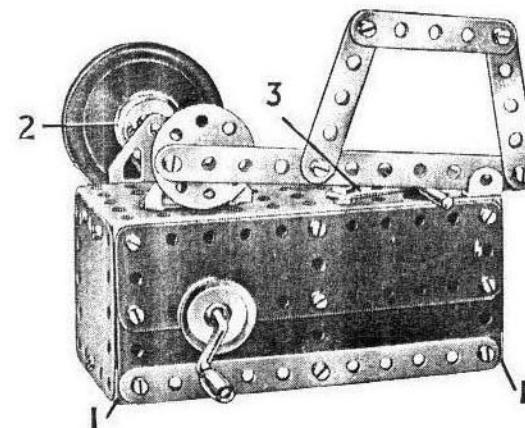

### 2.5 BEAM ENGINE

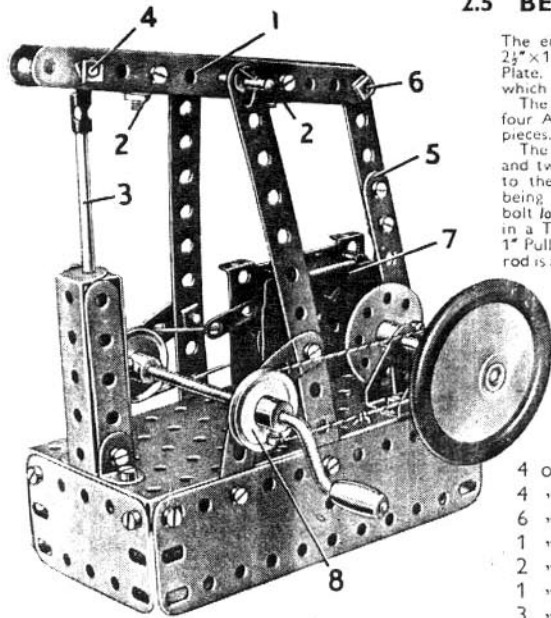

The engine bed or base consists of two  $5\frac{1}{2} \times 1\frac{1}{2}$ " and two  $2\frac{1}{2} \times 1\frac{1}{2}$ " Flexible Plates bolted to the sides of a Flanged Plate. Two  $5\frac{1}{2}$ " Strips form the supports for the beam (1), which pivots on a 2" Rod held in position by Spring Clips.

The beam is made from two  $5\frac{1}{2}$ " Strips held together by four Angle Brackets bolted in pairs to form two "U"-shaped pieces. The positions of the pieces are marked (2).

The cylinder consists of two  $2\frac{1}{2} \times \frac{1}{2}$ " Double Angle Strips and two  $2\frac{1}{2}$ " Strips. The piston rod (3) is a  $3\frac{1}{2}$ " Rod attached to the beam by a Rod and Strip Connector, the Bolt (4) being lock-nutted. The connecting Rod (5) is pivoted on a bolt lock-nutted to a Bush Wheel held on a 2" Rod journalled in a Trunnion and a Flat Trunnion. This Rod also carries a 1" Pulley and a Road Wheel. At its upper end the connecting rod is attached to the beam by the lock-nutted Bolt (6).

The Magic Motor (7) is bolted to the base by its flanges, and its pulley is connected by a Driving Band to a 1" Pulley on the Crank Handle. A further 1" Pulley (8) on the Crank Handle is connected by a belt of Cord to the Pulley on the 2" Rod.

Parts Required		
4 of No. 2	3 of No. 35	2 of No. 111c
4 " " 5	35 " " 37a	1 " " 126
6 " " 12	30 " " 37b	1 " " 126a
1 " " 16	3 " " 38	1 " " 187
2 " " 17	1 " " 40	2 " " 188
1 " " 19g	2 " " 48a	2 " " 189
3 " " 22	1 " " 52	1 " " 212
1 " " 24	2 " " 90a	1 Magic Motor
		(not included in Outfit)

### 2.7 BACON SLICER

#### Parts Required

3 of No. 2	1 of No. 17	40 of No. 37a	2 of No. 48a	1 of No. 125	2 of No. 188
6 " " 5	1 " " 19g	36 " " 37b	1 " " 52	2 " " 126a	2 " " 189
1 " " 10	4 " " 22	3 " " 38	2 " " 90a	1 " " 187	2 " " 190
8 " " 12	1 " " 24	1 " " 40			
1 " " 16	2 " " 35				

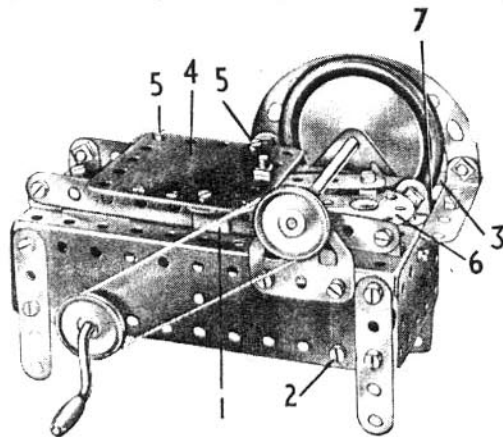

The base of the model consists of a Flanged Plate fitted with four  $2\frac{1}{2}$ " Strips for legs. Two  $5\frac{1}{2} \times 1\frac{1}{2}$ " and two  $2\frac{1}{2} \times 1\frac{1}{2}$ " Flexible Plates are bolted to the flanges of the Plate.

The guides for the sliding carriage (4) are formed by two  $5\frac{1}{2}$ " Strips attached to the Flanged Plate by Angle Brackets. The carriage consists of a  $2\frac{1}{2} \times 2\frac{1}{2}$ " Flexible Plate (4) and is guided along the strips by the Reversed Angle Bracket (1) and two Angle Brackets on the opposite side. The Angle Brackets are held in place by Bolts (5).

The cutting blade is represented by a Road Wheel fixed on a  $3\frac{1}{2}$ " Rod journalled in two Flat Trunnions. A Pulley on this Rod is connected by a belt of Cord to a second Pulley on the Crank Handle.

The carriage is moved backwards and forwards by a crank consisting of a Bush Wheel (6) fixed on a 2" Rod. This Rod is journalled in the Flanged Plate and in the centre hole of a Double Angle Strip fixed across the interior of the base by the Bolt (2) and another in a similar position on the opposite side. A 1" Pulley on the 2" Rod is connected by a crossed belt of Cord to a further 1" Pulley secured by the Crank Handle between the  $5\frac{1}{2} \times 1\frac{1}{2}$ " Flexible Plates.

A guard for the rotating blade is provided by two Curved Strips attached to a  $5\frac{1}{2}$ " Strip (3). This Strip is fastened at one end to the Flanged Plate by a  $2\frac{1}{2}$ " Strip and a Fishplate (7), and at its other end is attached to a  $2\frac{1}{2} \times 2\frac{1}{2}$ " Flexible Plate bolted horizontally to the Flanged Plate.

### 2.6 AUTOGIRO

#### Parts Required

4 of No. 2	
6 " " 5	
4 " " 10	
6 " " 12	
1 " " 16	
1 " " 17	
4 " " 22	2 of No. 90a
1 " " 24	1 " " 111c
3 " " 35	1 " " 125
25 " " 37a	2 " " 126a
25 " " 37b	2 " " 155
2 " " 38	2 " " 188
2 " " 48a	1 " " 199

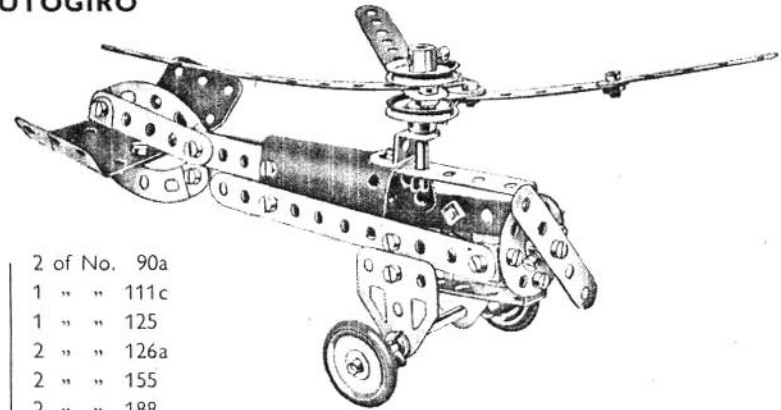

The rotor is made by passing a Rod through the next to end holes of two  $5\frac{1}{2}$ " Strips. Fishplates are bolted to the short ends of the Strips and the third blade of the rotor is fixed to them as shown.

### 2.8 CHARIOT AND DRIVER

The chariot is made by curving a  $5\frac{1}{2} \times 1\frac{1}{2}$ " Flexible Plate (1) to make a semi-circle with its ends bolted to the lugs of a  $2\frac{1}{2} \times \frac{1}{2}$ " Double Angle Strip. A second  $2\frac{1}{2} \times \frac{1}{2}$ " Double Angle Strip is bolted to the first with its lugs pointing downwards, the holes in the lugs forming supports for the chariot axle. A  $1\frac{1}{2}$ " radius Curved Plate is fixed to the front of the  $5\frac{1}{2} \times 1\frac{1}{2}$ " Flexible Plate. The shafts are  $5\frac{1}{2}$ " Strips and they are bolted to the  $5\frac{1}{2} \times 1\frac{1}{2}$ " Flexible Plate.

The driver's legs are  $2\frac{1}{2}$ " Strips. They are connected to Angle Brackets (2) fixed to a Flat Trunnion that is bolted by its pointed end to the centre holes of the Double Angle Strips. His body is made from two Trunnions joined by a Fishplate, and his arms are attached to the upper Trunnion by Angle Brackets (3). His head is a 1" Pulley held by its set-screw on a  $\frac{3}{8}$ " Bolt passed through a Fishplate (4). The body of the horse is a 'U'-section Curved Plate.

#### Parts Required

2 of No. 2
6 " " 5
4 " " 10
6 " " 12
1 " " 16
2 " " 17
4 " " 22
2 " " 35
31 " " 37a
31 " " 37b
1 " " 40
2 " " 48a
2 " " 90a
1 " " 111c
2 " " 126
2 " " 126a
3 " " 142c
1 " " 189
1 " " 199
1 " " 200

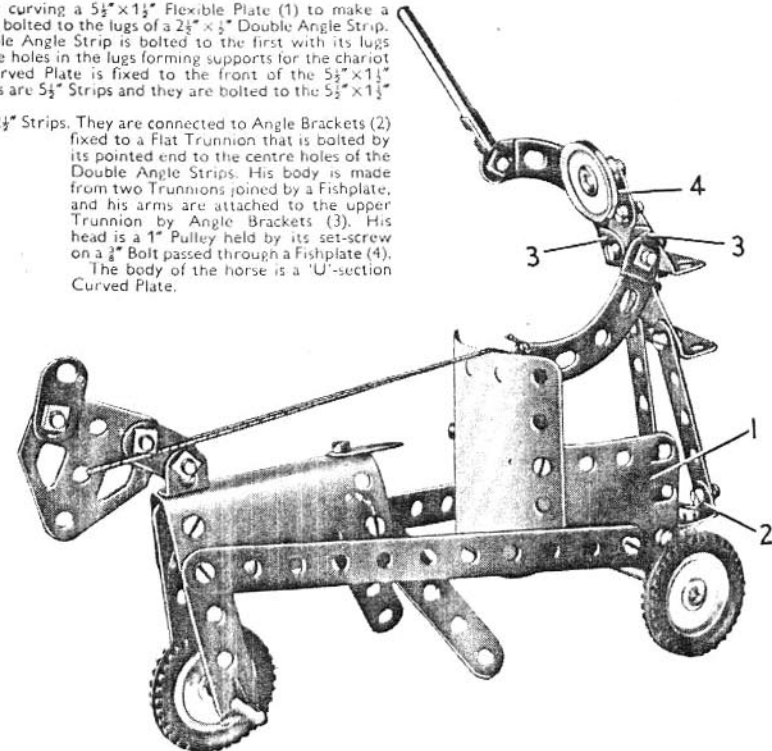

## 2.9 TRAMCAR

## Parts Required

4 of No. 2	1 of No. 52	2 of No. 190
6 " " 5	2 " " 90a	1 " " 191
2 " " 10	4 " " 111c	2 " " 200
4 " " 12	2 " " 126	1 " " 212
2 " " 16	2 " " 126a	
1 " " 19g	4 " " 155	
4 " " 22	2 " " 188	
46 " " 37a	2 " " 189	
40 " " 37b		
4 " " 38		
1 " " 40		
2 " " 48a		

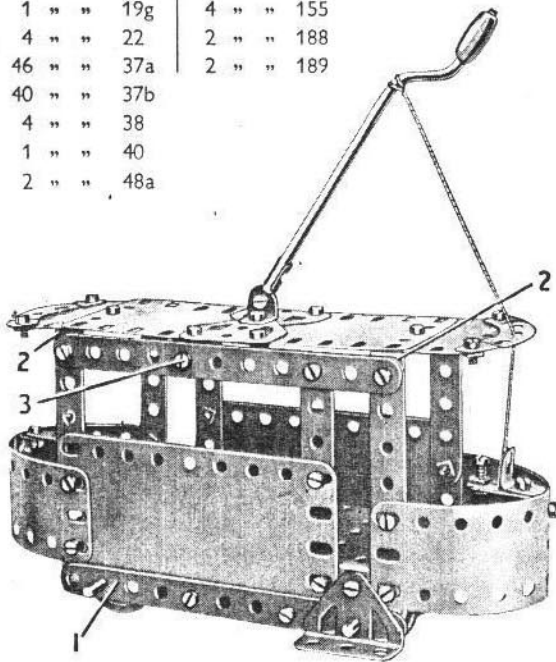

Two  $5\frac{1}{2} \times 1\frac{1}{2}$ " Flexible Plates are curved and bolted across the ends of a Flanged Plate to form the driving compartments at each end, and a  $4\frac{1}{2} \times 2\frac{1}{2}$ " Flexible Plate is used for one side of the model. This also is bolted to the Flanged Plate. The other side consists of two  $1\frac{1}{2}$ " radius Curved Plates, flattened and bolted in position. Both sides are strengthened by a  $5\frac{1}{2}$ " Strip, one of which is seen at (1).

The roof is supported on each side by three  $2\frac{1}{2}$ " Strips, connected at their upper ends by a  $5\frac{1}{2}$ " Strip. The roof is in halves, each half consisting of a  $2\frac{1}{2} \times 1\frac{1}{2}$ " and a  $2\frac{1}{2} \times 2\frac{1}{2}$ " Flexible Plate. The halves are joined at the centre by two Flat Trunnions, and the roof is secured to the Double Angle Strips (2) and Angle Brackets held by a Bolt (3) on each side. A Crank Handle is used to represent the trolley pole and it is held in a Rod and Strip Connector bolted to an Angle Bracket fixed to the Flat Trunnions.

The wheels are 1" Pulleys fixed on  $3\frac{1}{2}$ " Rods that run in holes in the sides of the model.

## 2.10 LUMBER TRUCK AND HORSE

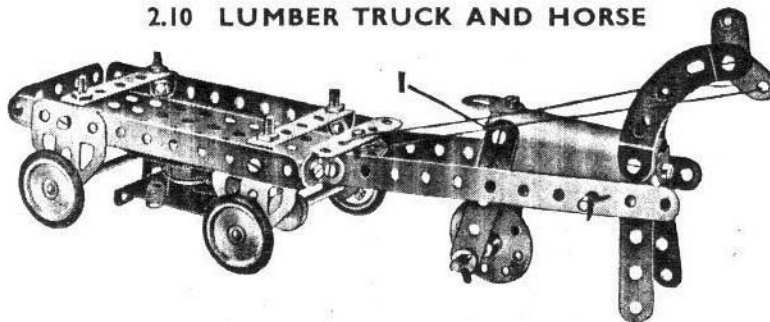

A Magic Motor is mounted beneath the cart, and the Driving Band is taken from the pulley on the Motor to a  $\frac{1}{2}$ " fixed Pulley (supplied with the Motor) fastened on the  $3\frac{1}{2}$ " Rod that forms the front axle.

The forelegs of the horse are held together by means of two Angle Brackets bolted in the positions shown. This construction is duplicated at (1) for the hind legs. The forelegs of the horse are held clear of the ground by the reins.

Parts Required		Parts Required	
4 of No. 2	4 of No. 35	2 of No. 126	
5 " " 5	27 " " 37a	2 " " 126a	
3 " " 10	23 " " 37b	4 " " 155	
6 " " 12	1 " " 40	1 " " 199	
2 " " 16	2 " " 48a	1 Magic Motor	
2 " " 17	1 " " 52	(not included in	
4 " " 22	2 " " 90a	Outfit)	
1 " " 24	4 " " 111c		

## 2.11 LAWN MOWER

## Parts Required

4 of No. 2	2 of No. 48a
4 " " 5	2 " " 90a
4 " " 10	1 " " 125
5 " " 12	2 " " 126
1 " " 16	2 " " 142c
4 " " 22	2 " " 200
24 " " 37a	
2 " " 37b	
4 " " 38	

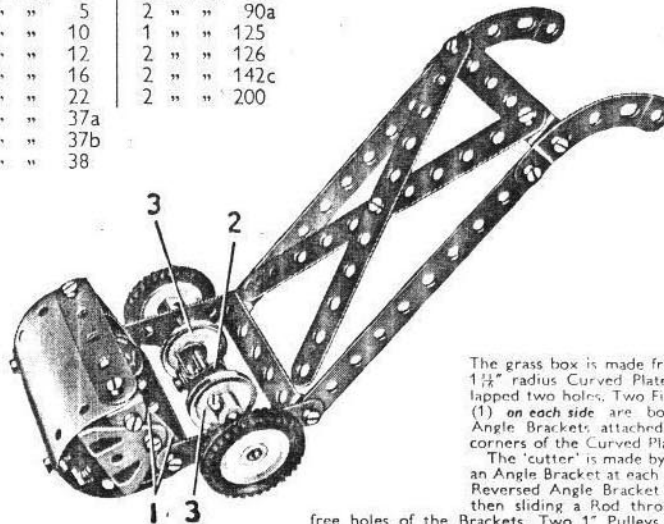

The grass box is made from two  $1\frac{1}{2}$ " radius Curved Plates overlapped two holes. Two Fishplates (1) on each side are bolted to Angle Brackets attached to the corners of the Curved Plates.

The 'cutter' is made by bolting an Angle Bracket at each end of a Reversed Angle Bracket (2) and then sliding a Rod through the free holes of the Brackets. Two 1" Pulleys (3) are placed on the Rod and pushed tightly against the cutter so as to grip it and make it rotate with the Rod as the wheels revolve.

## 2.12 PUNCHING MACHINE

## Parts Required

4 of No. 2	2 of No. 35	2 of No. 126
6 " " 5	46 " " 37a	2 " " 126a
3 " " 10	39 " " 37b	4 " " 155
7 " " 12	2 " " 38	2 " " 188
1 " " 16	2 " " 48a	2 " " 189
2 " " 17	1 " " 52	1 " " 199
4 " " 22	2 " " 90a	1 " " 212
1 " " 24	3 " " 111c	

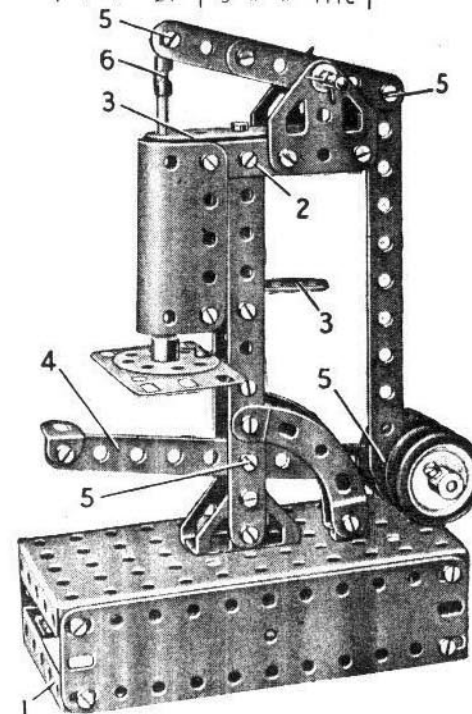

The base consists of a Flanged Plate, which is edged with two  $5\frac{1}{2} \times 1\frac{1}{2}$ " and one  $2\frac{1}{2} \times 1\frac{1}{2}$ " Flexible Plates. The  $5\frac{1}{2} \times 1\frac{1}{2}$ " Plates are braced together by the Double Angle Strips (1) at each end.

An upright column is formed from two  $5\frac{1}{2}$ " Strips fastened to two Trunnions attached to the base. They are joined at their upper ends by two Angle Brackets fixed together to form a 'U'-shaped piece. A 'U'-section Curved Plate is attached to the column at the top by a  $2\frac{1}{2}$ " Strip (2) and at its lower end by two Fishplates. The punch rod passes through holes in  $2\frac{1}{2}$ " guide Strips (3). One of these is bolted to the 'U'-shaped piece at the top of the column, and the other is fixed to an Angle Bracket bolted to the column.

Strips (2), one at each side of the machine, provide supports for two Flat Trunnions that carry a pivoted strip. The strip is formed from two  $2\frac{1}{2}$ " Strips overlapped three holes, and it is pivoted on a 2" Rod held in the Flat Trunnions. One end of this built-up strip is connected by a Rod and Strip Connector (6) to a  $3\frac{1}{2}$ " Rod representing the punching tool, and its rear end is connected to the foot-operated lever (4) by a  $5\frac{1}{2}$ " Strip. The lever is weighted by four 1" Pulleys fixed on a 2" Rod. The Bolts (5) seen at different points of the model are each 'lock-nutted'.

The punching table is a Bush Wheel bolted to a  $2\frac{1}{2} \times 1\frac{1}{2}$ " Flexible Plate attached to the column by a Fishplate and Angle Bracket.

### 2.13 DRAGLINE EXCAVATOR

Parts Required

4 of No.	2
6 " "	5
2 " "	10
8 " "	12
1 " "	16
2 " "	17
1 " "	19g
3 " "	22
1 " "	24
4 " "	35
44 " "	37a
40 " "	37b
1 " "	38
1 " "	40
1 " "	48a
1 " "	52
1 " "	57c
2 " "	90a
2 of No.	111c
2 " "	126
2 " "	126a
1 " "	176
1 " "	187
2 " "	188
2 " "	189
1 " "	190
1 " "	199
2 " "	200

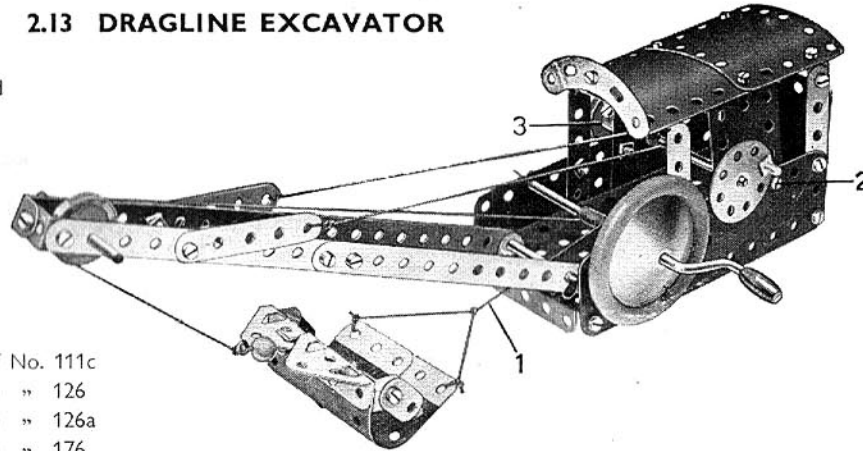

The Cord (1) is wound round the Crank Handle about 12 times, then one end of it is fastened to a small Loaded Hook and the other end to the Cord on the bucket.

A Curved Strip is pivoted by a  $\frac{3}{8}$ " Bolt through one of its ends in the position of Bolt (2), but on the rear side of the model. A 1" Pulley is attached with a  $\frac{3}{8}$ " Bolt to the other end of the Curved Strip to act as a weight. A loop of Cord is fastened through the slotted hole next to the bottom of the Strip, and then passes round the 1" Pulley (3) on the shaft of the Bush Wheel, to act as a brake band. The Cord should be long enough to allow the Strip to lie nearly horizontal. The luffing Cords are attached to two  $2\frac{1}{2}$ " Strips lock-nutted to the jib.

### 2.14 RAILWAY SERVICE CRANE

The bearings (1) are Fishplates bolted to the Flanged Plate and the Flexible Plates respectively. The jib is fastened to two Trunnions (2), which are bolted to the Bush Wheel (3). A 2" Rod is secured in the boss of the Bush Wheel (3). It then passes through a hole in the Flanged Plate, and is held in position by a Spring Clip underneath the Plate.

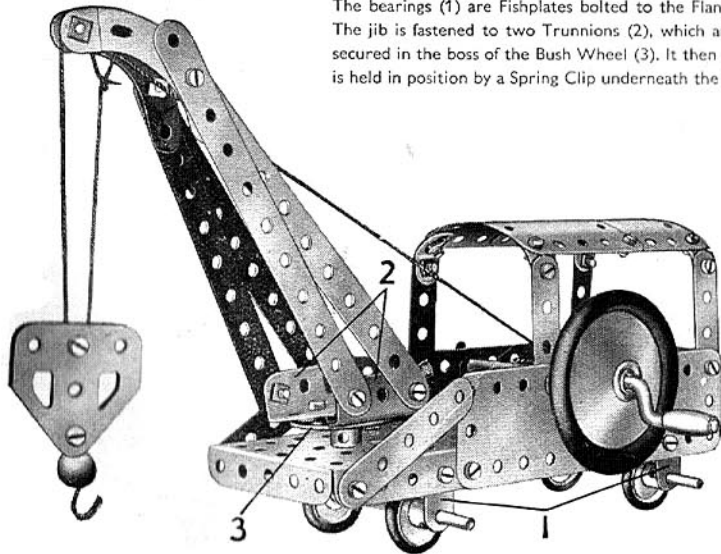

Parts Required

4 of No.	2	2 of No.	48a
6 " "	5	1 " "	52
4 " "	10	1 " "	57c
4 " "	12	2 " "	90a
2 " "	16	3 " "	111c
1 " "	17	2 " "	126
1 " "	19g	2 " "	126a
4 " "	22	4 " "	155
1 " "	24	1 " "	176
2 " "	35	1 " "	187
42 " "	37a	1 " "	188
39 " "	37b	2 " "	189
3 " "	38	1 " "	190
1 " "	40	2 " "	200

### 2.15 LETTER BALANCE

Each side of the model consists of a  $5\frac{1}{2}$ " x  $1\frac{1}{2}$ " Flexible Plate edged by  $5\frac{1}{2}$ " Strips (1). The sides are connected at the top by two  $2\frac{1}{2}$ " x  $\frac{1}{2}$ " Double Angle Strips (2), and a  $2\frac{1}{2}$ " Strip (3) is attached to one of them by Fishplates.

A  $2\frac{1}{2}$ " x  $1\frac{1}{2}$ " Flexible Plate and a  $2\frac{1}{2}$ " x  $2\frac{1}{2}$ " Flexible Plate bolted together are connected to the sides by Angle Brackets, to form the lower part of the front of the casing. A  $2\frac{1}{2}$ " x  $1\frac{1}{2}$ " Flexible Plate (4) is used to fill in the upper section of the front, and it is connected to one of the Double Angle Strips (2) by an Angle Bracket. The casing is attached to the Flanged Plate forming the base by two Angle Brackets and a Trunnion (5).

The pointer consists of a  $2\frac{1}{2}$ " Strip bolted to a Flat Trunnion, and it is gripped between two 1" Pulleys fitted with Rubber Rings. These Pulleys are fixed on a  $3\frac{1}{2}$ " Rod (6) supported in the  $2\frac{1}{2}$ " Strips (7) and (8).

A Rod and Strip Connector is attached to a 2" Rod (9), which is passed through Strip (3) and  $\frac{1}{2}$ " Reversed Angle Bracket. The Rod and Strip Connector is attached by a lock-nutted bolt to a connecting bar (10), made from two  $2\frac{1}{2}$ " Strips overlapped two holes. The lower end of the connecting bar is lock-nutted to a Bush Wheel, which is loose on a  $3\frac{1}{2}$ " Rod (11).

A length of Cord from the connecting bar is passed several times round the

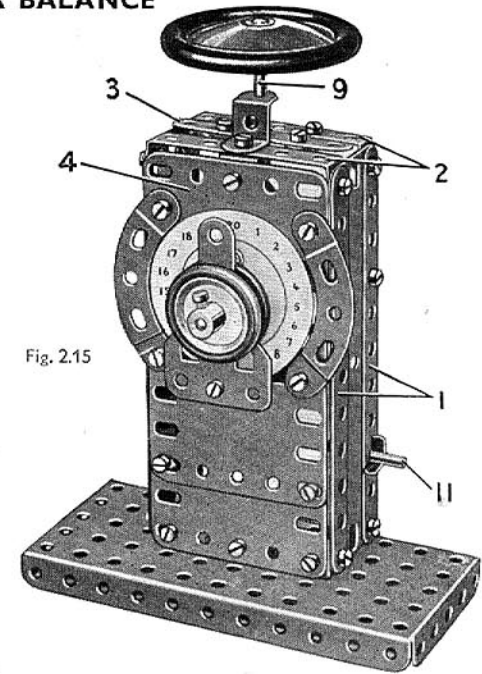
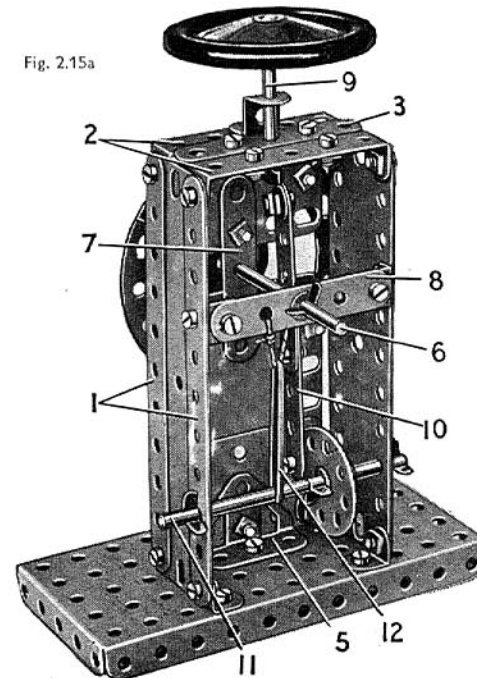

Fig. 2.15

Fig. 2.15a



Rod (6) and is tied to a Driving Band (12). The Driving Band is looped round the Rod (11).

A piece of cardboard is marked to form an indicator dial, which is then bolted to the front of the model.

Parts Required

4 of No.	2	1 of No.	52
6 " "	5	2 " "	90a
2 " "	10	1 " "	111c
7 " "	12	1 " "	125
2 " "	16	1 " "	126
1 " "	17	1 " "	126a
2 " "	22	2 " "	155
1 " "	24	1 " "	186
4 " "	35	1 " "	187
36 " "	37a	1 " "	188
33 " "	37b	2 " "	189
2 " "	38	2 " "	190
1 " "	40	1 " "	212
2 " "	48a		

### 2.16 RACING CAR

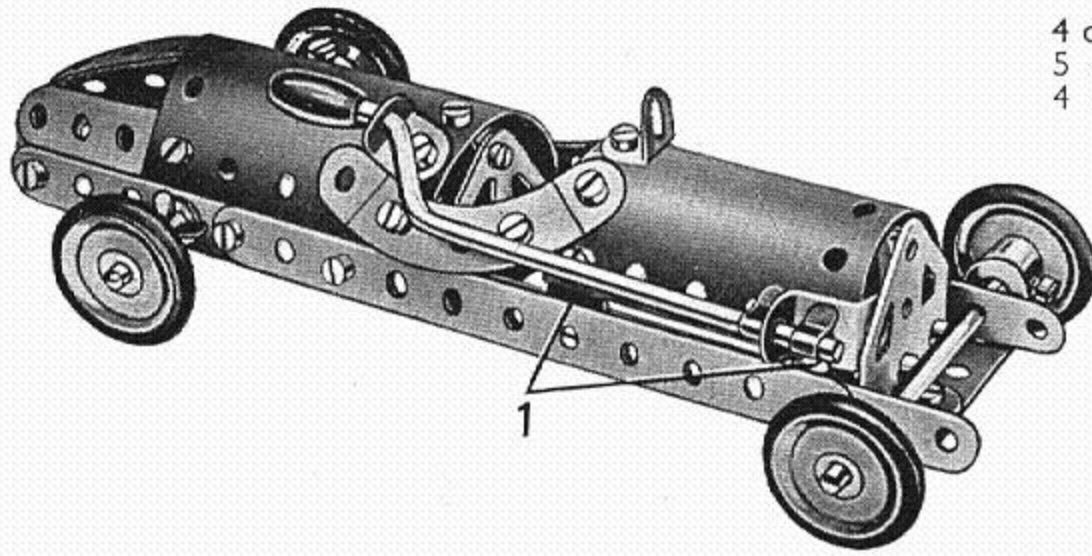

Parts Required		
4 of No. 2	8 of No. 12	1 of No. 48a
5 " " 5	2 " " 16	2 " " 90a
4 " " 10	1 " " 19g	1 " " 125
	4 " " 22	1 " " 126
	4 " " 35	1 " " 126a
	31 " " 37a	4 " " 155
	30 " " 37b	1 " " 199
	2 " " 38	1 " " 200

The Strips forming the side members of the chassis are fixed at the rear to a 'U'-shaped bracket made from two Angle Brackets bolted together. The tapered tail is formed by three 2½" Strips slightly curved.

The radiator and the bonnet are fastened to the chassis by Fishplates (1) at each side of the model.

### 2.17 HORSE AND TIPPING CART

The chassis of the cart is made from two 5½" Strips attached at each end to a Trunnion by means of Angle Brackets. The rear axle revolves in a Double Angle Strip bolted to the rear Trunnion, and the front axle in a similar Double Angle Strip *lock-nutted* to the other Trunnion so that it is free to pivot.

The tipping body (1) is made by bolting 5½" x 1½" Flexible Plates to the sides of a Flanged Plate. The body pivots about a 2" Rod, which passes through two Angle Brackets secured to the Flanged Plate and also through two Fishplates bolted to the chassis. A length of Cord (2) tied to the rear of the Flanged Plate is fastened to a Cord Anchoring Spring on the Crank Handle (3).

The body of the horse is formed by a 'U'-section Curved Plate. Four 2½" Strips represent the legs, the front pair supporting a Bush Wheel on a 2" Rod.

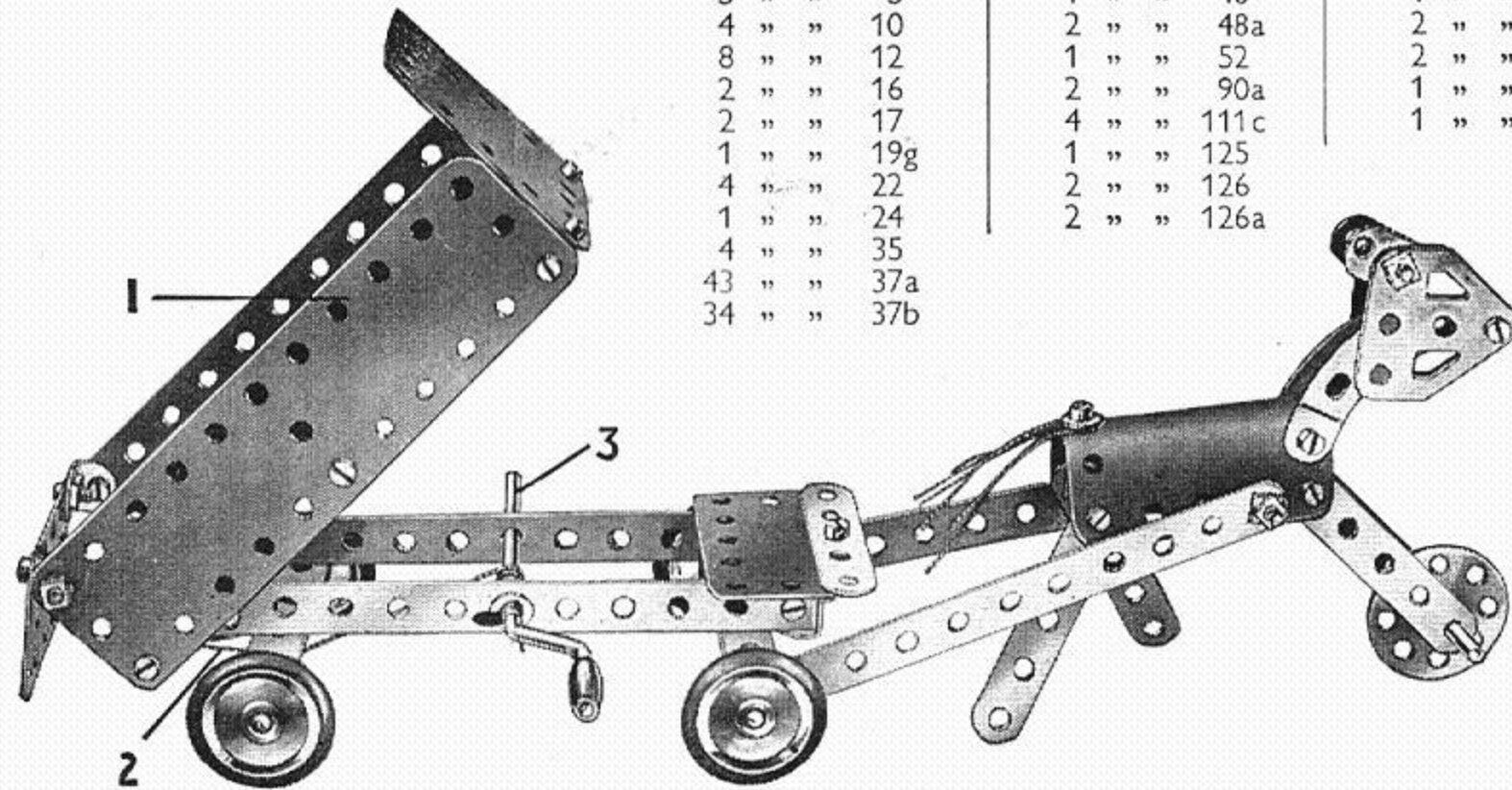

Parts Required		
4 of No. 2	4 of No. 38	4 of No. 155
5 " " 5	1 " " 40	1 " " 176
4 " " 10	2 " " 48a	2 " " 188
8 " " 12	1 " " 52	2 " " 189
2 " " 16	2 " " 90a	1 " " 190
2 " " 17	4 " " 111c	1 " " 199
1 " " 19g	1 " " 125	
4 " " 22	2 " " 126	
1 " " 24	2 " " 126a	
4 " " 35		
43 " " 37a		
34 " " 37b		

### 2.18 ELECTRIC DELIVERY VAN

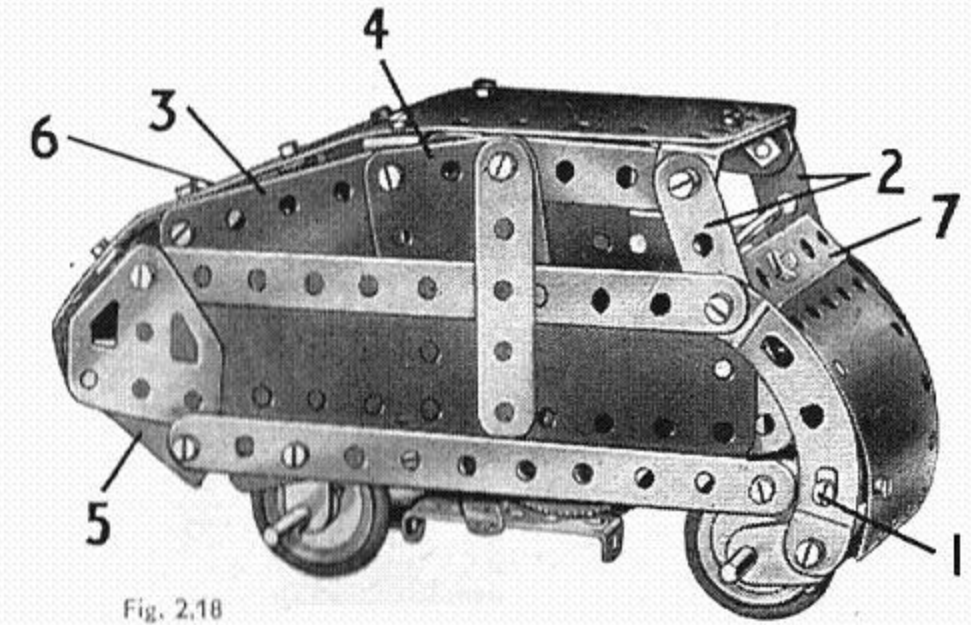

Fig. 2.18

The Curved Strips at the front are fixed by bolts (1) at each side to the Flanged Plate, and the 1½" radius Curved Plate is fixed by one bolt to the front end of the Flanged Plate. The upper ends of the Curved Strips support a 5½" Strip, a 5½" x 1½" Flexible Plate, and a 2½" Strip (2). The Strips (2) are connected by a Double Angle Strip, to which is bolted a 4½" x 2½" Flexible Plate forming part of the roof.

Part of each side of the model is filled in by a 2½" x 2½" Flexible Plate (3) and a 2½" x 1½" Flexible Plate (4). The tail is formed by a 'U'-section Curved Plate attached to Trunnions (5), and this is joined to the roof by a 1½" radius Curved Plate (6).

The rear axle is a 3½" Rod mounted in two Fishplates. A ½" Pulley on this Rod is connected by a Driving Band to a Magic Motor bolted underneath the Flanged Plate. The front axle is mounted in two Fishplates bolted to the Curved Strips.

The steering wheel is represented by a Bush Wheel, which is fastened to an Angle Bracket by a ⅜" Bolt, the Angle Bracket being secured to the Double Angle Strip (7).

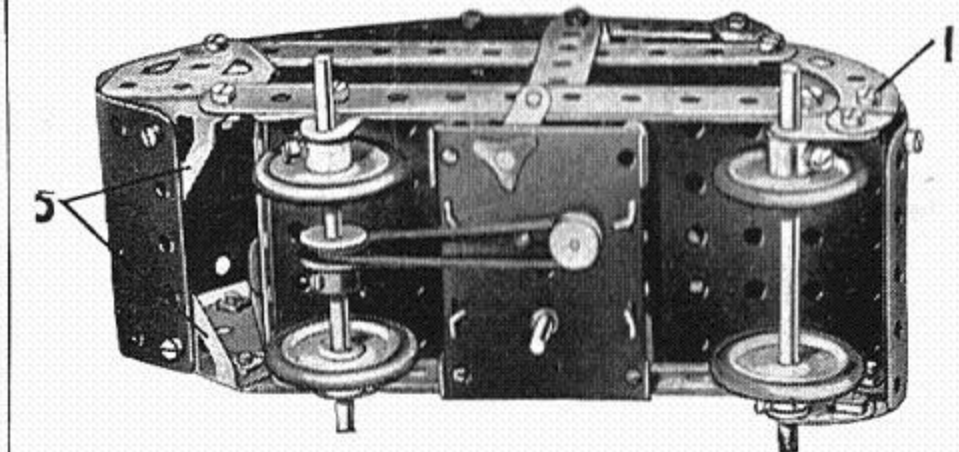

Fig. 2.18a

#### Parts Required

4 of No. 2	
6 " " 5	
4 " " 10	
5 " " 12	
2 " " 16	
4 " " 22	
1 " " 24	
38 " " 37a	
37 " " 37b	
2 " " 38	
2 " " 48a	
1 " " 52	
2 " " 90a	
1 " " 111c	
2 " " 126	
2 " " 126a	
4 " " 155	
2 " " 188	
2 " " 189	
2 " " 190	
1 " " 191	
1 " " 199	
2 " " 200	

1 Magic Motor  
(not included in Outfit)



### 2.19 FORK LIFT TRUCK

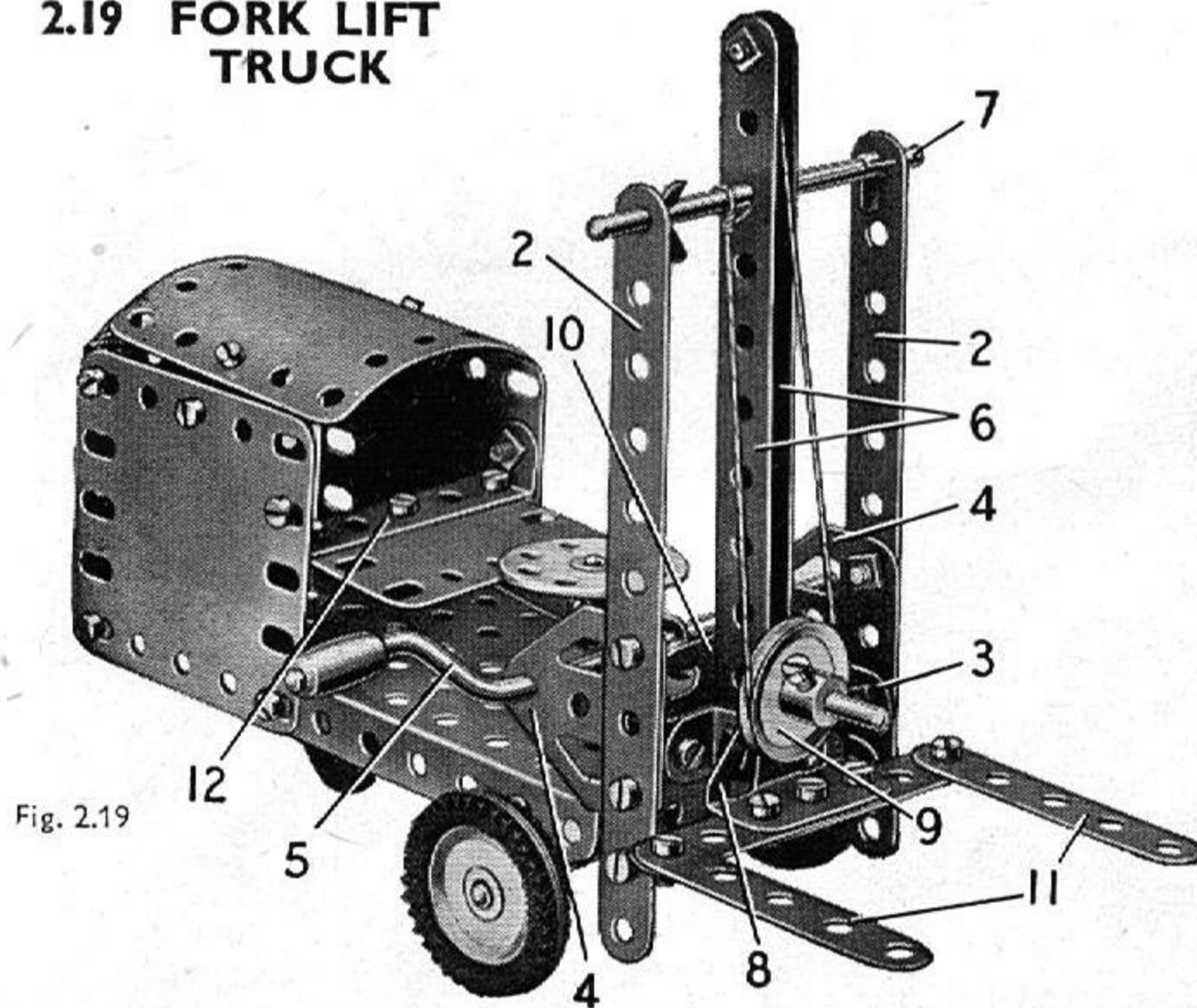

Fig. 2.19

The base of the truck is a  $5\frac{1}{2} \times 2\frac{1}{2}$  Flanged Plate, and the front wheels are fixed on a  $3\frac{1}{2}$  Rod supported in Fishplates bolted to the sides of the base. The single rear wheel is held by its set-screw on a  $\frac{3}{8}$  Bolt passed through a Trunnion (1). The Trunnion is connected to the base by a *lock-nutted*  $\frac{3}{8}$  Bolt, so that it can be turned to steer the model.

Two  $5\frac{1}{2}$  Strips (2) are attached to Angle Brackets fixed to the front flange of the Flanged Plate, and they are connected together by a  $2\frac{1}{2} \times \frac{1}{2}$  Double Angle Strip (3). The Bolts holding the Double Angle Strip serve also to fix the lower corner of a Flat Trunnion (4) to each of the Strips (2), and a Crank Handle (5) is supported in the Flat Trunnions.

Two  $5\frac{1}{2}$  Strips (6) are attached to Double Angle Strip (3) by Angle Brackets, and they are supported at their upper ends by a  $3\frac{1}{2}$  Rod (7) held by Spring Clips in the top holes of Strips (2).

Two  $2\frac{1}{2}$  Strips overlapped three holes are bolted to a Trunnion (8), and a 2" Rod fitted with a 1" Pulley (9) is passed through the Trunnion and between the Strips (6). The Rod is held in place in the Strips by a Fishplate (10) and a Spring Clip. The lifting forks are  $2\frac{1}{2}$  Strips (11) and they are bolted to the ends of the Strips fixed to Trunnion (8).

A length of Cord tied to the Crank Handle is passed over Rod (7) and round Pulley (9), and is tied finally to Rod (7).

The sides of the truck body consist of  $2\frac{1}{2} \times 2\frac{1}{2}$  Flexible Plates connected by a  $2\frac{1}{2} \times \frac{1}{2}$  Double Angle Strip (12). The back is a straightened  $1\frac{1}{2}$  radius Curved Plate and it is connected to the sides by Angle Brackets. The top also is a  $1\frac{1}{2}$  radius Curved Plate and the Angle Brackets used to fix it to the sides are opened out slightly to allow for the bend in the Plate.

The steering wheel is a Bush Wheel fixed on a 2" Rod passed through the Flanged Plate and through a Reversed Angle Bracket held by a Bolt (13). A brake on the Crank Handle is provided by a  $\frac{3}{4}$  Driving Band looped round the Crank Handle and the Reversed Angle Bracket.

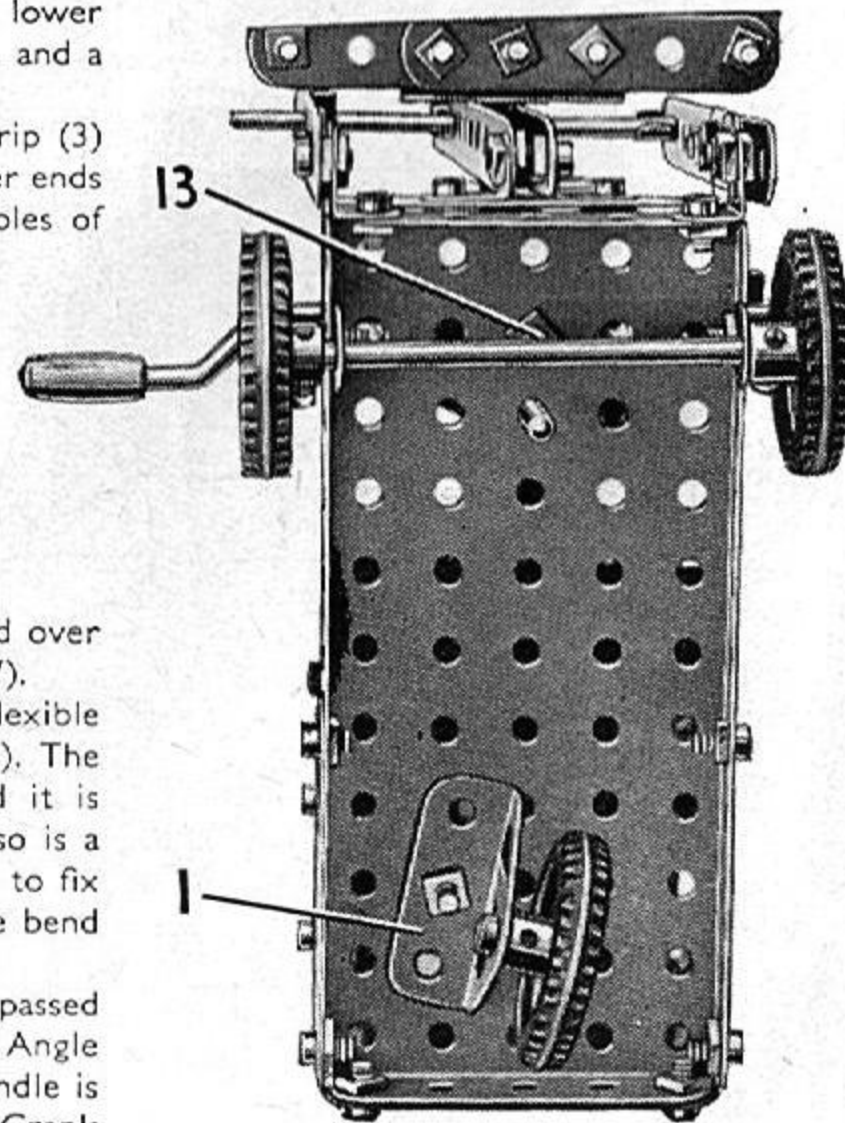

#### Parts Required

4 of No.	2
6 "	5
3 "	10
8 "	12
2 "	16
2 "	17
1 "	19g
4 "	22
1 "	24
4 "	35
43 "	37a
37 "	37b
1 "	38
1 "	40
2 "	48a
1 "	52
1 "	90a
4 "	111c
1 "	125
2 "	126
2 "	126a
3 "	142c
1 "	176
1 "	186
1 "	188
2 "	190
2 "	200

Fig. 2.19a

### 2.20 FLOATING CRANE

The jib consists of  $5\frac{1}{2}$  Strips and  $2\frac{1}{2}$  Strips. At its upper end these are joined by Angle Brackets, and at its lower end by Trunnions. Each side of the lower part of the crane consists of  $2\frac{1}{2}$  Strips and a  $2\frac{1}{2}$  stepped Curved Strip, the two sides being connected by a  $2\frac{1}{2} \times \frac{1}{2}$  Double Angle Strip. The jib is pivoted to this structure by means of a  $3\frac{1}{2}$  Rod, which carries at each end a 1" Pulley. The Cord (1) fitted with a Loaded Hook, is passed over a 2" Rod held in place in the jib by means of Spring Clips, and it is then wound around the Crank Handle.

The Cord (2) passes over a Rod held in the jib by a Cord Anchoring Spring, and is then wound round the Rod that forms the pivot for the jib. A third Cord is tied to a Bolt fastened in the two Trunnions at the base of the jib, and is wound round Rod (3). This Cord controls the luffing motion of the crane. A  $\frac{3}{4}$  Bolt passes through the Flanged Plate and is held by a set-screw in the boss of the Bush Wheel to which the jib is fastened. The Bush Wheel is bolted to the Double Angle Strip below the Rod (3). The roof of the cabin is bolted to a  $\frac{1}{2}$  Reversed Angle Bracket fixed to the Flanged Plate.

#### Parts Required

4 of No.	2	2 of No.	48a
6 "	5	1 "	52
3 "	10	1 "	57c
8 "	12	2 "	90a
2 "	16	4 "	111c
2 "	17	1 "	125
1 "	19g	2 "	126
4 "	22	1 "	126a
1 "	24	1 "	176
4 "	35	2 "	188
33 "	37a	2 "	189
29 "	37b	1 "	199
4 "	38	1 "	200
1 "	40		

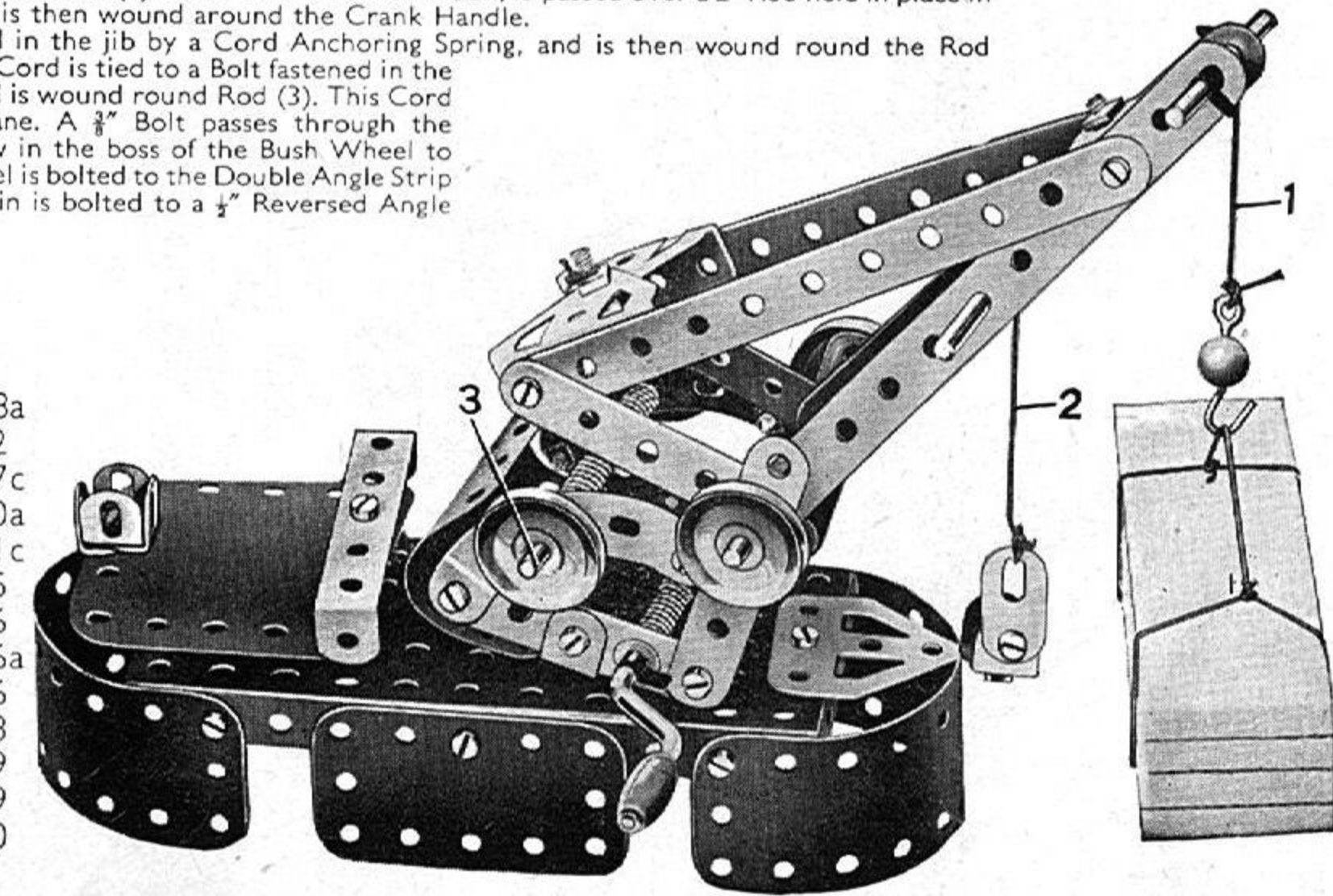

### 2.21 GAS ENGINE

The bearings for the Rod representing the crankshaft (1) are a Flat Trunnion and a Trunnion. The crankshaft carries a Road Wheel and a 1" Pulley at one end, a second 1" Pulley between the bearings, and a Bush Wheel at its other end.

The connecting rod (2) is made from two  $2\frac{1}{2}$  Strips overlapped two holes, and it is fastened to the Bush Wheel and to a Rod and Strip Connector (3) by *lock-nutted* Bolts (4). The Rod (5) is held in the Rod and Strip Connector. An Angle Bracket (6), carrying a Fishplate, is bolted inside the cylinder, and a similar arrangement is fitted at the other end. These form supports for the Rod (5).

The model is operated by the Crank Handle (9), which carries also a 1" Pulley connected to one of the 1" Pulleys on the crankshaft by a belt of Cord. A second Cord drives the governor (7), which is mounted on a  $3\frac{1}{2}$  Rod journalled in the  $5\frac{1}{2} \times 2\frac{1}{2}$  Flanged Plate and a Reversed Angle Bracket (8). The governor arms are each made from an Angle Bracket and a Fishplate. The arms are passed over the  $3\frac{1}{2}$  Rod and are clamped between a Spring Clip and a Cord Anchoring Spring.

#### Parts Required

3 of No.	5	4 of No.	38	
4 "	10	1 "	40	
7 "	12	2 "	48a	
2 "	16	1 "	52	
1 "	17	1 "	111c	
1 "	19g	1 "	125	
4 "	22	1 "	126	2 of No. 188
1 "	24	1 "	126a	2 " " 189
2 "	35	1 "	155	1 " " 190
35 "	37a	1 "	176	2 " " 200
31 "	37b	1 "	187	1 " " 212

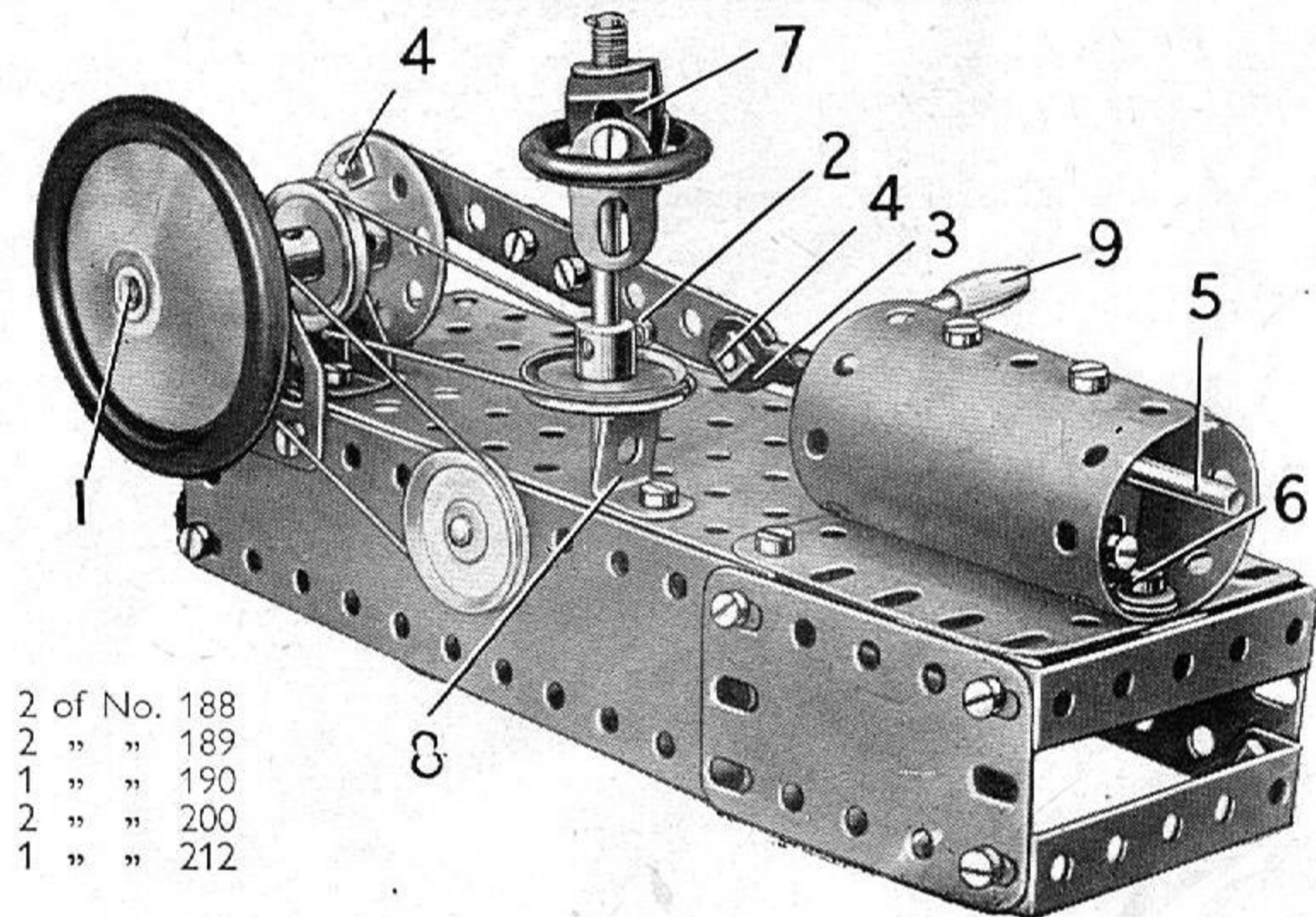

### 2.22 CRANE TRUCK

The base of the model is a  $5\frac{1}{2}'' \times 2\frac{1}{2}''$  Flanged Plate, fitted at one end with two  $2\frac{1}{2}'' \times \frac{1}{2}''$  Double Angle Strips (1), and a  $2\frac{1}{2}'' \times 2\frac{1}{2}''$  Flexible Plate. The Double Angle Strips are connected across their upper ends by a  $2\frac{1}{2}''$  Strip, and their lower lugs support a  $2\frac{1}{2}'' \times 1\frac{1}{2}''$  Flexible Plate that forms the driving platform. The double wheels are fixed on a  $3\frac{1}{2}''$  Rod mounted in Fishplates bolted to the flanges of the Flanged Plate. The single wheel is held by its set-screw on a  $\frac{3}{8}''$  Bolt passed through a Trunnion. The Trunnion is connected to the Flanged Plate by a lock-nutted  $\frac{3}{8}''$  Bolt (3).

The crane is assembled on a Bush Wheel (4). A 2" Rod is fixed in the Bush Wheel, and is passed through the Flanged Plate and through a  $\frac{1}{2}''$  Reversed Angle Bracket bolted underneath the Plate. A Cord Anchoring Spring is used to hold the Rod in place.

Four  $2\frac{1}{2}''$  Strips (6) are attached to Angle Brackets bolted to the Bush Wheel, and the Strips on each side are connected together by a Fishplate (7). A Rod (8) is passed through the upper holes of one pair of  $2\frac{1}{2}''$  Strips, and two Flat Trunnions and two  $5\frac{1}{2}''$  Strips (9) are pivoted on the Rod. The Strips (9) are connected to the Flat Trunnions by further  $5\frac{1}{2}''$  Strips (10), and Strips (10) are joined together at their outer ends by a lock-nutted  $\frac{3}{8}''$  Bolt (11). The Flat Trunnions are connected together by a  $2\frac{1}{2}''$  Strip fixed to Angle Brackets.

A length of Cord tied to the Crank Handle is passed over Rod (8) and the  $\frac{3}{8}''$  Bolt (11), and is fitted with a small Loaded Hook.

The Rod (12) carries a 1" Pulley fitted with an Angle Bracket and a  $\frac{3}{8}''$  Bolt that serves as the operating handle. A Bolt fitted with a nut is passed through the slotted hole of the Angle Bracket and is screwed into a hole in the boss of the Pulley. The nut is then tightened to fix the Angle Bracket firmly in place. A length of Cord tied to Rod (12) is passed under the Crank Handle and is fixed to the rear of the jib. A brake on Rod (12) is made by bolting an Angle Bracket (13) to one of the  $2\frac{1}{2}''$  Strips (6). A Spring Clip on Rod (12) is positioned so that its lugs rest against the top face of the Angle Bracket.

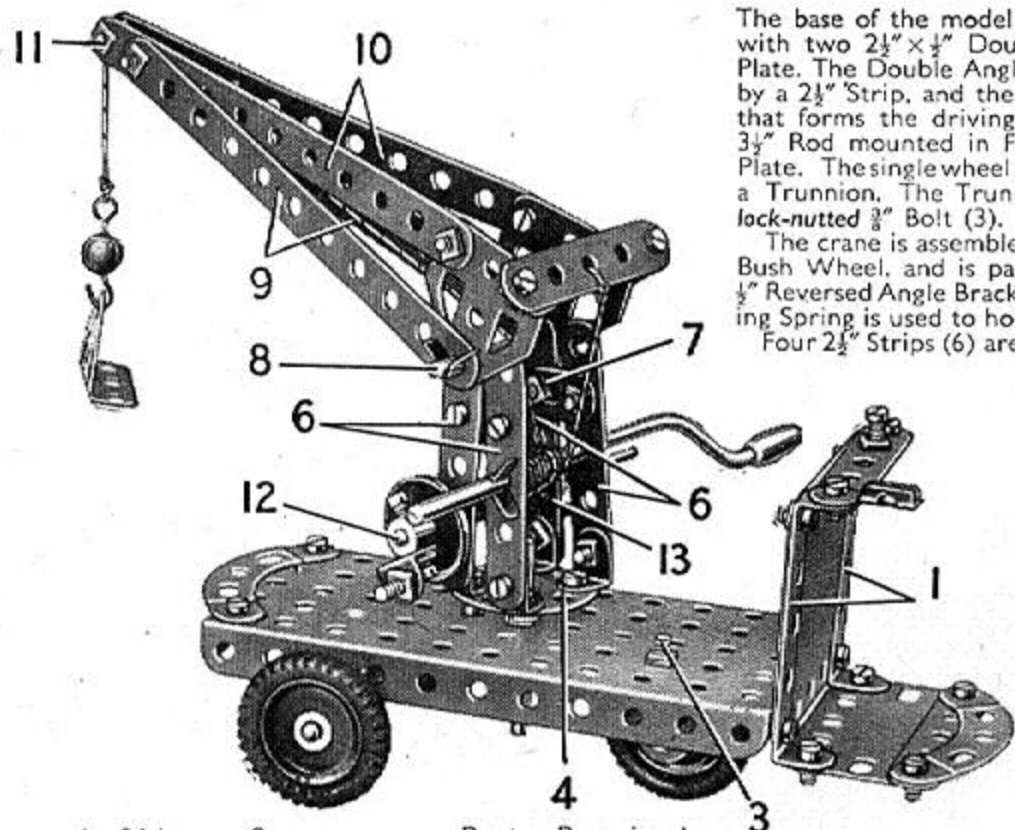

Parts Required			
4 of No.	2	40 of No.	37a
6 " "	5	34 " "	37b
4 " "	10	1 " "	40
8 " "	12	2 " "	48a
2 " "	16	1 " "	52
2 " "	17	1 " "	57c
1 " "	19g	2 " "	90a
4 " "	22	4 " "	111c
1 " "	24	1 of No.	125
4 " "	35	2 " "	126
		2 " "	126a
		3 " "	142c
		1 " "	176
		1 " "	188
		1 " "	190
		1 " "	212

### 2.23 PETROL-ENGINEED STATION TRACTOR

Each side of the tractor unit consists of a  $2\frac{1}{2}'' \times 2\frac{1}{2}''$  Flexible Plate bolted to a Double Angle Strip (1). A  $4\frac{1}{2}'' \times 2\frac{1}{2}''$  Flexible Plate is curved and attached to each side to form the top. The front and rear of the unit are each filled by a  $2\frac{1}{2}'' \times 1\frac{1}{2}''$  Flexible Plate and a Flat Trunnion. The front axle is mounted in two Fishplates.

The load carrier is made by bolting  $5\frac{1}{2}'' \times 1\frac{1}{2}''$  Flexible Plates to the sides of a Flanged Plate. The rear axle is carried in two Curved Strips, which are attached to  $2\frac{1}{2}''$  Strips and secured to the Flanged Plate by Angle Brackets.

The tractor unit and the load carrier are connected by a Trunnion bolted to the tractor and a  $2\frac{1}{2}''$  Strip (2) secured to the base of the load carrier. The  $\frac{3}{8}''$  Bolt (3) is passed through holes in these parts and is fitted with lock-nuts.

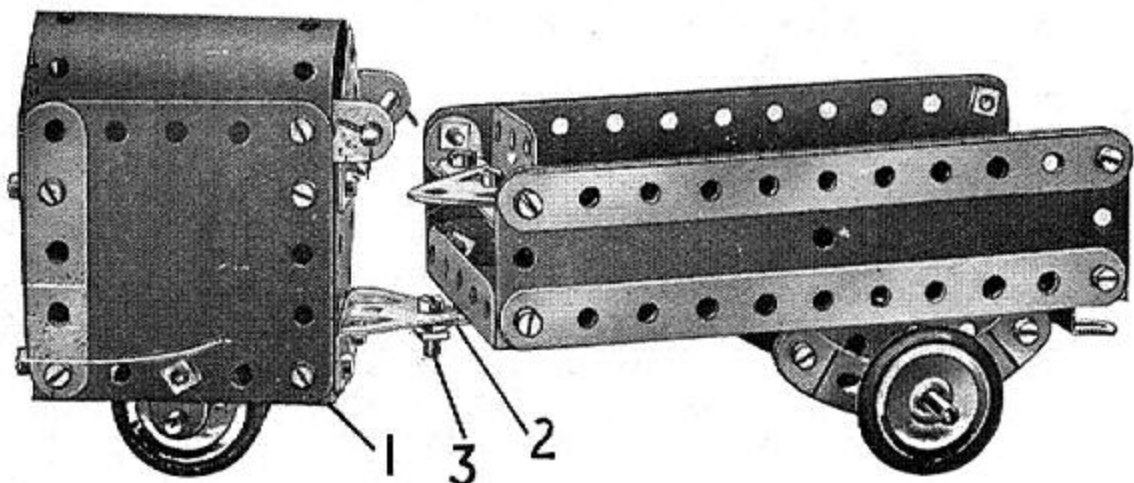

Parts Required	
4 of No.	2
6 " "	5
4 " "	10
8 " "	12
1 " "	16
2 " "	17
4 " "	22
2 " "	35
44 " "	37a
40 " "	37b
4 " "	38
2 " "	48a
1 " "	52
2 " "	90a
3 " "	111c
1 " "	125
2 " "	126
2 " "	126a
4 " "	155
2 " "	188
2 " "	189
2 " "	190
1 " "	191

### 2.24 MOBILE CONCRETE MIXER

#### Parts Required

2 of No.	2	1 of No.	125
5 " "	5	2 " "	126
4 " "	10	2 " "	126a
7 " "	12	4 " "	155
2 " "	16	1 " "	187
1 " "	17	2 " "	188
4 " "	22	2 " "	189
1 " "	24	1 " "	190
1 " "	35	1 " "	199
46 " "	37a	1 " "	200
40 " "	37b	1 Magic Motor (not included in Outfit)	
3 " "	38		
2 " "	48a		
1 " "	52		
2 " "	90a		
4 " "	111c		

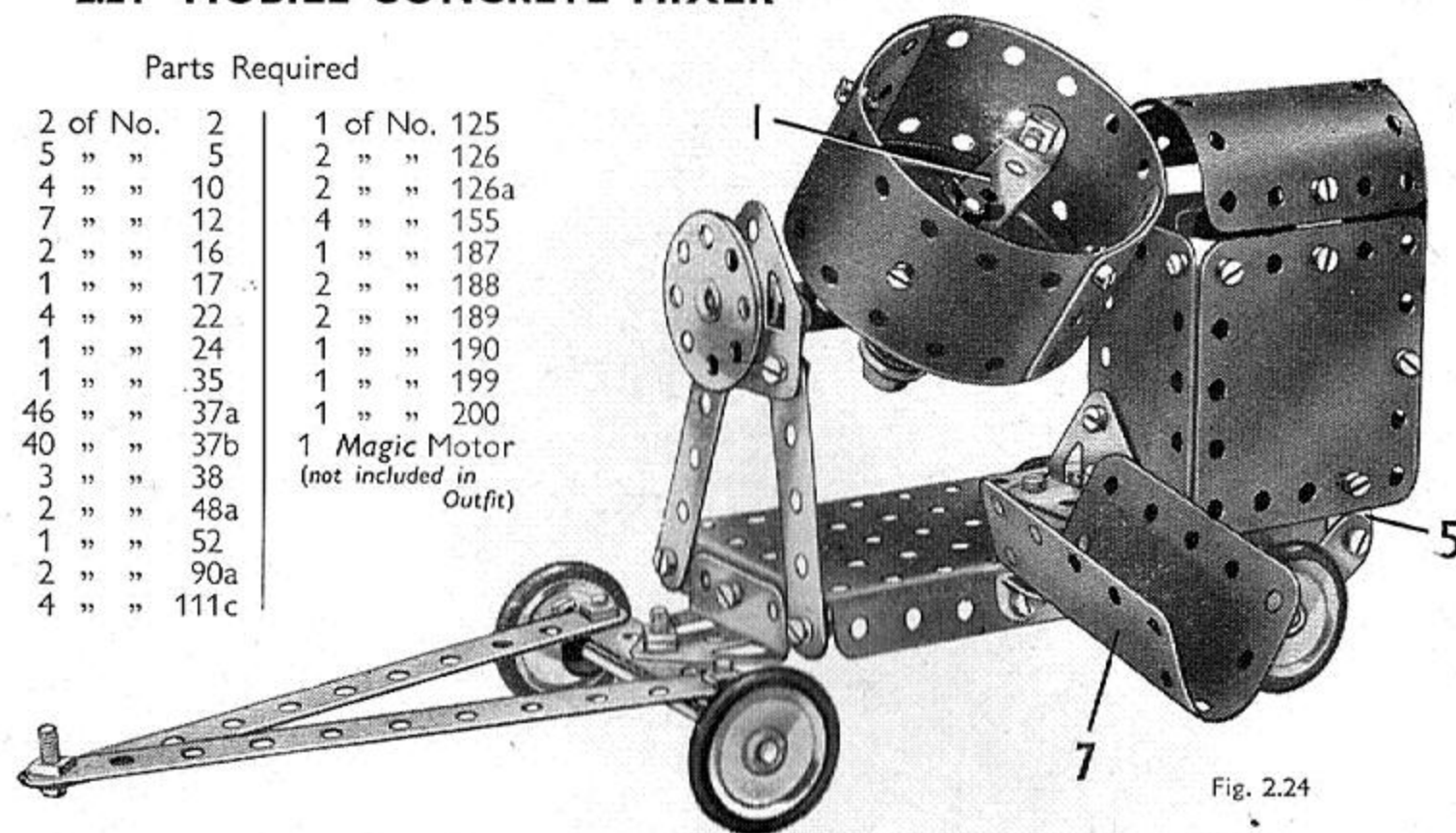

Fig. 2.24

The model is built up on a Flanged Plate. The front axle is mounted in a Double Angle Strip lock-nutted to a Trunnion bolted to the Plate. The rear axle runs in two Curved Strips.

The rotating drum is made by bending two  $5\frac{1}{2}'' \times 1\frac{1}{2}''$  Flexible Plates around a Road Wheel and a Double Angle Strip (1). The Road Wheel is fixed on a 2" Rod mounted in the centre hole of a built-up strip and a Reversed Angle Bracket (6). The built-up strip consists of two  $2\frac{1}{2}''$  Strips overlapped three holes, and an Angle Bracket is bolted to each end. One Angle Bracket is lock-nutted to the top hole of a  $2\frac{1}{2}''$  Strip (2) and a  $2\frac{1}{2}'' \times 1\frac{1}{2}''$  Flexible Plate forming part of the engine housing. The Strip (2) is attached to the base by a Trunnion.

The front support for the drum is provided by a Flat Trunnion attached to two  $2\frac{1}{2}''$  Strips. A  $\frac{3}{8}''$  Bolt is fixed to an Angle Bracket (3), and passes through the Trunnion. A Bush Wheel is fixed to the shank of the Bolt and is used for tipping the contents of the drum into the discharge chute (7).

The Magic Motor is fastened to the base by a Fishplate and two Angle Brackets. A  $2\frac{1}{2}'' \times 1\frac{1}{2}''$  Flexible Plate (4) is bolted to the flanges of the Motor, and a  $2\frac{1}{2}'' \times 2\frac{1}{2}''$  Flexible Plate is secured to the base by a Fishplate (5). The top of the engine housing is formed by a Curved Plate.

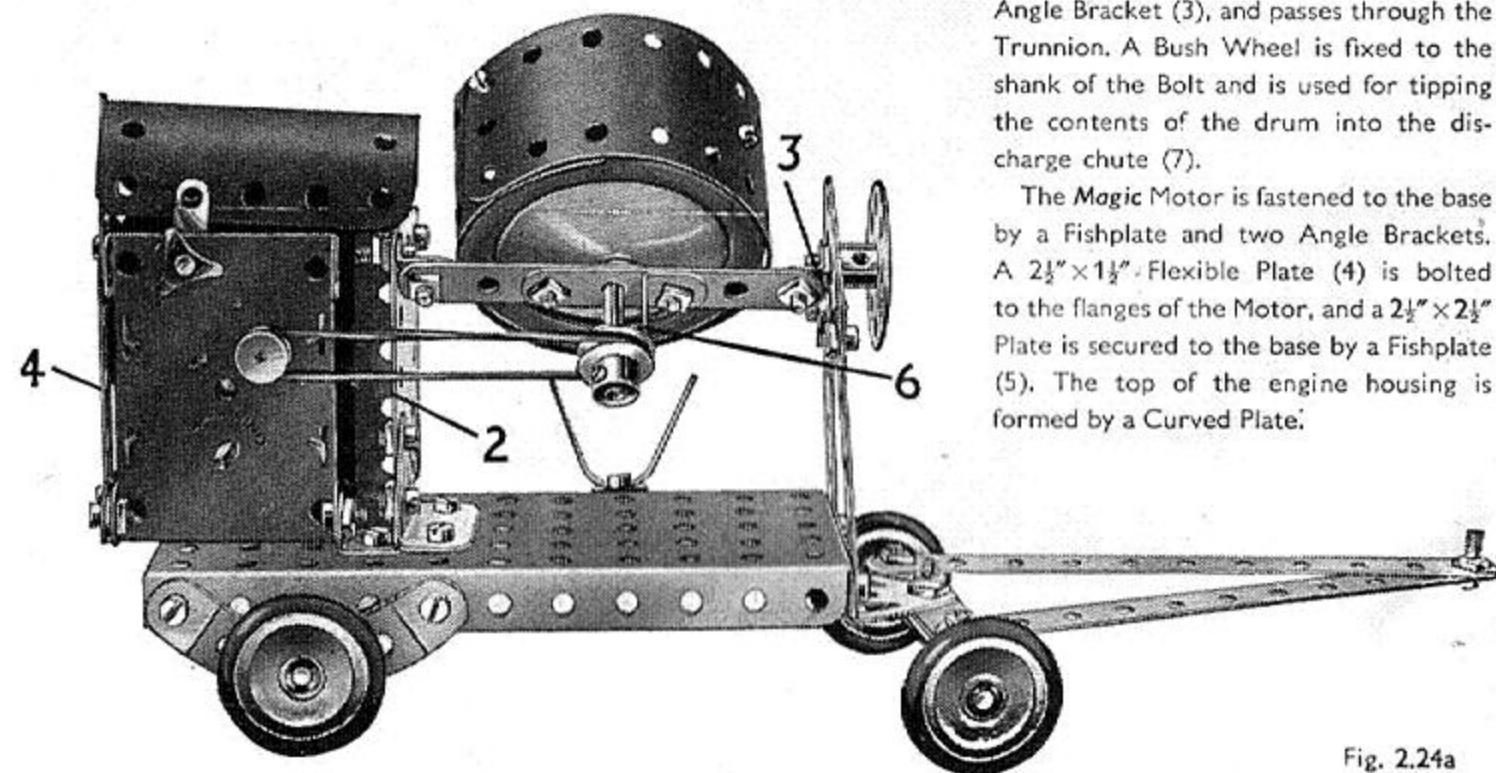

Fig. 2.24a

### 2.25 STEAM WAGON

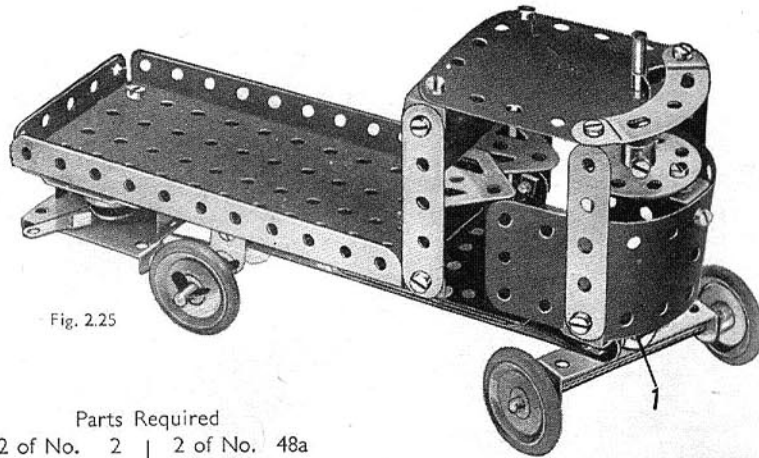

Fig. 2.25

Parts Required

2 of No. 2	2 of No. 48a
6 " " 5	1 " " 52
2 " " 10	1 " " 90a
8 " " 12	1 " " 125
2 " " 16	2 " " 126
1 " " 17	4 " " 155
4 " " 22	1 " " 188
1 " " 24	1 " " 189
4 " " 35	1 " " 190
32 " " 37a	1 " " 200
31 " " 37b	1 Magic Motor
4 " " 38	(not included in Outfit)

The front axle is carried in a  $2\frac{1}{2} \times \frac{1}{2}$ " Double Angle Strip that is pivoted to a Reversed Angle Bracket fastened to a  $2\frac{1}{2}$ " Strip below the cab by the lock-nutted Bolt (1). The Bolt is fastened sufficiently to hold the two front wheels in position when running along. The rear axle is a  $3\frac{1}{2}$ " Rod and it carries a  $\frac{1}{2}$ " fixed Pulley supplied with the Magic Motor.

The rear right-hand 1" Pulley is loose on the Rod, and is retained in place on the axle by Spring Clips.

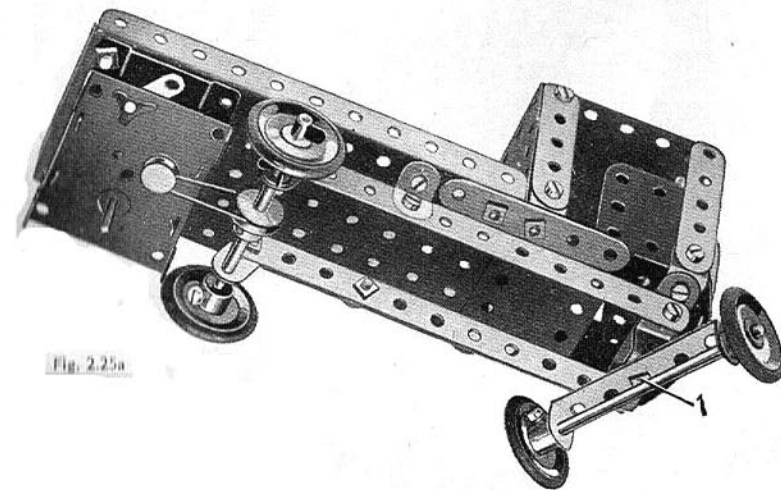
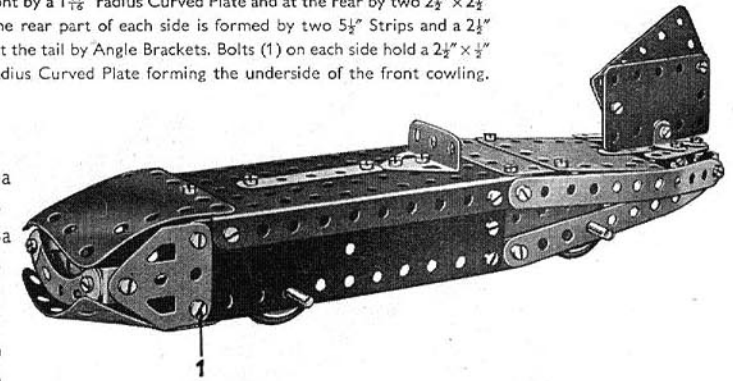

Fig. 2.25a

### 2.26 SPEED CAR

A  $5\frac{1}{2} \times 2\frac{1}{2}$ " Flanged Plate, extended at the front by a  $1\frac{1}{2}$ " radius Curved Plate and at the rear by two  $2\frac{1}{2} \times 2\frac{1}{2}$ " Flexible Plates, forms the top of the car. The rear part of each side is formed by two  $5\frac{1}{2}$ " Strips and a  $2\frac{1}{2}$ " Strip, the former being connected together at the tail by Angle Brackets. Bolts (1) on each side hold a  $2\frac{1}{2} \times \frac{1}{2}$ " Double Angle Strip that carries the  $1\frac{1}{2}$ " radius Curved Plate forming the underside of the front cowling.

Parts Required	
4 of No. 2	1 of No. 52
6 " " 5	2 " " 90a
2 " " 10	1 " " 126
4 " " 12	2 " " 126a
2 " " 16	4 " " 155
4 " " 22	2 " " 188
39 " " 37a	2 " " 189
38 " " 37b	2 " " 190
4 " " 38	2 " " 190
2 " " 48a	2 " " 200



### 2.27 WINDMILL

Parts Required

4 of No. 2	2 of No. 190
6 " " 5	1 " " 199
8 " " 12	2 " " 200
1 " " 16	
1 " " 19g	
4 " " 22	
1 " " 24	
2 " " 35	
32 " " 37a	
32 " " 37b	
3 " " 38	
1 " " 40	
2 " " 48a	
1 " " 52	
2 " " 90a	
2 " " 126	
2 " " 126a	
2 " " 155	
2 " " 188	
2 " " 189	

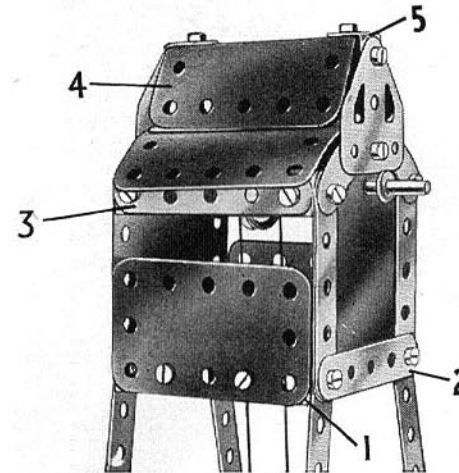

Fig. 2.27a

Four  $5\frac{1}{2}$ " Strips bolted to the Flanged Plate forming the base are connected at their upper ends by Double Angle Strips (1) and  $2\frac{1}{2}$ " Strips (2). A  $2\frac{1}{2} \times 1\frac{1}{2}$ " Flexible Plate is bolted at each side, and the front and rear walls consist of  $2\frac{1}{2} \times 2\frac{1}{2}$ " Flexible Plates. These Plates are connected together by  $2\frac{1}{2}$ " Strips (3) attached by Angle Brackets.

The mill roof is formed by two  $1\frac{1}{2}$ " radius Curved Plates, and is attached by two Angle Brackets to a Curved Strip bolted to each  $2\frac{1}{2} \times 2\frac{1}{2}$ " Flexible Plate. The 'U'-section Curved Plate (4) is secured by Angle Brackets (5) to two Flat Trunnions bolted to the Curved Strips.

The sails are  $5\frac{1}{2} \times 1\frac{1}{2}$ " Flexible Plates clamped between a 1" Pulley, fitted with a Rubber Ring, and a Bush Wheel. These parts are pushed tightly up against the Plates so as to grip them securely. The Pulley and Bush Wheel are fixed on a  $3\frac{1}{2}$ " Rod journalled in the  $2\frac{1}{2} \times 2\frac{1}{2}$ " Flexible Plates. A 1" Pulley on this Rod is connected by a belt of Cord to a similar Pulley on the Crank Handle.

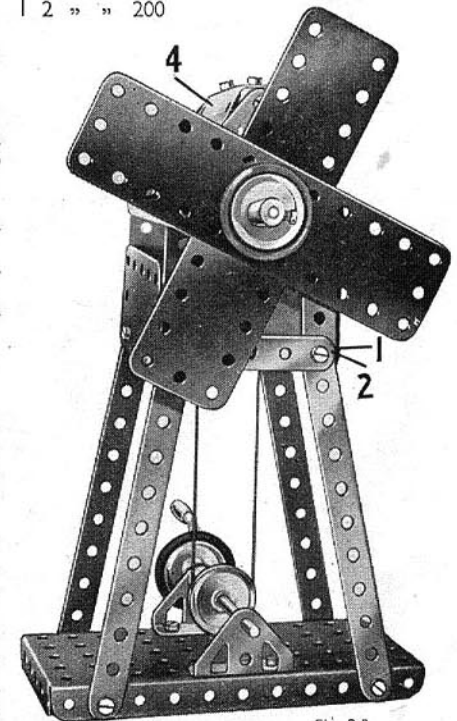

Fig. 2.27

### 2.28 TRAVELLING BREAKDOWN CRANE

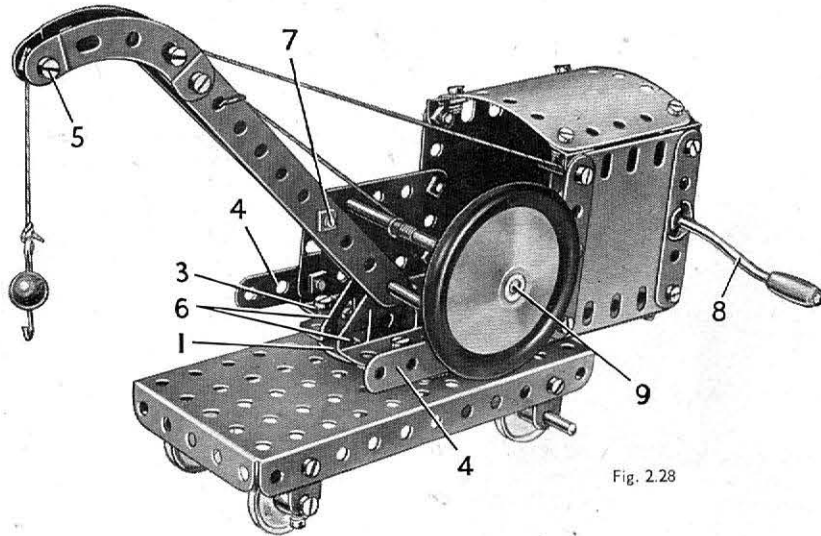

Fig. 2.28

The truck on which the crane is mounted is a  $5\frac{1}{2}'' \times 2\frac{1}{2}''$  Flanged Plate, and two of the wheels are fixed on a  $3\frac{1}{2}''$  Rod supported in Fishplates bolted to the flanges. The other wheels are held by their set-screws on  $\frac{3}{8}''$  Bolts passed through Fishplates also bolted to the flanges of the Flanged Plate.

The cab pivots on a Bush Wheel (1), which has a Rod in its boss. The Rod is passed through the Flanged Plate and through a  $\frac{1}{2}''$  Reversed Angle Bracket (2) bolted underneath the Plate. A Spring Clip is used to hold the Rod in position.

A  $2\frac{1}{2}'' \times \frac{1}{2}''$  Double Angle Strip (3) and a  $4\frac{1}{2}'' \times 2\frac{1}{2}''$  Flexible Plate are bolted to the face of Bush Wheel (1). The Flexible Plate forms the base of the cab, and each of the cab sides is assembled on a  $5\frac{1}{2}''$  Strip (4) fixed to one of the lugs of the Double Angle Strip. The sides are built from  $2\frac{1}{2}'' \times 1\frac{1}{2}''$  and  $2\frac{1}{2}'' \times 2\frac{1}{2}''$  Flexible Plates, and a second Double Angle Strip is bolted between the rear ends of Strips (4). The  $2\frac{1}{2}'' \times 2\frac{1}{2}''$  Flexible Plates are strengthened by  $2\frac{1}{2}''$  Strips, and the roof, a  $1\frac{1}{8}''$  radius Curved Plate, is attached to Angle Brackets. The Angle Brackets are opened out slightly to allow for the bend of the Curved Plate.

The jib is made from two  $5\frac{1}{2}''$  Strips, each extended by a  $2\frac{1}{2}''$  stepped Curved Strip. The Curved Strips are connected by a lock-nutted  $\frac{3}{8}''$  Bolt (5). The jib pivots on a  $2''$  Rod supported in Trunnions (6). These Trunnions are held in place by the same bolts that fix the Double Angle Strip (3) to the Bush Wheel. The  $5\frac{1}{2}''$  Strips of the jib are joined together at the centre by a bolt (7).

A length of Cord tied to the Crank Handle (8) is passed over Bolt (5) and is tied to a small Loaded Hook. A second Cord is fastened to a Cord Anchoring Spring on a  $3\frac{1}{2}''$  Rod (9), and is tied to the jib as shown. The Crank Handle and Rod (9) are held in place by Spring Clips.

The back of the cab is a  $1\frac{1}{8}''$  radius Curved Plate flattened out, and it is attached to the Double Angle Strip fixed between the ends of Strips (4).

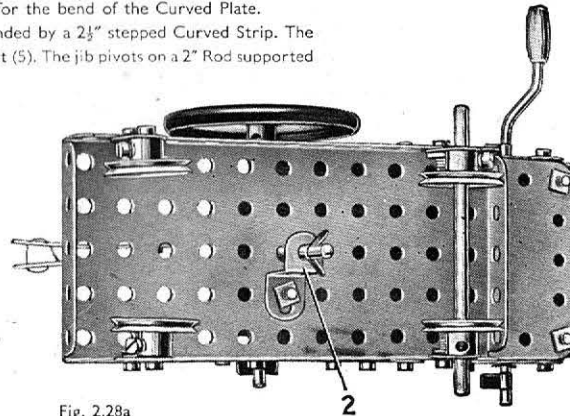

Fig. 2.28a

#### Parts Required

4 of No.	2
6 " "	5
4 " "	10
8 " "	12
2 " "	16
2 " "	17
1 " "	19g
4 " "	22
1 " "	24
4 " "	35
41 " "	37a
37 " "	37b
4 " "	38
1 " "	40
2 " "	48a
1 " "	52
1 " "	57c
2 " "	90a
4 " "	111c
1 " "	125
2 " "	126
1 " "	176
1 " "	187
2 " "	188
2 " "	190
1 " "	191
2 " "	200

### 2.29 AEROPLANE

#### Parts Required

4 of No.	2
6 " "	5
4 " "	10
8 " "	12
1 " "	16
1 " "	17
2 " "	22
1 " "	24
2 " "	35
35 " "	37a
35 " "	37b
2 " "	48a
2 " "	90a
1 " "	125

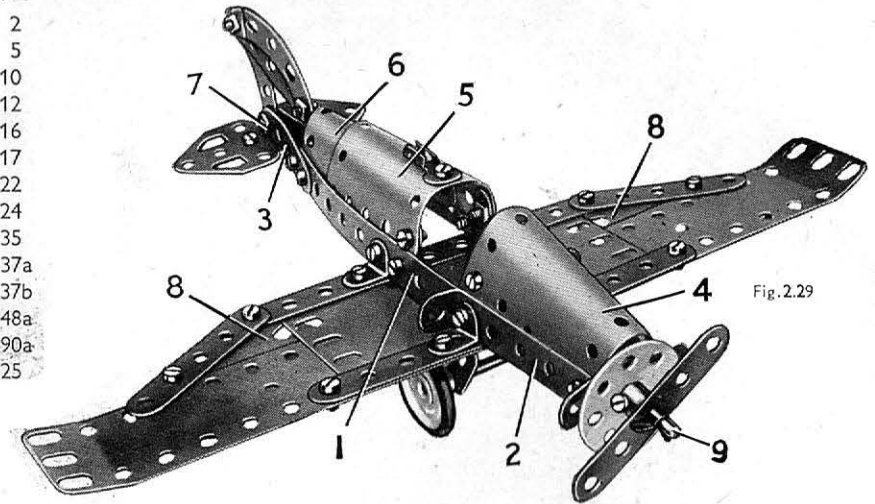

Fig. 2.29

2 of No.	126	2 of No.	189
2 " "	126a	1 " "	191
2 " "	155	1 " "	199
2 " "	188	2 " "	200
		1 " "	212

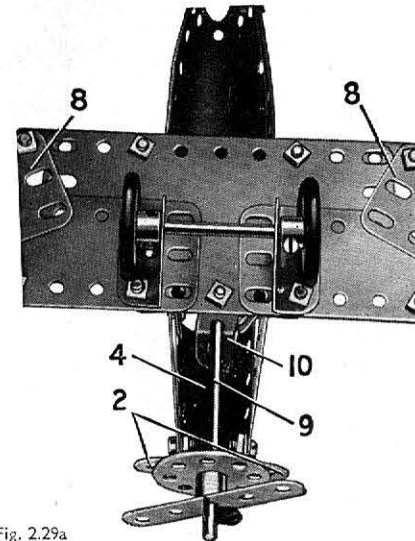

Fig. 2.29a

Each side of the fuselage is assembled on a  $5\frac{1}{2}''$  Strip (1), extended towards the nose by a  $2\frac{1}{2}'' \times \frac{1}{2}''$  Double Angle Strip (2), and at the tail by a  $2\frac{1}{2}''$  Strip (3). Strip (3) overlaps Strip (1) by two holes. The Double Angle Strips (2) are each fitted with an Angle Bracket, and a  $1\frac{1}{8}''$  radius Curved Plate (4) is held by the same bolts. The rear end of the Curved Plate is connected to the Double Angle Strips (2) by Fishplates. A  $1\frac{1}{8}''$  radius Curved Plate (5) is attached to Fishplates bolted to the Strips (1), and a "U"-section Curved Plate (6) is fixed direct to these Strips.

The Strips (3) are joined together at the tail by a  $\frac{3}{8}''$  Bolt (7), which holds also a Curved Strip and an Angle Bracket on each side. The Angle Brackets support Flat Trunnions, and a Curved Strip and a  $2\frac{1}{2}''$  Strip are bolted to the Curved Strip to complete the tailplane.

The centre section of the wings is a  $4\frac{1}{2}'' \times 2\frac{1}{2}''$  Flexible Plate edged by  $5\frac{1}{2}''$  Strips, and extended outward on each side by a  $5\frac{1}{2}'' \times 1\frac{1}{2}''$  Flexible Plate and a  $2\frac{1}{2}'' \times 1\frac{1}{2}''$  Flexible Plate (8). The wings are bolted to Angle Brackets fixed to each side of the fuselage.

A  $3\frac{1}{2}''$  Rod (9) is passed through the Angle Brackets bolted to the Double Angle Strips (2), and through a  $\frac{1}{2}''$  Reversed Angle Bracket (10). A Bush Wheel is fixed on the Rod, and a  $2\frac{1}{2}''$  Strip is freely mounted between the Bush Wheel and a Spring Clip. The wheels are fixed on a  $2''$  Rod supported in Trunnions bolted underneath the wings.

### 2.30 VERTICAL STEAM ENGINE

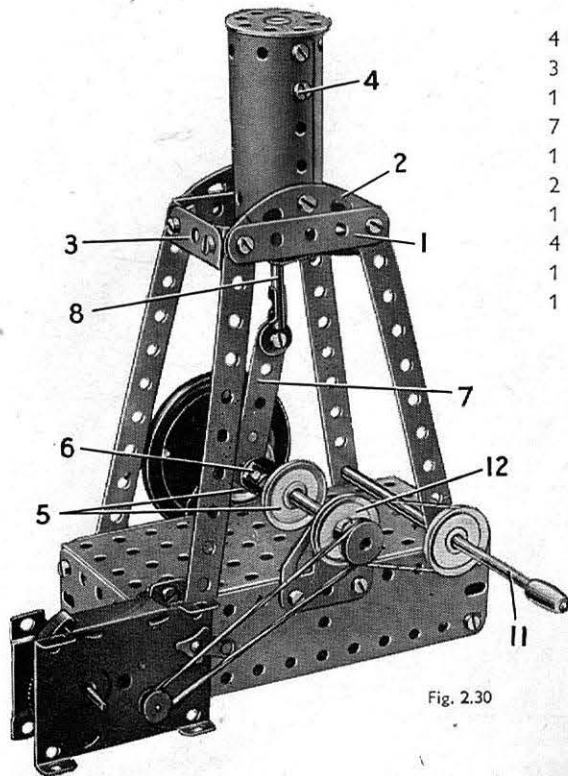

Fig. 2.30

Parts Required	
4 of No. 2	43 of No. 37a
3 " " 5	38 " " 37b
1 " " 10	4 " " 38
7 " " 12	1 " " 40
1 " " 16	2 " " 48a
2 " " 17	1 " " 52
1 " " 19g	2 " " 90a
4 " " 22	4 " " 111c
1 " " 24	1 " " 125
1 " " 35	2 " " 126
	2 of No. 126a
	1 " " 186
	1 " " 187
	2 " " 188
	2 " " 189
	2 " " 200
	1 " " 212
	1 Magic Motor
	(not included in Outfit)

The engine bed or base is a  $5\frac{1}{2} \times 2\frac{1}{2}$ " Flanged Plate, edged by two  $5\frac{1}{2} \times 1\frac{1}{2}$ " and two  $2\frac{1}{2} \times 1\frac{1}{2}$ " Flexible Plates. The lower corners of the Plates are connected to  $2\frac{1}{2} \times \frac{1}{2}$ " Double Angle Strips.

The columns supporting the cylinder consist of four  $5\frac{1}{2}$ " Strips bolted to the base. The upper ends of the Strips on each side are connected by a  $2\frac{1}{2}$ " Strip (1) and a Curved Strip (2), and two Trunnions (3) are attached to them by Angle Brackets.

The cylinder consists of two  $1\frac{1}{8}$ " radius Curved Plates, and is bolted to the Curved Strips (2). It is capped by a Bush Wheel, which is connected by a Bolt, screwed into its boss, to a  $\frac{1}{2}$ " Reversed Angle Bracket. The Reversed Angle Bracket is attached to the cylinder by a Bolt (4).

The crankshaft is assembled from two 2" Rods, each fitted at its inner end with a 1" Pulley (5). An Angle Bracket is fixed to the boss of each Pulley by a Bolt fitted with a nut. The Bolt is passed through the slotted hole of the Angle Bracket and is screwed into one of the threaded holes in the boss of the Pulley. The nut is then tightened to fix the Angle Bracket in place.

Each 2" Rod is supported in a Flat Trunnion, and the Angle Brackets on the Pulleys are connected by a  $\frac{3}{8}$ " Bolt (6). The Bolt is passed through one Angle Bracket and is held firmly by a nut. A  $2\frac{1}{2}$ " Strip (7) is slipped over the Bolt, which is then gripped tightly in the second Angle Bracket by two nuts, leaving Strip (7) freely pivoted.

The upper end of Strip (7) is lock-nutted to a Rod and Strip Connector on a  $3\frac{1}{2}$ " Rod (8). Rod (8) is passed through a Fishplate (9), and through a built-up reversed angle bracket (10) made from two Angle Brackets bolted together.

A 1" Pulley on the Crank Handle (11) drives a 1" Pulley (12) on the crankshaft through a Cord Belt.

The model can be fitted with a Magic Motor bolted direct to one of the lower corners of the base, and attached to the Flanged Plate by an Angle Bracket. The Motor pulley is connected to a  $\frac{1}{2}$ " Pulley on the crankshaft by a Driving Band. This  $\frac{1}{2}$ " Pulley is supplied with the Magic Motor.

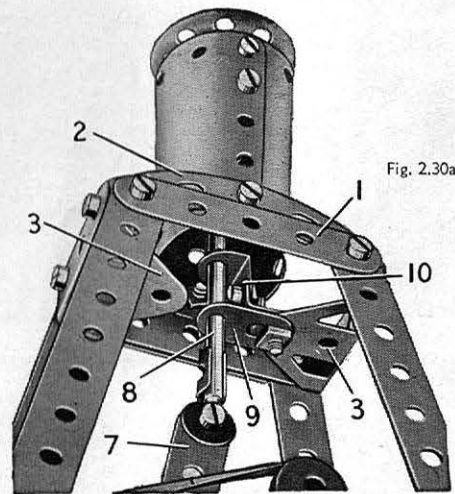

Fig. 2.30a

### 2.31 TRACTOR

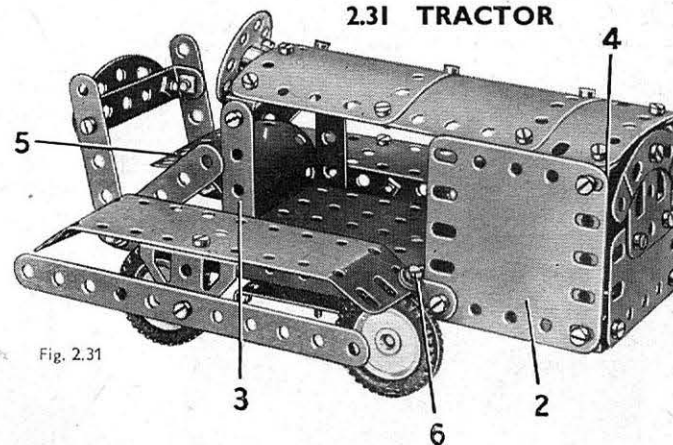

Fig. 2.31

The chassis of the model is made by bolting a  $5\frac{1}{2}$ " Strip (1) to each side of a  $5\frac{1}{2} \times 2\frac{1}{2}$ " Flanged Plate. The Strips overhang the Flanged Plate towards the rear by four holes. The wheels are fixed on  $3\frac{1}{2}$ " Rods supported in Fishplates as shown in Fig. 2.31a, and the rear axle is fitted with a  $\frac{1}{2}$ " Pulley that is connected by a Driving Band to the pulley of a Magic Motor. The Motor is bolted between the flanges of the Flanged Plate.

The bonnet on each side consists of a  $2\frac{1}{2} \times 2\frac{1}{2}$ " Flexible Plate (2) and a  $2\frac{1}{2}$ " Strip (3). The top of the bonnet is made from two  $1\frac{1}{8}$ " radius Curved Plates and a  $2\frac{1}{2} \times 1\frac{1}{2}$ " Flexible Plate bolted together. It is attached to the Strips (3) and one of the Flexible Plates (2) by Angle Brackets, and it is connected to the upper lug of a  $2\frac{1}{2} \times \frac{1}{2}$ " Double Angle Strip (4) bolted inside the front edge of the other Flexible Plate (2).

The steering wheel is a Bush Wheel and it is fixed on a  $\frac{3}{8}$ " Bolt passed through an Angle Bracket fixed to the top of the bonnet. The radiator is assembled as shown and is bolted to the front flange of the Flanged Plate.

The driver's seat is a 'U'-section Curved Plate (5) opened out slightly. It is fixed to the rear flange of the Flanged Plate. The back of the seat is made by bolting a  $2\frac{1}{2}$ " Strip to the end hole of each of the Strips (1). The  $2\frac{1}{2}$ " Strips are connected together by a  $2\frac{1}{2} \times \frac{1}{2}$ " Double Angle Strip fitted with a Curved Strip.

The track cover on each side is made from a  $5\frac{1}{2} \times 1\frac{1}{2}$ " Flexible Plate bent as shown and attached to the chassis by Angle Brackets. Two Washers are fitted on the Bolts (6) so that their shanks do not rub against the front wheels of the tractor. The track guards consist of  $5\frac{1}{2}$ " Strips fixed to Trunnions bolted to the  $5\frac{1}{2} \times 1\frac{1}{2}$ " Flexible Plates.

### Parts Required

4 of No. 2	43 of No. 37a
6 " " 5	38 " " 37b
4 " " 10	4 " " 38
8 " " 12	1 " " 40
2 " " 16	2 " " 48a
4 " " 22	1 " " 52
1 " " 24	2 " " 90a
41 " " 37a	4 " " 111c
39 " " 37b	1 " " 125
4 " " 38	2 " " 126
2 " " 48a	1 " " 126a
1 " " 52	4 " " 142c
2 " " 90a	1 " " 188
3 " " 111c	2 " " 189
1 " " 125	2 " " 190
2 " " 126	1 " " 199
1 " " 126a	2 " " 200
4 " " 142c	1 Magic Motor
1 " " 188	(not included in Outfit)
2 " " 189	
2 " " 190	
1 " " 199	
2 " " 200	

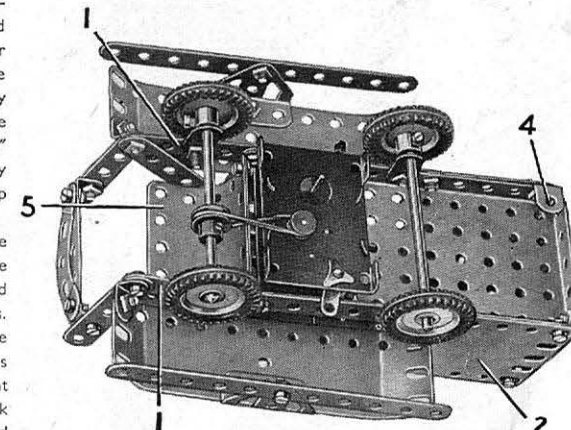
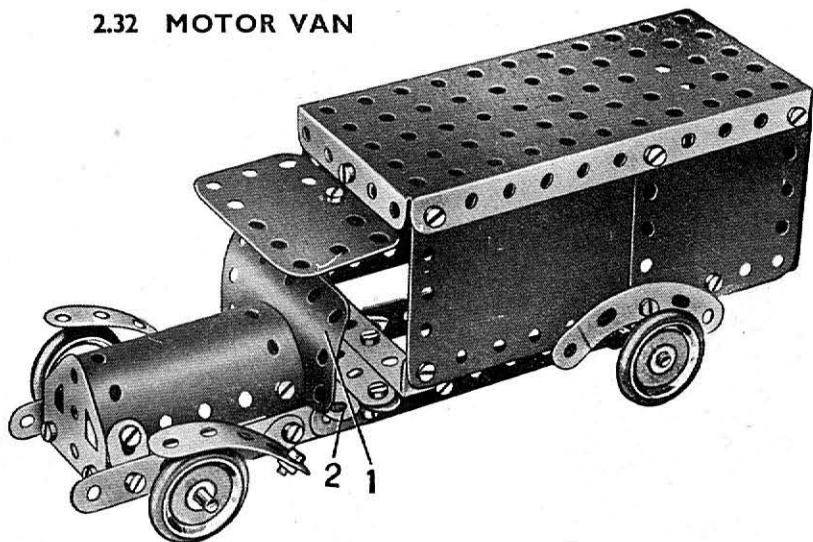

Fig. 2.31a

## 2.32 MOTOR VAN



## Parts Required

4 of No.	2
4 " "	5
4 " "	10
8 " "	12
2 " "	16
4 " "	22
4 " "	35
40 " "	37a
40 " "	37b
4 " "	38
2 " "	48a
1 " "	52
2 " "	90a
1 " "	126
2 " "	126a
4 " "	155
2 " "	188
2 " "	189
2 " "	190
1 " "	191
1 " "	199

Each of the side members of the chassis consists of two  $5\frac{1}{2}$ " Strips overlapped, and they are joined across at the centre by two  $2\frac{1}{2}$ " Strips, one of which is shown at (2), and a  $2\frac{1}{2}$ " x  $\frac{1}{2}$ " Double Angle Strip. The  $2\frac{1}{2}$ " Strip (2) and the Double Angle Strip are bolted to a Flat Trunnion, and between them is a second  $2\frac{1}{2}$ " Strip, which is fastened at each end to the chassis by Angle Brackets.

The Plate (1) is fastened to an Angle Bracket that is bolted to Strip (2). The side of the van seen in the illustration is made from a  $4\frac{1}{2}$ " x  $2\frac{1}{2}$ " Flexible Plate and a  $2\frac{1}{2}$ " x  $2\frac{1}{2}$ " Flexible Plate overlapped three holes. The other side consists of two  $5\frac{1}{2}$ " x  $1\frac{1}{2}$ " Flexible Plates bolted together along their longer edges. The body is fixed to the chassis by a Double Angle Strip and an Angle Bracket.

## 2.33 TRAVELLING CRANE

Parts Required	
4 of No.	2
6 " "	5
4 " "	10
6 " "	12
2 " "	16
2 " "	17
1 " "	19g
4 " "	22
1 " "	24
4 " "	35
40 " "	37a
38 " "	37b
3 " "	38
1 of No.	40
2 " "	48a
1 " "	52
1 " "	57c
2 " "	90a
2 " "	111c
2 " "	126
2 " "	126a
1 " "	176
1 " "	187
2 " "	188
2 " "	189
1 " "	200

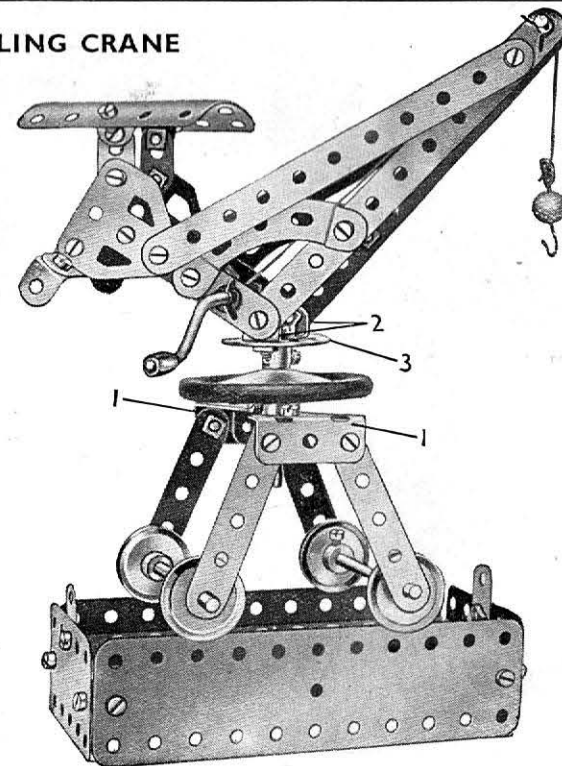

A 2" Rod is secured in the boss of the Bush Wheel (3). It then passes through the Road Wheel and through the centre of a  $2\frac{1}{2}$ " x  $\frac{1}{2}$ " Double Angle Strip bolted between the two Trunnions (1). A Washer and a Cord Anchoring Spring are pushed on to the Rod to hold it in position. The crane jib is attached to the Bush Wheel by the Angle Brackets (2).

## 2.34 LIFTING TRUCK

Parts Required					
4 of No.	2	3 of No.	22	2 of No.	48a
6 " "	5	4 " "	35	2 " "	90a
4 " "	10	45 " "	37a	2 " "	111c
8 " "	12	31 " "	37b	1 " "	125
2 " "	16	4 " "	38	2 " "	189
2 " "	17	1 " "	40	1 " "	191

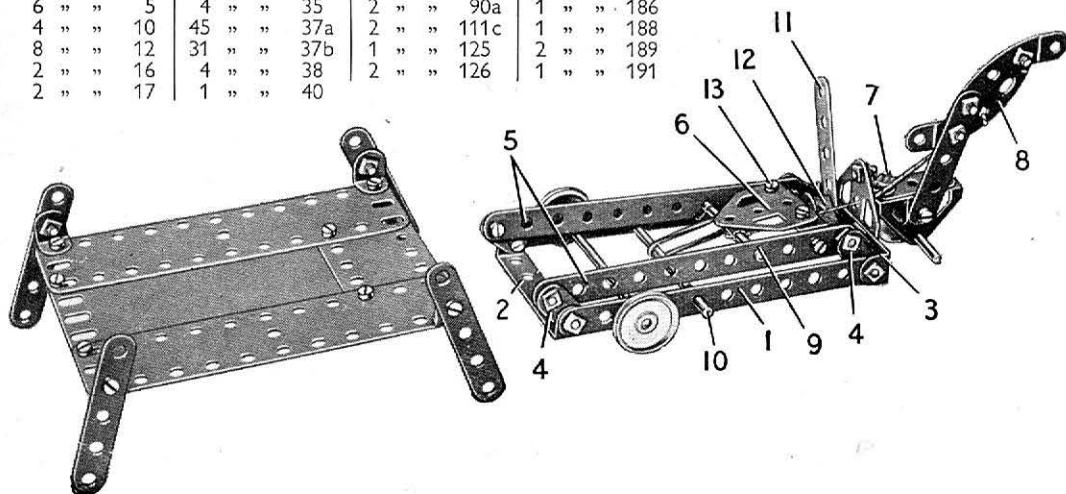

The truck chassis is made by attaching a  $5\frac{1}{2}$ " Strip (1) on each side to the lugs of  $2\frac{1}{2}$ " x  $\frac{1}{2}$ " Double Angle Strips (2) and (3). A Fishplate (4) is freely pivoted on each of the Bolts fixing the Strips (1) in place. The Bolt is passed through the round hole of the Fishplate and is fitted with a nut, *but the nut is not tightened against the Fishplate*. The Bolt is then passed through the Double Angle Strip and the Strip (1) and a *second nut is screwed tightly against the Strip*. A  $5\frac{1}{2}$ " Strip (5) is *lock-nutted* to the Fishplates on each side, and a Flat Trunnion (6) is attached to Angle Brackets bolted to these Strips.

The single wheel at the front is fixed on a 2" Rod supported in two Trunnions bolted together. The Trunnions are pivoted by a *lock-nutted*  $\frac{3}{8}$ " Bolt (7) to an Angle Bracket bolted to a Flat Trunnion. The Flat Trunnion is fixed to Double Angle Strip (3).

The lifting mechanism is operated by pushing down a handle (8), made from a  $2\frac{1}{2}$ " Strip and two  $2\frac{1}{2}$ " Stepped Curved Strips arranged as shown, and it is *lock-nutted* to one of the Trunnions. A length of Cord tied to the handle is passed through the Flat Trunnion fixed to Double Angle Strip (3) and is tied to a 2" Rod (9). Rod (9) is held in Strips (5) by Spring Clips, and a  $2\frac{1}{2}$ " Driving Band is looped between this Rod and a  $3\frac{1}{2}$ " Rod (10).

The release lever for the lifting mechanism is a  $2\frac{1}{2}$ " Strip (11). A  $\frac{1}{2}$ " Reversed Angle Bracket (12) is bolted tightly to the Strip by a nut on a  $\frac{3}{8}$ " Bolt, which is then passed through Double Angle Strip (3) and is fitted with *lock-nuts*. When the Strips (5) are in the raised position the Reversed Angle Bracket engages behind an Angle Bracket fixed to the Flat Trunnion (6) by the Bolt (13).

The load platform is assembled from Flexible Plates as shown, and the angles of the legs are adjusted so that the truck can pass freely under the platform when the Strips (5) are in the lowered position.

The model is operated as follows. The truck is pushed under the load platform with the handle (8) in the raised position. The handle is then pushed down to raise the Strips (5), so that the platform is lifted clear of the ground. The lever (11) is then moved until the Reversed Angle Bracket (12) engages behind the Angle Bracket held by Bolt (13), and locks Strips (5) in the raised position. The truck and platform can then be hauled away as a unit. To lower the platform, the lever (11) is operated to release the Reversed Angle Bracket from the Angle Bracket, and the tension of the Driving Band then pulls Strips (5) to the lowered position.

Here are a few simple and interesting movements showing how easily real mechanisms can be reproduced with Meccano

**USEFUL BAND BRAKE**

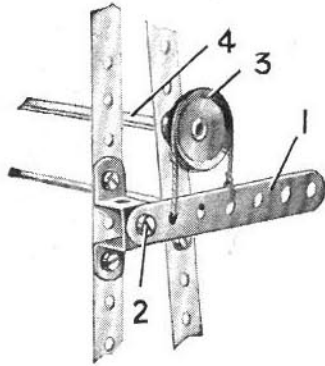

The brake lever consists of a  $3\frac{1}{2}$ " Strip (1), pivotally attached at a suitable point on the frame of the model by means of a lock-nutted  $\frac{3}{8}$ " Bolt (2). The driven shaft (4) is fitted at one end with a 1" fast Pulley (3) round which a short length of Cord is passed. The two ends of this Cord are secured to the brake lever at the points shown in the illustration. If increased braking effect is desired, a larger Pulley may be used in place of the 1" fast Pulley (3), the brake lever (1) being attached in a lower position if necessary. Alternatively, a weight can be hung from the end of the brake lever.

**SIMPLE STEERING GEAR**

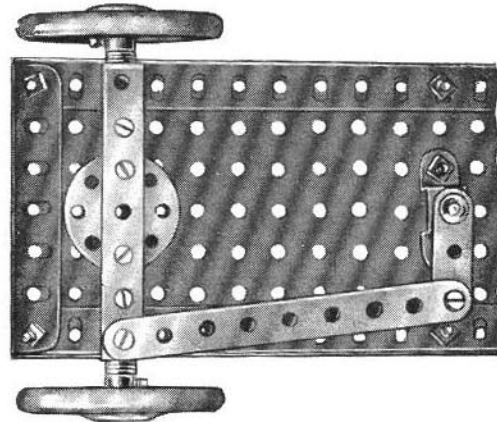

This simple steering gear will be found suitable for most small model vehicles.

In this example the two front wheels are mounted on separate stub axles that are secured to each end of a rigid front axle. The base of the chassis consists of two long Angle Girders connected together at the front end by a  $3\frac{1}{2}$ " Angle Girder and filled in along their length by means of  $5\frac{1}{2}$ " x  $3\frac{1}{2}$ " Flat Plates.

The front axle, a  $3\frac{1}{2}$ " x  $\frac{1}{2}$ " Double Angle Strip, is pivotally mounted at its centre on a Bush Wheel and short Rod. It is fitted,  $\frac{1}{2}$ " from each end, with a  $\frac{1}{2}$ " x  $\frac{1}{2}$ " Angle Bracket, this forming the inner bearing for its respective stub axle. The outer bearing for the axle consists of the upturned lug of the Double Angle Strip. One end of this latter part is fitted with a pivotally attached  $4\frac{1}{2}$ " Strip, by means of which the front axle is linked to a Crank fixed to the steering column.

**SAFETY CATCH FOR CRANE WINDING GEAR**

The Compression Spring (3) is mounted on the Crank Handle (1) between the Collar (4) and a Washer, and normally holds the Collar (2) against the inner side of the Plate. The Collar (2) is fitted with a  $\frac{3}{8}$ " Bolt, and if the Crank Handle commences to rotate, the head of this Bolt strikes against the stop (5) and prevents further movement.

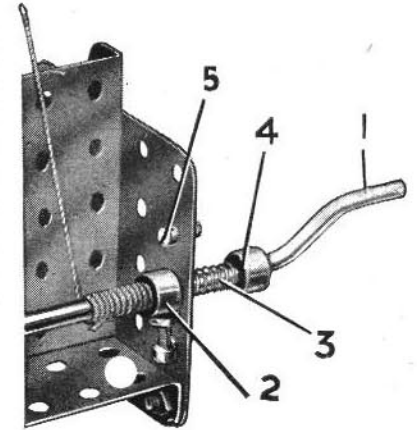

**SIMPLE REVERSING MECHANISM**

When a Magic Motor, which is non-reversing, is used for driving a small model such as a crane, a simple reversing mechanism that does not require any gears can be built up on the lines shown below.

The drive from the Motor is taken to a Rod (1) on which are fixed two 1" Pulleys each fitted with a Rubber Ring. This Rod is arranged to that it can be moved endways in its bearings, so as to bring either of the 1" Pulleys into Contact with a third 1" Pulley fixed on a Rod (2) placed at right angles to Rod (1). The direction of the drive can be changed by sliding Rod (1) as required.

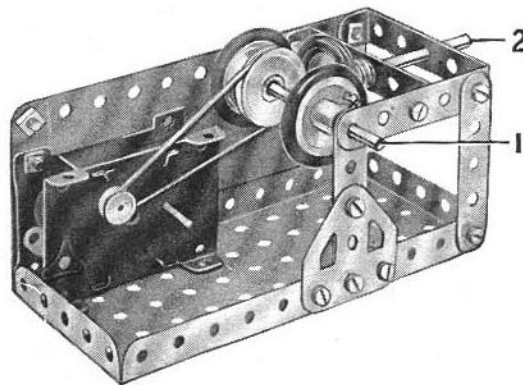

**USEFUL ROLLER BEARING**

The simple roller bearing shown below is suitable for use in model cranes and others having a swivelling superstructure.

The lower Pulley (1) should be firmly attached to the top of the crane tower or support. A 2" Rod is fixed in the Pulley, and on it is freely mounted a 'spider' that carries the roller wheels. The 'spider' is made by bolting two  $2\frac{1}{2}$ " x  $\frac{1}{2}$ " Double Angle Strips at right angles to each other across the face of a Wheel Disc. The roller wheels consist of two 1" loose and two 1" fixed Pulleys. The fixed Pulleys are free to turn on  $\frac{3}{8}$ " Bolts, and the loose Pulleys are mounted on  $\frac{1}{2}$ " Bolts. Each Bolt is then fixed by two nuts to one of the lugs of the Double Angle Strips.

The 1" Pulleys rest on the edge of the rim of the Pulley (1), and a further 3" Pulley (2) is passed over the 2" Rod and is held in place by a Collar.

The Pulley (2) is attached to the cab or superstructure of the model.

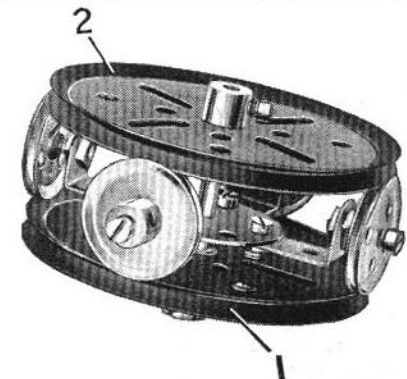







# MECCANO PARTS

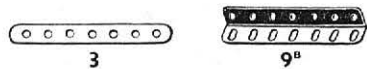

## PERFORATED STRIPS

No.	1. 12 $\frac{1}{2}$ "	2a. 4 $\frac{1}{2}$ "	No.	6. 2"
1a.	9 $\frac{1}{2}$ "	3. 3 $\frac{1}{2}$ "	6a.	1 $\frac{1}{2}$ "
1b.	7 $\frac{1}{2}$ "	4. 3"		
2.	5 $\frac{1}{2}$ "	5. 2 $\frac{1}{2}$ "		

## ANGLE GIRDERS

7.	24 $\frac{1}{2}$ "	8b.	7 $\frac{1}{2}$ "	9c.	3"
7a.	18 $\frac{1}{2}$ "	9.	5 $\frac{1}{2}$ "	9d.	2 $\frac{1}{2}$ "
8.	12 $\frac{1}{2}$ "	9a.	4 $\frac{1}{2}$ "	9e.	2"
8a.	9 $\frac{1}{2}$ "	9b.	3 $\frac{1}{2}$ "	9f.	1 $\frac{1}{2}$ "



10. Fishplate | 11. Double Bracket

## ANGLE BRACKETS

12.	1" x 1"	12b.	1" x 1"	12c.	Obtuse, 1" x 1"
12a.	1" x 1"				



17 | 19"

## AXLE RODS

13.	11 $\frac{1}{2}$ "	15a.	4 $\frac{1}{2}$ "	16b.	3"
13a.	8"	15b.	4"	17.	2"
14.	6 $\frac{1}{2}$ "	16.	3 $\frac{1}{2}$ "	18a.	1 $\frac{1}{2}$ "
15.	5"	16a.	2 $\frac{1}{2}$ "	18b.	1"
19g.	Crank Handle, 3 $\frac{1}{2}$ " shaft, with grip				
19h.	Crank Handle, 5" shaft, with grip				
19s.	Crank Handle, 3 $\frac{1}{2}$ " shaft, without grip				



19a. Spoked Wheel, 3" diam.  
20. Flanged Wheel, 1 $\frac{1}{2}$ " diam.  
20b. Flanged Wheel, 1" diam.

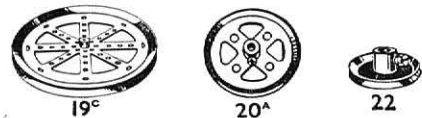

19c. Spoked Wheel, 3" diam., with boss and screw  
20a. 2" diam., with boss and screw  
21. 1 $\frac{1}{2}$ " diam., with boss and screw  
22. 1" diam., with boss and screw

## PULLEYS



22a. 3" diam., without boss  
23. 2" diam., without boss  
23a. 1 $\frac{1}{2}$ " diam., with boss and screw

## PULLEYS



No. 24. Bush Wheel, 1 $\frac{1}{2}$ " diam., eight holes  
24a. Wheel Disc, 1 $\frac{1}{2}$ " diam., without boss, eight holes  
24b. Bush Wheel, 1 $\frac{1}{2}$ " diam., six holes  
24c. Wheel Disc, 1 $\frac{1}{2}$ " diam., without boss, six holes

## PINIONS

25.	1" diam., 1" face, 25 teeth
25a.	1" diam., 1" face, 25 teeth
25b.	1" diam., 1" face, 25 teeth
26.	1" diam., 1" face, 19 teeth
26a.	1" diam., 1" face, 19 teeth
26b.	1" diam., 1" face, 19 teeth
26c.	1" diam., 1" face, 15 teeth



27. 1 $\frac{1}{2}$ " diam., 50 teeth  
27a. 1 $\frac{1}{2}$ " diam., 57 teeth  
27b. 3 $\frac{1}{2}$ " diam., 133 teeth  
27c. 2 $\frac{1}{2}$ " diam., 95 teeth  
27d. 1 $\frac{1}{2}$ " diam., 60 teeth

## GEAR WHEELS



28. 1 $\frac{1}{2}$ " diam., 50 teeth  
29. 1" diam., 25 teeth

## CONTRATE WHEELS

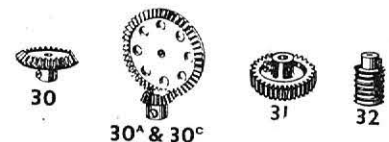

30. Bevel Gear, 1" diam., 26 teeth (for use in pairs)  
30a. Bevel Gear, 1" diam., 16 teeth | Can only be used together  
31. Gear Wheel, 1" diam., 4" face, 38 teeth  
32. Worm, 1" diam.  
34. Spanner



34b. Box Spanner  
35. Spring Clip  
36. Screwdriver  
36a. Screwdriver (longer)  
36c. Drift (for levering bolt holes into line)  
37. Nut and Bolt, 3/32"  
37a. Nut  
37b. Bolt, 1/2"  
38. Washer  
38d. Hank of Cord  
40. Hank of Cord



41. Propeller Blade | 43. Tension Spring, 2" long



No. 44. Bent Strip, stepped  
45. Double Bent Strip

## DOUBLE ANGLE STRIPS

46.	2 $\frac{1}{2}$ " x 1"	48.	1 $\frac{1}{2}$ " x 1"	48c.	4 $\frac{1}{2}$ " x 1"
47.	2 $\frac{1}{2}$ " x 1 $\frac{1}{2}$ "	48a.	2 $\frac{1}{2}$ " x 1"	48d.	5 $\frac{1}{2}$ " x 1"
47a.	3" x 1 $\frac{1}{2}$ "	48b.	3 $\frac{1}{2}$ " x 1"		



50. Slide Piece  
51. Flanged Plate, 2 $\frac{1}{2}$ " x 1 $\frac{1}{2}$ "  
52. Flanged Plate, 5 $\frac{1}{2}$ " x 2 $\frac{1}{2}$ "  
52a. Flat Plate, 5 $\frac{1}{2}$ " x 3 $\frac{1}{2}$ "  
53. Flanged Plate, 3 $\frac{1}{2}$ " x 2 $\frac{1}{2}$ "  
53a. Flat Plate, 4 $\frac{1}{2}$ " x 2 $\frac{1}{2}$ "

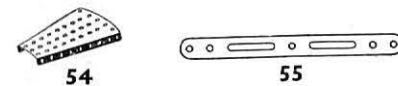

54. Flanged Sector Plate, 4 $\frac{1}{2}$ " long  
55. Perforated Strip, slotted, 5 $\frac{1}{2}$ " long  
55a. Perforated Strip, slotted, 2" long



57b. Hook, Loaded, large  
57c. Hook, Loaded, small  
58. Spring Cord, 40" length  
58a. Coupling Screw for Spring Cord  
58b. Hook for Spring Cord  
59. Collar, with screw

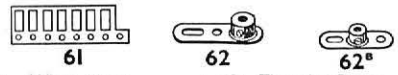

61. Windmill Sail Crank  
62. Crank | 62a. Threaded Crank  
62b. Double Arm Crank



63. Coupling Strip  
63b. Strip Coupling | 63c. Threaded Coupling  
63d. Short Coupling



64. Threaded Boss  
65. Centre Fork  
69. Set Screw, 1/32"

69a. Grub Screw, 1/32"  
69b. Grub Screw, 1/16"  
69c. Grub Screw, 1/8"

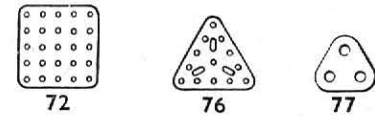

No. 70. Flat Plate, 5 $\frac{1}{2}$ " x 2 $\frac{1}{2}$ "  
72. Flat Plate, 2 $\frac{1}{2}$ " x 2 $\frac{1}{2}$ "  
73. Flat Plate, 3" x 1 $\frac{1}{2}$ "  
76. Triangular Plate, 2 $\frac{1}{2}$ "  
77. Triangular Plate, 1"



80a. 5"  
80b. 4 $\frac{1}{2}$ "  
80c. 3"  
81. 2"  
82. 1"

## CURVED STRIPS

89. 5 $\frac{1}{2}$ " (10" radius)  
89a. Stepped, 3" (1 $\frac{1}{2}$ " radius)  
89b. Stepped, 4" (4 $\frac{1}{2}$ " radius)  
90. 2 $\frac{1}{2}$ " (2 $\frac{1}{2}$ " radius)  
90a. Stepped, 2 $\frac{1}{2}$ " (1 $\frac{1}{2}$ " radius)

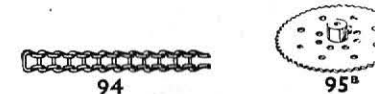

94. Sprocket Chain, 40" length

## SPROCKET WHEELS

95. 2" diam., 36 teeth  
95a. 1 $\frac{1}{2}$ " diam., 28 teeth  
95b. 3" diam., 56 teeth  
96. 1" diam., 18 teeth  
96a. 1" diam., 14 teeth

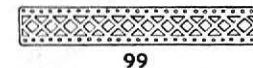

97. 3 $\frac{1}{2}$ " long  
97a. 3" long  
98. 2 $\frac{1}{2}$ " long  
99. 12 $\frac{1}{2}$ " long  
99a. 9 $\frac{1}{2}$ " long  
99b. 7 $\frac{1}{2}$ " long  
100. 5 $\frac{1}{2}$ " long  
100a. 4 $\frac{1}{2}$ " long



101. Heald for Loom | 102. Single Bent Strip

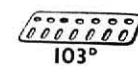

103. 5 $\frac{1}{2}$ " long  
103a. 9 $\frac{1}{2}$ " long  
103b. 12 $\frac{1}{2}$ " long  
103c. 4 $\frac{1}{2}$ " long  
103d. 3 $\frac{1}{2}$ " long  
103e. 3" long  
103f. 2 $\frac{1}{2}$ " long  
103g. 2" long  
103h. 1 $\frac{1}{2}$ " long  
103k. 7 $\frac{1}{2}$ " long

# MECCANO PARTS

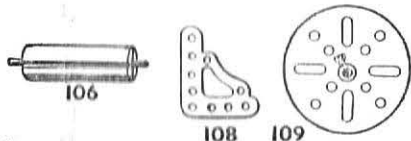

- No. 106. Wood Roller (complete with Rod and two Collars)  
 108. Corner Gusset  
 109. Face Plate, 2½" diam.

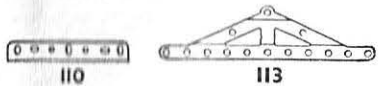

110. Rack Strip, 3½" long | 110a. Rack Strip, 6½" long

### BOLTS

111. Bolt  
 111a. Bolt | 111c. Bolt  
 | 111d. Bolt

113. Girder Frame



114. Hinge Threaded Pin | 116. Fork Piece, large  
 115. Threaded Pin | 116a. Fork Piece, small



118. Hub Disc, 5½" diam.



- 120b. Compression Spring, ⅝" long



122. Loaded Sack



123. Cone Pulley, 1½", 1" and ¾" diam.



124. Reversed Angle Bracket, 1"  
 125. Reversed Angle Bracket, ½"



126. Trunnion  
 126a. Flat Trunnion  
 128. Bell Crank, with boss



126a



128



- No. 130. Eccentric, Triple Throw, ¼", ⅜" and ½"  
 130a. Eccentric, Single Throw, ¼"

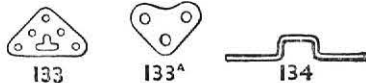

133. Corner Bracket, 1½"  
 133a. Corner Bracket, 1"  
 134. Crank Shaft, 1" stroke



136. Handrail Support | 136a. Handrail Coupling



136a

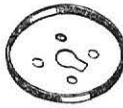

137. Wheel Flange



138. Ship's Funnel, Raked

138



139. Flanged Bracket (right)  
 139a. Flanged Bracket (left)



140. Universal Coupling

140



- 142a. Motor Tyre (to fit 2" diam. rim)  
 142b. Motor Tyre (to fit 3" diam. rim)  
 142c. Motor Tyre (to fit 1" diam. rim)  
 142d. Motor Tyre (to fit 1½" diam. rim)



143



144

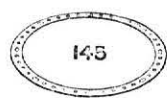

145. Circular Strip, 7½" diam. overall  
 146. Circular Plate, 6" diam. overall  
 146a. Circular Plate, 4" diam. overall

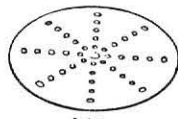

146

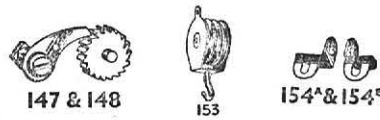

- No. 147. Pawl, with Pivot Bolt and nuts  
 147a. Pawl  
 147b. Pivot Bolt, with two nuts  
 147c. Pawl, without boss  
 148. Ratchet Wheel  
 151. Single Pulley Block  
 153. Triple Pulley Block  
 154a. Corner Angle Bracket, ½" (right-hand)  
 154b. Corner Angle Bracket, ½" (left-hand)  
 155. Rubber Ring (for 1" Pulley)



157. Fan, 2" diam.



160. Channel Bearing, 1½" x 1" x ½"

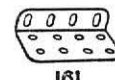

161. Girder Bracket, 2" x 1" x ½"

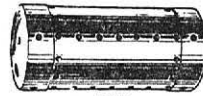

162. Boiler, complete, 5" long x 2½" diam.  
 162a. Boiler Ends, 2½" diam. x 3" long  
 163. Sleeve Piece, 1½" long x 1½" diam.  
 164. Chimney Adaptor, ½" diam. x ½" high



164



165. Swivel Bearing



166. End Bearing

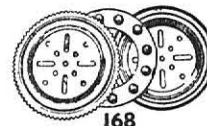

- 167b. Flanged Ring, 9½" diam.  
 168. Ball Thrust Bearing, 4" diam.  
 168a. Ball Thrust Race, flanged disc, 3½" diam.  
 168b. Ball Thrust Race, toothed disc, 4" diam.  
 168c. Ball Cage, 3½" diam., complete with balls  
 168d. Ball, ¾" diam.



171. Socket Coupling

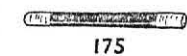

- 173a. Adaptor for Screwed Rod  
 175. Flexible Coupling Unit  
 176. Anchoring Spring for Cord



176



179. Rod Socket

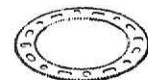

180. Gear Ring, 3½" diam. (133 ext. teeth, 95 int.)



- No. 185. Steering Wheel, 1½" diam.



- DRIVING BANDS**  
 186. 2½" (light) | 186c. 10" (heavy)  
 186a. 6" (light) | 186d. 15" (heavy)  
 186b. 10" (light) | 186e. 20" (heavy)  
 187. Road Wheel, 2½" diam.  
 187a. Conical Disc, 1½" diam.

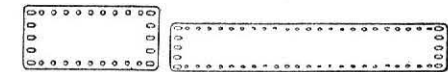

192

197

### FLEXIBLE PLATES

188. 2½" x 1½" | 190. 2½" x 2½" | 191. 4½" x 2½"  
 189. 5½" x 1½" | 190a. 3½" x 2½" | 192. 5½" x 2½"

### STRIP PLATES

196. 9½" x 2½" | 197. 12½" x 2½"



198



199



200

198. Hinged Flat Plate, 4½" x 2½"  
 199. Curved Plate, "U"-section, 2½" x 2½" x ⅜" radius  
 200. Curved Plate, 2½" x 2½" x 1½" radius



211a & 211b



212



213

- 211a. Helical Gear, 1" } Can only be used  
 211b. Helical Gear, 1½" } together  
 212. Rod and Strip Connector  
 212a. Rod and Strip Connector, right-angle  
 213. Rod Connector  
 213a. Three-way Rod Connector  
 213b. Three-way Rod Connector with boss

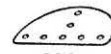

214



215



216

214. Semi-circular Plate, 2½"  
 215. Formed Slotted Strip, 3"  
 216. Cylinder, 2½" long, 1½" diam.

### TRIANGULAR FLEXIBLE PLATES

221. 2½" x 1½" | 223. 2½" x 2½" | 225. 3½" x 2"  
 222. 2½" x 2" | 224. 3½" x 1½" | 226. 3½" x 2½"  
 230. 4" Rod with Keyway  
 231. Key Bolt

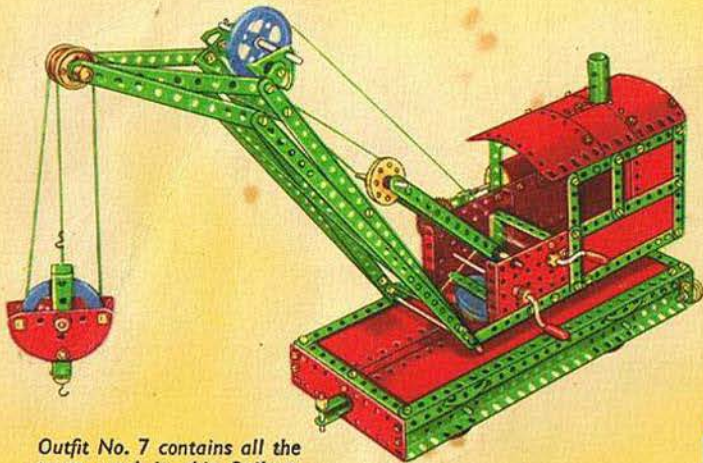

Outfit No. 7 contains all the parts used in this Railway Service Crane



A Helicopter built from Outfit No. 5

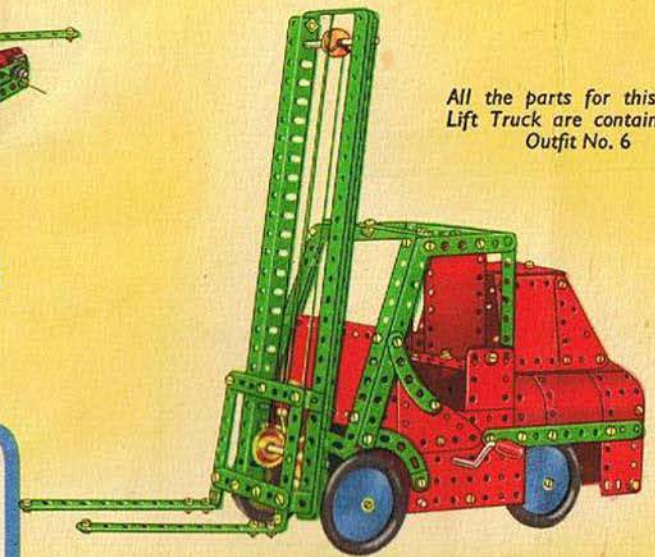

All the parts for this Fork Lift Truck are contained in Outfit No. 6

**HOW TO CONTINUE**

When you have built all the models shown in this Book of Instructions, you will be keen to build others bigger and more elaborate. Your next step, therefore, is to purchase the appropriate Accessory Outfit containing all the parts required to convert your present Outfit into the next larger complete Outfit, as explained on page 2 of cover. You will then be able to build a new range of fascinating models.

If you prefer to do so, you can build up and develop your present Outfit quite easily by adding various parts to it from time to time. The model-building possibilities of the Meccano System are unlimited, and the more Meccano parts you have, the finer and more varied the models you will be able to build.

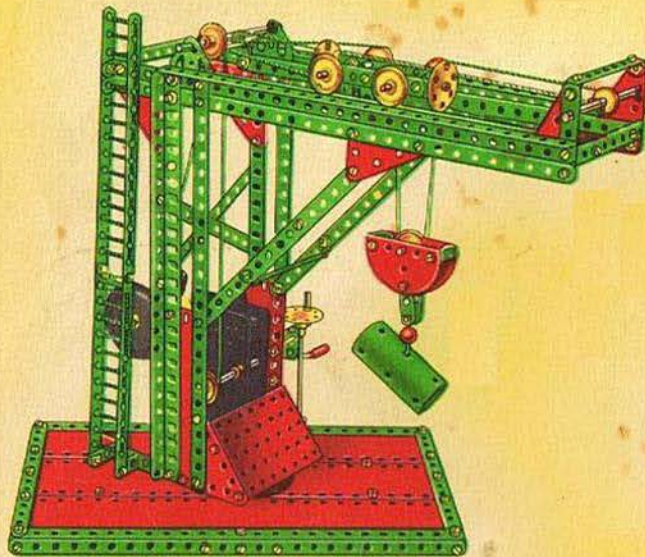

This Forge Crane is another of the fine working models built with Outfit No. 6

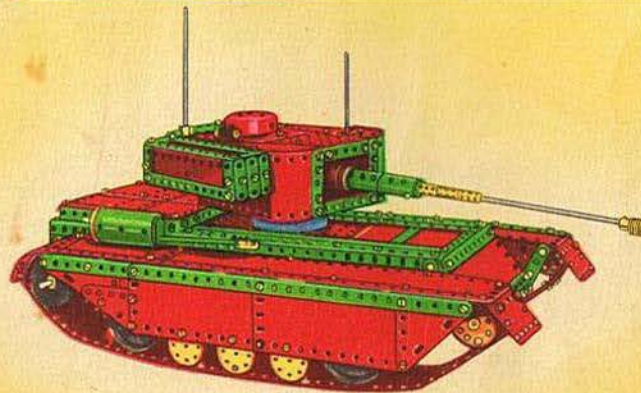

This Military Tank is one of the attractive models that can be built with Outfit No. 8

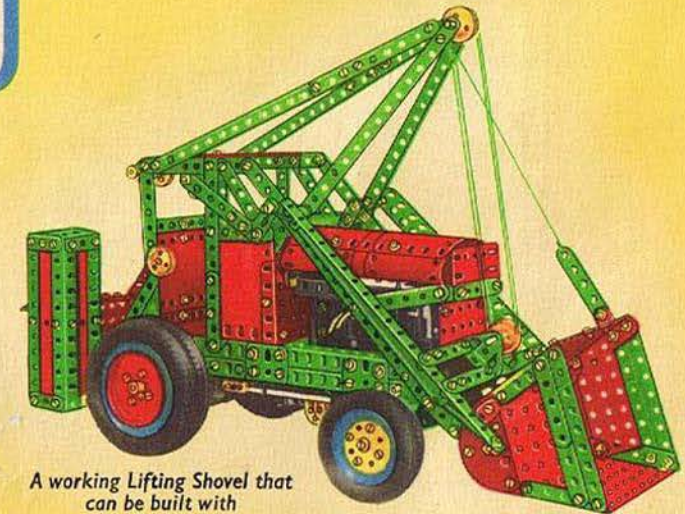

A working Lifting Shovel that can be built with Outfit No. 10