

MECCANO

Regd.
Trade
Mark

INSTRUCTIONS

Copyright by Meccano Ltd.

for No. Oa OUTFIT

Binns Road, Liverpool 13

No.
59.Oa



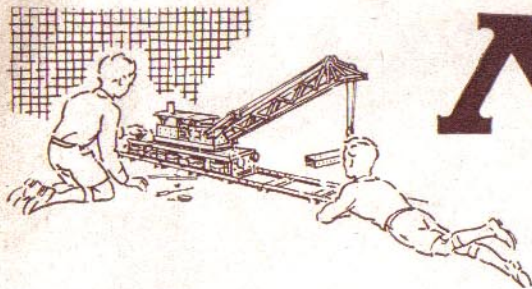

MECCANO

Registered Trade Mark

The World's Greatest Constructional Toy

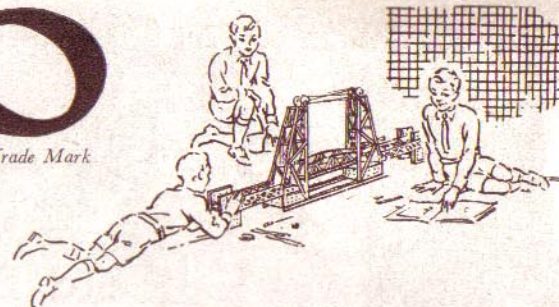

MODEL-BUILDING WITH MECCANO

SOME USEFUL HINTS

It will be noticed that with each model in this Book of Instructions is given a list of the parts required to build it. For the first few models it is a good plan to lay out on the table all the parts required for the one it is proposed to build, and put the remainder of the Outfit to one side. To help you pick out the correct parts for your model a complete list of Meccano parts is given at the back of this Book, and all the principal parts are illustrated. In the list the parts are all numbered, and in most cases, their measurements are given. There is no need, however, to measure the parts to find out which is which; as the size is easily found from the number of holes. All Meccano holes are spaced $\frac{1}{2}$ " apart, so that by counting two holes to the inch the size of a part can be found at once. For instance, Part No. 2 is listed as a $5\frac{1}{2}$ " Perforated Strip, so you look in your Outfit for a Strip with eleven holes. Similarly, No. 189 is a $5\frac{1}{2}$ " \times $1\frac{1}{2}$ " Flexible Plate, so you look for a Flexible Plate eleven holes in length and three holes in width.

Beginners sometimes wonder which section of a model should be built first. There cannot be any definite rule for this, as it depends on the design of the model. In stationary models the base usually should be built first. In most of the small models a $5\frac{1}{2}$ " \times $2\frac{1}{2}$ " Flanged Plate forms an important part of the structure, and often the best plan is to start building by bolting parts to this Plate. For other models a good general rule is that the sections that form supports for a number of other parts should be built first.

THE IMPORTANCE OF LOCK-NUTTING

In some models it is necessary to join certain parts together so that, although they cannot come apart, they are free to pivot or move in relation to one another. To do this the parts are bolted together as usual but the nut is not screwed up tightly, so that the parts are not gripped. Then, to prevent the nut from unscrewing, a second nut is screwed up tightly against it, the first nut being held with a spanner. This method of using a second nut is known as **Lock-nutting**.

A Rod is usually mounted in a support or bearing, such as a hole in a strip, so that it is free to revolve. The Rod is then said to be **Journalled** in the Strip.

DRIVING YOUR MODELS

Models can be driven by means of either clockwork or electric motors. Ask your dealer for details of these Meccano Motors. Small and light models can be driven direct from the driving pulley of the motor or through a belt running over two pulleys of the

same size giving what is known as a 1 : 1 (one-to-one) ratio. A better plan, however, is to take the drive from a small pulley on the motor shaft to a larger pulley on the driving shaft of the model. In most cases a 1" Pulley on the motor shaft and a 3" Pulley on the model shaft will be found satisfactory. This provides a reduction ratio of approximately 3 : 1.

Rubber bands are very convenient for driving belts. Sometimes, however, a rubber band of the right length is not available, and then Meccano Cord or thin string is used. To tie the Cord to form an endless belt you should use the familiar reef knot.

With the larger Outfits, belt drive can be replaced with advantage by gearing. To operate a slow-moving model demanding great power, such as a traction engine, gears that will provide a considerable reduction must be used. For example, a Worm meshed with a $\frac{1}{2}$ " Pinion will give a 19 : 1 reduction; a Worm meshed with a 57-tooth Gear will give a 57 : 1 reduction.

If the Motor is to operate successfully, however, you must make sure that there is no excessive friction in the mechanism of the model. This can be caused by shaft bearings being slightly out of line, or by a belt or Cord drive being too tight. Before condemning your motor, therefore, first make sure that every revolving shaft moves quite freely in its bearings, and that the bearings are in line with one another. The bearings can be brought into line by pushing through them a Drift (Part No. 36c) or a Rod, before the bolts holding the various parts are tightened up. Then apply a little light machine oil to every bearing or pivot on which moving parts are mounted.

Triangular Flexible Plates and Flexible Plates can be used for forming curved surfaces in models, but they should not be bent at a too sharp angle. With careful handling these Plates can be bent to the required curve and after use straightened again.

All Outfits from No. 2 upward include the Cord Anchoring Spring, Part No. 176. This part provides a neat and positive method of fastening a length of Cord to a Rod. The Spring is pushed on to a Rod or Crank Handle by turning it in such a way that its coils tend to unwind.

MECCANO SERVICE

If ever you are in any difficulty with your models, or if you want advice on anything connected with this great hobby, write to us. We shall be delighted to help you in any way possible. Address your letters to **Information Service**, Meccano Ltd, Binns Road, Liverpool 13.

1.1 KIDDIE CAR

Two Trunnions overlapped one hole, and fastened to the Flanged Plate by an Angle Bracket, form the seat.

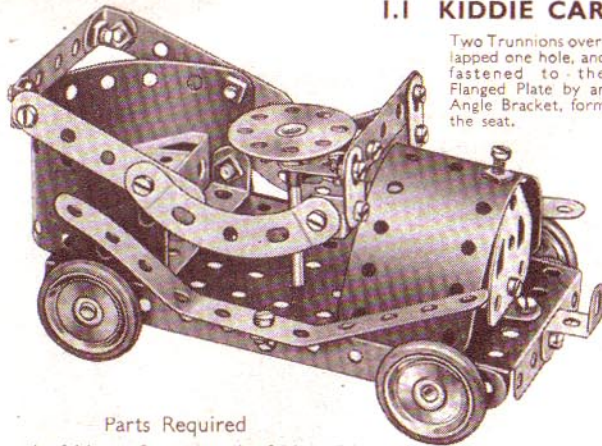

Parts Required

4 of No. 2	1 of No. 24	2 of No. 111c
4 " " 5	1 " " 35	1 " " 125
3 " " 10	27 " " 37a	2 " " 126
7 " " 12	24 " " 37b	1 " " 126a
2 " " 16	2 " " 48a	4 " " 155
1 " " 17	1 " " 52	2 " " 189
4 " " 22	2 " " 90a	

1.2 LETTER BALANCE

The Bolts (1) are lock-nutted. The 1" Bolt (2) is passed through the hole of the Angle Bracket and then held by the screw in the boss of the 1" Pulley.

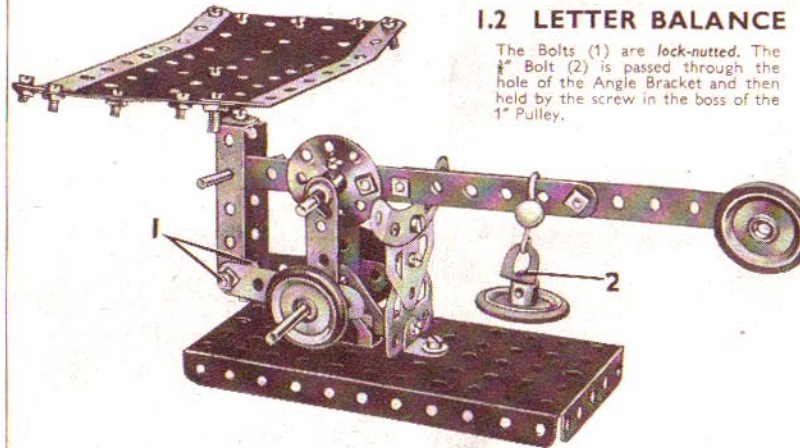

Parts Required

4 of No. 2	4 of No. 22	4 of No. 38	4 of No. 111c
4 " " 5	1 " " 24	2 " " 48a	1 " " 125
4 " " 10	4 " " 35	1 " " 52	2 " " 126
2 " " 12	28 " " 37a	1 " " 57c	2 " " 126a
1 " " 16	24 " " 37b	1 " " 90a	4 " " 155
2 " " 17			2 " " 189

1.3 RACING SEAPLANE

Each of the floats is secured to the wings by two Angle Brackets and one Fishplate.

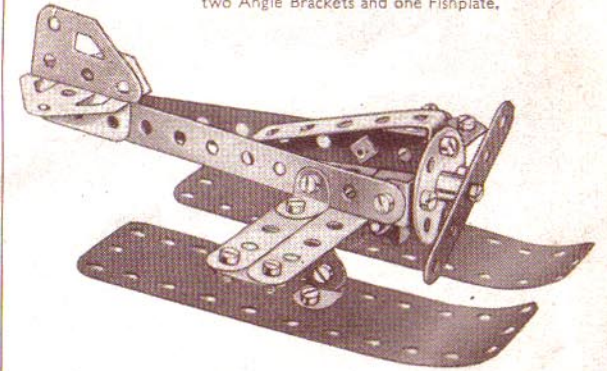

Parts Required

3 of No. 2	1 of No. 24	2 of No. 111c
3 " " 5	20 " " 37a	2 " " 126
4 " " 10	19 " " 37b	1 " " 126a
8 " " 12	1 " " 48a	2 " " 189

1.4 RAILWAY BREAKDOWN CRANE

The hoisting Cord is secured to the Crank Handle and then led over the 1" Bolt (1). It is then passed through the pulley block and fastened to the jib at (2). The jib is attached to the Bush Wheel (3) by means of Angle Brackets, and the complete unit is pivoted as follows. A 1" Bolt is passed through the 5 1/2" x 2 1/2" Flanged Plate from the underside, and is secured in the boss of the Bush Wheel by its set screw.

Parts Required

4 of No. 2	1 of No. 19s
4 " " 5	4 " " 22
1 " " 10	1 " " 24
4 " " 12	2 " " 35
2 " " 16	24 " " 37a
	20 " " 37b
	2 " " 38
	1 " " 40
	2 " " 48a
	1 " " 52
	1 " " 57c
	2 " " 90a

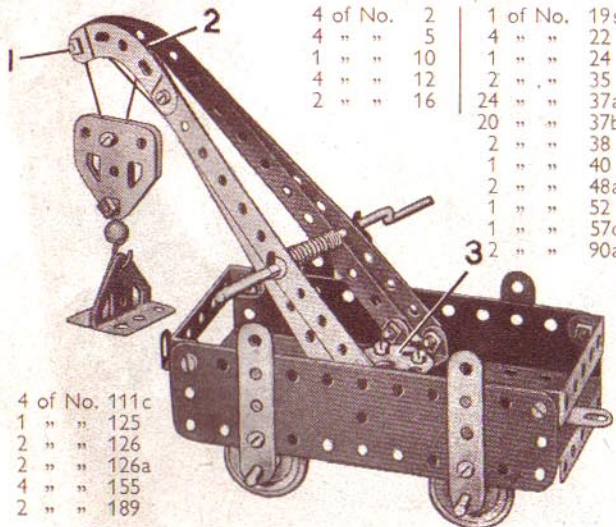

4 of No. 111c
1 " " 125
2 " " 126
2 " " 126a
4 " " 155
2 " " 189

1.5 TRICYCLE VAN

Parts Required

4 of No. 2	1 of No. 17	24 of No. 37b	2 of No. 111c
3 " " 5	3 " " 22	3 " " 38	2 " " 126
3 " " 10	1 " " 24	2 " " 48a	2 " " 126a
6 " " 12	4 " " 35	1 " " 52	2 " " 142c
2 " " 16	27 " " 37a	2 " " 90a	2 " " 189

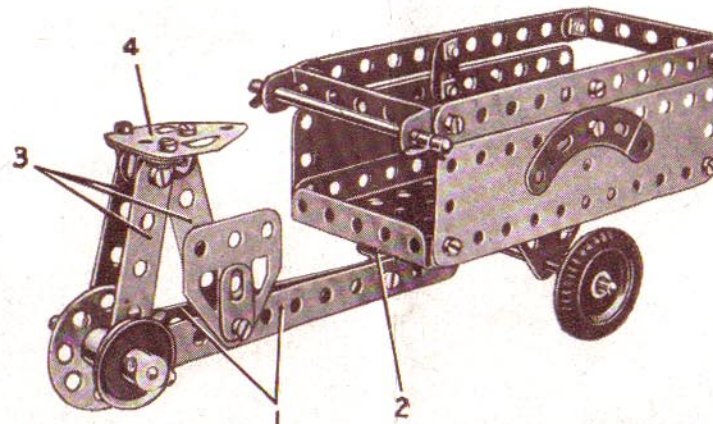

The frame of the cycle consists of two 5 1/2" Strips (1) connected at one end by a bolt that fixes them also to an Angle Bracket (2). The Angle Bracket pivots on a bolt lock-nutted to the Flanged Plate. The seat is carried by three 2 1/2" Strips (3), each of which is connected by an Angle Bracket to the Flat Trunnion (4). The front axle is carried in Trunnions bolted underneath the Flanged Plate.

1.6 STAMPING MILL

The anvil (1) is made up of two Trunnions bolted together. When the Crank Handle is rotated, the Fishplates bolted to the Bush Wheel strike the centre 1" Pulley on the hammer shaft and cause it to rise and fall.

Parts Required

4 of No. 2	1 of No. 90a
4 " " 5	4 " " 111c
4 " " 10	1 " " 125
4 " " 12	2 " " 126
1 " " 16	2 " " 126a
1 " " 19s	2 " " 189
4 " " 22	
1 " " 24	
2 " " 35	
27 " " 37a	
24 " " 37b	
2 " " 38	
2 " " 48a	
1 " " 52	

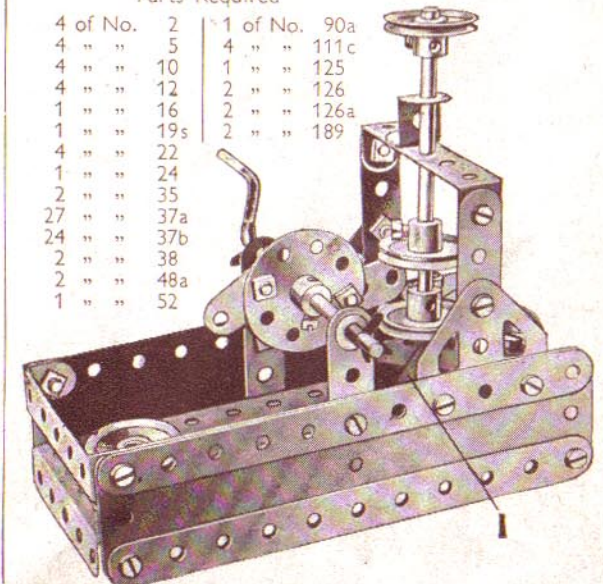

I.7 MOTOR LORRY

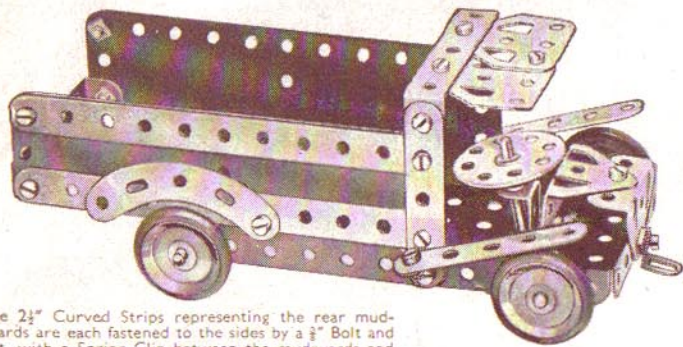

The 2½" Curved Strips representing the rear mudguards are each fastened to the sides by a ½" Bolt and nut, with a Spring Clip between the mudguards and the 5½" Strip to form a distance piece.

Parts Required			
4 of No. 2	4 of No. 22	2 of No. 48a	2 of No. 126
4 " " 5	1 " " 24	1 " " 52	2 " " 126a
3 " " 12	2 " " 35	2 " " 90a	4 " " 155
2 " " 16	23 " " 37a	3 " " 111c	2 " " 189
1 " " 17	19 " " 37b	1 " " 125	

I.8 MECHANICAL SHOVEL

The Bolts (1), on which the jib pivots, are lock-nutted. The shovel arm is pivoted on a 2" Rod and the shovel is supported by a Cord that passes over the ½" Bolt at the jib head and is fastened to a 2½" x ½" Double Angle Strip as shown. The Cord (2) is fastened to the jib and then passes over a 3¼" Rod journalled in the holes above the 2½" Curved Strips, and is attached to a Fishplate fastened by the lock-nutted Bolt (3) to the Bush Wheel.

When the Crank Handle is rotated, the Bush Wheel imparts a digging motion to the jib and shovel arm.

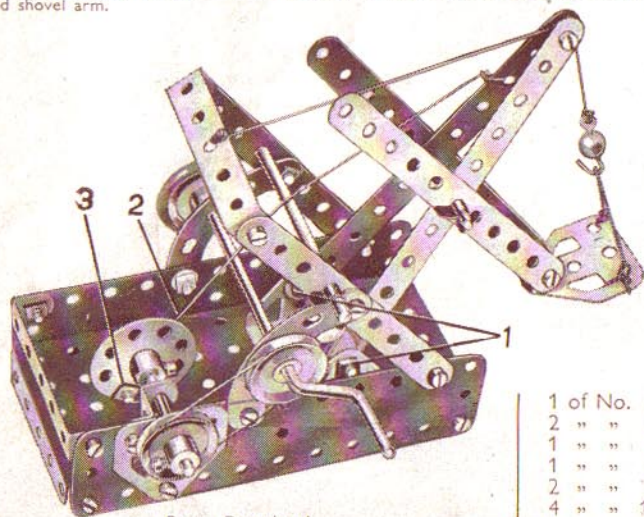

Parts Required		
4 of No. 2	1 of No. 16	1 of No. 24
4 " " 5	2 " " 17	28 " " 37a
1 " " 10	1 " " 19s	24 " " 37b
2 " " 12	3 " " 22	4 " " 38
		2 " " 40
		2 " " 48a
		1 " " 52
		1 " " 57c
		2 " " 90a
		4 " " 111c
		1 " " 125
		2 " " 126
		2 " " 126a
		1 " " 155
		2 " " 189

I.9 WINDMILL

The sails are gripped on the 3½" Rod by the 1" Pulley (with Rubber Ring) at the front and another 1" Pulley at the back of the sails. The Pulleys are pressed against the faces of the sails and locked on the Rod.

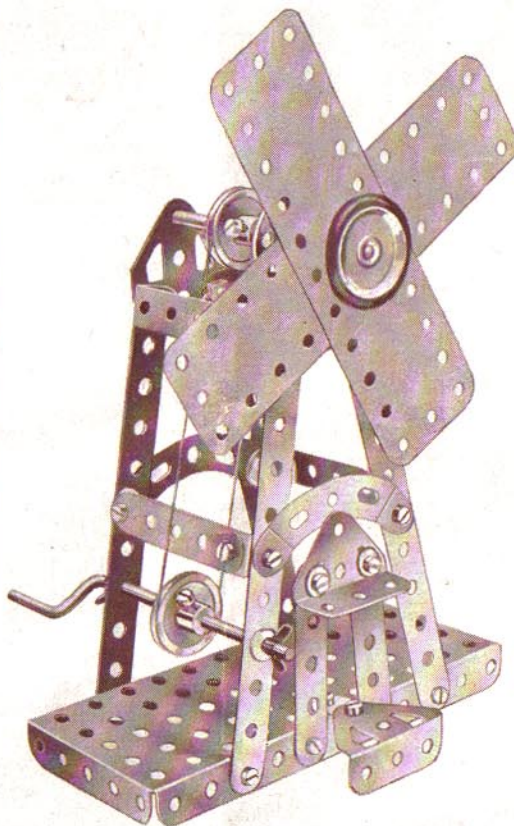

Parts Required		
4 of No. 2	1 of No. 24	1 of No. 52
4 " " 5	3 " " 35	2 " " 90a
1 " " 10	24 " " 37a	2 " " 126
4 " " 12	24 " " 37b	2 " " 126a
1 " " 16	4 " " 38	1 " " 155
1 " " 19s	1 " " 40	2 " " 189
4 " " 22	2 " " 48a	

I.10 COASTER

The Bolts (1) are lock-nutted. The rear axle Rod is pushed through the end hole of the Curved Strip (2) and through Fishplates bolted to the Flanged Plate.

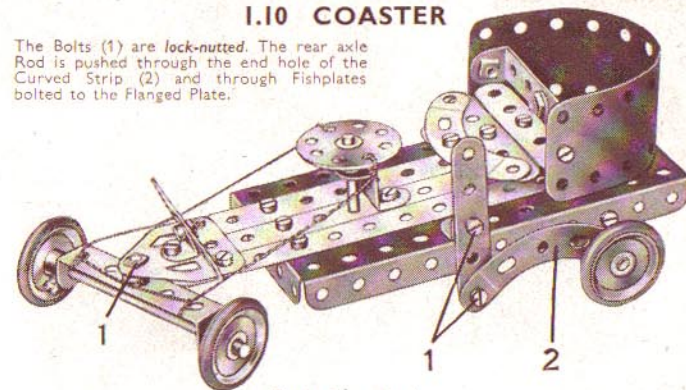

Parts Required			
3 of No. 2	4 of No. 22	1 of No. 40	2 of No. 126
4 " " 5	1 " " 24	2 " " 48a	2 " " 126a
2 " " 10	1 " " 35	1 " " 52	4 " " 155
5 " " 12	24 " " 37a	2 " " 90a	1 " " 189
2 " " 16	20 " " 37b	2 " " 111c	
1 " " 17	4 " " 38	1 " " 125	

I.11 STEAM WAGON

The front axle is supported in a 2½" x ½" Double Angle Strip (1) lock-nutted to a ½" Reversed Angle Bracket (2). The Reversed Angle Bracket is bolted to a 5½" Strip fixed to the centre of the Flanged Plate. The boiler is a 5½" x 1½" Flexible Plate rolled into a cylinder, and the Bush Wheel (3) is attached to an Angle Bracket. The roof is made from two Flat Trunnions bolted to a 2½" x ½" Double Angle Strip (4). The Curved Strips (5) are connected to the Flat Trunnions by Fishplates. A Trunnion (6) at each side is spaced from the Flanged Plate by two Washers.

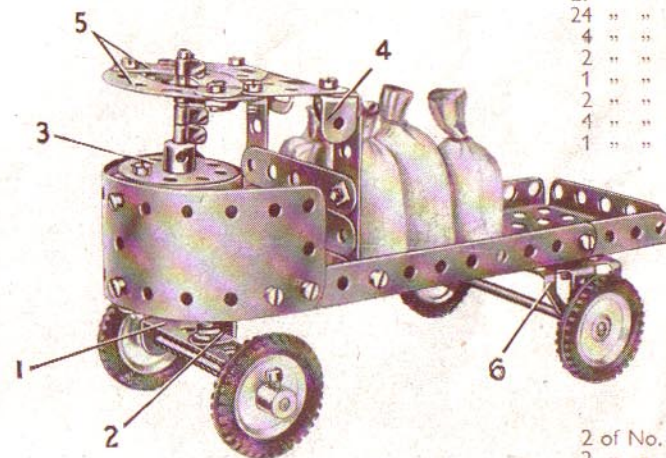

Note: The Loaded Sacks (Part No. 122) are not included in the Outfit

Parts Required	
3 of No. 2	2
4 " " 5	5
2 " " 10	10
4 " " 12	12
2 " " 16	16
1 " " 17	17
4 " " 22	22
1 " " 24	24
4 " " 35	35
29 " " 37a	37a
24 " " 37b	37b
4 " " 38	38
2 " " 48a	48a
1 " " 52	52
2 " " 90a	90a
4 " " 111c	111c
1 " " 125	125
2 of No. 126	126
2 " " 126a	126a
4 " " 142c	142c
2 " " 189	189

I.12 FLYING BOATS

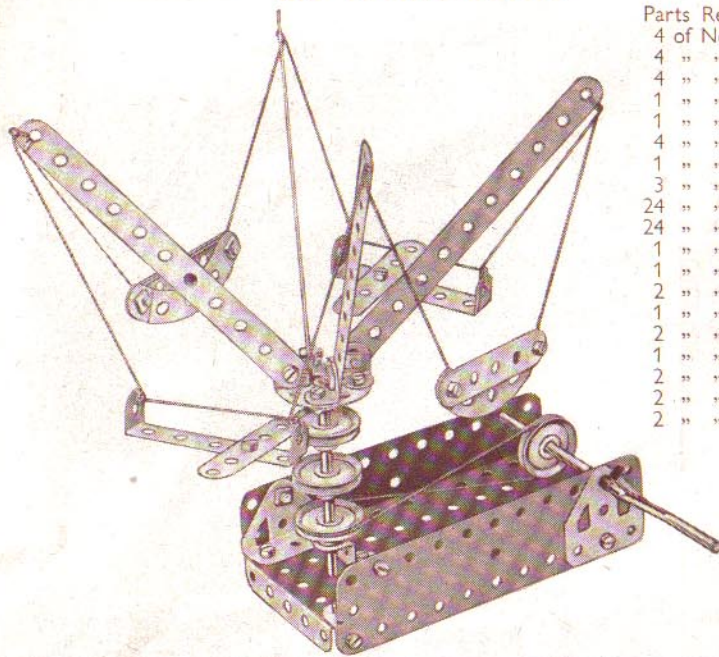

Parts Required

4 of No.	2
4 " "	5
4 " "	12
1 " "	16
1 " "	19s
4 " "	22
1 " "	24
3 " "	35
24 " "	37a
24 " "	37b
1 " "	38
1 " "	40
2 " "	48a
1 " "	52
2 " "	90a
1 " "	125
2 " "	126
2 " "	126a
2 " "	189

I.14 GYMNAST

The Bolts (1) are *lock-nutted*. The bearings for the Crank Handle in the Flexible Plates are reinforced by Trunnions bolted to the Flanged Plate.

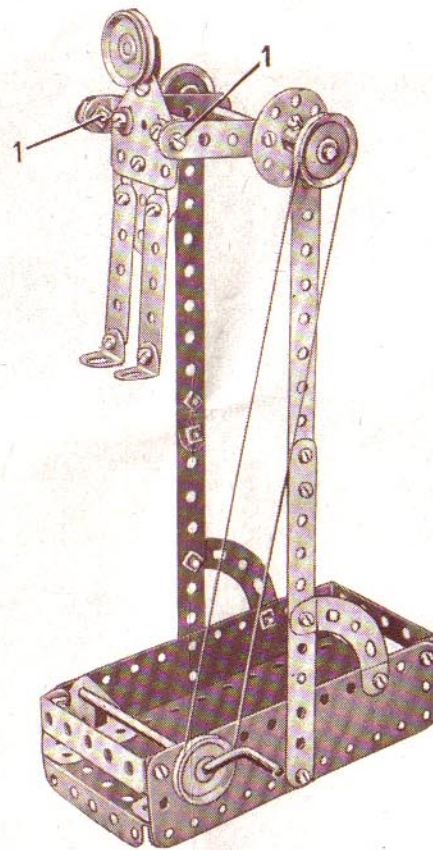

Parts Required

4 of No.	2	1 of No.	24	1 of No.	52
4 " "	5	2 " "	35	2 " "	90a
1 " "	10	29 " "	37a	4 " "	111c
4 " "	12	24 " "	37b	2 " "	126
1 " "	16	4 " "	38	2 " "	126a
1 " "	19s	1 " "	40	2 " "	189
4 " "	22	2 " "	48a		

I.15 SCALES

Parts Required

4 of No.	2
2 " "	5
2 " "	17
2 " "	22
1 " "	24
19 " "	37a
19 " "	37b
1 " "	38
1 " "	40
2 " "	48a
1 " "	52
2 " "	90a
1 " "	111c
2 " "	126
2 " "	126a
1 " "	155
2 " "	189

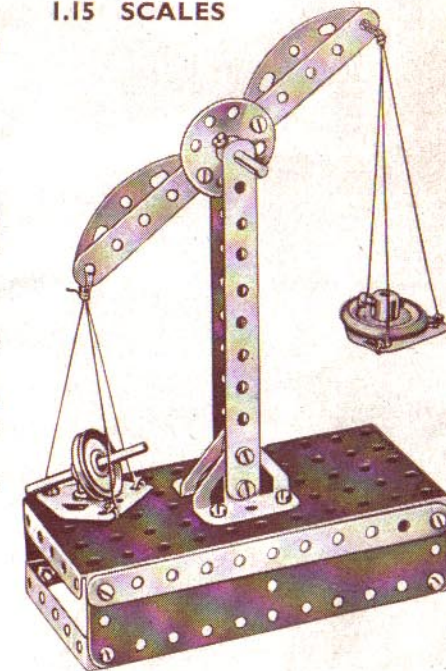

I.13 CIRCULAR SAW

The Bush Wheel (1) is fixed to a $3\frac{1}{8}$ " Rod that is passed through two Trunnions bolted to the Flanged Plate.

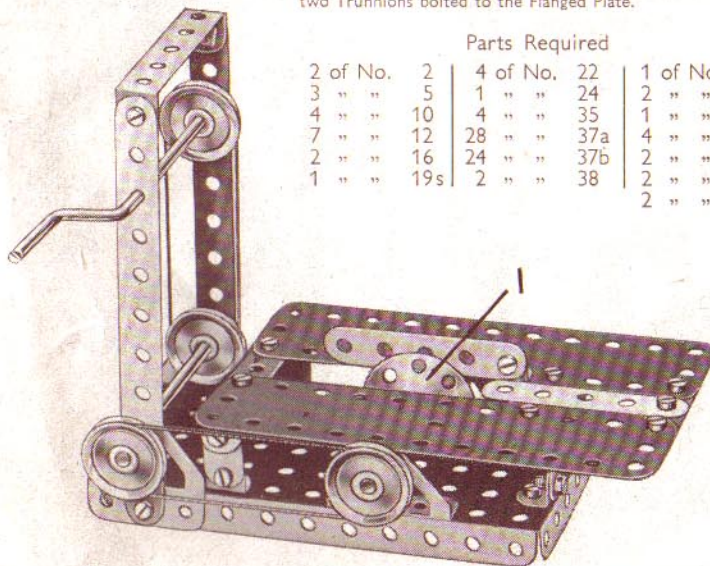

Parts Required

2 of No.	2	4 of No.	22	1 of No.	40
3 " "	5	1 " "	24	2 " "	48a
4 " "	10	4 " "	35	1 " "	52
7 " "	12	28 " "	37a	4 " "	111c
2 " "	16	24 " "	37b	2 " "	126
1 " "	19s	2 " "	38	2 " "	126a
				2 " "	189

I.16 DRILLING MACHINE

Parts Required

4 of No.	2	4 of No.	38
3 " "	5	1 " "	40
8 " "	12	1 " "	52
1 " "	16	2 " "	126
1 " "	17	2 " "	126a
1 " "	19s		
4 " "	22		
4 " "	35		
20 " "	37a		
20 " "	37b		

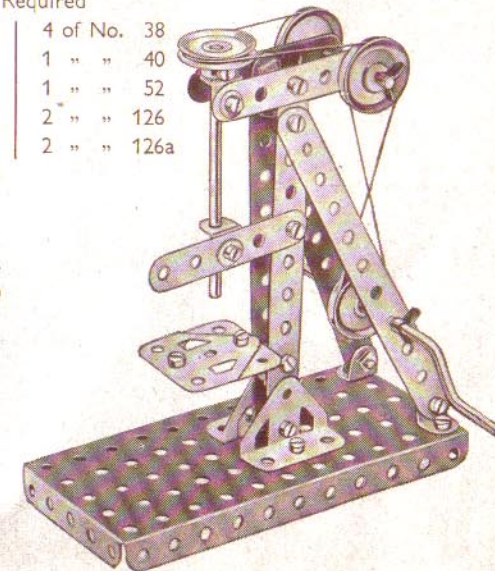

The drill table is made by bolting together two Flat Trunnions.

I.17 COSTER AND BARROW

The man's body is made from two $2\frac{1}{2}$ " x $\frac{3}{4}$ " Double Angle Strips, and a $\frac{1}{2}$ " Pulley (1) (supplied with the Magic Motor) is fixed on a 2" Rod that carries also a Bush Wheel (2). The leg (3) is lock-nutted to the Bush Wheel, and the foot, a 1" Pulley (4) with Rubber Ring, is attached by a Bolt passed through a Fishplate (5) and screwed into the boss of the Pulley. The head is a Flat Trunnion connected to an Angle Bracket.

To make the man walk successfully, the Pulley (4) and Fishplate (5) must be fixed as nearly as possible in the positions shown in the illustration.

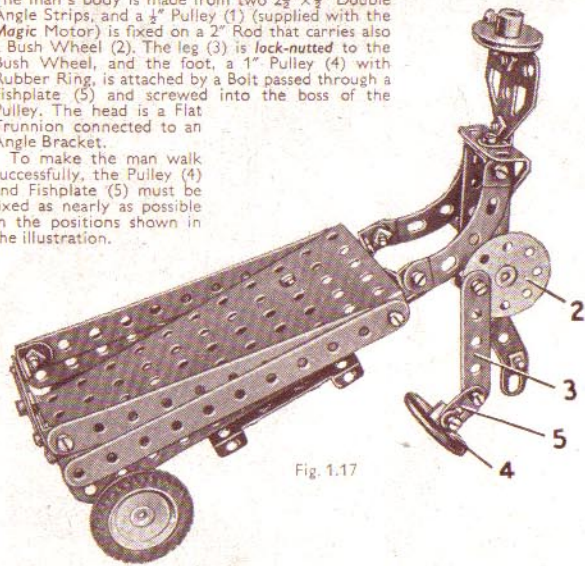

Fig. 1.17

Parts Required		Parts Required		1 Magic Clock-work Motor (not included in Outfit)
4 of No. 2	27 of No. 37a	2 of No. 126a		
3 " " 5	24 " " 37b	2 " " 142c		
4 " " 10	4 " " 38	1 " " 155		
6 " " 12	2 " " 48a			
1 " " 16	1 " " 52			
1 " " 17	2 " " 90a			
4 " " 22	3 " " 111c			
1 " " 24	1 " " 126			

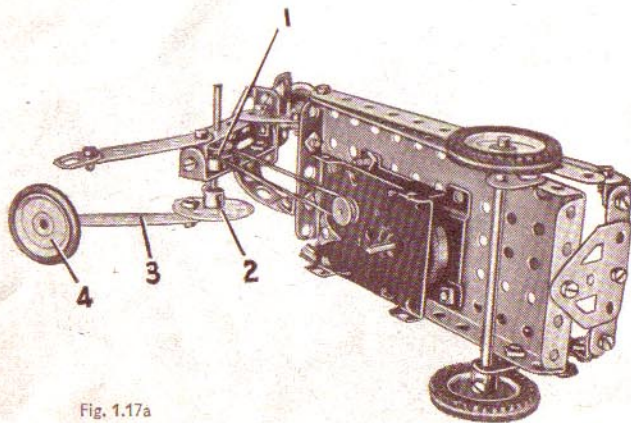
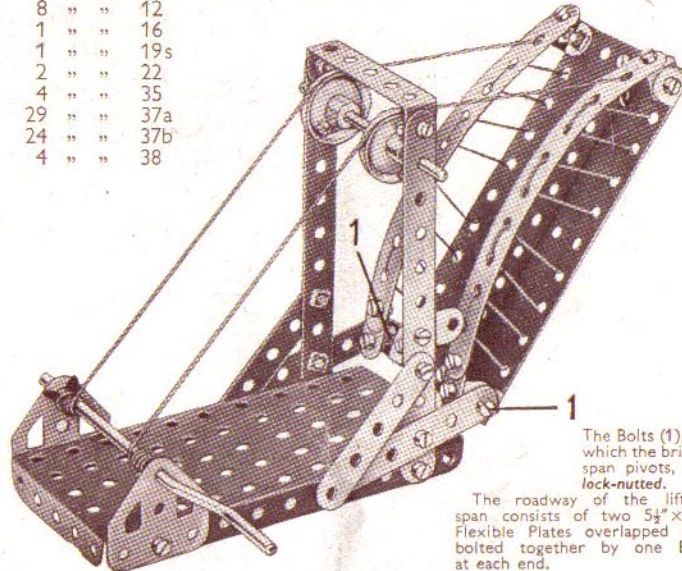

Fig. 1.17a

I.18 LIFTING BRIDGE

Parts Required		Parts Required	
4 of No. 2	1 of No. 40	3 of No. 111c	
4 " " 5	1 " " 48a	2 " " 126a	
3 " " 10	1 " " 52	2 " " 189	
8 " " 12			
1 " " 16			
1 " " 19s			
2 " " 22			
4 " " 35			
29 " " 37a			
4 " " 37b			
4 " " 38			



The Bolts (1), on which the bridge span pivots, are lock-nutted.

The roadway of the lifting span consists of two $5\frac{1}{2}$ " x $1\frac{1}{2}$ " Flexible Plates overlapped and bolted together by one Bolt at each end.

I.20 DERRICK CRANE

The jib is bolted to a Bush Wheel (1), which is fixed by its set-screw on a $\frac{3}{8}$ " Bolt passed through the Flanged Plate. The jib supporting Cord is passed round a 1" Pulley on a 2" Rod (2). This Rod is held in place by a Spring Clip placed underneath the Flat Trunnion.

The brake lever is lock-nutted to a $\frac{3}{8}$ " Reversed Angle Bracket (3). A brake is provided by a length of Cord passed over Pulley (4) and tied to the lever and to the Flanged Plate.

Parts Required		Parts Required		1 of No. 90a
4 of No. 2	4 of No. 35	21 " " 37a	2 " " 111c	
4 " " 5	20 " " 37b	1 " " 125	1 " " 126	
3 " " 12	1 " " 40	2 " " 126	1 " " 126a	
2 " " 17	2 " " 48a			
1 " " 19s	1 " " 52			
4 " " 22	1 " " 57c			
1 " " 24				

(Loaded Sack, Part No. 122, not included in Outfit)

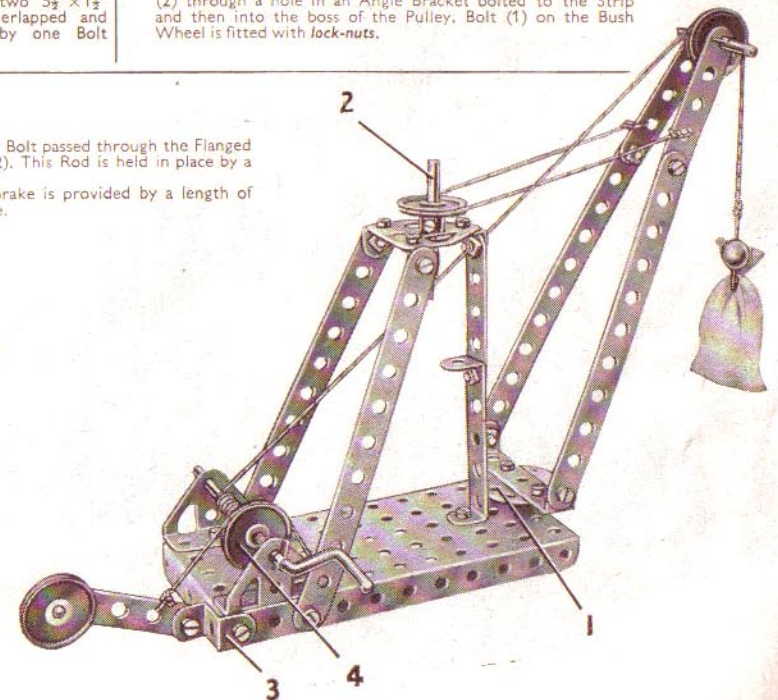

I.19 MECHANICAL SWING

Parts Required	
4 of No. 2	4 of No. 2
2 " " 5	2 " " 5
2 " " 10	2 " " 10
3 " " 12	3 " " 12
1 " " 16	1 " " 16
1 " " 19s	1 " " 19s
2 " " 22	2 " " 22
1 " " 24	1 " " 24
4 " " 35	4 " " 35
17 " " 37a	17 " " 37a
15 " " 37b	15 " " 37b
4 " " 38	4 " " 38
1 " " 40	1 " " 40
2 " " 48a	2 " " 48a
1 " " 52	1 " " 52
1 " " 111c	1 " " 111c
1 " " 125	1 " " 125
2 " " 126	2 " " 126
2 " " 189	2 " " 189

1 Magic Motor
(not included in Outfit)

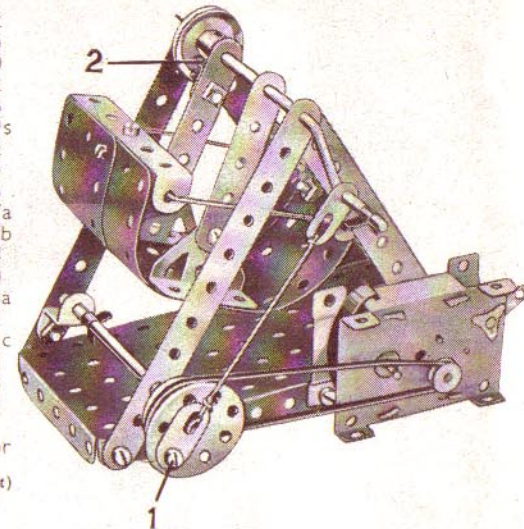

The left-hand $2\frac{1}{2}$ " Strip that supports the swing is connected to the Crank Handle by passing the set screw of the 1" Pulley (2) through a hole in an Angle Bracket bolted to the Strip and then into the boss of the Pulley. Bolt (1) on the Bush Wheel is fitted with lock-nuts.

I.21 OPEN TRAMCAR

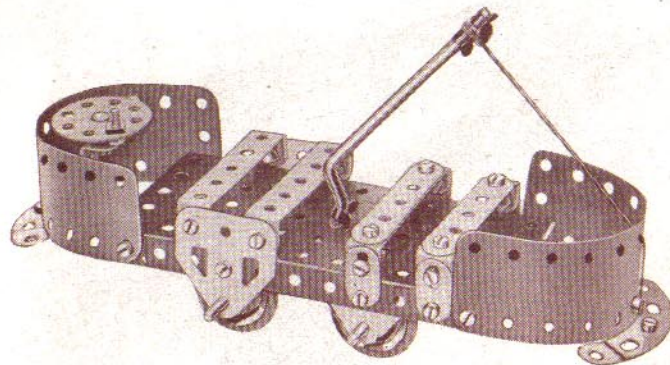

Parts Required		
2 of No. 5	1 of No. 19s	1 of No. 52
4 " " 10	4 " " 22	2 " " 90a
7 " " 12	1 " " 24	4 " " 111c
2 " " 16	4 " " 35	1 " " 125
	27 " " 37a	2 " " 126
	24 " " 37b	2 " " 126a
	1 " " 40	4 " " 155
	2 " " 48a	2 " " 189

I.22 FIRE ENGINE

Bolts (1) at each side are *lock-nutted*. The sides of the ladder are held together by two Angle Brackets (2), which are bolted together to form a 'U'-shaped bracket. The rear axle bearings (3) are Fishplates bolted inside the flange of the Flanged Plate. The Cord from the Crank Handle is tied in the fourth hole up the ladder so that when the Handle is turned it causes the ladder to lift.

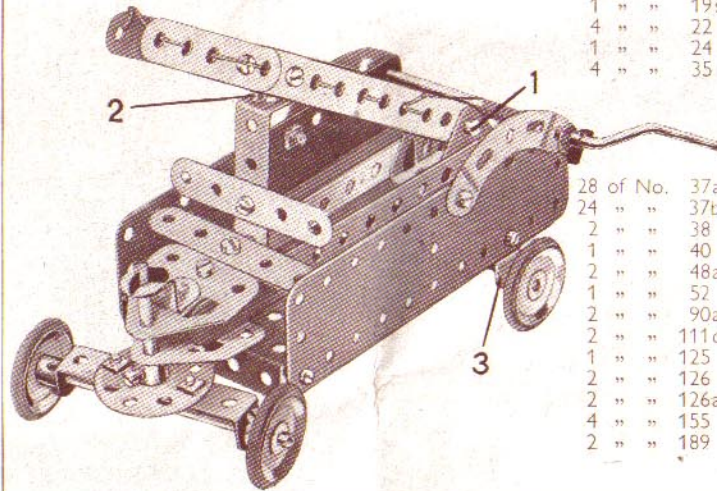

Parts Required	
4 of No. 2	
4 " " 5	
3 " " 10	
5 " " 12	
2 " " 16	
1 " " 17	
1 " " 19s	
4 " " 22	
1 " " 24	
4 " " 35	

28 of No. 37a	
24 " " 37b	
2 " " 38	
1 " " 40	
2 " " 48a	
1 " " 52	
2 " " 90a	
2 " " 111c	
1 " " 125	
2 " " 126	
2 " " 126a	
4 " " 155	
2 " " 189	

I.23 MOBILE CRANE

Parts Required		
4 of No. 2	4 of No. 35	3 of No. 111c
4 " " 5	29 " " 37a	1 " " 125
1 " " 10	23 " " 37b	2 " " 126
4 " " 12	2 " " 38	2 " " 126a
2 " " 16	1 " " 40	2 " " 142c
2 " " 17	2 " " 48a	2 " " 155
1 " " 19s	1 " " 52	2 " " 189
4 " " 22	1 " " 57c	
1 " " 24	2 " " 90a	

The rear wheels are fixed on a 2" Rod supported in two Trunnions (1) bolted tightly together by a 2" Bolt and nut. The Bolt is then passed through the Flanged Plate and is fitted with two nuts locked together, so that the wheels can pivot to steer the crane. The Bush Wheel (2) is on a 2" Rod passed through one of the jib supports and through a 2" Reversed Angle Bracket bolted to the support. A length of Cord tied to the Rod is attached to the rear end of the jib, and a Spring Clip and a Washer are used to prevent the Cord sliding off the Rod. The rear section of the jib is made from two 5 1/2" x 1 1/2" Flexible Plates joined by 'U'-shaped pieces, each made from two Angle Brackets bolted together. The 'U'-pieces are held by the Bolts (3) and (4).

For more new models to build, see the
MECCANO MAGAZINE
which is published on the first of every month.

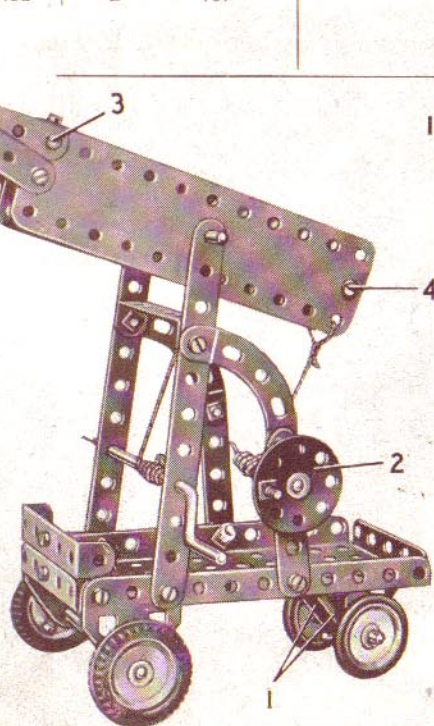

I.24 POWER PRESS

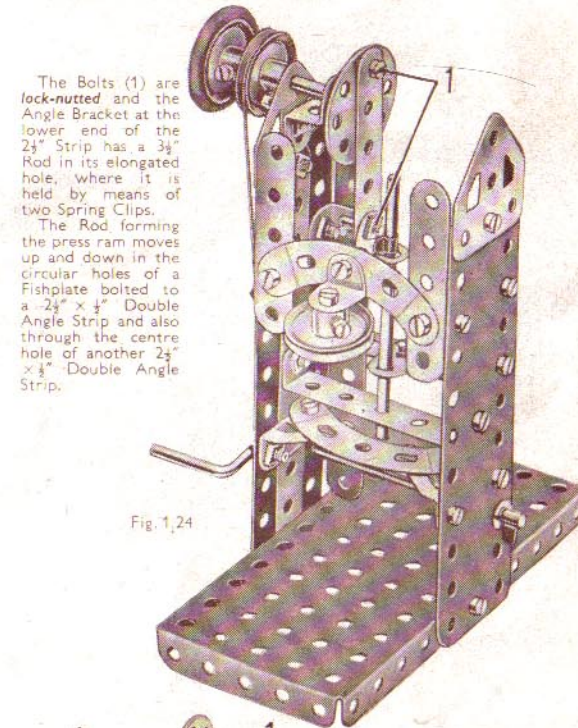

The Bolts (1) are *lock-nutted* and the Angle Bracket at the lower end of the 2 1/2" Strip has a 3/4" Rod in its elongated hole, where it is held by means of two Spring Clips. The Rod forming the press ram moves up and down in the circular holes of a Fishplate bolted to a 2 1/4" x 1/2" Double Angle Strip and also through the centre hole of another 2 1/4" x 1/2" Double Angle Strip.

Fig. 1.24

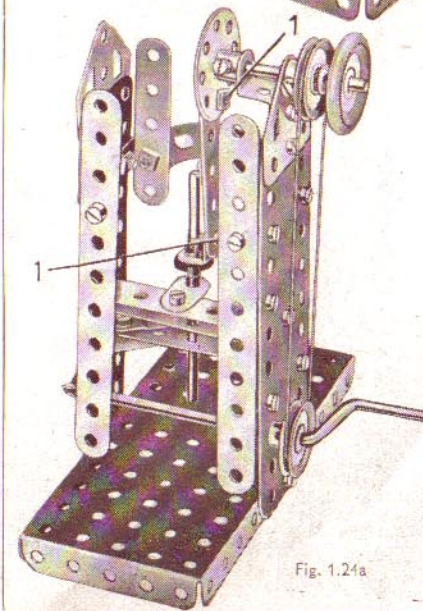

Parts Required	
4 of No. 2	
4 " " 5	
1 " " 10	
6 " " 12	
1 " " 16	
1 " " 17	
1 " " 19s	
4 " " 22	
1 " " 24	
3 " " 35	
29 " " 37a	
24 " " 37b	
1 " " 38	
1 " " 40	
2 " " 48a	
1 " " 52	
2 " " 90a	
4 " " 111c	
1 " " 125	
2 " " 126	
2 " " 126a	
1 " " 155	
2 " " 189	

Fig. 1.24a

1.25 TRIP HAMMER

Two Angle Brackets, one of which is seen at (1), are bolted together to form a 'U'-shaped bracket, and also are bolted to two 2½" Strips. The 1" fast Pulley (2) is fitted with a 1" Rubber Ring. The hammer striker is a 2½" Strip bolted to a Bush Wheel fixed on the Crank Handle.

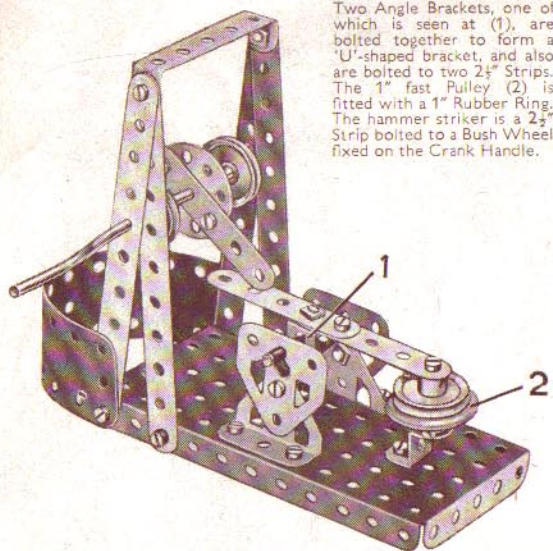

Parts Required			
4 of No.	2		
3 " "	5		
2 " "	12		
1 " "	17		
1 " "	19s		
4 " "	22		
1 " "	24		
4 " "	35		
17 " "	37a		
17 " "	37b		
1 " "	48a		
1 " "	52		
2 " "	111c		
1 " "	125		
2 " "	126		
2 " "	126a		
1 " "	155		
1 " "	189		

1.26 SIDE TIPPING WAGON

Parts Required

3 of No.	2	28 of No.	37a	1 of No.	125
4 " "	5	24 " "	37b	2 " "	126
4 " "	10	3 " "	38	2 " "	126a
7 " "	12	1 " "	40	4 " "	155
2 " "	16	2 " "	48a	2 " "	189
1 " "	17	1 " "	52		
4 " "	22	2 " "	90a		
1 " "	24	4 " "	111c		

1 Magic Motor
(not included in
Outfit)

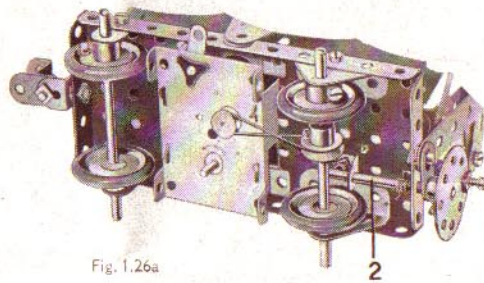

Fig. 1.26a

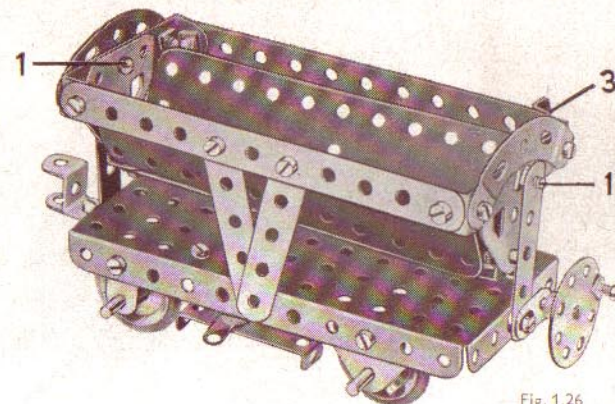

Fig. 1.26

Each of the Bolts (1) is lock-nutted. A piece of Cord is fastened to the Rod (2) (Fig. 1.26a) wrapped round it two or three times, and then is taken through the hole in the Flanged Plate above the Rod and secured to the Angle Bracket (3). By turning the Bush Wheel the container is tipped sideways.

1.27 TRAVELLING CRANE

Parts Required

4 of No.	2	1 of No.	17	20 of No.	37a	1 of No.	52
4 " "	5	1 " "	19s	20 " "	37b	1 " "	57c
4 " "	10	4 " "	22	4 " "	38	2 " "	90a
2 " "	12	1 " "	24	1 " "	40	1 " "	111c
2 " "	16	4 " "	35	1 " "	48a	2 " "	126
						2 " "	126a

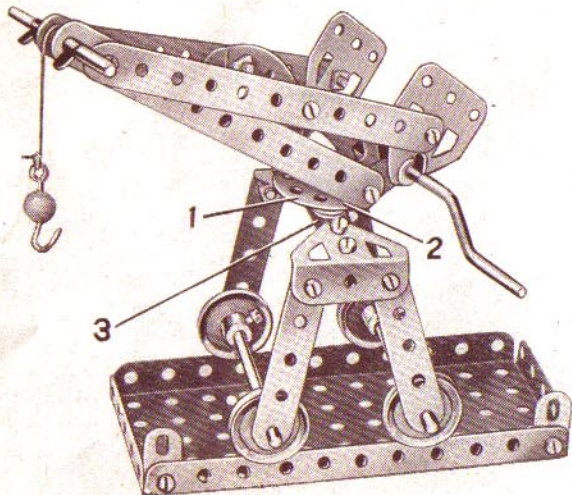

The sides of the jib are secured to the Bush Wheel (1) by two Angle Brackets (2), one on each side. A ½" Bolt is passed from the underneath side of Double Angle Strip (3) into the boss of the Bush Wheel (1) and the set screw is then tightened.

The Flat Trunnions at the lower end of the jib support the Crank Handle, which also passes through Fishplates bolted to the Angle Brackets (2) on the Bush Wheel (1). The Cord is fastened to the Crank Handle, and passes over the 2" Rod at the jib head.

1.28 ANTI-AIRCRAFT GUN

Parts Required

4 of No.	2
4 " "	5
1 " "	10
8 " "	12
2 " "	16
2 " "	17
1 " "	19s
4 " "	22
1 " "	24
4 " "	35
28 " "	37a
23 " "	37b
1 " "	38
2 " "	48a
1 " "	52
2 " "	90a
2 " "	111c
1 " "	125
2 " "	126
2 " "	126a
4 " "	142c
2 " "	189

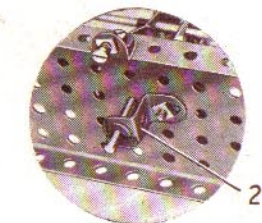

Fig. 1.28a

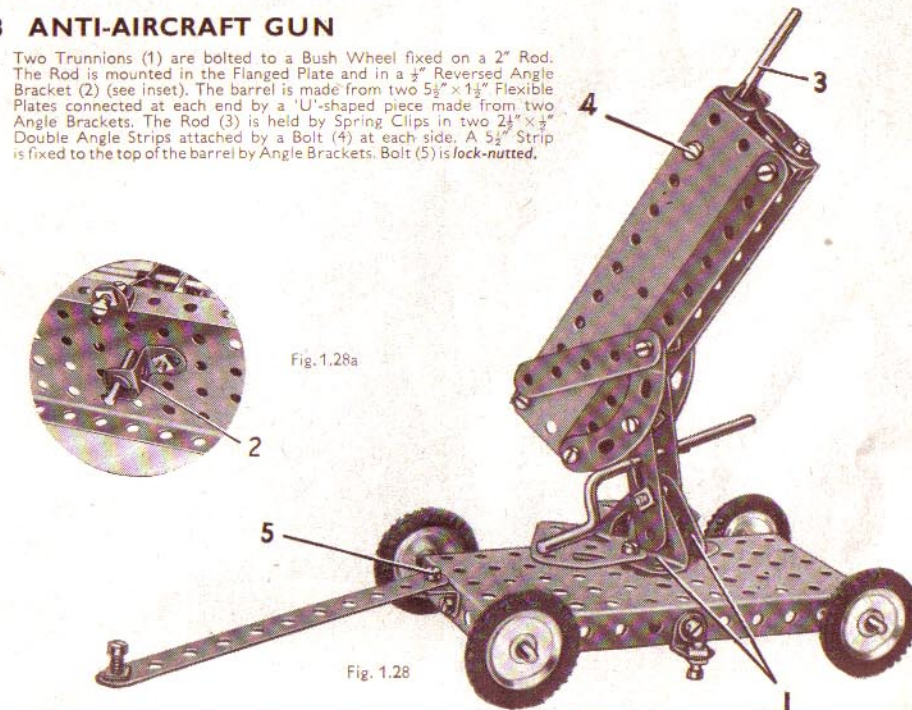

Fig. 1.28

1.29 PITHEAD GEAR

A Cord is taken from each side of the lift cage over the 1" Pulleys and secured to each end of the Crank Handle. The Cords must both be the same length, otherwise the lift will tilt.

The two guides for the lift consist of two pieces of Cord fastened to the Washers (1). The Cords are then passed through holes in the Double Angle Strip, through two corresponding holes in the lift cage (2), and then through the two corresponding holes in the Flanged Plate. Two more Washers are tied to the Cords beneath the Flanged Plate to keep the Cords tight. The lift cage (2) is made up of two Trunnions.

Note: In the illustration part of the 5 1/2" x 1 1/2" Flexible Plate forming one side of the tower is cut away to reveal the cage.

Parts Required

4 of No. 2	4 of No. 38
4 " " 5	1 " " 40
4 " " 10	2 " " 48a
2 " " 12	1 " " 52
1 " " 16	1 " " 90a
1 " " 19s	4 " " 111c
4 " " 22	2 " " 126
4 " " 35	2 " " 126a
24 " " 37a	2 " " 189
20 " " 37b	

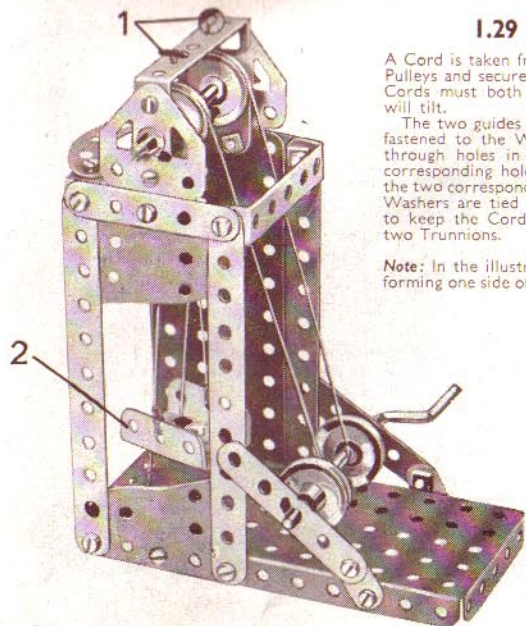

1.30 HORIZONTAL ENGINE

The cylinder is made from two 5 1/2" x 1 1/2" Flexible Plates rolled to shape and bolted to the base. The Bush Wheel (1) is fixed to an Angle Bracket. The crankshaft consists of two 2" Rods. One of them is passed through a Flat Trunnion, and the other is mounted in a Flat Trunnion and a 1" Reversed Angle Bracket (2). A 1" Pulley is fixed on the inner end of each 2" Rod, and an Angle Bracket (3) is fastened to the boss of each Pulley. A bolt fitted with a nut is passed through the hole of the Angle Bracket, and is screwed into the boss of the Pulley. The nut is then tightened against the Angle Bracket to hold it in position. A third Angle Bracket is similarly attached to a Pulley (4).

The connecting rod pivots on a 1/2" Bolt (5). This is passed through one of the Angle Brackets (3) and is held by a nut. The connecting rod is slipped over the Bolt, which is then fixed in the second Angle Bracket (3) by two nuts. The valve-operating rod is lock-nutted to the Angle Bracket fixed to Pulley (4).

Parts Required

4 of No. 2	4 of No. 35	4 of No. 111c
3 " " 5	30 " " 37a	1 " " 125
1 " " 10	22 " " 37b	2 " " 126
5 " " 12	1 " " 38	2 " " 126a
	2 " " 48a	2 " " 189
	1 " " 52	1 Magic Motor
		(not included in Outfit)

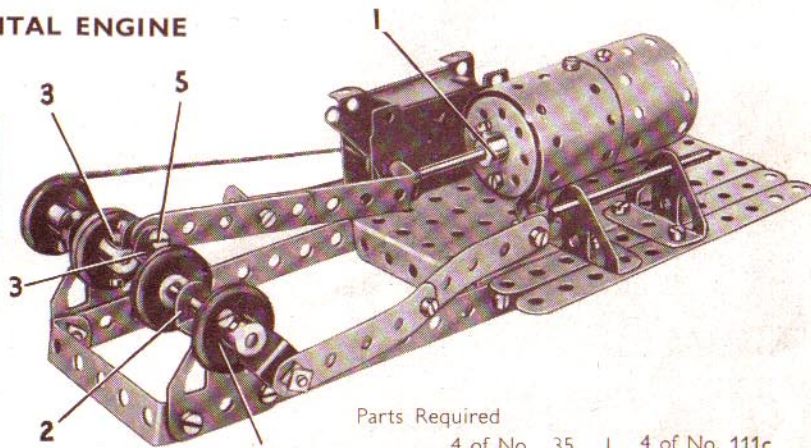

1.31 TELPHER SPAN

The anchoring piece (1) consists of two Trunnions bolted together, and a hook, which is made of two Angle Brackets, fastened to them. A 2" Rod carrying a 1" fast Pulley is journaled in the Trunnions. The anchoring piece is hooked on a picture rail or other suitable support and the Cord (2), which can be of any length, is passed round the 1" Pulleys as shown. When the Crank Handle is rotated the car moves either backward or forward.

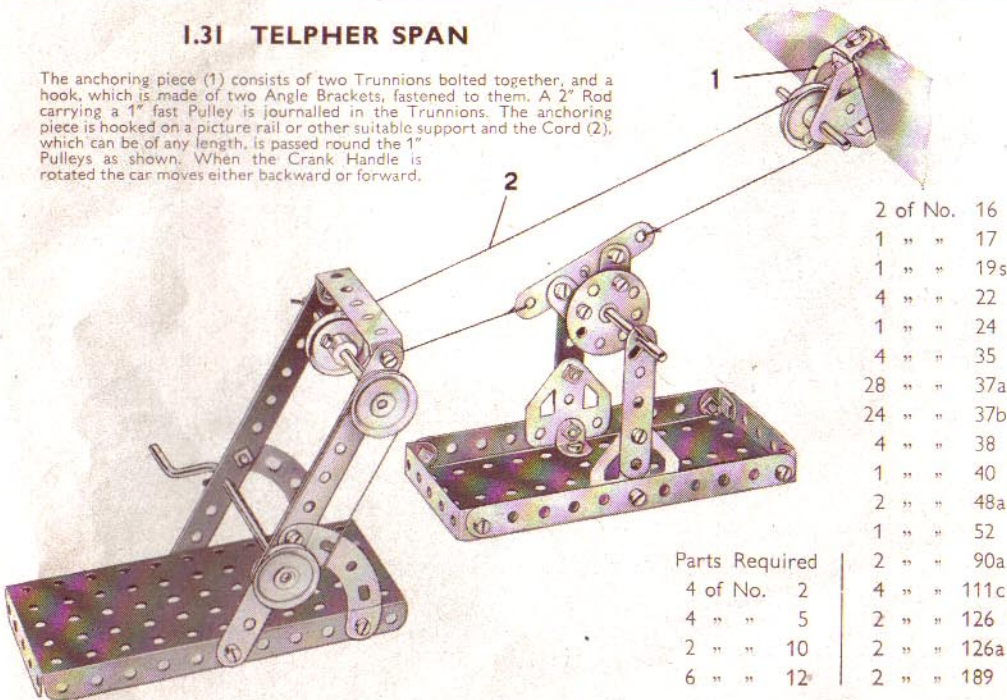

2 of No. 16
1 " " 17
1 " " 19s
4 " " 22
1 " " 24
4 " " 35
28 " " 37a
24 " " 37b
4 " " 38
1 " " 40
2 " " 48a
1 " " 52
2 " " 90a
4 " " 111c
2 " " 126
2 " " 126a
2 " " 189

Parts Required

4 of No. 2
4 " " 5
2 " " 10
6 " " 12

1.32 TRICYCLE ROUNDABOUT

The Curved Strips (1) are attached to Angle Brackets bolted to a 2 1/2" Strip (2). A Washer is placed on a Bolt (3) on each side before the nut is tightened, to locate it in the Flat Trunnion. The Flat Trunnion is fixed to an Angle Bracket, and the 1" Pulley (4) is held by its set-screw on a 3/8" Bolt passed through a 2 1/2" Strip (5). The model is set in motion by turning the Crank Handle.

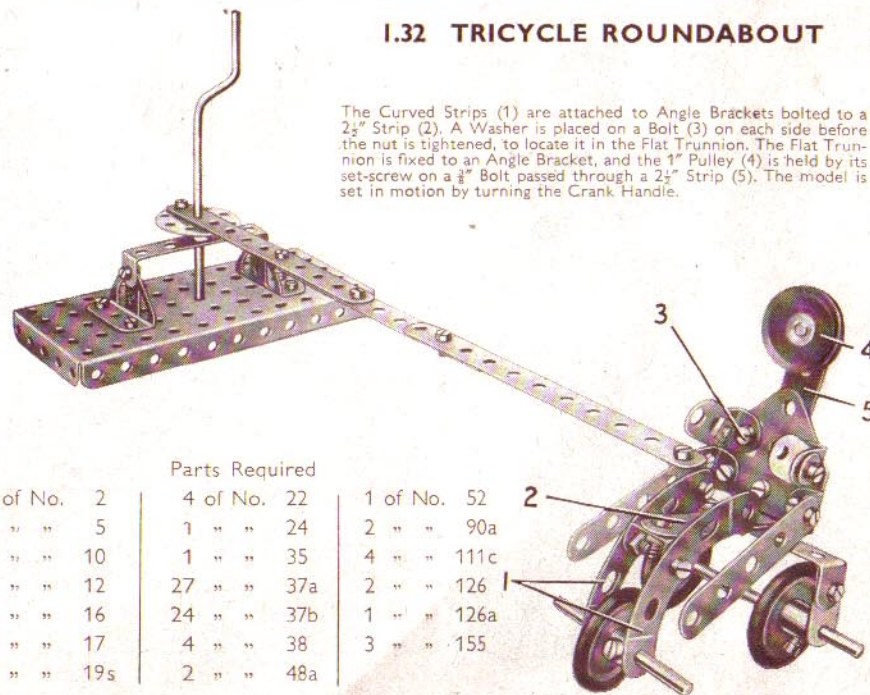

Parts Required

3 of No. 2	4 of No. 22	1 of No. 52
4 " " 5	1 " " 24	2 " " 90a
4 " " 10	1 " " 35	4 " " 111c
8 " " 12	27 " " 37a	2 " " 126
1 " " 16	24 " " 37b	1 " " 126a
1 " " 17	4 " " 38	3 " " 155
1 " " 19s	2 " " 48a	

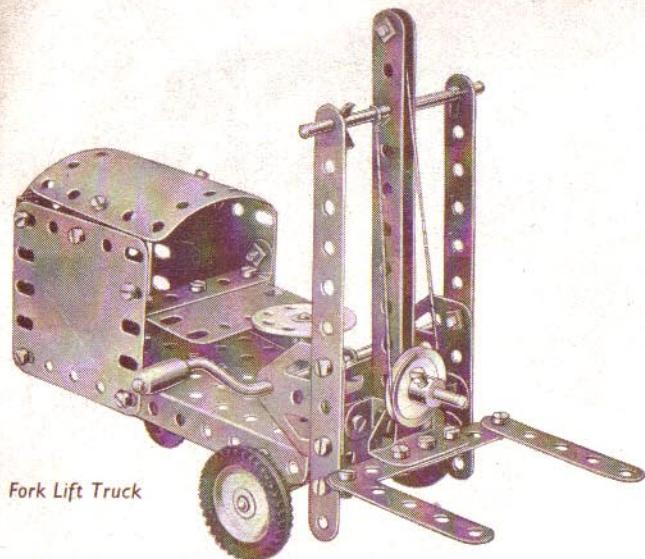

Fork Lift Truck

HOW TO CONTINUE

When you have built all the models shown in this Book of Instructions, you will be keen to build others bigger and more elaborate. Your next step is to purchase a Meccano No. 1a Accessory Outfit containing all the parts required to convert your No. 1 into a No. 2 Outfit. You will then be able to build the full range of No. 2 Outfit models, a few of which are illustrated on this page.

If you prefer to do so, you can build up and develop your Outfit quite easily by adding various parts to it from time to time. The variety of models you can make with Meccano is almost unlimited, and the more Meccano parts you have the bigger and better your models will be.

BUILD BIGGER AND BETTER MODELS

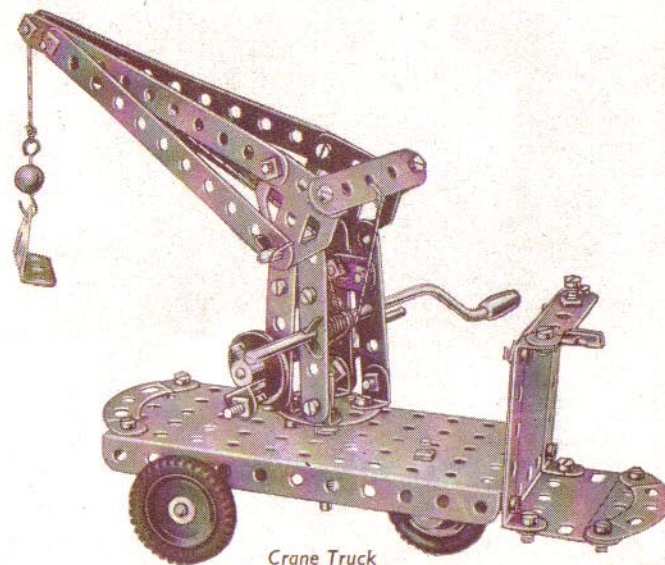

Crane Truck

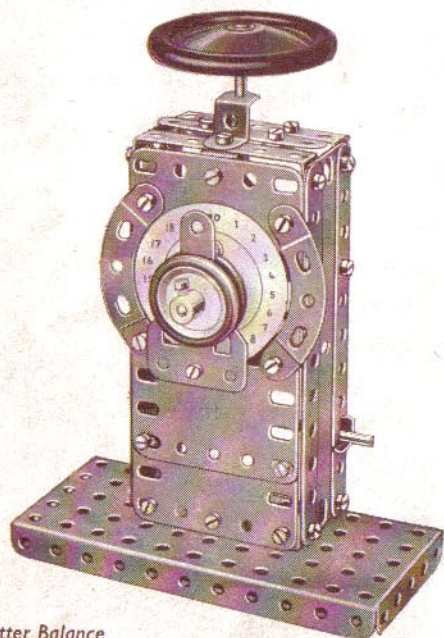

Letter Balance

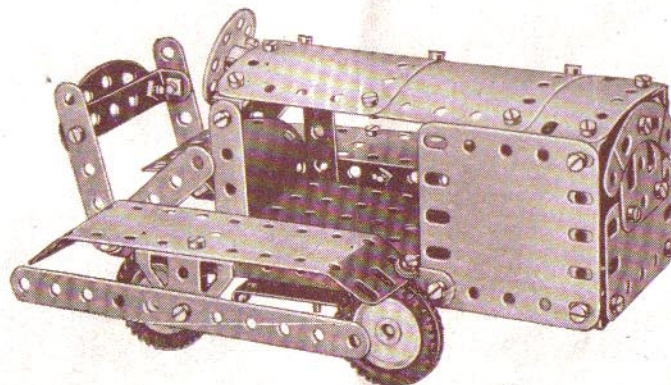

Tractor

Here is a selection of five models that are illustrated and described in the Instructions Book packed with Meccano Outfit No. 2.

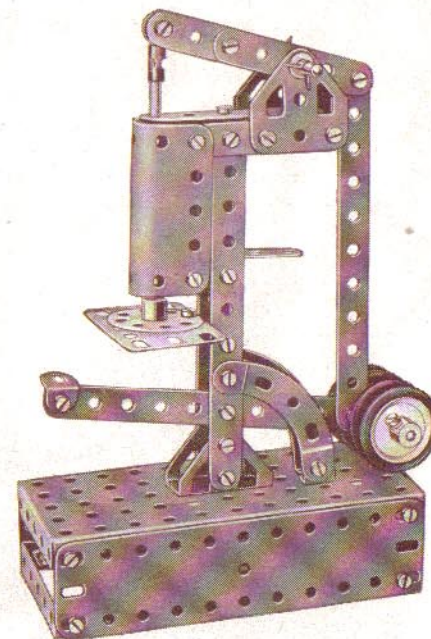

Punching Machine

MECCANO PARTS



PERFORATED STRIPS

- | | | | | | | | | |
|-----|-----|--------------------|-----|-----|-------------------|-----|-----|-------------------|
| No. | 1. | 12 $\frac{1}{2}$ " | No. | 2a. | 4 $\frac{1}{2}$ " | No. | 6. | 2" |
| | 1a. | 9 $\frac{1}{2}$ " | | 3. | 3 $\frac{1}{2}$ " | | 6a. | 1 $\frac{1}{2}$ " |
| | 1b. | 7" | | 4. | 3" | | | |
| | 2. | 5 $\frac{1}{2}$ " | | 5. | 2 $\frac{1}{2}$ " | | | |

ANGLE GIRDERS

- | | | | | | |
|-----|--------------------|-----|-------------------|-----|-------------------|
| 7. | 2 $\frac{1}{2}$ " | 8b. | 7 $\frac{1}{2}$ " | 9c. | 3" |
| 7a. | 18 $\frac{1}{2}$ " | 9. | 5 $\frac{1}{2}$ " | 9d. | 2 $\frac{1}{2}$ " |
| 8. | 12 $\frac{1}{2}$ " | 9a. | 4 $\frac{1}{2}$ " | 9e. | 2" |
| 8a. | 9 $\frac{1}{2}$ " | 9b. | 3 $\frac{1}{2}$ " | 9f. | 1 $\frac{1}{2}$ " |



10. Fishplate | 11. Double Bracket

ANGLE BRACKETS

- | | | | |
|------|---------------------------------------|------|---|
| 12. | 1 $\frac{1}{2}$ " x 1 $\frac{1}{2}$ " | 12b. | 1" x 1 $\frac{1}{2}$ " |
| 12a. | 1" x 1" | 12c. | Obtuse, 1 $\frac{1}{2}$ " x 1 $\frac{1}{2}$ " |



AXLE RODS

- | | | | | | |
|------|---|------|-------------------|------|-------------------|
| 13. | 11 $\frac{1}{2}$ " | 15a. | 4 $\frac{1}{2}$ " | 16b. | 3" |
| 13a. | 8" | 15b. | 4" | 17. | 2" |
| 14. | 6 $\frac{1}{2}$ " | 16. | 3 $\frac{1}{2}$ " | 18a. | 1 $\frac{1}{2}$ " |
| 15. | 5" | 16a. | 2 $\frac{1}{2}$ " | 18b. | 1" |
| 19g. | Crank Handle, 3 $\frac{1}{2}$ " shaft, with grip | | | | |
| 19h. | Crank Handle, 5" shaft, with grip | | | | |
| 19s. | Crank Handle, 3 $\frac{1}{2}$ " shaft, without grip | | | | |



- 19a. Spoked Wheel, 3" diam.
20. Flanged Wheel, 1 $\frac{1}{2}$ " diam.
20b. Flanged Wheel, 1" diam.



PULLEYS

- 19b. 3" diam., with boss and screw
19c. 6" diam., with boss and screw
20a. 2" diam., with boss and screw
21. 1 $\frac{1}{2}$ " diam., with boss and screw
22. 1" diam., with boss and screw



PULLEYS

- 22a. 1" diam., without boss
23. 1 $\frac{1}{2}$ " diam., without boss
23a. 1" diam., with boss and screw



- No. 24. Bush Wheel, 1 $\frac{1}{2}$ " diam., eight holes
24a. Wheel Disc, 1 $\frac{1}{2}$ " diam., without boss, eight holes
24b. Bush Wheel, 1 $\frac{1}{2}$ " diam., six holes
24c. Wheel Disc, 1 $\frac{1}{2}$ " diam., without boss, six holes

PINIONS

25. 1 $\frac{1}{2}$ " diam., 25 teeth
25a. 1 $\frac{1}{2}$ " diam., 25 teeth
25b. 1 $\frac{1}{2}$ " diam., 25 teeth
26. 1" diam., 19 teeth
26a. 1" diam., 19 teeth
26b. 1" diam., 19 teeth
26c. 1 $\frac{1}{2}$ " diam., 15 teeth



GEAR WHEELS

27. 1 $\frac{1}{2}$ " diam., 50 teeth
27a. 1 $\frac{1}{2}$ " diam., 57 teeth
27b. 3 $\frac{1}{2}$ " diam., 133 teeth
27c. 2 $\frac{1}{2}$ " diam., 95 teeth
27d. 1 $\frac{1}{2}$ " diam., 60 teeth



CONTRATE WHEELS

28. 1 $\frac{1}{2}$ " diam., 50 teeth
29. 1 $\frac{1}{2}$ " diam., 25 teeth

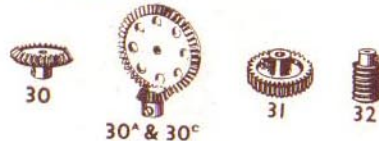

30. Bevel Gear, 1 $\frac{1}{2}$ " diam., 26 teeth (for use in pairs)
30a. Bevel Gear, 1 $\frac{1}{2}$ " diam., 16 teeth } Can only be used together
30c. Bevel Gear, 1 $\frac{1}{2}$ " diam., 48 teeth
31. Gear Wheel, 1" diam., 1" face, 38 teeth
32. Worm, 1" diam.



34. Spanner
34b. Box Spanner
35. Spring Clip
36. Screwdriver
36a. Screwdriver (longer)
36c. Drift (for levering bolt holes into line)
37. Nut and Bolt, 1 $\frac{1}{2}$ "
37a. Nut
37b. Bolt, 1 $\frac{1}{2}$ "
38. Washer
38d. Washer, 3 $\frac{1}{2}$ "
40. Hank of Cord



41. Propeller Blade | 43. Tension Spring, 2" long



- No. 44. Bent Strip, stepped
45. Double Bent Strip
46. Bent Strip, stepped

DOUBLE ANGLE STRIPS

- | | | | | | |
|------|---------------------------------------|------|------------------------|------|------------------------|
| 46. | 2 $\frac{1}{2}$ " x 1" | 48. | 1 $\frac{1}{2}$ " x 1" | 48c. | 4 $\frac{1}{2}$ " x 1" |
| 47. | 2 $\frac{1}{2}$ " x 1 $\frac{1}{2}$ " | 48a. | 2 $\frac{1}{2}$ " x 1" | 48d. | 3 $\frac{1}{2}$ " x 1" |
| 47a. | 3" x 1 $\frac{1}{2}$ " | 48b. | 3" x 1" | | |



50. Slide Piece
51. Flanged Plate, 2 $\frac{1}{2}$ " x 1 $\frac{1}{2}$ "
52. Flanged Plate, 3 $\frac{1}{2}$ " x 2 $\frac{1}{2}$ "
52a. Flat Plate, 5 $\frac{1}{2}$ " x 3 $\frac{1}{2}$ "
53. Flanged Plate, 3 $\frac{1}{2}$ " x 2 $\frac{1}{2}$ "
53a. Flat Plate, 4 $\frac{1}{2}$ " x 2 $\frac{1}{2}$ "



54. Flanged Sector Plate, 4 $\frac{1}{2}$ " long
55. Perforated Strip, slotted, 5 $\frac{1}{2}$ " long
55a. Perforated Strip, slotted, 2" long



- 57b. Hook, Loaded, Large
57c. Hook, Loaded, Small
58. Spring Cord, 40" length
58a. Coupling Screw for Spring Cord
58b. Hook for Spring Cord
59. Collar, with screw



61. Windmill Sail
62. Crank
62a. Threaded Crank
62b. Double Arm Crank



63. Coupling Strip Coupling
63c. Threaded Coupling
63d. Short Coupling



64. Threaded Boss
65. Centre Fork
69. Set Screw, 1 $\frac{1}{2}$ "
69a. Grub Screw, 1 $\frac{1}{2}$ "
69b. Grub Screw, 1 $\frac{1}{2}$ "
69c. Grub Screw, 1 $\frac{1}{2}$ "

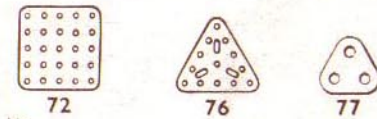

- No. 72. Flat Plate, 5 $\frac{1}{2}$ " x 2 $\frac{1}{2}$ "
76. Triangular Plate, 2 $\frac{1}{2}$ "
77. Triangular Plate, 1 $\frac{1}{2}$ "



SCREWED RODS

- | | | | | | |
|------|--------------------|------|-------------------|------|----|
| 78. | 11 $\frac{1}{2}$ " | 80. | 5" | 80c. | 3" |
| 79. | 8" | 80a. | 3 $\frac{1}{2}$ " | 81. | 2" |
| 79a. | 6" | 80b. | 4 $\frac{1}{2}$ " | 82. | 1" |

CURVED STRIPS

89. 5 $\frac{1}{2}$ " (10" radius)
89a. Stepped, 3" (1 $\frac{1}{2}$ " radius)
89b. Stepped, 4" (4 $\frac{1}{2}$ " radius)
90. 2 $\frac{1}{2}$ " (2 $\frac{1}{2}$ " radius)
90a. Stepped, 2 $\frac{1}{2}$ " (1 $\frac{1}{2}$ " radius)



94. Sprocket Chain, 40" length
95. 2" diam., 36 teeth
95a. 1 $\frac{1}{2}$ " diam., 28 teeth
95b. 3" diam., 56 teeth
96. 1" diam., 18 teeth
96a. 1" diam., 14 teeth

SPROCKET WHEELS



BRACED GIRDERS

- | | | | | | |
|------|------------------------|------|-------------------------|-------|------------------------|
| 97. | 3 $\frac{1}{2}$ " long | 99. | 12 $\frac{1}{2}$ " long | 100. | 5 $\frac{1}{2}$ " long |
| 97a. | 3" long | 99a. | 9 $\frac{1}{2}$ " long | 100a. | 4 $\frac{1}{2}$ " long |
| 98. | 2 $\frac{1}{2}$ " long | 99b. | 7 $\frac{1}{2}$ " long | | |



101. Head for Loom | 102. Single Bent Strip

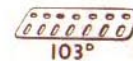

FLAT GIRDERS

- | | | | | | |
|-------|-------------------------|-------|------------------------|-------|------------------------|
| 103. | 5 $\frac{1}{2}$ " long | 103d. | 3 $\frac{1}{2}$ " long | 103h. | 1 $\frac{1}{2}$ " long |
| 103a. | 9 $\frac{1}{2}$ " long | 103e. | 3" long | 103k. | 7 $\frac{1}{2}$ " long |
| 103b. | 12 $\frac{1}{2}$ " long | 103f. | 2 $\frac{1}{2}$ " long | | |
| 103c. | 4 $\frac{1}{2}$ " long | 103g. | 2" long | | |

MECCANO PARTS

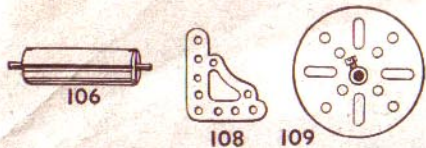

- No.
106. Wood Roller (complete with Rod and two Collars)
108. Corner Gusset
109. Face Plate, 2½" diam.

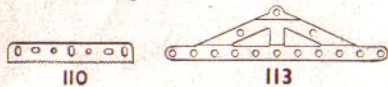

110. Rack Strip, 3½" long | 110a. Rack Strip, 6½" long

BOLTS

111. ¼" | 111c. ¼"
111a. ¼" | 111d. ¼"

113. Girder Frame

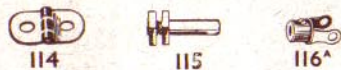

114. Hinge
115. Threaded Pin | 116. Fork Piece, large
116a. Fork Piece, small



118. Hub Disc, 5½" diam.



- 120b. Compression Spring, 7/16" long
122. Loaded Sack



123. Cone Pulley, 1½", 1" and ¾" diam.
124. Reversed Angle Bracket, 1"
125. Reversed Angle Bracket, ½"



126. Trunnion
126a. Flat Trunnion
128. Bell Crank, with Boss



- No.
130. Eccentric, Triple Throw, ½", ¾" and 1"
130a. Eccentric, Single Throw, ½"

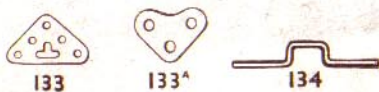

133. Corner Bracket, 1½"
133a. Corner Bracket, 1"
134. Crank Shaft, 1" stroke



136. Handrail Support | 136a. Handrail Coupling



137. Wheel Flange | 138. Ship's Funnel, Raked



139. Flanged Bracket (right)
139a. Flanged Bracket (left)
140. Universal Coupling



- 142a. Motor Tyre (to fit 2" diam. rim)
142b. Motor Tyre (to fit 3" diam. rim)
142c. Motor Tyre (to fit 1" diam. rim)
142d. Motor Tyre (to fit 1½" diam. rim)
143. Circular Girder, 5½" diam.
144. Dog Clutch

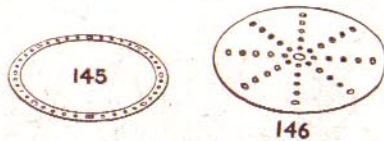

145. Circular Strip, 7½" diam. overall
146. Circular Plate, 6" diam. overall
146a. Circular Plate, 4" diam. overall

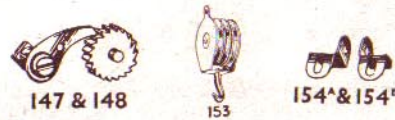

- No.
147. Pawl, with Pivot Bolt and Nuts
147a. Pawl
147b. Pivot Bolt, with two Nuts
147c. Pawl, without boss
148. Ratchet Wheel
151. Single Pulley Block
153. Triple Pulley Block
154a. Corner Angle Bracket, ½" (right-hand)
154b. Corner Angle Bracket, ½" (left-hand)
155. Rubber Ring (for 1" Pulley)



157. Fan, 2" diam.
160. Channel Bearing, 1½" x 1" x ½"
161. Girder Bracket, 2" x 1" x ½"

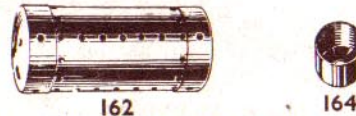

162. Boiler, complete, 5" long x 2½" diam.
162a. Boiler Ends, 2½" diam. x ¾"
163. Sleeve Piece, 1½" long x 1½" diam.
164. Chimney Adaptor, ¾" diam. x ½" high



165. Swivel Bearing
166. End Bearing
167b. Flanged Ring, 9½" diam.
168. Ball Thrust Bearing, 4" diam.
168a. Ball Thrust Race, flanged disc, 3½" diam.
168b. Ball Thrust Race, toothed disc, 4" diam.
168c. Ball Cage, 3½" diam., complete with balls
168d. Ball, ¾" diam.

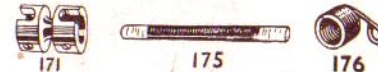

171. Socket Coupling
173a. Adaptor for Screwed Rod
175. Flexible Coupling Unit
176. Anchoring Spring for Cord



179. Rod Socket
180. Gear Ring, 3½" diam. (133 ext. teeth, 95 int.)



- No.
185. Steering Wheel, 1½" diam.

DRIVING BANDS

186. 2½" (light) | 186c. 10" (heavy)
186a. 6" (light) | 186d. 15" (heavy)
186b. 10" (light) | 186e. 20" (heavy)
187. Road Wheel, 2½" diam.
187a. Conical Disc, 1½" diam.

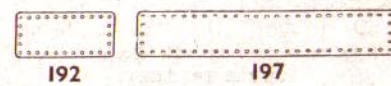

FLEXIBLE PLATES

188. 2½" x 1½" | 190. 2½" x 2½" | 191. 4½" x 2½"
189. 5½" x 1½" | 190a. 3½" x 2½" | 192. 5½" x 2½"

STRIP PLATES

196. 9½" x 2½" | 197. 12½" x 2½"



198. Hinged Flat Plate, 4½" x 2½"
199. Curved Plate, 'U'-section, 2½" x 2½" x ¾" radius
200. Curved Plate, 2½" x 2½" x 1½" radius



- 211 & 211a. Helical Gear, ½" | Can only be used
211b. Helical Gear, 1½" | together
212. Rod and Strip Connector
212a. Rod and Strip Connector, right-angle
213. Rod Connector
213a. Three-way Rod Connector
213b. Three-way Rod Connector with boss



214. Semi-circular Plate, 2½"
215. Formed Slotted Strip, 3"
216. Cylinder, 2½" long, 1½" diam.

TRIANGULAR FLEXIBLE PLATES

221. 2½" x 1½" | 223. 2½" x 2½" | 225. 3½" x 2"
222. 2½" x 2" | 224. 3½" x 1½" | 226. 3½" x 2½"
230. 4" Rod with Keyway
231. Key Bolt