

MECCANO

SPECIAL MODEL
LEAFLETS



COPYRIGHT BY MECCANO LTD. LIVERPOOL

MECCANO

Railway Service Crane

(MODEL No. 10.1)

SPECIAL FEATURES

The hoisting, lowering and luffing movements of the model are all driven by a Meccano E15R Motor through gearing, and the crane will lift considerable loads. The crane truck is strongly built and is mounted on eight wheels carried in swivelling bogies. Other details include outriggers and sliding doors in the cab.

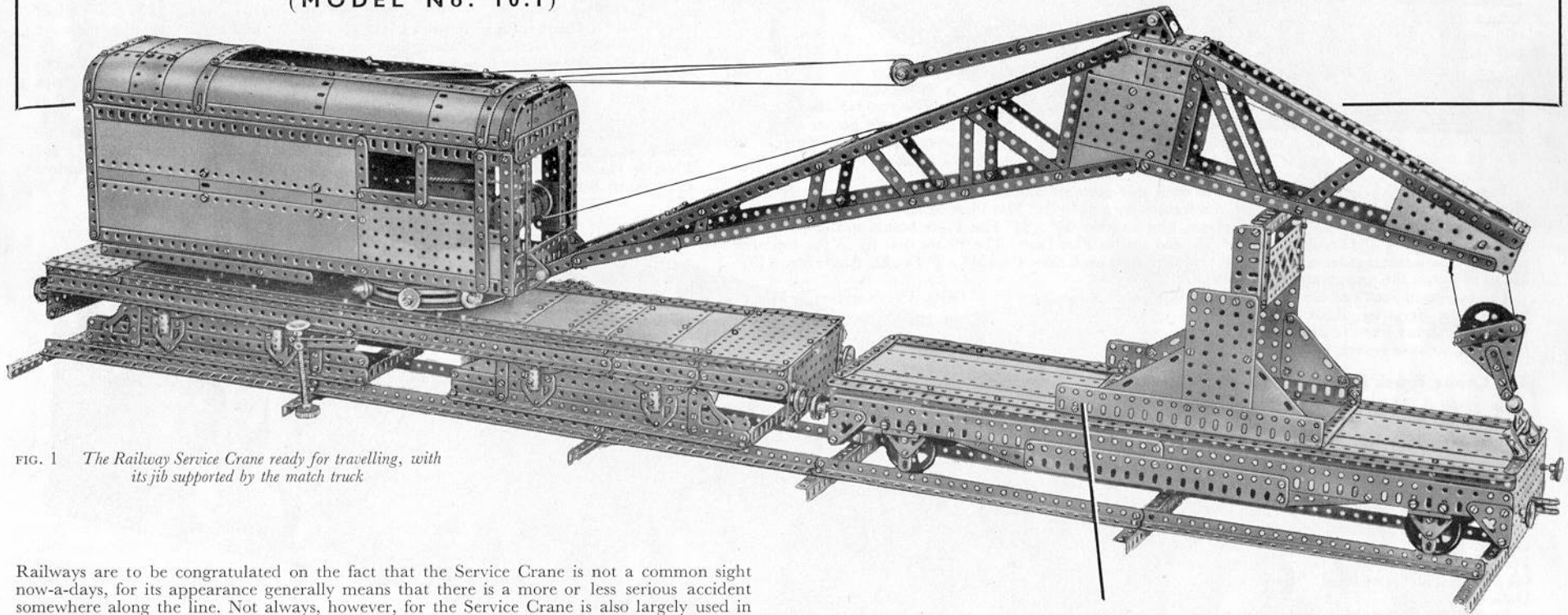

FIG. 1 The Railway Service Crane ready for travelling, with its jib supported by the match truck

Railways are to be congratulated on the fact that the Service Crane is not a common sight now-a-days, for its appearance generally means that there is a more or less serious accident somewhere along the line. Not always, however, for the Service Crane is also largely used in track laying operations and other constructional or maintenance work on the railways.

The Service train is usually made up of several vehicles in addition to the locomotive. These comprise vans containing tools, first-aid appliances, and accommodation for the train staff, and — most important from the Meccano boy's point of view — the crane itself. The latter is usually provided with a 'match truck', on which the jib rests when it is in the lowered position for travelling.

The Meccano model described in this leaflet is a faithful representation of a typical modern Service Crane. It reproduces the principal movements of its prototype and is fitted with outriggers and swivelling bogies. The crane is driven by a Meccano E15R Electric Motor and will lift considerable loads. The crane truck is about 30" in overall length and the match truck is approximately 24" long.

Crane Truck Underframe (Fig. 3)

Each side-member of the underframe consists of two built-up girders. One of these is a $2\frac{1}{2}$ " Angle Girder extended at each end by a $3\frac{1}{2}$ " Angle Girder and the other consists of a $2\frac{1}{2}$ " Angle Girder lengthened at one end by two $3\frac{1}{2}$ " Angle Girders. The built-up girders are connected together at the centre by a $2\frac{1}{2}$ " Flat Girder, and at each end by Fishplates.

The side-members are connected by two $5\frac{1}{2}$ " Angle Girders (1) and at each end a $5\frac{1}{2}$ " x $2\frac{1}{2}$ " Flat Plate is attached to the side-members by Angle Brackets. The Flat Plates are edged by $2\frac{1}{2}$ " and $5\frac{1}{2}$ " Strips, with a Stepped Bent Strip bolted to one of them to form a coupling between the crane truck and the match truck.

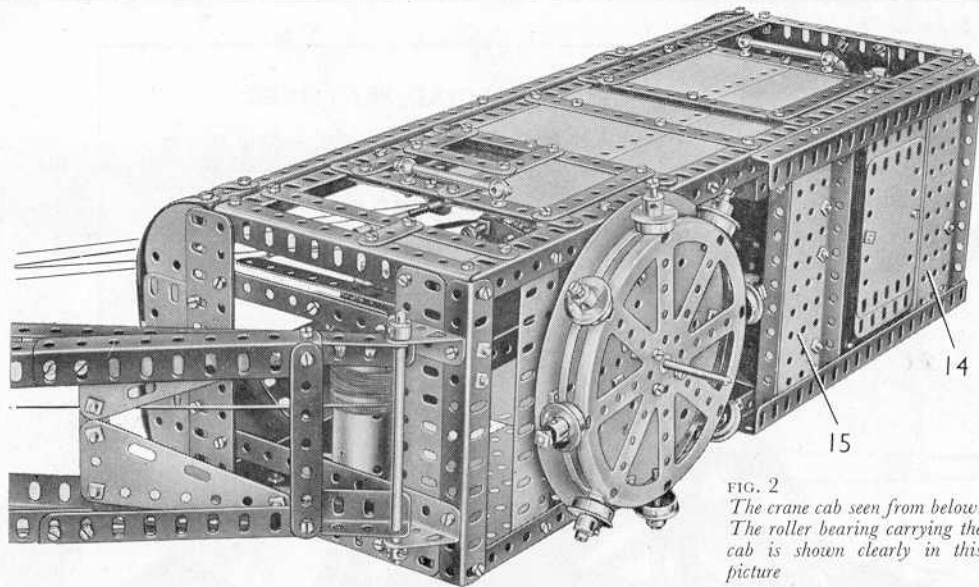

FIG. 2
The crane cab seen from below.
The roller bearing carrying the
cab is shown clearly in this
picture

Two $12\frac{1}{2}$ " Angle Girders (2) are fixed to each side-member and to these are bolted the Plates that fill in the top of the underframe. The top is formed by a $5\frac{1}{2}$ " \times $3\frac{1}{2}$ " Flat Plate at each end, two $5\frac{1}{2}$ " \times $2\frac{1}{2}$ " Flat Plates (3), ten $5\frac{1}{2}$ " \times $2\frac{1}{2}$ " Flexible Plates, and another $5\frac{1}{2}$ " \times $3\frac{1}{2}$ " Flat Plate bolted to the centre of the underframe. A 4" Circular Plate (4) is fixed to this Flat Plate. The Plates that fill in the top are connected along their outer edges by two $12\frac{1}{2}$ " Strips on each side. Two $5\frac{1}{2}$ " \times $\frac{1}{2}$ " Double Angle Strips (5) are fixed across the underframe as shown (Fig. 3).

The buffers at each end are 1" Pulleys, and they are held in place by $\frac{1}{2}$ " Bolts. The outrigger jacks are formed by Screwed Rods in Threaded Bosses, which are fixed to $2\frac{1}{2}$ " Angle Girders lock-nutted, so as to swivel, to the underframe.

The Crane Truck Bogies (Fig. 4)

In general design the two bogies are similar. Each consists of two $12\frac{1}{2}$ " Angle Girders (6) connected at their ends by $5\frac{1}{2}$ " Strips, to each of which a $4\frac{1}{2}$ " Angle Girder is fixed. To each of the Girders (6) are bolted a Corner Gusset and a vertical 2" Strip, and these support a $12\frac{1}{2}$ " Strip and a $7\frac{1}{2}$ " Flat Girder extended by a $1\frac{1}{2}$ " Flat Girder. A $2\frac{1}{2}$ " \times $1\frac{1}{2}$ " Triangular Flexible Plate is bolted to the Strip and the Flat Girder, at the opposite end to the Corner Gusset.

Two $4\frac{1}{2}$ " \times $\frac{1}{2}$ " Double Angle Strips are bolted between the Flat Girders on each side, and to them is fixed a 3" Pulley (7). The springs and axle boxes are represented by $2\frac{1}{2}$ " Curved Strips and Flat Trunnions arranged as shown, with Couplings held in position by $\frac{1}{2}$ " and $\frac{3}{4}$ " Bolts. The wheels of one bogie are $1\frac{1}{2}$ " Flanged Wheels fixed on 5" Rods, but those of the other are made from Wheel Flanges bolted to Face Plates. The 5" Rods are held in position by Collars.

A $3\frac{1}{2}$ " \times $2\frac{1}{2}$ " Flanged Plate is fixed to each of the Flat Plates (3) and two $3\frac{1}{2}$ " \times $\frac{1}{2}$ " Double Angle Strips are bolted between the flanges of each Flanged Plate. A 3" Pulley (8) is attached to the Double Angle Strips, and a $2\frac{1}{2}$ " Rod held in the boss of this Pulley is passed through the Pulley (7) of one of the bogies. A $1\frac{1}{2}$ " Pulley on the Rod is used to keep the bogie in position.

Details of the Cab

The side seen in Fig. 10 is built up on a framework formed by two $18\frac{1}{2}$ " Angle Girders (9) joined at each end by a $5\frac{1}{2}$ " Angle Girder. The side is partly filled in by four $5\frac{1}{2}$ " \times $2\frac{1}{2}$ " Flexible Plates and two $5\frac{1}{2}$ " \times $1\frac{1}{2}$ " Flexible Plates attached to three $5\frac{1}{2}$ " Strips, which are bolted to the Girders (9). The Plates are spaced from the Strips by Washers however, so that the sliding doors can pass freely in front of the Plates. At the front end of this side a $2\frac{1}{2}$ " \times $1\frac{1}{2}$ " Flexible Plate is bolted to the $5\frac{1}{2}$ " Angle Girder, and it is edged by a $1\frac{1}{2}$ " and a $5\frac{1}{2}$ " Strip.

The sliding door of the front end is made by bolting a $3\frac{1}{2}$ " \times $2\frac{1}{2}$ " Flexible Plate and three $3\frac{1}{2}$ " Strips between two $5\frac{1}{2}$ " Strips (10) (Fig. 8.) A $2\frac{1}{2}$ " Strip and a 3" Strip are attached to each Strip (10), but are spaced from it by a nut on each bolt. The ends of the Strips (10) are arranged in front of the Girders (9), and the 3" and $2\frac{1}{2}$ " Strips are placed behind the Girders to form guides for the door.

The rear door consists of two $4\frac{1}{2}$ " \times $2\frac{1}{2}$ " Flexible Plates and two $4\frac{1}{2}$ " Strips bolted to two $5\frac{1}{2}$ " Strips (11). A $5\frac{1}{2}$ " Strip is fixed behind each of the Strips (11), but the Strips are spaced apart by a nut on each bolt. These Strips form guides in the same way as those for the door at the front end.

The framework of the side seen in Fig. 1 is made in the same way as the one for the side already described. It is filled in with two $12\frac{1}{2}$ " \times $2\frac{1}{2}$ " Strip Plates, two $2\frac{1}{2}$ " \times $1\frac{1}{2}$ " Flexible Plates, two $5\frac{1}{2}$ " \times $1\frac{1}{2}$ " Flexible Plates and a $5\frac{1}{2}$ " \times $3\frac{1}{2}$ " Flat Plate. The window is edged by Strips as shown.

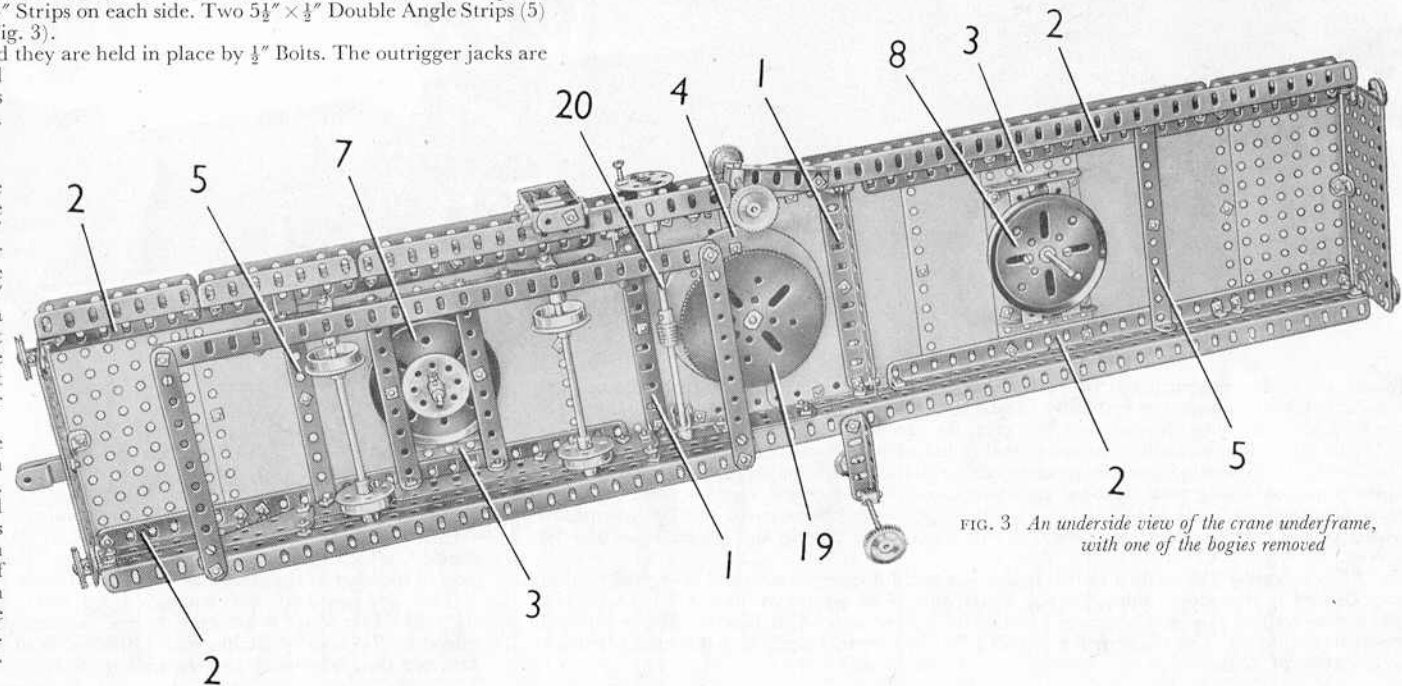

FIG. 3 An underside view of the crane underframe,
with one of the bogies removed

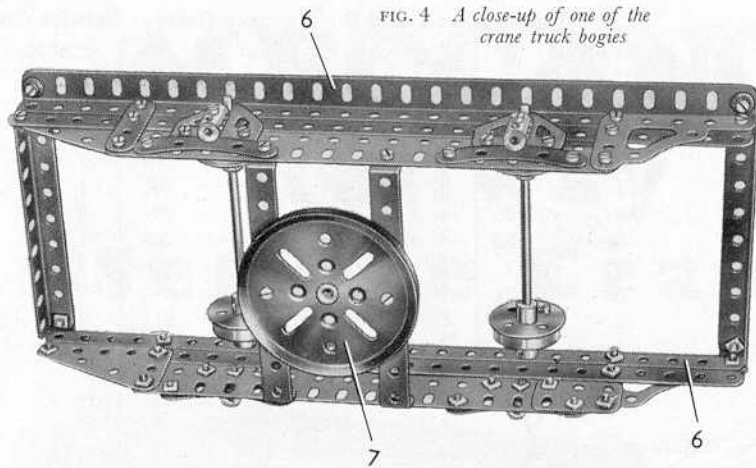

FIG. 4 A close-up of one of the crane truck bogies

The sides are connected at front and back by two $5\frac{1}{2}$ " Angle Girders bolted to the ends of the Girders (9). A $5\frac{1}{2}$ " Flat Girder is fixed to the top $5\frac{1}{2}$ " Angle Girder at each end, and to this are bolted a $2\frac{1}{2}$ " \times $1\frac{1}{2}$ " Flexible Plate and two Semi-Circular Plates. Another $5\frac{1}{2}$ " Flat Girder is fixed to the lower part of the front of the cab and two $5\frac{1}{2}$ " Strips (13) are bolted in position (Fig. 10). The back of the cab is filled in by a $5\frac{1}{2}$ " \times $1\frac{1}{2}$ " Flexible Plate and two $5\frac{1}{2}$ " \times $2\frac{1}{2}$ " Flexible Plates.

Two $5\frac{1}{2}$ " \times $2\frac{1}{2}$ " Flanged Plates (14) and (15) (Fig. 2) are fixed to the base of the cab and between them are a $5\frac{1}{2}$ " \times $2\frac{1}{2}$ " and a $5\frac{1}{2}$ " \times $1\frac{1}{2}$ " Flexible Plate. Two $9\frac{1}{2}$ " Angle Girders are attached to the flanges of the Flanged Plates. Seven $5\frac{1}{2}$ " \times $2\frac{1}{2}$ " Flexible Plates, fourteen $4\frac{1}{2}$ " \times $2\frac{1}{2}$ " Flexible Plates and three $3\frac{1}{2}$ " \times $2\frac{1}{2}$ " Flexible Plates are fixed to the floor between the Flanged Plates and act as a balance weight at the rear of the cab.

The Roller Bearing

A 6" Circular Plate is bolted to the lower one of the Girders (9) and to the corresponding Girder of the other side, but it is spaced from them by a nut on each bolt. The Circular Plate is supported also by a $5\frac{1}{2}$ " Angle Girder (16) and a $5\frac{1}{2}$ " Flat Girder (17) strengthened by a $5\frac{1}{2}$ " Strip. It is spaced from these parts by two nuts on each of the $\frac{3}{8}$ " Bolts that joins them together. A Bush Wheel (eight holes) is bolted to the centre of the Circular Plate, and two 1" Reversed Angle Brackets fixed to the Plate support four $2\frac{1}{2}$ " Strips (18) (Fig. 5).

The rollers are eight $\frac{3}{4}$ " Flanged Wheels. Six of these are freely mounted on $1\frac{1}{8}$ " Bolts, each of which is held by two nuts in a Hub Disc. The other two Wheels are retained by lock-nuts on 2" Screwed Rods, which are each fixed by two nuts in the Hub Disc.

A 6" Circular Plate is attached to the centre of the underframe by four $\frac{3}{8}$ " Bolts, but is spaced from it by four Washers on each Bolt.

A $3\frac{1}{2}$ " Rod is passed through the Strips (18) and is fixed in the boss of the Bush Wheel that is bolted to the Circular Plate attached to the cab. The Rod is passed freely through the Bush Wheel fixed to the Hub Disc, and through the centre of the 6" Circular Plate attached to the underframe. A $3\frac{1}{2}$ " Gear (19) (Fig. 3) is fixed to the Rod, but is spaced from the underframe by four $\frac{3}{4}$ " Washers and a Collar.

The cab can be rotated on the roller bearing by turning a Bush Wheel on a $6\frac{1}{2}$ " Rod (20) (Fig. 3). This Rod is held in place by a Collar and a small Fork Piece, and it carries a Worm that engages the $3\frac{1}{2}$ " Gear (19).

The Power Unit and Gear-Box

The housing for the gear-box is made by bolting three $3\frac{1}{2}$ " \times $2\frac{1}{2}$ " Flanged Plates, one of them numbered (21) and the other two indicated at (22), to the Flanged Plate (15) (Fig. 5). The top flanges of the Flanged Plates are connected by a $3\frac{1}{2}$ " Flat Girder, to which is bolted a 3 " \times $1\frac{1}{2}$ " Double Angle Strip. Two $3\frac{1}{2}$ " \times $\frac{1}{2}$ " Double Angle Strips are bolted to the Flanged Plate (21) and to one of the Flanged Plates (22). One of these Double Angle Strips is indicated at (23) and the other is attached in corresponding holes at the rear edges of the Flanged Plates (21) and (22).

An E15R Electric Motor is bolted to the Flanged Plate (14) (Fig. 2). A 50-tooth Gear on the armature shaft engages a $\frac{3}{4}$ " Pinion on an $11\frac{1}{2}$ " Rod. This Rod is mounted in the Motor side-plates and in the Double Angle Strips (23), and it carries a Worm that drives a 57-tooth Gear on a 4" Rod supported in the Flanged Plates (21) and (22). A $\frac{3}{4}$ " Pinion (24) is fixed on this Rod. Two 3" Rods (one of them is seen at (25) Fig. 5), are mounted in the Flanged Plates, and each of them is fitted with a 50-tooth Gear that can be engaged with the Pinion (24) by sliding the Rod. Rod (25) is fitted with a $\frac{3}{4}$ " Sprocket (26), and the other 3" Rod carries a $\frac{3}{4}$ " Sprocket 27.

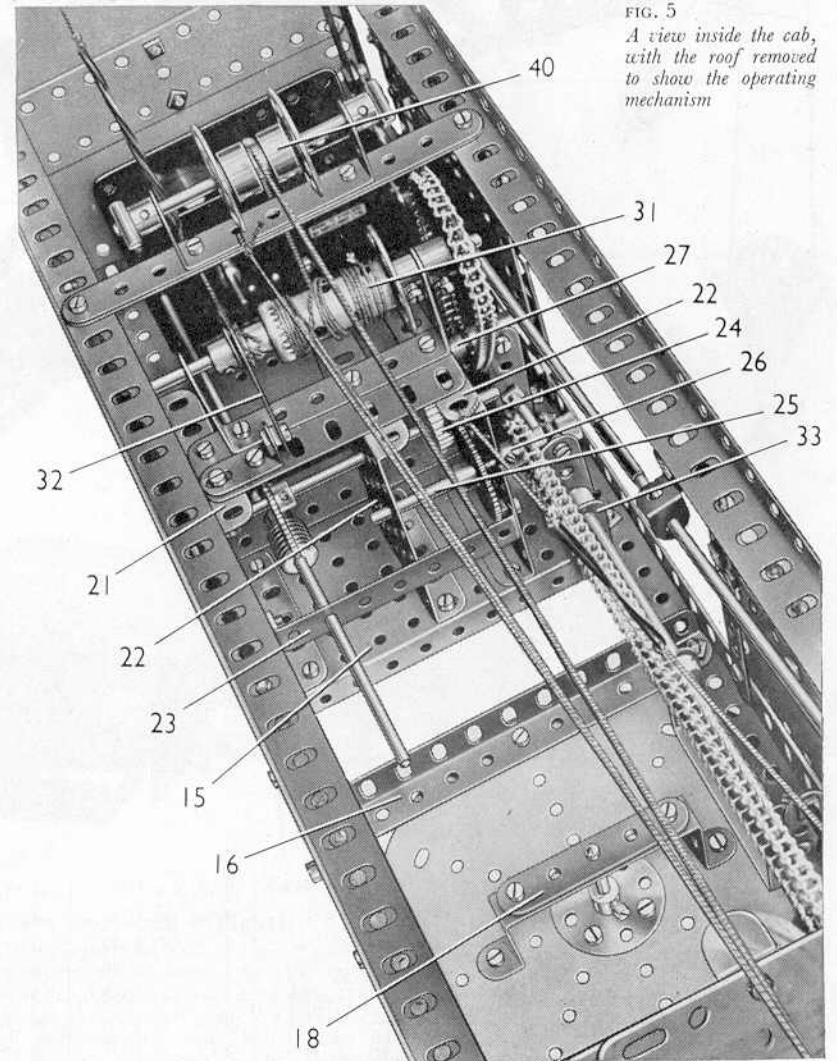

FIG. 5 A view inside the cab, with the roof removed to show the operating mechanism

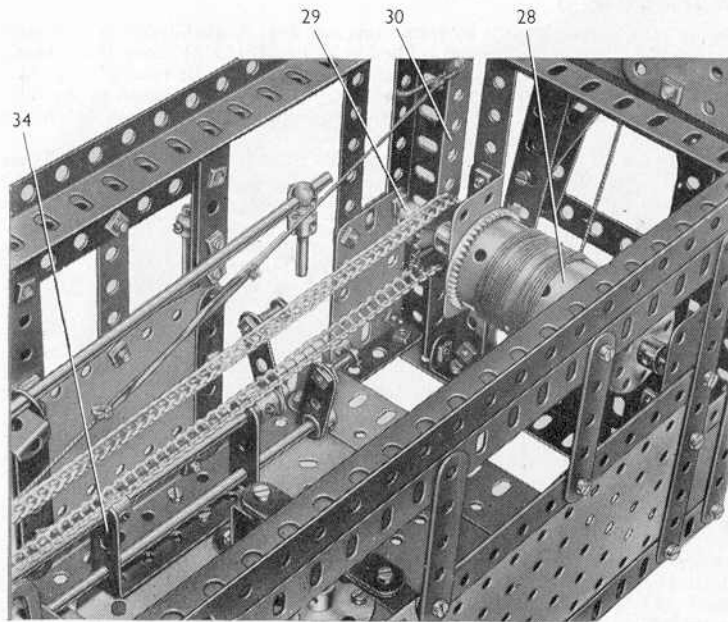

FIG. 6 The mechanism control levers and one of the winding drums are seen in this view

Sprocket (26) is connected by Chain to a 1" Sprocket on a 4½" Rod. This Rod is mounted in Girder Brackets bolted to the front of the cab, and it carries a winding drum (28) made from a Cylinder clamped between two 1½" Contrates. A ½" Pulley (29) is fixed on one end of the Rod and a 5½" Strip (30) engages in its groove (Fig. 6). The Strip is lock-nutted to a 1" x ½" Angle Bracket bolted to the base of the cab as shown. A length of Cord is tied to the top end of this Strip and to a Driving Band, which is stretched slightly and is connected by a length of Cord to one of the Flanged Plates (22). This arrangement provides a constant braking action on the winding drum.

The Sprocket (27) is connected by Chain to a 2" Sprocket on a 4" Rod, which is supported in the 3" x 1½" Double Angle Strip. This Rod carries a winding drum (31) made from a Sleeve Piece held between a ¾" Contrate and a Bush Wheel. A 2" Slotted Strip (32) engages in the groove of a ½" Pulley on the 4" Rod. The Slotted Strip is lock-nutted to a 1" x ½" Angle Bracket bolted to the Flat Girder that connects the Flanged Plates (21) and (22). A short piece of Cord is tied to the top end of the Slotted Strip and to a Driving Band, which is stretched slightly and is connected to Cord fastened to the back of the cab.

A 3" x 1½" Double Angle Strip (33) is bolted to the Flanged Plate (15) (Fig. 5), and a 2½" x 1½" Double Angle Strip (34) (Fig. 6), is spaced from the 6" Circular Plate by a nut on the bolt that holds it in place. These Double Angle Strips support an 8" Rod (35) and an 11½" Rod (36). Each of these Rods carries at its front end a Crank fitted with a Pivot Bolt that forms a control handle. A Crank (Fig. 8) is fixed on Rod (35), and a ¾" Bolt fixed in the Crank engages between two Collars on the end of rod (25). A Crank (37), extended upward by a 2" Strip fitted with a ¾" Bolt, is fixed on the Rod (36). The ¾" Bolt engages between two Collars on the Rod that carries the Sprocket (27).

A 3½" Strip (38) (Fig. 8) is lock-nutted at its upper end to an Angle Bracket bolted to the upper one of the Girders (9). The lower end of Strip (38) is lock-nutted to an arm of the E15R Electric Motor switch. A Rod and Strip Connector is lock-nutted to the Strip (38), and is fitted with an 8" Rod joined to a 6½" Rod by a Rod Connector. The 6½" Rod is supported by a Corner Angle Bracket bolted to the side of the cab, and it carries a handle (39) formed by a 1" Rod held in a Handrail Coupling.

Two 5½" Strips placed face to face are bolted across the top of the cab and to them is fixed a 2½" x 1" Double Angle Strip. A 3½" Rod held in the Double Angle Strip by Slide Pieces, carries a built-up pulley (40), which is made from a Socket Coupling and two Bush Wheels.

Assembly of the Cab Roof

Two 18½" Angle Girders are fixed to the Girders of the upper edges of the cab sides, and these support the Flexible Plates that form the roof. The general arrangement of these Plates can be seen in Figs. 1, 7 and 10.

Details of the Jib (Fig. 10)

The upper side members of the inner section of the jib each consist of a 24½" Angle Girder (41) (Fig. 10)—the lower members of this section are built-up girders (42) and are each made from an 18½" Angle Girder and a 4½" Angle Girder overlapped two holes. These parts are bolted together at their lower ends, and are connected at their upper ends by a 4½" Strip (43). A 4½" x 2½" Flat Plate, a 3" x 1½" Flat Plate, a 2½" x 2" Triangular Flexible Plate (44) and a 3½" x 2" Triangular Flexible Plate (45) are bolted together and are fixed to the Strip (43).

A 2½" Angle Girder (46) is connected to the Girder (41) by an Obtuse Angle Bracket, and is similarly connected to a 12½" Angle Girder (47). The Girder (47) is bolted to the top end of a 4½" Strip that is bolted to the Flat Plates, and another 12½" Angle Girder (48) is fixed to the lower end of the same Strip. The Girders (47) and (48) are connected at their front ends by a Flanged Sector Plate.

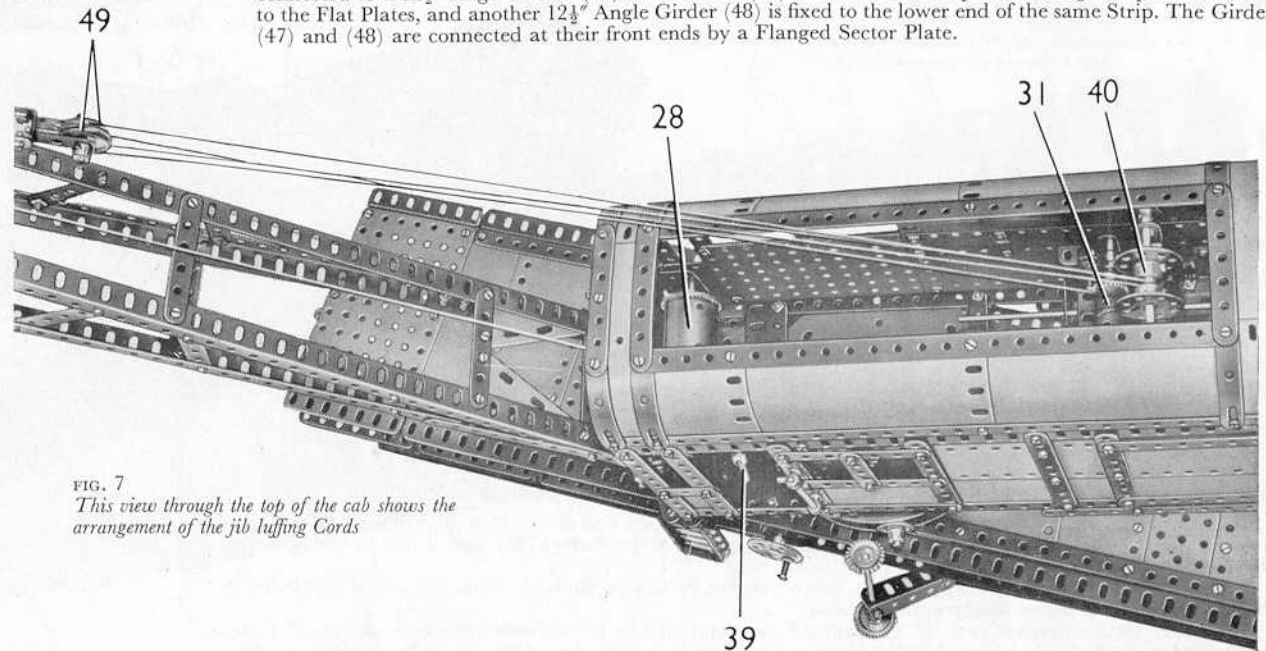

FIG. 7 This view through the top of the cab shows the arrangement of the jib luffing Cords

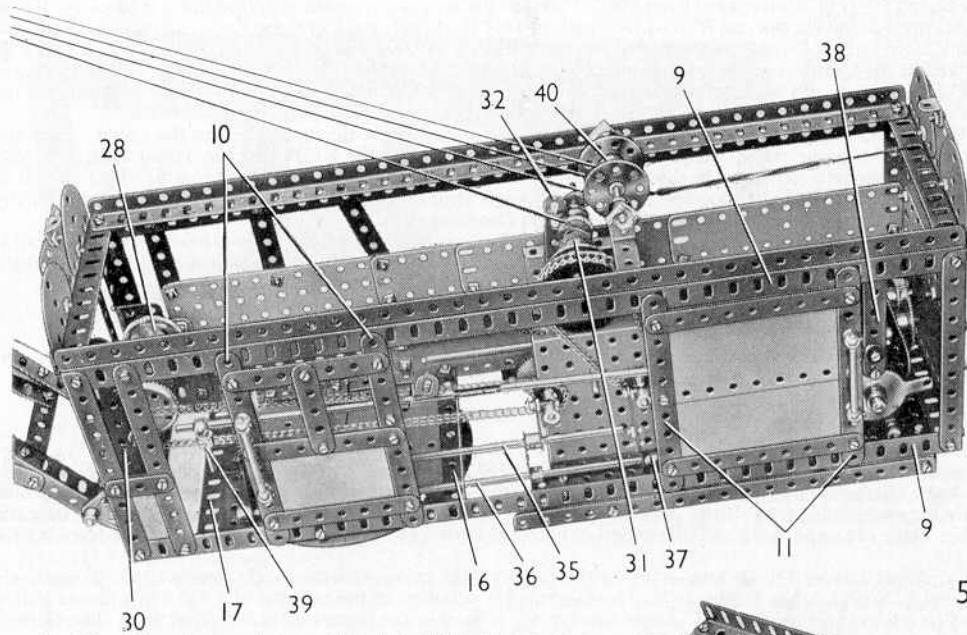

FIG. 8 The sliding doors, and the position of the E15R Electric Motor, can be seen in this view of the cab

The side-members of the jib are connected by $3\frac{1}{2}$ " and 3" Strips bolted between the Girders (41) and the built-up girders (42) of each side. A $2\frac{1}{2}$ " \times $2\frac{1}{2}$ " Flat Plate is fixed between the Girders (46), and at the jib head the Girders (47) are connected by a $1\frac{1}{2}$ " Strip. The Girders (48) are joined by a $1\frac{1}{2}$ " Angle Girder.

Two Trunnions are fixed to the $2\frac{1}{2}$ " \times $2\frac{1}{2}$ " Flat Plate bolted to the Girders (46), and these support a 2" Rod on which two built-up strips are held by Rod Sockets. Each of these strips is made from two $5\frac{1}{2}$ " Strips overlapped four holes. A Single Bent Strip is bolted to a Double Bracket fixed to the lower ends of the built-up strips, and a 1" Rod held by Collars in the Single Bent Strip carries two 1" loose Pulleys (49).

A 3" Pulley is fixed on a $3\frac{1}{2}$ " Rod (50), and a 2" Pulley at the jib head is held on a 2 $\frac{1}{2}$ " Rod (51).

The jib pivots on a $4\frac{1}{2}$ " Rod, which is supported in Trunnions bolted to the front of the cab.

Arrangement of the Jib Luffing and Load Hoisting Cords (Figs. 8 and 10)

The luffing Cord is fastened to the drum (31), then taken round one of the 1" Pulleys (49) and round the built-up pulley (40). The Cord is then taken round the second of the Pulleys (49), and is tied to the $5\frac{1}{2}$ " Strips that support the mounting for the pulley (40).

The hoisting Cord is tied to the drum (28), taken over the Pulleys on Rods (50) and (51), round a 2" Pulley in the pulley block and is tied finally to the jib head.

The pulley block consists of two $2\frac{1}{2}$ " Triangular Plates connected by three Double Brackets, and the 2" Pulley is mounted on a $1\frac{1}{2}$ " Rod. A large Loaded Hook is held by a $\frac{3}{4}$ " Bolt supported by two 2" Strips, each of which is bolted to one of the Triangular Plates.

The Match Truck (Fig. 9)

The top of the match truck is made by connecting two $24\frac{1}{2}$ " Angle Girders at their ends by $5\frac{1}{2}$ " \times $2\frac{1}{2}$ " Flanged Plates (52). The top is filled in by two $12\frac{1}{2}$ " \times $2\frac{1}{2}$ " Strip Plates along the centre and two $9\frac{1}{2}$ " \times $2\frac{1}{2}$ " Strip Plates at each side. At the middle two $5\frac{1}{2}$ " \times $3\frac{1}{2}$ " Flat Plates are bolted to the ends of the Strip Plates (Fig. 9), and are connected to the sides by $2\frac{1}{2}$ " Angle Girders. The $9\frac{1}{2}$ " \times $2\frac{1}{2}$ " Strip Plates are supported by 3" and $4\frac{1}{2}$ " Angle Girders bolted to the $24\frac{1}{2}$ " Angle Girders.

Each side of the match truck is extended downward by two $12\frac{1}{2}$ " Flat Girders. These are bolted to the Flanged Plates (52) and are braced by $1\frac{1}{2}$ " Corner Brackets, and at the centre are connected by a Fishplate to the $24\frac{1}{2}$ " Angle Girder. A $9\frac{1}{2}$ " Flat Girder (53) is bolted to each side as shown.

The wheels are 2" Pulleys, each of which is free to turn on a 5" Rod fixed in Double Arm Cranks bolted to Trunnions. The Trunnions are supported by $1\frac{1}{2}$ " Angle Girders fixed to the Flat Girders (Fig. 9). Each wheel is spaced from the Double Arm Crank by a $\frac{1}{2}$ " loose Pulley, and is held in position by a $\frac{1}{2}$ " Pinion.

The buffers are 1" Pulleys locked on Threaded Pins fixed in the Flanged Plates (52).

A $9\frac{1}{2}$ " Flat Girder (54) on each side is bolted at one end to the lug of a $5\frac{1}{2}$ " \times $\frac{1}{2}$ " Double Angle Strip fixed across the match truck, and at its other end the Flat Girder is attached to an Angle Bracket. A 4 " \times $2\frac{1}{2}$ " Flat Plate is bolted to each of the Flat Girders (54) and is extended upward by a 3" Flat Girder and a 3" Angle Girder. The 3" Angle Girders are connected by a $5\frac{1}{2}$ " Braced Girder and a $5\frac{1}{2}$ " Angle Girder. The Flat Plates are braced by $3\frac{1}{2}$ " \times $2\frac{1}{2}$ " Triangular Flexible Plates and $2\frac{1}{2}$ " \times $2\frac{1}{2}$ " Triangular Flexible Plates bolted to the Flat Girders (54).

In the travelling position the crane hook is anchored on a $3\frac{1}{2}$ " Rod (55), which is fixed in two Strip Couplings. These pivot on $\frac{3}{8}$ " Bolts passed through the lugs of a $2\frac{1}{2}$ " \times $\frac{1}{2}$ " Double Angle Strip bolted to the top of the truck.

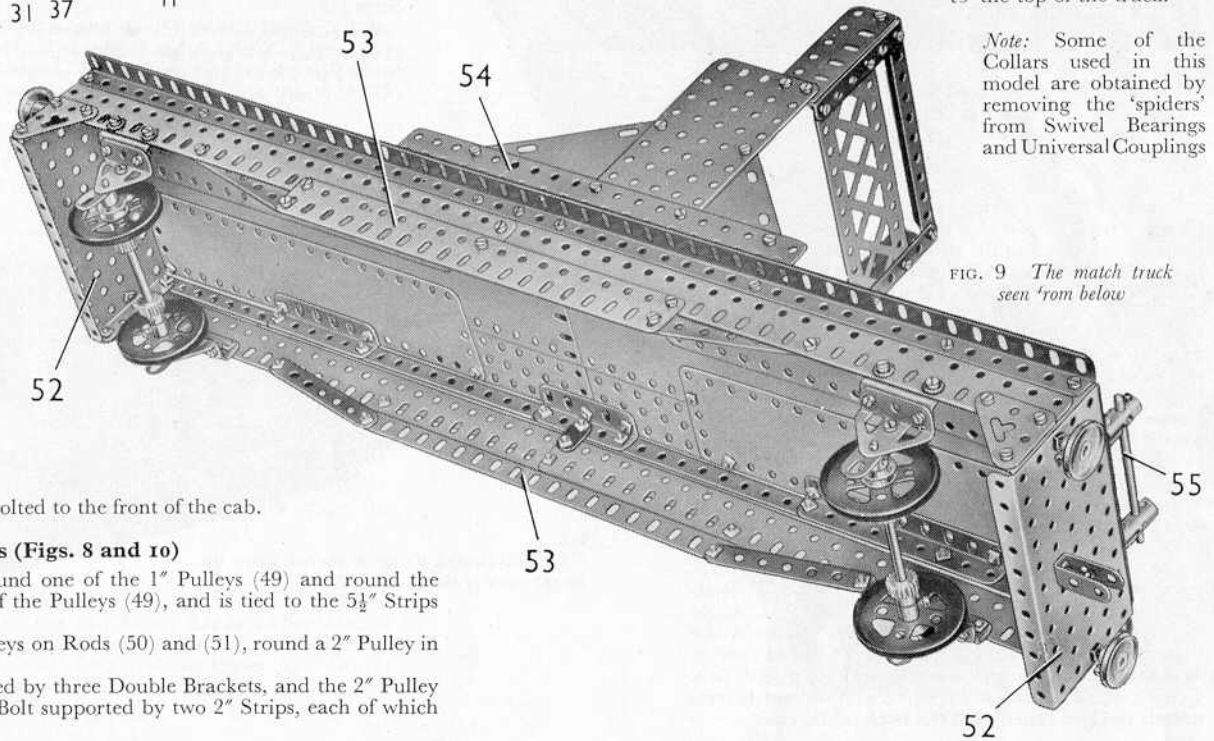

FIG. 9 The match truck seen from below

Note: Some of the Collars used in this model are obtained by removing the 'spiders' from Swivel Bearings and Universal Couplings

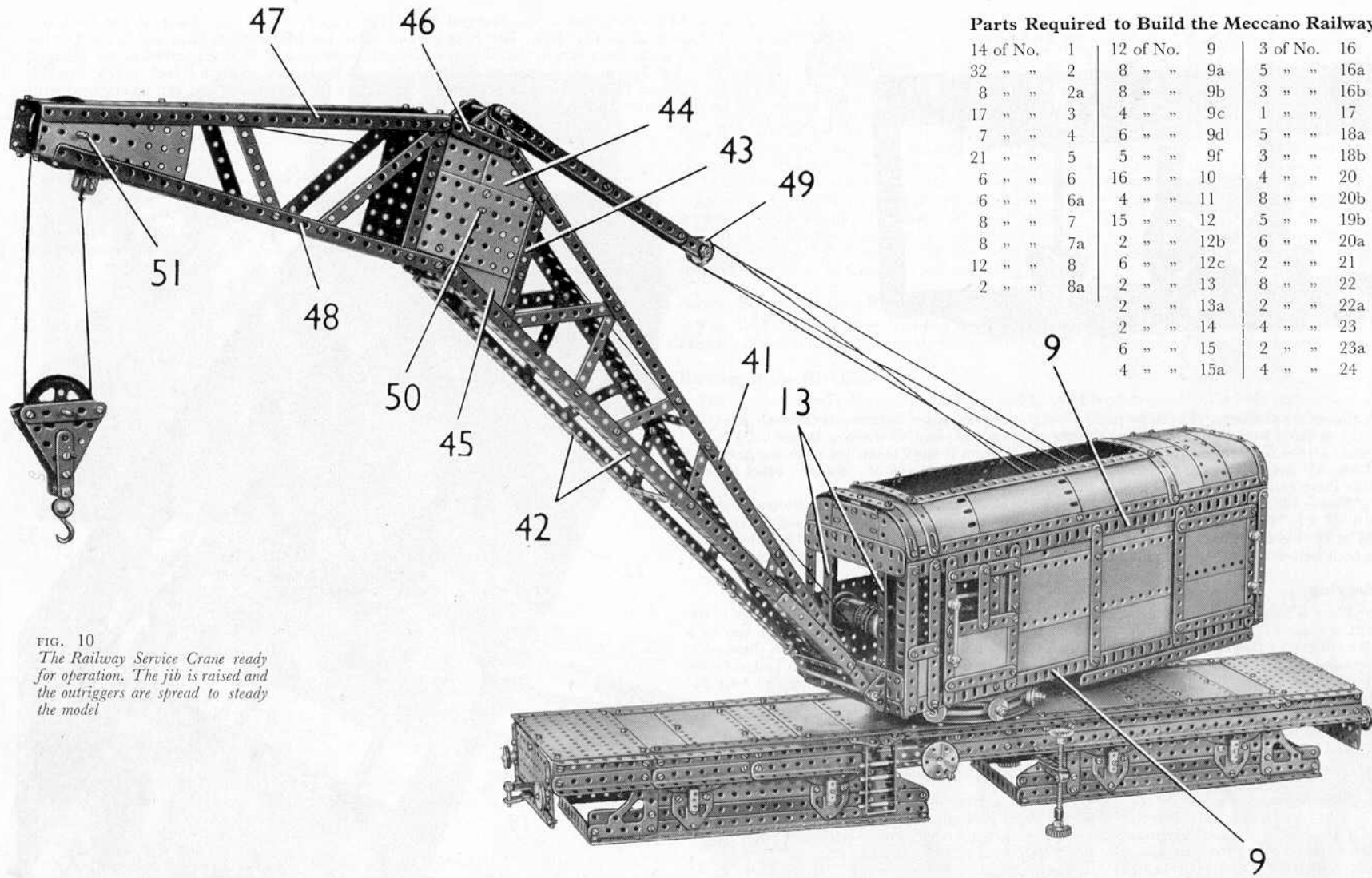

FIG. 10
The Railway Service Crane ready for operation. The jib is raised and the outriggers are spread to steady the model

Parts Required to Build the Meccano Railway Service Crane

14 of No. 1	12 of No. 9	3 of No. 16	2 of No. 24b
32 " " 2	8 " " 9a	5 " " 16a	2 " " 25
8 " " 2a	8 " " 9b	3 " " 16b	4 " " 26
17 " " 3	4 " " 9c	1 " " 17	3 " " 27
7 " " 4	6 " " 9d	5 " " 18a	1 " " 27a
21 " " 5	5 " " 9f	3 " " 18b	1 " " 27b
6 " " 6	16 " " 10	4 " " 20	2 " " 28
6 " " 6a	4 " " 11	8 " " 20b	1 " " 29
8 " " 7	15 " " 12	5 " " 19b	2 " " 30
8 " " 7a	2 " " 12b	6 " " 20a	2 " " 31
12 " " 8	6 " " 12c	2 " " 21	2 " " 32
2 " " 8a	2 " " 13	8 " " 22	8 " " 35
	2 " " 13a	2 " " 22a	723 " " 37a
	2 " " 14	4 " " 23	634 " " 37b
	6 " " 15	2 " " 23a	82 " " 38
	4 " " 15a	4 " " 24	4 " " 38d
			2 " " 40
			2 " " 44
			3 " " 46
			1 " " 47
			2 " " 47a
			1 " " 48a
			6 " " 48b
			4 " " 48c
			4 " " 48d
			2 " " 50

4 of No. 52	4 of No. 62b	1 of No. 80c	2 of No. 102	4 of No. 108	2 of No. 124	2 of No. 146	4 of No. 221
6 " " 52a	8 " " 63	2 " " 81	4 " " 103	4 " " 109	8 " " 126	1 " " 146a	2 " " 222
5 " " 53	2 " " 63b	1 " " 82	4 " " 103a	5 " " 111	8 " " 126a	6 " " 147b	2 " " 223
4 " " 53a	2 " " 64	8 " " 90	4 " " 103b	12 " " 111a	4 " " 133	1 " " 154a	2 " " 224
2 " " 54	4 " " 70	1 " " 94	1 " " 103d	15 " " 111c	2 " " 133a	2 " " 161	2 " " 225
2 " " 55a	1 " " 72	1 " " 95	2 " " 103e	6 " " 111d	4 " " 136	1 " " 163	2 " " 226
1 " " 57b	2 " " 73	1 " " 96	2 " " 103f	4 " " 115	1 " " 136a	2 " " 165	1 E15R
24 " " 59	2 " " 76	2 " " 96a	4 " " 103h	1 " " 116a	4 " " 137	1 " " 171	Electric Motor
4 " " 62	1 " " 80a	1 " " 100	4 " " 103k	1 " " 118	1 " " 144	1 " " 173a	(not included in Outfit)
							4 of No. 196
							2 " " 197
							4 " " 200
							1 " " 212
							1 " " 213
							4 " " 214
							8 " " 215
							1 " " 216
							30 " " 192

MECCANO

Sports Motor Car

(MODEL No. 10.2)

SPECIAL FEATURES

The car has a modern streamlined body and is fitted with a 3-speed and reverse gear-box, single plate clutch, independent front suspension and working differential.

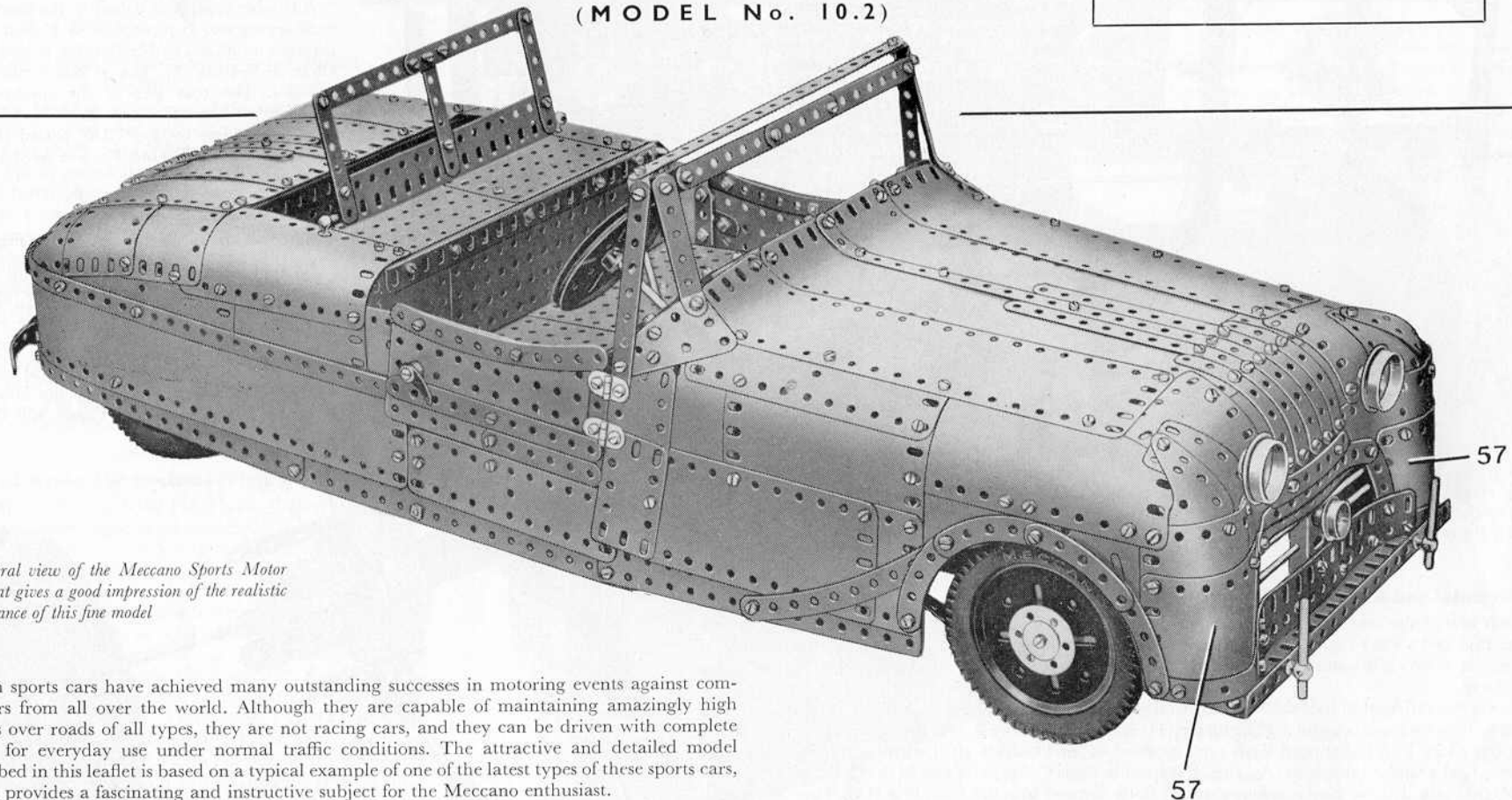

FIG. 1

A general view of the Meccano Sports Motor Car that gives a good impression of the realistic appearance of this fine model.

British sports cars have achieved many outstanding successes in motoring events against competitors from all over the world. Although they are capable of maintaining amazingly high speeds over roads of all types, they are not racing cars, and they can be driven with complete safety for everyday use under normal traffic conditions. The attractive and detailed model described in this leaflet is based on a typical example of one of the latest types of these sports cars, and it provides a fascinating and instructive subject for the Meccano enthusiast.

Construction of the Model: Details of the Chassis (Figs. 2 and 4)

Each of the chassis main girder members consists of two $2\frac{1}{2}$ " Angle Girders joined together by bolts through their round holes to form a U-section girder. At the rear end of this girder a $4\frac{1}{2}$ "

Flat Girder is bolted, and to this is fixed a $9\frac{1}{2}$ " Angle Girder (1). The chassis members are connected by a $3\frac{1}{2}$ " \times $\frac{1}{2}$ " Double Angle Strip (2) (Fig. 4), and a $3\frac{1}{2}$ " Angle Girder (3) fixed to Angle Brackets. They are joined also by a $7\frac{1}{2}$ " Angle Girder (4) braced by $1\frac{1}{2}$ " Corner Brackets. The Girder (3) is braced to the channel girders by two 3" Angle Girders.

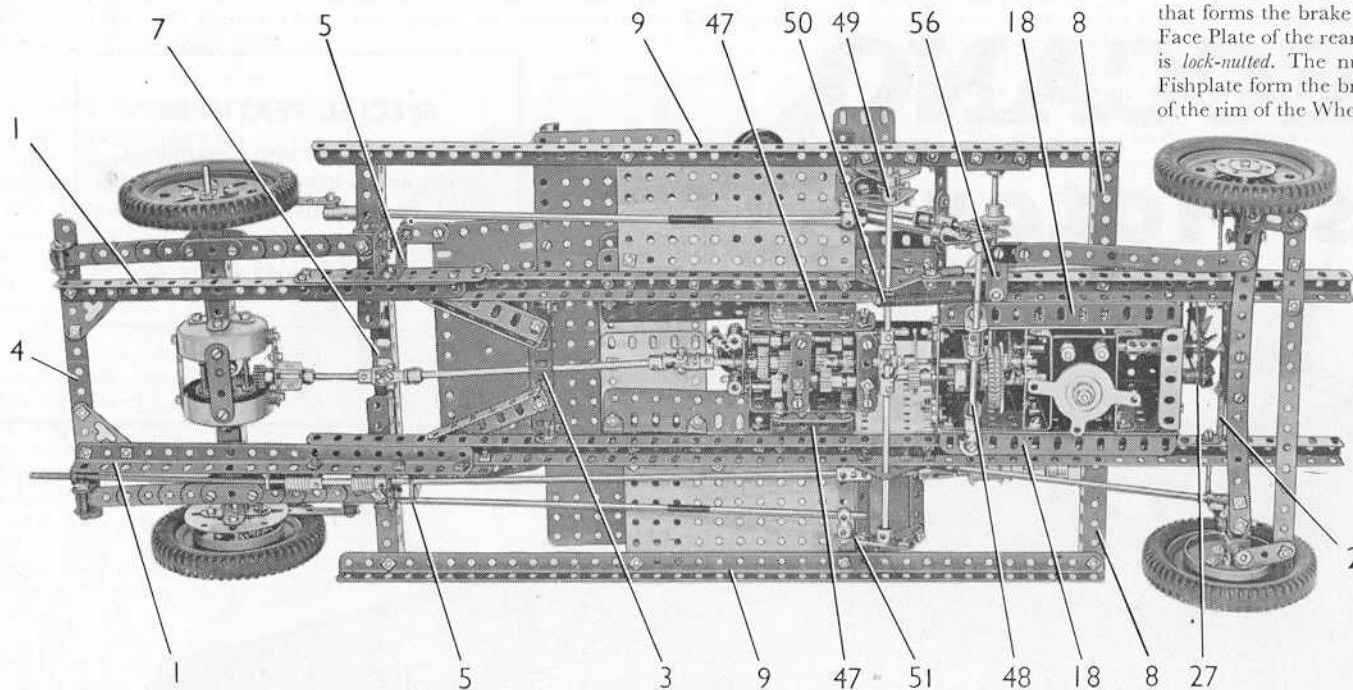

FIG. 2
This underneath view of the chassis shows the general arrangement of the drive transmission and the brake linkage

A Channel Bearing (5) is bolted to each side of the chassis, and to it is fixed a $4\frac{1}{2}$ " Angle Girder (6) fitted with a $1\frac{1}{2}$ " Corner Bracket. The Corner Brackets are connected by a $5\frac{1}{2}$ " Angle Girder (7) (Fig. 6). A $3\frac{1}{2}$ " Angle Girder (8) is fixed to each side of the chassis, and $18\frac{1}{2}$ " Angle Girders (9) are bolted to the ends of the Girders (6) and (8). A $5\frac{1}{2}$ " x $3\frac{1}{2}$ " Flat Plate is bolted between the chassis member and the Girder (9) on each side (see Fig. 2).

Differential and Rear Axle (Fig. 3)

Each half of the rear axle casing is formed by four $2\frac{1}{2}$ " x $\frac{1}{2}$ " Double Angle Strips bolted between a Boiler End and a Face Plate. When the differential is in place the Boiler Ends are connected by four 2" Strips, one of which is spaced from them by two Washers on each Bolt and has attached to it a Double Bent Strip.

One of the differential half-shafts is a 5" Rod passed through half of the casing. A $1\frac{1}{2}$ " Contrate (10) is free to turn on the Rod, and a $\frac{3}{4}$ " Contrate (11) is fixed on it. The Rod is then placed half way into a Coupling (12). Two 1" Screwed Rods are now fixed in the Contrate (10), with two nuts on each, and on each Rod a Collar is screwed. A $1\frac{1}{4}$ " Rod is fixed in these Collars and also in the Coupling (12). Two $\frac{3}{8}$ " Bevel Gears (13) are freely mounted on $\frac{3}{4}$ " Bolts screwed into the Coupling (12). They are spaced from the Coupling by Washers, and they mesh with the Contrate (11) and with another $\frac{3}{8}$ " Bevel fixed on a $4\frac{1}{2}$ " Rod that forms the other half-shaft.

The differential is driven by a $\frac{1}{2}$ " Pinion on a $2\frac{1}{2}$ " Rod mounted in the Double Bent Strip and the 2" Strip as shown. This Pinion engages the Contrate (10).

The rear wheels are 3" Pulleys, to each of which a Wheel Flange that forms the brake drum is bolted. A Fishplate is lock-nutted to each Face Plate of the rear axle, and to the Fishplate a $2\frac{1}{2}$ " Strip (14) (Fig. 6) is lock-nutted. The nuts on the bolt that connects the Strip and the Fishplate form the brake shoe, and can be pulled against the inner side of the rim of the Wheel Flange by means of the Strip (14).

Each of the rear springs is formed by a $7\frac{1}{2}$ ", a $5\frac{1}{2}$ ", a $4\frac{1}{2}$ ", a $3\frac{1}{2}$ ", a $2\frac{1}{2}$ " and a $1\frac{1}{2}$ " Strip connected by two $1\frac{1}{8}$ " Bolts. The Bolts pass on each side of the axle casing, through three $1\frac{1}{2}$ " Strips placed face to face. Nuts on the Bolts clamp the $1\frac{1}{2}$ " Strips and the axle casing securely to the spring (see Fig. 6).

A Double Bracket is bolted to the front end of each spring and is pivoted on a $\frac{3}{4}$ " Bolt passed through another Double Bracket bolted to the Channel Bearing (5). The $\frac{3}{4}$ " Bolt is fitted with lock-nuts. The rear end of the spring passes between the lugs of a large Fork Piece, and is kept in position by a $\frac{3}{4}$ " Bolt passed through the lugs. The large Fork Piece is fixed by a $\frac{1}{2}$ " Bolt to the Girder (4).

Construction of the Front Axle (Fig. 4)

Each of the front wheels is free to turn on a $\frac{3}{4}$ " Bolt fixed by a nut in a Coupling (15) on a 2" Rod. The Rods are fitted with Collars at their upper ends and are supported in the lugs of $1\frac{1}{2}$ " x $\frac{1}{2}$ " Double Angle Strips, bolted to 2" Strips. One of the Rods carries at its lower end a Bell Crank (16), and to the other Rod is fixed a Crank (17). The Crank and the Bell

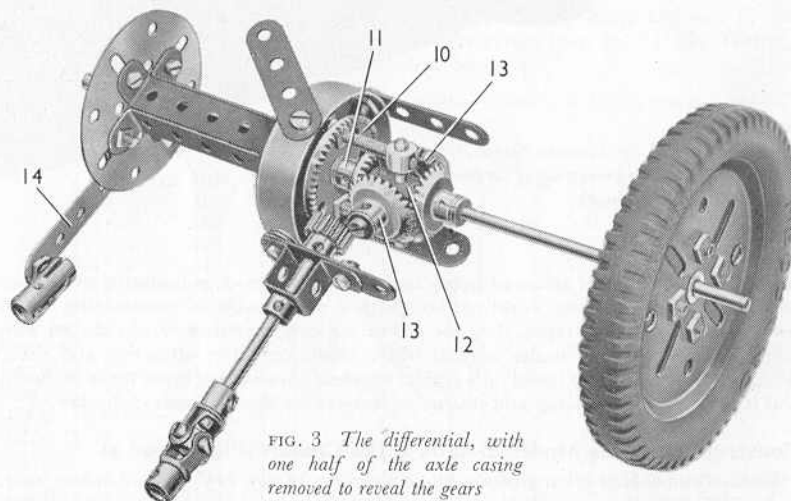

FIG. 3 The differential, with one half of the axle casing removed to reveal the gears

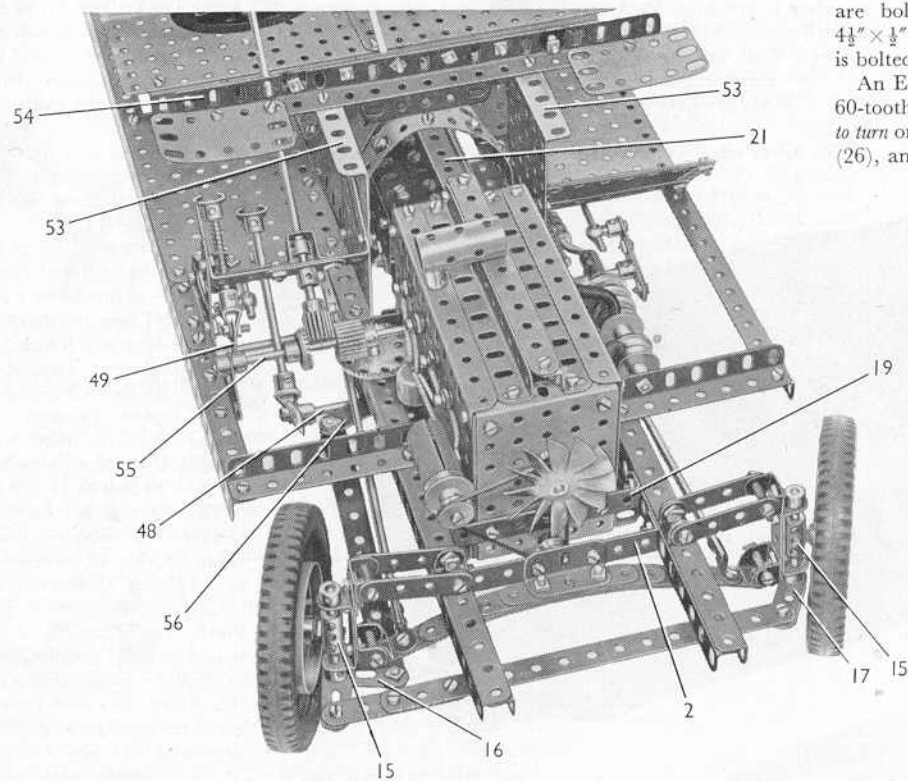

FIG. 4 A front view of the chassis showing the steering mechanism in detail

Crank are connected by *lock-nutted* bolts to a built-up strip made from a $7\frac{1}{2}$ " Strip and a $2\frac{1}{2}$ " Strip overlapped three holes.

A Double Bracket is bolted to each end of the 2" Strip on each side. The upper Double Brackets are connected pivotally to 2" Strips by *lock-nutted* $\frac{3}{4}$ " Bolts, and these Strips are *lock-nutted* to further Double Brackets bolted to the chassis. The lower Double Brackets are connected pivotally to Double Brackets bolted to the ends of the main leaf of the front spring. The connections are made by $\frac{3}{4}$ " Bolts passed through the lugs of the pairs of Double Brackets and fitted with *lock-nuts*. The main leaf of the spring is a $7\frac{1}{2}$ " Strip, and the other leaves are formed by a $5\frac{1}{2}$ ", a $4\frac{1}{2}$ ", a $3\frac{1}{2}$ " and a $2\frac{1}{2}$ " Strip. The complete spring is attached by $\frac{3}{8}$ " Bolts to a $1\frac{1}{2}$ " Angle Girder bolted to the Double Angle Strip (2). The spring is braced to the chassis on each side by a $6\frac{1}{2}$ " Rod held in Rod and Strip Connectors.

The Engine Unit (Figs. 4, 5 and 6)

Each side of the engine unit (Figs. 4 and 6) is a $5\frac{1}{2}$ " \times $3\frac{1}{2}$ " Flat Plate fitted at each end with a $3\frac{1}{2}$ " Angle Girder, at the top with a $5\frac{1}{2}$ " Angle Girder, and at its lower edge with a $5\frac{1}{2}$ " Angle Girder (18) (Fig. 5). The sides are connected at the front by a $3\frac{1}{2}$ " \times $2\frac{1}{2}$ " Flanged Plate, to which a $3\frac{1}{2}$ " \times $\frac{1}{2}$ " Double Angle Strip (19) is bolted, and at the rear are joined by a $2\frac{1}{2}$ " \times $2\frac{1}{2}$ " Flat Plate, a $3\frac{1}{2}$ " \times $\frac{1}{2}$ " Double Angle Strip and a $2\frac{1}{2}$ " Strip (20). At the top of the unit two $5\frac{1}{2}$ " Angle Girders

are bolted flanges upward, and to one of them a $5\frac{1}{2}$ " Strip is attached by Angle Brackets. A $4\frac{1}{2}$ " \times $\frac{1}{2}$ " Double Angle Strip (21) (Fig. 6) is fixed to the rear of the unit, and a $2\frac{1}{2}$ " \times $1\frac{1}{2}$ " Flanged Plate (22) is bolted between the sides.

An E20R Electric Motor is fixed to one side of the engine unit, and a $\frac{5}{16}$ " Pinion on its shaft drives a 60-tooth Gear (23) on a $2\frac{1}{2}$ " Rod. A $\frac{1}{2}$ " Pinion on the same Rod engages a 57-tooth Gear (24) that is *free to turn* on a $3\frac{1}{2}$ " Rod (25). A 1" Pulley fitted with a Motor Tyre, is gripped in the boss of a Socket Coupling (26), and this assembly also is free on Rod (25). The Socket Coupling and the Pulley turn with the Rod however, through a Collar fitted with a bolt that engages a slot in the Socket Coupling.

A Compression Spring is placed on Rod (25) between the Collar and the Socket Coupling, to force the Tyre on the 1" Pulley against the face of the Gear (24) and so form a friction clutch.

The front end of the Motor shaft is joined to a $1\frac{1}{2}$ " Rod by a Coupling. The Rod passes through the front of the housing and carries a $\frac{1}{2}$ " fixed Pulley and a Fan.

The dynamo is a Sleeve Piece fitted at one end with a Chimney Adapter and at the other with a $\frac{3}{4}$ " Flanged Wheel. A $\frac{1}{2}$ " loose Pulley is free to turn on a $\frac{1}{2}$ " Bolt gripped in the Flanged Wheel, and the Sleeve Piece is spaced from the engine unit by a nut on the bolt that holds it in place. A $\frac{1}{2}$ " loose Pulley (27) (Fig. 5), is free to turn on a Pivot Bolt. The three $\frac{1}{2}$ " Pulleys are connected by a Driving Band.

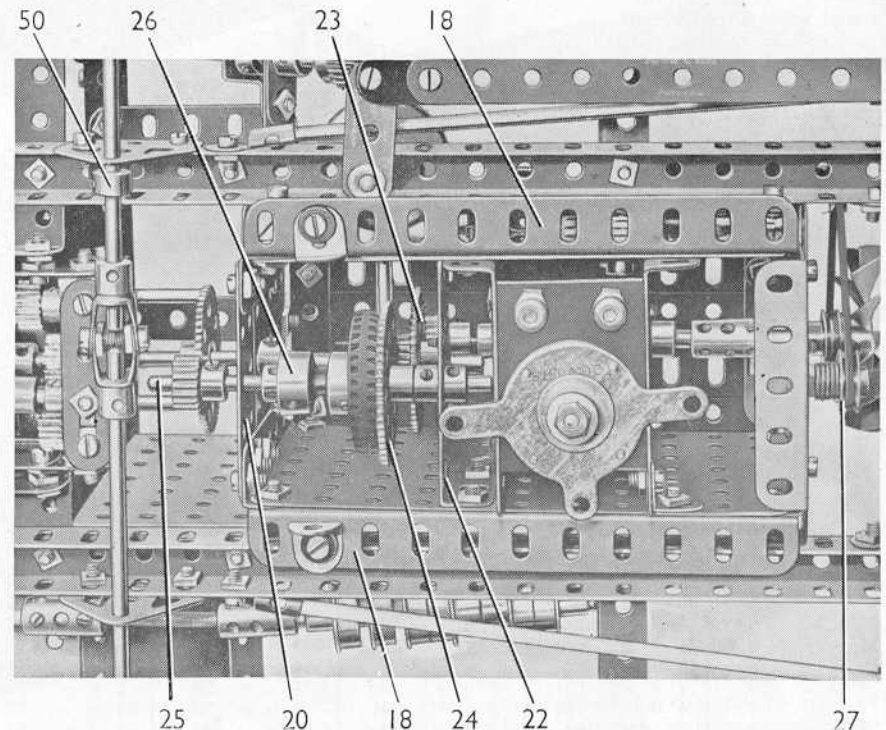

FIG. 5 The engine unit seen from below

The sparking plugs are $\frac{3}{8}$ " Bolts, that are connected to a Chimney Adaptor by four lengths of Spring Cord. The exhaust pipe consists of two Springs bolted to the housing and clamped at their lower ends between $\frac{3}{4}$ " Flanged Wheels on a $3\frac{1}{2}$ " Screwed Rod. One end of the Screwed Rod is fixed in one of the Girders (8) (Fig. 2), and to the other a Flexible Coupling Unit is attached by a Threaded Coupling. The Flexible Coupling Unit is joined by a Coupling to an $11\frac{1}{2}$ " Rod that passes through one of the Channel Bearings (5). This Rod carries two Worms, in one of which is held an Adaptor for Screwed Rods that supports a 6" Screwed Rod. The rear end of the Screwed Rod is fixed in an Angle Bracket bolted to the Girder 4.

Assembling the Gear-Box (Fig. 7)

The gears are located in a frame, the top of which consists of two 3" Flat Girders bolted together through their round holes, with a 3" Angle Girder fixed through its slotted holes to the outer edge of each Flat Girder. A $3" \times 1\frac{1}{2}"$ Flat Plate is attached to each Angle Girder. The bolts that connect the Flat Girders secure also a $1" \times 1"$ Angle Bracket (28) (Fig. 7), and a similar part at the opposite end of the frame. A $1" \times \frac{1}{2}"$ Angle Bracket is also fixed to the centre of the Flat Girders, with a Fishplate bolted to it, so that the round hole in the Fishplate covers the slotted hole in the Angle Bracket. The $1" \times \frac{1}{2}"$ Angle Bracket is located below the 2" Slotted Strip seen at the centre of the gear-box.

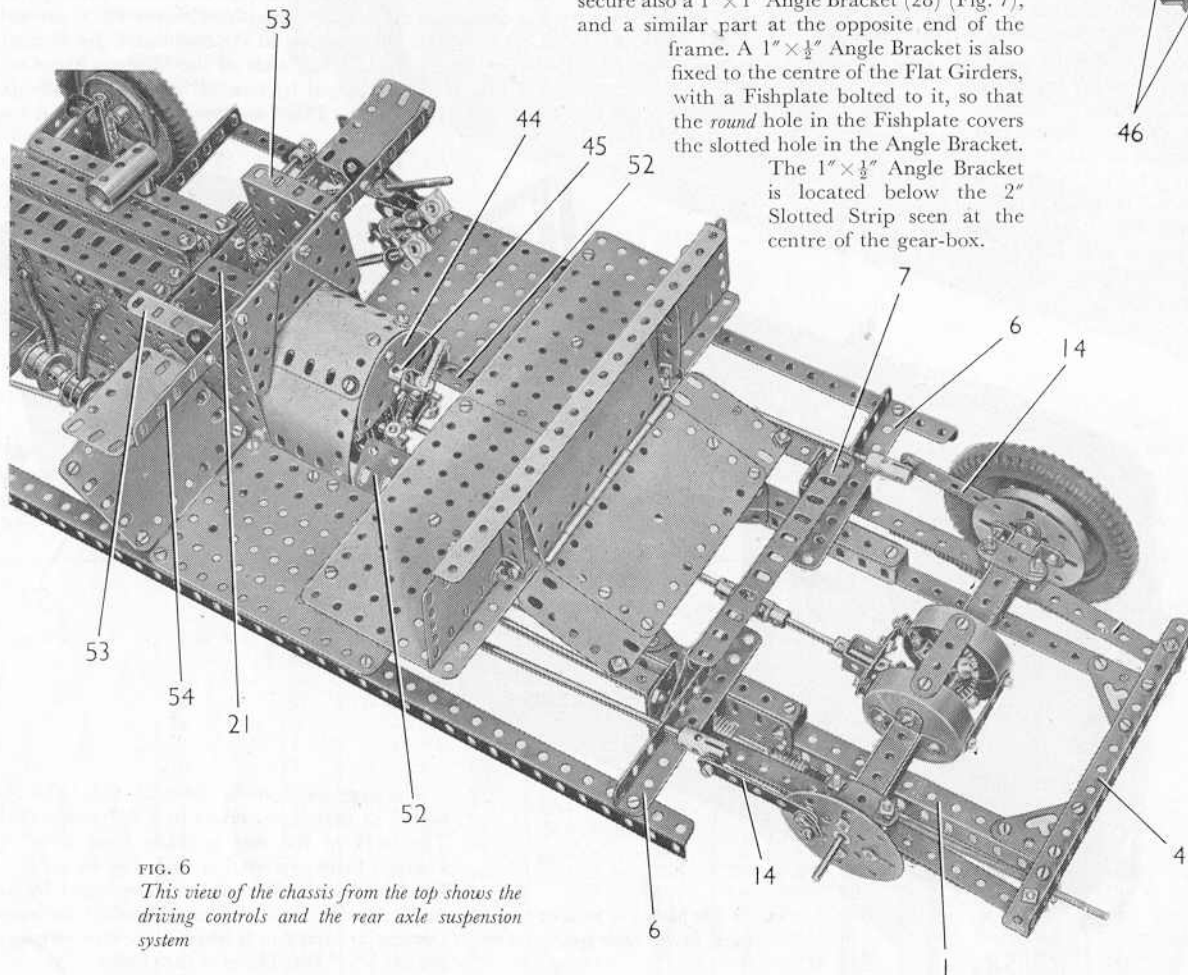

FIG. 6
This view of the chassis from the top shows the driving controls and the rear axle suspension system

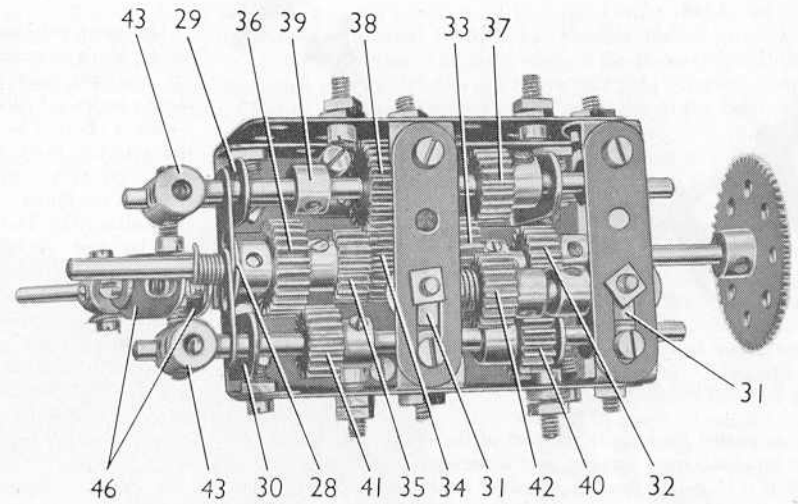

FIG. 7 A close-up of the 3-speed and reverse gear-box

The bolts that connect the Flat Girders and the Angle Girders fix also a $2\frac{1}{2}" \times 1"$ Double Angle Strip (29) on one side and a similar Double Angle Strip (30) on the other side. Use is made of the slotted holes in the Flat Girders and Angle Girders, so that $\frac{1}{2}"$ Pinions on Rods mounted in the Double Angle Strips (29) and (30), will mesh accurately with $\frac{3}{4}"$ Pinions on a Rod in the central Angle Brackets. Two 2" Slotted Strips are attached to Angle Brackets fixed to the sides of the frame, and to each Slotted Strip an Angle Bracket (31) is bolted.

The input shaft is a $3\frac{1}{2}"$ Rod mounted in one of the central $1" \times 1"$ Angle Brackets and in the $1" \times \frac{1}{2}"$ Angle Bracket. The Rod is fitted with a $\frac{1}{2}"$ Pinion (32), a $\frac{3}{4}"$ Pinion (33) and a $\frac{1}{2}"$ Pinion (34). The Rod projects about $\frac{1}{4}"$ beyond the Pinion (34) into a $\frac{1}{2}"$ Pinion (35) on the output shaft. This shaft is a 2" Rod, and it carries also a $\frac{3}{4}"$ Pinion (36). A Cord Anchoring Spring placed outside the Angle Bracket (28) keeps the Rod in position.

The 2nd and 3rd gears layshaft is a $3\frac{1}{2}"$ Rod mounted in the Double Angle Strip (29). The Rod carries a $\frac{1}{2}"$ Pinion (37), a $\frac{3}{4}"$ Pinion (38) and a Collar (39). Another Collar is positioned outside one of the lugs of the Double Angle Strip to limit the sliding movement of the Rod.

The layshaft for 1st and reverse gears is a $3\frac{1}{2}"$ Rod supported in the Double Angle Strip (30). This Rod carries a $\frac{3}{4}"$ Pinion (40), a $\frac{1}{2}"$ Pinion (41) and a Collar. The movement of the Rod is limited by a Collar in the same way as that of the other layshaft. The $\frac{1}{2}"$ reverse Pinion (42) is fixed on a $1\frac{1}{2}"$ Rod mounted in the Angle Brackets (31). The Pinion is spaced from one Angle Bracket by four Washers, and the Rod is held in place by a Collar.

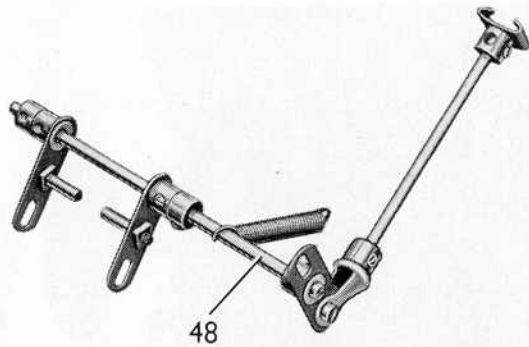

FIG. 8 The clutch pedal and release lever unit removed from the chassis

The gear selector shafts are $4\frac{1}{2}$ " Rods mounted above the layshafts, and each of them carries a Collar fitted with a $\frac{3}{8}$ " Bolt. The Bolt on the selector shaft for 2nd and 3rd gears engages between the Pinion (38) and the Collar (39). The Bolt on the 1st and reverse gear shaft is located between the Pinion (41) and the Collar. Fishplates are passed over the output shaft and the ends of the layshafts as seen in Fig. 7. A Coupling (43) is fixed to each selector shaft

and is passed freely over the end of the corresponding layshaft. These Couplings prevent the selector shafts from turning, and so serve to keep the $\frac{3}{8}$ " Bolts against the layshafts.

A $1" \times 1"$ Angle Bracket is bolted to the top at the rear end of the gear-box frame, and a Threaded Pin is passed through this Angle Bracket and through a Semi-Circular Plate (44) (Fig. 6). A Swivel Bearing (45) is fixed on the Threaded Pin, and in it is held a $2\frac{1}{2}$ " Rod that forms the gear lever. A Coupling, to which two Fishplates (46) are attached by bolts, is fixed to the lower end of the $2\frac{1}{2}$ " Rod. The Fishplates are arranged one on each side of bolts screwed into the Couplings (43). The movement of each selector shaft is restrained by a $\frac{3}{8}$ " Bolt held in the top of the gear-box frame by two nuts. The shank of this Bolt presses lightly against the selector shaft.

The gear-box is connected by $\frac{3}{8}$ " Bolts to Girder Brackets (47) bolted to the chassis (Fig. 2). The sides of the gear-box are spaced from the Girder Brackets by a nut on each bolt. A 57-tooth Gear on the input shaft is driven by a $\frac{1}{2}$ " Pinion on the Rod (25), and the drive to the rear axle is carried by a $6\frac{1}{2}$ " Rod and two Universal Couplings.

Clutch and Brake Mechanisms (Figs. 2, 5 and 8)

The clutch pedal is a Slide Piece on a $4"$ Rod that passes through an Obtuse Angle Bracket bolted to one of the $5\frac{1}{2}" \times 3\frac{1}{2}"$ Flat Plates of the chassis. The lower end of the Rod carries an End Bearing, and this pivots on a $\frac{3}{8}"$ Bolt passed through a Double Arm Crank on a $5"$ Rod (48) (Fig. 8). This Rod is held by Collars in Angle Brackets bolted to the Girders (18) of the engine unit, and it carries two Cranks fitted with Threaded Pins that engage the groove in the Socket Coupling (26).

The brake pedal is a Slide Piece on a $2"$ Rod, which is mounted in an Obtuse Angle Bracket bolted to a $1"$ Triangular Plate fixed to the $5\frac{1}{2}" \times 3\frac{1}{2}"$ Flat Plate. Two Compression Springs are placed on the Rod between the Slide Piece and the Obtuse Angle Bracket. An End Bearing on the lower end of the $2"$ Rod is lock-nutted to a Bell Crank (49) (Fig. 2) on a built-up axle. This axle consists of two $4\frac{1}{2}"$ Rods, each of which carries a small Fork Piece, and the Fork Pieces are bolted together by their lugs. The axle is supported in Flat Trunnions bolted to the chassis, and in a $1\frac{1}{2}"$ Strip fixed to a Trunnion attached to one of the Girders (9). The axle is held

in place by a Collar, and in addition to the Bell Crank (49) it carries half of a Dog Clutch (50) and a $2"$ Strip (51) bolted to a Double Arm Crank. Handrail Couplings are pivoted on bolts passed through the Bell Crank and the Strip (51), and each Handrail Coupling is connected by a built-up rod to a Strip Coupling that pivots on a bolt in one of the Strips (14) (Fig. 6). The built-up rods are each made from a $4"$ and an $8"$ Rod joined by a Rod Connector. A Spring is attached by a bolt to the half of the Dog Clutch (50) and is looped over the clutch shaft (48).

Gear-Box Cover, Dashboard and Front Seat (Fig. 6)

The Semi-Circular Plate (44) is bolted to the rear lug of the Double Angle Strip (21), and a $1\frac{11}{16}"$ radius Curved Plate also is attached to this Double Angle Strip, and is connected by further $1\frac{11}{16}"$ radius Curved Plates to Angle Brackets bolted to the chassis. Two $3\frac{1}{2}"$ Flat Girders (52) are attached to the chassis by Obtuse Angle Brackets, and are connected together by two $2\frac{1}{2}" \times 2\frac{1}{2}"$ Flexible Plates placed behind the gear lever.

Two $3\frac{1}{2}" \times 2\frac{1}{2}"$ Flanged Plates (53) are bolted to the chassis and are connected by a $9\frac{1}{2}"$ Angle Girder (54). A $2\frac{1}{2}" \times 1\frac{1}{2}"$ Flexible Plate and two $2\frac{1}{2}" \times 1\frac{1}{2}"$ Triangular Flexible Plates are bolted to this Girder above the gear-box cover. The compartments in the dashboard are formed by $2\frac{1}{2}" \times 1\frac{1}{2}"$ Flexible Plates curved slightly and bolted to the ends of the Girder (54). On the passenger side of the car a $3\frac{1}{2}" \times 2\frac{1}{2}"$ Flexible Plate, edged by two $3\frac{1}{2}"$ and two $2\frac{1}{2}"$ Strips, is connected by Obtuse Angle Brackets to the $5\frac{1}{2}" \times 3\frac{1}{2}"$ Flat Plate, and by an Angle Bracket to one of the Flanged Plates (53).

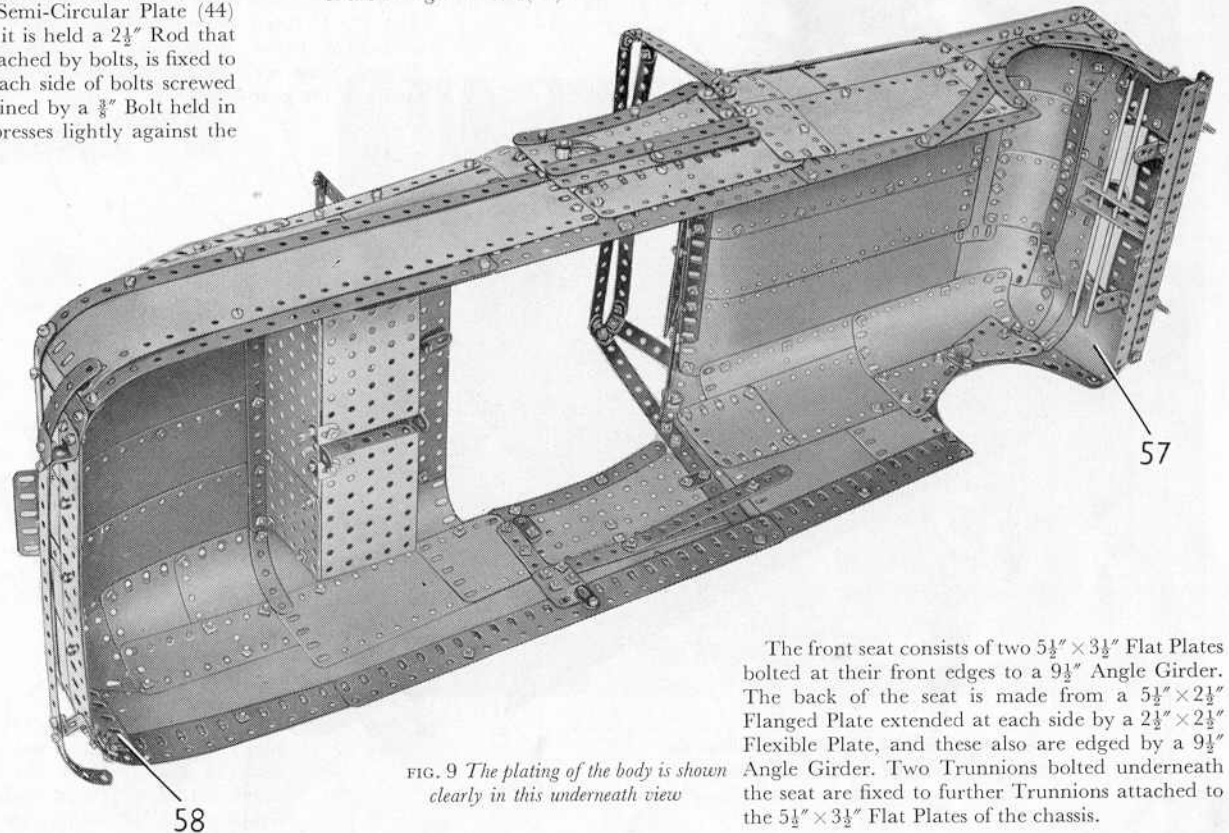

FIG. 9 The plating of the body is shown clearly in this underneath view

The front seat consists of two $5\frac{1}{2}" \times 3\frac{1}{2}"$ Flat Plates bolted at their front edges to a $9\frac{1}{2}"$ Angle Girder. The back of the seat is made from a $5\frac{1}{2}" \times 2\frac{1}{2}"$ Flanged Plate extended at each side by a $2\frac{1}{2}" \times 2\frac{1}{2}"$ Flexible Plate, and these also are edged by a $9\frac{1}{2}"$ Angle Girder. Two Trunnions bolted underneath the seat are fixed to further Trunnions attached to the $5\frac{1}{2}" \times 3\frac{1}{2}"$ Flat Plates of the chassis.

A Hinged Flat Plate is bolted behind the front seat, and its horizontal half is extended on each side by a $2\frac{1}{2}'' \times 1\frac{1}{2}''$ Flexible Plate. These plates are connected to the Channel Bearings (5) (Fig. 2) by $1'' \times 1''$ Angle Brackets.

The Steering Mechanism

The steering column is a $6\frac{1}{2}''$ Rod that is supported in an Angle Bracket bolted to Girder (54) (Fig. 6) and in a Double Bent Strip and a Double Arm Crank fixed to a $3'' \times 1\frac{1}{2}''$ Double Angle Strip. The Double Angle Strip is bolted to one of the Flanged Plates (53) and to a Corner Gusset supported by a $2''$ Angle Girder fixed to one of the Girders (9).

A $\frac{1}{2}''$ diameter $\frac{1}{2}''$ face Pinion on the lower end of the steering column engages a $\frac{3}{4}''$ Contrate on a $5''$ Rod (55) (Fig. 4). This Rod is supported in one side of the engine unit and in a Trunnion fixed to one of the Girders (9). A $\frac{3}{4}''$ diameter $\frac{1}{2}''$ face Pinion on Rod (55) meshes with a $1\frac{1}{2}''$ Contrate on a vertical $1\frac{1}{2}''$ Rod. The $1\frac{1}{2}''$ Rod is passed through one of the chassis members and is held in place by a Collar. A Crank (56) is fixed on the lower end of the $1\frac{1}{2}''$ Rod, and to it is *lock-nutted* a Fishplate. The Fishplate is bolted to a $5\frac{1}{2}''$ Strip *lock-nutted* to the Bell Crank (16).

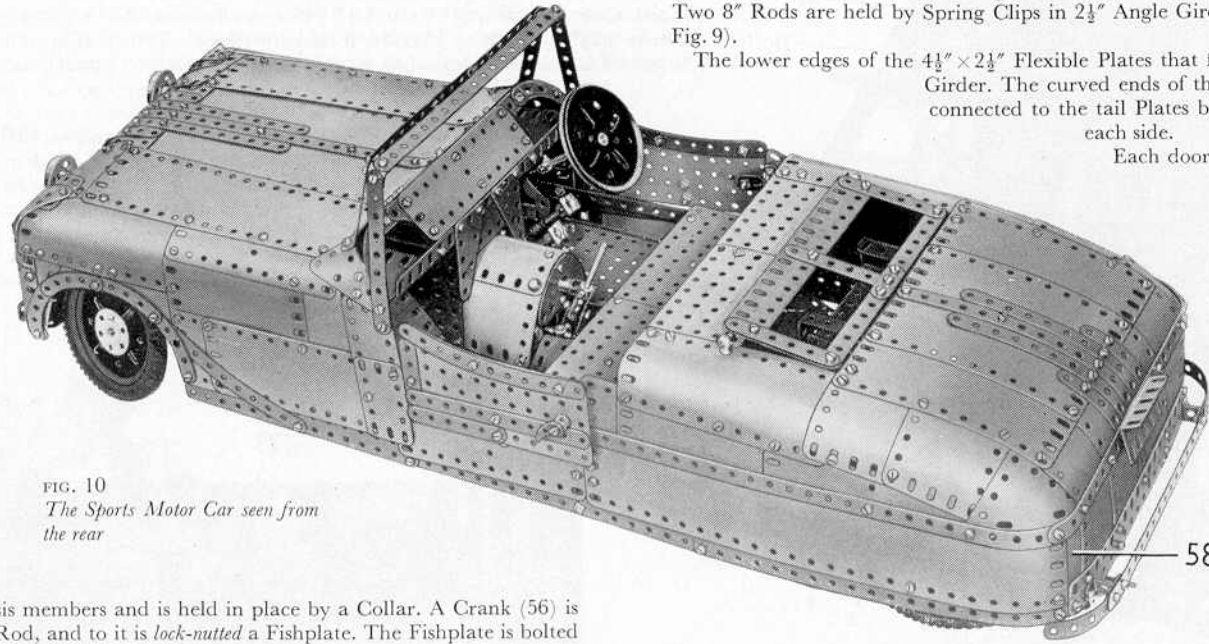

FIG. 10
The Sports Motor Car seen from the rear

attached to the front by Angle Brackets, and this supports a $9\frac{1}{2}''$ Angle Girder that forms the front bumper. The Plates (57) are extended upward by $5\frac{1}{2}'' \times 1\frac{1}{2}''$ Flexible Plates, which are joined at their inner ends to a $2\frac{1}{2}'' \times 1\frac{1}{2}''$ Flexible Plate. The inner edges of the Plates (57) and the $5\frac{1}{2}'' \times 1\frac{1}{2}''$ Flexible Plates are strengthened by two $2\frac{1}{2}''$ Curved Strips and a $5\frac{1}{2}''$ Curved Strip. Two $8''$ Rods are held by Spring Clips in $2\frac{1}{2}''$ Angle Girders bolted vertically to the front (see Fig. 9).

The lower edges of the $4\frac{1}{2}'' \times 2\frac{1}{2}''$ Flexible Plates that form the tail are bolted to a $9\frac{1}{2}''$ Flat Girder. The curved ends of the Strip Plates that form the sides are connected to the tail Plates by a $1\frac{1}{8}''$ radius Curved Plate (58) on each side.

Each door is a $5\frac{1}{2}'' \times 2\frac{1}{2}''$ Flat Plate edged at the top by a $5\frac{1}{2}''$ Curved Strip. The door on the driver's side hangs on Hinges, but the other does not open and is attached by Fishplates. The door catches are Pawls fixed on $\frac{1}{2}''$ Bolts passed through the doors and then fitted with Fishplates, each of which is fixed on its Bolt by two nuts.

The rear seat is formed by two $3\frac{1}{2}'' \times 2\frac{1}{2}''$ Flanged Plates connected by Angle Brackets to a $5\frac{1}{2}'' \times 2\frac{1}{2}''$ Flat Plate extended by a $2\frac{1}{2}'' \times 2\frac{1}{2}''$ Flat Plate. The Flat Plates are bolted to a $7\frac{1}{2}''$ Angle Girder fixed to the front edges of the tail plates. The arm rests at the sides are $2\frac{1}{2}''$ Angle Girders and $2\frac{1}{2}''$ Flat Girders, and the centre arm rest is a $2\frac{1}{2}'' \times 1\frac{1}{2}''$ Double Angle Strip.

The hinged windscreen for the rear seat is formed by a $7\frac{1}{2}''$ Flat Girder that is connected to a built-up strip by three $3''$ Strips. The built-up strip consists of a $1\frac{1}{2}''$ Strip and two $3\frac{1}{2}''$ Strips bolted together. Two Right-Angle Rod and Strip Connectors fixed to the Flat Girder are pivoted on $1''$ Rods, each of which is held in a Handrail Support.

Details of the Body

The general arrangement of the Plates that form the sides and the top of the body is shown clearly in Figs 1, 9, and 10. The curved front is formed by a $3\frac{1}{2}'' \times 2\frac{1}{2}''$ Flexible Plate (57) on each side, and the lower corners of these are connected by a $7\frac{1}{2}''$ Flat Girder. A $9\frac{1}{2}''$ Flat Girder is

Parts Required to Build the Meccano Sports Motor Car

5 of No. 1	4 of No. 9c	3 of No. 16a	1 of No. 26c	2 of No. 48	1 of No. 64	2 of No. 103h	4 of No. 133	2 of No. 164	11 of No. 200
2 " " 1a	5 " " 9d	3 " " 16b	2 " " 27a	8 " " 48a	3 " " 70	4 " " 103k	2 " " 133a	2 " " 165	4 " " 212
6 " " 1b	1 " " 9e	5 " " 17	1 " " 27d	3 " " 48b	2 " " 72	1 " " 108	4 " " 136	2 " " 166	2 " " 212a
18 " " 2	1 " " 9f	5 " " 18a	2 " " 28	1 " " 48c	2 " " 73	2 " " 109	2 " " 136a	1 " " 171	2 " " 213
7 " " 2a	21 " " 10	2 " " 18b	2 " " 29	2 " " 50	1 " " 77	15 " " 111	4 " " 137	1 " " 173a	1 " " 214
16 " " 3	12 " " 11	2 " " 20	3 " " 30	1 " " 51	1 " " 79a	12 " " 111a	2 " " 140	1 " " 175	4 " " 215
7 " " 4	30 " " 12	5 " " 19b	2 " " 32	1 " " 52	1 " " 80a	24 " " 111c	4 " " 142b	1 " " 176	6 " " 221
17 " " 5	5 " " 12a	8 " " 20b	4 " " 35	5 " " 52a	1 " " 82	6 " " 111d	1 " " 142c	1 " " 186a	2 " " 222
11 " " 6	4 " " 12b	1 " " 22	644 " " 37a	5 " " 53	6 " " 89	2 " " 114	1 " " 144	12 " " 188	2 " " 223
10 " " 6a	12 " " 12c	2 " " 23	544 " " 37b	2 " " 53a	10 " " 90	3 " " 115	1 " " 147a	10 " " 189	2 " " 224
4 " " 7	1 " " 13	1 " " 23a	75 " " 38	2 " " 55a	2 " " 90a	2 " " 116	1 " " 147b	12 " " 190	2 " " 225
2 " " 7a	4 " " 13a	2 " " 24b	4 " " 38d	24 " " 59	4 " " 103a	1 " " 116a	1 " " 147c	3 " " 190a	
6 " " 8a	4 " " 14	2 " " 24c	3 " " 43	4 " " 62	2 " " 103b	3 " " 120b	1 " " 157	6 " " 191	
3 " " 8b	3 " " 15	4 " " 25	2 " " 45	3 " " 62b	2 " " 103c	2 " " 125	2 " " 160	12 " " 192	
7 " " 9	5 " " 15a	1 " " 25a	2 " " 46	8 " " 63	2 " " 103d	6 " " 126	2 " " 161	4 " " 196	
2 " " 9a	2 " " 15b	8 " " 26	1 " " 47	2 " " 63b	2 " " 103e	2 " " 126a	2 " " 162a	2 " " 197	1 E20R
7 " " 9b	4 " " 16	1 " " 26a	1 " " 47a	1 " " 63c	3 " " 103f	2 " " 128	2 " " 163	1 " " 198	Electric Motor
									(not included in outfit)

MECCANO Coal Tippler

(MODEL No. 10.3)

SPECIAL FEATURES

The Coal Tippler is driven by a Meccano E15R type Electric Motor. While tipping is in process the wagon is held firmly on the tipping platform by a heavy pivoted beam that comes into action automatically as soon as tipping commences.

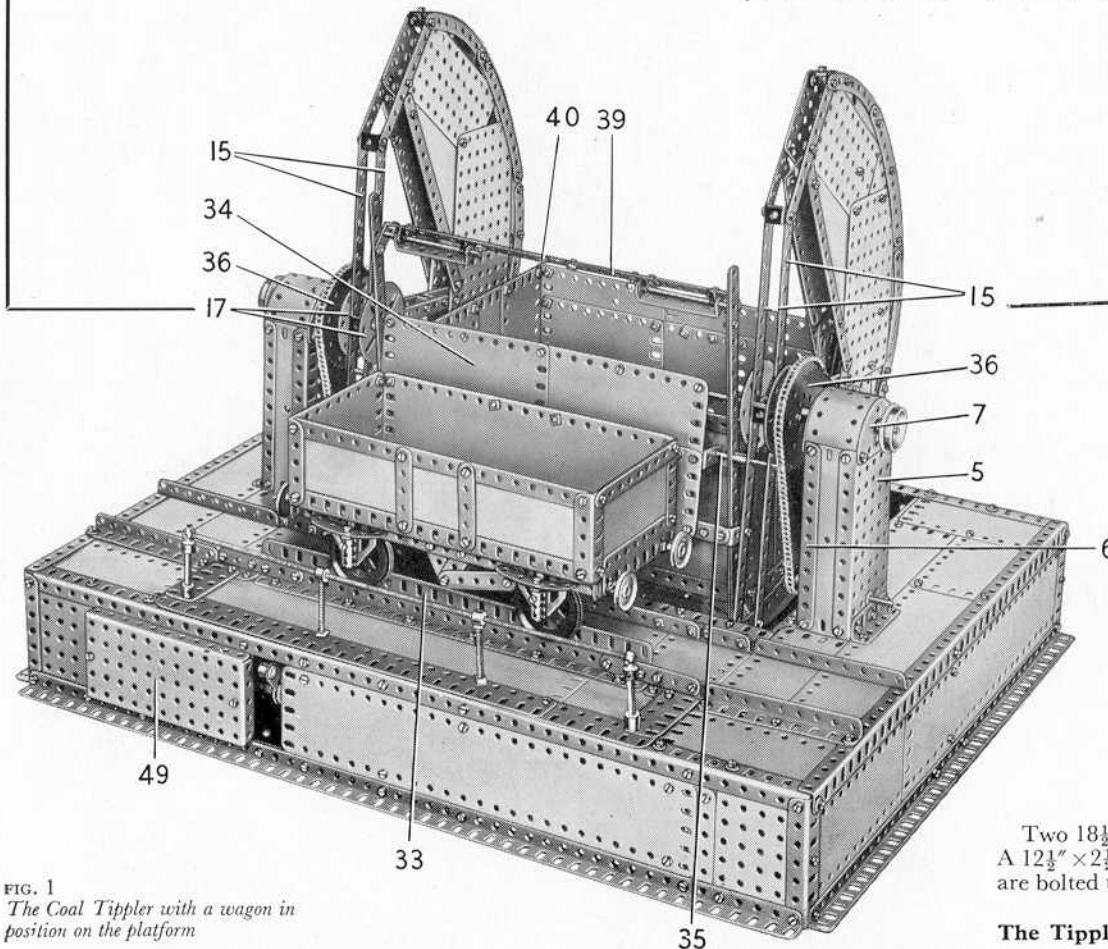

FIG. 1
The Coal Tippler with a wagon in position on the platform

Coal wagon tipplers are ingenious appliances that permit railway wagons to be emptied of their loads completely and quickly. Such discharge in bulk is required at power stations and many other industrial installations such as gas and steel works. Tipplers of various types are used also in connection with coal and ash handling plants at steam locomotive depots.

The operation of the model Tippler described in this leaflet is as follows. First the wagon is run on to the rails of the Tippler platform. Then the Motor is switched on and the

platform swings upward. As it does so a pivoted locking beam comes into action and presses on the top of the wagon to hold it firmly on the rails. At the peak of its travel the contents of the wagon are discharged into a hopper, and the Motor is then reversed to lower the platform and wagon to ground level again, so that the empty wagon can be drawn off and replaced by another loaded one.

Construction of the Model: The Base (Fig. 2)

Each side of the base consists of two $18\frac{1}{2}$ " Angle Girders joined at their ends by $3\frac{1}{2}$ " Angle Girders, and connected at the centre by a $3\frac{1}{2}$ " \times $2\frac{1}{2}$ " Flanged Plate (1) (Fig. 2). The sides are filled in by $12\frac{1}{2}$ " \times $2\frac{1}{2}$ " Strip Plates. The sides are connected at the front and the back by $24\frac{1}{2}$ " Angle Girders, with the corners strengthened by $3\frac{1}{2}$ " \times $2\frac{1}{2}$ " Flanged Plates (2). The $24\frac{1}{2}$ " Angle Girders are braced at the centre by $5\frac{1}{2}$ " \times $3\frac{1}{2}$ " Flat Plates, and at the front two 3 " \times $1\frac{1}{2}$ " Flat Plates (3) are bolted between the Girders. The front and the back are completed by $12\frac{1}{2}$ " \times $2\frac{1}{2}$ " Strip Plates, as shown in Figs. 1 and 2.

Two $18\frac{1}{2}$ " Angle Girders (4) are bolted across the top of the base at each end (Fig. 2). A $12\frac{1}{2}$ " \times $2\frac{1}{2}$ " Strip Plate, three $4\frac{1}{2}$ " \times $2\frac{1}{2}$ " Flexible Plates and two $5\frac{1}{2}$ " \times $2\frac{1}{2}$ " Flexible Plates are bolted to these Girders at each end to fill in the top.

The Tippler Supporting Columns (Figs. 1, 2, 3, 5 and 7)

The outer face of each column is a $5\frac{1}{2}$ " \times $2\frac{1}{2}$ " Flanged Plate (5) fixed to a $2\frac{1}{2}$ " Angle Girder bolted to one of the Girders (4). The inner face is formed by two $5\frac{1}{2}$ " Angle Girders (6) supported by a $2\frac{1}{2}$ " Angle Girder fixed to the second of the Girders (4). The Flanged Plate (5) and the Girders (6) are extended upward by Semi-Circular Plates (7) (Fig. 5), and the sides and top of the column are filled in by $5\frac{1}{2}$ " \times $1\frac{1}{2}$ " Flexible Plates. A $7\frac{3}{8}$ " Strip (8) (Fig. 7) is bolted to the inner face of the column, and a $2\frac{1}{2}$ " Strip (9) is fixed to the Flanged Plate (5) and to a $1\frac{1}{2}$ " Angle Girder attached to one of the Girders (4). The lower ends of Strips (8) and (9) are connected by a $1\frac{1}{2}$ " \times $\frac{1}{2}$ " Double Angle Strip.

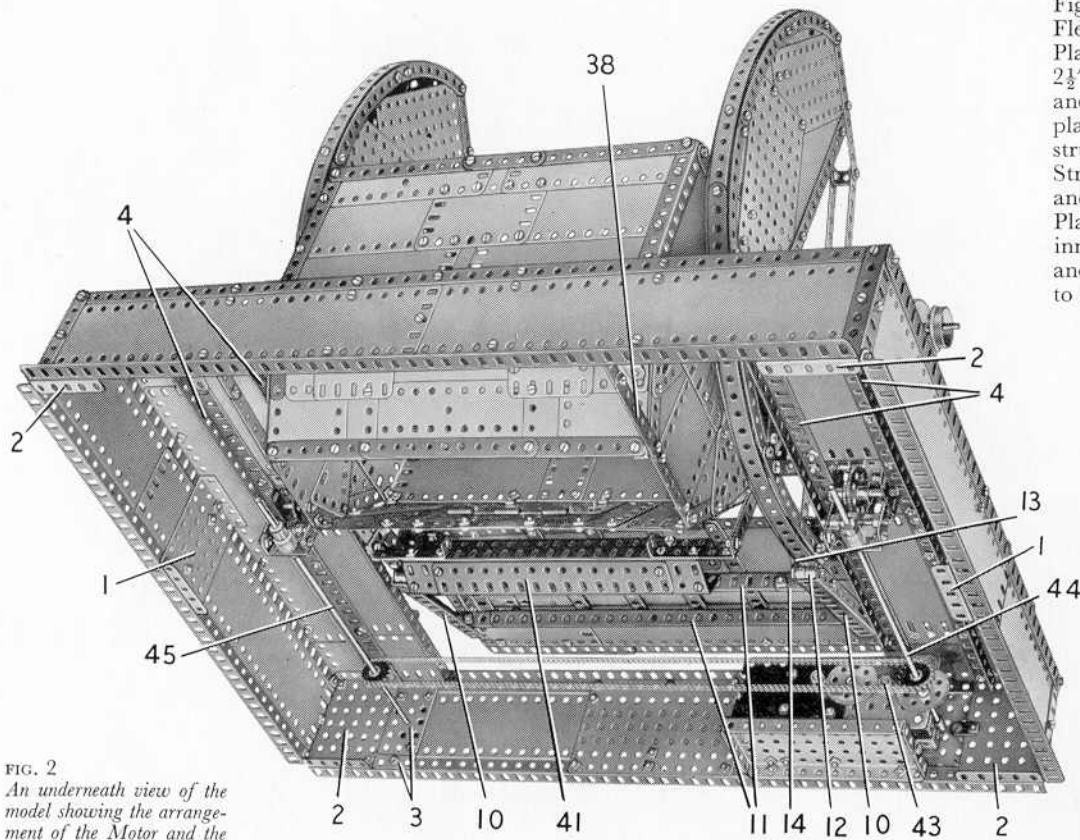

FIG. 2
An underneath view of the model showing the arrangement of the Motor and the gearing.

The Tippler Platform and Counter-Balance Weights (Figs. 1, 2, 3, and 5)

The frame that supports the platform (Fig. 3) consists of two $5\frac{1}{2}$ " Angle Girders (10) connected by $1" \times \frac{1}{2}"$ Angle Brackets to two built-up girders (11). Each of these girders is formed by two $12\frac{1}{2}"$ Angle Girders overlapped 23 holes. A Bell Crank (12), a $1"$ Corner Bracket (13), and a $1" \times 1"$ Angle Bracket (14) are fixed to the inner end of each of the Girders (10) by a $\frac{3}{4}"$ Bolt. This Bolt passes through the boss of the Bell Crank, and the Corner Bracket is spaced from the Bell Crank by a Collar. The Angle Brackets (14) are bolted to the inner one of the girders (11).

The frame that supports each counter-balance consists of two $12\frac{1}{2}"$ Strips (15) (Fig. 5) bolted to the Bell Crank (12) and to Corner Bracket (13). These Strips are connected at a point 14 holes from their lower ends, by a Double Bracket, and at their upper ends by another Double Bracket. The bolts that fix the centre Double Bracket secure also two $5\frac{1}{2}"$ Strips (16), to each of which is fastened a Face Plate (17) (Fig. 1). The Strips (16) are connected by a Double Bent Strip.

Two $4\frac{1}{2}"$ Strips (18) are fixed to the top ends of the Strips (15), and two $5\frac{1}{2}"$ Curved Strips (19) are bolted to their lower ends. The outer edges of the counter-balance are formed by two further $5\frac{1}{2}"$ Curved Strips and two $4"$ Stepped Curved Strips, as shown in

Fig. 5. The outer face of each counter-balance is filled in by a $2\frac{1}{2}" \times 2\frac{1}{2}"$ Triangular Flexible Plate (21), a $4\frac{1}{2}" \times 2\frac{1}{2}"$ Flat Plate (22), a $3\frac{1}{2}" \times 1\frac{1}{2}"$ Triangular Flexible Plate, a $5\frac{1}{2}" \times 3\frac{1}{2}"$ Flat Plate, two $2\frac{1}{2}" \times 1\frac{1}{2}"$ Triangular Flexible Plates (23), a $2\frac{1}{2}" \times 1\frac{1}{2}"$ Flexible Plate (24), a $5\frac{1}{2}" \times 2\frac{1}{2}"$ Flat Plate (25), a $5\frac{1}{2}" \times 2\frac{1}{2}"$ Flexible Plate and a $3\frac{1}{2}" \times 2\frac{1}{2}"$ Triangular Flexible Plate (27). Three $12\frac{1}{2}"$ Angle Girders placed together are bolted on the inside of these Plates to add to the weight of the structure, and the inner edges of the counter-balance are finished by $5\frac{1}{2}"$ and $7\frac{1}{2}"$ Strips as shown. The inside face of each counter-balance is formed by a $5\frac{1}{2}" \times 2\frac{1}{2}"$ Flexible Plate (28), a $5\frac{1}{2}" \times 2\frac{1}{2}"$ Flexible Plate (29), a $4\frac{1}{2}" \times 2\frac{1}{2}"$ Flexible Plate (30) and a $4\frac{1}{2}" \times 2\frac{1}{2}"$ Flat Plate (31). The inner and outer faces of the counter-balance are connected by Double Brackets, and two curved $12\frac{1}{2}"$ Strips are fixed to the outer edges by Angle Brackets.

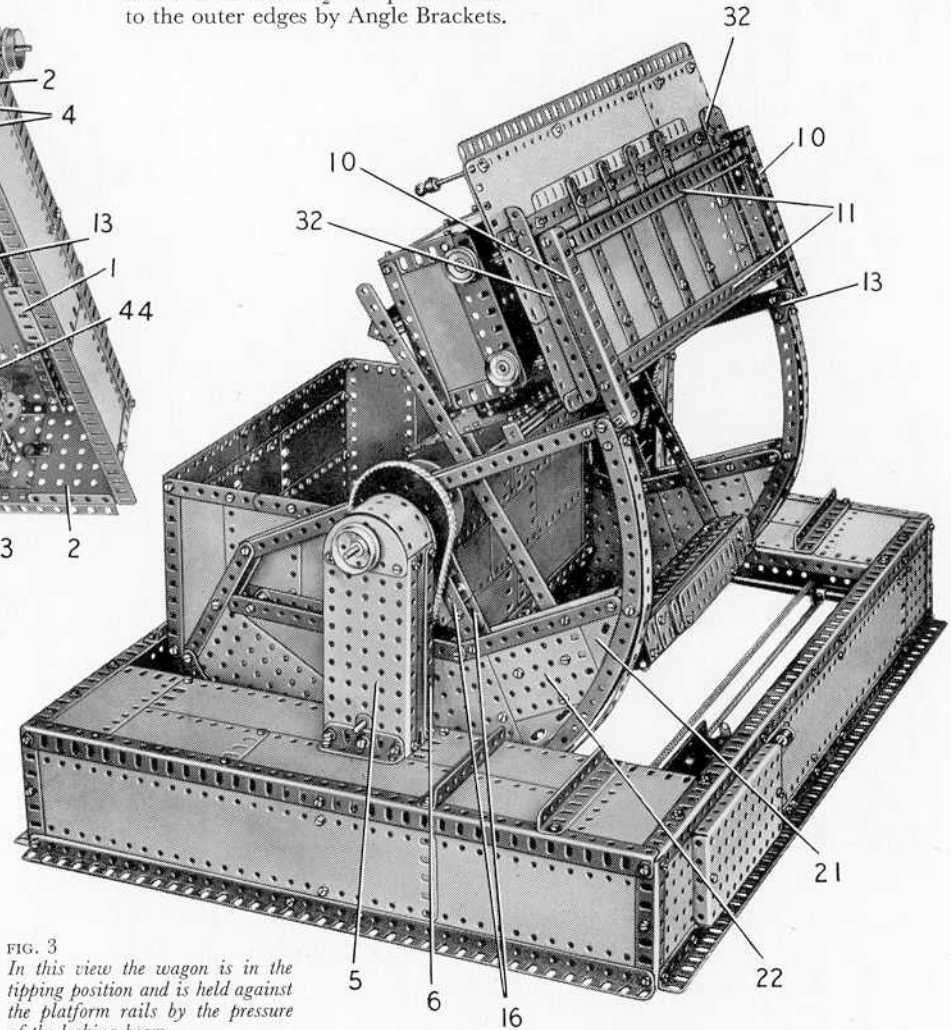

FIG. 3
In this view the wagon is in the tipping position and is held against the platform rails by the pressure of the locking beam

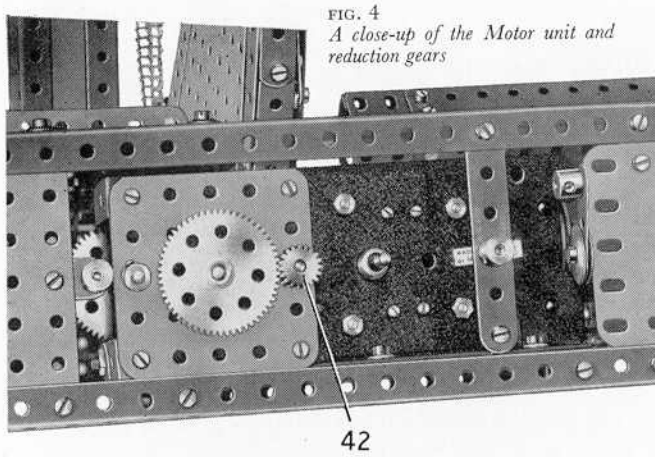

FIG. 4
A close-up of the Motor unit and reduction gears

A 12½" Angle Girder (37) is bolted along one side of the hopper and is fixed to the back of the base. Two 3" Strips (38) are connected to the back of the base by 1" × ½" Angle Brackets.

The Wagon Locking Beam (Figs. 1 and 2)

As the tippler operates the wagon is held against the rails on the platform by the swinging beam (39) (Fig. 1) which bears against the top of the wagon. The side-members of this beam are each formed by two 12½" Strips placed face to face and pivoted 12 holes from their top ends on the rod (35). The upper ends of these Strips are connected by a built-up strip (40), bolted to 1" × 1" Angle Brackets. The strip (40) consists of a 5½" Strip at each end overlapping a centre 5½" Strip by five holes. The end 5½" Strips have 2½" Strips bolted to them for strengthening purposes. A 2½" × ½" Double Angle Strip at each end of the strip (40) is pivoted on a 3½" Rod held by Spring Clips in two Angle Brackets bolted to the strip.

A weighted box-like structure (41) is bolted to two 2½" × ½" Double Angle Strips fixed to the lower ends of the 12½" Strips. It is made from four

The front section of the tippler platform consists of a 12½" × 2½" Strip Plate and a 4½" × 2½" Flexible Plate, overlapped three holes and edged by a 12½" and a 5½" Flat Girder. The platform is completed by five 5½" × 2½" Flexible Plates (Fig. 5). These Plates are strengthened underneath by two built-up strips, placed one along the rear edge of the platform and one below the join between the Strip Plate and the Flexible Plates. Each built-up strip is made from two 9½" Strips overlapped seven holes. The joins between the 5½" × 2½" Flexible Plates are strengthened by 5½" Strips. Two 5½" Angle Girders (32) (Fig. 3), are bolted underneath the platform and a Fishplate lock-nutted to each of these Girders is bolted to one of the Girders (10).

Each platform rail is formed by a 12½" Angle Girder and two 1½" Angle Girders connected by 3" Strips. A check rail (33) consists of a 12½" Flat Girder spaced from the running rail by two Washers on each of its securing bolts.

A backplate (34) (Fig. 1) above the platform is formed by four 5½" × 2½" Flexible Plates bolted together, with the joins and edges strengthened by two 4½" Strips and six 5½" Strips. This backplate is connected to two of the Strips (15) by 1" × 1" Angle Brackets, and two further 1" × 1" Angle Brackets are passed over a made-up rod (35). This Rod consists of a 1" Rod and two 6½" Rods connected by Couplings, and it is held in the Strips (15) by two Collars, and two further Collars space the backplate from Strips (15). Two 7½" Angle Girders are attached to the centre of the backplate by Angle Brackets.

A 3" Sprocket (36) is attached by two ¾" Bolts to the outer one of each pair of Face Plates (17). The platform and its counter-balances pivot on a made-up rod mounted in the Semi-Circular Plates (7). This rod consists of an 8" Rod and two 6½" Rods joined by Couplings, and it is held in position by two 1½" Flanged Wheels.

Assembly of the Hopper (Fig. 6)

The hopper is shown removed from the base in Fig. 6. It should be noted that the 3½" × 2" Triangular Flexible Plates seen at one end in Fig. 6 are replaced at the other end by 2½" × 1½" Triangular Flexible Plates. The top corners of the sloping sides of the hopper are strengthened by Corner Gussets.

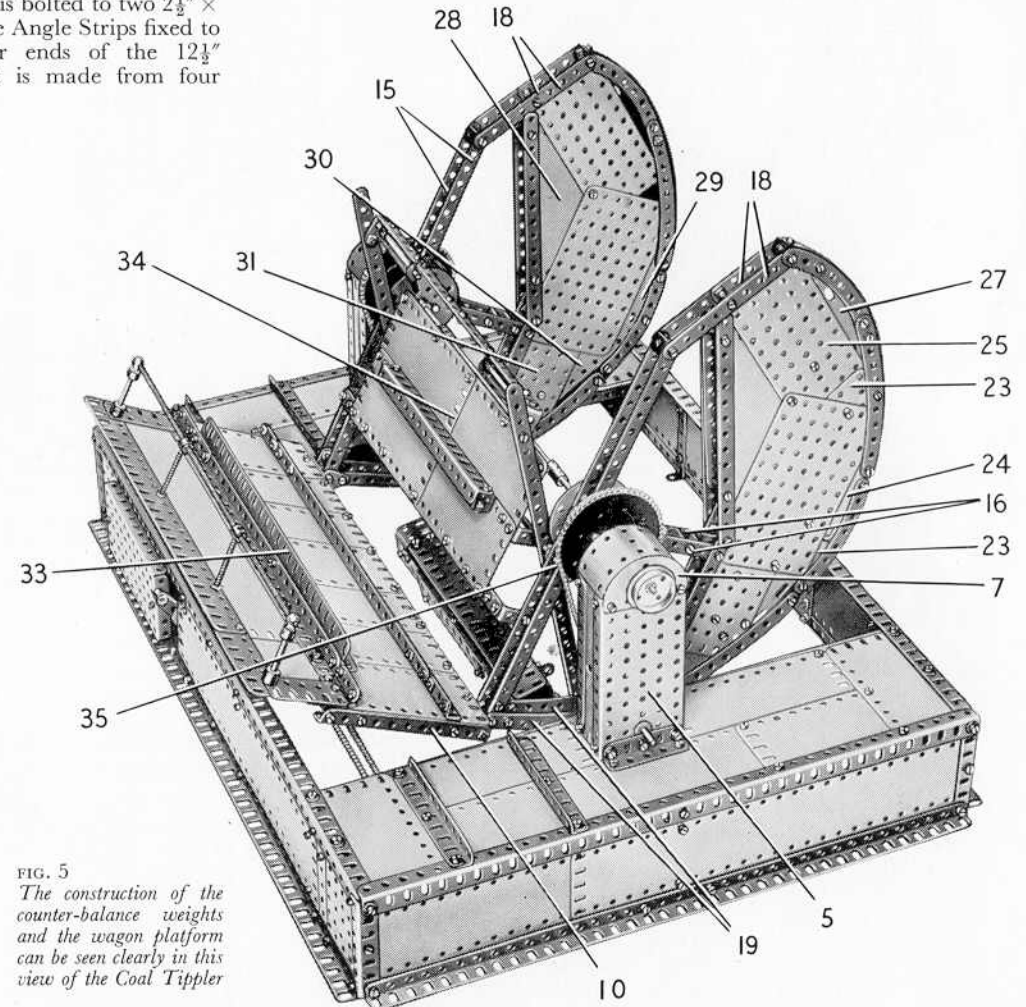

FIG. 5
The construction of the counter-balance weights and the wagon platform can be seen clearly in this view of the Coal Tippler

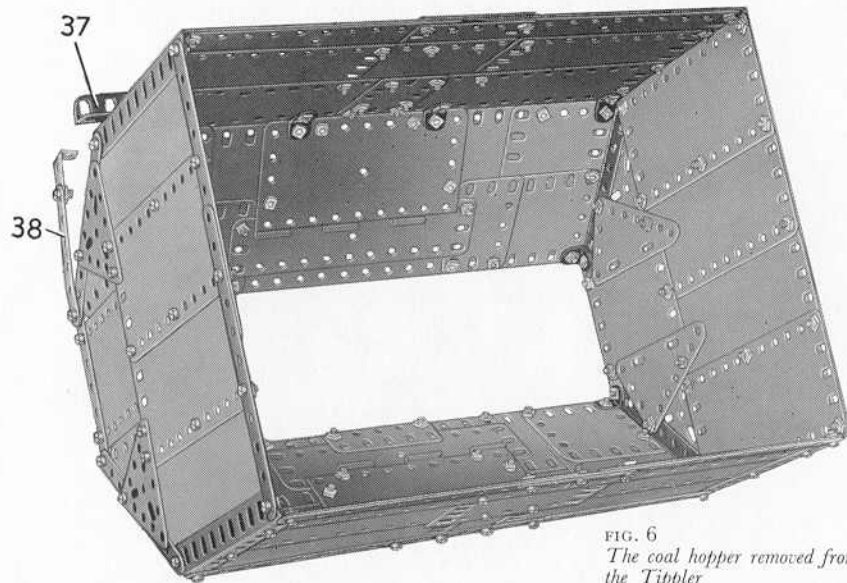

FIG. 6
The coal hopper removed from the Tippler

9½" Flat Girders connected together by two 9½" Angle Girders and two 7½" Angle Girders, and is weighted by bolting 7½", 5½" and 4½" Flat Girders to its sides.

Construction of the Wagon (Fig. 1)

The underframe of the wagon consists of two 9½" Angle Girders bolted to two 9½" × 2½" Strip Plates that form its floor. Its sides are also 9½" × 2½" Strip Plates. These are fixed to 9½" Angle Girders bolted to the floor and strengthened by a 9½" Strip and two 2½" Angle Girders. The ends are 4½" × 2½" Flexible Plates. The buffer beams are each made by bolting a 3½" Flat Girder to a 4½" Angle Girder fixed to the end of the floor. The buffers are 1" Pulleys held on Threaded Pins.

The wheels are 2" Pulleys free to turn on 4½" Rods and held in place by Collars.

Each Rod is supported in two Flat Trunnions and in Couplings attached to the Flat Trunnions by ½" Bolts. The dummy springs are each made from a 2½" and a 1½" Strip fixed to an Angle Bracket held by the same bolt as the Flat Trunnion.

The Operating Mechanism (Figs. 2, 4 and 7)

An E15R Electric Motor is bolted through its flanges to a 5½" × 2½" Flanged Plate fixed to the front of the base. Each side-plate of the Motor is extended by a 2½" × 2½" Flat Plate, and these are connected by two 1½" × ½" Double Angle Strips. The lower one of these Double Angle Strips is joined to the Flanged Plate by a ½" Reversed Angle Bracket. The inner 2½" × 2½" Flat Plate is connected to one of the Girders (4) by a Corner Angle Bracket. The Motor switch is extended outside the base by a Crank bolted to one of its arms.

A ½" Pinion on the Motor armature shaft drives a 57-tooth Gear on a 2½" Rod that carries also a ½" Pinion (42) (Fig. 4). This Pinion engages a 57-tooth Gear on another 2½" Rod fitted with a ½" Pinion (43) (Fig. 2), and the latter Pinion drives a 57-tooth Gear on an 11½" Rod (44) mounted as shown. Rod (44) carries a 1" Sprocket that is connected by Chain to a similar Sprocket on another 11½" Rod (45).

Each Rod (44) and (45) carries a Worm (46) (Fig. 7), which drives a ½" Pinion on a 2" Rod, and this Pinion engages a 57-tooth Gear (47) on another 2" Rod (Fig. 7). A ¾" Pinion is fixed also on this Rod and drives a 50-tooth Gear on a 3" Rod (48). A ¾" Sprocket on Rod (48) is connected by Chain to one of the 3" Sprockets (36).

A cover plate in front of the Motor is provided by a 5½" × 2½" Flanged Plate (49). Bolts are passed through this Plate into two Threaded Bosses, one of which is fixed by a bolt to a Fishplate bolted to one of the Flanged Plates (2), and the other is held by a bolt in a 3" Strip fixed to one of the 24½" Angle Girders, and is attached to a flange of the Motor by an Angle Bracket.

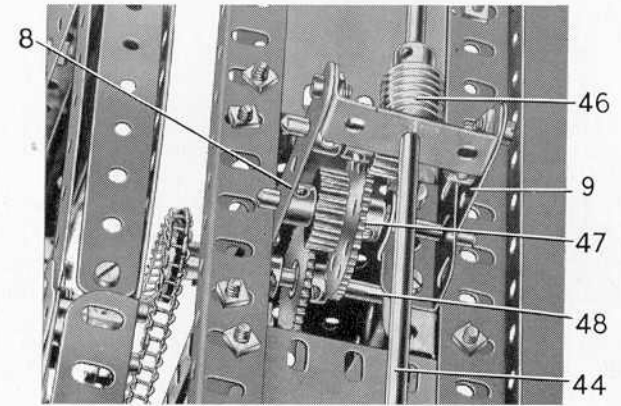

FIG. 7
A detail view of the gearing below one of the supporting columns

Parts Required to Build the Meccano Model Coal Tippler

12 of No. 1	6 of No. 8a	8 of No. 12c	4 of No. 20a	2 of No. 45	2 of No. 64	2 of No. 96a	22 of No. 111c	4 of No. 190a	2 of No. 226
6 " " 1a	4 " " 8b	2 " " 13	4 " " 22	4 " " 48	4 " " 70	4 " " 103	4 " " 115	16 " " 191	
6 " " 1b	12 " " 9	1 " " 13a	2 " " 25	4 " " 48a	2 " " 72	4 " " 103a	3 " " 125	30 " " 192	
35 " " 2	6 " " 9a	4 " " 14	5 " " 26	2 " " 48b	2 " " 73	2 " " 103b	4 " " 126a	4 " " 196	
8 " " 2a	4 " " 9b	2 " " 15a	2 " " 27	4 " " 52	4 " " 76	2 " " 103c	2 " " 128	10 " " 197	
15 " " 3	8 " " 9d	2 " " 16	5 " " 27a	6 " " 52a	2 " " 81	2 " " 103d	2 " " 133a	1 " " 198	
11 " " 4	6 " " 9f	2 " " 16a	2 " " 32	6 " " 53	2 " " 82	3 " " 103f	2 " " 136a	4 " " 214	
21 " " 5	14 " " 10	2 " " 16b	4 " " 35	4 " " 53a	12 " " 89	4 " " 103k	1 " " 154a	4 " " 221	
10 " " 6a	12 " " 11	4 " " 17	620 " " 37a	1 " " 58	8 " " 89b	4 " " 108	2 " " 179	2 " " 222	
4 " " 7	21 " " 12	2 " " 18a	565 " " 37b	22 " " 59	2 " " 94	4 " " 109	12 " " 188	2 " " 223	
8 " " 7a	8 " " 12a	1 " " 18b	74 " " 38	1 " " 62	2 " " 95b	6 " " 111	12 " " 189	2 " " 224	
13 " " 8	4 " " 12b	2 " " 20	2 " " 38d	8 " " 63	2 " " 96	6 " " 111a	16 " " 190	2 " " 225	1 E15R Electric Motor (not included in Outfit)

MECCANO

Cargo Ship

(MODEL No. 10.4)

SPECIAL FEATURES

This fine model reproduces the main external features of a typical high-capacity cargo vessel. It has a raked stem, streamlined funnel, and three cargo holds. The ship is over 7 ft. in length and has a beam of 13 in. approximately.

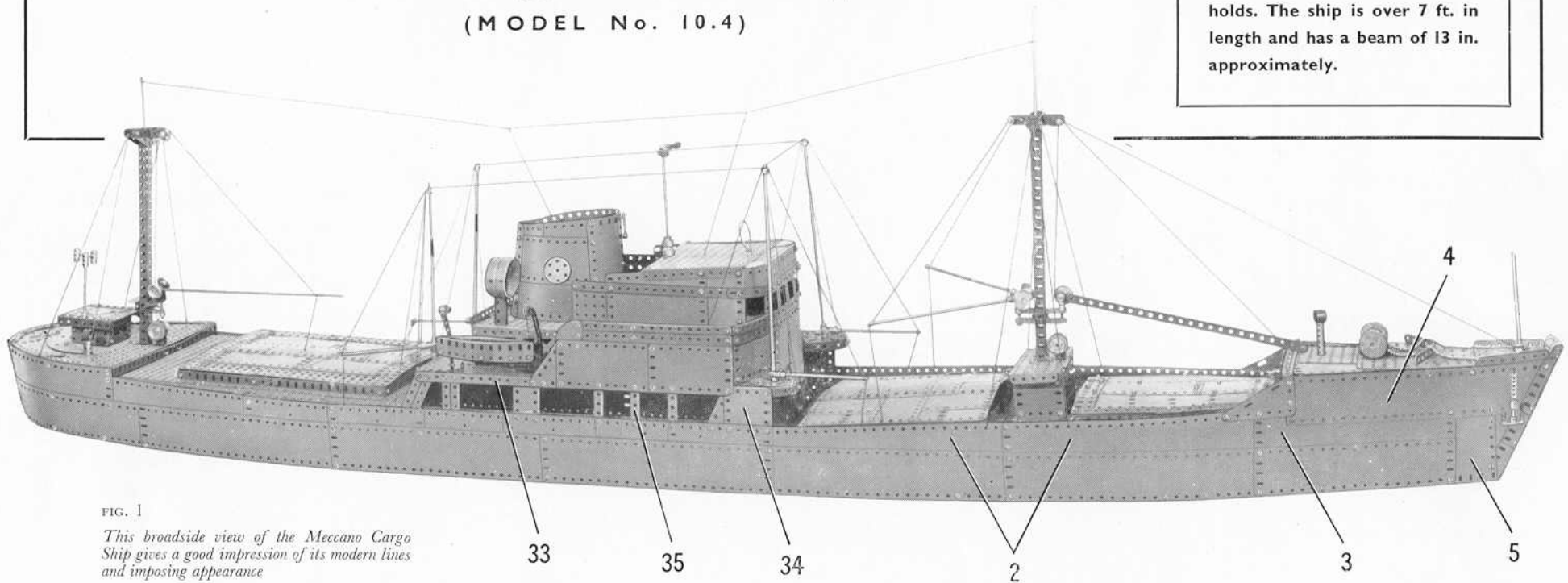

FIG. 1

This broadside view of the Meccano Cargo Ship gives a good impression of its modern lines and imposing appearance

The attractive cargo ship illustrated and described in this Leaflet contains many features of interest for ship-lovers, and its construction presents no difficulties even to an inexperienced model-builder. When completed the ship has a most realistic and imposing appearance as it is nearly 7 ft. 6 in. long and has a beam of 13 in.

Constructional Details: The Hull (Figs. 1, 3, 4 and 5)

The lower section of the plating on each side of the hull consists of a $9\frac{1}{2}'' \times 2\frac{1}{2}''$ Strip Plate and six $12\frac{1}{2}'' \times 2\frac{1}{2}''$ Strip Plates bolted together. These Plates are strengthened along their lower edges by $12\frac{1}{2}''$ Strips at the bow and the stern, and by a $24\frac{1}{2}''$ Angle Girder (1) (Fig. 5) amidships. The Strip Plates amidships are

extended upward by six $5\frac{1}{2}'' \times 1\frac{1}{2}''$ Flexible Plates, and towards the bow two $12\frac{1}{2}'' \times 2\frac{1}{2}''$ Strip Plates (2) are fixed at a slight angle (Fig. 1), and are extended forward by a $9\frac{1}{2}'' \times 2\frac{1}{2}''$ Strip Plate (3). A further $12\frac{1}{2}'' \times 2\frac{1}{2}''$ Strip Plate (4) and a $3\frac{1}{2}'' \times 2''$ Triangular Flexible Plate are fixed to the Plates 2 and 3 as shown. A $5\frac{1}{2}'' \times 2\frac{1}{2}''$ Flexible Plate (5) is bolted vertically to the front ends of the $9\frac{1}{2}'' \times 2\frac{1}{2}''$ Strip Plates.

The Strip Plates at the stern are curved, and are connected by a $3\frac{1}{2}'' \times 2\frac{1}{2}''$ Flexible Plate, whose lower edge is strengthened on the inside by a Formed Slotted Strip. The stern Plates are extended upward by a $12\frac{1}{2}'' \times 2\frac{1}{2}''$ Strip Plate (6) (Fig. 7) and two $5\frac{1}{2}'' \times 2\frac{1}{2}''$ Flexible Plates on each side, and a further $5\frac{1}{2}'' \times 2\frac{1}{2}''$ Flexible Plate is bolted in position above the $3\frac{1}{2}'' \times 2\frac{1}{2}''$ Flexible Plate.

The sides of the hull are connected by two $12\frac{1}{2}$ " Angle Girders (7) and (8) (Fig. 5) and by similar Girders (9) and (10) bolted to the ends of $18\frac{1}{2}$ " Angle Girders (11). Two $18\frac{1}{2}$ " Angle Girders fixed to the Girders (1) and (8) are supported at their rear ends by a $9\frac{1}{2}$ " Angle Girder (12), which is attached to the sides of the hull by Angle Brackets. Two $24\frac{1}{2}$ " Angle Girders are bolted to the Girders (1) and (7), and to a $9\frac{1}{2}$ " Angle Girder (13) that is connected to the hull by Angle Brackets.

The prow is formed by three U-section Curved Plates and a curved $2\frac{1}{2}$ " \times $1\frac{1}{2}$ " Flexible Plate bolted to the Plates forming the sides of the hull. The gaps between the U-section Curved Plates and the Plates (5) are filled in by $3\frac{1}{2}$ " \times $1\frac{1}{2}$ " Triangular Flexible Plates.

Assembly of the Decks

The foredeck consists of a Face Plate (14) (Fig. 2) at the bows bolted to two Flanged Sector Plates. Behind the Flanged Sector Plates are two $5\frac{1}{2}$ " \times $3\frac{1}{2}$ " Flat Plates, with a $5\frac{1}{2}$ " \times $2\frac{1}{2}$ " Flexible Plate on each side arranged at an angle. The aft ends of these Plates are supported by a made-up strip (15), consisting of a $5\frac{1}{2}$ " and a $3\frac{1}{2}$ " Strip, which is attached to the top lugs of $2\frac{1}{2}$ " \times $\frac{1}{2}$ " Double Angle Strips bolted to the sides. The lower lugs of these Double Angle Strips support a strip (16) (Fig. 3) made from a $5\frac{1}{2}$ " and a $2\frac{1}{2}$ " Strip. A $2\frac{1}{2}$ " \times $2\frac{1}{2}$ " and a $2\frac{3}{4}$ " \times $1\frac{1}{2}$ " Flexible Plate on each side are bolted together and are connected vertically to the strips (15) and (16) by Angle Brackets. They are bolted also to $2\frac{1}{2}$ " \times $\frac{1}{2}$ " Double Angle Strips fixed between these strips.

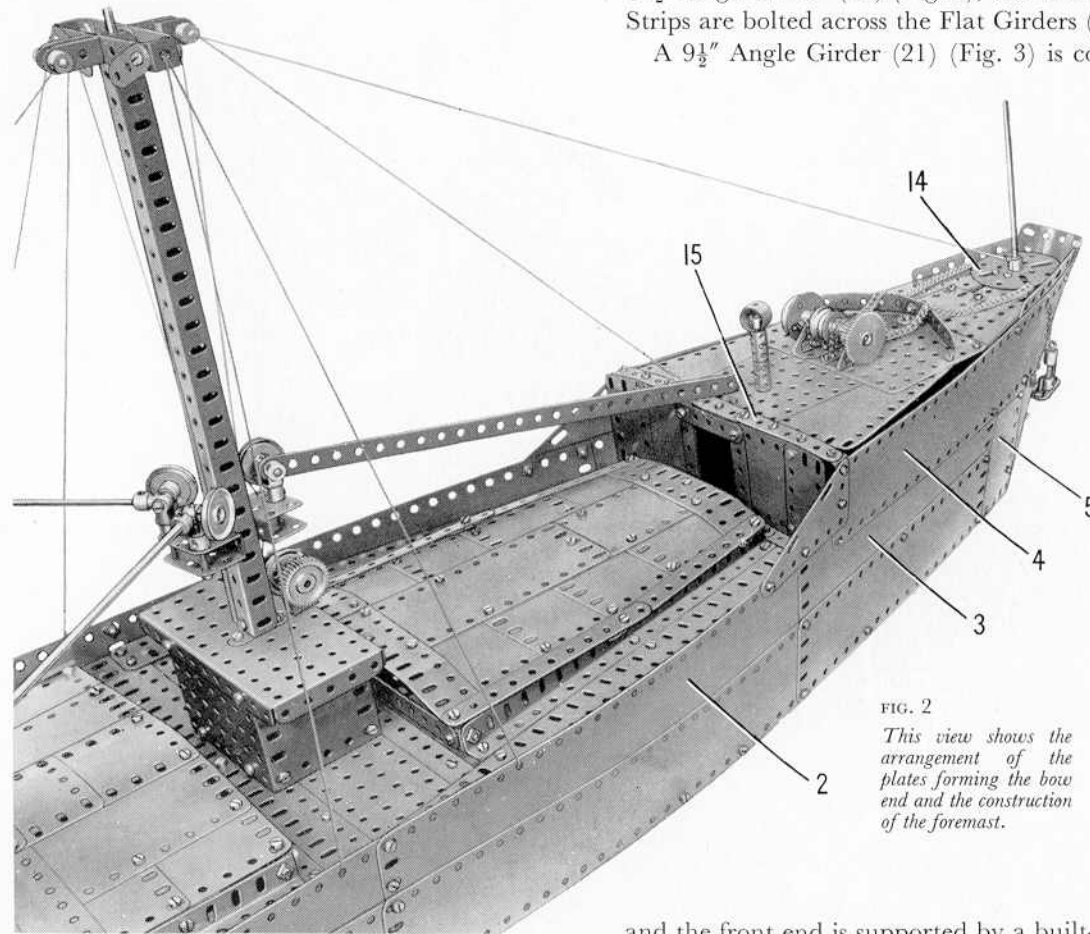

FIG. 2
This view shows the arrangement of the plates forming the bow end and the construction of the foremast.

A $7\frac{1}{2}$ " Strip (17), with a $5\frac{1}{2}$ " Angle Girder bolted centrally to it, is attached to the strip (16) by two Fishplates. A $12\frac{1}{2}$ " Flat Girder (18) on each side is supported by the Strip (17), and its rear end is joined by a 2" Flat Girder to a further $12\frac{1}{2}$ " Flat Girder (19). The front end of the latter part is connected to the side of the hull by an Angle Bracket, and the rear end is supported by a $12\frac{1}{2}$ " Angle Girder (20) (Fig. 5), which also is fixed to Angle Brackets. Two $12\frac{1}{2}$ " Strips are bolted across the Flat Girders (19) in front of the Angle Girder (20).

A $9\frac{1}{2}$ " Angle Girder (21) (Fig. 3) is connected to each Flat Girder (18) by three Fishplates, and $3\frac{1}{2}$ " \times $\frac{1}{2}$ " Double Angle Strips are bolted between these Flat Girders and the Angle Girder (13).

A $9\frac{1}{2}$ " Flat Girder (22), extended by a $2\frac{1}{2}$ " Flat Girder, is fixed to the Flat Girders (19), and two $5\frac{1}{2}$ " Strips (23) joined together are also attached to the Flat Girders (19). A $9\frac{1}{2}$ " Flat Girder (24) is connected to the Flat Girders (18) by a $1\frac{1}{2}$ " Strip at each end. Two $4\frac{1}{2}$ " \times $2\frac{1}{2}$ " Flat Plates are placed between the Flat Girders (22) and (24) as shown in Fig. 3.

The deck at the stern consists of two $5\frac{1}{2}$ " \times $2\frac{1}{2}$ " Flat Plates (25) (Fig. 7), a 6" Circular Plate and a 4" Circular Plate bolted to a $9\frac{1}{2}$ " Strip (26) (Fig. 4). A $3\frac{1}{2}$ " \times $2\frac{1}{2}$ " Flanged Plate and a $4\frac{1}{2}$ " \times $2\frac{1}{2}$ " Flexible Plate are fixed at each side, and the deck is edged by Curved Strips as shown. The rear end of Strip (26) is connected to the stern by an Angle Bracket,

and the front end is supported by a built-up girder made from a $7\frac{1}{2}$ " and a $4\frac{1}{2}$ " Angle Girder bolted together. This girder is connected to the sides of the hull by 1 " \times 1 " Angle Brackets, and two $18\frac{1}{2}$ " Angle Girders (27) (Fig. 4) are attached to it by Double Brackets. The front ends of the Girders (27) are joined to the Girder (10) by $1\frac{1}{2}$ " Strips. Two $12\frac{1}{2}$ " Strips are fixed to the Girders (27) behind the Girder (10). A $12\frac{1}{2}$ " Strip (28) on each side, extended by a $5\frac{1}{2}$ " Strip, is supported by one of the first-mentioned $12\frac{1}{2}$ " Strips and is connected to the

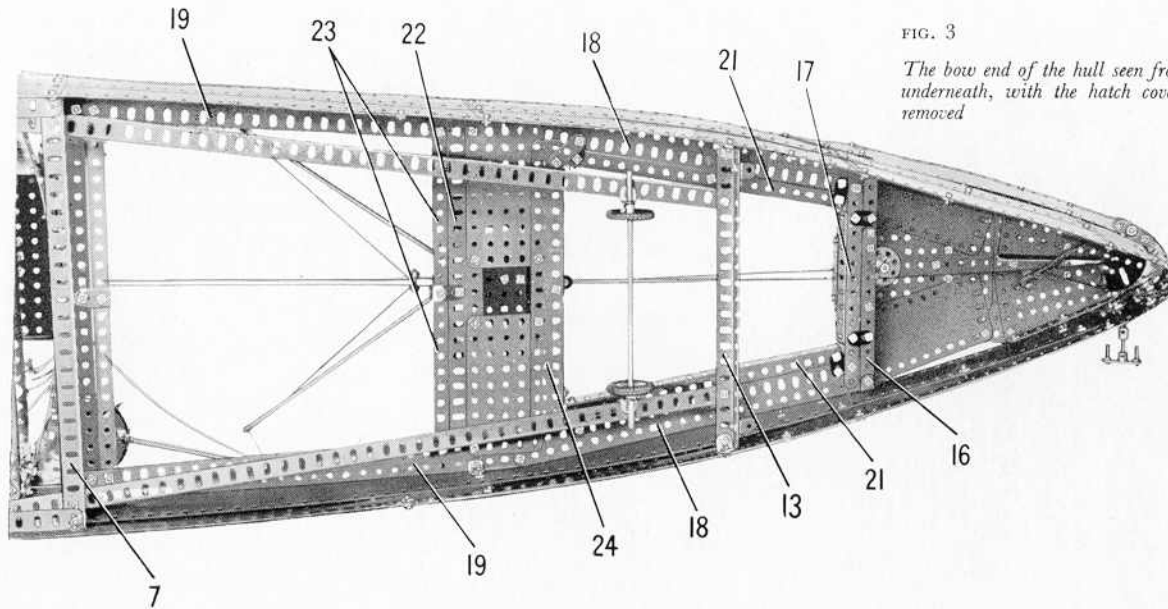

FIG. 3
The bow end of the hull seen from underneath, with the hatch covers removed

$2\frac{1}{2}'' \times 2''$ Triangular Flexible Plate are fixed to each of the strips (33).

The top edges of these Plates are strengthened by two $5\frac{1}{2}''$ Strips, and the front edge of the $4\frac{1}{2}'' \times 2\frac{1}{2}''$ Flexible Plate is braced by a vertical $7\frac{1}{2}''$ Strip (36) (Fig. 5). A $5\frac{1}{2}'' \times 2\frac{1}{2}''$ and a $4\frac{1}{2}'' \times 2\frac{1}{2}''$ Flat Plate on each side are attached by Angle Brackets to the strips (33). The Flat Plates are connected across by two $9\frac{1}{2}''$ Strips, two $4\frac{1}{2}'' \times 2\frac{1}{2}''$ Flexible Plates, and a built-up girder (37) made from a $7\frac{1}{2}''$ and a $5\frac{1}{2}''$ Angle Girder overlapped two holes. The rails on each side are $5\frac{1}{2}''$ and $3\frac{1}{2}''$ Strips bolted to the top ends of the Strips (35) and (36) and to a Semi-Circular Plate at the rear.

Girder (27) by Fishplates. A strip (29) on each side, made from a $5\frac{1}{2}''$ and a $4\frac{1}{2}''$ Strip, is bolted to a $5\frac{1}{2}''$ Angle Girder that is fixed to the side of the hull by bolts (30) (Fig. 7).

Two $5\frac{1}{2}'' \times 3\frac{1}{2}''$ Flat Plates, edged by a girder 31 (Fig. 4), are fixed to the rear ends of the Girders (27). The girder (31) is made from a $5\frac{1}{2}''$ and a $4\frac{1}{2}''$ Angle Girder, and it is connected to a $12\frac{1}{2}''$ Angle Girder on each side by a $1'' \times 1''$ Angle Bracket. The $12\frac{1}{2}''$ Angle Girders are fixed to the Girders (27), and they are joined by $1'' \times 1''$ Angle Brackets at their front ends to a built-up girder (32), which is made in the same way as the girder (31).

The Superstructure

A strip (33) (Fig. 1) on each side is made up from a $12\frac{1}{2}''$ and a $7\frac{1}{2}''$ Strip. It is then bolted to a $2\frac{1}{2}'' \times 2\frac{1}{2}''$ Flexible Plate (34), edged at the front by a 3" Strip and at the rear by a $2\frac{1}{2}'' \times 1\frac{1}{2}''$ Triangular Flexible Plate. It is also bolted to two $2\frac{1}{2}''$ Strips and a $5\frac{1}{2}''$ Strip (35), to a $2\frac{1}{2}'' \times 1\frac{1}{2}''$ Flexible Plate, to two $2\frac{1}{2}''$ Strips placed together and to two 3" Strips arranged at a slight angle (Fig. 1).

A $4\frac{1}{2}'' \times 2\frac{1}{2}''$ Flexible Plate, a $5\frac{1}{2}'' \times 2\frac{1}{2}''$ Flexible Plate, and a

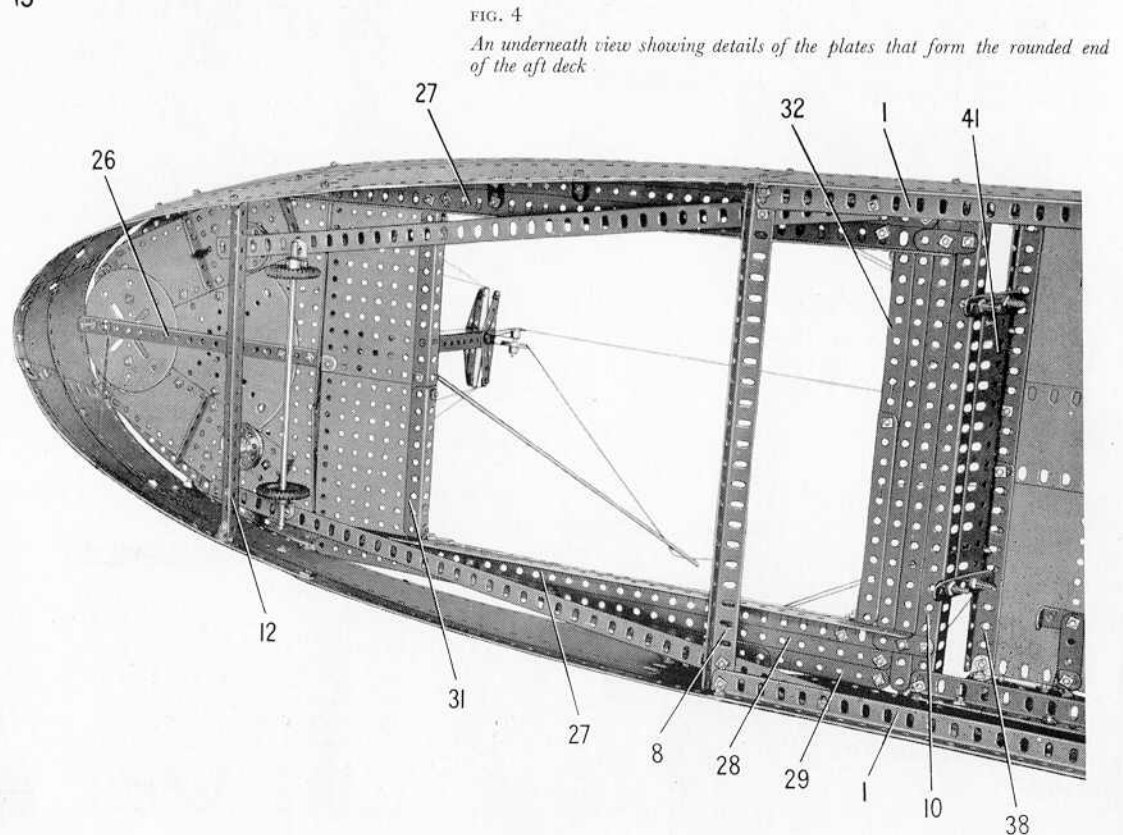

FIG. 4
An underneath view showing details of the plates that form the rounded end of the aft deck

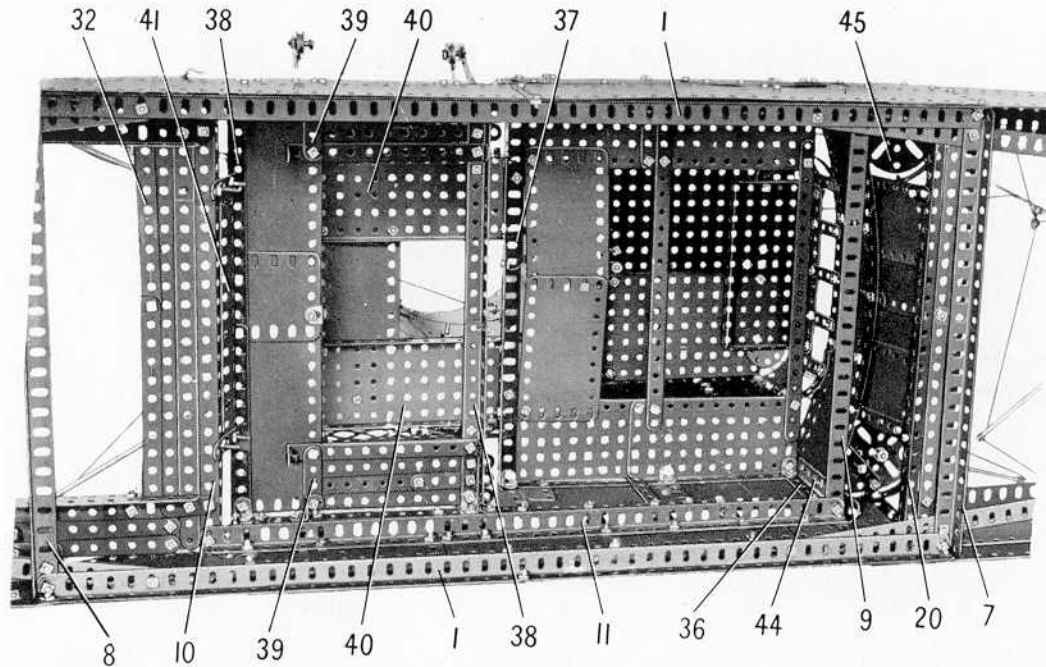

FIG. 5 This view shows the superstructure as seen from inside the hull, and the bracing girders that strengthen the hull amidships

Two built-up girders (38), each made from a $7\frac{1}{2}$ " and a $5\frac{1}{2}$ " Angle Girder, are attached to the strips (33) by Angle Brackets. Two $5\frac{1}{2}$ " \times $2\frac{1}{2}$ " Flexible Plates separated by a $2\frac{1}{2}$ " \times $2\frac{1}{2}$ " Flexible Plate are bolted to the rear girder (38), and the $5\frac{1}{2}$ " \times $2\frac{1}{2}$ " Flexible Plate on each side is connected to the front girder (38) by two $5\frac{1}{2}$ " Strips, a $5\frac{1}{2}$ " \times $\frac{1}{2}$ " Double Angle Strip and a built-up $5\frac{1}{2}$ " strip. The built-up strip is made from a $3\frac{1}{2}$ " and a 2" Strip, and the rear ends of the Strips are supported by a 2" Strip (39) that is connected to the strip (33) by a Corner Angle Bracket.

A $5\frac{1}{2}$ " \times $2\frac{1}{2}$ " Flanged Plate (40) on each side is bolted to the girder (37) and these are connected at their rear ends by *one half of a Hinged Flat Plate* (Fig. 5). A $5\frac{1}{2}$ " Braced Girder is fixed to the outer flange of each Flanged Plate, and two $4\frac{1}{2}$ " \times $2\frac{1}{2}$ " Flexible Plates overlapped two holes are bolted to the rear flanges. The lower edges of the Flexible Plates are strengthened by two $4\frac{1}{2}$ " Strips. A $7\frac{1}{2}$ "

Flat Girder (41) is bolted to two $2\frac{1}{2}$ " Strips that are fixed to the Angle Girder (10).

The front of the superstructure is filled in by two vertical $5\frac{1}{2}$ " \times $2\frac{1}{2}$ " Flexible Plates at the centre, and a $4\frac{1}{2}$ " \times $2\frac{1}{2}$ " Flexible Plate (42) and a $3\frac{1}{2}$ " \times $2\frac{1}{2}$ " Flexible Plate (43) on each side (Fig. 8). A $5\frac{1}{2}$ " Strip (44) is bolted to the outer edge of each of the Plates (42), and a $3\frac{1}{2}$ " Strip is fixed to the outer edge of each Plate (43). The Plates are edged at the front by two $12\frac{1}{2}$ " Strips as seen in Fig. 8, and on the inside by a $12\frac{1}{2}$ " Strip placed one hole below the lower edges of the Plates (42) and bolted to the Strips (44).

The Strips (44) are connected to the Strips (36) by Obtuse Angle Brackets, and the Plates (43) are attached to the Girder (20) by an Angle Bracket at the centre and a Fishplate at each end. A Face Plate (45), fitted with a $1\frac{1}{2}$ " Corner Bracket, is connected by an Angle Bracket to each of the Plates (34), and Formed Slotted Strips attached to the Face Plate by Angle Brackets are connected to the Plates (43) by 1 " \times $\frac{1}{2}$ " Angle Brackets.

Details of the Bridge

The front of the bridge consists of two 3 " \times $1\frac{1}{2}$ " Flat Plates bolted to a $5\frac{1}{2}$ " Strip that is attached to window frames formed by four 2" Strips and a $5\frac{1}{2}$ " Strip. Each rounded corner is formed by two Formed Slotted Strips and a $2\frac{1}{2}$ " \times $1\frac{1}{2}$ " Flexible Plate. Each side consists of two $5\frac{1}{2}$ " \times $2\frac{1}{2}$ " Flexible Plates, two $2\frac{1}{2}$ " \times $2\frac{1}{2}$ " Flexible Plates, and a $2\frac{1}{2}$ " \times $2\frac{1}{2}$ " Flat Plate, which are bolted together so that the upper edge slopes aft slightly. The sides are connected by Angle Brackets to the girder (37), and a $5\frac{1}{2}$ " Angle Girder is fixed to the top edge of each side. The roof consists of two $5\frac{1}{2}$ " \times $3\frac{1}{2}$ "

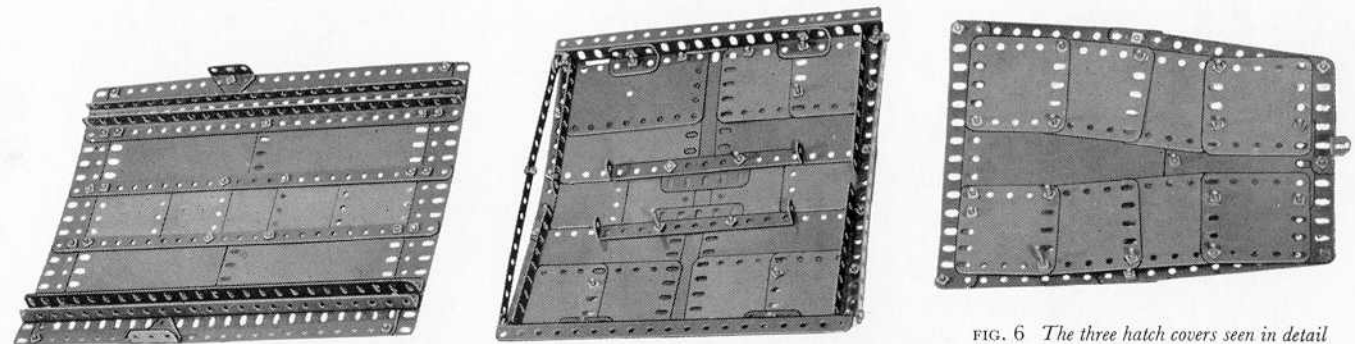

FIG. 6 The three hatch covers seen in detail

Flat Plates, a $5\frac{1}{2}'' \times 2\frac{1}{2}''$ Flanged Plate (46) (Fig. 8), and two Wheel Discs. The back is filled in by a $3\frac{1}{2}'' \times 2\frac{1}{2}''$ Flanged Plate bolted to each side and connected at the centre by a $2\frac{1}{2}'' \times 2\frac{1}{2}''$ Flexible Plate. A $7\frac{1}{2}''$ Flat Girder is attached to the roof and to the back by Obtuse Angle Brackets.

The direction-finding aerial is a loop of Spring Cord in a Handrail Support fixed to the roof. The radar aerial is formed by six 3" Stepped Curved Strips spaced by Washers on $\frac{3}{8}''$ Bolts and clamped between Collars on a $6\frac{1}{2}''$ Rod. This Rod is fitted with a $\frac{1}{2}''$ Pulley and a Socket Coupling, and is fixed in a Double Arm Crank bolted underneath the roof of the bridge.

The Masts and Funnel

Two $3\frac{1}{2}'' \times 2\frac{1}{2}''$ Flanged Plates are connected at their ends by $2\frac{1}{2}'' \times 2\frac{1}{2}''$ Flexible Plates and are bolted to a $5\frac{1}{2}'' \times 2\frac{1}{2}''$ Flanged Plate (47) (Fig. 8). This structure is attached to the deck by Angle Brackets. The foremast is formed by two $12\frac{1}{2}''$ Angle Girders bolted to Angle Brackets fixed to the Flanged Plate (47). The top ends of the Girders are bolted to the lugs of a large Fork Piece, which is placed with its boss downward, and supports a $6\frac{1}{2}''$ Rod. To each Angle Girder is fixed a Channel Bearing (48). Two $3\frac{1}{2}''$ Strips and four $1\frac{1}{2}''$ Strips connected by Double Brackets are fixed to the top of the Angle Girders, and a Stepped Bent Strip (49) and a Single Bent Strip (50) are attached to them (Fig. 8).

The front of the funnel consists of two vertical $5\frac{1}{2}'' \times 2\frac{1}{2}''$ Flexible Plates, and each side is formed by two horizontal $5\frac{1}{2}'' \times 2\frac{1}{2}''$ Flexible Plates. Two $1\frac{1}{16}''$ radius Curved Plates are used for the rear end. The sloping upper edges consist

of two $3\frac{1}{2}'' \times 2\frac{1}{2}''$ Triangular Flexible Plates and three $2\frac{1}{2}'' \times 1\frac{1}{2}''$ Flexible Plates. The funnel is attached to the Flanged Plates (40) by Angle Brackets.

The aft mast (Fig. 7), is generally similar to the foremast, but varies in slight details that can be seen in the illustration. Two Trunnions (51) and a $1\frac{1}{2}''$ Angle Girder are bolted to the mast.

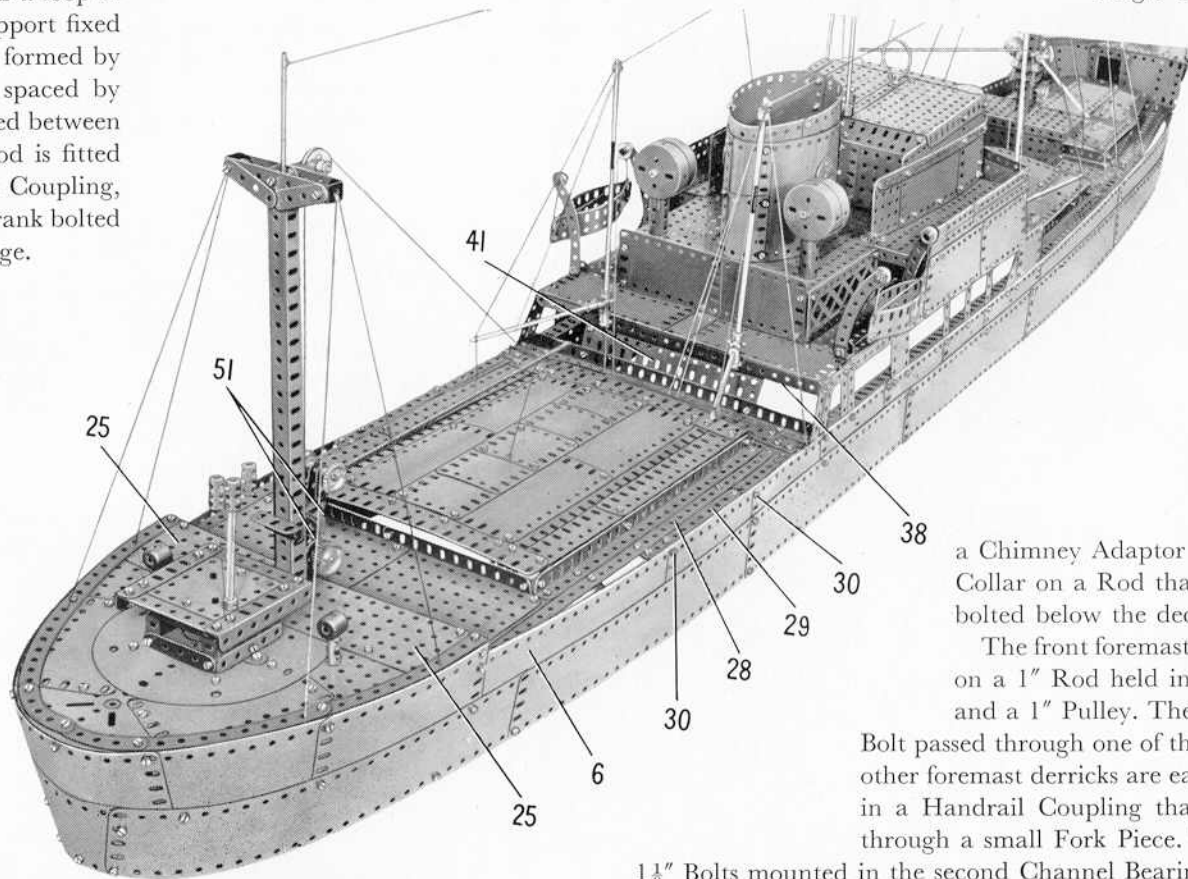

FIG. 7 A stern view of the Cargo Ship showing the aft mast and details of the superstructure

Deck Fittings and Derricks

The winch at the bows consists of a Ratchet Wheel, a $1\frac{1}{8}''$ Flanged Wheel, two $\frac{3}{4}''$ Flanged Wheels, a $\frac{3}{4}''$ Pinion and a 50-tooth Gear, on a Rod mounted in Trunnions. The anchors are Double Arm Cranks fitted with Threaded Pins, and they are fixed on $1\frac{1}{8}''$ Bolts passed through Threaded Bosses. The ventilator behind this winch is formed by

a Chimney Adaptor and two Couplings held by a Collar on a Rod that is fastened in a Bush Wheel bolted below the deck.

The front foremast derrick is a $12\frac{1}{2}''$ Strip pivoted on a 1" Rod held in an End Bearing by a Collar and a 1" Pulley. The End Bearing is fixed on a $\frac{3}{4}''$ Bolt passed through one of the Channel Bearings (48). The other foremast derricks are each formed by an 8" Rod fixed in a Handrail Coupling that pivots on a $\frac{3}{4}''$ Bolt passed through a small Fork Piece. The Fork Pieces are fixed on $1\frac{1}{8}''$ Bolts mounted in the second Channel Bearing (48). The winch below the derricks consists of a $\frac{1}{2}''$ Pulley, a 1" loose Pulley and a 1" Gear on a Rod held in a Stepped Bent Strip.

The two port and starboard derricks in front of the bridge are each made by fixing a 5" Rod in a Swivel Bearing held by a Collar on an $11\frac{1}{2}''$ Rod that is gripped in the Face Plate 45.

The derricks aft of the funnel are each made by fixing a $6\frac{1}{2}''$ and a $3\frac{1}{2}''$ Rod joined by a Rod Connector, in a Handrail Support attached to the girder (38). The $6\frac{1}{2}''$ Rod is passed through the spider and one fork piece of a Universal Coupling, and the other fork piece supports a 5" Rod.

The aft mast derrick is made by screwing an 11½" Screwed Rod into the boss of a ¾" Bevel Gear, which is fixed on a 1½" Rod mounted in a Single Bent Strip. A second Bevel Gear and a 1" loose Pulley are fitted on the Rod. The winch below the derrick consists of a 1" Gear, a 1" loose Pulley and a Pinion on a 1½" Rod supported in a Single Bent Strip.

Each of the ventilators on the bridge deck is formed by two Boiler Ends connected by a ¾" Bolt. The rear Boiler End is fixed by a nut on a Screwed Rod that is passed through a Sleeve Piece and the deck and is held in place by another nut.

The lifeboats are suspended by Cord passed round ½" loose Pulleys mounted on Pivot Bolts, which are fixed to 4" Stepped Curved Strips. The Curved Strips are bolted to Double Brackets attached to the deck. One side of each

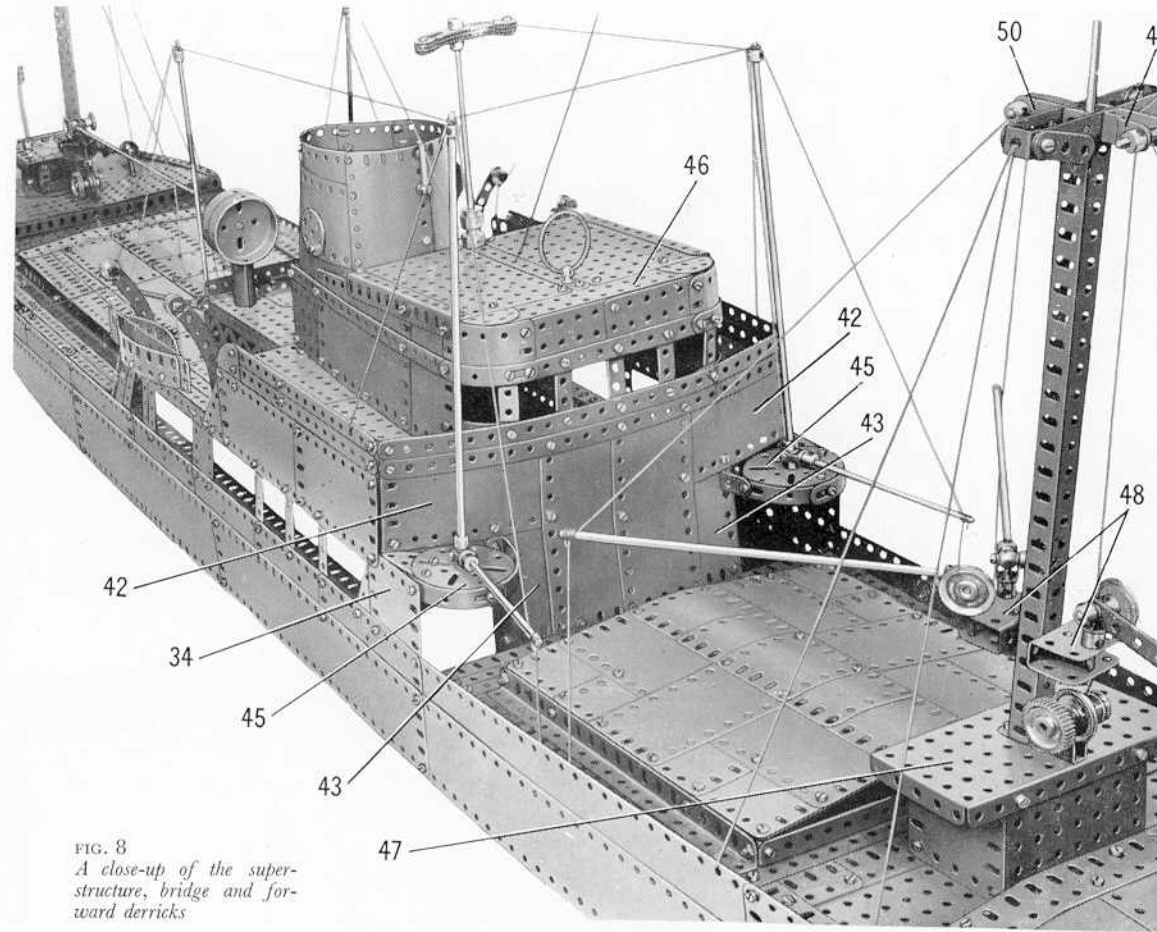

FIG. 8
A close-up of the superstructure, bridge and forward derricks

lifeboat is a 5½" Flat Girder; the other side is made from short Flat Girders joined together.

The deck-house in the stern consists of two 2½" x 1½" Flanged Plates connected at their ends by 2½" Strips. Two 2½" x ½" Double Angle Strips are bolted between the Flanged Plates, and each of these supports a 3½" Strip to which the roof is fixed. The frame of the roof is formed by two 3½" x ½" Double Angle Strips and two 3½" Angle Girders, and it is filled in by two 2½" x 2½" Triangular Flexible Plates. The Flanged Plates are bolted to Double Bent Strips fixed to the deck.

The hatch covers can be seen clearly in Fig. 6.

The model is completed by adding wheels as shown in Figs. 3 and 4, and by arranging Cord to represent the rigging and the derrick ropes.

Parts Required to Build the Meccano Model Cargo Ship

24 of No. 1	9 of No. 9	3 of No. 16	1 of No. 25	4 of No. 48d	2 of No. 73	2 of No. 103c	1 of No. 154b	30 of No. 192
6 " " 1a	8 " " 9a	4 " " 16a	1 " " 26	2 " " 51	1 " " 78	2 " " 103d	2 " " 160	4 " " 196
6 " " 1b	2 " " 9b	4 " " 18a	1 " " 27	4 " " 52	2 " " 81	2 " " 103e	1 " " 162	20 " " 197
36 " " 2	5 " " 9f	4 " " 18b	2 " " 30	6 " " 52a	2 " " 82	4 " " 103f	2 " " 162a	1 " " 198
7 " " 2a	20 " " 10	1 " " 20	2 " " 31	6 " " 53	4 " " 89	2 " " 103g	2 " " 163	12 " " 199
17 " " 3	10 " " 11	2 " " 20b	2 " " 37a	4 " " 53a	6 " " 89a	3 " " 103h	4 " " 164	12 " " 200
5 " " 4	50 " " 12	2 " " 21	680 " " 37b	2 " " 54	4 " " 89b	4 " " 103k	2 " " 165	2 " " 213
24 " " 5	8 " " 12a	6 " " 22	33 " " 38	1 " " 58	2 " " 90	3 " " 109	2 " " 166	2 " " 214
10 " " 6	7 " " 12b	3 " " 22a	3 " " 40	24 " " 59	1 " " 94	10 " " 111	1 " " 171	9 " " 215
9 " " 6a	10 " " 12c	4 " " 23	2 " " 44	2 " " 62b	2 " " 100	18 " " 111a	4 " " 176	4 " " 221
4 " " 7	2 " " 13	2 " " 23a	2 " " 45	7 " " 63	4 " " 102	24 " " 111c	1 " " 146	12 " " 188
6 " " 7a	4 " " 13a	1 " " 24	1 " " 48	2 " " 64	4 " " 103	4 " " 111d	1 " " 146a	12 " " 189
15 " " 8	4 " " 14	2 " " 24a	6 " " 48a	4 " " 70	4 " " 103a	4 " " 115	4 " " 147b	16 " " 190
6 " " 8a	5 " " 15	2 " " 24c	4 " " 48b	2 " " 72	4 " " 103b	2 " " 116	1 " " 148	4 " " 190a
4 " " 8b	1 " " 15b						1 " " 154a	2 " " 225
							16 " " 191	2 " " 226

MECCANO

Double Deck Bus

(MODEL No. 10.5)

SPECIAL FEATURES

A two-speed and reverse gear-box, clutch, differential, brakes and steering mechanism, are included in the chassis details of this fine model Double Deck Bus. It is driven by a Meccano E15R Electric Motor.

The model Double Deck Bus illustrated and described in this Leaflet is based on a rear-entry vehicle of the four wheel type, and is designed specially for construction from Meccano Outfit No. 10. It is driven by a Meccano E15R or E20R Electric Motor coupled to a two-speed and reverse gear-box through a neat friction clutch. Other chassis details include a working differential, rear wheel brakes, sprung axles and steering gear.

Construction of the model is simplified by the fact that the chassis and body are designed as separate complete units. It is best to start construction with the chassis, details of which follow.

Details of the Chassis (Fig. 2)

The centre section of the chassis consists of two channel girders, each of which is formed by two built-up girders joined together by Flat Girders. Each built-up girder is made from a $12\frac{1}{2}$ " Angle Girder and a $4\frac{1}{2}$ " Angle Girder overlapped three holes, and they are connected by a $12\frac{1}{2}$ " and a $4\frac{1}{2}$ " Flat Girder.

The upswept section of the chassis over the rear axle is made by bolting 4" Stepped Curved Strips to the rear ends of the channel girders. Each Curved Strip is extended by a 3" Stepped Curved Strip overlapped two holes, and this is further extended by another 4" Stepped Curved Strip, which also is overlapped two holes. A $3\frac{1}{2}$ " Strip, a Formed Slotted Strip and a $4\frac{1}{2}$ " Strip are bolted together and are fixed to a Double Bracket held by a bolt (1) and Angle Brackets attached to the Curved Strips. The $3\frac{1}{2}$ " Strip overlaps the end of the channel girder by two holes.

At the front on each side a 3" Strip is arranged to overlap the channel girder by two holes, and it is bolted at a slight angle so that this part of the chassis sweeps upward over the front axle. The 3" Strip is extended forward by a $5\frac{1}{2}$ " Curved Strip. A strip (2) made from a $3\frac{1}{2}$ " and a $5\frac{1}{2}$ " Strip, is bolted to the channel girder, and is connected to the $5\frac{1}{2}$ " Curved Strip by an Angle Bracket.

The two side-members of the chassis are connected at the front by a $5\frac{1}{2}$ " Strip (3), and by a similar strip at the rear. A $5\frac{1}{2}$ " Angle Girder (4) is bolted across the chassis and is strengthened by 1" Corner Brackets. Two $1\frac{1}{2}$ " Corner Brackets (5) are fixed to this Girder. The cross-member (6) consists of a $5\frac{1}{2}$ " Angle Girder and two $2\frac{1}{2}$ " Angle Girders. The $2\frac{1}{2}$ " Girders are connected at the centre by two $2\frac{1}{2}$ " Strips placed face to face. A $9\frac{1}{2}$ " Angle Girder (7) is bolted across the chassis as shown, and a $2\frac{1}{2}$ " Angle Girder (8) is fixed to each side and braced by a vertical $1\frac{1}{2}$ " Angle Girder.

The Rear Axle (Fig. 4)

The axle casing is in two sections, one of which consists of two $2\frac{1}{2}$ " x $\frac{1}{2}$ " Double Angle Strips bolted between a Boiler End and a Face Plate. In the other section $1\frac{1}{2}$ " x $\frac{1}{2}$ " Double Angle Strips are used in place of the $2\frac{1}{2}$ " x $\frac{1}{2}$ " Double Angle Strips. When the differential is assembled the sections are joined together by bolting four 2" Strips between the Boiler Ends. One of the 2"

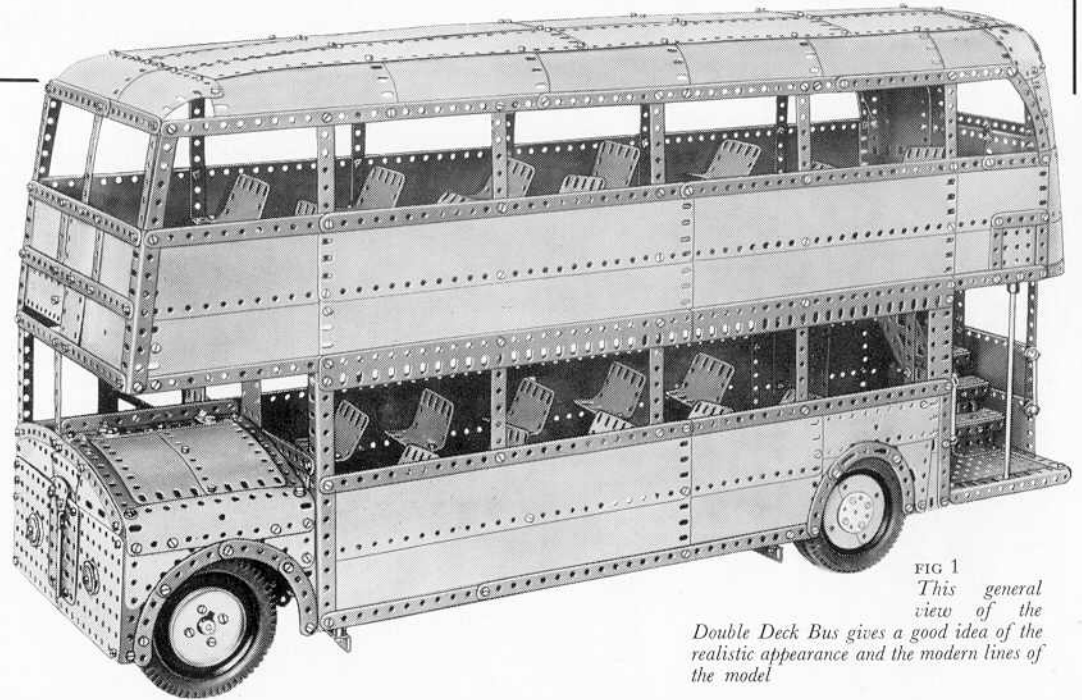

FIG 1
This general
view of the

Double Deck Bus gives a good idea of the realistic appearance and the modern lines of the model

Strips is attached by $\frac{3}{8}$ " Bolts and is spaced from the Boiler Ends by three Washers on each side. A Double Bent Strip is attached to this 2" Strip, and a $1\frac{1}{2}$ " Rod, fitted with a $\frac{1}{2}$ " Pinion (9), is mounted in these parts.

A 5" Rod is mounted in the longer section of the axle casing and on it a $1\frac{1}{2}$ " Contrate (10) is freely mounted. A $\frac{3}{4}$ " Contrate (11) is fixed on the Rod, which is then passed into the longitudinal hole of a Coupling (12). Two 1" Screwed Rods are fixed in the Contrate (10) by two nuts each, and a $1\frac{1}{2}$ " Rod is fixed in the Coupling (12) and in Collars screwed on to the Screwed Rods. Two $\frac{3}{8}$ " Pinions are mounted freely on Pivot Bolts, which are screwed into the Coupling (12). A $3\frac{1}{2}$ " Rod is passed through the short section of the axle casing and is fitted with a $\frac{3}{4}$ " Contrate. This Contrate and the Contrate (11), engage the teeth of the $\frac{3}{8}$ " Pinions. The Contrate (10) is spaced from the axle casing by Washers so that it meshes with the Pinion (9).

The inner wheel of each set of twin rear wheels has a Wheel Flange bolted to it, and the outer wheel of each set is fitted with two Semi-Circular Plates and a Wheel Disc. The Wheel Flange

forms the brake drum. The brake is made by fixing a Fishplate (13) on a $\frac{1}{2}$ " Bolt by means of a nut. Two Washers are placed on the Bolt, which is then passed through one of the Face Plates of the rear axle. A Fishplate (14), with a Washer on each side of it, is fixed on the Bolt by two nuts to form the brake shoe.

The rear axle is bolted to leaf-springs, each of which consists of a $7\frac{1}{2}$ ", a $4\frac{1}{2}$ ", a $3\frac{1}{2}$ ", a $2\frac{1}{2}$ " and a $1\frac{1}{2}$ " Strip. An Angle Bracket is bolted to each end of the $7\frac{1}{2}$ " Strip and one of them is *lock-nutted* to the inner lug of the Double Bracket held by the bolt (1). The other Angle Bracket is *lock-nutted* to a Fishplate, which is itself *lock-nutted* to an Angle Bracket bolted to the lower flange of the side-member channel girder.

Engine Unit and Clutch (Figs. 2, 3 and 6)

One side of the engine unit consists of two $4\frac{1}{2}$ " \times $2\frac{1}{2}$ " Flat Plates overlapped lengthways three holes and bolted to a $3\frac{1}{2}$ " Angle Girder (15) (Fig. 6). An E15R Electric Motor is bolted to this

on a $6\frac{1}{2}$ " Rod (19) mounted in $1\frac{1}{2}$ " Flat Girders bolted to the front and rear of the engine unit, and is retained in place by Collars.

The clutch shaft is a $3\frac{1}{2}$ " Rod mounted in the Double Angle Strip (18) and in the Strip (17). A Bush Wheel is fixed on the Rod, and next to it is placed a 1" loose Pulley fitted with a 1" Motor Tyre. A 57-tooth Gear is held in a Socket Coupling (20) and this assembly is free to turn on the Rod, but is pressed against the Motor Tyre by a Compression Spring, which is placed between the Socket Coupling and a Collar. A second Collar prevents the $3\frac{1}{2}$ " Rod from sliding in its bearings. The 57-tooth Gear is driven by a $\frac{1}{2}$ " Pinion fixed on the end of Rod (19).

The pedal (21) (Fig. 3) for operating the clutch is made by bolting an Angle Bracket to a Double Arm Crank, which pivots on a $\frac{1}{2}$ " Bolt fixed to the side of the engine unit by two nuts. A built-up strip, made from two 3" Strips overlapped three holes, is *lock-nutted* to the lower arm of the clutch pedal and is *lock-nutted* also to another Double Arm Crank on a $3\frac{1}{2}$ " Rod (22). This Rod is mounted in the $2\frac{1}{2}$ " Flat Girders of the unit, and is located in their slotted holes by Fishplates bolted to the Flat Girders. Two Double Arm Cranks, each fitted with a Threaded

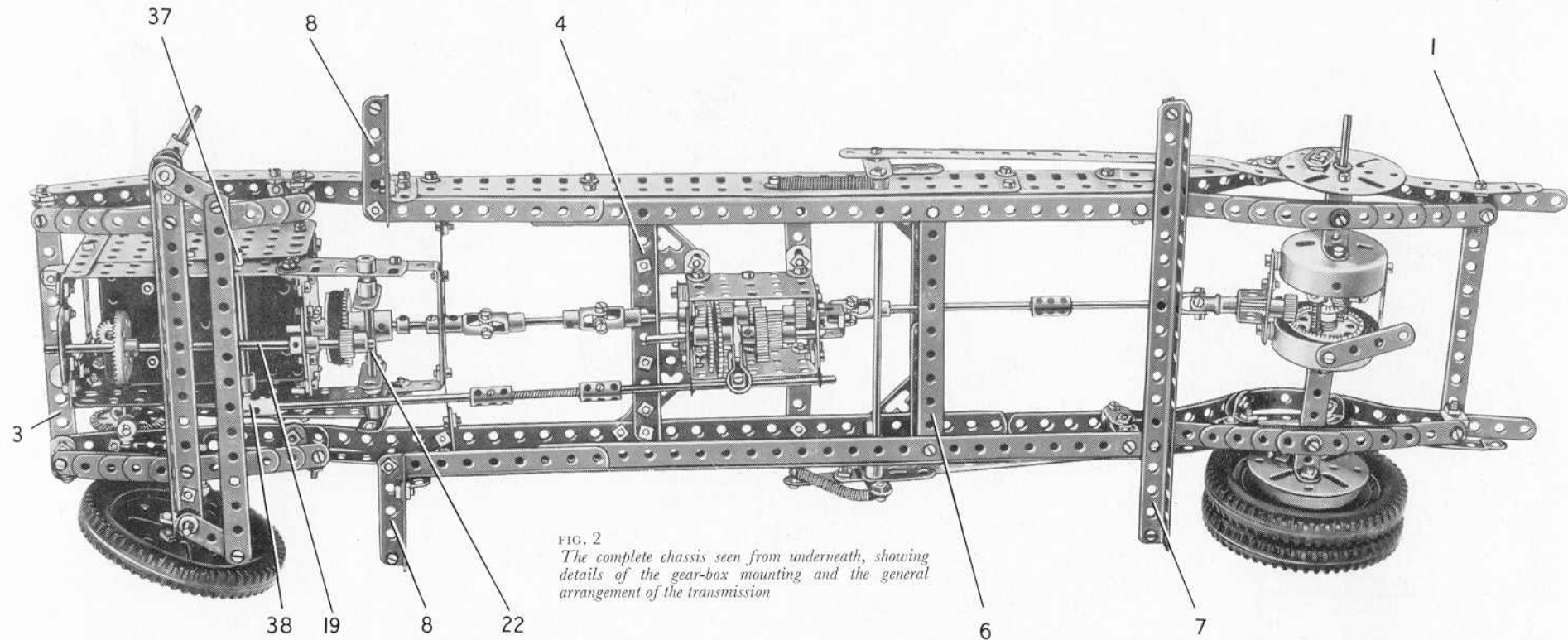

FIG. 2
The complete chassis seen from underneath, showing details of the gear-box mounting and the general arrangement of the transmission

side of the unit. The other side is a $4\frac{1}{2}$ " \times $2\frac{1}{2}$ " Flat Plate fitted at each end with a 3" Angle Girder (16). A $4\frac{1}{2}$ " Angle Girder is bolted to the top ends of the Girders (16).

The sides are connected at the front by two $2\frac{1}{2}$ " Strips bolted to the Angle Girders, and at the rear are joined by a $2\frac{1}{2}$ " Strip fixed to the Girder (16) of one side and attached to the other side by an Angle Bracket. Two $2\frac{1}{2}$ " Strips, the upper one indicated at (17) (Fig. 3) are fixed also to the Girder (16), and are attached to the opposite side by Angle Brackets. A $2\frac{1}{2}$ " Flat Girder is bolted to each side of the unit, and these are connected by a $2\frac{1}{2}$ " \times $1\frac{1}{2}$ " Double Angle Strip (18), which is strengthened by a $2\frac{1}{2}$ " Stepped Curved Strip.

A $\frac{7}{16}$ " Pinion on the Motor armature shaft drives a 60-tooth Gear on a 3" Rod supported in the Motor side-plates. The Rod is held in position by a Collar, and it carries at its lower end a $\frac{1}{2}$ " Pinion that is spaced from the Motor by three Washers. The Pinion engages a $1\frac{1}{2}$ " Contrate

Pin, are fixed on the Rod (22) between the Flat Girders. The Threaded Pins engage the groove of the Socket Coupling (20).

The engine unit is held in the chassis by Angle Brackets bolted to its front and to the Strip (3). A $4\frac{1}{2}$ " Strip is fixed to the Double Angle Strip (18) and is connected to the chassis by two $1"$ \times $\frac{1}{2}"$ Angle Brackets.

Details of the Gear-box (Figs. 3 and 5)

The gear-box is shown separately in Fig. 5. The housing consists of two $2\frac{1}{2}$ " \times $1\frac{1}{2}"$ Flanged Plates connected by a $1\frac{1}{2}$ " \times $\frac{1}{2}"$ Double Angle Strip (23) and joined at each end by two $1\frac{1}{2}"$ Strips. One of these Strips, indicated at (24) (Fig. 3), is spaced from the Flanged Plates by three Washers on each of the $\frac{3}{8}"$ Bolts that holds it in position.

The input shaft is a 2" Rod fitted with a $\frac{3}{8}$ " Pinion (25) and a $\frac{1}{2}$ " Pinion (26), and is mounted in the Strip (24). The output shaft, which also is 2" long and is supported as shown, carries a $\frac{1}{2}$ " Pinion (27) and a 1" Gear (28). The output shaft projects slightly beyond the Double Angle Strip (23) into the bore of the Pinion (26) in order to support the inner end of the input shaft.

The layshaft is a $3\frac{1}{2}$ " Rod that carries a 50-tooth Gear (29), a 57-tooth Gear (30), a 1" Gear (31) and a $\frac{1}{2}$ " Pinion (32). The Rod is free to slide in its bearings, but its movement is controlled by a selector formed by

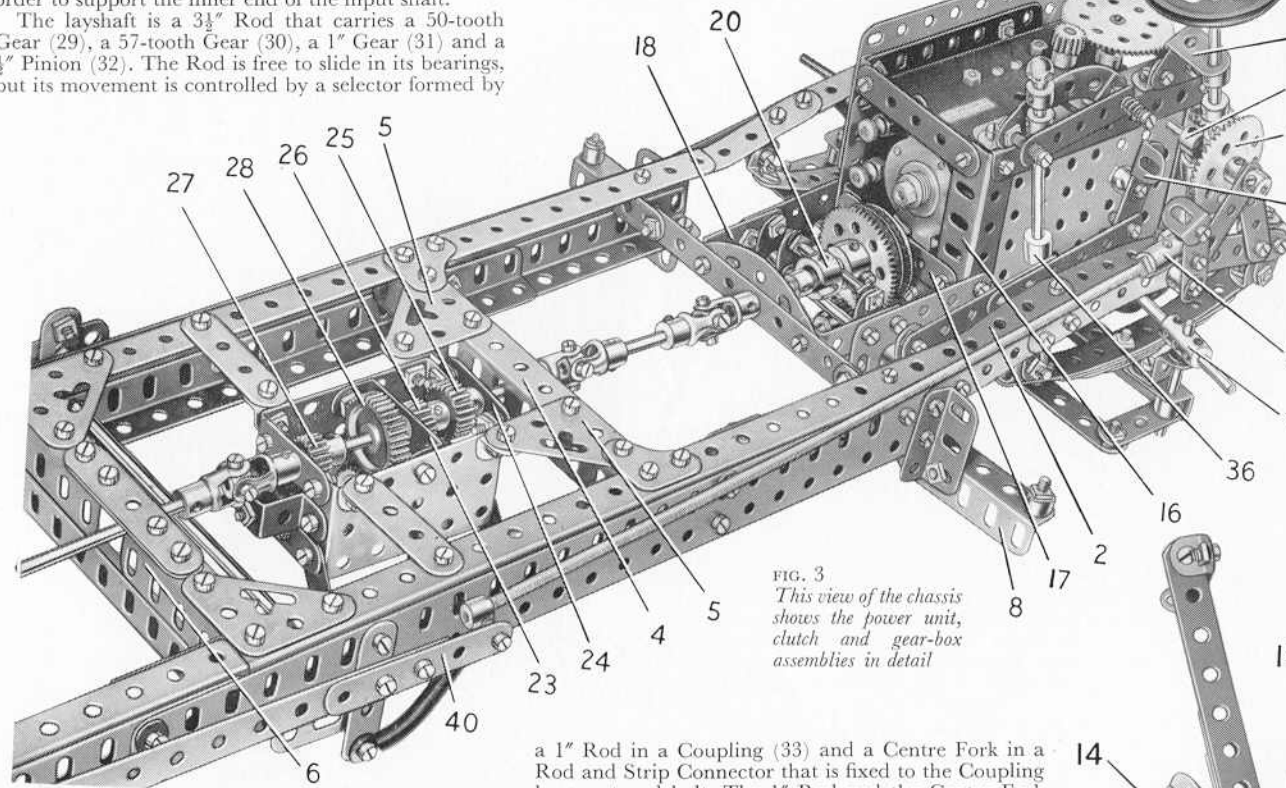

FIG. 3
This view of the chassis shows the power unit, clutch and gear-box assemblies in detail

a 1" Rod in a Coupling (33) and a Centre Fork in a Rod and Strip Connector that is fixed to the Coupling by a nut and bolt. The 1" Rod and the Centre Fork engage one on each side of the layshaft between the Gears (30) and (31). The Coupling is fixed on a $4\frac{1}{2}$ " Rod (34) supported in Fishplates bolted to the gear-box housing.

A $\frac{1}{2}$ " Pinion (35) is free to turn on a $1\frac{1}{8}$ " Bolt, but is held on it by two nuts screwed against each other. The Bolt is fixed by two nuts to the centre section of a Double Bent Strip bolted across the end of the housing.

Reverse gear is obtained when the Pinion (26) is in mesh with the Gear (30), and the Pinions (27), (32) and (35) are engaged. To arrange this the layshaft must be at the extreme left (Fig. 5). By moving the layshaft slightly to the right the Gears (28) and (31) are engaged while the Pinion (26) is still in mesh with the Gear (30). This provides low forward gear. When the layshaft is moved as far as possible to the right, the Pinion (25) and the Gear (29) are brought into mesh, with the Gears (28) and (31) still engaged, and top gear is obtained.

The gear-box is attached by Angle Brackets to 2" Strips bolted to the chassis, and is supported also by Angle Brackets fixed to the Corner Brackets (5). The input shaft is connected to the clutch shaft by a $1\frac{1}{2}$ " Rod and two Universal Couplings. The output shaft is connected to the rear axle driving-shaft by a $2\frac{1}{2}$ " Rod and a $3\frac{1}{2}$ " Rod joined by a Coupling, and by two made-up universal couplings, each of which consists of a Swivel Bearing and a small Fork Piece.

The gear selector lever is fixed at its lower end in a Rod Socket (36) (Fig. 3). The shank of the Rod Socket is screwed tightly into a Collar on a $3\frac{1}{2}$ " Rod (37) (Fig. 2), which is mounted in the engine unit and carries a Crank. A Strip Coupling (38) is pivotally attached to the Crank by a $\frac{1}{2}$ " Bolt, and is connected to the Rod (34) by a $4\frac{1}{2}$ " Rod, two Couplings and a Flexible Coupling Unit.

The top end of the gear-selector lever carries two Collars located between a $2\frac{1}{2}$ " Stepped Curved Strip and a $2\frac{1}{2}$ " Strip. The Stepped Curved Strip is fixed, by two nuts on each of two $\frac{3}{4}$ " Bolts, to Angle Brackets attached to the engine unit. The $2\frac{1}{2}$ " Strip is pressed against the Collars on the gear lever by a Compression Spring placed between the $2\frac{1}{2}$ " Strip and the head of each $\frac{3}{4}$ " Bolt.

The Brake Operating Mechanism (Fig. 2, 3 and 6)

The brake pedal is made by bolting an Angle Bracket to a Crank pivoted on a $\frac{1}{2}$ " Bolt attached to the chassis by two nuts (see Figs. 3 and 6). A Threaded Coupling (39) is locked by two nuts on a $\frac{3}{4}$ " Bolt passed freely through the Crank, and an $11\frac{1}{2}$ " Screwed Rod is fixed in the Threaded Coupling by a nut. A Collar is fixed on the rear end of the Screwed Rod by a $\frac{3}{8}$ " Bolt, which is passed through the end hole of a built-up strip (40). This strip consists of a $9\frac{1}{2}$ " and a $2\frac{1}{2}$ " Strip overlapped three holes, and its rear end is lock-nutted to a $\frac{3}{8}$ " Bolt passed through the Fishplate (13) (Fig. 6) of one of the brakes.

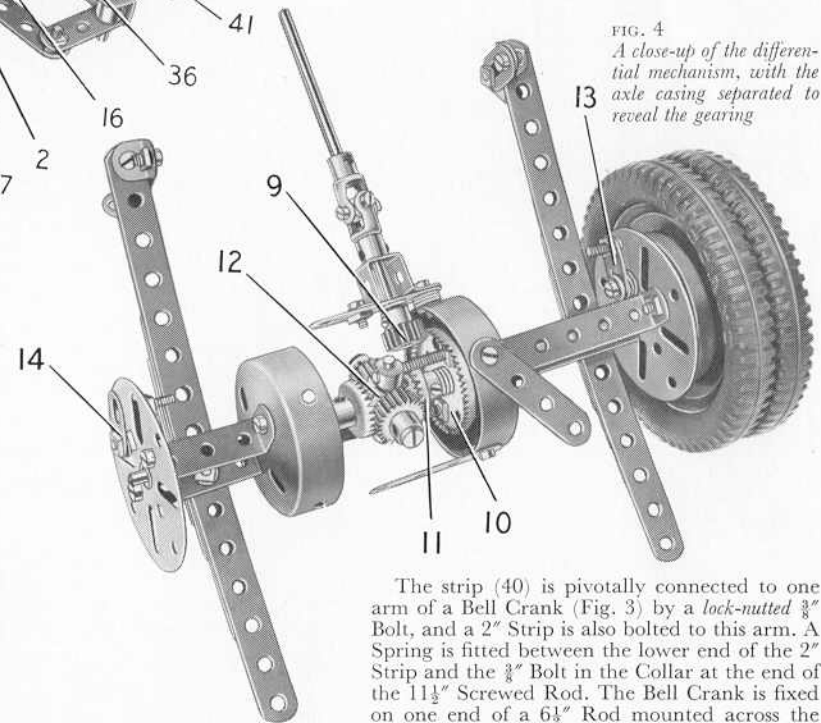
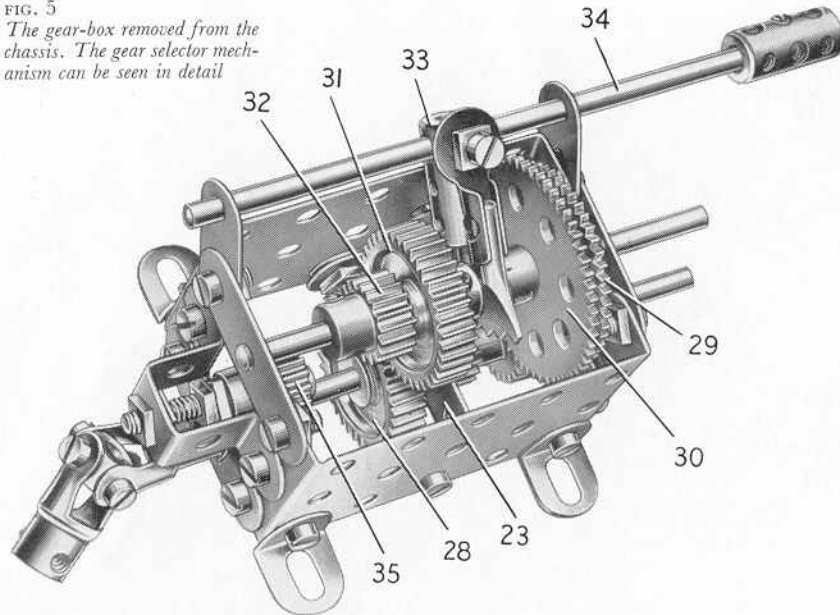

FIG. 4
A close-up of the differential mechanism, with the axle casing separated to reveal the gearing

The strip (40) is pivotally connected to one arm of a Bell Crank (Fig. 3) by a lock-nutted $\frac{3}{8}$ " Bolt, and a 2" Strip is also bolted to this arm. A Spring is fitted between the lower end of the 2" Strip and the $\frac{3}{8}$ " Bolt in the Collar at the end of the $11\frac{1}{2}$ " Screwed Rod. The Bell Crank is fixed on one end of a $6\frac{1}{2}$ " Rod mounted across the chassis, and another Bell Crank is secured to the

other end of the Rod. A 2" Strip is bolted to the second Bell Crank and a Spring is fitted between the lower end of this Strip and the chassis. A $9\frac{1}{2}$ " Strip is lock-nutted to the Bell Crank and to the Fishplate (13) of one of the brakes, in the same way as the strip (40).

FIG. 5
The gear-box removed from the chassis. The gear selector mechanism can be seen in detail



Front Axle and Steering (Figs. 2, 3 and 6)

The front axle beam is a 7½" Angle Girder (Fig. 2) and is attached to two leaf-springs, each of which consists of a 5½", a 4½", a 3½", a 2½" and a 1½" Strip. An Angle Bracket is fixed to each end of each spring, and these are lock-nutted to Fishplates bolted to the chassis. A ½" Reversed Angle Bracket is fixed to each end of the axle beam.

Each front wheel is freely mounted on a 1" Rod fixed in a Coupling (41) (Figs. 3 and 6). The wheels are held on the Rods by Collars. The Couplings (41) are fixed on 2" Rods supported in the ends of the axle beam and in the ½" Reversed Angle Brackets. Cranks fitted to the lower ends of the 2" Rods are connected by a 7½" Strip pivoted on lock-nutted bolts.

A 1½" Bevel (42) is fixed on a 2" Rod, and a Coupling is freely mounted between this Bevel and a Collar (43). The 2" Rod is supported in one side of the engine unit and in the top holes of a 2" Strip, and a 2" Slotted Strip, each of which is attached to the chassis as shown (Fig. 6). The steering column is a 3½" Rod free to turn in the Coupling on the 2" Rod, and it carries a ½" Bevel that engages the Bevel (42). The steering column is supported by a 1" × 1" Angle Bracket (44), bolted to a 1" Corner Bracket attached to the engine unit by two Angle Brackets.

A Rod Socket is screwed into the Collar (43) and is fixed in place by a nut. A 2" Rod in the Rod Socket carries at its lower end one half of a Dog Clutch (45), and to this a Rod and Strip Connector is pivotally attached by a nut and bolt. The Rod and Strip Connector is joined by a 1½" Rod to a similar part pivoted on a bolt screwed into a Collar on a 1½" Rod (46). Rod (46) is fixed in one of the Couplings (41) (Fig. 6).

The Lower Saloon (Figs. 8 and 9)

The side seen in Fig. 8 consists of two 12½" × 2½" Strip Plates and four 5½" × 2½" Flexible Plates, with a 5½" × 1½" Flexible Plate and a 3½" × 2" and a 2½" × 1½" Triangular Flexible Plate over the rear wheel arch. The Plates are fixed to a 7½" Angle Girder (47) at the front, and are edged along the top by two 12½" Strips and a 5½" Strip. The lower edges are strengthened by a 12½" Strip, a 5½" Strip and a 5½" Angle Girder (48), with a 12½" and a 5½" Angle Girder bolted to the inside (Fig. 7). A 9½" Angle Girder (49) is fixed vertically to the side, and to it are bolted a 4½" × 2½" Flexible Plate and a 3½" Flat Girder. The window divisions are 12½" Strips, each of which overlaps the side by four holes. These Strips are connected by three 9½" Flat Girders. A 2½" Angle Girder is bolted along the top row of holes in the Flat Girders, on the inside, starting at the Girder (49) so that it overhangs the Girder (47) by three holes.

The main section of the side seen in Fig. 1 is similar to the one already described, but it is shorter and ends at the Girder (49); also a 2½" × 2" Triangular Flexible Plate is used instead of a 2½" × 1½" Triangular Flexible Plate over the wheel arch. The window divisions are connected by two 12½" Flat Girders overlapped four holes.

The sides are connected at the front by two 5½" × 3½" Flat Plates overlapped three holes and edged at the top by a 9½" Strip. The Flat Plates are fixed to the Girders (47), and a 9½" Angle Girder (50) is bolted between their top ends. A vertical 5½" × 1½" Flexible Plate is attached to the centre of the Girder (50) and to the Flat Plates. At the rear the sides are connected by 9½" Angle Girders (51) and (52) (Fig. 7), bolted to the Girders (49).

The centre gangway consists of two 18½" Angle Girders connected by a 12½" × 2½" Strip Plate and a 5½" × 2½" Flexible Plate. At the front the gangway is supported by a 2½" Angle Girder bolted to the 5½" × 3½" Flat Plates, and at the rear it is extended by a 5½" × 2½" Flat Plate fixed to the Girder (51). The seats are made from Flexible and Curved Plates shaped as shown and supported by 1" × 1" Angle Brackets, 1" × ½" Angle Brackets and 1" Reversed Angle Brackets fixed to the gangway.

The Upper Saloon

The side seen in Fig. 8 consists of two 5½" × 2½" Flexible Plates, four 12½" × 2½" Strip Plates and two 4½" × 2½" Flexible Plates. These are fixed to the vertical 12½" Strips that form the window divisions. At the front a 4½" Angle Girder (53) is connected to the top edge of the lower saloon by a 7½" Strip. The top edges of the Plates are strengthened by two 12½" Strips and two 5½" Strips. A built-up strip (54), made from three 12½" Strips, is bolted to the top ends of the window divisions. In addition to the vertical 12½" Strips, two 5½" Strips, a 4" Curved Strip and a 3½" Strip at the front, are used to form the windows of the upper saloon.

The other side, which is seen in Fig. 1, is similar in general arrangement to the one already described, but it varies in slight details. The top edges of the Plates are strengthened by two 12½" Strips, a 5½" Strip and a 3" Strip, and the lower 4½" × 2½" Flexible Plate at the rear is replaced by a 2½" × 2½" Flexible Plate and a 2½" × 2½" Flat Plate. The Flat Plate is edged by 2½" Strips, but is spaced from them by nuts on the bolts to represent a recessed destination indicator.

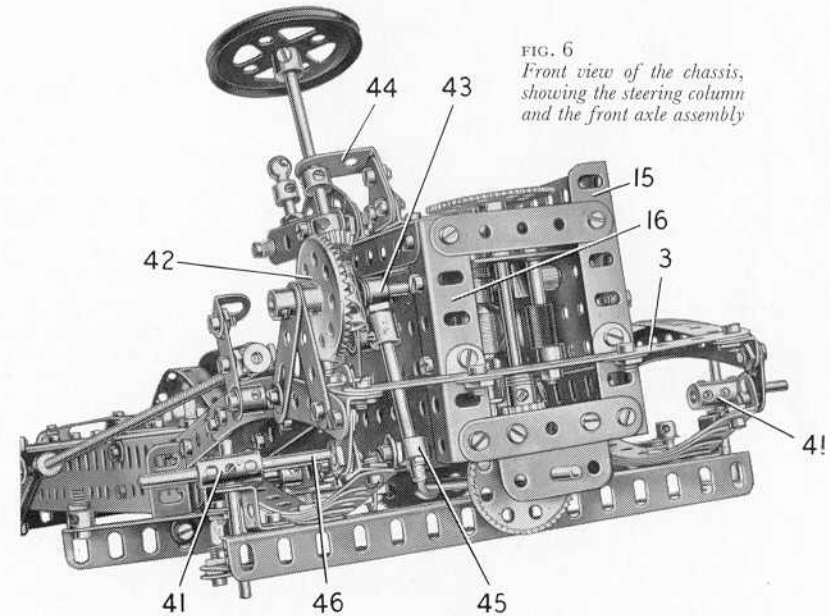

FIG. 6
Front view of the chassis, showing the steering column and the front axle assembly

At the front of the bus the Girders (53) are connected by two $9\frac{1}{2}$ " Strips and a built-up strip made from two $5\frac{1}{2}$ " Strips overlapped three holes (Fig. 8). The front is plated by three $3\frac{1}{2}$ " \times $2\frac{1}{2}$ " Flexible Plates at the top, with one half of a Hinged Flat Plate (55), a $2\frac{1}{2}$ " \times $1\frac{1}{2}$ " Flexible Plate and a $5\frac{1}{2}$ " \times $1\frac{1}{2}$ " Flexible Plate (56) below them. The Plate (56) is extended upward by another $5\frac{1}{2}$ " \times $1\frac{1}{2}$ " Flexible Plate, and this is recessed from the $3\frac{1}{2}$ " \times $2\frac{1}{2}$ " Flexible Plates by nuts on the bolts that fix them together. The front ends of the strips (54) are connected by Angle Brackets to two $5\frac{1}{2}$ " Strips overlapped three holes.

A $5\frac{1}{2}$ " \times $2\frac{1}{2}$ " Flanged Plate (57) (Fig. 7) is bolted to each side, and these are connected by a $5\frac{1}{2}$ " \times $3\frac{1}{2}$ " Flat Plate and a $5\frac{1}{2}$ " \times $2\frac{1}{2}$ " Flat Plate. At the rear a $9\frac{1}{2}$ " Flat Girder (58) is bolted between the top ends of the Girders (49) and a $5\frac{1}{2}$ " \times $2\frac{1}{2}$ " Flanged Plate is fixed between this Flat Girder and the rear panelling. Two $4\frac{1}{2}$ " \times $2\frac{1}{2}$ " Flexible Plates secured to the Flanged Plate provide a cover over the boarding platform. A $4\frac{1}{2}$ " Angle Girder is fixed to the centre of the Flat Girder (58).

The centre gangway consists of two $24\frac{1}{2}$ " Angle Girders connected by two $12\frac{1}{2}$ " \times $2\frac{1}{2}$ " Strip Plates. It is bolted to the Flat Plates that are fastened to the Flanged Plates (57), and to the Flanged Plate secured to the Flat Girder (58). The seats are made in the same way as those in the lower saloon, and they are supported by 1 " \times 1 " Angle Brackets and $2\frac{1}{2}$ " \times 1 ", $2\frac{1}{2}$ " \times $1\frac{1}{2}$ " and 3 " \times $1\frac{1}{2}$ " Double Angle Strips.

Rear Panelling and Boarding Platform (Figs. 7, 8 and 10)

The side of the lower saloon seen in Fig. 8 is extended at the rear by three curved $5\frac{1}{2}$ " \times $2\frac{1}{2}$ " Flexible Plates, the lower one edged by a Formed Slotted Strip at the bottom, and by a curved $5\frac{1}{2}$ " Strip along its top edge. The lower edge of the top Plate is covered by a curved $5\frac{1}{2}$ " Flat Girder. The lower rear panelling consists of

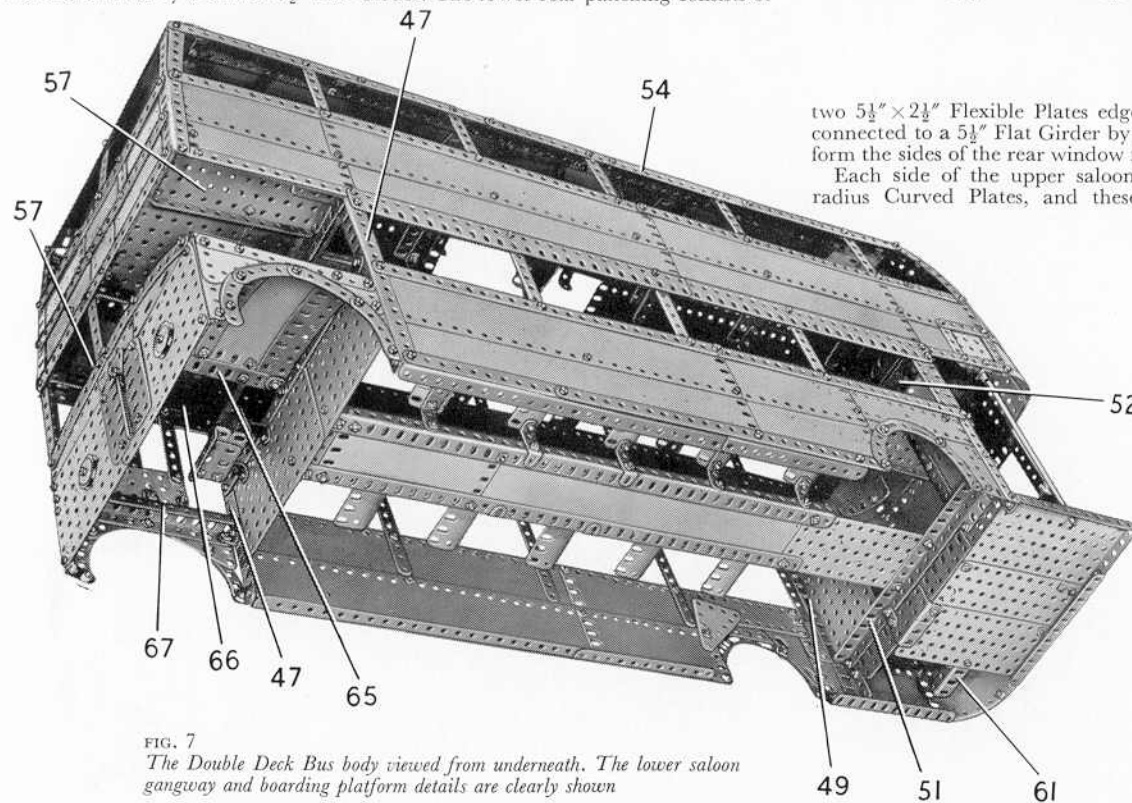

FIG. 7
The Double Deck Bus body viewed from underneath. The lower saloon gangway and boarding platform details are clearly shown

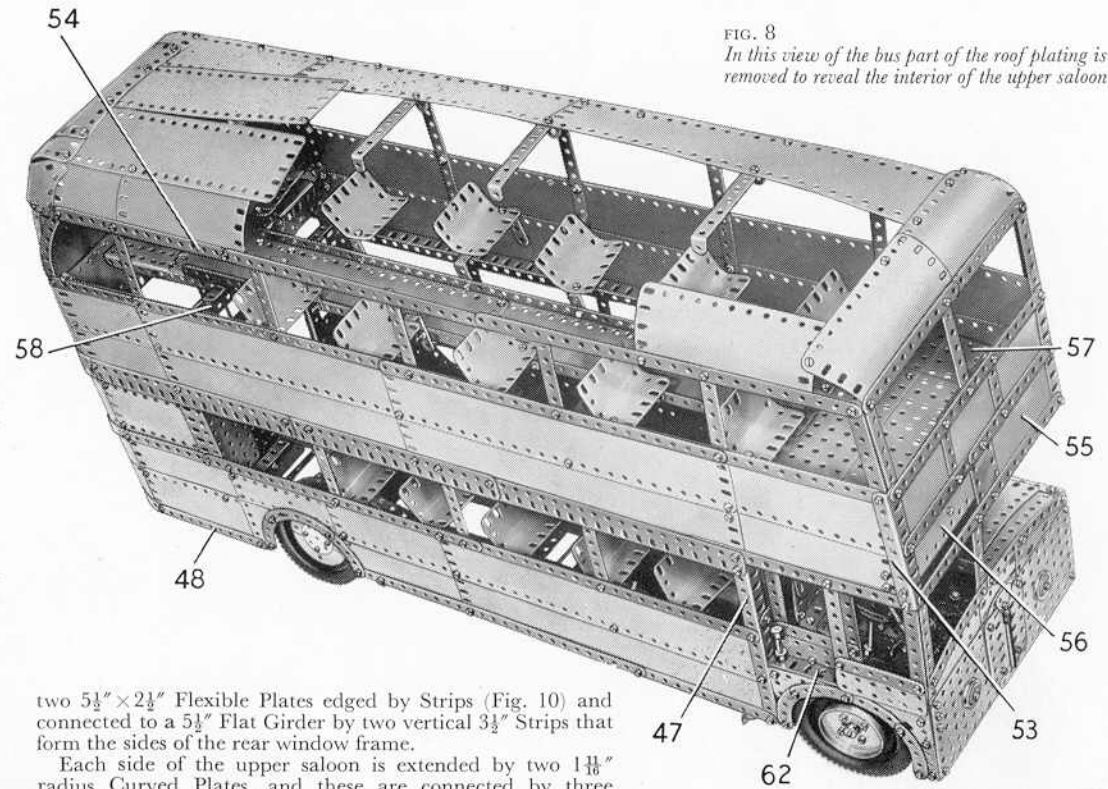

FIG. 8
In this view of the bus part of the roof plating is removed to reveal the interior of the upper saloon

two $5\frac{1}{2}$ " \times $2\frac{1}{2}$ " Flexible Plates edged by Strips (Fig. 10) and connected to a $5\frac{1}{2}$ " Flat Girder by two vertical $3\frac{1}{2}$ " Strips that form the sides of the rear window frame.

Each side of the upper saloon is extended by two $1\frac{1}{8}$ " radius Curved Plates, and these are connected by three $4\frac{1}{2}$ " \times $2\frac{1}{2}$ " Flexible Plates, a $2\frac{1}{2}$ " \times $2\frac{1}{2}$ " Flexible Plate and a $2\frac{1}{2}$ " \times $2\frac{1}{2}$ " Flat Plate. The Flat Plate is recessed by nuts as described previously.

The upper panelling at the rear of the body is completed by a $4\frac{1}{2}$ " \times $2\frac{1}{2}$ " Flexible Plate (Fig. 10), a $5\frac{1}{2}$ " \times $1\frac{1}{2}$ " Flexible Plate and a $3\frac{1}{2}$ " \times $2\frac{1}{2}$ " Triangular Flexible Plate. On the near side a $2\frac{1}{2}$ " \times $1\frac{1}{2}$ " Triangular Flexible Plate (60) is bolted in position, but on the off-side this is replaced by a $3\frac{1}{2}$ " \times $1\frac{1}{2}$ " Triangular Flexible Plate. The plating above the rear window of the upper saloon consists of two $4\frac{1}{2}$ " \times $2\frac{1}{2}$ " Flexible Plates and two $2\frac{1}{2}$ " \times $1\frac{1}{2}$ " Flexible Plates.

The platform floor is formed by a $5\frac{1}{2}$ " \times $3\frac{1}{2}$ " and two $5\frac{1}{2}$ " \times $2\frac{1}{2}$ " Flat Plates edged by $5\frac{1}{2}$ " Angle Girders as shown (Figs. 7 and 10). A built-up flat girder, made from a $7\frac{1}{2}$ " and a $2\frac{1}{2}$ " Flat Girder, is bolted to a $9\frac{1}{2}$ " Strip fixed across the Girders (49) and is connected to the floor by a Girder Bracket.

The division between the platform and the saloon on the off-side is a $4\frac{1}{2}$ " \times $2\frac{1}{2}$ " Flat Plate extended upward by a $2\frac{1}{2}$ " \times $2\frac{1}{2}$ " Flexible Plate, and on the near-side it consists of a $3\frac{1}{2}$ " \times $2\frac{1}{2}$ " Flexible Plate and a $5\frac{1}{2}$ " Strip.

Each step of the stairs is formed by a $2\frac{1}{2}$ " \times $1\frac{1}{2}$ " Flexible Plate bolted to a $2\frac{1}{2}$ " Angle Girder. The steps are connected to each other by Trunnions, and the lower one is bolted to a Girder Bracket fixed to the platform. The side rail is a $5\frac{1}{2}$ " Braced Girder attached at its lower end to a $2\frac{1}{2}$ " \times $2\frac{1}{2}$ " Flexible Plate bolted to a $5\frac{1}{2}$ " Angle Girder (61). The upper end of the Braced Girder is supported by another $5\frac{1}{2}$ " Angle Girder fixed vertically to the Girder (61).

Construction of the Roof

The assembly of this part of the model is shown clearly in Figs. 1, 8 and 10.

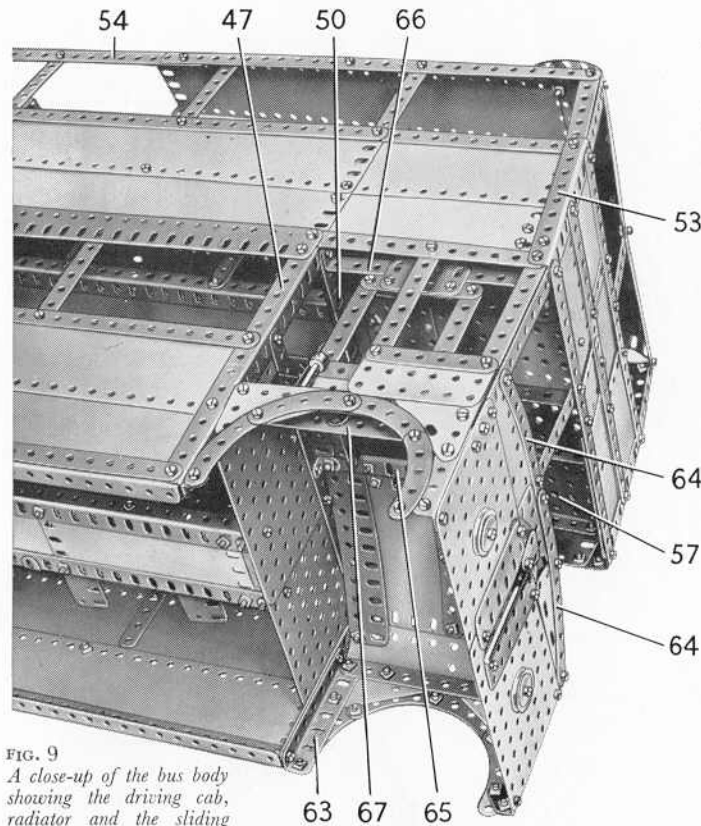

FIG. 9
A close-up of the bus body showing the driving cab, radiator and the sliding door partly open

The Bonnet and Cab (Figs. 8 and 9)

The off-side of the cab is made by attaching a 5 1/2" Angle Girder (62) (Fig. 8), to the Girder (47) by means of an Angle Bracket. The front end of the Girder (62) is connected to the Girder (53) by a 5 1/2" Strip. The side is plated by a 2 1/2" x 1 1/2" and a 2 1/2" x 2 3/4" Triangular Flexible Plate, and by a 3" x 1 1/4" Flat Plate.

The side of the bonnet (Fig. 1) is a 5 1/2" x 1 1/2" Flexible Plate curved lengthways and bolted to a 3" Angle Girder (63) (Fig. 9). A 2 1/2" x 1 1/2" Triangular Flexible Plate and a 2 1/2" x 2" Triangular Flexible Plate cover the near-side wheel arch. The front of the bonnet is made from two 5 1/2" x 3 1/2" Flat Plates overlapped three holes and bolted to 3" Angle Girders, which are attached to the sides of the cab and bonnet. The Flat Plates are extended upward by a 5 1/2" x 1 1/2" and a 2 1/2" x 1 1/2" Flexible Plate overlapped four holes, and by a 3 1/2" x 1 1/2" Triangular Flexible Plate. The tops of these Plates are edged by two 5 1/2" Curved Strips (64).

A 5 1/2" Angle Girder (65) is attached by Angle Brackets to the Curved Strips (64) and to the partition between the lower saloon and the cab. At each end this Girder is connected to the side of the cab by a curved 5 1/2" Flat Girder. The hinged top of the bonnet consists of two 4 1/2" x 2 1/2" Flexible Plates pivoted on Hinges bolted to the Girder (65).

The sliding door consists of two 3 1/2" Strips joined by a 3" Strip and a 3" x 1 1/2" Flat Plate. A 5 1/2" x 1 1/2" Double Angle Strip (66) is arranged as shown in Fig. 9, and a 5 1/2" Strip (67) is supported at each end by an Angle Bracket. A Fishplate bolted to the Flat Plate of the door slides between the Strip (67) and the edge of the Girder (62). A 2" Flat Girder is bolted to each side of the 3" Strip of the door, but one of them is spaced from the Strip by a 2" Strip. The Flat Girders slide freely on either side of the Double Angle Strip (66).

The driver's seat consists of two 2" Angle Girders connected by a 1 1/2" Flat Girder, and the back is another 1 1/2" Flat Girder supported by two 2" Strips. The seat is connected to the back of the cab by two Double Brackets.

The body is attached to the chassis by bolting the Girders that strengthen the lower edges of the body, to the ends of the

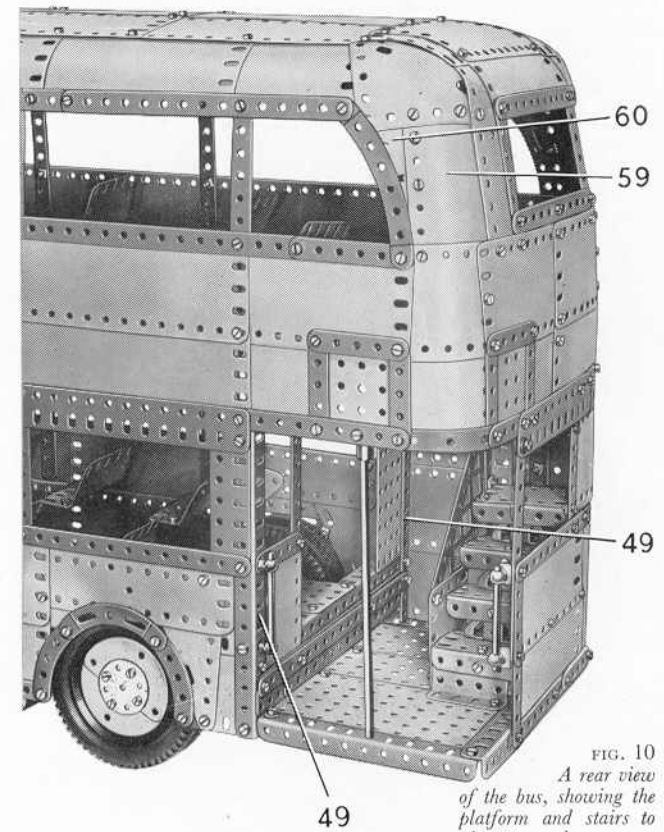

FIG. 10
A rear view of the bus, showing the platform and stairs to the upper saloon

Girders (7) and (8) (Fig. 2). At the front the body is spaced from each of the Girders (8) by a Collar.

Parts Required to Build the Meccano Double Deck Bus

21 of No. 1	12 of No. 9	2 of No. 15a	1 of No. 27	1 of No. 47	1 of No. 63b	4 of No. 103	2 of No. 114	2 of No. 140	16 of No. 191	2 of No. 226
6 " " 1a	8 " " 9a	6 " " 16	2 " " 27a	2 " " 47a	1 " " 63c	4 " " 103a	2 " " 115	6 " " 142b	30 " " 192	
6 " " 1b	4 " " 9b	4 " " 16a	1 " " 27d	3 " " 48	1 " " 65	4 " " 103b	1 " " 116	1 " " 142c	4 " " 196	
35 " " 2	2 " " 9c	3 " " 16b	2 " " 28	2 " " 48a	4 " " 70	2 " " 103c	2 " " 116a	1 " " 144	20 " " 197	
8 " " 2a	8 " " 9d	6 " " 17	2 " " 29	4 " " 48b	2 " " 72	2 " " 103d	3 " " 120b	2 " " 147b	1 " " 198	
16 " " 3	2 " " 9e	5 " " 18a	1 " " 30a	2 " " 48d	2 " " 73	2 " " 103e	4 " " 124	2 " " 161	12 " " 199	
8 " " 4	7 " " 9f	4 " " 18b	1 " " 30c	2 " " 51	2 " " 77	3 " " 103f	2 " " 125	2 " " 162a	4 " " 200	
28 " " 5	22 " " 10	6 " " 19b	2 " " 31	3 " " 52	1 " " 78	2 " " 103g	3 " " 126	2 " " 165	4 " " 212	
12 " " 6	4 " " 11	1 " " 20a	715 " " 37a	6 " " 52a	2 " " 82	4 " " 103h	1 " " 126a	1 " " 171	4 " " 214	
8 " " 6a	46 " " 12	3 " " 22a	638 " " 37b	4 " " 53a	4 " " 89	1 " " 103k	2 " " 128	1 " " 175	4 " " 215	
4 " " 7	8 " " 12a	1 " " 24	72 " " 38	2 " " 55a	4 " " 89a	2 " " 109	4 " " 133	2 " " 179	4 " " 221	
2 " " 7a	7 " " 12b	2 " " 24a	2 " " 38d	23 " " 59	6 " " 89b	4 " " 111	2 " " 133a	10 " " 188	2 " " 222	
6 " " 8	1 " " 13a	3 " " 25	2 " " 43	4 " " 62	12 " " 90	16 " " 111a	4 " " 136	11 " " 189	1 " " 223	
6 " " 8a	2 " " 14	7 " " 26	2 " " 45	4 " " 62b	3 " " 90a	24 " " 111c	1 " " 136a	12 " " 190	2 " " 224	
3 " " 8b	1 " " 15	1 " " 26c	4 " " 46	8 " " 63	1 " " 100	1 " " 111d	4 " " 137	4 " " 190a	2 " " 225	1 E15R Electric Motor (not included in Outfit)

MECCANO Lifting Shovel

(MODEL No. 10.6)

SPECIAL FEATURES

The model represents a popular type of mechanical loading shovel used on large construction jobs where quantities of spoil or other material have to be loaded into vehicles for removal from the site. Power is provided by a Meccano E15R Electric Motor that drives the road wheels through a differential. The lifting and unloading movements of the shovel are controlled from the cab, and the hoisting winch is fitted with an automatic brake.

Among the many labour-saving devices available to modern civil engineers probably few are more useful than the various types of mechanical shovels. These are available in many forms, and the subject of the model described in this Leaflet is a highly manoeuvrable machine known as a Lifting Shovel. The original is powered by a diesel or petrol engine, and is very compact. It is extremely useful for loading spoil or other material from heaps into wagons or trucks, and the model incorporates all the essential features. In building the model it is best to commence with the wheeled chassis, details of which follow.

Details of the Chassis (Fig. 2, 4, 5 and 8)

Each side-member is made from two $12\frac{1}{2}$ " Angle Girders joined together by two $1\frac{1}{2}$ " Flat Girders. They are connected at the rear by a $4\frac{1}{2}$ " \times $\frac{1}{2}$ " Double Angle Strip (1) (Fig. 4), and at the front by two $3\frac{1}{2}$ " \times $\frac{1}{2}$ " Double Angle Strips (2) (Figs. 2 and 5). To one of the Double Angle Strips (2) a Double Bent Strip (3) is bolted.

Two further $3\frac{1}{2}$ " \times $\frac{1}{2}$ " Double Angle Strips (4) are fixed across the chassis and between them a $2\frac{1}{2}$ " \times $\frac{1}{2}$ " Double Angle Strip (5) is bolted. Then a $1\frac{1}{2}$ " \times $\frac{1}{2}$ " Double Angle Strip is positioned between the Double Angle Strip (5) and the side of the chassis.

A Flat Trunnion is fixed to the $1\frac{1}{2}$ " \times $\frac{1}{2}$ " Double Angle Strip, and a similar part is bolted also to each of the Double Angle Strips (4). Two $3\frac{1}{2}$ " \times $\frac{1}{2}$ " Double Angle Strips (6) (Figs. 2 and 8) are fixed across the chassis as shown.

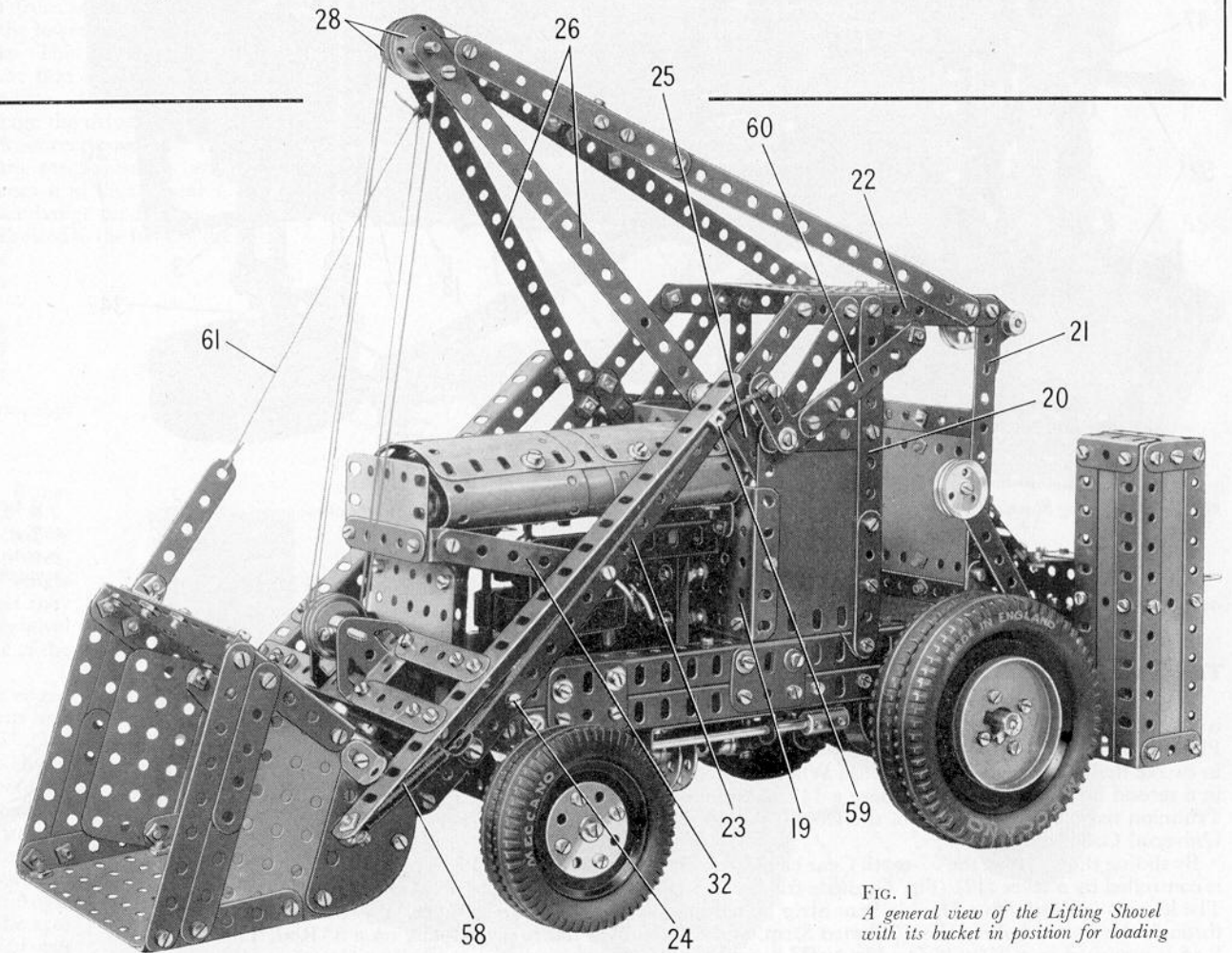

FIG. 1
A general view of the Lifting Shovel
with its bucket in position for loading

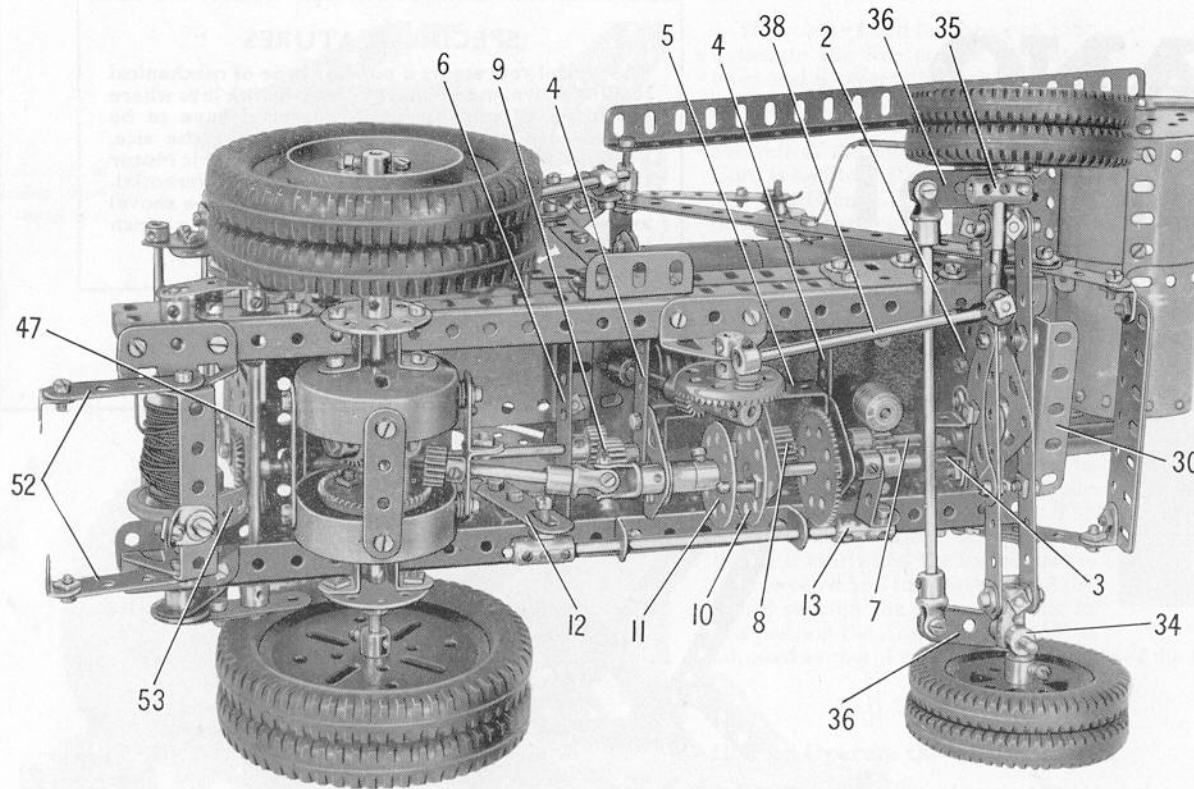

FIG. 2 The Lifting Shovel seen from underneath, with the reduction gearing and the driving mechanism clearly shown

An E15R Electric Motor is attached to the top flanges of the chassis side-members by two Fishplates on each side.

The Main Drive Gears (Figs. 2, 4 and 5)

A Worm on the lower end of the Motor armature shaft drives a $\frac{1}{2}$ " Pinion on a $4\frac{1}{2}$ " Rod (7). The Rod is supported in the Double Bent Strip (3) and in the Double Angle Strips (4), and it carries two $\frac{1}{2}$ " Pinions (8 and 9) (Fig. 2). A 57-tooth Gear and a Bush Wheel (10) are fixed on a $2\frac{1}{2}$ " Rod supported in two of the Flat Trunnions. The Bush Wheel is fitted with two Threaded Pins, and these engage holes in a second Bush Wheel (11), fixed on a $1\frac{1}{2}$ " Rod mounted in a Crank. The Crank is bolted to the Flat Trunnion fixed to the rear one of the Double Angle Strips (4), and the $1\frac{1}{2}$ " Rod is held in place by a Universal Coupling.

By sliding the $2\frac{1}{2}$ " Rod the 57-tooth Gear can be moved into mesh with the Pinion (8). This movement is controlled by a lever (12) (Fig. 4), made from a 3" Strip and a 2" Slotted Strip overlapped two holes. The lever is lock-nutted to a Double Bent Strip bolted inside the chassis side-member. A $\frac{1}{2}$ " Bolt is passed through the slotted hole of the 2" Slotted Strip, and is fixed by a nut in a Coupling on a 5" Rod. This Rod is mounted in a $2\frac{1}{2}$ " x $\frac{1}{2}$ " Double Angle Strip bolted to the chassis, and it carries a Coupling (13)

to which a $1" \times \frac{1}{2}"$ Angle Bracket is attached by means of a $\frac{3}{8}"$ Bolt. The slotted hole of the Angle Bracket is passed over the $2\frac{1}{2}"$ Rod as shown (Fig. 5), and a Collar is fixed on each side of it.

The Rear Axle and Differential (Figs. 2 and 3)

The rear axle is shown, partly dismantled, in Fig. 3. The axle casing is in two sections, each made by bolting two Double Brackets between a Boiler End and a Bush Wheel (8-holes) (14). When the differential is finally assembled the sections are connected by three 2" Strips and two $1" \times \frac{1}{2}"$ Angle Brackets (15), each of the latter being spaced from the casing by two Washers on a $\frac{3}{8}"$ Bolt.

A 4" Rod is passed through one section of the axle casing, and on it a $1\frac{1}{2}"$ Contrate (16) is free to rotate. A $\frac{3}{4}"$ Contrate (17) is fixed on the Rod, which is then inserted in a Coupling (18). Two 1" Screwed Rods are held in holes in the Contrate (16) by two nuts each, and Collars are screwed on to the ends of the Screwed Rods. A $1\frac{1}{2}"$ Rod is fixed in the Collars and in the centre hole of Coupling (18). Two $\frac{3}{4}"$ Pinions are free to turn on Pivot Bolts screwed into the Coupling. A second $\frac{3}{4}"$ Contrate is fixed on a $3\frac{1}{2}"$ Rod supported in the other section of the axle casing.

A 2" Rod is passed through one of the Angle Brackets (15), and a $\frac{1}{2}"$ Pinion on it engages the Contrate (16). The two $\frac{3}{4}"$ Contrates mesh with the $\frac{3}{4}"$ Pinions. Washers are placed on the Rods so that the Pinions and Contrates mesh accurately.

FIG. 3 The differential. One half of the axle casing is removed to reveal the arrangement of the gears

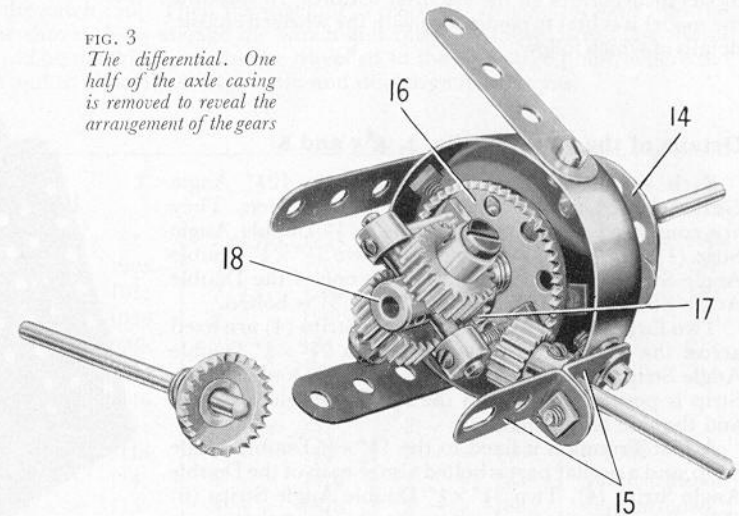

The axle is fitted to the chassis by bolting the Bush Wheels (14) to the side-members. The 2" Rod is fixed in the Universal Coupling on the Rod that carries the Bush Wheel (11).

Construction of the Cab (Figs. 2, 4, 7 and 8)

The cab front is made by bolting a 3½" x 2½" Flanged Plate (19) (Fig. 1) to a 3½" Angle Girder fixed across the chassis. A 3½" x 2½" Flexible Plate is attached to each flange of the Flanged Plate, and is edged at the top by a 2½" Strip and along its rear edge by a made-up strip (20), formed from a 5½" and a 2½" Strip overlapped four holes.

A 5½" Angle Girder (21) on each side is attached to the chassis by a 1½" Corner Bracket, and the top end of this Girder is connected to the strip (20) by a 4½" Strip (22). A 3" Strip is fixed between the Strip (22) and the top front corner of the 3½" x 2½" Flexible Plate, and a 3½" x ½" Double Angle Strip is bolted between these corners of the Plates on each side.

The Girders (21) are connected together by 3½" Strips and a 3½" x 2½" Flexible Plate as shown (Fig. 8). The floor of the cab is made from a 3½" x 2½" Flexible Plate and a 2½" x 1½" Flexible Plate (Fig. 4). The cab roof is a 3½" x 2½" Flanged Plate, to which two 3½" Strips are attached by means of two 2" Strips.

Details of the Jib (Figs. 1, 4 and 7)

Two 9½" Strips (23) placed face to face, are bolted between the front of the Strip (22) and the chassis on each side. Their lower ends are extended two clear holes by a 2½" Strip. A ¾" Bolt (24) is used to connect the Strips (23) to the chassis, and a nut is placed on the Bolt to space the Strips from the chassis. The lower ends of the 2½" Strips are connected by Angle Brackets to two 3½" Flat Girders placed face to face.

A 5½" Strip (25) on each side is bolted to the Strips (23) and is fixed to the chassis by the same bolt that holds the strip (20). A 1" Triangular Plate is attached to the Strips (23) by the same bolt as the Strip (25), and to this Triangular Plate a 7½" Strip (26) is attached. The bolt that secures the Strip (26) is screwed into the Threaded Boss 27 (Fig. 7).

A 1" Corner Bracket is bolted to the top of each of the Strips (26), and this is connected

to the Strip (22) by a built-up strip made from a 7½" and a 4½" Strip overlapped three holes. The assembled strips are joined across by a 1½" Strip supported by Angle Brackets. Two 1" loose Pulleys (28) are mounted between Collars on a 1½" Rod, which is supported in the end holes of the Strips (26).

Two 1½" Angle Girders are bolted to the back of the cab and each of them supports a 1" Triangular Plate. A 3" Rod held in the Triangular Plates by Collars carries a 1" Pulley (29) (Fig. 8).

Assembly of the Bonnet and Radiator (Figs. 1, 2, 4 and 7)

The bonnet consists of two 1½" radius Curved Plates that overlap a similar Plate at the centre by two holes each. Each side consists of three U-section Curved Plates, and the front pair of these is connected by a 2½" x 1½" Flexible Plate. A 2½" Stepped Curved Strip is bolted to a 2½" Strip attached to the 2½" x 1½" Flexible Plate by an Angle Bracket. The rear end of the bonnet is supported by Angle Brackets bolted to the Flanged Plate (19).

The radiator is made by bolting a 3½" x 2½" Flanged Plate (30) to the front edge of the 2½" x 1½" Flexible Plate. The Flanged Plate is supported by ½" Corner Angle Brackets (31) fixed to the chassis, and a 2½" x 2½" Flat Plate is attached to the Flanged Plate by ¾" Bolts, but is spaced from it by nuts. Two ½" Reversed Angle Brackets are fixed to the top of the 2½" x 2½" Flat Plate and these support a 2½" Strip and a 2½" x 1½" Flexible Plate. A 3" Strip (32) on each side is bolted to the Strip (23) and is connected to one of the ½" Reversed Angle Brackets by an Angle Bracket.

Front Axle and Steering Mechanism (Figs. 2, 4, 5 and 7)

The front axle beam, which is pivoted, consists of two 5½" Strips, with a Coupling (33) (Fig. 5) fixed between them at each end. The Coupling is attached to each Strip by a bolt, which carries a Washer and passes through the lug of a Double Bracket and through an end hole of the Strip. A second Washer is placed on the bolt and it is then screwed tightly into the Coupling. A ½" Bolt is passed through the centre portion of the Double Bracket and a Washer is placed on it before it enters the Coupling. A nut is screwed tightly on the Bolt to fix the Coupling and the Double Bracket firmly together.

A 2½" Stepped Curved Strip is bolted to each 5½" Strip of the axle beam, and a ¾" Bolt is passed through them and through the centre holes of Flat Trunnions bolted to

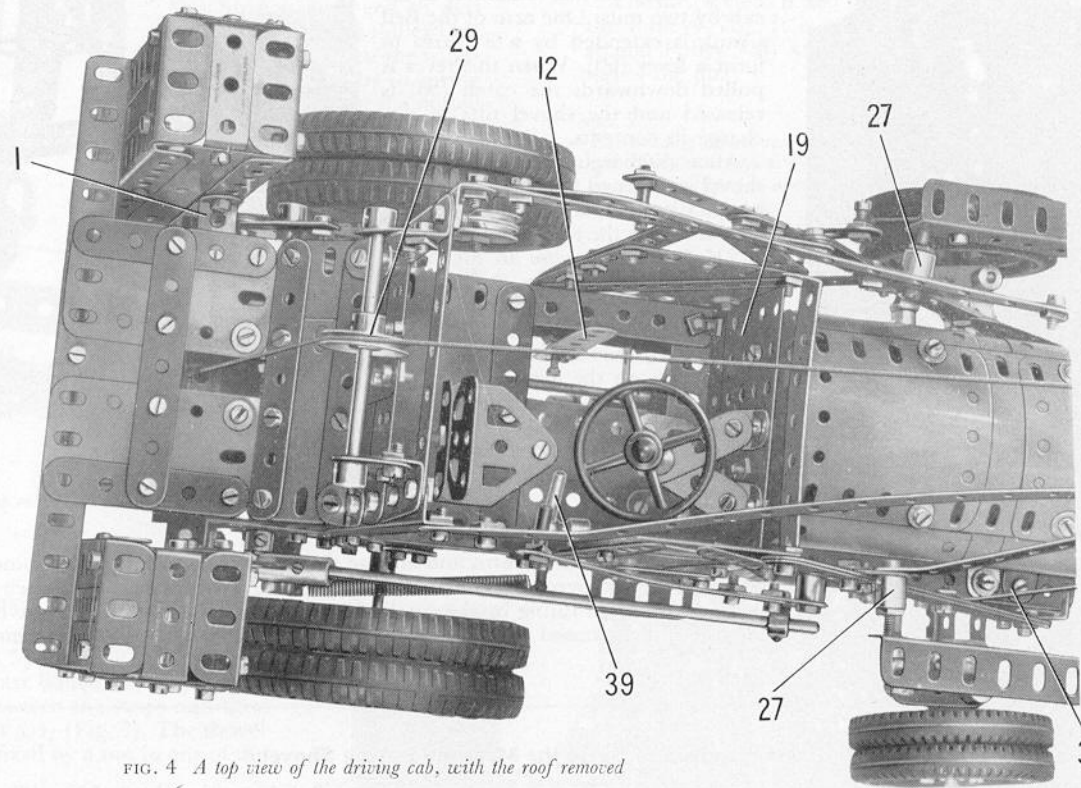

FIG. 4 A top view of the driving cab, with the roof removed

Double Angle Strips (2). A Collar and three Washers are placed on the Bolt between the Flat Trunnions, and the Bolt is fitted with *lock-nuts* to allow the axle beam to pivot freely.

A $1\frac{1}{8}$ " Bolt carrying two Washers is passed through the bosses of each pair of front wheels and another Washer is placed on the Bolt. One Bolt is then screwed into a Collar (34) and the other is screwed into a Coupling (35). The Collar and the Coupling are fixed on $1\frac{1}{2}$ " Rods, which are mounted in the Couplings (33). A Crank (36) on each Rod is spaced from the Coupling (33) by two Washers. An End Bearing is *lock-nutted* to each Crank, the End Bearings afterwards being linked together by a 5" Rod.

The steering column is a 5" Rod passed through the $3\frac{1}{2}$ " Angle Girder that supports the Flanged Plate (19). At its upper end the Rod is supported in holes in two $1\frac{1}{2}$ " Strips, each of which is connected to the Flanged Plate (19) by an Obtuse Angle Bracket (Fig. 4).

The lower end of the Rod is supported in a Coupling (37) (Fig. 5) which is fixed on a 1" Rod and is spaced from a $1\frac{1}{2}$ " Contrate by three Washers. The Contrate is free to turn on the Rod, which is then held by a Collar in a Trunnion bolted to the chassis. A $\frac{1}{2}$ " Pinion on the steering column engages the Contrate.

A $\frac{3}{8}$ " Bolt is passed through a hole in the Contrate, is fitted with two Washers and a nut, and is then fixed in a Collar on a $3\frac{1}{2}$ " Rod (38). A Rod and Strip Connector on the other end of Rod (38) is *lock-nutted* to another Rod and Strip Connector on a $1\frac{1}{2}$ " Rod. The $1\frac{1}{2}$ " Rod is fixed as shown in the Coupling (35).

The Motor Control Switch (Figs. 4 and 7)

A 1" Rod (39) is gripped in a Handrail Coupling, which is fixed on a $2\frac{1}{2}$ " Rod passed through the Flanged Plate (19) and held in place by a Collar and a Double Arm Crank (40) (Fig. 7). A 2" Strip is *lock-nutted* to the Double Arm Crank and to an arm of the Motor switch.

Arrangement of the Winch (Figs. 2, 6, 7 and 8)

The Pinion (9) drives a $\frac{1}{2}$ " Pinion on a 5" Rod supported in the Double Angle Strips (6) and held in place by a Collar. The rear end of this Rod carries a $\frac{7}{8}$ " Bevel (41) that drives a similar Bevel on a $4\frac{1}{2}$ " Rod (42) (Fig. 8), which is fitted with a

Collar (43). Rod (42) is held in position by two Collars.

The winch drum consists of a Sleeve Piece fitted at one end with a Chimney Adaptor and at the other end with a $\frac{3}{4}$ " Flanged Wheel. This assembly is fixed on a $4\frac{1}{2}$ " Rod passed through slotted holes in the chassis and held in place by a Collar at each end. A 1" Pulley (44), fitted with a Rubber Ring, is fixed on the Rod.

The drive to the winch is brought into operation by sliding the $4\frac{1}{2}$ " Rod upwards in the slotted holes until the Rubber Ring on Pulley (44) presses against the Collar (43). The movement of the Rod is controlled by a Crank (45) (Fig. 8), and a Double Arm Crank (46) extended by a $1\frac{1}{2}$ " Strip (Fig. 6). These are fixed on a 5" Rod (47) mounted in $1\frac{1}{2}$ " Strips that are bolted over slotted holes in the chassis. A Double Arm Crank (48) is fixed on Rod (47). The Crank (45) and the Strip bolted to the Double Arm Crank (46), are slipped over the ends of the Rod that carries the winch drum. At one side a balance arm (49) is fitted on the Rod, and is separated from the $1\frac{1}{2}$ " Strip by two $\frac{3}{8}$ " Washers. The balance arm consists of a 2" Slotted Strip and a $3\frac{1}{2}$ " Strip overlapped two holes, and it is held by a Collar at one end of the Rod (42). The top end of the arm is weighted by two 1" loose Pulleys.

The drive to the drum is engaged by operating a lever (50) (Fig. 7). This consists of a $3\frac{1}{2}$ " Strip bolted to a Bell Crank, which is mounted on a Pivot Bolt attached to one of the Strips (25) by two nuts. A Collar pivots on a bolt passed through the Bell Crank, and is connected by a $6\frac{1}{2}$ " Rod to a Strip Coupling (51). The latter is pivotally connected to one arm of the Double Arm Crank (48) by a $\frac{3}{8}$ " Bolt. A Spring is bolted to the other arm of the Double Arm Crank and is attached to the chassis by a Pivot Bolt as shown (Fig. 8).

The Balance-weight Boxes and Winch Cover (Figs. 1, 4 and 7)

At the rear of the chassis are two balance-weight boxes, each of which consists of four $5\frac{1}{2}$ " x $1\frac{1}{2}$ " Flexible Plates connected by four $5\frac{1}{2}$ " Angle Girders. The top of each box is filled in by two $1\frac{1}{2}$ " Angle Girders and a $1\frac{1}{2}$ " x $\frac{1}{2}$ " Double Angle Strip. The two boxes are connected by a $7\frac{1}{2}$ " Angle Girder, a $5\frac{1}{2}$ " Strip, a $7\frac{1}{2}$ " Strip and a $4\frac{1}{2}$ " x $2\frac{1}{2}$ " Flexible Plate. The boxes themselves are bolted to the lugs of the Double Angle Strip (1).

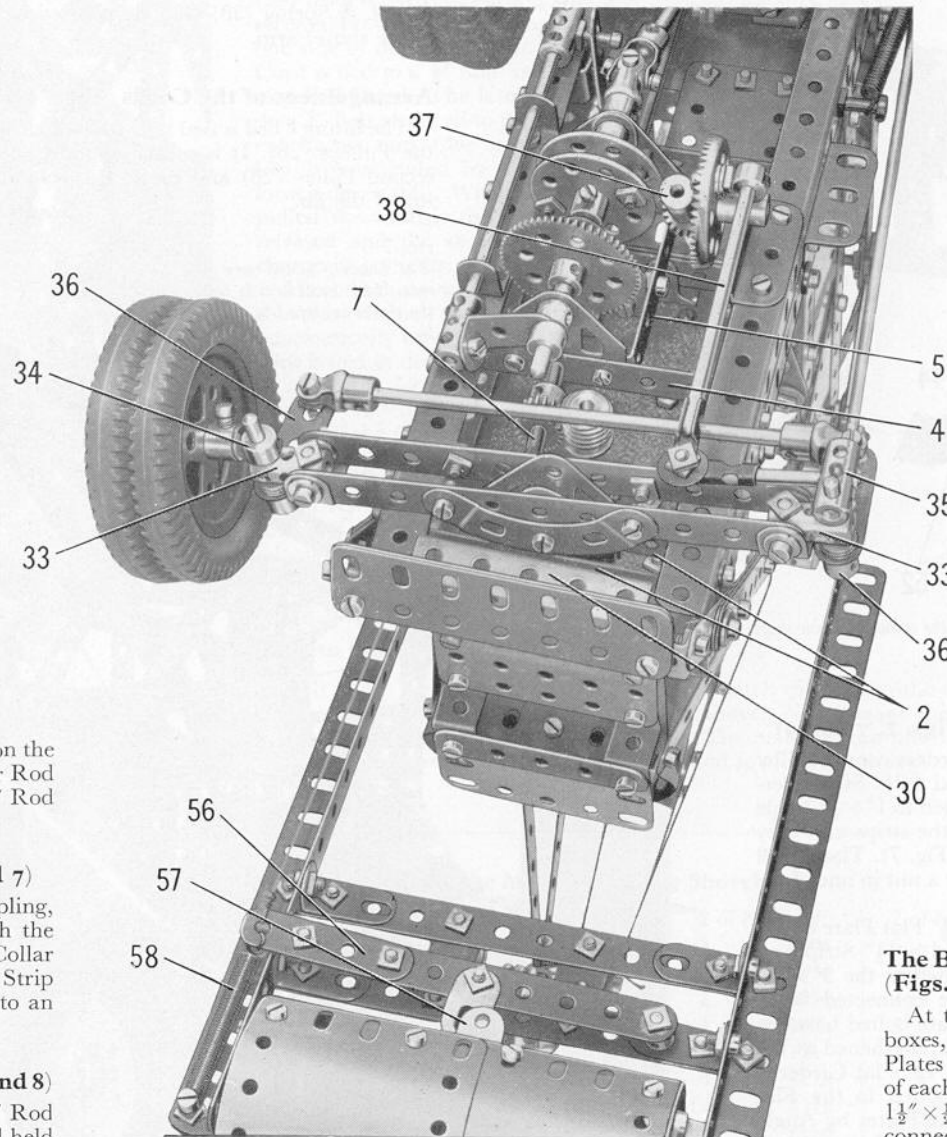

FIG. 5 A front and end view showing the pivoted front axle beam and details of the steering mechanism

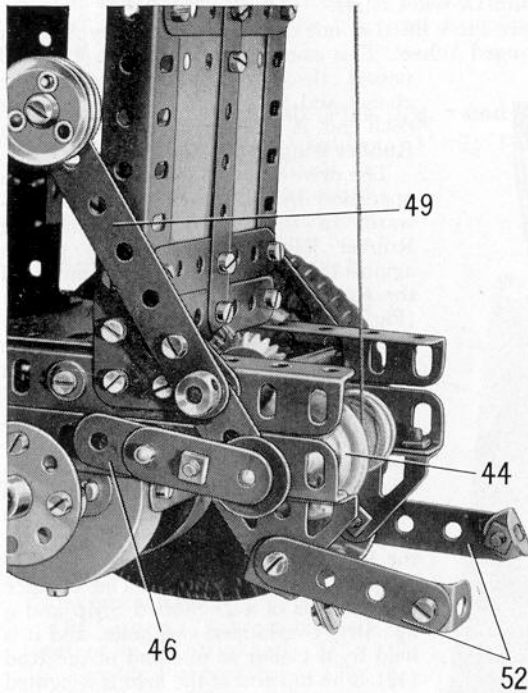

FIG. 6 The balance weight and lever fitted to one end of the winding drum shaft

Two 2" Strips (52) are connected to the 7½" Strip by Angle Brackets, and are bolted to Trunnions fixed to the chassis (Fig. 6). A 2½" x ½" Double Angle Strip is bolted between the Trunnions, and a 2½" Strip (53) is attached to it by an Obtuse Angle Bracket. This Strip is arranged so that the Rubber Ring on Pulley (44) bears against it when the winding drum is pulled by its spring to the lower limits of the slotted holes. This forms an automatic brake that is released when the winding drum is lifted to engage the drive.

A cover over the winding drum mechanism is arranged as shown in Figs. 4 and 7. The cover hangs on Hinges, which are bolted to the back of the cab.

A catch (56) is formed by a 4½" Strip extended one hole by a 2" Strip (Fig. 5). The catch pivots on a ½" Bolt passed through the shovel arm. A 'spider' from a Swivel Bearing is placed on the Bolt, which is then fixed by two nuts in a hole at one end of the catch. A Fishplate bolted to the catch engages an Angle Bracket (57) fixed to the back of the shovel. A Spring (58) (Fig. 1) is fitted between the free end of the catch and one side of the shovel arm.

Arrangement of the Cords (Figs. 1 and 7)

The lifting Cord is tied to the winch drum and is taken over the Pulley (29) and one of the Pulleys (28). It is passed round one of the Pulleys (54) of the shovel, round the second Pulley (28) and round the second Pulley (54). The Cord is tied finally to the top of the jib.

FIG. 7
The Loading Shovel seen from the rear. The shovel arm is raised and the shovel is tipped to discharge its load

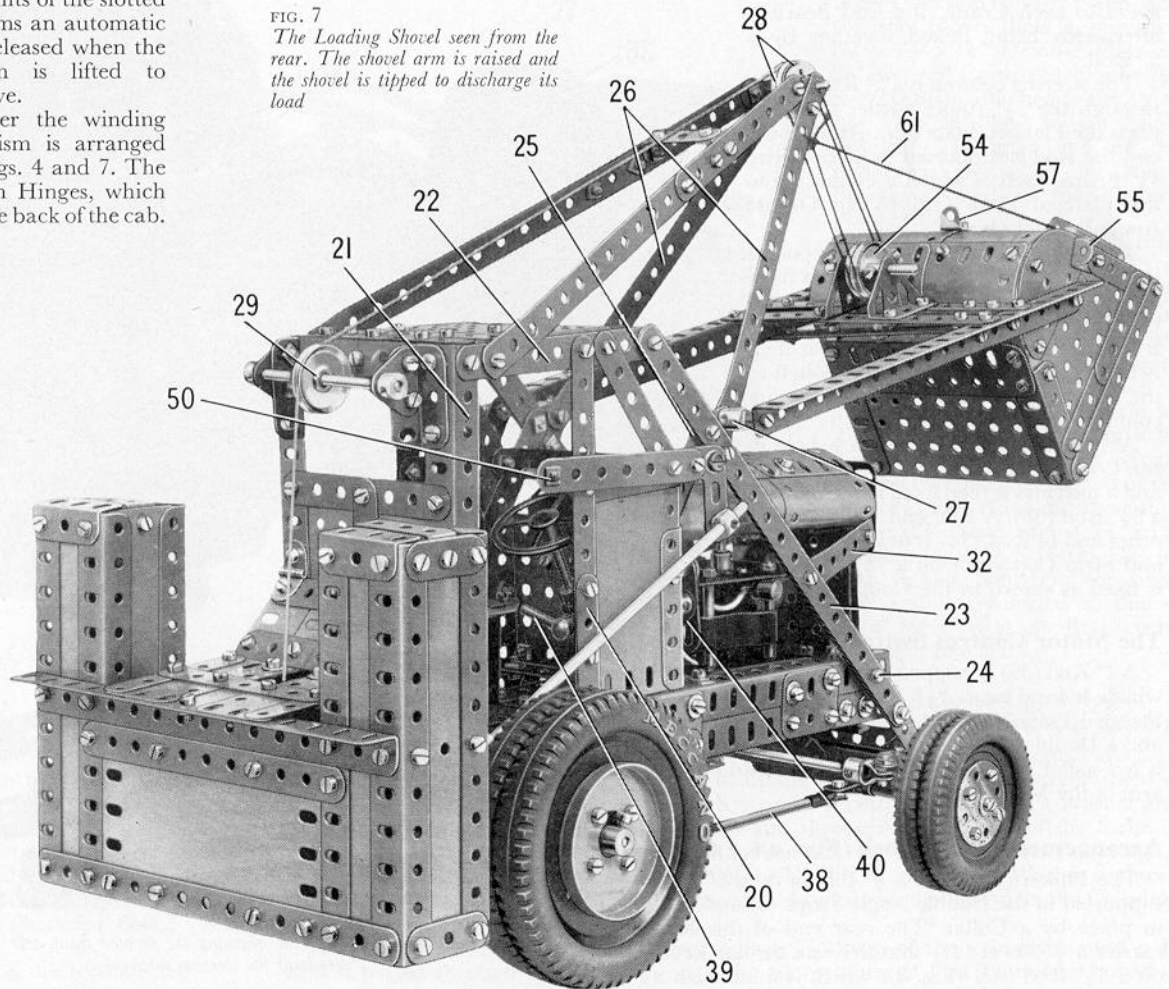

Details of the Shovel Arm and Shovel (Figs. 1, 7 and 9)

The shovel arm consists of two 9½" Angle Girders connected by two assembled strips, each made from a 5½" and a 2½" Strip overlapped four holes. The ends of the strips are bolted to 1" x ½" Angle Brackets. Two Trunnions are bolted between the strips and they carry a 2" Rod that bears two 1" Pulleys (54) (Fig. 7). The shovel arm pivots on ½" Bolts, each of which is fixed by a nut in one of the Threaded Bosses (27).

Each side of the shovel is formed by a 3" x 1½" Flat Plate edged by two 2½" Angle Girders, to which are bolted a 4½" Strip and two 2½" Strips. A Semi-Circular Plate is connected to the 3" x 1½" Flat Plate by two Fishplates. The sides are connected by a 4½" x 2½" Flexible Plate and a 4½" x 2½" Flat Plate bolted between the 2½" Angle Girders. Each of these Plates is strengthened at the top by a 4½" Strip, and along its lower edge a 4½" Flat Girder is bolted. Four 1⅞" radius Curved Plates are bolted to the Flat Girders and are connected to the Semi-Circular Plates by Angle Brackets. A stop (55) (Fig. 9) on each side is formed by an Angle Bracket. These stops control the angle of the shovel when the arm is lowered. The shovel pivots freely on ½" Bolts held by lock-nuts in the Semi-Circular Plates.

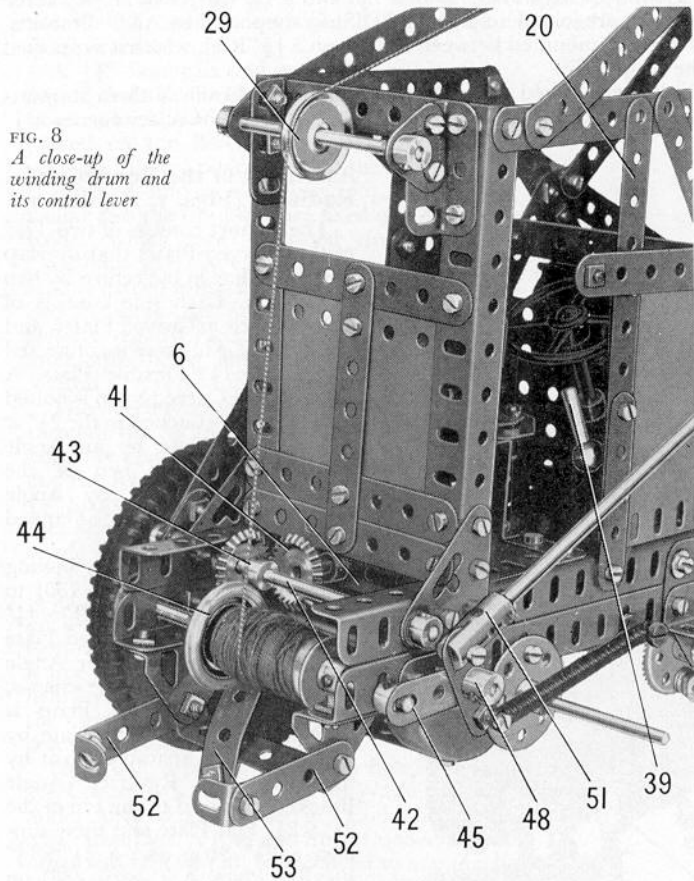

FIG. 8
A close-up of the winding drum and its control lever

The release Cord for the catch (56) is tied to the free end of the catch lever and is passed through a 'spider' (59) from a Swivel Bearing, which is screwed on to a bolt fixed by a nut in one side of the shovel arm. Then the Cord is tied to a $\frac{3}{8}$ " Bolt fixed by nuts in a Bell Crank. The latter is pivoted on a $\frac{3}{4}$ " Bolt attached to the side of the cab by two nuts. One arm of the Bell Crank is extended by a 3" Strip to form a lever (60). When this lever is pulled downwards the catch (56) is released and the shovel tilts to discharge its contents.

After discharging its contents the shovel is returned to its working angle automatically by a Cord (61) (Fig.1). This is tied to the top of the jib and to a $2\frac{1}{2}$ " Strip, lock-nutted to an Angle Bracket bolted to the shovel. The length of the Cord (61) is adjusted so that it is taut when the shovel arm is fully lowered and the lower face of the shovel rests on the ground. While in this position the Angle Bracket (57) is adjusted so that it engages the Fishplate of the catch (56).

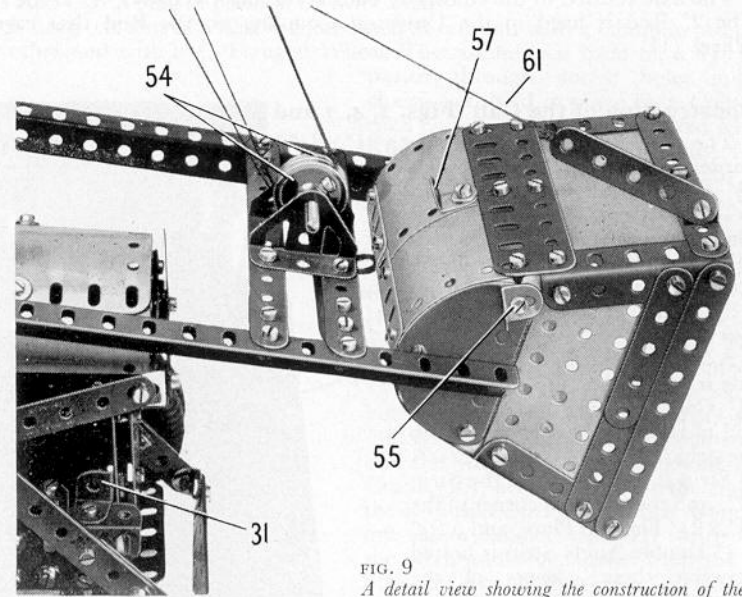

FIG. 9
A detail view showing the construction of the shovel and the catch that controls the discharging operation

How to Operate the Lifting Shovel

First lower the shovel arm and engage the catch (56). Then the machine is ready for driving forward into the material to be moved, in order to load the shovel. Now engage the winch and raise the shovel arm. The shovel is prevented from tilting by the catch (56). The machine can now be travelled to the discharge point, where the lever (60) is depressed to release the catch and so allow the shovel to tilt and discharge its contents.

Parts required to Build the Meccano Lifting Shovel

4 of No. 1a	10 of No. 9	1 of No. 15b	4 of No. 22a	381 of No. 37b	1 of No. 53a	2 of No. 82	2 of No. 125	4 of No. 147b	4 of No. 190a
5 " " 1b	1 " " 9b	2 " " 16	4 " " 24	85 " " 38	2 " " 55a	3 " " 90a	5 " " 126	1 " " 154a	2 " " 191
9 " " 2	5 " " 9d	2 " " 16a	2 " " 24a	2 " " 38d	24 " " 59	2 " " 103c	7 " " 126a	1 " " 154b	5 " " 199
8 " " 2a	8 " " 9f	1 " " 16b	2 " " 25	1 " " 40	4 " " 62	2 " " 103d	2 " " 128	1 " " 155	7 " " 200
13 " " 3	10 " " 10	2 " " 17	6 " " 26	2 " " 43	3 " " 62b	4 " " 103h	2 " " 133	2 " " 162a	2 " " 212
6 " " 4	6 " " 11	5 " " 18a	1 " " 27a	2 " " 45	7 " " 63	2 " " 111	2 " " 133a	1 " " 163	2 " " 214
18 " " 5	19 " " 12	3 " " 18b	2 " " 28	3 " " 48	1 " " 63b	8 " " 111a	1 " " 136a	1 " " 164	
9 " " 6	7 " " 12b	1 " " 20b	2 " " 29	4 " " 48a	2 " " 64	14 " " 111c	2 " " 137	2 " " 165	
10 " " 6a	7 " " 12c	4 " " 19b	2 " " 30	7 " " 48b	1 " " 72	2 " " 111d	1 " " 140	2 " " 166	1 E15R
4 " " 8	1 " " 14	4 " " 20a	1 " " 32	1 " " 48c	2 " " 73	2 " " 114	4 " " 142a	1 " " 185	Electric Motor
2 " " 8a	4 " " 15	4 " " 22	421 " " 37a	3 " " 53	4 " " 77	4 " " 115	4 " " 142b	9 " " 188	(not included
1 " " 8b	4 " " 15a							8 " " 189	in Outfit).

MECCANO

Block-setting Crane

(MODEL No. 10.7)

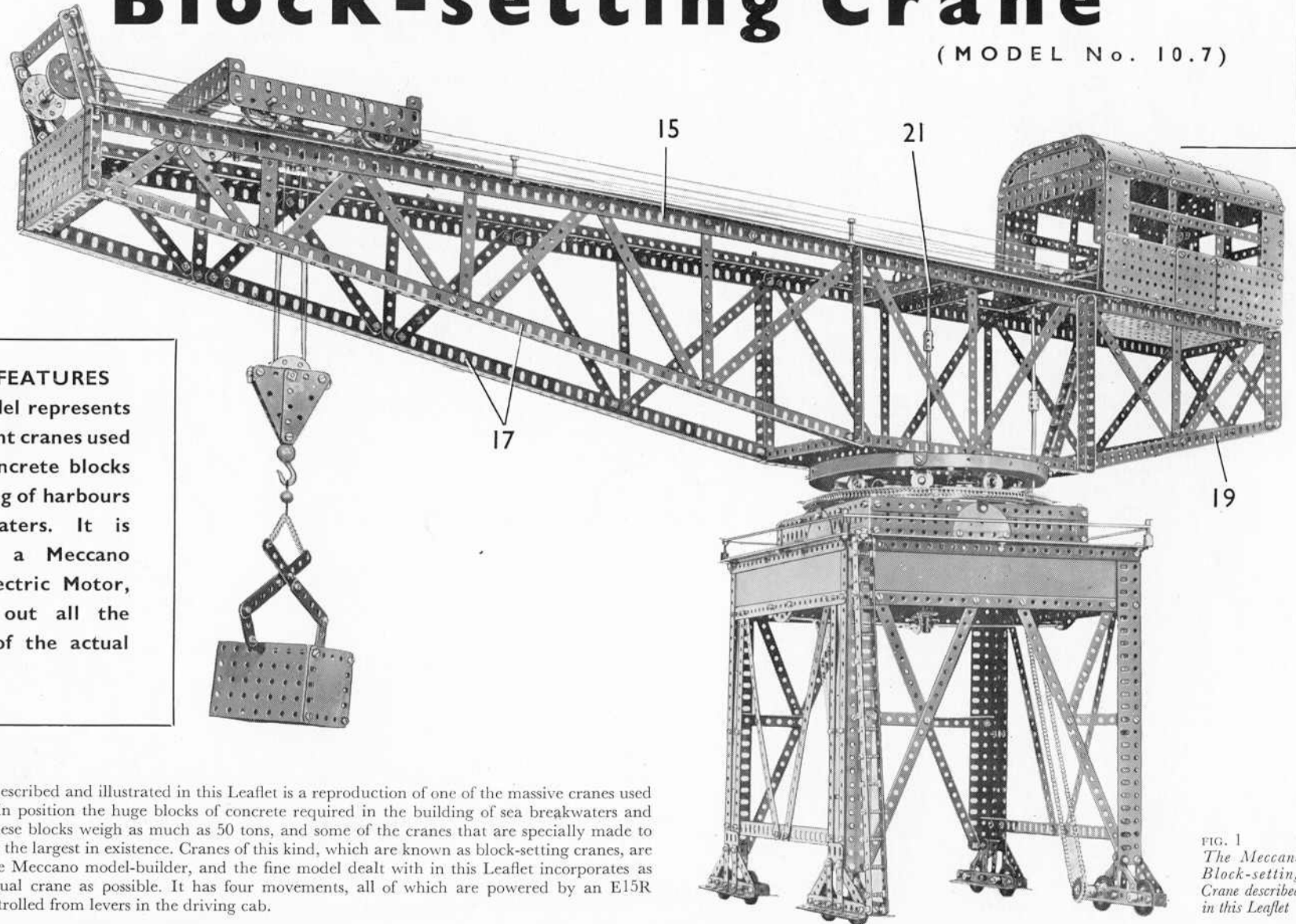

SPECIAL FEATURES

This fine model represents one of the giant cranes used for laying concrete blocks in the building of harbours and breakwaters. It is powered by a Meccano E15R type Electric Motor, and carries out all the movements of the actual crane.

The impressive model described and illustrated in this Leaflet is a reproduction of one of the massive cranes used for lifting and placing in position the huge blocks of concrete required in the building of sea breakwaters and harbour walls. Often these blocks weigh as much as 50 tons, and some of the cranes that are specially made to handle them are among the largest in existence. Cranes of this kind, which are known as block-setting cranes, are splendid subjects for the Meccano model-builder, and the fine model dealt with in this Leaflet incorporates as many details of an actual crane as possible. It has four movements, all of which are powered by an E15R Electric Motor and controlled from levers in the driving cab.

FIG. 1.
The Meccano
Block-setting
Crane described
in this Leaflet

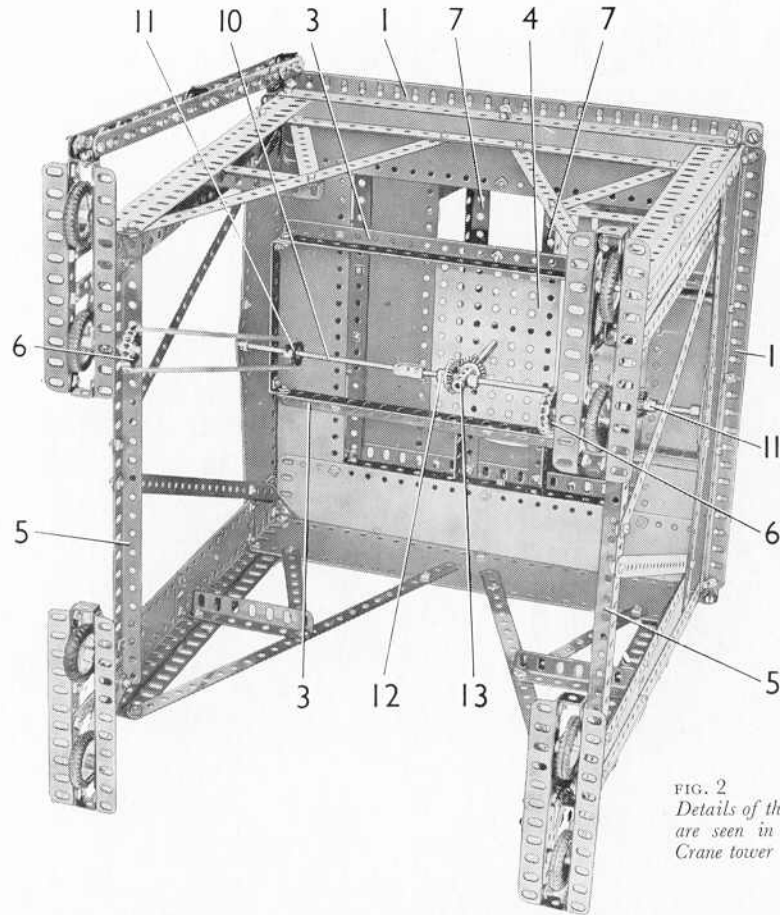

FIG. 2
Details of the drive to the travelling motion
are seen in this underneath view of the
Crane tower

Constructional Details: The Tower (Figs. 2, 3 and 8)

Each leg of the tower consists of a $12\frac{1}{2}$ " Angle Girder with a $12\frac{1}{2}$ " Flat Girder bolted to one of its flanges. To the other flange two $5\frac{1}{2}$ " \times $1\frac{1}{2}$ " Flexible Plates are fixed and these are strengthened along their inner edges by a $12\frac{1}{2}$ " Strip. A $1\frac{1}{2}$ " Flat Girder is bolted between the lower ends of the $12\frac{1}{2}$ " Angle Girder and the $12\frac{1}{2}$ " Strip.

The legs are connected at their upper ends by $12\frac{1}{2}$ " \times $2\frac{1}{2}$ " Strip Plates, which are edged by $12\frac{1}{2}$ " Angle Girders (1) and $12\frac{1}{2}$ " Strips (2). The joins between the ends of the Girders (1) are strengthened by $1\frac{1}{2}$ " Corner Brackets bolted to the Girders, and a $12\frac{1}{2}$ " \times $2\frac{1}{2}$ " Strip Plate is fixed to each of the Girders (1) as shown (Fig. 3). These Strip Plates are supported by $12\frac{1}{2}$ " Angle Girders (3) bolted to the lugs of $4\frac{1}{2}$ " \times $\frac{1}{2}$ " Double Angle Strips fastened to two of the Girders (1). A $5\frac{1}{2}$ " \times $3\frac{1}{2}$ " Flat Plate (4) is attached to the Girders (3).

The pairs of legs on each side are connected by a $12\frac{1}{2}$ " Angle Girder (5), and each leg is braced by two $12\frac{1}{2}$ " Strips, a $5\frac{1}{2}$ " Strip and a $3\frac{1}{2}$ " Angle Girder.

Each wheel unit consists of two $5\frac{1}{2}$ " Angle Girders connected at their ends by Double Brackets. Two vertical 2" Strips and two diagonal 3" Strips are fixed to one of the $5\frac{1}{2}$ " Angle Girders, and a Corner Gusset is bolted to the other Girder. The 2" and 3" Strips are fixed direct to one of the legs of the tower, and the Corner Gusset is attached to a Double Bent Strip bolted to the leg. The wheels are 1" Pulleys fitted with Motor Tyres. One

of the Pulleys of each unit is fixed on a 1" Rod, and the other is mounted on a $1\frac{1}{2}$ " Rod. The Rods are held in the $5\frac{1}{2}$ " Angle Girders by Collars, and 1" Sprockets (6) are fixed to two of the $1\frac{1}{2}$ " Rods.

Each side of the raised platform at the top of the tower is formed by a $9\frac{1}{2}$ " Angle Girder and a $9\frac{1}{2}$ " Flat Girder. These parts are connected at their ends by $1\frac{1}{2}$ " Angle Girders, and two $9\frac{1}{2}$ " \times $2\frac{1}{2}$ " Strip Plates and two $9\frac{1}{2}$ " Angle Girders (7) (Fig. 3) are bolted across the square structure thus formed. The $9\frac{1}{2}$ " Angle Girders of two of the sides are fixed to the top of the tower, and the $9\frac{1}{2}$ " Flat Girders of the other two sides are connected to the top by $3\frac{1}{2}$ " Angle Girders.

A Flanged Ring (8) is attached to the raised platform by four Fishplates. Eight built-up double brackets (9), each consisting of two Angle Brackets, are bolted round the Flanged Ring.

The guard rail round the top of the tower is a length of Spring Cord. It is held by Cord Anchoring Springs on two Adaptors for Screwed Rods and on Threaded Pins fixed in two Threaded Bosses.

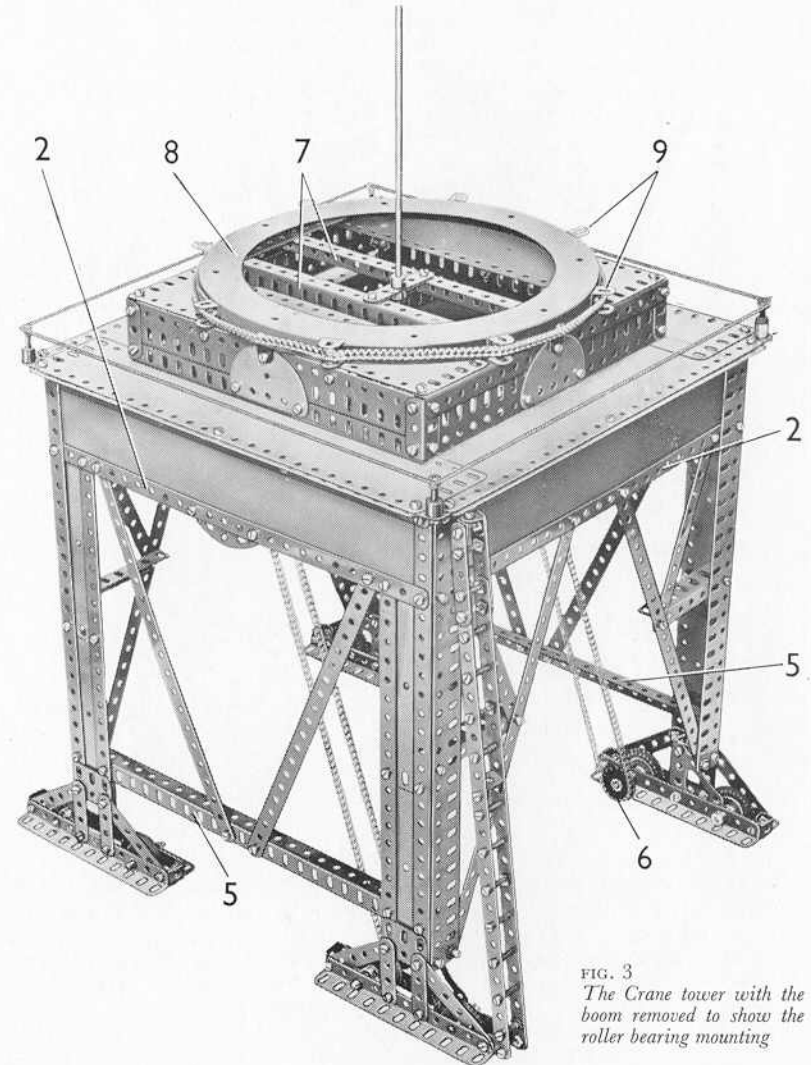

FIG. 3
The Crane tower with the
boom removed to show the
roller bearing mounting

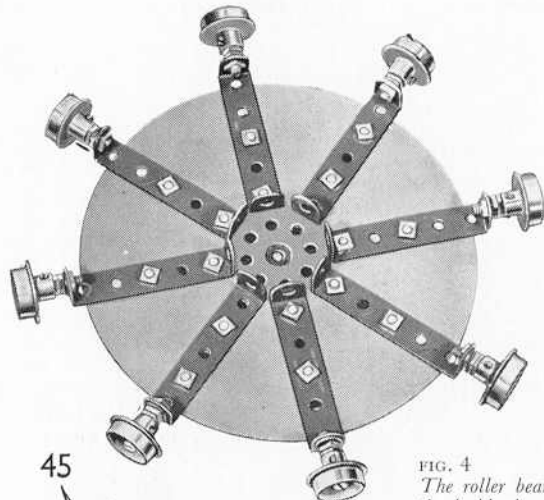

FIG. 4
The roller bearing wheel carrier, and the double sheave pulley block

A cross-shaft (10) is mounted across the tower in two $2\frac{1}{2}$ " Stepped Curved Strips. This shaft consists of an 8" and a 5" Rod joined by a Coupling, and it carries two $\frac{3}{8}$ " Sprockets (11), a $\frac{3}{8}$ " Bevel (12) and a Coupling (13) that is loose on the shaft but is held in position by a Collar. The Sprockets (11) are connected by Chain to the 1" Sprockets (6).

Details of the Boom (Figs. 1, 5, 7 and 8)

The centre section of each main girder of the boom consists of a $12\frac{1}{2}$ " Angle Girder (14) (Fig. 5) fitted at each end with a vertical $7\frac{1}{2}$ " Angle Girder and at the centre with a $7\frac{1}{2}$ " Strip. The $7\frac{1}{2}$ " Girders and the $7\frac{1}{2}$ " Strip are connected at the top by a built-up girder (15). The latter consists of a $24\frac{1}{2}$ " Angle Girder that overlaps an $18\frac{1}{2}$ " Angle Girder by three holes, with another $18\frac{1}{2}$ " Angle Girder overlapping the first by 13 holes. At the front a $2\frac{1}{2}$ " Angle Girder (16) (Fig. 7) is bolted to the girder (15), and is connected to the Angle Girder (14) by a built-up girder (17). Girder (17) consists of a $24\frac{1}{2}$ " and a $5\frac{1}{2}$ " Angle Girder overlapped one hole, and it is joined to the front of the girder (14) by a Fishplate. A $4\frac{1}{2}$ " Angle Girder (18) is fixed to the rear end of the girder (15) and to its lower end is bolted a $12\frac{1}{2}$ " Angle Girder (19). The latter is connected to the rear end of the Girder (14) by a Fishplate.

The main boom girders are connected at the rear by two $5\frac{1}{2}$ " \times $\frac{1}{2}$ " Double Angle Strips (20), and two $5\frac{1}{2}$ " \times $2\frac{1}{2}$ " Flanged Plates are bolted between the ends of the Angle Girders (14). At the front a $5\frac{1}{2}$ " \times $2\frac{1}{2}$ " Flanged Plate is fixed between the Angle Girders (16). Four $5\frac{1}{2}$ " \times $3\frac{1}{2}$ " Flat Plates are fixed together in pairs by their longer sides, and are fixed to the rear ends of the girders (15) to form the floor of the cab.

A $5\frac{1}{2}$ " \times $2\frac{1}{2}$ " Flanged Plate (21) (Fig. 8) is bolted between the girders (15), and a $12\frac{1}{2}$ " Strip (22) is attached to the Flanged Plates fixed to the Girders (14).

The rails on which the trolley travels are each made from a $24\frac{1}{2}$ " and an $18\frac{1}{2}$ " Angle Girder, placed end to end and connected by a 2" Strip. The rails are supported by Angle Brackets fixed to the girders (15). A 3" Angle Girder (23) is bolted to the front end of each rail and is braced by a 3" Strip. The top ends of these Girders are connected by a $5\frac{1}{2}$ " Strip. A 5" Rod is mounted in the Girders (23) and carries two built-up pulleys, each made from a 1" loose Pulley clamped between two Bush Wheels.

The boom girders are braced by Strips and built-up strips as shown in Figs. 1, 5, 7 and 8. A Flanged Ring (24) is attached to the Angle Girders (14) by four $1"$ \times $\frac{1}{2}"$ Reversed Angle Brackets.

The Roller Bearing (Figs. 2, 3, 4, 5 and 8)

A $5\frac{1}{2}$ " Strip is bolted diametrically across a 6" Circular Plate, and eight $2\frac{1}{2}"$ \times $\frac{1}{2}"$ Double Angle Strips are fixed to the Circular Plate

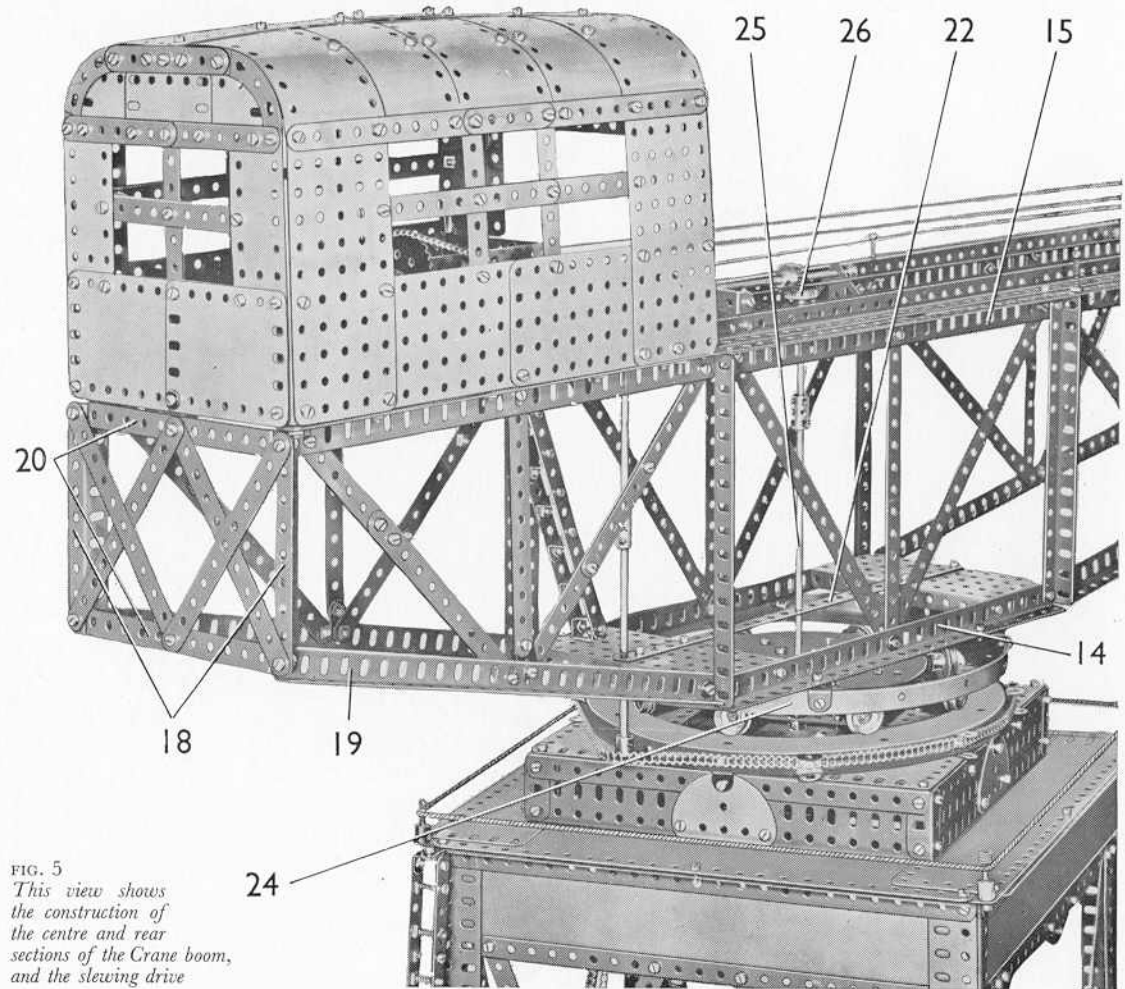
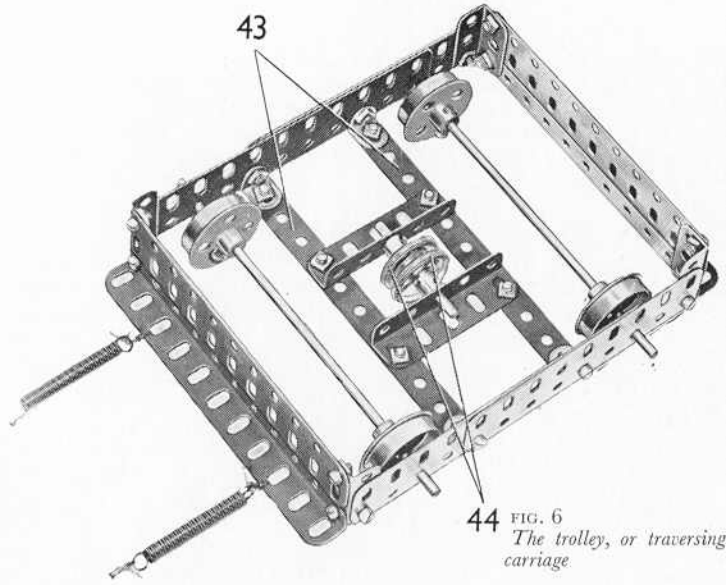

FIG. 5
This view shows the construction of the centre and rear sections of the Crane boom, and the slewing drive



43
44 FIG. 6
The trolley, or traversing carriage

as shown (Fig. 4). Eight $\frac{3}{4}$ " Flanged Wheels rotate freely on $\frac{3}{4}$ " Bolts, each of which is fixed to the outer lug of a Double Angle Strip by two nuts. The Flanged Wheel is spaced from the lug by a Washer and a third nut on the Bolt. The Flanged Wheels are placed between the inner edges of the Flanged Rings (8) and (24) (Figs. 3 and 5).

An axle (25) is passed through the Flanged Plate (21) and the Strip (22) (Fig. 8), through the $5\frac{1}{2}$ " Strip bolted to the Circular Plate, through two $2\frac{1}{2}$ " Strips bolted face-to-face to the Girders (7), and through the Flat Plate (4) (Fig. 2). The lower end of the axle turns freely in the Coupling (13), and a $\frac{7}{8}$ " Bevel drives the Bevel (12) on the cross-shaft. A $\frac{3}{4}$ " Contrate (26) is fixed on the top end of the axle, which is made from a 3" and a $11\frac{1}{2}$ " Rod joined by a Coupling.

Power Unit and Gear-Box (Figs. 8 and 9)

The sides of the gear-box are $4\frac{1}{2}$ " x $2\frac{1}{2}$ " Flat Plates bolted to $4\frac{1}{2}$ " Angle Girders fixed to the base of the cab. Each side is extended forward by a $3" \times 1\frac{1}{2}"$ Flat Plate, which is attached to the base at its front end by a $1" \times \frac{1}{2}"$ Angle Bracket. An E15R Electric Motor is bolted by its flanges to the base as shown (Fig. 8), and to one side-plate two 2" Angle Girders are fastened by bolts through their slotted holes. A 2" Flat Girder is fixed to each Angle Girder to form a deep section channel girder.

A $\frac{7}{16}$ " diameter Pinion on the Motor shaft drives a 60-tooth Gear on a $2\frac{1}{2}"$ Rod supported in the side-plates. This Rod carries a Worm (27), which drives a 57-tooth Gear on a 2" Rod mounted in the 2" Flat Girders. A 2" Sprocket on this Rod is connected by Chain to a similar Sprocket on an axle (28) (Fig. 9) made from a $3\frac{1}{2}"$ and a 2" Rod joined by a Coupling.

The axle (28) carries a $\frac{3}{4}"$ Pinion, and the 50-tooth Gears (29) and (30) can be moved into mesh with this Pinion by sliding the Rods on which they are mounted. The Gear (29) is fixed on a 5" Rod that carries a winding drum (31) made from two Bush Wheels clamped at the ends of a Cylinder by nuts on two 3" Screwed Rods. A Compression Spring is fitted between the winding drum and one side of the gear-box as shown (Fig. 9). The Gear (30) is fixed on a 5" Rod fitted with two $1\frac{1}{2}"$ Pulleys (32), with a Compression Spring placed between one of the Pulleys and the side of the gear-box. The Compression Springs normally hold the Gears (29) and (30) clear of the $\frac{3}{4}"$ Pinion, but they can be moved into mesh by operating levers. Each lever is a $2\frac{1}{2}"$ Rod in a Rod and Strip Connector, which is lock-nutted to a lug of a

$1\frac{1}{2}" \times \frac{1}{2}"$ Double Angle Strip bolted to the base. The levers engage between Collars on the ends of the 5" Rods.

The Motor switch is controlled by a lever (33), made from a $1\frac{1}{2}"$ Rod in a Rod and Strip Connector that is bolted to a Bell Crank. The Bell Crank is mounted on a Pivot Bolt, which is screwed tightly into a Threaded Coupling and is fixed by a nut. The Threaded Coupling is screwed on to a bolt passed through the base of the cab. A Crank (34) is mounted on a Pivot Bolt in the Bell Crank, and a Threaded Pin in the Crank engages a hole in the Motor switch.

A $1\frac{1}{2}"$ Sprocket on axle (28) is connected by Chain to a similar Sprocket on a 5" Rod (35). This Rod is held by Collars in the $3" \times 1\frac{1}{2}"$ Flat Plates, and it carries a Worm (36). The Worm is in constant mesh with a $\frac{1}{2}"$ diameter, $\frac{3}{4}"$ face Pinion, on an axle (37) made from an 8" and a 4" Rod joined by a Coupling. Axle (37) is supported in Trunnions bolted to the base of the cab and to the Flanged Plate (21), and in a $4\frac{1}{2}" \times \frac{1}{2}"$ Double Angle Strip attached to the trolley rails by Fishplates.

Axle (37) is able to slide endways in its bearings and its movement is controlled by a lever (38). This is a $1\frac{1}{2}"$ Rod held in a Coupling fixed on a $4\frac{1}{2}"$ Rod supported in 1" Corner Brackets bolted to the $3" \times 1\frac{1}{2}"$ Flat Plates. A Compression Spring is placed on the Rod between one of the Corner Brackets and a Coupling, to prevent the Rod from turning too easily. A Crank (39) is fixed on the $4\frac{1}{2}"$ Rod, and a Threaded Pin in the Crank engages the groove of a Socket Coupling (40), which is fixed to a Collar on the axle (37).

By sliding axle (37) to the left (Fig. 8) a $\frac{3}{4}"$ Pinion is moved into mesh with the $\frac{3}{4}"$ Contrate (26) to engage the drive to the travelling wheels. When axle (37) is moved to the right a $\frac{3}{4}"$ Pinion is engaged with a $\frac{3}{4}"$ Contrate (41). This Contrate is fixed on an axle made from a 5" and a $4\frac{1}{2}"$ Rod joined by a Coupling. The axle is supported in a strip (42), made from a $5\frac{1}{2}"$ and a $4\frac{1}{2}"$ Strip bolted face-to-face, and in one of the $5\frac{1}{2}" \times 2\frac{1}{2}"$ Flanged Plates fixed between the Girders (14). The axle carries at its lower end a 1" Sprocket, and this is connected by Chain to the Flanged Ring (8) as shown in Fig. 5.

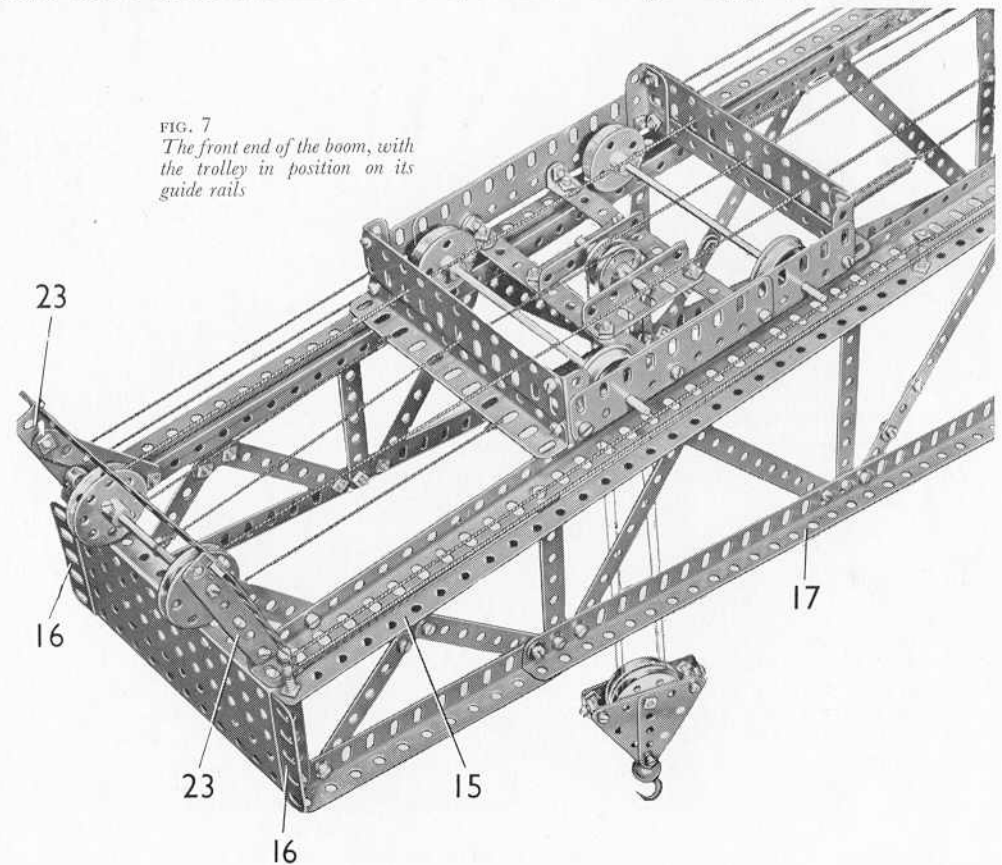

FIG. 7
The front end of the boom, with the trolley in position on its guide rails

The Trolley and the Pulley Block (Figs. 1, 4, 6 and 7)

The sides of the trolley are each made from a 5½" Flat Girder and a 4½" Flat Girder overlapped seven holes and fitted at each end with a 1½" Angle Girder. The sides are connected at each end by a 5½" Flat Girder and a 5½" Angle Girder. Two 5½" Strips (43) are supported by Angle Brackets, and two 2½" Angle Girders are bolted to them. These Girders support a 2" Rod that carries two 1" loose Pulleys (44) with a ½" loose Pulley between them. The trolley axles are 6½" Rods.

Each side of the pulley block is formed by two 2¼" x 1¼" Triangular Flexible Plates bolted

together. A 2½" x ½" Double Angle Strip is fixed to the top of one side, and two Angle Brackets are attached to the other side. The Angle Brackets and the lugs of the Double Angle Strip are used to connect the sides together. A Strip Coupling (Fig. 4) is held by a ½" Bolt that secures also a large Loaded Hook placed in the slot of the Strip Coupling. Two 1" loose Pulleys (45), each with a Wheel Disc (6 holes) on one side and a Wheel Disc (8 holes) on the other side, are freely mounted on a ¾" Bolt, which is held in place by a nut.

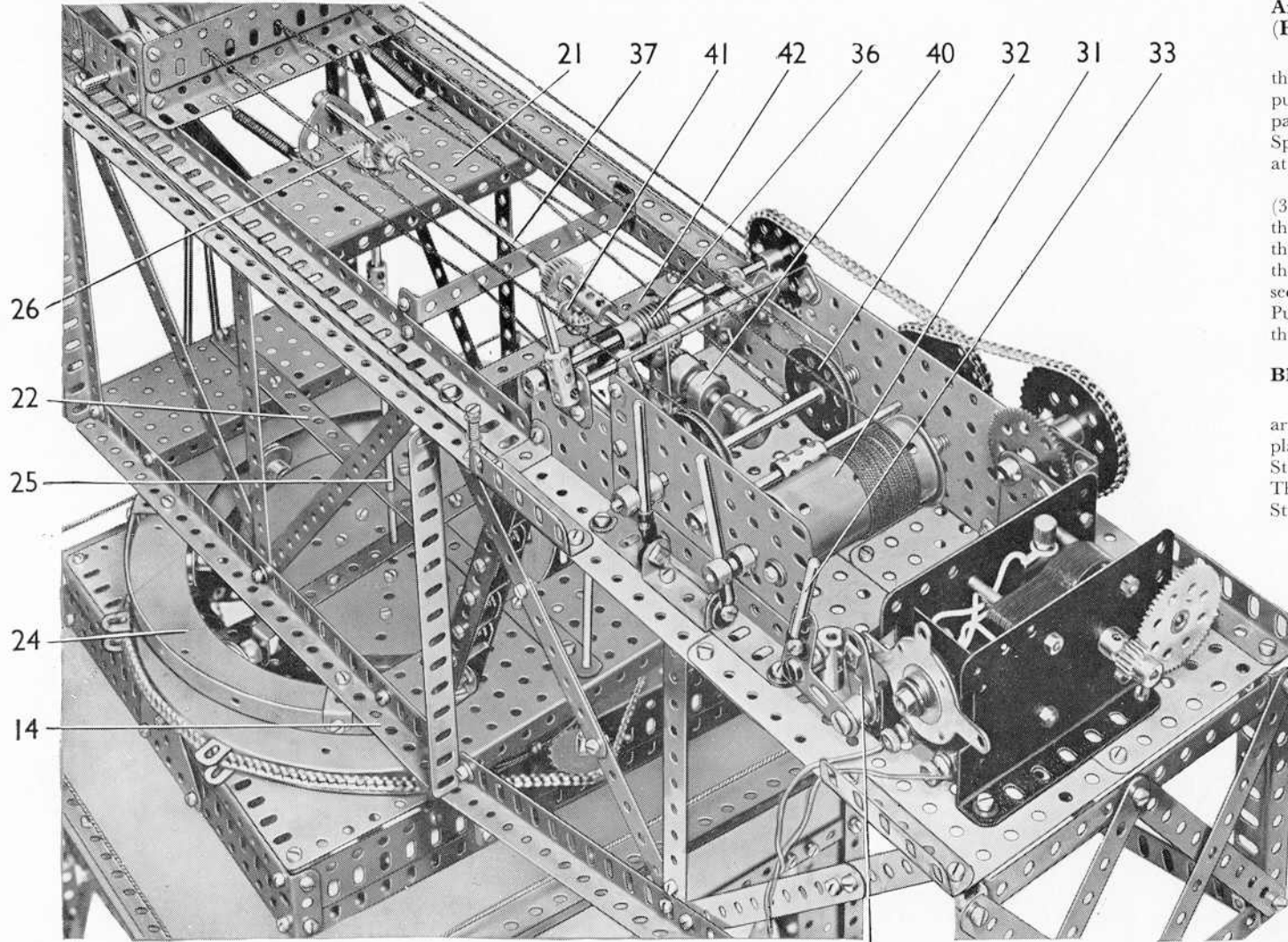

FIG. 8 The Motor and gear-box mechanism

Arrangement of the Cords (Figs. 1, 7, 8 and 9)

Two lengths of Cord are tied to the front of the trolley and are taken round the made-up pulleys at the front of the boom. The Cords are passed round the 1½" Pulleys (32) and are tied to Springs, which are stretched slightly and are attached by Cord to the rear of the trolley.

The hoisting Cord is fastened to the drum (31), then taken over one of the Pulleys (44) of the trolley and round one of the Pulleys (45) in the pulley block. Then the Cord is passed round the ½" loose Pulley of the trolley, round the second of the Pulleys (45) and over the second Pulley (44). The end of the Cord is then tied to the Rod at the front of the boom.

Block-Lifting Tackle (Fig. 1)

The block-lifting tackle consists of two pivoted arms (Fig. 1), each made from a 2½" Strip that is placed between the ends of two face-to-face 2½" Strips so that they form a made-up 4½" strip. This is extended at its lower end by two 1½" Strips, with a Pawl without boss bolted between them. The points of the Pawls engage holes in the block, which consists of three 3½" x 2¼" Flanged Plates and two 2½" x 2¼" Flexible Plates. A short length of Chain is tied to the upper ends of the arms, and a small Loaded Hook passed through the Chain is used to attach the lifting tackle to the Hook of the pulley block.

The Cab, Ladders, etc. (Figs. 1, 3 and 5)

The lower part of the side of the cab seen in Fig. 5 consists of two 4½" x 2½" Flat Plates, with a 5½" x 2¼" Flat Plate placed vertically at each end. The vertical Plates are connected at the top by two 5½" Strips and a 2½" Strip. The side shown in Fig. 1 consists of two 5½" x 2½" Flat Plates and a 2½" x 2¼" Flat Plate, with a vertical 5½" x 1½" Flexible Plate at each end. The top

ends of the Flexible Plates are connected by two 5½" Strips and a 3½" Strip. The roof is formed by five 4½"×2½" Flexible Plates along each side. These are curved and bolted together along the centre of the cab, with two 5½" Strips and a 2½" Strip covering the joins. The cab is bolted to 2½" Angle Girders fixed to the girders (15) of the boom.

The handrails along the boom are represented by Cord passed round six 1½" Bolts and two 1" Screwed Rods, each of which is fixed to the boom by two nuts.

The ladder between the cab and the lower part of the boom is formed by two 7½" Strips connected by six ½" Reversed Angle Brackets that form the rungs. An Angle Bracket at the top is bolted to a Fishplate fixed to the base of the cab, and two Angle Brackets at the lower end of the ladder are bolted to one of the 5½"×2½" Flanged Plates between the Girders (14).

The ladder giving access to the top of the tower consists of two 12½" Strips, each extended by a 2½" Strip overlapped two holes. The Strips are connected by three Double Brackets, the lower one of which is bolted to the Double Bracket between the 5½" Angle Girders of one of the wheel units. The upper Double Bracket is attached to the top of the tower by a Fishplate. The rungs are formed by nine ¾" Bolts, each fixed in place by a nut, and four ¾" Bolts, placed opposite to ¾" bolts passed through the opposite side of the ladder.

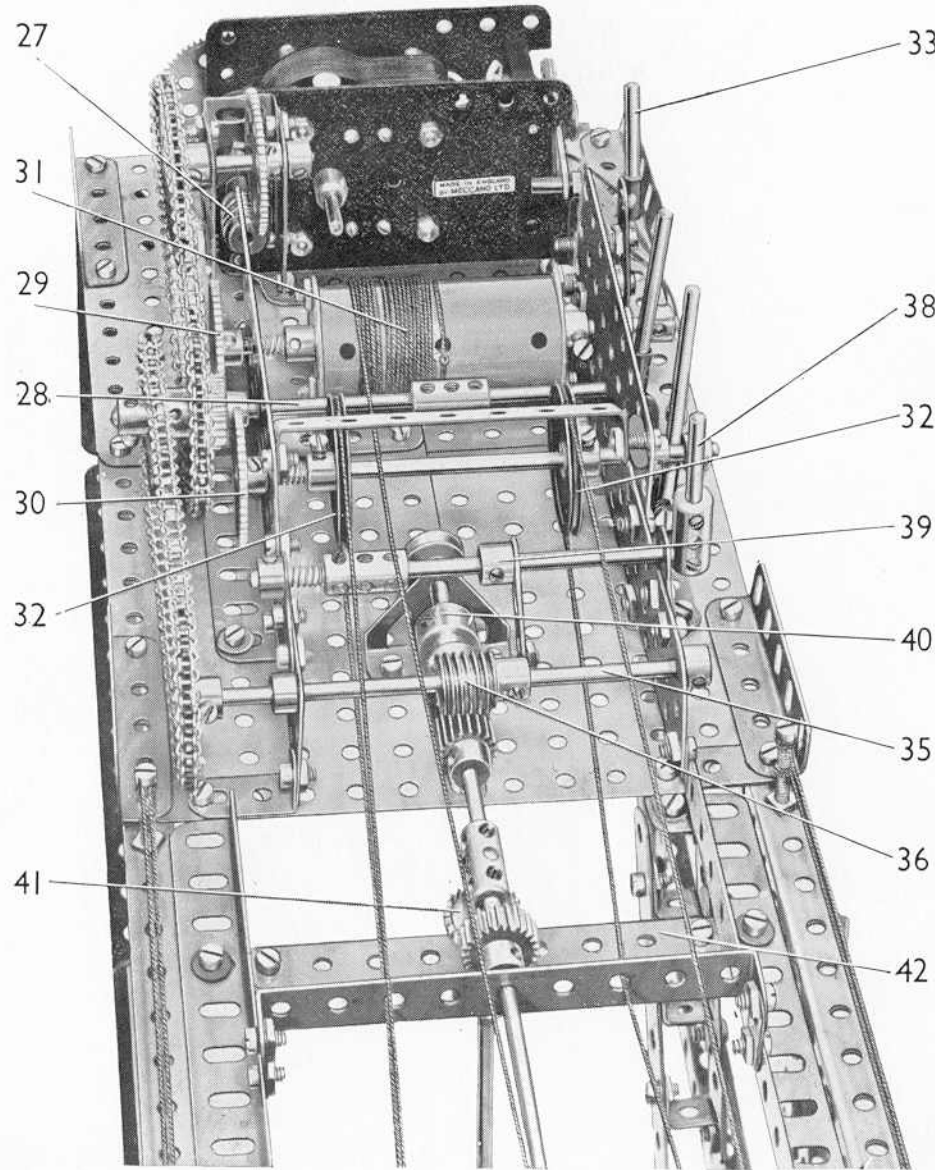

FIG. 9
The gear-box seen from the front and showing the layout of the drives to the slewing and travelling movements

Parts Required to Build the Meccano Block-setting Crane

21 of No.	1	6 of No.	7
6 " "	1a	6 " "	7a
6 " "	1b	16 " "	8
36 " "	2	6 " "	8a
8 " "	2a	4 " "	8b
18 " "	3	12 " "	9
12 " "	4	8 " "	9a
21 " "	5	8 " "	9b
12 " "	6	2 " "	9c
5 " "	6a	8 " "	9d

Parts Required (continued)

2 of No.	9e	1 of No.	63b
8 " "	9f	1 " "	63c
18 " "	10	2 " "	64
11 " "	11	4 " "	70
38 " "	12	1 " "	72
6 " "	12b	2 " "	73
1 " "	13	2 " "	77
2 " "	13a	2 " "	80c
2 " "	14	2 " "	82
6 " "	15	6 " "	90a
2 " "	15a	3 " "	94
1 " "	15b	2 " "	95
1 " "	16	2 " "	95a
3 " "	16a	3 " "	96
1 " "	16b	2 " "	96
4 " "	17	4 " "	103
5 " "	18a	4 " "	103a
4 " "	18b	4 " "	103b
4 " "	20	2 " "	103c
8 " "	20b	2 " "	103d
2 " "	21	2 " "	103g
8 " "	22	4 " "	103h
6 " "	22a	4 " "	108
1 " "	23	18 " "	111
2 " "	23a	1 " "	111a
4 " "	24	19 " "	111c
2 " "	24a	6 " "	111d
2 " "	24b	4 " "	115
2 " "	24c	3 " "	120b
3 " "	25	6 " "	125
1 " "	26b	2 " "	126
1 " "	26c	1 " "	128
2 " "	27	4 " "	133
1 " "	27a	2 " "	133a
1 " "	27d	8 " "	142c
2 " "	29	1 " "	144
2 " "	30	1 " "	146
2 " "	32	2 " "	147b
5 " "	35	2 " "	147c
657 " "	37a	2 " "	165
588 " "	37b	2 " "	167b
74 " "	33	1 " "	171
2 " "	40	2 " "	173a
2 " "	43	4 " "	176
4 " "	45	2 " "	186d
1 " "	48	6 " "	188
9 " "	48a	12 " "	189
1 " "	48b	2 " "	190
3 " "	48c	2 " "	190a
2 " "	48d	10 " "	191
4 " "	52	2 " "	196
5 " "	52a	8 " "	197
3 " "	53	3 " "	212
4 " "	53a	4 " "	214
1 " "	57b	1 " "	216
1 " "	57c	4 " "	221
1 " "	58	1 E15R	
24 " "	59	Electric Motor	(not included in Outfit)
2 " "	62		
8 " "	63		

MECCANO Beam Bridge

(MODEL No. 10.8)

SPECIAL FEATURES

The Beam Bridge described in this Leaflet has a span of $24\frac{1}{2}$ " which is raised by a Meccano E15R Electric Motor. The approach pier is fitted with traffic barriers that fall into position automatically when the span is raised.

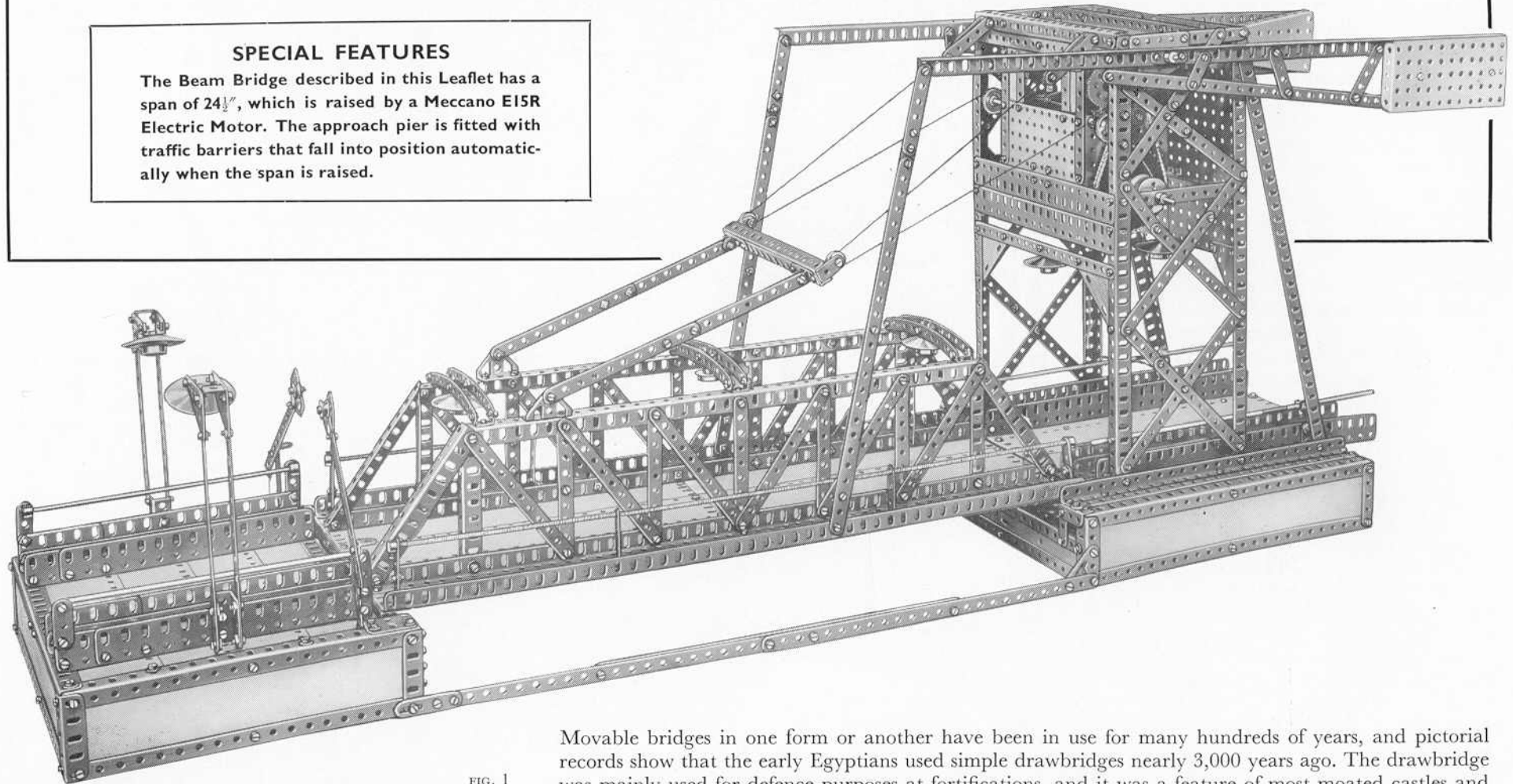

FIG. 1
General view of the Meccano Beam Bridge
described in this Leaflet

Movable bridges in one form or another have been in use for many hundreds of years, and pictorial records show that the early Egyptians used simple drawbridges nearly 3,000 years ago. The drawbridge was mainly used for defence purposes at fortifications, and it was a feature of most moated castles and forts of the middle ages. From the simple drawbridge engineers have developed more elaborate and efficient structures suitable for spanning navigable waterways, and which can be moved aside or upwards when required in order to allow the uninterrupted passage of ships.

The early drawbridge was a very crude affair and required a great amount of energy to hoist it into an upright position. Later the idea of fitting the hinged span or bascule with some kind of balance weight was conceived, and this resulted not only in a considerable saving in the power required to operate the bridge but also permitted the construction of bridges with much longer and heavier spans.

These bascule bridges as they are known took many forms, and they became very popular in the Netherlands for bridging the network of canals that are a feature of that country. In the most common type of small bascule bridge the lifting span is balanced by a pair of pivoted overhead levers or beams, which are fitted with counterweights at their shore ends to compensate for the weight of the span itself, to which they are linked by chains or girders. These bridges may be used either singly or double. That is, there may be one balanced span extending right across a narrow channel, or in the case of a wider channel, two spans, one on each side, the two meeting at the centre of the river.

The working Meccano model described and illustrated in this Leaflet is based on a typical balanced beam bridge of the larger type and will be found both attractive to construct and interesting to operate. It is powered by an E15R type Electric Motor housed in the tower, and it has a span of $24\frac{1}{2}$ in.

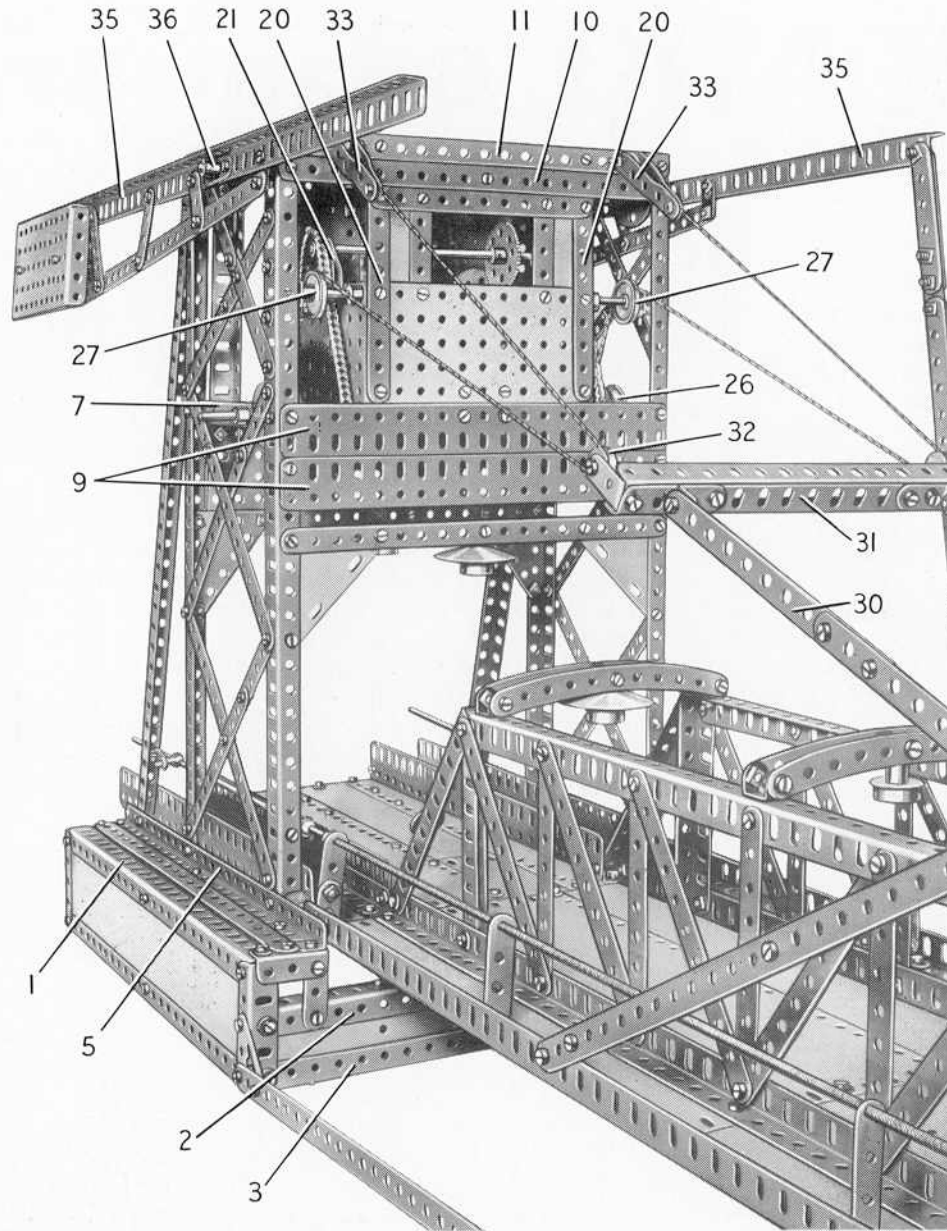

FIG. 2
The main pier and tower that supports the balanced beams

Construction of the Model: The Main Pier (Figs. 2 and 3)

Each side consists of a $12\frac{1}{2} \times 2\frac{1}{2}$ " Strip Plate strengthened by a $12\frac{1}{2}$ " Angle Girder (1) and a $12\frac{1}{2}$ " Strip. The back also is a $12\frac{1}{2} \times 2\frac{1}{2}$ " Strip Plate and it is edged by two $12\frac{1}{2}$ " Angle Girders. The back and the sides are connected by a $2\frac{1}{2}$ " Angle Girder at each corner. The front is formed by two $12\frac{1}{2}$ " Angle Girders (2) and (3) (Fig. 2), with a $2\frac{1}{2} \times 1\frac{1}{2}$ " and two $5\frac{1}{2} \times 1\frac{1}{2}$ " Flexible Plates bolted between them. The front is fixed to $2\frac{1}{2}$ " Angle Girders bolted to the sides, and a $1\frac{1}{2}$ " Angle Girder is bolted to the top end of each $2\frac{1}{2}$ " Angle Girder and is connected to the Girder (2) by a $1\frac{1}{2}$ " Strip. Two $12\frac{1}{2}$ " Angle Girders (4) are bolted across the base of the pier as shown in Fig. 6.

A $12\frac{1}{2}$ " Angle Girder (5) and a $12\frac{1}{2}$ " Strip on each side are fixed across the top, and two $12\frac{1}{2}$ " Strips held by bolts (6) (Fig. 3) are attached to the Girders (5). These Strips support the Plates that fill in the top of the pier. Three $12\frac{1}{2} \times 2\frac{1}{2}$ " Strip Plates, and a $9\frac{1}{2} \times 2\frac{1}{2}$ " Strip Plate extended by a $3\frac{1}{2} \times 2\frac{1}{2}$ " Flexible Plate, are used for this purpose. The Plates are bolted to the Strips so that one clear hole on each side is left in the Strips between the Plates and the Girders (5). The rear edges of the Plates are strengthened by a $5\frac{1}{2}$ " Strip and a $3\frac{1}{2}$ " Strip.

The guard rails between the roadway and the pavements are $12\frac{1}{2}$ " Flat Girders bolted to $12\frac{1}{2}$ " Angle Girders. The outer rail of one pavement is a $12\frac{1}{2}$ " Flat Girder supported by Angle Brackets, and the corresponding rail of the other pavement is made from

a $9\frac{1}{2}$ " Flat Girder and a $3\frac{1}{2}$ " Flat Girder. These Flat Girders also are attached to the base by Angle Brackets.

Construction of the Tower (Figs. 1, 2, 3 and 4)

Each side of the tower consists of two $18\frac{1}{2}$ " Angle Girders bolted vertically to the Girders (4) and (5) of the main pier. The top ends of the $18\frac{1}{2}$ " Girders on each side are connected by a $5\frac{1}{2}$ " Strip, and the Girders are braced by built-up strips as shown in Figs. 1 and 2. Two $5\frac{1}{2}$ " Strips (7) (Fig. 3) placed face-to-face, are fixed to the side. Each side is braced by an $18\frac{1}{2}$ " Angle Girder (8) bolted at its lower end to the Girder (5).

The sides of the tower are connected at the front by a $9\frac{1}{2}$ " Strip braced by two $2\frac{1}{2}$ " x $2\frac{1}{2}$ " Triangular Flexible Plates, by two $9\frac{1}{2}$ " Flat Girders (9), a $9\frac{1}{2}$ " Strip (10) and a $9\frac{1}{2}$ " Angle Girder (11). At the back a $9\frac{1}{2}$ " Strip (12) braced by two $2\frac{1}{2}$ " x 2 " Triangular Flexible Plates, is bolted between the sides. A $9\frac{1}{2}$ " Flat Girder (13) and a $9\frac{1}{2}$ " Strip (14) also are bolted across the back of the tower. Two $4\frac{1}{2}$ " x $2\frac{1}{2}$ " Flat Plates are attached to the Strip (12) and the Flat Girder (13), and a $5\frac{1}{2}$ " x $3\frac{1}{2}$ " Flat Plate and a $5\frac{1}{2}$ " x $2\frac{1}{2}$ " Flat Plate are bolted to the Flat Girder and are attached to the Strip (14) by Fishplates. A vertical $7\frac{1}{2}$ " Angle Girder (15) is bolted along the edge of the $5\frac{1}{2}$ " x $2\frac{1}{2}$ " Flat Plate and a similar Angle Girder (16) is fixed in position (Fig. 4).

A $5\frac{1}{2}$ " x $\frac{1}{2}$ " Double Angle Strip (17) is bolted between the Girders of each side of the tower, and a $9\frac{1}{2}$ " Angle Girder (18) is connected to these Double

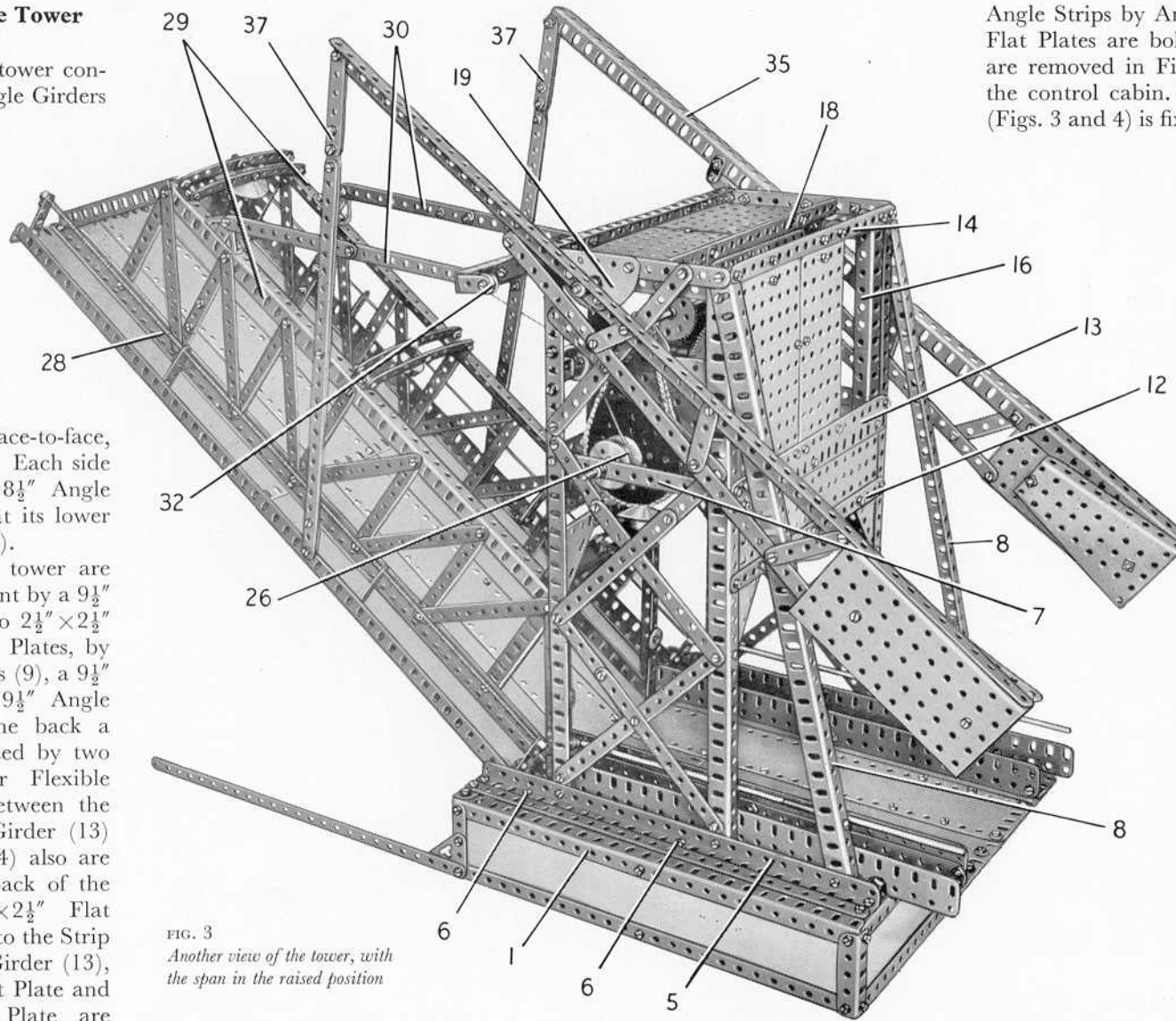

FIG. 3
Another view of the tower, with
the span in the raised position

Angle Strips by Angle Brackets. Two $5\frac{1}{2}$ " x $3\frac{1}{2}$ " Flat Plates are bolted to the Girder (18), but are removed in Fig. 4 to show the interior of the control cabin. A Semi-Circular Plate (19) (Figs. 3 and 4) is fixed to each side of the tower.

The imitation lamps fitted to the tower are $\frac{3}{4}$ " Flanged Wheels and Conical Discs, attached to Angle Brackets by $\frac{1}{2}$ " Bolts. The handrails along the pavements are fixed in Handrail Supports, which are attached to Angle Brackets bolted to the Girders of the tower.

Details of the Operating Cabin (Figs. 2, 3 and 4)

Each side of the cabin consists of a $5\frac{1}{2}$ " x $2\frac{1}{2}$ " Flat Plate with a vertical $5\frac{1}{2}$ " Strip (20) (Fig. 2) at each end. Two $2\frac{1}{2}$ " x $1\frac{1}{2}$ " Flexible Plates and two $2\frac{1}{2}$ " Strips are bolted to the side and are connected at their upper ends by a $5\frac{1}{2}$ " Strip. The ends of the cabin are $3\frac{1}{2}$ " x $2\frac{1}{2}$ " Flanged Plates, to each of which a Flat Trunnion (21) is bolted. Two $3\frac{1}{2}$ " x $2\frac{1}{2}$ " Flanged Plates fixed between the sides, form the floor of the cabin.

An E15R Electric Motor is bolted to the floor (Fig. 4), and a $\frac{7}{16}$ " diameter Pinion on the Motor shaft drives a 60-tooth Gear on a $2\frac{1}{2}$ " Rod. This Rod is mounted in the Motor side-plates, and it carries a $\frac{1}{2}$ " Pinion (22) that engages a 57-tooth Gear on a second $2\frac{1}{2}$ " Rod. The latter Rod also is supported in the Motor side-plates, and is fitted with a Worm (23).

A 6½" Rod mounted in the Flat Trunnions (21) carries a ¾" Sprocket (24) at each end and a 57-tooth Gear that is driven by the Worm (23). The operating cabin is fixed to the tower by bolting the top ends of the Strips (20) to the Angle Girders (11) and (18). The front of the cabin is connected to one of the Flat Girders (9) by two Fishplates. A Collar is screwed on to a bolt fixed by a nut in the top arm of the Motor switch. A 3½" Rod held in the Collar is passed through one of the Strips (20) and is fitted with a ½" fixed Pulley (25) (Fig. 4).

The Sprockets (24) are connected by Chain to 3" Sprockets on an 11½" Rod supported in the Strips (7). This Rod carries two winding drums (26), each of which consists of two 1⅞" Flanged Wheels (Figs. 2 and 3).

Two 1" Pulleys (27) are fixed on 1½" Rods, which are supported in the ends of the operating cabin and in Double Bent Strips bolted to the sides of the tower. The Rods are held in position by Collars (Fig. 2).

The Lifting Span (Figs. 2, 3 and 5)

The underside of the span is shown clearly in Fig. 5. The framework to which the roadway is bolted consists of two 24½" Angle Girders connected at each end by a 9½" Angle Girder. Three 5½" Angle Girders are attached to the 24½" Angle Girders by Angle Brackets. The roadway is formed by ten 12½" x 2½" Strip Plates bolted to the framework as shown, with the outer edges strengthened by 24½" Angle Girders (see Fig. 3).

Two 24½" Angle Girders (28) are fixed to the top of the roadway, and two 18½" Angle Girders (29) are supported by 5½" Angle Girders at each end. The Girders (28) and (29) are joined by vertical 4½" Strips and diagonal 5½" Strips, two of the 4½" strips each being made from a 3½" and a 2½" Strip. The Girders (29) are connected across by six 5½" Curved Strips, which are bolted in pairs to the lugs of Double

Brackets. A Double Bracket fixed to the centre of each pair of Curved Strips supports an imitation lamp formed by a ¾" Flanged Wheel. Two of the lamps carry shades made from Conical Discs.

The handrail along each side of the span is made from a length of Spring Cord. This is stretched slightly and is passed through 2" Strips, which are attached to the span by Angle Brackets. A Collar fitted with a ¾" bolt is fixed at each end of the Spring Cord to hold it in the Strips.

A Trunnion is bolted to each of the Girders (29), and to it is *lock-nutted* a built-up strip (30). This strip is made from three 5½" Strips, two of which are placed face-to-face and overlap the third Strip by three holes. The top ends of the Strips (30) are *lock-nutted* to 1" x ½" Angle Brackets bolted to a beam (31) (Fig. 2), made from two 7½" Angle Girders. A Single Bent Strip is fixed to each end of the beam and in it a ½" loose Pulley (32) is freely mounted on a ½" Bolt held by *lock-nuts*.

A length of Cord is fastened to each winding drum (26), is taken round Pulleys (27) and (32) and is tied to a pivoted bracket (33). Each of these brackets consists of two 2½" Strips bolted together at one end and splayed out slightly at the other end. The Strips fit over a Rod Socket fixed to the Angle Girder (11), and pivot on a ¾" Bolt that is screwed into the Rod Socket and is fitted with *lock-nuts*.

The span pivots on a 6½" Rod supported in 1" x 1" Angle Brackets (34) (Fig. 5), which are bolted to the Angle Girder (2).

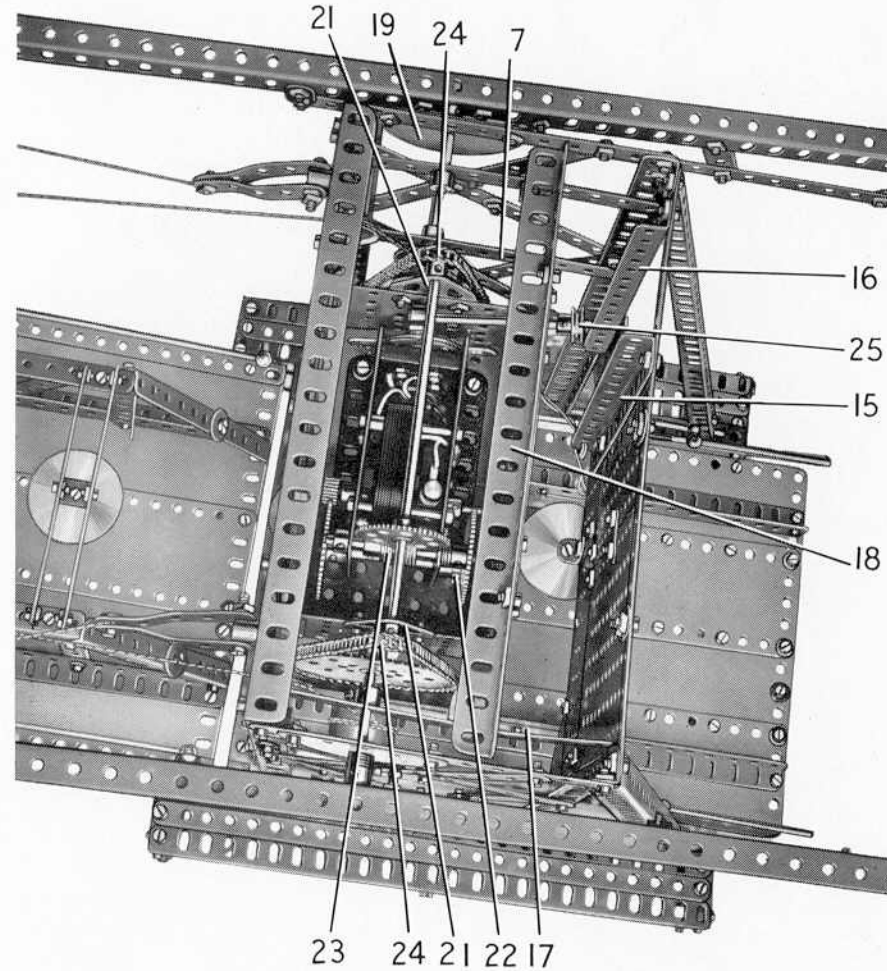
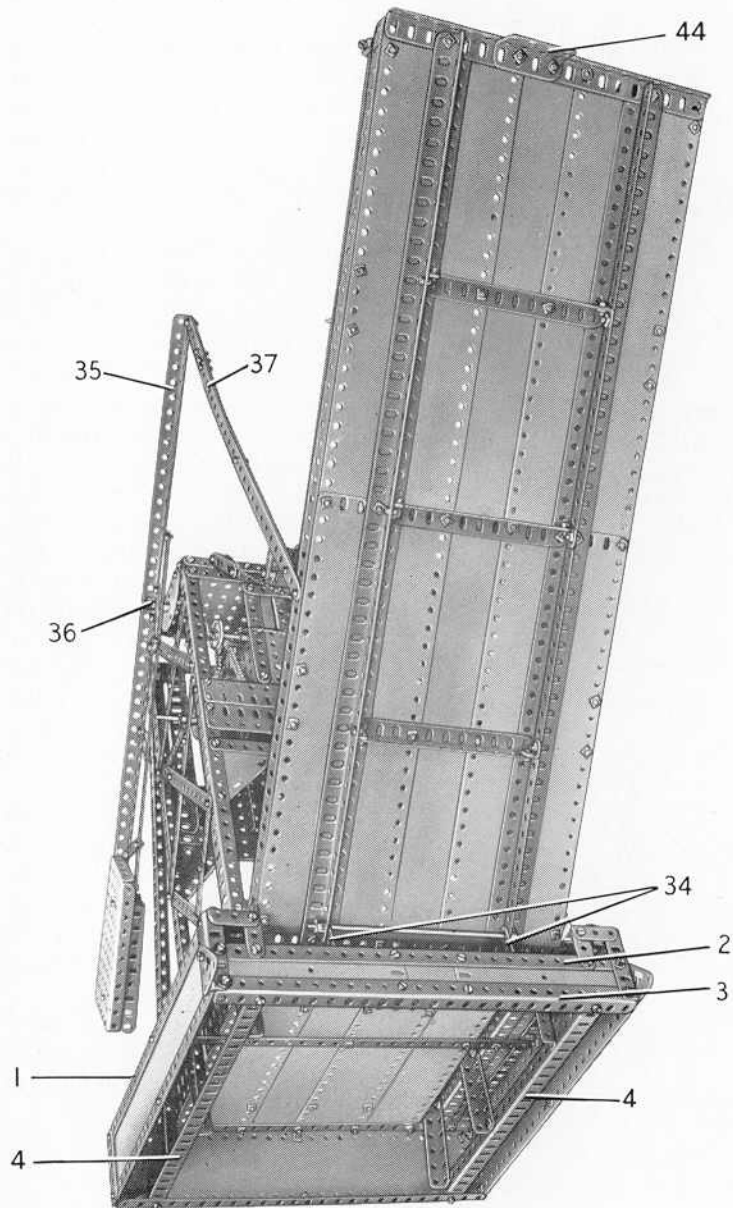

FIG. 4 A view looking into the top of the operating cabin with the plating removed, and showing the location of the driving Motor

Assembly of the Balance Beams (Figs. 2, 3 and 4)

Each beam is made from a 24½" Angle Girder (35), to one end of which a 5½" x 2½" Flanged Plate is bolted. A second 5½" x 2½" Flanged Plate is fitted



over the flanges of the first Plate, and is held in place by two $1\frac{1}{8}$ " Bolts that secure also a Flanged Sector Plate.

A $12\frac{1}{2}$ " Strip is bolted to one of the Flanged Plates and is connected to the Girder (35) by a Fishplate.

A Double Arm Crank (36) (Fig. 2) is bolted to each Angle Girder (35) and is fixed on a 2" Rod. This Rod is supported in the Semi-Circular Plate (19) and the Double Angle Strip (17) (Fig. 4), and is held in place by a Collar. The Girder (35) is spaced from the Semi-Circular Plate by a Collar and four Washers on the Rod.

Each beam is linked to the span by a built-up strip (37), which is *lock-nutted* at each end. The strip is made by placing two $12\frac{1}{2}$ " Strips face-to-face and then bolting two more $12\frac{1}{2}$ " Strips, one on each side, so that they *overhang* the face-to-face Strips at one end by *two* clear holes each. Two 3" Strips are then attached to the other ends of the face-to-face Strips in the same way, and overhang them by *four* clear holes each. In Fig. 2 one of the strips (37) is detached from the Girder (35) in order to show the details of the operating cabin clearly.

Construction of the Support Pier (Figs. 1, 6 and 7)

Each side of the support pier consists of a $9\frac{1}{2}$ " \times $2\frac{1}{2}$ " Strip Plate strengthened by a $9\frac{1}{2}$ " Angle Girder and a $9\frac{1}{2}$ " Strip. The back is a $12\frac{1}{2}$ " \times $2\frac{1}{2}$ " Strip Plate edged by a $12\frac{1}{2}$ " Angle Girder and a $12\frac{1}{2}$ " Strip, and it is connected to the sides by two $2\frac{1}{2}$ " Angle Girders. The front is formed by two $12\frac{1}{2}$ " Angle Girders and a $12\frac{1}{2}$ " Flat Girder, and these also are connected to $2\frac{1}{2}$ " Angle Girders bolted to the sides. Two $1\frac{1}{2}$ " Flat Girders (38) are fixed in position at the front.

The top of the support pier is filled in by four $12\frac{1}{2}$ " \times $2\frac{1}{2}$ " Strip Plates strengthened at the front by a $12\frac{1}{2}$ " Angle Girder (39). The guard rails are each made from a $7\frac{1}{2}$ " Flat Girder and a $2\frac{1}{2}$ " Flat Girder overlapped three holes and bolted to $4\frac{1}{2}$ " Angle Girders fixed to the top of the approach. The handrails are 8" Rods held in Collars, each of which is screwed on to a bolt that is fixed by a nut in a $1\frac{1}{2}$ " Strip.

FIG. 5 (left)
This underneath view shows how the lifting span is hinged to the main pier

FIG. 6 (right)
An underneath view of a section of the support pier, showing the arrangement of the cords that operate the traffic barriers

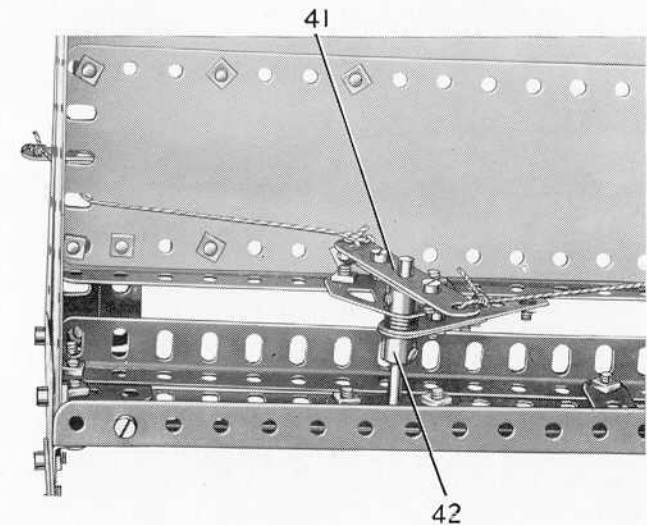

The lamps are attached to Double Brackets bolted between 2½" Strips and 2½" × 1½" Triangular Flexible Plates supported by 7½" Strips. Each pair of 7½" Strips is fixed to a Channel Bearing that is bolted to one of the guard rails.

Each section of the traffic barrier is a 5½" Strip (40) extended by a Flat Trunnion, to which a ½" loose Pulley is bolted. The Strips (40) are lock-nutted to 2½" × ½" Double Angle Strips fixed to the top of the approach as shown. A length of Cord tied to the outer end of each of the Strips (40) is passed through the floor of the pier and is fastened to one end of a 2½" Strip (41) (Fig. 6), which is bolted centrally to a Double Arm Crank. The Double Arm Crank is fixed on a 2" Rod, which is mounted in a Flat Trunnion bolted to the Angle Girder (39) and in a 1½" Strip that covers the slotted holes in the

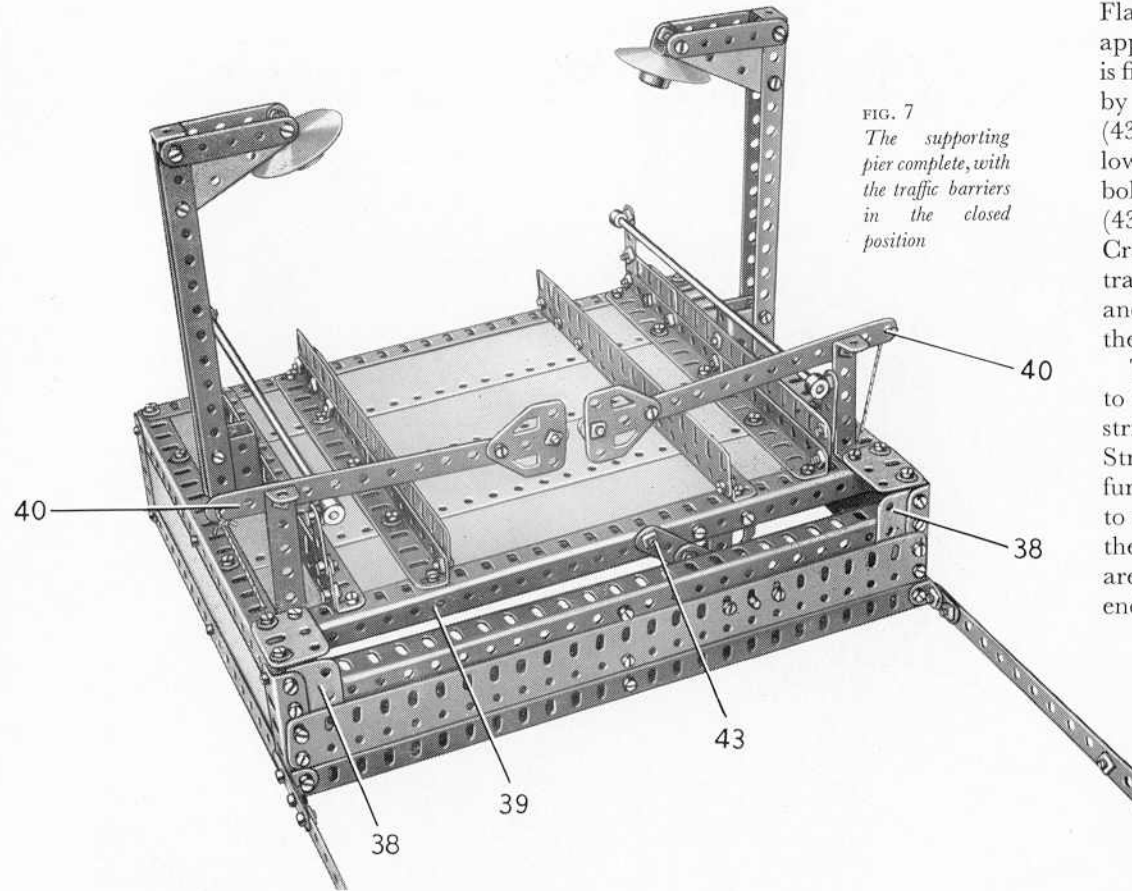

FIG. 7
The supporting pier complete, with the traffic barriers in the closed position

Flat Girder at the front of the approach. A Crank (42) (Fig. 6) is fixed on the Rod and is extended by a 2½" Strip fitted with a bolt (43) (Fig. 7). When the span is lowered a Girder Bracket (44) bolted to its end engages the bolt (43), and thus depresses the Crank (42). This movement is transmitted through the Strip (41) and the lengths of Cord, so that the barriers rise automatically.

The support pier is connected to the main pier by two built-up strips, each made from two 12½" Strips overlapped four holes. A further 12½" Strip is fixed centrally to the overlapped Strips to strengthen them. The built-up strips are extended at the support pier end by 2" Slotted Strips. The Slotted Strips are bolted to the sides of the pier, and the built-up strips are connected to the front by Angle Brackets.

Parts Required to Build the Meccano Beam Bridge

23 of No. 1	8 of No. 7	12 of No. 11	5 of No. 17	1 of No. 32	3 of No. 52a	6 of No. 89	4 of No. 103h	2 of No. 160	2 of No. 213
6 " " 1a	8 " " 7a	28 " " 12	4 " " 20	613 " " 37a	4 " " 53	1 " " 94	4 " " 103k	1 " " 161	2 " " 214
6 " " 1b	16 " " 8	2 " " 12a	7 " " 20b	560 " " 37b	2 " " 53a	2 " " 95b	2 " " 111	2 " " 179	4 " " 221
36 " " 2	6 " " 8a	6 " " 12b	2 " " 22	84 " " 38	2 " " 54	2 " " 96a	9 " " 111a	6 " " 187a	2 " " 222
8 " " 2a	4 " " 8b	1 " " 13	4 " " 23	4 " " 38d	2 " " 55a	2 " " 102	18 " " 111c	5 " " 188	2 " " 223
11 " " 3	11 " " 9	4 " " 13a	1 " " 23a	1 " " 40	1 " " 58	2 " " 103	4 " " 111d	2 " " 189	
4 " " 4	8 " " 9a	2 " " 14	1 " " 26	2 " " 45	20 " " 59	4 " " 103a	2 " " 126	1 " " 190a	1 E15R Electric Motor (not included in Outfit)
24 " " 5	8 " " 9d	2 " " 15b	1 " " 26c	2 " " 48a	1 " " 62	4 " " 103b	5 " " 126a	1 " " 192	
11 " " 6	2 " " 9f	2 " " 16a	2 " " 27a	2 " " 48d	3 " " 62b	1 " " 103d	2 " " 133	4 " " 196	
9 " " 6a	4 " " 10	1 " " 16b	1 " " 27d	4 " " 52	3 " " 70	4 " " 103f	4 " " 136	20 " " 197	

MECCANO Dumper Truck

(MODEL No. 10.9)

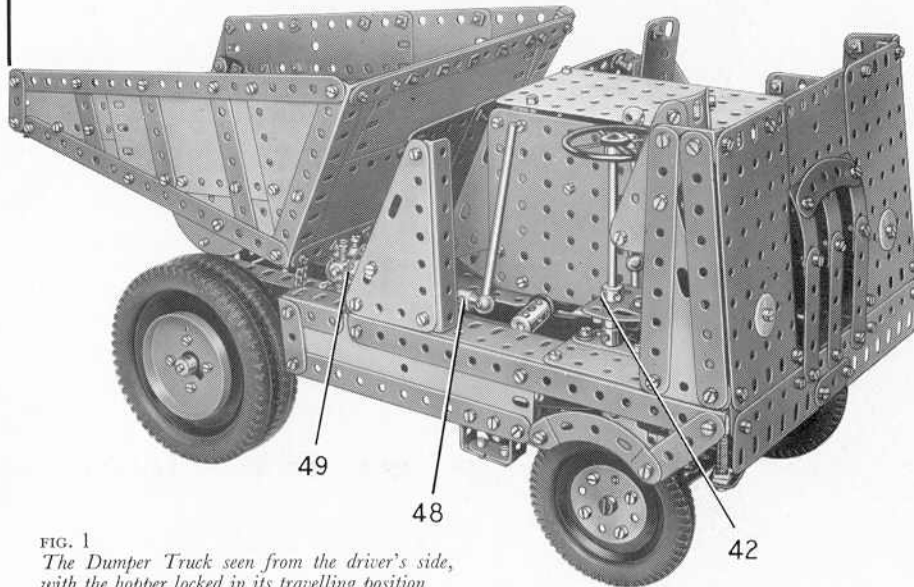

FIG. 1
The Dumper Truck seen from the driver's side,
with the hopper locked in its travelling position

The model described in this Leaflet represents one of the mobile trucks used in construction work for removing spoil from building sites. It is known as a Dumper Truck, and is fitted with a hinged hopper body that can be tipped to unload its contents. The model is equipped with a neat gear-box, attractive working steering gear, differential and swivelling seats for the driver and his mate, and it is powered by a Meccano E15R type Electric Motor.

Construction of the Model: The Chassis (Fig. 3)

Each side-member consists of two $12\frac{1}{2}$ " Angle Girders and a $12\frac{1}{2}$ " Flat Girder bolted together to make a channel section girder. The side-members are connected at each end by two $2\frac{1}{2}$ " \times $\frac{1}{2}$ " Double Angle Strips, and a similar Double Angle Strip (1) is fixed between the girders (Fig. 3).

Driving Axle and Differential (Figs. 3, 4 and 5)

The driving axle unit is shown removed from the chassis in Fig. 4. Each half of the axle casing is made by bolting two $1\frac{1}{2}$ " \times $\frac{1}{2}$ " Double Angle Strips between a Boiler End and a Wheel Disc (six holes). When the differential mechanism is assembled the Boiler

Ends are joined together by two 2" Strips, and bolts passed through two of the Double Angle Strips are bolted to the chassis.

A $4\frac{1}{2}$ " Rod is passed through one side of the casing, and on it a $1\frac{1}{2}$ " Contrate (2) is free to rotate. A $\frac{3}{4}$ " Contrate (3) is fixed on the Rod, which is then passed into the bore of a Coupling (4). Two 1" Screwed Rods are held by nuts in the Contrate (2), and on each of them a Collar is screwed. A $1\frac{1}{2}$ " Rod is fixed in these Collars and also in the centre cross hole of the Coupling. Two $\frac{3}{4}$ " Pinions are free to rotate on Pivot Bolts screwed into the Coupling (4). These Pinions engage the Contrate (3) and a similar Contrate on a $3\frac{1}{2}$ " Rod that is passed through the other half of the axle casing. The differential unit is spaced inside the casing by Washers, so that a $\frac{1}{2}$ " Pinion (5) on a 2" Rod meshes with the Contrate (2). The 2" Rod is supported in a Fishplate bolted to the Double Angle Strip (1).

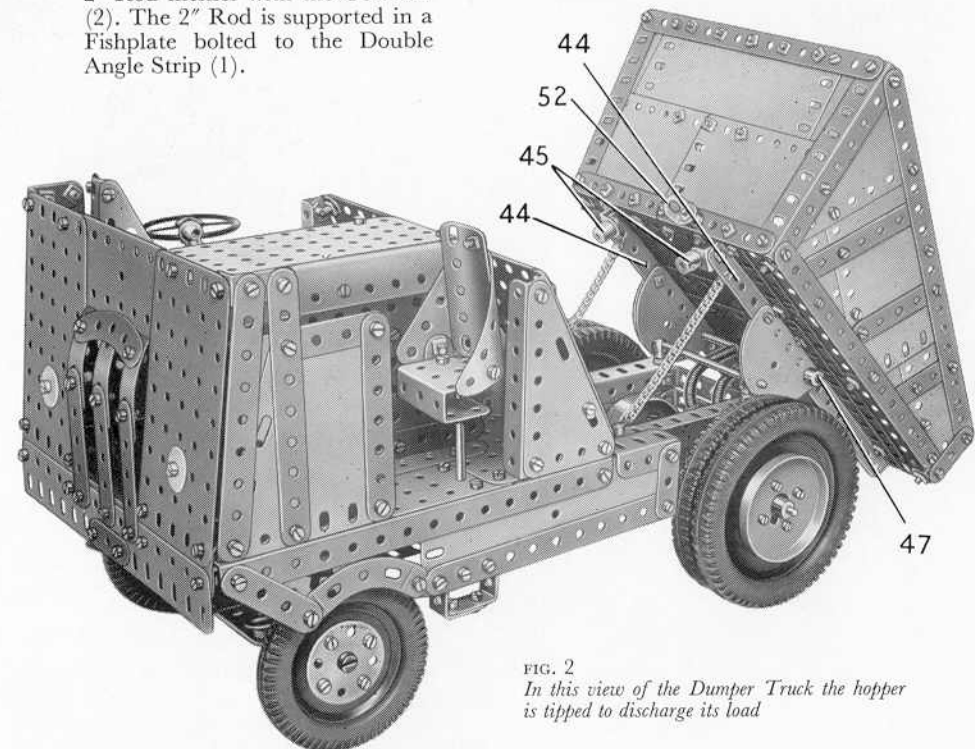

FIG. 2
In this view of the Dumper Truck the hopper
is tipped to discharge its load

Details of the Gear-box (Figs. 3 and 5)

The gear-box frame consists of two $3" \times 1\frac{1}{2}"$ Double Angle Strips (6) (Fig. 3) fixed together by their lugs, with a $1\frac{1}{2}"$ Flat Girder bolted, through its slotted holes, to each end of the assembly. At one end a $2\frac{3}{8}" \times 1"$ Double Angle Strip bolted to the chassis is held by the same bolts as the Flat Girder, and a Double Bent Strip (7) is fixed to the Flat Girder. At the opposite end a $2\frac{3}{8}"$ Strip is attached by the same bolts as the Flat Girder, and is connected to the chassis by Angle Brackets. A $1" \times 1"$ Angle Bracket (8) is fixed to one side of the gear-box frame.

The gear-box driving shaft is a $3"$ Rod that carries a $\frac{3}{4}"$ Pinion (9) (Fig. 5) and a $\frac{1}{2}"$ Pinion (10). The Rod is held in place by a Collar, and projects about $\frac{1}{4}"$ beyond the Pinion (10) into the bore of a $\frac{1}{2}"$ Pinion (11) on the output shaft. This shaft is a $2"$ Rod supported in one end of the frame and in the Angle Bracket (8), and it carries also a $\frac{3}{4}"$ diam. $\times \frac{1}{2}"$ face Pinion (12).

The layshaft is a $3\frac{1}{2}"$ Rod mounted as shown in Fig. 3, and it carries a $\frac{3}{4}"$ Pinion (13), a Collar, and a $\frac{1}{2}"$ Pinion (14)

FIG. 3
An underneath view of the model showing the gear-box. One of the front wheels is removed to reveal details of the steering gear

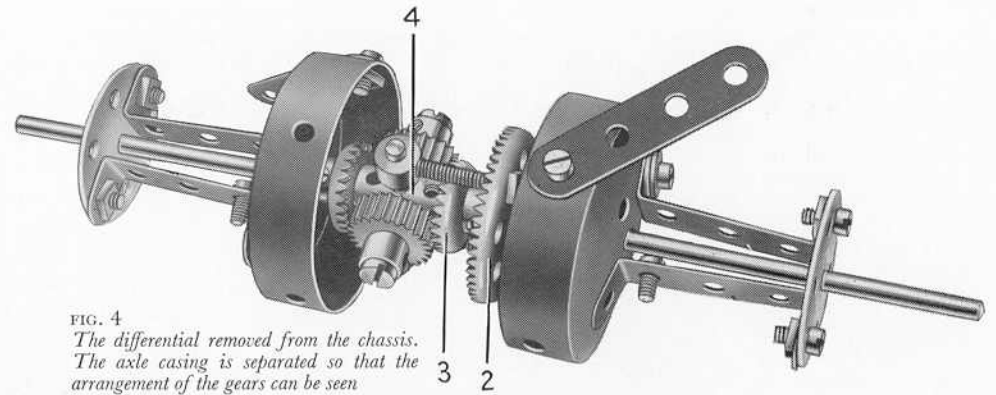
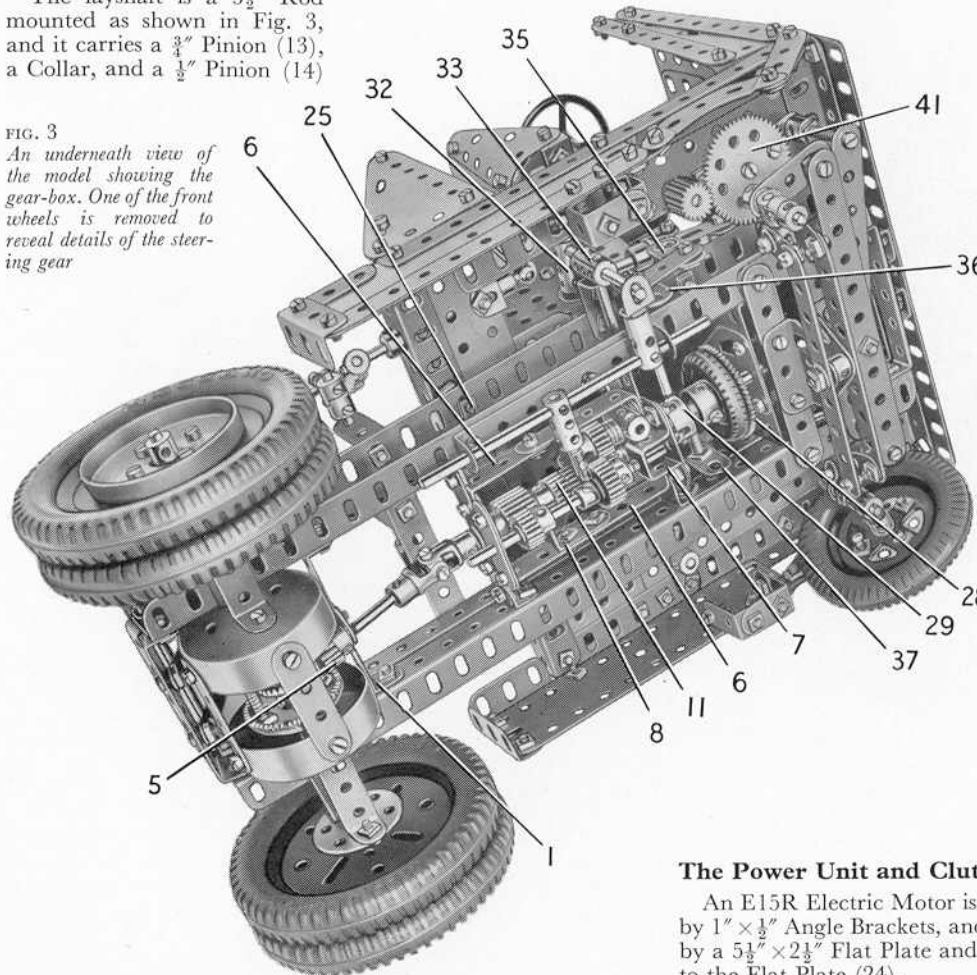

FIG. 4
The differential removed from the chassis. The axle casing is separated so that the arrangement of the gears can be seen

(Fig. 5). The reverse $\frac{1}{2}"$ Pinion (15) is free to turn on a $1\frac{1}{2}"$ Rod fixed in a Coupling (16). The Pinion is held on the Rod by a Spring Clip, and is spaced from the Coupling by five Washers. The Coupling is screwed tightly on to a $\frac{1}{2}"$ Bolt passed through one end of the gear-box frame, but is spaced from the frame by a Washer. The position of the Coupling (16) is arranged so that Pinion (15) can be meshed with both Pinions (9) and (13).

The gear ratio required is obtained by sliding the layshaft, the movement of which is controlled by a Rod and Strip Connector fitted over the $3\frac{1}{2}"$ Rod between the Pinion (13) and the Collar. The Rod and Strip Connector is joined by a $1"$ Rod to a Coupling that is fixed on a $5"$ Rod sliding in a $3\frac{1}{2}" \times \frac{1}{2}"$ Double Angle Strip bolted to the chassis. A Threaded Coupling (17) is fixed on the $5"$ Rod.

Construction of the Body (Figs. 2, 5 and 7)

The base frame of the body consists of four $7\frac{1}{2}"$ Angle Girders arranged in the form of a square. Two $5\frac{1}{2}" \times 2\frac{1}{2}"$ Flat Plates (18) and two $3" \times 1\frac{1}{2}"$ Flat Plates (19) and (20) are bolted to the frame (Fig. 7), and a $2\frac{1}{2}" \times 1\frac{1}{2}"$ Flexible Plate is fitted in front of the Plate (20). A $3\frac{1}{2}"$ Flat Girder is fixed between the Flexible Plate and the Plate (19), and a $4\frac{1}{2}"$ Flat Girder (21) (Fig. 5) is bolted centrally to the rear end of the frame.

Two $5\frac{1}{2}"$ Angle Girders (22) (Fig. 7) are bolted to the Plates (18) and to the Flat Girder (21). A $5\frac{1}{2}" \times 2\frac{1}{2}"$ Flat Plate (23) is attached by Fishplates to one of the Girders (22), and a $5\frac{1}{2}" \times 3\frac{1}{2}"$ Flat Plate (24) is attached by Angle Brackets to the second Girder.

The division between the engine and the dumper hopper consists of two $5\frac{1}{2}" \times 3\frac{1}{2}"$ Flat Plates attached by Angle Brackets to two $3\frac{1}{2}" \times 2"$ Triangular Flexible Plates. Each of the Triangular Flexible Plates is strengthened by a $3\frac{1}{2}"$ Angle Girder, and is bolted to a $2"$ Angle Girder fixed to the base frame.

On the driver's side two $4\frac{1}{2}"$ Strips and a $3\frac{1}{2}" \times 1\frac{1}{2}"$ Triangular Flexible Plate are bolted to a $1\frac{1}{2}"$ Angle Girder fixed to the base frame. On the other side two $4\frac{1}{2}"$ Strips and a $3\frac{1}{2}" \times 2\frac{1}{2}"$ Triangular Flexible Plate are bolted to a $3"$ Angle Girder.

The body is attached to the chassis by two Double Bent Strips at the rear (Fig. 5), and by Double Brackets held by bolts (25).

The Power Unit and Clutch (Figs. 3, 5 and 7)

An E15R Electric Motor is bolted by its flanges to Flat Plate (23) (Fig. 7). The Motor is connected to Flat Plate (24) by $1" \times \frac{1}{2}"$ Angle Brackets, and to one of the Girders (22) by $\frac{1}{2}" \times \frac{1}{2}"$ Angle Brackets. A cover over the Motor is provided by a $5\frac{1}{2}" \times 2\frac{1}{2}"$ Flat Plate and a curved $5\frac{1}{2}" \times 2\frac{1}{2}"$ Flexible Plate bolted together. The cover is pivoted on Hinges bolted to the Flat Plate (24).

A Worm fixed to the lower end of the Motor shaft drives a $\frac{1}{2}$ " Pinion on a $2\frac{1}{2}$ " Rod (26) (Fig. 5). This Rod is supported in two Flat Trunnions, one of which is bolted to a $2\frac{1}{2}$ " \times $\frac{1}{2}$ " Double Angle Strip and the other to a $2\frac{1}{2}$ " \times 1" Double Angle Strip. A $\frac{1}{2}$ " Pinion drives a 57-tooth Gear (28) on a $2\frac{1}{2}$ " Rod mounted in the Double Angle Strips.

A 1" Pulley fitted with a Motor Tyre is gripped in one end of a Socket Coupling (29). The Socket Coupling is free to slide on the gear-box input shaft, but is made to turn with the shaft by a bolt screwed into a Collar (30). This Collar is spaced from the gear-box by three Washers, and its bolt engages the slot in the Socket Coupling. A Compression Spring fitted between the Collar and the Socket Coupling presses the Motor Tyre against the Gear (28).

Arrangement of the Driving Controls (Figs. 5 and 7)

The gear-change lever is a $3\frac{1}{2}$ " Rod, fixed in a Handrail Support *lock-nutted* to Flat Plate (24) (Fig. 7). A Swivel Bearing (31) is fixed on the lower end of the lever, and is joined by a 1" Rod to a Rod and Strip Connector. A Pivot Bolt is passed through the Rod and Strip Connector and is fixed in a Coupling

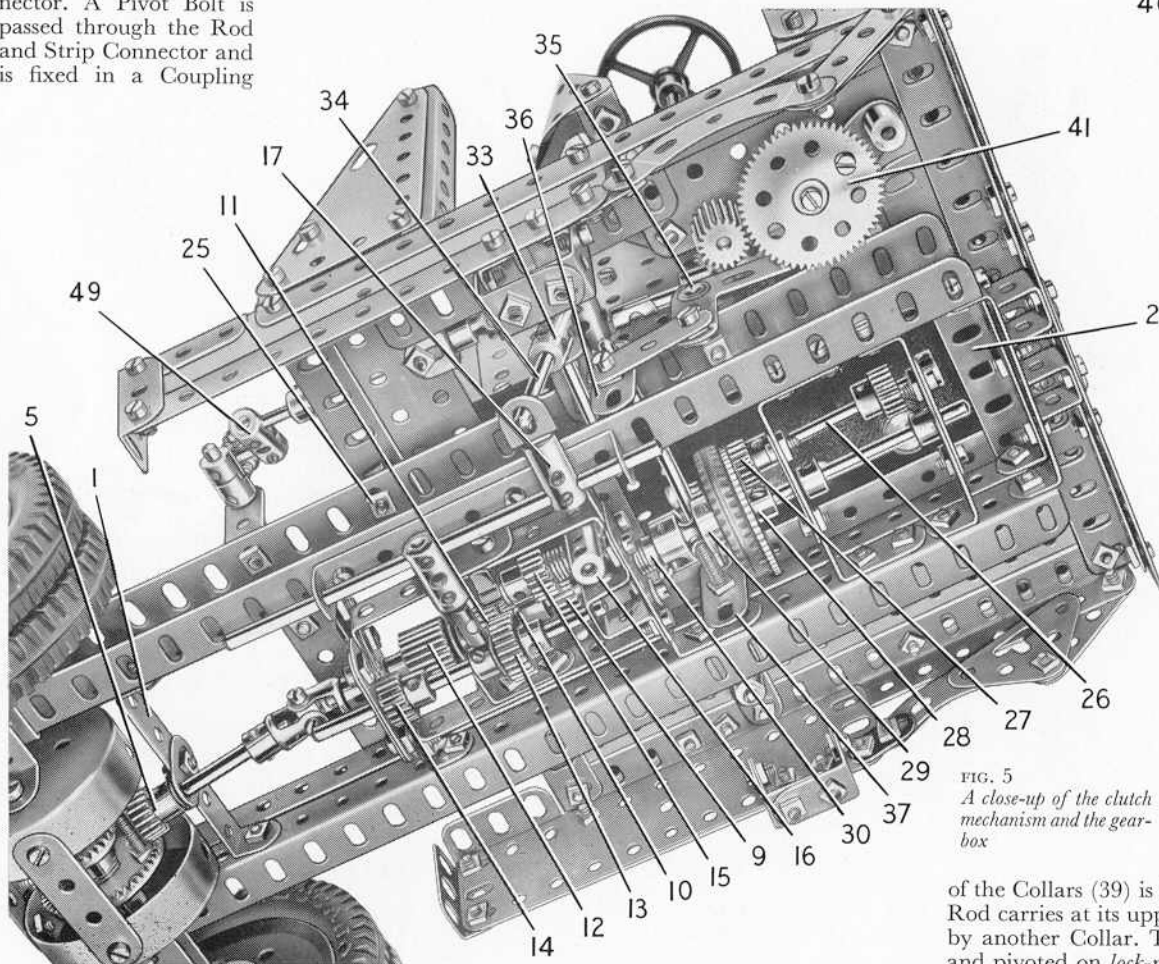

FIG. 5
A close-up of the clutch mechanism and the gear-box

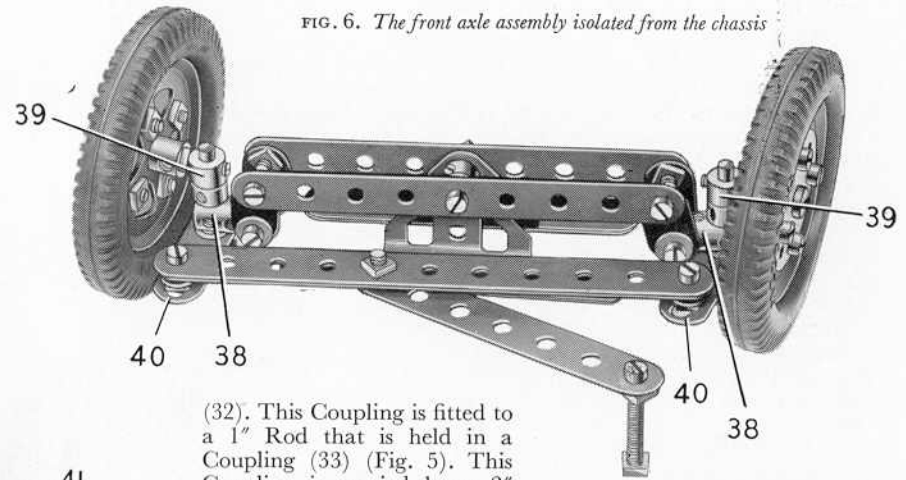

FIG. 6. The front axle assembly isolated from the chassis

(32). This Coupling is fitted to a 1" Rod that is held in a Coupling (33) (Fig. 5). This Coupling is carried by a 2" Rod supported in one of the chassis side-members and in a $1" \times \frac{1}{2}"$ Angle Bracket bolted to the top flange of the side-member. The 2" Rod is held in place by a Collar. A $1\frac{1}{2}"$ Rod (34) fixed in the Coupling (33) engages the slotted hole of an Angle Bracket, which is pivoted on a bolt fixed by a nut in the Threaded Coupling (17).

The clutch pedal is formed by a Threaded Boss held by a bolt in the short lug of a $1" \times \frac{1}{2}"$ Angle Bracket. The Angle Bracket is bolted to one arm of a Bell Crank (35) (Fig. 5), which is fixed on a 1" Rod. The 1" Rod is passed through a Handrail Support attached by its shank to the top flange of the chassis, and the Rod is held in place by a Collar. A $1\frac{1}{2}"$ Strip is *lock-nutted* to the other arm of the Bell Crank, and is *lock-nutted* also to a Crank (36) fixed on a $4\frac{1}{2}"$ Rod mounted across the chassis. A Crank (37) on this Rod is fitted with a $\frac{3}{4}"$ Bolt that engages the groove of the Socket Coupling (29).

The Steering Mechanism (Figs. 3, 5, 6 and 7)

The front axle is supported by Trunnions attached to four $3\frac{1}{2}"$ Strips. These Strips are arranged in pairs, each pair consisting of two Strips placed face-to-face, and they are bolted to the chassis. The axle beam is made from two $4\frac{1}{2}"$ Strips, which pivot on a $\frac{3}{4}"$ Bolt *lock-nutted* in the Trunnions. A Collar and a Washer are placed on the Bolt between the Trunnions, and a Washer is fitted between each $4\frac{1}{2}"$ Strip and the corresponding Trunnion. Fishplates are fastened to the ends of the $4\frac{1}{2}"$ Strips, and a Coupling (38) is fixed by two bolts to the Fishplates at each end (Fig. 6).

The front wheels are free to turn on Pivot Bolts, which are fitted with nuts and are then screwed into Collars (39). The nuts are tightened against the Collars to fix the Pivot Bolts in place. Each of the Collars (39) is locked on a $1\frac{1}{2}"$ Rod mounted freely in one of the Couplings (38). The Rod carries at its upper end a Crank (40), and the Collar (39) is spaced from the Coupling by another Collar. The Cranks (40) are connected by two $5\frac{1}{2}"$ Strips placed face-to-face and pivoted on *lock-nutted* bolts.

The steering column is a $4\frac{1}{2}$ " Rod mounted in a Double Arm Crank bolted to Flat Plate (20) (Fig. 7). The Rod is held in place by a $\frac{1}{2}$ " fixed Pulley placed above the Crank, and below the Flat Plate it is fitted with a $\frac{1}{2}$ " diameter $\times \frac{1}{2}$ " face Pinion. This Pinion engages a 57-tooth Gear (41) (Fig. 5), which is freely mounted on a $\frac{1}{2}$ " Bolt held by two nuts in the Flat Plate (20). A $3\frac{1}{2}$ " Strip is lock-nutted to a $1\frac{1}{8}$ " Bolt fixed in a Threaded Boss, attached to a Fishplate bolted to Gear 41. The other end of the Strip is lock-nutted to the $5\frac{1}{2}$ " Strips attached to the Cranks (40) (Fig. 6).

The driving seat is made by attaching a $2\frac{1}{2}$ " \times $1\frac{1}{2}$ " Flexible Plate and two $2\frac{1}{2}$ " \times $1\frac{1}{2}$ " Triangular Flexible Plates to a Flat Trunnion by Angle Brackets. A $1\frac{1}{2}$ " Strip is connected to the Flat Trunnions by an Obtuse Angle Bracket, and to a second Flat Trunnion (42) (Fig. 1) by another Obtuse Angle Bracket. Flat Trunnion (42) is passed over the steering column and is held in place by the 'spider' from a Swivel Bearing.

The seat for the second man is formed by a $2\frac{1}{2}$ " \times $1\frac{1}{2}$ " Flexible Plate and two $2\frac{1}{2}$ " \times 2 " Triangular Flexible Plates attached by Angle Brackets to a Bush Wheel and a Channel Bearing (see Fig. 2). A $2\frac{1}{2}$ " Rod fixed in the Bush Wheel is held in a Double Arm Crank bolted underneath the body.

The Tipping Hopper (Figs. 1, 2 and 7)

The floor of the hopper is formed by three $4\frac{1}{2}$ " \times $2\frac{1}{2}$ " Flexible Plates and two $2\frac{1}{2}$ " \times $1\frac{1}{2}$ " Flexible Plates, extended on each side by a $5\frac{1}{2}$ " \times $1\frac{1}{2}$ " and a $2\frac{1}{2}$ " \times $1\frac{1}{2}$ " Flexible Plate. The floor is strengthened by five $7\frac{1}{2}$ " Strips bolted to the Plates on the inside, and along the front edge are bolted a $4\frac{1}{2}$ " and a $3\frac{1}{2}$ " Flat Girder overlapped three holes. Two built-up girders (44) (Fig. 2), each made from a $5\frac{1}{2}$ " and a $2\frac{1}{2}$ " Angle Girder, are bolted to the underside of the floor.

Each side of the hopper consists of a $3\frac{1}{2}$ " \times $2\frac{1}{2}$ " Triangular Flexible Plate, two $2\frac{1}{2}$ " \times $1\frac{1}{2}$ " Triangular Flexible Plates, a $4\frac{1}{2}$ " \times $2\frac{1}{2}$ " Flexible Plate and a $5\frac{1}{2}$ " \times $1\frac{1}{2}$ " Flexible Plate. The Plates are strengthened by Strips and are connected to the hopper floor by Angle Brackets.

Two Semi-Circular Plates placed face-to-face are bolted to each of the girders (44), and they pivot on a 4" Rod held in Handrail Supports fixed to the chassis. Two short lengths of Sprocket Chain are hooked through holes in the girders (44), and are looped over Cord Anchoring Springs screwed into holes in the chassis. Two Rod Sockets (45) (Fig. 2) are fixed to Angle Brackets bolted to the girders (44). Two Tension Springs (46) (Fig. 7) are bolted to the front of the chassis, and are passed over a $4\frac{1}{2}$ " Rod (47) (Fig. 2).

The hopper locking lever is a $3\frac{1}{2}$ " Rod held in a Handrail Coupling (48) (Fig. 1). The Handrail Coupling is fixed on a 3" Rod

supported in the front $7\frac{1}{2}$ " Angle Girder of the body, and in an Angle Bracket bolted to Flat Plate (19) (Fig. 7). At its front end the 3" Rod carries a Coupling (49), which is fitted with a Centre Fork. The Centre Fork is located between two $\frac{3}{8}$ " Bolts, each of which is screwed into one half of a Dog Clutch on a $3\frac{1}{2}$ " Rod (50). This Rod is mounted in $1" \times 1"$ Angle Brackets bolted to a $3\frac{1}{2}$ " Strip fixed across the chassis. A Compression Spring is placed on Rod (50) between one of the Angle Brackets and a Collar (51). A $\frac{3}{4}$ " Bolt is screwed into the Collar and bears against the edge of the $3\frac{1}{2}$ " Strip to ensure that the $\frac{3}{8}$ " Bolts in the Dog Clutch remain in engagement with the Centre Fork. The end of Rod (50) passes into an Angle Bracket (52) (Fig. 2), which is spaced from the back of the hopper by a Collar on a $\frac{1}{2}$ " Bolt.

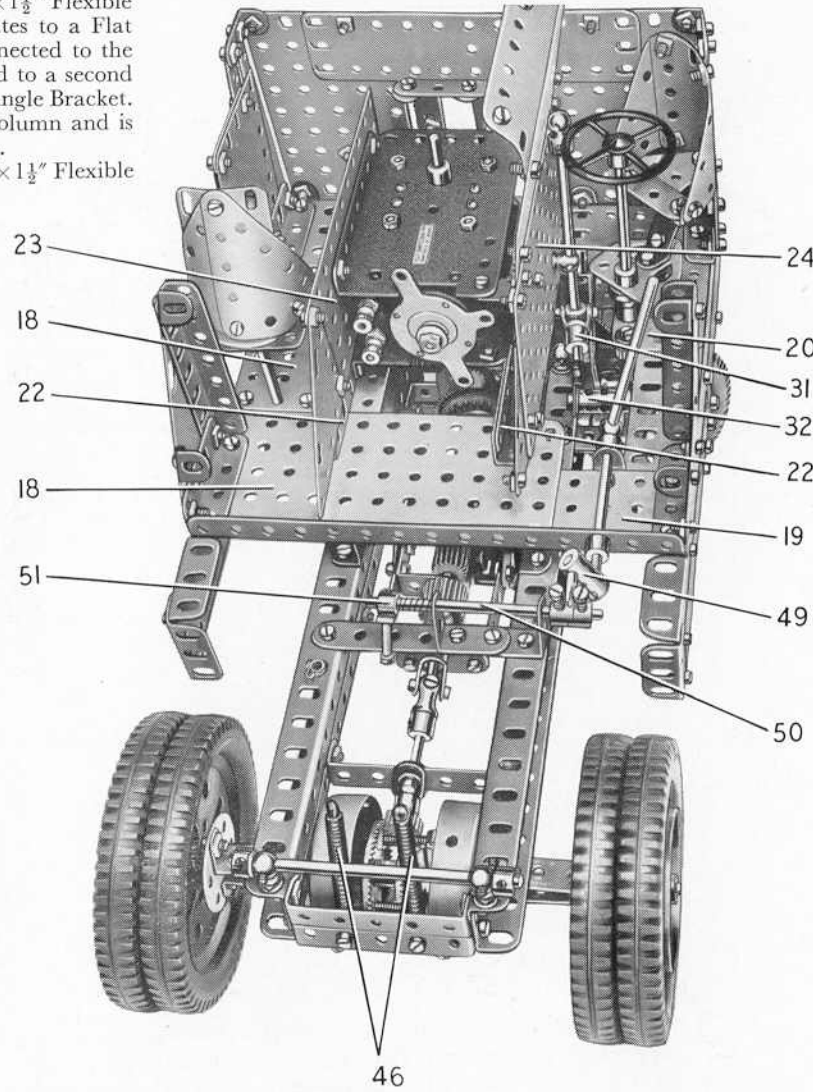

FIG. 7. An end view of the Dumper Truck, with the hopper and the front of the body removed to show how the E15R Electric Motor is mounted in place

Parts required to build the Meccano Dumper Truck

2 of No.	1a	1 of No.	26a	2 of No.	120b
6	1b	2	27a	2	126
9	2	1	28	4	126a
8	2a	2	29	1	128
11	3	1	32	2	133
15	5	1	35	2	133a
8	6	356	37a	4	136
10	6a	331	37b	2	136a
4	8	63	38	2	137
4	8b	2	38d	1	140
4	9	2	43	2	142a
2	9a	3	45	4	142b
2	9b	2	46	1	142c
1	9c	2	47a	1	144
2	9d	4	48	5	147b
2	9e	6	48a	1	160
5	9f	1	48b	2	162a
15	10	3	52a	2	165
2	11	2	53a	1	171
30	12	23	59	2	176
7	12a	4	62	2	179
6	12b	2	62b	1	185
2	12c	8	63	8	188
1	15	1	63c	8	189
4	15a	2	64	3	190a
1	15b	1	65	2	191
5	16	4	70	5	192
3	16a	2	73	2	212
2	16b	2	82	4	214
3	17	1	90	3	215
5	18a	2	90a	6	221
4	18b	1	94	2	222
4	19b	2	103b	2	223
2	20a	2	103c	2	224
1	22	2	103d	2	225
1	23a	2	103h	2	226
1	24	1	103k		
2	24a	4	111		
2	24c	4	111a		
4	25	10	111c		
1	25a	1	111d		
7	26	2	114		
				1 E15R	
				Electric Motor	
				(not included	
				in Outfit)	

MECCANO

Automatic Gantry Crane

(MODEL No. 10.10)

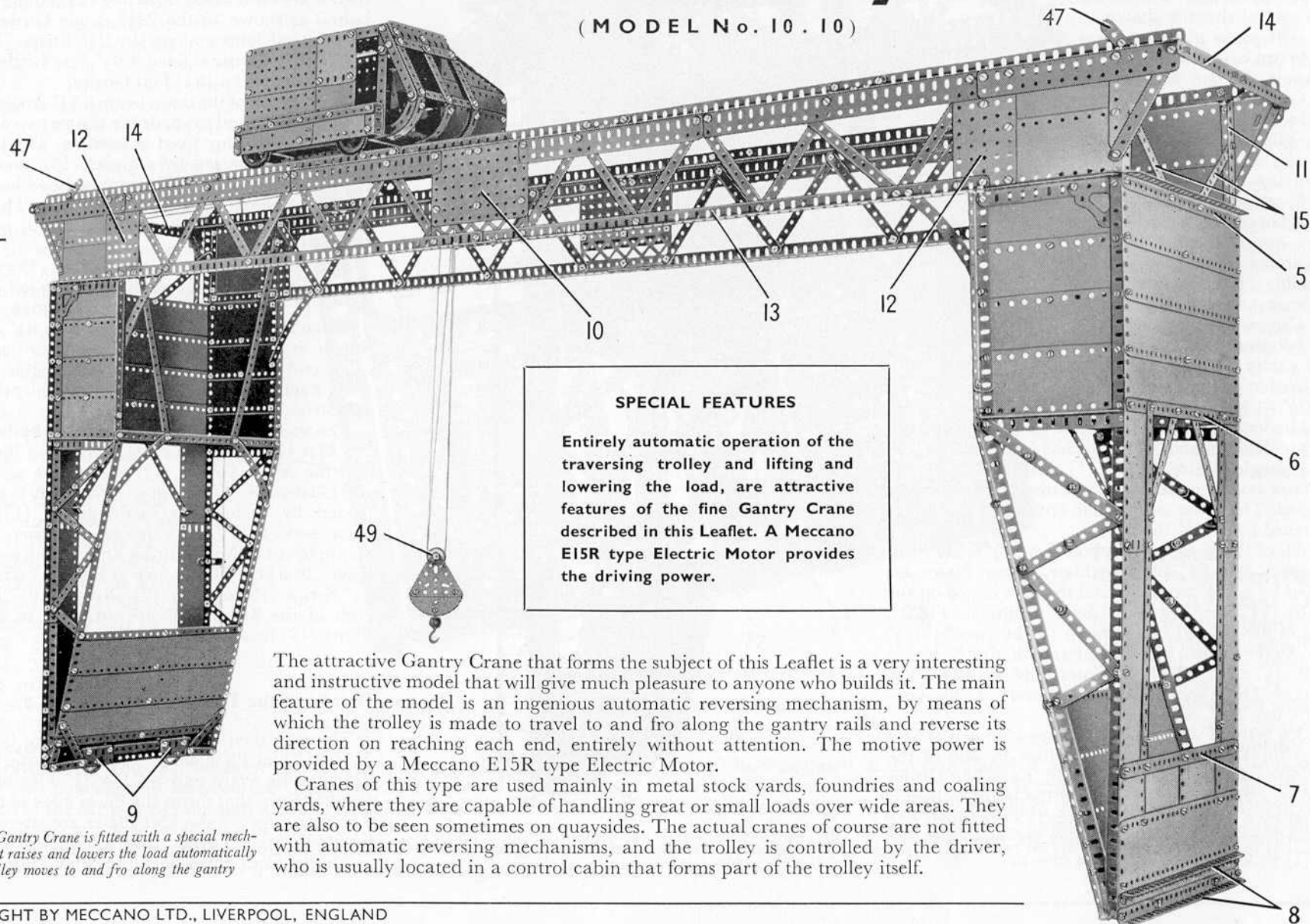

SPECIAL FEATURES

Entirely automatic operation of the traversing trolley and lifting and lowering the load, are attractive features of the fine Gantry Crane described in this Leaflet. A Meccano E15R type Electric Motor provides the driving power.

The attractive Gantry Crane that forms the subject of this Leaflet is a very interesting and instructive model that will give much pleasure to anyone who builds it. The main feature of the model is an ingenious automatic reversing mechanism, by means of which the trolley is made to travel to and fro along the gantry rails and reverse its direction on reaching each end, entirely without attention. The motive power is provided by a Meccano E15R type Electric Motor.

Cranes of this type are used mainly in metal stock yards, foundries and coaling yards, where they are capable of handling great or small loads over wide areas. They are also to be seen sometimes on quaysides. The actual cranes of course are not fitted with automatic reversing mechanisms, and the trolley is controlled by the driver, who is usually located in a control cabin that forms part of the trolley itself.

FIG. 1
This fine Gantry Crane is fitted with a special mechanism that raises and lowers the load automatically as the trolley moves to and fro along the gantry

Building the Model: The Gantry Supporting Towers (Figs. 1 and 2)

The towers or legs that support the gantry at each end are similar in construction, and a close-up view of one of them is shown in Fig. 2. The main girders (1) on each side are each made from an 18½" Angle Girder and a 9½" Angle Girder overlapped three holes. To the lower end of this built-up girder (1) an 18½" Angle Girder (2) is fixed, and this is extended upward by a built-up girder (3) made from a 7½" and a 2" Angle Girder. The girders (1) and (3) are connected by 5½" Angle Girders (4) and four 5½" × 2½" Flexible Plates, with the top rear corner strengthened by a Corner Gusset. Bracing strips are bolted between the Girder (2) and the girder (1) as shown.

The Girders (2) are connected at their lower ends by three 12½" × 2½" Strip Plates strengthened by two 12½" Strips. The lower ends of the girders (3) are joined by a 12½" Strip. The top ends of the girders (1) are connected by a 12½" Angle Girder (5) (Fig. 1), with four 12½" × 2½" Strip Plates bolted underneath it with their long edges overlapped. The lower edge of the bottom Strip Plate is strengthened by a 12½" Strip (6).

To each of the girders (1) is bolted a 12½" × 2½" Strip Plate and a 5½" × 2½" Flexible Plate. These Plates are connected by a 12½" Strip (7) and they are edged on the outside by 12½" Strips extended by 2" Strips (see Fig. 1). The Plates are braced to the Strip (6) by two 5½" × ½" Double Angle Strips. Bolted underneath the Strip (7) are two 4½" × 2½" Flexible Plates and a 12½" × 2½" Strip Plate. The lower ends of the girders (1) are connected by two 12½" Angle Girders (8).

Each leg is fitted with two 1½" Flanged Wheels. These are fixed on 1½" Rods held by Collars in one of the Girders (8) and in 2½" Flat Girders (9). Each Flat Girder is bolted to a 2½" Angle Girder, and the latter in turn is supported by a 3½" Angle Girder fixed to the upper one of the Girders (8). The Flat Girders are braced to the girders (1) by 2½" and 3½" Strips as shown.

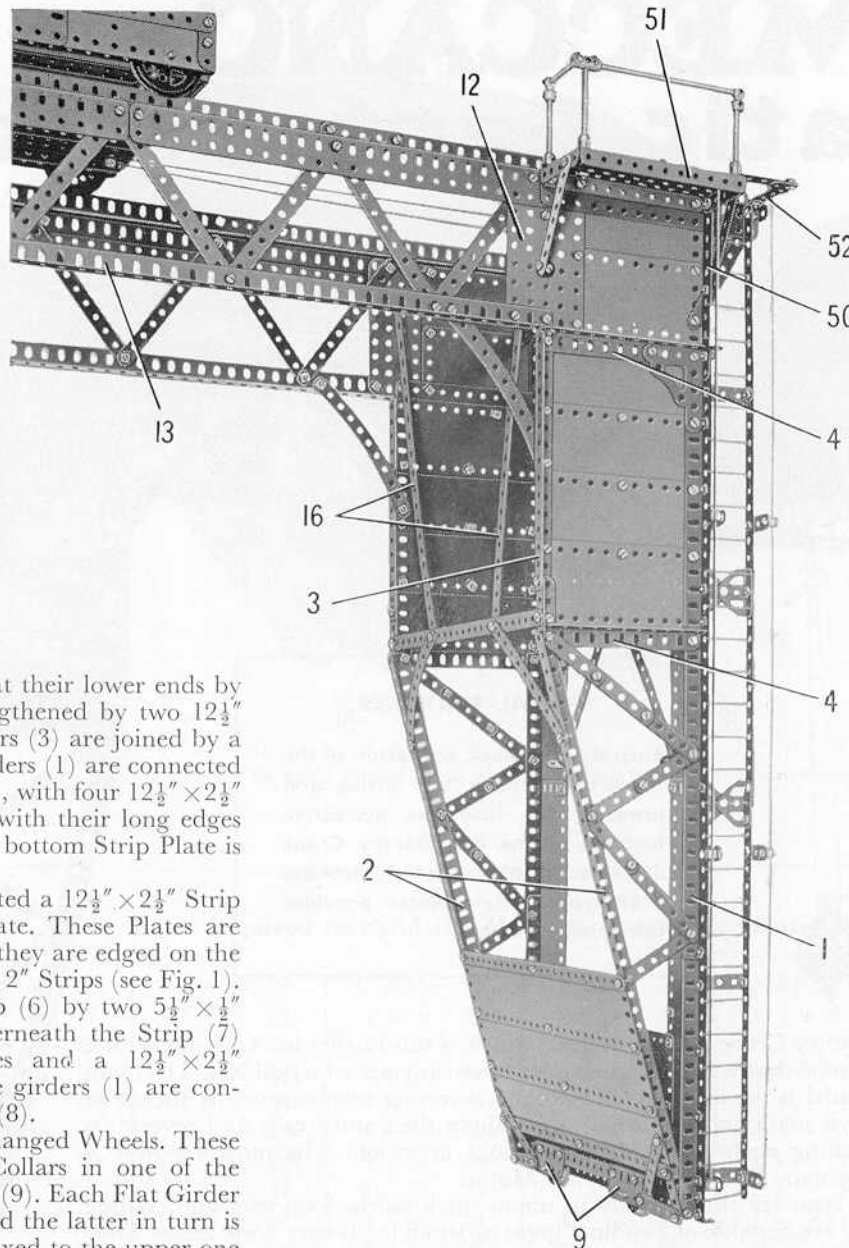

FIG. 2
A close-up view of one end of the gantry and its supporting tower. The ladder and the inspection platform can be seen in this picture

Construction of the Trolley Gantry (Figs. 1 & 2)

The main beam of each side of the gantry along which the trolley travels is made by bolting two 24½" Angle Girders to a 5½" × 3½" Flat Plate (10) at the centre (Fig. 1). The rails on which the trolley travels are each made from five 12½" Angle Girders bolted as shown to the 24½" Angle Girders, with the vertical joints covered by 2½" Strips. To each 24½" Angle Girder is fixed a 9½" Flat Girder, a 7½" Flat Girder and a 12½" Flat Girder.

At each end of the main beam a 4½" Angle Girder (11) is bolted, and towards the centre two 4½" × 2½" Flat Plates (12) are fixed in position. The two Flat Plates are connected by a girder (13), made from two 24½" Angle Girders overlapped one hole, with the joint strengthened by a 2½" Strip. The girder (13) is connected to the Flat Plate (10) by a 5½" Braced Girder.

The space between the Flat Plate (12) and the Angle Girder (11) at each end is filled by two 4½" × 2½" Flexible Plates. At one end a 3½" × 2" Triangular Flexible Plate, edged by a 4½" Strip as shown, is bolted to the Flexible Plates, but at the other end a 2½" × 1½" Triangular Flexible Plate is used. Each side of the gantry is braced by diagonal 5½" Strips.

The gantry is attached to each leg by bolting a 5½" Flat Girder to the ends of the Flat Plate (12) and the Angle Girder (11) and to the top one of the Girders (4). The sides of the gantry are connected by a built-up angle girder (14) made from two 12½" Strips joined together at the centre by a 1½" Angle Girder and at each end by an Angle Bracket. The gantry is tied to each leg by 5½" Strips (15) and by 12½" Strips (16). The top ends of the Strips (16) are attached to the Flat Plates (12) by Angle Brackets.

Details of the Trolley (Figs. 3, 6 and 7)

The side seen in Fig. 7 is made by bolting a 5½" × 3½" Flat Plate, a 5½" × 2½" Flat Plate, a 3½" × 2½" Flexible Plate and a 2½" × 2½" Flexible Plate to a 9½" Strip that forms the lower edge of the side. The rear edges of the Flat Plates are strengthened by a 5½" Angle Girder, and a 5½" Strip is bolted inside the front edges of the Flexible Plates. A 7½"

Strip extended by a $2\frac{1}{2}$ " Strip (17) is bolted along the top of the side. The Strip (17) is connected to the front end of the $9\frac{1}{2}$ " Strip by a $4\frac{1}{2}$ " Strip lengthened by a $1\frac{1}{2}$ " Strip. The side window of the control cabin is formed by a $4\frac{1}{2}$ " Strip (18) and a 3" Stepped Curved Strip.

The other side of the carriage is made by bolting a $5\frac{1}{2}$ " \times $3\frac{1}{2}$ " Flat Plate and two $3\frac{1}{2}$ " \times $2\frac{1}{2}$ " Flexible Plates to a $9\frac{1}{2}$ " Strip at the bottom and to a $7\frac{1}{2}$ " Strip extended by a $2\frac{1}{2}$ " Strip at the top. A $3\frac{1}{2}$ " Angle Girder is bolted to each end of this side. The sides are connected at the front by a $9\frac{1}{2}$ " Strip, attached at one end by an Angle Bracket and fixed at its other end to the $3\frac{1}{2}$ " Angle Girder. At the back a $9\frac{1}{2}$ " Angle Girder (19) is bolted to the $5\frac{1}{2}$ " and the $3\frac{1}{2}$ " Angle Girders.

Two $5\frac{1}{2}$ " \times $2\frac{1}{2}$ " Flanged Plates (20) and (21) are fixed to the Angle Girder (19) and to the sides of the carriage, and are connected at their inner ends by a $9\frac{1}{2}$ " Strip that supports a $4\frac{1}{2}$ " Angle Girder (22) (Fig. 3). A $5\frac{1}{2}$ " Strip (23) is bolted across the Flanged Plates.

The front of the trolley is partly filled in by a $5\frac{1}{2}$ " \times $2\frac{1}{2}$ " Flexible Plate and two $5\frac{1}{2}$ " \times $1\frac{1}{2}$ " Flexible Plates, one of which is bolted at an angle as shown in Fig. 7. The inner edges of these Plates are attached to a built-up strip (24) (Fig. 7) made from a $3\frac{1}{2}$ " and a $2\frac{1}{2}$ " Strip, and to this is fixed a $4\frac{1}{2}$ " Angle Girder (25), which is connected by an Angle Bracket to the Strip (18).

The front of the control cabin is formed by three $3\frac{1}{2}$ " Strips, each of which is connected to a Formed Slotted Strip by an Obtuse Angle Bracket. The Formed Slotted Strips are attached to the $9\frac{1}{2}$ " Strip at the front by Angle Brackets. The lower ends of the $3\frac{1}{2}$ " Strips are connected by a $4\frac{1}{2}$ " Strip, and two $2\frac{1}{2}$ " Strips are bolted to the upper ends. A $4\frac{1}{2}$ " Flat Girder is joined to the $2\frac{1}{2}$ " Strips by Fishplates. The

inner side window of the control cabin consists of a $3\frac{1}{2}$ " Strip and a $2\frac{1}{2}$ " Stepped Curved Strip, which is connected to the front of the trolley by an Angle Bracket. The front and side windows of the cabin are joined together by Angle Brackets bolted to the Strips.

The back of the trolley is filled in by a $5\frac{1}{2}$ " \times $3\frac{1}{2}$ " Flat Plate bolted vertically to the rear flange of the Flanged Plate (20) and to the $5\frac{1}{2}$ " Angle Girder of the side seen in Fig. 1. Another $5\frac{1}{2}$ " \times $3\frac{1}{2}$ " Flat Plate is bolted horizontally to the flange of the Flanged Plate (21) and to the $3\frac{1}{2}$ " Angle Girder of the corresponding side. A vertical $5\frac{1}{2}$ " \times $1\frac{1}{2}$ " Flexible Plate is fixed between the two Flat Plates, with another $5\frac{1}{2}$ " \times $1\frac{1}{2}$ " Flexible Plate bolted at an angle between the vertical Flexible Plate and the top outer corner of the horizontal $5\frac{1}{2}$ " \times $3\frac{1}{2}$ " Flat Plate. A $4\frac{1}{2}$ " Angle Girder (26) (Fig. 6) is fixed in position.

A $5\frac{1}{2}$ " \times $2\frac{1}{2}$ " Flat Plate (27) (Fig. 6) is bolted to a $2\frac{1}{2}$ " Angle Girder fixed to the back of the trolley, and is extended forward by a $5\frac{1}{2}$ " \times $1\frac{1}{2}$ " Flexible Plate connected to the strip (24) (Fig. 7) by an Angle Bracket. Two $4\frac{1}{2}$ " \times $\frac{1}{2}$ " Double Angle Strips are bolted between this assembly and the side of the trolley. The fixed section of the roof consists of two $9\frac{1}{2}$ " \times $2\frac{1}{2}$ " Strip Plates and these are bolted to the Double Angle Strips and to the Angle Girders (25) and (26).

The hinged part (28) of the roof is formed by two $9\frac{1}{2}$ " \times $2\frac{1}{2}$ " Strip Plates joined at the centre by a $4\frac{1}{2}$ ", a $3\frac{1}{2}$ ", and a 3" Flat Girder. The inner edge of this section is strengthened by a $7\frac{1}{2}$ " and a $2\frac{1}{2}$ " Strip, and a $9\frac{1}{2}$ " Strip is bolted along the outer edge. The ends are braced by $2\frac{1}{2}$ " Strips. This section is supported by two Hinges, one of which is bolted to the Flat Plate (27) and the other to the centre hole of the $5\frac{1}{2}$ " \times $1\frac{1}{2}$ " Flexible Plate that extends the

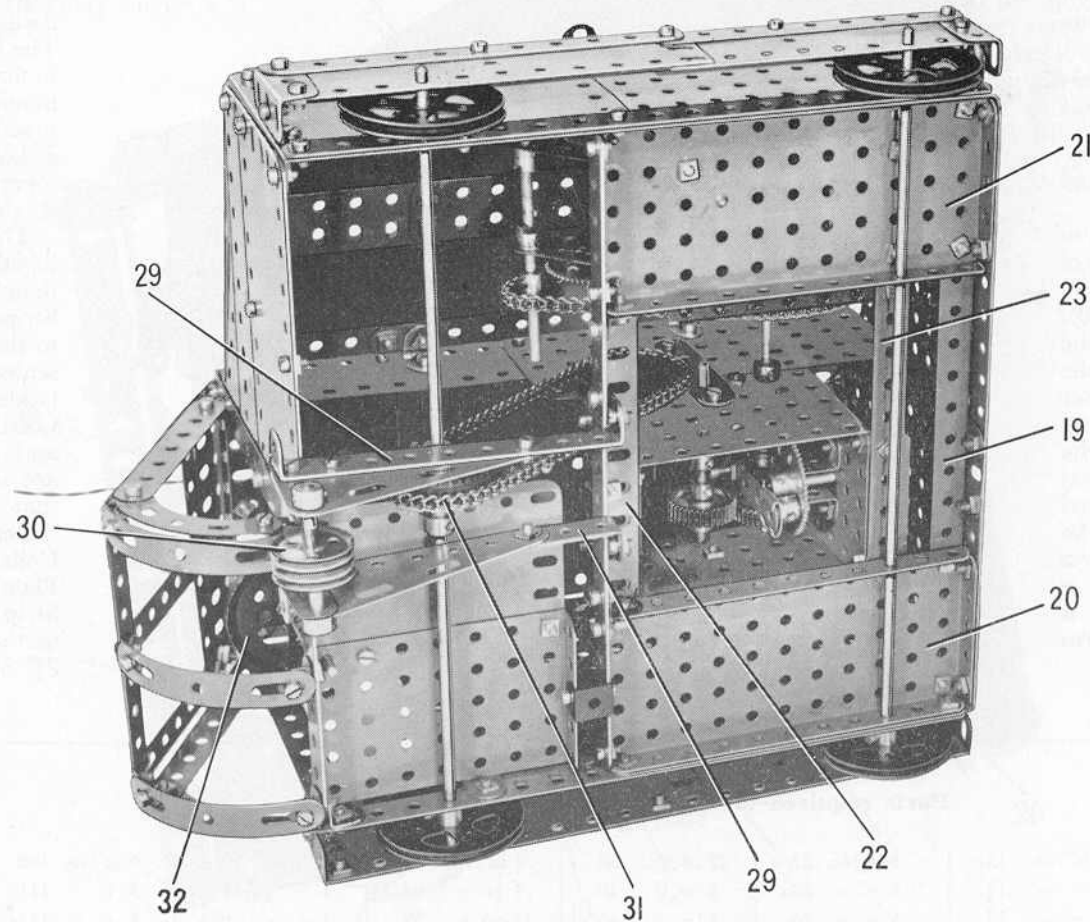

FIG. 3 The trolley seen from underneath, revealing the axle mountings and the friction drive fitted to the front axle

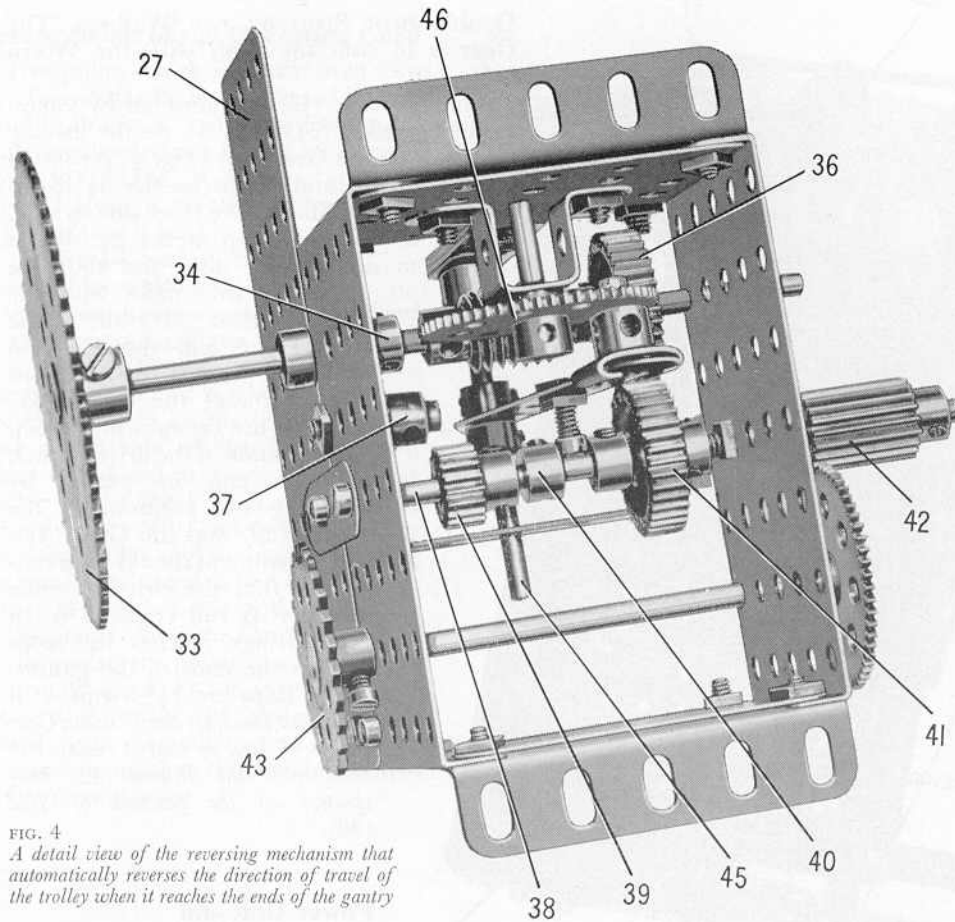

FIG. 4
A detail view of the reversing mechanism that automatically reverses the direction of travel of the trolley when it reaches the ends of the gantry

Flat Plate. The Hinges are spaced from the Plates by two Washers on each bolt.

Two $4\frac{1}{2}'' \times \frac{1}{2}''$ Double Angle Strips (29) (Fig. 3) are attached by Fishplates to the Angle Girder (22), and are connected by Corner Angle Brackets to the front of the trolley. A $3\frac{1}{2}'' \times 1\frac{1}{2}''$ Triangular Flexible Plate, edged at the front by a $1\frac{1}{2}''$ Strip, is bolted to each Double Angle Strip, and these support a 2" Rod that carries three 1" loose Pulleys indicated at (30) (Figs. 3 and 7).

The wheels on which the trolley is mounted are 2" Pulleys fixed on $1\frac{1}{8}''$ Rods. A $1\frac{1}{2}''$ Sprocket (31) (Fig. 3) is loose on the front Rod, but is pressed against a 1" Pulley (fitted with a Motor Tyre) by a Compression Spring placed between the Sprocket and a Collar. The 1" Pulley is fixed on the Rod, and this arrangement provides a friction drive that slips when the trolley reaches the stops at each end of the gantry, and continues to slip until the automatic mechanism reverses the direction of the drive and sends the trolley on its return journey.

The floor of the control cabin consists of a $3\frac{1}{2}'' \times 2\frac{1}{2}''$ Flanged Plate extended by a $3\frac{1}{2}'' \times 2\frac{1}{2}''$ Flexible Plate. The Flanged Plate is fixed to the front of the trolley and is connected to the Flexible Plate (20) by a Double Bracket. A Crank bolted to the $3\frac{1}{2}'' \times 2\frac{1}{2}''$ Flanged Plate supports a $1\frac{1}{2}''$ Rod fitted with a Coupling and a 2" Pulley (32). A curved $2\frac{1}{2}'' \times 1\frac{1}{2}''$ Flexible Plate and two curved $2\frac{1}{2}'' \times 1\frac{1}{2}''$ Triangular Flexible Plates are bolted together and are spaced by Washers from an Angle Bracket fixed underneath the Pulley.

The guards over the travelling wheels are made by bolting $5\frac{1}{2}'' \times 1\frac{1}{2}''$ Flexible Plates to a $9\frac{1}{2}''$ Angle Girder on one side and to a $5\frac{1}{2}''$ and a $4\frac{1}{2}''$ Angle Girder on the other side. Two $1\frac{1}{2}''$ Angle Girders are fixed to the ends of each guard, and these are connected to the sides of the trolley by Angle Brackets.

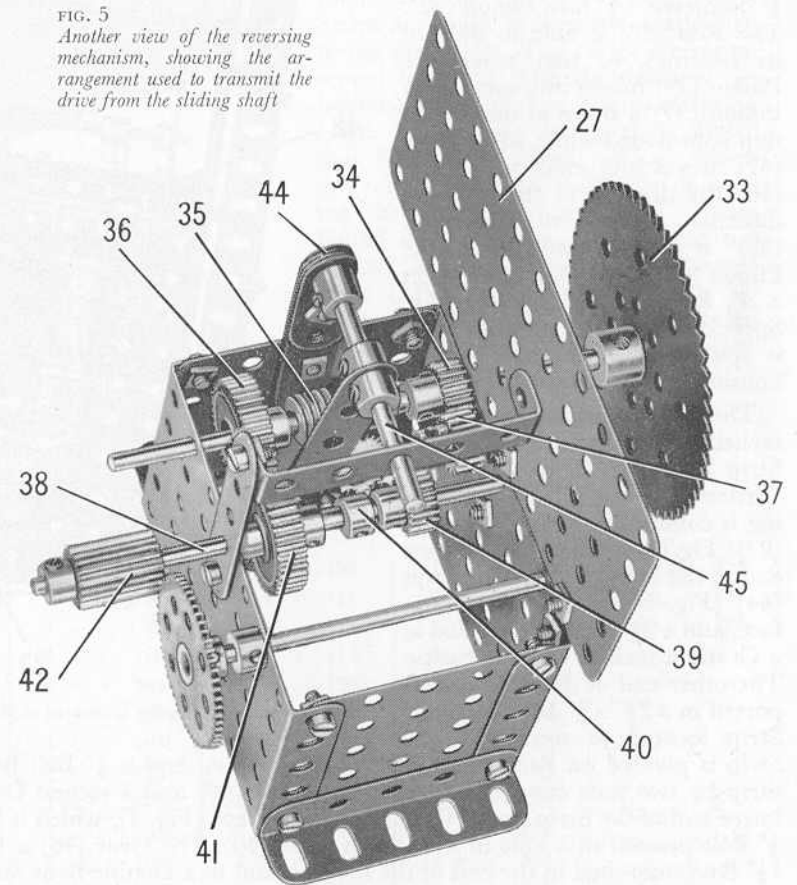

FIG. 5
Another view of the reversing mechanism, showing the arrangement used to transmit the drive from the sliding shaft

The Automatic Reversing Mechanism (Figs. 4 and 5)

The housing for the automatic reversing mechanism, which is enclosed in the trolley, consists of two $3\frac{1}{2}'' \times 2\frac{1}{2}''$ Flanged Plates connected at their ends by $2\frac{1}{2}'' \times 2\frac{1}{2}''$ Flat Plates. The driving shaft is a 5" Rod that carries a 3" Sprocket (33), a $\frac{1}{2}''$ Pinion (34), a Worm (35) and a 1" Gear (36). The Rod is mounted in the housing and is held in place by a collar. A $\frac{1}{2}''$ Pinion (37) is free to turn on a $\frac{3}{8}''$ Bolt fixed in the side of the housing by two nuts. The driven shaft is a $4\frac{1}{2}''$ Rod (38) fitted with a $\frac{1}{2}''$ Pinion (39), a Collar (40), a 1" Gear (41) and a $\frac{1}{2}''$ diameter $\times \frac{3}{4}''$ face Pinion (42). The Rod (38) is able to slide in its bearings, so that when the Pinion (39) moves into mesh with Pinion (37) a drive in one direction is provided while when Gear (41) moves into mesh with Gear (36) the drive is in the opposite direction. The drive from Rod (38) is transmitted from the Pinion (42) to a 57-tooth Gear on a 4" Rod, which carries a $1\frac{1}{2}''$ Sprocket (43). The 57-tooth Gear is spaced from the side of the housing by a Collar.

The mechanism housing is attached to the Girder (22) and the Strip (23) (Fig. 3) by $2\frac{1}{2}''$ Angle Girders, and one side of the housing is connected to the Flat Plate (27) (Fig. 6) by a $2\frac{1}{2}''$ Strip. At one end of the housing four $2\frac{1}{2}''$ Strips (44) (Fig. 5) are bolted face-to-face, and a $2\frac{1}{2}''$ Rod (45) is fixed in a Crank attached to these Strips. The other end of this Rod is supported in a $2\frac{1}{2}'' \times \frac{1}{2}''$ Double Angle Strip located as shown. A $3\frac{1}{2}''$ Strip is pivoted on Rod (45) between two Collars, and a $\frac{3}{8}''$ Bolt held in the Strip by two nuts engages between the Collar (40) and a second Collar. The lower end of the Strip passes through a Slide Piece (Fig. 4), which is fixed on a $\frac{3}{8}''$ Bolt pivoted in a hole in a 57-tooth Gear (46). The Gear (46) is fixed on a $1\frac{1}{2}''$ Rod, mounted in the end of the housing and in a Double Bent Strip bolted to it. The Rod is held in position by a Collar, and the Gear is spaced from the

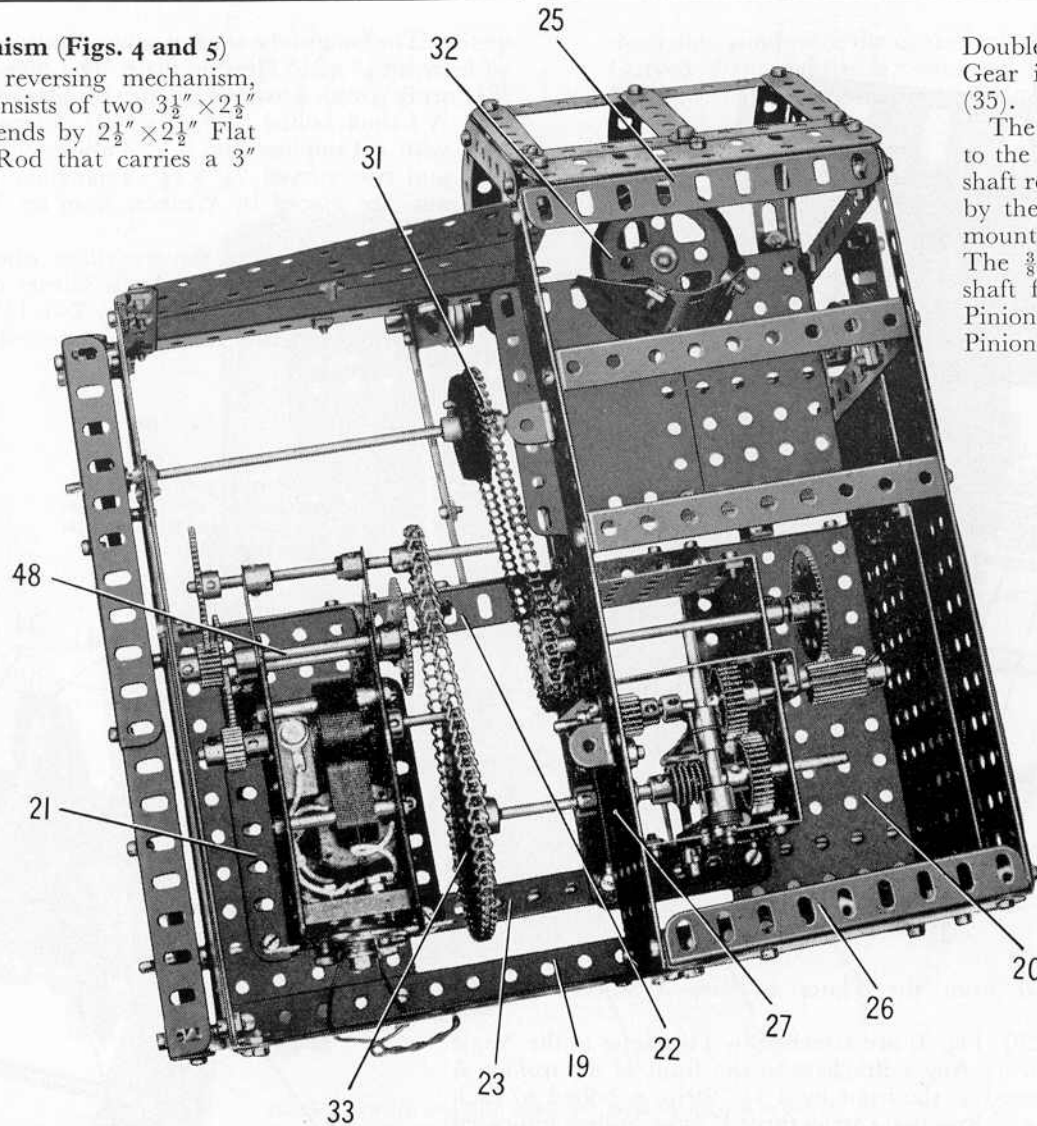

FIG. 6
The roof of the trolley is removed in this picture to show the reduction gearing fitted to the Electric Motor

Double Bent Strip by two Washers. The Gear is in constant mesh with the Worm (35).

The Sprocket (31) (Fig. 3). As the driving shaft rotates the Gear (46) (Fig. 4) is rotated by the Worm, and so carries the $3\frac{1}{2}''$ Strip mounted in the Slide Piece from side to side. The $\frac{3}{8}''$ Bolt in the Strip moves the driven shaft from side to side also, and thus the Pinion (39) is moved into mesh with the Pinion (37) when the Rod (38) slides to the right, Fig. 5, and when the Rod moves to the left these Pinions disengage and the Gears (41) and (36) are brought into mesh. The duration of the drive in each direction can be varied by adjusting the positions of the Pinion (39) and the Gear (41). The adjustment should be arranged so that the drive in each direction is still engaged when the carriage reaches the stops (47) at the ends of the gantry. These stops are $1\frac{1}{2}''$ Strips. *It is important to adjust the 57-tooth Gear on the 4" Rod so that it remains in mesh with the Pinion (42) irrespective of the position of Rod (38).*

Power Unit and Reduction Gearing (Fig. 6)

An E15R Electric Motor is bolted by its flanges to the Flanged Plate (21) and the Strip (23), and each side-plate is extended by a $1\frac{1}{2}''$ Corner Bracket bolted level with its top edge. A $\frac{1}{2}''$ Pinion on the Motor shaft drives a 57-tooth Gear on a 3" Rod (48), which is supported in the top holes of the side-plates and is held in place by a Collar. A $\frac{1}{2}''$ Pinion on Rod (48) drives a 57-tooth Gear on a 4" Rod that is held in the Corner Brackets by the separated halves of a Dog Clutch. A $\frac{3}{4}''$ Sprocket on the 4" Rod is connected by Chain to the 3" Sprocket (33).

Arrangement of the Operating Cord

The pulley block is made from two $2\frac{1}{2}$ " Triangular Plates connected by two Double Brackets, and each Triangular Plate is extended downward by a Semi-Circular Plate. A large Loaded Hook is pivoted on a $\frac{3}{4}$ " Bolt that is held by nuts in the Semi-Circular Plates. Two 1" loose Pulleys (49) (Fig. 1) are mounted on a $\frac{3}{4}$ " Bolt fixed in the Triangular Plates.

A length of Cord is tied at one end to the girder (14) and is taken over one of the Pulleys (30) on the trolley (Fig. 7) and round one of the Pulleys (49). Then the Cord is passed round the centre one of the Pulleys (30) and the second Pulley (49), and then taken over the third Pulley (30) and led back along the gantry, where it is tied again to the girder (14). When the trolley is nearest to the points where the Cord is attached to the girder, the pulley block should be at ground level. As the carriage moves along the gantry the pulley block is raised automatically, and then is lowered again when the carriage returns to its starting point.

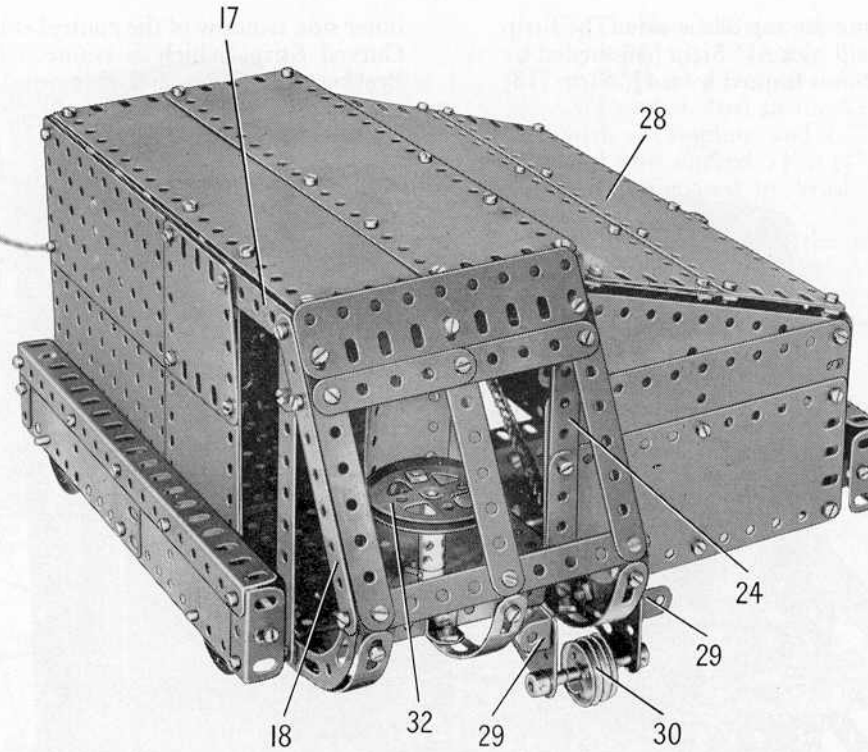

FIG. 7
A front view of the trolley showing details of the plating and the assembly of the operating cabin

The Inspection Ladder (Fig. 2)

The girder (1) of one leg of the crane is extended upward by a $5\frac{1}{2}$ " Strip (50), which is bolted at the top to an end flange of a $5\frac{1}{2}$ " x $2\frac{1}{2}$ " Flanged Plate (51). The Flanged Plate is fixed to the gantry to form a platform, and it is fitted with handrails as shown. The platform is braced by two $3\frac{1}{2}$ " Strips, one of which is bolted to the Strip (50) while the other is connected to the gantry by an Angle Bracket.

The ladder sides are made by bolting together three $12\frac{3}{8}$ " Strips, which are then fixed to $1\frac{1}{2}$ " x $\frac{1}{2}$ " Double Angle Strips and pairs of Trunnions attached to the girder (1). The rungs are represented by Cord. The Handrails of the ladder are provided by lengths of Spring Cord. These are arranged as shown and fixed in Collars, six of which are screwed on to the ends of bolts that are held by nuts in $1\frac{1}{2}$ " Strips bolted to the ladder. One of the top Collars is placed above the Flanged Plate (51) and the other above a $2\frac{1}{2}$ " Strip (52). The Strip (52) is connected to the Flanged Plate (51) by another $2\frac{1}{2}$ " Strip.

Parts required to build the Meccano Automatic Gantry Crane

24 of No. 1	16 of No. 8	3 of No. 12c	1 of No. 22	22 of No. 38	1 of No. 57b	2 of No. 95a	4 of No. 108	1 of No. 154b	4 of No. 221
5 " " 1a	6 " " 8a	2 " " 13	5 " " 22a	3 " " 40	1 " " 58	1 " " 95b	3 " " 111	2 " " 179	2 " " 224
6 " " 1b	4 " " 8b	2 " " 15	5 " " 26	1 " " 45	23 " " 59	1 " " 96a	4 " " 111c	1 " " 188	2 " " 225
36 " " 2	10 " " 9	1 " " 15a	1 " " 26b	3 " " 48	3 " " 62	2 " " 100	2 " " 114	9 " " 189	
7 " " 2a	8 " " 9a	1 " " 15b	1 " " 26c	1 " " 48a	2 " " 63	4 " " 103	1 " " 120b	1 " " 190	
17 " " 3	6 " " 9b	1 " " 16	4 " " 27a	4 " " 48c	2 " " 70	4 " " 103a	4 " " 126	4 " " 190a	
10 " " 4	7 " " 9d	3 " " 16a	1 " " 27d	4 " " 48d	2 " " 72	4 " " 103b	2 " " 133	12 " " 191	
54 " " 5	4 " " 9e	2 " " 16b	2 " " 31	1 " " 50	2 " " 76	2 " " 103c	1 " " 133a	21 " " 192	
7 " " 6	6 " " 9f	4 " " 17	1 " " 32	3 " " 52	8 " " 89	1 " " 103d	2 " " 136a	4 " " 196	
10 " " 6a	7 " " 10	5 " " 18a	2 " " 35	6 " " 52a	1 " " 89a	1 " " 103e	1 " " 142c	20 " " 197	
8 " " 7	3 " " 11	4 " " 20	685 " " 37a	3 " " 53	1 " " 90a	4 " " 103f	1 " " 144	2 " " 214	
8 " " 7a	36 " " 12	5 " " 20a	669 " " 37b	4 " " 53a	1 " " 94	4 " " 103k	1 " " 154a	3 " " 215	1 E15R Electric Motor (not included in Outfit)

MECCANO

Automatic Snow Loader

(MODEL No. 10.11)

In severe winters, when heavy and sometimes quite unexpected falls of snow often occur, one of the most urgent necessities is to maintain the roads and highways open for traffic. In large cities especially this is a gigantic task, and until comparatively recent years it had to be tackled manually by large numbers of men working with shovels. The problem is not so serious perhaps in Great Britain as in Canada and some parts of the United States, where the winters are more severe and the areas to be covered are much greater. It is therefore not surprising that machines have now been devised to clear away the snow and ice more quickly than it can be done by gangs of men armed with shovels and brushes.

One of the most interesting machines of this kind forms the prototype of the attractive working model described in this Leaflet, and which is shown complete in Fig. 1. This machine picks up snow and ice as it is driven along, and passes it by means of a conveyor belt either to one side of the road, where it does not interfere unduly with traffic, or directly into lorries that carry it away. The snow is picked up by means of a gathering head that projects from the front of the machine. This has a toothed edge that digs easily into the frozen snow, which is then swept by rotating sweeping arms on to a conveyor, that passes up through the driver's cab and overhangs the rear of the vehicle. The rear section of the conveyor can be swivelled sideways, so that the snow can be discharged into a lorry standing alongside or dumped at either side or rear of the vehicle. Some machines of this kind can clear as much as 15 to 20 cubic yards of snow and ice per minute.

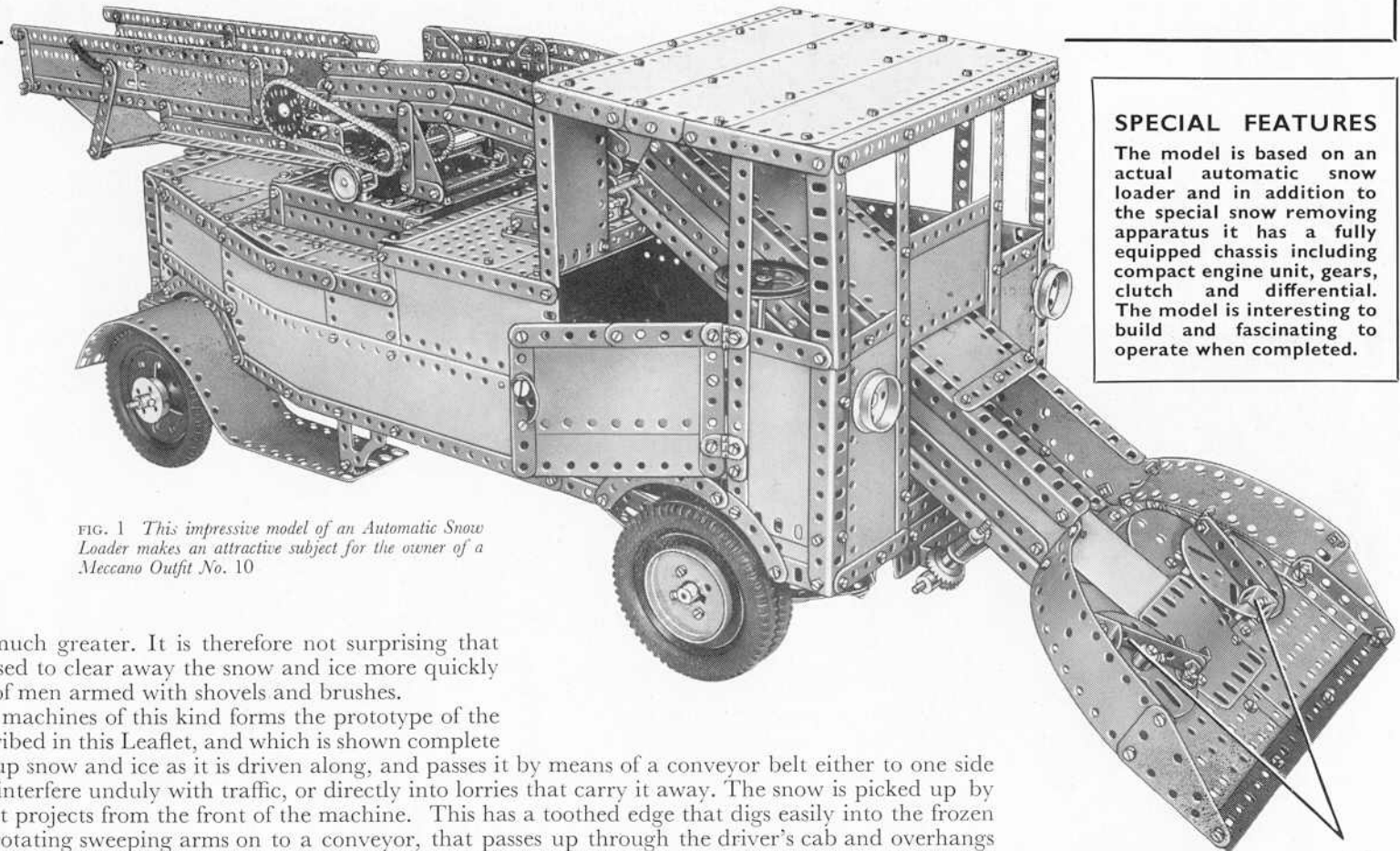

FIG. 1 This impressive model of an Automatic Snow Loader makes an attractive subject for the owner of a Meccano Outfit No. 10

SPECIAL FEATURES

The model is based on an actual automatic snow loader and in addition to the special snow removing apparatus it has a fully equipped chassis including compact engine unit, gears, clutch and differential. The model is interesting to build and fascinating to operate when completed.

The Meccano model shows all the main working features of the real machine and is a most interesting one to build and operate. It is driven by a Meccano E15R Electric Motor, and has a fully equipped chassis, including clutch, gear-box and differential.

Building the Model: The Chassis (Fig. 4)

Each side-member of the chassis consists of two 24 1/2" Angle Girders joined at their ends by Fishplates to form a channel section girder. The side-members are connected at each end by two 5 1/2" Angle Girders with the top corners braced by 1 1/2" Corner Brackets. At one end a 9 1/2" Angle Girder (1) (Fig. 3) is bolted across the chassis and a second 9 1/2" Angle Girder (2) is fixed in position as shown.

The box-like structure that supports the conveyors consists of two 4 1/2" Angle Girders on each side, connected at their lower ends by a 5 1/2" Strip, and at the top by a 5 1/2" Angle Girder (3) (Fig. 7). On one side a 5 1/2" x 3 1/2" Flat Plate is fixed between the vertical 4 1/2" Angle Girders, and on the other side a 5 1/2" x 2 1/2" Flat Plate is used. The Girders (3) are connected by a 5 1/2" x 2 1/2" Flat Plate (4), strengthened by a 5 1/2" Angle Girder and a 5 1/2" Strip. Two 5 1/2" Strips (5) placed face-to-face, and a single 5 1/2" Strip (6), are bolted also to the Girders (3) (Fig. 7). The structure is attached to the chassis side-members by two 1" x 1" Angle Brackets on each side.

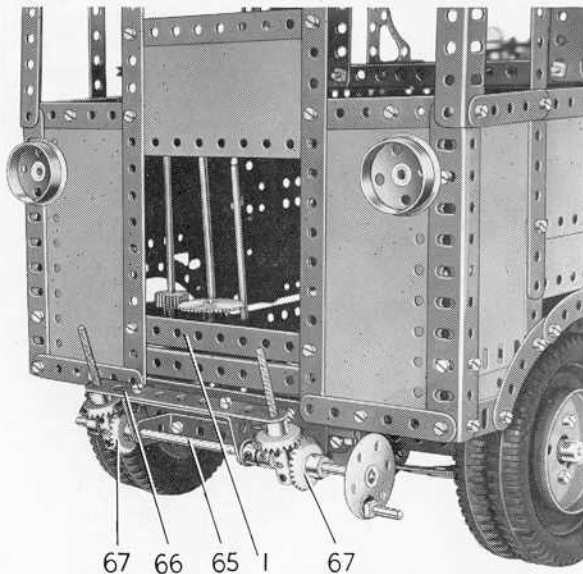

FIG. 2 A close-up of the Snow Loader cab, showing the screw mechanism provided for adjusting the height of the conveyor gathering head

Details of the Driving Axle (Figs. 3 and 4)

The axle casing is built in two sections, each of which is made by bolting four 2 1/2" x 1/2" Double Angle Strips between a Boiler End and a Face Plate. At a later stage when the differential unit is assembled, the sections are connected by fixing four 2" Strips between the Boiler Ends. One of these Strips is spaced from each Boiler End by two Washers, and a Double Bent Strip is bolted to this Strip. A 1/2" Pinion (7) (Fig. 4) is fixed on a 1 1/2" Rod, mounted in the Strip and the Double Bent Strip.

To assemble the differential a 5" Rod is passed through one section of the axle casing and on it a 1 1/2" Contrate is freely mounted. This Contrate is spaced from the Boiler End by Washers so that it meshes with the Pinion (7). A 3/4"

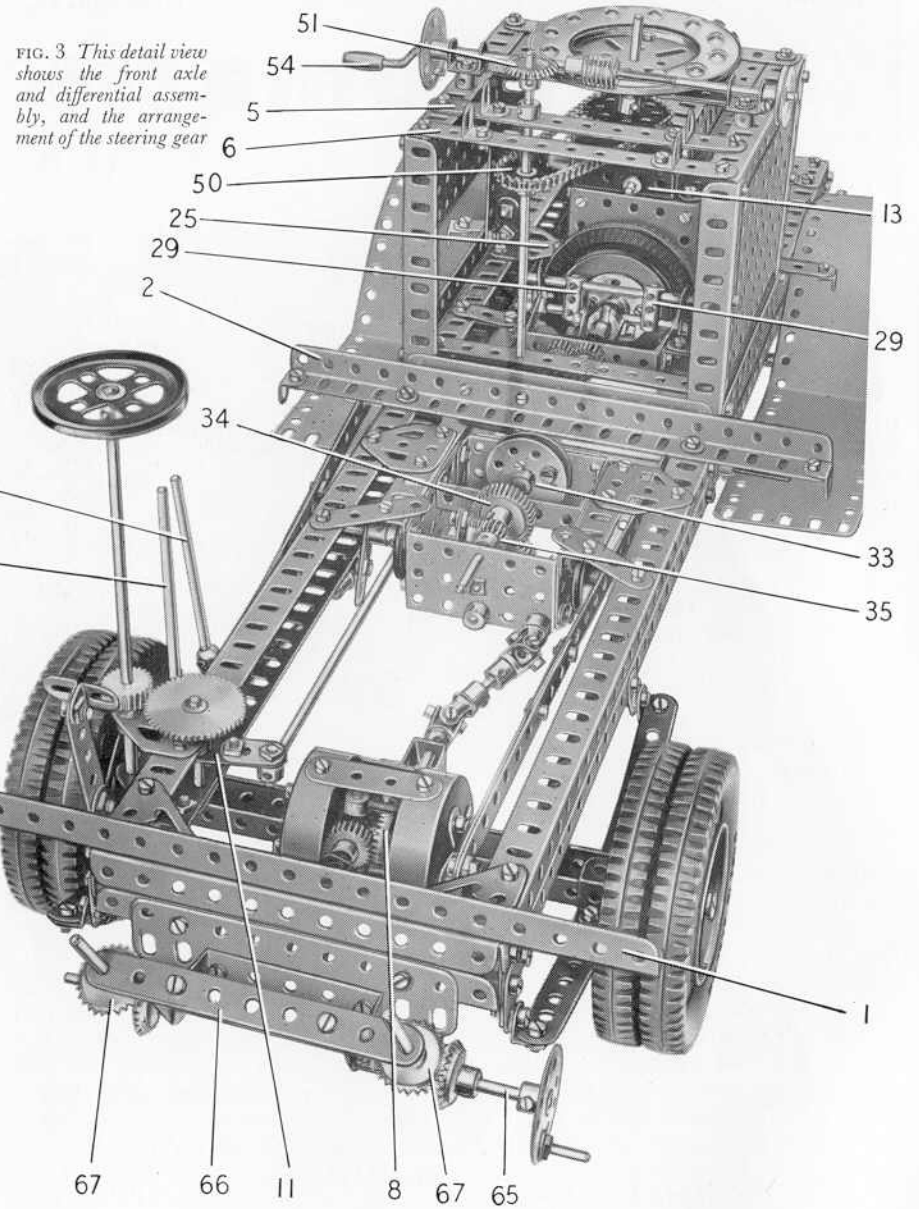

FIG. 3 This detail view shows the front axle and differential assembly, and the arrangement of the steering gear

Contrate (8) is fixed on the 5" Rod, but is spaced from the 1½" Contrate by two Washers. The end of the Rod is inserted in a Coupling, through the centre cross hole of which a 1½" Rod is passed. This Rod is gripped in two Collars, each of which is screwed on to the end of a 1" Screwed Rod fixed in a hole in the 1½" Contrate by two nuts. Two ¾" Pinions are freely mounted on Pivot Bolts and these are screwed tightly into the Coupling so that the Pinions mesh with the Contrate (8). A second ¾" Contrate is fixed on a 4½" Rod supported in the other half of the axle casing. This Contrate is spaced from its Boiler End by Washers, so that it meshes with the ¾" Pinions.

The axle is supported by leaf springs, each of which consists of a 7½", a 5½", a 4½", a 3½" and a 2½" Strip. The axle is clamped by the lug of a ½" Reversed Angle Bracket bolted to each spring, and is prevented from sliding by an Angle Bracket also secured to the spring.

Angle Brackets are bolted to the ends of each 7½" Strip, and one of them is lock-nutted to a 1" Corner Bracket fastened to the front of the chassis. The other Angle Bracket is lock-nutted to a Fishplate bolted to the chassis.

The rear axle beam is a 7½" Angle Girder bolted to the springs, with a 1½" Strip covering the slotted holes at each end of the Girder. A 1½" Rod on each side is mounted in the end hole of the Strip and in a ½" Reversed Angle Bracket bolted to the Angle Girder. Each of these Rods carries a Crank (9) at its lower end, and the two Cranks are connected by a built-up strip made from two 5½" Strips overlapped seven holes. The strip is attached to the Cranks by lock-nutted bolts.

One of the 1½" Rods is fitted with a Handrail Coupling placed between the Angle Girder and the Reversed Angle Bracket. A 2" Rod is fixed in the Handrail Coupling, and the road wheel is free to turn on it. The wheel is spaced from the Handrail Coupling by a 1½" Pulley and a 1" loose Pulley, and is held in position by a 1½" Flanged Wheel. A second Handrail Coupling is fixed to the top end of the vertical 1½" Rod and another 1½" Rod (10) is gripped in it (Fig. 4).

The vertical 1½" Rod at the other end of the axle beam carries a Coupling placed between the Girder and the ½" Reversed Angle Bracket. The road wheel is free

on a 2" Rod held in the Coupling but is spaced from it by a 1½" Pulley and is held in place by a 1½" Flanged Wheel.

The steering column is a 6½" Rod supported in Flat Trunnions bolted to the chassis (Fig. 3). A ¾" Pinion on the steering column engages a 50-tooth Gear on a 2" Rod that carries also a Crank (11). An 11½" Screwed Rod is fixed by a nut on a Collar, which pivots freely on a ½" Bolt held by two nuts in the Crank (11).

The Screwed Rod is connected by a Threaded Coupling to a 6½" Rod fitted

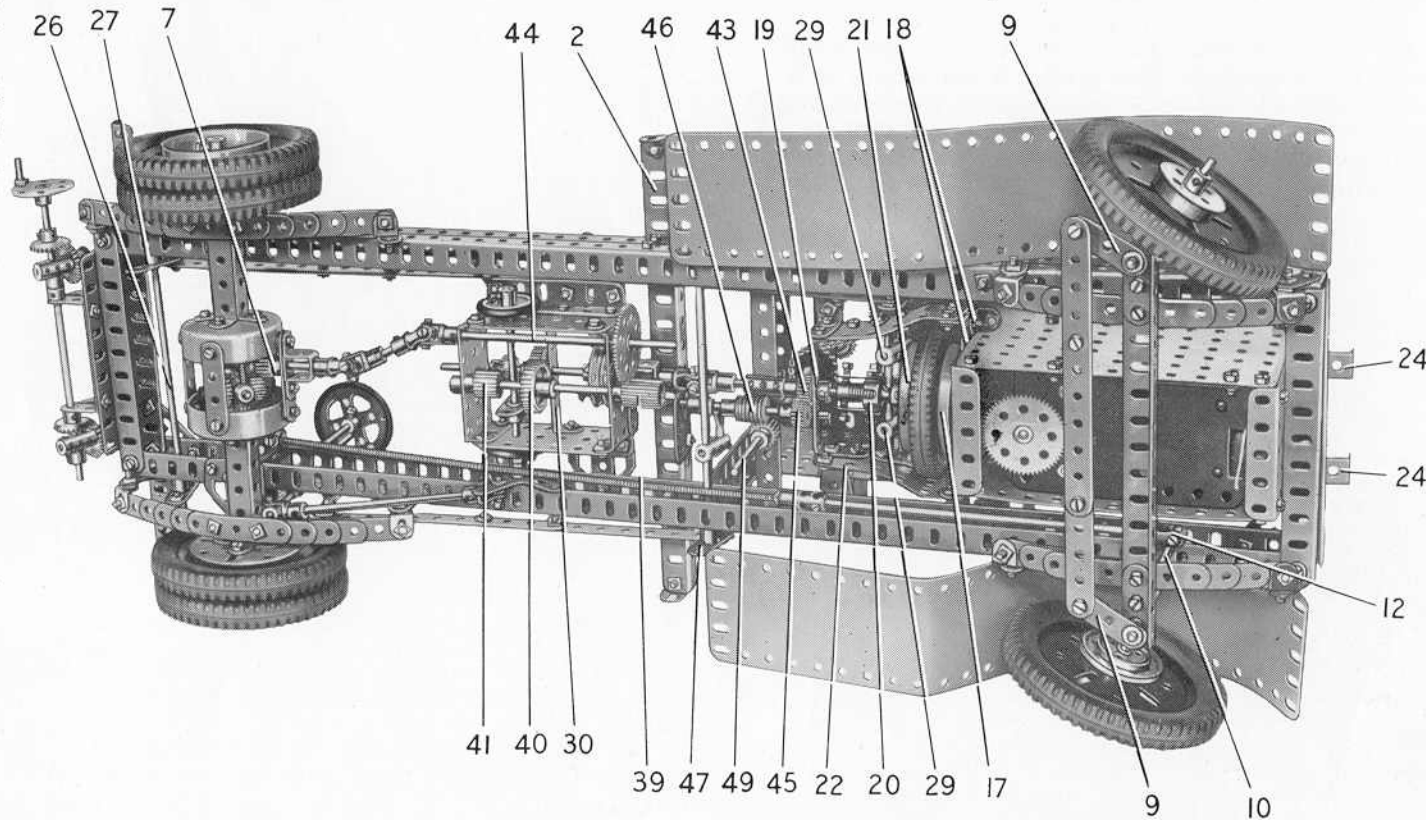

FIG. 4 This underneath view of the Snow Loader chassis reveals the arrangement of the drive to the front wheels

Rear Axle and Steering Mechanism (Fig. 4)

The vehicle steers by the rear wheels. Each of the rear springs consists of a 5½", a 4½", a 3½" and a 2½" Strip. The 5½" Strip is fitted at its ends with Angle Brackets, one of which is lock-nutted to a 1" Triangular Plate bolted to the chassis.

The other Angle Bracket is lock-nutted to a Fishplate also bolted to the chassis.

with a Swivel Bearing (12) (Fig. 4). The spider of the Swivel Bearing is fixed on the end of the Rod (10).

The Engine Unit and Clutch (Figs. 4, 5 and 6)

The sides of the engine unit are $5\frac{1}{2}'' \times 3\frac{1}{2}''$ Flat Plates, and the ends are $3\frac{1}{2}'' \times 2\frac{1}{2}''$ Flanged Plates connected to the former by $3\frac{1}{2}''$ Angle Girders. An E15R Electric Motor is fixed through its flanges to one side of the unit (Fig. 5). A Girder Bracket (13) (Fig. 5) is fixed to each of the $3\frac{1}{2}'' \times 2\frac{1}{2}''$ Flanged Plates and a 2" Angle Girder is bolted to it.

A $\frac{1}{2}''$ Pinion on the lower end of the Motor shaft drives a 57-tooth Gear on a $2\frac{1}{2}''$ Rod supported in the Motor side-plates. The top end of this Rod carries a $\frac{1}{2}''$ Pinion (14) (Fig. 5), and this engages a $1\frac{1}{2}''$ Contrate on a $2\frac{1}{2}''$ Rod mounted in one end of the engine unit and in a $2\frac{1}{2}'' \times \frac{1}{2}''$ Double Angle Strip (15) bolted across it. A $\frac{1}{2}''$ Pinion (16) is fixed on the $2\frac{1}{2}''$ Rod and engages a 57-tooth Gear on the clutch driving shaft, which is a 2" Rod supported in the end of the engine unit and in a Double Bent Strip bolted to the inside of the Flanged Plate that forms the end. A Wheel Flange (17) (Fig. 6) bolted to a Bush Wheel forms the fixed clutch plate.

The clutch housing is made by fixing two $3\frac{1}{2}'' \times \frac{1}{2}''$ Double Angle Strips (18)

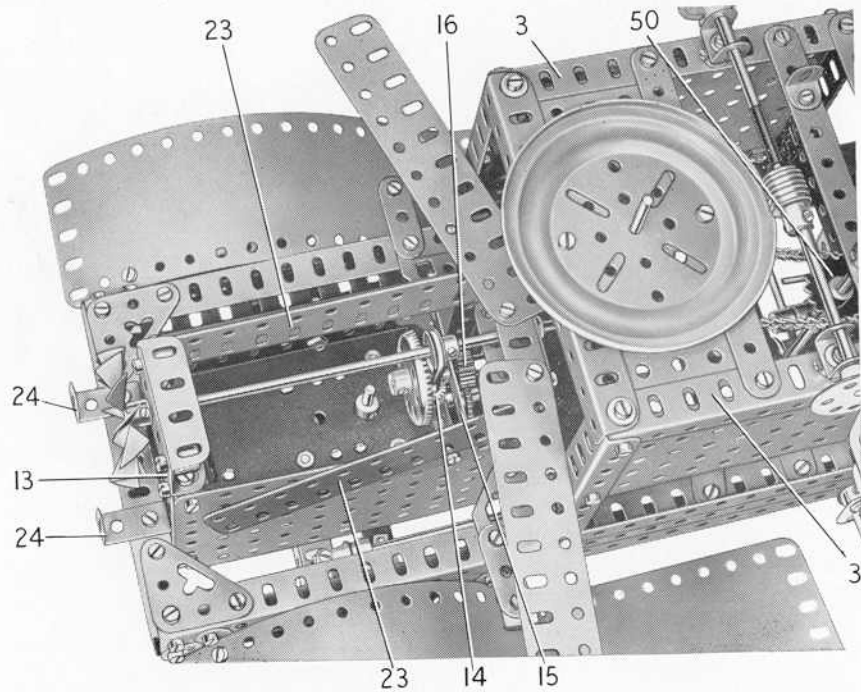

FIG. 5 The cover plates of the engine unit are swung aside here to reveal details of the speed reduction gearing and the drive to the cooling fan

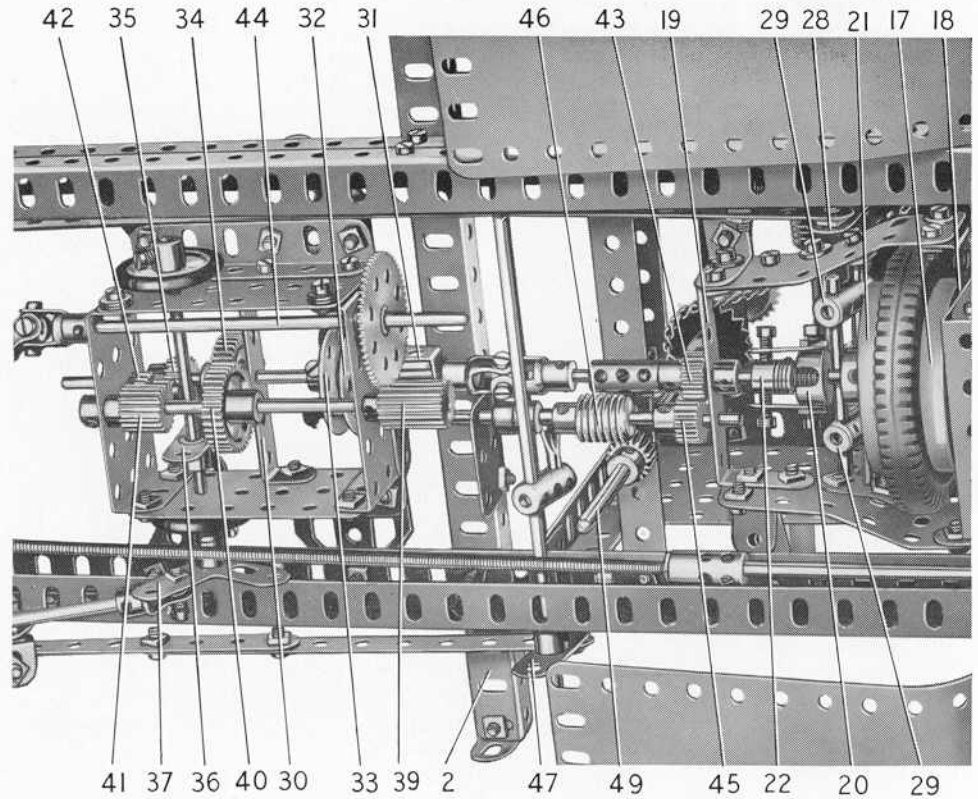

FIG. 6 A close-up of the clutch and gear-box mechanisms of the Snow Loader

across one end of the engine unit. Two 3" Flat Girders, shaped as shown, are bolted to the lugs of the Double Angle Strips (18) and are connected by a $2\frac{1}{2}'' \times 1''$ Double Angle Strip (19).

A Bush Wheel (8-holes) is gripped in a Socket Coupling (20) and is connected to a Wheel Flange (21) by two $\frac{3}{8}''$ Bolts, but is spaced from the Wheel Flange by nuts on the Bolts. The ends of the Bolts must not project beyond the nuts that fix them to the Wheel Flange. This arrangement is used so that the boss of a 2" Pulley can be supported in the large centre hole of the Wheel Flange (21). The 2" Pulley is fitted with a Motor Tyre and is free to turn on the clutch driving shaft.

The Bush Wheel and the Socket Coupling (20) are freely mounted on the clutch output shaft, but are made to turn with the shaft by two Fishplates, each of which is fixed by a nut and a bolt in the Socket Coupling. A $\frac{3}{8}''$ Bolt passed through the slotted hole of each Fishplate is screwed into a Collar (22) (Fig. 6) on the clutch output shaft. This shaft is a $2\frac{1}{2}''$ Rod, and a Compression Spring and four Washers are placed on it between the Collar (22) and the Socket Coupling. A second Collar is fixed on the shaft next to the Double Angle Strip (19). The Compression Spring presses the Wheel Flange (21) and the Tyre on the 2" Pulley into contact with the Wheel

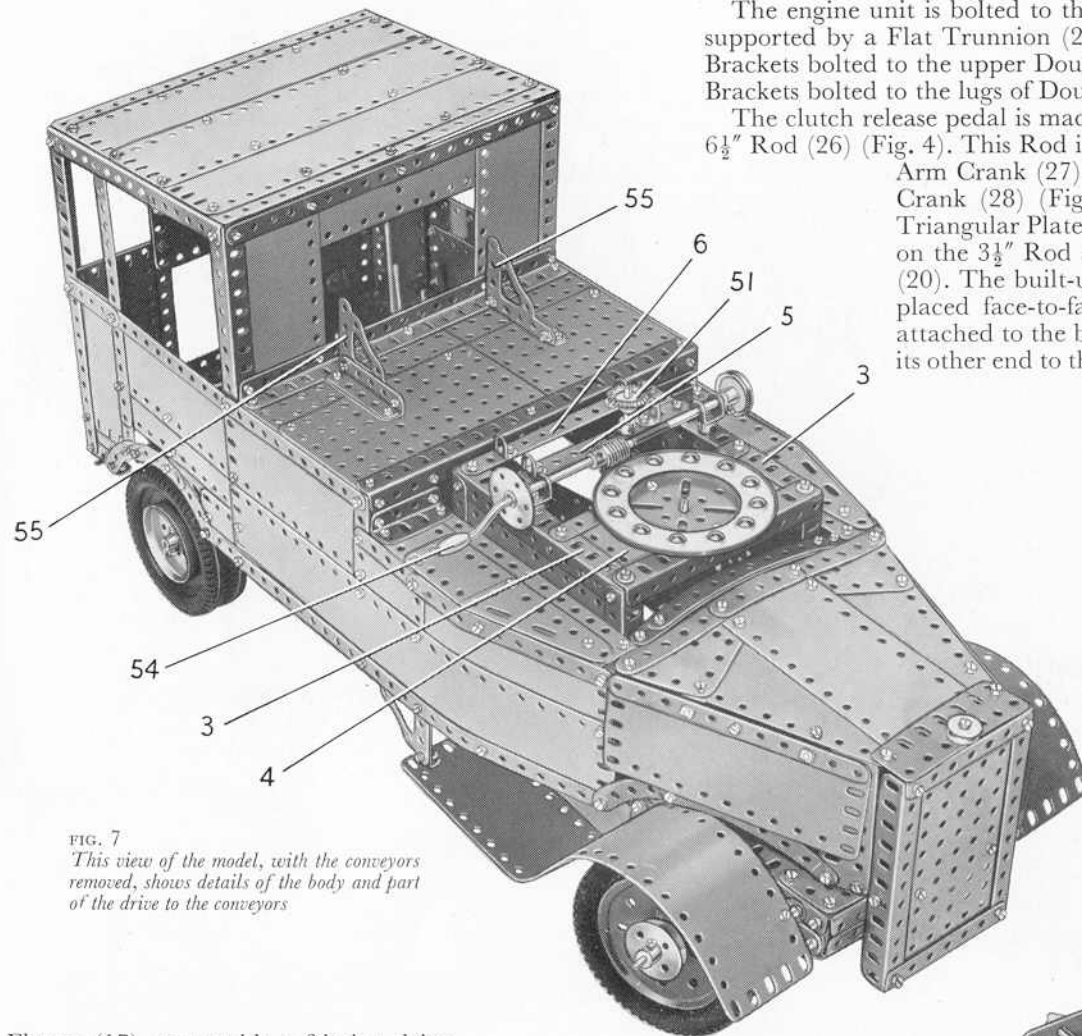

FIG. 7
This view of the model, with the conveyors removed, shows details of the body and part of the drive to the conveyors

Flange (17), to provide a friction drive to the output shaft.

A Fan is fixed on a $6\frac{1}{2}$ " Rod mounted in the Girder Brackets (13). This Rod is driven by a Driving Band passed round the Rod that carries the Pinion (16) (Fig. 5) and round a $\frac{1}{2}$ " Pulley on the $6\frac{1}{2}$ " Rod.

The top of the engine unit is completed by bolting two $5\frac{1}{2}$ " Flat Girders to the 2" Angle Girders, and by fixing on one side a $5\frac{1}{2}$ " Strip to the top flanges of the $3\frac{1}{2}$ " \times $2\frac{1}{2}$ " Flanged Plates. Two $5\frac{1}{2}$ " Flat Girders (23) (Fig. 5) are connected to one of the Girder Brackets by Angle Brackets. Bolts passed through the other ends of the Flat Girders (23) are screwed into Threaded Bosses, which are fixed by nuts to the second Girder Bracket.

The engine unit is bolted to the lugs of two 1" Reversed Angle Brackets (24) (Fig. 5), and is further supported by a Flat Trunnion (25) on each side (Fig. 3). These Flat Trunnions are attached to Angle Brackets bolted to the upper Double Angle Strip (18). The clutch housing is supported by 1" \times 1" Angle Brackets bolted to the lugs of Double Angle Strip (19) and fixed to $1\frac{1}{2}$ " Strips secured to the chassis.

The clutch release pedal is made by bolting a $3\frac{1}{2}$ " Strip to a Double Arm Crank fixed on one end of a $6\frac{1}{2}$ " Rod (26) (Fig. 4). This Rod is mounted across the front of the chassis, and it carries another Double Arm Crank (27). A built-up strip is lock-nutted to the Double Arm Crank (27) and to a Crank (28) (Fig. 6), which is fixed on a $3\frac{1}{2}$ " Rod. The $3\frac{1}{2}$ " Rod is supported in 1" Triangular Plates bolted to the 3" Flat Girders of the clutch housing. Two Couplings (29) on the $3\frac{1}{2}$ " Rod are fitted with 1" Rods that engage the groove of the Socket Coupling (20). The built-up strip consists of a $12\frac{1}{2}$ " Strip, extended at one end by two $5\frac{1}{2}$ " Strips placed face-to-face. The $5\frac{1}{2}$ " Strips overlap the $12\frac{1}{2}$ " Strip by four holes. A Spring attached to the built-up strip at a point two holes in front of the Crank (28), is bolted at its other end to the chassis to provide a return spring for the clutch release mechanism.

Details of the Gear-Box (Figs. 4 and 6)

The gear-box provides forward and reverse drives to the front axle. The housing consists of two $2\frac{1}{2}$ " \times $1\frac{1}{2}$ " Flanged Plates bolted to two 3" \times $1\frac{1}{2}$ " Flat Plates. A $2\frac{1}{2}$ " \times $\frac{1}{2}$ " Double Bent Angle Strip (30) is bolted across the housing, and a Double Bent Strip (31) is fixed at one end to the Flanged Plate. The input shaft is a $1\frac{1}{2}$ " Rod mounted in the Flanged Plate and the Double Bent Strip, and it carries a Bush Wheel (8-holes) (32). Two Pivot Bolts are passed through a Bush Wheel (8-holes) (33) and are fixed by their nuts in the Bush Wheel (32). The Bush Wheel (33), is fixed on the end of a $3\frac{1}{2}$ " Rod that carries a 1" Gear (34) and a $\frac{1}{2}$ " Pinion (35), and is mounted in the end of the housing and in the Double Angle Strip (30).

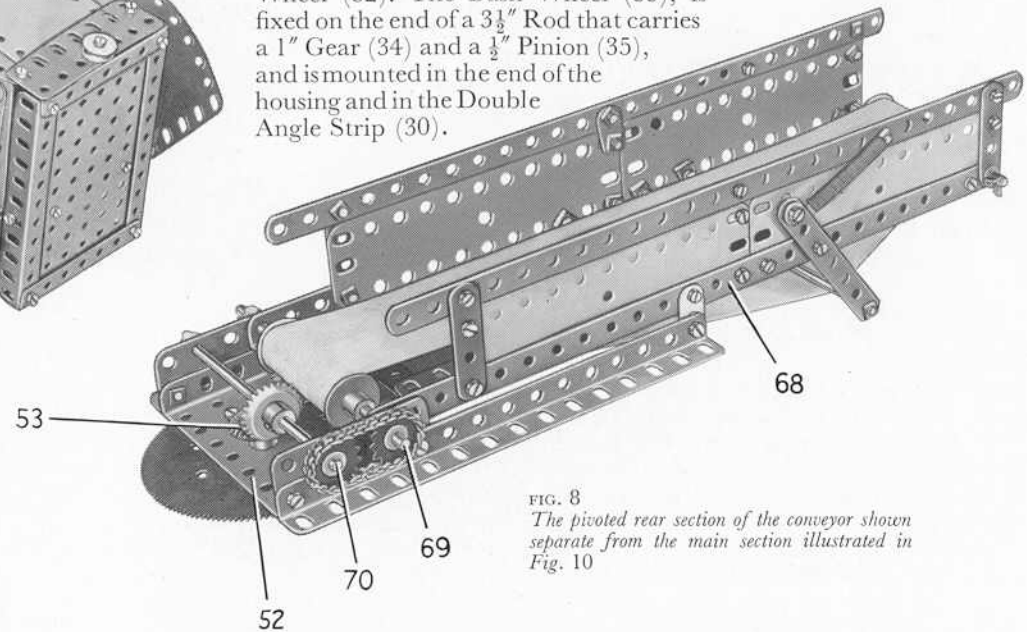
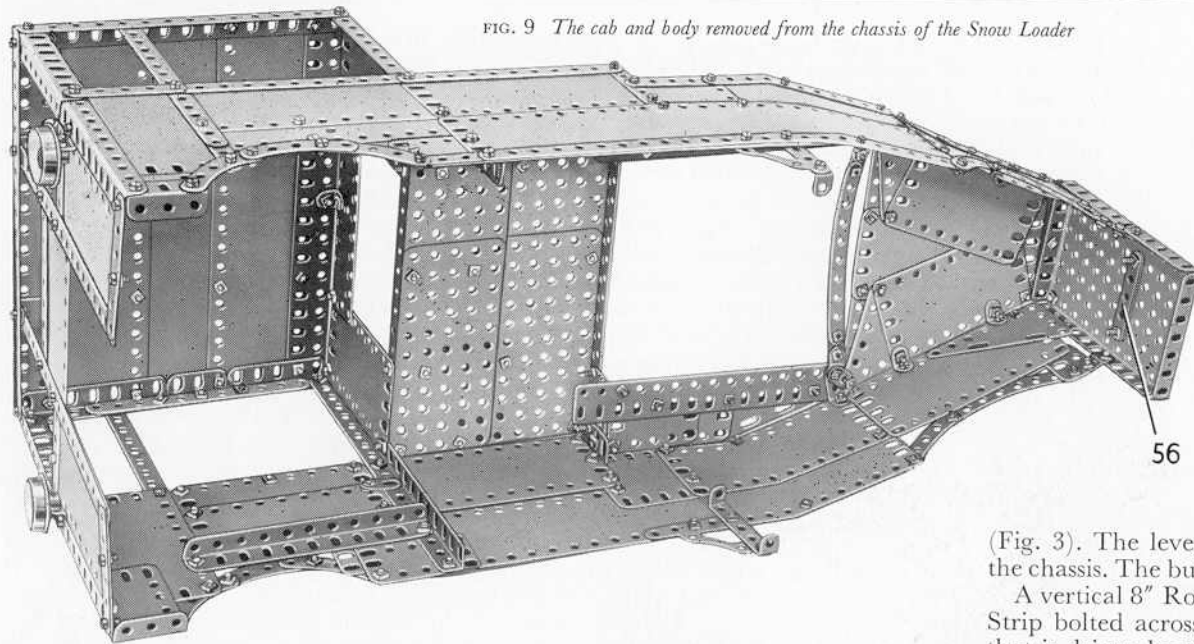

FIG. 8
The pivoted rear section of the conveyor shown separate from the main section illustrated in Fig. 10

FIG. 9 The cab and body removed from the chassis of the Snow Loader



The $3\frac{1}{2}$ " Rod is free to slide in its bearings, but it is driven by the input shaft through the Bush Wheels and the Pivot Bolts. The movement of the Rod is controlled by a $\frac{1}{2}$ " Bolt in a Double Arm Crank (36) (Fig. 6). The Bolt engages between the Gear (34) and the Pinion (35), and the Double Arm Crank is fixed on a $4\frac{1}{2}$ " Rod mounted across the housing. The Rod is held in place by two 1" Pulleys with Rubber Rings, which bear against the housing and prevent the Rod from turning too easily. A Bell Crank (37) is also fixed on the 4" Rod, and an End Bearing is pivoted on a $\frac{1}{2}$ " Bolt held in one arm of the Bell Crank by two nuts. The End Bearing is connected by a 5" Rod to a small Fork Piece, which is pivoted on two bolts screwed into a Collar on the lower end of a lever (38) (Fig. 3). This lever is a 5" Rod fixed in a Handrail Support *lock-nutted* to the chassis.

The gear-box output shaft is a 4" Rod fitted with a $\frac{1}{2}$ " diameter, $\frac{3}{4}$ " face Pinion (39), a 1" Gear (40), and a $\frac{1}{2}$ " diameter, $\frac{1}{2}$ " face Pinion (41). A $\frac{1}{2}$ " reverse Pinion (42) is free to turn on a $\frac{3}{4}$ " Bolt fixed to the rear of the housing by two nuts. When the sliding $3\frac{1}{2}$ " Rod is moved to the right (Fig. 6), the 1" Gears are engaged and provide the forward drive. When the Rod is moved to the left the three $\frac{1}{2}$ " Pinions are meshed together and reverse drive is obtained.

Two 3" Angle Girders are bolted to the gear-box housing and each of them is connected to the chassis by a Flat Trunnion and a 2" Strip. The input shaft is driven by the clutch shaft through a Coupling, a 1" Rod and a built-up universal coupling made from a small Fork Piece and a Swivel Bearing. A $\frac{1}{2}$ " Pinion (43) (Fig. 4) is fixed on the clutch shaft before the Coupling is locked in position.

The Pinion (39) drives a 57-tooth Gear on a 5" Rod (44) mounted as shown in Fig. 4. This Rod is connected to the front axle driving shaft by a 1" Rod and two Universal Couplings.

The Drive to the Conveyors (Figs. 3, 6, 7 and 8)

A $3\frac{1}{2}$ " Rod is supported in the Double Angle Strip (19) (Fig. 6) and in a $1\frac{1}{2}$ " Flat Girder bolted to the Girder (2). This Rod carries a $\frac{1}{2}$ " Pinion (45) and a Worm (46), and by sliding the Rod the Pinion can be engaged with the Pinion (43) on the clutch shaft. The movement of the Rod is controlled by a Centre Fork that engages between the Worm (46) and a Collar. The Centre Fork is held in a Coupling on an 8" Rod mounted across the chassis, and a Double Arm Crank (47) is fixed on this Rod also. A built-up strip is *lock-nutted* to the Double Arm Crank and to a Rod and Strip Connector on a lever (48) (Fig. 3). The lever is 4" Rod fixed in a Handrail Support that is *lock-nutted* to the chassis. The built-up strip is made from two $5\frac{1}{2}$ " Strips overlapped four holes.

A vertical 8" Rod (49) (Fig. 6) is mounted in Strips (5) (Fig. 3) and in a $5\frac{1}{2}$ " Strip bolted across the chassis. The Rod carries at its lower end a $\frac{1}{2}$ " Pinion that is driven by the Worm (46), at its centre a 1" Sprocket (50) (Fig. 3) and at its upper end a $\frac{3}{8}$ " Bevel (51).

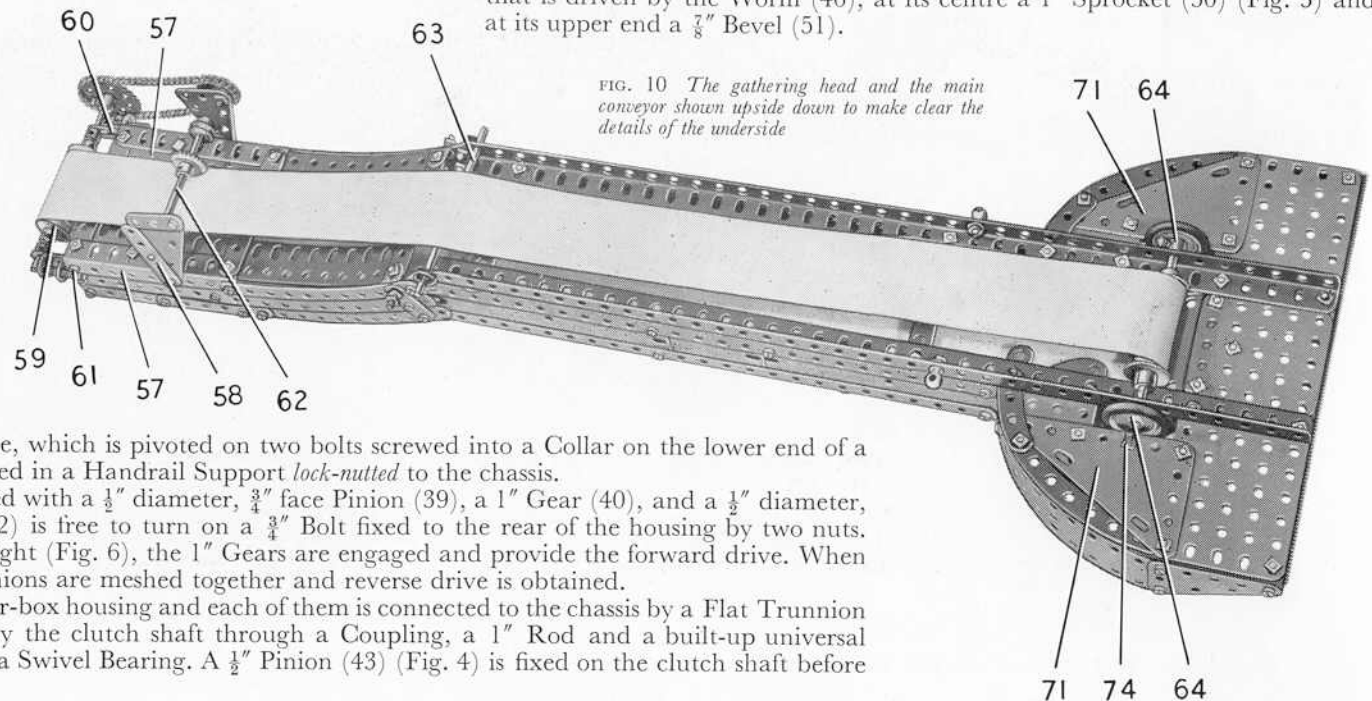

FIG. 10 The gathering head and the main conveyor shown upside down to make clear the details of the underside

The Sprocket (50) is connected by Chain to a $1\frac{1}{2}$ " Sprocket on a vertical 2" Rod that passes through the Flanged Disc of a Ball Thrust Race bolted to the Flat Plate (4) (Fig. 7). A $3\frac{1}{2}$ " Gear rests on the Ball Cage, and to the Gear is bolted the $3\frac{1}{2}$ " x $2\frac{1}{2}$ " Flanged Plate (52) of the conveyor (Fig. 8). The assembly is held on the 2" Rod by a $\frac{7}{8}$ " Bevel (53) (Fig. 8), leaving the Rod free to turn.

The $3\frac{1}{2}$ " Gear can be rotated by turning a Crank Handle (54) (Fig. 7) extended by a Rod joined to it by a Rod Connector. This assembly is mounted in the lugs of two large Fork Pieces, which are attached to the Girders (3) by $\frac{1}{2}$ " Bolts. A Worm on the Crank Handle engages the $3\frac{1}{2}$ " Gear.

Construction of the Body (Figs. 7 and 9)

The arrangement of the parts used to assemble the body is shown quite clearly in Fig. 9, and very little description is needed. The platform behind the cab is formed by two $5\frac{1}{2}$ " x $3\frac{1}{2}$ " Flat Plates and two $5\frac{1}{2}$ " x $2\frac{1}{2}$ " Flat Plates, and two Corner Gussets (55) (Fig. 7) are bolted to $2\frac{1}{2}$ " Angle Girders fixed to the platform. The radiator is a $5\frac{1}{2}$ " x $3\frac{1}{2}$ " Flat Plate edged by Angle Girders, and inside the Flat Plate three $2\frac{1}{2}$ " Strips (56) placed face-to-face are held by $\frac{1}{2}$ " Bolts. These Bolts are used to attach the radiator to the lugs of the Reversed Angle Brackets (24) (Fig. 5). The body is bolted to the Girder (1) (Fig. 2) at the front and to Angle Brackets fixed to the ends of the Girder (2) (Fig. 3).

The door catch is made by fixing a Pawl on a Pivot Bolt, which is passed through the door. A Fishplate is then fixed on the Pivot Bolt by two nuts.

Assembly of the Conveyors (Figs. 8 and 10)

The fixed section of the main conveyor (Fig. 10) consists of a $7\frac{1}{2}$ " Flat Girder

and a 2" Flat Girder on each side, connected by three $3\frac{1}{2}$ " Strips. The sides are each formed by a $4\frac{1}{2}$ " Angle Girder (57), a $4\frac{1}{2}$ " Strip, a $2\frac{1}{2}$ " Strip, a 3" Strip and three $5\frac{1}{2}$ " Curved Strips joined by two Flat Trunnions and a $1\frac{1}{2}$ " Strip. The fixed section is attached by $\frac{3}{8}$ " Bolts to the Corner Gussets (55) (Fig. 7), and is supported by two $2\frac{1}{2}$ " x $1\frac{1}{2}$ " Triangular Flexible Plates, which are strengthened by $2\frac{1}{2}$ " Strips (58) and $1\frac{1}{2}$ " Strips, and are attached by Angle Brackets to the Strips (5) and (6) (Fig. 7).

The driving roller (59) is formed by two $\frac{3}{4}$ " Flanged Wheels pressed over a Sleeve Piece. The roller is fixed on a 5" Rod mounted in the slotted holes of 2" Slotted Strips (60) (Fig. 10). A $\frac{1}{2}$ " x $\frac{1}{2}$ " Angle Bracket and a 1 " x $\frac{1}{2}$ " Angle Bracket on each side are fixed by the same bolt as the Slotted Strip, and a $1\frac{1}{8}$ " Bolt (61) (Fig. 10) is mounted in their lugs. A Compression Spring is placed on the Bolt between the $\frac{1}{2}$ " x $\frac{1}{2}$ " Angle Bracket and a nut. This forces the Bolt head against the 5" Rod and thus presses the Rod to the end of the slot in the Slotted Strip. This arrangement provides a tensioning device for the conveyor belt.

A $1\frac{1}{2}$ " Sprocket on the same Rod as the Roller (59) is connected by Chain to a 1" Sprocket on a 5" Rod (62), mounted in the Strips (58). A $\frac{7}{8}$ " Bevel on Rod (62) engages the Bevel (51) (Fig. 7).

The pivoted end section of the main conveyor consists of two $18\frac{1}{2}$ " Angle Girders connected by two $3\frac{1}{2}$ " Strips. The covered-in section is made by bolting a $12\frac{1}{2}$ " Angle Girder to

each side. A $2\frac{1}{2}$ " x $1\frac{1}{2}$ " and two $5\frac{1}{2}$ " x $1\frac{1}{2}$ " Flexible Plates are bolted to each $12\frac{1}{2}$ " Angle Girder, and a further $12\frac{1}{2}$ " Angle Girder is bolted to their upper edges. The latter Girders on each side are connected by $3\frac{1}{2}$ " Strips, to which a $9\frac{1}{2}$ " x $2\frac{1}{2}$ " Strip Plate is bolted. The pivoted section is mounted on a $4\frac{1}{2}$ " Rod (63) (Fig. 10), which is supported in Fishplates bolted to the fixed section of the conveyor. The lower roller is formed by two $\frac{3}{4}$ " Flanged Wheels pressed over a $4\frac{1}{2}$ " Rod that carries two 1" Pulleys (64), each fitted with a Rubber Ring.

The pivoted section can be raised or lowered by turning a $6\frac{1}{2}$ " Rod (65) (Fig. 3). This is mounted in a $2\frac{1}{2}$ " x 1" Double Angle Strip bolted to a $4\frac{1}{2}$ " Flat

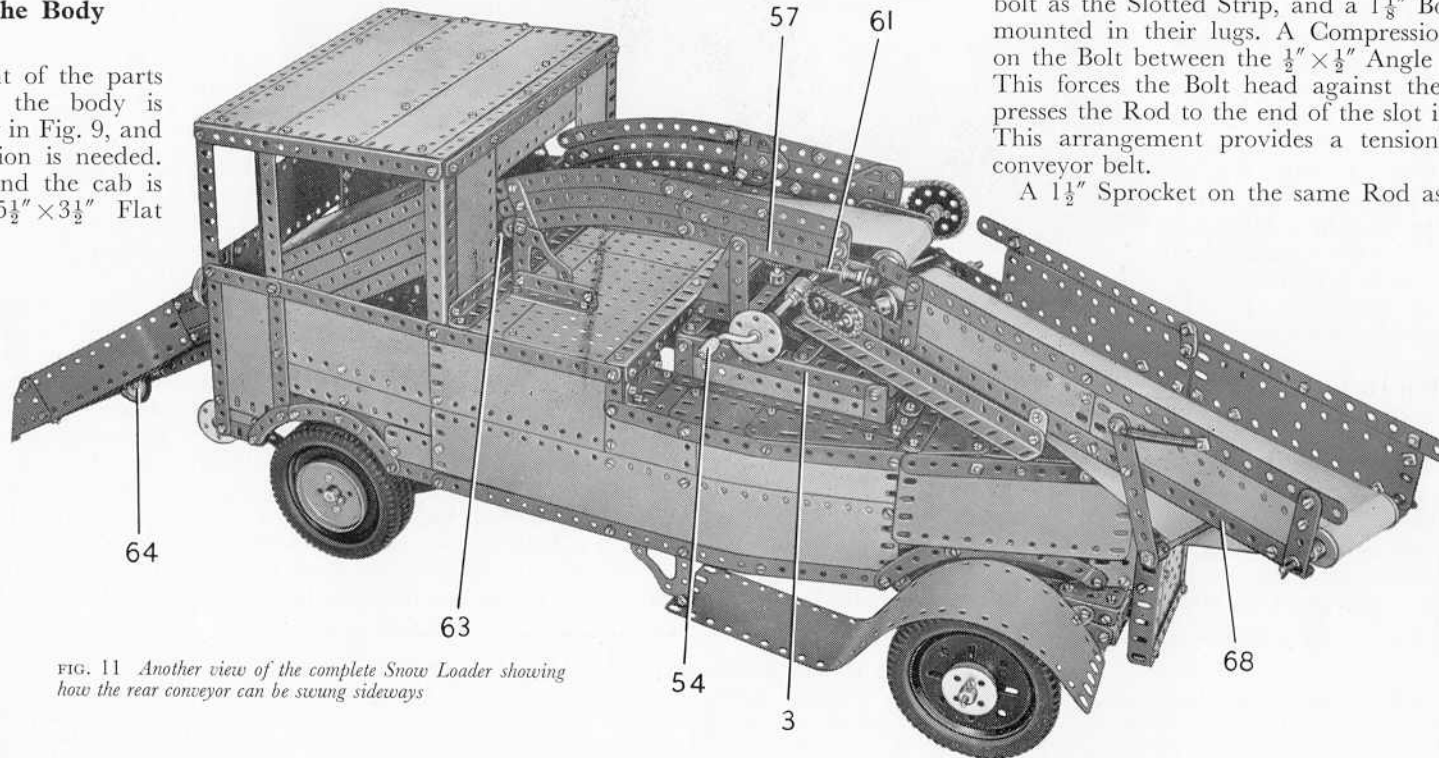

FIG. 11 Another view of the complete Snow Loader showing how the rear conveyor can be swung sideways

Girder fixed to the chassis, and on the Rod is pivoted a second $2\frac{1}{2}'' \times 1''$ Double Angle Strip, that supports a $4\frac{1}{2}''$ Strip (66). A 2" Screwed Rod is passed through each end of the Strip (66), is fitted with a $\frac{7}{8}''$ Bevel (67) and is passed into a Coupling on Rod (65). The Bevels (67) are driven by further Bevels as shown in Fig. 3, and the Screwed Rods are threaded into Handrail Supports *lock-nutted* to the conveyor as shown.

The rear section of the conveyor shown in Fig. 8 is made by bolting a $7\frac{1}{2}''$ Angle Girder to each flange of the Flanged Plate (52). A $2\frac{1}{2}''$ Flat Girder is also fixed to each flange, and a $12\frac{1}{2}''$ Angle Girder (68) is supported by the Flat Girder and by a Fishplate bolted to the $7\frac{1}{2}''$ Angle Girder. The Girders (68) are connected three holes from their outer ends by a $3\frac{1}{2}''$ Strip, and a $9\frac{1}{2}''$ and a $1\frac{1}{2}''$ Flat Girder are bolted to the slotted flanges of each of the Girders (68). The conveyor sides are $5\frac{1}{2}'' \times 1\frac{1}{2}''$ Flexible Plates attached to a framework of 2" and $12\frac{1}{2}''$ Strips.

The driving roller consists of two $\frac{3}{4}''$ Flanged Wheels spaced apart the width of the conveyor belt on a $4\frac{1}{2}''$ Rod (69). A $\frac{3}{4}''$ Sprocket on this Rod is driven by Chain from a similar Sprocket on a $4\frac{1}{2}''$ Rod (70), and a $\frac{7}{8}''$ Bevel on Rod (70) engages the Bevel (53). The roller at the rear end of the conveyor is formed by a Sleeve Piece and two $\frac{3}{4}''$ Flanged Wheels on a $4\frac{1}{2}''$ Rod. The device for tensioning this conveyor is made by *lock-nutting* a $3\frac{1}{2}''$ Strip to each of the Girders (68). A $3\frac{1}{2}''$ Rod is held in Rod Sockets fixed to the lower

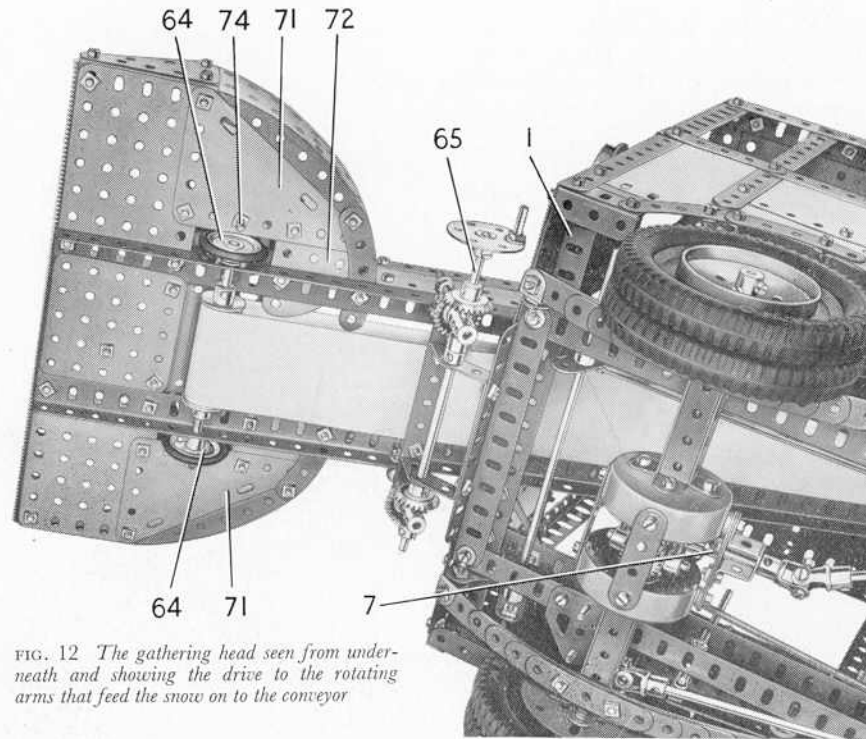

FIG. 12 The gathering head seen from underneath and showing the drive to the rotating arms that feed the snow on to the conveyor

ends of the Strips, and Springs are bolted to the top ends of the Strips and to the conveyor sides as shown.

The conveyor belts are strips of cloth or strong paper passed round the rollers as shown, and their ends joined to make endless belts.

The Gathering Head (Figs. 1, 10 and 12)

The snow gathering head is made by bolting two $4\frac{1}{2}'' \times 2\frac{1}{2}''$ Flat Plates and a $2\frac{1}{2}'' \times 2\frac{1}{2}''$ Flat Plate to the $18\frac{1}{2}''$ Angle Girders of the main conveyor (see Fig. 10). A $2\frac{1}{2}''$ Angle Girder is fixed to the outer end of each $4\frac{1}{2}'' \times 2\frac{1}{2}''$ Flat Plate, and each of these Plates is connected to one of the $18\frac{1}{2}''$ Angle Girders by a 4" Stepped Curved Strip and a $2\frac{1}{2}''$ Curved Strip. The space between the Girder and the Curved Strip on each side is filled by a $3\frac{1}{2}'' \times 2''$ Triangular Flexible Plate (71) and a Semi-Circular Plate (72) (Fig. 12). A $2\frac{1}{2}''$ Strip is bolted between the $4\frac{1}{2}'' \times 2\frac{1}{2}''$ Flat Plate and the Semi-Circular Plate.

The gathering arms (73) (Fig. 1) are Double Brackets bolted to $2\frac{1}{2}''$ Strips, each of which is attached by an Angle Bracket to a Face Plate. The Face Plate turns freely on a $1\frac{1}{8}''$ Bolt (74) (Fig. 12) which is held by two nuts in one of the Triangular Flexible Plates. The Face Plate rests on the Rubber Ring of one of the Pulleys (64) (Fig. 12) and is driven by this Pulley through the friction of the Rubber Ring.

Parts Required to Build the Meccano Automatic Snow Loader

5 of No. 1	7 of No. 9b	6 of No. 16a	8 of No. 26	3 of No. 46	2 of No. 73	2 of No. 103e	2 of No. 124	2 of No. 161	4 of No. 197
4 " " 1a	2 " " 9c	5 " " 17	1 " " 26a	12 " " 48a	4 " " 77	2 " " 103f	4 " " 125	2 " " 162a	1 " " 212
4 " " 1b	5 " " 9d	6 " " 18a	1 " " 26b	2 " " 48b	1 " " 78	2 " " 103g	10 " " 126a	2 " " 163	2 " " 213
31 " " 2	4 " " 9e	4 " " 18b	1 " " 27	2 " " 51	1 " " 79a	4 " " 103h	1 " " 128	4 " " 164	2 " " 214
48 " " 2a	5 " " 9f	6 " " 19b	3 " " 27a	6 " " 52a	2 " " 81	4 " " 103k	4 " " 133	2 " " 165	4 " " 221
18 " " 3	24 " " 10	1 " " 19g	1 " " 27b	3 " " 53	2 " " 82	4 " " 108	2 " " 133a	1 " " 166	2 " " 222
8 " " 4	4 " " 11	4 " " 20	2 " " 28	2 " " 53a	6 " " 89	4 " " 109	4 " " 136	1 " " 168a	1 " " 223
31 " " 5	39 " " 12	2 " " 20a	2 " " 29	2 " " 55a	4 " " 89b	2 " " 110a	2 " " 136a	1 " " 168c	2 " " 224
11 " " 6	6 " " 12a	8 " " 20b	8 " " 30	24 " " 59	10 " " 90	1 " " 111	4 " " 137	1 " " 171	2 " " 225
10 " " 6a	6 " " 12b	2 " " 21	2 " " 31	4 " " 62	1 " " 94	17 " " 111a	4 " " 140	2 " " 179	2 " " 226
4 " " 7	4 " " 12c	5 " " 22	2 " " 32	4 " " 62b	2 " " 95a	23 " " 111c	1 " " 142a	3 " " 186	
2 " " 7a	3 " " 13a	1 " " 22a	6 " " 35	8 " " 63	2 " " 96	4 " " 111d	4 " " 142b	11 " " 188	
6 " " 8	4 " " 14	1 " " 23	657 " " 37a	1 " " 63c	2 " " 96a	2 " " 114	1 " " 144	12 " " 189	
6 " " 8a	6 " " 15	2 " " 23a	575 " " 37b	2 " " 64	4 " " 103	1 " " 115	1 " " 147a	3 " " 190	1 E15R
4 " " 8b	6 " " 15a	4 " " 24	84 " " 38	1 " " 65	4 " " 103a	2 " " 116	5 " " 147b	9 " " 191	Electric Motor
12 " " 9	2 " " 15b	2 " " 24b	3 " " 43	4 " " 70	1 " " 103c	2 " " 116a	4 " " 155	12 " " 192	(not included
8 " " 9a	4 " " 16	3 " " 25	3 " " 45	1 " " 72	2 " " 103d	3 " " 120b	1 " " 157	4 " " 196	in Outfit)

MECCANO

4-4-0 Passenger Locomotive and Tender

(MODEL No. 10.12)

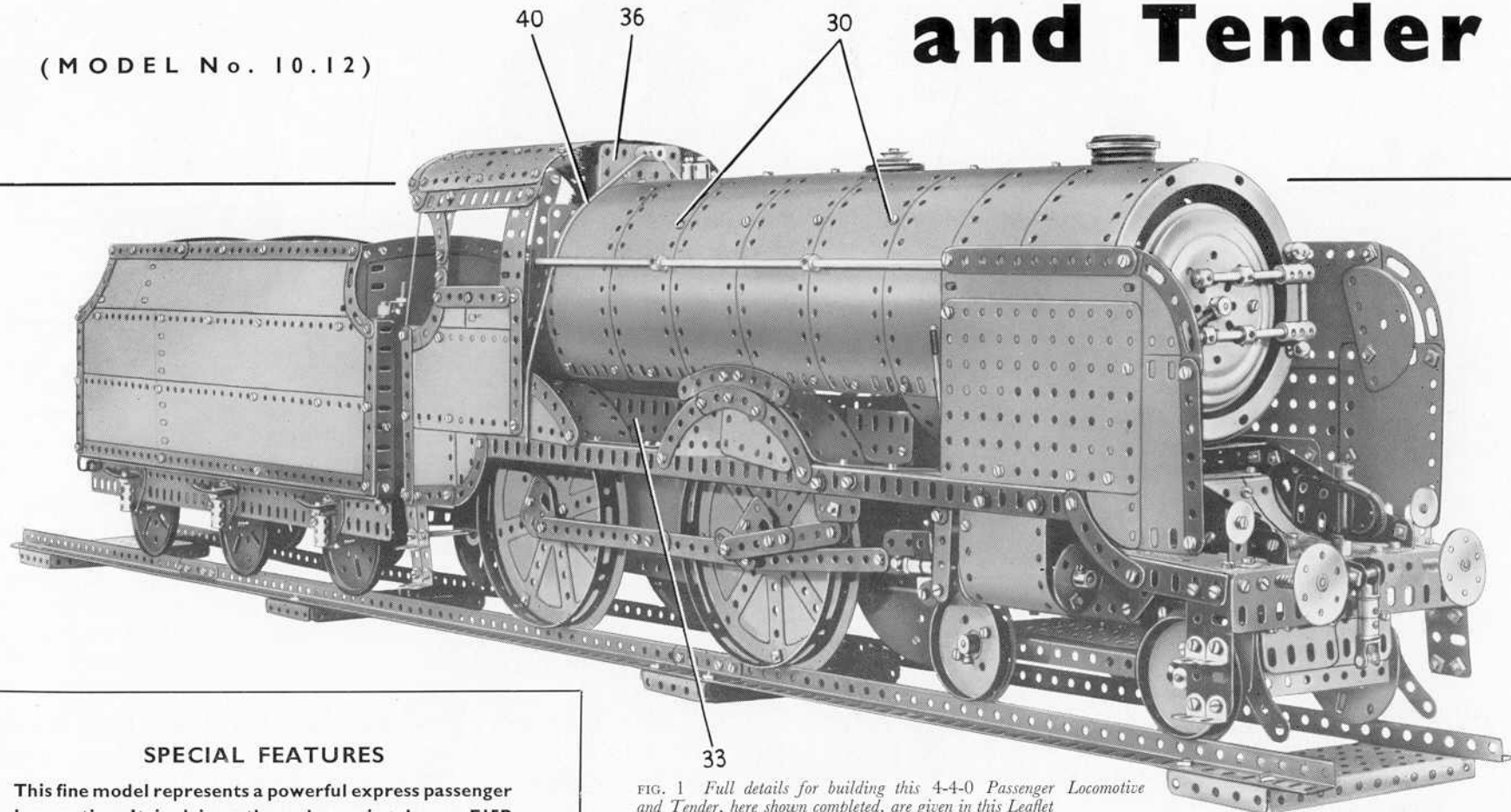

SPECIAL FEATURES

This fine model represents a powerful express passenger locomotive. It is driven through gearing by an E15R Electric Motor controlled from the cab and includes valve gear and smoke deflectors in its constructional details.

FIG. 1 Full details for building this 4-4-0 Passenger Locomotive and Tender, here shown completed, are given in this Leaflet

The attractive Meccano model described in this Leaflet represents a type of locomotive once popular in Great Britain and abroad. The actual locomotive on which it is based was one of the most powerful of its type in Great Britain, and was used to haul fast passenger trains at high speeds in Kent, Sussex and other southern counties.

Building the Model: The Main Frame and Running Plates (Figs. 2, 3 and 4)

Each side-member of the main frame consists of two $24\frac{1}{2}$ " Angle Girders connected by a $9\frac{1}{2}$ " \times $2\frac{1}{2}$ " Strip Plate at the front, a $5\frac{1}{2}$ " \times $2\frac{1}{2}$ " Flat Plate (1) (Fig. 6) and two $5\frac{1}{2}$ " \times $2\frac{1}{2}$ " Flexible Plates. The join between the Flexible Plates is strengthened on the inside by a Corner Gusset.

The side-members are joined together at each end by $3\frac{1}{2}$ " \times $2\frac{1}{2}$ " Flanged Plates (2) (Fig. 2), the front one of which carries a built-up girder (3) made

Girder and a 2" Angle Girder overlapped two holes.

The running plate on each side is made by bolting a $24\frac{1}{2}$ " Angle Girder (10) (Fig. 4) to the girder (3) and to $2\frac{1}{2}$ " Flat Girders fixed to the Flat Plate (6). Two $2\frac{1}{2}$ " \times $1\frac{1}{2}$ " Flexible Plates and three $5\frac{1}{2}$ " \times $1\frac{1}{2}$ " Flexible Plates are attached as shown to the Girder (10), and are curved to form the wheel splashers. The sides of the splashers over the leading driving wheels are each made from two $2\frac{1}{2}$ " \times $1\frac{1}{2}$ " Triangular Flexible Plates and three $2\frac{1}{2}$ " Curved Strips. The nameplate is represented by a 4" Stepped Curved Strip bolted to a 1" Triangular

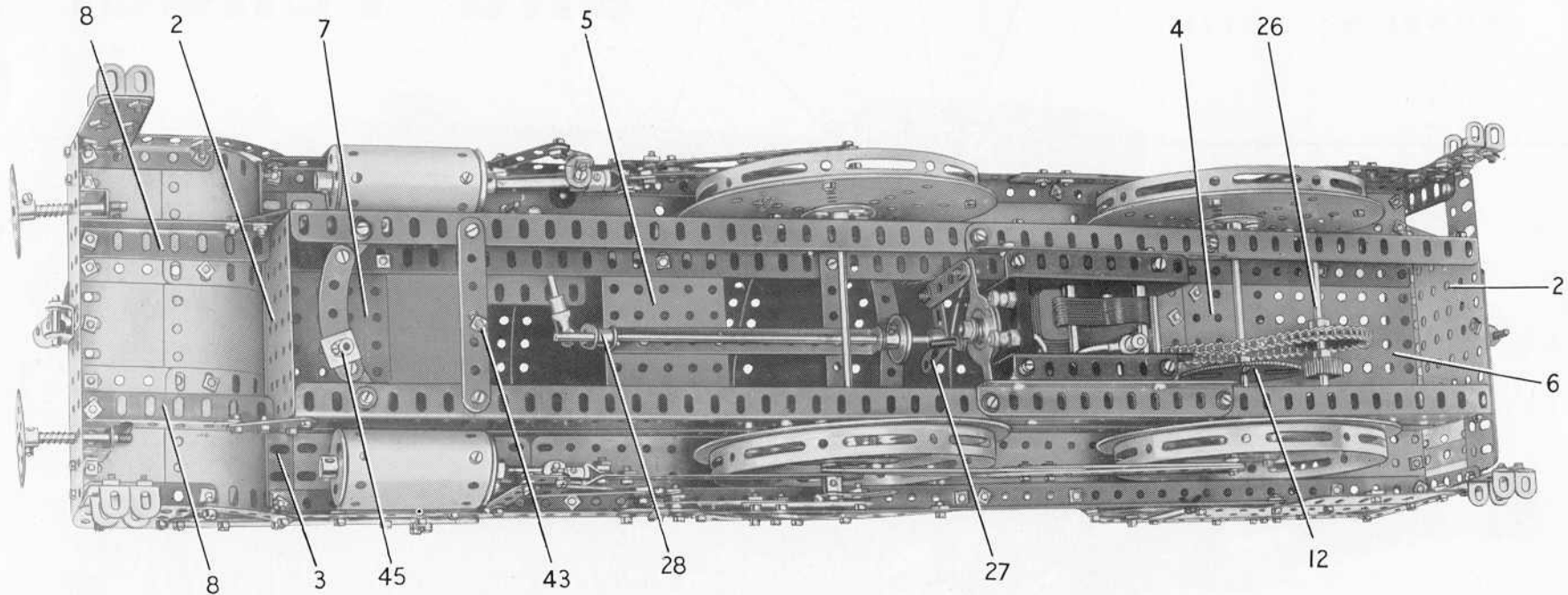

FIG. 2. Underneath view of the Locomotive showing details of the main frame and the driving arrangement

from a $5\frac{1}{2}$ " and a 2" Angle Girder overlapped two holes. Two further $3\frac{1}{2}$ " \times $2\frac{1}{2}$ " Flanged Plates (4) and (5) are fixed across the main frame (Fig. 2), and a $5\frac{1}{2}$ " \times $2\frac{1}{2}$ " Flat Plate (6) is bolted across the rear end. A $5\frac{1}{2}$ " \times $3\frac{1}{2}$ " Flat Plate fixed to the Flanged Plate (4) and the Flat Plate (6), forms the footplate. A $3\frac{1}{2}$ " \times $2\frac{1}{2}$ " Flanged Plate (7) (Fig. 3) is attached to the front end of the main frame by Angle Brackets and a $3\frac{1}{2}$ " \times $\frac{1}{2}$ " Double Angle Strip.

At the front the main frame is extended forward by two $3\frac{1}{2}$ " Angle Girders (8) (Fig. 2), which are fixed to $1\frac{1}{2}$ " Corner Brackets. The front ends of the Girders (8) are connected by a built-up girder (9) (Fig. 3) made from a $5\frac{1}{2}$ " Angle

Plate. The side of each rear splashers consists of a $3\frac{1}{2}$ " \times 2" Triangular Flexible Plate and a 4" Stepped Curved Strip, but these should not be fitted until the cab has been assembled.

The dropped section of the frame at the front (Fig. 3) is plated by three $1\frac{1}{16}$ " radius Curved Plates and three $2\frac{1}{2}$ " \times $2\frac{1}{2}$ " Flexible Plates bolted between the girders (3) (Fig. 2) and (9) (Fig. 3). The outer $2\frac{1}{2}$ " \times $2\frac{1}{2}$ " Flexible Plates are edged by $2\frac{1}{2}$ " Angle Girders, and these are connected to the Girders (10) (Fig. 4) by $2\frac{1}{2}$ " Curved Strips. The steps are Angle Brackets fixed to $2\frac{1}{2}$ " Flat Girders, which are supported by the $2\frac{1}{2}$ " Angle Girders.

Two $2\frac{1}{2}$ " Stepped Curved Strips, each extended forward by a 2" Strip, are connected by Fishplates to the flanges of the Flanged Plate (7), and the 2" Strips are bolted to the lugs of a $3\frac{1}{2}$ " \times $\frac{1}{2}$ " Double Angle Strip (11) (Fig. 3). A $3\frac{1}{2}$ " Strip is arranged between each Curved Strip and the Double Angle Strip and a $1\frac{1}{2}$ " Flat Girder is attached to the assembly as shown in Fig. 3.

The buffer beam consists of two $3\frac{1}{2}$ " Flat Girders bolted to the girder (9), and the buffers are Bush Wheels on 2" Rods. These Rods are mounted in the buffer beam and in $\frac{1}{2}$ " Reversed Angle Brackets bolted behind it, with a Compression Spring on each Rod between the beam and the Bush Wheel. The Rods are retained in their mountings by Spring Clips.

A vacuum brake pipe, route indicators and a coupling are assembled and fixed in position as shown in Fig. 3.

Driving Wheels and Motion (Figs. 2, 4 and 6)

Each of the main driving wheels consists of a Hub Disc bolted to a 6" Circular Plate, at the centre of which a Bush Wheel is bolted. The wheels are fixed in pairs on 5" Rods supported in the main frame (see Fig. 2), and at each end of each Rod a Double Arm Crank is held by its grub screw. A Flat Trunnion is fixed to each Double Arm Crank by a $\frac{1}{2}$ " Bolt, which passes also through a hole in the wheel (see Fig. 4). The Flat Trunnions form the crank assemblies. A $2\frac{1}{2}$ " Gear (12) (Fig. 2), is fixed on the rear 5" Rod.

The cylinder and valve assembly on each side is made by bolting one end of a $5\frac{1}{2}$ " \times $2\frac{1}{2}$ " Flexible Plate to the main frame. The Flexible Plate is

FIG. 3 The hinged smoke-box door, smoke deflectors and other details of the Locomotive front

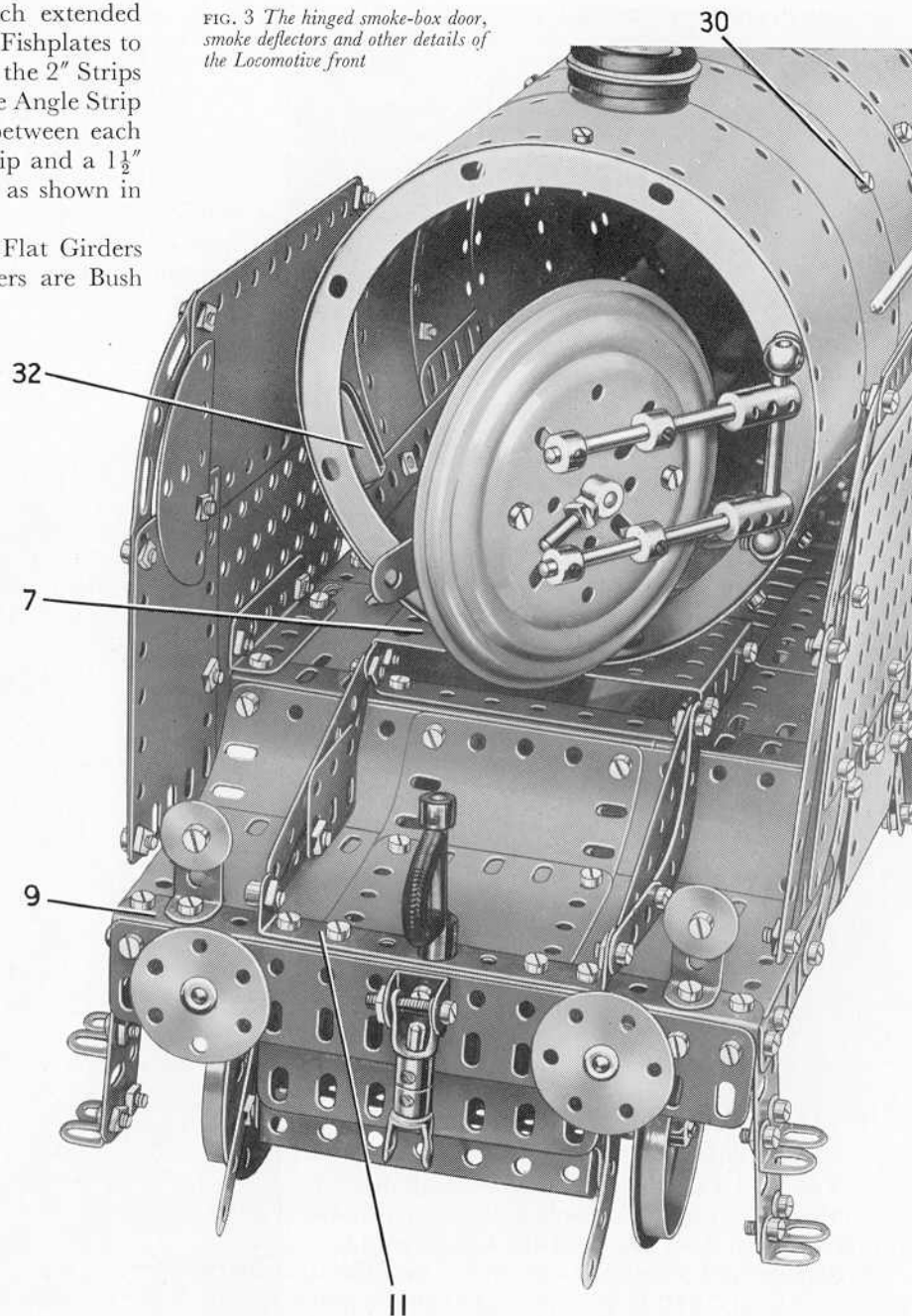

then curved to U-shape and its other end is attached to one of the Girders (10). The cylinder is a $2\frac{1}{2}$ " Cylinder bolted to the Flexible Plate, and fitted at each end with a $1\frac{1}{8}$ " Flanged Wheel. The Flanged Wheels are held in place by nuts on a 3" Screwed Rod, and to the rear Flanged Wheel a $1"$ \times $\frac{1}{2}$ " Angle Bracket is bolted. A $2\frac{1}{2}$ " Strip (13) (Fig. 6) fixed to this Angle Bracket forms the slide bar for the piston rod. A Chimney Adaptor is attached to the Flexible Plate by a bolt (14).

The driving wheels on each side are connected by a coupling rod formed by two $5\frac{1}{2}$ " Strips placed face-to-face and arranged to overlap another $5\frac{1}{2}$ " Strip by four holes. At its rear end the coupling rod is *lock-nutted* by a $\frac{1}{2}$ " Bolt to the Flat Trunnion forming the crank of the rear wheel. At its front end the coupling rod is *lock-nutted*, together with a $4\frac{1}{2}$ " Strip (15), to the crank of the leading driving wheel. A $\frac{3}{4}$ " Bolt is used at the front and a Crank (16) is fixed by its grub screw to this Bolt on one side. A Threaded Crank is fixed to the corresponding Bolt on the other side. The $\frac{3}{4}$ " Bolts are fixed tightly in the crank assemblies by two nuts each.

The Strip (15) is extended by a Fishplate that is *lock-nutted* to an End Bearing (17) (Fig. 4) on a $3\frac{1}{2}$ " Rod. This Rod slides freely in the Flanged Wheel forming the rear cover of the cylinder, and on it a Collar (18) is fixed. A $\frac{3}{4}$ " Bolt is then passed through the lugs of a Double Bracket (19) and is screwed into a hole in the Collar, so that the Double Bracket is able to slide freely on the slide bar (13).

A strip (20), made from two $2\frac{1}{2}$ " Strips overlapped two holes, is

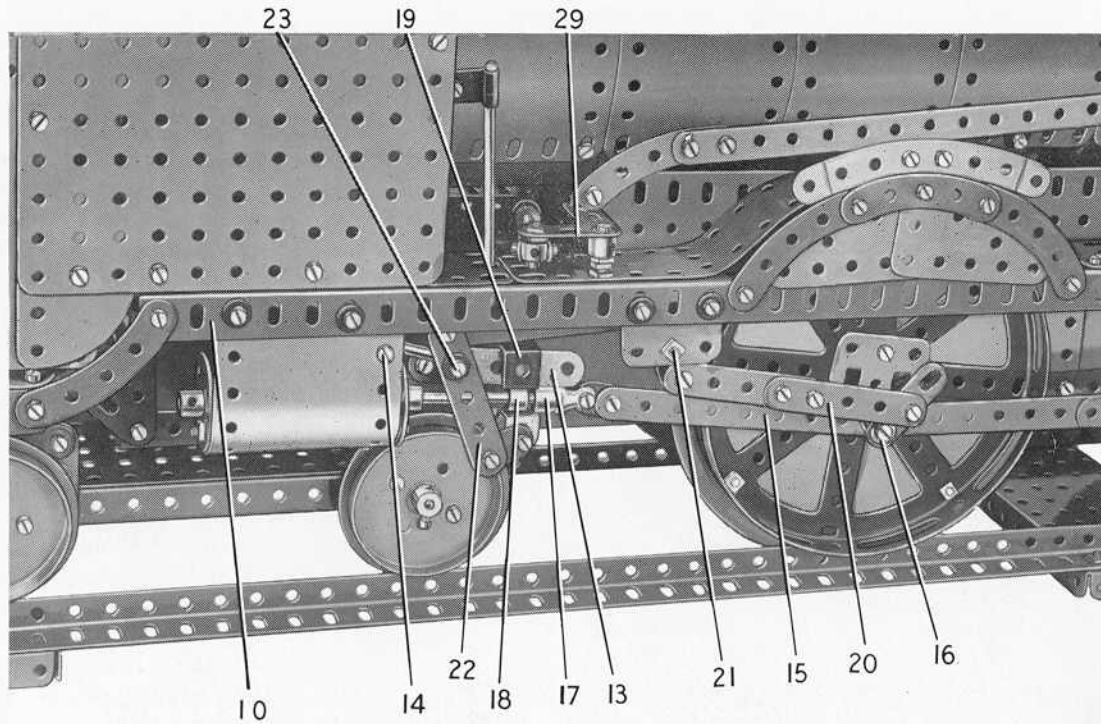

FIG. 4 A close-up picture of the valve motion and cylinder assembly

lock-nutted to the Crank (16) and to the lower end of a $1\frac{1}{2}$ " Strip. The $1\frac{1}{2}$ " Strip is lock-nutted through its centre hole on a bolt (21), so that it is free to pivot. This bolt is carried in a $1\frac{1}{2}$ " Flat Girder bolted to the Girder (10). The $1\frac{1}{2}$ " Strip is spaced from the Flat Girder by three Washers, and to its upper end a $3\frac{1}{2}$ " Strip is lock-nutted. This Strip is lock-nutted also to a $2\frac{1}{2}$ " Strip (22), which is pivoted on a bolt (23) screwed into a hole in a Collar fixed on a $3\frac{1}{2}$ " Rod that forms the valve rod. This Rod is passed through the Chimney Adaptor held by the bolt (14).

A Fishplate is lock-nutted to the lower end of Strip (22), and also to an Angle Bracket that is fixed by a nut and bolt screwed into the Collar (18). The nut is tightened against the Angle Bracket to hold it firmly on the bolt.

Arrangement of the Motor and Reduction Gearing (Figs. 2, 4, 5 and 6)

The E15R Electric Motor used to drive the model is attached by Angle Brackets to two $5\frac{1}{2}$ " Angle Girders bolted underneath the main frame (Fig. 5). A $\frac{1}{2}$ " Pinion on the Motor shaft drives a 57-tooth Gear on a $2\frac{1}{2}$ " Rod (24), which is passed through the Motor side-plates. A $\frac{1}{2}$ " Pinion on Rod (24) is meshed with another 57-tooth Gear on a 2" Rod (25). This Rod also is supported in the side-plates, above Rod (24), and it carries a $\frac{3}{4}$ " Sprocket connected by Chain to a 2" Sprocket on a 4" Rod (26). A $\frac{3}{4}$ " Pinion on Rod (26) engages the $2\frac{1}{2}$ " Gear (12) (Fig. 2) on the rear driving axle.

A 2" Strip is lock-nutted to one arm of the Motor switch and to a Bell Crank (27) (Fig. 2). The Bell Crank is fixed on an 8" Rod supported in a $5\frac{1}{2}$ " x $\frac{1}{2}$ " Double Angle Strip bolted to the Flanged Plate (5) and to a $3\frac{1}{2}$ " Strip placed across the main frame. The Rod carries a Crank (28), and a Swivel Bearing is pivoted on a $\frac{1}{2}$ " Bolt fixed in this Crank by two nuts. The Swivel Bearing is mounted on a 2" Rod fitted at its other end with a second Swivel Bearing, and this is pivotally attached to a Bell Crank (29) (Fig. 6) by a $\frac{1}{2}$ " Bolt that is fixed by two nuts. The Bell Crank is freely mounted on a $\frac{3}{4}$ " Bolt, and

FIG. 5
The electric driving Motor
with its reduction gearing
located in the Locomotive
chassis

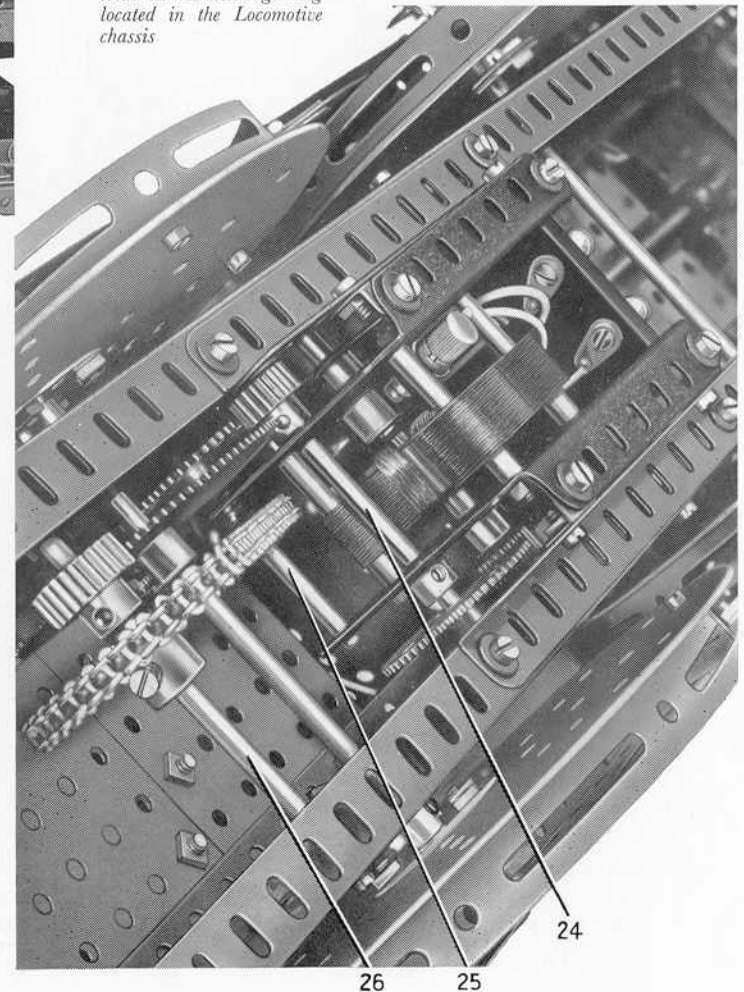

is held against the head of the Bolt by two nuts screwed against each other (see Fig. 4). The Bolt is then fixed in the running plate by two nuts.

Assembly of the Boiler and Smoke Deflectors (Figs. 1, 2, 3 and 6)

The boiler consists of eight curved $12\frac{1}{2}'' \times 2\frac{1}{2}''$ Strip Plates arranged as shown in Figs. 1 and 6, and bolted to three built-up strips placed inside the Plates. Each of these strips is made from a $12\frac{1}{2}''$ and a $9\frac{1}{2}''$ Strip, and one of them is bolted to the edges of the Plates on each side. The third strip is fixed along the centres of the Plates, so that it comes at the top of the boiler when the Plates are curved to shape. A $12\frac{1}{2}''$ Strip is attached to each side of the boiler by the bolts (30).

The ends of the front two $12\frac{1}{2}'' \times 2\frac{1}{2}''$ Strip Plates are connected by $5\frac{1}{2}'' \times 2\frac{1}{2}''$ Flexible Plates, and another $5\frac{1}{2}'' \times 2\frac{1}{2}''$ Flexible Plate is similarly bolted to the ends of the rear Strip Plate. A $1\frac{11}{16}''$ radius Curved Plate is fixed to each end of the third Strip Plate counting from the front, and a curved $5\frac{1}{2}''$ Strip is attached to one of the Strip Plates by a bolt (31) on each side. A Circular Girder is fixed inside each end of the boiler.

At its front end the boiler is bolted to the Flanged Plate (7) (Fig. 3) and at the rear is supported by a Double Bent Strip fixed to the Flanged Plate (4) (Fig. 2). The chimney consists of three 1" loose Pulleys and two Wheel Discs held in place by a $\frac{3}{4}''$ Bolt. A Rubber Ring is fitted to each Pulley.

The boiler dome is formed by a $\frac{1}{2}''$ loose Pulley, a 1" loose Pulley and a 1" loose Pulley fitted with a Rubber Ring, and these also are fixed in place by a $\frac{3}{4}''$ Bolt.

The safety valves are represented by Threaded Bosses.

Each handrail consists of an $11\frac{1}{2}''$ and a 5" Rod supported by Collars screwed on to bolts passed through the boiler. The join between the Rods is covered by one of the Collars, and the rear end of the 5" Rod is supported in the cab.

The smoke-box door is made by bolting together a Ball Thrust Race Flanged Disc and a 4" Circular Plate. Four Collars are screwed on to bolts passed through the Flanged Disc, and these support two $2\frac{1}{2}''$ Rods, each of which is fitted with a Coupling. The Couplings pivot on a 2" Rod fixed in Handrail Supports attached to the front Circular Girder (Fig. 3). A catch for the door is provided by a 3" Strip bolted to a Crank. The Crank is fixed on a 1" Rod supported in the Flanged Disc and in a $2\frac{1}{2}''$ Strip bolted across the Circular

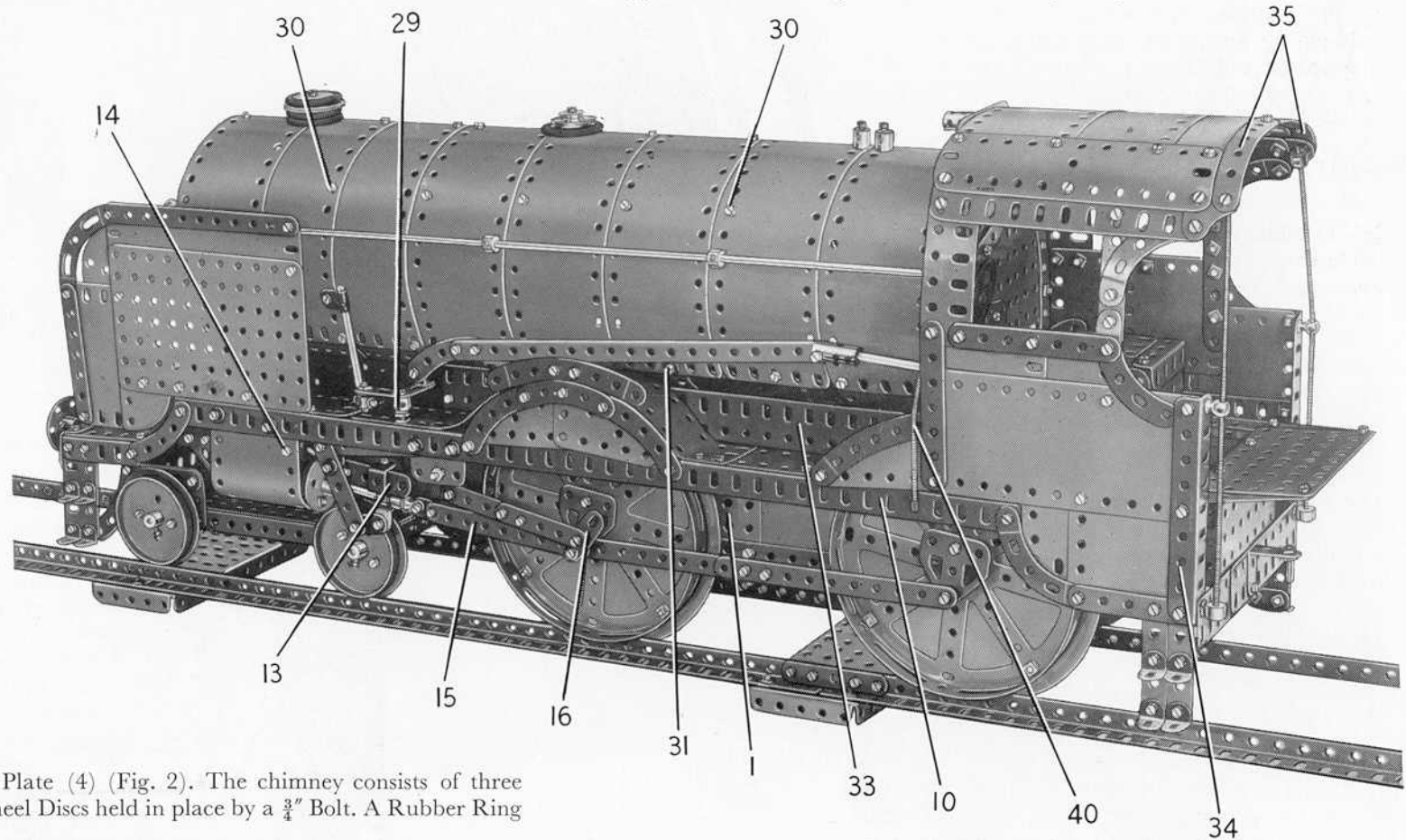

FIG. 6 Details of the connecting and coupling rods and the arrangement of the main wheel driving cranks are shown in this illustration of the completed Locomotive

Plate. A handle on the Rod is provided by a Threaded Pin screwed into a Collar. The end of the 3" Strip engages in a Single Bent Strip (32) attached to the boiler by an Angle Bracket.

A 12½" Flat Girder (33) (Fig. 1) on each side is fixed to the flanges of the Flanged Plates (5) and (4) (Fig. 2).

Each smoke deflector consists of a 5½" × 3½" Flat Plate bolted to a 2½" Angle Girder fixed to one end of one of the Girders (10). It is extended upward by a 5½" × 2½" Flexible Plate and forward by two Semi-Circular Plates and a 3½" × 2½" Flexible Plate. These Plates are edged by a 3½" Strip, a 5½" Strip and a 3" Stepped Curved Strip.

Details of the Cab (Figs. 6 and 7)

Each side of the cab consists of a 5½" × 2½" Flexible Plate, three 2½" × 2½" Flexible Plates and a 2½" × 1½" Flexible Plate, edged by Strips and Curved Strips and a 4½" Angle Girder (34) (Fig. 6). The side is bolted to a 5½" Angle Girder fixed to the rear end of one of the Girders (10). Each window frame is formed by a 3" Flat Girder and a 4½" Strip, which are connected at their upper ends by a 5½" Flat Girder.

The roof consists of three 4½" × 2½" Flexible Plates bolted to 5½" × 1½" Flexible Plates, which are fixed to the 5½" Flat Girders. Two curved 3½" Strips (35) are connected to these Flat Girders by 1" Corner Brackets.

The front of the cab is filled in by a 4½" × 2½" Flat Plate bolted vertically to a 2½" Angle Girder that is fixed to the footplate. A 5½" × 3½" Flat Plate is bolted across the 4½" × 2½" Flat Plate (Fig. 7) and at each side a 5½" Curved Strip is bolted to the projecting end of a 3½" Strip bolted behind the 4½" × 2½" Flat Plate. The top ends of the Curved Strips are connected by Angle Brackets

to the sides of the cab. A 2½" × 2½" Flat Plate (36) completes the front of the cab and a Channel Bearing (59), and other fittings representing the controls, are arranged as shown.

The footplate is extended by a 4½" × 2½" Flat Plate (37), fitted at each end with a 2½" Strip and at the back with a 5½" Strip. The 5½" Strip is connected to the Plate (6) (Fig. 2) by two ½" Bolts, but is spaced from the Plate by a Cord Anchoring Spring on each Bolt.

The boxes over the rear driving wheels are each made by bolting a Girder Bracket (38) (Fig. 7) to the footplate. A 1½" Angle Girder is fixed vertically to the inner edge of the Girder Bracket, and this supports a 3" × 1½" Flat Plate to which a 3" Angle Girder is fixed. A 2" Angle Girder (39) is bolted to the rear end of the 3" Angle Girder, and the top of the box is filled in by two 2½" × 1½" Flexible Plates attached to these Girders.

Two 4½" Flat Girders are bolted to the lower ends of the Girders (34) and to the Flanged Plate (2) (Fig. 7). Collars are screwed on to the bolts that connect the Angle Girders and the Flat Girders, and a length of Spring Cord is gripped in each Collar. The Spring Cord is passed through Handrail Supports as shown and is held in the spiders from Universal Couplings, which are screwed on to bolts in the cab roof. The cab steps are Angle Brackets fixed to 2½" Strips.

A steam pipe (40) (Fig. 6) is represented by Spring Cord, which is held at each end in the rounded part of a Spring Clip that projects through a slotted hole in one of the Girders (10). The Spring Cord passes through a Threaded Coupling fixed on a bolt in the Flat Plate (36) (Fig. 1) at the front of the cab.

The Motor starting and control lever is a ½" Pinion (41) (Fig. 7) on a 3½" Rod mounted in the front of the cab and in a Double Bent Strip. A Strip Coupling on the Rod is connected by a ⅜" Bolt to a

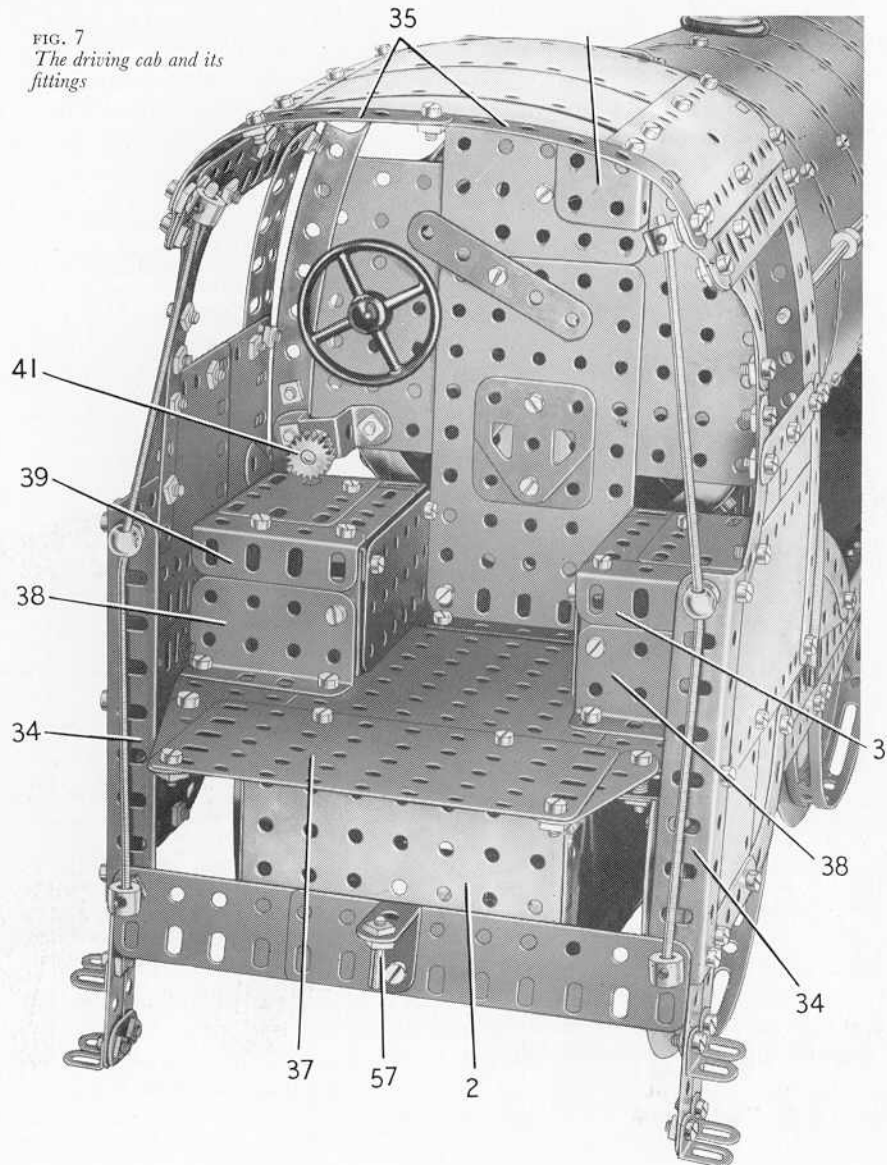

FIG. 7
The driving cab and its fittings

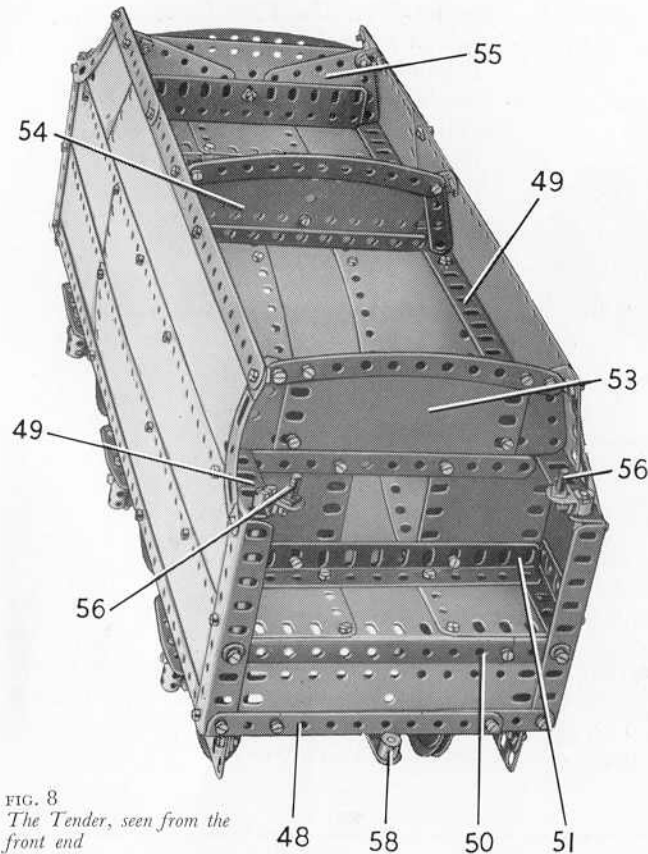

FIG. 8
The Tender, seen from the
front end

$9\frac{1}{2}$ " Strip, and this is extended by a $2\frac{1}{2}$ " Curved Strip (Fig. 6). The Curved Strip is *lock-nutted* to an Angle Bracket, which in turn is *lock-nutted* to the Bell Crank (29).

Construction of the Bogie (Fig. 10)

The bogie is made by bolting a $5\frac{1}{2}$ " \times $3\frac{1}{2}$ " Flat Plate and a $3\frac{1}{2}$ " \times $2\frac{1}{2}$ " Flanged Plate (42) (Fig. 10) to a $7\frac{1}{2}$ " Angle Girder on each side. A $3\frac{1}{2}$ " Angle Girder is bolted to one end and a $3\frac{1}{2}$ " \times $\frac{1}{2}$ " Double Angle Strip is fixed to the other end. A $2\frac{1}{2}$ " \times $1\frac{1}{2}$ " Flexible Plate is attached to each flange of the Plate (42) and is edged by a $2\frac{1}{2}$ " Strip and fitted with a $2\frac{1}{2}$ " Curved Strip arranged as shown. At the front two 2" Flat Girders are bolted together and are attached to the Flexible Plate by Angle Brackets. The bogie wheels are Wheel Flanges and Face Plates bolted together, and they are fixed on 5" Rods. Each of the Rods is held in place by two Collars.

The bogie is *lock-nutted* on a $1\frac{1}{8}$ " Bolt (43) (Fig. 2), which passes through a $3\frac{1}{2}$ " Strip bolted across the main frame. A $\frac{3}{4}$ " Bolt (44) (Fig. 10) is passed through the bogie and on it is placed a Compression Spring. The Bolt is then fixed in a Slide Piece (45) (Fig. 2), which is carried on a $2\frac{1}{2}$ " Curved Strip attached to the main frame by Fishplates.

Building the Tender (Figs. 8 and 9)

Each side of the underframe is made by bolting a $12\frac{1}{2}$ " Flat Girder and a $9\frac{1}{2}$ " Flat Girder to an $18\frac{1}{2}$ " Angle Girder (46) (Fig. 9). A further $18\frac{1}{2}$ " Angle Girder (47) is fixed to the Girder (46), and the sides are connected at each end by built-up girders (48), each made from a $5\frac{1}{2}$ " and a $2\frac{1}{2}$ " Angle Girder overlapped three holes. The wheels are free to turn between Spring Clips and 1" Pulleys on $6\frac{1}{2}$ " Rods, which are mounted in Flat Trunnions and in Couplings fixed to the Flat Trunnions by $\frac{3}{4}$ " Bolts. The leaf spring above each Coupling is formed by a $2\frac{1}{2}$ " Strip and a $1\frac{1}{2}$ " Strip supported by an Angle Bracket.

A $4\frac{1}{2}$ " Angle Girder is bolted vertically to each end of each of the Girders (47), and these are connected at their upper ends by an $18\frac{1}{2}$ " Angle Girder (49). The side between these Girders is filled in by Strip Plates as shown. One side is extended upward by a $12\frac{1}{2}$ " \times $2\frac{1}{2}$ " Strip Plate that overlaps a $4\frac{1}{2}$ " \times $2\frac{1}{2}$ " Flexible Plate by three holes. The other side is similar, but a $5\frac{1}{2}$ " \times $2\frac{1}{2}$ " Flexible Plate is used in place of the $4\frac{1}{2}$ " \times $2\frac{1}{2}$ " Flexible Plate. The Plates are edged by two 3" Stepped Curved Strips, a $12\frac{1}{2}$ " Strip and a $5\frac{1}{2}$ " Strip.

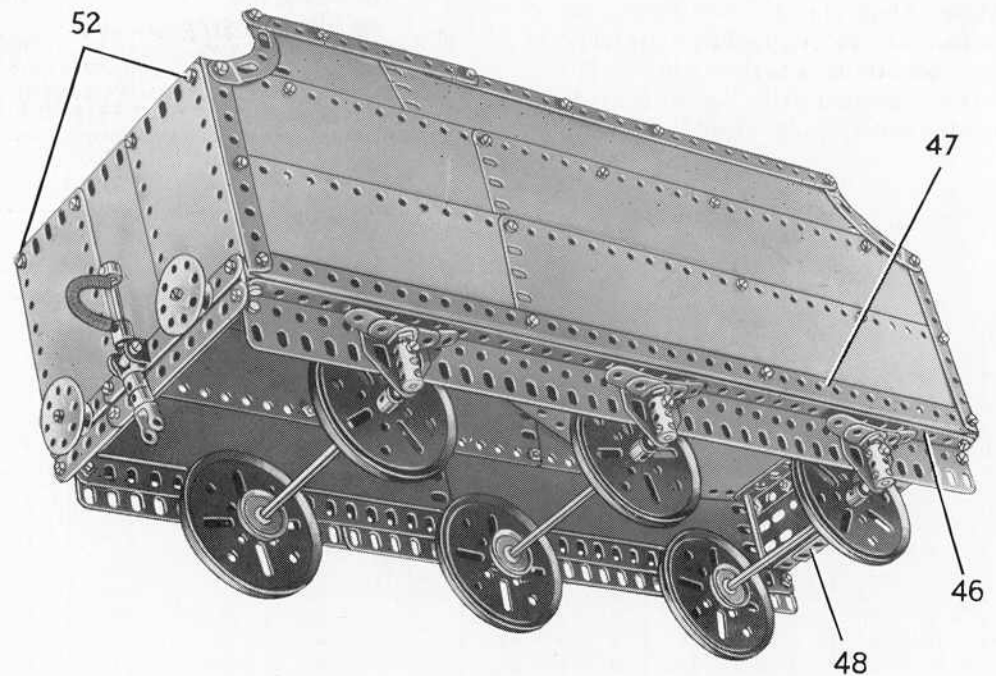

FIG. 9 Another view of the Tender

The front pair of $4\frac{1}{2}$ " Angle Girders is connected by a built-up girder (50), made from a $5\frac{1}{2}$ " and a $2\frac{1}{2}$ " Angle Girder. A $5\frac{1}{2}$ " \times $1\frac{1}{2}$ " Flexible Plate is fixed between this and the girder (48). A further built-up girder (51), made in the same way as the girder (50), is fixed in position, and to these girders are bolted three $12\frac{1}{2}$ " \times $2\frac{1}{2}$ " Strip Plates. The Strip Plates are curved as shown and are attached to the Girders (49). Each Strip Plate is extended by two $4\frac{1}{2}$ " \times $2\frac{1}{2}$ " Flexible Plates. These are supported at their rear ends by a built-up girder held by bolts (52) (Fig. 9), and made from a $5\frac{1}{2}$ " and a $1\frac{1}{2}$ " Angle Girder. A Boiler End is attached to this girder by an Angle Bracket.

The back of the tender is filled in by three $4\frac{1}{2}$ " \times $2\frac{1}{2}$ " Flexible Plates, edged at their lower ends by two built-up strips each made from two $4\frac{1}{2}$ " Strips. The buffers are Wheel Discs and $\frac{1}{2}$ " fixed Pulleys on $\frac{3}{4}$ " Bolts. The tender coupling and the brake pipe are arranged as shown in Fig. 9.

The partition (53) (Fig. 8) is made by bolting two $2\frac{1}{2}$ " \times $2\frac{1}{2}$ " Flexible Plates to the

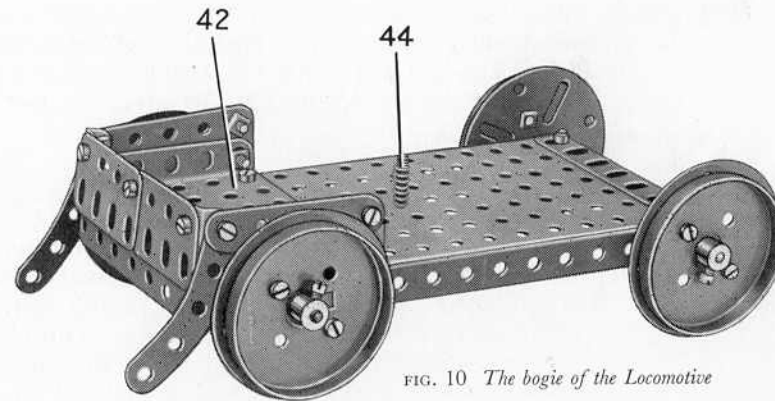

FIG. 10 The bogie of the Locomotive

MECCANO No. 10 OUTFIT INSTRUCTIONS LEAFLETS

The following Instructions Leaflets are now available each describing an attractive new model designed for construction with Outfit No. 10.

- | | |
|------------------------------------|---|
| No. 1 Railway Service Crane | No. 7 Block-setting Crane |
| No. 2 Sports Motor Car | No. 8 Beam Bridge |
| No. 3 Coal Tippler | No. 9 Dumper Truck |
| No. 4 Cargo Ship | No. 10 Automatic Gantry Crane |
| No. 5 Double Deck Bus | No. 11 Automatic Snow Loader |
| No. 6 Lifting Shovel | No. 12 4-4-0 Locomotive & Tender |

(Additional leaflets will be introduced periodically)

OBTAINABLE FROM YOUR MECCANO DEALER OR DIRECT FROM MECCANO LTD.

girder (51). The Flexible Plates are connected by a $5\frac{1}{2}$ " Strip and a $4\frac{1}{2}$ " \times $2\frac{1}{2}$ " Flexible Plate, which is extended at each side by a $3\frac{1}{2}$ " \times $1\frac{1}{2}$ " Triangular Flexible Plate. A $5\frac{1}{2}$ " Curved Strip attached to the Plates is connected to the sides of the tender by Angle Brackets.

The partition (54) is formed by a $5\frac{1}{2}$ " \times $1\frac{1}{2}$ " Flexible Plate and a $5\frac{1}{2}$ " Flat Girder, with a 2" Strip at each side and a $5\frac{1}{2}$ " Curved Strip along the top. This partition also is attached to the sides by Angle Brackets. The partition (55) is similar to (54), except that $2\frac{1}{2}$ " \times 2" Triangular Flexible Plates are used in place of the 2" Strips.

The handles (56) are made by fixing $\frac{3}{8}$ " Bolts in Angle Brackets, each of which is then attached to one half of a Dog Clutch by a nut and bolt. The halves of the Dog Clutch are fitted on Rods as shown.

The coupling for attaching the tender to the locomotive consists of a Threaded Pin (57) (Fig. 7), supported by a 1" \times 1" Angle Bracket. The Threaded Pin engages a Crank (58) (Fig. 8) that is lock-nutted to the front of the tender.

Parts Required to Build the Meccano 4-4-0 Passenger Locomotive and Tender

8 of No. 1	4 of No. 9c	5 of No. 16	2 of No. 24c	5 of No. 52a	2 of No. 77	2 of No. 103d	12 of No. 126a	1 of No. 162a	19 of No. 197
3 " " 1a	8 " " 9d	2 " " 16a	1 " " 25	6 " " 53	2 " " 80c	2 " " 103e	2 " " 128	2 " " 164	4 " " 200
13 " " 2	4 " " 9e	3 " " 16b	3 " " 26	2 " " 53a	5 " " 89	4 " " 103f	2 " " 133	2 " " 165	2 " " 212
8 " " 2a	3 " " 9f	5 " " 17	2 " " 27a	1 " " 58	6 " " 89a	2 " " 103g	2 " " 133a	2 " " 166	4 " " 214
16 " " 3	12 " " 10	2 " " 18a	1 " " 27c	24 " " 59	4 " " 89b	4 " " 103h	4 " " 136	1 " " 168a	2 " " 216
1 " " 4	4 " " 11	3 " " 18b	10 " " 35	3 " " 62	12 " " 90	2 " " 108	4 " " 137	2 " " 176	4 " " 221
26 " " 5	48 " " 12	6 " " 19b	595 " " 37a	1 " " 62a	8 " " 90a	4 " " 109	2 " " 140	2 " " 179	2 " " 222
4 " " 6	1 " " 12a	4 " " 20	518 " " 37b	4 " " 62b	1 " " 94	18 " " 111	2 " " 143	1 " " 185	2 " " 224
9 " " 6a	4 " " 12b	7 " " 22	80 " " 38	8 " " 63	1 " " 95	15 " " 111a	1 " " 144	12 " " 188	2 " " 225
6 " " 7	2 " " 13	5 " " 22a	3 " " 38d	1 " " 63b	1 " " 96a	23 " " 111c	1 " " 146	11 " " 189	
6 " " 7a	1 " " 13a	1 " " 23	2 " " 43	1 " " 63c	1 " " 102	1 " " 111d	1 " " 146a	12 " " 190	
2 " " 8b	3 " " 14	2 " " 23a	2 " " 45	2 " " 64	4 " " 103	4 " " 115	1 " " 147b	2 " " 190a	
12 " " 9	6 " " 15	4 " " 24	3 " " 48b	3 " " 70	2 " " 103a	4 " " 118	4 " " 155	14 " " 191	
6 " " 9a	1 " " 15a	2 " " 24a	1 " " 48d	2 " " 72	4 " " 103b	3 " " 120b	1 " " 160	14 " " 192	
3 " " 9b	2 " " 15b	2 " " 24b	1 " " 50	2 " " 73	2 " " 103c	2 " " 125	2 " " 161	4 " " 196	

1 E15R
Electric Motor
(not included
in Outfit)

MECCANO

Combine Harvester

(MODEL No. 10.13)

SPECIAL FEATURES

This model represents one of the many mechanical appliances used on modern farms. A two-speed and reverse gear-box gives different traction speeds, and other features include workable steering gear and a power-driven reel or beater.

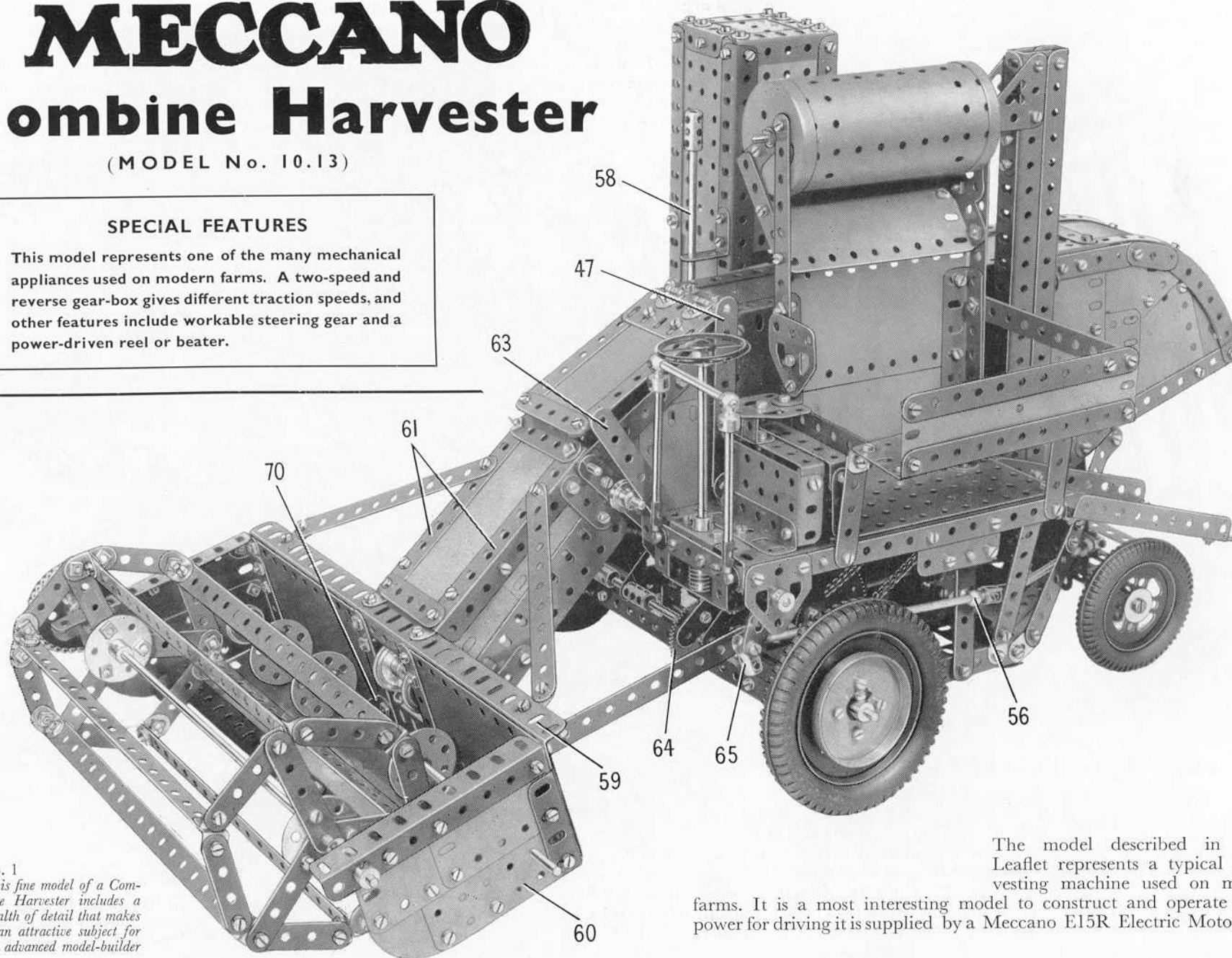
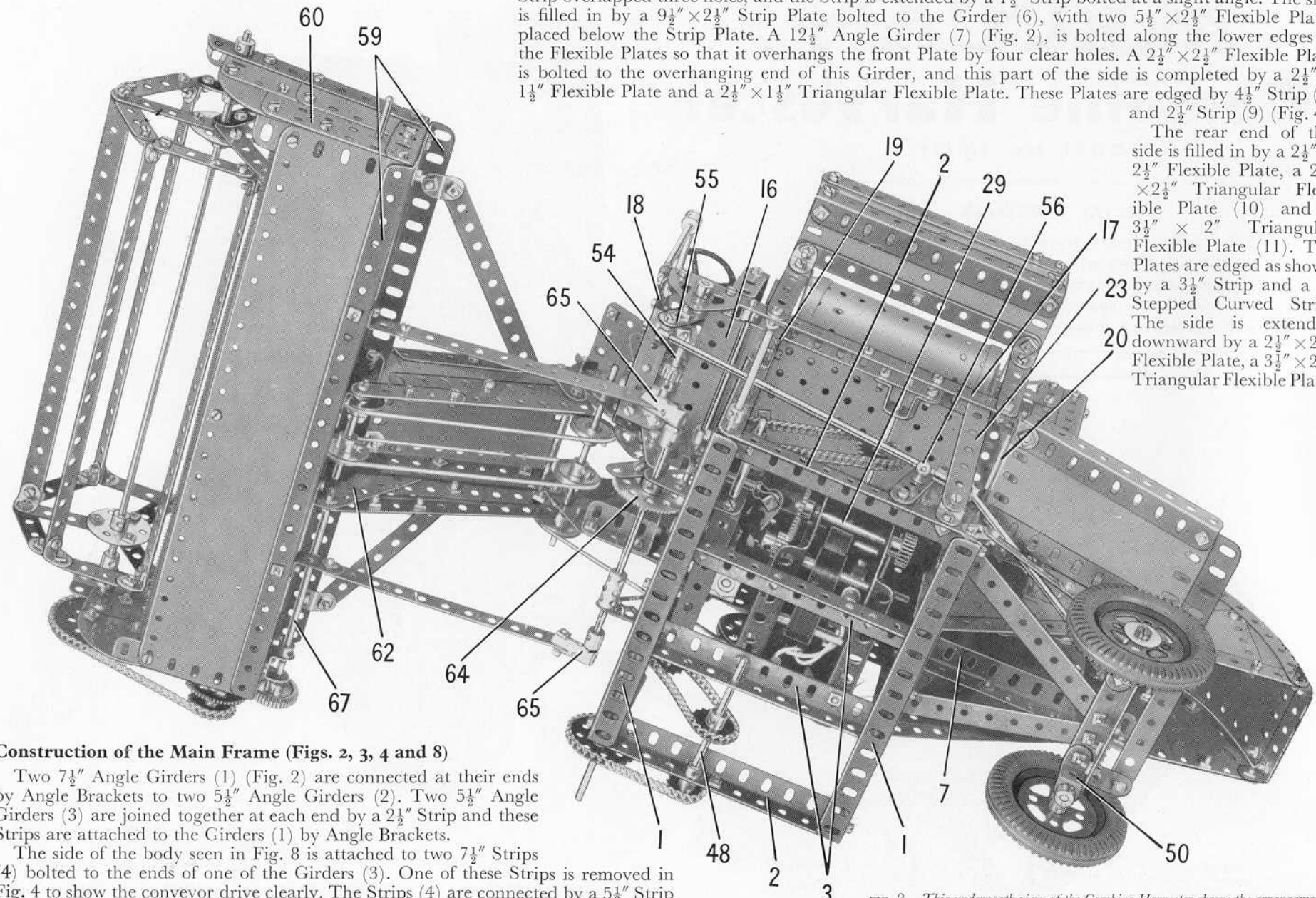

FIG. 1
This fine model of a Combine Harvester includes a wealth of detail that makes it an attractive subject for the advanced model-builder

The model described in this Leaflet represents a typical harvesting machine used on many farms. It is a most interesting model to construct and operate and power for driving it is supplied by a Meccano E15R Electric Motor.



Strip overlapped three holes, and the Strip is extended by a $1\frac{1}{2}$ " Strip bolted at a slight angle. The side is filled in by a $9\frac{1}{2}$ " \times $2\frac{1}{2}$ " Strip Plate bolted to the Girder (6), with two $5\frac{1}{2}$ " \times $2\frac{1}{2}$ " Flexible Plates placed below the Strip Plate. A $12\frac{1}{2}$ " Angle Girder (7) (Fig. 2), is bolted along the lower edges of the Flexible Plates so that it overhangs the front Plate by four clear holes. A $2\frac{1}{2}$ " \times $2\frac{1}{2}$ " Flexible Plate is bolted to the overhanging end of this Girder, and this part of the side is completed by a $2\frac{1}{2}$ " \times $1\frac{1}{2}$ " Flexible Plate and a $2\frac{1}{2}$ " \times $1\frac{1}{2}$ " Triangular Flexible Plate. These Plates are edged by $4\frac{1}{2}$ " Strip (8) and $2\frac{1}{2}$ " Strip (9) (Fig. 4).

The rear end of this side is filled in by a $2\frac{1}{2}$ " \times $2\frac{1}{2}$ " Flexible Plate, a $2\frac{1}{2}$ " \times $2\frac{1}{2}$ " Triangular Flexible Plate (10) and a $3\frac{1}{2}$ " \times 2 " Triangular Flexible Plate (11). The Plates are edged as shown by a $3\frac{1}{2}$ " Strip and a 4 " Stepped Curved Strip. The side is extended downward by a $2\frac{1}{2}$ " \times $2\frac{1}{2}$ " Flexible Plate, a $3\frac{1}{2}$ " \times $2\frac{1}{2}$ " Triangular Flexible Plate.

Construction of the Main Frame (Figs. 2, 3, 4 and 8)

Two $7\frac{1}{2}$ " Angle Girders (1) (Fig. 2) are connected at their ends by Angle Brackets to two $5\frac{1}{2}$ " Angle Girders (2). Two $5\frac{1}{2}$ " Angle Girders (3) are joined together at each end by a $2\frac{1}{2}$ " Strip and these Strips are attached to the Girders (1) by Angle Brackets.

The side of the body seen in Fig. 8 is attached to two $7\frac{1}{2}$ " Strips (4) bolted to the ends of one of the Girders (3). One of these Strips is removed in Fig. 4 to show the conveyor drive clearly. The Strips (4) are connected by a $5\frac{1}{2}$ " Strip (5) and by a $9\frac{1}{2}$ " Angle Girder (6). This Girder is extended towards the rear by a $2\frac{1}{2}$ "

FIG. 2 This underneath view of the Combine Harvester shows the arrangement of the conveyor, the underframe and the steering mechanism

FIG. 3
The driver's platform and
the bagging platform, seen
from above

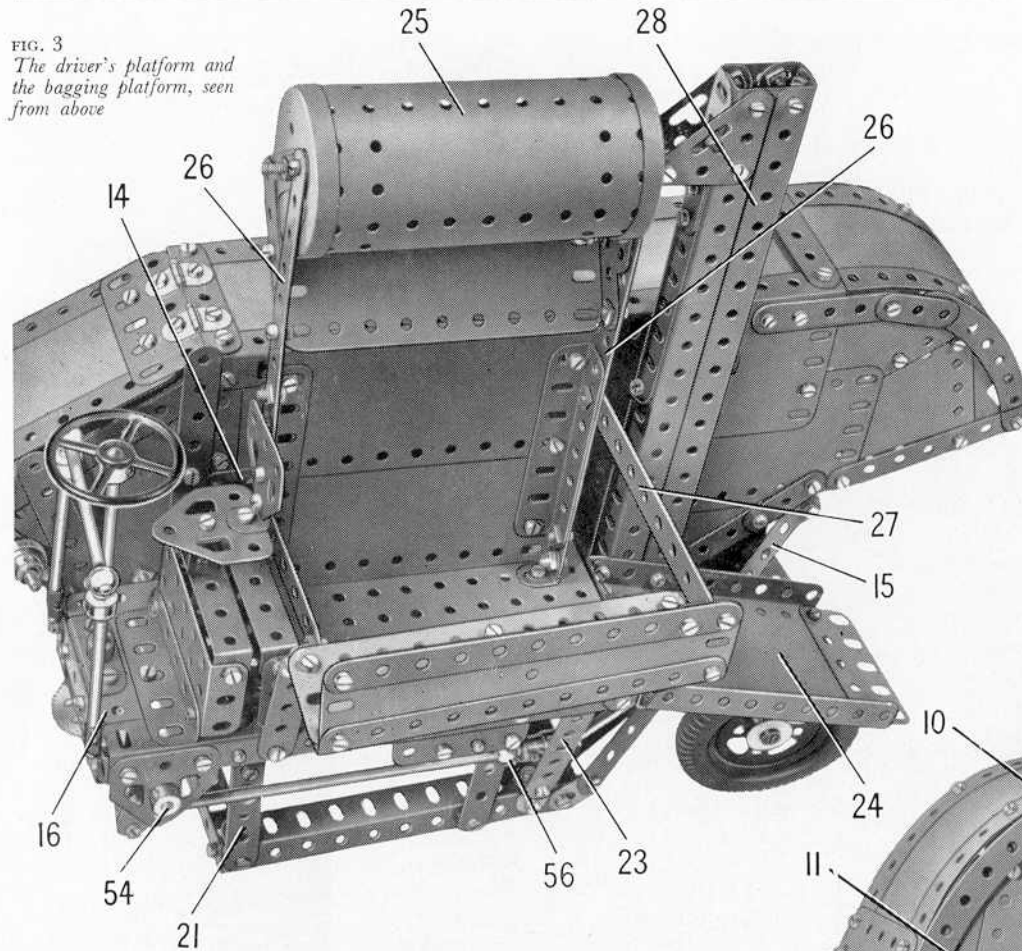

(12), and a $2\frac{1}{2}'' \times 1\frac{1}{2}''$ Triangular Flexible Plate (13), edged by a $5\frac{1}{2}''$ Strip that is extended one hole by a $1\frac{1}{2}''$ Strip.

The side seen in Fig. 1 is similar in general design, but only one $7\frac{1}{2}''$ Strip is fixed to the Girder (3), and the front one of the $5\frac{1}{2}'' \times 2\frac{1}{2}''$ Flexible Plates is replaced by a $4\frac{1}{2}'' \times 2\frac{1}{2}''$ Flexible Plate. This construction leaves a gap $\frac{1}{2}''$ wide in front of the Plate, and later this gap is used to accommodate the lever that controls the drive to the conveyor. The gap is edged by a $1\frac{1}{2}''$ Strip (14) (Fig. 3) and a $2\frac{1}{2}''$ Strip.

The sides are connected at the top by a $9\frac{1}{2}'' \times 2\frac{1}{2}''$ Strip Plate bolted to the Girders (6) (Fig. 4), with a $2\frac{1}{2}''$ Strip at each end of the Strip Plate. The rear section of the top is filled by a $5\frac{1}{2}'' \times 2\frac{1}{2}''$ Flexible Plate edged by two curved $5\frac{1}{2}''$ Strips and extended by a $2\frac{1}{2}''$ Flat Girder. The Flat Girder is bolted to a $2\frac{1}{2}'' \times \frac{1}{2}''$ Double Angle Strip fixed between the sides.

A stay (15) (Fig. 3) is attached to a Fishplate bolted to the body, and is connected to one of the Girders (2) by an Obtuse Angle Bracket. This stay consists of two $3\frac{1}{2}''$ Strips overlapped two holes.

The Driving and Bagging Platform (Figs. 1, 2 and 3)

The platform consists of a $5\frac{1}{2}'' \times 3\frac{1}{2}''$ Flat Plate extended forward by a $2\frac{1}{2}'' \times 2\frac{1}{2}''$ Flat Plate (16) (Figs. 2 and 3). The $5\frac{1}{2}'' \times 3\frac{1}{2}''$ Flat Plate is edged by a $7\frac{1}{2}''$ Angle Girder (17) (Fig. 2) and to this are bolted three $3\frac{1}{2}'' \times \frac{1}{2}''$ Double Angle Strips indicated at (18), (19) and (20). The inner lugs of these Double Angle Strips are used to attach the platform to the side of the body, the bolts being passed through the Girder (7) of this side.

FIG. 4
In this picture the air intake
is removed to reveal details
of the drive to the conveyor

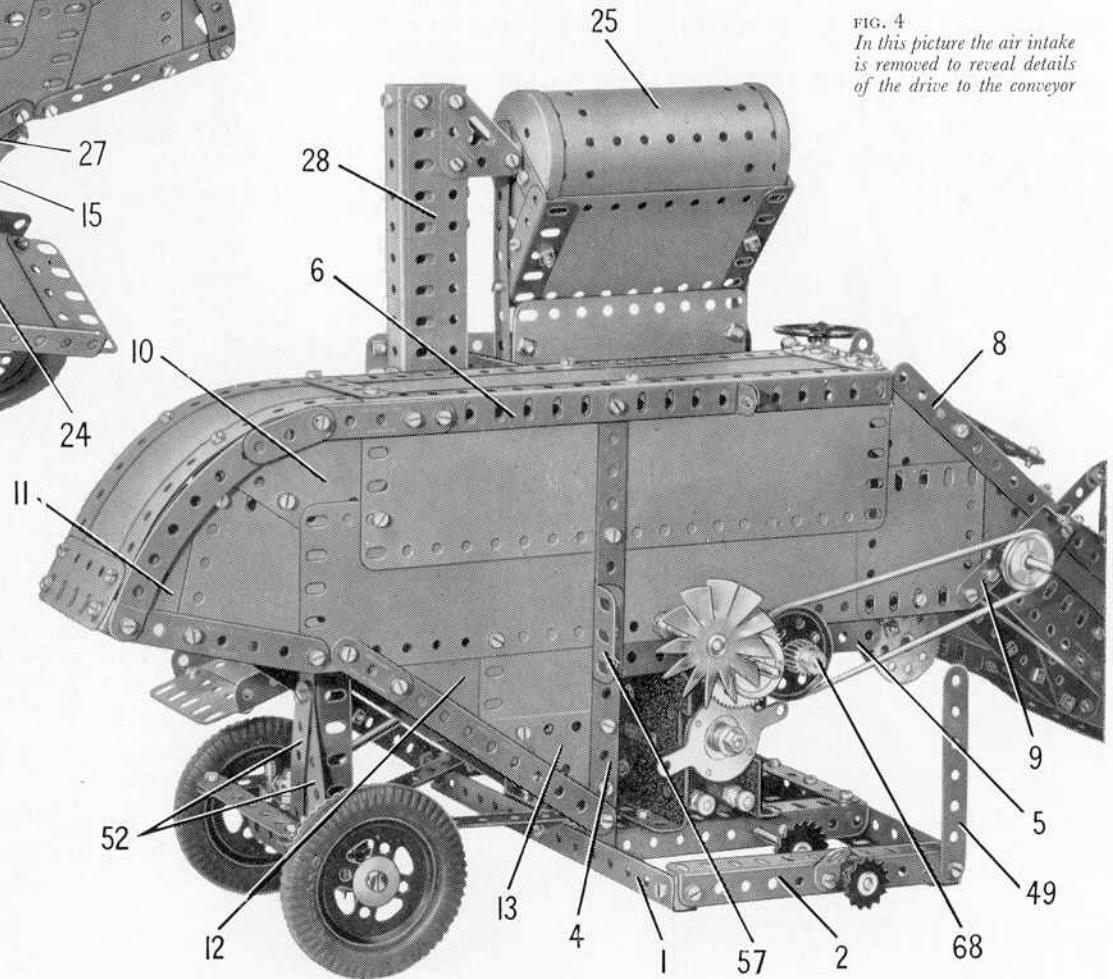

A built-up strip (21) (Fig. 3), made from two 2" Strips overlapped two holes, is bolted to one of the Girders (2) (Fig. 2) and is connected to Double Angle Strip (19) by an Angle Bracket. A 3" Angle Girder (22) (Fig. 10) is fixed to one of the Girders (1) and is attached to the Double Angle Strip (19) by a $\frac{1}{2}$ " Corner Angle Bracket (see Fig. 10). A $3\frac{1}{2}$ " Strip (23) is secured to the Girder (17) and is connected to one of the Girders (2) by an Obtuse Angle Bracket.

A chute (24) at the rear end of the bagging platform consists of a $4\frac{1}{2}$ " \times $2\frac{1}{2}$ " Flexible Plate edged by $4\frac{1}{2}$ " Angle Girders and fitted at one end with a $2\frac{1}{2}$ " Strip and at the other end with a $2\frac{1}{2}$ " Flat Girder. The chute is attached to the platform by Angle Brackets.

Bagging Attachment and Grain Elevator (Figs. 1, 3, 4 and 7)

The bagging attachment is represented by a cylinder (25) (Fig. 3) formed by a Boiler pressed into two Wheel Flanges. Each Wheel Flange is bolted to a Corner Gusset that is edged by a $2\frac{1}{2}$ " Angle Girder and is fixed to a $7\frac{1}{2}$ " Strip (26). A $4\frac{1}{2}$ " \times $2\frac{1}{2}$ " Flexible Plate is supported by the Angle Girders and the Strips are attached to the bagging platform by Angle Brackets. Two $3\frac{1}{2}$ " Angle Girders are bolted to the ends of two $4\frac{1}{2}$ " \times $2\frac{1}{2}$ " Flexible Plates, and are fixed to the Strips (26).

A seat is formed by two $5\frac{1}{2}$ " \times $1\frac{1}{2}$ " Flexible Plates connected by a $5\frac{1}{2}$ " Angle Girder, and is attached by Angle Brackets to $2\frac{1}{2}$ " Strips bolted to the Girder (17) (Figs. 2 and 10). The seat is connected to one of the Strips (26) by a 3" Strip and an Angle Bracket, and is braced to the other Strip (26) and to the side of the body by a $5\frac{1}{2}$ " \times $\frac{1}{2}$ " Double Angle Strip (27).

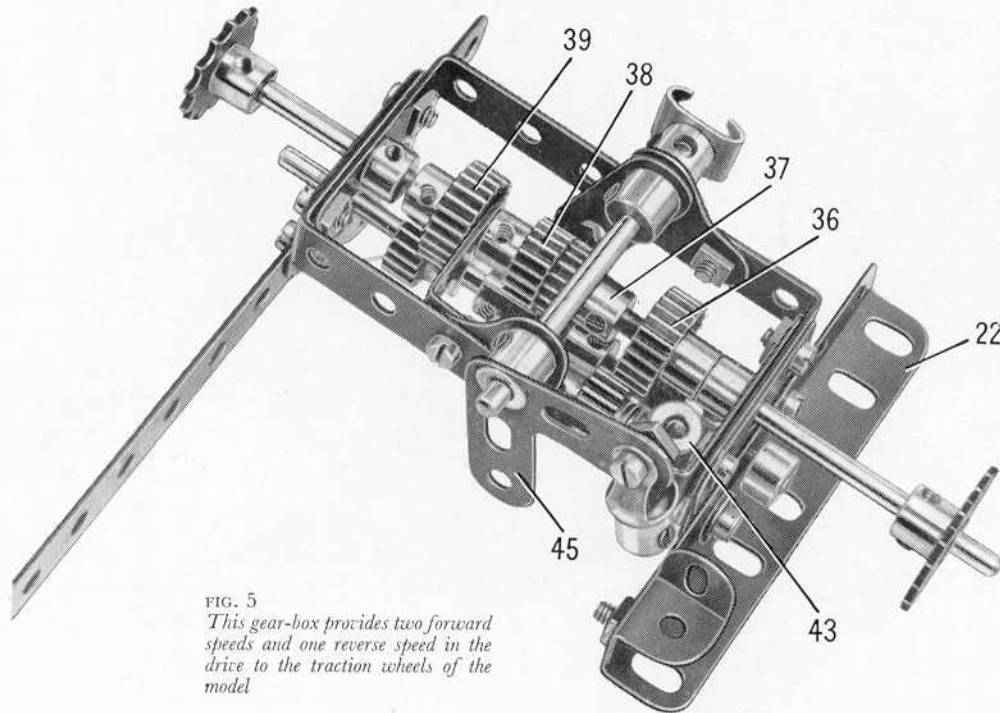

FIG. 5
This gear-box provides two forward speeds and one reverse speed in the drive to the traction wheels of the model

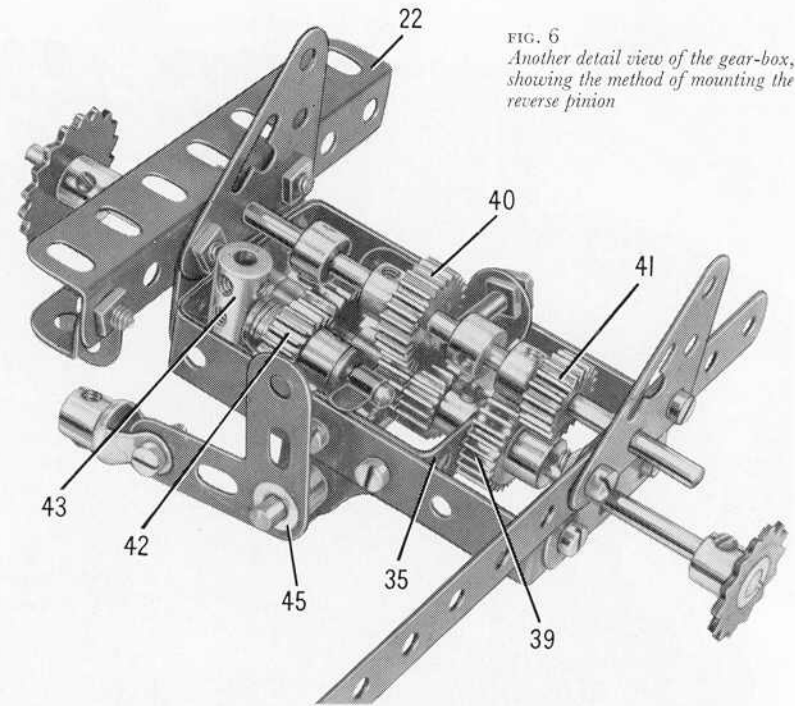

FIG. 6
Another detail view of the gear-box, showing the method of mounting the reverse pinion

The box that supports the driving seat consists of two $2\frac{1}{2}$ " \times $1\frac{1}{2}$ " Flanged Plates, each fitted with a $2\frac{1}{2}$ " \times $\frac{1}{2}$ " Double Angle Strip. One of the Flanged Plates is bolted to a $2\frac{1}{2}$ " Angle Girder fixed to the Flat Plate (16) (Fig. 3), and the other Flanged Plate is bolted to one of the Strips (26) and is attached to the bagging platform by an Angle Bracket. The seat is formed by two Flat Trunnions connected by a $1"$ \times $\frac{1}{2}"$ Angle Bracket, and it is attached to the box by a Double Bracket.

The cover (28) for the grain elevator consists of two $9\frac{1}{2}"$ Angle Girders connected at their upper and lower ends by $1\frac{1}{2}"$ Flat Girders. A $5\frac{1}{2}"$ Angle Girder is bolted to the top end of each $9\frac{1}{2}"$ Angle Girder and a $5\frac{1}{2}"$ Flat Girder is used to connect the $5\frac{1}{2}"$ Angle Girders together. The cover is attached to the body by a $1"$ \times $\frac{1}{2}"$ Angle Bracket, and it is bolted also to the chute (24). Two $1\frac{1}{2}"$ Corner Brackets are fixed to the top of the cover and are attached to the lugs of a Double Bracket that is bolted to one end of the cylinder (25).

Arrangement of the Power Unit, Reduction Gearing and Fan Drive (Figs. 2, 4, 8 and 9)

An E15R Electric Motor is bolted by its flanges to the Angle Girders (3) (Fig. 2), and a $\frac{1}{2}"$ Pinion on its armature shaft drives a 57-tooth Gear on a $2\frac{1}{2}"$ Rod (29). A $\frac{3}{4}"$ Pinion on this Rod engages a 50-tooth Gear on a $2\frac{1}{2}"$ Rod that carries a Worm (30) (Fig. 10). This Worm drives a $\frac{1}{2}"$ Pinion

on an 8" Rod (31), which is mounted at one end in a 2" Flat Girder bolted to the Angle Girder (17), and in a Double Bent Strip fixed to the Flat Girder. The Rod passes through holes in the Strips (5) (Fig. 4), and it carries a 1" Sprocket (32) (Fig. 10), a 57-tooth Gear (33) and a 1" Pulley (34) (Fig. 8). The Rod is held in place by a Collar and by the $\frac{1}{2}$ " Pinion driven by the Worm (30). This Pinion is located against a Double Bent Strip that is bolted to one of the Strips (5) (Fig. 4).

The Pulley (34) is connected by a Driving Band to a $\frac{1}{2}$ " fixed Pulley on a $4\frac{1}{2}$ " Rod that carries a Fan. The Rod is mounted in the sides of the body and is held in place by a Collar and one half of a Dog Clutch.

Gear-box and Drive to the Traction Wheels (Figs. 2, 5, 6 and 8)

The gear-box is shown removed from the machine in Figs. 5 and 6. The frame consists of two $3" \times 1\frac{1}{2}"$ Double Angle Strips with their lugs overlapped, and with a $1\frac{1}{2}"$ Flat Girder fixed at each end by bolts through its slotted holes. A $1" \times 1"$ Angle Bracket (35) is bolted to the frame at one side, the same bolts holding also a 1" Corner Bracket. Another 1" Corner Bracket is fastened to the other side of the frame.

The input shaft is a $3\frac{1}{2}"$ Rod that carries a $\frac{3}{4}"$ Pinion (36) and a $\frac{1}{2}"$ Pinion (37). The Rod projects slightly beyond the Pinion (37) into a $\frac{1}{2}"$ Pinion (38) on the output shaft. This shaft is a 3" Rod, and it carries also a $\frac{3}{4}"$ Pinion (39). The layshaft is a 4" Rod fitted with a $\frac{3}{4}"$ Pinion (40) and a $\frac{1}{2}"$ Pinion (41). The layshaft is able to slide in its bearings, but its movement is limited by Collars. A reverse $\frac{1}{2}"$ Pinion (42) is held by a Spring Clip on a $1\frac{1}{2}"$ Rod and is spaced from a Coupling (43) by four Washers. The Rod is fixed in the Coupling, which is screwed on to a bolt at one end of the gear-box housing. The housing is bolted to one of the Strips (4) and to the Girder (22) as shown in Figs. 8 and 10, and the $1\frac{1}{2}"$ Flat Girders are adjusted by their slotted holes so that the $\frac{1}{2}"$ and $\frac{3}{4}"$ Pinions mesh accurately. The bolts that fix the housing in place secure also $1\frac{1}{2}"$ Corner Brackets (44) (Fig. 8).

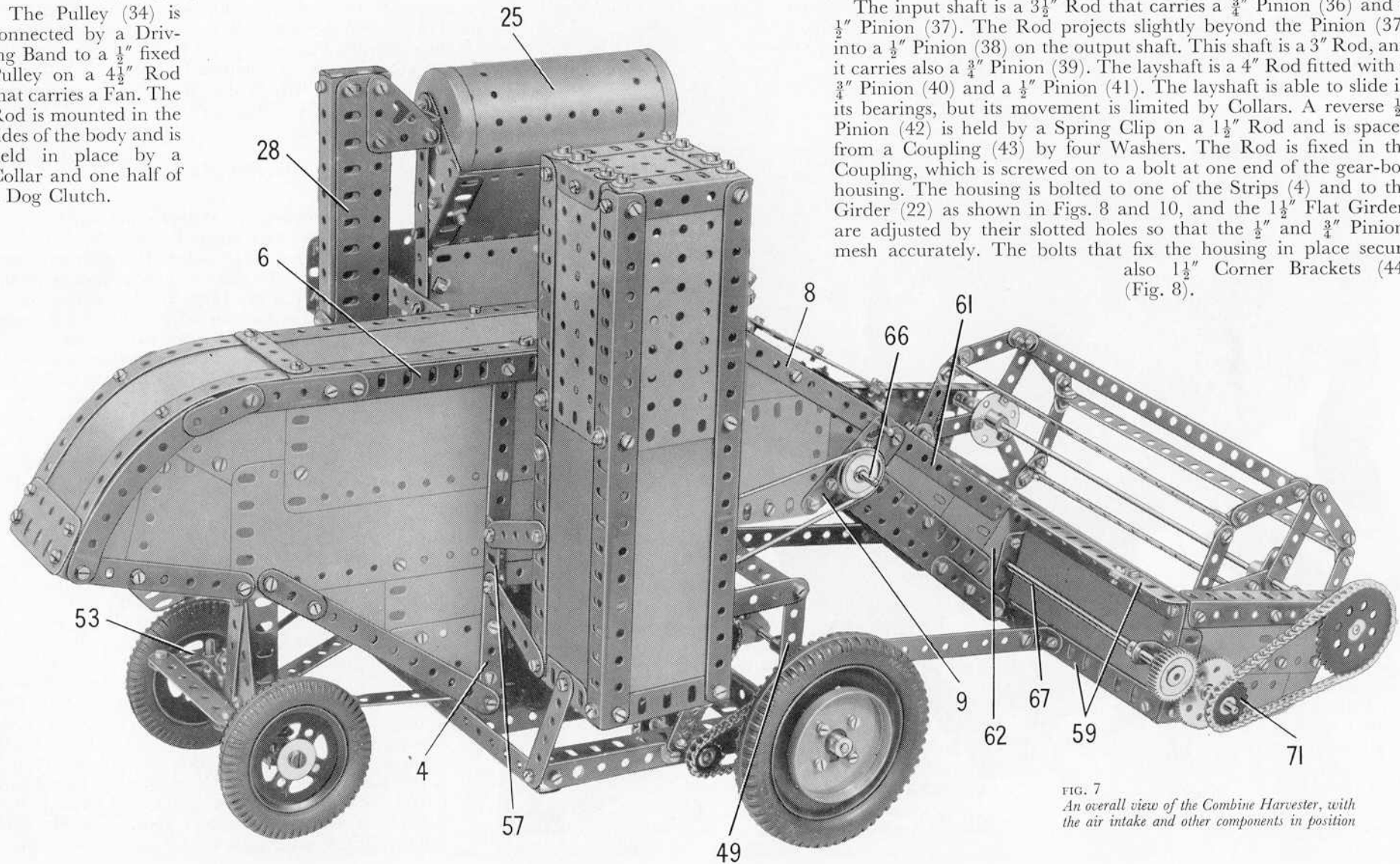

FIG. 7
An overall view of the Combine Harvester, with the air intake and other components in position

The movement of the gear-box is controlled by a Threaded Pin located between a Collar and the Pinion (40) (Fig. 6). The Threaded Pin is attached to a Crank, which is fixed on a $2\frac{1}{2}$ " Rod mounted in the 1" Corner Brackets and is held in place by a Bell Crank (45) and a Slide Piece. An End Bearing *lock-nutted* to the Bell Crank is connected by a 1" Rod to another End Bearing (46) (Fig. 9). The End Bearing (46) is *lock-nutted* to a lever (47), made from a $3\frac{1}{2}$ " Strip and a 3" Strip overlapped two holes. A Double Arm Crank is bolted to the lever with its boss over the third hole from the lower end of the $3\frac{1}{2}$ " Strip. The Double Arm Crank is fixed on a $4\frac{1}{2}$ " Rod mounted in one of the Girders (7) and in the Girder (17) (Fig. 10). The lever is spaced from the side of the body by four Washers, and the $4\frac{1}{2}$ " Rod is held in place by the other half of the Dog Clutch.

The Sprocket (32) (Fig. 10) is connected by Chain to a 1" Sprocket on the gear-box input shaft. A $\frac{3}{4}$ " Sprocket on the output shaft drives a 1" Sprocket on a $3\frac{1}{2}$ " Rod (48) (Fig. 8), and a $\frac{3}{4}$ " Sprocket on the same Rod is linked by Chain to a $1\frac{1}{2}$ " Sprocket on the main axle. This axle is an $11\frac{1}{2}$ " Rod mounted in the Strips (4) (Fig. 4) and (21) (Fig. 3), the Angle Girder (22) (Fig. 10), and in a $3\frac{1}{2}$ " Strip (49) (Fig. 8). This Strip is connected to the side of the body by a $2\frac{1}{2}$ " \times $\frac{1}{2}$ " Double Angle Strip.

When the layshaft is moved to the right (Fig. 6), the Pinion (40) engages Pinions (37) and (38) and bottom gear is engaged. By moving the layshaft slightly to the left Pinion (41) meshes with the Pinion (39) and Pinion (40) engages the Pinion (37), to provide top gear. Reverse is obtained by moving the layshaft to the extreme left, so that the drive is transmitted from Pinion (39) to Pinion (41) and through Pinions (36), (42) and (40).

Details of the Steering Mechanism (Figs. 2, 4, 7 and 10)

The axle beam is a $3\frac{1}{2}$ " Angle Girder fitted at each end with a $\frac{1}{2}$ " Reversed Angle Bracket (50) (Fig. 10). A vertical $4\frac{1}{2}$ " Strip (51) is bolted to the axle and to a $2\frac{1}{2}$ " Angle Girder fixed one clear hole from the ends of the Girders (7) (Fig. 2). The Strip (51) is strengthened at the back by a $3\frac{1}{2}$ " Angle Girder, and is braced to the axle beam by two $3\frac{1}{2}$ " Strips (52) (Fig. 4). The axle beam is connected to the main frame of the model (Fig. 2) by a $5\frac{1}{2}$ " Strip and a $4\frac{1}{2}$ " Strip.

Each of the steerable wheels is free to turn on a Pivot Bolt screwed into a Collar on a $1\frac{1}{2}$ " Rod. The wheel is spaced from the Collar by two Washers, and the $1\frac{1}{2}$ " Rod is mounted in the axle beam and in one of the Reversed Angle Brackets (50). The top end of one Rod is fitted with a Crank, and the other Rod carries a Bell Crank (53) (Fig. 10). The Bell Crank and the Crank are linked by a $3\frac{1}{2}$ " Strip pivoted on *lock-nutted* bolts.

The steering column is a 5" Rod supported in the Flat Plate (16) (Fig. 3) and in a $2\frac{1}{2}$ " Strip that is attached to the Double Angle Strip (18) (Fig. 2) by two $1" \times 1"$ Angle Brackets. A Worm on the steering column drives a $\frac{1}{2}$ " Pinion on a 4" Rod (54), which is mounted in a Double Bracket and an Angle Bracket bolted to the $1" \times 1"$ Angle Brackets, and in Flat Trunnions attached to the Girder (17) and one of the Girders (7). The Rod is held in place by Collars, and it carries a Crank (55) to which a Fishplate is bolted. A bolt passed through the Crank and the Fishplate is fixed by a nut in a Collar, which is fixed on a $6\frac{1}{2}$ " Rod held in a Handrail Support (56). The Handrail Support is *lock-nutted* to a $2\frac{1}{2}$ " Strip, and the Strip in

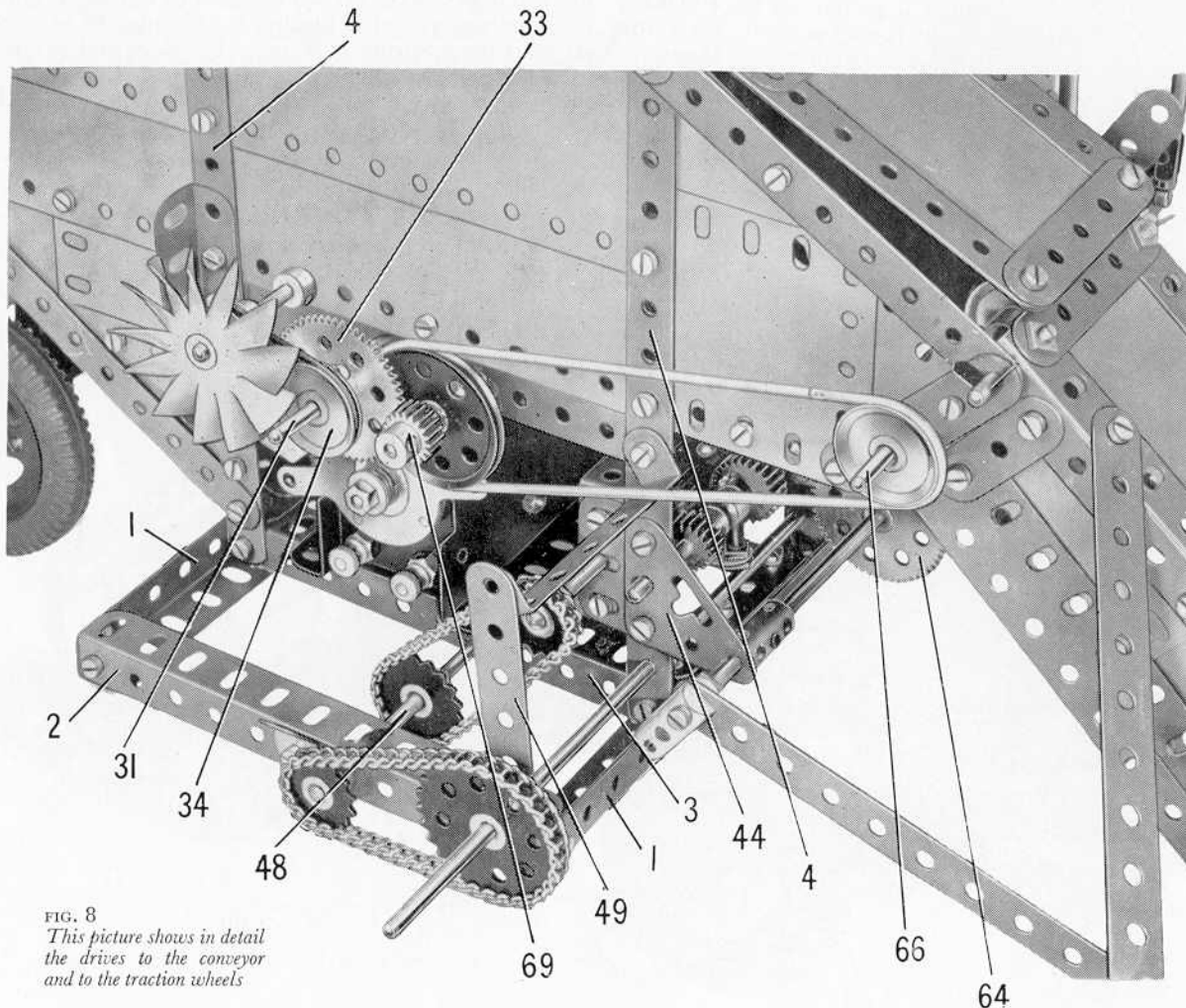

FIG. 8
This picture shows in detail the drives to the conveyor and to the traction wheels

turn is *lock-nutted* to one of the Girders (1). A Swivel Bearing is fixed on the rear end of the $6\frac{1}{2}$ " Rod, which carries also a second Swivel Bearing that is pivotally connected to an arm of the Bell Crank (53) (Fig. 10). A $\frac{1}{2}$ " Bolt passed through the 'spider' of the Swivel Bearing is fixed in the Bell Crank by two nuts.

The Radiator Air Intake (Fig. 7)

The air intake column is made from four $4\frac{1}{2}$ " \times $2\frac{1}{2}$ " Flat Plates and three $5\frac{1}{2}$ " \times $2\frac{1}{2}$ " Flexible Plates bolted to two $9\frac{1}{2}$ " Angle Girders and two built-up $9\frac{1}{2}$ " girders. Each built-up girder consists of a $5\frac{1}{2}$ " and a $4\frac{1}{2}$ " Angle Girder. The top and lower edges of the column are strengthened as shown in Fig. 7 by $2\frac{1}{2}$ " and $1\frac{1}{2}$ " Angle Girders, and the top is filled in by a $2\frac{1}{2}$ " \times $2\frac{1}{2}$ " Flat Plate. The column is attached to the body by two $2\frac{1}{2}$ " Strips bolted to a $1\frac{1}{2}$ " Angle Girder (57) (Fig. 7) and by a 3" Strip attached to the end of one of the Girders (1). Another 3" Strip is connected to the column by an Angle Bracket and is bolted to the Strip (49).

The exhaust pipe (58) (Fig. 1) is an 8" Rod supported in two $1" \times 1"$ Angle Brackets bolted to the column. The Rod carries a Coupling at each end, and at its lower end a cylinder formed by a Sleeve Piece and two $\frac{3}{8}$ " Flanged Wheels. The cylinder is placed above one of the $1" \times 1"$ Angle Brackets and the lower Coupling is fixed underneath the same Angle Bracket to hold the Rod in position.

Reaping and Gathering Head (Figs. 1, 2 and 7)

The head is made by bolting two $5\frac{1}{2}$ " \times $2\frac{1}{2}$ " Flexible Plates, each strengthened by two $2\frac{1}{2}$ " Strips, to the ends of two $12\frac{1}{2}$ " Angle Girders (59) (Figs. 1 and 7). A 2" Angle Girder is fastened to each end and to this is attached a $3" \times 1\frac{1}{2}"$ Flat Plate (60), two $2\frac{1}{2}" \times 1\frac{1}{2}"$ Flexible Plates and a Semi-Circular Plate. A $4\frac{1}{2}"$ Angle Girder is bolted along the top edges of the Flexible Plates and is attached to the top Angle Girder (59) by an Angle Bracket. A $12\frac{1}{2}" \times 2\frac{1}{2}"$ Strip Plate is bolted to the lower one of the Girders (59) and is connected to the Flat Plates (60) by $1\frac{1}{2}"$ Angle Girders. Two $6\frac{1}{2}"$ Rack Strips bolted along the front edge of the Strip Plate represent the cutters.

The frame for the conveyor between the gathering head and the body of the machine, consists of two $4\frac{1}{2}"$ Angle Girders (61) connected by two $2\frac{1}{2}"$ Strip; and a $4\frac{1}{2}" \times 2\frac{1}{2}"$ Flexible Plate. A $1\frac{1}{2}"$ Strip and a $2\frac{1}{2}" \times 2"$ Triangular Flexible Plate (62) are bolted to each of the Girders (61) and are connected at their lower ends by a $4\frac{1}{2}"$ Flat Girder that is extended by a $2\frac{1}{2}"$ Strip. Each side is filled in by two $2\frac{1}{2}" \times 1\frac{1}{2}"$ Flexible Plates. The Girders (61) are attached to the top Angle Girder (59) by Obtuse Angle Brackets, and 2" Angle Girders are bolted to the Triangular Flexible Plates (62) and to the back of the head. A $3\frac{1}{2}"$ Rod is passed

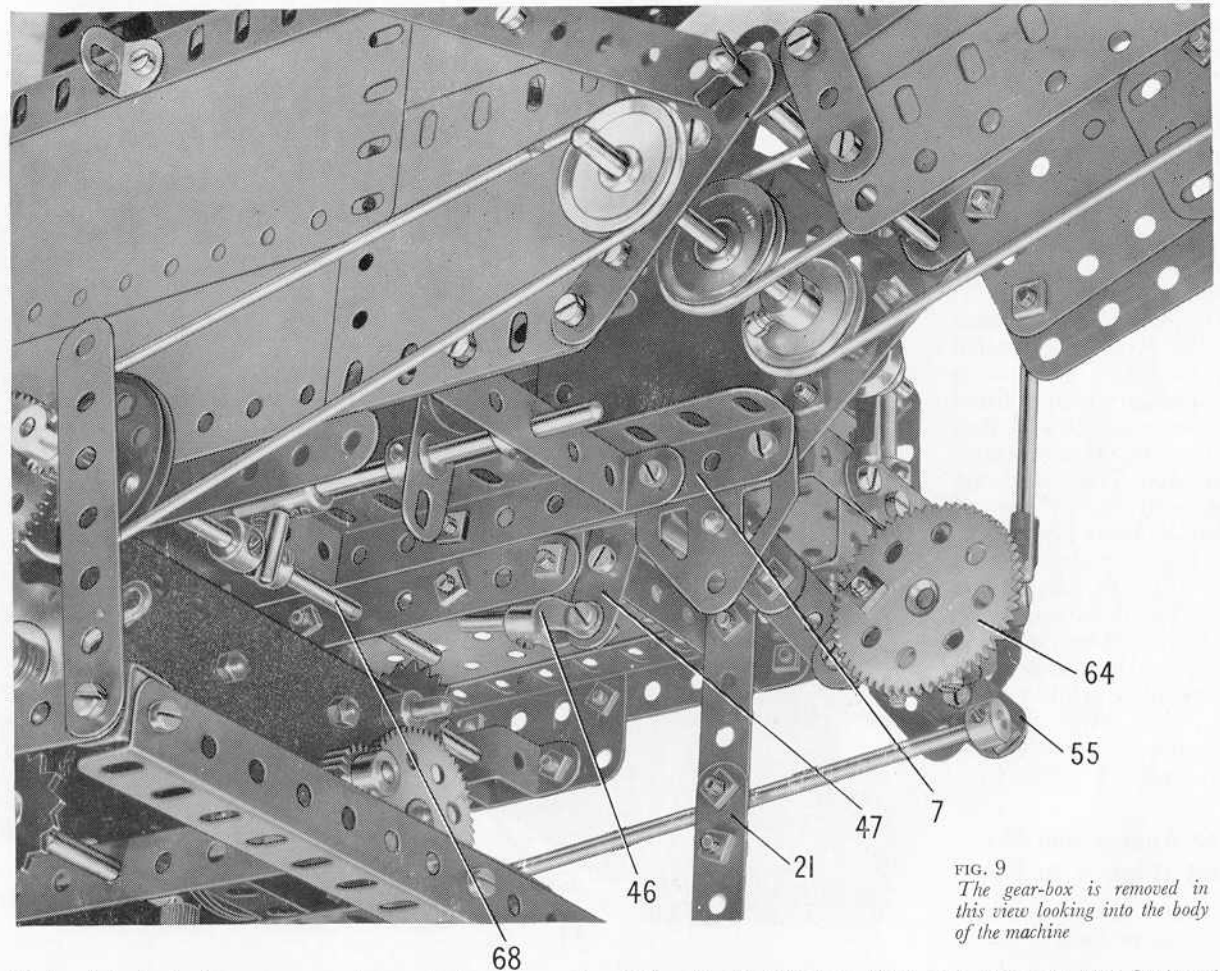

FIG. 9
The gear-box is removed in this view looking into the body of the machine

through the top ends of the Angle Girders (61) and through the Strips (8) (Fig. 7) and is held in place by Spring Clips.

The conveyor assembly and the head can be raised or lowered by operating a lever (63) (Fig. 1). This is a $5\frac{1}{2}"$ Strip to which a Double Arm Crank is bolted so that its boss is in line with the fourth hole from the lower end of the Strip. The Double Arm Crank pivots freely on the Rod (54) (Fig. 10). The lever is *lock-nutted* to a $1\frac{1}{2}"$ Strip, and this in turn is *lock-nutted* to a 57-tooth Gear (64) (Fig. 2). At each end of the Rod a Rod Socket is fixed, with a Strip Coupling (65) screwed on to the shank of the Rod Socket and held tightly in place by a nut. A $5\frac{1}{2}"$ Strip is pivoted on a $\frac{1}{2}"$ Bolt screwed through each Strip Coupling, and is *lock-nutted* to a $1" \times \frac{1}{2}"$ Angle Bracket that is bolted to the back of the gathering head.

The conveyor is represented by two endless belts of Spring Cord passed round 1" Pulleys on a $4\frac{1}{2}"$ Rod (66) and an 8" Rod (67) (Fig. 7). These Rods are

mounted as shown, and a 1" Pulley at one end of Rod (66) is driven by a Spring Cord belt from a 1 1/2" Pulley on a 5" Rod (68) (Fig. 4), which carries also a 1/2" Pinion (69) (see Fig. 8). The Rod (68) can be moved sideways in its bearings to bring the Pinion into mesh with the Gear (33) (Fig. 8). The movement of the Rod is controlled by a short Rod in a Coupling, which is fitted at one end with a 1" Rod and at the other end with a 3" Rod. These Rods are mounted in 2 1/2" x 1/2" Double Angle Strips bolted between the Girders (7) (Fig. 9). A Double Arm Crank is fixed on the 3" Rod, and to it is bolted a 2 1/2" Strip fitted at its other end with a Threaded Pin. The Strip projects through the gap edged by the Strip (14) (Fig. 3).

The Augers and the Reel (Figs. 1 and 2)

In the actual machine the augers form a spiral

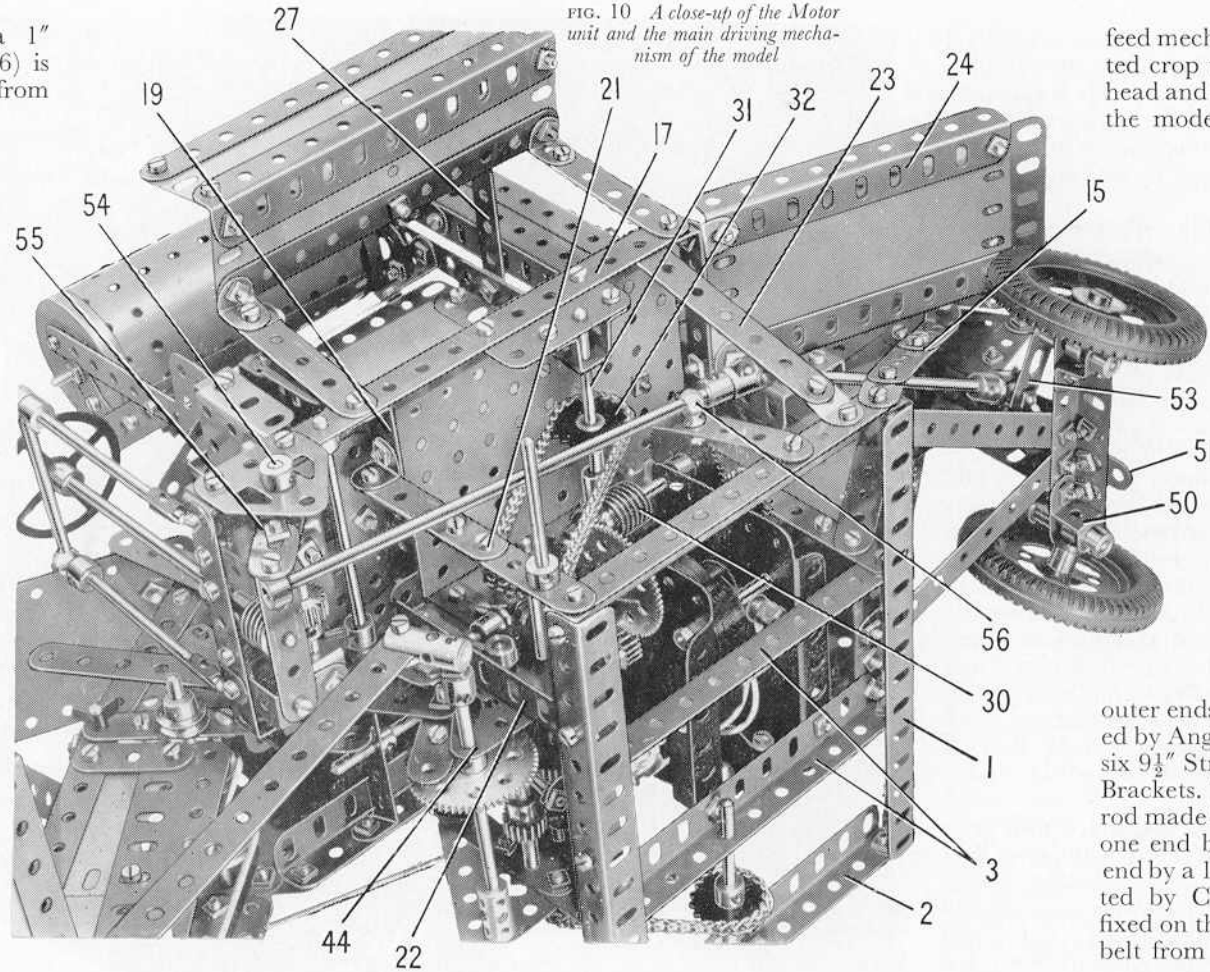

FIG. 10 A close-up of the Motor unit and the main driving mechanism of the model

feed mechanism that carries the harvested crop to the centre of the gathering head and loads it on to the conveyor. In the model the spirals are represented by four Bush Wheels (see Fig. 1) on a built-up rod mounted in the Flat Plates (60) and in Fishplates bolted to 1" x 1/2" Angle Brackets (70). The rod is made from an 8" and a 6 1/2" Rod joined by a Coupling, and it is held in place by 3/4" Flanged Wheels. A 1" Gear on the Rod (67) (Fig. 7) drives a 57-tooth Gear on the built-up rod, and a 1" Sprocket (71) also is fixed on this rod.

The reel or beater is made by bolting three 2 1/2" Strips as shown in Fig. 1 to each of two Bush Wheels (six-holes). The outer ends of the 2 1/2" Strips are connected by Angle Brackets and 2" Strips, with six 9 1/2" Strips bolted between the Angle Brackets. The reel is fixed on a built-up rod made from an 11 1/2" Rod extended at one end by a 1" Rod and at the other end by a 1 1/2" Rod. The Rods are connected by Couplings, and a 2" Sprocket fixed on the 1 1/2" Rod is driven by Chain belt from the 1" Sprocket (71) (Fig. 7).

Parts Required to Build the Meccano Combine Harvester

1 of No. 1	8 of No. 9a	3 of No. 15	2 of No. 23a	2 of No. 38d	3 of No. 62b	1 of No. 103a	2 of No. 128	1 of No. 163	2 of No. 212
6 " " 1a	5 " " 9b	4 " " 15a	4 " " 24	2 " " 45	8 " " 63	2 " " 103c	4 " " 133	2 " " 165	2 " " 214
5 " " 1b	7 " " 9d	4 " " 15b	2 " " 24b	2 " " 47a	2 " " 63b	3 " " 103f	2 " " 133a	2 " " 166	4 " " 221
14 " " 2	4 " " 9e	2 " " 15b	4 " " 25	6 " " 48a	2 " " 72	1 " " 103g	1 " " 136	2 " " 179	2 " " 222
5 " " 2a	8 " " 9f	3 " " 16	4 " " 26	3 " " 48b	2 " " 73	2 " " 103h	2 " " 136a	1 " " 185	2 " " 223
10 " " 3	4 " " 10	4 " " 16a	8 " " 27	1 " " 48d	1 " " 79a	2 " " 108	2 " " 137	1 " " 186	2 " " 225
6 " " 4	4 " " 11	4 " " 16b	1 " " 27a	1 " " 50	2 " " 79b	2 " " 110a	4 " " 137	10 " " 188	2 " " 226
36 " " 5	45 " " 12	4 " " 18a	4 " " 27a	1 " " 50	2 " " 89b	2 " " 110a	2 " " 142a	2 " " 189	
12 " " 6	6 " " 12a	4 " " 18b	1 " " 31	2 " " 51	1 " " 94	3 " " 111a	2 " " 142b	6 " " 190	
3 " " 6a	6 " " 12b	2 " " 19a	2 " " 32	1 " " 52a	1 " " 95	2 " " 111c	1 " " 144	1 " " 190a	
4 " " 8	8 " " 12c	2 " " 20a	3 " " 35	4 " " 53a	1 " " 95a	2 " " 114	2 " " 147b	6 " " 191	1 E15R
6 " " 8a	2 " " 13	4 " " 20b	445 " " 37a	1 " " 58	4 " " 96	2 " " 115	1 " " 154b	9 " " 192	Electric Motor
3 " " 8b	4 " " 13a	1 " " 21	429 " " 37b	24 " " 59	2 " " 96a	2 " " 125	1 " " 157	3 " " 196	(not included
9 " " 9	2 " " 14	6 " " 22	51 " " 38	3 " " 62	1 " " 103	4 " " 126a	1 " " 162b	1 " " 197	in Outfit)

MECCANO Eiffel Tower

(MODEL No. 10.14)

SPECIAL FEATURES

This imposing model of the famous Eiffel Tower in Paris is over 7 ft. in height. It is fitted with three lifts, which are operated by a Meccano E15R type Electric Motor.

FIG. 1
This striking model Eiffel Tower can be built with Meccano Outfit No. 10. Its construction is fully described in this Leaflet

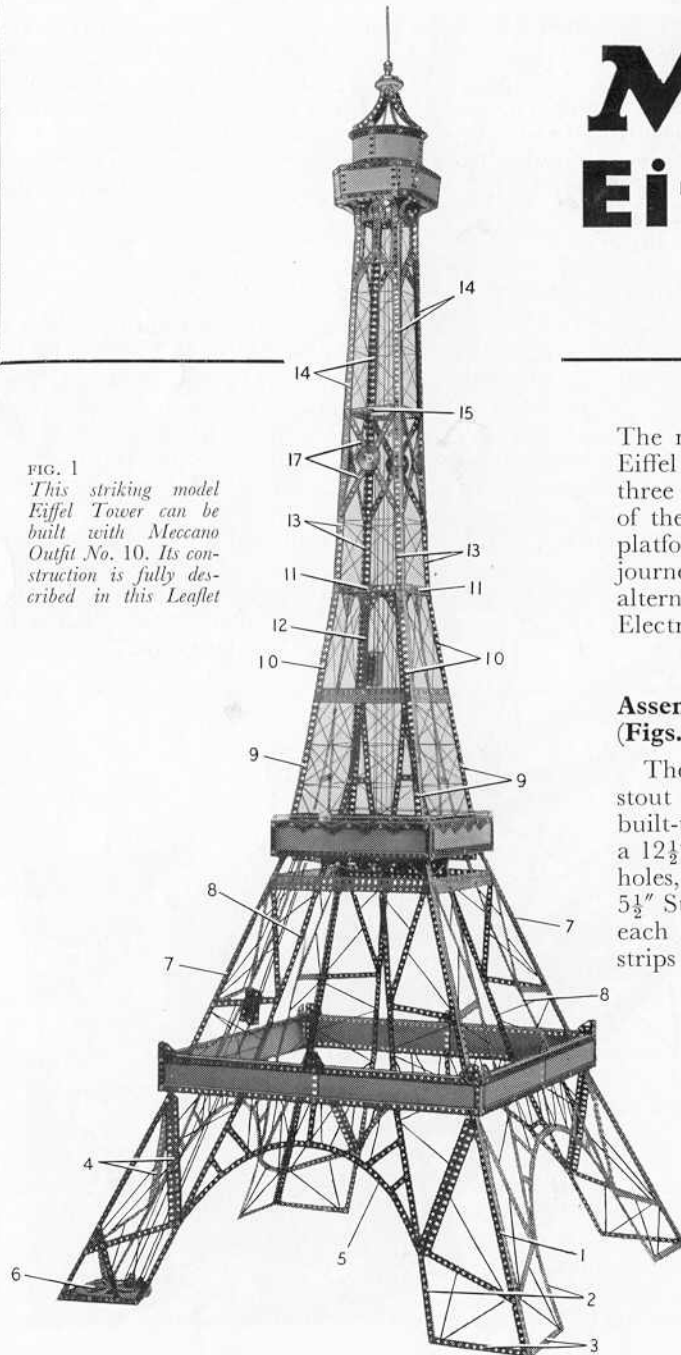

The model described in this Leaflet is based on the famous Eiffel Tower in Paris. It is over 7 ft. in height, and is fitted with three lifts. One of the lifts operates inside one of the main legs of the tower, between ground level and the centre landing platform, from which point the other two lifts continue the journey to the top of the tower, ascending and descending alternately. The power is provided by a Meccano E15R Electric Motor.

Assembly of the Lower Section of the Tower (Figs. 1 and 2)

The lower section of the tower consists essentially of four stout legs, each made from a built-up girder (1) and two built-up strips (2) (Figs. 1 and 2). The girder (1) is formed by a $12\frac{1}{2}$ " Angle Girder and a $5\frac{1}{2}$ " Angle Girder overlapped two holes, and each of the strips (2) consists of a $12\frac{1}{2}$ " Strip and a $5\frac{1}{2}$ " Strip overlapped three holes. The girder and the strips of each leg are connected at their lower ends by two built-up strips (3), each made from a $5\frac{1}{2}$ " and a $2\frac{1}{2}$ " Strip overlapped two holes. The upper ends of the girder (1) and the strips (2) are attached by Angle Brackets to a $24\frac{1}{2}$ " Angle Girder that forms the lower member of each side of the lower balcony. Each side of the balcony is completed by two $12\frac{1}{2}$ " x $2\frac{1}{2}$ " Strip Plates and a further $24\frac{1}{2}$ " Angle Girder, and the sides are connected at the corners by $2\frac{1}{2}$ " Angle Girders.

The legs of the tower are strengthened by built-up strips and by bracing pieces (4). Four of these bracing pieces are $9\frac{1}{2}$ " Flat Girders, two others are made from $5\frac{1}{2}$ " and $4\frac{1}{2}$ " Flat Girders and each of the remaining two consists of a $5\frac{1}{2}$ ", a $3\frac{1}{2}$ " and a 2" Flat Girder. The legs are joined across by arched structures (5), each of which is formed by four $2\frac{1}{2}$ " Strips and three $5\frac{1}{2}$ "

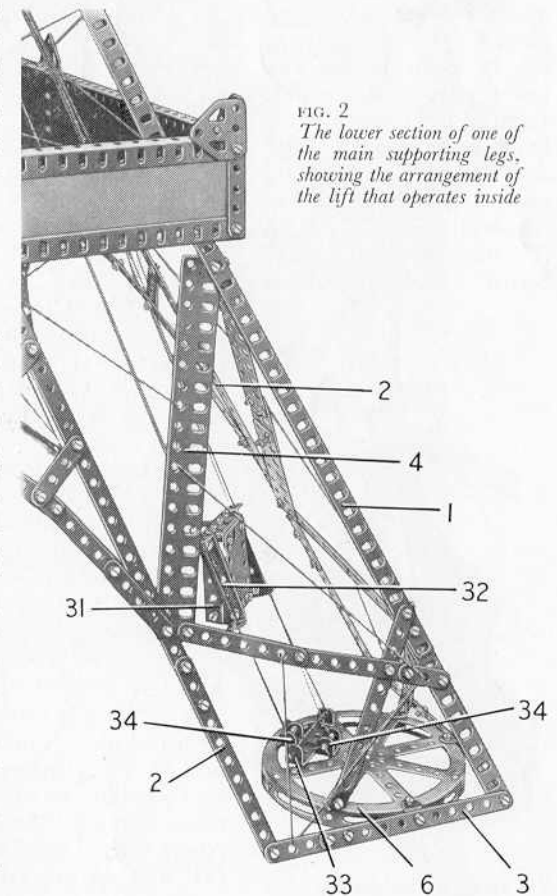

FIG. 2
The lower section of one of the main supporting legs, showing the arrangement of the lift that operates inside

Curved Strips. Each arch is connected to the balcony by $3\frac{1}{2}$ " Strips, and to the legs by $3\frac{1}{2}$ " and 2" Strips.

A Hub Disc (6) is attached by Angle Brackets to the strips (3) of one leg, and is braced to the girder (1) by $5\frac{1}{2}$ " Strips, which are connected to the Hub Disc by Angle Brackets.

Construction of the Tower : Centre Section (Figs. 1, 5 and 7)

The centre section is made by extending the girders (1) and the strips (2) of each leg of the lower part of the tower. Each of the girders (1) is lengthened by an $18\frac{1}{2}$ " Angle Girder (7) (Fig. 1), and each strip (2) is extended upward by a strip (8), made from two $12\frac{1}{2}$ " Strips overlapped two

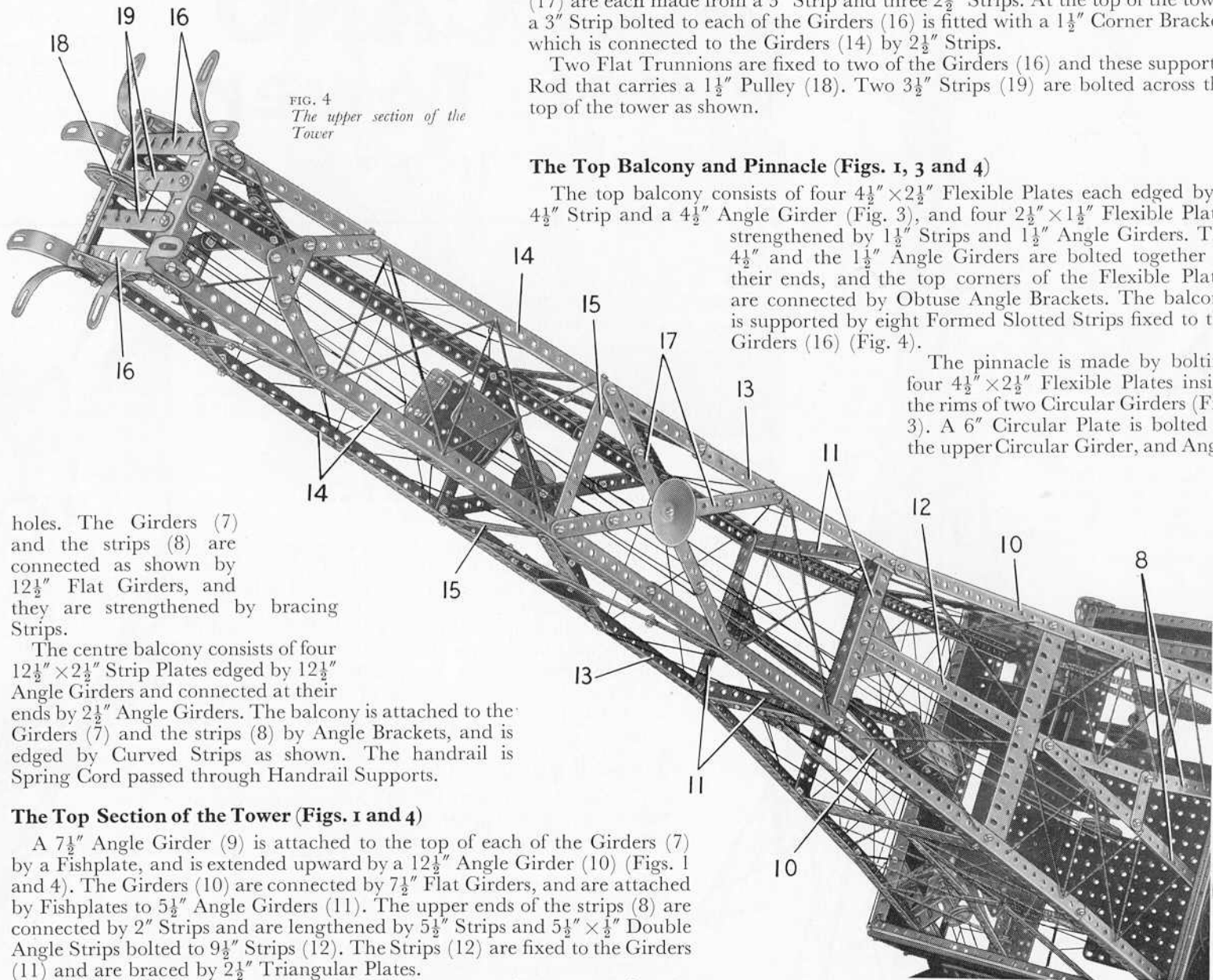

FIG. 4
The upper section of the Tower

Girder (14), are bolted to the ends of the Girders (11). The Girders (14) are joined together by $4\frac{1}{2}$ " Strips (15) and $3\frac{1}{2}$ " Angle Girders (16). The bracing strips (17) are each made from a 3" Strip and three $2\frac{1}{2}$ " Strips. At the top of the tower a 3" Strip bolted to each of the Girders (16) is fitted with a $1\frac{1}{2}$ " Corner Bracket, which is connected to the Girders (14) by $2\frac{1}{2}$ " Strips.

Two Flat Trunnions are fixed to two of the Girders (16) and these support a Rod that carries a $1\frac{1}{2}$ " Pulley (18). Two $3\frac{1}{2}$ " Strips (19) are bolted across the top of the tower as shown.

The Top Balcony and Pinnacle (Figs. 1, 3 and 4)

The top balcony consists of four $4\frac{1}{2}$ " x $2\frac{1}{2}$ " Flexible Plates each edged by a $4\frac{1}{2}$ " Strip and a $4\frac{1}{2}$ " Angle Girder (Fig. 3), and four $2\frac{1}{2}$ " x $1\frac{1}{2}$ " Flexible Plates strengthened by $1\frac{1}{2}$ " Strips and $1\frac{1}{2}$ " Angle Girders. The $4\frac{1}{2}$ " and the $1\frac{1}{2}$ " Angle Girders are bolted together at their ends, and the top corners of the Flexible Plates are connected by Obtuse Angle Brackets. The balcony is supported by eight Formed Slotted Strips fixed to the Girders (16) (Fig. 4).

The pinnacle is made by bolting four $4\frac{1}{2}$ " x $2\frac{1}{2}$ " Flexible Plates inside the rims of two Circular Girders (Fig. 3). A 6" Circular Plate is bolted to the upper Circular Girder, and Angle

holes. The Girders (7) and the strips (8) are connected as shown by $12\frac{1}{2}$ " Flat Girders, and they are strengthened by bracing Strips.

The centre balcony consists of four $12\frac{1}{2}$ " x $2\frac{1}{2}$ " Strip Plates edged by $12\frac{1}{2}$ " Angle Girders and connected at their ends by $2\frac{1}{2}$ " Angle Girders. The balcony is attached to the Girders (7) and the strips (8) by Angle Brackets, and is edged by Curved Strips as shown. The handrail is Spring Cord passed through Handrail Supports.

The Top Section of the Tower (Figs. 1 and 4)

A $7\frac{1}{2}$ " Angle Girder (9) is attached to the top of each of the Girders (7) by a Fishplate, and is extended upward by a $12\frac{1}{2}$ " Angle Girder (10) (Figs. 1 and 4). The Girders (10) are connected by $7\frac{1}{2}$ " Flat Girders, and are attached by Fishplates to $5\frac{1}{2}$ " Angle Girders (11). The upper ends of the strips (8) are connected by 2" Strips and are lengthened by $5\frac{1}{2}$ " Strips and $5\frac{1}{2}$ " x $\frac{1}{2}$ " Double Angle Strips bolted to $9\frac{1}{2}$ " Strips (12). The Strips (12) are fixed to the Girders (11) and are braced by $2\frac{1}{2}$ " Triangular Plates.

Four $9\frac{1}{2}$ " Angle Girders (13), each of which is extended by an $18\frac{1}{2}$ " Angle

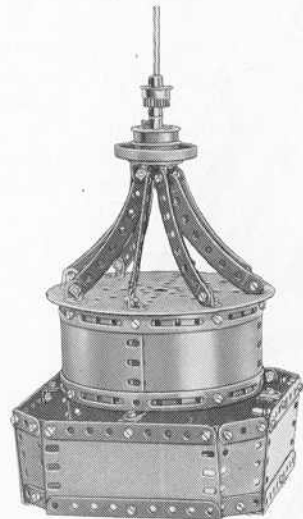

FIG. 3
The top balcony and pinnacle of the Eiffel Tower

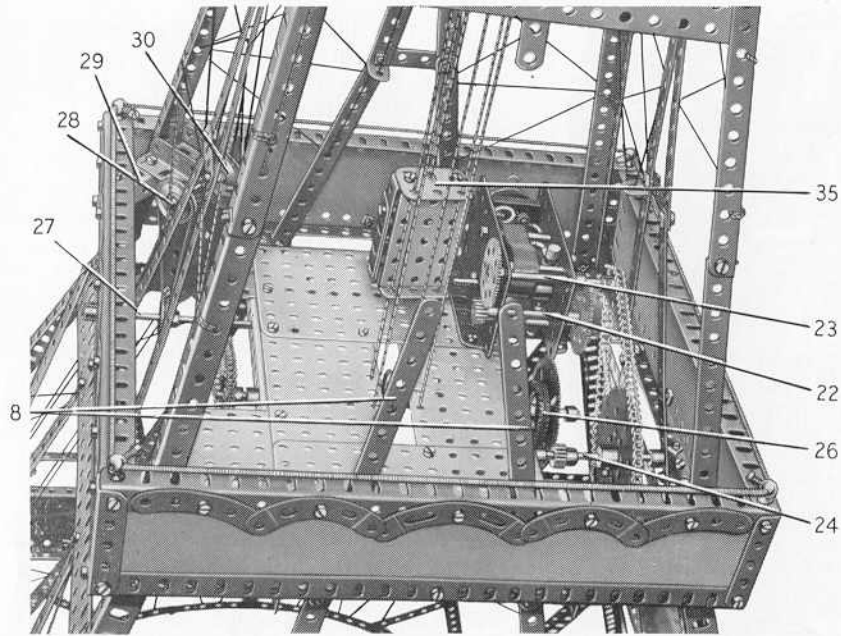

FIG. 5

The centre landing platform, showing the E15R Electric Motor in position and a lift ready to ascend

Brackets fixed to the Circular Plate support eight 4" Stepped Curved Strips. The top ends of four of the Curved Strips are connected by Angle Brackets to a Bush Wheel in which an 8" Rod is fixed. A Wheel Flange, two 1 $\frac{1}{8}$ " Flanged Wheels, a $\frac{3}{4}$ " Pinion and a $\frac{3}{4}$ " Flanged Wheel are fixed on the Rod. The pinnacle is supported by four Fishplates bolted to four Angle Brackets, which are attached to the top edges of the balcony.

The Centre Landing Platform and Operating Mechanism (Figs. 5, 6 and 7)

Two built-up girders (20) (Fig. 6) are bolted underneath the centre balcony and to them are bolted Flat Plates as shown in Figs. 5 and 6. These Plates comprise two 5 $\frac{1}{2}$ " x 3 $\frac{1}{2}$ " Flat Plates and four 4 $\frac{1}{2}$ " x 2 $\frac{1}{2}$ " Flat Plates. A 2 $\frac{1}{2}$ " x 1 $\frac{1}{2}$ " Triangular Flexible Plate (21) is arranged as shown at one corner of the platform.

An E15R Electric Motor is bolted to the platform and a $\frac{7}{16}$ " diameter Pinion on its armature shaft drives a 60-tooth Gear on a 2 $\frac{1}{2}$ " Rod (22) (Fig. 5). A $\frac{1}{2}$ " Pinion on this Rod engages a 57-tooth Gear on a 3 $\frac{1}{2}$ " Rod (23), which carries also a $\frac{3}{4}$ " Sprocket. This Sprocket is connected by Chain to a 3" Sprocket on a Rod (24) mounted in one of the girders (20) and in an Angle Bracket bolted underneath the balcony. A $\frac{1}{2}$ " Pinion on Rod (24) drives a 2 $\frac{1}{2}$ " Gear that is loosely mounted on a 6 $\frac{1}{2}$ " Rod (25). A Compression Spring is placed on this Rod between the Gear and a Collar, and it forces the Gear against a Motor Tyre (26) on a 1" Pulley fixed on the Rod. This arrangement forms a

friction drive, and if the lifts reach the limits of their travel before the Motor is reversed it allows the drive to slip.

A 1 $\frac{1}{2}$ " Sprocket on Rod (25) is connected by Chain to a $\frac{3}{4}$ " Sprocket on a 5" Rod (27) (Fig. 6). This Rod is mounted in one of the girders (20) and in an Angle Bracket bolted underneath the balcony. A Driving Band is passed round

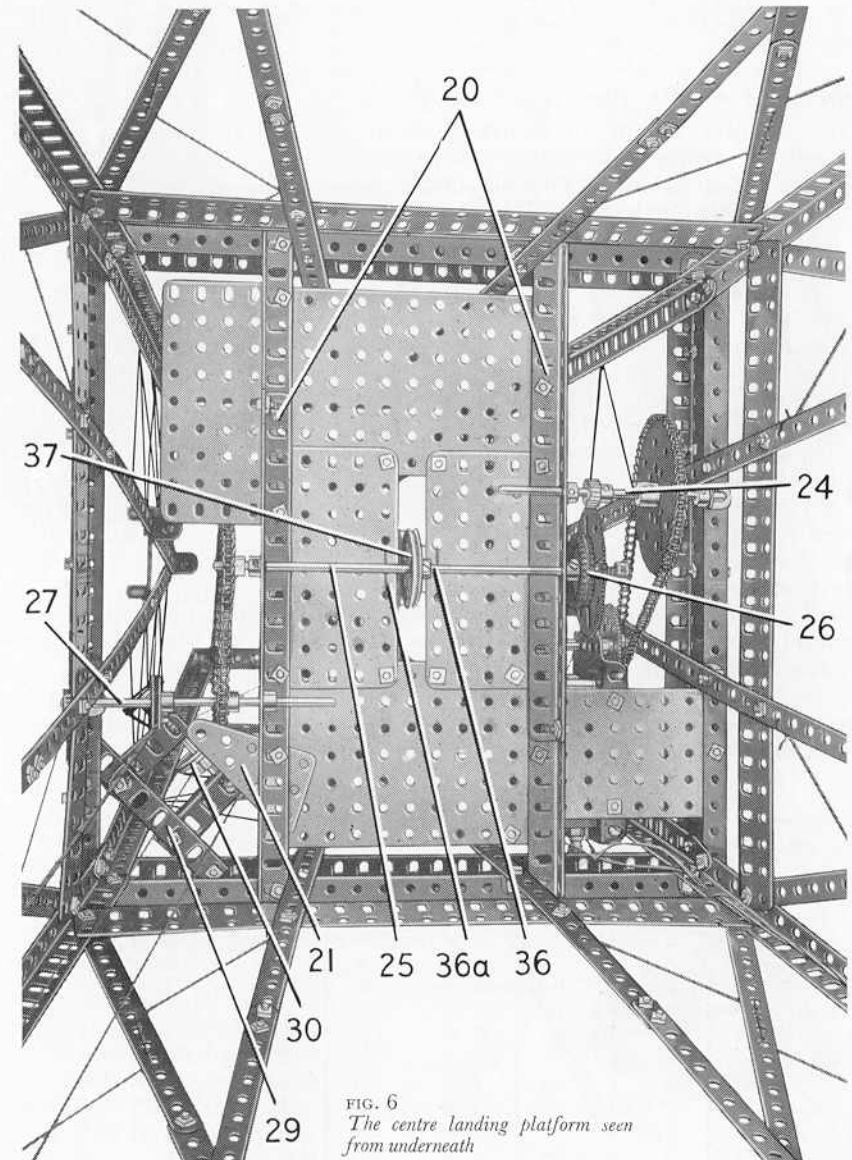

FIG. 6

The centre landing platform seen from underneath

a 1" Pulley on Rod (27) and round a similar Pulley on a 2½" Rod (28) (Fig. 5). Rod (28) is supported in two 2" Angle Girders bolted to a built-up girder (29). The girder (29) consists of a 3" Angle Girder and a 1½" Angle Girder bolted together. A 1" Pulley (30) is fixed on Rod (28).

Details of the Lifts (Figs. 2, 5, 6 and 7)

The lift working to the centre platform is made by bolting 1½" Angle Girders to each end of a 2½" x 1½" Flexible Plate. A 2½" x ½" Double Angle Strip (31) (Fig. 2) on each side is fixed between the Angle Girders, and a further 2½" x ½" Double Angle Strip (32) is arranged on each side. The Double Angle Strips (31) and (32) are bolted together at the top and are connected by a Fishplate at their lower ends. The guides for this lift are provided by a length of Cord tied to one of the 2" Angle Girders bolted to girder (29) (Fig. 7). The Cord is passed through the lugs of one of the Double Angle Strips (32), through a 2½" x ½" Double Angle Strip (33) (Fig. 2) bolted to the Hub Disc (6), and through the lugs of the other Double Angle Strip (32). The Cord is pulled tight and is tied to the second 2" Angle Girder. The lift-operating Cord is tied to a Fishplate bolted to the top 1½" Angle Girder of the lift and to a Tension Spring placed between the two Angle Girders; it is then taken over Pulley (30) (Fig. 7) and round two 1" Rods held by Spring Clips in Double Brackets (34) (Fig. 2). The Cord is then passed through the lower 1½" Angle Girder of the lift and is tied to the bottom loop of the Tension Spring so that the Spring is stretched slightly.

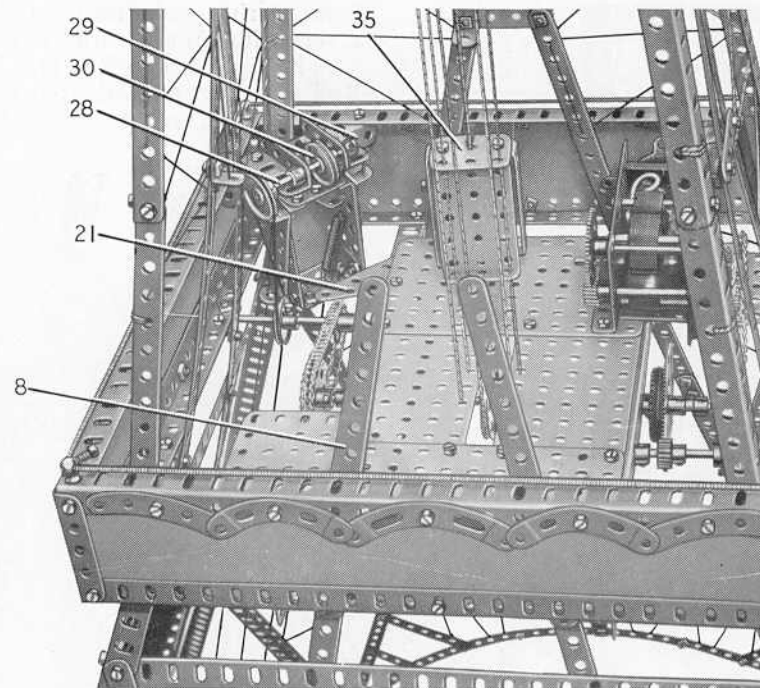

FIG. 7 Another view of the centre landing platform

The two lifts that operate between the centre platform and the top of the tower are each made by bolting two 2½" x ½" Double Angle Strips between the flanges of a 2½" x 1½" Flanged Plate. A Girder Bracket is fixed to one Double Angle Strip, and a 1½" Flat Girder (35) (Fig. 5) is bolted to each flange of the Flanged Plate. The guide Cord for the lifts is tied to one of the Strips (19) (Fig. 4), is passed through the Flat Girders (35) of one lift, and through the second stage platform as indicated at (36) (Fig. 6). The Cord is passed through the Flat Girders (35) of the second lift and is taken through holes in the Strips (19) before it is again passed through the Flat Girders of the second lift. The Cord is then taken through the centre platform at (36a) (Fig. 6) and is tied to one of the Strips (19).

The operating Cord for these lifts is tied at one end to a Tension Spring placed inside one of the lifts. The Cord is passed through the top 1½" Flat Girder of this lift, round the Pulley (18) and through the top 1½" Flat Girder of the second lift, where it is tied to another Tension Spring. A length of Cord fastened to the lower end of this Spring is passed through the bottom 1½" Flat Girder, is taken round a 1½" Pulley (37) (Fig. 6) on Rod (25), through the bottom of the second lift and is tied to the lower end of the Spring in this lift.

The Cord must be pulled tight so that the two Tension Springs are stretched as fully as possible. The lengths of Cord must also be adjusted so that as one lift reaches the top of the tower the other lift is at the level of the centre platform.

Parts Required to Build the Meccano Eiffel Tower

24 of No. 1	8 of No. 7	2 of No. 9e	2 of No. 16a	1 of No. 26c	9 of No. 48a	8 of No. 89b	2 of No. 103c	4 of No. 133	8 of No. 191
6 " " 1a	8 " " 7a	7 " " 9f	1 " " 16b	1 " " 27a	4 " " 48d	8 " " 90	2 " " 103d	4 " " 136	12 " " 197
6 " " 1b	16 " " 8	19 " " 10	2 " " 18b	1 " " 27c	2 " " 51	8 " " 90a	2 " " 103g	1 " " 137	8 " " 215
36 " " 2	6 " " 8a	2 " " 11	2 " " 20	1 " " 27d	2 " " 52a	1 " " 94	4 " " 103h	1 " " 142c	1 " " 221
8 " " 2a	4 " " 8b	44 " " 12	1 " " 20b	4 " " 35	4 " " 53a	1 " " 95a	4 " " 103k	2 " " 143	
18 " " 3	8 " " 9	10 " " 12c	2 " " 21	688 " " 37a	1 " " 58	1 " " 95b	8 " " 111c	± 1 " " 146	
12 " " 4	4 " " 9a	2 " " 13a	4 " " 22	680 " " 37b	11 " " 59	2 " " 96a	± 1 " " 118	2 " " 161	1 E15R
68 " " 5	6 " " 9b	1 " " 15	1 " " 24	8 " " 38	4 " " 76	4 " " 103	1 " " 120b	1 " " 186a	Electric Motor
12 " " 6	1 " " 9c	1 " " 15a	1 " " 25	6 " " 40	12 " " 89	4 " " 103a	4 " " 126	4 " " 187a	(not included
6 " " 6a	8 " " 9d	1 " " 15b	3 " " 26	2 " " 43	4 " " 89a	4 " " 103b	10 " " 126a	5 " " 188	in Outfit)

MECCANO

Showman's Traction Engine

(MODEL No. 10.15)

SPECIAL FEATURES

This working model of a showman's traction engine is fitted with a dummy twin-cylinder steam engine that can be set in motion by an Electric Motor. The 'engine' drives the rear traction wheels and also a dynamo at the front of the boiler. Steering of the front wheels is controlled from the driver's platform.

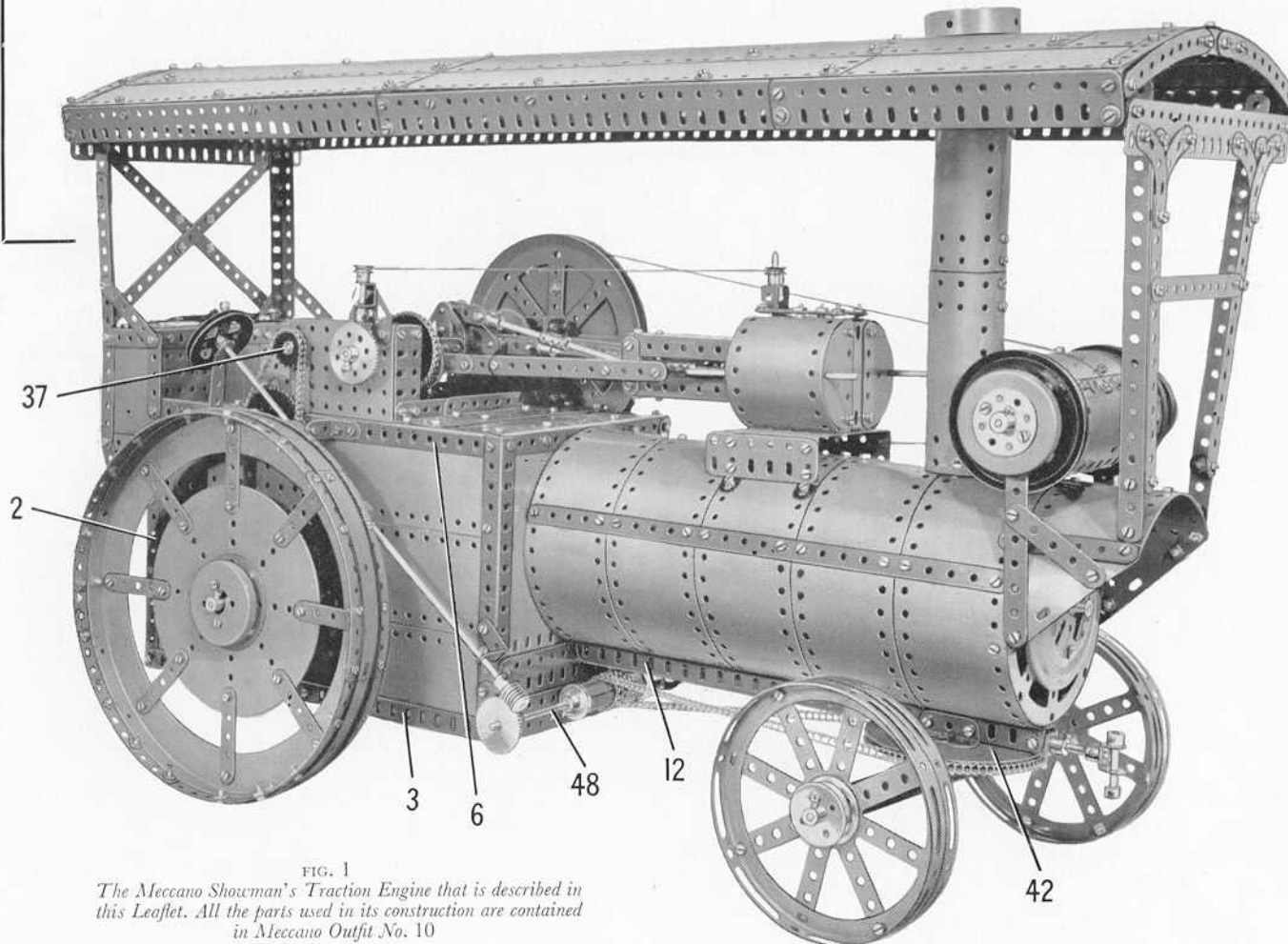

FIG. 1

The Meccano Showman's Traction Engine that is described in this Leaflet. All the parts used in its construction are contained in Meccano Outfit No. 10

The showman's traction engine, flaunting its gay colouring and gleaming brasswork, never fails to excite attention, and it is a matter for regret that the opportunities for seeing these fine old vehicles today are in some parts of the country much more rare than once was the case. They are to be seen in some amusement grounds and at country fairs, however, where they are usually a focal point of interest for admiring and excited youngsters, and indeed for many of us who are not so young.

There seems to be something peculiarly fascinating about these powerful machines, which are really miniature power plants, for they are used not only for hauling caravans, animal cages and wagon loads of roundabout props, but also for generating the electricity for driving the amusement machines and lighting the fairgrounds and sideshows.

The electric generator is mounted on top and at the front of the long boiler, and is driven at high speed by a belt from the huge and heavy flywheel of the steam engine that provides the motive power for the tractor. Those who have ever had the pleasure of seeing one of these machines in operation, will not easily forget the fascinating effect created by the whirr of the

dynamo, the swish of the belt, the hiss of escaping steam and the dazzle of the dozens of electric bulbs mounted around the tractor canopy, their brilliance reflected and enhanced by the gleaming twisted brass pillars of the canopy and the shining paintwork of the carefully polished boiler. As a background to all this would be the laughter of the crowds, the din of side-show attendants each trying to out-shout his rivals and the piercing high-pitched music of the whirligig organs.

It is a traction engine of this kind that forms the basis of the fine Meccano model described in this Leaflet, and although the model does not incorporate all the minor details of the original it does follow its general design as closely as possible.

Construction of the Body and Coal Bunker (Figs. 1, 2, 4 and 6)

Each side is assembled on a framework formed by a $7\frac{1}{2}$ " Angle Girder (1) and a made-up girder (2), connected by $12\frac{1}{2}$ " Angle Girders (3), (4) and (5) (Fig. 4). The girder (2) consists of a $5\frac{1}{2}$ " and a $4\frac{1}{2}$ " Angle Girder bolted together. A further $12\frac{1}{2}$ " Angle Girder (6) (Fig. 6) is bolted across the off-side of the model, but on the near side a $9\frac{1}{2}$ " Angle Girder (7) is used, to allow a gap at the rear for the cab entrance. The off-side is filled in by three $12\frac{1}{2} \times 2\frac{1}{2}$ " Strip Plates, and on the near side a $9\frac{1}{2} \times 2\frac{1}{2}$ " and two $12\frac{1}{2} \times 2\frac{1}{2}$ " Strip Plates are used.

The sides are connected together at the front by a $7\frac{1}{2}$ " Angle Girder (8) (Fig. 6), and a similar Girder (9) (Fig. 4). The front is partly filled in by a $5\frac{1}{2} \times 2\frac{1}{2}$ " Flexible Plate placed vertically at each side, and by two $7\frac{1}{2}$ " Flat Girders (10) (Fig. 2).

At the rear the sides are linked by a made-up girder (11) (Fig. 4), made from two $4\frac{1}{2}$ " Angle Girders overlapped three holes. The lower part of the rear of the body is filled in by three $5\frac{1}{2} \times 2\frac{1}{2}$ " Flat Plates arranged vertically. These Plates are extended upward by two vertical $4\frac{1}{2} \times 2\frac{1}{2}$ " Flat Plates and a $4\frac{1}{2} \times 2\frac{1}{2}$ " Flexible Plate, and they are edged at the top by two $4\frac{1}{2}$ " Angle Girders overlapped three holes. The floor of the driving compartment is made from a $5\frac{1}{2} \times 2\frac{1}{2}$ " and a $4\frac{1}{2} \times 2\frac{1}{2}$ " Flat Plate overlapped and bolted to the Girders (5).

The sides of the coal bunker are assembled as shown in Fig. 4. The back of the bunker is made from two $5\frac{1}{2} \times 3\frac{1}{2}$ " Flat Plates attached to the sides by Angle Brackets. The curved bottom is made from two $4\frac{1}{2} \times 2\frac{1}{2}$ " Flexible Plates overlapped three holes and attached to Obtuse Angle Brackets. A hinged lid is fitted as shown in Fig. 6.

The Boiler (Figs. 1 and 2)

The boiler is built up on two $12\frac{1}{2}$ " Angle Girders bolted together to form a channel section girder (12). The boiler consists of five built-up plates, each made from a $12\frac{1}{2} \times 2\frac{1}{2}$ " Strip Plate and a $5\frac{1}{2} \times 2\frac{1}{2}$ " Flexible Plate bolted end to end and curved to shape. A $12\frac{1}{2}$ " Angle Girder is fixed inside the boiler diametrically opposite to the girder (12) and two $12\frac{1}{2}$ " Strips are bolted along the sides. The front and rear ends of the boiler are Hub Discs, but before the front is fixed in place the rear Hub Disc should be bolted to the Girders (8) and (9) of the body (Figs. 2 and 4). At the front the Flanged Disc of a Ball Thrust Bearing is bolted to the Hub Disc, and a Threaded Pin is fixed in a Threaded Boss that is mounted on a $\frac{1}{2}$ " Bolt.

The Cylinder Unit (Figs. 2 and 3)

The cylinder block is assembled on a $3\frac{1}{2} \times 2\frac{1}{2}$ " Flanged Plate (13) (Fig. 3) fitted at each flange with

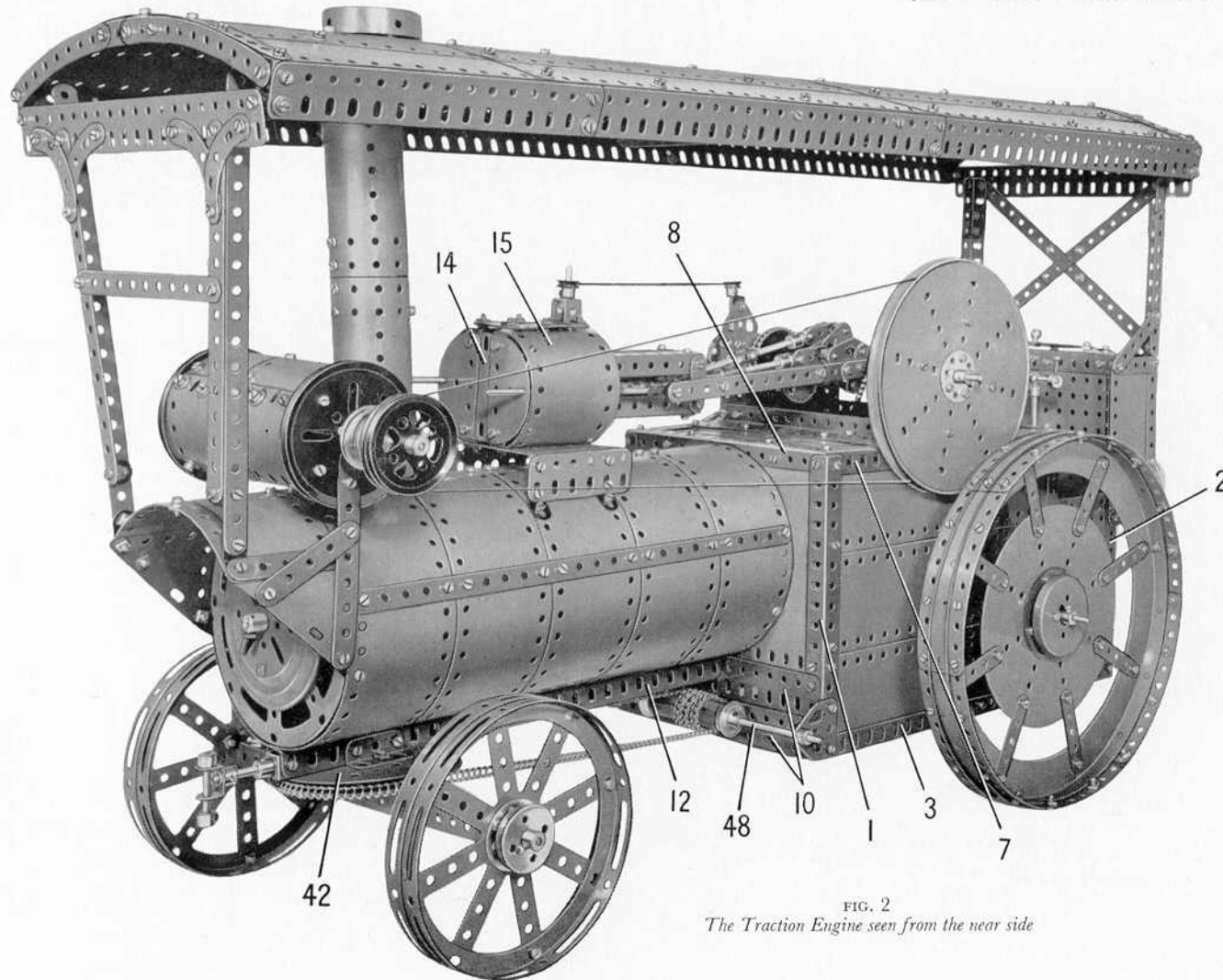

FIG. 2
The Traction Engine seen from the near side

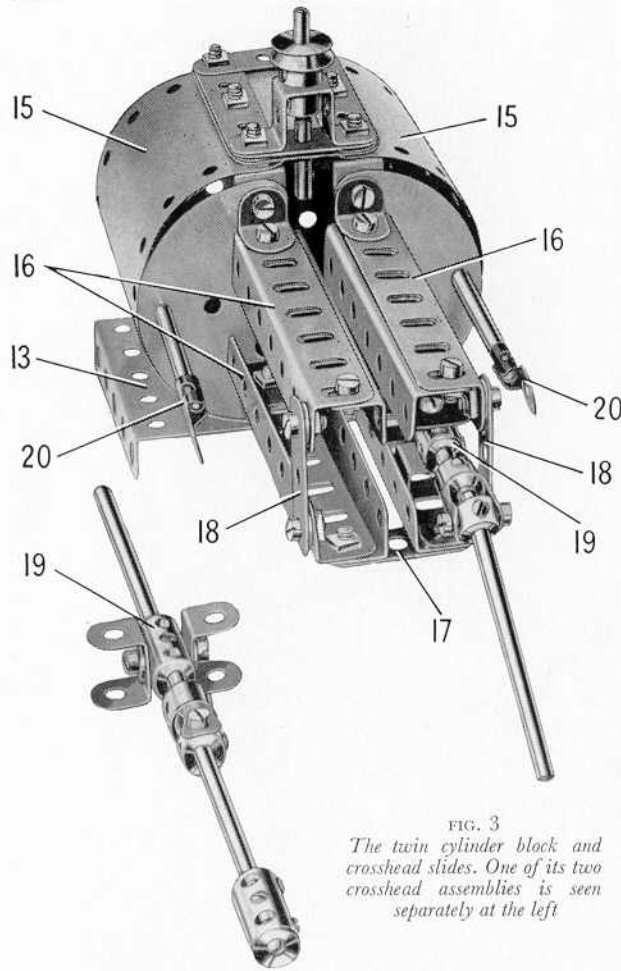

FIG. 3
The twin cylinder block and crosshead slides. One of its two crosshead assemblies is seen separately at the left

a 3" Flat Girder. The Flat Girders are attached to Obtuse Angle Brackets bolted direct to the boiler.

The front end of the cylinder block is made from a 2½" × 1½" Flexible Plate (14) (Fig. 2) fitted along its longer edges with Semi-Circular Plates, and the rear end is formed by two Semi-Circular Plates. The ends are joined together by four 2½" × ½" Double Angle Strips, and a 4½" × 2½" Flexible Plate (15) is curved to shape and bolted to the Double Angle Strips on each side. The lower pair of Double Angle Strips is bolted to the Flanged Plate (13). The top edges of the Plates (15) are connected to the Double Angle Strips by ⅜" Bolts placed with their shanks pointing upward. The top of the cylinder block is a 2½" × 1½" Flexible Plate edged by 2½" and 1½" Strips, and is held on the shanks of these Bolts by further nuts. A Double Bent Strip is fixed to the rear end of the 2½" × 1½" Flexible Plate and supports a 2" Rod that forms the governor shaft. The Rod is held in place by a Collar and a ½" fixed Pulley.

The piston rod slide bars are made from eight 3½" Angle Girders joined in pairs to make 3½" channel girders (16). Each channel girder is then attached to an Angle Bracket bolted to the rear of the cylinder block, and the lower girders are linked across by a 1½" Strip (17). The girders on each side are connected together by a 1½" Strip (18) that is spaced from the girders by a Washer on each bolt.

Each piston rod is a 3" Rod, and its crosshead is formed by a Coupling (19) fitted with two Double Brackets. Each Double Bracket is fixed firmly to one of the centre tapped holes of the Coupling by a bolt, and the Double Brackets slide freely in the channels formed by the pairs of girders (16). A 1" Rod is fixed in each of the Couplings (19) and each Rod carries a Swivel Bearing.

The valve rods are 5" in length, and each is fitted with a Rod and Strip Connector (20).

The Power Unit (Figs. 4 and 7)

The model is driven by an E15R Electric Motor housed in the body. The Motor is supported by two made-up girders (21) (Fig. 4) bolted across its flanges and attached to Girders (5) on each side. The girders (21) are each made from two 5½" Angle Girders. The Motor control switch is extended by a 2½" Strip fitted at the top with a ½" Bolt that forms an operating handle.

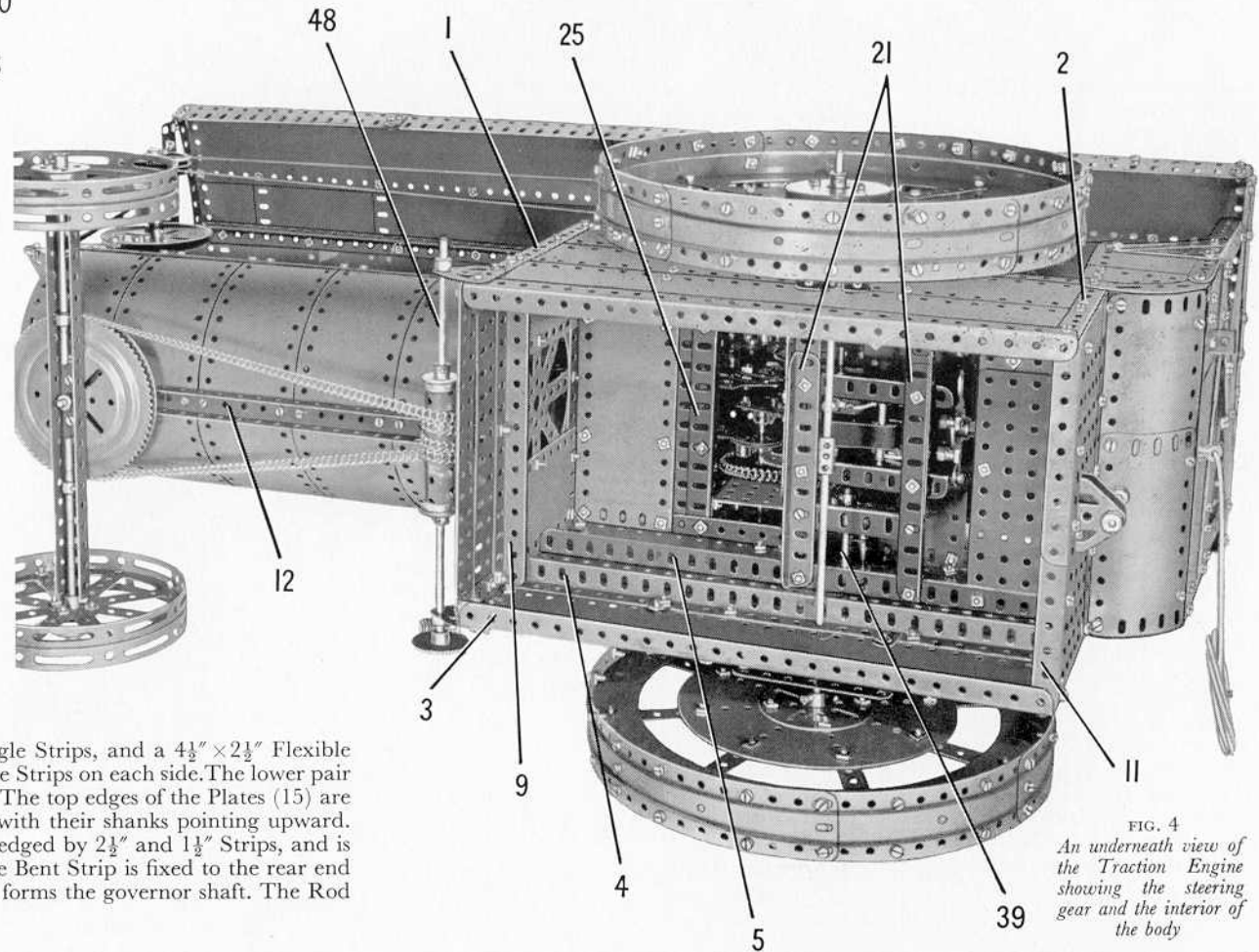
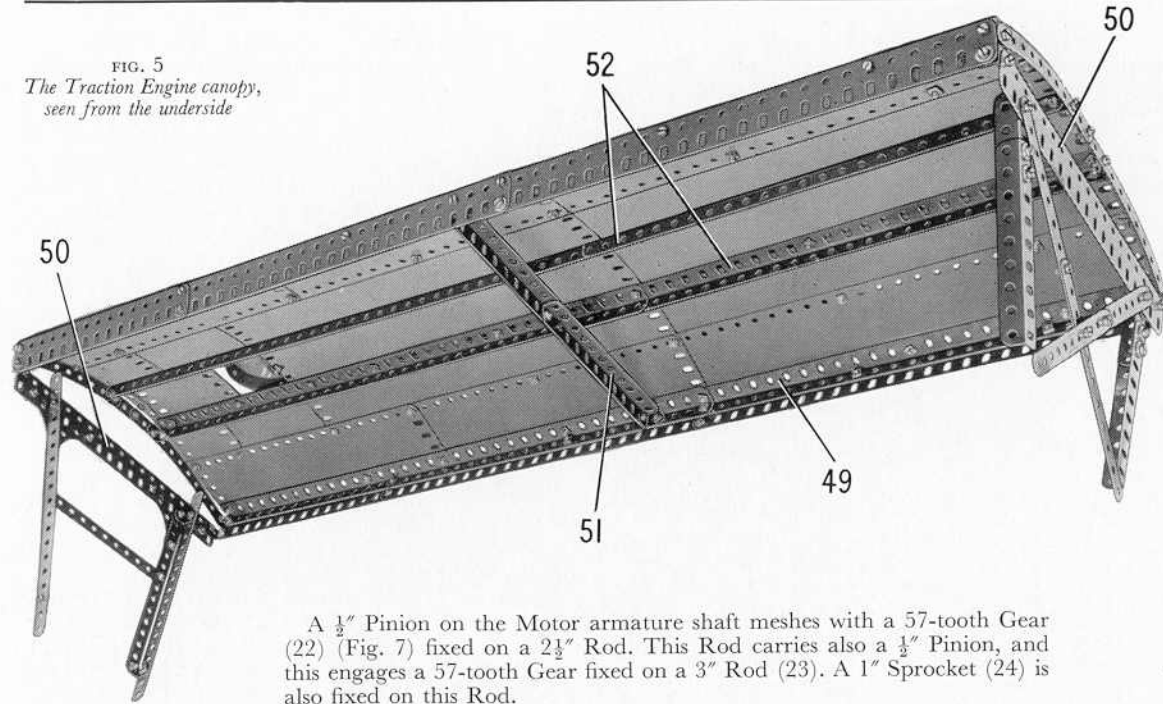

FIG. 4
An underneath view of the Traction Engine showing the steering gear and the interior of the body

FIG. 5
The Traction Engine canopy,
seen from the underside



A $\frac{1}{2}$ " Pinion on the Motor armature shaft meshes with a 57-tooth Gear (22) (Fig. 7) fixed on a $2\frac{1}{2}$ " Rod. This Rod carries also a $\frac{1}{2}$ " Pinion, and this engages a 57-tooth Gear fixed on a 3" Rod (23). A 1" Sprocket (24) is also fixed on this Rod.

The Crankshaft and Valve Control Eccentrics (Figs. 3, 6, 7 and 8)

The crankshaft is supported in two built-up bearings, each consisting of two $3\frac{1}{2}$ " x $2\frac{1}{2}$ " Flanged Plates joined by $2\frac{1}{2}$ " Flat Girders. The bearings are fixed to made-up girders (25) (Fig. 7) and (26) (Fig. 6), each of which is made from two $5\frac{1}{2}$ " Angle Girders overlapped.

The outer crankshaft webs are each made from a Flat Trunnion fitted with a Double Arm Crank (28) and a Crank (29). The inner web is made from two Flat Trunnions bolted together at right angles, the bolts holding also the Cranks (30) (Fig. 7). The webs are held together by 1" Rods fixed in the Cranks (29) and (30), and a $1\frac{1}{2}$ " Strip bolted to an End Bearing (31) is carried on each Rod. The crank webs are fixed on a $4\frac{1}{2}$ " Rod (32) (Fig. 6) on one side and a 4" Rod (33) on the other. A Triple Throw Eccentric is fixed on each Rod, and these are linked by made-up strips to the Rod and Strip Connectors (20) (Fig. 3) on the valve rods. The End Bearings (31) (Fig. 6) are connected by made-up rods to the Swivel Bearings on the piston rods. The made-up strips are formed by $5\frac{1}{2}$ " Strips overlapped, and each made-up rod consists of a 2" and a $2\frac{1}{2}$ " Rod joined by a Coupling.

The Rod (32) carries at its outer end a flywheel made by bolting two 6" Circular Plates to a 6" Pulley. Rod (33) carries a $1\frac{1}{2}$ " Bevel Gear (34) that meshes with a $\frac{1}{2}$ " Bevel fixed on a $1\frac{1}{2}$ " Rod. This Rod is mounted in a Double Bracket attached to a Flat Trunnion bolted to the crankshaft bearing, and the Rod carries also a $\frac{1}{2}$ " fixed Pulley that is connected by a Cord belt to the Pulley on the governor shaft.

The drive from the Motor to the crankshaft is taken from Sprocket (24) (Fig. 7) by a length of Sprocket Chain to a 1" Sprocket (35). Sprocket (35) is fixed on an 8" Rod that carries also a $\frac{3}{4}$ " Sprocket (36) and a 1" Sprocket (37). Sprocket (36) is linked by Chain to a 2" Sprocket on the crankshaft.

The Drive to the Rear Axle (Figs. 7 and 8)

Sprocket (37) (Fig. 7) is connected by Chain to a 2" Sprocket fixed on a 2" Rod (38). This Rod is

FIG. 6
A plan view of the
Traction Engine showing
the general layout

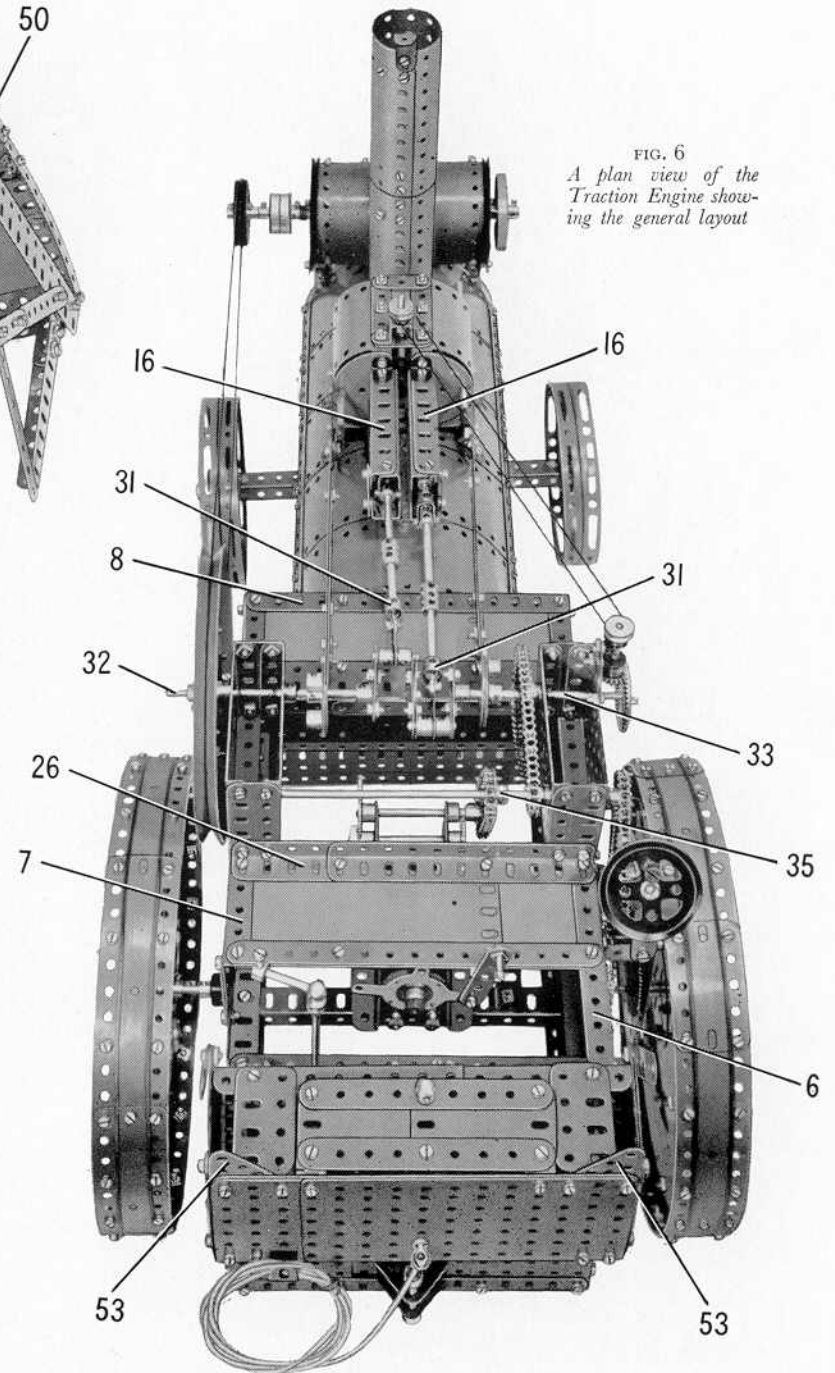

mounted in the side of the body and in a Double Bent Strip bolted inside the girder (6). The Rod is held in place by a Collar. A $\frac{1}{2}$ " Pinion is also fixed on Rod (38) and meshes with a $3\frac{1}{2}$ " Gear on a $3\frac{1}{2}$ " Rod (39), which is supported in the side of the body and in a $2\frac{1}{2}$ " Angle Girder bolted to the girders (21) (Fig. 4). Rod (39) carries between the Gear and the body, a $\frac{3}{8}$ " Sprocket, and this is linked by Chain to a 3" Sprocket on the rear axle. A cover over the gearing is provided by a $5\frac{1}{2}$ " x $3\frac{1}{2}$ " Flat Plate that is bolted to 1" Reversed Angle Brackets (40) (Fig. 8) and to Angle Brackets fixed to 1" x 1" Angle Brackets (41).

The rear axle is formed by two $6\frac{1}{2}$ " Rods joined by a Coupling. It is supported in the

sides of the body and in a Double Bent Strip bolted to the rear side. The off-side half of the axle passes through the $5\frac{1}{2}$ " x $3\frac{1}{2}$ " Flat Plate that forms the gear cover.

The Rear Wheels (Figs. 2 and 4)

The rim of each wheel is made by bolting a $2\frac{1}{2}$ " x $1\frac{1}{2}$ " and six $5\frac{1}{2}$ " x $1\frac{1}{2}$ " Flexible Plates round a Flanged Ring. The hub consists of a 6" Circular Plate bolted between two Face Plates that are fixed on the rear axle, and it is connected to the rim by eight $2\frac{1}{2}$ " Strips. A Wheel Flange bolted to a $1\frac{1}{2}$ " Sprocket is fixed on the end of the axle to complete the wheel. Driving Bands can be placed round the rim of the wheel as shown to provide it with a more even running surface.

The Front Axle and Steering Assembly (Figs. 2, 4 and 8)

The front axle is made from two $9\frac{1}{2}$ " Angle Girders bolted together and fitted at each end with two Angle Brackets spaced five holes apart. Each front wheel is fixed on a 5" Rod mounted in the pair of Angle Brackets and held in place by a Collar. Each wheel is made from a Hub Disc and a $5\frac{1}{2}$ " Circular Girder bolted together.

The complete axle is attached to the Toothed Disc of a Ball Thrust Bearing by bolts that secure also a Double Arm Crank. A $2\frac{1}{2}$ " Rod fixed in the Double Arm Crank is passed through a Bush Wheel and a 4" Circular Plate (42) (Fig. 2), which is bolted to $1\frac{1}{2}$ " Angle Girders fixed to the girder (12). The $2\frac{1}{2}$ " Rod passes inside the boiler and is held in place by a Collar.

The steering column is a made-up rod formed by two $6\frac{1}{2}$ " Rods, each of which is fitted with a Collar at one end. The Collars are gripped in a Socket Coupling (43) (Fig. 8) and the complete rod is mounted in a $2\frac{1}{2}$ " Strip (44), a 1" x 1" Angle Bracket (45), and an Obtuse Angle Bracket (46). The rod carries at its lower end a Worm (47), and this meshes with a 50-tooth Gear on a made-up rod (48) (Fig. 4), consisting of two $4\frac{1}{2}$ " Rods joined by a Coupling. The rod is mounted in Flat Trunnions bolted to the body, and it carries a drum formed by two Sleeve Pieces, each of which is fitted at its inner end with a Chimney Adaptor that fits over the Coupling. A $\frac{3}{4}$ " Flanged Wheel is pressed over each end of the drum and is fixed on rod (48). An endless length of Sprocket Chain is passed several times round the drum, and round the Toothed Disc of the front wheel assembly.

FIG. 7
Details of the crankshaft, Motor
and reduction gearing

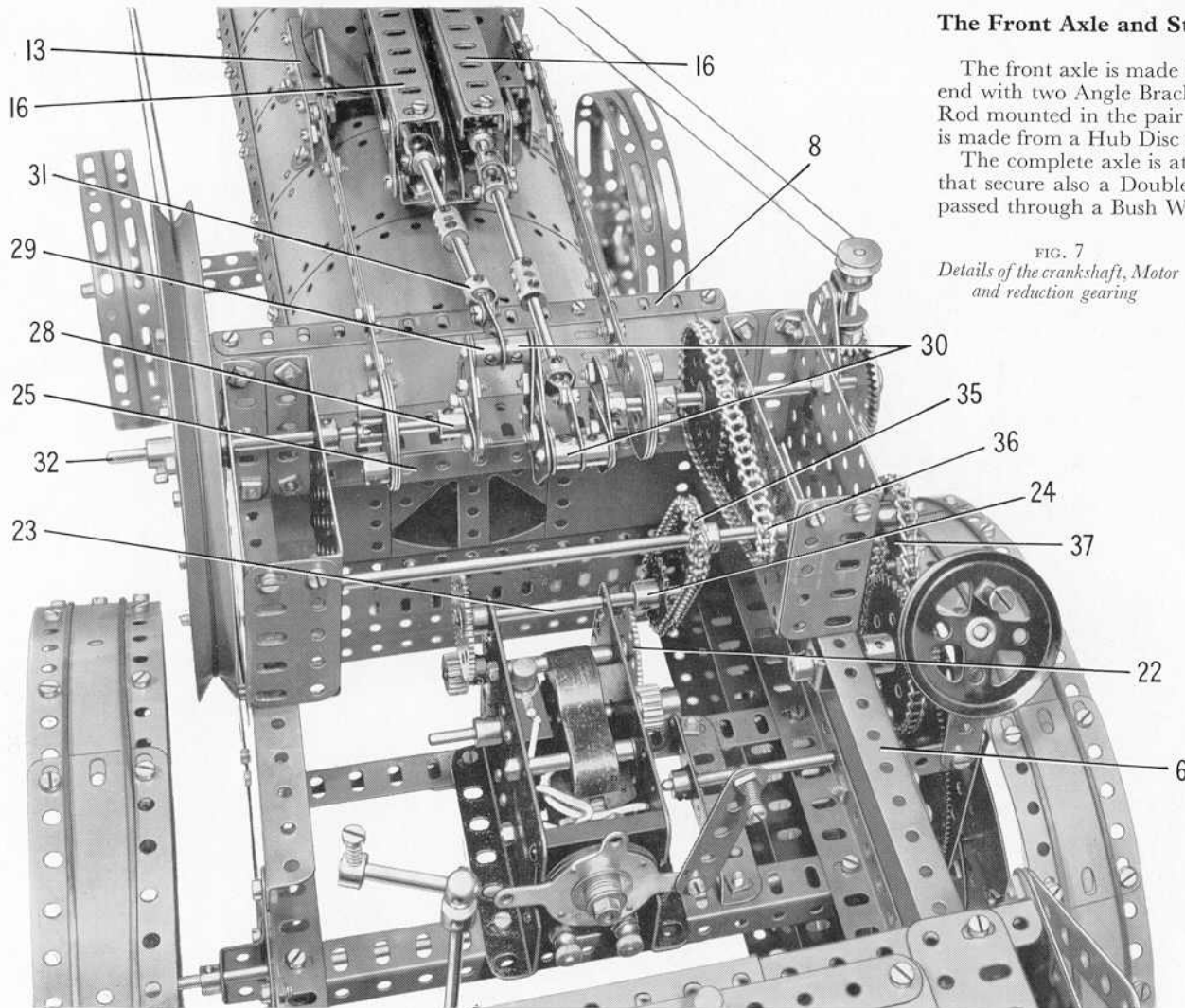

The Dynamo (Figs. 1 and 2)

The dynamo seen on top of the boiler at the front, is made by bolting two $4\frac{1}{2}$ " x $\frac{1}{2}$ " Double Angle Strips between two 3" Pulleys. Washers are placed between the lugs of the Double Angle Strips and the Pulleys, to allow two $5\frac{1}{2}$ " x $2\frac{1}{2}$ " Flexible Plates and two $1\frac{1}{8}$ " radius Curved Plates to be bolted in position as shown in Figs. 1 and 2.

The dynamo is mounted on a platform that forms a cowl over the boiler smoke-box. The cowl is made from a $5\frac{1}{2}$ " x $2\frac{1}{2}$ " Flexible Plate and two $2\frac{1}{2}$ " x $2\frac{1}{2}$ " Triangular Flexible Plates curved to shape and edged by a $5\frac{1}{2}$ " and two 3" Strips. This assembly is attached to the front end

of the boiler by three Fishplates and the projecting ends of the 3" Strips. A 4½" Strip bolted to each Pulley of the dynamo is fixed to the platform and is braced by a 2½" Strip.

An 8" Rod is passed through the 3" Pulleys, and is fitted at one end with a Wheel Flange bolted to a Bush Wheel. Two 1½" Flanged Wheels are fixed in position at the opposite end, and two 2" Pulleys are held by their set screws on the Rod. A belt made from a length of Cord is passed round one of these Pulleys and the 6" Pulley of the flywheel.

Construction of the Canopy and Chimney (Figs. 1, 2 and 5)

An underneath view of the canopy is shown in Fig 5. It is assembled on a framework, each side of which is formed by a made-up girder (49) that is attached by Angle Brackets to 9½" Flat Girders (50). The made-up girders are assembled from 18½" and 12½" Angle Girders, and they are linked at the centre by a girder (51) attached to Angle Brackets. The girder (51) is made from two 5½" Angle Girders overlapped two holes.

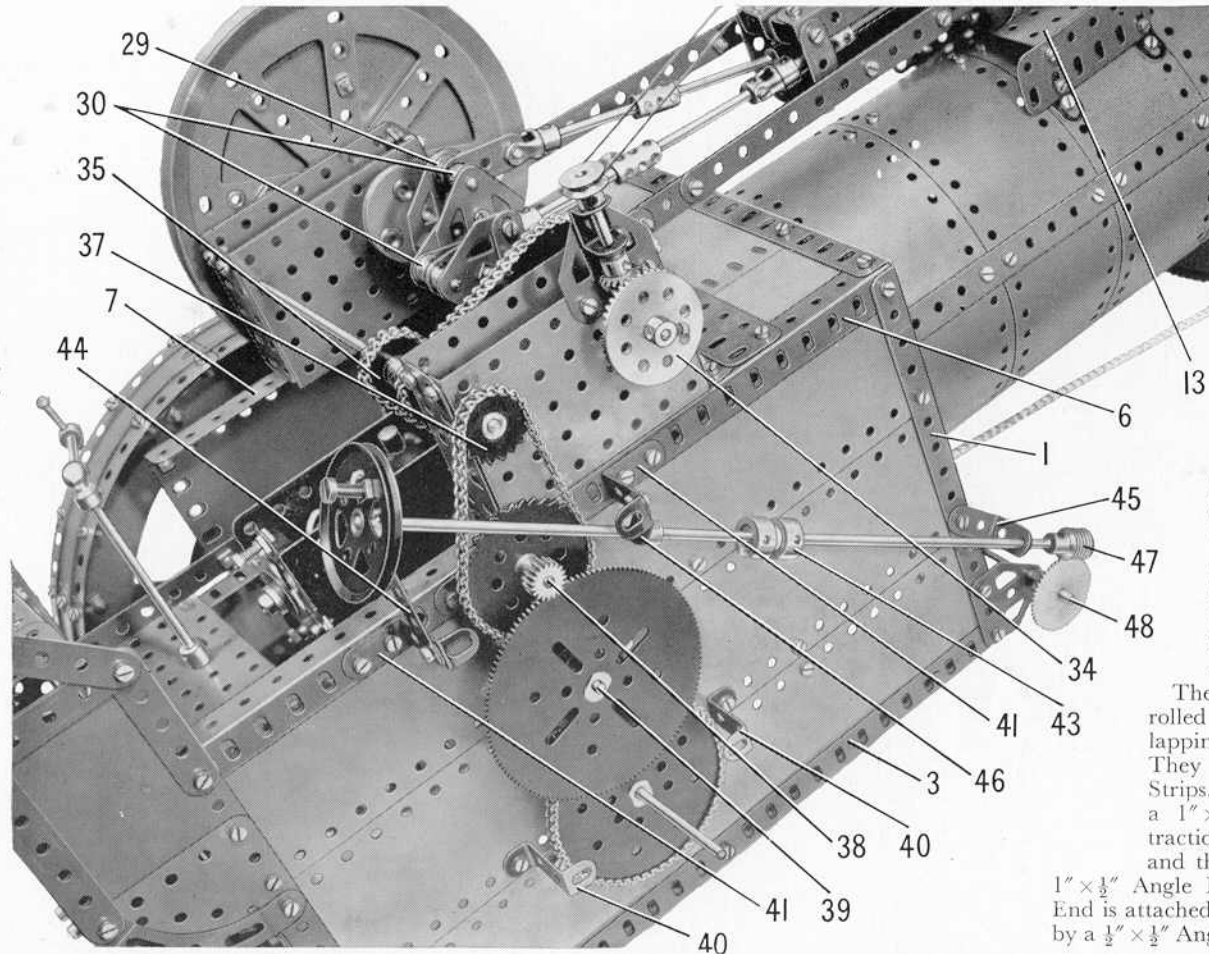

FIG 8. The off-side of the Traction Engine with the rear wheel removed to reveal the drive to the back axle

Two further made-up girders (52) are attached by Angle Brackets to 5½" Curved Strips connected to the girders (49). The framework is filled in by Flexible and Strip Plates bolted to the girders (49) and (52) and attached to the Curved Strips by Angle Brackets. The arrangement of the Plates is shown in Fig. 5.

The canopy is supported at the rear by two made-up angle girders bolted to 1½" Corner brackets (53) (Fig. 6) fixed to the body. Each of these girders consists of a 4½" and a 2" Angle Girder. The front supports are made from two built-up girders each consisting of a 9½" and a 7½" Strip joined by Angle Brackets. The lower ends of these girders are attached to Obtuse Angle Brackets fixed to the boiler cowl. The front and rear canopy supports are braced as shown in Figs 1 and 2.

The chimney is made from two Boilers rolled to a smaller diameter by overlapping their longer edges three holes. They are joined end to end by two Strips. The lower Boiler is attached to a 1" x 1" Angle Lracket fixed to the traction engine boiler behind the dynamo, and the upper Boiler is connected by a 1" x ½" Angle Bracket to the canopy. A Boiler End is attached to the canopy above the chimney by a ½" x ½" Angle Bracket.

Parts Required to Build the Meccano Showman's Traction Engine

2 of No. 1	12 of No. 9	5 of No. 15	2 of No. 23a	1 of No. 40	4 of No. 70	4 of No. 103f	7 of No. 126a	2 of No. 165	14 of No. 192
2 " " 1a	8 " " 9a	2 " " 15a	4 " " 24	3 " " 45	4 " " 89	2 " " 103g	2 " " 130	2 " " 166	3 " " 196
6 " " 1b	8 " " 9b	1 " " 15b	1 " " 24b	4 " " 48a	4 " " 89a	4 " " 103k	2 " " 133	2 " " 167b	20 " " 197
16 " " 2	1 " " 9c	2 " " 16	3 " " 26	3 " " 48c	4 " " 90a	4 " " 109	2 " " 136	1 " " 168a	2 " " 200
2 " " 2a	2 " " 9e	4 " " 16a	1 " " 27	3 " " 52a	2 " " 94	3 " " 111a	1 " " 136a	1 " " 168b	2 " " 212
4 " " 3	2 " " 9f	3 " " 16b	2 " " 27a	5 " " 53	2 " " 95	10 " " 111c	3 " " 137	1 " " 171	4 " " 214
4 " " 4	10 " " 10	5 " " 17	1 " " 27b	3 " " 53a	2 " " 95a	2 " " 114	2 " " 143	1 " " 179	2 " " 222
33 " " 5	5 " " 11	4 " " 18a	1 " " 30a	1 " " 58	1 " " 95b	1 " " 115	3 " " 146	2 " " 186d	2 " " 223
2 " " 6	36 " " 12	4 " " 18b	1 " " 30c	20 " " 59	3 " " 96	2 " " 116	1 " " 146a	2 " " 186c	
7 " " 6a	4 " " 12a	2 " " 19b	1 " " 32	4 " " 62	2 " " 96a	+ 4 " " 118	1 " " 147b	6 " " 188	
4 " " 7a	1 " " 12b	+ 1 " " 19c	660 " " 37a	3 " " 62b	2 " " 103a	2 " " 124	1 " " 162	12 " " 189	
14 " " 8	7 " " 12c	4 " " 20	642 " " 37b	6 " " 63	4 " " 103b	1 " " 125	1 " " 162b	2 " " 190	1 E15R
3 " " 8a	2 " " 13a	3 " " 20a	62 " " 38	1 " " 64	2 " " 103c	2 " " 126	2 " " 163	3 " " 190a	Electric Motor
4 " " 8b	4 " " 14	2 " " 20b					2 " " 164	7 " " 191	(not included in Outfit)

MECCANO

Twin-Cylinder MOTOR CYCLE ENGINE

(MODEL No. 10.16)

SPECIAL FEATURES

The Meccano Twin-Cylinder Motor Cycle Engine includes a counter-balanced crankshaft, camshafts and valves, and when set in motion by the E15R Electric Motor fixed to its base, provides a striking and interesting demonstration of the working of an engine of this type.

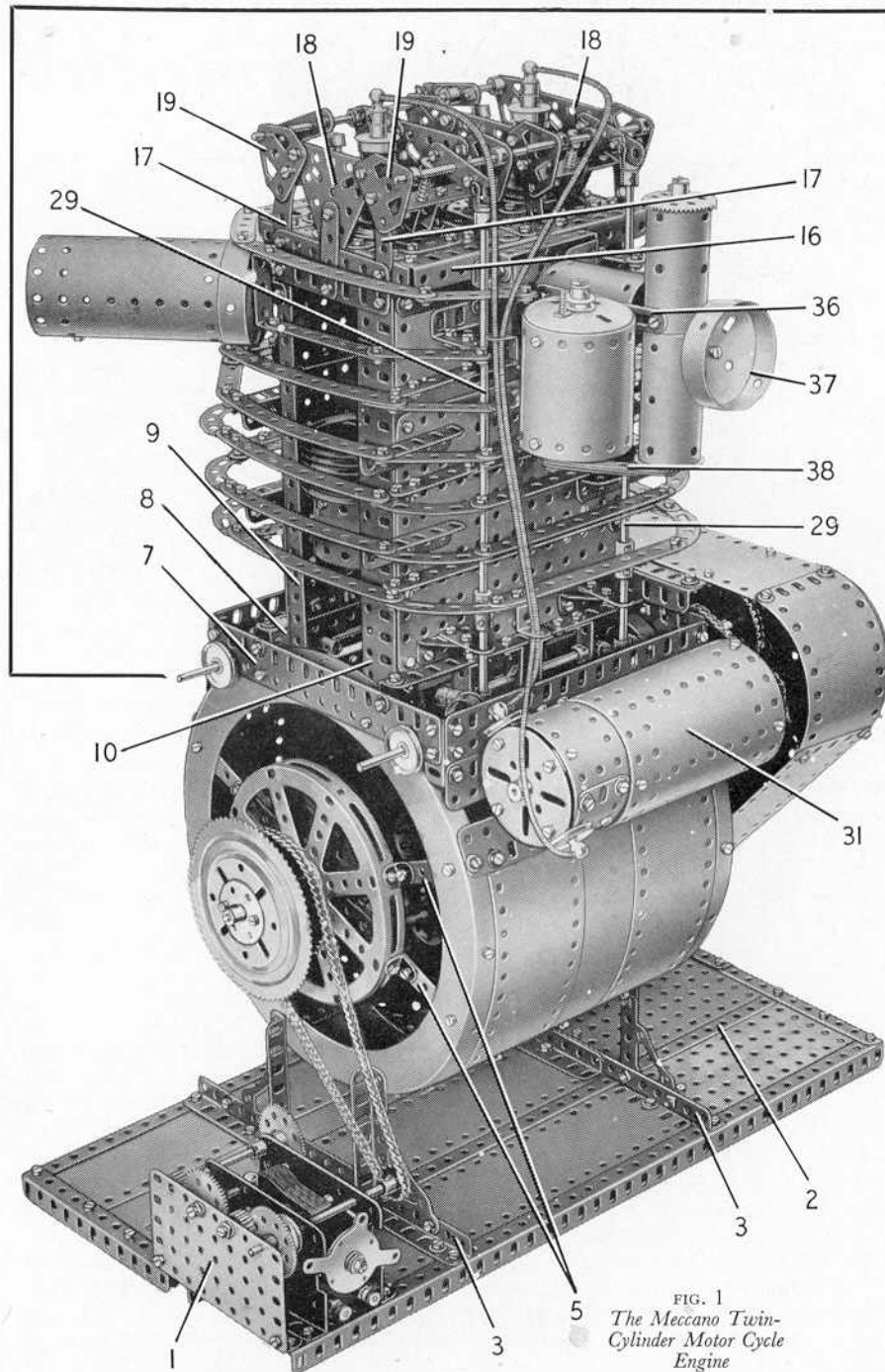

FIG. 1
The Meccano Twin-Cylinder Motor Cycle Engine

The model described in this Leaflet represents a twin-cylinder motor cycle engine designed to operate on the four-stroke principle, and it provides an interesting working demonstration of the basic features of an internal combustion engine of this kind.

Details of the Base (Figs. 1, 3, 4 and 10)

The longer sides of the base are each formed by an $18\frac{1}{2}$ " Angle Girder, and these are connected at each end by a $5\frac{1}{2}$ " and a $4\frac{1}{2}$ " Angle Girder bolted together. At one end the $4\frac{1}{2}$ " Angle Girder is placed with its flange upward, and to it is bolted a $4\frac{1}{2}$ " \times $2\frac{1}{2}$ " Flat Plate (1) (Fig. 1).

An $18\frac{1}{2}$ " Angle Girder (2) (Fig. 4) is fixed along the base and two $9\frac{1}{2}$ " Angle Girders (3) are bolted across the top. The top is filled in by four $12\frac{1}{2}$ " \times $2\frac{1}{2}$ " Strip Plates, a $5\frac{1}{2}$ " \times $3\frac{1}{2}$ " Flat Plate and two $5\frac{1}{2}$ " \times $2\frac{1}{2}$ " Flat Plates. The ends of the Flat and Strip Plates are connected by $1\frac{1}{2}$ " Strips, and the inner ends of three of the Strip Plates are attached to a $5\frac{1}{2}$ " Angle Girder, which is bolted to one of the Girders (3) (see Fig. 4).

Construction of the Crankcase (Figs. 1, 2, 4 and 7)

The rounded crankcase is made by bolting two $7\frac{1}{2}$ " Angle Girders (4) (Fig. 2) between two Flanged Rings. Two crossed $9\frac{1}{2}$ " Strips (5) (Fig. 7) are fixed across each Flanged Ring as shown, and to these Strips Hub Discs are attached by Angle Brackets. A Bush Wheel is bolted to the centre of the Hub Disc at one end to form a bearing for the crankshaft, and to the Hub Disc at the other end a Circular Girder is attached by Fishplates. A $5\frac{1}{2}$ " Strip (6) (Fig. 7) is bolted to the Circular Girder.

The crankcase is supported by four $3\frac{1}{2}$ " Angle Girders fixed to the Girders (3) of the base, and braced by Corner Gussets. A $7\frac{1}{2}$ " Flat Girder (7) (Fig. 1) is bolted to each Flanged Ring. At one side the ends of these Flat Girders are connected by a $7\frac{1}{2}$ " Flat Girder and two $4\frac{1}{2}$ " Flat Girders overlapped three holes. The Flat Girders are connected by $1\frac{1}{2}$ " Angle Girders (Fig. 4). On the other side a similar arrangement is used (Fig. 3) but in this case the two $4\frac{1}{2}$ " Flat Girders are replaced by a $5\frac{1}{2}$ " Flat Girder extended by a $2\frac{1}{2}$ " Flat Girder.

Two $7\frac{1}{2}$ " Angle Girders (8) (Figs. 4 and 7) are connected to the Flat Girders (7) by Angle Brackets. The crankcase cover consists of six $12\frac{1}{2} \times 2\frac{1}{2}$ " Strip Plates arranged in pairs, each pair being overlapped 11 holes. The cover is bolted to two $7\frac{1}{2}$ " Strips fixed between the Flanged Rings, and each outer edge of the cover is fitted with a $5\frac{1}{2}$ " Flat Girder extended by a $2\frac{1}{2}$ " Flat Girder. These Flat Girders also are bolted to the Flanged Rings, but the assembly of this part of the model should not be completed until the crankshaft and the cylinder block units are in place.

The Cylinder Block (Figs. 1, 4 and 7)

Each side wall of the cylinder block is made by bolting two vertical $9\frac{1}{2}$ " Angle Girders

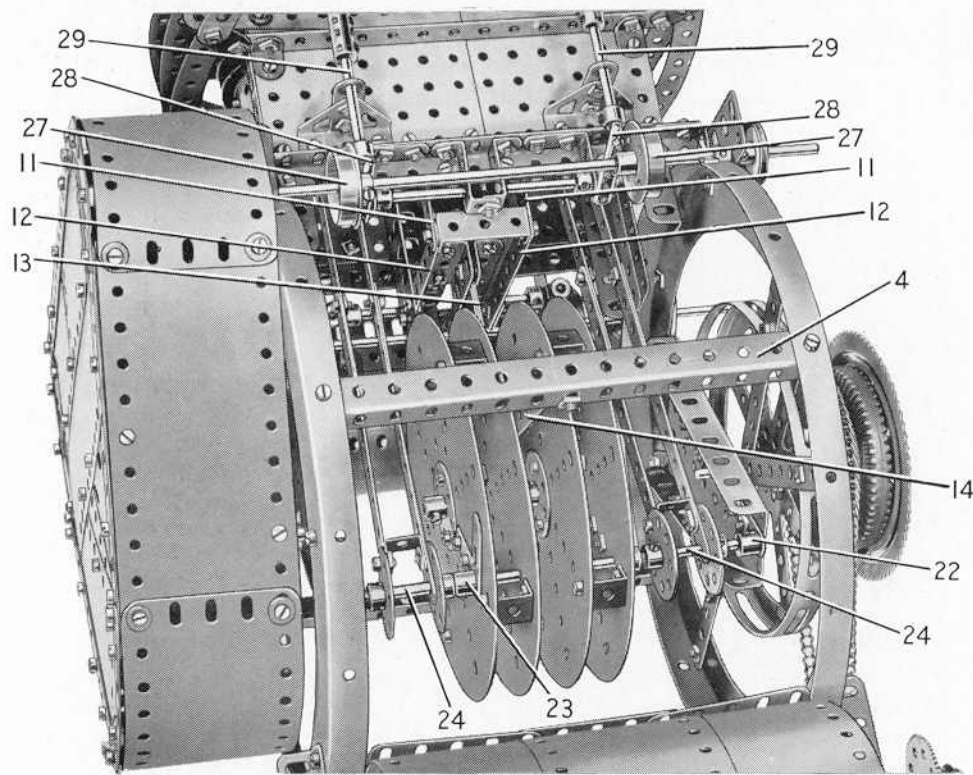

FIG. 2

In this view the crankcase plating has been removed in order to reveal the details of the crankshaft

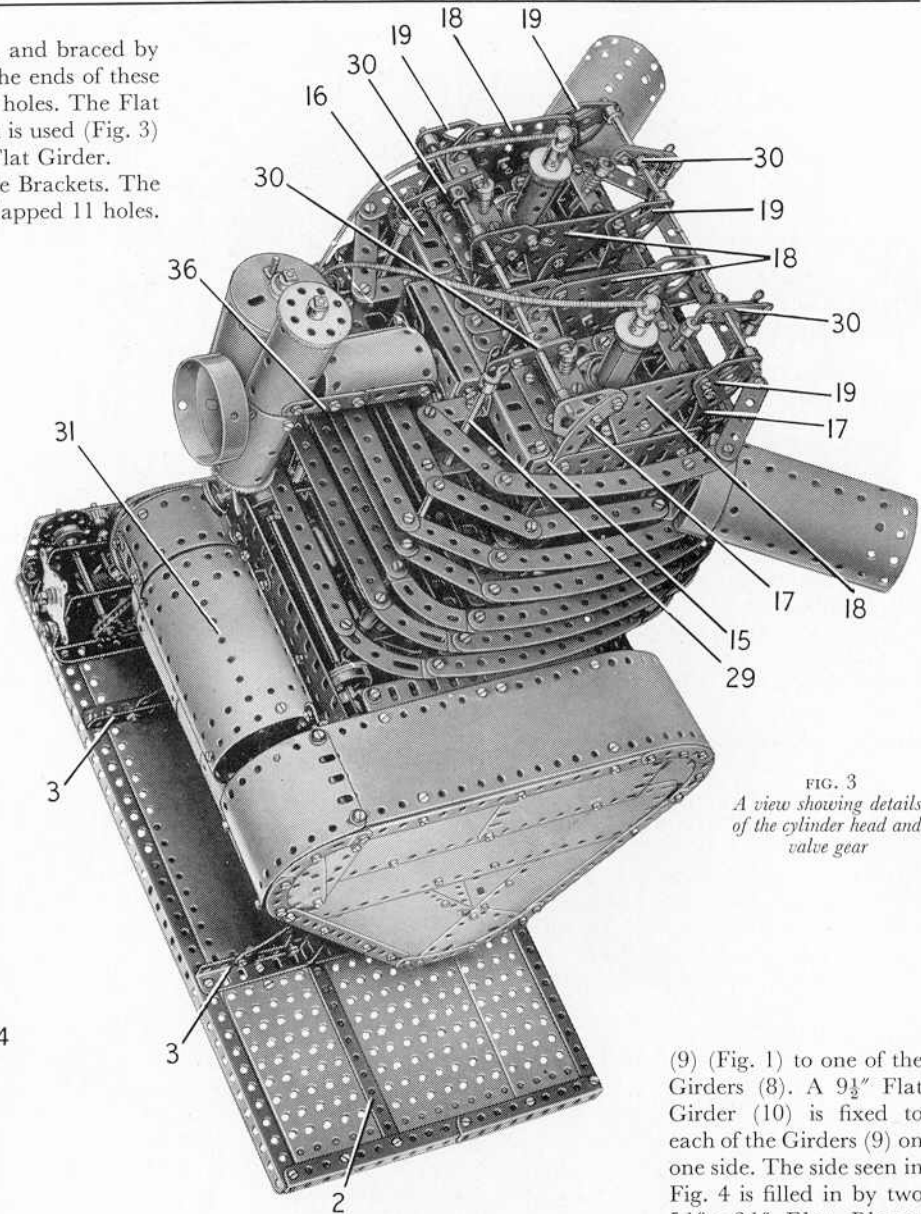

FIG. 3
A view showing details of the cylinder head and valve gear

(9) (Fig. 1) to one of the Girders (8). A $9\frac{1}{2}$ " Flat Girder (10) is fixed to each of the Girders (9) on one side. The side seen in Fig. 4 is filled in by two $5\frac{1}{2} \times 3\frac{1}{2}$ " Flat Plates placed vertically, with a horizontal $5\frac{1}{2} \times 2\frac{1}{2}$ " Flat Plate above them. The side in Fig. 1 consists of two vertical $5\frac{1}{2} \times 3\frac{1}{2}$ " Flat Plates, two vertical $4\frac{1}{2} \times 2\frac{1}{2}$ " Flexible Plates, and a $2\frac{1}{2} \times 1\frac{1}{2}$ " Flexible Plate placed between the top ends of the $4\frac{1}{2} \times 2\frac{1}{2}$ " Flexible Plates.

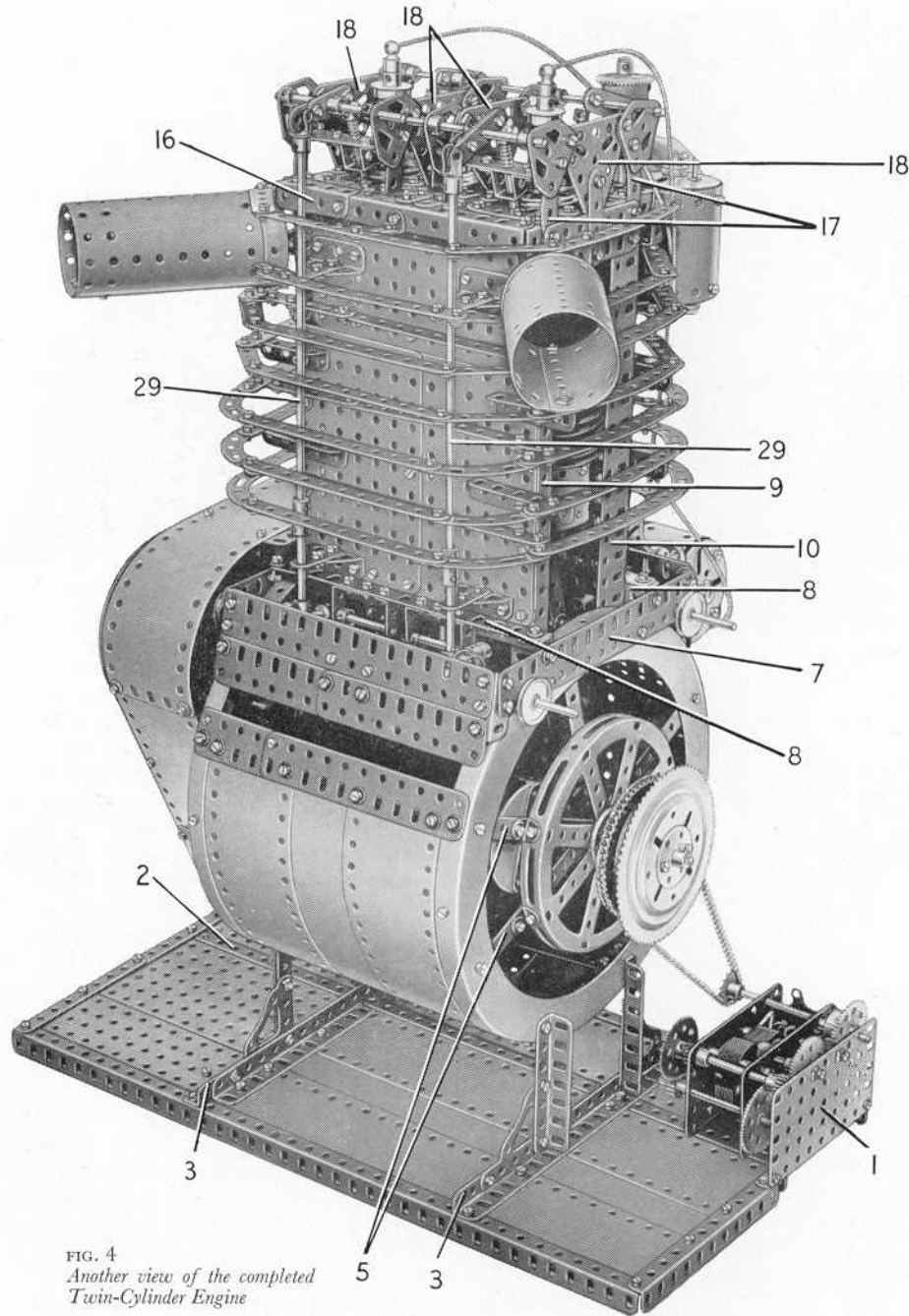

FIG. 4
Another view of the completed
Twin-Cylinder Engine

Two $9\frac{1}{2}$ " Angle Girders are bolted to one side of the cylinder block on the inside face, and to each of these Girders is fixed a $9\frac{1}{2}$ " Flat Girder that corresponds to one of the Flat Girders (10). To the other side of the block two $9\frac{1}{2}$ " Strips are attached by Angle Brackets. These Strips are indicated at (11) (Fig. 2). The lower ends of these Strips are connected by a $1\frac{1}{2}$ " \times $\frac{1}{2}$ " Double Angle Strip, and they are joined across to the $9\frac{1}{2}$ " Angle Girders of the opposite side by two $3\frac{1}{2}$ " Angle Girders (12) (Fig. 2). Three $4\frac{1}{2}$ " Strips (13) are placed face-to-face and are bolted between two $1\frac{1}{2}$ " Angle Girders, each of which is fixed to one of the Girders (12). The lower ends of the Strips (13) are braced to each of the Girders (4) by two $5\frac{1}{2}$ " Strips (14) placed face-to-face and connected to the Girders by Angle Brackets.

Details of the Cylinder Head (Figs. 1, 3 and 6)

Two $4\frac{1}{2}$ " Angle Girders (15) (Fig. 6) are attached to the top of the cylinder block by $3\frac{1}{2}$ " Flat Girders, and their outer ends are connected by made-up girders (16), each of which consists of a $5\frac{1}{2}$ " and a 2" Angle Girder. The top ends of the Strips (11) (Fig. 2) are joined to the Flat Girders opposite to them by 3" Strips, each of which supports a $2\frac{1}{2}$ " Angle Girder placed with its horizontal flange at the top. Two $4\frac{1}{2}$ " Angle Girders are fixed to the $2\frac{1}{2}$ " Angle Girders, and to these Girders and to the Girders (15) are bolted $2\frac{1}{2}$ " Curved Strips (17) (Fig. 3). A vertical 2" Strip is fixed to the centre of each $4\frac{1}{2}$ " Angle Girder and these support $2\frac{1}{2}$ " Triangular Plates (18). The Triangular Plates and the Curved Strips are bolted together as shown (Fig. 3), the bolts supporting also Flat Trunnions (19).

The cylinder head is filled in by three $4\frac{1}{2}$ " Strips across the centre, with two $1\frac{1}{2}$ " Flat Girders (20) (Fig. 6) bolted to $2\frac{1}{2}$ " Strips on each side. Each sparking plug is made by bolting a $1\frac{1}{2}$ " Pulley to two further $2\frac{1}{2}$ " Strips on each side. A 3" Rod is fixed in each Pulley and on it are placed a 1" loose Pulley, a Sleeve Piece and $\frac{3}{4}$ " Flanged Wheel and a Handrail Coupling. A $2\frac{1}{2}$ " \times $\frac{1}{2}$ " Double Angle Strip (21) (Fig. 6) fitted at its centre with a Double Bent Strip, is bolted between each pair of Curved Strips (17).

Assembly of the Crankshaft (Fig. 2)

Each outer web of the crankshaft is a Flanged Sector Plate with two Semi-Circular Plates and two $2\frac{1}{2}$ " Strips bolted to its wide end as balance weights. A Crank is bolted to the centre of the Flanged Sector Plate and another Crank (22) (Fig. 2) is fixed to its narrow end. The Crank at the

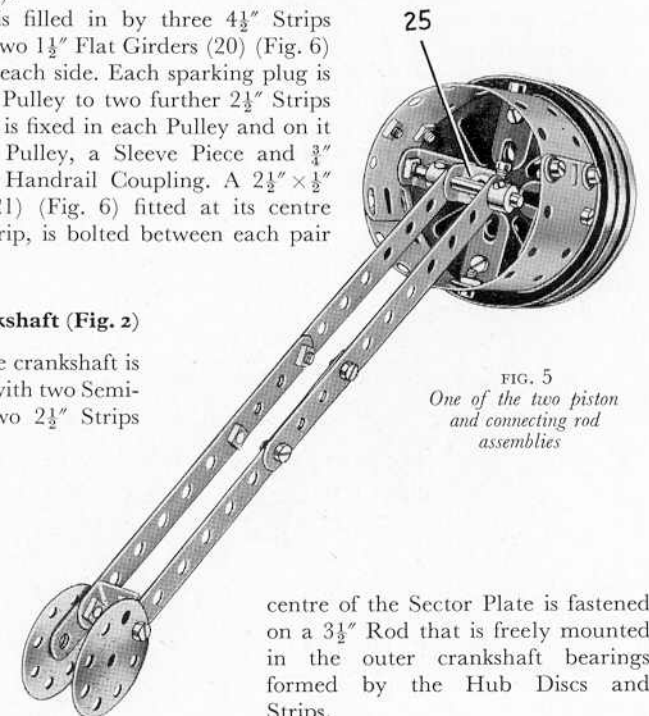

FIG. 5
One of the two piston
and connecting rod
assemblies

centre of the Sector Plate is fastened on a $3\frac{1}{2}$ " Rod that is freely mounted in the outer crankshaft bearings formed by the Hub Discs and Strips.

Each centre web of the crankshaft consists of two 6" Circular Plates joined together by four Double Brackets. A Bush Wheel is bolted to the centre of each Circular Plate and these are used to fix the webs to the ends of a 3" Rod, which is mounted in the end holes of the Strips (13). A Bell Crank (23) is bolted to the outer Circular Plate of each centre web. When the connecting rods and piston assemblies are completed the lower end of each connecting rod is freely pivoted on a 3" Rod (24) that connects the inner and outer webs together. These Rods are fixed in the Cranks (22) and the Double Arm Cranks (23).

The Pistons and Connecting Rods (Fig. 5)

One of the piston assemblies is shown removed from the model in Fig. 5. Each piston consists of three 3" Pulleys fixed on a 1½" Rod that carries at its lower end a large Fork Piece (25). The skirt is formed by two 5½" × 1½" Flexible Plates with their ends overlapped three holes. These Plates are bolted to 1" × ½" Angle Brackets fixed to the lower one of the 3" Pulleys.

The connecting rod is formed by two made-up strips, each consisting of two 5½" Strips overlapped four holes. The two strips are joined at their lower ends by a Double Bracket, the bolts holding these fixing also a Wheel Disc on each side. The Wheel Discs and the strips are passed over one of the Rods (24) (Fig. 2) of the crankshaft and are centred on the Rod by two Collars. The upper end of the connecting rod pivots on a 1½" Rod held in the Fork Piece (25) by Collars.

The pistons are arranged so that they can slide freely between the edges of the Angle Girders and the Flat Girders on the inside of the cylinder block assembly.

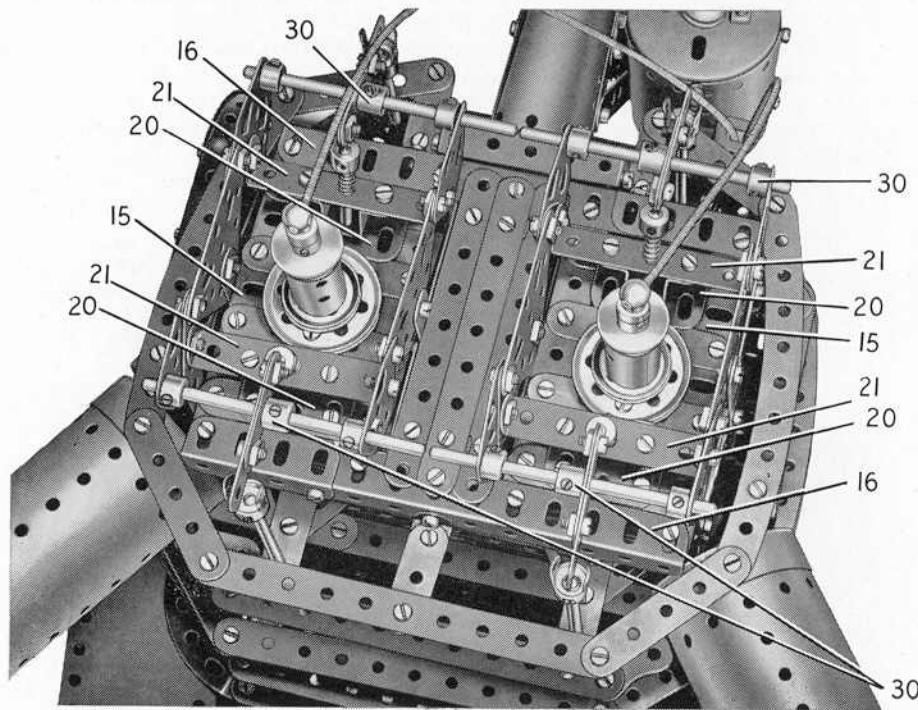

FIG. 6 A close-up view of the cylinder block head showing the valves, sparking plugs, etc.

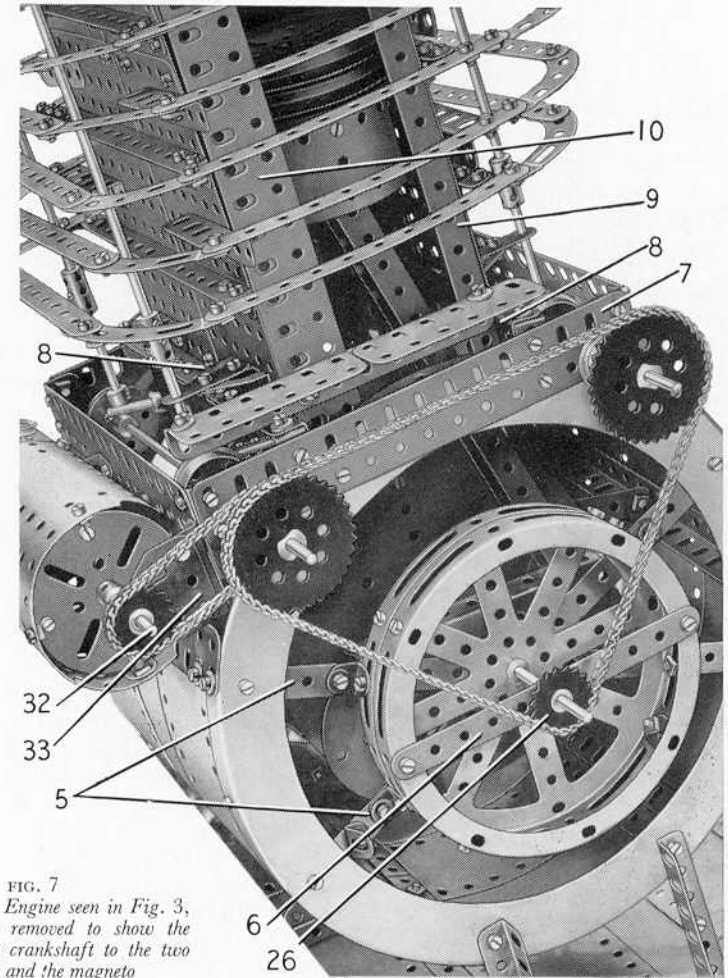

FIG. 7
The end of the Engine seen in Fig. 3,
with the cover removed to show the
drives from the crankshaft to the two
camshafts and the magneto

Arrangement of the Camshafts and the Valve Gear (Figs. 2, 3, 4, 6 and 7)

The camshafts are driven by Chain from a 1" Sprocket (26) (Fig. 7) fixed at one end of the crankshaft. The Chain passes round two 2" Sprockets, each of which is fixed on one of the two camshafts. The camshaft and valve assembly on each side of the model are alike in general arrangement, and each camshaft is an 11½" Rod held in the Flat Girders (7) by 1" Pulleys. Two 1½" Flanged Wheels (27) (Fig. 2) are fixed on the Rod.

The tappets (28) (Fig. 2) are each formed by a 1" Rod held in a Coupling fixed on a 2" Rod. These 2" Rods are supported in 1" × 1" Angle Brackets and 1" Reversed Angle Brackets bolted to the Girder (8) (Figs. 2 and 7), the lower lugs of the Reversed Angle Brackets being fixed together by a nut and bolt. The 1" Rod bears against the boss of

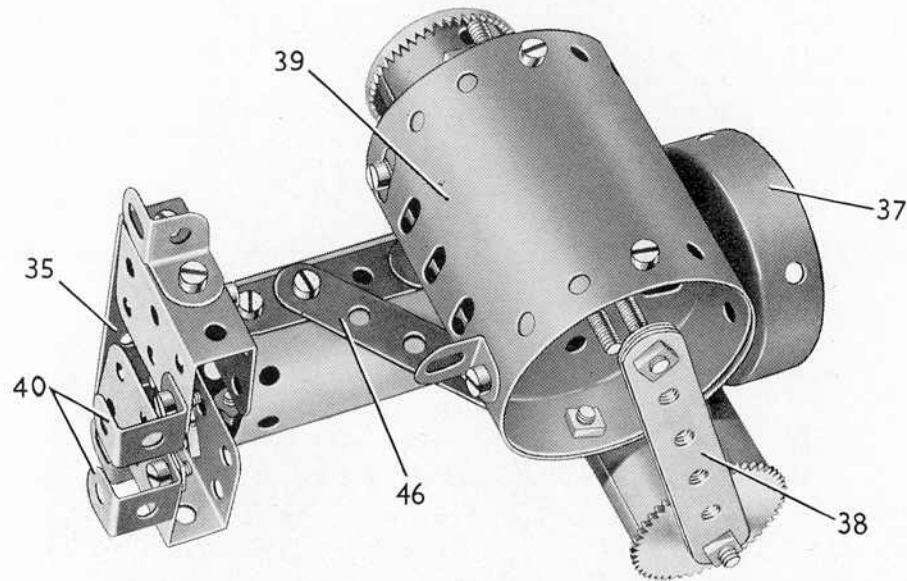

FIG. 8 The complete carburettor removed from the Engine

one of the Flanged Wheels (27) (Fig. 2), so that as the Flanged Wheel turns its set-screw raises and lowers the tappet.

The push-rods (29) (Fig. 2) are each made by joining a 2" and an 8" Rod by means of a Coupling. These rods slide in two bearings, the lower pair on each side being made from $1\frac{1}{2}$ " Strips bolted to Trunnions. The upper pair on one side consist of 2" Strips bolted to Trunnions, but on the other side the 2" Strips are supported by Girder Brackets (Fig. 1). Each push-rod carries at its lower end a Collar that rests on the 1" Rod of one of the tappets (28), and at its upper end a small Fork Piece arranged with its arms outside the end of one of the four rocker arms (30) (Fig. 6).

Each rocker arm consists of a 2" Strip bolted to a Double Arm Crank mounted on a $3\frac{1}{2}$ " Rod. The Rod is held by Collars in the Flat Trunnions (19) (Fig. 3). The inner end of the Strip bears against a Collar on a $2\frac{1}{2}$ " Rod that represents the valve stem. This Rod is supported in one of the Double Angle Strips (21) (Fig. 6) and its Double Bent Strip, and a Compression Spring is fitted between the Collar and the Double Angle Strip. A 1" Pulley on the lower end of the Rod represents the valve head.

A cover is fitted over the camshaft chain drive as shown in Figs. 1, 2, 3 and 4. The frame for the face of the cover consists of two $7\frac{1}{2}$ " Strips and a $5\frac{1}{2}$ " Strip connected at their ends by Curved Strips. This frame is filled in by a $9\frac{1}{2}$ " \times $2\frac{1}{2}$ " Strip Plate, and Flexible Plates and Triangular Flexible Plates of various sizes. The edges of the cover are formed by two $12\frac{1}{2}$ " \times $2\frac{1}{2}$ " Strip Plates, a $5\frac{1}{2}$ " \times $2\frac{1}{2}$ " and a $4\frac{1}{2}$ " \times $2\frac{1}{2}$ " Flexible Plate. These are connected to the front face by Angle Brackets and three $5\frac{1}{2}$ " Angle Girders.

The cover is supported at the top by two 3" Flat Girders, which are fixed to a $5\frac{1}{2}$ " Angle Girder attached to one side of the cylinder block. The lower part of the cover is bolted to two Angle Brackets fixed to the Strips 5.

Construction of the Magneto (Figs. 1, 7 and 9)

The magneto is a Boiler (31) (Fig. 9) opened out slightly and connected by Angle Brackets to a Face Plate at each end. A $6\frac{1}{2}$ " Rod (32) is free to turn in the bosses of the Face Plates and in a Flat Trunnion (33) (Fig. 7), which is attached to a $1\frac{1}{2}$ " Angle Girder bolted to one side of the crankcase. The Rod is held in position by one half of a Dog Clutch and a 1" Sprocket, which is driven by Chain from a similar Sprocket on one of the camshafts. A Rod Socket (34) (Fig. 9) fitted with a $\frac{1}{2}$ " and a $\frac{7}{32}$ " Bolt, is fixed on the other end of the Rod. Two $\frac{1}{2}$ " \times $\frac{1}{2}$ " Angle Brackets bolted to the Face Plate at the same end as the Rod Socket are set so that the $\frac{1}{2}$ " Bolt just clears them as it rotates. Two 1" \times 1" Angle Brackets are bolted to this Face Plate also to form clips that support the magneto cap.

The cap is made by bolting two $5\frac{1}{2}$ " \times $1\frac{1}{2}$ " Flexible Plates to Angle Brackets and a $2\frac{1}{2}$ " \times $1\frac{1}{2}$ " Double Angle Strip fixed to a Face Plate. The contacts are Handrail Supports spaced from the cap by 1" loose Pulleys, and lengths of Spring Cord are arranged between them and the Handrail Couplings of the sparking plugs as shown in Fig. 1.

Assembly of the Carburettor and the Exhaust Ports (Fig. 1, 3 and 8)

The carburettor is shown separately in Fig. 8. Two Channel Bearings are connected by a $2\frac{1}{2}$ " \times 1" Double Angle Strip (35) and two $1\frac{1}{8}$ " radius Curved Plates rolled into a cylinder are attached to each Channel Bearing by an Angle Bracket. The cylinder is strengthened by two $2\frac{1}{2}$ " Strips, each of which is extended by a 2" Slotted Strip (36) (Fig. 3). These Slotted Strips support the upper one of two $2\frac{1}{2}$ " Cylinders, which are joined together by Fishplates. A Boiler End (37) and a 1" Pulley are attached to the lower Cylinder by a $\frac{3}{4}$ " Bolt. A 6" Screwed Rod is passed through the two Cylinders and on it is held a $1\frac{1}{2}$ " Contrate at the top, and at its lower end are fixed a 50-tooth Gear and four 3" Strips (38) placed face-to-face.

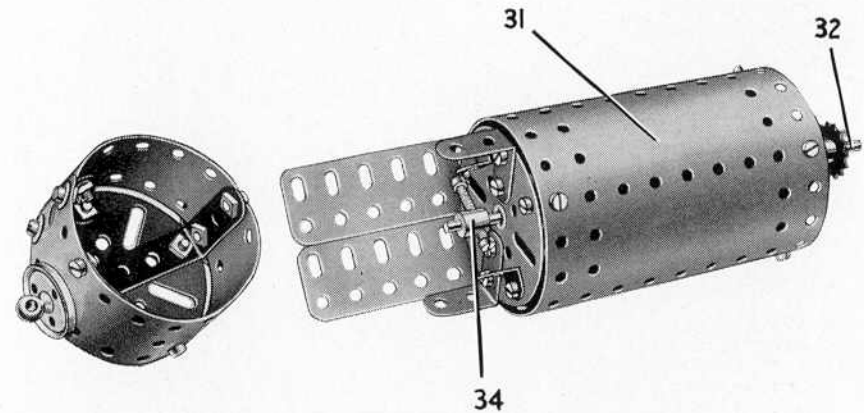

FIG. 9 The magneto, with the cap shown separately

MECCANO Trench Digger

(MODEL No. 10.17)

SPECIAL FEATURES

This model is based on an actual machine designed for digging narrow trenches suitable for laying drainage pipes, cables, etc. The trench is excavated by a continuous moving chain of sharp-edged digger buckets, and the depth of the trench can be adjusted as required.

The model can be steered as it travels and is powered by a Meccano E15R type Electric Motor.

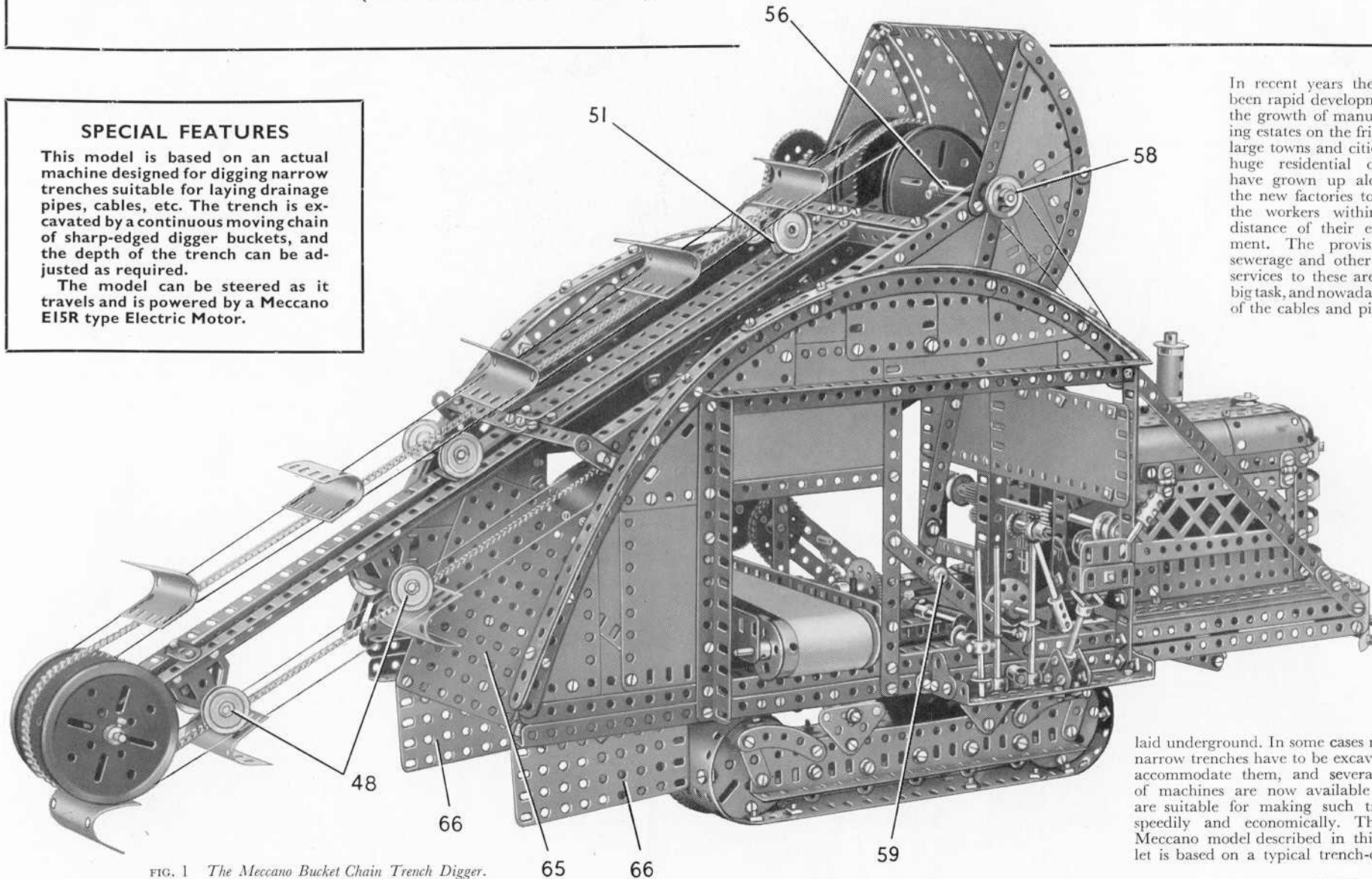

FIG. 1 The Meccano Bucket Chain Trench Digger.
Its construction is fully described in this Leaflet

In recent years there has been rapid development in the growth of manufacturing estates on the fringes of large towns and cities, and huge residential districts have grown up alongside the new factories to house the workers within easy distance of their employment. The provision of sewerage and other utility services to these areas is a big task, and nowadays most of the cables and pipes are

laid underground. In some cases miles of narrow trenches have to be excavated to accommodate them, and several types of machines are now available which are suitable for making such trenches speedily and economically. The fine Meccano model described in this Leaflet is based on a typical trench-digging

machine. It is fitted with an endless chain of buckets that bite into the ground as the machine moves slowly forward on its creeper tracks. The spoil falls on to a conveyor and is distributed alongside the trench as the machine moves along. The depth of the trench can be varied by adjusting the angle of the boom that carries the bucket chain.

Details of the Chassis (Figs. 2, 6 and 7)

Each side-member of the chassis consists of two $24\frac{1}{2}$ " Angle Girders arranged to form a channel section girder by bolting to them two $7\frac{1}{2}$ " Angle Girders (1) and (2) and a $7\frac{1}{2}$ " Strip (3) (Fig. 7). The top ends of the Girders (1) and (2) and the Strip (3) are connected by bolting to them a $12\frac{1}{2}$ " Angle Girder (4). The side-members are connected by two built-up strips (5) and (6) (Fig. 2), each made from two $5\frac{1}{2}$ " Strips overlapped seven holes. Two similar built-up strips (7) and (8) are fixed in position, and a further built-up strip (9) (Fig. 3) is bolted across the chassis. The strip (9) is made from two $4\frac{1}{2}$ " Strips overlapped three holes. Two $18\frac{1}{2}$ " Angle Girders (10) are bolted to the strips (5) and (6) as shown.

The Power Unit and Main Drive (Figs. 2, 3, 6 and 8)

An E15R Electric Motor is bolted by its flanges to the Girders (10) (see Fig. 6) and a

FIG. 2
An underneath view of the
Trench Digger showing details
of the chassis and main drive

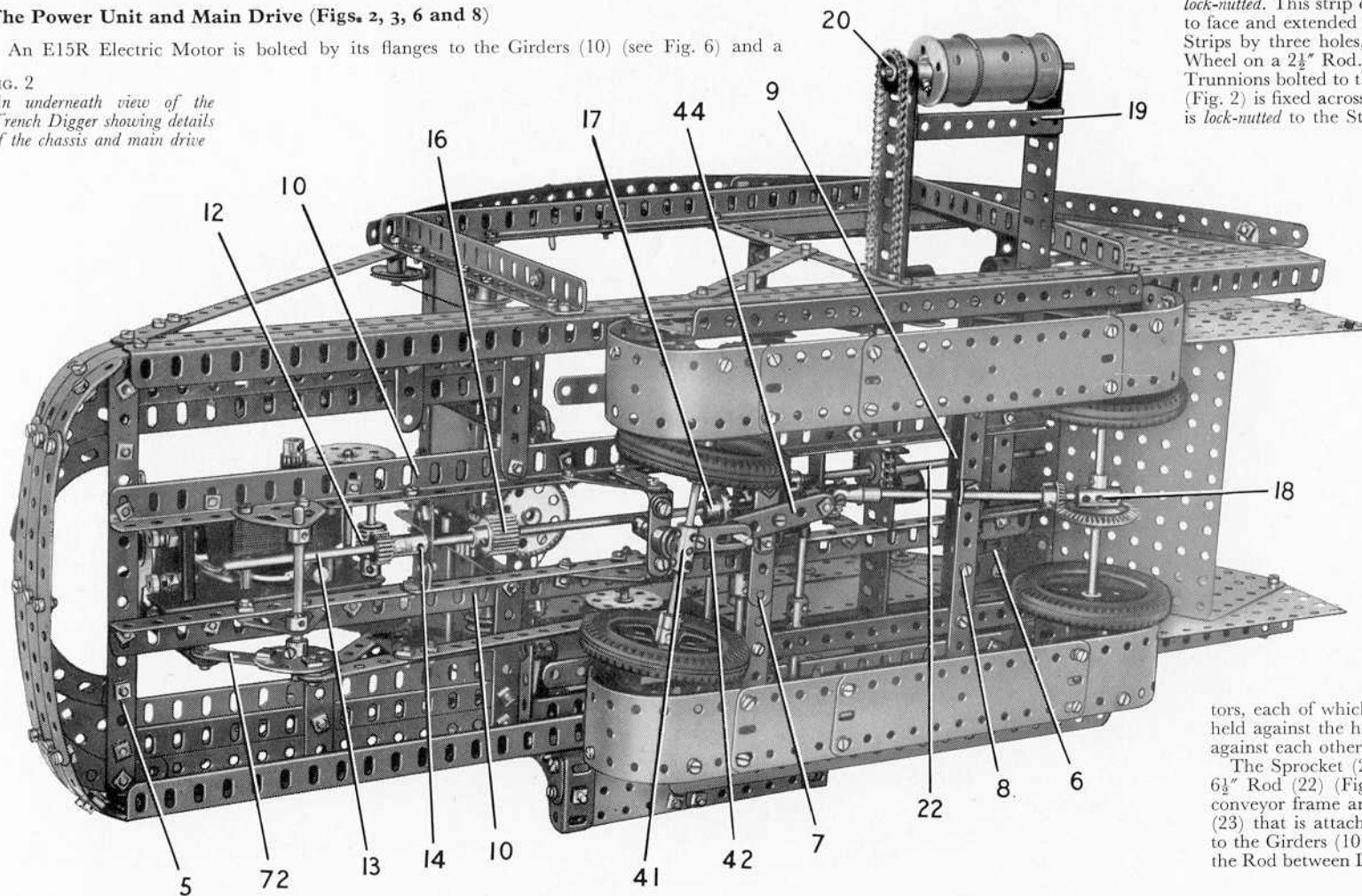

$\frac{7}{16}$ " Pinion on its armature shaft drives a 60-tooth Gear (see Fig. 2) on a 3" Rod mounted in the Motor side-plates. This Rod carries a $\frac{3}{8}$ " Pinion (11) (Fig. 6) that drives a 50-tooth Gear on a $2\frac{1}{2}$ " Rod. A Worm (12) (Fig. 2) fixed on this Rod engages a $\frac{1}{2}$ " Pinion on an $11\frac{1}{2}$ " Rod (13). The bearings for Rod (13) are provided by a Double Arm Crank (14) and a $1\frac{1}{2}$ " Strip, each of which is attached to the Girders (10) by two Angle Brackets. The $1\frac{1}{2}$ " Strip is positioned immediately behind a $\frac{1}{2}$ " Pinion (15) (Fig. 8) fixed on the Rod, which carries also a $\frac{3}{4}$ " diameter $\frac{1}{2}$ " face Pinion (16) and a $\frac{7}{8}$ " Bevel Gear (17).

A Universal Coupling is fixed to the end of Rod (13) (Fig. 2) and is fitted also with a $4\frac{1}{2}$ " Rod that is supported in an Obtuse Angle Bracket bolted to the strip (8). The $4\frac{1}{2}$ " Rod carries a $\frac{1}{2}$ " Bevel Gear and is free to turn in a Coupling (18). This Coupling is loosely mounted on the driving axle, between a Collar and a $1\frac{1}{2}$ " Bevel Gear that meshes with the $\frac{1}{2}$ " Bevel Gear. The driving axle is a 5" Rod supported in two Corner Gussets, which are fixed to $1\frac{1}{2}$ " Angle Girders bolted to the strips (6) and (9).

The Motor switch is operated by a lever (71) (Figs. 3 and 6) formed by a 2" Rod in a Coupling. The Coupling is fixed on a $3\frac{1}{2}$ " Rod mounted in Double Brackets bolted to the chassis, and the

Rod carries a Bush Wheel to which a built-up strip is lock-nutted. This strip consists of two $5\frac{1}{2}$ " Strips placed face to face and extended by a $3\frac{1}{2}$ " Strip that overlaps the $5\frac{1}{2}$ " Strips by three holes, and it is lock-nutted also to a Bush Wheel on a $2\frac{1}{2}$ " Rod. The Rod is held by Collars in Flat Trunnions bolted to the Girders (10), and a $2\frac{1}{2}$ " Strip (72) (Fig. 2) is fixed across the Bush Wheel. Another $2\frac{1}{2}$ " Strip is lock-nutted to the Strip (72) and is pivoted at its upper end on a $\frac{3}{8}$ " Bolt screwed into a Handrail Support that is lock-nutted to an arm of the Motor switch.

Assembly of the Conveyor (Figs. 2, 3, 7 and 8)

The conveyor frame consists of two $12\frac{1}{2}$ " Flat Girders, one of which is attached to the Girders (1) (Fig. 7) by $1" \times \frac{1}{2}"$ Angle Brackets while the other is similarly attached to the Strips (3). A $3\frac{1}{2}" \times \frac{1}{2}"$ Double Angle Strip (19) (Fig. 2) is bolted between the Flat Girders at one end.

The main conveyor rollers are formed by $1\frac{1}{8}"$ Flanged Wheels pressed into Cylinders, and each is fixed on a 4" Rod mounted in the Flat Girders. The Rod that supports the driving roller carries a $\frac{3}{8}"$ Sprocket (20) (Fig. 7), and two $2\frac{1}{2}"$ Driving Bands are stretched round this roller. The belt can be made from a length of cloth or strong paper joined together at its ends. The supporting rollers (21) (Fig. 3) are Chimney Adapters, each of which is free to turn on a $\frac{1}{2}"$ Bolt and is held against the head of the Bolt by two nuts screwed against each other.

The Sprocket (20) is driven by a 1" Sprocket on a $6\frac{1}{2}"$ Rod (22) (Fig. 3). This Rod is supported in the conveyor frame and in a $1\frac{1}{2}" \times \frac{1}{2}"$ Double Angle Strip (23) that is attached to $1" \times \frac{1}{2}"$ Angle Brackets bolted to the Girders (10). A Compression Spring is fitted on the Rod between Double Angle Strip (23) and a Collar

against each other.

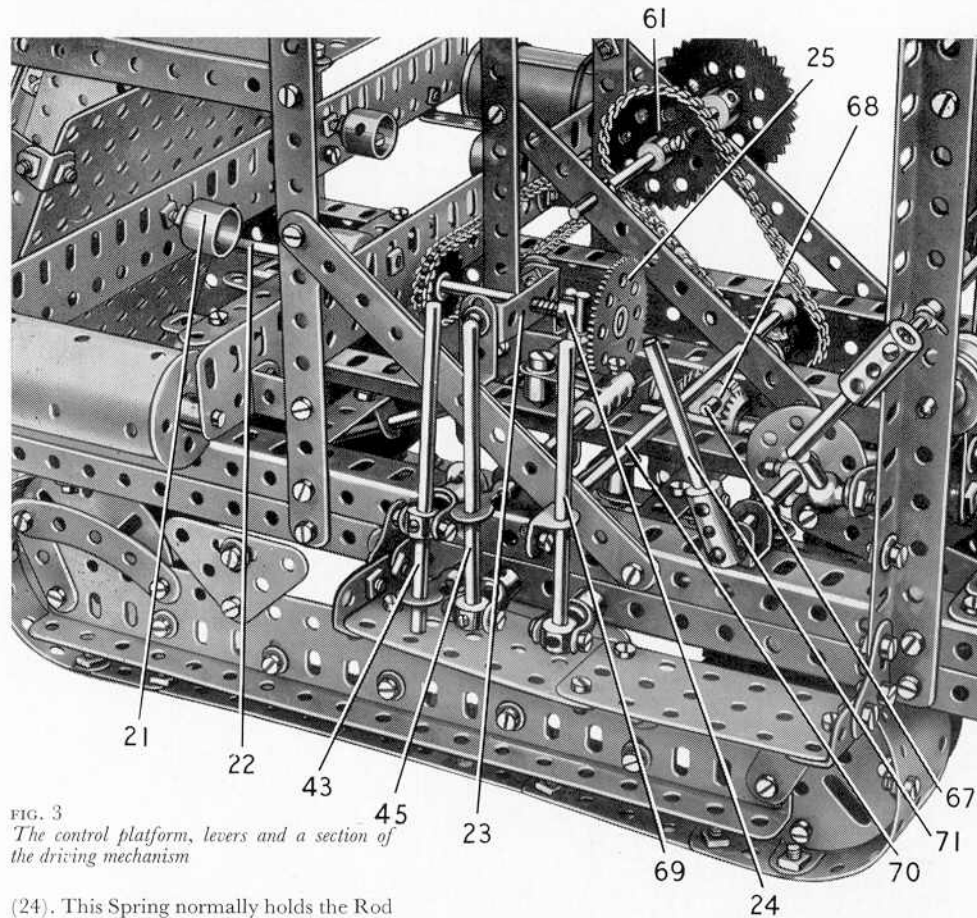

FIG. 3
The control platform, levers and a section of the driving mechanism

(24). This Spring normally holds the Rod so that a 57-tooth Gear (25) on it is kept clear of the Pinion (15) (Fig. 8). The Gear and Pinion can, however, be brought into mesh by sliding the Rod, to engage the drive to the conveyor. The movement of Rod (22) is restricted by a Collar placed inside the conveyor frame, and is controlled by a lever (45) (Fig. 3). This lever is a $3\frac{1}{2}$ " Rod fixed in a Swivel Bearing attached to the chassis by a Pivot Bolt. The lever carries as shown a Rod and Strip Connector fixed on a $3\frac{1}{2}$ " Rod that slides in a Double Bracket bolted to the chassis. A Strip Coupling on the $3\frac{1}{2}$ " Rod is connected by a $\frac{3}{8}$ " Bolt to one arm of a Bell Crank, and this is mounted freely on a Pivot Bolt fixed in one of the Girders (10). The other arm of the Bell Crank carries a Threaded Pin that engages between the Collar (24) and the Gear (25).

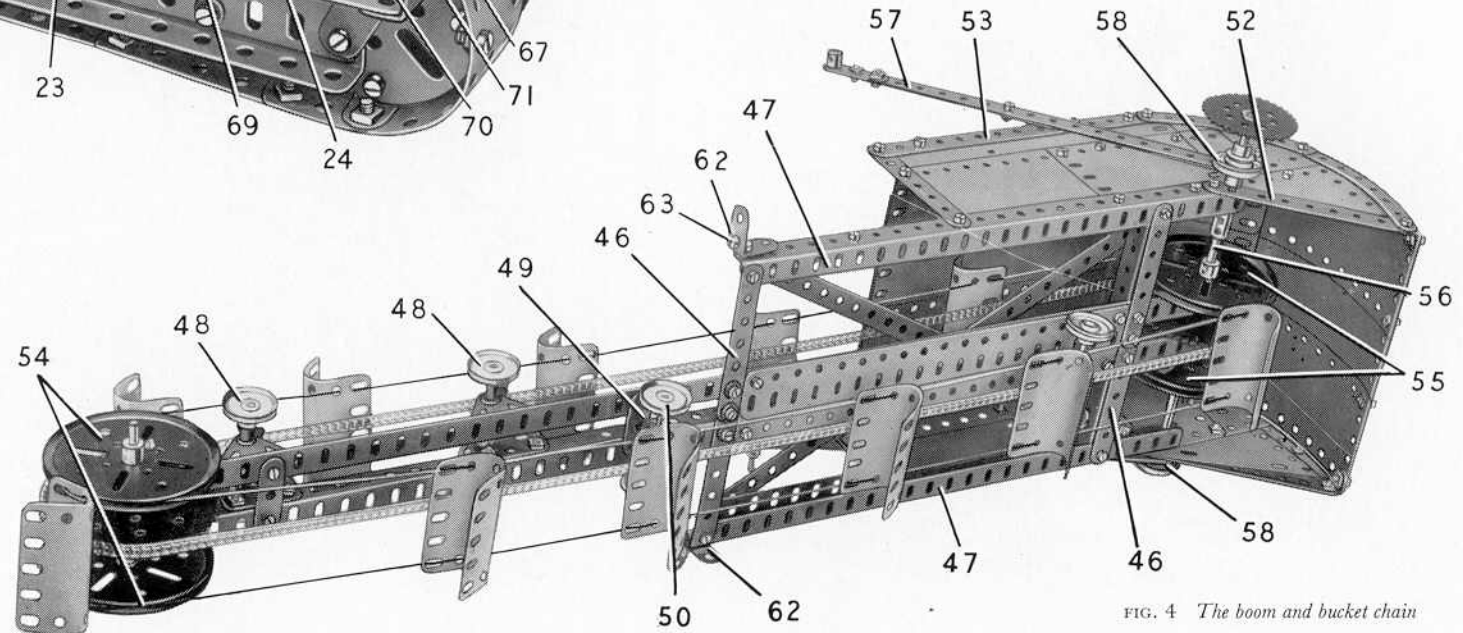

FIG. 4 The boom and bucket chain

Supporting Frame for the Bucket Boom (Figs. 1, 5, 7 and 8)

The outer edge of the frame on each side consists of a 3" Strip (26) and four $5\frac{1}{2}$ " Curved Strips. The rear Curved Strip is connected by a $9\frac{1}{2}$ " Strip and a 2" Strip to the rear end of the chassis. Two $12\frac{1}{2}$ " Strips (27) on each side are spaced apart by a nut on each of two $\frac{3}{8}$ " Bolts (28), and these Bolts attach the Strips to Angle Brackets bolted to the frame. Another $12\frac{1}{2}$ " Strip overlaps the rear ends of the Strips (27) by five holes, and this Strip also is connected to the frame by an Angle Bracket.

A built-up strip (29) (Fig. 8) is attached to the Strips (3), and a $5\frac{1}{2}$ " Strip is connected to the strip (29) by an Angle Bracket and bolted at its lower end to one of the Girders (10). The $5\frac{1}{2}$ " Strip is connected to the Girder (10) by another $5\frac{1}{2}$ " Strip (30). The strip (29) is made from two $4\frac{1}{2}$ " Strips overlapped three holes.

Two $5\frac{1}{2}$ " Angle Girders (31) are connected to the Girders (10) by Corner Angle Brackets, and each is joined to one of the Girders (2) by a 3" Strip. The Girders (31) are connected by two $5\frac{1}{2}$ " x $2\frac{1}{2}$ " Flexible Plates overlapped seven holes and edged by two $7\frac{1}{2}$ " Strips. These are attached to the Girders (2) by Angle Brackets. A $2\frac{1}{2}$ " x $\frac{1}{2}$ " Double Angle Strip (32), with a Double Arm Crank bolted to it, is fixed between the lower ends of the Angle Girders (31) (Fig. 6).

Drive to the Boom Winding Drums (Figs. 1, 5, 6, 7 and 8)

A $1\frac{1}{2}$ " Contrate that meshes with the Pinion (16) (Fig 6) is fixed on a $1\frac{1}{2}$ " Rod free in the Double Angle Strip (32) and in the boss of the Double Arm Crank. A $\frac{1}{2}$ " Pinion (33) is fixed on the upper end of the Rod. A cross shaft (34) is formed by a 5" Rod mounted in the Girders (31), and this carries two $\frac{3}{4}$ " Contrates arranged one on either side of the Pinion (33), with a Compression Spring between each Contrate and one of the Girders (31).

The movement of Rod (34) is controlled by a Bell Crank mounted on a Pivot Bolt (35) (Fig. 6). One arm of the Bell Crank is extended by a 1" Rod held in a Handrail Support, and a Threaded Pin is fixed in the other arm. The Threaded Pin engages a $\frac{1}{2}$ " loose Pulley (36) with a $\frac{3}{4}$ " Washer and a Collar on either side of it. A $\frac{1}{2}$ " Pinion on Rod (34) drives a $\frac{1}{2}$ " diameter, $\frac{1}{2}$ " face Pinion (37) on an 8" Rod (38). This Rod carries two pairs of $\frac{3}{4}$ " Flanged Wheels and a Ratchet Wheel (39). A Pawl on a $4\frac{1}{2}$ " Rod (40) engages

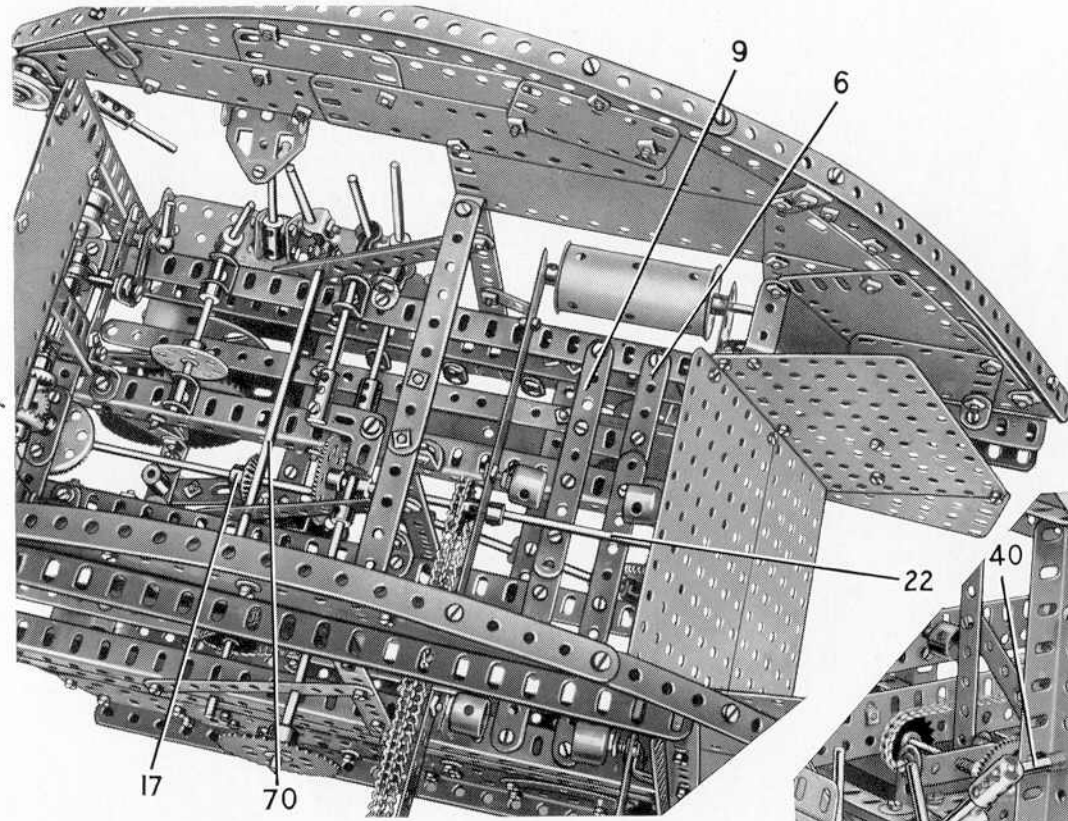

FIG. 5 Plan view of the Trench Digger with the boom and bucket chain removed

the Ratchet and can be released by operating a handle formed by a $1\frac{1}{2}$ " Rod held in a Coupling.

Arrangement of the Steering Mechanism (Figs. 1, 2 and 3)

Each steerable wheel is free to turn between two Collars on a 2" Rod, which is gripped in a Coupling (41). This Coupling is fixed on a $1\frac{1}{2}$ " Rod passed through a Double Arm Crank that is attached by Angle Brackets to two $1\frac{1}{2}$ " Strips bolted to the Girders (10). Each $1\frac{1}{2}$ " Strip is braced by a 2" Strip that also is bolted to the Girder (10). A Crank, fitted with a 2" Slotted Strip (42), is fixed on the $1\frac{1}{2}$ " Rod, which is held in place by a Collar.

The steering lever is a $3\frac{1}{4}$ " Rod (43), fixed in the 'spider' of a Swivel Bearing. The Swivel Bearing is fixed on a Pivot Bolt attached to an Angle Bracket bolted to the chassis. A Rod and Strip Connector is passed over the lower end of the lever and is fitted to one end of a made-up rod formed by two 2" Rods joined by a Coupling. The other end of the made-up rod also carries a Rod and Strip Connector, which is pivoted on a $\frac{3}{8}$ " Bolt fixed in a Rod Socket. The Rod Socket is bolted to a $2\frac{1}{2}$ " Strip (44), and this Strip pivots on a $\frac{3}{8}$ " Bolt fixed in a Double Arm Crank bolted to the strip (7). A Threaded Pin in Strip (44) engages the slotted hole of the Slotted Strip (42).

Details of the Tracks and Track Guards (Figs. 1, 2 and 7)

Each of the dummy tracks consists of three $5\frac{1}{2}$ " \times $1\frac{1}{2}$ " Flexible Plates and a $2\frac{1}{2}$ " \times $1\frac{1}{2}$ " Flexible Plate. A Face Plate is attached to each end by Angle Brackets and the track is then bolted underneath the chassis frame.

The track guards are each formed by a $9\frac{1}{2}$ " Angle Girder and a $9\frac{1}{2}$ " Flat Girder. Two $1\frac{1}{2}$ " Corner Brackets attached to the Flat Girder are connected to the chassis by Angle Brackets.

Construction of the Boom and the Bucket Chain (Figs. 1, 4 and 7)

The boom that supports the bucket chain consists of two $24\frac{1}{2}$ " Angle Girders connected by a $1\frac{1}{2}$ " Strip, two $9\frac{1}{2}$ " Flat Girders and two built-up strips (46) (Fig. 4), each made from two $3\frac{1}{2}$ " Strips. The upper one of the strips (46) is strengthened by a 3" Angle Girder on each side. A $12\frac{1}{2}$ " Angle Girder (47) on each side is bolted to the ends of the strips (46), and this structure is braced by two crossed $12\frac{1}{2}$ " Strips. The lower ends of the $12\frac{1}{2}$ " Strips are bolted to $4\frac{1}{2}$ " Angle Girders fixed to the Girders (47), and the upper ends are attached to Angle Brackets also bolted to the Girders (47).

Two pairs of Flat Trunnions are bolted to the $24\frac{1}{2}$ " Angle Girders as shown, and in each pair a 2" Rod is held by Spring Clips and is fitted with 1" Pulleys (48). A Threaded Coupling (49) is fixed on a bolt passed through a $1\frac{1}{2}$ " Strip, and in this a 2" Rod is freely mounted and is held in position by the separated halves of a Dog Clutch. This Rod carries two 1" Pulleys (50). A

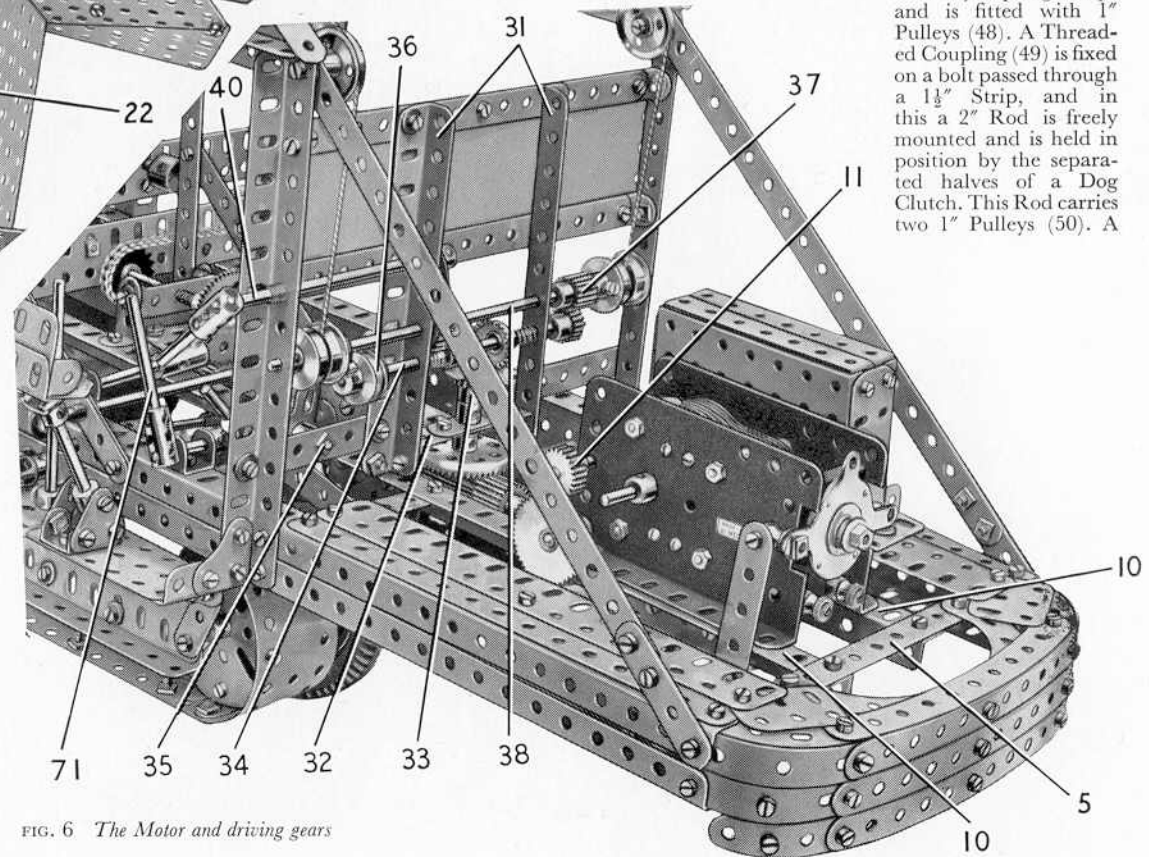

FIG. 6 The Motor and driving gears

Coupling (51) is fixed on a Threaded Pin bolted to the $9\frac{1}{2}$ " Flat Girders, and this also carries a 2" Rod fitted with two 1" Pulleys. The Rod is held in place by Collars.

The framework of each side of the hopper at the top of the boom consists of a $4\frac{1}{2}$ " Strip (52), a $3\frac{1}{2}$ " Strip and a built-up strip (53) made from a $5\frac{1}{2}$ " and a $4\frac{1}{2}$ " Strip. The rounded base of the hopper is formed by three $9\frac{1}{2}$ " \times $2\frac{1}{2}$ " Strip Plates and three $5\frac{1}{2}$ " \times $2\frac{1}{2}$ " Flexible Plates, attached to the sides by Angle Brackets.

At the lower end of the boom two 3" Pulleys (54) and a 3" Sprocket are fixed on a $3\frac{1}{2}$ " Rod. At the upper end two 3" Pulleys (55) and a 3" Sprocket are fixed on an axle (56) made from a $6\frac{1}{2}$ " and a $2\frac{1}{2}$ " Rod joined by a Coupling. The bucket chain consists of 12 U-section Curved Plates threaded on two endless belts of Cord, each of which is passed round the Pulleys (54) and (55) and is supported by the 1" Pulleys of the boom.

The boom is supported by two built-up strips (57), each made from a $9\frac{1}{2}$ " Strip and two $5\frac{1}{2}$ " Strips bolted together face to face to form a $9\frac{1}{2}$ " strip of double thickness. The top ends of these strips are passed over the ends of the axle (56), but are spaced from the hopper by a Collar on each side. Two 1" loose Pulleys (58) are mounted on the axle. One of them is held in place by a Collar and the other is retained on the axle by a $\frac{1}{2}$ " fixed Pulley. The lower ends of the strips (57) are

fitted with Cranks, one of which is fixed on a 1" Rod (59) that is held in the frame by a Collar. The other Crank is freely mounted on a 5" Rod (60), which is supported in the Strip (30) and in the Strip that braces one of the Strips (3). Rod (60) carries a $1\frac{1}{2}$ " Sprocket (61), and a 2" Sprocket that is connected by Chain to a similar Sprocket at one end of the axle (56).

A 1 " \times 1 " Angle Bracket (62) is lock-nutted to the Girder (47) on each side, and in the Angle Bracket is fixed a bolt (63) fitted with two Washers. The outer lugs of the Angle Brackets slide freely between the Strips (27) on each side.

A 1" loose Pulley (64) on each side is freely mounted on a $\frac{3}{8}$ " Bolt screwed into a Threaded Boss. The Threaded Bosses are screwed tightly on to bolts passed through the top ends of the Girders (2) (Fig. 7). A length of Cord on each side is fastened to the Rod (38) between the $\frac{3}{8}$ " Flanged Wheels, is passed over the Pulley (64) and then round the Pulley (58). The Cord is then tied to the Threaded Boss.

A $5\frac{1}{2}$ " \times $3\frac{1}{2}$ " Flat Plate (65) on each side, to which a $4\frac{1}{2}$ " \times $2\frac{1}{2}$ " Flat Plate (66) is bolted at

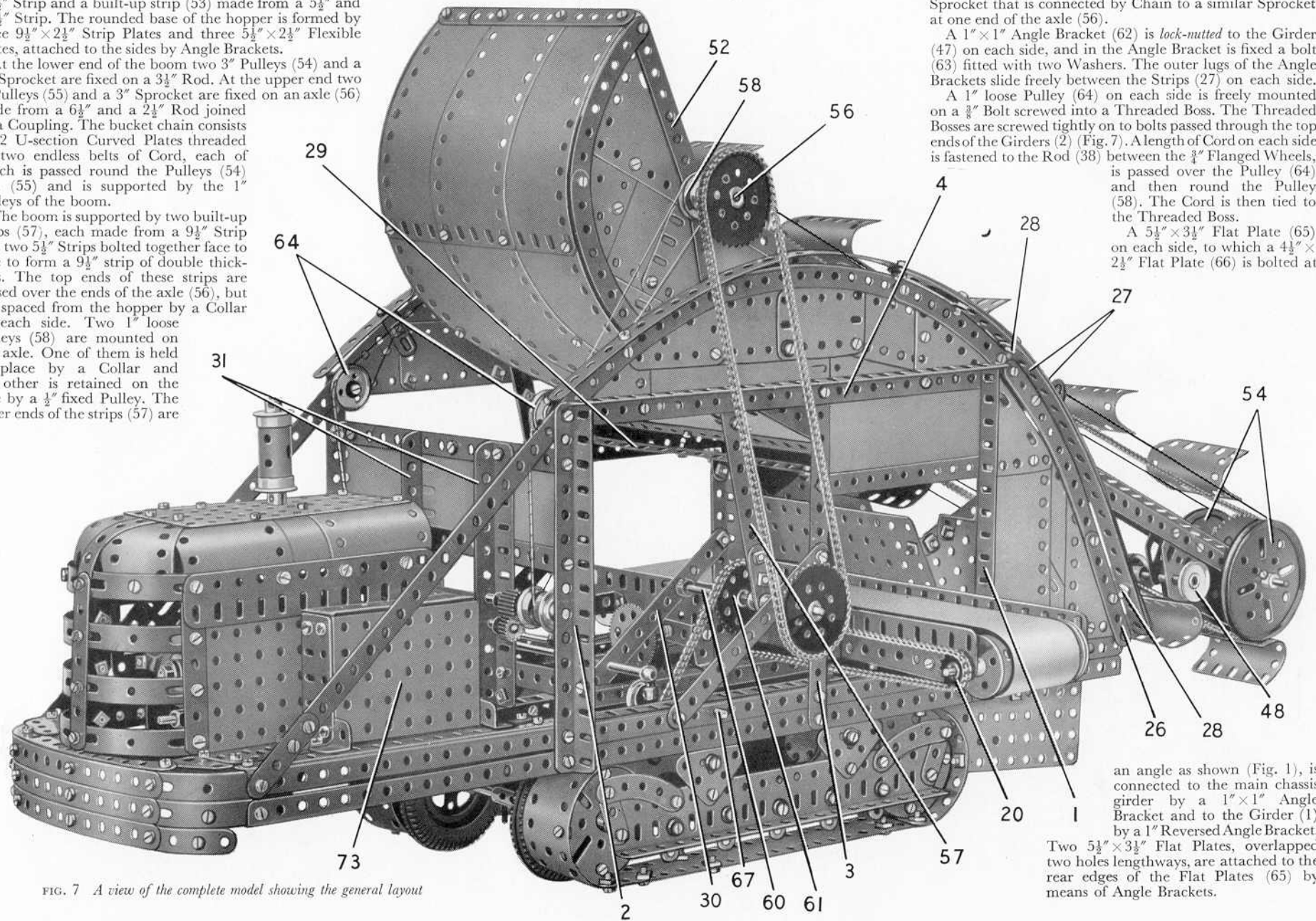

FIG. 7 A view of the complete model showing the general layout

an angle as shown (Fig. 1), is connected to the main chassis girder by a 1 " \times 1 " Angle Bracket and to the Girder (1) by a 1" Reversed Angle Bracket. Two $5\frac{1}{2}$ " \times $3\frac{1}{2}$ " Flat Plates, overlapped two holes lengthways, are attached to the rear edges of the Flat Plates (65) by means of Angle Brackets.

Drive to the Bucket Chain (Figs. 3, 5, 7 and 8)

A 4" Rod (67) (Fig. 3) is mounted in one of the Girders (10) and in one side of the chassis frame. The Rod carries a $\frac{7}{8}$ " Bevel Gear (68), a 1" Sprocket connected by Chain to the $1\frac{1}{2}$ " Sprocket (61), and a $\frac{3}{4}$ " Flanged Wheel. A Compression Spring is fitted on Rod (67) between the Girder (10) and the Flanged Wheel, and this normally holds the Rod in such a position that Bevel Gear (68) is clear of Bevel Gear (17). The two Bevel Gears can be meshed by moving a lever (69). The lever is a $3\frac{1}{2}$ " Rod held in a Swivel Bearing fixed on a Pivot Bolt bolted to the side of the chassis. An Angle Bracket passed over the lever is lock-nutted to a Rod and Strip Connector on a $6\frac{1}{2}$ " Rod (70) and a Handrail Coupling engages the $\frac{3}{4}$ " Flanged Wheel on Rod (67).

Assembly of the Driving Platform and the Engine Cover (Figs. 1, 3 and 7)

The driving platform consists of two $3" \times 1\frac{1}{2}"$ Flat Plates bolted together and fitted at each end with a $1\frac{1}{2}"$ Angle Girder that carries a 1" Corner Bracket. One of the Girders is connected to the chassis by an Angle Bracket and the other is fixed to the Girder (2).

The driver's seat is formed by a $1\frac{1}{2}"$ Flat Girder, a Flat Trunnion and a $1\frac{1}{2}" \times \frac{1}{2}"$ Double Angle Strip connected by a $1\frac{1}{2}"$ Angle Girder. It is bolted to an Obtuse Angle Bracket that is inserted between the lugs of a Slide Piece, and is held in place by a 2" Rod fixed in the Slide Piece. The 2" Rod is gripped in a Coupling. The Coupling is fixed by nuts and bolts between two 1" Triangular Plates connected by Double Brackets.

The side of the engine cover seen in Fig. 7 consists of a $5\frac{1}{2}" \times 2\frac{1}{2}"$ Flat Plate and a $5\frac{1}{2}"$ Flat Girder bolted at one end to a $3\frac{1}{2}"$ Strip and at the other end to a $3\frac{1}{2}"$ Flat Girder. The other side is formed by a $5\frac{1}{2}"$ Strip, a $5\frac{1}{2}"$ Flat Girder, a $3\frac{1}{2}"$ Flat Girder, a $3\frac{1}{2}"$ Strip and a $5\frac{1}{2}"$ Braced Girder attached to the $5\frac{1}{2}"$ Strip by two Hinges. A $5\frac{1}{2}"$ Angle Girder extended by a $2\frac{1}{2}"$ Angle Girder is bolted to the lower edge of each side of the engine cover, and these Girders are used to attach the structure to the chassis frame. At one side of the engine cover a box structure (73) is fitted (Fig. 7).

FIG. 8 A close-up showing part of the drive to the bucket chain

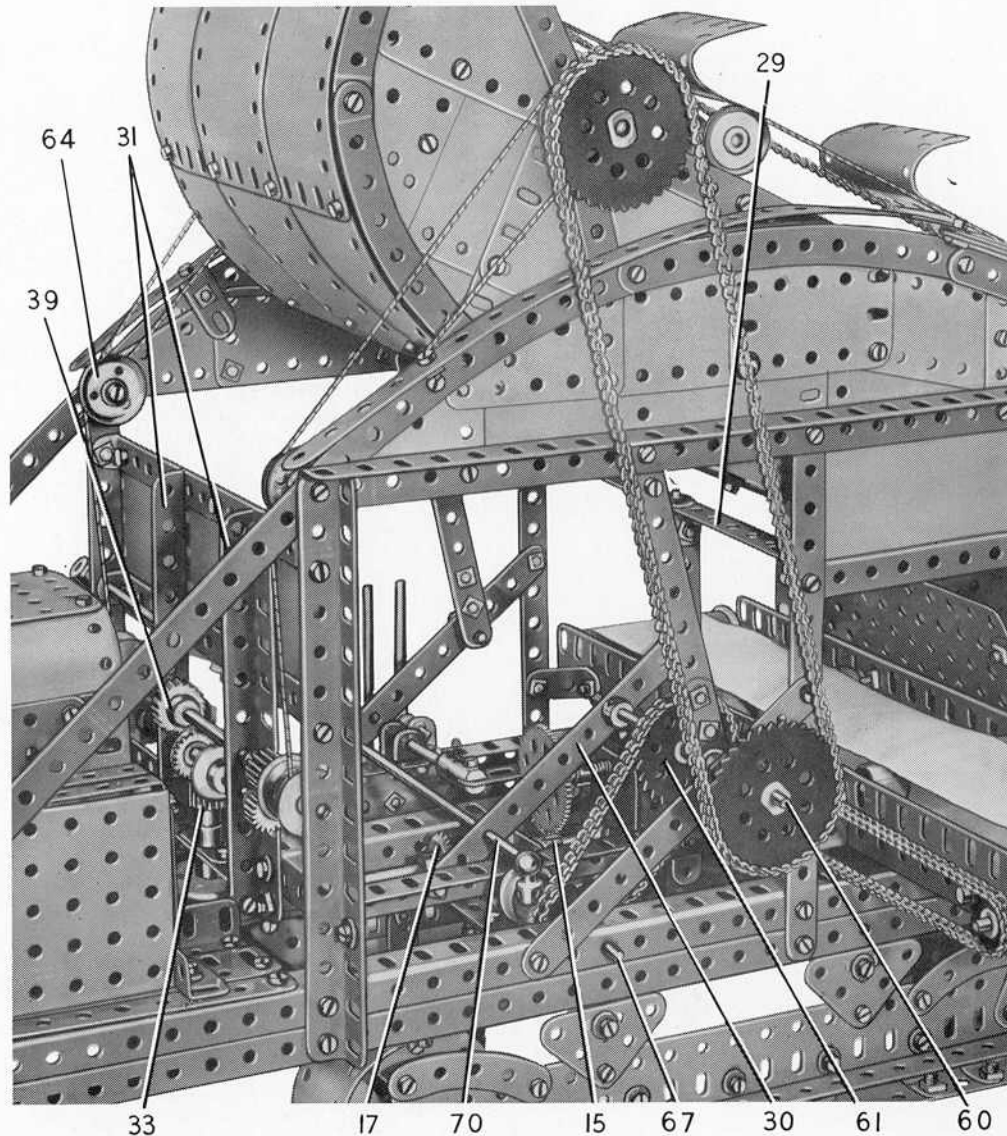

Parts Required to Build the Meccano Trench Digger

10 of No. 1	4 of No. 5	4 of No. 8b	5 of No. 11	3 of No. 14	8 of No. 17	2 of No. 103
4 " " 1a	7 " " 6	4 " " 9	50 " " 12	3 " " 15	2 " " 18a	4 " " 103a
5 " " 1b	10 " " 6a	2 " " 9a	4 " " 12a	3 " " 15a	3 " " 18b	2 " " 103b
29 " " 2	6 " " 7	2 " " 9c	8 " " 12b	2 " " 15b	4 " " 19b	2 " " 103d
8 " " 2a	2 " " 7a	2 " " 9d	3 " " 12c	5 " " 16	4 " " 20	2 " " 103f
10 " " 3	4 " " 8	7 " " 9f	1 " " 13	4 " " 16a	4 " " 20a	3 " " 103h
7 " " 4	2 " " 8a	21 " " 10	1 " " 13a	3 " " 16b	7 " " 20b	4 " " 103k
					8 " " 22	2 " " 108
					4 " " 22a	4 " " 109
					2 " " 23	8 " " 111a
					1 " " 23a	19 " " 111c
					2 " " 24	2 " " 114
					1 " " 25	4 " " 115
					1 " " 25a	4 " " 120b
					4 " " 26	2 " " 124
					1 " " 26a	7 " " 126a
					1 " " 26c	2 " " 128
					1 " " 27	4 " " 133
					1 " " 27a	2 " " 133a
					1 " " 27d	2 " " 136
					1 " " 28	1 " " 136a
					2 " " 29	2 " " 140
					2 " " 30	4 " " 142a
					1 " " 30a	1 " " 144
					1 " " 30c	1 " " 147a
					1 " " 32	5 " " 147b
					4 " " 35	1 " " 148
					503 " " 37a	1 " " 154a
					463 " " 37b	1 " " 154b
					80 " " 38	1 " " 163
					2 " " 38d	4 " " 164
					1 " " 40	2 " " 165
					2 " " 48	1 " " 176
					1 " " 48a	1 " " 179
					4 " " 48b	2 " " 186
					1 " " 50	11 " " 188
					4 " " 52a	12 " " 189
					2 " " 53	5 " " 190
					2 " " 53a	4 " " 190a
					1 " " 55a	4 " " 191
					24 " " 59	7 " " 192
					3 " " 62	3 " " 196
					4 " " 62b	12 " " 199
					8 " " 63	5 " " 200
					1 " " 63b	4 " " 212
					1 " " 63c	12 " " 215
					2 " " 64	2 " " 216
					2 " " 70	6 " " 221
					2 " " 73	2 " " 222
					2 " " 77	2 " " 223
					9 " " 89	2 " " 224
					4 " " 89b	2 " " 225
					4 " " 90	2 " " 226
					4 " " 90a	
					3 " " 94	
					2 " " 95	1 E15R
					1 " " 95a	Electric Motor
					2 " " 95b	(not included
					2 " " 96	in Outfit)
					1 " " 96a	
					1 " " 100	

MECCANO

Bottom Dump Truck

MODEL No. 10.18

SPECIAL FEATURES

A two-speed and reverse gear-box in the motor power unit, and special mechanism for controlling the opening and closing of the dumping doors, are attractive features of the Bottom Dump Truck described in this Leaflet. The model is an interesting one to build and operate and it is powered by an E15R type 15-20-volt Electric Motor.

FIG. 1
The Bottom Dump Truck in its completed state. An E15R 15-20-volt Electric Motor is concealed under the bonnet of the power unit

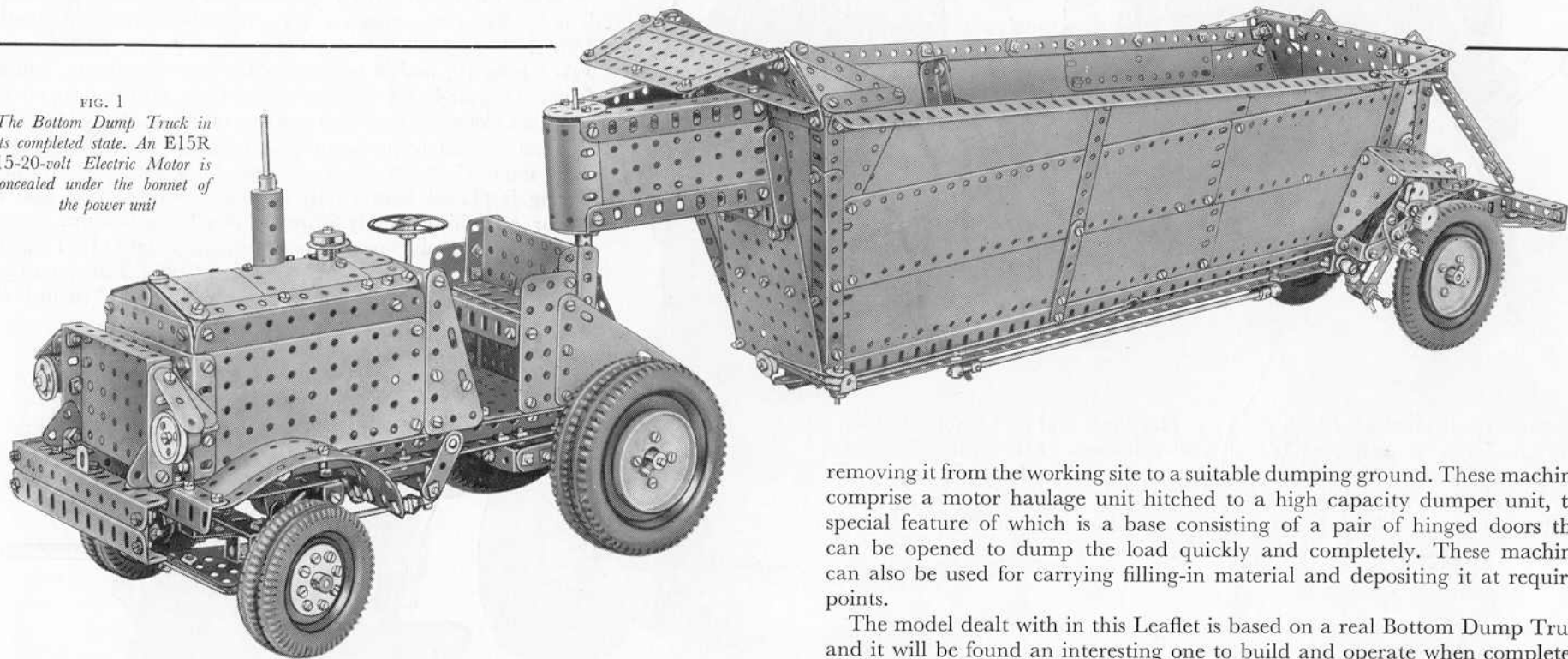

Machines used in the preparation of large building sites and in the work on modern civil engineering projects such as dams, road and drainage schemes, bridges, etc., take many forms, and most of them provide splendid subjects for the Meccano model-builder. One fine example is the Bottom Dump Truck used for conveying spoil excavated by mechanical shovels, grab cranes, etc., and

removing it from the working site to a suitable dumping ground. These machines comprise a motor haulage unit hitched to a high capacity dumper unit, the special feature of which is a base consisting of a pair of hinged doors that can be opened to dump the load quickly and completely. These machines can also be used for carrying filling-in material and depositing it at required points.

The model dealt with in this Leaflet is based on a real Bottom Dump Truck and it will be found an interesting one to build and operate when completed. It is best to commence construction with the motor power unit.

Construction of the Power Unit Chassis (Figs. 2 and 7)

Each side-member of the power unit chassis consists of two 12½" Angle Girders bolted together to form a channel section girder. At the rear the

FIG. 2
This illustration shows details of the power unit chassis, motor mounting and steering gear

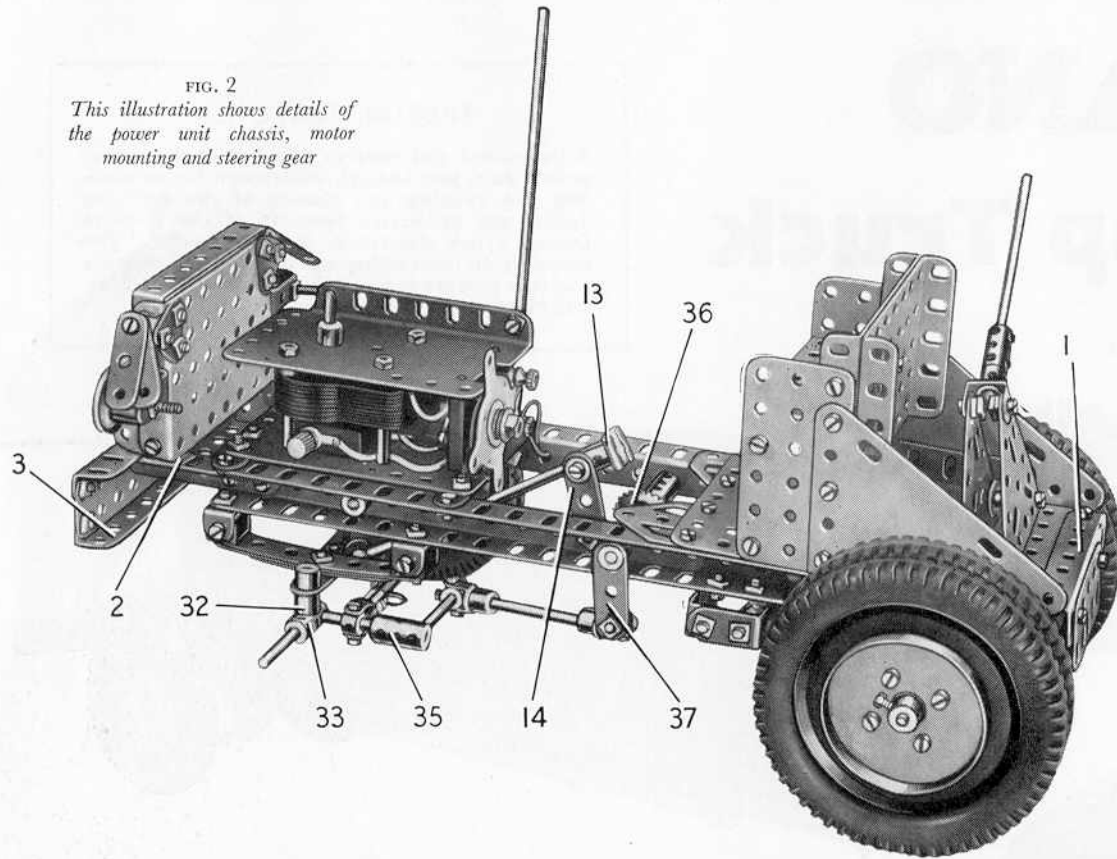

side-members are connected by a $5\frac{1}{2}'' \times 3\frac{1}{2}''$ Flat Plate and a $3\frac{1}{2}''$ Angle Girder (1), to which a $2\frac{1}{2}''$ Flat Girder is bolted. Each side-member is extended forward three clear holes by a $2\frac{1}{2}''$ Angle Girder (2) (Fig. 7), and to these is bolted a $5\frac{1}{2}''$ Angle Girder. A $5\frac{1}{2}''$ Flat Girder is fixed to the $5\frac{1}{2}''$ Angle Girder to support a further $5\frac{1}{2}''$ Angle Girder (3). Two Flat Trunnions are bolted to the front edge of the $5\frac{1}{2}'' \times 3\frac{1}{2}''$ Flat Plate as shown in Fig. 2.

The Power Unit, Clutch and Gear-Box (Figs. 2, 4, 6 and 7)

An E15R Electric Motor is bolted by one of its flanges to one side-member of the chassis, and is connected to the other side-member by two Fishplates (see Fig. 2). The frame of the gear-box consists of two $3'' \times 1\frac{1}{2}''$ Double Angle Strips bolted together by their lugs, with a $1\frac{1}{2}''$ Flat Girder attached at each end by bolts passed through its slotted holes. To one of the Flat Girders is fixed a Double Bent Strip (4) (Fig. 4), and to each Double Angle Strip is bolted a $1'' \times 1''$ Corner Bracket (5) (Fig. 6). A $1'' \times 1''$ Angle Bracket (6) is attached

to one side of the frame but is spaced from it by a $1\frac{1}{2}''$ Strip. At one end of the frame a $2''$ Strip (7) is attached.

Two Angle Brackets also are bolted to one side of the frame, and these are fixed direct to the chassis side-member. Two further Angle Brackets are spaced from the other side of the frame by a Washer on each bolt, and a $1\frac{1}{2}''$ Flat Girder bolted to these Angle Brackets (see Fig. 6) is attached to the chassis.

A Worm is fixed on the Motor shaft and is arranged to drive a $\frac{1}{2}''$ diameter, $\frac{1}{2}''$ face Pinion (8) (Fig. 7) fixed on a $3\frac{1}{2}''$ Rod. This Rod is mounted in the Strip (7) and in a $1\frac{1}{2}''$ Flat Girder (9) that is supported by a $1\frac{1}{2}''$ Angle Girder bolted to the Motor. The Pinion (8) is spaced from the Flat Girder by four Washers and the Rod is held in position by a Collar. The $3\frac{1}{2}''$ Rod also carries a $\frac{1}{2}'' \times \frac{1}{4}''$ Pinion that drives a 57-tooth Gear (10) on a 5" Rod (11). This Rod is supported in the Flat Girder (9) and in one end of the gear-box frame, and it forms the gear-box main shaft. The Gear (10) is gripped in a Socket Coupling (12) that is free to turn on Rod (11). The Gear is pressed by a Compression Spring against a Motor Tyre on a 1" Pulley fixed on Rod (11). The Compression Spring is placed between the Socket Coupling (12) and a Collar, and this assembly forms the clutch mechanism.

The clutch is disengaged by pressing a pedal (13) (Fig. 5), formed by a Slide Piece on a 4" Rod. A Collar is fixed on this Rod immediately below the Slide Piece, and a $1\frac{1}{2}''$ Strip (14)

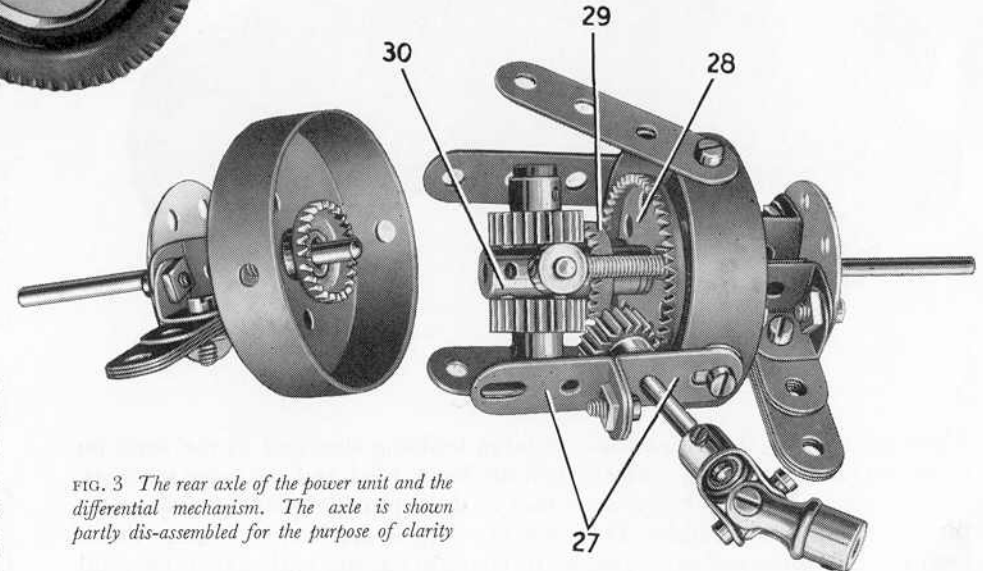

FIG. 3 The rear axle of the power unit and the differential mechanism. The axle is shown partly dis-assembled for the purpose of clarity

(Fig. 2) is pivoted on a bolt screwed into the Collar. The lower end of Strip (14) is *lock-nutted* to the chassis. A Rod and Strip Connector fitted to the lower end of the 4" Rod is *lock-nutted* to one arm of a Bell Crank on a 3" Rod, which is mounted in the chassis girders and is held in place by a Collar. A second Bell Crank (15) is fixed on the 3" Rod, and a Threaded Pin held in one of its arms engages the groove in the Socket Coupling (12).

The Rod (11) (Figs. 6 and 7) carries, inside the gear-box frame, a Collar, a $\frac{3}{4}$ " Pinion (16) and a $\frac{1}{2}$ " Pinion (17). The Rod projects about $\frac{1}{4}$ " beyond Pinion (17) into a $\frac{1}{2}$ " Pinion (18) on the output shaft. This shaft is a $2\frac{1}{2}$ " Rod mounted in one end of the frame and in the 1" x 1" Angle Bracket (6), and it carries also a $\frac{3}{4}$ " diameter, $\frac{1}{2}$ " face Pinion (19) (Fig. 6).

The layshaft is a $3\frac{1}{2}$ " Rod fitted with a $\frac{1}{2}$ " Pinion (20) (Fig. 7), a Collar and a $\frac{3}{4}$ " Pinion (21). The layshaft is mounted as shown (in Fig. 7) and is free to slide in its bearings, but the sliding movement is limited by one half of a Dog Clutch, which serves as a Collar. A $\frac{1}{2}$ " reverse Pinion (22) (see Fig. 4) is retained on a $1\frac{1}{2}$ " Rod by a Spring Clip but is free to turn on the Rod. The Rod is fixed in the centre cross hole of a Coupling (23), which is screwed as shown on to a bolt at one end of the frame. It should be noted that one of the bolts supporting the Double Bent Strip (4) (Figs. 4 and 7) is fitted with a nut before it is passed through the frame, so that the shank of the bolt is clear of the Coupling (23).

The sliding movement of the layshaft is controlled by a lever (24) (Fig. 6) which is formed by a 3" Strip *lock-nutted* at its lower end to the chassis. A Collar is screwed on to a bolt fixed in the lever by a nut, and a $1\frac{1}{8}$ " Bolt fixed in the Collar is fixed also in a Swivel Bearing (25) (Fig. 6). A $\frac{3}{8}$ " Bolt passed through the boss of the Swivel Bearing is screwed into a Collar fixed on a 2" Rod mounted in the Corner Brackets (5). A Crank (26) is fixed on the Rod, with a Compression Spring between it and one of the Corner Brackets (5), and a $\frac{1}{2}$ " Bolt held in the Crank by two nuts engages between the Pinion (21) and the Collar on the layshaft (Fig. 7).

Top gear is obtained by sliding the layshaft so that Pinion (21) (Fig. 7) engages both Pinions (17) and (18) (Fig. 6). Second gear is provided by meshing Pinion (19) (Fig. 6) with Pinion (20) (Fig. 7) and Pinion (21) (Fig. 7) with Pinion (17) (Fig. 6). Reverse is obtained when Pinion (19) (Fig. 6) is in mesh with Pinion (20) and Pinion (21) engages the reverse Pinion (22) (Fig. 7), which is in constant mesh with Pinion (16) (Fig. 6).

Rear Axle and Differential (Figs. 3 and 7)

Each half of the rear axle casing (Fig. 3) consists of a Boiler

End and a Wheel Disc (six holes) connected to each other by two Double Brackets. When the differential mechanism is assembled the halves of the casing are joined together by bolting three 2" Strips and two 1" x $\frac{1}{2}$ " Angle Brackets (27) between the Boiler Ends.

A $3\frac{1}{2}$ " Rod is passed through one half of the casing and on it a $1\frac{1}{2}$ " Contrate (28) is mounted *freely*. A $\frac{3}{4}$ " Contrate (29) is *fixed* on the Rod, which extends into a Coupling (30). Two 1" Screwed Rods are fixed by nuts in the Contrate (28) and on each of them a Collar is screwed as shown. A $1\frac{1}{2}$ " Rod passed through the Coupling (30) is fixed in the Collars. Two $\frac{3}{4}$ " Pinions are mounted *freely* on Pivot Bolts, which are screwed into the Coupling (30) opposite to each other. These Pinions engage the Contrate (29), and mesh also with a similar Contrate on a 3" Rod passed through the other half of the axle casing. Washers are placed on the 3" and $3\frac{1}{2}$ " Rods so that the Pinions and Contrates mesh accurately, and so that the Contrate (28) engages a $\frac{1}{2}$ " Pinion on a $1\frac{1}{2}$ " Rod supported in one of the Angle Brackets (27). This Rod is connected by a Universal Coupling to the gear-box output shaft (see Fig. 7).

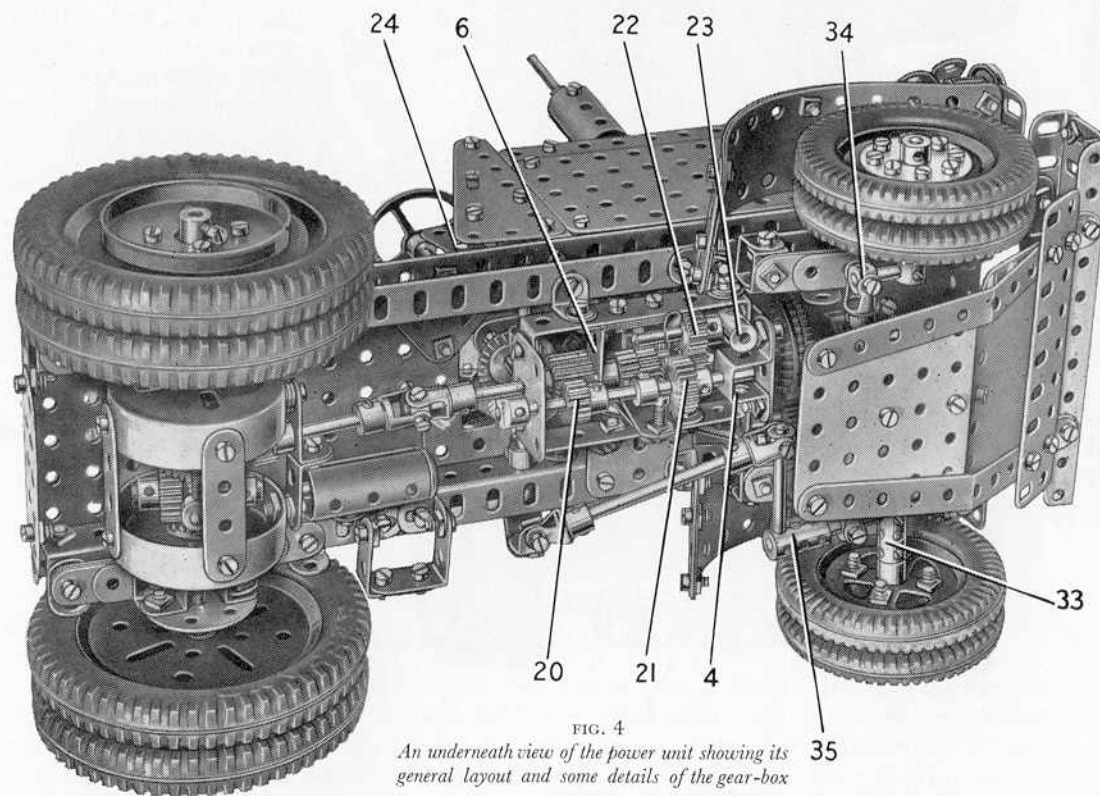

FIG. 4
An underneath view of the power unit showing its general layout and some details of the gear-box

The completed axle is connected by two Angle Brackets to each of the rear springs (see Fig. 7). These are each made from two $3\frac{1}{2}$ " Strips and a $2\frac{1}{2}$ " Strip and are attached to the chassis by $\frac{3}{8}$ " Bolts, each of which is fitted with an Angle Bracket. The rear ends of the springs are spaced from the chassis by four Washers on each Bolt.

The Bonnet and Bodywork (Figs. 1, 2 and 5)

Each side of the bonnet is a $5\frac{1}{2}$ " \times $2\frac{1}{2}$ " Flat Plate extended by a $5\frac{1}{2}$ " Flat Girder. The two sides are connected at the front by a $3\frac{1}{2}$ " \times $2\frac{1}{2}$ " Flanged Plate extended as shown in Fig. 1 by a $3\frac{1}{2}$ " Flat Girder, to which two 2" Strips are bolted at an angle. At the back a $3\frac{1}{2}$ " \times $2\frac{1}{2}$ " Flanged Plate is connected to the sides by Angle Brackets, and a $3\frac{1}{2}$ " \times $1\frac{1}{2}$ " Triangular Flexible Plate is bolted to each flange of the Flanged Plate. The sloping edges of the Triangular Flexible Plates are strengthened by $3\frac{1}{2}$ " Strips.

The top of the bonnet is filled in by two $3\frac{1}{2}$ " \times $2\frac{1}{2}$ " Flexible Plates and two $2\frac{1}{2}$ " \times $1\frac{1}{2}$ " Flexible Plates edged by Strips (Fig. 5). The Plates are curved slightly and the assembly is attached to the sides of the bonnet by Obtuse Angle Brackets. A $\frac{3}{4}$ " Flanged Wheel, capped by a $\frac{3}{4}$ " Washer, is fixed to the top by means of a $\frac{3}{4}$ " Bolt.

The bonnet and radiator assembly is attached to the chassis members by Angle Brackets. The exhaust pipe is represented by a 5" Rod fixed in a Collar screwed on to a bolt passed through a flange of the Electric Motor (Fig. 2). This Rod passes through the top of the bonnet, and on it is placed a Sleeve Piece fitted with a Chimney Adaptor and a $\frac{3}{4}$ " Washer. These parts are held on the Rod by the half of the Dog Clutch left over from the construction of the gear-box.

The radiator guard is a $3\frac{1}{2}$ " \times $2\frac{1}{2}$ " Flanged Plate fitted at the top with a $3\frac{1}{2}$ " \times $\frac{1}{2}$ " Double Angle

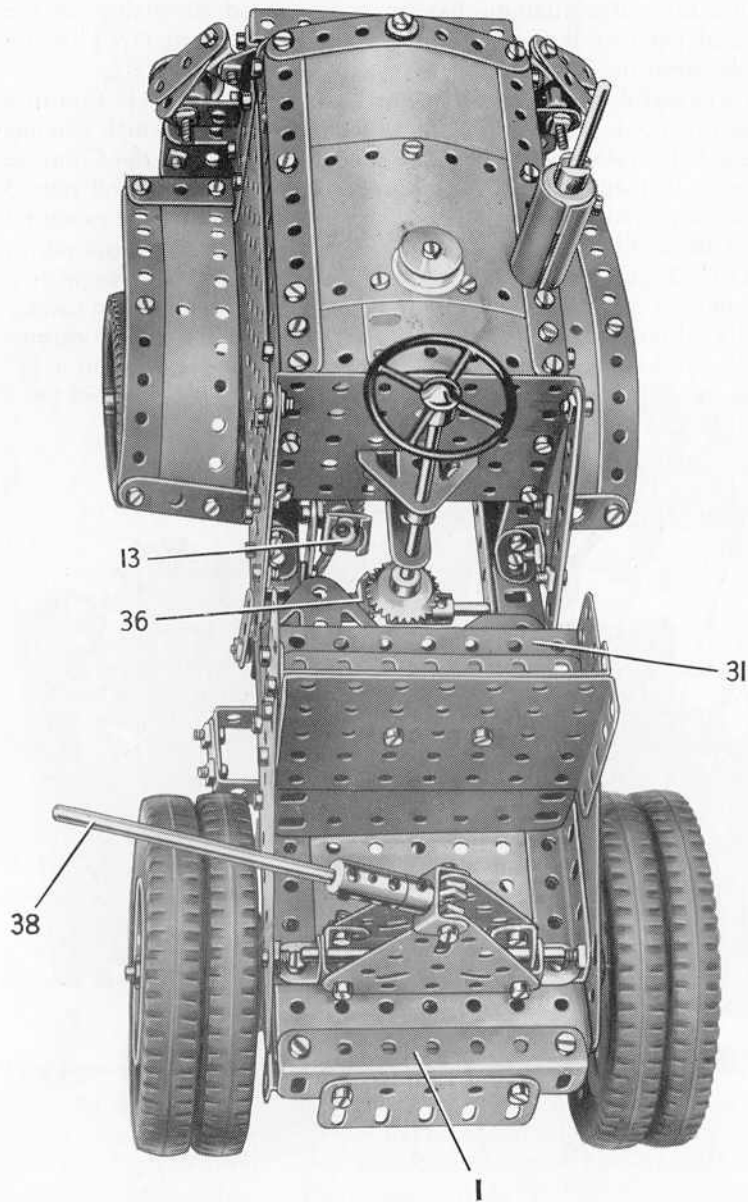

FIG. 5
Details of the bonnet and bodywork of the power unit

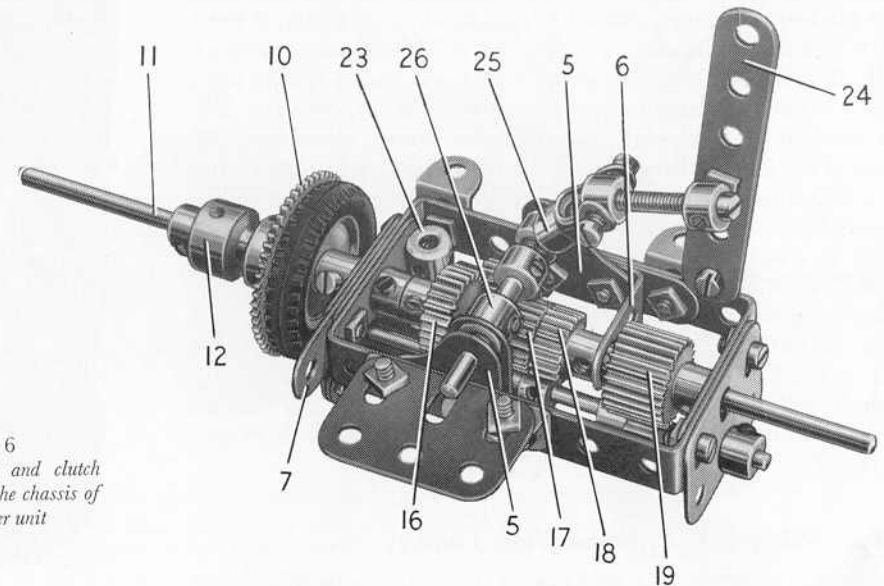

FIG. 6
The gear-box and clutch
removed from the chassis of
the power unit

Strip. The headlamps are 1" loose Pulleys and Chimney Adaptors fixed by 1 1/8" Bolts to 1" x 1/2" Angle Brackets. The shield over each headlamp consists of two 1 1/2" Strips bolted to an Angle Bracket, which is fixed to a 1" Triangular Plate that is attached to the Flanged Plate. The Flanged Plate is supported by Angle Brackets fixed to the chassis.

The driver's seat is formed by two 3 1/2" x 2 1/2" Flanged Plates placed back to back and extended by a 3 1/2" x 2 1/2" Flexible Plate (see Fig. 5). A 3" x 1 1/2" Flat Plate and a 3 1/2" x 2 1/2" Triangular Flexible Plate are bolted to each side as shown (Fig. 2), and these parts are fastened to 3 1/2" Angle Girders fixed to the chassis. A 3 1/2" Angle Girder (31) (Fig. 5) is connected to the Flat Plates by Angle Brackets, and a 3 1/2" Flat Girder behind Girder (31) is supported by a 1 1/2" Angle Girder bolted to the Flanged Plates.

Assembly of the Steering Mechanism (Figs. 2, 4, 5 and 7)

The front axle beam (see Fig. 2) consists of three 3 1/2" Strips with a Crank (32) fixed at each end with the boss holes of the Cranks overhanging the ends of the Strips. Each Crank is strengthened by a 2" Strip. The axle beam is attached to springs, each of which consists of three 3 1/2" Strips and a 2 1/2" Strip, and is fitted at each end with a Double Bracket. These Double Brackets are lock-nutted to further Double Brackets fixed to the chassis (see Figs. 2 and 7).

Each of the front wheels (see Figs. 4 and 7) consists of two 2" Pulleys clamped together by four 3/4" Bolts that fix a Wheel Disc to the face of the outer Pulley. The wheel is mounted freely on a 1 1/2" Rod held in a Coupling (33). These Couplings are fixed on 1" Rods that are free to turn in the Cranks (32) and are

held in place by Collars. Another 1" Rod is fixed in one of the Couplings (33) and is fitted with a Swivel Bearing (34). The latter is connected by a 2 1/2" Rod to a second Swivel Bearing on a 1 1/2" Rod held in the other Coupling (33). The 1 1/2" Rod carries another Coupling (35).

The steering column is a 4 1/2" Rod supported in a Trunnion and a 1" x 1" Angle Bracket bolted to the back of the bonnet (Fig. 5). The Rod carries a 7/8" Bevel Gear, and its lower end enters the centre hole of a Coupling mounted freely on a 3 1/2" Rod that carries a 7/8" Bevel Gear (36). The Rod is fitted also with a Crank (37) (Fig. 7), and is held in the chassis side-members by a Collar. An Angle Bracket is lock-nutted to Crank (37) and to the Angle Bracket in turn is lock-nutted an End Bearing fitted with a 2 1/2" Rod. This Rod is connected by a swivel bearing to a 2" Rod fixed in the Coupling (35). The swivel bearing is obtained from a Universal Coupling.

A protection plate is arranged underneath the steering mechanism as shown in Fig. 4. The plate is attached to the Girder (3) (Fig. 2) by Obtuse Angle Brackets, and is supported by a 1" Reversed Angle Bracket bolted to the axle beam.

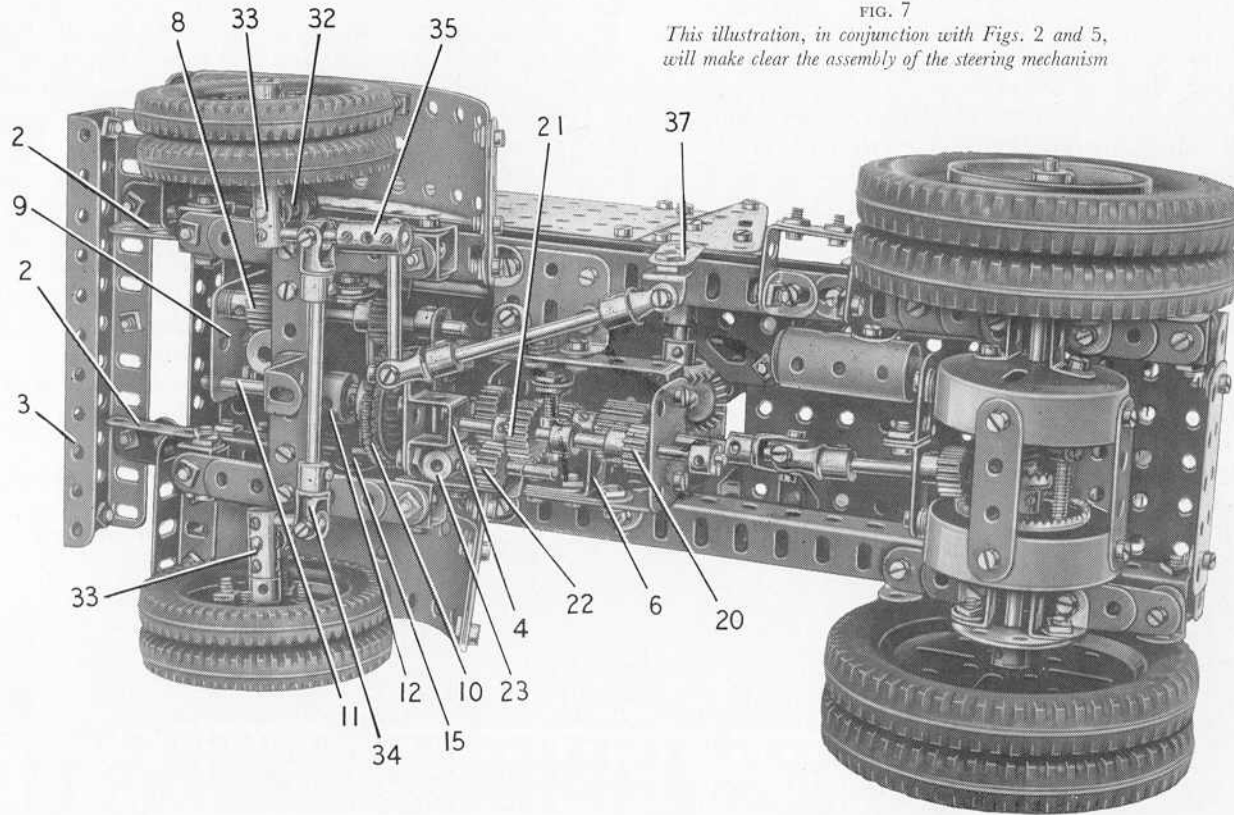

FIG. 7
This illustration, in conjunction with Figs. 2 and 5, will make clear the assembly of the steering mechanism

The Coupling Pivot for the Dumper (Fig. 5)

A 4 1/2" Rod (38), fitted with a Coupling, is fixed in a large Fork Piece lock-nutted to two 2 1/2" Triangular Plates. One of the Triangular Plates is fitted with a 2 1/2" x 1/2" Double Angle Strip, and the other carries two Angle Brackets. A 3" Rod passed through the lugs of the Double Angle Strip and through the Angle Brackets is mounted in further Angle Brackets bolted to the chassis.

Construction of the Dumper: The Body (Figs. 8 and 9)

Each side of the dumper body is formed with three $12\frac{1}{2}'' \times 2\frac{1}{2}''$ Strip Plates, two $9\frac{1}{2}'' \times 2\frac{1}{2}''$ Strip Plates, a $5\frac{1}{2}'' \times 1\frac{1}{2}''$ Flexible Plate (39) (Fig. 8) and a $3\frac{1}{2}'' \times 2''$ Triangular Flexible Plate (40). These Plates are bolted together as shown in Figs. 8 and 9, and are edged along the top by a girder (41), made from an $18\frac{1}{2}''$ Angle Girder and a $3''$ Angle Girder. A girder (42), made from a $5\frac{1}{2}''$ Angle Girder and a $2''$ Angle Girder, is bolted along the front edge of each side and is connected to a $24\frac{1}{2}''$ Angle Girder (43) by an Obtuse Angle Bracket. The side is strengthened by two $5\frac{1}{2}''$ Strips (44), a $3''$ Strip (45) and a built-up strip (46), the lower ends of these Strips being bolted to the Girder (43). The strip (46) consists of a $5\frac{1}{2}''$ and a $3''$ Strip.

The front end of the body consists of two $5\frac{1}{2}'' \times 3\frac{1}{2}''$ Flat Plates and two $5\frac{1}{2}'' \times 1\frac{1}{2}''$ Flexible Plates. These are bolted together and are strengthened by a $3\frac{1}{2}'' \times \frac{1}{2}''$ Double Angle Strip fixed between the front ends of the Girders (43), a $4\frac{1}{2}''$ Strip (47) and a $7\frac{1}{2}''$ Angle Girder (48). A $2''$ Strip on each side is bolted between the upper corner of the $5\frac{1}{2}'' \times 1\frac{1}{2}''$ Flexible Plate and the top corner of the upper $5\frac{1}{2}'' \times 3\frac{1}{2}''$ Flat Plate.

Each front corner of the dumper is covered by a $2\frac{1}{2}'' \times 2''$ Triangular Flexible Plate edged by a $2\frac{1}{2}''$ Strip and a $3''$ Strip. These Plates are connected to the upper $5\frac{1}{2}'' \times 3\frac{1}{2}''$ Flat Plate by Angle Brackets.

The rear end of the body consists of a $5\frac{1}{2}'' \times 3\frac{1}{2}''$ Flat Plate (49) (Fig. 9)

placed vertically, and bolted to a $3\frac{1}{2}'' \times \frac{1}{2}''$ Double Angle Strip and a $7\frac{1}{2}''$ Angle Girder (50). The Double Angle Strip is bolted between the Girders (43), and the Angle Girder (50) is attached to the girders (41) by Angle Brackets. A $5\frac{1}{2}''$ strip on each side is bolted between the lower corner of the Plate (49) and the next-to-end hole of the Girder (50). A $2\frac{1}{2}'' \times 2\frac{1}{2}''$ Triangular Flexible Plate on each side is used to fill in the gap between the $5\frac{1}{2}''$ Strip and the Flat Plate (49). A $2\frac{1}{2}'' \times 2\frac{1}{2}''$ Flat Plate (51), with a $2\frac{1}{2}'' \times 1\frac{1}{2}''$ Triangular Flexible Plate bolted to each side of it, is supported by a $3\frac{1}{2}'' \times \frac{1}{2}''$ Double Angle Strip fixed between the Girders (43).

A $12\frac{1}{2}''$ Strip extended by a $9\frac{1}{2}''$ Strip is bolted inside the top edge of each side of the body. The sides are tied together by a $5\frac{1}{2}''$ Flat Girder and a $4\frac{1}{2}''$ Flat Girder bolted to two $5\frac{1}{2}''$ Angle Girders (52). The lower ends of the Angle Girders are fixed to the sides, and their top ends are connected to the girders (41) by Corner Angle Brackets.

The Girders (43) are connected at their rear ends by two $7\frac{1}{2}''$ Angle Girders bolted together to form a channel girder (53). Two built-up girders, each made from a $5\frac{1}{2}''$ Angle Girder and a $1\frac{1}{2}''$ Angle Girder, are attached to the girder (53) by Angle Brackets and also to the Girder (50) by Obtuse Angle Brackets. Two other built-up girders (54) are bolted to the girder (53) and are connected to the Flat Plate (49) by Angle Brackets. Each of the girders (54) consists of a $3\frac{1}{2}''$ Angle Girder and a $1\frac{1}{2}''$ Angle Girder.

Each of the dumper wheels is fixed on a $2''$ Rod mounted in two Trunnions

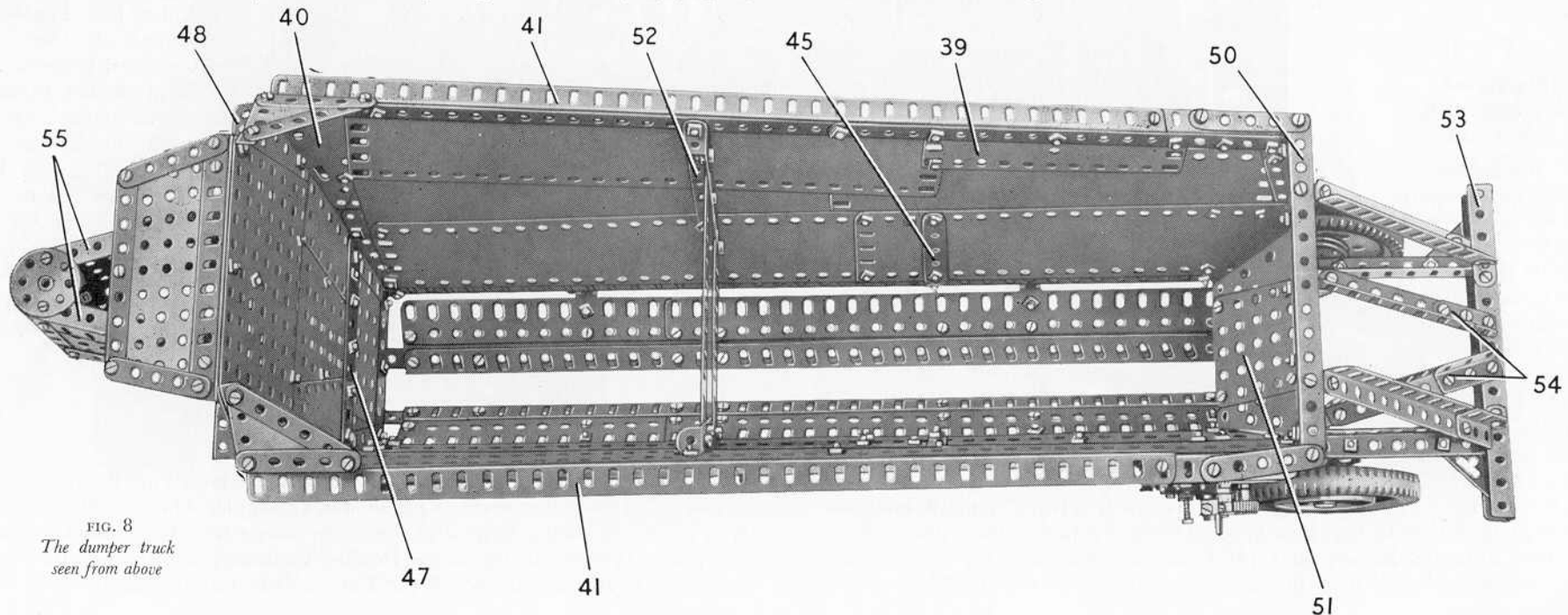

FIG. 8
The dumper truck
seen from above

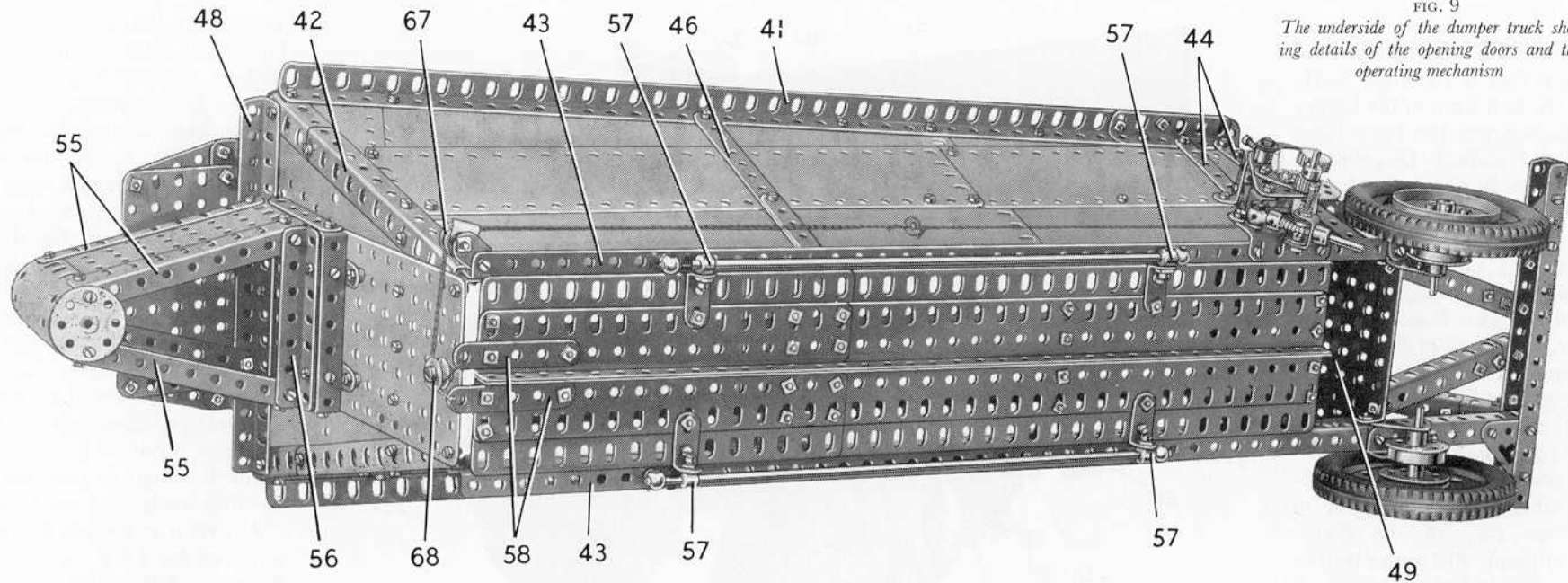

FIG. 9
The underside of the dumper truck showing details of the opening doors and their operating mechanism

bolted to one of the Girders (43). The Rod is held in place by a $1\frac{1}{2}$ " Pulley and a $1\frac{1}{8}$ " Flanged Wheel.

The supporting bracket for the coupling unit consists of a $4\frac{1}{2}$ " x $2\frac{1}{2}$ " Flat Plate on each side edged by two $4\frac{1}{2}$ " Angle Girders (55). The upper pair of Girders (55) is bolted to the Girder (48) and the lower pair is attached to a $3\frac{1}{2}$ " Angle Girder (56). The Girder (56) is connected to the front of the body by two $\frac{1}{2}$ " Reversed Angle Brackets, each of which is spaced from the body by two Washers. A $3\frac{1}{2}$ " x $\frac{1}{2}$ " Double Angle Strip is bolted to the remaining face of the $\frac{1}{2}$ " Reversed Angle Brackets, and to each lug of this Double Angle Strip a $2\frac{1}{2}$ " Strip is fixed.

The front ends of the Girders (55) are connected by a U-section Curved Plate and two Bush Wheels, as shown in Figs. 8 and 9. The Rod (38) (see Fig. 5) of the motor unit passes through the Bush Wheels to form the coupling between the motor and the dumper.

The Dumper Doors and Operating Mechanism (Figs. 8, 9 and 10)

The floor of the dumper takes the form of two opening doors each made from two $12\frac{1}{2}$ " Flat Girders, two $7\frac{1}{2}$ " Flat Girders and an $18\frac{1}{2}$ " Angle Girder, arranged as shown in Figs. 8 and 9. Two 1 " x $\frac{1}{2}$ " Angle Brackets are bolted to each door, and a bolt is fitted with a nut and then is passed through each Angle Bracket. Two Collars (57) are screwed tightly on to the bolts and then an $11\frac{1}{2}$ " Rod is pushed through them. The Rods are supported in Handrail Supports

fixed to the Girders (43). A $2\frac{1}{2}$ " Strip (58) is bolted to each door.

The dumper is fitted with special mechanism for opening and closing the bottom doors. They are opened for dumping the load by moving a handle that releases a ratchet device and allows them to drop downwards. After dumping is completed another lever is moved and the dumper is set in motion. As it moves slowly forward, the special mechanism comes into action and closes the doors automatically.

The arrangement of this mechanism, which can be seen in Figs. 1, 9 and 10, is as follows.

A Girder Bracket is bolted to one of the Girders (43) and to it is fixed a $\frac{1}{2}$ " Reversed Angle Bracket to which are bolted a $2\frac{1}{2}$ " Strip (59) (Fig. 10) and two $1\frac{1}{2}$ " Strips (60). A second $2\frac{1}{2}$ " Strip is fixed to the Girder Bracket and is connected to Strip (59) by an Angle Bracket and a 1 " Reversed Angle Bracket. The 1 " Reversed Angle Bracket is bolted to the side of the dumper body (Fig. 9). Two 3 " Strips are connected at their lower ends by a large Fork Piece (61), which is attached to one Strip by a *lock-nutted* $\frac{7}{32}$ " bolt and to the other Strip by a *lock-nutted* $\frac{3}{4}$ " Bolt (62). The 3 " Strips pivot on a 2 " Rod, which is held in the Strips (60) and the Girder Bracket by a $\frac{1}{2}$ " fixed Pulley and a $\frac{1}{2}$ " Pinion. A 1 " Rod is mounted freely in the top holes of the 3 " Strips and is fitted with a $\frac{3}{4}$ " Sprocket (63), a 57-tooth Gear (64) and a Ratchet Wheel. A Pawl, which is fitted with a $\frac{1}{2}$ " Bolt (65) to form a release handle, is mounted on a Pivot Bolt held in the Strip (59). The Pawl engages the teeth of the Ratchet and is held against them by a short piece of Spring Cord (66).

The Fork Piece (61) slides on a 2" Rod held in a Handrail Coupling that is mounted freely on a Pivot Bolt fixed in the Girder Bracket. Between the Fork Piece and the Handrail Coupling a Compression Spring is fitted.

One end of a length of Cord is tied to the boss of the Sprocket (63) and its other end is tied to a Washer. Two separate lengths of Cord are also fastened to the Washer, and each of these is led over one of two 1/2" loose Pulleys (67) (Fig. 9), which are mounted on a 3/4" Bolt held in a Fishplate by two nuts. Both Cords are then passed over a 1/2" loose Pulley (68), and each is tied to one of the Strips (58) of the doors. The Fishplate that supports the Pulleys (67) is bolted to one of the Girders (43) and an Angle Bracket on the 3/4" Bolt serves to keep the Cords on the Pulleys.

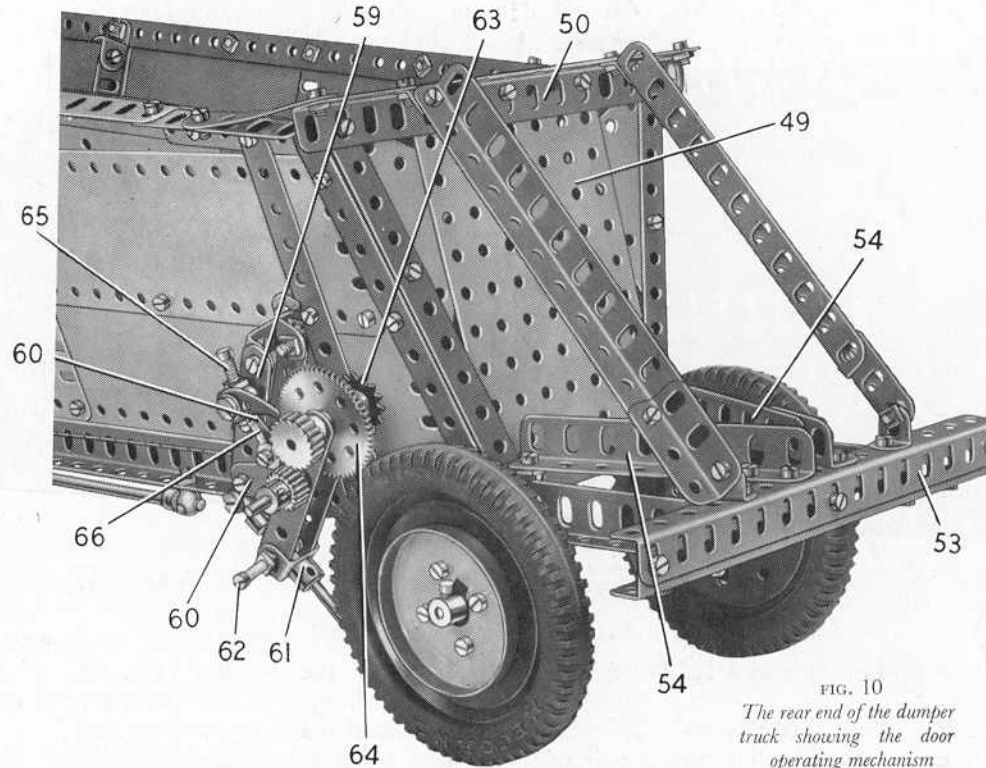

FIG. 10
The rear end of the dumper truck showing the door operating mechanism

The Pulley (68) is mounted on a Pivot Bolt attached to the front of the body, and is spaced on the Bolt by four Washers.

The doors are closed by moving the Bolt (62) against the action of the Compression Spring until the Gear (64) is pressed against the Tyre of one of the dumper wheels. When the truck is moved forward the Tyre turns the Gear, and thus the Cord is wound round the boss of the Sprocket (63) and the doors are closed. The doors can be opened for unloading the dumper by moving the handle (65) to release the Pawl from the teeth of the Ratchet, so that the Cord unwinds freely from the Sprocket.

A cover over the winding gear is provided by a 2 1/2" x 1 1/2" Flanged Plate and a 2 1/2" x 1 1/2" Triangular Flexible Plate attached to the side of the dumper by an Angle Bracket (Fig. 1).

Parts Required to Build the Meccano Bottom Dump Truck

2 of No. 1	7 of No. 9b	4 of No. 16	2 of No. 24	58 of No. 38	7 of No. 63	14 of No. 111	1 of No. 136a	4 of No. 164	2 of No. 222
2 " " 1a	2 " " 9c	3 " " 16a	2 " " 24a	2 " " 38d	2 " " 70	2 " " 111a	4 " " 137	2 " " 165	2 " " 223
14 " " 2	2 " " 9d	3 " " 16b	2 " " 24c	1 " " 40	2 " " 72	21 " " 111c	2 " " 140	1 " " 166	2 " " 224
4 " " 2a	4 " " 9e	6 " " 17	4 " " 25	1 " " 45	2 " " 73	3 " " 111d	4 " " 142a	1 " " 171	2 " " 225
18 " " 3	6 " " 9f	6 " " 18a	1 " " 25a	2 " " 47a	2 " " 76	1 " " 115	6 " " 142b	1 " " 179	2 " " 226
10 " " 4	4 " " 10	4 " " 18b	7 " " 26	1 " " 48a	4 " " 77	1 " " 116	1 " " 142c	1 " " 185	
19 " " 5	12 " " 11	6 " " 19b	1 " " 26a	5 " " 48b	2 " " 82	4 " " 120b	1 " " 144	2 " " 188	
12 " " 6	49 " " 12	2 " " 20	2 " " 27a	1 " " 50	1 " " 96a	2 " " 124	1 " " 147	6 " " 189	
8 " " 6a	4 " " 12a	4 " " 20a	1 " " 28	1 " " 51	4 " " 103	3 " " 125	5 " " 147a	1 " " 190	
2 " " 7	8 " " 12b	1 " " 20b	2 " " 29	4 " " 52a	4 " " 103b	5 " " 126	1 " " 148	4 " " 190a	
4 " " 7a	11 " " 12c	2 " " 21	2 " " 30	5 " " 53	2 " " 103c	2 " " 126a	1 " " 154a	4 " " 196	
4 " " 8	2 " " 13	1 " " 22	1 " " 32	3 " " 53a	2 " " 103d	2 " " 128	1 " " 154b	6 " " 197	
4 " " 8b	2 " " 15	2 " " 22a	3 " " 35	1 " " 58	1 " " 103f	2 " " 133	1 " " 161	1 " " 199	
9 " " 9	2 " " 15a	3 " " 23	504 " " 37a	24 " " 59	4 " " 103h	2 " " 133a	2 " " 162a	1 " " 212	
4 " " 9a	1 " " 15b	1 " " 23a	456 " " 37b	4 " " 62	4 " " 103k	4 " " 136	2 " " 163	3 " " 221	

1 E15R
Electric Motor
(not included
in Outfit)

MECCANO

Road Surfacing Machine

(MODEL No. 10.19)

SPECIAL FEATURES

This Model is operated by a Meccano E15R type 15-20-volt Electric Motor that provides power for four independently controlled mechanisms and movements, viz., a drive to the travelling wheels, a conveyor that carries the surfacing material to the grader and distributor head, a feed arrangement to spread the material as the machine travels along and a tamping device operated by eccentrics to consolidate the road surface. Each movement is controlled by a group of levers arranged conveniently close to the driver's seat.

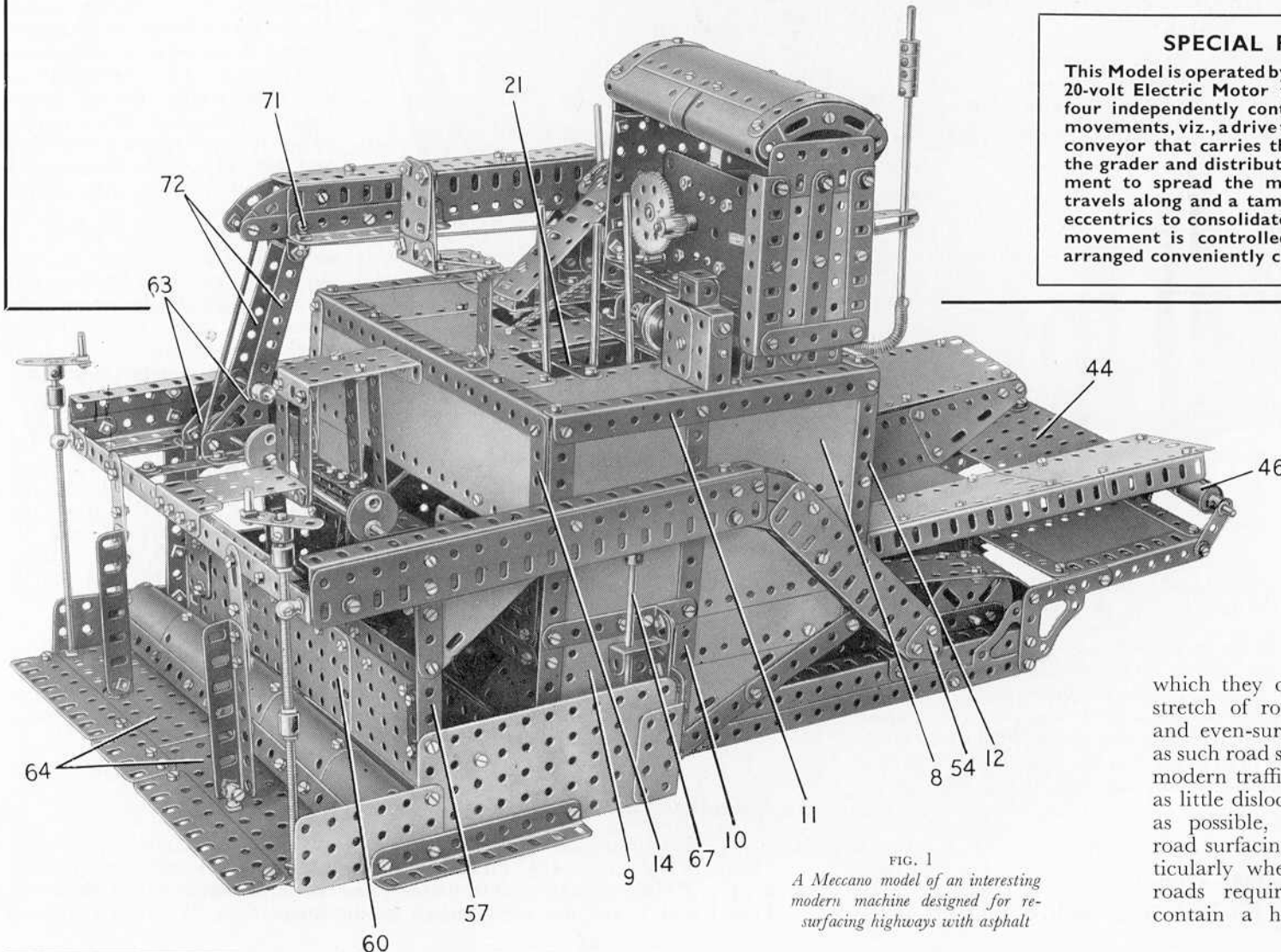

FIG. 1

A Meccano model of an interesting modern machine designed for re-surfacing highways with asphalt

We are all familiar with gangs of roadmakers, with their picks and shovels, tar boilers and steam or diesel rollers, busy at work re-making our highways, and few of us perhaps have not paused to watch them at work and to marvel at the comparative rapidity with which they convert a badly pitted and rough stretch of roadway into a beautifully graded and even-surfaced highway. Fast and efficient as such road surfacing methods can be, however, modern traffic conditions in some areas call for as little dislocation in the use of a thoroughfare as possible, and nowadays therefore special road surfacing machines are often used, particularly when very long stretches of asphalt roads require resurfacing. These machines contain a hopper into which the prepared

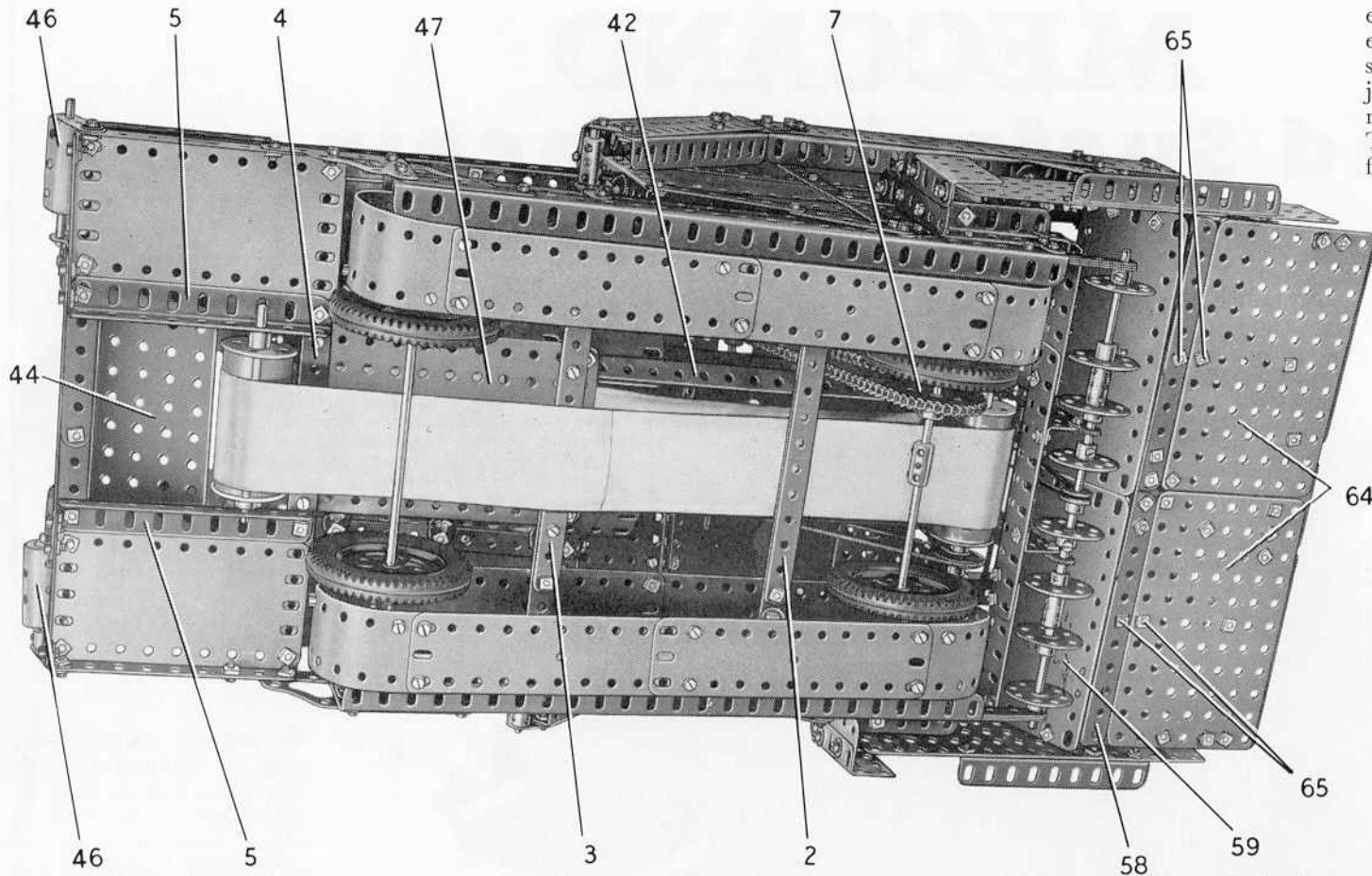

FIG. 2 An underneath view of the Road Surfacing Machine showing details of the main frame and the conveyor. As the asphalt leaves the conveyor it is distributed over the road surface by the column of revolving Bush Wheels seen at the rear end of the machine

asphalt is loaded. The hopper feeds a conveyor which carries the material under powerful heaters that make it sufficiently plastic for distribution, and a distributing device spreads it evenly over the road surface as the machine travels slowly along. There is also a tamping device that consolidates the material and an adjustable grading plate that gives the correct camber to the road surface.

The Meccano model reproduces most of the features of an actual machine of this kind, but of course the heating plant has had to be omitted for obvious reasons.

Construction of the Main Frame (Figs. 2 and 3)

Each side of the frame consists of two $12\frac{1}{2}$ " Angle Girders connected at one

end by a $7\frac{1}{2}$ " Strip (1) and at the other end by two Corner Gussets, arranged as shown in Fig. 3. The side members are joined together by three built-up strips numbered (2), (3) and (4) in Fig. 2. The strips (2) and (3) are each made from two $7\frac{1}{2}$ " Strips overlapped 11 holes, and strip (4) consists of two $5\frac{1}{2}$ " Strips overlapped three holes. The strip (4) is bolted to $4\frac{1}{2}$ " Angle Girders fixed to the Corner Gussets, and these Girders support also $4\frac{1}{2}$ " \times $2\frac{1}{2}$ " Flexible Plates. The outer ends of the $4\frac{1}{2}$ " Angle Girders are connected by two $5\frac{1}{2}$ " Strips overlapped three holes, and two $4\frac{1}{2}$ " Angle Girders (5) are bolted between these Strips and the strip (4).

A $12\frac{1}{2}$ " Strip (6) (Fig. 3) on each side is attached to the strip (2) by an Angle Bracket, and is connected to the main side member by two $1\frac{1}{2}$ " \times $\frac{1}{2}$ " Double Angle Strips, one of which is fixed below the strip (3) and the other is positioned in the third hole behind the strip (2). A Face Plate is bolted to each end of each of the Strips (6), and these support in their bosses the axles that carry the travelling wheels. These wheels are 2" Pulleys with Tyres. Two of them are fixed on an 8" Rod that is held in position by Collars. The other two are mounted on an

axle formed by a 5" Rod and a $4\frac{1}{2}$ " Rod joined by a Coupling and fitted with a 2" Sprocket (7) (Fig. 2).

The dummy creeper tracks are each made from six $5\frac{1}{2}$ " \times $1\frac{1}{2}$ " Flexible Plates bolted together and attached by Angle Brackets to the Face Plates. The inner edge of the lower side of each track is strengthened by two $5\frac{1}{2}$ " Strips.

Assembly of the Mechanism Housing (Figs. 1, 3, 4 and 7)

Each side of the housing consists of two $4\frac{1}{2}$ " \times $2\frac{1}{2}$ " Flexible Plates, two $3\frac{1}{2}$ " \times $2\frac{1}{2}$ " Flexible Plates, a $5\frac{1}{2}$ " \times $2\frac{1}{2}$ " Flexible Plate (8), a $2\frac{1}{2}$ " \times $2\frac{1}{2}$ " Flexible Plate (9) and a $3\frac{1}{2}$ " \times 2" Triangular Flexible Plate. These parts are arranged as shown in Figs. 1 and 3, and are strengthened by the Strip (1), a $7\frac{1}{2}$ " Strip (10), two

horizontal $3\frac{1}{2}$ " Strips, a $7\frac{1}{2}$ " Angle Girder (11), a $5\frac{1}{2}$ " Angle Girder (12) and a built-up strip. The built-up strip is made from a 3" and a $2\frac{1}{2}$ " Strip.

The front end of the housing is made by bolting a $9\frac{1}{2}$ " \times $2\frac{1}{2}$ " Strip Plate between the Girders (12). The Strip Plate is edged by a $9\frac{1}{2}$ " Strip and a $9\frac{1}{2}$ " Flat Girder, and is extended downward at each side by a $2\frac{1}{2}$ " \times $1\frac{1}{2}$ " Flexible Plate strengthened by a 2" Angle Girder (13). The rear of the housing (Fig. 1) consists of a $9\frac{1}{2}$ " \times $2\frac{1}{2}$ " Strip Plate bolted to a $9\frac{1}{2}$ " Angle Girder fixed between the Girders (11) of the sides. The Strip Plate is extended downward at each side by a $2\frac{1}{2}$ " \times $2\frac{1}{2}$ " Flexible Plate, and these are edged by $4\frac{1}{2}$ " Strips (14). The lower edges of the $2\frac{1}{2}$ " \times $2\frac{1}{2}$ " Flexible Plates are strengthened by a $9\frac{1}{2}$ " Strip (15) (Fig. 10), which is connected to the Strips (1) by Angle Brackets. A built-up strip (16), made from two $5\frac{1}{2}$ " Strips, also is attached to the Strips (1) by Angle Brackets, and a built-up flat girder (17), made from a $5\frac{1}{2}$ " and two 3" Flat Girders, is supported by $1"$ \times $\frac{1}{2}$ " Angle Brackets bolted to the Strips (1).

A $9\frac{1}{2}$ " Angle Girder (18) (Fig. 4) is bolted across the top of the housing and to it are fixed a $5\frac{1}{2}$ " \times $3\frac{1}{2}$ " Flat Plate (19) and a $4\frac{1}{2}$ " \times $2\frac{1}{2}$ " Flat Plate (20). The top of the housing is completed by two $4\frac{1}{2}$ " \times $2\frac{1}{2}$ " Flexible Plates, a $3\frac{1}{2}$ " \times $2\frac{1}{2}$ " Flexible Plate and two $2\frac{1}{2}$ " \times $1\frac{1}{2}$ " Flexible Plates, as shown in Fig. 7. A $5\frac{1}{2}$ " Strip (21) (Fig. 1) is bolted to the top.

The Power Unit and Reduction Gearing (Figs. 3 and 6)

An E15R Electric Motor is bolted by its flanges to two $5\frac{1}{2}$ " Angle Girders, which are connected at their ends by $2\frac{1}{2}$ " Angle Girders (22) (Fig. 6). A $3\frac{1}{2}$ " \times $2\frac{1}{2}$ " Flanged Plate is fixed to one of the Girders (22) and is extended upward by a $2\frac{1}{2}$ " Flat Girder. Two $3\frac{1}{2}$ " Angle Girders are bolted to the second Girder (22), and are connected by a $2\frac{1}{2}$ " \times $2\frac{1}{2}$ " Flat Plate, a $2\frac{1}{2}$ " Strip and a $2\frac{1}{2}$ " Flat Girder. A vertical $3\frac{1}{2}$ " Strip is bolted to the Flat Plate. The engine cover is formed by a $5\frac{1}{2}$ " \times $2\frac{1}{2}$ " Flexible Plate fitted at each side with three U-section Curved Plates, whose lower edges are connected by $5\frac{1}{2}$ " Strips. Two curved $3\frac{1}{2}$ " Strips are bolted to the Plates as shown and a 3" Stepped Curved Strip is attached to each end by an Angle Bracket. The cover is bolted at one end to the

top flange of the Flanged Plate. At the other end a $1\frac{1}{2}$ " Strip is bolted between the corners of the 'U'-section Plates and is connected to the radiator by an Angle Bracket.

A Trunnion is fixed by its flange to each of the Girders (22), and the Trunnions are bolted to $2\frac{1}{2}$ " Angle Girders (23) (Figs. 3 and 6) attached to the Flat Plate (19). The exhaust pipe is formed by a Dog Clutch and two Collars on a $6\frac{1}{2}$ " Rod, which is held by a Spring Clip in a Single Bent Strip bolted to the radiator. A Spring is passed over the lower end of the Rod and is bolted to an Angle Bracket fixed to one of the $5\frac{1}{2}$ " Angle Girders.

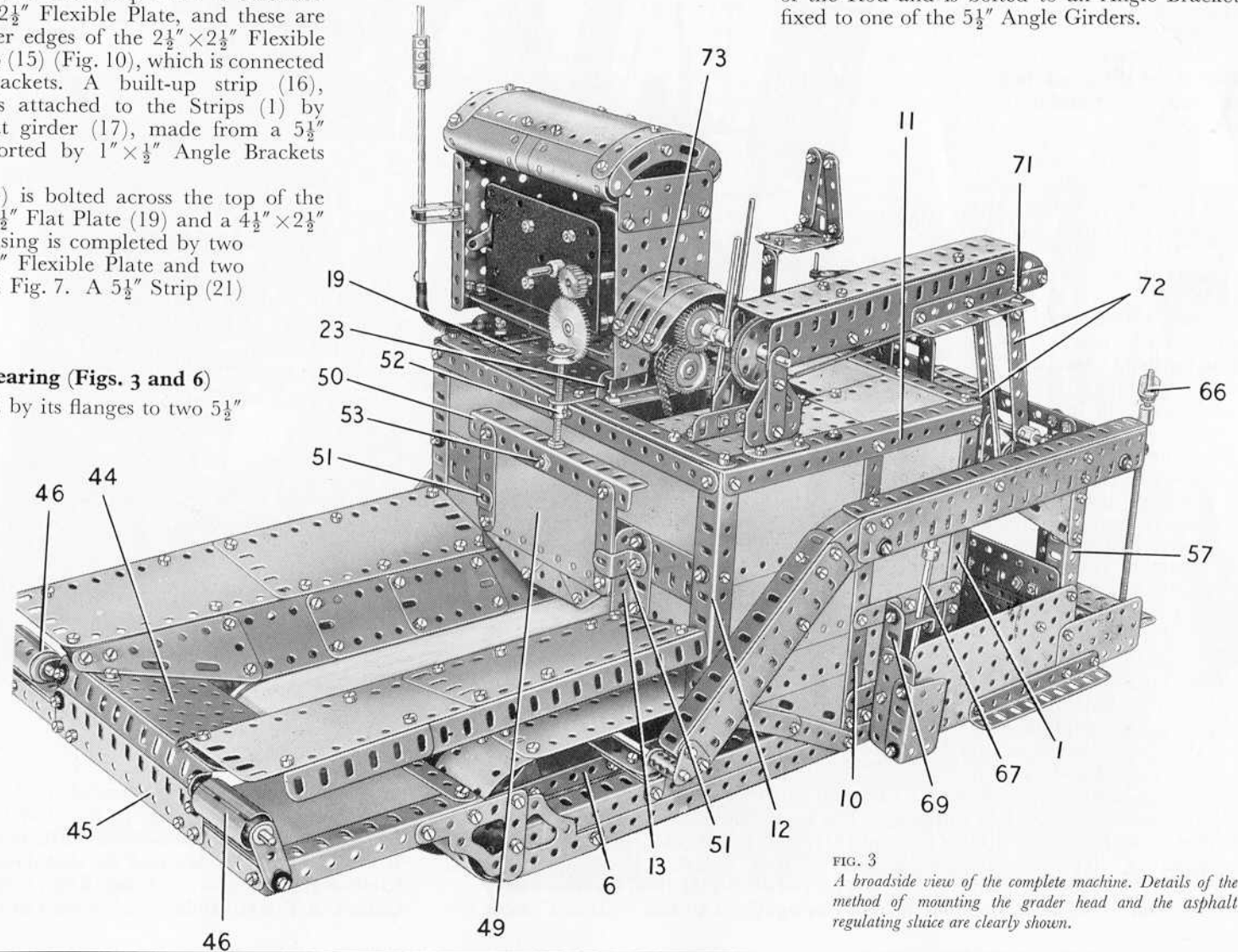

FIG. 3
A broadside view of the complete machine. Details of the method of mounting the grader head and the asphalt regulating sluice are clearly shown.

A $\frac{7}{16}$ " diameter Pinion on the Motor armature shaft drives a 60-tooth Gear on a $2\frac{1}{2}$ " Rod (24) (Fig. 6). A $\frac{3}{4}$ " Pinion on this Rod engages a 50-tooth Gear on a $2\frac{1}{2}$ " Rod (25), and this Rod carries a Worm placed between the Motor side-plates. Rod (25) is held in position by a Collar. A $6\frac{1}{2}$ " Rod supported in the Trunnions bolted to the Girders (22) is fitted with a $\frac{1}{2}$ " Pinion that is in constant mesh with the Worm. The Pinion is spaced from one of the Trunnions by five Washers, and the $6\frac{1}{2}$ " Rod carries a $\frac{3}{4}$ " Sprocket (26) and a 1" Gear (27).

**Details of the Gear-box
(Figs. 1, 2, 4, 8 and 9)**

The gear-box provides drives to the travelling wheels, the spreading screws and the conveyor belt. The housing is formed by two $3\frac{1}{2} \times 2\frac{1}{2}$ " Flanged Plates connected at their lower ends by two $1\frac{1}{2}$ " Strips. There are three input shafts, each of which is a 2" Rod fitted with a 1" Sprocket (28) and a $\frac{3}{4}$ " Pinion (29). The Rods are held in place by Collars. The Pinions (29) on the outer Rods are placed against one of the Flanged Plates, but the Pinion on the centre shaft is positioned towards the centre of the Rod.

The output shafts are numbered (30), (31) and (32) in Figs. 8 and 9. Each of these shafts carries a 50-tooth Gear that can be moved into mesh with one of the Pinions (29) by sliding the shaft in its bearings. The levers that control the sliding movements are each fitted with a Rod and Strip Connector that is *lock-nutted* to an Angle Bracket bolted to the gear-box housing. Two of the levers engage between Collars on the Rods (30) and (31), and the third lever is positioned between a Collar and $\frac{1}{2}$ " fixed Pulley (33) on Rod (32). Rod (31) carries a $\frac{3}{4}$ " Sprocket (34), and Rod (30) is fitted with a $1\frac{1}{2}$ " Pulley (35) (Fig. 9). The Pulley (33) is connected by an endless belt of Spring Cord to one of two 1" loose

Pulleys (36). These Pulleys are placed on a $\frac{1}{2}$ " Bolt that is screwed tightly into a Threaded Coupling fixed on a $2\frac{1}{2}$ " Rod. The Rod is held in the gear-box housing by a Collar.

The top flanges of the Flanged Plates are bolted to the Girder (18) and to the Strip (21) (Fig. 1). A $2\frac{1}{2}$ " Strip fixed to the lower end of the housing carries a $9\frac{1}{2}$ " Flat Girder (37) (Figs. 8 and 9) and a $1" \times 1"$ Angle Bracket (38) (Fig. 9). The Flat Girder (37) is connected to the sides of the mechanism housing by $1" \times \frac{1}{2}"$ Angle Brackets (Fig. 4), and the Angle Bracket (38) is bolted to the Strip (15) (Fig. 10).

A length of Sprocket Chain is passed round the Sprockets (26) and (28) as shown in Fig. 4. The arrangement of the Chain is such that the centre input shaft turns in the opposite direction to the two outer shafts. Thus by sliding shafts (30), (31) and (32) in one direction their 50-tooth Gears can be engaged with the Pinions (29) of the outer pair of input shafts, to engage the drive. When shafts (30), (31) and (32) are moved in the opposite direction their Gears mesh with the Pinion on the centre input shaft, and the direction of the drive is reversed.

The Sprocket (34) (Fig. 8) is connected by Chain to the Sprocket (7) (Fig. 2) to complete the drive to the travelling wheels.

**Drive to the Spreader
Screws (Fig. 10)**

In the actual machine the spreader screws used to distribute the surfacing material evenly over the section of the road traversed by the machine are spirals. In the model, however, the spirals are represented by six Bush Wheels and two Wheel Discs on a made-up axle consisting of a $4\frac{1}{2}$ " Rod and two 2" Rods joined by Couplings (see Fig. 10). The Bush Wheels are fixed on the axle and the Wheel Discs are clamped between the Couplings and Collars. A $\frac{1}{2}$ " fixed Pulley (39) is fixed at the centre of the axle.

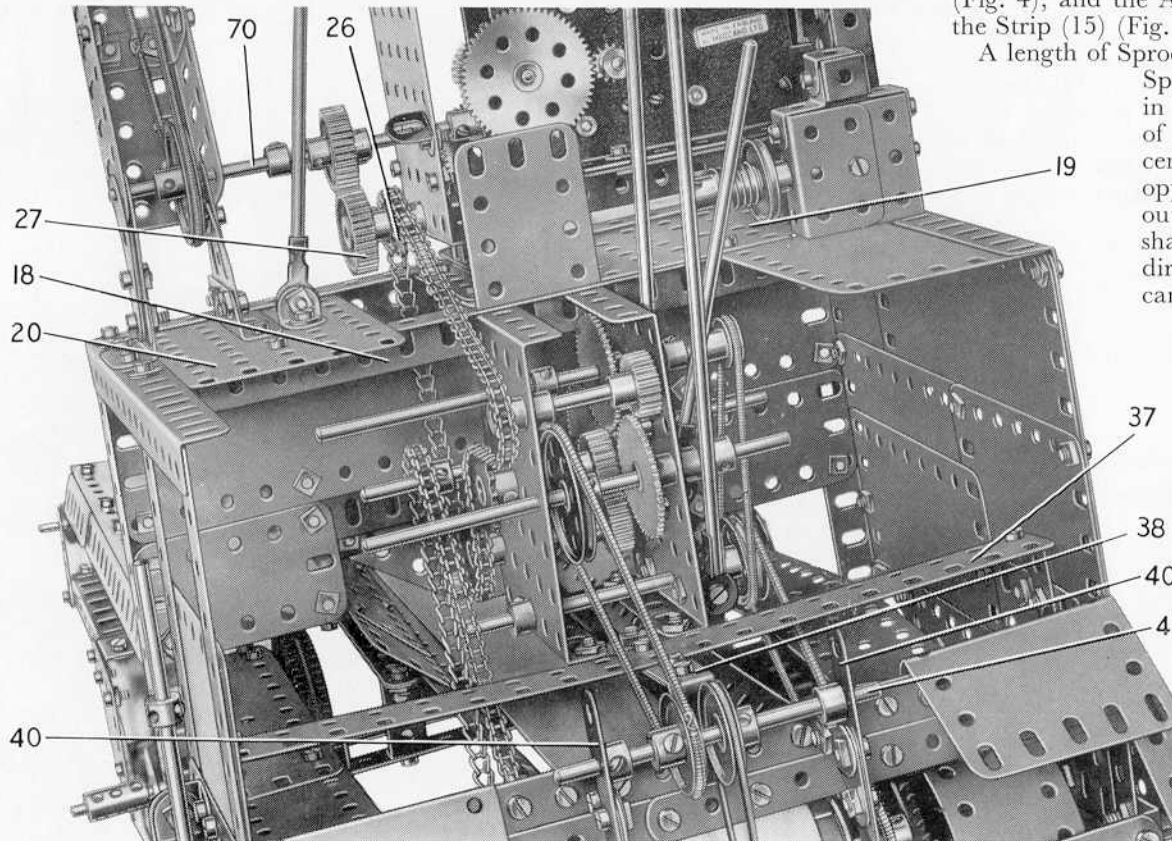

FIG. 4 A close-up, showing driving arrangements from the Electric Motor and gear-box

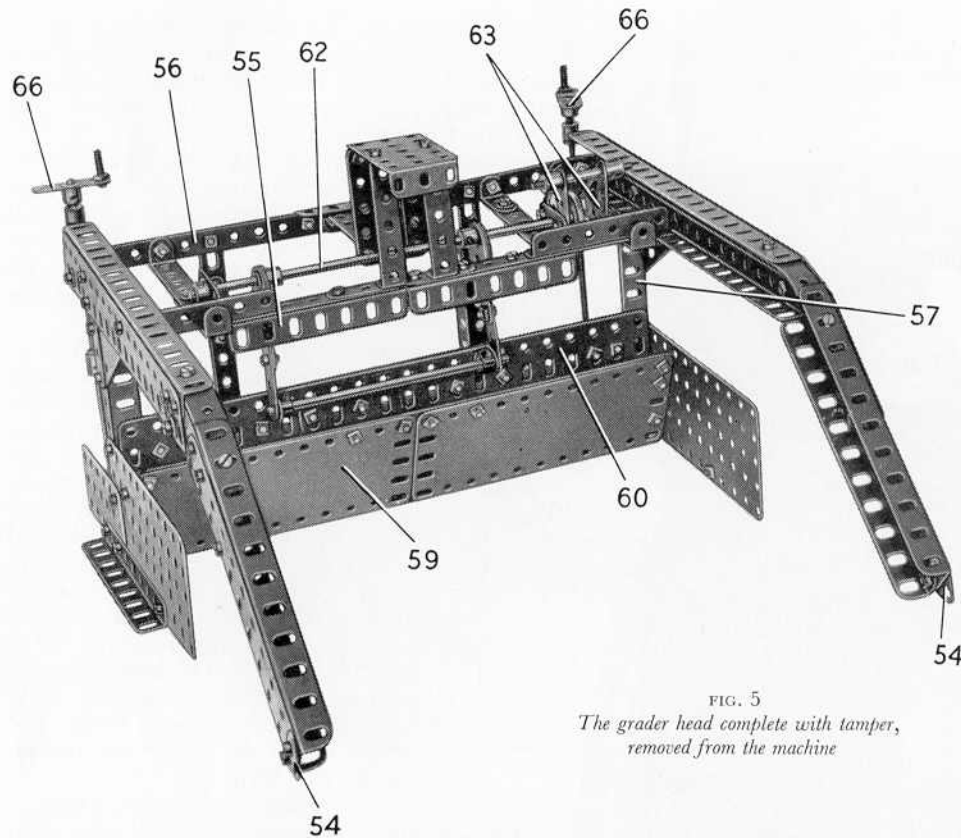

FIG. 5
The grader head complete with tamper,
removed from the machine

The axle is mounted at each end in three $2\frac{1}{2}$ " Strips bolted to the main frame, and at the centre it is supported in strips (40), each of which consists of a $4\frac{1}{2}$ " and a $3\frac{1}{2}$ " Strip placed face to face. The lower ends of the strips (40) are connected by $1" \times \frac{1}{2}"$ Angle Brackets to the flat girder (17). Their upper ends are fastened to the lugs of a $2\frac{1}{2}" \times 1"$ Double Angle Strip, with the joints strengthened by $1"$ Corner Brackets. The Double Angle Strip is attached to the Strip (15) by $\frac{3}{8}"$ Bolts, but is spaced from the Strip by four $2\frac{1}{2}"$ Strips. A $3\frac{1}{2}"$ Rod (41) mounted in the strips (40) is fitted with two $1"$ Pulleys. One of these Pulleys is connected by a Driving Band to the $\frac{1}{2}"$ Pulley (39), and the other is driven by an endless belt of Spring Cord passed round the Pulley (35) of the gear-box (Fig. 9).

Arrangement of the Hopper and Conveyor (Figs. 2, 3, 9 and 10)

The sloping sides of the hopper (Fig. 3) are each formed by four $2\frac{1}{2}" \times 1\frac{1}{2}"$ Flexible Plates and a $3\frac{1}{2}" \times 1\frac{1}{2}"$ Triangular Flexible Plate bolted to a built-up strip (42) (Fig. 2) on each side. These strips are made

from $12\frac{1}{2}"$ and $5\frac{1}{2}"$ Strips overlapped seven holes, and at their rear ends they are supported by Corner Angle Brackets fixed to the Strip (15) (Fig. 10) by bolts (43). The top edges of the sloping Plates on each side are connected by five Obtuse Angle Brackets to two $5\frac{1}{2}" \times 2\frac{1}{2}"$ Flexible Plates, strengthened along their inner edges by two $5\frac{1}{2}"$ Strips. The outer edges of the $5\frac{1}{2}" \times 2\frac{1}{2}"$ Flexible Plates are braced by a $7\frac{1}{2}"$ and a $3"$ Angle Girder, as shown in Fig. 3. The $7\frac{1}{2}"$ Angle Girders are connected by Angle Brackets to the Girders (12).

The front corners of the Triangular Flexible Plates are connected by Obtuse Angle Brackets to a $5\frac{1}{2}" \times 2\frac{1}{2}"$ Flat Plate (44), which is edged by a $5\frac{1}{2}"$ Angle Girder. This Girder is joined by Fishplates to a $5\frac{1}{2}"$ Flat Girder (45), and the latter is extended at each side by a $3"$ Strip. The $3"$ Strips are connected by Angle Brackets to the front end of the main frame. Two rollers are seen at (46). These are Sleeve Pieces fitted over Chimney Adaptors, which are freely mounted on Rods fixed in Cranks bolted to the main frame. The inner ends of the Rods are supported in Angle Brackets attached to the $5\frac{1}{2}"$ Angle Girder.

A supporting plate for the conveyor belt is provided by a $5\frac{1}{2}" \times 3\frac{1}{2}"$ Flat Plate (47) (Fig. 2). This is attached to the strip (4) by two $\frac{3}{8}"$ Bolts, but is spaced from the strip by nuts, and is supported also by two $1"$ Reversed Angle Brackets bolted to the strip (3) also seen in this view.

The driving roller for the conveyor belt is formed by two $1\frac{1}{8}"$ Flanged Wheels pressed into the ends of a Cylinder, around which two $2\frac{1}{2}"$ Driving Bands are

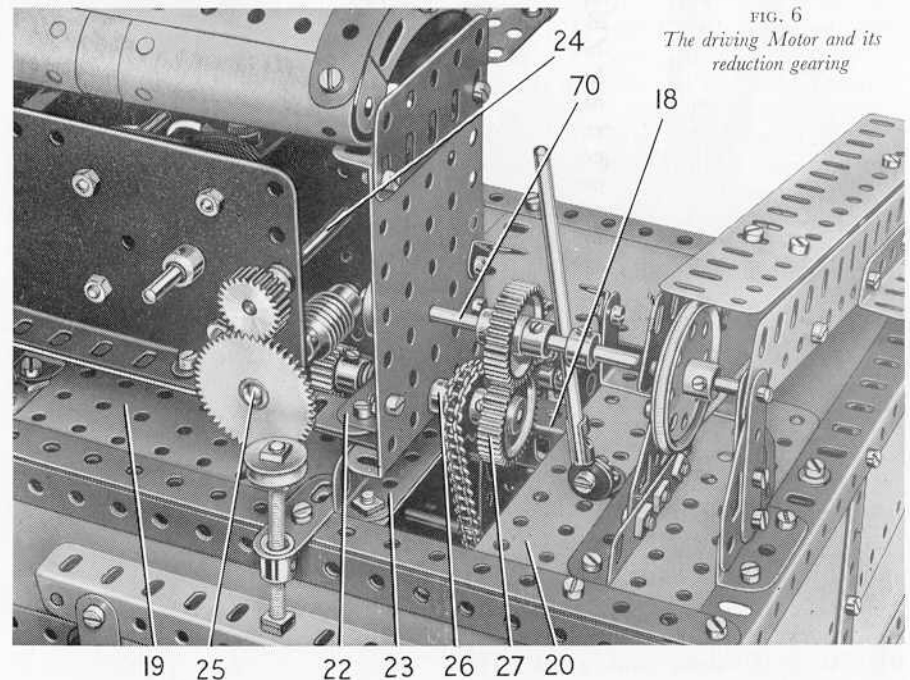

FIG. 6
The driving Motor and its
reduction gearing

then placed. The roller is fixed on a 4" Rod supported in two 2" Strips (48) (Fig. 10), which are attached by Angle Brackets to the Strip (15) and the built-up strip (16). A 1" Pulley on the Rod is connected to the outer one of the two Pulleys (36) (Fig. 9) by an endless belt of Spring Cord. The idling roller is also made from a Cylinder and two 1 1/8" Flanged Wheels, and it is fixed on a 4" Rod supported in the Girders (5) (Fig. 2). The conveyor belt can be made from an endless length of cloth or strong paper passed round the rollers.

The Feed Regulating Sluice (Fig. 3)

The flow of road surfacing material along the conveyor can be controlled by means of an adjustable sluice gate (49) (Fig. 3). This consists of a 4 1/2" x 2 1/2" Flexible Plate edged by a 5 1/2" Angle Girder (50) and two 2 1/2" Strips. The Flexible Plate is extended downward by two 2 1/2" x 2" Triangular Flexible Plates, which are connected at their lower corners by a 2" Flat Girder. The gate slides between the Girders (13) and 1/2" Reversed Angle Brackets (51) bolted to the Girders but spaced from them by a Washer on each bolt.

A 1/2" loose Pulley is fixed between two nuts on a 3 1/2" Screwed Rod, which is then screwed through a Threaded Crank (52) fixed as shown in Fig. 3. The Screwed Rod passes through the Girder (50) and through the long bore of a Coupling attached inside the gate by a nut and bolt (53). Lock-nuts are placed on the Screwed Rod above the Girder (50) and below the Coupling.

Building the Grader Head (Figs. 1, 2, 3, 5 and 7)

The grader head (Fig. 5) is supported in the machine by a pivoted arm on each side. These arms are each made from a 9 1/2" Flat Girder fitted with two 9 1/2" Angle Girders, and a 5 1/2" Flat

FIG. 7
A semi-plan view from the rear, showing the general layout of the Road Surfacing Machine

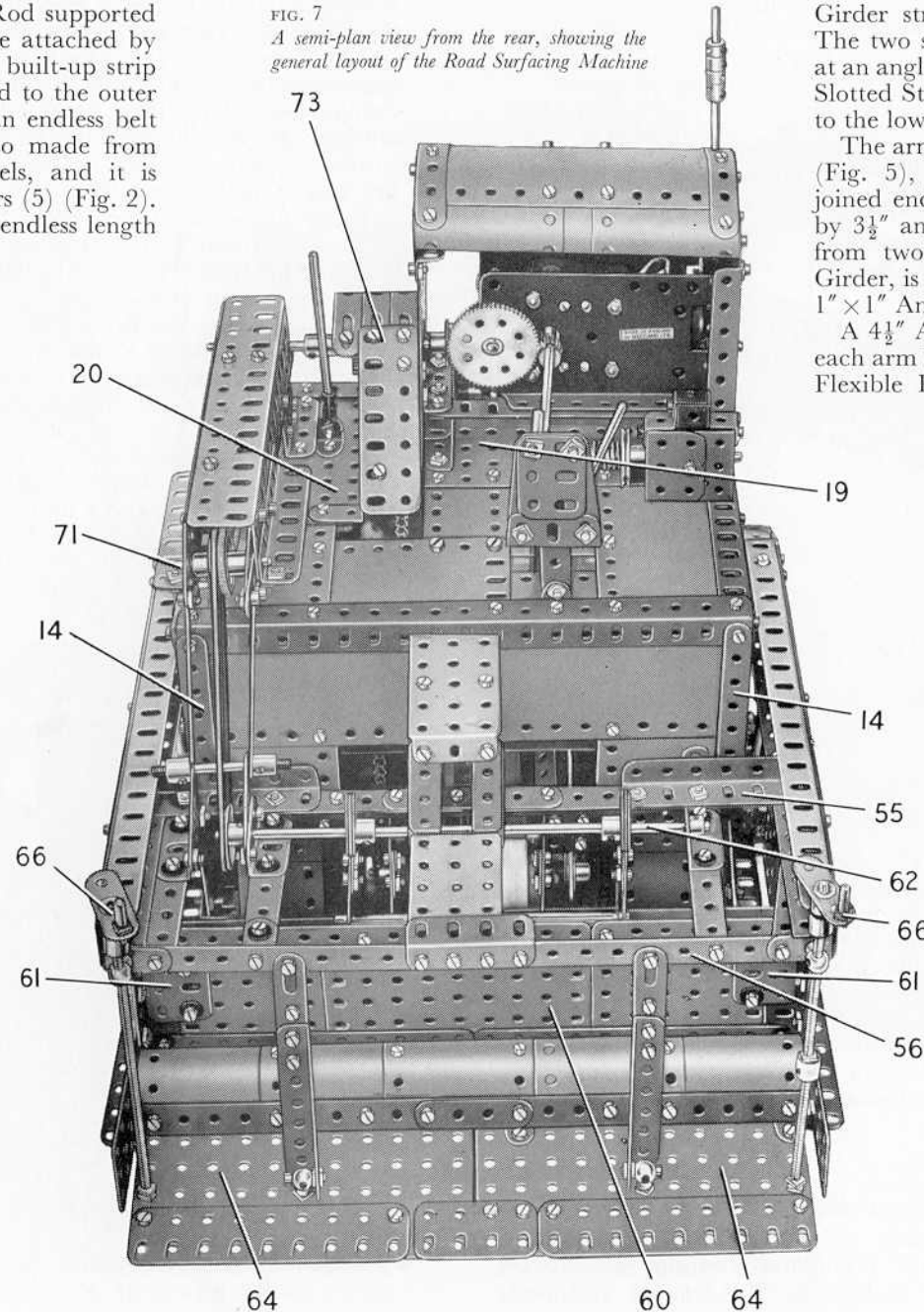

Girder strengthened by two 5 1/2" Angle Girders. The two sections of each arm are joined together at an angle by two 2 1/2" Curved Strips and a Formed Slotted Strip. A 1" Triangular Plate (54) is bolted to the lower end of each arm.

The arms are connected by a bridging piece (55) (Fig. 5), made as shown from two 5 1/2" Strips joined end-to-end by a 3" Strip and strengthened by 3 1/2" and 3" Angle Girders. A strip (56), made from two 5 1/2" Strips connected by a 2" Angle Girder, is attached to the front ends of the arms by 1" x 1" Angle Brackets.

A 4 1/2" Angle Girder (57) (Fig. 5) is attached to each arm by a 2 1/2" Strip and a 3 1/2" x 2 1/2" Triangular Flexible Plate. The lower ends of these Girders are connected by a built-up girder (58) (Fig. 2) made from two 5 1/2" Angle Girders joined at the centre by a 2" Strip. A 5 1/2" x 2 1/2" Flat Plate and a 3" x 1 1/2" Flat Plate are bolted to each of the Girders (57) and are connected on the outside by a 4 1/2" Angle Girder. A plate (59) (Fig. 5) is attached at an angle to the 5 1/2" x 2 1/2" Flat Plates by 1 1/2" Angle Girders. This plate consists of two 5 1/2" x 2 1/2" Flexible Plates bolted to two 5 1/2" Strips, which are connected end-to-end by a 3" Strip.

A tamping device (60) (Figs. 1 and 5) consists of two 4 1/2" x 2 1/2" Flat Plates that overlap a central 4 1/2" x 2 1/2" Flat Plate, one by four holes and the other by three holes. A 7 1/2" Flat Girder extended by a 3 1/2" Flat Girder fixed to the Plates, is arranged so that the ends of the Flat Girders are located behind the flanges of the Girders (57).

A 1 1/2" Flat Girder (61) (Fig. 7) at each end of the tamping plate in front of Girder (57), is spaced from the plate by a Washer on each bolt, and the complete plate slides freely over the flanges of the Girders (57). The tamping plate is given an up and down movement by two Single Throw Eccentrics on an 8" Rod (62). The Eccentrics are extended by 2" Strips

FIG. 8
The gear-box complete, removed
from the machine

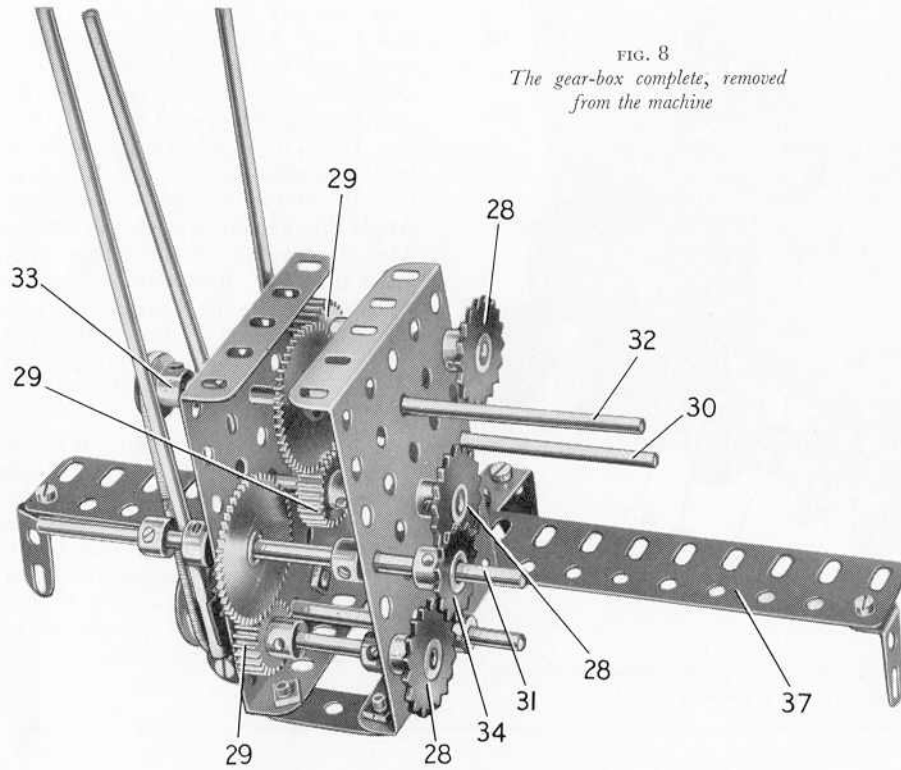

that pivot freely on a 5" Rod, which is held by Spring Clips in a $4\frac{1}{2}" \times \frac{1}{2}"$ Double Angle Strip bolted behind the tamping plate. At one end the Rod (62) is supported in a $1\frac{1}{2}"$ Angle Girder bolted to a $4\frac{1}{2}" \times \frac{1}{2}"$ Double Angle Strip fixed to the strip (56) (Fig. 5) and the bridging piece (55). The other end of the Rod is mounted in a $1\frac{1}{2}"$ Angle Girder fixed to a $3\frac{1}{2}"$ Strip bolted to the bridging piece and connected to strip (56) by a $1" \times \frac{1}{2}"$ Angle Bracket. The last-mentioned $1\frac{1}{2}"$ Angle Girder supports one of two $1\frac{1}{2}"$ Corner Brackets (63). The other Corner Bracket is fixed to another $1\frac{1}{2}"$ Angle Girder bolted to a $4\frac{1}{2}" \times \frac{1}{2}"$ Double Angle Strip.

Two $5\frac{1}{2}" \times 3\frac{1}{2}"$ Flat Plates (64) (Fig. 2) are pivotally connected to the girder (58) by Hinges held by bolts (65). The inner edges of the Flat Plates are loosely connected by a *lock-nutted* $\frac{3}{8}"$ Bolt passed through an Angle Bracket bolted to each Flat Plate at its rear inner corner. The front edges of the Flat Plates (64) carry Flat Girders, as shown in Fig. 7.

Each Flat Plate can be adjusted vertically by turning a handle (66) on the shank of an Adaptor for Screwed Rod fixed by a nut at the top end of a Screwed Rod. The two Screwed Rods are passed through the threaded holes of Handrail Supports fixed at the ends of the strip (56). The lower ends of the Screwed Rods turn freely in the Flat Plates (64) and each is held in place by two sets of *lock-nuts*, one set above and one below the Plate. On one side a 6"

Screwed Rod is used, but on the other side two 3" Screwed Rods are connected by a Threaded Boss and are fixed tightly in it by nuts. A $3\frac{1}{2}"$ Angle Girder is fixed by two nuts on a $\frac{1}{2}"$ Bolt that is mounted freely in a Handrail Support bolted to each of the Flat Plates (64). The Angle Girder is extended upward by a 2" Slotted Strip, the slotted hole of which is passed over a bolt held by two nuts in the strip (56). The joint between the Slotted Strip and the Angle Girder is strengthened by a $1\frac{1}{2}"$ Strip.

Five U-section Curved Plates seen in Figs. 1 and 7 represent the cover of the heaters of the actual machine. The assembly is connected to one of the Flat Plates (64) by Angle Brackets.

The Triangular Plates (54) of the grader head (Fig. 5) are passed over the ends of an $11\frac{1}{2}"$ Rod that is held by Couplings in $2\frac{1}{2}" \times \frac{1}{2}"$ Double Angle Strips bolted to the strip (3) (Fig. 2). A $4\frac{1}{2}"$ Rod (67) (Figs. 1 and 3) on each side is fitted in a Coupling held on a Threaded Pin fixed in a 3" Angle Girder (68) (Fig. 10). The Rod is supported by a 1" Reversed Angle Bracket attached to a vertical $2\frac{1}{2}"$ Angle Girder (69). A Girder Bracket is attached to this Angle Girder by means of a $2\frac{1}{2}"$ Flat Girder. The Rods (67) pass through the arms of the grader head, and the arms are supported on the Rods by 'spiders' obtained from Swivel Bearings (see Figs. 1 and 3).

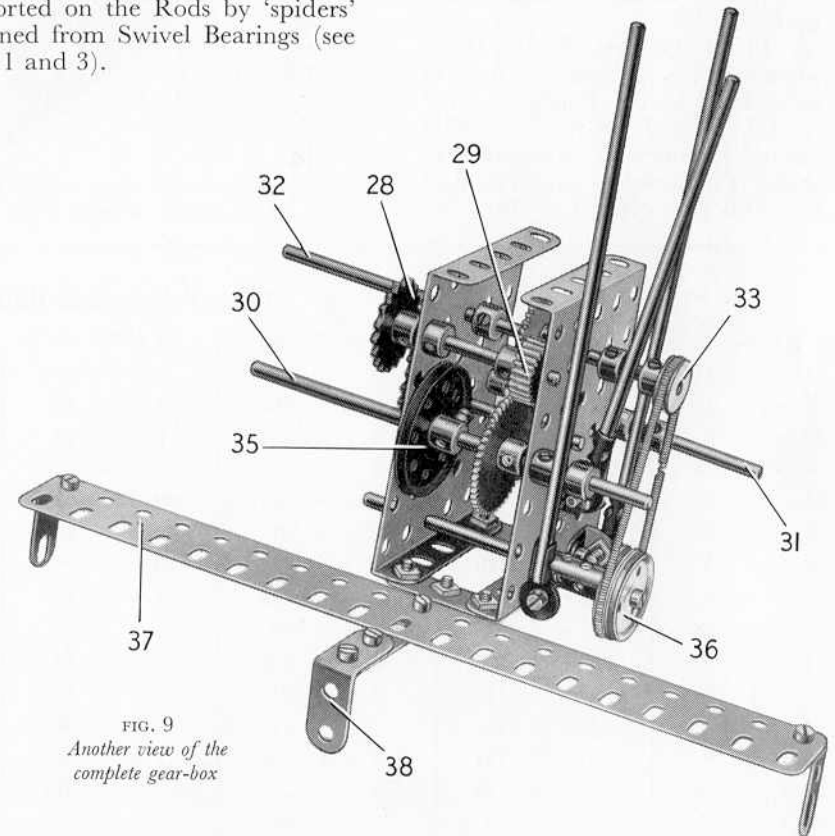

FIG. 9
Another view of the
complete gear-box

The Tamper Drive

(Figs. 3, 4, 6 and 7)

A 4½" Rod (70) (Figs. 4 and 6) is mounted in one end of the engine housing and in two 2" Strips, each of which is fixed to a Flat Trunnion. One of the Flat Trunnions is supported by a 1½" Angle Girder and the other is attached to a 2" Angle Girder. Rod (70) carries a 1" Gear, and by sliding the Rod this Gear can be meshed with the Gear (27). Movement of the Rod is controlled by a 3½" Rod that engages between Collars on Rod (70). The 3½" Rod is fitted at its lower end with a Rod and Strip Connector, which is lock-nutted to an Angle Bracket bolted to the Flat Plate (20).

A 1½" Pulley on Rod (70) is connected by an endless belt of Spring Cord to a 1" Pulley on a 1½" Rod (71) (Fig. 7). Rod (71) carries a second 1" Pulley and is mounted at the end of an arm that pivots on Rod (70). This arm consists of three 7½"

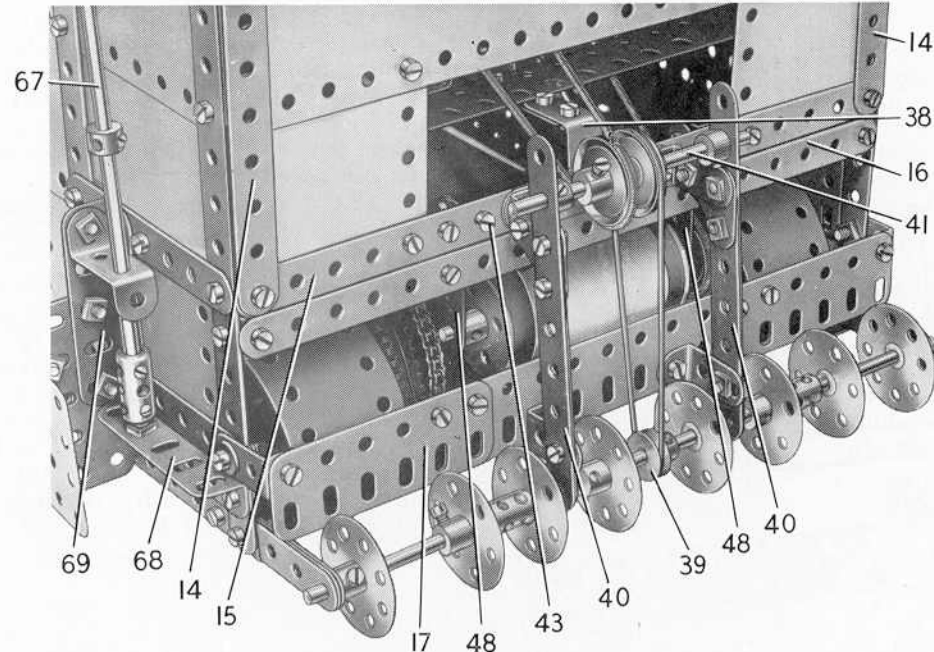

FIG. 10 The road surfacing material is distributed evenly over the highway as the machine travels along by means of a distribution spiral, represented in the model by a row of revolving Bush Wheels

Flat Girders connected by 1"×1" and 1"×½" Angle Brackets to form a deep section channel girder. It is extended at one end by two 3" Strips and two 2½" Stepped Curved Strips (see Fig. 1). A 3½" Angle Girder is bolted to each side of the arm, and two 3½" Strips (72) are lock-nutted to Angle Brackets fixed to these Girders. The lower ends of the Strips (72) pivot on a 1½" Rod that is held by Rod Sockets in the Corner Brackets (63). The second 1" Pulley on Rod (71) is connected by a Driving Band to a 1" Pulley on the end of Rod (62) (Fig. 7).

A cover plate (73) (Fig. 7) is made from three Formed Slotted Strips joined by 1½" Strips and extended by a 3½" Flat Girder. It is attached to one end of the engine housing by an Angle Bracket, and is supported by a ½"×½" Angle Bracket and a 1"×1" Angle Bracket bolted as shown in Fig. 7 to the Flat Plate (20).

Parts Required to Build the Meccano Road Surfacing Machine

4 of No. 1	8 of No. 9d	2 of No. 16b	4 of No. 27	2 of No. 55a	4 of No. 90	4 of No. 109	1 of No. 154b	2 of No. 196
4 " " 1a	4 " " 9e	3 " " 17	1 " " 27d	1 " " 58	2 " " 90a	4 " " 111a	2 " " 160	12 " " 199
6 " " 1b	8 " " 9f	2 " " 18a	2 " " 31	24 " " 59	1 " " 94	17 " " 111c	2 " " 161	4 " " 212
28 " " 2	7 " " 10	4 " " 20	2 " " 32	2 " " 62	1 " " 95	2 " " 114	2 " " 163	5 " " 215
4 " " 2a	2 " " 11	4 " " 20a	3 " " 35	1 " " 62a	3 " " 96	4 " " 115	4 " " 164	2 " " 216
12 " " 3	47 " " 12	1 " " 20b	599 " " 37a	2 " " 62b	2 " " 96a	4 " " 124	2 " " 165	2 " " 222
8 " " 4	7 " " 12a	2 " " 21	569 " " 37b	8 " " 63	1 " " 102	5 " " 125	2 " " 173a	2 " " 224
20 " " 5	8 " " 12b	7 " " 22	70 " " 38	1 " " 63c	4 " " 103	2 " " 126	2 " " 179	2 " " 225
12 " " 6	12 " " 12c	2 " " 22a	1 " " 43	1 " " 64	4 " " 103a	2 " " 126a	2 " " 186	2 " " 226
7 " " 6a	1 " " 13	1 " " 23	1 " " 46	3 " " 70	2 " " 103c	2 " " 130a	1 " " 186a	
4 " " 8	2 " " 13a	2 " " 23a	4 " " 48	1 " " 72	2 " " 103d	4 " " 133	1 " " 186c	
6 " " 8a	4 " " 14	4 " " 24	4 " " 48a	2 " " 73	2 " " 103e	2 " " 133a	12 " " 188	
4 " " 8b	6 " " 15	2 " " 24b	3 " " 48c	2 " " 77	4 " " 103f	4 " " 136	12 " " 189	
12 " " 9	5 " " 15a	2 " " 24c	2 " " 51	1 " " 79a	2 " " 103g	1 " " 140	4 " " 190	1 E15R
8 " " 9a	2 " " 15b	4 " " 25	4 " " 52a	1 " " 80a	3 " " 103h	4 " " 142a	4 " " 190a	Electric Motor
8 " " 9b	2 " " 16	1 " " 26	3 " " 53	2 " " 80c	4 " " 103k	1 " " 144	10 " " 191	(not included
4 " " 9c	6 " " 16a	1 " " 26c	4 " " 53a	2 " " 89a	4 " " 108	1 " " 154a	9 " " 192	in Outfit)

MECCANO Mechanical Loading Shovel

SPECIAL FEATURES

Powered by an E15R Electric Motor this model of a typical modern shovel excavator carries out all the essential motions of a real machine. Each movement is independently controllable from a conveniently grouped set of levers.

Shovel

(MODEL No. 10.20)

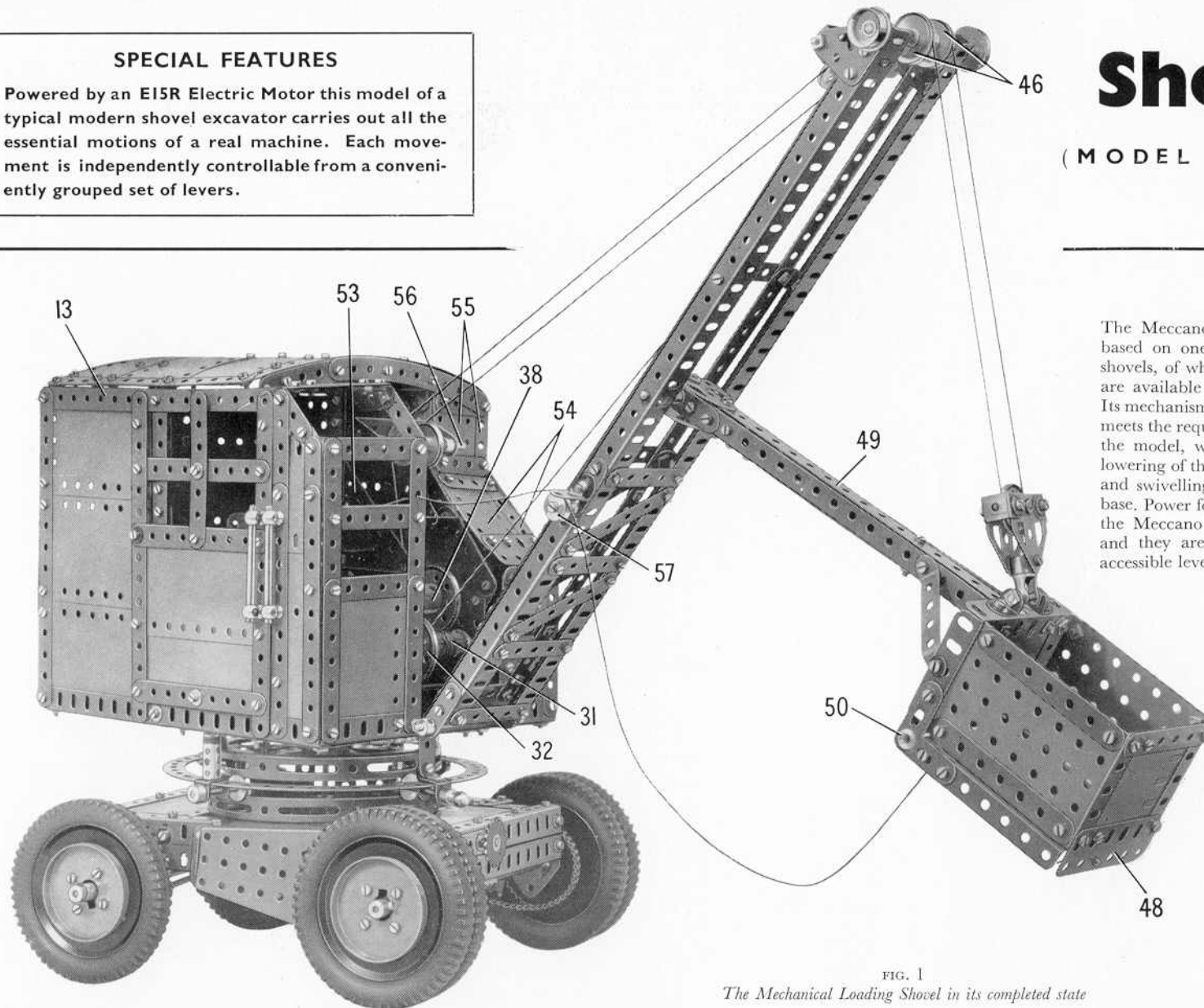

The Meccano model described in this Leaflet is based on one of the lighter types of mechanical shovels, of which many different kinds of all sizes are available to modern constructional engineers. Its mechanism, while quite simple to assemble, fully meets the requirements of the various movements of the model, which include travelling, raising and lowering of the jib, manipulation of the bucket arm and swivelling of the cab and jib on the wheeled base. Power for all these movements is provided by the Meccano E15R Electric Motor inside the cab and they are individually controlled from easily accessible levers.

Construction of the model should commence with the wheeled base or undercarriage, details of which are as follows.

The Wheeled Base (Figs. 2 and 4)

Each side-member of the base consists of two $9\frac{1}{2}$ " Angle Girders joined together by two $1\frac{1}{2}$ " Flat Girders. The side-members are connected at each end by two $5\frac{1}{2}$ " Angle Girders, which are bolted to Angle Brackets fixed to the $9\frac{1}{2}$ " Girders. A $5\frac{1}{2}$ " x $2\frac{1}{2}$ " Flexible Plate is bolted across the top of each end of the base, and the inner edges of these Plates are strengthened by $5\frac{1}{2}$ " Angle Girders (1) (Fig. 2).

FIG. 1

The Mechanical Loading Shovel in its completed state

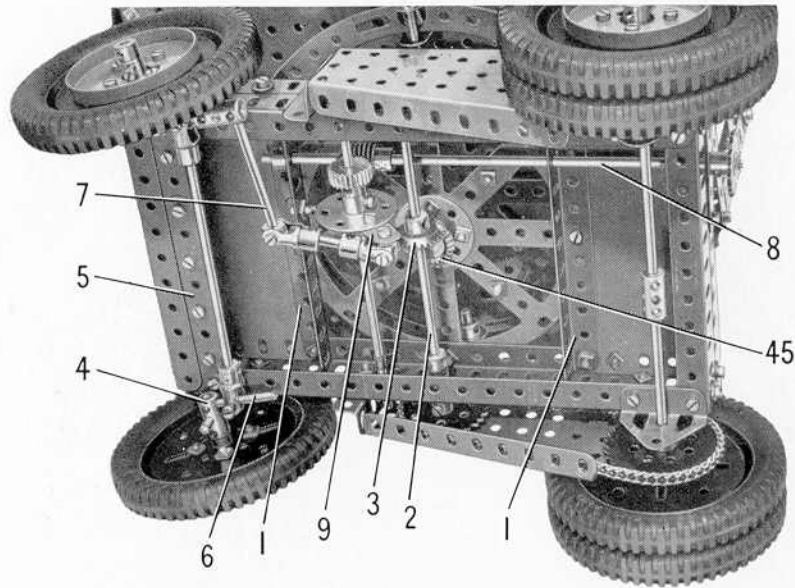

FIG. 2

The underside of the undercarriage or wheeled base, showing the steering arrangement

The driving wheels are mounted on an axle made from a $4\frac{1}{2}$ " and a 5" Rod joined by a Coupling. This axle carries a 2" Sprocket, and is supported in Trunnions bolted to the base. The axle is held in position by the 2" Sprocket and by a $1\frac{1}{2}$ " Sprocket, and the 2" Sprocket is connected by Chain to a $1\frac{1}{2}$ " Sprocket on a Rod (2), which is held in place by a Coupling and is fitted with a $\frac{3}{8}$ " Bevel Gear (3). A guard over the Chain drive is formed by a Flanged Sector Plate. The narrow end of this Plate is attached to a $1\frac{1}{2}$ " Angle Girder by an Angle Bracket, and its wide end is supported by a Fishplate bolted to the top of the base.

Each of the steerable wheels is free to turn on a 1" Rod gripped in a Coupling (4). These Couplings are fixed on $1\frac{1}{2}$ " Rods passed through the bosses of Cranks bolted to the ends of a strip (5). This strip is made from two $4\frac{1}{2}$ " Strips overlapped five holes, and each of the Couplings (4) is spaced from it by three Washers. The $1\frac{1}{2}$ " Rods that carry the Couplings are held in place by Collars.

Each of the Couplings (4) is fitted with a $1\frac{1}{2}$ " Rod (6), and these are connected by a 5" Rod and two Swivel Bearings. One of the Rods (6) carries also a Coupling fitted with a 2" Rod (7).

An 8" Rod (8) is mounted in $2\frac{1}{2}$ " Strips that cover the slotted holes in the Girder at one end of the base, and in one of the Girders (1). A Worm on this Rod drives a $\frac{3}{4}$ " Pinion on a $6\frac{1}{2}$ " Rod held in the base side-members by Spring Clips, and the latter Rod carries a Bush Wheel (6 holes) to which a $1\frac{1}{2}$ " Strip (9) is bolted. The Strip is linked to the Rod (7) by two swivel bearings connected by a $1\frac{1}{2}$ " Rod. These swivel bearings are obtained from Universal Couplings.

Details of the Roller Bearing (Figs. 4 and 5)

A Hub Disc, with a Bush Wheel (8 holes) bolted to its centre, is fixed to the top of the wheeled base. A second Hub Disc is connected to the first by four $1\frac{1}{2}$ " \times $\frac{1}{2}$ " Double Angle Strips, and a $\frac{1}{2}$ " fixed Pulley and three $\frac{1}{2}$ " loose Pulleys (10) are located between the rims of the two Hub Discs. A $3\frac{1}{2}$ " Gear (11) is fitted with four $\frac{3}{4}$ " Bolts held in place by nuts, and each Bolt is then fixed to the upper Hub Disc by two nuts.

The Cab: Floor and Sides (Figs. 1, 3 and 8)

The framework of the floor of the cab is made from two $9\frac{1}{2}$ " Angle Girders connected at the front by a $7\frac{1}{2}$ " Angle Girder, and it is filled in by three $5\frac{1}{2}$ " \times $2\frac{1}{2}$ " Flat Plates, two $4\frac{1}{2}$ " \times $2\frac{1}{2}$ " Flat Plates and a $5\frac{1}{2}$ " \times $3\frac{1}{2}$ " Flat Plate (Fig. 3). A Circular Strip (12) is attached to the floor by two brackets, each made from a $1" \times 1"$ and a $\frac{1}{2}" \times \frac{1}{2}"$ Angle Bracket bolted together. The bolts fixing the $\frac{1}{2}" \times \frac{1}{2}"$ Angle Brackets to the Circular Strip secure also Double Brackets. At each side of the base a Coupling and five Washers are placed on a 2" Screwed Rod, between the base and the Circular Strip, and the Screwed Rod is fixed in place by nuts. Double Brackets also are fixed by the Screwed Rods as shown. The Double Brackets support 2" Rods and on these are mounted the $\frac{1}{2}"$ Pulleys (10) of the roller bearing. The loose Pulleys are held on the Rods by Collars, and the Rods are retained in the Double Brackets by two Handrail Couplings, a Collar, and one half of a Dog Clutch.

The side of the cab seen in Fig. 8 consists of a $9\frac{1}{2}" \times 2\frac{1}{2}"$ Strip Plate, two $5\frac{1}{2}" \times 2\frac{1}{2}"$ Flexible Plates, a vertical $5\frac{1}{2}" \times 1\frac{1}{2}"$ Flexible Plate and a $3\frac{1}{2}" \times 2\frac{1}{2}"$ Flexible Plate placed at an angle. The side is strengthened by Strips and built-up strips as shown.

The rear part of the side seen in Fig. 1 is filled in by three $4\frac{1}{2}" \times 2\frac{1}{2}"$ Flexible Plates attached to two vertical $7\frac{1}{2}"$ Strips by $\frac{3}{8}"$ Bolts, but they are spaced from the Strips by a nut on each Bolt. The top edge of the upper Plate is strengthened by a strip (13), made from two $5\frac{1}{2}"$ Strips overlapped five holes. The front part of this side consists of a $5\frac{1}{2}" \times 1\frac{1}{2}"$ and a $2\frac{1}{2}" \times 1\frac{1}{2}"$ Flexible Plate overlapped three holes and edged by Strips as shown.

Power Unit and Reduction Gearing (Figs. 6 and 7)

A Meccano E15R Electric Motor is bolted to the cab base (Fig. 7), and a $\frac{1}{2}"$ Pinion on its armature shaft

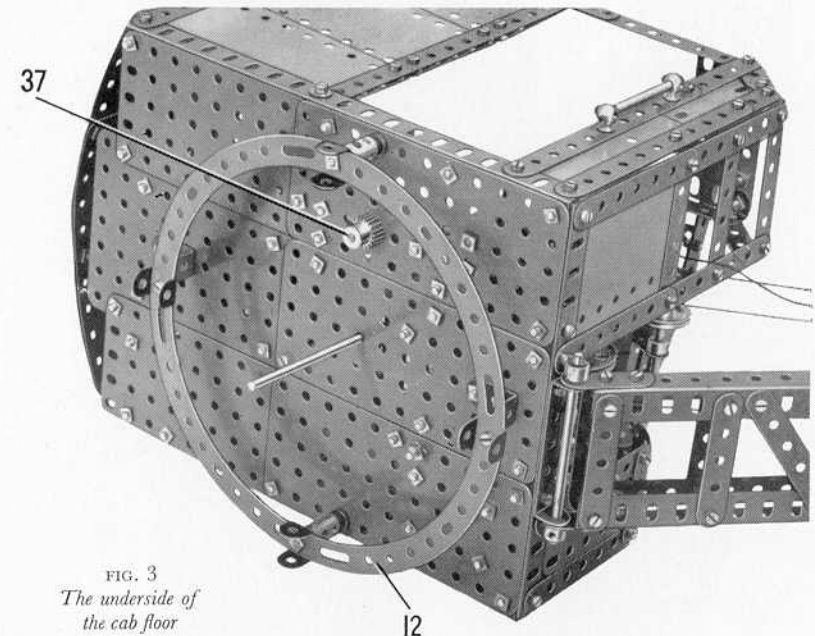
FIG. 3
The underside of the cab floor

drives a 57-tooth Gear (14) on a 3" Rod. A $\frac{1}{2}$ " Pinion on the opposite end of this Rod engages a 57-tooth Gear on a $3\frac{1}{2}$ " Rod (15). This Rod is supported in the top front holes of the Motor side-plates, and is retained in place by a $\frac{1}{2}$ " Pinion. A $\frac{3}{4}$ " Sprocket on Rod (15) is connected by Chain to a 2" Sprocket on a $4\frac{1}{2}$ " Rod (16). Rod (16) is mounted in the Motor side-plates as shown and in two $2\frac{1}{2}$ " \times $1\frac{1}{2}$ " Flanged Plates (17) bolted to the base. The top flanges of the Flanged Plates are joined by a 2" Strip, and a $2\frac{1}{2}$ " \times $\frac{1}{2}$ " Double Angle Strip is bolted to one of the Plates and to the Motor. The second Flanged Plate is connected to the Double Angle Strip by an Angle Bracket. A $\frac{1}{2}$ " Pinion on Rod (16) drives a 57-tooth Gear on a 2" Rod (18), which is mounted in the Flanged Plates. A $\frac{3}{4}$ " Sprocket (19) is fixed on the Rod (18).

Arrangement of the Gear-box Drive (Figs. 6, 7 and 11)

The housing for the gear-box is made by bolting two $3\frac{1}{2}$ " \times $2\frac{1}{2}$ " Flanged Plates (20) (Fig. 7) and a similar Flanged Plate (21) to the floor of the cab. The Plates are spaced from the floor by a $7\frac{1}{2}$ " Strip, one end of which is seen at (22) (Fig. 11). The Flanged Plate (21) and one of the Plates (22) are each extended towards the rear by a $2\frac{1}{2}$ " \times $2\frac{1}{2}$ " Flat Plate (23), which is connected to its Flanged Plate by Fishplates. A vertical $7\frac{1}{2}$ " Strip (24) (Fig. 11) is bolted to the front edge of each of the Flat Plates (23). These Strips are connected by a $2\frac{1}{2}$ " \times $\frac{1}{2}$ " Double Angle Strip as shown in Fig. 6, and by a similar part bolted between the top ends of the Strips. The Strips are braced to the upper rear corners of the Flat Plates (23) by $5\frac{1}{2}$ " Angle Girders (25) (Figs. 6 and 7) which are connected by three $2\frac{1}{2}$ " Strips (see Fig. 7).

A $2\frac{1}{2}$ " \times $\frac{1}{2}$ " Double Angle Strip is bolted between the Flat Plates (23) by a bolt (26) (Fig. 11) on each side, and a $2\frac{1}{2}$ " \times $1\frac{1}{2}$ " Double Angle Strip is used to connect the Flat Plates to the floor of the cab. The Flanged Plates (20) (Fig. 7) are joined together by two $1\frac{1}{2}$ " Strips bolted to their upper flanges.

The gear-box has three driving or input shafts, each of which is a 2" Rod supported in the Flanged Plates (20) and fitted with a 1" Sprocket and a $\frac{3}{4}$ " Pinion. One of these shafts is indicated at (27) (Figs. 6 and 7), and it is mounted in the next to top holes of the rear edges of the Flanged Plates (20). This shaft is used to engage the *forward* drive for the travelling movement and the lifting drive to the luffing drum. The second driving shaft is seen at (28) (Fig. 7). This shaft is mounted in the *centre* holes of the Flanged Plates (20), and it will be seen that its $\frac{3}{4}$ " Pinion is fixed towards the centre of the shaft, so that a gap sufficient to accommodate a 50-tooth Gear is left between the Pinions on the shafts (27) and (28). The shaft (28) is used to provide the reverse drives for all four movements of the gear-box, and it is located in its bearings by a collar formed by the other half of the Dog Clutch. Unfortunately the third driving shaft cannot be seen in our illustrations, but

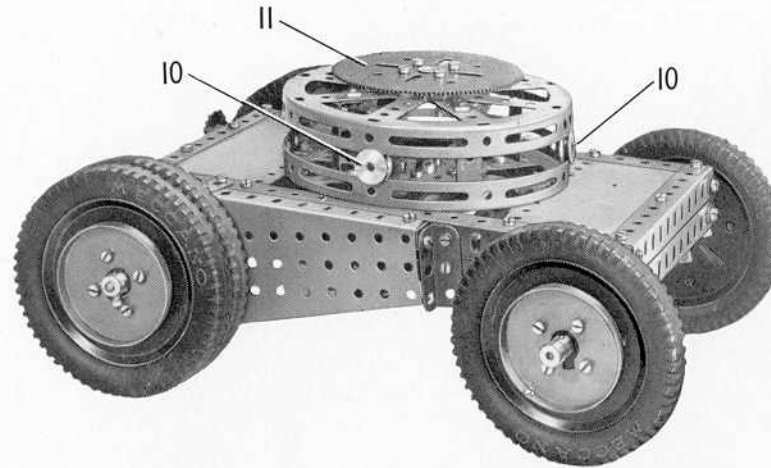

FIG. 4

A general view of the wheeled base or undercarriage

the arrangement of its Sprocket and Pinion is the same as for the shaft (27). This third shaft, however, is mounted in the next to bottom holes along the *front* edges of the Flanged Plates (20), and it provides the drive to the hoisting movement of the bucket, and also to the cab slewing motion in one direction. To simplify the description of the drives from the third shaft it will be referred to as shaft (29), but of course this number does not appear in the illustrations as the shaft cannot be seen.

The drive to the gear-box is by Chain from the Sprocket (19) (Fig. 7). The Chain passes *over* and round the Sprocket on shaft (27), *under* and round the Sprocket on shaft (28), and *over* and round the Sprocket on the hidden third shaft (29). This arrangement ensures that shaft (28) turns in the opposite direction to the shafts (27) and (29).

The Bucket Arm and the Slewing Motion Drives (Figs. 1, 5 and 11)

The shaft that carries the bucket arm hoisting drum is a 5" Rod (30) (Fig. 11), mounted in the Flanged Plates (20) and (21). The drum (seen at 31 Fig. 1) is a Sleeve Piece pressed inside the teeth of a $\frac{3}{4}$ " Contrate and fixed on the Rod between this Contrate and a $1\frac{1}{2}$ " Pulley (32). A length of Cord tied to the $7\frac{1}{2}$ " Angle Girder at the front of the cab is passed round the Pulley (32) and is fastened to a Driving Band. The Driving Band is stretched slightly and is placed over a $3\frac{1}{2}$ " Rod passed through holes in the lower edges of the Flanged Plate (21) and one of the Flanged Plates (20). This arrangement provides a constant braking effect on the winding drum shaft (30).

The drum shaft (30) carries a 50-tooth Gear arranged so that it can be meshed with the Pinion on the shaft (28) or the Pinion on the hidden shaft (29). The Gear is engaged with the appropriate Pinion by sliding the Rod (30) by means of a lever (33) (Fig. 11). This lever is a $2\frac{1}{2}$ " Rod fitted in a Rod and Strip Connector *lock-nutted* to a Double Bracket bolted to the base of the cab. The lever engages between two Collars on the drum shaft (30).

The drive to the slewing motion is engaged by meshing a 50-tooth Gear on a $6\frac{1}{2}$ " Rod (34) (Fig. 11) with either of the Pinions on shafts (28) and (29), in the same way as the drive to the drum shaft (30) already described. The movement of Rod (34) is controlled by a lever (35), which is a $1\frac{1}{2}$ " Rod held in a Rod and Strip Connector that is bolted tightly to a $1\frac{1}{2}$ " Strip. This Strip is *lock-nutted* to the other lug of the Double Bracket that supports the lever (33). A $\frac{3}{8}$ " Bolt fixed in the $1\frac{1}{2}$ " Strip by two nuts engages between a Collar and a $\frac{1}{2}$ " Pinion (36) on Rod (34). The outer end of the Rod (34) is supported by a $1"$ \times $1"$ Angle Bracket, which is spaced from the floor of the cab by a Fishplate.

Pinion (36) engages a $\frac{3}{4}$ " Contrate on a $3\frac{1}{2}$ " Rod, which is supported in the lugs of a $2\frac{1}{2}$ " \times $1"$ Double Angle Strip spaced from the floor of the cab by a $2\frac{1}{2}$ " Strip. Each lug is strengthened by a $1"$ \times $\frac{1}{2}"$ Angle Bracket bolted to the lug and to the floor. A $\frac{3}{8}$ " Bevel Gear on the $3\frac{1}{2}"$ Rod drives a similar

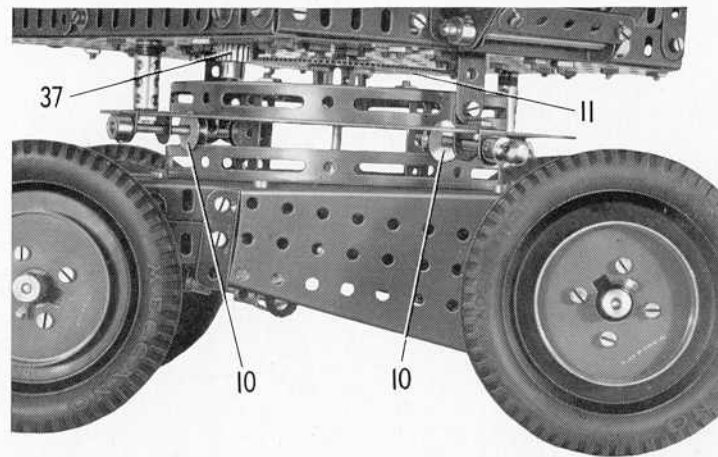

FIG. 5 A close-up of the roller bearing unit mounted on the wheeled base

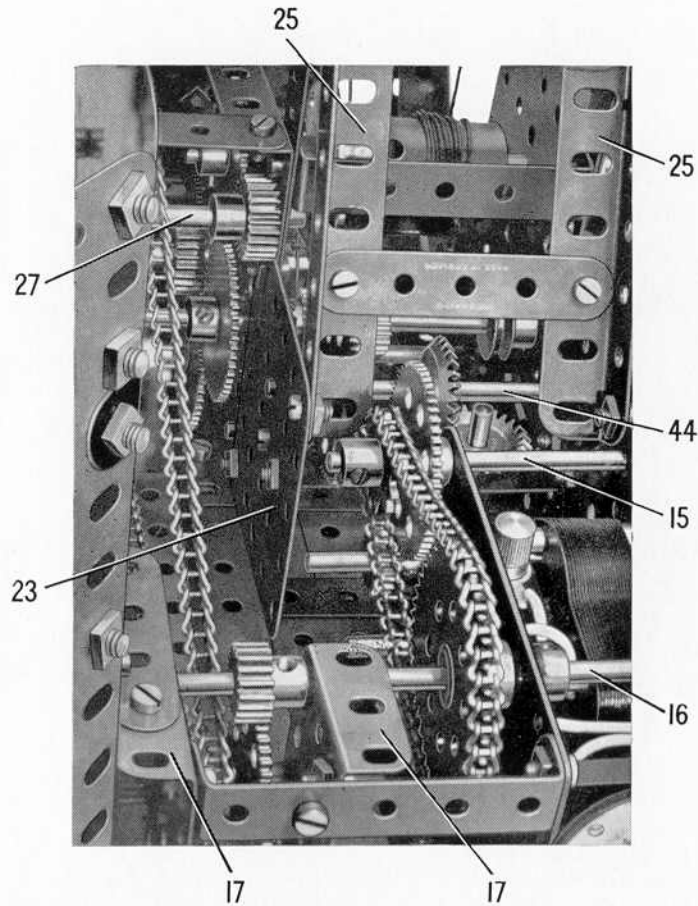

FIG. 6

A close-up of the Motor reduction gearing and the gear-box housed in the cab

Bevel Gear on a 1" Rod passed through the floor of the cab. A $\frac{1}{2}$ " Pinion (37) (Fig. 5) on the lower end of the 1" Rod engages the Gear (11) of the roller bearing.

Drives to the Luffing and Travelling Movements (Figs. 1, 2, 4, 5, 6, 7 and 11)

The luffing drum, which is seen at (38) (Fig. 1), consists of a Sleeve Piece fitted with a Chimney Adaptor at one end and connected at its other end to a $1\frac{1}{2}$ " Pulley by an Angle Bracket. The Pulley is fixed on a 5" Rod (39) (Fig. 11), and is provided with a Cord brake in the same way as the Pulley (32) (Fig. 1). Rod (39) carries a 50-tooth Gear that can be meshed with the Pinions on shafts (27) and (28), as already described in connection with the drive to Rod (30). The movement of Rod (39) is controlled by a lever (40) (Fig. 11), which is a 1" Rod in a Rod and Strip Connector that is bolted tightly to a $1\frac{1}{2}$ " Strip. The bolt head engages between two Collars on Rod (39), and the Strip is *lock-nutted* to an Angle Bracket bolted to the Flanged Plate (21).

The drive to the travelling motion is engaged by sliding a 5" Rod (41) (Fig. 11) to bring a 50-tooth Gear into mesh with the Pinion on either shaft (27) or shaft (28) (Fig. 7). The sliding motion is controlled by a lever (42) (Fig. 11), which is a $2\frac{1}{2}$ " Rod in a Rod and Strip Connector. The lever engages between two Collars on Rod (41), and the Rod and Strip Connector is *lock-nutted* to an Angle Bracket bolted to the floor of the cab. Rod (41) is fitted with a $\frac{1}{2}$ " diameter, $\frac{3}{4}$ " face Pinion (43), and this drives a 57-tooth Gear on a $2\frac{1}{2}$ " Rod (44) (Figs. 6 and 7). A $\frac{3}{8}$ " Bevel Gear on Rod (44) engages a similar Bevel Gear on a vertical Rod supported in the floor of the cab and in the Double Angle Strip held by the bolts (26). The vertical Rod passes freely through the Gear (11) (Figs. 4 and 5) and the centre of the roller bearing unit, and at its lower end it is fitted with a $\frac{3}{8}$ " Bevel Gear (45) (Fig. 2) that drives the Bevel Gear (3) of the wheeled base.

FIG. 7
A view of the general layout inside the cab

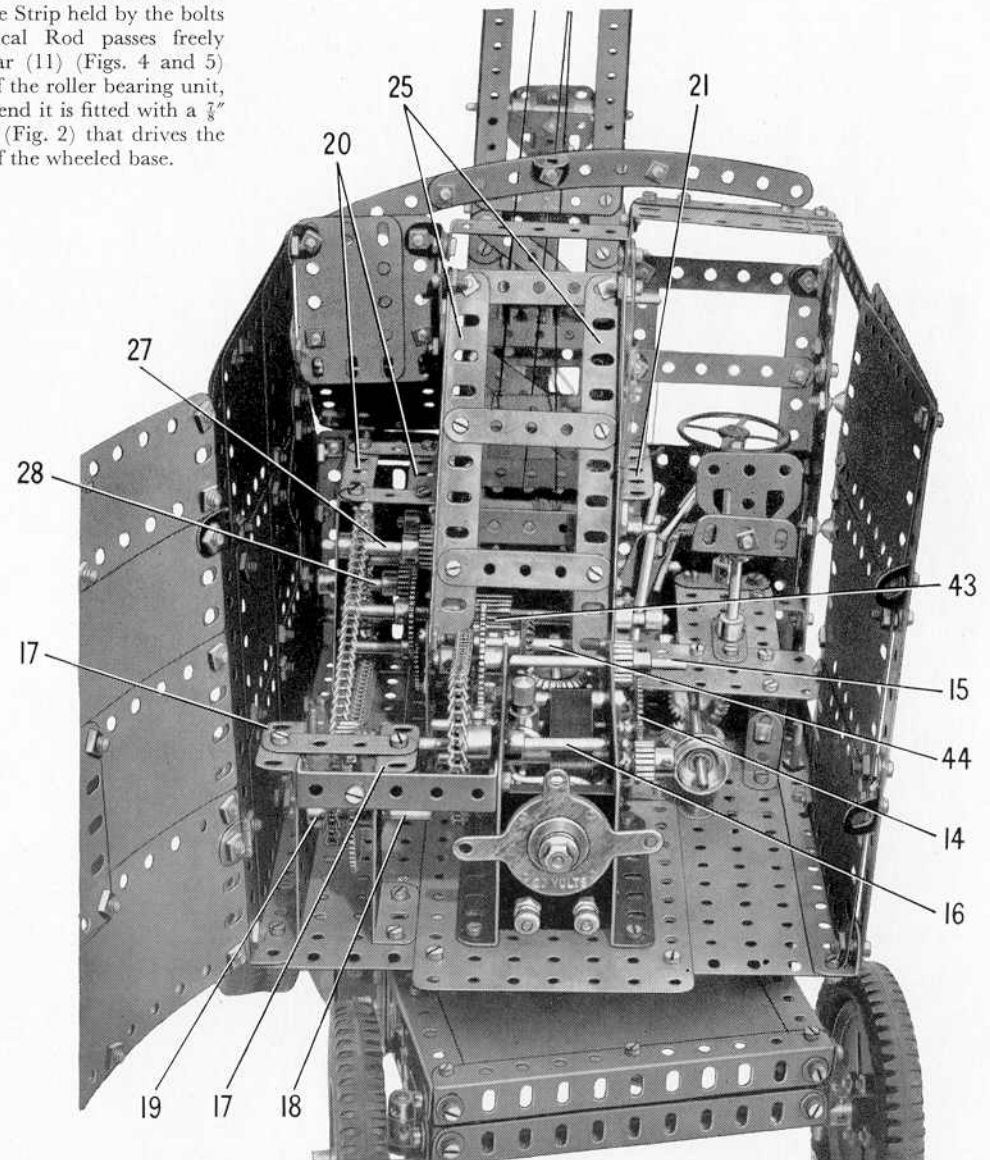

Details of the Jib (Figs. 1 and 8)

Two $1\frac{1}{2}$ " Angle Girders are connected together by $2\frac{1}{2}$ " Strips as shown (Fig. 1), and are braced by diagonal 3" Strips. Two $12\frac{1}{2}$ " Strips on each side are overlapped 13 holes, and are then attached to the Girder by Angle Brackets. The $12\frac{1}{2}$ " Strips are linked and braced by $2\frac{1}{2}$ " and 3" Strips in the same way as the Angle Girders. The lower end of each Angle Girder is extended one hole by a $1\frac{1}{2}$ " Strip. These Strips are mounted on a $3\frac{1}{2}$ " Rod supported in a $2\frac{1}{2}$ " \times $\frac{1}{2}$ " Double Angle Strip bolted to the front of the cab. A $3\frac{1}{2}$ " Rod is mounted at the top of the jib, and on it are placed two 1" Pulleys (46).

Two $1\frac{1}{2}$ " Corner Brackets are bolted to the top of the jib, and two $2\frac{1}{2}$ " \times $\frac{1}{2}$ " Double Angle Strips are *lock-nutted* to them by $\frac{3}{8}$ " Bolts. A Fishplate is bolted to the centre of each Double Angle Strip, and a 1" loose Pulley (47) (Fig. 8) is freely mounted on a Pivot Bolt passed through the Fishplates and fixed by its nuts. The Pulley is spaced centrally on the Pivot Bolt by Washers.

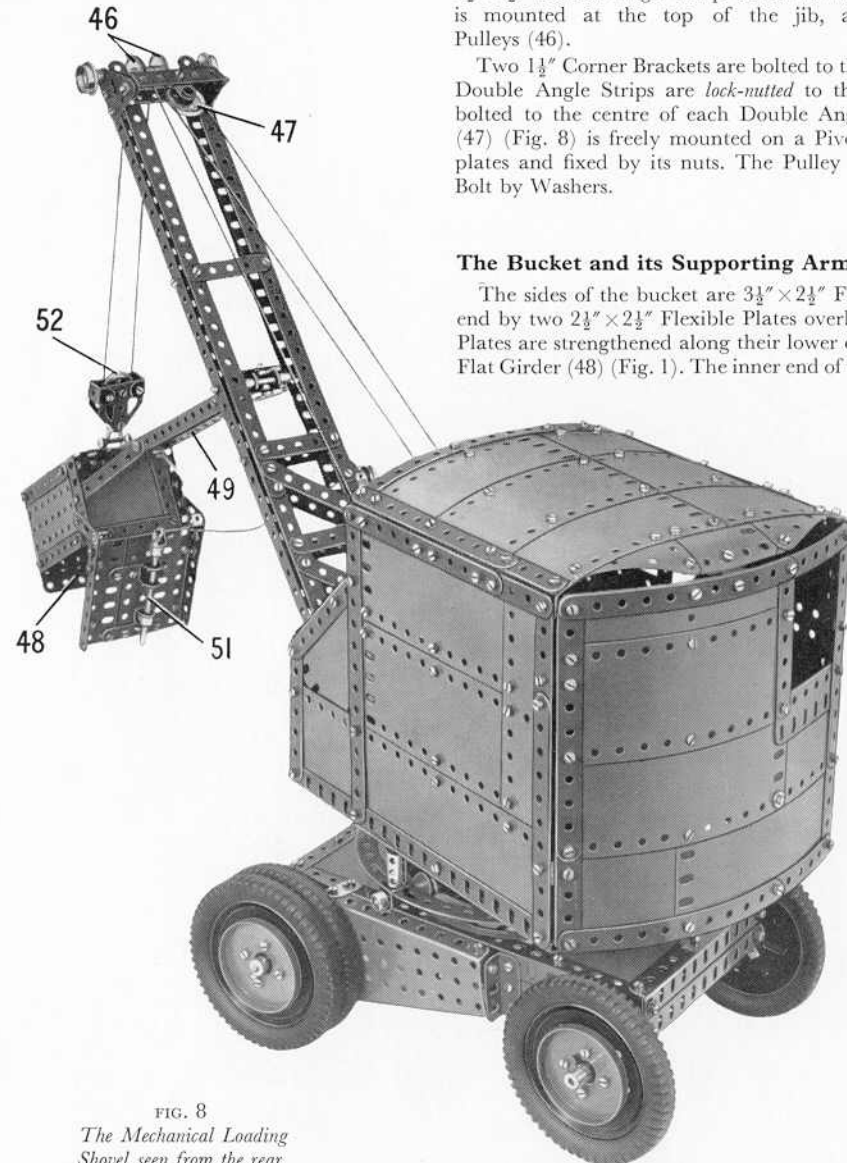

FIG. 8
The Mechanical Loading
Shovel seen from the rear

The Bucket and its Supporting Arm (Figs. 1 and 8)

The sides of the bucket are $3\frac{1}{2}$ " \times $2\frac{1}{2}$ " Flanged Plates, connected at each end by two $2\frac{1}{2}$ " \times $2\frac{1}{2}$ " Flexible Plates overlapped four holes. The inner end Plates are strengthened along their lower edges by a 3" Strip, and the outer end Plates by a 3" Strip and a 3" Flat Girder (48) (Fig. 1). The inner end of the bucket is edged by two $2\frac{1}{2}$ " Angle Girders and a 3" Angle Girder.

The bucket arm consists of four $9\frac{1}{2}$ " Strips. The two side Strips are attached to the bucket by Angle Brackets, and are tied to its sides by 3" Strips shaped as shown. Each of the side $9\frac{1}{2}$ " Strips is fitted at its inner end with a Crank, and these are fixed on a 3" Rod mounted in the jib. The arm is made into a box-section girder by two further $9\frac{1}{2}$ " Strips (49), each of which is fitted at its inner end with a Flat Trunnion. One of the Strips (49) is attached to the bucket by an Angle Bracket, and the two Strips are then held against the edges of the side $9\frac{1}{2}$ " Strips by $\frac{1}{4}$ " Bolts. These Bolts are passed through the Strips (49).

The bucket has a hinged flap (see Fig. 8) which consists of a $3\frac{1}{2}$ " Angle Girder and a $3\frac{1}{2}$ " Flat Girder on each side, connected by two 2" Strips bolted to the Flat Girders. Two $3\frac{1}{2}$ " Strips are fixed to the 2" Strips. A Bell Crank (50) is bolted to each $3\frac{1}{2}$ " Angle Girder, and is *lock-nutted* to one of the $2\frac{1}{2}$ " Angle Girders that edge the inner end of the bucket.

The hinged flap can be released to discharge the contents of the bucket by opening a catch (51) (Fig. 8). This is a $3\frac{1}{2}$ " Rod fitted with an End Bearing, and it slides freely in a Double Bracket and an Angle Bracket bolted to the back of the hinged flap. A Collar restricts the sliding movement of the Rod. When the flap is closed the lower end of the Rod passes through a hole in the Flat Girder (48).

A pivoted pulley block is fitted to the bucket as shown in Fig. 1. It is formed by two Flat Trunnions connected by Double Brackets, with a 1" loose Pulley (52) (Fig. 8) freely mounted on a Pivot Bolt. Bolts passed through the holes at the pointed ends of the Flat Trunnions are screwed into the boss of a small Fork Piece. The Fork Piece pivots on a 1" Screwed Rod, which is fixed by nuts in Angle Brackets bolted to the 3" Angle Girder.

The Cab: Front, Roof and Back (Figs. 1, 8 and 11)

The front of the control cabin is made from a $3\frac{1}{2}$ " \times $2\frac{1}{2}$ " Flexible Plate and Strips as shown in Fig. 1. The side window is formed by a $3\frac{1}{2}$ " Strip at the front, connected to the upper end of one of the Strips (24) (Fig. 11) by two 2" Strips. A $4\frac{1}{2}$ " Strip (53) is bolted diagonally across the window and is connected to the $3\frac{1}{2}$ " Strip by a 2" Strip, placed horizontally. A $2\frac{1}{2}$ " \times $\frac{1}{2}$ " Double Angle Strip is bolted between the Strip (53) and between a similar Strip on the opposite side. The roof over the cabin is made from two $2\frac{1}{2}$ " \times $1\frac{1}{2}$ " Flexible Plates supported by Angle Brackets.

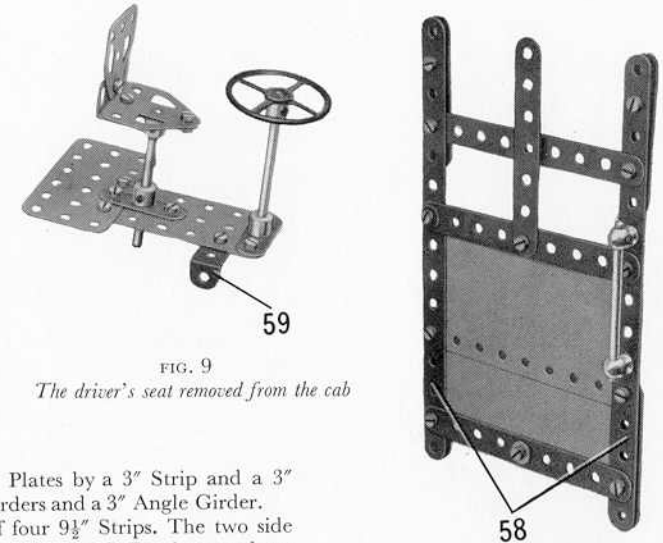

FIG. 9
The driver's seat removed from the cab

FIG. 10
Detail of the sliding
door of the cab

The lower part of the front opposite to the control cabin consists of two vertical $3\frac{1}{2}$ " Strips connected at their upper ends by a 2" Strip, and joined to the side of the cab by an Angle Bracket. A $2\frac{1}{2}$ " \times $1\frac{1}{2}$ " Flexible Plate is fixed to one of the $3\frac{1}{2}$ " Strips. Two $2\frac{1}{2}$ " \times $1\frac{1}{2}$ " Flexible Plates (54) (Fig. 1) are connected by a 2" Flat Girder and a 2" Strip, and this assembly is attached to the lower part of the front by an Obtuse Angle Bracket. Two further $2\frac{1}{2}$ " \times $1\frac{1}{2}$ " Flexible Plates (55) are connected to the side of the cab and to one of the Strips (24) (Fig. 11) by Angle Brackets, and are joined to the Plates (54) by two Obtuse Angle Brackets. The front is completed by two $5\frac{1}{2}$ " Curved Strips overlapped seven holes.

The roof is formed by $4\frac{1}{2}$ " \times $2\frac{1}{2}$ " Flexible Plates, two $2\frac{1}{2}$ " \times $1\frac{1}{2}$ " Flexible Plates and two $2\frac{1}{2}$ " \times $1\frac{1}{2}$ " Triangular Flexible Plates, arranged as shown in Fig. 8 and edged by Strips. The joints between the Plates are strengthened on the inside by pairs of $5\frac{1}{2}$ " Strips overlapped six holes each. The roof is attached to the sides of the cab by Obtuse Angle Brackets, and to the Curved Strips of the front by an Angle Bracket.

The construction of the back is shown in Fig. 8. It is attached to one side by two Hinges, and bolted to Obtuse Angle Brackets fixed to the other side.

Arrangement of the Cords (Figs. 1 and 8)

The luffing Cord is tied to the drum (38) (Fig. 1), is passed over a 1" Pulley on a Rod (56) and round the 1" loose Pulley (47) (Fig. 8). It passes over a second 1" Pulley on Rod (56) (Fig. 1) and is tied to the $2\frac{1}{2}$ " \times $\frac{1}{2}$ " Double Angle Strip that is bolted to the Strip (53). The

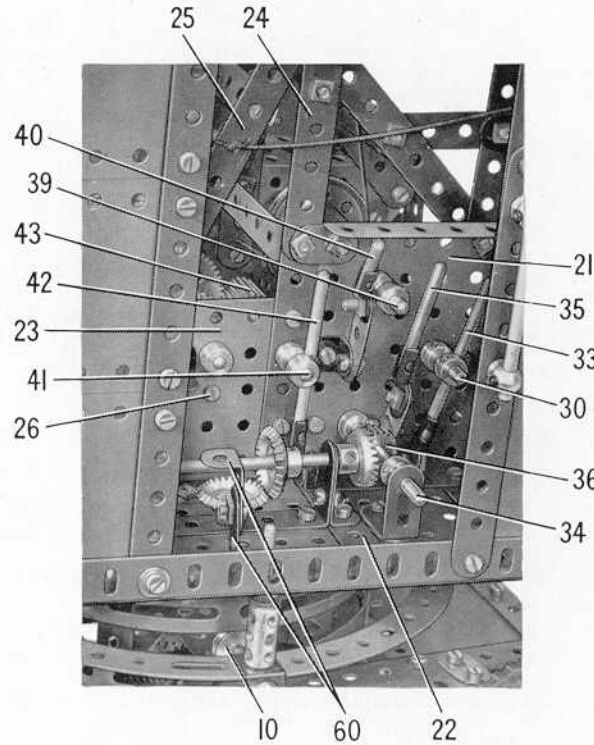

FIG. 11

The control levers are grouped together, and access to them is gained by sliding the movable cab door

Rod (56) is mounted in a $2\frac{1}{2}$ " \times 1" Double Angle Strip bolted to the upper ends of the Girders (25) (Fig. 7).

The Cord for controlling the bucket is fastened to the drum (31), is taken over one of the Pulleys (46) (Fig. 1), round Pulley (52) (Fig. 8) of the bucket, and is passed over the second Pulley (46). The Cord is tied finally to one of the bracing Strips of the jib.

A length of Cord tied to the End Bearing of the bucket discharge catch is taken over a $\frac{1}{2}$ " loose Pulley (57) (Fig. 1) and is fastened inside the cab. Pulley (57) is free to turn on a $\frac{1}{2}$ " Bolt, which is fixed by a nut in a Threaded Crank bolted to the jib. The Cord is retained in the groove of the Pulley by a Fishplate bolted to an Angle Bracket, which is fixed to the jib.

The Cab: Sliding Door and the Driver's Seat

The sliding door of the cab is made by bolting two $4\frac{1}{2}$ " \times $2\frac{1}{2}$ " Flexible Plates between two $7\frac{1}{2}$ " Strips (58) (Fig. 10). The window frame is made from Strips as shown. A $2\frac{1}{2}$ " Strip is attached to each end of each Strip (58) by two $\frac{3}{8}$ " Bolts, but is spaced from the Strip (58) by a nut and a Washer on each Bolt. The lower ends of the Strips (58) and their $2\frac{1}{2}$ " Strips fit over the Angle Girder that edges the floor of the cab, and the upper ends of the Strips slide freely over the strip (13) (Fig. 1).

The driver's seat is seen removed from the cab in Fig. 9. It is connected to the side of the cab by a 1 " \times $\frac{1}{2}$ " Angle Bracket (59), and is supported by two 1 " \times $\frac{1}{2}$ " Angle Brackets (60) (Fig. 11) bolted together as shown.

Parts Required to Build the Meccano Mechanical Loading Shovel

4 of No. 1	2 of No. 9b	1 of No. 15b	1 of No. 24	85 of No. 38	3 of No. 62b	2 of No. 103e	4 of No. 137	4 of No. 190
4 " " 1a	1 " " 9c	6 " " 16	1 " " 24b	1 " " 40	7 " " 63	1 " " 103g	2 " " 140	2 " " 190a
6 " " 1b	2 " " 9d	6 " " 16a	4 " " 25	3 " " 46	3 " " 70	4 " " 103h	6 " " 142b	11 " " 191
23 " " 2	3 " " 9f	\pm 4 " " 16b	6 " " 26	1 " " 47	2 " " 72	6 " " 111	1 " " 144	9 " " 192
8 " " 2a	14 " " 10	8 " " 17	1 " " 26b	4 " " 48	2 " " 73	1 " " 111a	\pm 1 " " 145	1 " " 196
16 " " 3	9 " " 11	6 " " 18a	4 " " 27	8 " " 48a	2 " " 81	14 " " 111c	2 " " 147b	4 " " 212
12 " " 4	48 " " 12	4 " " 18b	4 " " 27a	2 " " 51	1 " " 82	2 " " 114	2 " " 163	2 " " 221
34 " " 5	4 " " 12a	6 " " 19b	1 " " 27b	1 " " 52a	2 " " 89	\pm 2 " " 118	2 " " 164	
11 " " 6	5 " " 12b	3 " " 20b	2 " " 29	5 " " 53	1 " " 94	2 " " 126	2 " " 165	
9 " " 6a	9 " " 12c	2 " " 21	\pm 6 " " 30	2 " " 53a	2 " " 95	6 " " 126a	1 " " 166	
2 " " 7a	1 " " 13a	4 " " 22	1 " " 32	2 " " 54	2 " " 95a	2 " " 128	1 " " 185	1 E15R
6 " " 8a	3 " " 14	2 " " 22a	4 " " 35	24 " " 59	4 " " 96	2 " " 133	2 " " 186	Electric Motor
1 " " 8b	4 " " 15	4 " " 23	539 " " 37a	4 " " 62	2 " " 96a	4 " " 136	10 " " 188	(not included
8 " " 9	4 " " 15a	2 " " 23a	474 " " 37b	1 " " 62a	2 " " 103d	2 " " 136a	5 " " 189	in Outfit)