

MECCANO®

BOOK OF MODELS

VOORBEELDENBOEK

LIVRE DES MODÈLES

LIBRO DEI MODELLI

MODELLBUCH

MODELLBOK















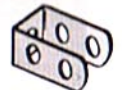











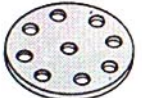

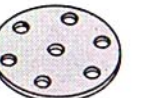







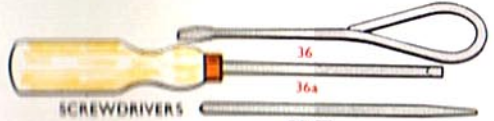
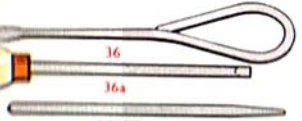

LIBRO DE MODELOS

LIVRO DE MODELOS

MODELLBOK

5/6/7

Complete list of Meccano Parts
Komplete lijst van Meccano-onderdelen
Liste complète des pièces Meccano
Distinta delle componenti del Corredo Meccano
Vollständige Liste der Meccano-Teile
Fullständig förteckning över Meccanodelar
Lista completa de piezas de Meccano
Lista completa de peças do Meccano
Komplett liste over Meccanodeler

 <p>5 PERFORATED STRIPS</p> <p>1 - 12½"; 32 cm 1a - 9½"; 24 cm 1b - 7½"; 19 cm 2 - 5½"; 14 cm 2a - 4½"; 11½ cm</p> <p>6</p> <p>3 - 3½"; 9 cm 4 - 3"; 7½ cm 5 - 2½"; 6 cm 6 - 2"; 5 cm 6a 1½"; 38 mm</p>	 <p>9c ANGLE GIRDERS</p> <p>7 - 24½"; 62 cm 7a - 18½"; 47 cm 8 - 12½"; 32 cm 8a - 9½"; 24 cm 8b - 7½"; 19 cm 9 - 5½"; 14 cm</p> <p>9a - 4½"; 11½ cm 9b - 3½"; 9 cm 9c - 3"; 7½ cm 9d - 2½"; 6 cm 9e - 2"; 5 cm 9f - 1½"; 38 mm</p>	 <p>FISHPLATE 10</p>	 <p>DOUBLE BRACKET 11 - ½" × ½"; 12 × 12 mm</p>	 <p>DOUBLE BRACKET 11a - 1" × ½"; 25 × 12 mm</p>	 <p>12 ANGLE BRACKETS</p> <p>12 - ½" × ½"; 12 × 12 mm 12a - 1" × ½"; 25 × 25 mm 12b - 1" × ¼"; 25 × 12 mm</p>	 <p>ANGLE BRACKET (OBTUSE) 12c - ½" × ¼"; 13 × 13 mm</p>	 <p>AXLE RODS</p> <p>13 - 11½"; 29 cm 13a - 8"; 20 cm 14 - 6½"; 16½ cm 14a - 5½"; 14 cm 15 - 5"; 13 cm 16a - 4½"; 11½ cm 16 - 4"; 10 cm</p> <p>16 - 3½"; 9 cm 16a - 2½"; 6 cm 16b - 3"; 7½ cm 17 - 2"; 5 cm 18a - 1½"; 38 mm 18b - 1"; 25 mm</p>		
 <p>SPOKED WHEEL 19a - 3"; 75 mm</p>	 <p>PULLEYS 19b - 3"; 75 mm 20a - 2"; 5 cm</p>	 <p>PULLEY 19c - 6"; 15 cm</p>	 <p>CRANK HANDLE 19h - 5"; 13 cm 19s - 3½"; 9 cm</p>	 <p>FLANGED WHEELS 20 - 1½"; 38 mm 20b - ½"; 19 mm</p>	 <p>PULLEY 21 - 1½"; 38 mm</p>	 <p>PULLEY 22 - 1"; 25 mm</p>			
 <p>22a PULLEYS 22a - 1"; 25 mm 23 plastic - ½"; 12 mm 23b metal - ½"; 12 mm</p> <p>23 & 23b 23a - ½"; 12 mm</p>	 <p>BUSH WHEEL 24 - 1½"; 34 mm</p>	 <p>WHEEL DISC 24a - 1½"; 34 mm</p>	 <p>BUSH WHEEL 24b - 1½"; 34 mm</p>	 <p>WHEEL DISC 24c - 1½"; 34 mm</p>	 <p>25 PINIONS</p> <p>25 - 2" × 1"; 19 × 6 mm 25a - 2" × 1"; 19 × 12 mm 25b - 2" × 1"; 19 × 19 mm 26 - 2" × 1"; 12 × 6 mm 26a - 2" × 1"; 12 × 12 mm 26b - 2" × 1"; 12 × 19 mm 26c - 1½" × 1"; 11 × 6 mm</p>	 <p>27 GEAR WHEELS</p> <p>27 - 1½"; 38 mm 27a - 1½"; 38 mm 27d - 1½"; 41 mm</p> <p>27c GEAR WHEELS</p> <p>27b - 3"; 9 cm 27c - 2½"; 6 cm</p>			
 <p>27f MULTI-PURPOSE GEAR WHEEL</p>	 <p>28 CONTRATE WHEEL 28 - 1½"; 38 mm 29 - ½"; 19 mm</p>	 <p>30 BEVEL GEAR For use in pairs. 30 - ½"; 22 mm</p>	 <p>30a BEVEL GEARS can only be used together. 30a - ½"; 12 mm 30c - ½"; 38 mm</p>	 <p>31 GEAR WHEEL 31 - 1" × ½" 25 mm × 6 mm</p>	 <p>32 WORM 32 - ½"; 12 mm</p>	 <p>34 SPANNER</p>	 <p>35 SPRING CLIP</p>	 <p>36 SCREWDRIVERS 36a</p>	 <p>36c DRIFT</p>
 <p>37b BOLT 37b - ½"; 5 mm</p>	 <p>38 WASHERS 38 - ½"; 10 mm 38d - ½"; 19 mm</p>	 <p>37a NUT</p>	 <p>37 NUT AND BOLT</p>	 <p>40 HANK OF CORD</p>	 <p>41 PROPELLER BLADE</p>	 <p>43 TENSION SPRING 43 - 2"; 5 cm</p>	 <p>44 BENT STRIP STEPPED</p>	 <p>45 DOUBLE BENT STRIP</p>	 <p>50 SLIDE PIECE</p>
<p>DOUBLE ANGLE STRIPS</p> <p>46 - 2½" × 1"; 60 × 25 mm 47 - 2" × 1½"; 60 × 38 mm 47a - 3" × 1½"; 75 × 38 mm 48 - 4" × 1"; 38 × 12 mm 48a - 2" × 1"; 60 × 12 mm 48b - 3" × 1"; 90 × 12 mm 48c - 4" × 1"; 115 × 12 mm 48d - 5" × 1"; 140 × 12 mm</p>									

5

5.1.

Car Ferry
Autovervoerboot
Ferry-boat pour voitures
Traghetto per automobili
Autofähre
Bilfärja
Buque transbordador de vehículos
Ferry-boat
Bilferge

4- 1	2- 35	2-126
8- 2	107- 37a	2-126a
2- 3	93- 37b	4-142c
8- 5	11- 38	2-155
3- 10	2- 38d	2-188
2- 11	1- 40	2-189
1- 11a	2- 48	4-190
10- 12	5- 48a	2-191
1- 12c	1- 51	2-192
4- 16	1- 52	1-193
1- 18a	2- 53a	2-194
1- 18b	2- 54	1-212
4- 22	2- 90a	2-212a
2- 22a	2-111	2-214
1- 23	4-111c	4-221
2- 24	2-125	

4- 1	1- 40
7- 2	3- 48a
2- 3	1- 51
6- 5	2- 53a
1- 10	2- 54
2- 11	2- 90a
1- 11a	1-111
10- 12	2-111c
1- 12c	2-125
2- 16	2-126
1- 18a	4-142c
1- 18b	2-188
4- 22	2-189
2- 22a	4-190
1- 23	2-191
1- 24	2-192
81- 37a	1-212
73- 37b	1-212a
10- 38	2-214
1- 38d	4-221

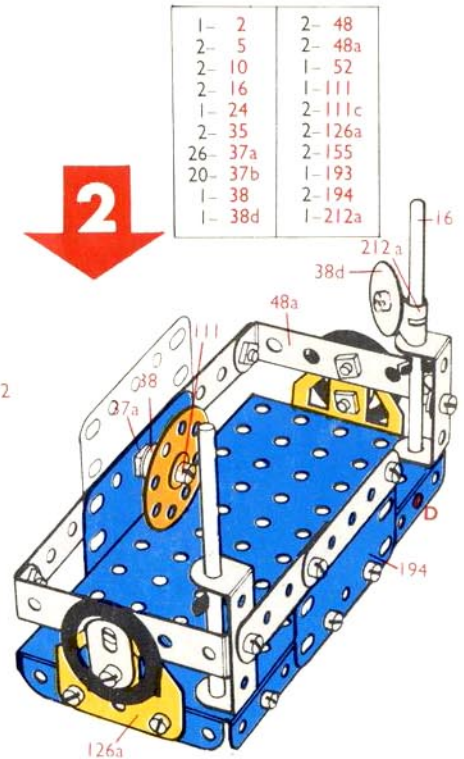
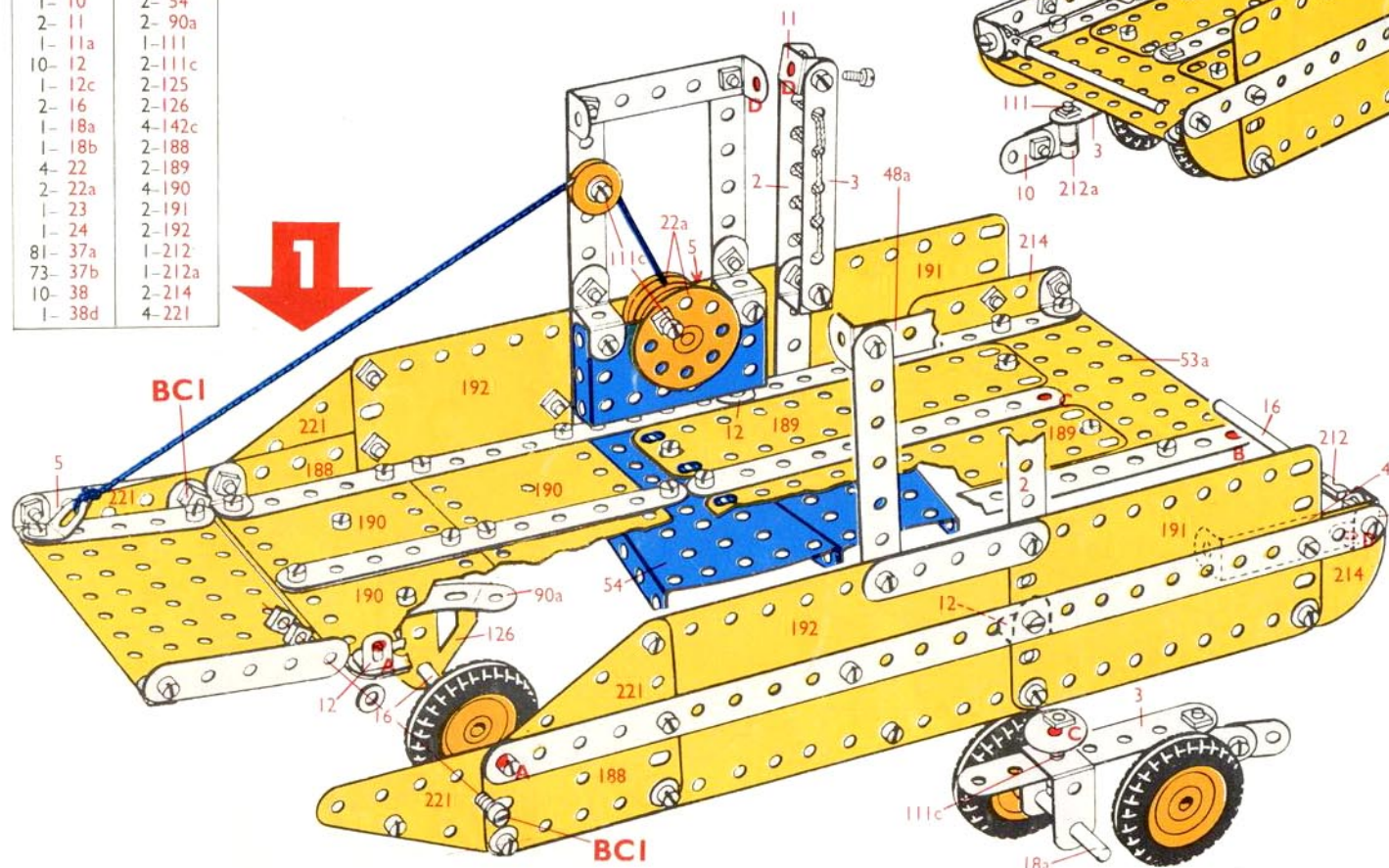
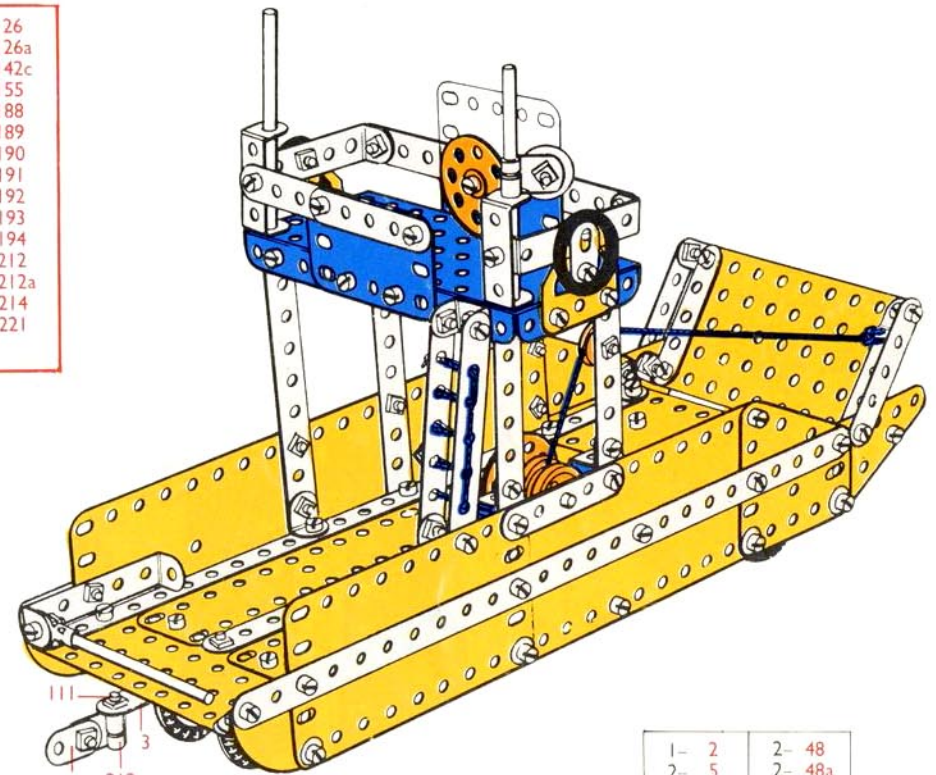

1- 2	2- 48
2- 5	2- 48a
2- 10	1- 52
2- 16	1-111
1- 24	2-111c
2- 35	2-126a
26- 37a	2-155
20- 37b	1-193
1- 38	2-194
1- 38d	1-212a

5.2.

Swing Bridge
Draaibrug
Pont basculant
Ponte girevole
Drehbrücke
Svängbro
Puente giratorio
Ponte levadiça
Svingbro

4- 1	2- 24	4-111c
8- 2	2- 27f	2-125
2- 3	4- 35	2-126
9- 5	101- 37a	2-126a
4- 10	93- 37b	2-188
1- 11	13- 38	2-189
9- 12	1- 40	4-190
2- 12c	6- 48a	2-191
1- 15b	1- 51	2-192
3- 16	1- 52	2-194
1- 19s	2- 53a	2-212a
1- 20a	2- 54	2-214
3- 22	4- 90a	4-221
1- 23a	2-111a	

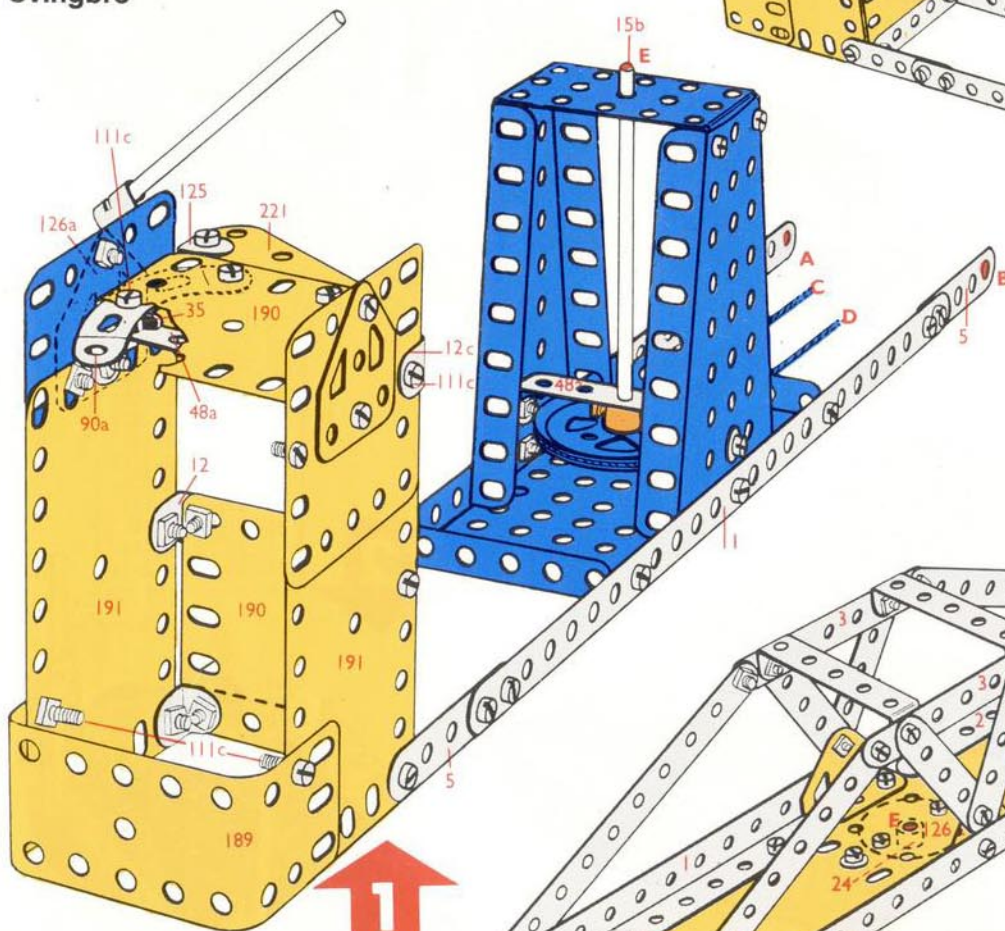
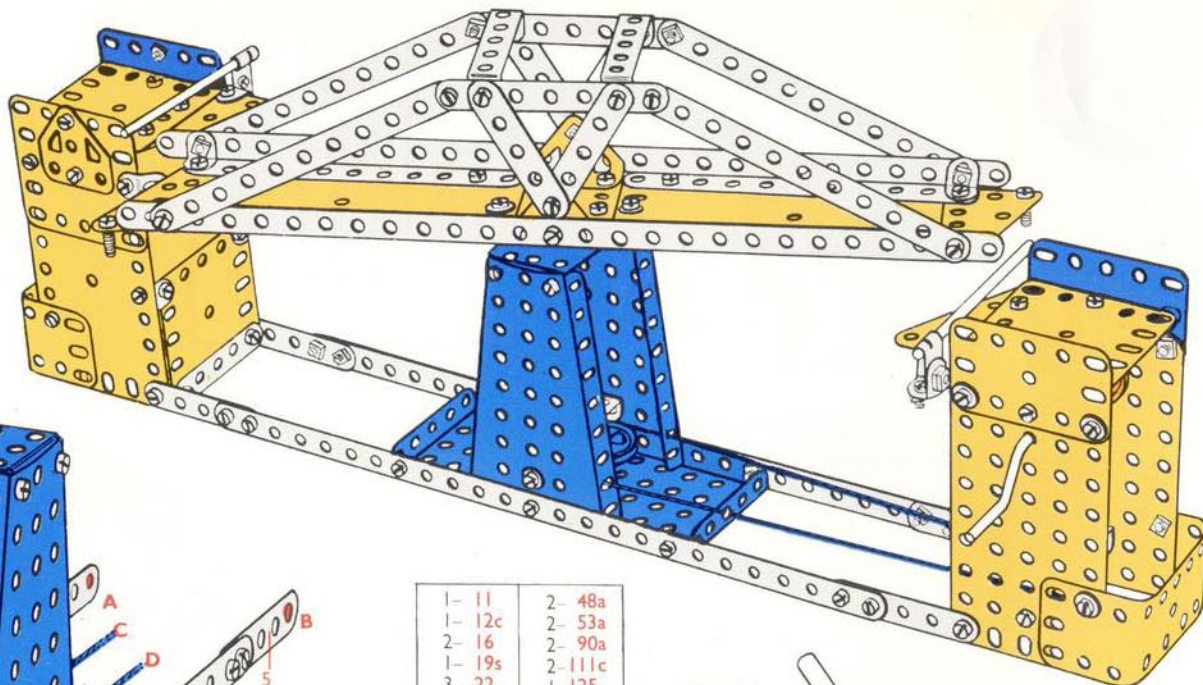

1- 11	2- 48a
1- 12c	2- 53a
2- 16	2- 90a
1- 19s	2-111c
3- 22	1-125
1- 23a	1-188
1- 24	1-189
2- 27f	1-190
2- 35	1-194
20- 37a	1-212a
17- 37b	1-221
9- 38	

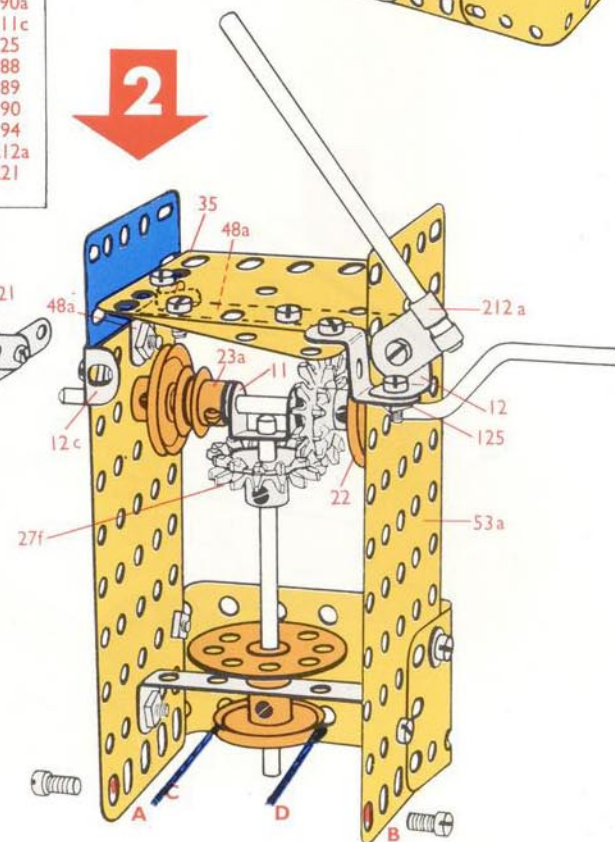
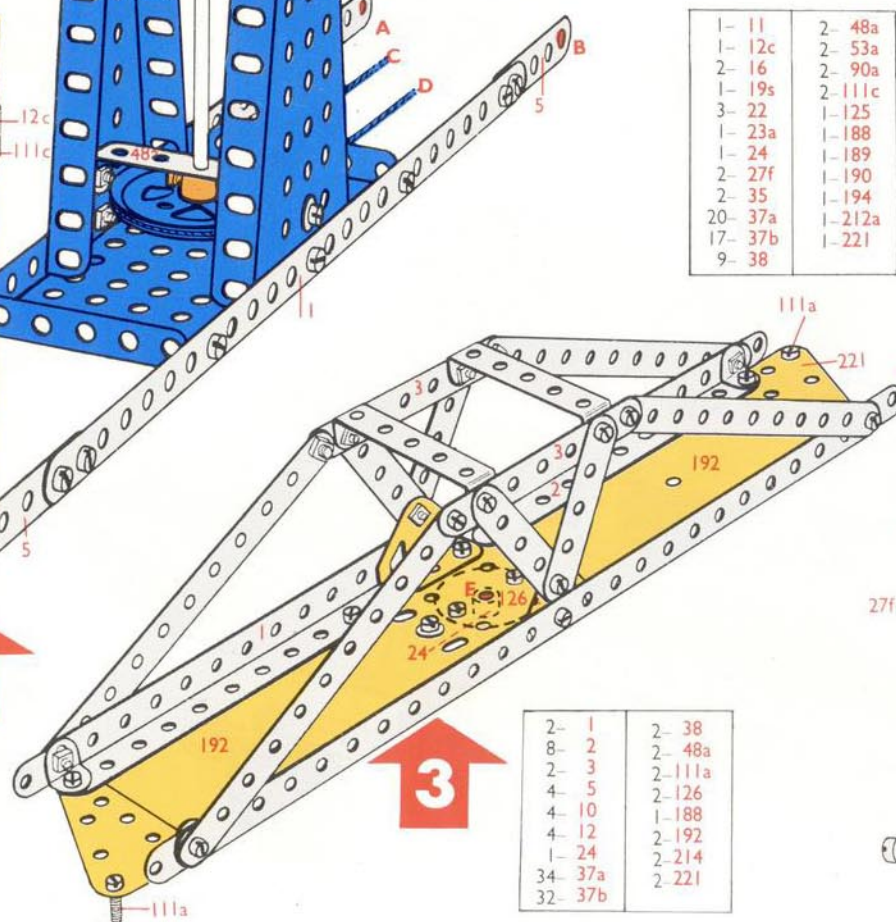

2- 1	44- 37b	1-125
5- 5	2- 38	2-126a
5- 12	1- 40	1-189
1- 12c	2- 48a	3-190
1- 15b	1- 51	2-191
1- 16	1- 52	1-194
1- 20a	2- 54	1-212a
2- 35	2- 90a	1-221
47- 37a	4- 111c	

2- 1	2- 38
8- 2	2- 48a
2- 3	2-111a
4- 5	2-126
4- 10	1-188
4- 12	2-192
1- 24	2-214
34- 37a	2-221
32- 37b	

5.3.

Heavy Goods Lorry

Zware vrachtwagen

Camion poids-lourd

Autocarro per servizio pesante

Schwerlastwagen

Tung lastbil

Camión de mercancías pesadas

Camião de carga

Tung lastebil

4- 1	2- 22	1- 52	2-189
8- 2	2- 22a	2- 53a	4-190
2- 3	1- 23	3- 90a	2-191
9- 5	1- 23a	1-111	2-192
4- 10	1- 24	1-111a	2-193
2- 11	8- 35	6-111c	1-193a
1- 11a	107- 37a	2-125	2-194a
6- 12	93- 37b	2-126	2-212a
1- 12c	14- 38	2-126a	1-213
2- 16	2- 38d	1-155	2-214
2- 17	2- 48	*1-186b	4-215
2- 18a	6- 48a	4-187	4-221
1- 18b	1- 51	2-188	*1-M2

- * Non inclus dans la boîte
- * Not included in set

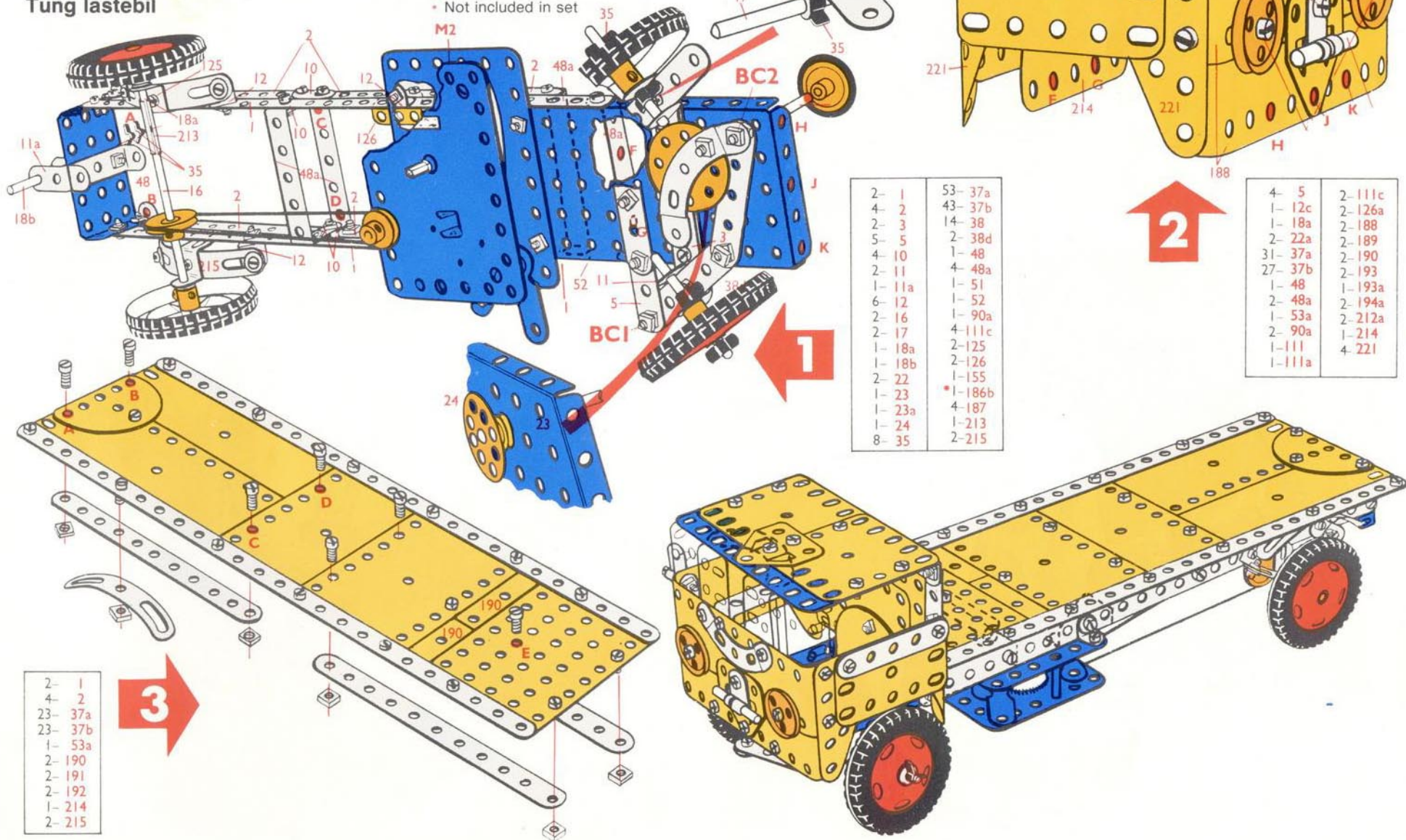

2- 1	53- 37a
4- 2	43- 37b
2- 3	14- 38
5- 5	2- 38d
4- 10	1- 48
2- 11	4- 48a
1- 11a	1- 51
6- 12	1- 52
2- 16	1- 90a
2- 17	4-111c
1- 18a	2-125
1- 18b	2-126
2- 22	1-155
1- 23	*1-186b
1- 23a	4-187
1- 24	1-213
8- 35	2-215

4- 5	2- 111c
1- 12c	2- 126a
1- 18a	2- 188
2- 22a	2- 189
31- 37a	2- 190
27- 37b	2- 193
1- 48	1- 193a
2- 48a	2- 194a
1- 53a	2- 212a
2- 90a	1- 214
1- 111	4- 221
1- 111a	

2- 1
4- 2
23- 37a
23- 37b
1- 53a
2- 190
2- 191
2- 192
1- 214
2- 215

5.4.

Moon Explorer
Maanvoertuig
Engin d'exploration lunaire
Esploratore lunare
Mondfahrzeug
Månfarkost
Explorador lunar
Måneutforsker

4- 1	1- 18a	2- 48	1- 176
8- 2	1- 18b	6- 48a	1- 186
2- 3	1- 19s	1- 51	3- 187
7- 5	1- 20a	1- 52	2- 188
4- 10	4- 22	2- 53a	2- 192
2- 11	1- 22a	2- 54	1- 212
1- 11a	2- 24	2- 90a	1- 212a
10- 12	9- 35	1- 111a	1- 213
4- 12c	105- 37a	6- 111c	1- 215
1- 15b	83- 37b	1- 126	2- 221
2- 16	8- 38	3- 142c	
2- 17	1- 40	1- 155	

1- 2	4- 38
7- 5	1- 40
1- 11a	1- 48
2- 12	2- 90a
1- 16	1- 111a
1- 19s	6- 111c
1- 20a	1- 176
1- 22	1- 186
5- 35	2- 188
40- 37a	2- 221
18- 37b	

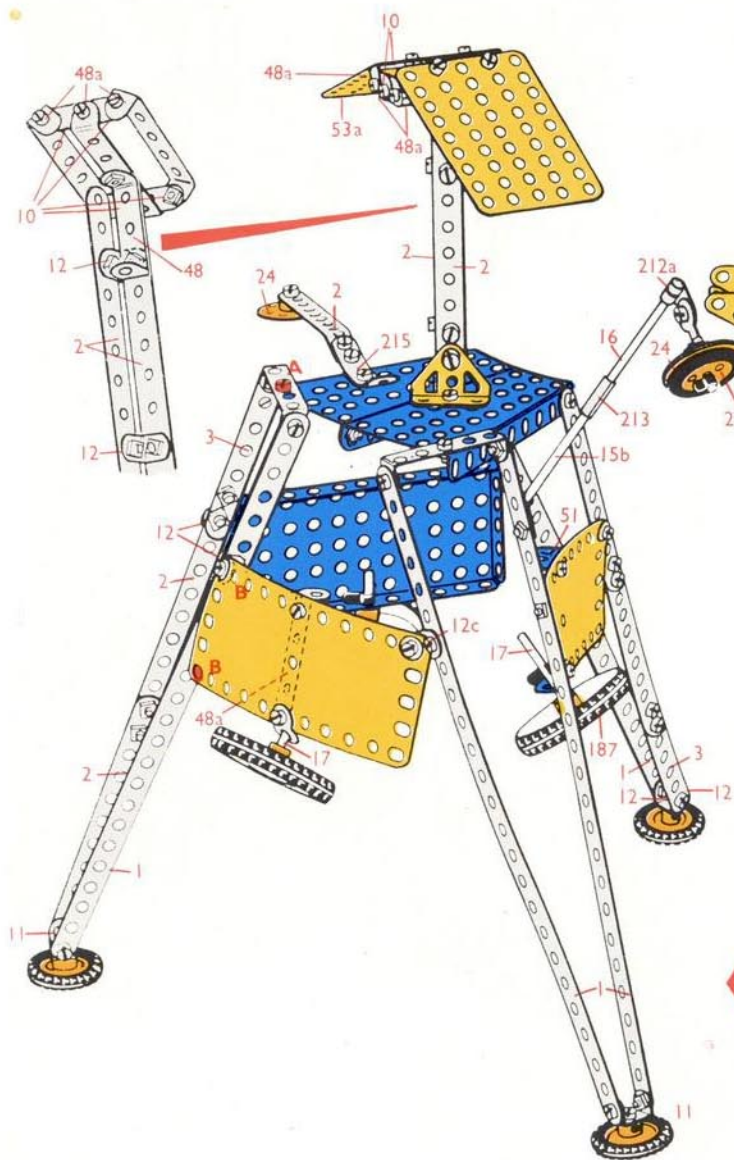

1

4- 1	65- 37b
7- 2	4- 38
2- 3	1- 48
4- 10	6- 48a
2- 11	1- 51
8- 12	1- 52
4- 12c	2- 53a
1- 15b	2- 54
1- 16	1- 126
2- 17	3- 142c
1- 18a	1- 155
1- 18b	3- 187
3- 22	2- 192
1- 22a	1- 212
2- 24	1- 212a
4- 35	1- 213
61- 37a	1- 215

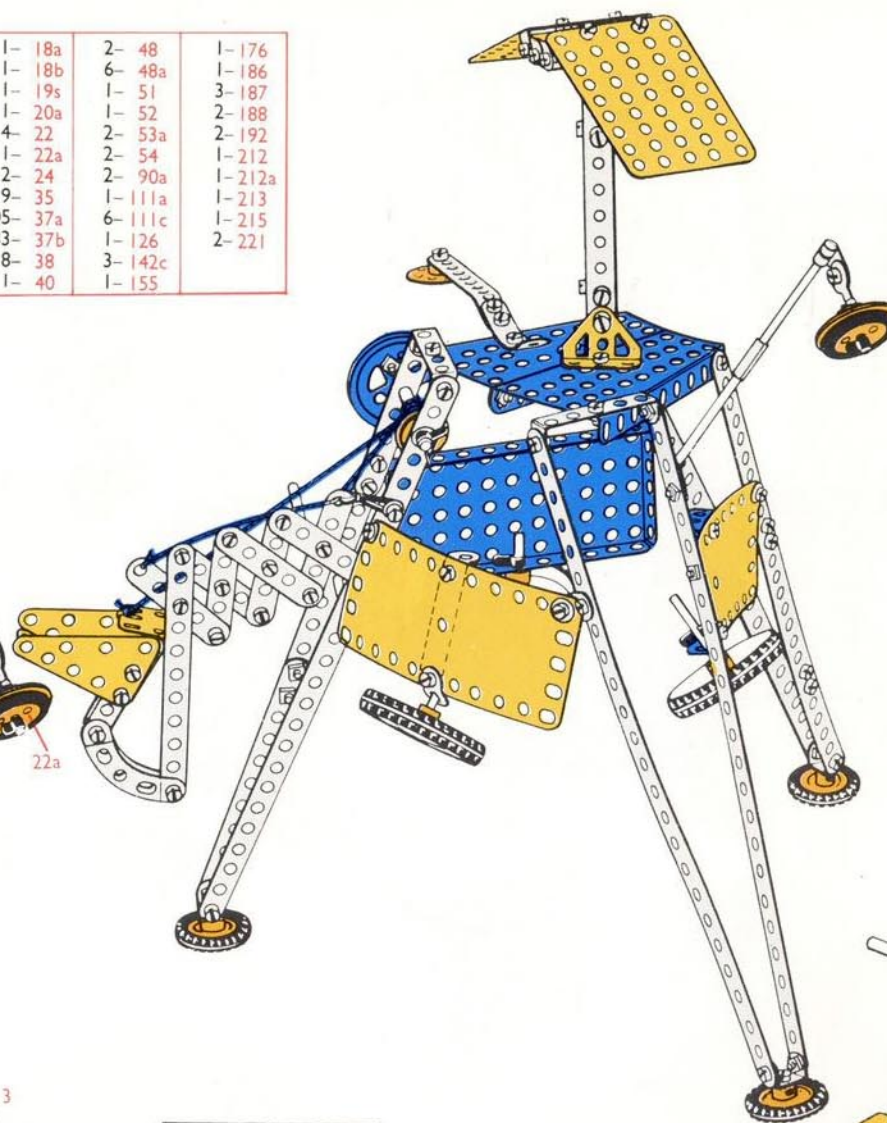

2

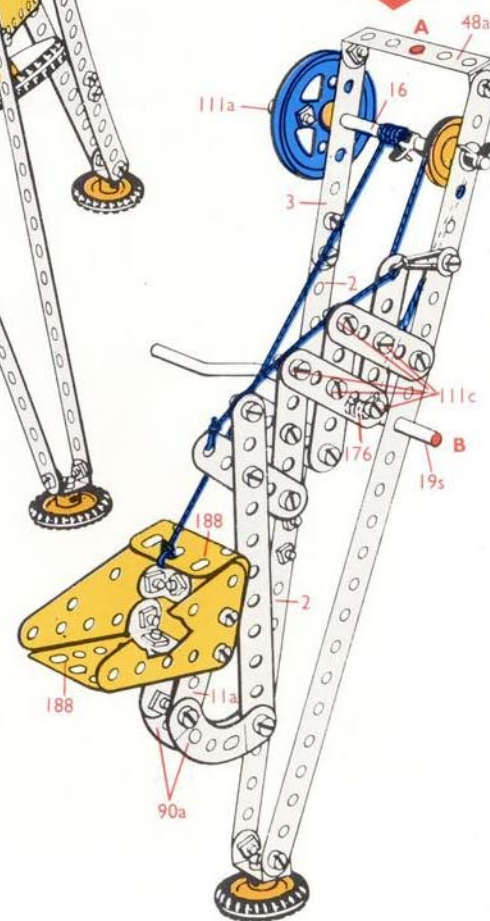

5.5.

Car Ramp
 Auto-oprit
 Rampe pour voitures
 Rampa per auto
 Autorampe
 Bilbrygga
 Rampa para automóviles
 Rampa para automóveis
 Bilrampe

4- 1	1- 18b	1- 40	4- 142c
8- 2	1- 19s	1- 48	1- 186
2- 3	1- 20a	6- 48a	2- 188
9- 5	4- 22	1- 52	2- 189
4- 10	2- 22a	2- 53a	2- 191
2- 11	2- 24	2- 54	2- 192
4- 12	7- 35	3- 90a	1- 193
2- 12c	74- 37a	5- 111c	2- 212a
1- 15b	66- 37b	2- 125	2- 221
2- 16	14- 38	2- 126	
1- 17	2- 38d	2- 126a	

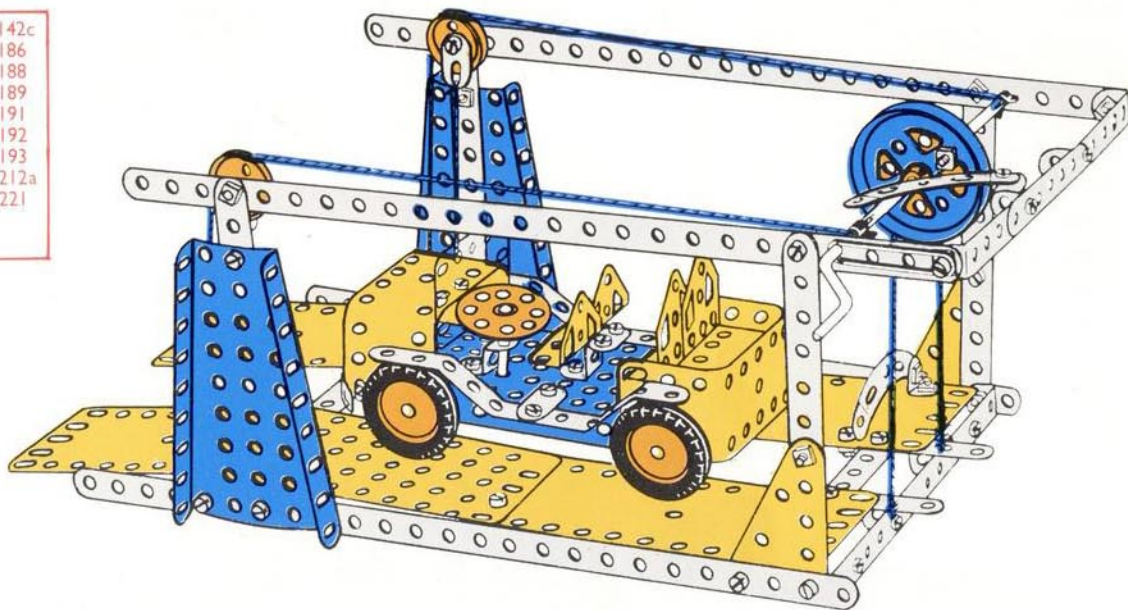

4- 1	1- 20a	6- 48a
6- 2	2- 22a	2- 53a
2- 3	1- 24	2- 54
9- 5	5- 35	3- 90a
2- 10	56- 37a	5- 111c
1- 11	48- 37b	1- 186
2- 12	4- 38	2- 191
1- 15b	2- 38d	2- 192
1- 18b	1- 40	2- 212a
1- 19s	1- 48	2- 221

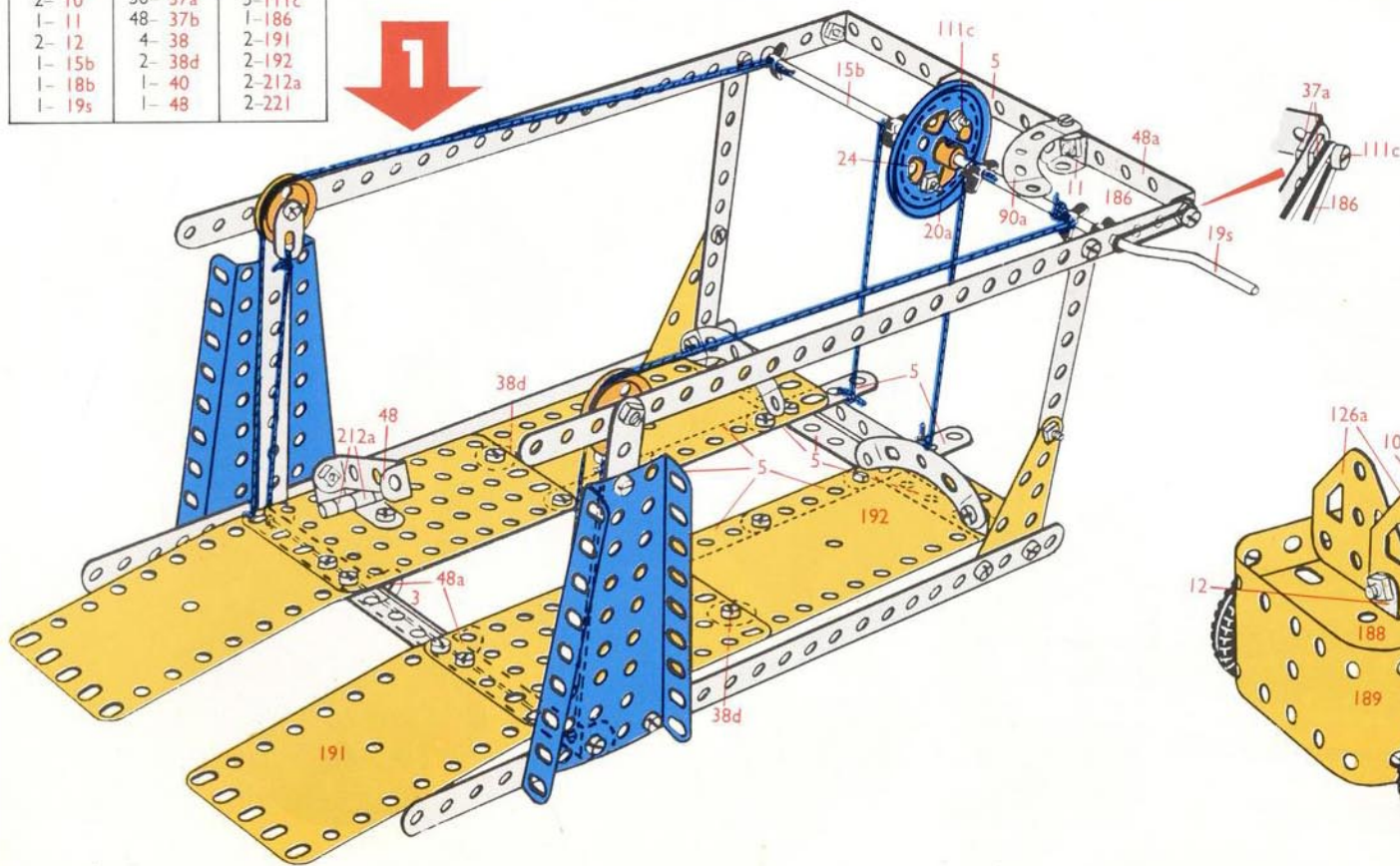

2- 2	4- 22	2- 125
2- 10	1- 24	2- 126
1- 11	2- 35	2- 126a
2- 12	18- 37a	4- 142c
2- 12c	18- 37b	2- 188
2- 16	10- 38	2- 189
1- 17	1- 52	1- 193

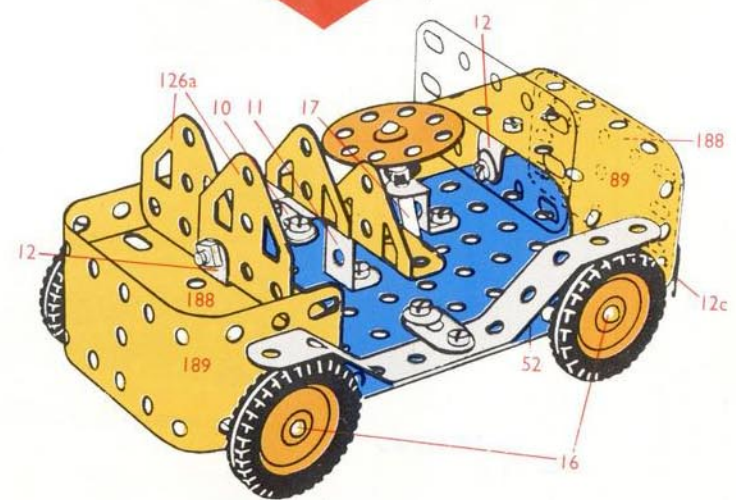

5.6.

Jumbo Crane
 Jumbokraan
 Grue géante
 Gru Jumbo
 Jumbo Kran
 Tung lyftkran
 Grúa gigante
 Guindaste gigante
 Jumbo-kran

2- 1	1- 20a	6- 48a	1- 176
8- 2	4- 22	1- 51	4- 187
2- 3	1- 23	1- 52	2- 188
9- 5	1- 23a	2- 54	2- 189
2- 10	2- 24	1- 57c	1- 190
2- 11	2- 27f	2- 90a	2- 191
1- 11a	10- 35	2- 111	2- 194
4- 12	104- 37a	2- 111a	1- 200
2- 15b	88- 37b	1- 111c	1- 212
2- 16	15- 38	2- 126	2- 212a
2- 17	2- 38d	2- 126a	2- 214
2- 18a	1- 40	1- 142c	4- 221
1- 19s	2- 48	2- 155	

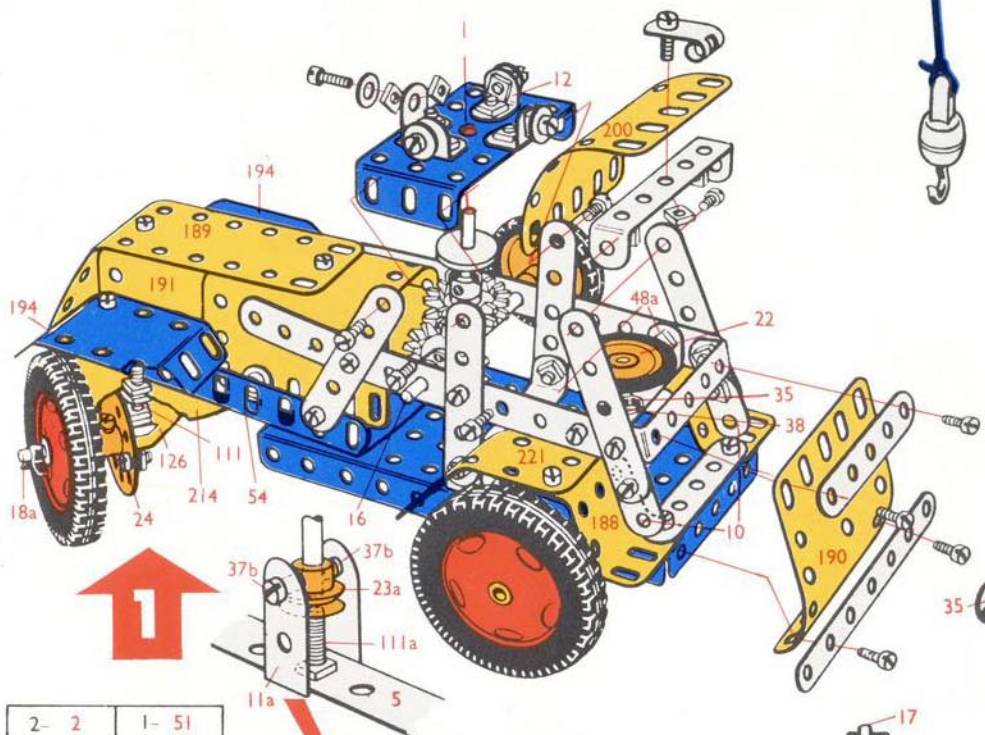

2- 2	1- 51
1- 3	1- 52
8- 5	1- 54
2- 10	2- 90a
4- 12	2- 111
1- 15b	2- 126
1- 16	1- 142c
2- 17	1- 155
2- 18a	4- 187
2- 22	2- 188
2- 24	1- 189
2- 27f	1- 190
5- 35	2- 191
72- 37a	2- 194
62- 37b	1- 200
7- 38	1- 212a
2- 38d	2- 214
1- 48	2- 221
4- 48a	

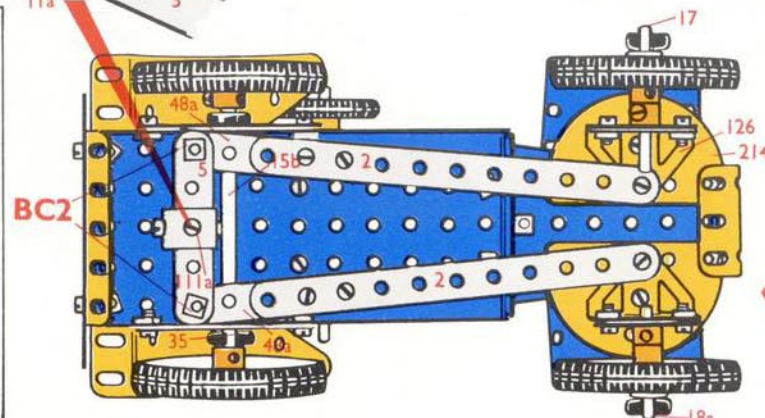

2- 2
1- 5
1- 11a
1- 23a
13- 37a
10- 37b
2- 48a
1- 111a

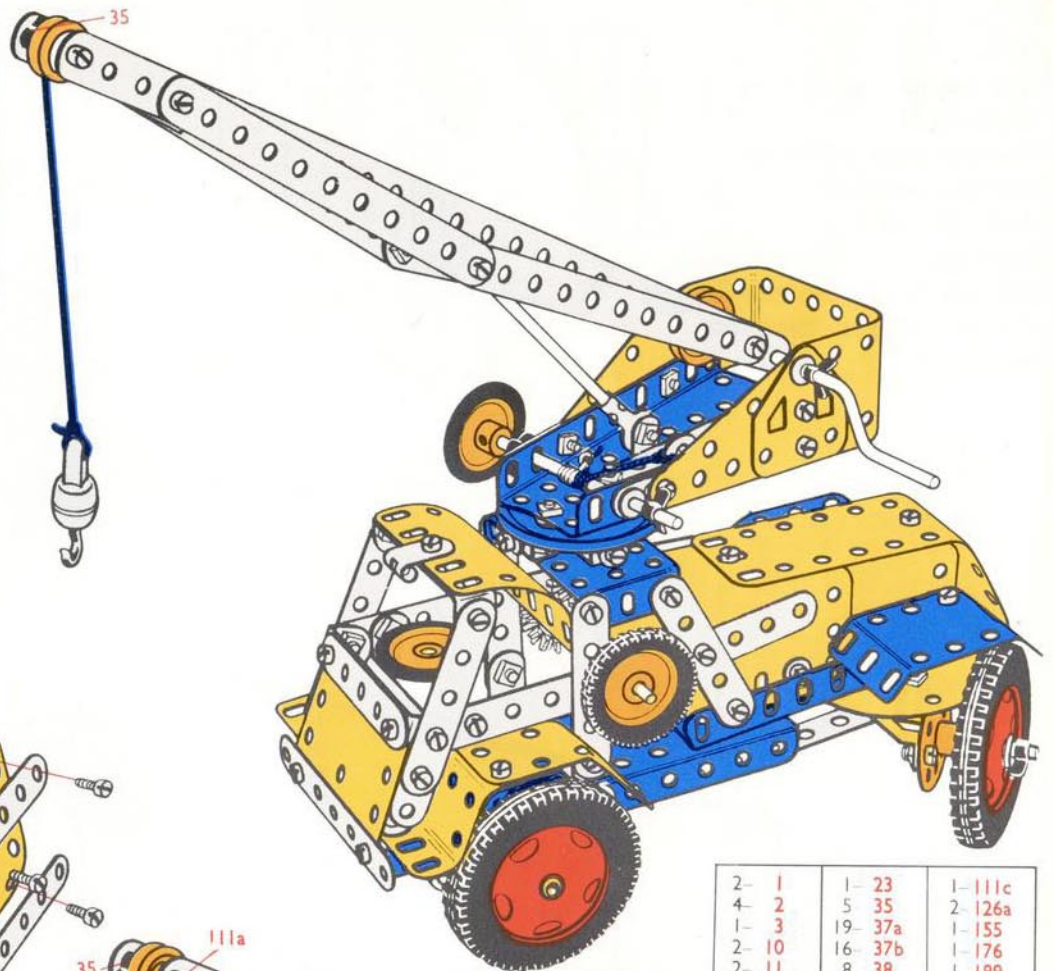

2- 1	1- 23	1- 111c
4- 2	5- 35	2- 126a
1- 3	19- 37a	1- 155
2- 10	16- 37b	1- 176
2- 11	8- 38	1- 189
1- 15b	1- 40	1- 212
1- 16	1- 48	1- 212a
1- 19s	1- 54	2- 221
1- 20a	1- 57c	
2- 22	1- 111a	

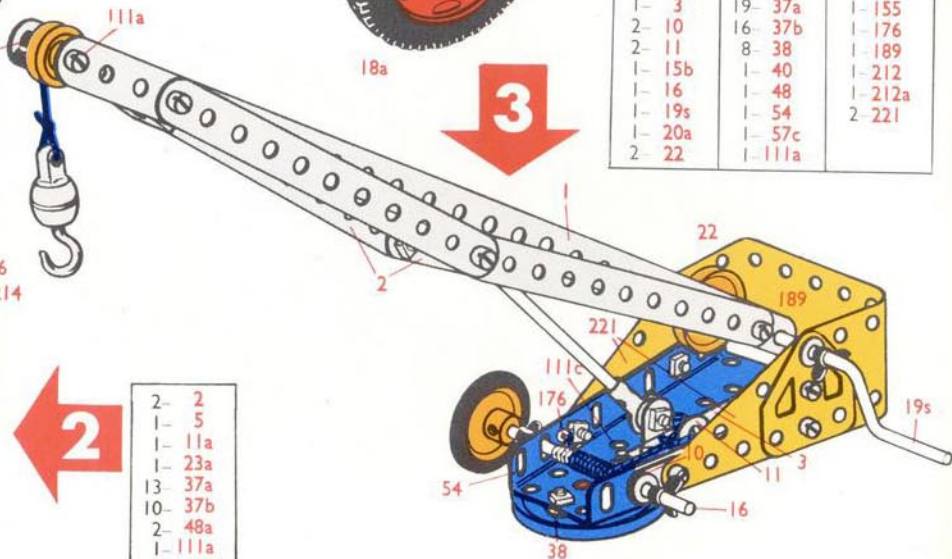

5.7.
Loading Shovel
Lepelschop
Pelle de chargement
Motopala
Schaufellader
Skoplastare
Pala cargadora
Pá de carregar
Lasteskuffe

8- 2	1- 19s	1- 52	3- 190
2- 3	4- 22	2- 53a	2- 191
9- 5	2- 24	2- 54	1- 199
1- 10	2- 27f	4- 90a	1- 200
2- 11	16- 35	4- 111c	1- 212
1- 11a	95- 37a	2- 125	2- 212a
10- 12	93- 37b	2- 126	1- 213
4- 12c	12- 38	2- 126a	2- 214
2- 15b	2- 38d	1- 155	4- 221
4- 16	1- 40	1- 176	
2- 17	1- 48	1- 186	
2- 18a	6- 48a	4- 187	
1- 18b	1- 51	1- 188	

2- 2	2- 22	1- 51	1- 188
2- 3	1- 24	1- 52	3- 190
2- 5	2- 27f	2- 54	2- 191
1- 11a	3- 35	2- 90a	1- 200
4- 12c	55- 37a	2- 111c	1- 212
2- 16	53- 37b	2- 126	2- 212a
1- 18a	4- 38	2- 126a	2- 214
1- 18b	2- 38d	1- 155	
1- 19s	4- 48a	1- 176	

5- 5	9- 37b
2- 11	4- 38
2- 16	1- 48a
2- 17	1- 111c
1- 24	4- 187
7- 35	1- 199
10- 37a	1- 213

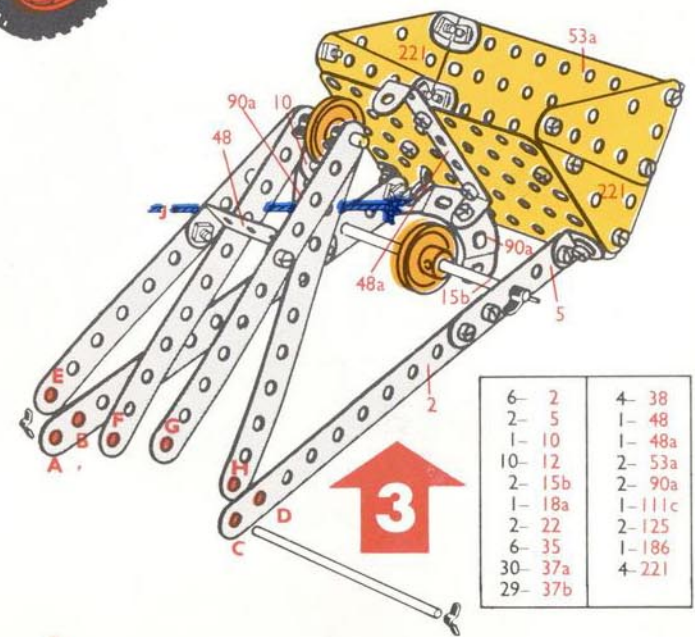
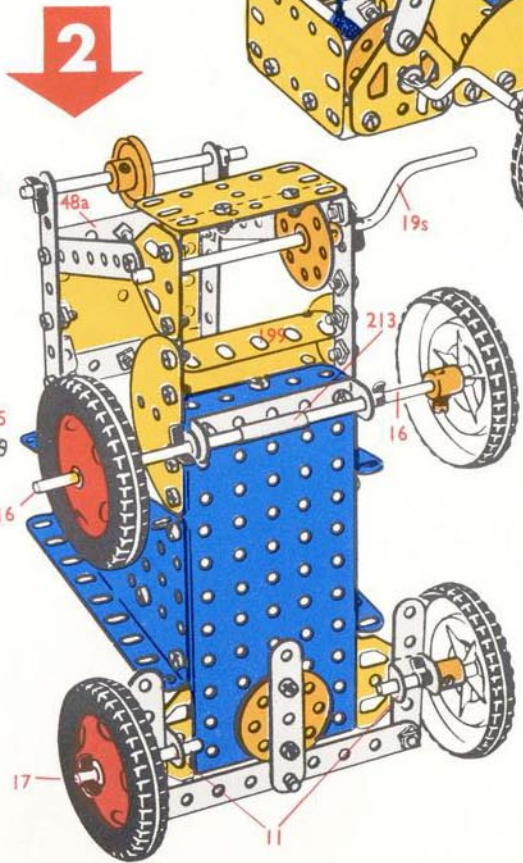
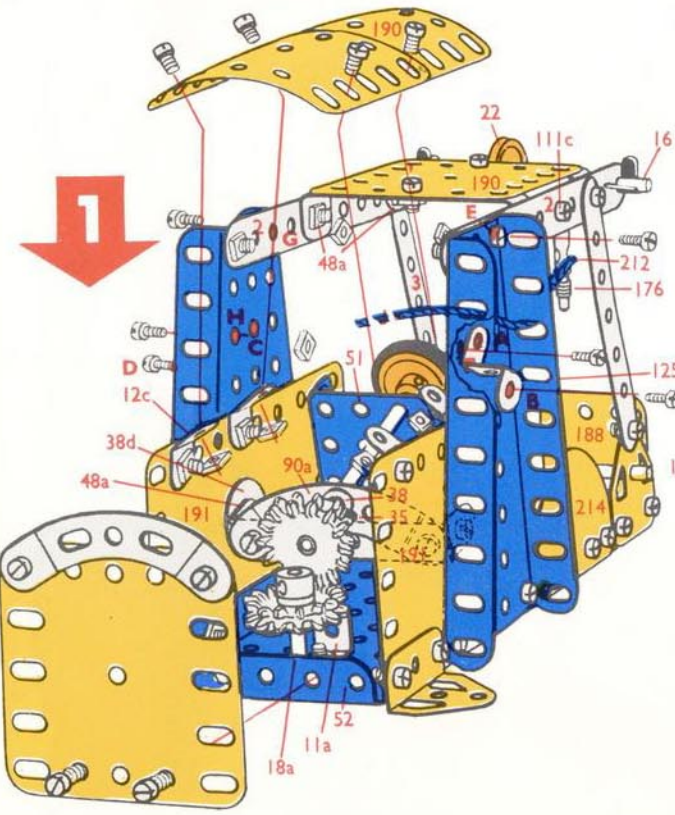
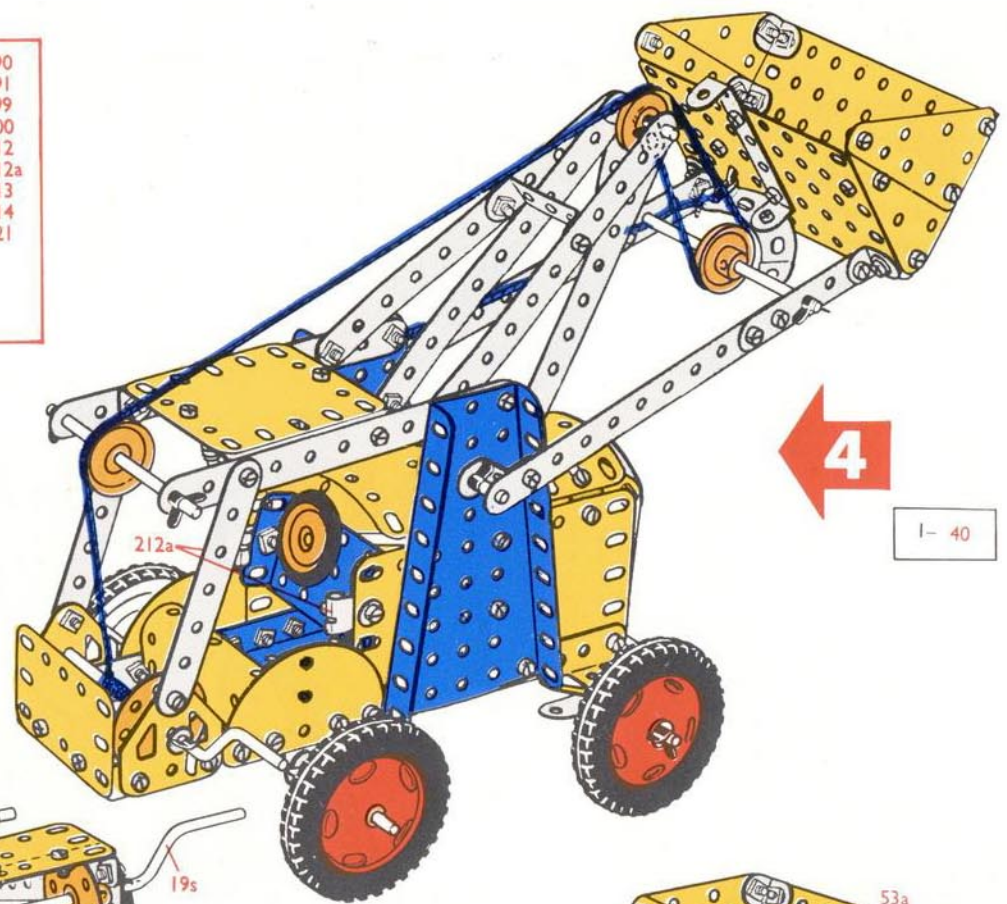

6- 2	4- 38
2- 5	1- 48
1- 10	1- 48a
10- 12	2- 53a
2- 15b	2- 90a
1- 18a	1- 111c
2- 22	2- 125
6- 35	1- 186
30- 37a	4- 221
29- 37b	

5.8.

Helicopter
Hefschroefvliegtuig
Hélicoptère
Elicottero
Hubschrauber
Helikopter
Helicóptero

4- 1	4- 22	1- 51	1-191
8- 2	2- 22a	2- 54	2-192
2- 3	1- 23	3- 90a	2-193
9- 5	2- 24	2-111	1-193a
1- 10	2- 27f	2-125	1-199
1- 11a	1- 35	2-126	1-200
5- 12	94- 37a	2-126a	1-213
4- 12c	91- 37b	2-142c	2-214
2- 15b	11- 38	2-155	4-215
1- 16	1- 38d	1-186	4-221
1- 18a	1- 40	2-188	
2- 19b	1- 48	2-189	
1- 20a	4- 48a	3-190	

1- 1	1- 20a	1- 48	1-186
1- 2	3- 22	4- 48a	2-188
2- 3	2- 22a	1- 51	3-190
4- 5	1- 23	2- 54	2-193
1- 11a	2- 27f	3- 90a	1-193a
3- 12	1- 35	1-111	1-200
4- 12c	54- 37a	2-125	1-213
2- 15b	52- 37b	2-126	2-214
1- 16	7- 38	2-126a	3-215
1- 18a	1- 38d	2-142c	4-221
2- 19b	1- 40	2-155	



3- 1	4- 38
1- 2	1-111
2- 5	2-189
1- 10	1-191
2- 12	2-192
1- 22	1-199
25- 37a	1-215
24- 37b	



6- 2
3- 5
2- 24
15- 37a
15- 37b

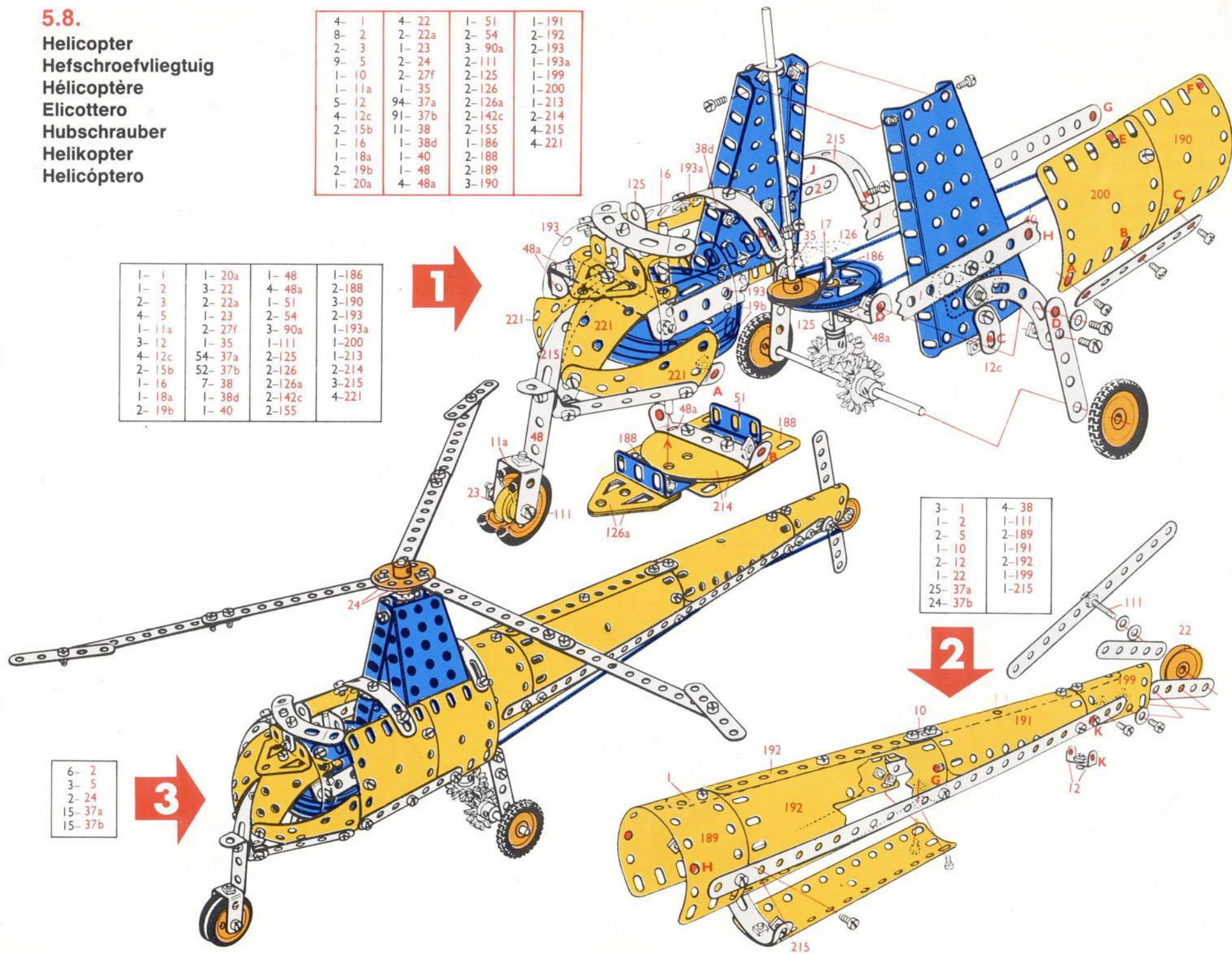

5.9.

Construction Crane with Grab
Constructiekraan met gripper
Grue de construction avec benne preneuse
Gru per cantiere con benna
Baukran mit Greifer
Byggnadskran med gripanordning
Grúa para obras, con bivalva
Guindaste de construção com garras
Kran med grabb

4- 1	1- 19s	2- 38d	2- 126a
8- 2	1- 20a	1- 40	1- 176
2- 3	4- 22	2- 48	1- 186a
9- 5	2- 22a	6- 48a	* 1- 186b
4- 10	1- 23	1- 51	2- 187
2- 11	* 1- 23a	1- 52	2- 188
1- 11a	1- 23a	2- 53a	2- 189
10- 12	2- 24	2- 54	1- 190
1- 12c	2- 27f	4- 90a	1- 200
2- 15b	16- 35	2- 111	2- 212a
4- 16	103- 37a	2- 111a	1- 213
2- 17	93- 37b	2- 111c	2- 221
2- 19b	14- 38	2- 126	* 1- M5

* Non inclus dans la boîte
 * Not included in set

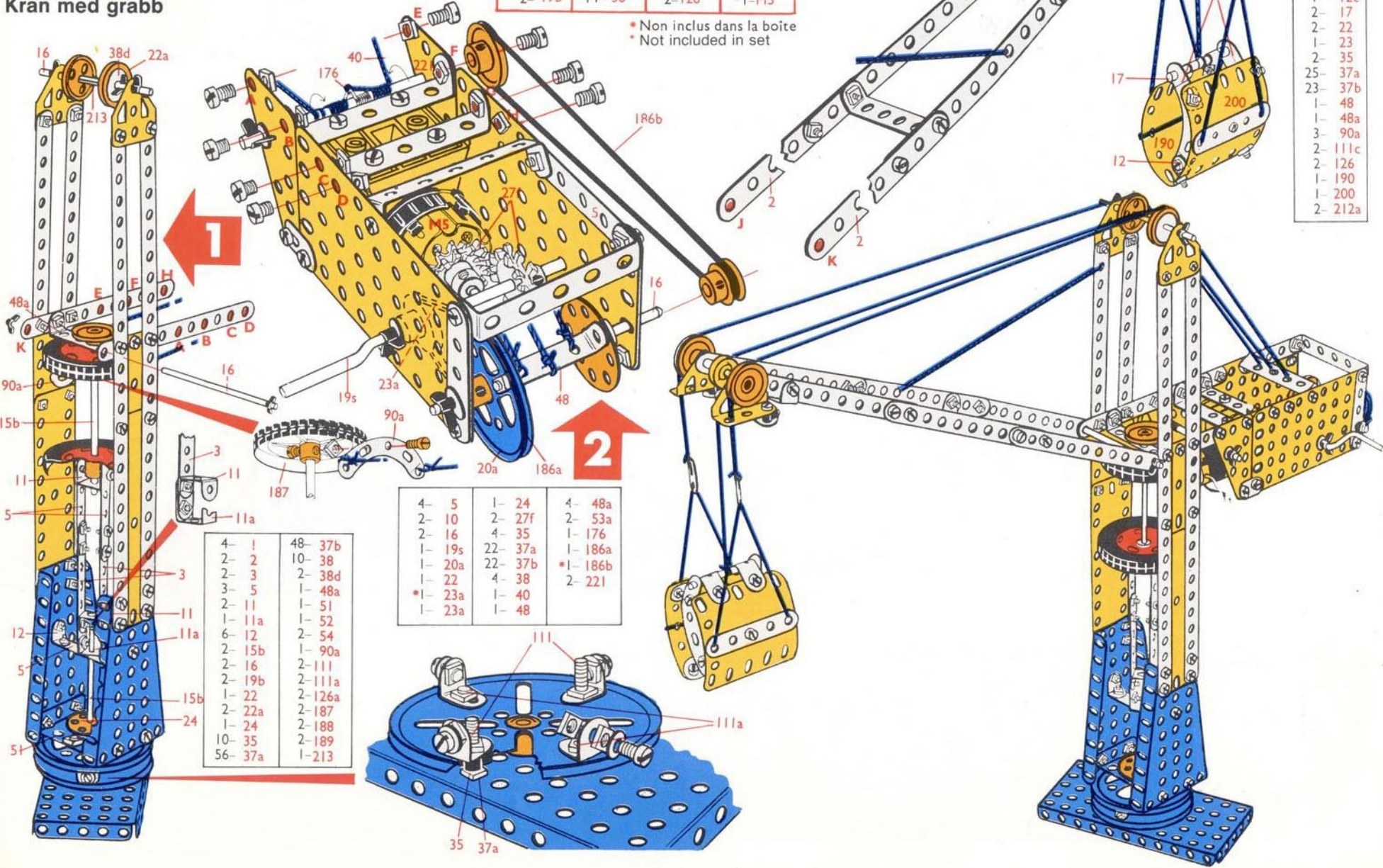

16	38d	22a
213		
48a		
90a		
15b		
11		
5		
12		
5		
51		

4- 1	48- 37b
2- 2	10- 38
2- 3	2- 38d
3- 5	1- 48a
2- 11	1- 51
1- 11a	1- 52
6- 12	2- 54
2- 15b	1- 90a
2- 16	2- 111
2- 19b	2- 111a
1- 22	2- 126a
2- 22a	2- 187
1- 24	2- 188
10- 35	2- 189
56- 37a	1- 213

4- 5	1- 24	4- 48a
2- 10	2- 27f	2- 53a
2- 16	4- 35	1- 176
1- 19s	22- 37a	1- 186a
1- 20a	22- 37b	* 1- 186b
1- 22	4- 38	2- 221
* 1- 23a	1- 40	
1- 23a	1- 48	



6- 2	5
2- 10	
4- 12	
1- 12c	
2- 17	
2- 22	
1- 23	
2- 35	
25- 37a	
23- 37b	
1- 48	
1- 48a	
3- 90a	
2- 111c	
2- 126	
1- 190	
1- 200	
2- 212a	

5.10.

Diesel Electric Locomotive
 Diesel-elektrische locomotief
 Locomotive électrique Diesel
 Locomotore diesel/eletrico
 Elektro-Diesel-Lokomotive
 Dieselelektriskt lok
 Locomotora diesel eléctrica
 Locomotiva Diesel eléctrica
 Diesel-lokomotiv

2- 1	32- 37b
2- 2	1- 38
4- 5	2- 38d
4- 10	2- 48a
1- 11a	1- 51
1- 12	1- 52
1- 16	3-111c
* 1- 23a	2-126
1- 24	2-126a
2- 35	1-212
40- 37a	

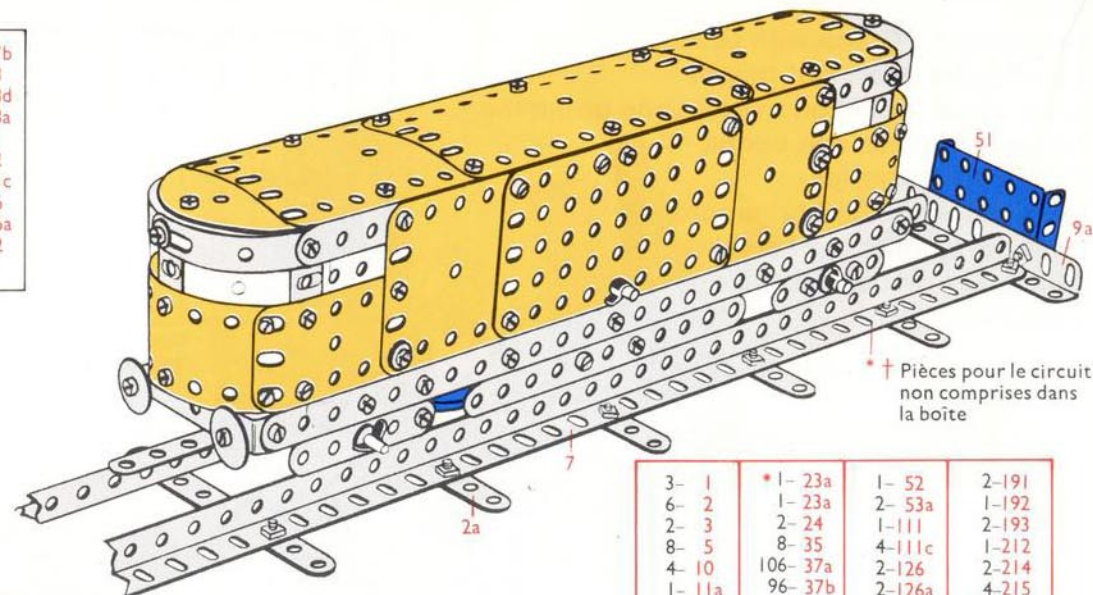

† Pièces pour le circuit non comprises dans la boîte

3- 1	* 1- 23a	1- 52	2-191
6- 2	1- 23a	2- 53a	1-192
2- 3	2- 24	1-111	2-193
8- 5	8- 35	4-111c	1-212
4- 10	106- 37a	2-126	2-214
1- 11a	96- 37b	2-126a	4-215
7- 12	13- 38	1-186	* 1-M5
4- 16	2- 38d	2-188	
1- 20a	6- 48a	2-189	
4- 22	1- 51	4-190	

* Non inclus dans la boîte
 * Not included in set

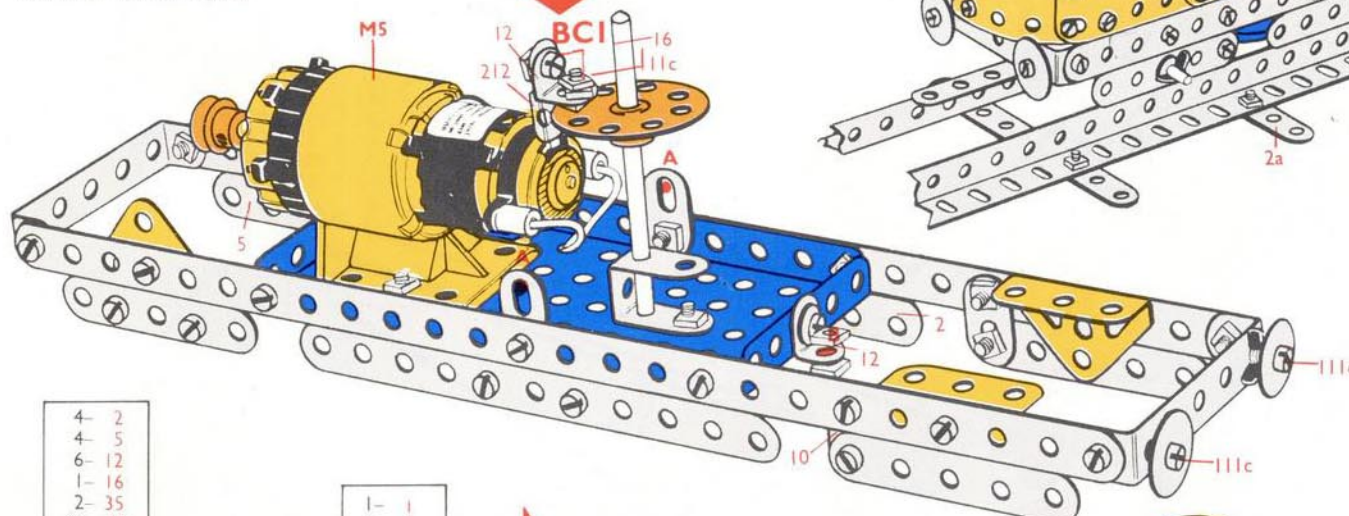

4- 2
4- 5
6- 12
1- 16
2- 35
60- 37a
60- 37b
8- 38
4- 48a
2- 53a
2-188
2-189
4-190
2-191
1-192
2-193
2-214
4-215

1- 1
2- 3
2- 16
1- 20a
4- 22
1- 23a
1- 24
4- 35
6- 37a
3- 37b
4- 38
1-111
1-111c
1-186

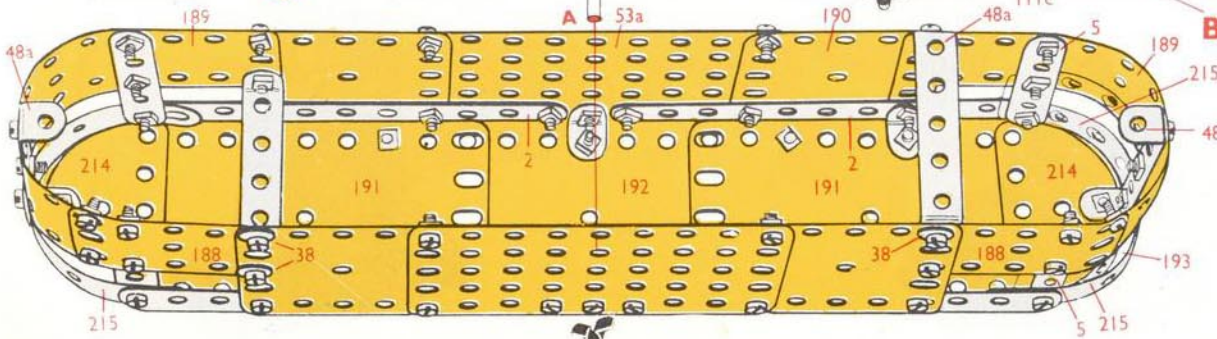
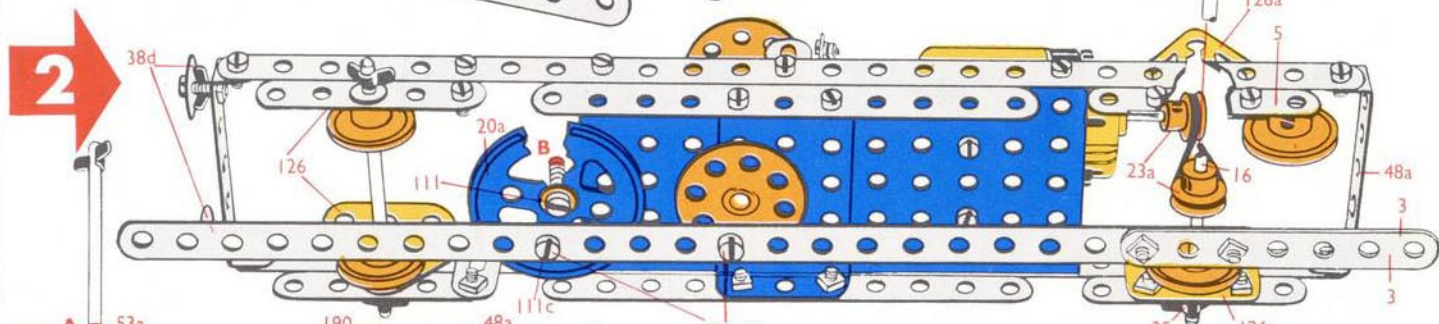

Pièces pour circuit de 62 cm non comprises dans la boîte
 Parts non included in box for the circuit 62 cm

Pièces No	2a	7	9a	37a	37b	51
† Quantité		2	2	22	22	2

5.11.

Traction Engine
 Tractiewagen
 Moteur de traction
 Motore di trazione
 Zugmaschine
 Lokomobil
 Máquina de tracción
 Motor de tracção

8- 2	4- 22	2- 48	*1-186a
2- 3	2- 22a	6- 48a	1-186a
8- 5	1- 23	1- 52	2-187
2- 11	*1- 23a	2- 53a	2-188
1- 11a	1- 23a	1-111	3-190
10- 12	2- 24	2-111c	2-191
4- 12c	2- 27f	2- 125	2-192
2- 15b	7- 35	2-126	1-194a
4- 16	97- 37a	2-126a	1-199
2- 17	85- 37b	1-142c	1-212
1- 18a	10- 38	1- 155	*1- M4
2- 19b	2- 38d	1- 176	
1- 20a	1- 40	1- 186	

• Non inclus dans la boîte
 • Not included in set

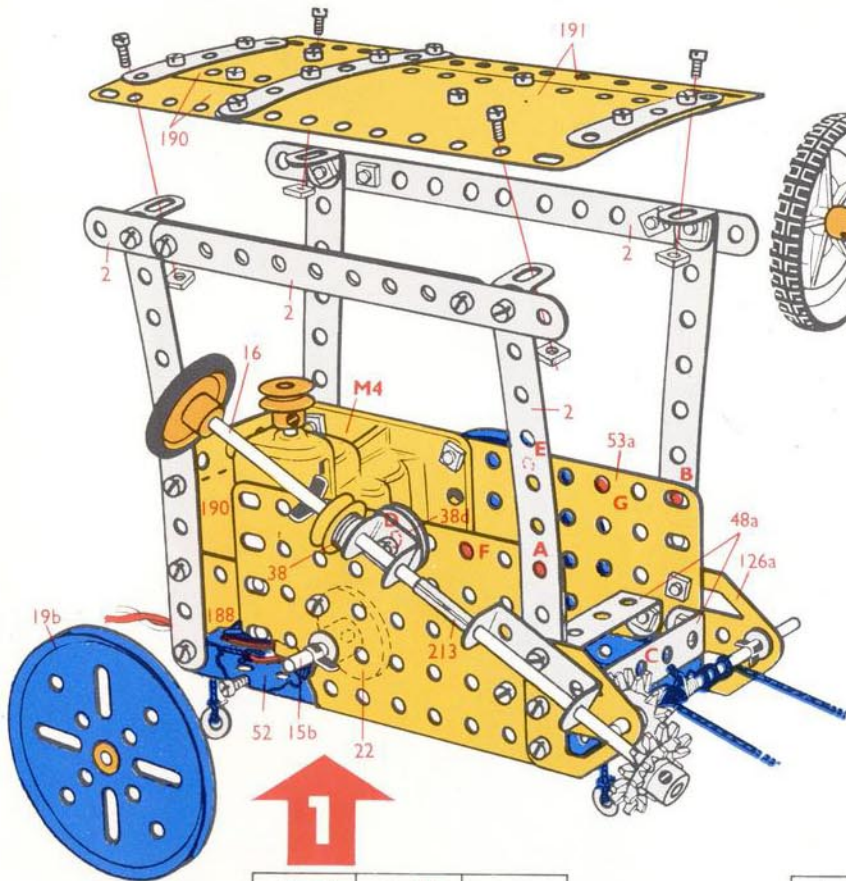

8- 2	1- 23a	1- 52
1- 3	2- 27f	2- 53a
3- 5	4- 35	2-126a
1- 11	52- 37a	1-155
6- 12	52- 37b	1-176
1- 15b	10- 38	1-192
3- 16	2- 38d	3-190
2- 19b	1- 40	2-191
2- 22	1- 48	
1- 23	2- 48a	

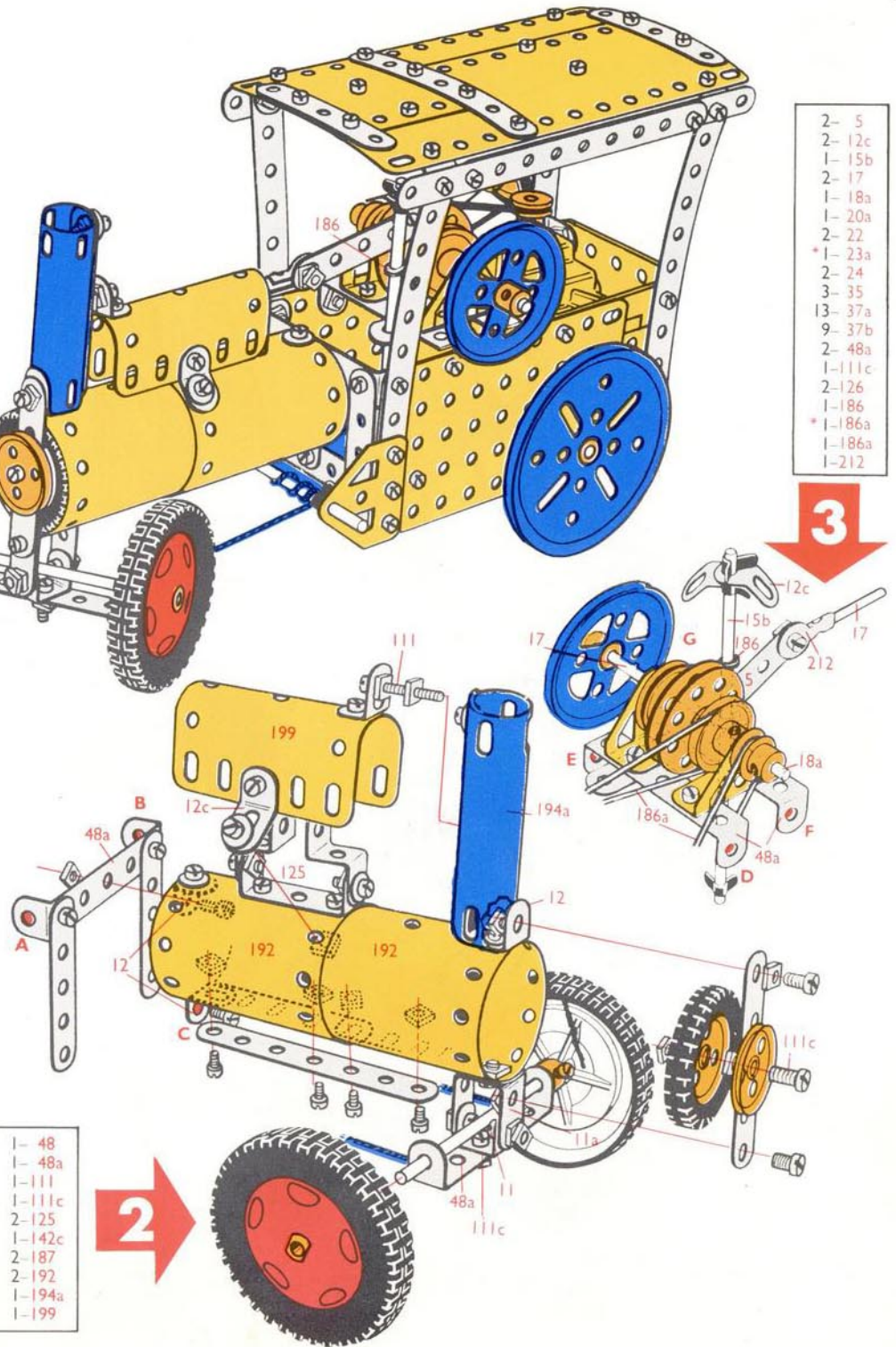

1- 3	1- 48
3- 5	1- 48a
1- 11	1-111
1- 11a	1-111c
4- 12	2-125
2- 12c	1-142c
1- 16	2-187
2- 22a	2-192
32- 37a	1-194a
24 37b	1-199

2- 5
2- 12c
1- 15b
2- 17
1- 18a
1- 20a
2- 22
*1- 23a
2- 24
3- 35
13- 37a
9- 37b
2- 48a
1-111c
2-126
1-186
*1-186a
1-186a
1-212

5.12.

Dumper Truck
 Stortwagen
 Dumper
 Ribaltabile
 Kipplaster
 Tipptruck
 Camión volquete
 Carrinho basculante
 Dumperbil

2- 2	1- 20a	6- 48a	*1- 186b
2- 3	4- 22	1- 51	2- 187
9- 5	2- 22a	2- 53a	2- 188
4- 10	1- 23	2- 54	2- 189
2- 11	*1- 23a	4- 90a	2- 191
1- 11a	1- 23a	2- 111	1- 192
10- 12	2- 24	5- 111c	1- 212
2- 15b	15- 35	2- 125	2- 212a
4- 16	91- 37a	2- 126	2- 214
1- 17	79- 37b	2- 126a	2- 221
1- 18a	14- 38	2- 142c	*1- M4
1- 18b	2- 48	1- 155	

* Non inclus dans la boîte
 * Not included in set

2- 3	25- 37a
4- 5	17- 37b
1- 10	2- 38
2- 11	1- 48
2- 12	2- 111
1- 17	2- 126
1- 18a	2- 142c
1- 18b	2- 212a
2- 22	1- 214
2- 35	

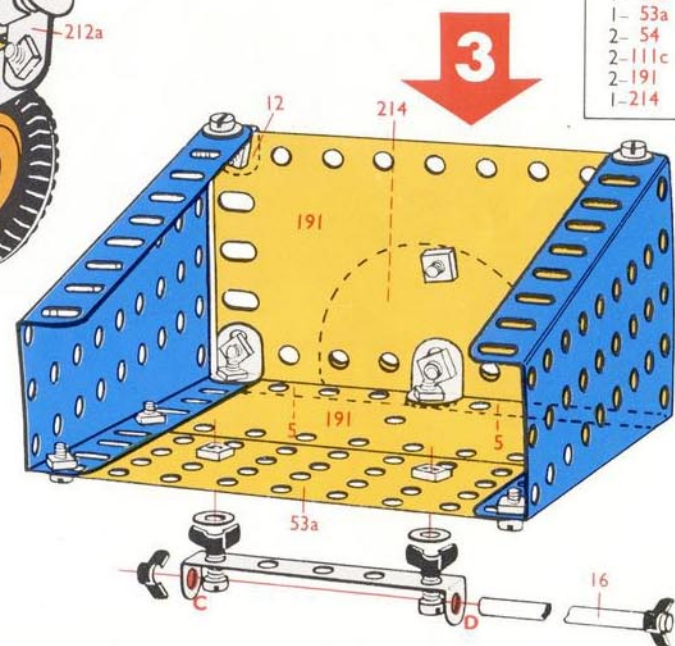
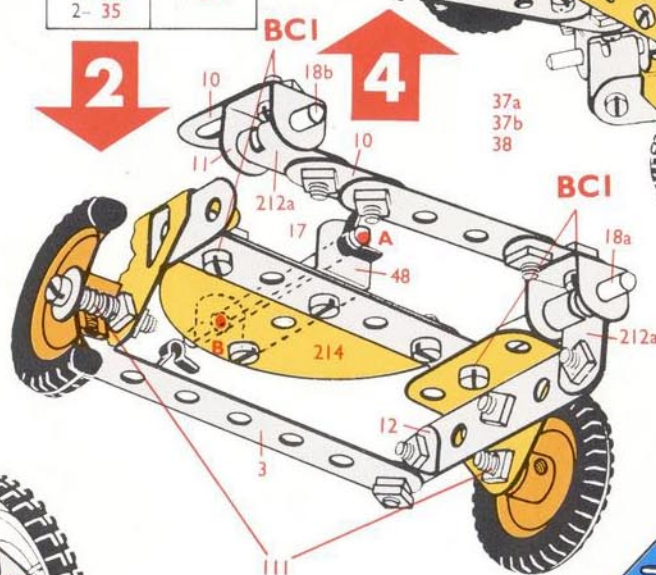
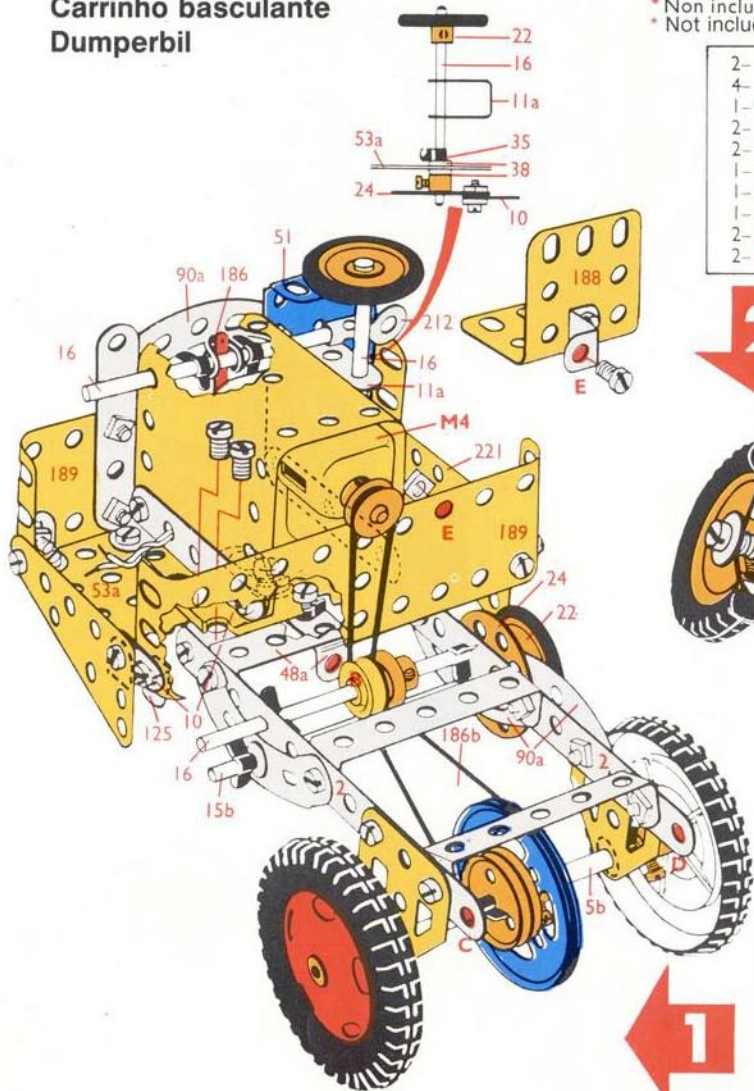

2- 5
5- 12
1- 16
4- 35
17- 37a
15- 37b
6- 38
1- 48a
1- 53a
2- 54
2- 111c
2- 191
1- 214

2- 2	1- 23a	2- 125
3- 5	2- 24	2- 126a
3- 10	9- 35	1- 155
1- 11a	48- 37a	*1- 186b
3- 12	46- 37b	2- 187
2- 15b	6- 38	2- 188
3- 16	1- 48	2- 189
1- 20a	5- 48a	1- 192
2- 22	1- 51	1- 212
2- 22a	1- 53a	2- 221
1- 23	4- 90a	
*1- 23a	3- 111c	

5.13.

Food Mixer
Mixer voor voedingsmiddelen
Mixer pour aliments
Frullino
Speisemixer
Hushållsmaskin
Batidora
Misturadora para cozinha
Matblander

7- 2	4- 22	3- 48a	2-126a
2- 3	1- 23	1- 51	*1-186b
8- 5	*1- 23a	1- 52	2-188
4- 10	1- 23a	2- 53a	2-189
2- 11	2- 24	2- 54	1-191
8- 12	2- 27f	4- 90a	2-192
2- 15b	2- 35	2-111	1-199
1- 17	87- 37a	1-111a	1-213
1- 18a	80- 37b	2-111c	2-214
1- 18b	13- 38	1-125	3-215
1- 20a	2- 48	2-126	*1-M5

* Non inclus dans la boîte
 * Not included in set

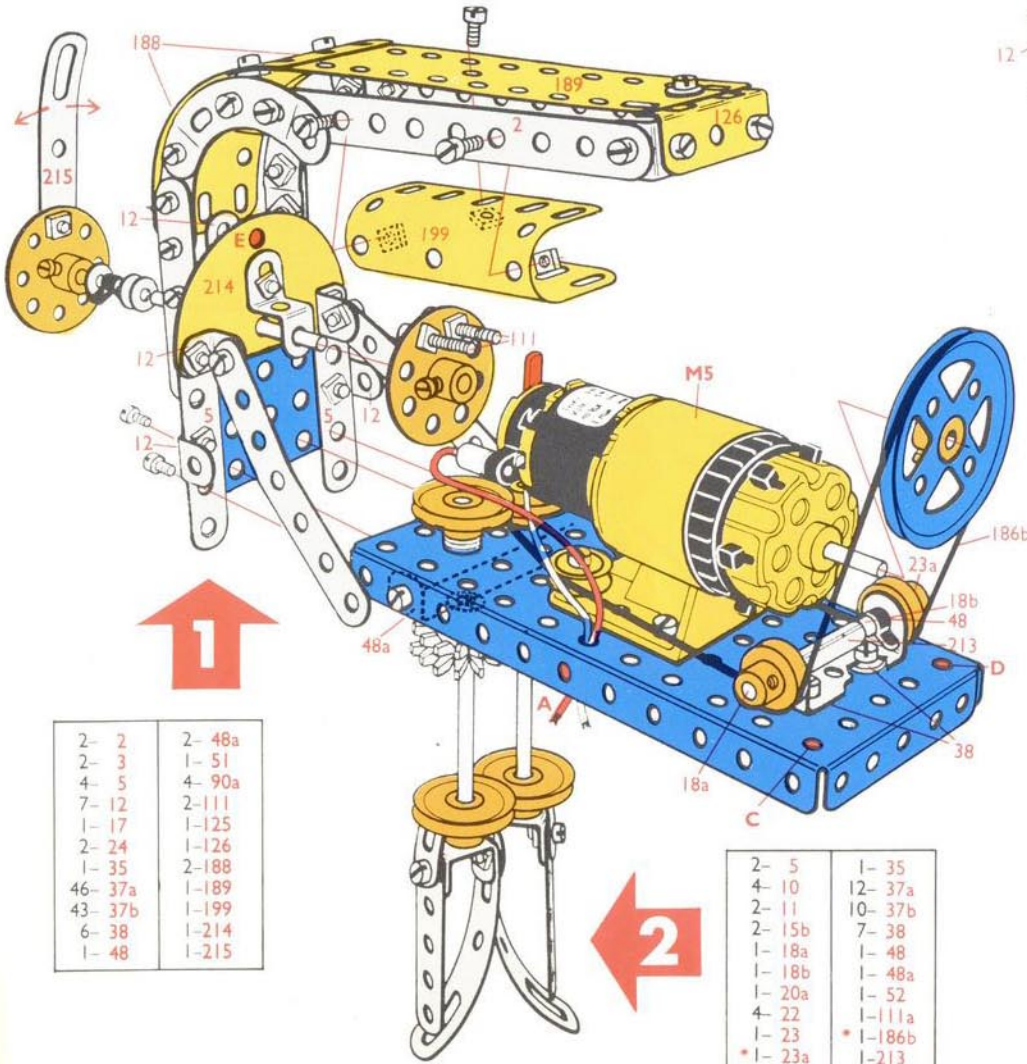

2- 2	2- 48a
2- 3	1- 51
4- 5	4- 90a
7- 12	2-111
1- 17	1-125
2- 24	1-126
1- 35	2-188
46- 37a	1-189
43- 37b	1-199
6- 38	1-214
1- 48	1-215

2- 5	1- 35
4- 10	12- 37a
2- 11	10- 37b
2- 15b	7- 38
1- 18a	1- 48
1- 18b	1- 48a
1- 20a	1- 52
4- 22	1-111a
1- 23	*1-186b
*1- 23a	1-213
1- 23a	2-215
2- 27f	

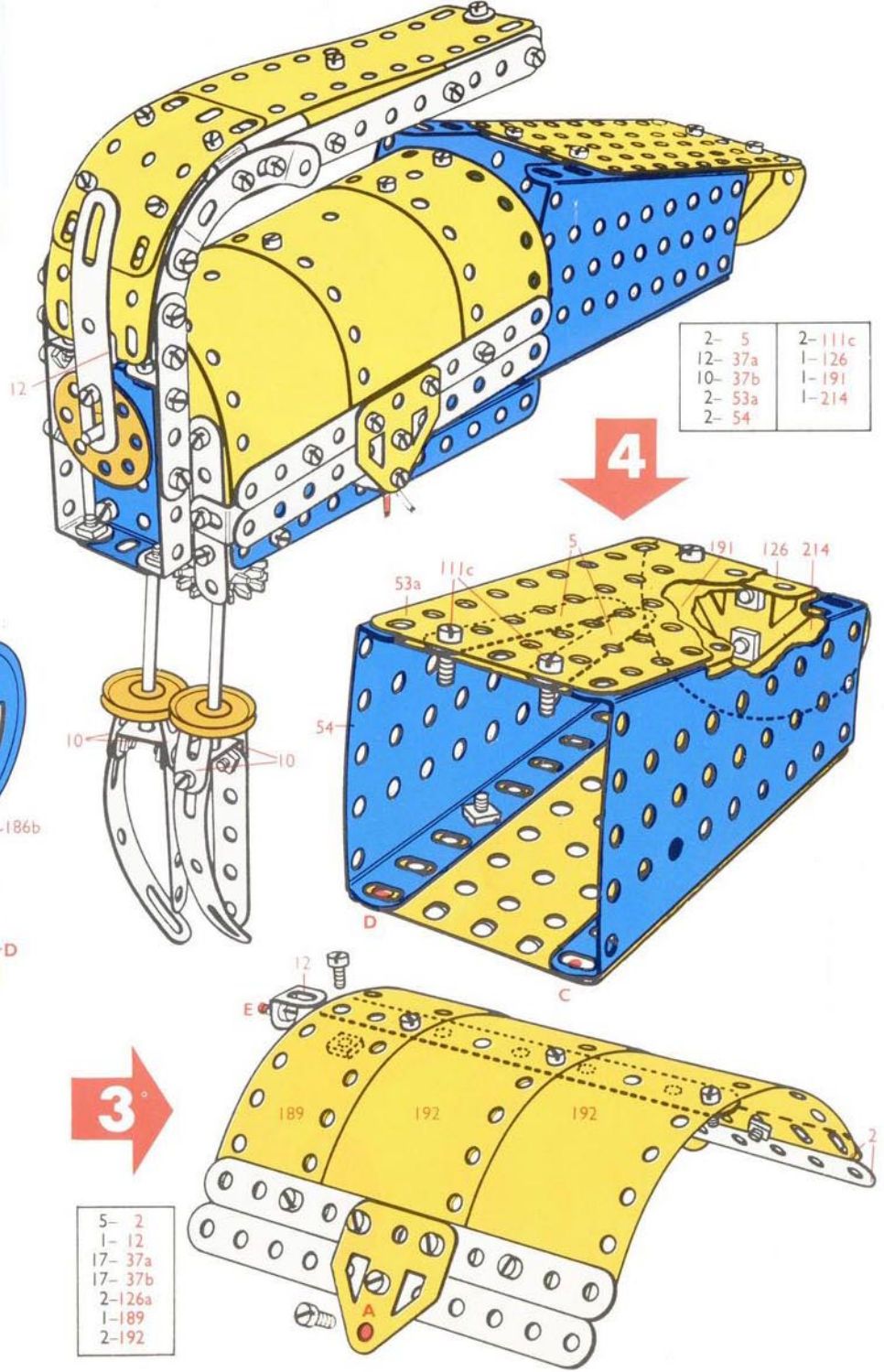

2- 5	2-111c
12- 37a	1-126
10- 37b	1-191
2- 53a	1-214
2- 54	

5- 2
1- 12
17- 37a
17- 37b
2-126a
1-189
2-192

5.14.

Scorpion
Schorpioen
Scorpione
Skorpion
Escorpión
Escorpião

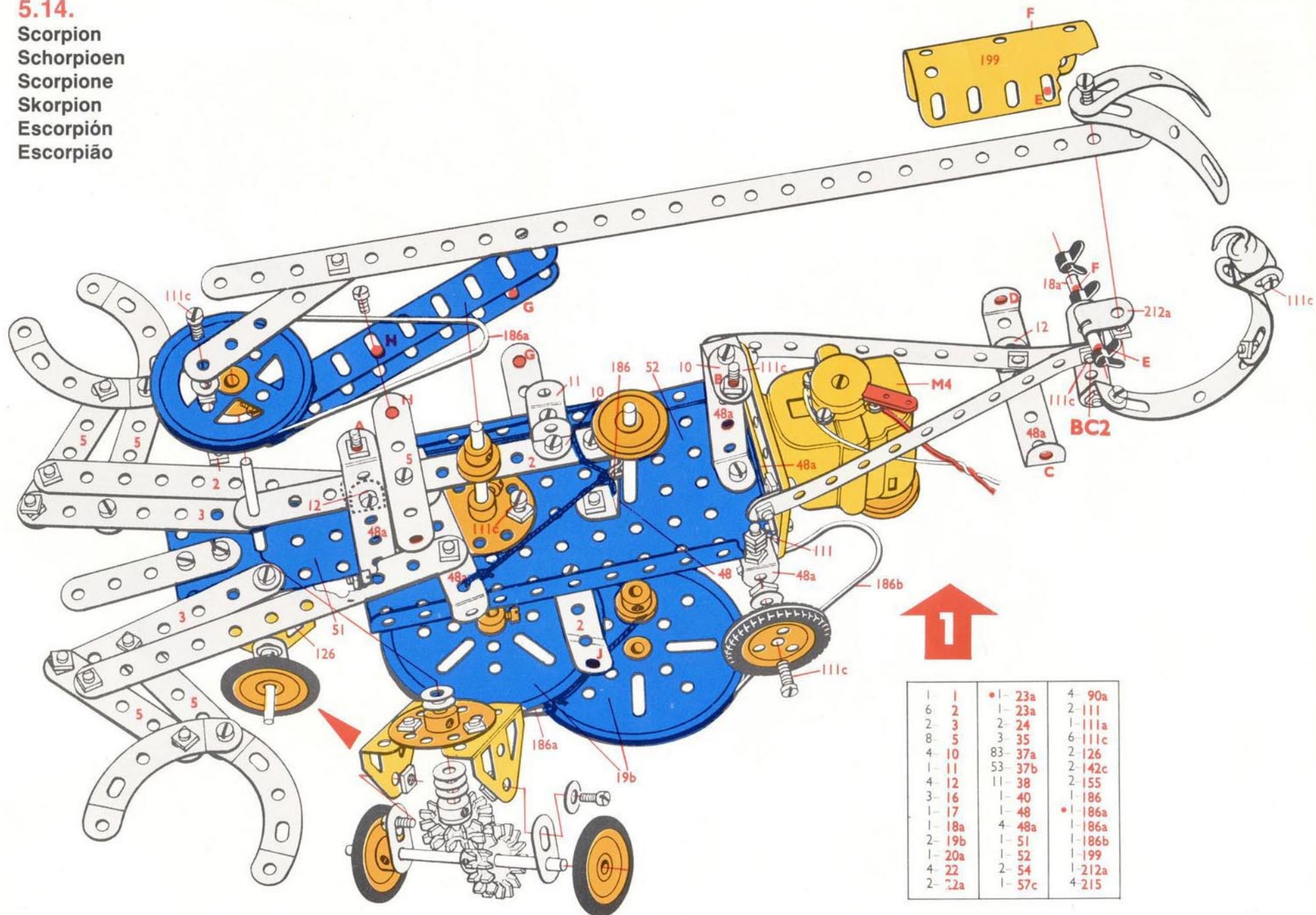

1- 1	• 1- 23a	4- 90a
6- 2	1- 23a	2- 111
2- 3	2- 24	1- 111a
8- 5	3- 35	6- 111c
4- 10	83- 37a	2- 126
1- 11	53- 37b	2- 142c
4- 12	11- 38	2- 155
3- 16	1- 40	1- 186
1- 17	1- 48	• 1- 186a
1- 18a	4- 48a	1- 186a
2- 19b	1- 51	1- 186b
1- 20a	1- 52	1- 199
4- 22	2- 54	1- 212a
2- 22a	1- 57c	4- 215

1- 1	2- 22a	1- 57c	2- 191
8- 2	*1- 23a	4- 90a	2- 192
2- 3	1- 23a	2- 111	1- 193
8- 5	2- 24	1- 111a	2- 194
4- 10	3- 35	6- 111c	1- 199
1- 11	107- 37a	2- 126	1- 200
4- 12	75- 37b	2- 142c	1- 212a
3- 12c	13- 38	2- 155	2- 214
3- 16	1- 40	1- 186	4- 215
1- 17	1- 48	*1- 186a	4- 221
1- 18a	4- 48a	1- 186a	*1- M4
2- 19b	1- 51	1- 186b	
1- 20a	1- 52	1- 189	
4- 22	2- 54	4- 190	

- * Non inclus dans la boîte
- * Not included in set

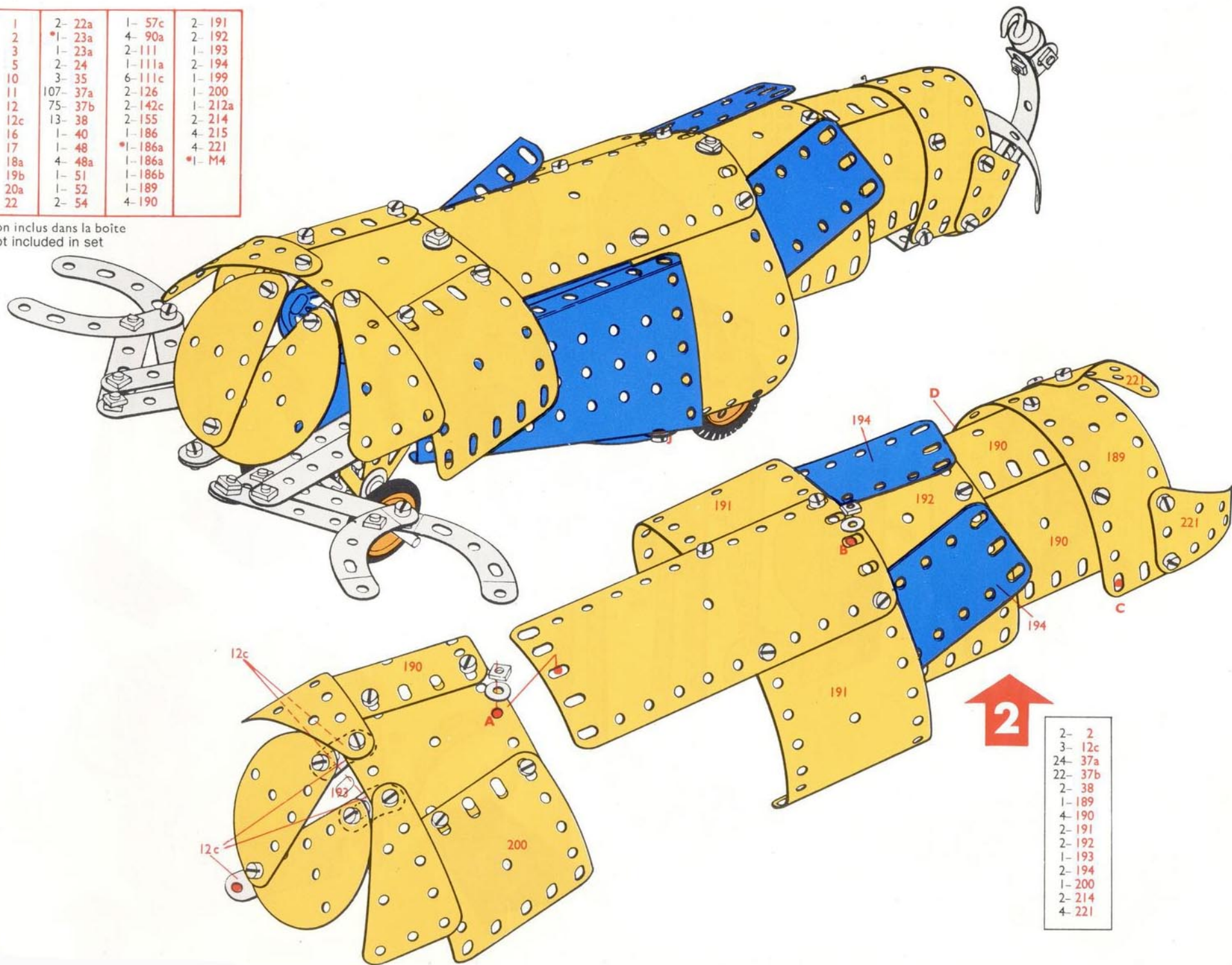

2- 2
3- 12c
24- 37a
22- 37b
2- 38
1- 189
4- 190
2- 191
2- 192
1- 193
2- 194
1- 200
2- 214
4- 221

5.15.

Martian
Marsbewoner
Martien
Marziano
Marsmensch
Marsinnevånare
Marciano
Marsianer

4- 1	1- 20a	1- 51	2-189
8- 2	1- 22	1- 52	4-190
2- 3	1- 23a	2- 53a	2-191
9- 5	2- 24	2- 54	2-192
2- 10	2- 35	3- 90a	2-194a
2- 11	105- 37a	2-111	1-200
1- 11a	94- 37b	1-111a	1-212a
10- 12	17- 38	4-111c	2-214
2- 17	2- 38d	2-126	4-215
1- 18a	1- 40	2-126a	4-221
1- 18b	2- 48	2-187	*1-M5
2- 19b	6- 48a	2-188	

- * Non inclus dans la boîte
- * Not included in set

4- 2	2- 38d
1- 3	2-111c
2- 12	1-192
2- 17	2-194a
2- 19b	2-214
2- 35	4-215
21- 37a	4-221
19- 37b	

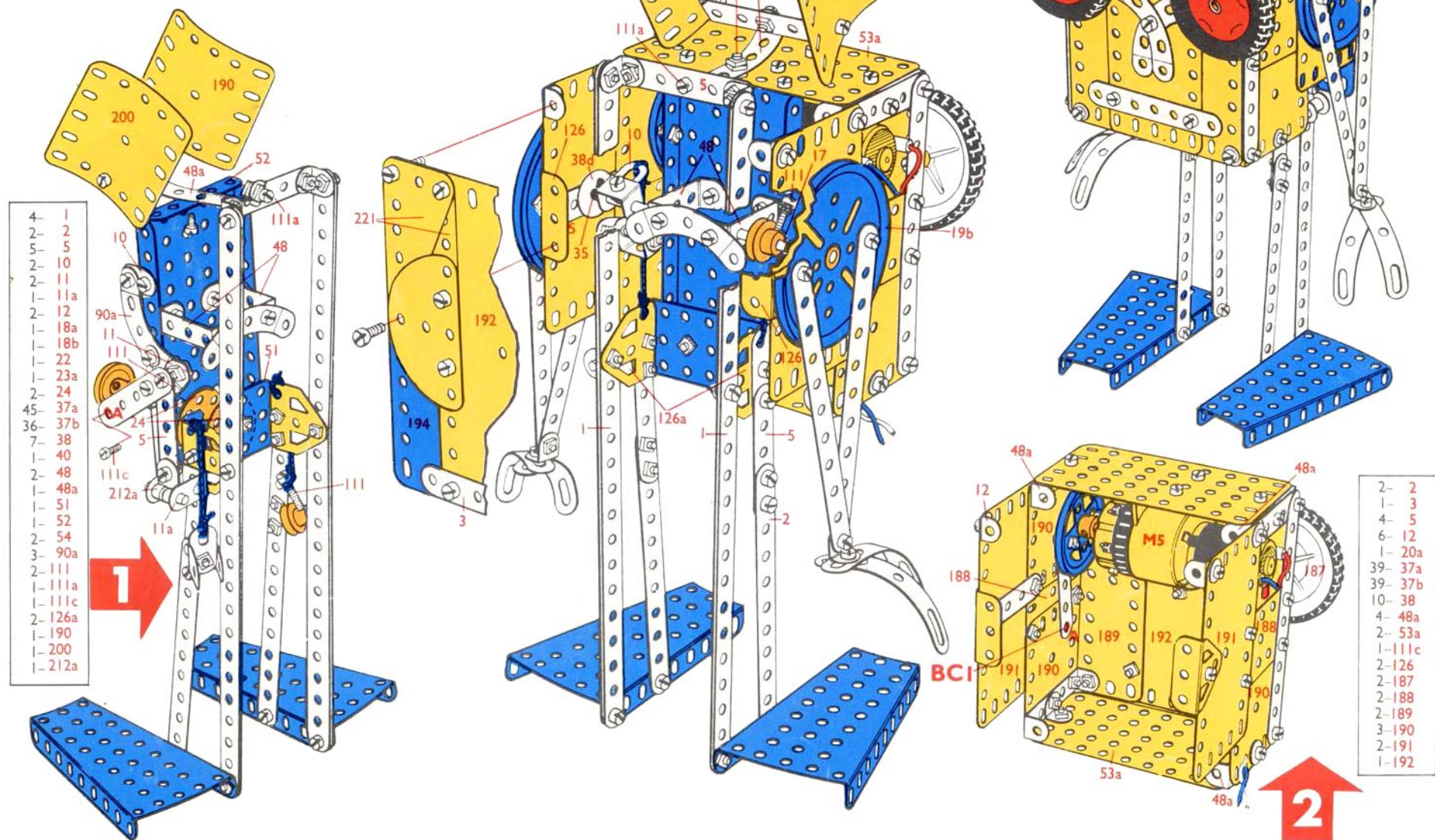

ELECTRONIC 5.16.

Automatic Press
 Automatische pers
 Presse automatique
 Pressa automatica
 Automatische Presse
 Automatisk press
 Prensa automatica
 Prensa Automatica
 Automatpresse

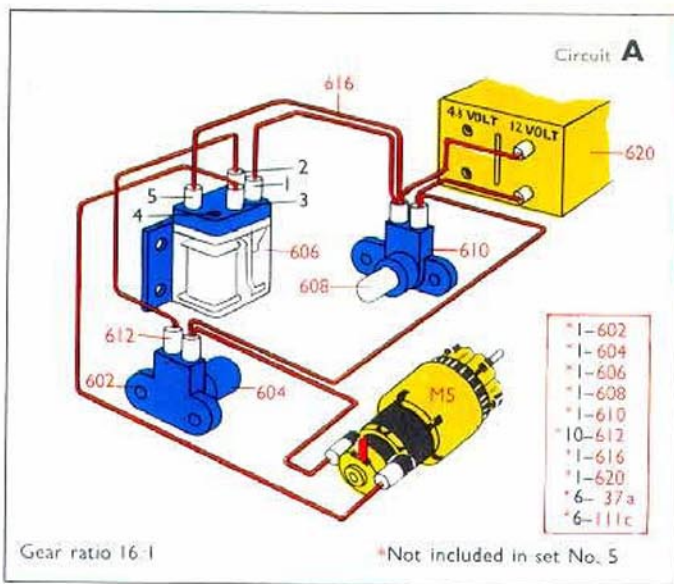

8- 2	1- 23a	1-111a
1- 3	2- 24	5-111c
5- 5	2- 27f	2-126
2-10	7- 35	2-126a
2-15b	52- 37a	1-186a
1-16	44- 37b	*1-186b
2-17	16- 38	1-191
2-18a	2- 48	1-212
1-18b	6- 48a	1-213
1-19b	1- 51	2-214
1-20a	1- 52	*1-M5
4- 22	2- 53a	
*1- 23a	2- 54	

*Not included in set No. 5

2- 2	2- 35
1- 3	16- 37a
2- 5	14- 37b
2-15b	8- 38
1-20a	1- 52
2-22	2- 54
1-23a	2-111c
*1-23a	2-126
2-27f	1-186a

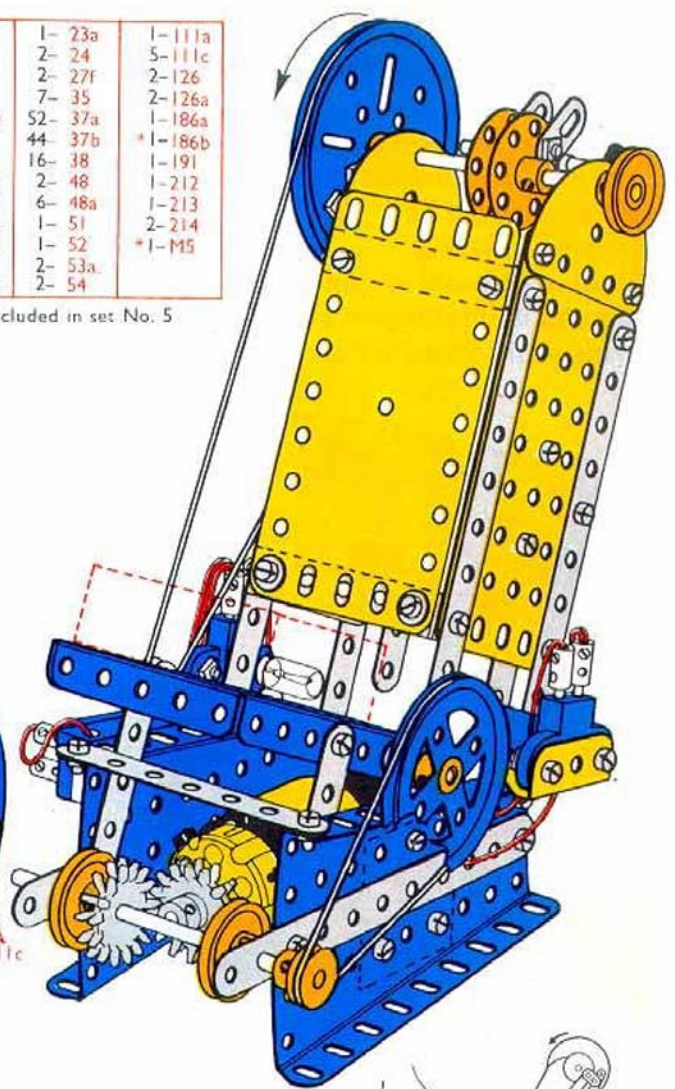
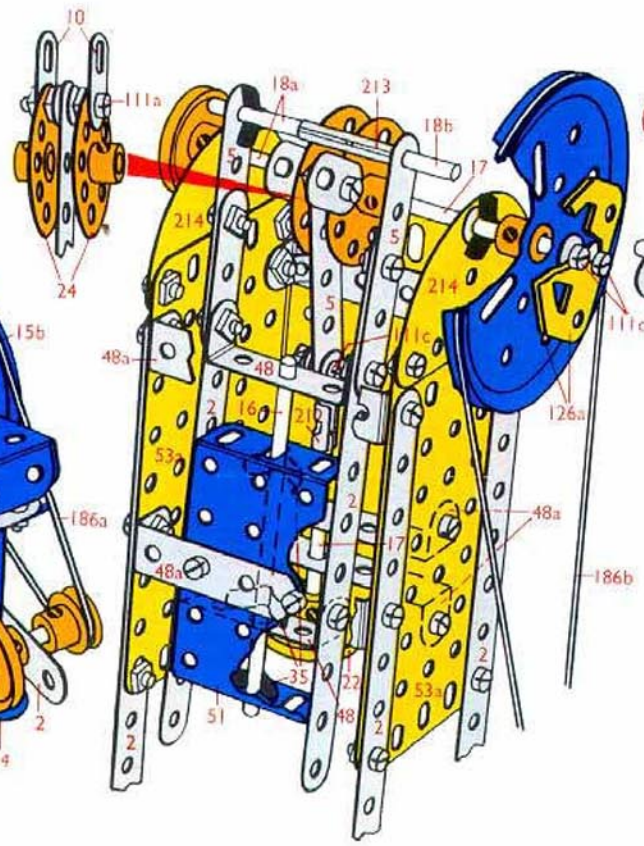
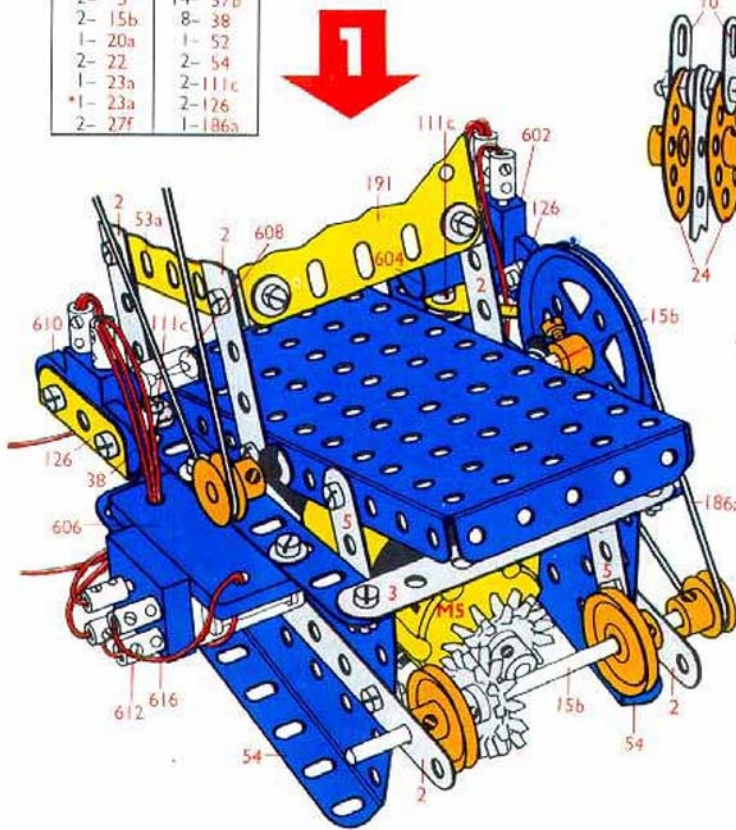

6- 2	2- 24	1-111a
3- 5	5- 35	3-111c
2-10	29- 37a	2-126a
1-16	22- 37b	1-186b
1-17	8- 38	1-191
2-18a	2- 48	1-212
1-18b	6- 48a	1-213
1-19b	1- 51	2-214
2-22	2- 53a	



ELECTRONIC 5.17.

injection Moulding Machine

Spuitsgietmachine

Machine à moulage par injection

Formatrice ad iniezione

Spritgussmaschine

Formsprutmaskin

Máquina de moldeo por inyección

Máquina de Moldagem por Injeção

Formemaskin med innsprøyting

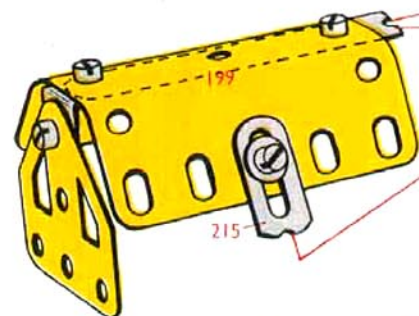

4-	1	2-	54
8-	2	2-	90a
2-	3	2-	111
8-	5	2-	111c
2-	10	2-	126
1-	11	2-	126a
10-	12	2-	142c
1-	12c	1-	176
2-	15b	1-	186a
4-	16	*1-	186a
1-	19b	4-	187
1-	19s	2-	188
1-	20a	2-	189
4-	22	4-	190
1-	22a	2-	191
1-	23	2-	192
1-	23a	2-	193
2-	24	2-	193a
2-	27f	2-	194
3-	35	2-	194a
99-	37a	1-	199
95-	37b	1-	212
18-	38	2-	212a
1-	38d	1-	213
2-	48	2-	214
6-	48a	4-	215
1-	51	4-	221
1-	52	*1-	M5
2-	53a		

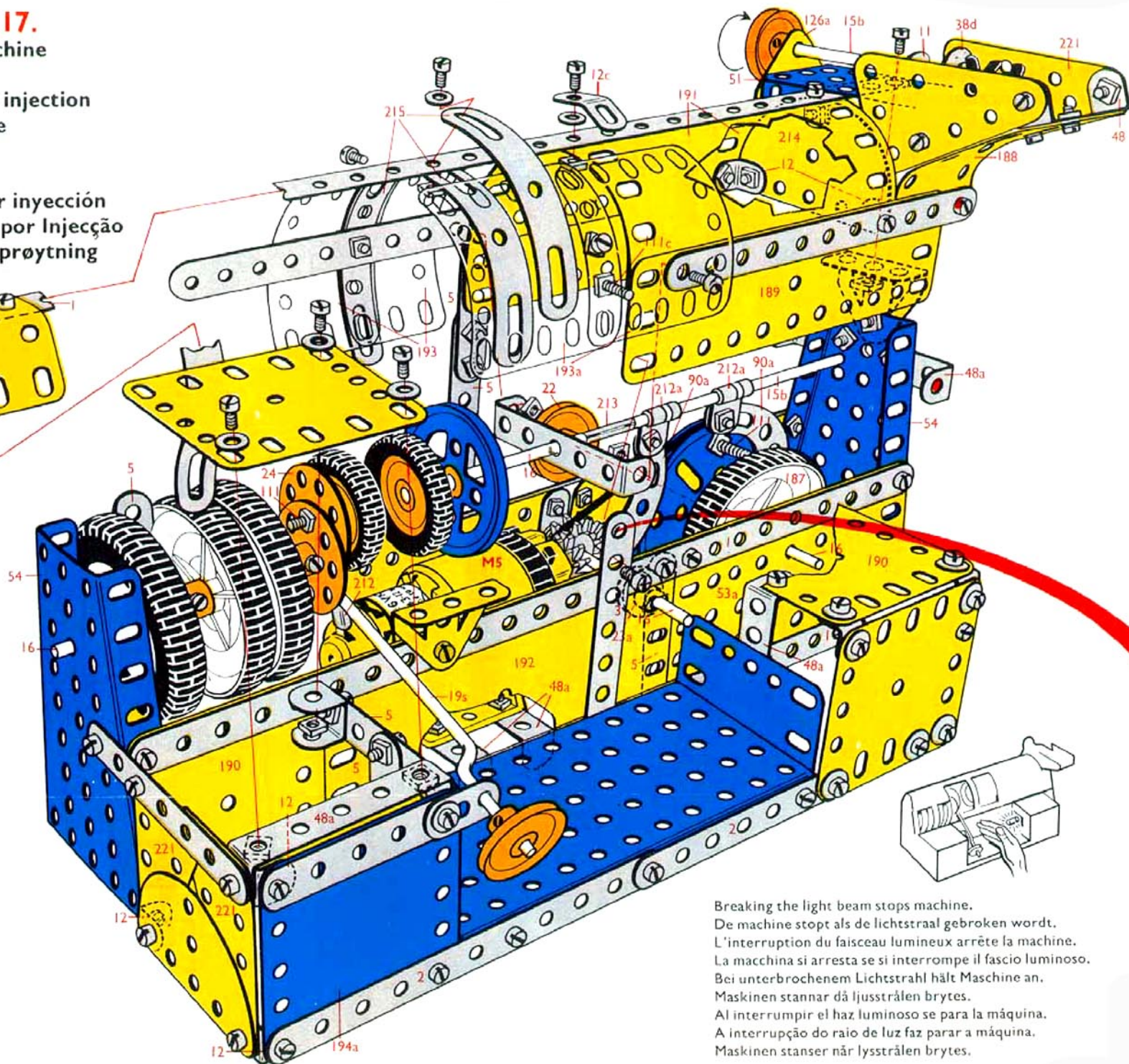

Breaking the light beam stops machine.
 De machine stopt als de lichtstraal gebroken wordt.
 L'interruption du faisceau lumineux arrête la machine.
 La macchina si arresta se si interrompe il fascio luminoso.
 Bei unterbrochenem Lichtstrahl hält Maschine an.
 Maskinen stannar då ljustrålen brytes.
 Al interrumpir el haz luminoso se para la máquina.
 A interrupção do raio de luz faz parar a máquina.
 Maskinen stanser når lysstrålen brytes.

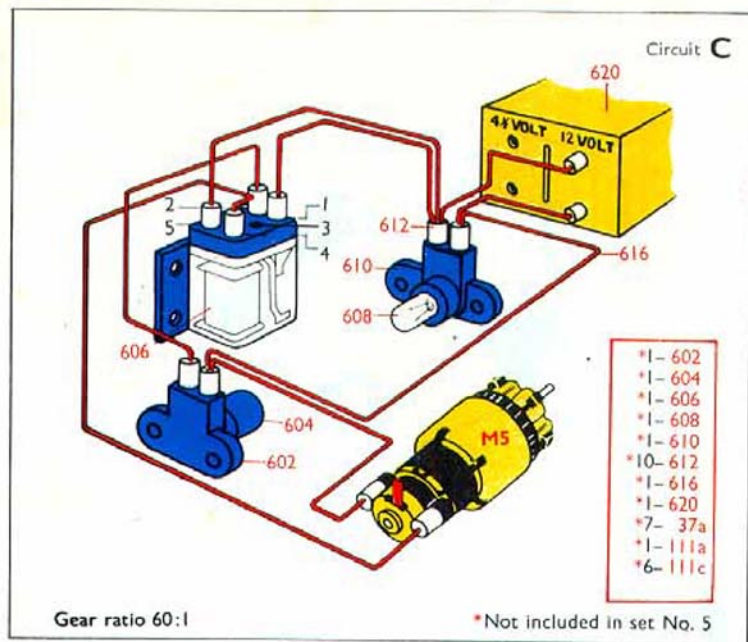

4- 1	1- 23	2- 90a	2- 193
8- 2	1- 23a	2- 111	2- 193a
2- 3	2- 24	2- 111c	2- 194
8- 5	2- 27f	2- 126	2- 194a
2- 10	3- 35	2- 126a	1- 199
1- 11	99- 37a	2- 142c	1- 212
10- 12	95- 37b	1- 176	2- 212a
1- 12c	18- 38	1- 186a	1- 213
2- 15b	1- 38d	*1- 186a	2- 214
4- 16	2- 48	2- 48	4- 215
1- 19b	6- 48a	2- 188	4- 221
1- 19s	1- 51	2- 189	*1- M5
1- 20a	1- 52	4- 190	
4- 22	2- 53a	2- 191	
1- 22a	2- 54	2- 192	

*Not included in set No. 5

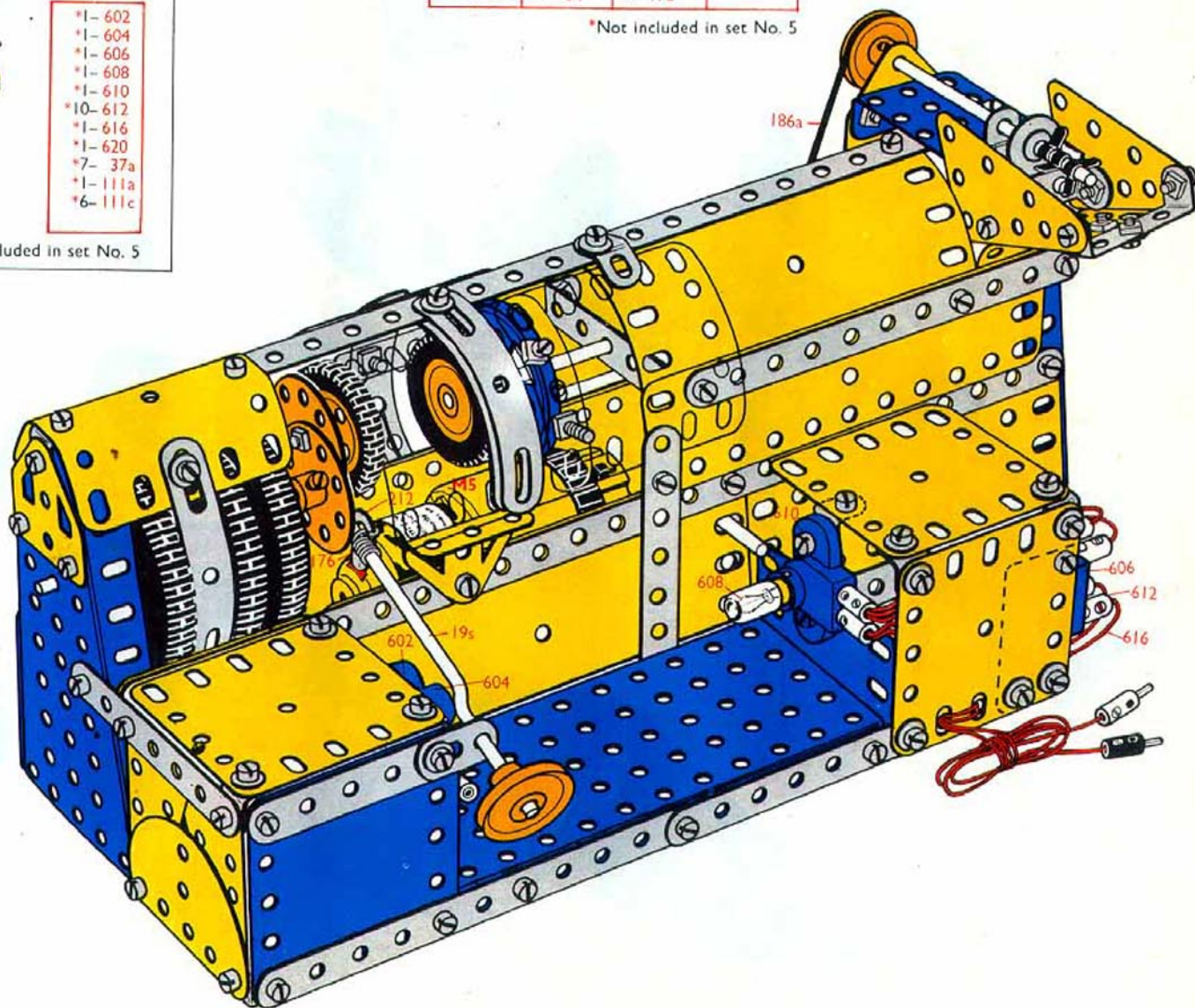
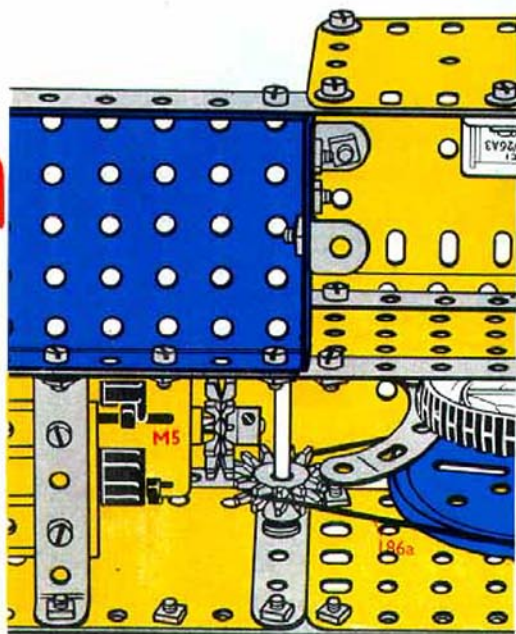

ELECTRONIC 5.18.**Counting Conveyor****Teltransporteur****Convoyeur-compteur****Trasportatore contatore****Zahlforderer****Transportor med rakneverk****Transportador contador****Transportador Contador****Telletransportor**

4- 1	1- 23a	2-111a
5- 2	2- 24	2-111c
2- 3	2- 27f	2-126
9- 5	14- 35	2-126a
4- 10	87- 37a	1-155
2- 11	71- 37b	1-186
1- 11a	18- 38	1-186a
8- 12	2- 38d	*1-186a
2- 15b	1- 40	2-190
4- 16	1- 48	2-192
1- 17	6- 48a	1-212
2- 19b	1- 51	2-212a
1- 20a	1- 52	1-213
4- 22	2- 53a	2-214
2- 22a	2- 54	*1-M5
1- 23	4- 90a	
*1- 23a	1-111	

*Not included in set No. 5

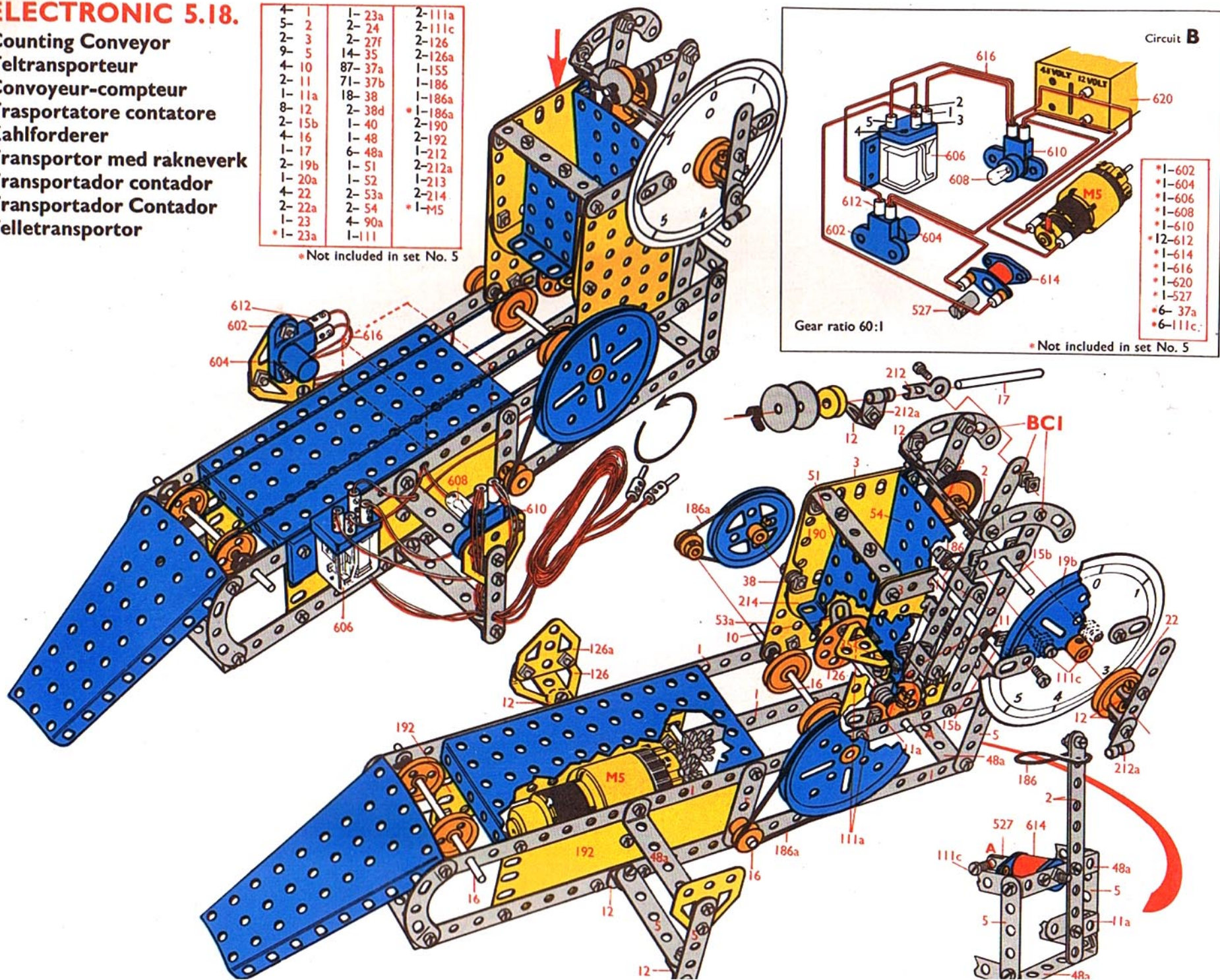
Circuit **B**

Gear ratio 60:1

*Not included in set No. 5

BCI**A**

6.1.
Breakdown Truck
Takelwagen
Camion de dépannage
Carro attrezzi
Abschleppwagen
Bärgningsbil
Camión-grúa
Camião de Reboque
Service-vogn

14- 2	2- 22a	1- 52	1- 176
2- 3	1- 23a	2- 53a	4- 187
12- 5	2- 24	2- 54	4- 188
2- 6a	1- 26	1- 57c	2- 189
4- 11	1- 27a	1- 80c	3- 190
1- 11a	9- 35	4- 90a	2- 191
12- 12	144- 37a	2- 111a	3- 192
2- 12a	128- 37b	4- 111c	2- 212a
2- 15	21- 38	1- 115	2- 214
1- 15a	2- 38d	4- 125	4- 215
2- 17	1- 40	2- 126	4- 221
3- 18a	2- 48	1- 126a	
1- 18b	8- 48a	1- 147b	
2- 22	1- 51	1- 155	

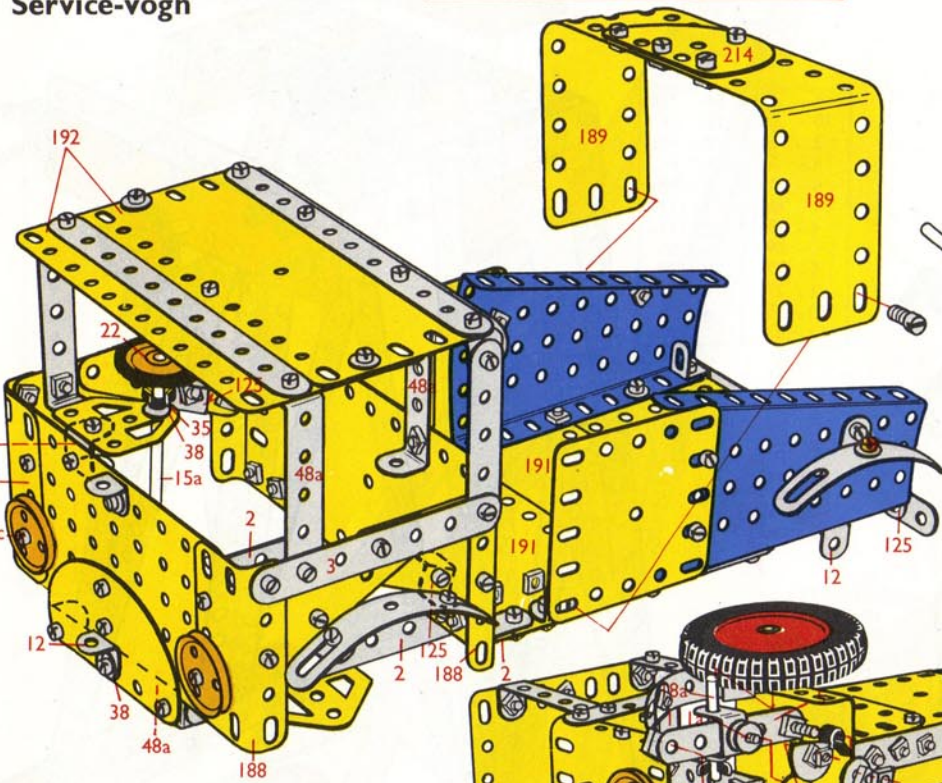
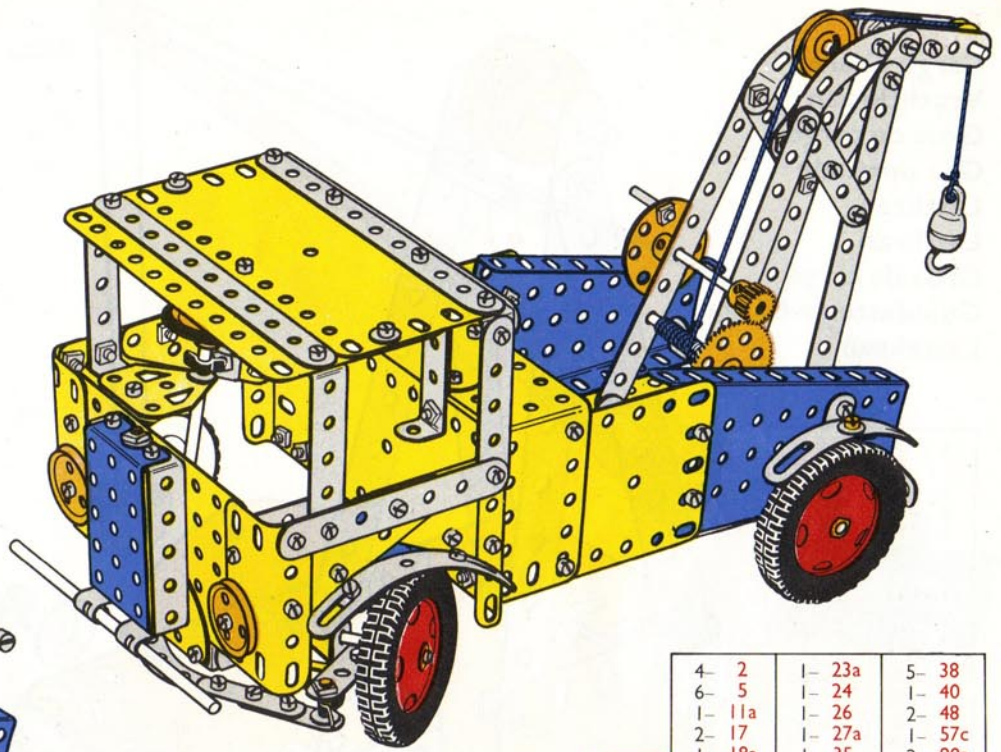

4- 2	1- 23a	5- 38
6- 5	1- 24	1- 40
1- 11a	1- 26	2- 48
2- 17	1- 27a	1- 57c
1- 18a	1- 35	2- 90a
1- 18b	22- 37a	1- 115
1- 22	22- 37b	1- 176



10- 2	2- 53a
2- 3	2- 54
2- 5	2- 111c
1- 11	4- 125
12- 12	1- 126a
2- 12a	1- 155
1- 15a	4- 188
1- 22	2- 189
2- 22a	3- 190
1- 35	2- 191
96- 37a	3- 192
94- 37b	2- 214
9- 38	4- 215
6- 48a	4- 221
1- 52	

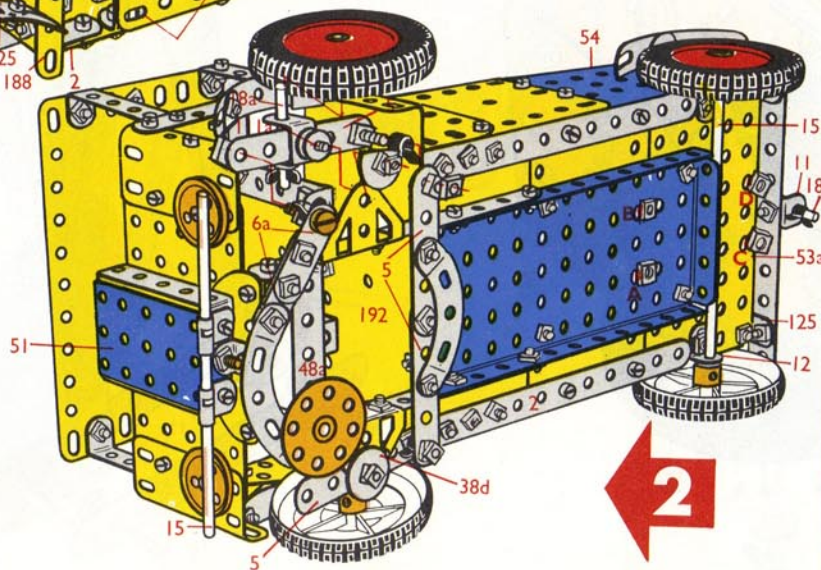

4- 5
2- 6a
3- 11
2- 15
3- 18a
1- 24
7- 35
26- 37a
12- 37b
7- 38
2- 38d
2- 48a
1- 51
1- 80c
2- 90a
2- 111a
2- 111c
2- 126
1- 147b
4- 187
2- 212a

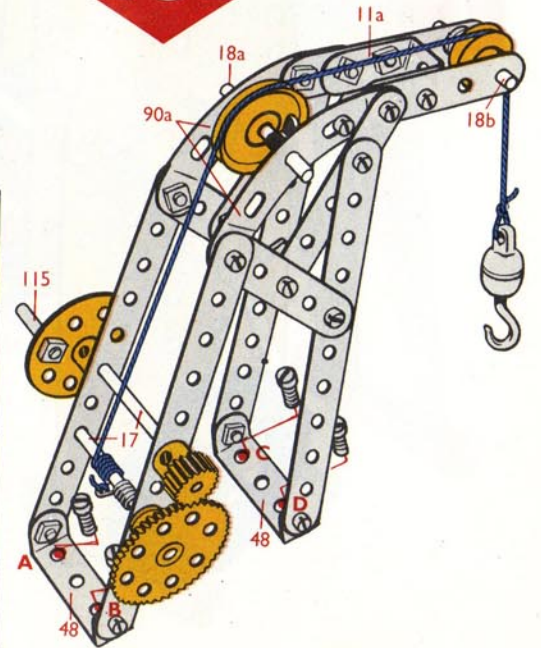

6.2.

Cargo Crane
 Vrachtkraan
 Grue de cargo
 Gru portuale
 Lastkran
 Lastkran
 Grúa de carga
 Guindaste de Carga
 Lastekran

4	2	1	40
3	5	1	48
2	16	4	48a
2	17	1	52
1	19b	2	53a
1	19s	1	111c
1	20a	1	176
2	22a	2	188
1	26	2	190
1	27a	2	191
3	35	1	192
44	37a	2	193
38	37b	1	193a
7	38	1	213
2	38d	2	214

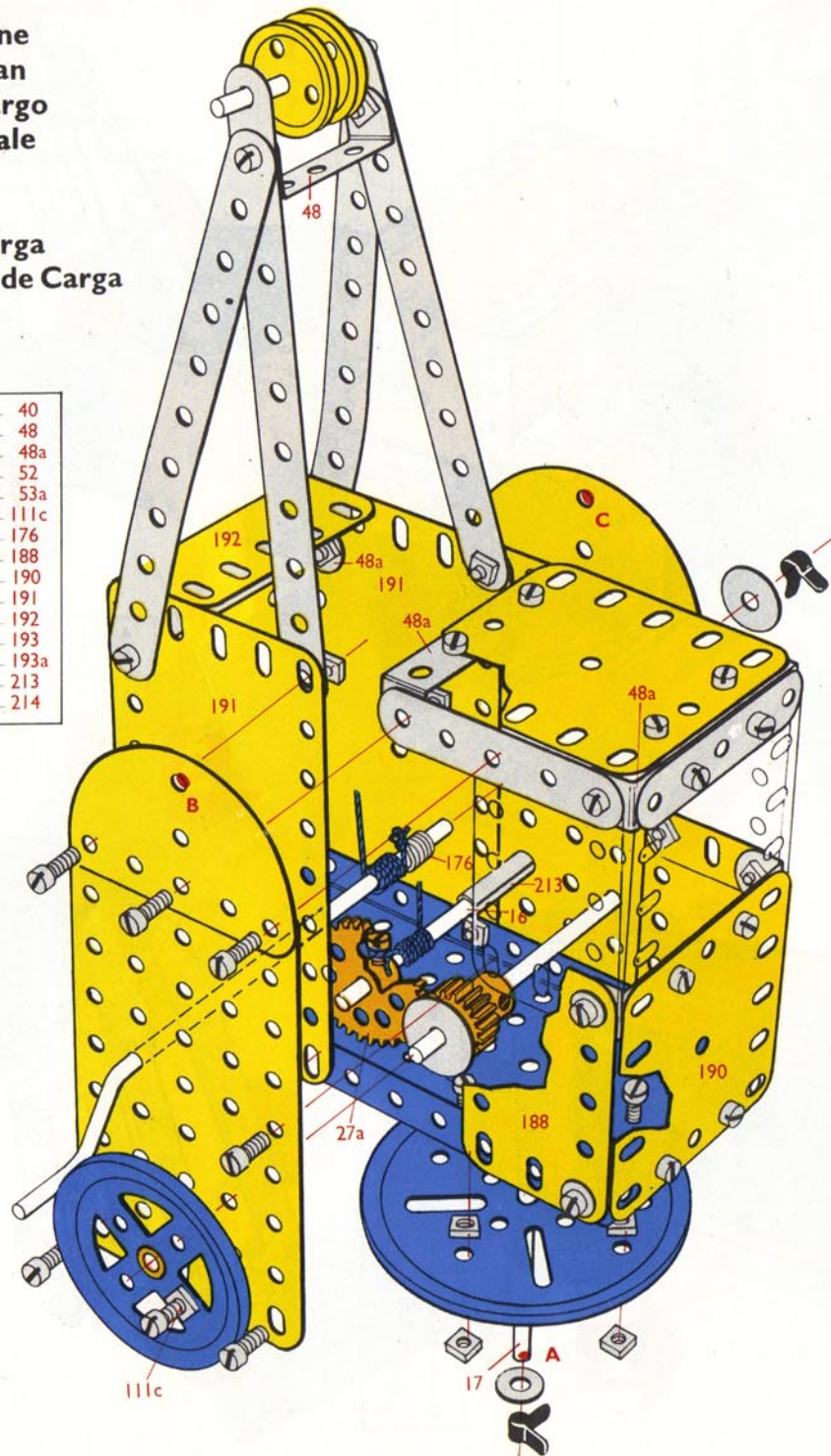

4	1	54	37b
10	2	12	38
2	5	2	48a
4	8	1	51
4	11	2	90a
1	16	2	111
4	18a	2	111a
1	19b	1	155
5	22	2	188
2	27f	4	189
10	35	2	188
62	37a	4	221

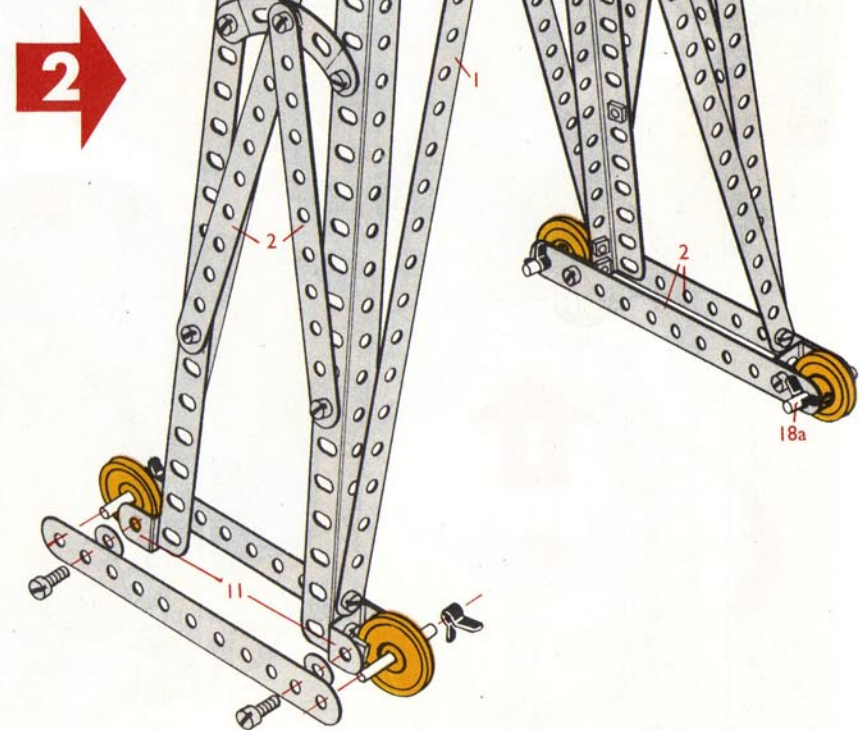

10- 1	1- 19s	2- 38d	2- 126a
14- 2	1- 20a	1- 40	1- 147b
2- 3	5- 22	2- 48	1- 155
9- 5	2- 22a	8- 48a	1- 176
2- 6a	1- 23	1- 51	4- 188
4- 8	1- 23a	1- 52	4- 189
4- 11	2- 24	2- 53a	2- 190
1- 11a	1- 26	2- 54	2- 191
4- 12	1- 27a	1- 57c	1- 192
1- 15b	2- 27f	2- 90a	2- 193
3- 16	13- 35	2- 111	1- 193a
2- 17	137- 37a	4- 111a	1- 213
4- 18a	117- 37b	1- 111c	2- 214
2- 19b	24- 38	1- 115	4- 221

6- 1
2- 3
4- 5
2- 6a
1- 11a
4- 12
1- 15b
1- 23
1- 23a
2- 24
31- 37a
25- 37b
5- 38
1- 48
2- 48a
2- 54
1- 57c
2- 111a
1- 115
2- 126a
1- 147b

3 →

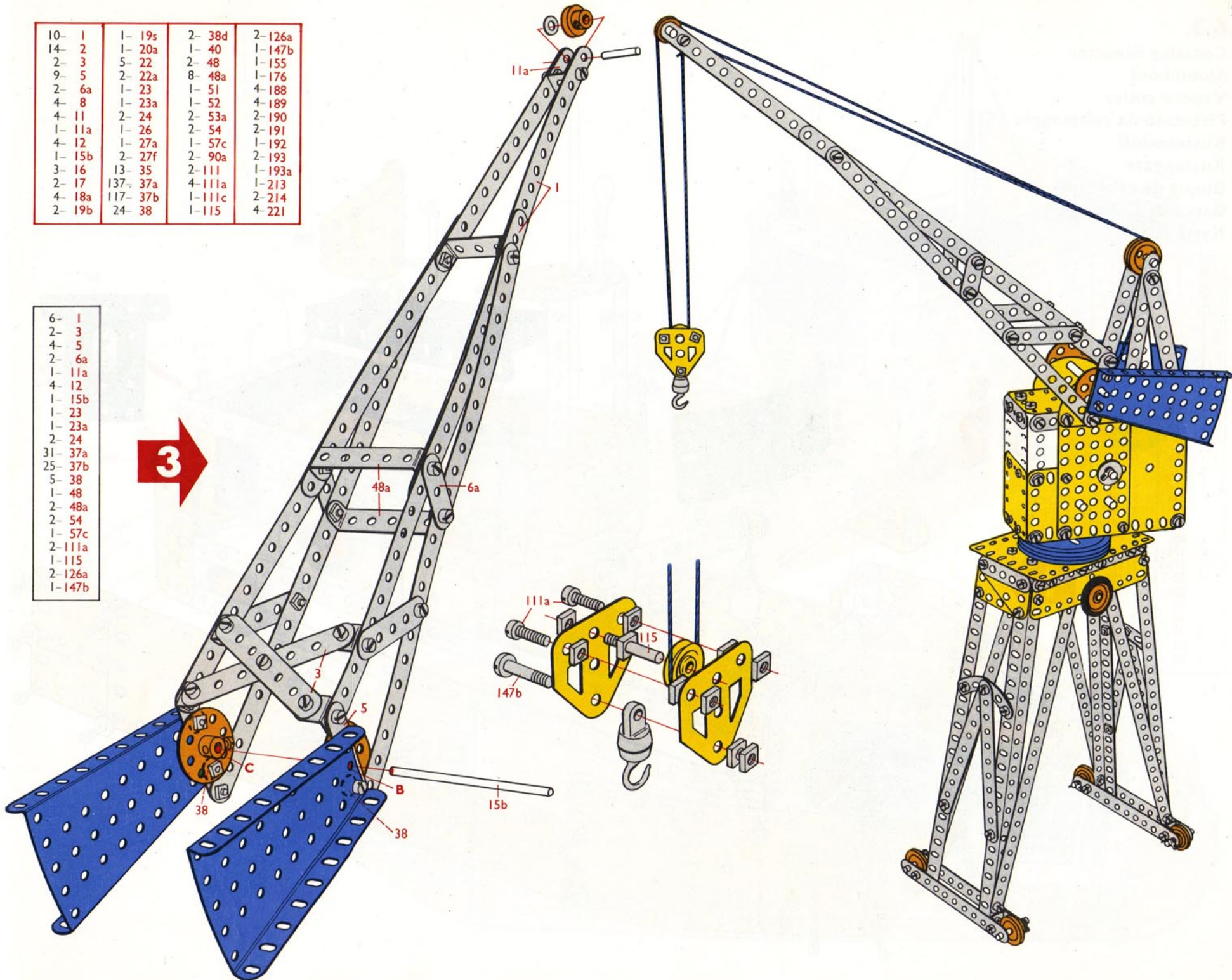

6.3.

Coasting Steamer
 Stoomboot
 Vapeur cotier
 Piroscfo da cabotaggio
 Küstenschiff
 Kustangare
 Buque de cabotaje
 Barco de Cabotagem
 Kystbat

4-	1	2-	53a
6-	2	1-	54
2-	3	1-	57c
12-	5	4-	90a
2-	6a	1-	111
4-	10	2-	111a
1-	11a	2-	111c
11-	12	1-	115
2-	12a	2-	125
8-	12c	2-	126
2-	15	2-	126a
1-	15a	4-	142c
1-	16	1-	147b
1-	17	1-	155
1-	18b	1-	176
5-	22	3-	188
1-	23	4-	189
1-	23a	4-	190
1-	24	2-	191
1-	26	4-	192
6-	35	2-	193
130-	37a	2-	193a
122-	37b	2-	194
24-	38	2-	194a
1-	38d	1-	200
1-	40	1-	212
2-	48	2-	214
8-	48a	4-	215
1-	51	2-	221
1-	52	2-	222

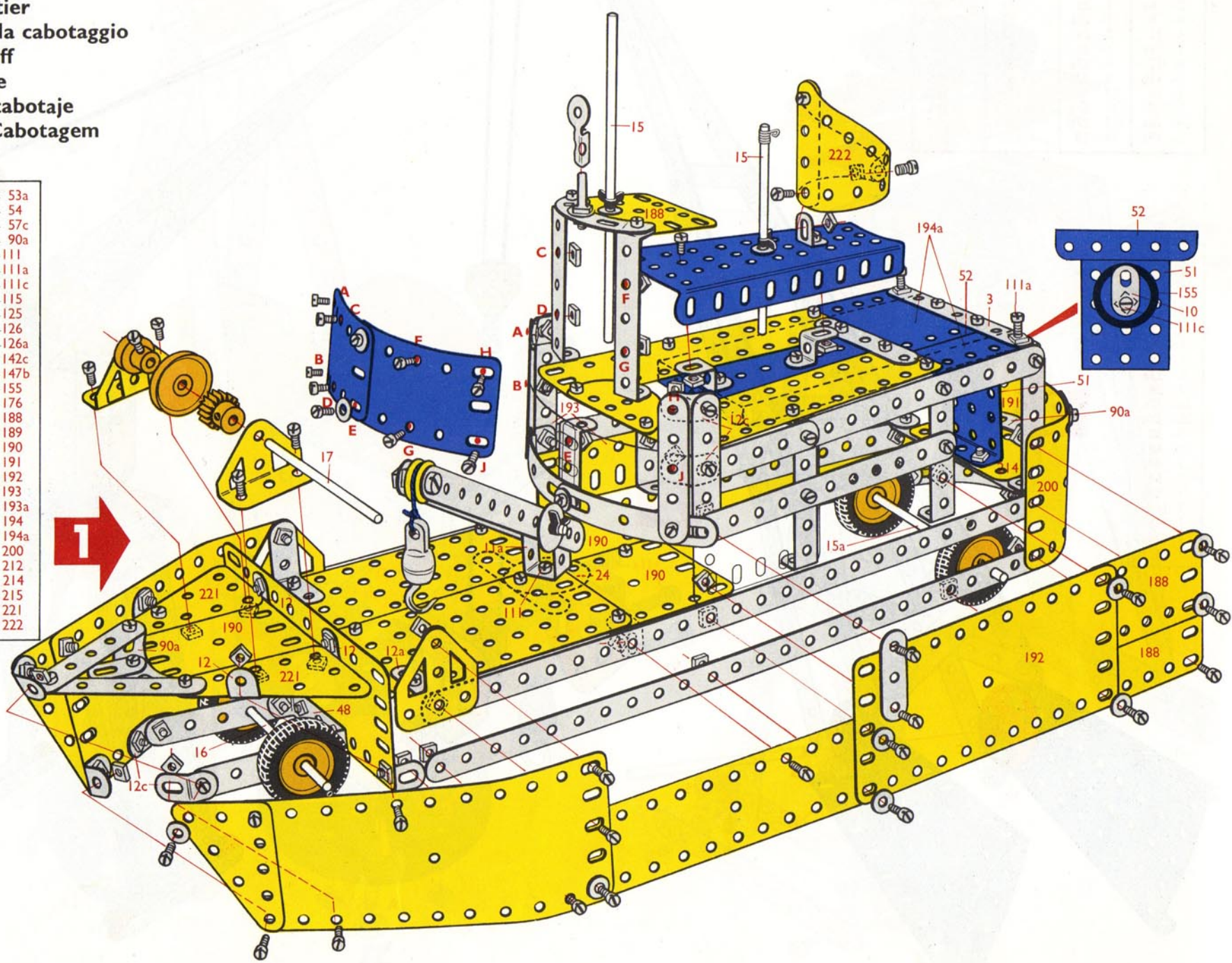

4- 1	5- 22	2- 53a	3- 188
6- 2	1- 23	1- 54	4- 189
2- 3	1- 23a	1- 57c	4- 190
12- 5	1- 24	4- 90a	2- 191
2- 6a	1- 26	1- 111	4- 192
4- 10	6- 35	2- 111a	2- 193
1- 11a	130- 37a	2- 111c	2- 193a
11- 12	122- 37b	1- 115	2- 194
2- 12a	24- 38	2- 125	2- 194a
8- 12c	1- 38d	2- 126	1- 200
2- 15	1- 40	2- 126a	1- 212
1- 15a	2- 48	4- 142c	2- 214
1- 16	8- 48a	1- 147b	4- 215
1- 17	1- 51	1- 155	2- 221
1- 18b	1- 52	1- 176	2- 222

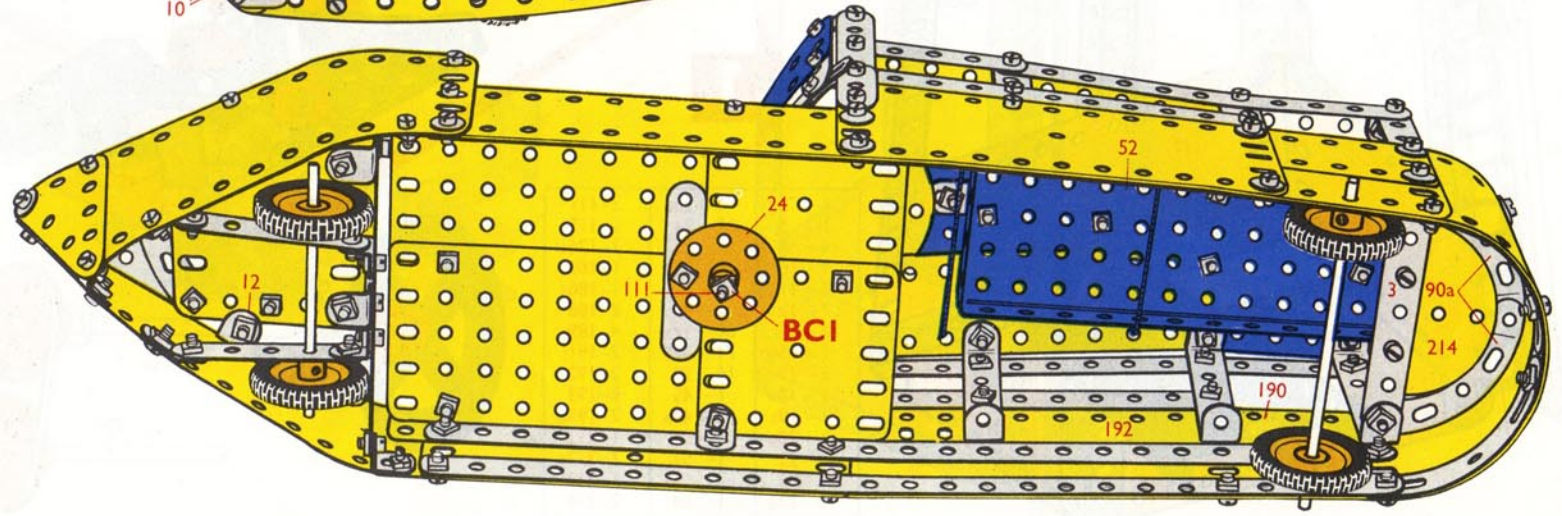
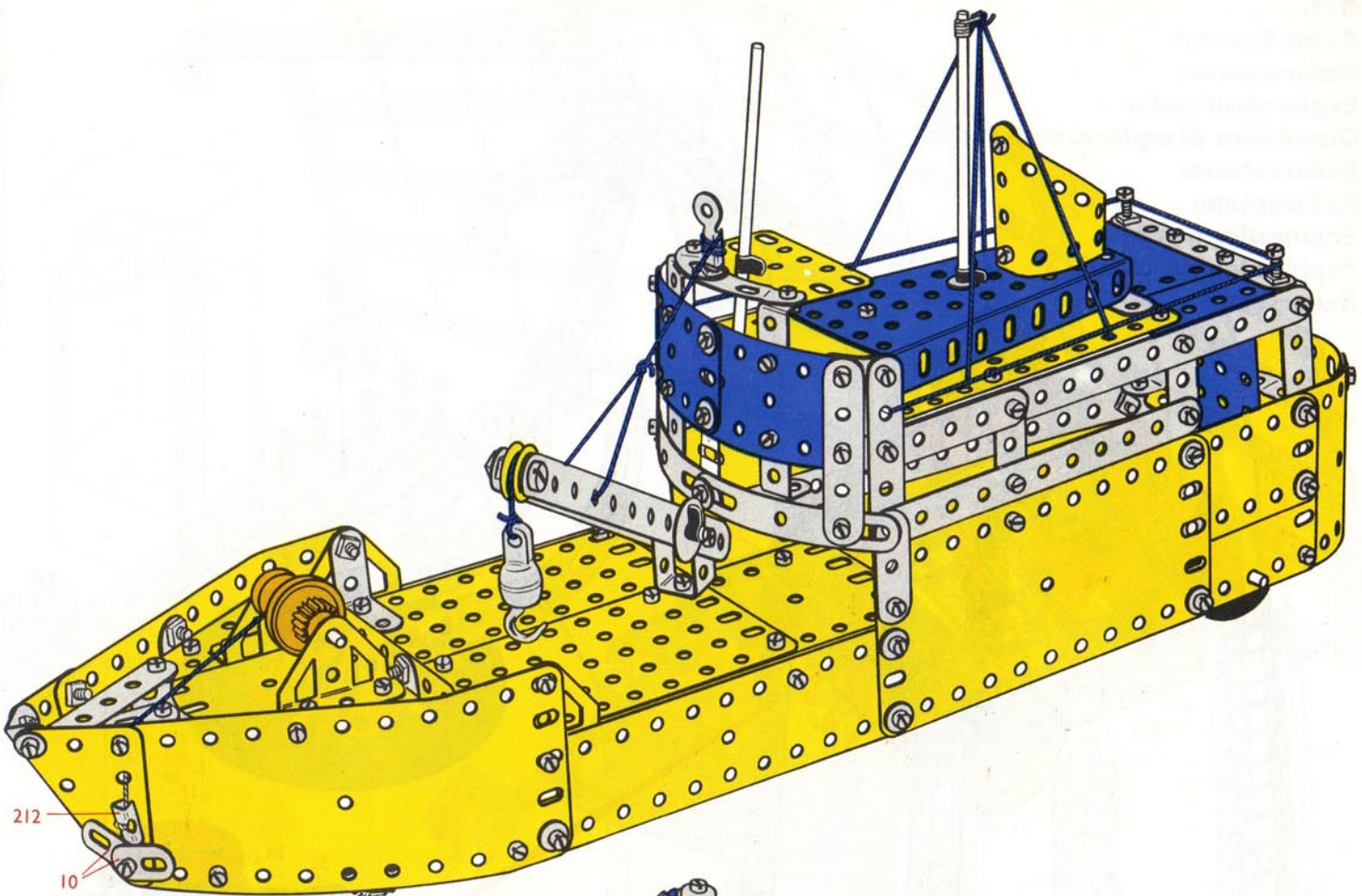

6.4.
Radar Scanner
Radarscanner
Explorateur radar
Dispositivo di esplorazione radar
Radarabtaster
Radarrantenn
Explorador de radar
Explorador de Radar
Radarsoker

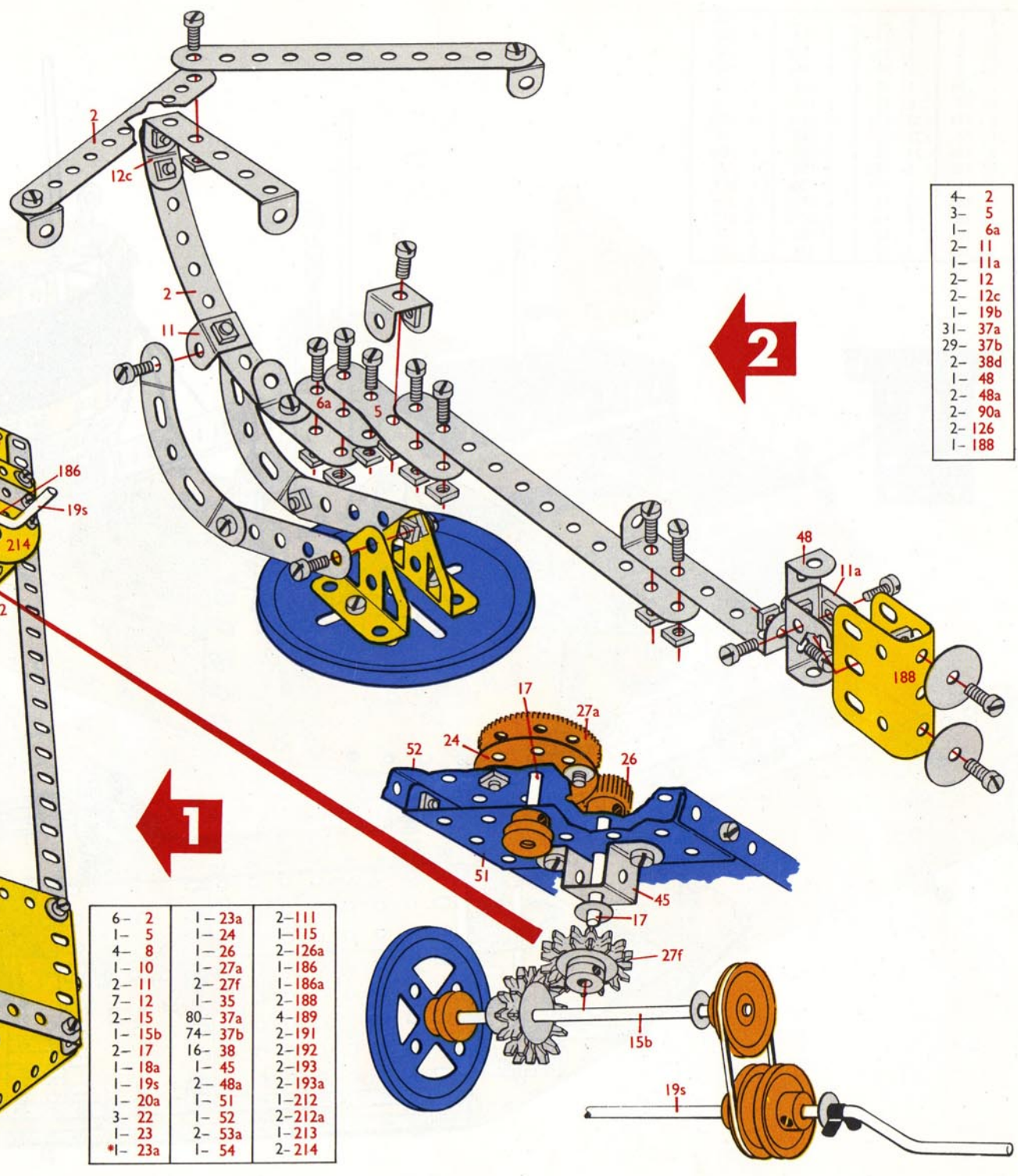
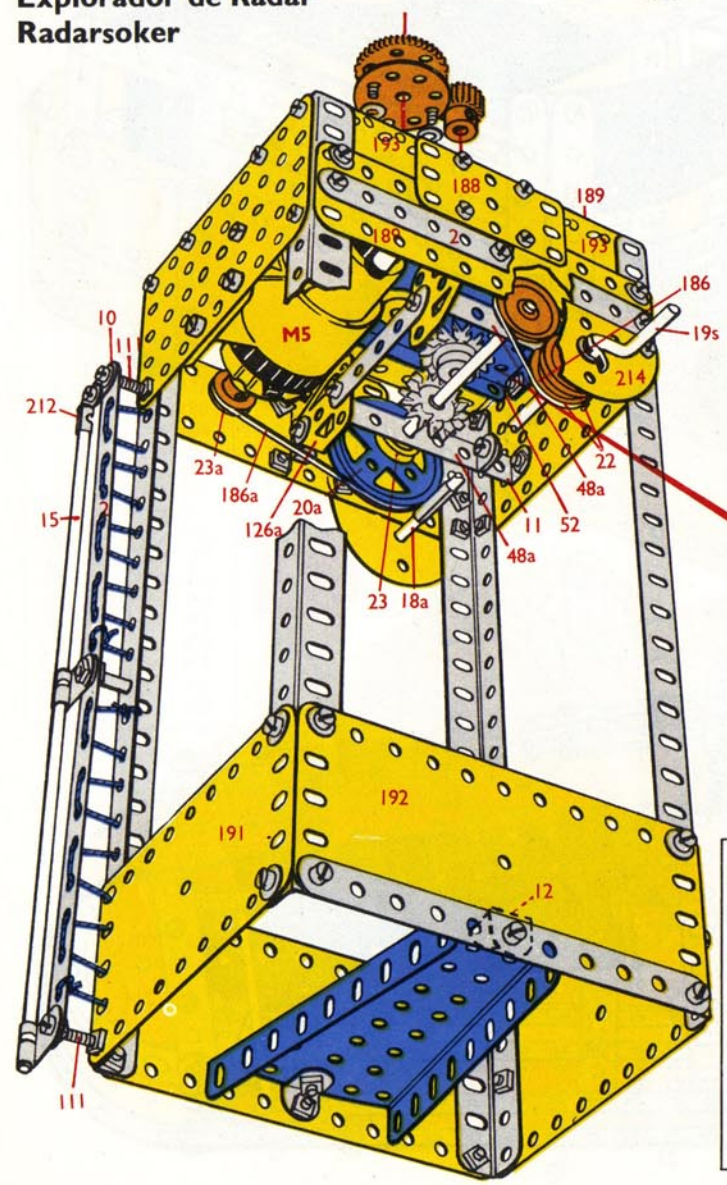

- 4- 2
- 3- 5
- 1- 6a
- 2- 11
- 1- 11a
- 2- 12
- 2- 12c
- 1- 19b
- 31- 37a
- 29- 37b
- 2- 38d
- 1- 48
- 2- 48a
- 2- 90a
- 2- 126
- 1- 188

- | | | |
|---------|---------|---------|
| 6- 2 | 1- 23a | 2- 111 |
| 1- 5 | 1- 24 | 1- 115 |
| 4- 8 | 1- 26 | 2- 126a |
| 1- 10 | 1- 27a | 1- 186 |
| 2- 11 | 2- 27f | 1- 186a |
| 7- 12 | 1- 35 | 2- 188 |
| 2- 15 | 80- 37a | 4- 189 |
| 1- 15b | 74- 37b | 2- 191 |
| 2- 17 | 16- 38 | 2- 192 |
| 1- 18a | 1- 45 | 2- 193 |
| 1- 19s | 2- 48a | 2- 193a |
| 1- 20a | 1- 51 | 1- 212 |
| 3- 22 | 1- 52 | 2- 212a |
| 1- 23 | 2- 53a | 1- 213 |
| *1- 23a | 1- 54 | 2- 214 |

10- 1	1- 19b	1- 40	1-186a
14- 2	1- 19s	1- 45	4-188
2- 3	1- 20a	1- 48	4-189
12- 5	3- 22	6- 48a	2-191
1- 6a	1- 23	1- 51	2-192
4- 8	*1- 23a	1- 52	2-193
1- 10	1- 23a	2- 53a	2-193a
4- 11	1- 24	1- 54	1-212
1- 11a	1- 26	2- 80c	2-212a
9- 12	1- 27a	2- 90a	1-213
2- 12a	2- 27f	2-111	2-214
2- 12c	5- 35	4-111c	4-221
2- 15	144- 37a	1-115	*1- M5
1- 15b	133- 37b	2-126	
2- 17	16- 38	2-126a	
1- 18a	2- 38d	1-186	

* Not included in set No.6

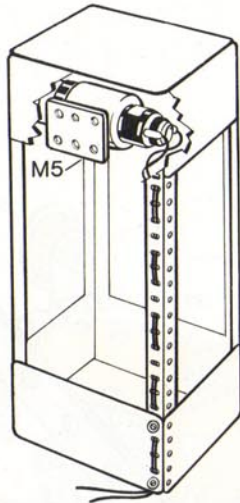

10- 1
4- 2
2- 3
8- 5
27- 37a
27- 37b
1- 40

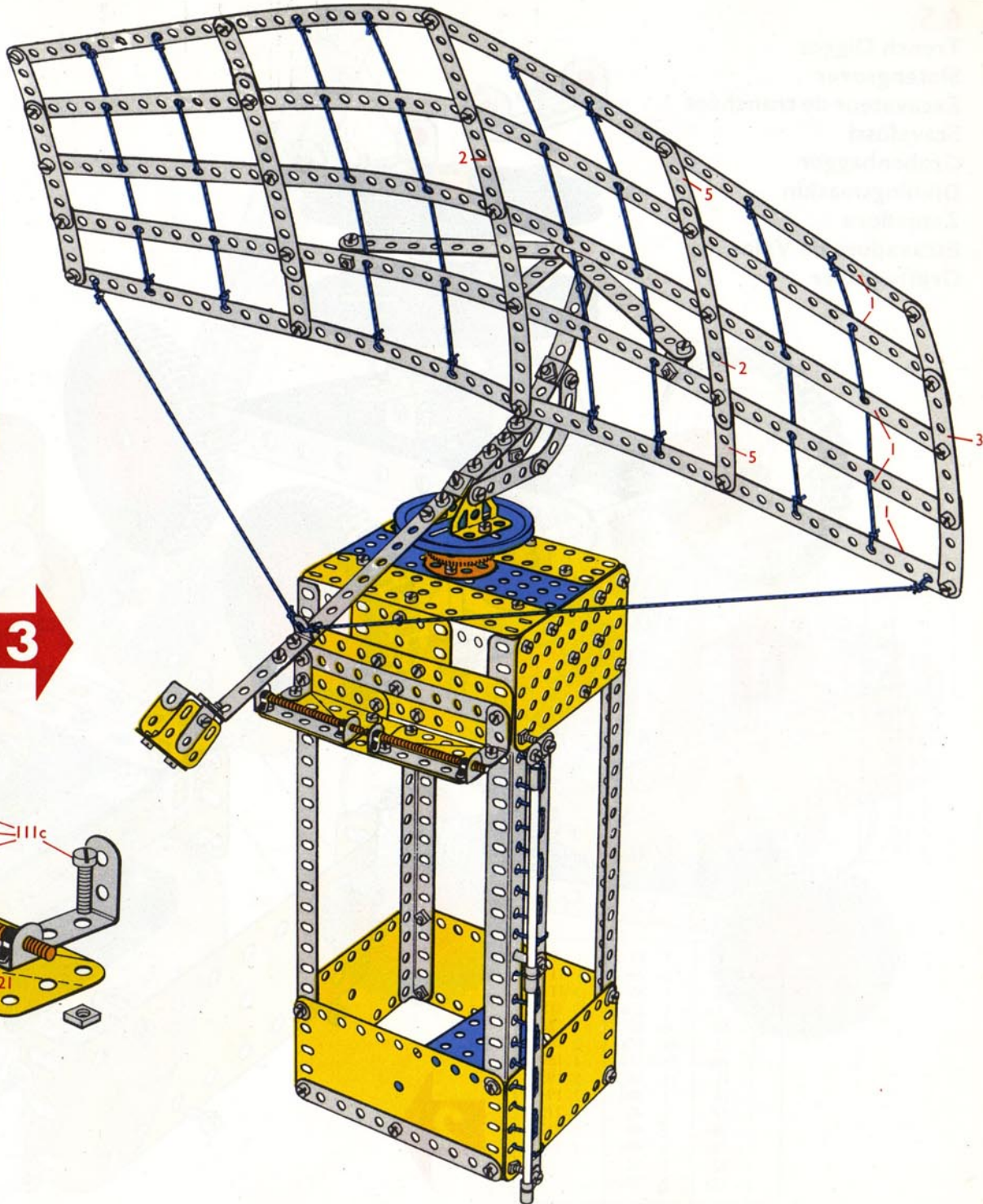

2- 12a
4- 35
6- 37a
4- 37b
2- 48a
2- 80c
4-111c
1-188
4- 221

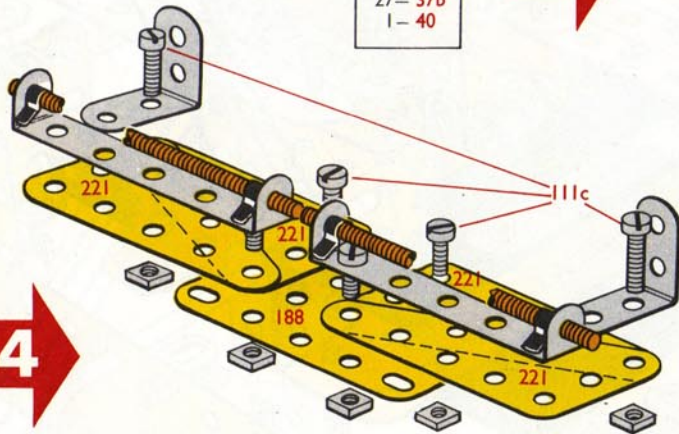

6.5.
Trench Digger
Slotengraver
Excavateur de tranchées
Scavafossi
Grabenbagger
Dikningsmaskin
Zanjadora
Escavadora de Valas
Grøftegraver

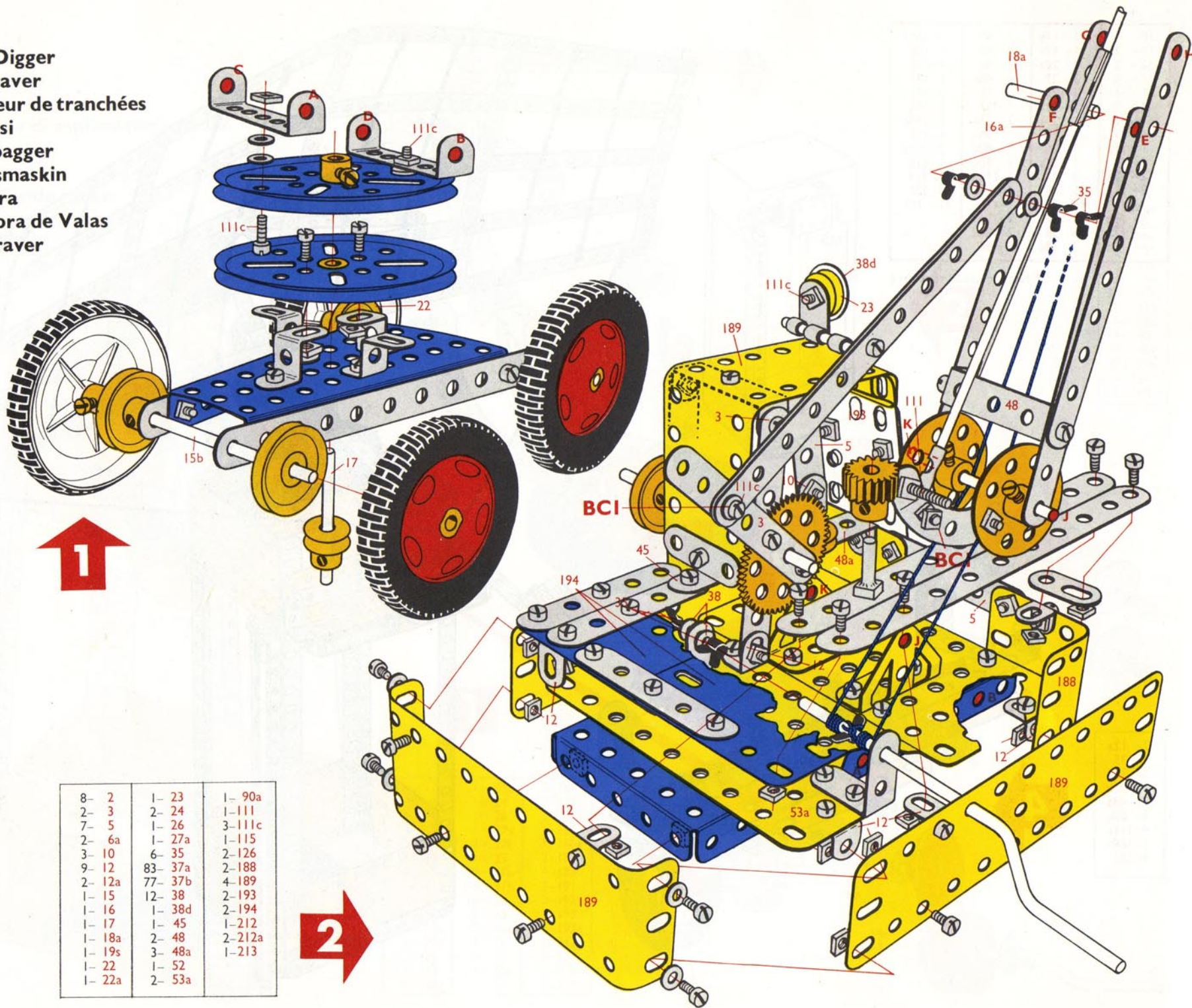

2- 2
 1- 15a
 1- 15b
 1- 17
 2- 19b
 4- 22
 1- 23a
 12- 37a
 10- 37b
 4- 38
 2- 48a
 1- 54
 2- 111c
 4- 125
 4- 187

8- 2	1- 23	1- 90a
2- 3	2- 24	1- 111
7- 5	1- 26	3- 111c
2- 6a	1- 27a	1- 115
3- 10	6- 35	2- 126
9- 12	83- 37a	2- 188
2- 12a	77- 37b	4- 189
1- 15	12- 38	2- 193
1- 16	1- 38d	2- 194
1- 17	1- 45	1- 212
1- 18a	2- 48	2- 212a
1- 19s	3- 48a	1- 213
1- 22	1- 52	
1- 22a	2- 53a	

14- 2	2- 18a	1- 38d	2-126
2- 3	2- 19b	1- 40	4-187
12- 5	1- 19s	1- 45	4-188
2- 6a	5- 22	2- 48	4-189
3-10	1- 22a	7- 48a	2-193
3-11	1- 23	1- 51	2-194
1-11a	1- 23a	1- 52	1-200
11-12	2- 24	2- 53a	2-212
2-12a	1- 26	1- 54	2-212a
2- 15	1- 27a	1- 90a	1-213
1-15a	8- 35	1-111	2-214
1-15b	136-37a	3-111c	4-221
1- 16	126-37b	1-115	
2- 17	18- 38	4-125	

4- 2	2- 38
5- 5	1- 40
3-11	4- 48a
1-11a	1- 51
2-12	2-188
1- 15	1-200
1-18a	1-212
2- 35	2-214
41-37a	4-221
39-37b	

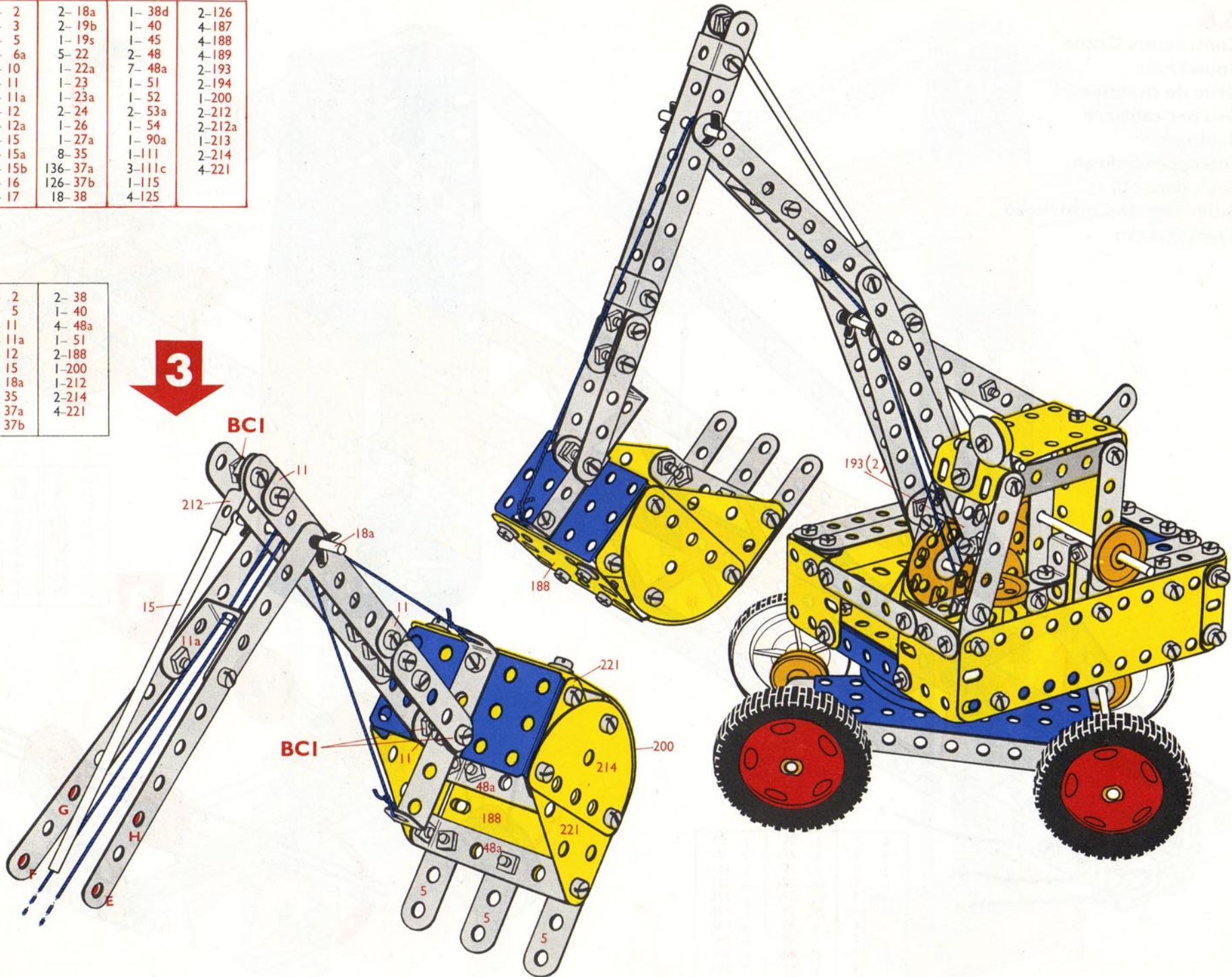

6.6.

Contractors Crane
 Bouwkraan
 Grue de chantier
 Gru per cantiere
 Baukran
 Entreprenörskran
 Grúa para obras
 Guindaste de Construção
 Byggningskran

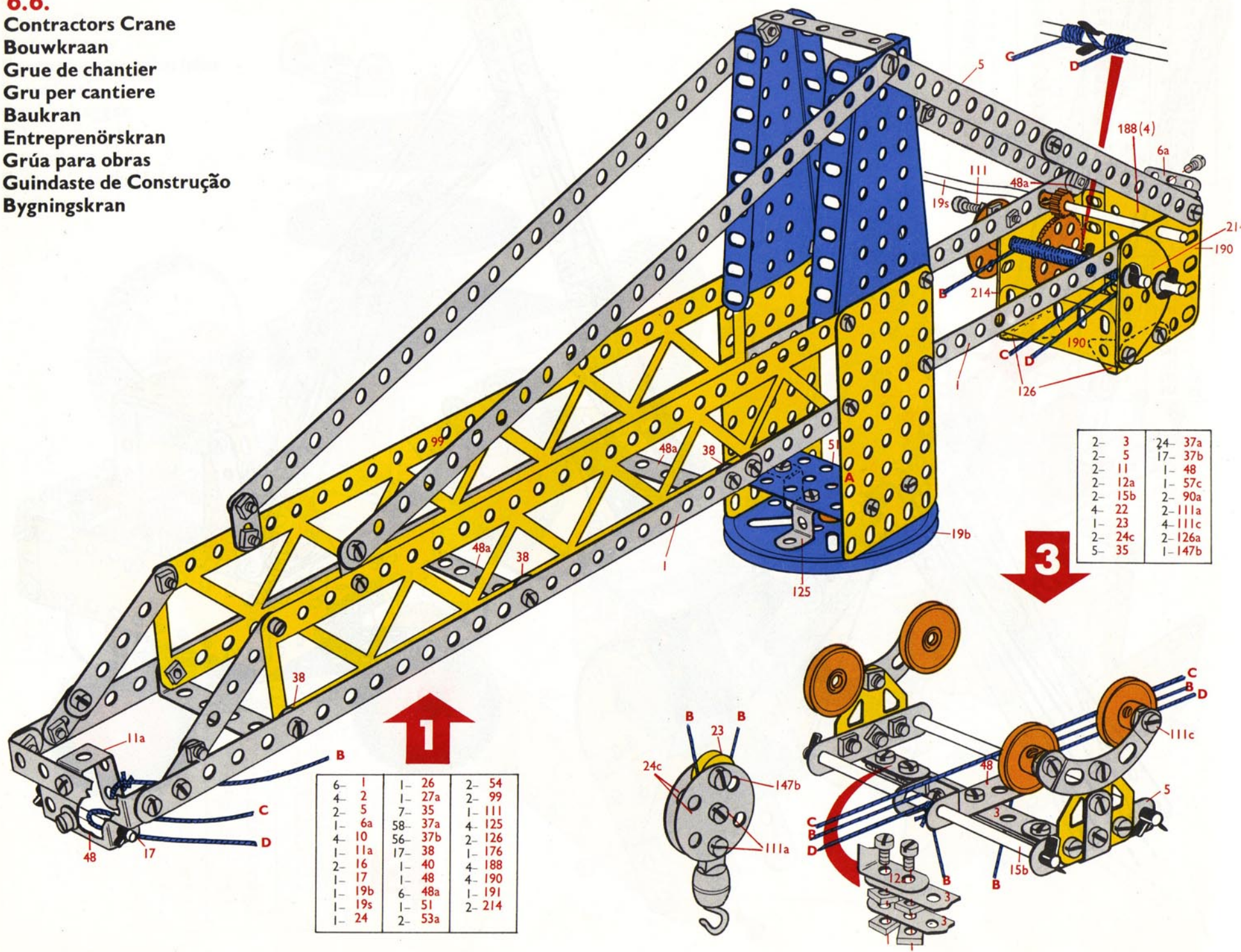

2-	3	24-	37a
2-	5	17-	37b
2-	11	1-	48
2-	12a	1-	57c
2-	15b	2-	90a
4-	22	2-	111a
1-	23	4-	111c
2-	24c	2-	126a
5-	35	1-	147b

6-	1	1-	26	2-	54
4-	2	1-	27a	2-	99
2-	5	7-	35	1-	111
1-	6a	58-	37a	4-	125
4-	10	56-	37b	2-	126
1-	11a	17-	38	1-	176
2-	16	1-	40	4-	188
1-	17	1-	48	4-	190
1-	19b	6-	48a	1-	191
1-	19s	1-	51	2-	214
1-	24	2-	53a		

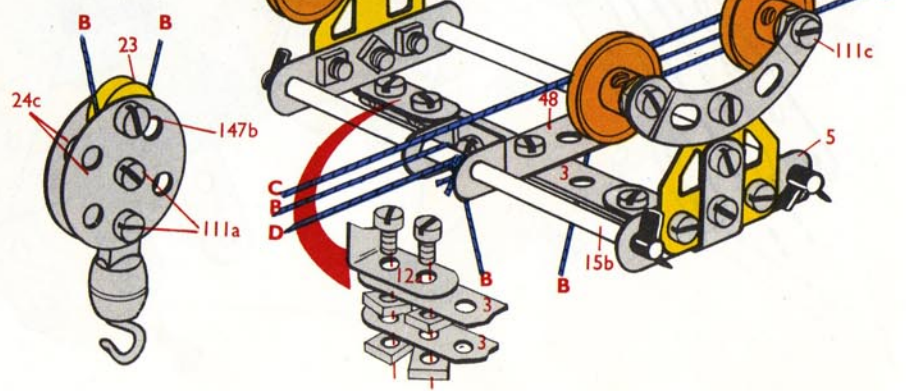

10-	1	1-	17	129-	37b	2-	111a
14-	2	2-	19b	18-	38	6-	111c
2-	3	1-	19s	1-	40	1-	115
12-	5	5-	22	2-	48	4-	125
1-	6a	1-	23	8-	48a	2-	126
4-	8	1-	23a	1-	51	2-	126a
4-	10	2-	24	1-	52	1-	147b
2-	11	2-	24c	2-	53a	1-	176
1-	11a	1-	26	2-	54	4-	188
8-	12	1-	27a	1-	57c	4-	190
2-	12a	2-	27f	4-	90a	1-	191
2-	15b	12-	35	2-	99	4-	192
4-	16	142-	37a	1-	111	2-	214

4-	1
10-	2
8-	5
4-	8
8-	12
2-	16
1-	19b
1-	22
1-	23a
1-	24
2-	27f
60-	37a
56-	37b
1-	38
2-	48a
1-	52
2-	90a
2-	111c
1-	115
4-	192

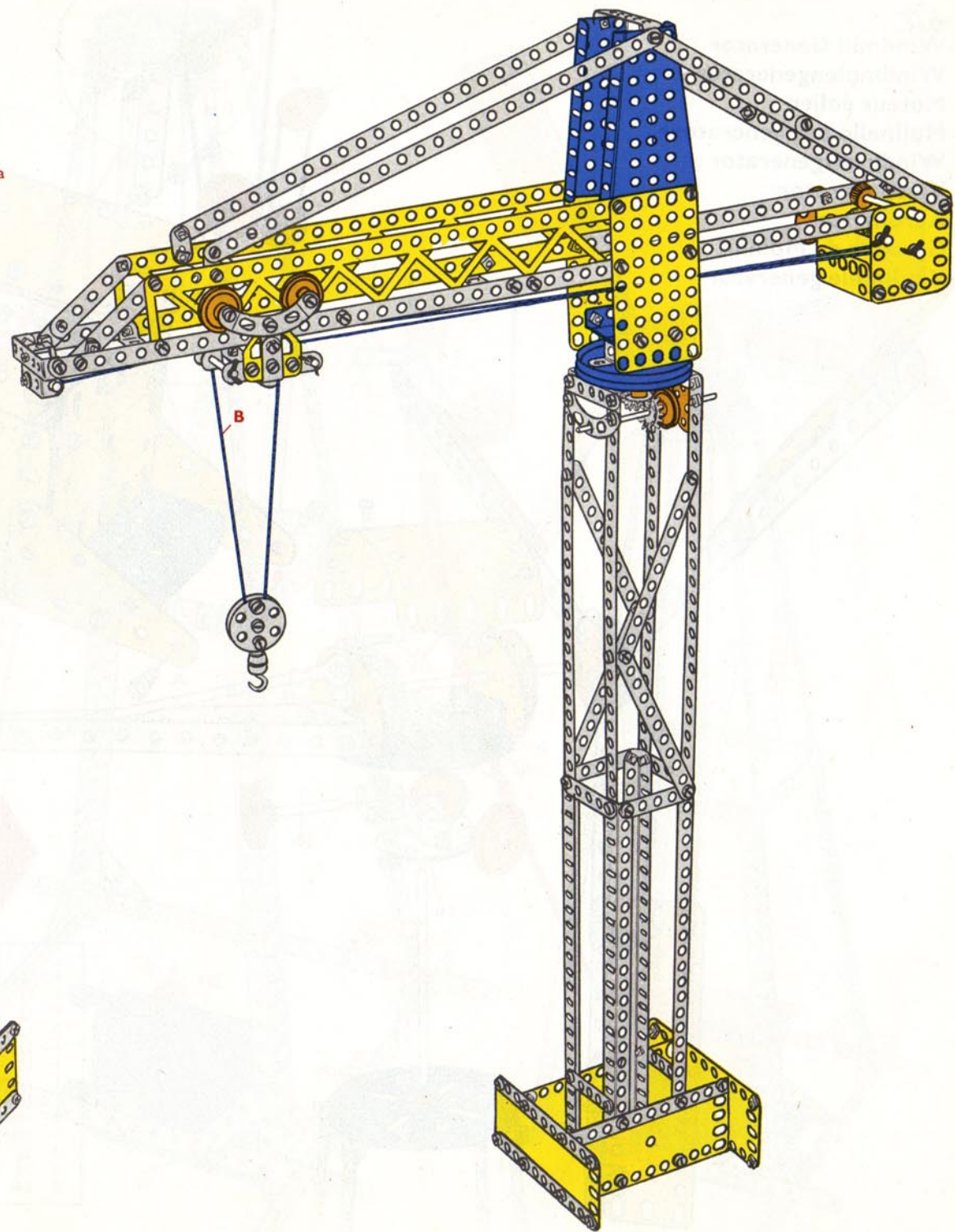
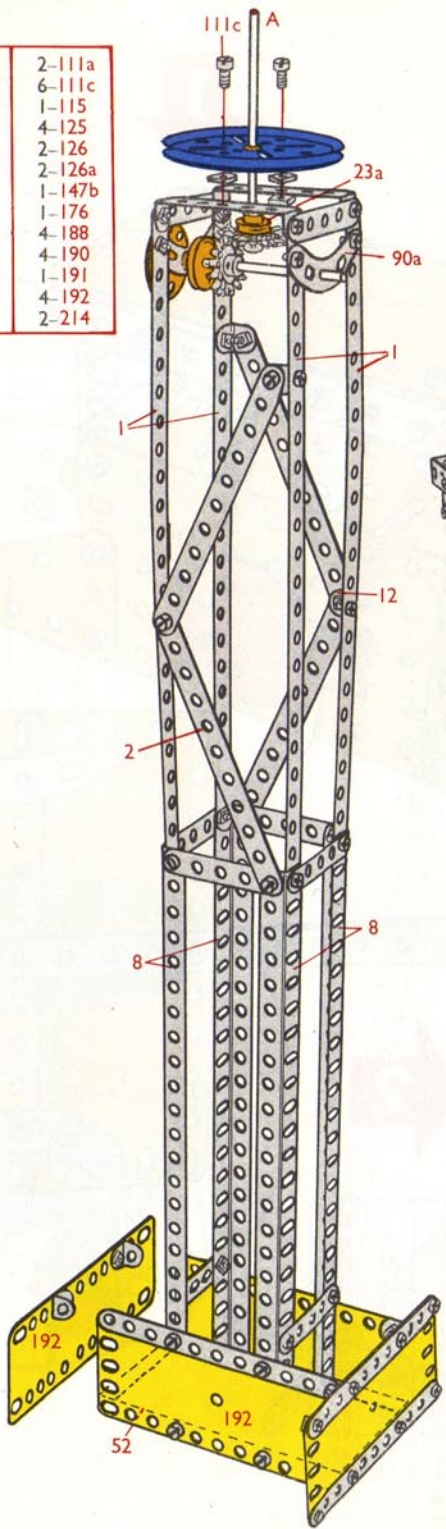

6.7.
Windmill Generator
Windmolengenerator
Moteur éolien
Mulinello per generatore
Windkraftgenerator
Vindgenerator
Aeromotor
Gerador de Moinho
Vindmølle generator

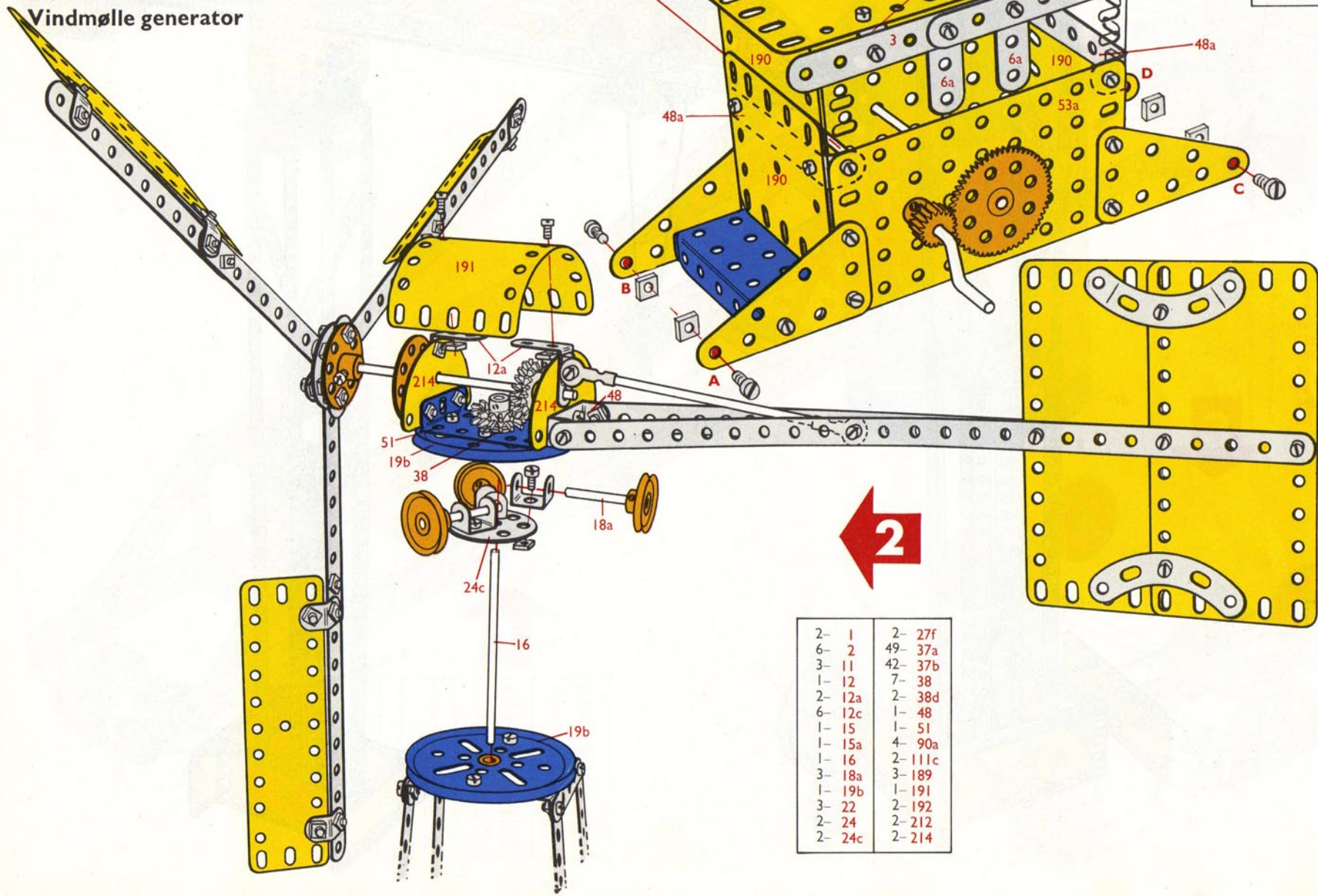

2-	3	4-	38
2-	5	4-	48a
2-	6a	1-	52
1-	16	2-	53a
1-	19s	1-	111c
1-	22	1-	115
1-	23	1-	147b
*1-	23a	1-	186
1-	23a	3-	190
1-	26	1-	191
1-	27a	1-	192
1-	35	1-	193
35-	37a	1-	193c
33-	37b	4-	221

2-	1	2-	27f
6-	2	49-	37a
3-	11	42-	37b
1-	12	7-	38
2-	12a	2-	38d
6-	12c	1-	48
1-	15	1-	51
1-	15a	4-	90a
1-	16	2-	111c
3-	18a	3-	189
1-	19b	1-	191
3-	22	2-	192
2-	24	2-	212
2-	24c	2-	214

10- 1	2- 19b	143- 37a	1-147b
14- 2	1- 19s	134- 37b	1-186
2- 3	1- 20a	15- 38	*1-186
12- 5	4- 22	2- 38d	3-189
2- 6a	2- 22a	1- 40	3-190
4- 8	1- 23	1- 48	2-191
3- 11	*1- 23a	8- 48a	3-192
5- 12	1- 23a	1- 51	1-193
2- 12a	2- 24	1- 52	1-193c
6- 12c	2- 24c	2- 53a	2-212
1- 15	1- 26	4- 90a	2-214
1- 15a	1- 27a	3-111c	4-221
3- 16	2- 27f	1-115	*1-M2
3- 18a	5- 35	2-125	

*Not included in set

8- 1	2- 22a
8- 2	4- 35
10- 5	59- 37a
4- 8	59- 37b
4- 12	4- 38
1- 16	1- 40
1- 19b	4- 48a
1- 20a	2-125

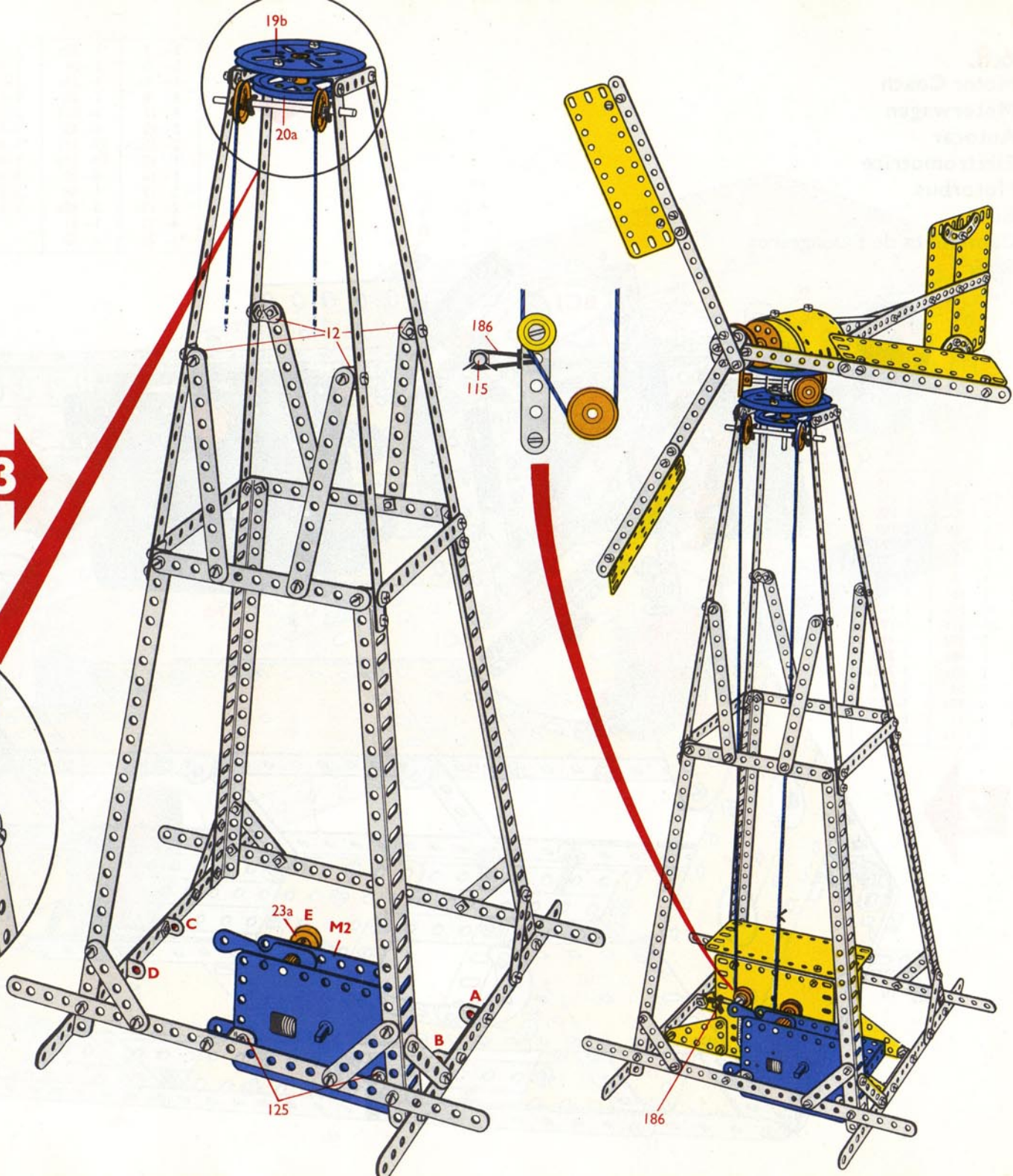
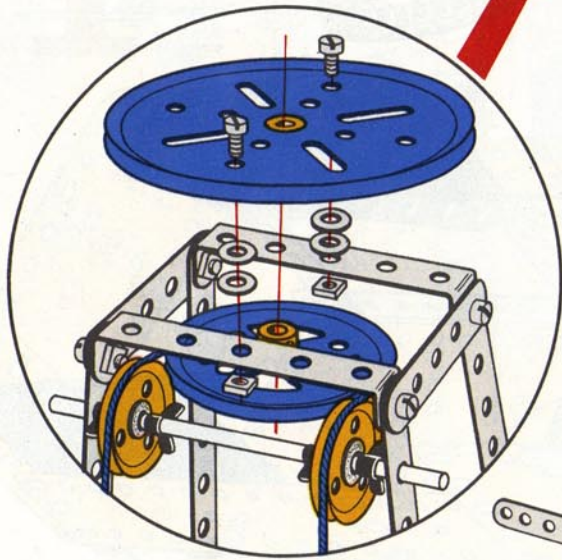

6.8.
Motor Coach
Motorwagen
Autocar
Elettromotrice
Motorbus
Buss
Camioneta de Passageiros
Buss



2- 3	1- 23a	1- 53a
5- 5	2- 24	2-111c
1- 6a	2- 24c	2-125
4- 8	1- 26	2-126
4- 11	1- 27a	2-126a
2- 12	6- 35	1-155
2- 12a	59- 37a	*1-186a
1- 15	51- 37b	1-186a
1- 16	8- 38	4-187
2- 17	1- 48	1-213
2- 18a	3- 48a	2-215
4- 22	1- 51	
*1- 23a	1- 52	

10- 1	4-111c
8- 2	1-115
7- 5	3-188
1- 6a	4-189
2- 10	4-190
8- 12	2-191
1- 15	4-192
1- 35	2-193a
87- 37a	1-193c
83- 37b	1-193e
2- 38d	1-199
5- 48a	1-200
1- 53a	2-212a
2- 54	2-214
4- 90a	4-221
2-111	1-222
3-111a	

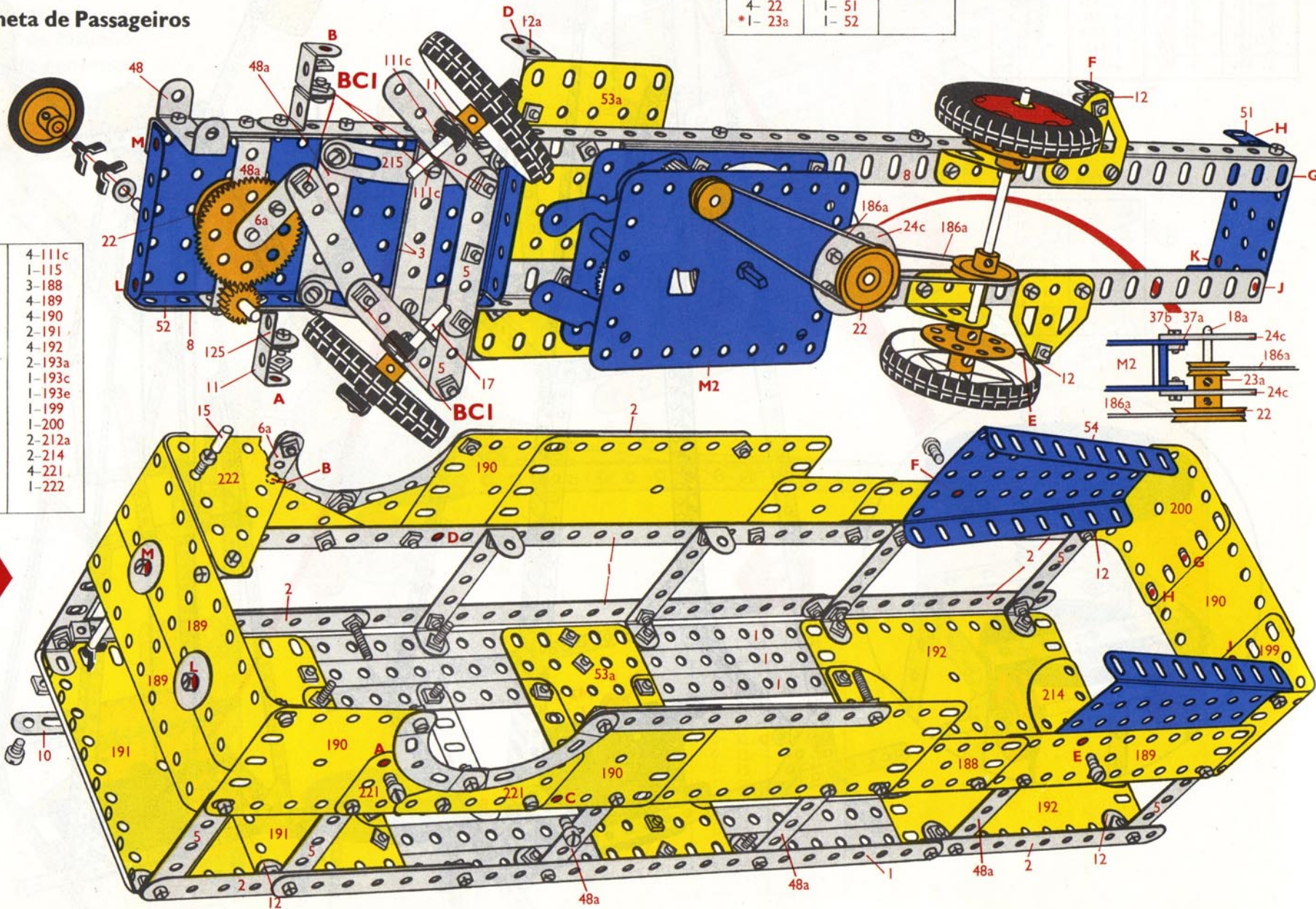

10- 1	1- 23a	4- 90a	4-192
8- 2	2- 24	2-111	2-193a
2- 3	2- 24c	2-111a	1-193c
12- 5	1- 26	5-111c	1-193e
2- 6a	1- 27a	1-115	1-199
4- 8	7- 35	2-125	1-200
2-10	146- 37a	2-126	2-212a
4-11	134- 37b	2-126a	1-213
10-12	8- 38	1-155	2-214
2-12a	2- 38d	*1-186a	2-215
2-15	1- 48	1-186a	4-221
1-16	8- 48a	4-187	1-222
2-17	1- 51	3-188	*1-M2
2-18a	1- 52	4-189	
4-22	2- 53a	4-190	
*1-23a	2- 54	2-191	

* Not included in set

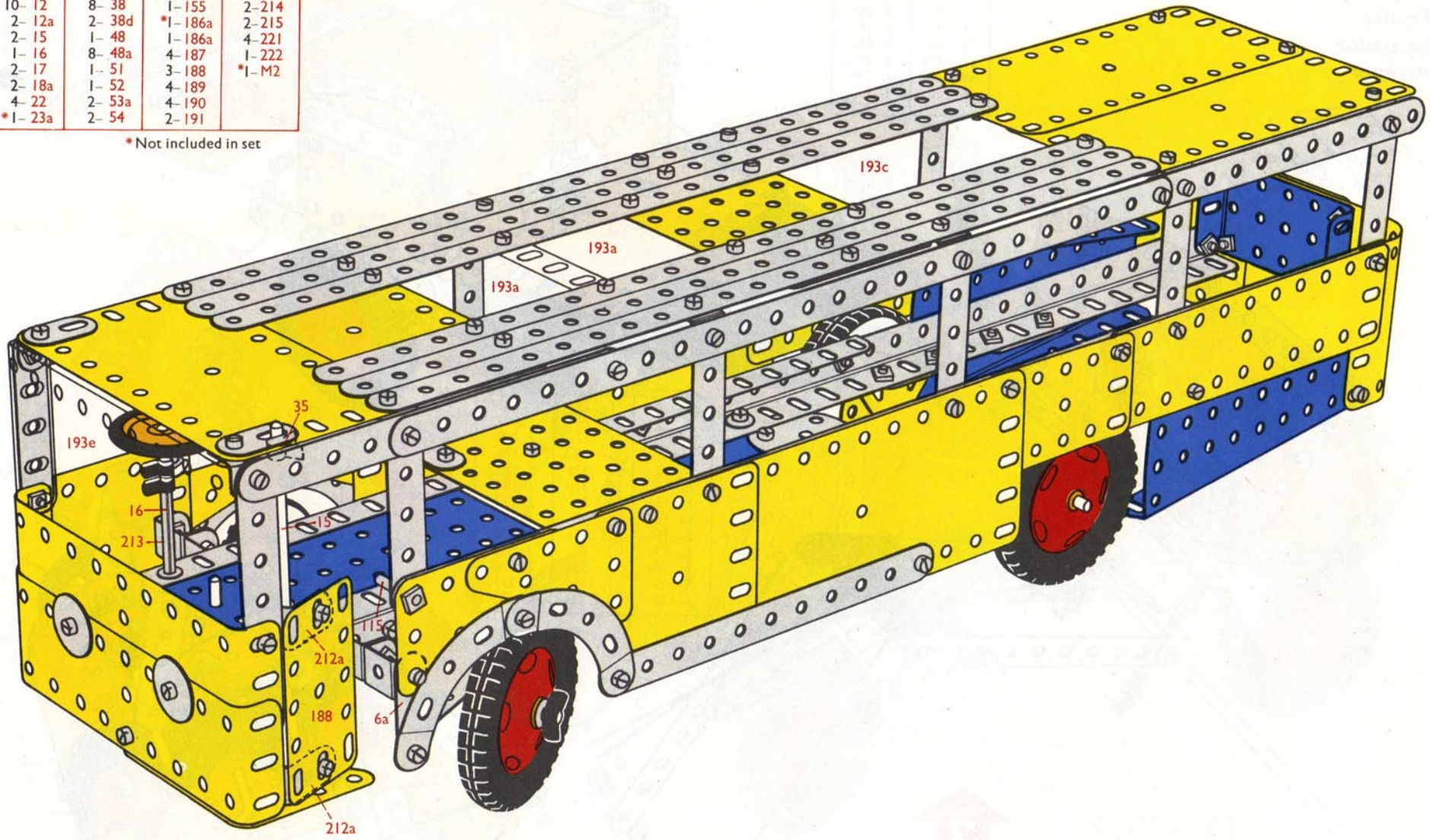

6.9.

Scraper
Schrafer
Schraper
Vägskrapa
Trailla
Raspador
Skrafer

3- 2	2- 48
2- 3	2- 48a
4- 5	2- 54
4- 10	4- 90a
3- 11	2- 111c
2- 12	3- 125
1- 15	2- 187
1- 15b	2- 188
1- 17	4- 189
1- 24	1- 191
2- 35	1- 192
57- 37a	2- 194a
49- 37b	1- 199
6- 38	1- 213

1

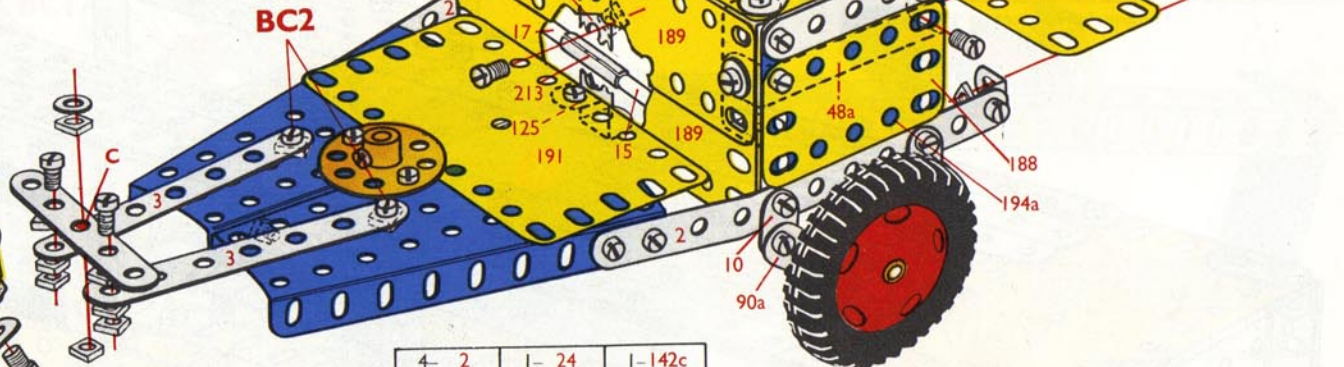
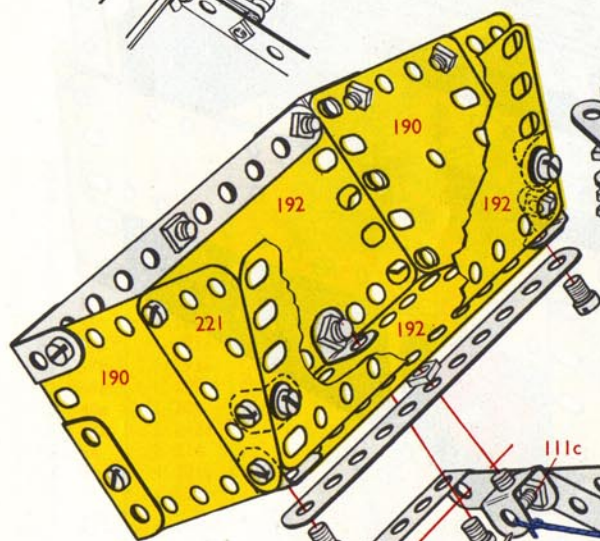
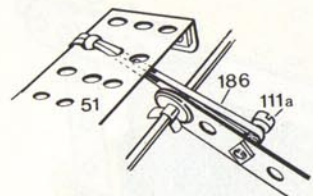

4- 2	1- 24	1- 142c
5- 5	1- 26	1- 147b
2- 6a	1- 27a	1- 155
1- 11a	5- 35	1- 176
4- 12	50- 37a	2- 187
1- 15	50- 37b	2- 188
1- 15a	8- 38	2- 190
1- 16	1- 40	1- 191
2- 18a	5- 48a	2- 193a
1- 19s	1- 52	1- 200
1- 20a	2- 53a	2- 214
5- 22	1- 115	2- 221
1- 23	2- 126a	2- 222

2

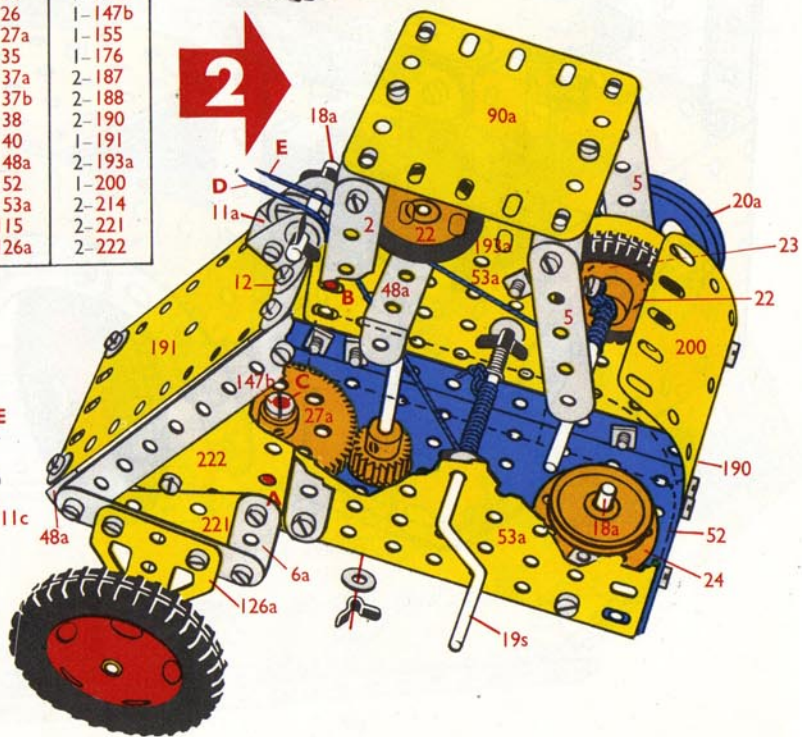

7- 2	4- 38
3- 5	1- 48a
1- 11	1- 51
6- 12	3- 111c
2- 12a	2- 126
1- 15b	1- 186
2- 16	2- 190
8- 35	3- 192
39- 37a	2- 221
31- 37b	

3

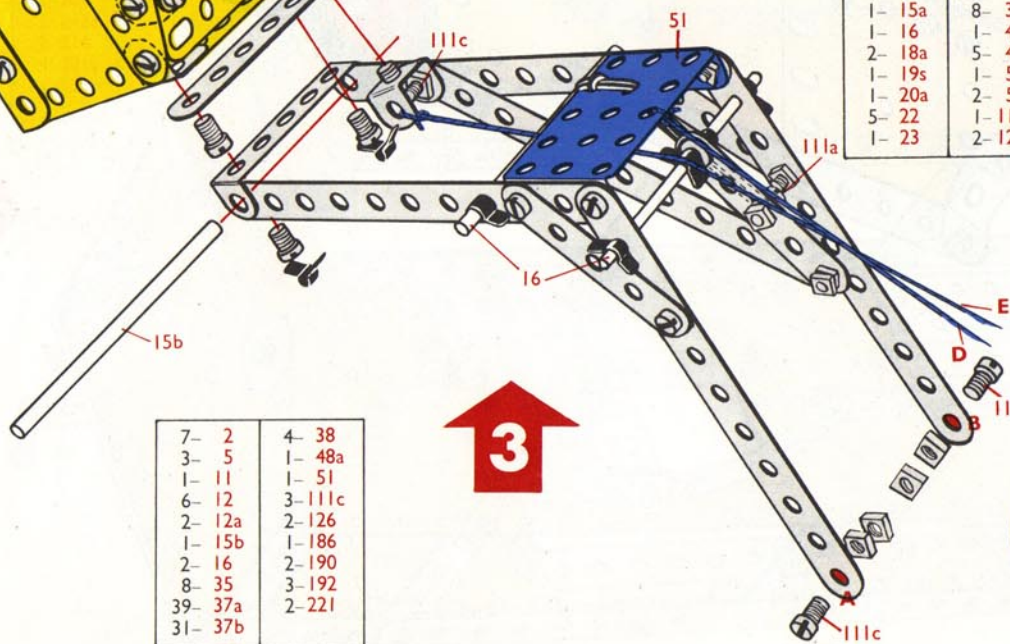

14- 2	1- 19s	1- 52	4- 188
2- 3	1- 20a	2- 53a	4- 189
12- 5	5- 22	2- 54	4- 190
2- 6a	1- 23	4- 90a	2- 191
4- 10	2- 24	5- 111c	4- 192
4- 11	1- 26	1- 115	2- 193a
1- 11a	1- 27a	3- 125	2- 194a
12- 12	15- 35	2- 126	1- 199
2- 12a	146- 37a	2- 126a	1- 200
2- 15	130- 37b	1- 142c	1- 213
1- 15a	18- 38	1- 147b	2- 214
2- 15b	1- 40	1- 155	4- 221
3- 16	2- 48	1- 176	2- 222
1- 17	8- 48a	1- 186	
2- 18a	1- 51	4- 187	

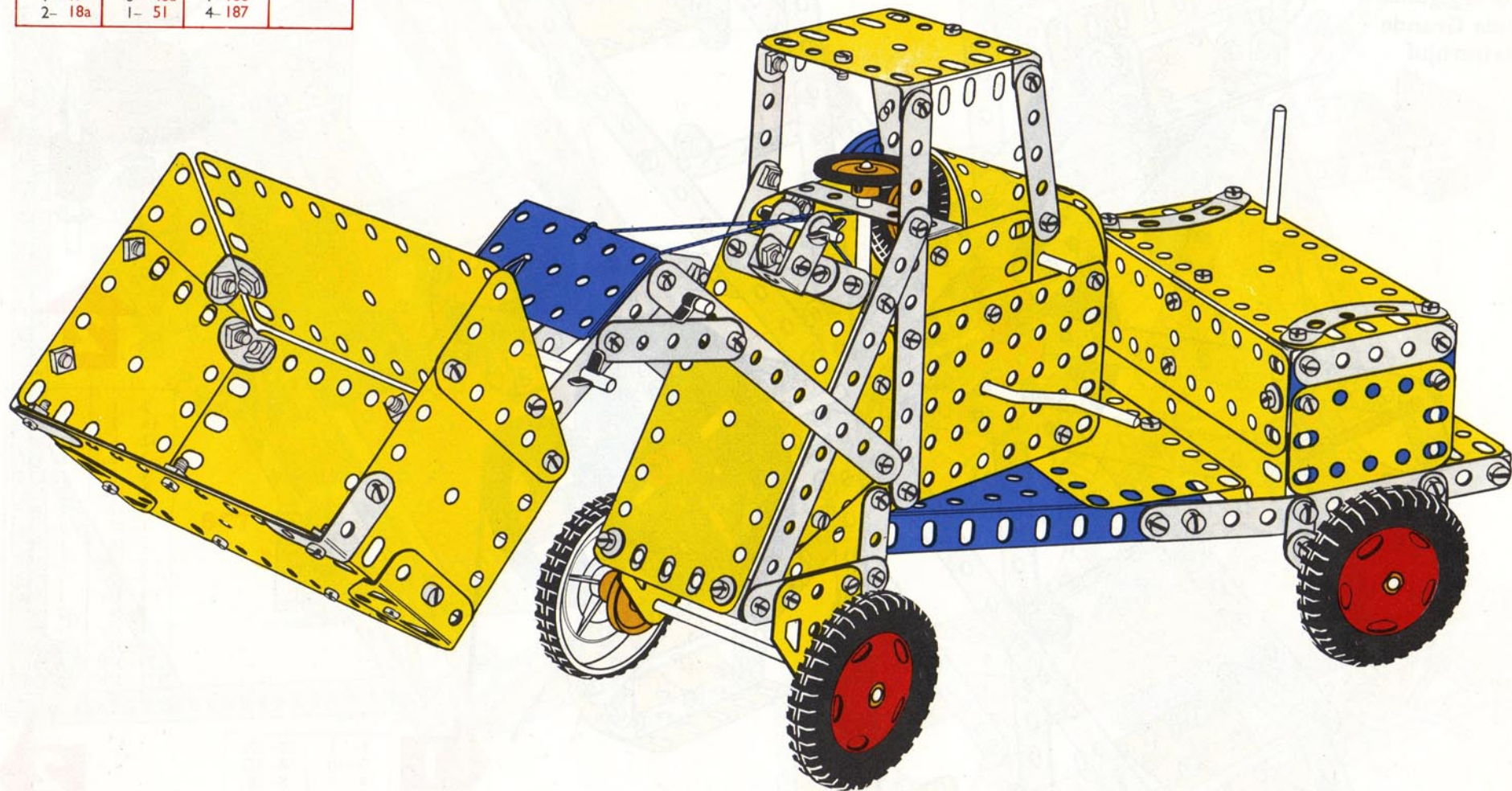

6.10.

Big Wheel
Groot wiel
Grande roue
Ruota gigante
Riesenrad
Pariserhjul
Noria gigante
Roda Grande
Pariserhjul

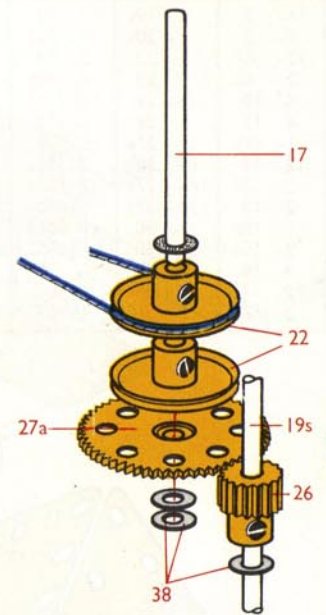
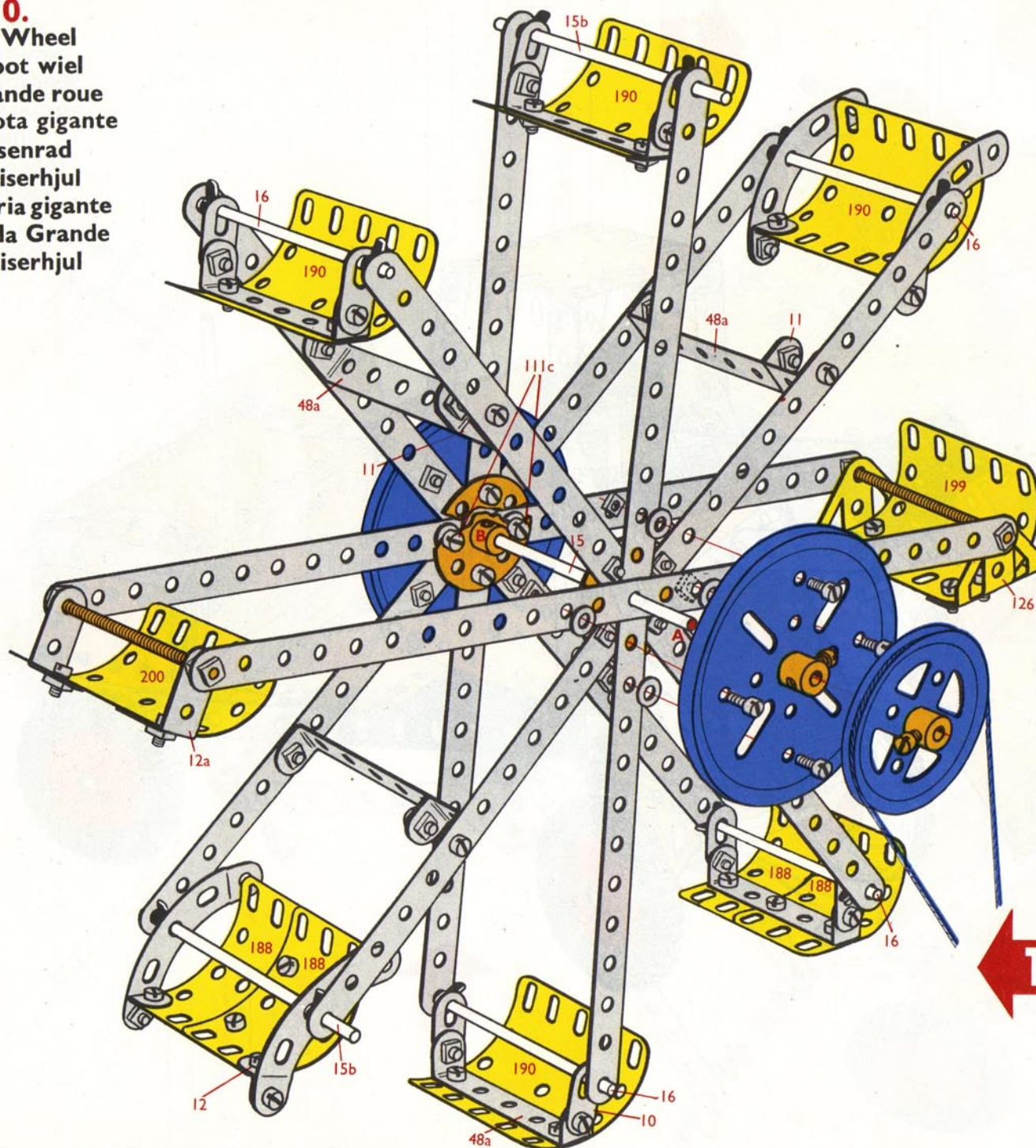

2-	1	1-	40
14-	2	1-	45
12-	5	2-	48
2-	6a	1-	51
4-	8	1-	52
1-	11a	2-	53a
8-	12	2-	99
1-	17	2-	111a
2-	18a	1-	115
1-	19s	2-	125
3-	22	1-	176
1-	23a	1-	186a
1-	26	2-	192
1-	27a	1-	213
4-	35	2-	214
73-	37a	4-	221
71-	37b	2-	222
5-	38		

8-	1	70-	37a
8-	10	58-	37b
4-	11	8-	38
4-	12	8-	48a
2-	12a	2-	80c
1-	15	4-	90a
2-	15b	4-	111c
4-	16	2-	126
2-	19b	4-	188
1-	20a	4-	190
2-	24	1-	199
12-	35	1-	200

2

10- 1	2- 18a	1- 45	1-176
14- 2	2- 19b	2- 48	1-186a
12- 5	1- 19s	8- 48a	4-188
2- 6a	1- 20a	1- 51	4-190
4- 8	3- 22	1- 52	2-192
8-10	1- 23a	2- 53a	1-199
4-11	2- 24	2- 80c	1-200
1-11a	1- 26	4- 90a	1-213
12-12	1- 27a	2- 99	2-214
2-12a	16- 35	2-111a	4-221
1-15	143- 37a	4-111c	2-222
2-15b	129- 37b	1-115	*1-M5
4-16	13- 38	2-125	
1-17	1- 40	2-126	

*Not included in set No.6

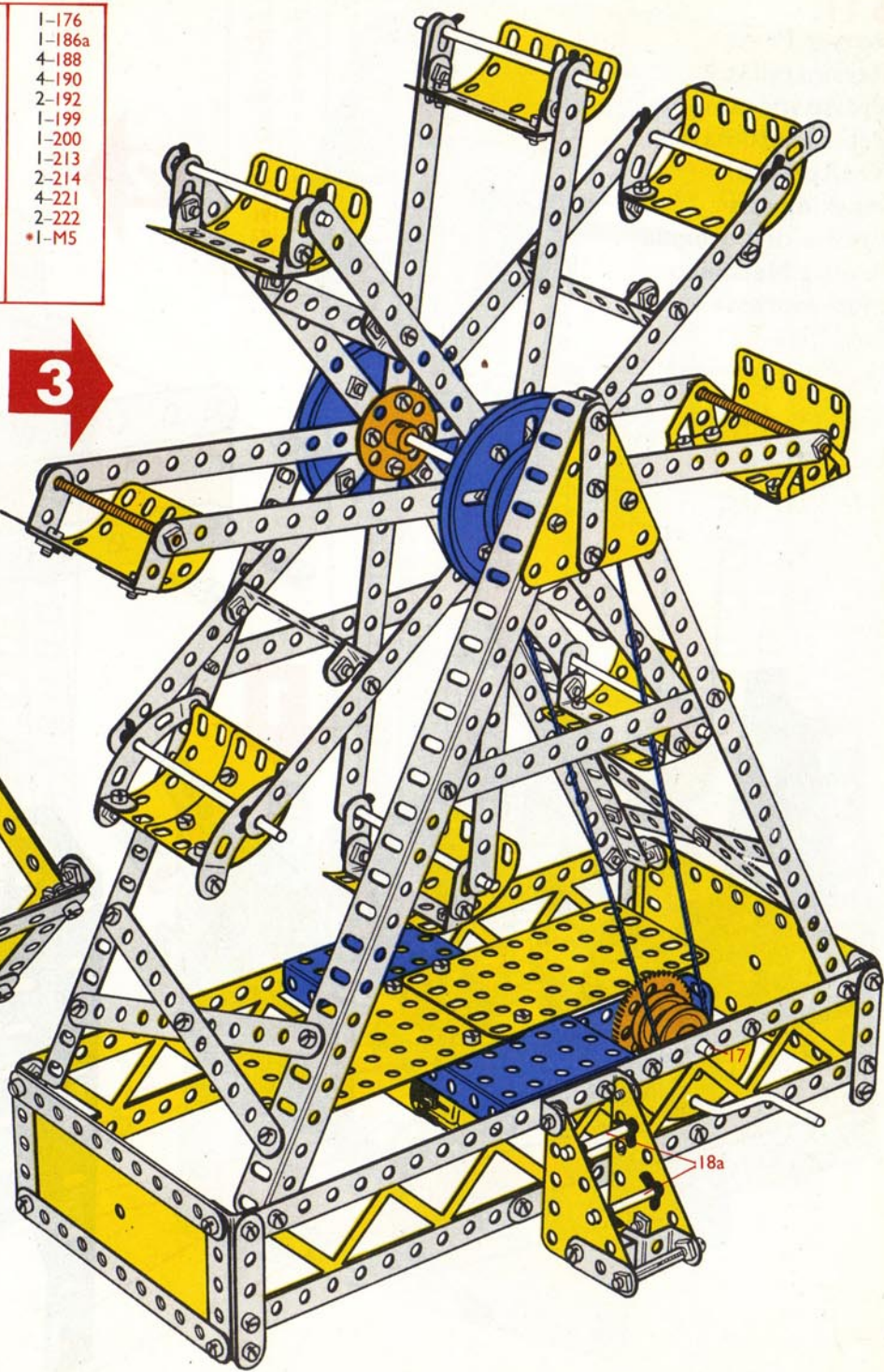
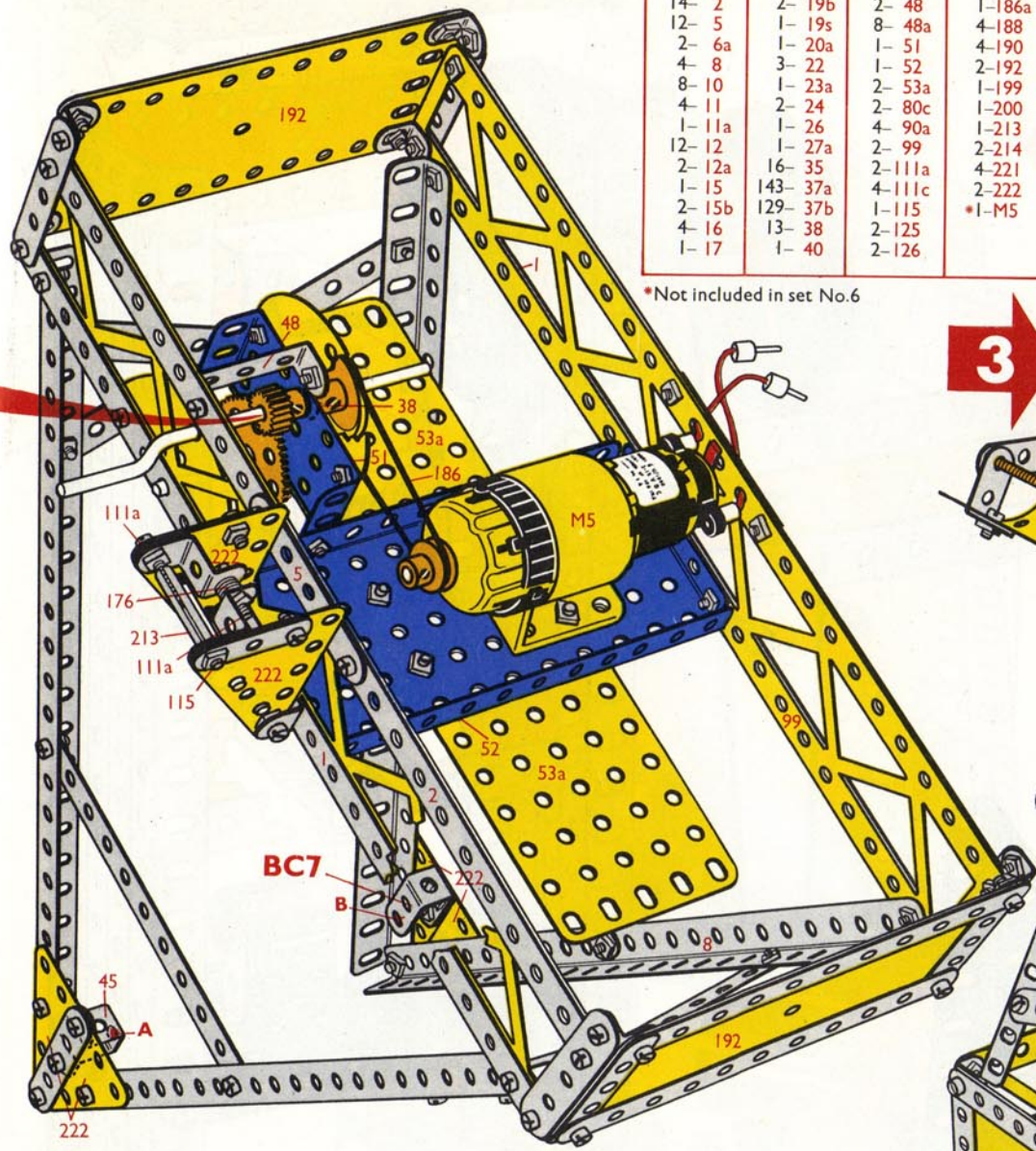

6.11.
Power Press
Persinstallatie
Presse mécanique
Pressa automatica
Kraftpresse
Maskinpress
Pressa de potencia
Pressa Necânico
Maskinpresse

6-	1	79-	37a
8-	2	75-	37b
11-	5	8-	38
1-	6a	1-	45
4-	8	6-	48a
1-	11a	1-	51
4-	12	1-	52
2-	12a	1-	80c
2-	16	2-	126
2-	17	2-	189
1-	19b	2-	191
1-	20a	1-	192
1-	24c	2-	214
10-	35		

6-	2	6-	35
1-	10	37-	37a
4-	12	37-	37b
2-	15	11-	38
2-	16	1-	40
1-	18a	2-	48a
1-	19s	2-	53a
5-	22	2-	54
1-	23a	2-	90a
2-	24	2-	142c
1-	24c	1-	186a
1-	26	1-	189
1-	27a	1-	213

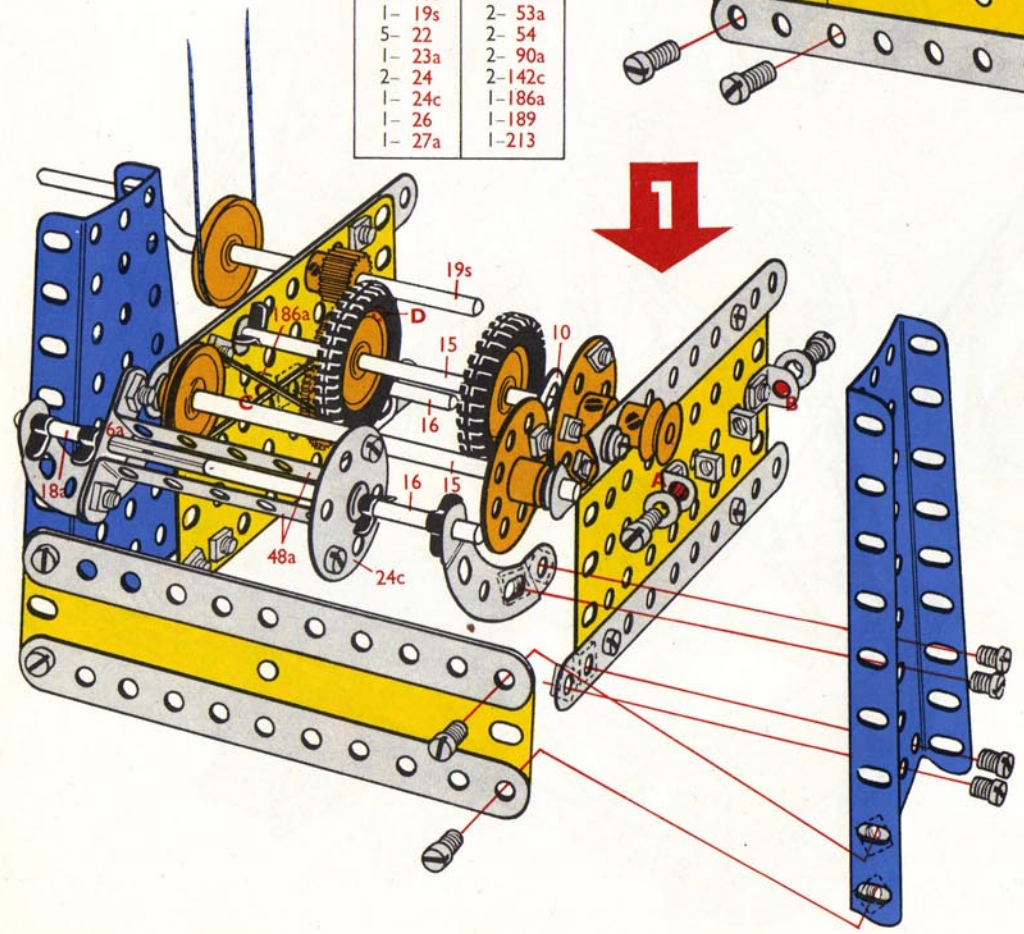
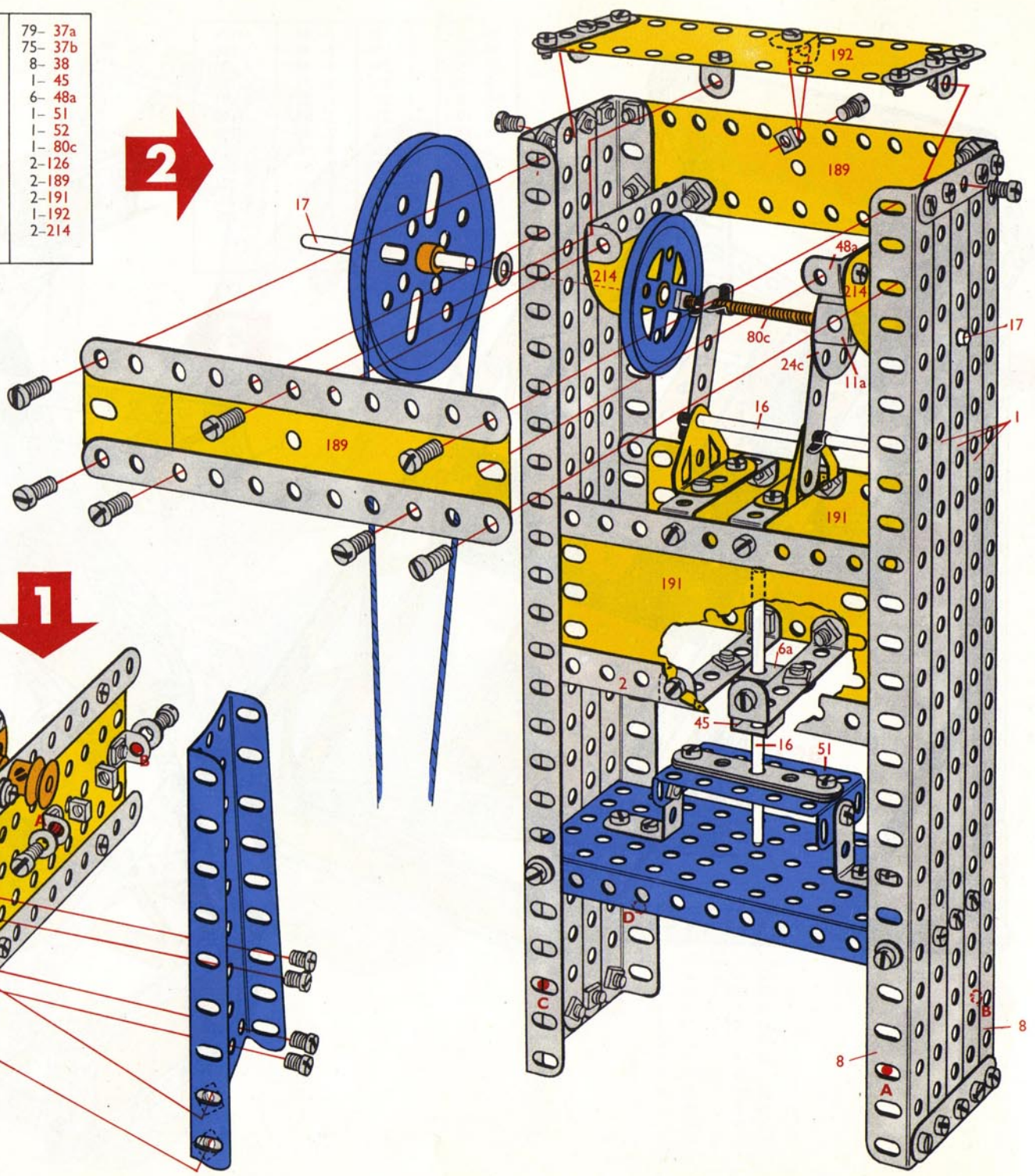

6-	1	2-	17	16-	35	1-	80c
14-	2	1-	18a	116-	37a	2-	90a
11-	5	1-	19b	112-	37b	2-	126
1-	6a	1-	19s	19-	38	2-	142c
4-	8	1-	20a	1-	40	1-	186a
1-	10	5-	22	1-	45	3-	189
1-	11a	1-	23a	8-	48a	2-	191
8-	12	2-	24	1-	51	1-	192
2-	12a	2-	24c	1-	52	1-	213
2-	15	1-	26	2-	53a	2-	214
4-	16	1-	27a	2-	54		

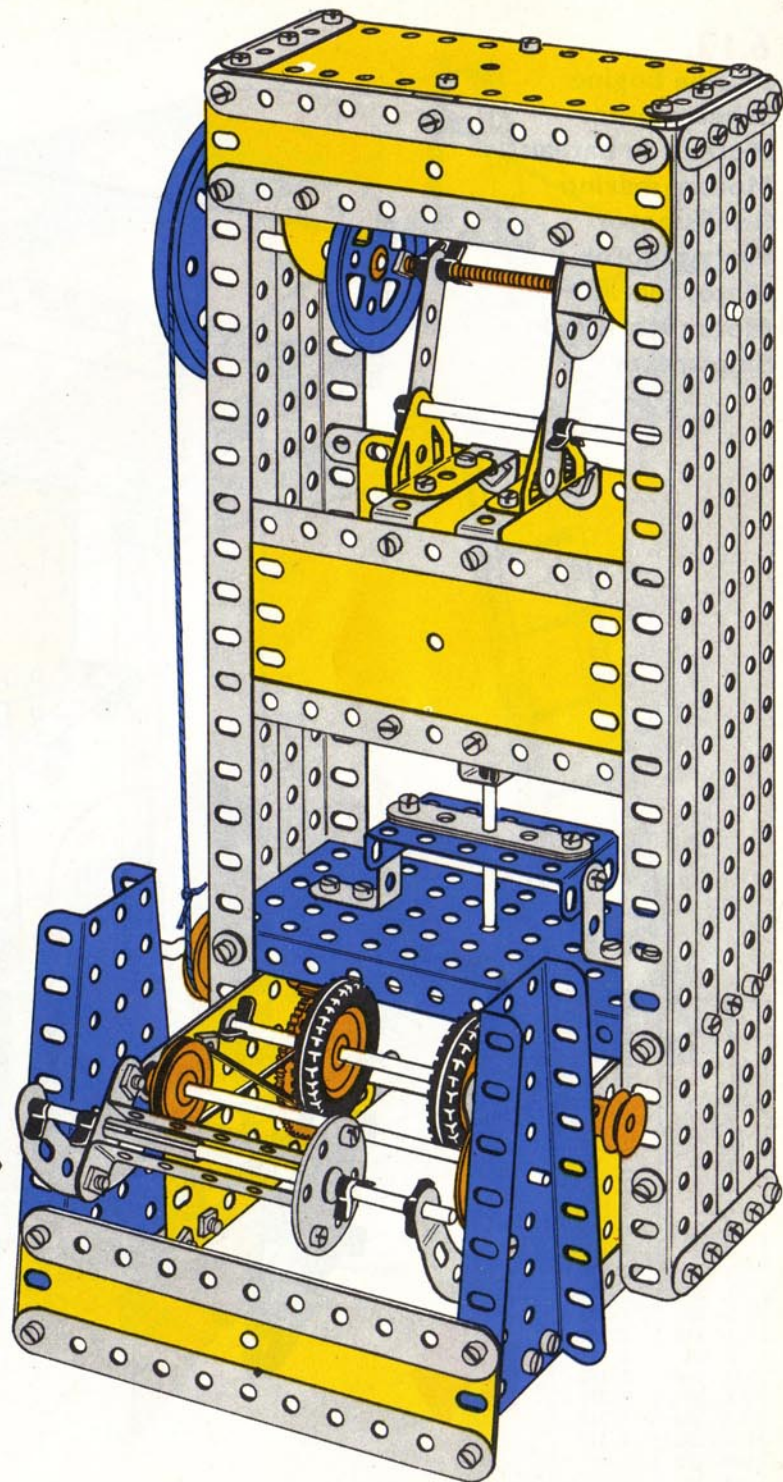
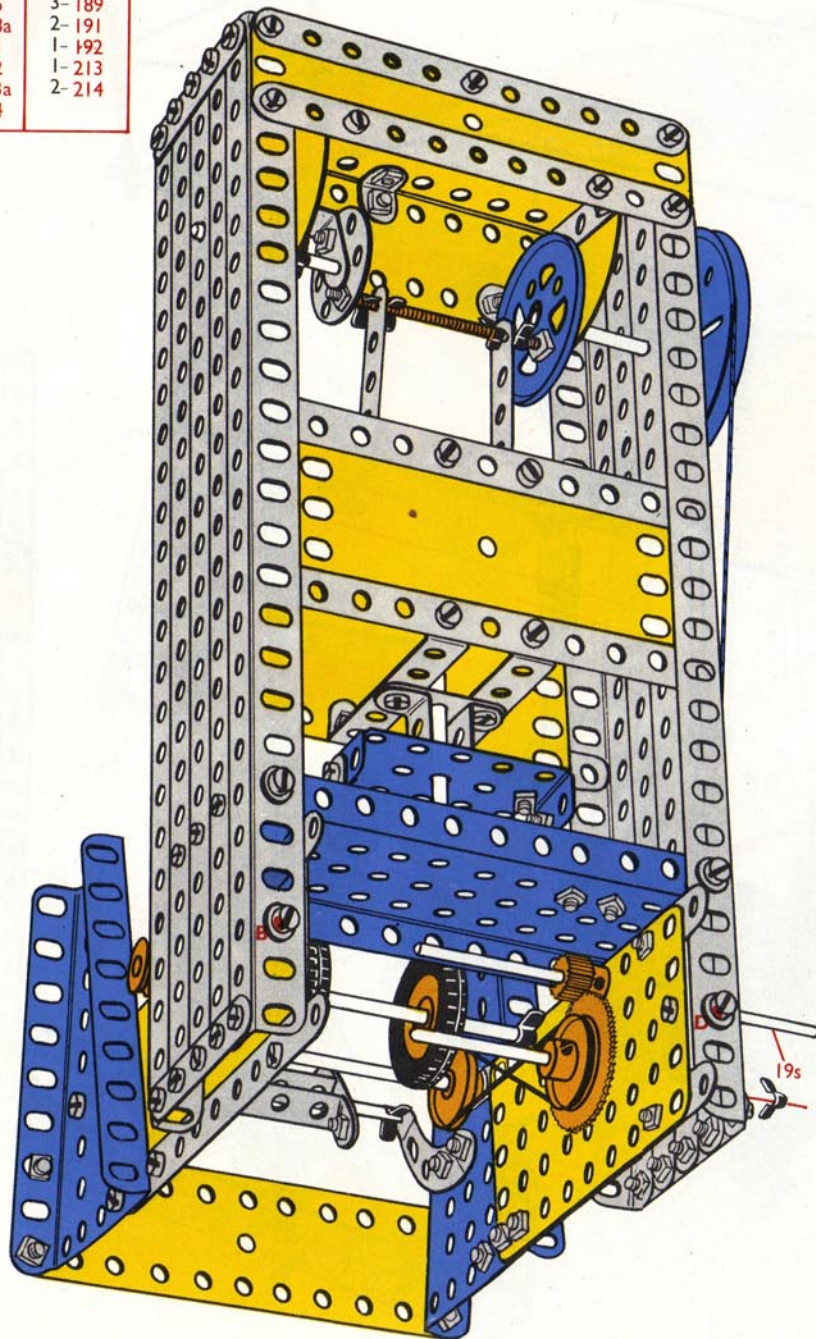

6.12.
Marine Engine
Scheepsmotor
Moteur de bateau
Motore marino
Schiffsmotor
Fartygsmotor
Motor marino
Motor Marítimo
Skipsmotor

5-	1	20-	37b
6-	2	1-	40
2-	11	2-	48a
1-	11a	2-	80c
2-	12a	1-	111c
1-	17	1-	176
1-	18a	2-	192
1-	18b	2-	212a
1-	35	1-	213
31-	37a		

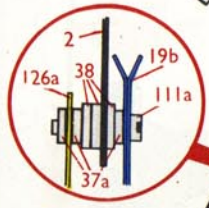
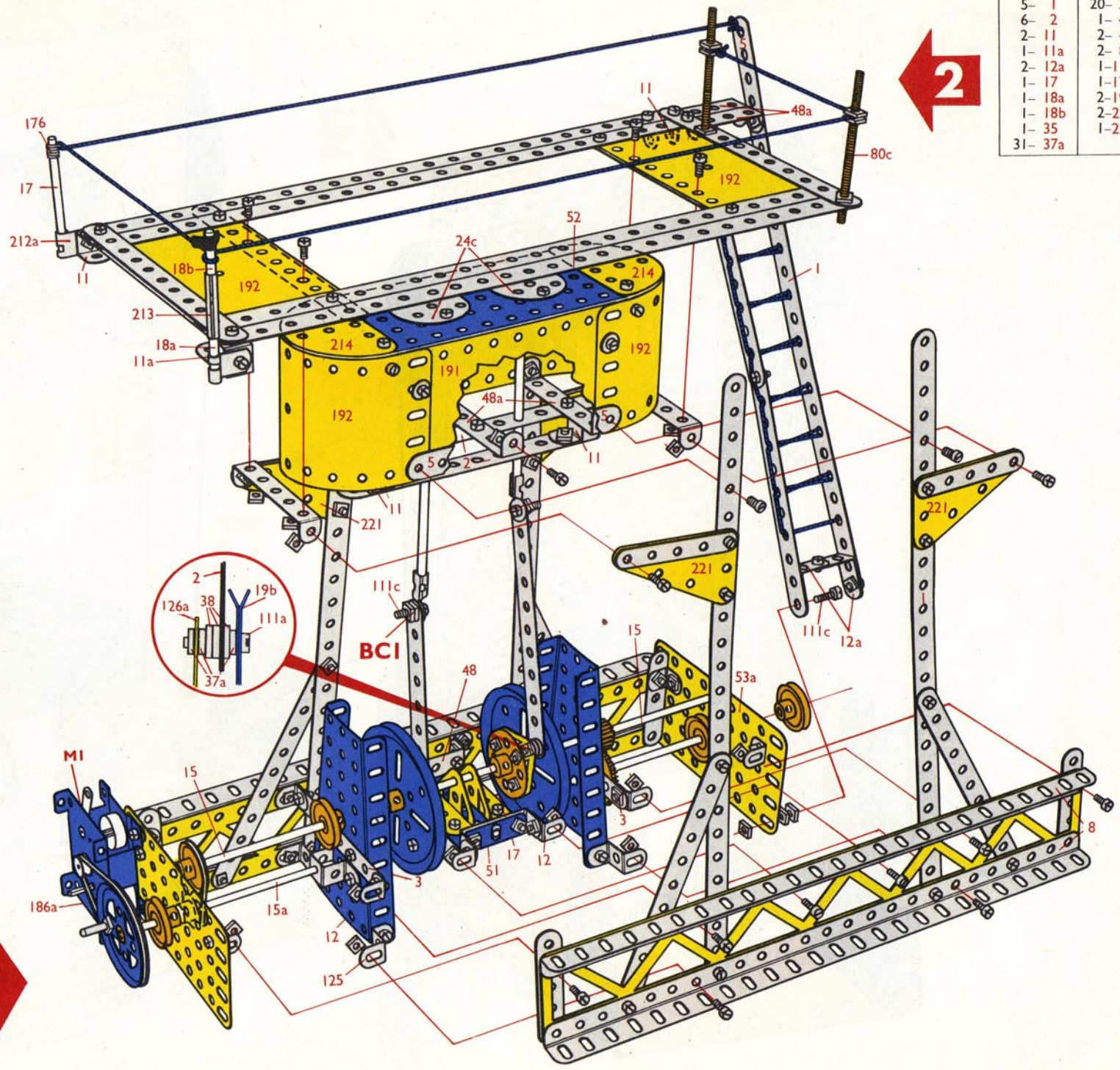

4-	1	1-	45
8-	2	2-	48
2-	3	5-	48a
12-	5	1-	51
4-	8	1-	52
2-	11	2-	53a
12-	12	2-	54
2-	15	2-	99
1-	15a	2-	111a
1-	15b	2-	111c
2-	16	1-	115
1-	17	4-	125
2-	19b	2-	126
1-	20a	2-	126a
5-	22	1-	186
1-	23a	1-	186a
2-	24	2-	191
2-	24c	2-	192
1-	26	2-	212
1-	27a	2-	214
111-	37a	4-	221
101-	37b		
13-	38		



9- 1	1- 18a	1- 40	2-126
14- 2	1- 18b	1- 45	2-126a
2- 3	2- 19b	2- 48	1-176
12- 5	1- 20a	7- 48a	1-186
4- 8	5- 22	1- 51	1-186a
4- 11	1- 23a	1- 52	2-191
1- 11a	2- 24	2- 53a	4-192
12- 12	2- 24c	2- 54	2-212
2- 12a	1- 26	2- 80c	2-212a
2- 15	1- 27a	2- 99	1-213
1- 15a	1- 35	2-111a	2-214
1- 15b	142- 37a	3-111c	4-221
2- 16	121- 37b	1-115	*1-M1
2- 17	13- 38	4-125	

*Not included in set

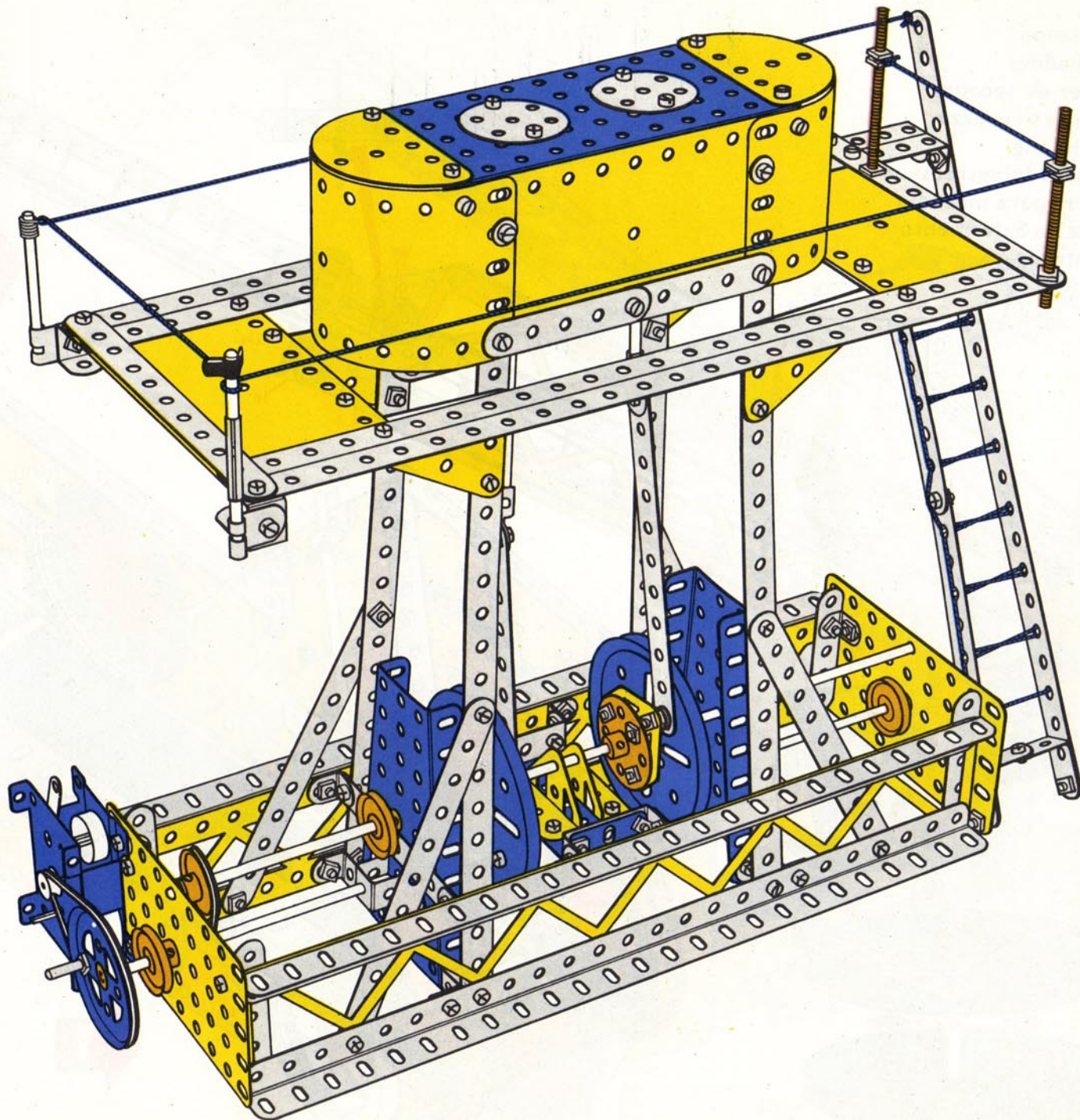

6.13.
Fire Escape
Brandladder
Escalier de secours
Uscita di sicurezza
Notausgang
Brandräddningsredskap
Escalera para incendio
Escada de Salvamento
Brantrapp

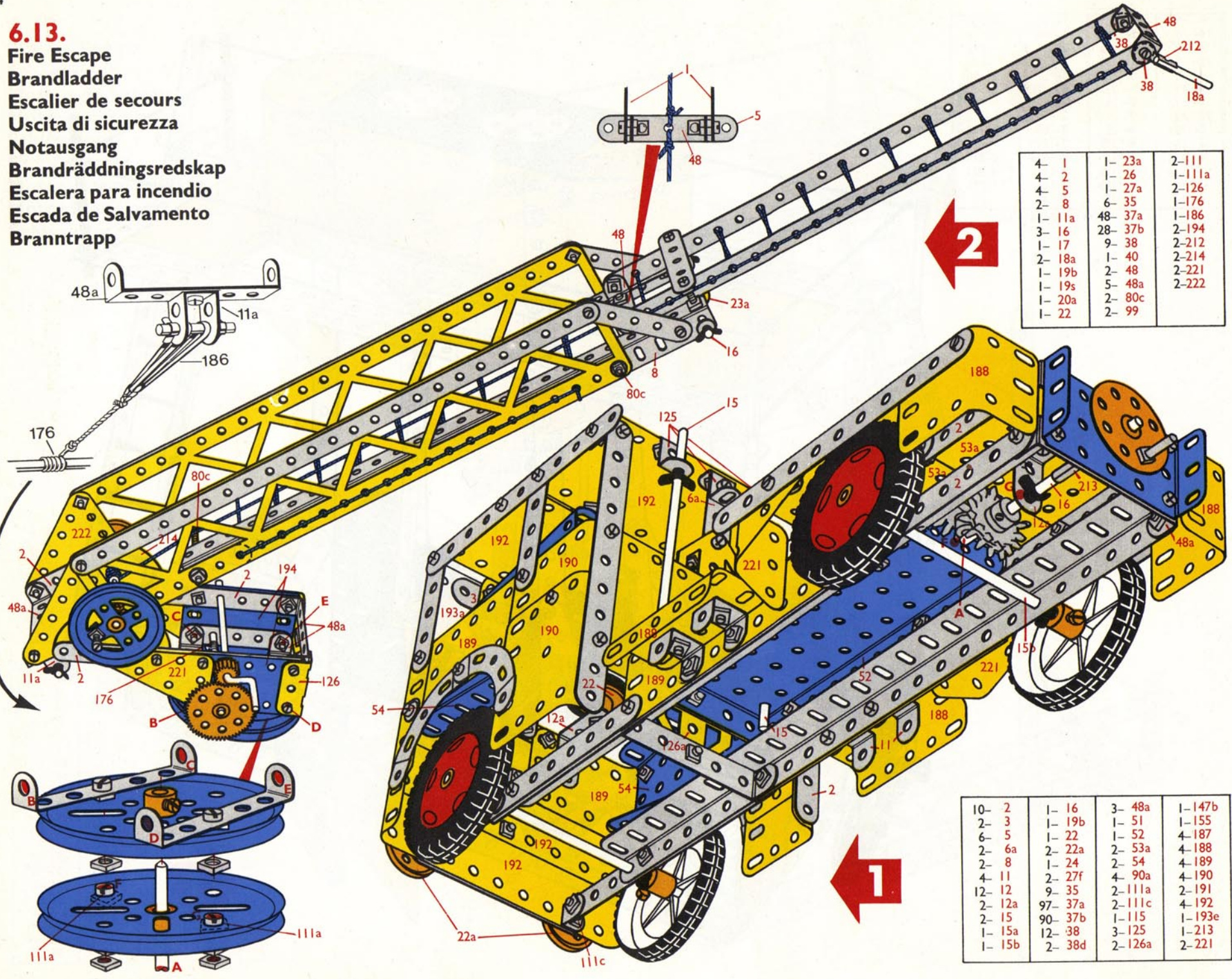

4- 1	1- 23a	2-111
4- 2	1- 26	1-111a
4- 5	1- 27a	2-126
2- 8	6- 35	1-176
1-11a	48- 37a	1-186
3-16	28- 37b	2-194
1-17	9- 38	2-212
2-18a	1- 40	2-214
1-19b	2- 48	2-221
1-19s	5- 48a	2-222
1-20a	2- 80c	
1-22	2- 99	

10- 2	1- 16	3- 48a	1-147b
2- 3	1- 19b	1- 51	1-155
6- 5	1- 22	1- 52	4-187
2- 6a	2- 22a	2- 53a	4-188
2- 8	1- 24	2- 54	4-189
4-11	2- 27f	4- 90a	4-190
12-12	9- 35	2-111a	2-191
2-12a	97- 37a	2-111c	4-192
2-15	90- 37b	1-115	1-193e
1-15a	12- 38	3-125	1-213
1-15b	2- 38d	2-126a	2-221

4- 1	2- 19b	2- 48	1- 147b
14- 2	1- 19s	8- 48a	1- 155
2- 3	1- 20a	1- 51	1- 176
10- 5	2- 22	1- 52	4- 187
2- 6a	2- 22a	2- 53a	4- 188
4- 8	1- 23a	2- 54	4- 189
4- 11	1- 24	2- 80c	4- 190
1- 11a	1- 26	4- 90a	2- 191
12- 12	1- 27a	2- 99	4- 192
2- 12a	2- 27f	2- 111	1- 193e
2- 15	15- 35	3- 111a	2- 194
1- 15a	145- 37a	2- 111c	2- 212
1- 15b	118- 37b	1- 115	1- 213
4- 16	21- 38	3- 125	2- 214
1- 17	2- 38d	2- 126	4- 221
2- 18a	1- 40	2- 126a	2- 222

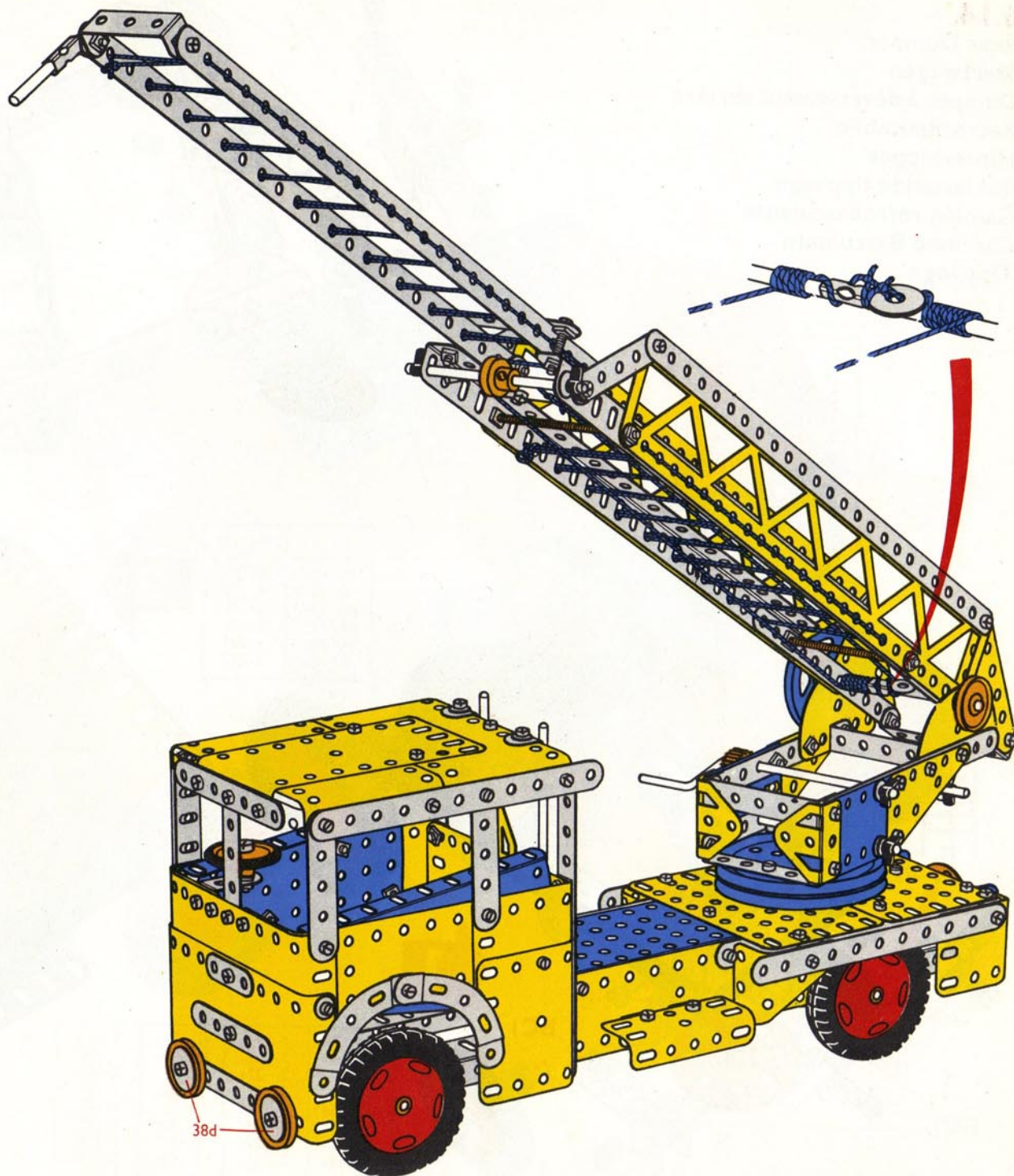

6.14.

Rear Dumper
Stertswagen
Dumper à déversement arrière
Retroribaltabile
Hinterkipper
Baklastande tippvagn
Camión retrobasculante
Carrinho Basculante
Tippvogn

7- 2	1- 16	58- 37a	1- 126
2- 3	1- 18b	58- 37b	2- 126a
2- 5	1- 19s	8- 38	1- 147b
2- 10	2- 22	1- 45	2- 187
1- 11	1- 24	2- 48	2- 214
1- 11a	2- 24c	2- 48a	1- 215
8- 12	1- 26	1- 51	
2- 12a	1- 27a	3- 90a	
1- 15	5- 35	2- 125	

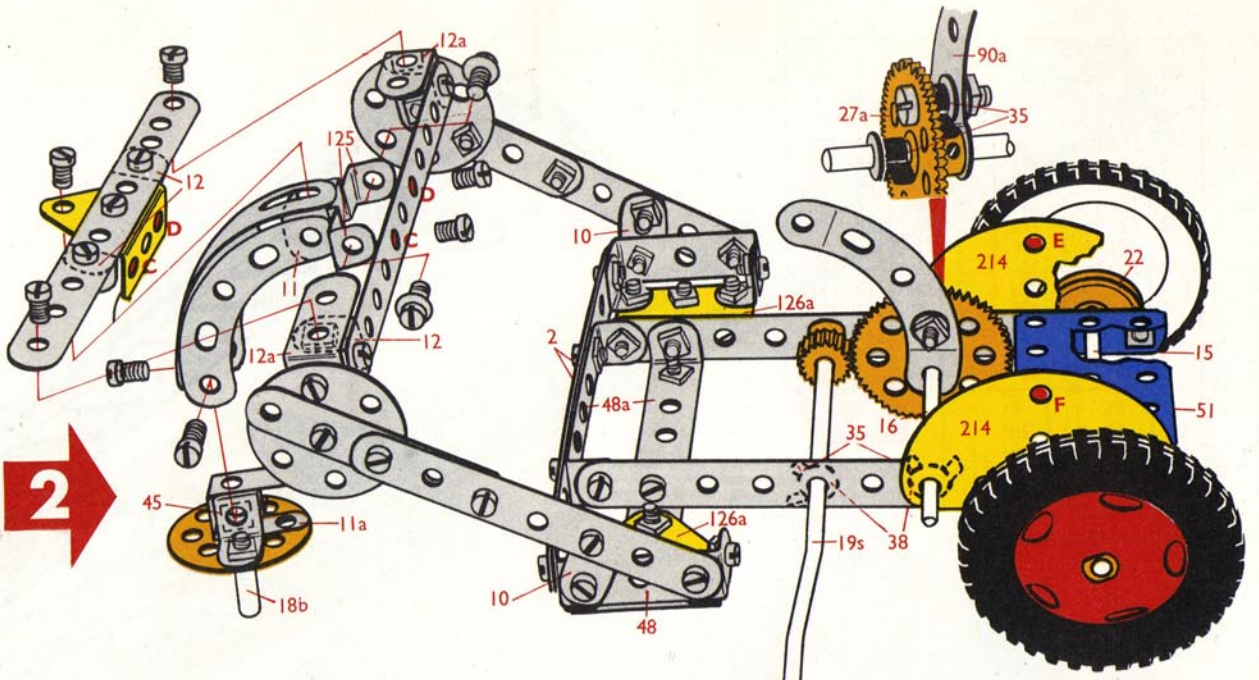

5- 5	1- 53a
4- 12	2- 54
8- 12c	2- 125
1- 16	4- 188
47- 37a	2- 190
47- 37b	2- 191
4- 38	4- 221
1- 48a	2- 222

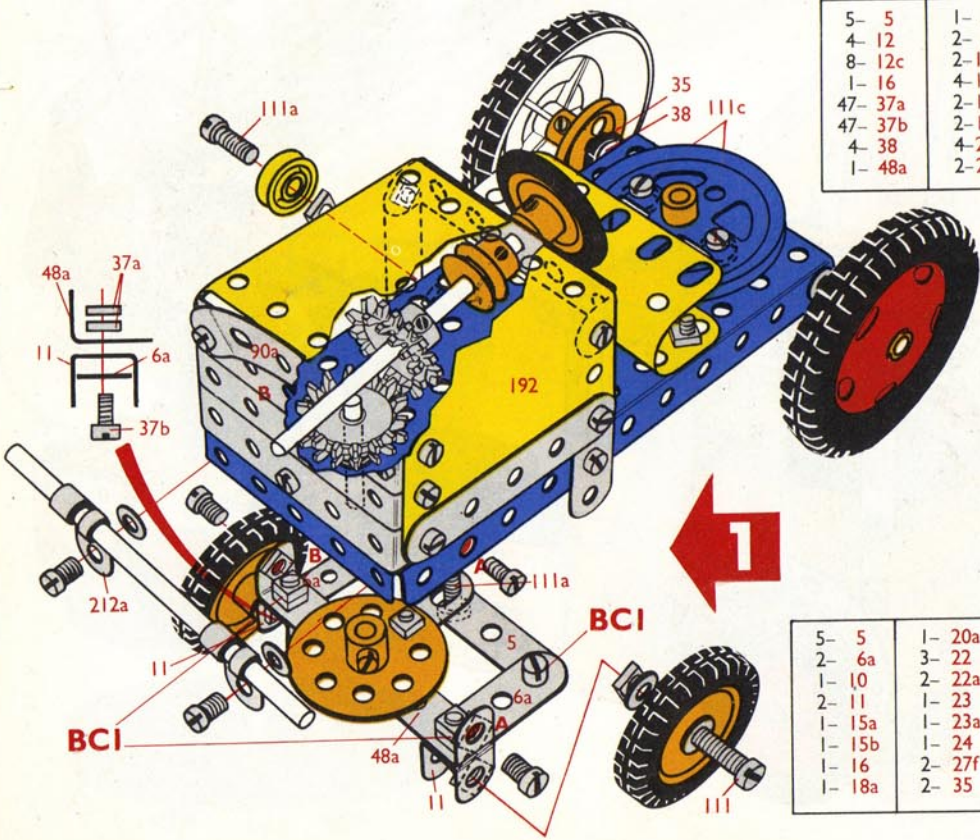
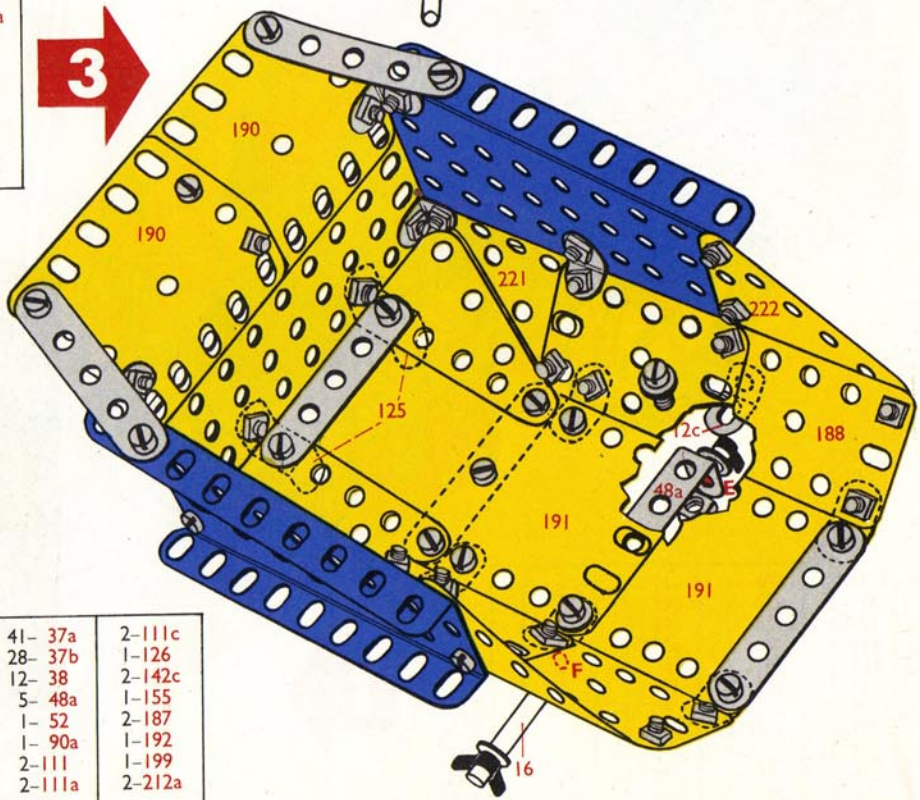

5- 5	1- 20a	41- 37a	2- 111c
2- 6a	3- 22	28- 37b	1- 126
1- 10	2- 22a	12- 38	2- 142c
2- 11	1- 23	5- 48a	1- 155
1- 15a	1- 23a	1- 52	2- 187
1- 15b	1- 24	1- 90a	1- 192
1- 16	2- 27f	2- 111	1- 199
1- 18a	2- 35	2- 111a	2- 212a

7-	2	1-	18b	24-	38	2-	142c
2-	3	1-	19s	1-	45	1-	147b
12-	5	1-	20a	2-	48	1-	155
2-	6a	5-	22	8-	48a	4-	187
3-	10	2-	22a	1-	51	4-	188
3-	11	1-	23	1-	52	2-	190
1-	11a	1-	23a	1-	53a	2-	191
12-	12	2-	24	2-	54	1-	192
2-	12a	2-	24c	4-	90a	1-	199
8-	12c	1-	26	2-	111	2-	212a
1-	15	1-	27a	2-	111a	2-	214
1-	15a	2-	27f	2-	111c	1-	215
1-	15b	7-	35	4-	125	4-	221
3-	16	146-	37a	2-	126	2-	222
1-	18a	133-	37b	2-	126a		

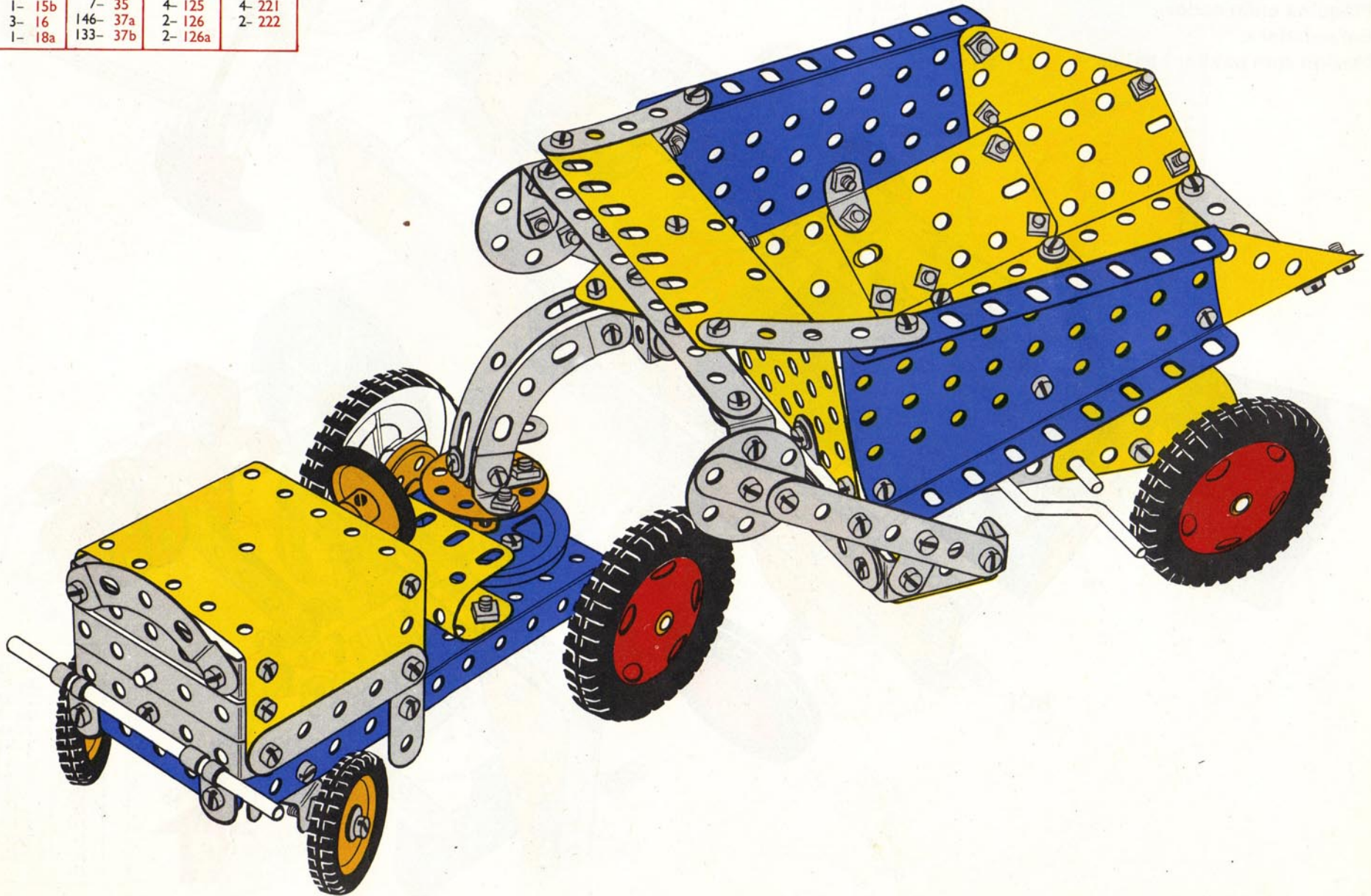

6.15.

Baling Machine

Baleners

Presse à balles

Imballatrice

Emballiermaschine

Balpress

Máquina enfardadora

Enfardadora

Maskin som pakker i baller

2-	1	1-	52
4-	2	2-	53a
8-	5	1-	54
2-	6a	2-	80c
4-	8	2-	90a
4-	12	2-	111c
1-	12a	2-	125
2-	15	2-	126
1-	27f	2-	126a
4-	35	4-	187
80-	37a	2-	188
70-	37b	4-	190
12-	38	1-	200
1-	48	2-	214
6-	48a		

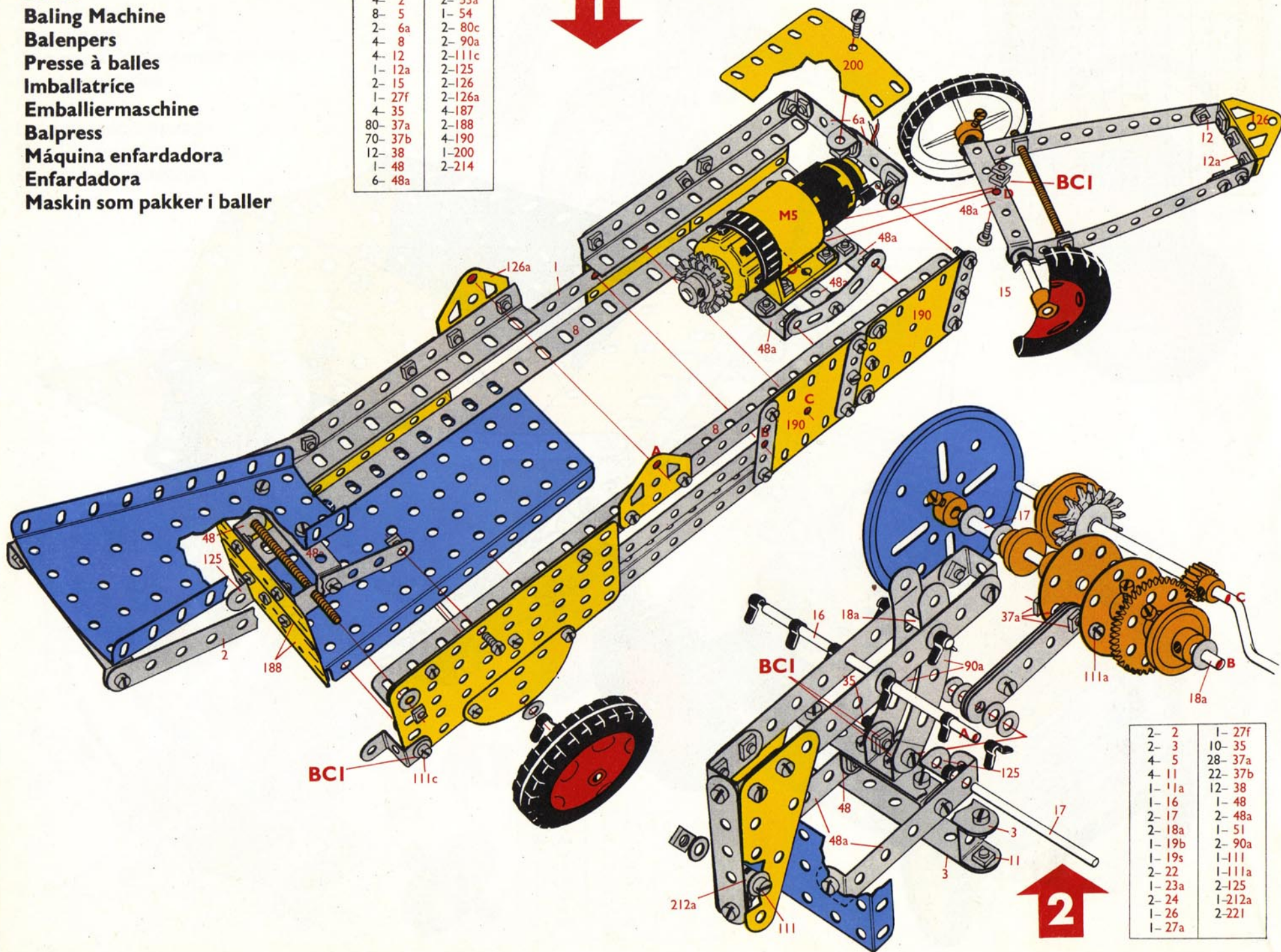

2-	2	1-	27f
2-	3	10-	35
4-	5	28-	37a
4-	11	22-	37b
1-	11a	12-	38
1-	16	1-	48
2-	17	2-	48a
2-	18a	1-	51
1-	19b	2-	90a
1-	19s	1-	111
2-	22	1-	111a
1-	23a	2-	125
2-	24	1-	212a
1-	26	2-	221
1-	27a		

2- 1	2- 18a	2- 48	2- 126a
6- 2	1- 19b	8- 48a	4- 187
2- 3	1- 19s	1- 51	2- 188
12- 5	2- 22	1- 52	4- 190
2- 6a	1- 23a	2- 53a	1- 200
4- 8	2- 24	1- 54	1- 212a
4- 11	1- 26	2- 80c	2- 214
1- 11a	1- 27a	4- 90a	2- 221
4- 12	2- 27f	1- 111	*1- M5
1- 12a	14- 35	1- 111a	
2- 15	108- 37a	2- 111c	
1- 16	92- 37b	4- 125	
2- 17	24- 38	2- 126	

*Not included in set No. 6

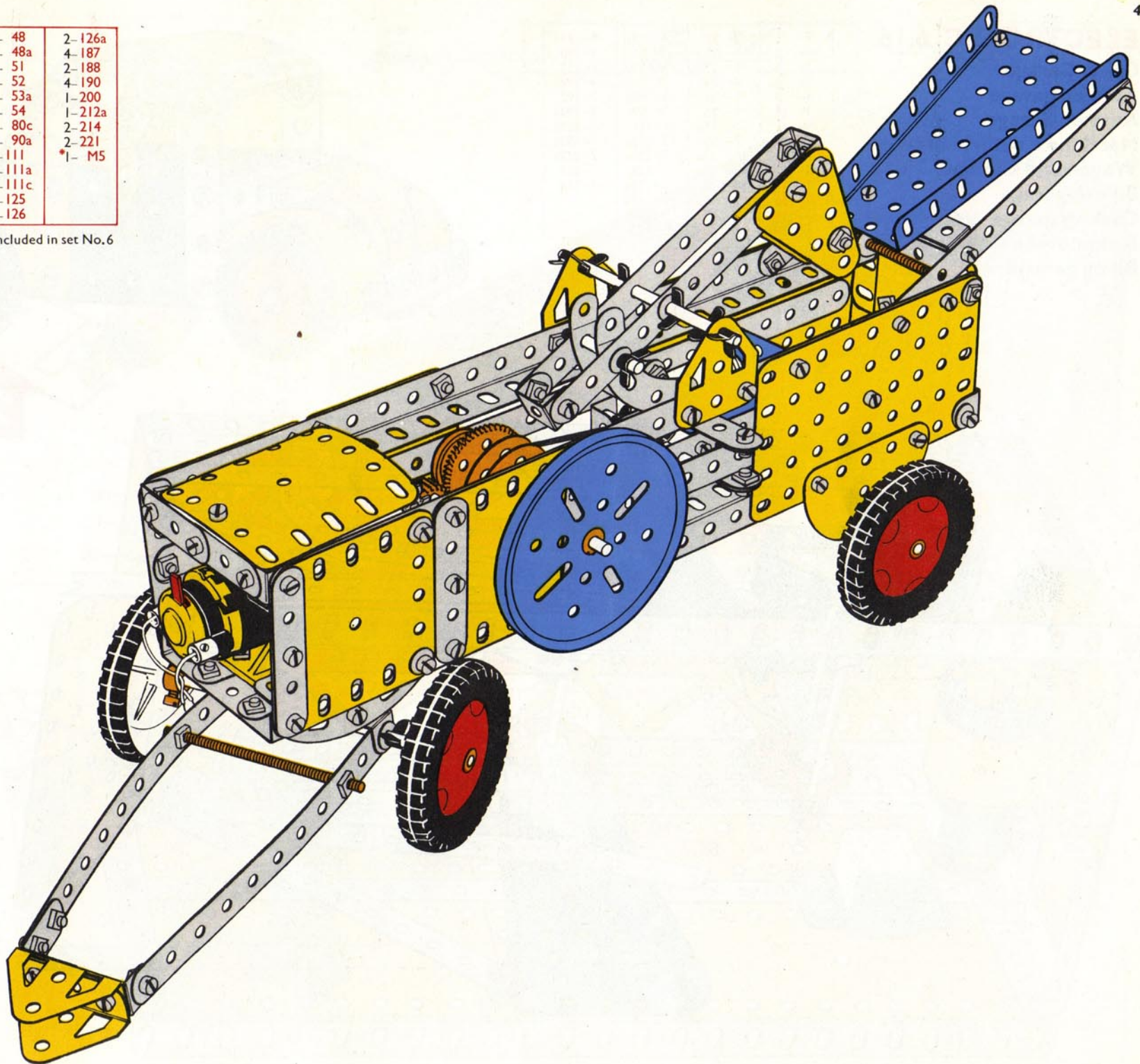

ELECTRONIC 6.16.

Car & Garage
 Auto en garage
 Auto et Garage
 Macchina e autorimessa
 Wagen und Garage
 Bil och garage
 Coche y garage
 Automovel e Garagem
 Bil og garasje

9-	1	1-	23	4-	48a	4-	189
14-	2	1-	23a	1-	51	4-	190
7-	5	*1-	23a	2-	53a	2-	191
2-	6a	2-	24	2-	54	4-	192
4-	8	1-	24c	2-	90a	2-	193
1-	10	1-	26	2-	99	2-	193a
4-	11	1-	27a	1-	111	1-	193c
1-	11a	7-	35	2-	111a	1-	193e
2-	12	115-	37a	5-	111c	2-	212a
2-	15	93-	37b	1-	115	1-	213
1-	15b	24-	38	2-	126a	1-	214
1-	16	2-	38d	1-	147b		
1-	18a	1-	45	1-	186a		
1-	19b	2-	48	4-	188		

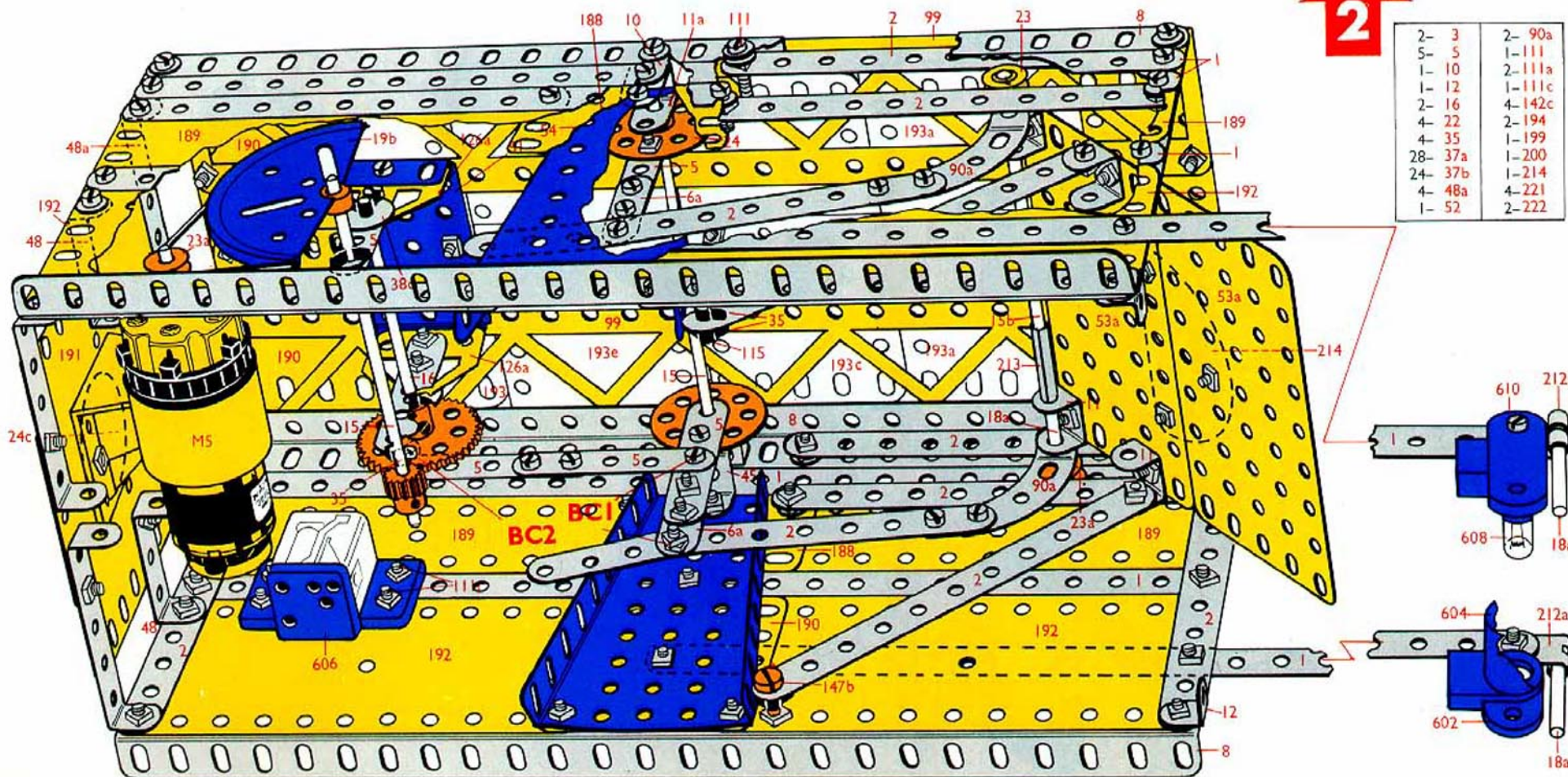
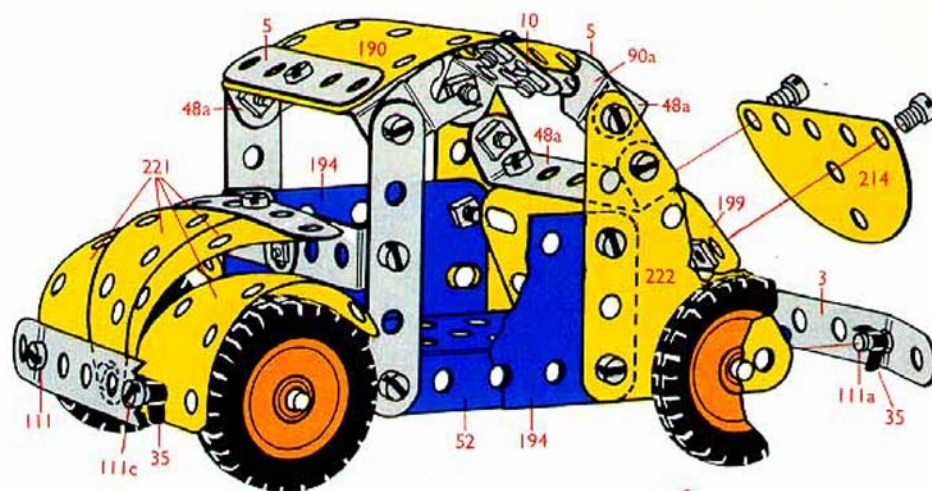

2-	3	2-	90a
5-	5	1-	111
1-	10	2-	111a
1-	12	1-	111c
2-	16	4-	142c
4-	22	2-	194
4-	35	1-	199
28-	37a	1-	200
24-	37b	1-	214
4-	48a	4-	221
1-	52	2-	222

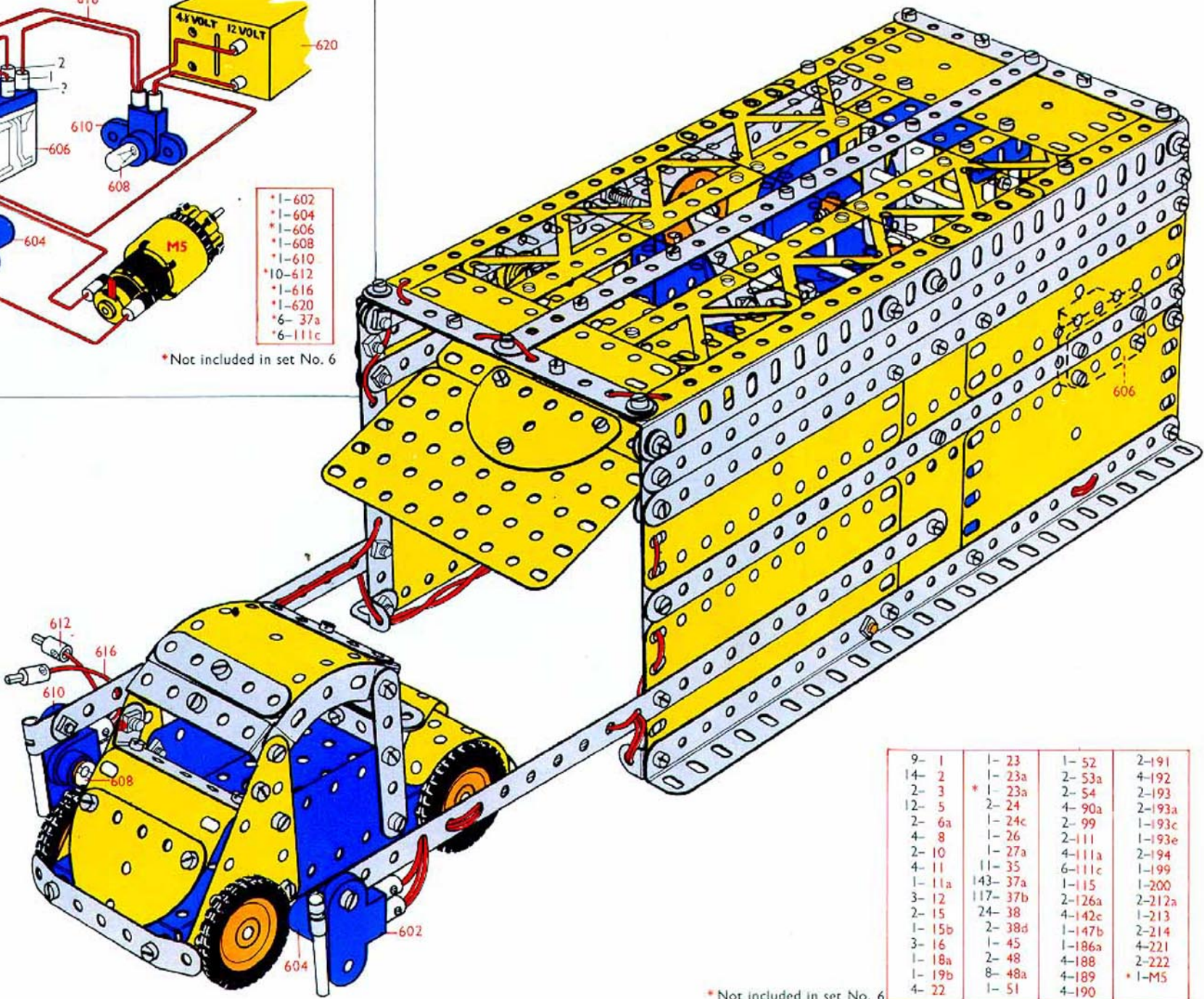
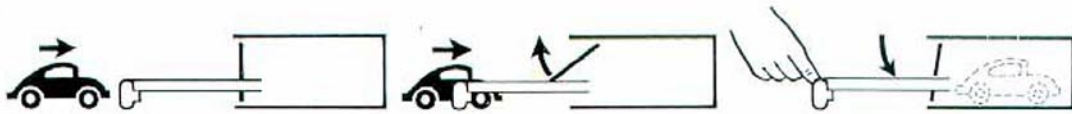
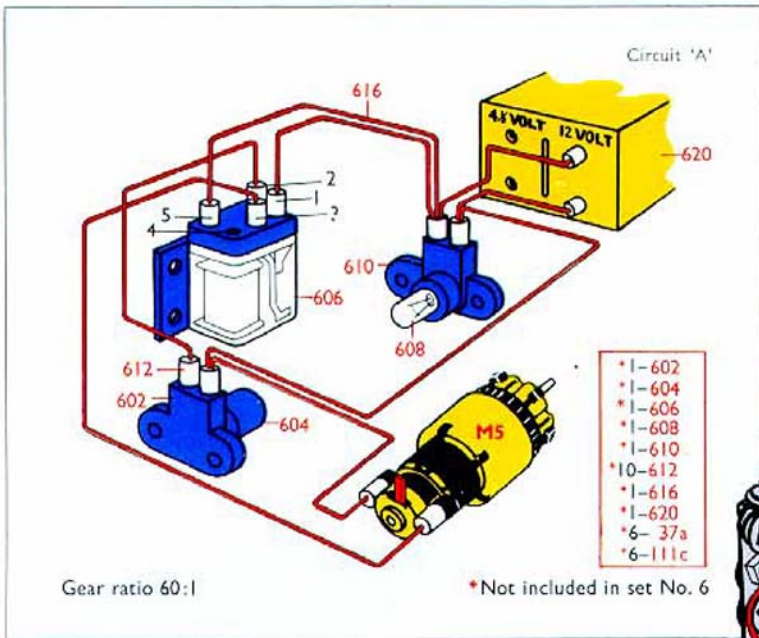

9- 1	1- 23	1- 52	2-191
14- 2	1- 23a	2- 53a	4-192
2- 3	* 1- 23a	2- 54	2-193
12- 5	2- 24	4- 90a	2-193a
2- 6a	1- 24c	2- 99	1-193c
4- 8	1- 26	2-111	1-193e
2-10	1- 27a	4-111a	2-194
4-11	11- 35	6-111c	1-199
1-11a	143- 37a	1-115	1-200
3-12	117- 37b	2-126a	2-212a
2-15	24- 38	4-142c	1-213
1-15b	2- 38d	1-147b	2-214
3-16	1- 45	1-186a	4-221
1-18a	2- 48	4-188	2-222
1-19b	8- 48a	4-189	1-M5
4-22	1- 51	4-190	

* Not included in set No. 6

ELECTRONIC 6.17.

Sorting Conveyor

Sorteertransporteur

Convoyeur-trieur

Trasportatore classificatore

Sortierförderer

Sorteringstransportör

Transportador clasificador

Transportador Seleccionador

Sorteringstransportör

2- 1	1- 20a	24- 38	1-115
1- 2	4- 22	1- 40	2-125
2- 3	2- 22a	2- 48	2-126
5- 5	1- 23a	3- 48a	1-147b
1- 6a	2- 24	1- 51	1-186a
2- 8	1- 26	1- 52	•1-186b
5-12	1- 27a	2- 54	2-212
2-12a	12- 35	2- 99	•1-M5
1-15b	46- 37a	1-111a	
4- 16	44- 37b	2-111c	

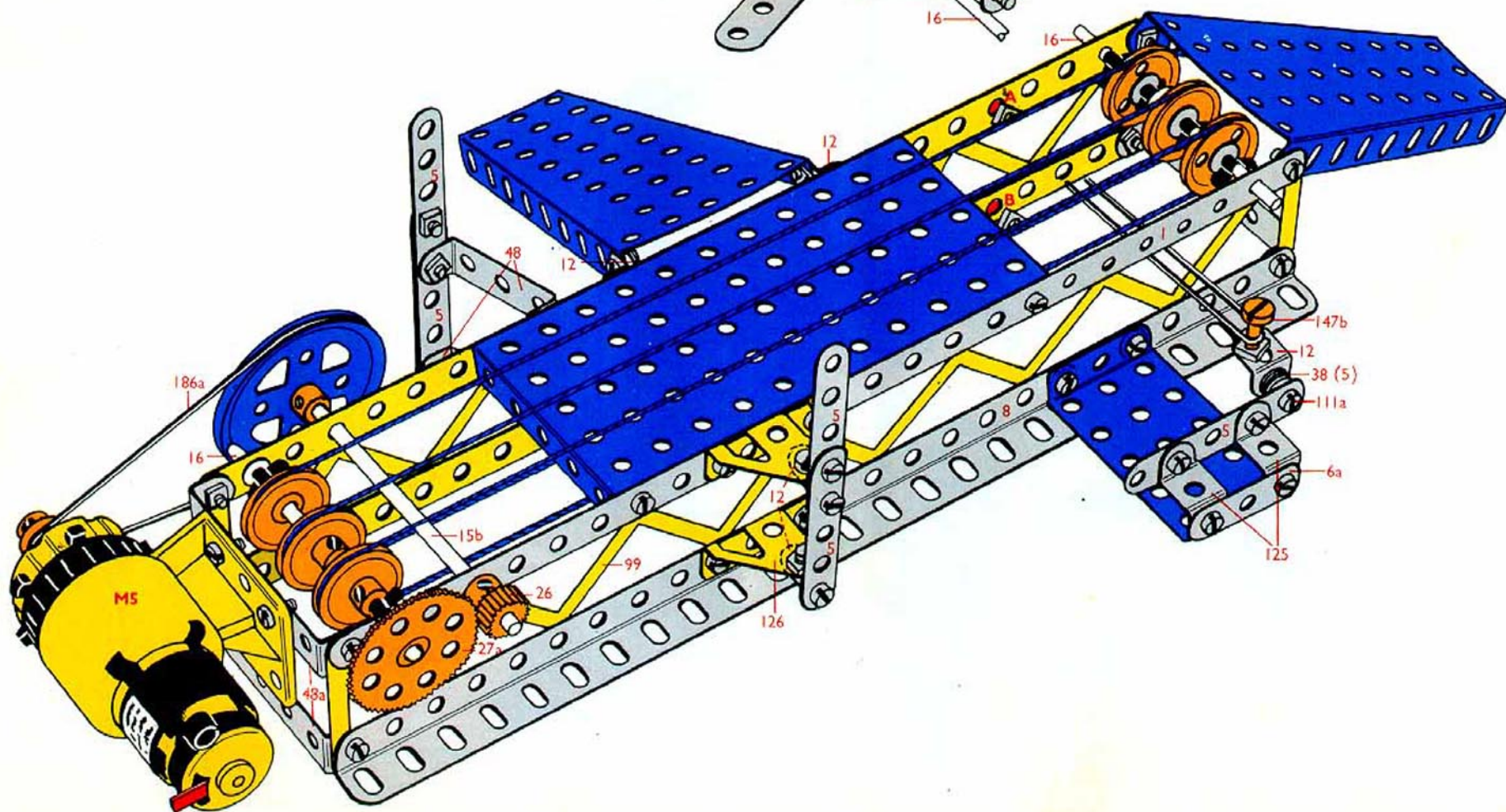
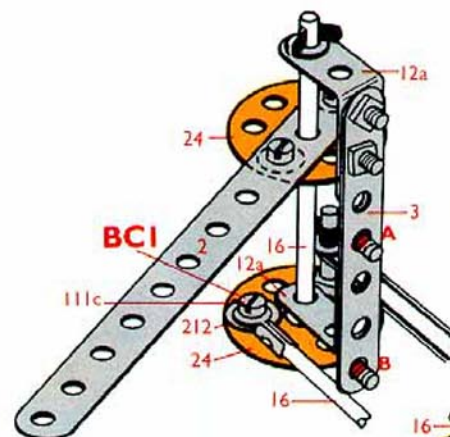

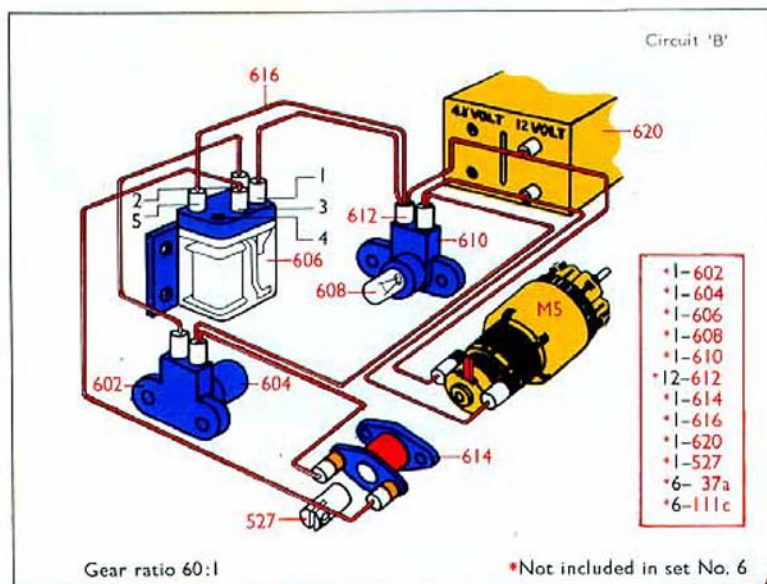

2- 1	1- 20a	24- 38	1-115
1- 2	4- 22	1- 40	2-125
2- 3	2- 22a	2- 48	2-126
5- 5	1- 23a	3- 48a	1-147b
1- 6a	2- 24	1- 51	1-186a
2- 8	1- 26	1- 52	*1-186b
5-12	1- 27a	2- 54	2-212
2-12a	12- 35	2- 99	*1-M5
1-15b	46- 37a	1-111a	
4- 16	44- 37b	2-111c	

*Not included in set No. 6

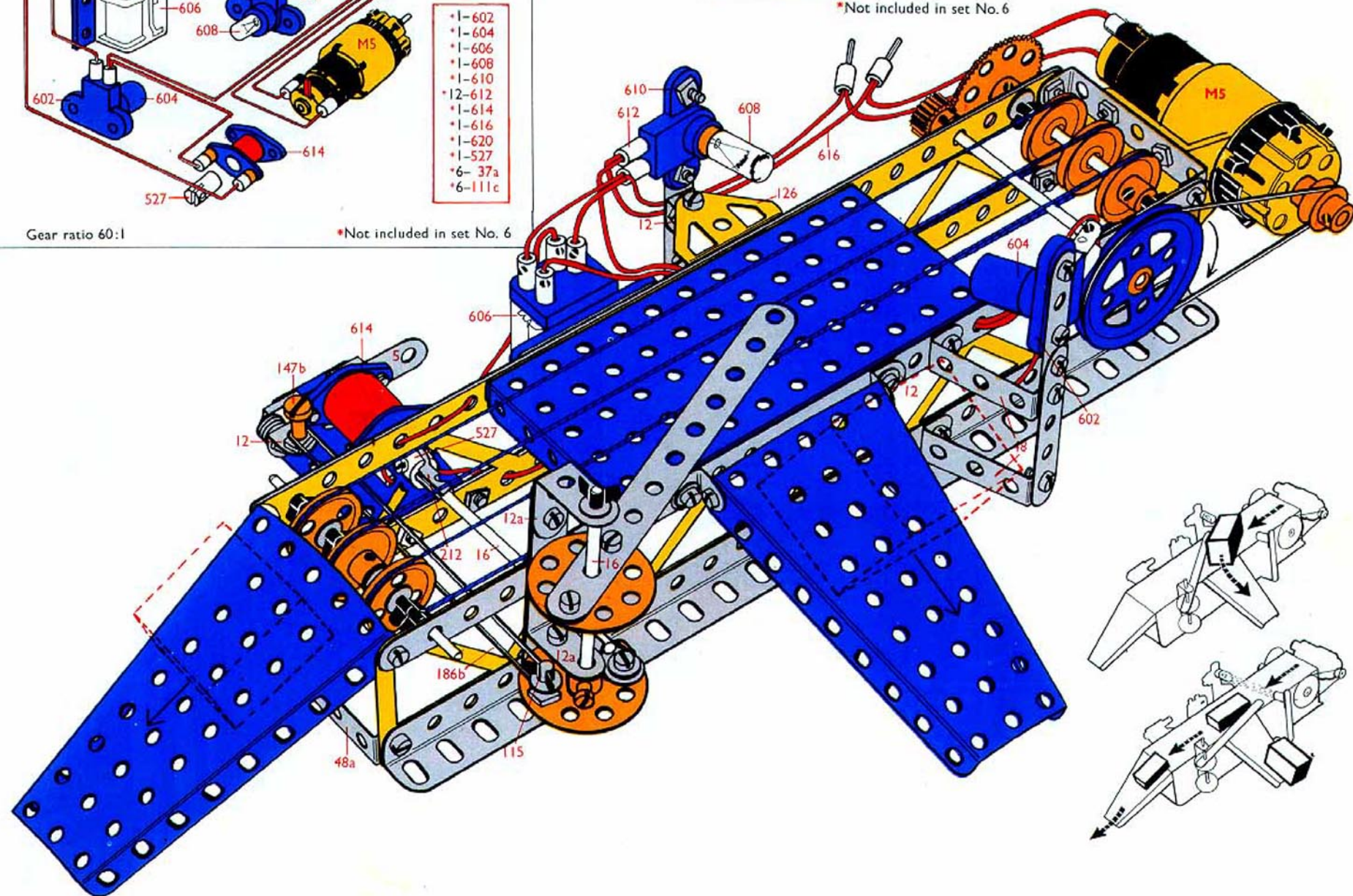

ELECTRONIC 6.18.

Shooting Range
 Schietbaan
 Tir
 Tiro a segno
 Schiessstand
 Skjutbana
 Poligono de tiro
 Carreira de Tiro
 Skytebane

1- 1	1- 23a
1- 5	2- 24
2- 16	2- 27f
1- 18a	8- 37a
1- 18b	6- 37b
1- 19b	6- 38
1- 20a	1- 186a
2- 22	*1- 186b
1- 23	1- 213
*1- 23a	1- 214

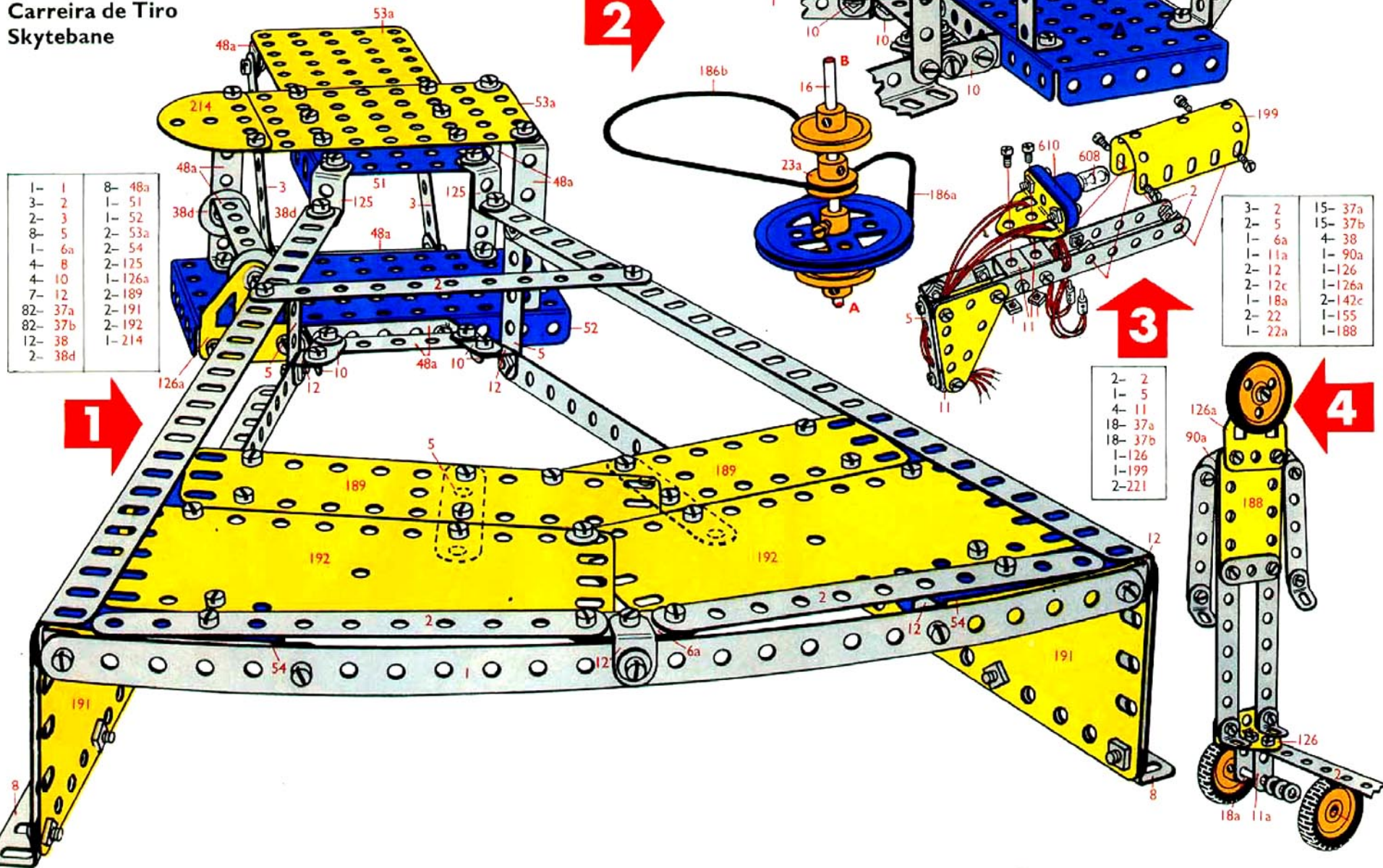

1- 1	8- 48a
3- 2	1- 51
2- 3	1- 52
8- 5	2- 53a
1- 6a	2- 54
4- 8	2- 125
4- 10	1- 126a
7- 12	2- 189
82- 37a	2- 191
82- 37b	2- 192
12- 38	1- 214
2- 38d	

3- 2	15- 37a
2- 5	15- 37b
1- 6a	4- 38
1- 11a	1- 90a
2- 12	1- 126
2- 12c	1- 126a
1- 18a	2- 142c
2- 22	1- 155
1- 22a	1- 188

2- 2
1- 5
4- 11
18- 37a
18- 37b
1- 126
1- 199
2- 221

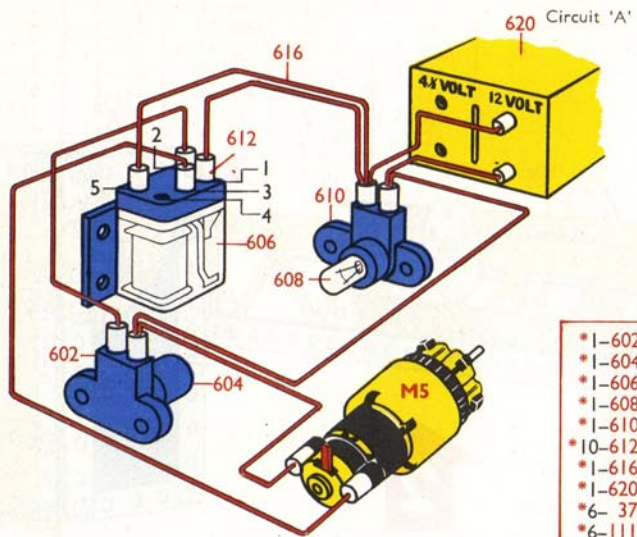

- *1-602
- *1-604
- *1-606
- *1-608
- *1-610
- *10-612
- *1-616
- *1-620
- *6-37a
- *6-111c

Gear ratio 60:1

*Not included in set No. 6

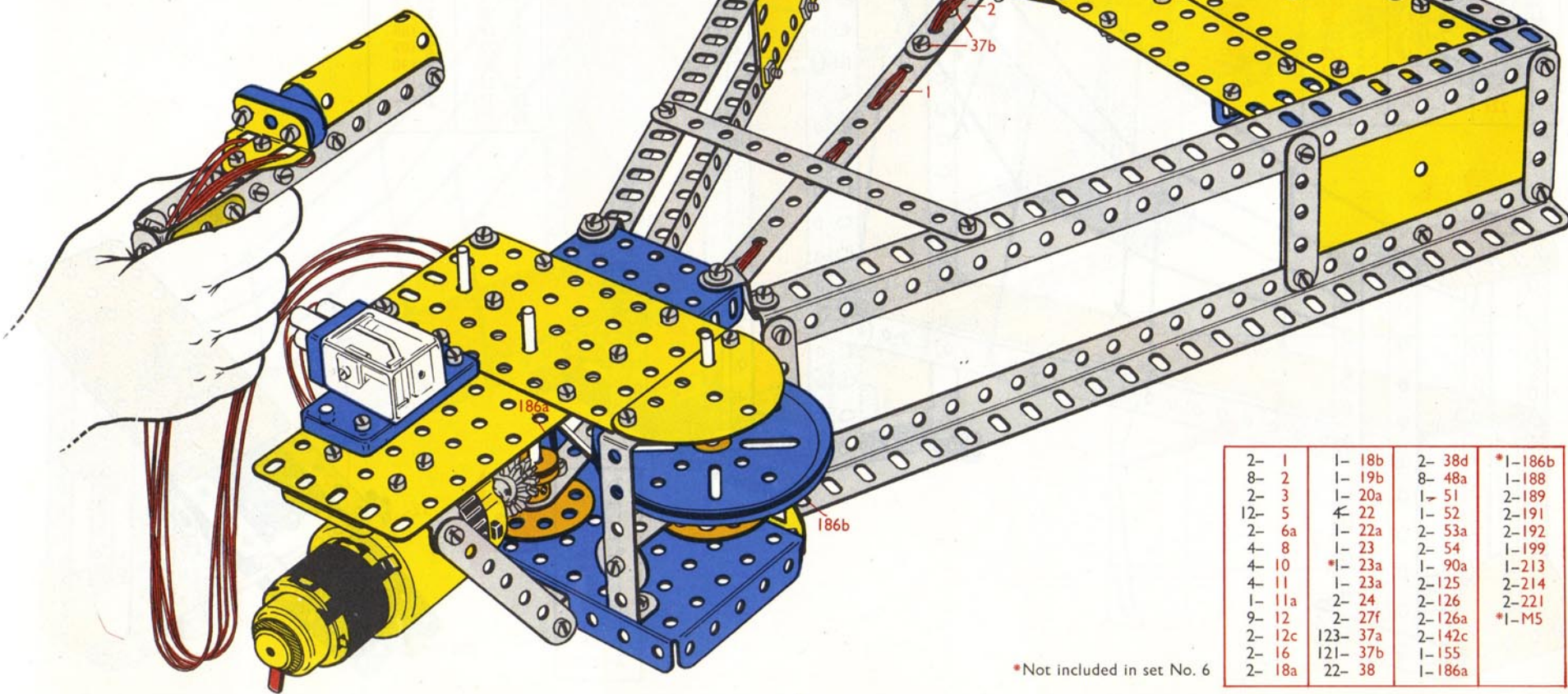
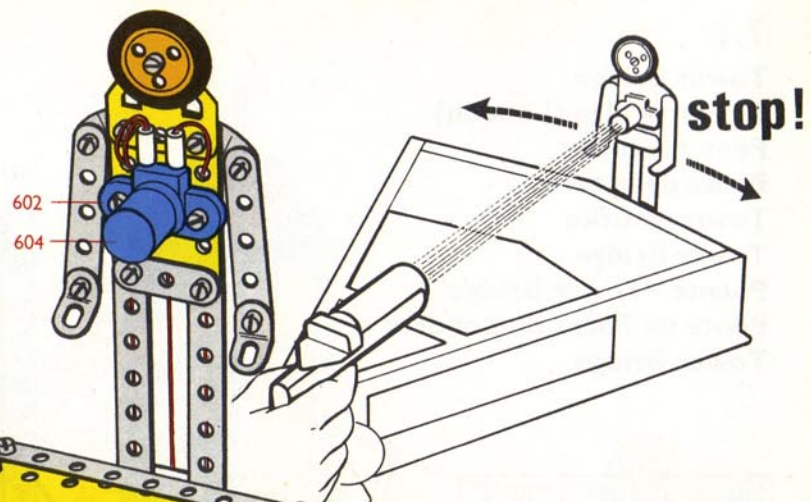

2- 1	1- 18b	2- 38d	*1-186b
8- 2	1- 19b	8- 48a	1-188
2- 3	1- 20a	1- 51	2-189
12- 5	4- 22	1- 52	2-191
2- 6a	1- 22a	2- 53a	2-192
4- 8	1- 23	2- 54	1-199
4- 10	*1- 23a	1- 90a	1-213
4- 11	1- 23a	2-125	2-214
1- 11a	2- 24	2-126	2-221
9- 12	2- 27f	2-126a	*1-M5
2- 12c	123- 37a	2-142c	
2- 16	121- 37b	1-155	
2- 18a	22- 38	1-186a	

*Not included in set No. 6

7.1

Tower Bridge
Tower Bridge (London)
Pont basculant
Ponte della torre
Tower-Brücke
Tower Bridge
Puente "Tower Bridge"
Ponte da Torre de Londres
Tower Bridge

6- 1	1- 24	1-176
4- 2	6- 35	2-188
2- 3	73- 37a	2-189
6- 5	69- 37b	2-190
2- 8	13- 38	1-191
4-10	1- 40	2-192
2-11	4- 48a	1-197
4-12	1- 52	1-200
2-12a	1- 53	1-212a
1-15b	2- 59	1-214
1-16	2-111a	2-221
1-18a	2-111c	2-222
1-19s	2-125	2-223
1-22	2-126a	
1-22a	1-142c	

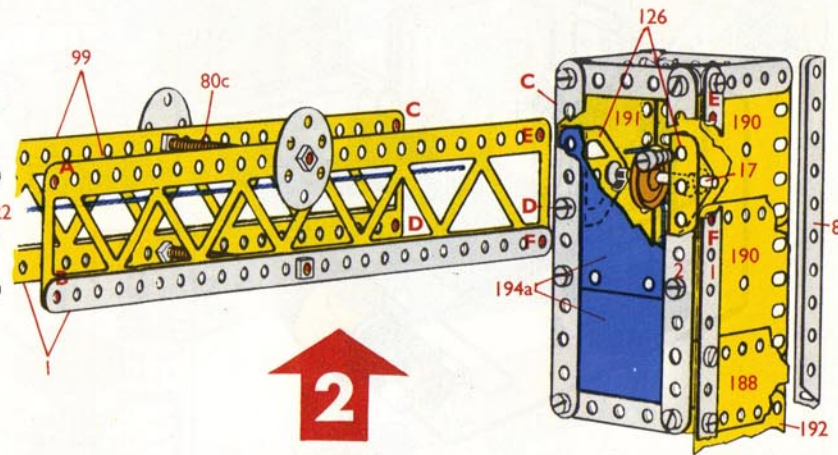
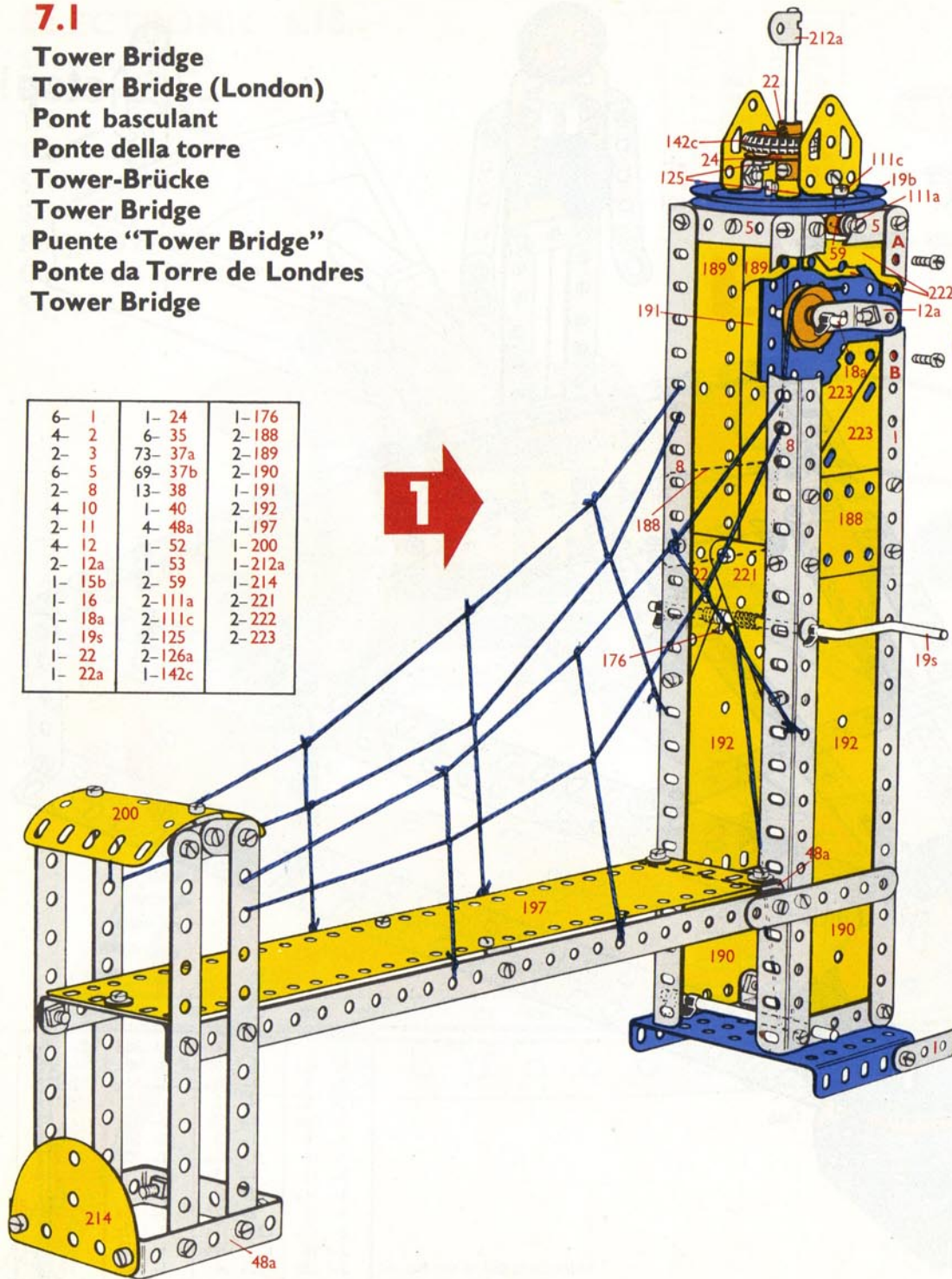

2- 1	2- 38
2- 2	2- 80c
5- 5	2- 99
2- 8	2-126
1-17	2-188
1-22	2-189
2-24c	2-190
2-35	1-191
38-37a	2-194a
30-37b	



2- 2
1-12
1-16
2-35
9-37a
9-37b
1-38d
1-48
1-53a
1-54
2-90a

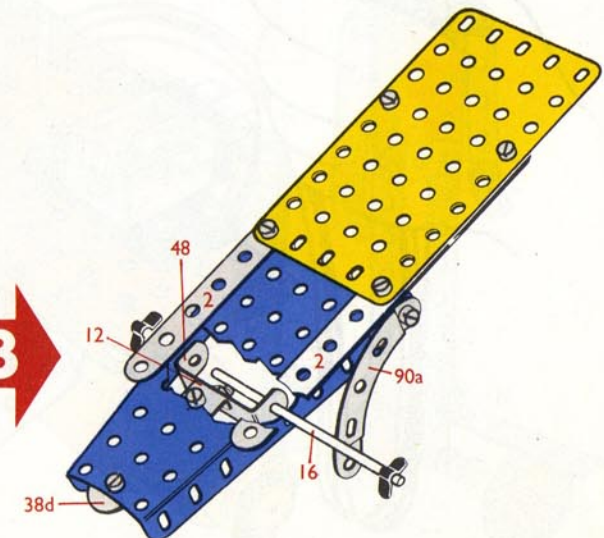

12- 1	1- 18a	2- 40	4-111c	2-197
14- 2	2- 19b	2- 48	4-125	1-199
4- 3	1- 19s	8- 48a	2-126	1-200
14- 5	3- 22	1- 52	4-126a	2-212a
4- 8	1- 22a	2- 53	2-142c	2-214
8- 10	2- 24	2- 53a	1-176	4-221
4- 11	2- 24c	2- 54	4-188	2-222
14- 12	14- 35	4- 59	4-189	2-223
2- 12a	168- 37a	2- 80c	6-190	
2- 15b	156- 37b	4- 90a	2-191	
4- 16	18- 38	2- 99	4-192	
1- 17	2- 38d	4-111a	2-194a	

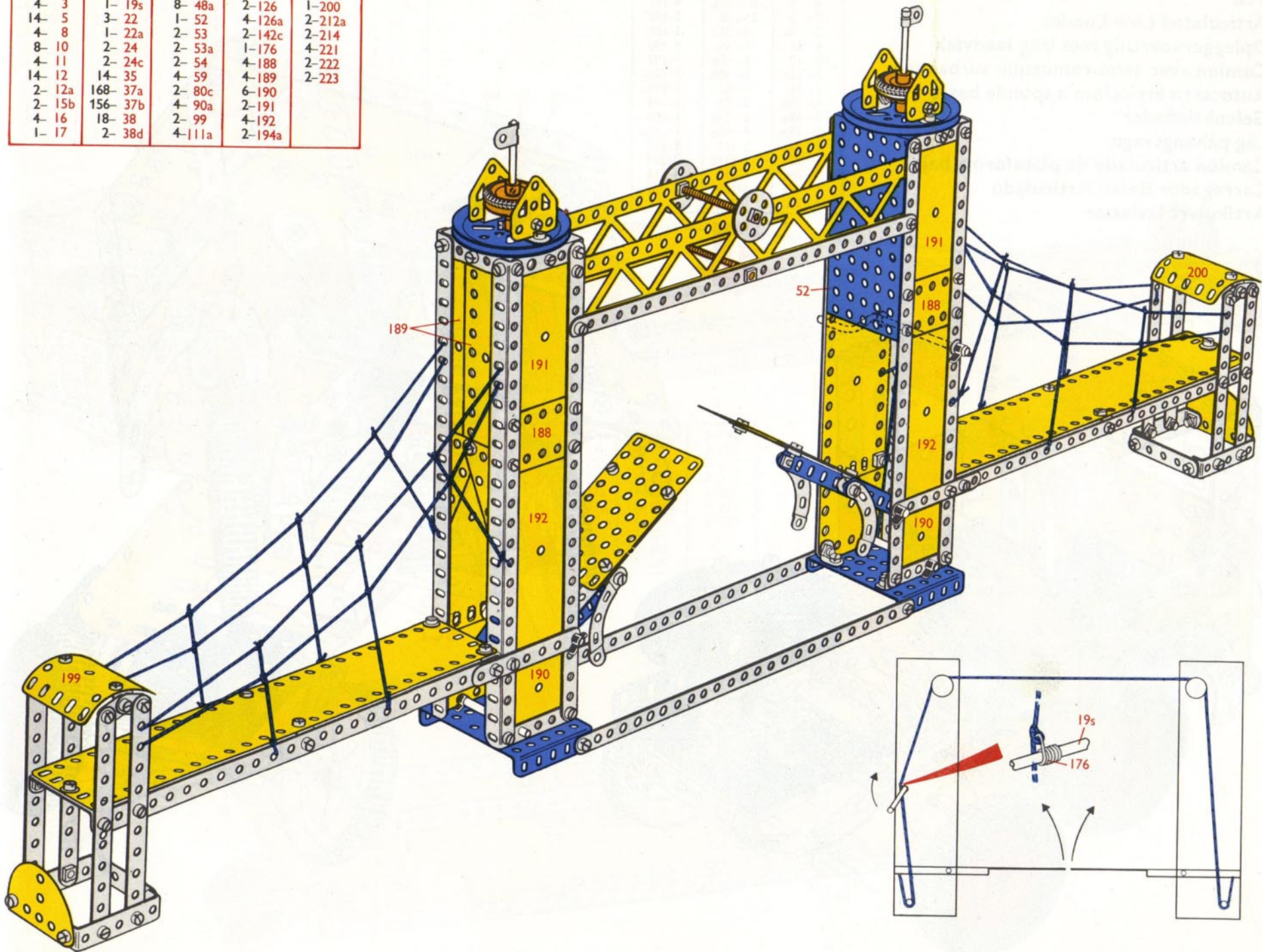

7.2

Articulated Low Loader

Opleggervoertuig met laag laadvlak

Camion avec semi-remorque surbaissée

Autocarro articolato a sponda basse

Gelenktieflader

Låg påhängsvagn

Camión articulado de plataforma baja

Carregador Baixo Articulado

Artikulert lavlaster

7- 2	110- 37a	1-155
4- 3	100- 37b	4-187
12- 5	21- 38	2-188
2- 6a	2- 38d	1-189
4- 11	1- 45	4-190
10- 12	6- 48a	1-192
3- 12c	2- 48b	2-193a
1- 15	1- 51	1-193e
1- 15b	2- 53	1-199
3- 18a	2- 53a	1-200
1- 19b	4- 90a	1-212a
1- 22	1-111	2-213
1- 23a	2-111c	2-214
1- 26	1-115	4-215
1- 27a	4-125	2-221
3- 35	1-126	

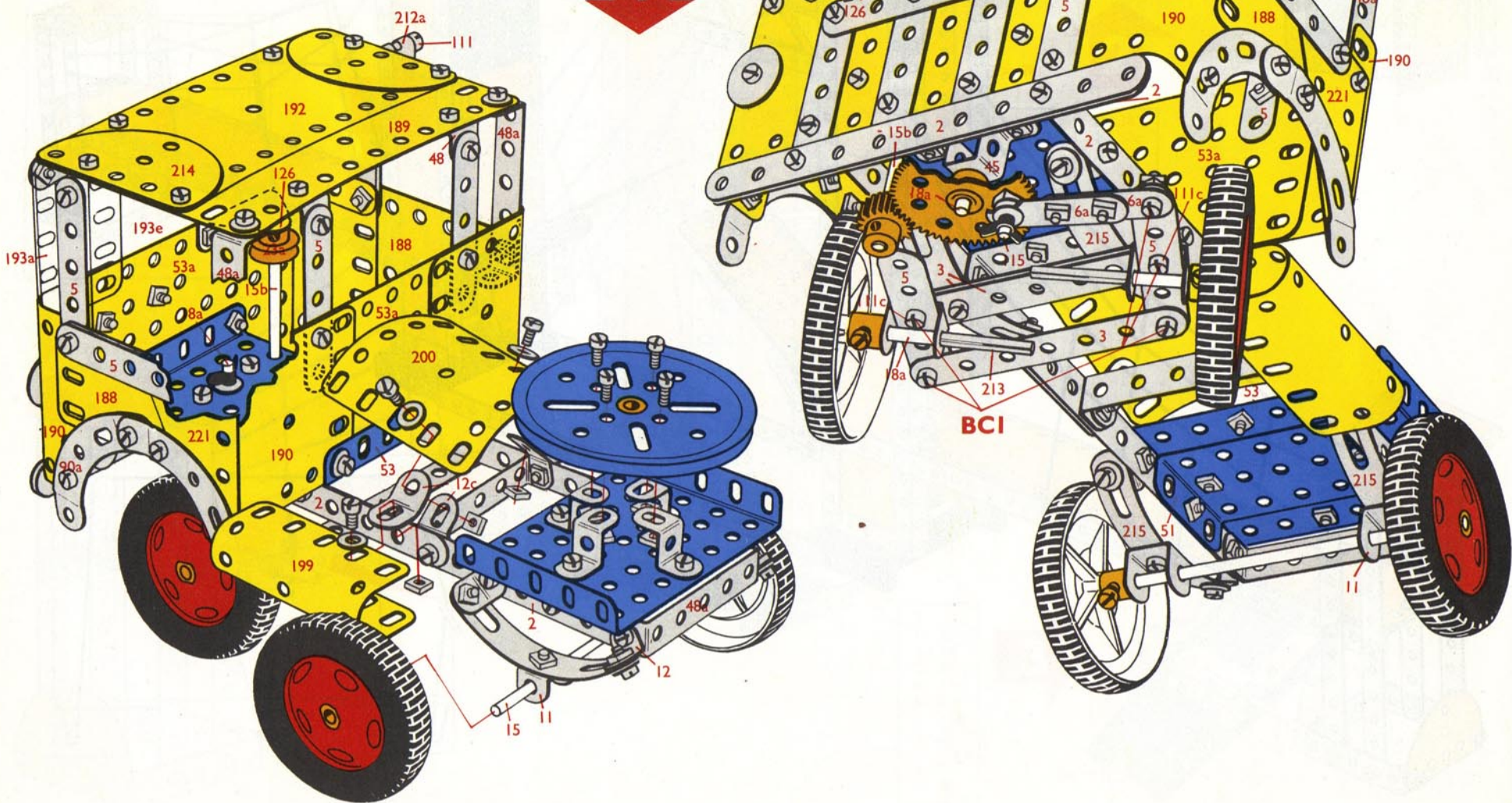

2- 1	1- 15b	169- 37a	2- 53a	4- 142c	1- 200
14- 2	2- 16	159- 37b	1- 54	1- 155	2- 212
4- 3	1- 17	30- 38	1- 57c	1- 176	1- 212a
2- 4	3- 18a	2- 38d	4- 59	4- 187	2- 213
14- 5	2- 19b	1- 40	4- 90a	4- 188	2- 214
4- 6a	1- 19h	1- 45	1- 111	4- 189	4- 215
4- 8	5- 22	2- 48	4- 111a	5- 190	4- 221
4- 11	1- 23a	8- 48a	2- 111c	4- 192	2- 222
16- 12	1- 24	2- 48b	1- 115	2- 193a	2- 223
2- 12a	1- 26	1- 51	4- 125	1- 193e	
3- 12c	1- 27a	1- 52	1- 126	2- 197	
1- 15	3- 35	2- 53	2- 126a	1- 199	

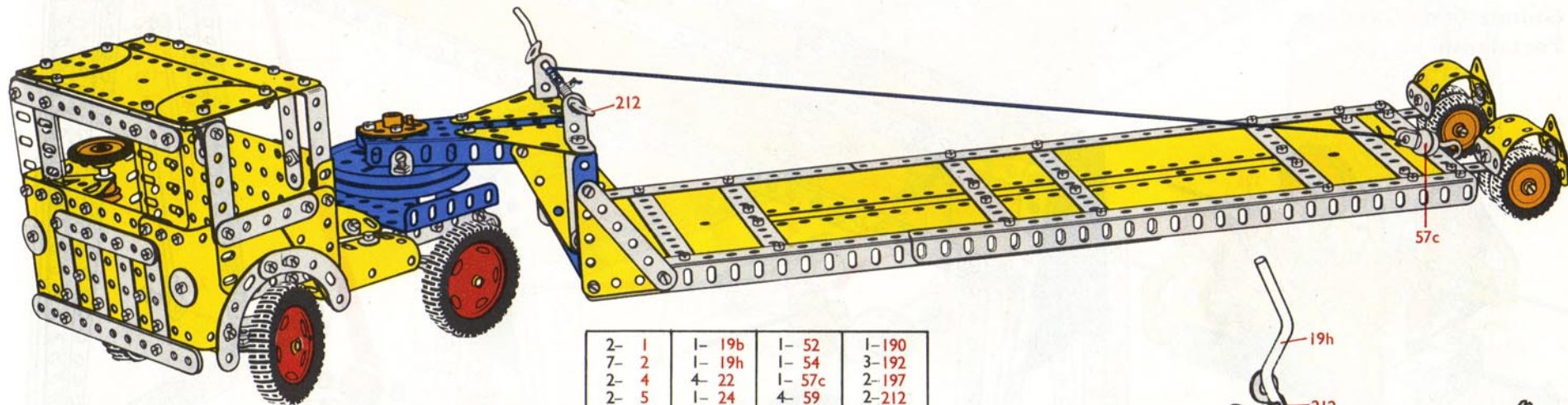

2

2- 1	1- 19b	1- 52	1- 190
7- 2	1- 19h	1- 54	3- 192
2- 4	4- 22	1- 57c	2- 197
2- 5	1- 24	4- 59	2- 212
2- 6a	59- 37a	4- 111a	2- 221
4- 8	59- 37b	2- 126a	2- 222
6- 12	9- 38	4- 142c	2- 223
2- 12a	1- 40	1- 176	
2- 16	2- 48	2- 188	
1- 17	2- 48a	3- 189	

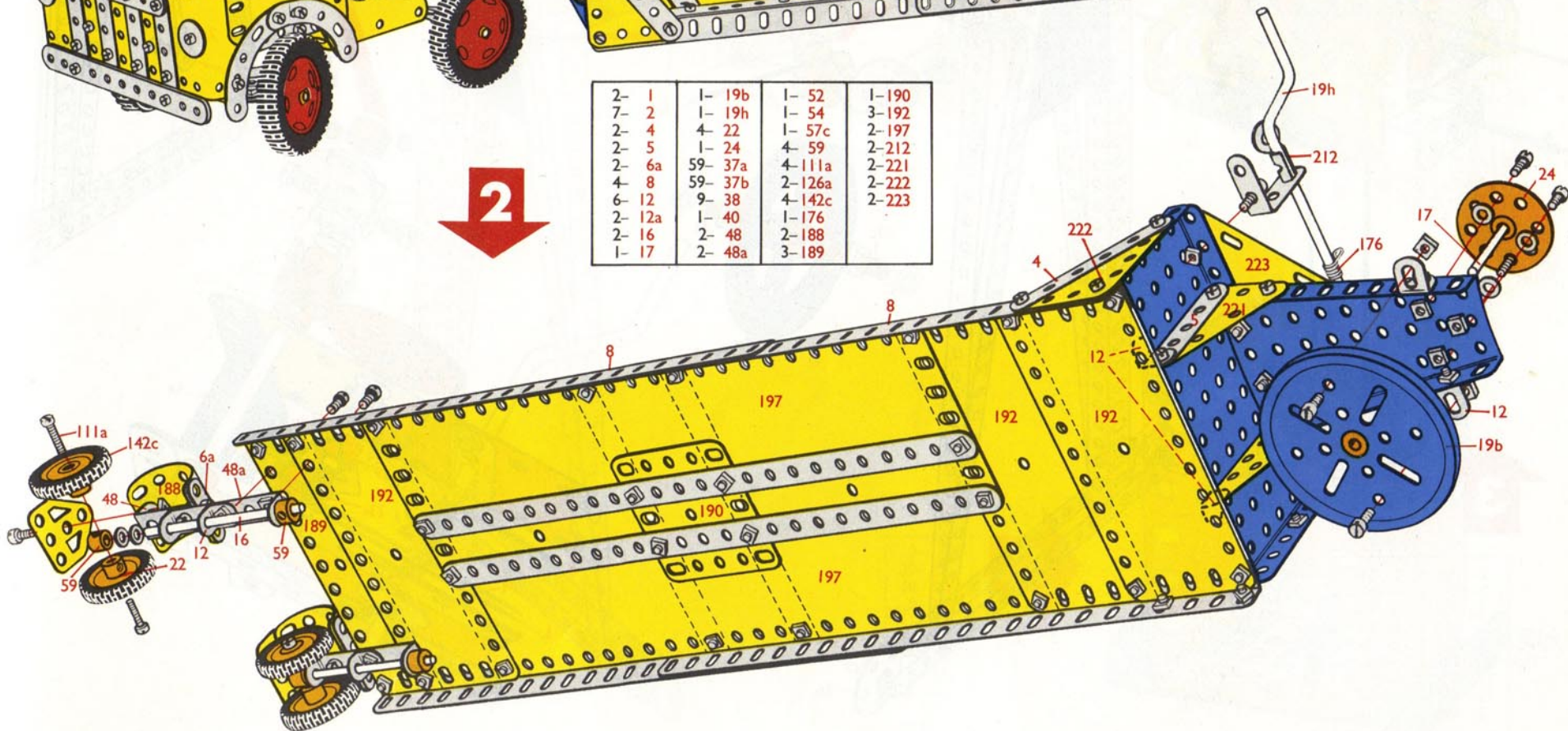

7.3

Gantry Crane
 Loopkraan
 Pont roulant
 Gru a cavalletto
 Portalkran
 Portalkran
 Grúa pórtico
 Guindaste de Cavalete
 Portalkran

12- 1	1- 14	1- 26	2- 80c
14- 2	1- 15a	1- 27a	2- 111
4- 3	1- 16	13- 35	6- 111c
2- 4	1- 17	122- 37a	4- 125
12- 5	4- 18a	98- 37b	1- 176
2- 6a	1- 18b	18- 38	4- 192
4- 8	1- 19s	2- 38d	2- 197
1- 10	1- 20a	1- 40	2- 212
1- 11	1- 23	2- 48	2- 212a
1- 11a	1- 23a	1- 51	1- 213
8- 12	2- 24	2- 54	
1- 13	2- 24c	4- 59	

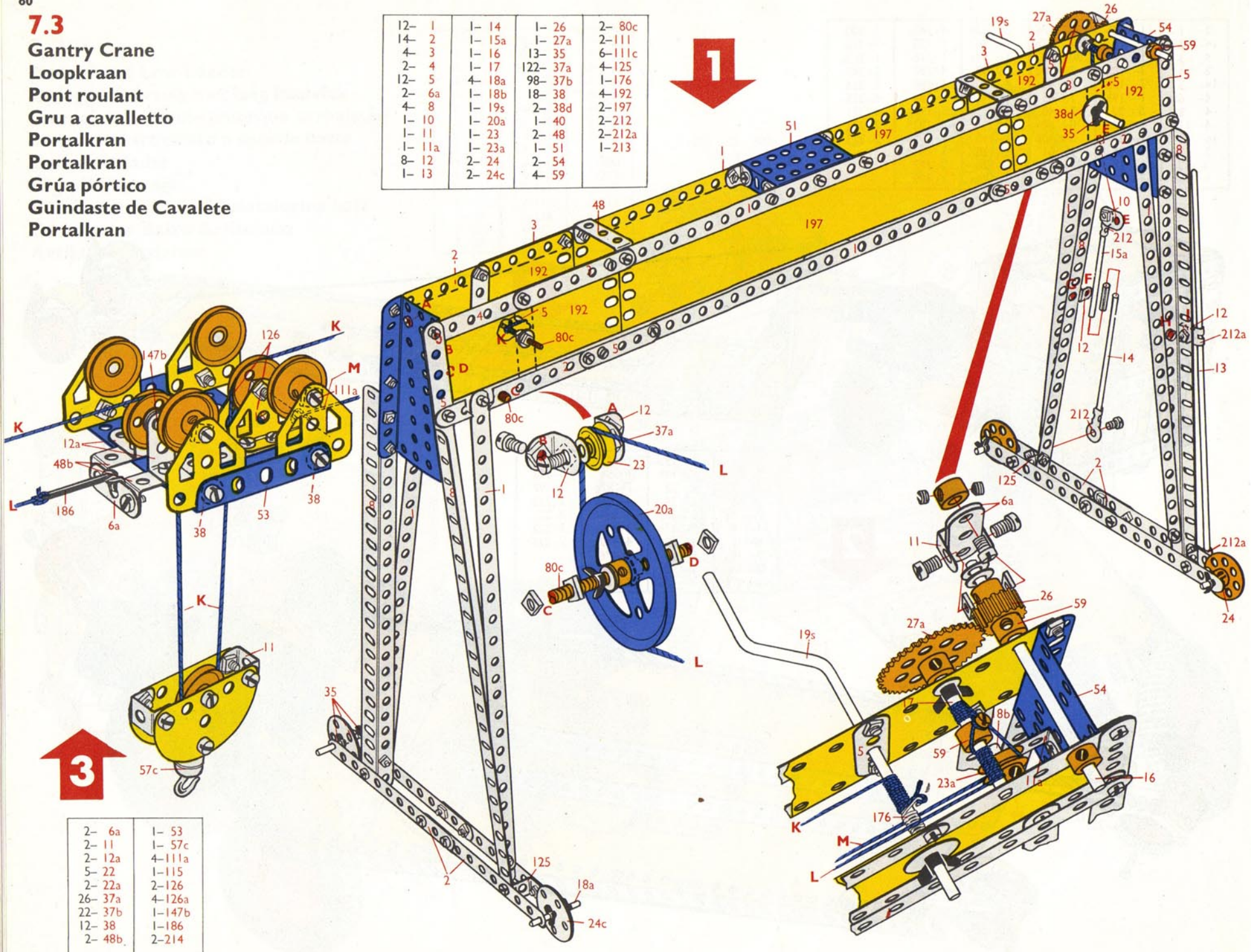

2- 6a	1- 53
2- 11	1- 57c
2- 12a	4- 111a
5- 22	1- 115
2- 22a	2- 126
26- 37a	4- 126a
22- 37b	1- 147b
12- 38	1- 186
2- 48b	2- 214

12-	1	1-	17	30-	38	4-	125
14-	2	4-	18a	2-	38d	2-	126
4-	3	1-	18b	1-	40	4-	126a
2-	4	1-	19s	2-	48	1-	147b
14-	5	1-	20a	8-	48a	1-	176
4-	6a	5-	22	2-	48b	1-	186
4-	8	2-	22a	1-	51	5-	190
1-	10	1-	23	2-	53	4-	192
3-	11	1-	23a	2-	54	2-	193
1-	11a	2-	24	1-	57c	2-	193a
8-	12	2-	24c	4-	59	2-	197
2-	12a	1-	26	2-	80c	2-	212
1-	13	1-	27a	2-	111	2-	212a
1-	14	13-	35	4-	111a	1-	213
1-	15a	178-	37a	6-	111c	2-	214
1-	16	150-	37b	1-	115		

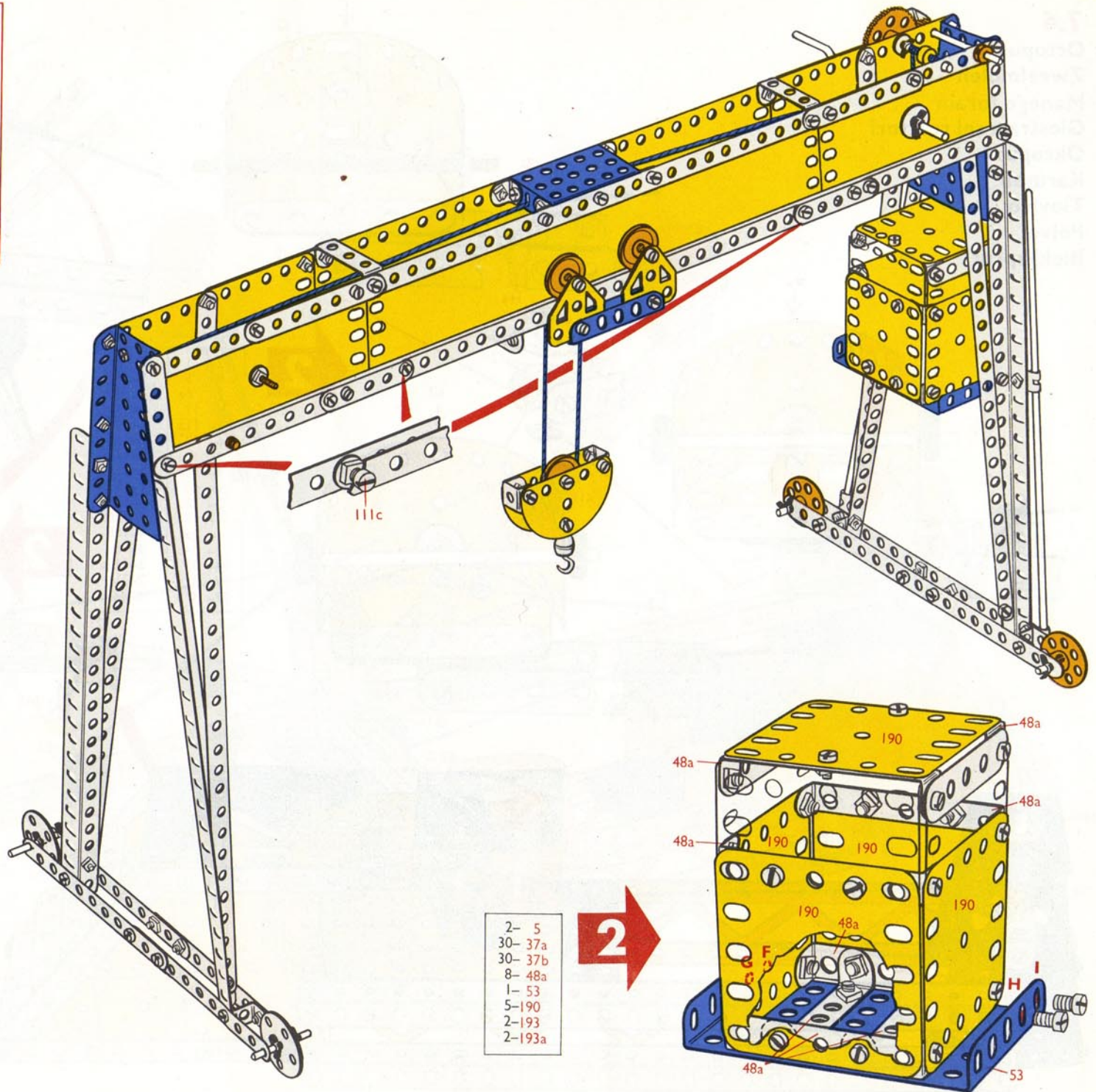

- 2- 5
- 30- 37a
- 30- 37b
- 8- 48a
- 1- 53
- 5- 190
- 2- 193
- 2- 193a

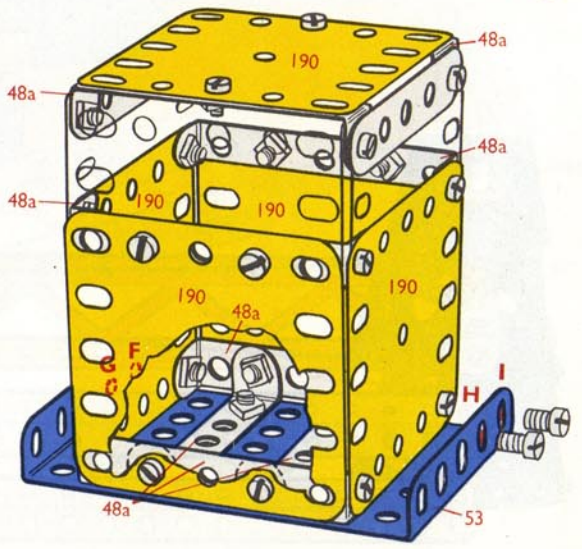

7.4

Octopus
Zweefmolen
Manège forain
Giostra a sei reattori
Oktopus
Karusell
Tiovivo
Polvo
Blekksprut

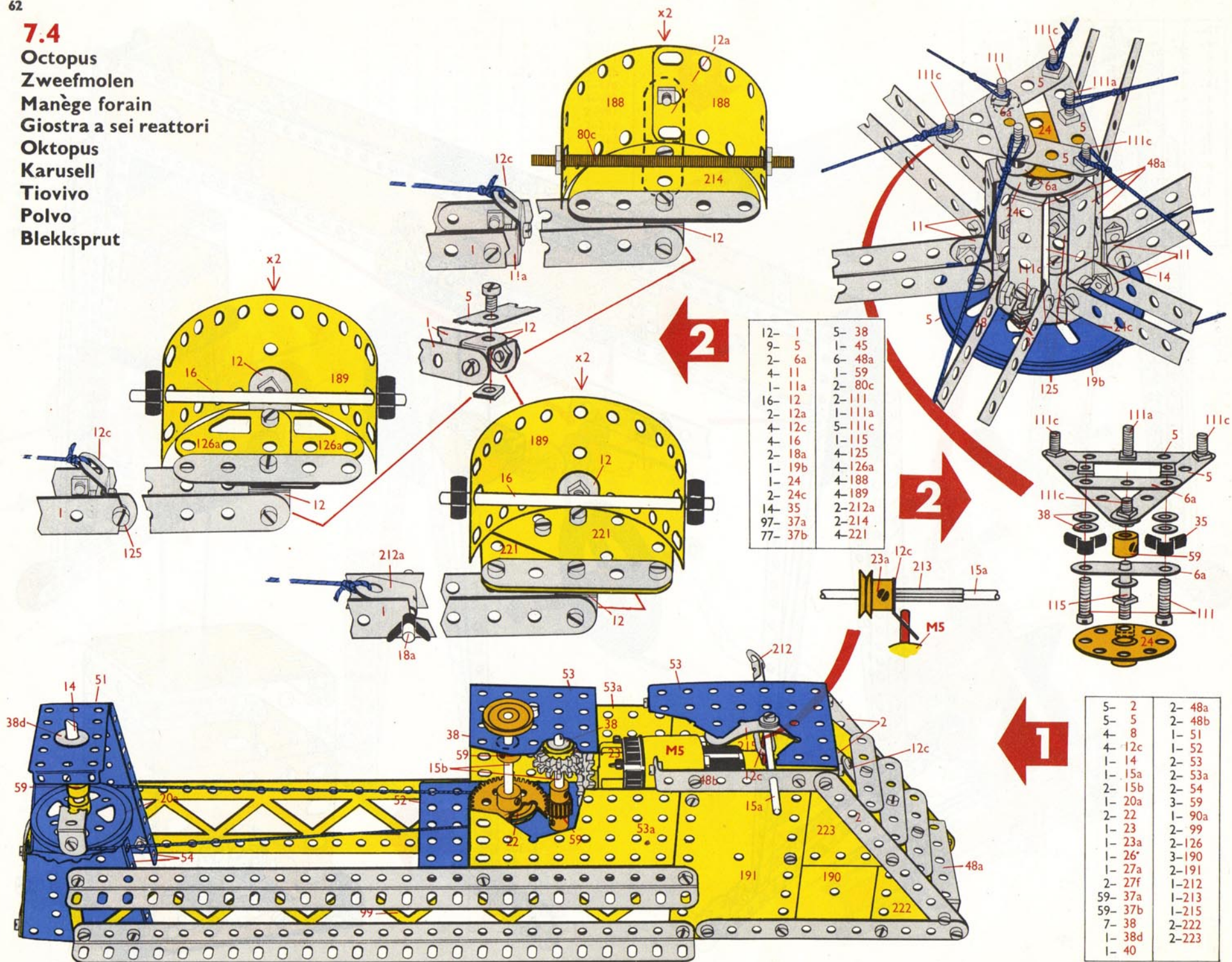

12-	1	5-	38
9-	5	1-	45
2-	6a	6-	48a
4-	11	1-	59
1-	11a	2-	80c
16-	12	2-	111
2-	12a	1-	111a
4-	12c	5-	111c
4-	16	1-	115
2-	18a	4-	125
1-	19b	4-	126a
1-	24	4-	188
2-	24c	4-	189
14-	35	2-	212a
97-	37a	2-	214
77-	37b	4-	221

5-	2	2-	48a
5-	5	2-	48b
4-	8	1-	51
4-	12c	1-	52
1-	14	2-	53
1-	15a	2-	53a
2-	15b	2-	54
1-	20a	3-	59
2-	22	1-	90a
1-	23	2-	99
1-	23a	2-	126
1-	26'	3-	190
1-	27a	2-	191
2-	27f	1-	212
59-	37a	1-	213
59-	37b	1-	215
7-	38	2-	222
1-	38d	2-	223
1-	40		

12- 1	1- 20a	8- 48a	2-126
5- 2	2- 22	2- 48b	4-126a
14- 5	1- 23	1- 51	4-188
2- 6a	1- 23a	1- 52	4-189
4- 8	1- 24	2- 53	3-190
4- 11	2- 24c	2- 53a	2-191
1- 11a	1- 26	2- 54	1-212
16- 12	1- 27a	4- 59	2-212a
2- 12a	2- 27f	2- 80c	1-213
8- 12c	14- 35	1- 90a	2-214
1- 14	156- 37a	2- 99	1-215
1- 15a	136- 37b	2-111	4-221
2- 15b	12- 38	1-111a	2-222
4- 16	1- 38d	5-111c	2-223
2- 18a	1- 40	1-115	*1-M5
1- 19b	1- 45	4-125	

*Not included in Set No. 7

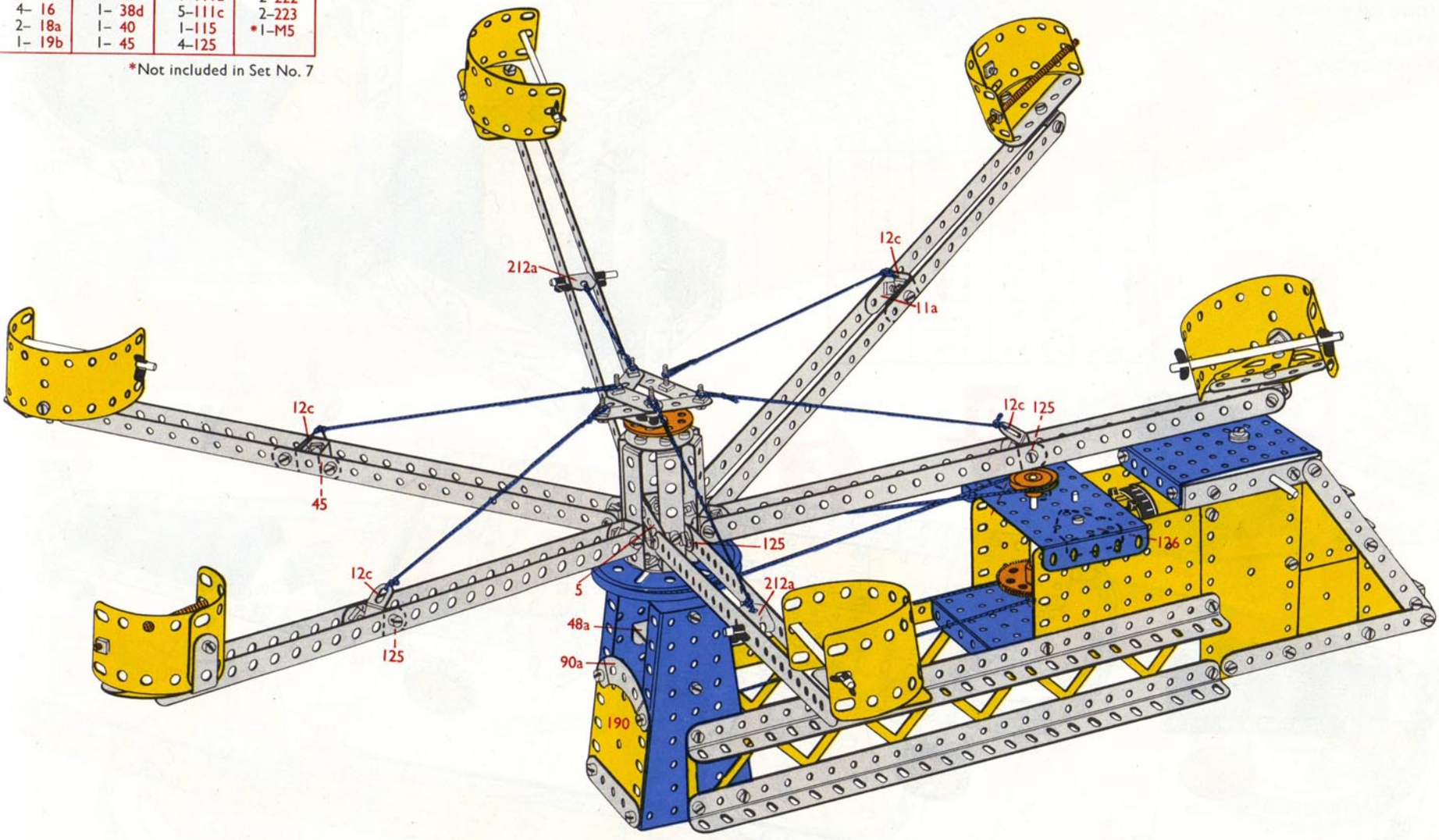

7.5

Naval Vessel
 Marinevaartuig
 Navire de guerre
 Nava da guerra
 Schiff
 Krigsfartyg
 Buque de guerra
 Navio
 Marinefartøy

2-	5	1-	52
6-	10	2-	53
1-	11	1-	80c
1-	11a	2-	90a
5-	12	2-	111a
1-	18a	3-	111c
6-	35	4-	188
34-	37a	1-	193
29-	37b	1-	212
7-	38	1-	212a
4-	48a	2-	215
2-	48b	2-	221

8-	1	1-	18a	2-	54	1-	199
14-	2	1-	20a	1-	90a	1-	212
4-	3	4-	22	3-	111c	1-	212a
9-	5	2-	24	2-	126a	2-	215
3-	6a	1-	24c	4-	142c	2-	221
4-	8	4-	35	4-	189	2-	222
2-	11	114-	37a	4-	190	2-	223
3-	12	111-	37b	2-	191		
2-	12a	11-	38	2-	192		
6-	12c	1-	48a	2-	194		
2-	15	1-	51	2-	194a		
1-	16	2-	53a	2-	197		

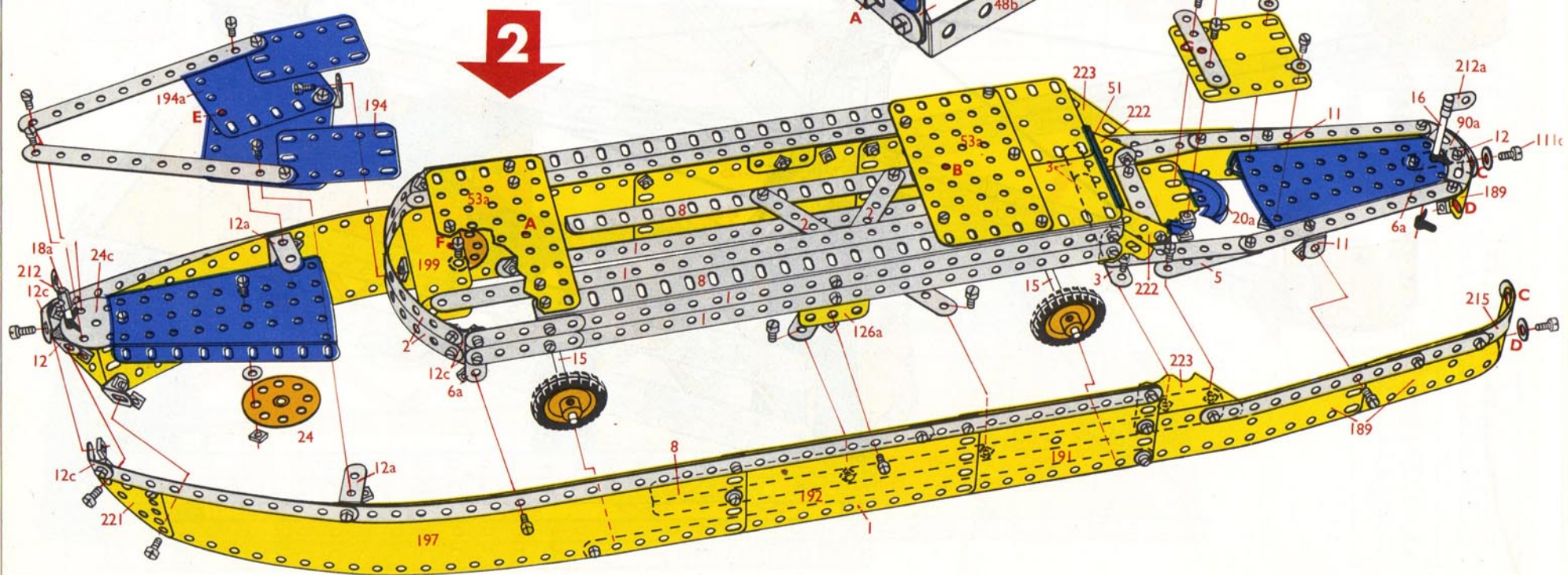
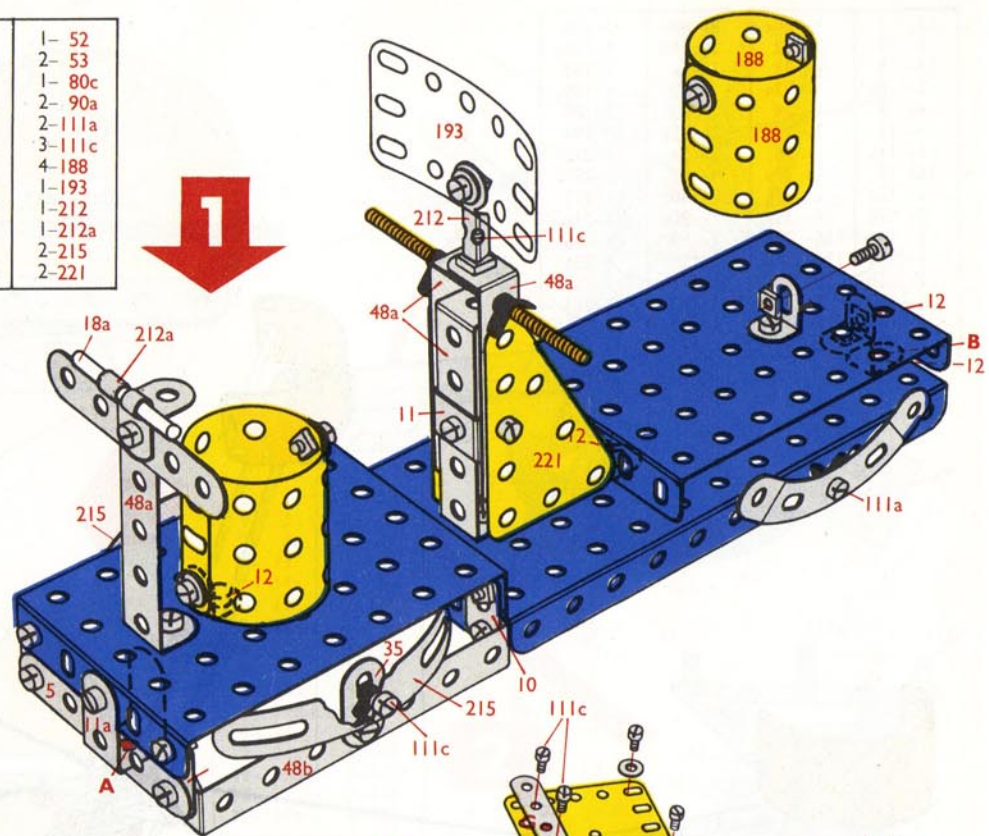

8- 1	1- 16	8- 48a	4- 125	2- 194a
14- 2	2- 17	2- 48b	2- 126	2- 197
4- 3	3- 18a	1- 51	4- 126a	1- 199
2- 4	1- 20a	1- 52	4- 142c	2- 212
13- 5	4- 22	2- 53	1- 147b	2- 212a
4- 6a	2- 24	2- 53a	1- 186	2- 213
4- 8	2- 24c	2- 54	3- 187	2- 214
7- 10	10- 35	4- 59	4- 188	4- 215
4- 11	170- 37a	1- 80c	4- 189	4- 221
1- 11a	157- 37b	3- 90a	4- 190	2- 222
10- 12	25- 38	2- 111	2- 191	2- 223
2- 12a	2- 38d	4- 111a	2- 192	
6- 12c		1- 45	1- 193	
2- 15	2- 48	1- 115	2- 194	

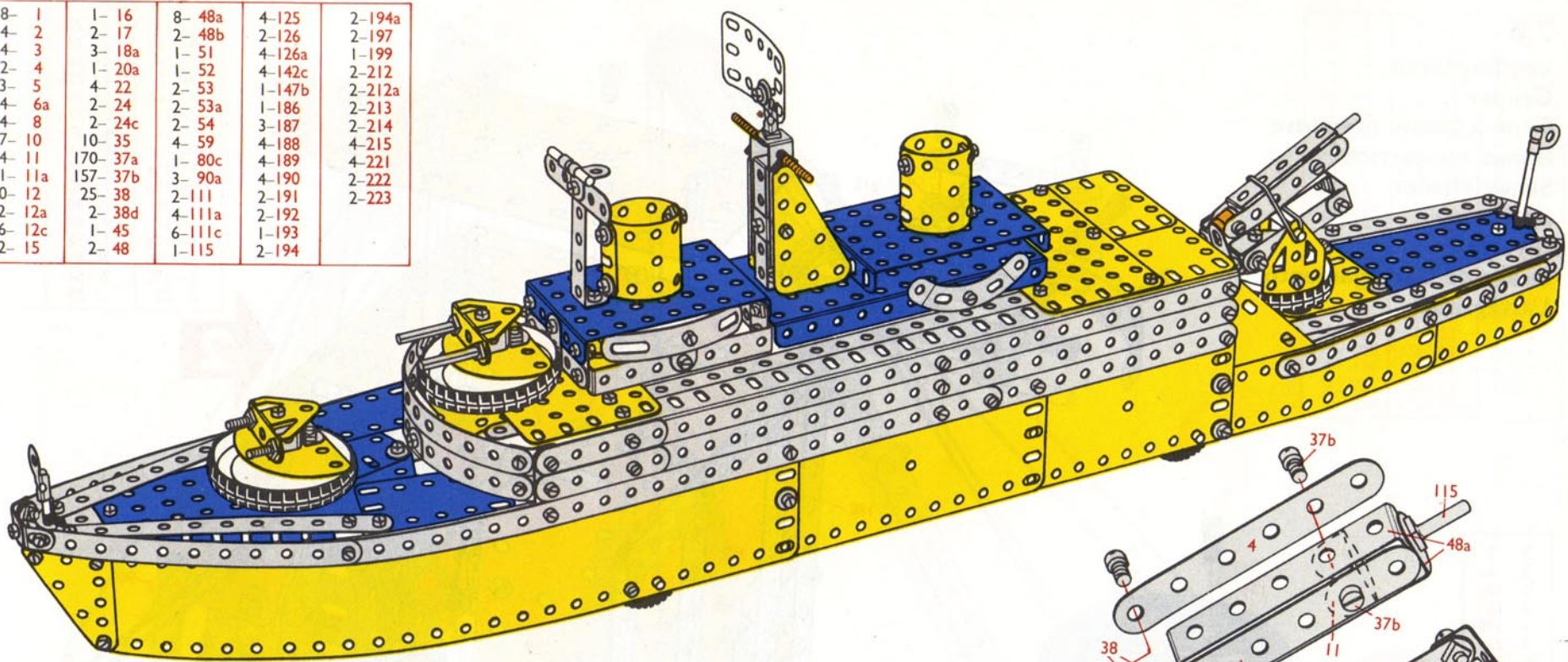

2- 4	2- 18a	2- 48	2- 126
2- 5	1- 24c	3- 48a	2- 126a
1- 6a	22- 37a	4- 59	1- 147b
1- 10	20- 37b	2- 111	1- 186
1- 11	7- 38	2- 111a	3- 187
2- 12	2- 38d	1- 115	2- 213
2- 17	1- 45	4- 125	2- 214

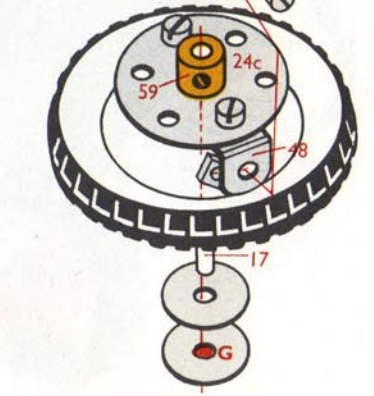
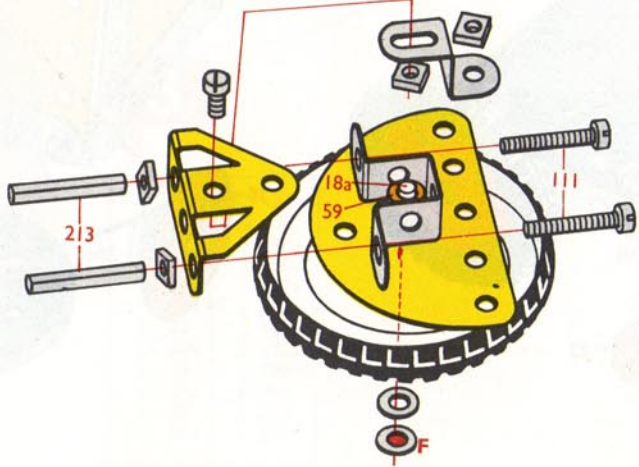
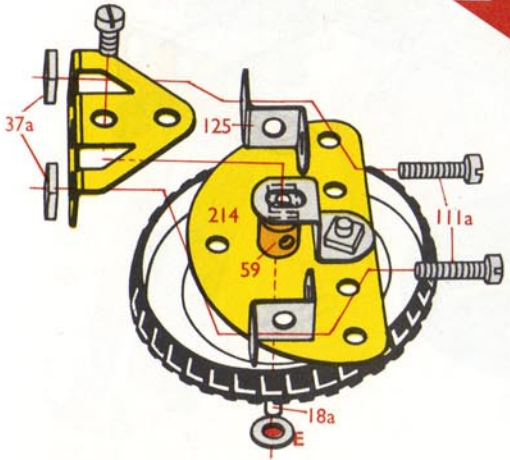
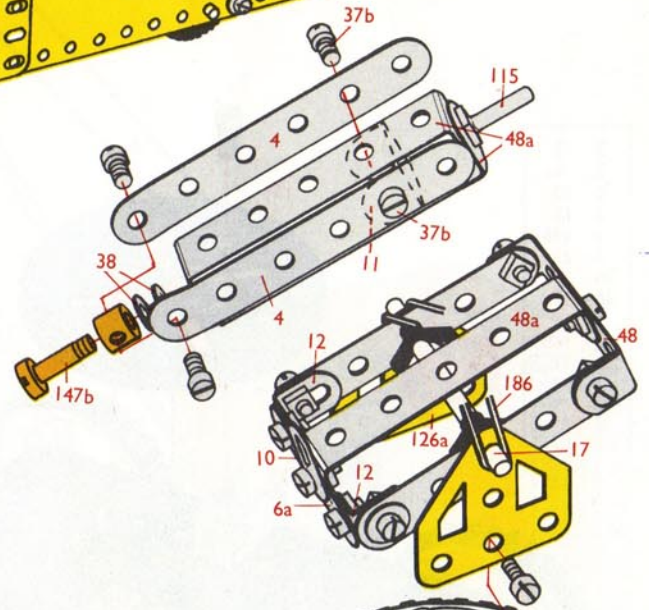

7.6

Loading Grab

Grijper

Grue à benne preneuse

Benna caricatrice

Schaufellader

Lastskopa

Bivalva

Draga de Carregamento

Lastgrab

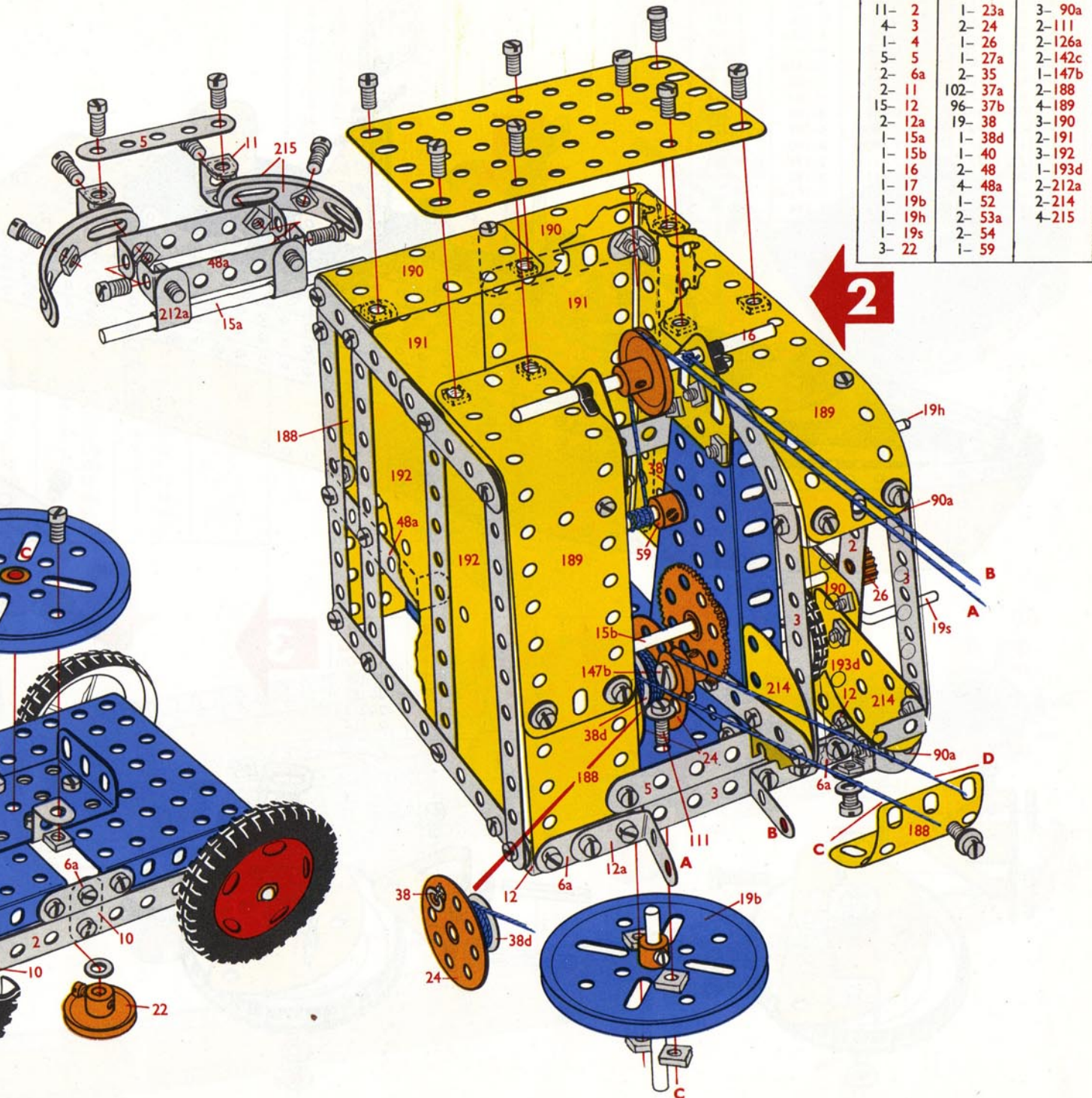

11- 2	1- 23a	3- 90a
4- 3	2- 24	2-111
1- 4	1- 26	2-126a
5- 5	1- 27a	2-142c
2- 6a	2- 35	1-147b
2- 11	102- 37a	2-188
15- 12	96- 37b	4-189
2- 12a	19- 38	3-190
1- 15a	1- 38d	2-191
1- 15b	1- 40	3-192
1- 16	2- 48	1-193d
1- 17	4- 48a	2-212a
1- 19b	1- 52	2-214
1- 19h	2- 53a	4-215
1- 19s	2- 54	
3- 22	1- 59	

2- 2
2- 6a
6- 10
2- 15
1- 19b
1- 22
26- 37a
26- 37b
5- 38
2- 48b
1- 51
2- 53
2-125
4-187

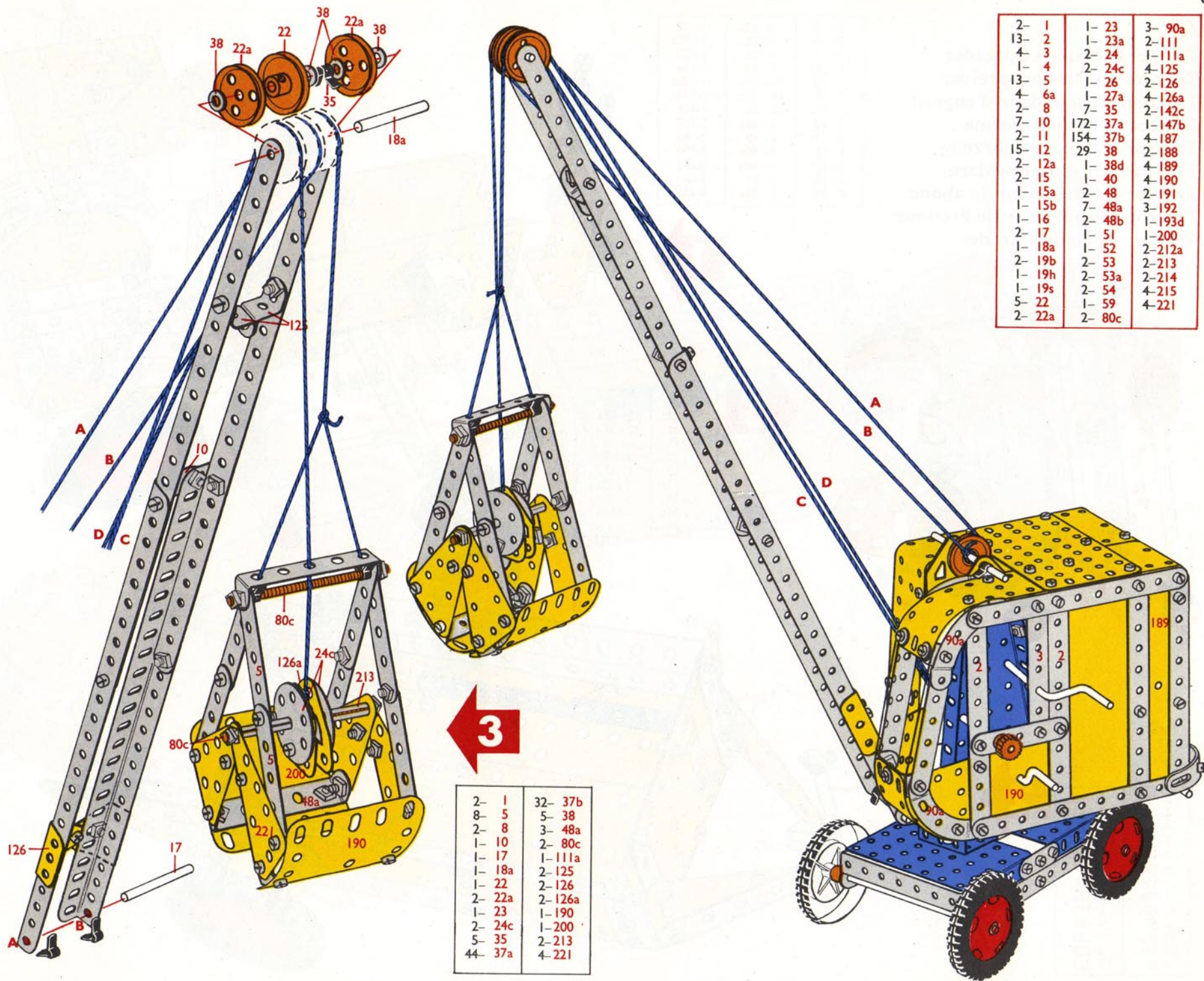

2-	1	1-	23	3-	90a
13-	2	1-	23a	2-	111
4-	3	2-	24	1-	111a
1-	4	2-	24c	4-	125
13-	5	1-	26	4-	126
4-	6a	1-	27a	4-	126a
2-	8	7-	35	2-	142c
7-	10	172-	37a	1-	147b
2-	11	154-	37b	4-	187
15-	12	29-	38	2-	188
2-	12a	1-	38d	4-	189
2-	15	1-	40	4-	190
1-	15a	2-	48	2-	191
1-	15b	7-	48a	3-	192
1-	16	2-	48b	1-	193d
2-	17	1-	51	1-	200
1-	18a	1-	52	2-	212a
2-	19b	2-	53	2-	213
1-	19h	2-	53a	2-	214
1-	19s	2-	54	4-	215
5-	22	1-	59	4-	221
2-	22a	2-	80c		

3

2-	1	32-	37b
8-	5	5-	38
2-	8	3-	48a
1-	10	2-	80c
1-	17	1-	111a
1-	18a	2-	125
1-	22	2-	126
2-	22a	2-	126a
1-	23	1-	190
2-	24c	1-	200
5-	35	2-	213
44-	37a	4-	221

7.7**Tractor & Manure Spreader****Trekker en mestverspreider****Tracteur et épandeur d'engrais****Trattore e spandiconcime****Traktor und Düngefahrzeug****Traktor och gödselspridare****Tractor y distribuidor de abono****Tractor e Espalhador de Estrume****Traktor og gjødselspreder**

2- 2	1- 22a	3- 59
2- 3	1- 23a	1- 90a
1- 5	1- 24	1-125
1- 6a	2- 27f	2-126
1- 10	70- 37a	1-126a
1- 11	66- 37b	2-142c
1- 11a	20- 38	1-186
9- 12	2- 38d	2-187
2- 12a	2- 48	2-188
1- 15	4- 48a	3-190
1- 15a	1- 48b	2-212
3- 16	1- 51	2-214
2- 22	2- 53a	4-215

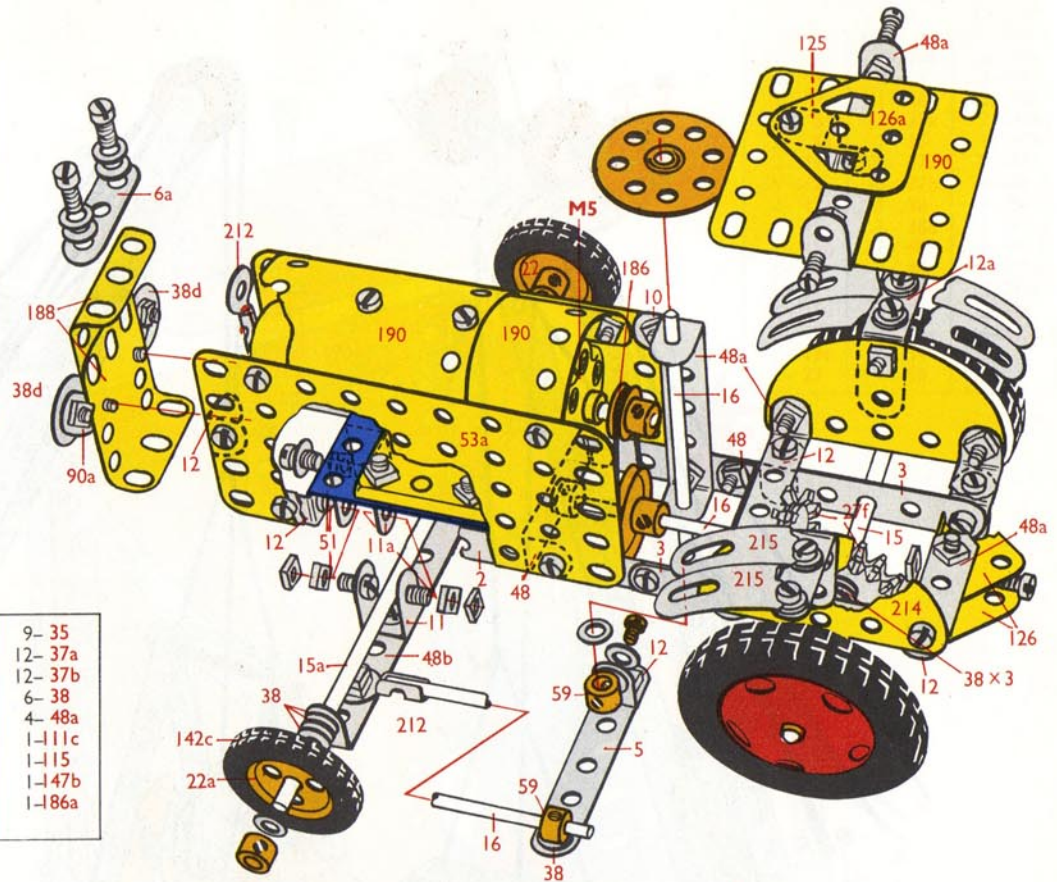

2- 11	9- 35
2- 15b	12- 37a
1- 16	12- 37b
1- 17	6- 38
3- 22	4- 48a
1- 23	1-111c
*1- 23a	1-115
1- 24	1-147b
2- 24c	1-186a
1- 26	

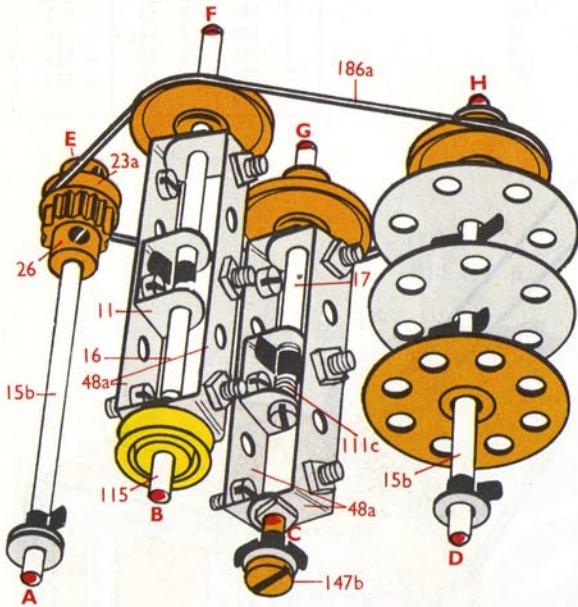

8- 2	1- 48b
2- 3	2- 53
6- 5	2- 90a
2- 6a	1-125
2-12	2-126a
8-12a	2-187
1-15	2-188
1-18a	3-189
1-27a	2-190
3-35	2-191
58-37a	4-221
58-37b	2-222
4-38	2-223

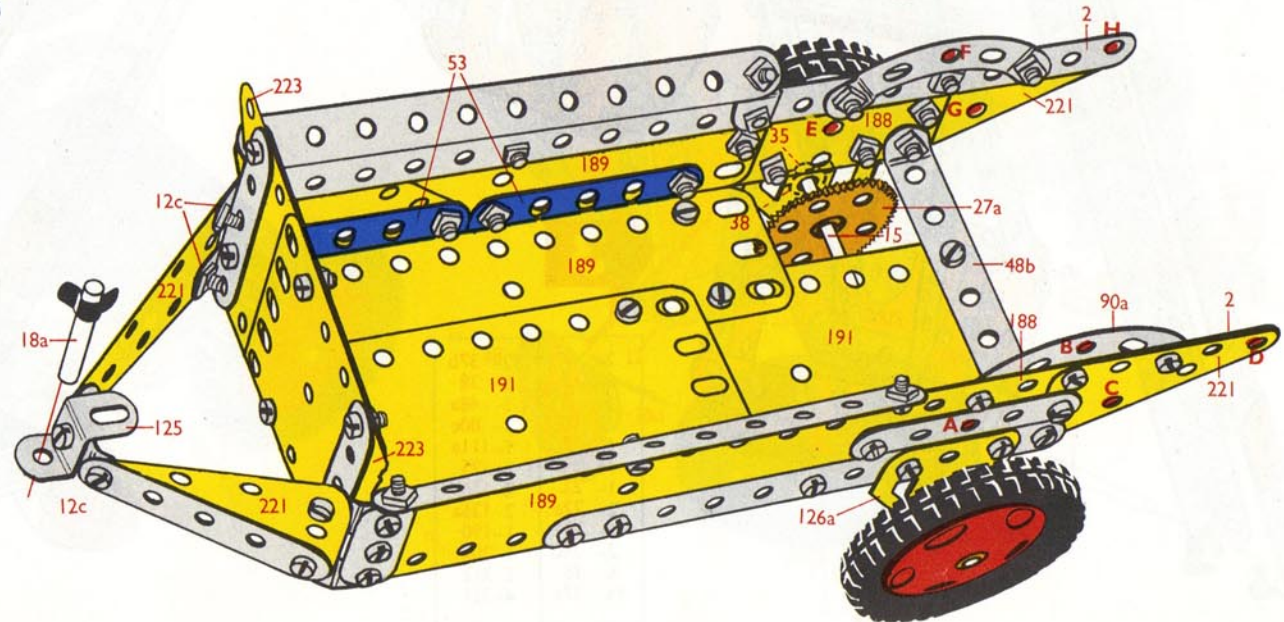

10- 2	2- 15b	1- 27a	2- 53a	4-187
4- 3	4- 16	2- 27f	3- 59	4-188
7- 5	1- 17	12- 35	3- 90a	3-189
3- 6a	1- 18a	140- 37a	1-111c	5-190
1- 10	5- 22	136- 37b	1-115	2-191
3- 11	1- 22a	30- 38	2-125	2-212
1- 11a	1- 23	2- 38d	2-126	2-214
11- 12	* 1- 23a	2- 48	3-126a	4-215
2- 12a	1- 23a	8- 48a	2-142c	4-221
8- 12c	2- 24	2- 48b	1-147b	2-222
2- 15	2- 24c	1- 51	1-186	2-223
1- 15a	1- 26	2- 53	1-186a	* 1-M5

* Not included in set No. 7

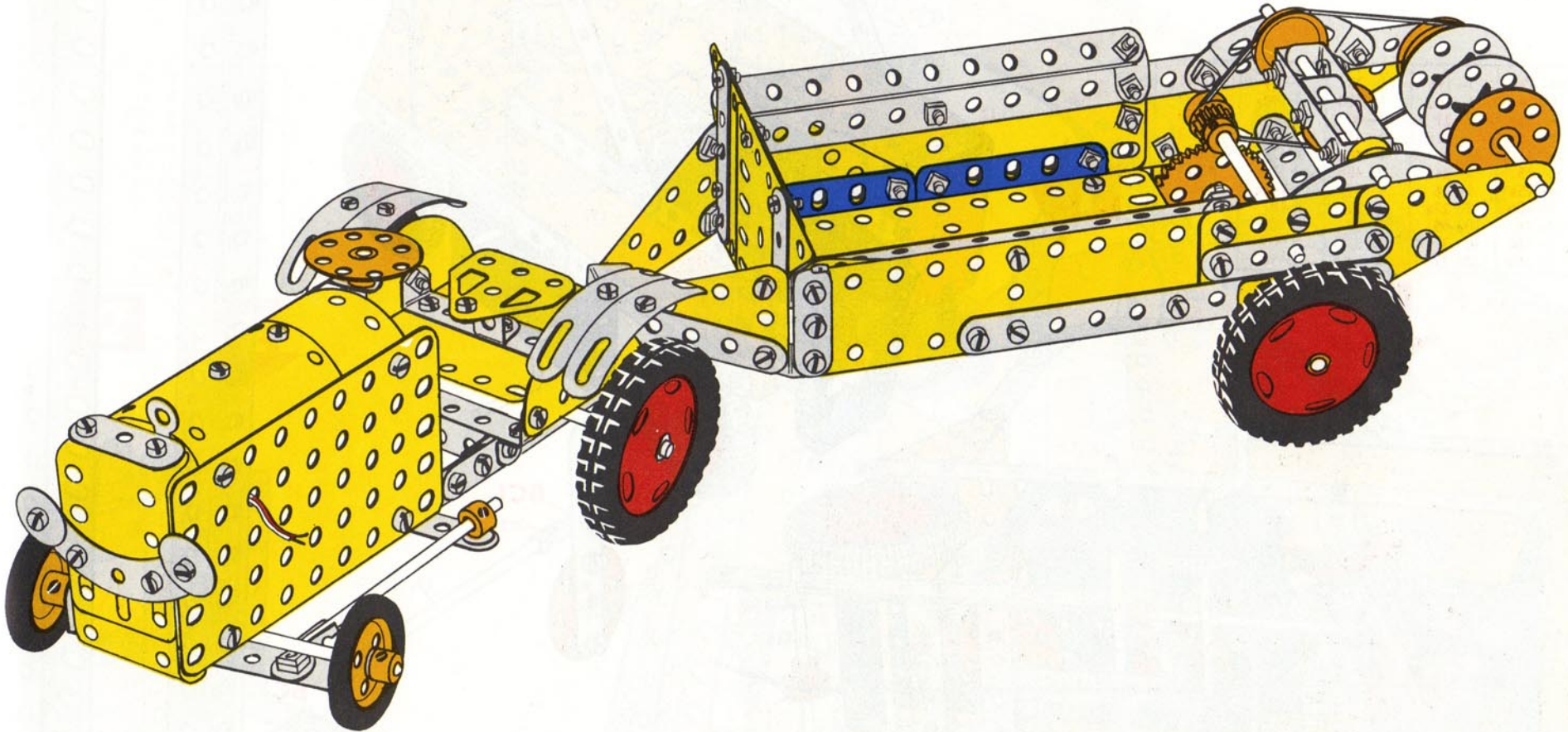

7.8

Fork Lift Truck

Vorkheftruck

Chariot à fourche

Carrello sollevatore a forca

Gabelstapler

Gaffeltruck

Carretilla elevadora de horquilla

Camião de Forquilha

Gaffeltruck

14- 2	1- 19h	11- 38	1- 59	2-191
1- 4	1- 20a	1- 38d	4- 90a	4-192
4- 5	2- 22	1- 40	3-111c	1-199
4- 6a	1- 23a	1- 45	4-125	1-212
14- 12	1- 24	8- 48a	2-126	2-213
2- 15	1- 24c	2- 48b	4-126a	4-221
1- 15a	1- 26	1- 51	1-142c	2-222
1- 15b	1- 27a	1- 52	4-187	
2- 16	10- 35	2- 53	4-188	
2- 18a	138- 37a	2- 53a	4-189	
1- 18b	127- 37b	2- 54	1-190	

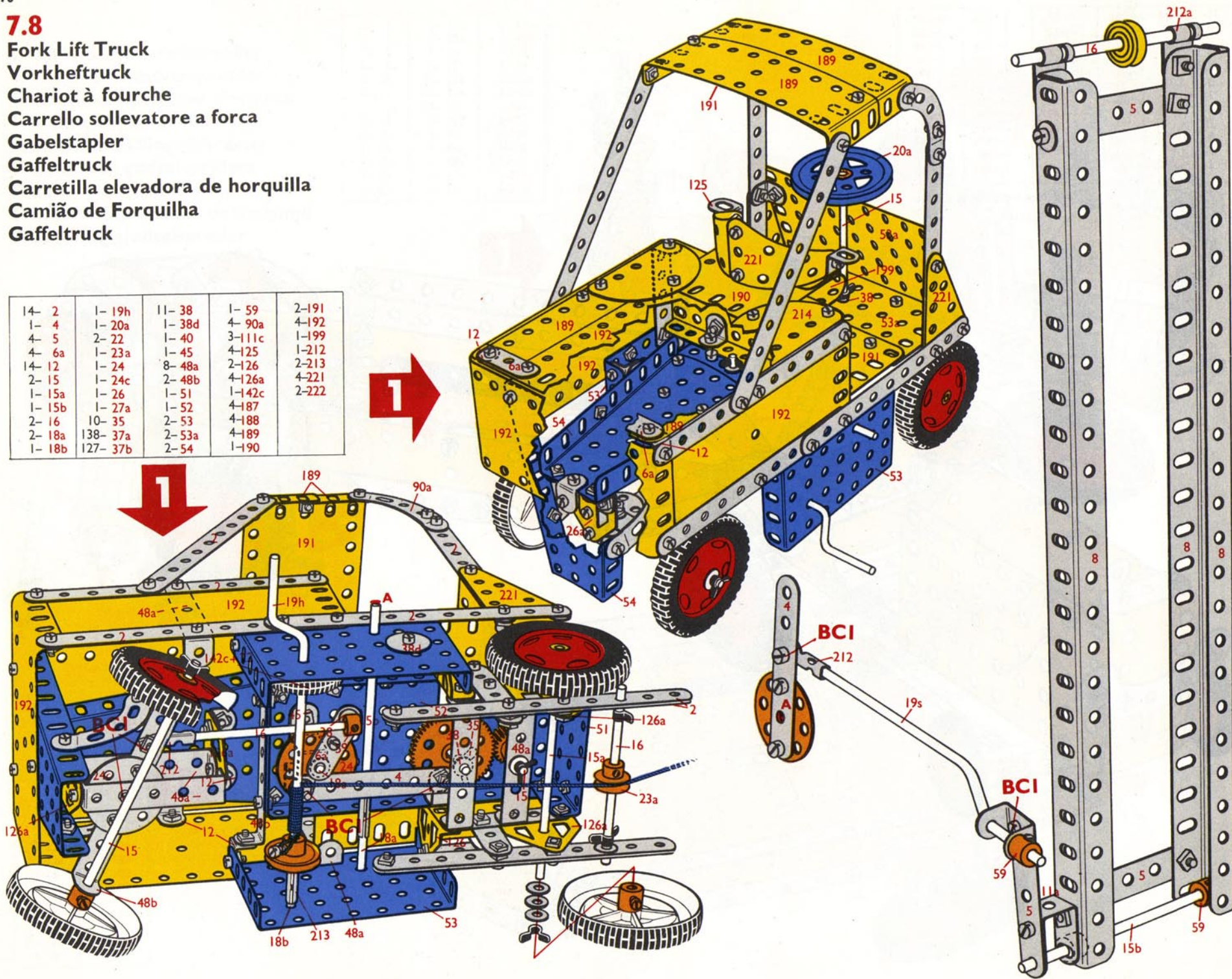

14- 2	2- 15b	1- 27a	2- 53	4- 188
4- 3	3- 16	10- 35	2- 53a	4- 189
2- 4	2- 18a	177- 37a	2- 54	1- 190
14- 5	1- 18b	164- 37b	4- 59	2- 191
4- 6a	1- 19h	15- 38	4- 90a	4- 192
4- 8	1- 19s	1- 38d	1- 111a	1- 199
2- 10	1- 20a	1- 40	3- 111c	2- 212
4- 11	2- 22	1- 45	1- 115	2- 212a
1- 11a	1- 23	2- 48	4- 125	2- 213
14- 12	1- 23a	8- 48a	2- 126	4- 221
2- 12a	2- 24	2- 48b	4- 126a	2- 222
2- 15	1- 24c	1- 51	1- 142c	
1- 15a	1- 26	1- 52	4- 187	

4- 3	1- 24
1- 4	39- 37a
10- 5	37- 37b
4- 8	4- 38
2- 10	2- 48
4- 11	3- 59
1- 11a	1- 111a
2- 12a	1- 115
1- 15b	1- 212
1- 16	2- 212a
1- 19s	
1- 23	

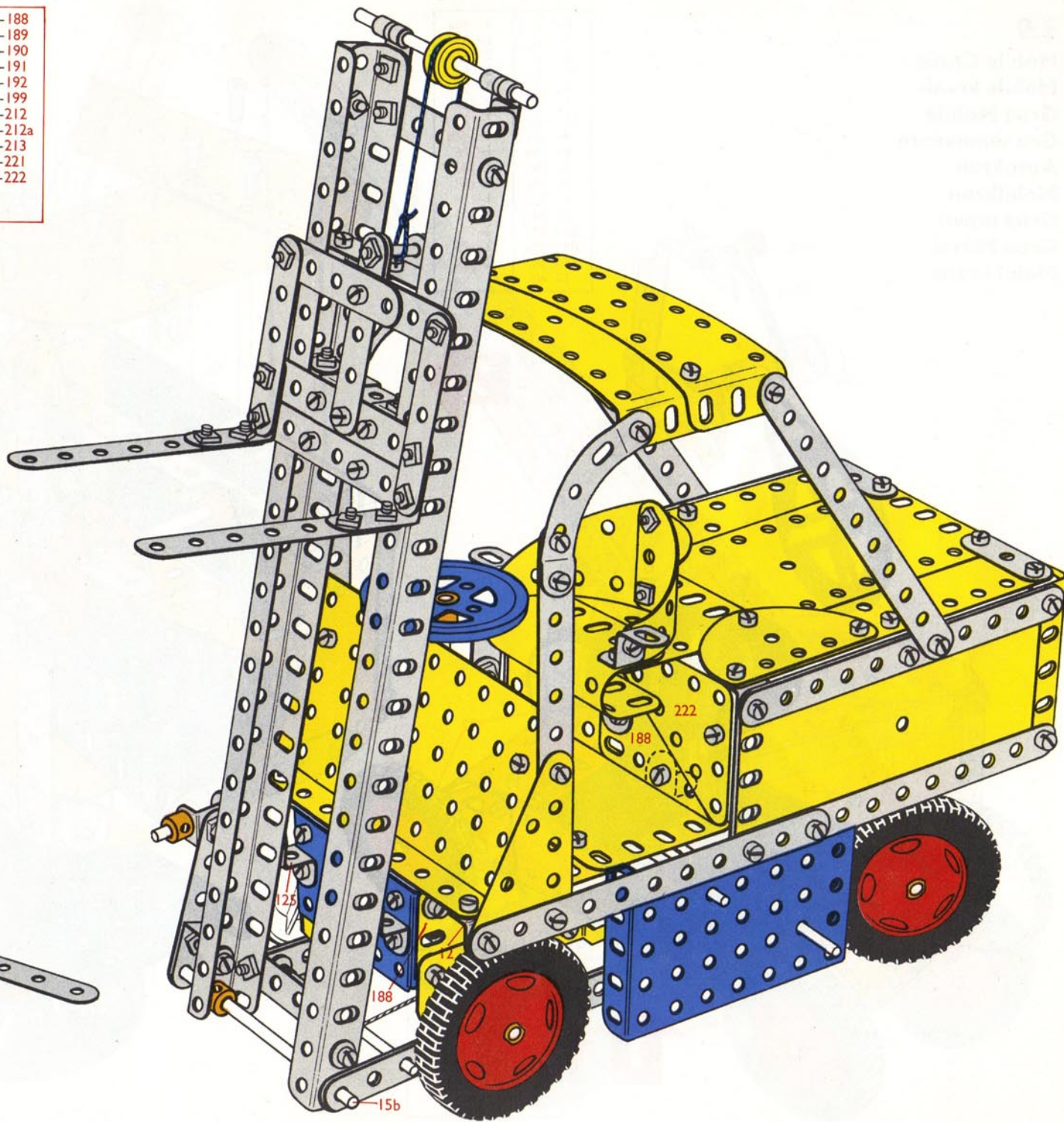
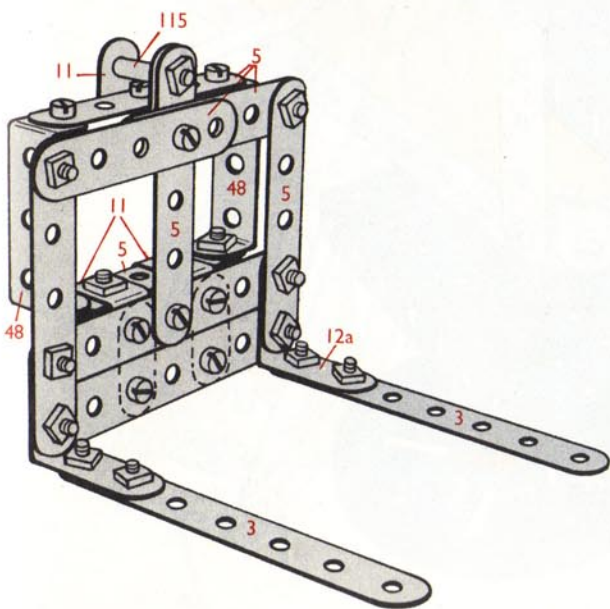

7.9

Mobile Crane
 Mobile kraan
 Grue Mobile
 Gru semovente
 Autokran
 Mobilkran
 Grúa móvil
 Grua Móvel
 Mobil kran

6-	2	8-	48a
4-	3	2-	53
2-	4	2-	53a
11-	5	2-	54
3-	10	3-	59
1-	11a	2-	111
11-	12	2-	126
4-	12c	1-	147b
1-	19b	1-	176
1-	19h	1-	186
1-	19s	2-	188
1-	20a	1-	189
2-	24	1-	190
86-	37a	2-	191
84-	37b	2-	192
15-	38	2-	214
1-	40		

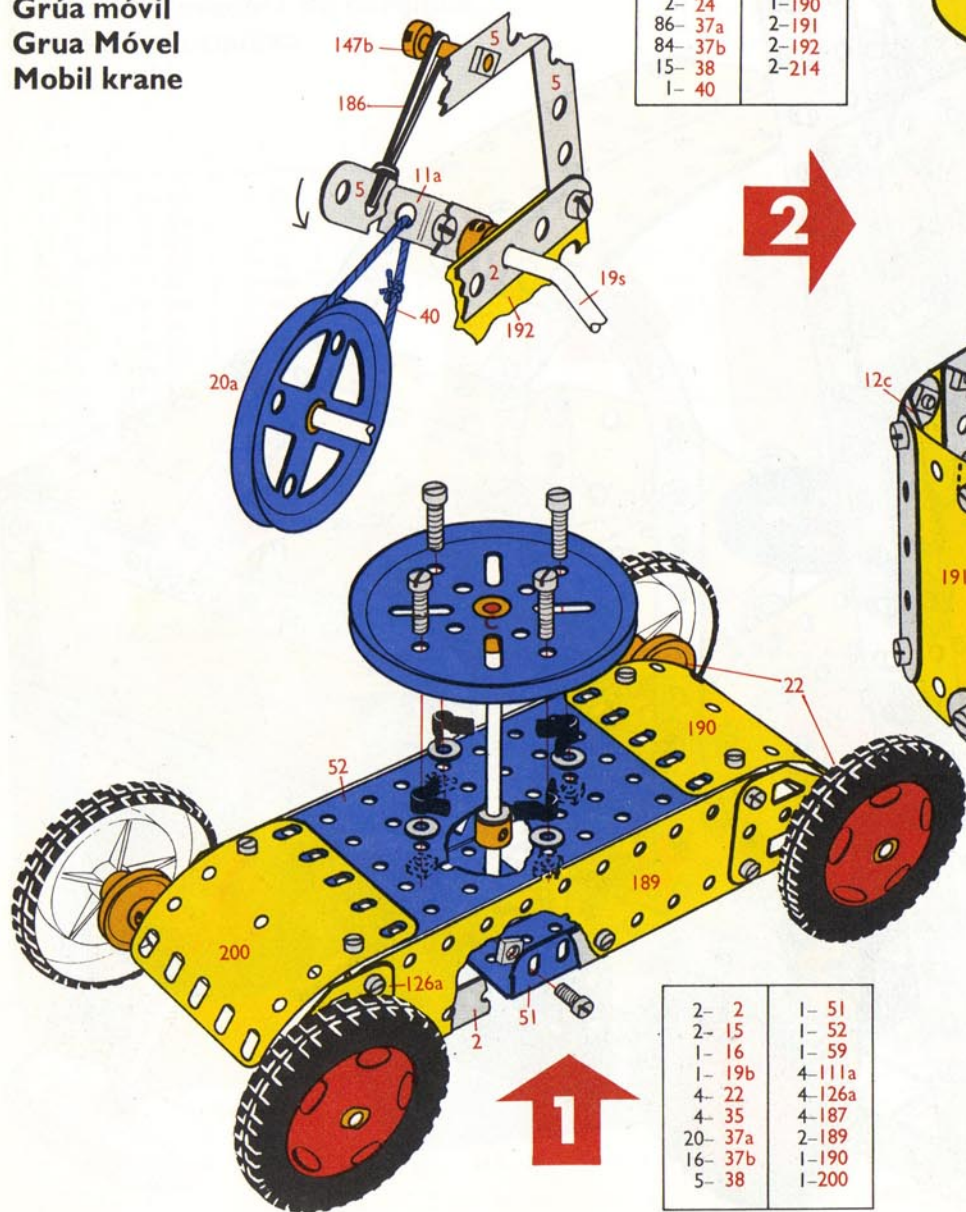

1

2-	2	1-	51
2-	15	1-	52
1-	16	1-	59
1-	19b	4-	111a
4-	22	4-	126a
4-	35	4-	187
20-	37a	2-	189
16-	37b	1-	190
5-	38	1-	200

2

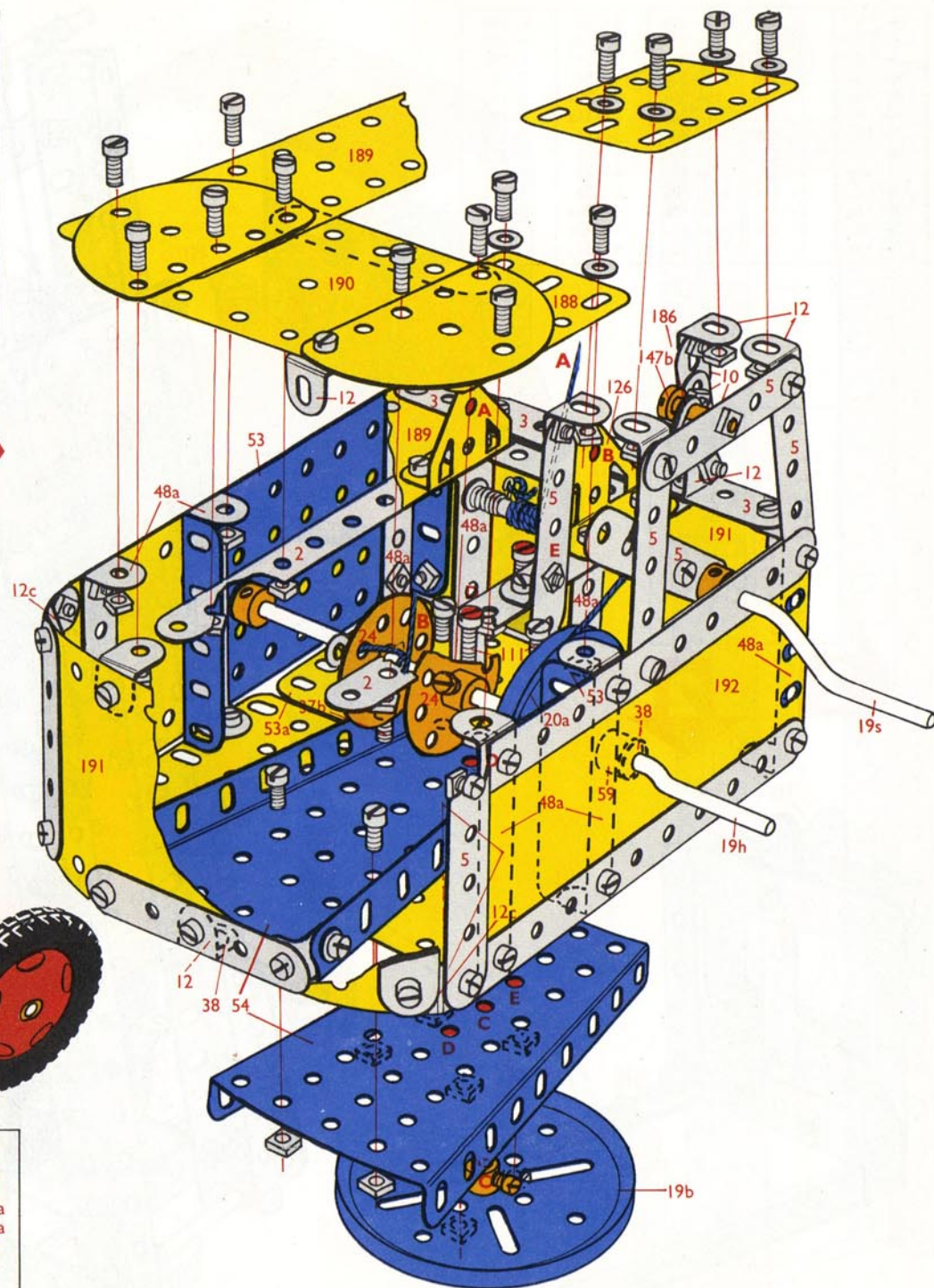

4- 1	1- 18b	24- 38	2- 126
10- 2	2- 19b	1- 40	4- 126a
4- 3	1- 19h	2- 48	1- 147b
2- 4	1- 19s	8- 48a	1- 176
13- 5	1- 20a	1- 51	1- 186
4- 6a	4- 22	1- 52	4- 187
5- 10	1- 22a	2- 53	2- 188
1- 11	1- 23	2- 53a	3- 189
1- 11a	1- 23a	2- 54	2- 190
13- 12	2- 24	1- 57c	2- 191
4- 12c	2- 24c	4- 59	2- 192
2- 15	8- 35	2- 111	1- 200
1- 16	127- 37a	4- 111a	2- 214
2- 17	119- 37b	2- 111c	2- 222

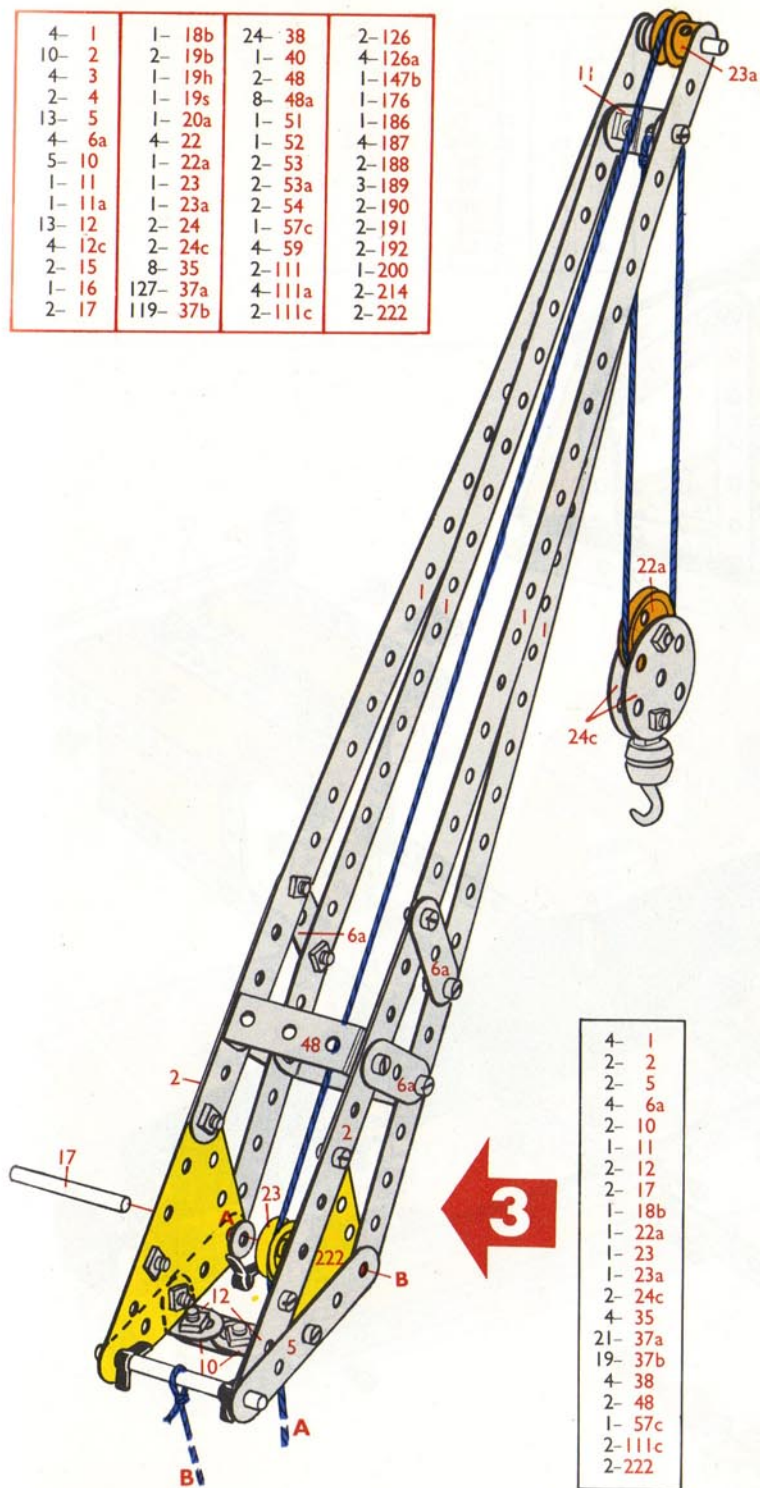

4- 1
2- 2
2- 5
4- 6a
2- 10
1- 11
2- 12
2- 17
1- 18b
1- 22a
1- 23
1- 23a
2- 24c
4- 35
21- 37a
19- 37b
4- 38
2- 48
1- 57c
2- 111c
2- 222

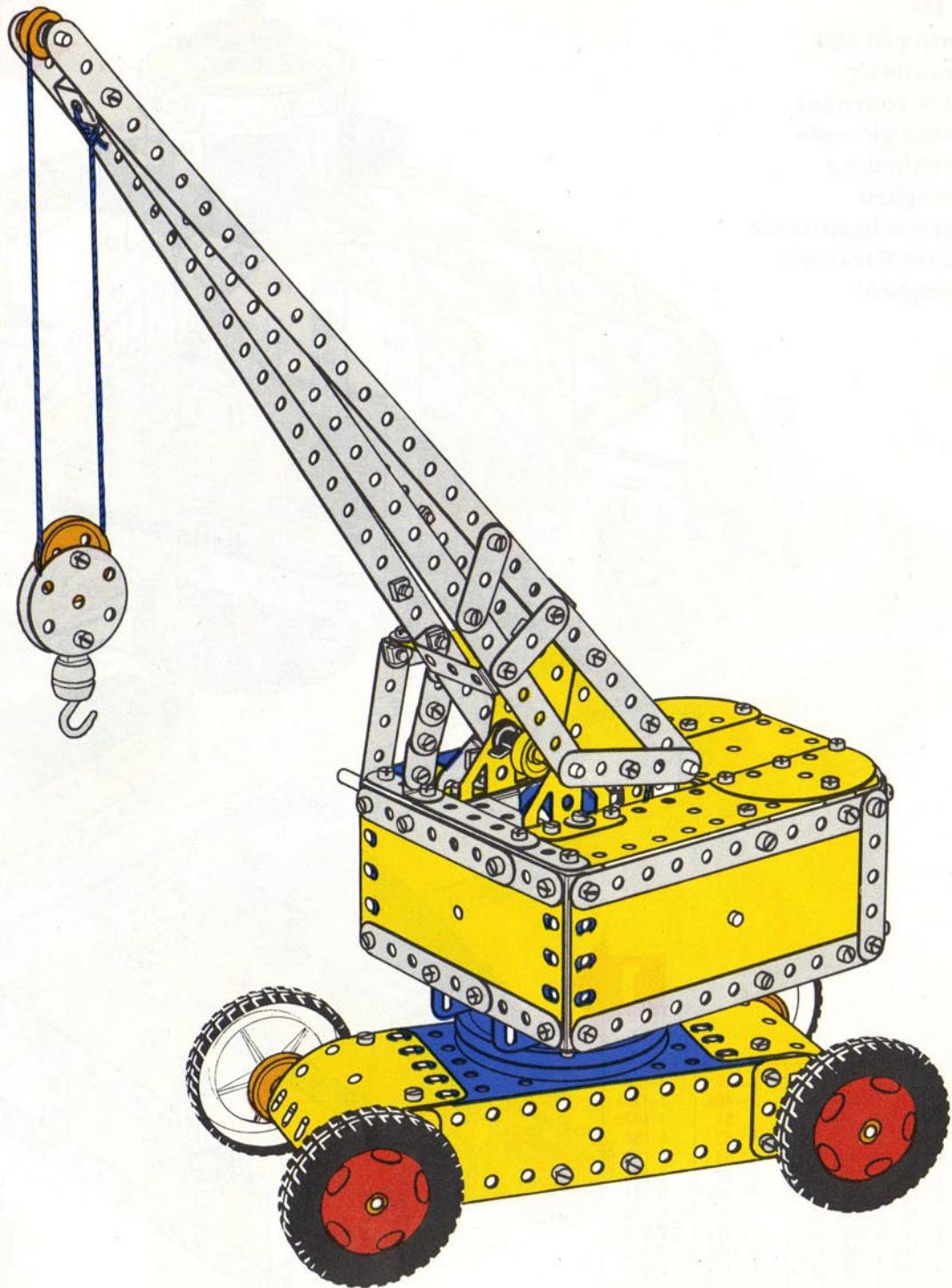

7.10

Swing Bridge
 Draaibrug
 Pont tournant
 Ponte girevole
 Drehbrücke
 Svängbro
 Puente basculante
 Ponte Giratória
 Svingbro

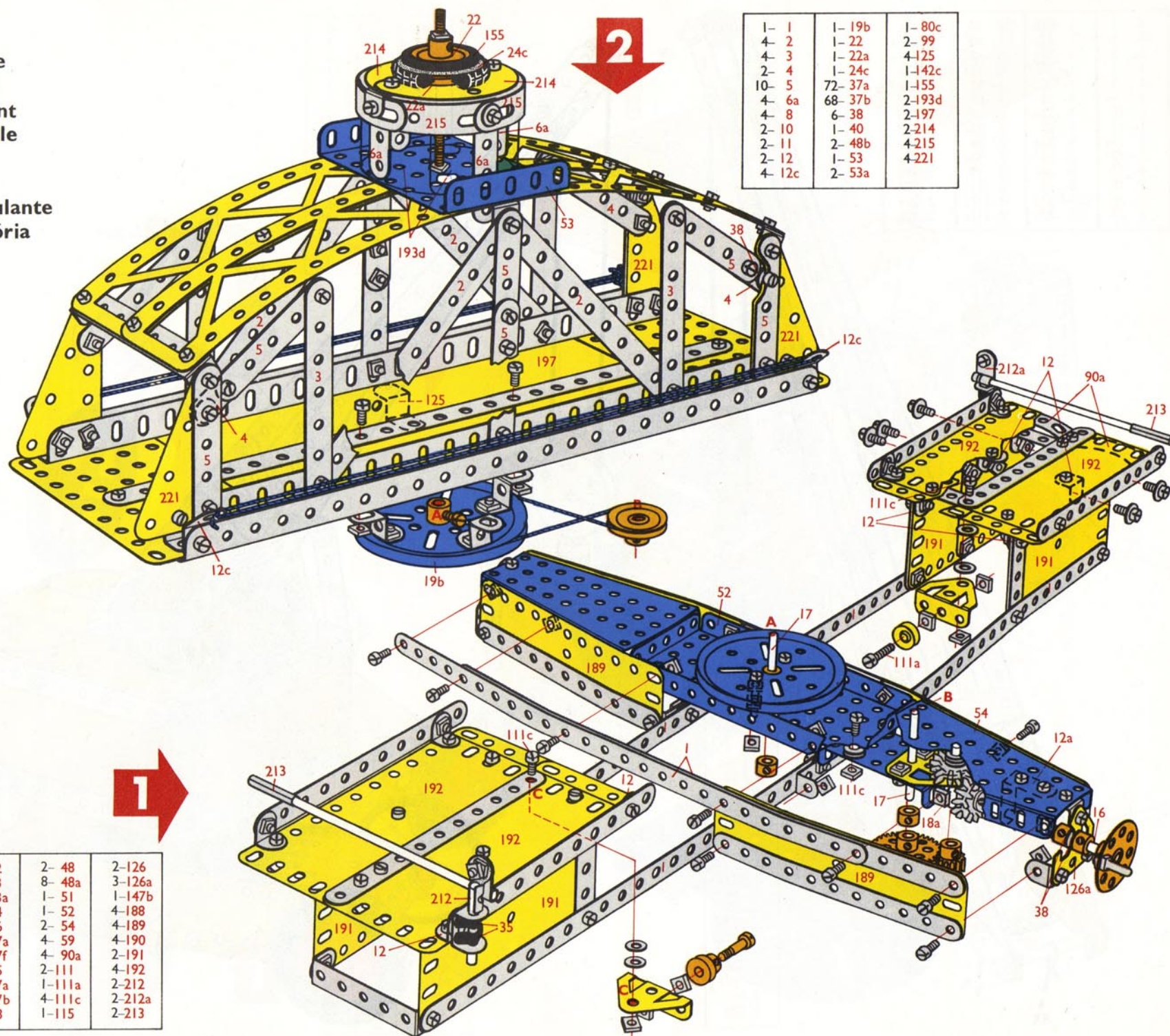

1- 1	1- 19b	1- 80c
4- 2	1- 22	2- 99
4- 3	1- 22a	4-125
2- 4	1- 24c	1-142c
10- 5	72- 37a	1-155
4- 6a	68- 37b	2-193d
4- 8	6- 38	2-197
2- 10	1- 40	2-214
2- 11	2- 48b	4-215
2- 12	1- 53	4-221
4- 12c	2- 53a	

8- 1	1- 22	2- 48	2-126
10- 2	1- 23	8- 48a	3-126a
4- 5	1- 23a	1- 51	1-147b
2- 11	1- 24	1- 52	4-188
14- 12	1- 26	2- 54	4-189
1- 12a	1- 27a	4- 59	4-190
2- 15	2- 27f	4- 90a	2-191
1- 16	4- 35	2-111	4-192
2- 17	102- 37a	1-111a	2-212
3- 18a	90- 37b	4-111c	2-212a
1- 19b	20- 38	1-115	2-213

9- 1	2- 17	158- 37b	2- 99	2- 191
14- 2	3- 18a	26- 38	2- 111	4- 192
4- 3	2- 19b	1- 40	1- 111a	2- 193d
2- 4	2- 22	2- 48	4- 111c	2- 197
14- 5	1- 22a	8- 48a	1- 115	2- 212
4- 6a	1- 23	2- 48b	4- 125	2- 212a
4- 8	1- 23a	1- 51	2- 126	2- 213
2- 10	1- 24	1- 52	3- 126a	2- 214
4- 11	1- 24c	1- 53	1- 142c	4- 215
16- 12	1- 26	2- 53a	1- 147b	4- 221
1- 12a	1- 27a	2- 54	1- 155	
4- 12c	2- 27f	4- 59	4- 188	
2- 15	4- 35	1- 80c	4- 189	
1- 16	174- 37a	4- 90a	4- 190	

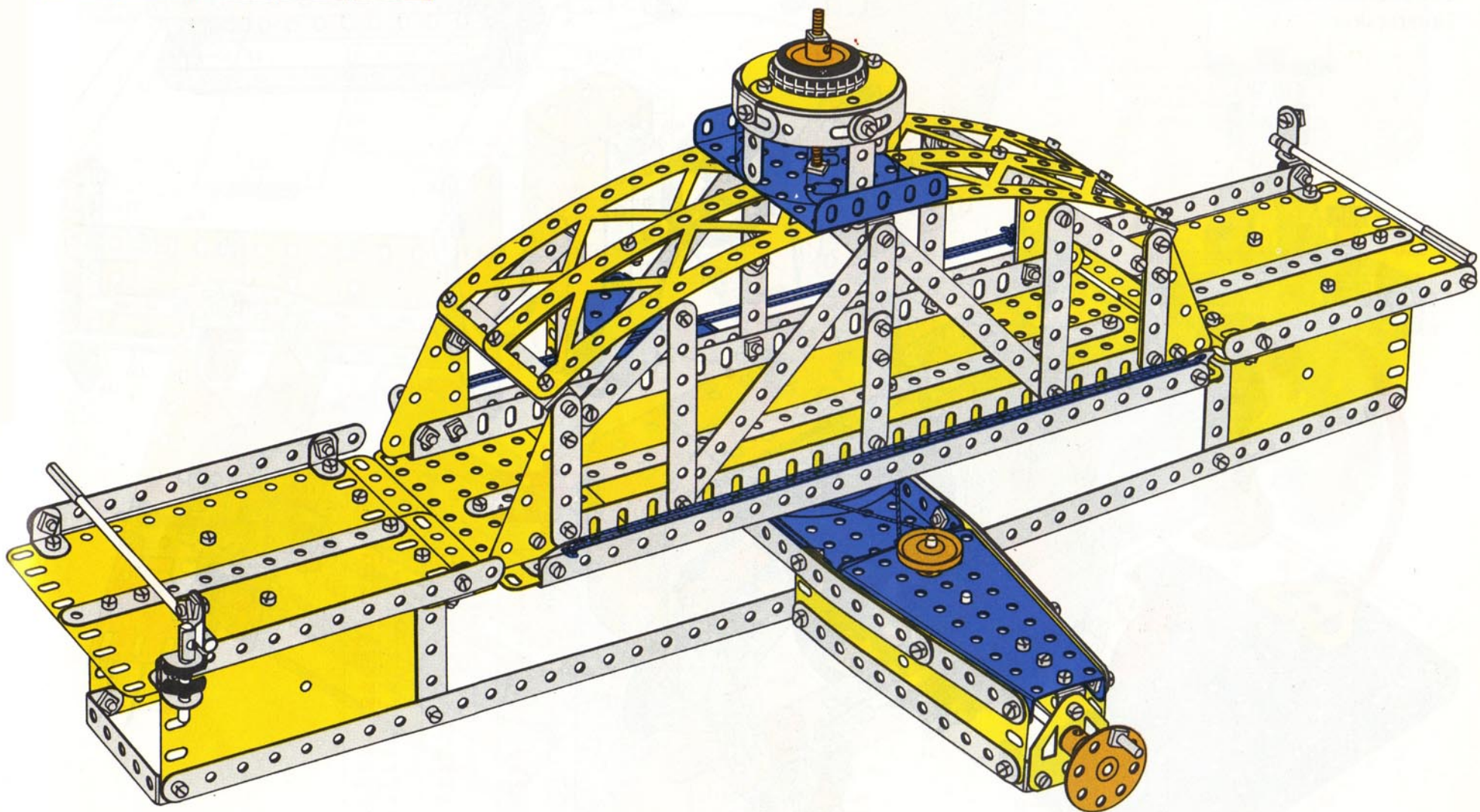

7.11

Combine Harvester
 Maaidorsmachine
 Moissonneuse-batteuse
 Mietitrebbia
 Mähdrescher
 Skördetröska
 Cosechadora
 Ceifadora/Debulhadora
 Skurtresker

10- 2	2- 15b	71- 37b	1- 186a
2- 3	2- 16	10- 38	4- 188
6- 5	1- 18a	2- 48	2- 189
2- 6a	3- 22	6- 48a	4- 190
8- 10	1- 23	2- 59	2- 213
1- 11a	1- 23a	1- 80c	2- 214
8- 12	2- 24c	3- 90a	
2- 12a	4- 35	1- 111	
1- 15a	78- 37a	2- 111a	

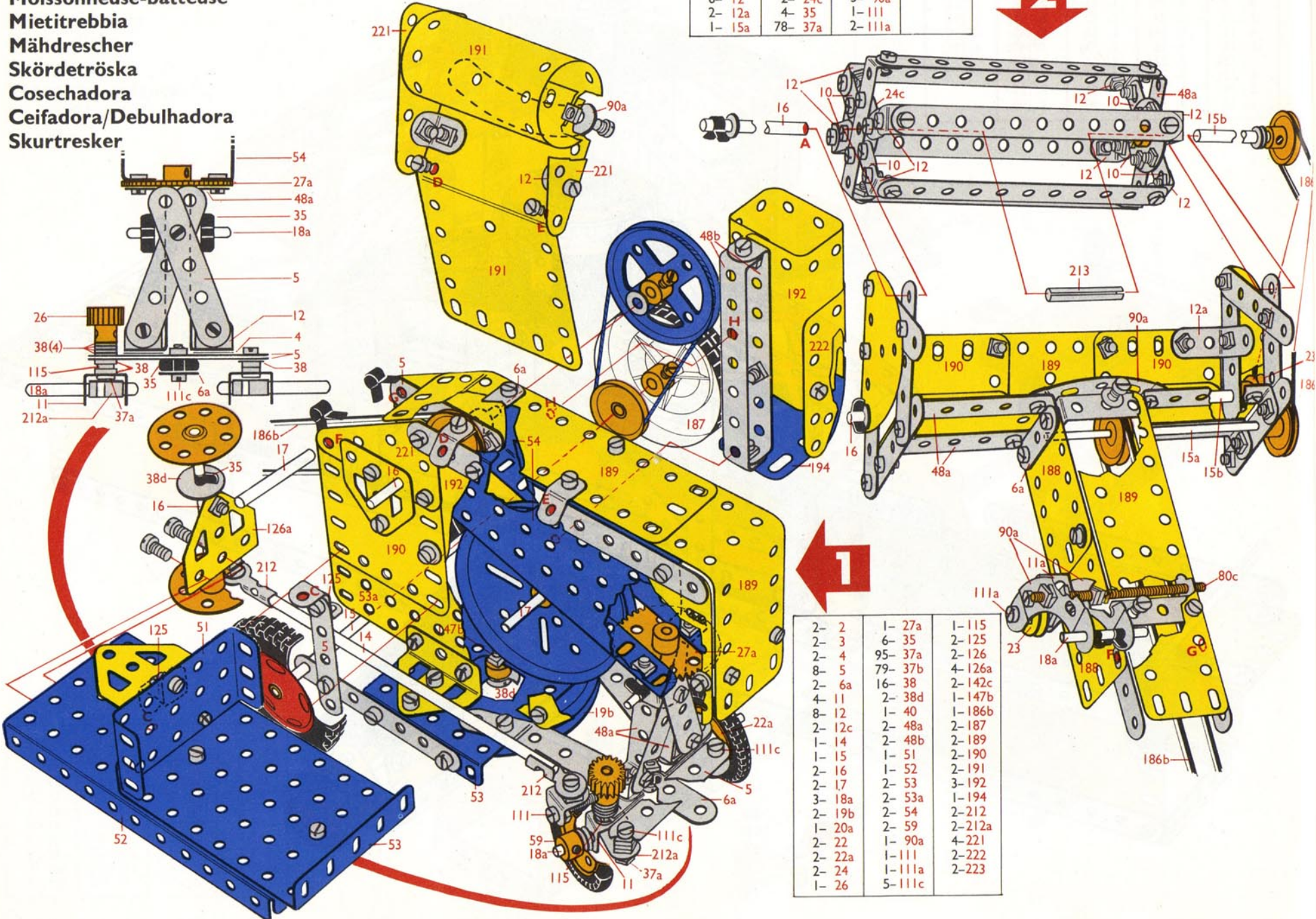

2- 2	1- 27a	1- 115
2- 3	6- 35	2- 125
2- 4	95- 37a	2- 126
8- 5	79- 37b	4- 126a
2- 6a	16- 38	2- 142c
4- 11	2- 38d	1- 147b
8- 12	1- 40	1- 186b
2- 12c	2- 48a	2- 187
1- 14	2- 48b	2- 189
1- 15	1- 51	2- 190
2- 16	1- 52	2- 191
2- 17	2- 53	3- 192
3- 18a	2- 53a	1- 194
2- 19b	2- 54	2- 212
1- 20a	2- 59	2- 212a
2- 22	1- 90a	4- 221
2- 22a	1- 111	2- 222
2- 24	1- 111a	2- 223
1- 26	5- 111c	

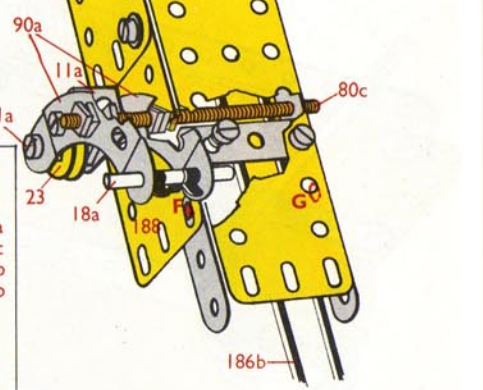

12- 2	2- 15b	10- 35	4- 59	2-187
4- 3	4- 16	173- 37a	1- 80c	4-188
2- 4	2- 17	150- 37b	4- 90a	4-189
14- 5	4- 18a	26- 38	2-111	6-190
4- 6a	2- 19b	2- 38d	3-111a	2-191
8- 10	1- 20a	1- 40	5-111c	3-192
4- 11	5- 22	2- 48	1-115	1-194
1- 11a	2- 22a	8- 48a	2-125	2-212
16- 12	1- 23	2- 48b	2-126	2-212a
2- 12a	1- 23a	1- 51	4-126a	2-213
2- 12c	2- 24	1- 52	2-142c	2-214
1- 14	2- 24c	2- 53	1-147b	4-221
1- 15	1- 26	2- 53a	1-186a	2-222
1- 15a	1- 27a	2- 54	1-186b	2-223

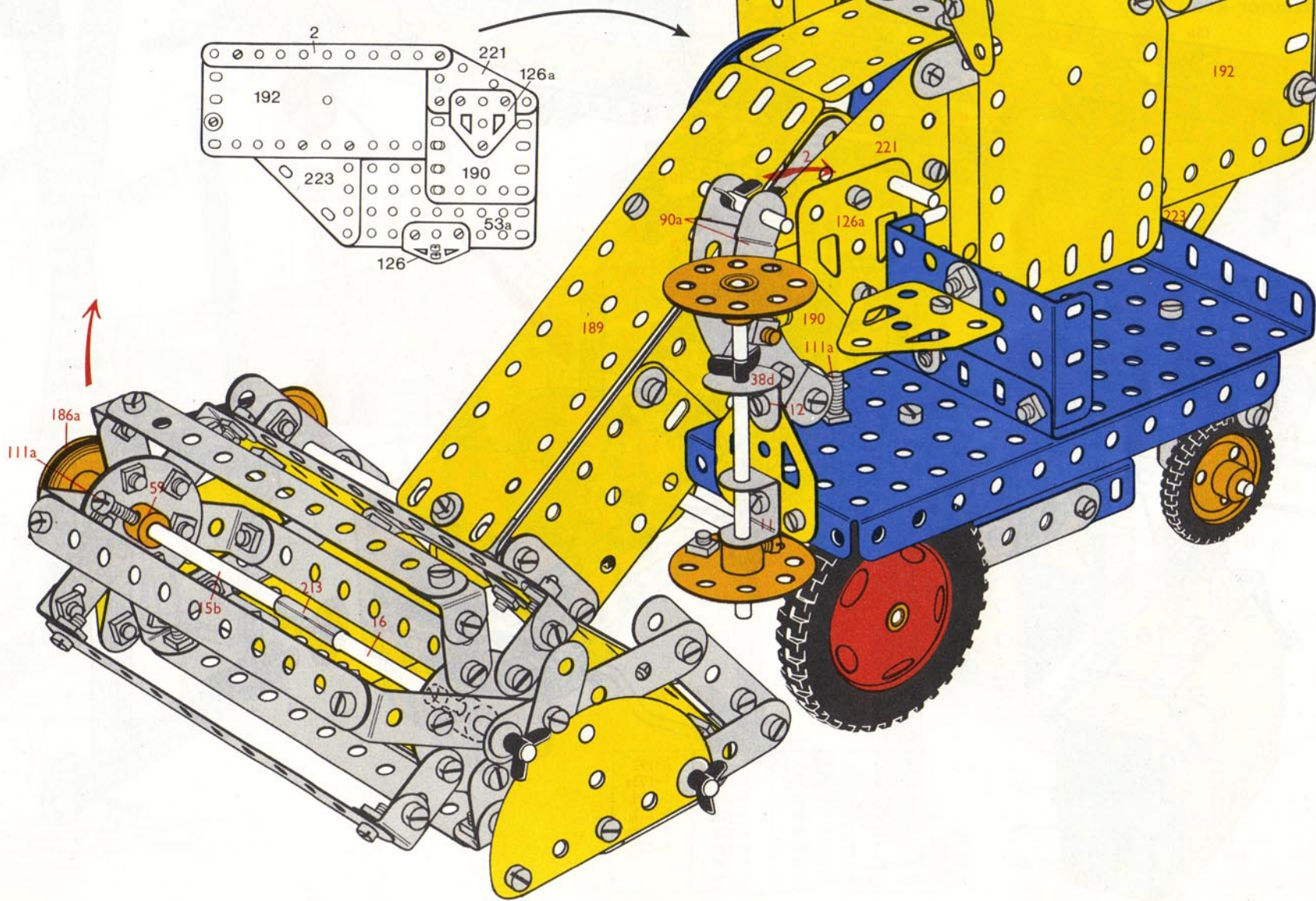

7.12

Container Crane

Laadkistenkraan also: containerkraan

Grue de déchargement

Gru maneggio container

Containerkran

Transportbehallarkran

Grúa de "containers"

Grua de Recipientes

Container-kran

8- 1	1- 18b	13- 38	2- 99
2- 3	1- 19h	2- 38d	1- 115
2- 4	1- 19s	2- 40	1- 147c
2- 5	1- 20a	6- 48a	1- 186
6- 10	1- 23	1- 52	2- 188
1- 11a	1- 23a	2- 53	4- 189
1- 12	1- 27a	2- 53a	1- 190
1- 15b	8- 35	4- 59	2- 192
2- 16	70- 37a	2- 80c	1- 213
1- 17	48- 37b	3- 90a	2- 214

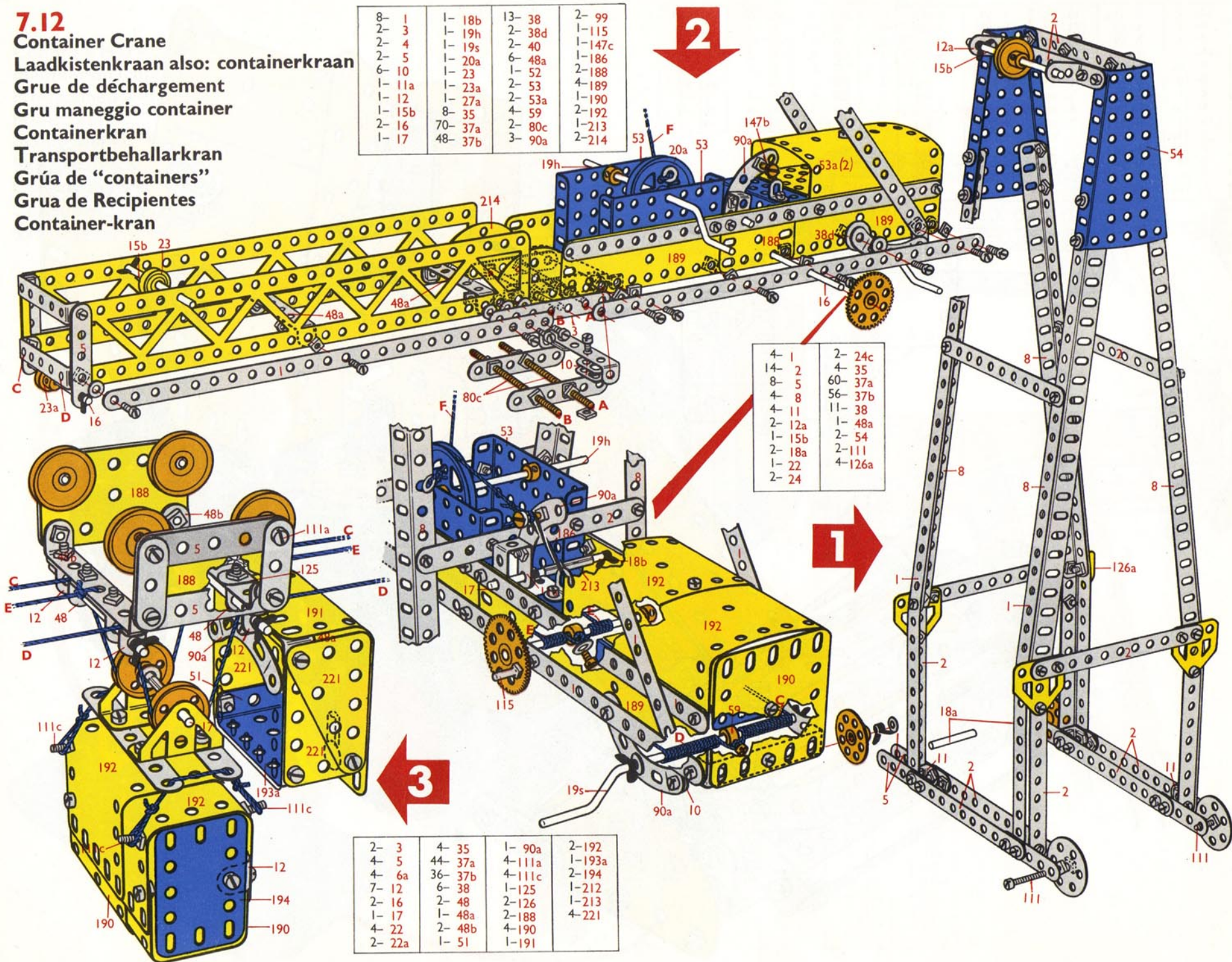

12- 1	4- 16	1- 27a	2- 53a	1-147b
14- 2	2- 17	16- 35	2- 54	1-186
4- 3	2- 18a	174- 37a	4- 59	4-188
2- 4	1- 18b	140- 37b	2- 80c	4-189
14- 5	1- 19h	30- 38	4- 90a	5-190
4- 6a	1- 19s	2- 38d	2- 99	1-191
4- 8	1- 20a	2- 40	2-111	4-192
6-10	5- 22	2- 48	4-111a	1-193a
4-11	2- 22a	8- 48a	4-111c	2-194
1-11a	1- 23	2- 48b	1-115	1-212
8-12	1- 23a	1- 51	1-125	2-213
2-12a	2- 24	1- 52	2-126	2-214
2-15b	2- 24c	2- 53	4-126a	4-221

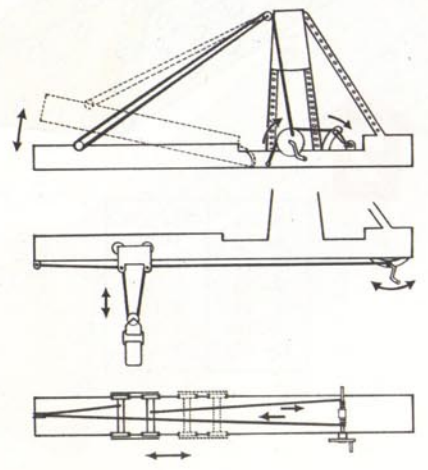
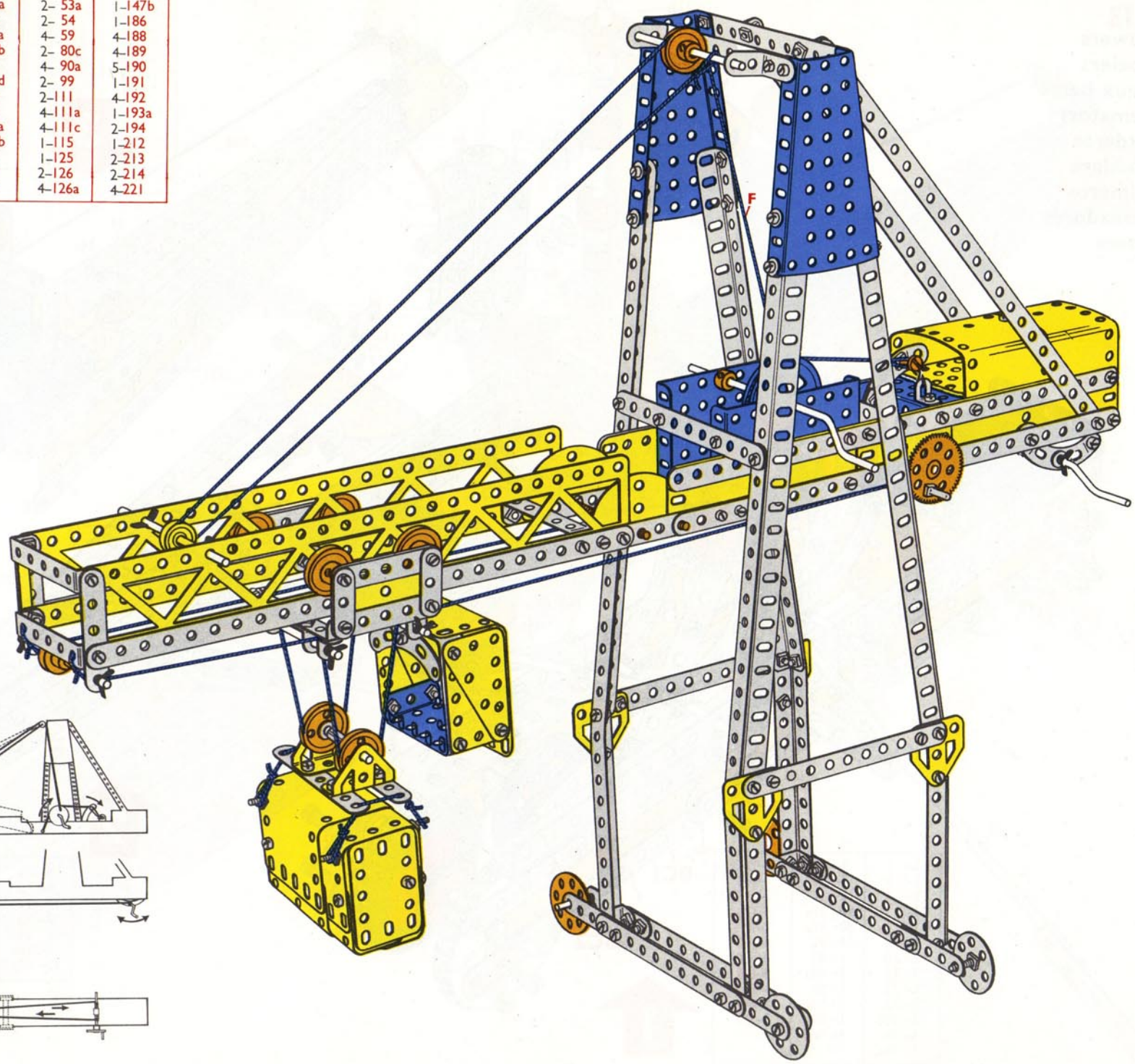

7.13

Rowers
 Roeiers
 Deux barré
 Rematori
 Ruderer
 Roddare
 Remeros
 Remadores
 Roere

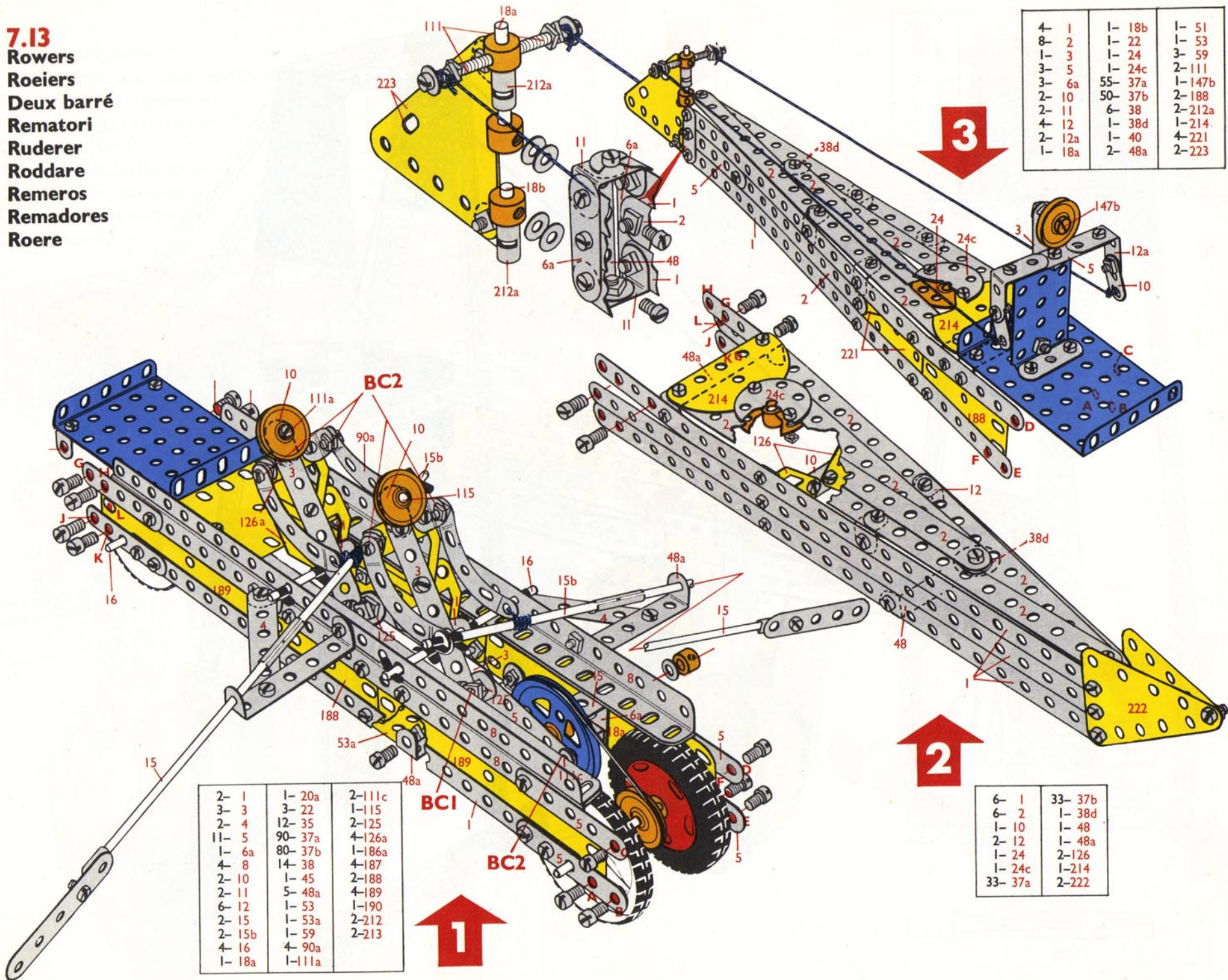

4-	1	1-	18b	1-	51
8-	2	1-	22	1-	53
1-	3	1-	24	3-	59
3-	5	1-	24c	2-	111
3-	6a	55-	37a	1-	147b
2-	10	50-	37b	2-	188
2-	11	6-	38	2-	212a
4-	12	1-	38d	1-	214
2-	12a	1-	40	4-	221
1-	18a	2-	48a	2-	223

2-	1	1-	20a	2-	111c
3-	3	3-	22	1-	115
2-	4	12-	35	2-	125
11-	5	90-	37a	4-	126a
1-	6a	80-	37b	1-	186a
4-	8	14-	38	4-	187
2-	10	1-	45	2-	188
2-	11	5-	48a	4-	189
6-	12	1-	53	1-	190
2-	15	1-	53a	2-	212
2-	15b	1-	59	2-	213
4-	16	4-	90a		
1-	18a	1-	111a		

6-	1	33-	37b
6-	2	1-	38d
1-	10	1-	48
2-	12	1-	48a
1-	24	2-	126
1-	24c	1-	214
33-	37a	2-	222

12-	1	2-	15b	2-	38d	2-	111c	2-	212a
14-	2	4-	16	1-	40	1-	115	2-	213
4-	3	2-	18a	1-	45	2-	125	1-	214
2-	4	1-	18b	1-	48	2-	126	4-	221
14-	5	1-	20a	8-	48a	4-	126a	2-	222
4-	6a	4-	22	1-	51	1-	147b	3-	223
4-	8	2-	24	2-	53	1-	186a		
5-	10	2-	24c	1-	53a	4-	187		
4-	11	12-	35	4-	59	4-	188		
12-	12	178-	37a	4-	90a	4-	189		
2-	12a	163-	37b	2-	111	1-	190		
2-	15	20-	38	1-	111a	2-	212		

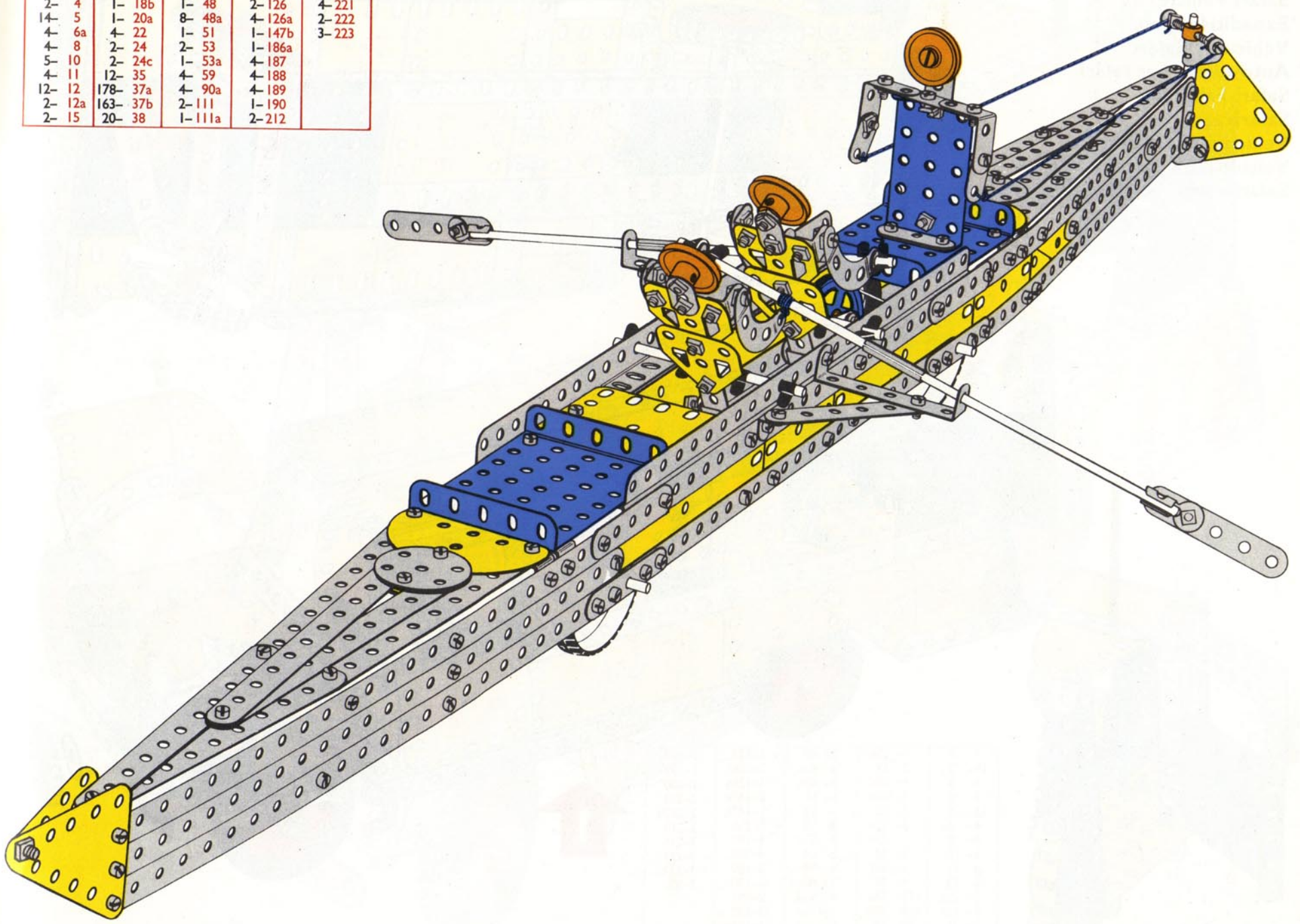

7.14

Safari Vehicle
 Expeditiewagen
 Véhicule "Safari"
 Autoveicolo per safari
 Safari-Fahrzeug
 Safarivagn
 Vehiculo de safari
 Veículo para Safari
 Safari-vogn

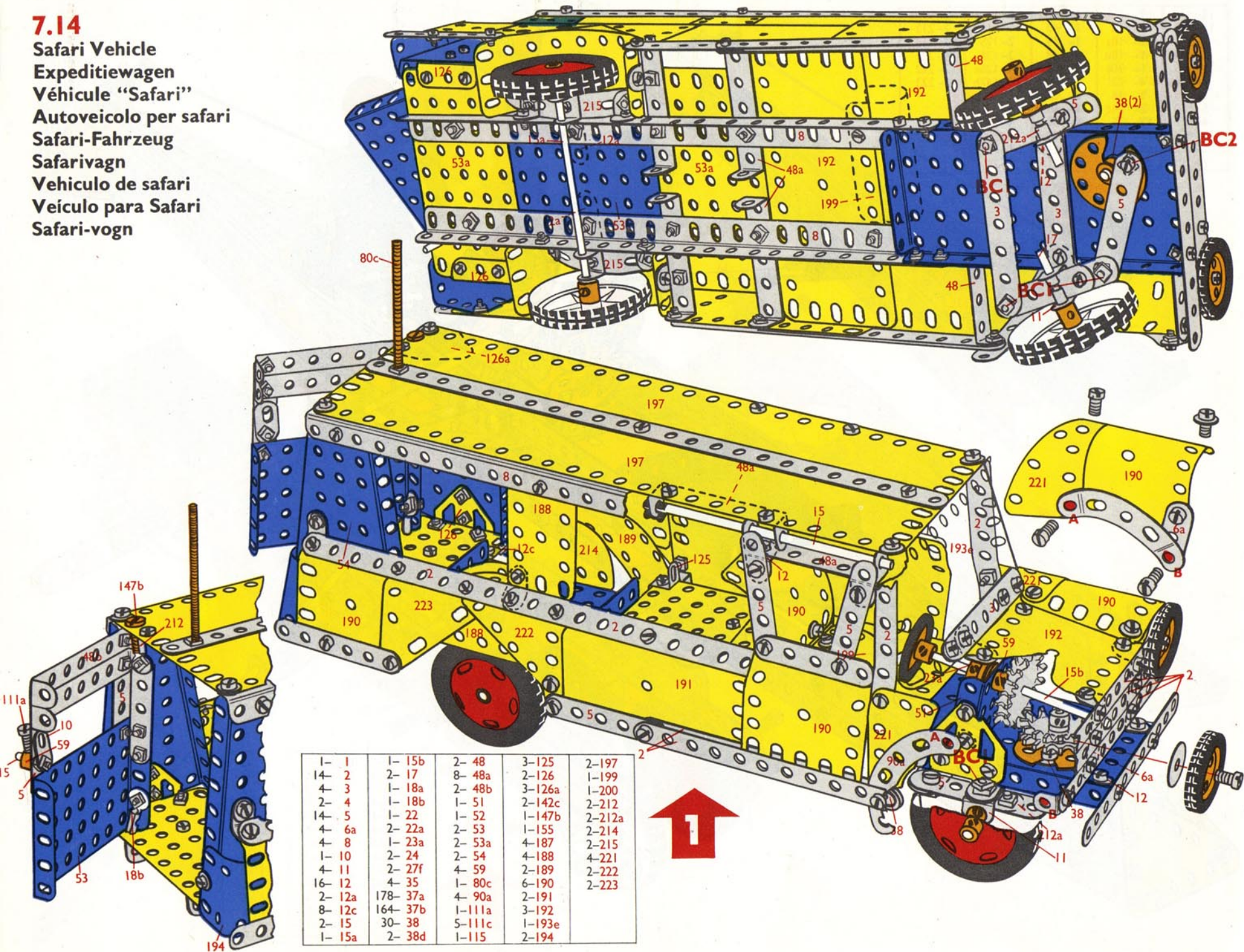

1- 1	1- 15b	2- 48	3- 125	2- 197
14- 2	2- 17	8- 48a	2- 126	1- 199
4- 3	1- 18a	2- 48b	3- 126a	1- 200
2- 4	1- 18b	1- 51	2- 142c	2- 212
14- 5	1- 22	1- 52	1- 147b	2- 212a
4- 6a	2- 22a	2- 53	1- 155	2- 214
4- 8	1- 23a	2- 53a	4- 187	2- 215
1- 10	2- 24	2- 54	4- 188	4- 221
4- 11	2- 27f	4- 59	2- 189	2- 222
16- 12	4- 35	1- 80c	6- 190	2- 223
2- 12a	178- 37a	4- 90a	2- 191	
8- 12c	164- 37b	1- 111a	3- 192	
2- 15	30- 38	5- 111c	1- 193e	
1- 15a	2- 38d	1- 115	2- 194	

1- 1	1- 18b	2- 53a	6- 190
14- 2	1- 22	2- 54	2- 191
4- 3	2- 22a	4- 59	3- 192
2- 4	1- 23a	1- 80c	1- 193e
14- 5	2- 24	4- 90a	2- 194
4- 6a	2- 27f	1- 111a	2- 197
4- 8	4- 35	5- 111c	1- 199
1- 10	178- 37a	1- 115	1- 200
4- 11	164- 37b	3- 125	2- 212
16- 12	30- 38	2- 126	2- 212a
2- 12a	2- 38d	3- 126a	2- 214
8- 12c	2- 48	2- 142c	2- 215
2- 15	8- 48a	1- 147b	4- 221
1- 15a	2- 48b	1- 155	2- 222
1- 15b	1- 51	4- 187	2- 223
2- 17	1- 52	4- 188	
1- 18a	2- 53	2- 189	

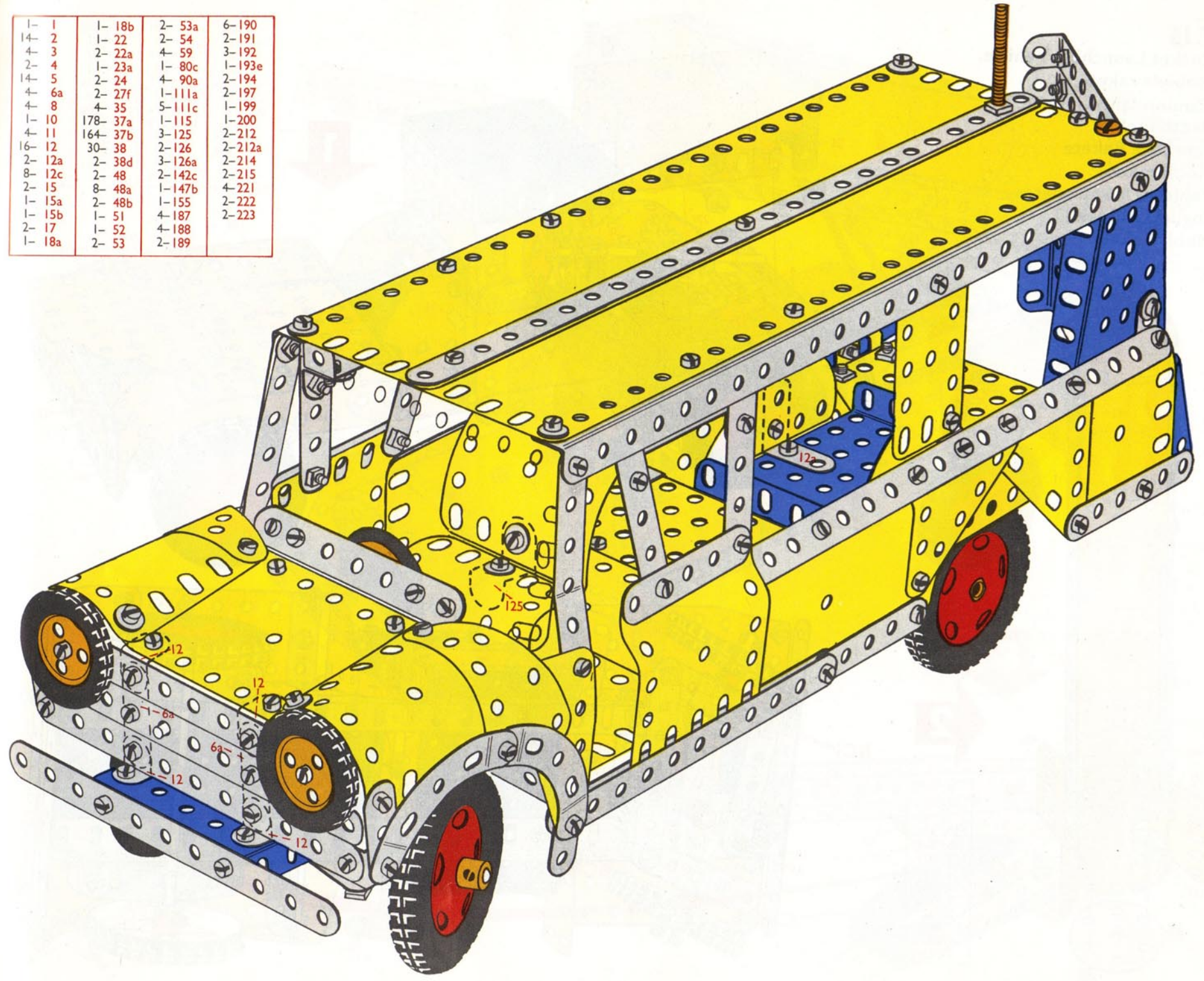

ELECTRONIC 7.16

Car Wash

Autowaschinrichtung

Station lave-voitures

Stazione lavaggio automobili

Wagenwäsche

Biltvätt

Lavadero de coches

Lavagem de Automóveis

Bilvask

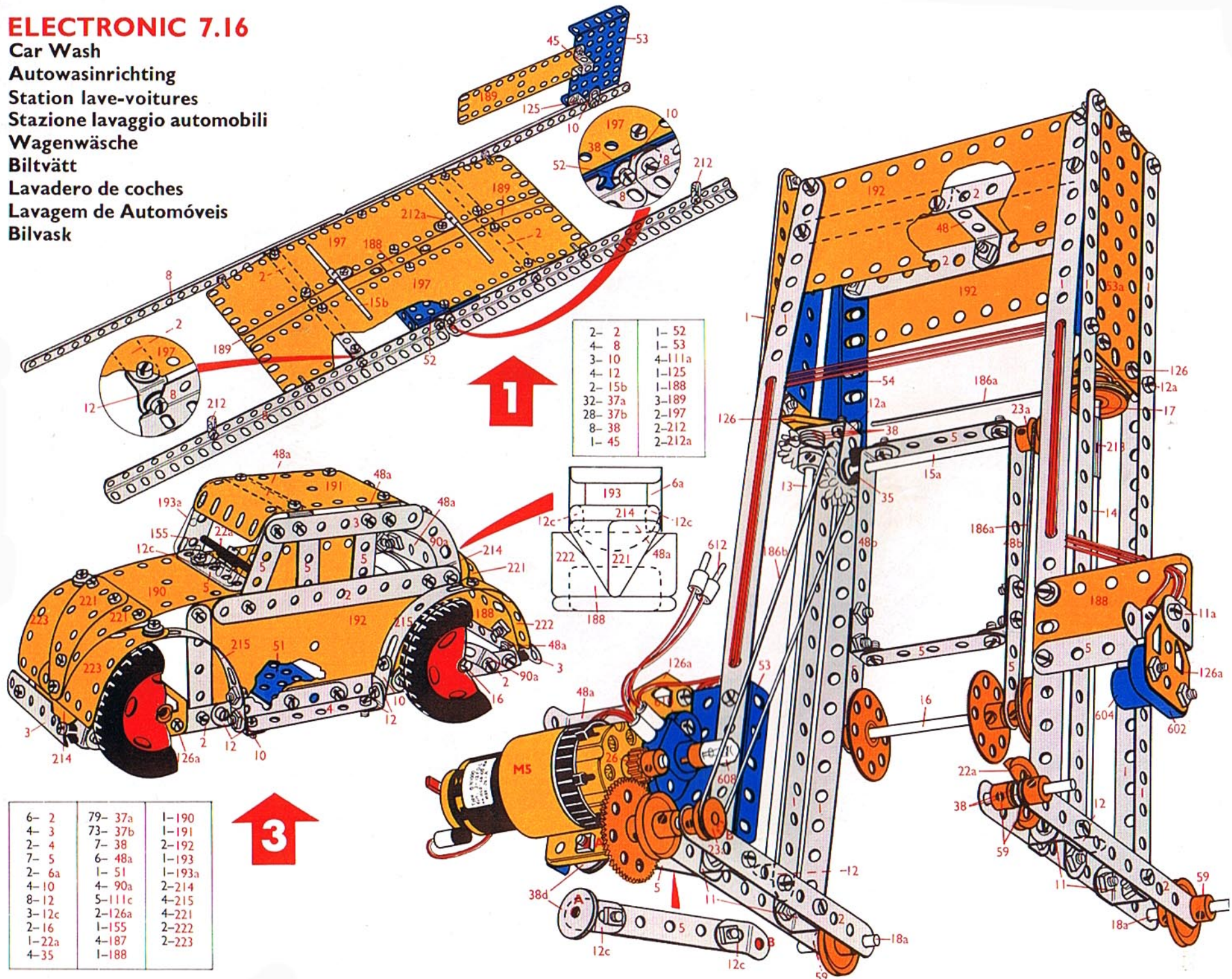

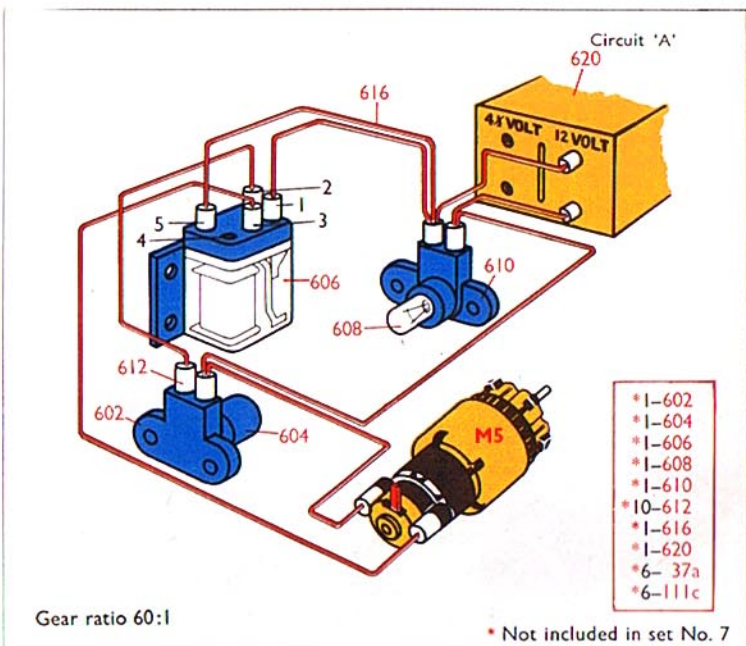

8- 1	1- 22a	1- 53
6- 2	*1- 23a	2- 53a
6- 5	1- 23a	2- 54
4- 11	2- 24	4- 59
1- 11a	1- 26	1-111c
2- 12	1- 27a	2-126
2- 12a	2- 27f	2-126a
2- 12c	1- 35	*1-186a
1- 13	59- 37a	1-186a
1- 14	58- 37b	1-186b
1- 15a	12- 38	1-188
1- 16	2- 38d	2-192
1- 17	1- 48	1-213
4- 18a	1- 48a	
5- 22	2- 48b	

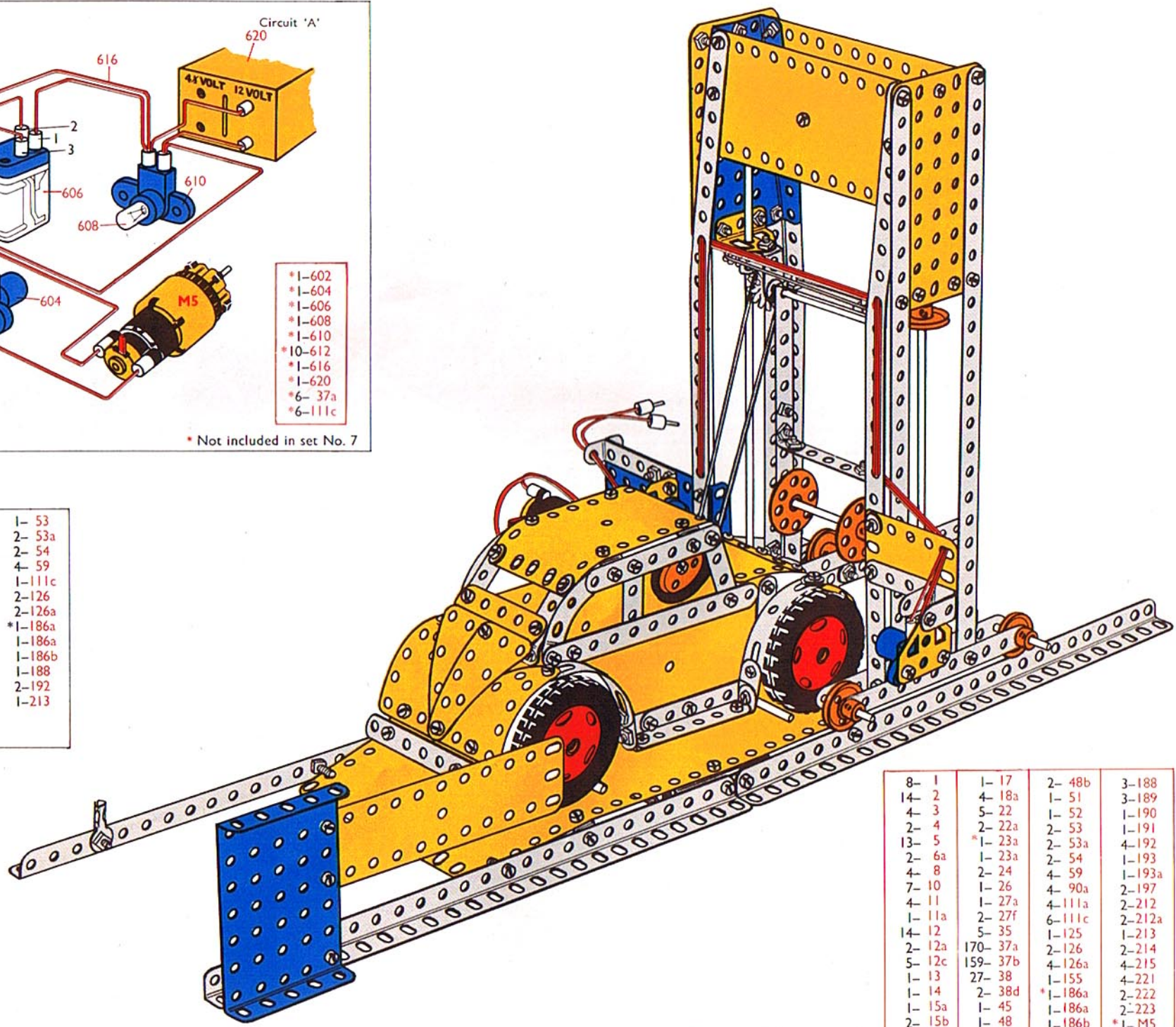

8- 1	1- 17	2- 48b	3-188
14- 2	4- 18a	1- 51	3-189
4- 3	5- 22	1- 52	1-190
2- 4	2- 22a	2- 53	1-191
13- 5	*1- 23a	2- 53a	4-192
2- 6a	1- 23a	2- 54	1-193
4- 8	2- 24	4- 59	1-193a
7- 10	1- 26	4- 90a	2-197
4- 11	1- 27a	4-111a	2-212
1- 11a	2- 27f	6-111c	2-212a
14- 12	5- 35	1-125	1-213
2- 12a	170- 37a	2-126	2-214
5- 12c	159- 37b	4-126a	4-215
1- 13	27- 38	1-155	4-221
1- 14	2- 38d	*1-186a	2-222
1- 15a	1- 45	1-186a	2-223
2- 15b	1- 48	1-186b	*1- M5
3- 16	7- 48a	4-187	

* Not included in set No. 7

ELECTRONIC 7.17

Loading Conveyor

Laadtransporteur

Convoyeur

Trasportatore caricatore

Lastförderer

Lasttransportör

Transportador de carga

Transportador de Carga

Lastettransportor

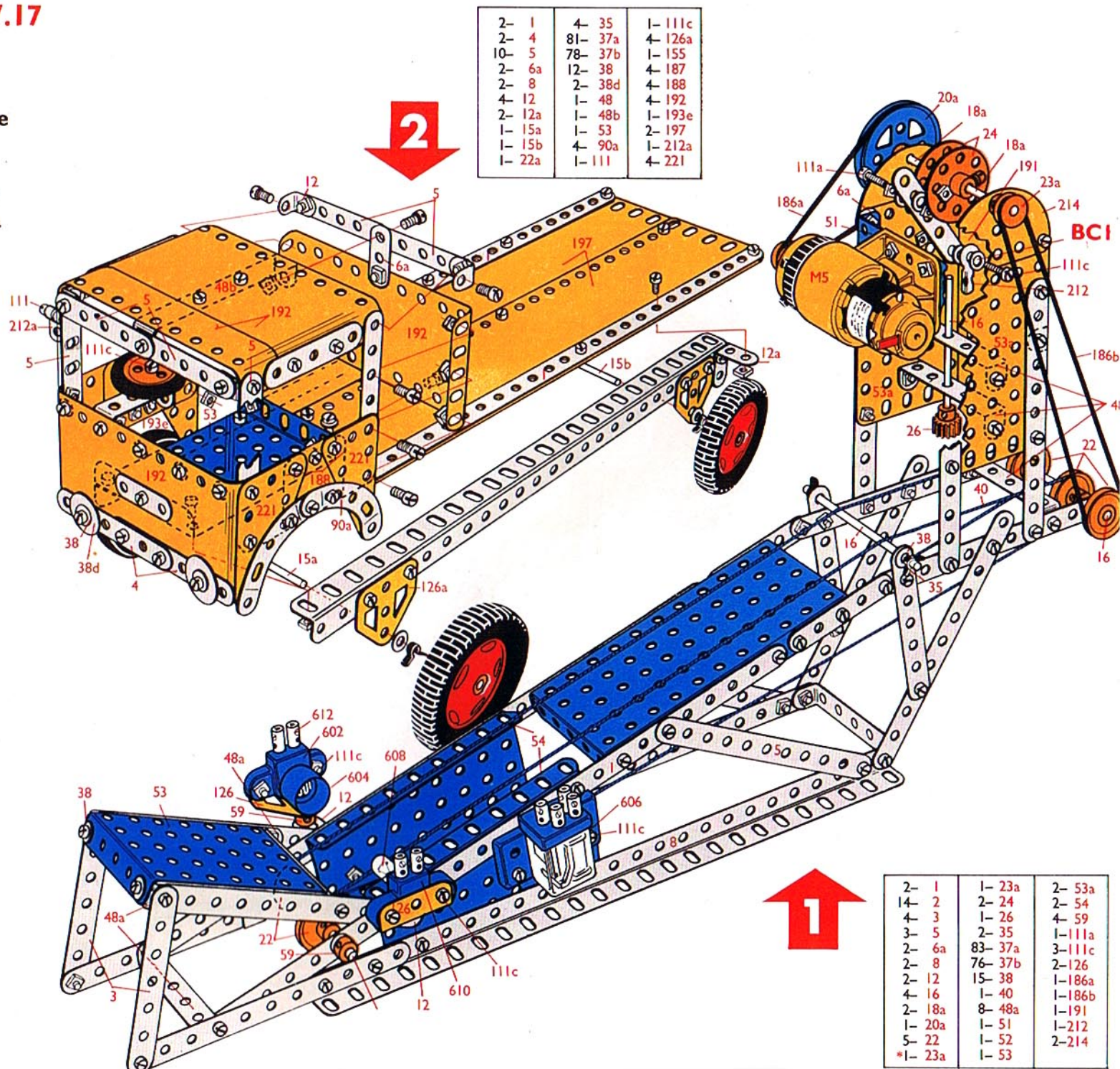

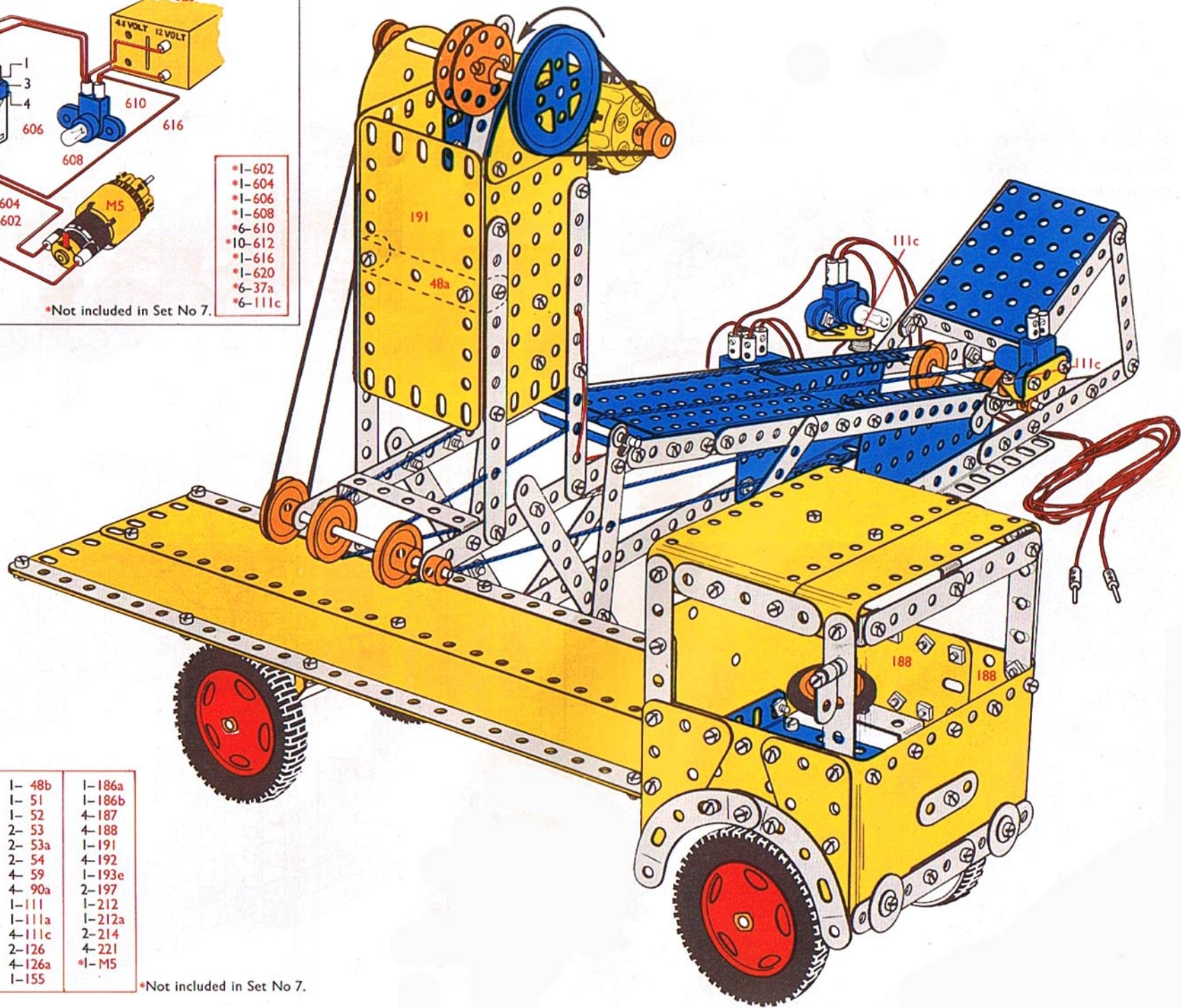
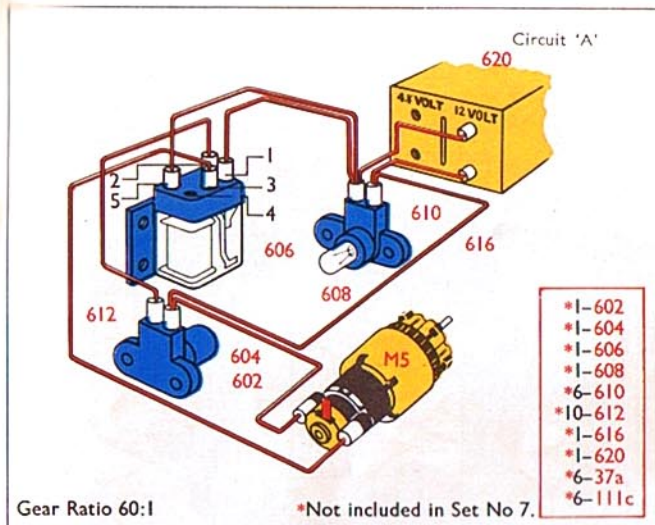

4- 1	5- 22	1- 48b	1-186a
14- 2	1- 22a	1- 51	1-186b
4- 3	*1- 23a	1- 52	4-187
2- 4	1- 23a	2- 53	4-188
13- 5	2- 24	2- 53a	1-191
4- 6a	1- 26	2- 54	4-192
4- 8	6- 35	4- 59	1-193e
6- 12	164- 37a	4- 90a	2-197
2- 12a	154- 37b	1-111	1-212
1- 15a	27- 38	1-111a	1-212a
1- 15b	2- 38d	4-111c	2-214
4- 16	1- 40	2-126	4-221
2- 18a	1- 48	4-126a	*1-M5
1- 20a	8- 48a	1-155	

*Not included in Set No 7.

ELECTRONIC 7.18

Warehouse & Lift

Pakhuis en lift

Entrepôt avec monte-charge

Centro immagazzinaggio e ascensore

Lagerhaus und Aufzug

Magasin och hiss

Almacén y montacargas

Elevador e Armazém

Lagerhus og heis

8- 5	7- 37b
2- 6a	9- 38
1- 11a	1- 48b
1- 18b	1- 53
1- 23a	4- 111c
15- 37a	2- 126a

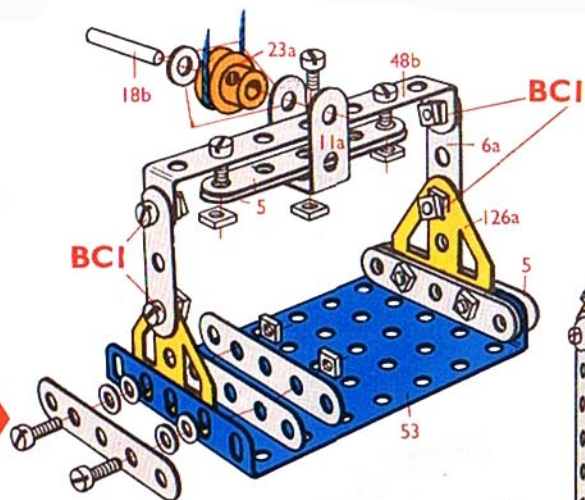

12- 1	1- 51
14- 2	1- 52
4- 3	1- 53
2- 4	2- 53a
6- 5	2- 54
4- 8	2- 59
4- 10	2- 80c
1- 11	4- 90a
15- 12	2- 99
2- 12a	2- 111a
8- 12c	1- 111c
1- 15	3- 125
1- 15a	1- 126
1- 16	1- 126a
1- 23a	1- 147b
2- 24	2- 188
1- 24c	4- 189
8- 35	5- 190
158- 37a	2- 191
149- 37b	4- 192
2- 48	2- 197
8- 48a	2- 212
1- 48b	2- 214

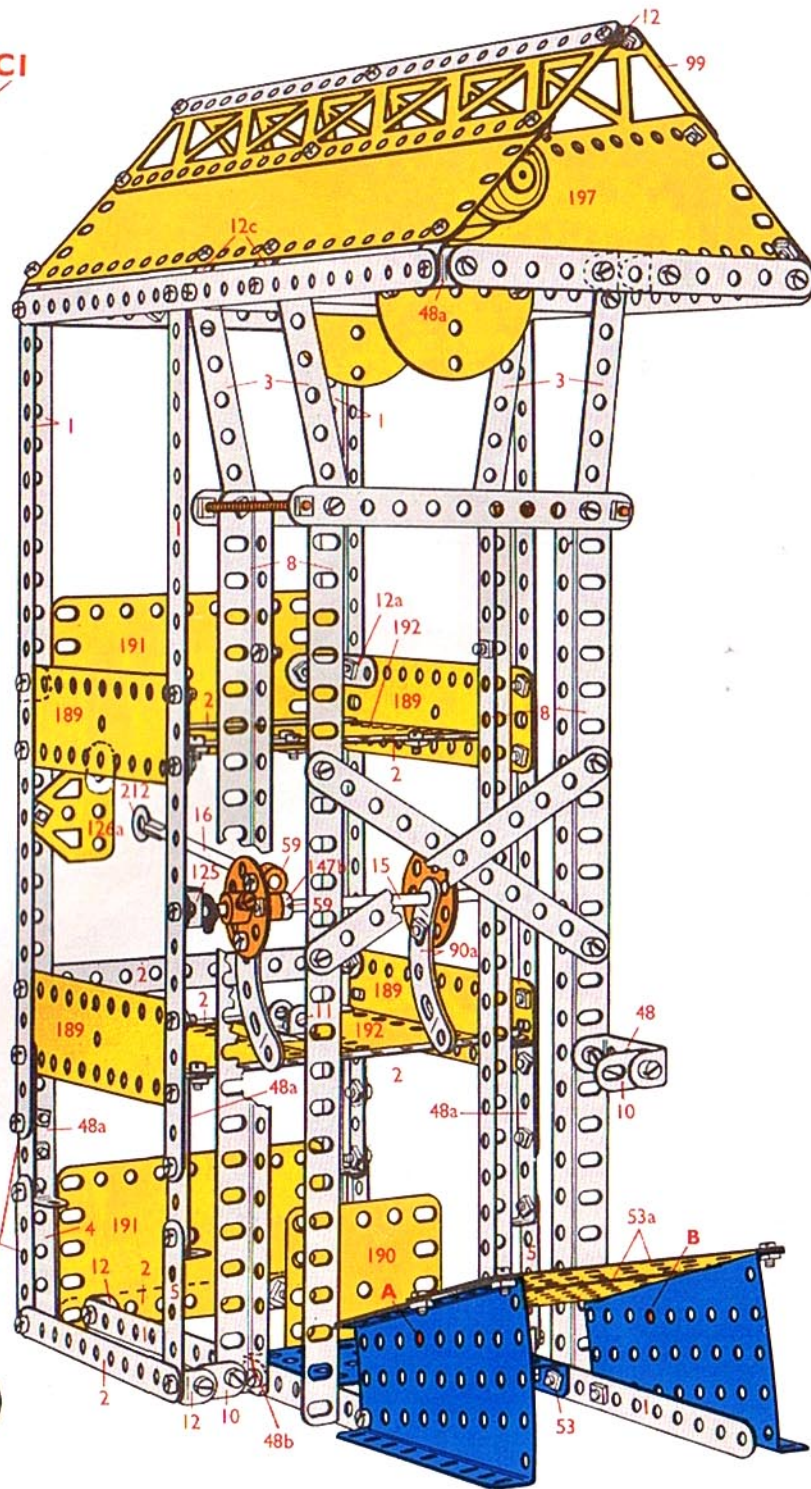

1- 12	1- 26	1- 40
2- 15b	1- 27a	2- 59
1- 20a	3- 37a	1- 142c
4- 22	3- 37b	1- 186a
1- 22a	6- 38	

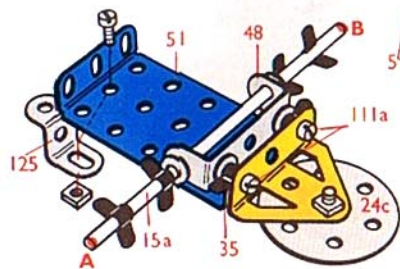

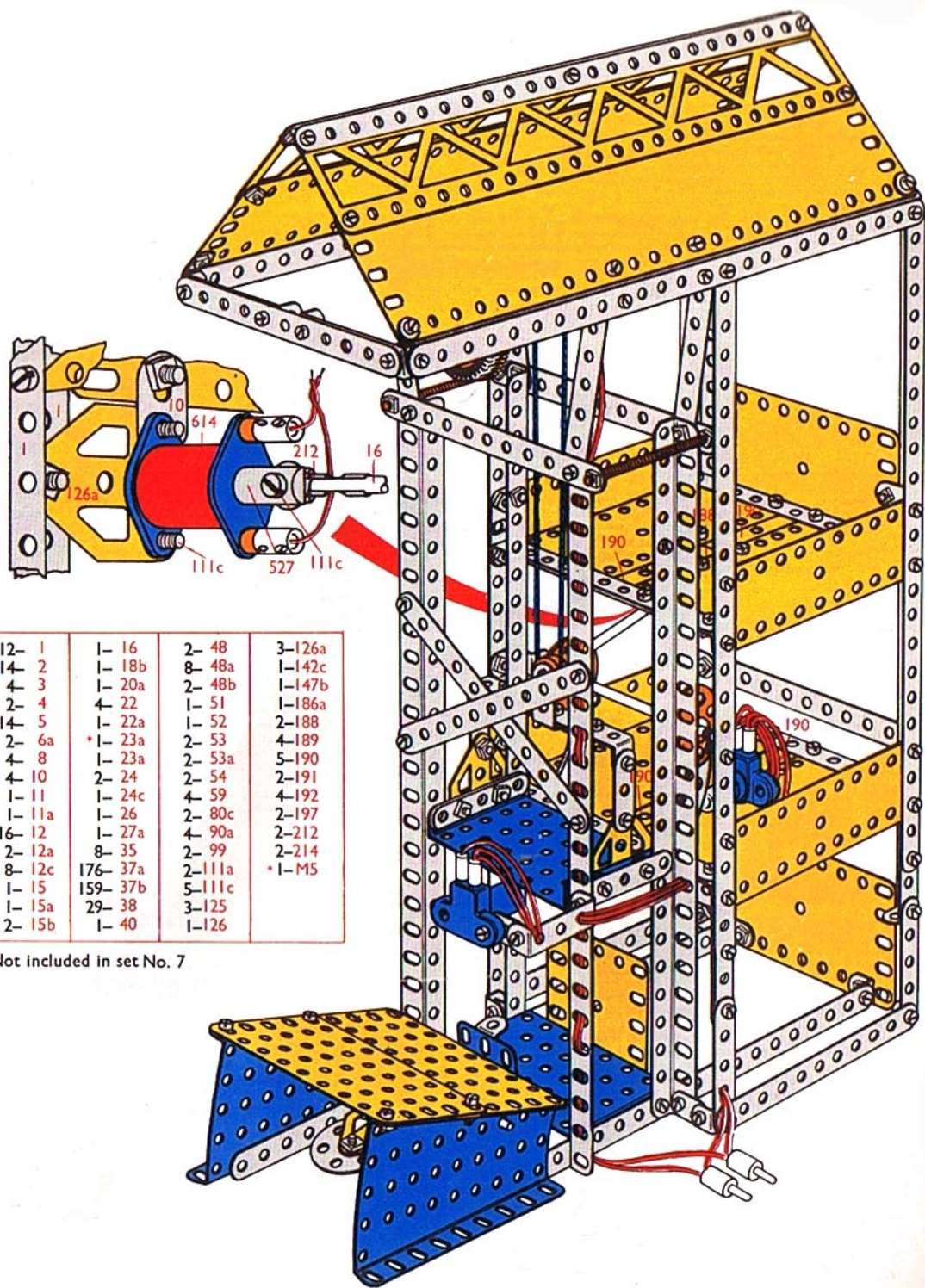
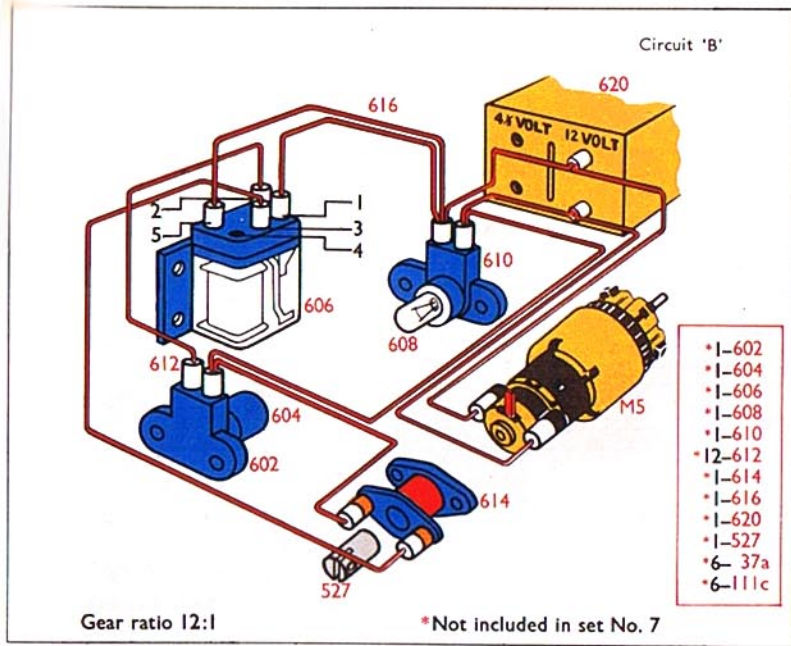

12- 1	1- 16	2- 48	3-126a
14- 2	1- 18b	8- 48a	1-142c
4- 3	1- 20a	2- 48b	1-147b
2- 4	4- 22	1- 51	1-186a
14- 5	1- 22a	1- 52	2-188
2- 6a	*1- 23a	2- 53	4-189
4- 8	1- 23a	2- 53a	5-190
4- 10	2- 24	2- 54	2-191
1- 11	1- 24c	4- 59	4-192
1- 11a	1- 26	2- 80c	2-197
16- 12	1- 27a	4- 90a	2-212
2- 12a	8- 35	2- 99	2-214
8- 12c	176- 37a	2-111a	*1-M5
1- 15	159- 37b	5-111c	
1- 15a	29- 38	3-125	
2- 15b	1- 40	1-126	

*Not included in set No. 7

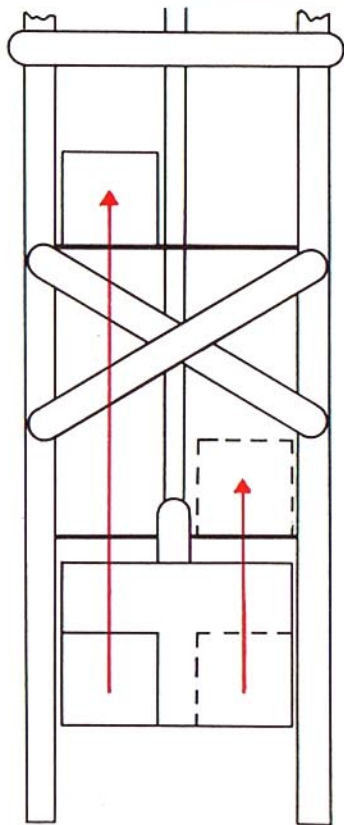

MECCANO—THE PROGRESSIVE SYSTEM

The standard Meccano system consists of a range of Main Sets numbered from 1 to 10, which get progressively larger as the Set number increases. This means that Set 2 contains all the parts included in Set 1, plus a quantity of additional Parts, while Set 3 contains all the Parts in Set 2, plus a further quantity of additional Parts, and so on, right up to the No. 10 Set. Also included in the standard system is a series of eight Conversion Sets. These are not intended as constructional sets in their own right, but simply contain the necessary extra Parts to convert a main Set into the next larger, e.g. Set 1 together with Conversion Set 1X makes Set 2, and so on. Also available is a series of motorised Sets: 3M, 4M, and 5ME. These are equivalent to Main Sets 3, 4, and 5 with the addition of a Meccano Motor—the Junior Power Drive Unit in Sets 3M and 4M and the Power Drive Unit in the 5ME Set. The 5ME Set also includes the components contained in the Electronics Accessory Set. Other current outfits are the Gears and Mechanisms Sets, both of which contain a selection of standard gears to further mechanise your models, and the 4EL Set equivalent to the standard No. 4 set with the addition of special electrical parts.

MECCANO—IL SISTEMA PROGRESSIVO

Il Sistema Meccano standard è costituito da una serie di Scatole Base numerate da 1 a 10 che, con il crescere del numero, diventano progressivamente più grandi e più complete. La Scatola 2 contiene tutti i Pezzi compresi nella Scatola 1 più un certo numero di Pezzi addizionali; la Scatola 3 contiene tutti i Pezzi della Scatola 2 più un certo numero di Pezzi addizionali, e così via fino al Meccano 10.

Il Sistema Meccano comprende inoltre 8 Scatole di Conversione, le quali non possono essere utilizzate da sole, ma contengono i Pezzi necessari per convertire una Scatola Base in quella immediatamente più grande, per esempio la Scatola 1 più la Scatola di Conversione 1X formano la Scatola 2 e così via.

L'assortimento Meccano comprende anche Scatole motorizzate 3M, 4M, 5ME e 6ME, che sono equivalenti alle Scatole Base 3, 4, 5 e 6 ciascuna con l'aggiunta di un Motorino Meccano: il Motorino Elettrico Junior nelle Scatole 3M e 4M, e il Motorino Elettrico con Cambio a 6 Velocità nella Scatola 5ME.

Nella Scatola 5ME sono incluse anche Parti Meccano della Serie Elettronica. Fanno parte del sistema Meccano anche le Scatole Ingranaggi e Meccanismi contenenti vari ingranaggi standard Meccano che servono per "meccanizzare" maggiormente i modelli e la Scatola 4-EL corrispondente alla Scatola 4 però con l'aggiunta di speciali pezzi elettrici.

MECCANO—EL JUGUETE PROGRESIVO

El Meccano standard se compone de una serie de Juegos Básicos, numerados de 1 a 10, cuyo surtido de piezas aumenta progresivamente según el número de referencia del juego. Es decir, el Juego No. 2 contiene todas las piezas incluidas en el No. 1 más una serie de elementos adicionales; el Juego 3 tiene todas las piezas del No. 2 complementadas con varias más, y así sucesivamente hasta el Juego No. 10.

En el Meccano standard figura también una serie de Equipos de Conversión. Estos no son juegos de construcción propiamente dichos, sino que reúnen los complementos necesarios para convertir un Juego Básico determinado en el del número siguiente. Por ejemplo, el Juego No. 1 y el Equipo de Conversión 1X forman el Juego 2, etc. etc. Se ofrece también una serie de juegos motorizados: 3M, 4M y 5ME, los cuales equivalen a los Juegos Básicos 3, 4 y 5 complementados con un Motor Meccano (unidad motriz Junior Power en los nos 3M y 4M unidad motriz Power en 5ME). El Juego 5ME contiene también las piezas comprendidas en el Equipo de Accesorios Electrónicos.

Entre otros equipos comprendidos en la serie actual se encuentran los juegos de engranajes y mecanismos, ambos de los cuales cuentan con una selección de ruedas dentadas standard para mecanizar aún más el funcionamiento de sus modelos, así como el Juego 4 EL que equivale al juego standard no. 4 complementado con piezas eléctricas especiales.

MECCANO—HET PROGRESSIEVE SYSTEEM

Het standaard Meccano-systeem omvat een serie hoofd-sets, genummerd van 1 t/m 10, die progressief groter worden met het opklimmen van de nummers. Dit betekent dat set 2 alle onderdelen bevat van set 1, plus een aantal extra onderdelen, terwijl set 3 alle onderdelen van set 2 bevat, plus een aantal extra onderdelen, enz., tot set no. 10. Tevens omvat het standaard systeem een serie uitbreidingssets, nl. 8 stuks. Deze zijn niet bedoeld als op zichzelf staande constructiesets, maar bevatten de noodzakelijke extra onderdelen om een hoofdsat uit te breiden tot het volgende set-nummer, zodat bijvoorbeeld Set No. 1 tezamen met de uitbreidingsset IX gelijk wordt aan Set No. 2, enz. Ook zijn gemotoriseerde sets leverbaar, nl. 3M, 4M, en 5ME. Deze zijn gelijkwaardig aan de hoofdsats 3, 4 en 5 met toevoeging van een Meccano motor—the Junior Power Drive Unit (Junior drijfwerkuitrusting) in sets 3M en 4M of drijfwerkuitrusting in 5ME. Set 5ME bevat ook de onderdelen uit de elektronische uitbreiding set.

Andere nieuwe uitrustingen omvatten tandwiel- en gemechaniseerde sets, die beide een serie standard tandwielen bevatten om de modellen verder te mechaniseren. Tevens is de set 4 EL leverbaar, die gelijk is aan de standaard set no. 4, met bijvoeging van speciale elektrische onderdelen.

MECCANO—DAS STUFENWEISE AUSBAUBARE SYSTEM

Das Meccano-Standardsystem besteht aus einer Reihe von Hauptkästen, die mit den Zahlen 1 bis 10 bezeichnet sind; diese Bausätze werden umfassender, je höher die Kennziffer ist, d.h. dass Bausatz 2 nicht nur alle Teile von Kasten 1 enthält, sondern ausserdem eine Reihe von Zusatzeilen. Das gleiche gilt für Satz 3; er verfügt über alle Teile aus Satz 2 und daneben über zahlreiche Zusatzeile. Das geht so weiter bis Satz 10.

Zum Standardsystem gehören weiterhin eine Reihe von acht Ergänzungskästen. Sie sind nicht als eigenständige Bausätze gedacht, sondern umfassen lediglich die notwendigen Zusatzeile, um einen Hauptkasten so zu vervollständigen, dass er der nächst höheren Stufe entspricht; das bedeutet z.B., dass Satz 1 plus Ergänzungskasten 1X über die gleiche Anzahl von Teilen verfügt, wie sie in Satz 2 vorliegen usw. Weiterhin sind Bausätze mit Motor erhältlich: 3M, 4M und 5ME. Sie entsprechen den Kästen 3, 4 und 5 und enthalten ausserdem einen Meccano-Antriebsmotor; bei Satz 3M und 4M handelt es sich dabei um die Junior-Antriebseinheit, bei 5ME um die grosse Einheit. Der Kasten 5ME umfasst weiterhin die Einzelteile aus dem Elektronikbauteilekasten.

Weitere erhaltliche Kästen umfassen Sätze mit Zahnrädern, Getrieben und anderen Teilen, die eine Reihe von Standardbauteilen enthalten, mit deren Hilfe die gebauten Modelle noch weiter mechanisiert werden können. Der Satz 4 EL umfasst neben den Standardbauteilen des Kastens Nr. 4 zusätzliche Elektrobauteile.

MECCANO—O SISTEMA PROGRESSIVO

O sistema normal Meccano consiste numa linha de Jogos Principais numerados de 1 a 10, que se tornam progressivamente maiores à medida que o número do jogo aumenta. Isto significa que o Jogo No. 2 tem todas as peças incluídas no Jogo No. 1, mais um certo número de peças adicionais; o Jogo No. 3 contém todas as peças do Jogo No. 2 mais um certo número de peças adicionais e assim por diante, até ao Jogo No. 10.

Incluído no sistema normal está uma série de oito Jogos de Conversão. Estes jogos por si só não são jogos de construção, mas contêm simplesmente o número de peças extras necessárias a converter um Jogo Principal no jogo que se lhe segue, isto é o Jogo No. 1 juntamente com o Jogo de Conversão IX completa o Jogo No. 2, e assim por diante. Também se encontra à venda uma série de Jogos com motores: 3M, 4M e 5ME. Estes são equivalentes aos Jogos Principais Nos. 3, 4 e 5 mais com um motor Meccano—a Unidade de Accionamento Junior nos Jogos 3M e 4M e a Unidade de Accionamento no Jogo 5ME. O Jogo 5ME também inclui os componentes do Jogo de Accesorios Electrónicos.

Outros equipamentos de fabrico corrente são os conjuntos de Engrenagens e Mecanismos os quais têm uma seleção de engrenagens normais para tornar os modelos ainda mais mecanizados, e o Jogo 4 EL, equivalente ao jogo normal No. 4 tem ainda peças eléctricas especiais.

MECCANO—LE SYSTEME PROGRESSIF

Le système Meccano consiste en une série de boîtes principales, numérotées de 1 à 10, et dont l'importance augmente avec le numéro de série. Cela signifie que la boîte No. 2 contient toutes les pièces de la boîte No. 1, plus un certain nombre de pièces supplémentaires. Il en est de même pour la boîte No. 3 qui contient toutes les pièces du No. 2 auxquelles s'ajoutent un certain nombre de pièces supplémentaires, et ainsi de suite jusqu'au 10.

Une série de huit boîtes complémentaires fait également partie de ce système. Cependant, ce ne sont pas des boîtes de construction car elles ne contiennent que les pièces supplémentaires nécessaires à la conversion d'une boîte donnée en celle du numéro suivant; par exemple, la boîte complémentaire 2X transforme une boîte 2 en boîte 3, et ainsi de suite. Il existe également une série de boîtes motorisées: 3M, 4M et 5ME. Celles-ci correspondent très exactement aux boîtes 3, 4 et 5, avec l'addition d'un moteur Meccano, le "Junior Power Drive Unit" pour les boîtes 3M et 4M et le "Power Drive Unit" dans la boîte 5ME. La boîte 5ME comprend également les éléments contenus dans la boîte d'accessoires électroniques. Les autres accessoires courants comprennent des jeux de mécanismes et d'engrenages qui contiennent tous deux une sélection d'engrenages standard permettant la mécanisation de vos modèles, et le jeu 4 EL, équivalent du jeu standard No. 4 avec des éléments électriques spéciaux supplémentaires.

MECCANO—DET UTBYGGBARA SYSTEMET

Meccano standardsystem består av en serie huvudbyggsatser från 1 till 10, vilka ökar i storlek med numret. Detta innebär, att sats 2 innehåller alla delarna i sats 1 plus ett antal extra delar och att sats 3 innehåller alla delarna i sats 2 plus ytterligare ett antal extra delar o.s.v. ända upp till sats 10.

I standardsystemet ingår också en serie på åtta tilläggsatser. Dessa är inte avsedda att vara byggsatser i sin egen rätt utan innehåller helt enkelt de erforderliga extra delar, som behövs för att förvandla en huvudbyggsats till närmaste större sats. Sats 1 i förening med tilläggsats 1X till exempel resulterar i sats 2 o.s.v. Dessutom finns det en serie motorsatser: 3M, 4M och 5ME. De motsvarar huvudbyggsatserna 3, 4 och 5 med tillägg av en Meccanomotor—Junior drivaggregat i satserna 3M och 4M samt det kraftigare drivaggregatet i sats 5ME. Sats 5ME innehåller också delar, vilka ingår i elektronikbihangsatsen.

Annat nuvarande utrustning utgörs av kuggghjul och mekanismer, och båda dessa slags uppsättningar innehåller ett urval standarddrev för ytterligare mekanisering av modellerna. Uppsättning 4 EL motsvarar standard-upsättning 4, med tillägg av speciella elektriska delar.

MECCANO—DET GRADVISE SYSTEMET

Meccanos standardsystem består av en rekke hovedsett som er nummererte fra 1 til 10 og som blir gradvis større i takt med nummereringen. Dette vil si at Sett 2 inneholder alle delene i Sett 1, pluss noen tilleggsdeler, mens Sett 3 inneholder alle delene i Sett 2, pluss ytterligere deler. Og så videre, like til Sett nr. 10.

Inkludert i standardsystemet er også en serie på åtte omdannings-sett. Disse er ikke ment som byggesett i seg selv, men inneholder bare ganske enkelt de nødvendige ekstra deler som skal til for å omdanne et hovedsett til neste størrelse. F.eks.: Sett 1 sammen med omdanningssett 1X utgjør Sett 2 osv. I tillegg til dette er der en serie motorsett: 3M, 4M og 5ME. Disse tilsvarer hovedsettene 3, 4 og 5 med tillegg av en Meccano motor—Junior Power Drive Unit i Settene nr. 3M og 4M, og Power Drive Unit i Sett nr. 5ME. Sett 5ME inneholder også de delene som inngår i Elektronikk-reservsettet.

Andre sett som kan fåes er gir- og mekanisme-settene; begge disse inneholder et utvalg av standard gir slik at modellene kan mekaniseres ytterligere, og 4 EL settet som tilsvarer standard sett nr. 4, men med tillegg av spesielle elektriske deler.



51
FLANGED PLATES
51 - 2½" × 1¼"; 60 × 38 mm
52 - 5½" × 2¼"; 14 × 6 cm
53 - 3½" × 2¼"; 9 × 6 cm

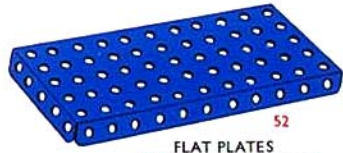

52
FLAT PLATES
52a - 5½" × 3¼"; 14 × 9 cm
53a - 4¼" × 2¼"; 11½ × 6 cm

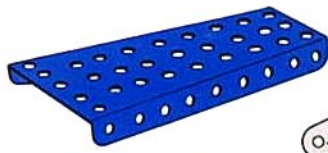

54 - 4½"; 115 mm
FLANGED SECTOR PLATE

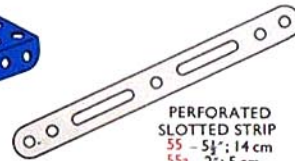

PERFORATED SLOTTED STRIP
55 - 5½"; 14 cm
55a - 2"; 5 cm



HOOK
57b



HOOK
57c



WIRE HOOK
57d



58 **SPRING CORD** - 40"; 1 metre



COUPLING SCREW FOR 58
58a



HOOK FOR 58
58b



COLLAR WITH SCREW
59



61
WINDMILL SAIL



62
CRANK
62a **THREADED CRANK**



DOUBLE ARM CRANK
62b



63
COUPLING



63c
THREADED COUPLING



63b
STRIP COUPLING



63d
SHORT COUPLING



64
THREADED BOSS



65
CENTRE FORK



69 - ⅝"; 4 mm
SET SCREW



69a - ⅝"; 4 mm
GRUB SCREWS



69b - ⅞"; 5 mm



69c - ⅞"; 3 mm

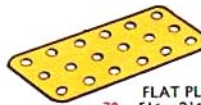

70 - 5½" × 2¼"; 14 × 6 cm
72 - 2½" × 2¼"; 6 × 6 cm
73 - 3" × 1½"; 75 × 38 mm
74 - 1½" × 1½"; 38 × 38 mm
76
FLAT PLATES

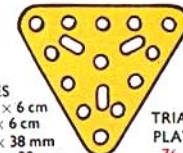

76
TRIANGULAR PLATES
76 - 2¼"; 6 cm
77 - 1"; 25 mm



80a - 1½"; 29 cm
80b - 4½"; 11½ cm
80c - 3"; 7½ cm
81 - 2"; 5 cm
82 - 1"; 25 mm
80a - 3½"; 9 cm
80 - 5"; 12½ cm
80 - 8"; 20 cm
80 - 11½"; 29 cm
80 - 1"; 25 mm
80 - 2"; 5 cm
80 - 3"; 7½ cm
80 - 4½"; 11½ cm
80 - 5"; 12½ cm
80 - 6"; 15 cm
80 - 7"; 17½ cm
80 - 8"; 20 cm
80 - 9"; 22½ cm
80 - 10"; 25 cm

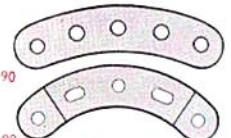

90a
CURVED STRIP
89 - 5½"; 14 cm
90 - 2¼"; 6 cm
89a - 3"; 7½ cm
89b - 4"; 10 cm
90a - 2¼"; 6 cm
CURVED STRIP STEPPED



94 - 40"; 1 metre
SPROCKET CHAIN



95 - 2"; 5 cm
95a - 1¼"; 38 mm
95b - 3"; 75 mm
96 - 1"; 25 mm
96a - ½"; 19 mm
SPROCKET WHEELS

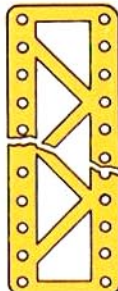

101
HEAD FOR LOOM

102
SINGLE BENT STRIP

97 - 3½"; 9 cm
99 - 12½"; 32 cm
99a - 9½"; 24 cm
99b - 7½"; 19 cm
100 - 5½"; 14 cm
BRACED GIRDEES

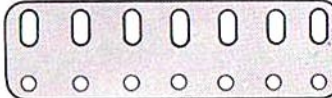

103 - 5½"; 14 cm
103a - 9½"; 24 cm
103b - 12½"; 32 cm
103c - 4½"; 11½ cm
103d - 3½"; 9 cm
103e - 3"; 7½ cm
103f - 2¼"; 6 cm
103g - 2"; 5 cm
103h - 1½"; 38 mm
103i - 1½"; 38 mm
103j - 1½"; 38 mm
103k - 7½"; 19 cm
FLAT GIRDEES

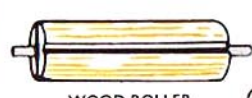

106
WOOD ROLLER

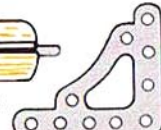

108
CORNER GUSSET



109 - 2¼"; 6 cm
FACE PLATE



110 - 3½"; 9 cm
110a - 6½"; 16½ cm
RACK STRIPS



111 - ½"; 19 mm
111a - ⅞"; 12 mm
111c - ⅞"; 9 mm
111d - 1"; 28½ mm
BOLTS

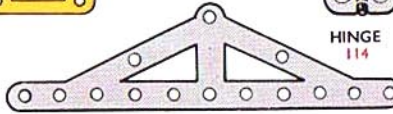

113
GIRDER FRAME



114
HINGE



115a
THREADED PINS
115a long. 1½"; 34 mm



116a
FORK PIECE LARGE



116a
FORK PIECE SMALL

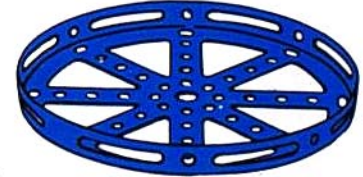

118 - 5½"; 14 cm
HUB DISC



120b - ⅞"; 14 mm
COMPRESSION SPRING



122
LOADED SACK



123 - 1½" × 1" × ¾"; 32 × 25 × 19 mm
CONE PULLEY



124 - 1"; 25 mm
125 - ½"; 12 mm
REVERSED ANGLE BRACKETS



126
TRUNNION



126a
FLAT TRUNNION



128
BELL CRANK



130 - ¼" × ¾" × ¼"; 6 × 9 × 12 mm
ECCENTRIC TRIPLE THROW



130a - ¼"; 6 mm
ECCENTRIC SINGLE THROW



131
CAM



133 - 1½"; 38 mm
133a - 1"; 25 mm
CORNER BRACKETS



134 - 1"; 25 mm
CRANK SHAFT



136
HANDRAIL SUPPORT COUPLING



136a
HANDRAIL COUPLING

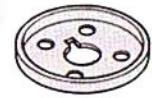

137
WHEEL FLANGE



138
SHIP'S FUNNEL



139 (right)
139a (left)
FLANGED BRACKET



140
UNIVERSAL COUPLING



142a - 2"; 5 cm
142b - 3"; 7½ cm
142c - 1"; 25 mm
142d - 1½"; 38 mm
MOTOR TYRES



143 - 5½"; 14 cm
CIRCULAR GIRDER



144
DOG CLUTCH



145 - 7½"; 19 cm
CIRCULAR STRIP

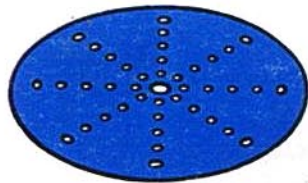

CIRCULAR PLATES
146a - 4"; 10 cm
146 - 6"; 15 cm



PAWL WITH PIVOT BOLT & NUTS
147



PAWL
147a



PIVOT BOLT
147b



147c PAWL WITHOUT BOSS



RATCHET WHEEL
148



PULLEY BLOCKS
153 TRIPLE
151 SINGLE



CORNER ANGLE BRACKET
154a - 1/2"; 12 mm (right)
154b - 1/2"; 12 mm (left)



RUBBER RING
155 - 1"; 25 mm



FAN
157 - 2"; 5 cm



CHANNEL BEARING
160 - 1 1/2" x 1" x 1/2";
38 x 25 x 12 mm

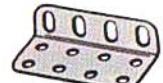

GIRDER BRACKET
161 - 2" x 1" x 1/2";
50 x 25 x 12 mm

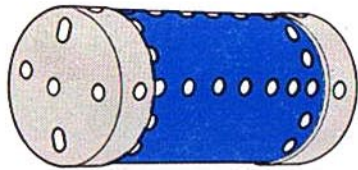

BOILER
162 BOILER COMPLETE - 5" x 2 1/2"; 12 1/2 x 5 cm
162a BOILER END - 2 1/2" x 2"; 50 x 19 mm



SLEEVE PIECE
163 - 1 1/2" x 1 1/2";
38 x 17 mm



CHIMNEY ADAPTOR
164 - 1/2" x 1/2";
16 x 12 mm



SWIVEL BEARING
165



END BEARING
166



LARGE TOOTHED QUADRANT PINION
167c



FLANGED RING
167b - 9 1/2"; 25 cm



LARGE TOOTHED QUADRANT
167a

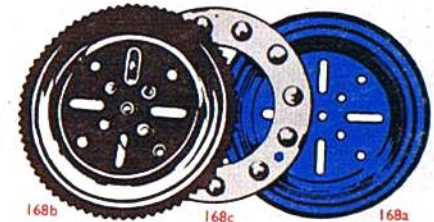

168 BALL THRUST BEARING COMPLETE 4"; 10 cm
168a AND 168b BALL THRUST RACES
168c BALL CAGE



168d BALL
3/8"; 9 1/2 mm



173a ADAPTOR FOR SCREWED ROD



179 ROD SOCKET



171 SOCKET COUPLING



176 ANCHORING SPRING



175 FLEXIBLE COUPLING UNIT



GEAR RING
180 - 3 1/2"; 9 cm



STEERING WHEELS
185 - 1 1/2"; 4 1/2 cm
185a - 2"; 60 mm



DRIVING BANDS
light 186 - 2 1/2"; 6 cm 186c - 10"; 25 cm
heavy 186a - 6"; 15 cm 186d - 15"; 37 1/2 cm
186b - 10"; 25 cm 186e - 20"; 50 cm



ROAD WHEELS
187 - 2 1/2"; 60 mm
187b - 4 1/2"; 108 mm



CONICAL DISC
187a - 1 1/2"; 47 mm

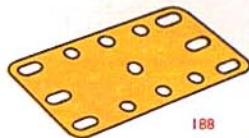

188 FLEXIBLE PLATES
188 - 2 1/2" x 1 1/2"; 60 x 38 mm
189 - 5" x 1 1/2"; 140 x 38 mm
190 - 2" x 2 1/2"; 6 x 6 cm
190a - 3" x 2 1/2"; 9 x 6 cm
191 - 4" x 2 1/2"; 11 1/2 x 6 cm
192 - 5" x 2 1/2"; 14 x 6 cm
193 TRANSPARENT PLATES
193 - 2 1/2" x 1 1/2"; 60 x 38 mm
193a - 2 1/2" x 2 1/2"; 60 x 60 mm

193b - 3 1/2" x 2 1/2"; 90 x 60 mm
193c - 4 1/2" x 2 1/2"; 115 x 60 mm
193d - 5 1/2" x 1 1/2"; 140 x 38 mm
193e - 5 1/2" x 2 1/2"; 140 x 60 mm
BLUE PLASTIC PLATES
194 - 2 1/2" x 1 1/2"; 60 x 38 mm
194a - 2 1/2" x 2 1/2"; 60 x 60 mm
194b - 3 1/2" x 2 1/2"; 90 x 60 mm
194c - 4 1/2" x 2 1/2"; 115 x 60 mm
194d - 5 1/2" x 1 1/2"; 140 x 38 mm
194e - 5 1/2" x 2 1/2"; 140 x 60 mm

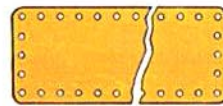

STRIP PLATES
195 - 7 1/2" x 2 1/2"; 19 x 6 cm
196 - 9 1/2" x 2 1/2"; 24 x 6 cm
197 - 12 1/2" x 2 1/2"; 32 x 6 cm

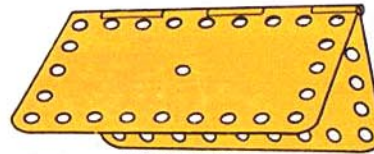

HINGED FLAT PLATE
198 - 4 1/2" x 2 1/2"; 11 1/2 x 6 cm

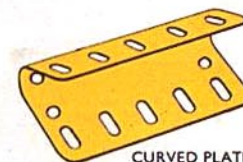

CURVED PLATE U SECTION
199 - 2 1/2" x 2 1/2" x 1/8";
60 x 60 x 7 mm

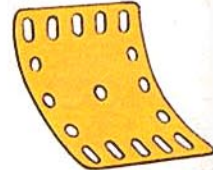

CURVED PLATE
200 - 2 1/2" x 2 1/2" x 1 1/8";
60 x 60 x 43 mm

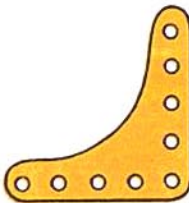

FLEXIBLE GUSSET PLATE
201 - 2 1/2" x 2 1/2";
60 x 60 mm



HELICAL GEARS
211a - 1/2"; 12 mm
211b - 1 1/2"; 38 mm
can only be used together.



212 ROD AND STRIP CONNECTOR
212a ROD AND STRIP CONNECTOR RIGHT ANGLE

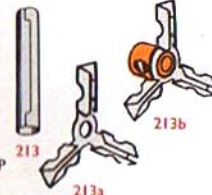

ROD CONNECTORS
213

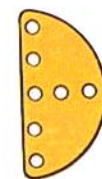

SEMI-CIRCULAR PLATE
214 - 2 1/2"; 6 cm

FORMED SLOTTED STRIP
215 - 3"; 7 1/2 cm

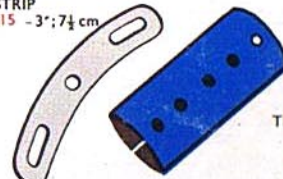

CYLINDER
216 - 2 1/2" x 1 1/2";
60 x 30 mm

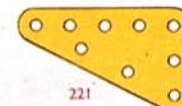

221 TRIANGULAR FLEXIBLE PLATES
221 - 2 1/2" x 1 1/2"; 60 x 38 mm
222 - 2 1/2" x 2"; 60 x 50 mm
223 - 2 1/2" x 2 1/2"; 60 x 60 mm
224 - 3 1/2" x 1 1/2"; 90 x 38 mm
225 - 3 1/2" x 2"; 90 x 50 mm
226 - 3 1/2" x 2 1/2"; 90 x 60 mm



223 KEY BOLT
231



ROD WITH KEYWAY
230 - 4"; 10 cm

NARROW STRIPS
235 - 2 1/2" x 1 1/2"; 60 mm x 9 mm
235a - 3" x 1 1/2"; 75 mm x 9 mm
235b - 3" x 1 1/2"; 90 mm x 9 mm
235d - 4 1/2" x 1 1/2"; 115 mm x 9 mm
235f - 5 1/2" x 1 1/2"; 140 mm x 9 mm